

Foreword

Thank you for choose BJ40.

Before using this vehicle for the first time, please read this manual carefully. This manual is applicable to BJ2021, BJ2022 series light off-road vehicle and its derivative models. This manual is helpful for you to get familiar with the structure, functions, usage and related regulations of the company. Any loss caused by failure to follow the instructions of this manual or modification without the approval of the company, the user will lose the right to claim, and any warranty claim will be denied by the authorized service provider of the company. The contents contained in the manual will help you master the correct methods of driving and maintenance of the vehicle, so that you can enjoy driving fully.

This manual aims to provide users with instructions on the use and maintenance of BJ2021, BJ2022 series light off-road vehicles and their derivative models. Please check the purchase contract for the specific configuration of the vehicles you purchase. If you have any questions about this car and this manual, please contact BAIC authorised dealership in your territory.

The equipment and performance of subsequent models will be subject to change without prior notice, as the company will continue to modify and improve the vehicles. . Please note that this manual applies to all models and explains all equipment, including options. Therefore, you may find some explanations for equipment not installed on your vehicle.If you have any questions about the vehicle and this manual, please contact BAIC authorised dealership in your territory.

Drivers must strictly abide by all car-related laws and regulations. At the time of writing this manual, the relevant effective laws and regulations have been fully considered and complied with, but some of the items may not meet the latest revised laws and regulations at the time of purchase.

When you resell the vehicle, please attach this manual to the new user so that the new user can obtain the relevant information in the manual.

Foreword

Warnings, cautions, tips, and certain special symbols will appear frequently in this manual. Special attention should be paid to these contents. Ignoring these warning instructions may result in personal injury or damage to your vehicle.



“Warning” means that failure to follow instructions will likely result in serious personal injury or death.



“Caution” means that dangerous or unsafe operations will result in personal injury or damage to the vehicle;



“tip” Give useful information.

* All content with this symbol indicates that the equipment and features mentioned are optional part or optional function.

The company will continue to improve all models, so we reserve the right to make changes to any part of the vehicle, equipment or technical specifications at any time, thanks for your understanding. Data related to delivery scope, appearance, performance, size, weight, fuel consumption rate, specifications, and vehicle functions are all accurate at the time of printing. Some of the equipment described in this article may not be equipped on the model (please contact BAIC authorised dealership in your territory).

No part of this manual may be reproduced, copied, or translated without the written consent of the company, and may not be reproduced, stored in a public retrieval system, or transmitted electronically, mechanically, or in any other form.

The company reaffirms that it is solely responsible for the revision, interpretation and explanation of this user manual, and reserves all rights and rights of modification as stipulated in the Copyright Law.

BAIC International Development Co., Ltd

1.Safety operation instruction..... 3

Safety Driving4
Seat Belt10
Airbag system21
Children safety33
Safety label.....39

2. Operation of each component 40

Driving cabin.....41
Start and stop.....74
A/C system098
Headlight and view.....108
Seats and storage119
Accessories and refitting132

3. Driving Guide 134

Start and driving.....135
Drivetrain system145
Brake system.....146
Parking assistant system160
Driving skills.....164

4. Maintenance..... 173

Safety Maintenance.....174
Fuel System177
Internal maintenance180
External maintenance183
Engine compartment190
Engine oil.....194

Coolant	198
Brake fluid	202
Power Steering fluid.....	205
Battery.....	207
Windshield washer fluid and wiper blade.....	211
Tyre.....	214

5. When trouble arise..... 222

Warning triangle	223
Spare tire and tools.....	224
Fuse replacement.....	232
Bulb replacement	239
Emergency Start.....	239
Emergency to be towed	241

6. Technical data..... 134

Identification code	135
Vehicle parameters	145

1. Safe operation instruction

Safe Driving	4
Seat Belt	10
Airbag system	21
Vehicle safety for Children	33
Safety Label	39

Safe Driving

General Instructions

This chapter mainly introduces important information, operating methods, recommendations and safety precautions for safe driving. For the safety of you and the occupants, please read and abide by relevant regulations.

Cautions

- **The user should correctly identify the names of the various parts of the car before driving to understand the correct use of each switch.**
- **Learn about the proper use of the accelerator pedal, brake pedal, steering wheel, transmission, ABS system, and more.**

Warning

Please be sure to bring this manual with you. If you borrow or resell the vehicle, please be sure to hand this manual to the new owner.

Correctly adjust the seat

Before drive the vehicle, all passengers should make the seat back upright, adjust the seat back and fasten the seat belt correctly.

Always fasten the seat belt

Seat belts provide the best protection in all types of crashes. Although the airbag can assist the seat belt to protect it, the airbag is designed to inflate only when it hits the medium to severe front (within 30 degrees to the left and right). In addition, if the seat belt is not fasten before the crash, the airbag will even hurt the passengers. So even if your vehicle is equipped with airbags, make sure that you and all the passengers fasten the seat belts correctly.

All children are properly accommodated

Children should be properly placed in the rear seats instead of the front seats, which is the safest. When a child is too small to fasten a seat belt, it must be properly placed in the child protection device.

Be aware of the dangers of air bags

Airbags provide protection, but they can also cause serious or even fatal injuries to passengers who are too close or not properly protected. Especially for babies, young children and short stature adults. Be sure to follow all the instructions in this manual

Do not drive after drinking

You can't drive after drinking. After drinking, your ability to respond to changes in the environment will be reduced. The more you drink, the slower the reaction. So don't drink and drive, don't let your friends drink and drive.

Control the speed

Overspeed is the main cause of crash accidents. The faster the speed, the greater the risk. Do not overspeed the specified maximum speed limit and safety conditions beyond driving.

Keep the vehicle in safe driving

Tire bursting or mechanical failure is extremely dangerous. To reduce the possibility of such problems, the tires and condition should be checked frequently and the regular maintenance as specified in the maintenance schedule should be completed.

⚠ Warning

- Do not distract yourself from outside factors while driving, such as talking to the passengers or making a phone call.
- Do not drive a car when the reaction capacity is declining. Drugs, alcohol and drugs can weaken people's responsiveness.
- Strictly abide by traffic regulations and speed limits.
- Always pay attention to reduce the speed of the car and always adapt the speed to the current road conditions, traffic flow and weather conditions.

The properly sitting posture

Correct Sitting Posture of Driver

The sitting posture of the driver relates directly to driving safety and the degree of driver fatigue.

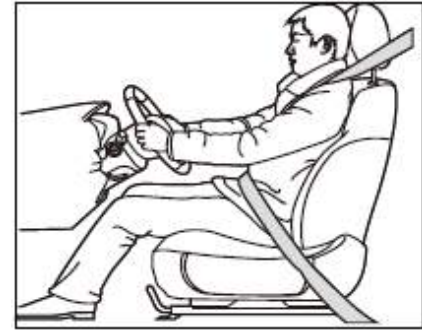

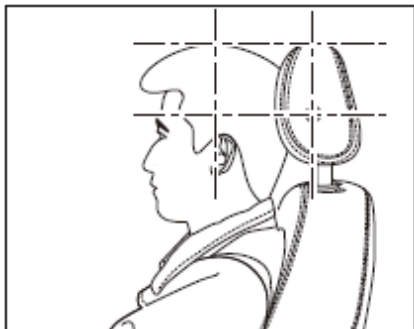

For his/her safety and the safety of passengers and to reduce the risk of personal injury and death during an accident, the driver should perform the following operations:

- Adjust the steering wheel so that a distance of at least 25cm is maintained between the chest and the steering wheel.
- Move the seat back and forth to a suitable position, so that the accelerator pedal and the brake pedal can be fully depressed when you slightly bend your knees.
- Ensure that you can hold the highest point of the steering wheel by slightly bending your elbow.

- Adjust the headrest so that its upper edge is level with the top of your head, and keep the back of your head as close to the headrest as possible.
- Adjust the backrest to a suitable angle so that your back fully fits against the backrest.
- Correctly fasten the Seat Belt

⚠ Warning

To reduce the risk of injury during an accident, please make sure that passengers strictly follow the following instructions:

- **Do NOT allow your chest to get too close to the steering wheel. Otherwise, the airbag system cannot provide effective protection and may even cause serious harm to you.**
- **Hold both hands on the outer ring of the steering wheel (positioned between point 9-10 at left hand and point 3-4 at right hand) to ensure that you can see all the instruments and indicator lights on the combination instrument.**
- **Adjust the steering wheel so that it faces your chest and confirm that the adjustment mechanism has been firmly locked. This can effectively reduce any harm which may be caused if the airbag is triggered.**
- **When driving, do NOT tilt the seat backrest too far. Make sure you wear your seat belt correctly and maintain the correct sitting position so as to**

Correct Sitting Posture of Front Passenger

To ensure his/her safety and to reduce the risk of injury, the front passenger should perform the following operations:

- Adjust his/her seat so that there is a suitable distance between the front passenger and the dashboard. This will ensure that when the airbag is triggered, it provides the most effective degree of safety protection.
- Adjust the headrest so that its upper edge is level with the top of your head, and keep the back of your head as close to the headrest as possible.
- Adjust the back rest so that his/her back fits the contours of the back rest.
- Correctly Wear a Seat Belt
- Put both feet in the foot well in front of the front seat.

⚠ Warning

To reduce the risk of injury during an accident, please make sure that passengers strictly follow the following instructions:

- **The front passenger must not be too close to the dashboard. Otherwise, the airbag system cannot provide effective protection and may even cause serious injuries to the front passenger.**
- **When driving, do NOT put feet on the dashboard, extend legs out of the window, or sit cross-legged on the seat. Be sure to put both feet inside the foot well. Otherwise, the front passenger could very easily be injured during emergency braking or in the event of an accident.**
- **When driving, do NOT tilt the seat too much. Be sure to wear the seat belt correctly and maintain the correct sitting posture, so as to prevent injuries during emergency braking.**

Correct Sitting Posture for Rear Passengers

To ensure safety and reduce the risk of injuries during accidents, rear passengers must comply with the following instructions:

- Adjust the headrest so that its upper edge is level with the top of your head, and keep the back of your head as close to the headrest as possible.
 - Maintain an upright sitting posture and keep the back as close to the seat backrest as possible.
 - Put both feet in the foot well in front of the rear seat and keep the feet close to the floor.
 - Correctly Fasten the Seat Belt
- When carrying children, make sure to adopt proper measures in accordance with the relevant provisions.

Correctly Adjust Headrest

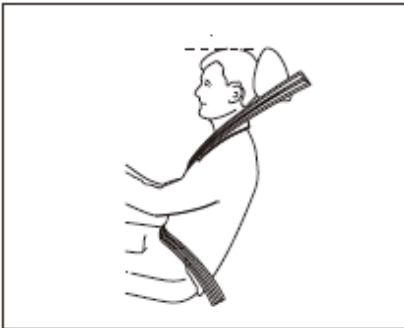

Adjust the headrest so that its upper edge is level with the top of your head, and keep the back of your head as close to the headrest as possible.

👁 Cautions

The lowest position of BJ40L rear seat headrest is not the service position, so before using it, the user must adjust it to the effective lock position to avoid hazard.

⚠ Warning

If the headrest is removed or is improperly adjusted, passengers could easily be injured or even be killed during emergency braking or accidents! To reduce the risk of accident injuries, be absolutely sure to strictly follow the following instructions:

- The headrest must always remain in the correct position, and be correctly adjusted.
- The driver and all passengers must adjust their headrest to the right position based on their body characteristics. The upper edge of the headrest must be level with the top of the head as much as possible, and the back of the head should be as close to the headrest as possible.
- While the vehicle is running, do NOT adjust the headrest. If you feel that you have to adjust your headrest after the vehicle has

been started, be sure to immediately stop the vehicle and only start driving again after you have adjusted the headrest to the correct position.

The Pedal Area

(Only for models with manual transmission)

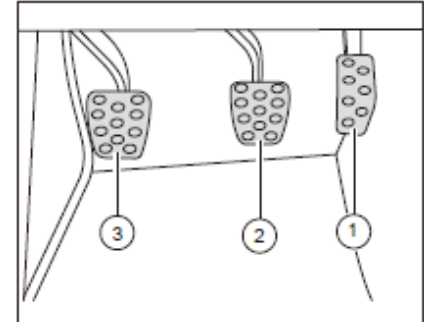

1. Accelerator pedal
2. Brake pedal
3. Clutch pedal

(Only for model with automatic transmission)

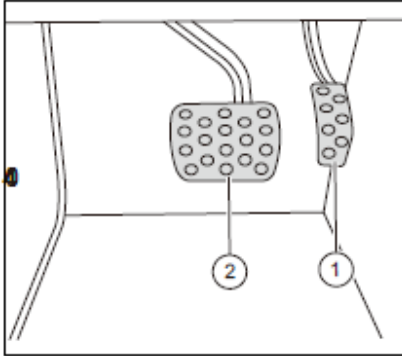

1. Accelerator pedal
2. Brake pedal

When driving the vehicle, ensure that all the pedals can be fully pressed to their limit and come back to their original positions, with no obstruction in the whole process.

When the braking system has a fault, the brake pedal may require a longer pedal stroke and force to stop the vehicle.

⚠ Warning

Pedal obstructions can easily cause serious accidents, leading to serious injuries.

Do NOT put any subjects inside the driver's foot well. Otherwise, such subjects may slip into the pedal area and obstruct the driver's pedal operations. In the event of emergency braking or other emergency situations, if the driver cannot operate the brake pedal, it could easily cause an accident.

Driver Side Foot Mat

The foot mat should be fixed inside the foot well and should not obstruct pedal movement

⚠ Warning

- Ensure that the foot mat is firmly fixed inside the driver side foot well.
- Do NOT lay other foot mats or covers over the foot mat. This may reduce the pedal stroke and obstruct pedal movement.
- If the foot mats removed from the vehicle for cleaning it must be properly fixed again when re-installed.

Seat Belt

1. General Instructions

Your life is precious. Please make sure that you wear a seat belt!

- This Section conveys the message that correct use of seat belts can markedly reduce the risk of injury!
- Wear a seat belt as required by this Manual. Ensure that the seat belt is available for use at any time and free of damage.

⚠ Warning

To reduce the risk of accident injuries, make sure that you strictly follow these instructions:

- Failure to correctly wear a seat belt or failure to wear a seat belt at all will increase your risk of serious injury.
- Correctly wearing a seat belt can reduce serious injuries in the event of emergency braking and accidents. For safety reasons, whenever you drive your vehicle, you and passengers should wear seat belts throughout.

⚠ Warning

- Pregnant women and the disabled must also wear seat belts. Otherwise, these drivers or passengers may also be seriously injured. The best way to protect unborn babies is to properly protect the mother during her entire term of pregnancy.
- Seat belts can only play a protective role when used correctly. Failure to wear a seat belt or failure to wear a seat belt correctly increases the risk of injury and death.
- Before driving off, make sure your seat belt is properly configured. Even if you are only driving in urban traffic, your front and rear passengers should also wear their seat belts to ensure their safety.
- Do NOT share a seat belt between two people (even if they are children). If your child sits on your knees, wearing a seat belt in this way can be dangerous to your child.

⚠ Warning

- When driving, do NOT loosen a fastened seat belt.
- The seat belt must not be in contact with fragile subjects (such as glasses, ball pen, etc.), because this may lead to injury.
- The latch of the seat belt must be correctly inserted into the buckle. Wearing the seat belt in the wrong way will affect the protective function of the seat belt.
- Before wearing the seat belt, be sure to remove loose clothing (such as overcoats), so as to prevent them from affecting the fit between the seat belt and the body and affecting the protective function of the seat belt.
- The seat belt must be kept clean at all times. A very dirty seat belt may not retract properly into the automatic retractor housing.

⚠ Warning

- Even pregnant women should wear seat belts. The seat belt should be close to the hip as much as possible, so as to prevent it from exerting pressure on the lower abdomen.
- Pregnant women should sit in the back seat and remain upright as much as possible. They should stay clear of the steering wheel and dashboard. This can reduce injury to the mother and baby in the event of a vehicle collision, or when the airbag is triggered.
- If passengers do not wear their seat belts correctly, the seat belts cannot play their corresponding protective role.
- The latch socket must not be blocked with paper or similar objects, or it will not be possible to insert the latch into the buckle.

⚠ Warning

- If the seat belt is disjointed or broken, or there is damage to the seat belt joint, the automatic retracting device or the locking element, serious injury may be caused in the event of an accident. Therefore, be sure to regularly check all seat belt components.
- Do NOT attempt to repair, adjust, install or remove the pyrotechnic pre-tensioner or the other components of the seat belt. Do NOT attempt to make changes to the seat belt in any way. The components of the seat belt can only be installed, altered or removed by an authorized BAIC dealership.
- After an accident has occurred, be sure to have any damaged or deformed seat belts replaced at an authorized BAIC dealership. Even if there is no apparent deformation in the seat belts' appearance, they must still be replaced. In addition, also be sure to check the fastening device of the seat belt.

The other sections of this Chapter will explain in greater detail how to ensure your safety to the maximum extent.

However, please note that even when a seat belt is used correctly and the airbag has been inflated, it is still not possible to completely rule out the risk of death in accidents involving violent vehicle collisions.

Why should seat belt be used?

When a vehicle is in a frontal collision, the seat belt can reduce the forward inertia of the driver and passengers and minimize impact injuries on the vehicle passengers.

Physical Principles of Frontal Collisions

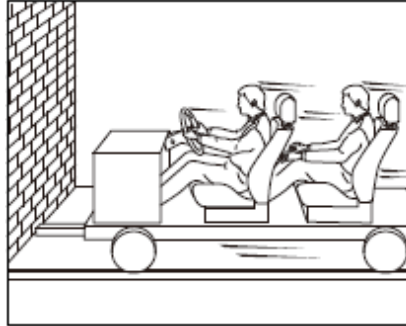

When driving, the vehicle and passengers all have energy (kinetic energy). The intensity of this energy depends on the vehicle speed and the mass of the passengers on board. The greater the speed and the mass, the greater the energy released during a collision. Among these factors, the vehicle's speed plays a decisive role. For example, when the vehicle's speed increases from 25 Km/h to 50 Km/h, the kinetic energy released will increase four times.

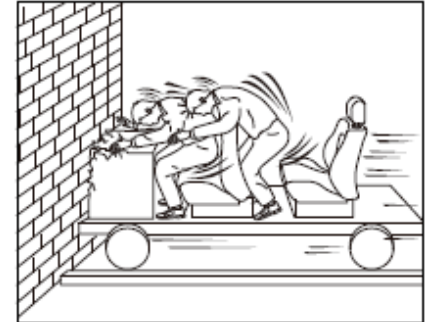

Passengers who do not fasten their seat belts are not “combined” with the vehicle into one body. Consequently, during a frontal collision, these vehicle occupants will continue to move forward at the pre-collision speed. The physical principle of collision introduced in this example applies to both frontal vehicle collisions and all other types of vehicle collision.

Consequences of Not Wearing a Seat Belt

Many people think that during a light vehicle collision, they can use their hands to protect their body and thus prevent injury. This is a misunderstanding!

During a vehicle collision, inertia will continue to propel all vehicle occupants not using seat belts, forward at the pre-collision speed. However, at this time, the vehicle will not continue to move with these occupants. Therefore, any unsecured, unbelted occupants may be seriously injured.

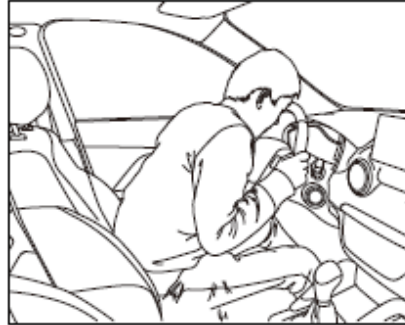

Even if the vehicle's speed is very low, the force acting on the human body is still very large during a collision. There is absolutely no way for vehicle occupants to use their hands to protect themselves. Any vehicle occupants who do not fasten their seat belts will be thrown forward. Once they bump into any object inside the vehicle, serious injury may result.



Rear passengers must also wear seat belts correctly. Otherwise, they will be thrown violently forward during a collision. Those rear passengers who are not wearing seat belts will not only be injured, but also endanger other occupants inside the vehicle.

⚠ Warning

- **Do NOT use your hands to try to protect your body during a collision. It may cause serious injury to you.**
- **There is no way for the airbag to replace the function of the seat belt. Regardless of whether an airbag is equipped, it is always necessary to wear a seatbelt correctly.**
- **Rear passengers must also wear seat belts correctly.**

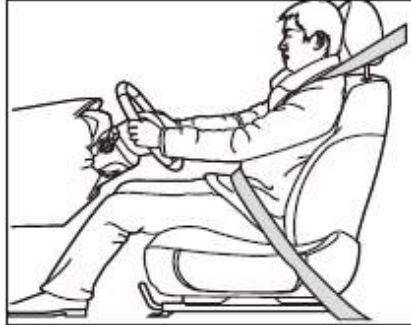

Wearing seat belts correctly can keep the driver and passengers in proper position and from injury. Correctly wearing a seat belt can prevent the driver and passengers from moving in an uncontrolled way and being placed in danger. A seat belt can absorb most of the kinetic energy generated during a collision. In addition, the crumple zone and other passive safety systems of the vehicle will concurrently absorb the energy generated in a collision and work in synergy with the seat belt to further reduce possible injury to the driver and passengers.

⚠ Warning

- **The seat belt must be worn in the correct position.**
- **Sharing one seat belt between two people is prohibited, even if they are children.**
- **When driving, be sure to constantly maintain the correct sitting posture, and wear a seat belt throughout your journey. Do NOT unfasten your seat belt during your journey. This can lead to accidents and injury.**
- **Do NOT damage or clamp the seat belt or allow it come into contact with sharp edges which may cause friction.**
- **When wearing a seat belt, try to avoid wearing loose clothing (remove it if you have already put it on) so as to prevent it from affecting the fit between the belt and the body.**
- **Be sure to always keep the seat belt system clean and in good condition. Do NOT let alien matter or liquid enter the buckle of the seat belt.**
- **Unauthorized seat belt removal or repair is strictly prohibited.**

Seat Belt Unfastened Warning Light



If the ignition switch has been turned on but the driver does not fasten the seat belt, the seat belt indicator light on the display screen of the instrument information center will be lit. If the driver does not fasten the seat belt and the vehicle speed exceeds 25km/h, or when the vehicle moves forward of a distance of 500m or for more than 60s at a speed of under 25km/h, the warning light will immediately be lit, accompanying an audible alarm.

Front passenger seat is also provided with seat belt unlock alarm to warn the passengers of correct use of the seat belt.

Correctly Wear a Seat Belt Wear a Front Seat Belt

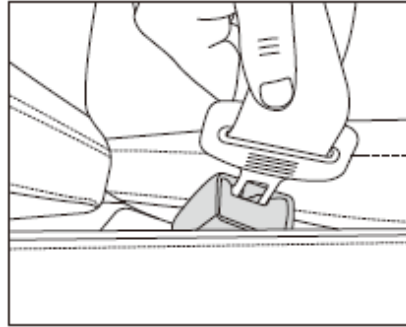

Correctly adjust the front seat and its headrest, pull out the seat belt from the retractor, insert the latch of the seat belt into the buckle, and tighten the seat belt. When the latch is locked inside the buckle, a clicking sound will be heard.

The seat belt length will automatically be adjusted according to your body size and seat position. In the event of emergency braking or collision, the tensioner will tighten the seat belt.

If you lean forwards too fast, the tensioner will also tighten.

Slowly and smoothly moving the expendable seat belt will allow you to move freely.

Be sure to pull out the seat belt after it has fully retracted. If the seat belt cannot be pulled out of the tensioner, you may first have to pull the seat belt with force and then release it. After this, you will be able to smoothly pull the seat belt out of the tensioner.

⚠ Warning

If the seat belt cannot be pulled out, you should pay attention to driving safety and go to an authorized BAIC dealership to have the seat belt checked.

Wear a Rear Seat Belt



Adjust the headrest of the rear seat if needed, sit upright in the rear seat and make your back fit the seat backrest as much as possible. Pull the seat belt out of the tensioner in the upper part of the nearer side, insert the latch of the seat belt into the buckle, and tighten the seat belt. When the latch is locked inside the buckle, a clicking sound will be heard.

⚠ Warning

In the event of an accident, failure to correctly wear the seat belt will make it impossible for the seat belt to play its protective role, thus causing serious personal injury.

- Only when the passenger is in the correct sitting position and is wearing the seat belt correctly can the seat belt fully play its role.
- The latch of the seat belt must correspond with the buckle and be correctly inserted.

i Tips

The other points of attention concerning the wearing of rear seat belts are the same as those of the front seat belts.

Seat belt Wearing Position

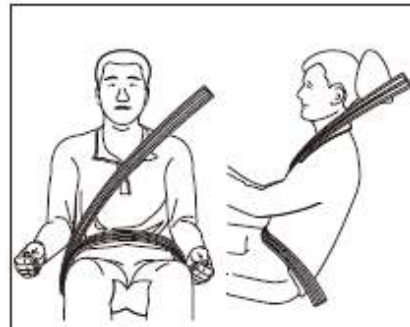

Seat belt design has fully taken into account the bone structure of the human body (such as pelvis, sternum and shoulders).

The protective role of the seat belt can only come into full play when it is correctly worn. A non-upright sitting posture will also reduce the protective role of the seat belt and could easily cause serious injuries. If the airbag is triggered during an accident, the impact of the airbag may cause serious injury to any occupant not in an upright sitting posture.

⚠ Warning

The protective role of the seat belt can only come into full play when the back rest is in an upright position and the seat belt is correctly fastened. In the event of an accident, wearing a seat belt incorrectly may cause serious injury to passengers!

● The seat belt must pass over the mid-part of the shoulders of the passenger. Do NOT tie it round the neck.

● The seat belt must remain flat and lay close to the chest of the user.

● The seat belt must pass over the pelvic area of the user. Do NOT press it against the stomach. The seat belt must lay flat, be close to the pelvic area, and be tightened as needed.

● If the seat belt is not fastened tightly enough and slides towards the stomach or neck, it may cause serious injury to passengers.

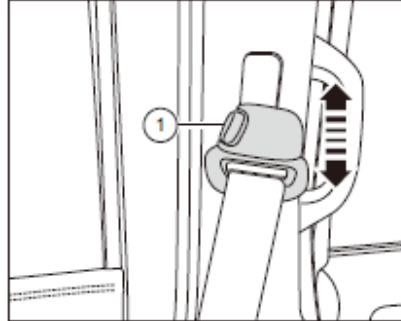
Adjust seat belt height

Use the seat belt height adjustment device to move the seat belt up and down so that it can fit the body snugly.

To adjust the seat belt upwards, directly raise the seat belt height adjustment device until it reaches the proper position. The methods to adjust the seat belt downwards areas follows:

1. Hold the guiding element of the seat belt -1-.
2. Move the guiding element downwards and adjust the seat belt to a position which suits your body.
3. Release the guiding element of the seat belt.
4. After adjusting the seat belt height, tug the seat belt and check whether the guiding element is firmly locked.

1 **How Should Pregnant Women Wear a Seat Belt?**

If you are a pregnant woman, the best way to protect yourself and your fetuses is to always wear your seat belt correctly when driving or sitting in the passenger seat, and letting the waist part of the seat belt run across your hips as low as possible.

When driving, you should keep an upright sitting posture and move the driver's seat backwards to a proper position to ensure that you can freely operate the vehicle. If you are sitting in front seat, make sure you move the seat backwards as much as possible, this will reduce the risk of injury to both mother and fetus during a collision when the front airbag inflates.

During each pre-natal check, be sure to ask the doctor whether it is still wise for you to drive.

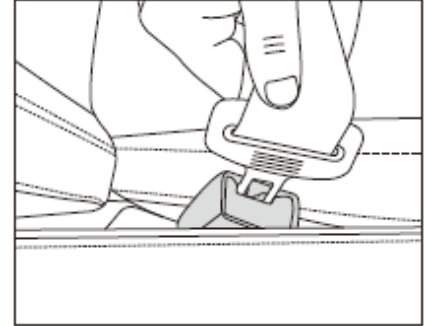
Unfastening Seat Belt

1. Press the red button beside the buckle of the seat belt, and the latch will automatically eject.
2. Hold the latch and move it back, and the tensioner will automatically retract the seat belt.

⚠ Warning

When driving, unfastening the seat belt is strictly prohibited, in order to prevent serious injury in the event of an accident.

👁 Cautions

- Before the vehicle fully stops, it is prohibited to unfasten the seat belt.
- When unfastening the seat belt, after the latch is released, it is necessary to retract the seat belt with the help of your hand to prevent the metal latch of the belt from injuring passengers when the seat belt is retracting quickly.

Seat Belt Retractor

All the front seats of this vehicle are equipped with seat belt retractors. When serious frontal or tail collisions happen, the sensor will trigger the seat belt retractor, and the retractor will tighten the seat belt in the direction of retraction and restrict the forward movement of the passengers.

The explosive pre-tensioner device of the seat belt can only be used once. In the event of a minor frontal collision, side collision or rear collision, side tipping or an accident without notable frontal action force, the seat belt retractor will not work.

👁 Cautions

- When the seat belt retractor is triggered, a small amount of smoke will be emitted. This is a normal occurrence and does not indicate that the vehicle has caught fire. There is no need to worry about it.
- When the seat belt retractor is discarded, the relevant safety regulations must be complied with. Authorized BAIC dealerships which are familiar with the relevant safety regulations may provide you with an enquiry service

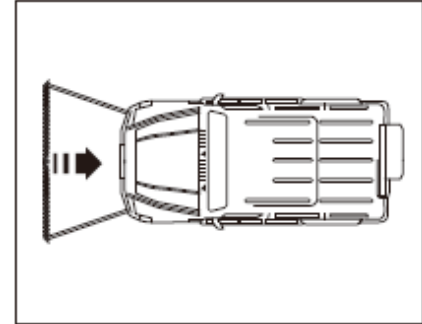

If any of the following situations arise, please contact an authorized BAIC dealership as soon as possible:

- The front part (marked in the figure) has been damaged, and the seat belt retractor does not work.
- The seat belt retractor or its surrounding parts are scratched, broken or have other damage.

Seat Belt Retractor Recycling and Disposal

The seat belt retractor is part of the seat belt system. All operations on the seat belt retractor or the removal of the seat belt retractor, as required for the repair of other vehicle parts, must be carried out by an authorized BAIC dealership. Otherwise, damage may be caused to the seat belt, and the seat belt retractor may not work normally during an accident.

To prevent personal injury or environmental pollution, all dismantled seat belt retractors must be disposed of in accordance with the relevant laws and regulations. Authorized BAIC dealerships which are familiar with the relevant safety regulations may provide you with an enquiry service.

Warning

Failure to get seat belt retractors renewed and checked by a BAIC authorized repair shop or professional personnel, or failure to correctly use the seat belt retractors in accordance with these provisions is bound to increase the risk of accident injuries.

- **Unauthorized repair, removal or installation of seat belts or seat belt retractor components is prohibited.**
- **All operations on the seat belt retractors and seat belts, including those to remove system components to allow the repair of other vehicle parts must be carried out by an authorized BAIC dealership.**
- **Each seat belt retractor can only be triggered once. All triggered seat belt retractors must be replaced.**

Airbag System

General Instructions

Correctly using seat belts can effectively reduce the risk of accident injuries. To enable the triggered airbag system to fully play its protective role, the driver and passengers must wear their seat belts correctly before the vehicle is started. The driver must correctly adjust the driver's seat and steering wheel, correctly adjust the headrest position and use a suitable child seat to protect any children in the vehicle.

Warning

The powder emitted when the airbag deploys may irritate the eyes and skin. It may also trigger asthma in susceptible people. After the airbag has deployed during an accident, use warm water and mild soap to thoroughly clean all exposed skin.

The Role of the Airbag

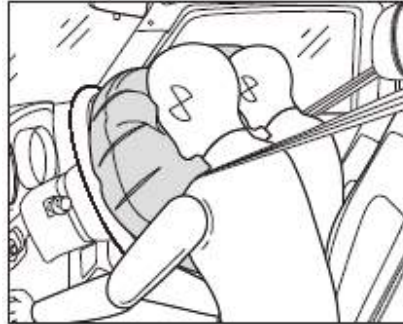

When a vehicle is involved in a serious collision with an obstacle, the airbag will quickly open out into a fully-inflated air cushion to prevent collision injuries to the driver and passengers as a result of inertia.

In the event of serious vehicle collisions, the airbag will fast deploy within an extremely short period of time. Therefore, the driver and passengers must maintain the correct sitting posture and wear their seat belts correctly to prevent serious injuries. In the event of a violent collision, any passengers who is not wearing his/her seat belt may be thrown forward into the

deployment area of the airbag. The fast-deploying airbag may cause injury or death of these passengers. This is particularly true in the case of children.

The driver and passengers must keep as far away from the front airbag as possible. This will effectively protect them because the airbag canfully inflate after triggering.

The factors that determine whether the airbags will trigger are the angle of collision and the magnitude of collision energy when an accident occurs. If the angle of collision and the magnitude of collision energy measured by the control unit at the time of the collision are below the ignition threshold of the control unit, the system will not trigger the air bag. Therefore, even if there is serious vehicle damage, it does not mean that the airbag will always be triggered.

 Warning

The factors that determine whether the airbag is triggered or not at the time of collision are related to the magnitude of collision energy, the type of accident, collision angle, and obstacle and vehicle speed.

 Cautions

If the chassis undergoes severe shock during driving of the vehicle, the airbag may be opened. As a result, to avoid unexpected opening of the airbag, take care when driving on grounds without manual treatment or not designed for driving of the vehicle.

Why Wearing Seat Belts and Adopting the Correct Sitting Posture Are Important

To enable the airbag to play its best protective role when triggered, it is necessary for the vehicle occupants to wear their seat belts correctly and assume the correct sitting posture. For your own safety and the safety of passengers, please pay attention to the following matters before driving:

- Always wear a seat belt in the correct way.
- Correctly adjust the position of the driver's seat and the steering wheel.
- Correctly adjust the position of the front passenger's seat.
- Correctly adjust headrest.
- Use suitable child seats to ensure the safety of children travelling in the vehicle.

 Warning

The release of the airbag happens very quickly. If you are not in the correct sitting position when it triggers, you may be fatally injured. It is therefore necessary to ensure that all passengers maintain the correct sitting posture during all journeys.

In the event of emergency braking or collision, any passengers not wearing seat belts may be thrown into the release space of the airbag. As the airbag is triggered, this may lead to fatal injuries to the passengers. This is particularly true for children.

Keep as far away from the front airbags as possible. There is only one way for the front airbags to deploy completely and play their protective role during an accident.

Danger of Installing a Child Seat on the Front Passenger Seat

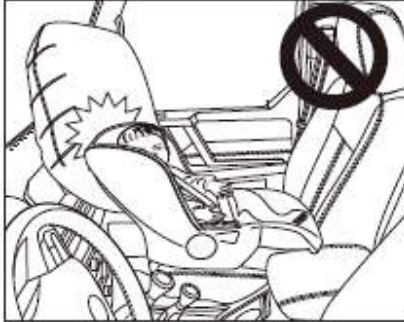

Installing a child seat facing backwards on the front passenger seat is prohibited. In the event of an accident, the triggered front passenger airbag will exert a great impact on the child seat and may cause fatal injury to the child.

The airbag fault warning light



The airbag fault warning light on the display screen of the combination instrument will alert you to any faults with the airbag and the seat belt pre-tensioner.

When the ignition switch is in the “ON” position, the warning light will be lit up and flash for 6-8s before going out, indicating that the system is working normally. When the ignition switch is in the “ACC” or “OFF” position, the airbag will not work.

If the following symptoms occur, it shows that the system is faulty and the airbag and seat belt pre-tensioner may not work normally in a collision. In such a case, you must go to an authorized BAIC dealership to arrange a check:

1. When the ignition switch is in the “ON” position, the airbag fault warning light does not light up or flash.
2. When the ignition switch is in the “ON” position, the airbag fault warning light is lit for several seconds but does not go out.
3. While the vehicle is running, the airbag fault warning light is lit.

Warning

If the system is faulty, the airbag will not be able to execute their protective functions normally.

1 Airbag Repair, Maintenance and Scrapping

Components of the airbag system are installed in different positions around the vehicle. All operations of the airbag system or operations that require the removal of airbag system components to allow the repair of other vehicle components must be performed by an authorized BAIC dealership. Otherwise, the airbag system may be damaged. As a result, in the event of an accident, the system may abnormally trigger the airbag or fail to trigger the airbag at all.

When scrapping the entire vehicle or airbag components, be absolutely sure to follow the relevant safety regulations. Authorized BAIC dealerships which are familiar with the relevant safety regulations may provide you with an enquiry service.

⚠ Warning

If repairs are not carried out by specialized technicians at an authorized BAIC dealership, the potential risk of injuries is increased. This is because the system may not trigger the airbag or trigger it when it is not needed in the event of an accident, thus serious injury or even death may be caused to passengers.

- Do NOT paste anything or cover the steering wheel or the soft plastic surface of the dashboard of the frontal passenger-side airbag assembly, or attempt to make any refitting to any of the above positions.

- Do NOT install devices such as a cup holder or telephone bracket on the airbag assembly casing.

- Do NOT fix items such as notepads or telephone brackets on the windscreen above the front passenger-side airbag. Otherwise, if the front passenger-side airbag is triggered, these items may fall and cause injuries to driver and passengers.

⚠ Warning

When cleaning the steering wheel or the dashboard, only use a dry or damp cloth. Do NOT use a solvent-containing cleaning agent to clean the surface of the dashboard or the airbag assembly. This is because solvents can cause the loosening of these components. When the airbag is triggered, broken plastic may cause serious injuries.

- The airbag system can only be triggered once, and all triggered airbags must be replaced.

- Do NOT try to repair, remove or install any of the airbag system components on your own.

- All operations on the airbag or all operations to remove the airbag required for the repair of other vehicle components (such as the steering wheel) must be performed by an authorized BAIC dealership. This is because authorized BAIC dealerships are equipped with special tools, repair documents and qualified specialist technicians.

⚠ Warning

- **Make sure to go to an authorized BAIC dealership to have the airbag system checked and repaired.**
- **Do NOT try to refit the front bumper or any of the vehicle body structures on your own.**

If you want to sell the vehicle, please tell the new owner that the vehicle is equipped with an airbag system and let him/her know the date of replacements of the airbag and its components. If the vehicle is scrapped, the undeployed airbag will pose potential risks. Therefore, before scrapping the vehicle, be sure to ask specialized personnel to safely deploy the airbag under special safe conditions.

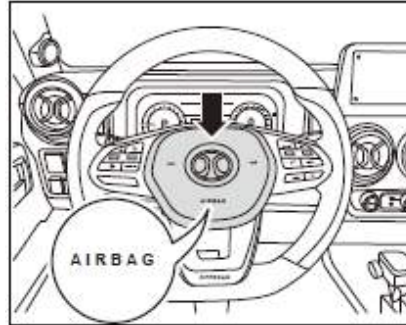
Front Airbags

The airbag for the driver is situated inside the steering wheel. Its position is marked with the word "AIRBAG".

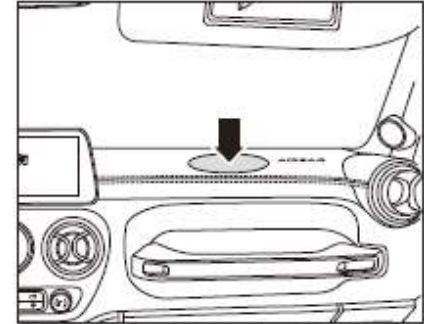

The airbag for the front passenger is installed inside the dashboard above the glove box and its position is marked with the word "AIRBAG". If the front passenger assumes the correct sitting posture and correctly fastens his/her seat belt, when the vehicle suffers a severe impact, the front airbag will provide additional protection to his/her chest and face.

The front airbag mainly consists of three parts:

- Electronic control and monitoring device.
- Two front airbags with gas generators.
- The airbag fault warning light is located on the display screen of the information center of the combination instrument.

The airbags are monitored by the electronic monitoring system of the airbag control unit. When the ignition switch is in the “ON” position, the airbag fault warning light will be lit for several seconds and then go out after self-detection is completed.

In the event of a serious frontal collision, the front airbags will act as a supplement to the three-point seat belt and protect the head and chest of the driver and the front passenger.

The airbag system cannot replace the seat belt. It is only one part of the passive safety system of the vehicle. Please note: The airbag system can play its protective role to the greatest extent when the seat belt is correctly fastened and the headrest is correctly adjusted. Therefore, it is necessary to always wear a seat belt, not only to comply with regulations, but also to serve safety needs.

Warning

- **Make sure to go to an authorized BAIC dealership to have the airbag system checked and repaired.**
- **Do NOT try to refit the front bumper or any of the vehicle body structures on your own.**

Caution

The deployment or shrinkage of the frontal airbag is completed within a very short period of time. The airbag cannot play a protective role against secondary impacts that may subsequently happen.

To ensure that the frontal airbag can correctly deploy and unfold, there should be no blocking objects between the frontal airbag and the passenger.

Caution

Placing any subjects near or over the steering wheel, the dashboard and the airbag assembly, inside the dashboard, or above the passenger-side glove box is prohibited. This is because, when the vehicle is involved in a collision serious enough to deploy the airbag, these subjects will fly out and cause injuries.

How Do the Front Airbags Work?

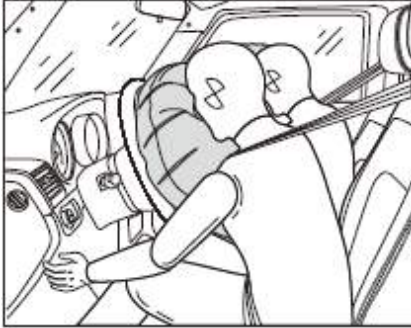

In the event of a collision, the airbag control unit will monitor the deceleration or acceleration caused by the collision and determine whether the front airbags should be deployed.

Whether the frontal airbags work is determined not by the vehicle's speed but by the collision object, direction of the collision, and the rate of vehicle deceleration. Therefore, some minor collisions may cause injuries because the frontal airbags do not deploy. By contrast, some relatively small structural damage may result in the deployment of the front airbags.

The event of serious frontal collision, the two front airbags and the seat belt will work and provide protection.

⚠ Caution

The front airbags are not intended for protection against rear impacts, minor frontal impacts or side impacts. Nor are they intended to deploy during vehicle tipping. The front bags do not play a role when the vehicle is engaged in emergency braking or is running along a bumpy road surface or low-lying land.

⚠ Warning

If the driver or passengers are not wearing their seat belts correctly or have failed to adopt the correct sitting posture, serious injury or even death may be caused in the event of an accident.

- The driver and passengers must make sure to correctly wear their seat belts and adjust their sitting posture before beginning a journey.

- When driving, do NOT let other passengers (children), pets or objects occupy the space between the front passenger and the airbag. Do NOT cover or paste anything to the surface of the steering wheel or the dashboard.

- On triggering, the airbags will contract quickly and will not block the driver's vision.

- Do Not try to repair, adjust or refit any part of the front airbags.

- Airbags can only be triggered once. If an airbag has been triggered accidentally, you must go to an authorized BAIC dealership to have it replaced.

If any of the following situations arises, please contact an authorized BAIC dealership as soon as possible:

- A frontal airbag has been inflated.
- The front of the vehicle (shaded part in the figure) encounters an accident, but the front airbag is not inflated.

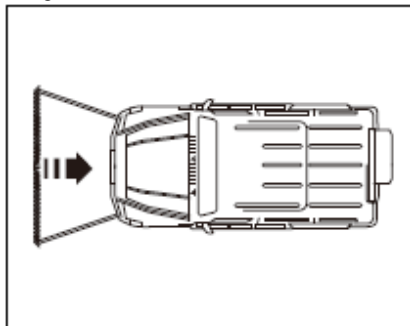

- The pad part of the steering wheel or the cover of the front passenger airbag (area shown by the arrow in the figure) is scratched or broken or has sustained other damage.

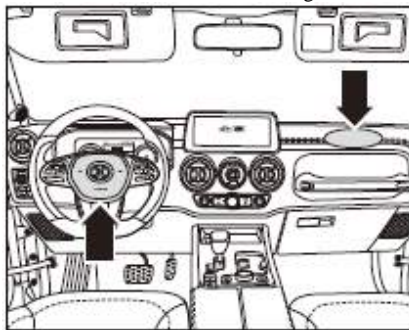

Deployment of the airbag

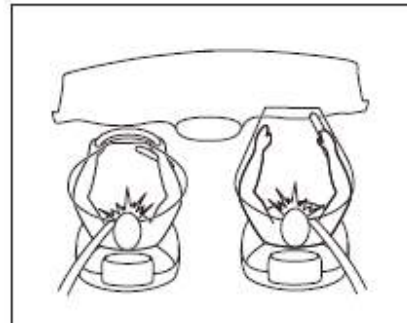

The front airbags deploy momentarily and apply a very large force, accompanied by a very loud sound. The deployed front airbag, together with the seat belt limiting system, restricts the distance of movement of the front passenger, thus reducing the risk of injury to the head and the trunk.

 Caution

After the front airbag has deployed, some of its components will be hot. Do not touch it before it cools down.

Airbags are designed especially to discharge gas in a controlled way under the pressure of the vehicle occupant's body and softly support the head and upper part of the body. During an accident, the airbag will continue to discharge gas to allow normal vision through the windscreen to be restored.

To promptly provide a protective cushion when an accident occurs, the airbag will quickly deploy at very high speed. When the airbag deploys, a small amount of smoke will be generated. This is completely normal. Do NOT mistake it for fire inside the vehicle.

If the vehicle is subjected to severe impact from the bottom, such as flying over a step, striking a step or hard object, crossing a deep pit or scraping the chassis, even if the deformation of the vehicle is slight, but because the rigid parts of the vehicle are affected, the airbag may also expand when the detected deceleration exceeds the set threshold value.

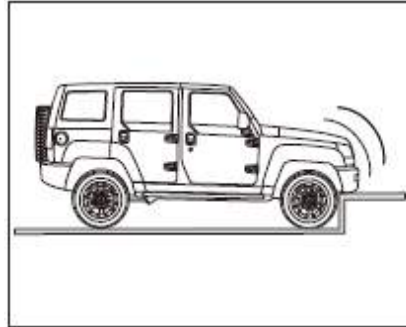

Hit a roadside step or hard object

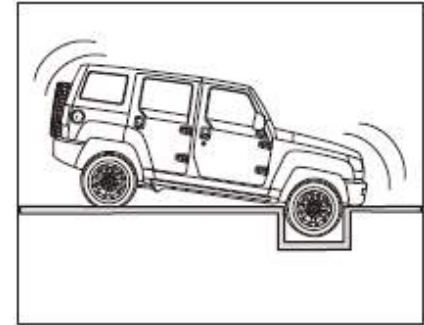

Vehicles Crossing Deep Pits

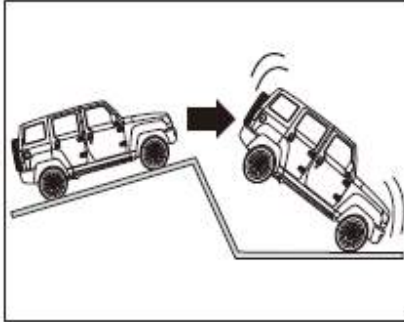

Vehicles falling or leaping steps

Seating Position

To ensure the best protective function, during serious impacts, the front airbags must unfold within a certain period of time.

If the vehicle passengers are too close to the front airbag, the deploying and deploying front airbag may bruise the face or injure other parts of the body.

⚠ Warning

To reduce injuries caused when the front airbag deploys, be sure to keep your seat belt fastened all times. In addition, the driver and front passenger must adjust their seat positions, and leave sufficient distance between them and the front airbags.

Conditions Under Which Airbag Does Not Deploy

In many types of accident, such as when the rear part of the vehicle is in a collision or a second or third time collision during a chain of collisions, or a low-speed collision, even if the airbags deploy, they may still not provide additional protection.

**Rear-End Collision**

When the front airbag is triggered, it is ejected from the driver's side or passenger's side and deploys. In the event of rear-end collision, under the action of inertia, passengers will move towards the back rest, and the airbag cannot protect them. In these circumstances, the airbag will not work.

**Side Collision**

In the event of a side collision, passengers move towards the point of impact. Therefore, an airbag which deploys in front of them cannot protect the passengers. In these circumstances, the front airbags will not deploy.

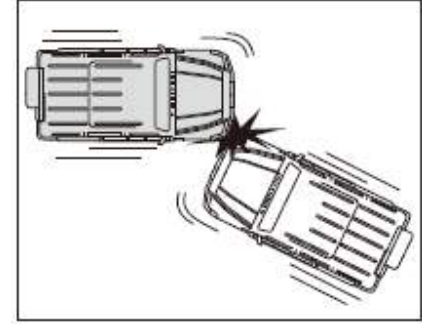
**Slanted Collision (oblique collision)**

In the event of a slanted collision, the collision force will move the passengers in a direction in which the front airbag cannot provide additional protection. At this time, the front airbags will not deploy.

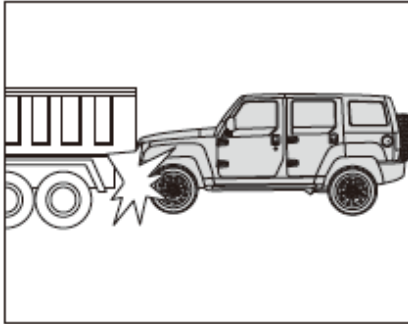
**Rear collision**

In the event of a rear collision, the driver will by instinct engage in emergency braking. At this time, the front of the vehicle will tend to dive towards the ground. In the event of this kind of collision or a rear-end collision, the front part of the vehicle will tend to dive into the other vehicle and the impact energy received by the collision sensor will not be large. In this situation, the front airbag will not work.

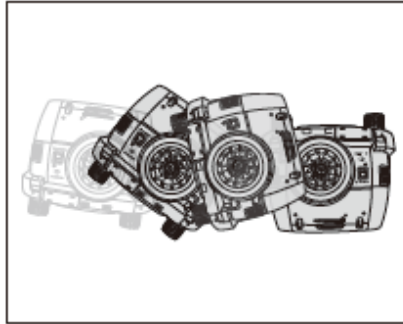
**Tipping Accident**

In a tipping accident, the front airbag will not deploy, because even if it deploys, it still could not provide proper protection to the vehicle passengers.

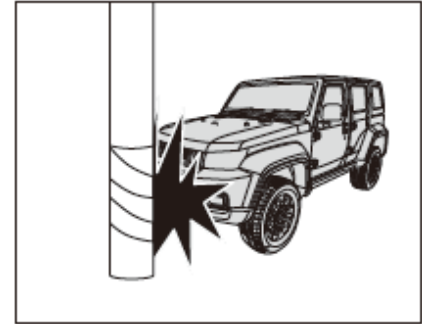
**Special Collisions**

If the vehicle collides with certain objects, such as electricity poles or trees, the collision point is concentrated in one place and the whole of the collision force is not transmitted to the sensor. In these circumstances the front airbags will not deploy.

Car Safety for Children

General Instructions

Accident statistics verify that it is safer for children to sit in the rear rather than the front seats of a vehicle.

It is recommended that children younger than 12 or no taller than 1.5m shall seat in the rear seats. Based on the child's age, height and weight, use a child seat or the seat belt to ensure the safety of children in the rear seats. For safety reasons, a child seat should be installed on the rear seat behind the front passenger seat.

Child seats should be installed and used in accordance with the relevant regulations and the child seat manufacturer's instructions.

We suggest that you put the child seat instructions and this Manual together and keep them in your vehicle.

When Several Child Passengers Have To Be Carried

There are three rear seats in your vehicle and you can use them to properly place child passengers.

When you need to carry more than three child passengers in your vehicle:

- For the child who has grown up to be suitable for wearing the seat belt, he/she can sit on the front seat (observe related national traffic laws to ensure safety).
- Move the vehicle seats backwards as much as possible.
- Encourage the children to sit close to the backrest and sit upright.
- Check whether they have correctly put on and fastened their seat belts.

Safety Instructions for Child Seats



When driving, **NEVER** hold a baby to your chest. The baby will be at serious risk of death if you ignore this instruction.

Using a child seat correctly can significantly reduce the risk of injury! As the driver, you should be responsible for the children in your vehicle:

- Choose a suitable child seat and use it correctly.
- Pay attention to the rules of the child seat manufacturer and ensure that the children wear their seat belts correctly

- When driving, do NOT become distracted by the children in your vehicle.
- When driving over a long period of time, be sure to have a rest midway through your trip every two hours at least.

⚠ Warning

- The protective role of seat belts can only work to the maximum extent when they are worn correctly.
- When driving, do NOT hold children or babies to your chest. Otherwise, in the event of an accident, injury or even death may be caused to children.
- Only a suitable child seat can effectively protect children.
- Do NOT leave children inside the vehicle alone. Due to significant regional weather variations, the internal temperature may become extremely high or low. If children are left inside the vehicle alone, fatal injuries may result.
- If there is no child protection system available, children under 1.5m in height must not use the conventional seat belt fitted inside the vehicle, If they do, in the

- event of emergency braking or accident, their abdomen or neck may be injured.
- One child seat can only be used by one child.
- Make sure to carefully read and follow the use instructions and precautions provided by the child seat manufacturer.
- Child seats should be installed and used in accordance with relevant regulations and provisions, with the relevant state laws and local regulations prevailing.



Do NOT install a child protection device facing backwards in the front seat of the vehicle. If you do this, when the airbag deploys, it will impact the back of the child protection device with a tremendous force, causing serious injury and even death to the child within it.

Child Seat

Child Seat Grade Classification (for reference use only):

Class 0/0+ child seats

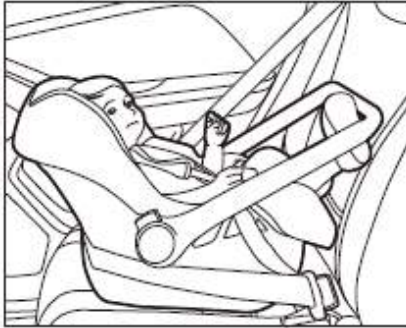

Babies who are under nine months old and have a body weight of under 10Kg, and babies who are under 18 months old and have a body weight of under 13Kg should use a class 0/0+ child seat which can be adjusted into a lying down position.

Class 1 child seats



Babies or infants who are under 4 years old and have a body weight of 9-18Kg should use a Class 1 child seat with a safety belt.

Class 2 child seats



Children who are under seven years old and have a body weight of 15-25Kg should use a three-point seat belt along with a Class 2 child seat.

⚠ Warning

- The upper part of the seat belt must run over the mid-point of the shoulder. In no circumstances should it run across the neck. The seat belt should also firmly fit the body.
- The lower part of the seat belt must run over the hips but not round the abdomen, and should always closely fit the body. If necessary, the seat belt may be adjusted.

Class 3 child seats



Children who are more than seven years old, and have a body weight of 22-36Kg and a height under 1.5m should use a three-point seat belt along with a Class 3 child seat.

⚠ Warning

- The upper part of the seat belt must run over the mid-point of the shoulder. In no circumstances should it run across the neck. The seat belt should also firmly fit the body.
- The lower part of the seat belt must run over the hips but not round the abdomen, and should always closely fit the body. If necessary, the seat belt may be adjusted.

ℹ Tips

Children who are over 1.5m tall may use the vehicle's existing seat belt without a child seat.

Correctly install the Child Seat

Before installing a child seat on the rear seat, make sure you adjust the front seat to a suitable position according to the dimensions of the child seat and the body size of the child. In the event of a collision or during emergency braking, a child sitting in the rear seat is less likely to be injured if coming into contact with hard objects inside the vehicle. Moreover, the child will also be protected against injury caused by airbag inflation. Absolutely do NOT carry babies on your knees.

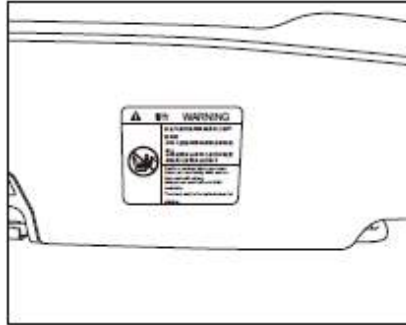

There is a warning label pasted onto the vehicle visor on the front passenger side, reminding you and the front passenger of the dangers posed by the front airbag. Be absolutely sure to read and follow the instructions on this label.

⚠ Warning

The seat belts of this vehicle do not provide a child seat strapping function. Do NOT use the seat belt to secure the child seat.

Installing a Child Seat Equipped with an ISOFIX System and Top Fastening Cord

Be absolutely sure to install and remove the child seat in strict accordance with the use instructions of the child seat manufacturer.

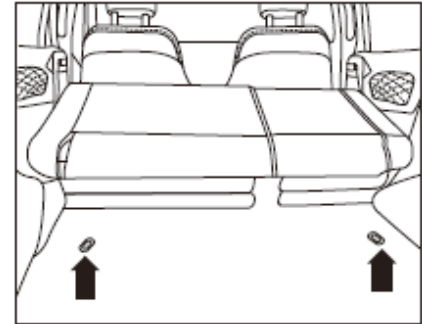

Installing

1. Slightly push up the headrest behind the child seat.
2. Run the top fastening cord through the headrest or, depending on the child seat construction, put the top fastening cord on both side of the headrest, and then pull the top fastening cord backwards towards the back of the rear seat.
3. Press the ISOFIX child seat into the fixing ring in the front part of the seat until a distinctive engagement sound is heard from the child seat.
4. Pull the two sides of the child seat and check whether it is firmly engaged.
5. Engage the ISOFIX fastening ring (in the position indicated by the arrow in the figure) of the top fastening cord and the top fastening cord hook of the rear seats.
6. Tighten the top fastening cord so that the child seat closely fits the back rest of the rear seat.

 **Warning**

- **The ISOFIX fixing ring on the back of the rear seats can only be used for the ISOFIX system.**
- **Do NOT connect fastening belts, non-ISOFIX child seats or any other items to the fixing ring.**
- **Only one top fastening cord can be connected to the rear fixing ring on the back of the rear seat. No other cords (such as luggage fastening cords) are to occupy this fixing ring.**

Safety label

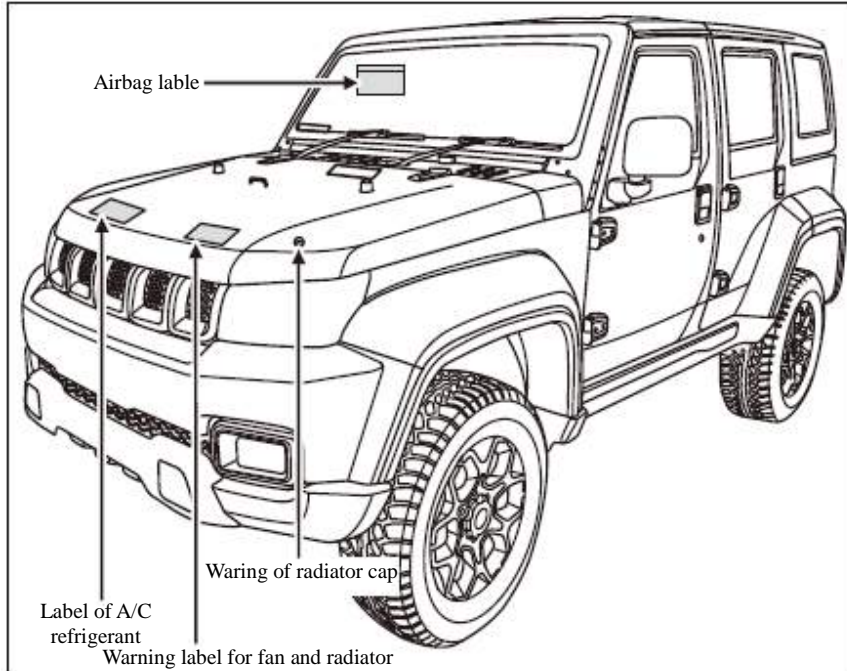

The positions of the safety labels of the vehicle are as shown in the figure. The airbag label is pasted to the outer side of the sun visor (in a closed state) on the front passenger's side, while the A/C refrigerant label, the fan & radiator label and the radiator cover danger warning label can only be seen after the engine hood is opened.

These labels are used to remind you to pay attention to those potential dangers which may cause serious injury. Please carefully read these labels. If a label falls off or becomes unclear, please promptly contact an authorized BAIC dealership to obtain a replacement.

2. Operation and Equipment

Cab	41
Locking and unlocking the vehicle	74
A/C system	98
Light and vision field.....	108
Seat and storage facilities	119
Accessories and Refitting	132

※Note: Numbers in all pictures of this chapter are for illustrative purpose only and do not necessarily reflect the real situation of the vehicle.

Cab

General Layout of Instruments and Operating Mechanisms

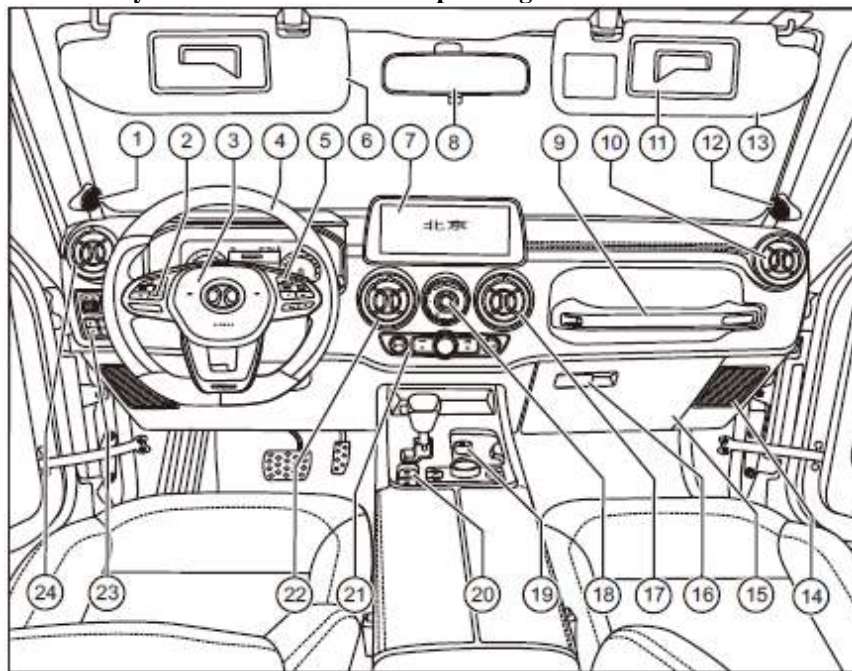

1. Left loudspeaker
2. Steering wheel left button group
3. Horn
4. Steering wheel
5. Steering wheel right button group
6. Driver's visor
7. Central display screen
8. Vehicle Rearview Mirror
9. Passenger handrail
10. Right air conditioning outlet
11. Sunshade makeup mirror (co-pilot side)
12. Right loudspeaker
13. Visor (passenger side)
14. Speaker
15. Glove box

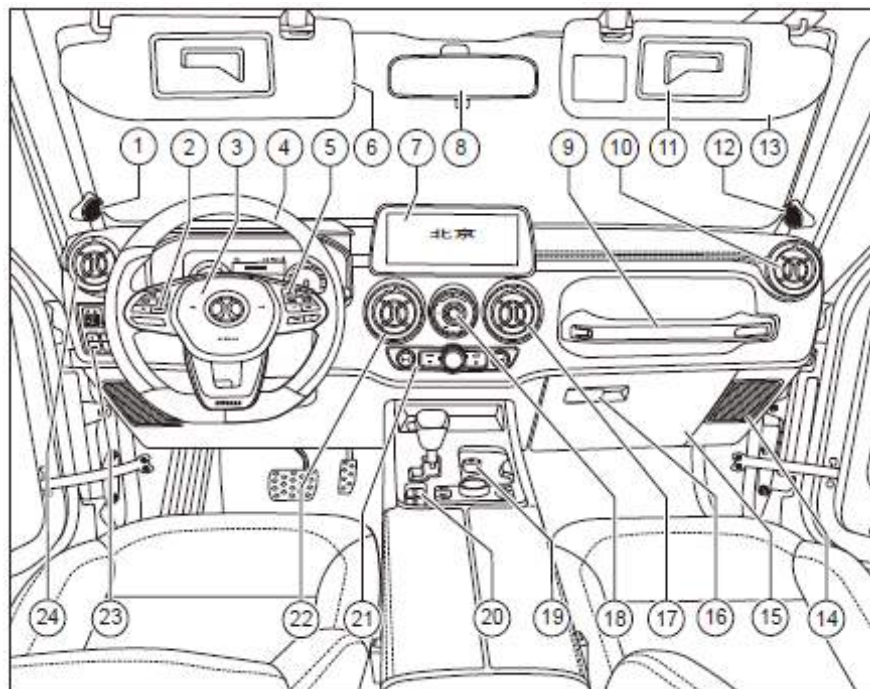

16. Glove box handle
17. Right air conditioning central outlet
18. Start/stop buttons, 4WD switches
19. The cigarette lighter
20. Electrical switch
21. Air conditioning control panel
22. Left air conditioning central outlet
23. Multifunctional Switch Set
24. Left air conditioning outlet

Central passageway layout (for vehicles equipped with manual gearbox)

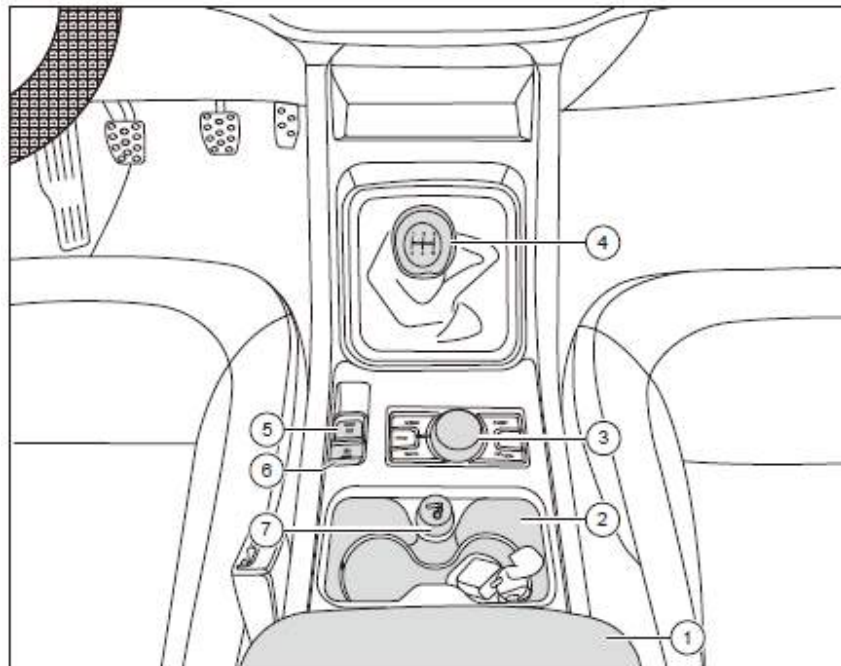

1. Front row central armrest
2. Cup holder
3. Multifunctional keys
4. Gearbox shift lever
5. Electronic Parking Brake Key
6. AUTOHOLD Key *
7. The cigarette lighter

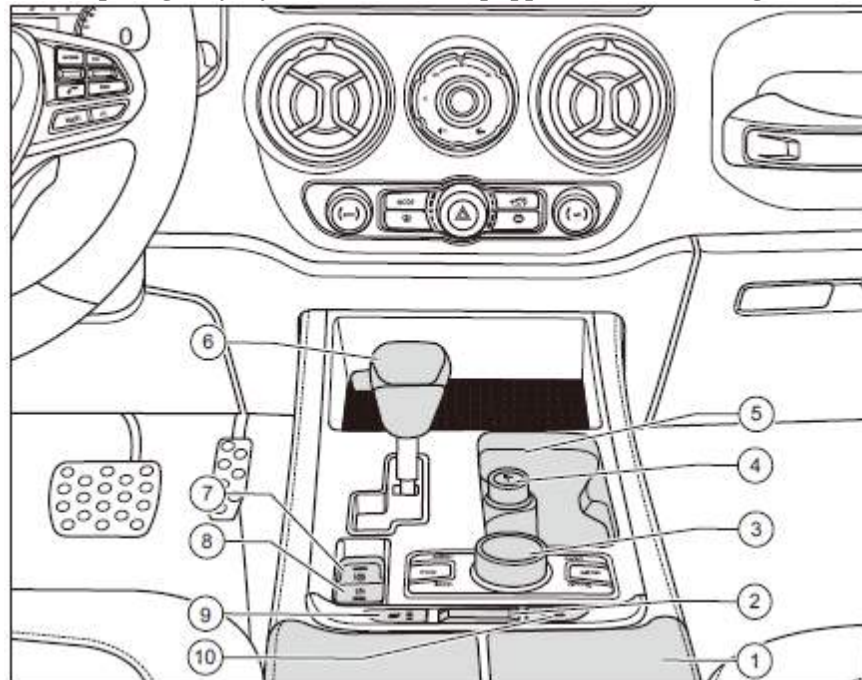
Central passageway layout (for vehicles equipped with automatic gearbox)

1. Front row central armrest/storage box
2. Central Storage Box Switch
3. Multifunctional keys
4. The cigarette lighter
5. Cup holder
6. Gearbox shift lever
7. Electronic Parking Brake Key
8. AUTOHOLD Key
9. Driver seat heating button
10. Passenger seat heating button

Instrument Cluster (Mode 1)

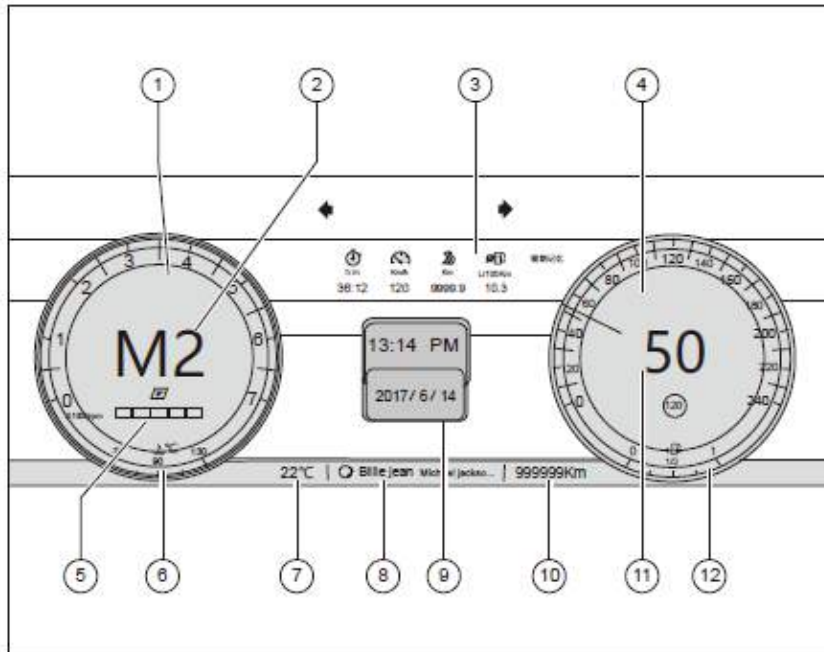

1. Tachometer
2. Gear Display
3. Trip computer: Short-term Memory, Long-term Memory, Fuel Consumption Information, Other Information and System Failure Information
4. Speedometer
5. Turbine pressure
6. Engine coolant temperature gauge
7. Outdoor temperature
8. Multimedia Information
9. Information display center: calendar/time, navigation (if equipped), tire pressure system (if equipped), front wheel steering (if equipped), off-road information, system Settings, alarm and prompt information
10. Odometer
11. Digital speedometer
12. Fuel gauge

Instrument Cluster (mode 2)

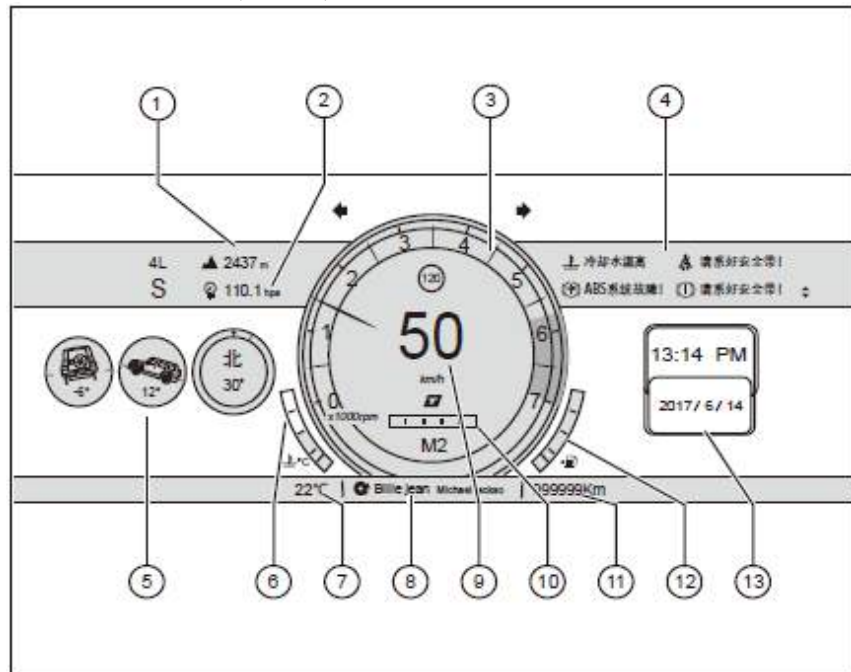

1. Relative height
2. The atmospheric pressure
3. Tachometer
4. Trip Computer: Short-term Memory, Long-term Memory, Fuel Consumption Information, Other Information and System Failure Information
5. Off-road Information
6. Engine coolant temperature gauge
7. Outdoor temperature
8. Multimedia Information
9. Digital Speedmeter
10. Turbine pressure
11. Odometer
12. Fuel Meter
13. Information Display Center: Navigation (if equipped), tire pressure system (if equipped), front wheel steering (if equipped), system settings, alarm and prompt information.

Engine tachometer

The engine tachometer represents the engine's speed per minute. (rpm)

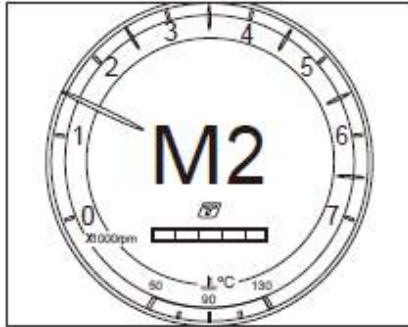

The starting point of the red area in the dial indicates the maximum allowable speed of the engine. When the engine has to undergo normal grinding and merging to normal working temperature, it can run at this maximum speed for a short time.

⚠ Caution

Engine tachometer should not be kept in red area, otherwise the engine will be easily damaged.

ℹ Tips

**Promptly shift up helps to save fuel and reduce engine noise.
The recommended RPM for manual gearing is 1900-2500.**

Speedometer



Speedometer represents the real-time speed of a vehicle in km/h.

Fuel Gauge

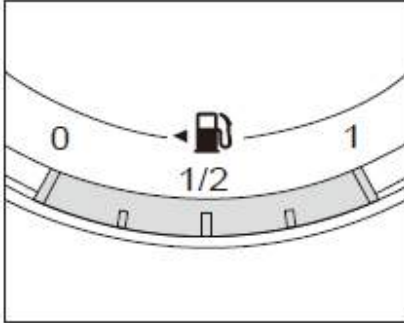

The fuel gauge is located at the lower part of the speedometer. When the start/stop button is located in the "RUN" position, the fuel gauge shows the remaining fuel in the fuel tank. The fuel tank is empty to full from "0" to "1". When the start/stop button is in the "OFF" position, the current remaining fuel cannot be displayed.

When braking, accelerating, turning or ramping, the fuel in the fuel tank will shake, which will affect the accuracy of fuel gauge display. The vehicle should be placed on a flat road to check the fuel volume.

After filling the fuel, it will take some time for the fuel level to stabilize before the fuel gauge can reflect the real fuel volume.

Fuel alarm lamp

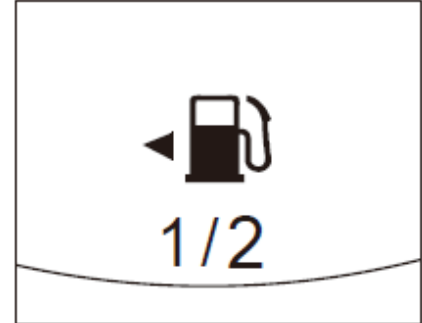

The fuel alarm lamp is located in the speedometer. When the remaining fuel in the fuel tank is too low, the alarm lamp lights up, prompting the driver to fill the fuel immediately. In addition, alarm information will appear in the display screen of information center.

Tips

Vehicles driving on uphill and downhill or bumpy road will cause fuel level instability, which will cause fuel alarm lamp alarm, please take the fuel level display in stable state as the standard.

If the following situation occurs, please immediately send the car to BAICdealerships for inspection:

- The fuel alarm lights continued to flash.
- When the vehicle is full of fuel, the fuel meter shows that the fuel is insufficient, and the fuel alarm lamp lights up and flash.

Engine coolant temperature gauge

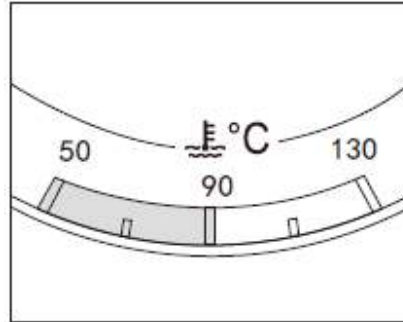

The meter is located at the lower side of the engine tachometer. When the start/stop button is in the "RUN" position, the engine coolant thermometer shows the coolant temperature.

In normal driving, the scale indicates that the temperature is generally near the middle position.

The needle of the engine coolant temperature gauge enters the high temperature zone, indicating that the coolant temperature is too high, which may cause serious damage to the engine, stop immediately to check or seek help if safety conditions permit.

If the scale bar is biased or stays in the high temperature range of the water thermometer for many times, and the coolant alarm lamp in the tachometer is lit, the engine should be stopped and extinguished as soon as possible in an appropriate position to check whether the coolant level and the coolant pipeline are leaking.

⚠ Warning

When the engine is running, it is strictly forbidden to open the coolant expansion tank cover. Because it's hot and cold under high pressure.

But the liquid and steam will be ejected, causing burns. Make sure that the engine is completely cooled before opening the coolant expansion tank. When operating, cover the coolant expansion tank with a large and thick cloth to prevent steam scalding of operators. When filling with oil and coolant, do not sprinkle oil on engine parts or exhaust system, because there may be fire, engine coolant can be ignited in certain condition

Engine coolant alarm lamp

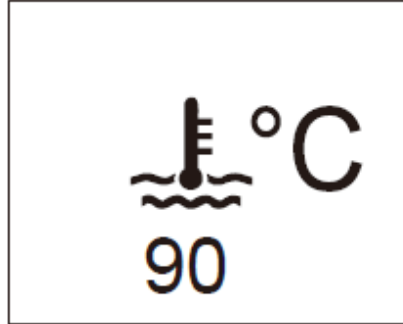

The engine coolant alarm lamp (red) is located in the engine tachometer. When the engine coolant temperature is too high, the alarm lamp lights up and the alarm interface pops up. At the same time, the buzz is 5. At this time, the engine should be stopped and extinguished as soon as possible in the right place, and the level of coolant and the leakage of coolant pipeline should be checked.

Left and Right Turn Indicators

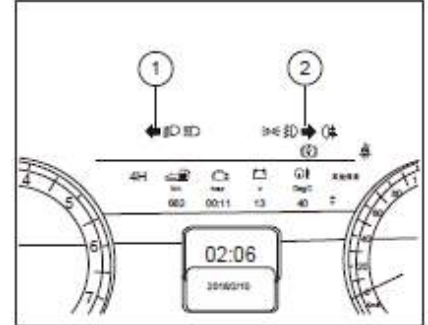

When the steering light is turned on by the light control lever, the indicator light on the corresponding side of the instrument - 1 - or - 2 - flashes and emits a rhythmic prompt sound.

ⓘ Tips

If the indicator lights flicker faster than normal frequency or are always on and not flickering, please check whether the bulb of the relevant side steering light or its circuit is out of order.

Four-drive status indicator

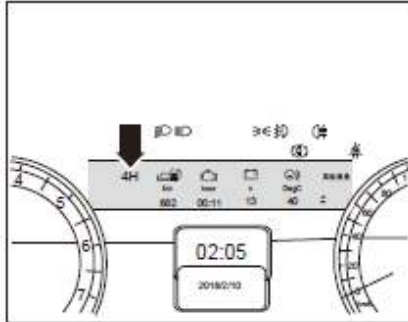

1. Four-wheel-drive high-grade status indicator "4H": When this light is on, it indicates that the vehicle is in the high-grade status of four-wheel-drive.
 2. Four-wheel-drive low-grade status indicator "4L": When this light is on, it indicates that the vehicle is in a four-wheel-drive low-grade condition.
- File usage status.

Trip Computer

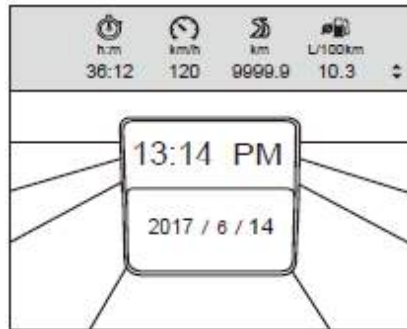

Short-term memory, long-term memory, other information and fuel consumption display are selected by pressing "UP" / "DOWN" button.

Information Center Display Screen

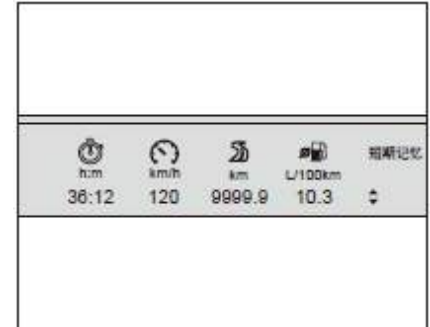

Short-term memory and long-term memory information from left to right are driving time, average speed, subOdometer and average fuel consumption. Short-term memory automatically resets and resets to zero after more than 2 hours of car stalling.

After the last short-term/long-term memory zero, the cumulative average speed of the vehicle starts from the time the vehicle is powered on and calculates from the last short-term/long-term memory zero; the subOdometer is from the last short-term.

Accumulated driving kilometres after long-term memory zero;

Average fuel consumption since the last short-term/long-term memory zero shows the average fuel consumption during vehicle driving.

Other information

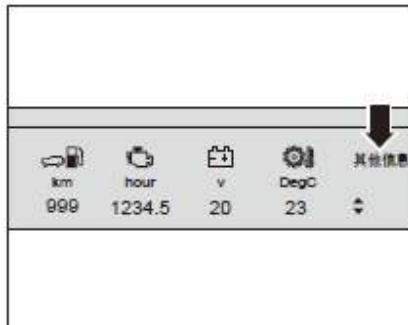

Other information from left to right are range, engine working time display, oil temperature display of gearbox (if equipped), and vehicle voltage display.

Running mileage: Display the mileage (km) that the vehicle can continue with the current fuel consumption. This data is updated in real time according to the average fuel consumption. In the course of driving, if the average fuel consumption is reduced, the remaining mileage will increase.

Engine working time: The accumulated time after the start of the automobile engine can be cleared in the following two ways: under the engine working time interface, by pressing the BACK button for 5 seconds for a long time, and by disconnecting the battery.;

Oil Temperature of Gearbox (if equipped): Display Oil Temperature of Gearbox, Celsius Display Range

Oil Temperature of Gearbox (if equipped): Display Oil Temperature of Gearbox, Celsius Display Range: 40°C ~ 214°C;

Vehicle Voltage: Display Vehicle Voltage,

Display Range 0 ~ 20V (For reference only)

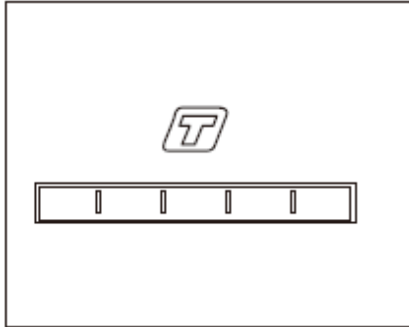
Turbine Pressure Display

The degree of turbocharger operation is indicated by the progress bar. The driver can understand the current working pressure of turbocharger under this interface.

Overspeed Alarm

Users set alarm speed by themselves in menu, and display alarm when the speed exceeds the set alarm speed.

Fuel consumption display

Fuel consumption information includes idling instantaneous fuel consumption and driving instantaneous fuel consumption. Instantaneous fuel consumption display "-. -L/h" when engine is not starting (RUN gear) and no fuel injection output.

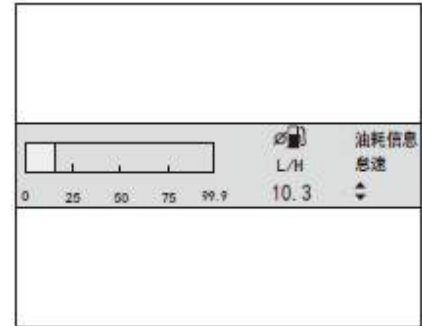
**Idle Instantaneous Fuel Consumption**

The demonstration range of instantaneous fuel consumption in idling process is as follows: 0.0 ~ 99.9L/h;

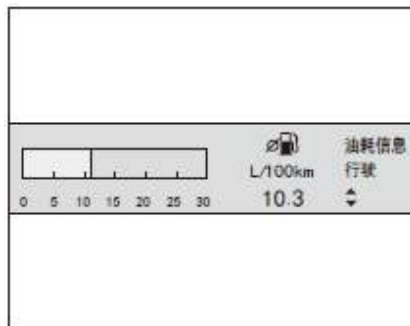

Instantaneous fuel consumption:

The demonstration range of instantaneous fuel consumption during driving is as follows: 0 ~ 30.0L/100km

Computer information for driving below

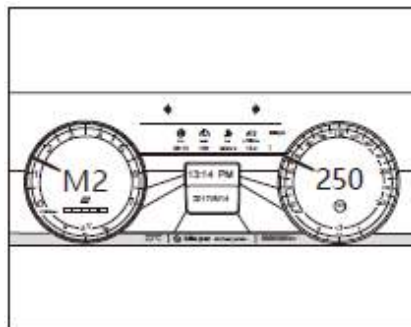

From left to right, the order is outside temperature display date/time display, cumulative mileage.

Outdoor temperature display:

When the vehicle is in normal condition, the area shows the current temperature outside the vehicle. This data comes from the temperature sensor outside the vehicle. It shows that the temperature is the ambient temperature of the temperature sensor, not the human body temperature.;

Date/time display:

Display format YYYY/MM/DD HH/MM/SS, default display 24-hour system;

Odometer display:

Displays the total distance the vehicle has been driven. This mileage cannot be cleared.

Information Display Center

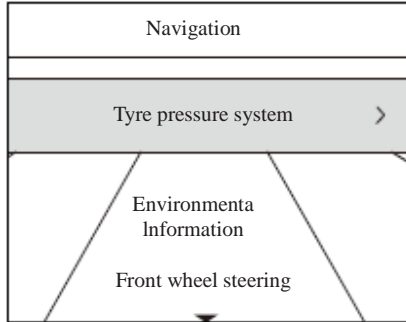

The information display center displays the time and calendar after ignition, enters the menu bar by pressing "OK" key, chooses by pressing "UP"/"DOWN" key, enters the corresponding Trip Computer interface by pressing "OK" key, and then clicks "OK" key again, and calls out the "menu bar" as follows: /

- Navigation interface* (if equipped)
- Tire Pressure System Interface* (if equipped)
- Environmental Information Interface

- Front wheel steering interface* (if equipped)
- System Setup Interface

Information Display Center

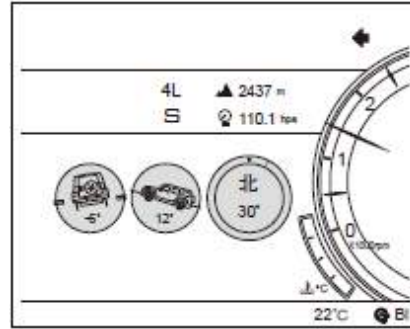

1. Clinometer

Display range: longitudinal inclination angle 40 degrees, lateral inclination angle 60°.

Tips

Geomagnetic principle the compass is greatly affected by the magnetic field. If it passes through areas with complex magnetic field or areas with large electromagnetic interference, the direction indicated by the compass will be inaccurate. After the magnetic field is stabilized, the compass needs to be calibrated again..

2. Compass

Display the direction of the front. The electronic compass function used in this vehicle is based on the principle of geomagnetic positioning, which can indicate eight directions vaguely. The display direction includes: north, northeast, east, southeast, south, southwest, West and northwest, and the direction angle ranges from 0 to 359°.

Environment Information Interface

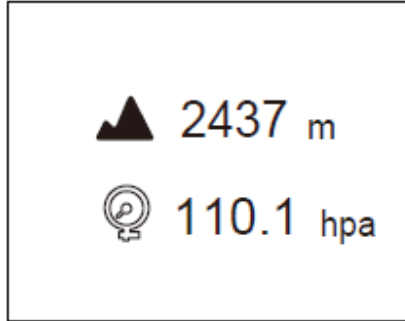

1. Atmospheric Pressure

Environment information interface, showing the current vehicle position of the atmospheric pressure.

2. Relative height

The height reference value obtained from the difference between the atmospheric pressure detected by the vehicle instrument and the standard atmospheric pressure.

Tips

The relative height value is not recommended for height measurement because the atmospheric pressure is related to the change of air temperature, wind speed and other environmental factors. It is only used to display real-time height relative change when the vehicle is in motion.

Vehicle Alarm Information Interface

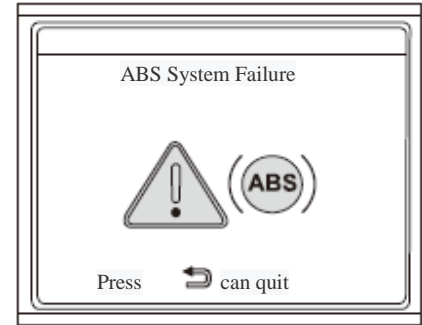

The figure shows an example of ABS system fault alarm interface. In addition to the interface, the following faults will be warned:

- Left turn signal failure
- Right turn signal failure
- Left low beam lights failure
- Right low beam lights failure
- Fuel sensor failure
- Airbag failure

- Brake fluid level is low
- Low oil pressure
- High engine temperature
- The oil problem caused the engine to knock
- Gearbox failure
- Limited function of gearbox
- ABS system failure
- Brake failure
- ESP system failure
- Downhill auxiliary system failure
- Auto hold system failure
- Please fasten the driver's safety belt to release the electronic handbrake
- Depress the brake pedal while release the electronic handbrake
- EPB system failure
- Car DVR fault
- The SD card of Car DVR has not been inserted, please insert the SD card
- SD card is out of order. Please replace it
- SD card is not formatted, please format SD card
- Please check the parking monitor video
- Photo storage folder full, please delete photos
- Emergency video recording space of Car DVR is full, please clean up!
- The tire deflates quickly
- The tire high temperature
- Tire pressure
- Tire low pressure
- Missing tire pressure sensor
- Low battery in tire pressure sensor
- Tire pressure sensor malfunction
- Tire pressure system malfunction
- System failure with one key startup
- No intelligent key found
- Please apply the brake to start
- Please switch to P/N to start
- Please step on the clutch to start
- Please switch to P stop
- Forgotten keys in the car
- Key out
- Low key battery
- Immobilizer failed
- The electron steering column is not unlocked
- Steering malfunction, please stop
- Steering column malfunction, please repair
- Please turn the steering wheel
- Parking assist system malfunction

Prompt Message Interface

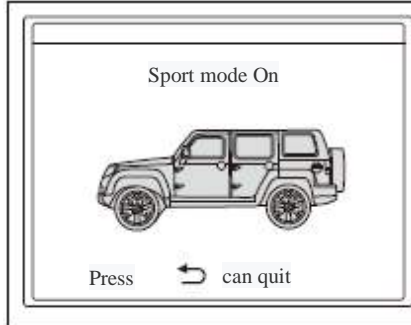

The figure above shows an example of the prompt interface in motion mode. In addition to the prompt interface, the following information will be prompted:

Door opening status display (left front door, right front door, left back door, right back door, tail door)

Seat belt status (Driver and passenger)

Backlight brightness adjustment tips

Please fill it up with fuel

From next maintenance (500/200/100km)
Please maintain immediately
Please turn off the light
The vehicle speed has exceeded XXXKM /h
The vehicle speed exceeded 120km/h
Vehicle stability system shutdown/vehicle stability and traction torque control system shutdown/vehicle stability and traction control system shutdown
4 h / 4 l interface
Snow mode/sport mode

Tips

After the failure prompt interface, it is suggested to immediately go to the nearest authorised dealership for maintenance.

Information Center System Settings System Setting Interface

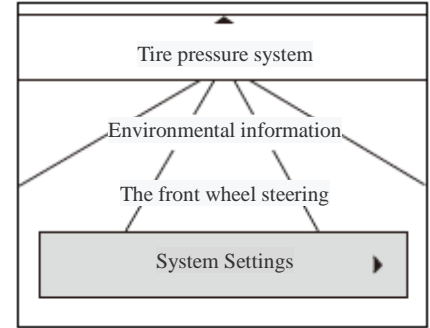

Enter the system Settings page through the menu.

Press "OK" to enter the system setting interface. Press "UP"/"DOWN" to select the corresponding setting item. Press "OK" to enter the corresponding setting item.

System Settings include the following Settings:

Overspeed Alarm

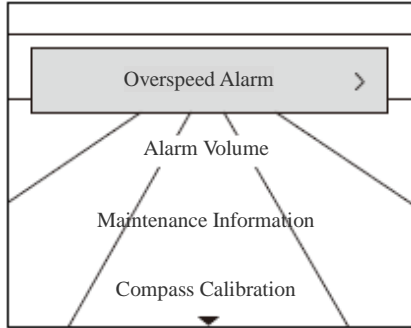

1. Enter the overspeed alarm setting interface through the menu, and press "OK" to enter the setting of the speed value. Press "OK" or "BACK" to return to the parent menu
Yes, then the interface will return to the parent menu;

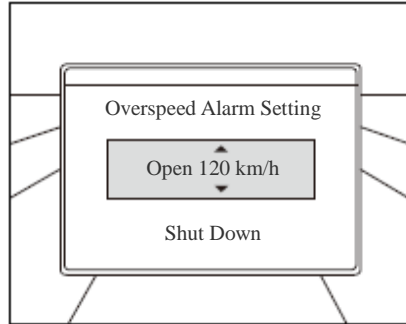

2. The default value of overspeed alarm setting is 30km/h, setting range: 30-200km/h;
3. Short press "UP" and "DOWN" keys to increase or decrease the step speed according to the step value of 5.

Alarm Volume

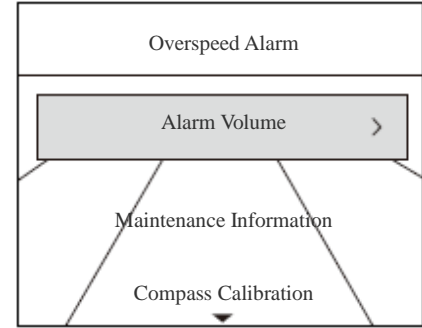

Enter the alarm volume setting page through the menu.

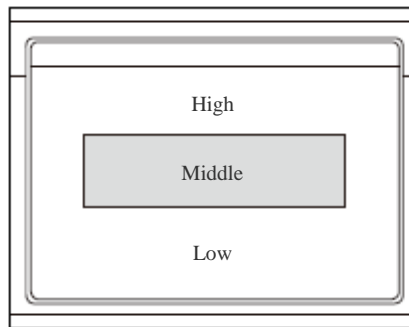

Enter the alarm volume setting interface through the menu, press "UP"/"DOWN" to select, and press "OK" to confirm.

Maintenance Information

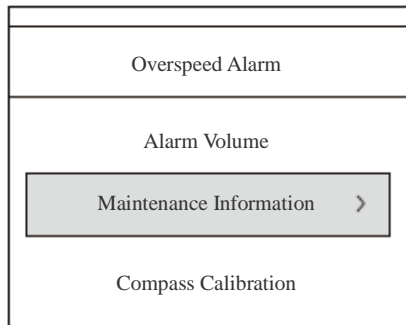

Enter the maintenance information inquiry page through the menu.

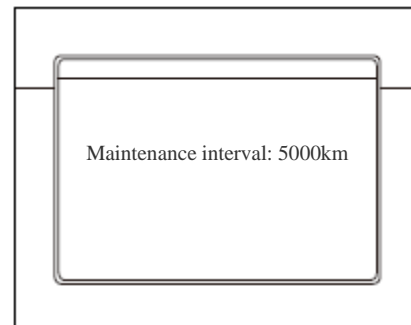

After entering the maintenance information inquiry interface through the menu, press "BACK" button to return to the superior menu.

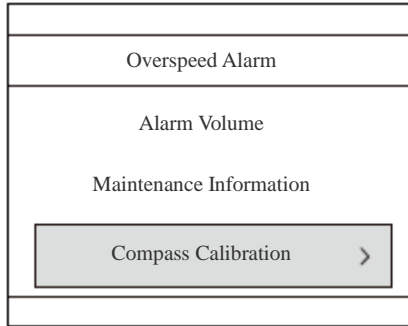
Compass Calibration

Enter the compass calibration page through the menu;

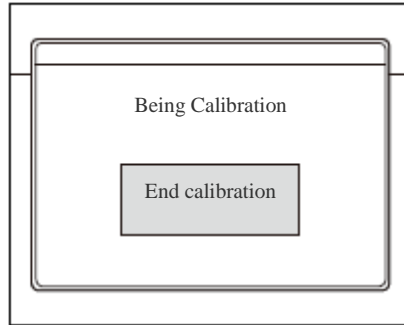

1. After entering the compass calibration page from the menu, the user shall immediately start calibration. If the user needs to cancel the calibration of the compass or has not completed the calibration of the compass during the calibration process, the user can actively end the calibration of the compass by pressing "OK/BACK".

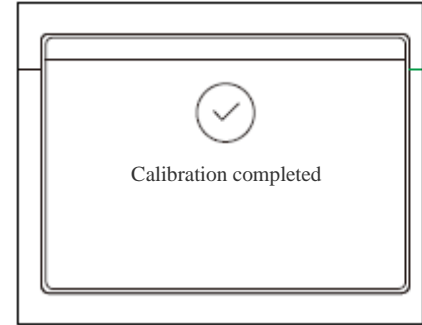

2. The driver needs to slowly start the car to drive the "circle" route on the flat ground, either clockwise or counterclockwise. When the calibration of the compass is completed, the instrument will be displayed. That is, the "calibration completed" interface is displayed.

Mode Switch

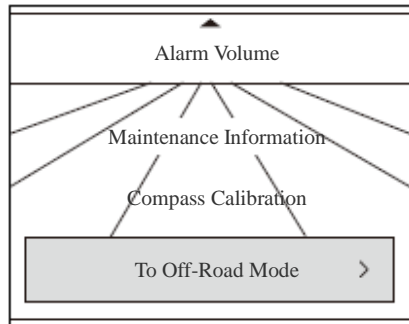

Press "OK" to switch between "city mode" and "off-road mode", and press "BACK" to return to the superior menu.

Current Fault Query



Long press "DOWN" 5s in the first level interface to pull DOWN "current fault inquiry interface".



1. After entering the current fault inquiry interface, the current existing faults of the vehicle will be displayed in the form of a list.
2. When there are many faults, press "UP"/"DOWN" to switch UP and DOWN;
3. When the vehicle is trouble-free, the "current trouble-free" information will be displayed.

Warning Light

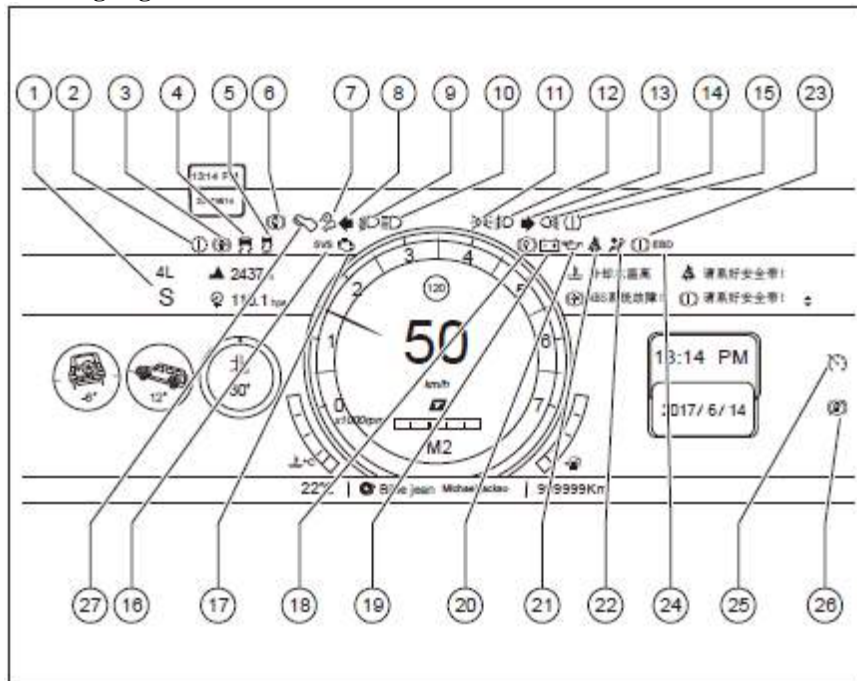

1. 4H (four-wheel drive high-grade) / 4L (four-wheel drive low-gear), indicator light for snow mode/sports mode
2. Gearbox failure indicator
3. ABS failure indicator
4. ESP indicator
5. ESP turn off indicator
6. Autohold system indicator
7. Downhill auxiliary work/fault indicator
8. Turn left indicator
9. Low beam indicator
10. High beam indicator
11. Position light indicator
12. Front fog indicator
13. Turn right indicator
14. Rear fog indicator
15. Tire pressure indicator
16. Engine electronic trouble light

17. Engine discharge indicator
18. EPB indicator
19. Battery indicator
20. Oil pressure indicator
21. Safety belt indicator
22. Airbag malfunction indicator
23. Brake low level indicator
24. Brake system fault indicator
25. Cruise control indicator
26. EPB failure indicator
27. Press the brake pedal to release the EPB light

1. 4H (four-wheel drive high-grade) / 4L (four-wheel drive low-gear), indicator light for snow mode/sports mode

When the four-wheel drive high-grade state indicator is on for 4H, it indicates that the vehicle is in the four-wheel drive high-grade use state.

When the four-wheel drive low-gear indicator light 4L is on, it indicates that the vehicle is in low-gear four-wheel drive.

When the motion mode indicator S is on, the vehicle is in motion mode.

When the snow mode indicator light is on, the vehicle is in snow mode.

2. Gearbox failure indicator  (Yellow)

When the automatic transmission fault indicator is on, it indicates that there is a fault in the automatic transmission system. Please park your car in a safe place and contact the authorised dealership immediately.

3. ABS failure indicator  (Yellow)

The lamp is on when the ABS system fails.

When the start/stop button is in the "RUN" position (the engine is not started), the vehicle self-check, the light will be on for a few seconds, and then off.

Make sure the lights go out before the vehicle moves.

Warning

If the warning light is on during driving, you can drive to the destination under the condition of ensuring safety, but you should send the vehicle to authorised dealership for inspection as soon as possible.

If the brake fault light is on at the same time, stop immediately and contact the authorised dealership.

4. ESP indicator  (Yellow)

When the ESP work indicator flashes rapidly, indicating that the motor is not started when the start/stop button of the ESP is located in the "RUN" position. When the ESP light continues to be on

it indicates a failure of the system and must be checked at a nearby 4S store as soon as possible.

5. ESP turn off indicator  (Yellow)

When the start/stop button is in the "RUN" position (the engine is not started), the indicator will be on for a few seconds and then off.

Transfer 2 hours: the indicator light will be on when the ESP function is off; Transfer box 4H/4L: to be opened by itself;

6. Autohold system indicator  (Green)

When the auto parking function is turned on to stop the car in motion (for example, at a red light), AUTOHOLD will automatically brake the car and release the brake when the accelerator is pressed at the start.

7. Downhill auxiliary work/fault indicator  (Green)

When the start/stop button is in the "RUN" position (the engine is not started), the light will be on for a few seconds and then off;

When the HDC switch is pressed, the HDC lamp will continue to be on; When the HDC indicator flashes quickly, it indicates that the HDC function of the vehicle is in working state; When the HDC switch is pressed, the HDC lamp does not work, indicating that the system has a fault. Please go to the authorised dealership nearby for maintenance as soon as possible.

8. Turn left indicator  (Green)

When the left turn signal is turned on by the light control joystick, the indicator light on the corresponding side of the meter will flash and give out a rhythmic prompt sound.

9. Low beam indicator  (Green)

When the headlight is turned on, the indicator light is on.

10. High beam indicator  (Blue)

When the headlight is on, the indicator is on.

11. Position light indicator  (Green)

When the light knob is rotated to the width indicator, the indicator light is on.

12. Front fog indicator  (Green)

When the front fog light is on, the indicator light is on.

13. Turn right indicator  (Green)

When the right turn signal is turned on by the light control joystick, the indicator light on the corresponding side of the meter will flash and give out a rhythmic prompt sound. .

14. Rear fog indicator  (Yellow)

When the rear fog light is on, the indicator light is on.

15. Tire pressure indicator  (Yellow) *

When the tire pressure alarm light is on, it indicates that there is a fault in the tire pressure system of the vehicle. When the start/stop button is in the "RUN" position, the light will go on for a few seconds and then go off. If the warning light does not go out or is on during driving, please park your car in a safe place and contact authorised dealership immediately.

6. Engine electronic trouble light  (Yellow)

When the engine is started or the light

remains on for several seconds, it indicates that there is a fault in the system, but the vehicle can still run normally. Please go to authorised dealership for testing and troubleshooting as soon as possible.

 Warning

If there is any engine related problem, please stop the car as soon as possible and contact authorised dealership.
Failure to take action can lead to serious performance problems.

17. Engine discharge indicator  (Yellow)
 The light is on when the engine emission control system is not running steadily and the start/stop button is in the "RUN" position (the engine is not started). The lamp should be extinguished after the engine is started. If the warning light is still on after starting the engine, or if it is on or flashing during driving, it indicates that the relevant parts of the engine control system have failed. At this time, the vehicle can still run, but must go to the nearby authorised dealership for maintenance as soon as possible.

 Warning

If there is any engine related problem, please stop the car as soon as possible and contact authorised dealership.
Failure to take action can lead to serious performance problems.

8. EPB indicator  (Red)

When the electronic parking brake button is pressed, the indicator light will be on. If the indicator light is still on after pressing the electronic parking brake button, it may be a fault of the braking system. You must go to the authorised dealership nearby for maintenance as soon as possible.

9. Battery indicator  (Red)

When there is a problem with the battery system and the start/stop button is in the "RUN" position (the engine is not started), the battery charging warning light will be on, and the engine should be extinguished after starting.

If the warning light does not go out, please go to the authorised dealership nearby for maintenance as soon as possible.

20. Oil pressure indicator  (Red)

This warning light is on when the engine oil pressure is below normal and the start/stop button is in the "RUN" position. The engine should be extinguished after starting. If the warning light does not go out after the engine is started or is lit while the vehicle is moving, please park the vehicle in a safe place and extinguish the engine immediately. Do not start the engine until the oil pressure is restored.

⚠ Warning

If the warning light is on during driving, stop immediately and contact the authorised dealership while ensuring safety. Failure to take action can lead to serious performance problems.

21. Safety belt indicator  (Red)

When the start/stop button is located in the "RUN" position, if the safety belt is not worn, the warning light will be on, and the alarm sound will be triggered after driving for a period of time. The warning light goes out when you put on your seat belt.

ℹ Tips

If the safety belt has been properly worn, but the warning light is on during driving, contact the authorised dealership in case of ensuring safety.

22. Airbag malfunction indicator  (Red)

When the start/stop button is in the "RUN" position (the engine is not started), the warning light flashes for several seconds and then goes out. If it keeps flashing or does not go out after several seconds, it indicates that there is a fault in the airbag system. At this time, please go to the 4S store for inspection as soon as possible.

⚠ Warning

If this fault warning light is on, the airbag system cannot be guaranteed to be in normal state. It should be sent to authorised dealership immediately for inspection and maintenance.

23. Brake low level indicator  (Red)

The lamp is lit when the parking brake is applied or the brake fluid level is lower than the prescribed level. Before driving the vehicle should fully release the standing brake, and ensure that the brake system status and fault warning lights go out.

If the light is on while the vehicle is in motion, it means less effective braking. At this point should be parked in a safe place as soon as possible, and authorised dealership contact.

⚠ Warning

If the warning light is on during driving, stop immediately and contact the authorised dealership while ensuring safety. Failure to take action can lead to serious performance problems and even the risk of accidents.

 Tips

When the brake system status and fault warning light is on, please park the vehicle to a safe place according to the following steps:

● **If the braking effect is not obvious when stepping on the brake pedal, apply more force to continue.**

● **If the braking effect is still not obvious, should reduce the transmission gear, and then remove the parking brake, while stepping on the brake pedal.**

4. Brake system fault indicator  (Red)

If the lights of ABS and EBD are on at the same time, it indicates that the ABS and EBD systems in the vehicle are out of order. At this time, the vehicle can still be stopped by conventional braking methods, but the ABS and EBD systems do not work. Please contact the authorised dealership for maintenance as soon as possible.

25. Cruise control indicator  (Green)

When the light is on, it indicates that the vehicle is cruising at a constant speed.

26. EPB failure indicator  (Yellow)

When the start/stop button is in "RUN" mode, the light will be on for about 3 seconds for self-check, and then go out after self-check.

This indicator indicates the status of the EPB system. When the EPB system fails, the light is on. The alarm popup displays "EPB system failure" and has five prompts. If the alarm light is on during driving, please contact authorised dealership for maintenance.

 Warning

● **If the warning light is on during driving, stop immediately and contact the authorised dealership while ensuring safety.**

● **Failure to take action can lead to serious performance problems.**

27. Press the brake pedal to release the EPB light  (Green)

When the indicator light is on, it indicates that the driver needs to press the brake pedal to release the electronic handbrake. When this light is on, the alarm popup displays "please press the brake pedal to release the electronic handbrake."

Cross-country information

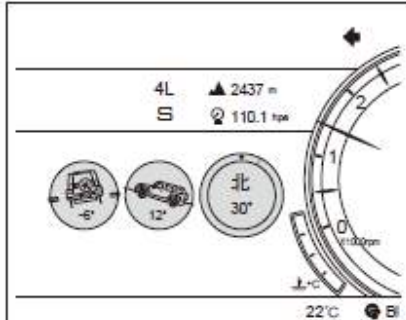

The horizontal and vertical angles of the vehicle can be read from the meter, which allows you to know the current position status of the vehicle relative to the horizontal plane.

Intelligent car service *

Intelligent development of intelligent car machine cloud platform, system hardware using 4G communication module, realize online voice recognition, online navigation, online music, driving behavior analysis, news and information and other functions;

The function interface

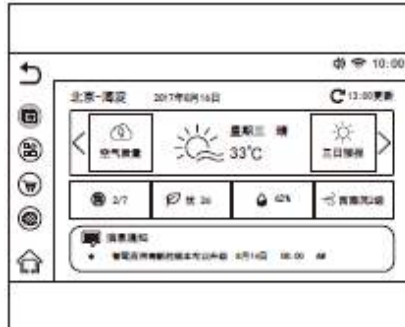

The interface is the home page of the application, which includes the following functions:
Weather Air quality News



Above is the application mall interface
There are four level functions on the left side of the interface from top to bottom: Home page, Application management, Application mall, Settings.
Each of these primary functions contains several secondary functions.
Application management interface includes: application delete.
Application store interface includes: download applications, update applications.

Service renewal, order inquiry, order deletion information, SIM card status inquiry, SIM card replacement, user agreement inquiry, user information modification, user logout, OTA update.

Steering Wheel Adjust steering wheel position

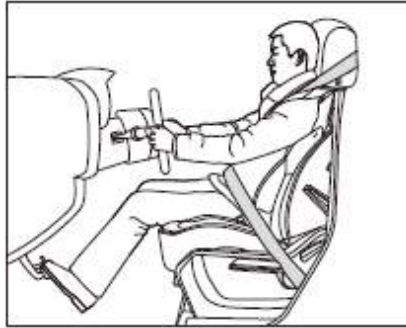

The driver can adjust the height of the steering wheel according to his body shape.

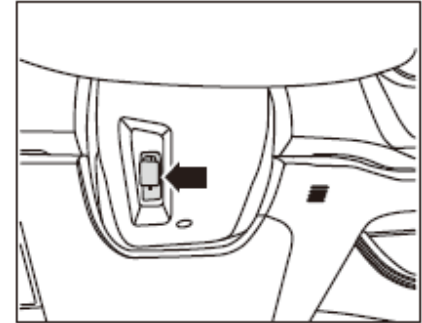

1. Adjust the driver's seat to the correct position, then push down the lock handle to unlock the steering wheel.
2. Position the steering wheel up and down so that it is facing the driver's chest, ensuring that the driver can see all the instruments and indicators on the dashboard.
3. Then push up the locking handle to lock it.
4. Move the steering wheel up, down, front and back to confirm that the steering wheel is firmly locked.

⚠ Warning

- **Improper use of steering wheel position adjustment devices and incorrect posture can result in serious injuries.**
- **To avoid dangerous driving conditions and accidents, only adjust the steering wheel when the vehicle is stationary!**
- **Note when adjusting the driver's seat or steering wheel: the distance between the steering wheel and the chest should not be less than 25 cm. If it's less than 25 centimeters, the airbag system won't protect you.**
- **The lock handle must be tightly pressed to prevent the position of the steering column from changing during the driving of the vehicle.**

⚠ Warning

Do not direct the steering wheel to your face. Otherwise, the driver's front airbag will not provide effective protection when an accident occurs. The steering wheel should be facing the driver's chest.

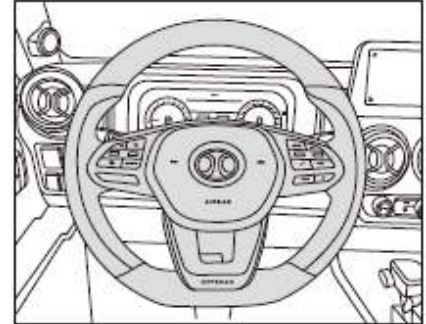
Multi-function steering wheel

This car is equipped with multi-function steering wheel, equipped with operation, switch, adjustment and other function keys in the steering wheel, the details are as follows:

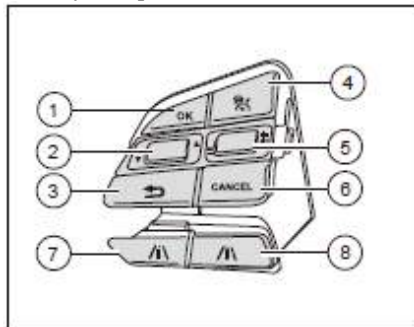
Left Key Group

1. Press the OK button on the left side of the steering wheel -1- , enter the instrument information function setting and confirmation.
2. Up and down move the left side of the steering wheel to dial button -2- to realize up and down selection of instrument information.
3. Press the return button -3- on the left side of the steering wheel to exit the setting of instrument information function.
4. Press the cruise button on the left side of the steering wheel -4-, cruise function on/off.

5. Move up and down the left side of the steering wheel to right dial -5-, cruise recovery/speed plus (RES +), cruise Settings/speed minus (SET -).

6. Press "CANCEL" on the left side of the side panel -6- to CANCEL the constant speed cruise.

7. Press the button to decrease the left distance of the steering wheel -7- to shorten the distance between cruise and car.

8. Press the button to increase the distance from the left side of the steering wheel -8- to increase the distance from the cruise to the car.

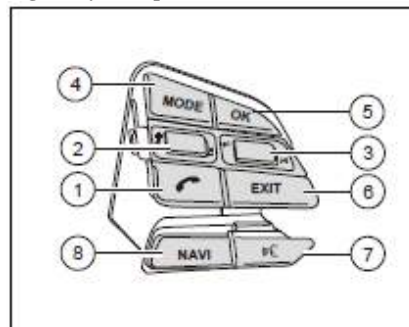
Right Key Group *

1. Click the bluetooth phone button on the right side of the steering wheel -1- to receive incoming calls. Long press 3s right and left bluetooth phone button on the right side of the steering wheel -1- to hang up the phone.
2. Up and down move the right side of the steering wheel to turn the left button -2- to increase or decrease the sound volume.
3. Up and down turn the right side of the steering wheel to press button 3- to change tracks or radio channels.

4. Press MODE button -4- on the right side of the steering wheel to switch the MODE interface in the large audio screen.
5. Press the OK button on the right side of the steering wheel -5- to confirm the host function.
6. Press EXIT button -6- on the right side of the steering wheel to EXIT the host function.
7. Press the language control button on the right side of the steering wheel -7- to realize voice control.
8. Press NAVI button -8- on the right side of the steering wheel to enter the navigation function.

Middle Channel Multi-function Button

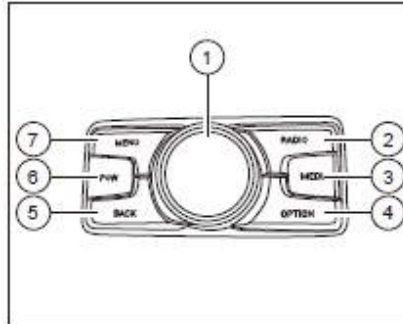

1. Middle knob: rotate to select the current entry of the host, move up and down in the left and right directions to select the menu of the host's upper and lower levels and switch operation areas. Press to select and confirm;

2. RADIO button: RADIO select button;
3. MEDIA button: multimedia button;
4. OPTION key: menu shortcut OPTION;
5. BACK button: BACK to the previous button;
6. POW button: in the power-on state, short press is silent; long press is power off; in the power-off state, short press is power on;
7. MENU button: home button.

Open and Close Doors

Intelligent Remote Control Key

This car is equipped with 2 intelligent remote control keys, the intelligent remote control key contains the mechanical key, the mechanical key is used in an emergency. If the smart remote key doesn't work, the mechanical key can be used to open the door.

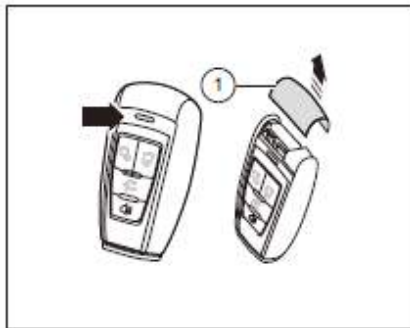

1. Press the release button - arrow -
2. Remove mechanical key cover -1- along - arrow - direction.

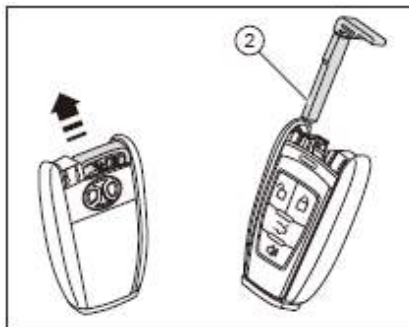

3. Pull out the mechanical key -2- along the - arrow - direction.

Intelligent remote control key: the wireless remote control function can be used to lock or unlock all the doors, open the trunk and realize the function of finding the car.

Mechanical key: in the normal power supply of the vehicle, the mechanical key can lock and unlock all doors.

When bringing a key with wireless remote control function onto an aircraft, make sure you do not press any buttons on the key while inside the aircraft cabin.. Pressing the button could cause an intelligent remote key to emit radio waves, which could interfere with aircraft flight.

Caution

When using intelligent remote control keys with transceiver chips, please follow the following instructions:

- Do not attach smart remote keys to anything that cuts off electromagnetic waves (e.g. metal seals).
- Don't hit other objects with smart remote keys.
- Do not expose smart remote keys to high temperatures for long periods of time, such as in direct sunlight on the dashboard or bonnet.
- Do not immerse the smart remote key in water or wash it in an ultrasonic scrubber.
- Do not place smart remote keys with devices that emit electromagnetic waves, such as mobile phones.



Tips

After using the mechanical key, be sure to put it back.

Intelligent Remote Control Key

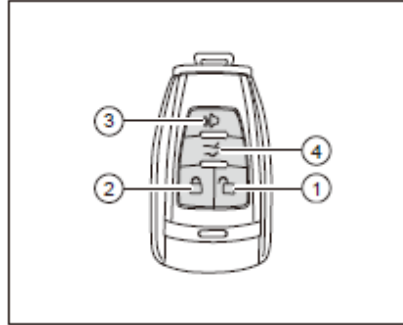

The intelligent remote control key has four keys, which are:

1. Unlock key: unlock the door lock;
2. Lock key: lock the car door lock;
3. Car search button: press this button in the state of defense, and the vehicle will emit lights and sounds to remind you;
4. Tail door unlock key: unlock tail door (long press).

The effective range of the remote key is about 25 meters, but in some special circumstances, such as electromagnetic interference nearby or in the blind spot area of the signal, the range will be reduced. For details, please contact authorised dealership. If the key cannot operate the door or operate within the normal distance:

Check the vicinity for radio transmitters that interfere with the proper operation of keys and the surrounding environment, such as radio stations or airports.

The battery may have run out. Check the battery in the key. To replace batteries, see "replace batteries."

If the key is lost, please contact authorised dealership as soon as possible, so as not to steal the car.

 Caution

When unlocking/locking is pressed continuously, the door lock protection function will be triggered, and the unlocking function will be temporarily disabled.

 Caution

When operating the Remote control key, do not need to align the Remote control key with the car, but the remote can be work within a certain range.

Please note that the working range of the Remote control key is affected by the battery power level, and sometimes by physical and geographical factors.

For safety reasons, do remote control when near the door.

Key Battery Replacement

When the power is insufficient, the display screen of driving computer will display "low power of smart keys" to remind the replacement of battery.

When changing battery, open the battery cover on the key. If it is not operated properly, it is easy to caused damage. Therefore, it is suggested that authorised dealership to replace battery

 Warning

● Touch circuit boards can generate static electricity. Causing damage to remote control keys

● Not to lose any parts when replacing the key battery.

● Only the same model or the battery recommended by BAIC can be used for replacement.

● Waste batteries must be disposed of in accordance with local laws.

 Caution

● Ensure that the positive and negative poles of Remote control key batteries are installed correctly.

● Do not replace the battery with wet hands. Water will cause corrosion of the batteries.

● Do not touch or move any parts in the remote control key, otherwise it will affect the function of the remote control key.

● Do not bend the electrodes when inserting Remote control key batteries, and no dust or oil is allowed in the battery box.

Replace the key battery by following steps:

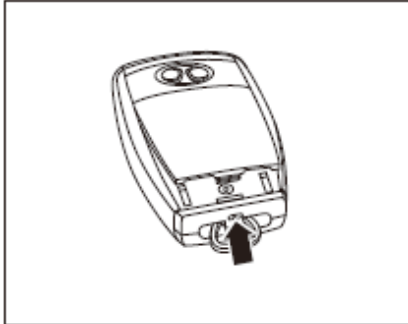

1. Insert sharp tools into the hole at the bottom of the Remote control key.

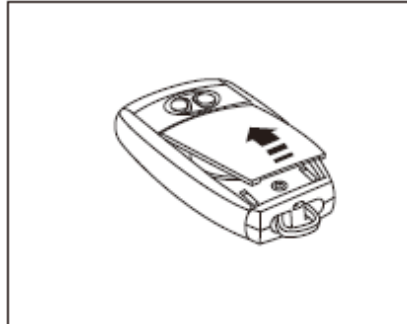

2. Unlock the key battery lock, up open the battery cover

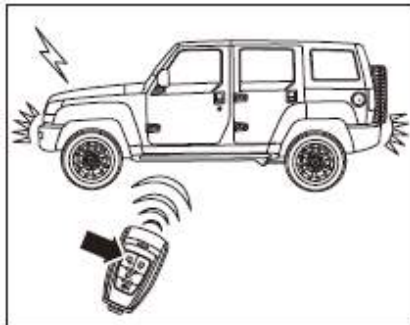

3. Remove batteries to avoid contact with circuit boards and battery clamps
4. Avoid touching the surface of battery and wipe them clean before installation when installing battery.
5. Installation should ensure that the battery cover meshes well and avoid dust and water vapor entering.
6. After replaced, it is necessary to test whether the function of the Remote control key is normal. If the Remote control key still does not work properly, please contact authorised dealership.

Unlock the door

When the unlock key is pressed, all doors are unlocked at the same time. The turn signal flashes twice at this time.

After pressing the Remote control key unlocking function, should be open any door within about 30 seconds, otherwise all doors will automatically lock.

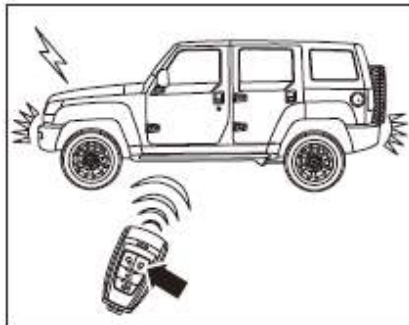
Lock the door

The remote control key is outside the car, the ignition switch is in "OFF" mode, the engine cover and all the doors are closed, press the lock key to lock the door.

Remote control key matching

If loss of remote control key , needs to be matched , please go to BAIC's service Store, and the relevant operation is carried out by professional staff through special equipment.

 **Caution**

After the Remote control keys are re-matched, the used -loss Remote control keys that matched before will no longer be used.

So,all Remote control keys that need to be used should be matched when matching again.

Anti-theft alarm system

The anti-theft alarm system is installed on the vehicle. In order to ensure safety and operation convenience, we strongly recommend that you read this chapter carefully in order to fully understand its characteristics and use methods.



Anti-theft remote control key setting

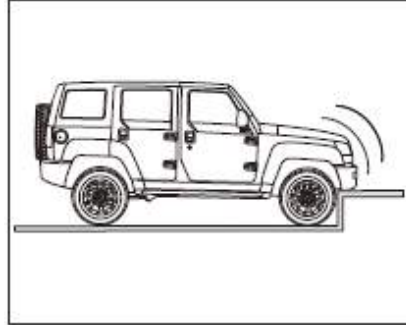

Press the lock key, and if each door and trunk door are closed, the turn light flashes once, while the door and trunk door are closed. The anti-theft status indicator of the instrument information center starts to flicker, indicating that the system has entered a state of anti-theft alert.

In this state, the anti-theft system will monitor the door, rear door, one-button start switch and start/stop button in the "RUN" position. If the lock key is pressed again at this time, the turning light flashes once, and the system performs lock action once.

If the vehicle does not satisfy the locking condition, that is, any door is not closed or the ignition switch key is located in the "RUN" position, so the vehicle will not respond when pressing the locking key, and the vehicle can not be locked and fortified at this time.

Vehicle locking conditions:

- The door lock and trunk door lock are normal, and the door and trunk door are normal closed.
- One key start switch is closed and the ignition switch is in the "OFF" position.

 Caution

After setting the anti-theft state, the engine also enters the anti-theft state. At this time, insert the original matched mechanical key to entry the car and start the engine within 15 seconds, the anti-theft can be lifted.

Remove theft by remote control key

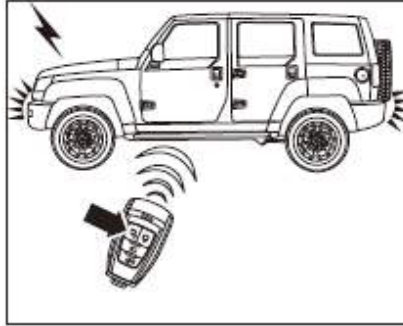

When the alarm is not triggered, pressing the unlock key, all doors are unlocked at the same time, and the turn signal flashes twice at this time.

After using the remote control unlocking function. After a period of time, all doors will automatically lock again and re-enter the anti-theft alert state after a while if the door is not opened.

Trigger alert

When the anti-theft system is triggered, the turning light starts to flicker and the horn gives out an alarm at the same time.

Whether the trigger signal is removed or not, the system will stop alarming after one cycle of alarming.

When there is a new trigger, the alarm will be sent again. When the alarm is triggered, the anti-theft status indicator of the instrument indicator center flashes at a certain frequency for a certain time.

 Caution

After setting the anti-theft state, the engine also enters the anti-theft state. At this time, insert the original matched mechanical key to entry the car and start the engine within 15 seconds, the anti-theft can be lifted.

This system only monitors the door status signal, trunk door status signal and ignition switch signal. Alarm only when the above signal is triggered illegally.

Unlocked trunk door by Remote controlled key



In the locked state, press the trunk door key for a long time, and the trunk door will be unlocked. After opening the trunk door, the trunk door will be closed. After a period of time, the trunk door will be automatically locked.

Pressing the trunk door key, but the trunk door is not opened. After a period of time, the trunk door is locked automatically and enters the defensive state immediately .

When opening the trunk door and closing the trunk door, please do not put the key in the car, so as not to be automatically locked in the car.

Secondary fortification

When the vehicle alarm is triggered, when pressing the unlock key, the state is released. If the state of key and door has not changed in a certain period of time, the system will re-enter the theft-proof alert state automatically. If the unlock key is pressed again within this specified time, the timing is restarted.

Central Lock System

Operating Instructions of Central Lock System

The central lock system can lock and unlock all doors of car:

1. Manipulating Central Lock System with Remote Control Key
2. Manipulating Central Lock System with Mechanical Key
3. Manipulating the Central Lock System with the Lock Switch on the Driver's Side Door.

Manipulating central door lock with remote control key

Press the lock key of the remote control key. If the vehicle meets the lock condition, the central door lock system will be locked, the whole vehicle's door will be locked.

Press the unlock key of the remote control key. If the vehicle meets the unlock condition, the central door lock system will be unlocked, the whole vehicle's door will be unlocked.

Manipulating central door lock with Mechanical key

When the vehicle meets the lock condition, insert the key into the driver's side door lock hole and Rotate back to the vehicle(Clockwise), the central door lock system is unlocked; Rotate the key in the front (counterclockwise) direction of the car, doors are locked.

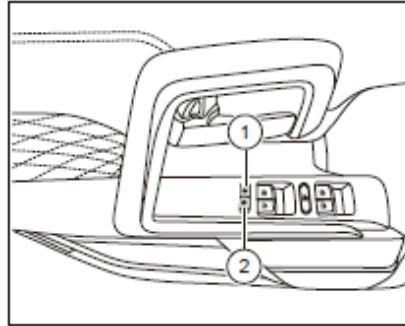

The central door lock button is located on the driver's side door as shown in the figure.

Press the button-1-, the central door lock system is unlocked, press the button-2-is locked. The behavior of unlocking/lock the door by mechanical key only applies to the corresponding door lock, and can not control all the doors at the same time.

Manipulating the central door lock with the switch on the driver's side door (Equipped vehicles only)

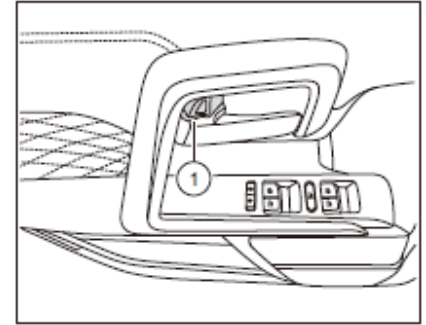

The switch is located on the driver's side door. Pull the central door lock switch - 1 -, the central door lock system will be unlocked, and press back inwards will be locked.

⚠ Warning

Do not leave children or disabled persons alone in the car! Because once the doors are locked, it is difficult for children or disabled people to leave the car by themselves in an emergency, and it will be more difficult for them to rescue if the doors are locked in an accident.

Automatic unlocking function

1. In the course of driving, if there is a collision and the airbag has been detonated, the door lock will be automatically unlocked.
2. Vehicles go from running to stopping, the central door lock system will be unlocked automatically when the engine is out of operation and the ignition switch is placed in the "OFF"/ "ACC" position.

Automatic locking function

When the vehicle is running at a speed greater than 20 km/h, the central door lock system will automatically lock.

When the speed is between 5 km/h and 20 km/h and lasts about 30 seconds, the central door lock system will automatically lock.

Thermal Protection Function of Door Lock Motor

The door lock motor has thermal protection function. If the door lock is opened and closed many times in a short time, it may trigger the thermal protection function of the door lock motor, which will lead to the failure of the door lock function in a short time.

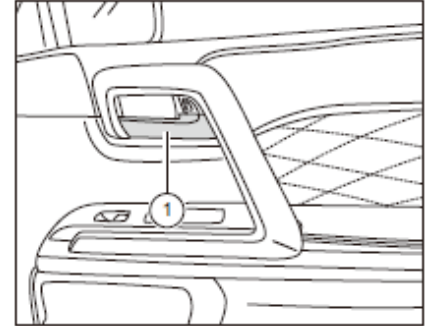
Car Door

When the door is unlocked, the door can be opened by pulling the handle-1-

Car windows

Electric window

The car is equipped with electric windows on the left and right doors, which can be controlled by the buttons of the electric windows in the driver's side door switch group.

Manipulate windows by buttons on electric windows

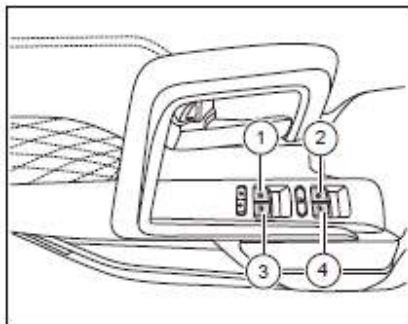

As shown in the figure, the electric window button is located on the driver's side door.

- ① Control the lift of left rear door and window
 - ② Controlling the lift of driver's side door and window
 - ③ Control right rear door and window lifting
 - ④ Control of door and window lift of passenger side car
- Continuously press or dial up the control switch, the window stops rising and falling when the switch is loosening.

⚠ Warning

The car lifts are not equipped with anti-pinch function. Make sure that any part of the body is not above the glass trajectory during the glass lifting process, so as to avoid pinch injury.

👁 Caution

In order to avoid damaging the electric window motor, the protective device will start after the windows are switched on and off repeatedly, and the electric window can not be operated. After waiting for a period of time, the electric window can resume normal operation.

Passenger and rear window

(The car is equipped with electric windows on the back door side of the car)

The steps are as follows

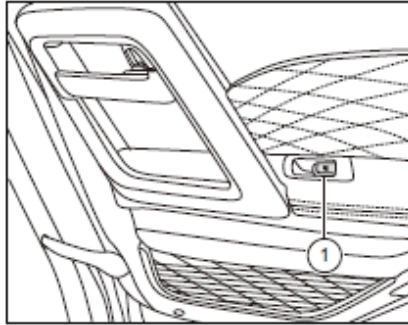

Press the motor window lifting switch - 1-, which can control the up and down of the window.

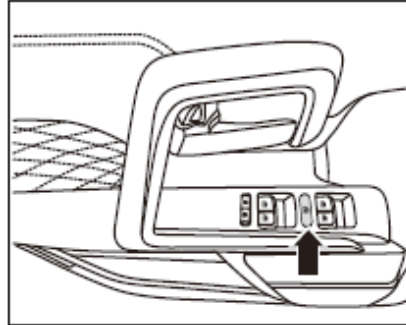
Safety lock switch

As shown in the figure: Located on the driver's side door, press the switch in the direction of the arrow, which will lock the lifting function of the rear window.

 **Warning**

Be cautious when using electric doors and windows, improper use may cause accidents or injuries!

● **Make sure that no one is in the lifting range of doors and windows when working doors and windows**

● **Do not leave children or disabled persons alone in the car when the car is locked, because it is impossible to open doors and windows in case of emergency.**

● **Keep your car keys with you when you leave the car, because you will not be able to lift doors and windows after closing a key to start the switch.**

● **Must be use safety lock switch to close the rear window lifting function when children sitting in the rear seat , so that it can not be works.**

Trunk door

During the trunk door on unlocked saturation, the trunk door can be opened by pulling the external handle of the trunk door.

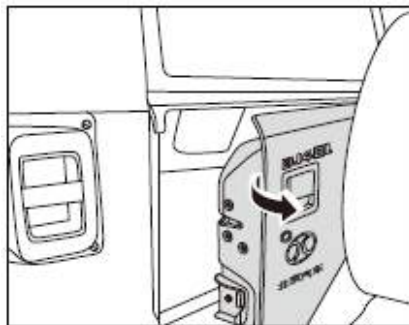

⚠ Warning

Do not let the child open or close the trunk door, otherwise it may cause the child's hand, head or neck to be pinched by the closing door.

Rear windshield

Before open the rear windshield, the trunk door should be opened to the maximum position, then the lower and middle part of the rear windshield should be held by hand, and the rear window should be rotated upward forcefully. The rear windshield will stop at the maximum position with the support of the air spring. Closing is the opposite of opening. When the rear windshield is closed, the trunk door must also be opened to the maximum position.

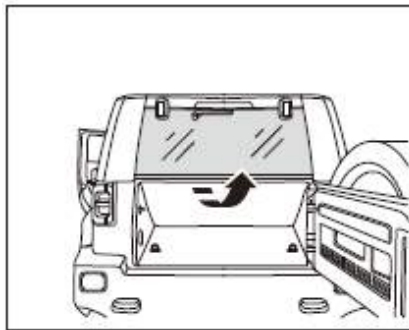

i Tips

Must keep the rear windshield closed during driving.

Points for attention

Taken to avoid clipping fingers and other body parts when closing the trunk door and rear window

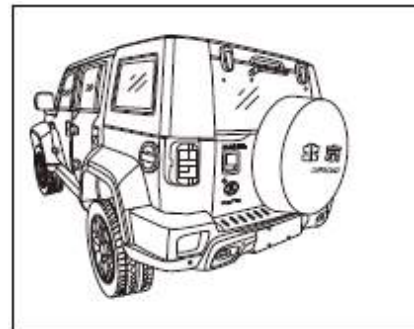

Sidebar



Passengers and drivers can step on the sidebar when get on the car.

Anti-roll Bar

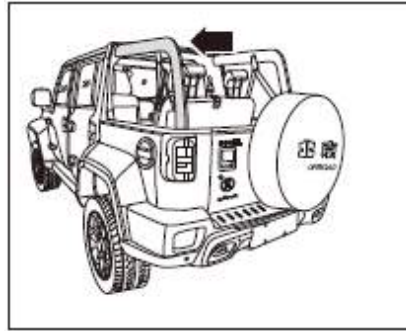

When the vehicle overturns unexpectedly, the anti-roll bar can support the vehicle body. Driver's head will not be squeezed while the vehicle overturns if the driver wears the seat belt correctly. Thus effectively protecting the driver and passenger.

Roof cover

The roof cover of the car can be disassembled. The specific steps are as follows.

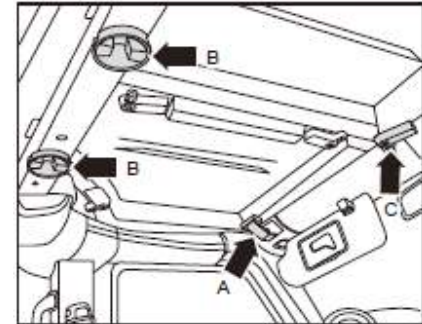

1. Rotating graphics Fixed handle - arrow C - (5 places), pull back with your hand - A - clasp (2 places in total). Remove the two installation knobs - B - in the middle of the body counter clock wise, and place them properly in a safe place to prevent loss or damage.

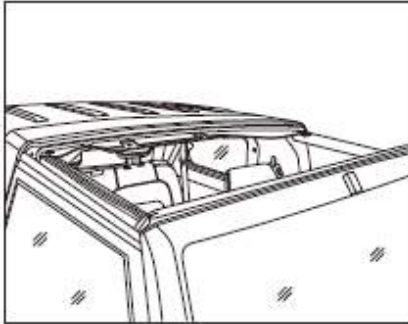

2. Push up and remove the roof cover (first move the left cover and then move the right cover). Place the removed cover piece on a soft object to prevent to damage.

⚠ Warning

The installation position of the roof cover must be correct, and the installation of relevant parts must be reliable to ensure sealing performance and avoid leakage, air leakage and dust caused by improper installation.

Installation steps are contrary to disassembly steps

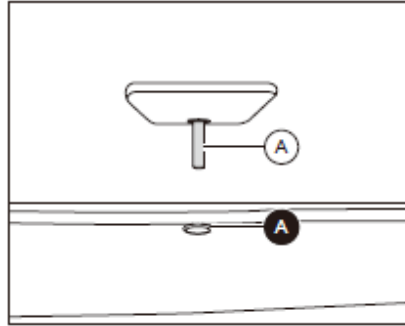

As shown in the figure, when placing the roof cover, attention should be paid to the alignment of the positioning pin-A on both sides of the cover with the positioning hole-A on the roll bar on both sides of the body.

In addition, before tightening the bolts again, make sure that the outer surface of the top cover is level with the car body.

Bandage Binding Front Door Hole with Sealing Strip

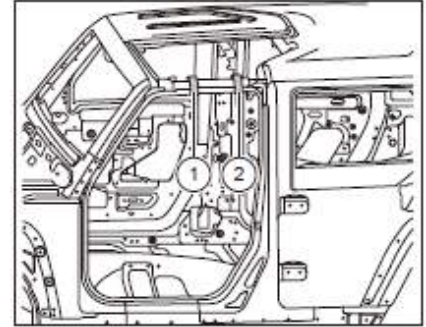

After removing the front top cover, the upper part of the door seal strip is suspended in the air. It is necessary to remove the door seal strip binding (self-adhesive) from the toolbox and fix the sealing strip-1-, -2-on the front roll bar as shown in the figure.

Rear top cover

The rear roof cover of the car can be disassembled, but it can only be achieved by special tools. If encounter problems in operation, consult the professional staff of the authorised dealership.

Detailed disassembly steps are as follows:

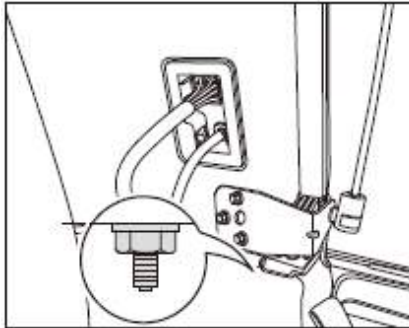

1. Pull the interior parts in the rear area of the vehicle and unscrew the nuts as shown in the figure (1 left and 1 right) .

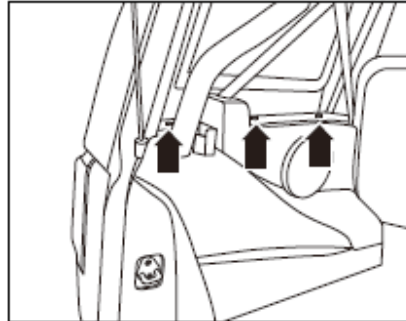

2. Remove the bolts (3 bolts) on the left rear circumference as shown in the figure-arrow.

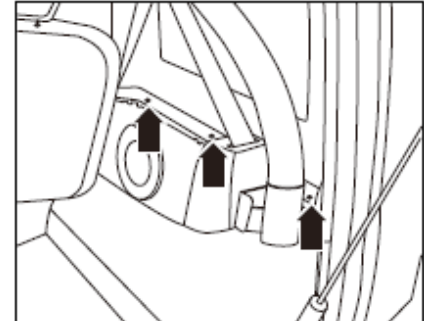

3. Remove the bolts (3 bolts) on the right rear circumference as shown in the figure-arrow.

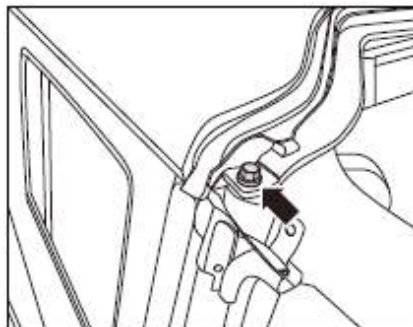

4. Remove bolts (left and right) above column B as shown in Figure

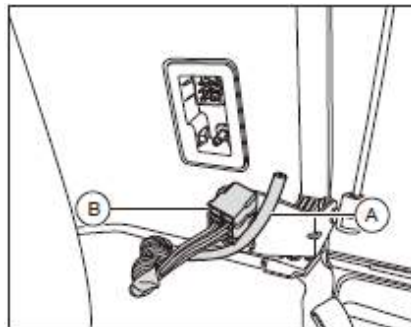

5. Unplug the right side of the rear panel - B-and Rubber tube - A - (illustrated position).

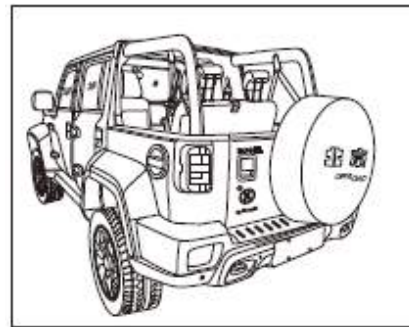

Lift the roof up slightly and move to back.

i Tips

This operation may require a lot of help. After removal, the Rear top cover should be placed on the horizontal ground or on soft objects to prevent damage.

Installation can be done in the reverse order of disassembly. When installing, it should be noted that the rear cover should be level with the car body (or slightly lower than 1 mm).

 **Warning**

Professional tools are needed when disassembling and assembling the Rear top cover. If the operation is improper, it is easy to cause damage to vehicle parts. Or there are unpredictable problems with unreasonable assembly. Serious cases can also lead to personal injury, so we strongly recommend that you consult the authorised dealership before doing related operations.

Front windshield overturned

Apart from the removable roof cover, the front windshield can also be rolled forward on the engine hatch cover to enjoy the pleasure of driving in the field.

 **Caution**

Front windshield can prevent the intrusion of flying stones, branches and other objects on the road, especially in some traffic accidents can play a very important role in safety protection, so when the front windshield folds forward and overturns on the engine compartment cover, please do not drive on the road.

To fold the front windshield, a series of disassembly and assembly work is needed, during which many professional tools and parts are used, and operators are required to have some relevant experience. If the operation is improper, it is easy to cause damage to vehicle parts and even personal injury.

 **Warning**

Therefore, we strongly recommend that you consult Beijing Automobile Special Distribution Store before proceeding with relevant operations. If you want to feel the driving feeling of the front windshield flipping forward, please flip the front windshield forward and fix the front windshield firmly with the engine hatch cover after the front windshield flipping forward. Fasten your seat belt before driving. When driving, it is recommended that the speed should not exceed 16 km/h and keep driving in low gear. Before returning to normal driving, please restore the front windshield to its original position and install the components.

 **Warning**

In the process of disassembly, each component must be properly placed in a safe place in order to prevent parts from being lost or damaged, or causing danger to personnel.

Detailed disassembly steps are as follows:

1. Remove the roof cover according to the previous description, place the roof cover and fixing bolts in a safe place to prevent damage or danger.

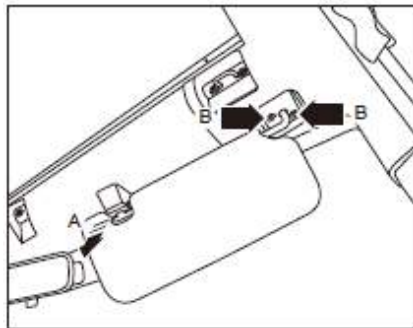

2. First pull out the shade shafts on both sides along the direction of arrow A, remove two locking screws-arrow B-, and finally remove two front shades (take the right side of the vehicle as an example).

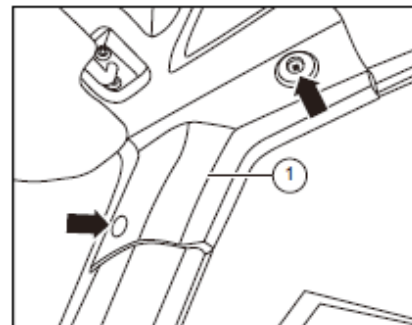
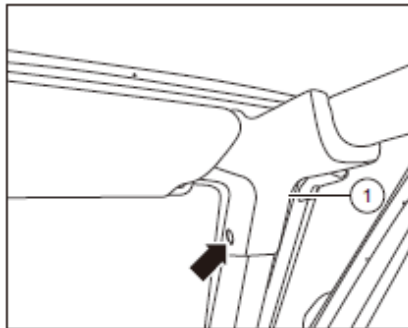

3. Remove the locking screw-arrow-on both sides, and then remove the windshield angle trim-1-. (Take the right side of the vehicle as an example).

 **Caution**

The tree-shaped clasp on the interior panel is a disposable part, which needs to be replaced after disassembly.

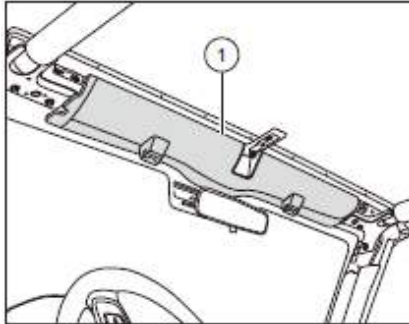

4. Remove the beam interior panel above the windshield as shown in the figure. -1-

Caution

The beam interior panel on the windshield is fixed by 10 fasteners, and the fastener is a disposable part. New parts need to be replaced after disassembly.

5. Release the A-pillar speaker plug

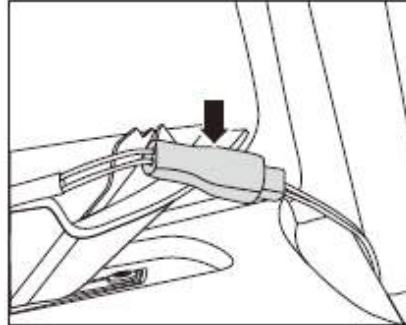

First remove the A-pillar trim on both sides, and then release the icon plug (take the right side of the vehicle as an example)

Caution

The beam interior panel on the windshield is fixed by 10 fasteners, and the fastener is a disposable part. New parts need to be replaced after disassembly.

6. Loosen the antenna plug of the front windshield, which is located in the dashboard on the passenger side.

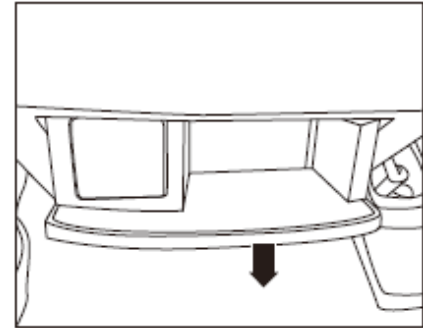

First remove the glove box: Open the glove box and slowly pull out the glove box in the direction of the arrow shown.

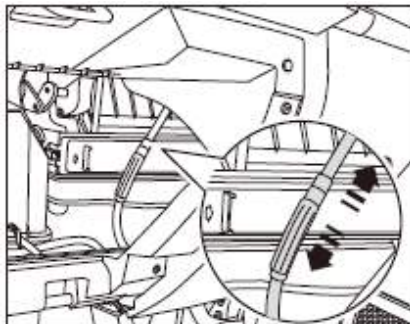

Find the antenna plug of the front windshield and loosen it according to the graphic method (the plug is inside the glove box).

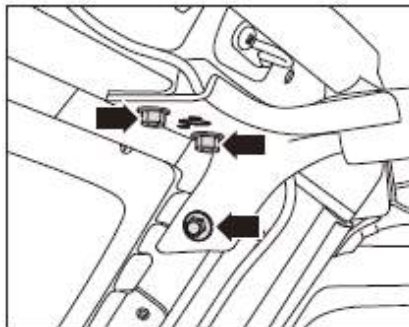

7. Remove the fastening bolts connecting the front windshield with the left and right anti-roll bars. There are 3 fastening bolts on each side, total 6 bolts. (Take the right side of the vehicle as an example).

 **Caution**

These bolts are installed with a torque requirement of $24 \pm 2\text{Nm}$.

8. Remove wiper arm

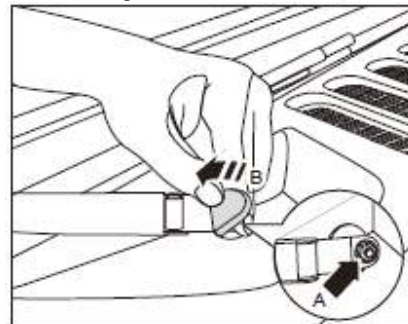

Open the wiper arm nut cover along the arrow B shown in the figure, and remove the fixed nut - arrow A-. Both wiper arm retaining nuts need to be removed (The right side as an example)

 **Caution**

The requirement torque of fixed wiper arm nut is $19 \pm \text{NM}$

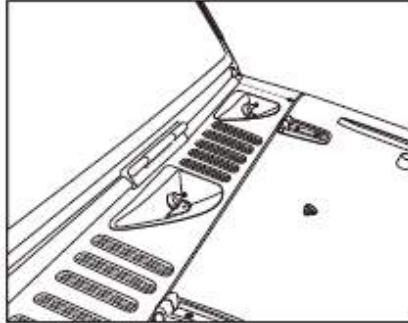

Pull the wiper arm out of the wiper motor shaft with a puller (pay attention to the installation position when disassembling, so that it can be used normally when recovering).

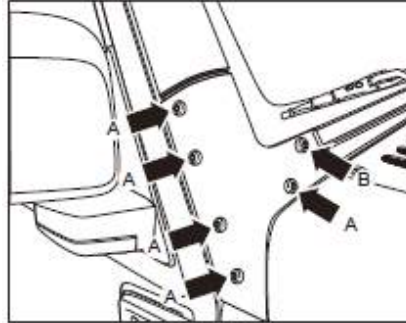

9. Remove the round head screw that fixes the lower left and right sides of the front window, 6 units on each side, total 12 units. Remove the triangle plate of the front window (take the right side of the vehicle as an example).

Caution

The length of these screw is not exactly the same. The screw in the figure-A-position is slightly shorter than that in the figure-B-position. It should not be confused in installation. In addition, the screw has a torque requirement of $20 + 2\text{NM}$ during installation.

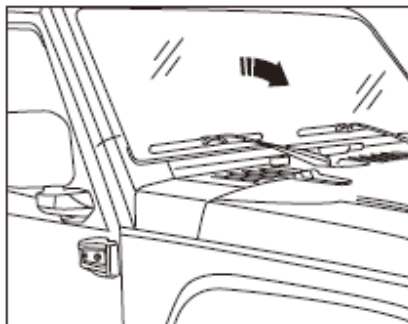

10. In the direction of the arrow as shown in the figure, slowly put the front windshield down and firmly fasten the front windshield to the engine hood.

Caution

The front windshield fixing straps provided among the accompanying tools may be used to firmly fasten the front windshield to the engine hood.

11. Remove B-pillar trim panel. 2

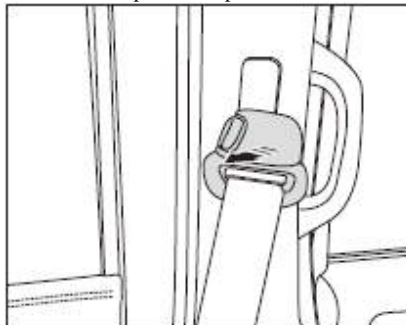

To do so, it is necessary to first remove the seat belt height adjusters on both sides (the picture here takes the right side of the vehicle as an example). As shown in the figure, pry and remove the outer housing of the seat belt height adjuster. Tips

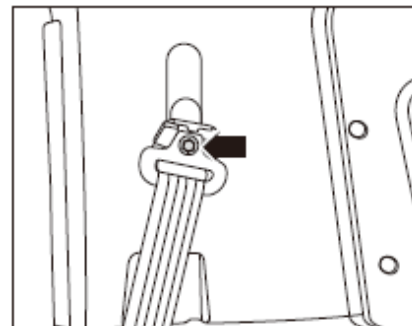

Unscrew the retaining bolts of the seat belt height adjuster and then remove the seat belt height adjuster (the picture here takes the right side of the vehicle as an example).

Caution

A torque of $45 \pm 10 \text{ Nm}$ Is required when reinstalling this bolt.

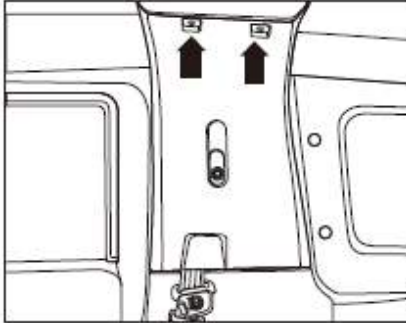

Loosen the expansion screws in the position shown in the figure (there are a total of 4 expansion screws, with 2 on each side), remove the B-pillar trim panel (the picture here takes the right side of the vehicle as an example).

 **Caution**

The expansion parts of the expansion screws and the knuckles which are used to fasten the B-pillar trim panel are all disposable parts and must be replaced with new pieces after removal.

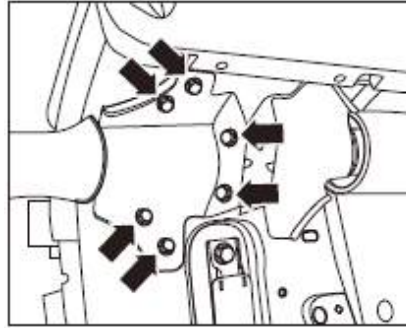

12. Remove the retaining bolts which connect B-pillar and the left and right stabilizer bars. There are a total of 12 retaining bolts, with 6 on each side. (The picture here takes the right side of the vehicle as an example.) Then, remove the stabilizer bars on both sides and put them in a safe place.

 **Caution**

A torque of 24 ± 2 Nm is required when reinstalling these bolts.

13. Before driving the vehicle, be sure to reset the seat belts on both sides by taking steps which are the opposite of the steps described in Item 11 above. The front windshield folding down operation is now at an end.

A/C System

General Instructions

The A/C system can reduce the air temperature and humidity inside the vehicle.

The A/C is only available when the engine is running. At this time, all the vehicle windows should be closed.

The running of the A/C system adds an extra load to the engine. Under extremely hot conditions or when the engine needs to run at full load (such as when climbing a long mountainous road or driving amidst congested traffic), this will result in high engine temperature. If the pointer approaches the red area of the thermometer, you should switch off the A/C until the engine temperature returns to normal.

To cool the engine, the radiator cooling fan may continue to run after the engine is turned off. During this period, if the A/C and the air volume adjustment knob are in ON mode, the A/C switch indicator light will continue to work.

If the humidity is rather high, when the A/C system is turned on, minor mist or fogging may be found on the vehicle windows. This is normal for most vehicles which are equipped with an electronic A/C system. It is not a fault. After the A/C system has run for approximately several seconds, the fogging will disappear.

Caution

Only when the fan is turned on can the A/C start to operate. When the air volume adjustment knob is off, or when the temperature approaches zero degrees, the A/C will not cool the air.

The A/C filter can remove pollen and dust which the hot and cold air system brings in from outside.

The A/C filter must be replaced at the time of regular maintenance.

If you often drive in areas of poor air quality, you should shorten the A/C air filter replacement cycle. If it is found that the air flow emitting from the outlets is not as smooth as usual, you should replace the A/C air filter as soon as possible. When the ignition key is turned from the "LOCK" or "ACC" position to the "ON" position, the A/C

Controller circuit will be powered on. It will automatically resume the working state of the A/C controller stored after the last time power was removed, and restore the initial settings of the A/C system automatically. Warning

Warning

- **Vehicle window blurring and smudging can extremely easily increase the risk of accidents and death. For the sake of safety, all vehicle windows must be free from ice, snow and fog, so as to ensure clear vision.**
- **For example, murky air inside the vehicle can easily make the driver feel tired, sluggish and detracted, and thus susceptible to accidents and death.**
- **The A/C system must be diagnosed and repaired by technicians with special knowledge and using special tools. Therefore, when the A/C system has a fault, make sure to contact an authorized BAIC dealership for checks.**

Tips

● When the exterior temperature and humidity are both very high, the moisture in the air will condense on the evaporator of the refrigeration system and form water drops which fall off from the evaporator, causing water accumulation under the vehicle. This is a normal occurrence and there is no need to worry about it.

● Be sure to keep the air inlet at the front part of the windshield free of blockage by snow, ice or tree leaves so as to ensure normal heating and refrigeration and prevent fogging of the front windshield.

● Only after the vehicle windows are closed can the A/C system play its maximum role. However, if it is very hot inside the vehicle due to exposure to strong sunlight, be sure to temporarily open the vehicle windows to let the hot air inside escape. This will speed up cooling inside the vehicle.

A/C Control Panel

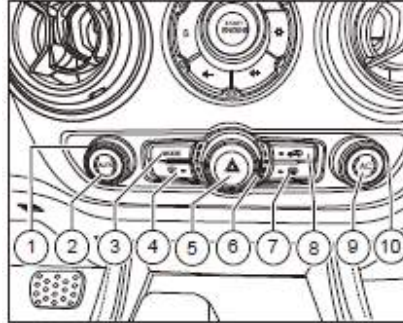

1. Left temp. knob
2. AUTO mode switch
3. Mode selection switch
4. Front defroster switch
5. Hazard warning switch
6. Fan speed knob
7. Rear defroster switch
8. Mixed vent knob

9. A/C switch

10. Right temp. Knob

When DUAL button isn't operated, manually operate this button, you may adjust driver and passenger side outlet air temperature. When DUAL button is operated, manually operate this button, you may only adjust driver side outlet air temperature.

The temperature's control range is from LO 18.5~HI 31.5, per step of the button represents 0.5 °C。 Temperature changes are displayed synchronously on the large central control screen

Rotate the button in anticlockwise direction, setting lower temperature. When temperature is lower than 18.5 °C, LO is appeared, it will start max cooling state, Mode switch automatically changes to face blowing mode, max air flow rate, go on rotating in anticlockwise direction, no change temperature.

When the temperature is higher than 31.5°C, HI is appeared, max heating mode is started, automatically change to foot blowing mode, max air flow, rotate in clockwise direction, no any change.

In OFF condition, the temperature operation knob no use, A/C don't start work.

Under max cooling state: go on rotate the knob in anticlockwise direction, no change; rotate the knob in clockwise direction, exit max cooling state, setting temperature to 18.5 °C , other settings go back to before max cooling state.

Under max heating state: go on rotate the knob in clockwise direction, no change; rotate the knob in anticlockwise direction, exit max heating state, setting temperature to 31.5 °C , other settings go back to before max heating state.

Front defrost mode: under max cooling, heating state, no exit front defrost mode while operating the knob, air blowing temperature is automatically controlled according to current atmosphere.

 **Caution**

In order to avoid personnel error operation, while the knob is rapidly continuously rotated, the temperature can only be adjusted by 2.5°C at most. Because the rear defrost needs large power consumption, only start work while the engine is started.

2. AUTO mode switch

After pressing the AUTO switch, the working indicator light will be on, and the air conditioning system will enter the automatic control program. Air outlet temperature, air volume, air outlet direction and air circulation are all automatically controlled by the air conditioning system. AUTO working status is displayed synchronously in the large central control screen.

Users can adjust left and right temperature knobs according to their own feelings, which can change the default temperature setting value of the air conditioning system to improve comfort; in the AUTO state, the left temperature knob can be adjusted to enter the maximum refrigeration or heating state, and automatically withdraw from the AUTO mode. At this time,

the left temperature knob can be operated without operating other switches, and the air conditioning system can be operated. It will withdraw from the maximum refrigeration or heating state and restore the AUTO state. The left temperature is based on the set value.

The direction of the wind will be selected according to the five modes of blowing surface, blowing surface-blowing foot, blowing foot, blowing surface-defrosting and defrosting. When it is blowing foot-defrosting, pressing this switch again will adjust to blowing surface mode. The wind mode state is displayed synchronously in the large screen of the central control system.

The direction of the wind will be selected according to the five modes of blowing surface, blowing surface-blowing foot, blowing foot, blowing surface-defrosting and defrosting. When it is blowing foot-defrosting, pressing this switch again will adjust to blowing surface mode. The wind mode state is displayed synchronously in the large screen of the central control system.

4. Front defrost switch

Manual operation of this switch, air conditioning outlet mode for window blowing, external circulation, issued A/C open request Signal, A/C working indicator lights up, air volume air conditioning automatically adjusts to 5 gear(if the air volume is greater than 5 gear

before defrosting switch, the original air volume is maintained). The defrosting working state before defrosting is displayed synchronously in the large screen of central control. For quick defrosting, please manually adjust the air volume to the maximum gear after defrosting switch before operation

In AUTO state, operate this switch, the air conditioner will be defrosted before entering the working state, and withdraw from AUTO Status.

Operate this switch under any working condition and the air conditioning system will enter the pre-defrosting mode. If this switch is operated again, the air conditioning system will automatically restore to the working state before defrosting, including OFF status.

6. Air volume and shutdown knob

When the knob is operated clockwise, the air volume of the air conditioner increases until the maximum air volume is no longer changed. Operate the knob counter-clockwise, the air volume of the air conditioner decreases until the air volume decreases to a first-class air, again After counter-clockwise rotation, the air conditioning system shuts down and enters the OFF state. The air volume status is displayed synchronously in the large screen of the central control system.

When the air conditioning system is in OFF state, the air volume knob is operated manually, the air volume is 1 gear, and other modes are restored. Return to the state before the last OFF. In the AUTO state, when the switch is operated, the air volume increases or decreases by 1 gear (if it is reduced to 0, it enters the shutdown state, if it is 8 gear, it remains unchanged), exits the AUTO state, and other modes remain unchanged. In the mode of maximum refrigeration, maximum heating and front defrosting, the air volume will increase or decrease by operating this knob. Small 1 (if reduced to 0, enter shutdown state, if 8, remain unchanged), other modes remain unchanged.

Caution

In order to avoid misoperation, the air volume knob is set when it is rotated rapidly and continuously. Air volume changes can only be adjusted at most two gears at a time, and in any case, The air volume must be adjusted to gear before the air conditioning system can be shut down. When the air conditioning system is shut down, the operation of this knob can only reach 1 wind volume first, and then adjust to the required air volume.

7. Rear defroster switch

After the “Rear defrost” button is pressed down, the system will start to heat up the rear windshield for 15min. The left and right external rearview mirrors will start to warm up too. Meanwhile, the work indicator light will be lit. When the “Rear defrost” button is pressed down again, the system will continue to heat up the rear windshield glass and the left and right external rearview mirrors will stop heating. Meanwhile, the work indicator light will go out.

 Caution

Rear defroster function is only worked while the engine is working because it has much electricity consumption.

8. Internal & External Circulation Switchover Key

When the internal & external circulation switchover key is not pressed, the defaulting running state of the system is the external circulation mode. After the internal & external circulation switchover key is pressed down, the indicator light on this key will be lit and the running mode of the system will be internal circulation.

While the system is in a standby state,

9. A/C switch

When A/C indicator is ON, so the refrigeration function is started. When A/C indicator is OFF, so the refrigeration function is closed. Only the engine is working, A/C can start work; when the engine doesn't work, though the A/C indicator is ON, but A/C can't work.

Press down the automatic running key(AUTO), and the air conditioning system will enter automatic running mode. The key indicator light will also be lit and the AUTO icon will appear on the display screen. If any key other than the rear defrosting key, the system OFF key or the temperature key is pressed down while the system is in automatic running mode, the system will then execute the command of this key. As the icon on the screen disappears, the key indicator light will go off at the same time. Other originally automatically running function will continue to be automatically controlled by the system.

10. Right temperature knob

Whatever DUAL is started or not, when operate this knob manually, only the temperature of air blowing of passenger side can be adjusted, but not the driver side.

Temperature range is from 18-18.5~31.5-32, each step of the knob means 0.5℃.

Rotate the knob in anticlockwise direction, temperature will go down.
if you go on rotating the knob, no change of the temperature.

Rotate the knob in clockwise direction, the temperature will go up. When the temperature is higher than 32℃, if you go on rotating the knob, no change of the temperature.

In OFF condition, no need of operating temperature knob, A/C doesn't work.
when operate this knob in AUTO condition, only the temperature of air blowing of passenger side can be adjusted. In max cooling and heating state, no need of right temperature knob.

 Caution

To avoid operation mistake, when the temperature knob is rotated continuously fast, only 2.5℃ is permitted once.

Dual Temperature Zone Switchover Key (DUAL)

This key is used to switch over between the single zone mode and the dual zone mode. The system is in the single zone mode by default. Pressing this key can switch to dual zone mode, and the display screen will display DUAL icon. In the single zone mode, only the set temperature of the set side can be adjusted. In other words, when the set temperature increase/decrease key of the right side is adjusted, the set temperature of the right side will also increase/decrease; if the set temperature of the right side is adjusted in the single zone mode, the system will enter the dual zone mode and the set temperature of the right side will also change. But, the set temperature of the left side will remain unchanged. When the single/dual zone switchover key is pressed under the single zone control mode, the system will switch to the dual zone mode. In other words, when the set temperature of the left side, the set temperature of the right side will not change, and vice versa. When the system is in the automatic running mode, press down this key and the system will remain in the automatic running state and the AUTO icon display will not change. When the system is in a standby state, pressing down this key will be deemed as an invalid command.

Interior heating

1. Turn the left/right temp. knob to above 24°C.
2. Select Mode switch, set airflow distribution, blowing foot mode is recommended.
3. Turn the Air volume knob, set the amount of air coming out.

Interior refrigeration

1. Turn the left/right temp. knob to lower than 24°C.
2. Press the A/C switch, start refrigeration function, the indicator light is ON.
3. Press the Mode switch, set the airflow mode, head blowing is recommended.
4. Press the A/C outlet airflow mode switch-3-, set airflow mode, face direction blowing mode is recommended.

Fast cooling

For maximum refrigeration, all windows must be closed. Press the A/C button, turn the mode selection knob to head mode, turn the mixed vent adjustment knob to the lowest temperature point and put the air volume control knob to the Grade 8 position.

Caution

If the temperature inside the vehicle is very high when the engine is started, it may take some time for the A/C to fully take effect. Before turning on the A/C, set the fan to maximum speed and open the vehicle windows. Circulate air inside the vehicle for a short period of time so as to quickly lower the temperature inside the vehicle.

A/C Maintenance

The A/C system is fully sealed. The main maintenance work of the system should only be done by qualified technical personnel. To enable the system remains in its best state, the vehicle owner should make sure to operate the system for a short period of time each week (even in winter). When the engine is at normal operating temperature, start the A/C and keep it on for at least 10 minutes while driving the vehicle at a stable speed.

The extra moisture generated during the dehumidification process is drained outside by the system via the drainage pipe in the vehicle bottom. This may cause water accumulation on the road surface when the vehicle is still. This is no cause for concern.

A/C Filter

The A/C filter (as a standard configuration for vehicles equipped with an A/C) is located inside the A/C box case at the left front side of the glove box. It helps to keep the air inside the vehicle fresh and prevent pollen and dust from entering the vehicle. To keep it working properly, it is necessary to check whether the filter is dirty every time the vehicle is inspected. If necessary, it should be replaced.

Caution

- **Park the vehicle in a cool place as much as possible. Parking in the hot sun can heat up the air inside the vehicle, thus increasing the time taken to cool the vehicle. If you have to park your vehicle in direct sunlight, please open the vehicle windows to let out the hot air inside for the first few minutes after the A/C system is turned on.**
- **When using the A/C system, please close the vehicle windows. The entry of air from outside will lower A/C efficiency.**
- **When the A/C system is running, please confirm that the air inlet in front of the front windshield is unobstructed, such as by tree leaves or other objects. The accumulation of blocking objects at the air inlet will affect the flow of air.**

A/C Outlets

The A/C system of this vehicle has a total of 4 outlets

1. Side outlets

There are 2 side outlets, one each on the left and right side of the instrument panel.

2. Central outlets

There are 2 central outlets, which are located in the middle of the instrument panel.

3. Foot outlets

2, respectively located in the driver's and the front passenger's step space.

4. Rear outlets

There are 2 rear outlets, which are located on the back of the front center armrest.

Central Air outlets

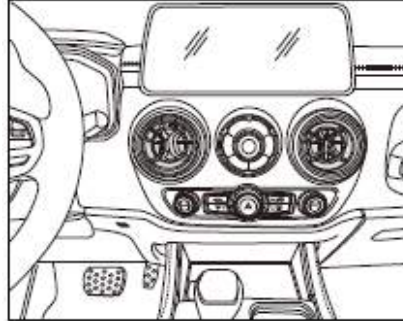

To adjust the volume of airflow of each outlet, it is necessary to push any arrow-marked place of the outlet,

Driver Side Air outlets

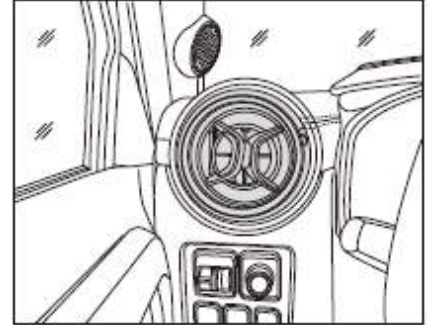

To adjust the volume of airflow of each outlet, it is necessary to push any arrow-marked place of the outlet,

Front Passenger outlets

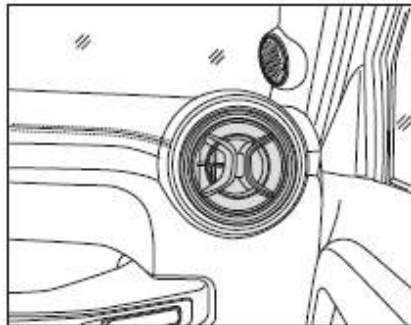

The driver's side outlets is adjusted in the same way as the central outlets.

Rear outlets

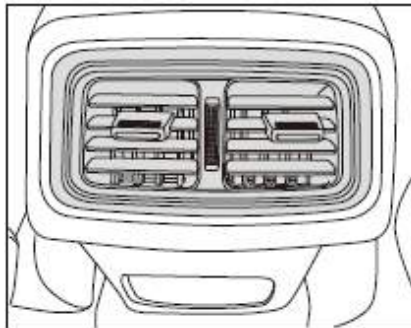

To adjust the direction of the air flow of the outlets, turn the convex tongue at the center of the outlets upwards and downwards and left and right.

Rear Left outlets

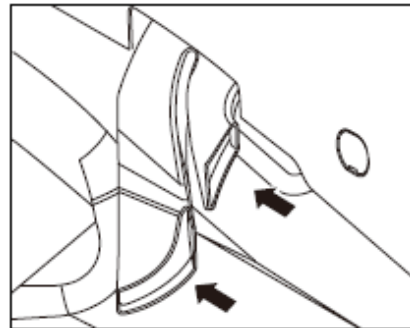

Rear left outlets for foot

Rear Right outlets

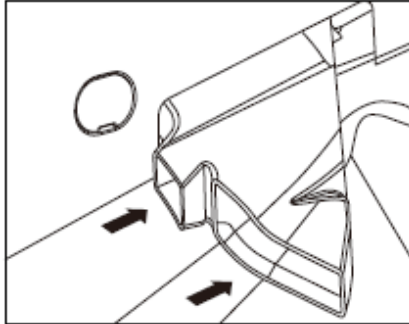

Rear right outlets for foot

Outlets Switch

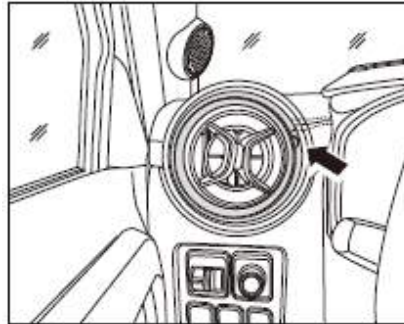

Outlets switch makes open or close of vent door, the vent door is closed in clockwise direction to the end position, the vent door is closed in opened in anticlockwise direction to the end position.

Vehicle Lights and Vision

Exterior Vehicle Lights

The vehicle light control part is located on the rear left multi-functional operating lever of the steering wheel.

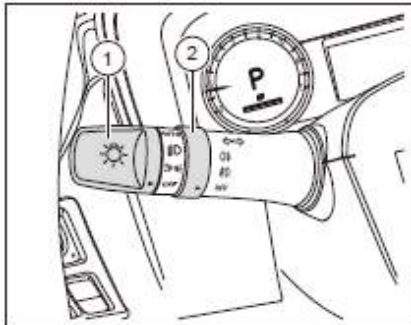

1. Vehicle light switch knob
2. Fog light control knob

Vehicle Light Switches

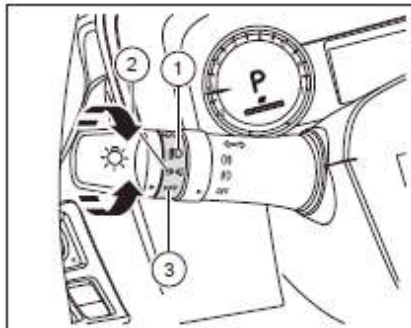

As shown in the figure, when the vehicle light control knob is turned to the “OFF” position-3-, it indicates that all the vehicle lights are switched off and none are lit (except the hazard warning lights). When the knob is turned to position -2-, namely the small lights position, the parking lights, the tail light, the front and rear marker lights, the vehicle plate light and the instrument backlight will be lit. Meanwhile, the display screen backlight of the information center of the instrument will be reduced to 40% of its daytime brightness to prevent dazzling. When the knob is turned to position -1-, namely the low beam position, the headlight low beam will also be switched on.

Caution

- When the engine is turned off, do not leave the headlights or other lights on for long periods of time. Otherwise, the battery power will be reduced.
- During periods of rain or when the vehicle is being washed, mist may form on the inner side of the translucent mirrors of the headlights. This is not a fault but a normal phenomenon, like the fogging of windows in damp weather. After the lights are turned on, the heat produced will evaporate any mistiness. However, if water condenses inside the headlights, please take the vehicle to an authorized BAIC dealership to have it checked.

indicate that you want to change your driving lane. When the operating lever is released, the turn signal light will go out.

Low/High Beam Light Switchover

When the headlight low beam is turned on, push the left multi-functional operating lever in the opposite direction to the steering wheel. The headlights will change from low beam to high beam. In addition, the blue indicator light on the combination instrument will be lit again. Then, reset the operating lever on the left side, and the headlights will change from high beam back to low beam again.

Overtaking Flashing Signal

No matter where the vehicle light switch knob is, pull the left multi-functional operating lever in the direction of the steering wheel, and the high beam light of the headlight will be lit. Upon release, the operating lever will automatically be restored to its original state.

Turn signal lights

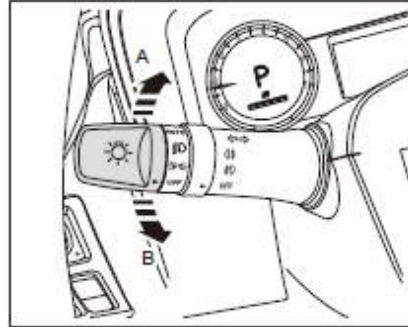

Pull the left multi-functional operating lever -Arrow A- upwards, and the right turn signal light will be switched on. Meanwhile, the green indicator light of the combination instrument will flash; push the left multi-functional operating lever -Arrow B- downwards, and the left turn signal light will be switched on. Meanwhile, the green indicator light of the combination instrument will flash. After the turning action is completed and the steering wheel is reset, the lights handle will automatically be reset too. The exterior turn signal light and the steering indicator light on the combination instrument will go out. By lightly pulling the operating lever upwards or downwards by half of the scale, you can

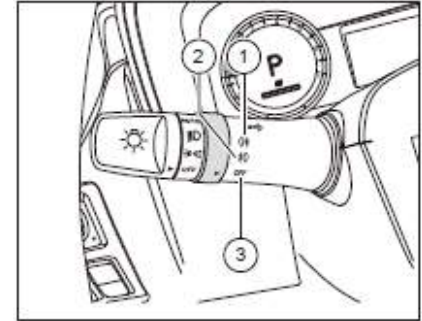

Fog Light Control Switch

When the light switch is in the small light position or the low beam light position, turn the fog light control knob to position -2-, and the front fog light will be switched on. Turn the fog light control knob to position -1-, and the front and rear fog lights will be both switched on. When the fog light control knob points to position -3-, the front and rear fog lights will be both switched off, rear fog light can't be lit separately.

Manual Adjustment of Headlight Height

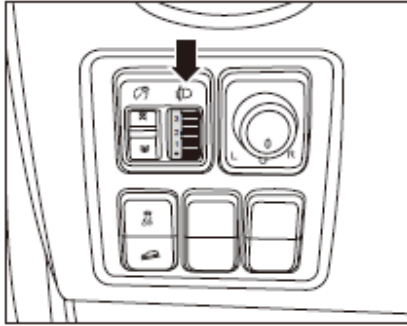

The angle of the low beam lights is affected by the distribution of passenger and luggage weight inside the vehicle. Adjust the headlight height to ensure the correct adjustment so there is sufficient lighting to the front of the vehicle, without dazzling other road users. As shown in the figure, the headlight height manual adjustment roller is located in the dashboard switch array.

Use the following road surface conditions as references and adjust the lighting height of the headlights by turn the rolling wheel upwards and downwards:

● Position "0"

Only use this to adjust the headlights when the driver, or only the driver and front passenger are in the vehicle (when there is no luggage).

● Position "1"

All seats are filled.

● Position "2"

All seats are filled and the trunk load is evenly distributed (reach the permissible axle load of the rear axle and do not exceed the maximum permissible laden mass).

● Position "3"

Only the driver, and the trunk load is evenly distributed (reach the permissible axle load of the rear axle and do not exceed the maximum permissible laden mass).

High Beam Delay

The high beam delay function will provide you with lighting via the headlights after you leave the vehicle.

Before moving the ignition key from the "ON" position, if the light switch is in the low beam light position, turn off the engine, park the vehicle, turn off the low beam light switch, and remove the key. After leaving the vehicle, press down the locking button of the remote control key, and then the headlights will be automatically lit and show you the road ahead. The duration over which the headlights are lit can be set up via the information center of the instrument panel. For details, refer to Page 051 "Information Center".

Light Reminder

If a vehicle light is not switched off after the ignition switch has been turned off, there will be a buzzing sound when the door on the driver's side is opened.

Hazard Warning Light

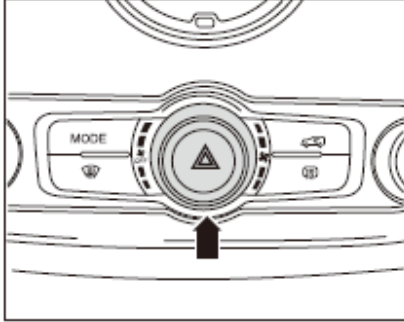

As shown in the figure, the hazard warning light switch is located inside the central control switch array.

In the event of emergency congestion, the hazard warning light may be used to draw the attention of other road users and avoid traffic accidents. In the event of the following situations, the hazard warning light should be turned on:

1. Vehicle breaks down due to technical fault.
2. Vehicle is at the end of the vehicle flow in traffic congestion.

3. There is emergency congestion.

4. When the vehicle tows another vehicle or is towed by another vehicle.

After the hazard warning light is switched on, all the turn signal lights will flash at the same time. The two turn signal lights on the combination instrument and the indicator light on the hazard warning light switch will also flash and issue a rhythmic prompting sound. When the ignition switch is turned off, the hazard warning lights will still work.

Caution

● **Long hours of using the hazard warning light will consume battery power. Even when the ignition switch is turned off, it will still consume battery power.**

● **When using the hazard warning light, be sure to strictly follow the relevant laws and regulations.**

● **If the hazard warning light does not work, other ways must be adopted to draw the attention of other road users to your vehicle. The method used must comply with the relevant traffic laws and regulations.**

Interior Lights

Reading light

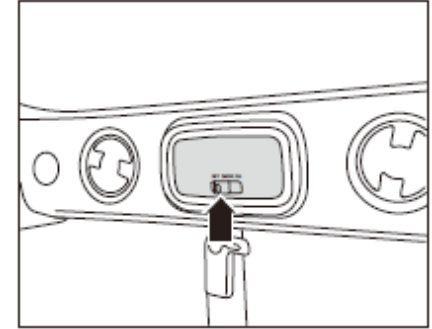

The reading light is located in the middle of the underside of the roof. As shown in the figure, the reading light switch has a total of 3 positions:

DOOR: The reading light will be automatically lit after the vehicle door is opened and gradually go out after approximately 15s of continuous lighting. Interior lights have an energy-saving mode and will automatically go out after a maximum length of lighting of approximately 8 minutes.

OFF: The reading light is turned off.

ON: Regardless of the state of the vehicle doors, the reading light can be lit.

ON: Regardless of the state of the vehicle doors, the reading light can belt.

Backlight Brightness Adjustment

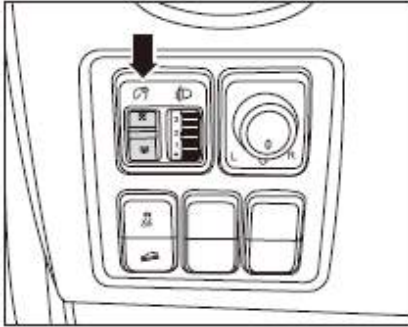

As shown in the figure, the backlight brightness adjustment roller is located in the dashboard switch array on the driver's side. When the vehicle light control knob is in the small light position or the low beam light position, the backlights of the various buttons, the main instrument and the radio will be lit. Turning the adjustment roller upwards increases the amount of backlighting, while turning it downwards reduces it.

Tips

If the ignition key is in the LOCK position or in pulled-out mode, the power leakage protection function will be turned on: The fog lights, the headlights and the reading light will be turned off after approximately 8 minutes. If one or several of the fog lights, the headlights and the reading light are switched on again, the timing will start again. In the event of remote locking within 8 minutes, the corresponding light(s) will be turned off.

Windshield Wiper Tips

The front windshield wiper

The control part of the front windshield wipers is a function contained in the rear right multi-functional operating lever on the steering wheel.

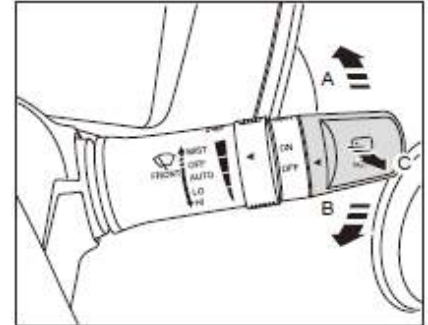

Point Wiping

In the "OFF" position, push the right multi-functional operating lever in the direction of -Arrow A- as shown in the figure, and the wipers will carry out point wiping. In other words, every time the operating lever is operated, the wipers will wipe once only. After the upward push action is completed, the operating lever will automatically reset.

Intermittent wiping and continuous wiping

In the “OFF” position, press the right multi-functional operating lever downwards by 1 position in the direction of -Arrow B-, and the front windshield wipers will start intermittent wiping. Press it downwards by 2 positions, and the wipers will start continuous wiping at low speed. Press it downwards by 3 positions, and the wipers will start continuous wiping at high speed.

Front Windshield Cleaning

In the direction of -Arrow C-(towards the chest of the driver), pull the right multi-functional operating lever, and the washing nozzle of the front windshield will spray windshield cleaning agent and the wipers will automatically wipe in several cycles.

When the windshield washer is working, after the ignition switch is turned off, the wipers will continue to run until they stop after being reset. In washing and wiping mode, if the position of the wiper control lever on the right side changes, then the corresponding function will be executed. An exception is as follows: If the intermittent mode is selected, the wiper will only start to enter the intermittent mode after completing the

When the washing and wiping cycle ends, if the wiper control lever is in any position other than “OFF”, then the wipers will continue to execute the corresponding mode after completing the washing and wiping cycle.

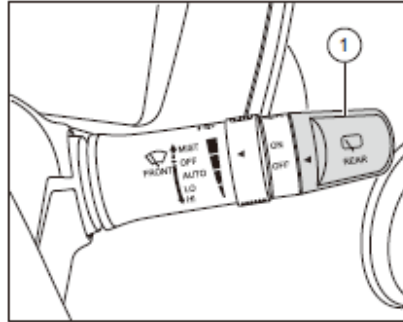

Intermittent Wiping Frequency

As shown in the figure, turn the end position -1- of the operating lever on the right side, and the intermittent wiping frequency of the front windshield wipers can be controlled. Turning it upwards (clockwise) will reduce the frequency, while turning it downwards (anticlockwise) will increase the frequency of intermittent wiping.

Caution

- It is prohibited to use the wipers when the windshield glass is dry.
- Before using the wipers in low temperatures or hot conditions, make sure that the wiper blades are not frozen or stuck to the windshield.
- In winter, be sure to clear snow and ice which are accumulated on the wiper arms and the wiper blades, including the areas which the wiper blade may reach.

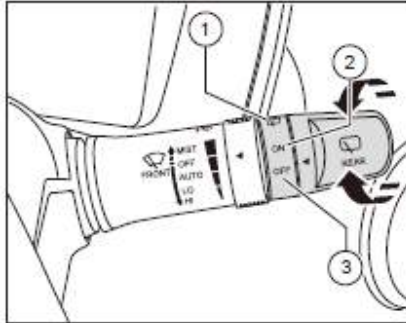
Rear Windshield Wiper

The figure shows the control unit of the rear windshield wiper. It is located on the right multi-functional operating lever. This unit includes the following switch positions:

1. Rear windshield washing

When the control ring is turned to the upper or lower limit position -1-, the spray nozzle of the rear windshield washer will spray cleaning agent onto the rear windshield and then the rear windshield wiper will automatically wipe several times in cycles. Upon release, the control ring will automatically reset.

2. OFF

In this position, the rear windshield wiper will be switched off.

3. Intermittent wiping by rear wiper

In this position, the rear windshield wiper will execute the intermittent wiping action.

4. Continuous, low-speed wiping by rear wiper

In this position, the rear windshield wiper will execute the continuous, low-speed wiping action.

Rearview Mirror**Interior Rearview Mirror**

This vehicle is equipped with a manual dimming interior rearview mirror.

Be sure to keep the surface of the interior rearview mirror clean and adjust it to the best visual angle. Before starting driving, be sure to properly adjust the rearview mirror.

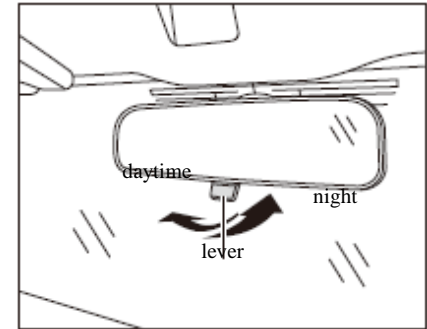
Manual anti dazzle interior rearview mirror

There are two positions for the manual interior anti-glare rearview mirror, which are day and night positions.

The adjustment level can be moved back and forth to adjust the interior rearview mirror. At night, the lever on the mirror base can be pulled backwards to the “Night” position to reduce the dazzling effect which the light of vehicles behind may cause to the driver. When the lever is pushed backwards, the interior rearview mirror will return to the initial position, namely the “Daytime” position and normal vision will be restored.

Exterior Rearview Mirror

This vehicle is equipped with an electronic exterior rearview mirror, which has the electric adjustment and electronic folding functions.

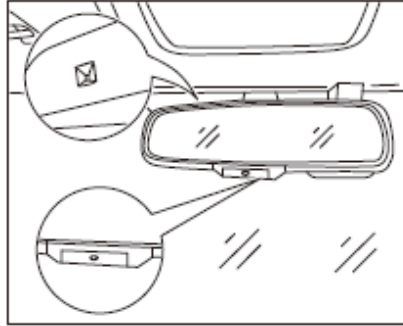

Automatic anti-glare inner and rear mirror can automatically adjust the inner and rear mirror according to the intensity of the front and rear light.

The color depth can reduce the dizziness caused by the rear vehicle lights to the eyes.

⚠ Warning

- In order to ensure the normal function of the anti-glare sensors on both sides of the endoscope, it is forbidden to use finger or object contact or cover sensor.
- In order to ensure the normal function of camera in streaming media system, it is forbidden to cover camera lens with objects. Area. In order to make the camera image clear, please be timely when the lens and rear windshield are dirty. Clean up. Streaming media rearview mirror system does not display video Out of Head Vision, Under Bumpers or Vehicles The following children, pedestrians, cyclists, Cars, animals or other objects come on either side. sense The known distance may be different from the actual distance. No To rely solely on streaming media camera screen To turn to. Lack of concentration before turning may lead to Injury, death or vehicle damage. Steering and Be sure to check behind and around the vehicle before braking Area.

The inside rearview mirror can display an image of the mirror camera.

The choice of the brightness of the interior mirror screen can be set on the radio navigation entertainment system.

The user can turn off the display of the camera video through the switch on the inner rear view mirror.

Thereby switching to a physical mirror mirror.

Outside rear view mirrors

The car is equipped with an electric exterior mirror, and the Outside rear view mirror has electric adjustment and electric folding.

Outside rear view mirror electric adjustment

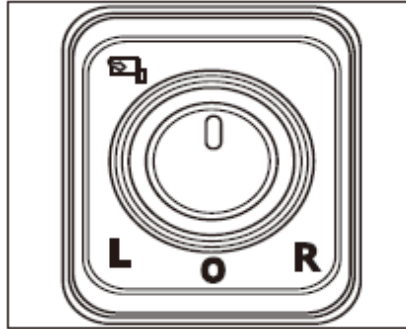

As shown in the figure, the Outside rear view mirrors are controlled by the mirror adjustment switch.

The mirror adjustment switch is located in the driver's side instrument panel switch group.

Rotate the adjustment knob to the left to indicate that the left Outside rear view mirror is selected.

Rotating to the right indicates that the right Outside rear view mirror is selected.

Then you can adjust the position of the exterior side mirrors by pulling the adjustment knob up and down and left and right.

Move up and down to adjust the vertical position of the mirror. Move left and right to adjust the horizontal position of the mirror.

Caution

When rotating the mirror to adjust the switch knob, Don't use too much force. Too much force may cause the knob to fail.

Caution

The field of view shown in the Outside rear view mirror may affect the driver's mastery of the exact position of the rear vehicle. Please pay special attention!

Outside rear view mirrors for electric folding *

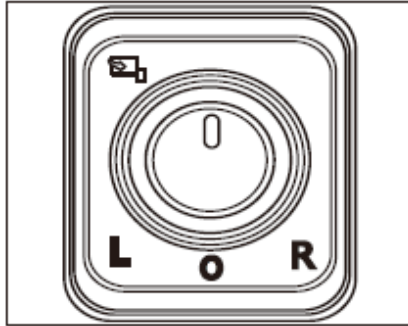

As shown in the figure, the Outside rear view mirrors electric folding button is in the driver's side instrument panel switch group.

The switch knob is rotated to the upper side, the exterior rear view mirror is electrically folded, rotated to other gear positions, and the exterior rear view mirror is electrically deployed.

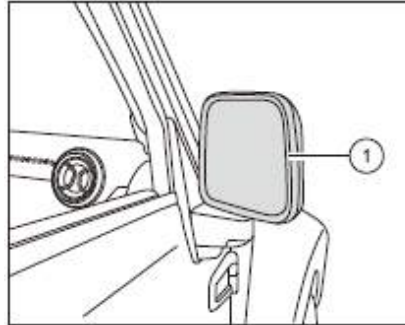

Caution

It is forbidden to drive the vehicle in any Outside rear view mirrors-1- when folded. Doing so will result in reduced visual perception and may result in an accident!

Tips

- If the ignition key is in the LOCK position or in pulled-out mode, the power leakage protection function will be turned on: The fog lights, the headlights and the reading light will be turned off after approximately 8 minutes.
- If one or several of the fog lights, the headlights and the reading light are switched on again, the timing will start again. In the event of remote locking within 8 minutes, the corresponding light(s) will be turned off.

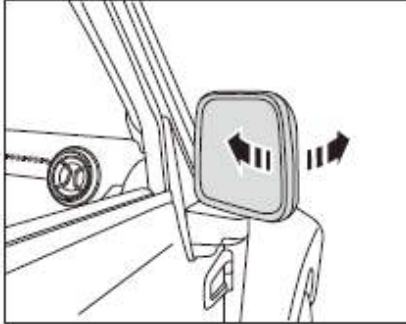
Manual rear view mirror folding *

Pushing the Outside rear view mirrors forward or backward allows the Outside rear view mirrors to be unfolded or folded.

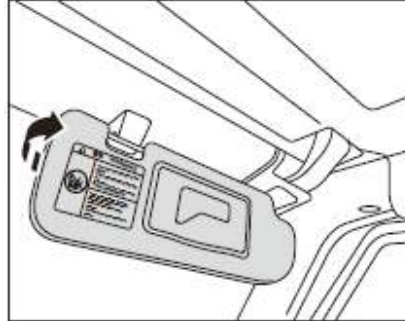
Sun visor with makeup mirror

The sun visor on the driver's and passenger's side can be pulled out of the respective brackets and then turned in the direction of the - arrow - to block the sunlight from the door window. (In the figure, the sun visor on the passenger's side is taken as an example).

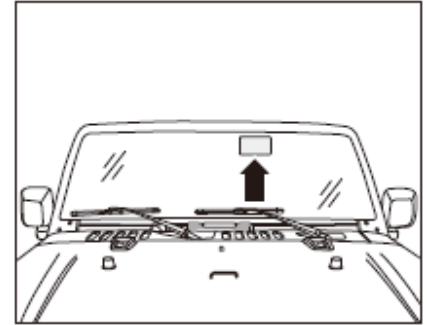
Car electronic identification microwave window

The microwave window is used to install the electronic sign of the car. The installation position does not allow the film to be attached, the heated wire is not allowed, the antenna is not allowed, the driving field of view is not affected, and the data is effectively read.

The microwave window is allowed to be embodied in the form of pitting, and the black area and the pitting point have no effect on the electronic identification receiving signal.

Seat and storage facilities

The importance of correct seats adjustment

Properly adjusting the seat ensures that the seat belt and airbag are fully protected.

The driver and front passenger seats can be adjusted in a variety of occupant sizes.

Always adjust the front seats correctly before driving the car:

- It is able to operate all the operating mechanisms on the instrument panel accurately, efficiently and safely.
- Relax in a sitting position and not fatigue.
- Fully utilize the protection of seat belts and airbags.

⚠ Warning

Incorrect seating posture of the driver and passenger can cause serious injury

All drivers and passengers must sit in their seats.

● **All occupants must wear the seat belts on their seats correctly.**

Children on the road must be protected with a suitable child protection system.

● **All headrests must be properly adjusted according to the height of the occupants and always wear a seat belt to give the occupants the best protection.**

● **Keep your feet in the foot space while the vehicle is in motion, not on the dashboard, out of the window or on the seat. Incorrect sitting posture can cause serious injury when the airbag is triggered.**

⚠ Warning

● **The seat can only be adjusted while the vehicle is stationary. If the seat is adjusted while the vehicle is running, it can easily lead to accidents.**

● **For the driver and the Passenger, the torso should always be at least 25 cm away from the steering wheel or dashboard. If the spacing is less than 25 cm, the airbag system will not be fully functional – risk of injury**

Headrest

Correct adjustment of the headrest is essential to protect the occupants and reduce accident and injury rates.

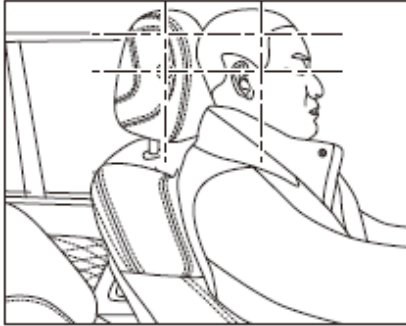

Adjust the headrest so that the center of your back is right in the center of the headrest.

If the center of your head and the center of the headrest do not maintain the correct position as shown in the figure, it is extremely vulnerable in the event of an accident.

⚠ Warning

- If the headrest is removed or the headrest is adjusted/improperly installed, it is very easy to seriously injure the occupant in the event of an accident.
- The occupant must adjust the headrest according to his or her body shape.
- If the headrest is not properly adjusted, it will increase the risk of injury to the occupant if there is an emergency or emergency braking while driving.
- The height of the headrest must be suitable for the height of the occupant. The upper edge should be as high as possible on the top of the head, and the center of the head should be as close as possible to the center of the headrest.

Adjust the front seat headrest

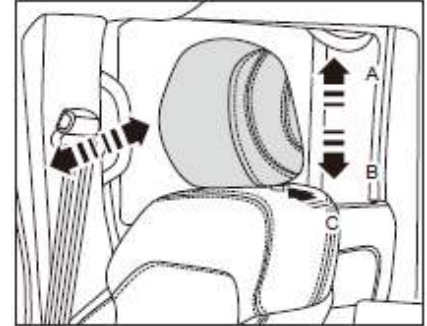

For safety and comfort, adjust the headrest before driving.

1. Grasp the sides of the headrest and lift the headrest along the – arrow A– direction to lift the headrest to the desired position.
2. Grasp both sides of the headrest, press the adjustment button in the direction of – arrow C–, and then press the headrest down in the – arrow B– direction to press the headrest down to the desired position.

Seat**Front seat****Driver seat****⚠ Warning**

When the driver's airbag is inflated, there is extreme pressure, especially if the driver is very close to the airbag, which can cause serious injury or even death.

Because the danger zone of the driver's airbag is within 50-75 mm of the front of the airbag, it provides you with enough safety space at a distance of 25 cm from the driver's airbag. This distance is the distance from the center of the steering wheel to your sternum. If you are sitting less than 25 cm, you can adjust the driver's seat position in the following ways:

- Move the seat as far back as possible while still ensuring that the pedal is still comfortable.

3. Front and rear adjustment of the headrest: The occupant sits on the seat, grab both sides of the headrest at the same time, adjust the headrest forward to the proper position; adjust the headrest to the front gear and continue to adjust the headrest forward, the headrest can be returned To the last position.

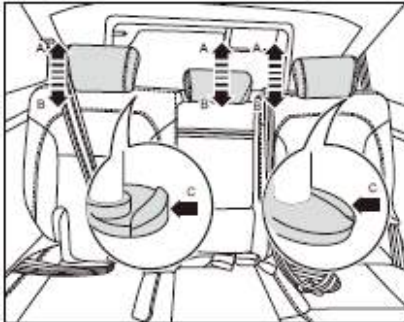
Vehicle with three headrests

For safety and comfort, adjust the headrest before driving.

1. Grasp the sides of the headrest and lift the headrest along the – arrow A– direction to lift the headrest to the desired position.

2. Grasp the sides of the headrest and press the adjustment button in the direction of – arrow C – and then press the headrest down in the direction of – arrow B – to lower the headrest to the desired position.

⚠ Warning

Do not remove the headrest, otherwise the person will be seriously injured in the event of an accident:

- After installing the headrest, the headrest must be properly adjusted according to its body shape for best protection.
- Please read and follow the warning instructions carefully.

● Slightly tilt the seat back. Although the vehicle design is different, for most drivers, even if the driver's seat is moved to the front position, the seat back can be tilted slightly back to a distance of 25 cm. If it is difficult for the driver to see the road ahead after tilting the seat back, use a hard non-slip cushion to raise the seat or raise the seat (if your vehicle has this feature).

● If the steering wheel is adjustable, tilt it down. Position the airbag against your chest instead of the head and neck.

Front passenger seat

⚠ Warning

The front passenger airbag also has considerable pressure when it is opened, so when the front passenger is very close to the airbag, it can cause serious injury or even death. Adjust the seat back so that the front passenger seat is as far away as possible from the airbag. **Front passenger seat**

Front seat heating *

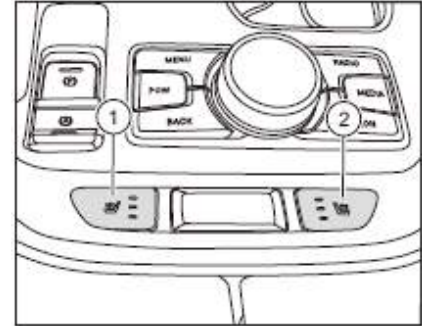

1. Driver seat heating button
2. Passenger seat heating button

When the start/stop button is in the “RUN” mode, the three working indicators of the driving and Passenger side seat heating switches are illuminated. At this time, the seat temperature is the highest, and once the button is pressed, the indicator lights are turned off from top to bottom. The seat temperature is lowered by one step, and so on, and the switch button is cycled. Some models may not be equipped with this switch depending on the model.

Front seat electric adjustment*

The driver's seat has a 6-way electric adjustable function and the front passenger seat has a 4-way electric adjustable function.

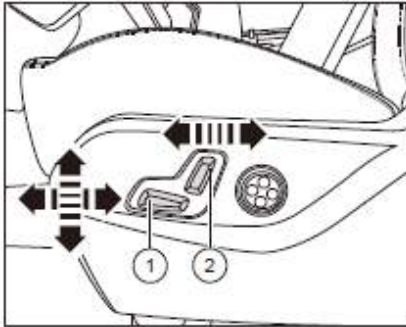
**Driver seat adjustment:**

Toggle switch -1-, according to the left side - arrow - direction in the figure, you can adjust the height of the seat or move back and forth. Front and rear toggle switch -2-, according to the right side of the figure - arrow - direction, you can adjust the backrest angle of the seat back.

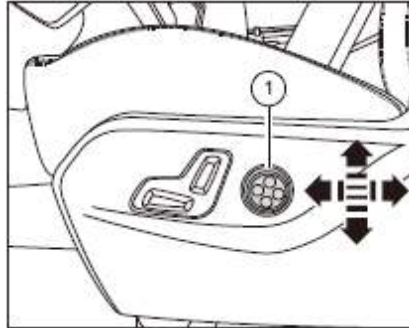
**Electric waist support (such as equipment):**

The electric waist control button -1- is located on the outside of the driver's seat. Press the upper part of the control button to move the waist support upwards; Press the lower part of the control button to move the waist support downwards; Press the front of the control button to move the waist forward; Press the back of the control button to move the waist back;

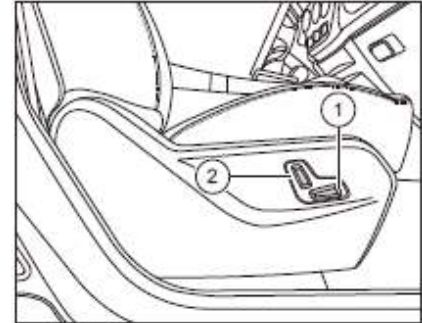
**Coupon seat electric adjustment:**

Push the front and rear switch -1- to adjust the front and rear movement of the seat position. Front and rear toggle switch -2- upper, the backrest angle of the seat back can be adjusted.

Front seat manual adjustment *

The driver's seat has a 6-way adjustable function and the front passenger's seat has a 4-way adjustable function.

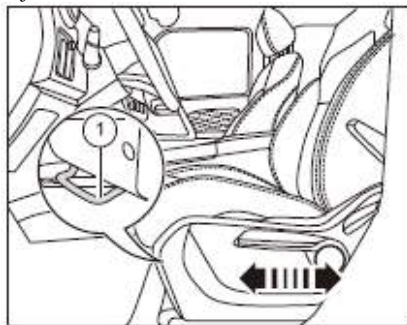
**Seat front and rear adjustment:**

The front two seats can be adjusted back and forth, here the driver side is taken as an example. Pull up the adjustment lever -1- under the front of the seat and adjust the seat to the proper position. Loosen the adjustment lever and move the seat slightly back and forth until the seat lock mechanism is locked.

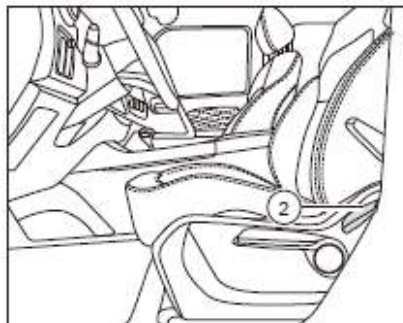
**Seat back adjustment:**

The backrests of the two seats in the front row can also be adjusted. The picture here takes the driver's seat as an example. If the driver and the Passenger want to adjust the seat back, lean the body forward slightly, and gently pull up the horizontal part -2- on the seat back angle adjustment handle, and lean back to close the seat back. In a comfortable position, release the handle and the seat back is locked in that position.

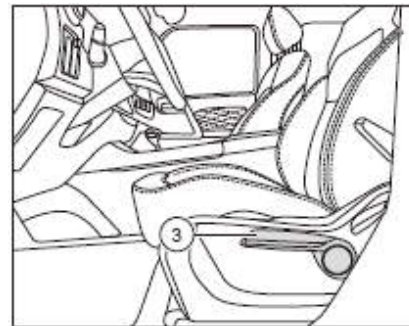
**Seat height adjustment (only for driver seat):**

Press the height adjustment handle down and down -3-, the seat surface will move downwards; the height adjustment handle will be pulled back and forth, and the seat surface will move upwards.

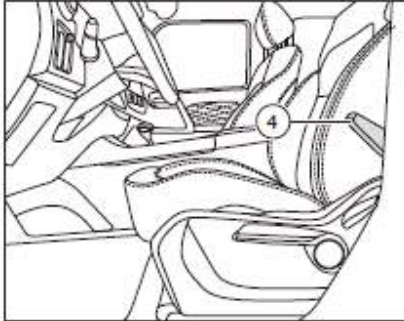

Backrest lumbar adjustment (only for driver seat):

Pull the adjustment handle up and down -4- to increase the lumbar support; press the adjustment handle down and down to lower the lumbar support.

 **Caution**

- After adjusting the seat position, try sliding the seat back and forth to ensure that the seat is locked in place.
- Push the upper part of the seat back back and forth to ensure that the seat back is securely locked, otherwise it may interfere with the normal operation of the seat belt.
- Do not place objects under the driver's or front passenger's seat. Otherwise, the seat lock mechanism may be affected or the seat position adjustment lever may be pushed up accidentally. The seat may suddenly move and cause the vehicle to be easily driven. out of control.

 **Caution**

- The seat position set by the manufacturer: the front and rear adjustment stroke is 240mm, the seat design position can be adjusted forward 200mm, rearward adjustment 40mm; the driving seat design position can be adjusted upward 20mm downward adjustment 25mm; front row back design The angle is 22°, the design position can be adjusted backward by 50°, and the forward adjustment is 25°; with the 4-way adjustment headrest, it can be adjusted back and forth for a total of 3 steps of about 26mm.

 **Warning**

- Never adjust the seat while the vehicle is moving, as the seat can move unexpectedly and cause the vehicle to lose control
- Do not let the seat hit the occupants or luggage when adjusting the seat. Seat and storage facilities

Rear seat**Rear seat folding**

This car is equipped with a rear 4/6 split seat. If you need to place large items in the rear seat, you can fold and flip the back seat back.

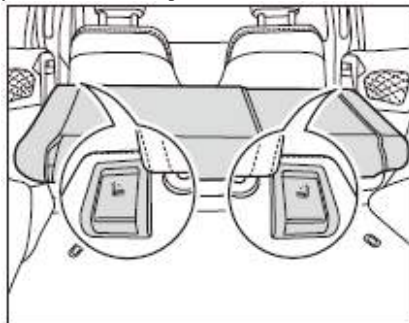

As shown in the figure above, pull up the two folding locks on the back seat backrest to control the seat down function on the left or right side of the rear row.

Fold the seat back to full contact with the seat cushion

Tips

Before folding the rear seats, it is necessary to adjust the front seat position to ensure the rear seat folding space.

Flip

Pull down the seat straps under the sides of the seat as shown, and then lift the seat up.

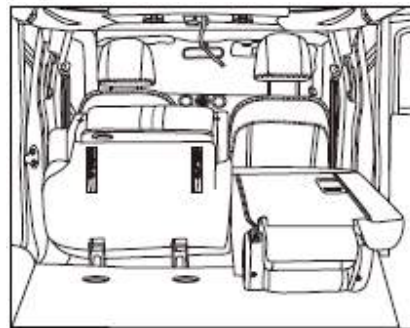
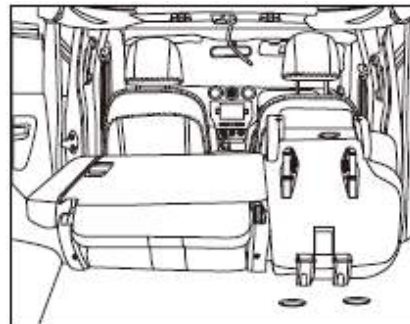
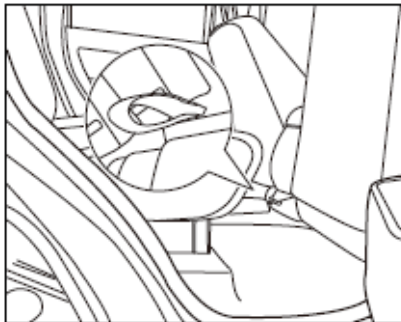

Then turn the seat up and forward to the extreme position to reverse the rear seat.

When the one seat is double-turned, the seat belt buckle is stuck to the felt on the side of the other side seat.

The advanced 4/6 split seat allows for different space requirements on both sides to accommodate living loads.

When you need to restore, you can reverse the operation. After recovery, push the seat to confirm that the seat is fully locked.

Backrest angle design requirements:

The backrest is designed for an angle of 23°, 4° forward and 10° backward.

Tips

Push the upper part of the seat back back and forth to ensure that the seat back is securely locked, otherwise it may interfere with the normal operation of the seat belt.

Caution

When the vehicle is moving, the rear seat that needs to be carefully turned up is down. At this time, the fixing hook in the seat pocket of the seat should be hung on the armrest of the body side guard as indicated by the arrow.

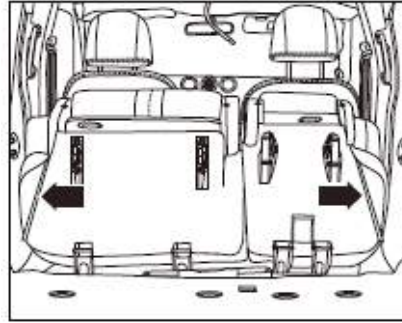

Warning

- It is very dangerous to ride in the baggage area. In a crash, an occupant riding in this area is likely to be seriously injured or even killed.
- Make sure that every occupant in the car is seated on the seat and properly fasten the seat belt.
- In a crash, if the seat is not properly locked to the fixture, the occupant may be injured. Make sure the seat is fully locked.

Warning

- To prevent personal injury, passengers should not sit in the rear luggage area or fold the rear seats up.
- The rear luggage space is for the carriage of goods only, not for passenger seats. Passengers should sit in the seat and fasten their seat belts.

Storage facility

Storage facility Front passenger side glove box

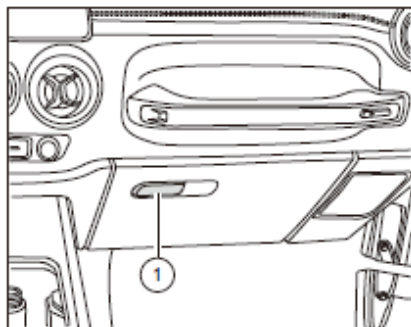

Pull the handle -1- to open the glove box and push the glove box cover to close the glove box.

Caution

- When storing liquid in the glove box, only tightly closed or unopened containers can be stored. Spilled liquid can damage the decorations and electrical components inside the glove box and dashboard.
- The glove box must be closed when the vehicle is running, otherwise the items in the glove box may fly out during an emergency braking or an accident, causing injury to the occupants.

Cup holder

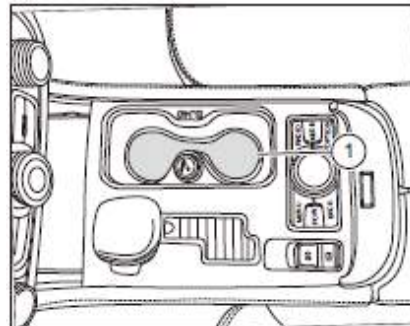

The cup holder -1- is located in the front center console, where an ashtray can also be placed (purchased by yourself).

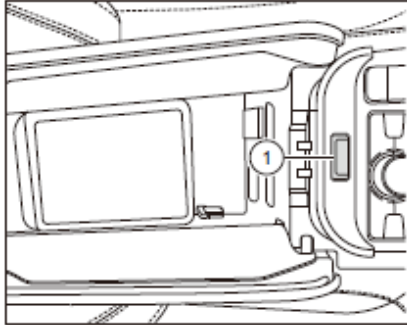
Front central armrest storage box

As shown in the figure, press the switch -1- near the front passenger side and lift the storage compartment cover upwards to open the upper storage compartment of the front center armrest. Lower the front storage compartment upper storage compartment by placing the storage compartment cover down.

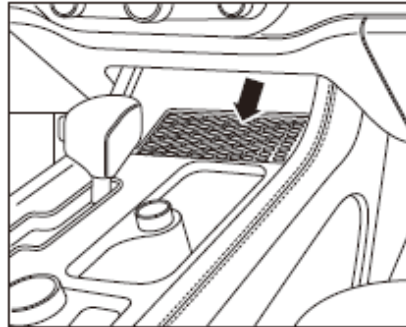
Small storage box

The storage box (arrow position shown) is located next to the cigarette lighter and can store small items.

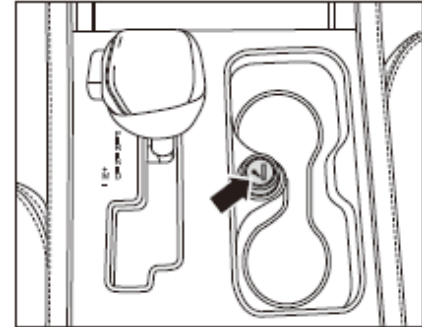
Front row integrated power outlet (cigarette lighter / 12V power supply)

The cigarette lighter (the position of the arrow shown) is located below the instrument control panel.

1. Press the cigarette lighter button.
2. Wait until the cigarette lighter pops up automatically.
3. Pull out the cigarette lighter and ignite the cigarette at the reddish heating coil.
4. After use, plug the cigarette lighter back into the outlet.
5. When the cigarette lighter is used as a power outlet, it can be connected to an electrical device such as a mobile phone. Some electrical accessories may not be compatible with the cigarette lighter socket and may blow the vehicle or adapter fuse.

Precautions:

1. Frequent plugging and unplugging of the cigarette lighter will invalidate the function of the cigarette lighter. Please fix the purpose of the cigarette lighter as much as possible. Do not switch between the cigarette lighter and the power socket function frequently.
2. Pressing the cigarette lighter while the cigarette lighter is heating will make the cigarette lighter unable to open the heating core when it is very hot. Overheating can damage the cigarette lighter or the heating core or the fuse may blow. Do not hold the cigarette lighter while the cigarette lighter is heating.

3. Adding any electrical equipment to the vehicle may damage the vehicle or cause other parts to malfunction. The resulting repairs are not covered by the warranty. Never use equipment with a maximum power rating of more than 120W. Please consult BAIC Special Service Center before adding electrical equipment.
4. Be sure to use the power plug that does not touch the metal shrapnel inside the cigarette lighter. Otherwise, the function of the cigarette lighter will be invalid.
5. The cigarette lighter is used as a power socket. Improper use may cause damage. These damages are not guaranteed.
6. Never hang any type of accessory or auxiliary bracket on the plug.

Door debris bag

There is a sundries bag arrow below each side of the door (- different models are not the same), can be used to store small items such as maps. The weight of the load shall not exceed 0.6kg, and the diameter of the round object shall not exceed 70cm. The picture here uses the right door as an example.

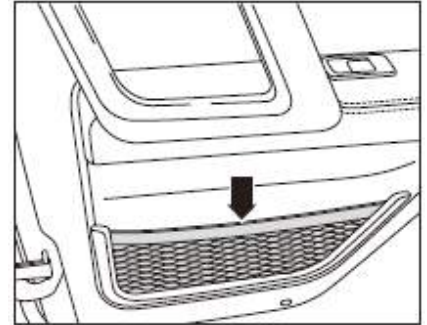

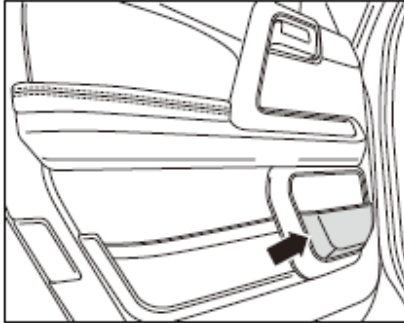
Driver's side door storage boxes

The storage box is located below the driver's side door.

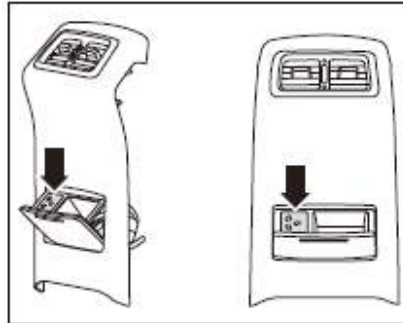
220V power interface*

Located under the rear exhaust vent

1. The 220V power supply can only be used while the engine is running. Connect the electrical plug and insert the plug into the socket to the limit position.
2. Use a plug that matches the power outlet to avoid damaging the outlet;
3. Please use only accessories approved by BAIC;
4. LED indicator Light Green When the 220V power supply is in normal working condition, the red light flashes 220V and the power supply is in an abnormal state. Please go to the after-sales service center for inspection and maintenance.

 **Caution**

- Do not use more than 150W of electrical appliances, otherwise the electrical system may be damaged;
- Improper use of the outlet may result in serious personal injury or fire, so do not allow the child to stay alone in the vehicle;
- Do not spill liquids into the power outlet, as this may be dangerous.

Parts and modification

When the vehicle leaves the factory, the engine compartment front wall, B-pillars and other components are affixed with data labels and signs, which are marked with important data and information on the use of the vehicle. Do not remove or damage labels and tags, and always keep the data and information clear and readable.

The company has adopted the latest safety technology to design the car to ensure that the car has excellent active safety and passive safety. Therefore, in order to maintain the excellent characteristics of the car, please be sure to contact BAIC Auto Special Dealer before installing accessories or replacing parts.

It is recommended that you always use accessories and parts approved by our company. If you install parts that are not approved by our company, we will not undertake the quality guarantee.

Warning

Installation of unsuitable accessories or modified vehicles may affect the handling stability and other performance of the vehicle and may result in serious injury or death.

If the car phone, alarm device, transceiver radio communication device and low-power audio system are properly installed, it will not interfere with the computer control system on the car, such as the anti-lock braking system (ABS).

Before installing any accessories, you should be aware of:

Make sure that the attachment does not cause the lights to dim or affect the normal handling or performance of the vehicle.

Modified

Removing the parts on the vehicle or replacing the original parts with parts not approved by BAIC Auto will seriously impair the handling stability and reliability of the vehicle.

E.g.:

- Installing larger or smaller wheels and tires will interfere with the normal operation of the vehicle's anti-lock braking system (ABS) and other systems.
- Modification of the steering wheel and other safety features may cause system malfunction.

⚠ Warning

- Improper modification or improper installation of the vehicle can easily lead to malfunctions and accidents. It is recommended to always use the accessories and parts approved by the company, because the adaptability, reliability and safety of the above accessories and parts have been strictly verified by our company.
- Improper modification or repair of the vehicle may impair the protection of the airbag, resulting in system failure and fatal accidents. Accessories such as beverage cup holders, telephone holders, etc. must not be mounted or attached to the enclosure of the airbag module or within the scope of the airbag.
- Improper operation or modification of the vehicle will affect the function of the airbag system and cause serious injury or death.
- Do not install wheels and tires that are not approved by our company.

⚠ Warning

- Modifications to the front of the vehicle and the engine compartment may deteriorate the pedestrian protection of the vehicle and violate road driving regulations.

3. Driving guide

Start and drive	135
Transmission system	145
Braking System	146
Parking assist system	160
Driving skills	164

Start and drive

Start/stop button

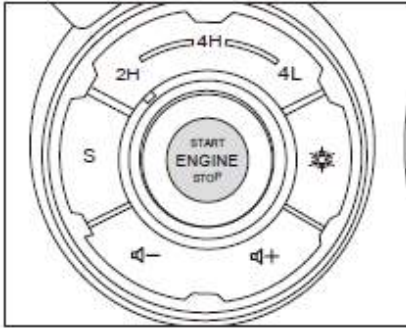

The start/stop button is located in the middle of the air conditioning vent of the center console.

Power mode switching:

Automatic transmission: Put the shift lever in the P or N position with the brake pedal released;

Manual transmission: When the clutch pedal is not pressed; press the start/stop button, the power mode will switch in the following order:

- When the button is pressed for the first time: the “RUN” mode is turned on, the meter is lit, and all the powered devices such as the display are in the on state;
 - When the button is pressed for the second time: “ACC” mode is turned on, and the accessory circuit such as radio and cigarette lighter is turned on.
 - When the button is pressed for the third time: Returns to the “OFF” mode.
- Press the start/stop button one by one to cycle through the three modes “OFF” → “RUN” → “ACC” .

Steering system

1. Do not leave the steering wheel in the dead position (left or right) for more than 15 seconds, which will damage the power steering system.
2. For cold zone users whose temperature is below -20 °C, the steering fluid needs to be replaced with a special low temperature resistant steering fluid at the authorised dealership.

Tips

- **Automatic transmission model:** The shift lever is in the P or N position and the brake pedal must be depressed to start the engine.
- **Manual transmission model:** The clutch pedal must be depressed to start the engine. For safety reasons, it is strongly recommended to place the shift lever in the neutral position before starting the engine.
- Pressing the start/stop button allows the engine to start or switch the power mode, but the smart key must be placed in an effective area that the vehicle can detect.

Electrical anti-theft function

Electronic anti-theft function is used to prevent others from illegally stealing vehicles. The transceiver chip in the remote key is equipped with an electronic code that is sent to the vehicle. The engine can only be started if the chip's electronic code matches the vehicle's ID code. If you use an incorrectly coded key (or other tool), the engine will not work.

Automatic driving lock/ stop unlock

When all the doors are locked, after unlocking the door with the smart key, no one of the four doors and two doors has been opened within 30 seconds, and the central door lock will automatically lock. When the vehicle speed is higher than the set value, the central door lock will automatically lock all doors. When the vehicle stalls, the doors unlock automatically.

Smart key standby starting function

If the vehicle is in a strong signal interference area, or the battery of the intelligent remote control key is low, when you press the start/stop button to try to start the vehicle, the display screen of the driving computer on the meter will display "no intelligent key found", at this time, the standby start function should be adopted.

Vehicle with AT

Put the gear in the "P/N" position, press the brake pedal, put the smart key into the designated key identification position in the cup holder, and press the start/stop button to start the engine.

Vehicle with MT

Put in neutral position, press the clutch pedal, put the smart key into the designated key identification position in the cup holder, press the start/stop button, and start the engine.

Emergency stop function

Emergency shutdown mode can be used when normal mode fails to shut down the engine. Step on the brake, and press the start/stop button twice or long press the start/stop button 2s within 2s continuously to shut down the engine. Start engine

Start the engine with the start/stop button

When the intelligent key is within the effective detection range, the starting method of the vehicle equipped with start/stop function is as follows:

Manual transmission model:

- Press the clutch pedal to the bottom and hold it; Put the shift lever in neutral position;
- Press the start/stop button to start the engine.

Automatic transmission model:

Press the brake pedal to the bottom and hold it;

Put the shift lever in the position of P or N;

Press the start/stop button to start the engine



Tips

● If the engine does not start successfully within about 10 seconds, release the start/stop button and wait 10 to 15 seconds to repeat the normal start procedure.

● If multiple starts are unsuccessful, please go to Authorised dealership to check the vehicle for troubleshooting.

Warning

● Do not start or run the engine in a poorly ventilated place or enclosed room. Because the engine exhaust is colorless odorless toxic gas, can cause coma and even asphyxiation death.

● Do not leave the vehicle unattended while the engine is running.

● Do not start the engine with a start assist. Otherwise, explosion or high speed engine operation may occur, causing casualties.

● To prevent damage to the starter, start the engine for no more than about 10 seconds at a time, and wait 10 to 15 seconds before starting again.

Caution

When starting a cold engine, it takes several seconds for the oil to reach the normal working pressure, which may cause running noise.

Vehicle start

Idle speed and engine coolant temperature. The engine idle speed gradually decreases to normal idle speed with the increase of coolant temperature. In cold weather, it may take longer for the engine to idle from high to low. To start at a high idle speed, run the engine for at least 15 seconds. At the same time, release the clutch pedal or brake pedal at a speed not too fast, in case the vehicle suddenly forward and cause an accident.

Shut down the engine

Stop the car, apply parking brake, put the shift lever in neutral, automatic transmission should be placed in P, release the brake pedal or clutch pedal, press the start/stop button, shut off the engine.

Put the start/stop button in "ACC" position and the engine will stop

Caution

After a heavy load operation, it is recommended that the engine run at idle for a few minutes before shutting down. This allows the cooling system to continue working to lower the temperature of the engine.

MT *

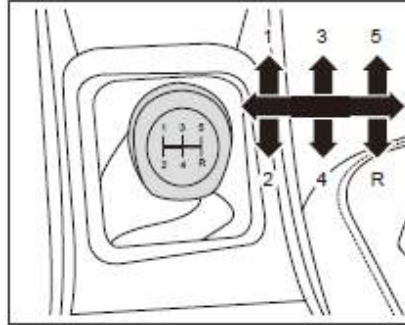

Press the clutch pedal to the bottom and start the engine. Shift the transmission lever from neutral into "1", slowly lift the clutch pedal, and the car starts to drive

When changing gear, be sure to step on the clutch pedal to the end, after changing to the next gear, should slowly release the clutch pedal.

Caution

- Don't try to start the engine when the transmission is in gear, because the car may move.
- Before starting the engine, make sure that the shift lever is in neutral position.
- Do not start the vehicle in a gear other than 1st and reverse to avoid damage to the engine, gearbox and clutch.

Vehicle speed recommend

gear	speed (km/h)	
	normal	acceleration
1 st	5-20	0-30
2 st	15-40	20-60
3 st	30-70	40-100
4 st	50 以上	70-150
5 st	70-140	—

Tips

Forced gear reduction: the vehicle speed shall not exceed 50km/h when shifting to second gear;The speed should not exceed 30km/h when changing gears.

Corrective operation for MT

Shift with gentle force, avoid excessive force, prevent damage to transmission gear.

Do not put your hand on the shift lever all the time when the car is running, to avoid premature wear of the shift fork.

Switch from forward to reverse, or from reverse to forward, and be sure to stop completely to avoid damaging the transmission.

Do not use low gear for long periods of time at high speeds, so as not to reduce engine life. When the vehicle is in a gear at a high speed, do not force into a low gear, so as not to damage the engine or transmission.

When slowing down or going uphill, do not overload the engine or drive too slowly in a certain high gear. The engine should be shifted to a lower gear to avoid overheating.

When the vehicle is running or the engine is idling, do not put your foot on the clutch pedal, lest the clutch overheat or even damage.

Do not use "half clutch" method to stop the car on the slope, so as not to damage the clutch.

When changing gears, the clutch should be fully pressed down to avoid damage to the transmission or clutch.

When the vehicle is stuck and needs to be hit by forward and reverse gear rotation, the vehicle speed should not be more than 25km/h to avoid damage to the transmission system.

Warning

- **Don't glide downhill in neutral or turn off the engine. When slowing down or going uphill, do not overshoot the engine. To drive too slowly under load or in a high gear. The engine should be shifted to a lower gear to avoid overheating.**
- **Don't drive too fast in reverse.**

Reverse gear

When the engine is running, the clutch pedal should be pressed to the end before hanging the reverse gear, pause for a moment and then put the shift lever into reverse gear. Otherwise, the gear will crash when hanging the reverse gear. Once the gear is put into reverse gear, the reversing indicator will be lit up, and the instrument will issue a prompt sound. For information on reversing radar systems, page 160, reversing radar systems.

⚠ Warning

Put the car in reverse only when it has stopped.

Driving instruction

AT* gear instruction

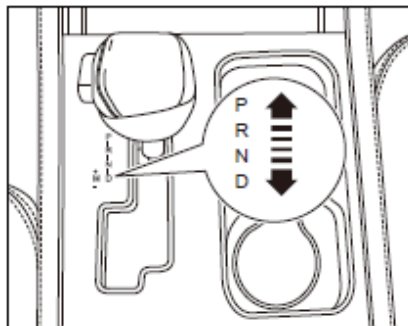

● The gear shifting control mechanism is a step gear shifting type. According to the gear changing prompt on the gear changing panel, the gear shifting operation is carried out in a specific direction.

● Only after the vehicle is safe and stable, and the brake to the bottom can be put into or out of "P" gear.

● The automatic shift control mechanism has a P lock structure, which means that the gear can only be moved from P when the brake pedal is pressed down and the vehicle is powered up or started.

"R" (reverse):

● When the vehicle is in "R" gear, make sure that it is completely stable. When the vehicle is in "R" gear from "P" or "N" gear, the brake pedal must be pressed to the bottom. When the vehicle is in "R" gear, the reversing light will automatically light up.

"N" (neutral):

● Choose "N" when the vehicle is completely stationary and the engine needs to be idling for a short period of time, such as waiting for a traffic signal. In neutral position, transmission is not locked, must use parking brake or pedal.

"D" (driving gear):

● Generally, this gear is used when the vehicle is driving forward. The system will automatically put into high or low gear according to the engine load and speed.

"M" (manual) :

● When shifting the shift lever from "D" to "M", the transmission will enter the M gear mode, and the dashboard will display the current actual gear M, push forward and backward through the shift lever, and then enter the manual mode, and the dashboard will display the corresponding actual gear.

Driving operation:

- Press the brake pedal to the bottom, put the shift lever in P/N, and start the engine.
- Step on the brake pedal, put the shift lever into "D" and enter the normal shift procedure.
- After the vehicle is put into gear, the electronic parking brake is released first, and then the brake pedal is released and the accelerator pedal is pressed slowly. The vehicle can start to drive. When parking, press down the brake pedal, stop the vehicle, apply parking brake, and put the shift lever into "P" gear.

 Caution

- According to the change of resistance (such as traction, climbing a long slope, etc.), the vehicle will start the corresponding gear shift process, by changing into a lower gear to provide greater power to the vehicle. This prevents frequent gear changes.
- A cold engine starts at a high speed, so be careful when you put it into "D" or "R" before the engine warms up.
- Before starting the engine, make sure the gear is in "P" or "N". Do not try to start the engine in other gears.

- Put the shifter lever in its other gear from "N", leaving the engine idling.
- When driving in manual mode, the vehicle will not automatically shift up. Please also pay attention to the speed and load of the vehicle to shift up timely, otherwise the engine and automatic transmission will be damaged.
- When the car is being towed, remove the drive wheel from the ground.

 Warning

- **The driver must carry the remote control key with him when he leaves the car. Otherwise, people who stay in the car may mistakenly start the engine or electrical equipment, causing serious injuries.**
- **Be sure to apply parking brake when stopping. If parking, do not leave anyone in the vehicle, otherwise it may inadvertently remove the parking brake and cause the vehicle to move.**
- **When parking or stopping with the engine running, be careful not to press the accelerator pedal for too long. Otherwise, the engine or exhaust system may overheat and cause a fire.**
- **Do not park vehicles near inflammable and explosive objects, pay attention to the direction of vehicles, do not make exhaust spray to plants and damage the green belt.**

Shift gear display *

On models equipped with automatic transmissions, the shift position display in the assembly instrument will show the current shift position of the shift lever.

The gear character on the gear shift panel has the function of displaying with the gear, that is, when the gear shift lever is in a certain gear position, the character of the gear position is backlit and displayed. When the shift lever is in any gear position of manual mode, M, M+ and M- gear characters are backlit.

How to use automatic transmission

The following information is especially important for drivers unfamiliar with vehicles equipped with automatic transmissions.

Start the

- The engine can only be started when the shift lever is in "P" or "N".
- The brake pedal should be pressed before starting the engine.
- When "D" or "R" is selected and the vehicle is stationary, do not allow the engine to run at high speed.

- Always apply parking brake until you are ready to drive away. Remember that once you have selected the driving gear, the automatic gear will slow forward or backward.

- After selecting the driving gear and the engine is running, do not keep the vehicle stationary (always choose "N" if you need to idle for a long time).

- Vehicles in the wet slippery road, should choose snow mode to start. Specific operation: after the vehicle stops completely, put the gear lever into the D gear, press the button on the center console, enter the snow mode, step on the accelerator slowly, and start driving.

 Caution

- Do not put the vehicle into "P" or "R", otherwise the transmission will be seriously damaged.
- When the vehicle is driving, especially when idling, please do not slip into neutral.
- When the vehicle is parked for a long time, please hang the "P" for parking brake.

Special case in which transmission functions are limited

When the transmission hardware, CAN communication or TCU work failure, the vehicle function limits the use, enters the corresponding limping mode (the vehicle may not be able to lift the gear normally, or fixed in a specific gear, etc.), and through the TCU fault indicator light or text on the meter to warn. The vehicle can continue to drive, it is suggested to repair as soon as possible.

Reverse

1. Park the vehicle steadily
2. Press the brake pedal and put the shift lever into the "R" position
3. After putting into "R" gear, slowly release the brake pedal and drive in reverse gear.

In reverse

- the reversing lights are on
- reverse rear-view system starts automatically and displays the reverse image in the multimedia display screen (suitable for some car models)
- when the reversing radar is started and approaching an obstacle, it will be prompted by the sound alarm of different frequencies (see "reversing radar system" on page 160).

Electric transfer Case

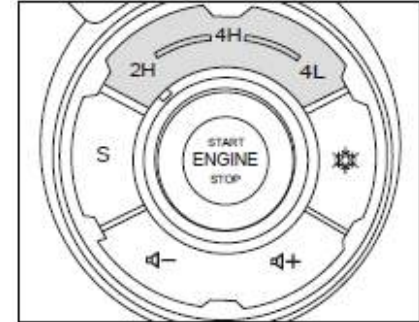

This vehicle is equipped with electric four-wheel drive transfer box, which has the following gears:

2H: two-wheel drive, rear wheel drive, used in normal driving conditions, no need for four-wheel drive driving.

4H: four-wheel drive high-grade, four-wheel drive, can be used for a short time for rain, snow, mud, gravel or general off-road road surface, not allowed to use on dry or paved road surface.

4L: four-wheel drive, low-gear, four-wheel drive, can be used for a short time on off-road roads requiring low speed and high traction. It is not allowed to be used on dry or paved roads.

Switch gear

Switch between 2H and 4H

During the driving process of the vehicle (the required speed is less than 30km/h), the driver can switch between 2H and 4H at will without stopping the vehicle, but should be in a straight and uniform speed.

Switch between 4H and 4L:

1. Stop and keep the engine running;
2. Press the clutch pedal or move the transmission lever to position N;
3. Turn transfer transfer switch to 4L or 4H gears. Note: for MT models, don't lift the clutch until transfer is completed; In the process of gear changing, the target gear blinking, after the completion of gear changing, the target gear is always bright.

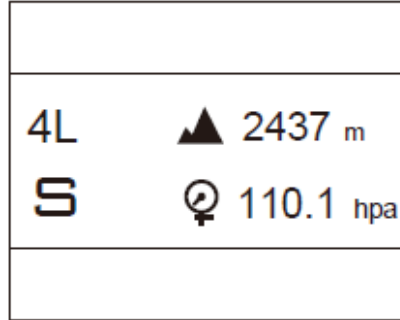

The upper left position of cluster displays the current shift position

Caution

In order to avoid parts failure caused by incorrect operation, this model does not support the vehicle to install wheel side clutch!

Warning

- if the transfer gear is not fully engaged, it may cause damage to the transfer or the vehicle loses power and control, resulting in personal injury accident
- do not use four-wheel drive mode in dry hard road for a long time.
- if abnormal vibration of chassis is found when turning, please check whether the transfer gear is not placed in "2H".
- use 4L only when additional traction is required, and do not use 4L for long periods of time.
- the driving speed of vehicles in four-wheel drive mode shall not be higher than 60KM/H

Transmission System

General descriptions

Improper operation of the driver on off-road road will cause abnormal damage to the transmission system.

Operation requirements (steep slope, uneven mountain area, muddy road section):

1. Four-wheel low-gear drive, maintain stable throttle. Drive slowly, not exceeding 25 km/h.
2. Avoid rapid acceleration and violently lift the clutch to avoid abnormal damage to the transmission system.
3. Once the vehicle cannot get out of the jam by itself, do not force the operation. Please call for help immediately.

Caution

When entering the off-road zone, drive slowly and do not exceed 25km/h.

Avoid sudden acceleration, to prevent the wheel suddenly violent rotation, resulting in idling skid

When the vehicle is released from the jam, it is forbidden to accelerate sharply or lift the clutch suddenly.

The following will cause transmission parts failure,

1. Depress the brake pedal and accelerator pedal at the same time, and lift the clutch.
2. The front wheel encounters a large obstacle, depress the accelerator pedal in a hurry to get out of the jam.
3. The wheel flips out and slams on the gas pedal.
4. Kill the steering wheel at the same time, one side of the wheel under stress (such as: a step or pit) drive axle stress is too large.

Brake system

General descriptions

Disc brakes are installed on all four wheels of the vehicle. The booster helps reduce the force required to the brake pedal.

The driving brake system has two sets of brake pipes. One line failed and the other stopped the vehicle properly. However, the brake pedal must be pressed harder than usual. Go to Authorised dealership for maintenance as soon as possible.

Placing the foot on the brake pedal while the vehicle is in motion will cause the brake to operate slightly and generate heat, thereby reducing brake effectiveness and shortening the life of brake friction pads and reducing fuel efficiency. Braking lights on all the time can also cause confusion among rear drivers

When going down a long slope, continuous use of the brake will make it accumulate heat, thereby reducing the effectiveness of the brake

At this point, the foot should be removed from the accelerator pedal and should be shifted to a lower gear to use the engine to assist braking.

After passing through deep water, the brake must be checked. Step on the brake moderately, see if it feels normal. If abnormal, should frequently light step on the brake until it returns to normal.

The braking operation includes sensing time and reaction time.

First, to decide whether to step on the brake pedal, this is the feeling time. Then you have to lift your foot and press the pedal. That's the reaction time

The average reaction time is about three quarters of a second. But that's just the average time. Maybe one driver's reaction time is shorter, but the other driver's reaction time is two to three seconds, or even longer. Age, physical condition, alertness, coordination and vision all affect reaction times, as do alcohol, drugs and depression. Even though the reaction time is about three-quarters of a second, when the vehicle speed is 100km/h,

Vehicles will also travel 20 meters, too far in an emergency. So it's important to have a good distance from other cars.

Of course, the actual braking distance varies greatly depending on the road surface (highway or sand road), road conditions (wet, dry, icy), tire tread, brake condition, vehicle weight and brake force size.

Avoid slamming on the brake pedal unnecessarily. It is wrong for some drivers to drive too hard, such as slamming on the accelerator pedal and then the brake pedal, rather than keeping pace with traffic. The brake has no time to cool down between successive emergency braking, and if the brake pedal is frequently slammed, the brake wear will be accelerated. Keeping pace with the flow of traffic and keeping a certain distance will greatly reduce unnecessary braking, which will improve braking effect and extend brake life.

If the engine flameout in the road, should take the normal brake but do not use the inching brake, otherwise the brake pedal will be more laborious. Even if the engine stalls, there is still some brake power available for braking, but it is used when braking. Once the brake assistance is exhausted, the braking time will be prolonged and the brake pedal will be more laborious.

Influence factor for braking effect

1. Wear

The wear of brake friction plates depends largely on the mode of use and driving conditions, especially for those cars that often drive in urban traffic and short distances or drive in sports mode. Therefore, it is very necessary to check the thickness of brake friction plate in Authorised dealership within the specified time interval.

In downhill driving should be timely change low gear, so as to use the engine brake power, so as to reduce the brake load. If you want to increase the braking force, do not continue braking, but should be interrupted braking.

Wet /sprinkle salt

In some driving conditions, such as in water or rain after driving, or after washing the car, because of wet or in winter because of low temperature brake disc and friction disc ice, brake action will occur delay lag, must first brake several times, dry the brakedisc.

In rainy days and wet slippery road driving, should control the speed, prevent skidding; In the encounter of water, should be low uniform speed through. After passing through the section with deep water, because the brake friction disc and brake disc will be soaked by water, affecting the braking effect, to lightly step on the brake several times, so that the brake parts to maintain dry recovery performance.

In the salt road, if there is no braking for a long time, the braking effect will be delayed and delayed, so it is necessary to remove the salt layer on the brake disc and friction plate.

3. Plateau environment

Due to the long mountain slope in the plateau area, the brake has a high use frequency, a long time and often works continuously under the forced dynamic working condition. All these factors will make the braking effect worse. Therefore, we advise the vehicle not to taxi in neutral and avoid frequent braking when going downhill. Use low gear to control the speed through the braking action of the engine itself, which can reduce the working intensity of the wheel brake, reduce the brake temperature.

In the use of engine braking, the lower the transmission gear, the higher the engine speed, the greater the drag force, the more obvious the braking effect.

The plateau region has thin air and low air pressure, which is different from the atmospheric pressure of the plain. In plateau area, due to the effect on the brake booster diaphragm per unit area of the atmospheric pressure is less than a standard atmospheric pressure, so the brake power will become smaller, and produce the same power effect time get longer, and this is a normal physical phenomena, so when braking in plateau region need to put greater brake pedal force. When braking is needed, do not slam on the brake pedal many times, but keep the foot on the brake pedal to ensure the braking effect by controlling the brake pedal force.

4. Snow and ice

Due to the low friction coefficient of snow & ice covered surface, the braking distance will be greatly extended during braking, and the braking distance will increase with the increase of vehicle speed. Therefore, special attention should be paid to control the speed and maintain a large safe distance from the leading vehicle or the lateral vehicle when driving on snow & ice covered surface.

No idling on ice and snow road.

5. Surface rust

If the vehicle has been parked for a long time or you have not used the brake system for a long time, then the brake disc friction plate may develop rust, and the friction plate may develop dirt. We recommend that you clean the brake disc several times before driving.

6. Braking system failure

If you find that the braking distance suddenly becomes longer or the brake pedal travel becomes longer, there may be a fault with the braking system. In this case, should immediately drive to the nearest Beijing car dealership repair. During the way, keep the speed low, adjust your driving style, and apply more force to the brake pedal when braking.

7. Brake overheating

When you do not need to brake, do not lightly step on the brake pedal and make the brake "skid", which will lead to overheating of the brake, extend the braking distance and increase wear.

If spoiler, wheel trim plate, etc., must not affect the flow of air to the front brake, otherwise the brake will overheat.

The brake pedal

Do not place thick MATS or other foreign objects near the brake pedal. This will affect the travel of the brake pedal in an emergency. Ensure that the brake pedal is fully operational under all circumstances.

Do not rest your foot on the brake pedal when braking is not required. Otherwise, brake temperature will rise, brake disc premature wear, or even damage the brake.

Brake friction pad

Disc brakes with warning devices emit a squeal of metal friction when the brake pads wear out to the limit. If you hear this sound, go to Authorised dealership as soon as possible to replace the new brake friction pad.

Emergency braking should be avoided as far as possible during the first 200km of driving after replacement of the friction pad.

Warning

Do not drive a vehicle with worn brake pads, which can make braking difficult and may lead to accidents

Brake system status and brake system failure

Warning lights

When parking brake is applied or the brake fluid level is below the specified level, the brake warning light will be on. Before driving, the parking brake should be completely released and the brake warning lights should be off. If the brake warning lights come on while the vehicle is in motion, this means that the brake is less effective. Park the vehicle in a safe place by:

- if the brake pedal is pressed, when the braking effect is weakened, press the brake pedal with more force.

Electric parking brake (EPB)

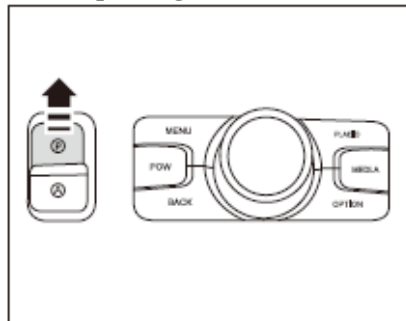

Manually apply electronic parking:

When the vehicle is in a stationary state and the start/stop button is in the "RUN" mode, pull the electronic parking switch button upward along the arrow direction to apply the electronic parking brake and prevent car slipping. At this time, the red parking light on the instrument cluster will be on.

Automatically apply electronic parking:

The vehicle is in any gear and

when the start/stop button is placed in "OFF" mode, the vehicle will park automatically, and then the red parking light on

Apply Secondary electronic parking:

In some special cases, the second clamping of brake calipers can be realized by putting the start/stop button in "RUN" mode and pulling the electronic parking switch button upward along the arrow direction for 3 seconds when the vehicle is already parked.

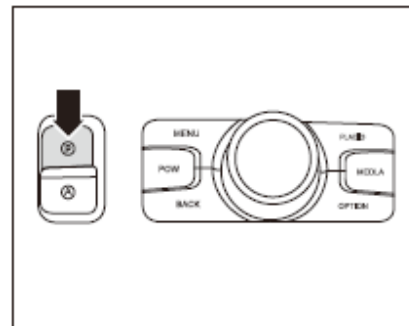

Manually release electronic parking:

When the start/stop button is in "RUN" mode, press the brake pedal and push down the electronic parking switch button along the arrow direction to release the electronic parking brake. At this time, the red parking light on the combined instrument is off

 Caution

- if the brake pedal is not pressed, push down the electronic parking switch, the electronic parking will not release. cluster display prompt "please brake.
- after the automatic gear stops, apply the electronic parking first, and then put the shift lever in the "P" position.
- in some special cases, if the electronic parking brake is not required , the electronic parking switch can be pushed downward and hold on more than 3s before turning off the start/stop button, then the vehicle will not apply brake.

 Caution

- when transfer box is at 4L, transmission is on D /R transmission; if EPB is used for a long time, the combined instrument display will prompt "if long"
- if two or more wheel speed sensors fail, the start/stop button in the "RUN" state cannot stop by pulling up the electrical park to realizes parking. The cluster display indicates "if parking, please turn off the engine and pull the EPB switch long" . When start/stop button In the "OFF" state, pull up the electronic parking switch for 3 seconds to realize parking.

 Caution

- When the start/stop button is in the "OFF" state, if the electronic parking is in the release state, the parking can be realized by pulling up the electronic parking switch for 3 seconds.
- when the yellow indicator light on the cluster is on, it means that the electronic parking system fails. Please contact authorised dealership Vehicle maintenance.

Automatic release of electronic parking:

First make sure the doors are closed and fasten the seat belt well. Shift from P or N to D or R, step on the accelerator, and the electronic parking will be automatically released.

 **Caution**

- **make sure the driver's safety belt is fasten, otherwise parking automatic release function cannot be realized.**
- **if the driver does not fasten the safety belt, the cluster display will prompt "please fasten the driver's safety belt to release the electronic handbrake".**

ABS anti-lock brake system

Anti-lock braking system (ABS) can prevent the wheel from locking when the vehicle is braking, which will ensure the vehicle's controllability and directional stability during braking.

The main function of ABS anti-lock braking system is to improve the active safety when driving. ABS will automatically adjust the braking pressure of each wheel. Before the wheel is about to lock, the brake pressure decreases automatically, and then increase the brake pressure to the wheel until it is about to lock. The electronic components of the brake system receive signals from the wheel speed sensor, which accurately contain the speed of wheel rolls. This information is continuously processed to adjust brake pressure as accurately as possible. Braking pressure can be adjusted up to 12 times per second, but ABS cannot be expected to shorten braking distance in all cases. For example, on gravel or freshly fallen snow surfaces, braking distances can be long, even if you drive carefully and slowly.

ABS working mode

When the vehicle speed reaches about 20km/h, an automatic detection process is started. You can hear the pump running.

ABS can't shorten the braking distance on gravel and icy roads, but it retains some steering control because the wheels don't lock completely.

It is normal to feel the brake pedal shake and hear the click sound when ABS system is working. If the speed range of a wheel is too low relative to the vehicle speed and tends to lock, ABS will reduce the braking pressure on the wheel. This adjustment process can be detected by the brake pedal noise. As a driver, you know that the wheels tend to lock (ABS range). At this point to continue to keep the brake pedal completely down, steering the vehicle out of danger.

Before the vehicle stops or danger situation ends, must not loosen the brake pedal! The brake pedal cannot be repeatedly pressed, which will stop ABS work and may increase the braking distance.

If the road is slippery, ABS is enabled even when the brake pedal is lightly pressed, which allows the driver to obtain information about road characteristics through braking and then adjust his driving style.

 Warning

ABS braking system cannot violate the principles of physics. So get into good driving habits and don't take advantage of the ABS system to drive too fast.

To get the shortest possible braking distance and improve track stability on dry and wet roads, brake as hard as possible and conduct emergency avoidance operation as needed.

ABS warning lights

ABS integrates a monitoring system to check all system related electrical components in real time.

When the anti-lock braking system fails, the ABS warning lamp will be on. When the start/stop button is in the "RUN" position, the light will be on for 2~3 seconds, and then off. Make sure the lights go off before the vehicle moves.

When the ABS warning light is on during the driving process, do not make emergency braking, or the vehicle may have the risk of unstable driving. Be sure to gently press the brake pedal and park the vehicle in a safe place. Restart the engine and check if the warning lights go off after a few minutes of driving. If the warning lights are off during driving, there is no problem.

If the warning light is not off, or if the warning light is on again while driving. Please go to Authorised dealership to repair the vehicle as soon as possible.

 Warning

After the failure of ABS system, the normal braking system will still work and will not be affected by the loss of ABS function, but the braking distance will increase correspondingly.

ABS system daily maintenance

ABS system is composed of mechatronic components, with high reliability, usually without regular maintenance. The following points are helpful to improve the performance of the system and further reduce the failure rate of the system:

- ABS ECU is composed of precision electronic parts, strong collision and knock easy to damage the electronic parts, therefore, try to avoid ECU by collision.
- do not let oil pollution to ABS electrical connectors, especially metal terminals, so as not to cause poor electrical contact.
- do not make the wheel sensor contaminated with oil or other debris, especially in the gear ring position near.

● high water content of brake fluid will not only cause bad braking due to evaporation of water, and may corrosion of the braking system, leading to ABS performance decline, so, should be replaced regularly, generally at least two years replacement.

● When the ABS warning lamp:

1. Keep ON
2. Light up for a long time during driving
3. When the start/stop button changes from "OFF" state to "RUN" state, the ABS alarm lamp on the combined instrument does not work all the time.

It must be repaired in time. When using the braking system before troubleshooting, attention must be paid to controlling the braking strength to avoid wheel lock.

EBD electronic braking force distribution system

Automatically adjust the braking force distribution ratio of front and rear axles to improve braking efficiency (to a certain extent, it can shorten the braking distance), and cooperate with ABS to improve braking stability.

ESP electronic stability system *

ESP can effectively reduce the risk of sideslip. The ESP only works when the engine is running. In exceptional circumstances, ESP functions can be disabled, such as:

- When the vehicle is equipped with anti-skid chains.
 - driving on deep snow or soft roads
 - When a vehicle is stuck somewhere (e.g. on a muddy road) and has to move back and forth
- In the absence of these conditions, the ESP electronic stability system should be turned on.

ESP improves control of the vehicle at its dynamic limits, such as acceleration and corners. It can reduce the risk of sideslip in all road conditions, thus improving the driving stability of vehicles.

In the electronic stability system, it also integrates anti-lock braking system (ABS), electronic braking force distribution system (EBD) and traction control system (TCS), ramp auxiliary function (HHC), HBA, HDC, anti-roll (RMI), AUTOHOLD

The ESP indicator

When the start/stop button is located in the "ON" position, the ESP indicator in the combined instrument will light up, and the self-inspection will begin, indicator will be off after self-checking

If the ESP light flashes during driving, the ESP system is currently operating.

If the ESP light does not go out after the self-inspection or continues to light during driving, the ESP system is defective and the vehicle should drive at a low speed to the nearest Authorised dealership for maintenance.

ESP OFF Function

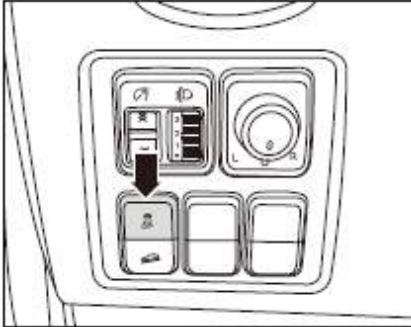

Transfer case 2H: it is at default that ESP function is on.

Press ESP OFF button to switch off ESP function, and the ESP OFF indicator light  on the combination instrument will be on.

Press ESPOFF button again to start ESP function, and the ESPOFF indicator light  on the combination instrument will be off.

 Caution

● Transfer case 4H/4L, Press ESP OFF button fleetly < 3s, It is only for switching off ESP and Torque Control with TCS, Retain other functions.

● Transfer case 4H/4L, Press ESP OFF button for a long time (3s-10s), It is only for switching off ESP and TCS, Retain other functions.

● Transfer case 2H: Press ESP OFF button < 10s. It is only for switching off ESP and TCS, Retain other functions.

● When switching off the ESP function by pressing ESP OFF button, the ESP function will be automatically restored and the ESP OFF indicator light becomes off when the vehicle is driving at speeds above 80km/h.

Transfer case 4H/4L: ESP OFF indicator light is automatically on, indicating that the ESP system is in partial functional state, including ABS, EBD, TCS, HHC, HBA and HDC. Hill descent function. While ESP system is in service, ESPOFF indicator light is off and ESP indicator light flashes.

 Warning

Electronic Stability Program (ESP) only provides limited control on stability of the vehicle during driving, so even when the vehicle is equipped with ESP, you must adjust your driving method at any time depending on the road conditions and traffic situation. This is especially important for driving on smooth and wet pavements. To eliminate possibility of accidents, don't take a risk to drive even though the driving safety is improved with this system.

Traction Control System (TCS) *

TCS can prevent the driving wheel from slipping during acceleration.

TCS is a part of ESP. Under extremely unfavorable road conditions, start, acceleration and driving uphill is possible or easier only with the traction control system (TCS).

Operation methods of TCS:

TCS can automatically function, without intervention from the driver. It monitors speed of the driving wheel through the sensor of ABS. In case of wheel slipping, the engine torque will be automatically reduced to enable the driving force comply with road conditions, which can be achieved within all speed ranges.

TCS works jointly with ABS. In case of fault to ABS, TCS is also disabled.

Hydraulic Brake Assist (HBA)*

The brake assist system is for purpose of brake force optimization. The brake assist system helps to improve the brake force and shorten the brake distance. When the driver depresses the brake pedal very quickly, the brake assist system will automatically adjust the brake force to the maximum value until ABS provides control intervention. Keep depressing the brake pedal until the required braking is achieved. Once the brake pedal is released, the brake assist system will be automatically shut down.

In case ABS fails, the brake assist system is also out of service.

Hill-start Hold Control (HHC)*

In case of grade more than 4° , either to continue driving after parking during driving uphill or to reverse after parking during driving downhill, the hill-start hold control is automatically activated at any time, and within about 0.5~2S after the brake is released, HHC can still provide powerful brake force to ensure brake of the vehicle so as to prevent the vehicle from sliding and to enable easy driving, and with elimination of slope sliding trouble, comfort and control safety will be greatly improved.

Hill Descent Control (HDC)*

HDC enables driving at constant speed during driving downhill.

As an additional function to ESP system, HDC can be used when the driver hopes to maintain constant speed (Transfer case 2H/4H, between 8km/h~35km/h; Transfer case 4L, between 4km/h~35km/h) when driving downhill.

HDC operation methods:

1. Press HDC switch to activate Hill Descent Control function, and green HDC indicator light will be on indicating that HDC function is activated and ready; press HDC switch again to shut down HDC function;
2. When HDC is on and the vehicle is driving downhill, if the driver does not perform brake operation or acceleration operation and the vehicle will be driving at speeds between 4km/h (Transfer case 4L) 8km/h (Transfer case 2H/4H) ~35km/h, HDC starts functioning and the vehicle can remain driving at the initial speed, and at this time, HDC indicator light is flashing;

3. When the driver increases the speed of the vehicle to more than 35km/h through the accelerator pedal, HDC exits and is on standby; when the speed keeps increasing to more than 60km/h, HDC completely exits, and HDC indicator light is off, indicating that HDC is switched off.

4. When the yellow HDC indicator light is on, it indicates that the HDC is disabled. Please go as soon as possible to Beijing auto dealership repair vehicles.

Roll Movement Intervention (RMI)*

RMI is started when there is overturn potential after lateral inclination of vehicle body or height of the wheel above the ground exceeds a certain limit during driving, or the steering angle exceeds a certain limit, and it can reduce the overturn risks by braking the wheels and reducing the engine torque.

Autohold

The auto hold function can help driver to take off easily on the ramp. After releasing the brake pedal, the system continues to brake, the driver had enough time to press the accelerator pedal to take off, and this function ensures the takeoff convenience at the time of automatic parking relief.

Turn On Autohold

When the engine is operating and the driver has fastened his seat belt, driver side door closed, press the AUTOHOLD switch button to activate this function. and then the indicator lamp of auto-hold switch button will go on.

Active Autohold

1. When the engine is operating and the driver has fastened his seat belt, driver side door closed, turn on AUTO HOLD. Depress the brake pedal until the vehicle stops, AUTO HOLD function is working, the parking indicator lamp on the instrument will turn green.

2. The accelerator pedal is depressed during take off, AUTOHOLD function is automatically removed, and the parking indicator lamp on the instrument will turn off.

3. If the accelerator is not pressed after 3 min, switch to EPB mode, EPB red parking lights point.

Turn Off Autohold

Press the "AUTOHOLD" switch from function is off, switch indicator is off.

Autohold Is Forced To Exit

Since the driver's seat belt is unfastened, driver side door opened and Engine shuts down, the auto hold function will be forced to exit.

If AUTOHOLD is enabled, at the same time as the driver's seat belt is unfastened, driver side door opened and Engine shuts down or Press the "AUTOHOLD" switch, the brake pedal was not pressed down, Enter EPB mode, instrument green indicator

Lights off, electronic parking red indicator lights point.

Autohold Function Auto Exit

When the AUTOHOLD function is active, Put it in D or R, the accelerator pedal is depressed, AUTOHOLD auto exit, the vehicle will takeoff.

Caution

● For MT vehicles, On a level road, pull in Neutral, the accelerator pedal is depressed, AUTOHOLD function auto exit, Please take care of safety.

● AUTOHOLD monitors vehicle status, If the brake pedal is released after monitoring the brake Insufficient pressure, ESP will be actively pressurized Keep the vehicle stationary. ESP actively increase Pressure will generate noise which is the ESP electricity pump The working sound of the machine is normal.

● When the instrument display prompt "since AUTOHOLD system failure ", said AUTOHOLD is disabled. Please as soon as possible Go to Beijing car dealership to inspect and repair the car Vehicles.

Parking Assist System

Explanatory Notes on the Parking Assist System

Four sensors for the reversing radar system are installed on the rear bumper. When in reverse, the parking radar system is automatically activated. When the system is activated, it will check the approximate distance from the rear of the vehicle. And based on the distance to the obstacle, it displays information on the control screen. And sent by loudspeaker, it makes the corresponding prompt sound.

The indicator bar on the central control display screen is based on obstacles that are detected in the rear distance orientation of the vehicle. And the closer the obstacle is to the vehicle, the higher the frequency of the sound signal will be. (The indicator in the figure above shows bar signal strength for example, possibly with actual situation discrepancy).

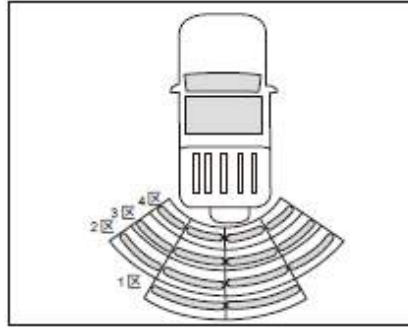

Acoustical Signal

The audio alarm signal of the parking assist system is sent out by the loudspeaker driven by the central control display. As the distance between the obstacle and the vehicle gets closer, the frequency of intermittent chirping increases. The distance between the barrier and the spare tire. When it's less than 30 centimeters, it becomes continuous.

Display Signal

Left, center and right sensors are composed of four layers set of indicators that show the status of obstacles. Each group of display bars independently displays the information of measured obstacles. Group to group display does not interfere with each other.

When there are multiple obstacles in the detection range, the nearest obstacle is displayed.

The display bar in zone 4 is red to represent obstacles about 0 ~30 cm from the rear of the vehicle. Within the scope of;

The display bar in zone 3 is yellow to represent obstacles about 30 cm ~60 cm from the rear of the vehicle. Within the scope of;

The display bar in zone 2 is yellow, representing obstacles about 60 cm ~ 90 cm from the rear of the vehicle. Within the scope of;

The display bar in zone 1 is green, representing obstacles about 90 cm ~150 cm from the rear of the vehicle. Within the scope of.

Reversing Rearview System*

General Instructions

The reversing rearview camera on the rear bumpers can assist the driver in reversing or dispatching. Vehicle rear images from rearview camera are displayed on the screen of the original navigation system.

Reversing rearview system is a system for display of the rear environment while parking the vehicle at low speed (like entering the garage). The reversing rearview system is only a reversing assist system. It cannot replace the driver's objective analysis of objects.

Detection Range

The detection range of the sensor is limited to the vicinity of the rear bumper. Be sure to determine the safe distance around the vehicle and drive slowly. The maximum detection distance of the sensor varies with the size of obstacles. The sensor can detect fairly large objects such as walls at a maximum distance of 150cm away. However, for small obstacles particularly rod-shaped objects, its detection distance is less than 150cm.

The detection range at the edge angles of the vehicle rear is 90cm.

The detection range in the middle of the vehicle rear is 150cm.

⚠ Warning

- **While reversing, pay particular attention to those obstacles which are higher or lower than the reversing sensor.**
- **In certain particular situations, some obstacles very close to the vehicle will not be detected by the reversing radar system and thus may cause damage to the vehicle, or to objects such as short stumps, flower bed edges, etc.**
- **Sensor being damaged and polluted, snow or ice covering the sensor or ultrasonic waves generated near the vehicle (such as: by big trucks' air braking or pneumatic hammers) may all affect the normal working of the sensor.**

System Start

When the vehicle is at R gear, the reverse rearview system will be automatically started, and reverse rearview interface is shown on the DVD display screen. Reversing radar signals are superposed and displayed on the reversing rearview image.

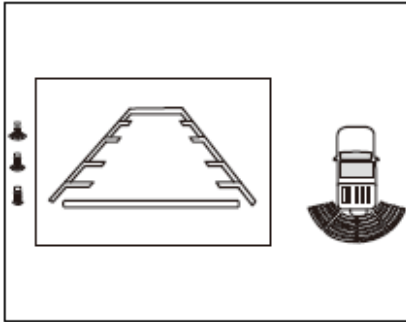

Reversing radar system image will be superposed and displayed in the reversing rearview image, and for details, refer to “Reversing Radar System” on page 160.

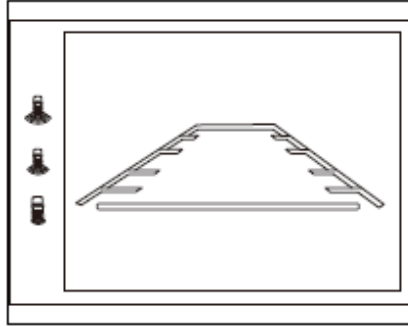

The red line block is a safety warning area, indicating 0.3m position;
The yellow line block is a safety prompt area, Yellow scale by near the distance is 1 m, 1.5 m, 2 m, 2.5 m, 3 m.

System Exit

In the following two cases, the reversing rearview system exits:

1. At speed > 15km/h, DVD display will show “Warning!!! Over-speed! PAS system is OFF. Please drive safely! , and exit the reverse rearview image after 1s; when the speed is < 15km/h again, go to the reverse rearview image again;
2. Bring the vehicle to exit R gear.

Precautions for Reversing Rearview System

The reversing rearview system is only a reversing assist system. It cannot replace the driver's objective analysis of objects. The camera has some blind areas, so some positions are beyond its reach.

Keep the camera clean and free of ice so that it can properly function. When using high pressure cleaning equipment to wash the vehicle, do not spray and wash the camera for a long time. During spray cleaning, the nozzle must be more than 10cm from the camera.

System Fault

In case of fault to reverse rearview system, no image will be shown on the reverse rearview interface, and words "reverse rearview camera fails" appear on DVD display screen. At this time, the reverse rearview system fails to operate properly, and it should be repaired and detected at an authorized BAIC dealership.

- During reversing, don't be completely absorbed by the reversing rearview image, but also observe the surrounding traffic situation at any time, including traffic situation in front of the vehicle.

- It is impossible to accurately judge the distance between the vehicle and the object with the rearview camera, so environmental conditions shall be judged based on physical conditions.

- The reversing rearview system inevitably has some blind areas, and things in these areas are beyond its reach.

- Keep the rearview camera clean because the camera covered with ice, snow or foreign matters will result in vague or no image.

- Extreme weathers, like bright sunshine, ice and snow, may influence the display effects of the reverse rearview images, so adjust the driving method accordingly.

- While reversing, the driver must be responsible for checking whether there are people (especially children) and small animals in the operating area. During reversing, don't completely rely on the reversing rearview system. Observe the surroundings even at very low speed during operation.

Driving Skills

Driving Tips

Driving on Paved Road

Compared with ordinary vehicles, this vehicle has a large ground clearance, so as to adapt to driving on off-road. The special design means that the vehicle is taller than ordinary vehicles. While driving this vehicle, try to avoid abruptly turning to prevent the vehicle from going out of control or even overturning.

Driving on Off-Road

To gain a bigger traction improve operability on wet and skid or difficult road sections while driving off-road, be sure to put the transfer case into low gear.

When dragging or controlling the vehicle at low speed on a road surface covered with thick snow, change the transmission to low gear and when necessary, also shift the transfer case to low gear. However, do not drive the vehicle in too low a gear. Otherwise, it will generate too large a torque and make the wheels skid.

While driving on ice or wet, slippery roads, do not use too low a gear, because the braking action of the engine may cause the wheels to skid or go out of control.

A vehicle equipped with a limited slip differential rear axle assembly should be driven more slowly over bends than a vehicle with an ordinary differential vehicles, because under the limited-slip effect, high-speed cornering may cause the wheels to skid or loss control.

When the rear wheels on one side of a vehicle equipped with a limited slip differential rear axle assembly skid, they may generate fast impact rotations. This is a result of the structure of the limited slip differential and it is a normal occurrence.

Caution

Despite the off-road functions of this vehicle, the driver still needs to pay attention and watch the road conditions so as to prevent accidents and personal injury.

Preparations Before Driving

It is best to carry out safety checks before driving. Spending just a few minutes checking will help you drive safely and enjoy your driving. You can make the check as long as you are basically familiar with the various parts of the vehicle.

Warning

Drunk driving is one of the most common causes of accidents. One's driving ability falls significantly with the rise in alcoholic content in the driver's blood. If you have drunk alcohol, do NOT drive. Passengers should travel in vehicles driven by people who has not consumed alcohol. Instead, they may take a taxi or other public transport instead. After drinking alcohol, even coffee or cold shower will not keep you alert. Similarly, some prescription or non-prescription drugs will affect people's alertness, sensory sharpness and reaction time. Before driving under the impact of these drugs, please consult with the doctor or druggist.

Before Starting the Engine

Tire: check tire pressure and whether the tires have cuts, damage or excessive wear.

Wheel nuts: ensure that no nuts are lost or loose.

Vehicle lights: ensure that the front lights, brake lights, high brake lights, taillights, steering signal lights and other vehicle lights all work normally. Check the beam direction of the headlights. Check light direction of the headlight.

Seat belt: ensure that you and other passengers have seated and fastened your seat belt properly (children sit in the rear row and use special seat belts).

Move the driver's seat backwards as much as possible. Meanwhile, ensure good vision and effectively control the steering wheel, the clutch pedal, the brake pedal, the accelerator pedal and other control components which are used during normal driving. Check whether there is any display of faults on the instrument panel.

Move the front passenger's seat backwards as much as possible.

Ensure that babies and children are properly positioned in accordance with regulatory requirements so as to ensure that they receive maximum protection in the event of an accident.

Instruments and controllers: in particular, be sure that the instrument indicator lights and the defroster all work normally.

Brake pedal: be sure that the pedal has sufficient free clearance.

All oil levels: ensure that all the oil levels are normal.

12V battery and cable conditions: based on the colors of the indicator, check 12V battery conditions. Check for corrosion or looseness on the blocks or cracks on the casing. Check that the cables are well connected.

After Starting the Engine

Fuel leakage: After the vehicle has parked for a while, check for leakage of fuel, engine oil, water or other liquids in the vehicle. After use, there may be water drops from the A/C. This is a normal occurrence.

While Driving

Instruments: Be sure that instruments work normally.

Brake: On a safe road, check and confirm that when braked, the vehicle will not tilt towards any side.

Other abnormalities: Check whether parts are loosened or have leaks and listen for abnormal noises.

Driving During Run-In Period

To ensure the service life of the vehicle, a run-in period is needed in the early stages after the vehicle is put into use. Only after the run-in period has completed can the vehicle be put into normal use. Provisions on the Run-In Period:

- Select a fairly good road and drive with reduced load and in limited speed.
- Do NOT drive with the accelerator fully depressed or accelerate abruptly.
- Avoid emergency braking.
- Strictly execute the operating specifications and keep the engine at its normal working temperature. Before regular maintenance, do NOT replace the engine oil.
- Make sure to regularly maintain the vehicle, fasten external bolts and nuts. Pay attention to changes in the sound and temperature of various assemblies while driving, and promptly make adjustments.

Wear in the Engine

A new engine must undergo a wearing-in of 1500km.

The vehicle speed should be under 80km/h in the first 160km and under 90km/h in the first 800km.

During the run-in period, be sure to comply with the following:

- After a cold start, run the engine for 15s before starting to drive.
- During the initial driving period, avoid driving for a long period of time at full acceleration or at the maximum vehicle speed. Also avoid driving over a long period of time at the same vehicle speed or a high idle speed.
- During the initial driving period, no engine adjustment is usually needed.
- Unless the workload is very heavy, before the specific initial maintenance mileage, it is not necessary to replace the engine oil or the engine oil filter.
- During the initial driving period, do not add any friction-reducing additive into the engine oil, because such additives will affect the run-in of the piston rings.

In the early period of wearing in, the inner frictional resistance of the engine is much bigger than after the wearing-in. Only after wearing it in can all the moving parts of the engine reach the best coordinated state.

After wearing it in according to the above requirements, the engine will have both a prolonged service life and reduced fuel consumption.

Wearing in Tires and Brake Pads

In the first 500km, be sure to drive at medium speed so that the tires can be properly worn in.

In the first 200km, new brake pads cannot reach the best frictional state and careful wearing-in is needed.

 Warning

- New tires and braking pads that have not been worn in do not have the best attachment force or frictional force. Therefore, within the first 500km, be sure to drive carefully to wear in the tires and protect against accidents.
- New brake pads must also be worn in accordance with the above requirements.
- While driving, be sure to keep a suitable distance from other vehicles and be careful to prevent situations which require emergency braking. Because in such situations, the new tires and braking pads have not been worn in and could easily cause traffic accidents.
- If the brake is wet or ice forms on it, or when the vehicle is driven on road sprayed with salt, its braking effect will fall.

 Warning

- When driving on a downward slope, the brake is stressed, which could extremely easily cause overheating. It is therefore suggested that you switch to a low gear before driving downhill so as to reduce vehicle speed and fully leverage the braking effect of the engine to reduce the load of the brake.
- Be sure to apply the brake based on road and traffic conditions. Do NOT depress the brake pedal when it is not necessary to do. Doing so will wear down and overheat the brake , resulting in overly long braking distance and excessive wear of the brake.
- Do NOT turn off the engine and let the vehicle coast. Doing so will cause the braking booster to not work and the braking distance will greatly increase, thus increasing the risk of accidents.
- Do NOT use the brake fluid for too long. Be sure to replace the brake fluid by the specified cycle.

Key Points of Driving in Different Situations

- In side winds, be sure to drive at low speed. This will help controlling the vehicle.
- Keep the correct angle, and avoid driving on tall objects, or objects with sharp edges, or on other road obstacles, because this may cause tire puncturing and other types of serious damage.
- When driving on bumpy or uneven roads, be sure to reduce the vehicle speed. Any impacts or scratches from failing to do so may seriously damage the vehicle.
- When the vehicle is washed or when the vehicle is driven through deep water, the brake may get wet. Look around to see whether it is safe and lightly depress the brake pedal. If you cannot sense the normal braking force, the brake may have become wet. To make it dry, drive the vehicle at a low speed while ensuring safety. Meanwhile, lightly depress the brake pedal. Drive carefully. If the brake still does not work safely, you need to park the vehicle on the road side and contact an authorized BAIC dealership for assistance.

 Warning

- Before driving, ensure that the parking brake has been fully released.
- While driving, do NOT put your foot on the brake pedal. Doing so will cause the braking pads to overheat and result in unnecessary wear and fuel waste.
- When driving down long and steep slopes, be sure to slow down and shift to a low gear. Remember that excessive use of the brakes will make them overheat and be unable to work normally.
- While driving on slippery road, exercise extra care when accelerating, raising or lowering the gear or braking. Sudden acceleration or engine braking may cause the vehicle to slide or the wheels to run in idle.
- If the brake is already wet, the braking distance required will be longer than normal. In addition, the vehicle may tilt to one side and the parking brake will not be able to firmly brake the vehicle.

Driving During Rain

When driving on slippery roads

- When there is rain, please drive carefully because the visibility is low, the vehicle windows are foggy, and the road is very slippery.
- When rain starts to fall, be sure to drive carefully because the road surface becomes slippery.
- When rain is falling, do NOT drive at high speed on expressways. This is because a water film will form between the tires and the road surface, which affects the normal operation of the steering and braking systems.

 Warning

- When driving on slippery road, emergency braking, acceleration and steering may cause the tires to skid. This will reduce the steering performance of the vehicle and thus cause an accident.
- When the engine speed changes drastically, such as in the event of emergency engine braking, it may cause the vehicle to skid and result in an accident.
- After driving through a water puddle, lightly depress the brake pedal to ensure that the brake functions normally. Wet brake pads cannot guarantee normal braking. If the brake on one side becomes wet and cannot work normally, it will affect steering control and cause accidents. Do NOT drive on road full of water after heavy rains. This may cause serious damage to the vehicle.

Driving in Water

Although your vehicle can drive in shallow water, the following precautions shall be taken into account prior to driving in water:

Caution

When driving in water, the speed must not exceed 8km/h. As a preventive measure, make sure to ascertain the water depth before driving in the water, and check all fluids after the driving. Damages which may be caused by driving in water are beyond the warranty of new vehicle.

Take care when driving in water to ensure safety and to prevent damage to your vehicle. If the vehicle has to drive in water, before that, try to determine the water depth and conditions in water (as well as position of obstacle). Take care when driving in deep water, and maintain steady speed less than 8km/h to reduce impacts by water wave.

While driving in water, besides maintaining low speed, try to avoid stopping the vehicle or shifting the gear.

Don't release the accelerator or accelerate the vehicle. The vehicle should be driven at constant speed at the lower gear and with moderate-high accelerator opening, but not at high speed, in order to prevent water spraying. After leaving the road with surface water, the vehicle must be driven at slow speed, and lightly depress the brake pedal for several times to dry the moisture on the brake pad.

Don't immediately start the engine which has shut down while the vehicle is running in water, but place the vehicle to "N" gear as soon as possible and drag it to a safe location with less accumulated water.

Running Water

If the water is running and the water level is rising (for example during rainstorm), avoid crossing the water, but continue to drive after the water level drops and/or the flow speed is reduced. If the vehicle has to pass the water, avoid driving in water more than 20cm deep. Running water will erode the river bed, which will make the vehicle trapped in deeper water. Determine the entry point and the exit point in advance.

Still Water

Avoid driving in still water more than 50cm deep, and slow down the vehicle as appropriate to reduce impacts by water wave. When driving in water more than 50cm deep, the max speed shall not exceed 8km/h.

Maintenance

After driving in water, check your vehicle for its working fluid and lubricants (engine oil, transmission oil, axle and transfer case) to ensure that the fluids are not contaminated. Wash/replace the contaminated fluids (which appear to be milky or foamed) as soon as possible to avoid damage to components.

⚠ Warning

- **When driving on slippery road, emergency braking, acceleration and steering may cause the tires to skid. This will reduce the steering performance of the vehicle and thus cause an accident.**
- **When the engine speed changes drastically, such as in the event of emergency engine braking, it may cause the vehicle to skid and result in an accident.**
- **After driving through a water puddle, lightly depress the brake pedal to ensure that the brake functions normally. Wet brake pads cannot guarantee normal braking. If the brake on one side becomes wet and cannot work normally, it will affect steering control and cause accidents. Do NOT drive on road full of water after heavy rains. This may cause serious damage to the vehicle.**

Key Points of Driving in Winter

Be sure to fully warm up the engine. After starting the engine, pre-heat it for a while so that the engine oil fully lubricates the various cylinders, and then drive the vehicle slowly. Drive off at low speed. This will give a sufficient time for the lubrication oil of the transmission, the transfer case and the rear axle to lubricate all lubrication positions.

Check the Condition of the Battery and Power Cables

Check the battery, including its joints and electric wire. Extremely cold weather will affect the battery. This is because more energy is needed to start and drive vehicle and the battery capacity will fall. Before driving the vehicle, check whether the engine speed is normal. Check whether the headlights are as bright as usual. If necessary, charge or replace the battery. In extremely cold weather, battery of low capacity may be frozen and thus makes it impossible to start the vehicle.

Be sure that engine oil viscosity is suitable for driving in cold weather.

In winter, a lot of summer-used engine oil remaining inside the engine may make the vehicle difficult to start. If you are not sure which engine oil should be used, please contact an authorized BAIC dealership for help.

Check Engine Coolant

Be sure to use a coolant that is recognized by BAIC.

If it is found that insufficient engine coolant is left, please promptly replenish the coolant.

Avoid the freezing of door locks

Spray some de-icer or glycerol into the door lock holes to prevent them from being frozen. Use glass detergent containing anti-freeze agent. This product is sold at all authorized BAIC dealerships.

Prevent snow or ice from accumulating in fender.

When snow or ice accumulates in the fender, it will make steering difficult. When driving in cold weather, be sure to frequently stop the vehicle and check whether snow or ice has accumulated in fender.

For different driving destinations, BAIC suggests that some necessary emergency supplies should be carried.

Items that may need to be put in the vehicle include: tire anti-skid chains, vehicle window scrapers, sandbags or salt bags, signal flash devices, small shovels, jumper cables, etc.

Efficient Use of Vehicle

● Maintain the proper tire pressure. Insufficient air pressure will cause tire wear and waste fuel.

● Wheels must be positioned accurately. If they aren't, this will cause overly fast wear of the tires. It will also increase the engine load and waste fuel.

● Do NOT let the vehicle carry unnecessary loads. Overly heavy loads will increase the burden of the engine load and consume a lot of fuel.

● Accelerate slowly and steadily and avoid sudden starts. Shift to a high gear to drive as soon as possible.

● Avoid areas with traffic congestion as much as possible, and avoid continuous acceleration and deceleration. Stop-and-go driving wastes fuel.

● Avoid unnecessary parking and braking, and maintain a steady vehicle speed. Drive in tune with the traffic signal lights to reduce stop times to a minimum, or drive on access roads without traffic lights. Keep a suitable driving distance from other vehicles so as to avoid emergency braking. This will also reduce brake wear.

● Do NOT keep your foot on the brake pedal. This will cause overly early wear, overheating and fuel waste.

● While driving, avoid collisions with curbs. Be sure to lower vehicle speed when driving on uneven road.

● Prevent mud and other objects from sticking to the chassis of the vehicle. This can not only reduce the weight of the vehicle but also prevent corrosion.

● Adjust the vehicle and keep it in its best working state.

Dirty air filters, unsuitable valve clearances, dirty spark plugs, dirty engine oil and grease will all reduce engine performances and waste fuel. To prolong the service life of all parts and lower operating expenses, be sure to carry out regular maintenance. When frequently driving in harsh conditions, be sure to maintain the vehicle more frequently.

Fuel Economy

Fuel economy is related to many factors. Personal driving habits have a major impact on fuel consumption. The recommendations below will help to achieve the best fuel economy:

- After starting from a low temperature, drive slowly for several minutes and speed up after the engine has warmed up.
- Remove unnecessary objects and drive.
- Maintain a suitable tire pressure.
- Choose to drive on good road.
- Do NOT drive too violently. Accelerate slowly. Do NOT quickly depress the accelerator at starting or quickly apply the brake when stopping.
- When driving at high speeds, do NOT open the vehicle windows.
- Rationally use the A/C, the audio system, etc.
- Turn off unnecessary switches.
- When parking for a long period of time, turn off the engine and avoid letting the engine run at idle speed for a long time.
- On flat road, drive at an economical speed.
- Based on the driving speed, choose a suitable gear and do NOT drive at high speeds at low gear.

- Perform regular maintenance in accordance with the maintenance requirements.
- When the vehicle has stopped at a signal light or a stop sign and needs to be restarted, be sure to accelerate slowly at an even speed.
- Plan the driving route to avoid unnecessary stops.
- Keep tire pressures at the recommended level.
- Keep the air filter clean and maintain the vehicle in accordance with the recommendations and requirements in the User Manual.
- Keep the vehicle condition well adjusted. Improper engine adjustment will waste fuel and increase expenses.

4 Maintenance and Service

Safety maintenance.....	174
Fuel system.....	177
Interior maintenance.....	180
Exterior maintenance.....	183
Engine compartment.....	190
Engine oil	194
Coolant	198
Brake fluid.....	202
Power steering fluid.....	205
Battery	207
Windshield washing liquid and wiper blade	211
Tire	214

Safety and Maintenance

Service items not mentioned in this chapter should all be performed by accredited or other qualified technicians.

Safety Precautions

To avoid potential dangers, before starting maintenance, please read the contents of this section and confirm that you have the needed tools and techniques.

- Park the vehicle on flat ground, turn off the engine, and apply the parking brake.
- When cleaning parts, be sure to use degreasing agents or parts cleaning agents sold on the market. Use of gasoline is prohibited.
- It is prohibited to put lit cigarettes, sparks or open fires close to batteries or the relevant parts of the fuel system.
- When maintaining batteries or compressed air, be sure to wear goggles and protective clothing.

Warning

Incorrect vehicle maintenance or driving problematic vehicles may cause traffic accidents, serious injury or even death.

Potential Vehicle Hazards

- Carbon monoxide: The carbon monoxide of the engine exhaust is a toxic gas. Be sure to operate the engine in well-ventilated places.
- Scalding: While at work, the engine, cooling system and the exhaust system will generate high temperatures, which can scald extremely easily. Thus, wait approximately 30 minutes after the vehicle has been turned off for the engine, cooling system and the exhaust system to cool down before touching the parts.

Caution

Only some important safety precautions are listed in this section. We are unable to list all of the dangers which you may come across during your maintenance operations.

Routine Maintenance

Vehicle safety, reliable drive ability and good performance all partly depend on how you maintain your vehicle.

Because maintenance is the responsibility of the vehicle owner, you must follow BAIC's suggestions to perform routine maintenance of your vehicle, replace the engine oil and routinely check and replace the brake fluid and coolant.

Maintenance Record

The Warranty Manual includes maintenance record pages, which you can use to record information on the engine oil replacements and inspections which have been made for your vehicle. Our authorized dealerships will also use the maintenance record pages to record information on brake fluid replacements, airbag module replacements, seat belt tightening devices, etc.

After each engine oil replacement and inspection, be sure to ask the authorized BAIC dealership to sign and seal the maintenance record page.

Replace Brake Fluid

Regardless of the driven mileage of a vehicle, its brake fluid should be replaced every two years. When the two-year period expires, our authorized dealership will replace the brake fluid when it is replacing the engine oil or performing inspections, thus saving you from making an extra visit to the dealership.

Replace Coolant

Regardless of the driven mileage of a vehicle, its engine coolant should be replaced at least every two years. When the two-year period expires, our authorized dealership will replace the coolant when it is being replaced the engine oil or performing inspections, thus saving you from making an extra visit to the dealership.

Exhaust Emission Control

Your vehicle has been equipped with exhaust emission and evaporation devices which comply with the state and legal provisions. You should be aware that: all unauthorized replacements, refitting and adjustments of these devices by the vehicle owner him/herself or vehicle repair personnel are unlawful and the vehicle owner him/herself or vehicle repair personnel shall be responsible for any consequences thus caused.

In addition, you should not make any adjustment to the engine settings. The purpose of formulating these provisions is to ensure that your vehicle complies with the strict laws and regulations on exhaust emission. Incorrect engine settings will have a negative impact on exhaust emission, engine performance and fuel consumption and generate high temperatures, thus causing damage to the three-way catalytic converter and the engine.

Maintenance by Vehicle Owner

1. Check coolant level
2. Check brake fluid level
3. Check power steering fluid level
4. Check windshield cleaning agent level
5. Check tire pressure and state
6. Check the air-conditioning effects

Special Operational States

If your vehicle is often driven in dusty environments, extreme weather, or extremely high or low ambient temperature, you should pay extra attention to vehicle maintenance. For details, please contact the authorized BAIC dealership

Safety during Vehicle Repair

After the engine stops running, the cooling fan may continue to run for some time. Be sure to keep away from the fan when working on the engine compartment.

To maintain the vehicle, be sure to comply with the following safety points:

1. Keep your hands and clothes a safe distance from the drive belt and pulley.
2. If the vehicle has just been used, do NOT touch any part of the exhaust or cooling system before the engine fully cools down.
3. When the engine is running or the start/stop button is turned on, do NOT touch the electrical wires or electrical parts.
4. Do NOT let the engine operate in a poor ventilation place because the exhaust is toxic and is extreme dangerous.
5. Do NOT work under a vehicle which is only supported by a jack when its wheels are replaced.

6. Make sure that sparks are kept far away from the engine compartment.

7. Wear protective clothing if working on the vehicle. If possible, be sure to wear gloves which are made of non-absorbent material.

8. While working on the engine compartment, be sure to remove any watches or jewelry.

9. Do NOT let the metal parts of the tools or the vehicle come into contact with the wiring terminals of the battery.

Fuel System

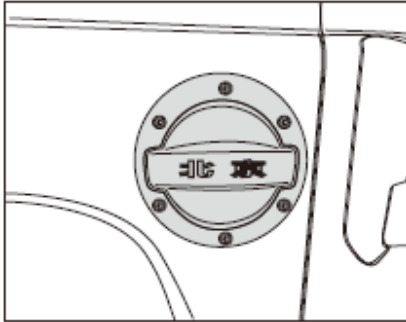

The fuel filler is located on the left rear wall panel.

Adding Fuel

Before adding fuel, please turn off the engine first. Then, follow the steps below:

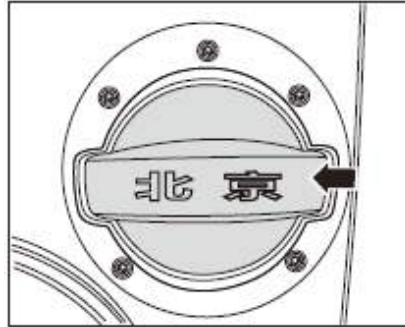

1. Unlock by remote key or central lock switch, then press the area pointed by arrow in picture

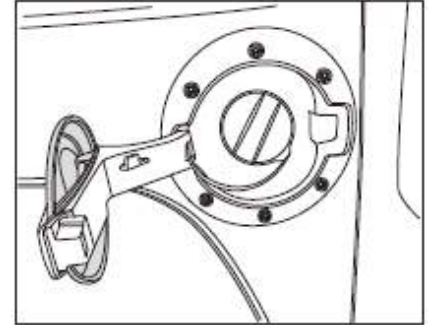

2. Refueling door will open, then remove the cap and start adding fuel.
3. Add fuel. At this point, pay attention to the gesture of holding the nozzle: Do not tilt the nozzle and try to insert it into the fuel adding pipe as deep as possible.
4. When the refueling nozzle automatically stops, continue refueling at a lower refueling speed. The second time the refueling nozzle stops, do not attempt to continue refueling any more.
5. Close the cap and rotate slowly clockwise until hear three clicks.

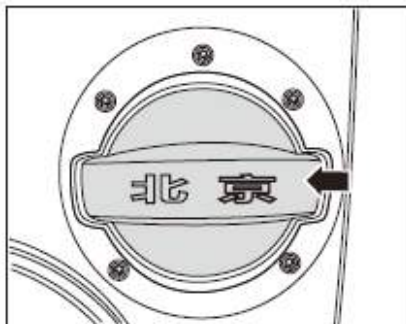

6. Closed the refueling cap, and then press the arrow area to close the refueling door.
7. When the door lock is locked, the refueling door is locked.

⚠ Warning

- When refueling, must not smoke. There should be no spark or open flame.
- When you open the fuel tank cap, do not remove it immediately. In hot weather, if the fuel filler cap is suddenly removed, high-pressure gas can be ejected from the refueling piper and resulting in injuries.
- Ensure that fuel filler cap is tightened to prevent fuel spillage in an accident.

👁 Caution

As long as you follow the above instructions for refueling, after the second automatic stop of the refueling gun, the tank is "full" and no further refueling is required, otherwise the expansion space in the tank will also be filled up -- fuel may overflow when heated.

Immediately wipe the fuel that spills onto the paint

Try not to run out of fuel on cars which equipped catalyst. Since irregular fuel supply may lead to fire missing, the unburned fuel will enter the exhaust and cause the catalyst overheating or damaged.

Fuel

Use the specific gasoline to ensure the performance (see technical data section for details)

Using low-rating or poor quality gasoline can lead to engine damage .

 **Caution**

If the gasoline octane rating (RON) used in an emergency is lower than engine required. The engine can only run at medium speed and low load. Heavy engine load or high engine speed at full throttle can damage the engine. If possible, it is required that fill with fuel that meets the octane rating.

Vehicles equipped with catalyst can only use unleaded gasoline, the catalyst can be damaged once after using the leaded gasoline.

interior Maintenance

Caution

- Be sure **NOT** use a solvent-containing cleaning agent to clean the surface of the dashboard or the airbag module.
- Solvent-containing cleaning agents can penetrate the surface of the part being cleaned, boring fine holes in the surface and making the part loose. When an airbag is released, such loose plastic parts will markedly increase the risk of injury!
- Be sure **NOT** use any solvent (such as gasoline or turpentine), floor wax, shoe polish or similar liquids to treat leather.
- Avoid exposing your vehicle to strong sunlight for a long period of time so as to prevent the leather or similar items of the vehicle from fading. If you have to park your vehicle outdoors for a long period of time, please cover the leather of the vehicle so as to prevent it from coming into direct contact with sunlight.

Caution

- Subjects with sharp edges on clothes (such as zippers or rivets) may leave permanent scratches or marks on the surface of leather. When cleaning the seat belts, do **NOT** remove the belts.
- Do **NOT** use chemical cleaning agents to clean the seat belts because chemical cleaning agents will damage fabric.
- The seat belt must be kept away from corrosive liquids.
- Regularly check the state of the seat belt. If damage is found in the seat belt fabric, seat belt connection, automatic retracting device or the seat belt lock, be sure to go to an authorized BAIC dealership to get it repaired.

Cleaning & Maintenance of Instruments and Plastic Parts

Use a dry, clean and soft cloth and water to clean the surfaces of instruments and plastic parts.

If the surfaces cannot be cleaned, use solvent-free plastic cleaning agents to clean them.

Warning

Cabin spray agents or solvent-containing cleaning agents must not be used to clean the surfaces of the dashboard and the airbag module. They may loosen the surface, trigger the airbags, and cause serious injury to passengers.

Cleaning and Maintenance of Carpet

Frequently use a vacuum cleaner to suck dust up from the carpet.

Regularly wash with detergents and keep the carpet clean.

Caution

- **Subjects with sharp edges on clothes (such as zippers or rivets) may leave permanent scratches or marks on the surface of leather. When cleaning the seat belts, do NOT remove the belts.**
- **Do NOT use chemical cleaning agents to clean the seat belts because chemical cleaning agents will damage fabric.**
- **The seat belt must be kept away from corrosive liquids.**
- **Regularly check the state of the seat belt. If damage is found in the seat belt fabric, seat belt connection, automatic retracting device or the seat belt lock, be sure to go to an authorized BAIC dealership to get it repaired.**

Cleaning & Maintenance of Leather

1. Use a vacuum cleaner to suck dust.
2. Use a clean and soft cloth and water to clean leather.
3. Use another dry and soft cloth to wipe it dry.
4. If all the above cleaning is not enough to remove stains, you can also clean with washing soap or detergent.

Caution

After cleaning leather using a leather detergent, use a soft and dry cloth to wipe it dry.

Do NOT put any soft cloth soaked with detergent on any interior part for a long period of time so as to prevent the fading or breakage of the resins or fibers of the interior fabric.

Cleaning and Maintenance of Seat Belts

1. Slowly pull a seat belt out and keep it in a pulled state.
2. Use a soft brush and neutral soap water to remove dirt from the seat belt.
3. Wait for the seat belt to dry completely and then retract it.

 Warning

- Chemical cleaning agents must not be used to clean seat belts, so as to prevent damage and affect their functioning.
- When replacing a seat belt, be sure to use a new seat belt of the same model and structure to make the replacement.
- Keep foreign matter or liquids from entering the seat belt the lock catch, or else the lock catch and seat belts may not work normally.
- Do not remove or modify the seat belts without permission.
- Be sure to regularly check the status of all seat belts of the vehicle. In the event of damage to the backing tapes, connection devices, retracting mechanisms or the lock catches of the seat belts, be sure to go to an authorized BAIC dealership to have them repaired or replaced.

 Caution

- Be sure to wait for the seat belts to completely dry before retracting them, or else it may damage the seat belt retractor.
- Regularly check all seat belts of the vehicle to ensure that they are clean and work normally.

Exterior Maintenance

Caution

- When the brake is wet or icy, it may affect the functioning of the brake.
- When you clean the bottom of the vehicle, the lower side of the fender (wheel cover) and the wheel covering board, please operate with care so as to prevent sharp metal edges from hurting your hands.
- While the vehicle is being cleaned, the ignition switch must be turned off.
- Please do not use a coarse sponge or corrosive cleaning product to clean the vehicle. These might damage the paint surface!
- Do NOT use concentrated beam washing nozzle to clean tires! Even spraying from far distance will still cause damage

Caution

- It is suggested that new vehicles can only be waxed after six months of use.
- Do NOT wax vehicle windows.
- Do NOT use any sharp object to clean the headlight surface. This will damage the protective paint surface and leave cracks on the headlights.
- Pay attention to the following when cleaning wheels: moisture, ice or sprayed salt will affect the functioning of the brake.
- Do NOT install protective boards or coat anti-corrosive materials around the exhaust muffler, exhaust pipes, the catalytic purifier or other hot parts. When the vehicle is running, these substances may cause fire.

Washing vehicle

Frequent vehicle washing helps maintain the appearance of the vehicle.

The vehicle should be washed in a cool place. Do NOT wash the vehicle in direct sunlight. If the vehicle has been placed in sun light for a long period of time, be sure to wait for the surface of the vehicle body to cool down before washing it.

When washing the vehicle using an automatic washing machine, please be sure to follow the instructions of the machine operator

Caution

- The body paint of the vehicle is strong enough to endure the washing of an automatic vehicle washing machine. However, attention should be paid to the impact on the paint surface. When the structure, cleaning agent used, the filtering state of water or type of wax solvent of the vehicle washing machine does not meet the relevant requirement, it may cause damage to the paint surface.
- Before washing the vehicle, the ignition switch must be turned off.

The Automatic Vehicle Washing Device

The vehicle paint possesses certain durability. Usually, washing the vehicle inside an automatic washing device will not affect the state of the vehicle paint. The impact on the body paint depends to a great extent on the structure of the vehicle washing equipment, the water filter used for vehicle washing and the type of cleaning agent and maintenance agent used. If the body paint has no gloss or has scratches after the vehicle is washed, be sure to immediately point it out to the washing equipment operator.

Manual Washing of Vehicle

1. Use water to wash the vehicle to clear floating dust from it.
2. Prepare a bucket of water, add some cleaning agent, and mix them.
3. Use a soft cloth, sponge or soft brush to lightly wash the vehicle, then rinse the vehicle from top to bottom several times.
4. Wheels and the footstep should be washed last. During the cleaning, be sure to change the sponge or soft cloth.
5. After you finish washing and wiping, use water to thoroughly rinse the vehicle.

Caution

When there is asphalt or dirt on the vehicle body, be sure to use a special cleaning agent to clean it and then wash it with water so as to prevent damage to the finish of the vehicle body. While wiping dry the vehicle body, be sure to check whether there is chipped paint or scratches on the vehicle body. If there are, be sure to go to an authorized BAIC dealership to have it repaired.

Extra care is needed when washing the vehicle with a high pressure washer. Be sure to operate it in accordance with the usage instructions and requirements. Special attention should be paid to the working pressure and the spraying distance.

 Warning

- If there is water, ice or anti-skid salt inside the braking system, it will make the brake slow to react and increase braking distance, thus increasing risk of traffic accidents.
- Before driving, lightly depress the brake pedal and test the brake.
- Before removing the ice or anti-skid salt attached to the brake, be sure to avoid emergency braking. When braking, special attention should be paid to avoid accidents.

 Warning

- Before use, be sure that you have carefully read and followed the relevant information and warning instructions.
- When washing the vehicle, be sure to pay attention to personal safety. Special attention needs to be paid to the vehicle bottom and the inner side of the wheel cover so as to prevent sharp parts from injuring the hands and arms.
- When washing the vehicle, do NOT flush water into the engine compartment. Otherwise it will affect the service life of the parts of the engine compartment.

Waxing

Regularly waxing can protect the body paint and keep the vehicle body clean.

Only after the whole vehicle is wiped dry can the waxing operation start.

A superior quality paint protection wax should be selected.

To effectively protect the body paint, it is suggested that a superior quality hard wax should be applied once a year so as to protect the paint surface from erosion by adverse external environment and protect it from light mechanical scratches.

Types of Superior Quality Waxes

Body wax: Wax which is used to protect the paint surface from sunlight, air pollution and other adverse external environments. It is usually used on new vehicles.

Polish wax: It can restore gloss to those paint surfaces which have been oxidized or have lost gloss. Mainly used to restore the gloss of the paint surface.

 Caution

Do NOT wax in a dusty environment.

Polishing

Polishing is needed only when the body paint color fading and even waxing materials cannot deliver good gloss. If the polishing agent does not contain anti-corrosive ingredient, waxing is necessary after polishing.



Caution

Lusterless parts and plastics cannot be treated with polishing agents or hard wax.

4

Body Paint Damage

Slight body paint damage (such as scratches, scrapes or stone striking marks) should be covered with body paint before steel rusting. If rusted, the rust must be thoroughly removed. In addition, the rusted portion must have an anti-corrosive base paint and a covering paint spread over it. All such work must be done at an authorized BAIC dealership.

Cleaning and Maintenance of Exterior Plastic Parts

Usually, exterior plastic parts can be cleaned using water, a soft cloth or soft brush. Otherwise use cleaning agent without solvent for plastic parts.



Caution

Do not use solvent containing cleaning materials when cleaning plastic parts, or it will easily cause damage to plastic parts.

Maintenance of Chromium-Plated Parts

Chrome plated parts can be cleaned with a wet cloth and then wiped with a soft dry cloth. If the effect is not good enough, can use chromium maintenance agent..

Stains and the dirt layer on chromium-plated parts can be cleaned using a chrome maintenance agent. Regularly using a chrome maintenance agent can prevent the formation of a dirt layer on the surface. When a chrome maintenance agent is used, be sure to cover evenly the entire surface.

Cleaning of Window Glass and Rearview Mirror

Clean window glass and rearview mirror with alcohol-based glass cleaner, then dry the glass surfaces with a clean soft cloth or fur.

Caution

Do not use the fur that brushed over the paint to clean window glass or external rearview mirror, because the wax remained in the fur will make the glass surface blurred. If rubber, grease or silicone substances remain on the glass, a special window cleaning agent or silicone cleaning agent must be used to clean them.

After the body surface has been maintained, the wax that remains on the glass should be cleaned off using a special cleaning agent and a cleaning cloth so as to prevent scratching the wiper blade.

A small brush may be used to clear the snow that has accumulated on the windows and the rearview mirror of the vehicle.

An ice-removing spray agent or an ice scraper may be used to clear accumulated ice, the scraper should wipe in the same direction, be cautious so as to prevent damaging the parts.

Caution

- **Do not use the fur that brushed over the paint to clean window glass or external rearview mirror, because the wax remained in the fur will make the glass surface blurred.**
- **If rubber, grease or silicone substances remain on the glass, a special window cleaning agent or silicone cleaning agent must be used to clean them.**

Cleaning of Front Windshield Wiper Blade

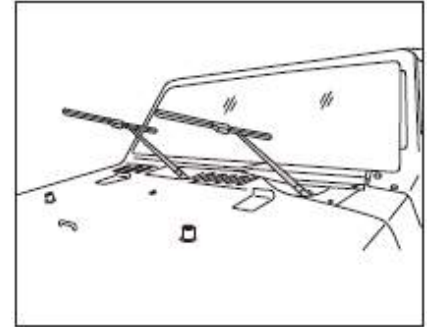

The Cleaning Operations:

1. Lift the wiper arm off the windshield glass.
2. During the operation, only the wiper blade bracket should be held.
3. Use soft cloth to carefully wipe the dust and dirt from the wiper blade.
4. After cleaning is completed, lightly put the wiper arm in its original position.

 Caution

- Replace the damaged wiper blade promptly.
- A layer of graphite is coated on the surface of a new wiper blade. This layer makes wiping smooth and produces no wiping noise. Damage to the graphite layer will increase wiping noise. The wiper blade should therefore be promptly replaced if this occurs.
- Before using the wiper in winter or cold conditions, be sure to check that the wiper blade is not frozen to the windshield. If it is, clear the ice first. Otherwise, it will damage the wiper blade and the wiper motor.

Maintenance of Sealing Strip

Frequent maintenance to these doors' or windows' rubber sealing strip can keep its in good flexibility, good sealing and also can prolong its lifetime, make the door easy to open, reduce the door slamming sound, and it is not easy to be frozen in winter.

The Maintenance Operation:

1. Use a soft cloth to clear dust and dirt from the surfaces of the sealing strips.
2. Regularly use a special protective agent to coat the sealing strips.

 Caution

The two sides of the front roof cover are designed as drainage outlets, and there will deposit a small amount of water after rain, the rain water may fall into the car when the front door being opened.

Cleaning and Maintenance of Wheels

Regular maintenance will keep the wheels pleasing to the eye. It is also necessary to regularly clear anti-skid salt and braking scraps from the wheels so as to keep the polish on the surfaces of the wheels and prolong their service life.

Regular Operations:**Every two weeks**

Clear anti-skid salt and braking scraps from the wheels.

Use an acid-free cleaning agent to clean the wheels.

Every three months

Apply quality hard wax on the alloy wheels.

 Warning

- **Be sure to use an acid-free cleaning agent to clean the alloy wheels.**
- **Do NOT use a polishing agent or other abrasive material to treat the surfaces of the wheels surface.**
- **Any wheel with damaged surface protective layer must be remedied in a timely manner.**
- **Using a pressure washer may cause permanent or invisible damage to wheels, thus causing fatal accidents.**
- **Do NOT use concentrated beam washing nozzle to clean tires! Even spraying from far distance or in a short time, it will still cause damage, it will still cause damage to the tires and cause traffic accidents.**

Chassis protection:

The bottom of the vehicle has undergone protective treatment which can reduce the degree of chemical and mechanical damage. However, while the vehicle is running, it is inevitable that protective layer will be damaged. It is suggested that check the protective layers of the vehicle bottom and the chassis before winter or spring. Reparation should be done if necessary. Authorized BAIC dealerships can provide suitable repair services.

 Warning

If the bottom of vehicle accidentally impacted the road during the process of use, please immediately go to the nearby BAIC authorized service station for maintenance

Explanatory Notes on the Catalytic Exhaust Purifier

Since exhaust emissions will generate high temperature after burning, additional insulation panel is installed in the catalytic exhaust purifier area.

Do NOT use any other protection layer onto the insulation panel, the catalyst or the exhaust pipes. Do NOT remove the insulation panel.

Anti-Corrosive Treatment of Cavities

All vehicle cavities vulnerable to corrosion have undergone durability protection by BAIC. Anti-corrosive treatment needs neither checks nor follow-up treatment. If hard wax falls off from a cavity due to high temperature outside, it can be cleared by using a scraper or cleaning agent.

Engine Compartment

Safety Instructions of work at Engine Compartment

When working on the engine or the engine compartment, such as checking or adding engine fluids, scalding or other injuries may occur. There is also a risk of accident and fire!

Therefore, it is necessary to pay attention to the following warning instructions and basic safety rules.

When adding the engine fluids, do not mix the working fluids. Otherwise, serious functional faults will be caused.

⚠ Warning

- If any observable steam or coolant overflowing from the engine compartment, be sure to **NOT** open the engine hood. **Otherwise, there is a danger of scalding!** The engine hood can only be opened when no steam or coolant overflows and the engine has cooled down.
- **Do NOT** make any work fluid onto the hot engine or exhaust device. **Otherwise, there is a danger of fire!**
- **Do NOT** touch the cooling fan. Since the cooling fan is temperature-controlled, it can start work even when vehicle is power off.
- For safety, the engine hood must be tightly locked while driving. Therefore, after the engine hood is closed, it is necessary to check whether the locking device has been engaged. The engine hood should be aligned with the around parts if the engine hood been well locked.

⚠ Warning

- If any observable steam or coolant overflowing from the engine compartment, be sure to **NOT** open the engine hood. **Otherwise, there is a danger of scalding!** The engine hood can only be opened when no steam or coolant overflows and the engine has cooled down.
- **Do NOT** make any work fluid onto the hot engine or exhaust device. **Otherwise, there is a danger of fire!**
- **Do NOT** touch the cooling fan. Since the cooling fan is temperature-controlled, it can start work even when vehicle is power off. For safety, the engine hood must be tightly locked while driving. Therefore, after the engine hood is closed, it is necessary to check whether the locking device has been engaged. The engine hood should be aligned with the around parts if the engine hood been well locked.

Opening/Closing of the Engine Hood

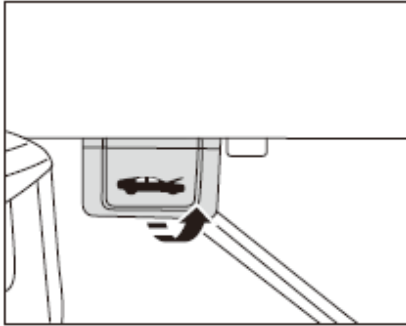

Park the vehicle properly, apply the parking brake, and pull up the engine hood unlock handle from inside. Then the main lock of the engine hood will be unlocked and the engine hood will slightly open upwards.

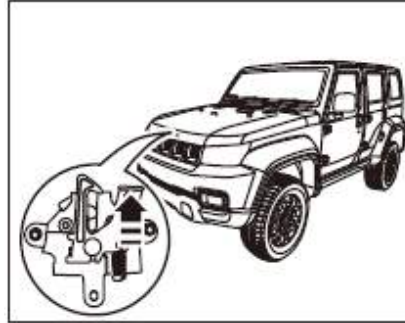

Lightly lift the engine hood, press the Level-2 unlocking handle upwards with your fingers, and raise the engine hood.

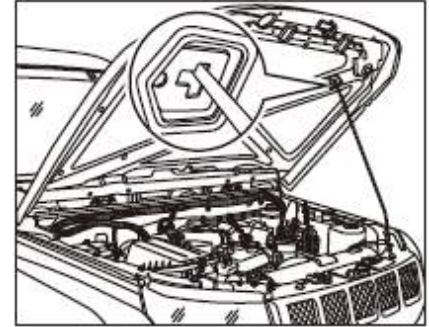

Prop up the support rod of the engine hood which is located in the front part of the hood, and insert its upper end into the designated position of the compartment hood to ensure that the engine hood is fixed to the limiting position

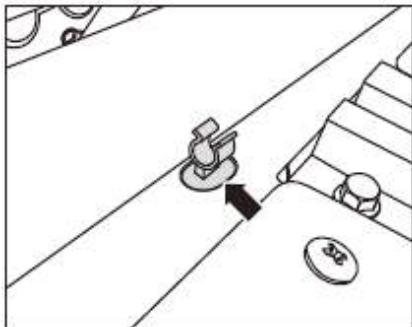

To close the engine hood, remove the support rod and put it back to the bracket in the front part of the engine compartment. Lower the engine hood to a position close to the fender and then release the engine hood. After the engine hood is closed, be sure to check that the lock catch has been firmly locked.

⚠ Warning

It's not allowed to drive if the engine hood is not tightly closed

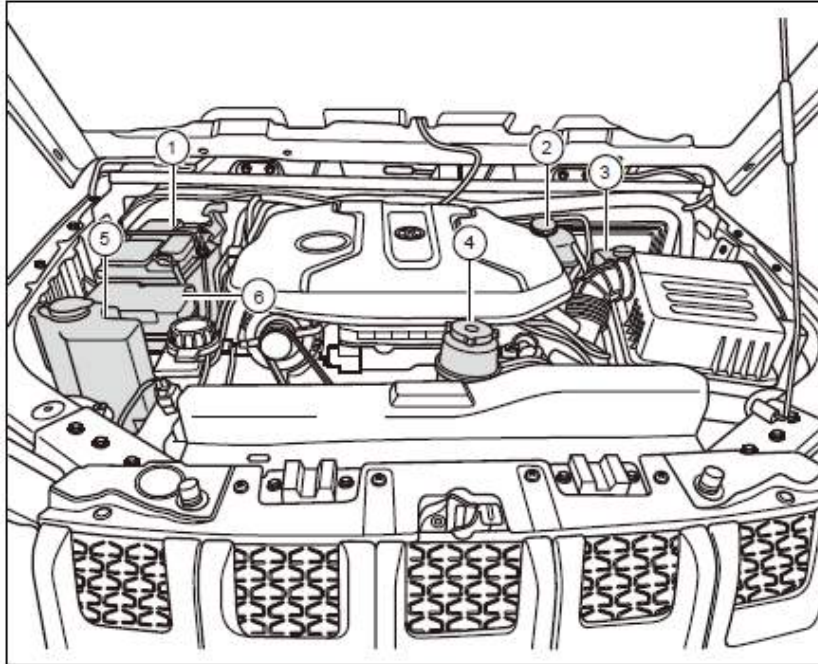
Engine compartment layout

1. Battery
2. Coolant reservoir
3. Brake fluid reservoir
4. Power steering fluid reservoir
5. Windshield washing liquid reservoir
6. Fuse box (under the covering panel)

Caution

Before the engine hood is opened to the full extent, make sure to remove the washer pipeline from the clip to prevent the pipeline from being broken. Before closing the engine hood, re-install the washer pipeline.

Engine Oil

Check the engine oil level each week. If it is below the lower limit mark, then you need to promptly park the vehicle on flat ground. When the engine is in a cold state, it is the ideal time for checking the engine oil level. If the engine is running or has already warmed up, then please turn off the engine and wait for at least 5 minutes before checking the engine oil level.

Engine Oil Pressure Alarming

The engine oil pressure warning light is located on the display screen of the information center. When the ignition key is in the ON position (the engine has not been started), the vehicle will perform self-checking and the engine oil pressure warning light will be lit. After the engine has started, the warning light will go out. If the warning light flashes while driving, be sure to immediately turn off the engine and check the engine oil level. When necessary, add engine oil.

If the engine oil level is normal but the warning light still flashes, be sure NOT to continue driving, even running at idle speed. Should contact the authorized BAIC dealership as soon as possible to have the system checked and repaired.

Warning

Ignoring the warning light or the relevant warning instructions may cause serious accidents.

Checking Engine Oil Level

If the warning light on the display screen of the information center is on, Please immediately check the engine oil level and add engine oil as needed.

Using a dipstick to check the engine oil level.

- Lacking of engine oil may damage the engine;
- Excess engine oil may damage the catalyst.

Warning

If need to check engine oil level when the engine in hot condition, please turn off the engine and wait for at least 5 minutes until all the engine oil flow back to oil pan.

If it is in a cold state, engine oil level can be checked directly.

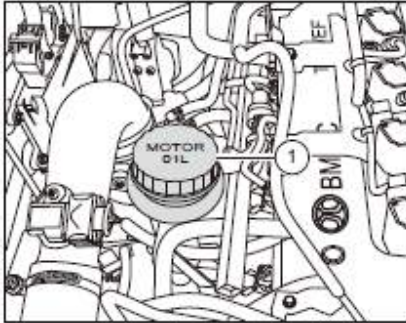

The specific steps are as follows:

1. Park the vehicle on level ground.
2. Open the engine hood and remove the engine trim cover. Engine trim cover removal method: pull the engine trim cover upwards with both hands holding both sides in the front.
3. Rotate counterclockwise and pull out the oil dipstick as indicated on figure -1-.

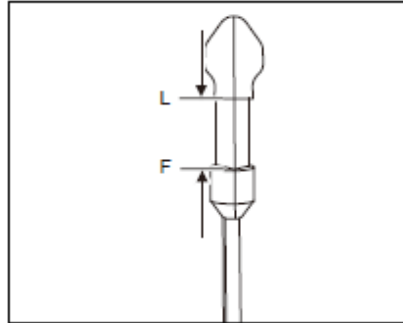

4. Pull out the dipstick.
5. Wipe the oil from the dipstick with clean cloth and insert the dipstick into the engine oil dipstick port to the full extent.
6. Pull out the dip stick again, check the engine oil level, and add engine oil according to the oil level.
 - F-Upper limit mark for engine oil.
 - L - Lower limit mark for engine oil.
 - The oil level should be between the upper limit mark and the lower limit mark.

A certain amount of engine oil will be normally consumed during drive, the amount of engine oil consumed will depend on driving habit and vehicle running condition. Therefore, it is necessary to regularly check the engine oil level. It is recommended to check the engine oil level before each time charging fuel or before a long journey.

When the vehicle is driven for a long distance on a high-way in the summer, or when towing a trailer, or climbing a mountainous road, the engine is ran under harsh conditions and the engine oil level should not exceed the upper limit mark -F-.

Adding Engine Oil

Engine oil should be added by a small amount over several times.

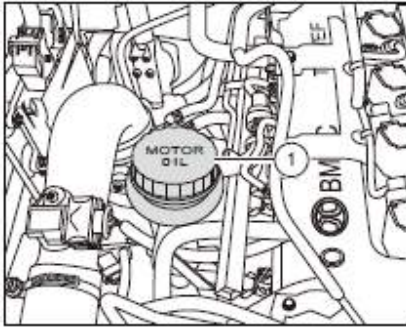

1. Park the vehicle on flat pavement.
2. Open the engine hood.
3. Press the engine oil filler cover, by turning it counterclockwise
4. To avoid adding excessive engine oil, a small amount of engine oil should be added each time, check the engine oil level and add oil again depending on the oil level.

5. Once the oil level approaches the upper limit mark, please immediately stop fueling and put on and tighten the engine oil filler cover.

⚠ Warning

- Before starting the maintenance, be sure to carefully read and follow the relevant warning instructions.
- Engine oil is a highly inflammable substance. While adding engine oil, be sure to exercise care. Be careful to NOT spray engine oil onto any engine part or the exhaust system.
- The engine oil filler cover must remain in a tightened state, so as to prevent engine oil from splashing out and causing fire when the engine runs.
- Be sure to use a type of engine oil that suits the engine of the vehicle which you have purchased.
- If an engine oil of a specification not suitable for the engine of this vehicle is used, it may damage the engine and thus cause accidents.

👁 Caution

If the engine oil level exceeds the upper limit mark, do not start the engine. Otherwise, it may damage the catalytic converter and the engine

👁 Caution

- Be sure to add an engine oil which is of an SN grade or higher of the API grade system.
- When the vehicle left the factory, superior quality engine oil was already added to the engine. Except in extremely cold weather, this engine oil can be used for the whole year.
- Engine oils of different trademarks should not be mixed and used

Replacing Engine Oil

Replace the engine oil by the cycle which is specified in BAIC's Warranty Manual. The service life of the engine can only be guaranteed if it is maintained and the engine oil is replaced in accordance with the provisions.

Engine oil replacement must be made by an authorized BAIC dealership.

If the vehicle needs to run under harsh conditions, or use fuels with a high sulfur content, or often drive short distances, or run at idle speed over long periods of time (such as a taxi), or run in dusty regions, or frequently tows trailers, or run in high and cold regions, then it will be necessary to increase the frequency of some maintenance items or shorten the regular maintenance.

The additives in the engine oil may soon make the color of a new engine oil fade soon. This is a normal occurrence. There is no need to replace the engine oil ahead.

Warning

- If you have no relevant professional knowledge, do NOT replace the engine oil on your own.
- Be sure to perform maintenance after the engine has cooled down so as to prevent scalding by hot engine oil.
- When untightening the engine oil drain bolt, be sure to put the arm in a horizontal position so as to avoid the engine oil flowing along the arm.
- Wash thoroughly if engine oil is splashed onto your skin.
- The discharged waste engine oil should be stored in a special container and the container must be big enough to contain all the waste engine oil.
- Do NOT store waste engine oil in a container which has been used to hold foods or in a container rather than the original one, so as to prevent confusion and poisoning due to ingestion by mistake.
- Engine oil is a toxic substance. Before handling waste engine oil, be sure to store it in a safe place and keep it out of children's reach.

Caution

Do NOT add any additives into the engine oil. This may damage the engine. Problems resulting from the addition of lubricants are not within the scope of the warranty. If the vehicle is parked at temperature lower than-35 ℃ for extended period of time or frequently travels in such regions, it is recommended that the oil must be changed to a grade more suitable for such regions (remember to clean the oil pipeline while changing the oil) in order to reduce cold-start difficulties of the vehicle and damage to the engine.

Tips

- Handling waste engine oil is a type of highly specialized work, requiring the corresponding professional knowledge and necessary, specialized tools. It is therefore suggested that waste engine oil should be handled by an authorized BAIC dealership.
- Waste engine oil is extremely harmful to the environment and water sources. Therefore, do NOT dump waste engine oil into the water pipes or onto the ground. In addition, it is extremely expensive to treat oils which have absorbed waste engine oil.

Coolant

Role of Coolant

Correctly using coolant can play the role of protection against corrosion, cavitations leakage, radiator boiling, water scale and freezing. It can keep the cooling system constantly it's best working state and ensure the normal working temperature of the engine.

When this vehicle left the factory, Glycol-based antifreeze have been added into the cooling system



Tips

Regardless of whether anti-freeze is needed or not, a coolant that meets the specifications should be used throughout the year.

To improve the anti-freeze ability of the coolant in cold seasons, please change to a coolant which suits use in the lowest local air temperature.

Warning

- **The coolant must be stored in a closed container. Do NOT let children come into contact with it.**
- **Do NOT store the coolant in a container which has been used to hold foods or in a container which is not the original, so as to prevent confusion and poisoning due to ingestion by mistake. The discharged waste coolant should be treated accordingly.**
- **To ensure the anti-freeze ability of the coolant in cold weather conditions, be sure to use a suitable anti-freeze liquid based on the ambient temperature. Otherwise, the coolant may freeze, causing vehicle damage. This will cause the heating system to not work, and the driver and passengers may be exposed to extreme cold, with danger of**

Caution

Do NOT add into the coolant the coolant of another manufacturer.

● **Do NOT mix the coolant with another coolant which is not recognized by this Company. This may seriously damage the engine and the cooling system.**

● **If the coolant in the coolant expansion tank has faded in color and there is no coolant of another color mixed with it, simply replace the coolant according to the required cycle.**



Tips

Waste brake fluid must be collected and disposed of in accordance with the environmental protection laws and regulations.

Coolant Temperature

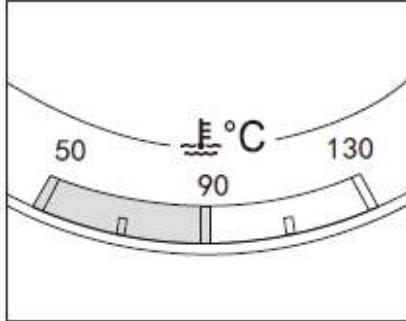

When the ignition key is turned to the “ON” position, the coolant thermometer will display engine coolant temperature. If the engine coolant temperature is too low, the thermometer pointer will remain at the “L” (low) position until the engine warms up. In normal driving conditions, the instrument scale should be in the middle about 90° position. When the engine runs under a high

load and the ambient temperature is very high, the coolant temperature will rise and the corresponding scale reading will also increase. When the coolant temperature is too high, the pointer will point to the

red area and the warning light will be lit, reminding the driver that the vehicle has a fault. At this time, be sure to immediately stop the vehicle if it is safe to do so, turn off the engine, wait for the coolant to cool down and then check the coolant level.

If the coolant level is normal, it may be that a radiator fan fault has caused the system to overheat. Check to see whether the radiator fan fuse has smelt and make replacement if necessary.

After the coolant temperature warning light is lit again after driving over a short distance, you must immediately stop the vehicle in a safe place, turn off the engine and contact an authorized BAIC dealership as soon as possible to have the system checked

⚠ Warning

When performing maintenance on the engine compartment, be sure to exercise extra care
 ● Before starting the maintenance, be sure to carefully read and follow the relevant warning instructions.

● The engine compartment is a high-hazard area. Before opening the engine hood, be sure to carefully read and follow the relevant warning instructions.

● If you can see the overflowing of steam or coolant from the engine compartment, then do NOT open the engine hood so as to prevent scalding. Wait until no steam or coolant overflows and then open the engine hood.

Checking Coolant Level and Adding Coolant

A normal coolant level is vitally important for the engine cooling system to work normally. Before opening the engine hood, be sure to park the vehicle on a flat road. Also be sure to carefully read and follow the relevant warning instructions

Tips

Coolant Specification: G 1 y col- based antifreeze

Checking Coolant Level

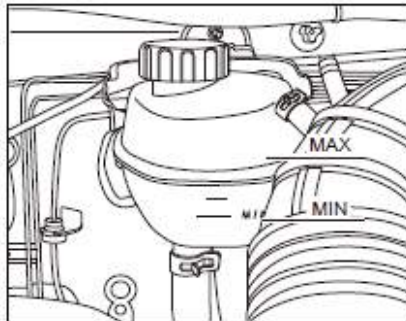

When the engine is in a cold state is the best time to check whether the coolant level is within the marked range on the side of the expansion tank.

- “MAX” for upper limit of coolant.
- “MIN” for lower limit of coolant.
- The coolant level should be between the upper limit mark and the lower limit mark. If the level is below the “LOW” mark, then coolant must be added.

Opening Coolant Expansion Tank Cover

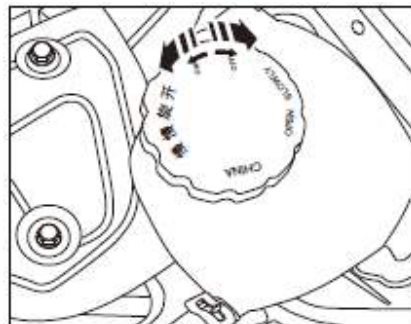

The engine must not be running. To avoid scalding, wrap the coolant recovery reservoir cover with a piece of large and thick cloth, and uncover it counterclockwise as indicated by the Arrow.

Tips

The coolant expansion tank cover should be opened when the engine is in a cold state.

Adding Coolant

Only new coolant can be added.

After filling, the coolant level must be located between “MIN” line and “MAX” line.

Caution

The level must not be above the “MAX” marker line

Closing the Coolant Expansion Tank Cover

Mount and tighten the expansion tank cover.

Tips

When the engine is in a hot state, the coolant level may be slightly higher than the upper limit mark.

Caution

It is suggested that coolant should be added when the engine is in the cold state, but the coolant level must not exceed the upper limit mark. Otherwise, when the engine reaches a hot state, the excessive coolant will overflow.

Only new coolant can be added. The coolant must comply with the provisions of this Manual. If no suitable coolant can be bought, do NOT add another type of coolant. If necessary, pure water may be temporarily added.

However, coolant must be added as soon as possible in accordance with the provisions. If too much coolant has been consumed, then be sure to add cold coolant after the engine has cooled down. Otherwise, it may damage the engine. If a lot of coolant is consumed, it indicates that the cooling system has a leak. At this time, you should go to an authorized BAIC dealership to have the cooling system checked to prevent it from damaging the engine.

Brake Fluid

The Function of Brake Fluid

The brake fluid is used to transmit power in the hydraulic braking system of the vehicle

⚠ Warning

The brake fluid is corrosive – please keep the container sealed and put it in a place out of reach of children. If accidental swallowing of brake fluid occurs, please immediately see a doctor.

Keep your skin and eyes from coming into contact with the brake fluid. If such contact is made, please immediately use a large amount of clear water to wash the skin or the eye.

Do NOT to splash any brake fluid on the hot engine. This may cause a fire

When in use, the liquid level of the brake liquid tank may slightly drop due to the wear of the brake pad. If this does occur, you may decide whether to immediately add any brake fluid based on the brake fluid level. If the brake pedal depression accidentally becomes longer or the brake fluid level falls markedly, please immediately contact an authorized BAIC

dealership. If the brake fluid level is below the minimum mark of the storage tank, do NOT drive the vehicle.

👁 Caution

Brake fluid must be completely replaced every two years.

⚠ Warning

Failure to replace the brake fluid by the specified time may cause the braking system to malfunction, resulting in serious accidents and personal injuries

Brake Fluid Level

The brake fluid level must be checked according to the cycle as specified in the Warranty Manual



When the engine is in the cold state is the best time to check whether the brake fluid level is within the marked range on the side of the storage tank.

- “MAX” is the upper limit mark for the brake fluid.
- “MIN” is the lower limit mark for the brake fluid.
- The brake fluid level should be between the upper limit mark and the lower limit mark

If the brake fluid is below the “MIN” mark, then it is necessary to add brake fluid.

Before opening the engine hood, be sure to carefully read and follow the relevant warning instructions.

The brake fluid storage tank of the vehicle is located inside the engine compartment. The brake fluid storage tank cover is yellow.

Due to the wear of the brake pad, the braking system of the vehicle will automatically adjust the braking pads. As a result, the brake fluid level will slightly drop. This is a normal occurrence. There is no need to worry about it.

If the brake fluid level falls markedly over a short period of time, then it indicates that the braking system may have a leak. In such a situation, you must immediately stop the vehicle. Do NOT continue driving. You should contact an authorized BAIC dealership as soon as possible so as to have the braking system thoroughly checked.

Warning

● **Before opening the engine hood, be sure to carefully read and follow the relevant warning instructions.**

● **If the braking system warning light does not go out, or lights up while driving, it is likely that the brake fluid level of the brake fluid storage tank is too low. In order to prevent accidents, in such a situation, you must immediately stop the vehicle. Do NOT continue driving. You should contact an authorized BAIC dealership as soon as possible to have the system checked**

Replacing Brake Fluid

The brake fluid is absorbent and can absorb the moisture in the surrounding air. . If the brake fluid contains too much moisture, it will corrode the braking system. This will lower the boiling point of the brake fluid and result in a reduction of braking effect

The brake fluid used in this vehicle is specially developed by BAIC for the braking system of this vehicle. To ensure that the braking system can work normally, it is suggested that an authorized BAIC dealership should be asked to replace brake liquid with one that meets the relevant standard.

Tips

Brake fluid type:DOT4.

 Warning

- Incorrect maintenance will result in braking failure and cause injury.
- Before adding brake fluid, be sure to clear oil dirt and dust from the storage tank. Contaminated brake fluid may cause braking failure and thus serious accidents.
- Only use the specified brake fluids. Brake fluids of different brands contain different additives, which may have chemical reactions between them. Don't mix brakefluids of different brands.
- The container used to store brake fluid must be clean. Any mixture of even a minor amount of other liquids or impurities may cause braking failure.
- After normal maintenance checks, the brake fluid level should not fall fast. If it does, immediately go to an authorized BAIC dealership to have the vehicle checked.

 Warning

- Use of waste brake fluid or a brake fluid which is not suitable for this vehicle will greatly reduce the braking effect, or even make the braking system lose effect.
- The brake fluid type is marked on the brake fluid packaging container. Only a brake fluid which meets the correct specification should be used.
 - Brake fluid is a toxic substance.
 - Do NOT store the brake fluid in a container which has been used to hold food or in a container which is not the original, so as to prevent confusion and poisoning due to accidental ingestion. The brake fluid must be stored in the original sealed the container and the container should be put in a safe place. Be careful to prevent children from touching it. Otherwise, they may be poisoned

 Caution

The brake fluid has a corrosive effect on the paint surface of the vehicle body. Be sure to promptly clean brake fluid which has been splashed onto the paint surface

 Tips

Waste brake fluid must be collected and disposed of in accordance with the environmental protection laws and regulations.

 Warning

The brake fluid must be replaced according to the cycle as specified in the Warranty Manual. If the brake fluid stays in the system for too long, air resistance will be caused inside the pipeline of the system when the brake is applied. This will reduce the braking effect and driving safety, or even cause the braking system to be completely ineffective, thus resulting in accidents.

Power Steering Fluid

The power steering fluid transmits power in the hydraulic power steering system and thus assists in steering

⚠ Warning

● **Power steering fluid is corrosive. Please keep the container sealed and put the container out of reach of children. If it is found that someone has swallowed the power steering liquid by accident, immediately see a doctor.**

● **If power steering fluid comes into contact with the skin or the eye, immediately use a large amount of clear water to wash it**

Checking the Power Steering Fluid Level

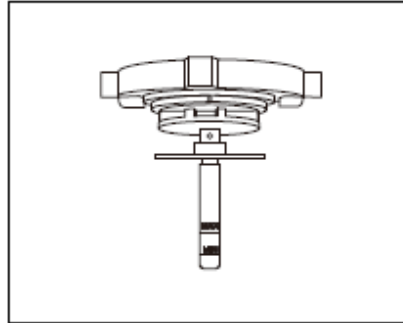

To prevent dust from entering the storage tank, wipe the filler cover and unscrew the filler cover as shown in the picture before checking the fluid level:

● “MAX” is the upper limit mark for the power steering fluid.

● “MIN” is the lower limit mark for the power steering fluid.

● The power steering fluid level should be between the upper limit mark and the lower limit mark.

If the fluid level is below the “MIN” mark, be sure to add power steering fluid

Adding Power Steering Fluid

Slowly add power steering fluid with care and do NOT exceed the upper limit mark so as to prevent an impact on the braking effect.

Meanwhile, prevent the power steering fluid from overflowing.

It is suggested that an authorized BAIC dealership should be asked to add power steering fluid

ⓘ Tips

Power steering fluid will damage the paint surface. Be sure to immediately use an absorbent cloth to absorb the power steering liquid which has been splashed onto any vehicle part and use a vehicle cleaning agent mixed with clear water to wash it.

ⓘ Tips

Power steering fluid which meets the ATF III H specifications and is recognized by BAIC may be used

 Caution

●The color of a commercial power steering fluid which can be used may be different from the color of the power steering fluid injected into the system in the manufacturing process. This is no cause for concern.

●If an unspecified power steering fluid is used or two kinds of fluid are mixed, it may cause sealing failure and then power steering failure, parts damage or other faults

Emergency Operation





In the event of regular loss of the power steering fluid, ask an authorized BAIC dealership to inspect your vehicle.

In all circumstances, when the power steering fluid level is below the “MIN” mark or a fast and noticeable loss of the power steering fluid is detected, be sure NOT to drive the vehicle. If it is confirmed that the power steering fluid is slowly leaking, you may add more power steering fluid to the “MAX” mark to ensure that you can drive your vehicle for a short distance to an authorized BAIC dealership to have it checked.

If the power steering fluid level is below the MIN mark, you must add steering liquid before starting the engine. Otherwise, it will damage the steering pump

Battery

Battery Operation Warning Symbols and Their Explanations

	1.Be sure to wear goggles during maintenance!
	2.The battery electrolyte is a highly corrosive substance. When operating it, you must wear protective gloves and goggles!
	3.The work place must be free of open fire, sparks, cover-free lights and smoking!
	4.When charged, batteries will generate explosive mixed gases!
	5.Children must be kept far away from the electrolyte and vehicle batteries!

If you are unfamiliar with the repair processes or have no required tools, be sure to NOT perform any maintenance on the electrical system of the vehicle. If not absolutely sure, ask an authorized BAIC dealership to carry out the relevant maintenance.

⚠ Warning

There is a danger of injury, corrosion, accident or fire in the maintenance of vehicle batteries and electrical parts!

● Do NOT let acidic or lead-containing particles fall into your eyes, or onto your skin or clothes.

● The acid in batteries is highly corrosive. Be sure to wear protective gloves and goggles when maintaining them. Do NOT turn batteries. Otherwise, the acid inside will flow out from their exhaust hole. If battery acid is splashed into your eye, be sure to immediately use clear water to wash it out and then go to see a doctor right away. If battery acid is splashed onto the skin or clothes, be sure to immediately use a dense soap liquid to neutralize it and then use a large amount of water to wash it. If the acid is swallowed by mistake, be sure to immediately go to see a doctor.

● When charged, batteries will generate explosive mixed gases. Therefore, batteries should be charged in a well-ventilated space.

⚠ Warning

● Open fire, sparks, string lights and smoking are prohibited. When handling power cables and electrical equipment and removing static loads, it is necessary to prevent sparks from being generated. Do NOT make the battery terminals short-circuit. Otherwise, the high-energy sparks generated in the short-circuit may harm the maintenance personnel.

● When dismantling a battery, remove the negative cable first and then the positive cable.

● Children should be kept far away from acids and batteries. Before connecting the battery again, be sure to turn off all electrical equipment. Connect the positive cable first and then the negative cable. Do NOT connect the power cables in the wrong way. This may cause fire! Do NOT remove or place batteries on your own, because in some situations, such an operation will cause serious damage to the batteries and the fuse box. If such maintenance is indeed needed, please contact an authorized BAIC dealership.

Checking Battery Power

If the vehicle needs to be driven over a long distance or in a hot region or the battery is used for too long, be sure to regularly check battery power

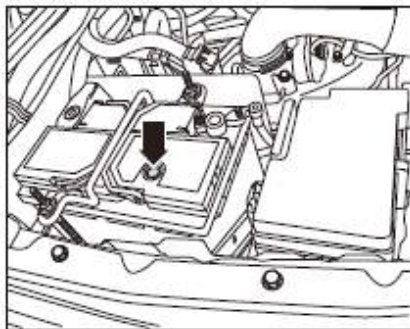

- If the color inside the monitoring indicator window is green, it indicates that the battery power is excellent.
- If the color inside the monitoring indicator window is black, it indicates that the battery liquid volume is insufficient.
- If the monitoring indicator window is colorless, it indicates that the battery needs to be replaced

Tips

If the monitoring indicator window is colorless, you may use a screwdriver to lightly tap the monitoring indicator window to drain air bubbles. If the color inside the monitoring indicator window does not change, the battery must be replaced.

In the event of the following usage conditions or situations, be sure to regularly check battery power:

- Vehicle with a long driven mileage.
- Driving in hot countries or regions.
- Battery is too old.
- Driving in cold countries and regions.

Warning

- Before starting battery maintenance, be sure to carefully read and follow the safety warning instructions for battery maintenance.
- Be sure NOT open the battery so as to prevent chemical scalding and battery explosions.
- Do NOT connect a damaged or leaking battery. Damaged or leaking batteries must be recycled and disposed of in accordance with environmental protection laws and regulations.
- The work place must be free of open fire, sparks, cover-free lights and smoking. When opening power cables and electrical equipment, attention must be paid to preventing electric sparks or static from being generated, Do NOT make the battery terminals short-circuit. Otherwise, the high energy electric sparks generated during the short circuit may injure the operating personnel

Working in winter

There are especially strict requirements for batteries in winter, because the starting power which they can provide at low temperatures is only part of the starting power in room temperature. We therefore suggest that before the cold season starts you should check your vehicle's battery with an authorized BAIC dealership. Charging should be performed if necessary.

If your vehicle is not driven for several weeks under an extremely cold situation, you should remove the battery and keep it indoors so as to protect it from damage.

Charging and Replacing Battery

Only when you possess the essential professional knowledge should you perform maintenance on the battery.

If the vehicle is frequently driven over short distances or is parked and not used for a long time, be sure to increase the frequency of battery checks between the specified maintenance cycles.

In the event of battery damage, the battery power will be insufficient, making it difficult to start the vehicle. In such a situation, it is suggested that you go to an authorized BAIC dealership to have the battery charged or replaced.

Caution

Only electrical equipment which meets the national specification on electromagnetic compatibility and is recognized by BAIC can be used.

Charging Battery

If the battery has been used for a rather long time, it may not maintain charging efficiency when it is completely new. If the vehicle is used too infrequently, or the vehicle makes too many short starts, or runs in a cold environment, then its battery needs to be charged regularly.

Before charging, be sure to check the state of the battery

Warning

- **Do NOT charge the battery when it is connected with the vehicle, this may seriously damage the electrical system of the vehicle.**
- **If the display of the battery monitoring indicator window is colorless, do NOT attempt to charge the battery.**
- **If the battery is frozen, do NOT attempt to charge it.**

While being charged, the battery will generate corrosive acidic volatile gases, as well as an electric current that can cause serious damage. When charging a battery, always pay attention to the following precautions:

● Before charging, disconnect the battery terminals from the vehicle and remove the battery. Charging a battery whose wires have been connected will damage the electrical system of the vehicle.

● Before turning on the charger switch, confirm that the wires of the battery charger are safely clipped to the terminals of the battery. Once the charger is turned on, no wire can be moved

● While charging the battery, be careful to protect your eyes.

● Make sure the top and vicinity of the battery is properly ventilated, and avoid strong light near the battery (before and after the battery is charged, it will generate flammable hydrogen). When the color display in the battery monitoring indicator window is green, stop charging. Otherwise, this will lead to excessive battery charging.

● When charging finishes, you need to turn off

the battery charger before disconnecting the wires from the battery terminals.

After the engine is turned off, if the ignition switch remains in the ON mode for a long time or the headlights or the lighting equipment is still in the ON mode, the battery may discharge quickly, resulting in power deficiency

 **Caution**

In a cold environment, it may take a long time to charge the battery. Before installing the battery onto the vehicle after charging, it is necessary to put the battery to one side for one hour so as to dispel inflammable gases and minimize the danger of fire or explosion

Replacing Battery

Only use a battery of the same model and the same specification as that of the battery to be replaced. Otherwise, there may be situations of inconsistent dimensions or different terminal positions, thus likely to cause battery damage, leakage or fire.

When replacing a battery, ensure that it is correctly installed. Be sure that the battery tray and the pressing board are correctly fixed so as to prevent the battery from moving in the event of an accident or emergency braking.

BAC's original batteries can meet the vehicle maintenance, performance and safety requirements

 **Caution**

Before starting battery maintenance, be sure to carefully read and follow the safety warning instructions for battery maintenance.

Windshield Washing Liquid and Wiper Blade

Windshield Washing Liquid and Wiper Blade



The washing liquid of both the front and rear windshield is supplied from the washing liquid storage tank inside the engine compartment. If it is found the washing liquid level is too low, be sure to promptly add washing liquid into the storage tank.

It is difficult to use pure water to thoroughly clean the front and rear windshields. In a cold environment, pure water may also freeze. Therefore, please use a windshield washing liquid

⚠ Warning

When performing maintenance on the engine compartment, be sure to exercise extra care.

● Before starting the maintenance, be sure to carefully read and follow the relevant warning instructions.

● Do NOT add any coolant or any other additives into the windshield washing liquid. They will leave oil stains when the windshield is cleaned, thus seriously affecting the front vision and resulting in accidents.

Replacing Windshield Wiper Blades

👁 Caution

● The wiper blade must be kept in good state. This is essential for maintaining clear vision.

● To prevent the formation of streams, the wiper blade should be regularly cleaned using a windshield cleaning agent. If the windshield glass is very dirty, such as with insect remains, you cause a sponge and cloth to clean and wipe the wiper blade.

● If the weather is cold, before the windshield washer is opened each time, check whether the wiper blades are frozen. Only when the front and rear wiper blades are free of interference and obstruction can the windshield washer be operated

If there is a frictional sound in the wiper blade, it may be caused by the following factors:

●When the vehicle is washed inside an automatic washing device, hard wax residues are fixed to the windshield glass. Such hard wax residues can only be cleared using a special cleaning agent. Add a windshield cleaning agent that can dissolve paraffin, and this frictional sound can be eliminated. Ordinary washing liquids which can only dissolve grease cannot clear such deposits.

●If the wiper blade is damaged, it may also generate a frictional sound. At this time, the wiper blade should be replaced.

●The positioning angle of the wiper arm is incorrect. Please to go to an authorized BAIC dealership to have the positioning angle checked and adjusted.

It is necessary to regularly check the wiper blade and replace the wiper blade as required. Otherwise, it will damage the front and rear windshield.

Replacing Front Wiper Blade

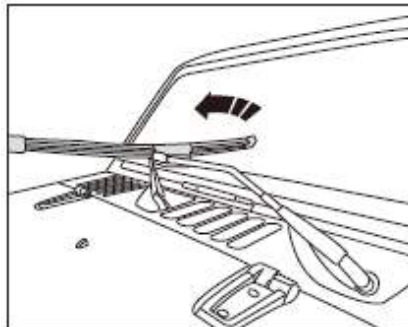

Pull up the wiper arm, follow the direction of - Arrow A- and turn the wiper blade to the position as shown in the figure

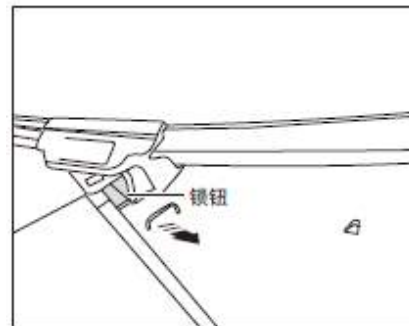

Press the key to unlock the wiper, and then pull the wiper along the -Arrow- direction

Replacing Rear Wiper Blade

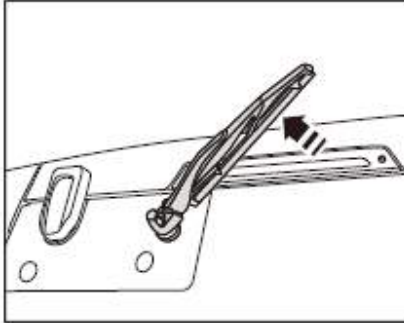

Pull up the rear wiper arm -Arrow-

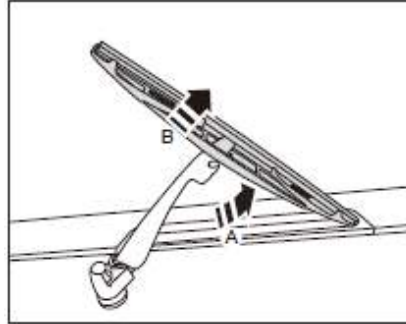

In the direction of -Arrow A-, turn the wiper blade to the position as shown in the figure to separate it from the fixing groove on the rear wiper arm and then remove the blade in the direction of -Arrow B-.

Rear wiper blade can be installed following the sequence opposite that of removing the rear wiper blade.

⚠ Warning

While driving, be sure to clean all vehicle window glass to maintain good vision! □

- Regularly clean the wiper blade and all vehicle window glass.
- The wiper blade should be replaced once or twice a year.
- Avoid wiping the windshield with dry wiper blades so as to prevent the rubber strips from aging and wear and the vehicle windows from fluffing, which would otherwise affect driving safety.

Tires

Defective tires are very dangerous! If tires are damaged, excessively worn, or have improper pressure, do NOT continue the driving.

While driving, pay close attention to the state of tires and regularly check for deformations (bulging) in the treads and tire sides. Also check for scratches, abnormal wear, cracks, nails, etc.

The most common causes of tire ineffectiveness:

- Impacting or friction with curbs
- Driving over deep pits on the road
- Tire pressure being too low or too high

Caution

Be careful to prevent tire wear from the erosion of engine oil, grease, gasoline and other vehicle liquids.

Storage Instructions for Tires

Before removing tires, be sure to mark them indicating their turning direction. When installing the tires, follow the marks to reposition them. This can ensure that the turning direction and dynamic balancing state of the wheels will be kept unchanged.

The removed wheels and tires should be stored in a cool and dry place, ideally in shade, away from sunlight.

Tires which are not yet installed on the vehicle should be stored vertically

Tire Pressure

The correct tire pressure can prolong the service life of tires. It can also ensure the best combination of driving comfort, fuel economy and drivability.

When the tire pressure is too low, it will intensify tire wear, greatly affect the drivability and fuel economy of the vehicle and increase the danger of lost tire effectiveness. If the tire pressure is too high, it will cause driving unstable and

uneven tire wear, thus reducing the service life of the tires. Check tire pressure (including spare tires) at a frequency of at least once a week. Tires must be checked when they are in a state of room temperature - as long as the vehicle has been driven for 1.6km, it is enough to make tires fully heat up, thus affecting tire pressure.

The pressure of hot tires is bound to increase. If tire pressure has to be checked when the tires are hot (after the vehicle has been driven for a period of time), the pressure should have risen by approximately 0.2~0.5bar. In such a situation, please do NOT deflate the tires for the purpose of making the tire pressure up to the standard.

For details about cold tire pressure criteria, refer to “Wheel” on page 250.

When to Check Tire Pressure?

Tires should be checked at least once a week.

Do NOT forget to the pressure of spare tires. Their pressure should be 220kPa.

How to Check Tire Pressure?

Besides the tire pressure monitoring system, tire pressure can also be checked with high-quality pocket-type tire pressure gauge. It is not possible to determine whether the tire pressure is normal by visual checks alone. Even if not adequately inflated, radial tires still look very normal. Check inflated tire pressure when they are cold. “Cold state”

means tires that have not been driven for more than three hours or have been driven not over 1.6km.

Remove the valve cap from the valve core of the tire, press the tire pressure gauge to the valve with force, and then the tire pressure will be displayed. No adjustment will be needed if the inflated pressure of the tire in a cold state meets the recommended pressure value on the tire and loading information label. If the pressure is too low, then it is necessary to inflate the tire to the recommended value. If the pressure is too high, it is possible to press the air gate element to discharge air until the pressure reaches the recommended value.

After the check is completed, be sure to screw the valve cap back on the valve core. The valve cap can prevent dust and moisture from entering the tire

Tire Puncturing

Your vehicle is equipped with treadless tires. When the tires are punctured by a sharp object, there may not be apparent air leakage in the tires. If you spot such a situation, immediately slow down and drive carefully. Replace the punctured tire with a spare tire or repair it.

This type of puncturing will cause reduced tire pressure. It is therefore very important to regularly check tire pressure. Punctured or damaged tires must be immediately repaired or replaced as soon as possible

Hidden Damage

Damage to the tires and rims is often difficult to be noted. While the vehicle is running, if the vehicle vibrates abnormally or deviates, it is likely that one tire has a fault. In such a situation, you should go to an authorized BAIC dealership to have the tire checked as soon as possible.

Warning

In the initial 500km, it is unlikely that new tires will not reach a state of their best road adhesion. Therefore, you should carefully drive the vehicle at a medium speed so as to prevent accidents.

●Tires that have not undergone a wear-in period or tires that have been over-worn will have insufficient road adhesion. This will directly affect the braking effect.

●If the tires are damaged, do NOT continue to drive, because damaged tires may get punctured while driving, thus resulting in traffic accidents and personal injuries.

●The tire pressure must meet the provisions. Otherwise, it may cause accidents. If the vehicle is still driven at a high speed when tire pressure is insufficient, it will make the tires bend, thus extremely easy to cause tire overheating. Tire bursting may result.

●Do NOT use damaged wires or wires which have been worn to their pattern wear mark. Such tires should be promptly replaced.

●Avoid using tires which are over six years old as much as possible. If such tires have to be used, be sure to exercise extra care while driving and drive slowly.

●Do NOT use used wheels or used tires of an unknown origin, because such wheels and tires may have been damaged, although they bear no visible damage. While driving, they may cause the vehicle to go out of control and result in traffic accidents.

● While driving, if you spot any abnormal vibration or deviation of the vehicle, be sure to immediately stop and check to see if the tires are damaged.

Valve Hole

Keep the valve hole cap tightly screwed to prevent dust from entering the valve hole. While checking tire pressure, check whether the valve hole leaks (ideally use a soap liquid to see if air bubbles emerge).

Tips

A suitable amount of home-use washing liquid may be added to clear water, and spread in the valve hole to see whether air bubbles are generated. If bubbles are produced, it indicates that there is gas leakage.

Tire Check and Rotation

It is suggested that tires should be rotated every 12,000km driven, or more frequently based on needs.

Whenever abnormal wear is found, you should rotate the tires as soon as possible and check the wheel alignment. It is also necessary to check to see whether the tires or wheels are damaged.

In addition, it is also necessary to regularly check the tightening torque of the wheel nuts. The corrected torque is required to reach (140 ± 10) Nm. It is suggested that the tightening torque of each wheel nut should be checked after the vehicle has been driven for 1500km, 5000km and 8000km. Every time the wheel assembly is dismantled, tightening must be made in strict accordance with the torque requirements.

Tips

The purpose of regularly rotating tires is to make all tires wear evenly.

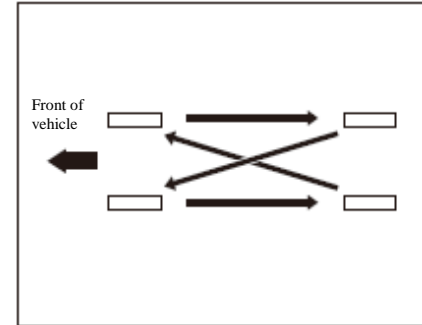

When rotating tires, be sure to follow the correct rotation mode as shown in the figure.

After the tires are rotated, adjust the inflation pressures of the front and rear tires according to the tire and loading information label. Ensure that all wheel nuts have been correctly fastened.

⚠ Warning

Rusting or dirt on the wheels or wheel connectors will cause the loosening of the wheel nuts after a certain period of time, thus resulting in the falling-off of wheels and traffic accidents. Therefore when replacing wheels, it is necessary to clear any rust or dirt on the wheels

4 and their connectors. In emergency situations, cloth or tissues may be used to clean. If necessary, a scraper or a wire brush may be used to clear all rust or dirt. Meanwhile, regularly check the tightening torque of the wheel nuts and the corrected torque is required to reach $(140\pm 10)\text{Nm}$. It is suggested that the tightening torque of each wheel nut should be checked after the vehicle has been driven for

1500km, 5000km and 8000km. Every time the wheel assembly is dismantled, tightening must be made in strict accordance with the torque requirements.

When To Replace Tires?

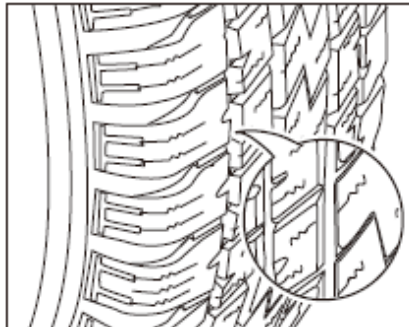

All original tires bear wear indication marks. These marks are located on the narrow strips inside the tread patterns and distributed in the tire periphery. On the road side of the tires, there are small triangle signs indicating the position of the marks. When the tread pattern has been worn to the indication mark, the tires should be promptly replaced.

ⓘ Tips

If the tires are worn unevenly (only on one side) or excessively, ask an authorized BAIC dealership to align the wheels.

If any of the following situations occurs, tires need to be replaced:

- The tire wear indication mark has shown signs of wear.
- Cord threads or fabric in the tire rubber is visible.
- Treads or tire walls crack to a depth that makes cord threads or fabric visible.
- Tires bulge, warp or stratify.
- Tires are punctured, scratched or bear other damage, and the size and position of the damage can hardly be repaired.

Tire Information

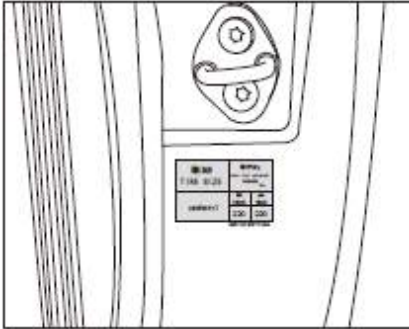

A tire information label is pasted to the B-pillar on the driver's side. Be sure to inflate tires according to the tire pressure specified on the label.

Buy New Tires

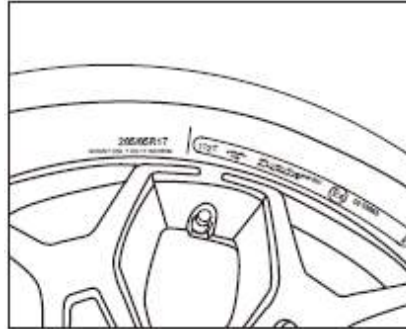

View the tire and loading information label on the vehicle to get information on the model and dimension of the tires needed.

⚠ Warning

Mixed use of tires will make the vehicle run out of control while driving. If you mix tires of different dimensions or models (radial tires and bias-belted tires), it will not be possible to steer the vehicle normally, thus causing accidents. Use of tires of different dimensions may damage the vehicle. Therefore, all wheels must have the same dimension and model. □

Wheel Balance

Before the vehicle left the factory, the wheels already underwent dynamic balance treatment. However, many factors in the vehicle use process will affect wheel balance, thus resulting in wheel imbalance.

Be sure to promptly perform dynamic Balance treatment on imbalanced wheels.

4 Otherwise, it will cause excessive wear to the steering system, the suspension system and tires.

After tires are replaced, the wheels must be dynamically balanced again.

Dynamic balance standard for wheels: cumulative $\leq 10g$.

Inaccurate Wheel Alignment

Inaccurate wheel alignment will result in uneven wear to the tires, thus lowering driving safety. If excessive uneven tire wear is found, be sure to go to an authorized BAIC dealership to have the wheels aligned.

Replacement of the Rim

Bent, cracked or seriously rusting or corroded rims should be replaced. If the wheel nuts often become loose, the wheels and wheel nuts should be replaced. Wheels that leak should be replaced (except for some repairable aluminum wheels). If the above situations occur, be sure to go an authorized BAIC dealership to have repairs made.

The authorized BAIC dealership knows which type of rim should be used. The new rim should have the same load capacity, diameter, width and alignment as those of the original wheels. The new rim should also be installed identically as the original wheels.

Rims can only be replaced using BAIC's new original parts. This will ensure that the new rims match with your vehicle.

Warning

Use of an unsuitable rim will be dangerous. It will affect the braking and steering performance of the vehicle, resulting in tire leakage and making the vehicle run out of control. It may cause accidents, injuring you or others.

Use of the wrong rim will also cause problems to the life of the bearing, the cooling of the brake, the calibration of the speedometer or odometer, the focusing of the headlights, the height of the bumper, the ground clearance of the vehicle, and the clearance between the tires or tire snow chain and the vehicle body and chassis, etc.

Use of a used rim on the vehicle can be very dangerous. There is no way for you to know how the used rim has been used or how many miles it has been driven. Such rims may suddenly break down and cause an accident. If you need to replace rims, be sure to use BAIC's new and original rims.

When Encountering Tire Puncturing

Tire puncturing is not often seen while driving. This is particularly true when the tires are properly maintained. If a tire leaks, it could be very slow. However, once tire puncturing is encountered, the phenomena that occur and the suggested measures for coping with them are as follows:

If a front tire is punctured, the drag effect of the flat tire will make the vehicle deviate to its side. At this time, you should immediately lift off the accelerator pedal and tightly hold the steering wheel. Steer the vehicle to keep it in the original lane and lightly depress the brake to stop the vehicle in the emergency lane or a safe place.

If a rear tire is punctured, you should release the accelerator pedal. Turn the steering wheel to your desired driving direction so as to keep control over the vehicle. It could be very bumpy and noisy, but you can still control the vehicle. Lightly depress the brake to stop the vehicle in the emergency lane or a safe place.

Snow chains

Do NOT install any snow chain which is not consented by BAIC. Otherwise, it may damage the brake parts.

Unsuitable snow chains will damage the tires, rims, suspension, brake, and body of the vehicle. Only snow chains recommended by an authorized BAIC dealership and tested by BAIC can be used. In the use of snow chains, pay 4 attention to the following requirements:

1. The snow chain can be installed only on the driving wheel;
2. Follow the tightening instructions for the installing of snow chains and the vehicle speed limits under various road conditions;
3. Don't drive at speed > 50km/h.
4. To avoid damage to tires and the excessive wear of snow chain, when driving on snow-free road, be sure to remove the snow chain.

5 Handling of Accidents

Warning Triangles and Fire Extinguisher	223
Spare Tires and Tools	224
Replacement of fuse	232
Replacement of bulb.....	242
Emergency start	242
Emergency traction.....	244

Warning Triangles and Extinguisher

Warning Triangles

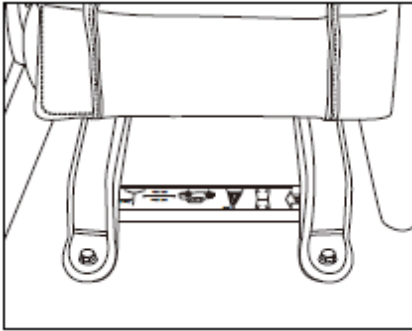

Tips

The warning triangles are located under the driver's seat.

If the vehicle breaks down on the road, park it on the emergency lane or in a safe place, turn on the danger warning light, get warning triangle from the driver's seat, fold them out, and put them in the designated positions so that drivers of other vehicles can spot the danger, slow down and pass by.

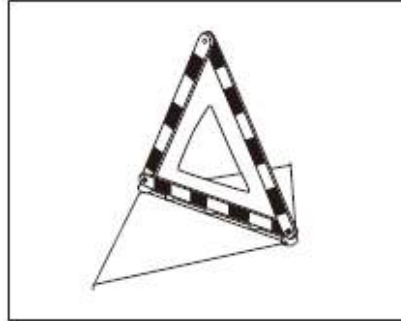

The warning triangles should be placed behind the vehicle driving direction in accordance with the relevant State regulations. When placing a warning triangle on an ordinary highway in day time, put it in a place which is about 50-100m away in the direction of coming vehicles. In expressways, the warning triangle should be put in a place which is at least 150m away in the direction of coming vehicles. In the event of night, the distance should be increased based on the specific situation.



Caution

Please according to the national relevant laws and regulations, correct use warning Triangle.

Spare Tires and Tools

Spare Tire

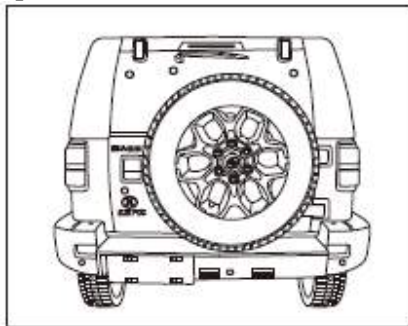

The spare tire is located under the spare tire rack of the tailgate. To use it, please take it out according to the following steps:

1. Take the wheel lock key and the wheel nut wrench out from the accompanying tool box.

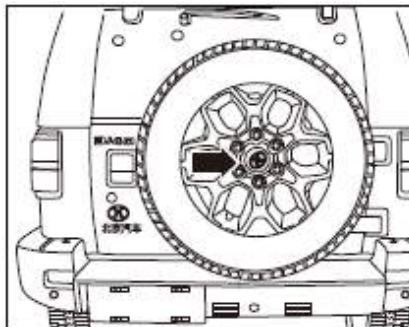

2. Pull out the hub cap of the spare wheel in the axial direction.

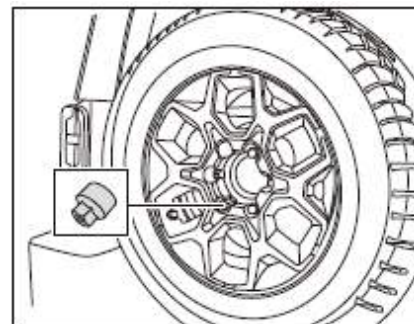

3. Follow the right angle to insert the wheel lock key into the wheel lock nut and turn the wheel lock key to remove the nut; then, sequentially remove the other three ordinary wheel nuts.

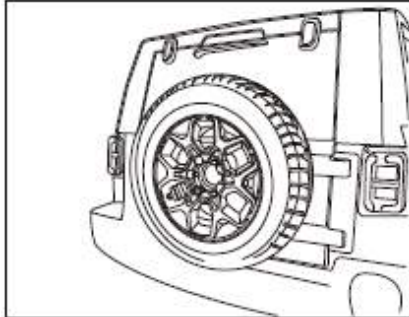

4. Align the center hole of the replaced wheel to the stud in the spare wheel pit.
5. Use your hand to pre-tighten 4 nuts and then the 3 ordinary wheel nuts with a tightening torque should be (110 ± 5) Nm. Finally, follow the right angle to insert the wheel lock key into the wheel lock nut, and tighten the lock nut with a tightening torque of (50 ± 5) Nm.
6. Align the spare wheel clamp with the aluminum wheel clamp and press it with force in the axial direction. Press all the six clamps in, complete the assembly.

⚠ Warning

- Do NOT use damaged spare wheels or spare wheels which have been worn to the maximum limit.
- Spare tires which are more than six years old can only be used under emergency situations, and the vehicle must be driven carefully.
- After the spare tire is installed, be sure to check tire pressure as soon as possible and ensure that it is within the specified range.

ℹ Tips

The air pressure of the spare tires is 220kPa.

Tools

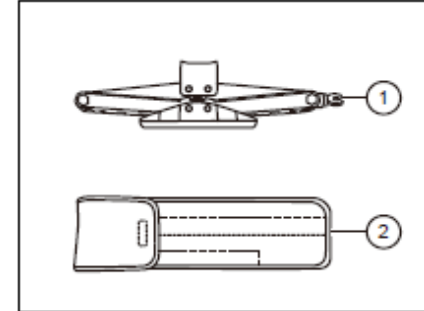

ℹ Tips

The accompanying tools of the care are located under the rear seats.

Vehicle tools include:

1. Jack
2. Tool kit

The jack is fixed to the vehicle floor using locking bolts, and the accompany toolkit is located behind the jack.

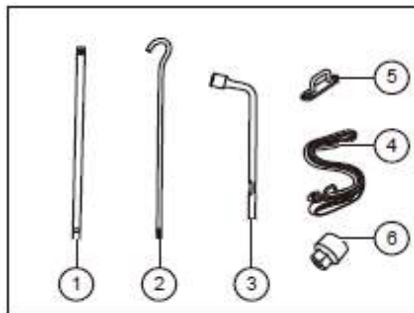

The vehicle tool kit includes:

1. Jack-use wrench
2. Jack-use wrench extension rod
3. Wheel assembly dismantling wrench
4. Front windshield fixing strap
5. Front windshield fixing strap's fixing ring
6. Key to wheel lock

⚠ Warning

- Improper use of the jack may cause serious injuries.
- The jack can only be used on a hard and flat surface.
- The jack can only be used for replacing the wheels of this vehicle. It cannot be used to lift other heavy objects or vehicles.
- When the jack is used, be sure to NOT start the engine. Otherwise, it will cause accidents.
- When using the jack to lift the vehicle, be sure to remember that you must not put any part of your body under the vehicle (to prevent accidents).
- If it is indeed needed to operate under the vehicle, a suitable protective support must be placed under the vehicle.

👁 Caution

After use, the jack must be put back to its original place. Also pay attention to the supporting angle of the jack and ensure that the jack can be put into the installation box.

⚠ Warning

- Follow the specified tightening torque to correctly tighten the wheel nuts. Otherwise, when the vehicle is driven, the nuts may become loose, thus increasing the chance of traffic accidents.
 - When the wheel assembly dismantling wrench provided along with the vehicle is used to fasten the wheel nuts but it is not possible to guarantee the torque value, rationally control vehicle speed when driving, avoid sudden acceleration and emergency braking and go to a specialized place to calibrate and ensure that the wheel nuts reach the required tightening torque.
- The wheel nut torque is: $130 \pm 5 \text{ Nm}$.

Replacement of Flat Tires

The dimensions of the emergency spare tires and their rims of this vehicle are the same as those of the damaged wheels.

After an emergency spare tire is installed, the steering performance of the vehicle will change. Please rationally control vehicle speed, and avoid abrupt acceleration and emergency braking.

Emergency spare tires can only be used for a short period of time.

The maximum vehicle speed should not exceed 70km/h.

While driving, do NOT use more than one emergency spare tire.

Preparatory Work

If you find that a tire is flat, you should slowly drive the vehicle to a flat place where safe maintenance can be performed so as to prevent further damage to the tire and the rim. Also, put a warning triangle in a suitable place behind the vehicle, and turn on the emergency warning light.

⚠ Warning

There are risks when tires are replaced. The vehicle may slide off the jack, tip over or fall upon you or others, thus causing serious injury.

Please find a flat and safe place to replace tires. The relevant laws and regulations must be strictly complied with. All passengers must leave the vehicle and wait in a safe place.

To prevent the vehicle from moving, the following measures should be taken:

- 1. Apply the parking brake.**
- 2. Set the shift lever to the Neutral Gear “N”.**
- 3. Turn off the engine. When the vehicle is being lifted, do NOT start the engine again.**
- 4. Do NOT let passengers stay inside the vehicle.**

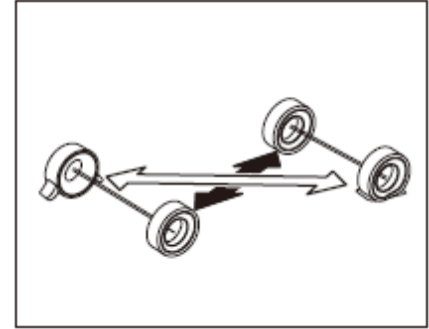

To further ensure that the vehicle will not move, you may place a stopper in front of and behind the tire which is farthest away from the tire to be replaced (e.g. the tire which is diagonal to the tire to be replaced).

Loosening Wheel Nuts

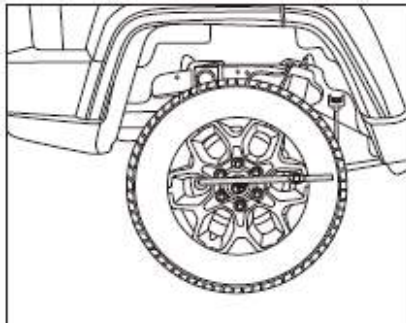

Before jacking the vehicle, be sure to loosen the wheel nuts first.

Turn the wheel nuts counter-clockwise to loosen them.

To get maximum torque, be sure to put the nut into the wrench as shown in the figure above, hold the end part of the wrench handle and pull it upwards. But, be sure to NOT let the wrench go off the nut.

Do NOT remove the nut. Instead, just loosen it by approximately one turn.

Tips

Before lifting the vehicle using the jack, only loosen the wheel nuts by one turn.

● The wheel assembly wrench provided with the vehicle may be used to do the loosening.

Lifting Vehicle

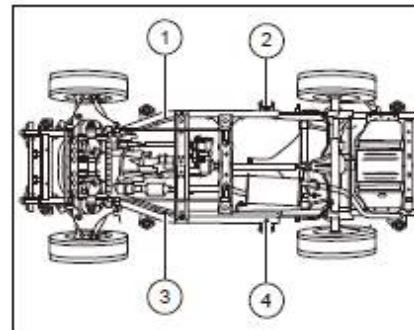

Put the jack at the right lifting point. Be sure that the jack is placed on flat, solid ground.

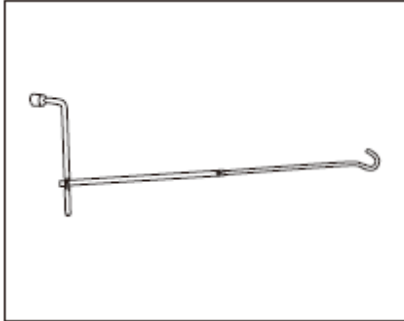

As shown in the figure, first assemble the jack-use wrench, the jack-use wrench extension rod and the wheel assembly wrench as shown.

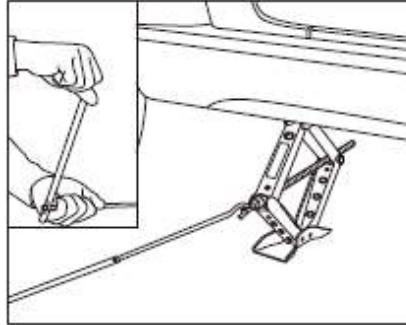

Use the assembled tool to turn the jack clockwise and lift the vehicle until the leaking tires off the ground.

Remove the wheel nuts first and then the leaking tire. Be sure to exercise care when touching the wheel nuts, because these nuts could have become very hot due to vehicle driving. Put the leaking tire on the ground, with its outer surface facing upwards.

⚠ Caution

The lifting and follow-up replacement procedures could only be performed after the nuts of the wheel have been loosened.

⚠ Warning

- The jack must be used on a hard and flat surface.
- The jack must be put at a suitable lifting point. 5
- Strictly follow the operational precautions of the jack.
- When a trailer is towed, the trailer must be separated from the main vehicle.
- While lifting, you should continuously watch the vehicle condition. If you feel that the vehicle body is apparently tilting, you should stop lifting, find out what the problem is and only resume lifting after the problem has been fixed.

Mount Spare Tire

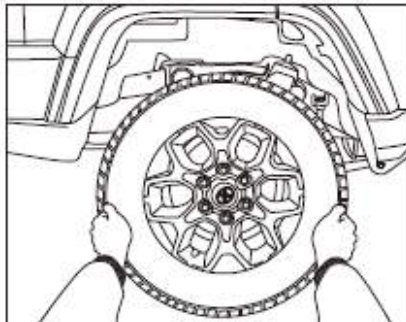

Align the installing hole of the spare wheel with the installing hole in the brake disc.

 Caution

Before installing the tire, be sure to use a wire brush (or similar tool) to remove all corrosive items from the installing surface.

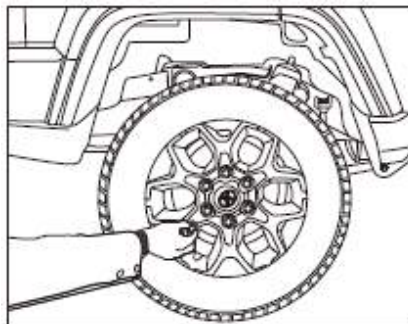

When installing the wheel nuts, use your hand to tighten them first. Then, push the wheel backwards to see if it can be tightened a bit more.

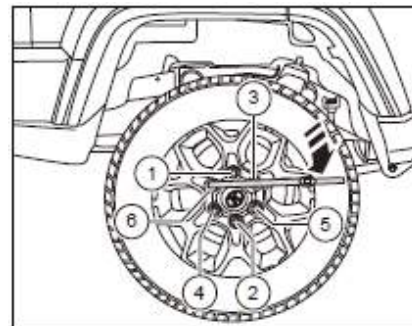

Turn the jack handle clockwise to lower the vehicle.

Use the wheel assembly wrench to tighten the wheel nuts. Aside from your hand, do NOT use other tools or leverage tools like a hammer, a pipe or a foot, and be sure that the wrench is tight on the nut.

Following the sequence as shown in the figure and evenly tighten the wheel nuts.

 Caution

- The wheel nuts should be evenly tightened following the sequence as shown in the figure.
- After the wheel is installed, go to an authorized BAIC dealership as soon as possible to have the wheel nut tightening torque checked.
- If a nut is rusted or difficult to turn when the wheel is replaced, the nut must be replaced when checking the wheel nut tightening torque, and the bolt thread should be cleaned.

 Warning

The threads on the wheel nuts and the hub must be kept clean and free of grease and other attached items.

Instructions for Replacement of Wheel

- The replaced wheel should promptly and correctly installed into the spare tire storage place.
- After use, the accompanying tools should be promptly cleaned and put back to their original place.
- Check the wheel nut tightening torque as soon as possible.
- Damaged wheels must be repaired as soon as possible.

 Caution

The emergency spare tire or the replaced wheel must be reliably fixed to the spare tire rack.

 Warning

- Spare tires which are more than six years old can only be used under emergency situations, and the vehicle must be driven carefully.
- After a spare wheel is installed, be sure to check the tire pressure as soon as possible so that it is within the specified range.
- When a spare tire is used, the vehicle speed must not exceed 70km/h. Avoid abrupt acceleration and emergency braking as much as possible.

Replacement of Fuse

Fuse Box

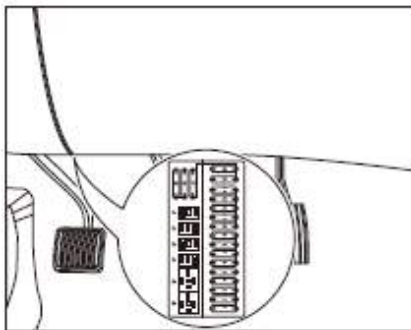

Tips

The fuse box is located on the left side of the lower steering column of the instrument panel, at the back of knee board. To facilitate viewing during inspections or repair, the lower knee board needs to be removed.

Remove the knee protective panel

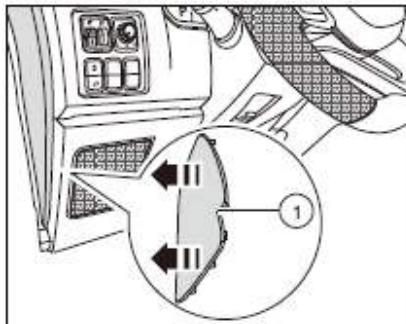

1. Adjust the steering column to the bottom position;
2. Attach a piece of 50 × 100mm protective strip (made of non-woven fabrics or similar materials) on the knee protective panel close to the ignition lock to protect the knee protective panel against scratching during the removal and installation;
3. Force backward on both the left and the right from bottom to top to remove the knee protective panel;

With knee protective panel

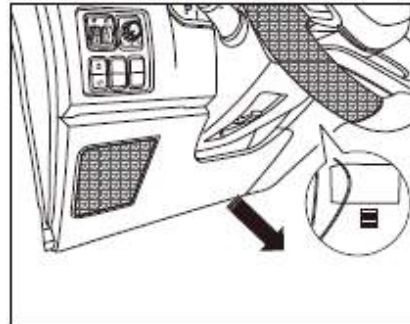

1. Check to ensure the steering column is adjusted to the bottom position, and the knee protective panel is attached with a protective strip.
2. Force forward on both the left and the right from bottom to top to install the knee protective panel;
3. Remove the protective non-woven fabrics;

Install Fuse Box

- 1 Check and ensure the steering column had adjusted the lowest position. The knee protection cover is with a protection cover
- 2 Install knee protection cover plate, from bottom to top, to forward force by left and right sides at the same time.
- 3 Rip cover nonwovens.

Engine Compartment Power

Distribution Center

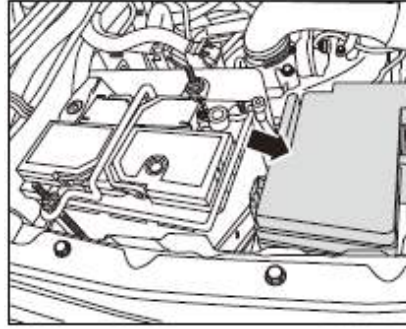

Tips

The engine compartment power distribution center is located at the front end of the battery.

Check and Replace Fuse

If a certain electrical device stops working, you should check whether it is caused by fuse damage. You may follow the graphs of Engine Compartment Power Distribution Center the position map on the fuse box cover and tables to determine the one or several fuses that control the component. Before you are able to determine whether the fault is caused by fuse damage, you may replace all damaged fuses and check if electrical devices can work normally. If the fault still exists, please contact an authorized BAIC dealership.

Pull out the fuse of the electrical device which has stopped working, and check it out.

Find the melted metal wire in the fuse. If the fuse has melted (the fuse in the place of the arrow in the figure has been disconnected), be sure to use a spare fuse of the same or lower amperage to replace it.

If no spare fuse can be used and the vehicle cannot be moved as a result, a fuse of the same or lower amperage may be removed from another circuit to make

the replacement. However, you must be sure that even if this circuit, such as the circuit of the cigarette lighter or the radio, is temporarily not used, and that it will not affect you to drive.

If the alternative fuse of the same rated value melts again within a short time, it then indicates that the vehicle may have a serious electrical fault. At this time, you should leave the melted fuse in the circuit and contact an authorized BAIC dealership.

 Caution

If you use a spare fuse of a rather low amperage to replace the melted fuse, it may melt again. If the fault is fixed, you should also use a fuse of the correct rated value to replace it as soon as possible.

Engine Compartment Power Distribution Center Layout

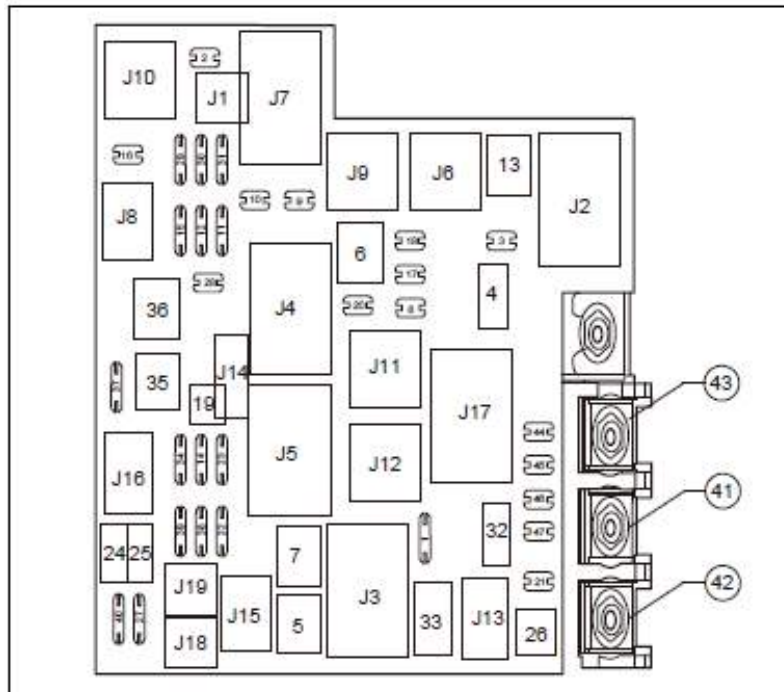

Specifications and Functions of Engine Compartment Power Distribution Center

Position	Specification	Function
1	10A	EMS
2	15A	A/C compressor
3	5A	PEPS BCM ST
4	30A	Starter excitation
5	---	Reserved
6	40A	Low-speed fan 1
7	40A	Low-speed Fan 2
8	15A	Fuel pump
9	10A	Main relay 2
10	10A	Blower relay coil
11	15A	Injection nozzle, sensor
12	15A	Ignition coil, brake switch
13	30A	Main relay
14	25A	ABS/ESP B+
15	---	Reserved
16	15A	Vacuum pump
17	15A	Left front headlight
18	15A	Right front headlight
19	---	Reserved
20	20A	Front wiper
21	15A	lef front foglight
22	15A	Right front foglight

23	15A	Horn
24	---	Reserved
25	30A	BCM
26	30A	BCM
27	25A	BCM
28	25A	BCM
29	20A	Ignition switch IG
30	15A	TCU IG
31	10A	EMS/ABS steering angle, yaw angle sensor IG
32	20A	220V Power
33	40A	Blower
34	5A	TCU B+ (AT specified)
35	40A	ABS/ESP B+
36	---	Reserved
37	---	Reserved
38	---	Reserved
39	---	Reserved
40	---	Reserved
41	80A	Cab fuse box power supply
42	175A	Alternator
43	80A	High -speed fun-speed fan 1
44	5A	Spare fuse
45	10A	Spare fuse
46	15A	Spare fuse
47	20A	Spare fuse

J1	HFKA	Compressor relay
J2	V4	Starter relay
J3	V7	Reserved
J4	V7	Low-speed fan 1
J5	V7	Low-speed Fan 2
J6	V9	Fuel pump relay
J7	V4	Main relay
J8	V11	Vacuum pump relay
J9	V9	Low beam light relay
J10	V9	Reserved
J11	V9-Z	Front wiper low-speed relay
J12	V9-Z	Front wiper high-speed relay
J13	V11	Left front fog light relay(The light bulb fog lamps specified)
J14	HFKA	Horn relay
J15	V11	Right front fog light relay(The light bulb fog lamps specified)
J16	HFKA	Reserved
J17	V4	Blower relay
J18	HFKA	Reserved
J19	HFKA	Reserved

i Tips

As shown in the figure, there is a spare fuse inside the engine compartment power distribution center. If a fuse of your vehicle is damaged, you may use the spare fuse to replace it.

i Tips

It is not guaranteed that the fuse specifics described above apply to all vehicle models. For detailed information about the use of fuses, please refer to the specific vehicle. Different vehicle models may have slightly different fuses.

Some electrical devices may be equipped with several fuses. It may also be possible that several electrical devices share one fuse.

Engine Compartment Power Distribution Center Layout

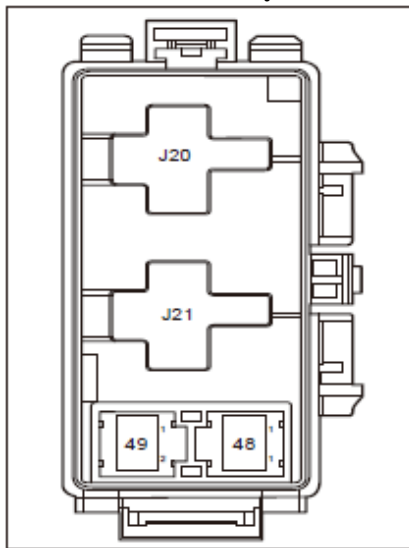

Position	Specification	Function
48	50A	High-speed Fan 1
49	50A	High-speed Fan 2
J20	V7	High-speed Fan 1
J21	V7	High-speed Fan 2

i Tips

As shown in the figure, there is a spare fuse inside the engine compartment power distribution center. If a fuse of your vehicle is damaged, you may use the spare fuse to replace it.

i Tips

It is not guaranteed that the fuse specifics described above apply to all vehicle models. For detailed information about the use of fuses, please refer to the specific vehicle. Different vehicle models may have slightly different fuses.

Some electrical devices may be equipped with several fuses. It may also be possible that several electrical devices share one fuse.

Cabin fuse box Layout

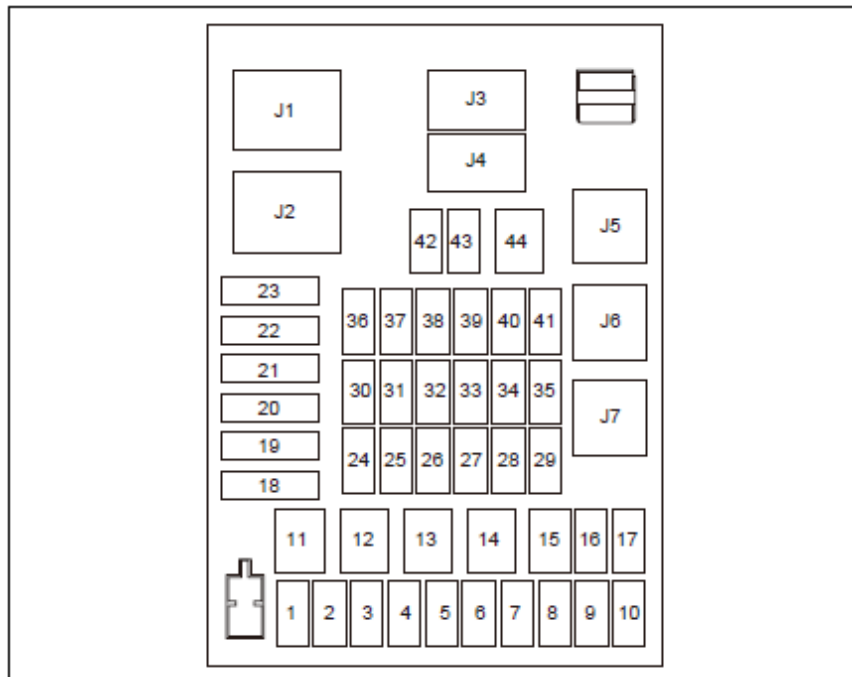

Specifications and Function of fuse box in cabin

Position	Specification	Function
1	30A	ACC relay
2	30A	IG1 relay
3	30A	Four wheel controller
4	30A	Right EPS motor
5	30A	Left EPS motor
6	20A	Heating of The driving seat
7	20A	Heating of Passengers
8	20A	Refrigerator relay
9	—	Reserved
10	—	Reserved
11	30A	Left front/left rear module
12	30A	Right front/right rear module
13	30A	The driving seat adjustment
14	30A	The passengers seat adjustment
15	10A	SEB/GR/ A/C module/ A/C /A/C control panel
16	20A	Rear fog light relay
17	10A	glove box light/ Luggage light/Trunk Light
18	10A	Instrument/ESCL/off-country information
19	5A	ESOS power1

20	5A	PEPS power 2
21	10A	Electronic mirror/Defroster relay/EPB switch/USB charge plug
22	10A	Brake switch
23	5A	automobile data recorder
24	---	Reserved
25	---	Reserved
26	---	Reserved
27	---	Reserved
28	---	Reserved
29	---	Reserved
30	10A	Four doors modul/Four-wheel drive controller/BCM/Reversing Radar/Rear Cameras
31	10A	off-road information/EPB controller/PEPS/Instrument
32	10A	Air bag
33	10A	GW/TPMS/ A/C /panel/Gearshift
34	10A	driving and Passenger seat/Electronic mirror/EPB switch/Interior Rearview Mirror/Headlight height/backlight adjustment
35	5A	rain sensor
36	10A	PEPS/BCM

37	10A	USB/EHC/220V/EHC swtich
38	15A	Cigarette lighter,
39	---	Reserved
40	---	Reserved
41	---	Reserved
42	---	Reserved
43	---	Reserved
44	---	Reserved
J1	V4	Reserved
J2	V4	Defroster relay
J3	V6	Rear fog light relay
J4	---	Reserved
J5	V4	ACC relay
J6	V4	IG1 relay
J7	V4	Reserved

Tips

As shown in the figure, there is a spare fuse inside the engine compartment power distribution center. If a fuse of your vehicle is damaged, you may use the spare fuse to replace it.

Tips

It is not guaranteed that the fuse specifics described above apply to all vehicle models. For detailed information about the use of fuses, please refer to the specific vehicle. Different vehicle models may have slightly different fuses.

Some electrical devices may be equipped with several fuses. It may also be possible that several electrical devices share one fuse.

Replacement of Bulbs

Usually, it is not possible to replace a bulb without removing other parts of the vehicle. This is particularly true for those bulbs which can only be operated from inside the engine compartment. Such work requires professional skills.

Warning

Particular care should be exercised when working on the engine compartment! There is pressure in bulbs. During the replacement, explosion may occur.—be aware of injury!

Emergency Startup

If discharging makes it impossible to start the engine, you may start it by using the battery of another vehicle via a jumper cable. The following points should also be observed:

- The rated voltage of the power-supplying batteries should be 12V and their capacity (Ah) should not be below that of the vehicle battery which has discharged.
- Only jumper cables with a sufficient cross section can be used. Attention should be paid to the instructions provided by the power cable manufacturer.
- Only jumper cables with an insulated electrode holder should be used.

Tips

The capacity of the battery equipped for this vehicle is 60Ah.

The capacity of the battery equipped for this vehicle is 60Ah.

Warning

Absolutely do NOT charge frozen batteries. This may cause explosions! Even if unfrozen, acids may overflow when the battery is charged, thus causing corrosive damage. Frozen batteries must be replaced.

Caution

When starting the engine via jumper cables, do NOT allow the two vehicles to come into contact. Otherwise, once the positive poles of the two batteries are connected, the current is immediately connected, and danger may occur.

Jumper Cables

To connect batteries via jumper cables, it is necessary to connect the positive terminals first and then the negative terminals.

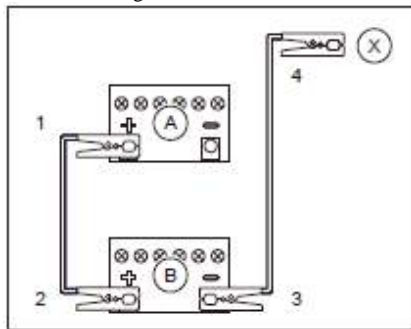

1. Wear protective goggles properly, and remove watches, bracelets and other metal ornaments to prevent electric shock;
2. Put the ignition key to the "LOCK" position.
3. Connect the end -1- of the red power cable with the anode (+) of the power-receiving battery "A".
4. Connect the other end -2- to the power-supplying battery "B".

5. Connect the end -3- of the black cable with the negative electrode (-) of the power-supplying battery "B" and the other end -4- with the engine cylinder of the power-receiving battery "A" or the metal component which is reliably connected with the engine cylinder.

6. Start the vehicle with the power-supplying battery and let it run in idle speed, and then start the engine of the vehicle with the power-receiving battery and let run for a period of time so that the motor charges the power-receiving battery.

7. Remove the power cable in a sequence opposite to the steps above. During removal, be careful not to be injured by the revolving leather belt or fan.

Caution

- Properly arrange the jumper cables to prevent contact between the cable and moving parts of the engine.
- When dismantling the jumper cable, open the blower or rear window heater of the vehicle with battery low in order to reduce the peak voltage while the cable is being dismantled.
- To ensure successful jumper connection, the engine must be running idle when the cables are removed.

Warning

Improper use of the jumper cable may result in battery explosion and thus bring serious personal injury.

● The engine compartment is a high-risk area. Improper maintenance could cause fatal accidents extremely easily.

● Absolutely do NOT directly connect the negative power cable to the negative pole of the power-receiving battery. Otherwise, sparks will be generated the moment when the power cables are connected. The inflammable gases generated by the battery may be ignited by the sparks, thus causing explosive accidents.

● Absolutely do NOT connect the negative power cable with any part of the fuel system or the brake pipeline. Doing so may cause fire.

● While performing maintenance, be sure to NOT bend down and face the battery so as to protect against scalding by acids.

● Do NOT touch open flames. Doing so may cause explosions.

Emergency Towing

The front and rear parts of the vehicle are both equipped with a towing hook which can be used for towing things. When your vehicle breaks down or has an accident, the front or rear towing hook can be used as a traction point to tow your vehicle.

Caution

The towing hook must not be used to tow other vehicles. It cannot be used to tow trailers.

The best towing method is to use a special towing vehicle. If hoisting towing (with the front wheels lifted) is needed or the vehicle must be towed with all four wheels on the ground, attention should be paid to:

When the ignition key is located "ON" position, turn on the hazard warning light.

The shift lever of the transmission needs to be put to the neutral and N position, while the transfer case shift lever must be put to the 2H position.

Towing from the Front

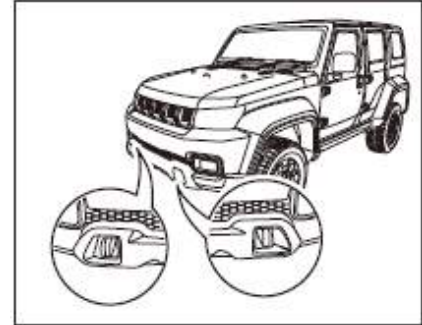

This vehicle has two front towing hooks, symmetrically distributed on the left and right sides of the front bumper of the vehicle, as shown in the figure.

Warning

● **Inexperienced drivers must NOT attempt to tow other vehicles so as to prevent accidents.**

Caution

● **The driver of the towed vehicle must turn on their emergency warning light. They should also comply with the relevant laws and regulations.**

● **Ensure the traction rope is always in the tension state.**

Towing from the Rear

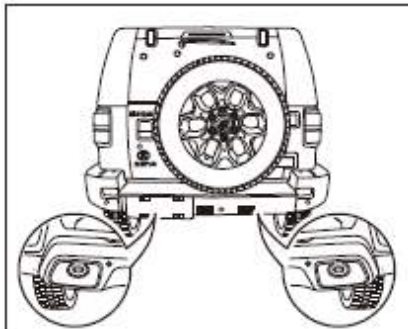

The rear traction ring (as indicated with the Arrow) is installed on the welded plate in the rear of the vehicle.

Towing the Vehicle Warning

If the vehicle needs to be dragged, we suggest that you entrust an authorized BAIC dealership or a commercial towing company to do it for you. When you contact them, you must tell them how the vehicle needs to be dragged.

To drag the vehicle, a suitable towing device may be used to ensure that the vehicle is dragged without damage. Personnel from commercial towing companies are familiar with the national/provincial/municipal and local towing laws. You may seek help from them.

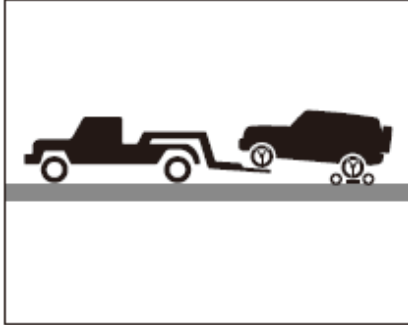
Towing from front

Caution

Do NOT tow the vehicle from the front when its rear wheels are on the ground. When the wheels are lifted, be sure to confirm that the opposite end of the lifted side keeps a suitable clearance off the ground. Otherwise, during the towing the bumper or body of the towed vehicle might be damaged.

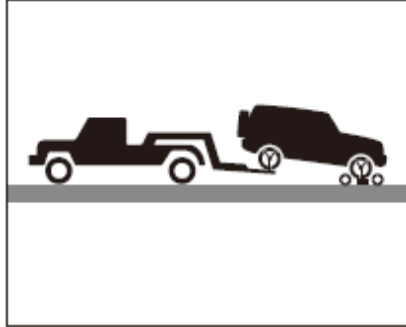
Towing from rear

Caution

Do NOT tow the vehicle from the rear when the front wheels are on the ground. This will seriously damage the transmission of the vehicle.

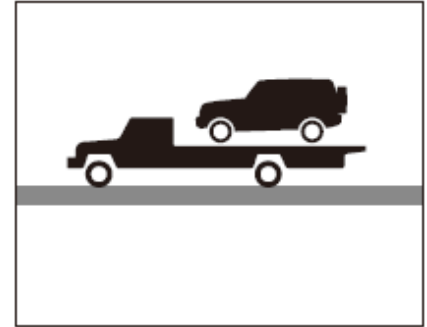
Using a Flatbed Truck to Drag the Vehicle

Caution

Be sure to apply the parking brake and fix all four wheels properly to prevent the vehicle from moving in the event of emergency braking.

6. Vehicle specifications

Identification code	245
Vehicle parameter	248

Identification Number

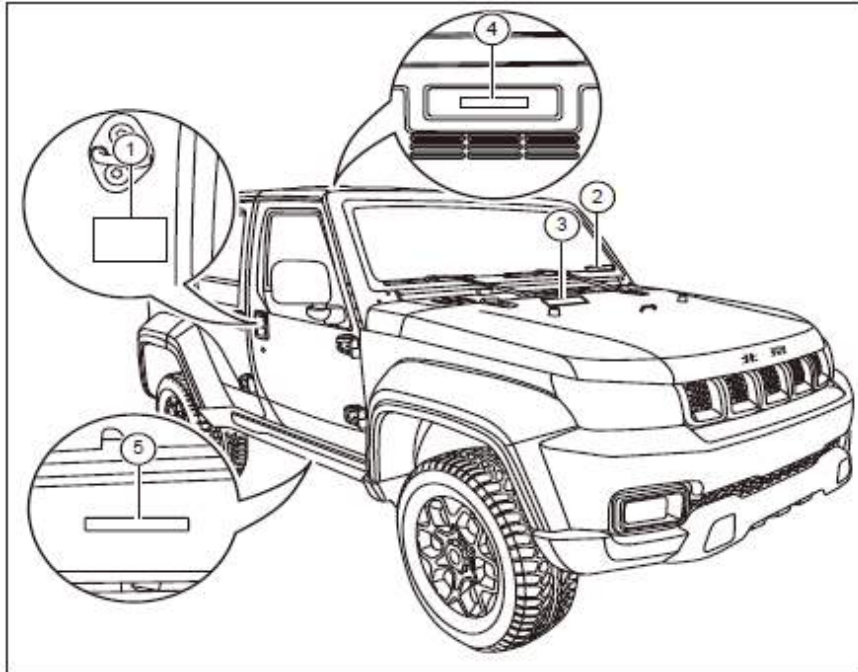

On this vehicle, the vehicle identification number (VIN) is indicated in 5 positions, namely on the vehicle data plate -1-*, on the bottom of the left windshield glass -2-, on the body between the two hinges of the engine hood -3- (only visible when the engine hood is fully opened), on the inside of the tailgate) -4-, and on the beam of the right vehicle -5-.

The vehicle data plate is pasted to the middle and lower part of the B-pillar on the right side*.

For some models, the data plate is riveted to the facade of the right side of the engine compartment.

Diagnostic tester
Part code: T11200001
Part name: BAIC Diagnostic system
Part code: T19900010
Part name: PAD Diagnostic tester

Engine Transmission & Transfer case Codes

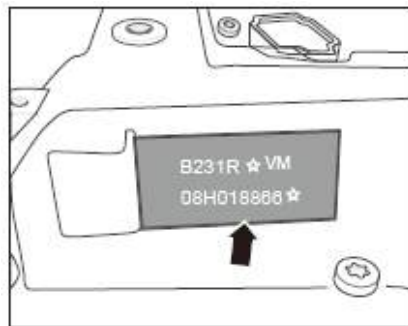

The engine code is pasted on the engine cover.

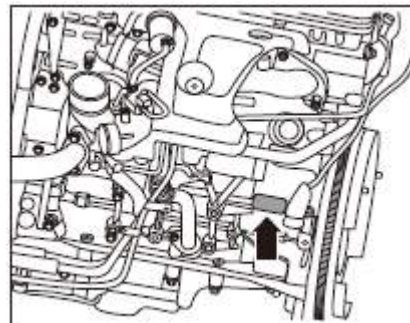

The engine code is imprinted on the engine body.

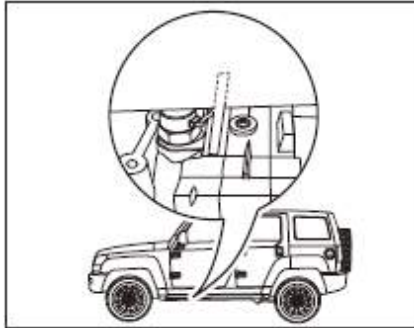

The transmission code is imprinted on the transmission casing.

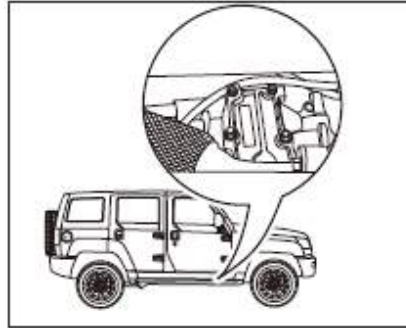

The transfer case code is imprinted on the transfer case casing.

Vehicle Data Nameplate

The product label is in the middle and lower part of the B-pillar on the front passenger's side*. The following information can be read from the product label:

1. Vehicle identification number
2. Brand & vehicle model
3. Engine model & maximum engine net power
4. Engine displacement & maximum permissible total mass
5. Number of passengers & date of manufacturer

※Note: For some models, the data plate is riveted to the facade of the right side of the engine compartment.

Vehicle Parameters

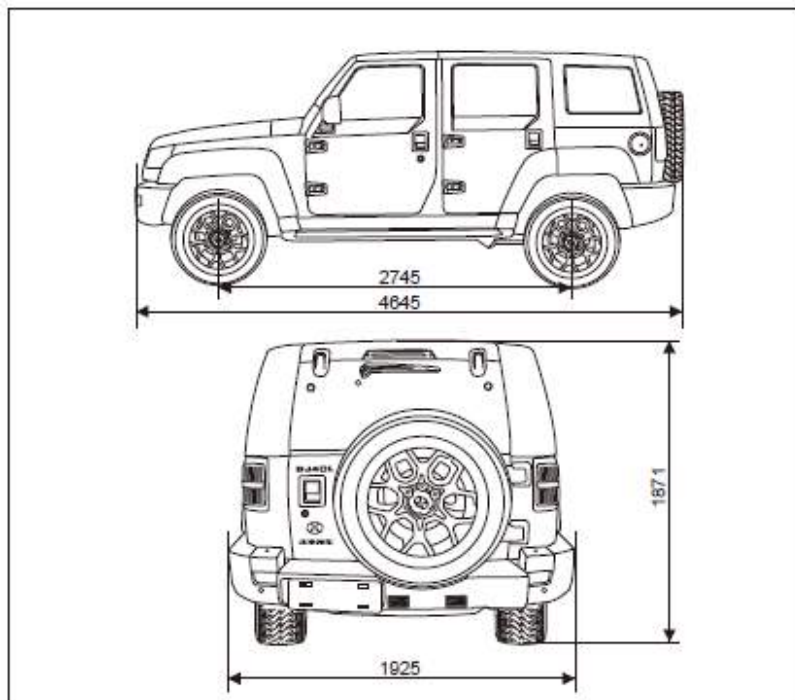

Item	Dimension
Length (mm)	4645
Width (mm)	1925
Height(mm)	1871
Wheelbase (mm)	2745
Minimum ground clearance (full load (mm))	≥ 210
Front wheel track (mm)	1610
Rear wheel track (mm)	1610

The outside rearview mirrors is not included in the vehicle outside profile size.

The outside rearview mirrors is located at the middle of left & right front door,

Main type and parameters

Vehicle type	BJ2021F7VA3B	BJ2022F7VM3B
Engine type	B231R	B201R
driving type	4WD	4WD
The vehicle production emission	Euro V	Euro V
Length (mm)	4645	4645
Width (mm)	1925	1925
Height (mm)	1871	1871
Wheelbase (mm)	2745	2745
Front wheel thread (mm)	1610	1610
Rear wheel thread (mm)	1610	1610
Minimum ground clearance (full load (mm))	≥210	≥210
Maximum passenger	5	5
Min. turning diameter	12.5	12.5
Approach angle (°)	37	37
Departure angle (°)	31	31
curb weight	2095	2055
axle load front/rear (stut of curb)	1099/996	1078/977
Total mass(kg)	2520	2480
axle load front/rear (stut of full load)	1184/1336	1166/1314
100Km/h time of continuous shift start acceleration (s)	≤13	≤15
maximum vehicle speed (km/h)	≥160	≥160
Max. grade ability (%) on dry and hard cement pavement	≥60	≥60
Fuel consumption under comprehensive working conditions (L/100km)	10	9.4
Fuel consumption at equal speed of 90Km/h (L/100km)	11	10.5

Structural Parameters

Minimum turning diameter (m)	12.5
Approach angle (°)	≥37
Departure angle (°)	≥31
Seat number	5

Front Wheel Alignment Parameters

Front wheel camber	0° ±30'
Caster angle	5° 30' ±30'
Kingpin inclination	13° 24' ±20'
Front toe-in (one side)	0° 9' ±3'

Wheel parameter

Item	Front wheel	Rear wheel	Spare tire
Tire pressure (Cold state)(kPa)	220	220	220
Rim dimension	17X8J		
Tire Dimension	265/65R17		
Wheel nut torque (N•m)	140±10	140±10	110±5
dynamic balancing	Unilateral residual unbalance≤10g		

The Braking System

Brake pedal's free stroke (mm)	10~20
Clutch pedal's free stroke (mm)	10~20
limit of front brake pad (not including backboard thickness) (mm)	2
limit of rear brake pad (not including backboard thickness) (mm)	2

Electrical Equipment

Type of battery	Free of maintenance
20h rate capacity	70AH
Voltage & electrode	12V, negative pole (-) grounding
Rated output value of AC motor	13.5V/140A
Power of starter motor	1.4kW

Engine Parameters

Model	B201R (2.0T)	B231R (2.3T)
Type and category	Inline four-cylinder, turbocharger, DOHC	Inline four-cylinder, turbocharger, DOHC
Emission standard	Euro V	EuroV
Fuel type	92# or higher Unleaded gasoline	92# or higher Unleaded gasoline
Cylinder bore X stroke, Displacement mm	90X78	90X90
Compression ratio	1.985	2.29
Cylinder bore X stroke, Displacement mm	8.8:1	9.3:1
Max. net power	150/5500	184/5300
Max. net power(speed) kW (r/min)	145/5500	170/5300
Max. net torque(speed) N m (r/min)	280/1900-4500	350/1900-4300
Idle speed (A/C not working)(The Engine is hot)	750±50	750±50
Idling (A/C working) (The engine is hot)	750±50	750±50

Consumption and filling amount

	reference quantity(L)	Type
Fuel tank capacity	75	More than 92# gasoline (2.0Tengine); More than 95# gasoline or higher (2.3T engine)
Engine Oil	5.5	Brand: FUCHS TITAN EM5C 530SAAB; grade:ACEA A3/B3; viscosity: 5W-30; (0W-30 or 0W-40 at ambient temperature below -35°C)
MT transmission oil	2.6	GL-4 75W/90
AT transmission oil	Free of maintenance	
BW47-45 Electronic transfer	1.5	Dexron III
Coolant	7.66	-35
Windshield washing liquid	2.3	-
Power Steering Fluid	1	ATF III H
Brake Fluid	0.6	HZY4 (DOT4)
Front axle gear oil	1	GL-5 SAE80W-90
Rear axle gear oil	2	GL-5 SAE80W-90

Light Bulbs

Name	Model	Specification
Front combination lights (Low and high light, Position light, Turn signal light)	LED	—
Rear combination lights (Position light, Brake light, Reverse light, Turn signal light)	LED	—
High brake light	LED	—
Daytime running light (high-level configuration)	LED	—
Trunk Light	LED	—
Foot space light	LED	—
Ambient light	LED	—
Front fog light (low-level configuration)	H8	12V35W
Rear fog light	P21W	12V21W
Roof light	C10W	12V10W
Glove box light	C5W	12V5W