

owner's manual

# ALHAMBRA



**SEAT**

auto emoción



# COMPLIMENTS BIG\_KEY

## Foreword

This owner's manual and the corresponding supplements should be read carefully to familiarise yourself with your vehicle.

Also, the regular care and maintenance and correct handling of the vehicle will contribute to preserve its value.

**For safety reasons, note the information concerning accessories, modifications and parts exchange.**

If selling the vehicle, give all of the onboard documentation to the new owner as this should be kept with the vehicle.



## Contents

<b>The structure of this manual</b> .....	5	<b>Operating instructions</b> .....	63	Roof carrier .....	148
<b>Content</b> .....	6	Cockpit .....	63	Cooling and heating box* .....	149
<b>Safety First</b> .....	7	Overview .....	63	<b>Heating, Ventilation and Air conditioning</b> ..	152
Safe driving .....	7	Instruments .....	64	Climatronic .....	152
Brief introduction .....	7	Display in the instrument panel .....	69	<b>Driving</b> .....	160
Proper sitting position for occupants .....	10	Warning lamps .....	72	Address .....	160
Pedal area .....	15	On board computer with multifunction display ..	81	Safety .....	161
Stowing luggage .....	15	Steering wheel controls .....	86	Ignition lock .....	162
<b>Seat belts</b> .....	18	Steering wheel .....	86	Starting and stopping the engine .....	164
Introduction .....	18	<b>Unlocking and locking</b> .....	88	Manual gearbox .....	166
Why wear seat belts? .....	20	Keys .....	88	Automatic gearbox .....	167
Seat belts .....	23	Central locking .....	89	Handbrake .....	173
Belt tension devices .....	31	Key with remote control .....	95	Parking distance warning system* .....	174
<b>Airbag system</b> .....	33	Anti-theft alarm system .....	97	Cruise control system (CCS) .....	176
Brief introduction .....	33	Tailgate .....	99		
Front airbags .....	37	Windows .....	102	<b>Tips and Maintenance</b> .....	179
Side airbags .....	40	Sliding/tilting sun roof .....	105	Intelligent technology .....	179
Curtain airbags .....	42	<b>Lights and visibility</b> .....	109	Brakes .....	179
Deactivating airbags* .....	44	Lights .....	109	<b>Driving and the environment</b> .....	185
<b>Child safety</b> .....	46	Visibility .....	115	Running-in .....	185
Brief introduction .....	46	Windscreen washers .....	117	Exhaust gas emission control system .....	186
Child seats .....	48	Mirrors .....	119	Driving abroad .....	187
Installation of child seats in vehicle seats .....	51	<b>Seats and stowage</b> .....	122	Trailer towing .....	188
Integrated child seat .....	54	The importance of correct seat adjustment .....	122	Driving economically and with respect for the	
		Head restraints .....	123	environment .....	191
		Front seats .....	125	<b>Cleaning and caring for your vehicle</b> .....	193
		Rear seats .....	127	General notes .....	193
		Stowage compartments .....	134	Care of the vehicle exterior .....	194
		Ashtrays, cigarette lighter and electrical sockets ..	140	Care of the vehicle interior .....	199
		Hazard warning triangles and first aid kit .....	143		
		Luggage compartment .....	143		

Accessories, parts replacement and modifications .....	202	Technical Data .....	262
Accessories and parts .....	202	Checking fluid levels .....	262
Modifications .....	202	Petrol engine 2.0l 85 kW (115 bhp) 6 gear ....	263
Roof aerial* .....	203	Petrol engine 2.0 litre 85 kW (115 hp). Automatic	264
Mobile telephones and two-way radios .....	203	Petrol engine 1.8l 110 kW (150 bhp) 6 gear ...	266
Retrofitting a towing bracket .....	204	Petrol engine 1.8l 110 kW (150 bhp). Automatic	267
Checking and refilling levels .....	206	Petrol engine 2.8l VR6150 kW (204 bhp) 6 gear	269
Refilling .....	206	Petrol engine 2.8l VR6 150 kW (204 bhp)	
Petrol types .....	207	Automatic .....	270
Diesel .....	207	Petrol engine 2.8l VR6150 kW (204 bhp) 6 gear	
Working in the engine compartment .....	209	four-wheel drive .....	272
Engine oil .....	212	Diesel engine 1.9l TDI 85 kW (115 bhp) 6 gears	
Coolant .....	216	four-wheel drive .....	273
Washer fluid and windscreen wiper blades ....	218	Diesel engine 1.9l TDI 85 kW (115 bhp) 6 gears	275
Brake fluid .....	221	Diesel engine 1.9 TDI 85 kW (115 bhp).	
Battery .....	223	Automatic .....	276
Wheels .....	225	Diesel engine 2.0l TDI 103 kW (140 bhp) 6 gears	278
If and when .....	231	Dimensions and capacities .....	280
Vehicle tools*, spare wheel*, breakdown set* and		<b>Index .....</b>	<b>281</b>
towing bracket .....	231		
Breakdown set* .....	234		
Changing a wheel .....	236		
Fuses .....	241		
Changing a light .....	245		
Jump-starting .....	249		
Towing and tow-starting .....	252		
Lifting the vehicle .....	255		
<b>Technical Data .....</b>	<b>257</b>		
General notes on the technical data .....	257		
What you should be aware of .....	257		
How are the figures measured? .....	259		
Towing a trailer .....	260		
Wheels .....	260		

## The structure of this manual

### Before reading this manual it must be understood

This manual contains a description of the **vehicle equipment** at the time of publication. Some of the equipment described here will not be available until a later date, or is available only in certain markets.

**Because this is a general manual for the ALHAMBRA, some of the equipment and functions that are described in this manual are not included in all types or variants of the model; they may vary or be modified depending on the technical requirements and on the market; this is in no way deceptive advertising.**

The **illustrations** are intended as a general guide, and may vary from the equipment fitted in your vehicle in some details.

The **direction indications** (left, right, front, rear) appearing in this manual refer to the normal forward working direction of the vehicle except when otherwise indicated.

The **equipment marked with an asterisk\*** is supplied as standard on certain versions of the model only, it can be supplied as an option on some models, or else it is only on sale in certain countries.

- © All registered marks are indicated with ©. Even if the copyright symbol does not appear this does not mean that the mark is not copyrighted.
- ▶ The section is continued on the following page.
- This shows the **end of the section**.



### WARNING

Texts with this symbol contain safety information. They warn you of serious dangers, possibly involving accident or injury.



### Caution

Texts with this symbol draw your attention to a possible risk of damage to your vehicle.



### For the sake of the environment

Texts with this symbol refer to points relevant to the protection of the environment.



### Note

Texts preceded by this symbol contain additional information. ■

## Content

This manual is structured to give you the information you need as quickly and clearly as possible. The contents of this Manual are grouped into relatively short **sections** making up **chapters** (e.g. "Air conditioning"). The entire manual is divided into five large parts which are:

### 1. Safety First

Information on the vehicle equipment relating to passive safety such as seat belts, airbags, seats, etc.

### 2. Controls and equipment

Information about the distribution of controls in the driver position of the vehicle, about the seat adjustment possibilities, how to create a suitable climate in the passenger compartment, etc.

### 3. Tips and Maintenance

Advice relating to driving, care and maintenance of your vehicle and certain problems which you may solve yourself.

### 4. Technical Data

Figures, data, dimensions and measurements (for example fuel consumption) of your vehicle.

### 5. Alphabetic index

At the end of this manual there is a detailed alphabetical index, this will help you to rapidly find the information you require. ■



# Safety First

## Safe driving

### Brief introduction

#### Dear SEAT Driver

##### *Safety first!*

This chapter contains important information, tips, suggestions and warnings that you should read and follow in the interest of your own safety and the safety of your passengers.

#### **WARNING**

- This manual contains important information concerning the driver's and passengers' handling of the vehicle. The other booklets in the vehicle wallet also contain further information that you should be aware of for your own safety and for the safety of your passengers.
- Ensure that the onboard documentation is kept in the vehicle at all times. This is especially important when lending or selling the vehicle to another person. ■

### Safety equipment

*The safety equipment is a part of the occupant protection system and can reduce the risk of injury during an accident.*

Never “gamble” with your safety and the safety of your passengers. In the event of an accident, the safety equipment could reduce the risk of injury. The following list includes most of the safety equipment in your SEAT:

- optimised three-point seat belts for all seats,
- seat belt tension devices for driver and passenger,
- Belt height adjustment for the front seats and outer seats in the second row,
- frontal airbags for driver and passenger,
- side airbags for driver and passenger,
- curtain airbags,
- ISOFIX anchorage for ISOFIX child seats in the outside seats in the second and third rows,
- Height-adjustable head restraints and
- adjustable steering column.

The safety equipment mentioned above works together to provide you and your passengers with the best possible protection in accident situations. But this safety equipment cannot help you or your passengers if you or your passengers assume an incorrect sitting position or do not properly adjust or use this equipment. ▶

Therefore, you have been provided with information about why this equipment is so important, how it protects you, what you have to observe when using it and how you and your passengers can achieve the greatest possible benefit from the safety equipment fitted. This manual includes important warnings that you and your passengers should observe in order to reduce the risk of injury.

**Safety is everyone's business! ■**

### Before every trip

*The driver bears the responsibility for his passengers and the operational worthiness of the vehicle.*

For your own safety and the safety of your passengers, always note the following points before every trip:

- Ensure that the vehicle's lights and turn signals operate flawlessly.
- Check tyre pressure.
- Ensure that all windows provide a clear and good view of the surroundings.
- Securely restrain all parcels ⇒ page 15.
- Make sure that no objects can interfere with the pedals.
- Adjust front seat, head restraint and mirrors properly for your size.
- Instruct passengers to adjust the head restraints according to their height.

- Protect children with appropriate child seats and properly applied seat belts ⇒ page 46.
- Assume the correct sitting position. Instruct your passengers also to assume a proper sitting position ⇒ page 10.
- Fasten your safety belt securely. Instruct your passengers also to fasten their seat belts properly ⇒ page 18. ■

### What affects driving safety?

*Driving safety is largely determined by your driving style and the personal behaviour of all occupants.*

As driver, you are responsible for yourself and your passengers. When your concentration or driving safety is affected, you endanger yourself as well as others on the road ⇒ , for this reason:

- Do not allow yourself to be distracted from the traffic around you, e.g. by passengers or telephone conversations.
- Never drive when your driving ability is impaired (e.g. by medication, alcohol, drugs).
- Observe traffic laws and speed limits.
- Always reduce your speed as appropriate for road, traffic and weather conditions.
- When travelling long distances, take breaks regularly - at least every two hours. ▶

- If possible, avoid driving when you are tired or are under pressure of time.

**WARNING**

**When driving safety is impaired during a trip, the risk of injury and accidents increases. ■**

## Proper sitting position for occupants

### Proper sitting position for driver

The proper sitting position for the driver is important for safe and relaxed driving.

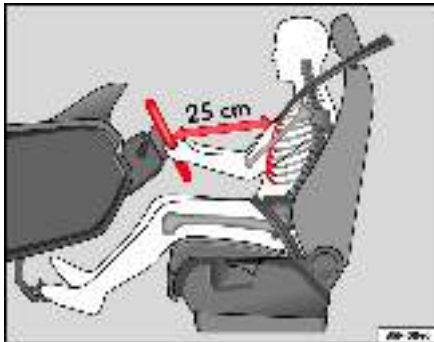

**Fig. 1** The proper distance between driver and steering wheel

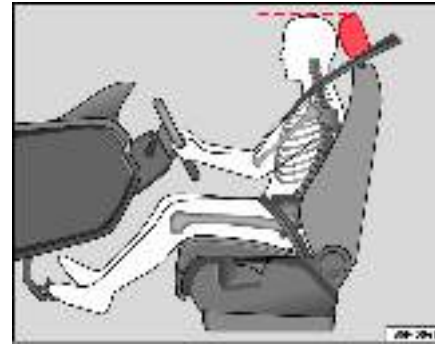

**Fig. 2** Proper head restraint position for driver

For your own safety and to reduce the risk of injury in the event of an accident, we recommend the following adjustments for the driver:

- Adjust the steering wheel so that there is a distance of at least 25 cm between the steering wheel and the centre of your chest ⇒ fig. 1.
- Move the driver's seat forwards or backwards so that you are able to press the accelerator, brake and clutch pedals to the floor with your knees still slightly angled ⇒ ⚠.
- Ensure that you can reach the highest point of the steering wheel.
- Adjust the head restraint so that its upper edge is at the same level as the top of your head, or as close as possible to the same level as the top of your head ⇒ fig. 2.
- Move the backrest to an upright position so that your back rests completely against it. ▶

- Fasten your seat belt correctly ⇒ page 18.
- Keep both feet in the foot well so that you have the vehicle under control at all times.

Adjustment of the driver's seat ⇒ page 122.



### WARNING

- An incorrect sitting position of the driver can lead to severe injuries.
- Adjust the driver's seat so that there is at least 25 cm distance between the centre of the chest and the hub of the steering wheel ⇒ page 10, fig. 1. If you are sitting nearer than 25 cm, the airbag system cannot protect you properly.
- If your physical constitution prevents you from maintaining the minimum distance of 25 cm, contact a qualified workshop. The workshop will help you decide if special specific modifications are necessary.
- When driving, always hold the steering wheel with both hands on the outside of the ring at the 9 o'clock and 3 o'clock positions. This reduces the risk of injury when the driver airbag is triggered.
- Never hold the steering wheel at the 12 o'clock position, or in any other manner (e.g. in the centre of the steering wheel). In such cases, you may sustain injuries to the arms, hands and head.
- To reduce the risk of injury to the driver during sudden braking manoeuvres or an accident, never drive with the backrest tilted far back! The airbag system and seat belts can only provide optimal protection when the backrest is in an upright position and the driver is wearing his or her seat belt properly. The further the backrests are tilted to the rear, the greater the risk of injury due to incorrect positioning of the belt web or the incorrect sitting position!
- Adjust the head restraint properly to achieve optimal protection. ■

## Proper sitting position for front passenger

*The front passenger must sit at least 25 cm away from the dash panel so that the airbag can provide the greatest possible protection in the event that it is triggered.*

For your own safety and to reduce the risk of injury in the event of an accident, we recommend the following adjustments for the front passenger:

- Move the front passenger seat back as far as possible ⇒ .
- Move the backrest to an upright position so that your back rests completely against it.
- Adjust the head restraint so that its upper edge is at the same level as the top of your head, or as close as possible to the same level as the top of your head ⇒ page 13.
- Keep both feet in the foot well in front of the front passenger seat.
- Fasten your seat belt correctly ⇒ page 18.

It is possible to deactivate the passenger airbag in **exceptional circumstances** ⇒ page 25.

Adjusting the front passenger's seat.



### WARNING

- An incorrect sitting position of the front passenger can lead to severe injuries.
- Adjust the front passenger seat so that there is at least 25 cm between your breastbone and the dash panel. If you are sitting nearer than 25 cm, the airbag system cannot protect you properly. ▶

 **WARNING** (continued)

- If your physical constitution prevents you from maintaining the minimum distance of 25 cm, contact a qualified workshop. The workshop will help you decide if special specific modifications are necessary.
- Always keep your feet in the foot well when the vehicle is moving; never rest them on the instrument panel, out the window or on the seat. An incorrect sitting position exposes you to an increased risk of injury in the event of a braking manoeuvre or an accident. If the airbag is triggered, you could sustain severe injuries due to an incorrect sitting position.
- To reduce the risk of injury to the front passenger during sudden braking manoeuvres or an accident, never travel with the backrest tilted far back! The airbag system and seat belts can only provide optimal protection when the backrest is in an upright position and the front passenger is wearing his or her seat belt properly. The further the backrests are tilted to the rear, the greater the risk of injury due to incorrect positioning of the belt web or the incorrect sitting position!
- Adjust the head restraint properly to achieve maximum protection. ■

### Correct sitting position for passengers in the rear seats

*Passengers in the individual seats must sit up straight, keep their feet in the footwells and wear their seat belts properly.*

To reduce the risk of injury in the event of a sudden braking manoeuvre or an accident, passengers in the individual seats must observe the following:

- The backrest of the 3-seat seat bench must be in the upright position and securely engaged in this position.

- Adjust the head restraint so that its upper edge is at the same level as the top of your head.
- Keep both feet in the footwell in front of the individual seat.
- Fasten your safety belt securely.
- Use an appropriate child restraint system when you take children in the vehicle.

 **WARNING**

If the passengers on the individual seats are not sitting properly, they could sustain severe injuries.

- Adjust the head restraint properly to achieve maximum protection.
- The seat belts can only provide optimal protection when the backrests are properly engaged in the upright position and the passengers are wearing their seat belts properly. If passengers on the individual seats are not sitting in an upright position, the risk of injury due to incorrect positioning of the belt web increases. ■

### Correct sitting position for passengers in the rear seats

*Passengers in the rear seats must sit up straight, keep their feet in the footwells and wear their seat belts properly.*

To reduce the risk of injury in the event of a sudden braking manoeuvre or an accident, passengers on the rear bench seat must observe the following:

- Adjust the headrest to the correct position. ►

- Keep both feet in the foot well in front of the rear seat.
- Fasten your seat belt correctly ⇒ page 18.
- Use an appropriate child restraint system when you take children in the vehicle ⇒ page 46.

**⚠ WARNING**

- If the passengers on the rear seat are not sitting properly, they could sustain severe injuries.
- Adjust the head restraint properly to achieve maximum protection.
- Seat belts can only provide optimal protection when backrests are in an upright position and the passengers are wearing their seat belts properly. If passengers on the rear seat are not sitting in an upright position, the risk of injury due to incorrect positioning of the belt web increases. ■

### Correct adjustment of head restraints

*Properly adjusted head restraints are an important part of occupant protection and can reduce the risk of injuries in most accident situations.*

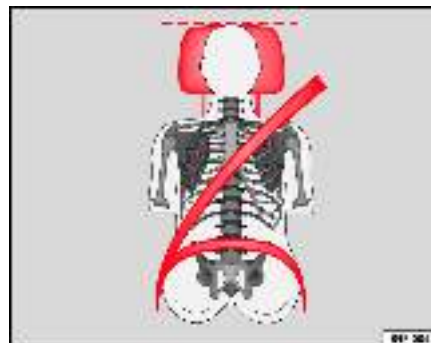

**Fig. 3** Properly adjusted head restraint viewed from the front

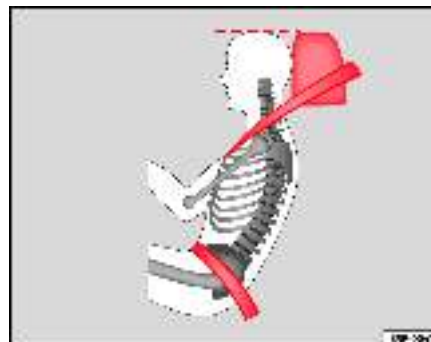

**Fig. 4** Properly adjusted head restraint viewed from the side

Adjust the head restraint properly to achieve maximum protection.

- Adjust the head restraint so that its upper edge is at the same level as the top of your head, or as close as possible to the same level as the top of your head and, at the very least, at eye level ⇒ page 13, fig. 3 and ⇒ page 13, fig. 4.

	<b>WARNING</b>
<ul style="list-style-type: none"> <li>• Travelling with the head restraints removed or improperly adjusted increases the risk of severe injuries.</li> <li>• Incorrectly adjusted head restraints could result in death in the event of a collision or accident.</li> <li>• Incorrectly adjusted head restraints also increase the risk of injury during sudden or unexpected driving or braking manoeuvres.</li> <li>• The head restraints must always be adjusted according to the occupant's size. ■</li> </ul>	

### Examples of incorrect sitting positions

*An incorrect sitting position can lead to severe injuries to occupants.*

Seat belts can provide optimal protection only when the belt webs are properly positioned. Incorrect sitting positions substantially reduce the protective function of seat belts and increase the risk of injury due to incorrect belt web position. As the driver, you are responsible for all vehicle occupants, especially children.

- Never permit anyone to assume an incorrect sitting position in the vehicle while travelling ⇒ .

The following list contains examples of sitting positions that could be dangerous for all occupants. The list is not complete, but we would like to make you aware of this issue.

#### Therefore, whenever the vehicle is in motion:

- Never stand in the vehicle,
- never stand on the seats,
- never kneel on the seats,
- never tilt your backrest far to the rear,
- never lean against the dash panel,
- never lie on the rear bench,
- never sit on the front edge of a seat,
- never sit sideways,
- never lean out of a window,
- never put your feet out of a window,
- never put your feet on the dash panel,
- never put your feet on the surface of a seat,
- never travel in a foot well,
- never travel on a seat without wearing the seat belt,
- never carry any person in the luggage compartment.

	<b>WARNING</b>
<ul style="list-style-type: none"> <li>• Every incorrect sitting position increases the risk of severe injuries.</li> <li>• Sitting in an incorrect position exposes the occupants to severe injuries if airbags deploy, striking an occupant who has assumed an incorrect sitting position.</li> <li>• Before the vehicle moves, assume the proper sitting position and maintain it throughout the trip. Before every trip, instruct your passengers to assume the proper sitting position and to maintain it during the trip ⇒ page 10, “Proper sitting position for occupants”. ■</li> </ul>	



## Pedal area

### Pedals

*The operation and freedom of movement of all pedals must never be impaired by objects or floor mats.*

- Ensure that you can always press the accelerator, brake and clutch pedals unimpaired to the floor.
- Ensure that the pedals can return unimpaired to their initial positions.

Use only floor mats which leave the pedal area free and can be securely fastened in the foot well.

If a brake circuit fails, the brake pedal must be free to move further than normal in order to bring the vehicle to a stop.

#### Wear suitable shoes

Always wear shoes which support your feet properly and give you a good feel for the pedals.

#### WARNING

- Restricting pedal operation can lead to critical situations while driving.
- Never place objects in the driver foot well. An object could move into the pedal area and impair pedal operation. In the event of a sudden driving or braking manoeuvre, you will not be able to operate the brake, clutch or accelerator pedal. Risk of accident! ■

### Floor mats on the driver side

*Only floor mats may be used which can be securely fastened in the foot well and do not impair operation of the pedals.*

- Ensure that the floor mats are securely fastened during the trip and do not obstruct the pedals ⇒ .

Only use floor mats which leave the pedals clear and which are secured to prevent them from slipping. You can obtain suitable floor mats from a qualified dealership.

#### WARNING

- If the pedals are obstructed, you could cause an accident. Risk of serious injuries.
- Ensure that the floor mats are always securely attached.
- Never lay or fit floor mats or other floor coverings over the original floor mats. This would reduce the pedal area and could obstruct the pedals. Risk of accident. ■

## Stowing luggage

### Loading the luggage compartment

*All luggage and other loose objects must be safely secured in the luggage compartment.*

Unsecured objects which shift back and forth could impair the driving safety or driving characteristics of the vehicle by shifting the centre of gravity. ►

- Distribute the load evenly in the luggage compartment.
- Lay and stow heavy luggage as far forward as possible in the luggage compartment.
- Stow heavy luggage as low as possible in the luggage compartment.
- Secure heavy objects to the fitted fastening rings ⇒ page 16.

### WARNING

- Loose luggage and other objects in the luggage compartment can cause serious injuries.
- Always stow objects in the luggage compartment and secure them on the fastening rings.
- Use suitable specialist straps to secure heavy objects.
- During sudden manoeuvres or accidents, loose objects can be thrown forward, injuring vehicle occupants or passers-by. This increased risk of injury will be further increased if a loose object is struck by an inflating airbag. If this happens, objects can be transformed into “missiles”. Risk of fatal injury.
- Please note that the centre of gravity may shift when transporting heavy objects; this may affect the vehicle's handling and lead to an accident. Therefore, it is essential to adjust your speed and driving style accordingly, to avoid accidents.
- Never exceed the allowed axle loads or allowed maximum weight. If the allowed axle load or the allowed total weight is exceeded, the driving characteristics of the vehicle may change, leading to accidents, injuries and damage to the vehicle.
- Never leave your vehicle unattended, especially when the tailgate is open. Children could climb into the luggage compartment closing the door

### WARNING (continued)

**behind them; they will remain trapped without help and there is a mortal risk.**

- Never allow children to play in or around the vehicle. Close and lock both the tailgate and all the doors when you leave the vehicle. Before you lock the vehicle, make sure that there are no adults or children in the vehicle.
- Never transport passengers in the luggage compartment. Every passenger must be properly belted in ⇒ page 18.

### Note

- Air circulation in the vehicle helps reduce fogging of the windows. Used air escapes through ventilation slits in the side trim of the luggage compartment. Ensure that the ventilation slits are never covered.
- Straps for securing the load to the fastening rings are commercially available. ■

## Fastening rings

*There are four fastening rings in the luggage compartment which can be used to secure luggage and other objects.*

- Always use suitable and undamaged straps to secure luggage and other objects to the fastening rings ⇒  in “Loading the luggage compartment” on page 15.
- Pull up the fastening rings to attach the straps. ▶

The retainers for the detachable seat belts for the third row of seats and the floor anchorings for the seats can be used as fastening rings for items of luggage.

During a collision or an accident, even small and light objects can build up so much energy that they can cause very severe injuries. The amount of “kinetic energy” depends on the speed of the vehicle and the weight of the object. The most significant factor, however, is the speed of the vehicle.

Example: An object weighing 4.5 kg is lying unsecured in the vehicle. During a frontal collision at a speed of 50 km/h, this object generates a force corresponding to 20 times its weight. That means that the effective weight of the object increases to about 90 kg. You can imagine the severity of the injuries which might be sustained if this “projectile” strikes an occupant as it flies through the passenger compartment. This increased risk of injury will be further increased if a loose object is struck by an inflating airbag.

**WARNING**

**If pieces of baggage or other objects are secured to the fastening rings with inappropriate or damaged retaining cords, injuries could result in the event of braking manoeuvres or accidents.**

- **To prevent pieces of luggage or other objects from flying forward, always use appropriate retaining cords which are secured to the fastening rings.**
- **Never secure a child seat on the fastening rings. ■**

## Seat belts

### Introduction

#### Before driving: remember your seat belt!

*Properly worn seat belts can save lives!*

In this chapter you will learn why seat belts are so important, how they work and how to properly fasten, adjust and wear them.

- Read and observe all the information as well as the warnings in this chapter.

#### WARNING

- If the seat belts are worn incorrectly or not at all, the risk of severe injuries increases.
- Properly worn seat belts can reduce severe injuries in the event of sudden braking manoeuvres or accidents. Therefore, you and your passengers should always wear the seat belts properly as long as the vehicle is in motion.
- Pregnant women or persons with physical disabilities must also use seat belts. Like all other occupants, these persons can also sustain severe injuries if they are not wearing their seat belts properly. ■

#### Number of seats

##### Vehicles with five seats

Your vehicle has **five** passenger places, two individual front seats and three places on the rear seat.

The front seats and the outer rear seats are fitted with a three-point automatic seat belt.

##### Vehicles with seven seats\*

The vehicle has **seven** seats, two seats in the front, three seats in the second row and two seats in the third row.

#### WARNING

- Never transport more people than there are seats available in the vehicle.
- Every occupant in the vehicle must properly fasten and wear the seat belt belonging to his or her seat. Children must be protected with an appropriate child restraint system. ■

#### Seat belt warning lamp\*

*The warning lamp acts as a reminder to the driver to fasten the seat belt.*

Before starting the vehicle:

- Fasten your safety belt securely. 

- Instruct your passengers to fasten their seat belts properly before driving off.
- Protect children by using child seats of the correct height for the age of the child.

The warning lamp  in the combi-instrument lights up if the driver seat belt is not fastened when the ignition is switched on. In addition, an acoustic signal can also be heard for a couple of seconds.

The warning lamp\*  does not go out until the driver seat belt is fastened while the ignition is switched on. ■

## Why wear seat belts?

### Frontal collisions and the laws of physics

*In the event of a frontal collision, a large amount of kinetic energy is generated.*

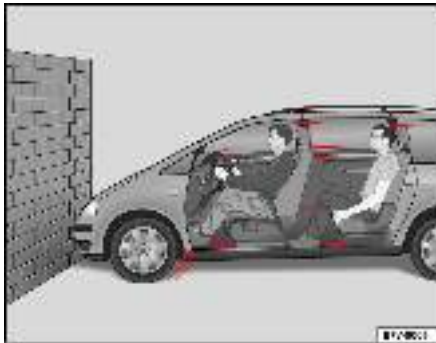

**Fig. 5** Vehicle about to hit a wall: the occupants are not wearing seatbelts

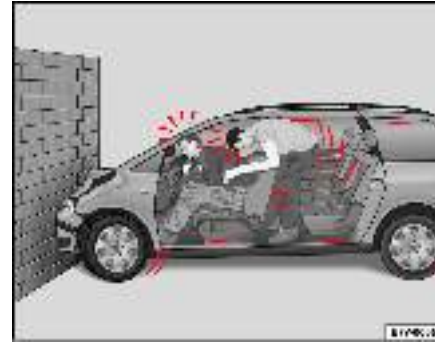

**Fig. 6** The vehicle hits the wall: the occupants are not wearing seatbelts

It is easy to explain how the laws of physics work in the case of a head-on collision: When a vehicle starts moving  $\Rightarrow$  fig. 5 there is a certain amount of energy known as “kinetic energy”, both in the vehicle and in the occupants.

The amount of “kinetic energy” depends on the speed of the vehicle and the weight of the vehicle and passengers. The higher the speed and the greater the weight, the more energy there is to be “released” in an accident.

The most significant factor, however, is the speed of the vehicle. If the speed doubles from 25 km/h to 50 km/h, for example, the kinetic energy increases by a factor of four.

Because the passengers in our example are not restrained by seat belts, the entire amount of kinetic energy has to be absorbed at the point of impact  $\Rightarrow$  fig. 6.

Even at speeds of 30 km/h to 50 km/h, the forces acting on bodies in a collision can easily exceed one tonne (1,000 kg). At greater speed these forces are even higher.

Passengers not wearing seat belts are not “attached” to the vehicle. In a frontal collision they will continue to move forward at the speed their vehicle  $\blacktriangleright$

was travelling just before the impact. This example applies not only to frontal accidents, but to all accidents and collisions. ■

### The danger of not using the seat belt

*Many people believe that the occupants can protect themselves with their hands in a minor collision, this is false.*



**Fig. 7** A driver not wearing a seat belt is thrown forward violently.



**Fig. 8** The unbelted rear passenger is thrown forward violently, hitting the driver wearing a seat belt.

Even at low speeds the forces acting on the body in a collision are so great that it is not possible to brace oneself with one's hands. In a frontal collision, unbelted passengers are thrown forward and will make violent contact with the steering wheel, dashboard, windscreen or whatever else is in the way ⇒ fig. 7.

The airbag system is not a substitute for the seat belts. When deployed, airbags provide only additional protection. All occupants (including the driver) must be wearing seat belts properly during the trip. This will reduce the risk of severe injuries in the event of an accident – regardless of whether an airbag is fitted for the seat.

Note that airbags can be triggered only once. To achieve the best possible protection, the seat belt must always be worn properly so that you will be protected in accidents in which no airbag is deployed.

It is also important for the rear passengers to wear seat belts properly, as they could otherwise be thrown forward violently in an accident. Rear passengers who do not use seat belts endanger not only themselves but also the front occupants ⇒ fig. 8. ■

## Seat belts protect

*Passengers not wearing seat belts risk severe injuries in the event of an accident.*



**Fig. 9 Driver wearing the seat belt properly: is secured by the belt in sharp braking**

Properly worn seat belts hold the vehicle occupants in the correct sitting positions and substantially reduce the kinetic energy in the event of an accident. Seat belts also help to prevent uncontrolled movements that could lead to severe injuries. In addition, properly worn seat belts reduce the danger of being thrown from the car.

Passengers wearing their seat belts correctly benefit greatly from the ability of the belts to absorb kinetic energy. The front crumple zones and other passive safety features (such as the airbag system) are also designed to absorb the kinetic energy generated in a collision. Taken together, all these features reduce the forces acting on the occupants and consequently the risk of injury.

Our examples describe frontal collisions. Of course, properly worn seat belts reduce substantially the risk of injury in all other types of accidents. This is

why it is so important to fasten seat belts before every trip, even when "just driving around the corner".

Ensure that your passengers wear their seat belts as well. Accident statistics have shown properly worn seat belts to be an effective means of substantially reducing the risk of injury and improving the chances of survival in a serious accident. Furthermore, properly worn seat belts improve the protection provided by airbags in the event of an accident. For this reason, wearing a seat belt is required by law in most countries.

Although your vehicle is equipped with airbags, the seat belts must be fastened and worn. The front airbags, for example, are only triggered in some frontal accidents. The front airbags will not be triggered during minor frontal collisions, minor side collisions, rear collisions, rolls or accidents in which the airbag trigger threshold in the control unit is not exceeded.

Therefore, you should always wear your seat belt and ensure that your passengers have fastened their seat belts properly before you drive off! ■

## Safety notes on using seat belts

*If seat belts are used correctly, they can reduce the risk of injury in an accident.*

- Always wear the seat belt as described in this booklet.
- Ensure that the seat belts can be fastened at all times and are not damaged.

### **WARNING**

- **If the seat belts are worn incorrectly or not at all, the risk of severe injuries increases. The optimal protection from seat belts can be achieved only if you use them properly.**



**⚠ WARNING (continued)**

- Fasten your seat belt before every trip - even when driving in town. That applies also to your front and rear passengers – danger of injury!
- The seat belt cannot offer its full protection if the belt web is not positioned correctly.
- Never allow two passengers (even children) to share the same seat belt.
- Keep both feet in the foot-well in front of your seat as long as the vehicle is in motion.
- Never unbuckle a seat belt while the vehicle is in motion. Risk of fatal injury.
- The belt webbing must never be twisted while it is being worn.
- The belt webbing should never lie on hard or fragile objects (such as glasses or pens, etc.) because this can cause injuries.
- Do not allow the seat belt to be damaged or jammed, or to rub on any sharp edges.
- Never wear the seat belt under the arm or in any other incorrect position.
- Loose, bulky clothing (such as an overcoat over a jacket) impairs the proper fit and function of the belts, reducing their capacity to protect.
- The slot in the seat belt buckle must not be blocked with paper or other objects, as this can prevent the latch plate from engaging securely.
- Never use seat belt clips, retaining rings or similar instruments to alter the position of the belt webbing.
- Frayed or torn seat belts or damage to the connections, belt retractors or parts of the buckle could cause severe injuries in the event of an accident. Therefore, you must check the condition of all seat belts at regular intervals.
- Seat belts which have been worn in an accident and stretched must be replaced by a qualified workshop. Renewal may be necessary even if there is no apparent damage. The belt anchorage should also be checked.

**⚠ WARNING (continued)**

- Do not attempt to repair a damaged seat belt yourself. The seat belts must not be removed or modified in any way.
- The belts must be kept clean, otherwise the retractors may not work properly. ■

## Seat belts

### Fastening seat belt (one buckle)

*The seat belts on the front seats and the seats in the second and third row are fastened using one buckle.*

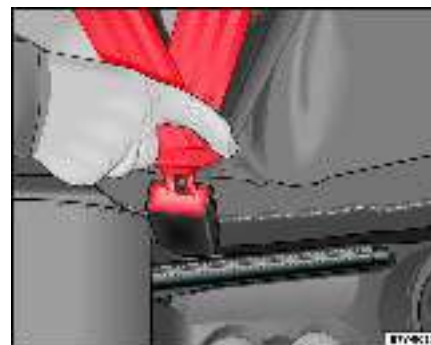

**Fig. 10** Belt buckle and latch plate of seat belt

The seat belt cannot offer its full protection if the belt web is not positioned correctly. ▶

- Adjust the seat and head restraint correctly.
- To fasten the belt, take hold of the latch plate and pull it slowly across your chest and lap ⇒ .
- Insert the latch plate into the buckle for the appropriate seat and push it down until it is securely locked with an audible click ⇒ [page 23, fig. 10](#).
- Pull the belt to ensure that the latch plate is securely engaged in the buckle.

Every seat belt is equipped with an automatic belt retractor on the shoulder belt. Full freedom of movement is permitted when the shoulder belt is pulled slowly. However, during sudden braking, during travel in mountains or bends and during acceleration, the automatic retractor on the shoulder belt is locked.

The automatic belt retractors on the front seats are fitted with belt tension devices.

### WARNING

An incorrectly worn seat belt web can cause severe injuries in the event of an accident.





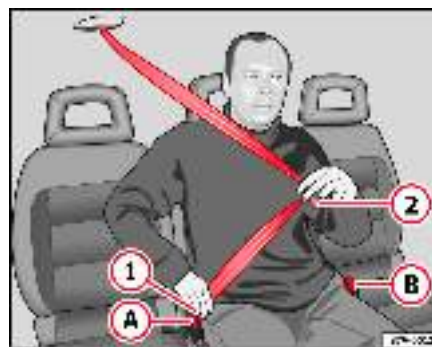

- The seat belts offer best protection only when the backrests are in an upright position and the seat belts have been fastened properly.
- Never put the latch plate in the buckle of another seat. If you do this, the seat belt will not protect you properly and the risk of injury is increased.
- If an occupant is incorrectly belted in, the belt cannot protect him or her properly. An incorrectly positioned belt web can cause extremely severe injuries. ■

### Fastening seat belts (with two buckles)

*The seat belt for the centre seat in the second row of seats is fastened using two buckles.*



**Fig. 11** Fastening the seat belt on the centre seat in the second row of seats

- Adjust the seat and head restraint correctly.
- Pull the belt so that the tongue ⇒ [fig. 11](#)  is pulled down.
- Insert latch plate  into the buckle belonging to the seat  and push it down until it is securely locked with an audible click.
- Use latch plate of the belt  to pull the belt across your lap.
- Insert latch plate  into the buckle belonging to seat  and push it down until it is securely locked with an audible click.
- Pull the belt to ensure that **both** latch plates are securely engaged in the buckles.

The seat belt for the centre seat in the second row of seats has a belt retractor fitted in the car roof. Full freedom of movement is permitted when the shoulder belt is pulled slowly. However, during sudden braking, during travel in mountains or bends and during acceleration, the automatic retractor on the seat belt is locked.

**⚠ WARNING**

An incorrectly worn seat belt web can cause severe injuries in the event of an accident.

- The seat belts offer best protection only when the backrests are in an upright position and the seat belts have been fastened properly.
- Never put the latch plate in the buckle of another seat. If you do this, the seat belt will not protect you properly and the risk of injury is increased.
- If an occupant is incorrectly belted in, the belt cannot protect him or her properly. An incorrectly positioned belt web can cause extremely severe injuries.

**i Note**

An illustration of how to fasten the seat belts can be found on each buckle. ■

## Seat belt position

*Seat belts offer their maximum protection only when they are properly positioned.*

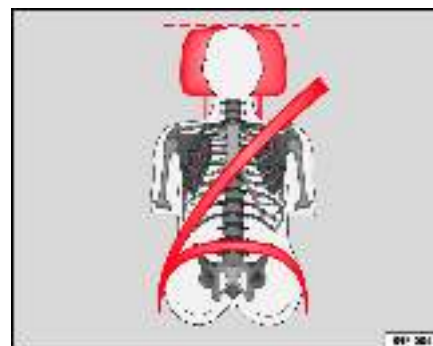

Fig. 12 Correct belt web and head restraint positions, viewed from front

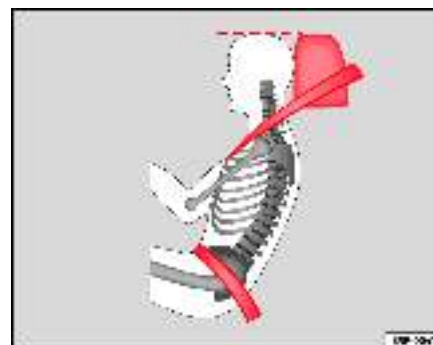

Fig. 13 Correct belt web and head restraint positions, viewed from side ▶

The following features are available to adjust the seat belt in the shoulder region:

- Belt height adjustment for the front seats and the outer seats in the second row,
- front seat height adjustment\*.

### WARNING

An incorrectly worn seat belt web can cause severe injuries in the event of an accident.

- The shoulder part of the seat belt must lie on the centre of the shoulder, never across the neck. The seat belt must lie flat and fit comfortably on the torso
- The lap part of the seat belt must lie across the pelvis, never across the stomach. The seat belt must lie flat and fit comfortably on the pelvis Pull the belt tight if necessary to take up any slack.
- Read and observe the warnings ⇒ page 23. ■

### Pregnant women must also fasten their seat belts properly

*The best protection for the unborn child is for the mother to wear the seat belt properly at all times during the pregnancy.*



**Fig. 14 Positioning seat belts during pregnancy**

The seat belt provides maximum protection only when the belt web is properly positioned ⇒ page 25.

- Adjust the front seat and head restraint correctly ⇒ page 10.
- Holding the latch plate, pull the belt evenly across your chest and as low as possible over the pelvis ⇒ fig. 14.
- Insert the latch plate into the buckle for the corresponding seat and push it down until it is securely locked with an audible click ⇒ .
- Pull the belt to ensure that the latch plate is securely engaged in the buckle. ▶

### WARNING

- An incorrectly worn seat belt web can cause severe injuries in the event of an accident.
- For pregnant women, the lap part of the seat belt must lie as low as possible over the pelvis, never across the stomach, and always lie flat so that no pressure is exerted on the abdomen.
- Read and observe the warnings ⇒ page 22. ■

## Belt height adjustment

Using the height adjusters for the front seats and the outer seats in the second row the position of the seat belts can be adjusted in the shoulder area according to the height of the occupant.

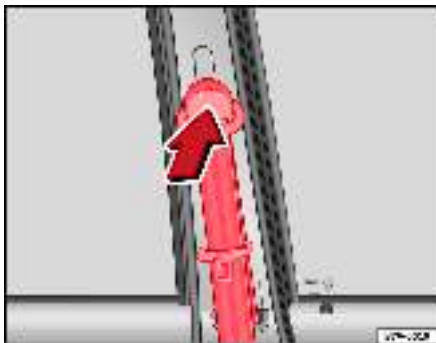

Fig. 15 Location of the belt height adjuster

The seat belt adjustment for the front seats and the outer seats in the second row can be used to adjust the proper belt web position at the shoulder.

- Press the upper part ⇒ fig. 15 of the shoulder belt guide in the direction of the arrow and hold it in this position.
- Move the shoulder belt guide up or down until you have the seat belt in a position suitable for your size.
- Release the shoulder belt guide.
- After adjusting, pull the shoulder belt sharply to check that the catch on the shoulder belt guide is engaged securely. ■

## Unfastening seatbelt (with one buckle)

The seat belt must not be unfastened until the vehicle has come to a standstill.



Fig. 16 Removing latch plate from buckle

- Press the red button on the belt buckle ⇒ page 27, fig. 16. The latch plate is released and springs out ⇒ ⚠.
- Guide the belt back by hand so that it rolls up easily and the trim will not be damaged.

**⚠ WARNING**

Never unbuckle a seat belt while the vehicle is in motion. If you do, you increase the risk of sustaining severe or fatal injuries. ■

### Unfastening seat belts (with two buckles)

*The seat belt must not be unfastened until the vehicle has come to a standstill.*



**Fig. 17 Unfastening seat belt with two buckles**

- Press the red button in the belt buckle ⇒ fig. 17 ①. The latch plate is released and springs out.
- Press the red button in the belt buckle ②. The latch plate is released and springs out.
- Guide the belt back by hand holding both latches so that the belt rolls up easily without damaging the trim.

**⚠ WARNING**

Never unbuckle a seat belt while the vehicle is in motion. If you do, you increase the risk of sustaining severe or fatal injuries. ■

## Detachable seat belts

The seat belts in the third row of seats can be detached.

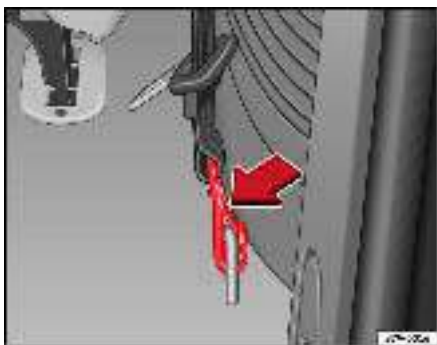

Fig. 18 Retainer with spring hook for the detachable seat belt

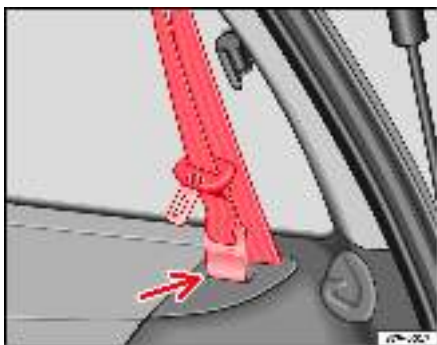

Fig. 19 Storage for the detached seat belt

### Detaching the seat belt

- Push the the spring hook ⇒ fig. 18 in the direction of the arrow and remove the hook by pulling down.
- Guide the seat belt with the spring hook up and hang the spring hook in the retainer ⇒ fig. 19 -arrow- in the side trim.

### Fitting the seat belt

- Remove the spring hook from the retainer and guide the seat belt down.
- Fir the hook and pull it up until the spring hook functions again ⇒ ⚠.

Remove the spring hook again if the seat belt is twisted after it has been fitted. Turn it in the appropriate direction and reengage the spring hook securely..

#### WARNING

**Pull on the seat belt to ensure that the hook is engaged properly. The hook could disengage itself whilst the vehicle is in motion if it has not been properly fitted - Risk of fatal injury! ■**

### Belt retainer\*

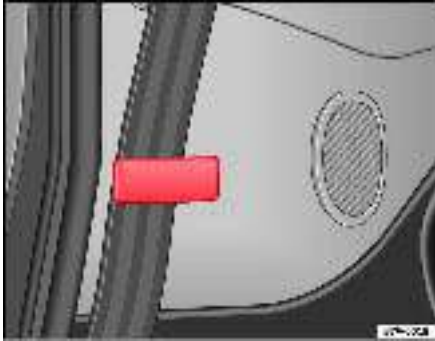

Fig. 20 Belt retainer for outer seats in centre row

#### WARNING

- When the belt for the outer seats in the centre row is removed insert the webbing behind the guide of the side trim ⇒ fig. 20, in order to lower the backrest without damaging the webbing.
- The seat belts must be removed from the holder before removing the individual seats. This means that the belts will not be damaged. ■

### Belt height adjustment

Seat belt height adjusters can be used to adjust the position of the seat belt at the shoulder.

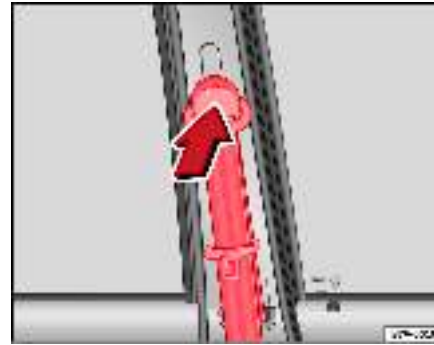

Fig. 21 Location of the belt height adjuster

The seat belt adjustment for the front seats and the outer seats in the second row can be used to adjust the proper belt web position at the shoulder.

- Press the upper part ⇒ fig. 21 of the shoulder belt guide in the direction of the arrow and hold it in this position.
- Move the shoulder belt guide up or down until you have adjusted the seat belt to the correct position.
- After adjusting, pull the shoulder belt sharply to check that the catch on the shoulder belt guide is engaged securely. ■



## Incorrectly fastened seat belts

*Incorrectly worn seat belts can cause severe injuries.*

Seat belts can provide optimal protection only if the belt web is properly worn. This is particularly true of seat belts with two buckles. The seat belts must be fastened exactly in the order described in this chapter. An incorrect sitting position impairs substantially the protection a seat belt offers and can lead to severe or fatal injuries. The risk of severe or fatal injuries is especially increased when a deploying airbag strikes an occupant who has assumed an incorrect sitting position. As driver, you are responsible for the safety of all vehicle occupants, especially children. Therefore:

- Never permit anyone to assume an incorrect sitting position in the vehicle while travelling ⇒ .



### WARNING

**An incorrectly worn seat belt increases the risk of severe injuries.**

- **Before every trip, instruct your passengers to adjust their seat belts properly and to wear them during the trip.**
- **Read and always observe information and warnings concerning the use of seat belts ⇒ page 23 and ⇒ page 28. ■**

## Belt tension devices

### Function of the belt tension device

*During a frontal collision, the seat belts on the front seats are retracted automatically.*

The seat belts for the front occupants are equipped with belt tension devices. Sensors will trigger the belt tension devices during severe head-on, lateral and rear collisions only if the seat belt is being worn. This retracts and tightens the seat belts, reducing the forward motion of the occupants.

The belt tension device can be triggered only once.

The belt tension devices will not be triggered in the event of a light frontal, side or rear collision, if the vehicle overturns, or in situations where no large forces act on the front, side or rear of the vehicle.



### Note

- If the belt tension devices are triggered, a fine dust is produced. This is normal and is no indication that there was a fire in the vehicle.
- The relevant safety requirements must be observed when the vehicle or components of the system are scrapped. A qualified workshop is familiar with these regulations and will be pleased to pass on the information to you. ■

### Service and disposal of belt tension devices

The belt tension devices are components of the seat belts that are installed in the seats of your vehicle. If you work on the belt tension devices or remove and install parts of the system when performing other repair work, the seat belt may be damaged. The consequence may be that, in the event of an accident, the belt tension devices function incorrectly or not at all. ►

So that the effectiveness of the belt tension device is not reduced and that removed parts do not cause any injuries or environmental pollution, regulations, which are known to the qualified workshops, must be observed.

**WARNING**

- If repairs are not carried out by a professional, or if the belt tension devices are used incorrectly, the risk of severe or fatal injuries increases. The belt tension devices may fail to trigger or may trigger in the wrong circumstances.
- Never attempt to repair, adjust, remove or install parts of the belt tension devices or seat belts.
- The belt tension device and seat belt including its automatic retractor cannot be repaired.
- Any work on the belt tension devices and seat belts, including the removal and refitting of system parts in conjunction with other repair work, must be performed by a qualified workshop only.
- The belt tension devices will only provide protection for one accident and must be changed if they have been activated. ■

## Airbag system

### Brief introduction

#### Why wear a seat belt and assume the correct sitting position?

*For the inflating airbags to achieve the best protection, the seat belt must always be worn properly and the correct sitting position must be assumed.*

For your own safety and the safety of the passengers, please ensure the following before you drive:

- Always wear the seat belt properly ⇒ page 18.
- Adjust the driver seat and the steering wheel correctly ⇒ page 10.
- Adjust the front passenger seat correctly ⇒ page 11.
- Adjust the head restraint seat correctly ⇒ page 13.
- Use the correct child restraint system to protect children in your vehicle ⇒ page 46.

The airbag deploys in fractions of a second and with a high velocity. If you have assumed an incorrect seating position at that moment, you could sustain critical injuries. Therefore, it is essential that all occupants maintain a correct sitting position while travelling.

Braking heavily the moment before an accident may cause an occupant not wearing a seat belt to be thrown forward into the area of the deploying airbag.

In this case, the inflating airbag may inflict critical or fatal injuries upon the occupant. This applies particularly to children.

Always maintain the greatest possible distance between yourself and the front airbag. This way, the front airbags can completely deploy when triggered, providing their maximum protection.

The most important factors that will trigger an airbag are: the type of accident, the angle of collision and the speed of the vehicle.

Whether the airbags are triggered depends primarily on the vehicle deceleration rate resulting from the collision and detected by the control unit. If the vehicle deceleration occurring during the collision and measured by the control unit remains below the specified reference values, the front, side and/or curtain airbag will not be triggered. Take into account that the visible damage in a vehicle following an accident, for whatever reason, are not an indication as to why the airbags were triggered.

 <b>WARNING</b>
<ul style="list-style-type: none"> <li>● <b>Wearing the seat belt incorrectly or assuming an incorrect sitting position can lead to critical or fatal injuries.</b></li> <li>● <b>All occupants, including children, who are not properly belted can sustain critical or fatal injuries if the airbag is triggered. You should always transport all children up to 12 years of age on the rear seat. Never transport children in the vehicle if they are not restrained or the restraint system is not appropriate for their age, size or weight.</b></li> <li>● <b>If you are not wearing a seat belt or if you lean forward or to the side or assume an incorrect sitting position, the risk of injury is increased substantially. This increased risk of injury will be further increased if you are struck by an inflating airbag.</b></li> <li>● <b>To reduce the risk of injury from an inflating airbag, always wear the seat belt properly ⇒ page 18.</b></li> </ul>

 **WARNING** (continued)

- Always properly adjust the front seats. ■

### Conditions for fitting a rear facing childseat in the front passenger seat

*Rear-facing child seats must never be used on the front passenger seat when the front passenger airbag is enabled.*

An enabled front airbag on the front passenger side is potentially a major danger to a child. ⇒  The front passenger seat is life threatening to a child if you transport the child in a rear-facing child seat. You should always transport all children up to 12 years of age on the rear seat.

If a rear-facing child seat is secured to the front passenger seat, an inflating airbag can strike it with such great force that critical or fatal injuries may result.

Therefore we urgently recommend that you transport children on the rear seats. That is the safest place in the vehicle for children. Alternatively, the front and side airbags for the front passenger ⇒ page 44 can be disabled with the ignition key. When transporting children, use a child seat appropriate to the age and size of each child.

 **WARNING**

**If a child seat is mounted in the front passenger seat, the child is exposed to a greater risk in the event of an accident.**

- Never secure a rear-facing child seat to the front passenger seat if the front passenger airbag is enabled. The child can suffer critical or fatal injuries when the front passenger airbag is triggered.

 **WARNING** (continued)

- An inflating front passenger airbag can strike the rear-facing child seat and hurl it with great force against the door, the roof or the backrest.
- If, under special circumstances, it should be necessary to transport a child in a rear-facing child seat on the front passenger seat, it is absolutely essential that you observe the following safety measures:
  - Disabling front and side airbags for front passenger ⇒ page 44.
  - The child seat must be approved by the child seat manufacturer for use on a front passenger seat with front or side airbag.
  - Follow the installation instructions of the child seat manufacturer and absolutely observe the warnings ⇒ page 46.
  - Before properly installing the child seat, push the front passenger seat all the way to the rear so that the greatest possible distance to the front passenger airbag is ensured.
  - Ensure that no objects prevent the front passenger seat from being pushed completely back.
  - The backrest of the front passenger seat must be in an upright position. ■

### Warning lamp for airbag and belt tensioner system

*This warning lamp monitors the airbag and belt tension device system.*

The warning lamp monitors all airbags and belt tension devices in the vehicle, including control units and wiring connections. ►

### Monitoring of airbag and belt tension device system

The functionality of the airbag and belt tension device system is constantly monitored electronically. The warning lamp  will light up for four seconds every time the ignition is switched on. (selfdiagnosis).

If at least one airbag has been deactivated in a specialised workshop, the warning light  flashes for 12 seconds before starting the engine. This does **not** apply when the front and side airbags have been deactivated using the key switch ⇒ page 44.

#### The system must be checked when the warning lamp :

- does not come on when the ignition is switched on,
- does not go off after four seconds, after switching on the ignition,
- goes out and then comes on again after the ignition is switched on,
- or if it comes on or flickers while the car is moving.

In the event of a malfunction, the warning lamp remains on continuously. In addition, depending on the malfunction, an appropriate fault message appears in the display <sup>1)</sup> of the instrument panel. In this event, you should have a qualified workshop check the system immediately.

#### WARNING

If there is a malfunction, the airbag and belt tension device system cannot properly perform its protective function.

- If a malfunction should occur, have the system checked immediately by a qualified workshop. Otherwise there is a risk that, in the event of an accident, the airbag system and belt tension devices may not be triggered, or may not be triggered correctly. ■

<sup>1)</sup> Depending on the version of the model.

### Repair, care and disposal of the airbags

The parts of the airbag system are installed in various places in your vehicle. If you work on the airbag system or remove and install parts of the system when performing other repair work, parts of the airbag system may be damaged. The consequence may be that, in the event of an accident, the airbag inflates incorrectly or does not inflate at all.

The relevant safety requirements must be observed when the vehicle or components of the airbag are **scrapped**. The specialist workshops and the Vehicle disposal centres are familiar with these requirements.

#### WARNING

- If repairs are not carried out by a professional, or if the airbags are used incorrectly, the risk of severe or fatal injuries is increased. The airbags may fail to inflate, or could inflate in the wrong circumstances.
- Do not cover or stick anything on the steering wheel hub or the soft plastic surface of the airbag unit on the passenger side of the dashboard, and do not obstruct or modify them in any way.
- It is important not to attach any objects such as cup holders or telephone mountings to the surfaces covering the airbag units.
- To clean the steering wheel or dash panel, you may use only a dry cloth or one moistened with water. Never clean the dash panel and surface of the airbag module with cleansers containing solvents. Solvents cause the surface to become porous. If the airbag inflates, disintegrating plastic parts can cause substantial injuries.
- Never attempt to repair, adjust, remove or install parts of the airbag system.
- Any work on the airbag system or removal and installation of the airbag components for other repairs (such as repairs to the steering wheel) should be performed only by a qualified workshop. Qualified workshops have the necessary tools, repair information and qualified personnel. ►

 **WARNING (continued)**

- We urgently recommend that you go to a qualified workshop for all work on the airbag system.
- Never attempt to alter the front bumper or the body.
- The airbags provide protection for one accident only, if they have been deployed they must be replaced. ■

## Front airbags

### Description of front airbags

*The airbag system is not a substitute for the seat belts.*



**Fig. 22** Driver airbag located in steering wheel



**Fig. 23** Front passenger airbag located in dash panel

The front airbag for the driver is located in the steering wheel ⇒ fig. 22 and the airbag for the front passenger is located in the dash panel ⇒ fig. 23. Airbags are identified by the text “AIRBAG”.

In conjunction with the seat belts, the front airbag system gives the front occupants additional protection for the head and chest in the event of a severe frontal collision ⇒ page 38.

In addition to their normal function of restraining the occupants, the seat belts also hold the driver and front passenger in a position where the airbags can provide maximum protection in a frontal collision.

The airbag system is not a substitute for seat belts, but is an integral part of the vehicle's overall passive safety system. Please bear in mind that the airbag system can only work effectively when the occupants are wearing their seat belts. For this reason, it is most important to wear the seat belts at all times, not only because this is required by law in most countries, but also for your safety.

#### The main parts of the front airbag system are:

- an electronic control and monitoring system (control unit),
- the two front airbags (airbag with gas generator) for the driver and front passenger,
- a warning lamp  in the dash panel insert.

The functionality of the airbag system is monitored electronically. The airbag warning lamp will light up for a few seconds every time the ignition is switched on (self-diagnosis).

#### There is a fault in the system if the warning lamp

- does not come on when the ignition is switched on ⇒ page 34,
- does not go off after four seconds, after switching on the ignition,
- goes out and then comes on again after the ignition is switched on,
- or if it comes on or flickers while the car is moving.

The front airbag system will not be triggered if:

- if the ignition is switched off,
- during a minor frontal collision,
- during a minor side collision,
- during a rear-end collision,
- or if the vehicle rolls.

**⚠ WARNING**

- The seat belts and airbags can only provide maximum protection if the occupants are seated correctly.
- If a fault should occur in the airbag system, have the system checked immediately by a qualified workshop. Otherwise there is a danger that during a frontal collision, the system may fail to trigger, or not trigger correctly. ■

## Function of front airbags

*Inflated airbags reduce the risk of head or chest injury.*



**Fig. 24** Inflated front airbags

The airbag system is designed so that the front airbags for the driver and front passenger are triggered in a severe frontal collision.

In certain types of accident the front, curtain and side airbags may be triggered together.

When the system is triggered, the airbags fill with a propellant gas and deploy in front of the driver and front passenger ⇒ fig. 24. The fully deployed airbags cushion the forward movement of the front occupants and help to reduce the risk of injury to the head and the upper part of the body.

The special design of the airbag allows the controlled escape of the propellant gas when an occupant puts pressure on the bag. Thus, the head and chest are surrounded and protected by the airbag. Once the impact has been absorbed, the airbag deflates sufficiently for the front occupants to see forward. ▶



In order to provide the desired extra protection in an accident, the airbags have to deploy extremely rapidly (within fractions of a second). A fine dust may develop when the airbag deploys. This is normal and is no indication that there was a fire in the vehicle. ■

### The function of the airbag covers if the airbags are triggered

The airbag covers fold out of the steering wheel or dash panel when the driver and front passenger airbags deploy. The airbag covers remain connected to the steering wheel or the dash panel. ■

### Safety notes on front airbag system

*If you use airbags correctly, they can considerably reduce the risk of injury in many kinds of accident.*

When the front airbags are triggered they fill the zones marked in red (radius of action). Therefore additional accessories should never be placed in these areas ⇒ .

The airbag covers fold out of the steering wheel or dash panel when the driver and front passenger airbags deploy. The airbag covers remain connected to the steering wheel or the dash panel.

#### **WARNING**

- It is important that the driver keeps at a minimum of 25 cm from the steering wheel. It is important that the passenger moves the seat back as far as possible, to keep a safe distance away from the instrument panel. Failure to respect the minimum distance means that the airbag will not protect you. Risk of fatal injury. In addition, the front seats and head

#### **WARNING (continued)**

restraints must always be positioned correctly for the height of the occupant.

- If you are not wearing a seat belt or if you lean forward or to the side or assume an incorrect sitting position, the risk of injury is increased substantially. This increased risk of injury will be further increased if you are struck by an inflating airbag.
- Never let a child travel on the front seat without an appropriate restraint system. If the airbag is triggered in an accident, children can sustain serious or fatal injuries from the airbag as it inflates ⇒ page 46.
- Occupants sitting in the front of the vehicle must never carry any objects or pets in the deployment space between them and the airbags, or allow children or other passengers to travel in this position.
- The airbags provide protection for one accident only, if they have been deployed they must be replaced.
- It is also important not to attach any objects such as cup holders or telephone mountings to the surfaces covering the airbag units.
- Nothing should be placed on the windscreen area above the passenger side airbag, for example notebooks or telephone holders. If the airbag is activated, these objects may fly uncontrollably around the vehicle interior and could cause injury.
- Do not attempt to modify components of the airbag system in any way. ■

## Side airbags

### Description of side airbags

*The airbag system is not a substitute for the seat belts.*

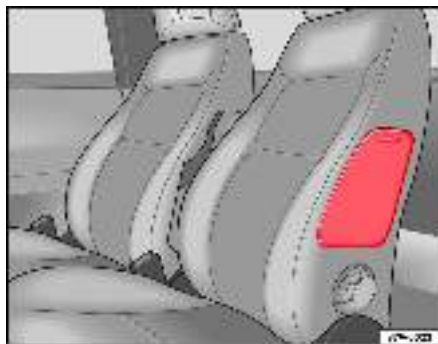

**Fig. 25** Side airbag in left rear seat

The side airbags are located in the driver seat and front passenger seat backrests ⇒ [fig. 25](#).

In conjunction with the seat belts, the side airbag system gives the front seat occupants additional protection for the upper body in the event of a severe side collision ⇒ [page 41](#), “Safety notes on the operation of the side airbag system”.

In a side collision the side airbags reduce the risk of injury to passengers on the front seats to the areas of the body facing the impact. In addition to their normal function of protecting the occupants in a collision, the seat belts also hold the passengers on the front seats in a position where the side airbags can provide maximum protection.

The airbag system is not a substitute for seat belts, but is an integral part of the vehicle's overall passive safety system. Please bear in mind that the airbag system can only work effectively when the occupants are wearing their seat belts. For this reason, it is most important to wear the seat belts at all times, not only because this is required by law in most countries, but also for your safety.

#### The side airbag system will not be triggered

- if the ignition is switched off,
- during a minor side collision,
- during a minor frontal collision,
- during a rear-end collision,
- or if the vehicle rolls.

#### The main parts of the airbag system are

- an electronic control and monitoring system (control unit),
- the side airbags in the sides of the backrests of the front seats,
- a warning lamp  in the dash panel insert.

The functionality of the airbag system is monitored electronically. The airbag warning lamp will light up for a few seconds every time the ignition is switched on (self-diagnosis).



#### WARNING

- **The seat belts and airbags can only provide maximum protection if the occupants are seated correctly.**
- **If a fault should occur in the airbag system, have the system checked immediately by a qualified workshop. Otherwise there is a danger that during a side collision, the system may fail to trigger, or not trigger correctly. ■**

## Function of side airbags

*Inflated airbags reduce the risk of head or chest injury.*

In some **side collisions** the side airbag is triggered on the impact side of the vehicle.

In certain types of accident the front, curtain and side airbags may be triggered together.

When the system is triggered, the airbag is filled with propellant gas.

In order to provide the desired extra protection in an accident, the airbags have to deploy extremely rapidly (within fractions of a second). A fine dust may develop when the airbag deploys. This is normal and is no indication that there was a fire in the vehicle.

The fully deployed airbags cushion the movement of the occupants of the front seats and help to reduce the risk of injury to the upper body.

The special design of the airbag allows the controlled escape of the propellant gas when an occupant puts pressure on the bag. Thus, the head and chest are surrounded and protected by the airbag. ■

## Safety notes on the operation of the side airbag system

*Correct behaviour considerably reduces the risk of injury.*



### WARNING

- If you do not wear a seat belt, if you lean forward, or are not seated correctly while the vehicle is in motion, you are at greater risk of injury should the side airbag system be triggered in an accident.



### WARNING (continued)

- In order for the side airbags to provide their maximum protection, the prescribed sitting position must always be maintained with seat belts fastened while travelling.
- The built-in coat hooks should be used only for lightweight clothing. Do not leave any heavy or sharp-edged objects in the pockets.
- Great forces, such as hard blows or kicks, must not be exerted upon the backrest bolster because the system may be damaged. In this case the side airbags would not be triggered.
- Under no circumstances should protective covers be fitted over the driver seat or front passenger seat unless the covers have been expressly approved for use in your vehicle. Because the airbag deploys from the side of the backrest, the use of conventional seat covers would obstruct the side airbag, seriously reducing the airbag's effectiveness.
- Any damage to the original seat upholstery or around the seams of the side airbag units must be repaired immediately by a qualified workshop.
- The airbags provide protection for one accident only, if they have been deployed they must be replaced.
- When children assume an incorrect sitting position, they expose themselves to an increased risk of injury in the event of an accident. This is particularly the case if the child is travelling on the front passenger seat and the airbag system is triggered in an accident; this could have critical consequences including serious injury or death ⇒ page 46.
- Any work on the side airbag system or removal and installation of the airbag components for other repairs (such as removal of the front seat) should only be performed by a qualified workshop. Otherwise, a fault may be introduced into the operation of the airbag system.
- Do not attempt to modify components of the airbag system in any way. ■

## Curtain airbags

### Description of curtain airbags

*The airbag system is not a substitute for the seat belts.*

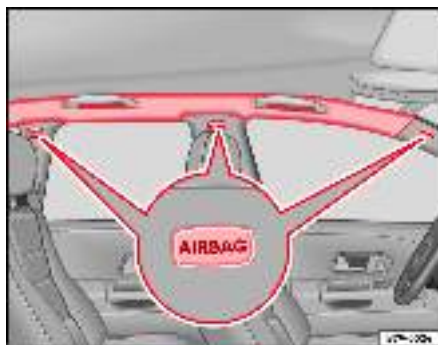

**Fig. 26** Location of left curtain airbag

The curtain airbags are located on both sides in the interior above the doors ⇒ [fig. 26](#) and are identified with the text “AIRBAG”.

In conjunction with the seat belts, the curtain airbag system gives the occupants additional protection for the head and upper body in the event of a severe side collision ⇒ [page 40](#).

The airbag system is not a substitute for seat belts, but is an integral part of the vehicle's overall passive safety system. Please bear in mind that the airbag system can only work effectively when the occupants are wearing their seat belts correctly and have adjusted the head restraints properly. For this reason, it is most important to wear the seat belts at all times, not only because this is required by law in most countries, but also for your safety.

**The main parts of the curtain airbag system are:**

- an electronic control and monitoring system (control unit),
- the curtain airbags (airbags with gas generator) for the driver, front passenger and passengers on the rear seats,
- a warning lamp  in the dash panel insert.

The functionality of the airbag system is monitored electronically.

**The curtain airbag system will not be triggered**

- if the ignition is switched off,
- during a frontal collision,
- during a rear-end collision,
- if the vehicle rolls,
- during a minor side collision.



#### **WARNING**

**If a fault should occur in the airbag system, have the system checked immediately by a qualified workshop. Otherwise there is a danger that during a collision, the system may fail to trigger, or not trigger correctly. ■**

## Function of curtain airbags

Fully inflated airbags reduce the risk of head or chest injury in a side collision.



Fig. 27 Deployed curtain airbags

During some **side collisions** the curtain airbag is triggered on the impact side of the vehicle ⇒ fig. 27.

In certain types of accident the front, side and curtain airbags may be triggered together.

When the system is triggered, the airbag is filled with propellant gas. In the process, the curtain bag covers the side windows and door pillars.

In order to provide the desired extra protection in an accident, the airbags have to deploy extremely rapidly (within fractions of a second). A fine dust may develop when the airbag deploys. This is normal and is no indication that there was a fire in the vehicle.

The fully deployed airbags cushion the movement of the front occupants and help to reduce the risk of injury to the upper body.

The special design of the airbag allows the controlled escape of the propellant gas when an occupant puts pressure on the bag. Thus, the head and chest are surrounded and protected by the airbag. ■

## Safety notes on the operation of the curtain airbag system

If you use airbags correctly, they can considerably reduce the risk of injury in many kinds of accident.



### WARNING

- In order for the side airbags to provide their maximum protection, the prescribed sitting position must always be maintained with seat belts fastened while travelling.
- For safety reasons, the head air bag must be disconnected in those vehicles fitted with a passenger compartment separation screen. See an Authorised Service Centre to make this adjustment.
- There must be no other persons, animals or objects between the occupants of the outer seats and the deployment space of the curtain airbags so that the curtain airbag can deploy without restriction and provide the greatest possible protection. Therefore, sun blinds which have not been expressly approved for use in your vehicle may not be attached to the side windows.
- The built-in coat hooks should be used only for lightweight clothing. Do not leave any heavy or sharp-edged objects in the pockets. When using the coat hooks, do not hang the clothes on coat hangers.
- The airbags provide protection for one accident only, if they have been deployed they must be replaced.
- Any work on the curtain airbag system or removal and installation of the airbag components for other repairs (such as removal of the roof lining) should only be performed by a qualified workshop. Otherwise, a fault may be introduced into the operation of the airbag system. ▶

**⚠ WARNING (continued)**

- Do not attempt to modify components of the airbag system in any way.
- The side and head airbags are managed through sensors located in the interior of the front doors. To ensure the correct functioning of the side and head airbags neither the doors nor the door panels should be modified in any way (e.g. fitting loudspeakers). If the front door is damaged in any way, this may affect the correct working of the system. All work carried out on the front door must be made in a qualified workshop. ■

## Deactivating airbags\*

### Disabling front passenger front and side airbags

*The passenger airbags must be disconnected when a rear facing child seat is fitted in the front passenger seat.*

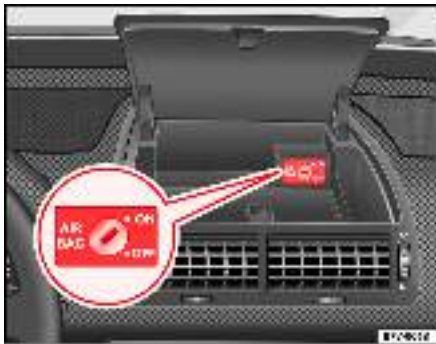

**Fig. 28** Interior of centre compartment on instrument panel: Key switch for switching off the front passenger airbags



**Fig. 29** Warning lamp for disabling airbag in dash panel

The key switch can be used to *disconnect* the front and side airbag for the passenger seat. All the other airbags in the vehicle remain functional.

#### Disabling front and side airbags for front passenger

- Switch off ignition.
- Open centre compartment on instrument panel.
- Using the ignition key, turn the switch to **OFF** ⇒ [fig. 28](#).
- Check if, when the ignition is switched on, that the warning lamp “PASS AIRBAG OFF” on the instrument panel ⇒ [fig. 29](#) remains lit ⇒ .
- Close centre compartment on instrument panel.

#### Enabling front and side airbags for front passenger

- Switch off ignition.



- Open centre compartment on instrument panel.
- Using the ignition key, turn the switch to **ON** ⇒ page 44, fig. 28.
- Check if, when the ignition is switched on, that the warning lamp “PASS AIRBAG OFF” on the instrument panel ⇒ page 44, fig. 29 does not light up ⇒ .
- Close centre compartment on instrument panel.

**WARNING**

- The driver is responsible for the proper position of the key-operated switch.
- You should only disable the front and side passenger airbags if, in exceptional cases, you have to use a rear-facing child seat on the front passenger seat. ⇒ page 46
- Never fit a child seat in the passenger seat, where the child faces backwards to the direction of travel and the frontal airbag has not been deactivated. This is highly dangerous for the child. However, if it is necessary in exceptional circumstances to transport a child in a rear-facing child seat on the front passenger seat, you must always disable the front passenger airbag.
- As soon as the child seat will no longer be used on the front passenger seat, enable the front and side passenger airbag again.
- Only deactivate the front and side passenger airbag when the ignition is off, otherwise a fault may occur in the airbag system, this will create the risk of the front, curtain or side airbag not deploying properly or not at all in the event of an accident.
- If, while the front and side passenger airbag are turned off, the indicator PASS. AIRBAG OFF does not remain lit, this could indicate a fault in the airbag system:

**WARNING (continued)**

- Have the airbag system inspected immediately by a qualified workshop.
- Do not use a child seat on the front passenger seat! The front and side passenger airbag may deploy during an accident in spite of the fault.
- It is impossible to determine whether the front or side airbags will be triggered in case of accident. Inform your passengers of this. ■

## Child safety

### Brief introduction

#### Introduction

*Statistics show that children are generally safer on the rear seat than on the front passenger seat.*

We recommend that children under 12 years of age be transported on the rear seats. Children travelling on the rear seat must use a child restraint system or the seat belts provided, depending on their age, height and weight. For safety reasons, the child restraint system should be installed in the centre of the rear seat or behind the front passenger's seat.

The physical principles involved and the forces acting in a collision apply to children just as much as adults ⇒ page 20. But unlike adults, children do not have fully developed muscle and bone structures. This means that children are subject to a greater risk of injury.

To reduce this risk, children must always use special child restraint systems when travelling in the vehicle.

We recommend the use of child safety products from the SEAT Genuine Accessories Program including systems for all ages made by "Peke"<sup>2)</sup>.

These systems have been especially designed and approved, complying with the ECE-R44. regulation.

Follow the manufacturer's instructions and observe any statutory requirements when installing and using child seats. Always read and observe ⇒ page 46.

<sup>2)</sup> Not for all countries

We recommend that you include the manufacturer's directions for child seat use in the vehicle wallet and always keep them in the vehicle. ■

#### Safety notes on using child seats

*Proper use of child seats substantially reduces the risk of injury in an accident!*

As the driver, you are responsible for any children you transport in your vehicle.

- Protect your children by properly using appropriate child seats.
- Always ensure that the belt webbing is properly positioned according to the instructions provided by the manufacturer of the child seat.
- When travelling, do not allow children to distract you from traffic.
- Take breaks regularly during long trips. Take a break at least every two hours.

We recommend that you include the manufacturer's directions for child seat use in the vehicle wallet and always keep them in the vehicle.



#### WARNING

- **Never fit a child seat in the passenger seat, where the child faces backwards to the direction of travel and the frontal airbag has not been deactivated. This is highly dangerous for the child. If it is necessary, in excep-**



 **WARNING (continued)**

tional circumstances, to transport a child on the front passenger seat, always disable the front passenger airbag ⇒ page 44.

- All passengers, especially children, must assume the proper sitting position and be properly belted in while travelling.
- Never hold children or babies on your lap, this can result in potentially fatal injuries to the child!
- Never allow a child to be transported in a vehicle without being properly secured, or to stand up or kneel on a seat while travelling. In an accident, the child could be flung through the vehicle, causing possibly fatal injuries to themselves and other occupants.
- If children assume an improper sitting position when the car is moving, they expose themselves to greater risk of injury during a sudden braking manoeuvre or in an accident. This is particularly the case if the child is travelling on the front passenger seat and the airbag system is triggered in an accident; this could have consequences including serious injury or death.
- A suitable child seat can protect your child!
- Make sure that no hard or sharp objects, for example toys, are on the child seats. Risk of injury.
- Never leave a child unsupervised in a child seat or alone in the vehicle.
- Depending on the time of year, the interior of a parked vehicle can reach extreme temperatures which may endanger the life of people and animals.
- Children who are less than 1.5 metres tall must not wear a normal seat belt without a child restraint system, as this could cause injuries to the abdominal and neck areas during a sudden braking manoeuvre or in an accident.
- Do not allow the belt webbing to become twisted or jammed, or to rub on any sharp edges.
- Incorrectly worn seat belts can cause injuries even in a minor collision or sudden braking manoeuvres.

 **WARNING (continued)**

- The seat belt cannot offer its full protection if the belt web is not positioned correctly.
- Only one child may occupy a child seat. ■

## Child seats

### Categorisation of child seats into groups

*Use only child seats that are officially approved and suitable for the child.*

Child seats are subject to the regulation ECE-R 44. ECE-R means: Economic Commission for Europe Regulation

The child seats are grouped into 5 categories:

**Group 0:** Children up to 10 kg

**Group 0+:** Children up to 13 kg

**Group 1:** from 9 to 18 kg

**Group 2:** from 15 to 25 kg

**Group 3:** from 22 to 36 kg

Child seats that have been tested and approved under the ECE R 44 standard bear the test mark on the seat (the letter E in a circle with the test number below it). ■

### Group 0 and 0+ child seats

*A suitable child seat and a correctly adjusted seat belt can help to protect your child.*

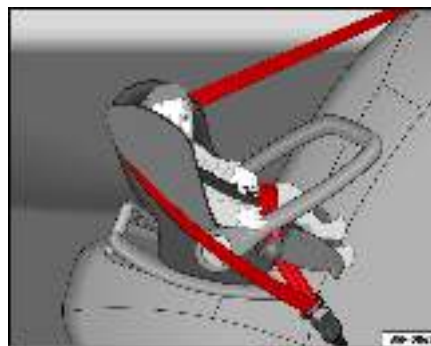

**Fig. 30** A group 0 rear-facing child seat fitted on the rear seat.

**Group 0:** For babies from about 9 months old and 10 kg in weight the most suitable seats are those appearing in the illustration ⇒ fig. 30.

**Group 0+:** For babies from about 18 months old and 13 kg in weight the most suitable seats are those appearing in the illustration.

Follow the manufacturer's instructions and observe any statutory requirements when installing and using child seats.

We recommend that you include the manufacturer's directions for child seat use in the vehicle wallet and always keep them in the vehicle.



**WARNING**

**Read and always observe information and warnings concerning the use of child seats ⇒ page 46. ■**

### Group 1 child seats

*A suitable child seat and a correctly adjusted seat belt can help to protect your child.*



**Fig. 31** A category 1 forward-facing child seat fitted on the rear seat.

Child seats using the “ISOFIX” system or seats in which the child faces the rear of the car are most appropriate for babies and small children weighing between 9 and 18 kg.

Follow the manufacturer's instructions and observe any statutory requirements when installing and using child seats.

We recommend that you include the manufacturer's directions for child seat use in the vehicle wallet and always keep them in the vehicle.



#### **WARNING**

**Read and always observe information and warnings concerning the use of child seats ■**

### Group 2 and 3 child seats

*A suitable child seat and a correctly adjusted seat belt can help to protect your child.*



**Fig. 32** Forward-facing child seat installed on rear seat.

Follow the manufacturer's instructions and observe any statutory requirements when installing and using child seats.

We recommend that you include the manufacturer's directions for child seat use in the vehicle wallet and always keep them in the vehicle.

#### **Group 2 child seats**

Children *under* 7 years of age weighing between 15 and 25 kg are best protected by group 2 child seats in conjunction with properly adjusted seat belts.

#### **Group 3 child seats**

Children *over* 7 years of age weighing between 22 and 36 kg but less than 1.5 metres tall are best protected by seat cushions with head restraints in conjunction with properly worn seat belts ⇒ fig. 32. ▶

**WARNING**

- The shoulder part of the seat belt must lie approximately on the centre of the shoulder, never across the neck or the arm. The seat belt must lie close to the torso. The lap belt part must lie across the pelvis, not across the stomach, and always fit closely. Pull the belt tight if necessary to take up any slack ⇒ page 23, “Seat belts”.
- Read and always observe information and warnings concerning the use of child seats ⇒ page 46. ■

## Installation of child seats in vehicle seats

### General notes

The correct fitting of child seats in the different seats is described below.

Child restraint systems that have been checked according to ECE-R 44 are suitable for installation on the front passenger seat or on the rear seats.



#### Note

The passenger seat and the rear seats comply with directive 77/541 EEC for the installation of child restraint systems. ■

### Front passenger seat

*Only the use of an officially approved child seat corresponding to the weight and height of the child is permitted.*

Universal seats for children in groups 0, 0+, 1, 2, or 3 (⇒ page 54) ⇒ ⚠ can be fitted in the passenger seat.

To fit a child seat, position the seat in the upright position and move the passenger seat as far back as possible. The seat must be in the highest position <sup>3)</sup> on vehicles with a height-adjustable ⇒ ⚠ front passenger seat.



#### WARNING

- **Never fit a child seat in the passenger seat, where the child faces backwards to the direction of travel and the frontal airbag has not been deactivated. This is highly dangerous for the child. If it is necessary in excep-**

<sup>3)</sup> Optional equipment



#### WARNING (continued)

**tional cases to transport a child on the front passenger seat, you must always disable the front and side passenger airbags ⇒ page 44.**

- **Children must travel in a child seat appropriate to their weight and height.**
- **The vehicle seat must always be fitted in the direction of travel when securing child restraint systems in weight class 0 or 0+.**
- **Read and always observe information and warnings concerning the use of child seats ⇒ ⚠ in “Safety notes on using child seats” on page 46.**
- **Please always read and follow the information and warnings provided by the child seat manufacturer. ■**

### Outer seats in the second row of seats and seats in the third row of seats

*Only the use of an officially approved child seat corresponding to the weight and height of the child is permitted.*

In the outer seats of seats in the second and third row universal child seats for groups 0, 0+, 1, 2, or 3 (⇒ page 54) ⇒ ⚠ may be fitted.

#### Seat with ISOFIX retainers

These seats are suitable for ISOFIX child seats specially designed for this type of vehicle in accordance with regulation ECE-R 44 ⇒ ⚠.

#### Vehicle seat with integrated child seat

Universal child restraint systems for any group can be fitted to this seat if the integrated child seat ⇒ page 54, “Integrated child seat” is not used ⇒ ⚠. ▶

 **WARNING**

- Children must travel in a child seat appropriate to their weight and height.
- The vehicle seat must always be fitted in the direction of travel when securing child restraint systems in weight class 0 or 0+.
- Read and always observe information and warnings concerning the use of child seats ⇒  in “Safety notes on using child seats” on page 46.
- Please always read and follow the information and warnings provided by the child seat manufacturer.

 **Note**

- Due to space limitation, only the two outer seats can be used if two ISOFIX system seats are to be fitted in the second row of seats. ■

### Centre seat in the second row of seats (with three-point roof-anchored belt)

---

*Only the use of an officially approved child seat corresponding to the weight and height of the child is permitted.*

The centre seat **with** the three-point roof-anchored belt is suitable for weight classes 0 to 2 ⇒ .

#### Seat with ISOFIX retainers

Child seats fitted with the ISOFIX system can be used on the centre seat if it is equipped with ISOFIX retainers ⇒ .

 **WARNING**

The central seat with three-point roof anchored belt is not suited to universal child seats in group 3.

- The vehicle seat must always be fitted in the direction of travel when securing child restraint systems in weight class 0 or 0+.
- Children must travel in a child seat appropriate to their weight and height.
- Read and always observe information and warnings concerning the use of child seats ⇒  in “Safety notes on using child seats” on page 46.
- Please always read and follow the information and warnings provided by the child seat manufacturer.

 **Note**

- Due to space limitations, no further ISOFIX restraint systems can be fitted in the second row of seats once an ISOFIX system has been fitted to the centre seat. ■

## ISOFIX child seat mounting system

ISOFIX child seats can be mounted in the second and third row seats quickly, safely and easily.



Fig. 33 Retaining rings for ISOFIX child seats in the frames of the outer seats in the second row of seats



Fig. 34 Backrest adjustment when using ISOFIX child seats

When removing or fitting the child seat, please be sure to follow the manufacturer's instructions.

- Press the child seat onto the ISOFIX retaining rings ⇒ fig. 33 (arrows) until the child seat can be heard to engage securely.
- Pull on both sides of the child seat to ensure that it is secure.

When a child seat is mounted in seats equipped with the "ISOFIX" system, the backrest should be fitted in one of two positions ⇒ fig. 34 ① or ②.

**Two** ISOFIX retaining rings are secured to the body behind the seats in the second and third rows. The ISOFIX retaining rings are attached to the seat frames.

Child seats with ISOFIX mountings are available from Authorised SEAT Service Centres.

### WARNING

- The retaining rings are designed only for use with ISOFIX child seats.
- Never secure retaining belts, objects or non-ISOFIX child seats to the fastening rings. Risk of fatal accidents. ■

## Integrated child seat

### Basic information on the integrated child seat

*Proper use of child seats substantially reduces the risk of injury in an accident!*

It can be adjusted to suit the child's size and is suitable for children in the following groups according to the ECE-R 44 norm: Group 1 (9 - 18 Kg), Group 2 (15 - 25 kg) and Group 3 (22 - 36 kg).

**The integrated child seat for children in the Groups 1 and 2 must be used with the slumber roll delivered with the seat.**

For safety reasons, we recommend that the child seat for children in Group 1 is installed facing against the direction of travel. To do this, simply remove the seat and fit it again facing in the opposite direction. The child must be fastened in using the harness belt.

**The child seat may only be fitted in the direction of travel for children in Groups 2 and 3 who are fastened in using the three-point belt fitted in the vehicle.**

#### WARNING

- With the integrated child seat, the backrest may only be adjusted to the first or second backrest position for children in Groups 1 to 3.
- The slumber roll must always be fitted for children in Groups 1 and 2.
- The integrated child seat must not be modified in any way.
- Do not allow the belt webbing to become twisted or jammed, or to rub on any sharp edges.
- If the child seat or any parts of the seat are damaged, or if the child seat has to withstand the force of a collision in an accident, the seat, or part of the seat, must be replaced - preferably by a qualified dealership. ■

### Group 1 integrated child seat

*A suitable child seat and a correctly adjusted seat belt can help to protect your child.*



**Fig. 35** Using the integrated child seat

#### Setting up the child seat

- Pull the loop to the front in the direction of the arrow ⇒ fig. 35 **1**.
- Push the seat cushion in direction of the arrow **2** until it engages in position.
- Pull the loop **3** to fold down the child seat cushion in direction of arrow **4**.

#### Restoring the normal seat

- First fold the child seat cushion up. ▶



- Pull the loop ① in the direction of the arrow and push the seat cushion down until it engages.

### Fitting the slumber roll

- Remove the head restraint.
- Fit the head restraint onto the slumber roll.
- Reinsert the head restraint and push down until it can be heard to engage.

### Removing the slumber roll

- Remove the head restraint.
- Pull the slumber roll off the head restraint.
- Reinsert the head restraint and push down until it can be heard to engage.

For safety reasons, we recommend that the child seat for children in Group 1 is installed facing against the direction of travel. ■

## Adjusting the belt routing for larger children in Group 1

*A correctly adjusted seat belt helps to protect your child!*

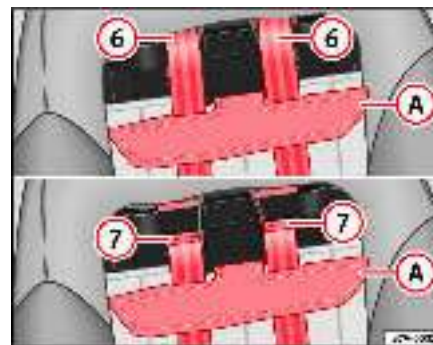

**Fig. 36** Integrated child seats. adjusting the belt routing

- Pull the upper part ⇒ fig. 36 ① of the support off the Velcro fasteners to the front.
- For larger children, guide the two shoulder belts in the side slots to the upper position ⑥.
- Then push the support ① under the belts and secure it ⇒ ⚠.

For smaller children, guide the two belts in the side slots to the lower position ⑦.



### WARNING

The support ⇒ fig. 36 ① must be pressed onto the seat in the area of the Velcro fastener in such a way that the belts can move freely in the slots. ■

### Fastening the harness belt for children in Group 1

*A correctly adjusted seat belt helps to protect your child!*

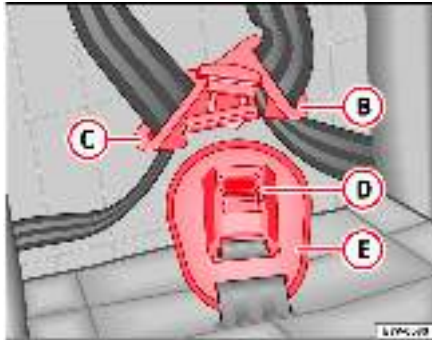

Fig. 37 Integrated child seats. closing harness belt



Fig. 38 Integrated child seats. adjusting harness belt

- Sit the child so that its bottom is as far back on the seat as possible.
- Place the belt to the right and left over the child's shoulders.
- Push the belt lock element ⇒ fig. 37 **B** with the tongue through the other lock element **C**.
- Insert both elements with the tongue at the front into the lock **D** until they click into place (**Pull to ensure they are securely engaged!**).
- Make sure that the protective cushion **E** is always underneath the belt lock **D**.
- Pull the upper part of the harness belt ⇒ fig. 38 **1** down in the direction of the arrow until the belt fits firmly against the body of the child.

#### **WARNING**

The harness belt must always fit firmly against the body of the child (even with thick or winter clothing) so that the child seat can provide the maximum amount of protection possible. ■

### Releasing the harness belt for children in Group 1

*A correctly adjusted seat belt helps to protect your child!*



Fig. 39 Integrated child seats. adjusting harness belt

- Press and hold the release button ⇒ fig. 39 ② in the direction of the arrow.
- With the release button pressed, pull the lower part of the harness belt ③ down in the direction of the arrow. ■

### Group 2 integrated child seat

*A suitable child seat and a correctly adjusted seat belt can help to protect your child.*

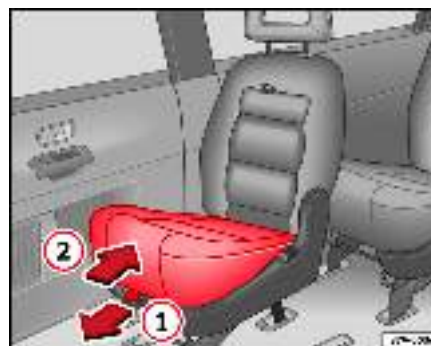



Fig. 40 Integrated child seats. lift up the cushion

#### Setting up the child seat

- Pull the loop to the front in the direction of the arrow ⇒ fig. 40 ①.
- Push the seat cushion in direction of the arrow ② until it engages in position.
- Remove the head restraint out of the backrest of the integrated child seat and replace the head restraint together with the slumber roll ①A.

#### Fastening the three-point belt

- Guide the shoulder part of the belt underneath the slumber roll. ►

- To fasten the three-point belt, take hold of the tongue and pull it slowly across the chest and lap.
- Push the tongue of the belt into the lock for that seat so that it engages audibly (**pull to check!**).
- Adjust the three-point belt to suit body size ⇒ .

### Restoring the normal seat

- Pull the loop  in the direction of the arrow and push the seat cushion down until it engages.

### Removing the slumber roll

- Remove the head restraint.
- Pull the slumber roll off the head restraint.
- Reinsert the head restraint and push down until it can be heard to engage.

Use the following measures to guarantee the proper routing of the shoulder belt:

- Seatbelt height setting
- Adjustment of the seat forwards and backwards
- Backrest angle adjustment

### WARNING

- For safety reasons, the seat for children in Group 2 may only be fitted in the direction of travel and in one of the outer positions (not on the centre seat).
- The risk of injury is increased if the belt is not correctly routed.

### WARNING (continued)

- The shoulder part of the belt should be positioned roughly over the centre of the shoulder, never across the neck, and fit closely against the upper part of the body.
- The lap belt part must lie across the pelvis, not across the stomach, and always fit closely. check the fitting of the belt. ■

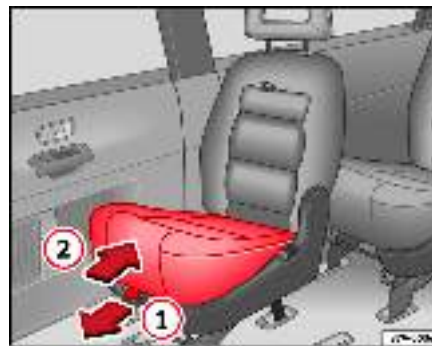

## Group 3 integrated child seat

*A suitable child seat and a correctly adjusted seat belt can help to protect your child.*



**Fig. 41** Using the integrated child seat

### Setting up the child seat

- Pull the loop to the front in the direction of the arrow ⇒ **fig. 41**  

- Push the seat cushion in direction of the arrow ② until it engages in position.

### Fastening the three-point belt

- To fasten the three-point belt, take hold of the tongue and pull it slowly across the chest and lap.
- Push the tongue of the belt into the lock for that seat so that it engages audibly (**pull to check!**).
- Adjust the three-point belt to suit body size ⇒ ⚠.

### Restoring the normal seat

- Pull the loop ① in the direction of the arrow and push the seat cushion down until it engages.

Use the following measures to guarantee the proper routing of the shoulder belt:

- Seatbelt height setting
- Adjustment of the seat forwards and backwards
- Backrest angle adjustment

### ⚠ WARNING

- For safety reasons, the seat for children in Group 3 may only be fitted in the direction of travel and in one of the outer positions (not on the centre seat).
- The risk of injury is increased if the belt is not correctly routed.
- The shoulder part of the belt should be positioned roughly over the centre of the shoulder, never across the neck, and fit closely against the upper part of the body.

### ⚠ WARNING (continued)

- The lap belt part must lie across the pelvis, not across the stomach, and always fit closely. check the fitting of the belt. ■

## Cleaning the child seat

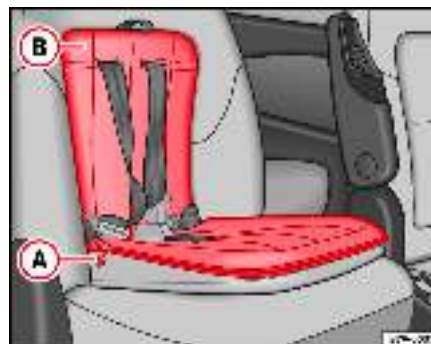

Fig. 42 Section of integrated child seat

- Open the zip ⇒ fig. 42 ① fully and undo it at the end.
- Pull the cover from the Velcro fastening in area ②.
- Guide the belt lock and the harness belts through the cover and remove the child seat cover.

The child seat cover can be washed in a washing machine at a maximum temperature of 30°C.

**WARNING**

When refitting the child seat cover, please ensure that the cover is fitted to the seat in the area of the Velcro fastening in such a way that the belts can move freely in the slots. ■



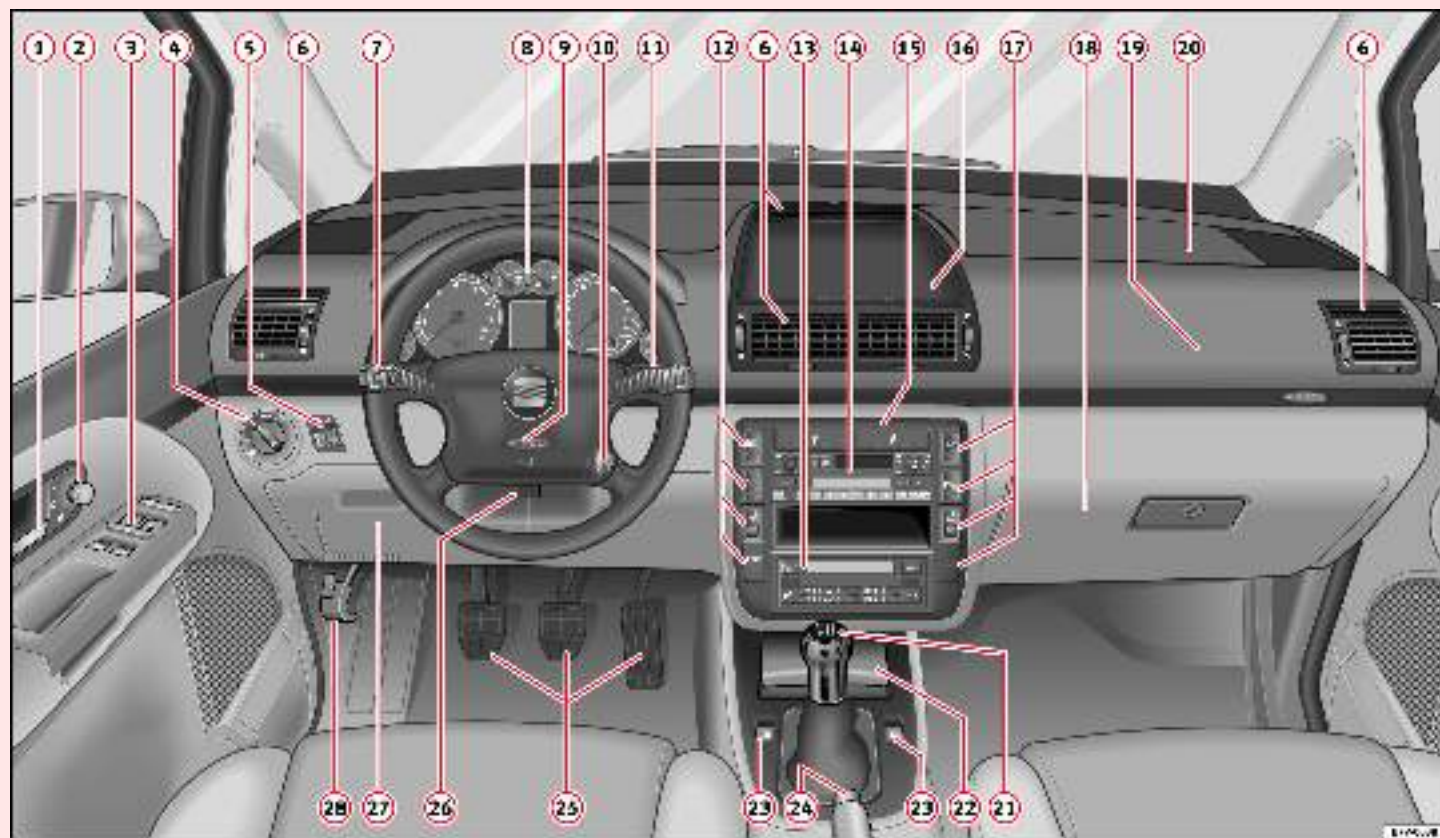

Fig. 43 Instrument panel



# Operating instructions

## Cockpit

### Overview

#### Overview of the instrument panel

*This overview will help you to familiarise yourself with the controls and displays.*

①	Door release lever .....	93
②	Electric wing mirror adjustment control .....	120
③	Electric window control .....	102
④	Light switch .....	110
⑤	Instrument lighting control / Headlamp range control .....	110
⑥	Air outlets	
⑦	main beam and turn signal light lever/ Cruise control* .....	112,176
⑧	Instrument panel / warning lights .....	64, 72
⑨	Horn / Driver's airbag* .....	37
⑩	Ignition lock .....	162
⑪	Windscreen wiper lever .....	117
⑫	Switches for:	
	– rear window heater .....	116
	– windscreen heater* .....	116
	– left seat heating* .....	126
	– ESP* .....	182
⑬	Climatronic .....	152
⑭	Radio	

⑮	Cup holder* .....	137
⑯	Central upper stowage compartment .....	135
⑰	Switches for:	
	– hazard warning light switch .....	111
	– PDC* (parking distance control) .....	174
	– right seat heating* .....	126
	– cover for supplementary switch	
⑱	Glove box/Stowage compartment .....	135
⑲	Passenger airbag* .....	37
⑳	Passenger side upper stowage compartment .....	134
㉑	Gear lever .....	166
㉒	Ash tray/ lighter .....	140
㉓	Electric side window controls* .....	102
㉔	Handbrake .....	173
㉕	Pedals	
㉖	Steering control adjustment lever* .....	160
㉗	Fusebox cover .....	241
㉘	Unlock bonnet lever .....	211



#### Note

- Some of the items of equipment listed here are fitted only on certain models/model years or are optional extras.
- In versions with the steering wheel on the right, the layout of the control elements is somewhat different. But the symbols assigned to the controls ▶

correspond to the symbols used in the versions with the steering wheel on the left. ■

## Instruments

### Instrument overview

*The instruments display the vehicle operating status.*

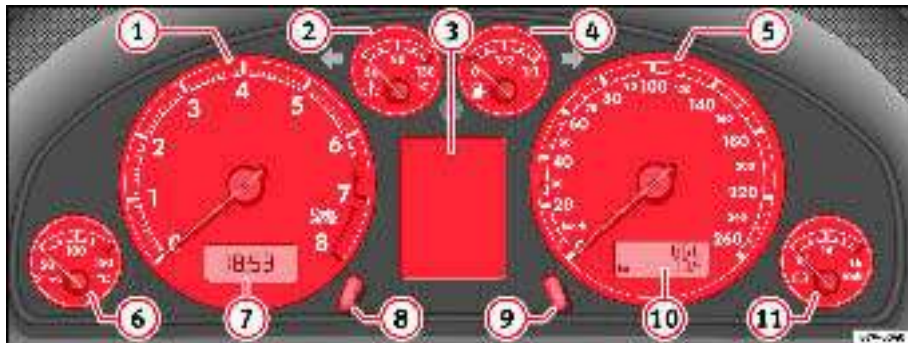

Fig. 44 Detailed view of dash panel instrument panel

- ① Rev counter ⇒ page 65
- ② Engine coolant temperature gauge ⇒ page 65
- ③ Display in the combi-instrument<sup>4)</sup> and warning lamps ⇒ page 72<sup>4)</sup>
- ④ Fuel gauge ⇒ page 66
- ⑤ Speedometer
- ⑥ Engine oil temperature gauge<sup>4)</sup> ⇒ page 67
- ⑦ Clock ⇒ page 67
- ⑧ Setting knob for the clock
- ⑨ Adjust kilometre button
- ⑩ Odometer (total mileage / trip recorder) ⇒ page 67
- ⑪ Voltmeter<sup>4)</sup> ⇒ page 67 ■

<sup>4)</sup> Optional equipment

## Rev counter

The rev. counter displays the engine speed in revolutions per minute.

If, for example, the needle is directly over the 2, this corresponds to an engine speed of 2000 rpm (revolutions per minute) ⇒ page 64, fig. 44 ①.

The start of the red zone on the dial indicates the maximum engine speed which may be used briefly when the engine is warm and after it has been run in properly. However, it is advisable to change up a gear or move the selector lever to D (or lift your foot off the accelerator) before the needle reaches the red zone.

### ⚠ Caution

The rev counter needle must never enter the red zone on the scale. Risk of engine damage.

### 🌸 For the sake of the environment

Changing up a gear early will help you to save fuel and minimise engine noise. ■

## Engine coolant temperature display

This gauge shows the engine coolant temperature.



Fig. 45 Instrument panel: engine coolant temperature gauge

The display only works when the ignition is switched on. The symbol  will also light up in the display for some seconds as a function check.

### Needle in cold zone A

Avoid high engine speeds and heavy engine loads ⇒ fig. 45 2.

### Needle in normal zone B

In normal driving conditions, the needle should be in the middle section of the scale. The temperature may also rise when the engine is working hard, especially at high outside temperatures. This is no cause for concern, as long as the warning lamp C does not light up ⇒ page 72.

### Needle in warning zone C

The warning lamp  9 will light up if the needle is in the warning zone. The warning text <sup>5)</sup> **STOP CHECK COOLANT SERVICE MANUAL** may also appear in ►

the combi-instrument display. **Stop the car and switch off the engine.** Allow the engine to cool and check the coolant level ⇒ .

Even if the coolant level is correct **do not continue driving.** You should obtain technical assistance.

### **WARNING**

Read and observe the warnings “Working in the engine compartment” before opening the bonnet to carry out work in the engine compartment.

### **Caution**

Accessories in front of the air inlet reduce the cooling effect of the coolant. At high outside temperatures and high engine loads, there is a risk of the engine overheating. ■

## Fuel gauge

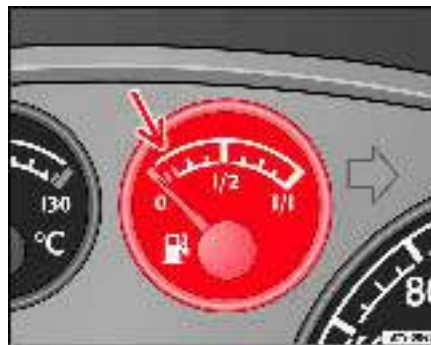



Fig. 46 Instrument panel: fuel gauge

The fuel tank has a capacity of approx. 70 litres.

When the needle reaches the reserve zone ⇒ fig. 46 -arrow-, the warning lamp  lights up in the display. The text<sup>6)</sup> **PLEASE REFUEL** may appear in the combi-instrument display. At the same time, an audible warning is given **as a reminder to fill up**. At this point there are still about 8 litres of fuel in the tank. ■

<sup>5)</sup> Depending on model version

<sup>6)</sup> Depending on model version

## Engine oil temperature display

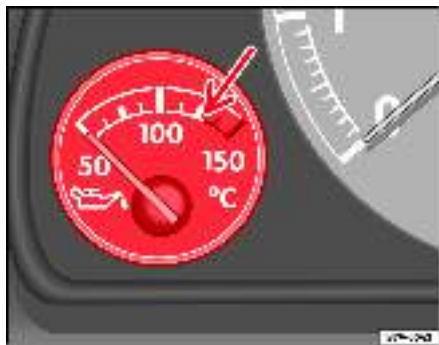

Fig. 47 Engine oil temperature gauge

Do not drive at full throttle if the temperature gauge indicates that the oil in the engine is still cold. The engine revs should be reduced if the pointer goes into the red area ⇒ fig. 47 -arrow-. The needle must then return to the normal zone.

If the pointer remains in the red zone, switch off the engine and check the engine oil level. If the oil level is correct and the oil pressure warning lamp does not start flashing when the engine is started, you can drive on to the nearest qualified dealer, but do not run the engine at high speeds. ■

## Setting the clock

*The setting knob is located beneath the rev counter.*

### Setting the hour

- Turn the setting knob ⇒ page 64, fig. 44 ⑧ briefly in an anti-clockwise direction to move the hour forward by one hour or
- Turn and hold the setting knob in an anti-clockwise direction to move the hour forward more quickly.

### Setting the minutes

- Turn the setting knob briefly in a clockwise direction to set the clock forward by one minute or
- Turn and hold the setting knob in a clockwise direction to set the minutes forward more quickly. ■

## Mileage display

The top counter of the mileage display ⇒ page 64, fig. 44 ⑩ registers the total mileage covered by the vehicle.

The lower counter registers the short journeys. The last digit indicates steps of 100 metres. The trip recorder counter may be reset by the reset button ⇒ page 64, fig. 44 ⑨. ■

## Voltmeter

The voltmeter ⇒ page 64, fig. 44 ⑪ indicates the voltage of the vehicle electrical system. The voltage of the electrical system should normally be ►

between 12 and 15 volts. If the voltage drops below 12 volts when the engine is running, you should have the power supply (battery and alternator) checked by a qualified dealership.



### Note

The voltage may drop below 8 volts while the engine is being started. ■

## Service Interval Display

The service display is shown either on the mileage display ⇒ page 64, fig. 44 (10) or in the display <sup>7)</sup> in the combi-instrument ⇒ page 64, fig. 44 (3).

### Service warning

A service pre-warning will appear in the odometer if a service is due soon. A spanner symbol  appears in the display along with the **miles** and the number of kilometres until the next service. The service message will disappear approximately 20 seconds after the ignition is switched on or if the engine is running.

The distance quoted to the next scheduled service is reduced in increments of 100 miles.

The following information text displayed in the instrument panel display : **SERVICE IN... KM OR SERVICE IN... DAYS**. The service message will disappear approximately 20 seconds after the ignition is switched on or the engine is running. The normal display can be resumed by pressing the reset button on the trip counter or by pressing the rocker switch of the windscreen wiper lever (B).

If a **service is due**, a gong signal will sound and the flashing “spanner” symbol will appear for approximately 20 seconds. The following information text displayed in the instrument panel display: **SERVICE NOW**.

<sup>7)</sup> Optional equipment

With the ignition switched on, you can call up the current **service message** by pressing the trip counter reset knob for 2 seconds.

An **overdue service** is indicated by a minus sign in front of the mileage or day information.

### Resetting the service display

The display is reset by the SEAT dealer after the service has been carried out. You will receive a print-out from the SEAT dealership as confirmation that this work has been carried out.

If the service is not carried out by a SEAT Service centre, the service interval display will have to be reset manually as follows:

- Switch off ignition.
- Press and hold the reset knob for the trip meter.
- Turn the ignition on and turn the reset button to the right. The display will return to the normal mode.



### Note

- The next service will be displayed after 15,000 km (10,000 miles) if you reset the service display yourself. The service interval will not be determined individually.
- Do not reset the display between service intervals as the display will otherwise be incorrect. ■

## Display in the instrument panel

### Fault messages

*Faults are shown by warning lamps and / or as symbols with warning and information reports on the display.*

The system runs a check on certain components and functions when the ignition is switched on and while the vehicle is moving. Functional problems are shown by warning lamps and / or red or yellow symbols with fault texts on the

combi-instrument. Depending on the exact nature of the functional problem, audible warnings may also be given.



#### Note

- The size of the display depends on the type of combi-instrument you have fitted. In some models, the combi-instrument does not have an integrated display.
- In addition to warning messages given on a fault, you will receive information in the display on procedures or will be asked to carry out certain tasks. ■

### Overview of selected fault messages



*Fault messages are displayed on the combi-instrument display.*

The following overview does not show all fault messages. Not all fault messages are displayed with a symbol.









#### Warning symbols (priority 1)

If the symbol lights up again after a fault has been corrected, you should stop the vehicle immediately, switch off the engine and seek professional advice.

Fault message	Symbol	Action
<b>STOP BRAKE FAULT SERVICE MANUAL</b>		Stop the car, turn the engine off and check the brake fluid level ⇒ page 221.
<b>HANDBRAKE ON</b>		Release the handbrake.
<b>STOP BRAKE FAULT SERVICE MANUAL</b>	 and 	Stop the car, turn the engine off and seek professional help ⇒ page 179
<b>STOP CHECK COOLANT SERVICE MANUAL</b>		Checking coolant level ⇒ page 216

Fault message	Symbol	Action
<b>STOP OIL PRESSURE ENGINE OFF SERVICE MANUAL</b>		Stop the car, turn the engine off and check the brake fluid level ⇒ page 214.
<b>ALTERNATOR WORKSHOP!</b>		Take the vehicle to a qualified workshop as soon as possible and have the alternator checked.
<b>FASTEN SEATBELT</b>		Fasten your seat belt correctly; and make sure your passengers are also properly belted in ⇒ page 18.

#### Information symbols (priority 2)

Fault message	Symbol	Action
<b>CHECK OIL LEVEL</b>		Check the oil level and top up with the right engine oil. ⇒ page 214
<b>OIL SENSOR WORKSHOP</b>		Take the vehicle to an Authorised Service Centre as soon as possible and have the engine checked.
<b>STOP BRAKE FAULT SERVICE MANUAL</b>		Take the vehicle to a qualified workshop as soon as possible and have the ABS checked.
<b>PLEASE REFUEL</b>		Refuel as soon as possible.
<b>TOP UP WASHER FLUID</b>		Fill up with water and washer fluid.
<b>CHECK BRAKE PADS</b>		Take the vehicle to a qualified workshop immediately and have the brake pads checked.
<b>EXHAUST WORKSHOP</b>		Take the vehicle to an Authorised Service Centre as soon as possible and have the engine checked.
<b>ENGINE FAULT CONSULT WORKSHOP</b>	 or <b>EPC</b>	Take the vehicle to an Authorised Service Centre as soon as possible and have the engine checked.
<b>AIRBAG FAULT</b>		Take the vehicle to a qualified workshop immediately and have the airbag system checked.



## Fault message priorities

---

### Priority 1 fault messages (red)

If one of these faults occurs, the warning lamp will flash or light up and will be accompanied by **three audible warnings** ⇒ . This is a **danger** warning. Stop the car and switch off the engine. Check the fault and correct it. Obtain professional assistance if necessary.

If several priority 1 faults are detected at the same time, the symbols will be displayed one after the other for about 2 seconds at a time. The symbols will keep flashing until the faults have been rectified.

No menus will be shown in the display for the duration of a priority 1 warning report.

### Priority 2 fault messages (yellow):

If one of these faults occurs, the warning lamp lights up, and is accompanied by **one audible warning**. The function should be checked as soon as possible.

If several priority 2 warning reports are detected at the same time, the symbols are displayed one after the other for about 2 seconds at a time.

**Priority 2** warning reports will not be shown until all **Priority 1** warning reports have been dealt with!



### WARNING

Failure to observe fault texts and warning lamps can result in serious personal injury or damage to your vehicle. ■





## Warning lamps













### Overview of the warning lamps

The warning lamps indicate a number of different functions and possible faults.



Fig. 48 Instrument panel with warning lamps. Some of the items of equipment listed here are fitted only on certain models/model years or are optional extras.

Item	Symbol	Meaning of warning and control lamps	Further information
①		Airbag	⇒ page 34
②		Trailer turn signals*	⇒ page 74
③		Cruise control	⇒ page 75
④		Operate the foot brake	⇒ page 75
⑤		Rear fog light	⇒ page 75

Item	Symbol	Meaning of warning and control lamps	Further information
6		<b>If lit:</b> preheating system active. <b>If flashing:</b> there is a fault in the engine management (diesel engines). Contact a specialist workshop.	⇒ page 75
7		Turn signals	⇒ page 75
8	<b>EPC</b>	Engine fault (petrol engine)	⇒ page 75
9		Main beam headlights	⇒ page 75
10		Fault in the emission control system	⇒ page 76
11		Traction control system TCS	⇒ page 76
11		Electronic Stabilising Program* (ESP)	⇒ page 76
12		Anti-lock brake system ABS	⇒ page 76
13		Diesel particulate filter	⇒ page 77
14		Brakes/Handbrake	⇒ page 78
15		Alternator	⇒ page 78
16		Seat belt warning lamp*	⇒ page 18
17		Fuel reserve	⇒ page 78
18		Fault in lights*	⇒ page 78

Item	Symbol	Meaning of warning and control lamps	Further information
19		Tailgate open display*	⇒ page 79
20		Windscreen washer fluid*	⇒ page 79
21		Door open display*	⇒ page 79
22		Brake pad wear indicator*	⇒ page 79
23		Engine oil level/pressure*	⇒ page 79
24		Coolant temperature/level gauge	⇒ page 80

### WARNING

- Failure to observe warning lamps and warning messages can result in serious personal injury or damage to your vehicle.
- The risk of an accident increases if your vehicle breaks down. Use a warning triangle to draw the attention of other road users to your stationary vehicle so that it does not represent a danger.
- The engine compartment of any motor vehicle is a dangerous area! Before you open the bonnet to work on the engine or in the engine compartment, you must switch off the engine and allow it to cool to reduce the risk of scalding or other injuries. Read and observe the relevant warnings ⇒ page 209.

### Note

- The appropriate warning lamp for a fault will light up in vehicles without warning or information texts in the display.

- In vehicles with warning or information texts in the display, the appropriate warning lamp for a fault will light up and a warning or information text will also appear in the display. ■

### Trailer turn signals

*This warning lamp also flashes when the turn signals are operated while towing a caravan or trailer.*

The warning lamp flashes when the turn signals are operated, provided a trailer is correctly attached and connected to the vehicle.

The warning lamp will not flash if one of the turn signals on the trailer fails. ■

### Cruise control system\*

*The warning lamp comes on when the cruise control system is switched on.*

The warning lamp  lights up when the cruise control system is switched on. For further notes on the cruise control system see ⇒ page 176. ■

### Operating the foot brake

The footbrake must be depressed when this warning lamp lights up. This is necessary when the automatic gearbox\* selector lever is moved out of the positions **P** or **N**. ■

### Rear fog light

This warning lamp lights up when the rear fog light is switched on . Further information ⇒ page 109. ■

### Faults in diesel engines



*This indicator monitors the engine management system for diesel engines.*

If a malfunction occurs in the engine management system while you are driving, the control lamp will flash . Take the vehicle to an Authorised Service Centre as soon as possible and have the engine checked.

At the same time, a text message or the necessary operations may appear on the instrument panel. ■

### Turn signals

*The warning lamp flashes when the turn signals are in operation.*

Depending on which turn signal is operated, either the left  or right  indicator lamp flashes. Both warning lamps will flash at the same time when the hazard warning lights are switched on.

If one turn signal fails, the warning lamp will start flashing twice as fast.

Further information on the turn signals ⇒ page 112. ■

### Engine management EPC

*This warning lamp monitors the engine management system for petrol engines.*

The warning lamp **EPC** (Electronic Power Control) lights up when the ignition is switched on to show that the lamp is working properly. It should go out when the engine has started running.

If a fault develops in the electronic engine management system while you are driving, this warning lamp will light up. Take the vehicle to an Authorised Service Centre as soon as possible and have the engine checked. ■

### Main beam headlights

*This warning lamp lights up when the main beams are on.*

The warning lamp  lights up when the main beams are on or when the headlight flasher is operated.

Further information ⇒ page 112. ■

## Fault in the exhaust system\*

### Exhaust gas indicator

If the indicator  **flashes** it signals possible damage to the catalytic converter caused by defective combustion. Reduce speed immediately and go to the nearest specialised workshop to check the engine. At the same time, a text message or the necessary operations may appear on the instrument panel.

If the indicator  **lights up**, a fault has developed during driving which affects the quality of the exhaust gas (e.g. lambda probe fault). Reduce speed immediately and go to the nearest specialised workshop to check the engine. At the same time, a text message or the necessary operations may appear on the instrument panel. ■

## Traction control system (TCS)\*

*The traction control system prevents the driven wheels from spinning when the vehicle is accelerating*

The warning lamp lights up when the ignition is switched on and should turn out after about 2 seconds.

When the TCS is operating while driving, the warning lamp flashes. If the system is deactivated or if there is any fault in the same, the warning lamp will remain lit.

It will also come on if a fault should occur in the ABS because the TCS operates in conjunction with the ABS. For further information see ⇒ page 181 ■

## Electronic stabilisation programme (ESP)\*

*This warning lamp monitors the electronic stabilisation programme.*

This programme includes the ABS, EDL and TCS.

The warning lamp  has the following functions:

- It will light for about 2 seconds when the ignition is switched on while a test of the function is carried out.
- It flashes when the ESP is activated when driving.
- It will light up continuously if there is a malfunction in the ESP.
- It will light up continuously if the ESP is switched off.
- It will also come on if a fault should occur in the ABS because the ESP operates in conjunction with the ABS.

If the ESP warning lamp  lights up and stays on after the engine is started, this may mean that the control system has temporarily switched off the ESP. In this case the ESP can be reactivated by switching the ignition off and then on again. If the warning lamp goes out, this means the system is fully functional. ■

## Anti-lock brake system (ABS)

*A warning lamp system monitors the ABS.*

The warning lamp  should light up for a few seconds when the ignition is switched on. It goes out again after the system has run through an automatic test sequence.

**There is a fault in the ABS if:**



- The warning lamp  does not light up when the ignition is switched on.
- The warning lamp does not go out again after a few seconds. ►

- The warning lamp lights up when the vehicle is moving.



The vehicle can still be braked in the normal way (except that the ABS control function will not function). Please take the vehicle to a qualified workshop as soon as possible. For further information on the ABS see the ⇒ page 180.

If a fault occurs in the ABS, the ESP\* warning lamp will also light up.

### Brake system fault

If the ABS warning lamp  lights up together with the brake warning lamp , this indicates not only a fault in the ABS function, but also a possible fault in the brake system ⇒ .

### WARNING



- **Before opening the bonnet, read and observe the warnings on ⇒ page 209, “Working in the engine compartment”.**
- **If the brake warning lamp  should light up together with the ABS warning lamp , stop the vehicle immediately and check the brake fluid level in the reservoir ⇒ page 221, “Brake fluid”. If the fluid level has dropped below the “MIN” mark you must not drive on. Risk of accident. Obtain technical assistance.**
- **If the brake fluid level is correct, the fault in the brake system may have been caused by a failure of the ABS system. This could cause the rear wheels to lock quickly when you brake. This could cause the rear to break away. Risk of skidding. Drive carefully to the nearest qualified workshop and have the fault corrected. ■**

### Differential lock fault (EDL)\*

*EDL operates along with the ABS in vehicles equipped with an Electronic Stabilisation Program (ESP)\**

A malfunction in the EDL is indicated by the ABS warning lamp . Please take the vehicle to a qualified workshop as soon as possible. For further information on the EDL ⇒ page 182. ■

### Diesel particulate filter indicator lamp\*

When the indicator  lights on the instrument panel it signals that the filter is blocked by soot because of frequent short journeys. To clean the filter of these particulates, drive at a constant speed of 60 km/h for 15 minutes. Always respect the speed limit. The most efficient way to clean the diesel particulate filter is to drive in 4th or 5th gear, at approximately 2,000 rpm. ⇒ . This causes a temperature increase sufficient to burn the soot in the filter.

If the lamp  remains lit afterwards, go to a specialised workshop to examine the problem.

While the lamp  is lit (filter blockage signal) fuel consumption increases and the engine may lose power in some cases.

At the same time, a text message or the necessary operations may appear on the instrument panel.

### WARNING

- **Try to always adapt the speed of the vehicle to weather, road and traffic conditions. The indications suggested by the warning lights should not lead you to disobey the highway code. ■**



## Brake system\* / handbrake

*The warning lamp lights up if the handbrake is applied, if the brake fluid level falls too low or if there is a fault in the brake system.*

**This warning lamp  lights up if**

- If the handbrake is on
- If the brake fluid level is too low
- If there is a fault in the brake system

This warning lamp can light up together with the anti-lock brake system warning lamp.

 <b>WARNING</b>
<ul style="list-style-type: none"> <li>• <b>Before opening the bonnet, read and observe the warnings on</b></li> <li>• <b>If the brake warning lamp does not go out, or if it lights up when driving, the brake fluid level in the reservoir is too low. Risk of accident. Stop the vehicle and do not drive on. Obtain technical assistance.</b></li> <li>• <b>If the brake warning lamp  lights up together with the ABS warning lamp , the control function of the ABS could be out of action. This could cause the rear wheels to lock quickly when you brake. This could cause the rear to break away. Risk of skidding. Drive carefully to the nearest qualified workshop and have the fault corrected. ■</b></li> </ul>

## Alternator

*This warning lamp signals a fault in the alternator.*

The warning lamp  lights up when the ignition is switched on. It should go out when the engine has started running.

If the warning lamp  lights up while driving, the alternator is no longer charging the battery. You should immediately drive to the nearest qualified workshop.

You should avoid using electrical equipment that is not absolutely necessary because this will drain the battery.

If the indicator flashes the voltage is insufficient for normal vehicle operation. ■

## Fuel level / reserve

*This symbol lights up to indicate that the fuel tank is down to the reserve level.*

This lights when only 7 litres of fuel remain in the tank. Also, an **audible warning** is given. This serves as a reminder to fill up with fuel at the earliest opportunity ■

## Bulb defect

*The warning lamp lights up when a bulb in the vehicle's exterior lighting is defective.*

The warning lamp  lights up when a bulb in the vehicle's exterior lighting (e.g. left-hand main beam) is defective. ■



## Tailgate open display\*

When the ignition is switched on, the warning light indicates that the tailgate is open.

The warning light only goes off when the tailgate is completely closed. ■

## Washer fluid

*This warning lamp lights up to indicate that the windscreen washer level is too low.*

This serves as a reminder to fill up the reservoir at the earliest opportunity → page 218. ■

## Door open display\*

This light comes on when a door is open or incorrectly closed. ■

## Brake pad wear indicator\*

As the brake pad wear indicator only monitors the front brake pads, it is advisable to have the rear brake pads inspected at the same time.

### **WARNING**

**Have the brake pads inspected immediately by a qualified Dealership if the warning display  lights up. ■**

## Engine oil pressure

*The warning light indicates that the engine oil pressure is too low or that the oil gauge does not operate correctly.*

### **It lights up or flashes in red (oil pressure too low)**

If the warning light lights up or starts to flash in red while driving, a sound signal will also be emitted three times when the engine speed exceeds 1500 rpm. Stop and switch off the engine: check the oil level and replace if necessary → page 214.

If the warning light flashes even though the oil level is correct, do not continue driving. The engine should not be turning even at idle speed. Obtain technical assistance.

If, while driving, the engine speed falls to below idling speed, the oil pressure warning light may come on. Increase the engine speed by accelerating or dropping to a lower gear.

### **A yellow light comes on (oil level\* too low)**

If the warning light comes on in yellow, this indicates that the oil level is too low. Switch off engine, check oil level, replacing where necessary.

When the bonnet is opened the oil level warning will fall to zero. But if it is not topped with oil, the light will come back on after approximately 100 km.

### **Yellow flashing (defective oil level\* )**

If the oil gauge is faulty, a sound signal is emitted and the warning light flashes several times.

At the same time, a warning appears briefly on the on board computer display\*. The engine should immediately be checked by a Technical Service Centre.

From the moment the defect appears until the engine is checked, the level of oil should be constantly monitored, preferably every time the vehicle is refuelled. ■

## Coolant Level\* / temperature

*The warning lamp lights up if the coolant temperature is too high or if the coolant level is too low.*

### There is a fault if:

- The warning symbol does not go out again after a few seconds.
- The warning lamp lights up or flashes while the vehicle is moving, while **three acoustic warning signals** ⇒  are emitted.

This means that either the coolant level is too low or the coolant temperature is too high.

### Coolant temperature too high

First look at the coolant temperature gauge. The coolant temperature is too high if the needle is over the warning area on the dial. **Stop the vehicle, switch off the engine and wait for it to cool down.** Check the coolant level.

If the coolant level is correct, the overheating may be caused by a malfunction of the radiator fan. Check the radiator fan fuse and have it replaced if necessary ⇒ page 241.

If the warning lamp lights up again after driving on for a short distance, **stop the vehicle and switch off the engine.** Contact an Authorised Service Centre or a qualified workshop.

### Coolant level too low

The following information text is displayed in the instrument panel display:

First look at the coolant temperature gauge. If the needle is in the normal range, top up with coolant at the earliest opportunity ⇒ .

### WARNING

- If your vehicle is immobilised for any technical reasons, move it to a safe distance from traffic. Turn off the engine, turn on the hazard lights and place the warning triangle.

### WARNING (continued)

- **Never open the bonnet if you can see or hear steam or coolant escaping from the engine compartment. Risk of scalding. Wait until you can no longer see or hear escaping steam or coolant.**
- **The engine compartment of any motor vehicle is a dangerous area! Before carrying out any work in the engine compartment, switch off the engine and allow it to cool down. Always note the corresponding warnings ⇒ page 209. ■**

## On board computer with multifunction display

### Description

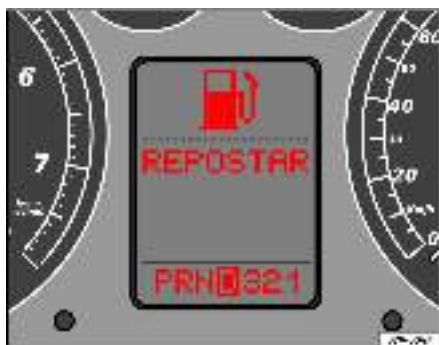

Fig. 49 Vehicle instrument panel display with telematic or navigation system.



Fig. 50 Display in vehicle with on-board computer.

The information from the multi-function indicator and on board computer is shown on these displays. The functions and indications of the multi-function indicator are described in the chapter “Instruments”.

When the ignition is switched on, the on-board computer continually controls the working of certain systems and vehicle components while the vehicle is in motion.

Faults in the operation or urgent repairs or services are indicated by sound signals and light warnings in red or yellow, depending on priority, on the instrument panel.

In addition to the red and yellow symbols, text messages appear on the driver's display.



#### Note

- Depending on the model version or the country, it is possible that the equipment installed in your vehicle does not display certain messages, or they do not correspond with those in this manual. For this reason, we advise you to consult the chapter “Luminous Indicators” for complementary information on the different symbols and a description of their function. ■

### Check operation

#### Vehicles with a manual gearbox

If faults exist, these will be indicated after the ignition is switched on. The corresponding sound signal is emitted at the same time.

#### Vehicles with an automatic gearbox

Once the ignition is switched on with the lever in position **P** or **N**, the driver warning appears on the display:

#### WITH CAR STOPPED, DEPRESS BRAKE TO SELECT GEAR

After selecting a gear (**R**, **D**, etc) the warning is erased. ▶

Where one or more faults exist, the warning disappears some 15 seconds after the engine is started, and the corresponding fault symbols with their respective text messages appear on the display.

#### For all vehicles

A sound signal is emitted in the event of a fault:

- **Priority 1 - three buzzes**
- **Priority 2 - one buzz**

If priority 1 and 2 faults occur at the same time, three buzzes are emitted.

In the event of a fault, the symbol with the corresponding text message is displayed.



#### Note

Priority 2 faults are displayed after repairing or eliminating priority 1 faults. ■

### Priority 1 (red symbols)

*Priority 1 symbols warn of a dangerous situation. Therefore the engine should be stopped and switched off.*

Where various priority 1 faults exist, the symbols appear one by one for approx 2 seconds. The symbols will keep flashing until the faults have been rectified.

The following priority 1 warnings or faults may appear:

#### Engine oil pressure

The corresponding warning is:

**STOP PRES. OIL**

**STOP ENGINE!**

If this symbol begins to flash while driving, stop and switch off the engine immediately. Check the oil level and replace if necessary.

If the symbol continues flashing, even though the oil level is correct, do not continue driving. The engine should not turn over even at idling speed, technical assistance is necessary.

#### Brake system

The corresponding warning is:

**STOP BRAKE FLUID**

**SERVICE MANUAL.**

This symbol lights up if the level of brake fluid is too low. Stop the vehicle immediately and check the level of the brake fluid.

#### 2. ABS, EDL\*, TCS\* and ESP\* systems

The corresponding warning is:

**STOP BRAKES FAULTY**

**SERVICE MANUAL.**

If the brake warning light flashes while the ABS warning light is lit up, this indicates that the ABS system is faulty and that the behaviour of the normal brake system may be damaged.

The EDS system works in conjunction with the ABS. If the EDS stops working, the ABS warning lamp comes on. When the ASR and the ESP fail this light also comes on. Consult a Technical Service Centre as soon as possible.

#### 3. Handbrake

The corresponding warning is:

**HANDBRAKE ON**

The handbrake warning lamp lights up when the handbrake is applied with the ignition on. It should go out when the handbrake is released. If it does not this indicates a fault in the brake system. ▶

An audible signal is also given if the car is driven faster than 6 km/h (approx. 4 mph) with the handbrake applied.

### Coolant temperature/level gauge

The corresponding warning is:

#### STOP CHECK LEVEL COOLANT

#### SERVICE MANUAL.

If the symbol flashes while driving, this means that either the coolant temperature is too high or the coolant level is too low. Stop immediately, switch off the engine and check the level. Top up coolant if necessary.

If the coolant level is correct, the overheating may be caused by a malfunction of the radiator fan. In this case, check the radiator fan fuse, and replace if necessary.

If the warning light does not go out, although the coolant level is correct and the fan fuse is correct, do not continue driving. Obtain technical assistance.

If the fault is only in the radiator fan, it is possible to continue driving as far as the nearest Technical Service Centre, as long as the coolant level is correct and the display light is off.

### Alternator

The corresponding warning is:

#### ALTERNATOR WORKSHOP!

The warning lamp lights up when the ignition is switched on. It should go out when the engine is started.

The alternator is operated by a long-lasting drive belt.

If the warning light lights up while driving, stop, switch off the engine and check the drive belt. If the belt is loose or broken, do not continue driving, as the coolant pump will not be driven. The belt should be checked or replaced.

If the warning light comes on even though the belt is neither loose nor broken, it is usually possible to continue driving to the nearest Technical Service Centre.

As the vehicle battery will discharge, it is advisable to switch off all non-vital electrical consumers.

### Seat belt warning lamp

The corresponding warning is:

#### FASTEN SEAT BELT

This warning light (only in some countries) lights up for approximately 6 seconds when the ignition is switched on to remind occupants to fasten seat-belts. If the seat belts are not fastened, a sound signal is emitted when the ignition is switched on which will stop when the seat belts are fastened or after approximately 6 seconds.



#### WARNING

- If the brake fluid level is below the "MIN" mark, you should wait for assistance from specialised personnel before continuing to drive.
- If the fluid level is correct, the fault may lie in the ABS. If the ABS control system fails, the rear wheels may block rapidly on braking. This, in certain circumstances, could cause the vehicle to skid.
- Never open the bonnet if you see steam or coolant escaping from the engine compartment. Risk of burns. Wait until you can no longer see or hear escaping steam or coolant.
- Do not touch the fan, as it could suddenly start to operate, even if the ignition is switched off.
- To prevent burns from boiling coolant, the following should be observed:
- Take care when opening the coolant expansion tank!. When the engine is warm or hot, the system is pressurised! Therefore wait until the engine cools before opening the cap.

 **WARNING** (continued)

- To protect your face, hands and arms from hot steam or fluid, cover the fan cap with a large cloth in order to open it.
- Take care to avoid coolant spilling on the exhaust pipe or any other hot component as antifreeze is inflammable. ■

## Priority 2 (yellow symbols)

If a yellow symbol appears, a sound signal is emitted. The symbols indicate a dangerous situation. The function shown should be controlled as fast as possible. If various faults occur at the same time, the symbols will be displayed one by one for approx. 2 seconds.

### Oil level too low

The corresponding warning is:

#### CHECK LEVEL OIL

If the symbol lights up: stop, switch off the engine and check the oil level, topping up where necessary.

### Oil level too low

The corresponding warning is:

#### OIL SENSOR WORKSHOP!

If the symbol flashes this probably means that the oil level sensor is defective. The vehicle should immediately be taken to a Technical Service Centre. It is possible to continue driving, but the oil level should be continually monitored, e.g. every time the vehicle is refuelled.

### Engine fault

#### - Petrol engine EPC

### - Diesel engine

The corresponding warning is:

#### ENGINE FAULT WORKSHOP!

If a fault in the running of the engine arises while driving, the corresponding light will come on (petrol engine) or flash (diesel engine). In this case the engine should be checked immediately by a Technical Service Centre.

### Anti-lock brake system (ABS)

The corresponding warning is:

#### ABS FAULT

A fault in the ABS system is shown in the following manner:

If the ABS warning light comes on separately, it is possible to brake the vehicle using the normal brake system (without ABS). Consult a Technical Service Centre as soon as possible.

### Electronic immobiliser

The corresponding warning is:

#### IMMOBILIS.ACTIVE

When the ignition is switched on, the vehicle key data is automatically consulted. The warning light will flash to confirm that the data is being checked

If an unauthorised key is used, the warning light will flash constantly. It will not be possible to start the vehicle.

### Tailgate/bonnet open display \*

The corresponding warning is:

#### TAILGATE OPEN

This warning light only indicates that the tailgate is open. 

The warning light only goes off when the tailgate is completely closed (to the second position).

### Windscreen washer\*

The corresponding warning is:

#### TOP UP WASHER FLUID

This symbol lights up to indicate that the windscreen washer level is too low. Top up windscreen and headlight washer fluid\*.

### Fuel level low

The corresponding warning is:

#### PLEASE REFUEL ■

## Navigation system\*



Fig. 51 Button on the windscreen washer lever:



Fig. 52 On-board computer display:

If the vehicle has a navigation system it is possible to go from one display to the other using the button on the windscreen wiper lever (by holding it pressed in for over 2 seconds):

- Navigation display
- Multifunction display

When the navigation display or the multifunction display are activated, the possible faults are mainly displayed on the on-board computer screen.

Instructions for the use of the SEAT navigation system are included in a separate handbook. ■

## Steering wheel controls

### Steering wheel

#### Multifunction steering wheel\*

These controls enable you to perform various functions without taking your hands off the steering wheel.



Fig. 53 Multi-function steering wheel with controls:



The controls in the multi-function steering wheel ⇒ fig. 53 work only when the ignition is switched on.

- ① Rocker switch for the **cruise control system** (CCS):
  - By briefly pressing the button **(RES+)** the programmed speed is recovered.
  - If the button **(RES+)** is held down the speed increases. The speed of the vehicle at the moment the button is released will be stored.
  - By briefly pressing the button **(SET-)** the actual speed is stored.

- If the button **(SET-)** is held down the speed decreases. The speed of the vehicle at the moment the button is released will be stored.
- ② Button **(CANCEL)** for switching off CCS temporarily. The target speed remains stored. Further information .
- ③ Rocker switch for **volume control**<sup>8)</sup> for the radio unit.
  - Press button **(VOL+)** to raise the volume of the radio.
  - Press button **(VOL-)** to reduce the volume of the radio.

<sup>8)</sup> only for factory-fitted radio.



- ④ Rocker switch for various functions:
- Button  for: station search, forwards (radio), listening to TIM messages, starting with oldest (radio / navigation), fast forward (cassette mode), next track (CD mode).
  - Button  for: station search, backwards (radio), listening to TIM messages, starting with latest (radio / navigation), fast rewind (cassette mode), last track (CD mode).
- ⑤ Pushbutton for switching lighting on and off on the controls on the multi-function steering wheel (on the side of the steering wheel).

**Note**

The cruise control system is switched on and off using the button on the turn-signal / main beam lever. ■

## Unlocking and locking

### Keys

#### Key set

The set of keys includes a remote control, a key without a remote control and a key tab with the number of the key.



Fig. 54 Set of keys

The key set belonging to your vehicle consists of the following items:

- one remote control key ⇒ fig. 54 (A) with folding key bit\*,
- one key with a remote control (B),
- one key tab (C) with the key number.

#### Plastic key tab

Spare keys cannot be issued without the key number on the key tab ⇒ fig. 54 (B). Therefore:

- Always keep the key tab in a safe place.
- Never leave the key tab in the vehicle.

If you sell the vehicle, please give the plastic key tab to the new owner.

#### Duplicate keys

If you need a replacement key, take your key tab to an Authorised Service Centre.

#### WARNING

- **Incorrect use of the keys can result in critical injuries.**
- **Never leave children or disabled persons in the vehicle; in case of emergency they may not be able to leave the vehicle or look after themselves.**
- **Unsupervised use of a key could mean that the engine is started or that electrical equipment is used (e.g. electric windows). Risk of accident. The doors can be locked using the remote control key. This could result in people being trapped in the vehicle in an emergency.**
- **Never leave any of the vehicle keys in the vehicle. Unauthorised use of your vehicle could result in injury, damage or theft. Always take the key with you when you leave the vehicle.**
- **Never remove the key from the ignition if the vehicle is in motion. Risk of accident. The steering lock could engage suddenly, and you would not be able to steer the vehicle.**

#### Caution

There are electronic components in the key and remote control. Protect the keys from moisture and excessive vibration. ■

## Remote control keys\*

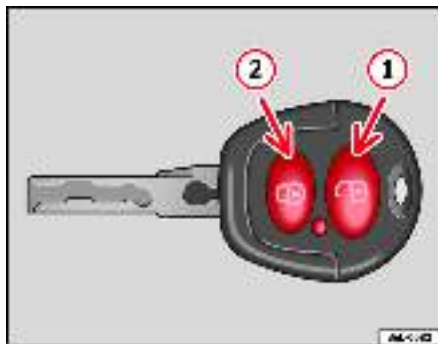

Fig. 55 Remote control keys

Two keys are supplied in vehicles with remote control, a folding key and a fixed key ⇒ fig. 55.

### Note

In certain versions of the model, the remote control key may be folding. The key works, in terms of remote control, in the same way as other remote control keys ⇒ page 95. ■

## Folding key\*

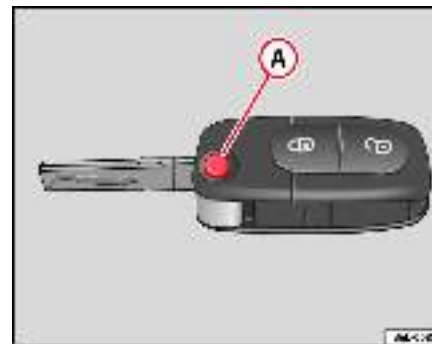

Fig. 56 Folding key

To unfold key bit, press button **A** ⇒ fig. 56. This unfolds with a spring action.

To fold the key bit, press button **A** and push key down until it clicks into place. ■

## Central locking

### Description of the central locking system

*The central locking system enables you to lock and unlock all the doors and the tailgate from one point.*

Central locking can be operated using any of the following options:

- mechanically with the key in the driver door ⇒ page 88, ▶

- the key with remote control<sup>9)</sup> ⇒ page 95 ,
- with the central locking button ⇒ page 92.

### Individual opening of doors<sup>9)</sup>

An Authorised SEAT Service Centre can programme the individual opening of doors.

When the key is turned *once* in the driver's door lock, in the direction of opening, or when button ⇒ page 95, fig. 61  on the remote control key is pressed, only the driver's door will unlock.

When the key is turned a second time or the button  is pressed a second time, all the doors and the tailgate are unlocked.

### WARNING

- **Do not leave anyone in the car if it has been locked from the outside. It is not possible to open the doors from the inside. Locked doors could delay assistance in an emergency. People could become trapped inside in an emergency.**
- **Never close the doors without observing and ensuring it is clear, to do otherwise could cause serious injury to you and others. Make sure that no one is in the path of the door.**

### Note

The entire vehicle is unlocked if the airbags are triggered during an accident. The vehicle cannot be locked from the inside unless the ignition is first switched off and back on. Following an accident, the vehicle cannot be locked from the outside. Contact an Authorised Service Centre. ■

<sup>9)</sup> Optional equipment

## Opening and closing the doors with the key

### Opening the doors

- Insert the key in the lock on the driver door.
- Turn the key to the open position. The doors and the tailgate are unlocked.

### Closing the doors

- Insert the key in the lock on the driver door.
- First turn the key once to the locking position ⇒ . The doors and the tailgate are locked.

### Notes on unlocking

The following applies if you wish to unlock your vehicle manually using the key:

- The deadlock mechanism, the interior monitoring system<sup>10)</sup> and the anti-theft alarm<sup>10)</sup> will be deactivated immediately. The deactivation is confirmed by the turn signals flashing briefly twice.
- The interior lights in the courtesy position will be switched on for approximately 20 seconds when the vehicle is unlocked.
- If the key is held in the unlocking position, all windows (apart from the electric vent wing at the rear) will be opened on vehicles equipped with electric windows.

### Notes on locking

The following applies if you wish to lock your vehicle manually using the key: ▶

<sup>10)</sup> Optional equipment

- The deadlock mechanism, the interior monitoring system<sup>10)</sup> and the anti-theft alarm<sup>10)</sup> will be activated **immediately** if the key is turned **once** in the lock. The activation is confirmed by the turn signals flashing briefly.
- The deadlock mechanism, the interior monitoring system and the anti-theft alarm will **not** be activated if the key is turned in the lock **twice** within one second. All the doors and the tailgate will, however, be locked. The doors can be unlocked from the inside if the deadlock mechanism has not been activated. To do this, operate the door opening lever on the door in question. The alarm will go off.
- When locking the vehicle, the interior lights in the courtesy switch position will be switched off.
- A warning lamp in the driver door flashes to indicate the deadlock is working. The warning lamp will switch off after 14 days. This is to prevent the vehicle battery from discharging completely when the vehicle is not used for a longer period. The system is still active.
- Windows, or the sliding roof, which are still open can be closed automatically on vehicles equipped with electric windows and electric vent windows or with an electric sliding roof. To do this, the key must be kept held in the locking position until all windows and the sliding roof are fully closed.

 **WARNING**

If the vehicle is locked, children and disabled people may be trapped inside.

- **Never leave children or disabled persons in the vehicle; in case of emergency they may not be able to leave the vehicle or look after themselves.**
- **Always take your car keys with you when you leave the vehicle. Misuse of the keys, for example, by children, may result in serious damage and accident.**
  - The engine may accidentally be started and be out of control.
  - If the ignition is switched on, the electric equipment could be activated with risk of injury, for example, in the electric windows.

 **WARNING (continued)**

- **The doors can be locked using the remote control key. This could result in people being trapped in the vehicle in an emergency.**
- **Always take the key with you when you leave the vehicle.**
- **Never remove the key from the ignition if the vehicle is in motion. Risk of accident. The steering lock could engage suddenly, and you would not be able to steer the vehicle.**

 **Caution**

Each key contains electronic components. Protect the keys from moisture and excessive vibration.

 **Note**

- Any SEAT Service centre can programme the central locking system so that only the driver's door is unlocked when the key is turned once to open. ■

## Central locking buttons

*The vehicle can be locked and unlocked from the inside using the central locking button in the driver door.*

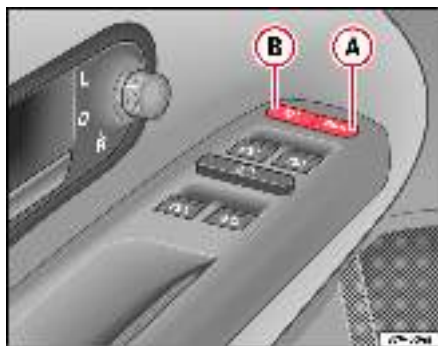



Fig. 57 Detail of driver door: central locking system button

### Locking the vehicle

- Press button  ⇒ fig. 57  ⇒ .

### Unlocking the vehicle

- Press button  .

The central locking button is still operative when the ignition is switched off. Neither the deadlock mechanism nor the anti-theft alarm can be activated or deactivated via the central locking button<sup>11)</sup>. The central locking button will not function when the deadlock is activated.

Please note the following when you use the central locking button to lock your vehicle:

- The deadlock mechanism and the anti-theft alarm<sup>11)</sup> are **not** activated when the button  is pressed.
- It will not be possible to open the doors or the tailgate from the *outside* (this may offer extra safety, for instance when stopped at traffic lights).
- The driver door is not locked if it is open. This prevents you from locking yourself out of the vehicle.
- You can unlock all the doors separately from inside the car. You will have to pull the door release lever *once*. The door will be opened by pulling the door release lever again.

### WARNING

**If the vehicle is locked, children and disabled people may be trapped inside.**

- **Never leave children or disabled people alone in the car. The doors will be locked when the central locking button is activated. Vehicle occupants could become trapped in the vehicle. In the event of an accident they would not be able to reach safety. Locked doors could make it more difficult to assist vehicle occupants in the event of an accident. ■**

## Deadlock

*The deadlock mechanism makes it more difficult to break into the vehicle because the door release lever and the central locking button are not active.*

### Activating deadlock

- Turn the key *once* in the driver's door lock to lock or 

<sup>11)</sup> Optional equipment

- press *once* the locking button (🔒) on the remote control<sup>12)</sup>. A red warning lamp in the driver door flashes to indicate the deadlock is working.

#### Deactivating deadlock when the vehicle is locked

- Turn the key *twice* in the driver's door lock to lock or
- press *twice* the locking button (🔒) on the remote control<sup>12)</sup>. The vehicle is locked without activating the deadlock.

The doors can be unlocked from the inside if the deadlock mechanism has not been activated. You will have to pull the door release lever once. The door will be opened by pulling the door release lever again. When the deadlock is deactivated, the anti-theft alarm<sup>12)</sup> ⇒ page 97 and the interior monitoring system are also deactivated<sup>12)</sup>.



#### WARNING

**Nobody should remain in the vehicle if the deadlock mechanism has been activated. It is not possible to open the doors from the inside. Locked doors could delay assistance in an emergency. People could become trapped inside in an emergency. ■**

<sup>12)</sup> Optional equipment

#### Door release lever

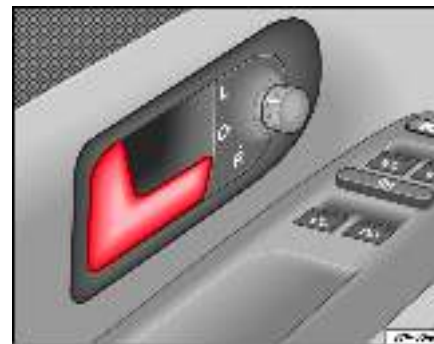

**Fig. 58 Driver's door release lever in normal position**

The doors and the tailgate can also be locked and unlocked centrally by operating the driver's door release lever. Press or pull lever ⇒ fig. 58. In this case the deadlock is not activated. The door release lever for the front passenger door and the rear doors have no influence on the other safety areas. When used, these release levers will only lock and unlock their own areas.

The **opened** driver's door cannot be locked using the door release lever. This prevents you from locking yourself out of the vehicle.



#### Note

The deadlock mechanism will be activated if the vehicle is locked from the inside by accident using the radio remote control. The doors can then no longer be opened from the inside or the outside. The deadlock mechanism will be released if the ignition is switched on. The doors can be opened using the door release levers. First push the door release lever in and then pull it out. ■

## Childproof locks

*The childproof lock prevents the rear doors being opened from the inside.*

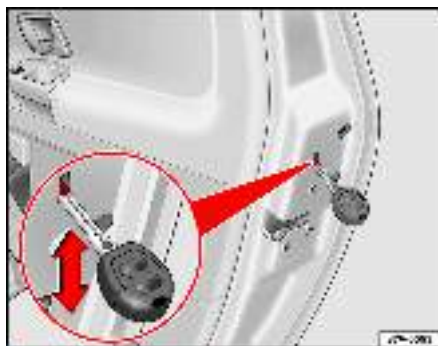

**Fig. 59 Release for the child lock in the rear left-hand door**

The childproof lock can be activated to prevent children opening the doors by accident. When the childproof lock is activated, the door can be opened from the outside only. The childproof lock can be activated and deactivated using a key when the door is open. ■

### Activating the childproof lock

- Unlock the car and open the door you wish to child-proof.
- Move the lever using the vehicle key in the direction of the arrow ⇒ fig. 59.

### Deactivating the childproof lock

- Unlock the car and open the door on which you wish to deactivate the child-proof lock.
- Move the lever using the vehicle key in the opposite direction to the arrow.



## Key with remote control

### Unlocking and locking vehicle

The remote control key enables you to lock and unlock the vehicle from a distance.



Fig. 60 Range of the remote control



Fig. 61 Assignment of buttons on the remote control key

#### Unlocking the vehicle

- Press button  ⇒ fig. 61 ① on remote control to unlock all the doors and tailgate.

#### Locking the vehicle

- Press button  ② on remote control to lock all the doors and tailgate.

When either of these buttons is pressed, the battery indicator lamp on the key ⇒ fig. 61 ④ lights up.

Using button ⇒ fig. 61 ③ on the control, the key shaft is released.

The remote control transmitter and the batteries are integrated in the remote control. The receiver is in the interior of the vehicle. The remote control, when fitted with new batteries, has a range of several metres around the car. Obstacles between the remote control and the vehicle, bad weather conditions and discharged batteries can considerably reduce the range of the remote control ⇒ page 96.

 **WARNING**

- **Never leave children or disabled persons in the vehicle; in case of emergency they may not be able to leave the vehicle or look after themselves.**
- **Always take your car keys with you when you leave the vehicle. Misuse of the keys, for example, by children, may result in serious damage and accident.**
  - The engine may accidentally be started and be out of control.
  - If the ignition is switched on, the electric equipment could be activated with risk of injury, for example, in the electric windows.
  - The doors can be locked using the remote control key. This could result in people being trapped in the vehicle in an emergency.
  - Always take the key with you when you leave the vehicle.
- **Never remove the key from the ignition if the vehicle is in motion. Risk of accident. The steering lock could engage suddenly, and you would not be able to steer the vehicle.**

 **Note**



- An Authorised SEAT Service Centre can programme the individual opening of doors. In this case, when the unlock button  on the remote control is pressed once, only the driver's door is unlocked ⇒ page 90. When the button is pressed once more, all doors and the tailgate will be unlocked. Seat Service will be happy to provide more information on the activation of this function.
- The remote control transmitter and the batteries are integrated in the remote control. The receiver is in the interior of the vehicle. Obstacles between the remote control and the vehicle, bad weather conditions and discharged batteries can considerably reduce the range of the remote control.
- The remote control only locks and unlocks the vehicle when it is used within range.
- The vehicle will be locked again automatically if you do not open one of the doors or the tailgate 30 seconds after unlocking the car. This function



prevents the vehicle from remaining unlocked if the unlocking button is pressed by mistake.

- If it is not possible to open or close the vehicle using the remote control, this should be re-synchronised ⇒ page 96 or change the battery ⇒ page 96.
- The working of the remote control may be momentarily affected if there is transmitter using the same waveband (e.g. radiotelephone, mobile telephone, etc) in the vicinity of the vehicle. ■

## Synchronising the remote control key

### Synchronising the remote control key

- Briefly press the open button  ⇒ page 95, fig. 61  once.
- Then open or close the vehicle using the key bit within one minute ⇒ page 90.

The vehicle can no longer be opened and closed with the remote control if you press button  ⇒ page 95, fig. 61  a long way outside the effective range of the radio wave remote control. The remote control key will have to be re-synchronised.

Spare remote control keys are available from SEAT Service. They must be matched to the locking system.

Up to four remote control keys can be used. ■

## Replacing the battery

If the battery indicator on the remote control ⇒ page 95, fig. 61  does not flash when the buttons are pushed, the battery must be replaced. ►

We recommend having the batteries changed by a qualified workshop if required.

### ⚠ Caution

Use of inappropriate batteries may damage the remote control. For this reason, always replace the dead battery with another of the same size and power.

### ♻ For the sake of the environment

The flat batteries must be disposed of in accordance with regulations governing the protection of the environment. ■

## Anti-theft alarm system

### Description of anti-theft alarm system

*The anti-theft alarm triggers an alarm if unauthorised movements are detected around the vehicle.*



Fig. 62 Interior monitoring system sensor

### Activating the anti-theft alarm

- Blocking the engine.

### Deactivating the alarm

- Unblock the vehicle using the unlock button on the remote control or switch on ignition.

### Opening the doors mechanically (emergency opening)

- If the remote control function fails, you will have to use the key to unlock the car. This is done as follows: ▶

- Press button ⇒ page 95, fig. 61  to fold out the key bit.
- Use the lock on the driver door to unlock the vehicle. The anti-theft alarm system remains active, but an alarm is not triggered immediately.
- Switch on the ignition within 15 seconds. When the ignition is switched on, the electronic immobiliser recognises a valid vehicle key and deactivates the anti-theft alarm system. If you do not switch on the ignition within 15 seconds, the alarm is triggered.

The anti-theft alarm makes it more difficult to break into the vehicle or steal it. Audible and visible alarms <sup>13)</sup> are triggered if the car is opened using the mechanical key, or if unauthorised access is gained to the vehicle.

#### When does the system trigger an alarm?

The system triggers an alarm if the following unauthorised actions are carried out when the car is *locked*:

- Opening of vehicle using mechanical key without switching on ignition within the next 15 seconds
- Opening a door
- Opening the bonnet
- Opening the tailgate
- Switching on the ignition
- Movement inside the vehicle (in vehicles with interior monitoring).

The acoustic signals sound and the indicators flash for approx. 30 seconds.

#### Interior monitoring system

The sensors for the interior monitoring system are located at the top of the door post between the front and rear door ⇒ page 97, fig. 62. The sensors must not be covered, as they will otherwise not be able to function properly.

The windows must be closed when the interior monitoring system is active as the anti-theft alarm could be triggered by a draft of air.



#### Note

- If, after the alarm goes off, access is gained to a second secured zone (e.g. the tailgate is opened after a door has been opened), the warning signal is triggered again.
- Vehicle monitoring remains active even if the battery is disconnected or not working for any reason. ■

<sup>13)</sup> Optional equipment

## Tailgate

### Opening the tailgate

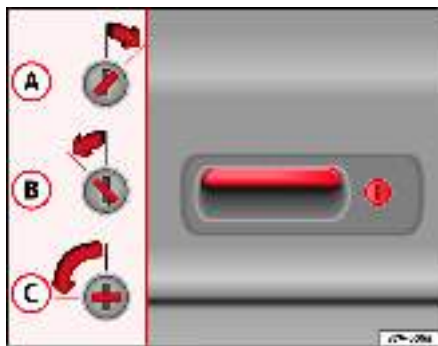

Fig. 63 Key slot positions of tailgate lock

### Unlocking the tailgate

- Make sure that the key slot is vertical.
- Operate the handle and pull up the tailgate ⇒ ⚠.

### Closing the tailgate

- Take hold of one of the recessed handles in the interior trim of the tailgate.
- Close the tailgate hard ⇒ ⚠ in “Safety instructions for the tailgate” on page 101.

A warning appears on the instrument panel<sup>14)</sup> if the tailgate is open or not properly closed. Depending on the level of equipment fitted, an audible

warning<sup>14)</sup> will be given either while the vehicle is stationary or when you drive.

### Locking and unlocking the tailgate

- The doors and the tailgate will be locked by turning the vehicle key to position ⇒ fig. 63 **A**.
- The doors and the tailgate will be unlocked by turning the vehicle key to position **B**.

### Key slot positions

- A** Windows, or the sliding roof, which are still open can be closed automatically on vehicles equipped with electric windows and electric vent windows or with an electric sliding roof. To do this, the vehicle key must be kept held in position ⇒ fig. 63 **A** until all windows and the sliding roof are fully closed.
- B** If the key is held in position **B**, all windows (apart from the electric vent wing) will be opened on vehicles equipped with electric windows.
- C** The tailgate can, if the central locking system or the servomotor lock is defective, be unlocked manually by turning the vehicle key to position **C**.

### Convenience opening of the tailgate

It is **not** possible to open the tailgate when the ignition is on. This helps prevent theft (e.g. at traffic lights). This function will remain active for approx. 30 seconds after the ignition is switched off as long as no door is opened. When a door is opened, the tailgate immediately unlocks.

For greater convenience, it is possible to open the tailgate for up to 30 seconds **after the last door has been closed** and the ignition is switched on. ▶

<sup>14)</sup> Optional equipment

### Driving with the tailgate open

If the tailgate is open or incorrectly closed, the following warning may be appear on the display<sup>14)</sup>. Please note that theft of your cargo is more likely if the tailgate is open.

#### WARNING

If you have to drive with the tailgate open, please observe the following warnings:

- **Observe the following points to reduce the danger of poisoning from exhaust fumes entering the vehicle interior:**
  - Close all windows.
  - Close the sliding/tilting roof,
  - Switch off air recirculation.
  - Open the air outlets in the dash panel,
  - Set the fresh air blower to the highest speed.
- Drive particularly carefully and think ahead. If possible, avoid sudden braking and driving manoeuvres as this could cause the open tailgate to move unpredictably. Risk of injury.
- When carrying objects that protrude from the boot, the correct signals should be used; otherwise there is a risk of accident. Observe legal requirements when doing so.
- Always secure objects in the boot. Loose items could fall out of the vehicle and injure other road users.
- If a baggage rack is fitted on the tailgate, it should be removed before travelling with the tailgate open.
- Read and always observe the safety information concerning the use of the tailgate ⇒ page 101. ■

### Closing the tailgate

Before closing the tailgate, make sure that the key has not been left inside the boot.

#### Closing the tailgate

- Take hold of the grip in the inside trim of the tailgate ⇒  and pull the tailgate down.
- Pull hard.

A display appears in the combi-instrument if the tailgate is not properly closed<sup>15)</sup>.

#### WARNING

**Always close the tailgate properly. Risk of accident or injury.**

- Do not close the tailgate by pushing it down with your hand on the window. The glass could shatter. Risk of injury!
- Ensure the tailgate is locked after closing. If not, it may open unexpectedly while driving.
- Never allow children to play in or around the vehicle. A locked vehicle can be subjected to extremely high and low temperatures, depending on the time of year. This could cause serious injuries/illness. It could even have fatal consequences. Close and lock both the tailgate and all the other doors when you are not using the vehicle.
- Never close the tailgate without observing and ensuring it is clear, to do otherwise could cause serious injury to you and others. Make sure that no one is in the path of the tailgate. ■

<sup>15)</sup> Optional equipment

## Safety instructions for the tailgate



### WARNING

For safety reasons, you should always keep the tailgate fully closed when driving. Always close the tailgate properly. Risk of accident or injury.

- Ensure the tailgate is locked after closing. If not, it may open unexpectedly while driving.
- Never close the tailgate without observing and ensuring it is clear, to do otherwise could cause serious injury to you and others. Make sure that no one is in the path of the tailgate.
- Loose objects which could fall out of the vehicle when the tailgate is opened could cause injury.
- If you have objects (for example bicycles) on a rack fitted to the tailgate, you may not be able to open the tailgate fully, or the additional weight could close the tailgate. For this reason, you should support the tailgate or remove the objects from the rack. Risk of injury.
- Never allow children to play in or around the vehicle. A locked vehicle can be subjected to extremely high and low temperatures, depending on the time of year. This could cause serious injuries/illness. It could even have fatal consequences. Close and lock both the tailgate and all the other doors when you are not using the vehicle. Make sure first that there is no one in the vehicle.
- If you have to drive with the tailgate open, observe the all notes ⇒ page 100 to reduce the risk, for example, of poisoning caused by exhaust fumes entering the passenger compartment. ■

## Windows

### Opening and closing the windows electrically

All electric windows can be operated using the controls in the driver door. The other doors each have a switch for their own window.

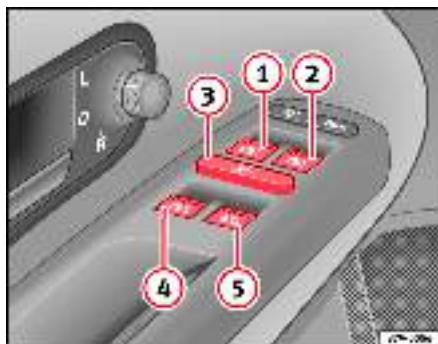





Fig. 64 Detail of driver door: buttons for front and rear electric windows

### Opening and closing the windows

- Press button ⇒ fig. 64 ①, ②, ④ or ⑤ to open the corresponding window.
- Pull button  to close a window ⇒ .

Always close the windows fully if you park the vehicle or leave it unattended ⇒ .

You can use the electric windows for approx. 10 minutes after switching off the ignition if neither the driver door nor the front passenger door has been opened.

### Buttons in the driver door

- ① Button for the left front door window with one-touch opening and closing ⇒ page 103
- ② Button for the right front door window with one-touch opening and closing ⇒ page 103
- ③ Safety switch<sup>16)</sup> for deactivating the electric window buttons in the rear doors
- ④ Button for window in rear left door<sup>16)</sup>
- ⑤ Button for window in rear right door<sup>16)</sup>

### Safety switch

Safety switch ⇒ fig. 64 ③ in the driver door can be used to disable the electric window buttons in the rear doors.

Safety switch not pressed: buttons on rear doors are activated.

Safety switch pressed: buttons on rear doors are deactivated.

### WARNING

Incorrect use of the electric windows can result in injury.

- Never close the tailgate without observing and ensuring it is clear, to do otherwise could cause serious injury to you and others. Make sure that no one is in the path of a window.
- Always take the vehicle key with you when you leave the vehicle.
- Never leave children or disabled persons in the vehicle, particularly if they have access to the keys. Misuse of the keys, for example, by children, may result in serious damage and accident.
  - The engine may accidentally be started and be out of control.

<sup>16)</sup> Optional equipment



 **WARNING** (continued)



- If the ignition is switched on, the electric equipment could be activated with risk of injury, for example, in the electric windows.
- The doors can be locked using the remote control key. This could result in people being trapped in the vehicle in an emergency.
- Always take the key with you when you leave the vehicle.
- The electric windows will work until the ignition has been switched off and one of the front doors has been opened.
- If necessary, use the safety switch to disable the rear electric windows. Make sure that they have been disabled.

 **Note**

If the window is not able to close because it is stiff or because of an obstruction, the window will automatically open again ⇒ page 104. If this happens, check why the window could not be closed before attempting to close it again. ■

## One-touch closing and opening

*One-touch opening and closing means you do not have to hold down the button.*

The one-touch closing and opening of the electric windows can only be controlled with the switches on the driver's door. The buttons ⇒ page 102, fig. 64  and  have two levels for opening the front windows and two for closing. This makes it easier to open or close windows to the desired position.

### One-touch closing

- Pull up the button for the window briefly to the second position. The window closes fully.

### One-touch opening

- Push down the button for the window briefly to the second position. The window opens fully.

### Restoring one-touch opening and closing

- The one-touch opening and closing function is not active after the vehicle battery has been disconnected or is empty and will have to be reset.
- Close all windows and doors.
- Use the key to lock the vehicle from outside and hold the key in the lock position for at least one second. The one-touch function is now ready for operation.

If you push (or pull) a button to the first stage, the window will open (or close) until you release the button. If you push or lift the button briefly to the second stage, the window will open (*one-touch opening*) or close (*one-touch closing*) automatically. If you operate the button while the window is opening or closing, it stops at this position.

The one-touch opening and closing function will not function once the ignition has been switched off.

The one-touch function and roll-back function will not work if there is a malfunction in the electric windows. Contact an Authorised Service Centre. ■

### Roll-back function on electric windows\*

*The windows have a roll-back function. This reduces the risk of injuries when the windows are closing.*

- If a window is obstructed when closing automatically, the window stops at this point and opens immediately ⇒ .
- If this happens, check immediately (within 10 seconds) why the window could not be closed before attempting to close it again. After 10 seconds, the window's closing force is automatically increased.
- If the window is still obstructed, the window stops at this point.
- If there is no obvious reason why the window cannot be closed, try to close it again within five seconds. **The roll-back function is now deactivated. The window closes with maximum force.**

If more than 5 seconds pass, the window will open fully when you operate one of the buttons. One-touch closing is reactivated.

The one-touch function and roll-back function will not work if there is a malfunction in the electric windows. Contact an Authorised Service Centre.

#### WARNING

Incorrect use of the electric windows can result in injury.

- Always take the key with you when leaving the vehicle, even if you only intend to be gone for a short time. Please ensure that children are never left unsupervised in the vehicle.
- The electric windows will work until the ignition has been switched off and one of the front doors has been opened.
- Never close the windows without observing and ensuring it is clear, to do otherwise could cause serious injury to you and others. Make sure that no one is in the path of a window.
- Never allow people to remain in the vehicle when you close the vehicle from the outside. The windows cannot be opened even in an emergency.

#### WARNING (continued)

- The roll-back function does not prevent fingers or other parts of the body getting pinched against the window frame. Risk of accident.

#### Note

The roll-back function is deactivated if the windows are closed from the outside of the vehicle using the ignition key for convenience closing ⇒ page 106. ■

### Convenience opening and closing

*The windows can be opened and closed centrally from outside the vehicle.*

- **Using the door lock:** Hold the key in the door lock of the driver's door in either the locking or the unlocking position until all windows with electric function are either opened or closed.
- Release the key to interrupt this function.

#### WARNING

Never close the windows without observing and ensuring it is clear, to do otherwise could cause serious injury to you and others. The windows will be closed with the rollback function if the convenience closing function is used. Make sure that no one is in the path of a window. ■

## Mechanical vent wings

The rear vent wings can be opened and closed manually.

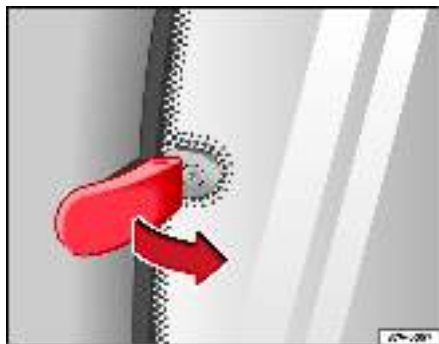

Fig. 65 Release lever for mechanical vent wing

### Opening

- Pull the release lever ⇒ fig. 65 in the direction of the arrow and push it out at the same time until the lever engages.

### Closing

- Pull the release lever in the opposite direction to the arrow and push it back until the lever engages.

### WARNING

Incorrect use of the vent wings can result in injury!

- Never close the windows without observing and ensuring it is clear, to do otherwise could cause serious injury to you and others. Make sure that no one is in the path of a window. ■

## Sliding/tilting sun roof

### Opening and closing the sliding/tilting roof

The sliding/tilting roof is opened and closed using the switch when the ignition is switched on.



Fig. 66 Interior roof trim: control of sliding/tilting roof

### Opening sliding/tilting roof

- Press the surface ⇒ fig. 66 ①.

### Tilting the sliding/tilting sunroof

- Press the surface ②.

### Closing the sliding/tilting roof,

- Press the surface ③ ⇒ .

Always close the sliding/tilting roof fully if you park the vehicle or leave it unattended ⇒ ⚠.

If you wish to tilt the roof when the sliding roof is open, press surface ② until the function has been carried out. If the sliding roof is to be opened directly from the tilted position, press surface ① to carry out the required function.

Once the ignition has been switched off, the sliding/tilting sun roof can no longer be opened or closed.

### Sunroof blind

The sunroof blind is opened together with the sliding/tilting roof. If required, it can be closed by hand when the sunroof is closed.

#### WARNING

Incorrect use of the sliding/tilting sunroof can result in injury.

- Never close the sliding/tilting sunroof without observing and ensuring it is clear, to do otherwise could cause serious injury to you and others. Make sure that no one is in the path of the sliding/tilting sunroof.
- Always take the vehicle key with you when you leave the vehicle.
- Never leave children or disabled persons in the vehicle, particularly if they have access to the keys. Unsupervised use of a key could mean that the engine is started or that electrical equipment is used (e.g. electric windows). Risk of accident. The doors can be locked using the remote control key. This could result in people being trapped in the vehicle in an emergency.
- The sliding/tilting sunroof operates as long as the ignition is switched on.

#### Note

The roof can be closed by hand if the system is defective. ■

### Convenience closing\*

- **Using the door lock:** keep the key in the driver's door lock in the close position until the sliding/tilting sunroof has closed.
- Release the key to interrupt this function.

During convenience closing, first the windows and then the sliding roof will be closed.

#### WARNING

Never close the sliding/tilting sunroof without observing and ensuring it is clear, to do otherwise could cause serious injury to you and others. The sliding/tilting sunroof closes with the roll-back function activated. However, always make sure that no one is in the path of the sliding/tilting sunroof.

#### Note

The sliding/tilting sunroof rotary button remains in the last position selected if the roof is closed using convenience closing from outside the vehicle and will have to be re-positioned the next time you drive. ■

## Roll-back function of the sliding/tilting roof



Fig. 67 Interior roof trim:  
control of sliding/tilting  
roof

The sliding/tilting roof has a *roll-back function* which prevents larger objects getting trapped when the roof is closed. ⇒ ⚠ The roll-back function does not prevent fingers getting pinched against the roof opening. The sliding/tilting sunroof stops and opens again immediately if it is obstructed when closing.

If the sliding/tilting roof has been opened again by the roll-back function, it can be closed only by pressing button ⇒ page 105, fig. 66 ③ until the sliding/tilting roof has closed fully. **The sliding/tilting roof then closes without the roll-back function.**

If it still does not close, consult a specialised workshop.



### WARNING

Incorrect use of the sliding/tilting sunroof can result in injury.

### ⚠ WARNING (continued)

- Never close the sliding/tilting sunroof without observing and ensuring it is clear, to do otherwise could cause serious injury to you and others. Make sure that no one is in the path of the sliding/tilting sunroof. ■

## Manual release



Fig. 68 Manual release



Fig. 69 Manual release

- Remove the interior light. To do so, insert a screwdriver on the right-hand side, between the light and the covering and turn the screwdriver.
- Invert the screwdriver head and undo the two Philips screws (1) ⇒ fig. 68.
- Move the cover in the direction of the arrow (2) and remove ⇒ fig. 68.
- Turn the cover (A) ⇒ fig. 69 of the lever opening in the direction of the arrow.
- Remove the lever from its casing, insert it in the opening and close the roof.
- Replace the lever in its casing and turn the cover (A) ⇒ fig. 69 over the lever opening.
- Replace the cover and interior light. ■

In the event of a breakdown, the sunroof may be closed manually.

# Lights and visibility

## Lights

### Switching lights on and off



Fig. 70 Detailed view of dash panel lights, fog light and rear fog light control

#### Switching on the daylight driving light (only available in some countries)

- To switch on the daylight driving lights, leave the light switch in position O when you turn on the ignition.

#### Switching on the side lights

- Turn the light switch  $\Rightarrow$  fig. 70 to position  $\Rightarrow$    $\Rightarrow$  .



#### Switching on dipped headlights

- Turn the light switch to position  $\Rightarrow$  .

#### Switching off the lights

- Turn the light switch to position O.



#### Switching on the front fog lights<sup>17)</sup>

- Pull the switch out of position  $\Rightarrow$   or  $\Rightarrow$   to the first stop. The symbol  in the light switch lights up.

#### Switching on the rear fog lights (vehicles with no front fog lights)

- Pull the switch out of position  $\Rightarrow$   to the last stop. A warning lamp lights up in the instrument panel .

#### Switching on the rear fog lights (vehicles with front fog lights)

- Pull the switch out of position  $\Rightarrow$   or  $\Rightarrow$   to the second stop. A warning lamp lights up in the control panel .

The **dipped beam headlights** will only work with the ignition on. The headlights are automatically switched to the side light setting while the engine is being started and after the ignition has been switched off.

The **daylight driving light**<sup>18)</sup> automatically comes on when the ignition is switched on. It is not necessary to turn on the light switch. The daylight driving lights are switched on as long as the ignition is switched on.

#### Rear fog light

The rear fog light is so bright that it may dazzles drivers behind. You should use the rear fog light only when visibility is very poor. 

<sup>17)</sup> Optional equipment

<sup>18)</sup> for selected markets only

If you are towing a trailer equipped with a rear fog light on a vehicle with a factory-fitted **towing bracket**<sup>17)</sup>, the rear fog light on the car will automatically be switched off.

### WARNING

- **Never drive with just the side lights on. Risk of accident. The side lights are not bright enough to illuminate the road ahead and to ensure that other road users are able to see you. Always use your dipped headlights if it is dark or if visibility is poor.**

### Note

- If the lights are left on after the key has been taken out of the ignition lock, a buzzer sounds when the driver door is opened. This is a reminder to switch off the lights.
- The rear fog light is so bright that it can dazzle drivers behind you. You should use the rear fog light only when visibility is very poor.
- If you are towing a trailer equipped with a rear fog light on a vehicle with a factory-fitted *towing bracket*, the rear fog light on the car will automatically be switched off.
- The use of the lighting described here is subject to the relevant statutory requirements. ■

## Coming Home function (guide lights)

*The Coming Home function (guide lights) allows the vehicle lights to stay on for approximately 3 minutes after the ignition is switched off.*

To activate the Coming Home function the vehicle lights should have already been switched on.

- Switch off vehicle lights.
- Switch off ignition.
- Keep all doors closed.
- Briefly pull the turn signal lever towards the steering wheel within a maximum of 2 minutes after switching off the lights.
- Open the driver door.

When the driver's door is opened, the vehicle lights automatically light up for approx. 3 minutes. If the door is closed within 3 minutes, the guide lights will stay on for approximately. 30 seconds. If the door is closed after 3 minutes, the vehicle lights switch off and the guide lights are not activated. ■

## Illumination of instruments and switches and headlight range control



**Fig. 71 Instrument panel: headlight range control ① and illumination of instruments and switches ②**



### Illumination of instruments and switches ①

When the headlights are switched on, the brightness of the instruments and switch lighting can be regulated to suit your requirements by turning the switch → page 110, fig. 71 ①.

### Headlight range control ②

Using the headlight range control, you can adjust the headlight range to the load level that is being carried in the vehicle. In this way it is possible to avoid dazzling oncoming traffic more than necessary. At the same time, the driver has the best possible lighting for the road ahead using the correct headlight settings.

The headlights can only be adjusted when the dipped beam is switched on. To lower the beam, turn the switch down ② from the basic setting 0.

The settings on the switch correspond roughly to the following load conditions:	
-	Front seats occupied and light luggage in the vehicle
1	Several seats occupied and light luggage in the vehicle
2	All seats occupied and heavy luggage in luggage compartment
3	Front seats occupied and heavy luggage in luggage compartment

If the vehicle load does not correspond to those shown in the table, it is possible to select intermediary positions.

### Dynamic headlight range control

Vehicles with **gas discharge lamps**<sup>19)</sup> ("xenon lamps") are equipped with **dynamic headlight range control**. When the dipped light is switched on, the range of the headlights adjusts to the vehicle load condition. In these vehicles, the control ② is not available.

<sup>19)</sup> Optional equipment

**! WARNING**

In order not to dazzle other drivers, the dipped light should be adjusted according to the vehicle load using the headlight range control. If not, an accident may occur.

- Use the switch to lower the light cone, depending on the vehicle load. ■



### Hazard warning lights ⚠

The hazard warning lights are used to draw the attention of other road users to your vehicle in emergencies.



Fig. 72 Switch for hazard warning lights

If you have a breakdown:

1. Park your vehicle at a safe distance from moving traffic.
2. Press button  ⇒ fig. 72 to switch on the hazard warning lights ⇒ .

3. Switch the engine off.
4. Apply the handbrake firmly.
5. On a manual gearbox engage 1st gear. On an automatic move the selector lever to P.
6. Use the warning triangle to draw the attention of other road users to your vehicle.
7. Always take the key with you when you leave the vehicle.

You should switch on the hazard warning lights to warn other road users, for instance when:

- reaching the tail end of a traffic jam
- there is an emergency
- your vehicle breaks down due to a technical defect
- you are towing another vehicle or your vehicle is being towed.

All turn signals flash simultaneously when the hazard warning lights are switched on. The turn signal lights  $\leftarrow \rightarrow$  and the button warning light  $\triangle$  will also flash. The hazard warning lights also work when the ignition is switched off.

### WARNING

- The risk of an accident increases if your vehicle breaks down. Always use the hazard warning lights and a warning triangle to draw the attention of other road users to your stationary vehicle.
- Never park where the catalytic converter could come into contact with inflammable materials under the vehicle, for example dry grass or spilt petrol. This could start a fire!

### Note

- The battery will run down if the hazard warning lights are left on for a long time - even if the ignition is switched off.
- If the hazard warning lights are not working, you must use an alternative method of drawing attention to your vehicle. This method must comply with traffic legislation.
- The use of the hazard warning lights described here is subject to the relevant statutory requirements. ■

### Turn signal and main beam headlight lever

*The turn signal and main beam lever also operates the parking lights and the headlight flasher.*

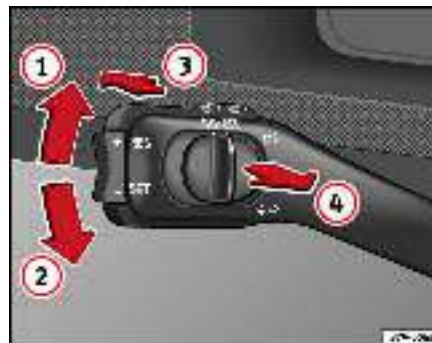

**Fig. 73** Turn signal and main beam headlight lever

The turn signal and main beam headlight lever has the following functions:

### Switching on the turn signals

- Move the lever all the way up ⇒ [page 112, fig. 73](#) ① to indicate **right**, and all the way down ② to indicate **left**.

### Signalling a lane change

- Move the lever upwards ① or downwards ② to change lanes.

### Switching main beam on and off

- Turn the light switch to position  ⇒ [page 109, fig. 70](#).
- Press the lever forward ③ to switch on the main beams.
- Pull the lever back towards you to switch the main beam headlights off again.

### Headlight flasher

- Pull the lever towards the steering wheel ④ to operate the flasher.

### Switching on parking lights

- Switch off the ignition and remove the key from the lock.
- Move the lever up or down to turn on the right or left-hand parking lights respectively.









#### WARNING

The main beam can dazzle other drivers. Risk of accident! Never use the main beam headlights or the headlight flasher if they could dazzle other drivers.



#### Note

- The *turn signals* only work when the ignition is switched on. The corresponding warning lamp  or  flashes in the combi-instrument. The warning lamp<sup>20)</sup>  flashes when the turn signals are operated, provided a trailer is correctly attached and connected to the vehicle. If a turn signal bulb is defective, the warning lamp flashes at double speed. If the trailer turn signal bulbs are damaged, warning lamp  does not light up. You should have the bulbs replaced.
- Both warning lamps will flash at the same time when the hazard warning lights are switched on.
- If one turn signal fails, whether that of the vehicle or of the trailer, the warning lamp will start flashing twice as fast.
- The *main beam headlights* can only be switched on if the dipped beam headlights are already on. The warning lamp  then comes on in the combi-instrument.
- The *headlight flasher* comes on for as long as you pull the lever – even if no other lights are switched on. The warning lamp  then comes on in the combi-instrument.
- When the *parking light* is switched on, the front side light and the rear light of the corresponding side of the vehicle stay lit. The parking lights will only work if the key is removed from the ignition.
- If the turn signal lever is left on after the key has been taken out of the ignition lock, a buzzer sounds when the driver door is opened. This is a reminder to switch off the turn signal, unless of course you wish to leave the parking light on. ■

<sup>20)</sup> Optional equipment

## Interior lights and reading lights

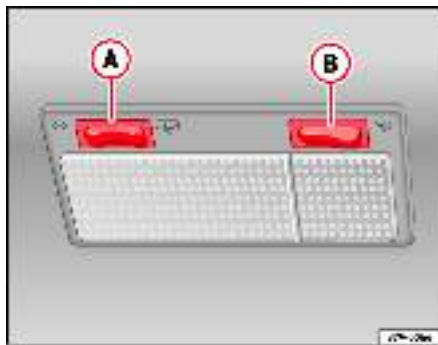

Fig. 74 Interior roof trim: Interior lighting and reading light in the front of vehicle

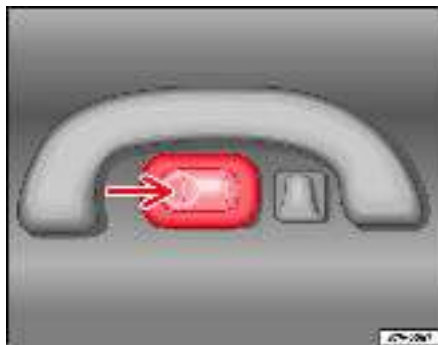

Fig. 75 Reading light in the passenger compartment

The rocker control  $\Rightarrow$  fig. 74 **A** for the interior lights has the following positions: permanently lit  $\text{☞}$ , door contact connection  $\text{☞}$  and off.

### Courtesy light position $\text{☞}$

The interior lights are automatically switched on when the vehicle is unlocked or a door is opened, and turn off about 20 seconds after the closure of the doors. They also go off when the vehicle is locked or when the ignition is switched on.

### Interior light switched on $\text{☞}$

Press the symbol  $\text{☞}$  on the rocker switch to switch the interior lights at front and rear permanently.

### Switching off the interior light

When the switch is in the intermediary position, the front and rear lights are permanently switched off.

### Reading light for the front passenger $\text{☞}$

The reading light for the front passenger is switched on and off with the button  $\Rightarrow$  fig. 74 **B**.

### Reading light in the passenger compartment

There is a reading light above each rear door  $\Rightarrow$  fig. 75.

Using the button -arrow- the reading light is switched on or off.

### Glove compartment light

The light in the glove box on the front passenger side will only light up if the lights are switched on and the glove box is open.

### Luggage compartment lighting

The light is switched on automatically when the tailgate<sup>21)</sup> is opened and is switched off when it is closed.  $\blacktriangleright$

<sup>21)</sup> Optional equipment

### Note

- If not all the vehicle doors are closed, the interior lights will be switched off after approx. 10 minutes, providing the key has been removed and the courtesy light position selected. This prevents the battery discharging.
- Reading lights function independently of the interior lights and must be switched off manually to prevent the battery being drained when the engine is switched off. ■

## Interior light

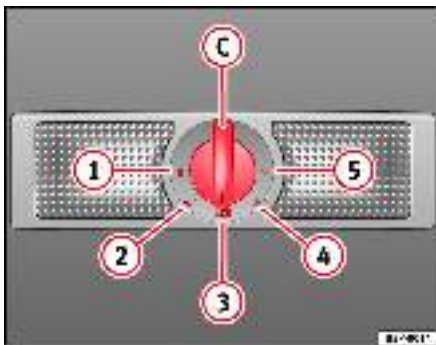

Fig. 76 Interior light

### Interior light permanently switched off

- In switch position **1** ⇒ fig. 76, the interior and reading lights are switched off.

### Switching on the reading light

- Turn the switch to position **2** (left reading light) or to position **4** (right reading light).

### Door light position

- Turn the control to position **3**. The interior lights are automatically switched on when the vehicle is unlocked or the key removed from the ignition lock. The light turns off about 20 seconds after the closure of the doors. The interior lights are switched off when the vehicle is locked or when the ignition is switched on.

### Interior lights or both reading lights switched on

- Turn the control to position **5**. ■

## Visibility

### Sun visors

The sun visors for the driver and front passenger can be folded down or pulled out of their mountings and turned towards the doors.

The make-up mirrors in the sun visors have covers. When you open the cover **2**, a lamp\* in the roof lights up.

The roof light goes off when the cover of the make-up mirror is closed.

### Note

Before you leave the car, you should make sure that the make-up mirror cover in the visor is closed. This prevents the battery discharging. ■

## Rear window heating



Fig. 77 Centre console:  
rear window heating  
button

To connect the rear window heater, press the button  $\Rightarrow$  fig. 77  on the console with the ignition on. A symbol in the button lights up when the rear window heating is switched on.

The rear window heating is switched off after a delay of approx. 20 minutes. It can also be switched off beforehand by pushing the button. ■

## Windscreen heating\*



Fig. 78 Centre console:  
windscreen heating  
button

Press button  $\Rightarrow$  fig. 78  in the central console while the engine is running to switch on the windscreen heating. A symbol in the button lights up when the windscreen heating is switched on.

The windscreen heating is switched off automatically after a delay of approx. 10 minutes. The windscreen heating works only when the engine is running.

### Note

- The passenger compartment heating blower will be switched off when the windscreen heating is switched on.
- In vehicles fitted with an air conditioning system  $\Rightarrow$  page 152 the windscreen heating function is automatically switched on for a maximum of 4 minutes depending upon the outside weather conditions, to aid deicing. ■

## Windscreen washers

### Windscreen wiper

The windscreen wiper lever controls the windscreen wipers and the automatic wash and wipe.



Fig. 79 Windscreen wiper and windscreen wash lever

The windscreen wiper lever ⇒ fig. 79 has the following positions:

#### Intermittent wipe

- Move the lever up to position ①.
- Move the control ①A to the left or right to set the length of the intervals. Control to the left: long intervals; control to the right: short intervals. Four wiper interval stages can be set using switch ①A.

#### Slow wipe

- Move the lever up to position ②.

#### Continuous wipe

- Move the lever up to position ③.

#### Brief wipe

- Move the lever down to position ④ to give the windscreen a brief wipe.

#### Windscreen wiper and washer system

- Pull the lever to position ⑤. A jet of water will be sprayed on the windscreen while the lever is held in this position.
- Release the lever. The wipers will keep running for approximately 4 seconds.

#### Switching off the wipers

- Move the lever to position ①.

#### WARNING

Worn and dirty wiper blades obstruct visibility and reduce safety levels.

- In cold conditions, you should not use the wash / wipe system unless you have warmed the windscreen with the heating and ventilation system. The washer fluid could otherwise freeze on the windscreen and obscure your view of the road.
- Observe the warnings “Changing wiper blades”.

### ⚠ Caution

In icy conditions, always check that the wiper blades are not frozen to the glass before using the wipers for the first time. If you switch on the wipers when the wiper blades are frozen to the windscreen, you could damage both the wiper blades and the wiper motor. ■

### Rear window wiper

*The windscreen wiper lever controls the rear window wipers and the automatic rear window wash and wipe.*



**Fig.80** Windscreen wiper and windscreen wash lever rear window wiper

### Connecting the intermittent wipe

- Press the lever forwards to position ⇒ fig. 80 ⑥. The wiper will wipe the window approximately every 6 seconds.

### Switching off the interval wipe function

- Pull the lever back from position ⑥ towards the steering wheel. The wiper will continue to function for a short period if you switch off whilst the wipers are in motion.

### Connect the rear window automatic wipe

- Press the lever fully forwards to position ⇒ fig. 80 ⑦. The rear window washer starts to work immediately while the rear window wiper starts a little later and continues working while the lever is in this position.
- Release the lever. The wiper then wipes for approximately 4 seconds, and then in intervals again.

### WARNING

- A worn or dirty wiper blade will obstruct visibility and reduce safety.
- Observe the warnings “Changing wiper blades”.

### ⚠ Caution

In icy conditions, always check that the wiper blade is not frozen to the glass before using the wiper for the first time. If you switch on the wiper when the wiper blade is frozen to the glass, this could damage both the wiper blade and the wiper motor.

### Note

- The rear window wiper will only function when the ignition is switched on and the tailgate is closed.
- The rear window wiper is automatically connected when the windscreen wiper is on and reverse gear is engaged (manual gearbox) or the selector lever of the automatic gear box is placed in position **R**. ■



## Headlamp washer\*

*The headlight washers clean the headlight lenses.*

The headlight washers are activated automatically when the windscreen washer is used and the windscreen wiper lever is pulled towards the steering wheel → page 117, fig. 79 ⑤ for at least 5 seconds – provided the dipped headlights or main beams are switched on. Clean off stubborn dirt (insects, etc.) from the headlights at regular intervals, for instance when filling the fuel tank.



### Note

To ensure that the headlight washers work properly in winter, keep the nozzles in the bumper free of snow and remove any ice with a de-icer spray. ■

## Mirrors

### Interior mirror

*It is dangerous to drive if you cannot see clearly through the rear window.*

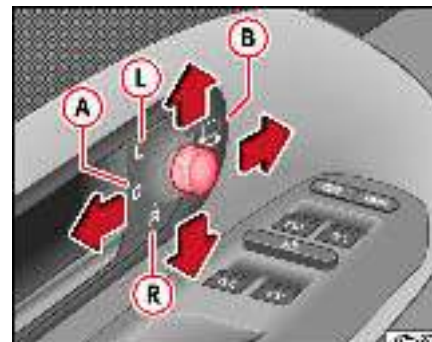

**Fig. 81 Automatic anti-dazzle function for interior mirror**

### Manual anti-dazzle function for interior mirror

When the rear-view mirror is in standard position, the lever on the lower edge of the mirror should face forwards. Pull the lever to the back to select the anti-dazzle function.

### Automatic anti-dazzle function for interior mirror<sup>22)</sup>

When the ignition is on, the interior mirror will darken *automatically* according to the amount of light it receives. The mirror will return to the normal position if the reverse gear is selected. ▶

<sup>22)</sup> Optional equipment

This function can be activated and deactivated by pressing the rearview mirror switch ⇒ page 119, fig. 81 ①. When it is activated, the warning lamp lights up ②. ■

## Exterior mirrors

The exterior mirrors can be adjusted using the rotary knob in the driver's door.

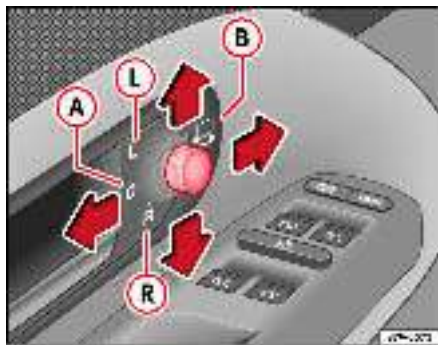

Fig. 82 Detail of driver door: wing mirror controls

### Basic setting of exterior mirrors

1. Turn knob ⇒ fig. 82 to position ① (left exterior mirror).
2. Turn the rotary knob to position the mirror so that you have a good view to the rear of the vehicle.
3. Turn knob to position ② (right exterior mirror).

4. Swivel the rotary knob to position the mirror so that you have a good view to the rear of the car ⇒ ⚠.

### Electric folding wing mirror housings<sup>23)</sup>

- Turn knob to position ③ to fold in the wing mirrors electrically.

### Folding wing mirrors back out<sup>23)</sup>

- Turn the knob to another position to fold the exterior mirrors back out ⇒ ⚠.

### Synchronised wing mirror adjustment<sup>23)</sup>

1. Turn the control to the position ④ (left exterior mirror).
2. Turn the rotary knob to position the mirror so that you have a good view to the rear of the vehicle. The **right exterior mirror** will be adjusted at the same time (synchronised). If necessary the right wing mirror adjustment may need correcting.

### Heated wing mirrors<sup>23)</sup>

The heated wing mirrors are heated while the rear window heater ⇒ page 116 and the ignition are switched on.

#### WARNING

- The rear view convex or aspheric mirror increase the field of vision however the objects appear smaller and further away in the mirrors. If you use these mirrors to estimate the distance to vehicles behind you when changing lane, you could make a mistake. Risk of accident.

<sup>23)</sup> Optional equipment

 **WARNING (continued)**

- If possible, use the interior mirror to estimate distances to vehicles behind you.
- Make sure that you do not get your finger trapped between the mirror and the mirror base when folding back the mirrors. Risk of injury!

**For the sake of the environment**

The exterior mirror heating should be switched off when it is no longer needed. Fuel is wasted otherwise.

**Note**

- If the electrical adjustment ever fails to operate, the mirrors can be adjusted by hand by lightly pressing the edge of the mirror glass.
- In vehicles with electric wing mirrors, the following points should be observed: if, due to an external force (e.g. a knock while manoeuvring), the adjustment of the mirror housing is altered, the mirror will have to be completely folded **electrically**. Do not readjust the mirror housing by hand, as this will interfere with the mirror adjuster function. ■

## Seats and stowage

### The importance of correct seat adjustment

*Proper seat adjustment optimises the level of protection offered by seat belts and airbags.*

The driver seat, front passenger seat, and seats in the passenger compartment, can be adjusted in many ways to suit the physical requirements of the vehicle occupants. The correct seat position is very important for:

- fast and easy operation of all controls on the instrument panel,
- relaxed posture that does not cause drowsiness,
- safe driving,
- optimum protection from the seat belts and airbag system ⇒ page 7.

#### Vehicle seats

Your vehicle has a total of **five** or **seven**<sup>24)</sup> seats.

- First row of seats: two seats
- Second row of seats: three seats
- Third row of seats<sup>24)</sup>: two seats

Each seat is equipped with a three-point seat belt.



#### WARNING

If the driver and passengers assume improper sitting positions, they may sustain critical injuries.

- **Never transport more people than there are seats available in the vehicle.**



#### WARNING (continued)

- **Every occupant in the vehicle must properly fasten and wear the seat belt belonging to his or her seat. Children must be protected with an appropriate child restraint system. Section “Child Safety”.**
- **The seats and all head restraints must always be adjusted to body size and the seat belt must always be properly adjusted to provide you and your passengers with optimum protection.**
- **Always keep your feet in the footwell when the vehicle is moving; never rest them on the dash panel, out of the window or on the seat. This also applies to passengers. An incorrect sitting position exposes you to an increased risk of injury in the event of a braking manoeuvre or an accident. If the airbag is triggered, you could sustain fatal injuries due to an improper sitting position.**
- **It is important for the driver and front passenger to maintain a distance of at least 25 cm from the steering wheel or dash panel. Failure to respect the minimum distance means that the airbag will not protect you. Risk of fatal injury. The distance between the driver and the steering wheel or between the front passenger and the dash panel should always be as great as possible.**
- **Adjust the driver or front passenger seat only when the vehicle is stationary. Otherwise your seat could move unexpectedly while the vehicle is moving. This could increase the risk of an accident and therefore injury. In addition, while adjusting your seat, you will assume an incorrect sitting position. Risk of fatal accidents.**
- **Special guidelines apply to installing a child seat on the front passenger seat. When installing a child seat, observe the warning note in “Child safety”.**
- **The seats in the third row of seats may, for safety reasons, only be used if the luggage compartment cover has been removed. ■**

<sup>24)</sup> Optional equipment

## Head restraints

### Correct adjustment of head restraints

*Properly adjusted head restraints are an important part of occupant protection and can reduce the risk of injuries in most accident situations.*



**Fig. 83 Front view: head restraints and seat belts correctly adjusted**

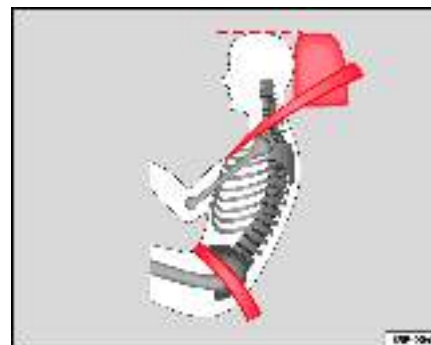

**Fig. 84 Side view: head restraints and seat belts correctly adjusted**

- Adjust the head restraint so that its upper edge is at the same level as the top of your head ⇒ [fig. 83](#) and ⇒ [fig. 84](#).

Adjusting the head restraints ⇒ [page 124](#).

#### **WARNING**

Travelling with the head restraints removed or improperly adjusted increases the risk of severe injuries.

- Improperly adjusted head restraints could lead to death in the event of a collision or accident.
- Incorrectly adjusted head restraints also increase the risk of injury during sudden or unexpected driving or braking manoeuvres.
- The head restraints must always be adjusted according to the occupant's size. ■

## Removing or adjusting head restraints

The head restraints can be adjusted by moving them up and down.



Fig. 85 Adjusting and removing the head restraints

### Adjusting height

- Hold the side of the head restraint.
- Push the head restraint up (in the direction of the arrow) or push it down with the button pressed ⇒ fig. 85 (arrow). Correct setting ⇒ page 123.
- Make sure that the head restraint engages securely in position.

### Removing the head restraint

- Push the head restraint up as far as it will go.
- Press the button ⇒ fig. 85 -arrow-.

- Pull head restraint out of fitting without releasing the button.

### Fitting the head restraint

- Insert the head restraint into the guides on the rear backrest.
- Press and hold button ⇒ fig. 85 (arrow) and push the head restraint down **as far as it will go**.
- Adjust the head restraint to suit body size.

### WARNING

Never drive if the head restraints have been removed. Risk of injury.

- After refitting the head restraint, you must always adjust it properly for height to achieve optimal protection.
- Please observe the safety warnings ⇒ page 123, “Correct adjustment of head restraints”. ■

## Front seats

### Adjusting front seats

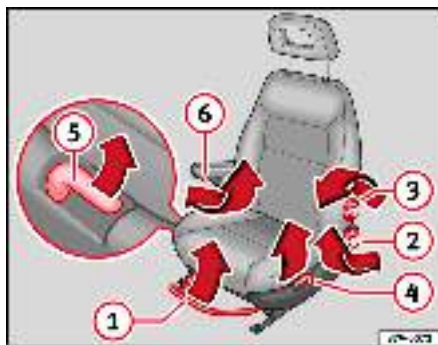

Fig. 86 Front left seat controls

The control elements ⇒ fig. 86 are mirrored for the front right-hand seat.

#### ① Adjusting the seat forwards and backwards

- Pull up the lever and move the seat forwards or backwards ⇒ ⚠.
- Then release the grip ① and move the seat further until the catch engages.

#### ② Adjusting the backrest angle

- Take your weight off the backrest and turn the hand wheel.

#### ③ Adjusting the lumbar support<sup>25)</sup>

- Take your weight off the backrest and turn the hand wheel.

#### ④ Turning the seat<sup>25)</sup>

- Adjust the seat surface to its lowest position and push the seat back as far as it will go.
- On the *driver's seat*, adjust the backrest fully forward so that it will not hit the steering wheel when turning the seat round.
- Lift the lever ④ and turn the seat round ⇒ ⚠.

#### ⑤ Adjusting the seat height

- Pull the lever up or push down (several times if necessary) from its home position. This adjusts the seat height in stages ⇒ ⚠.

#### ⑥ Adjusting the armrest<sup>25)</sup>

- Turn the thumb wheel underneath the arm rest to adjust it to the size of the occupant.

The curvature of the cushioned area is determined by the settings made in the lumbar region. This supports the natural curvature of the spine very effectively.

<b>⚠ WARNING</b>
<ul style="list-style-type: none"> <li>• <b>Never adjust the driver or front passenger seat while the vehicle is in motion. While adjusting your seat, you will assume an incorrect sitting position. Risk of injury. Adjust the driver or front passenger seat only when the vehicle is stationary.</b></li> </ul>

<sup>25)</sup> Optional equipment

**⚠ WARNING (continued)**

- To reduce the risk of injury to the driver and front passenger during sudden braking manoeuvres or an accident, never drive with the backrest tilted far back. Risk of injury. The maximum protection of the seat belt can be achieved only when the backrests are in an upright position and the driver and front passenger have properly adjusted their seat belts. The further the backrests are tilted to the rear, the greater the risk of injury due to improper positioning of the belt web!
- Exercise caution when adjusting the seat height or forwards/backwards position. Injuries can be caused if the backrest is tilted without due care and attention.
- Never turn the driver or front passenger seat while the vehicle is in motion. While adjusting your seat, you will assume an incorrect sitting position. Risk of injury. Only turn the driver or passenger seats when the vehicle is stationary.
- When the vehicle is in motion, the rotating front seats must be securely engaged and facing the direction of travel. These front seats may be used only when the vehicle is stationary.

**⚠ Caution**

The driver seat and front passenger seat must not be occupied while they are being turned. If the seat is occupied when it is turned, it could be damaged. ■

## Seat heating

*The seat cushions and backrests of the front seats can be heated electrically.*



**Fig. 87 Centre console:  
Seat heating controls**

- Turn the appropriate switch ⇒ **fig. 87** to switch on the seat heating. The seat heating is switched off in the **0** position.

The seat heating only works when the ignition is switched on. The left switch controls the left seat heating and the right switch the right seat heating.

**⚠ Caution**

To avoid damaging the heating elements, please do not kneel on the seat or apply sharp pressure at a single point to the seat cushion and backrest. ■



## Rear seats

### Characteristics of seat equipment

The seats in the passenger compartment have the following features, depending on the equipment level:

- Integrated three-point seat belt with adjustable latch plate holder,
- Integrated ISOFIX anchor points for a child seat,
- Height-adjustable head restraints ⇒ page 123,

- Room for just one person,
- Adjustable armrests<sup>26)</sup>,
- Individual seats can be removed ⇒ page 130,
- Integrated child seats<sup>26)</sup>.

#### Seat with integrated child seat

Seats with an integrated child seat have the same functions as the conventional individual seats. The integrated child seat is described in “Safety first”. ■

<sup>26)</sup> Optional equipment

### Seat layout

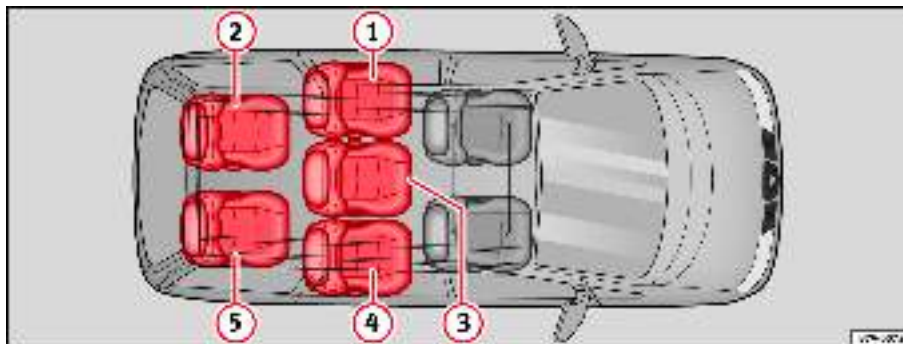

Fig. 88 Maximum number of seats in the Alhambra

- ① Second row, left seat.
- ② Third row, left seat.
- ③ Second row, centre seat.



④ Second row, right seat.<sup>27)</sup>

⑤ Third row, right seat<sup>27)</sup>.

#### Notes on the installation of the seats

- Seats ① and ② are of the same construction and thus interchangeable.
- Seats ④ and ⑤ are of the same construction and thus interchangeable.
- Seat ② can be installed in positions ①.
- Seat ③ can be installed in place of seats ①, ②, ④ and ⑤. ■

### Moving seats



Fig.89 Adjustment of the seat forwards and backwards

- Make sure that the vehicle is not on a steep slope.
- Pull the unlock lever ⇒ fig. 89 upwards, in the direction of the arrow, and hold in this position.

- Move the seat.
- Release the lever.
- Always ensure that the seat is securely engaged.

#### WARNING

- Please be careful when adjusting the seat backwards and forwards! Injuries can be caused if the backrest is tilted without due care and attention.
- Adjust the seat only when the vehicle is stationary. Otherwise your seat could move unexpectedly while the vehicle is moving. This could increase the risk of an accident and therefore injury.
- Please observe safety recommendations concerning seats ⇒ page 132. ■

<sup>27)</sup> Optional equipment

## Folding the backrest and the seat forwards

There are two ways to fold the backrest and lift the seat.



Fig. 90 Side of seat: fold the backrest and lift seat forwards

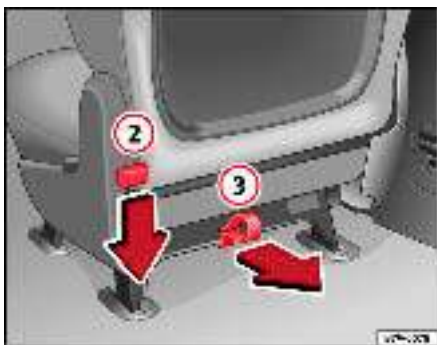

Fig. 91 Rear of seat: fold the backrest and lift seat forwards

### Folding the individual seat forwards

- Pull the release lever at the seat surface ⇒ fig. 90 ② up or press the lever on the rear side of the seat ⇒ fig. 91 ② down.
- Press the backrest down until the backrest engages.

### Folding seat forward

- Push the head restraint down as far as it will go ⇒ page 124.
- Fold down the backrests.
- Pull the release lever at the seating surface ⇒ fig. 90 ③ up or pull the loop on the rear side of the seat ⇒ fig. 91 ③ down.
- Fold the seat forwards.

### Folding seat back

- Fold the seat back until it engages in the rear floor anchorings.
- Fold back the backrest.
- Pull the seat up to ensure that it is properly engaged in the floor anchorings.
- Adjust the head restraint to suit body size.

The backrest is locked in position when folded forwards. That is why the release lever ② must be either pulled or pushed again to push the backrest up again. ▶

### WARNING

If you do not hold the backrest firmly when you operate the lever for adjusting the backrest angle, the backrest will be pushed forward by springs. Risk of injury.

- Always hold the backrest firmly when you adjust the backrest angle.
- Please observe safety recommendations concerning seats

⇒ page 132. ■

## Removing and fitting individual seats

*The seats can be fitted and removed more easily by two people than by one person.*

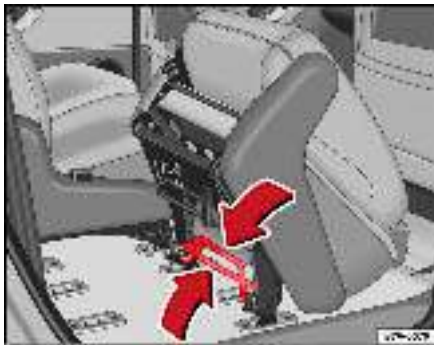

Fig. 92 Bar for removing and installing the individual seat

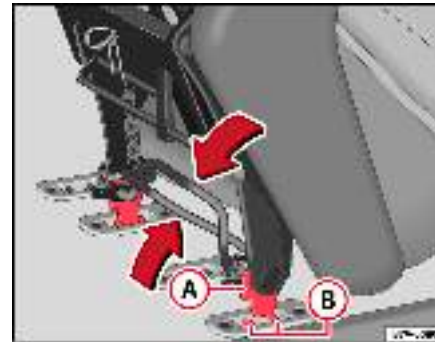

Fig. 93 Assembling seat: bar and retaining bolts

### Removing an individual seat

- Push the head restraint down as far as it will go ⇒ page 124.
- Fold down the backrests ⇒ page 129.
- Fold the seat forwards ⇒ page 129.
- When removing a seat in the third row <sup>28)</sup>, push the seat back as far as it will go and forwards as far as it will go when removing a seat in the second row.
- Push the two bars ⇒ fig. 92 under the seat together in the direction of the arrow and lift the seat out of the floor anchorings.

### Assembling seat

- Push the bars underneath the seat together in the direction of the arrow and hold them in this position. ▶

<sup>28)</sup> Optional equipment

- Place the seat frame ⇒ page 130, fig. 93 **A** between the retaining bolts **B** in the floor anchorings and release both bars.
- Pull the seat up to ensure that it is properly engaged in the front floor anchorings.
- Fold the seat back until it engages in the rear floor anchorings.
- Fold the backrest back and adjust the head restraint to suit body size.

#### Covers for the floor anchorings

After removing the seats in the passenger compartment, it is possible to fix covers to the floor anchorings to stop dirt getting into them, for example. You will receive 12 covers delivered with the vehicle.

Guide the cover into the floor anchoring and press it in.

The covers will have to be removed by levering them off with the vehicle key before you can install the seats.



#### WARNING

Please observe safety recommendations concerning seats ⇒ page 132. ■

## Armrests

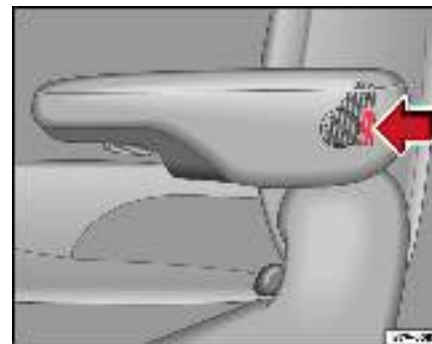

Fig. 94 Removable armrest: button



Fig. 95 Protective bag for the removable armrests ▶

### Adjusting the armrest

- Turn the thumb wheel underneath the armrests to adjust the angle of the armrests to your requirement.

### Removable armrest\*<sup>29)</sup>

- Take hold of the armrest at the rear and press the button ⇒ [page 131, fig. 94](#) in the direction of the arrow.
- With the button pressed, pull the armrest off to the side out of the holder.
- When **installing**, please ensure that the armrest engages securely in the holder.

The removable armrests for the second row of seats can be found in a transport bag ⇒ [page 131, fig. 95](#).

The bag hangs from a head restraint of a seat in the last row of seats or, in vehicles with 4 integrated child seats <sup>29)</sup>, on the centre seat of the second row of seats.

#### WARNING

- The transport bag should always be secured properly when travelling in the vehicle as it could otherwise be a safety risk in an accident or braking manoeuvre. We recommend that you keep the bag at home.
- The bag, if you do decide to keep it in the vehicle, may not be secured to the head restraint of an integrated child seat. The backrest could be forced forward in an accident or braking manoeuvre due to the weight of the bag. ■

### Safety instructions for seats

#### WARNING

- Occupants may travel on the seats in the passenger compartment only if the following conditions are fulfilled at the same time:
  - The seats must always be fitted in the appropriate floor anchorings and must be securely engaged.
  - The backrest of all seats must be in the upright position and securely engaged in this position.
  - The seat occupants must have access to the seat belts. The seat belts must be fitted correctly.
  - All the occupants of the vehicle must be correctly seated while driving.
- A seat which has been removed can cause injury if it is transported in the vehicle. Each seat must always be fitted in the floor anchorings and must be securely engaged. The backrest must be in an upright position. If a bench seat is not properly secured, it could become a life-threatening hazard for all vehicle occupants.
- Make sure that the seat feet of seats are not soiled or damaged when removed from the vehicle.
- All adjustment to the seats, including fitting and removal, may be carried out only when the vehicle is stationary. ■

<sup>29)</sup> Optional equipment

## Some seat settings for the Alhambra

Examples of how the seating layout can be altered.

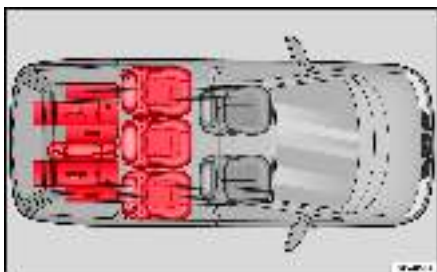

Fig. 96 Alhambra loaded with luggage.

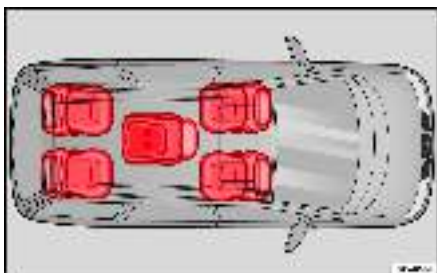

Fig. 97 Alhambra transformed into conference room

Of course, the illustrations show only some of the many seat combinations possible in the Alhambra. You can, for example, purchase corresponding retainers for your bicycle from SEAT Service. That means you will be able to protect your bicycles from both theft and the weather when transporting them.

Or you turn <sup>30)</sup> the driver and front passenger seats 180° to use the Alhambra as a conference room or breakfast room. Or you can easily remove the seats in the third row <sup>30)</sup> in order to travel with a lot of luggage.

### WARNING

- Luggage and other items in the luggage or passenger compartment can be thrown forward in a braking manoeuvre. Please ensure that these items are secured properly.
- Do not release the backrest of a seat in the second row when folding a seat in the third row of seats forwards. Serious injuries can occur if a backrest has not been properly engaged in position. ■

<sup>30)</sup> Optional equipment

## Stowage compartments

### Stowage compartment on the front passenger side

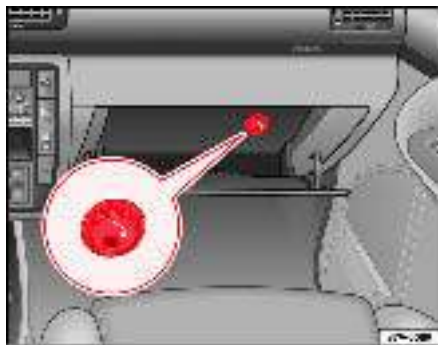

Fig. 98 Passenger side: stowage compartment

The compartment can be opened by pulling the lever ⇒ fig. 98. It is locked when the key slot\* is horizontal.

#### Vehicle wallet compartment

The vehicle wallet should always be kept in the glove compartment.

#### Cooling the stowage compartment on the front passenger side

There is an air outlet on the right of the rear panel ⇒ fig. 98. If the air conditioning is switched on, cooled air can be fed into the compartment. Turn the air vent to open and close it.

### WARNING

Always keep the stowage compartment cover closed while the vehicle is in motion to reduce the risk of injury during a sudden braking manoeuvre or in the event of an accident. ■

### Central stowage on instrument panel



Fig. 99 Central stowage on instrument panel

**To open** stowage compartment, press on the part closest to the air vents (dotted area) in the direction of the arrow, this opens by spring action ⇒ fig. 99.

**To close**, lower the cover by hand until it is completely closed. ■



### Upper right stowage on instrument panel

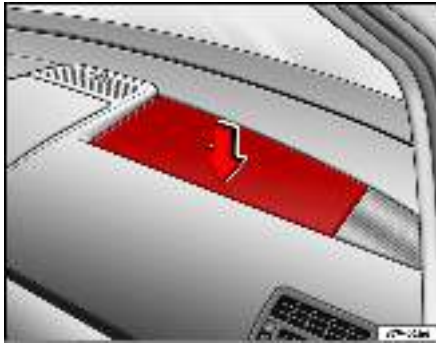
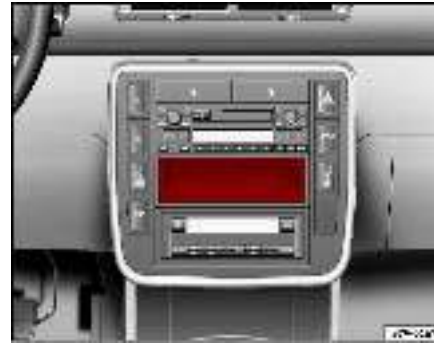

**Fig. 100** Upper right stowage on instrument panel

**To open**, press as shown by arrow ⇒ fig. 100. The stowage compartment opens by spring action.

**To close**, lower the cover by hand until it is completely closed. ■

### Stowage compartment on centre console\*



**Fig. 101** Stowage compartment on centre console

Some versions of the model may include a stowage compartment between the radio and the Climatronic. ■

### Stowage compartment in the luggage compartment

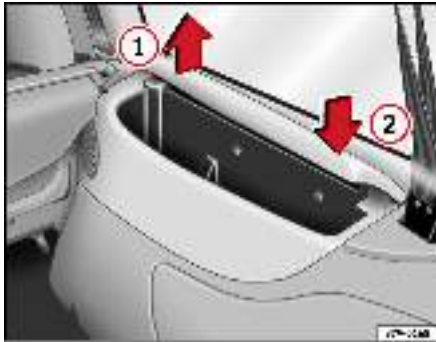

Fig. 102 Stowage compartment in the luggage compartment

On the right there is a stowage compartment which can be used to store the hazard warning triangles for example.

**To open**, pull cover in the direction of the arrow ① ⇒ fig. 102.

**To close**, push cover in the direction of the arrow ② ⇒ fig. 102. ■

### Other stowage areas



Fig. 103 Stowage area in the roof

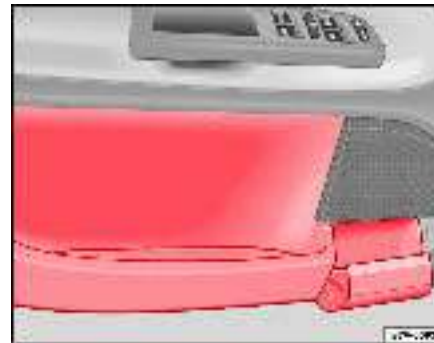

Fig. 104 Stowage area in the driver door

Further stowage facilities can be found in the front passenger door ⇒ fig. 104 as well as in the roof ⇒ fig. 103 in vehicles with a curtain airbag<sup>31</sup>). ▶

Coat hooks are located in the roof. They are integrated in the grab handles in the passenger compartment.

#### Location of CD changer<sup>31)</sup>

The CD changer, which can be factory fitted, is located either in the dash panel or in the right-hand stowage compartment in the luggage compartment.

#### WARNING

- Ensure that no objects can fall from the dash panel or other stowage areas into the driver footwell while the vehicle is moving. In the event of a sudden braking manoeuvre, you will not be able to use the brake, clutch or accelerator. Risk of accident.
- Clothing hung on the coat hooks must not restrict the driver's view. Risk of accident. The coat hooks are intended only for use with light articles of clothing. Do not leave any hard, sharp or heavy objects in hanging articles of clothing. During sudden braking manoeuvres or accidents, especially those involving airbag deployment, these objects could injure the vehicle occupants. ■

<sup>31)</sup> Optional equipment

## Cup holders

*In the centre console: there are two cup holders*

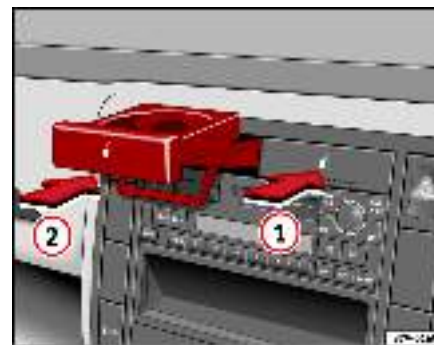

Fig. 105 Cupholder in the centre console

#### Opening cup holder

- Press the symbol on the cup holder briefly. The spring mechanism will release the holder.

#### Closing the cup holder

- Push the cup holder up in the direction of the arrow ⇒ fig. 105 until it engages.

#### WARNING

Improper use of the cup holders can cause injury.

- For reasons of safety, the cup holders should be used only for standard drinks cans and bottles with a maximum capacity of 0.5 litres. ▶

**⚠ WARNING (continued)**

- Never place hot drinks in the drink holders. During normal or sudden driving manoeuvres, sudden braking or an accident, the hot drink could be spilled. Danger of scalding.
- Ensure, when driving, that no can or other object is dropped in the driver footwell, as it could get under the pedals and obstruct their working. In the event of a sudden driving or braking manoeuvre, you will not be able to operate the brake, clutch or accelerator pedal. Risk of accident!
- Never leave closed drinks cans in direct sunlight for any length of time. If the inside temperature is high they could explode.

**⚠ Caution**

When driving, do not leave open cans in the cup holders. The drink might be spilled on braking, for example, and could damage the vehicle.

**i Note**

There is no left-hand cup holder on vehicles fitted with a hands-free telephone system<sup>32)</sup>. ■

## Folding table

*Folding tables are fitted to the rear of the front seat backrests.*



**Fig. 106** Folding table on right-hand front seat

### Folding out the folding table

- Fold the table up in the direction of the arrow ⇒ **fig. 106** until it engages.

### Folding the table back

- Push the table down in the opposite direction of the arrow ⇒ **fig. 106** until it engages.

<sup>32)</sup> Optional equipment

**! WARNING**

The folding tables may not be folded down whilst the vehicle is in motion and anyone is seated on the second row of seats. There is a risk on injury during a sudden braking manoeuvre! The table must therefore be closed and properly secured whilst the vehicle is in motion. ■

## Clothes hangers

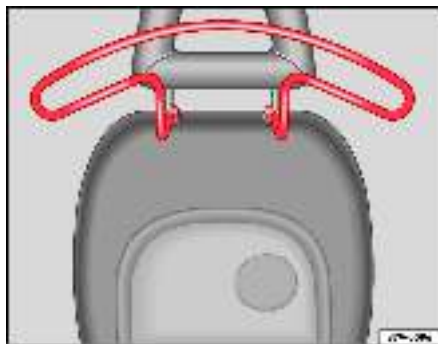

Fig. 107 Clothes hangers on the front seat

### Removing the clothes hanger

- Remove the head restraint ⇒ page 124.
- Pull the clothes hanger <sup>33)</sup> off the rods of the head restraint ⇒ fig. 107.

<sup>33)</sup> Optional equipment

**! WARNING**

- The hanger must never be attached to the head restraint of a seat used by children, as the head restraint does not engage completely and will come off in the event of an accident.
- A hanger may only be fitted on a head restraint when no-one is seated in the seat behind. In the event of an accident, it could cause injury.

**! Caution**

The clothes hangers should only be secured on the driver and front passenger seats and not on the seats in the passenger compartment. The side trim will otherwise be damaged when folding the seats backwards and forwards. ■

## Net bag for small objects



Fig. 108 Net bag on seats in second row

The seats in the second row are fitted with a net bag ⇒ page 139, fig. 108 for the stowage of small objects.

The bag will hold a newspaper, can or standard bottle of up to a maximum of 0.5 litres ⇒ ⚠.

### ⚠ WARNING

- Ensure, when driving, that no can or other object is dropped in the driver footwell, as it could get under the pedals and obstruct their working. In the event of a sudden driving or braking manoeuvre, you will not be able to operate the brake, clutch or accelerator pedal. Risk of accident! ■

## Ashtrays, cigarette lighter and electrical sockets

### Front ashtray



Fig. 109 Front ashtray

### Opening and closing the ashtray

- To open move the ashtray cover ⇒ fig. 109 forwards (arrow), until it engages.
- To close, push the cover down as far as it will go.

### Emptying the ashtray

- To remove the ashtray insert, pull it to the front until it engages.
- Take out the ashtray.

No-smoking versions of the vehicle have a stowage compartment in place of the ashtray.

### ⚠ WARNING

- Never put paper in the ashtray. Hot ash could ignite the paper in the ashtray. ■

## Rear ashtrays



Fig. 110 Rear ashtray

### Emptying the rear door ashtrays

- Open the ashtray and remove the interior of the ashtray.

#### **WARNING**

- Never put paper in the ashtray. Hot ash could ignite the paper in the ashtray. ■

## Cigarette lighter



Fig. 111 Cigarette lighter in the ashtray

- Open the ashtray ⇒ page 140, fig. 109.
- Press the lighter button ⇒ fig. 111 inwards ⇒ .
- Wait for the lighter to pop out slightly.
- Pull out the cigarette lighter and light the cigarette on the glowing coil.

No-smoking versions of the vehicle are fitted with a 12 volt socket in place of the lighter ⇒ page 142.

#### **WARNING**

- Improper use of the cigarette lighter can lead to serious injuries or start a fire. ▶

**⚠ WARNING (continued)**

- Take care when using the cigarette lighter. Carelessness or negligence when using the cigarette lighter can cause burns, risk of injury.
- The cigarette lighter also works when the ignition is off and when the ignition key is removed. To avoid the risk of fire, never leave children unsupervised in the vehicle. ■

## Sockets

Electrical equipment can be connected to any of the 12 volt sockets.

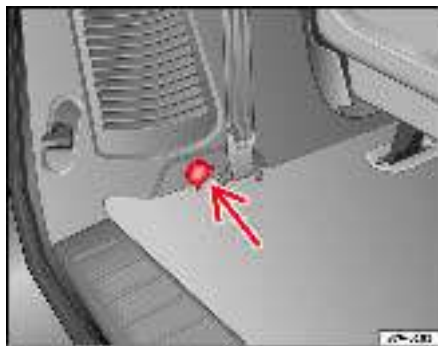

**Fig. 112 Socket, luggage compartment**

### Socket in the centre console

The 12 Volt socket in the stowage area or the 12 Volt socket of the cigarette lighter<sup>34)</sup> can be used for further electrical consumers with a power rating of up to 120 Watt.

### Socket, luggage compartment <sup>34)</sup>

Electrical equipment can be connected to the 12-volt socket in the luggage compartment ⇒ fig. 112. The appliances connected to each socket must not exceed a power rating of 120 Watt.

The socket is supplied with electricity from the additional battery on vehicles equipped with an additional battery<sup>34)</sup>.

**⚠ WARNING**

**The electrical sockets and any appliances connected to them are also functional with the ignition switched off and the key removed. Improper use of the sockets or electrical accessories can lead to serious injuries or cause a fire. To avoid the risk of injury, never leave children unsupervised in the vehicle.**

**i Note**

- Using electrical appliances with the engine switched off will drain the battery.
- Before using any electrical accessories, see the instructions on ⇒ page 202. ■

<sup>34)</sup> Optional equipment



## Hazard warning triangles and first aid kit

### Warning triangle

The hazard warning triangle may be fitted in the bracket behind the right trim of the luggage compartment.



#### Note

The warning triangle is not part of the vehicle's standard equipment. ■

### First-aid kit

In the bracket located behind the right hand trim in the luggage compartment there is space for a standard first aid kit and the hazard warning triangle.

For reasons of space, in vehicles fitted with a removable tow bar<sup>35)</sup> the bracket only holds a smaller first aid kit and the hazard warning triangle.



#### Note

- In some vehicles the first aid kit bracket is behind the left hand trim in the luggage compartment.
- The first aid kit is **not** issued as a standard feature with the vehicle.
- The first aid kit must comply with legal requirements.
- Observe the expiry date of the contents of the first aid kit. You should purchase a new first-aid kit as soon as possible after the shelf-life date of the first-aid kit has expired.
- Before buying accessories and replacement parts, refer to the note "Accessories, modifications and renewal of parts". ■

<sup>35)</sup> Optional equipment

## Luggage compartment

### Loading the luggage compartment

*All luggage and other loose objects must be safely secured in the luggage compartment.*

Please observe the following points to ensure the vehicle handles well at all times:

- If necessary, remove the seats to increase the load area.
- Distribute the load as evenly as possible in the luggage compartment.
- Place and stow heavy objects directly on the floor of the vehicle. If possible they should be positioned above or in front of the rear axle.
- Drive particularly carefully if you are transporting heavy objects ⇒ page 145.
- Use suitable straps to secure heavy objects to the fitted fastening rings ⇒ page 144.
- If objects protrude over the end of the vehicle, you must draw the attention of other road users to this. Observe legal requirements when doing so.

When driving with the tailgate open, please observe the instructions on ⇒ page 100. ▶

 **WARNING**

Loose luggage and other objects in the luggage compartment can cause serious injuries.

- Always stow objects in the luggage compartment and secure them on the fastening rings.
- Use suitable specialist straps to secure heavy objects.
- During sudden manoeuvres or accidents, loose objects can be thrown forward, injuring vehicle occupants or passers-by. This increased risk of injury will be further increased if a loose object is struck by an inflating airbag. If this happens, objects can be transformed into “missiles”. Risk of fatal injury.
- Remember that transporting heavy objects modifies the driving conditions as the centre of gravity has been altered. There is a risk of accident. Therefore, it is essential to adjust your speed and driving style accordingly, to avoid accidents.
- Never exceed the allowed axle loads or allowed maximum weight. If the allowed axle load or the allowed total weight is exceeded, the driving characteristics of the vehicle may change, leading to accidents, injuries and damage to the vehicle.
- Never leave the vehicle unattended, especially when the tailgate is open. Children could climb into the luggage compartment closing the door behind them; they will remain trapped without help and there is a mortal risk.
- Never allow children to play in or around the vehicle. Close and lock both the tailgate and all the doors when you leave the vehicle. Before you lock the vehicle, make sure that there are no adults or children in the vehicle.
- Never transport passengers in the luggage compartment. Every passenger must be properly belted in.

 **Caution**

- Avoid overloading small areas by placing heavy objects on the vehicle floor.
- The wires of the heating element in the rear window and the window aerial in the rear side windows could be damaged if objects on the luggage compartment cover rub against them.
- If you have removed the seats from the passenger compartment, you should place a large, robust covering over the floor anchorings to prevent damage.

 **Note**

- Air circulation in the vehicle helps reduce fogging of the windows. Used air escapes through ventilation slits in the side trim of the luggage compartment. Ensure that the ventilation slits are never covered.
- Straps for securing the load to the fastening rings are commercially available. ■

### Fastening rings

*There are fastening rings in the luggage compartment which can be used to secure luggage and other objects.*

- Always use suitable undamaged belts for fastening the luggage or any other object to the anchorage rings ⇒  in “Loading the luggage compartment” on page 143.

The retainers for the detachable seat belts for the third row of seats and the floor anchorings for the seats can be used as fastening rings for items of luggage. ▶

During a collision or an accident, even small and light objects can build up so much energy that they can cause very severe injuries. The amount of “kinetic energy” depends on the speed of the vehicle and the weight of the object. The most significant factor, however, is the speed of the vehicle.

Example: An object weighing 4.5 kg is lying unsecured in the vehicle. During a frontal collision at a speed of 50 km/h, this object generates a force corresponding to 20 times its weight. That means that the effective weight of the object increases to about 90 kg. You can imagine the severity of the injuries which might be sustained if this “projectile” strikes an occupant as it flies through the passenger compartment. This increased risk of injury will be further increased if a loose object is struck by an inflating airbag.



#### WARNING

If pieces of baggage or other objects are secured to the fastening rings with inappropriate or damaged retaining cords, injuries could result in the event of braking manoeuvres or accidents.

- To prevent pieces of luggage or other objects from flying forward, always use appropriate retaining cords which are secured to the fastening rings.
- Never secure a child seat on the fastening rings. ■

### Loading heavy objects

*Special care is required when loading heavy objects and when driving a vehicle which contains heavy objects.*

Observe the following points to prevent damage and accidents:

- If necessary, remove the seats to increase the load area.

- **Before** loading the vehicle place a sturdy mat or similar cover flush on floor of the vehicle.
- Where necessary, do not cover protruding parts of the vehicle floor.
- Protect the seat anchor points from damage.
- Avoid overloading small areas - spread the load.
- Use suitable straps to secure the objects to retaining rings.
- Drive particularly carefully and think ahead.
- If possible, avoid sudden braking and driving manoeuvres.



#### WARNING

For safety reasons, you should read and observe all information on loading the vehicle ⇒ page 145.



#### Caution

- If you have removed the seats from the passenger compartment, you should place a large, robust covering over the seat rails to prevent damage.
- Avoid overloading small areas - spread the load. ■

### Safety notes on loading the vehicle



#### WARNING

Loose luggage and other objects in the luggage compartment can cause serious injuries. ►

**⚠ WARNING (continued)**

- Always stow objects safely in the vehicle and secure them on the fastening rings if necessary.
- Use suitable specialist straps to secure heavy objects.
- Loose objects in the vehicle can move suddenly. As the centre of gravity moves, safety is impaired and the vehicle becomes difficult to handle.
- During sudden manoeuvres or accidents, loose objects can be thrown forward, injuring vehicle occupants or passers-by. This increased risk of injury will be further increased if a loose object is struck by an inflating airbag. If this happens, objects can be transformed into “missiles”. Risk of fatal injury.
- Remember that transporting heavy objects modifies the driving conditions as the centre of gravity has been altered. There is a risk of accident. Therefore, it is essential to adjust your speed and driving style accordingly, to avoid accidents.
- Never exceed the allowed axle loads or allowed maximum weight. If the allowed axle load or the allowed total weight is exceeded, the driving characteristics of the vehicle may change, leading to accidents, injuries and damage to the vehicle.
- Never leave the vehicle unattended, especially when the tailgate is open. Children could climb into the interior of the vehicle closing the door behind them; they will remain trapped without help and there is a mortal risk.
- Never allow children to play in or around the vehicle. Close and lock all windows, the tailgate and all doors when you leave the vehicle.
- Never transport passengers in the luggage compartment. Every passenger must be properly belted in. ■

### Luggage compartment cover

*The luggage compartment cover protects your luggage from prying eyes.*

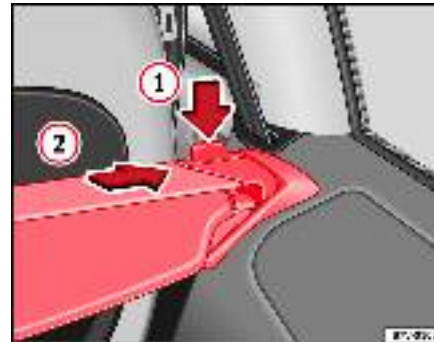

Fig. 113 Luggage compartment cover: holders on the right

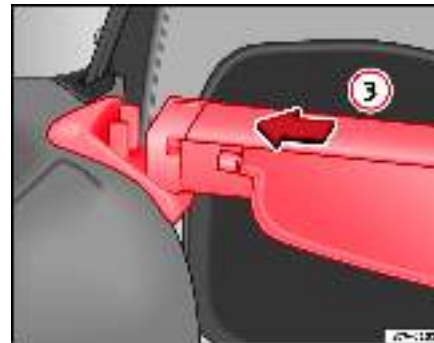

Fig. 114 Luggage compartment cover: holders on the right

### Opening the luggage compartment cover

- After fitting the luggage compartment cover, pull the handle on the cover back and hook in the cover on the side.

### Removing the luggage compartment cover

- Press the unlock button (with the luggage compartment cover rolled up) ⇒ page 146, fig. 113 ① in the direction of the arrow and remove the cover from the right holder upwards.
- Remove the cover from the left holder in the direction of the arrow ② and remove from the vehicle.

### Fitting the luggage compartment cover

- Push the luggage compartment cover to the stop in the direction of the arrow ⇒ page 146, fig. 114 ③ into the left-hand holder.
- Press the cover down into the right-hand holder until it engages in position.

Light items of clothing or other objects on the luggage compartment cover can restrict visibility through the rear window.

#### **WARNING**

- **Never leave hard, heavy or sharp objects on the shelf (unrolled) or in the pockets of clothing on the luggage compartment cover. Animals must never be allowed onto the luggage compartment cover. During a sudden braking or driving manoeuvre or an accident, these objects and animals endanger all vehicle occupants. Risk of injury.**

#### **Caution**

The wires of the heating element in the rear window and the window aerial in the rear side windows could be damaged if objects on the luggage compartment cover rub against them. ■

### Net bag\*

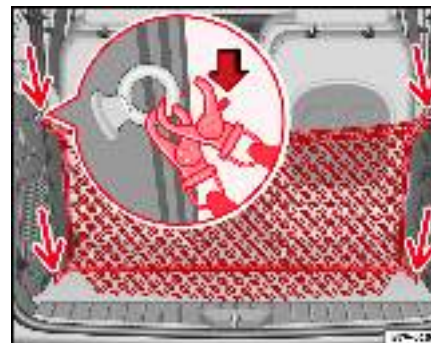

**Fig. 115 Net partition fitted in the vehicle**

- To remove the net bag unhook the six hooks ⇒ fig. 115 (arrows).

The net bag behind the last row of seats is used to store **light** items of luggage. The net partition can prevent items of luggage from being thrown forward into the vehicle in sudden braking manoeuvres or in accidents. ►

 **WARNING**

Always fit the net partition carefully, observing the instructions. Risk of injury.

- Heavy, pointed or sharp items which are not stowed securely can cause injury in the event of sudden braking manoeuvres or accidents, even if the net bag is correctly assembled.
- For reasons of safety, vehicle occupants must not travel behind a fitted safety net. ■

## Roof carrier

### Safety notes on using the roof carrier

*The roof carrier system must always be installed exactly according to the instructions provided.*

- Your vehicle has special roof rails on the right and left for fitting the mounts. Therefore, standard roof carriers cannot be used.
- The mounts are the basis of a complete roof carrier system. Special fixtures must then be added in order to safely transport luggage, bicycles, skis, surf boards or boats on the roof. All these system components are available from SEAT Service. We recommend you use genuine SEAT roof carrier systems. If you wish to use a different roof carrier, make sure that it can be fitted securely to your vehicle and that it cannot damage your vehicle.
- We recommend that you keep the assembly instructions provided by the roof carrier manufacturer in your vehicle wallet.
- Only the fitted retainers may be used to secure the carrier feet on vehicles **without a roof railing**. These retainers are located underneath the plastic rain channel between the markings.

- In vehicles **with roof edging**<sup>36)</sup>, the basic supports can be fitted on the edge making sure to adapt the distance between the supports to the objects to be carried. On vehicles with a sliding/tilting roof<sup>36)</sup>, however, the front carrier may not be fitted near the rear edge of the sliding/tilting roof when the roof is open.

#### When should the roof carrier be removed?

- When it is not needed (to save fuel, reduce wind noise and avoid theft).
- Before cleaning in an automatic car wash.

 **WARNING**

- If you do not use mounts approved by SEAT or fail to fit them according to instructions, the load or the roof carrier itself may fall off the vehicle roof and onto the street. Risk of accident or injury.
- The risk of an accident is increased by transporting heavy or bulky loads on the roof, which affects the car's handling by shifting the centre of gravity and increasing susceptibility to cross winds. Both circumstances increase the risk of accident. Therefore you must adapt your driving style and speed to the prevailing conditions - avoid sudden braking or driving manoeuvres when there is a load on the roof carrier.
- The roof carrier system must always be installed exactly according to the instructions provided.

 **Caution**

- Check all bolted connections and fastenings for the roof carrier system before every trip. If necessary, tighten bolted connections and check the system at regular, appropriate intervals, e.g. at each stop during a long trip.
- The height of your vehicle is changed by the installation of the roof carrier and the load secured on it. Bear this in mind when driving through garage doors or low underpasses – there is danger of damage to the vehicle. ▶

<sup>36)</sup> Optional equipment

- Damage to the vehicle caused by incorrect installation of mounts or roof carrier systems not approved by the factory are excluded from the vehicle warranty. ■

## Securing the load

*Loads transported on the roof carrier must be securely attached. The car's handling is affected when transporting loads.*

The maximum permissible roof load for your vehicle is **75 kg**. The load limit applies to the combined weight of the carrier system and the load itself.

Distribute the load evenly. However, if you are using a roof carrier with a lower weight rating, you will not be able to carry the maximum roof load. Do not exceed the maximum weight limit for the roof carrier which is listed in the fitting instructions.

### WARNING

- If damaged, fine or inadequate securing straps are used to fasten objects carried on the roof, they could break in the event of sharp braking. This could cause an accident and serious injury.
- Always use appropriate securing straps to secure objects on the roof carrier against sliding or flying off., This could cause an accident. The load must be correctly secured.
- Always respect the maximum authorised weight for the roof, the maximum authorised weight on the axles and the total maximum authorised weight of the vehicle. Otherwise there is danger of causing an accident.
- The risk of an accident is increased by transporting heavy or bulky loads on the roof, which affects the car's handling by shifting the centre of gravity and increasing susceptibility to cross winds. Both circumstances

### WARNING (continued)

**increase the risk of accident. Therefore you must adapt your driving style and speed to the prevailing conditions - avoid sudden braking or driving manoeuvres when there is a load on the roof carrier.**

### Caution

Please take extra care not to let the tailgate or rear window strike the roof load when open – there is a risk of damage to the vehicle.

### For the sake of the environment

The roof carrier is often left on the roof for convenience even if it is not being used. However, increased air resistance means that the vehicle uses more fuel. For this reason you should always take off the roof carrier when it is not in use. ■

## Cooling and heating box\*

### Notes on usage

*The cooling and heating box may only be installed in the position of rear left seat in the third row.*

Power can be supplied by any of the 12 Volt sockets in the vehicle. It consumes approximately 33 watts and has a capacity of approximately 32 litres.

The battery will discharge if the cooling and heating box is used for a long period while the engine is switched off. ►

Before using the cooling and heating box for the first time, you should clean it using a household detergent.

Disconnect the power supply and clean the box if you do not plan to use the cooling and heating box for a long period. Place a folded towel between the box and its lid. This prevents mould and damp stains forming in the cooling and heating box.

Whenever possible, food and drinks should be stored in air-tight containers in the box.

Do not overfill the box - this would prevent air circulation within the box.

Place crumpled paper (or similar) between bottles and other containers in the box to prevent clanking noises.

Do not fill the interior of the box with liquid or ice.



### Caution

- Do not place objects, blankets, or clothes on top of the cooling/heating box, as the air intake and output may be obstructed and the box will disconnect itself.
- Do not place any containers, food items or other objects into the box if they are warmer than +50°C. This could damage the cooling and heating box.
- The cold/hot box is not suitable for transporting corrosive material or material containing solvents.
- Never leave the cold/hot box in the rain or damp.



### Note

- The cooling and heating box is not designed to heat or cool the interior of the vehicle. The cooling and heating box should be used only for cooling and warming food and drinks and for transporting heat-sensitive items on short journeys.

- A corresponding manual for the installation and use of the cooling and heating box is included by the manufacturer and should be kept with the vehicle wallet. ■

## Cooling or heating

*The contents of the cooling and heating box can be cooled or kept warm.*

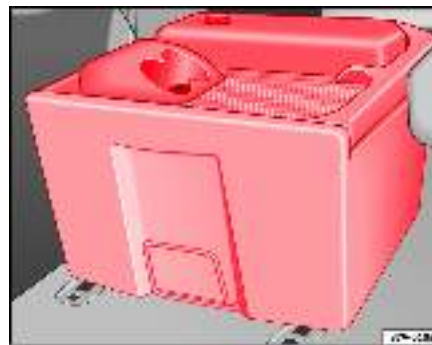

**Fig. 116 Cooling and heating box as installed**

## Switching on the cooling function

- Insert the cable plug in the cooling and heating box so that the **blue** marking on the plug is pointing to the notch.
- Insert the connector cable plug into one of the vehicle's 12 volt sockets.
- Keep the lid of the cooling and heating box closed. ▶



### Switching on the heating function

- Insert the cable plug in the cooling and heating box so that the **red** marking on the plug is pointing to the notch.
- Insert the connector cable plug into one of the vehicle's 12 volt sockets.
- Keep the lid of the cooling and heating box closed.

### Switching the cooling and heating box off fully

- Disconnect the power supply to the 12 Volt socket.

The internal temperature of the cooling and heating box is dependent on the temperature in the vehicle. In cooling mode, the internal temperature can be max. 20 degrees below the temperature in the vehicle. In heating mode it can be max. 35 degrees above the temperature in the vehicle ⇒ ⚠ in “Safety notes on using the cooling and heating box” on page 151.

If you switch directly from cooling to heating (or vice versa) it will take a relatively long time for the interior to reach the desired temperature.

### Faults

If the cooling and heating box does not work, proceed as follows:

- Check whether there is power and whether the plug is securely in the socket.
- Make sure the power cable is not damaged.
- Check the fuse for the power supply to the 12 Volt socket.
- Run the engine to recharge the battery.

If these steps do not help, contact a qualified dealership. ■

### Safety notes on using the cooling and heating box

#### WARNING

- For reasons of safety, the cooling and heating box lid must always be closed and latched when the vehicle is in motion. The cooling and heating box must always be firmly secured in the correct floor anchorings.
- If the temperature in the vehicle is too low, the temperature in the box may fall below +2 degrees and the contents may freeze. Bottles and other containers could burst. Risk of injury.
- For reasons of safety, the cooling and heating box lid must not be used as a table or shelf when the vehicle is in motion.
- Always close the lid of the cooling and heating box before the vehicle moves off. If the flap is open, it could drop down when the vehicle moves off. Risk of injury. ■

## Heating, Ventilation and Air conditioning

### Climatronic

#### Controls

The Climatronic maintains the selected vehicle temperature automatically.

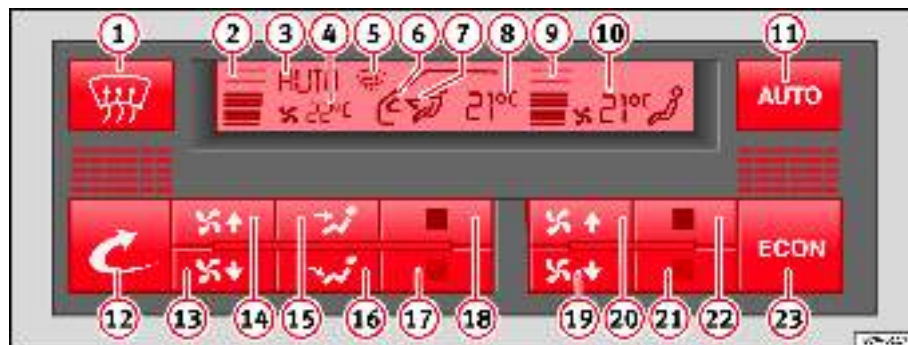



Fig. 117 Instrument panel: Climatronic controls













The cooling system only works when the engine is running and the blower is switched on.

- To switch a function on or off, press the appropriate button  
⇒ fig. 117.

The temperature and the blower can be controlled individually at the front or rear of the vehicle.

- ① Button  – defrost function for the windscreen. The air recirculation and ECON mode are switched off and the windscreen heating<sup>37)</sup> is switched on. The air drawn in from outside the vehicle is directed at the windscreen.
- ② Display of the blower setting for the front
- ③ Display:
  - **AUTO** (automatic mode) or

<sup>37)</sup> Optional equipment

- **ECON** (cooling system off) or
  - **OFF** (entire system off)
- 4 Outside temperature display
  - 5 Display for windscreen defrosting – lights up when the windscreen defrosting function is switched on
  - 6 Display for air recirculation mode
  - 7 Display for air flow
  - 8 Display of the selected interior temperature **front**
  - 9 Display of the blower setting **rear**
  - 10 Display of the selected interior temperature **rear**
  - 11 Button  for the automatic mode
  - 12 Button  for air recirculation mode
  - 13 Button  for reducing the blower speed **front**
  - 14 Button  for raising the blower speed **front**
  - 15 Button  for directing the air flow to the chest
  - 16 Button  for directing the air flow to the footwell
  - 17 Button  for reducing the temperature **front**
  - 18 Button  for raising the temperature **front**
  - 19 Button  for reducing the blower speed **rear**
  - 20 Button  for raising the blower speed **rear**
  - 21 Button  for reducing the temperature **rear**
  - 22 Button  for raising the temperature **rear**
  - 23 Button  for switching the cooling system off

### Switching between Celsius and Fahrenheit

Press and hold the  button and press the  button.

The selected temperature unit is then displayed.



### WARNING

For road safety all windows must be clear of ice, snow, and condensation. This is essential to ensure good visibility. Please familiarise yourself with the correct operation of the heating and ventilation system, including the demist/defrost functions for the windows.



### Note

Please observe the general notes ⇒ page 158. ■

## Automatic mode

*In automatic mode air temperature, flow, and distribution are automatically regulated so that a specified temperature is attained as quickly as possible and then maintained.*

### Switching on automatic mode

- Press the button .
- Select the desired temperature We recommend 22°C (72°F).

A comfortable interior climate is quickly reached when a temperature of +22°C (72°F) is set in automatic mode. It can be changed as necessary to suit individual preferences or particular circumstances. It is possible to select interior temperatures from +18°C (64°F) to +29°C (86°F). These are approximate temperatures and the actual temperature may be slightly higher or lower depending on the outside conditions.

If a temperature below +18°C (64°F) is selected, the display switches to **LO** The temperature is not controlled and in AUTO mode, the system runs at maximum cooling output. ►

If a temperature above +29°C (86°F) is selected, the display switches to **HI** In this setting the system runs at maximum heating output and the temperature is not controlled.

Climatronic maintains a constant temperature level fully automatically. This is done by automatically adjusting the temperature of the air supplied to the interior, the blower setting, and the air distribution. The system also allows for the effect of strong sunlight, so there is no need for manual adjustment. Therefore, **automatic mode** provides the best comfort for the vehicle occupants in virtually all conditions throughout the year.

Automatic mode is switched off whenever an adjustment is made using the buttons for air distribution or blower. The temperature continues to be regulated.

### Note

In the automatic mode, at least one outlet in the instrument panel must be open. The cooling system could otherwise ice over. ■

## Manual mode

*In manual mode you can adjust the air temperature, flow, and distribution yourself.*

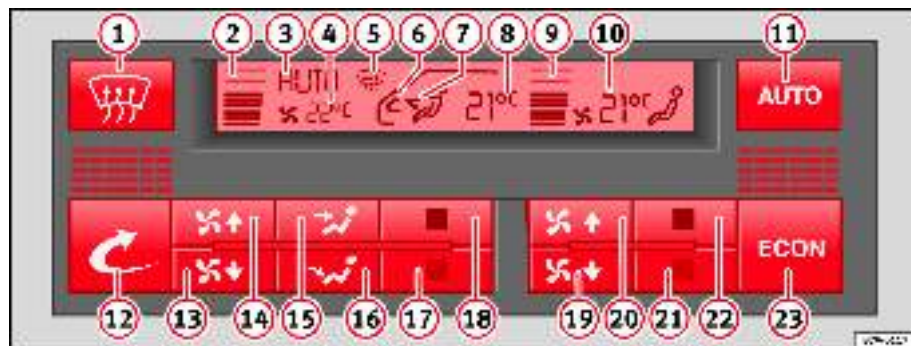

Fig. 118 Instrument panel: Climatronic controls

### Switching on manual mode

- Press one of the air distribution buttons ⇒ fig. 118 **15** or **16** several times, or one of the temperature buttons **17** or **18**. **AUTO**

is deleted from the display. ▶



## Temperature

The selected temperature setting is shown on the display. It is possible to select interior temperatures from +18°C (64°F) to +29°C (86°F). These are approximate temperatures and the actual temperature may be slightly higher or lower depending on the outside conditions.



If a temperature below +18°C (64°F) is selected, the display switches to **LO**. The temperature is not controlled and in AUTO mode, the system runs at maximum cooling output.

If a temperature above +29°C (86°F) is selected, the display switches to **HI**. In this setting the system runs at maximum heating output and the temperature is not controlled.

## Blower

The blower can be adjusted gradually using the controls  and . Always have the blower running at a low setting to ensure a constant flow of fresh air into the vehicle. If the blower is set to 0, the Climatronic is switched off.



## Air distribution

The air distribution is adjusted using the buttons  and . It is also possible to open and close some of the air outlets separately.

## Switching off the cooling system

Pressing the button  switches off the air cooling system to save fuel. The temperature continues to be controlled, but the air cannot be cooled. The set temperature can then only be reached if it is higher than the outside temperature.

## Switching the Climatronic on/off

Press button  until **OFF** is shown on display . The Climatronic is switched off. This function should be used in certain situations only (e.g. if the system develops a fault).

The Climatronic is switched back on by pressing button .







## WARNING

**When the Climatronic is off open a window to ensure an adequate supply of fresh air in the vehicle. Otherwise, when the Climatronic is switched off, no fresh air enters the vehicle. Stale or contaminated air inside the vehicle may cause drowsiness, increasing the risk of accident. ■**

## Air recirculation mode

*Air recirculation mode prevents fumes or unpleasant smells from entering the vehicle.*

- Press the button   page 154, fig. 118  to switch air recirculation mode on or off. This is ON if the symbol   is displayed on the screen.

Air recirculation mode prevents strong odours in the ambient air from entering the vehicle interior, for example when passing through a tunnel or in queuing traffic.

When the outside temperature is low, using air recirculation mode provides more effective heating by heating air from the vehicle interior instead of cold air from outside.

When the outside temperature is high, using air recirculation mode provides more effective cooling by cooling air from the vehicle interior instead of warm air from outside. ▶

### WARNING

Do not leave the air recirculation function on for long periods. In air recirculation mode, no fresh air enters the vehicle interior. Also, if the cooling system is switched off, the windows can quickly mist over. Stale or contaminated air inside the vehicle may cause drowsiness, increasing the risk of accident. ■

## Climatronic for the passenger compartment

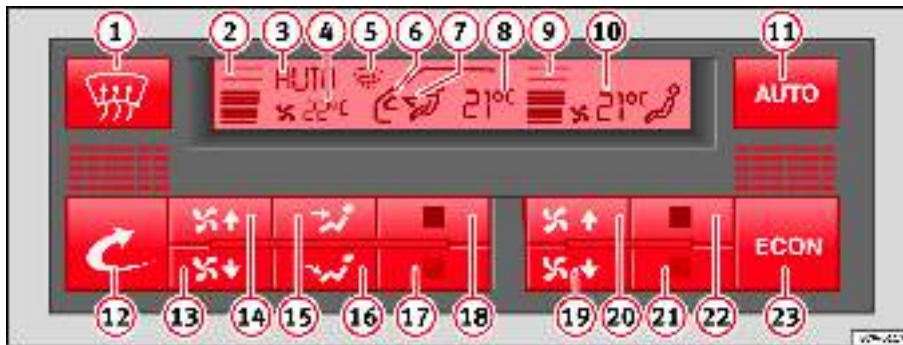

Fig. 119 Instrument panel: Climatronic controls

### Setting the blower speed for the passenger compartment

- The temperature is selected with buttons ⇒ fig. 119 21 and 22. It remains stored until another temperature is selected.

### Setting the blower speed for the passenger compartment

- Buttons 19 and 20 are used to lower or raise the blower speed and thus adjust the air volume.

The Climatronic for the rear works only in air recirculation mode. Fresh air is not drawn into the vehicle. ►

The Climatronic can be fitted either with or without an additional cooling system<sup>38)</sup> for the passenger compartment.

#### Climatronic for the passenger compartment without additional cooling system

The temperature setting for the rear can be max. 3°C higher than the temperature in the passenger compartment. A lower temperature can **not** be set.

If the Climatronic detects that the passenger compartment has to be **heated**, it activates the additional heat exchanger. The air outlets on the floor guide warm air into the vehicle ⇒ page 157.

If the Climatronic detects that the passenger compartment has to be **cooled**, cooled air is fed into the vehicle via the air outlets in the front of the vehicle only ⇒ page 157.

#### Climatronic for the passenger compartment with additional cooling system

The temperature setting for the rear can be max. 3°C lower than the temperature in the passenger compartment.

If the Climatronic detects that the passenger compartment has to be **heated**, it activates the additional heat exchanger. The air outlets on the floor guide warm air into the vehicle ⇒ page 157.

If the Climatronic detects that the passenger compartment has to be **cooled**, cooled air is fed into the rear of the vehicle via the open air outlets in the roof ⇒ page 157. ■

<sup>38)</sup> Optional equipment

### Air outlets in the passenger compartment

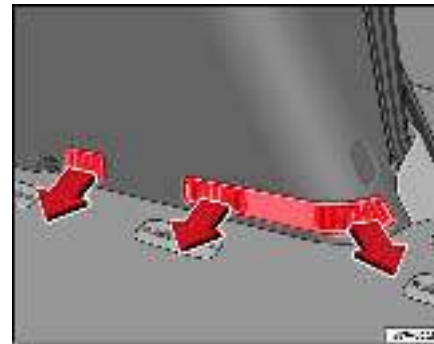

Fig. 120 Air outlets for heating the passenger compartment



Fig. 121 Cold air vents in the roof

#### Air outlets for heating the passenger compartment

The air outlets ⇒ fig. 120 for the passenger compartment heating system are located at the bottom of the left side panel at the rear. ▶

### Air vents in the roof

In vehicles with a second cooling system<sup>39)</sup> for ventilating the passenger compartment, an air outlet is fitted in the roof above each rear seat  
⇒ fig. 121.

The air outlets in the roof can be opened and closed individually and adjusted by moving the grid.

Each air outlet has two thumb wheels. The left thumb wheel can be used to open and close the air outlet. The right thumb wheel can be used to direct the air towards the head and chest.

	<b>WARNING</b>
<b>Never leave objects, food or medicines in front of the air outlets in the rear seats. The hot air could damage or destroy heat-sensitive objects, food or medicines.</b>	



### Caution

Do not use the area in front of the outlets to store objects. This could cause the blower to overheat and switch off. The blower could also be damaged.



### Note

In the cooling mode, at least one air outlet in the roof must be open. The cooling system could otherwise ice over. ■

## General notes

### The pollution filter

The pollution filter serves as a barrier against impurities in the ambient air (e.g. dust and pollen).

For the air conditioning system to work with maximum efficiency, the pollen filter must be replaced at the intervals specified in the Service Schedule.

If the filter loses efficiency prematurely due to use in areas with very high levels of air pollution, the pollen filter must be changed more frequently than stated in the Service Schedule.

### Instructions for use

If the air conditioning or Climatronic<sup>40)</sup> is not switched on for a long period, deposits on the evaporator can cause unpleasant smells. To prevent these odours, the cooling system should be run at the highest blower setting at least once a month when temperatures are over +5°C. Briefly open a window at the same time.

### Faults in the operation of the air conditioning

There is a fault if all the symbols in the Climatronic flash for approx. 15 seconds when the ignition is switched on. Contact a specialist workshop.

If the air conditioning system cannot be switched on this may be caused by the following reasons:

- the engine is not running.
- The blower is switched off.
- The outside temperature is lower than +5°C.
- the cooling system compressor has been temporarily switched off because the engine coolant temperature is too high.
- The air conditioning fuse is faulty.

<sup>39)</sup> Optional equipment

<sup>40)</sup> Optional equipment



- Another fault in the vehicle. Have the air conditioning checked by a qualified workshop.

**WARNING**

Please note that when the Climatronic is switched off, no fresh air will enter the vehicle interior. For this reason you should ensure that sufficient fresh air is able to enter the vehicle by opening a window or the sliding/tilting sunroof<sup>40)</sup> when the Climatronic is switched off.

**Caution**

- If you suspect that the air conditioning is damaged, switch off the air conditioning with button **ECON** to prevent further damage and have it checked by a qualified workshop.
- Repairs to the air conditioning system require specialist knowledge and special tools. Therefore, we recommend that you take the vehicle to a qualified workshop should problems occur.

**Note**

- If the humidity and temperature outside the vehicle are high, **condensation** can drip off the evaporator in the cooling system and form a pool underneath the vehicle, this is completely normal and there is no need to suspect a leak.
- Keep the air intake slots in front of the windscreen free of snow, ice and leaves to ensure heating and cooling is not impaired, and to prevent the windows misting over.
- The air conditioning system operates most effectively with the windows and the sliding /tilting roof<sup>40)</sup> closed. However, if the sun has heated up the vehicle, the air inside can be cooled more quickly by opening the windows for a short period.

- Do not smoke while air recirculation mode is on, as smoke drawn into the cooling system leaves a residue on the evaporator, producing a permanent unpleasant odour. ■

## Driving

### Address

#### Adjusting the steering wheel position

The height and reach of the steering wheel can be freely adjusted to suit the driver.

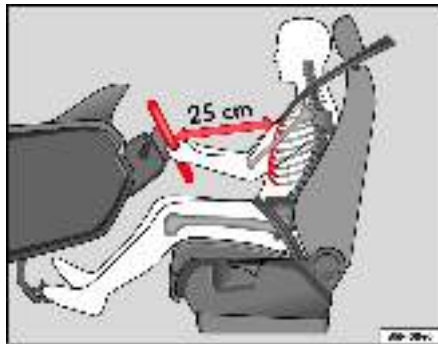

Fig. 122 Adjusting the steering wheel position



Fig. 123 Proper sitting position for driver

- Adjust the driver seat to the correct position.
- Push the lever under the steering column ⇒ fig. 122 down ⇒ ⚠.
- Adjust the steering wheel in this way until the correct position is set ⇒ fig. 123.
- Then push the lever up again firmly ⇒ ⚠.

#### ⚠ WARNING

- Incorrect use of the steering column adjustment function and an incorrect seating position can result in serious injury.
- To avoid accidents, the steering column should be adjusted only when the vehicle is stationary. Risk of accident.

**⚠ WARNING (continued)**

- Adjust the driver seat or steering wheel so that there is a distance of at least 25 cm between the steering wheel and your breast bone ⇒ page 160, fig. 123. If you fail to observe the minimum distance, the airbag will not protect you. Risk of fatal injury.
- If your physical constitution prevents you from maintaining the minimum distance of 25 cm, contact an Authorised Service Centre. The Authorised Service Centre will help you decide if special specific modifications are necessary.
- If you adjust the steering wheel so that it points towards your face, the driver airbag will not protect you properly in the event of an accident. Make sure that the steering wheel points towards your chest.
- When driving, always hold the steering wheel with both hands on the outside of the ring at the 9 o'clock and 3 o'clock positions. Never hold the steering wheel at the 12 o'clock position, or in any other manner (e.g. in the centre of the steering wheel, or on the inside of the rim). In such cases, you could receive severe injuries to the arms, hands and head. ■

## Safety

### Electronic stabilisation programme (ESP)

*ESP helps make driving safer in certain situations.*



**Fig. 124** Detailed view of dash panel ESP button

The Electronic Stabilisation Programme (ESP) contains the electronic differential lock (EDL) and the traction control system (TCS). The ESP works together with the anti-locking brake system (ABS). Both warning lamps will light up if the ESP or ABS systems are faulty.

The ESP is started automatically when the engine is started.

In specific circumstances where you require less traction, you can switch off the ESP by pressing button ⇒ fig. 124 .

For example:

- when driving with snow chains,
- when driving in deep snow or on loose surfaces, ▶

- when rocking the vehicle backwards and forwards to free it from mud, for example.

You should press the button to switch the ESP back on when you no longer need wheel spin.

The TCS and EDL are also switched off if the ESP is switched off. This means that this technology is not available for as long as the ESP remains switched off.

**When does the  inscription OFF light up on the button?**

- It will light up continuously if there is a malfunction in the ESP.
- It will light up continuously if the ESP is switched off.

### WARNING

- The electronic stabilisation programme (ESP) cannot defy the laws of physics. This should be kept in mind, particularly on slippery and wet roads and when towing a trailer.
- Always adapt your driving style to suit the condition of the roads and the traffic situation. Do not let the extra safety afforded by ESP tempt you into taking any risks when driving, this can cause accidents.
- Please refer to the corresponding warning notes on ESP. ■

## Ignition lock

### Position of the ignition key





Fig. 125 Ignition key positions

#### Ignition switched off, steering lock

In position  $\Rightarrow$  fig. 125  the ignition is switched off, and the steering wheel lock can be engaged.

To **engage the steering wheel lock**, take out the key and turn the wheel slightly until you hear the pin engage. You should always lock the steering wheel when you leave your vehicle. This makes vehicle theft more difficult  $\Rightarrow$  .

#### Switching on the ignition or glow plug system

Turn the ignition key to this position and let go of the key. If the key cannot be turned or is difficult to turn from position  to position , move the steering wheel (to take the load off the steering lock mechanism) until the key turns freely. 

### Starting ③

The engine is started when the key is in this position. Electrical components with a high power consumption are switched off temporarily.

Each time that the vehicle must be started, the ignition key must be turned to the position ①. The **repetitive start prevention lock** of the ignition prevents possible damage to the starter motor if the engine is already running.



#### WARNING

- **Wait for the vehicle to come to a standstill before removing the ignition key from the lock. The steering lock could be activated immediately - Risk of accident!**
- **Always remove the key from the ignition lock when leaving the vehicle, even if you only intend to be gone for a short period. This is especially important if you must leave children or disabled people in the vehicle, they could accidentally start the engine or work electrical equipment such as the windows possibly resulting in an accident.**
- **Unsupervised use of the keys could result in the engine being started or electrical systems, such as the electric windows, being used. This can result in serious injury.**



#### Caution

The starter must not be used unless the vehicle is at a standstill (key position ③). If the starter is used as soon as the engine is switched off, the starter or the engine could be damaged. ■

### Safety interlock for ignition key

*The ignition key can only be taken out of the ignition lock if the selector lever is in position P.*

After switching off the ignition, you can remove the ignition key only if the automatic gearbox gear selector lever ⇒ page 168 is in position **P**. The selector lever is blocked after the ignition key has been removed. ■

### Electronic immobiliser

*The immobiliser prevents unauthorised persons from driving the vehicle.*

Inside the key there is a chip that deactivates the electronic immobiliser automatically when the key is inserted into the ignition.

The electronic immobiliser is automatically activated when you take the key out of the ignition lock.

The engine can only be started using a genuine SEAT key with the correct code.



#### Note

The vehicle cannot be operated properly if you do not have a genuine SEAT key. ■

## Starting and stopping the engine

### Starting a petrol engine

*The engine can only be started using a genuine SEAT key with the correct code.*

- Place the gear in neutral (if it is an automatic gearbox, place the gear lever in **P** or in **N**).
- In vehicles with a manual gearbox, depress the clutch pedal fully and hold it in this position, the starter will then only have to turn the engine.
- Turn the ignition key to position ⇒ page 162, fig. 125  to start the engine.
- Let go of the ignition key as soon as the engine starts; the starter motor must not be allowed to run on with the engine.

You may need to press the accelerator briefly after starting a very hot engine.

When starting from cold, the engine may be a little noisy for the first few seconds until oil pressure has built up in the hydraulic valve lifters. This is quite normal, and no cause for concern.

If the engine does not start immediately, switch off the starter after about 10 seconds and try again after about half a minute. If the engine still does not start, the fuel pump fuse should be checked.



#### WARNING

- **Never start or run the engine in unventilated or closed rooms. The exhaust fumes contain carbon monoxide, an odourless and colourless**



#### WARNING (continued)

**poisonous gas. Risk of fatal accidents. Carbon monoxide can cause people to lose consciousness. It can also cause death.**

- **Never leave the vehicle unattended if the engine is running.**
- **Never use “cold start sprays”, they could explode or cause the engine to run at high revs. Risk of injury.**



#### Caution

- When the engine is cold, you should avoid high engine speeds, driving at full throttle and over-loading the engine. Risk of engine damage.
- The vehicle should not be pushed or towed for more than approximately 50 metres to start the engine. Fuel could enter the catalytic converter and damage it.
- Before attempting to push-start or tow a vehicle to start it, you should first try to start it using the battery of another vehicle. Observe the warnings in the chapter Help with Ignition.



#### For the sake of the environment

Do not warm up the engine by running it with the car stationary. You should drive off as soon as you start the engine. This helps the engine reach operating temperature faster and reduces emissions. ■

### Starting a diesel engine

*The engine can only be started using a genuine SEAT key with the correct code.*

- Place the gear in neutral (if it is an automatic gearbox, place the gear lever in **P** or in **N**). ▶

- In vehicles with a manual gearbox, depress the clutch pedal fully and hold it in this position, the starter will then only have to turn the engine.
- Turn the ignition key to position ⇒ [page 162, fig. 125](#) ②. The warning lamp  lights up to show that the glow plugs are preheating the engine.
- When the warning lamp goes out, turn the key to position ③ to start the engine. Do not press the accelerator.
- Let go of the ignition key as soon as the engine starts, the starter motor must not be allowed to run on with the engine.

When starting from cold, the engine may be a little noisy for the first few seconds until oil pressure has built up in the hydraulic valve lifters. This is quite normal, and no cause for concern.

If you have problems starting the engine, please refer to Help with Ignition.

### Glow plug system

To avoid unnecessary loads on the battery, do not use any other major electrical equipment while the glow plugs are preheating.

Start the engine as soon as the glow plug warning lamp goes out.

### Starting a diesel engine after the fuel tank has been completely run dry.

If the fuel tank has been completely run dry, it may take longer than normal (up to one minute) to start a diesel engine after refuelling. This is because air needs to be bled from the fuel system while starting.



#### WARNING

- **Never start or run the engine in unventilated or closed rooms. The exhaust fumes contain carbon monoxide, an odourless and colourless**



#### WARNING (continued)

**poisonous gas. Risk of fatal accidents. Carbon monoxide can cause people to lose consciousness. It can also cause death.**

- **Never leave the vehicle unattended if the engine is running.**
- **Never use “cold start sprays”, they could explode or cause the engine to run at high revs. Risk of injury.**



#### Caution

- When the engine is cold, you should avoid high engine speeds, driving at full throttle and over-loading the engine. Risk of engine damage.
- The vehicle should not be pushed or towed for more than approximately 50 metres to start the engine. Fuel could enter the catalytic converter and damage it.
- Before attempting to push-start or tow a vehicle to start it, you should first try to start it using the battery of another vehicle. Observe the warnings in the chapter Help with Ignition.



#### For the sake of the environment

Do not warm up the engine by running it with the car stationary. You should drive off as soon as you start the engine. This helps the engine reach operating temperature faster and reduces emissions. ■

### Switching off the engine

- Stopping the engine.
- Turn the ignition key to position ⇒ [page 162, fig. 125](#) ①. ▶

After the engine is switched off the radiator fan may run on for up to 10 minutes, even if the ignition is switched off. The radiator fan can start automatically if the hot engine causes the coolant temperature to rise, or if the sun heats the engine compartment.

### WARNING

- Never switch off the engine until the vehicle is stationary.
- The brake servo and the power assisted steering work only when the engine is running. You need more strength to steer and brake the vehicle when the engine is switched off. As you cannot steer and brake in the normal manner, there is a greater risk of accidents and serious injury.
- The steering lock can engage immediately when the key is removed from the ignition lock. The vehicle cannot be steered. Risk of accident.

### Caution

If the engine has been driven hard for a long period, the engine could over-heat when it is switched off. Risk of engine damage. For this reason, you should idle the engine for approx. 2 minutes before you switch it off. ■

## Manual gearbox

### Manual gearbox



Fig. 126 Manual gearbox with shift diagram

### Selecting the reverse gear

- The vehicle should be stationary with the engine idling. Press the clutch right down.
- Put the gearlever ⇒ fig. 126 in the middle (neutral).
- Press the gearstick down and then to the left and forwards into the reverse position shown on the gearstick.

The reverse gear can only be engaged when the vehicle is stationary. When the engine is running, before engaging this gear wait about 6 seconds with the clutch pressed in fully in order to protect the gearbox.

When reverse gear is engaged and the ignition is switched on the following takes place: ▶



- The reversing lights come on.
- The heating or air conditioning automatically change to air recirculation mode.
- The rear window heater switches on when the windscreen wiper is activated.



### WARNING

- **When the engine is running, the vehicle will start to move as soon as a gear is engaged and the clutch released.**
- **Never select the reverse gear when the vehicle is in motion. Risk of accident.**



### Caution

- Do not rest your hand on the gear lever when driving. The pressure of your hand could cause premature wear on the selector forks in the gearbox.
- When changing gear, you should always depress the clutch fully to avoid unnecessary wear and damage.
- Do not hold the car “on the clutch” on hills. This causes premature wear and damages the clutch. It can also prevent power being transferred from the engine to the gearbox. ■

## Automatic gearbox

### Gearbox programmes

*The automatic gearbox has two gearbox programmes.*



**Fig. 127** Centre console: selector lever of the automatic gearbox with locking button

The gearbox management system is equipped with two driving programmes. Depending on the driver or the driving situation, either a consumption oriented programme or a more “sporty” programme will be selected.

The programme selection will be carried out automatically depending on how the accelerator is used.

- The consumption-oriented programme will be selected if you use the accelerator slowly or normally. This means that the gearbox will shift up earlier and down later.
- A more “sporty” driving programme which shifts up gear later will be selected if you use the accelerator more quickly.

**Note**

A programme will, depending on the driving resistance, be selected automatically that guarantees more pulling power, thus avoiding having to shift gear constantly. ■

### Selector lever lock

---

*The selector lever lock in position P or N prevents gears from being engaged inadvertently, which would cause the vehicle to move.*

The selector lever lock is released as follows:

- Switch on the ignition.
- Press and hold the brake pedal and press the selector lever lock on the left of the selector lever at the same time ⇒ page 167, fig. 127.

The selector lever lock only works if the vehicle is stationary or driving at speeds up to 5 km/h (approx. 3 mph). At higher speeds the selector lever lock is disengaged automatically in the **N** position.

The selector lever lock is not engaged if the selector lever is moved quickly through position **N** (e.g. when shifting from **R** to **D**). This makes it possible, for instance, to “rock” the vehicle backwards and forwards if it is stuck in snow or mud. The selector lever lock engages automatically if the brake pedal is not depressed and the lever is in position **N** for more than about 1 second. ■

### Driving a car with an automatic gearbox

---

*The gearbox changes the forward gears up and down automatically.*

#### Switching on

- Start the engine with the selector lever in position **P** or **N**. Further information ⇒ page 164.

#### Driving

- Press and hold the brake pedal.
- Press and hold the lock button (button on the knob of the selector lever) ⇒ page 167, fig. 127, select gear position (**R**, **D** or **S**).
- Release the lock button and wait for the gearbox to engage the gear (a slight movement can be felt).
- Release the brake and press the accelerator ⇒

#### Stopping briefly

- Use the foot brake to prevent the car “creeping” forwards, e.g. at traffic lights. The selector lever does not need to be put into the positions **P** or **N** for this.
- Do not press the accelerator.

#### Parking the vehicle

- Press and hold the brake pedal until the vehicle comes to a standstill ⇒ .
- Apply the handbrake firmly.

- Press and hold the lock button, move the selector lever to **P** and release the lock button.

### Driving up and down hills

- Press the selector lever from position **D** to the right into the “Tiptronic” selector gate.
- Lightly press the selector lever back to change down.

### Holding the car on a hill

- You should *always* hold the vehicle in position with the footbrake to stop it from “rolling backwards” ⇒ . Do **not** try to prevent the vehicle from “rolling backwards” by increasing the engine speed while a range of gears is selected.

### Moving away on an incline

- With a gear engaged, take your foot from the brake and depress the accelerator.

The steeper the gradient, the lower the gear you will need. This increases the braking effect of the engine. For example, you should drive down a very steep slope in 3rd gear. If the engine brake effect is not sufficient, the vehicle will gain speed. The automatic gearbox / direct shift gearbox automatically changes up to prevent the engine over revving. Use the foot brake to reduce speed and change into 3rd gear using “Tiptronic” ⇒ .

Your vehicle has an automatic interlock which prevents the selector lever being put into a position for driving forwards or in reverse from positions **P** or **N** if the brake pedal is not depressed.

The ignition key cannot be removed unless the selector lever is in position **P**.



### WARNING

- As a driver you should never leave your vehicle if the engine is running and a gear is engaged. If you have to leave your vehicle while the engine is running, you must apply the parking brake and engage parking lock P.
- If the engine is running and if **D**, **S** or **R** is engaged, you will need to hold the car on the foot brake. The car will creep forward as the power transmission is not fully interrupted even when the engine is idling.
- Never press the accelerator when you move the selector lever. Risk of accident.
- Never move the selector lever to **R** or **P** when driving. Risk of accident!
- Before you drive down a steep gradient, reduce your speed and use “Tiptronic” to select a low gear.
- If you have to stop the vehicle on a gradient, always hold the vehicle in position using the foot brake to stop it from rolling back.
- Never allow the brake to rub and do not use the brake pedal too often or for long periods. Constant braking will cause the brakes to overheat and will considerably reduce the brake effect. This increases the braking distance and could cause the brake system to fail.
- Never allow the car to roll down a gradient with the gear in neutral **N**, or in selector lever position **D**, even if the engine is not running.



### Caution

- If you stop the vehicle on a gradient, do not attempt to stop it from rolling by depressing the accelerator when a gear has been selected. Otherwise, the automatic gearbox / direct shift gearbox\* may overheat causing damage. Pull the handbrake on fully or depress the brake pedal to prevent the vehicle from rolling away.
- If you allow the car to roll with the selector lever in position **N** with the engine switched off, the automatic gearbox / direct shift gearbox\* will be damaged as it will not be lubricated.



### Note

The two clutch system of the direct shift gearbox\* has a system to protect against excess strain, which may occur, for example, when the vehicle is held on a hill with the clutch and the gearbox oil overheats. When the clutch is overloaded, the vehicle begins to *jerk* and the position indicator of the selector lever begins to flash. To avoid breakdowns, the clutch breaks the power transmission between the engine and the gearbox, as a result of which the vehicle loses impetus. If the clutch opens automatically due to overloading, depress the brake pedal and wait a few seconds before continuing. ■

## Selector lever positions

*The selector lever positions and gears are shown on the display in the combi-instrument.*



**Fig. 128** Instrument panel: display showing position of selector lever

### Selector lever positions

The gear selected is displayed on the side of the selector lever and on the display ⇒ **fig. 128** in the combi-instrument.

#### P - parking lock

When the selector lever is in this position, the drive wheels are locked mechanically.

The parking lock must be engaged only when the vehicle is *stationary* ⇒ .

To **move** the selector lever from position **P**, the locking button in the selector lever handle must be pressed *and* the brake pedal depressed at the same time when the ignition is switched on.

Only the locking button has to be pressed to **select** the selector lever position **P**.

If the battery has discharged, the selector lever cannot be removed from the **P** position.

#### R - reverse gear

The reverse gear is engaged in this position.

Reverse gear must be engaged only when the vehicle is *stationary* and the engine is idling ⇒ .

To move the selector lever to position **R**, press in the lock button *and* at the same time press the brake pedal, with the ignition switched on.

With the selector lever in position **R** and the ignition switched on the following occurs:

- The reversing lights come on.
- The heating or air conditioning automatically change to air recirculation mode.
- The rear window heater switches on when the windscreen wiper is activated.

### N - neutral (idling)

If this position is selected, the gearbox is in neutral. Power is not transmitted to the wheels and the engine does not have a braking function.

Never use the **N** position to drive down a hill. The engine does not function as a brake and the brakes are subjected to excessive stain.

You could damage the automatic gearbox if you drive down hills with the selector lever in position **N** and the engine switched off.

### D - Drive (forwards)

In this position the gearbox automatically changes automatically to a longer or shorter gear, according to the driving style and speed. The braking effect of the engine when driving downhill is very limited when the selector is in this position. The display also shows which gear has been selected in addition to position **D**.

If position **N** has been selected and you wish to select **D**, you must press the foot brake if the vehicle is stationary, or travelling at under 5 km/h (approx. 3 mph) ⇒ .



#### WARNING

- **Never move the selector lever to R or P when driving. Risk of accident!**
- **Never drive the vehicle with the engine and the ignition switched off. You could lose control of the vehicle. The brake servo only functions when the engine is running as does the electro-mechanical steering system. You need more strength to steer and brake the vehicle when the engine and the ignition are switched off. As you cannot steer and brake in the normal manner, there is a greater risk of accidents and serious injury.**



#### Caution

If you allow the car to roll with the selector lever in position **N** with the engine switched off, the automatic gearbox will be damaged as it will not be lubricated.



#### Note

If the lever is moved accidentally to **N** when driving, take your foot off the accelerator and let the engine speed drop to idling before selecting **D** again. ■

## Changing gear with “Tiptronic”

The “Tiptronic” system allows the driver to change gears manually.



Fig. 129 Centre console: gearbox selector lever with locking button



Fig. 130 Instrument panel: display showing position of selector lever

## Changing gear with “Tiptronic” (selector lever)

- Press the selector lever from position **D** to the right into the “Tiptronic” selector gate ⇒ fig. 129.
- Lightly press the selector to the front **+** to change up.
- Lightly press the selector lever back **-** to change down.

When accelerating, the automatic gearbox automatically shifts up to the next gear shortly before the maximum permitted engine speed is reached.

If a lower gear is selected, the automatic gearbox does not change down until the point is reached where the engine could no longer over rev.

### Gear selection display for Tiptronic

If the automatic gearbox is shifted manually or using “Tiptronic”, the individual gears are shown on the display ⇒ fig. 130. ■

## Kick-down function

The kick-down feature is designed to give maximum acceleration.

If you press the accelerator right down, the gearbox automatically changes down a gear, depending on speed and engine speed, to give the vehicle full acceleration.

The gearbox does not shift up to the next gear until the engine reaches the maximum determined engine speed for the gear.

### WARNING

You could lose control of the vehicle if you accelerate quickly on slippery surfaces. This may result in serious injury. ▶

 **WARNING** (continued)

- Be particularly careful, therefore, when using the kick-down function on slippery road surfaces.
- You should use the kick-down function only when traffic and weather conditions allow it to be used safely. ■

## Handbrake

### Using the handbrake

*The handbrake should be applied firmly to prevent the vehicle from accidentally rolling away.*

Always apply the handbrake when you leave your vehicle and when you park.

#### Using the handbrake

- Firmly pull the handbrake lever up all the way.

#### Releasing the handbrake

- Firmly pull the handbrake lever up all the way.
- Push in the lock button on the handbrake lever.
- Keep the locking knob pressed and push the lever all the way down ⇒ .

The handbrake is located at the side of the driver seat. Always apply the handbrake *firmly*. This prevents you driving with the handbrake applied ⇒ .

The handbrake warning lamp  lights up when the handbrake is applied and the ignition switched on. The warning lamp goes out when the handbrake is released.

 **WARNING**

- Never use the handbrake to slow down the vehicle when it is in motion. The braking distance is considerably longer, as braking is only applied to the rear wheels. Risk of accident!
- Never drive with the handbrake slightly applied. This could cause the rear brakes to overheat and lose their braking efficiency. Risk of accident. This also causes premature wear on the rear brake pads/linings.

 **Caution**

Always apply the handbrake before you leave the vehicle. On cars with a manual gearbox engage 1st gear, or on an automatic move the selector lever to **P**. ■

### Parking

*The handbrake should always be firmly applied when the vehicle is parked.*

Always note the following points when parking the vehicle:

- Use the foot brake to stop the vehicle.
- Apply the handbrake firmly.
- On a manual gearbox engage 1st gear. On an automatic move the selector lever to **P**. ▶

- Switch off the engine and remove the key from the ignition lock. Turn the steering wheel slightly to engage the steering lock.
- Always take your car keys with you when you leave the vehicle  
⇒ .

#### Additional notes on parking the vehicle on gradients:

Turn the steering wheel so that the vehicle would roll against the kerb if it did start to roll.

- If the vehicle is facing **downhill**, turn the front wheels so that they point *towards the kerb*.
- If the vehicle is facing **uphill**, turn the front wheels so that they point *away from the kerb*.

#### **WARNING**

Take measures to reduce the risk of injury when you leave your vehicle unattended.

- **Never park where the hot exhaust system could ignite inflammable materials, such as dry grass, low bushes, spilt fuel etc.**
- **Never allow vehicle occupants to remain in the vehicle when it is locked. They would be unable to open the vehicle from the inside, and could become trapped in the vehicle in an emergency. In the event of an emergency, locked doors will delay assistance to occupants.**
- **Never leave children unsupervised in the vehicle. They could set the vehicle in motion, for example, by releasing the handbrake or the gear lever / selector lever.**
- **Depending on weather conditions, it may become extremely hot or cold inside the vehicle. This can be fatal. ■**

## Parking distance warning system\*

### Description

*The parking distance warning system is a parking aid which draws your attention to obstacles in front or behind the vehicle.*

The parking distance warning system assists the driver when parking. If the rear of the vehicle is approaching an obstacle, an intermittent sound signal is emitted. The shorter the distance, the shorter the intervals between tones. If the vehicle is too close to the obstacle, the sound signal becomes constant.

The distance to an obstacle at the front is indicated via a high tone and via a low tone at the rear. The shorter the distance, the shorter the intervals between tones. If the vehicle is too close to the obstacle, the sound signal becomes constant.

#### **The obstacle may no longer be detected if the vehicle gets even closer to it!**

The warning signal will stop when

- the vehicle moves away from the obstacle.
- the outer sensors measure a constant distance for approximately 3 seconds.

The signal will not be switched off once the vehicle has reached the permanent tone area.

#### Registering the obstacle

- Exterior front and rear sensors: from approx 80 cm
- Front central sensors: from approx 120 cm
- Rear central sensors: from approx 160 cm ■



## Switching the parking distance warning system on and off



Fig. 131 Detailed view of dash panel Control button for the parking distance warning system

### Switching on the parking distance warning system

The parking distance warning system is activated by either pressing the button ⇒ fig. 131  or by selecting the reverse gear. A warning lamp in the button will indicate that the system is active.

### Switching off the parking distance warning system

The parking distance warning system is switched off by pressing the button  (the warning lamp in the button goes out) or exceeding speeds of approx. 25 km/h.



#### WARNING

- The parking distance warning system cannot replace the driver's assessment of the situation. The driver is personally responsible for safe parking and other manoeuvres.
- The sensors have blind spots in which obstacles and people are not registered.



#### WARNING (continued)

- Be particularly aware of small children or animals when reversing. The sensors may not always be able to detect them.



#### Caution

- The system may not always be able to detect objects such as trailer draw bars, thin rails, fences, posts etc. This could result in damage to your car.
- The parking distance warning system works only at speeds of under approx. 15 km/h.
- The parking distance warning sensors in the bumpers must be kept clean and free of ice. When cleaning with pressure hoses and steam cleaners, the sensors should be sprayed only briefly. A distance of 10 cm between the sensors and the steam / hose nozzle must be observed.



#### Note

- A system fault will be indicated via a tone when activated for the first time and by the warning lamp flashing in the button. Switch the system off at the button and have it checked by a qualified dealership as soon as possible.
- If your vehicle has a factory-fitted towing attachment<sup>41)</sup>, the parking distance warning system is **not** active when the reverse gear is engaged if you are towing a trailer.
- The parking distance warning system registers water as an obstacle. ■

<sup>41)</sup> Optional equipment

## Cruise control system (CCS)

### Cruise control operation

*The cruise control system (CCS) is able to maintain the set speed in the range from approx. 30 km/h to 180 km/h.*

Once the desired speed has been reached and the setting stored, you may take your foot off the accelerator.

In vehicles fitted with a manual gearbox and in vehicles with an automatic gearbox with the lever in positions **P**, **N** or **R** the cruise control does not operate in first gear.

#### **WARNING**

**It could be dangerous to use the cruise control system (CCS) if it is not possible to drive at constant speed.**

- **Do not use the cruise control in heavy traffic or on steep roads, with several bends or in slippery circumstances (snow, ice, rain or loose gravel), as there is a risk of accident.**
- **Always adapt your speed and the distance to the vehicles ahead to take the traffic situation into consideration. This is the duty of the driver. The cruise control system is merely an aid to the driver.**
- **Never use the cruise control system when driving off-road or on unpaved roads. This feature is designed for use on paved roads only. Risk of accident.**
- **Always switch off the CCS when you have finished using it. This will prevent you using it by mistake.**
- **It is dangerous to use a set speed which is too high for the prevailing road, traffic or weather conditions. This may cause an accident.**

#### **Caution**

Vehicles with a manual gearbox: if the cruise control is activated the gearbox should not be set in neutral without first releasing the clutch, as the the engine speed will increase and this may cause damage.

#### **Note**

When travelling down hills, the CCS cannot maintain a constant speed. The vehicle will accelerate under its own weight. Reduce gears (with an automatic gearbox, reduce gears using the “Tiptronic”) or brake using the footbrake. ■

## Lever for cruise control

The CCS can be operated using the controls on the turn signal lever or on the multi-function steering wheel.

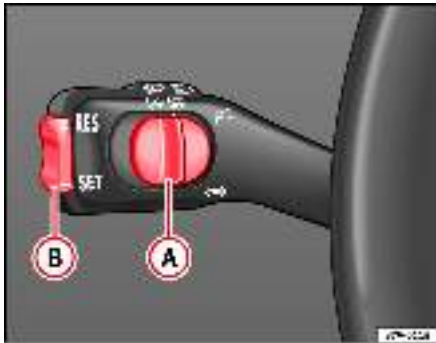



Fig. 132 Turn signal and main beam headlight lever control (A) and rocker switch (B) for cruise control



Fig. 133 Multifunction steering wheel: CCS controls

## Switching on the system

- Move the control ⇒ fig. 132 (B) to the left to **ON**. The  symbol lights up in the combi-instrument when the cruise control system is switched on.

## Switching off system

- Move the control ⇒ fig. 132 (A) to the right to **OFF** or press the key ⇒ fig. 133 (CANCEL) once.

## Setting speed

- Press the lower part **SET** of the rocker switch ⇒ fig. 132 (B) once briefly when you have reached the speed you wish to set ⇒ fig. 133 (SET-). This speed is then stored and maintained.

## Increasing the stored speed

- To reach the desired speed hold down the upper part of the rocker button **RES+** ⇒ fig. 132 (B) or button ⇒ fig. 133 (RES+).

## Reducing the set speed

- To reach the desired speed hold down the lower part of the rocker button **SET-** ⇒ fig. 132 (B) or button ⇒ fig. 133 (SET-). The speed falls as the vehicle is no longer accelerating, not due to sharp braking.

If you increase speed by using the accelerator, the previously programmed speed will be resumed when the accelerator pedal is released. This will not be the case, however, if the vehicle speed is more than 10 km/h higher than the stored speed for longer than 5 minutes. The speed will have to be stored again. ▶

Control of the set speed is switched off if you reduce speed by depressing the brake pedal. You can reactivate the control by pressing once on the upper part of the rocker switch or button **RES+**.

 **WARNING**

It is dangerous to use a set speed which is too high for the prevailing road, traffic or weather conditions. This may cause an accident. ■

To resume the control function, release the brake or clutch pedal, move the switch **A** to ON or press the button  $\Rightarrow$  page 177, fig. 132 **RES+** or button  $\Rightarrow$  page 177, fig. 133 once.

 **WARNING**

It is dangerous to use a set speed which is too high for the current road, traffic or weather conditions. Risk of accident. ■

## Switching off system temporarily

### Switching off the control temporarily in vehicles with a manual gearbox

- Depress the brake or clutch pedal or
- Push the switch  $\Rightarrow$  page 177, fig. 132 **A** to “OFF”, or
- Press the lower part of the button **CANCEL**.

### Switching off the control temporarily in vehicles with an automatic gearbox

- Press the brake pedal or
- Select positions **N** or **1** or
- Push the switch  $\Rightarrow$  page 177, fig. 132 **A** to “OFF”, or
- Press the lower part of the rocker button **CANCEL**.

The speed stored will remain in the memory if the control is switched off temporarily, unless you select positions **N** or **1**. In this case, the speed stored in the memory will be deleted.

# Tips and Maintenance

## Intelligent technology

### Brakes

#### Brake servo

The brake servo supplements the pressure you exert on the brake pedal. It works **only when the engine is running**.

If the brake servo does not operate, for example, when the vehicle is being towed or due to a fault in the system, the brake pedal must be depressed harder.



#### WARNING

The braking distance can also be affected by external factors.

- Never let the vehicle coast with the engine switched off. Failure to do so could result in an accident. The braking distance is increased considerably as the brake servo does not function.
- If the brake servo is out of action, for example if the car is being towed, you will have to press the brake pedal considerably harder than normal. ■

#### Brake pads wear display

If this light comes on, check the brake pads immediately.

At the same time, a text message or the necessary operations may appear on the instrument panel.









#### WARNING

If the warning lamp lights up  or the corresponding message appears on the instrument panel, immediately have the brake pads checked and replaced, if necessary, at a specialised workshop. ■

#### Brake warning lamp

*If the warning lamp comes on, this may be caused by the following reasons:*

- **With the handbrake on** the warning light comes on  on the instrument panel. If you are travelling at over 6 km/h with the hand brake on, a text message or the required operations may appear on the instrument panel. In addition a warning signal is heard.
- In the event of **insufficient brake fluid** the warning lamp lights up  on the instrument panel. At the same time, a text message or the necessary operations may appear on the instrument panel. Stop the vehicle immediately and check the level of the brake fluid ⇒ page 221.
- In the event of a **fault in the brake system** the warning lamp lights up  on the instrument panel and three buzzes are emitted. At the same time, a text message or the necessary operations may appear on the instrument panel. Stop the vehicle and do not drive on. You should obtain professional assistance. This warning lamp  can light up together with the anti-locking brake system warning lamp  ⇒  ▶

 **WARNING**

Special care must be taken when working on the engine or on components in the engine compartment.

- It is important that you read and observe the corresponding warnings before working in the engine compartment ⇒ page 209.
- If the brake warning symbol does not go out, or if it lights up when driving, the brake fluid level in the reservoir is too low or there is a fault in the brake system. Risk of accident. Stop the vehicle and do not drive on. You should obtain professional assistance.
- If the brake warning lamp (ⓘ) lights up together with the ABS warning lamp (Ⓜ), the control function of the ABS could be out of action. This could cause the rear wheels to lock quickly when you brake. This could cause the rear to break away. Risk of skidding. Drive carefully to the nearest qualified workshop and have the fault corrected. ■

## Brake assist system (BAS)

The brake servo (BAS) works only when the engine is running.

In an emergency, most drivers brake in time, but not with maximum force. This results in unnecessarily long braking distances.

In these cases the brake assist servo comes into action: on activating the brake pedal quickly, the assistant interprets this as an emergency. It then very quickly builds up the full brake pressure so that the ABS can be activated more quickly and efficiently, thus reducing the braking distance.

Do not reduce the pressure on the brake pedal. The brake assist system switches off automatically as soon as you release the brake.

 **WARNING**

Try to always adapt the speed of the vehicle to weather, road and traffic conditions. Do not let the extra safety afforded by the system tempt you into taking any risks when driving. Risk of accident.

- The risk of accident is higher if you drive too fast, if you do not keep your distance from the car in front, and when the road surface is slippery or wet. The increased accident risk cannot be reduced by the brake assist system.
- The brake assist system cannot defy the laws of motion. Slippery and wet roads are dangerous even with the brake assist system!
- Modifications to the vehicle or work carried out incorrectly (e.g. to the engine, the brake system, running gear or any components affecting the wheels and tyres) could affect the efficiency of the ABS, EDL, ESP and TCS and lessen their efficiency. ■

## Anti-locking brake system (ABS)

*The anti-lock brake system prevents the wheels locking during braking.*

The anti-lock brake system (ABS) is an important part of the car's active safety system.

### How the ABS works

If one of the wheels is turning too slowly in relation to the road speed, and is close to locking, the system will reduce the pressure for this wheel. The driver is made aware of this control process by a **pulsating of the brake pedal** and audible noise. This is a deliberate warning to the driver that one or more of the wheels is tending to lock and the ABS control function has intervened. In this situation it is important to keep the brake pedal fully depressed so the ABS can regulate the brake application. Do not “pump” the brake pedal. ►

On braking sharply on slippery ground, this system helps to keep the vehicle under control, as the wheels do not lock.

However, ABS will not necessarily guarantee shorter braking distances in *all* conditions. The braking distance could even be longer if you brake on gravel or on fresh snow covering a slippery surface.

### WARNING

Try to always adapt the speed of the vehicle to weather, road and traffic conditions. Do not let the extra safety afforded by the system tempt you into taking any risks when driving. Risk of accident.

- The anti-lock brake system cannot defy the laws of motion. Slippery and wet roads are dangerous even with ABS! If you notice that the ABS has been activated, you should reduce speed immediately to suit the road and traffic conditions.
- The ABS cannot reduce the risk of accident if, for example, you are driving with an unsuitable load or too close to the preceding vehicle.
- Modifications to the vehicle or work carried out incorrectly (e.g. to the engine, the brake system, running gear or any components affecting the wheels and tyres) could affect the efficiency of the ABS, EDL, ESP and TCS and lessen their efficiency.
- The effectiveness of ABS is also determined by the tyres fitted  
⇒ page 225. ■

## ABS warning lamp

*The warning lamp monitors the ABS.*

The warning lamp  should light up for a few seconds when the ignition is switched on. It goes out again after the system has run through an automatic test sequence.



### There is a fault in the ABS if:

- The ABS warning lamp  does not light up when the ignition is switched on.
- The warning lamp does not go out again after a few seconds.
- The warning lamp lights up when the vehicle is moving.

The vehicle can still be braked in the normal way (except that the ABS control function is out of action). Please take the vehicle to a qualified workshop as soon as possible.

If a fault occurs in the ABS, the ESP warning lamp will also light up.<sup>42)</sup>



### Brake system fault

If the ABS warning lamp  lights up together with the brake warning lamp , this indicates not only a fault in the ABS function, but also a possible fault in the brake system ⇒ .

At the same time, a text message or the necessary operations may appear on the instrument panel.

### WARNING

Special care must be taken when working on the engine or on components in the engine compartment.

- It is important that you read and observe the corresponding warnings before working in the engine compartment ⇒ page 209.
- If the brake warning lamp  should light up together with the ABS warning lamp , stop the vehicle immediately and check the brake fluid level in the reservoir ⇒ page 221. If the fluid level has dropped below the “MIN” mark you must not drive on. Risk of accident. You should obtain professional assistance.
- If the brake fluid level is correct, the fault in the brake system may have been caused by a failure of the ABS control function. This could cause the 

<sup>42)</sup> Optional equipment

**⚠ WARNING (continued)**

rear wheels to lock quickly when you brake. This could cause the tail of the vehicle to skid sideways. Drive carefully to the nearest qualified workshop and have the fault corrected. ■

### Electronic differential lock (EDL)

*The electronic differential lock helps prevent the loss of traction caused if one of the driven wheels starts spinning.*

The electronic differential lock (EDL) only works when the engine is running. EDL helps the vehicle to start moving, accelerate and climb a gradient in slippery conditions where this may otherwise be difficult or even impossible.

It uses the ABS sensors to monitor the speed of the driven wheels.

At speeds of up to approximately 80 km/h, it is able to balance out differences in the speed of the driven wheels of approximately 100 rpm caused by a slippery road surface on *one side* of the vehicle. It does this by braking the wheel which has lost traction and distributing more driving force to the other driven wheel via the differential.

To prevent the disc brake of the braked wheel from overheating, the EDL cuts out automatically if subjected to excessive loads. The car remains operational and will behave in the same way as a car without EDL. For this reason, the driver is not informed that the EDL has been switched off.

The EDL will switch on again automatically when the brake has cooled down.

**⚠ WARNING**

**Try to always adapt the speed of the vehicle to weather, road and traffic conditions. Do not let the extra safety afforded by the system tempt you into taking any risks when driving. Risk of accident.**

**⚠ WARNING (continued)**

- When accelerating on a slippery surface, for example on ice and snow, press the accelerator carefully. Despite EDL, the driven wheels may otherwise start to spin. This could impair the car's stability.
- Always adapt your driving style to suit road conditions and the traffic situation.
- Modifications to the vehicle or work carried out incorrectly (e.g. to the engine, the brake system, running gear or any components affecting the wheels and tyres) could affect the efficiency of the ABS, EDL, ESP and TCS and lessen their efficiency. ■

### Electronic stabilisation programme (ESP)

*The electronic stabilisation programme helps to reduce the danger of skidding.*

The electronic stabilisation programme (ESP) consists of ABS, EDL and TCS and only works when the engine is running.

The ESP should generally be left switched on at all times. Only when the necessary drive can not be obtained should the ESP be disconnected.

For example:

- when driving with snow chains,
- when driving in deep snow or on loose surfaces,
- when rocking the vehicle backwards and forwards to free it from mud, for example.

You should press the button to switch the ESP back on when you no longer need wheel spin. ►



When the ESP is deactivated, the TCS is switched off at the same time. This means that this technology is not available for as long as the ESP remains switched off.

#### How ESP works



ESP reduces the danger of skidding by braking the wheels individually. The system uses the steering wheel angle and road speed to calculate the changes of direction desired by the driver, and constantly compares them with the actual behaviour of the car. If the desired course is not being maintained accurately (for instance if the car is beginning to skid) the ESP compensates automatically by applying the brake at the appropriate wheel.

The forces acting on the braked wheel bring the car back to a stable condition. If the car is tending to oversteer (break away at the rear) the brake application is concentrated on the outside front wheel; if the car is understeering (tending to follow a wider radius in a bend), the brake is mainly applied to the inside rear wheel.

#### How the Traction Control System (TCS) works

TCS reduces engine power to help prevent the driven wheels of front-wheel drive vehicles losing traction during acceleration. The system works in the entire speed range in conjunction with ABS. If a malfunction should occur in the ABS, the TCS will also be out of action. TCS helps the car to start moving, accelerate and climb a gradient in slippery conditions where this may otherwise be difficult or even impossible.

#### When does the warning lamp light up or flash ?

- The warning lamp  lights up when the ignition is switched on and should go out again after a few seconds.
- The warning lamp  will start flashing to indicate that the ESP and TCS are counteracting an unstable driving condition.
- It  will light up continuously if there is a malfunction in the ESP.
- It will light up continuously if the ESP is switched off.
- It will also come on if a fault should occur in the ABS because the ESP operates in conjunction with the ABS.

If the warning lamp  lights up and stays on after the engine is started, this may mean that the control system has temporarily switched off the function. In this case the ESP can be reactivated by switching the ignition off and then on again. If the warning lamp goes out, this means the system is fully functional.

If the battery is disconnected, the warning lamp  lights after turning the ignition on. This should turn off after a brief trip.



#### WARNING

**Try to always adapt the speed of the vehicle to weather, road and traffic conditions. Do not let the extra safety afforded by the system tempt you into taking any risks when driving. Risk of accident.**

- **The ESP and TCS cannot defy the laws of motion. This should be kept in mind, particularly on slippery and wet roads and when towing a trailer.**
- **Always adapt your driving style to suit the condition of the roads and the traffic situation.**
- **The ESP cannot reduce the risk of accident if, for example, you are driving with an unsuitable load or too close to the preceding vehicle.**
- **Modifications to the vehicle or work carried out incorrectly (e.g. to the engine, the brake system, running gear or any components affecting the wheels and tyres) could affect the efficiency of the ABS, EDL, ESP and TCS and lessen their efficiency.**
- **The effectiveness of the ESP is also determined by the tyres fitted**  
⇒ **page 225.**



#### Caution

In order to ensure that ESP and TCS function correctly, all four wheels must be fitted with the same tyres. Any differences in the rolling radius of the tyres can cause the system to reduce engine power when this is not desired. ■

## Power steering

Power steering does not work if the engine is not running or if the power steering system has developed a fault. In this case the steering wheel is very hard to turn.



### Caution

Do not keep the steering wheel in the full-lock position for longer than 15 seconds when the engine is running. This could cause damage to the power steering system. ■

## Four-wheel drive\*

*In vehicles with four-wheel drive, the engine power is distributed to all four wheels*

The four-wheel drive system is fully automatic and does not require intervention by the driver. The engine power is permanently distributed to all four wheels. The engine power is distributed automatically to both axles according to the road conditions and how you drive.

### Winter tyres

Thanks to its four-wheel drive, your car will have plenty of traction in winter conditions, even with the standard tyres. Nevertheless, we still recommend that, in keeping with cars with front or rear wheel drive, winter tyres or all-season tyres should be fitted on *all* four wheels when winter road conditions are expected, mainly because this will give a better *braking response*.

### Snow chains

On roads where snow chains are mandatory, they must be fitted to the front wheels of cars with four-wheel drive.

## Replacing tyres

In vehicles with four-wheel drive, all four tyres should have the same amount of wear. All four wheels must have the same rolling circumference.



### WARNING

**Never drive too fast on icy, slippery or wet surfaces. You could lose control of your vehicle if you drive too fast. This may result in serious injury.**

- **Therefore, it is essential that you adjust your speed to suit the road and traffic conditions. Do not let the extra safety afforded by four-wheel drive tempt you into taking any risks when driving.**
- **The four-wheel drive gives the vehicle good acceleration even in winter. When braking, a four-wheel drive vehicle handles in the same way as a front drive vehicle.**
- **On wet roads the front wheels may start to “aquaplane” and lose contact with the road if the car is driven too fast. If this should happen, there will be no sudden increase in engine speed to warn the driver, as with a front-wheel drive car.** ■

## Driving and the environment

### Running-in

#### Running in a new engine

*The engine needs to be run-in over the first 1,500 km.*

##### Up to 1,000 kilometres

- Do not drive faster than three quarters of top speed.
- Do not use full throttle.
- Avoid high engine revolutions.
- Do not tow a trailer.

##### From 1000 to 1500 km

- Speeds can be *gradually* increased to the maximum road speed or maximum permissible engine speed (rpm).

During its first few hours of running, the internal friction in the engine is greater than later on when all the moving parts have bedded down.



#### For the sake of the environment

If the engine is run in gently, the life of the engine will be increased and its oil consumption reduced. ■

#### Running in tyres and brake pads

*New tyres should be run-in carefully for the first 500 km. New brake pads should be run-in carefully for the first 200 km.*

During the first 200 km, you can compensate for the reduced braking effect by applying more pressure to the brake pedal. If you need to make an emergency stop, the braking distance will be longer with new brake pads than with brake pads which have been run-in.



#### WARNING

- **New tyres do not give maximum grip to start with, and need running in. This may cause an accident. Drive particularly carefully in the first 500 km.**
- **New brake pads must be “run in” and do not have the correct friction properties during the first 200 km. However, you can compensate for the slightly reduced braking effect by applying more pressure on the brake pedal. ■**

#### Braking effect and braking distance

*The braking effect and braking distance are influenced by driving situations and road conditions.*

The efficiency of the brakes depends directly on the **brake pad** wear. The rate of wear of the brake pads depends to a great extent on the conditions under which the vehicle is operated and the way the vehicle is driven. If you often drive in town traffic, drive short distances or have a sporty driving style, we recommend that you have the thickness of your brake pads checked by SEAT Service more frequently than recommended in the service schedule. ►

If you drive with **wet brakes**, for example, after crossing areas of water, in heavy rainfall or even after washing the car, the effect of the brakes is lessened as the brake discs are wet or even frozen (in winter): in this case, “dry” the brakes by applying the brakes carefully several times.

### WARNING

**Longer braking distances and faults in the brake system increase the risk of accidents.**

- **New brake pads must be run in and do not have the correct friction during the first 200 km. The slightly reduced braking effect can be compensated for by increasing pressure on the brake pedal. This also applies when new brake pads are fitted.**
- **If brakes are wet or frozen, or if you are driving on roads which have been gritted with salt, braking power may set in later than normal.**
- **When driving downhill, the brakes work hard and get hot very quickly. Before driving down a long steep gradient, it is advisable to reduce speed and change to a lower gear (or move the selector lever to a lower gear if your vehicle has automatic transmission). In this way you will make use of the engine braking effect and relieve the load on the brakes.**
- **Never let the brakes “rub” by only applying light pressure. Continuous braking will cause the brakes to overheat and will increase the braking distance. Apply and then release the brakes alternately.**
- **Never let the vehicle coast with the engine switched off. The braking distance is increased considerably as the brake servo does not work.**
- **Very heavy use of the brakes may cause a vapour lock if the brake fluid is left in the system for too long. This impairs the braking effect.**
- **Non-standard or damaged front spoilers could restrict the airflow to the brakes and cause them to overheat. Observe the notes ⇒ page 202 before buying accessories.**
- **If a brake circuit fails, the braking distance will be increased considerably. Contact a qualified workshop immediately and avoid unnecessary journeys. ■**

## Exhaust gas emission control system

### Catalytic converter\*

#### To conserve the useful life of the catalytic converter

- Always use unleaded petrol.
- Do not run the fuel tank dry.
- For engine oil changes, do not replenish with too much engine oil ⇒ page 215, “Topping up engine oil 

If you notice misfiring, uneven running or loss of power when the vehicle is moving, reduce speed immediately and have the vehicle inspected at the nearest qualified workshop. These symptoms are communicated by the exhaust gas warning lamp ⇒ page 72. If this happens, unburnt fuel can enter the exhaust system and escape into the environment. The catalytic converter can also be damaged by overheating.

### WARNING

**The catalytic converter reaches very high temperatures! Fire hazard!**

- **Never park where the catalytic converter could come into contact with dry grass or inflammable materials under the vehicle.**
- **Do not apply additional underseal or anti-corrosion coatings to the exhaust pipes, catalytic converter or the heat shields on the exhaust system, because the heat from the engine could ignite them.**

### Caution

Never fully drain the fuel tank, in this case, the irregularity of the fuel supply may cause ignition problems. This allows unburnt fuel to enter the exhaust system, which could cause overheating and damage the catalytic converter.

### For the sake of the environment

Even when the emission control system is working perfectly, there may be a smell of sulphur from the exhaust under some conditions. This depends on the sulphur content of the fuel used. Quite often the problem can be remedied by changing to another brand of fuel. ■

## Diesel particulate filter\*

*The diesel particulate filter retains and burns the soot derived from the combustion process.*

The diesel particulate filter system is made up of the following elements:

- Additive deposit with integrated pump
- Additive
- Diesel particulate filter
- Lambda probe

The diesel particulate filter removes practically all the particulates of soot from the exhaust gas. The filter retains these particulates and burns them.

By adding **additive** automatically, the ignition temperature of the soot is lowered. The additive is in a separate deposit and, after settling, is pumped to the interior of the fuel tank. The additive is also burned in the filter with the soot, and so is not released into the atmosphere.

### WARNING

The particulate filter attains very high temperatures. Fire hazard!

- Never park where the catalytic converter could come into contact with dry grass or inflammable materials under the vehicle.
- Do not apply additional underseal or anti-corrosion coatings to the exhaust pipes, catalytic converter or the heat shields on the exhaust system, because the heat from the engine could ignite them.

### WARNING

The additive is toxic.

- If any work is required on the additive deposit, go to a specialized workshop because of the danger of toxicity.
- The additive should be stored in the closed original container in a safe place out of reach of children. There is a toxic risk.

### Caution

- Vehicles with the diesel particulate filter should **not** use RME fuel (biodiesel) as it may damage the fuel system.
- Using diesel fuel with a high sulphur count can reduce the working life of the filter. Your SEAT dealership will be able to tell you which countries have diesel with a high sulphur content. ■

## Driving abroad

### Notes

For driving abroad, the following must be taken into consideration: ►

- For vehicles fitted with a catalytic converter ensure that unleaded petrol is available for the journey. See the chapter “Refuelling”. Automobile organisations will have information about service station networks selling unleaded fuel.
- In some countries it is possible that a vehicle model is sold under conditions where some spare parts are not available or that the Authorised Service Centre may only carry out limited repairs.

SEAT importers and distributors will gladly provide information about the technical preparation of your vehicle in addition to necessary maintenance and repair possibilities. ■

### Adhesive strips for headlights

---

If you have to drive a right-hand drive vehicle in a left-hand drive country, or vice versa, the asymmetric dipped beam headlights will dazzle oncoming traffic.

To prevent dazzling, you must apply stickers to certain parts of the headlight lenses. Further information is available from your Authorised Service Centre. ■

## Trailer towing

### What do you need to bear in mind when towing a trailer?

---

The vehicle can, if suitably equipped, be used to tow a trailer or caravan.

If the car is supplied with a **factory-fitted** towing bracket it will already have the necessary technical modifications and meet the statutory requirements for towing a trailer. If you wish to **retrofit** a towing bracket ⇒ page 204.

### Connectors

Your vehicle is fitted with a 12-pin connector for the electrical connection between the trailer and the vehicle.

If the trailer has a **7-pin** plug, you will need to use an adapter cable. This is available from SEAT Service.

### Trailer weight / draw bar loading

Never exceed the maximum permitted trailer weights. If you do not load the trailer up to the maximum permitted trailer weight, you can then climb correspondingly steeper gradients.

The maximum trailer weights listed are only applicable for **altitudes** up to 1,000 m above sea level. With increasing altitude the engine power and therefore the vehicle's climbing ability are impaired because of the reduced air density. The maximum trailer weight has to be reduced accordingly. The weight of the vehicle and trailer combination must be reduced by 10% for every further 1,000 m (or part thereof). Where possible, operate the trailer with the maximum permitted **draw bar weight** on the ball joint of the towing bracket, but do not exceed the specified limit.

The figures for **trailer weights** and **draw bar weights** given on the data plate of the towing bracket are for certification purposes only. The correct figures for your specific model, which may be *lower* than these figures for the towing bracket, are given in the registration documents and “Technical data”.

### Gross combination weight

The gross combination weight is the actual weight of the laden vehicle plus the actual weight of the laden trailer. If the maximum permissible trailer weight is to be utilized, the weight of the vehicle may have to be reduced.

### Distributing the load

Distribute loads in the trailer so that heavy objects are as near to the axle as possible. Loads carried in the trailer must be secured to prevent them moving. ▶

### Tyre pressure

Set tyre pressure to the maximum permitted pressure shown on the sticker on the inside of the tank flap. Set the tyre pressure of the trailer tyres in accordance with the trailer manufacturer's recommendations.

### Exterior mirrors

Check whether you can see enough of the road behind the trailer with the standard mirrors. If this is not the case you should have additional mirrors fitted. Both exterior mirrors should be mounted on hinged extension brackets. Adjust the mirrors to give sufficient vision to the rear.

### Headlight adjustment

If towing a trailer the dipped light may dazzle other drivers. Use the headlight range control to lower the cone of light. If you do not have headlight range control, have the headlights adjusted by a qualified dealership.

#### WARNING

- Never transport people in a trailer. This could result in fatal accidents.
- To avoid dazzling other drivers, adjust the dipped beam according to the load. If not, an accident may occur.

#### Note

- Towing a trailer places additional demands on the vehicle. We recommend additional services between the normal inspection intervals if the vehicle is used frequently for towing a trailer.
- Find out whether special regulations apply to towing a trailer in your country. ■

### Ball coupling of towing bracket

The removable ball coupling of the towing bracket is stored with the tools on board behind the right-hand side trim of the luggage compartment.

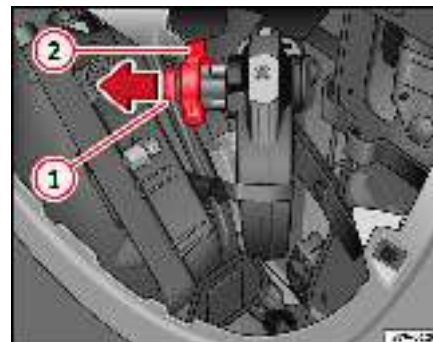

Fig. 134 Location of towing bracket

It is necessary to first tense the towing bracket removing the ball coupling.

#### Remove the towing bracket from the luggage compartment

- Open the lock by turning the key ⇒ fig. 134 ① clockwise.
- Take out the wheel completely ② in the direction of the arrow and turn clockwise to the maximum.
- Release the wheel. The towing bracket is pretensed.
- Remove the towing bracket.



### Storing towing bracket in the luggage compartment

- First tension the towing bracket.
- Place the towing bracket in its casing on the right-hand side of the luggage compartment. The bracket engages and the tension is released ⇒ .
- Check that it is correctly fitted.

The ball coupling is provided with instructions on fitting and removing the ball coupling of the towing bracket.

If the ball coupling is fitted it is possible to store the cover of the tow-bar in a plastic bag next to the tools.

#### **WARNING**

**The towing bracket ball coupling must be stored securely to prevent it being flung through the vehicle and causing injury.**

- **When the pretensed towing bracket is being fitted, there is a risk of injury in the event that the wheel goes back on itself.**

#### **Note**

By law, the ball coupling must be removed if a trailer is not being towed and it obscures the number plate.

- When placing the towing bracket in the casing check that it is no longer tensed and securely fastened. ■

### Driving tips

*Driving with a trailer always requires extra care.*

#### **Weight distribution**

The weight distribution of a loaded trailer with an unladen vehicle is very unfavourable. However, if this cannot be avoided, drive extra slowly to allow for the unbalanced weight distribution.

#### **Speed**

The stability of the car and trailer is reduced with increasing speed. For this reason it is advisable not to drive at the maximum permissible top speed in unfavourable road, weather or wind conditions. This applies especially when driving downhill.

You should always reduce speed immediately if the trailer shows the slightest sign of **snaking**. Never try to stop the “snaking” by increasing speed.

Always brake in good time. If the trailer has an **overrun brake**, apply the brakes *gently at first* and then firmly. This will prevent the jerking that can be caused by the trailer wheels locking. Select a low gear (in both manual and automatic gearboxes) in good time before going down a steep hill. This enables you to use the engine braking effect to slow down the vehicle.

#### **Overheating**

At very high temperatures and during prolonged ascents, driving in a low gear and high engine speed, always monitor the temperature indicator for the coolant.

#### **Electronic Stabilisation Program**

Do not switch off the ESP when towing a trailer. The ESP makes it easier to stabilise if the trailer starts to snake. ■



## Driving economically and with respect for the environment

### General Observations

---

Fuel consumption, environmental pollution and wear to the engine, brakes and tyres depends in large part on your driving style. Fuel consumption may be reduced from 10 to 15 % by driving defensively and economically. Below we will give you some suggestions to "alleviate" some of the strain in the environment and, at the same time, your wallet.

#### Anticipate the traffic situation well in advance

A vehicle uses most fuel when accelerating. When you anticipate the situation, you will have to brake less often and, thus, accelerate less. If it is possible, let the vehicle roll with a **gear engaged**, for example, if you see a red light ahead.

#### Change gear early to save energy

An effective way of saving fuel is to change up through the gears *quickly*. Running the engine at high rpm in the lower gears uses an unnecessary amount of fuel.

**Manual gearbox:** Change from first to second gear as quickly as possible. We recommend that, whenever possible, you change to a higher gear upon reaching 2,000 rpms.

**Automatic gearbox:** Accelerate slowly and avoid the "kick-down" position.

#### Avoid driving at high speed

We advise you not to drive at the top speed permitted by the vehicle. Fuel consumption, exhaust emissions and noise levels all increase very rapidly at higher speeds. Driving at moderate speeds will help to save fuel.

#### Avoid idling

It is worthwhile switching off the engine when waiting in a traffic jam, at level crossings or at traffic lights with a long red phase. The fuel saved after only 30 - 40 seconds is greater than the amount of fuel needed to restart the engine.

The engine takes a very long time to warm up when it is running at idling speed. Mechanical wear and pollutant emissions are also especially high during this initial warm-up phase. It is therefore best to drive off immediately after starting the engine. Avoid running the engine at high speed.

#### Periodic maintenance

Periodic maintenance work guarantees that, before beginning a journey, you will not waste fuel. A well-serviced engine gives you the benefit of **improved fuel efficiency** as well as maximum reliability and an enhanced resale value.

A maladjusted engine may mean an increase of 10 % over normal fuel consumption.

Check the **oil level** every time you fill the tank. **Oil consumption** depends to a great extent on the engine load and engine speed. It is quite normal that the oil consumption of a new engine only reaches its lowest level after a certain mileage. This means that the oil consumption can only be properly assessed after about 5,000 km. Depending on your personal driving style, oil consumption can be up to 0.5 litres per 1,000 km.

#### Avoid short journeys

To reduce the consumption and emission of polluting gases, the engine and the exhaust filtration systems should reach the optimum **service temperature**.

With the engine cold, fuel consumption is proportionally higher. The engine does not warm up and fuel consumption does not regularise until having driven some *four* kilometres. This is the reason why we recommend avoiding short trips wherever possible. ▶

### Maintain the correct tyre pressures

Bear in mind that keeping the tyres at an adequate pressure saves fuel. If the tyre pressures are just 1 bar too low, this can put the fuel consumption up by as much as 5 %. Due to the greater rolling resistance, under-inflation also increases **tyre wear** and impairs handling.

The tyre pressures should always be checked when the tyres are *cold*.

Do not use **winter tyres** all through the year: they will increase fuel consumption by up to 10 %.

### Avoid unnecessary weight

Every kilo of **extra weight** will put up the fuel consumption, so it is worth checking the luggage compartment occasionally to make sure that no unnecessary loads are being transported.

### Save electrical energy

The engine activates the alternator, which produces electricity. With the need for electricity, fuel consumption is also increased. Because of this, always turn off electrical equipment when you do not need them. Examples of equipment that use a lot of electricity are: the fan at high speeds, the rear window heating or the seat heaters\*.

### Logbook

A good way of keeping a check on **fuel consumption** is to take regular notes. You will be able to note the variations (both positive and negative) and react accordingly. ■

## Environmental friendliness

---

Environmental protection is a top priority in the design, choice of materials and production of your new Seat.

### Design measures for economical recycling

- Joints and connections designed for ease of dismantling
- Modular construction to facilitate dismantling
- Increased use of single-grade materials
- Plastic parts and elastomers are labelled in accordance with ISO 1043, ISO 11469 and ISO 1629

### Choice of materials

- Nearly all materials used can be recycled
- Similar types of plastics grouped together for easy recycling
- Recycled materials used in manufacture
- Reduced “vapour emissions” from plastics
- CFC-free refrigerant in air conditioning

**Compliance with prohibited materials laws:** cadmium, asbestos, lead, mercury, chrome VI.

### Manufacturing methods

- Use of recycled material for manufacturing plastic parts
- Solvent-free cavity sealing
- Solvent-free wax for protecting the vehicles in transit
- Solvent-free adhesives
- No CFCs used in production
- Surplus materials used extensively for energy conversion and building materials
- Overall water consumption reduced
- Heat recovery systems
- Water-soluble paint ■

## Cleaning and caring for your vehicle

### General notes

*Regular washing and care help maintain the value of your vehicle.*

#### Regular care

Regular and expert care helps to **maintain the value** of the vehicle. This may also be one of the requirements for acknowledging warranty claims in the event of corrosion or paint defects.

The best way to protect the car against environmental contaminants is to wash and wax it *frequently*. The longer substances such as insects, bird droppings, resinous tree sap, road dirt, industrial deposits, tar, soot or road salt and other aggressive materials remain on the vehicle, the more damage they do to the paintwork. High temperatures (for instance in strong sunlight) further intensify the corrosive effect.

After the period when salt is put on the roads it is important to have the **underside** of the vehicle washed thoroughly.

#### Car care products

Car care products are available from your Authorised Service Centre. Keep the product instructions until you have used up the product.

#### WARNING

- Car care products can be toxic. For this, they must always be kept closed in their original container. Keep out of children's reach. Failure to comply could result in poisoning.
- Always read and observe the instructions and warnings on the package before using car care products. Improper use could damage your health or

#### WARNING (continued)

**your vehicle. The use of certain products may produce noxious vapours; these should be used in well ventilated areas.**

- Never use fuel, turpentine, engine oil, nail varnish remover or other volatile fluids. These are toxic and highly flammable. There is a fire / explosion risk.
- Before you wash your vehicle, or carry out any maintenance, switch off the engine, apply the handbrake firmly and remove the key from the ignition.

#### Caution

Never attempt to remove dirt, mud or dust if the surface of the vehicle is dry. Never use a dry cloth or sponge for cleaning purposes. This could damage the paintwork or glass on your vehicle. Soak dirt, mud or dust with plenty of water.

#### For the sake of the environment

- When purchasing car care products, try to select ones which are not harmful to the environment.
- Left over car care products should not be disposed of with ordinary household waste. Observe the disposal information on the package. ■

## Care of the vehicle exterior

### Automatic car washes

The paint is so durable that the car can normally be washed without problems in an automatic car wash. However, the effect on the paint depends to a large extent on the design of the car wash, the brushes used, the filtering of the wash water and the type of detergents and wax solutions used, etc.

After the car has been washed, the **brakes** could respond later than normal as the brake discs and brake pads will be wet, or even frozen in winter. “Dry” the brakes by braking several times.

	<b>WARNING</b>
Moisture, ice and salt on the brakes may affect braking efficiency. Risk of accident. ■	

### Washing by hand

#### Washing the vehicle

- First soften the dirt with plenty of water and rinse off.
- Clean the vehicle with a soft sponge, a glove or a brush. Start on the roof and work your way down. Use only light pressure.
- Rinse the sponge or glove as much as possible.
- Special car shampoo should only be used for very stubborn dirt.
- Clean the wheels, sill panels etc. last using a different sponge or glove.

- Rinse the vehicle thoroughly with water.
- Dry the surface of the vehicle gently using a chamois leather.
- If it is **cold**, dry the rubber seals and the surfaces they touch with a cloth to prevent them freezing. Apply silicone spray to the rubber seals.

#### After cleaning the vehicle

- If possible, avoid sudden braking directly after washing the vehicle. “Dry” the brakes by braking several times.

	<b>WARNING</b>
<ul style="list-style-type: none"> <li>● The ignition must always be switched off before the vehicle is washed.</li> <li>● Protect your hands and arms from cuts on sharp metal edges when cleaning the underbody, the inside of the wheel housings etc. Risk of injury.</li> <li>● Moisture, ice and salt on the brakes may affect braking efficiency. Risk of accident.</li> </ul>	

#### Caution

- Never attempt to remove dirt, mud or dust if the surface of the vehicle is dry. Never use a dry cloth or sponge for cleaning purposes. This could scratch the paintwork or glass on your vehicle.
- Washing the vehicle in low temperatures: if the vehicle is rinsed with a hose, do not direct the water into the lock cylinders or the gaps around the doors, luggage compartment, or bonnet. Otherwise there is a risk of malfunction. ►



### For the sake of the environment

In the interests of environmental protection, the car should be washed only in specially provided wash bays. This prevents toxic, oil-laden waste water entering the sewerage system. In some districts, washing vehicles anywhere else may be prohibited.



### Note

Do not wash the vehicle in direct sunlight. ■

## Washing the car with a high pressure cleaner

*Be particularly careful when using a high pressure cleaner!*

- Always observe the instructions for the high-pressure cleaner, particularly those concerning the **pressure** and the **spraying distance**.
- Increase the spraying distance for soft materials and painted bumpers.
- Do not use a high pressure cleaner to remove ice or snow from windows ⇒ page 196.
- Never use concentrated jet nozzles or so-called “dirt blasters” ⇒
- If possible, avoid sudden braking directly after washing the vehicle. “Dry” the brakes by braking several times.



### WARNING

- **Never wash tyres with a concentrated jet or cylindrical jet (“rotating nozzle”). Even at large spraying distances and short cleaning times, visible and invisible damage can occur to the tyres. This may cause an accident.**
- **Moisture, ice and salt on the brakes may affect braking efficiency. Risk of accident.**



### Caution

- Do not use water hotter than 60°C. This could damage the car.
- To avoid damage to the vehicle, maintain a sufficient distance from sensitive materials for example: flexible hoses, plastic, sound proofing, etc. This is especially important for bumpers painted in the same colour as the vehicle. The closer the nozzle is to the surface, the greater the wear on the material. ■

## Waxing the car

*Regular waxing protects the paintwork.*

You need to apply wax to your car if water does not form small drops and run off the paintwork when it is *clean*.

Good quality *hard wax* is available from your Authorised Service Centre.

A good coat of wax helps to protect the paintwork from environmental contaminants ⇒ page 193. It is also effective in protecting against minor scratches.

Even if a **wax solution** is used regularly in the car wash, it is advisable to protect the paint with a coat of hard wax at least twice a year. ■

## Polishing the paintwork

*Polishing brings back gloss to the paintwork.*

Polishing is only necessary if the paint has lost its shine, and the gloss cannot be brought back by applying wax. Polish can be obtained from your Authorised Service Centre.

The car must be waxed after polishing if the polish used does not contain wax compounds to seal the paint ⇒ page 195, “Waxing the car”.



### Caution

To prevent damage to the paintwork:

- Do not use polishes and hard wax on painted parts with a matte finish or on plastic parts.
- Do not polish your vehicle in a sandy or dusty environment. ■

## Caring for plastic parts

*Solvents will damage plastic parts.*

If normal washing fails to clean plastic parts, clean them with special **solvent-free** plastic cleaning and care products.



### Caution

- The use of liquid air freshener directly over the air vents of the vehicle may damage the plastic parts if the liquid is accidentally spilled.
- Cleaning products which contain solvents will damage the material. ■

## Cleaning windows and exterior mirrors

### Cleaning the windows

- Moisten the windows with commercially available, alcohol based glass cleaner.
- Dry the windows with a clean chamois leather or a lint-free cloth.

### Removing snow

- Use a small brush to remove snow from the windows and mirrors.

### Removing ice

- Use a de-icer spray.

Use a clean cloth or chamois leather to dry the windows. Chamois leathers which have been used on painted surfaces are not suitable for use on windows. They will be soiled with wax deposits which would smear the windows.

If possible use a de-icing spray to remove ice. If you use an ice scraper, push it in one direction only. Do not move it to and fro.

Use window cleaner or a silicone remover to clean off rubber, oil, grease and silicone deposits.

Wax deposits have to be removed with a special cleaner which is available from your Authorised Service Centre. Wax deposits on the windscreen could cause the wiper blades to judder. A window cleanser specifically for removing wax will stop the blades juddering if added to the windscreen washer fluid. Grease removing cleansers will not remove wax deposits.



### Caution

- Never use warm or hot water to remove snow and ice from windows and mirrors. This could cause the glass to crack! ▶

- The heating element for the rear window is located on the inner side of the window. To prevent damage, do not put stickers over the heating elements on the inside of the window. ■

## Cleaning windscreen wiper blades

---

Clean wiper blades are essential for clear vision.

1. Use a soft cloth to remove dust and dirt from the windscreen wiper blades.
2. Use window cleanser to clean the windscreen wiper blades. Use a sponge or a cloth to remove stubborn stains. ■

## Care of rubber seals

---

*If rubber seals are well looked after, they will not freeze so quickly.*

1. Use a soft cloth to remove dust and dirt from the rubber seals.
2. Apply a specialist care product to the rubber seals.

The weather strips on the doors, windows, bonnet and rear lid will remain pliable and last longer if they are treated with a suitable care product (for example silicone spray).

Caring for rubber seals will also prevent premature ageing and leaks. The doors will be easier to open. If rubber seals are well looked after, they will not freeze so quickly in winter. ■

## Door lock cylinders

---

*The door lock cylinders can freeze up in winter.*

To de-ice the lock cylinders you should only use spray with lubricating and anti-corrosive properties. ■

## Cleaning chrome parts

---

1. Clean chrome parts with a damp cloth.
2. Polish chrome parts with a soft, dry cloth.

If this does not provide satisfying results, use a specialist **chrome cleaning product**. Chrome cleaning products will remove stains and coatings from the surface.



### Caution

To prevent scratching chrome surfaces:

- Never use an abrasive care product on chrome.
- Do not clean or polish chrome parts in a sandy or dusty environment. ■

## Cleaning alloy wheels

---

### Every two weeks

- Wash salt and brake dust from alloy wheels.
- Use an acid free detergent to clean the wheels. ▶

### Every three months

- Apply a hard wax compound to the wheels.

Alloy wheels require regular attention to preserve their appearance. It is important to remove road salt and brake dust by washing the wheels at regular intervals, otherwise the finish will be impaired.

Always use an acid-free detergent for alloy wheels.

Car polish or other abrasive agents should not be used. If the protective coating is damaged, e.g. by stone impact, the damaged area should be repaired immediately.

#### WARNING

- **Never wash tyres with a cylindrical jet. Even at large spraying distances and short cleaning times, visible and invisible damage can occur to the tyres. This may cause an accident.**
- **Moisture, ice and salt on the brakes may affect braking efficiency. Risk of accident. If possible, avoid sudden braking immediately after washing the vehicle. "Dry" the brakes by braking several times. ■**

### Underbody sealant

*The underside of the vehicle is coated to protect it from corrosion and damage.*

The protective coating could be damaged when driving. We recommend that the protective coating under the body and on the running gear should be checked, and reinstated if necessary, before and after the winter season.

We recommend that repair work and additional anti-corrosion work is carried out by your Authorised Service Centre.

#### WARNING

**Do not apply underseal or anti-corrosion coatings to the exhaust pipes, catalytic converter or the heat shields on the exhaust system. The heat of the exhaust system or the engine could cause them to ignite! This is a fire hazard. ■**

### Cleaning the engine compartment

*Take special care when cleaning the engine compartment.*

#### Anti-corrosion treatment

The engine compartment and the surface of the power unit are given anti-corrosion treatment at the factory.

Good corrosion protection is particularly important in winter when the car is frequently driven on salted roads. To prevent the salt corroding the vehicle, the entire engine compartment should be thoroughly cleaned before and after the salting period.

**Your Authorised Service Centre** is able to provide the correct cleaning and preserving products and has the necessary equipment. For this reason, we recommend having this work performed by them.

The anti-corrosion protection is usually removed if the engine compartment is cleaned with grease removing solutions, or if you have the engine cleaned. If this job is carried out, you should ensure that all surfaces, seams, joints and components in the engine compartment are given anti-corrosion treatment afterwards.

#### WARNING

- **When working in the engine compartment, always observe the safety warnings ⇒ page 209.**



 **WARNING** (continued)

- Switch off the engine, apply the parking brake firmly and always remove the key from the ignition before you open the bonnet.
- Allow the engine to cool before you clean the engine compartment.
- Do not clean the underside of vehicle, wheel arches without protecting your hands and arms. You may cut yourself on sharp-edged metal parts. Failure to comply could result in injury.
- Moisture, ice and salt on the brakes may affect braking efficiency. Risk of accident. If possible, avoid sudden braking immediately after washing the vehicle.
- Never touch the radiator fan. It is temperature-controlled and could start automatically, even when the key is removed from the ignition!

**For the sake of the environment**

Fuel, grease and oil deposits could be removed when the engine is washed. The polluted water must be cleaned in an oil separator. For this reason, engine washing should be carried out only by a qualified workshop or a suitable filling station. ■

## Care of the vehicle interior

### Cleaning plastic parts and the dash panel

- Use a clean, damp cloth to clean plastic parts and the dash panel.
- If this does not provide satisfactory results, use a special **solvent-free** plastic cleaning product.

 **WARNING**

Never clean the dash panel and surface of the airbag module with cleansers containing solvents. Solvents cause the surface to become porous. If the airbag inflates, disintegrating plastic parts can cause substantial injuries.

**Caution**

Cleaning products which contain solvents will damage the material. ■

### Cleaning wooden trim\*

- Clean the wooden trim with a clean cloth moistened with water.
- If this does not provide satisfactory results, use a *gentle* soap solution.

**Caution**

Cleaning products which contain solvents will damage the material. ■

### Cleaning cloth seat covers and fabric trim

Cloth seat covers and fabric trim on the doors, headlining etc. can be cleaned with a special interior cleanser or with dry foam and a soft brush. ■

## Cleaning leather\*

### Normal cleaning

- Moisten a cotton or woollen cloth with water and wipe over the leather surfaces.

### Cleaning stubborn stains

- More stubborn dirt can be removed using a mild soap solution (pure liquid soap; two tablespoons diluted in one litre of water) and a cloth.
- Do not let the water soak through the leather or soak into the seams.
- Then wipe off with a soft, dry cloth.

### Leather care

- The leather should be treated regularly (about twice a year) with a special leather-care product, which is available from your Authorised Service Centre.
- Apply these products very sparingly.
- Then wipe off with a soft, dry cloth.

SEAT does everything possible to preserve the special qualities of leather, as a natural product. Because of the natural properties of the specially selected hides employed, the finished leather has a certain sensitivity to grease and dirt, etc. so a degree of care is required in everyday use and when looking after the leather.

Dust and grit in the pores and seams can scratch and damage the surface. If the vehicle is left standing in the sun for long periods, the leather should be

protected against direct sunlight to prevent it from fading. However, slight colour variations in high-quality natural leather are normal.



### Caution

- Do not use solvents, wax polish, shoe cream, spot removers or similar products on leather.
- To avoid damage, stubborn stains should be removed by a qualified workshop. ■

## Cleaning seat belts

*A dirty belt may stop the seat belt working properly.*

Keep the seat belts clean and check all seat belts regularly.

### Cleaning seat belts

- Carefully pull the dirty seat belt right out and leave it out.
- Clean the dirty seat belts with a *gentle* soap solution.
- Allow the seat belt fabric to dry.
- Do not roll up the seat belt until it is dry.

If large stains form on the belts the belt will not retract correctly into the automatic belt retractor.



### WARNING

- Do not use chemical cleaning agents on the seat belts, as this can impair the strength of the webbing. Ensure that the belts do not come into contact with corrosive fluids.

 **WARNING (continued)**

- Check the condition of all seat belts at regular intervals. If you notice that the belt webbing, fittings, retractor mechanism or buckle of any of the belts is damaged, the belt must be replaced by a specialist workshop.
- Do not attempt to repair a damaged seat belt yourself. The seat belts must not be removed or modified in any way.

**Caution**

After cleaning, allow seat belts to dry completely before rolling them up. Otherwise the belt retractors could become damaged. ■

### Cleaning the cool/thermos box

---

- **Before** using the insulated box for the first time, you should clean it, using a household detergent.
- Always clean the inside of the insulated box when it is soiled.

If you do not plan to use the insulated box for a long period, disconnect the power supply and clean the inside and outside of the box. Place a folded towel between the box and its lid. This prevents mould and damp stains forming in the cooling and heating box. ■

## Accessories, parts replacement and modifications

### Accessories and parts

*Always consult an Authorised Service Centre before purchasing accessories and parts.*

Your vehicle is designed to offer a high standard of active and passive safety.

Before purchasing accessories and parts, and before making technical changes to your car, we recommend that you consult your Authorised Service Centre.

SEAT dealerships will be happy to provide you with the latest information about the use, legal requirements and recommendations from the manufacturer regarding accessories and parts.

We recommend you use only **SEAT Approved Accessories®** and **SEAT Approved Spare Parts®**. This way, SEAT can guarantee that the product in question is suitable, reliable and safe. Authorised Service Centres have the necessary experience and facilities to ensure that parts are installed correctly and professionally.

Despite continuous observation of the market, SEAT is not able to assess the reliability, safety and suitability of parts **not approved by SEAT**. For this reason SEAT cannot assume responsibility for any non-genuine parts used, even if these parts have been approved by an official testing agency or are covered by an official approval certificate.

Any **equipment subsequently installed** which has a direct effect on the vehicle and/or the way it is driven (e.g. cruise control system or electronically-controlled suspension) must be approved by SEAT for use in your vehicle and bear the **e** mark (the European Union's authorisation symbol).

If any **additional electrical components** are fitted which do not serve to control the vehicle itself (for instance a refrigerator box, laptop or ventilator

fan, etc.), these must bear the **CE** mark (European Union manufacturer conformity declaration).

#### **WARNING**

**Accessories, for example telephone holders or drink holders, should never be fitted on the covers of, or within the working range of, the airbags. If they are, there is a danger of resulting injury if the airbag is triggered in an accident. ■**

### Modifications

*Modifications must always be carried out according to our specifications.*

Unauthorised modifications to the electronic components or software in the vehicle may cause malfunctions. Due to the way the electronic components are linked together in networks, other systems may be affected by the faults. This can seriously impair safety, lead to excessive wear of components, and also invalidate your vehicle registration documents.

SEAT Authorised Service Centres cannot be held liable for any damage caused by modifications and/or work performed incorrectly.

For this reason, we recommend that all work should be performed by an Authorised Service Centre using **genuine and SEAT® approved parts and accessories**. ▶

 **WARNING**

**Incorrectly performed modifications or other work on your vehicle can lead to malfunctions and cause accidents. ■**

## Roof aerial\*

The vehicle may be fitted with a collapsible roof aerial\* with antitheft system\*, which can be folded backwards, when, for example, going through an automatic carwash.

### To fold

Unscrew the aerial rod, tilting it backwards into a horizontal position and then screw in again.

### To return to working position

Continue in the reverse order to that given in the previous instruction. ■

## Mobile telephones and two-way radios

*You will require an external aerial for mobile phones and two-way radios.*

SEAT has approved your vehicle for use with mobile telephones and two-way radios providing the following conditions are observed:

- The correct installation of an external aerial,
- transmitting power of maximum 10 watts.

An external aerial is needed to give the equipment its optimal range.

First consult your Authorised Service Centre if you wish to use a mobile telephone or a two-way radio with a transmitting power in excess of 10 watts. Here you will receive information concerning the technical possibilities for retrofitting this equipment.

Mobile telephones and two-way radios should be fitted only by a qualified workshop, for example an Authorised Service Centre.

 **WARNING**

- **Always concentrate primarily on driving. If you are distracted while driving you could have an accident.**
- **Never attach the telephone mountings to the surfaces covering the airbag units or within the range of the airbags, danger of injury if the airbag is triggered.**
- **If you use mobile telephones or two-way radios in the vehicle without an external aerial, electromagnetic radiation in the vehicle could exceed authorised limits. This also applies to external aerials that have not been correctly installed.**

 **Caution**

Failure to observe the above conditions could cause the electronics to malfunction. The most common causes of faults are:

- no external aerial,
- external aerial incorrectly installed,
- transmitting power in excess of 10 watts.

 **Note**

Please observe the operating instructions of your mobile telephone / two-way radio. ■

## Retrofitting a towing bracket

*The vehicle can be retrofitted with a towing bracket.*

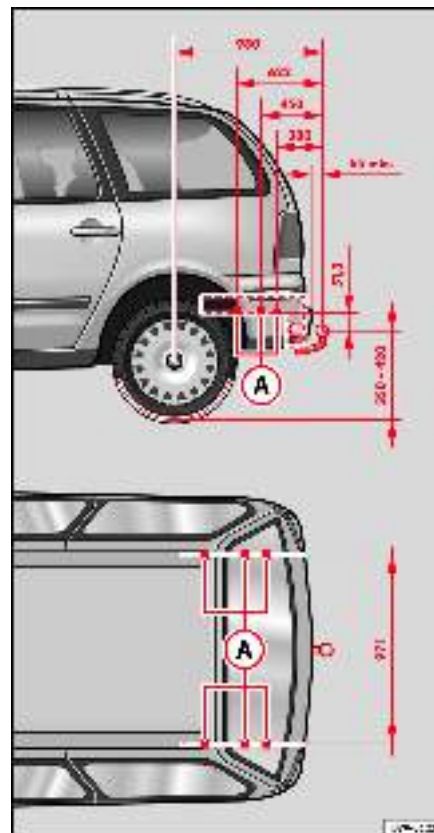



Fig. 135 Attachment points for towing bracket ►

If a towing bracket is to be retro-fitted to the car, it must be done according to the instructions of the towing bracket manufacturer.

The attachment points for the towing bracket ⇒ page 204, fig. 135  are underneath the vehicle.

Always observe the minimum distance from the middle of the ball coupling to the ground (350 to 420 mm). This also applies when the vehicle is fully laden, including maximum drawbar load.

#### Fitting a towing bracket

- Driving with a trailer implies additional work for the vehicle. Therefore, before fitting a towing bracket, please contact an Authorised Service Centre to check whether your cooling system needs modification.
- Observe the legal requirements in your country (e.g. the fitting of a separate pilot lamp).
- Certain vehicle components, e.g. the rear bumper must be removed and reinstalled. The towing bracket securing bolts have to be tightened using a torque wrench, and a socket connected to the vehicle's electrical system. This requires specialist knowledge and tools.
- The figures in the illustration show the dimensions and attachment points which must be observed if you are retrofitting a towing bracket.



#### WARNING

**If a towing bracket is retrofitted, it should be done by a qualified dealer.**

- **If the towing bracket is incorrectly fitted, this could cause a safety risk.**
- **For your own safety, please observe the instructions provided by the manufacturer of the towing bracket.**



#### Caution

If the connector socket is not fitted correctly, this could cause damage to the vehicle's electrical system. ■

## Checking and refilling levels

### Refilling



**Fig. 136** Tank filler neck and tank flap

The tank filler neck is located at the rear right-hand side of the vehicle.

The tank flap is locked and unlocked automatically by the central locking system.

The fuel tank holds about 70 litres.

The tank cap can, once unscrewed, be hung on the tank flap ⇒ [fig. 136](#).

After filling up, screw the tank cap back in firmly and close the tank flap until it engages.

#### **WARNING**

All legal stipulations must be observed when transporting a reserve supply. For safety reasons, we do not recommend carrying a spare fuel canister in the vehicle. The canister could be damaged in an accident and leak.

#### **Caution**

- Never run the fuel tank empty on vehicles equipped with a catalytic converter. An irregular fuel supply could cause misfiring. In this way the fuel can arrive without burning the exhaust system, which could cause the catalyser to overheat resulting in damage.
- Spilt fuel should be removed from the vehicle paint finish as quickly as possible as the paint could otherwise be damaged. Especially if biodiesel fuel is being used ⇒ [page 207](#).

#### **For the sake of the environment**

If the automatic filler nozzle is operated correctly, it will switch itself off as soon as the tank is “full”. Never attempt to fill beyond this point, as this will fill the expansion chamber. Fuel may leak out if ambient conditions are warm. ■



## Petrol types

*The correct petrol types are listed on a sticker inside the fuel tank flap.*

Only **unleaded petrol, corresponding to the standard DIN EN 228**, may be used for vehicles with catalytic converters (EN = “European Norm”).

Fuel types are differentiated by the **octane rating**, e.g: 91, 95, 98 RON (RON = “Regulation Octane Number, unit for determining the knock resistance of petrol”). You may use petrol with a higher octane number than the one recommended for your engine. However, this has no advantage in terms of fuel consumption and engine power. If, in exceptional circumstances, the correct octane rating is not available:

- For engines which require **Premium unleaded petrol (95 RON)** the following is valid: Regular unleaded fuel with 91 RON can also be used. This can, however, result in a slight loss of power under certain driving conditions.
- For engines which require **Premium unleaded petrol (98 RON)** the following is valid: Premium unleaded fuel with 95 RON can also be used. This can, however, result in a slight loss of power under certain driving conditions. – If premium unleaded petrol is not available, the engine can be run on regular unleaded petrol with 91 RON as an “emergency measure”. In this case only use moderate engine speeds and a light throttle. Avoid using full throttle. Fill up with premium petrol as soon as possible.



### Caution

- Petrol that follows EN 228 may be mixed with small quantities of ethanol. However, the so-called “bioethanol fuels” available at commercial establishments with reference E50 or E85, which contain a high percentage of ethanol, may **not** be used, as they will damage the fuel system.
- Even one tankfull of leaded fuel would permanently impair the efficiency of the catalytic converter.

- High engine speed and full throttle can damage the engine when using petrol with an octane rating lower than the correct grade for the engine.



### For the sake of the environment

Just one full tank of leaded fuel would seriously impair the efficiency of the catalytic converter. ■

## Diesel

### Diesel\*

**Diesel fuel** must correspond to DIN EN 590 (EN = “European standard”). It must have a cetane number (CN) of at least 51. The cetane number indicates the ignition quality of the diesel fuel.

Notes on filling with fuel ⇒ page 206. ■

### RME fuel\*

*Only vehicles fitted with special equipment may drive with biodiesel fuel in accordance with standard DIN EN 14214.*

The biodiesel fuel must comply with the DIN EN 14.214 (FAME) Standard.

- Biodiesel is a methylester obtained from rapeseed oil.
- DIN is a German abbreviation for “**D**eutsches **I**nstitut für **N**ormung e.V.”, the German standards institute.
- EN means **E**uropean **N**orm.
- FAME is the English abbreviation “**F**atty **A**cid **M**ethyl **E**ster”



If the date sticker of the vehicle includes the number PR 2G0 optional equipment) this means that that vehicle has been prepared for biodiesel use.

Your Authorised Service Centre or automobile association will be able to advise on where you can obtain RME biodiesel fuel.

Your Authorised Service Centre can also be consulted to know if the vehicle has been prepared for biodiesel use.

#### Things to note about RME fuel (biodiesel)

- The performance of a vehicle using biodiesel maybe somewhat reduced.
- Fuel consumption of a vehicle using biodiesel may be slightly higher.
- RME fuel can be used in winter at temperatures down to approx. -10°C.
- At outside temperatures below -10°C, we recommend using winter diesel fuel.

**For technical reasons, vehicle fitted with diesel particulate filters cannot use biodiesel under any circumstances.**

Your authorized SEAT dealer will confirm whether your vehicle is prepared to use biodiesel.



#### Caution

- RME fuel can damage the fuel system in vehicles which are not suitably adjusted.
- If you decide to use biodiesel in your vehicle, please use only RME fuel which is DIN E 14,214 compliant.
- If you use biodiesel that does not meet the required standard, the fuel filter could become clogged.
- Your authorized SEAT dealer will be able to tell you if your vehicle is suitable for use with biodiesel, or whether it requires modifications in order to use it.
- Vehicles fitted with a diesel particulate filter should not use biodiesel under any circumstance, or even start the engine, at the risk of damaging the fuel system.



#### Note

- In case of low exterior temperatures and a fuel biodiesel percentage of higher than 50%, an increase in gas emission may occur during operation of the independent heating.
- The fuel filter may become clogged when fuel is changed to biodiesel. For this reason, we recommend that, about every 300 or 400 km, following a fuel change, also change the fuel filter. Also, note the instructions in the inspection and maintenance plan.
- If the vehicle is to remain parked for more than about two weeks, we recommend filling the fuel tank with biodiesel and driving about 50 km in order to avoid damage to the injection system. ■

## Winter driving

*Diesel can thicken in winter.*

#### Winter-grade diesel

When using “summer-grade diesel fuel”, difficulties may be experienced at sub-zero temperatures because the fuel thickens due to wax separation. For this reason, “winter-grade diesel fuel” is available in some countries during the cold months. It can be used at temperatures as low as -22°C.

In countries with different climatic conditions the diesel fuel sold generally has different temperature characteristics. Check with an Authorised Service Centre or filling stations in the country concerned regarding the type of diesel fuels available.

#### Filter pre-heater

Your vehicle is fitted with a fuel filter pre-heater, making it well equipped for operation in winter. This ensures that the fuel system remains operational to approx. -24°C, provided you use winter-grade diesel which is safe to -15°C. ►

However, if the fuel has waxed to such an extent that the engine will not start at temperatures of under -24°C, simply place the vehicle in a warm place for a while.



### Caution

Do not mix fuel additives (“thinners”, or similar additives) with diesel fuel. ■

## Supplementary heating system

The supplementary heating system raises the calorific capacity of the heating while the engine is running and outside temperatures are very low. The supplementary heating system connects and disconnects automatically.

The exhaust fumes produced are eliminated through an exhaust pipe below the vehicle.



### Note

- For short journeys, very low outside temperatures and a percentage of biodiesel fuel of over 50 % too much smoke may be produced.
- Every time the engine is switched off, the fan continues to operate for a short time in order to more quickly cool the heater. When refuelling it is not necessary to wait until the fan stops operating. ■

## Working in the engine compartment

### Safety instructions on working in the engine compartment

*Any work carried out in the engine compartment or on the engine must be carried out cautiously.*

Before starting any work on the engine or in the engine compartment:

1. Switch off the engine and remove the key from the ignition.
2. Apply the handbrake.
3. Move the gear stick to neutral or the selector lever to position **P**.
4. Wait for the engine to cool down.
5. Keep children away from the vehicle.
6. Raise the bonnet ⇒ page 99.

You should not do any work in the engine compartment unless you know exactly how to carry out the jobs and have the correct tools! Have the work carried out by a qualified workshop if you are uncertain.

All service fluids and consumables, e.g. coolant, engine oil, spark plugs and batteries, are being constantly developed. SEAT provides a constant flow of information to the Authorised Service Centres concerning modifications. For this reason we recommend that you have service fluids and consumables replaced by an Authorised Service Centre. Please observe the relevant instructions ⇒ page 202. The engine compartment of any motor vehicle is a hazardous area ⇒ . ▶

 **WARNING**

All work on the engine or in the engine compartment, e.g. checking and refilling fluids, involves the danger of injury and scalding as well as the risk of accident or fire.

- Never open the bonnet if you see steam, smoke or coolant escaping from the engine compartment. Otherwise, there is a risk of sustaining burns. Wait until no more steam or coolant is emitted, then allow the engine to cool before carefully opening the bonnet.
- Switch off the engine and remove the key from the ignition.
- Apply the handbrake and move the gear stick to neutral or selector lever to position P.
- Keep children away from the vehicle.
- Never touch hot engine parts. There is a risk of burns.
- Never spill liquids on a hot engine or on a hot exhaust gas system. This is a fire hazard.
- Avoid causing short-circuits in the electrical system, particularly at the points where the jump leads are attached ⇒ page 250. The battery could explode.
- Never touch the radiator fan. It is temperature controlled and could start automatically, even when the engine has been switched off and the key removed from the ignition!
- Do not unscrew the cap on the expansion tank when the engine is hot. If the coolant is hot, the cooling system will be pressurised!
- Protect face, hands and arms by covering the cap with a large, thick cloth to protect against escaping coolant and steam.
- Always make sure you have not left any objects, such as cleaning cloths and tools, in the engine compartment.
- If you have to work underneath the vehicle, you must use suitable stands additionally to support the vehicle, there is a risk of accident!. A hydraulic jack is insufficient for securing the vehicle and there is a risk of injury.

 **WARNING (continued)**

- If any work has to be performed when the engine is started or with the engine running, there is an additional, potentially fatal, safety risk from the rotating parts, such as the drive belts, alternator, radiator fan, etc., and from the high-voltage ignition system. You should also observe the following points:
  - Never touch the electrical wiring of the ignition system.
  - Ensure that jewellery, loose clothing and long hair do not get trapped in rotating engine parts. Danger of death. Before starting any work remove jewellery, tie back and cover hair, and wear tight-fitting clothes.
  - Always think carefully about pressing the accelerator if a gear is engaged in either an automatic or manual gearbox. The vehicle could move, even if the handbrake is applied. Danger of death.
- If work has to be carried out on the fuel system or on electrical components, you must observe the following safety notes in addition to the above warnings:
  - Always disconnect the battery. The vehicle must be unlocked when this is done, otherwise the alarm will be triggered.
  - Do not smoke.
  - Never work near naked flames.
  - Always have a fire extinguisher on hand.

 **Caution**

When changing or topping up service fluids, make absolutely certain that you fill the fluids into the correct reservoirs. Failure to observe this point will result in serious malfunctions and engine damage! ▶



### For the sake of the environment

Service fluids leaks are harmful to the environment. For this reason you should make regular checks on the ground underneath your vehicle. If you find spots of oil or other fluids, have your vehicle inspected in a qualified workshop. ■

## Opening the bonnet

*The bonnet is released from inside the vehicle.*



**Fig. 137** Detail of footwell area on driver's side: lever for unlocking the bonnet.



**Fig. 138** Detail of radiator grille: lever for unlocking the bonnet.

Before you open the bonnet, make sure that the windscreen wiper arms are in contact with the windscreen. Failure to do so could damage the paintwork.

### Opening the bonnet

- To release the bonnet, pull the lever under the dashboard ⇒ **fig. 137** in the direction indicated (arrow). The bonnet is unlocked by a spring ⇒ .
- Gently lift the bonnet and press the unlock button ⇒ **fig. 138** in the direction of the arrow.
- Open the bonnet to the point where it is held open by the gas struts.



#### WARNING

Hot coolant can scald!

 **WARNING** (continued)

- Never open the bonnet if you see steam, smoke or coolant escaping from the engine compartment.
- Wait until no more steam, smoke or coolant is emitted from the bonnet, then carefully open the bonnet.
- Make sure that the support rod is inserted securely and properly in the holder in the open bonnet.
- When working in the engine compartment, always observe the safety warnings ⇒ page 209. ■

## Closing the bonnet

### Closing the bonnet

1. To close the bonnet, pull it down to overcome the gas strut pressure.
2. Make sure that the bonnet catches onto its clasp. *Do not press down* ⇒ .

If the bonnet does not close properly, open it again and close it properly.

 **WARNING**

If the bonnet is not closed properly, it could open while you are driving and completely obscure your view of the road. Risk of accident.

- After closing the bonnet, always check that it is properly secured. The bonnet must be flush with the surrounding body panels.
- If you notice that the bonnet latch is not secured when the vehicle is moving, stop the vehicle immediately and close the bonnet properly. Risk of accident. ■

## Engine oil

### Engine oil specifications

*The engine oil used must conform with exact specifications.*

#### Specifications

The engine comes with a special, high quality, multi grade oil that can be used in all seasons of the year except for those regions affected by extreme cold.

As the use of good quality oil is necessary for the correct operation and long service life of the engine, when it becomes necessary to replenish or change the oil, always use an oil that complies to the VW standards.

If it is not possible to find oil conforming to the VW standards then oil conforming to the ACEA or API standards with an appropriate viscosity at atmospheric temperature should be used instead. The use of this type of oil may have some repercussions on the performance of the engine for example, long starting time, increased consumption and a higher emission level.

If a top up is required then different oils may be mixed as long as they all conform to the VW standards.

The specifications (VW standards) set out in the following page should appear on the container of the service oil; the container will display together the different standards for petrol and diesel engines, the oil can be used for both types of engines. ■

## Oil properties

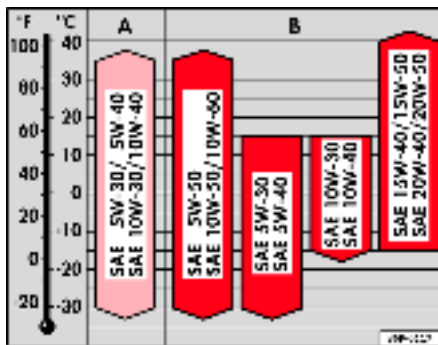

Fig. 139 Types of oil according to temperature

### Viscosity

The viscosity class of the oil is selected according to the diagram.

When the ambient temperature falls outside the limits of the scale for a short period, an oil change is not required.

Engine type	Specification
Petrol	VW 501 01/ VW 502 00/ VW 504 00
Diesel	VW 505 00/ VW 505 01/ VW 507 00/ VW 506 01
Diesel Injector Pump <sup>a)</sup>	VW 505 01/ VW 507 00/ VW 506 01
Diesel Injector Pump Motor 118 kW <sup>a)</sup>	VW 506 01/ VW 507 00
Diesel Engines with Particulate filter (DPF) <sup>a)</sup>	VW 507 00

<sup>a)</sup> Only use recommended oils, otherwise you may damage the engine.

### Mono-grade oil

Single grade oils are generally not suitable for all year round use, due to ranges of viscosity<sup>43)</sup>.

<sup>43)</sup> Viscosity: oil density

These oils are only useful in a climate that is constantly very cold or very warm.

### Engine oil additives

No type of additive should be mixed with the engine oil. The deterioration caused by these additives is not covered by the warranty. ▶

### Note

Before a long trip, we recommend finding an engine oil that conforms to the corresponding VW specifications and keeping it in the vehicle. This way, the correct engine oil will always be available for a top-up if needed. ■

## Checking the engine oil level

*The engine oil dipstick indicates the level of the oil.*

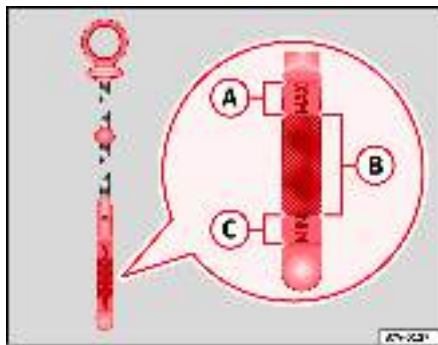

Fig. 140 Dipstick

Before opening the bonnet, read and observe the warnings  
⇒ page 209.

- Park the vehicle on an even surface.
- Stop the engine and wait a few minutes for the oil to drain back into the sump.
- Raise the bonnet ⇒ page 211.

- Pull out the dipstick.
- Wipe the dipstick with a cloth and insert it again, pushing it in as far as it will go.
- Then pull the dipstick out again and check the oil level.
- Replace the dipstick, pushing it in as far as it will go.

If the oil level is in area ⇒ fig. 140 **(A)**, you must not top up with oil.

If the oil level is in area **(B)**, you may top up with oil (approx. 0,5 l).

If the oil level is in area **(C)**, you must top up with oil (approx. 1,0 l).

It is normal for the engine to consume a certain amount of oil. Consumption can be up to 1.0 litres per 1,000 km. For this reason the engine oil level must be checked at regular intervals, preferably when filling the tank and before a journey.

When the engine is working hard, for instance during sustained high-speed motorway cruising in summer, when towing a trailer or climbing on mountain passes, the oil level should preferably be kept within area **(A)** (but not above).

### WARNING

**Special care must be taken when working on the engine or on components in the engine compartment.**

- **When working in the engine compartment, always observe the safety warnings ⇒ page 209.**

### Caution

If the oil level is above the area **(A)** do not start the engine. This could result in damage to the engine and catalytic converter. Contact SEAT Service Centre®. ■





## Topping up engine oil

Top up gradually with small quantities of oil.



Fig. 141 In the engine compartment: Engine oil filler cap

Before opening the bonnet, read and observe the warnings ⇒  in “Safety instructions on working in the engine compartment” on page 209.

- Unscrew cap from oil filler opening ⇒ fig. 141.
- Top-up oil in small amounts, using the correct oil.
- To avoid over-filling with engine oil, you should top-up using small quantities, wait a while and check the oil level before adding any more oil.
- As soon as the oil level is in area , carefully close the cap.

The position of the oil filler opening is shown in the corresponding engine compartment diagram ⇒ page 262.

Engine oil specification ⇒ page 212.

### WARNING

Oil is highly inflammable! Ensure that no oil comes into contact with hot engine components when topping up.

### Caution

If the oil level is above the area  do not start the engine. This could result in damage to the engine and catalytic converter. Contact a qualified workshop.

### For the sake of the environment

The oil level must never be above area . Otherwise oil can be drawn in through the crankcase breather and escape into the atmosphere via the exhaust system. ■

## Changing engine oil

*The engine oil must be changed at the intervals given in the service schedule.*

We recommend that you have the engine oil changed by an Authorised Service Centre.

The two different oil change intervals are shown in the Inspection and Maintenance Plan.

### WARNING

Only change the oil yourself if you have the specialist knowledge required! ▶

 **WARNING** (continued)

- Before opening the bonnet, read and observe the warnings ⇒ page 209, “Safety instructions on working in the engine compartment”.
- Wait for the engine to cool down. Hot oil may cause burn injuries.
- Wear eye protection to avoid injuries caused by splashes of oil.
- When removing the oil drain plug with your fingers, keep your arm horizontal to help prevent oil from running down your arm.
- Wash your skin thoroughly if it comes into contact with engine oil.
- Engine oil is poisonous! Used oil must be stored in a safe place out of the reach of children until it is disposed of.

 **Caution**

No additives should be used with engine oil. This could result in engine damage. Any damage caused by the use of such additives would not be covered by the factory warranty.

 **For the sake of the environment**

- Because of the disposal problems, the necessary special tools and specialist knowledge required, we recommend that you have the engine oil and filter changed by an Authorised Service Centre.
- Never pour oil down drains or into the ground.
- Use a suitable container when draining the used oil. It has to be large enough to hold all the engine oil ■

## Coolant

### Coolant specifications

*Coolant is a mixture of water and at least 40% coolant additive.*

The cooling system must be filled with a mixture of water and at least 40 % of our coolant additive G 12+ or an additive with the specification TT-VW 774 F (it is dyed purple). This mixture gives the necessary frost protection down to -25°C and protects the alloy parts of the cooling system against corrosion. It also prevents scaling and raises the boiling point of the coolant.

The concentration of coolant must *always* be at least 40% - even if frost protection is not required.

If greater frost protection is required in very cold climates, the proportion of the antifreeze additive G 12+ can be increased. However, the percentage of coolant additives should not exceed 60%, as this would reduce the frost protection. It would also reduce the cooling effect. A mixture with 60% coolant additive will give frost protection to approx. -40°C.

 **WARNING**

- **The coolant additive is toxic. There is a toxic risk. Always keep the coolant additive in the original container which should be stored out of the reach of children. The same applies to coolant which you have drained off.**
- **The coolant additive G 12+ must be added in sufficient quantities to provide anti-freeze protection at the coldest ambient temperatures that can be expected. At extremely cold ambient temperatures, the coolant could freeze, causing the vehicle to breakdown. As the heater would also not work in this situation, there is a risk of suffering exposure!**

### ⚠ Caution

- Other additives may give considerably inferior corrosion protection. The resulting corrosion in the cooling system can lead to a loss of coolant, causing serious damage to the engine.
- The coolant additive G 12+ (purple) can be mixed with the additive G 12 (red) or G 11. Never mix G12 (red colour) with G 11. ■

### Checking the coolant level and topping up

*The correct coolant level is important for fault-free functioning of the engine cooling system.*



**Fig. 142** In the engine compartment: Coolant expansion tank cap

Before opening the bonnet, read and observe the warnings ⇒  in “Safety instructions on working in the engine compartment” on page 209.

### Opening the coolant expansion tank

- Switch off the engine and allow it to cool.
- To prevent scalding, cover the cap on the expansion tank with a thick cloth and carefully unscrew the cap ⇒ .

### Checking coolant level

- Look into the open coolant expansion tank and read off the coolant level.
- If the level is underneath the “MIN” mark, top up with coolant.

### Topping up coolant

- Only use **new** coolant.
- Do not fill above the “MAX” mark.

### Closing the coolant expansion tank

- Screw the cap on again *tightly*.

The position of the coolant expansion reservoir is shown in the corresponding engine compartment diagram ⇒ page 262.

Make sure that the coolant meets the required specifications ⇒ page 216. Do not use a different type of additive if coolant additive G 12+, is not available. In this case use only water and bring the coolant concentration back up to the correct level as soon as possible by putting in the specified additive ⇒ page 216.

Always top up with *new* coolant.

Do not fill above the “MAX” mark. Otherwise the excess coolant will be forced out of the cooling system when the engine is hot. 

The coolant additive G 12+ (dye purple) may be mixed with G 12 (dye red) and also with G 11.

### WARNING

Any work carried out in the engine compartment or on the engine must be carried out cautiously.

- When working in the engine compartment, always observe the safety warnings ⇒ page 209.
- When the engine is warm or hot, the cooling system is pressurised! Do not unscrew the cap on the expansion tank when the engine is hot. This is a burn injury risk.

### Caution

- When mixed with other additives the colour of G 12 will change to brown. If this occurs you should have the coolant changed immediately. Failure to do so will result in engine damage!
- If a lot of coolant has been lost, wait for the engine to *cool down* before putting in cold coolant. This avoids damaging the engine. Large coolant losses are an indication of leaks in the cooling system. See a specialised workshop immediately and have the cooling system checked. Otherwise, there is a risk of engine damage. ■

## Washer fluid and windscreen wiper blades

### Topping up washer fluid

*The water for cleaning the windscreen should always be mixed with washer fluid.*



**Fig. 143** In the engine compartment: Cap of windscreen washer fluid reservoir.

The **windscreen washer** and the **headlight washing system** are supplied with fluid from the windscreen washer fluid container in the engine compartment.

The reservoir is located on the right-hand side of the engine compartment.

Plain water is not enough to clean the windscreen and headlights. We recommend that you always add a product to the windscreen washer fluid.

Approved windscreen cleaning products exist on the market with high detergent and anti-freeze properties, these may be added all-year-round. Please follow the dilution instructions on the packaging. ▶

### WARNING

Any work carried out in the engine compartment or on the engine must be carried out cautiously.

- When working in the engine compartment, always observe the safety warnings ⇒ page 209.

### Caution

- Never put radiator anti-freeze or other additives into the windscreen washer fluid.
- Always use approved windscreen cleansing products diluted as per instructions. If you use other washer fluids or soap solutions, the tiny holes in the fan-shaped nozzles could become blocked. ■

## Changing the front windscreen wiper blades

*Damaged wiper blades should be replaced immediately.*

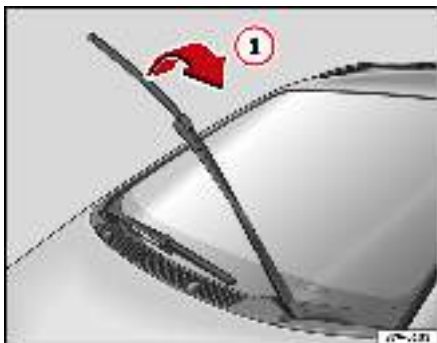

Fig. 144 Windscreen wipers raised

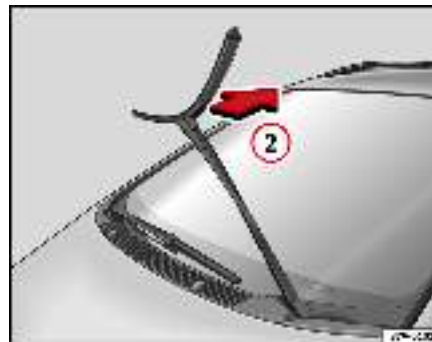

Fig. 145 Removing front wipers

Check the condition of the wiper blades regularly. Change them as required.

### Change the windscreen wiper blades

- Lift the wiper arm away from the glass. Do not pull the arm by the blade.
- Turn the wiper blade as shown by arrow ⇒ fig. 144 ① as far as it will go and then pull it off as shown by arrow ⇒ fig. 145 ②.
- Push a new wiper blade **of the same length and version** onto the wiper arm and turn the wiper blade to the stop against the direction shown by arrow ①.
- Place the wiper arm in the starting position.

These are available from SEAT Service®.

**If the wipers scrape** they must be changed if they are damaged, or cleaned if they are dirty. ▶

If this does not produce the desired results, the setting angle of the windscreen wiper arms might be incorrect. They should be checked by a qualified workshop and corrected if necessary.

### **WARNING**

**Do not drive unless you have good visibility through all windows!**

- Clean the windscreen wiper blades and all windows regularly.
- The wiper blades should be changed once or twice a year.

### **Caution**

- Damaged or dirty windscreen wipers could scratch the windscreen.
- Never use fuel, nail varnish remover, paint thinner or similar products to clean the windows. This could damage the windscreen wiper blades.
- Never move the windscreen wiper or windscreen wiper arm manually - this could cause damage!

### **Note**

- On fitting the wiper blades, do not exchange the driver and passenger side blades. ■

## Changing the rear wiper blade

*A damaged wiper blade should be replaced immediately.*

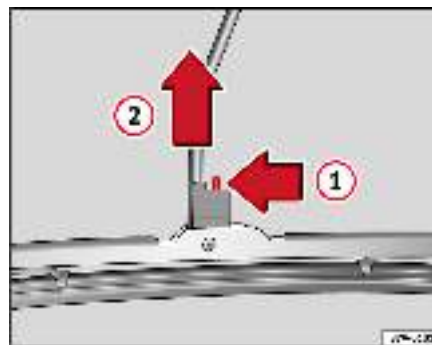

**Fig. 146** Changing a rear wiper blade

Check the condition of the wiper blade regularly. Change as required.

### Changing the rear wiper blade

- Lift the wiper arm away from the rear window.
- Release the wiper blade as shown by arrow ⇒ **fig. 146** **1** and, at the same time, pull the wiper blade as shown by arrow **2**.
- Unhook the wiper blade from the wiper arm.
- Now take off the wiper blade from the wiper arm in the opposite direction to arrow **2**. ▶

- Insert a new wiper blade **of the same length and design** in the direction of arrow ② and hook the blade back onto the wiper arm.
- Now pull the wiper blade against the direction of arrow ② until it engages.
- Push the wiper arm back against the glass.

These are available from SEAT Service®.

**If the wiper scrapes**, it should be replaced if damaged, or cleaned if soiled.

If this does not produce the desired results, the setting angle of the windscreen wiper arms might be incorrect. They should be checked by a qualified workshop and corrected if necessary.

### WARNING

**Do not drive unless you have good visibility through all windows!**

- Clean the windscreen wiper blades and all windows regularly.
- The wiper blades should be changed once or twice a year.

### Caution

- Damaged or dirty windscreen wipers could scratch the windscreen.
- Never use fuel, nail varnish remover, paint thinner or similar products to clean the windows. This could damage the windscreen wiper blades.
- Never move the windscreen wiper or windscreen wiper arm manually - this could cause damage!

### Note

- The wiper arms can be moved to the service position only when the bonnet is properly closed. ■

## Brake fluid

### Checking the brake fluid level

*The brake fluid is checked at the intervals given in the service schedule.*

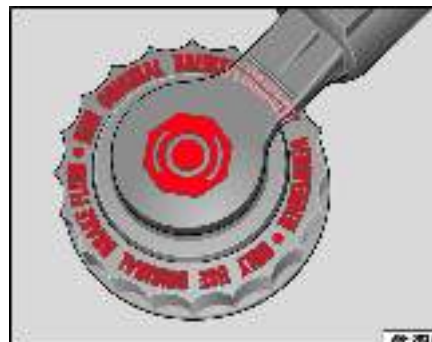

**Fig. 147** In the engine compartment: Brake fluid reservoir cover

- Read off the fluid level at the transparent brake fluid reservoir. It should always be between the “MIN” and “MAX” marks.

The position of the brake fluid reservoir is shown in the corresponding engine compartment diagram ⇒ page 262. The brake fluid reservoir has a black and yellow cap.

The brake fluid level drops slightly when the vehicle is being used as the brake pads are automatically adjusted as they wear. ▶

However, if the level goes down noticeably in a short time, or drops below the “MIN” mark, there may be a leak in the brake system. A display on the instrument panel will warn you if the brake fluid level is too low ⇒ page 72.

### WARNING

Before opening the bonnet to check the brake fluid level, read and observe the warnings ⇒ page 209. ■

## Changing the brake fluid

*The Maintenance Program indicates the brake fluid change intervals.*

We recommend that you have the brake fluid changed by an Authorised Service Centre.

Before opening the bonnet, please read and follow the warnings ⇒  in “Safety instructions on working in the engine compartment” on page 209 in “Working in the engine compartment”.

Brake fluid absorbs moisture. In the course of time, it will absorb water from the ambient air. If the water content in the brake fluid is too high, the brake system could corrode. This also considerably reduces the boiling point of the brake fluid. Heavy use of the brakes may then cause a vapour lock which could impair the braking effect.

It is important that you use only brake fluid compliant with the US standard FMVSS 116 DOT 4. We recommend the use of Genuine SEAT brake fluid.

### WARNING

Brake fluid is poisonous. Old brake fluid impairs the braking effect.

### WARNING (continued)

- Before opening the bonnet to check the brake fluid level, read and observe the warnings ⇒ page 209.
- Brake fluid should be stored in the closed original container in a safe place out of reach of children. There is a toxic risk.
- Complete the brake fluid change according to the Maintenance Program. Heavy use of the brakes may cause a vapour lock if the brake fluid is left in the system for too long. This would seriously affect the efficiency of the brakes and the safety of the vehicle. This may cause an accident.

### Caution

Brake fluid could damage the paintwork. Wipe off any brake fluid from the paintwork immediately.





### For the sake of the environment

Brake fluid must be drained and disposed of in the proper manner observing environmental regulations. ■



## Battery

### Warnings on handling the battery

	Wear eye protection
	Battery acid is very corrosive and caustic. Wear protective gloves and eye protection!
	Fires, sparks, naked lights and smoking are prohibited!
	A highly explosive mixture of gases is released when the battery is under charge.
	Keep children away from acid and batteries!

#### WARNING

Always be aware of the danger of injury and chemical burns as well as the risk of accident or fire when working on the battery and the electrical system:

- Wear eye protection. Protect your eyes, skin and clothing from acid and particles containing lead.
- Battery acid is very corrosive and caustic. Wear protective gloves and eye protection. Do not tilt the batteries. This could spill acid through the vents. Rinse battery acid from eyes immediately for several minutes with clear water. Then seek medical care immediately. Neutralize any acid splashes on the skin or clothing with a soapy solution, and rinse off with plenty of water. If acid is swallowed by mistake, consult a doctor immediately.
- Fires, sparks, naked lights and smoking are prohibited. When handling cables and electrical equipment, avoid causing sparks and electrostatic

#### WARNING (continued)

charge. Never short the battery terminals. High-energy sparks can cause injury.

- A highly explosive mixture of gases is released when the battery is under charge. The batteries should be charged in a well-ventilated room only.
- Keep children away from acid and batteries.
- Before working on the electrical system, you must switch off the engine, the ignition and all consumers. The negative cable on the battery must be disconnected. When a light bulb is changed, you need only switch off the light.
- Deactivate the anti-theft alarm by unlocking the vehicle before you disconnect the battery! The alarm will otherwise be triggered.
- When disconnecting the battery from the vehicle electrical system, disconnect first the negative cable and then the positive cable.
- Switch off all electrical consumers before reconnecting the battery. Reconnect first the positive cable and then the negative cable. Never reverse the polarity of the connections. This could cause an electrical fire.
- Never charge a frozen battery, or one which has thawed. This could result in explosions and chemical burns. Always replace a battery which has frozen. A flat battery can freeze at temperatures around 0°C.
- Ensure that the vent hose is always connected to the battery.
- Never use a defective battery. This may be fatally explosive. Replace a damaged battery immediately.



#### Caution

- Never disconnect the battery if the ignition is switched on or if the engine is running. This could damage the electrical system or electronic components.
- Do not expose the battery to direct sunlight over a long period of time, as the intense ultraviolet radiation can damage the battery housing. ▶

- If the vehicle is left standing in cold conditions for a long period, protect the battery from frost. If it “freezes” it will be damaged. ■

### Checking the electrolyte level

*The electrolyte level should be checked regularly in high-mileage vehicles, in hot countries and in older batteries.*

- Open the bonnet and open the battery cover at the front ⇒  in “Safety instructions on working in the engine compartment” on page 209 ⇒  in “Warnings on handling the battery” on page 223.
- Check the colour display in the “magic eye” on the top of the battery.
- If there are air bubbles in the window, tap the window gently until they disperse.

The position of the battery is shown in the corresponding engine compartment diagram ⇒ page 262.

The round window (“magic eye”) on the top of the battery changes colour, depending on the charge level and electrolyte level of the battery.

If the colour in the window is **colourless or bright yellow**, the electrolyte level of the battery is too low. Have the battery checked by a qualified workshop.

The colours green and black are used by the workshops for diagnostic purposes. ■

### Charging and changing the vehicle battery

*The battery is maintenance-free and is checked during the inspection service. All work on the vehicle battery requires specialist knowledge.*

If you often drive short distances or if the vehicle is not driven for long periods, the battery should be checked by a qualified workshop between the scheduled services.

If the battery has discharged and you have problems starting the vehicle, the battery might be damaged. If this happens, we recommend you have the vehicle battery checked by an Authorised Service Centre where it will be re-charged or replaced.

#### Charging the battery

The vehicle battery should be charged by a qualified workshop only, as batteries using special technology have been installed and they must be charged in a controlled environment.

#### Replacing a vehicle battery

The battery has been developed to suit the conditions of its location and has special safety features.

Genuine SEAT batteries fulfil the maintenance, performance and safety specifications of your vehicle.

#### WARNING

- **We recommend you use only maintenance-free or cycle free leak-proof batteries which comply with the standards T 825 06 and VW 7 50 73. This standard applies as of 2001.**
- **Before starting any work on the batteries, you must read and observe the warnings ⇒  in “Warnings on handling the battery” on page 223.**



### For the sake of the environment

Batteries contain toxic substances such as sulphuric acid and lead. They must be disposed of appropriately and must not be disposed of with ordinary household waste. ■

## Wheels

### General notes

#### Avoiding damage

- If you have to drive over a kerb or similar obstacle, drive very slowly and as near as possible at a right angle to the kerb.
- Keep grease, oil and fuel off the tyres.
- Inspect the tyres regularly for damage (cuts, cracks or blisters, etc.). Remove any foreign objects embedded in the treads.

#### Storing tyres

- Mark tyres when you remove them to indicate the direction of rotation. This ensures you will be able to install them correctly when you replace them.
- When removed, the wheels and/or tyres should be stored in a cool, dry and preferably dark location.
- Store tyres in a vertical position if they are not fitted on wheel rims.

#### New tyres

New tyres have to be run in ⇒ page 185.

The tread depth of new tyres may vary, according to the type and make of tyre and the tread pattern.

#### Concealed damage

Damage to tyres and rims is often not readily visible. If you notice unusual vibrations or the car pulling to one side, this may indicate that one of the tyres is damaged. The tyres should be checked immediately by an Authorised Service Centre.

#### Tyres with directional tread pattern

An arrow on the tyre sidewall indicates the direction of rotation on tyres with directional tread. Always observe the direction of rotation indicated when fitting the wheel. This guarantees optimum grip and helps to avoid aquaplaning, excessive noise and wear.



#### WARNING

- **New tyres do not have maximum grip in the first 500 km. Drive particularly carefully to avoid risk of accident.**
- **Never drive with damaged tyres. This may cause an accident.**
- **If you notice unusual vibration or if the vehicle pulls to one side when driving, stop the vehicle immediately and check the tyres for damage. ■**

## Checking tyre pressure

The correct tyre pressure can be seen on the sticker on the inside of the tank flap.

1. Read the required tyre inflation pressure from the sticker. The values refer to Summer tyres. For Winter tyres, you must add 0.2 bar to the values given on the sticker.
2. The tyre pressures should only be checked when the tyres are cold. The slightly raised pressures of warm tyres must not be reduced.
3. Adjust the tyre pressure to the load you are carrying.

### Tyre pressure

The correct tyre pressure is especially important at high speeds. The pressure should therefore be checked at least once a month and before starting a journey.

#### WARNING

A tyre can easily burst if the pressure is too low, causing an accident!

- At continuously high speeds, a tyre with insufficient pressure flexes more. In this way it becomes too hot, and this can cause tread separation and tyre blow-out. Always observe the recommended tyre pressures.
- If the tyre pressure is too low or too high, the tyres will wear prematurely and the vehicle will not handle well. Risk of accident!



#### For the sake of the environment

Under-inflated tyres will increase fuel consumption. ■

## Tyre service life

The service life of tyres is dependent on tyre pressure, driving style and fitting.



Fig. 148 Tyre tread wear indicators

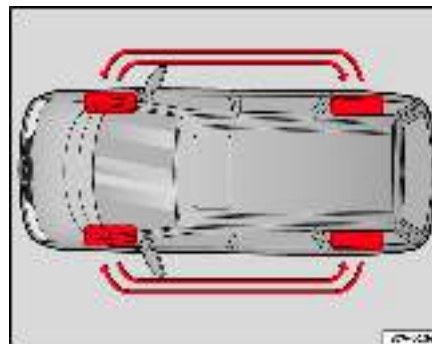



Fig. 149 Changing wheels

### Wear indicators

The original tyres on your vehicle have 1.6 mm high “tread wear indicators” ⇒ page 226, fig. 148, running across the tread. Depending on the make, there will be six to eight of them evenly spaced around the tyre. Markings on the tyre sidewall (for instance the letters “TWI” or other symbols) indicate the positions of the tread wear indicators. The minimum tread depth required by law is 1.6 mm (measured in the tread grooves next to the tread wear indicators). Worn tyres must be replaced. Different figures may apply in export countries ⇒ .

### Tyre pressure

Incorrect tyre pressure causes premature wear and could cause tyre blow-out. For this reason, the tyre pressure should be checked at least once per month ⇒ page 226.

### Driving style

Fast cornering, heavy acceleration and hard braking all increase tyre wear.

### Changing wheels around

If the front tyres are worn considerably more than the rear ones it is advisable to change them around as shown ⇒ page 226, fig. 149. All the tyres will then last for about the same time.

### Wheel balance

The wheels on new vehicles are balanced. However, various factors encountered in normal driving can cause them to become unbalanced, which results in steering vibration.

Unbalanced wheels should be rebalanced, as they otherwise cause excessive wear on steering, suspension and tyres. A wheel must also be rebalanced when a new tyre is fitted.

### Incorrect wheel alignment

Incorrect wheel alignment causes excessive tyre wear, impairing the safety of the vehicle. If tyres show excessive wear, you should have the wheel alignment checked by an Authorised Service Centre.

### WARNING

**There is a serious danger of accidents if a tyre bursts during driving!**

- **The tyres must be replaced at the latest when the tread is worn down to the tread wear indicators. Failure to do so could result in an accident. Worn tyres do not grip well at high speeds on wet roads. There is also a greater risk of “aquaplaning”.**
- **At continuously high speeds, a tyre with insufficient pressure flexes more. This causes it to overheat. This can cause tread separation and tyre blow-out. Risk of accident. Always observe the recommended tyre pressures.**
- **If tyres show excessive wear, you should have the running gear checked by an Authorised Service Centre.**
- **Keep chemicals such as oil, fuel and brake fluid away from tyres.**
- **Damaged wheels and tyres must be replaced immediately!**



### For the sake of the environment

Under-inflated tyres will increase fuel consumption. ■

## New tyres and wheels

*New tyres and wheels have to be run-in.*

The tyres and wheel rims are an essential part of the vehicle's design. The tyres and rims approved by SEAT are specially matched to the characteristics of the vehicle and make a major contribution to good road holding and safe handling ⇒ .

Tyres should be replaced at least in pairs and not individually (i.e. both front tyres or both rear tyres together). A knowledge of tyre designations makes it ▶

easier to choose the correct tyres. Radial tyres have the tyre designations marked on the sidewall, for example:

### 195/65 R15 91T

This contains the following information:

195 Tyre width in mm  
 65 Height/width ratio in %  
 R Tyre construction: Radial  
 15 Rim diameter in inches  
 91 Load rating code  
 T Speed rating

The tyres could also have the following information:

- A direction of rotation symbol
- “Reinforced” denotes heavy-duty tyres.

The manufacturing date is also indicated on the tyre sidewall (possibly only on the inner side of the wheel).

“DOT... 1105...” means, for example, that the tyre was produced in the 11th week of 2005.

We recommend that work on tyres and wheels is carried out by an Authorised Service Centre. They are familiar with the procedure and have the necessary special tools and spare parts as well as the proper facilities for disposing of the old tyres.

Any Authorised Service Centre has full information on the technical requirements when installing or changing tyres, wheels or wheel trims.

#### WARNING

- **We recommend that you use only wheels and tyres which have been approved by SEAT for your model. Failure to do so could impair vehicle handling. Risk of accident.**

#### WARNING (continued)

- **Avoid running the vehicle on tyres that are more than six years old. If you have no alternative, you should drive slowly and with extra care at all times.**
- **Never use old tyres or those with an unknown “history of use”.**
- **If wheel trims are retrofitted, you must ensure that the flow of air to the brakes is not restricted. This could cause them to overheat.**
- **All four wheels must be fitted with radial tyres of the same type, size (rolling circumference) and the same tread pattern.**



#### For the sake of the environment

Old tyres must be disposed of according to the laws in the country concerned.



#### Note

- For technical reasons, it is not generally possible to use the wheels from other vehicles. This can also apply to wheels of the same model. The use of wheels or tyres which have not been approved by SEAT for use with your model may invalidate the vehicle's type approval for use on public roads.
- If the spare tyre is not the same as the tyres that are mounted on the vehicle - for example with winter tyres - you should only use the spare tyre for a short period of time and drive with extra care. Refit the normal road wheel as soon as possible. ■

## Wheel bolts

*Wheel bolts must be tightened to the correct torque.*

The design of wheel bolts is matched to the rims. If different wheel rims are fitted, the correct wheel bolts with the right length and correctly shaped bolt ►

heads must be used. This ensures that wheels are fitted securely and that the brake system functions correctly.

In certain circumstances, you may not use wheel bolts from a different car - even if it is the same model ⇒ page 202.



### WARNING

**If the wheel bolts are not tightened correctly, the wheel could become loose while driving. Risk of accident.**

- **The wheel bolts must be clean and turn easily. Never apply grease or oil to them.**
- **Use only wheel bolts which belong to the wheel.**
- **If the prescribed torque of the wheel bolts is too low, they could loosen whilst the vehicle is in motion. Risk of accident! If the tightening torque is too high, the wheel bolts and threads could be damaged.**



### Caution

The prescribed torque for wheel bolts for steel and alloy wheels is 120 Nm. ■

## Winter tyres

*Winter tyres will improve the vehicles handling on snow and ice.*

In winter conditions winter tyres will considerably improve the vehicles handling. The design of summer tyres (width, rubber compound, tread pattern) gives less grip on ice and snow.

Winter tyres must be inflated to a **pressure** 0.2 bar higher than the pressures specified for summer tyres (see sticker on tank flap).

Winter tyres must be fitted on all four wheels.

Information on permitted **winter tyre sizes** can be found in the vehicle's registration documents. Use only radial winter tyres. All tyre sizes listed in the vehicle documentation also apply to winter tyres.

Winter tyres lose their effectiveness when the tread is worn down to a depth of 4 mm.

The speed rating code ⇒ page 227, "New tyres and wheels" determines the following **speed limits**: ⇒

Q	max. 160 km/h
S	max. 180 km/h
T	max. 190 km/h
H	max. 210 km/h

In some countries, vehicles which can exceed the speed rating of the fitted tyre must have an appropriate sticker in the driver's field of view. These stickers are available from your Authorised Service Centre. The legal requirements of each country must be followed.

Do not have winter tyres fitted for unnecessarily long periods. Vehicles with summer tyres handle better when the roads are free of snow and ice.

If you have a flat tyre, please refer to the notes on the spare wheel ⇒ page 227, "New tyres and wheels".



### WARNING

**The maximum speed for the winter tyres must not be exceeded. Otherwise, this could lead to tyre damage and thus, an accident risk.**



### For the sake of the environment

Fit your summer tyres in good time. They are quieter, do not wear so quickly and reduce fuel consumption. ■

## Snow chains

---

Snow chains may be fitted only to the front wheels, and only to certain tyre sizes ⇒ page 260.

Snow chains must have fine-pitch links which do not protrude more than 15 mm, including tension device.

Remove wheel hub covers and trim rings before fitting snow chains. For safety reasons cover caps, available in any Authorised Service Centre, must then be fitted over the wheel bolts.



### WARNING

Observe the fitting instructions provided by the snow chain manufacturer.



### Caution

You must remove the snow chains to drive on roads which are free of snow. Otherwise they will impair handling, damage the tyres and wear out very quickly.



### Note

In some countries, the speed limit for using snow chains is 50 km/h. The legal requirements of the country should be followed. ■



## If and when

### Vehicle tools\*, spare wheel\*, breakdown set\* and towing bracket

#### Location

The vehicle tools, the spare wheel and the removable ball coupling of the towing bracket are stored in the luggage compartment.

#### Vehicle tool kit and removable ball coupling

The vehicle tool kit and removable towing bracket ball coupling are stored on the right of the luggage compartment, behind a cover.

#### Spare wheel

The spare wheel is stored underneath the vehicle ⇒ page 232.

#### ⚠ Caution

Make sure that the spare wheel / removed wheel and the tools are stored safely in the luggage compartment. ■

#### Vehicle tools\*

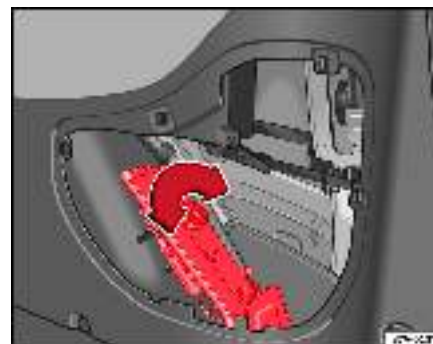

Fig. 150 Storage of vehicle tools

The vehicle tools are stored in the luggage compartment, behind the side cover on the right and are secured using a thumb screw ⇒ fig. 150 ①. The tool kit comprises the following items:

- ① Tool box<sup>44)</sup>
- ② Screwdriver with hexagon socket in the handle for slackened wheel bolts. The screwdriver blade is reversible. The screwdriver is in the wheel bolt.
- ③ Towing eye, removable
- ④ Open jaw spanner 10 x 13 mm
- ⑤ Wire hook<sup>44)</sup> for pulling off the centre cover and the wheel bolt caps ▶

<sup>44)</sup> Optional equipment

- ⑥ Box spanner for wheel bolts
- ⑦ Jack. Before you return the jack to the tool box, you must fully wind in the claw. The crank must then be folded tight against the side of the jack.

The removable towing bracket<sup>44)</sup>, the key for unlocking the sunroof in an emergency<sup>44)</sup> and the anti-theft wheel bolt adaptor<sup>44)</sup> are stored next to the vehicle tools.

#### Adapter for anti-theft wheel bolts

We recommend you carry the wheel bolt adaptor<sup>44)</sup> in the vehicle tool kit at all times.

The **code number** of the anti-theft wheel bolt is stamped on the front of the adapter. You will need this number to replace the adapter if lost. Make a note the code number of the anti-theft wheel bolt and keep it in a safe place - but not in your vehicle.

#### WARNING

- **Do not use the hexagonal socket in the screwdriver handle to tighten the wheel bolts. It is not suitable for tightening the bolts to the necessary torque. This may cause an accident.**
- **The jack supplied by the factory is only designed for changing wheels on this model. Never attempt to use it for lifting heavier vehicles or other loads. Risk of injury.**
- **Use the jack only on firm, level ground.**
- **Never start the engine when you have raised the vehicle on the jack. Risk of accident.**
- **Never place your body (e.g. arm or leg) underneath the vehicle if it is only supported by the jack. Risk of injury.**
- **If you have to work underneath the vehicle, you must use suitable stands additionally to support the vehicle - Risk of accident! ■**

### Taking out the spare wheel

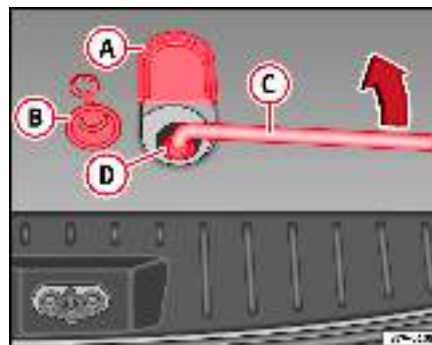



Fig. 151 Taking out the spare wheel

1. Lift the cover (A) ⇒ fig. 151 located on the floor of the luggage compartment, next to the tailgate lock.
2. Pull the ring of the rubber seal (B) upwards.
3. Remove the box spanner (C) from the vehicle tools.
4. Fit the box spanner on the bolt, to the maximum, and hold in this position. At the same time press the safety ring (D) downwards ⇒ .
5. Turn the box spanner (C) several times to the left, until the spare wheel can be fitted, hanging from a wire, vertically behind the vehicle.
6. Separate the plastic pieces so that they may be inserted into the central aperture of the rim and so free the wheel. ▶

**! WARNING**

- If you are driving without the spare wheel, the cable should be rolled up and the bracket fastened to the floor of the luggage compartment. ■

### Fitting the defective wheel in the spare wheel casing



Fig. 152 Resting point for the spare wheel on the bumper

1. Place the wheel behind the vehicle.
2. Insert the support on the inside of the defective wheel, through a central opening.
3. Insert the defective wheel below the vehicle, with the outer side facing downwards.

4. Remove the box spanner ⇒ page 232, fig. 151 (C) and turn the bolt on the floor of the luggage compartment several times to the right, until the defective wheel is firmly secured against the inside of the luggage compartment floor ⇒ ! in “Taking out the spare wheel” on page 232.
5. Close the opening with the rubber seal ⇒ page 232, fig. 151 (B) and lower the cover (A).

**! WARNING**

Tighten the bolt of the luggage compartment to a maximum torque of 25 Nm. ■

## Breakdown set\*

### Components

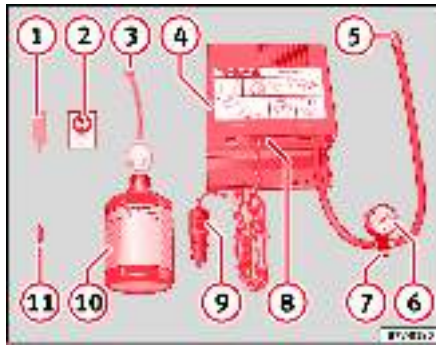

Fig. 153 Contents of anti-puncture kit

### Components

The anti-puncture kit contains the following components:

- ① Tyre valve remover
- ② Sticker indicating maximum speed “max. 80 km/h” or “max. 50 mph”
- ③ Filler tube with cap
- ④ Compressor
- ⑤ Tube for inflating tyres
- ⑥ Pressure gauge
- ⑦ Air bleed screw
- ⑧ ON/OFF switch
- ⑨ 12 volt connector
- ⑩ Bottle of sealant ⇒ ⚠
- ⑪ Spare tyre valve

### ⚠ Caution

- Note the expiry date on the bottle of tyre sealant Do not use sealant paste that has expired. A bottle of tyre sealant can be obtained at any SEAT dealer.
- Dispose of used or expired sealant observing any legal requirements.
- Likewise, note any instructions from the anti-puncture kit's manufacturer (if included).

### i Note

- In vehicles fitted with a towing bracket, it is first necessary to remove the tools in order to reach the anti-puncture kit. ■

### Preparation of anti-puncture kit

*Small punctures (up to 4 mm in diameter), particularly ones in the tread, can be sealed using the anti-puncture set.*

If you have a puncture, stop the car well away from moving traffic. Switch on the hazard warning lights and set the emergency triangle in position. Please observe legal requirements when doing so.

- Take the compressor and the bottle of sealant from the luggage compartment.
- Remove the anti/puncture sticker ⇒ fig. 153 ② and apply it to the instrument panel where it can be seen clearly.
- Leave the foreign body (e. g. screw, nail) in the tyre.
- Take the cap off the tyre valve.



- Use the enclosed extractor ⇒ page 234, fig. 153 ① to unscrew the valve insert. Place the valve insert on a clean surface.
- Vigorously shake the sealant bottle ⇒ page 234, fig. 153 ⑩ for several seconds. ■

## Sealing and inflating tyres

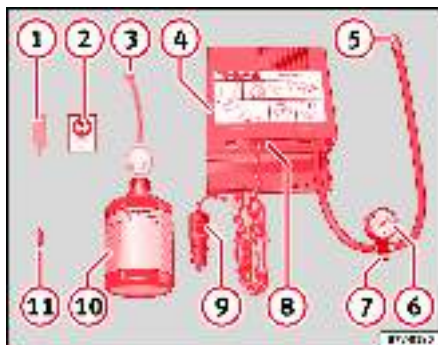

Fig. 154 Contents of anti-puncture kit

### Inflating the tyre

- Thread the inflating tube ⇒ fig. 154 ⑤ on the valve.
- Check that the air bleed screw ⑦ is screwed tight.
- Start the engine and leave it running in neutral.
- Attach the connector ⑨ to a 12 volt socket of the vehicle.
- Connect the compressor using the ON/OFF switch ⑧ for at least six minutes.
- Run the compressor until a tyre pressure of between 2,0 and 2,5 bar has been reached. This should take a maximum of 6 minutes.
- Detach the compressor when the pressure reaches 2,0 and 2,5 bars.
- If the desired pressure is not reached, unscrew the valve inflator tube and store the compressor back in the vehicle.
- Move the vehicle some 10 metres forwards or backwards so that the sealant is evenly distributed in the tyre interior.
- Take the compressor out again, screw the inflator tube well into the valve and inflate the tyre again.
- If the required pressure can still not be reached, the tyre is too badly damaged. The tyre cannot be sealed with the anti-puncture kit. Do not attempt to travel in the vehicle and contact the nearest qualified dealership.
- Disconnect the compressor and unscrew the compressor tyre filler hose from the tyre valve.
- Drive the vehicle at a maximum speed of 80 km/h (50 mph) once a tyre pressure of 2.0 - 2.5 bar has been reached.
- Check the tyre pressure after you have been driving for **10 minutes**.

 **WARNING**

- Do not allow the sealant to get onto your skin or into your eyes. Risk of injury.
- Keep children away from the sealant. ■

## Changing a wheel

### Preparation

*You must park the vehicle correctly before changing a tyre.*

- If you have a flat tyre or puncture, park the car as far away from the flow of traffic as possible on a flat surface.
- Switch off the engine. Switch on the hazard warning lights.
- Apply the handbrake firmly and engage a gear or put the selector in the **P** position.
- Chock the wheel opposite the wheel being changed with a stone or similar object.
- If you are towing a trailer, unhitch it from your vehicle.
- Remove the spare wheel and the vehicle tools from the luggage compartment.
- All passengers should leave the car. They should wait in a safe place (for instance behind the safety barrier).

 **WARNING**

- If you have a puncture, stop the car well away from moving traffic. Switch on the hazard warning lights and set the emergency triangle in position. Please observe legal requirements when doing so.
- All passengers should leave the car.
- Apply the handbrake firmly and engage a gear or put the gear selector in the **P** position. Chock the wheel opposite the wheel being changed with a stone or similar object.
- If you are towing a trailer, unhitch it from your vehicle.
- Only use jacks which have been approved for your vehicle by SEAT.
- Never use other jacks, even if they have been approved for use on other SEAT models. The jack could slip. Risk of injury.
- Never start the engine when the vehicle is raised. This may cause an accident.
- Never place your body (e.g. arm or leg) underneath the vehicle if it is only supported by the jack Risk of injury.
- If you have to work underneath the vehicle, you must use suitable stands additionally to support the vehicle - Risk of accident!. ■

## Removing the hubcaps

The hubcaps must be removed to gain access to the wheel bolts.



Fig. 155 Removing the hubcaps

- Take the wire hook from the vehicle tool kit.
- Insert the hook into a hole in the cover ⇒ fig. 155.
- Pull off the cover. ■

## Removing the caps from the wheel bolts

The caps must be removed from the wheel bolts before the wheel bolts are unscrewed.

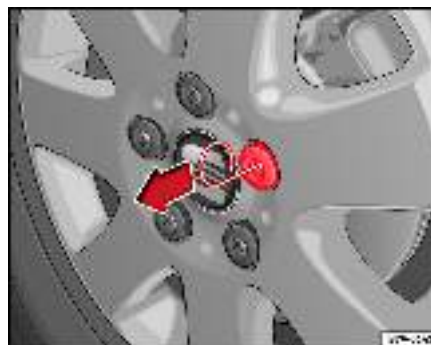

Fig. 156 Use the hook to pull off the cap

- Take the wire hook from the vehicle tool kit.
- Insert the hook through the opening in the middle of the cap ⇒ fig. 156.
- Use the wire hook to remove the caps.

The caps protect the wheel bolts and should be replaced after changing the tyre.

When fitting, make sure that the caps click securely into place. They could otherwise fall off. ■

## Loosening the wheel bolts

A special adapter is required to slacken the anti-theft wheel bolts. It is contained in the vehicle tool kit.



Fig. 157 Changing the wheel: loosen the wheel bolts

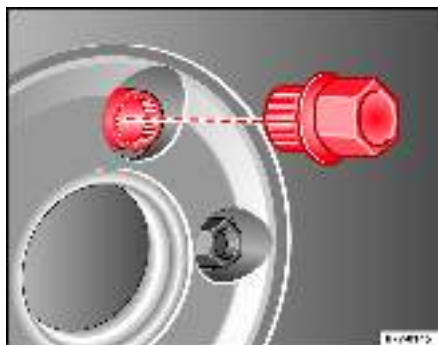

Fig. 158 Changing the wheel: anti-theft wheel bolts and adapter

## Loosening wheel bolts

- Fit the **box spanner** as far as it will go over the wheel bolt ⇒ fig. 157.
- Grip the end of the box spanner and turn the wheel bolt *one* turn anti-clockwise ⇒ ⚠.

## Loosening anti-theft wheel bolts

- Take the adapter for anti-theft wheel bolts out of the vehicle tool kit<sup>45)</sup>.
- Insert the adapter<sup>45)</sup> into the wheel bolt. Push it in as far as it will go ⇒ fig. 158.
- Fit the box spanner as far as it will go over the adapter.
- Grip the end of the box spanner and turn the wheel bolt *one* turn anti-clockwise ⇒ ⚠.

## Loosening wheel bolts

If the wheel bolt is very tight, you may be able to loosen it by pushing down the end of the spanner carefully with your foot. Hold on to the car for support and take care not to slip.



### WARNING

- Loosen the wheel bolts only about one turn before raising the vehicle with the jack.
- For wheels with a bolted outer ring, the grooved wheel bolts should never be loosened. This could cause leaks resulting in accident. ■

<sup>45)</sup> Optional equipment



## Raising the vehicle

Raise the vehicle using only the designated jacking points.



Fig. 159 The jacking points



Fig. 160 Jack at rear on right

Do not raise the vehicle until you have slackened the wheel bolts on the wheel you wish to remove ⇒ page 238.

### Jacking up the vehicle

1. Look for the jacking point ⇒ fig. 159 (arrow) ⇒ ⚠ closest to the tyre which has to be changed.
2. Raise the jack under the jacking point until it just fits under the car.
3. Check that the foot of the jack has full contact with the ground.
4. Adjust the jack and continue to crank the claw up until it is in position around the vertical rib ⇒ fig. 160 (arrow) underneath the vehicle ⇒ ⚠.
5. Crank the jack further until the wheel is just clear of the ground.

The jack may be applied only at the jacking points shown ⇒ fig. 159. The front jacking point is approx. 11 cm from the wheel arch. The rear jacking point is approx. 14 cm from the wheel arch. Notches on both sides in the sills show where the jacking points are under the vehicle.

⚠ WARNING	
<ul style="list-style-type: none"> <li>• You could injure yourself or damage the vehicle if you do not observe the correct jacking points.</li> <li>• Soft ground under the jack may cause the vehicle to slip off the jack. Always provide a firm base for the jack on the ground. If necessary use a large, strong board or similar support. On a hard, slippery surface (such as tiles) use a rubber mat or similar to prevent the jack from slipping.</li> <li>• The jack claw must grasp the vertical rib under the sill properly so that the jack does not slip off when you are raising the vehicle ⇒ fig. 160.</li> </ul>	▶

**Note**

The hexagonal socket in the screwdriver handle should be used for turning wheel bolts only. Do not use it to loosen or tighten the wheel bolts. ■

## Changing a wheel

---

### Removing the wheel

- Using the hexagonal socket in the screwdriver handle, unscrew the slackened wheel bolts and place them on a clean surface.
- Take off the wheel.
- Store the defective wheel as described on ⇒ page 233.

### Fitting the spare wheel

- Put the spare wheel in place.
- Screw in the wheel bolts and tighten them *lightly* using the hexagonal socket.
- Lower the vehicle on the jack.
- Tighten the wheel bolts firmly using the box spanner. Do not tighten the bolts in clockwise or anti-clockwise sequence. Tighten them in diagonal sequence.

### Tyres with directional tread pattern

Tyres with directional tread pattern must be mounted so that they rotate in the correct direction.

A directional tread pattern can be identified by arrows on the sidewall that point in the direction of rotation. Always observe the direction of rotation

indicated when mounting the wheel. This is important so that these tyres can give maximum grip and avoid excessive noise, tread wear and aquaplaning.

If, in an emergency, you have to mount a wheel so it rotates in the wrong direction, you must drive extremely carefully. The tyre will not give optimum performance. This is particularly important when driving on wet roads. To benefit from the advantages of tyres with directional tread pattern, the tyre should be replaced as soon as possible so that it rotates in the correct direction.

**Caution**

- The wheel bolts should be clean and turn easily. Do not grease or oil them.
- The hexagonal socket in the screwdriver handle should be used for turning wheel bolts only. Do not use it to loosen or tighten the wheel bolts. ■

## After changing a wheel

---

- Place the wheel with the defective tyre in the spare wheel bracket ⇒ page 233.
- Have the flat tyre replaced as quickly as possible.
- Have the tightening torque of the wheel bolts checked as soon as possible with a torque wrench ⇒ page 240.
- Check tyre pressure at the next opportunity.
- Avoid fast driving manoeuvres. ▶

### WARNING

- If the prescribed torque of the wheel bolts is too low, they could loosen whilst the vehicle is in motion. Risk of accident! If the tightening torque is too high, the wheel bolts and threads could be damaged.

### Caution

The stipulated torque for the wheel bolts on steel wheels and alloy wheels is 170 Nm with a tolerance of  $\pm 10$  Nm. You should visit a specialised workshop as soon as possible to check the torque with a torque wrench.

### Note

- The wheel bolts should be clean and turn easily. Do not grease or oil them.
- The hexagonal socket in the screwdriver handle should be used only for turning wheel bolts which have been slackened off. Do not use it to loosen or tighten the wheel bolts.
- If you notice that the wheel bolts are corroded and difficult to turn when changing a wheel, they must be replaced before you have the tightening torque checked.
- If the spare tyre is not the same as the tyres that are mounted on the car - for example with winter tyres - you should only use the spare tyre for a short period of time and drive with extra care. Refit the normal road wheel as soon as possible.
- Have the flat tyre replaced as quickly as possible. ■

## Fuses

### Changing a fuse

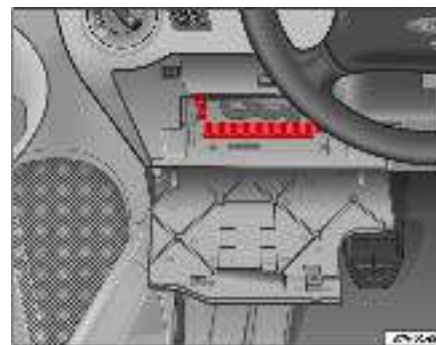

Fig. 161 Left side of dash panel fusebox

- Use the fuse tables, to find out where, and in which fuse box, the damaged fuse is located  $\Rightarrow$  page 242.
- Switch off the ignition and the component concerned.
- Remove the fuse box cover  $\Rightarrow$  fig. 161.
- Use the plastic pliers in the fuse box to remove the fuse.
- If the fuse has blown (the metal strip will have melted), replace it with a new fuse of the *same* amp rating (same colour and same imprint) and size.

The individual electrical circuits are protected by fuses. It is advisable to carry several spare fuses at all times. ►

### Colour coding of fuses

Colour	Amp rating
violet	3
light brown	5
brown	7,5
red	10
blue	15
yellow	20
transparent	25
green	30

### WARNING

Never “repair” damaged fuses and never replace them with higher rating fuses. This could cause fires.

### Note

- If a newly inserted fuse blows after a short time, you must have the electrical system checked by a qualified dealership as soon as possible.
- If you replace a fuse with a stronger fuse, you could cause damage to another location in the electrical system. ■



### Fuse table















The table shows the fuse locations for the most important consumers. The right-hand columns contain the insert location, the figures in brackets indicate the Ampère rating for the fuse. One single consumer could have more than one fuse.









Several consumers could run over one single fuse.

The fuse box has space for replacement fuses.

There are other fuses in the vehicle. These should be changed by a qualified dealership.

Electrical consumer	Symbol
Dipped headlights	
Electrical socket for trailer	-
Turn signals	
Brake lights	

Electrical consumer	Symbol
Main beam headlights	
Rear window heater	
Rear windscreen wiper	
Horn	
Interior lights	
Electric windows	
Usable electric windows	
Fog lights	
Rear fog light	
Hazard warning light switch	
Instrument panel lighting	
Climate control	
Heating	
Radio, navigation system	
Rear light	-
Registration plate light	

Electrical consumer	Symbol
Windscreen washers	
Windscreen washer system	
Sliding sunroof	
Seat heating	
Mirror adjustment	
Heating the exterior mirrors	
Side lights	
Socket (luggage compartment)	
Central locking.	-

## Changing a light

### Bulbs, changing

*Bulbs should be changed by a professional mechanic only.*

Technical knowledge is required to change bulbs. This is because, in certain cases, access can be gained only by removing other vehicle components. This applies in particular to bulbs which can be accessed only from the engine compartment.

We recommend bulbs are changed by a qualified dealership or, if this is not possible, by a qualified person.

However, if you wish to change the bulb, please observe the following:

**Before** changing a bulb, you must switch off the light (light switch in 0 position), and the turn signal lever must be in the neutral position.

Always replace damaged bulbs with identical bulbs with the same designation. The type is inscribed on the bulb, either on the glass or on the base.

You should store spare light bulbs in the vehicle for safety-relevant lights. Bulbs can be obtained from SEAT Service Centres.

#### **WARNING**

- The high voltage element of gas discharge lamps must be handled correctly. Failure to comply could result in fatal injuries.
- H7\* bulbs are pressurised and could explode when they are being changed. Risk of injury.
- In vehicles fitted with gas discharge lamps \*, there is a mortal danger if the high voltage section of the lamp is incorrectly handled.
- When working in the engine compartment, always observe the safety warnings ⇒ page 209. ■

### Side indicator lamps

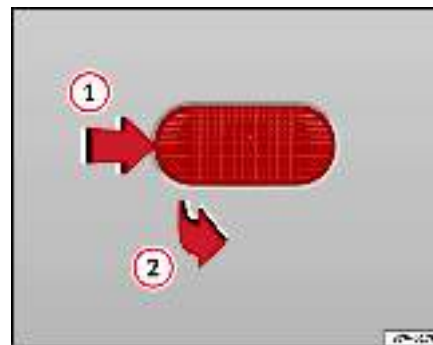

Fig. 162 Side indicator

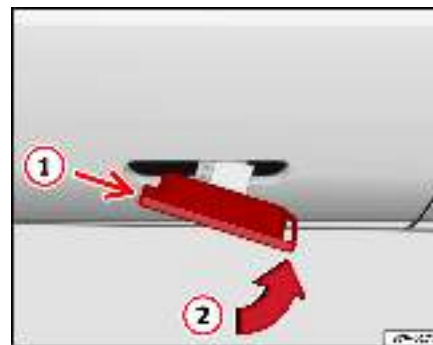

Fig. 163 Side indicator

- Slide the turn signal forwards ① ⇒ fig. 162 and remove ②.
- Remove the lamp holder and separate. ▶

- Remove the failed glass bulb and replace with a new bulb.
- Insert the lamp holder in the turn signal guide rail.
- First fit the turn signal in the opening of the chassis, securing with the tabs ① ⇒ fig. 163 and then, fit the bulb as shown by the arrow ②. ■

## Rear lights

Before changing a bulb, the tailgate should always be opened.

The lights have the following layout:

### On the body

Turn signals, pilot light and brake/rear light

### On the tailgate / rear door

Reversing light and rear antifog light. ■

## Lights on vehicle body

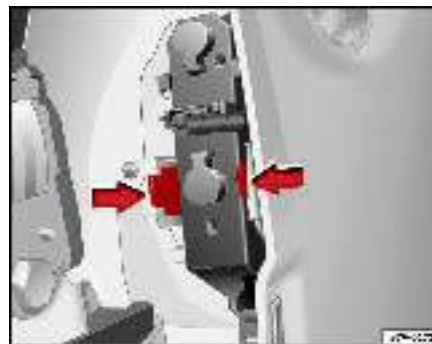

Fig. 164 Lights on vehicle body

- Open the cover in the luggage compartment trim.
- Press the side tabs in the direction of arrow ⇒ fig. 164.
- Press the defective bulb into the bulb carrier, then turn it to the left and remove it.
- Fit the new bulb and turn to the right as far as possible.
- Fit the lampholder, press in until the tabs “click” into place. ■



## Lights on tailgate

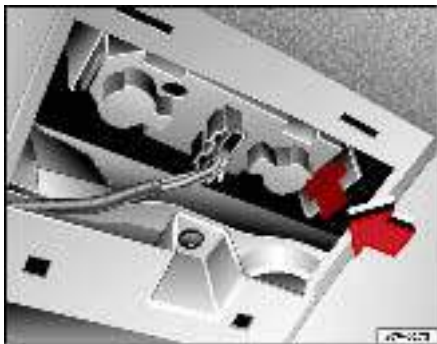

Fig. 165 Lights on tailgate

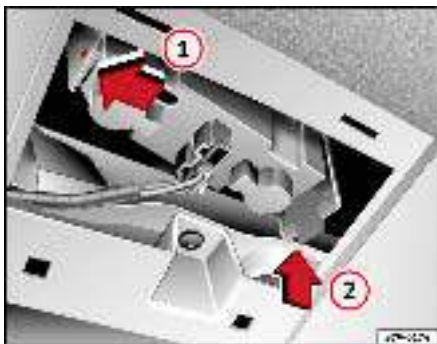

Fig. 166 Lights on tailgate

- Remove the cover in the trim.

- Press the elastic tab in the direction of the arrow ⇒ page 247, fig. 165 and remove the lampholder downwards.
- Press the defective bulb into the bulb carrier, then turn it to the left and remove it.
- Fit the new bulb and turn to the right as far as possible.
- Fit the lampholder in the corresponding opening (1) at the front tab and press the lampholder upwards at the back (2), until the elastic tab engages ⇒ page 247, fig. 166.
- Replace the cover. To do so, insert the the two tabs of the exterior part of the cover behind the tailgate trim and push the cover upwards until it goes into position. ■

## Registration plate light

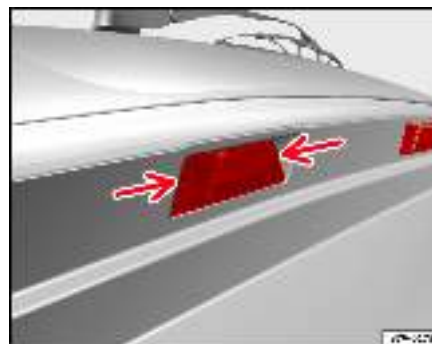

Fig. 167 Registration light

- Remove the glass.
  - Remove the failed glass bulb and replace with a new bulb.
  - Bolt down the glass without overtightening, ensuring that the seal is perfectly fitted.
  - Fit the reflector in the corresponding space in the tailgate ensuring that the rubber seal and the light are assembled correctly.
  - Do not bolt down the glass too tightly. ■
- Replace the bulb.
  - Replace the glass in the casing. ■

### Interior light

---



Fig. 168 Interior light

- Insert a fine screwdriver or similar between the casing and the glass (arrow) ⇒ fig. 168 and carefully remove the glass.

## Reading light



Fig. 169 Reading lights

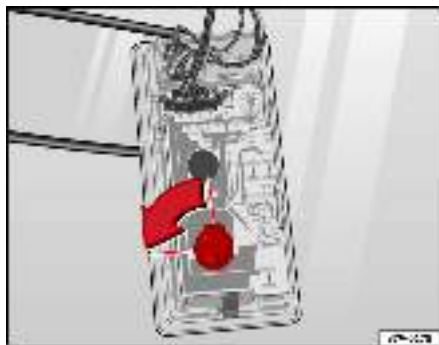

Fig. 170 Reading lights

- Remove the complete bracket (interior light and reading light), place the flat end of a screwdriver between the light and the ceiling trim and turn the screwdriver.

- Turn the lampholder of the back of the lamp in the direction of the arrow ⇒ fig. 169 and separate.
- Remove the defective lamp (with glass bulb).
- Fit a new lamp.
- Replace the mount in the casing and guide it towards the right as far as possible.
- Replace the bracket, first on the left and then insert it in the opening in the ceiling trim. ■

## Jump-starting

### Jump leads

*The jump lead must have a sufficient wire cross section.*

If the engine fails to start because of a discharged battery, the battery can be connected to the battery of another vehicle to start the engine.

#### Jump leads

Jump leads must comply with the standard **DIN 72553** (see manufacturer's documentation). The wire cross section must be at least 25 mm<sup>2</sup> for petrol engines and at least 35 mm<sup>2</sup> for diesel engines.



#### Note

- The vehicles must not touch each other, otherwise electricity could flow as soon as the positive terminals are connected.
- The discharged battery must be properly connected to the vehicles electrical system. ■

## How to jump start: description

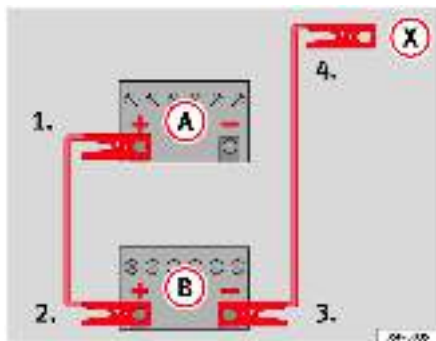









Fig. 171 How to connect the jump leads

In ⇒ fig. 171, the flat battery is **A** and the charged battery **B**.

### Jump lead terminal connections

- Switch off the ignition on both vehicles ⇒ .
1. Connect one end of the red jump lead to the positive ⇒ fig. 171  terminal of the vehicle with the flat battery ⇒ .
  2. Connect the other end of the red jump lead to the positive terminal  in the vehicle providing assistance.
  3. Connect one end of the black jump lead to the negative terminal  on the battery of the vehicle providing assistance.

4. Connect the other end of the black jump lead  to a solid metal component which is bolted on to the engine block, or onto the engine block itself of the vehicle with the flat battery. Do not connect it to a point near the battery ⇒ .
5. Position the leads in such a way that they cannot come into contact with any moving parts in the engine compartment.

### Starting

6. Start the engine of the vehicle with the boosting battery and let it run at idling speed.
7. Start the engine of the car with the flat battery and wait one or two minutes until the engine is “running”.

### Removing the jump leads

8. Before you remove the jump leads, switch off the headlights (if they are switched on).
9. Turn on the heater blower and rear window heater in the vehicle with the flat battery. This helps minimise voltage peaks which are generated when the leads are disconnected.
10. When the engine is running, disconnect the leads in reverse order to the details given above.

Connect the battery clamps so they have good metal-to-metal contact with the battery terminals.

If the engine fails to start, switch off the starter after about 10 seconds and try again after about half a minute. ►

**WARNING**

- Please note the safety warnings referring to working in the engine compartment ⇒ page 209, “Working in the engine compartment”.
- The battery providing assistance must have the same voltage as the flat battery (12V) and approximately the same capacity (see imprint on battery). Failure to comply could result in an explosion.
- Never use jump leads when one of the batteries is frozen. Danger of explosion! Even after the battery has thawed, battery acid could leak and cause chemical burns. If a battery freezes, it should be replaced.
- Keep sparks, flames and lighted cigarettes away from batteries, danger of explosion. Failure to comply could result in an explosion.
- Observe the instructions provided by the manufacturer of the jump leads.
- Do not connect the negative cable from the other vehicle directly to the negative terminal of the flat battery. The gas emitted from the battery could be ignited by sparks. Danger of explosion.
- Do not attach the negative cable from the other vehicle to parts of the fuel system or to the brake line.
- The non-insulated parts of the battery clamps must not be allowed to touch. The jump lead attached to the positive battery terminal must not touch metal parts of the vehicle, this can cause a short circuit.
- Position the leads in such a way that they cannot come into contact with any moving parts in the engine compartment.
- Do not bend over the batteries. This could result in chemical burns.

**Note**

The vehicles must not touch each other, otherwise electricity could flow as soon as the positive terminals are connected. ■

## Towing and tow-starting

### Tow-starting\*

*The use of jump leads is preferable to tow-starting.*

We recommend that you do **not** tow-start your vehicle. Jump-starting is preferable ⇒ page 249.

#### However, if your vehicle has to be tow-started:

- Engage the 2<sup>nd</sup> or the 3<sup>rd</sup> gear.
- Keep the clutch pressed down.
- Switch on the ignition.
- Once both vehicles are moving, release the clutch.
- As soon as the engine starts, press the clutch and move the gear lever into neutral. This helps to prevent driving into the towing vehicle.

#### **WARNING**

**The risk of accidents is high when tow-starting. The vehicle being towed can easily collide with the towing vehicle.**

#### **Caution**

When tow-starting, fuel could enter the catalytic converter and damage it. ■

## Towing eye at the front of the vehicle



**Fig. 172 Towing eye at the front of the vehicle**

The towline anchorage is located on the right of the front bumper ⇒ fig. 172. To access the housing it is necessary to remove the cover.

#### Removing the cover of the front towing eye

- Remove the cover in the direction shown by the arrow ⇒ fig. 172 levering it out with a screwdriver.

#### Assembling the cover of the front towing eye

- Put the cover into its socket and press until it is firmly in place.
- Check that it is correctly fitted.

The towing eye should always be kept in the vehicle. Remember the instructions for tow starting or towing that are in the user's manual. ■

## Rear towline anchorage



Fig. 173 Rear towline anchorage

On the right hand side of the lower rear section of the body, there is a fixed towline anchorage ⇒ fig. 173 (arrow).

### Towing bracket

If the vehicle has a factory-fitted towing bracket, it should also be used for towing other vehicles. ■

## Tow-starting

*The use of jump leads is preferable to tow-starting.*

We recommend that you do **not** tow-start your vehicle. Jump-starting is preferable ⇒ page 250.

### However, if your vehicle has to be tow-started:

- Engage 2<sup>nd</sup> or 3<sup>rd</sup> gear.
- Keep the clutch pressed down.
- Switch on the ignition and switch on the hazard warning lights.
- Once both vehicles are moving, release the clutch.
- As soon as the engine starts, press the clutch and move the gear lever into neutral. This helps to prevent driving into the towing vehicle.



### WARNING

The risk of accidents is high when tow-starting. The vehicle being towed can easily collide with the towing vehicle.



### Caution

When tow-starting, fuel could enter the catalytic converter and damage it.



### Note

- The legal requirements concerning towing should be observed.
- Switch on the hazard warning lights of both vehicles. However, observe any regulations to the contrary.
- For technical reasons, vehicles with an automatic gearbox must not be tow-started. ■

## Notes for tow-starting or towing

If a cable is used for towing the vehicle, please observe the following:

### As the driver of the towing vehicle

- Switch on the hazard warning lights. However, observe any regulations to the contrary.
- Drive slowly at first until the tow-rope is taut. Then accelerate gradually.
- Begin and change gears cautiously. If you are driving an automatic vehicle, accelerate gently.
- Remember that the brake servo and power steering are not working in the vehicle you are towing. Brake earlier than you would normally, but with a more gentle pressure on the brake.

### As the driver of the vehicle being towed

- Switch on the hazard warning lights. However, observe any regulations to the contrary.
- Place the gearstick in neutral or position **N**.
- Ensure that the tow-rope remains taut at all times.

### Tow-rope or tow-bar

It is easier and safer to tow a vehicle with a tow-bar. You should only use a tow-rope if you do not have a tow-bar.

A tow-rope should be slightly elastic to reduce the loading on both vehicles. It is advisable to use a tow-rope made of synthetic fibre or similarly elastic material.

Attach the tow-rope or the tow-bar only to the towing eyes provided or a towing bracket.

### Driving tips

Towing requires some experience, especially when using a tow-rope. Both drivers should be familiar with the technique required for towing. Inexperienced drivers should not attempt to tow-start or tow away another vehicle.

Do not pull too hard with the towing vehicle and take care to avoid jerking the tow-rope. When towing on an unpaved road, there is always a risk of overloading and damaging the anchorage points.

The ignition of the vehicle being towed must be switched on to prevent the steering wheel from locking and also to allow the use of the turn signals, horn, windscreen wipers and washers.

If the vehicle is towed, with the hazard warning lights on and the ignition switched on, the turn signal may be used to indicate that you are going to change direction. Move the turn signal lever accordingly. Meanwhile, the hazard warning lights will go off. When the turn signal lever is returned to the rest position, the hazard warning lights will automatically reconnect.

The brake servo works only when the engine is running. In this case the pedal has to be pressed harder.

As the power assisted steering does not work if the engine is not running, you will need more strength to steer than you normally would.

### Towing vehicles with an automatic gearbox

- Move the selector lever to **N**.
- Do not drive faster than 50 km/h when towing a vehicle.
- Do not tow further than 50 km.
- If a breakdown truck is used, the vehicle must be towed with the front wheels raised.



### WARNING

The braking behaviour and capacity of a vehicle changes when being towed or when you are trying to start the vehicle by pulling. Please observe the following notes in order to prevent injury and accident:

- Inexperienced drivers should refrain from trying in order to avoid accident.
- Notes for the driver of the towed vehicle
  - The brake must be depressed much harder as the brake servo does not operate. Take care not to bump into the towing vehicle.
  - More strength is required at the steering wheel as the power steering does not operate when the engine is switched off.
- Notes for the driver of the towing vehicle
  - Accelerate smoothly and avoid any sudden movement.
  - Brake more in advance than usual and brake gently.

### Caution

When tow-starting, fuel could enter the catalytic converter and damage it  
 ⇒ page 252.

### Note

- Observe legal requirements when towing or tow-starting.
- For technical reasons, vehicles with an automatic gearbox must not be tow-started.
- If, due to a breakdown, the gearbox does not have lubricant, the vehicle should be towed with the drive wheels suspended.
- If it is necessary to tow a vehicle with an automatic gearbox for more than 50 km, it should be towed by qualified personnel and with the drive wheels suspended. ■

## Lifting the vehicle

### Vehicle lifting points

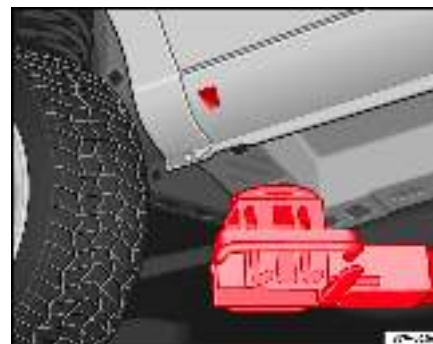

Fig. 174 Lifting with the lifting platform: lifting point at front left

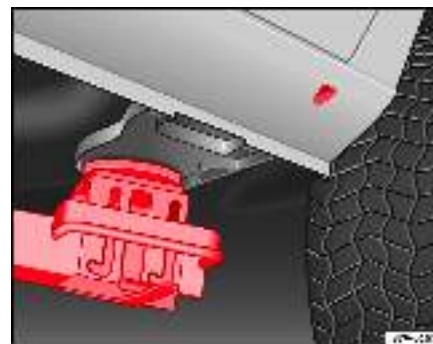



Fig. 175 Lifting with the lifting platform: lifting point at rear left

Your vehicle may only be lifted by a lifting platform at the points shown in the illustrations ⇒ page 255, fig. 174 and ⇒ page 255, fig. 175 ⇒ .

Using the jack to lift the vehicle ⇒ page 239.

To prevent damage to the underside of the vehicle when lifting the vehicle, **rubber pads** must be used.

Before driving onto a lifting platform, you must check there is sufficient clearance between low parts of the vehicle and the lifting platform.

- Before driving onto a lifting platform, you must check there is sufficient clearance between low parts of the vehicle and the lifting platform. ■



### WARNING

If the lifting platform is inappropriate or the vehicle is lifted incorrectly, accidents or injuries may be caused. The vehicle could even fall from the lifting platform.

- All occupants should leave the vehicle before it is lifted.
- The vehicle must only be lifted at the points indicated in the diagrams ⇒ page 255, fig. 174 and ⇒ page 255, fig. 175. If the vehicle is not lifted at the indicated points, it may fall from the platform while the engine or gearbox is being dismantled, for example.
- Never start the engine when the vehicle is raised. Risk of accident. The vehicle may fall from the platform due to the engine vibrations.
- When work is being carried out underneath the vehicle, it must be secured using suitable frames. If not, an accident may occur.
- To lift the vehicle, only two-pillar or two-post lifting platforms with sufficiently long arms and load-bearing capacity should be used.
- Lifting platforms with fluid filled cushions may not be used for lifting the vehicle.



### Caution

- The vehicle should never be lifted at the engine oil sump, the gearbox, or the front or rear axle. This could cause serious damage to the vehicle.

# Technical Data

## General notes on the technical data

### What you should be aware of

#### General notes

*All data in the official vehicle documents take precedence over this data.*

All data in these documents are valid for the basic model as offered in Spain. The vehicle data card included in the inspection and maintenance schedule in the vehicles registration documents show which engine is installed in the vehicle.

The figures may be different if additional equipment is fitted, for different models, for special vehicles and for other countries.

#### Abbreviations used in this paragraph of the Technical Data

Abbreviation	Meaning
kW	Kilowatt, engine power measurement.
bhp	Brake horse power, formerly used to denote engine power
at rpm	Revolutions per minute - engine speed.
Nm	Newton metres, unit of engine torque.
l/100 km	Fuel consumption in litres per 100 kilometres
g/km	Carbon dioxide emissions in grams per kilometre.
CO <sub>2</sub>	Carbon dioxide
CN	Cetane number, indication of the ignition quality of the diesel.
RON	Research octane number, indication of the knock resistance of petrol.

## Vehicle identification data

---

### Vehicle identification number

The vehicle identification number (chassis number) can be read from outside the vehicle through a viewer in the windscreen. This is located on the left-hand side of the vehicle in the lower area of the windscreen. It is also located on the right hand side of the engine compartment.

### Type plate

The type plate is located on the left rib inside the engine compartment.

### Vehicle data

The data sticker is placed on the inside of the spare wheel recess in the luggage compartment.

The following information can be found in the vehicle information:

- Vehicle identification number (chassis number)
- Vehicle type / engine power / gearbox type
- Engine and gearbox code / paint number / interior equipment
- Optional extras / PR numbers

This information also figures in the Maintenance Program. ■

## How are the figures measured?

### Fuel consumption

*The consumption and emission details shown on the vehicle data sticker differ from one vehicle to another.*

The fuel consumption, CO<sub>2</sub> emissions and actual kerb weight of the vehicle are noted on the vehicle data sticker.

The fuel consumption and emissions figures given are based on the weight category of the car, which is determined according to the engine/gearbox combination and the equipment fitted.

The consumption and emission figures are calculated in accordance with the EC test requirements 1999/100/EC. These test requirements specify a realistic test method based on normal everyday driving.

The following test conditions are applied:

Urban cycle	The urban cycle starts with an engine cold start. City driving is then simulated.
Extra urban cycle	In the extra urban cycle the vehicle undergoes frequent acceleration and braking in all gears, as in normal everyday driving. The road speed ranges from 0 to 120 km/h.
Combined	The average overall consumption is calculated with a weighting of around 37% for the urban cycle and 63% for the extra urban cycle.
CO <sub>2</sub> emissions	The exhaust gases are collected during both driving cycles to calculate carbon dioxide emissions. The gas composition is then analysed to evaluate the CO <sub>2</sub> content and other emissions.



#### Note

- Actual consumption may vary from quoted test values, depending on personal driving style, road and traffic conditions, the weather and the condition of the vehicle. ■

## Weights

Kerb weight refers to the basic model with a fuel tank filled to 90% capacity and without optional extras. The figure quoted includes 75 kg to allow for the weight of the driver.

For special versions and optional equipment fittings or for the addition of accessories, the weight of the vehicle will increase ⇒ ⚠.

### WARNING

- Please note that the centre of gravity may shift when transporting heavy objects; this may affect the vehicle's handling and lead to an accident. Always adjust your speed and driving style to suit road conditions and requirements.
- Never exceed the gross axle weight rating or the gross vehicle weight rating. If the allowed axle load or the allowed total weight is exceeded, the driving characteristics of the vehicle may change, leading to accidents, injuries and damage to the vehicle. ■

## Towing a trailer

### Trailer weights

#### Trailer weights

The trailer weights and drawbar loads approved are selected in intensive trials according to precisely defined criteria. The approved trailer weights are valid for vehicles in the EU for maximum speeds of 80 km/h (in certain circumstances up to 100 km/h). The figures may be different in other countries. All data in the official vehicle documents take precedence over these data ⇒ ⚠.

### Drawbar load

The *maximum* permitted weight exerted by the trailer drawbar on the ball joint of the towing bracket must not exceed **85 kg**.

In the interest of road safety, we recommend that you always tow approaching the maximum drawbar load. The response of the trailer on the road will be poor if the drawbar load is too small.

If the maximum permissible drawbar load cannot be met (e.g. with small, empty and light-weight single axle trailers or tandem axle trailers with an axle base of less than 1 metre), at least 4% of the actual trailer weight is a legal stipulation for a drawbar load.

### WARNING

- For safety reasons, you should not drive at speeds above 80 km/h when towing a trailer. This also applies to countries where higher speeds are permitted.
- Never exceed the maximum trailer weights or the draw bar loading. If the permissible axle load or the permissible total weight is exceeded, the driving characteristics of the vehicle may change, leading to accidents, injuries and damage to the vehicle. ■

## Wheels

### Tyre pressure, snow chains, wheel bolts

#### Tyre pressures

The sticker with the tyre pressure values can be found on the inside of the tank flap. The tyre pressure values given there are for *cold* tyres. The slightly raised pressures of warm tyres must not be reduced ⇒ ⚠. ▶

### Snow chains

Snow chains may be fitted only to the *front wheels*.

Consult the chapter “wheels” of this manual.

### Wheel bolts

After the wheels have been changed, the **tightening torque** of the wheel bolts should be checked as soon as possible with a torque wrench ⇒ ⚠. The tightening torque for steel and alloy wheels is **120 Nm**.



#### WARNING

- Check the tyre pressure at least once per month. Correct tyre pressure is very important. If the tyre pressure is too high or too low, there is an increased danger of accidents, particularly at high speeds.
- If the torque of the wheel bolts is too low, they could loosen whilst the vehicle is in motion. Risk of accident! If the tightening torque is too high, the wheel bolts and threads could be damaged.



#### Note

We recommend that you ask your Authorised Service Centre for information about appropriate wheel, tyre and snow chain size. ■

## Technical Data

### Checking fluid levels

*From time to time, the levels of the different fluids in the vehicle must be checked. Never fill with incorrect fluids, to do so may cause serious damage to the engine.*

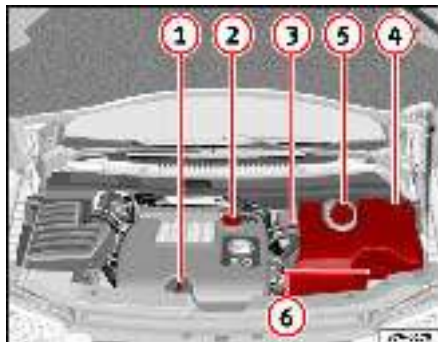

**Fig. 176** Diagram for the location of the various elements

- ① Engine oil dipstick
- ② Oil filler neck
- ③ Brake fluid reservoir
- ④ Vehicle battery (underneath a cover)
- ⑤ Coolant temperature deposit
- ⑥ Windscreen washer fluid reservoir

The checking and replenishment of the service fluids are carried out on the components mentioned above. These operations are described in the ⇒ page 209.

#### Overview

Further explanations, instructions and restrictions on the technical data are contained as of ⇒ page 257. ■



## Petrol engine 2.0l 85 kW (115 bhp) 6 gear

### General engine data

Power output in kW (bhp)	rpm	85 (115)/ 5200
Maximum torque	in Nm at rpm	170/ 2600-4200
No. of cylinders, capacity	in cm <sup>3</sup>	4/ 1984
Compression		10,5 ± 0,5
Fuel		Super 95 RON <sup>a)</sup> /Normal 91 RON <sup>b)</sup>

a) Research-Octane-Number = Measure of the predetonation power of the petrol.

b) With a slight power loss

### Performance figures

Maximum speed	in km/h	177
Acceleration from 0-80 km/h	in sec.	10,6
Acceleration from 0-100 km/h	in sec.	15,2

### Consumption (litres/100 km)/ CO<sub>2</sub> (g/km)

Urban cycle	12,8/302
Extra urban cycle	7,4/172
Combined	9,4/223

**Weights**

Gross vehicle weight	in kg	2430
Weight in working order (with driver)	in kg	1653/1973
Gross axle weight, front	in kg	1210
Gross axle weight, rear	in kg	980
Permitted roof load	in kg	75

**Trailer weights**

With no brakes, gradients up to 12%	700
With brakes, gradients up to 12%	1800

**Engine oil capacity**

Approximate engine oil capacity with oil filter change	4.0 litres
--------------------------------------------------------	------------

## Petrol engine 2.0 litre 85 kW (115 hp). Automatic

**General engine data**

Power output in kW (bhp)	rpm	85 (115)/ 5200
Maximum torque	in Nm at rpm	170/ 2600-4200
No. of cylinders, capacity	in cm <sup>3</sup>	4/ 1984
Compression		10
Fuel		Super 95 RON <sup>a)</sup> /Normal 91 RON <sup>b)</sup>

a) Research-Octane-Number = Measure of the predetonation power of the petrol.

b) With a slight power loss

**Performance figures**

Maximum speed	in km/h	173
Acceleration from 0-80 km/h	in sec.	11,3
Acceleration from 0-100 km/h	in sec.	17,2

**Consumption (litres/100 km)/ CO<sub>2</sub> (g/km)**

Urban cycle	14,2/339
Extra urban cycle	8,1/195
Combined	10,4/250

**Weights**

Gross vehicle weight	in kg	2450
Weight in working order (with driver)	in kg	1673/1993
Gross axle weight, front	in kg	1240
Gross axle weight, rear	in kg	1280
Permitted roof load	in kg	75

**Trailer weights**

With no brakes, gradients up to 12%	700
With brakes, gradients up to 12%	1800

**Engine oil capacity**

Approximate engine oil capacity with oil filter change	4.0 litres
--------------------------------------------------------	------------

## Petrol engine 1.8l 110 kW (150 bhp) 6 gear

### General engine data

Power output in kW (bhp)	rpm	110 (150)/ 5800
Maximum torque	in Nm at rpm	210/ 1800-4300
No. of cylinders, capacity	in cm <sup>3</sup>	4/ 1781
Compression		9,5 ± 0,5
Fuel		95 super RON <sup>a)</sup>

a) Research-Octane-Number = Measure of the predetonation power of the petrol.

### Performance figures

Maximum speed	in km/h	199
Acceleration from 0-80 km/h	in sec.	7,2
Acceleration from 0-100 km/h	in sec.	10,9

### Consumption (litres/100 km)/ CO<sub>2</sub> (g/km)

Urban cycle	13,0/318
Extra urban cycle	7,4/178
Combined	9,4/225

**Weights**

Gross vehicle weight	in kg	2450
Weight in working order (with driver)	in kg	1674/1994
Gross axle weight, front	in kg	1240
Gross axle weight, rear	in kg	1280
Permitted roof load	in kg	75

**Trailer weights**

With no brakes, gradients up to 12%	700
With brakes, gradients up to 12%	1900

**Engine oil capacity**

Approximate engine oil capacity with oil filter change	4.3 litres
--------------------------------------------------------	------------

## Petrol engine 1.8l 110 kW (150 bhp). Automatic

**General engine data**

Power output in kW (bhp)	rpm	110 (150)/ 5500
Maximum torque	in Nm at rpm	210/ 1850-4500
No. of cylinders, capacity	in cm <sup>3</sup>	4/ 1780
Compression		9,5
Fuel		95 super RON <sup>a)</sup>

a) **R**esearch-**O**ctane-**N**umber = Measure of the predetonation power of the petrol.

**Performance figures**

Maximum speed	in km/h	195
Acceleration from 0-80 km/h	in sec.	8,3
Acceleration from 0-100 km/h	in sec.	12,1

**Consumption (litres/100 km)/ CO<sub>2</sub> (g/km)**

Urban cycle	14,1/337
Extra urban cycle	8,2/197
Combined	10,3/247

**Weights**

Gross vehicle weight	in kg	2480	
Weight in working order (with driver)	in kg	1707/2005	1707/2027
Gross axle weight, front	in kg	1240	
Gross axle weight, rear	in kg	1280	
Permitted roof load	in kg	75	

**Trailer weights**

With no brakes, gradients up to 12%	700
With brakes, gradients up to 12%	1900

**Engine oil capacity**

Approximate engine oil capacity with oil filter change	4.3 litres
--------------------------------------------------------	------------

## Petrol engine 2.8l VR6150 kW (204 bhp) 6 gear

### General engine data

Power output in kW (bhp)	rpm	150 (204)/6200
Maximum torque	in Nm at rpm	265/3400
No. of cylinders, capacity	in cm <sup>3</sup>	6/ 2792
Compression		10,75 ± 0,25
Fuel		Super 98 RON <sup>a)</sup> /Super 95 RON <sup>b)</sup>

a) **R**esearch-**O**ctane-**N**umber = Measure of the predetonation power of the petrol.

b) With a slight power loss

### Performance figures

Maximum speed	in km/h	217
Acceleration from 0-80 km/h	in sec.	7,2
Acceleration from 0-100 km/h	in sec.	9,9

### Consumption (litres/100 km)/ CO<sub>2</sub> (g/km)

Urban cycle	14,5/348
Extra urban cycle	8,2/198
Combined	10,5/252

**Weights**

Gross vehicle weight	in kg	2470
Weight in working order (with driver)	in kg	1694/2014
Gross axle weight, front	in kg	1240
Gross axle weight, rear	in kg	1280
Permitted roof load	in kg	75

**Trailer weights**

With no brakes, gradients up to 12%	700
With brakes, gradients up to 12%	2000

**Engine oil capacity**

Approximate engine oil capacity with oil filter change	5.5 litres
--------------------------------------------------------	------------

## Petrol engine 2.8l VR6 150 kW (204 bhp) Automatic

**General engine data**

Power output in kW (bhp)	rpm	150 (204)/6200
Maximum torque	in Nm at rpm	265/3400
No. of cylinders, capacity	in cm <sup>3</sup>	6/ 2792
Compression		10,75 ± 0,25
Fuel		Super 98 RON <sup>a)</sup> /Super 95 RON <sup>b)</sup>

a) Research-Octane-Number = Measure of the predetonation power of the petrol.

b) With a slight power loss



**Performance figures**

Maximum speed	in km/h	217
Acceleration from 0-80 km/h	in sec.	7,4
Acceleration from 0-100 km/h	in sec.	10,4

**Consumption (litres/100 km)/ CO<sub>2</sub> (g/km)**

Urban cycle	16,2/388
Extra urban cycle	8,6/207
Combined	11,4/274

**Weights**

Gross vehicle weight	in kg	2500	
Weight in working order (with driver)	in kg	1727/2020	1727/2025
Gross axle weight, front	in kg	1240	
Gross axle weight, rear	in kg	1280	
Permitted roof load	in kg	75	

**Trailer weights**

With no brakes, gradients up to 12%	700
With brakes, gradients up to 12%	2000

**Engine oil capacity**

Approximate engine oil capacity with oil filter change	5.5 litres
--------------------------------------------------------	------------

## Petrol engine 2.8l VR6150 kW (204 bhp) 6 gear four-wheel drive

### General engine data

Power output in kW (bhp)	rpm	150 (204)/6200
Maximum torque	in Nm at rpm	265/3400
No. of cylinders, capacity	in cm <sup>3</sup>	6/ 2792
Compression		10,75 ± 0,25
Fuel		Super 98 RON <sup>a)</sup> /Super 95 RON <sup>b)</sup>

a) Research-Octane-Number = Measure of the predetonation power of the petrol.

b) With a slight power loss

### Performance figures

Maximum speed	in km/h	214
Acceleration from 0-80 km/h	in sec.	7,4
Acceleration from 0-100 km/h	in sec.	10,3

### Consumption (litres/100 km)/ CO<sub>2</sub> (g/km)

Urban cycle	14,9/357
Extra urban cycle	8,7/210
Combined	11,0/265

**Weights**

Gross vehicle weight	in kg	2510	
Weight in working order (with driver)	in kg	1786/2047	1786/2084
Gross axle weight, front	in kg	1240	
Gross axle weight, rear	in kg	1330	
Permitted roof load	in kg	75	

**Trailer weights**

With no brakes, gradients up to 12%	700
With brakes, gradients up to 12%	2000

**Engine oil capacity**

Approximate engine oil capacity with oil filter change	5.5 litres
--------------------------------------------------------	------------

## Diesel engine 1.9l TDI 85 kW (115 bhp) 6 gears four-wheel drive

**General engine data**

Power output in kW (bhp)	rpm	85 (115)/ 4000
Maximum torque	in Nm at rpm	310/1900
No. of cylinders, capacity	in cm <sup>3</sup>	4/1896
Compression		18
Fuel		Petrol min. 51 CN <sup>a)</sup> or Biodiesel 5 % as in EN 14214

<sup>a)</sup> Cetane-Number (cetane index) = Measure of the combustion power of the diesel.

**Performance figures**

Maximum speed	in km/h	178
Acceleration from 0-80 km/h	in sec.	9,3
Acceleration from 0-100 km/h	in sec.	14,7

**Consumption (litres/100 km)/ CO<sub>2</sub> (g/km)**

Urban cycle	9,1/240
Extra urban cycle	5,9/156
Combined	7,1/188

**Weights**

Gross vehicle weight	in kg	2510
Weight in working order (with driver)	in kg	1784
Gross axle weight, front	in kg	1260
Gross axle weight, rear	in kg	1330
Permitted roof load	in kg	75

**Trailer weights**

With no brakes, gradients up to 12%	700
With brakes, gradients up to 12%	2000

**Engine oil capacity**

Approximate engine oil capacity with oil filter change	4.3 litres
--------------------------------------------------------	------------

## Diesel engine 1.9l TDI 85 kW (115 bhp) 6 gears

### General engine data

Power output in kW (bhp)	rpm	85 (115)/ 4000
Maximum torque	in Nm at rpm	310/1900
No. of cylinders, capacity	in cm <sup>3</sup>	4/1896
Compression		18 ± 0,5
Fuel		Petrol min. 51 CN <sup>a)</sup> or Biodiesel 5 % as in EN 14214

a) Cetane-Number (cetane index) = Measure of the combustion power of the diesel.

### Performance figures

Maximum speed	in km/h	181
Acceleration from 0-80 km/h	in sec.	9,1
Acceleration from 0-100 km/h	in sec.	13,7

### Consumption (litres/100 km)/ CO<sub>2</sub> (g/km)

Urban cycle	8,0/211
Extra urban cycle	5,6/148
Combined	6,5/172

**Weights**

Gross vehicle weight	in kg	2510
Weight in working order (with driver)	in kg	1724/ 2003
Gross axle weight, front	in kg	1240
Gross axle weight, rear	in kg	1280
Permitted roof load	in kg	75

**Trailer weights**

With no brakes, gradients up to 12%	700
With brakes, gradients up to 12%	2000

**Engine oil capacity**

Approximate engine oil capacity with oil filter change	4.3 litres
--------------------------------------------------------	------------

## Diesel engine 1.9 TDI 85 kW (115 bhp). Automatic

**General engine data**

Power output in kW (bhp)	rpm	85 (115)/ 4000
Maximum torque	in Nm at rpm	310/1900
No. of cylinders, capacity	in cm <sup>3</sup>	4/1896
Compression		18 ± 0,5
Fuel		Petrol min. 51 CN <sup>a)</sup> or Biodiesel 5 % as in EN 14214

a) Cetane-Number (cetane index) = Measure of the combustion power of the diesel.

**Performance figures**

Maximum speed	in km/h	177
Acceleration from 0-80 km/h	in sec.	9,9
Acceleration from 0-100 km/h	in sec.	15,1

**Consumption (litres/100 km)/ CO<sub>2</sub> (g/km)**

Urban cycle	10,0,0/264
Extra urban cycle	5,9/156
Combined	7,4/196

**Weights**

Gross vehicle weight	in kg	2510	
Weight in working order (with driver)	in kg	1757/2032	1757/2020
Gross axle weight, front	in kg	1240	
Gross axle weight, rear	in kg	1280	
Permitted roof load	in kg	75	

**Trailer weights**

With no brakes, gradients up to 12%	700
With brakes, gradients up to 12%	2000

**Engine oil capacity**

Approximate engine oil capacity with oil filter change	4.3 litres
--------------------------------------------------------	------------

## Diesel engine 2.0l TDI 103 kW (140 bhp) 6 gears

### General engine data

Power output in kW (bhp)	rpm	103(140)/ 4000
Maximum torque	in Nm at rpm	310/1900-2500
No. of cylinders, capacity	in cm <sup>3</sup>	4/1968
Compression		18,5 ± 0,5
Fuel		Petrol min. 51 CN <sup>a)</sup>

a) Cetane-Number (cetane index) = Measure of the combustion power of the diesel.

### Performance figures

Maximum speed	in km/h	192
Acceleration from 0-80 km/h	in sec.	8,5
Acceleration from 0-100 km/h	in sec.	12,2

### Consumption (litres/100 km)/ CO<sub>2</sub> (g/km) without DPF <sup>46)</sup>

<sup>46)</sup> Diesel particulate filters

Urban cycle	8,3/219	8,5/225
Extra urban cycle	5,7/151	5,7/151
Combined	6,6/175	6,7/177



**Weights**

Gross vehicle weight	in kg	2510
Weight in working order (with driver)	in kg	1740/2024
Gross axle weight, front	in kg	1240
Gross axle weight, rear	in kg	1280
Permitted roof load	in kg	75

**Trailer weights**

With no brakes, gradients up to 12%	700
With brakes, gradients up to 12%	2000

**Engine oil capacity**

Approximate engine oil capacity with oil filter change	4.3 litres
--------------------------------------------------------	------------

## Dimensions and capacities

Dimensions		
Length, width	4,634 mm/ 4,739 mm	1,810 mm/ 1,816 mm
Height at kerb weight	1,707 mm/ 1,820 mm	
Front and rear projection	892 mm/ 907 mm	
Wheelbase	2,835 mm	
Turning circle	11.93 m	
Track width <sup>a)</sup>	Front	Rear
	1,532 mm	1,518 mm
	1,520 mm	1,506 mm
Capacities		
Fuel tank	70 l. Reserve 8 l.	
Windscreen washer fluid container with headlight washer	3.5 l/ 6 l	
Tyre pressure		
<b>Summer-grade tyres:</b>		
The correct tyre pressure can be seen on the sticker on the inside of the tank flap.		
<b>Winter tyres:</b>		
The pressure of these tyres is the same as the summer tyre pressure plus 0.2 bar.		

<sup>a)</sup> This data will change depending on the type of wheel rim.

## Index

- 4MOTION ..... 184
- A**
- ABS ..... 180  
     Warning lamp ..... 76  
     warning lamp ..... 181
- Accessories ..... 202
- Acoustic signal ..... 19
- Acoustic warning ..... 162
- Additional instruction manual  
     Roof carrier ..... 148
- Adjust seats  
     rear seats ..... 128
- Adjusting lumbar support ..... 125
- Air conditioning manual  
     faults in operation ..... 158
- Air conditioning system  
     Climatronic ..... 152  
     General notes ..... 158
- Air recirculation mode  
     Climatronic ..... 155
- Airbag cover ..... 39
- Airbag covers ..... 39
- Airbag system ..... 33  
     Curtain airbags ..... 42  
     Front airbags ..... 37  
     Side airbags ..... 40  
     Warning lamp ..... 34
- Airbags  
     Care ..... 35  
     Disposal ..... 35  
     Safety notes ..... 35
- Alarm system ..... 97  
     Switching off ..... 97
- Alterations to the vehicle ..... 202
- Alternator  
     Warning lamp ..... 78
- Anti-freeze ..... 216
- Anti-lock brake system  
     Warning lamp ..... 76
- Anti-locking brake system ..... 180  
     warning lamp ..... 181
- Anti-puncture kit ..... 234  
     Sealing and inflating tyres ..... 235
- Anti-theft alarm system ..... 97  
     Switching off ..... 97
- Anti-theft wheel bolts ..... 238
- Aquaplaning ..... 227
- Armrest ..... 131
- Ashtrays  
     Front ..... 140  
     rear ..... 141
- Automatic belt retractor ..... 23
- Automatic car washes ..... 194
- Automatic gearbox ..... 167  
     Safety interlock for ignition key ..... 163
- Automatic gearbox with Tiptronic ..... 172
- Automatic mode  
     Climatronic ..... 153
- Automatic wipe  
     Windscreen wiper and washer ..... 117
- automatic wipe  
     Rear window wiper and wash ..... 118
- B**
- Ball coupling ..... 189
- BAS ..... 180
- Battery  
     Changing ..... 224  
     Charging ..... 224  
     Winter conditions ..... 223
- Belt height adjustment ..... 27, 30
- Belt retainer ..... 30
- Belt tension device  
     Disposal ..... 31
- Belt tension devices ..... 31

- Belt tensioner
    - Warning lamp ..... 34
  - Biodiesel ..... 207
  - Bonnet ..... 211
  - Brake assist system ..... 180
  - Brake fluid ..... 221
    - Changing ..... 222
  - Brake pad wear
    - Warning lamp ..... 179
  - Brake pad wear indicator\*
    - Indicator ..... 79
  - Brake pads ..... 185
  - Brake servo ..... 179, 185
  - Brake system ..... 221
    - brake servo ..... 179
    - Warning lamp ..... 78
    - warning lamp ..... 179
  - Brakes ..... 179, 185
  - Braking distance ..... 185
  - Breakdown set
    - storage ..... 231
  - Bulb change ..... 245
  - Bulb defect
    - warning lamp ..... 78
  - Buzzer ..... 162
- C**
- Car care
    - Exterior ..... 194
  - Car care products ..... 193
  - Car phone ..... 203
  - Car washes ..... 194
  - Catalytic converter ..... 186
  - CCS ..... 176
  - CD changer
    - Location ..... 137
  - Central locking ..... 89
    - individual opening of doors ..... 90
  - Central locking button ..... 92
  - Central stowage on instrument panel ..... 134
  - Cetane number ..... 207
  - Changing a light ..... 245
  - Changing a wheel ..... 236, 240
  - Changing brake pads ..... 185
  - Changing bulbs
    - lights on tailgate/rear door ..... 247
    - Lights on vehicle body ..... 246
    - Reading light ..... 249
    - Registration plate light ..... 247
  - Changing gear
    - See Manual gearbox ..... 166
  - Changing the bulbs
    - interior light ..... 248
    - rear lights ..... 246
  - Changing the lamps
    - Side indicator lights ..... 245
  - Chassis number ..... 258
  - Checking ..... 224
  - Checking battery electrolyte level ..... 224
  - Checking engine oil level ..... 214
  - Child safety ..... 46
  - Child seat ..... 48
    - Categorisation in groups ..... 48
      - Group 1 ..... 49
      - Group 2 ..... 49
      - Group 3 ..... 49
      - Groups 0 and 0+ ..... 48
    - in front passenger seat ..... 34
    - Safety notes ..... 46
      - securing ..... 51
  - Childproof locks ..... 94
  - Cigarette lighter ..... 141
  - Cleaning alloy wheels ..... 197
  - Cleaning and caring for your vehicle ..... 193
  - Cleaning chrome ..... 197
  - Cleaning cloth seat covers ..... 199
  - Cleaning dash panel ..... 199
  - Cleaning engine compartment ..... 198
  - Cleaning fabric trim ..... 199
  - Cleaning leather ..... 200
  - Cleaning plastic parts ..... 199
  - Cleaning seat belts ..... 200
  - Cleaning windows ..... 196
  - Cleaning wooden trim ..... 199
  - Climatronic ..... 152
    - Air outlet ..... 157
    - Controls ..... 152
    - faults ..... 158
    - General notes ..... 158
    - Second cooling system ..... 156

- Clock ..... 64
    - setting ..... 67
  - Coat hooks ..... 137
  - Cockpit ..... 63
  - Code number ..... 232
  - Coming Home function ..... 110
  - Control lamps ..... 72
  - Controls
    - Electric windows ..... 102
  - Convenience closing
    - Sliding/tilting roof ..... 106
    - Windows ..... 104
  - Convenience opening
    - Windows ..... 104
  - Cool box
    - cleaning ..... 201
  - Coolant ..... 216, 217
  - Coolant Level ..... 217
  - Coolant level
    - warning light ..... 80
  - Coolant Loss ..... 217
  - Coolant temperature
    - Display ..... 65
    - Safety instructions ..... 80
  - Cooling and heating box
    - Cooling ..... 150
    - Faults ..... 151
    - Heating ..... 150
    - Notes on usage ..... 149
    - Safety notes ..... 151
    - Switching off ..... 150
  - Correct adjustment of front head restraints ..... 13
  - Cruise control system ..... 176
    - Warning lamp ..... 75
  - Cup holders ..... 137
  - Curtain airbags ..... 42
    - Description ..... 42
    - Function ..... 43
    - Safety notes ..... 43
- D**
- Daylight driving lights ..... 109
  - Deadlock ..... 92
  - Diagram of gears ..... 166
  - Diesel ..... 207
    - Diesel engine
      - Winter driving ..... 208
    - Diesel particulate filter ..... 187
      - warning lamp ..... 77
  - Differential lock fault (EDL)
    - warning lamp ..... 77
  - Dipped headlights ..... 109
  - Disabling airbag
    - front passenger airbag ..... 44
  - Disabling front and side passenger airbag
    - Safety notes ..... 45
  - Disabling frontal airbag ..... 44
  - Display
    - Instrument panel ..... 69
  - Door lock cylinders ..... 197
  - Door open display
    - warning light ..... 79
  - Door release lever ..... 63, 93
  - Drink holders ..... 137
  - Driving
    - Driving abroad ..... 187
      - Economically / With Respect for the Environment ..... 191
        - With a trailer ..... 188, 190
        - With four-wheel drive ..... 184
    - Driving abroad ..... 187
      - Headlights ..... 188
    - Driving economically ..... 191
    - Driving safety ..... 8
    - Driving with respect for the environment .... 191
    - Duplicate keys ..... 88
    - Dust filter ..... 158
    - Dynamic headlight range control ..... 110, 111
- E**
- EDL ..... 182
    - warning lamp ..... 181
  - EDS
    - Warning lamp ..... 76
  - Electric consumers ..... 115, 149
  - Electric windows
    - controls ..... 102
      - one-touch closing and opening ..... 103
      - roll-back function ..... 104
  - Electrical accessories ..... 142

- Electrical windows ..... 102
- Electronic differential lock ..... 182
- Warning lamp ..... 76
  - warning lamp ..... 181
- Electronic immobiliser ..... 163
- Electronic stabilisation program ..... 182
- Electronic stabilisation programme ..... 76
- Description ..... 161
  - warning lamp ..... 162, 183
- Electronic stabilisation programme (ESP)
- warning lamp ..... 76
- Emergency opening
- Doors ..... 97
- Engine
- Running in ..... 185
- Engine compartment
- Working in the engine compartment ..... 209
- Engine coolant ..... 216
- Engine fault
- indicator ..... 75
- Engine hood
- See* Bonnet ..... 211
- Engine management
- Warning lamp ..... 75
- Engine oil ..... 212
- Changing ..... 215
  - Checking level ..... 214
  - Oil properties ..... 213
  - Specifications ..... 212
  - Topping up ..... 215
- Engine oil dipstick ..... 214
- Engine oil pressure
- Warning lamp ..... 79
- Engine oil temperature display ..... 67
- Engine oil temperature gauge ..... 64
- Environment ..... 191
- Environmental friendliness ..... 192
- ESP ..... 76, 182
- warning lamp ..... 183
- Exhaust gas indicator ..... 76
- Exhaust gas purification system
- diesel particulate filter ..... 187
- Exterior mirrors ..... 120, 196
- External aerial ..... 203
- F**
- Fastening rings ..... 16, 144
- Fastening seat belt ..... 23
- Fault in the exhaust system\* ..... 76
- Fault messages ..... 69
- Overview ..... 69
- Faults in operation of air conditioning ..... 158
- First-aid kit ..... 143
- Floor mats ..... 15
- Fog lights ..... 109
- Foot brake
- Warning lamp ..... 75
- Four-wheel drive ..... 184
- Replacing tyres ..... 184
  - Snow chains ..... 184
  - Winter tyres ..... 184
- Front airbags ..... 37
- Description ..... 37
  - Function ..... 38
  - Safety notes ..... 39
- Front passenger airbags ..... 44
- Front seats
- adjusting ..... 125
  - heating ..... 126
  - safety instructions ..... 132
- Fuel
- Diesel ..... 207
  - Petrol ..... 207
- Fuel level
- Display ..... 66
- Fuel reserve ..... 78
- Fuel tank ..... 206
- See also* Fuel reserve ..... 78
- Fuel tank cap ..... 206
- Fuel: save ..... 191
- Fuse box ..... 242
- Fuses ..... 241
- G**
- G 12 ..... 216
- Gear selector lever
- See* Automatic gearbox ..... 170
  - See* Automatic gearbox with Tiptronic ..... 172
- General overview of the engine compartment ..... 262
- Glove compartment ..... 134
- Glove compartment light ..... 114

- Glow plug system ..... 165
- Guide lights ..... 110
- H**
- Hand brake  
warning lamp ..... 179
- Handbrake ..... 173  
Warning lamp ..... 78, 173
- Hazard warning lights ..... 111
- head restraints  
Adjusting ..... 123, 124  
fitting ..... 124  
Removing ..... 124
- Headlamp washer ..... 119
- Headlight flasher ..... 113
- Headlight range control ..... 110
- Headlights  
Driving abroad ..... 188
- Heated rear window  
Heating elements ..... 144
- High pressure cleaners ..... 195
- Hubcaps ..... 237
- I**
- Identification number ..... 258
- Ignition key ..... 162
- Ignition lock ..... 162
- Illumination of instruments and switches .... 110
- Indicator lights  
indication lamp ..... 75
- Individual opening of doors ..... 90
- Information messages ..... 69
- Instrument lighting control ..... 63
- Instrument panel ..... 63
- Instruments ..... 64
- Integrated child seat ..... 54  
Adjusting belt routing ..... 55  
Cleaning the child seat ..... 59  
Fastening harness belt ..... 56  
Group 1 ..... 54  
Group 2 ..... 57  
Group 3 ..... 58  
Releasing harness belt ..... 57
- Interior light ..... 115
- Interior lights ..... 114
- Interim monitoring system ..... 98
- Intermittent wipe  
rear window wiper ..... 118  
windscreen wiper ..... 117
- J**
- Jack ..... 239
- Jump leads ..... 249
- Jump-starting ..... 249
- K**
- Key tab ..... 88
- Key with remote control ..... 95  
buttons ..... 95
- Keys ..... 88
- Kick-down function ..... 172
- L**
- Lifting platform ..... 255
- Lifting the vehicle ..... 255
- Lighting of controls ..... 63
- Lights ..... 109
- Load compartment  
*See* Luggage compartment ..... 15
- Loading area  
*See* Luggage compartment ..... 143
- Locks ..... 197
- Luggage compartment ..... 15, 143  
*See also* Luggage compartment ..... 15, 143
- Luggage compartment cover ..... 146
- M**
- Main beam ..... 113
- Main beam headlights  
Indicator lamp ..... 75
- Manual gearbox ..... 166
- Manual mode  
Climatronic ..... 154
- Mileage display ..... 67, 68

- Mirrors
- Exterior mirrors ..... 120
  - Interior mirror ..... 119
  - Make-up mirrors ..... 115
- Mobile phone ..... 203
- Modifications ..... 202
- Multifunction steering wheel ..... 86
- N**
- Navigation system\* ..... 85
- Net bag ..... 147
- Number of seats ..... 18
- O**
- Observations ..... 187
- Octane number ..... 207
- Oil ..... 212
- Oil change ..... 215
- Oil properties ..... 213
- On board computer with multifunction display\*
- Check working ..... 81
  - Message on display ..... 81
- One-touch closing and opening  
electric windows ..... 103
- Overview
- Control lamps ..... 72
  - Instrument panel ..... 63
  - Instruments ..... 64
- Multifunction steering wheel ..... 86
- Warning lamps ..... 72
- P**
- Paintwork
- Polishing ..... 196
  - Waxing ..... 195
- Parking ..... 173
- Parking aid ..... 174
- Parking distance warning system ..... 174
- Parking lights ..... 113
- Parts ..... 202
- Parts replacement ..... 202
- Passenger compartment
- Climatronic ..... 156
- Pedals ..... 15
- Petrol ..... 207
- Trips to foreign countries ..... 187
- Physical principles of a frontal collision ..... 20
- Plastic key tab ..... 88
- Plastic parts ..... 196
- Pollution filter ..... 158
- Power steering ..... 184
- Preheating system
- indicator ..... 75
- R**
- Raising the vehicle with the vehicle tool kit jack . . .  
239
- Reading lights ..... 114
- Rear door
- driving with the tailgate open ..... 100
- Rear fog light ..... 109
- Warning lamp ..... 75
  - warning light ..... 109
- Rear seats
- characteristics of seat equipment ..... 127
  - moving ..... 128
  - safety instructions ..... 132
- Rear window heating ..... 116
- Heating element wires ..... 197
- Rear window wiper ..... 118
- Rear-view mirror ..... 119
- Refilling ..... 206
- Remote control key
- Replacing the battery ..... 96
  - Synchronising ..... 96
- Repairs
- Airbags ..... 35
- Replacement keys ..... 88
- Replacing the battery
- Remote control key ..... 96
- Replacing tyres
- Four-wheel drive ..... 184
- Retractor
- See Automatic belt retractor ..... 23
- Retrofitting a towing bracket ..... 204
- Rev counter ..... 65



- Reverse gear
    - Automatic gearbox ..... 170
    - Manual gearbox ..... 166
  - Risk of front passenger seat airbag for a rear facing child seat ..... 34
  - RME fuel (biodiesel) ..... 207
  - Roll-back function
    - Sliding/tilting roof ..... 107
    - windows ..... 104
  - Roof aerial\* ..... 203
  - Roof carrier ..... 148, 149
    - saving fuel ..... 149
  - Roof load ..... 149
  - Rubber seals ..... 197
  - Running in
    - Brake pads ..... 185
    - Engine ..... 185
    - Tyres ..... 185
  - Running in tyres ..... 185
- S**
- Safe driving ..... 7
  - Safety ..... 8
  - Safety equipment ..... 7
  - Safety instructions
    - Coolant temperature ..... 80
  - Safety notes
    - Belt tension devices ..... 31
    - Curtain airbags ..... 43
    - Disabling front and side passenger airbag . 45
    - Front airbags ..... 39
    - Side airbags ..... 41
    - Using child seats ..... 46
    - Using seat belts ..... 22
  - Saving fuel
    - roof carrier ..... 149
  - Sealant ..... 234
  - Seals ..... 197
  - Seat adjustment ..... 122
    - Front seats ..... 125
  - Seat belt position
    - Pregnant women ..... 26
  - Seat belts ..... 25
  - Seat belt warning lamp ..... 18
  - Seat belts ..... 18
    - Detachable ..... 29
    - Incorrectly fastened ..... 31
    - Not worn ..... 21
    - one buckle ..... 23
    - Safety notes ..... 22
    - Warning lamp ..... 18
    - With two buckles ..... 24
  - Seat belts protect ..... 22
  - Seat heating ..... 126
  - Seat layout ..... 127
  - Seats ..... 18
    - Folding backrest forwards ..... 129
    - Lifting seat ..... 129
    - Removing and fitting ..... 130
  - Securing load ..... 149
  - Selector lever lock ..... 168
  - Service interval display ..... 68
  - Shoes ..... 15
  - Side airbags ..... 40
    - Description ..... 40
    - Function ..... 41
    - Safety notes ..... 41
  - Side lights ..... 109
  - Sitting position
    - Driver ..... 10
    - Front passenger ..... 11
    - Incorrect sitting position ..... 14
    - Passengers ..... 12
  - Sitting position, occupants ..... 10
  - Sliding/tilting sun roof ..... 105
  - Snow chains ..... 230, 261
    - Four-wheel drive ..... 184
  - Sockets ..... 142
  - Spare wheel
    - Storage ..... 231
    - storage ..... 231
  - Speedometer ..... 64
  - Starting
    - a petrol engine ..... 164
  - Starting the engine
    - after the fuel tank has been run dry ..... 165
    - With the ignition key ..... 164
  - Steam cleaners ..... 195
  - Steering ..... 160
    - Steering lock ..... 162

- Steering wheel audio controls
    - audio + telephone version . . . . . 86
    - audio version . . . . . 86
  - Steering wheel height adjustment . . . . . 160
  - Stowage
    - Other stowage areas . . . . . 136
  - Stowage compartment
    - Front passenger side . . . . . 134
  - Sun visor
    - front . . . . . 115
  - Sunroof blind
    - Sliding/tilting roof . . . . . 106
  - Switches
    - Exterior mirrors . . . . . 120
    - Hazard warning lights . . . . . 111
    - lights . . . . . 109
    - Sliding/tilting roof . . . . . 105
  - Switching off the engine
    - With the ignition key . . . . . 165
- T**
- Tailgate . . . . . 99
    - Closing . . . . . 100
    - Convenience opening . . . . . 99
    - Opening . . . . . 99
    - safety instructions . . . . . 101
  - Tailgate open display\*
    - warning light . . . . . 79
  - Tank
    - Fuel level . . . . . 66
    - Tank capacity . . . . . 66
  - Tank capacity . . . . . 206
  - TCS . . . . . 183
  - TCS (Traction control system)
    - Warning lamp . . . . . 76
  - The danger of not using the seat belt . . . . . 21
  - Thermos box
    - cleaning . . . . . 201
  - Tightening torque of wheel bolts . . . . . 261
  - Tools . . . . . 231
  - Towing . . . . . 252
  - Towing a trailer . . . . . 188, 260
  - Towing bracket . . . . . 189
  - storage . . . . . 231
  - Towing eye . . . . . 252
  - Towline anchorage
    - Rear . . . . . 253
  - Tow-starting . . . . . 252, 253
  - Traction control system
    - warning lamp . . . . . 76
  - Trailer turn signals
    - Indicator lamps . . . . . 74
    - Warning lamp . . . . . 113
  - Trailer weights . . . . . 260
  - Trips, checklist . . . . . 8
  - Turn signals . . . . . 113
    - Warning lamp . . . . . 75, 113
  - Two-way radio . . . . . 203
  - Type plate . . . . . 258
  - Tyre pressure . . . . . 226
  - Tyre pressures . . . . . 260
  - Tyres and wheels
    - Dimensions . . . . . 227
    - Tyres service life . . . . . 226
    - Tyres tread depth . . . . . 227
    - Tyres with directional tread pattern . . . . . 225
- U**
- Underbody sealant . . . . . 198
  - Unfastening seat belt
    - (with one buckle) . . . . . 27
  - Unfastening seat belts
    - (with two buckles) . . . . . 28
  - Upper right stowage on instrument panel . . . 135
- V**
- Vehicle
    - Lifting . . . . . 255
  - Vehicle battery . . . . . 223
  - Vehicle data . . . . . 258
  - Vehicle identification data . . . . . 258
  - Vehicle identification number . . . . . 258
  - Vehicle paint
    - Car care products . . . . . 193
  - Vehicle tool kit jack . . . . . 239
  - Vehicle tools . . . . . 231
    - storage . . . . . 231

- Vehicle wallet storage ..... 134
- Ventilation slits ..... 16, 144
- Voltmeter ..... 67
- W**
- Warning lamp ..... 34
- warning lamp
  - diesel particulate filter ..... 77
  - ESP ..... 183
  - exhaust gas indicator ..... 76
- Warning lamps ..... 72
- Warning messages ..... 69
- Warning triangle ..... 143
- Warnings ..... 71
- Washer fluid ..... 218
- Washing by hand ..... 194
- Washing the vehicle ..... 194
- Washing with high pressure cleaners ..... 195
- Water in the windscreen washer tank ..... 218
- Wear indicators ..... 227
- Wheel bolt caps ..... 237
- Wheel bolts ..... 238, 261
  - Torque ..... 228
- Wheels ..... 225, 260
- Why assume the correct sitting position? ..... 33
- Why should head restraints be correctly adjusted?  
13
- Why wear seat belts? ..... 18, 20
- Why wear seatbelts? ..... 33
- Window aerial ..... 144
- Windows ..... 102
  - Opening and closing electrically ..... 102
- Windscreen heating ..... 116
- Windscreen washer fluid
  - Warning lamp ..... 79
- Windscreen wiper ..... 117
- Windscreen wiper blades
  - Cleaning ..... 197
- Windscreen wipers
  - Changing the front blades ..... 219
  - Changing the rear blade ..... 220
- Winter driving
  - Diesel engine ..... 208
- Winter tyres ..... 229
  - Four-wheel drive ..... 184
- Working in the engine compartment ..... 209

SEAT S.A. is permanently concerned about continuous development of its types and models. For this reason we ask you to understand, that at any given time, changes regarding shape, equipment and technique may take place on the car delivered. For this reason no right at all may derive based on the data, drawings and descriptions in this current handbook.

All texts, illustrations and standards in this handbook are based on the status of information at the time of printing. Except for error or omission, the information included in the current handbook is valid as of the date of closing print.

Re-printing, copying or translating, whether total or partial is not allowed unless SEAT allows it in written form.

SEAT reserves all rights in accordance with the "Copyright" Act.

All rights on changes are reserved.

 This paper has been manufactured using bleached non-chlorine cellulose.

© SEAT S.A. - Reprint: 15.09.07

Inglés S82551ABA20 (07.07) (GT9)

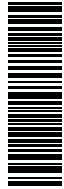

S82551ABA20



**SEAT**  
auto emoción