



GRANDE

OWNER'S MANUAL & SERVICE BOOK

TATA MOTORS

CAR IDENTIFICATION AND RECORD

OWNER'S NAME _____

ADDRESS _____

SELLING DEALER CODE _____

DATE OF DELIVERY _____

DATE OF REGISTRATION _____

REGISTRATION NO. _____

CHASSIS NO. _____

ENGINE NO. _____

GEAR BOX NO. _____

REAR AXLE NO. _____

BATTERY MAKE _____

BATTERY SR. NO. _____

BATTERY CODE _____

THE WARRANTY ON THIS CAR IS VALID ONLY IF THE DETAILS ARE
FILLED, SIGNED & STAMPED BY THE SELLING DEALER.

DEALER'S SIGNATURE
AND STAMP



**Following items are provided with
your TATA SUMO GRANDE :**

1. Owner's Manual & Service Book
2. Battery Warranty Card
3. First Aid Kit
4. Advance Warning Triangle
5. Jack & Handle
6. Spare Headlamp Bulbs - 2 Nos.
7. Spare Fuses (Provided in fuse box)
8. Tool Kit
 - a. Spanner C8X10
 - b. Screw Driver 1.0X6.5X150
 - c. Screw Driver A1X75
 - d. Wheel Spanner 18 A/F
 - e. Slip Joint Plier
9. Manufacturer's Manual for Music System (If fitted)

TATA GRANDE

(DICOR / TURBO)

Owner's Manual & Service Book

This owner's manual should be considered as a permanent part of the vehicle and must remain with the vehicle.

TATA MOTORS

Passenger Car Business Unit (PCBU)

● Mumbai ● Pune ●

- **This Owner's Manual is advised to be kept in the vehicle at all times.**
- **This book will help you to understand the vehicle better, maximise uptime of the vehicle & obtain better performance at optimum cost.**
- The recommended routine maintenance servicing along with any running repairs that may be required, should be entrusted to TATA Authorised Workshop to ensure that only latest methods and genuine **TATA MOTORS** replacement parts are used for the continued reliability, safety and performance of the vehicle.
- Some of the items / accessories / features shown / given in this book may not be fitted on your vehicle, but they are applicable for other versions of **TATA GRANDE.**
- **(C) Copyright 2004 TATA MOTORS**
- All rights reserved. The material in this manual may not be reproduced or copied, in whole or in part, in any form without written permission from **TATA MOTORS.**
- The information and specifications given in this book are valid as on the date of printing. **TATA MOTORS** Limited reserves the right to make changes in design and specifications and/or to make additions to or improvements in this product without obligation to install them on products previously sold.
- In the event of the Vehicle being sold, please ensure that this manual is left in the vehicle for the reference of the new owner.

Dear Customer,

Thank you for selecting **TATA GRANDE** the vehicle of your choice

We welcome you to the world of advanced automotive engineering in a form especially suited to your operating conditions.

This book gives you all the information necessary for making your ownership of this vehicle a thoroughly satisfying experience.

To assist you in maintaining your vehicle as per recommended schedule, we have a widespread network of dealers and service centres. The list is included in this book for your convenience.

Should you need any special assistance, please call on our Regional / Area offices which are also listed in this book.

Please note that by adhering to the correct operating procedures and by availing the scheduled maintenance services at our authorised service centres, you can obtain the maximum performance from your vehicle.

We request you to go through the book and derive many miles of motoring pleasure.

WE WISH YOU GOOD LUCK AND PROSPERITY

TATA MOTORS LIMITED

IMPORTANT INFORMATION ABOUT THIS MANUAL

Safety and vehicle damage warnings

In this manual, you will see CAUTION and NOTICE warnings.

CAUTION

This is a warning. May cause injury to people if the warning is ignored. You are informed what you must or must not do in order to avoid or reduce the risk to yourself and other people.

NOTICE

This is a warning. May cause damage to the vehicle or its equipment if the warning is ignored. You are informed what you must or must not do in order to avoid or reduce the risk of damage to your vehicle and its equipment.

WARNING

Indicates a strong possibility of severe personal injury or death if the instructions are not followed.

Safety symbol



In this manual, you will also see a circle with a slash. This means "Do not", "Do not do this", or "Do not let this happen".

Know your TATA GRANDE	6	Fuel Flap Tank Opening	44
Warranty - Terms & Condition	8	Gear Shift Lever & Parking Brake	45
Environmental Care	10	Anti Theft / Immobiliser system	46
Tata Grande At A Glance		Getting Started	
Driving Controls	13	Key & Door Lock	54
Instrument Cluster	14	Child Lock	55
Operating Switches	22	Tail Gate Locking / Opening	55
Steering Lock cum Ignition Switch	24	Seats, Seat Adjustments & Seat Belts	56
Combi Switch	25	Driving	
Analog Clock & Music System	28	Checks Before Driving	64
Heating, Ventillation & Air Conditioning	29	Safety Checks	64
Lamps	35	Fuel Saving Tips	66
Sun visor, Goggle case & Grab Handle	38	Starting & Stopping the Engine	67
Rear View Mirrors	39	Gear Shifting	67
Glove Box, Cup holder & Utility Pockets	40	Braking	69
Cigarette lighter	41	Driving In Adverse Conditions	70
Power Windows & Manual Window Winding	42	Incase Of Emergency	
Rear Side Glasses	43	Jack Location / Warning Triangle	72
Steering Wheel Position Adjustment	43	Flat Tyres replacement	73

Contents

Spare Wheel	73
Limp Home Mode	75
Starting The Engine with Jump Leads	76
Towing the Vehicle	77
Routine Service	78

Preliminary Trouble shooting 79

Electrical Maintenance

Fuses & Relays	86
Bulb Specification	90
Bulb Replacement	91

Vehicle Care

Washing & Cleaning	94
General Precautions	96

Maintenance

Opening & Closing The Bonnet	99
Engine Compartment	100
Air Filter & Engine Oil	102
Engine Coolant	103
Brake Fluid & Power Steering Reservoir	104
Clutch Fluid & Sedimenter	106

Fuel Filter & Priming Pump	107
Windshield washer & Tyre	109
Tyre Inspection	110
Tyre Rotation	111
Wheel Alignment, Balancing & Catalytic converter maintenance	112
Battery	113

Important Technical Information

Belt Tension	114
Fuel, Lubricants & Coolants	115
Oil Filling & Drain Points	118
Technical Specification	119
Information At a Glance (Dimensions)	122

Vehicle Identification

Location of Aggregate Number	123
------------------------------	-----

PDI Service 125

Service Schedule 127

Record of Repairs Carried Out 134



Your **TATA GRANDE** is a new generation multi utility vehicles and is a result of extensive research and development by **TATA MOTORS LIMITED**. This vehicle also incorporates all the well known and proven features of **TATA MOTORS** precision and advanced technology.

Easy maneuverability and economic life cycle cost makes **TATA GRANDE** ideal for operating in both urban as well as rural areas.

This vehicle is powered by 4DL TCIC BS-III Engine and a new generation 2.2L DICOR BS-III engine which is in turn mated to a 5 speed fully synchromesh gearbox with overdrive for excellent fuel efficiency and tubeless tyres for better road holding and grip.

Your **TATA GRANDE**'s 2.2L DICOR engine is a refined power plant employing a sophisticated common rail fuel system. The engine's ECU (Electronic Control Unit), basically a 32 bit microprocessor, controls the engine's fuel injection, operation of the Variable Geometry Turbocharger (VGT) and other related parameters for it to perform optimally.



Know Your Tata Grande

Your **TATA GRANDE** has Vacuum assisted independent hydraulic brakes on the front and rear wheels through tandem master cylinder and tandem booster, ventilated front disc brakes with twin pot calipers on front wheels for better braking and safety. The front independent suspension setup has telescopic shock absorbers and an anti roll bar. The rear suspension is via parabolic springs. This suspension setup ensures good road holding and stability. The 483 DL TC IC is a SOHC, turbocharged engine with intercooler, and indirect fuel injection system.



An ergonomically designed cab with added features like collapsible power steering, central locking, power windows, highly effective HVAC for comfort, music system, state of art headlamp and rear lamps, good all-found visibility and easy access to areas of daily maintenance is some of the other user-friendly features of the **TATA GRANDE**.

TATA vehicles are backed by well established service network with trained and skilled manpower ensuring proper maintenance. Timely maintenance and servicing as recommended in this manual ensure trouble free operation over long year.

WARRANTY - TERMS & CONDITIONS

We **WARRANT** each **TATA GRANDE** vehicles & parts thereof manufactured by us to be free from defect in material and workmanship, subject to the following terms & conditions :

1. This warranty shall be for 3 years from the date of sale of the vehicle or 1,00,000 kms whichever occurs earlier. However, for the vehicles with yellow number plates used for commercial application (including those used for hire or reward viz those operating with a yellow no plate), the warranty shall be limited to 2 years or 75,000 kms whichever occurs earlier.
2. Our obligation under this warranty shall be limited to repairing or replacing, free of charge, such parts of the vehicle which, in our opinion, are defective, on the vehicle being brought to us or to our dealers within the warranty period. The parts so repaired or replaced shall also be warranted for quality and workmanship but such warranty shall be co-terminus with this original warranty.
3. Any part which is found to be defective and is replaced by us under the warranty shall be our property.
4. As for such parts as tyres, batteries, transfer case, rubber parts, electrical equipment and fuel injection equipment, power steering equipment, A.C. equipment not manufactured by us but supplied by other parties, this warranty shall not apply, but buyers of the vehicle shall be entitled to, so far as permissible by law, all such rights as we may have against such parties under their warranties in respect of such parts. Our Dealers/TASC's will assist the purchaser in taking up the complaint with the respective manufacturers and their decision on the warranty will be final.
5. This warranty shall not apply if the vehicle or any part thereof is repaired or altered otherwise than in accordance with our standard repair procedure, or by any person other than our sales or service establishments, our authorised dealers or service centres or service points in any way so as, in our judgement which shall be final and binding, to effect its reliability, nor shall it apply if, in our opinion which shall be final and binding the vehicle is subjected to misuse, negligence, improper or inadequate maintenance or accident or loading in excess of such carrying capacity as certified by us, or such services as prescribed in our Owner's Manual and Service Book are not carried out by the buyer through our sales or service establishments, our authorised dealers or service centres or service points.
6. This warranty shall not cover normal wear and tear or any inherent normal deterioration of the vehicle or any of its parts arising from the actual use of the vehicle or any damage due to negligent or improper operation or storage of the vehicle. This warranty shall not apply to normal maintenance services viz. oils & fluid changes, head lamps focussing, fastener

WARRANTY - TERMS & CONDITIONS

- retightening, wheel balancing, tyre rotation, adjustment of valve clearance, fuel timing, ignition timing and consumables like bulbs, fuel filters and oil filters etc. This warranty shall not apply to any damage or deterioration caused by environmental pollution or bird droppings. This warranty shall not apply to V-belts, hoses and gas leaks in case of air conditioned vehicle. Slight irregularities not recognised as affecting the function or quality of the vehicle or parts such as slight noise or vibration and defects appearing only under particular or irregular operations or items considered characteristic of the vehicle.
7. This warranty shall be null and void if the vehicle is subjected to abnormal use such as rallying, racing or participation in any other competitive sports. This warranty shall not apply to any repairs or replacement as a result of accident or collision.
8. This warranty is expressly in lieu of all warranties, whether by law or otherwise, expressed or implied, and all other obligations or liabilities on our part and we neither assume nor authorise any person to assume on our behalf, any other liability arising from the sale of the vehicle or any agreement in relation thereto.
9. The buyer shall have no other rights except those set out above and have, particular, no right to repudiate the sale, or any agreement or to claim any reduction in the purchase price of the vehicle, or to demand any damages or compensation for losses, incidental or indirect, or inconvenience or consequential damages, loss of vehicle, or loss of time, otherwise, incurred or accrued.
10. Any claim arising from this warranty shall be recognised only if it is notified in writing to us or to our concerned dealer without any delay soon after such defect as covered and ascertained under this warranty.
11. This warranty shall stand terminated if the vehicle is transferred or otherwise alienated by the buyer without our prior written consent.
12. We reserve our rights to make any change or modification in the design of the vehicle or its parts or to introduce any improvement therein or to incorporate in the vehicle any additional part or accessory at any time without incurring any obligation to incorporate the same in the vehicles previously sold.

TATA MOTORS LIMITED

TATA MOTORS LTD. is committed to produce the vehicles using environmentally sustainable technology. A number of features have been incorporated in Tata Motors passenger vehicles which have been designed to ensure environmental compatibility throughout the life cycle of the vehicle. We would like to inform you that your vehicle meets emission norms and this is being regularly validated at the manufacturing stages.

As a user you too can protect the environment by operating your vehicle in a proactive manner. A lot depends on your driving style and the way you maintain your car. We have given few tips below for your guidance.

DRIVING

- Avoid frequent and violent accelerations.
- Do not carry any unnecessary weight on the vehicle as it overloads the engine. Avoid using devices requiring high power consumption during slow city traffic condition.
- Monitor the vehicle's fuel consumption regularly and if showing rising trend get the vehicle immediately attended at the Company's Authorised Service Outlets.
- Switch off the engine during long stops at traffic jams or signals. If you need to keep the engine running, avoid unnecessary revving it up or stopping and starting.
- It is not necessary to rev up

the engine before turning it off as it unnecessarily burns the fuel.

- Shift to higher gears as soon as it is possible. Use each gear upto 2/3rd of it's maximum engine speed. A chart indicating gear shifting speeds is given in this book.

MAINTENANCE

- Ensure that recommended maintenance is carried out on the vehicle regularly at the Authorised Service Outlets.
- As soon as you see any leakages of oil or fuel in the vehicle we recommend to get it attended immediately.
- Use only recommended grades and quantity of lubricants and clean/uncontaminated and correct fuels.

Know Your Tata Grande

ENVIRONMENTAL CARE

- Get your vehicle checked for emission periodically by authorised dealer
- Ensure that fuel filter, oil filter and breather are checked periodically and replaced, if required, as recommended by Tata Motors.
- Do not pour the used oils or coolants into the sewage drains, garden soil or open streams. Dispose the used filters and batteries in compliance with the current legislation.
- Do not allow unauthorised person to tamper with engine settings or to carry modifications on the vehicle.
- Never allow the vehicle to run out of fuel.
- Parts like brake liners, clutch disc should be vacuum cleaned. Do not use

the compressed air for cleaning these parts which may spread the dust in the atmosphere.

- **While carrying out the servicing or repairs of your vehicle you should pay keen attention to some of the important engine aggregates and wiring harness which greatly affect emission. These components are :-**

1. **Fuel injection equipments - pump, rail, injectors, Nozzles and high pressure pipes.**
2. **Air Intake & Exhaust system especially for leakages.**
3. **Cylinder head for valve leakage.**
4. **All filters such as air, oil & fuel filters (check periodically).**

5. **Turbocharger & Vacuum Modulator OR it's vacuum hoses.**
6. **EGR System & components.**
7. **Electrical connections**
8. **'Service' lamp contineously glows, please take the vehicle to Service Station.**
9. **Catalytic Converter**
10. **EMS wiring harness i.e. electrical connections to all sensors and actuators.**

This owner's manual contains further information on driving precautions and maintenance care leading to environment protection. Please familiarise yourself with these aspects before driving.

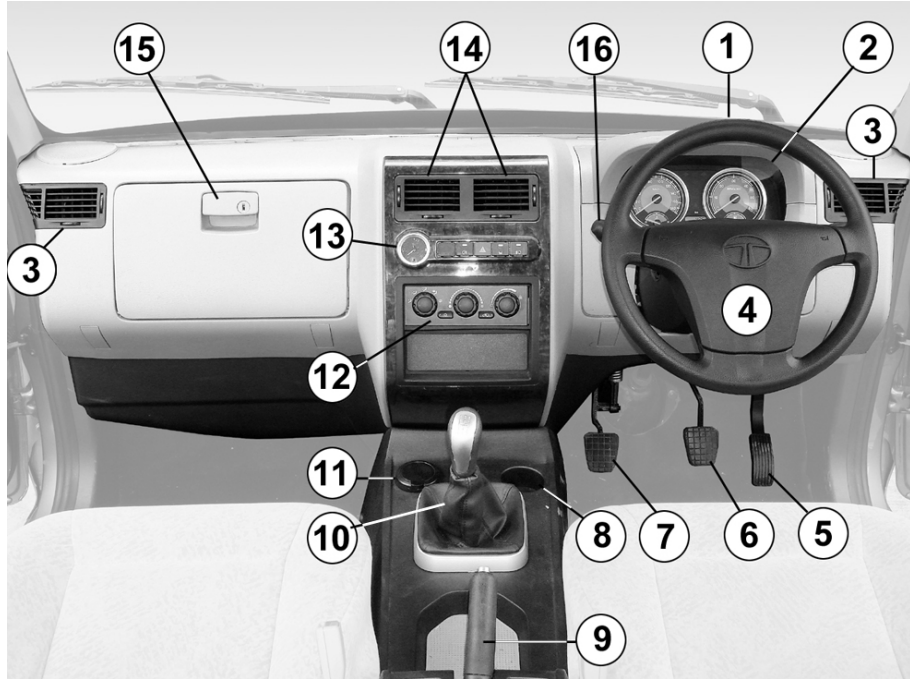

1. Steering Wheel
2. Instrument Cluster
3. Side Air Vents
4. Horn Pads
5. Accelerator Pedal
6. Brake Pedal
7. Clutch pedal
8. Cup Holder
9. Parking Brake
10. Gear Shifting Lever
11. Coin Box
12. Music System
12. A.C.Controls
13. Analog Clock
14. Central A.C. Air Vents
15. Glove Box

Tata Grande At a Glance

INSTRUMENT CLUSTER (GX)

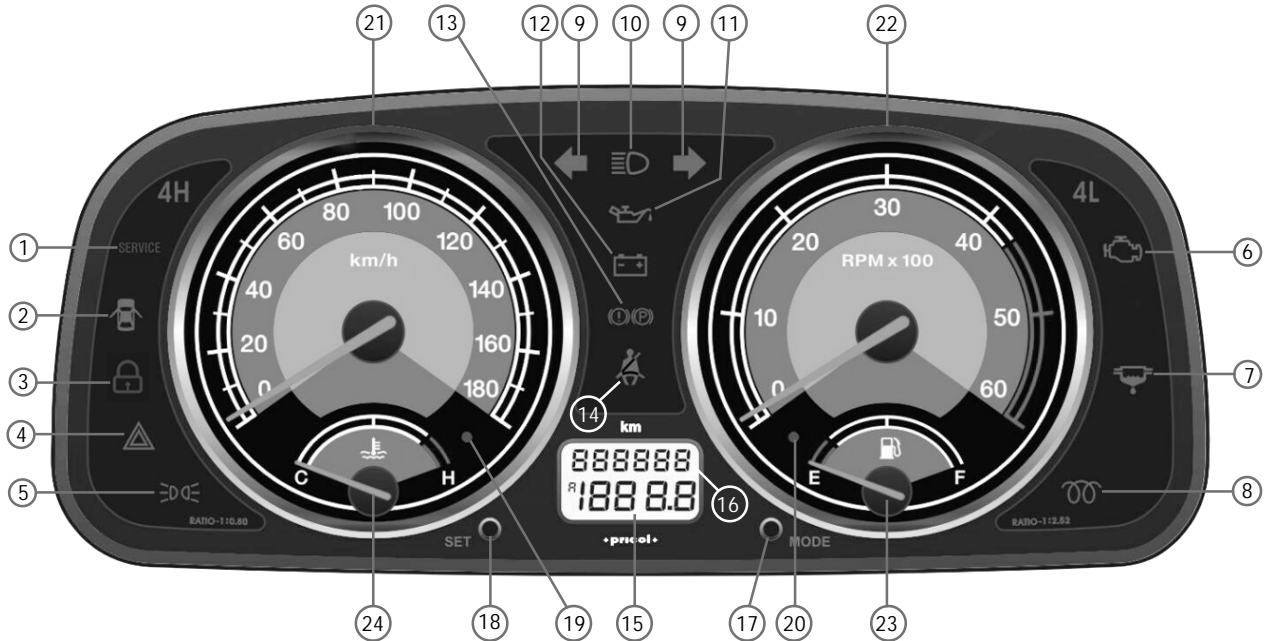

All indicators may not be provided on some instrument cluster and may not be applicable to all models.

Tata Grande At a Glance

INSTRUMENT CLUSTER (EX)

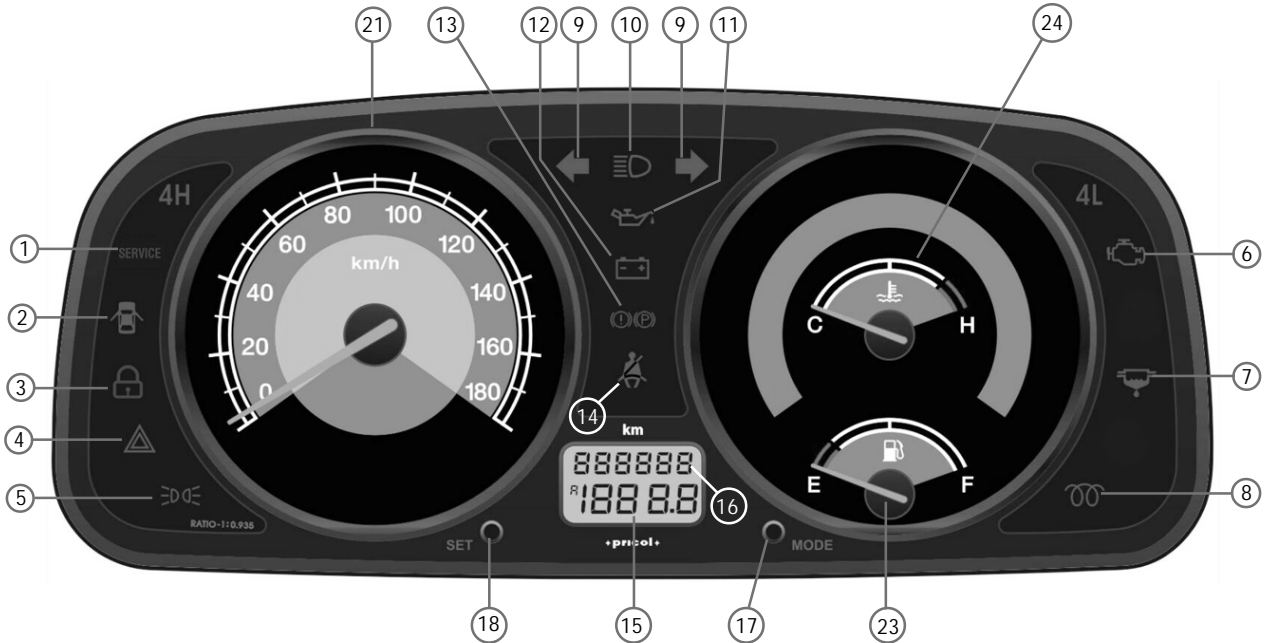

All indicators may not be provided on some instrument cluster and may not be applicable to all models.

Tata Grande At a Glance

INSTRUMENT CLUSTER

1. SERVICE Indicator (Red)
2. Door Open Indicator (Red)
3. Lock Indicator Warning Light
4. Hazard Warning Indicator
5. Position Lamp Indicator
6. MIL Indicator (Amber) If fitted
7. High Water level Indicator in Sedimenter (Amber)
8. Glow Plug "ON" Indicator (Amber) - If fitted
9. Direction Indicator (Green)
10. Head Lamp Main Bean Indicator (Blue)
11. Low Engine Oil Pressure Indicator (Red)
12. Battery Charging Indicator (Red)
13. Brake Fluid Level Check/Parking Brake Indicator (Red)
14. Seat Belt Indicator (Red)
15. Trip Odometer
16. Cumulative Odometer
17. Mode Selector Knob (Odometer)
18. Set Knob (Odometer)
19. High Temperature Warning
20. Low Fuel warning
21. Speedo Meter
22. RPM Meter
23. Fuel Gauge
24. Temperature Gauge

INSTRUMENT CLUSTER

SERVICE Indicator :**SERVICE**

This lamp indicates your vehicle's engine condition when a malfunctioning occurs in the engine, wiring harness, EMS, etc. this lamp indicates as below:

1. Comes 'ON' when key is in 'IGN' position and goes 'OFF' when engine is running.
2. Remains "ON" while the engine is running if malfunctioning occurs.

⚠ CAUTION

When "Service" lamp is ON while the engine is running, the engine's performance deteriorates marginally and sometimes drastically. Please get the malfunctioning rectified at a nearest authorized service outlet.

Door Open Warning:

Prior to driving ensure that all the door are properly closed. If any

one of the doors is partially open, the door open indicator will come on. In addition to this, in case driver side door is not properly closed an audio beep will come for few seconds, when the key is inserted.

Hazard Warning:

This can be operated without ignition 'ON'. Press the hazard warning switch (red knob) on the centre of the dash board, all turn indicator lights will flash simultaneously to warn the other road users about any hazardous condition of the car. Press the knob again to switch 'OFF' the hazard function.

NOTE

If lights do not blink or blink rapidly, it is an indication of problem in the blinker electrical system or the indicator bulb at front or rear has fused. Get it rectified immediately.

Position Lamp Indicator :

Symbol lights up when the position lamps are switched 'ON'. (instrument cluster illumination lamps when the position lamps are 'ON'). Position lamps can be used as parking lamps.

Malfunction Indicator Lamp - MIL (if installed)

This indicator comes 'ON' when the ignition is turned on and goes OFF once the engine is cranked. The indicator remains on for any engine sensor related fault due to which emissions of the vehicle may cross the regulatory limit.

⚠ CAUTION

MIL illuminates / flashes when a malfunction occurs in the engine emission system. Do not drive the vehicle if this indicator remains 'ON' or Flashes. Get the problem attended to immediately

INSTRUMENT CLUSTER

at a TATA Authorised Service Outlet. Driving the car in this condition may cross the regulatory emission limit and / or damage the catalytic converter.

Water in fuel sedimenter indicator :(DICOR)



This light indicates excess water accumulation in the sedimenter. It will come on when ignition is turned 'ON' and will go off in approximately five seconds. When this lamp remains ON, water needs to be drained from sedimenter immediately.

⚠ CAUTION

If water is not drained from the sedimenter, it can cause serious damage to the fuel injection system.

Lock Indicator Warning Light :



This system disables the starter motor circuit, ignition supply and fuel cutoff solenoid supply. The vehicle can be unlocked only pressing the "Unlock" button of the corresponding vehicle remote.

It will blink when vehicle is immobilised condition. Unlock with remote and start vehicle.

Turn Signal:



Turn signal lamps can be operated only when the ignition supply is 'ON' and by using the turn indicator switch on the combi switch. The direction indicator arrow ◀ (LHS) and ▶ (RHS) on the instrument cluster flashes along with external indicator lights as selected.

High Beam Indicator:



Symbol lights up when the headlamp high beam is 'ON'.

Low Oil Pressure Indicator:



When the ignition key is turned to the 'IGN' position, symbol lights up and goes off as soon as the required engine oil pressure is developed after starting the engine.

If the low oil pressure indicator does not glow or remains 'ON' with the 'IGN' on and engine is running, it indicates a fault in the electrical circuit/lubrication system. Check & get the problem attended to at an Authorised Service outlet.

Battery Indicator:



Symbol lights up when the 'IGN' is turned 'ON' and should go 'OFF' after the engine starts.

NOTE

If it remains 'ON' while the engine is running. It indicates that the battery is not getting charged. Switch off all unnecessary electrical equipment and get the problem attended to at an Authorised Service outlet.

Parking Brake Indicator cum Low Brake Fluid Warning Light :



This indicator has multiple functions as follows :

- It lights up when the parking brakes is applied and goes off when parking brake is released.
- It also lights up when brake fluid level is low.

- When ignition key is turned to "IGN" position, this indicator lights up and goes off when engine starts in normal condition. If it continuously ON while engine is running, get the problem attended to an Authorised Service Outlet.

Seat Belt Indicator:



The indicator initially flashes with a buzzer for 6.5 sec. when the ignition is ON and seat belt is not fastened. It will continue to flash until the vehicle exceeds a speed of 10 kmph. After that, it will remain continuously ON accompanied by a buzzer that will buzz approximately for 100 seconds. After that, the buzzer goes OFF but the indicator continues to remain ON.

Odometer and Trip meter (on LCD):

The odometer records the total distance the vehicle has been driven. The trip meter can be used to measure the distance traveled on each trip or between fuel fillings. Keep track of the odometer reading & follow the maintenance schedule regularly for meeting service requirements.

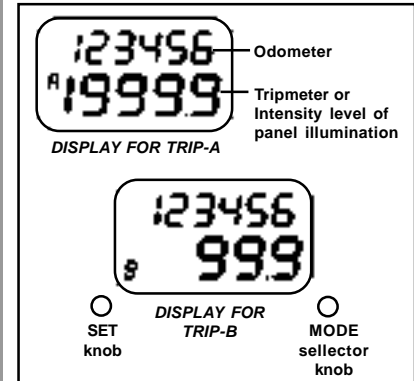

INSTRUMENT CLUSTER

Odometer, Trip meter and Illumination intensity control on instrument panel (LCD):

The instrument panel has an LCD to display the following :

Main Odometer (Non- resettable)

- Counts up to 999999 kms

- Trip meter A (Resettable) - Counts up to 1999.9 kms
- Trip meter B (Resettable) - Counts up to 1999.9 kms
- Intensity level of instrument panel illumination – selection among preset levels.

LCD has two line display. The first line displays the Odometer count.

The second line displays either of Trip meter A, Trip meter B, Intensity level of panel illumination.

The selection and control of functions are done through 'MODE' and 'SET' push buttons (knobs) provided on either side of

the LCD. The 'MODE' knob is used to select one of the Trip meter A, Trip meter B OR Intensity level of panel illumination. Switching among the above three functions can be done by pressing the knob.

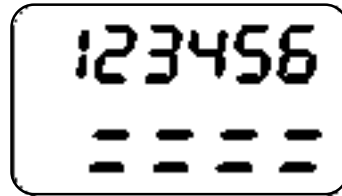

Intensity Level Indicator

The 'SET' knob is used to control the chosen function. Pressing the knob for a few seconds resets the chosen trip meter and varies the intensity level of instrument panel illumination.

The panel illumination intensity varies among preset levels as follows:

= Min

=== Max

This display returns to Trip meter A after a few seconds of intensity level selection, if left in this mode.

NOTE

Main odometer and trip meter 'A' indication will remain on display even if the ignition key is removed.

Low Fuel Indicator:



(Amber/Orange) :

It comes on when fuel level in low and needs refill at the earliest.

Temperature gauge:

The gauge indicates the temperature of the engine coolant. The red zone at 'H' indicates temperature higher than the normal. Avoid driving, when the pointer is in the red zone. It indicates engine overheating, which may be due to insufficient coolant in the radiator or due to any other defect. At this stage take the car to the nearest Authorised Service outlet for necessary attention.

Caution: *Never remove the radiator pressure cap from the radiator when the engine is hot. Do not restart the engine until the problem has been duly attended.*

The speedometer: The speedometer indicates the vehicle speed in km/hr.

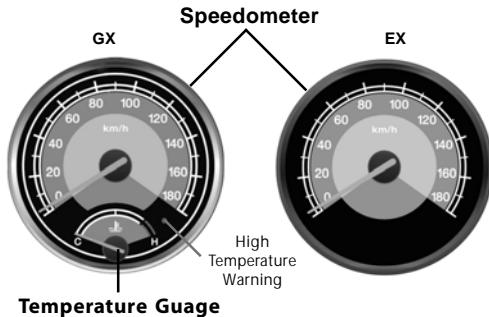
**RPM meter (if provided) :**

The meter indicates engine speed in revolutions per minute (rpm) Change gears at appropriate engine rpm and vehicle speed to get optimum fuel economy. The permitted engine rpm upper limit is the start of Red Zone on the dial.

Fuel Gauge:

The fuel gauge indicates the approximate fuel level in the tank. Refill the fuel tank at the earliest, before the needle touches the red band on the gauge. At this point, fuel level in tank is low and it is advised to get fuel filled immediately

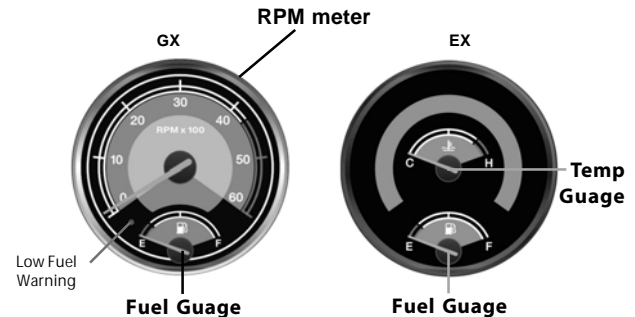

OPERATING SWITCHES

OPERATING SWITCHES :

Four operating switches are provided on the console.

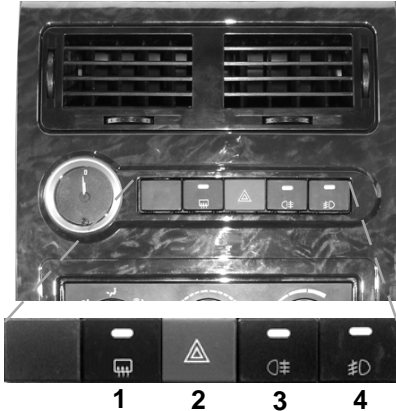

1. Rear Windshield Demister
2. Hazard Warning Switch
3. Rear Fog Lamp Switch
4. Front Fog Lamp Switch

Rear Windshield Demister : (Unlatched switch)

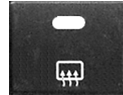

This switch can be operated when Ignition is ON. Demister is provided to clear the visibility of Rear Windshield on tail gate when required. Push the rear windshield demister operating switch to turn the demister ON. The demister will switch off automatically after 15 minutes. Rear Wind Shield Demister will work effectively when battery is fully charged.

NOTICE

Clean the rear windshield glass carefully from inside to avoid damage to demister heater element.

Hazard Warning Switch:



Hazard warning is used in case of breakdown especially during night and vehicle has to be parked at the side of the road or vehicle being operated in adverse condition.

This can be operated without Ignition ON. Press hazard warning switch to switch ON. All outside turn signal lights and indicators on cluster will flash simultaneously to warn the other road users about hazardous condition of the vehicle. Depress the switch to switch OFF the hazard function.

CAUTION

Ensure that all turn signal indicators are working properly. Get it rectified in case of problem.

**Front Fog Lamps :
(Unlatched switch)**

The fog lamps are provided on front bumper to improve the visibility in foggy weather or during heavy rains. The front fog lamps can be switched ON with ignition and parking lamp ON and can be remain on till the parking lamp is switched ON.

NOTICE

Use only during foggy conditions or heavy rains if required.

**Rear Fog Lamps :
(Unlatched switch)**

The fog lamps are provided on rear bumper to improve the visibility and warning in foggy weather or during heavy rains. The rear fog lamps can be switched on with ignition and parking lamp and front fog lamps ON and can be remain ON till the parking lamp is switched ON. The rear fog lamps can also be switched ON even if only headlights are ON.

NOTICE

Use only during foggy conditions or heavy rains if required.

Tata Grande At a Glance

STEERING LOCK CUM IGNITION SWITCH

Steering Lock cum Ignition Switch:

Key of ignition switch is common for door lock, steering lock and glove box lock.

The ignition switch is on the right side of the steering column. For your convenience, to locate ignition key in the dark, there is an illuminated key ring around the switch that lights up when driver's door is opened. It dims out (like the Roof Lamp) once the door is closed.

The ignition switch has four positions. Turn the key clockwise for further functions.

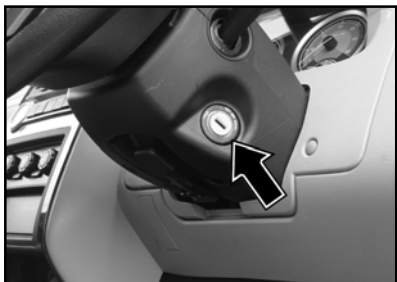

- LOCK - Steering Locked
- OFF - 'KEY IN' position.
- IGN - All electricals 'ON'
- START - Engine crank

LOCK:

You can insert or remove the key only in this position. The steering column is locked when the key is removed.

WARNING

Do not remove the key while driving. It will lock the steering and can cause loss of control. Remove the key only when the vehicle is parked.

OFF (key IN):

By turning key to OFF (key in) position. 'KEY IN' driven load like music system will be 'ON'.

IGN:

All electricals and accessories ON.

START :

Turn the key further clockwise to the START position (spring loaded) to start the engine. As soon as the

engine starts release the ignition key to ON position. While cranking, all accessories will be momentarily 'OFF'.

NOTICE

Do not crank the engine more than 10 secs. continuously. If the engine does not start wait for 30 secs. before cranking it again. Release the key immediately after starting the engine otherwise starter motor/flywheel ring may get damaged.

By turning the ignition key from 'IGN' position to 'OFF' position, engine can be stopped.

NOTICE

When driver's door is opened, the key ring is illuminated and goes off slowly (similar to a theatre effect) when the door is closed.

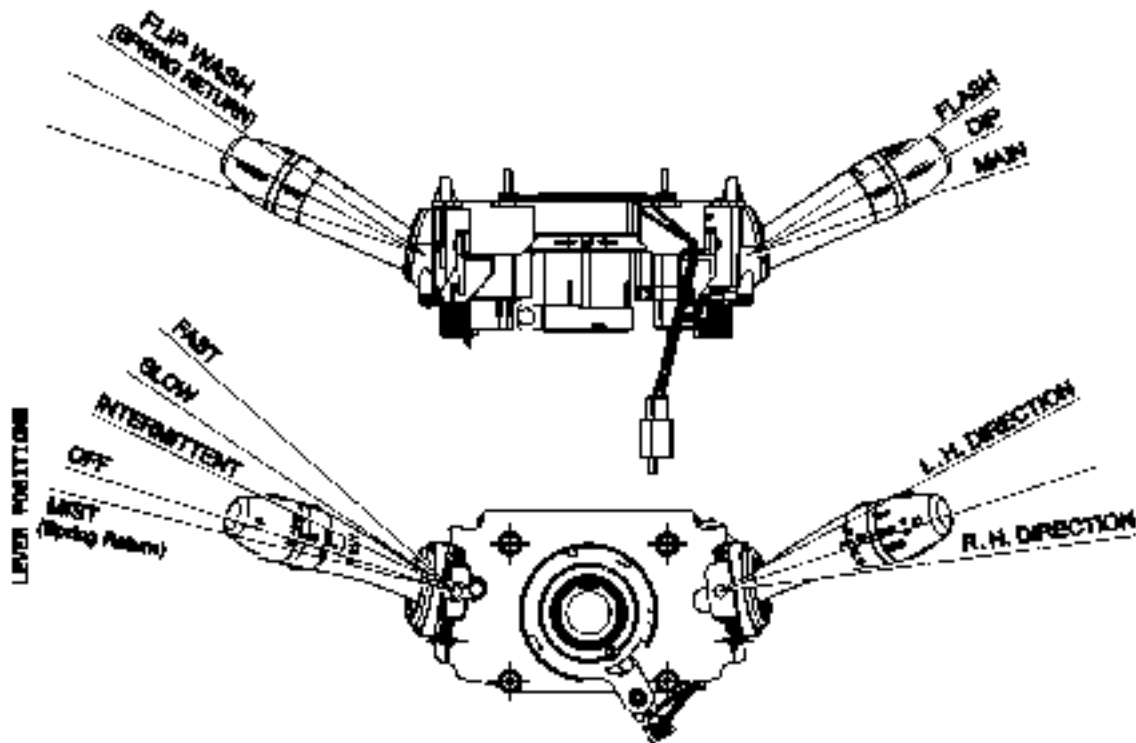

COMBI SWITCH

A) RIGHT HAND STALK

1) Head lamp leveling rotary switch:



Inner rotary switch on right hand stalk is provided for head lamp leveling. Setting is done by rotating the knob to select one of the 3 level positions depending upon the loading of the vehicle. Head lamp leveling can be done with head lamp in Low Beam and in ON position.

Setting should be done only when vehicle is stationary

NOTICE

Since the leveling switch takes care of headlamp focus pattern under varying load conditions, it is advisable to select the correct position before starting a trip (depending on load)

2) Light stalk:

Outer rotary switch on right hand stalk is provided for selecting Position or Head lamp High/Low beam. It operates with Ignition switch in "IGN" position.

a) Head / Position lamp OFF.

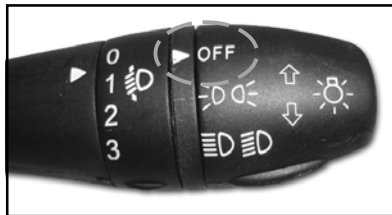

Head lamp, position (Parking) lamp and tail lamp will be OFF in this position.

b) Position lamp in ON.

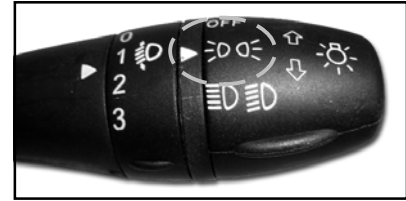

Position (Parking) lamp and tail lamp will be ON in this position.

c) Head / Position lamp ON.



Head lamp, position (Parking) lamp and tail lamp will be ON in this position. Toggling the lever (Stalk)

COMBI SWITCH

in upward direction changes the Low beam to High beam and vice versa. For High beam flash, pull the lever halfway. For keeping the in High beam position pulls up the lever further up to latch.

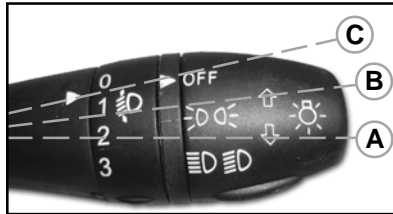
3) Light stalk (Side Indicator):

Push the stalk upwards for changing lane or turning to Left and downwards for changing lane or turning to Right according to requirement. It has three positions.

- A) Side indicator OFF
- B) Lane change for Left or Right Turn (Spring Return)
- C) Lane change for Left or Right

Turn (Self cancellation / Manual return type)

LEFT HAND STALK :

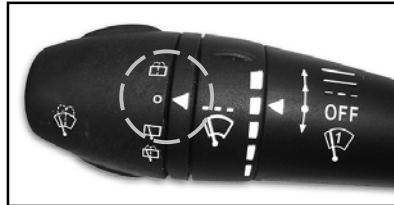
1) Rear windshield - Wipe & Wash rotary switch:

Outer rotary switch on left hand stalk is provided for rear windshield wiper & wash. The top (1st) position denotes wash, which is spring loaded. After releasing, the switch returns to the OFF position. First position below OFF position is for Wipe and second position is for Wash + Wipe which is spring loaded.

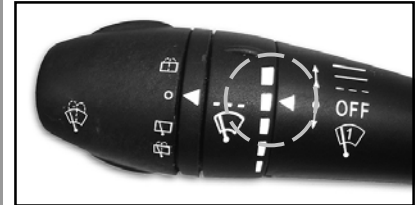
2) Intermittent front wiper delay:

Inner rotary switch on left hand stalk is provided for intermittent front wiper delay. The switch has 5 delay timers for intermittent function.

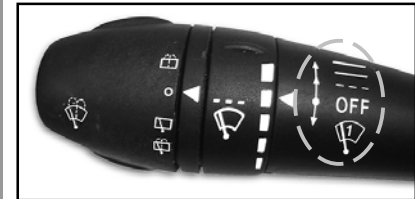
3) Front windshield-Wipe & Wash rotary switch:

Pull the stalk upwards to operate intermittent wipe (- - -), Slow wipe (—) or fast wipe (———). Pull the

Tata Grande At a Glance

ANALOG CLOCK & MUSIC SYSTEM

stalk down for wipe and wash. Pull towards driver for Flick Wipe (spring return).

NOTICE

After wash function is activated, there will be three wipes of wiper. There will be one more wipe after 5 seconds to clean traces of water on wind screen.

Analog Clock :

The vehicle is fitted with an analog clock on the center console. It has a knob at the bottom of the dial for resetting the time.

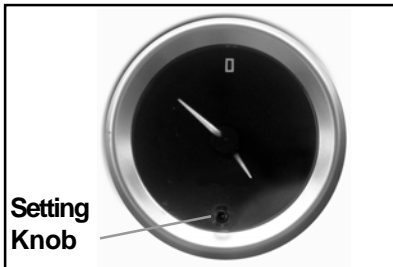

Music System :

The music system is provided on the fascia & the speakers are fitted on doors and tweeters on dashboard.



Music System

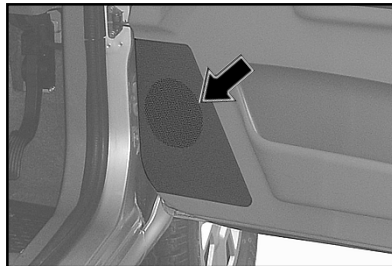

Speaker Location on doors



Tweeter Location on dash board

For operation and more information of music system please refer manufacturer's manual.

Antenna: The antenna is located over the inner rear view mirror.

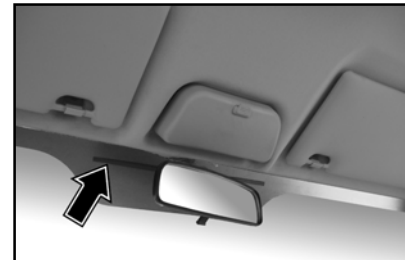

HEATING, VENTILATION & AIR CONDITIONING



Central Console

A.C. Controls

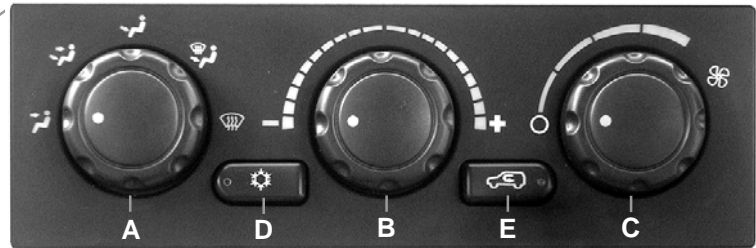

- A - Air Direction Control Knob
- B - Temperature Control Knob
- C - Blower Speed Regulation Knob
- D - A.C. ON/OFF Switch
- E - Air Recirculation / Fresh Air Switch

HEATING, VENTILATION & AIR CONDITIONING

A. Air Direction Control Knob :

The air flow can be changed by turning the knob (A) to the desired direction.



-  Towards face

-  Towards face and feet

-  Towards feet

-  Towards feet & windshield
(Recommended for clearing mist on windshield)

-  Air demist/defrost windshield
(Recommended for clearing heavy fog or snow)

B. Temperature-Control Knob :

The air temperature in the vehicle can be controlled by operating the temperature control knob (B) on the control panel. The temperature can be increased by rotating the knob towards the red segment and decreased by rotating it towards the blue segment.



C. Blower Speed Regulation Knob :

The HVAC system has a four speed blower. The blower speeds can be regulated to any one of the following speeds by operating the blower knob (C) centre of the control panel.



HEATING, VENTILATION & AIR CONDITIONING

D. A.C. ON/OFF Switch :

The A.C. can be switched 'ON' by pressing the switch (D) on the A.C. control panel provided the blower is 'ON' and the engine is running. The indicator lamp will show that the A.C. is 'ON'.

**E. Recirculation / Fresh Air Switch :**

- In HVAC version to put air circulation mode in recirculation, press switch 'E'. The indicator lamp will show air circulation is in recirculation.
- To put vehicle in Fresh mode release switch 'E'. Indicator lamp will be 'OFF'.

- In recirculation mode, air inside the vehicle is circulated again and again. In Fresh mode, air is taken from atmosphere and circulated in the vehicle.

Recirculation mode can be used

- While driving in dusty condition
- To avoid traffic pollution
- To get quick cooling/heating as required.

Whenever discomfort is felt switch air circulation mode to fresh.

**NOTICE**

- The A.C. can be switched 'ON' only if the blower is 'ON' and engine is running. When A.C. is switched 'ON' engine idling RPM increases marginally, to adjust to the A.C. compressor load. When desired temperature is achieved A.C. trips 'OFF' automatically.
- The A.C. compressor gets switched 'OFF' automatically when engine gets overheated. The A.C. is automatically switched 'ON' when the engine cools down.

HEATING, VENTILATION & AIR CONDITIONING

Normal Heating :

(For vehicles fitted with HVAC & Heating system only)

Knob 'A' - Towards face & feet

Knob 'B' - Suitable temperature position

Knob 'C' - Suitable blower speed

A.C. - OFF

Air Circulation - Fresh switch

Quick Heating :

All settings as explained before except air circulation switch to recirculation.

Once vehicle is heated, switch back to fresh mode.

Normal Cooling :

A.C. - ON

Knob 'C' - desired speed position

Knob 'A' - towards face

Switch 'E' - suitably as explained

Quick Cooling :

Switch 'ON' the A.C. and keep the

blower at maximum speed. Keep air direction in face mode. All vents should be opened completely. Keep the air circulation switch in the recirculation mode and temperature control switch in the maximum cooling (Blue) position. At maximum cooling, A.C. trips off automatically when the desired temperature is achieved.

- In case you find reduction in air flow or foul smell in the passenger compartment clean the evaporator

Demisting :

In this mode, air flows out from Feet and Windshield vents. The FRESH air mode and AC ON is automatically selected. The FRESH air indicator will be selected and AC indicator will turn off.

In this mode, switching to

Recirculation mode or turning off AC is not permissible. This is as per programmed logic (inbuilt). However, status of AC "ON" condition (Blue LED indicator comes on) can be turned on by pressing AC button. AC is maintained in ON condition regardless of whether or not the AC indicator is ON. This is a safety feature to avoid flash fogging of windscreen in humid condition.

The fresh air indicator will give warning signal by blinking indicator 3 times in case of attempt to turn the setting to Recirculation mode. This is as per programmed logic (inbuilt).

Defrosting :

In this mode, air flows out from Windshield vents only. The FRESH air mode and AC ON is automatically selected. The

HEATING, VENTILATION & AIR CONDITIONING

FRESH air indicator will be selected and AC indicator will turn off. This setting clears the front view quickly.

In this mode, switching to Recirculation mode or turning off AC is not permissible. This is as per programmed logic (inbuilt). However, status of AC “ON” condition (Blue LED indicator comes on) can be turned on by pressing AC button. AC is maintained in ON condition regardless of whether or not the AC indicator is ON. This is a safety feature to avoid flash fogging of windscreen in humid condition.

The fresh air indicator will give warning signal by blinking indicator 3 times in case of attempt to turn the setting to Recirculation mode. This is as per programmed logic (inbuilt).

Operating Tips:***Demisting***

The inside of the windshield. For the best results, set controls as follows:

Fan speed - To the desired fan speed

Temperature – At suitable temperature

Air Direction – Full Demist/Defrost mode

When moving to Full Demist/Defrost mode, the air intake selects FRESH and AC gets ON automatically. This is to clean up the front view quickly.

Defrosting

- The outside of the windshield. For the best results, set controls as follows:

Fan speed - To the desired fan speed

Temperature – Towards high temperature

Air Direction – Full Demist/Defrost mode

When moving to Full Demist/Defrost mode, the air intake selects FRESH and AC gets ON automatically. This is to clean up the front view quickly.

Ventilator :

The air flow can be adjusted continuously with the rotary control knob at the vents on the dash board. The air vents can be adjusted upward and downward.

NOTICE

Refrigerant charged in the air conditioning circuit has been identified on the label over front body member. Use only refrigerant as given in the label for topping up or recharge, i.e. do not charge R12 (CFC) in the

Tata Grande At a Glance

vehicle earlier charged with R134a (Non CFC) or vice versa.

Fresh air is taken from the grill opening provided at base of windshield glass outside the vehicle. Keep these openings clear and free from fallen leaves etc.

NOTICE

AC Gas charging Quantity should be 700 ± 20 gms. (R 134a - Non CFC)

Rear AC:

Rear AC is provided for rear seats passengers. When front AC is ON, it will provide cool air from front AC. When front AC is OFF, it can be used as blower (supplying normal air). Rear AC switch is provided on roof and can be used to switch ON the blower and select the blower

speed. four adjustable air vents are provided on roof. Air flow and direction can be adjusted on each air vent.



Head Lamp:

Head lamps are clear lens type having multi focal reflector and are

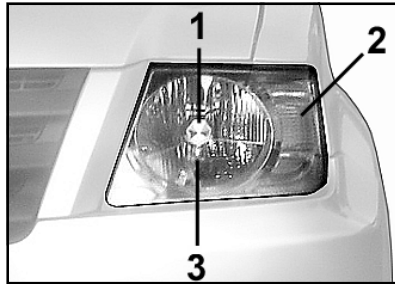

- 1 Main/Dip Beam
- 2 Position/Parking Lamp
- 3 Direction Indicator

provided with H4 halogen lamp with double fitment for providing straight ahead illumination of the road for the long distance or deep beam which illuminates the road immediately ahead for short distance visibility. It also contains side indicator lamp and a parking lamp.

Tail Lamp:

The tail lamp assembly incorporates the following

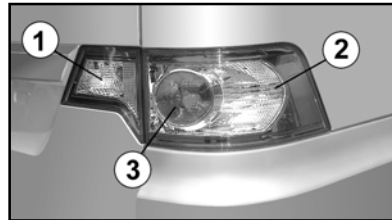

- 1 Reverse Lamp
- 2 Direction Indicator
- 3 Tail / Brake Lamp

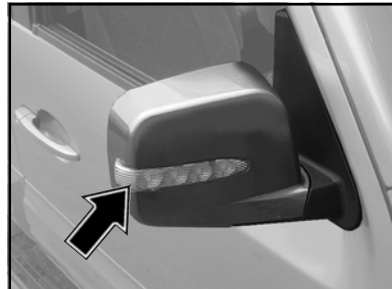
Side Repeater Indicator Lamp**Fog Lamp :**

Front and rear fog lamps are provided for your convenience and they can be operated by rotating the Selector on Combi switch.

**Front Fog Lamp****Rear Fog Lamp**

Tata Grande At a Glance

LAMPS

High Mounted Stop Lamp:

High mounted stop lamp is provided on the tail gate, and it glows whenever service brake is applied.

Registration Plate Lamps:

Two concealed lamps are provided for illumination of the rear registration number plate.

High Mounted Stop Lamp



Registration Plate Lamps

Door Lamp :

These are provided on the inner side of the front and rear doors to warn the traffic coming from the rear that the door is open.



Door Ajar Lamp :

This is provided on the bottom side of the doors to assist the user for easy entry and exit during night.

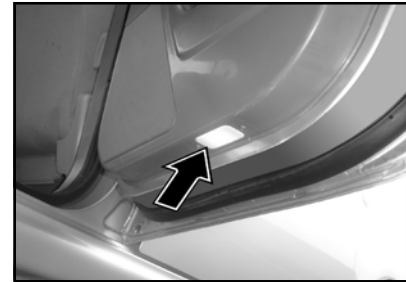

Engine Compartment Lamp :

This lamp is provided for your convenience.

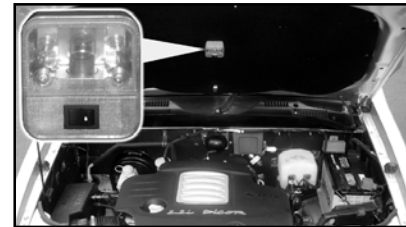

Engine Compartment Lamp

Front interior light with reading lamps:

Interior roof lighting and reading lamps with inbuilt switches are provided on the roof near the rear view mirror.

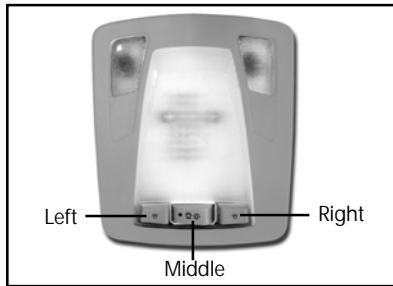

The central rectangular switch has three positions:

ON - The lamp will come 'ON' as long as switch is in this position.

DOOR - In this position the lamp comes on when either of the doors are opened. When the door is closed, the lamp will not go 'OFF' immediately, but remain 'ON' for 5-8 sec. This helps settling in the seat and inserting the key

in the ignition switch. When the key is turned to the 'IGN' position, the lamp goes 'OFF' immediately with unlock pulse it will come 'ON', if it is kept at 'DOOR' position..

OFF - In this position the lamp will not come 'ON' at all. Two rectangular shaped push type 'ON / OFF' switches are provided separately for the right and left reading lamps.

Rear roof lamp :

A roof mounted lamp is provided above the rear seat. It has following three positions :

ON, DOOR & OFF

The function of this switch is similar to front interior light.



“Follow me home” Headlamps :

When the parking lamp switch is 'OFF' and key is not inserted, then if the headlamp flash input is made active (by pulling right hand stalk), if any of the doors is opened within 20 sec., the headlamp low beam will turn 'ON' for 1 minute to help you to reach your destination in the dark.

If any of the doors is NOT opened within 20 sec., then the head lamp beam is turned 'OFF' in 20 sec. The remote lock operation will be ignored within 60 sec. for follow me condition.

If lock input comes after 60 sec., then the head lamp beam will be 'ON' for another 30 sec. after which head lamp 'ON' time can not be extended again with remote lock input. The maximum time in which the head lamp 'ON' time can be extended after head lamp flash input is 5 minutes.

Tata Grande At a Glance

SUNVISORS & GRAB HANDLE

Sun visors:

Two adjustable sun visors are provided inside the cab above the windshield to prevent sun glare. Lower the sun visors to protect the eyes from bright sunlight. The sun visors can also be moved sideways towards the door.

A vanity Mirror has been provided on the back of the Co-driver's sunvisor.

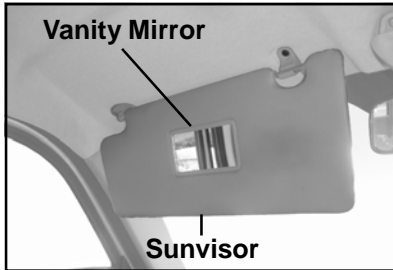

NOTE

When not in use keep the sunvisors in their original position otherwise they may block the driver's vision.

Goggle Case :

A goggle case is provided near inner rear view mirror for keeping the goggle. Pull the cover to open, place the goggle (keeping glass facing towards antidust cloth) and press to lock.

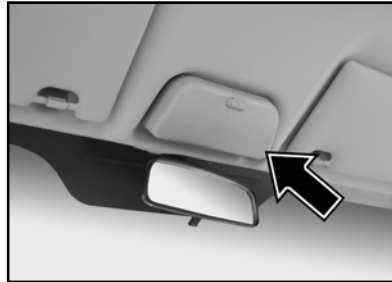

Roof Grab Handle :

These are provided on all seats except driver seat. This helps in comfortable positioning of passengers during journey.

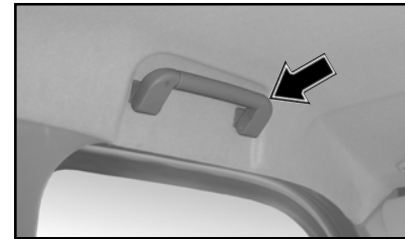

REAR VIEW MIRRORS

Inner Rear View Mirror:

Antiglare mirror The antiglare mirror is fitted inside the cab. Provision has been made for two positions:

1. Normal position
2. Antiglare position

Use antiglare position only when necessary, as it reduces rear view clarity.

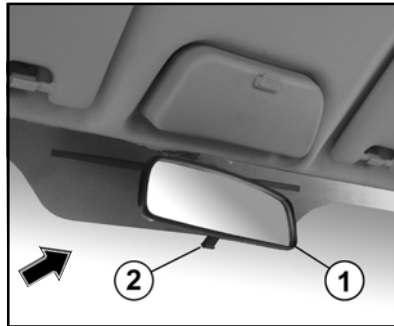

1. Inner Rear View Mirror
2. Operating Knob

Motorised Outer Rear View Mirror :

Motorised Rear View Mirrors are fitted on both front doors and can be adjusted to the desired position with the help of a switch provided on the driver side door. The switch facilitates the driver to adjust the mirrors without lowering the window glasses and without moving from his/her position.

1. Move the main switch to **L** (for adjusting left side mirror) and **R** (for adjusting right side mirror)
2. Use the 4 positions of the knob to adjust the rear view mirrors to correct angles.

NOTE : Manually adjusted outer rear view mirror are also available in few version



Motorised Outer Rear View Mirror



Mirror Adjustment Switch

Tata Grande At a Glance

GLOVE BOX, CUP HOLDER & UTILITY POCKET

Glove Box:

The glove box is located on the dash board in front of the co-driver's seat. The glove box can be locked with the ignition key.



Glove Box

Cup holder :

Two cup holders are provided in the glove box lid for your convenience.



Cup holder

Utility pocket / box :

Utility pocket is provided to all the doors to keep magazines / books etc.



Front utility pocket / box



Rear utility pocket / box

Floor Console :

Cigarette Lighters:

Two cigarette lighters are provided on floor console at front and rear.

Press the cigarette lighter in the socket to heat up. When it reaches the desired temperature, it will pop up and can be used. These lighters will operate only when Engine is ON or Ignition key in ON position.

⚠ CAUTION

Handle the lighter carefully to avoid personal injury.

If lighter does not pop out, remove it to avoid overheating.

Avoid smoking inside the vehicle; it may spoil inside ambience, interiors, upholstery etc.



Cigarette Lighter for front passengers



Cigarette Lighter for Rear passengers

Tata Grande At a Glance

WINDOW GLASS

Power Windows

Glasses on all four windows of your vehicle can be operated by switches provided on the main control panel located on the driver's arm rest. They work only when the key is in the "IGN" position.

Glasses are wound up by pulling the switch and are lowered by pressing it down. If you would prefer to have the glass at its lower most position, press the switch down a little longer and the glass glides down. This feature is known as "Express Down".

A safety locking arrangement has also been provided and can be activated by a push type switch located at the centre, below the window switches. It has two positions:

LOCK – When switch is pressed

UNLOCK – When switch is released

When the switch is in "LOCK" position, the rear window switches (located on rear doors) do not function. The rear window glasses can



still be operated by using the switches on the console. Illumination on the rear window switch goes off when the switch is in locked condition. Press down the lock button to unlock. Individual window winding switches have been provided only on other doors.

WARNING

While raising the glass, take care to avoid fingers / hands getting trapped between glass and the frame.

Power window switch (On Rear Doors): Individual window winding switches have been provided only on the rear doors.

To close the door window glass pull the knob up and to open, push the knob down.

If key is taken out, power windows can be operated within 30 sec. without giving 'IGN'.



WINDOW GLASS & STEERING ADJUSTMENT

Manual window winding :

In few versions, power windows are not provided. In such vehicle, use winder handle manually for lowering down or raising up window glasses.

Rear Side Window Glasses :

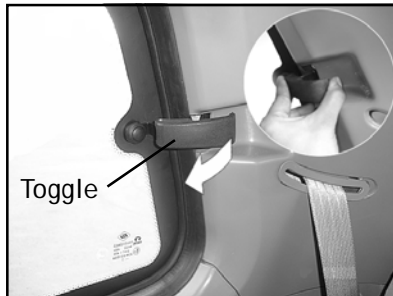

Butterfly windows are provided on both rear sides of vehicle to provide ventilation for 3rd row occupants when required. Pull the toggle to unlock and open the window. For

locking, pull toggle lever and press it to lock.

NOTICE

It is advisable not to open the windows when AC is ON. This will adversely affect the AC performance.

Steering Wheel Position Adjustment

You can adjust the steering wheel position to suit your convenience. Adjust the steering wheel position as follows before you start driving.

1. Adjust the seat to a comfortable position.
2. The lever to tilt the steering wheel is under steering column. Pull the lever up and hold in that position.
3. Move the steering wheel up or down to the desired position.

Position the wheel such a way that all the instrument panel gauges and warning lights are visible.

4. Release the lever. Make sure that steering wheel is securely locked by moving up and down.

CAUTION

Steering wheel should be adjusted only when the vehicle is stationary.



Steering Adjustment Lever

Tata Grande At a Glance

FUEL FLAP OPENING

Fuel Tank flap opening:

The fuel flap is located on the left rear side of the vehicle. The fuel flap can be opened by pulling the opening lever located at the right hand side of the driver's side for RHD vehicle & left hand side for LHD vehicle

WARNING

Fuel vapour is extremely hazardous. Always stop the engine before refueling and never refuel near sparks or open flames.

CAUTION

Remove the fuel filler cap slowly, and wait for any hissing to stop, then remove it. The fuel may be under pressure & may spray out, causing injury if the cap is opened suddenly.

Always use only original specification fuel cap or an approved equivalent, available at Authorised Dealers. The wrong cap can result in a serious malfunction of the fuel system and the emission control system.

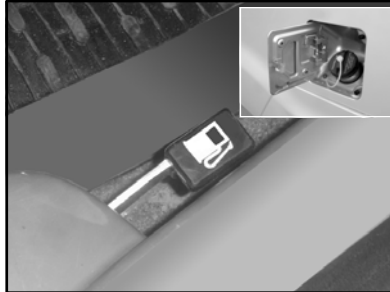

Fuel Flap Opening Lever

GEAR SHIFT LEVER & PARKING BRAKE

Gearshift lever & shifting pattern:

The gearshift lever is mounted on the center console between the two front seats. The gearshift pattern is shown on the gear lever knob.

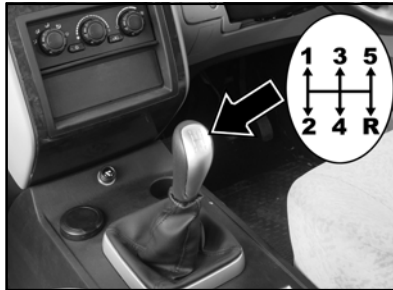

NOTICE

The reverse gear should be engaged only when the vehicle is stationary. Wait for 5 seconds after declutching to ensure smooth engagement of the reverse gear.

Parking brake:

Mechanical parking brake acting only on the rear wheel is provided on your vehicle. The parking brake lever is located behind the gearshift lever. To apply the parking brake, pull the lever up fully. The indicator light on the instrument panel will become 'ON'. To release it, pull the lever up slightly, press the release button and push the lever down. The parking brake indicator on the instrument panel will go 'OFF' when the parking brake lever is fully released.

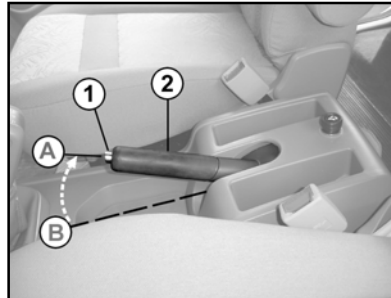

1. Release Button
 2. Parking brake lever
- A.** Applied Condition
B. Released Condition

NOTICE

- Apply the parking brake properly before leaving the vehicle & release it before moving.
- When parking on a steep slope, do not rely on the hand brake alone to hold the vehicle. Leave the vehicle parked with gear box in low forward gear when facing uphill and reverse gear when facing downhill.

Anti Theft/ Immobiliser cum Keyless Entry System (If fitted)

ANTI THEFT /IMMOBILISER CUM KEYLESS ENTRY SYSTEM :

This system is essentially an anti-theft security system, which has a keyless operation for door unlock/lock. It immobilizes the vehicle by disabling starter motor, ignition and fuel supply in case of unauthorised entry.

The system consists of following :

1. One User "Remote" with **LOCK** and **UNLOCK** button for normal use.
2. Body Control Module (BCM).
3. "**Lock Indicator Warning**" on instrument cluster for indication of "mode" of the system.

Features :

- Locking/ unlocking the vehicle from distant place. (Refer arm mode)



- Immobilisation of vehicle and continuous flashing of turn indicators and hooting, if theft is detected (Refer Armed Panic).
- Protection when user forgets to lock using remote.(Refer Auto Arm Mode).
- Immobilisation of vehicle if theft is detected in Auto Arm mode. (Refer Auto Arm immobilised)
- Finding the vehicle. (Refer car seek).
- Manual central door locking/unlocking (Refer central door locking feature).
- Unlocks all doors in case of an accident. (In case of vehicle crash)
- Continuous flashing of turn indicators and hooting (Refer Forced Panic).

Anti Theft/ Immobiliser cum Keyless Entry System

- Auto lock and unlock optional feature on some vehicles. (Refer Auto lock and unlock).
- Additional/ new remote can be added. Stolen remote can be disabled. (Refer Learning Additional Remote / Unlearning Lost Remote).

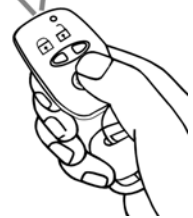

MODES OF THE SYSTEM :

	MODE	MODE INDICATION	VEHICLE STATUS
1	LOCK (To lock the vehicle) Press ' LOCK' on the remote	Turn indicators two flashes and LOCK'LED starts blinking	Vehicle gets locked
2	LOCATE (To locate the vehicle in the park) Press 'LOCK' button on the remote after locking the vehicle by remote 'LOCK' pulse	Turn indicators give three flashes	Vehicle gets locked
3	UNLOCK (To unlock the vehicle) Press 'UNLOCK' button on the remote	Turn indicators give single flash.	Vehicle gets unlocked
4	FORCED PANIC (To seek for help)- Press 'LOCK' or 'UNLOCK' button simultaneously	Turn indicators start flashing along with hooting. To stop hooting, flashing, press LOCK or UNLOCK button on the remote	During this mode vehicle remains in the previous state i.e. LOCK / UNLOCK state.

Anti Theft/ Immobiliser cum Keyless Entry System (If fitted)

DESCRIPTION OF MODES AND USAGE OF "REMOTE" ARM MODE:

Used to lock the vehicle from Distant place (Do not use Mech. Key).

Press "LOCK" on User Remote.

- Gives two flashes. Locks all doors. Gives delayed flash through turn indicators after locking.
- Lock Indicator  on instrument cluster starts blinking (typically once in 1.5 sec)

The vehicle arms (i.e. Vehicle cannot be driven. If attempted, the system goes to immobilised Mode). Press UNLOCK to disarm the vehicle.

UNLOCK/ DISARM MODE :

Used to UNLOCK the vehicle from Distant Place. (Do not use Mechanical Key)

Press "UNLOCK" on User Remote.

- Gives one flash on turn indicators.
- Unlocks all door.
- Lock Indicator on dashboard stops blinking and remain 'OFF'.
- The vehicle disarms (User can drive the vehicle).

NOTE : To disarm the vehicle, unlock button must be pressed before turning the key to ignition position.

This procedure ensures user authentication.

ARMED PANIC MODE :

In Armed Mode, if Theft is detected (door opened/Key inserted in ignition switch/cranking attempted) vehicle immobilises and flashes the turn indicators for about 25 to 30 seconds (To stop the flashing press any button on the user Remote; Hooting gets enabled along with flashing for 30 sec.

AUTO ARM MODE :

Protection when user forgets to lock the vehicle using remote.

- In Unlock mode, after the key is taken out of the Ignition switch and leaving the vehicle (door is opened and closed), vehicle arms automatically in 55 sec., (i.e. Vehicle cannot be driven without pressing UNLOCK button on the User remote. If attempted, vehicle goes to auto armed immobilised mode)

Anti Theft/ Immobiliser cum Keyless Entry System (If fitted)

- As an additional security measure, the system has a back up facility. In Unlock mode after taking the key out of Ignition switch, the vehicle arms automatically in 4.5 sec., even if no door activity is detected.
- The Lock Indicator on the instrument cluster starts blinking once in 1.5 seconds.

When Lock Indicator on instrument cluster is blinking, the vehicle cannot be driven. Press UNLOCK to disarm the vehicle.

AUTO ARMED IMMOBILISED MODE :

In Auto Armed Mode if Theft is detected (Key inserted in ignition switch/or attempt to crank)

Lock Indicator on the dashboard starts blinking at faster rate and the vehicle immobilises. When Lock Indicator on instrument cluster is

blinking the vehicle cannot be driven. Press unlock to disarm the vehicle.

CAR SEEK :

Used to locate the vehicle.

Press "LOCK" on User Remote when the vehicle is locked.(Range 7.5 meters max.) approx. from vehicle.

- Gives three flashes on turn indicators and remains locked.

FORCED PANIC MODE :

- Press "LOCK" and "UNLOCK" on User Remote simultaneously.
- Hooting and flashing will start continuously.

CENTRAL DOOR LOCKING FEATURE :

All doors can be locked/unlocked by manually locking / unlocking the driver's door (using mechanical key/knob)

Press any button on the remote to stop flashing.

AUTO LOCK AND UNLOCK :

(When driving the vehicle)

- 1. New locking strategy :** When ever vehicle is cranked and engine is fired, all doors will be locked automatically once vehicle reaches above 10 kmph provided they are closed properly. If any one of the doors is open, then locking will not take place.
- 2. After the key is taken out from the Ignition switch, the system automatically unlocks the all doors.**

Anti Theft/ Immobiliser cum Keyless Entry System (If fitted)

EMERGENCY DISARMING PROCEDURE :

THIS PROCEDURE IS APPLICABLE IN CASE OF LOST REMOTE & SYSTEM IN ARMED / IMMOBILISED STATE I.E. CLUSTER LED IS BLINKING

1. Enter the vehicle by opening the door through physical key & close the door. In case the vehicle is in armed condition, the system will enter armed panic in immobilised state-will hoot (if provided) and flash for max. 27 seconds.
2. Open driver door or turn on hazard switch.
3. Turn ignition 'ON' and 'OFF' 3 times within 5 seconds.
4. On successful completion of step 3, the system will come out of the immobilised state to enter emergency dis-arming state. (This state is similar to

the immobilised state without the hooting and side indicator flashing). The left and right indicators will remain ON for 5 sec. and will go OFF after that.

NOTE: If step 3 is not completed within 5 seconds the system will remain in immobilised state and the left and right indicators will not come ON as in point no.4. Close the driver's door and follow the step no. 2

5. Then the left and right indicators start flashing (ON /OFF) for max. 9 counts the user. Must count the number of flashes and turn ignition 'ON' as soon as this count matches the first digit of secret code. The left and right indicators will stop flashing.
6. Switch 'OFF' the ignition.
7. The user must enter the 2nd,

3rd and 4th digit of the secret code in a similar fashion as described in step 6 & 7 above.

9. After successful entry of all the four digits of secret codes the cluster left and right indicators stop flashing. The system will dis-armed and vehicle will get mobilised.
9. Close driver door or turn 'OFF' hazard switch.
10. In case of any error in entering the secret code digits the left and right indicators continue to flash and the system remains in immobilised state to re-enter secret code. Perform step 10 and start the procedure from step 2 onwards.
11. All previously learned remotes will get unlearned.
12. Vehicle engine is released for 5 cranks only.

Anti Theft/ Immobiliser cum Keyless Entry System (If fitted)

13. The vehicle can be cranked and driven.

LEARNING OF NEW REMOTE :
THIS PROCEDURE IS APPLICABLE IN CASE OF LOST REMOTE & SYSTEM IN ARMED/ AUTO ARMED/IMMOBILISED STATE I.E. CLUSTER LED IS BLINKING.

Step 1-12 mentioned above, should be completed successfully and then follow steps 1,2 below, within 30 sec.

1. Open driver door (OR turn 'ON' hazard switch).
2. Parking light should be 'OFF'.
3. Turn ignition 'ON' & 'OFF' 5 times within 10 sec.
4. The system enters the learn mode. The left and right indicators remain 'ON' for 30 sec.
5. Press any key on the remote once within 5 sec.

6. On successful learning of the remote, system gives single flash.
7. Repeat step 4 & 5 above for learning other remote (Max.4 remotes)
8. Learning mode will be exited in 30 seconds, if any of the remotes is not learnt during this time. The learning process has to be repeated.

CHANGING OF SECRET CODE :

THIS PROCEDURE IS APPLICABLE IN CASE WHEN THE USER WANTS TO CHANGE THE SECRET CODE.

CHANGING OF PIN WILL BE POSSIBLE WHEN IMMOBILISER IS IN UNSET STATE OR REMOTE KEY ENTRY IN UNLOCK STATE

1. Press UNLOCK button from the remote.
2. Switch 'ON' the parking lights.

3. Turn ignition 'ON' and 'OFF' 3 times within 5 sec.
4. If step 3 is not completed within five seconds, the left and right indicators will not become ON as is case 4. Switch OFF the parking light and follow step 2 onwards.
5. The Left and right indicators start flashing (0.5 sec. ON / 0.5 sec. OFF) for max. 9 counts.
6. The user has to enter the existing secret number. The user must count number of left and right indicators flashes and turn the ignition switch ON as soon as the count matches the '1st' digit of the existing secret code. On successful entry, the right and left indicators will stop flashing.
7. Switch OFF the ignition.

Anti Theft/ Immobiliser cum Keyless Entry System (If fitted)

8. The user must enter the 2nd, 3rd and 4th digit of secret code in similar fashion as described in step 6,7 and 8 above.
 9. After successful entry of all the 4 digits of existing secret code, the left and right indicators stops flashing for 10 sec.
 10. If a wrong secret code is entered, the LED continues to flash and the system remains in immobilised state. To re-enter secret code, switch OFF the parking lights and start procedure from step 2 onwards.
 11. Repeat steps 7, 8 and 9 but with the new 4 digit number. The digits to be entered can be from 1 to 9. After successful entry of all 4 digits of new secret codes the left and right indicators stops flashing for 10 sec.
 12. Again repeat the steps 7,8 and 9 with the same new 4 digit number. After successful entry of all the 4 digits of new secret code, the left and right indicators stops flashing for 10 sec.
 13. If the new secret code entered twice is not matching then the flashing of side indicators will start for 5 sec. To restart the procedure of entering new code, steps from 12 onwards to be performed. The left and right indicators starts flashing after 10 sec.
 14. If secret code entered twice is matching then the system gives information of newly entered code with the equivalent number of left and right indicators flashes for each digit, with a 5 sec. gap between two digits.
 15. Switch OFF the parking lights.
 16. The newly entered secret number to be used here after emergency dis-arming and remote learning.
- NOTE : No remote will get unlearned with this procedure.**
- During this procedure any key pressed from the remote will be ignored.
- REPLACEMENT OF REMOTE BATTERY :**
(replace every year for normal use)
1. Place the remote button-side facing down and remove screws.
 2. Change the battery with GOLDEN POWER Battery GP 23A or equivalent (eg:- Duracell MS21/MN21).
 3. Put back the screws.
 4. Press any button and check that the LED on the remote glows.

Anti Theft/ Immobiliser cum Keyless Entry System (If fitted)

GUIDELINES FOR USER :

- **The vehicle does not start (Engine does not crank/fire)**

Check the Lock Indicator on the dashboard. If it is blinking then the vehicle is not supposed to start (Arm Mode/Auto Arm Mode). Press UNLOCK button on the User Remote and then start the vehicle.

If the turn indicators are blinking, pressing the UNLOCK button of the User Remote will stop the blinking of the lamps. The next pressing of the UNLOCK button of the User Remote will unlock / disarm the vehicle and then the vehicle can be driven. Contact the dealer if the vehicle still could not be started.

- **Pressing UNLOCK/LOCK does not UNLOCK/LOCK the vehicle.**

If the turn indicators are blinking, pressing UNLOCK / LOCK will stop the blinking of lamps. The next UNLOCK / LOCK press will actually unlock / disarm the vehicle and the vehicle can be driven.

- **Battery Low Indication :**

1. Operating Distance has come down

2. LED on user remote flashes whenever UNLOCK / LOCK button is pressed on the remote (under normal battery conditions, the LED on the user remote lights continuously whenever UNLOCK / LOCK button is pressed).

3. Replace the battery to get in creased range.

- Press any of keys on remote, if LED of the remote is contineously 'ON' means

battery is OK. If it is blinking, then remote battery is to be replaced.

NOTE : Remote may not be operative in near transmission vicinity of high power antenna (Like TV)

KEYS & DOOR LOCK

Keys:

The key operates all locks and Ignition switch.

A code number is stamped on the plate attached to the key set. Detach this plate and store at safe place (Not in the vehicle). This reference number is necessary while getting duplicate keys from your Authorized Dealer. It advisable to keep another key at safe place for use in case of emergency.

NOTICE

Do not use locally made keys, get duplicate key through your authorized dealer.

Front Doors (Driver & Co-driver)

Locking / unlocking doors with key from outside :

Both front doors (drivers & co-driver) have separate locking facility. Front doors can be locked or unlocked from outside with key.

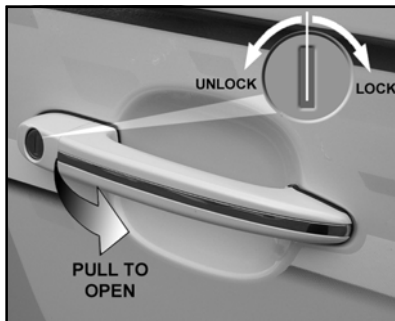

Insert the key and turn it anti-clockwise to open or clockwise to lock the door. Pull the Door handle to open an unlocked door.

Locking without a key from inside:

All the doors can also be locked or unlocked independently from inside by pressing or pulling the knob (1).

NOTE

When locking doors this way, do not leave the key inside the vehicle.

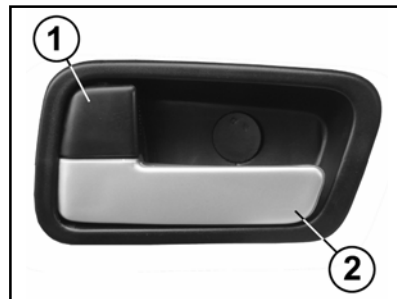

DOOR LOCK & CHILD LOCK

Opening the doors from inside :

All doors can be opened from inside. To open pull the door opening lever / latch (2).

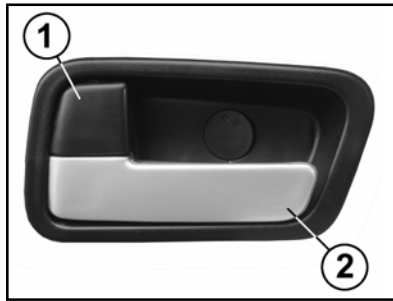

Location of door opening lever/ latch

Childproof lock :

Both the rear doors of the vehicle are provided with child proof lock. Push the lock lever located on vertical face near the lock downward before closing the door. The door which has been locked cannot be opened from inside, it can be opened only from the outside.

⚠ CAUTION

Deactivate the childproof lock when not required.

**Tail gate Locking / Unlocking :**

Insert the key and turn it anti-clockwise to open or clockwise to lock the door. Pull the Door handle to open an unlocked door and just by closing the tail gate to its original position, it gets locked.



Tail gate Swing Handle

SEAT ADJUSTMENTS

Seats :

Bucket type seats are provided with a lever and recliner handle knob, to adjust seat positions.

Lumbar Support :

The lumbar support is provided to give you maximum driving comfort. and adjusted by the lever (1) provided at the side of the seat backrest.

Seat Back Recliner :

To change the seat back angle, lean forward slightly and raise the lever (2). Then lean back to the position you want and release it. Make sure that lever return to its original position.

Moving the Seat Forward & Backward:

To adjust the seat position, lift the lever under the seat cushion front, then slide the seat to the desired position and release the lever. Once the desired position is

achieved release the lever to lock the seat. Make sure the seat is locked in position.

Height Adjustment (Driver's Seat):

Driver's seat height can be adjusted by a lever located on the seat base on the right hand side, just ahead of the seat back adjustment lever. You can raise the seat height by pumping / pulling the lever upwards until appropriate seat height is reached and lower it by pumping / pushing the lever downwards.

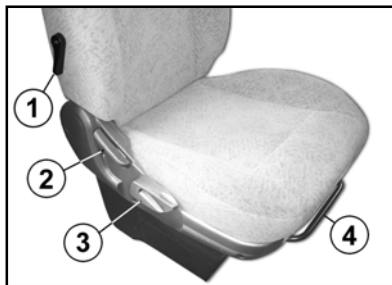

1. Lumbar Support
2. Seat Back Recliner
3. Seat Height Adjustment Lever
4. Lever for forward/backward movement
5. Utility Tray (C0-driver Side)

Head restraint :

Adjustable head restraints are provided for bucket seats in front. Neck rest for rear bench seat (Crew cab) cannot be adjusted. To increase the height lift up and leave at desired click position. To reduce the height, press the unlock button & push the head restraint down wards.

⚠ CAUTION

Avoid driving the car with the head-rest removed as it is a safety item. Do not attempt to adjust the head-rest while driving the vehicle.

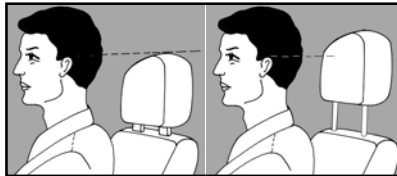

Poor Adjustment

Good Adjustment

REAR SEAT ADJUSTMENTS

REAR SEAT ADJUSTMENTS

Middle seats-Split type (if fitted)

Middle row seat is in 2 parts i. e. 60 / 40 split. Two adjustable neck restraints are provided on the middle row seat. Foldable arm rest is provided in centre of the seat. Pull out the arm rest when needed and fold back when not required.

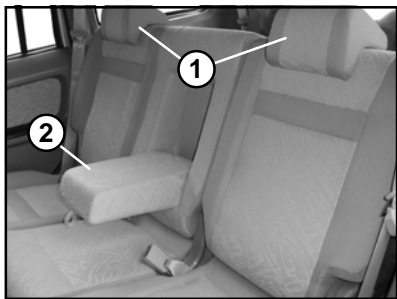

1. Head Restraint 2. Foldable Handrest

These seats can be independently folded as and when required while entering and getting down from the vehicle for the third row seat

passenger or for carrying extra luggage.

Folding of middle row seats from outside the vehicle.

Latches are provided on both seats on outer side for folding the seat backrest. Operate the seat latch 'A' to fold the seat back on seat base.

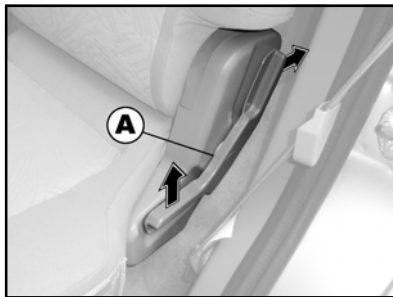

Pull the seat release strap 'B' provided on seat base and tilt the seat base up so that it is vertical and touching front seat.

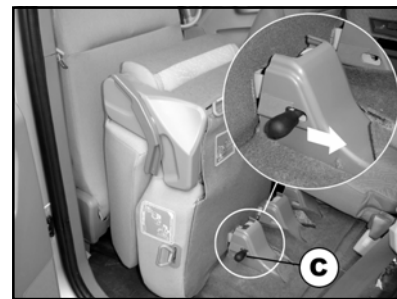

To unfold the seat, slide the knob 'C', drop the seat. Operate latch 'A' to unfold back rest.

REAR SEAT ADJUSTMENTS

Folding of middle row seats from inside the vehicle (from third row seat).

Operate the seat latch 'A' to fold the seat back on seat base.

Pull the seat release strap 'D' provided on seat base rear side and tilt the seat base up so that it is vertical and touching front seat.

To unfold the seat, slide the knob 'D', drop the seat. Operate latch 'A' to unfold back rest.

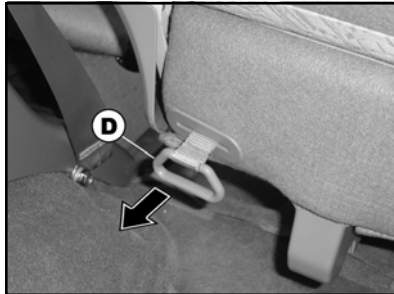
**Front facing third row seat (if fitted)**

The third row seat is also front facing. It can be accessed after folding one of the middle row seats. Two adjustable neck restraints are provided on the third row seat.

This seat can be folded and also can be removed as and when required for more luggages.

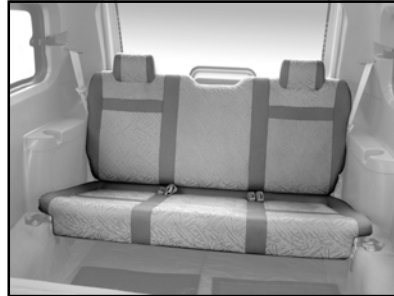
**Folding of third row seat**

Latch is provided on back rest for folding the seat backrest. Open the tail gate to access the latch. Pull

the seat latch '1' to drop the seat back on seat base.

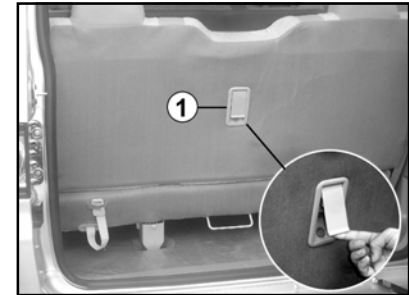

Lift the handle '2' and tilt the seat base up so that it is vertical and touching middle row seat.

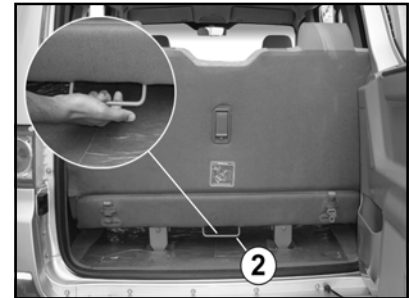

SEAT FOLDING

Hook the straps provided on seat base rear side into middle row seat neck restraints. This will hold the seat firmly.

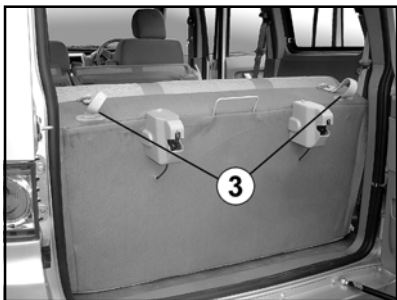

Removal of third row seat

Once the seat is folded, it can be taken out from the vehicle. Operate the levers to release the seat and carefully take out seat from vehicle.

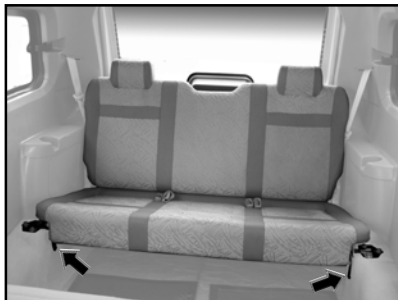

Seat Release Lever

Side Facing seats (if fitted) :



In this there are two options, 7-Seater and 9-seater. In the 7-seater option, two occupants can be accommodated and in 9-seater option, four occupants can be accommodated in the rear most part of the vehicle.

In this version, 60:40 split type middle seat is not provided. A cushion bench seat is provided for the middle passengers.

Seat Belts

The safety of the occupants is of prime importance to us.

This vehicle is equipped with seat belts as a part of occupant restraint system.

Why Seat Belts

Wearing seat belts properly can protect you from being thrown against the inside of the vehicle, against other occupants or out of the vehicle, in case of an accident or sudden braking. It will reduce the chances of severe injury.

How to use seat belts

This vehicle has three point inertia reel type front and rear seat belts in the out board positions and a lap belt for middle passenger on rear seat. In normal driving the belt lets you move freely in your seat. In case of an accident or sudden braking inertia reel automatically

tightens the belt to help restrain your body.

The anchor end of the shoulder belt is adjustable to suit the height of the passenger wearing it. The lap belt has one manually adjusted belt that fits across the hip bone. It is similar to safety belt used in aeroplanes.

Make sure that your seat is adjusted to a good driving position and the back of the seat is upright.



1. Seat Belt
2. Tongue

3. Lock Buckle
4. Lap Belt

1. Pull the tongue across your body and insert it into the buckle.

2. Check and ensure that the belt is not twisted.

WARNING

Twisted seat belts can cause injury, in a collision, the full width of the belt isn't available to absorb the impact. This puts more force on the bones beneath the belt, which could break them or cause other serious injury. Don't wear twisted seat belts.

3. Position the lap portion of the belt as low as possible across your hip bone.
4. Pull up the shoulder part of the belt to remove the slack. Make sure that the belt goes over your collar bones and across chest.
5. To unlatch the belt, press the red button on the buckle. Guide the belt to the pillar as it retracts.

SEAT BELTS

WARNING

Improper positioning of the shoulder portion of the seat belt is dangerous. An improperly positioned belt will provide little or no protection in a collision. Always make sure the shoulder portion of the seat belt is positioned across your shoulder and near your neck, but never under your arm, on your neck, or on your upper arm.

6. Each belt should be used by one occupant only . The belt must not be put round a child, seated on passengers lap.
7. When the belt has been in use in a serious accident or shows signs of severe fraying or of having been cut, replace with an approved belt kit.
8. The belt must not be altered or modified during use.

WARNING

Using one seat belt for more than one person at a time is dangerous. A seat belt used In this way can't spread the impact forces properly and the two passengers could be crushed together and seriously injured. Never use one belt for more than one person at a time.

- 9 The belts are meant (intended) for adult occupants only.
- 10.The belts if required should be replaced, by Authorised personnel only.
- 11.The belt should not be disassembled. If required, authorised personnel only should carry out disassembly and assembly.
- 12 Clean the webbing with a mild soap solution recommended for upholstery or bleach or dye the webbing this may weaken it.

Lap belt

Pull the tongue to the desired length.

Insert it into the buckle until you hear a click.

Adjust the belt length. To lengthen the belt, hold the tongue at a right angle to the webbing and pull. To shorten, pull the loose end of the webbing.

To unfasten, depress the button in the buckle.

WARNING

Positioning the lap portion of the Seat Belt too high can be dangerous, in a collision, this would concentrate the impact force directly on the abdominal area, causing serious injury. Wear the lap portion of the belt snugly and as low as possible.

TATA MOTORS strongly urges that the driver and passengers in the vehicle be properly restrained at all times with the seat-belts. Failure to do so could increase the chance of injury and / or the severity of injury in accidents.

Baby or Small Child :

Use child restraint system appropriate for the child until the child becomes large enough to properly wear the vehicle's seat-belts.

If a child is too large for a child restraint system, the child should sit in the seat and must be restrained using the vehicle's seat-belt.

Also use the seat-belt while the child is in the rear seat. According to accident statistics, the child is safer when properly restrained in the rear seat than in the front seat.

Child restraint systems are available. **TATA MOTORS** recommend the use of a type which fits to your vehicle. Before installation, always read the manufacturer's instructions.

Pregnant Woman :

TATA MOTORS recommends the use of a seat-belt. Doctors advise is recommended. The lap belt should be worn securely and as low as possible over the hips and not to waist.

Injured person :

TATA MOTORS recommends the use of a seat-belt for injured person. Depending on the injury, consult your doctor for specific recommendations.

SAFETY CHECKS

Before Driving, please ensure to check (Refer maintenance)

1. Tyre pressure and condition of tyres. Inflate recommended tyre pressure if required.
2. Coolant level to Max level.
3. Engine oil level up to Max mark on dipstick.
4. Brake fluid level .
5. Water in windshield washer reservoir. Top up if required.
6. Power steering oil level.
7. Battery electrolyte level.
8. Fuel level. Ensure sufficient Fuel.

Adjust

1. Check position of seat. If required adjust to your convenience.
2. Check adjustment of all rear view mirrors.

Ensure

1. Bonnet is fully closed.
2. All doors are properly closed & locked.
3. Check that any items you may be carrying inside with you are stored properly or fastened down securely.
4. Seat belts are fastened
5. Ensure all mirrors, windows and outside lights are clean and unobstructed. Remove dust, frost, snow or ice if any, on these.
6. All switches & lamps are working
7. Check and ensure that all the gauges and indicators in the instrument cluster are working.
8. Gear shift lever is in neutral position
9. Parking brake is released.
10. Adjust steering wheel position.

SAFETY CHECKS

Windshield/wiper/windshield washer

Always keep windshield glass clean to avoid any distraction in visibility. Ensure proper working of wipers and condition of wiper blade. Ensure that windshield washer reservoir is full. Do not operate wiper alone when the windshield glass is dry, this would damage the windshield.

Headlights

Keep headlight lenses clean. Check for operation of headlamps in both high/low beam condition. Check for correct focusing of headlamps. Use only recommended type of bulbs. Do not use the high beam unless it is inevitable. Its dazzle may glare the driver of the oncoming car the condition thus causing an accident.

DRIVING SAFETY**Side indicators / Hazard warning**

Ensure that all side indicators/hazard warning lights are always in working condition and they are used when required.

Horn

Ensure the horn is working properly. Horn provides safety to other road users by alerting your presence.

Brakes

Ensure brakes are working properly. Check brake fluid level in reservoir. Do not drive the car when brake warning lamp is 'ON'.

Tyres

Check the condition of tyres for any abnormalities. Maintain correct tyre pressure, it is very important particularly when subjected to extreme conditions, such as high speed, high load and high outside temperature. Do not use worn or bald tyres specially on the front wheels.

First Aid Kit

First aid kit is provided in your vehicle. This is for use in case of minor injuries. It is to be regularly checked for any disintegration and should be updated regularly.

Documents

Always carry vehicle registration papers, insurance, valid PUC certificate and driving licence with you.

DRIVING SAFETY**Seat Belt**

Seat-belts are life saving equipment, use of seat-belt reduces the chance of injury and severity of injury in case of an accident. It is strongly recommended that all the car occupants should always wear seat-belt, while vehicle is in motion.

Influence of Alcohol

Avoid driving under the influences of alcohol or drugs. Alcohol and drugs will severely impair your control of the

vehicle and increase the risk of injury yourself and others.

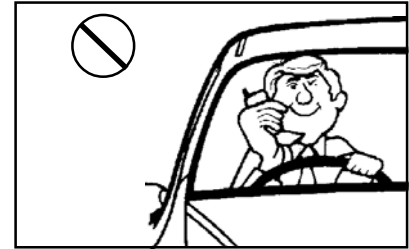
Mobile phones

Avoid using mobile phones while driving a vehicle. This could divert your attention from the road and result in an accident.

Fatigue 'Rest Revive survive'

Do not attempt driving when you feel tired, sleepy. Long distance driving can tire you very much and fatigue can dull your reflexes and judgment. Take a rest and get refreshed at intervals.

FUEL SAVING TIPS

FRIENDLY TIPS TO IMPROVE FUEL ECONOMY :

Your vehicle's fuel economy is mainly dependent on your style of driving.

To operate your vehicle as economically as possible, use the following driving suggestions.

Avoid Excessive Idling :

Stop the engine and start it again, if you have to wait for more than a minute while you are stopped.

Avoid fast starts & unnecessary stops :

Start off slowly from traffic lights or stop signs to prevent increased fuel consumption and shortening of engine life. Avoid unnecessary deceleration (stopping or slowing down) and then acceleration which uses more fuel.

Always maintain clean air-filter:

The amount of air supplied will reduce due to clogged air-filter, resulting in wastage of fuel due to incomplete combustion.

Avoid incorrect tyre pressures:

Under-inflated tyres result in increased running resistance of the tyres, leading to wastage of fuel.

(Refer tyre maintenance section)

Proper Driving Practices :

Keep a safe distance from other vehicles to avoid braking suddenly.

NOTICE

Do not rest your foot on the clutch pedal. It does not allow full engine power to be transmitted to the vehicle and reduces clutch life.

Fuel economy speeds :

Gear	Speed (kmph)
1st	15
2nd	30
3rd	45
4th	60
5th	80

STARTING, STOPPING THE ENGINE**Starting the Engine**

Before starting

1. Apply parking brake.
2. Ensure gear lever in neutral.
 - A. Insert the key in steering cum ignition lock and turn it to 'ON' position.
 - B. Press the clutch pedal fully.
 - C. Now crank the engine.
 - D. If the engine does not start turn the key to off position and try after 30 seconds.

NOTICE

After starting run the engine in idle speed for at least 30 seconds. Do not press accelerator pedal while starting the engine to avoid damage to turbocharger.

Stopping the Engine

Before switching off the engine, run the engine in idle condition for atleast 30 seconds and then switch

off. This will allow the engine oil to lubricate the turbocharger, till its speed is fully reduced and also allow the unit to cool down.

Above precautions will ensure satisfactory life and performance from the turbocharger.

Running-in Period

Avoid rapid acceleration and prolonged high speed running of the engine while using the new vehicle for the first 1500-1800 km of operation.

Do not exceed the following vehicle speed during running in period.

Gear	DICOR Kmph	TURBO Kmph
1 st	20	20
2 nd	40	40
3 rd	65	60
4 th	90	80
5 th	110	100

Gear box

Gear box has all synchromesh gears including reverse. The 5th gear is an over drive.

When shifting the gear up or down make sure you press the clutch pedal fully and shift to the next gear and then release the clutch pedal gradually.

STARTING, STOPPING THE ENGINE

Before shifting in to reverse gear bring your vehicle to a complete stop and depress the clutch pedal fully.

Do not shift into reverse gear with vehicle moving forward.

While shifting the gears it is recommended to shift at the speeds given in the table.

You can get extra braking from the engine when slowing down by shifting to a lower gear.

This can help you to maintain a safe speed and prevent your brakes from overheating while going down a steep hill.

CAUTION

Avoid excessive revving up of engine rpm.

CAUTION

Running Engine under idle condition for long duration and also in high idle (fly-up rpm) should be avoided

Gear Shifting :

Gear Change Speeds during upshift :

Gear	DICOR Kmph	TURBO Kmph
1-2	20	20
2-3	45	35
3-4	70	60
4-5	90	80

Gear Change Speeds during downshift :

Gear	Kmph
2-1	15
3-2	25
4-3	45
5-4	60

Brakes

The brake system on your vehicle is an advanced vacuum assisted hydraulic brake system, equipped with:

- Brake booster : This assists the driver in braking with an ergonomic pedal force on brake pedal;
- Tandem Master Cylinder, for fail safe braking.
- Twin pot calipers, for efficient energy absorption.
- Load Sensing Proportionating Valve, to avoid rear wheel locking in extreme load condition.
- Auto adjusted rear brakes which are designed for trouble free performance.

The system is designed with an H circuit, this has an advantage of providing minimum braking even if one circuit fails, however the pedal will be harder to press and stopping

distance will increase. At the same time brake indication light would glow on dash board.

If you observe any abnormality in brake system contact your nearest TATA Motors authorized workshop.

In case of failure of vacuum supply to the brake booster the vehicle can still be stopped with a higher pedal effort. In case of vacuum failure or brake circuit failure, slow down the vehicle by shifting to lower gear and lifting your foot from the accelerator pedal. Pull the side of the road as soon as it is safe.

⚠ CAUTION

Brake system failure is very hazardous. It is best to have your vehicle towed, but if you drive the vehicle in this condition, be extremely cautious. Have your vehicle attended immediately.

Put your foot on brake pedal to apply brake. Do not ride the brakes as they may overheat and the performance may be impaired. The brake lights may confuse the other road users behind you.

Use engine to assist the brakes by shifting to a lower gear and lifting your foot from accelerator pedal.

Constant application of brakes while going down the hill builds heat and reduces braking efficiency.

Check your brakes after driving through deep water. Apply the brakes moderately to feel that they are normal. If not, apply them gently and frequently until they do. With wet brakes you should be extra cautious and alert in your driving.

DRIVING IN ADVERSE CONDITIONS

Driving Through Water :



Never venture to drive through water when it flows over guard stones.

Engine may get seriously damaged if attempted to cross over through deep water.

If at all the situation demands that you have to drive through water then;

- Keep engine in fast idling and crawl the vehicle in low gear.
- After driving through water apply brakes several times to dry liners and to regain original braking.

Do not attempt to start the engine if vehicle gets flooded due to water.

Tow the vehicle to a safe place.

Take the vehicle to nearest **AUTHORISED** Workshop to check entry of water in cylinders.

It will also be necessary to replace lubricants of engine, gearbox, transfer case, front axle and rear axle if water has entered.

Get the starter and alternator checked.

Driving on a Rainy Day :



Check brakes, steering and windows.

Check tyres for wear and tyre pressure.

Check wiper blades for proper functioning.

Avoid harsh braking and sharp turns. It may cause loss of control and lead to a skid.

For slowing down, shift to lower gears and brake gently.

Keep lights **ON** if visibility is poor.

Night Driving :



Dip the head lamp for oncoming traffic during night driving.

Maintain a speed such that you can stop within illuminated distance of head lamps.

Use head lamp main/dip beam to alert other road users on turns/

DRIVING IN ADVERSE CONDITIONS

cross roads etc.

Use side indicators for lane change or turning.

- Put on hazard warning switch in case of hazardous parking or if your vehicle is disabled to warn the passing traffic.

Climbing Sharp Gradients on Loose Surfaces :



Start off smoothly in any suitable gear. Apply power smoothly so that there is no loss of traction by over-revving of the engine.

Choose as smooth a slope as possible and select the appropriate

gear so that gear changing in the middle of the climb is not required.

Changing gears in the middle of the climb can cause loss of momentum and engine stalling. Shifting to lower gear has to be done cautiously to avoid loss of traction.

Under no conditions should the vehicle be moved diagonally across a hill. The danger is in loss of traction and sideways slippage, possibly resulting in tipping over. If unavoidable, choose as mild an angle as possible and keep the vehicle moving.

If the wheels start to slip within few feet of the end of the climb, motion can be maintained by swinging the steered wheels left and right, thereby providing increased grip.

If the vehicle stalls or losses headway while climbing a steep hill, make a quick shift to reverse and allow the vehicle to move back

with the control of engine compression.

Descending Sharp Gradients :



Depending on the severity of the gradient, shift into appropriate gear. Use engine braking judiciously without over-revving the engine.

Brake application under such situations should be done very smoothly to avoid loss of control. Select appropriate gear so that gear changing or clutch disengagement is not involved while descending the gradient.

JACK LOCATATION, WARNING TRIANGLE & FLAT TYRE REPLACEMENT

Advance Warning Triangle



There is an advanced warning triangle provided along with your vehicle. In case there is a breakdown and or the vehicle is to be parked at the side of road, then the triangle is to be used as per instructions given below:

1) Remove advance warning triangle from case and assemble.

2) Place the triangle on the road behind the vehicle where it is stranded.

3) The triangle must be at least 50 meters behind the vehicle in the same lane of traffic.

4) Increase the distance to 150 meters on a highway or if a bad/hill top obscures the view.

Hazard Warning Switch :

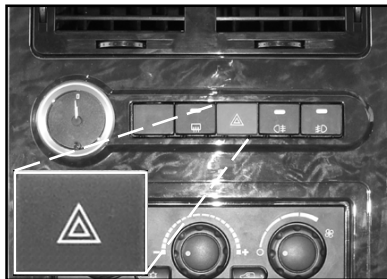

Use Hazard Warning lights besides advance warning triangle in case of breakdown specially during night time and vehicle has to be

parked at the side of the road or vehicle is being operated in adverse condition.

This can be operated without ignition 'ON'. Press the hazard warning switch (red knob) on the left side of the dash board, all side indicator lights will flash simultaneously to warn the other road users about any hazardous condition of the vehicle. Depress the knob again to switch 'OFF' the hazard function.

⚠ CAUTION

If lights do not blink or blink rapidly, it is an indication of problem in the blinker electrical system or the indicator bulb at front or rear has fused. Get it rectified immediately.

JACKING POINTS, FLAT TYRES REPLACEMENT

IF YOU HAVE A FLAT TYRE

Reduce vehicle speed gradually keeping it is a straight line. Move cautiously off the road to safe place away from traffic. Park the vehicle on a level and firm ground. Apply parking brake & engage 1st gear.

Turn on Hazard warning switch. Keep advance-warning triangle at least 50 meters behind the vehicle as an indication of breakdown.

Take out the tool kit, jack and handle from the vehicle which is kept below driver seat

Removal of Spare wheel

Spare wheel is mounted below cab at rear side of vehicle.

Open the tail door

Lift the carpet cutout covering the spare wheel winch screw hole.

Rotate the wheel winch screw in anti-clockwise direction using the

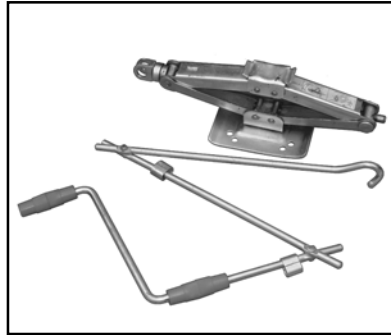

wheel spanner to lower the spare wheel.

Let the wheel touch the ground. Loosen it further to take out retaining plate from spare wheel. Remove spare wheel.

Incase Of Emergency

SPARE WHEEL

Fitting the spare wheel back

Place the spare wheel on the ground below its location with outer side of the wheel rim facing upwards.

Locate the retaining plate in the central hole of the spare wheel.

Using the wheel spanner, the spare wheel can be raised by rotating the wheel winch screw in clockwise direction.

Align one of the wheel mounting screw holes with the locating pin on the frame while raising the spare wheel.

Continue to rotate the wheel winch screw in anticlockwise direction to raise the spare wheel is completely until you hear a 'CLICK' sound. This ensures spare wheel is in position.

Changing the flat tyre

Block the wheel which is diagonally opposite to the flat tyre

Take out wheel cover (If fitted) and loosen the wheel mounting nuts of flat tyre. (Do not remove the flat tyre at this stage).



Set the jack properly at correct jack point as shown for front or rear wheel and slowly lift the vehicle with the help of jack handle.



Jacking point - Rear



Jacking point - Front

SPARE WHEEL & LIMP HOME MODE

⚠ CAUTION

Do not lift the vehicle with some one inside.

Raise the vehicle only high enough to remove and change the flat tyre.

Do not carry any other work under the vehicle supported by jack otherwise personnel injury may occur.

Do not start or run the vehicle while supported by jack.

Remove wheel-mounting nuts and take out flat tyre.

Roll the spare wheel into position and align the holes in the wheel with studs. Then reinstall the wheel nuts (taper end inward) and tighten them as much as you can by hand.

Lower the jack completely then tighten the wheel nuts one by one using wheel spanner. Fit the wheel cover back (if fitted).

Restore all the tools and jack at their respective location.

Place the flat tyre at spare wheel location as described and tighten properly.

⚠ CAUTION

Check and correct the tyre pressure and nut tightness of the changed wheel as per recommendation at nearest Service station. Also get the punctured tyre repaired.

Limp Home Mode : DICOR



When water gets accumulated in water sedimenter “water in fuel indicator lamp” on instrument cluster remains ON continuously.

This causes the vehicle to run on “Limp Home Mode”; there is a drastic reduction in performance of the vehicle in Limp Home Mode.

NOTICE

At initial “Key-ON” the water in fuel lamp indication on the dashboard glows for 2 seconds and goes ‘OFF’ automatically. If this lamp does not glow, vehicle has to be taken to the service station for verification and necessary attention.

STARTING THE ENGINE WITH JUMP LEADS

Starting the Engine with Jump Leads :

The engine with a discharged battery may be started by transferring electrical power from a battery in another vehicle.

This may be dangerous as any deviation from the following instructions could lead to personal injury resulting from any battery explosion, as well as damage to the electrical systems in both vehicle.

CAUTION

Do not allow battery electrolyte to come in contact with eyes, skin, fabrics or painted surfaces. The fluid contains sulphuric acid which can cause injury and severe damage. Wear rubber gloves, to avoid

risk of contact.

To lessen the risk of injury, wear eye protection when working near

any battery.

- Make sure that the battery providing the jump start has the same voltage as the battery in your vehicle (12 V). Its capacity must be approximately the same as the original battery capacity. The voltage and capacity are given on the batteries.
- Do not disconnect the discharged battery from the vehicle.
- Switch off all unnecessary electrical loads.
- Do not lean over the battery during jump starting.
- Do not allow the terminals of one lead to touch those of the other lead.
- Apply the hand brake. Keep the gearshift lever in neutral.
- Do not connect the lead to the negative terminal of the discharged battery.
- The connection of the -ve lead point should be as far away

from the discharged battery as possible and close to the starter motor on engine/transaxle.

- Route the leads so that they cannot get caught by the rotating parts in the engine compartment.
- The engine of the vehicle

Connect leads in the order as shown in the sketch

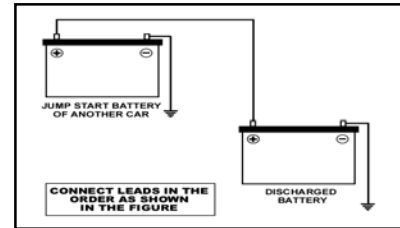

providing the jump start can be allowed to run during starting. Attempts to start the engine of the vehicle with the discharged battery should be made at intervals of one minute and should not last more than 15 seconds. After starting, allow both engines to idle for approximately 3 minutes with the leads still connected.

Towing the Vehicle :

- For towing a vehicle, the best way is to use a wrecker.
- Alternatively use a rigid tow bar.
- Avoid using a flexible cable or rope as your vehicle may crash into the vehicle towing your car when it stops suddenly.
- Switch 'ON' the hazard warning signals of both the vehicle to warn other road users.
- Where possible, keep the engine idling so that power steering assistance and brake vacuum are available.
- Limit the speed to 20-30 kmph.
- In case of brake failure, use the parking brake to control the vehicle.

Front and Rear Tow Hook Location :



Tow Hook Location at Front



Tow Hook Location at Rear

ROUTINE SERVICE

This manual will help you to understand your vehicle. Inspection, maintenance of the vehicle should be handled by professionals only.

Please be careful while personally inspecting / maintaining the vehicle as it may cause damage to the vehicle and may be unsafe.

The ignition and fuel systems are highly important in view of emission control and for efficient engine operation. Similarly the brake system for safety. Do not tamper with them.

All inspections and adjustments must be made by a qualified technician. We strongly recommend that all servicing related to these systems be done by an Authorised dealer/TASC.

OWNER MAINTENANCE

Routine Service

We highly recommend that these items be inspected at least every week.

Engine Oil Level, Engine coolant Level, Brake Fluid Level, Washer Fluid Level, Battery, Tyre inflation pressure

Do it Yourself Service

Improper or incomplete service may result in problems.

Several maintenance procedures can be done only by a qualified service technician with special tools. Improper do it yourself maintenance during the warranty period may affect warranty coverage. If you're unsure about any servicing or maintenance procedure, have it done by an Authorized Dealer / TASC.

WARNING

Maintenance procedures:

Performing maintenance work on a vehicle can be dangerous. You can be seriously injured while performing some maintenance procedures. If you lack sufficient knowledge and experience or the proper tools and equipment to do the work, have it done by qualified technician.

ENGINE

(These tips are given for your guidance and preliminary jobs to be done in an emergency situation. In normal case, the problems should be attended in an Authorised Workshop by following the repair procedures given in Workshop Manual)

SR. NO.	PROBLEM OBSERVED	CAUSE	ACTION TO BE TAKEN
ENGINE			
1.	Engine not cranking	Dead battery loose or dirty battery connections	<ul style="list-style-type: none"> • Get battery checked&/or changed • Clean and tighten battery connections
2.	Engine cranks but does not start	Air in the fuel system	<ul style="list-style-type: none"> • Press pear pump for air removal • Check leakages
		Service lamp should glow EMS fuse blown	<ul style="list-style-type: none"> • Get defect rectified • Replace the fuse
3.	Engine overheats	Coolant level low	<ul style="list-style-type: none"> • Top up coolant, check and correct leakages
		Hose collapse / torn	<ul style="list-style-type: none"> • Get the hose replaced
		Low engine oil level	<ul style="list-style-type: none"> • Add oil
		Radiator cap not sealing properly	<ul style="list-style-type: none"> • Fit the radiator cap correctly
		A.C. condensers fans not working	<ul style="list-style-type: none"> • Get defect rectified
		Brakes binding	<ul style="list-style-type: none"> • Get defect rectified
		Electric fan not working	<ul style="list-style-type: none"> • Get defect rectified
		High delivery pressure in A.C. refrigerant circuit	<ul style="list-style-type: none"> • Get defect rectified
4.	Charging indicator continuously remains 'ON'	Battery not getting charged due to loose belt drive	<ul style="list-style-type: none"> • Get the belt tension adjusted • Replace if broken

Preliminary Trouble shooting

CLUTCH & GEAR BOX

SR. NO.	PROBLEM OBSERVED	CAUSE	ACTION TO BE TAKEN
5.	Poor pickup	Loose contact of connectors Blocked fuel filter Clogged air filter EGR malfunctioning	<ul style="list-style-type: none">• Get defect rectified.• Clean/replace fuel filter element• Clean / replace the element• Get checked & corrected• Check for loose pipes & connections.
6.	Does not accelerate	Accelerator pedal module defective	<ul style="list-style-type: none">• Get defect rectified
7.	Belt squeal	Loose belt Belt glazed	<ul style="list-style-type: none">• Get belt tension adjusted• Get belt replaced
CLUTCH			
1.	Clutch does not get disengaged	Air in the hydraulic system Less fluid in the master cylinder	<ul style="list-style-type: none">• Bleed the system• Get the clutch fluid filled
2.	Clutch pedal goes too low	Air in the hydraulic system Less fluid in the master cylinder	<ul style="list-style-type: none">• Bleed the system• Get the clutch fluid filled
3.	Clutch pedal return sluggish	Blocking of vent in clutch fluid bottle	<ul style="list-style-type: none">• Open the cap from the bottle & clean the breather hole, if clogged
GEAR BOX			
1.	Hard gear shifting / crash engagement	Clutch does not disengage properly	<ul style="list-style-type: none">• Get the clutch hydraulic system attended

AXLE & BRAKE

SR. NO.	PROBLEM OBSERVED	CAUSE	ACTION TO BE TAKEN
REAR AXLE			
1.	Loss of lubricant (Oil)	Breather hole clogged Differential cover gasket torn Pinion oil seal damaged	<ul style="list-style-type: none"> • Clean the breather hole on the axle housing • Get replaced • Get replaced
2.	Differential housing overheating	Insufficient oil Incorrect lubricant used	<ul style="list-style-type: none"> • Get the oil filled • Drain, flush and get correct lubricant filled
BRAKES			
1.	Poor brakes	Insufficient brake fluid. Air in the system Malfunction of automatic adjuster Vacuum leakage Brake fluid contamination Brake fluid, grease, oil or water on pad /drum Worn brake lining/pad Excessive worn drums at rear soft or weak hose	<ul style="list-style-type: none"> • Get the brake fluid filled • Bleed the system • Check & rectify auto adjuster mechanism or replace • Rectify the leakage • Replace the brake fluid • Replace the leaking line, bleed the system. Clean pad/lining. replace seals if leaking • Get the liners/pad replaced • Replace rear drums • Check & replace

Preliminary Trouble shooting

BRAKES

SR. NO.	PROBLEM OBSERVED	CAUSE	ACTION TO BE TAKEN
2.	Spongy pedal	Air in the system	<ul style="list-style-type: none">• Bleed the system
3.	Brake pulling to one side	Oil on the lining/pad One side shoe (pad) worn Loose brake anchor plate Wheel adjustment disturbed Unequal tyre pressure One side brake pipe clogged	<ul style="list-style-type: none">• Clean the pad lining• Get the shoe pad replaced• Tighten the bolts• Adjust• Adjust• Get the brake line cleaned & bleed the system
4.	Brake grab	Improperly adjusted parking brake Brake fluid container breather hole clogged No brake pedal free play/brake pedal not returning fully Defective tandem master cylinder	<ul style="list-style-type: none">• Get correctly adjusted• Clean the hole on the container• Adjust brake pedal• Replace/rectify tandem master cylinder
5.	Brake Squeal	Defective brake lining/pad Glazed lining/pad Loose rivets Wrong lining/pad Shoe return spring broken Front pads /Antisqueal shims rubbing on the disc	<ul style="list-style-type: none">• Replace• Clean or replace lining/pad• Install rivets properly• Install correct lining/pad• Replace• Get corrected

ANTI-LOCK BRAKING SYSTEM & STEERING

SR. NO.	PROBLEM OBSERVED	CAUSE	ACTION TO BE TAKEN
ANTI-LOCK BRAKING SYSTEM (IF FITTED)			
1.	ABS warning lamp stays 'ON'	<p>ABS unit faulty No supply to ABS unit</p> <p>Electrical circuit problem : Intermittent contact, Wiring connections / connections loose/ faulty</p> <p>Component and sensor failure : RPM sensors/toner rings fitting loose, gap disturbances, Sensor signal that deviates from the specified levels</p> <p>Circuit / bulb failure</p> <p>Leakage from hydraulic unit ports</p> <p>Hydraulic unit fluid level low</p> <p>Unusual response and malfunction in the actuators</p>	<ul style="list-style-type: none"> • Check wiring connections & battery condition. • Check wiring harness connections • Check gap between sensor & toner ring • Replace bulb • Eliminate leakage by tightening • Check reservoir fluid level and bleed properly. • Check sensor condition & replace if necessary.
STEERING SYSTEM			
1.	Hard steering	Less fluid in the power steering tank	<ul style="list-style-type: none"> • Get the fluid topped up to correct level

Preliminary Trouble shooting

ELECTRICAL & AIR CONDITIONING

SR. NO.	PROBLEM OBSERVED	CAUSE	ACTION TO BE TAKEN
		Air in the system	<ul style="list-style-type: none">• Get the air removed by bleeding the system
		Loose pump belt	<ul style="list-style-type: none">• Get the belt correctly adjusted
ELECTRICAL			
1.	No lights on the dash board after turning on the ignition key	Battery terminal got disconnected Battery completely dead	<ul style="list-style-type: none">• Get the battery properly connected• Get the battery charged• Get the alternator & charging circuit checked
2.	Non functioning electrical accessories such as power windows, head lamps, fuel tank flap, wiper and washer etc.	Blown fuse in the circuit Loose connectors Circuit relay loose in the mounting Defective components	<ul style="list-style-type: none">• Check for parking lamp fuse• Replace the fuse if blown• Get the connection properly tightened• Tighten the relay correctly• Get the defective component replaced from Authorised Workshop
AIR CONDITIONING			
1.	Fan motor does not operate	Blown fuse Faulty connection Faulty motor	<ul style="list-style-type: none">• Replace fuse and correct any wiring short• Properly connect poor connections• Replace motor if no conductance

WIPERS

SR. NO.	PROBLEM OBSERVED	CAUSE	ACTION TO BE TAKEN
2.	Motor operates but air flow is minimum	Faulty or poor connection at resistor Faulty fan switch Obstruction at evaporator inlet Air leak Faulty thermostat	<ul style="list-style-type: none"> • Replace resistor block if defective • Replace switch • Clean evaporator • Correctly seal • Adjust or replace thermostat
3.	Insufficient cooling, Air flow normal and compressor operating	Incorrect refrigerant quantity or defect in system aggregates	<ul style="list-style-type: none"> • Get the defect rectified at nearest authorised service centre

WIPERS

1.	Narrow streaks are left on the wind shield making it hard to see	Foreign matter has attached to the blade or	<ul style="list-style-type: none"> • Clean the edge of the blade. If streaks still appear, replace the blade edge of the blade is worn out.
2.	The wiper blade jumps across the windshield and makes a lot of noise (Un-smooth operation)	No proper contact of wiper blade with wind shield glass and wiper blade does not move smoothly across the surface but vibrates, noisily and bounces.	<ul style="list-style-type: none"> • Clean the wind shield. If jumping persists replace the blade.
3.	The wiper leaves large un-wiped spots.	Rubber deformed	<ul style="list-style-type: none"> • Replace the blade
4.	The blade does not contact with the wind shield surface evenly, leaving a large un-wiped surface.	Deformed wiper blade / arm	<ul style="list-style-type: none"> • Replace wiper blade / arm

FUSES & RELAYS

FUSES AND RELAYS (DICOR)

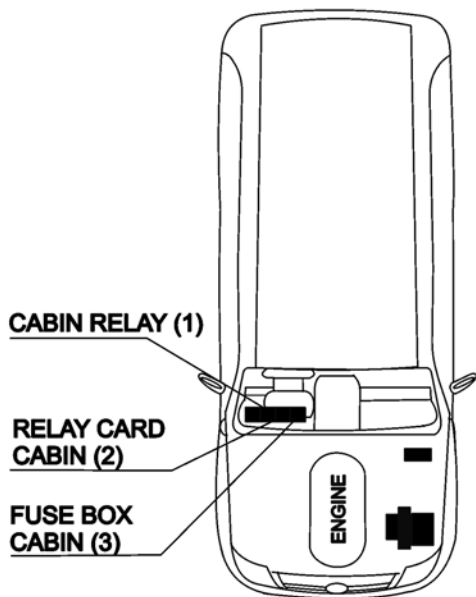

CABIN RELAY (1)

BUZZER	WINDOW WINDING RELAY
---------------	-----------------------------

CABIN RELAY CARD (2)

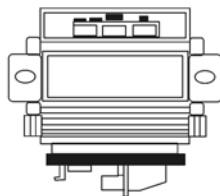

CABIN FUSE BOX (3)

MUSIC SYSTEM KEY IN	5A	WW 30A	PARK LH	5A
MUSIC SYSTEM CLOCK	10A		PARK RH	5A
ROOF AC	30A		INST. CLUSTER BATT	10A
COMBI SW AC CTRL	15A		EMS DIAGS	5A
INTERIOR LAMP	10A	BCM 40A	ACC RL COIL	5A
CIGAR	15A		FRONT WIPER	15A
ELECT. TAPPING	10A		REV. STOP	10A
INST. CLUSTER EMS IGN	10A		REAR WIPER	10A
BCM IGN.	5A			
FRONT AC	30A			

FUSES AND RELAYS (TURBO)

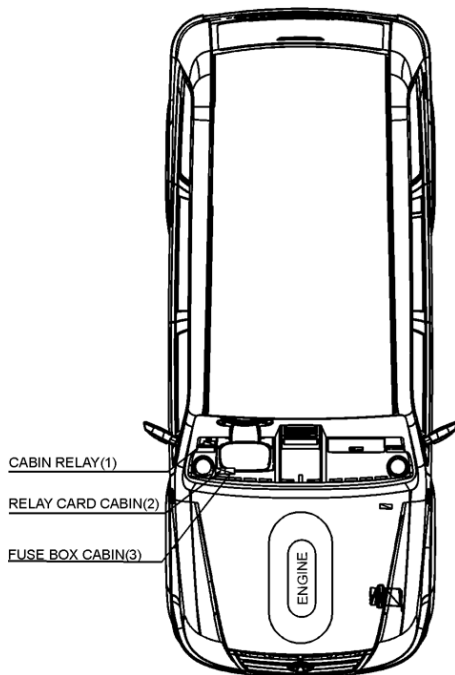

CABIN RELAY (1)

BUZZER	EGR CONTROLLER
--------	----------------

RELAY CARD CABIN (2)

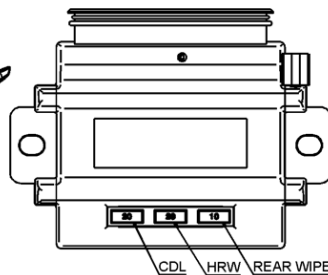

FUSE BOX CABIN

MUSIC SYSTEM KEY-IN	5A	WW30A	PARK LH.	5A
MUSIC SYSTEM CLOCK	10A		PARK RH.	5A
REAR BLOWER	30A		INST. CLUSTER BATT.	10A
COMBI SW HVAC CTRL	15A		EMS DIAGS.	5A
INTERIOR LAMP	10A	BCM40A	ACC RLY COIL	5A
CIGAR	15A		WIPER	15A
ELECTRIC TAPING	10A		REV. STOP	10A
INST. CLUST. GPT. IGN	10A	[]		
BCM IGN.	5A			
FRONT BLOWER	30A			
USE THE DESIGNATED FUSES ONLY				

FUSES & RELAYS

FUSES AND RELAYS (DICOR)

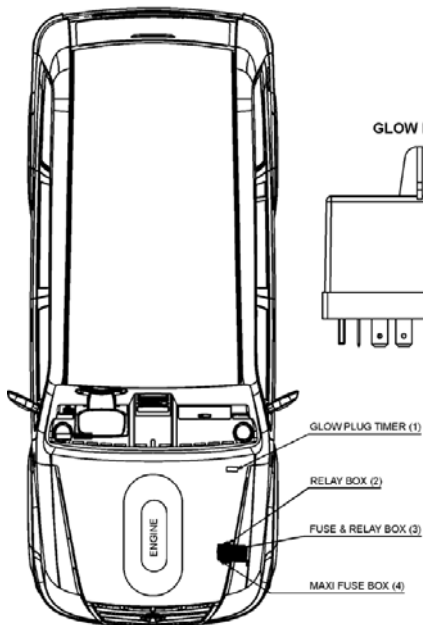

GLOW PLUG TIMER (1)

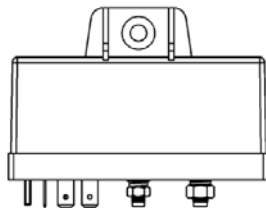

RELAY BOX (2)

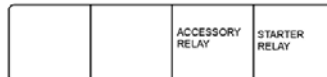

FUSE & RELAY BOX (3)

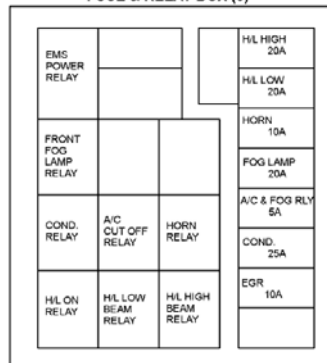

MAXI FUSE BOX (4)

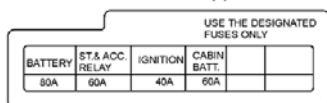

FUSES AND RELAYS (TURBO)

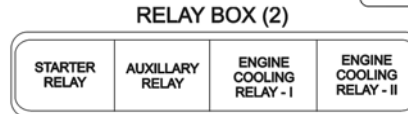
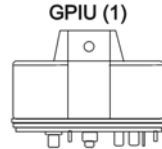
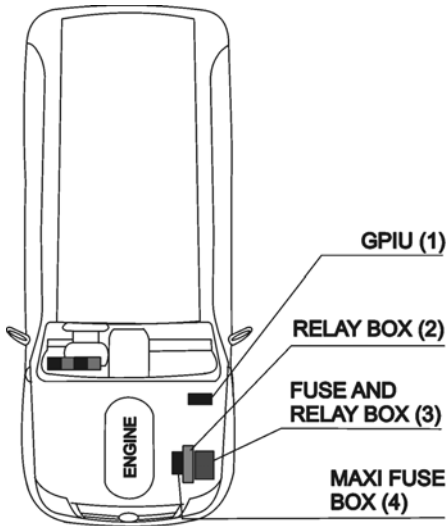

FUSE & RELAY BOX (3)

EMS POWER RELAY			ENG. COOL FAN COIL 5A	H/L HIGH 20A
FRONT FOG LAMP RELAY		ENGINE COOLING RELAY II		H/L LOW 20A
COND. RELAY	AC CUT OFF RELAY	HORN RELAY		HORN 10A
				FOG LAMP 20A
				A/C/FOG RLY 5A
				COND. 25A
				EMS RELAY 30A
H/L RELAY	H/L LOW BEAM RELAY	H/L HIGH BEAM RELAY		EMS RELAY COIL 5A

MAXI FUSE BOX (4)

USE THE DESIGNATED FUSES ONLY					
BATTERY	ST. & ACC. RELAY	IGNITION	CABIN BATT.	ENG. COOL FAN-I	ENG. COOL FAN-II
80A	60A	40A	40A	40A	40A

BULB SPECIFICATION

BULB SPECIFICATION				
DESCRIPTION	CAP TYPE	COLOUR	SPECIFICATION	QTY
Head lamp - Halogen H4	P43t	White	H4 12V,55/60 W	2
Parking lamp - Front	Wedge base (w 2.1 x 9.5d)	White	12V, 5W	2
Front fog lamp	H11 PGJ 19-2	White	H11 12V, 55W	2
Direction Indicator lamp - Front	BAU15S	Amber	12V, 21W	2
Direction Indicator lamp - Side	Wedge base (w 2.1 x 9.5d)	Amber	12V, 5W	2
Direction Indicator lamp - Rear	BAU15S	Amber	12V, 21W	2
Stop lamp + parking lamp - Rear	BA15S	White	12V, 21/5W	2
Reverse lamp	BA15S	White	12V, 21W	2
Rear fog lamp	BA15S	White	12V, 21W	2
Cabin lamp - 1st Row	Festoon	White	12V, 10W	1
Spot lamp - 1st Row	Wedge base (w 2.1 x 9.5d)	White	12V, 5W	2
Cabin lamp - 1st Row	Wedge base (w 2.1 x 9.5d)	White	12V, 5W	1
Cabin lamp - 1st Row	Wedge base (w 2.1 x 9.5d)	White	12V, 5W	1
Cabin lamp - 1st Row	Wedge base (w 2.1 x 9.5d)	White	12V, 5W	1
Engine lamp	BA15S	White	12V, 10W	1
Puddle lamp - All doors	Wedge base (w 2.1 x 9.5d)	White	12 V, 5W	5
LED DETAILS				
Door Ajar lamp - Front & Rear Doors	Not applicable	Red	LED	NA
High Mounted stop lamp - Rear		Red	LED	
Instrument cluster illumination		White	LED	
Key hole illumination		White	LED	
Facia switches, Window winding switches		White	LED	

BULB REPLACEMENT

Bulb Replacement :**Replacing the Headlight Bulb :**

Your vehicle's headlights have replaceable halogen bulbs. Headlight bulb can be replaced without even disturbing or removing the entire headlight unit.

WARNING**Handling Halogen Bulbs:**

It is dangerous if a halogen bulb breaks,. These bulbs contain pressurized gas and if broken, will explode and serious injuries could be caused by the flying glass. Halogen bulbs can break if the glass portion is touched with bare hands, body oil could cause the bulb to overheat and explode when lit. Never touch the glass portion of the bulb with your bare hands and always wear eye protection when handling or working around halogen bulbs. Always keep halogen bulbs out of the reach of children.

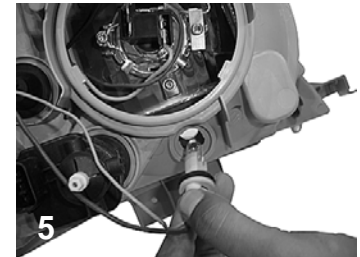
**Procedure :**

1. Make sure light stalk is in ' OFF' position & bulb is not hot.
2. Lift the engine bonnet to access the headlight bulb.

BULB REPLACEMENT

3. Remove the dust cover at the back of Headlamp **Fig. 1.**
4. Disconnect the electrical connector **Fig.2.**
5. Press and release the bulb retaining spring **Fig.3.**
6. Swing the retaining spring out to free the headlight bulb from the socket by pulling it straight back.
7. Carefully remove the headlight bulb from the socket **Fig. 4.**
8. Replace the bulb.
9. Install in the reverse order of removal.

Replacing the Parking Bulb :

1. Make sure lighting stalk is in 'OFF' position.
2. Lift the engine bonnet. The parking bulb is located below the Headlamp bulb on the assembly.
3. Pull the bulb holder from the socket.
4. Carefully remove the parking bulb from the socket by pulling it straight back **Fig. 5.**
5. Replace the bulb.
6. Install in the reverse order of removal.

Replacing Tail Lamp Bulb:

1. Make sure lighting stalk is in 'OFF' position.
2. Open the tail gate.
3. Remove the bolts (2 nos) holding the tail lamp cluster using a size 10 (10mm) spanner. Take out the entire tail lamp assy. by disconnecting the connector. **Fig. 1 & 2.**
4. Rotate and pull out the socket with bulb to be replaced. **Fig. 3.**
5. Carefully remove the fused bulb from the socket by rotating and pulling it.
6. Replace the bulb.
7. Install in the reverse order of removal.

BULB REPLACEMENT

Replacing Reversing light lamp Bulb :

1. Open the tail gate.
2. Remove the cover located on the inner side of tail gate. **Fig. 4.**
3. Rotate and pull out the socket with bulb to be replaced. **Fig. 6.**
4. Carefully remove the fused bulb from the socket by rotating and pulling it.
5. Replace the bulb.
6. Install in the reverse order of removal.

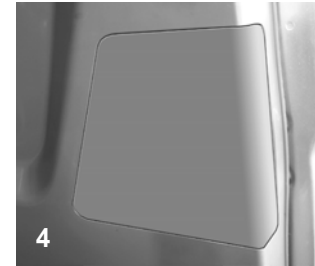
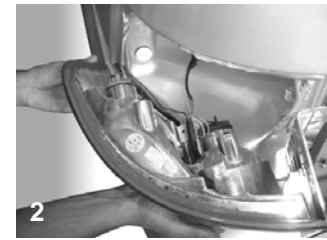
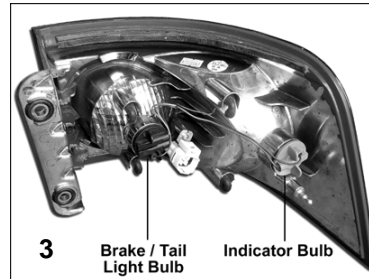

WASHING & CLEANING

VEHICLE CARE :

The Vehicle is subjected to many external influences such as climate, road conditions, industrial pollution and proximity to the sea. These conditions demand regular care of the Vehicle body. Dirt, insects, bird droppings, oil, grease, fuel and stone chippings should be removed as soon as possible.

Washing :

Do not wash the Vehicle in direct sunlight, wash in shade. Spray the Vehicle thoroughly with a cold water jet (Vehicle on a washing pit or hoist). Mix Vehicle shampoo in the wash water. No solvent (fuel, thinners) need be used.

NOTICE

Avoid wiping of painted surface in dry condition as it may leave scratches on the painted surface.

Use a soft bristle brush, sponge or soft cloth and rinse it frequently while washing. When you have washed the whole exterior, dry it with a chamois or soft cloth. After drying the Vehicle, inspect it for chips and scratches that could allow corrosion to start. Apply touch up paint where necessary.

Polishes :

Polishes and cleaners can restore shine to the painted surface that has oxidised and become dull. They normally contain mild abrasives and solvents that remove the top layer of the finish coat. Polish your Vehicle, if the finish does not regain its original shine after using wax.

Cleaning of Carpets :

Vacuum clean the carpet regularly to remove dirt. Dirt will make the carpet wear out faster. Periodically shampoo the carpet to keep it looking new.

Use carpet cleaners (preferably foam type). Follow the instructions that come with the cleaner, applying it with a sponge or soft brush. Keep the carpeting as dry as possible by not adding water to the foam.

Cleaning of Windows, Front & Rear Glasses :

Clean the windows inside and outside with commercially available glass cleaners.

This will remove the haze that builds up on the inside of windows. Use a soft cloth or paper towels to clean all glass and plastic surfaces.

WASHING & CLEANING

Non use maintenances :

Park the Vehicle in covered, dry and if possible well-ventilated premises. Engage a gear.

Remove the battery terminal cables (first remove the cable from the negative terminal).

Make sure the hand brake is not engaged.

Clean and protect the painted parts using protective wax.

Clean and protect the shiny metal parts using commercially available special compounds.

Sprinkle talcum powder on the rubber windscreen wiper and lift them off the glass.

Slightly open the windows.

Cover the Vehicle with a cloth or perforated plastic sheet. Do not use sheets of imperforated plastic as they do not allow moisture on the Vehicle body to evaporate.

Inflate the tyres to 0.5 bar above the normal specified pressure and check it at regular intervals.

Check the battery charge every six weeks.

Do not drain the engine cooling system.

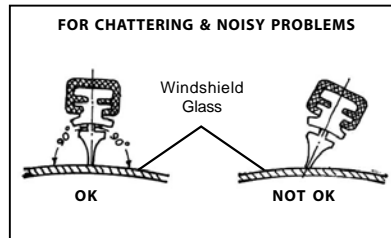
Wiper Care :

Wiper blade attack angle on windshield glass should be 90° i.e. perpendicular.

Remove wiper blade and root wiper arm on windshield glass in the centre position. Check the gap between arm strip and glass.

FOLLOWING GUIDELINES WILL HELP YOU TO PROTECT YOUR VEHICLE FROM CORROSION EFFECTIVELY.

PROPER CLEANING :

In order to protect your vehicle from corrosion it is recommended that you wash your vehicle thoroughly and frequently in case :

1. There is an heavy accumulation of dirt and mud especially on the underbody.
2. It is driven in areas having high atmosphere pollution due to smoke, soot, dust, iron dust & other chemical pollutants.
3. It is driven in coastal areas.
4. The underbody must be thoroughly pressure washed after every three months.

In addition to regularly washing your vehicle, the following precautions need to be taken.

GENERAL PRECAUTIONS

PERIODIC INSPECTION :

1. Regularly inspect your vehicle for any damage in the paint film such as deep scratches and immediately get them repaired from an authorised service outlet, as these defects tend to accelerate corrosion.
2. Inspect mud liners for damages.
3. Keep all drain holes clear from clogging.

PROPER PARKING :

Always park your vehicle in shade to protect it from harsh sunlight or in a well-ventilated garage so that there is no dampness on any part of the vehicle.

WASHING YOUR VEHICLE :

Following these tips while washing your vehicle.

HAND WASH :

1. Always wash your vehicle in shade and the surface is at room temperature.
2. Wash with mild car wash soap like 'Car Shampoo' and use a soft 100% cotton cloth to avoid scratches.
3. To avoid scratches, please wear soft gloves . Remove finger rings, nails, wrist watch while washing.
4. To remove stubborn stains and contaminants like tar, use turpentine or cleaners like 'Stain remover' which are safe for paint surfaces.
5. Avoid substances like petrol, diesel, kerosene, benzene or

other solvents that cause damage to paint.

6. Dry your vehicle thoroughly to prevent any damp spots.
7. Rinse all surfaces thoroughly to prevent any traces of soap and other cleaners as this may lead to the formation of stains on the painted surface later.

GENERAL PRECAUTIONS

WAXING :

Waxing and polishing a recommended to maintain the gloss and wet-look appearance of your paint finish.

1. Use a good quality polish and wax for your vehicle.
2. Re-wax your vehicle when the water does not slip off the surface and collects over the surface in patches.

Further tips for the care of your new vehicle finish :

If your vehicle is washed in an automatic car wash , please remember that the paint can be scratched by type of brushes, unfiltered washing water or the washing process itself. Scratching reduces paint durability and gloss, especially on darker colours. It is suggested to wash the vehicle by hand with cool and clean water using a soft cloth or sponge. Please do not use soap but a car shampoo recommended by your dealer.

Please take the following precautions :

1. Always wash your vehicle in shade, avoiding direct exposure to sunlight during washing.
2. Dry wiping your vehicle may lead to the formation of

scratches and hence always use a soft cloth and clean water while wiping your vehicle.

3. Always keep your vehicle parked in a well ventilated shade. Exposure to heat with entrapped moisture promotes corrosion.
4. Avoid driving on gravel roads, as the possibility of paint chip off due to the impact of stones is high. If you are driving on freshly tarred road, check immediately afterwards for any stains & clean them.
5. External contamination in the form of sap or industrial fall-out may mar or develop spots on a new finish. Hence avoid parking your vehicle near trees, which are known to drop sap, or near factories, which give out heavy smoke.

GENERAL PRECAUTIONS

6. The acid content in bird droppings may damage the newly painted finish and hence any bird dropping must be immediately washed off.
7. The paint finish is susceptible to damage in case petrol, brake fluid, liquid from car battery, oil, antifreeze, transmission fluid or windshield solvent spills onto the painted surface. In case of such a spillage immediately rinse the affected area with water. Avoid wiping the area far as possible, however if wiping is required, ensure that you wipe the area gently with soft cotton cloth.
8. Avoid using sharp objects to scrap off tar or mud from a painted surface as it may develop scratches or may peel off the paint.

Vehicle Exterior Enrichment :

Why vehicles are painted?

- For Corrosion protection of the metal surfaces.
- Ease of application from other corrosion protection treatments.
- Cheaper than other corrosion protection methods eg.galvanizing, anodizing.
- For decoration and identification.

Various Environmental Hazards affecting paints :

- Environmental hazards : destroy your vehicle's finish.
- Even as your new vehicle rolls off the assembly line, the paint is not protected.

The enemy :

Ultraviolet Rays, Pollution, Tree Sap, Bird Droppings, Car Wash Chemicals, Road Salt, Acid Rain.

Benefits of Vehicle Exterior Enrichment :

- Removal of medium scratches, orange peel, oxidation , dust nibs etc & swirl marks from painted surface.
- Restoration of original gloss levels UV protection after gloss is restored.
- Cleaning & dressing of tyres, Bumpers & all exterior plastic moldings/trims.

TATA MOTORS has tied up with **M/s Opulent (Waxoyl brand) and M/s 3M** for this world class treatment at affordable prices. This treatment is available in all authorized workshops. The Dealer Service Marketing Executive will explain to you the benefits and terms and conditions of this treatment.

OPENING & CLOSING THE BONNET

Opening & Closing the Bonnet

Opening:

1. Ensure that the vehicle is in neutral gear with the parking brake applied.
2. Pull the bonnet release lever located under the right hand corner of the dash board. The bonnet will pop up slightly.
3. Raise the bonnet slightly and with your finger lift the secondary lock lever located under the bonnet centre.
4. Lift the bonnet up. Pull the bonnet stay rod from its clip and insert the free end into the slot in the bonnet, slide stay rod outward to secure.

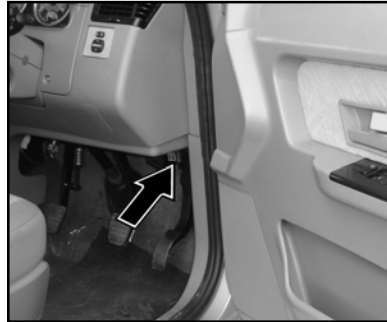

Location of Bonnet release lever



Bonnet release Lever

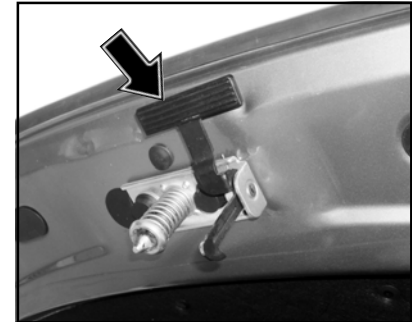

Bonnet opening secondary lock lever

Closing :

1. To close the bonnet disengage the stay rod & clamp it properly.
2. Lower the bonnet and drop it from a short height to shut.

⚠ CAUTION

Ensure that the bonnet is properly locked before driving. Do not press the bonnet onto the bonnet lock.

ENGINE COMPARTMENT (DICOR)

ENGINE COMPARTMENT - DICOR

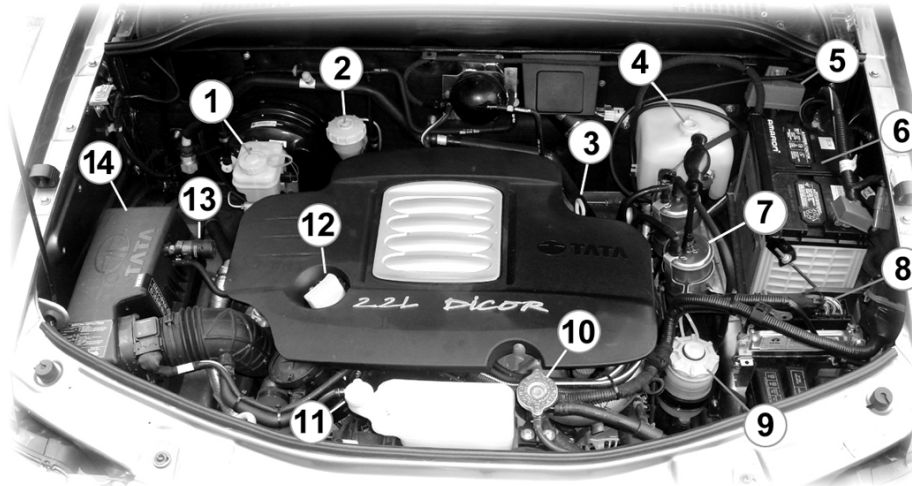

- | | | |
|---------------------------------|-----------------------------|-----------------------------|
| 1. Brake fluid reservoir | 2. Clutch fluid reservoir | 3. Engine Oil Dipstick |
| 4. Wind shield washer container | 5. Glow Plug Interface Unit | 6. Battery |
| 7. Sedimenter | 8. ECU | 9. Power steering reservoir |
| 10. Radiator Pressure Cap | 11. Auxiliary tank | 12. Engine Oil Filling Cap |
| 13. Service Indicator | 14. Air Filter | |

ENGINE COMPARTMENT (TURBO)

ENGINE COMPARTMENT - TURBO

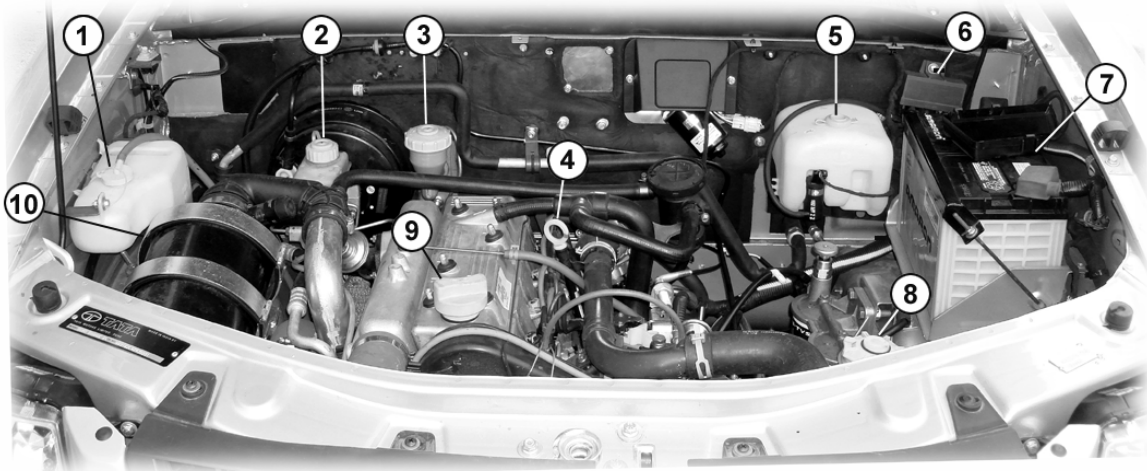

- | | | |
|------------------------|-----------------------------------|---------------------------|
| 1. Engine Coolant Tank | 2. Brake fluid reservoir | 3. Clutch fluid reservoir |
| 4. Engine Oil Dipstick | 5. Wind shield washer container | 6. Relay |
| 7. Battery | 8. Power Steering Fluid Reservoir | 9. Engine Oil Filling Cap |
| 10. Air Filter | | |

AIR FILTER & ENGINE OIL

AIR FILTER :

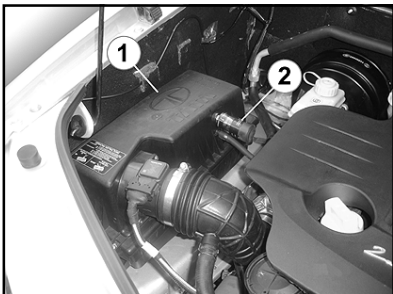

1. Air Filter 2. Service Indicator
(DICOR)

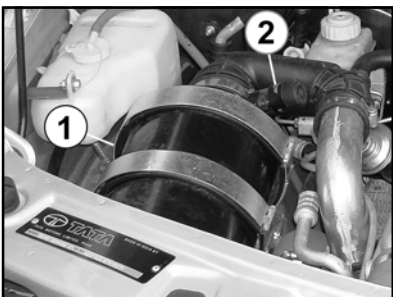

1. Air Filter 2. Service Indicator
(TURBO)

The air filter element should be periodically cleaned. Replace the air filter element with a new one, when air cleaner service indicator shows red band, even after cleaning.

Always use a genuine air filter element.

The air filter is located on the LH side of the engine compartment.

- a) When a vehicle is driven under dusty conditions, frequent cleaning and replacement of the air-cleaner element is necessary.
- b) Clogged air-cleaners lead to greater intake resistance and result in increased fuel consumption. Using low pressure compressed air, blow off dust on the air cleaner element. If the air cleaner element appears to be choked, replace it with a new one.

ENGINE OIL LEVEL CHECKING

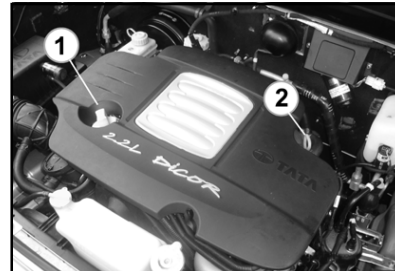

1. Engine oil filling cap 2. Dip Stick
(DICOR)

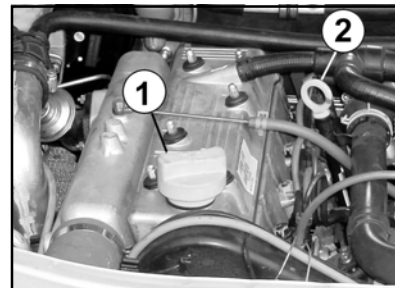

1. Engine oil filling cap 2. Dip Stick
(DICOR)

Warm up the engine to normal operating temperature.

ENGINE OIL LEVEL & ENGINE COOLANT LEVEL

Turn it off and wait 5 minutes for the oil to return to the oil pan

Be sure the Vehicle is on a level surface.

Pull out the dipstick, wipe it clean, and reinsert if fully.

Pull it out again and examine the oil level. it should be between 'Min' & 'Max' level. If not, top up with recommended engine oil.

ENGINE COOLANT LEVEL :

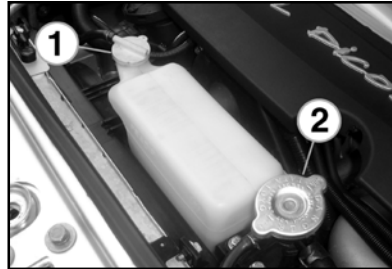

1. Auxiliary tank cap
2. Radiator Pressure Cap (DICOR)

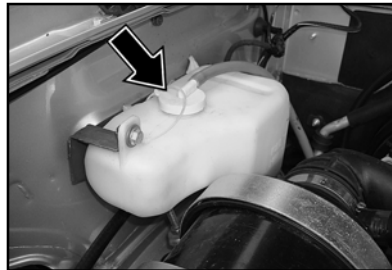

Auxiliary tank cap (TURBO)

Check the coolant level in the radiator auxiliary tank.

It should be in between maximum & minimum lines. If the auxiliary tank is completely empty, please check the coolant level in radiator as follows :

WARNING

Do not remove radiator cap when engine is hot. It may spray hot coolant on you causing serious injuries.

1. Ensure engine and radiator are cool.
2. Turn the radiator cap anti clockwise (without pressing it) until it stops. This will relieve the pressure, if any in the cooling system.
3. Remove the radiator cap by pushing down and turning anti clockwise.
4. The level of coolant should be upto the base of the filler neck.

BRAKE FLUID LEVEL

Coolant should be added if it is low.

5. Secure the radiator cap in its place.
6. Add coolant into the auxiliary tank up to the high mark.
7. Put the cap back, on the auxiliary tank.

NOTICE

Topping of the coolant should be done in the auxiliary tank only. Radiator cap should not be removed, if coolant is present in the auxiliary tank.

BRAKE FLUID LEVEL :

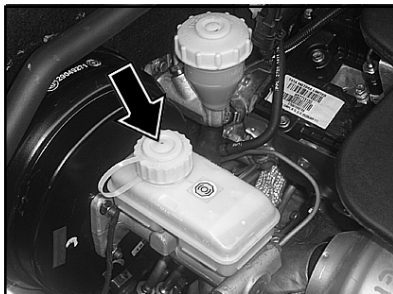

Brake Fluid Reservoir Cap (DICOR)

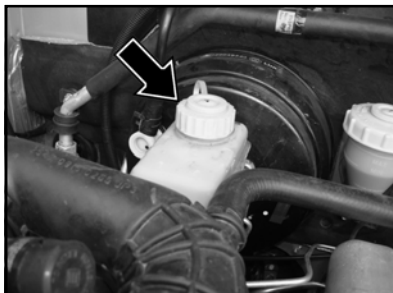

Brake Fluid Reservoir Cap (TURBO)

The level of the brake fluid must be between the min. & max. marks on the side of the brake fluid container. If the level falls below the min. mark, add recommended brake fluid. (Refer chapter - Fuels, coolants & lubricants)

In case of spongy or hard pedal or low brake efficiency, please contact the nearest Authorised Service outlet.

CAUTION

1. Do not allow brake fluid to make contact with the skin or eyes.
2. Do not allow brake fluid to splash or spill on the paint surface as it will damage the paint. In case of spillage, wipe it off immediately.

POWER STEERING FLUID LEVEL & LCRV

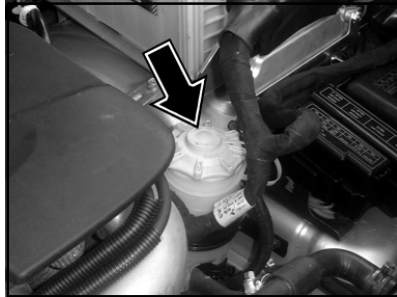
Power steering reservoir :

Power Steering Reservoir (DICOR)



Power Steering Reservoir (TURBO)

The level of the power steering fluid must be between the min. & max. marks on the side of the power steering fluid container. If the level falls below the min. mark, add recommended fluid. **(Refer chapter - Fuels, coolants & lubricants)**

In case of leakage or hard steering, please contact the nearest Authorised Service outlet.

⚠ CAUTION

Do not start the engine without oil in the power steering system.

LOAD CONSCIOUS PRESSURE REDUCING VALVE (LCRV)

A LCRV is required in the brake system during severe braking. That time, most of the car weight is transferred to the front, and the front brakes do most of the braking. The rear wheels are left with but little traction and in this condition, under high pressure, they have a tendency to skid.

The valve is installed in the line to the rear brake drum. During heavy braking the valves limits the pressure to the rear wheels & this allows rear wheels to keep turning instead of locking up and skidding.

If any alteration is done in Rear suspension the performance of this valve will be impaired.

The valve stem gap should be adjusted whenever rear spring is changed.

CLUTCH FLUID LEVEL & SEDIMENTER

Clutch Fluid Level :



Clutch Fluid Container (DICOR)

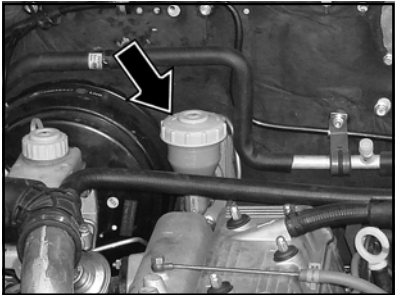

Clutch Fluid Container (TURBO)

The level of the clutch fluid must be between the min. & max. marks on the side of the clutch fluid container. If the level falls below the min. mark, add recommended clutch fluid. (Refer chapter - Fuels, coolants & lubricants)

Water draining Procedure from Sedimenter :

The water sedimenter is part of the fuel filtration system, fitted to the chassis frame, near fuel tank below the vehicle. It is used in the fuel supplying system in order to reduce the water content in the fuel provided to the DICOR system.

A water sensor is fitted to the water sedimenter in order to indicate to the driver that the sedimenter has to be drained. Whenever water in fuel sedimenter indicator glows in instrument cluster, the water need to be drained from the sedimenter. Water drain operation to be done on sedimenter.

Procedure

- 1 Stop the engine, and wait until pressure stabilizes.
- 2 Unclip one of the diesel connections (either inlet or outlet) and the electric connector of the water sensor.

SEDIMENTER, FUEL FILTER & PRIMING PUMP (DICOR)

- 3 Place a container underneath the water sedimenter.
- 4 Unscrew the water sensor about 2 - 3 turns

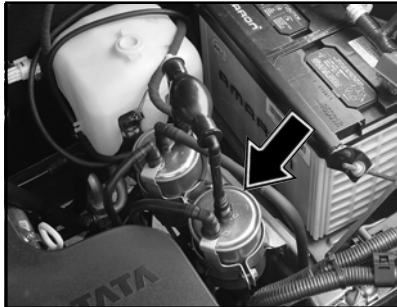

Water draining from Sedimenter

- 5 Wait until all the water has drained out of the water sedimenter.
- 6 As soon as the flow is free of water, screw the water sensor.
- 7 Clip the hydraulic connector and the electric connector to the water sensor.
8. Use hand primer/Pear pump to refill the line before restarting.

Fuel Filter (DICOR):



Fuel Filter

Fuel filter separates dust particles from the fuel & allows clean fuel in to the common rail system. It also separates & stores water.

Priming Pump / Pear pump (DICOR) :

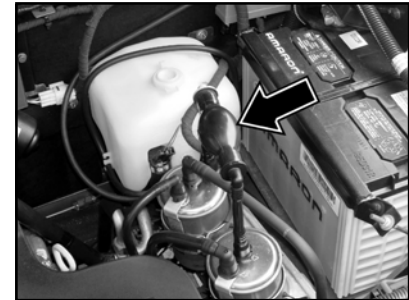

Priming/Pear pump (DICOR)

This is used for priming the fuel manually after overhauling of the engine or after refitment of fuel lines or after changing either fuel filter or sedimenter pump, by means of priming pump / pear pump until all air in the fuel line removed. Before cranking the engine ensure that there is no air in the fuel system.

NOTICE

Do not loosen the HP lines of DICOR system for bleeding the air from fuel system.

FILTER & PRIMING PUMP (TURBO)

Fuel Filter (TURBO):



Fuel Filter (TURBO)

Changing fuel filter element :

Unscrew drain plug and drain fuel from fuel filter bowls. Remove fuel filter top cover from mounting bracket.

Unscrew fuel filter bowl mounting bolt and replace bowl with new element.

Replace fuel tank side filter element at specified intervals and FIP side filter element.

Assemble fuel filter and fit it on mounting bracket.

Priming Pump (TURBO)



Priming/Pear pump (TURBO)

Unscrew the fuel lift pump plunger knob. Pull and push it 10-14 times (30-40 times if fuel tank has been completely emptied). Tighten fuel lift pump plunger knob. Start the engine and check for smooth running.

If you still feel, the fuel supply is erratic, check for air suction in fuel pipeline from fuel tank to FIP and rectify.

WINDSHIELD WASHER & TYRE

Windshield Washer :

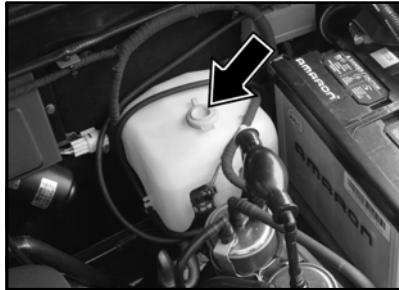

**Windshield Washer Fluid Container
(DICOR)**

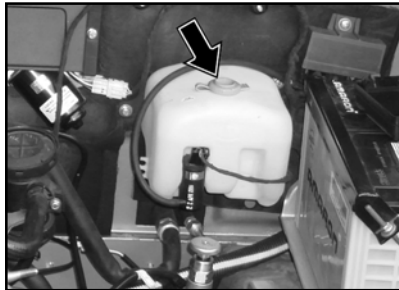

**Windshield Washer Fluid Container
(TURBO)**

Windshield washer fluid container is located behind the front right hand side panel and its filler neck is provided near auxiliary tank in the engine compartment.

NOTICE

Do not add detergent or any solvent in the windshield washing water.

Tyres :

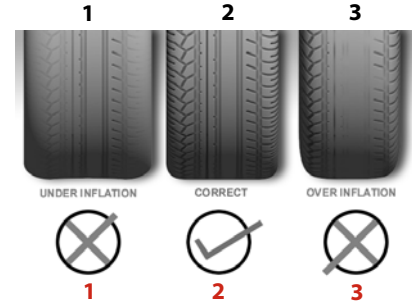

1. Underinflation - Excessive Side Tread Wear
2. Correct Tyre Pressure - Uniform Tyre Wear
3. Overinflation - Excessive Centre Tread Wear

Check for inflation and condition of your car tyres periodically.

Inflation :

Check the pressure in the tyres when they are cold.

TYRE INSPECTION

You should have your own tyre pressure gauge and use it at all times. This makes it easier for you to tell if pressure loss is caused by a tyre problem and not by variation between gauges.

Keeping the tyres properly inflated gives you the best combination of riding comfort, handling, tyre life and better fuel efficiency.

Over inflation of tyres makes the car ride bumpy and harsh. Tyres are more prone to uneven wear and damage from road hazards.

Under inflated tyres reduce your comfort in car handling and are prone to failures due to high temperature. They also cause uneven wear and more fuel consumption.

Recommended Tyre Pressures

Veh. condition	Wheels	Tyre 235/70 R16*	
		PSI	Bar
Unladen	Front	30	2.1
	Rear	30	2.1
Laden	Front	30	2.1
	Rear	30	2.1

* Tubeless tyre

CAUTION

- Every time you check inflation pressure, you should also examine tyres for damage, foreign objects & wear.
- Bumps or bulges in the tread or the side of the tyre. Replace the tyre if you find either of these conditions.
- Cuts, splits or cracks in the side of the tyre. Replace the tyre if you notice this on the fabric or cord.
- Excessive tread wear or non uniform tyre wear.

Repairing a Tyre/Tube :

Mark the tyre position suitably (if original colour dot mark is not visible) with respect to valve stem hole to ensure that the tyre is refitted in the original location on the wheel rim.

Ensure that balancing weights are not disturbed during removal of tyres.

Check the balance weight prior to the removal of the tyre. If found loose, mark its location on the rim & refit properly.

Balance the wheel after every dismantling and assembly of tyre on the wheel rim.

While fitting wheels on the vehicle ensure that wheel pins are free from dust, scratches, dirt, dents, etc.

Ensure the tube being replaced has the correct valve.

NOTICE

Do not apply any oil on the wheel pins. Wipe off the oil if present.

CARE FOR TUBELESS TYRES & TYRE ROTATION

Special care for tubeless tyres

1. While removing tyre from wheel rim and mounting it back on wheel rim, take precautions not to damage tyre bead. Use tyre removal and assembly machines. Damage or cut on tyre bead may cause gradual loss of air and deflation of tyre.
2. Do not scratch inside of tubeless tyre with metallic or sharp object. Tubeless tyres are coated with impermeable layer of rubber from inside which holds the air inside the tyre. Removal of this layer due to scratching may cause gradual loss of air and deflation.
3. If wheel rim gets damaged in service, get the wheel rim repaired/replaced immediately. Running the vehicle with damaged rim may cause deflation of tyre and subsequent dislodging of tyre from rim.
4. Maintain recommended inflation pressure. Over-inflation, in particular, may cause puncture or bursting of tyre.

NOTICE

Life and wear pattern of tyres depends on various parameters like tyre pressure, wheel alignment, wheel balancing, tyre rotation, etc. It also largely depends on vehicle speed, load carried, usage, driving habits, road conditions, tyre quality, etc. In case fault is suspected to be due to poor quality of tyres, the same may be taken up with concerned tyre manufacturer.

Tyre Rotation

To help increase tyre life and distribute wear more evenly you should have tyres rotated at specified intervals or earlier depending on the operation of vehicle.

The illustrations shows how to rotate tyres when normal spare wheel is included in tyre rotation.

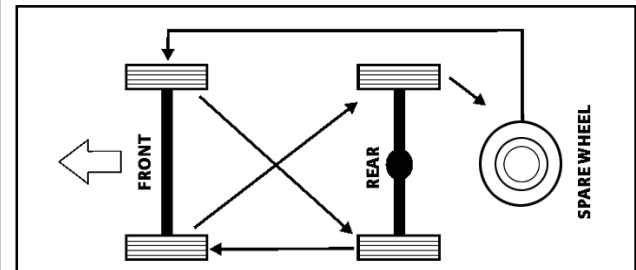

WHEEL ALIGNMENT, BALANCING, CATALYTIC CONVERTER MAINTENANCE

Wheel alignment :

Incorrect wheel alignment causes excessive and uneven tyre wear. Check wheel alignment at specified intervals. Wheel alignment values are given below :

Caster : $3^{\circ} \pm 30'$

Camber : $0^{\circ} \pm 10'$

Toe in : ± 1 or $-9'$ $+9'$

On vehicles with torsion bar suspension, wheel alignment needs to be checked only after adjusting chassis height as per procedure. Chassis height for 16 inch tyre is 510 ± 3 mm. Check and maintain tyre pressure periodically to obtain longer tyre life.

Wheel Balancing :

Wheels of your vehicle are balanced for better ride comfort and longer tyre life. Balancing needs to be done whenever tyre is removed from rim.

1. Permissible imbalance for tyre with rim = 250 gm-cm max.
2. Total balance weight should be within 140 gms on each side.
3. Relocate the tyre if the weight required to balance is more than 140 gm.
4. Balance weights are available from 10 gms to 140 gms in steps of every 10 gms and from 15 gms to 135 gms in steps of every 10 gms.
5. Do not use more than one balance weight on one side.

Care for the Catalytic Converter:

The catalytic Converter does not require any special maintenance however, following precaution should be taken for the effective functioning of the converter and to avoid damage to the Converter.

- It is mandatory to use Diesel fuel with sulphur content less than 350mg/kg. Use of any other diesel fuel can increase the pollutants.

CAUTION

Avoid parking the vehicle over inflammable materials, such as dry leaves, grass etc., as the exhaust system is hot enough to initiate 'FIRE'.

BATTERY

BATTERY :

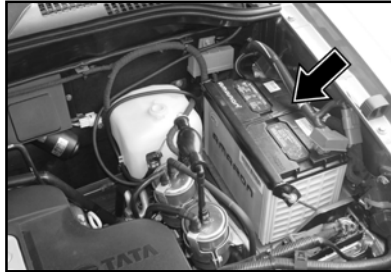

Check the battery for proper electrolyte level and corrosion on the terminals.

1. Check the battery for electrolyte level against the marking on the battery outer case.
2. Check the battery terminals for corrosion (a white or yellowish powder). To remove it, cover the terminals with a solution of baking soda. It will bubble up and turn brown.

3. When this stops wash it off with plain water. Dry off the battery with a cloth or paper towel.
4. Coat the terminal with petroleum jelly to prevent future corrosion.

Use a proper wrench to loosen and remove cables from the terminals.

Always disconnect the negative (-ve) cable first and reconnect it last.

Clean the battery terminals with a terminal cleaning tool or wire brush.

Reconnect and tighten the cables, coat the terminals with petroleum jelly.

Ensure that battery securely mounted.

If you need to connect the battery to a charger, disconnect both cables to prevent damage to the vehicle's electrical system.

NOTICE

During normal operation, the battery generates gas which is explosive in nature, a spark or open flame can cause the battery to explode causing very serious injuries.

Keep all sparks & open flames and smoking materials away from the battery.

Getting electrolyte in your eyes or on the skin can cause severe burns. Wear protective clothing and a face shield or have a skilled technician to do the battery maintenance.

The battery contains sulphuric acid (electrolyte) which is poisonous and highly corrosive in nature.

BELT TENSION

Belt Tension :

Edges of belts on the engine are prone to cracking or fraying and so routine checks need to be carried out.

Check the tension of the belt by pushing on it with your thumb for Alternator belt and A.C. compressor belt and Power Steering belt.

The belts should have deflection of 8 to 10 mm.

If the belt tension is not proper, get it attended at the nearest authorised service outlet.

FUEL, LUBRICANTS & COOLANTS

PLEASE USE ONLY FOLLOWING GENUINE OILS, COOLANTS , LUBRICANTS , ANTI RUST & SOUND DEADENING COATS, WINDSCREEN SEALANT, ADHESIVES & FUEL ADDITIVES BRANDED BY TATA MOTORS FOR OPTIMUM PERFORMANCE OF YOUR TATA GRANDE...

ITEM	SPECIFICATION	COMPANY & BRAND	QTY
ENGINE OIL	API-CH4+MB228.3 OR Higher grade	CASTROL - Castrol GTX (Diesel) HPCL - HP MILCY TURBO PLUS	7.5 Litres (DICOR) 6.8 Litres (TURBO)
COOLANT (Antifreeze agent + Soft water)	Class II / JIS K2234	SUNSTAR - Golden Cruiser Premium 1400 M HPCL - HP Thanda Raja P CASTROL - Radicool	8-8.5 Litres (DICOR) 10.0 Litres (TURBO)
GEAR BOX (G-76)	SAE 75W90 - GL4	HPCL - HP Gear Oil XP 75W90 CASTROL - Castrol Syntro 75W90 GL4	1.6 Litres
POWER STEERING OIL	ATF Type A, Suffix A	HPCL - HP-ATF Dex II CASTROL - Castrol TQD	1.4 Litres
REAR AXLE, LIVE FRONT AXLE,	SAE 85W140 GL5 Angolmol AG043	HPCL - HP AXLE OIL 85W140 CASTROL - Castrol Long Drain 85W140	2.2 (Rear) 1.2(Front)
BRAKE / CLUTCH FLUID	SAE J 1703, DOT 4	HPCL - Super Duty Brake Fluid DOT - 3 CASTROL - Universal Brake Fluid DOT 3	As required
WHEEL BEARING & CHASSIS	SS6805	HPCL - HP Multipurpose Grease-2 CASTROL - Castrol AP2	As required
ANTI RUST TREATMENT & SOUND DEADENING		DINITROL - Dinitrol WUERTH - Wuerth 3M - 3M	— —
WIND SCREEN SEALANT		WUERTH - Wuerth 3M - 3M Car System - Car System	— —

FUEL, LUBRICANTS & COOLANTS

Fuel : High Speed diesel conforming to IS1460 or EN 590 or equivalent is recommended to be used as fuel.

At very low temperature fluidity of diesel may become insufficient due to paraffin separation. It is therefore necessary to mix supplementary fuel with summer or winter grade diesel. The supplementary fuel to be used is kerosene or aviation turbine fuel.

Ratio for mixing of supplementary fuel and diesel are shown in the table.

Ambient temperature upto Deg. C	Percentage	
	Summer grade diesel	Supplementary fuel
Upto 0	100	0
0 to -10	70	30
-10 to -15	50	50

Care should be taken that diesel and supplementary fuel are thoroughly mixed before filling.

Ambient temperature upto Deg. C	Percentage	
	Winter grade diesel	Supplementary fuel
Upto -15	100	0
-15 to -20	70	30
-20 & below	50	50

WARNING

Do not mix gasoline or alcohol with diesel. This mixture can cause explosion.

NOTICE

Where oxidation catalytic converter is fitted, it is mandatory to use Diesel fuel with sulphur contents as under. Use of any other diesel fuel can increase the pollutants.

Recommended Fuel Specification for engines to be added.

Parameter	Unit	BS III
1 Cetane Number (min)	CN	51
2 Sulphur content	mg/kg	350
3 Lubricity (HFRR)	micon	460

Lubricants and Oils :

Recommended lubricants conform to the following specifications :

- Engine oil** -API-CH4 + MB 228.3 or higher grade engine oil
- Gear Box oil** - 75W90 GL-4
- Power Steering** - ATF Type A, Suffix A
- Rear axle** - M/Grade oil SAE 85W 140 GL5 Angolmol AG043 oil
* Friction modifier 40819 (2- 5%) to be added to oil for Limited Slip Differential
- Chassis and wheel bearing**- SS6805 bearing grease

Please use only recommended grades for good performance.

DO NOT mix grease of different brands and optional grades. Replace old grease completely.

The oil change periods recommended in maintenance schedule should be adhered to.

Engine Qty : 7.5 Litres

Recommended grades of engine oil for range of ambient temperature :

Ambient Temp °C	Engine Oil Grade
- 5 and above	SAE 15W/40
- 10 to 0	SAE 5W30
- 20 and -10	SAE 0W30

Front live axle and rear axle oil (Spicer axles)

Use Multigrade oil SAE 85W 140
Angolmol A6043 oil

Capacity :

For Rear axle - 2.2 litres

Gear Box oil : Qty : 1.6 Litres

75W90, (Synthetic oil GL4)

Hub bearing grease :

Use lithium base multipurpose grease-

Quantity : 92 gms per hub.

(Front axles 4X4)

47 gms per hub.

(Front axles 4X2)

25 gms per hub.**(Rear)**

Brake and Clutch Fluid :

Brake fluid confirming to SAE J 1703, DOT 3 is recommended.

Spicer propeller shaft :

Lubricant slip joint with NLGI-2 grade grease.

Coolants

Qty : Approx. 8 - 8.5 Litres

Presence of dirt in coolant chokes up passages in radiator, cylinder head and crankcase, thereby causing overheating of engine.

To prevent rust formation and freezing of coolant inside the passages of radiator, crankcase and cylinder head use premixed coolant as recommended.

It is recommended that the entire cooling system should be drained and filled with fresh premixed coolant.

Engine coolant antifreeze coolant as per class II, JIS K2234

Windscreen Washer Antifrost

Make - Antifrost- K
Concentration - 1 : 5 For 0°C
1 : 1 For 10°C
2 : 5 For 16°C
1 : 0 For 37°C

OIL FILLING & DRAIN POINTS

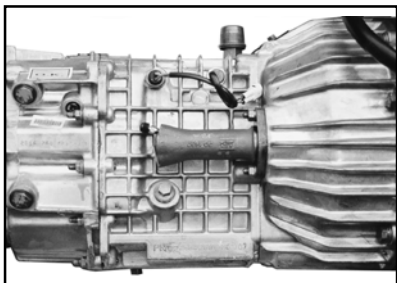

GEARBOX (G-76)
A. OIL LEVEL PLUG B. DRAIN PLUG



ENGINE OIL FILLING CAP (DICOR)

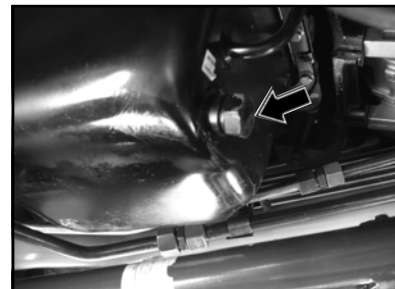

ENGINE OIL DRAIN PLUG (DICOR)

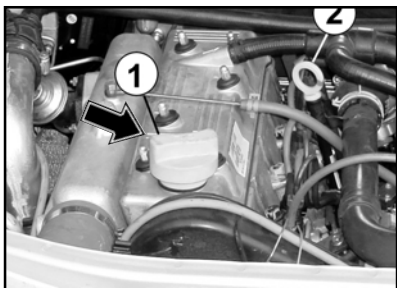

ENGINE OIL FILLING CAP (TURBO)

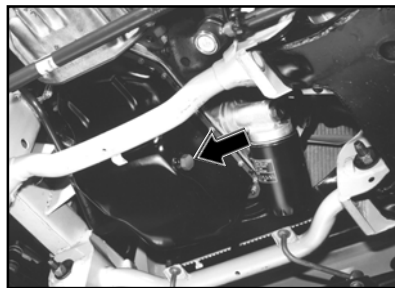

ENGINE OIL DRAIN PLUG (TURBO)

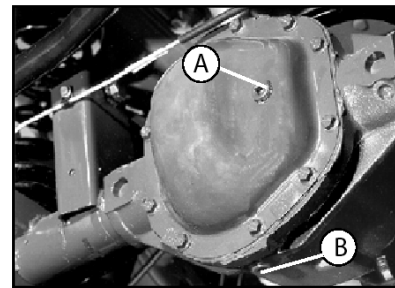

REAR AXLE (SPICER)
A. OIL LEVEL PLUG B. DRAIN PLUG

TECHNICAL SPECIFICATION

1. ENGINE

Model	: TATA 2.2L DICOR (DICOR) TATA 483 DL TCIC 55 (TURBO)
Type	: Direct Injection Common Rail Turbo Charged Intercooled Diesel Engine
No. Of Cylinders	: 4 Inline
Bore / Stroke	: 85 mm x 96 mm (DICOR) 83 mm X 90 mm (TURBO)
Capacity	: 2179 cc (DICOR) / 1948 cc (TURBO)
Max. Engine Output	: 88.3 kW @ 4000 rpm (DICOR) / 68 kW @ 4500 rpm (TURBO) as per CMVR/TAP-115/116
Max. Torque	: 250 Nm @1500-3000 rpm (DICOR) 190 Nm @ 2000-3000 rpm (TURBO) as per CMVR/TAP-115/116
Firing Order	: 1 - 3 - 4 - 2
Engine Oil Capacity	: 5.5 Litre Min. & 7.5 Litre Max. (DICOR) 7.7 Litres Max. (TURBO)

2. CLUTCH

Type	: Single plate dry friction diaphragm type.
Outside diameter of clutch lining	: 240 mm (DICOR) 228 mm (TURBO)
Friction area	: 503 sq.cm. (Approx.) (DICOR) 463 sq.cm. (Approx.) (TURBO)

3. GEAR BOX

Model	: GBS-76-5/4.1 with overdrive
Type	: Double Synchromesh on all gears.
No. of gears	: 5 forward, 1 reverse.
Gear Ratios	: 1st - 4.10 2nd - 2.22 3rd - 1.37 4th - 1.00 5th - 0.77 Rev. - 3.75

4. REAR AXLE

: Single Reduction, Salisbury Type Rear Axle with Hypoid Gears and Semi-Floating Axle Shafts & Without limited slip differential.

Ratio : 4.10 (**DICOR**) / 4.55 (**TURBO**)

5. FRONT AXLE

Type : Independently suspended

TECHNICAL SPECIFICATION

6. STEERING

- Type** : Power Steering
Ratio : 18.2:1
Steering Wheel : 380 mm dia.
Steering column : Collapsible with tilt. Standard fitment

7. BRAKES

- Service brakes** : Vacuum Assisted Independent Hydraulic Brakes on Front and Rear wheels through Tandem Master Cylinder & Tandem Booster.
- Front brake** : 281 dia. Ventilated Disc Brakes with Twin Pot Calliper.
- Rear brake** : 282 dia. Drum Brake With Auto Adjuster with 25.4 mm wheel cylinder
- Load conscious pressure reducing valve** : Provided for rear brakes
- Parking brake** : Lever type Floor console mounted handle, Cable Operated Mechanical Linkages Acting on Rear Wheels.

8. FRAME

- Type** : Ladder Type Cranked Frame with Boxed Section Long Members & bolted / Welded Cross Members.

9. SUSPENSION

- Front** : Double Wishbone Type coil spring
Rear : Parabolic Leaf Springs.
Shock Absorber : Hydraulic Double Acting Telescopic Type at Both Front & Rear.
Antiroll Bar : At both Front and Rear.

10. WHEELS & TYRES

- Tyres** : 235/70 R 16 Tubeless tyre
Tyre Pressure : Unladen: Front-30 psi, Rear- 30 psi
 Laden : Front-30 psi, Rear- 30 psi
Wheel rims : 6.5 J x 16
No. of wheels : Front - 2, rear - 2, spare - 1.

11. FUEL TANK

- Capacity** : 65 liters

12. CAB

- Type** : Normal Control All Steel Shell.
Ventilation : HVAC

13. ELECTRICAL SYSTEMS

- System Voltage** : 12 volts (-ve earth)
Alternator Capacity : 125 Amp. (DICOR) / 75 Amp (TURBO)
Battery : 12 V, 80 Ah

TECHNICAL SPECIFICATION

14. PERFORMANCE

Max. speed : 140 kmph (**DICOR**)
125 kmph (**TURBO**)

Max. gradeability at rated GVW : 38% (**DICOR**)
28% (**TURBO**)

15. MAIN CHASSIS DIMENSIONS AS PER ISO:612 in mm(Nominal) (TOLERANCES AS PER INTERE UROPE STVZO)

Wheel Base : 2550
Track Front : 1496
Track Rear : 1490
Overall Length : 4421 (For FF Seats) /
4500 (For SF Seats)
Max. Width : 1780 / 1853 (With Side foot step)
Front Overhang : 830 (**DICOR**) / 834 (**TURBO**)
Rear Overhang : 1041 (**DICOR**) / 1037 (**TURBO**)
Overall Height (Unladen/laden) : 1940 / 1903
Minimum Turning Circle Dia. : 10.5 m
Minimum Turning Clearance Circle Dia. : 11.3 m
Ground Clearance : 201 mm

16. WEIGHTS (kg) (TOLERANCE AS PER INTEREUROPE STVZO)

Complete vehicle kerb weight as per ISO:1176 (with sparewheel and tools)

DICOR : 1940 (FAW-1000) (RAW-940)
: 1900 (FAW-990) (RAW-910) - **CX**
TURBO : 1940 (FAW-1000) (RAW-940)-**OTHER**
1905 (FAW-990) (RAW-915)-**CX (9S)**

Gross Vehicle Weight : 2625 (FAW-1100) (RAW-1525)

Max. Permissible FAW : 1150

Max. Permissible RAW : 1600

17. PASSENGER CAPACITY :

Option I - Driver + 6
Option II - Driver + 7
Option III - Driver + 8

INFORMATION AT A GLANCE - Dimensions

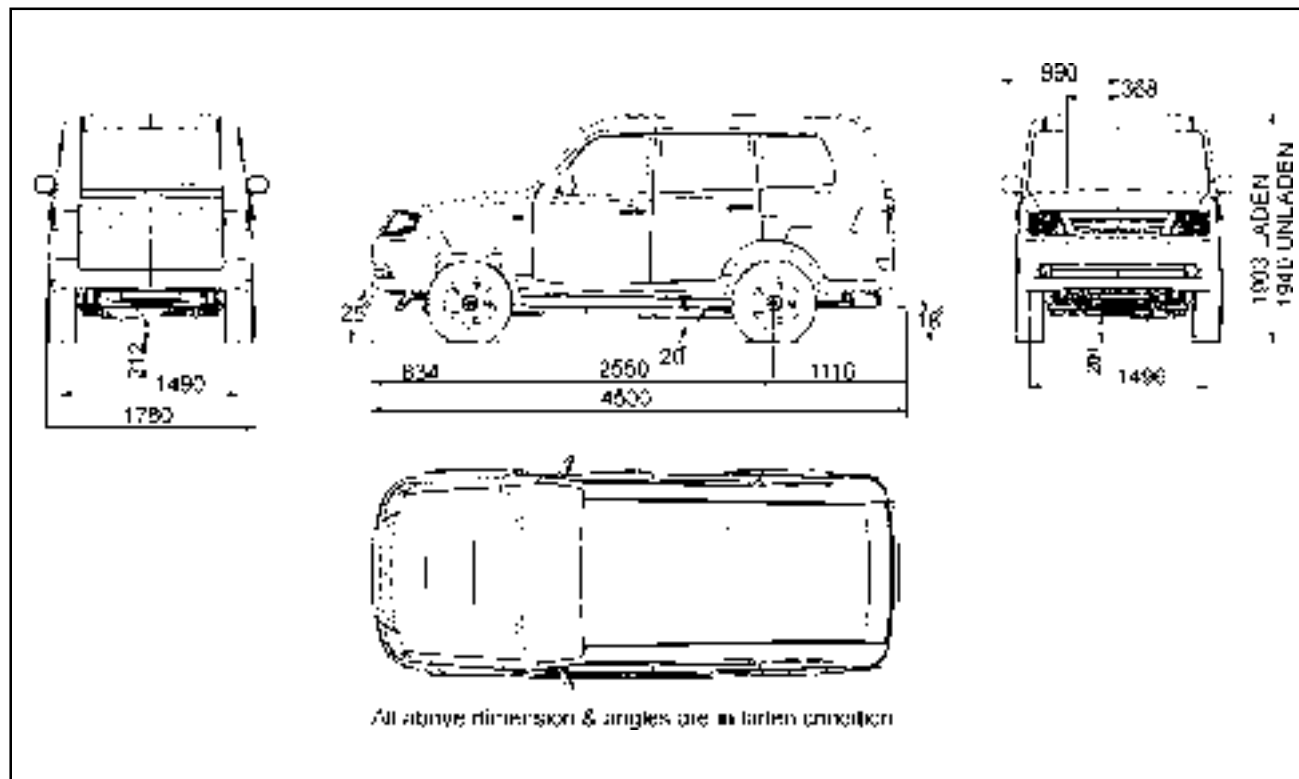

LOCATATION OF AGGREGATE NUMBER

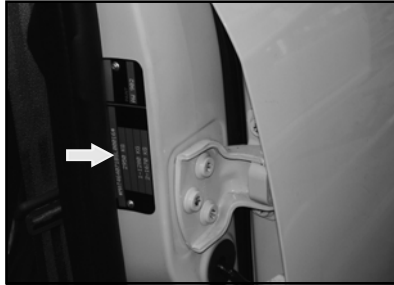

**CHASSIS NUMBER PLATE ON LH
FRONT DOOR 'B' PILLER**

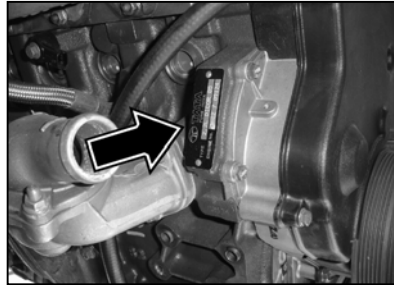

ENGINE NUMBER (DICOR)



ENGINE NUMBER (DICOR)



ENGINE NUMBER (TURBO)

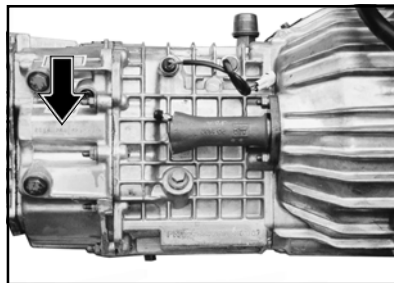

GEARBOX NUMBER



REAR AXLE NUMBER (SPICER)

LOCATATION OF AGGREGATE NUMBER



CHASSIS NUMBER ON FRAME

SERVICE RECOMMENDATIONS

Pre-Delivery Inspection

Following jobs are to be performed at PDI.

1. Wash & Clean the vehicle thoroughly.
2. Road test the vehicle. Check for proper functioning of Engine, Clutch, Transmission, Steering, Brakes etc.
3. Check vehicle behavior : Pulling to LH/RH, Wobbling, Self centering, Acceleration etc.
4. Static test : Start engine & check for idling rpm & Maximum rpm (look for any abnormal noise), Water temperature etc.
5. Check Engine oil level. Level is acceptable if found between mid and max mark.
6. Check for any leakages of engine oil.
7. Check for any leakages in the fuel system.
8. Check Coolant level in transparent auxiliary tank. Acceptable if level found between mid and max.
9. Check for any Leakages of coolant.
10. Drain water from fuel water separator.
11. Check hose, clamps & pipes at all locations in cooling system.
12. Check hose, clamps & pipes at all locations in air intake system.
13. Check for leakages of gear box oil.
14. Check for Proper fitment of gear shift level rubber boot.
15. Check level of Clutch and brake fluid. Acceptable if found between mid and max.
16. Check for oil leakages in clutch/brake circuit.
17. Check clutch/brake pedal free play.
18. Check for fitment of split pins at Tie rod ball joints, Stub axles.
19. Check for fitment of grease nipples at all locations.
20. Check for leakages of front live axle oil (if applicable).
21. Check for leakages of rear axle oil.
22. Check tightness of propeller shaft Centre bearing bracket mounting nut & bolt.
23. Check Power steering oil level in reservoir. Acceptable if found between min & max marks.

SERVICE RECOMMENDATIONS

24. Check for oil leakages in power steering circuit.
25. Check for Steering wheel free play and adjustment.
26. Check functioning of all bulbs.
27. Check for proper functioning of blinkers, horn, head lamp, parking light, reverse light, wiper system, washer system etc.
28. Check headlamp alignment and adjust if necessary.
29. Check tightness of electrical connection at battery, Starter Motor, Alternator & Starter relay.
30. Check all fuses.
31. Check all the earth points for looseness.
32. Check for functioning of all gauges/meters/warning lamps.
33. Check connectors in all electrical circuits.
34. Check for proper opening and closing of doors.
35. Check functioning of door locks, latches and windows.
36. Check for any complaints on cab fittings, instrument panel, glove box etc.
37. Check and tighten hand loose fasteners.
38. Check for any breakages, bends, failure of any component/assembly/unit.
39. Check for any fouling between two components which may lead to leakages or other complaints. Check for fouling of fuel lines, brake pipes, clutch pipes, air intake pipe, power steering hydraulic pipe, clutch/

brake linkages, accelerator rod etc.

40. Grease with grease gun : All locations appearing in lubrication chart.

NOTE

While delivering a long storage vehicle (more than 6 months from production month), service/maintenance operations as prescribed by us for long storage, also needs, to be carried out before delivery.

NOTE

Do not wash DICOR system components with forced water.

SERVICE OPERATIONS TO BE PERFORMED

1. The vehicle has been built to give you thousands of kilometers of economical and trouble-free performance. This is however, possible only if this vehicle is systematically maintained and operated strictly according to the instructions contained in this book.

2. The free services should be availed of, at the following km & time range (**DICOR**)

- 1st Free Service** At 1,000 -1,500 km OR 1 month Whichever is earlier
- 2nd Free Service** At 5,000-5,500 km OR 6 months Whichever is earlier
- 3rd Free Service** At 15,000-15,500 km OR 12 months Whichever is earlier
- 4th Free Service** At 30,000 - 30,500 km OR 24 months Whichever is earlier
- 5th Free Service** At 45,000 - 45,500 km OR 36 months Whichever is earlier

The free services should be availed of, at the following km & time range (**TURBO**)

- 1st Free Service** At 1,000 -1,500 km OR 1 month Whichever is earlier
- 2nd Free Service** At 5,000-5,500 km OR 6 months Whichever is earlier
- 3rd Free Service** At 10,000-10,500 km OR 12 months Whichever is earlier
- 4th Free Service** At 20,000 - 20,500 km OR 24 months Whichever is earlier
- 5th Free Service** At 30,000 - 30,500 km OR 36 months Whichever is earlier

3. The respective service coupon should be detached and handed over to the concerned Servicing Agency for the service performed.

The selling dealer should fill up details of vehicle particulars on the inside cover page of the Owner's Manual.

4. These services can be satisfactorily performed only by one of our Authorised Dealers'/TASC's/TASP's Workshops in India, irrespective of the dealer who sold the vehicle, provided the vehicle is sent to them at the kilometerages specified and that this service book is produced before them.

The vehicle is entitled to pre-delivery service with free labour. After the delivery of the vehicle, in the subsequent '**5 free services'** labour would be free but materials, if any would be charged for.

All services, other than the above, must be paid for both for materials and labours; material at prevailing rates for the quantity consumed and labour at our scheduled rates available with our Authorised Dealers'/TASC's/TASP's.

5. In the event of a schedule Service not performed within specified kilometers the respective coupons will be detached by the Authorised Dealer's Workshop when the vehicle is sent to them next. Should a major service have been missed, all the works listed for such service must be performed when the vehicle is taken next to one of our Authorised Dealer's/ TASC's/TASP's Workshop.

6. It is an important condition of our sales policy that no warranty claims shall be entertained by us unless all services upto time of the claim arising have been performed on the vehicle by one of our Authorised Dealer's / TASC's/TASP's Workshops.

Failure to carry out the services listed in this book can cause considerable damage to the vehicle and inconvenience to you. It is, therefore, in your own interest to take your vehicle to one of our Authorised Dealer's, TASC's, TASP's, Workshop for servicing.

7. All our Authorised Dealer's/TASC's Workshops have been equipped with special tools and are manned by technical personnel trained by us. Besides, they have adequate stocks of genuine spare parts for replacement purposes, should the need arise. Our Authorised Workshops are therefore in a position to render you any expert advice and service your vehicle may need. Please give them an opportunity to serve you, so that you may obtain economical and trouble free performance from your vehicle.

8. For any technical advice concerning your vehicle, please contact the nearest Authorised Dealer.

Service Schedule

SERVICE OPERATIONS TO BE PERFORMED (TATA GRANDE 2.2 L DICOR)

	OPERATION	FREQUENCY X 1000	PDI	1-1.5	5-5.5	15-15.5	30-30.5	45-45.5	60-60.5	75-75.5	90-90.5	105-105.5
	GENERAL											
1	Wash the vehicle & Clean the condenser with compressed air	Every Service	x	x	x	x	x	x	x	x	x	x
2	Check & Top up Fluids if required: Coolant, Brake / Clutch Fluid, Battery Electrolyte, Power Steering Oil, Gear Box Oil, Transfer Case & Front Axle (4X4)/ Rear Axle Oil	Every Service	x	x	x	x	x	x	x	x	x	x
3	Drain water accumulated in Sedimenter (OR Whenever warning lamp glows)	Every Service	x	x	x	x	x	x	x	x	x	x
4	Check Engine Compartment for loose Fasteners, Low pressure fuel lines, Coolant hoses, air hoses, Vacuum hoses, hydraulic line connections for leakages if any, Attend if necessary	Every Service	x	x	x	x	x	x	x	x	x	x
5	Check Underbody for loose Fasteners, hydraulic line connections, Exhaust system/ Fuel Pipes for Damages / Leakages if any. Attend if necessary	Every Service	x	x	x	x	x	x	x	x	x	x
6	Apply grease on door latches, door lock, door check stop, striker, bonnet opening lever & lock plate, tailgate hinges & door lock inner ratchet.	Every Service	x	x	x	x	x	x	x	x	x	x
7	Check & ensure normal working of engine using Diagnostic Equipment.	Every Service	x	x	x	x	x	x	x	x	x	x
	2.2L DICOR ENGINE											
1	Clean air cleaner filter element, Change if red band appears on service indicator even after cleaning	Every Service	x	x	x	x	x	x	x	x	x	x
2	Change engine Oil and Oil filter.	Every Service	x	x	x	x	x	x	x	x	x	x
			OR 1 Year whichever is earlier									
3	Check All accessory Drive belts, adjust tension if required, change if damaged	Every Service	x	x	x	x	x	x	x	x	x	x
			OR 1 Year whichever is earlier									
4	Change fuel filter	Every Service	x	x	x	x	x	x	x	x	x	x
			OR 2 Years whichever is earlier									
5	*Replace air filter element (OR if RED band appears on Service Indicator)	45,000 km						x			x	
6	Change coolant in the cooling system	60,000 km							x			
			OR 2 Years whichever is earlier									

Service Maintenance Schedule

SERVICE OPERATIONS TO BE PERFORMED (TATA GRANDE 2.2 L DICOR)

	OPERATION	FREQUENCY	PDI	1-1.5	5-5.5	15-15.5	30-30.5	45-45.5	60-60.5	75-75.5	90-90.5	105-105.5
7	Change Sedimenter / Water seperator	1,05,000 km										x
8	Change Timing Belt & Timing Belt Idler	1,05,000 km										x
9	Change vacuum hoses for Vacuum Modulator, Turbocharger, EGR valve & throttle valve	60,000 km							x			
	GEAR BOX											
1	*Change oil in gear box (First at 45,000 KM, there after every 90,000 KM)							x				x
2	Change oil in transfer case	45,000 KM						x				x
3	Clean breather in gear box (also Transfer case in case of 4X4)	Every Oil Change						x				x
	PROPELLER SHAFT											
1	Grease propeller shaft with grease gun (at slip joint - splines end) & Check Centre bracket mounting bolts for looseness. Tighten if necessary	15,000 km				x	x	x	x	x	x	x
	FRONT AXLE (for 4x4) / REAR AXLE											
1	Change oil in axle (First at 15,000 KM, there after every 75,000 KM)					x						x
2	Clean breather in Axle	Every Service	x	x	x	x	x	x	x	x	x	x
	SUSPENSION & STEERING											
1	Grease idler arm (seal type idler arm)	15,000 km				x	x	x	x	x	x	x
2	Check wheel alignment & balancing, chassis height & adjust if necessary	15,000 km				x	x	x	x	x	x	x
3	Check condition of rubber bushes in the following & replace if necessary. 1)Top wishbone 2)Lower wishbone 3)Anti roll bars 4)Rear links 5)Panhard rod 6) Vibration damper	30,000 km					x		x			x
4	Check shock absorber, bushes & steering damper bushes,replace if necessary	30,000 km					x		x			x
5	Grease steering spindle and sleeve	30,000 km					x		x			x
6	Check & adjust front wheel bearing play & Change grease in front hubs	45,000 km						x				x
7	Change oil in power steering system & change filter element	75,000 km								x		

Service Schedule

SERVICE OPERATIONS TO BE PERFORMED (TATA GRANDE 2.2 L DICOR)

	OPERATION	FREQUENCY	PDI	1-1.5	5-5.5	15-15.5	30-30.5	45-45.5	60-60.5	75-75.5	90-90.5	105-105.5
	CLUTCH & BRAKES											
1	Check parking brakes, adjust if necessary	15,000 km				x	x	x	x	x	x	x
2	Check front brake pads & rear brake linings. Replace if necessary	15,000 km				x	x	x	x	x	x	x
3	Change Clutch & Brake Fluid (Or 2 years whichever is earlier)	30,000 km					x		x		x	
	ELECTRICALS											
1	Check headlamp focussing & functioning of other electrical equipment	15,000 km				x	x	x	x	x	x	x
2	Check specific gravity of battery electrolyte	30,000 km					x		x		x	
	HVAC											
1	Check the HVAC System for Satisfactory Performance & attend if required	Every Service	x	x	x	x	x	x	x	x	x	x
	WHEELS & TYRES											
1	Tyre rotation	15,000 km				x	x	x	x	x	x	x

* Under severe driving conditions, additional maintenance is required. Please Refer to "Additional Maintenance Schedule under severe driving conditions":
 Precautions to be taken while cleaning engine compartment : It is recommended to use dry low pressure air. Do not use pressurised water.

ADDITIONAL MAINTENANCE SCHEDULE UNDER SEVERE DRIVING CONDITIONS :

- A.. Driving in conditions such as Patrolling, Taxi, Pickup Van, Vehicle Towing, with Trailer Towing
- B. Driving on Dusty / Sandy roads
- C. More than 50% (in terms of kms) driving in heavy city traffic
- D. Frequently operating in mountainous area

	ITEM	INTERVAL	CONDITION			
			A	B	C	D
1.	Engine Oil & Oil Filter	Change every 7500 kms.	x	x	x	x
2.	Air Filter Element	Clean at every 7500 kms. & replace at 30,000 kms.		x		
3.	Front (for 4X4) & Rear Axle Oil Change	Change First at 15000 kms & thereafter at 45,000 kms.	x	x	x	x

SERVICE OPERATIONS TO BE PERFORMED (TATA GRANDE 4DL TCIC)

	OPERATION	FREQUENCY	1000 - 1500	5,000 - 5,500	10,000 - 10,500	20,000 - 20,500	30,000 - 30,500	40,000 - 40,500	50,000 - 50,500	60,000 - 60,500	70,000 - 70,500	80,000 - 80,500	90,000 - 90,500	100,000 - 100,500
	GENERAL													
1	Wash the vehicle & Clean the condenser with compressed air	Every Service	x	x	x	x	x	x	x	x	x	x	x	x
2	Check & Top up Fluids if required: Coolant, Engine oil, Brake / Clutch Fluid, Battery Electrolyte, Power Steering Oil, Gear Box Oil, Transfer Case & Front Axle (4X4) / Rear Axle Oil	Every Service	x	x	x	x	x	x	x	x	x	x	x	x
3	Drain water accumulated in fuel filter	Every Service	x	x	x	x	x	x	x	x	x	x	x	x
4	Check Engine Compartment for loose Fasteners, Low pressure fuel lines, Coolant hoses, air hoses, Vacuum hoses, hydraulic line connections for leakages if any, Attend if necessary	Every Service	x	x	x	x	x	x	x	x	x	x	x	x
5	Check Underbody for loose Fasteners, hydraulic line connections, Exhaust system / Fuel Pipes for Damages / Leakages if any. Attend if necessary	Every Service	x	x	x	x	x	x	x	x	x	x	x	x
6	Apply grease on door latches, door lock, door check stop, striker, bonnet opening lever & lock plate, tailgate hinges & door lock inner ratchet.	Every Service	x	x	x	x	x	x	x	x	x	x	x	x
	4DL ENGINE													
1	*Clean air cleaner filter element, Change if red band appears on service indicator even after cleaning	Every Service	x	x	x	x	x	x	x	x	x	x	x	x
2	*Change engine Oil and Oil filter cartridge	10,000 km			x	x	x	x	x	x	x	x	x	x
			OR 1 Year whichever is earlier											
3	Change fuel filter element (tank side)	10,000 km			x	x	x	x	x	x	x	x	x	x
4	Change both fuel filter elements	20,000 km				x		x		x		x		x

Service Schedule

SERVICE OPERATIONS TO BE PERFORMED (TATA GRANDE 4DL TCIC)

	OPERATION	FREQUENCY	1000 - 1500	5,000 - 5,500	10,000 - 10,500	20,000 - 20,500	30,000 - 30,500	40,000 - 40,500	50,000 - 50,500	60,000 - 60,500	70,000 - 70,500	80,000 - 80,500	90,000 - 90,500	100,000 - 100,500
5	Replace air filter element (Earlier if vehicle operates in Dusty / Off road conditions)	40,000 km						x				x		x
6	Check timing belt tension, adjust if necessary, replace if defective	50,000 km							x					x
7	Change coolant in the cooling system	50,000 km							x					x
			OR 2 years whichever is earlier											
8	Replace timing belt	100,000 km												x
			OR 3 Years whichever is earlier											
9	Check alternator, Power steering, A/C belt, adjust tension if necessary, replace if defective	Every Service	x	x	x	x	x	x	x	x	x	x	x	x
10	Check injection nozzle for opening pressure and spray characteristics	40,000 km						x				x		
11	Check intercooler for any dust/dirt accumulation. Clean by compressed air.	20,000 km				x		x		x		x		x
GEAR BOX														
1	*Change oil in gear box (First at 40,000 KM, there after every 90,000 KM)							x						
2	Clean breather in gear box	Every Oil Change					x						x	
PROPELLER SHAFT														
1	Grease propeller shaft with grease gun (at slip joint - splines end) & Check Centre bracket mounting bolts for looseness. Tighten if necessary	10,000 km			x	x	x	x	x	x	x	x	x	x
REAR AXLE														
1	Change oil in axle (First at 10,000 KM, there after every 70,000 KM)				x								x	
2	Clean breather in Axle	Every Service	x	x	x	x	x	x	x	x	x	x	x	x

SERVICE OPERATIONS TO BE PERFORMED (TATA GRANDE 4 DL TCIC)

	OPERATION	FREQUENCY	1000 - 1500	5,000 - 5,500	10,000 - 10,500	20,000 - 20,500	30,000 - 30,500	40,000 - 40,500	50,000 - 50,500	60,000 - 60,500	70,000 - 70,500	80,000 - 80,500	90,000 - 90,500	100,000 - 100,500
	SUSPENSION & STEERING													
1	Grease idler arm (seal type idler arm)	10,000 km		x	x	x	x	x	x	x	x	x	x	x
2	Check wheel alignment & balancing, chassis height & adjust if necessary	10,000 km		x	x	x	x	x	x	x	x	x	x	x
3	Check condition of rubber bushes in the following & replace if necessary. 1)Top wishbone 2)Lower wishbone 3) Anti roll bars 4) Rear links 5) Panhard rod	30,000 km				x			x			x		
4	Check shock absorber, its bushes & steering damper bushes, replace if necessary	30,000 km					x		x			x		
5	Grease steering spindle and sleeve	30,000 km					x		x			x		
6	Check & adjust front wheel bearing play & Change grease in front hubs	40,000 km					x			x				
7	Change oil in power steering system & change filter element	70,000 km								x				
	CLUTCH & BRAKES													
1	Check parking brakes, adjust if necessary	10,000 km		x	x	x	x	x	x	x	x	x	x	x
2	Check front brake pads & rear brake linings. Replace if necessary	10,000 km		x	x	x	x	x	x	x	x	x	x	x
3	Change Clutch & Brake Fluid (Or 2 years whichever is earlier)	30,000 km				x			x			x		
	ELECTRICALS													
1	Check headlamp focussing & functioning of other electrical equipment	10,000 km		x	x	x	x	x	x	x	x	x	x	x
2	Check specific gravity of battery electrolyte	30,000 km				x			x			x		
	HVAC													
1	Check the HVAC System for Satisfactory Performance & attend if required	10,000 km		x	x	x	x	x	x	x	x	x	x	x
	WHEELS & TYRES													
1	Tyre rotation	10,000 km		x	x	x	x	x	x	x	x	x	x	x

Record Of Repairs Carried Out

Chassis No. - _____

Date	Odometer reading km	Repair Order No.	Particulars of Repair	Servicing Dealer's Signature & Stamp

Chassis No.

Engine No.

Gear Box No.

At 5,000 - 5,500 km OR 6 months whichever earlier (**DICOR & TURBO**)

please bring your vehicle for this service as per details given in the Service Schedul

2

FREE LABOUR

TATA MOTORS
WORK DONE TO MY SATISFACTION

Sign. of Customer

Speedo Reading Km. seal O.K. / Broken

R.O. No. Date

Dealer's / Authorised Service Centre's

Stamp & Signature

At the time of delivery of vehicle please ensure

pre-delivery inspection has been carried out as per details given in the Service Schedule.

Chassis No.

Engine No.

Gear Box No.

PDI

FREE LABOUR

TATA MOTORS
WORK DONE TO MY SATISFACTION

Sign. of Customer

Speedo Reading Km. seal O.K. / Broken

R.O. No. Date

Dealer's / Authorised Service Centre's

Stamp & Signature

Chassis No.

Engine No.

Gear Box No.

Rear Axle No.

At 15,000 - 15,500 km OR 12 months whichever earlier (**DICOR**)

At 10,000 - 10,500 km OR 12 months whichever earlier (**TURBO**)

please bring your vehicle for this service as per details given in the Service Schedule.

3

FREE LABOUR

TATA MOTORS
WORK DONE TO MY SATISFACTION

Sign. of Customer

Speedo Reading Km. seal O.K. / Broken

R.O. No. Date

Dealer's / Authorised Service Centre's

Stamp & Signature

Chassis No.

Engine No.

At 1,000-1,500 km OR 1 month whichever earlier (**DICOR & TURBO**)

please bring your vehicle for this service as per details given in the Service Schedule.

1

FREE LABOUR

TATA MOTORS
WORK DONE TO MY SATISFACTION

Sign. of Customer

Speedo Reading Km. seal O.K. / Broken

R.O. No. Date

Dealer's / Authorised Service Centre's

Stamp & Signature

Tata Grande

Tata Grande

Tata Grande

Tata Grande

Chassis No.

Engine No.

Gear Box No.

Rear Axle No.

At 30,000 - 30,500 km OR 24 months whichever earlier (**DICOR**)
At 20,000 - 20,500 km OR 24 months whichever earlier (**TURBO**)

please bring your vehicle for this service as per
details given in the Service Schedule.

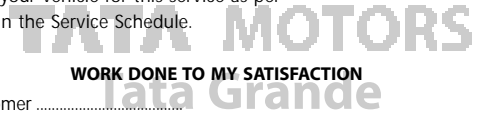

WORK DONE TO MY SATISFACTION

Sign. of Customer

Speedo Reading Km. seal O.K. / Broken

R.O. No. Date

Dealer's / Authorised Service Centre's

Stamp & Signature

4

**FREE
LABOUR**

Chassis No.

Engine No.

Gear Box No.

Rear Axle No.

At 45,000 - 45,500 km OR 36 months whichever earlier (**DICOR**)
At 30,000 - 30,500 km OR 36 months whichever earlier (**TURBO**)

please bring your vehicle for this service as per
details given in the Service Schedule.



WORK DONE TO MY SATISFACTION

Sign. of Customer

Speedo Reading Km. seal O.K. / Broken

R.O. No. Date

Dealer's / Authorised Service Centre's

Stamp & Signature

5

**FREE
LABOUR**



TATA MOTORS | SERVICE

RESPONSIVE • RELIABLE • BEST VALUE



TATA MOTORS | SERVICE
RESPONSIVE



24x7

ON-ROAD ASSISTANCE
1822 236 7373



TATA MOTORS | SERVICE
RESPONSIVE



DOORSTEP SERVICE

MOBILE SERVICE



TATA MOTORS | SERVICE
RESPONSIVE



ONLINE SERVICE

APPOINTMENT
AT A CLICK



TATA MOTORS | SERVICE
RESPONSIVE



QUICK REPAIR

REPAIR IN MINUTES



TATA MOTORS | SERVICE
RESPONSIVE



SPEED-O-SERVICE

FASTER SERVICE
WHATEVER



TATA MOTORS | SERVICE
BEST VALUE



EXTENDED WARRANTY

UP TO 4 YEARS



TATA MOTORS | SERVICE
BEST VALUE



RAPID REPAIR

MINOR BODY REPAIRS



TATA MOTORS | SERVICE
BEST VALUE

TOP

ORIGINAL PARTS

UNMATCHED QUALITY



TATA MOTORS | SERVICE
BEST VALUE



VALUE CARE

MAINTENANCE PLANS



TATA MOTORS | SERVICE
RELIABLE



DIAGNOSTIC EXPERT

HIGH SKILLED TECHNICIAN



TATA MOTORS | SERVICE
RELIABLE



QUALITY SERVICE

SERVICE QUALITY
ASSURANCE

HORIZONEXT



2895 5840 99 01



TATA MOTORS | SERVICE

RESPONSIVE + RELIABLE + BEST VALUE

Call Us : 1-800-209-7979

Mail Us : customercare@tatamotors.com

Visit Us : www.customercare@tatamotors.com

Designed & Developed by : Content Creation & Publication, Customer Support, PVBU, Pune