

# SYSTEM WIRING DIAGRAMS

## Article Text

1996 Suzuki Esteem

For

Copyright © 1998 Mitchell International

Tuesday, April 06, 1999 08:10AM

### ARTICLE BEGINNING

1996 System Wiring Diagrams  
Suzuki - Esteem

### AIR CONDITIONING

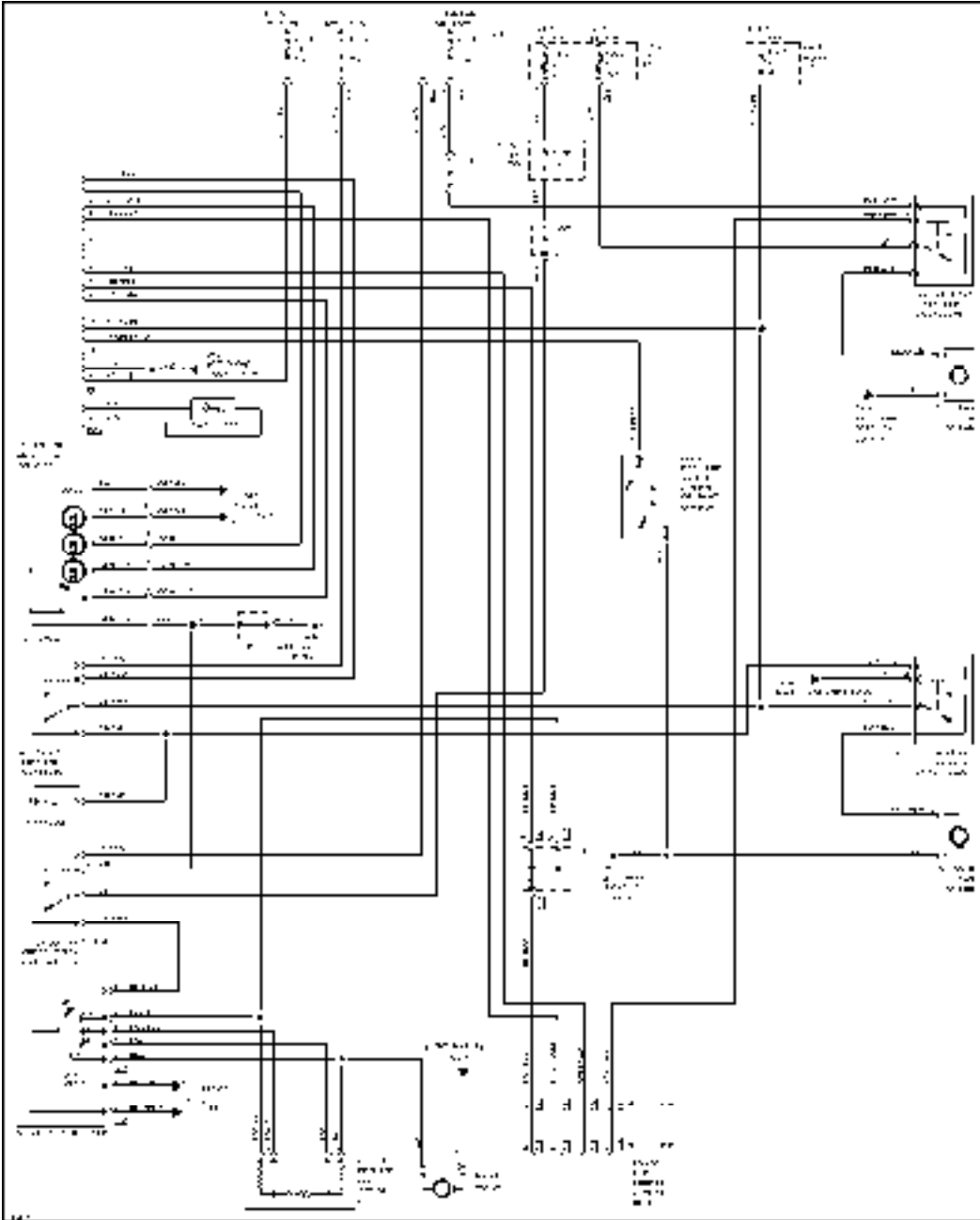

A/C Circuit

# SYSTEM WIRING DIAGRAMS

Article Text (p. 2)

1996 Suzuki Esteem

For

Copyright © 1998 Mitchell International

Tuesday, April 06, 1999 08:11AM

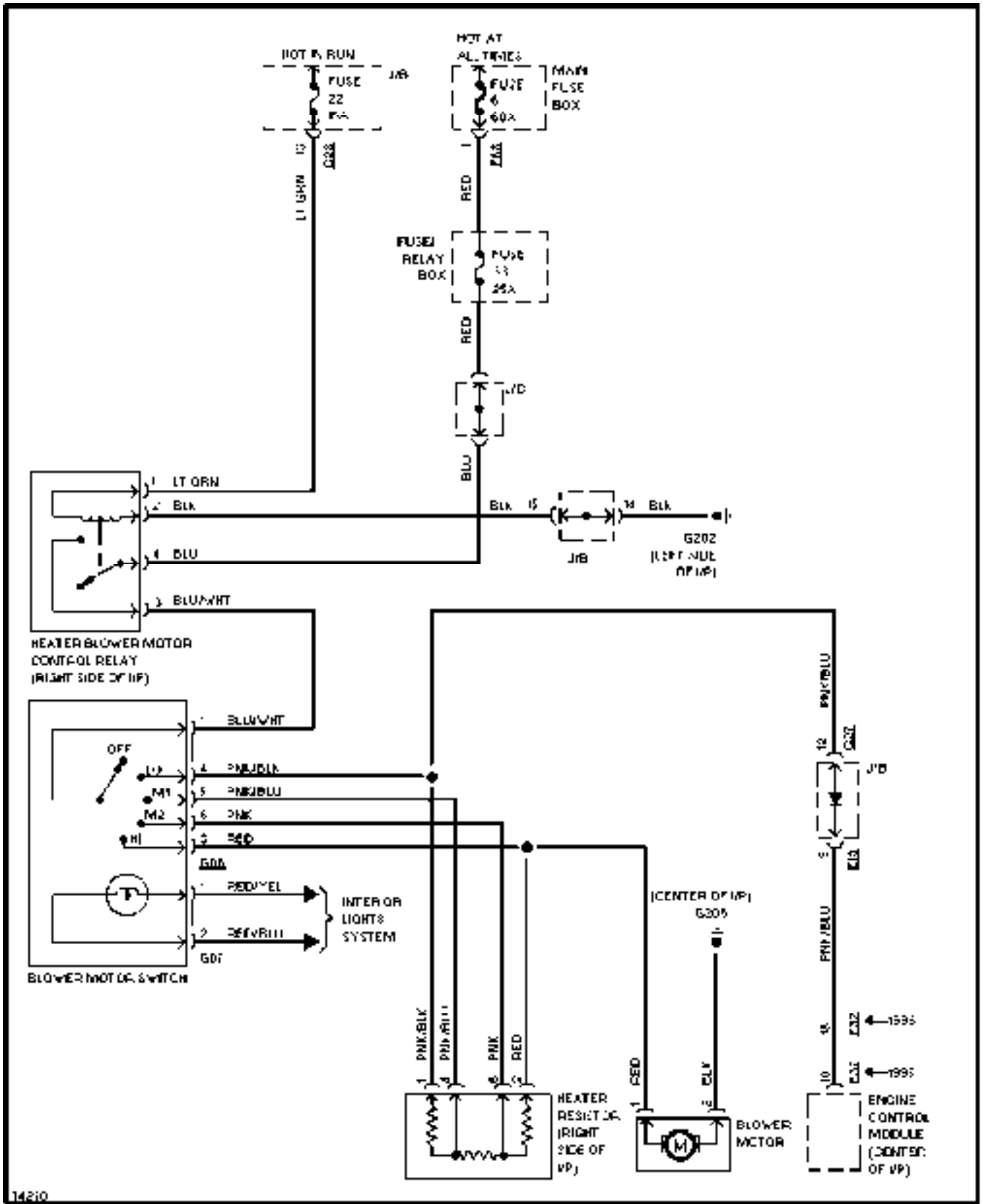

Heater Circuit

## ANTI-LOCK BRAKES

# SYSTEM WIRING DIAGRAMS

## Article Text (p. 3)

1996 Suzuki Esteem

For

Copyright © 1998 Mitchell International

Tuesday, April 06, 1999 08:11AM

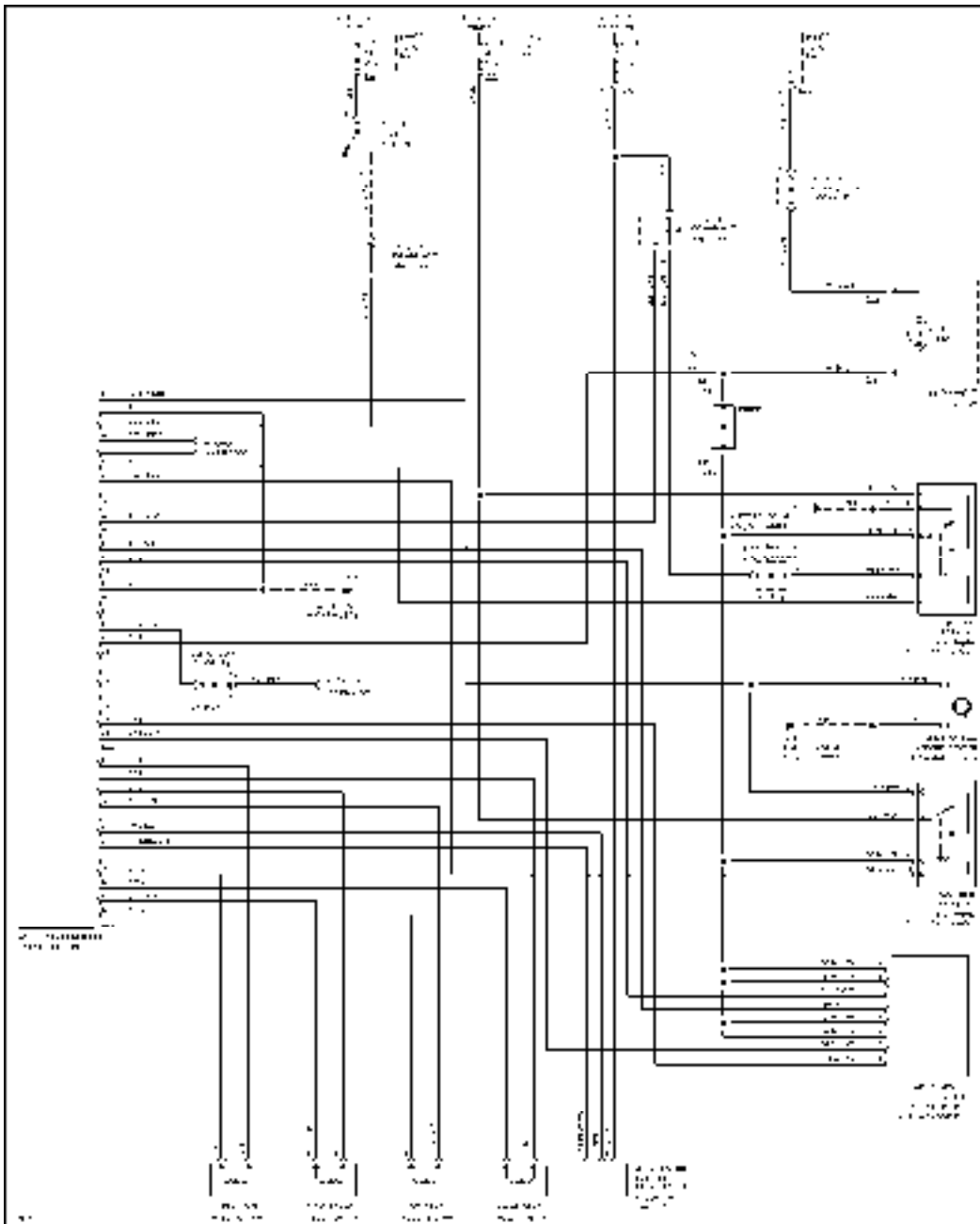

Anti-lock Brake Circuits

### COMPUTER DATA LINES

# SYSTEM WIRING DIAGRAMS

Article Text (p. 4)

1996 Suzuki Esteem

For

Copyright © 1998 Mitchell International

Tuesday, April 06, 1999 08:11AM

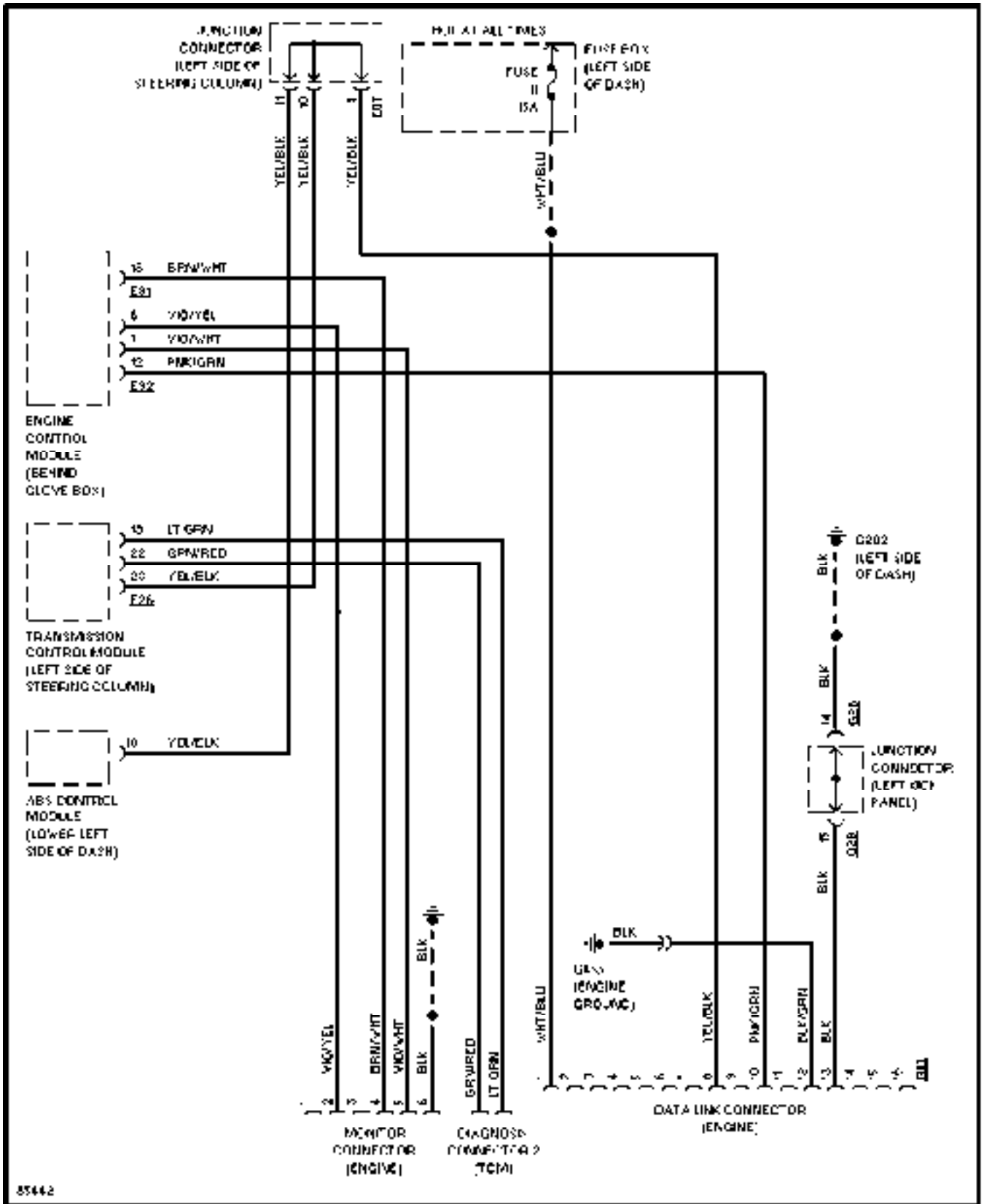

Computer Data Lines

COOLING FAN

# SYSTEM WIRING DIAGRAMS

Article Text (p. 5)

1996 Suzuki Esteem

For

Copyright © 1998 Mitchell International

Tuesday, April 06, 1999 08:11AM

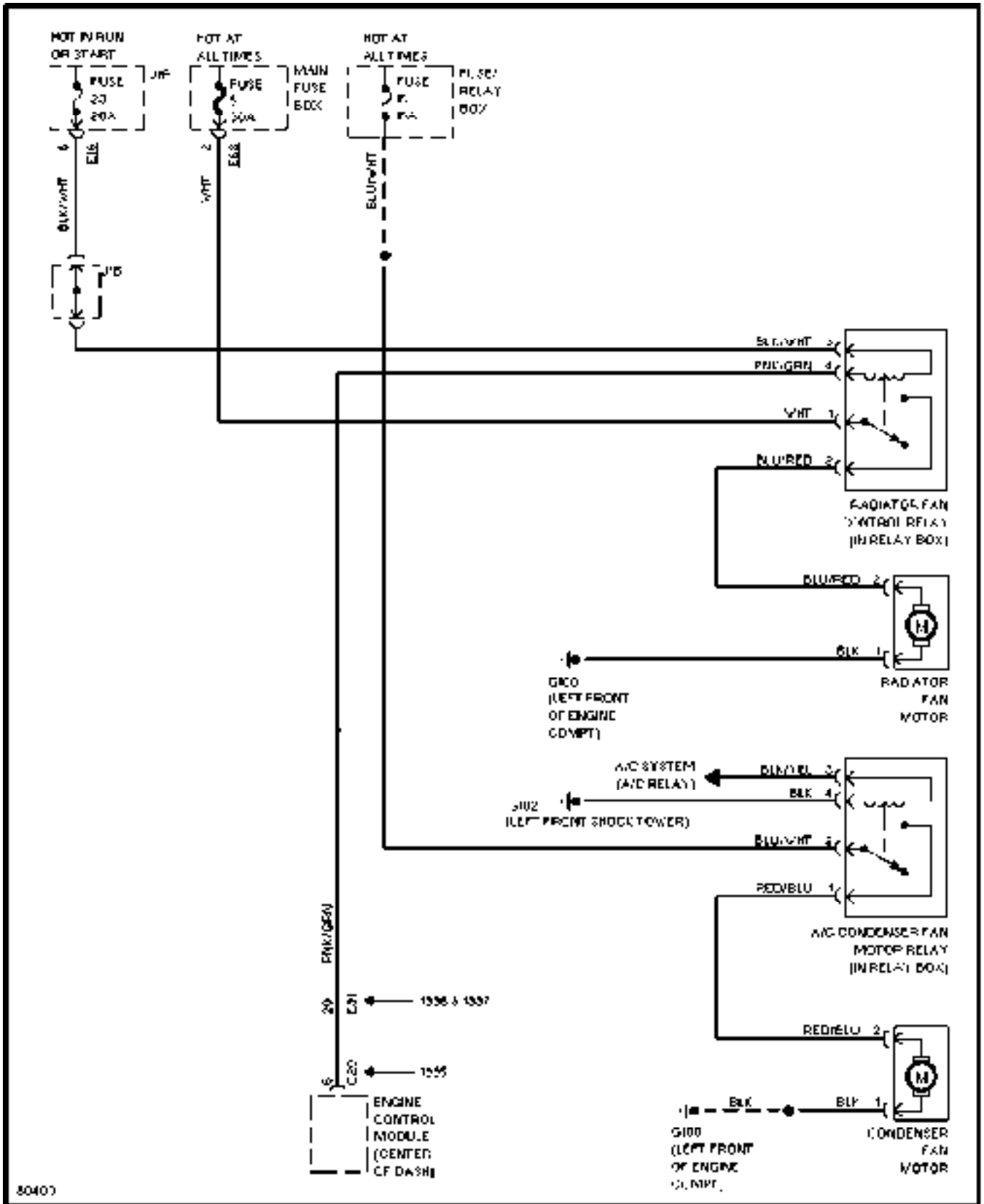

Cooling Fan Circuit

## CRUISE CONTROL

# SYSTEM WIRING DIAGRAMS

Article Text (p. 6)

1996 Suzuki Esteem

For

Copyright © 1998 Mitchell International

Tuesday, April 06, 1999 08:11AM

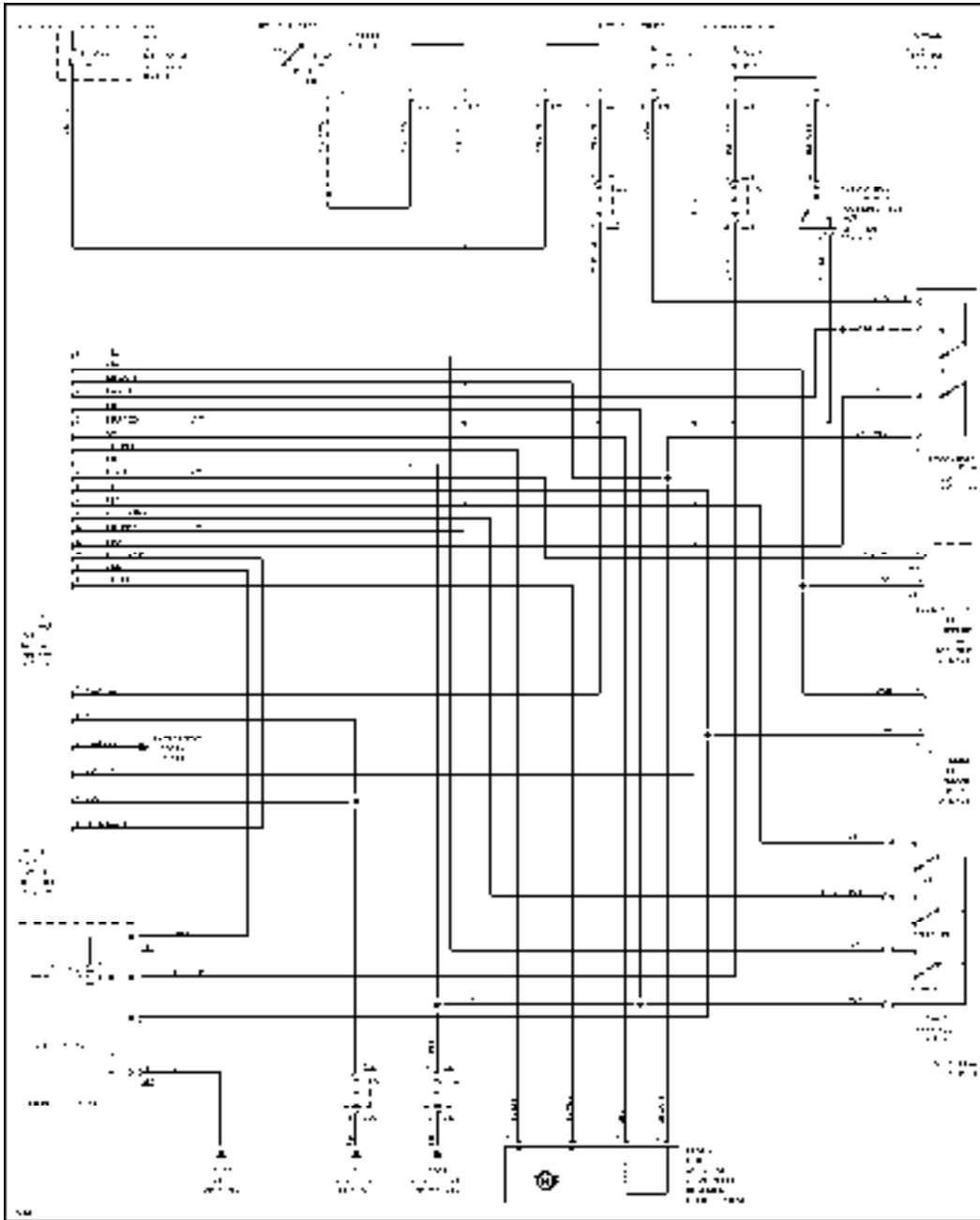

Cruise Control Circuit

## DEFOGGERS

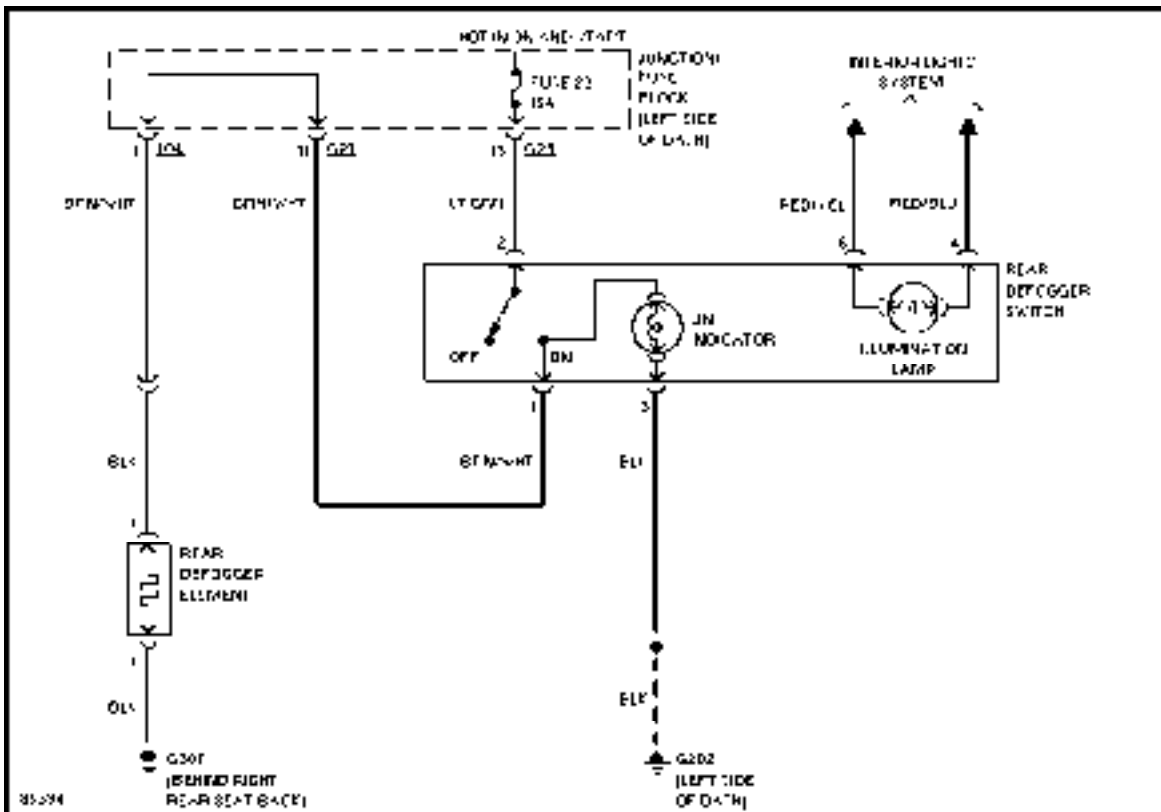

Defogger Circuit

# SYSTEM WIRING DIAGRAMS

Article Text (p. 7)

1996 Suzuki Esteem

For

Copyright © 1998 Mitchell International

Tuesday, April 06, 1999 08:11AM

## ENGINE PERFORMANCE

1.6L

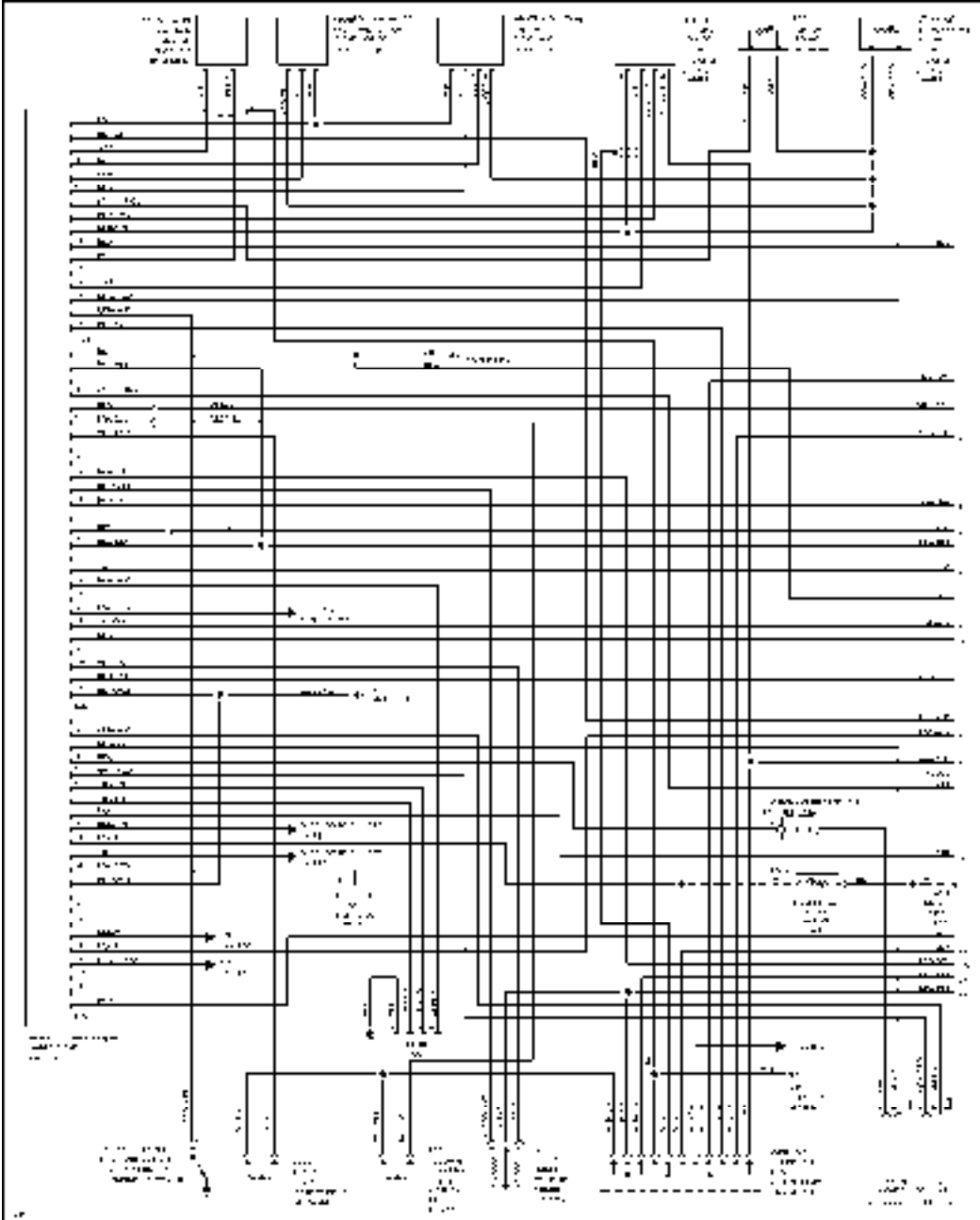

1.6L, Engine Performance Circuits (1 of 2)

# SYSTEM WIRING DIAGRAMS

Article Text (p. 8)

1996 Suzuki Esteem

For

Copyright © 1998 Mitchell International

Tuesday, April 06, 1999 08:11AM

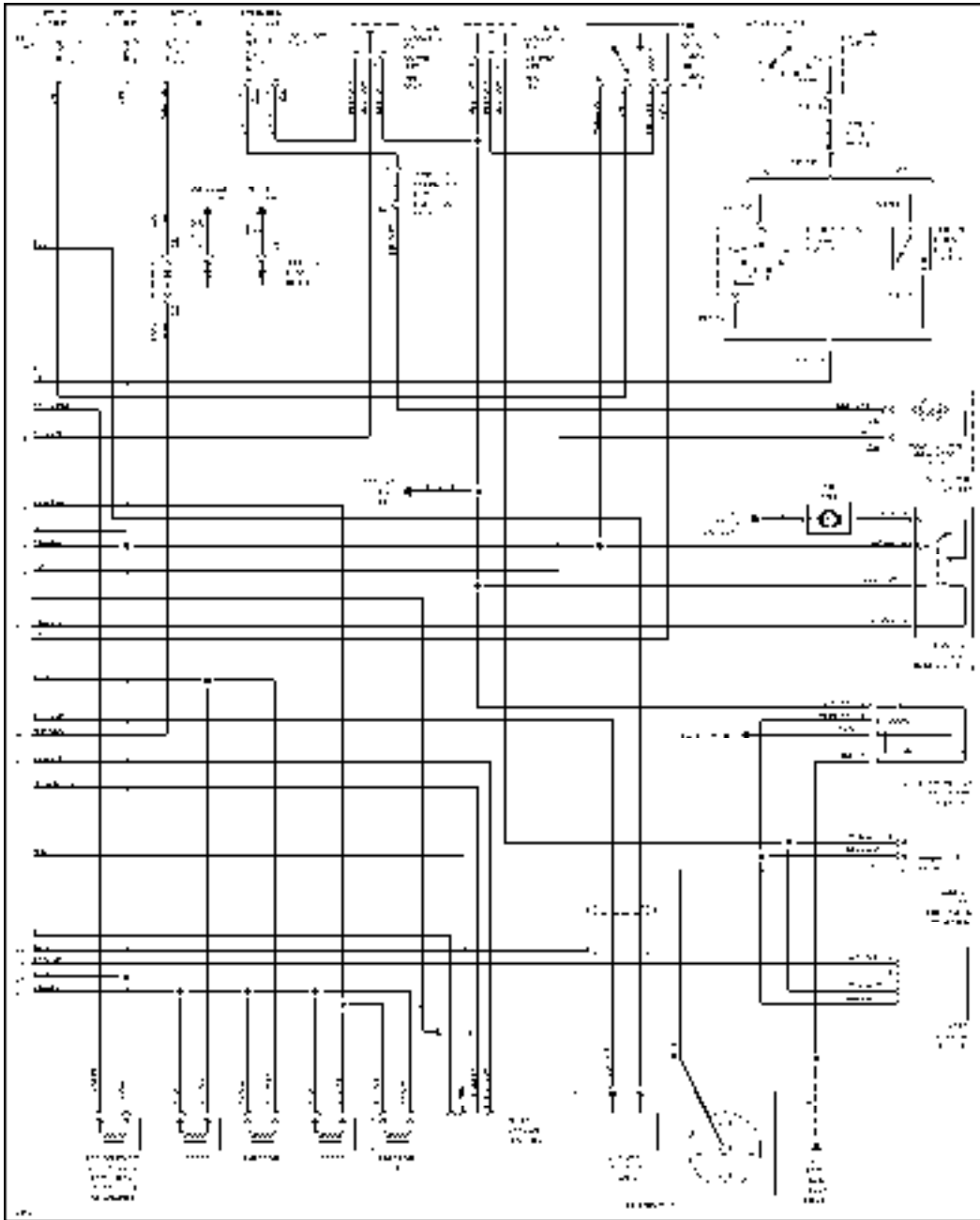

1.6L, Engine Performance Circuits (2 of 2)

## EXTERIOR LIGHTS

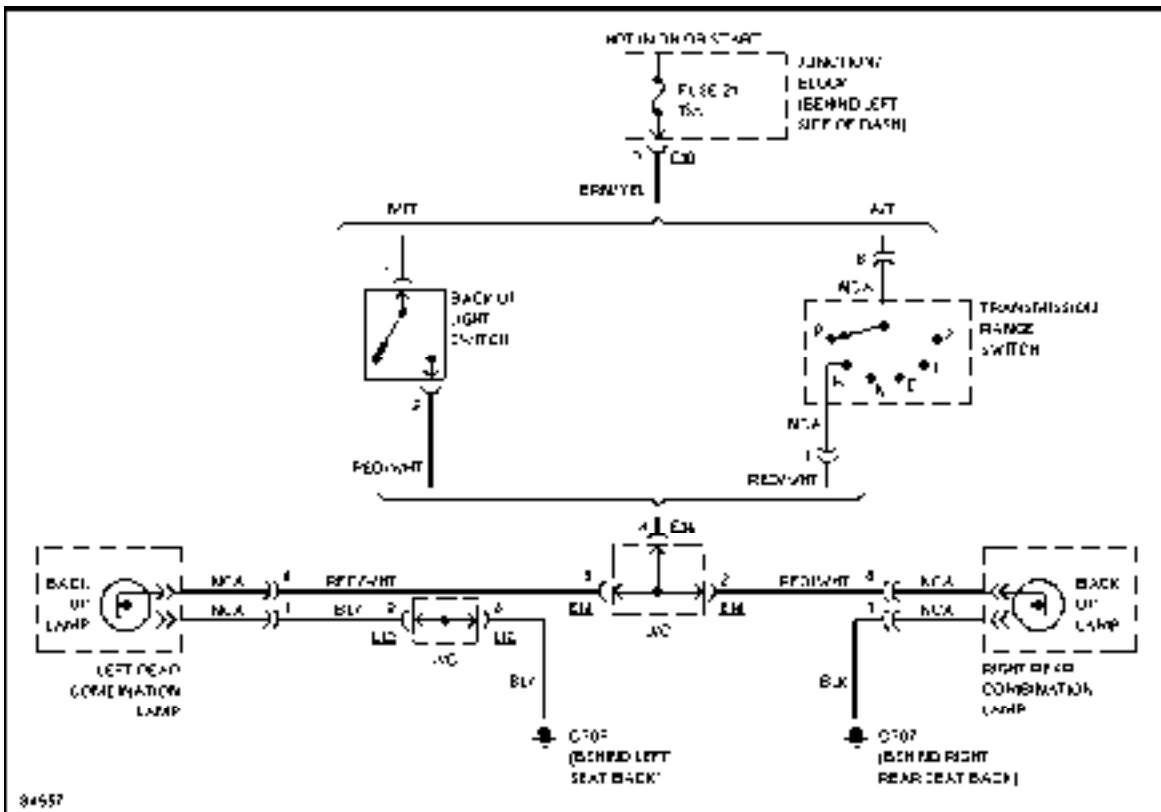

Back-up Lamps Circuit



# SYSTEM WIRING DIAGRAMS

Article Text (p. 9)

1996 Suzuki Esteem

For

Copyright © 1998 Mitchell International

Tuesday, April 06, 1999 08:11AM

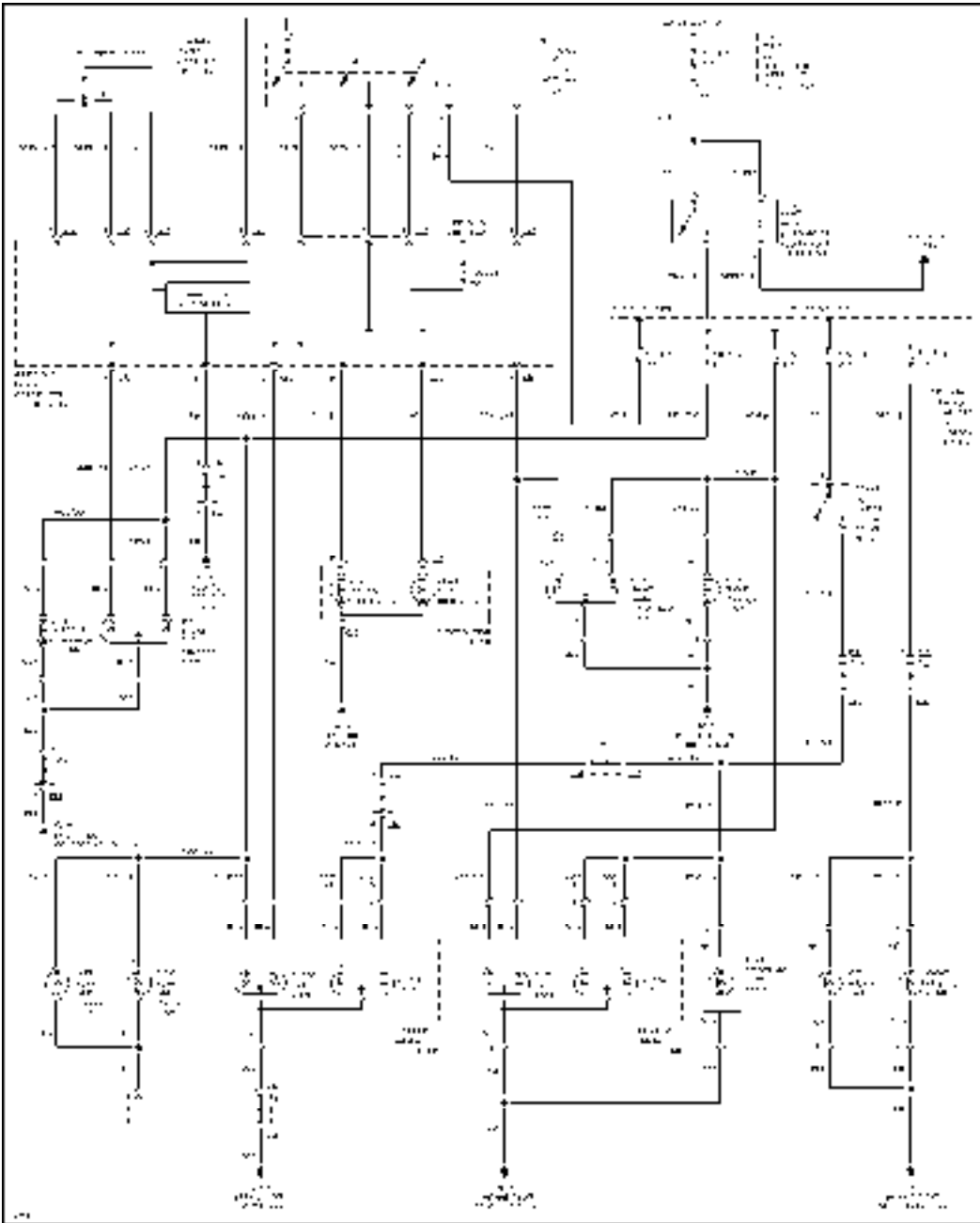

Exterior Lamps Circuit

## GROUND DISTRIBUTION

# SYSTEM WIRING DIAGRAMS

Article Text (p. 10)

1996 Suzuki Esteem

For

Copyright © 1998 Mitchell International

Tuesday, April 06, 1999 08:11AM

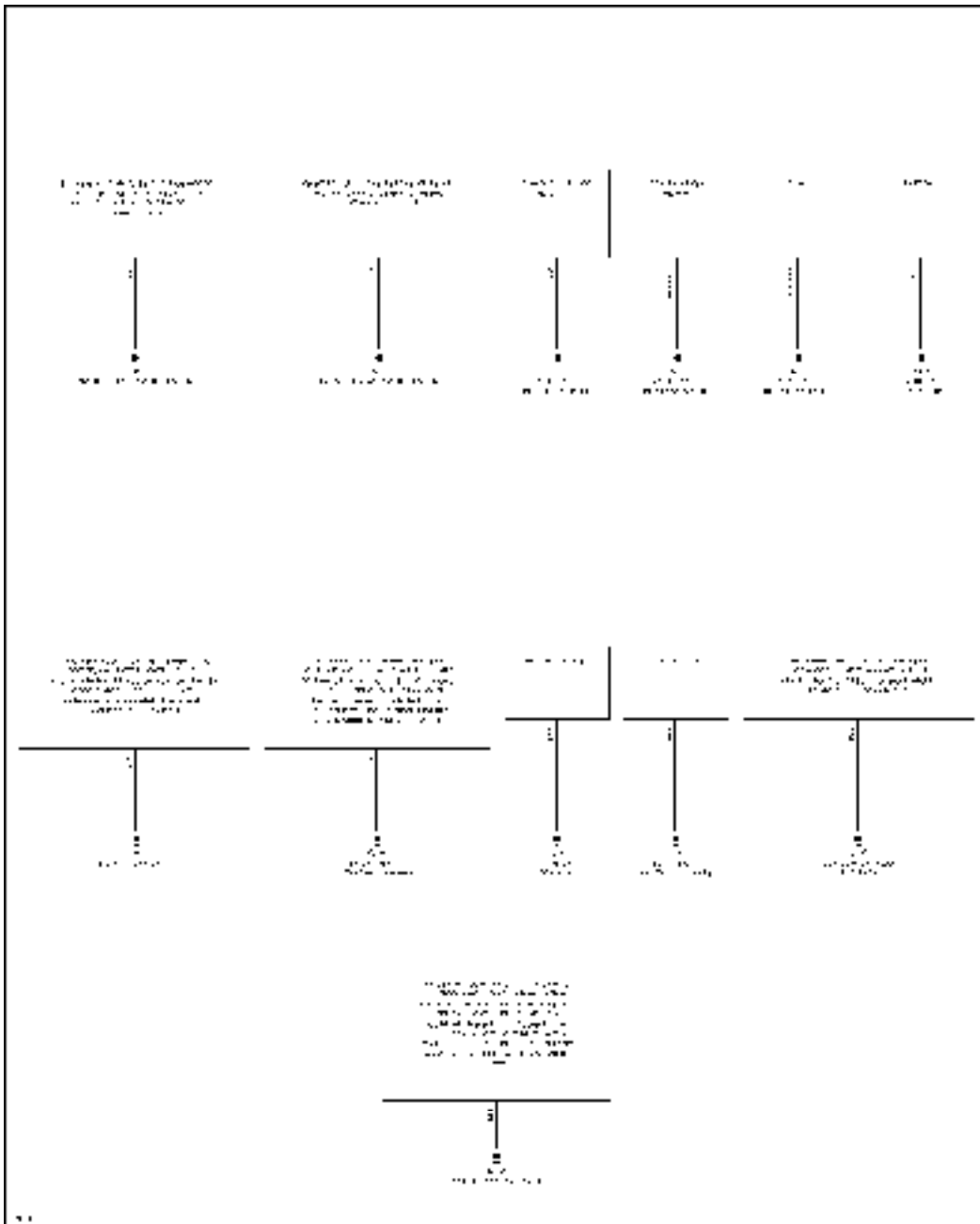

Ground Distribution Circuit

## HEADLIGHTS

# SYSTEM WIRING DIAGRAMS

Article Text (p. 11)

1996 Suzuki Esteem

For

Copyright © 1998 Mitchell International

Tuesday, April 06, 1999 08:11AM

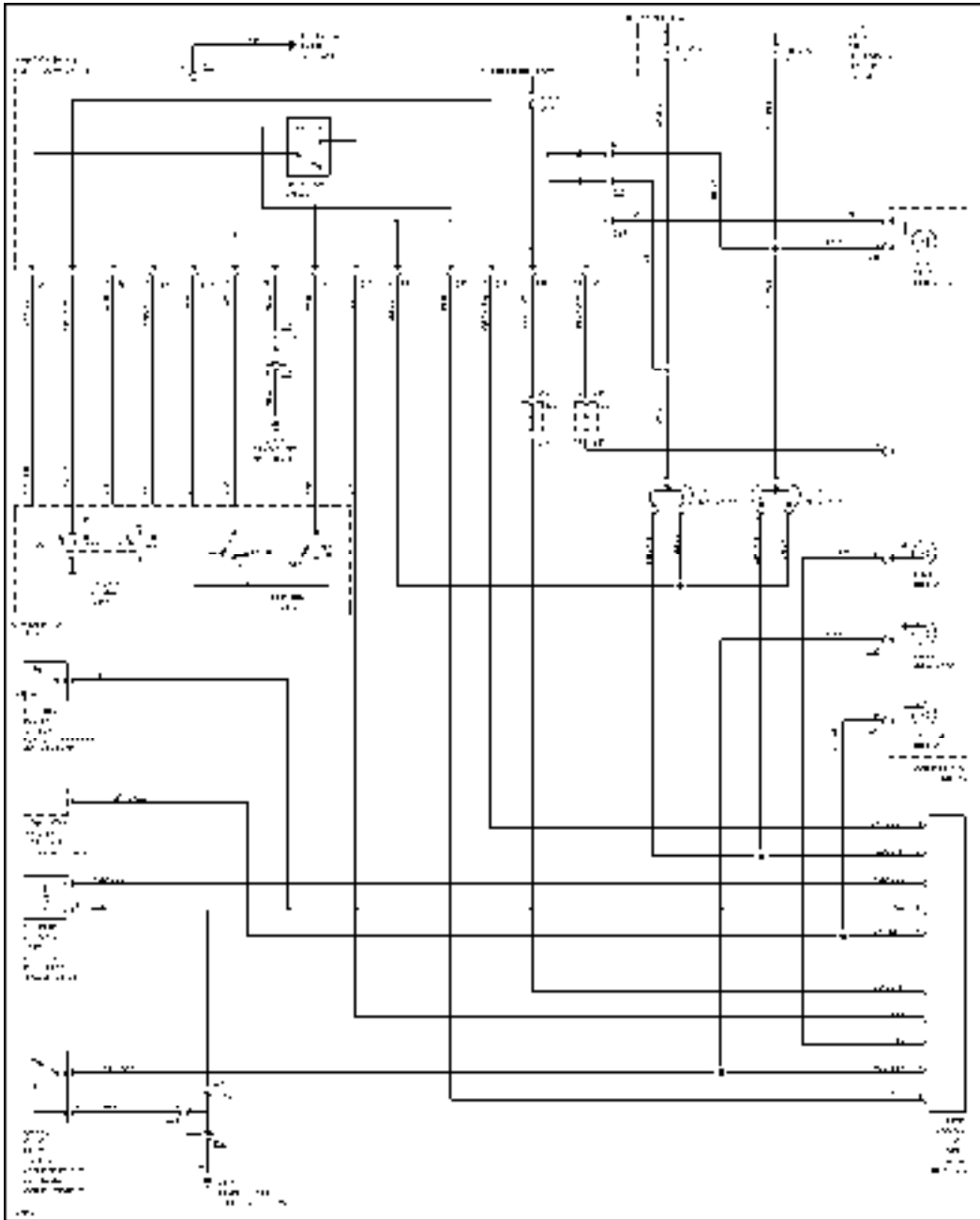

Headlight Circuit

## HORN

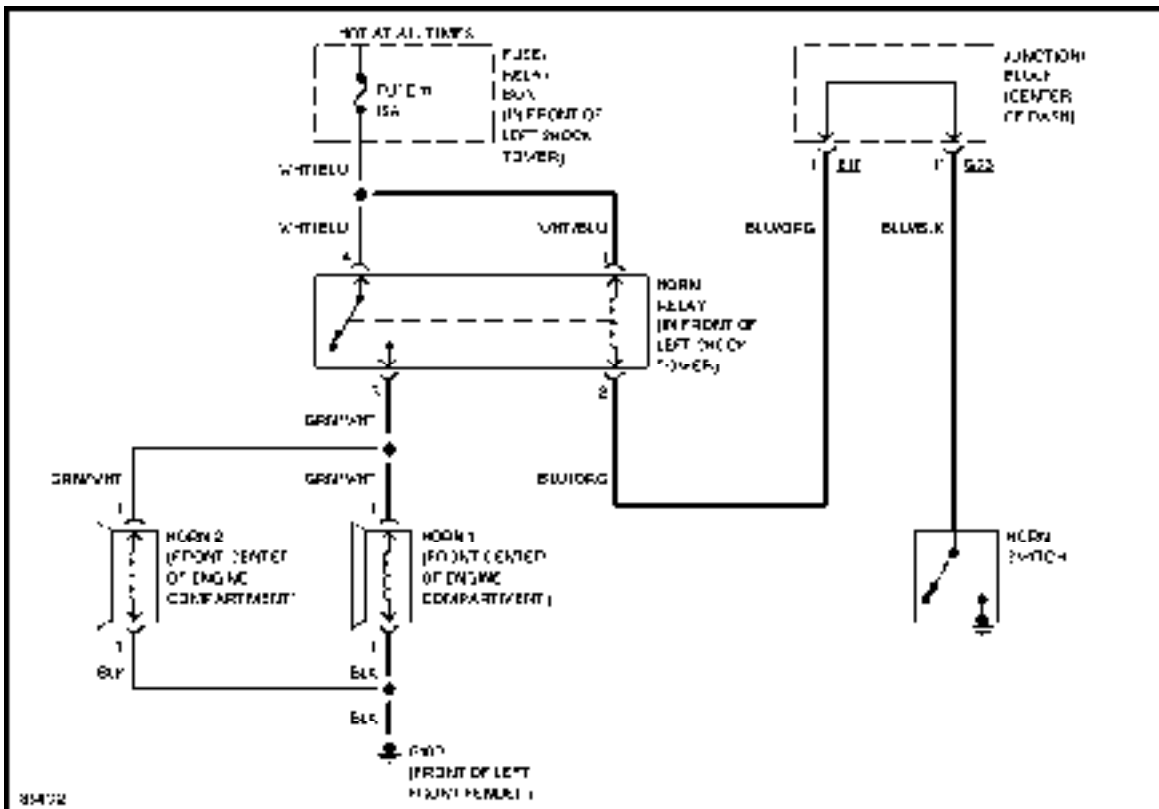

Horn Circuit

# SYSTEM WIRING DIAGRAMS

Article Text (p. 12)

1996 Suzuki Esteem

For

Copyright © 1998 Mitchell International

Tuesday, April 06, 1999 08:11AM

## INSTRUMENT CLUSTER

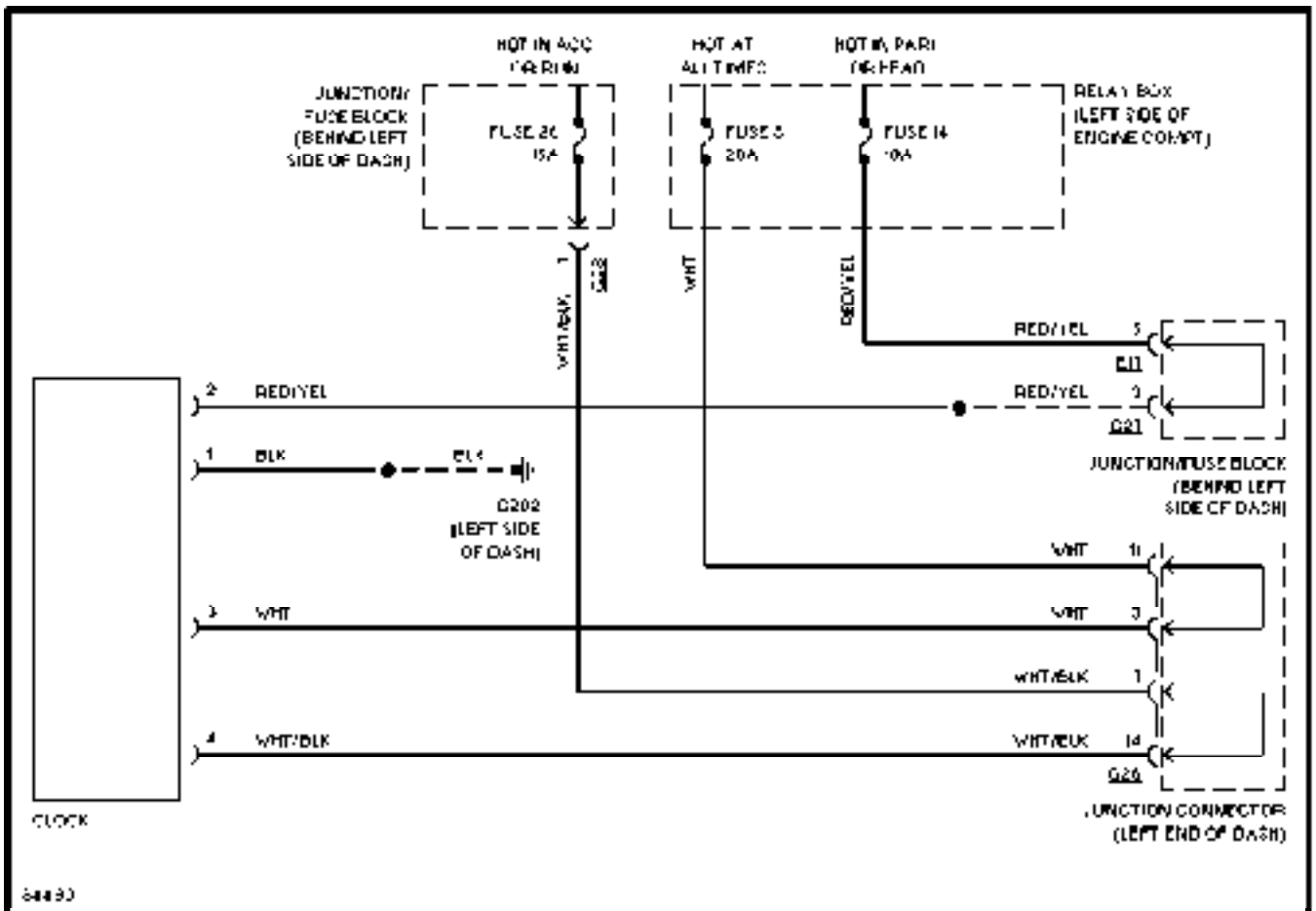

Clock Circuit

# SYSTEM WIRING DIAGRAMS

## Article Text (p. 13)

1996 Suzuki Esteem

For

Copyright © 1998 Mitchell International

Tuesday, April 06, 1999 08:11AM

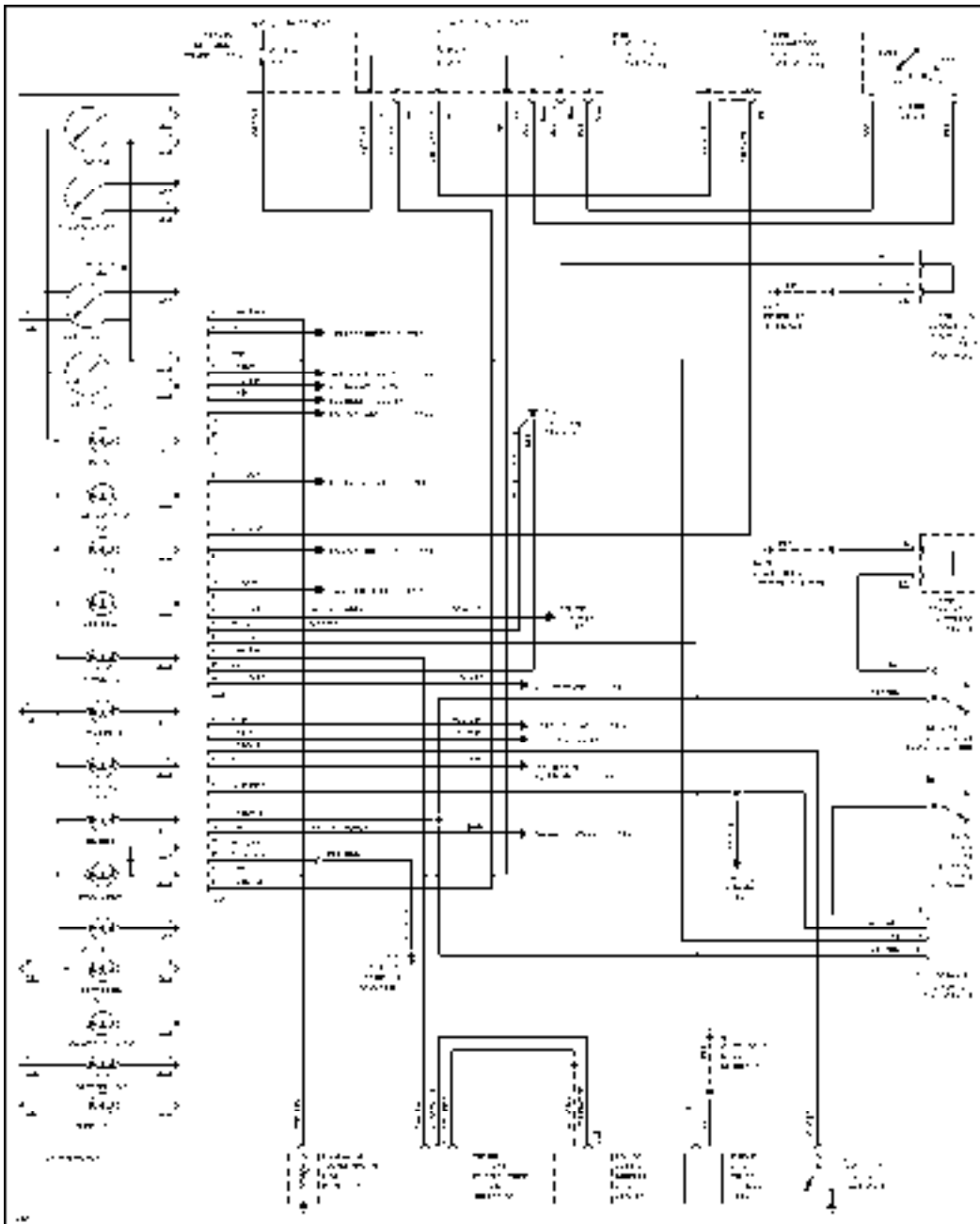

Instrument Cluster Circuit

## INTERIOR LIGHTS

# SYSTEM WIRING DIAGRAMS

## Article Text (p. 14)

1996 Suzuki Esteem

For

Copyright © 1998 Mitchell International

Tuesday, April 06, 1999 08:11AM

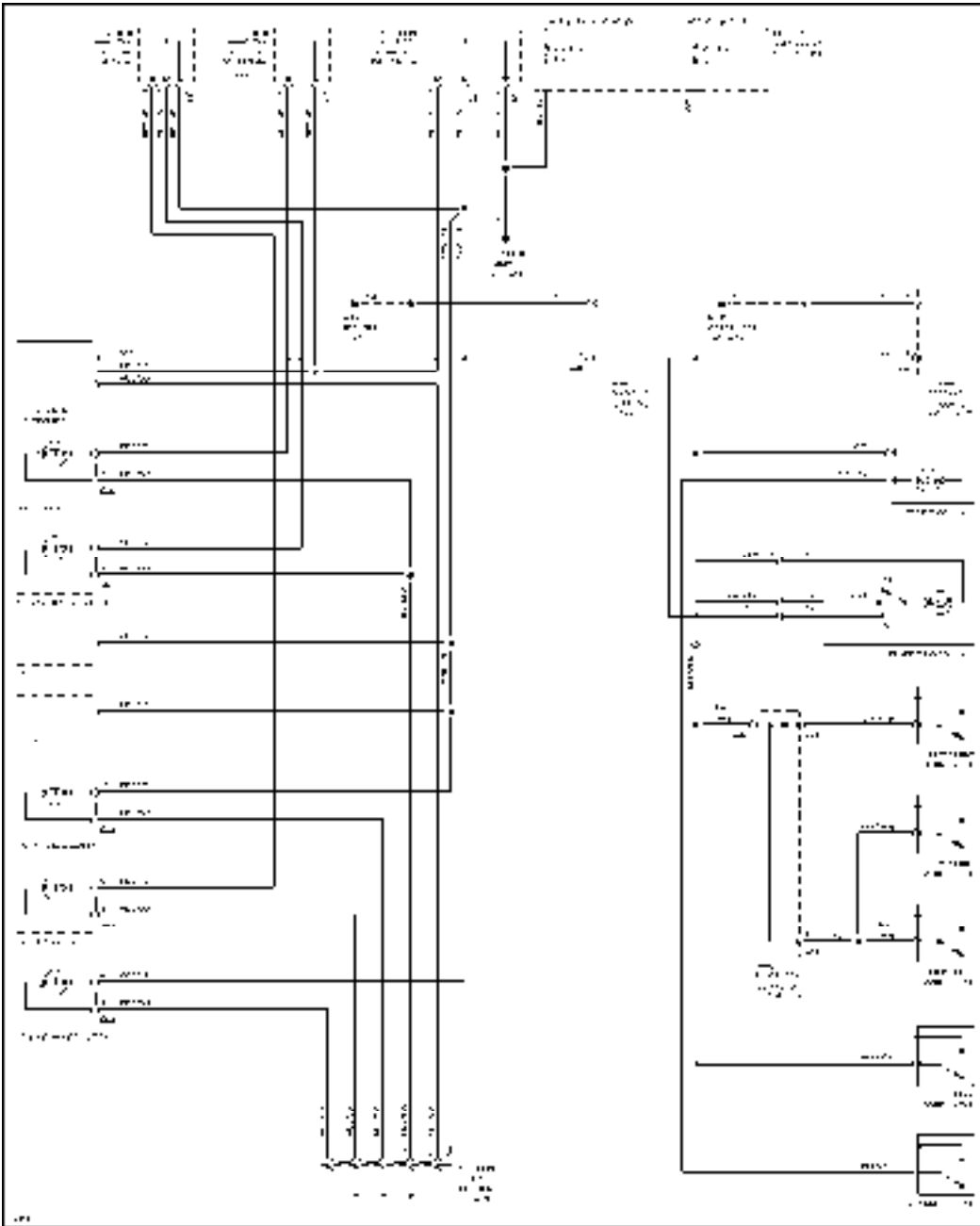

Interior Light Circuit

### POWER DISTRIBUTION

# SYSTEM WIRING DIAGRAMS

## Article Text (p. 15)

1996 Suzuki Esteem

For

Copyright © 1998 Mitchell International

Tuesday, April 06, 1999 08:11AM

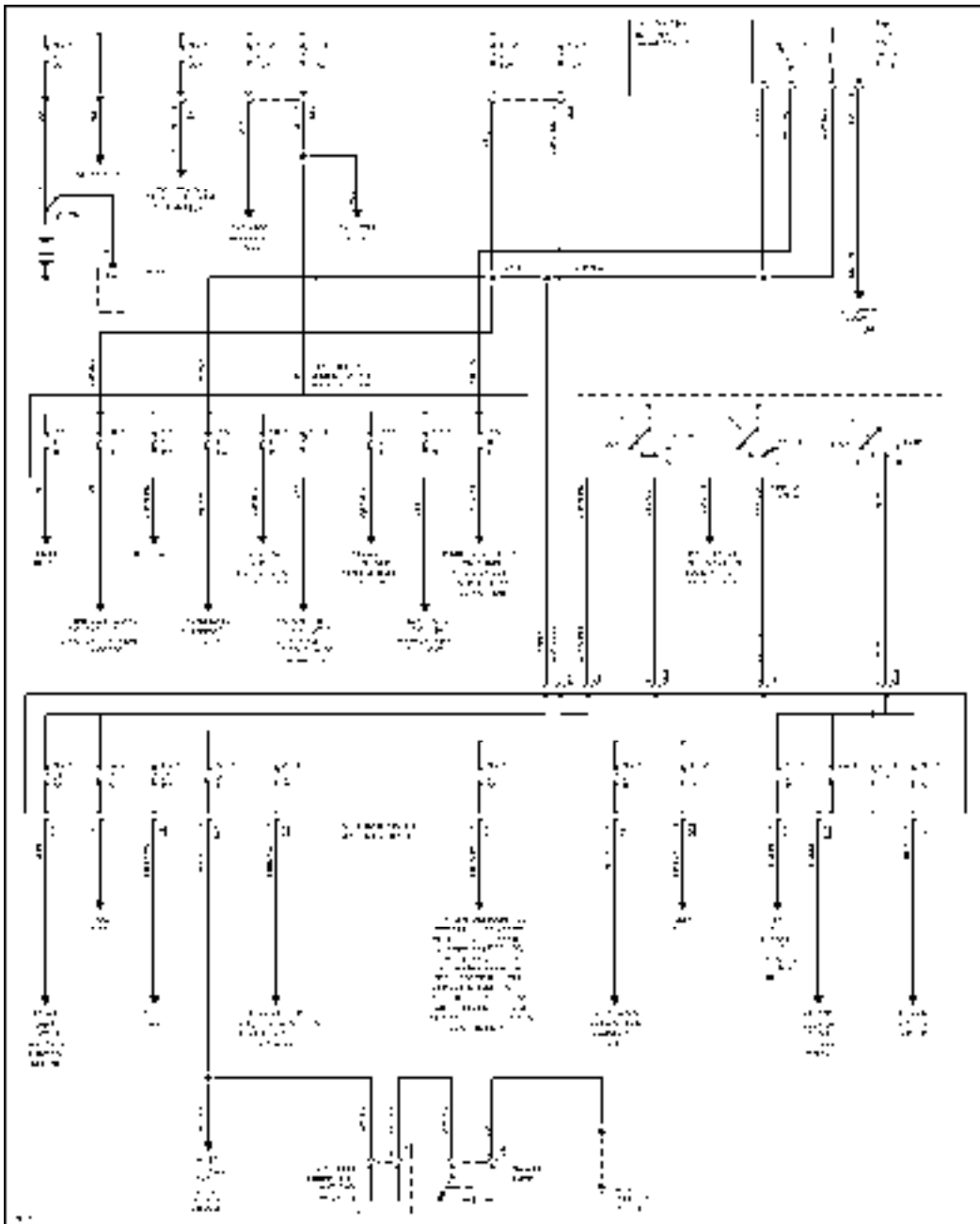

Power Distribution Circuit

### POWER DOOR LOCKS

# SYSTEM WIRING DIAGRAMS

Article Text (p. 16)

1996 Suzuki Esteem

For

Copyright © 1998 Mitchell International

Tuesday, April 06, 1999 08:11AM

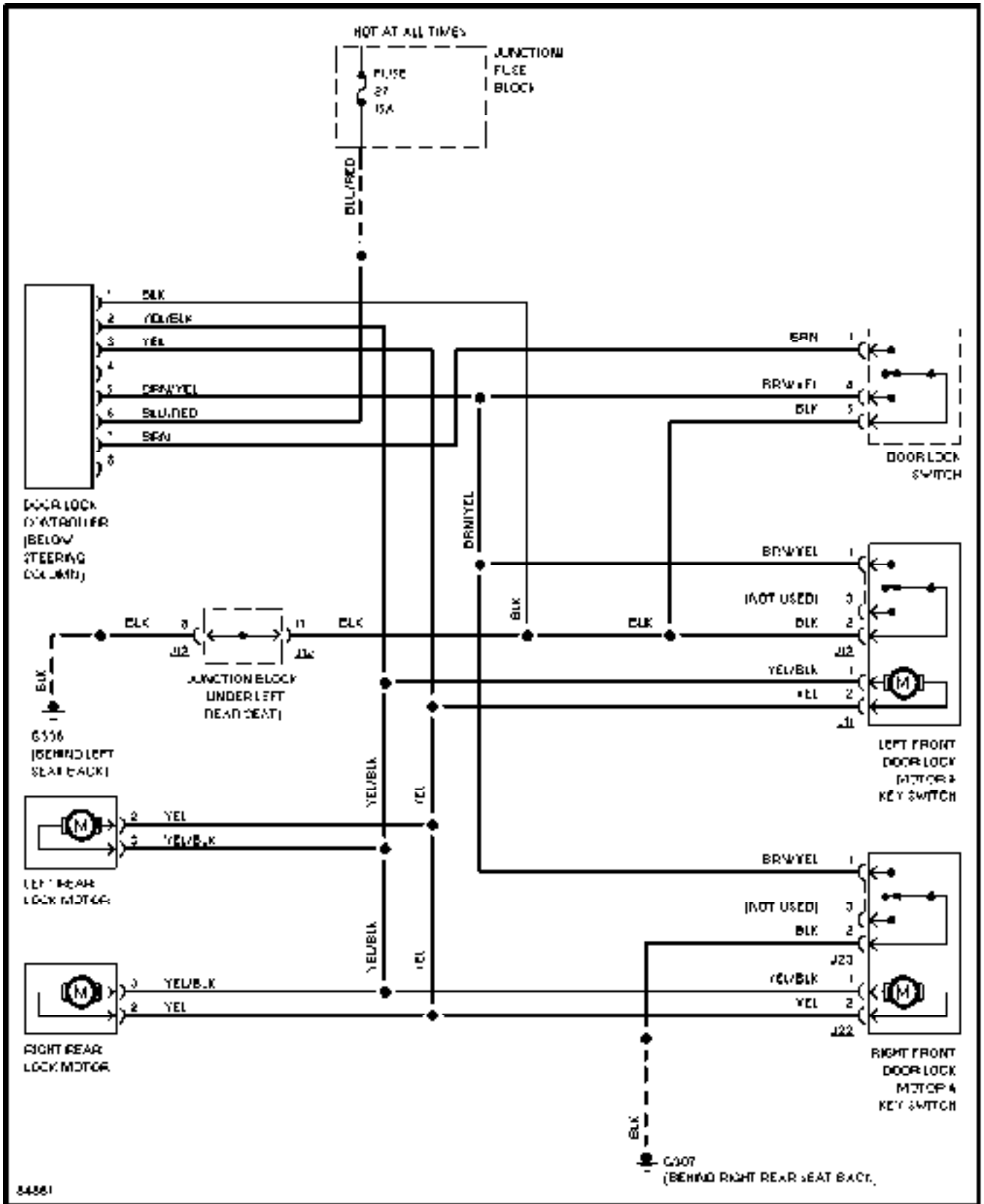

Power Door Lock Circuit

## POWER MIRRORS



# SYSTEM WIRING DIAGRAMS

Article Text (p. 17)

1996 Suzuki Esteem

For

Copyright © 1998 Mitchell International

Tuesday, April 06, 1999 08:11AM

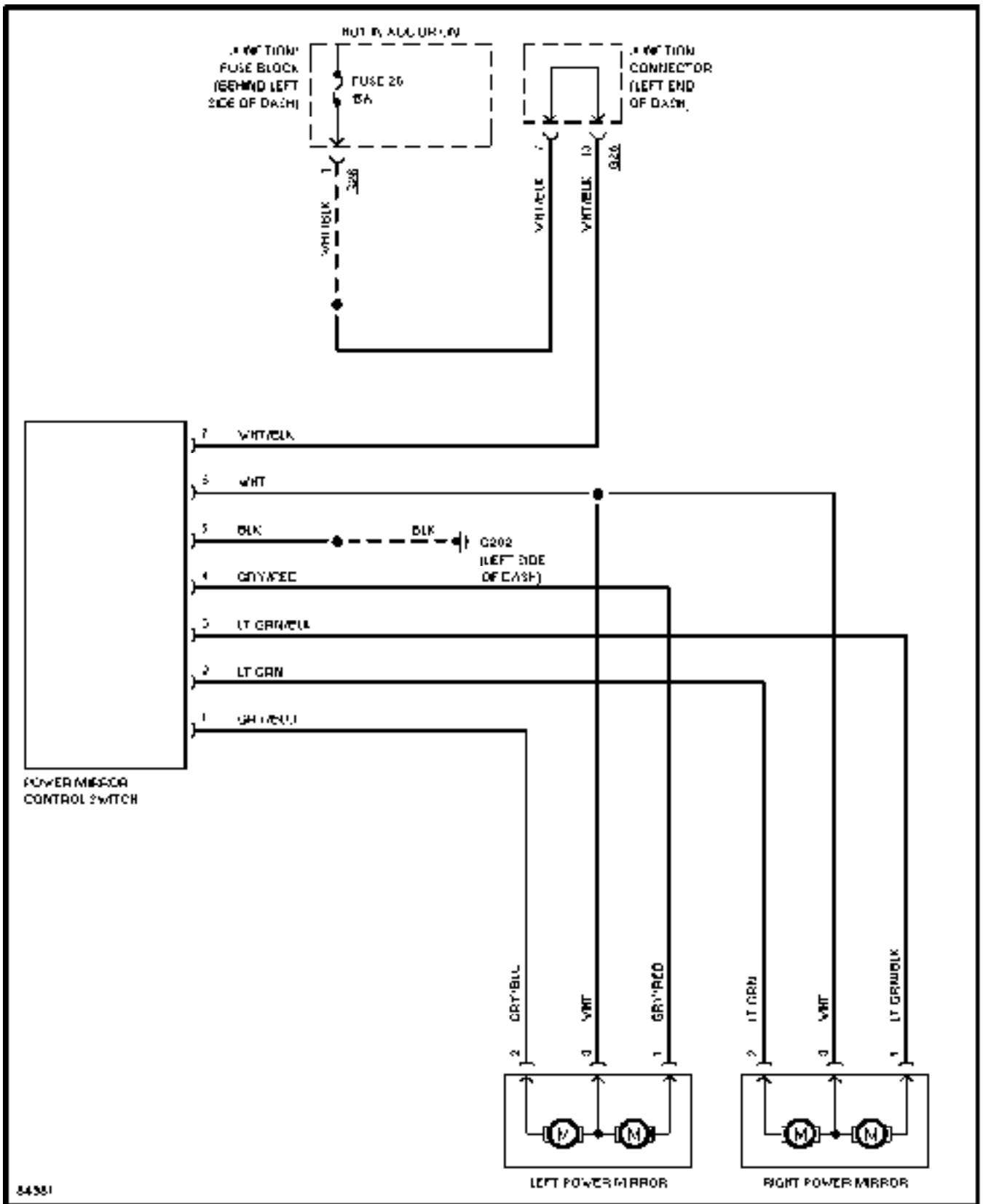

Power Mirror Circuit

## POWER WINDOWS

# SYSTEM WIRING DIAGRAMS

Article Text (p. 18)

1996 Suzuki Esteem

For

Copyright © 1998 Mitchell International

Tuesday, April 06, 1999 08:11AM

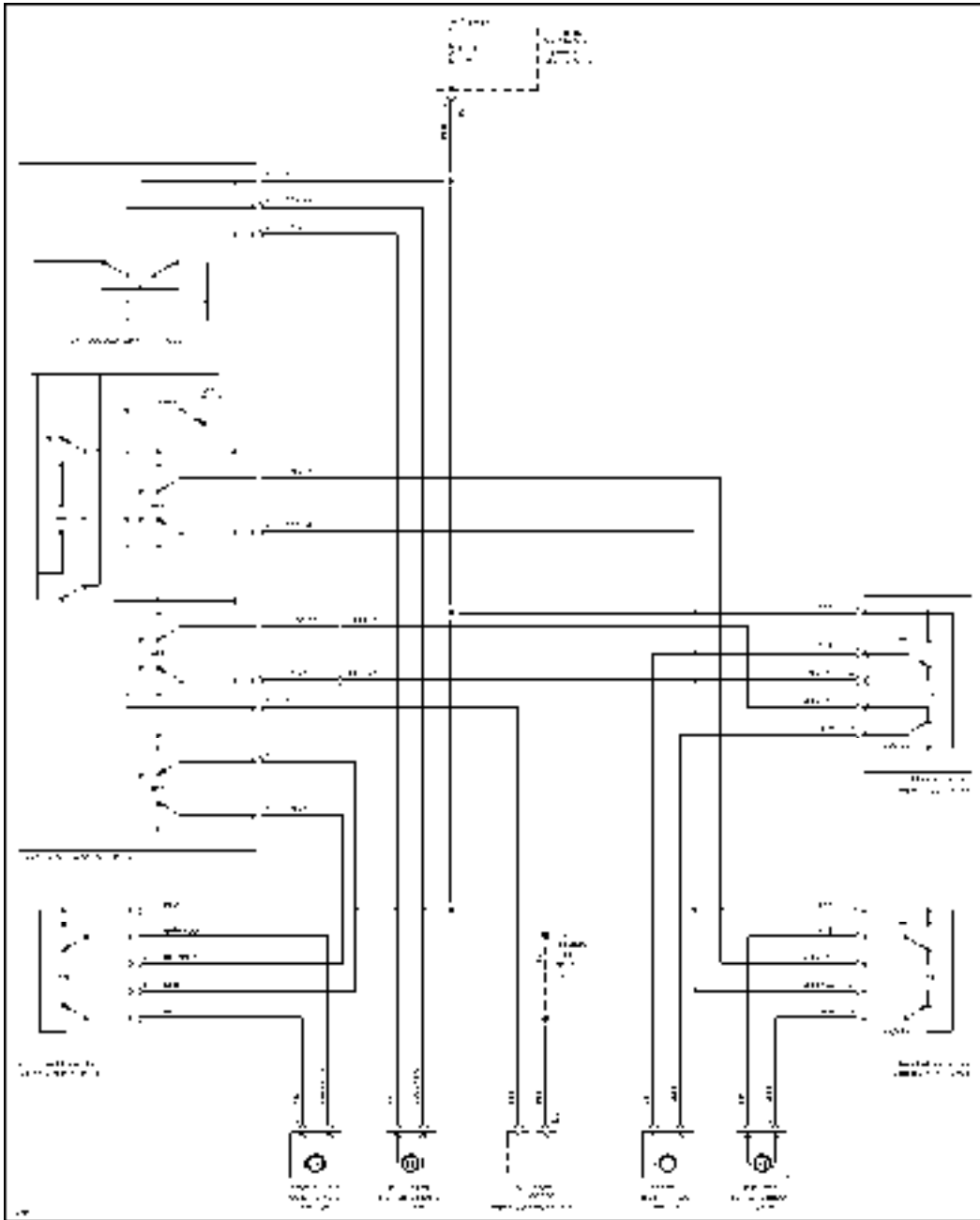

Power Window Circuit

## SHIFT INTERLOCKS

# SYSTEM WIRING DIAGRAMS

Article Text (p. 19)

1996 Suzuki Esteem

For

Copyright © 1998 Mitchell International

Tuesday, April 06, 1999 08:11AM

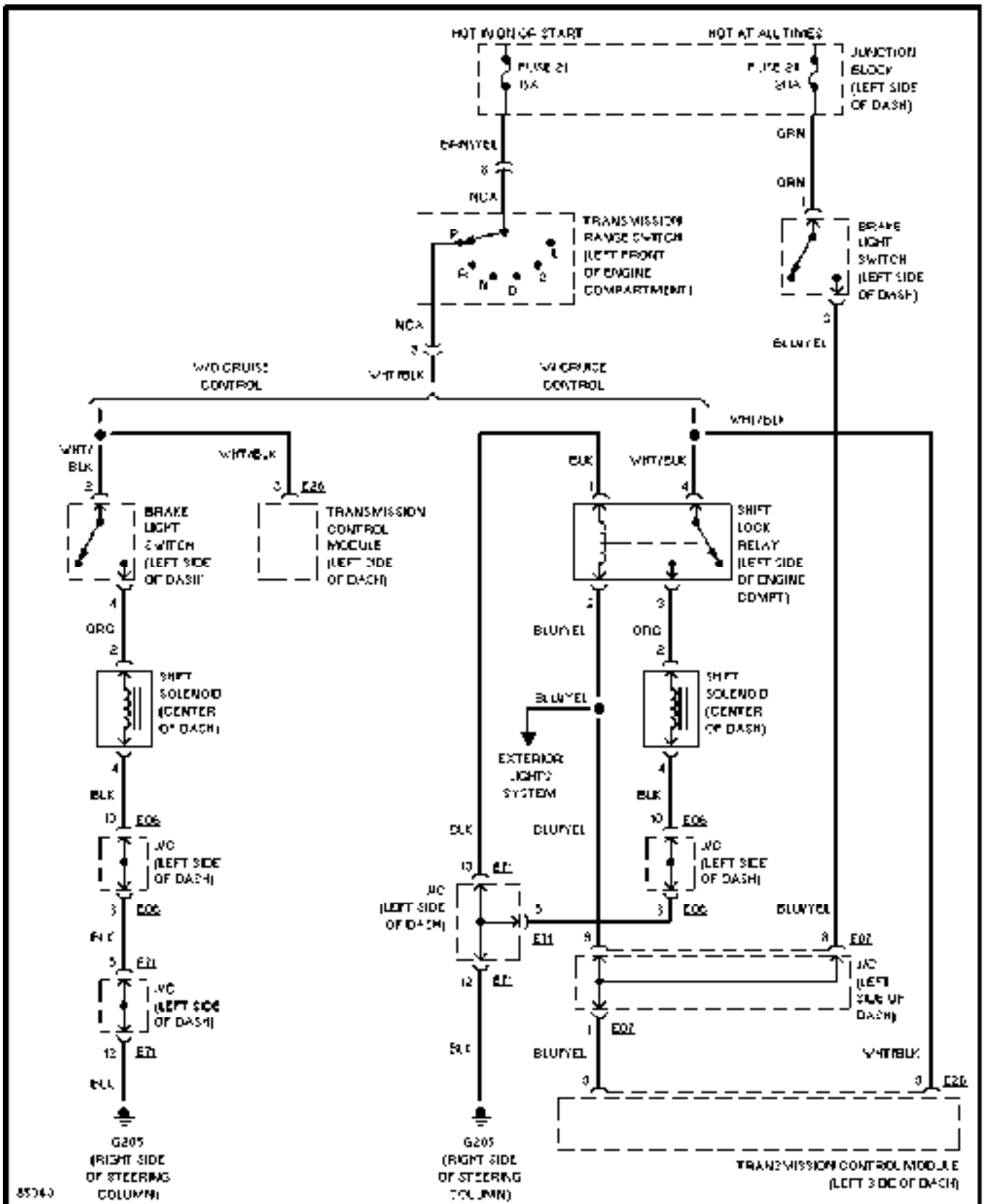

Shift Interlock Circuit

## STARTING/CHARGING

# SYSTEM WIRING DIAGRAMS

Article Text (p. 20)

1996 Suzuki Esteem

For

Copyright © 1998 Mitchell International

Tuesday, April 06, 1999 08:11AM

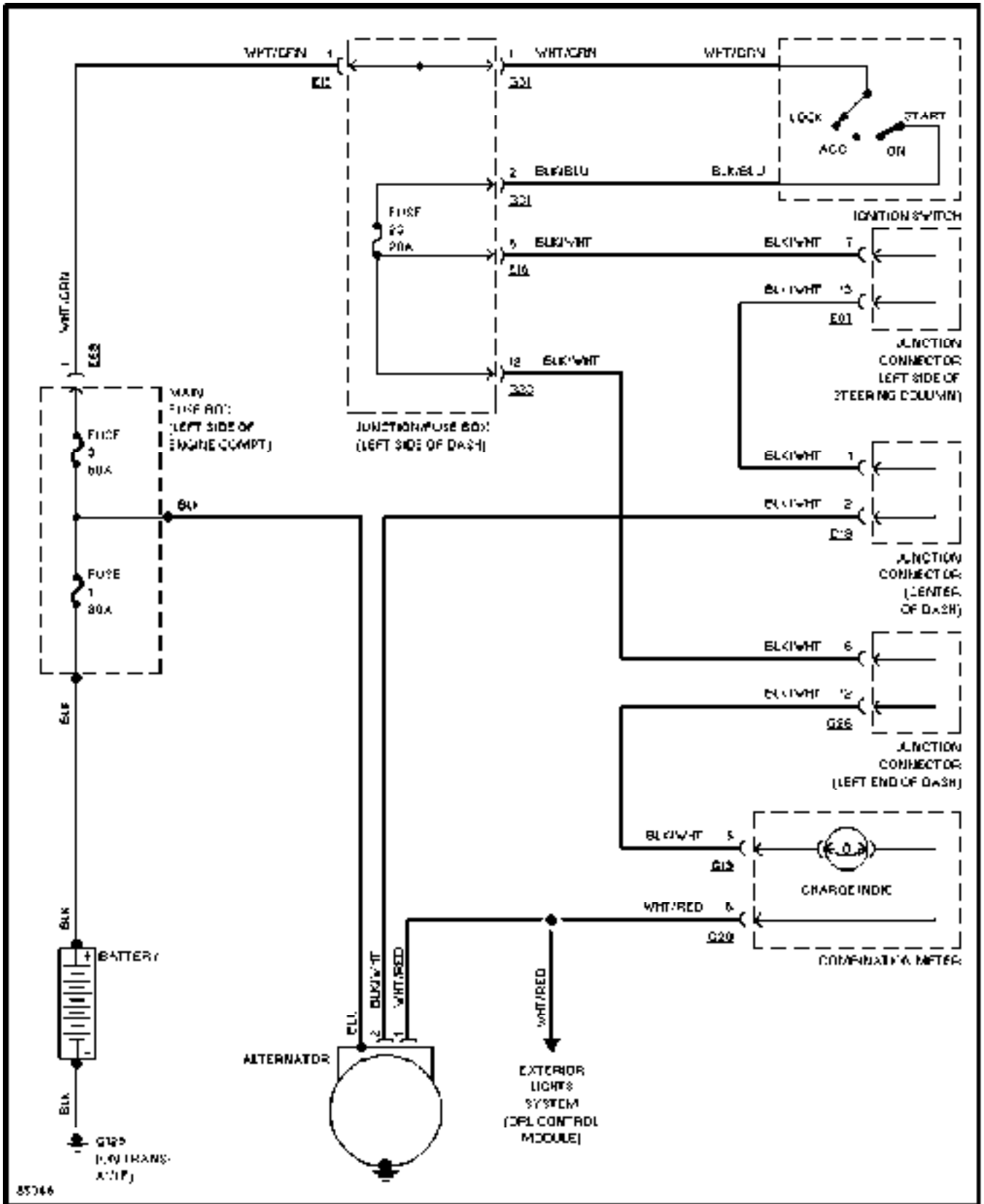

Charging Circuit

# SYSTEM WIRING DIAGRAMS

Article Text (p. 21)

1996 Suzuki Esteem

For

Copyright © 1998 Mitchell International

Tuesday, April 06, 1999 08:11AM

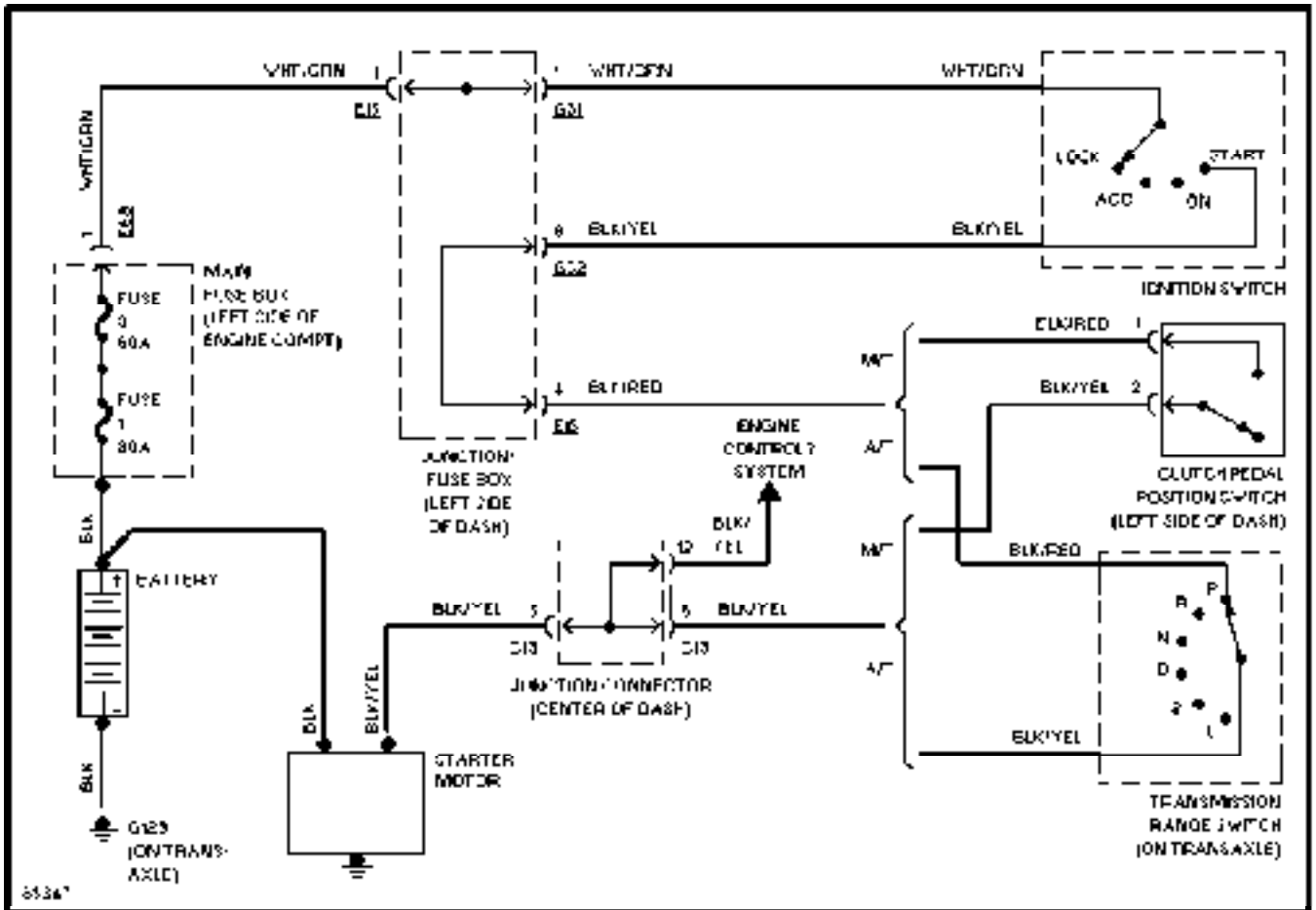

## SUPPLEMENTAL RESTRAINTS

# SYSTEM WIRING DIAGRAMS

Article Text (p. 22)

1996 Suzuki Esteem

For

Copyright © 1998 Mitchell International

Tuesday, April 06, 1999 08:11AM

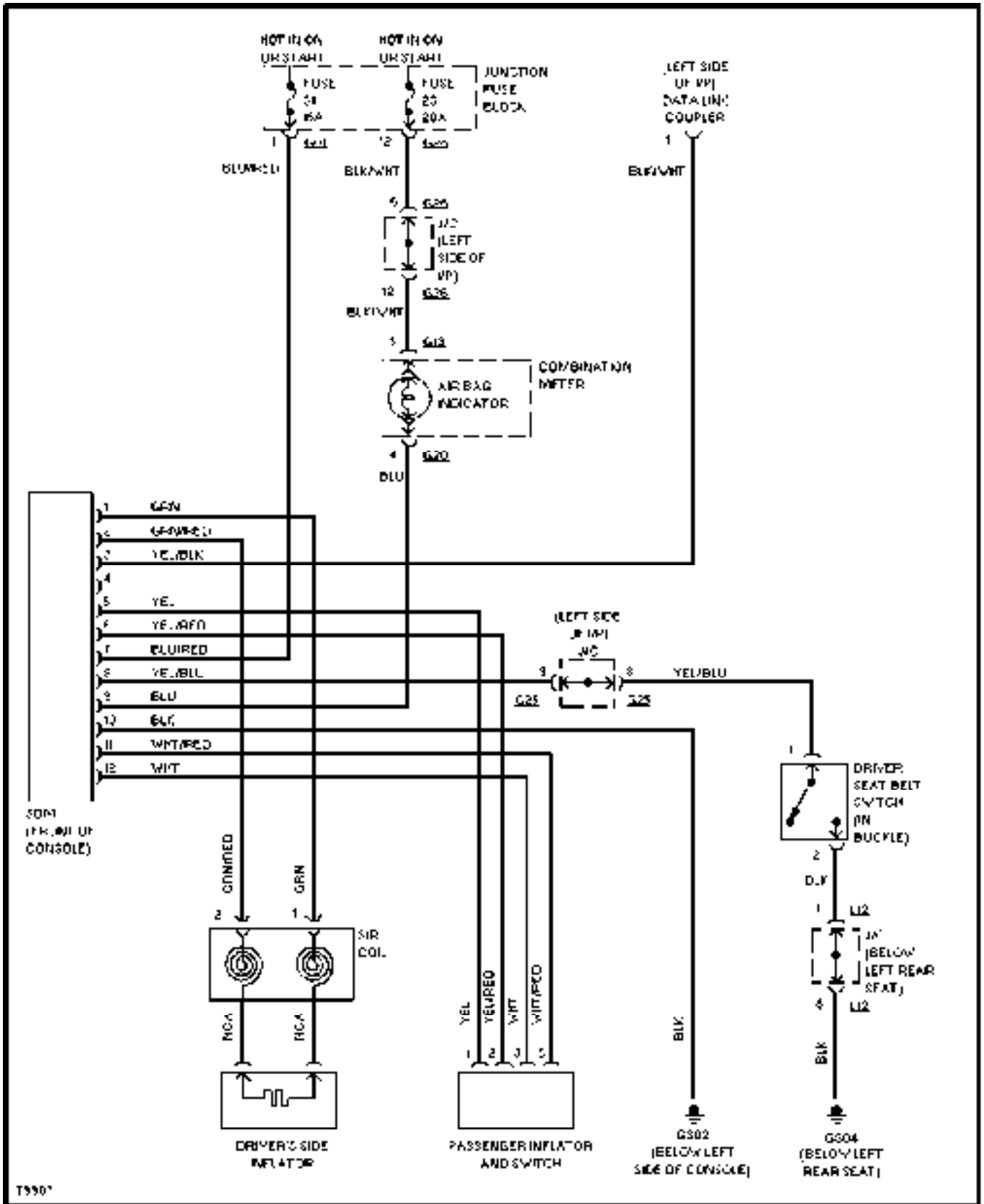

Supplemental Restraint Circuit

## TRANSMISSION

# SYSTEM WIRING DIAGRAMS

Article Text (p. 23)

1996 Suzuki Esteem

For

Copyright © 1998 Mitchell International

Tuesday, April 06, 1999 08:11AM

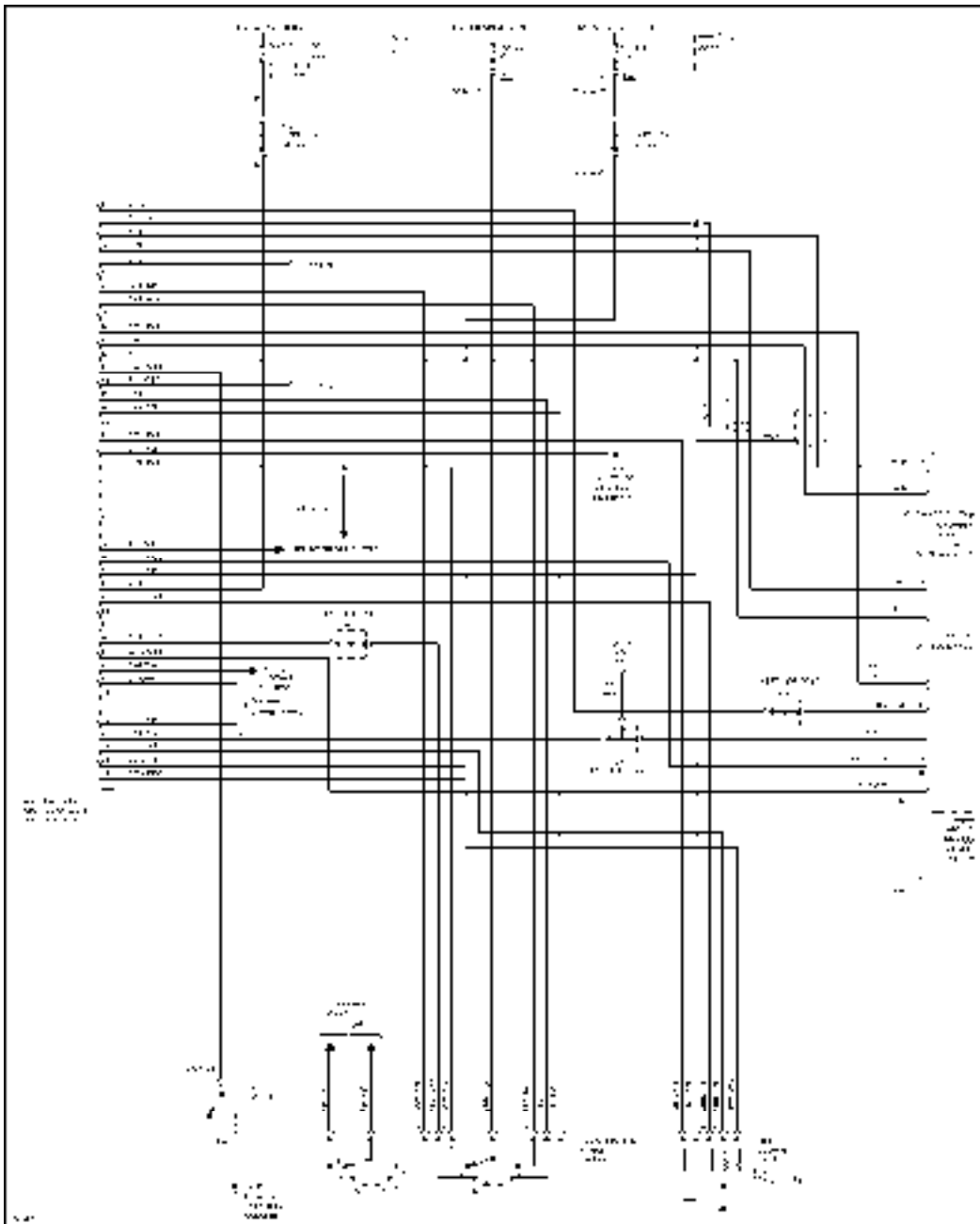

Transmission Circuit

## WARNING SYSTEMS

# SYSTEM WIRING DIAGRAMS

Article Text (p. 24)

1996 Suzuki Esteem

For

Copyright © 1998 Mitchell International

Tuesday, April 06, 1999 08:11AM

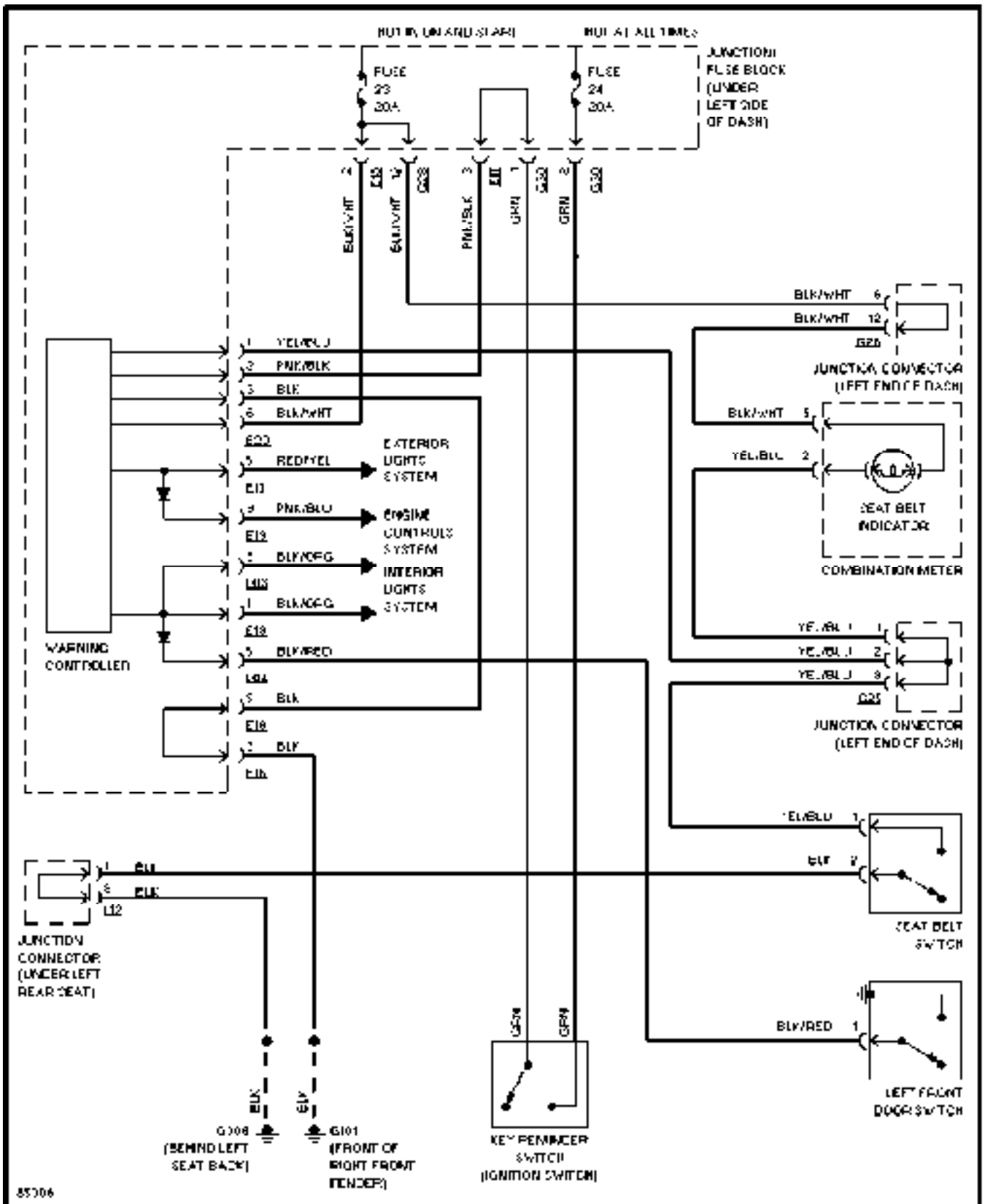

Warning System Circuits

## WIPER/WASHER



# SYSTEM WIRING DIAGRAMS

Article Text (p. 25)

1996 Suzuki Esteem

For

Copyright © 1998 Mitchell International

Tuesday, April 06, 1999 08:11AM

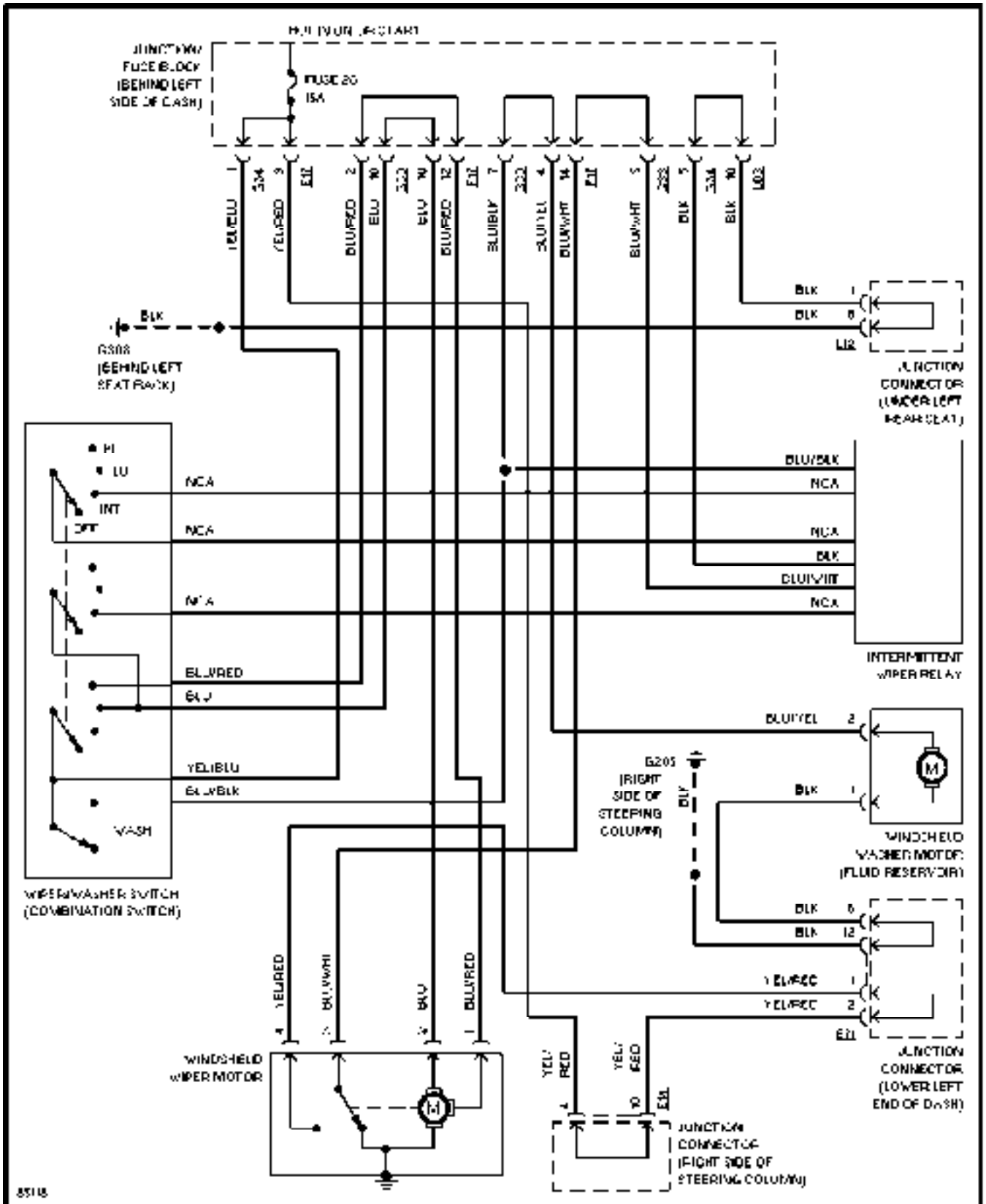

Wiper/Washer Circuit

END OF ARTICLE