

# Renault **KIGER**

Vehicle user manual





**RENAULT**  
Passion for life



# Castrol, exclusive Renault partner



Benefit from cutting-edge technology born out of competition to ensure the performance and longevity of your Renault thanks to wide range of engine lubricants developed specially by Renault and Castrol.

Renault recommends 

   [renault.com](https://www.renault.com)



# Welcome aboard your vehicle

---

**This vehicle user manual** contains the information necessary:

- for you to familiarise yourself with your vehicle, to use it to its best advantage and to benefit fully from all the functions and the technical developments it incorporates.
- to ensure that it always gives the best performance by following the simple, but comprehensive advice concerning regular maintenance.
- to enable you to deal quickly with minor faults not requiring specialist attention.

It is well worth taking a few minutes to read this manual to familiarise yourself with the information and guidelines it contains about the vehicle and its functions and new features. If certain points are still unclear, our authorised dealers will be pleased to provide you with any additional information.

The following symbol will help you when reading this manual.



and



These appear in the vehicle and indicate that you should consult the manual for detailed information and/or limits on operations with respect to your vehicle's equipment.

↪ anywhere in the manual indicates a transfer to a page.



**To indicate a hazard, danger or safety recommendation.**

The descriptions of the models given in this manual are based on the technical specifications at the time of writing. **This manual covers all items of equipment** (both standard and optional) **available for these models, but whether or not these are fitted to the vehicle depends on the version, options selected and the country where the vehicle is sold.**

**This manual may also contain information about items of equipment to be introduced later in the model year.**

**The diagrams in the user manual are provided as examples.**

Enjoy driving your new vehicle.

Translated from English. Copying or translation, in part or in full, is forbidden unless prior written permission has been obtained from the vehicle manufacturer.



## EXTERIOR

53076

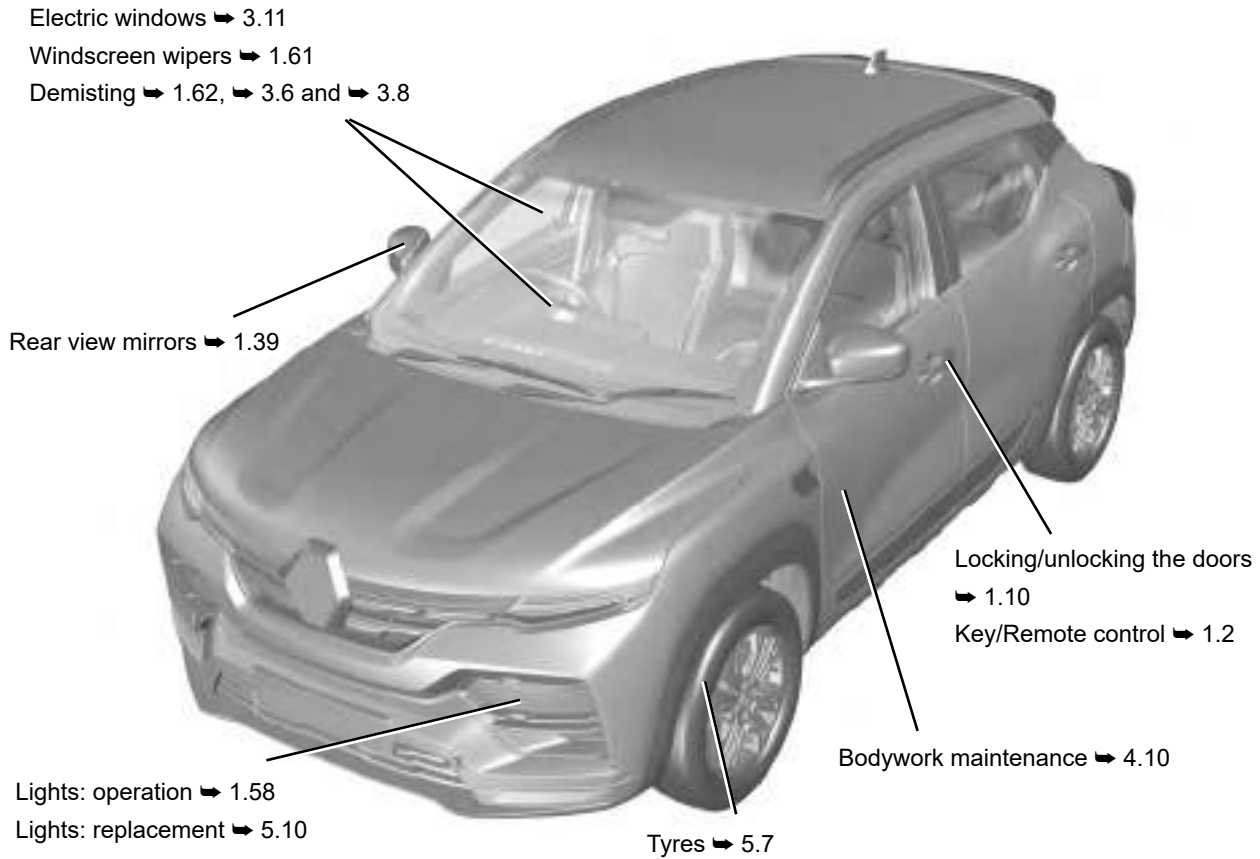

# PASSENGER COMPARTMENT

Passenger compartment storage/fit-  
tings ➔ 3.16

Adjusting your driving position ➔ 1.19

Rear headrest ➔ 3.19

Rear seat ➔ 3.20

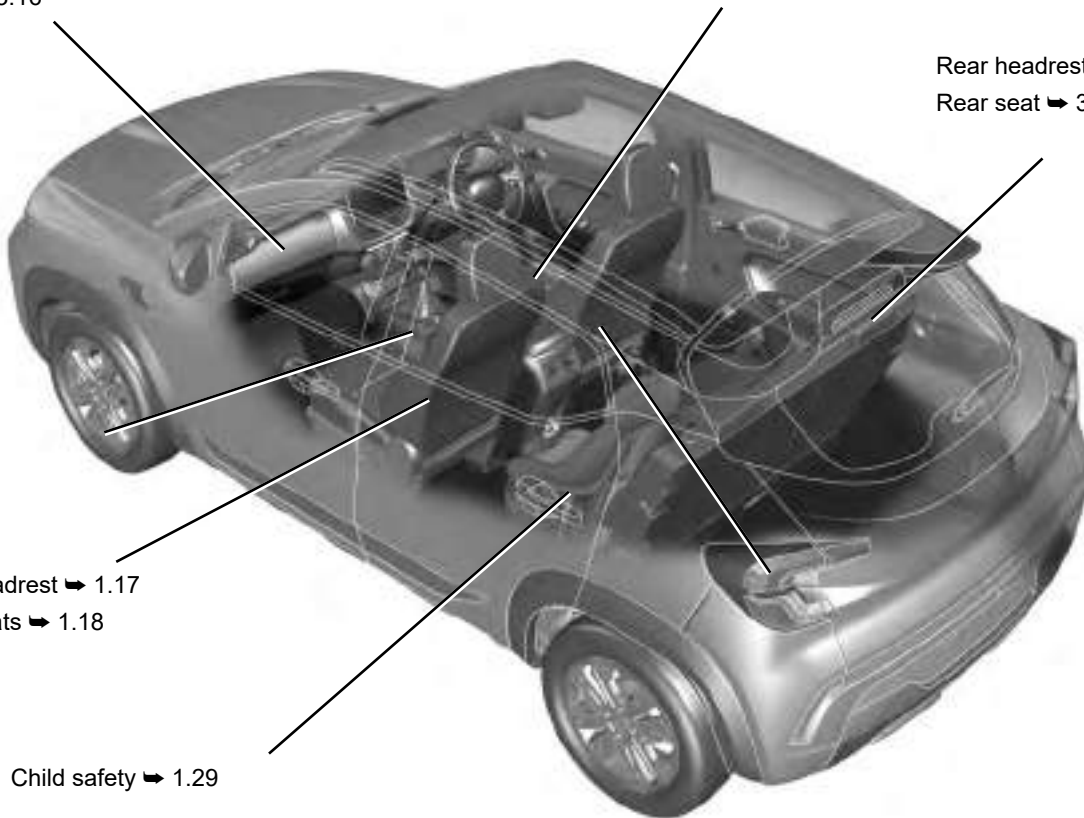

Front headrest ➔ 1.17

Front seats ➔ 1.18

Child safety ➔ 1.29

030011



# DRIVER'S POSITION

53678

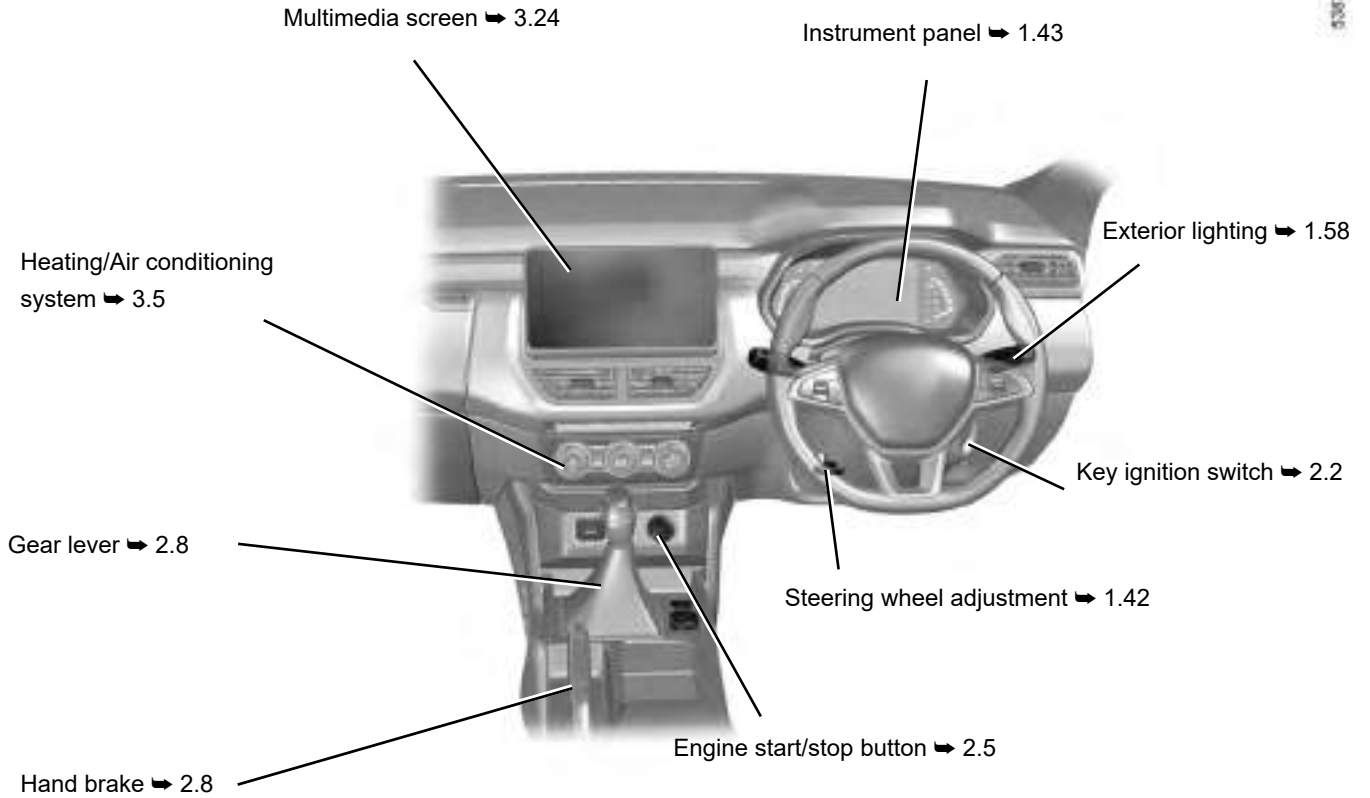

## DRIVING AIDS

ABS (anti-lock braking system)  
ESC (electronic stability control)  
Braking assistance  
↳ 2.10

Parking distance control ↳ 2.25



Reversing camera ↳ 2.27

## SAFETY ON BOARD

Front airbags → 1.22

Seat belts → 1.19

Side Airbags → 1.28

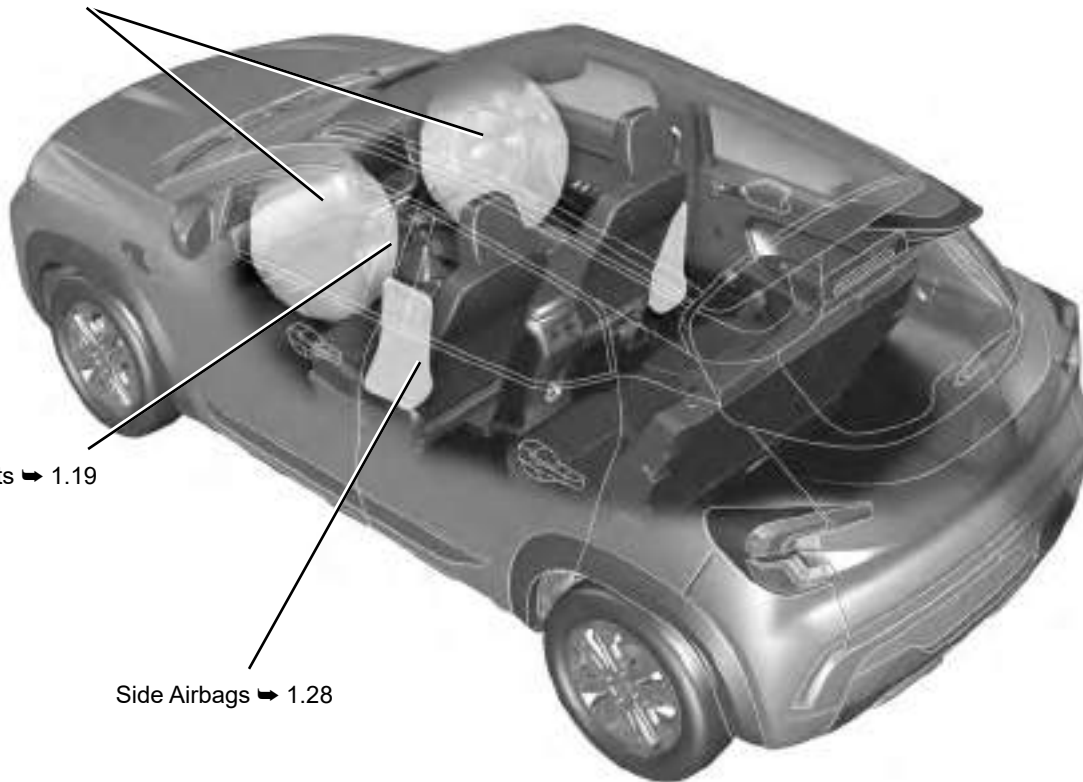



# IDENTIFYING A VEHICLE - LABELS

53677



Review of a vehicle identification number ➔ 6.2

Engine identification plate ➔ 6.3



Tyre pressure labels ➔ 4.9



# THE ENGINE COMPARTMENT (routine maintenance)

53661

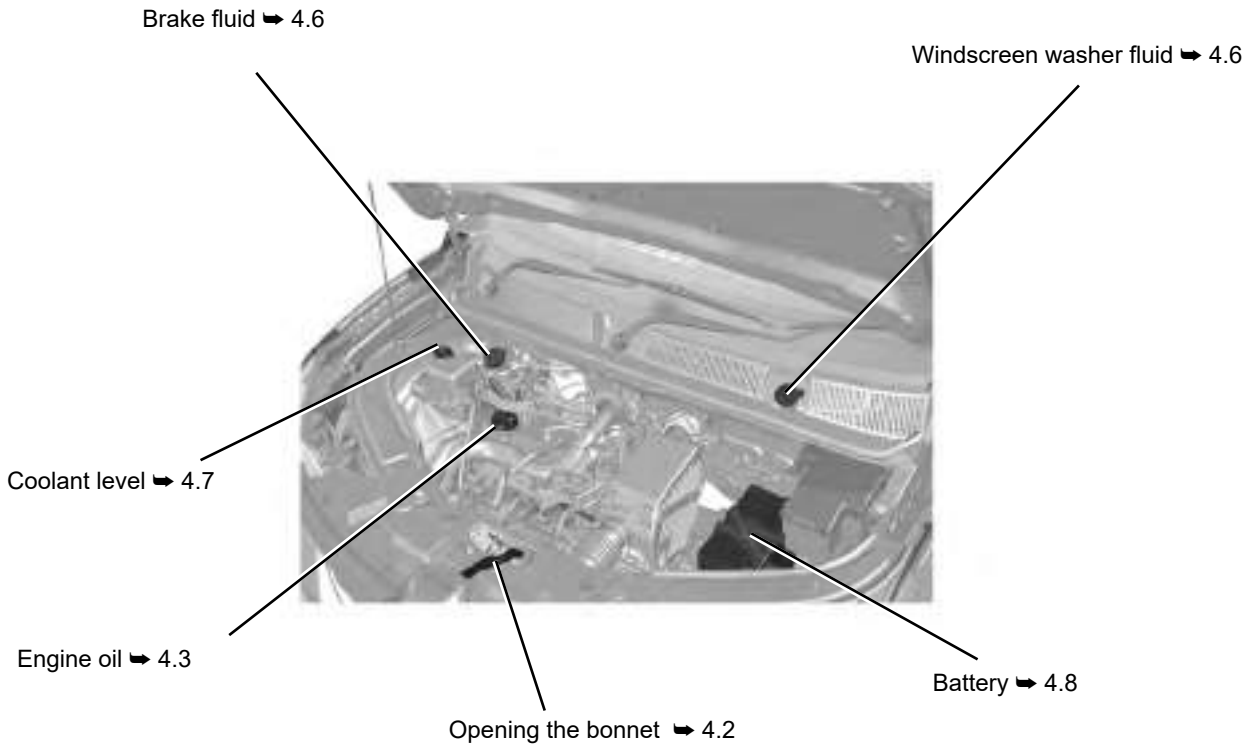

# BREAKDOWN RECOVERY

53182

Replacing front windscreen wiper blade(s) ➔ 5.23

Replacing headlight bulbs ➔ 5.10

Front towing point ➔ 5.24



Puncture ➔ 5.2

Tools ➔ 5.4

Emergency spare wheel ➔ 5.2

Changing a wheel ➔ 5.5

Replacing windscreen wiper blade(s) ➔ 5.23

Replacement of the rear lights ➔ 5.12

Fuses ➔ 5.13

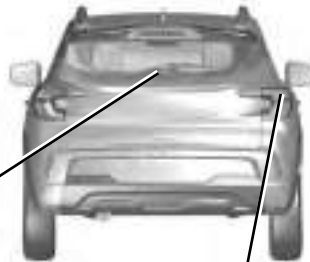

0.10



# C O N T E N T S

## Sections

**Getting to know your vehicle** .....

**1**

**Driving** .....

**2**

**Your comfort** .....

**3**

**Maintenance** .....

**4**

**Practical advice** .....

**5**

**Technical specifications** .....

**6**

**Alphabetical index** .....

**7**



0.12



# **Section 1: Getting to know your vehicle**

Keys, radio frequency remote control: general information . . . . .	1.2
Radio frequency remote control:use . . . . .	1.3
Hands free card:general information . . . . .	1.4
Hands free card:use . . . . .	1.6
Locking and unlocking the doors . . . . .	1.10
Automatic locking of doors . . . . .	1.13
Opening and closing the doors . . . . .	1.14
Engine Immobiliser . . . . .	1.16
Front headrests . . . . .	1.17
Front seats. . . . .	1.18
Seat belts. . . . .	1.19
Methods of restraint in addition to the front seat belts. . . . .	1.22
Side protection devices . . . . .	1.28
Child safety : general information . . . . .	1.29
Child safety : choosing a child seat mounting . . . . .	1.31
Child safety : fitting a child seat. . . . .	1.34
Child seats : attachment by the seat belt. . . . .	1.35
Child seats : attachment using the ISOFIX system . . . . .	1.37
Mirrors . . . . .	1.39
Driving Position - Right Hand Drive . . . . .	1.40
Steering wheel/Power assisted steering . . . . .	1.42
Warning lights . . . . .	1.43
Displays and indicators . . . . .	1.47
On-board computer . . . . .	1.52
Clock . . . . .	1.57
Exterior lighting and signals. . . . .	1.58
Headlight height adjustment . . . . .	1.59
Audible and visual signals . . . . .	1.60
Screen washer/wiper . . . . .	1.61
Fuel tank (filling with fuel) . . . . .	1.63



## KEYS, RADIO FREQUENCY REMOTE CONTROL: general information



### Key A

Depending on vehicle,

- 1 Coded key for ignition switch.



### Radio frequency remote control key B

Depending on vehicle,

- 2 Locks all doors.
- 3 Unlocks all doors.
- 4 Coded key for ignition switch.

### The remote control unit operating range

This varies according to the environment. It is therefore important when handling the remote control to ensure that you do not lock or unlock the vehicle by inadvertently pressing the buttons.

### Interference

The presence of certain objects (metal objects, mobile telephones, or an area with strong electromagnetic radiation, etc.) close to the key may create interference and affect the operation of the system.

### Replacement and additional keys or remote controls

If you lose your remote control key or require another, you can obtain one from an approved dealer.

If a remote control or key is replaced, it will be necessary to take the vehicle **and all of its remote control keys** to an authorised dealer to reset them.

You may use up to four remote control keys per vehicle.



### Driver's responsibility when parking or stopping the vehicle

Never leave an animal, child or adult who is not self-sufficient alone in your vehicle, even for a short time.

They may pose a risk to themselves or to others by starting the engine, activating equipment such as the electric windows or locking the doors, for example.

Also, in hot and/or sunny weather, please remember that the temperature inside the passenger compartment increases very quickly.

**RISK OF DEATH OR SERIOUS INJURY**



## RADIO FREQUENCY REMOTE CONTROL: use

44354



### Unlocking the doors

Press unlocking button **2**.

The hazard warning lights and side indicator lights **flash once** to indicate that the doors have unlocked.

If the vehicle has been unlocked but neither the doors nor tailgate are open, it locks again automatically after two minutes.

### Locking the doors

Press locking button **1**.

The hazard warning lights and side indicator lights **flash twice** to indicate that the doors have locked.

If a door or the tailgate is open or not properly shut, the doors and tailgate lock then quickly unlock and the hazard warning lights and side indicator lights do not flash.

The key must not be used for any function other than those described in the handbook (removing the cap from a bottle, etc.).



### Driver's responsibility when parking or stopping the vehicle

Never leave an animal, child or adult who is not self-sufficient alone in your vehicle, even for a short time.

They may pose a risk to themselves or to others by starting the engine, activating equipment such as the electric windows or locking the doors, for example.

Also, in hot and/or sunny weather, please remember that the temperature inside the passenger compartment increases very quickly.

### RISK OF DEATH OR SERIOUS INJURY

**Advice : Avoid leaving the remote control in hot, cold or humid areas.**

## CARD: general information (1/2)

43418



- 1 Unlocking the doors and tailgate.
- 2 Locking all doors and tailgate.
- 3 Unlocking/locking the tailgate.
- 4 Switching on the interior lighting remotely.

### The card is used for:

- locking/unlocking the opening elements (doors, tailgate);
- switching on the vehicle interior lighting (refer to the following pages);
- starting the engine (refer to the information on “Starting the engine -Vehicle with card” in Section 2).

### Battery life

Make sure that the correct battery type is being used, and that the battery is in good condition and inserted correctly. Its service life is approximately two years: replace it when the message “Keycard Battery Low” appears on the instrument panel (refer to section “Card: battery” in Section 5).

### Card operating range

This varies according to the environment: take care not to accidentally lock or unlock the vehicle by inadvertently pressing the buttons on the card.

**Note:** if a door or the tailgate is open or not closed properly, the doors and tailgate lock then unlock quickly.

### Interference

Interference by factors in the immediate vicinity (external installations or the use of equipment operating on the same frequency as the card) may disrupt its operation.

When the battery is flat, you can still lock/unlock and start your vehicle. Refer to the information on “Locking/unlocking the doors” in Section 1 and “Starting the engine” in Section 2.



## CARD: general information (2/2)

43418



### Distance lighting function

Pressing button **4** switches ON the interior lighting for approximately 20 seconds. This can be used, for example, to identify your vehicle from a distance when parked in a car park.

**Note:** Pressing button **4** again switches off the lighting.

### Advice

Avoid leaving the card in hot, cold or humid areas.

Do not keep the card in a place where it could be bent or damaged accidentally, such as in a back pocket of a garment.

### Replacement: need for an additional card

If you lose your card or require another, you can obtain one from an authorised dealer.

If a card is replaced, it will be necessary to take the vehicle **and all its cards** to an approved Dealer to re-set the system.

You may use up to four cards per vehicle.



### Driver's responsibility when parking or stopping the vehicle

Never leave an animal, child or adult who is not self-sufficient alone in your vehicle, even for a short time.

They may pose a risk to themselves or to others by starting the engine, activating equipment such as the electric windows or locking the doors, for example.

Also, in hot and/or sunny weather, please remember that the temperature inside the passenger compartment increases very quickly.

### RISK OF DEATH OR SERIOUS INJURY

## “HANDS-FREE” CARD: use (1/4)

There are two ways to unlock/lock the vehicle:

- the card in “hands-free” mode;
- the card in remote control mode.

Do not store the card anywhere it may come into contact with other electronic equipment (computer, phone etc.) as this could hinder its operation.

1.6



### Driver's responsibility when parking or stopping the vehicle

Never leave an animal, child or adult who is not self-sufficient alone in your vehicle, even for a short time.

They may pose a risk to themselves or to others by starting the engine, activating equipment such as the electric windows or locking the doors, for example.

Also, in hot and/or sunny weather, please remember that the temperature inside the passenger compartment increases very quickly.

### RISK OF DEATH OR SERIOUS INJURY

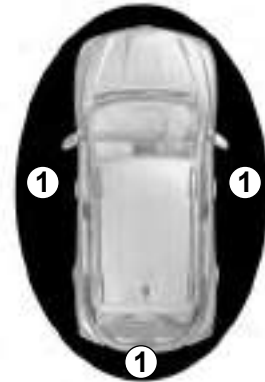

### Using the card in “hands-free” mode

In “hands-free” mode, it is possible to lock/unlock the vehicle without using any of the card buttons, as long as the card is within the access zone **1**.

**Note:** if the vehicle has not been used for more than 8 days, the hands-free system switches to standby. To reactivate it, press the unlocking button on the card.

## “HANDS-FREE” CARD: use (2/4)

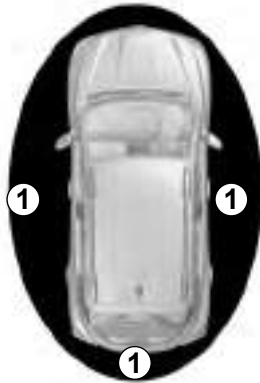

### “Hands-free” unlocking/Approach unlock

Vehicle will get unlocked when the customer enters into the access zone **1** with the card. Unlocking of the vehicle is indicated by one flash of the indicator lights and hazard warning lights.

### Remote “Hands-free” locking

With the card on you, and doors and tailgate closed, move away from the vehicle: it will lock automatically once you have left the access zone.

**Note:** The distance at which the vehicle locks depends on the surroundings.

Locking of the vehicle is indicated by one flash of the indicator lights and it lights up approximately for four seconds accompanied by a single beep sound.

### Special features of the locking system

If a door is open or not properly closed, when you go away, the vehicle will not get locked.

## “HANDS-FREE” CARD: use (3/4)



### Particular features of the locking system (continued)

If the card has been within range for approximately 15 minutes, remote locking is disabled.

The vehicle will not lock if a card is in area **2**. If you unlock the vehicle by pressing the button on the card but do not open the doors or the boot, “hands-free” remote locking is disabled.



### Using the card as a remote control

#### Unlocking with the card

Press button **3**.

Unlocking is indicated by **one flash** of the hazard warning lights and the indicator lights..

### Locking using the card

With the doors and boot closed, press button **4**. The vehicle will lock. The hazard warning lights and rear indicator lights **flash twice** to indicate that the vehicle is locked.

**Note:** The maximum distance at which the vehicle locks depends on the surroundings.

### Special features

If an opening element (a door or the luggage compartment) is open or not properly closed, the vehicle cannot be locked. The vehicle will lock/unlock in quick succession, but the hazard warning lights and the side indicator lights will not flash.

If you press button **4** for more than 5 seconds, “hands-free” mode is disabled until the next time you unlock the vehicle by pressing button **3**.

Activation or deactivation of “hands-free” mode is indicated by a beep.

The card buttons are deactivated when the engine is running.



## “HANDS-FREE” CARD: use (4/4)



If, **while the engine is running**, a door is opened and closed, and the card is no longer in the zone **2**, the message “Keycard Not Detected” indicates that the card is not inside the vehicle. This will, for example, prevent you from driving away after dropping off a passenger who has kept the card on them.

The warning disappears when the card is detected again.



### Locking/unlocking only the boot

Press the button **5** to lock/unlock the boot only.



### Driver’s responsibility when parking or stopping the vehicle

Never leave an animal, child or adult who is not self-sufficient alone in your vehicle, even for a short time.

They may pose a risk to themselves or to others by starting the engine, activating equipment such as the electric windows or locking the doors, for example.

Also, in hot and/or sunny weather, please remember that the temperature inside the passenger compartment increases very quickly.

**RISK OF DEATH OR SERIOUS INJURY**

## LOCKING AND UNLOCKING THE DOORS (1/3)

### If the remote control or, depending on the vehicle, the card does not work

In the below cases, the radio frequency remote control or the card may not work:

- card/radio frequency remote control battery worn or run flat, vehicle battery flat etc.
- use of appliances operating on the same frequency as the card (mobile phone, etc.);
- vehicle located in a high electromagnetic radiation zone.

It is then possible:

- depending on the vehicle, use the radio frequency remote control or the emergency key integrated in the card to unlock the front right-hand door;
- to lock each of the doors manually;
- to use the interior door locking/unlocking control (refer to the following pages).



### The card's built-in key

The integrated **2** key is used to lock or unlock the front right-hand door if the card does not work.



### Access with key 2

Slide the rear casing **1** downwards while pressing on zone **A**





## LOCKING AND UNLOCKING THE DOORS (2/3)



### Using the key integrated in the card

Insert the key **2** into the lock **3** and lock or unlock the front right-hand door.

Once you are inside the vehicle, put the key back in its casing in the card.

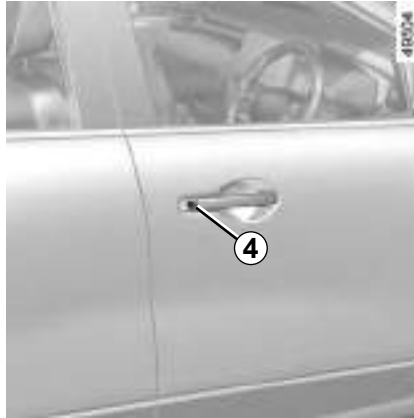

### Vehicles with key/remote control

#### From outside

Unlock the driver door using the key **4** into key barrel integrated in the front right-hand door handle.



#### From the inside

Push in button **5** to lock and lift button **5** to unlock. It is impossible to open the door if **5** is pushed in.



## LOCKING AND UNLOCKING THE DOORS (3/3)



### Electric central locking

If equipped, It simultaneously locks or unlocks all the doors and tail gate. Lock or unlock the doors by pressing switch **6**.

**Note:** if a door or the tailgate is open or not closed properly, the doors and tailgate gets unlock quickly.

### Locking the opening elements without the card or the key

For example, in the event of a discharged battery or the card or key temporarily not working etc.

**With the engine switched off and a door or tailgate open**, press and hold the **6** switch for more than five seconds.

When the door is closed, all the doors and the tailgate will be locked.

Unlocking the vehicle from the outside is only possible with the card in the vehicle access zone or by using the key.



### Driver's responsibility when parking or stopping the vehicle

Never leave an animal, child or adult who is not self-sufficient alone in your vehicle, even for a short time.

They may pose a risk to themselves or to others by starting the engine, activating equipment such as the electric windows or locking the doors, for example.

Also, in hot and/or sunny weather, please remember that the temperature inside the passenger compartment increases very quickly.

**RISK OF DEATH OR SERIOUS INJURY**



## AUTOMATIC LOCKING OF DOORS



### Operating principle

After the vehicle is started, the system automatically locks the doors when you are driving at approximately 10km/h (6mph) and over.

The door can be unlocked

- by pressing the button **1** to unlock the doors;.
- by opening a front door (vehicle stationary).

### Activating/deactivating the function

With the engine running, press the button **1** for approximately 5 seconds, until you hear a warning beep.

### Operating faults

If you experience an operating fault (no automatic locking, the indicator light incorporated in button **1** does not light up when trying to lock the opening elements, etc.), first check that the opening elements are properly closed.

If they are properly closed, contact an authorised dealer.

If a door is opened or closed, it will automatically lock again when the vehicle reaches a speed of 10 km/h (6 mph)



### Driver's responsibility

If you decide to keep the doors locked when you are driving, remember that it may be more difficult for those assisting you to gain access to the passenger compartment in the event of an emergency.

## OPENING AND CLOSING THE DOORS (1/2)



### Opening the doors from the outside

With the doors unlocked (refer to the information on “Locking/unlocking the doors” in Section 1), place your hand on the handle **1** and pull towards you.

#### Special note

Depending on the vehicle, accessories (e.g. radio) stop working either when the engine is switched off or when the doors are locked.

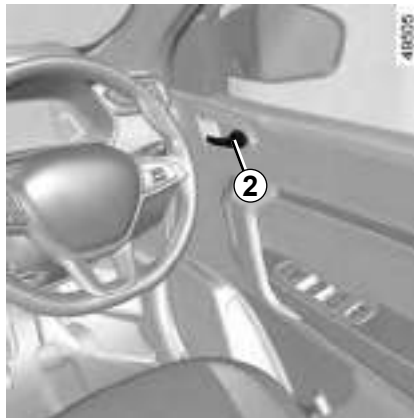

### Opening from the inside

Pull handle **2**.

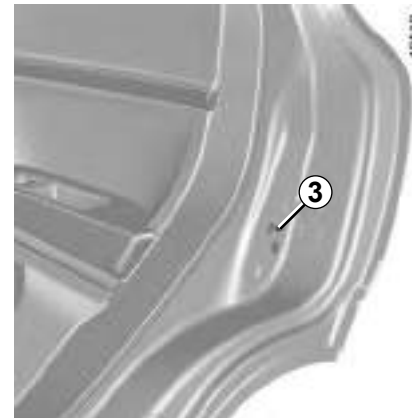

### Child safety

If equipped, this feature is to make it impossible for the rear doors to be opened from the inside, move lever **3** in the direction indicated on each rear door and check from the inside that the doors are securely locked.



As a safety precaution, the doors should only be opened or closed when the vehicle is stationary.



## OPENING AND CLOSING THE DOORS (2/2)

### Lights-on reminder buzzer

If you have left the lights on after switching off the ignition, a warning buzzer will sound when a front door is opened (to prevent the battery from discharging, etc.).

### Door/tailgate open buzzer

Depending on the vehicle, this alarm is fitted to the driver's side door or on all opening elements.

With the vehicle at a standstill, a warning light  will come on if any of the door or the boot is open or not properly closed.

While driving, as soon as the vehicle reaches 20 km/h (12 mph), a warning light  comes on with an audio beep.

### Special note

Depending on the vehicle, accessories (e.g. radio) stop working either when the engine is switched off or when the driver's door is opened or when the doors are locked.



### Driver's responsibility when parking or stopping the vehicle

Never leave an animal, child or adult who is not self-sufficient alone in your vehicle, even for a short time.

They may pose a risk to themselves or to others by starting the engine, activating equipment such as the electric windows or locking the doors, for example.

Also, in hot and/or sunny weather, please remember that the temperature inside the passenger compartment increases very quickly.

### RISK OF DEATH OR SERIOUS INJURY

## ENGINE IMMOBILISER

(Depends on vehicle)

**Engine Immobiliser prevents the vehicle from being driven by anyone not in possession of the vehicle's coded ignition key.**

### Operating principle

The vehicle is automatically protected a few seconds after the ignition is switched off.

If the vehicle does not recognise the coded ignition key or wrong key is used, the engine cannot be started.

### System operation

When the ignition is switched on, the vehicle has recognised the code. You can then start the engine.

### Vehicle protection

The vehicle will only be protected after the ignition has been switched off.

### Operating faults

After the ignition has been switched on, if warning light  continues to flash or remains continuously lit, there is a system operating fault.

**In all cases, it is essential to contact an approved dealer as they are qualified to repair the engine immobiliser.**

**If the coded ignition key is faulty, use the second key (supplied with the vehicle).**



Any unauthorised work carried out on the engine immobiliser (computers, wiring, etc.) could be dangerous. Work must be carried out by qualified personnel.



### Driver's responsibility when parking or stopping the vehicle

Never leave an animal, child or adult who is not self-sufficient alone on your vehicle, even for a short time.

They may pose a risk to themselves or to others by starting the engine, activating equipment such as the electric windows or by locking the doors.

Also, in hot and/or sunny weather, please remember that the temperature inside the passenger compartment increases very quickly.

**RISK OF DEATH OR SERIOUS INJURY.**



## FRONT HEADREST



### To raise the headrest

Pull the headrest upwards to the desired height.

### To lower the headrest

Press button **1** and guide the headrest down to the desired height.



### To remove the headrest

Press button **1** and lift the headrest to release it (tilt the seatback backwards, if necessary).

### To refit the headrest

Insert the rods into the sleeves, with the notches facing forwards, and lower the headrest to the desired height. Ensure that it is correctly locked.



The headrest is a safety component. Ensure that it is fitted and in the correct position: the top of your head should be in line with the top of the headrest.

## FRONT SEATS

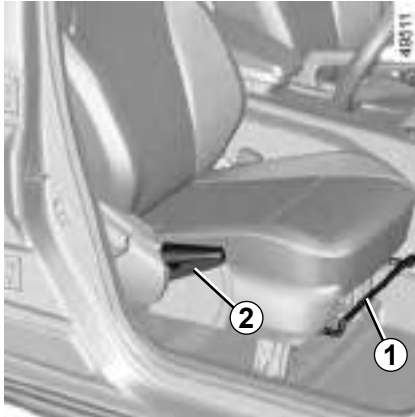

### Move forward or backward

Lift the lever **1** to move the seat forward or backward. Release the lever **1** in desired position of seat and ensure that the seat is fully locked into place.

### To adjust the seat height

Lift the knob **2** upward to adjust the seat height and release the knob in the desired height. Ensure seat is locked properly after release.

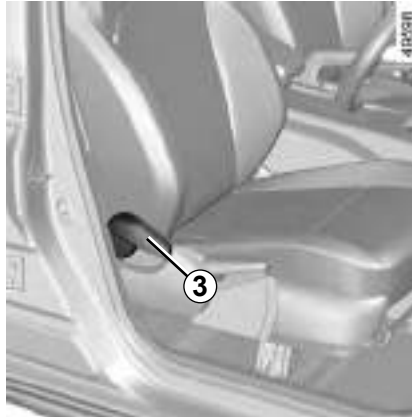

### To tilt the seatback

Lift the knob **3** upward to unlock recliner mechanism. Tilt the seat back to desired position and release knob. Ensure seat back is locked properly after release.



For safety reasons, carry out any adjustments when the vehicle is not being driven.

We would advise you not to recline the seatbacks too far to ensure that the effectiveness of the seat belts is not reduced. Nothing should be placed on the floor (area in front of driver) as such objects may slide under the pedal during braking manoeuvres, thus obstructing its use.





## SEAT BELTS (1/3)



### Adjusting the seat belts

Sit with your back firmly against the seatback.

The shoulder strap **1** should be as close as possible to the base of the neck but not on it.

Lap belt **2** must be worn flat over the thighs and against the pelvis. The seat belt must be worn as close to the body as possible. i.e.: avoid wearing heavy clothing or keeping bulky objects under the belts, etc. **Before starting, first adjust your driving position, then ask all occupants to adjust their seat belts to ensure optimum protection.**

### Adjusting your driving position (depending on the vehicle)

- **Sit well back in your seat** (having removed your coat or jacket etc.). This is essential to ensure your back is positioned correctly.
- **adjust the distance between the seat and the pedals.** Your seat should be as far back as possible while still allowing you to depress the clutch pedal fully. The seatback should be adjusted so that your arms are slightly bent when you hold the steering wheel.

Always wear your seat belt when travelling in your vehicle. You must also comply with the legislation of the particular country you are in. Make sure that the rear bench seat is locked in correct position so that the rear seat belts will operate efficiently. Refer to the information on the Seats in Section 1.



Incorrectly adjusted or twisted seat belts may cause injuries in the event of an accident.

Use one seat belt per person, whether child or adult.

Even pregnant women should wear a seat belt. In this case, ensure that the lap belt is not exerting too much pressure on the abdomen, but do not allow any slack.



- Ensure that no objects are placed in the area around the seat belt latch as they could prevent it from being properly secured.

- Make sure the seat belt latch is properly positioned (it should not be hidden away, crushed or flattened by people or objects).

## SEAT BELTS (2/3)



### To fasten

Unwind the belt **slowly and smoothly** and ensure that buckle **5** locks into latch **3** (check that it is locked by pulling on buckle **5**).

If the belt jams, allow it to return slightly before attempting to unwind it again.

If your seat belt is completely jammed, pull slowly, but firmly, so that just over 3 cm unwinds. Allow it to return slightly before attempting to unwind it again. If there is still a problem, contact an approved dealer.



### Unlocking

Press the button **4** on buckle **5** and the seat belt will be rewound by the inertia reel. Hold by the buckle to make this easier.

### Seat belt reminder light

Depending on the vehicle, it comes on in the cluster when the ignition is ON and goes off after few seconds and if the driver's and/or passenger's seat belt is not fastened. When the vehicle is being driven, it comes on and a beep sounds for approximately 2 minutes until the driver's/passenger seat belt is fastened.

**Note:** an object placed on the passenger seat base may activate the warning light in some cases.



– No modification may be made to the component parts of the originally fitted restraint system: seat belts, seats and their mountings. For special operations (e.g. fitting child seats), contact an authorised dealer.

- Do not use devices which allow any slack in the belts (e.g. clothes pegs, clips, etc.): a seat belt which is worn too loosely may cause injury in the event of an accident.
- Never wear the shoulder strap under your arm or behind your back.
- Never use the same belt for more than one person and never hold a baby or child on your lap with your seat belt around them.



## SEAT BELTS (3/3)

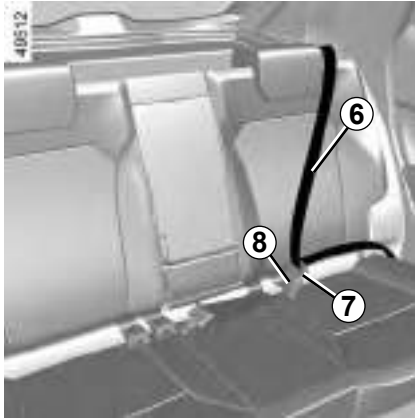

### Adjusting the second row side seat belts

Slowly unwind belt **6** and click latch **7** into red buckle **8**. In all cases, check that the seat belts are operating correctly.

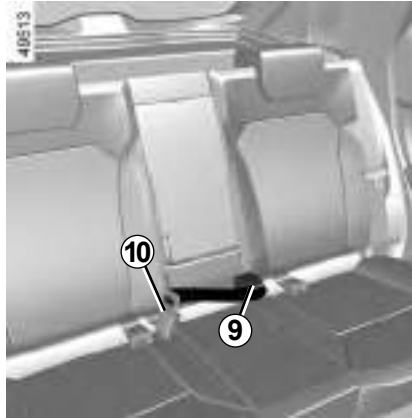

### Adjusting the second row centre seat belts (depending on vehicle)

Fasten sliding latch **9** into the red buckle **10**.



- The belt should never be twisted.
- Following an accident, have the seat belts checked and replaced. If necessary, always replace your seat belts as soon as they show any signs of wear.
- Make sure that the buckle is inserted into the appropriate latch.

## METHODS OF RESTRAINT IN ADDITION TO THE FRONT SEAT BELTS (1/6)

Depending on the vehicle, they will consist of:

- **seat belt inertia reel pretensioners;**
- **chest-level load limiters;**
- **air bags for driver and front passenger.**

These systems are designed to act independently or together when the vehicle is subjected to a frontal impact.

Depending on the severity of the impact, the system can trigger:

- seat belt locking;
- the seat belt inertia reel pretensioner (which engages to correct seat belt slack);
- airbags.

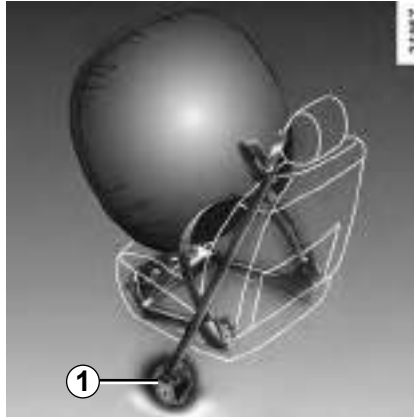

### Pretensioners

The pretensioners (in driver side) hold the seat belt against the body, holding the occupant more securely against the seat, thus increasing the seat belt's efficiency.

With the ignition on, following a significant frontal impact and depending on the severity of the impact, the system may trigger the seat belt inertia reel pretensioner **1**, which instantly retracts the seat belt.



- Have the entire restraint system checked following an accident.
- No operation whatsoever is permitted on any part of the system (pretensioners, air bags, computers, wiring) and the system components must not be reused on any other vehicle, even if identical.
- To avoid incorrect triggering of the system which may cause injury, only qualified personnel from an approved Dealer may work on the pretensioner and air bag system.
- The electric trigger system may only be tested by a specially trained technician using special equipment.
- When the vehicle is scrapped, contact an approved Dealer for disposal of the pretensioner and air bag gas generators.



## METHODS OF RESTRAINT IN ADDITION TO THE FRONT SEAT BELTS (2/6)

### Load limiter

Above a certain severity of impact, this mechanism is used to limit the force of the belt against the body so that it is at an acceptable level.

### Airbags for driver and front passenger

Fitted to the driver and passenger side.

The presence of this equipment is indicated by the word "Air bag" on the steering wheel and dashboard (air bag zone **A**) and, depending on the vehicle, a symbol on the lower section of the windscreen.

Each air bag system consists of:

- an air bag and gas generator fitted on the steering wheel for the driver and in the dashboard for the front passenger;
- an electronic unit for system monitoring which controls the gas generator electrical trigger system;
- a single  warning light on the instrument panel.



The air bag system uses pyrotechnic principles. This explains why, when the air bag inflates, it will generate heat, produce smoke (this does not mean that a fire is about to start) and make a noise upon detonation. In a situation where an air bag is required, it will inflate immediately and this may cause some minor, superficial grazing to the skin or other problems.

## METHODS OF RESTRAINT IN ADDITION TO THE FRONT SEAT BELTS (3/6)



### Operation

This system is only operational when the ignition is switched on.

In a severe **frontal** impact, the air bags inflate rapidly, cushioning the impact of the driver's head and chest against the steering wheel and of the front passenger against the dashboard. The air bags then deflate immediately so that the passengers are not in any way hindered from leaving the vehicle.

### Operating faults

This warning light  will light up on the instrument panel when the ignition is switched on and then go out after a few seconds.

If it does not light up when the ignition is switched on, or comes on when the engine is running, there is a fault in the system.

Contact your approved Dealer as soon as possible. Your protection will be reduced until this fault is rectified.



## METHODS OF RESTRAINT IN ADDITION TO THE FRONT SEAT BELTS (4/6)

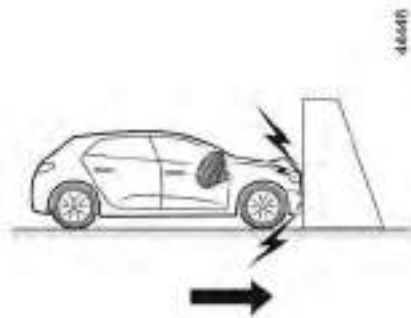

**The following cases cause the pretensioners or airbags to operate.**

**In a frontal impact** against a rigid (non-deformable) surface at an impact speed equal or greater than **25 km/h (16 mph)**

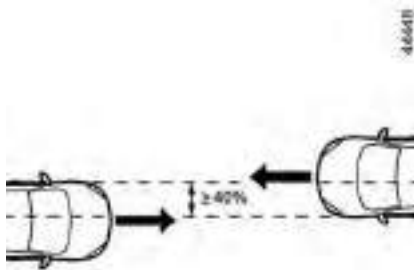

**In a frontal impact** with another vehicle of an equivalent or higher category, with an impact area equal to or greater than 40%, where the speed of both vehicles is equal or greater than **40 km/h (25 mph)**.

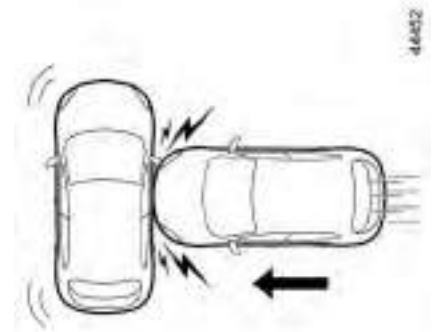

**In a side impact** with another vehicle of an equivalent or higher category, at an impact speed equal to or greater than **50 km/h (31 mph)**.

## METHODS OF RESTRAINT IN ADDITION TO THE FRONT SEAT BELTS (5/6)



**In the following examples, the pre-tensioners and airbags could operate:**

- impacts to the underside of the vehicle from kerbs, for example;
- potholes;
- a fall or a hard landing;
- stones;

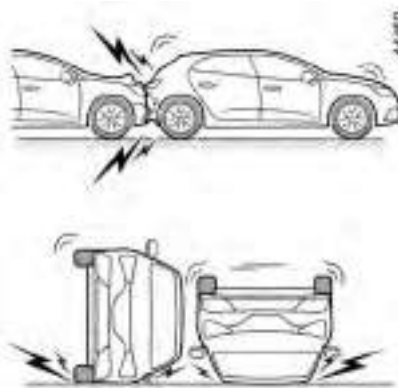

**In the following examples, the pre-tensioners and airbags might not operate:**

- in the event of a rear impact, however severe;
- if the vehicle overturns;

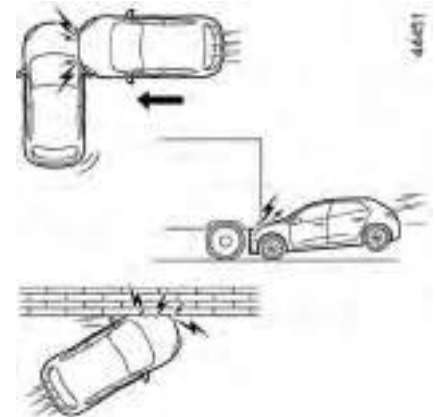

- in the event of a side impact, affecting the front of the vehicle;
- in the event of a frontal impact, under the tail of a lorry;
- in the event of a frontal impact against an obstacle with a sharp angle;



## METHODS OF RESTRAINT IN ADDITION TO THE FRONT SEAT BELTS (6/6)

All of the warnings below are given so that the air bag is not obstructed in any way when it is inflated and also to prevent the risk of serious injuries caused by items which may be dislodged when the air bag inflates.



### **Warnings concerning the driver's air bag**

- Do not modify the steering wheel or the steering wheel boss.
- Do not cover the steering wheel boss under any circumstances.
- Do not attach any objects (badge, logo, clock, telephone holder, etc.) to the steering wheel boss.
- The steering wheel must not be removed (except by qualified personnel from our Network).
- When driving, do not sit too close to the steering wheel. Sit with your arms slightly bent (see the information on “Adjusting your driving position” in Section 1). This will allow sufficient space for the air bag to deploy correctly and be fully effective.

### **Warnings concerning the passenger air bag**

- Do not attach or glue any objects (badge, logo, clock, telephone holder, etc.) to the dashboard on or near the air bag.
- Do not place anything between the dashboard and the passenger (pet, umbrella, walking stick, parcels, etc.).
- The passenger must not put his or her feet on the dashboard or seat as there is a risk that serious injuries may occur. In general, parts of the body should be kept away from the dashboard (knees, hands, head, etc.).
- The devices in addition to the front passenger seat belt should be reactivated as soon as a child seat is removed, to ensure the protection of the passenger in the event of an impact.

**A REAR-FACING CHILD SEAT MUST NOT BE FITTED TO THE FRONT PASSENGER SEAT**

## SIDE PROTECTION DEVICES

### Side Airbags

Depending on vehicle, these airbags may be fitted at the sides of the front seats and are deployed at the sides of the seats (door side) to protect the occupants in the event of a severe side impact.

Depending on the vehicle, a marking on the seat side trims informs you of the presence of additional means of restraint (air bags, pretensioners, etc.) in the passenger compartment.



### Warnings concerning the side air bag

- **Fitting seat covers:** seats equipped with an airbag require covers specifically designed for your vehicle. Contact an authorised dealer to find out if these covers are available. The use of any covers other than those designed for your vehicle (including those designed for another vehicle) may affect the operation of the airbags and reduce your protection.
- In the front, do not place any accessories, objects or even pets between the seatback, the door and the internal fittings. Do not cover the seatback with objects such as clothes or accessories. This may prevent the airbag from operating correctly or cause injury when the airbag is deployed.
- No work or modification whatsoever may be carried out on the seat or internal fittings, except by qualified personnel from an approved dealer.



## CHILD SAFETY: general information (1/2)

### Carrying children

Children, and adults, must be correctly seated and strapped in for all journeys. The children being carried in your vehicle are your responsibility.

A child is not a miniature adult. Children are at risk of specific injuries as their muscles and bones have not yet finished growing. The seat belt alone would not provide suitable protection. Use an approved child seat and ensure you use it correctly.

CHILD RESTRAINT SEAT provision is given in Rear Left seat belt.



To prevent the doors being opened, use the childproof locks (refer to the information on “Locking/unlocking the doors” in Section 1).



A collision at 50 km/h is the same as falling a distance of 10 metres. Transporting a child without a restraint is the equivalent of allowing him or her to play on a fourth floor balcony without railings.

Never travel with a child held in your arms. In the event of an accident, you will not be able to keep hold of the child, even if you yourself are wearing a seat belt.

If your vehicle has been involved in a road accident, replace the child seat and have the seat belts and fittings checked.

It is recommended that children and infants are seated in child restraint. You choose a child restraint that fits your vehicle. Always follow the manufacturer's instruction for installation and use. In addition there are many types of child restraint available for larger children that should be used for maximum protection.

## CHILD SAFETY: general information (2/2)

### Using a child seat

The level of protection offered by the child seat depends on ability to restrain child and on its installation. Incorrect installation risks the protection of the child in the event of harsh braking or an impact.

Before purchasing a child seat, check that it complies with the regulations and that it can be fitted in your vehicle. Consult an approved dealer to find out which seats are recommended for your vehicle. Before fitting a child seat, read the manual and respect its instructions. If you experience any difficulties during installation, contact the manufacturer of the equipment. Keep the instructions with the seat.

Set a good example by always fastening your seat belt and teaching your child:

- to strap themselves in correctly.
- to always get in and out of the car at the kerb, away from busy traffic.

Do not use a second-hand child seat or one without an instruction manual.

Check that there are no objects in the vicinity of the child seat which could impede its operation.



Never leave a child unattended in the vehicle. Check that your child is always strapped in and that the belt or safety harness used is correctly set and adjusted. Avoid wearing bulky clothing which could cause the belts to slacken.

Never let your child put their head or arms out of the window.

Check that the child is in the correct position for the entire journey, especially if asleep.



## CHILD SAFETY: CHOOSING A CHILD SEAT MOUNTING (1/3)

There are two ways of attaching child seats: via the seat belt or using the ISOFIX system.

### Attachment via the seat belt

The seat belt must be adjusted to ensure that it is effective in the event of harsh braking or an impact.

Ensure that the strap paths indicated by the child seat manufacturer are respected.

Always check that the seat belt is correctly fastened by pulling it up, then pulling it out fully whilst pressing on the child seat.

Check that the seat is correctly held by moving it from side to side and back to front: the seat should remain firmly fixed.

Check that the child seat has not been installed at an angle and that it is not resting against a window.



Before using an ISOFIX child seat that you purchased for another vehicle, check that its installation is authorised. Consult the list of vehicles which can be fitted with the seat from the equipment manufacturer



The seat belt must never be twisted or the tension relieved. Never pass the shoulder strap under the arm or behind the back. Check that the seat belt has not been damaged by sharp edges. If the seat belt does not operate normally, it will not protect the child. Consult an approved dealer. Do not use this seat until the seat belt has been repaired.

### Attachment using isofix system

Authorised ISOFIX child seats are approved in accordance with regulation ECE-R44 in one of the three following cases

- ISOFIX universal 3-point forward-facing seat
- ISOFIX semi-universal 2-point seat;.
- specific.

For the latter two, check that your child seat can be installed by consulting the list of compatible vehicles.

Attach the child seat with the ISOFIX locks, if these are provided. The ISOFIX system allows quick, easy, safe fitting. The ISOFIX system consists of 2 rings and, in some cases, a third ring.

## CHILD SAFETY: CHOOSING A CHILD SEAT MOUNTING (2/3)

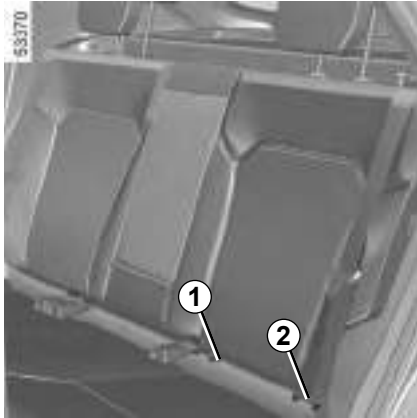

The two rings **1** and **2** are located between the seatback and the seat base of the seat and are identified by a marking.

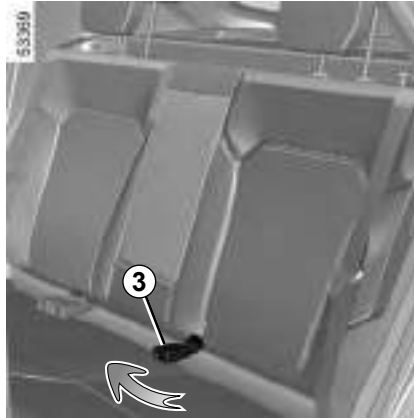

Before installing an ISOFIX seat in the rear at the side, please ensure that you have retracted the seat belt buckle **3** between the seatback and the seat base to give access to the lock **1**. Make sure that the seat is correctly fitted to the locks **1** and **2**.

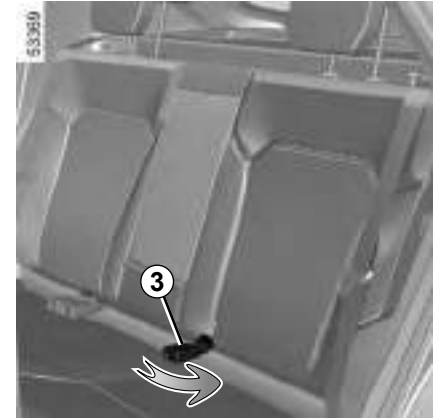

**Note:** if you remove the ISOFIX seat, remember to take out and reposition the seat belt buckle **3**.



No modifications may be made to the component parts of the restraint system (seat belts, ISOFIX and seats and their mountings) originally fitted.



## CHILD SAFETY: CHOOSING A CHILD SEAT MOUNTING (3/3)

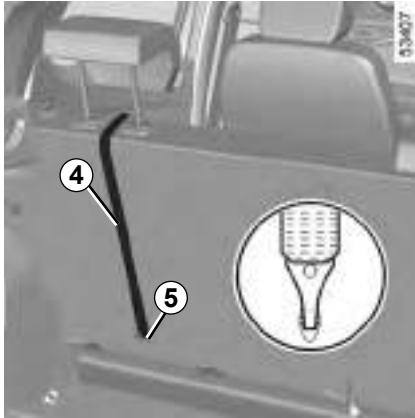

The third ring **5** is used to attach the upper strap on some child seats. The **4** belt should be positioned between the seatback and the rear parcel shelf. To do this, remove the rear parcel shelf (refer to the information on the "Rear parcel shelf" in Section 3). Attach the hook to one of the **5** rings, identified using the  symbol.

Pull the belt **4** so that the back of the child seat comes into contact with the vehicle seatback.



The ISOFIX anchorage points have been exclusively designed for child seats with the ISOFIX system. Never fit a different type of child seat, seat belt or other objects to these anchorage points. Check that nothing is obstructing the anchorage points. If your vehicle has been involved in a road accident, have the ISOFIX anchorage points checked and replace your child seat.



Do not use the child seat if it may unfasten the seat belt restraining it: the base of the seat must not rest on the buckle and/or catch of the seat belt.



It is imperative to attach the child seat strap to the corresponding ring. You must not use any other fixing point



Check that the seatback of the forward-facing child seat is in contact with the seatback of the vehicle seat. In this case, the child seat may not always rest on the seat base of the vehicle seat.

## CHILD SAFETY: FITTING A CHILD SEAT: General information

Some seats are not suitable for fitting child seats. The diagram on the following page shows you how to attach a child seat.

The types of child seats indicated may not be available. Before using a different child seat, check with the manufacturer that it can be fitted.



Fit the child seat in a rear seat wherever possible.

Make sure the child seat or the child's feet do not prevent the front seat from locking correctly.

Check that when installing the child seat in the vehicle it is not at risk of coming loose from its base.

If you have to remove the headrest, check that it is correctly stored so that it does not come loose under harsh braking or impact.

Always attach the child seat to the vehicle even if it is not in use so that it does not come loose under harsh braking or impact.

### In the rear side seat

A carrycot can be installed across the vehicle and will take up at least two seats. Position the child with his or her feet nearest the door.

Before fitting a child seat to the ISOFIX anchorages on the rear side seat, ensure that the seat belt buckles are not positioned between the two ISOFIX anchorages on this seat. If necessary, move the buckle from the seat in question towards the centre of the vehicle.

Move the front seat as far forward as possible to install a rear-facing child seat, then move back the seat in front as far as it will go, although without allowing it to come into contact with the child seat.

For the safety of the child in the forward-facing seat, do not move the seat in front back past the middle of the runner, do not tilt the seatback too far (maximum of 25°) and raise the seat as much as possible.



Ensure that the child seat or the child's feet do not prevent the front seat from locking correctly.

Refer to the information on the "Front seats" in Section 1.



### IMPORTANT

Since front passenger airbag triggering and the position of a rear-facing child seat are incompatible, NEVER use a rear-facing child restraint on a seat with an airbag.

**The airbag could cause SERIOUS OR FATAL INJURY if inflated.**



## CHILD SEATS: ATTACHMENT BY THE SEAT BELT (1/2)

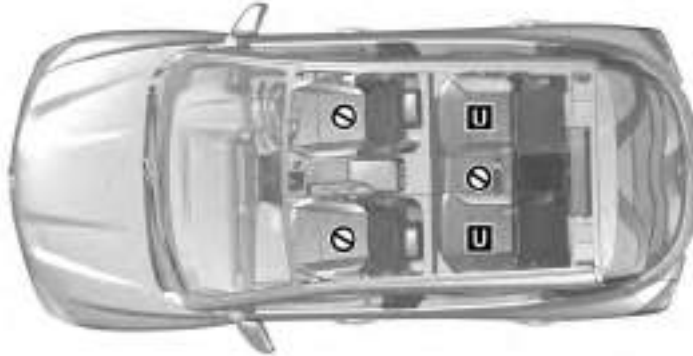

**RISK OF DEATH OR SERIOUS INJURY:** before fitting a rear-facing child seat on the front passenger seat, check that the airbag has been deactivated (please refer to the information on “Child safety: front passenger airbag deactivation, activation” in Section 1).



Using a child safety system which is not approved for this vehicle will not correctly protect the baby or child. They risk serious or even fatal injury.

### Child seat attached using the belt

**U** Seat which allows a child seat with “Universal” approval to be attached by a seat belt.

**X** Seat not suitable for fitting child seats.

## CHILD SEATS: ATTACHMENT BY THE SEAT BELT (2/2)

The table below summarises the information already shown in the diagram on the previous pages, to ensure the applicable regulations are respected.

Seating Position					
Mass Group	Weight of the child	Front passenger seat	Second row seats		
			LEFT	RIGHT	CENTRE
Group 0	Upto 10 kg	X	U	U	X
Group 0+	Upto 13 kg	X	U	U	X
Group I	9 to 18 kg	X	U	U	X
Group II	15 kg to 25 kg	X	U	U	X
Group III	22 kg to 36 kg	X	U	U	X

**X** = Seat not suitable for fitting child seats.

**U** = Seat which allows a child seat with “Universal” approval to be installed using a seat belt; check that it can be fitted.



## CHILD SEATS: attachment using the ISOFIX system (1/2)

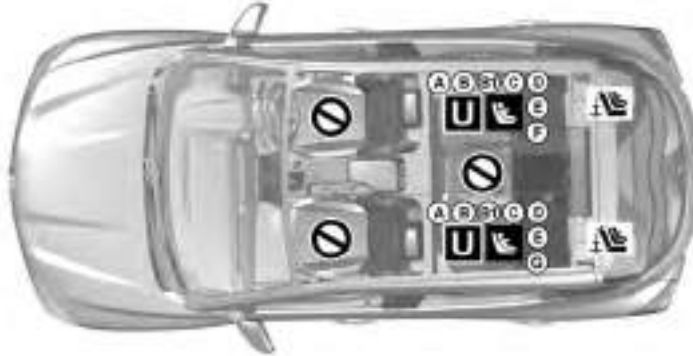

Seat not suitable for fitting child seats.



Seat which allows a child seat



Using a child safety system which is not approved for this vehicle will not correctly protect the baby or child. They risk serious or even fatal injury.

**Child seat attached using the ISOFIX system**

**(depending on the vehicle)**



Seat which allows an ISOFIX child seat to be attached.



The rear seats are fitted with an anchorage point which allows a forward-facing ISOFIX child seat with universal approval to be attached. The anchorage points are located on the backs of the rear seats.

The size of the ISOFIX child seat is indicated by a letter:

- A, B and B1: for forward-facing seats in group 1 (9 to 18 kg);
- C and D: shell seat or rear-facing seats in group 0+ (less than 13 kg) or group 1 (9 to 18 kg);
- E: rear-facing seats in group 0 (less than 10 kg) or 0+ (less than 13 kg);
- F and G: cots in group 0 (less than 10 kg).

## CHILD SEATS: attachment using the ISOFIX system (2/2)

The table below summarises the information already shown on the diagram on the previous page, to ensure the regulations in force are respected.

Type of child seat	Weight of the child	Seat size ISOFIX	Front passenger seat	Rear side seats	Rear centre seat
<b>Carrycot fitted across the vehicle</b> Group 0	< 10 kg	F, G	X	X	X
<b>Rear-facing seat</b> Groups 0 or 0 +	< 10 kg and < 13 kg	E	X	IL (1)	X
<b>Rear-facing seat</b> Groups 0+ and 1	< 13 kg and 9 to 18 kg	C, D	X	IL (1)	X
<b>Forward-facing seat</b> Group 1	9 to 18 kg	A, B, B1	X	IUF - IL (2)	X
<b>Booster seat</b> Groups 2 and 3	15 to 25 kg and 22 to 36 kg		X	IUF - IL (2)	X

**X** = Seat not suitable for fitting child seats ISOFIX.

**IUF/IL** = On equipped vehicles, seat which allows a child seat with "Universal/Semi-universal or vehicle specific" approval to be fitted using the ISOFIX system; check that it can be fitted correctly.

- (1) If necessary, position the vehicle seat as far back as possible. Move the front seat as far forward as possible to install a rear-facing child seat, then move back the seat in front as far as it will go, although without allowing it to come into contact with the child seat.
- (2) In all situations, remove the rear headrest of the seat on which the child seat is positioned. This must be done before fitting the child seat. Please refer to the information on the "Rear headrests" in Section 3. Move the seat in front of the child forwards, move the seatback forward to avoid contact between the seat and the child's legs.

## MIRRORS



### Exterior rear view mirror 1

(depending on the version)

#### Automatic adjustment

With ignition ON, slide the switch 2 to select the door mirror, then use the control 3 to adjust it to the desired position.

#### Manual adjustment

Adjust the door mirror according to rear vision by adjusting the knob 5.

#### Foldable door mirrors

The door mirrors can be folded: simply fold them manually against the door window.

### Automatic folding door mirrors

Depending on the variant, door mirrors will be folded automatically by pressing the switch 4.

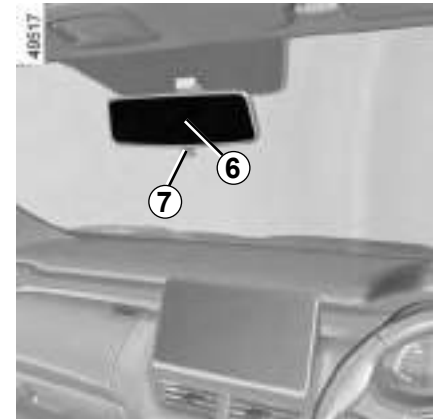

### Interior rear view mirror 6

(depending on the version)

The interior rear-view mirror 6 is manually adjustable. When driving at night, tilt the mirror by lever 7 or by hand to avoid being dazzled by the headlights of the vehicle behind.



Objects observed in the door mirror glass are actually closer than they appear. For your safety, take this into account in order to correctly assess the distance before any manoeuvre.



For safety reasons, carry out any adjustments when the vehicle is not being driven.

# DRIVING POSITION, RIGHT-HAND DRIVE (1/2)

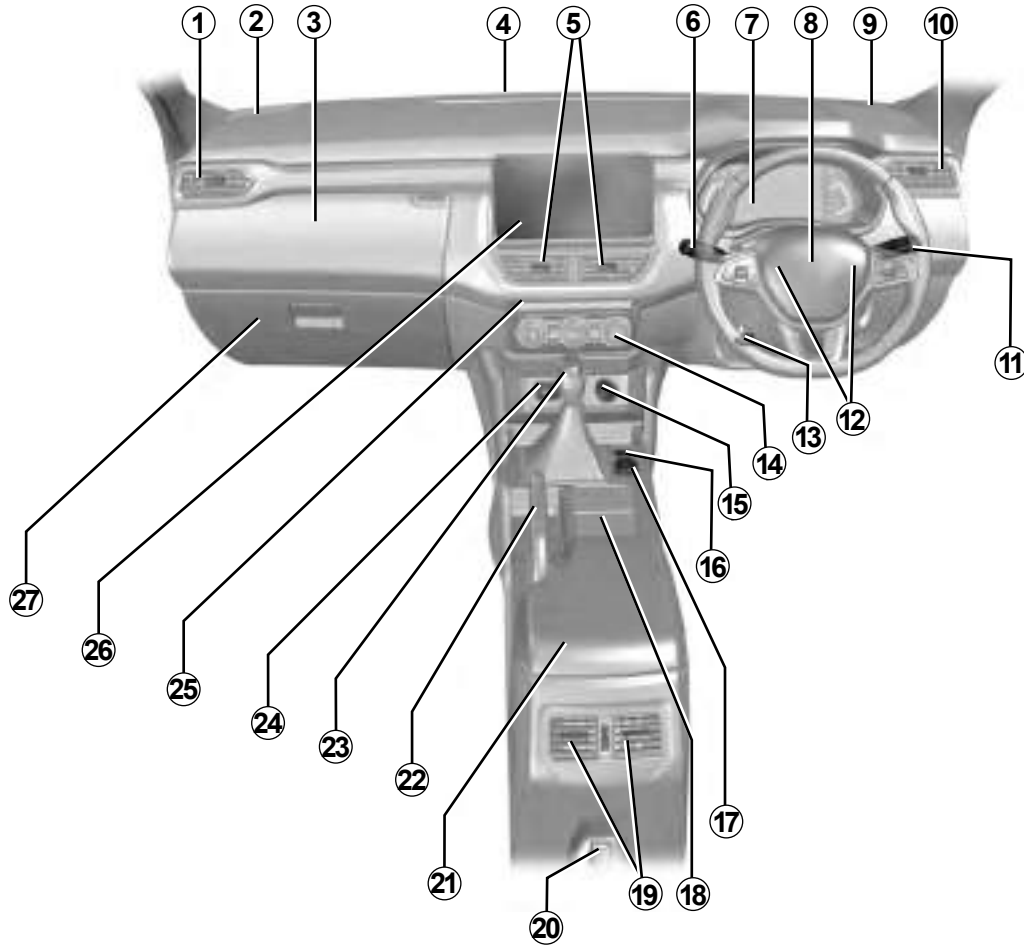

49518



## DRIVING POSITION, RIGHT-HAND DRIVE (2/2)

The presence of the equipment **DEPENDS ON THE VEHICLE VERSION AND COUNTRY.**

**1** Left side air vent

**2** Location for left tweeter

**3** Upper Glove Box

**4** Windscreen demisting vents

**5** Centre air vents

**6** Steering column stalk for

- Front windscreen wash / wiper;

- Front windscreen wash / wiper;

**7** Instrument panel

**8** Location for driver's airbag

**9** Location for right tweeter

**11** Steering column stalk for

- direction indicator lights;

- exterior lights,

**12** Horn

**13** Steering wheel height adjustment

**14** Heating and ventilation controls

**15** Start/Stop switch

**16** Ambient lighting switch

**17** Multi-sense switch

**18** Console storage location

**19** Rear console airvent

**20** 12V Accessories socket

**21** Rear console armrest

**22** Handbrake

**23** Gear lever

**24** USB port

**25** Switch for

- activation / de-activation of central locking (or) tail gate lock/unlock;

- activation / de-activation of ECO MODE (or) rear defogger;

- activation / de-activation of hazard warning lights;

- activation / de-activation of Electronic stability control;

**26** Location for radio/ Navigation System

**27** Lower Glove Box

## STEERING WHEEL/POWER-ASSISTED STEERING



### Steering wheel height adjustment

Lower the lever **1** and place the steering wheel in the required position; raise the lever to lock the steering wheel.

Make sure that the steering wheel is correctly locked.

### Power Assisted Steering

With the engine running, do not leave the steering wheel at full lock while stationary as this may damage the power-assisted steering pump.

With the engine switched off, or if there is a system fault, it is still possible to turn the steering wheel. The force required will be greater.

Never leave the steering wheel at full lock while stationary.

With the engine switched off, or if there is a system fault, it is still possible to turn the steering wheel. The force required will be greater.



For safety reasons, only adjust the steering wheel when the vehicle is stationary.



Never switch off the ignition when travelling downhill, and avoid doing so in normal driving (assistance is not provided).





## WARNING LIGHTS (1/4)





The display of information shown below **DEPENDS ON THE VEHICLE EQUIPMENT AND COUNTRY.**



Instrument Panel A



Instrument Panel B

-  **Main beam headlight tell-tale light.**
-  **Dipped beam headlight tell-tale.**
-  **Left-hand direction indicator tell-tale.**
-  **Right-hand direction indicator tell-tale.**
-  **Gear change indicator**  
This lights up to advise you to change to a higher gear (up arrow) or lower gear (down arrow).



If no lights or sounds are apparent, this indicates a fault in the instrument panel. This indicates that it is essential to stop immediately (as soon as traffic conditions allow). Ensure that the vehicle is correctly immobilised and contact an approved Dealer.

Orange warning light  comes on while you are driving, **drive carefully** to an authorised dealer as soon as possible. Failure to follow this recommendation risks damaging your vehicle.



The red warning light  requires you to stop immediately, for your own safety, as soon as traffic conditions allow. Switch off the engine and do not restart it. Contact an Authorised Dealer.

## WARNING LIGHTS (2/4)

The presence and operation of the warning lights **DEPEND ON THE EQUIPMENT AND COUNTRY.**



### Warning light malfunction (red or orange)

#### Warning light (orange)

This lights up when the ignition is switched on and goes out after 3 seconds. It may come on in conjunction with other warning lights on the instrument panel. It means you should **drive very carefully** to an authorised dealer as soon as possible. If you fail to follow this recommendation, you risk damaging your vehicle.

#### Urgent stop warning light (red)

This lights up when the ignition is switched on and goes out as soon as the engine is started and is accompanied by a beep. It requires you to stop immediately, for your own safety, as soon as traffic conditions allow. Switch off the engine and do not restart it. Contact an approved Dealer.



### Stop light

This lights up when the ignition or engine is switched on and goes out as soon as the engine is running. It comes on with other warning lights and/or messages on the instrument panel. It requires you to stop immediately, for your own safety, as soon as traffic conditions allow. Switch off the engine and do not restart it. Contact an approved Dealer.



### Warning light

This lights up when the ignition or engine is switched on and goes out as soon as the engine is running. It can light up in conjunction with other warning lights and/or messages on the instrument panel.

It means you should **drive very carefully** to an approved dealer as soon as possible. If you fail to follow this recommendation, you risk damaging your vehicle.



### Door(s) open warning light

Refer to "Opening/closing the doors" in Section 1

Depending on the variants, if any of the door is opened, warning light will come ON indicating the exact door location in open condition accompanied by a warning message, "DOOR OPEN" in the instrument panel.



### Anti-lock braking warning light

This lights up when the ignition is switched on and goes out after a few seconds.

If it does not go out after the ignition is switched on, or lights up when driving, there is a fault with the ABS. Braking will then be as normal, without the ABS system.

Contact an approved Dealer as soon as possible.



## WARNING LIGHTS (3/4)

The presence and operation of the warning lights **DEPEND ON THE EQUIPMENT AND COUNTRY.**



### Handbrake “on” warning light and brake circuit incident warning light

This comes on when the ignition is switched on and goes out when parking brake is dis-engaged. If it comes on during braking and is accompanied by a beep, it indicates that fluid level in circuit is low. It may be dangerous to continue driving. Contact approved dealer.



### Variable power-assisted steering warning light

It lights up when the ignition or the engine is switched on and goes off after a few seconds.

If it comes on while driving, this means there is a system fault. Contact an authorised dealer.



### Battery charge warning light

If it comes on when you are driving, it indicates that the circuit has discharged. Consult an approved Dealer as soon as possible.



### Air bag warning light

This comes on when the ignition is switched on and goes out after a few seconds.

If it does not go out when the ignition is switched on, or comes on when the engine is running, there is a fault in the system.

Contact your approved Dealer as soon as possible.

### Over Speed Warning beep Primary Warning

When vehicle speed exceeds around 80 km/h (50 mph), a beep sounds for every 2 minutes until the driver reduces the speed less than 80 km/h (50 mph)

### Secondary Warning

When vehicle speed exceeds around 120 km/h (75 mph), a beep sounds for every 2 seconds until the driver reduces the speed less than 120 km/h (75 mph), after which it will switch to the primary warning.



Warning light **STOP** requires you to stop immediately, for your own safety, as soon as traffic conditions allow. Switch off the engine and do not restart it. Contact an approved Dealer.

Warning light  means you should drive very carefully to an approved dealer as soon as possible. If you fail to follow this recommendation, you risk damaging your vehicle.

## WARNING LIGHTS (4/4)

The presence and operation of the warning lights **DEPEND ON THE EQUIPMENT AND COUNTRY.**



### Warning light for monitoring exhaust gas

It comes on when the ignition is switched on and then goes out.

- If it lights up continuously, consult an approved dealer as soon as possible.
- If it flashes, reduce the engine speed until the light stops flashing. Contact your approved Dealer as soon as possible.

Refer to the information on “Advice: antipollution, fuel economy, driving” in Section 2.



### Warning light for the electronic stability program (ESC) and traction control system

There are several reasons for the warning light to come on: see “Electronic Stability Program ESC with understeer control and traction control” in Section 2



### Indicator light ESC

Refer to the information on “Driving correction devices and aids” in Section 2



### Low fuel level warning light

This warning light gets ON when ignition is ON and remains lit permanently (or) depending on the variant, the warning light goes off after few seconds

Depending on the variants, if it blinks (or) gets ON when driving and accompanied by a beep, it indicates the fuel level is getting low. Fill up with fuel as soon as possible.

Before starting the vehicle, always check the fuel level indicator in the instrument panel.



### Oil pressure warning light

This comes when ignition is ON and goes out after few seconds. If it comes on when you are driving accompanied and a beep, it is essential to stop and switch off the ignition. Contact an approved Dealer



### Coolant temperature warning display

This bar display comes ON when ignition is ON and remains lit permanently (or) depending on the variant, the warning light goes off after few seconds. Depending on the variants, if it blinks (or) gets ON when driving, this means the engine is overheating. Stop and allow the engine to run at idle speed for a minute or two. The temperature should drop. If not, stop the engine. Let it cool down. Contact an authorised dealer if necessary.



## DISPLAYS AND INDICATORS (1/5)



### Instrument panel A

This is applicable depending on the variant.

It lights up when the ignition is switched on. In some cases, the appearance of a warning light is accompanied by a message.



### Rev counter 1 (rpm X1000)

### On-board computer 2

Please refer the instructions under chapter 1: On-board computer



### Coolant temperature warning display 3

Please refer the instructions under "Section 1 under Warning lights chapter."

### Fuel level warning display 4

Please refer the instructions under "Section 1 under Warning lights chapter."

## DISPLAYS AND INDICATORS (2/5)



### Instrument panel **B**

This is applicable depending on the variant.

It lights up when the ignition is switched on. In some cases, the appearance of a warning light is accompanied by a message.



Driving mode indicator:ECO mode **5**

Rev counter **6**

Temperature **7**

Instantaneous/Average fuel consumption **8**

Trip distance recorder **9**

Total distance recorder **10**



Gear mode display **11**

Estimated range with remaining fuel **12**

Gear shift display **13**



## DISPLAYS AND INDICATORS (3/5)



**Clock 14**

**Driving mode  
indicator: Normal mode 15**



**Service due reminder display  
16**



**Instantaneous fuel economy  
17**

**Average fuel economy 18**



## DISPLAYS AND INDICATORS (4/5)



### Display to change the settings 19

This display will allow you to customise the **brightness** of the display in both day and night mode



### Fuel economy history display 20





## DISPLAYS AND INDICATORS (5/5)



**Driving mode indicator: Sport mode 21**

**Rev counter 22 (rpm X1000)**

**Air quality indicator 23**



**Warning lights indicator 24,25**

When driving, if multiple tell-tale lights triggered, the lights **24, 25** will rotate for every 4 seconds.

**Torque display 26**

**Power range display 27**

**Acceleration display 28**



## ON-BOARD COMPUTER (1/5)



### On-board computer A

The display depends on the vehicle and the country.

Scroll through the following information by pressing the button **1**.



### On-board computer B

The display depends on the vehicle and the country.

Press the **2** switch to browse between menus and select functions by repeatedly pressing the **3** or **4** switch, then if necessary use the **5** switch to confirm "OK".

Refer to the information under, 'Displays and indicators' in chapter :1 for more information.

- a) Total distance recorder.
- b) Trip distance recorder.
- c) Fuel used in litre (from last reset).
- d) Average fuel consumption (from last reset).
- e) Current fuel consumption.
- f) Estimated fuel range (DTE - distance to empty).
- g) Distance travelled from last reset.
- h) Average speed from the last Reset.
- i) Display settings
- j) Service reminder



## ON-BOARD COMPUTER (2/5)

### Resetting the trip mileage

To reset the trip mileage recorder, the display must show the Trip meter function.

Press and hold button **1** or **6**.

### Interpreting some of the values displayed after resetting

The values showing average fuel consumption, range and average speed will become more stable and reliable the further you travel after pressing the reset button.

For the first few kilometres after pressing the reset key you will notice that the range increase/decrease as you travel. This range takes into account the average fuel consumption since the last time the reset button was pressed.

Refer to the table on the following pages showing display examples.

The current fuel consumption may increase when,





- the vehicle stops accelerating.
- the engine reaches its operating temperature (if the engine was cold when the reset key was pressed).
- when driving from an urban area onto the open road.

Resetting is automatic when the maximum capacity of any of the memories is exceeded.

By pressing the button **5**, the messages appearing in the instrument panel will be acknowledged and will be stored.

## ON-BOARD COMPUTER (3/5)





The display of information shown below **DEPENDS ON THE VEHICLE EQUIPMENT AND COUNTRY.**

DISPLAY	Interpreting the display selected
	Total distance recorder
	Trip distance recorder
	Fuel used (since the last time the reset button was pressed)
	Average fuel consumption (since the last time the reset button was pressed) This value is displayed after driving 400 metres. This takes into account the distance travelled and the fuel used since the last time the reset button was pressed.





## ON-BOARD COMPUTER (4/5)

The display of information shown below **DEPENDS ON THE VEHICLE EQUIPMENT AND COUNTRY.**

DISPLAY	Interpreting the display selected
	Current fuel consumption
	Estimated range with remaining fuel
	Distance travelled (since the last time the reset button was pressed for <b>TRIP B</b> )
	Average speed (since the last time the reset button was pressed)
	Time taken to travel the distance

## ON-BOARD COMPUTER (5/5)

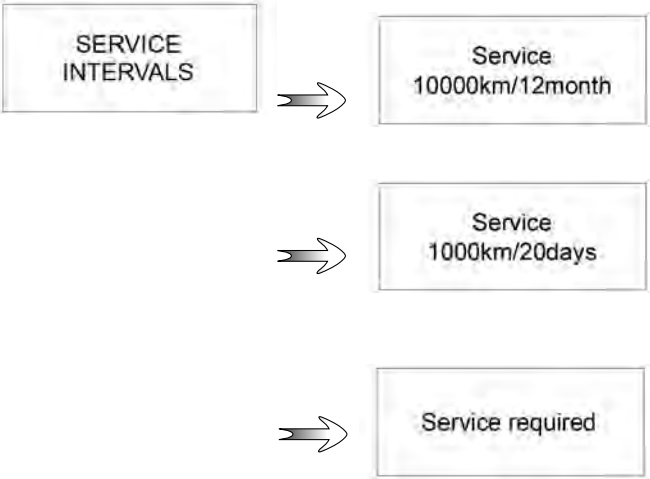
The display of information shown below **DEPENDS ON THE VEHICLE EQUIPMENT AND COUNTRY.**

DISPLAY	Interpreting the display selected
	<p><b>Mileage before service</b>            With the ignition switched on, the engine not running and the display set to “SERVICE INTERVALS”, press the button <b>1</b> or <b>2</b> for approximately 10 seconds to display the mileage before service (distance or time to the next service). When the distance value approaches its limit, there are several possible scenarios:</p> <ul style="list-style-type: none"> <li>– distance/time remaining is less than 1500 km or one month: the message “Service” is displayed accompanied by the nearest term (distance or time);</li> <li>– distance equals 0 km or date of service reached: the message “Service required” is displayed and depending on the variants accompanied by warning light .</li> </ul> <p>The vehicle requires a service as soon as possible.</p>
<p><b>Resetting:</b> to reset the distance before service, press and hold button <b>1</b> for approximately 10 seconds until the display shows the service mileage without flashing.</p> <p><b>NB:</b> if a service is performed without changing the engine oil, only the mileage before the next service should be reset. In the event of an oil change, both the distance before the next service and the next oil change should be reset.</p>	



## CLOCK

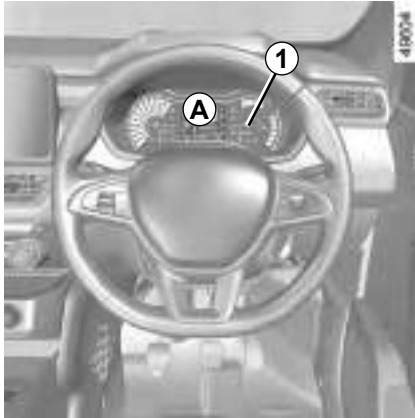

### Display A or B

To access the display **3** for setting the time, press button **1** (or **2**) and Wait a few seconds; the hours and minutes will begin to flash. You are now in setting mode, press and hold button **1** or **2**



Wait a few seconds, the minutes will flash: repeatedly press or press and hold button **1** or **2** to set the time.

When setting is complete, the hours and minutes remain displayed continuously for 2 seconds: your setting is registered.

You may change the display.

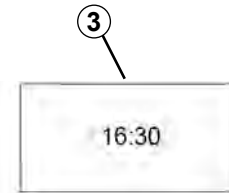

If the power supply is cut (battery disconnected, supply wire cut, etc.), the clock must be reset.

We recommend that you do not adjust these settings while driving.

## EXTERIOR LIGHTING AND SIGNALS

44033

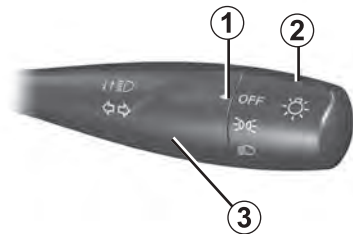

### Side lights

Turn the end of stalk **2** until the symbol is opposite mark **1**.

### Dipped beam headlight

Depending on the vehicle, turn the end of stalk **2** down until the symbol is opposite mark **1**.

### Main beam headlights

With the dipped beam headlights lit, push down stalk **3**. The indicator on instrument panel comes on. To return to dipped headlight, pull the stalk **3** upward.

### OFF Switching off the lights

Turn the end of stalk **2** until the symbol is opposite mark **1**.

**Headlight flasher** : Pull stalk **3** towards you to flash the headlights.

### Daytime running lights function (front lights only)

If fitted on the vehicle, the daytime running lights come on automatically with no action on stalk, when the ignition is on and go off once the ignition is off.

When the position function is ON, the daytime running lights will get dimmed.

Automatic lighting of headlights will come ON only in ENGINE ON condition.



## HEADLIGHT HEIGHT ADJUSTMENT



### Headlight height Adjustment:

Knob **A** is used to adjust height of the headlight beam according to load. Turn control **A** anticlockwise to lower the beams and clockwise to raise them.

	Position
Only Driver	Zero
Driver + front passenger	Zero
Driver + Passenger in front seat + Rear seats occupied	o
Driver + Luggage in boot	o
Passenger in all seats	oo
Passenger in all seats + Luggage in boot	oo

## AUDIBLE AND VISUAL SIGNALS



### Horn

Press on the centre or sides of the high-lighted (horn pad) to use the horn.



### Hazard warning lights

Press switch 2.

This switch activates all four direction indicators and the side indicator lights simultaneously.

It must only be used in an emergency to warn drivers of other vehicles that you have had to stop in an area where stopping is prohibited or unexpected, or that you are obliged to drive under special conditions.

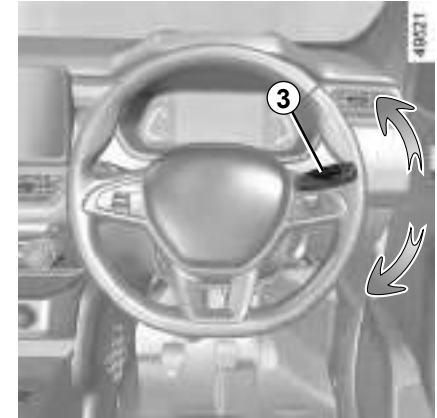

### Direction indicators

Move stalk 3 parallel to the steering wheel and in the direction you are going to turn it.

When driving on motorway, the steering is not usually turned sufficiently to enable the stalk to return automatically to home position. There is intermediate position where the stalk will not be held for lane change indication and there will be 3 blinks of indicator lights in dedicated direction.

If it does not return back automatically, release the stalk manually and it will return to its home position.



## WINDSCREEN WASHING / WIPING (1/2)

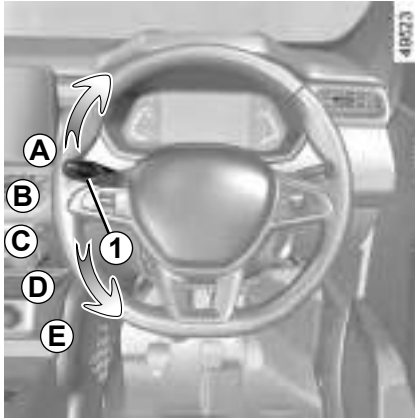

### Windscreen Wiper

With the ignition on, move the stalk **1** around the steering wheel (depending on the version):

- A** One time Mist removal function.
- B** Park;
- C** Intermittent wiping (depends on vehicle version) - The wiper will pause for several seconds between sweeps.
- D** Normal wiping speed.
- E** Fast wiping speed.



### Windscreen Wiper

With the ignition on, pull the stalk **1** towards you.

A brief pull will trigger a single sweep of the wipers, in addition to the windscreen washer.

A longer pull will trigger three sweeps of the wipers, in addition to the windscreen washer.



When working in the engine compartment, ensure that the windscreen wiper stalk **1** is in the **B** position (park). Risk of injury.



Before any action on the windscreen (washing the vehicle, de-icing, cleaning the windscreen, etc.), return stalk **1** to position **B** (park).

Risk of injury and/or damage.

In frosty weather, make sure that the wiper blades are not stuck by ice (risk of motor overheating).

Keep an eye on the condition of the blades. They should be replaced as soon as they become less efficient.

This will occur approximately once a year. Clean your windscreen regularly.

If you switch off the ignition before switching off the windscreen wiper (position **A**) the blades will stop at random on the windscreen.

After switching the ignition back on, simply move stalk **1** to position **B** to place them in the park position.

## WINDSCREEN WASHING / WIPING (2/2)

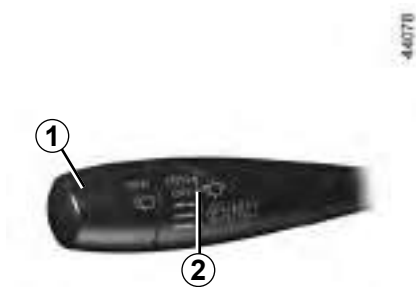

### Rear screen wiper

Depending on the variants, with the ignition on, turn the end of stalk **1** to align the symbol with mark **2**

### Rear screen washer/wiper

With the ignition on, turn the end of stalk **1** to align the symbol with mark **2**.

When the stalk is released, it returns to the rear wipe position.

A longer push will trigger three sweeps of the wipers, in addition to the wind screen washer.

Before using the rear wiper, check that no object is obstructing the travel of the blade.

In frosty weather, make sure that the wiper blades are not stuck by ice (to avoid the risk of the motor overheating).

Keep an eye on the condition of the blades. They should be replaced as soon as they become less efficient. This will occur approximately once a year. Clean your windscreen regularly.



### Heated rear screen

Depending on the variants, with the engine running, press button **3** (the indicator light on the instrument panel lights up).

This function de-ices/demists the rear screen.

The function is stopped:

- automatically after a period of time set by the system (warning light goes out);
- by pressing button **3** again (the warning light goes out).



## FUEL TANK (1/2)

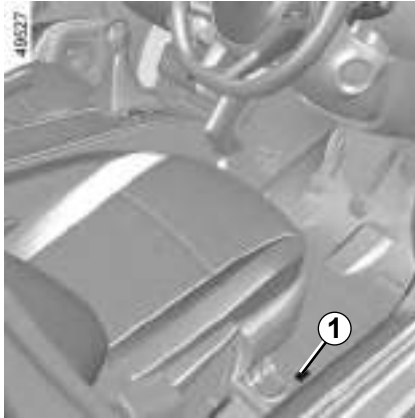

### Opening the Fuel Flap

- Stop the Engine.
- Pull up the fuel filler door release lever **1** located on the floor, right front side of driver's seat which unlocks the Fuel Flap **A**.
- Turn the fuel filler cap **2** counter-clockwise slowly and completely unscrew the cap.
- Remove the cap.



Do not wash the filler area with a high-pressure washer.



- After refuelling, replace cap. Turn it clockwise and screw completely.
- Push the fuel filler door closed until it latches.

**NOTE:** In cold weather, if the fuel filler door does not open, tap the door lightly. Then try to open it again.

Make sure that no water enters the fuel tank during filling.

**Fuel filler cap: this is specific to the vehicle type.** If you have to replace it, make sure the new cap is of the same type. Contact an approved dealer.

It is **essential** to use unleaded petrol. Using leaded petrol will damage the antipollution system and may lead to a loss of warranty.

**Capacity of the fuel tank:** 40 litres approximately.



To fill up with fuel, the engine must be stopped (not in stand by). You **MUST** switch off the ignition.

**Fire hazard**

## FUEL TANK (2/2)

### Filling up with fuel

With the ignition off, insert the nozzle **fully** before turning it on to fill the fuel tank (risk of splashing).

Keep the nozzle in this position throughout the entire filling operation. When the pump cuts out automatically at the end of the filling procedure, a maximum of two further filling attempts may be made, as there must be sufficient space in the fuel tank to allow for expansion.

### Fuel grade

Use a high-grade fuel that complies with the legislation in force in each country and which must comply with the specifications given on the label on cover **A**. Please refer to the information on “Engine specifications” in Section 6.

#### **Petrol version**

It is essential to use unleaded petrol. The octane rating (RON) must comply with the information provided under Section 6 on “Engine specifications



- Never place the cap near a source of heat or flame.
- Do not add any additives to the fuel, you risk damaging the engine.



- If you notice a persistent fuel odour you should:
- stop the vehicle as soon as traffic conditions allow and switch off the ignition;
  - switch on the hazard warning lights and ask your passengers to leave the vehicle and stay clear of the traffic.
  - contact an approved Dealer.



# **Section 2: Driving**

***(Advice on use relating to fuel economy and the environment)***

Running in, Ignition switch . . . . .	2.2
Starting / Stopping the engine : vehicle with key . . . . .	2.3
Starting / Stopping the engine : vehicle with Hands free card . . . . .	2.5
Gear lever, Hand brake . . . . .	2.8
Special features of petrol versions . . . . .	2.9
Driver correction devices/AIDS . . . . .	2.10
Driving advice, ECO driving . . . . .	2.13
Maintenance and anti-pollution advice . . . . .	2.16
Environment . . . . .	2.17
Automated manual transmission . . . . .	2.18
Continuously variable transmission . . . . .	2.22
Parking distance control . . . . .	2.25
Reversing Camera . . . . .	2.27



## RUNNING IN, IGNITION SWITCH

### Running in

For the first **1,000 km**, do not exceed 80 km/h in the highest gear.

You may only expect top performance from your vehicle after approximately **3,000 kms**.

**Oil change frequency:** Please refer to your vehicle's maintenance schedule.

**NOTE :** During the running in period, do not accelerate hard while the engine is still cold and do not let the engine to run in higher rpm.

**Service intervals:** refer to the Maintenance Schedule for your vehicle.



### Stop and steering lock position *St*

To lock: remove the key and turn the steering wheel until the steering column locks.

To unlock: turn the key and the steering wheel slightly.

### Accessories position *A*

When the ignition is switched off, any accessories (radio, etc.) will continue to function.

### Ignition on position *M*

The ignition is switched on:

– the engine may be started.

### Start position *D*

If the engine fails to start at the first attempt, turn the key back to home position before activating the starter again.

Release the key as soon as the engine starts.

#### **NOTE:**

- Do not attempt to start/crank the engine in running/geared condition;
- Do not attempt to crank the engine more than 5 times repeatedly if the vehicle does not start. Wait for sometime and crank the engine. If the vehicle did not start, contact the nearby authorised dealer;





## STARTING/STOPPING THE ENGINE - VEHICLE WITH KEY (1/2)

### Starting the engine

In cold condition: switch on the ignition for several seconds **before** starting the engine, so that it is easier to start the engine.

### Petrol injection

- Activate the starter **without pressing the accelerator**.
- Release the key as soon as the engine starts.

### Vehicles with an sequential gearbox

Refer to the information on the “Automated manual transmission” in section 2.

### Stopping the engine

With the engine idling, turn the key back to “Stop” position **St**.

### Special note

Depending on the vehicle, accessories (e.g. radio) stop working either when the engine is switched off or when the doors are locked.



Never leave your vehicle with the key or remote control inside and never leave a child (or a pet) unsupervised, even for a short while.

The reason for this is that the child may endanger himself or others by starting the engine, activating equipment such as the window winders for example, or locking the doors.

Risk of serious injury.

**Never switch off the ignition before the vehicle has stopped completely.** Once the engine has stopped, the brake servo, power assisted steering and passive safety equipment such as air bags will no longer operate.

The steering is locked when the key is removed.

## STARTING/STOPPING THE ENGINE - VEHICLE WITH KEY (2/2)

### Starting problems

To avoid damage, **do not keep** trying to start the engine (by pushing or towing the vehicle) **without having identified and corrected the cause of the fault.**

If the fault cannot be identified, do not continue to try and start the engine, but contact an approved dealer.

The following operating conditions should be avoided:

- driving for long periods when the low fuel level warning light is lit.
- using leaded petrol.
- using fuel or lubrication additives which are not approved.

Operating faults such as:

- faulty ignition, running out of fuel or disconnected spark plugs resulting in the engine misfiring or cutting out when driving.
- loss of power.

may cause overheating, reducing efficiency **which may irreparably damage vehicle components and also the vehicle.**

If you notice any of the above operating faults, have the necessary repairs carried out as soon as possible by an approved dealer.

These faults may be avoided by regularly taking your vehicle to an approved Dealer at the intervals specified in the Maintenance Schedule.



Do not park the vehicle or run the engine in locations where combustible substances or materials such as grass or leaves can come into contact with the hot exhaust system.



## STARTING/STOPPING THE ENGINE - VEHICLE WITH CARD (1/3)



40002

The card must be in detection zone 1.

To start:

- vehicles with an automatic gearbox, place the lever in position **N**, press brake pedal and press button **2**;
- vehicles with a manual gearbox, depress the brake or clutch pedal and press the button **2**. If a gear is engaged, the vehicle may only be started by depressing the clutch pedal.



### Special features

- If one of starting conditions is not applied, the message “BRAKE + START” or “CLUTCH + START” or “Select **NEUTRAL**” is displayed on the instrument panel;
- in some cases, it will be necessary to move the steering wheel whilst pressing the start button **2** to help unlock the steering column; the message “TURN+ START” will warn you of this;

### Starting with tail gate open in hands-free mode.

In this case, hands free card must not be located in the luggage compartment.



**Never switch off the ignition before the vehicle has stopped completely.**

Once the engine has stopped, the brake servo, power assisted steering and passive safety equipment such as air bags will no longer operate.

The steering is locked when the key is removed.

## STARTING/STOPPING THE ENGINE - VEHICLE WITH CARD (2/3)

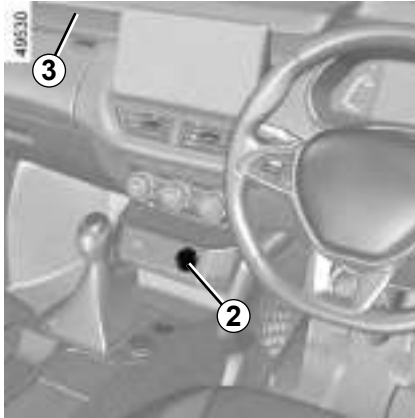

### Accessories function

(switching on the ignition)

Once you have gained access to your vehicle, you may use some of its functions (radio, navigation, wipers, etc.).

To use the other functions, with the card in the passenger compartment, press the **2** button without pressing the pedals.



### Operating faults

In certain cases, the hands-free card may not work:

- when the card battery is drained, flat battery, etc.,
- near to appliances operating on the same frequency as the card (monitor, mobile phone, video game, etc.);
- vehicle located in a high electromagnetic radiation zone.

The message, "**KEY NOT DETECTED**" appears on the instrument panel.

Press the brake or clutch pedal, then place the hands free card in contact with position **3** inside the centre console (depending on variants, slide the console door to access the position 3) around 2 seconds. Press **2** to start the vehicle, the message goes out.



Never leave your vehicle with the key or remote control inside and never leave a child (or a pet) unsupervised, even for a short while.

The reason for this is that the child may endanger himself or others by starting the engine, activating equipment such as the window winders for example, or locking the doors.

Risk of serious injury.



## STARTING/STOPPING THE ENGINE - VEHICLE WITH CARD (3/3)



### Conditions for stopping the engine

The vehicle must be stationary, with the lever positioned in **N** for vehicles with an automatic gearbox.

With the card in the vehicle, press button **2**: the engine stops. The steering column is locked when the driver's door is opened or the vehicle is locked.

If the card is no longer in the passenger compartment when you try to switch the engine off, the message "PRESS HOLD START" appears on the instrument panel: press button 2 for longer than two seconds. If the card is no longer in the passenger compartment, make sure you can retrieve it before pressing and holding the button. Without the card, you will not be able to restart the vehicle.

With the engine switched off, any accessories being used (radio, etc.) will continue to function for approximately 10 minutes.

When the driver's door is opened, the accessories stop working.



When you leave your vehicle, especially if you have your card with you, check that the engine is completely switched off.



Do not park the vehicle or run the engine in locations where combustible substances or materials such as grass or leaves can come into contact with a hot exhaust system.



Never switch off the ignition before the vehicle has stopped completely. Once the engine has stopped, the brake servo, power-assisted steering, etc., and the passive safety devices such as the airbags and pretensioners will no longer operate.

## GEAR LEVER, HAND BRAKE



### Selecting reverse gear (vehicle in stationary condition)

**Vehicles with manual gearbox:** refer to the grid on the gear lever knob **1**.

Depending on variants, pull the release knob **A** in upward direction and then engage the reverse gear. Shifting the reverse gear should not be done quickly. Wait for 3 seconds approximately and shift the reverse gear.

### Gear change indicators

Depending on the vehicle, to obtain optimum consumption levels, an indicator light on the instrument panel lets you know the best time to move up or down a gear.



### Handbrake

#### To release

Pull lever **3** up slightly, press button **2** and then lower the lever to the floor.

The red warning light on the instrument panel will come on and a sound if you are driving with an incorrectly released handbrake.

#### To apply

Pull lever **3** upwards and make sure the vehicle is immobilised.



An impact to the underside of the vehicle while manoeuvring (e.g.: striking a post, raised kerb or other street furniture) may result in damage to the vehicle (e.g.: deformation of an axle). To prevent any risk of accident, have your vehicle checked by an approved dealer.



Make sure that the handbrake is properly released when driving (red indicator light off), otherwise overheating, or even damage, may occur.



Depending on the gradient and/or vehicle load, it may be necessary when stationary to apply the brake by at least a further two notches and engage a gear (1<sup>st</sup> or reverse gear).



## SPECIAL FEATURES OF PETROL VERSIONS

The following operating conditions:

- driving for long periods when the low fuel level warning light is lit;
- using leaded petrol;
- using fuel or lubrication additives which are not approved.

Or operating faults such as:

- faulty ignition system, running out of fuel or disconnected spark plugs resulting in the engine misfiring or cutting out when driving;
- loss of power.

as they may cause the catalytic converter to overheat and thus reduce its efficiency, **or damage it irreparably and cause heat damage to the vehicle.**

If you notice any of the above operating faults, have the necessary repairs carried out as soon as possible by an approved Dealer.

These faults may be avoided by regularly taking your vehicle to an approved Dealer at the intervals specified in the Maintenance document.

### Starting problems

To avoid damaging the catalytic converter, **do not keep** trying to start the engine (using the start button, or by pushing or towing the vehicle) **without having identified and corrected the starting fault.**

If the fault cannot be identified, do not keep trying to start the engine, but contact an approved dealer.



Do not park the vehicle or run the engine in locations where combustible substances or materials such as grass or leaves can come into contact with the hot exhaust system.

## DRIVER CORRECTION DEVICES/AIDS (1/3)

Depending on the vehicle, this is composed of:

- the **ABS (anti-lock braking system)**;
- the **emergency brake assist**;
- **electronic stability program ESC with understeer control and traction control**.



These functions are an additional aid in the event of critical driving conditions, enabling the vehicle behaviour to be adapted to suit the driving conditions.

However, the functions do not take the place of the driver. They do not increase the vehicle's limits and should not encourage you to drive more quickly. Therefore, they can under no circumstances replace the vigilance or responsibility of the driver when manoeuvring the vehicle (the driver must always be ready for sudden incidents which may occur when driving).

### **ABS (anti-lock braking system)**

Under heavy braking, the ABS prevents the wheels from locking, allowing the stopping distance to be managed and keeping control of the vehicle. Under these circumstances, the vehicle can be steered to avoid an obstacle whilst braking. In addition, this system can increase stopping distances, particularly on roads with low surface grip (wet ground etc.).

You will feel a pulsation through the brake pedal each time the system is activated. The ABS does not in any way improve the vehicle's physical performance relating to the road surface and roadholding. It is still essential to follow the rules of good driving practice (such as driving at a safe

In an emergency, apply firm and continuous pressure to the brake pedal. There is no need to pump it repeatedly. The ABS will modulate the force applied in the braking system.



Under some driving or climatic conditions, occasional brake squeaks, squeals or other noises may be heard. Occasional brake noise during light to moderate stops is normal and does not affect the function or performance of the brake system.





## DRIVER CORRECTION DEVICES/AIDS (2/3)

### Operating faults

- If the  warning light on the instrument panel comes on while you are driving, **the brakes will still work normally without ABS**;
- If the  and  warning lights on the instrument panel come on while you are driving, **there is a fault in the braking system**.

In both cases, consult an approved Dealer.

### Emergency brake assist with electronic brake distribution

(depending on the vehicle)

This system supplements the ABS and helps reduce vehicle stopping distances.

#### Operating principle

The system is for detecting an emergency braking situation. In this case, the braking assistance immediately develops maximum power and may trigger ABS regulation.

ABS braking is maintained as long as the brake pedal is applied.



Your braking systems are partially operational. However, it is **dangerous to brake suddenly** and it is essential to stop immediately, as soon as traffic conditions allow. Contact an approved dealer.



### Electronic stability program ESC with understeer control and traction control

#### Electronic Stability Program ESC (depending on the vehicle)

This system helps you to keep control of the vehicle in critical driving conditions (avoiding an obstacle, loss of grip on a bend, etc.).

## DRIVER CORRECTION DEVICES/AIDS (3/3)

### Understeer control

This system optimises the action of the ESC in the case of pronounced understeering (loss of front axle road holding).

### Traction control

This system helps to limit wheelspin of the drive wheels and to control the vehicle when pulling away accelerating or decelerating.

### Deactivating the ESC function

In some situations (driving on very wet ground: snow, mud, etc. or driving with snow chains fitted), the system may reduce the engine output to limit wheelspin.

If this is not required, it is possible to deactivate the function by pressing switch **1**.

The warning light  on the instrument panel comes on to warn you of this.

If you deactivate this function, the traction control system will also be deactivated.

With the Electronic Stability Program ESC with understeer control and traction control providing additional safety, you are advised not to drive with the function disabled. Correct this as soon as possible by pressing the switch **1** again.

**Note:** The function is automatically reactivated when the ignition is switched on, or when the speed exceeds (30 mph) 50 km/h.



### Operating principle

A sensor in the steering wheel detects the direction selected by the driver.

Other sensors throughout the vehicle measure the actual direction. The system compares driver input to the actual trajectory of the vehicle and corrects the trajectory if necessary by controlling the braking of certain wheels and/or engine power. In the event that the system is engaged, the indicator

light  flashes on the instrument panel.

### Operating faults

When the system detects an operating fault the warning lights  and  appear on the instrument panel.

In this case, the Electronic Stability Program ESC with understeer control and traction control are deactivated.

Please consult an authorised dealer if these warning lights remain displayed on the instrument panel after the ignition is switched off and on again



## DRIVING ADVICE, ECO DRIVING (1/3)

Fuel consumption is accredited in accordance with a standard regulatory method. Identical for all manufacturers, this enables vehicles to be compared with one another. Consumption in real time depends on vehicle usage conditions, the equipment fitted and the user's driving style. To optimise fuel consumption, please refer to the following advice.

Depending on the vehicle, you will have various functions which enable you to lower your fuel consumption:

- the rev counter;
- gear change indicator;;
- **ECO** mode activated by the **ECO** button.

### Gear change indicator

Depending on the vehicle, in order to optimise consumption, an indicator light on the instrument panel will inform you of the best moment to upshift or downshift gears:

Gear upshift/downshift



ECO mode is a function which optimises fuel consumption. It acts on certain power consuming systems in the vehicle (heating, air conditioning, power-assisted steering, etc.) and on certain driving actions (acceleration, gear changing, etc.).

Limiting acceleration enables low fuel consumption in urban and surrounding areas. When ECO mode is in use, it is normal for changes in the heating level to occur.

### Activating the function

Press switch **1**. The warning light **ECO** goes out on the instrument panel to confirm the activation.

While driving, it is possible to leave the **ECO** mode temporarily in order to improve engine performance.

To do this, press the accelerator pedal firmly and fully.

**ECO** mode is reactivated when you take pressure off the accelerator pedal.

### Disabling the function

Press switch **1**. The warning light **ECO** goes out on the instrument panel to confirm deactivation

## DRIVING ADVICE, ECO DRIVING (2/3)



### Driving advice and ECO driving

#### Behaviour

- Drive carefully for the first few kilometres until the engine reaches its normal operating temperature, rather than let it warm up while the vehicle is stationary.
- Speed is expensive.
- Dynamic driving with a lot of frequent acceleration and braking is expensive on fuel in comparison to the time saved.
- Do not overrev the engine in the intermediate gears.
- You should always use the highest gear possible.
- Avoid sudden acceleration.
- Brake as little as possible. If you anticipate an obstacle or bend in advance, you may then simply release the accelerator pedal.
- Do not try to maintain the same speed up a hill, accelerate no more than you would on the level. Keep your foot in the same position on the accelerator pedal.
- Double declutching and accelerating before switching off are unnecessary in modern vehicles.
- On versions with a sequential/automatic gearbox, it is preferable to keep the gear lever in position **D**.
- Bad weather, flooded roads.
- Do not drive through floods if the water is above the lower edge of the wheel rims.



On the driver's side, only use mats suitable for the vehicle, attached with the pre-fitted components, and check the fitting regularly. Do not lay one mat on top of another.

**Risk of pedals jamming.**



## DRIVING ADVICE, ECO DRIVING (3/3)

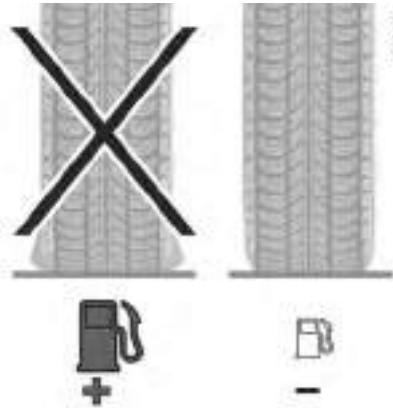

### Tyres

Increased fuel consumption could be the result of:

- insufficient pressure.
- using non-recommended tyres.



### Advice on use

- Favour the ECO mode.
- Electricity is fuel; switch off all the electrical components which are not really needed. However (safety first), keep your lights on when the visibility is bad ("see and be seen").
- Use the air vents. Driving with the windows open at approximately 100 km/h (60 mph) will increase fuel consumption.
- Never fill the fuel tank right to the brim to avoid overflow..

- **In vehicles fitted with air conditioning**, it is normal to observe an increase in fuel consumption (especially in urban conditions) when it is used. For vehicles fitted with manual air conditioning, switch off the system when it is not required.

### Advice for reducing consumption and therefore helping to preserve the environment:

If the vehicle has been parked in the sun, open the doors for a few moments to let the hot air escape before starting the engine.

- Do not leave an empty roof rack fitted to the vehicle
- Avoid using the car for door-to-door calls (short journeys with long waits in between) because the engine never reaches its normal operating temperature.

## MAINTENANCE AND ANTIPOLLUTION ADVICE

Your vehicle complies with criteria for recycling and recovering vehicles at the end of their service life, which entered into force in 2015.

Some of the parts on your vehicle have been designed to be recycled later. These parts are easily removable in order to be collected and reprocessed in recycling networks.

Furthermore, by virtue of its design, moderate fuel consumption and initial settings, your vehicle also conforms to current anti-pollution regulations. The manufacturer is actively striving to reduce pollutant exhaust gas emissions and to save energy. However, the fuel consumption of your vehicle and the level of pollutant exhaust gas emissions are also your responsibility. Ensure that it is maintained and used correctly.

### Maintenance

It is important to remember that failure to respect anti-pollution regulations could lead to legal action being taken against the vehicle owner.

In addition, replacing engine, fuel supply system and exhaust components with parts other than those originally recommended by the manufacturer may alter your vehicle so that it no longer complies with anti-pollution regulations.

Have your vehicle adjusted and checked by an authorised dealer, in accordance with the instructions given in your maintenance schedule: they will have all the equipment necessary for ensuring that your vehicle is maintained to its original standard.

### Engine adjustments

- **Spark plugs:** for optimum conditions of use, output and performance the specifications laid down by our design department must be strictly applied. If the spark plugs have to be changed, use the make, type and gap specified for your vehicle's engine. Contact an authorised dealer for this.

- **Air filter, fuel filter:** a choked element will reduce efficiency. It must be replaced.
- **Ignition and idle speed:** no adjustment is needed.

### Exhaust gas monitoring system

The exhaust gas monitoring system will detect any operating faults in the vehicle's antipollution system.

If this system malfunctions, toxic substances may be released into the atmosphere or damage may occur.



This warning light on the instrument panel will indicate if there are any faults in the system: This lights up when the ignition is switched on and goes out when the engine is started.

- If it lights up continuously, consult an approved dealer as soon as possible;
- if it flashes, reduce the engine speed until the light stops flashing. Contact an authorised dealer as soon as possible.



## ENVIRONMENT

Your vehicle has been designed with respect for the **environment** in mind for its entire service life: during production, use and at the end of its life.

This commitment is illustrated by the manufacturer eco<sup>2</sup> signature.

### Manufacture

Your vehicle has been manufactured at a factory which complies with a policy to reduce the environmental impact on the surrounding areas (reduction of water and energy consumption, visual and noise pollution, atmospheric emissions and waste water; sorting and re-using waste).

### Emissions

For the usage phase, your vehicle was designed to emit fewer greenhouse gases (CO<sub>2</sub>) and therefore to consume less fuel.

Our vehicles are also equipped with a particle filter system including a catalytic converter, an oxygen sensor and an active carbon filter (the latter prevents vapour from the fuel tank being released into the open air).

### **Please make your own contribution towards protecting the environment too**

- Worn parts replaced in the course of routine vehicle maintenance (vehicle battery, oil filter, air filter, batteries, etc.) and oil containers (empty or filled with used oil) must be disposed of through specialist organisations.
- In all cases, comply with local legislation.

### Recycling

Your vehicle is 85% recyclable and 95% recoverable.

To achieve these objectives, many of the vehicle components have been designed to enable them to be recycled. The materials and structures have been carefully designed to allow these components to be easily removed and reprocessed by specialist companies.

In order to preserve raw material resources, this vehicle incorporates numerous parts made from recycled plastics or renewable materials (vegetable or animal-derived materials such as cotton or wool).

## AUTOMATED MANUAL TRANSMISSION (1/4)



46074

### Gear Shifter 1

This allows you to engage forward gear, reverse and neutral.

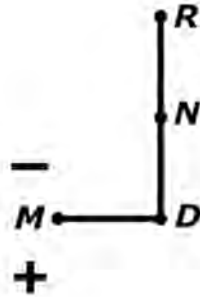

36131

### Gear shift pattern

(see the marking on the lever)

+: Manually moving up a gear

-: Manually moving down a gear

**M** manual mode

**D** automatic mode

**N** neutral

**R** reverse

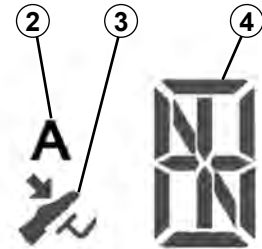

36149

### Instrument panel Display

**2** : automatic mode.

**3** : brake pedal press indicator light.

**4** : current gear display.

The current gear (**1**, **2**..., **5**, or **D**, **N**, **R**) is indicated on the display **4** on the instrument panel. In automatic mode, **A** and the engaged gear are displayed.



For safety reasons, do not switch off the ignition before the vehicle has come to a complete standstill.



## AUTOMATED MANUAL TRANSMISSION (2/4)

### Operation

Switch on the ignition.

The display on the instrument panel switches on.

If neutral (**N**) is displayed, start the engine but do not press the accelerator.

If any gear other than neutral is engaged, **N** flashes on the display; press the brake pedal and place the lever in position **N**. Start the engine.

**NB:** Do not attempt to start the engine by pushing the vehicle if the battery is flat (the display remains OFF when the ignition is switched ON).

Under certain conditions, the engine starter may take some time. Keep the key in the starting position.

Once the vehicle is switched to ignition ON position, the gearbox initializes. This produces a light sound. This is normal. Crank the engine after 3 seconds.

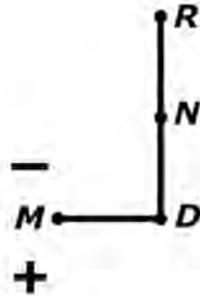

### Starting

**Moving forwards** (starting in neutral)

**The gear display shows Neutral**

With the brake pedal pressed, position the selector lever to **D**. The letter **A** (**Automatic**) appears on the cluster.

Release the brake pedal:

- The engine's idle speed is sufficient for parking manoeuvres.
- Accelerate gently to move forwards.

**Reverse gear** (from neutral, with the vehicle stationary)

With the brake pedal pressed, position the selector lever to **R**. The letter **R** appears on the display.

Release the brake pedal:

- The engine's idle speed is sufficient for parking manoeuvres.
- Accelerate gently to reverse.

There is a beep when reverse gear is engaged.

You may shift from reverse gear to a forwards gear by pushing the lever to **D** once the vehicle is stationary.

**Note:** When the vehicle is stationary, you must depress the brake pedal to engage a gear. Otherwise, warning

light  will come on.

## AUTOMATED MANUAL TRANSMISSION (3/4)

### Creeping

It is a function that enables the vehicle to move slowly without pressing accelerator pedal. Follow the steps:

- Start the engine as instructed in “Starting the engine” section.
- With brake pedal pressed, shift the lever to D position.
- Release the parking brake and brake pedal to activate creeping.



Exactly like a vehicle equipped with a manual gearbox, a vehicle equipped with a sequential gearbox is unable to prevent the vehicle from rolling on a slope if the handbrake is not applied or the brake pedal constantly not pressed. The vehicle can be in stationary place on an incline for 2 seconds (Giving Driver enough time to take his foot off the brake & press the accelerator)

### Driving in manual mode

This mode can be activated at any time when driving by pushing the lever to position **M**.

To shift up a gear, simply push the selector lever backwards without necessarily releasing the accelerator.

To shift down a gear, simply push the selector lever forwards without necessarily releasing the accelerator.

The system will not tolerate a series of up or down changes that cause the engine to underrev or overrev.

By pushing the lever backwards twice, you can move up two gears at a time (except if under-revving). By pushing the lever forwards twice, you can move down two gears at a time (except if over-revving).

When decelerating with the foot off the pedal, the gears will automatically drop to the low engine speed limit to avoid stalling. The vehicle may be kept stationary (stop, red light etc.) by depressing the brake pedal without shifting into neutral **N**.

The vehicle will move off again:

- either slowly, if you release the brake without accelerating (e.g. when in a traffic jam),
- or quickly, if you release the brake and accelerate.

**Note:** Neutral **N** may only be selected when the vehicle is being driven or is stationary or without touching the brake pedal.

If the engine speed is too high or too low, the system will choose the optimum gear.

Manual mode can be deactivated and reactivated at any time with the engine running by moving the lever to position **D** and respectively to **M**.



## AUTOMATED MANUAL TRANSMISSION (4/4)

### Driving in automatic mode

Each time the ignition is switched on, starting in neutral, shift the lever to **D** with brake pedal pressed condition to be able to shift directly to automatic mode.

The letter **A** appears on the display. The vehicle is controlled using the accelerator and the brake. Gears will change automatically at the correct moment and at a suitable engine speed because automatic mode takes into consideration the road surface and the chosen driving style.

#### Note:

Automatic mode takes account of:

- the position and speed of pressing the accelerator pedal to assess driving style and select the optimum gear,
- the position and speed of pressing the brake pedal to start engine braking in preparation for a downshift.

If the engine is being overrevved or underrevved, the system will select the optimal gear.

When stopped at traffic lights, with the gear engaged, you can keep the vehicle stationary by pressing the brake pedal without changing to neutral **N**.

The vehicle will move off again:

- either slowly, if you release the brake (Creeping) without accelerating (e.g. when in a traffic jam),
- or quickly, if you release the brake and accelerate.

### Economical driving

When driving, always leave the lever in position **D**, keeping the accelerator pedal lightly pressed to ensure automatic gear changes at a lower engine speed.

It is recommended to shift to Manual mode from Auto mode with most adopted gear, to have quick acceleration during overtaking.

### Accelerating and overtaking

- slowly press the accelerator pedal to accelerate gradually,
- **to obtain maximum vehicle performance regardless of the mode selected (automatic or manual), quickly press the accelerator pedal beyond the kickdown point.**

**The speed with which you press the pedal will allow you to upshift according to the vehicle's capabilities.**

Depending on the variant, if the warning message, "GEARBOX OVERHEAT" appears on the cluster when driving, it means the clutch gets overheated and creeping gets deactivated.

To avoid getting the message,

- use parking brake to move the vehicle in slope;
- do not press the brake pedal/accelerator pedal simultaneously for long time;
- do not keep vehicle in standstill in slope using accelerator pedal;

If you are not doing any of above mentioned manoeuvres but the warning message, "GEARBOX OVERHEAT" appears, then contact your dealer

## CONTINUOUSLY VARIABLE TRANSMISSION (1/3)



Depending on the vehicle, the vehicle is either fitted with a continuously variable transmission.

### Selector lever 2

Display **A** on the instrument panel shows the mode and gear selected.

**P:** park

**R:** reverse gear

**N:** neutral

**D:** automatic mode

**L:** Low gear mode

: zone displaying gearbox mode.



### Operation

With gear lever **2** in position **P** or **N**, switch on the ignition.

With the foot on the brake pedal (warning light  on the display **A** goes out), move the lever out of position **P**.

**Only engage D or R when the vehicle is stopped, with your foot on the brake and the accelerator pedal released.**

**To move out of position P, you must depress the brake pedal before pressing the release button 1.**

### Creeping

It is a function that enables the vehicle to move slowly without pressing accelerator pedal. Follow the steps:

- Start the engine as instructed in 'Starting' section..
- With brake pedal pressed, shift the lever to D position.
- Release the parking brake and release the brake pedal gradually to activate creeping..

**Press brake pedal completely if any obstacles found.**

Once the vehicle is switched to ignition ON position, the gearbox initializes. This produces a light sound. This is normal. Crank the engine after 3 seconds.



## CONTINUOUSLY VARIABLE TRANSMISSION (2/3)

### Driving in automatic mode

Select position **D**. In the majority of traffic conditions, you will not have to touch the gear selector lever again: the gear will be changed automatically at the right time and at the most suitable engine speed because the automatic system takes into account the vehicle load and road contour and adjusts itself to the particular driving style you have chosen.

### Economical driving

When driving, leave the lever in position **D**, keeping the accelerator pedal lightly depressed to ensure automatic gear changes at comparatively low engine speeds.

### Accelerating and overtaking

Depress the accelerator pedal firmly and fully (so that it goes beyond the kickdown point).

**This will enable you to change down to the optimum gear within the engine range.**

### Special cases

Under certain driving conditions (eg. engine protection, or electronic stability program (ESP) operational etc.) the automatic system may change gear automatically.

Likewise, to prevent incorrect manoeuvres, a gear change may be refused by the automatic system: in this case the gear display flashes for a few seconds as a warning.

### Special circumstances

– **If the bends and road surface** do not allow you to stay in automatic mode (e.g. in the mountains), we recommend that you change to **L** mode.

This will prevent repeated gear changes when climbing and will enable engine braking on long descents.

– **In very cold weather**, to avoid stalling the engine, start the engine and wait a few seconds before moving the lever from position **P** or **N** to position **D** or **R**.

– **Vehicles not fitted with traction control**: to avoid wheelspin when starting on a slippery or low grip surface, change to **L** mode before moving off.

## CONTINUOUSLY VARIABLE TRANSMISSION (3/3)

### Parking the vehicle

When the vehicle is stopped, move the lever to position **P** while keeping your foot on the brake pedal: the gearbox is in neutral and the drive wheels are mechanically locked by the driveshaft..



An impact to the underside of the vehicle while reversing (e.g.: striking a post, raised kerb or other street furniture) may result in damage to the vehicle (e.g.: deformation of the rear axle).

To avoid any risk of accident, have your vehicle checked by an approved Dealer.

2.24

### Operating faults

**When setting off**, if the lever is locked in position **P** even though you are depressing the brake pedal, the lever can be released manually. To do this, unclip the cover at the base of the lever. Then simultaneously;

- press the button located under cover (using a flat-blade screwdriver or similar tool);
- depress the brake pedal;
- press button **1**.

Then shift the lever.

#### **Special note for vehicles equipped with continuously variable transmissions:**

Under certain driving conditions at high speeds, the gearbox may temporarily limit the maximum engine speed. This is normal.



For safety reasons, do not switch off the ignition before the vehicle has come to a complete standstill.



## PARKING DISTANCE CONTROL (1/2)

### Operating principle

Ultrasonic sensors, fitted in the vehicle's rear bumper, measure the distance between the vehicle and an obstacle when reversing.

This measurement is indicated by beeps which become more frequent the closer you come to the obstacle, until they become a continuous beep when the vehicle is approximately 35 centimetres from the obstacle.

There is a beep when reverse gear is engaged. If the beep sounds for a long time (3 seconds), this signals an operating fault.

**NB:** ensure that the ultrasonic sensors are not obscured (by dirt, mud, snow, etc.).



#### Note:

Depending on the vehicle, the screen **1** shows the vehicle surroundings alongside the beeps.



An impact to the underside of the vehicle while manoeuvring (e.g.: striking a post, raised kerb or other street furniture) may result in damage to the vehicle (e.g.: deformation of an axle).

To avoid any risk of accident, have your vehicle checked by an approved dealer.



#### Operation:

When reverse gear is selected, most objects which are less than approximately 1.20 metres from the rear of the vehicle are detected, a beep sounds and, depending on the vehicle, the display **1** comes on.

## PARKING DISTANCE CONTROL (2/2)

### Operating faults

When the system detects an operating fault, there will be a three-second continuous beep as a warning. Please consult an authorised dealer.



This function is an additional aid that uses sound to indicate the distance between the vehicle and an obstacle when manoeuvring. Therefore, it can under no circumstances replace the driver's care or responsibility whilst performing manoeuvres.

The driver should always look out for sudden hazards during driving: always ensure that there are no moving obstacles (such as a child, animal, pram or bicycle, etc.) or small, narrow objects such as stones or posts in your path when manoeuvring.





## REVERSING CAMERA (1/2)



### Operation

Depending on the variants, when using reverse gear, the camera 1 sends a view of the area behind the vehicle to the multimedia display 2 together with a static guide line.

This system is used with the aid of a fixed distance gauge. When the red zone is reached, stop the vehicle.



**Note:** make sure that the reversing camera is not obscured (by dirt, mud, snow, etc.).



This function is an additional aid. It cannot, therefore, under any circumstances replace the vigilance or the responsibility of the driver.

The driver should always pay attention to sudden incidents during driving: always ensure that there are no moving obstacles (such as a child, animal, pram, bicycle, etc.) or small, narrow objects such as stones or posts in your path when manoeuvring.

## REVERSING CAMERA (2/2)

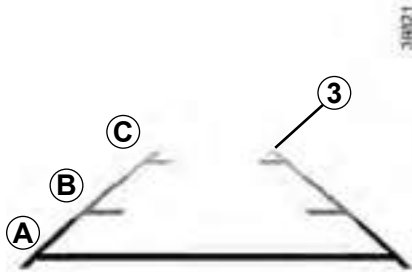

### Static guide line 3:

The static guide line **3** has coloured markers **A**, **B** and **C** showing the distance behind the vehicle:

- **A** (red) approximately 30 centimetres from the vehicle;
- **B** (yellow) approximately 70 centimetres from the vehicle;
- **C** (green) approximately 150 centimetres from the vehicle.

The screen shows a reverse image.

The frames are a representation projected onto flat ground; this information must not be taken into account when superimposed on a vertical object or an object on the ground.

Objects which appear on the edge of the screen may be deformed.

In very bright light (snow, vehicle in sunshine etc.), the camera vision may be adversely affected.

This gauge **3** remains fixed and indicates the vehicle trajectory if the wheels are in line with the vehicle.

The rear camera display will not work if the vehicle speed exceeds 30 Kmph



## Section 3: Your comfort

Multi-sense . . . . .	3.2
Air vents, air outlets . . . . .	3.3
Heating, Ventilation, Air conditioning . . . . .	3.5
Automatic climatic control . . . . .	3.7
Air conditioning: information and advice on use . . . . .	3.10
Windows . . . . .	3.11
Interior lighting . . . . .	3.13
Sun visor/Grab handle . . . . .	3.15
Passenger compartment storage . . . . .	3.16
Accessories socket . . . . .	3.18
Rear headrest . . . . .	3.19
Rear Bench seat . . . . .	3.20
Boot . . . . .	3.21
Rear parcel tray . . . . .	3.22
Longitudinal roof bars . . . . .	3.23
Multimedia equipment . . . . .	3.24



## MULTI-SENSE

The “MULTI-SENSE” system enables a choice between three driving modes that can be used to control driving, vehicle engine performance, steering effort (depending on the vehicle):

- the “Eco” and “Sport” modes are preconfigured and cannot be customised;

The drive modes affect the:

- power-assisted steering;
- Electronic Stability Program (depending on the vehicle);
- the response of the engine and gearbox.

They also affect the:

- information displayed on the multimedia screen and, depending on the mode selected, on the instrument panel. Please refer to the informations under, “Displays and indicators” in Section-1;
- depending on the vehicle, the engine performance;
- depending on the vehicle, the steering effort.

Engine settings are specific to each of the driving modes and cannot be customised.



### Accessing the menu

You can access “MULTI-SENSE” (depending on the vehicle) using the rotary switch **1**.

- If the rotary switch is rotated 45 degrees clockwise vehicle will be in **SPORT** mode;
- If the rotary switch is rotated 45 degrees counter clockwise vehicle will be in **ECO** mode;
- If the rotary switch is pushed down, vehicle will be in **NORMAL** mode;

### “Eco” mode

“Eco” mode focuses on energy saving. The steering is smooth, engine and gearbox management enable fuel consumption to be reduced.

### “Sport” mode

This mode enables an increased responsiveness from the engine and the gearbox. The steering is firmer.

After the engine is switched off, the vehicle will always restart in the **NORMAL** mode before engine gets switched off.



## AIR VENTS, air outlets (1/2)

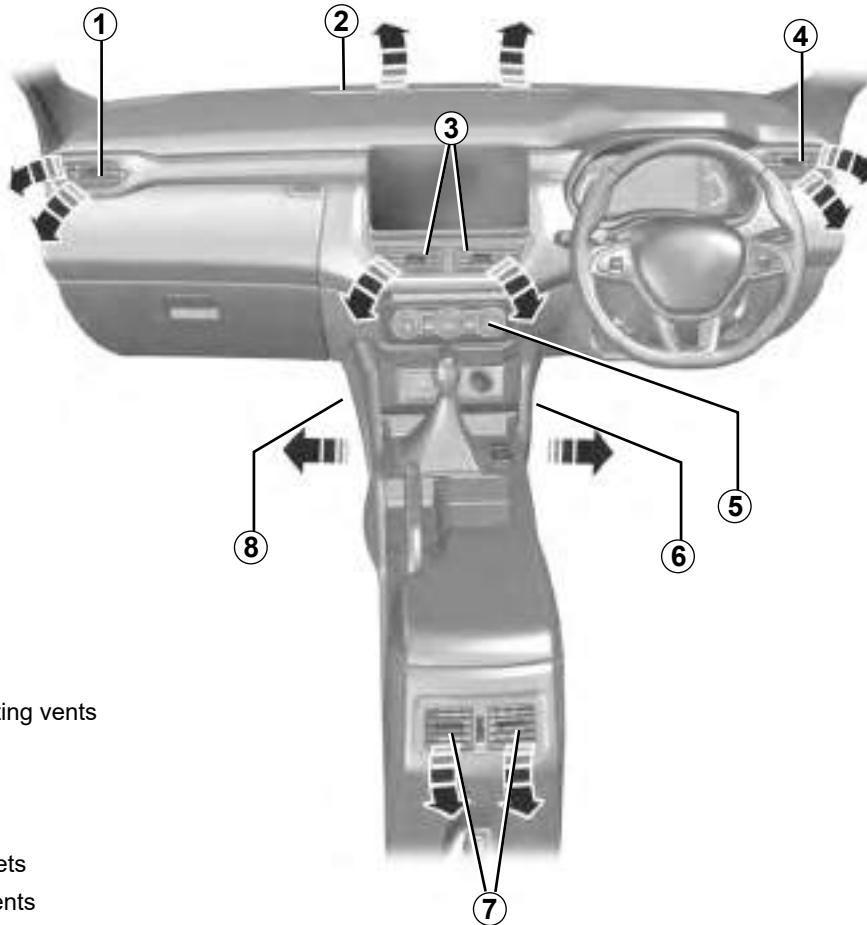

49538

- 1 Left side air vents
- 2 Windscreen demisting vents
- 3 Centre air vents
- 4 Right side vents
- 5 Control panel
- 6 Driver footwell outlets
- 7 Rear console air vents
- 8 Front passenger footwell outlets



## AIR VENTS, air outlets (2/2)

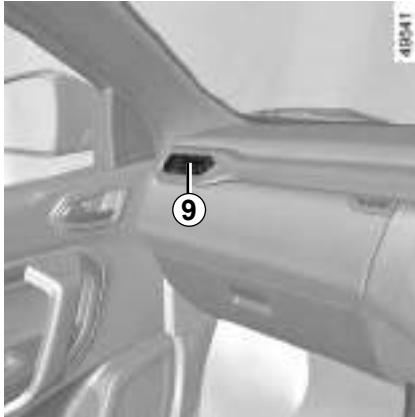

### Air flow

#### Lateral Air vents(Left and Right)

- To move the front vanes up/down, move the centre knob **9** upwards/downwards;
- To open/close the side vanes (inside the centre knob), move the centre knob **9** towards outside/innerside respectively;

Air vents are having rear fixation.To service air vents, complete Instrument panel assembly had to be disassembled.



### Centre Air Vents

(depends on the vehicle)

- To move the front vanes up/down, move the centre knob **10** upwards/downwards;
- To open/close the centre vanes (inside the centre knob), move the centre knob **10** towards outside/innerside respectively;

Air vents are having rear fixation.To service air vents, complete Instrument panel assembly had to be disassembled.

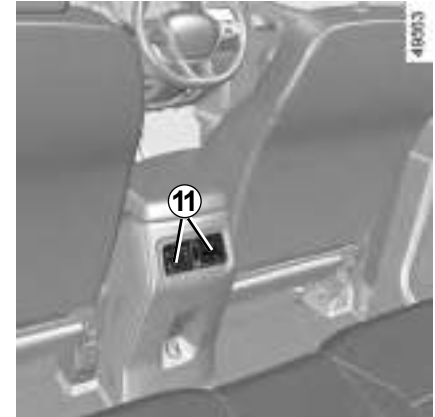

### Rear console Air Vents

(depends on the vehicle)

- To move the front vanes up/down, move the centre knob **11** upwards/downwards;
- To open/close the centre vanes (inside the centre knob), move the centre knob **11** towards outside/innerside respectively;

Air vents are having rear fixation.To service air vents, complete console assembly had to be disassembled.



## HEATING, VENTILATION, AIR CONDITIONING (1/2)

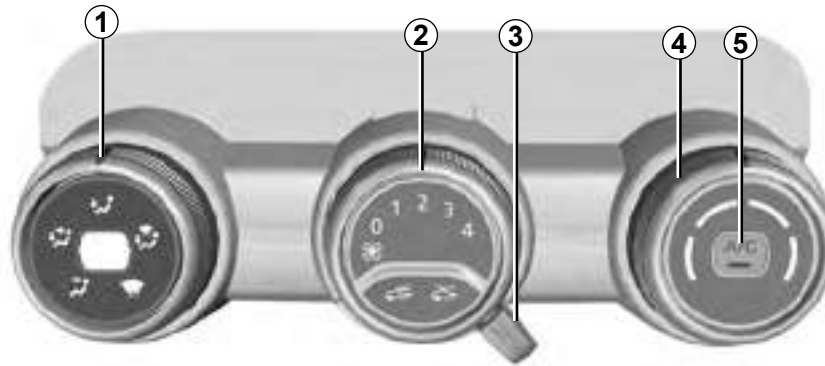

### Controls

The controls will depend on the vehicle equipment level.

- 1 Distribution of Air.
- 2 Adjusting the ventilation fan speed.
- 3 Switching passenger compartment to fresh air mode / air recirculation mode.
- 4 Air temperature adjuster
- 5 Switching air conditioning on/off (if light gets ON, it indicates the air conditioning system is ON).

**Information and advice on use:** refer to information on "Air conditioning: information and advice on use".

### Adjusting the air temperature

Turn control **4** to obtain the desired temperature. The further towards the red the slide is, the higher the temperature will be.

### Adjusting the ventilation fan speed.

Turn control **2** from 0 to 4. The further to the right it is positioned, the more air is blown into the passenger compartment. If you want to shut off the flow of air completely and stop the system, set control **2** to 0.

The system is deactivated: the ventilation speed for the passenger compartment air is zero (vehicle stationary), you can however still feel a slight flow of air when the vehicle is moving.

Leaving this control in position 0 for prolonged periods can lead to condensation forming on the side windows and windscreen and problems due to the use of non-renewed air in the passenger compartment.

## HEATING, VENTILATION, AIR CONDITIONING (2/2)

### Switching passenger compartment isolation mode/ air recirculation mode on.

Bring lever **3** to position .

Under these conditions, air is taken from the passenger compartment and is recirculated, with no air being taken from outside the vehicle.

### Air recirculation is used to:

- to isolate the passenger compartment from the external atmosphere.
- to bring the passenger compartment to the desired temperature as quickly as possible.

### Rapid demisting

- Turn control **4** on full hot position.
- Turn control **2** on max speed position 4.
- Turn control **1** to full defrost mode



- move slider knob **3** to fresh air mode.

Using the climate control increases the speed of demisting.

**Information and advice on use:** refer to information on “Air conditioning: information and advice on use”.

Prolonged use of air recirculation can lead to condensation forming on the windscreen, and discomfort due to the use of non-renewed air in the passenger compartment. You are therefore advised to pick-up external air as soon as the air recirculation function is no longer required, by sliding control **3** to the right.





## AUTOMATIC CLIMATE CONTROL (1/3)

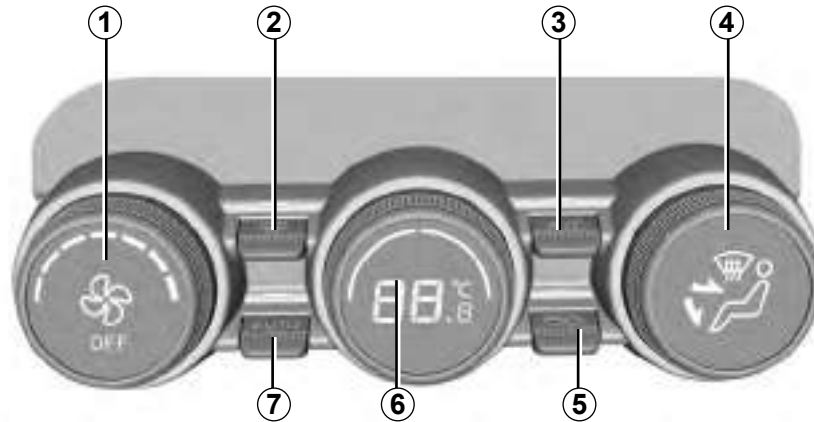

### The controls (depending on vehicle)

- 1 Adjusting the ventilation fan speed..
- 2 De-icing/demisting of the front screen and, depending on the vehicle, the door mirrors.
- 3 Air conditioning control.
- 4 Passenger compartment air distribution adjustment.
- 5 Air recirculation.
- 6 Air temperature adjuster.
- 7 Automatic mode.

### Automatic mode

The automatic climate control system guarantees comfort in the passenger compartment and good visibility (except in the event of extreme conditions), while optimising consumption. The system controls the ventilation speed, air distribution, air recirculation, and starting and stopping the air conditioning and air temperature.

**AUTO:** allows the selected comfort level to be best attained, depending on the exterior conditions. Press button 7.

### Varying the ventilation speed

In automatic mode, the system uses the most suitable amount of air to reach and maintain the desired comfort level.

You can still adjust the ventilation speed by turning control 1 to increase or reduce the ventilation speed.

### Adjusting the air temperature

Turn control 6 to obtain the desired temperature.

Turning the control to the right increases the temperature.

**Special note:** the maximum and minimum settings allow the system to produce a minimum or maximum temperature (19°C and 29°C).

## AUTOMATIC CLIMATE CONTROL (2/3)

### Switching air conditioning on or off

In automatic mode, the system switches the air conditioning system on or off, depending on the climate conditions.

Press button **3** to switch off the air conditioning; the integrated indicator comes on.

### Front screen de-icing/demisting

Press button **2** – the integrated indicator light comes on. This function enables rapid demisting or de-icing of the front screen and de-icing of the door mirrors (on equipped vehicles).

**To exit this function**, press button **2** again. Demisting automatically stops.

Depending on the vehicle, in the event of setting the “Wake up every 2 hours” remote starting function, the ventilation system must be stopped before leaving the vehicle.

Please see your vehicle’s multimedia instructions.

### Adjusting the distribution of air in the passenger compartment

By rotating the knob **4**, the integrated warning light in the button comes on.



The air flow is mainly distributed between the front side window demisting air vents and the windscreen demisting vents.



The air flow is mainly directed to the dashboard face air vents.



The air flow is directed mainly towards the footwells.



The air flow is directed towards the dashboard face airvents, the front footwells, depending on the vehicle, the second row footwells.



The air flow is distributed between front side window demisting vents, the windscreen demisting vents and the footwells.



## AUTOMATIC CLIMATE CONTROL (3/3)

### Air recirculation (isolation of the passenger compartment)



This function is managed automatically (operation is confirmed by a warning light on button **5**), but you can also activate it manually.

#### NB:

- during recirculation, air is taken from the passenger compartment and is recycled, with no air being taken from outside the vehicle;
- air recirculation allows the external atmosphere to be cut off (when driving in polluted areas, etc.);
- bringing the passenger compartment to the desired temperature as quickly as possible.

### Manual use

Press button **5** – the integrated indicator light comes on.

Prolonged use of this position may lead to odours, caused by non-renewal of air, and the formation of condensation on the windows.

We therefore advise you to return to automatic mode as soon as air recirculation is no longer needed, by pressing button **5**.

To exit this function, press button **5** or button **7** again.

### Stopping the system

Turn control **1** to “OFF” to stop the system. To start, turn control **1** again to adjust the blower speed or press button **7**.

The demisting/de-icing will still take priority over the air recirculation.

## AIR CONDITIONING: information and advice on use

### Fuel consumption

You will normally notice an increase in fuel consumption (especially when driving in town) when the air conditioning is operating.

### Advice for reducing consumption and helping to preserve the environment.

Drive with the air vents open and the windows closed.

If the vehicle has been parked in the sun, open the doors for a few moments to let the hot air escape before starting the engine.

### Maintenance

Refer to the Maintenance Document for your vehicle for the inspection frequency.

### Operating faults

As a general rule, contact your approved dealer in the event of an operating fault.

- **Reduction in de-icing, demisting or air conditioning performance.**  
Contact an approved dealer.
- **No cold air is being produced.**  
Check that the controls are set correctly and that the fuses are sound. Otherwise, switch off the system.

### Presence of water under the vehicle

After prolonged use of the air conditioning system, it is normal for water to be present under the vehicle. This is caused by condensation.



**Do not open the refrigerant fluid circuit.** The fluid may damage eyes or skin.



## WINDOWS (1/2)



### Electric window

Press/pull the switch to raise/lower the windows to the desired height (the rear windows do not open fully).

From the driver's seat, use

**1** for driver side;

**2** and **4** for rear passenger side;

**3** for driver to prevent operation of rear electric windows. A confirmation message will display in the cluster;

**5** for front passenger side.



### Electric window

Depending on the variants, use **6** to raise/lower the rear passenger windows to the desired height.



### Manual window winders

Depending on the variants, turn handle **7** to lower or raise the window to the desired height.



## WINDOWS (2/2)

### One-touch mode

Depending on the vehicle, this mode works in addition to the operation of the electric windows described previously. It is only fitted to the driver's window. Briefly press or pull switch 1 fully: the window is fully lowered or raised. Pressing the switch again stops the window moving.

Note: If the driver's window detects resistance when closing (e.g. tree branch, etc.), it stops and then lowers again by a few centimetres.



Avoid resting any objects against a half-open window: there is a risk that the electric window could be damaged.



### Driver's responsibility

If a body part gets trapped, reverse the direction of travel of the window as soon as possible by pressing the relevant switch. Never leave your vehicle with the key inside and never leave a child (or a pet) unsupervised, even for a short while. They may pose a risk to themselves or to others by starting the engine, activating equipment such as the electric windows or by locking the doors.

The system functions with the ignition off until one of the front doors is opened (limited to approximately 3 minutes).

## INTERIOR LIGHTING (1/2)

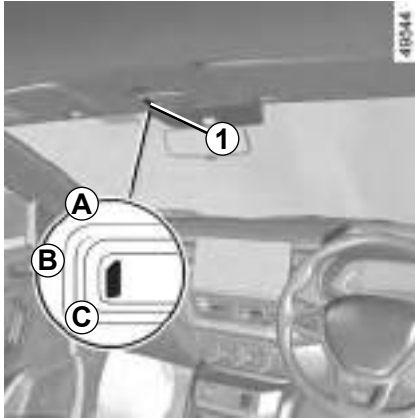

### Front Courtesy light

This feature depends on the vehicle version.

Press switch **1** to position

- **A** for switching **OFF** the light.
- **B** for auto-ON lighting, which activates when a door is opened and switches off when the doors have been closed correctly.
- **C** for switching **ON** the light.

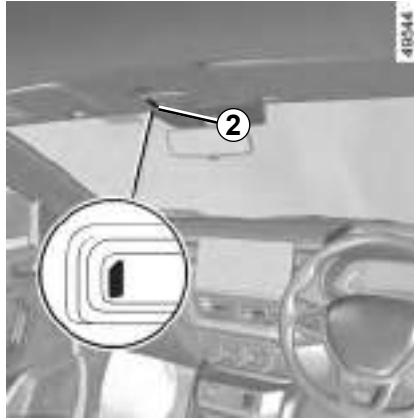

### Front Map reading light

This feature depends on the vehicle version.

Pressing switch **2** provides:

- Continuous lighting;
- no lighting.



## INTERIOR LIGHTING (2/2)



### Interior ambient light

This feature depends on the vehicle version.

Pressing switch **3** will activate/deactivate the interior ambient lighting. This will activate the lighting in door trims and in the centre console storage area.

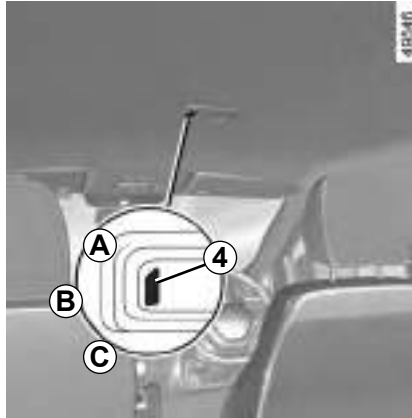

### Rear Courtesy light

This feature depends on the vehicle version.

Press switch **4** to position

- **A** for switching **OFF** the light.
- **B** for auto-ON lighting, which activates when a door is opened and switches off when the doors have been closed correctly.
- **C** for switching **ON** the light.





## SUN VISOR/GRAB HANDLE

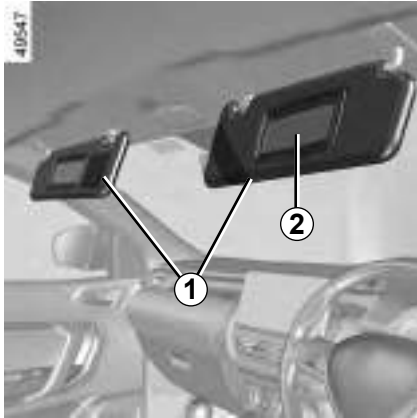

### Front sun visor

Lower the sun visor **1** over the wind-screen or unclip it and turn it over the side window.

### Courtesy mirrors

Depending on variants, it is fitted with courtesy mirrors **2**.

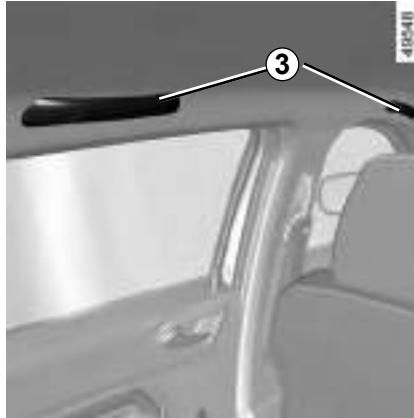

### Grab handle **3**

This offers support and can be held when the vehicle is being driven. Do not use it for getting into or out of the vehicle.



## PASSENGER COMPARTMENT STORAGE (1/2)



### Upper Glove Box

Depending on variant, Press **1** to open the upper glove box.

### Lower Glove box

Pull handle **2** to open lower glove box.



### Cooled Glovebox

Depending on the variant, opening/closing the valve **3** along the arrow direction will enable/disable the cooling inside glove box..

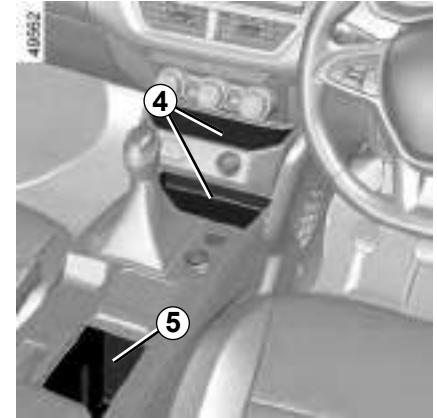

### Centre console - Front storage area **4**

### Centre console - Rear storage area **5**

Depending on the variant, slide the door frontward/backward to access the storage area **5**

## PASSENGER COMPARTMENT STORAGE (2/2)



### Front door storage 6

They can hold 1litre bottle.



### Rear door storage 7

They can hold 1litre bottle.



### Front seat storage 8

Depending on variants, front seat storage available behind the front seat backrest.



Ensure that no hard, heavy or pointed objects are placed in the “open” storage compartments in such a way that they may fall onto passengers during sudden turning, braking or in the event of an accident.



Nothing should be placed on the floor area in front of the driver as such objects may slide under the pedal during braking manoeuvres, thus obstructing its use.



## ACCESSORIES SOCKET

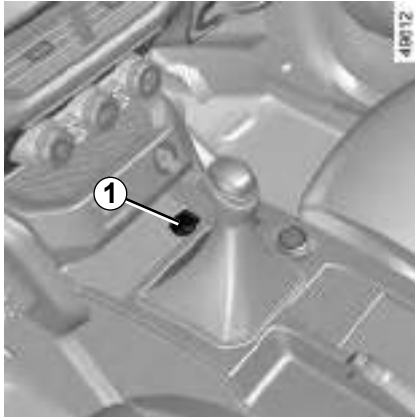

### Accessories socket 1,2

It is provided for connecting accessories approved by our technical department.

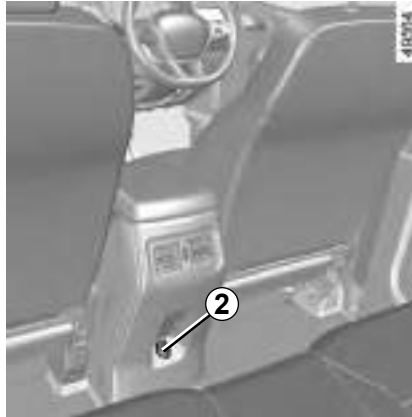

Connect accessories with a maximum power of 120 watts (12 V) only. When several accessory sockets are used at the same time, the total power of the connected accessories must not exceed 180 watts.

**Fire hazard.**



## REAR HEADRESTS

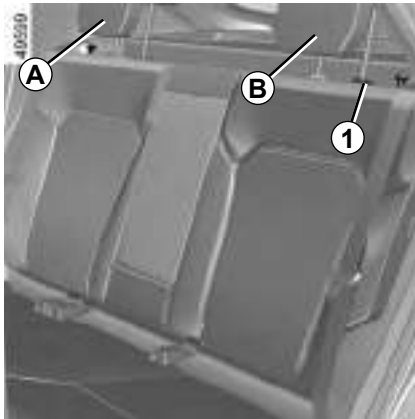

### To remove the headrests **A** or **B**

Raise the headrest as far as it will go, then press button **1** and remove the headrest.

### To adjust the height of the headrest **A** (depending on vehicle)

Press the button **1** and simultaneously slide the headrest to the desired height.

### To reinstall the headrests **A** or **B**

Insert the rods in the holes, press button **1**, lower the headrest and check that it is securely in place.



The headrest is a safety component. Ensure that it is fitted and in the correct position: the top of your head should be in line with the top of the headrest.

## REAR SEATS

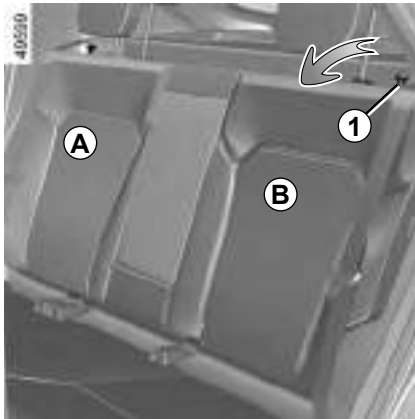

Depending on the vehicle, the seatback **A** or **B** may be folded away.

### To fold the back **A** or **B**

Ensure that the front seats are far enough forward.

Lower the rear headrests completely (refer to the information on the "Rear headrests" in Section 3).

Lift the knob **1** and fold back the seatback **A** or **B**.

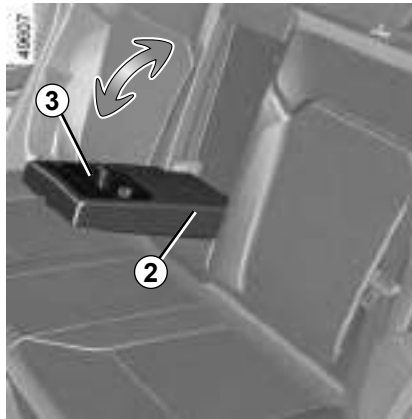

Depending on the vehicle, rear seat is fitted with armrest **2** and cup holder **3**.

Open/close the armrest **2** along the arrow direction to access the cup holder **3**.



Ensure the absence of objects in the armrest cavity before closing the armrest **2** to its initial position.

Always keep the arm rest in closed position when not in use.



When refitting the seatback, make sure it is correctly locked in place.

If seat covers are fitted, make sure these do not prevent the seatback latch from locking in. Make sure that the seat belts are positioned correctly.

Check that the rear seat belts are positioned and operating correctly each time the rear seat is moved.

Never allow anyone to ride in the luggage area or on second row seat when it is in the fold-down position. Use of these areas by passengers without proper restraints could result in serious injury in an accident or sudden stop.

Properly secure all luggage to help prevent it from sliding or shifting. Do not place luggage higher than the backrest.

When operating the backrest, be careful not to scratch or damage seat belts.



## BOOT



### To open

#### From the outside

Depending on the vehicle, press unlocking button in the Radio frequency remote control key (or) press Unlocking/locking the tailgate button in handsfree card and lift the tail gate.

(Refer to the instructions in chapter1)

### Opening the tail gate manually from the inside

If it is impossible to unlock the tailgate from outside, it can be done manually from inside;

- access the luggage compartment by tilting the rear bench seatback(s);
- insert a pencil or similar object in recess **1** and slide the unit as shown in the illustration;
- push the tail gate to open it.



### To open

#### From inside

Depending on the vehicle, press **2** to lock (or) unlock the tail gate.



The attaching of any carrying device (bike rack, luggage box etc) resting on the luggage compartment lid is prohibited. To install a carrying device on your vehicle, contact an authorised dealer.

## REAR PARCEL SHELF



### Rear Parcel shelf 2

(depending on the vehicle)

- Unhook the two straps **1** of the trunk door;

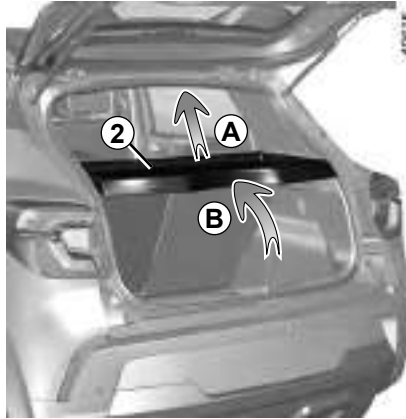

- Lift the parcel shelf **2** to certain height in the direction **A**;
- Incline the parcel shelf **2** along the direction **B** to certain angle and pull to remove the parcel shelf out from the vehicle.

To refit, proceed in the reverse order.



Do not place any objects, especially heavy or hard objects, on the parcel shelf. These may pose a risk to the vehicle occupants if the driver has to brake suddenly or if the vehicle is involved in an accident.





## LONGITUDINAL ROOF BARS



Depending on the vehicle, if fitted, you can transport luggage or additional equipment (bike racks, ski racks, etc):

- on a roof rack;
- on transverse roof bars which must in turn be attached to roof bars fitted lengthways **1**;
- directly onto the longitudinal roof bars.

It is forbidden to fit longitudinal roof bars on vehicles which are not originally equipped/ not recommended by manufacturer.



Depending on the vehicle, it is equipped with longitudinal style roof bars **2**. These roof bars are meant only for aesthetic purpose and do not carry any load.

For information on the range of equipment adapted to your vehicle, we advise you to consult an approved Dealer. Refer to the manufacturer's instructions for information on how to fit and operate the equipment.

Please keep these instructions with the rest of the vehicle document.

**Maximum permissible load on roof rack:** refer to the information on "Weights" in Section 6.

## MULTIMEDIA EQUIPMENT



The presence and location of this equipment depends on the vehicle's version and multimedia equipment.

- 1 Radio or navigation system.
- 2 Microphone.



### Hands-free telephone integrated control

On equipped vehicles, use microphone 2.

- In all cases, it is very important to follow the manufacturer's instructions carefully.
- The specifications of the brackets and wires (available from our network) vary depending on the equipment level of your vehicle and the type of radio. Consult your approved Dealer to find out the correct part number.
- No work may be carried out on the vehicle's electrical or radio circuits, except by approved Dealers: an incorrectly connected system may result in damage being caused to the electrical equipment and/or the components connected to it.

If your vehicle is not fitted with an audio system, one can be fitted and locations have been provided for the radio 1.

To install any equipment, please consult an authorised dealer.

Refer Multimedia manual for more details.



#### Using the telephone

We remind you of the need to conform to the legislation in force concerning the use of such equipment.

To use this equipment, consult the instructions for the equipment which should be kept with the other vehicle documentation.



# Section 4: Maintenance

Bonnet . . . . .	4.2
Engine Oil - Topping up, filling . . . . .	4.3
Levels : . . . . .	4.6
Brake fluid . . . . .	4.6
Windscreen washer . . . . .	4.6
Engine coolant . . . . .	4.7
Filters . . . . .	4.7
Battery . . . . .	4.8
Tyre pressure . . . . .	4.9
Bodywork maintenance . . . . .	4.10
Interior trim maintenance . . . . .	4.13
	4.1



# BONNET



To open the bonnet, pull the knob **1**.

## Unlocking the bonnet latch

To unlock, gently lift the bonnet and push tab **3** in the direction of arrow **A** to release the latch **2**.

## Opening the bonnet

Lift the bonnet; remove the Hood-Stay rod **4** from lock clip from the hood and place into the hole to hold the Hood open.



Do not press down on the bonnet: there is a risk that the bonnet may accidentally close.

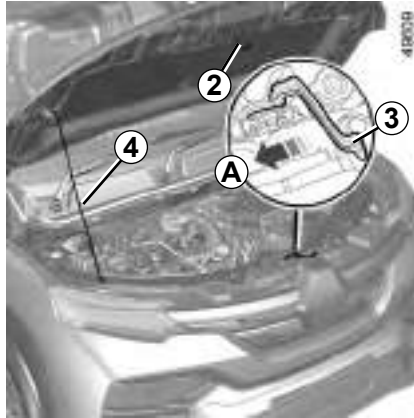

## Closing the bonnet

To close the bonnet again, remove the Hood-Stay rod **4** from the hole and place to the lock clip. Lower it to 20 cm above the closed position, then release it. It will latch automatically under its own weight.



The engine may be hot during operations in close proximity. In addition, the engine cooling fan may come on at any moment.

Risk of injury.



In the event of even a slight impact involving the radiator grille or bonnet, have the bonnet lock checked by an approved Dealer as soon as possible.



When working in the engine compartment, ensure that the windscreen wiper stalk is in the park position.

Risk of injury.



Ensure that the bonnet is properly locked. Ensure that nothing is preventing locking (grit, cloths, etc.).



Make sure nothing is left in the engine compartment (cloth, tools, etc.).

These may damage the engine or cause a fire.



## ENGINE OIL LEVEL: topping up, filling (1/3)

It is normal for an engine to use oil for lubrication and cooling of moving parts and it is normal to top up the level between oil changes.

However, contact your approved Dealer if more than 0.5 litres is being consumed every 1,000 kms after the running in period.

**Oil change frequency: check the oil level from time to time and certainly before any long journey to avoid the risk of damaging your engine.**

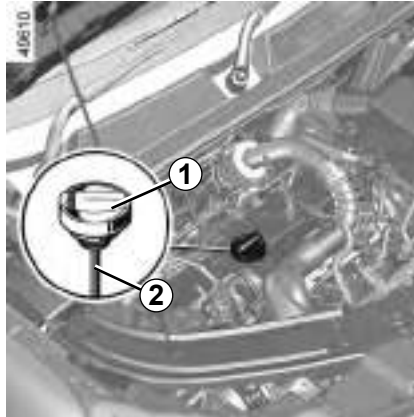

### Reading the oil level

- Remove the dipstick and wipe with a clean, lint-free cloth.
- Guide the dipstick in as far as it will go (for vehicles equipped with a cap-type dipstick, screw the cap in as far as it will go).
- Take out the dipstick again.
- Read the level: it should never fall below minimum mark or exceed maximum mark.

In order to prevent splashback, it is recommended that a funnel be used when topping up/filling with oil.

Consult your approved dealer at once if you notice an abnormal or repeated drop in any of the fluid levels.

Once the operation has been completed, ensure that the dipstick is guided in as far as it will go or that the “cap-type dipstick” is completely screwed in.



### Exceeding the maximum engine oil level

Under no circumstances must the maximum fill level be exceeded: risk of damage to the engine and catalytic converter. If the oil level exceeds the maximum level, **do not start your vehicle** and contact an approved Dealer.



Before performing any action in the engine compartment, the ignition must be switched off by pressing the engine stop button (please see the information on “Starting, stopping the engine” in Section 2).

## ENGINE OIL LEVEL: topping up, filling (2/3)

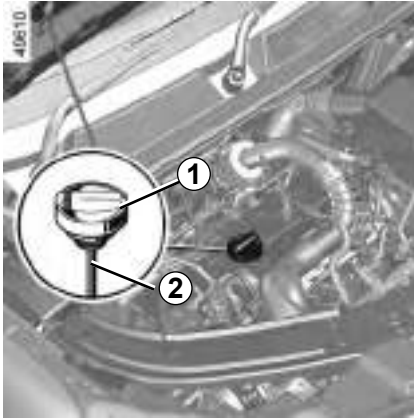

### Topping up/Filling

The vehicle must be parked on level ground and the engine should be cold (for instance, before the engine is started up for the first time in the day).

Do not exceed the **max** level and do not forget to refit cap **1**.

- Unscrew cap **1**.
- top up the level (as a guide, the capacity between the minimum and maximum reading on the dipstick **2** is approximately 0.85 litres, (depending on the engine).
- wait for approximately 20 minutes to allow the oil to flow into the engine.
- check the level using the dipstick **2** (as described above).

Once the level has been read, ensure that the "cap-type dipstick" is completely screwed in.

In order to prevent splashback, it is recommended that a funnel be used when topping up/filling with oil.

Consult an approved dealer at once if you notice an abnormal or repeated drop in any of the fluid levels.



Never run the engine in an enclosed space as exhaust gases are poisonous.



The engine may be hot during operations in close proximity. In addition, the engine cooling fan may come on at any moment.

Risk of injury.



**Engine oil change:** if you are changing the oil when the engine is hot, be careful not to scald yourself if the oil overflows.



## ENGINE OIL LEVEL: topping up, filling (3/3)

### Oil change

**Service interval:** refer to the Maintenance Document for your vehicle.

### Oil change capacity

Please refer to the maintenance document for your vehicle, or contact an authorised dealer.

Always check the engine oil level using the dipstick, as explained previously (it should never fall below the minimum.

### Engine oil grade

Refer to the maintenance document for your vehicle.



#### Exceeding the maximum engine oil level

The oil level should only be read with the dipstick as explained above. If the oil level exceeds the maximum level, **do not start your vehicle** and contact an approved dealer.



#### Filling:

Take care when topping up the oil that no oil drips onto engine components.

#### RISK OF FIRE

Remember to re-fit the cap securely as there is a risk of fire if oil splashes onto hot engine components.

## LEVELS (1/2)

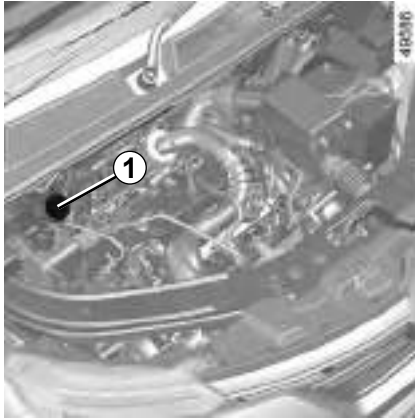

### Brake fluid level

This should be checked frequently, and immediately if you notice even the slightest loss in braking efficiency. The level should be read with the engine switched off and on level ground.



The engine may be hot during operations in close proximity. In addition, the engine cooling fan can come on at any moment.

Risk of Burns and Injury.

### Level 1

It is normal for the level to drop as the brake shoes become worn, but it must never drop lower than the “MIN” warning line shown on brake fluid reservoir.

If you wish to check the disc and drum wear yourself, you should obtain the document explaining the checking procedure from the approved dealer network or from the manufacturer’s web site.

### Topping Up

After any operation on the hydraulic circuit, a specialist must replace the fluid. Only use fluids approved by our Technical department and which have been taken from a sealed container.



Consult your approved dealer at once if you notice an abnormal or repeated drop in any of the fluid levels. No operations should be carried out on the cooling circuit when the engine is hot.



### Windscreen washer

#### Topping up

With the engine switched off, open the cap. Fill **2** until you can see the fluid, then replace the cap.

**Liquid:** Special windscreen washer fluid (antifreeze product for winter).

**Jets:** Use a tool such as a needle to adjust the height of the windscreen washer jets.





## LEVELS (2/2) / FILTERS

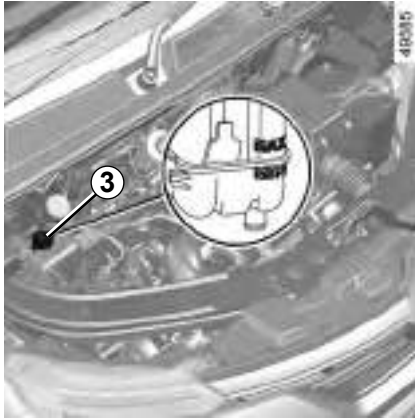

### Coolant

With the engine switched off and on ground level, the level **when cold** must be between the MIN and MAX marks on reservoir **3**.

Top this level up **when cold** before it reaches the MIN mark.



No operations should be carried out on the cooling circuit when the engine is hot.

**Risk of burns.**

### Checking intervals

**Check the coolant level regularly** (very severe damage is likely to be caused to the engine if it runs out of coolant).

If the level needs to be topped up, only use products approved by our Technical Department which ensure:

- protection against freezing.
- anti-corrosion protection of the cooling system.

### Replacement intervals

Refer to the Maintenance Schedule for your vehicle.

### Filters

The replacement of filter elements (air filter, cabin filter, fuel filter, etc.) is scheduled in the maintenance operations for your vehicle.

**Replacement intervals for filter elements:** please refer to your vehicle's maintenance schedule.



The engine may be hot during operations in close proximity. In addition, the engine cooling fan may come on at any moment.

**Risk of injury.**

Consult an approved dealer at once if you notice an abnormal or repeated drop in any of the fluid levels.

## BATTERY

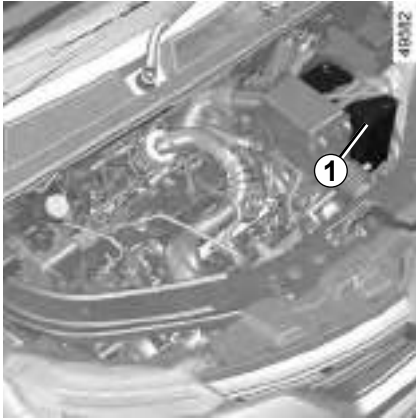

The battery **1** does not require any maintenance. **You must not open it or perform any added liquid.**



Handle the battery with care as it contains sulphuric acid, which must not come into contact with eyes or skin. If it does, wash the affected area with plenty of water and see a doctor if necessary.

Ensure that naked flames, red hot objects and sparks do not come into contact with the battery as there is a risk of explosion.

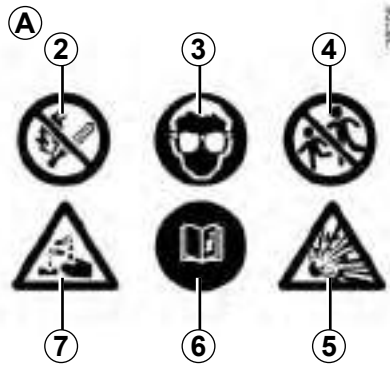

### Label A

Observe the indications on the battery:

- **2** Naked flames and smoking are forbidden.
- **3** Eye protection required.
- **4** Keep away from children.
- **5** Explosive materials.
- **6** Refer to the handbook.
- **7** Corrosive materials.

The charge status of your battery can decrease especially if you use your vehicle:

- for short journeys.
- for driving in town.
- when the temperature drops.
- after extended use of consumers (radio etc.) with the engine switched off;
- prolonged vehicle parking.

### Replacing the battery

As this operation is complex, we advise you to contact an approved Dealer.



The engine may be hot during operations in close proximity. In addition, the engine cooling fan may start at any moment.

Risk of injury.



## TYRE PRESSURE

Adhere to the tyre pressures (including the emergency spare wheel). The tyre pressures should be checked at least once a month and additionally before any long journey.

Tyre pressures should always be checked when the tyres are cold, ignore higher pressures which may be reached in hot weather or following a fast journey.

If the tyre pressures cannot be checked when the tyres are cold, increase the pressures from 0.2 to 0.3 bar (or 3 PSI).

### Never deflate a hot tyre.

Refer the tyre pressure labels 1 details pasted on the driver door of the vehicle.



### Special note for fully-loaded vehicles (maximum authorised load weight) and vehicles towing a trailer:

the maximum speed must be limited to **(62 mph) 100 km/h** and the tyre pressure increased by 0.2 bar.

Please refer to the information on "Weights" in Section 6.

### Risk of tyre blowouts.

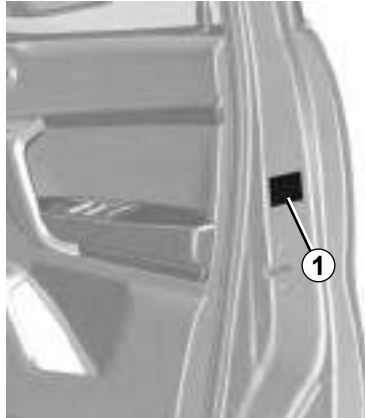

For your safety, please respect the speed limit.

When they need to be replaced, only tyres of the same make, size, type and profile should be used on a single axle.

They must: either have a load capacity and speed rating at least equal to those of the original tyres, or conform to those recommended by an authorised dealer. Failure to heed these instructions could endanger your safety and affect your vehicle's roadworthiness. Risk of loss of control of the vehicle.



**Incorrect tyre pressures** lead to abnormal tyre wear and unusually hot running.

These are factors which may affect safety and lead to poor road holding,

- risk of bursting or tread separation.
- The pressure depends on the load and the speed of use. Adjust the pressure according to the conditions of use.
- Please be aware that a poorly tightened or missing valve cap can make the tyres less airtight and lead to pressure loss.
- Always use valve caps identical to those fitted originally and tighten them fully.

## BODYWORK MAINTENANCE (1/3)

A well-maintained vehicle will last longer. It is therefore recommended to maintain the exterior of the vehicle regularly.

Your vehicle has been treated with very effective anti-corrosion products. It is nevertheless subject to various outside influences.

### Corrosive agents in the atmosphere

- atmospheric pollution (built-up and industrial areas);
- saline atmospheres (near the sea, particularly in hot weather);
- seasonal and damp weather conditions (e.g. road salt in winter, water from road cleaners, etc.).

### Minor impacts

#### Abrasive action

Dust and sand in the air, mud, road grit thrown up by other vehicles, etc.

You should take a number of minor precautions in order to safeguard your vehicle against such risks.

### You should

Wash your car frequently, **with the engine off**, with cleaning products recommended by the manufacturer (never use abrasive products). Rinse thoroughly beforehand with a jet:

- spots of tree resin and industrial grime;
- mud in the wheel arches and underneath the body which forms damp patches;
- **bird droppings**, which cause a chemical reaction with the paint that **rapidly discolours paintwork and may even cause the paint to peel off**;  
wash the vehicle **immediately** to remove these marks since it is impossible to remove them by polishing;
- salt, particularly in the wheel arches and underneath the body after driving in areas where the roads have been gritted.

Remove any plant matter (resin, leaves, etc.) from the vehicle regularly.

Respect local regulations about washing vehicles (e.g. do not wash your vehicle on a public highway).

Observe the vehicle stopping distances when driving on gravelled surfaces to prevent paint damage.

Repair, or have repaired quickly, areas where the paint has been damaged, to prevent corrosion spreading.

Remember to visit the body shop periodically in order to maintain your anti-corrosion warranty. Refer to the Maintenance Document.

If it is necessary to clean mechanical components, hinges, etc., spray them with products approved by our Technical Department to protect them after they have been cleaned.

We have selected special products to care for your vehicle and you can obtain these from the manufacturer's accessory outlets.



## BODYWORK MAINTENANCE (2/3)

### What you should not do

Wash the vehicle in bright sunlight or freezing temperatures.

Do not scrape off mud or dirt without pre-wetting.

Allow dirt to accumulate on the exterior.

Allow rust to form following minor impacts.

Do not use solvents not approved by our Technical Department to remove stains as this could damage the paintwork.

Do not drive in snow or muddy conditions without washing the vehicle, particularly under the wheel arches and body.



Degrease or clean using high-pressure cleaning equipment or by spraying on products not approved by our Technical Department:

- mechanical components (e.g.: engine compartment);
- underbody;
- parts with hinges (e.g.: inside the doors);
- painted plastic external fittings (e.g.: bumpers).

Doing this could give rise to corrosion or operational faults.

## BODYWORK MAINTENANCE (3/3)

### Vehicles with a matte paint finish

This type of paint requires certain precautions.

#### You should do the following

Wash the vehicle by hand using plenty of water, using a soft cloth or a gentle sponge.

#### Do not do the following

Use wax-based products (polishing).

Rub too hard.

Wash the vehicle in a roller-type car wash.

Attach stickers to the paintwork (risk of leaving marks).



Wash the vehicle using a high-pressure cleaning device.

### Using a roller type car wash

Return the wiper stalk to the park position. Check the mounting of external accessories, additional lights and rear view mirrors, and ensure that the wiper blades are secured with adhesive tape.

Remove the radio aerial mast if your vehicle is fitted with this equipment.

Remember to remove the tape and refit the antenna after washing.

### Cleaning the headlights, sensors and cameras

Use a soft cloth or cotton wool. If this does not clean them properly, moisten the cloth with soapy water, then wipe clean with a soft damp cloth or cotton wool.

Finally, carefully dry off with a soft dry cloth.

**Do not use cleaning products containing alcohol or utensils (e.g.: a scraper).**



## INTERIOR TRIM MAINTENANCE (1/2)

A well-maintained vehicle will last longer. It is therefore recommended to maintain the interior of the vehicle regularly.

A stain should always be dealt with swiftly.

Whatever type of stain is on the trim, use **cold** (or warm) **soapy water with natural soap**.

**Detergents (washing-up liquid, powdered products, alcohol-based products) should not be used.**

Use a soft cloth.

Rinse and soak up the excess.

### instrument panel

(e.g. instrument panel, clock, exterior temperature display, radio display, etc.)

Use a soft cloth (or cotton wool).

#### Caution:

No liquid cleaning agents and water should be used to clean the Instrument panel.

It is recommended to use only soft and dry cloth to clean the instrument panel as there is no glass screen on the same.

**Cleaning products containing alcohol must not be used under any circumstances.**

### Seat belts

These must be kept clean.

Use products selected by our Technical Department (Approved outlets) or warm, soapy water and a sponge and wipe with a dry cloth.

**Detergents or dyes must not be used under any circumstances.**

### Textiles (seats, door trim, etc)

Vacuum-clean the textiles **regularly**.

#### Liquid stain

Use soapy water.

Dab lightly (never rub) with a soft cloth, rinse and remove the excess.

#### Solid or semi-solid stain

Carefully remove the excess solid or pasty material **immediately** with a spatula (working from the edges to the centre to avoid spreading the stain). Clean in a similar way as a liquid stain.

#### Special instructions for sweets or chewing gum

Put an ice cube on the stain to solidify it, then proceed as for a solid stain.

For further recommendations for maintaining the interior, and/or for any unsatisfactory results, please see an authorised dealer.

## INTERIOR TRIM MAINTENANCE (2/2)

### Removal/replacing removable equipment originally fitted in the vehicle

If you need to remove equipment in order to clean the passenger compartment (for example, mats), always ensure that they are correctly refitted and they are at correct position. (The driver's mat should be fitted on the driver's side, etc.) and fit them with the components supplied with the equipment (for example, the driver mat should always be fixed using the pre-fitted mounting components).

With the vehicle stationary, ensure that nothing will impede driving (anything obstructing the pedals, heel wedged by the mat, etc.).

### You should not:

You are strongly advised not to position objects such as deodorants, scents, etc. near air vents, as this could damage your dashboard trim.



You are strongly recommended not to use high-pressure or spray cleaning equipment inside the passenger compartment: use of such equipment could impair the correct functioning of the electrical or electronic components in the vehicle, or have other detrimental effects.



Use high-pressure cleaning equipment or sprays inside the passenger compartment:

Without careful use, this equipment could impair the correct functioning of the electrical or electronic components in the vehicle, or have other detrimental effects.





# Section 5: Practical advice

Puncture, emergency spare wheel . . . . .	5.2
Wheel trim, tools . . . . .	5.4
Changing a wheel . . . . .	5.5
Tyres . . . . .	5.7
Front lights-Changing headlamps main bulbs . . . . .	5.10
Interior lighting - Changing the bulbs . . . . .	5.11
Exterior lighting - Changing the bulbs . . . . .	5.12
Fuses. . . . .	5.13
Battery - Troubleshooting . . . . .	5.17
Radio frequency remote control: batteries. . . . .	5.19
Hands free card: battery . . . . .	5.21
Windscreen wiper - lift/replace wiper blades . . . . .	5.23
Towing . . . . .	5.24
Accessories . . . . .	5.25
Operating faults . . . . .	5.26



## PUNCTURE, EMERGENCY SPARE (1/2)



### Spare Wheel

The spare wheel is located in the luggage compartment.

To access it :

- Have all passengers get out from the vehicle;
- Open the tail gate and lift the trunk carpet **1** as shown in the direction;
- Take the jack and wrench out from the vehicle;
- Unscrew the spare wheel lock **2**;
- remove emergency spare wheel **3**.



### To store the wheel in the storage location:

Repeat the steps in the reverse order to fit back the spare wheel in the same location.



If spare wheel is stored for long, get it checked by Dealer to ensure that it is safe to use.

- Never fit more than one emergency spare wheel to the same vehicle.
- Replace the emergency spare wheel as soon as possible with the original one.



## PUNCTURE, EMERGENCY SPARE (2/2)

**Note:** ensure that the emergency spare wheel or punctured wheel are correctly positioned. Check that the boot carpet is correctly positioned in its bump stops to prevent it from being damaged.



If the vehicle is parked on the hard shoulder, you must warn other road users of your vehicle's presence with a warning triangle or with other devices as per the legislation applying to the country you are in.



If the emergency spare wheel has been stored for several years, have it checked by your Dealer to ensure that it is safe to use.

### **Vehicle fitted with an emergency spare wheel that differs from the other wheels:**

- Never fit more than one emergency spare wheel to the same vehicle.
  - The punctured wheel is wider than the emergency spare wheel, so the height of the vehicle ground clearance is reduced.
  - Replace the emergency spare wheel as soon as possible with a wheel identical to the original one.
  - When this is fitted to the vehicle, which must only be a temporary measure, the driving speed must not exceed the speed indicated on the label on the wheel.
  - Fitting an emergency spare wheel may alter the way the vehicle usually runs.
- Avoid sudden acceleration or deceleration and reduce your speed when cornering.

## WHEEL TRIM, TOOLS

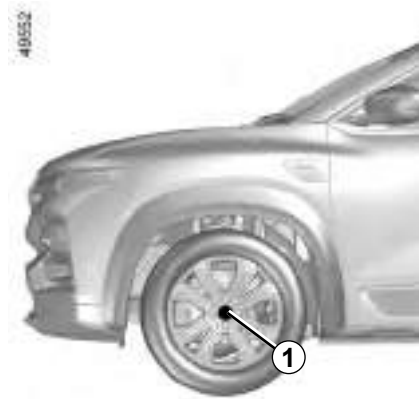

### Central wheel trim with visible wheel bolts

(example: wheel trim 1)

Depending on the version, the bolts are accessible directly or after removing the wheel cap.



### Accessing the tools

Jack 2 and wrench 3 are placed inside the spare wheel in the luggage compartment.

To access the tools, open the tail gate and lift the trunk carpet. Refer to the instructions in Chapter 5, "PUNCTURE, EMERGENCY SPARE".



Never leave tools unsecured in the vehicle: there is a risk that they may be thrown about during braking. After use, make sure the tools are correctly positioned in their housings: there is a risk of injury. The jack is designed for wheel changing purposes only. Under no circumstances should it be used for carrying out repairs underneath the vehicle or to gain access to the underside of the vehicle.



Jack must be placed only in specific places provided for it. Placing jack against Rear Axle or Front Transversal Link is strictly prohibited.



## CHANGING A WHEEL (1/2)



Switch on the hazard warning lights. Keep the vehicle away from traffic and on a level surface where it will not slip (if necessary, place a solid support under the jack base). Apply the parking brake and engage a gear (first or reverse).

Ask all passengers to leave the vehicle and keep them away from traffic. If the vehicle is parked on the hard shoulder, you must warn other road users of your vehicle's presence with a warning triangle.



### Removing the Wheel

Use the wheel wrench to loosen the wheel bolts by firmly holding the wrench and applying force to unscrew.

Remove all the bolts **A** completely to separate the wheel from the hub.



Place the jack under the body, and align it to the locating triangle markings. It is forbidden to lift the car by placing any jack under front control arms, rear axle and subframe.

Crank the jack using wheel wrench until the tyre raises up and sufficient.

## CHANGING A WHEEL (2/2)

### Refitting the Carwheel

By aligning one of the hole in the wheels to the hole in the wheel drum/disc.

Keep the wheel cover (on select variants) and wheel bolts handy, place and hold the wheel cover to align with the wheel holes.

Using the wrench, tighten the bolts evenly. Uncrank (release) the jack using wheel wrench till the jack becomes free from holding the vehicle anymore.

Now tighten the wheel bolts completely.

Place the punctured or removed wheel inside the spare wheel storage location and screw the spare wheel lock to hold the spare wheel tight.

Place the wheel wrench and jack in the same location.



If the vehicle is parked on the hard shoulder, you must warn other road users of your vehicle's presence with a warning triangle or with other devices as per the legislation applying to the country you are in.



If you have a puncture, replace the wheel as soon as possible. A tyre which has been punctured should always be inspected (and repaired, where possible) by a specialist."



## TYRES (1/3)

The tyres are the only contact between the vehicle and the road, so it is essential to keep them in good condition. You must make sure that your tyres conform to local road traffic regulations.



For your safety, please respect the speed limit.

When they need to be replaced, only tyres of the same make, size, type and profile should be used on a single axle.

**They must: either have a load capacity and a speed capacity at least equal to the original tyres, or correspond to those recommended by your authorised dealer.**

Failure to heed these instructions could endanger your safety and affect your vehicle's roadworthiness.

**Risk of loss of control of the vehicle.**



### Maintaining the tyres

The tyres must be in good condition and the tread form must have sufficient depth; tyres approved by our Technical Department have tread wear indicators **1** which are **indicators moulded into the tread at several points.**

When the tread has worn down to the wear warning strips, **these strips will become visible 2**: it is then necessary to replace your tyres because the tread rubber is now **only 1.6 mm deep at most, resulting in poor road holding on wet roads.**

An overloaded vehicle, long journeys by motorway, particularly in very hot weather, or continual driving on poorly surfaced minor roads will lead to more rapid tyre wear and affect safety.



Incidents which occur when driving, such as striking the kerb, may damage the tyres and wheel rims, and could also lead to misalignment of the front or rear axle geometry. In this case, have the condition of these checked by an approved dealer.

## TYRES (2/3)

### Tyre pressures

Adhere to the tyre pressures (including the emergency spare wheel). The tyre pressures should be checked at least once a month and additionally before any long journey (refer to the label affixed to the edge of the driver's door).



#### Incorrect tyre pressures

lead to abnormal tyre wear and unusually hot running.

These are factors which may seriously affect safety and lead to:

- poor road holding.
- risk of bursting or tread separation.

The pressure depends on the load and the speed of use. Adjust the pressure according to the conditions of use (refer to the label affixed to the edge of the driver's door).

The pressures should be checked cold: ignore higher pressures which may be reached in hot weather or following a high speed journey.

If the tyre pressures cannot be checked when the tyres are **cold**, increase the pressures from **0.2 to 0.3 bar** (or **3 PSI**).

**Never deflate a hot tyre.**

#### Special note

Depending on the vehicle, there may be an adapter which needs to be positioned on the valve before air is added.



Please be aware that a poorly tightened or missing valve cap can make the tyres less airtight and lead to pressure loss.

Always use valve caps identical to those fitted originally and tighten them fully.

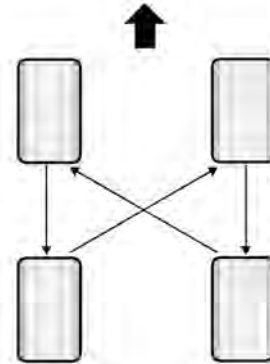

### Changing wheels around

Swap the wheels as shown in above picture with every regular intervals 12 months / 10000 Kms (which ever comes earlier).

Swapping needs to be done along with wheel balancing and wheel alignment.

#### Emergency spare wheel

Refer to the information on the “Emergency spare wheel” and “Changing a wheel” in Section 5.



## TYRES (3/3)



### Fitting new tyres

For safety reasons, this operation must be carried out by a specialist.

Fitting different tyres may change your vehicle as follows:

- it may mean that your vehicle no longer conforms to current regulations.
- it may change the way it handles when cornering.
- it may cause the steering to be heavy.
- It may affect the use of snow chains.



### Changing a wheel

As the tyre pressure monitor may take several minutes to correctly determine the positions of the wheels and the pressure values after driving, check the tyre pressures following any operation.

## Use in winter

### Chains

**For safety reasons, fitting snow chains to the rear axle is strictly forbidden.**

**Chains cannot be fitted** to tyres which are larger than those originally fitted to the vehicle.

### Snow or Winter tyres

We would recommend that these be fitted to all **four wheels** to ensure that your vehicle retains maximum adhesion.

**Warning:** These tyres sometimes have a specific direction of rotation and a maximum speed index which may be lower than the maximum speed of your vehicle.



Snow chains may only be fitted to tyres of the same size as those originally fitted to **your vehicle**.

## Studded tyres

This type of equipment may only be used for a limited period and as laid down by local legislation. It is necessary to observe the speed specified by current legislation.

These tyres must, at a minimum, be fitted to the two front wheels.

### Snow or Winter tyres

We recommend that these be fitted to all four wheelers to ensure that your vehicle remains maximum adhesion.

### Warning:

These tyres sometimes have a specific direction of rotation and a maximum speed index which may be lower than the maximum speed of your vehicle.

In all cases, we would recommend that you contact an authorised dealer who will be able to advise you on the choice of equipment which is most suitable for your vehicle.

## FRONT LIGHTS-CHANGING BULBS



### Main beam Headlights

- keep the engine in OFF condition;
- Tilt the steering towards right hand side completely to access the left side headlamp;
- Remove the flap/ cover **1** from the under fender/ Wheel;
- Remove head Lamp Dust cover **2** ;
- Disconnect the Bulb wiring harness;
- Unclip the spring and remove the bulb;
- Repeat the same process to access right side headlamp by tilting the steering towards left hand side.

**Bulb type: H7**

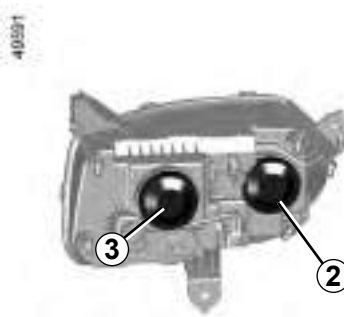

### Low beam Headlights

- keep the engine in OFF condition;
- Tilt the steering towards Right hand side completely to access the left side headlamp;
- Remove the flap/ cover **1** from the under fender/ Wheel;
- Remove head Lamp Dust cover **3** ;
- Disconnect the Bulb wiring harness;
- Unclip the spring and remove the bulb;
- Repeat the same process to access right side headlamp by tilting the steering towards left hand side.

**Bulb type: H7**

The headlamps can be replaced. However, we recommend you to have them replaced with an approved dealer, if it proves difficult. To comply with legislation, or as a precaution, you can obtain an emergency kit containing a set of spare bulbs and fuses from an approved dealer.



The engine may be hot during operations in close proximity. In addition, the engine cooling fan may come on at any moment.  
Risk of injury.



The bulbs are under pressure and can break when replaced.  
Risk of injury.



## INTERIOR LIGHTING: changing bulbs

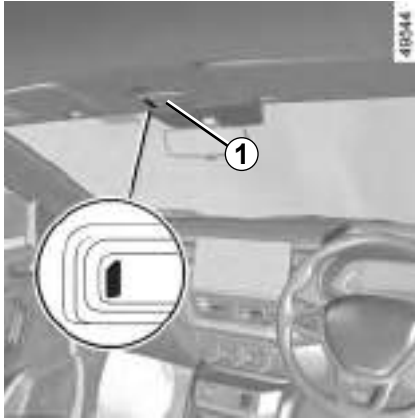

### Front lights 1

Please consult an authorised dealer.

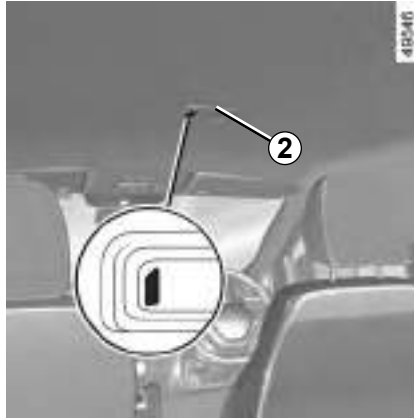

### Rear lights 2

Please consult an authorised dealer.



## EXTERIOR LIGHTS: changing bulbs



4100510

### Rear lighting 1 (Brake lights/ direction indicator lights/Reversing lights)

Please consult an authorised dealer.



4100557

### Direction indicator lights / LED daytime running lights 2

Please consult an authorised dealer.



The bulbs are under pressure and can break when replaced.

**Risk of injury.**



## FUSES (1/4)



### Passenger compartment fuses **A**

If any electrical component does not work, check the condition of the fuses. Pull the flap **A** from the lower edge to remove it to access the fuses.

To comply with current legislation, or as a precaution, you can obtain an emergency kit from your approved dealer containing a set of spare bulbs and fuses.

### Removing the fuses

Remove the fuse, located at the back of flap **A** from its position  
To remove the fuse, slide the fuse.  
It is not advisable to use the free fuse locations.



The engine may be hot when working in close proximity. In addition, the engine cooling fan may come on at any moment.

Risk of injury.



Check the fuse in question and replace it,  
If a fuse is fitted where the rating is too high, it may cause the electrical circuit to over-heat (risk of fire) in the event of an item of equipment using an excessive amount of current.

Allocation of fuses in the passenger compartment  
(presence of some fuses DEPENDS ON VEHICLE EQUIPMENT LEVEL)

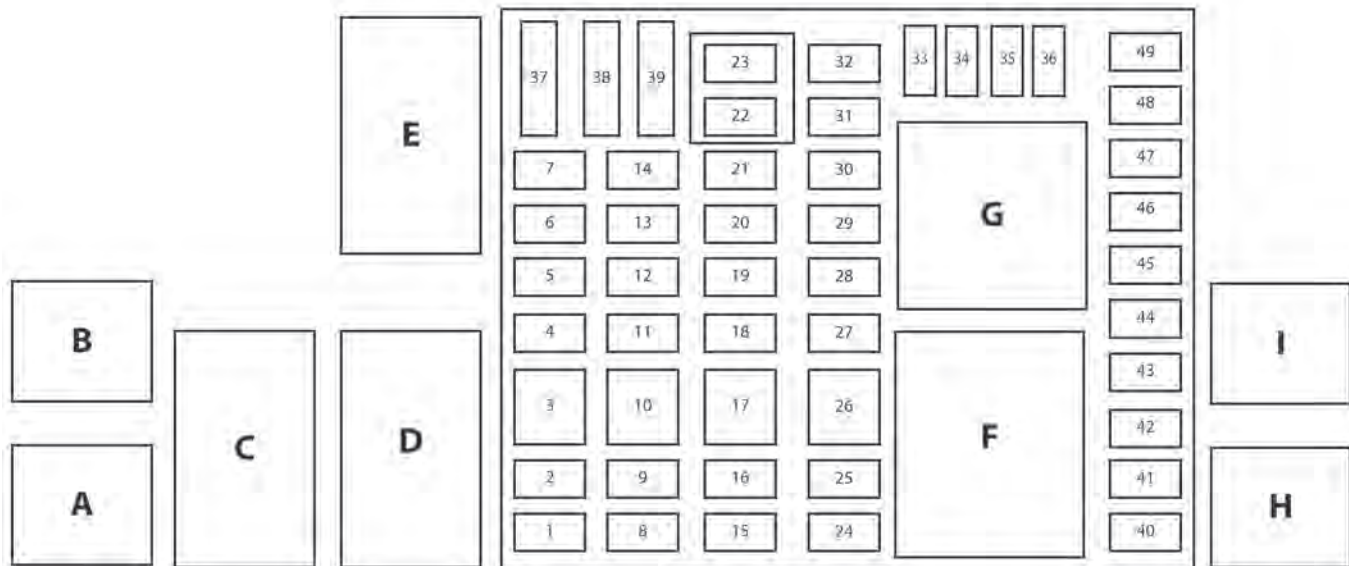

Number	Allocation
<b>A</b>	Defogger
<b>B</b>	Anti-pinch
<b>C</b>	Child safety
<b>D</b>	Power window - Front and Rear
<b>E</b>	Ignition primary supply
<b>F</b>	Power window - Front
<b>G</b>	Air conditioning - Manual/ Automatic
<b>H</b>	Backup light - Continuous variable transmission / Automated manual transmission
<b>I</b>	Accessory socket

Number	Allocation
<b>1</b>	Not used
<b>2</b>	Day light running light / Ambient lighting
<b>3</b>	Continuous variable transmission
<b>4</b>	Not used
<b>5</b>	Child safety
<b>6</b>	Rear power window
<b>7</b>	BCM/Multimedia/ Accessory socket/ Accessory relay coil
<b>8</b>	Hands free mode
<b>9</b>	Hands free mode
<b>10</b>	Not used
<b>11</b>	Starter - Non Handsfree mode variant
<b>12</b>	Roof lamp - Front/Rear / Anti-pinch relay coil / Power window relay coil / Automatic Air conditioning unit

Number	Allocation
<b>13</b>	Cluster
<b>14</b>	Combination switch
<b>15</b>	Radio/Ultra low cost navigation/BIA/Diagnostic socket
<b>16</b>	Combination switch
<b>17</b>	BCM
<b>18</b>	Horn
<b>19</b>	Door latch / Tail gate latch
<b>20</b>	BCM
<b>21 to 23</b>	Not used
<b>24</b>	BIA / Outer rear view mirror
<b>25</b>	Defogger relay coil / multifunction switch (defogger)
<b>26</b>	Backup light/Rear wiper washer/neutral sensor
<b>27</b>	Front wiper

Number	Allocation
<b>28</b>	Fuel pump relay coil/BCM/ ECU/Powertrain control unit/Gear shift lever/ Cluster
<b>29</b>	Electronic power steering
<b>30</b>	Airbag
<b>31</b>	Stop lamp
<b>32</b>	Transponder/Clutch travel end switch/stop lamp/ABS
<b>33</b>	Second row accessory socket
<b>34 to 36</b>	Not used
<b>37</b>	Air conditioning - Manual / Automatic
<b>38 to 41</b>	Not used
<b>42</b>	Anti pinch
<b>43</b>	Front anti-pinch power window

Number	Allocation
<b>44</b>	First row accessory socket
<b>45</b>	Position lamp
<b>46</b>	Right hand side low beam headlamp
<b>47</b>	Left hand side low beam headlamp
<b>48</b>	Right hand side high beam headlamp
<b>49</b>	Left hand side high beam headlamp



## BATTERY: troubleshooting (1/2)

### To avoid all risk of sparks:

- Ensure that all electrical equipments (courtesy lights, etc.) are switched off before disconnecting or reconnecting the battery.
- when charging, stop the charger before connecting or disconnecting the battery.
- to avoid creating a short circuit between the terminals, do not place metal objects on the battery.
- always wait at least one minute after the engine has been switched off before disconnecting a battery.
- make sure that you reconnect the battery terminals after refitting.

### Connecting a battery charger

**The battery charger must be compatible with a battery with nominal voltage of 12 volts.**

Do not disconnect the battery when the engine is running. **Follow the instructions given by the manufacturer of the battery charger you are using.**



Some batteries may have specific conditions for re-charging. Consult your approved dealer. Avoid the risk of sparks, as this could cause a sudden explosion, and always charge the battery in a well-ventilated area.

Risk of serious injury.



Handle the battery with care as it contains sulphuric acid, which must not come into contact with eyes or skin. If it does, wash the affected area with plenty of cold water and consult a doctor, if necessary.

Ensure that naked flames, red hot objects and sparks do not come into contact with the battery as there is a risk of explosion.

The engine may be hot when carrying out operations in close proximity. In addition, the engine cooling fan can come on at any moment.

Risk of injury.

## BATTERY: troubleshooting (2/2)

### Starting the vehicle using the battery from another vehicle

If you have to use the battery from another vehicle to start, obtain suitable jump leads (with a large cross section) from an approved dealer or, if you already have jump leads, ensure that they are in perfect condition.

**The two batteries must have an identical nominal voltage of 12 volts.** The battery supplying the current should have a capacity (amp-hours, Ah) which is at least the same as that of the discharged battery.

Ensure that there is no risk of contact between the two vehicles (risk of short circuiting when the positive terminals are connected) and that the discharged battery is properly connected. Switch off your vehicle ignition.

Start the engine of the vehicle supplying the current and run it at an intermediate engine speed.

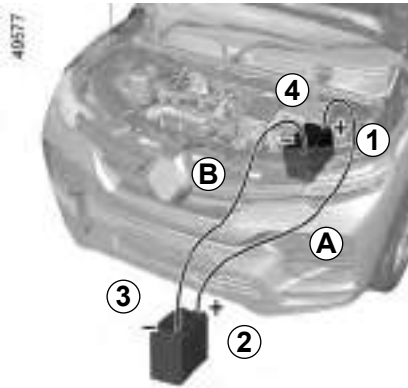

Connect the positive cable (+) **A** to the (+) terminal **1** of the discharged battery, then to the (+) terminal **2** of the battery supplying the current.

Connect the negative cable (-) **B** to the (-) **3** terminal of the battery supplying the current and then to the (-) **4** terminal of the discharged battery.

Start the engine as normal. As soon as it starts, disconnect cables **A** and **B** in reverse order (**4-3-2-1**).



Check that there is no contact between leads **A** and **B** and that the positive lead **A** is not touching any metal parts on the vehicle supplying the current.

Risk of serious injury and/or damage to the vehicle.

## RADIO FREQUENCY REMOTE CONTROL: batteries (1/2)

### Operating faults

If the battery is too weak to ensure correct operation, you can still start and lock/unlock the vehicle (please refer to the information on “Locking/unlocking the opening elements” in Section 1).



### Replacing the battery

Open the case at slot **1** using a flatblade screwdriver or similar, and replace the battery **2**, observing the type and polarity shown on the back of the cover.

Ensure that the cover is correctly clipped on and the screw tightened.

Note: It is not advisable to touch the electronic circuit in the key cover when replacing the battery.



When replacing:

– make sure that the batteries are correctly inserted.

#### Risk of explosion.

– if the flap does not close correctly, do not use and keep out of reach of children.



When they need to be replaced, be sure to use the same or equivalent type of battery (consult an approved Dealer).

## RADIO FREQUENCY REMOTE CONTROL: batteries (2/2)



### Precautions relating to batteries:

– keep (new or used) batteries out of reach of children;

– do not swallow batteries;

Risk of chemical burns which may prove fatal.

– if ingested or inserted into any part of the body, consult a doctor as soon as possible.



Do not throw away your used batteries; give them to an organisation responsible for collecting and recycling batteries.

The batteries are available from approved dealers, and their service life approximately two years. Check that there is no dye on the battery: risk of an incorrect electrical contact.

## HANDS FREE CARD:BATTERY (1/2)



### Replacing the battery

When the message “Keycard Battery Low” appears on the instrument panel, replace the battery in the card:

- slide the rear casing **1** downwards while pressing on zone **A**;
- remove the battery cover **2**;
- remove the battery by pressing on one side and lifting the other;
- replace it according to the direction and template shown inside the cover.



When refitting, proceed in the reverse order, then press one of the buttons on the card four times, close to the vehicle: the message will disappear.

Check that the cover is clipped shut.

**Note:** Do not touch the electronic circuit or contacts on the card when replacing the battery.



### Operating faults

If the battery is too weak to ensure correct operation, you can still start and lock/unlock the vehicle (please refer to the information on “Locking/unlocking the opening elements” in Section 1).

## HANDS FREE CARD: BATTERY (2/2)



When replacing:

- make sure that the batteries are correctly inserted.

Risk of explosion.

- if the flap does not close correctly, do not use and keep out of reach of children.

Do not throw away your used batteries; give them to an organisation responsible for collecting and recycling batteries.

The batteries are available from approved dealers, and their service life approximately two years. Check that there is no dye on the battery: risk of an incorrect electrical contact.



**Precautions relating to batteries:**

- keep (new or used) batteries out of reach of children;

- do not swallow batteries;

Risk of chemical burns which may prove fatal.

- if ingested or inserted into any part of the body, consult a doctor as soon as possible.



When they need to be replaced, be sure to use the same or equivalent type of battery (consult an Approved Dealer).



## WINDSCREEN WIPER - TO LIFT/REPLACE WIPER BLADES

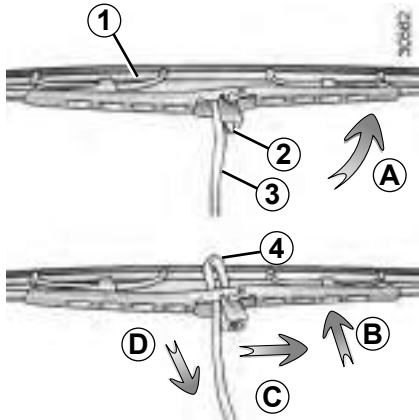

### Replacing windscreen wiper blades 1

- With the ignition off, lift wiper arm **3**.
- Turn the blade horizontally (movement **A**).
- Press tab **2** and slide the wiper blade downwards (movement **D**) until hook **4** on the wiper arm is released.
- Slide the blade (movement **C**) then lift it (movement **B**) to release it.

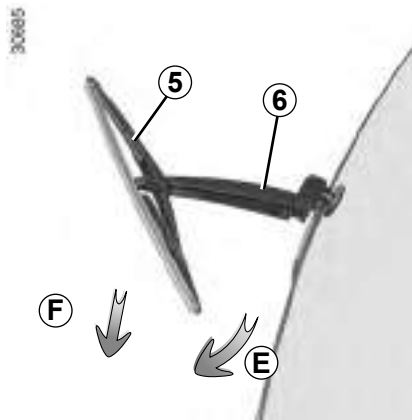

### Replacing the rear screen wiper blades 5

- With the ignition off, lift wiper arm **6**.
- Turn blade **5** until some resistance is met (movement **E**).
- Pull the blade to release it (movement **F**).

### Refitting windscreen wiper blades

To refit the wiper blade, proceed in the reverse order to removal. Make sure that the blade is correctly locked in position.

Check the condition of the wiper blades. You are responsible for their service life:

- clean the blades, windscreen and rear screen regularly with soapy water;
- do not use them when the windscreen or rear screen are dry;
- free them from the windscreen or rear screen when they have not been used for a long time.



- In frosty weather, make sure that the wiper blades are not stuck by ice (to avoid the risk of the motor overheating).

- Check the condition of the wiper blades.

Replace the wiper blades as soon as they begin to lose efficiency (approximately once a year).

While changing the blade, take care not to drop the arm onto the window after it has been removed as this may break the window.

## TOWING

40571

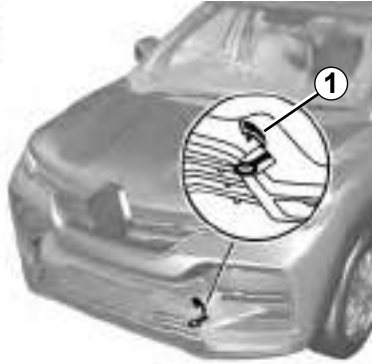

The steering wheel must be unlocked and the ignition key must be in ignition **ON** condition to provide brake lights and hazard warning lights on the towed vehicle. At night the vehicle must have its lights on.

### Front towing point.

Remove the tow hook cover **1** to access the tow hook. This towing point must only be used for towing: never use it for lifting the vehicle directly or indirectly.

Before towing, unlock the steering column. Press clutch and shift the gear lever to 1st gear (**N/R** in automatic transmission vehicle). Insert the Hands free card into the card reader, press and hold the engine start button for 2 seconds. Shift the gear lever to **N** (position **N** in automatic transmission vehicle). The steering column gets unlocked and accessory mode gets ON to have the brake lights and hazard warning lights ON in the towed vehicle.

Do not remove the Hands free card from the drive while towing.

Ensure the towing hook should be fitted completely until the end of thread.

Always pull straight ahead when using tow hooks. It is prohibited to pull the vehicle from sides or at a vertical angle.



Do not remove the key from the ignition when the vehicle is being towed.

When the engine is stopped, steering and braking assistance are not operational.

- Do not leave the tools unsecured inside the vehicle as they may come loose under braking;
- A vehicle must not be towed if it is not fit to be driven;
- Use a rigid towing bar. If a rope or cable is used, (where the law allows this), the vehicle being towed must be able to brake.



Do not leave the tools unsecured inside the vehicle as they may come loose under braking.



It is prohibited to hang the car to lower arm or Rear Axle. To hang car there is a specific place provided.





## ACCESSORIES



### **Electrical and electronic accessories**

Before installing this type of accessory, make sure it is compatible with your vehicle. You can get advice from an authorised dealer.

Connect accessories with a maximum power of 120 watts only. **Fire hazard.**

No work may be carried out on the vehicle's electrical or radio circuits, except by authorised dealers: an incorrectly connected system may result in damage being caused to the electrical equipment and/or the components connected to it.

If the vehicle is fitted with any aftermarket electrical equipment, make sure that the installation is correctly protected by a fuse. Establish the rating and position of this fuse.

### **Use of transmission/receiving devices (telephones, CB equipment etc.).**

Telephones and CB equipment with integrated aerials may cause interference to the electronic systems originally fitted to the vehicle: it is advisable only to use equipment with an external aerial. **Furthermore, we remind you of the need to conform to the legislation in force concerning the use of such equipment.**

### **Fitting after-market accessories**

If you wish to install accessories on the vehicle: please contact an authorised dealer. Also, to ensure the correct operation of your vehicle, and to avoid any risk to your safety, we recommend that you use only accessories specifically designed for your vehicle, which are the only accessories for which the manufacturer will provide a warranty.

If you are using an anti-theft device, only attach it to the brake pedal.

### **Obstructions to the driver**

On the driver's side, only use mats suitable for the vehicle, attached with the pre-fitted components, and check the fitting regularly. Do not lay one mat on top of another. **There is a risk of wedging the pedals.**



## OPERATING FAULTS (1/3)

The following advice will enable you to carry out quick, temporary repairs. For safety reasons you should always contact an approved dealer as soon as possible.

The starter is activated	POSSIBLE CAUSES	WHAT TO DO
Warning lights dim or fail to come on; the starter does not run.	Battery terminals disconnected, oxidised or incorrectly secured.	Retighten them, reconnect them or clean them if they are oxidised.
	Battery discharged or worn.	Connect another battery to the faulty battery. Refer to the information on "Battery: troubleshooting" in Section 5 or replace the battery if necessary. Do not push the vehicle if the steering column is locked.
The engine is not starting.	Starting conditions are not fulfilled.	Please refer to the information on "Starting, stopping the engine" in Section 2.
The steering column remains locked.	Steering wheel locked.	To unlock, gently move the key and the steering wheel (refer to the information on the "Ignition switch" in Section 2).
Traces of condensation in the lights.	This is not a fault. Traces of condensation are a natural phenomenon caused by variations in temperature. The traces will disappear slowly once the lights are switched on.	



## OPERATING FAULTS (2/3)

<b>On the road</b>	<b>POSSIBLE CAUSES</b>	<b>WHAT TO DO</b>
Vibrations.	Tyres not inflated to correct pressures, incorrectly balanced or damaged.	Check the tyre pressures; if this is not the cause, have their condition checked by an approved dealer.
Coolant boiling in the coolant reservoir.	Mechanical fault: cylinder head gasket damaged, faulty coolant pump.	Stop the engine. Contact an approved dealer.
	Engine cooling fan not working.	Contact an approved dealer.
Smoke under the bonnet.	Short circuit or cooling system leak.	Stop, switch off the ignition, move away from the vehicle and contact an approved dealer.
The oil pressure warning light comes on:		
on a bend or under braking	The engine oil level is too low.	Top up the engine oil level (refer to the information on "Engine oil level: topping up/filling" in Section 4).
at idle speed	Low oil pressure.	Go to your nearest approved dealer.
The oil pressure warning light takes a long time to go out or remains lit during acceleration.	Loss of oil pressure.	Stop the vehicle: contact an approved dealer.



## OPERATING FAULTS (3/3)

On the road	POSSIBLE CAUSES	WHAT TO DO
The engine overheats. The coolant temperature indicator light comes on.	Engine cooling fan not working.	Stop the vehicle, switch off the engine and contact an approved dealer.
	Coolant leaks.	Stop the vehicle, switch off the engine and check the coolant reservoir: it should contain fluid. If there is no coolant, consult an approved dealer as soon as possible.
The wiper does not work.	Wiper blade stuck.	Free the blades before using the wipers.
	Faulty electrical circuit.	Consult an approved dealer.
The wiper does not stop.	Faulty electrical controls.	Consult an approved dealer.
Direction indicators flashing more quickly.	Bulb blown.	Replace the bulb.
The direction indicators do not work.	Faulty electrical circuit.	Consult an approved dealer.
The headlights do not switch on or off.	Faulty electrical circuit or control.	Consult an approved dealer.
Abnormal white smoke from the exhaust	Mechanical fault: damaged cylinder head gasket.	Stop the engine. Contact an approved dealer.



**Radiator:** If there is a significant lack of coolant, remember that it must never be topped up using cold coolant while the engine is very warm. After any procedure on the vehicle which has involved even partial draining of the cooling system, it must be refilled with a new mixture prepared in the correct proportions. Reminder: only products approved by the Technical Department may be used for this purpose.

# ***Section 6: Technical specifications***

Vehicle Identification plates . . . . .	6.2
Engine Identification plates . . . . .	6.3
Engine specifications . . . . .	6.4
Dimensions . . . . .	6.5
Weights . . . . .	6.6
Replacement parts and repairs . . . . .	6.7
Service sheets . . . . .	6.8
Anticorrosion check . . . . .	6.14
	6.1



## VEHICLE IDENTIFICATION PLATES



The information shown on the vehicle identification plate should be quoted on all correspondence or orders.

Open up the bonnet to access the Vehicle Identification number Plate.

**Vehicle identification number A**  
Identification number.



Depending on the vehicle, Vehicle identification number **A** is located at the front driver lower side of the vehicle.



Depending on the vehicle, Vehicle identification number **A** is located at the front windscreen.



## ENGINE IDENTIFICATION PLATES

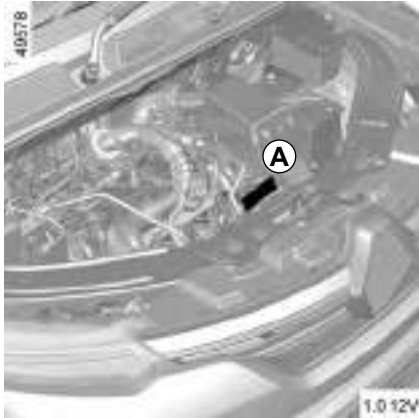

**Engine identification plate A**

Identification number

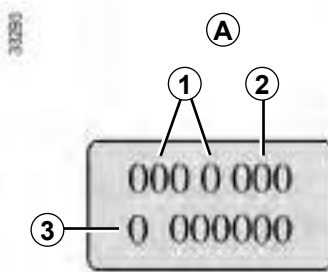

**Please quote the information on the engine plate or label A in all correspondence or orders.**

(Location varies depending on engine)

- 1 Engine type.
- 2 Engine suffix.
- 3 Engine number.

## ENGINE SPECIFICATIONS

<b>Versions</b>	<b>1.0 12V</b>	<b>1.0 12V</b>
<b>Engine type</b> (see engine plate)	BR10DE / B4D	HR10DET / H4Dt
<b>Cubic capacity (cc)</b>	999	
<b>Type of fuel octane rating</b>	Petrol. The use of unleaded petrol is essential. It is preferable to use fuel with octane rating 91 and higher.	
<b>Spark plugs</b>	Only use spark plugs specified for your vehicle's engine. The type should be marked on a label stuck inside the engine compartment. If it is not, then Contact your approved Dealer for replacement of Spark Plugs. Fitting spark plugs other than those specified may damage the engine.	





## DIMENSIONS (in metres)

40500

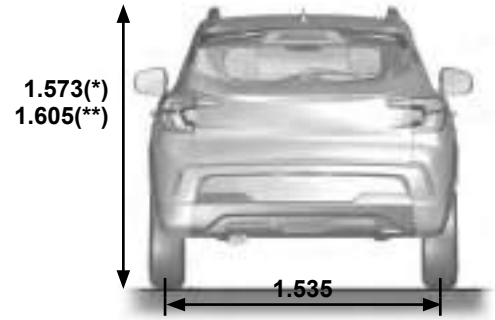
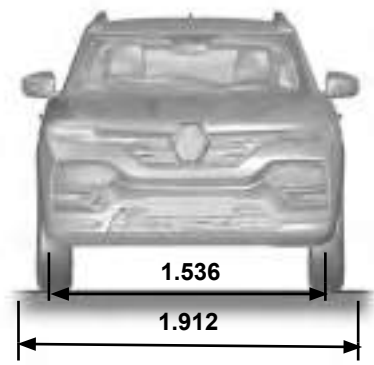
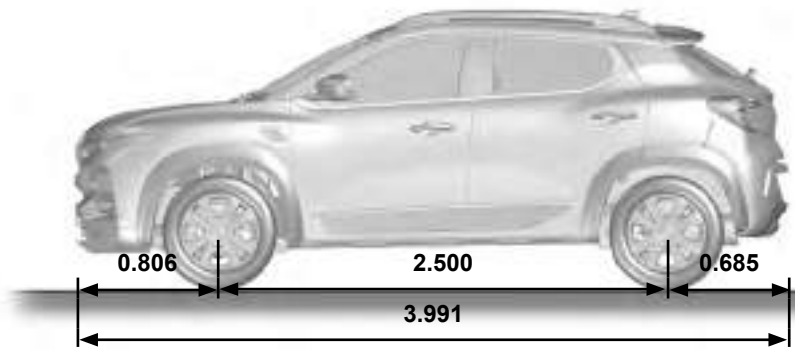

(\*) unladen - with Roof rail

(\*\*) unladen - with Shark antenna



## WEIGHTS (in kg)

The weights indicated for a basic vehicle without options: they vary depending on the your vehicle's equipment. Consult your approved Dealer.

<b>Minimum Weight - Unladen condition (Depending on vehicle)</b>	910 Kg
<b>Maximum Weight - Unladen condition (Depending on vehicle)</b>	1036 Kg
<b>Maximum Weight - Laden condition (Depending on vehicle)</b>	1461 Kg
<b>Maximum permissible load on roof (with carrying device)</b>	50 kg (maximum)



## **REPLACEMENT PARTS AND REPAIRS**

Original parts are based on strict specifications and are subject to highly specialized tests. Therefore, they are of at least the same level of quality as the parts fitted originally.

If you fit genuine replacement parts always to your vehicle, it will perform well. Furthermore, repairs carried out within manufacturers network using original parts are guaranteed according to the conditions set out on the reverse of repair order.



# SERVICE SHEETS (1/6)

VIN: .....

Date:		Miles (Km):	Invoice number:		Comments/miscellaneous
<b>Type of operation:</b>		<b>Stamp</b>			
Service <input type="checkbox"/>					
..... <input type="checkbox"/>					
<b>Anti-corrosion check:</b>					
OK <input type="checkbox"/> Not OK* <input type="checkbox"/>					
*See specific page					
Date:		Miles (Km):	Invoice number:		Comments/miscellaneous
<b>Type of operation:</b>		<b>Stamp</b>			
Service <input type="checkbox"/>					
..... <input type="checkbox"/>					
<b>Anti-corrosion check:</b>					
OK <input type="checkbox"/> Not OK* <input type="checkbox"/>					
*See specific page					
Date:		Miles (Km):	Invoice number:		Comments/miscellaneous
<b>Type of operation:</b>		<b>Stamp</b>			
Service <input type="checkbox"/>					
..... <input type="checkbox"/>					
<b>Anti-corrosion check:</b>					
OK <input type="checkbox"/> Not OK* <input type="checkbox"/>					
*See specific page					



# SERVICE SHEETS (2/6)

VIN: .....

Date:		Miles (Km):	Invoice number:	Comments/miscellaneous
<b>Type of operation:</b>		<b>Stamp</b>		
Service <input type="checkbox"/>				
..... <input type="checkbox"/>				
<b>Anti-corrosion check:</b>				
OK <input type="checkbox"/> Not OK* <input type="checkbox"/>				
*See specific page				
Date:		Miles (Km):	Invoice number:	Comments/miscellaneous
<b>Type of operation:</b>		<b>Stamp</b>		
Service <input type="checkbox"/>				
..... <input type="checkbox"/>				
<b>Anti-corrosion check:</b>				
OK <input type="checkbox"/> Not OK* <input type="checkbox"/>				
*See specific page				
Date:		Miles (Km):	Invoice number:	Comments/miscellaneous
<b>Type of operation:</b>		<b>Stamp</b>		
Service <input type="checkbox"/>				
..... <input type="checkbox"/>				
<b>Anti-corrosion check:</b>				
OK <input type="checkbox"/> Not OK* <input type="checkbox"/>				
*See specific page				



# SERVICE SHEETS (3/6)

VIN: .....

Date: _____ Miles (Km): _____		Invoice number: _____		Comments/miscellaneous	
<b>Type of operation:</b> Service <input type="checkbox"/> ..... <input type="checkbox"/>		<b>Stamp</b>			
<b>Anti-corrosion check:</b> OK <input type="checkbox"/> Not OK* <input type="checkbox"/> *See specific page					
Date: _____ Miles (Km): _____		Invoice number: _____		Comments/miscellaneous	
<b>Type of operation:</b> Service <input type="checkbox"/> ..... <input type="checkbox"/>		<b>Stamp</b>			
<b>Anti-corrosion check:</b> OK <input type="checkbox"/> Not OK* <input type="checkbox"/> *See specific page					
Date: _____ Miles (Km): _____		Invoice number: _____		Comments/miscellaneous	
<b>Type of operation:</b> Service <input type="checkbox"/> ..... <input type="checkbox"/>		<b>Stamp</b>			
<b>Anti-corrosion check:</b> OK <input type="checkbox"/> Not OK* <input type="checkbox"/> *See specific page					



# SERVICE SHEETS (4/6)

VIN: .....

Date: _____ Miles (Km): _____		Invoice number: _____		Comments/miscellaneous	
<b>Type of operation:</b> Service <input type="checkbox"/> ..... <input type="checkbox"/>		<b>Stamp</b>			
<b>Anti-corrosion check:</b> OK <input type="checkbox"/> Not OK* <input type="checkbox"/> *See specific page					
Date: _____ Miles (Km): _____		Invoice number: _____		Comments/miscellaneous	
<b>Type of operation:</b> Service <input type="checkbox"/> ..... <input type="checkbox"/>		<b>Stamp</b>			
<b>Anti-corrosion check:</b> OK <input type="checkbox"/> Not OK* <input type="checkbox"/> *See specific page					
Date: _____ Miles (Km): _____		Invoice number: _____		Comments/miscellaneous	
<b>Type of operation:</b> Service <input type="checkbox"/> ..... <input type="checkbox"/>		<b>Stamp</b>			
<b>Anti-corrosion check:</b> OK <input type="checkbox"/> Not OK* <input type="checkbox"/> *See specific page					



# SERVICE SHEETS (5/6)

VIN: .....

Date: _____ Miles (Km): _____		Invoice number: _____		Comments/miscellaneous	
<b>Type of operation:</b>		<b>Stamp</b>			
Service <input type="checkbox"/>					
..... <input type="checkbox"/>					
<b>Anti-corrosion check:</b>					
OK <input type="checkbox"/> Not OK* <input type="checkbox"/>					
*See specific page					
Date: _____ Miles (Km): _____		Invoice number: _____		Comments/miscellaneous	
<b>Type of operation:</b>		<b>Stamp</b>			
Service <input type="checkbox"/>					
..... <input type="checkbox"/>					
<b>Anti-corrosion check:</b>					
OK <input type="checkbox"/> Not OK* <input type="checkbox"/>					
*See specific page					
Date: _____ Miles (Km): _____		Invoice number: _____		Comments/miscellaneous	
<b>Type of operation:</b>		<b>Stamp</b>			
Service <input type="checkbox"/>					
..... <input type="checkbox"/>					
<b>Anti-corrosion check:</b>					
OK <input type="checkbox"/> Not OK* <input type="checkbox"/>					
*See specific page					





# SERVICE SHEETS (6/6)

VIN: .....

Date:		Miles (Km):	Invoice number:		Comments/miscellaneous
<b>Type of operation:</b>		<b>Stamp</b>			
Service <input type="checkbox"/>					
..... <input type="checkbox"/>					
<b>Anti-corrosion check:</b>					
OK <input type="checkbox"/> Not OK* <input type="checkbox"/>					
*See specific page					
Date:		Miles (Km):	Invoice number:		Comments/miscellaneous
<b>Type of operation:</b>		<b>Stamp</b>			
Service <input type="checkbox"/>					
..... <input type="checkbox"/>					
<b>Anti-corrosion check:</b>					
OK <input type="checkbox"/> Not OK* <input type="checkbox"/>					
*See specific page					
Date:		Miles (Km):	Invoice number:		Comments/miscellaneous
<b>Type of operation:</b>		<b>Stamp</b>			
Service <input type="checkbox"/>					
..... <input type="checkbox"/>					
<b>Anti-corrosion check:</b>					
OK <input type="checkbox"/> Not OK* <input type="checkbox"/>					
*See specific page					



# ANTICORROSION CHECK (1/5)

If the continuation of the warranty is subject to repair, it is indicated below.

VIN: .....

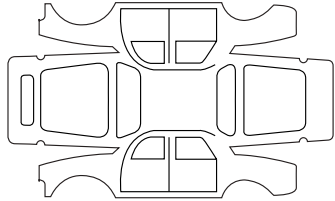
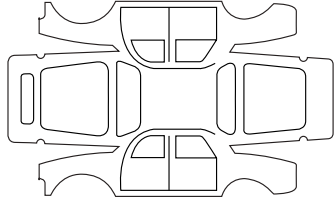
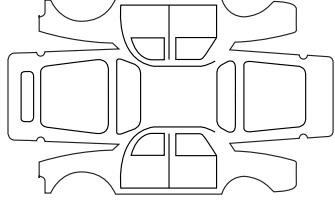
<b>Corrosion repair operation to be carried out:</b>		
<b>Date of repair:</b>		<b>Stamp</b>
<b>Repair to be carried out:</b>		
<b>Date of repair:</b>		<b>Stamp</b>
<b>Repair to be carried out:</b>		
<b>Date of repair:</b>		<b>Stamp</b>



# ANTICORROSION CHECK (2/5)

If the continuation of the warranty is subject to repair, it is indicated below.

VIN: .....

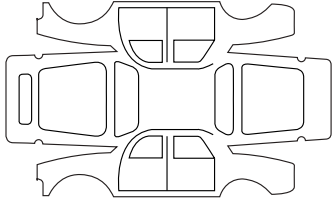
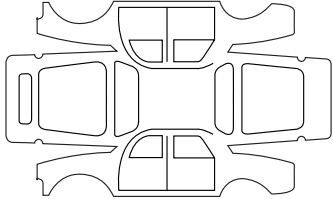
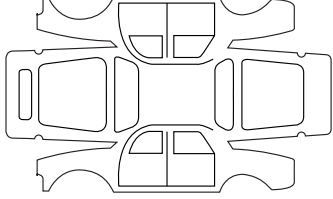
Corrosion repair operation to be carried out:		
Corrosion repair operation to be carried out:		Stamp
Date of repair:		
Repair to be carried out:		
Repair to be carried out:		Stamp
Date of repair:		
Repair to be carried out:		
Repair to be carried out:		Stamp
Date of repair:		



# ANTICORROSION CHECK (3/5)

If the continuation of the warranty is subject to repair, it is indicated below.

VIN: .....

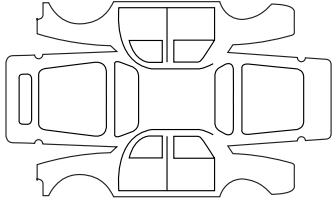
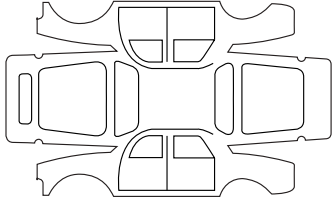
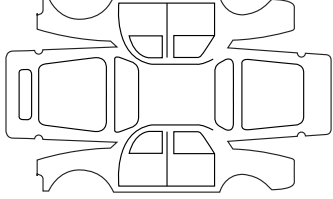
<b>Corrosion repair operation to be carried out:</b>		
<b>Date of repair:</b>		<b>Stamp</b>
<b>Repair to be carried out:</b>		
<b>Date of repair:</b>		<b>Stamp</b>
<b>Repair to be carried out:</b>		
<b>Date of repair:</b>		<b>Stamp</b>



# ANTICORROSION CHECK (4/5)

If the continuation of the warranty is subject to repair, it is indicated below.

VIN: .....

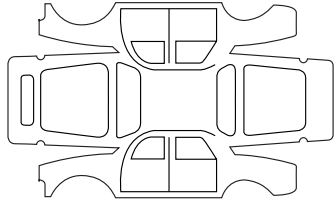
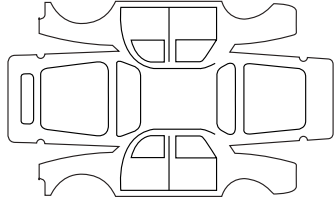
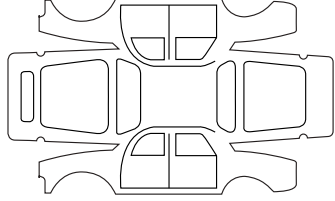
Corrosion repair operation to be carried out:		
Corrosion repair operation to be carried out:		Stamp
Date of repair:		
Repair to be carried out:		
Repair to be carried out:		Stamp
Date of repair:		
Repair to be carried out:		
Repair to be carried out:		Stamp
Date of repair:		



# ANTICORROSION CHECK (5/5)

If the continuation of the warranty is subject to repair, it is indicated below.

VIN: .....

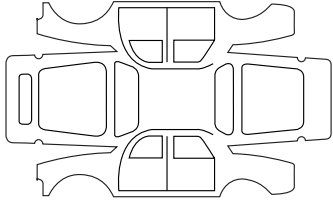
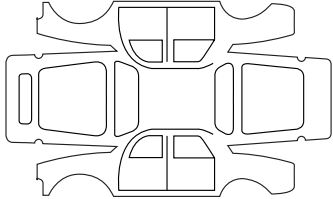
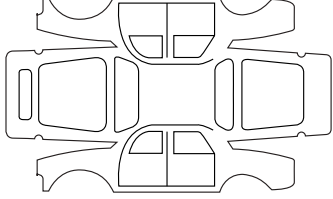
<b>Corrosion repair operation to be carried out:</b>		
<b>Date of repair:</b>		<b>Stamp</b>
<b>Repair to be carried out:</b>		
<b>Date of repair:</b>		<b>Stamp</b>
<b>Repair to be carried out:</b>		
<b>Date of repair:</b>		<b>Stamp</b>



## ALPHABETICAL INDEX (1/3)

- A**  
accessories..... 5.25  
accessories socket ..... 3.18  
adjusting your driving position ..... 1.19  
air bag..... 1.22 → 1.27  
air conditioning ..... 3.5 → 3.9  
air vents ..... 3.3 – 3.4  
anti-corrosion check ..... 6.14 → 6.18  
anti-corrosion protection ..... 4.10 → 4.12  
antipollution  
    advice ..... 2.16  
automated manual transmission..... 2.18 → 2.21  
automatic climatic control ..... 3.7 → 3.9  
automatic locking of doors..... 1.13
- B**  
battery..... 4.8  
    troubleshooting ..... 5.17 – 5.18  
battery (remote control) ..... 5.19 – 5.20  
battery (Renault card)..... 5.21 – 5.22  
bonnet..... 4.2  
brake fluid ..... 4.6
- C**  
central door locking ..... 1.12  
changing a wheel..... 5.5 – 5.6  
changing gear..... 2.8, 2.18 → 2.21, 2.22 → 2.24  
child safety : general information..... 1.29 – 1.30  
child safety : choosing a child seat mounting ..... 1.31 → 1.33  
child safety : fitting a child seat..... 1.34  
child seats : attachment by the seat belt ..... 1.35 – 1.36  
child seats : attachment using the ISOFIX ..... 1.37 – 1.38  
cleaning:  
    inside the vehicle ..... 4.13 – 4.14  
closing the doors ..... 1.14 – 1.15  
continuously variable transmission..... 2.22 → 2.24
- control instruments ..... 1.43 → 1.46  
courtesy light ..... 3.13 – 3.14
- D**  
dashboard..... 1.40 – 1.41  
dimensions ..... 6.5  
displays and indicators ..... 1.47 → 1.51  
doors..... 1.10 → 1.15  
driver correction devices/AIDS ..... 2.10 → 2.12  
driving... 1.40 – 1.41, 2.2, 2.3 → 2.7, 2.18 → 2.21, 2.22 → 2.24
- E**  
electric door locking..... 1.12  
electric windows ..... 3.11 – 3.12  
emergency spare wheel ..... 5.2 – 5.3  
engine  
    identification plates ..... 6.3  
    technical specifications ..... 6.4  
engine coolant ..... 4.7  
engine immobiliser  
    system ..... 1.16  
engine oil ..... 4.3 → 4.5  
engine oil capacity ..... 4.3 → 4.5  
engine oil grade ..... 4.3 → 4.5  
engine specifications ..... 6.4
- F**  
faults  
    operating faults ..... 5.26 → 5.28  
filter ..... 4.7  
fittings ..... 3.16 – 3.17  
front lights-changing head lamps main bulbs ..... 5.10  
front seat adjustment ..... 1.18  
front seats ..... 1.18  
fuel  
    advice on fuel economy ..... 2.13 → 2.15

## ALPHABETICAL INDEX (2/3)

grade.....	1.64
fuel economy .....	2.13 → 2.15
fuel filler cap .....	1.63
fuel grade.....	1.63 -1.64
fuel tank.....	1.63 -1.64
fuses.....	5.13 → 5.16

### G

gear lever.....	2.8
glove box.....	3.16
grab handle.....	3.15

### H

handbrake.....	2.8
hands-free telephone integrated control.....	3.24
Hands free card : general information .....	1.4 - 1.5
Hands free card : use .....	1.6 → 1.9
hazard warning lights signal .....	1.60
headlight beam adjustment .....	1.59
heating and air conditioning system .....	3.5 → 3.10
heating system .....	3.5 → 3.10
horn .....	1.60

### I

ignition switch .....	2.2
indicators:	
direction indicators.....	1.60
instrument panel .....	1.40 -1.41
instrument panel.....	1.40 -1.41
instrument panel messages.....	1.43 → 1.46
Interior lights - changing the bulbs.....	5.11
interior trim	
maintenance .....	4.13 - 4.14

### K

keys .....	1.2-1.3
------------	---------

7.2

### L

levels .....	4.6 - 4.7
lifting the vehicle	
changing a wheel.....	5.5 - 5.6
lighting	
exterior.....	1.58
Interior.....	3.13
lights .....	1.58
lights:	
dipped beam headlights.....	1.58
main beam headlights.....	1.58
side lights.....	1.58
locking the doors.....	1.10 → 1.13
longitudinal roof bars .....	3.23

### M

maintenance:	
bodywork .....	4.10 → 4.12
interior trim.....	4.13 - 4.14
mechanical.....	4.8, 6.7 → 6.18
multimedia equipment .....	3.24
multi-sense .....	3.2

### N

navigation .....	3.24
navigation system.....	3.24

### O

opening the doors.....	1.14-1.15
operating faults .....	5.26 → 5.28

### P

paintwork	
maintenance .....	4.10 → 4.12
parking distance control.....	2.25 → 2.26
practical advice.....	5.26 → 5.28





## ALPHABETICAL INDEX (3/3)

puncture..... 5.2 – 5.3

### R

radio frequency remote control/key  
    use ..... 1.3  
rear headrest ..... 3.19  
rear parcel shelf ..... 3.22  
rear seat ..... 3.20  
rear view mirrors ..... 1.39  
remote control door locking  
    batteries ..... 5.19 – 5.20  
remote control door locking unit ..... 1.11  
replacement parts ..... 6.7  
Reverse camera ..... 2.27 – 2.28  
reverse gear  
    selecting ..... 2.8, 2.18 → 2.21, 2.22 → 2.24  
running in ..... 2.2

### S

seat belts ..... 1.19 → 1.21  
sequential gearbox ..... 2.18 → 2.21  
service sheets ..... 6.8 → 6.13  
signals and lights ..... 1.58  
starting ..... 2.3 → 2.7  
starting the engine ..... 2.3 → 2.7  
steering wheel adjustment ..... 1.42  
storage compartment ..... 3.16 – 3.17  
sun visor ..... 3.15

### T

tailgate ..... 3.21  
tanks and reservoirs  
    brake fluid ..... 4.6  
    coolant ..... 4.7  
tanks and reservoirs:  
    windscreen washer ..... 4.6

technical specifications ..... 6.4  
telephone ..... 3.24  
tool kit ..... 5.4  
towing  
    breakdown ..... 5.24  
towing hitch ..... 5.24  
transporting children ..... 1.29 → 1.39  
trip computer and warning system ..... 1.52 → 1.56  
trunk door ..... 3.21  
tyre pressure ..... 4.9  
tyres ..... 4.10, 5.7 → 5.9

### V

vehicle identification plates ..... 6.2  
ventilation  
    heating and air conditioning system ..... 3.5 → 3.10

### W

warning lights ..... 1.43 → 1.46  
washing ..... 4.13 – 4.14  
weights ..... 6.6  
wheel trim ..... 5.4  
windows ..... 3.11 – 3.12  
windscreen washer ..... 1.61 – 1.62  
wipers ..... 1.61– 1.62, 5.23

7.4



# RENAULT NEW VEHICLE WARRANTY

## Terms & Conditions

### INDIA

- 1. Warning:** Your RENAULT vehicle is manufactured to meet the regulations and environmental requirements of the country where such RENAULT vehicle is originally sold. In case you relocate it to another country, it may be very difficult to make modifications to comply with the regulations and environmental requirements of that country and it may be difficult to perform repair service in that country. Please note that a RENAULT vehicle relocated to another country is not covered by the warranty.

## 2. The RENAULT New Vehicle Warranty

**2.1 Duration of Manufacturer's New Vehicle Warranty:** Vehicles in the Renault range, delivered as new from 1 May 2011 to the Customer by the authorised RENAULT DEALER, are warranted against any material, assembly or manufacturing defects by the Manufacturer New Vehicle Warranty for a duration of 2 years or 50,000 kilometers (whichever is earlier), starting from the delivery date shown in the Owner's Manual issued to the Customer upon delivery of the vehicle. Transfer of ownership does not alter the warranty period of a vehicle.

### 2.2 Geographical coverage:

**2.2.1** This warranty covers any new vehicle sold within geographical boundaries of INDIA.

**2.2.2** If the vehicle is to be driven and, more importantly, registered outside the geographical area defined above, such vehicle will not be covered under the current warranty as stated herein.

### **3. Field of application:**

- 3.1 **The Customer is covered for:** free repair (parts, consumables and labour) of any material or assembly defect duly found in the vehicle, at their own request, as well as any repairs on damage caused by this defect to other vehicle parts. It is the authorised RENAULT Dealer's discretion to decide whether it is appropriate to repair or replace the defective part, whilst keeping the Customer informed,
- 3.2 **24/7 assistance** services as defined in the "Renault Assistance" section under clause 6.
- 3.3 Original equipment Batteries, Tyres and Audio systems are warranted directly by the respective manufacturers. However, authorised RENAULT dealers shall provide assistance for dealing with the defects to the respective manufacturer.

### **4 The RENAULT New Vehicle Warranty does not cover and Renault India Private Limited (RIPL) and / or RENAULT authorised workshop shall not be responsible for the following:**

- 4.1 Normal maintenance services other than the three free services, including without limitation, cleaning and polishing, minor adjustments, engine tuning, oil/fluid changes, filters replenishment, fastener retightening, wheel balancing, wheel alignment and tyre rotation etc.
- 4.2 The indirect and remote consequences of any fault (loss of operation, duration of immobilization, etc.);
- 4.3 Vehicle components which have undergone conversion work, and/or specification and design changes and the consequences (deterioration, premature wear and tear, alterations, etc.) of the conversion work on other vehicle parts or components, or on its specifications;
- 4.4 The costs incurred by the Customer for routine maintenance

4.5 Replacement of parts due to normal wear and tear resulting from use of the vehicle or from its mileage including but not limited to clutch, shocker absorbers, wiper blades, brake drum, brake disk, brake pads, brake shoe, lamp, plugs, belts, linings, bulbs, fuses, parts made of rubber, etc.

**4.6 Damage or failure resulting due to the following causes:**

- 4.6.1 Poor vehicle maintenance, in particular if the instructions for the treatment, the frequency of maintenance or care to be applied to the vehicle set out in the Owner's Manual have not been observed;
- 4.6.2 Due to lack of use / operation of vehicle over prolonged period[s];
- 4.6.3 Misuse, abuse, negligence, improper driving habits, theft etc. of the vehicle;
- 4.6.4 Damage from stress, like use of vehicles in races, rallies, etc.,
- 4.6.5 Use of parts other than Renault Genuine Parts.
- 4.6.6 Any device and/or accessories not supplied by RIPL.
- 4.6.7 Modifications, alterations, tampering or improper repair.
- 4.6.8 Parts used in applications of which they were not designed or not approved by RIPL.
- 4.6.9 Slight irregularities not recognized as affecting quality or function of the vehicle or parts, such as slight noise or vibrations, or items considered characteristic of the vehicle.

**4.7 Damage caused by the following external causes:**

- 4.7.1 Accidents, impacts, scratches, scoring, projection of gravel or solid bodies, hail, acts of vandalism;
- 4.7.2 Failure to observe the Manufacturer recommendations;
- 4.7.3 Deposits due to atmospheric pollution, plant-based deposits such as resin, animal-based deposits such as bird droppings, chemical deposits;

- 4.7.4 Transportation of the vehicle;
- 4.7.5 Using an adulterated/ incorrect fuel;
- 4.7.6 Fitting accessories not approved by the Manufacturer;
- 4.7.7 Fitting accessories approved by the Manufacturer, but installed without observing the recommendations defined by the Manufacturer;
- 4.7.8 Damage due to airborne fallout, industrial fall out, acid rain, hail and wind storms, or other force majeure events like lightning, fire, floods, earthquakes, war, riots, attacks etc.;
- 4.7.9 Damage caused due to hydro-static lock.
- 4.7.10 Paint scratches, dents or similar paint or body damage.

4.8 **Incidental or consequential damages** , including without limitation, loss of time, inconvenience, loss of use of vehicle or commercial loss.

## **5 How does the RENAULT New Vehicle Warranty work?**

### **5.1 To be eligible for the RENAULT New Vehicle Warranty, the Customer must:**

- 5.1.1 check that the Owner's Manual does contain the delivery date of the vehicle - their warranty entitlement is dependent on this;
- 5.1.2 contact any member of the authorised RENAULT workshop – only such members have authorisation for operations of this sort;
- 5.1.3 show the duly completed Owner's Manual, as proof of entitlement to the warranty and that the maintenance operations recommended by the Manufacturer have been carried out;
- 5.1.4 have the defect covered by the RENAULT New Vehicle Warranty confirmed as soon as possible, by a Renault authorised workshop in writing. If the vehicle is un-roadworthy, the

Customer must contact the nearest RENAULT authorised workshop member or **Renault Assistance**.

**5.2 The RENAULT New Vehicle Warranty does not apply, and RIPL and RENAULT authorised dealer members are exempt from all liabilities, if:**

- 5.2.1** The vehicle has been driven under conditions not in accordance with those stated in the Owner's Manual (example: vehicle overloaded or taking part in any type of sports competition, etc.);
  - 5.2.2** The defect observed is due to the Customer having had the vehicle repaired or serviced in a workshop outside the RENAULT authorized network and not observing the manufacturer's recommendations on the subject.
- 5.3 By way of consideration for the parts supplied by RIPL under the RENAULT New Vehicle Warranty, parts replaced under this warranty legally become the property of RIPL.
- 5.4 All operations, parts and labour, carried out under the RENAULT New Vehicle Warranty are guaranteed until the new vehicle warranty expires.
- 5.5 Transferring ownership of the vehicle does not alter the application conditions of the RENAULT New Vehicle Warranty.

## **6 RENAULT Assistance**

- 6.1 **Renault Assistance:** **Renault Assistance** is a special assistance program provided by RIPL to the Customers, who have purchased Renault vehicles.
- 6.2 **Eligible parties:** The Customer, or the authorised driver, and all passengers accompanying this driver (limited in number to the number of vehicle seats stated on the certificate of vehicle registration) will be eligible for assistance under the conditions defined below.

6.3 **Intervening cause:** The vehicle is immobilized by a breakdown resulting from an unforeseen mechanical, electrical or electronic fault, covered by the Manufacturer's New Vehicle Warranty.

6.4 **Assistance service provider**

6.4.1 The Assistance services are exclusively provided by **Renault Assistance**.

6.4.2 RIPL and Renault authorized dealers shall not be liable to reimburse the Customer for the expenses/ cost of repair or replacement of any parts or any labour charges or any other expenses incidental or ancillary thereto, if the Customer does not avail the services of Renault Assistance as detailed herein.

6.4.3 Before calling **Renault Assistance**, the Customer should make a note of the following information so that the breakdown can be dealt with as efficiently as possible:

6.4.3.1 **Precise location of the breakdown:** road and number, motorway and milepost, visible landmarks, etc.

6.4.3.2 **Vehicle identification:** identification number - refer to sticker located on rear left side door quarter glass or stated in the Owner's Manual, vehicle registration number, engine type.

6.4.3.3 **Telephone number** on which the Customer can be reached.

6.4.4 On receiving the call from the Customer, and depending on the circumstances, **Renault Assistance** shall arrange and cover the costs of the services defined below:

6.4.4.1 The Customer will not be liable to pay any costs in advance, excluding any costs for connecting journeys and, taking into account current regulations, any towing costs in the event that the vehicle is towed on a motorway or similar highway. In this case, the Customer must advise **Renault Assistance** as soon as they exit the motorway or similar highway.

6.5 **WARNING: Renault Assistance** will not be liable for any costs accrued by the Customer without prior written consent from Renault.



6.6 **Roadside repair:** Where possible, **Renault Assistance** shall repair the vehicle at the roadside as soon as possible. If the vehicle cannot be repaired at the roadside and the vehicle must be towed, the driver and their passengers, as defined in the “Eligible parties” section, will be eligible for the following services:

**6.6.1 Towing:** The vehicle will be towed to the nearest RENAULT authorized workshop, or failing that, to the nearest garage where the repair can be carried out.

**6.6.2 Cab Assistance:** If customer vehicle is recovered to a dealer by Renault Assistance, the driver and passengers will be provided with one free cab ride, only up to 50 Kms., from the breakdown location, to facilitate them to continue their onward journey. Cost of travel beyond 50 Kms., from the breakdown location, and for any other expenses incurred by the Customer, shall be paid by the Customer and RIPL shall not be responsible or liable for it.

6.7 **Renault assistance** will be available in India except the following geographical areas:  
Arunachal Pradesh, Meghalaya, Manipur, Mizoram, Nagaland, Sikkim, Tripura, J &K, Andaman & Nicobar Islands and Lakshadweep.

## 7 The RENAULT Anticorrosion Warranty

7.1 **Duration of the Anticorrosion Warranty:** This warranty will apply from the delivery date given on the Owner's Manual for a period of 2 years or 50,000 kilometers (whichever is earlier), for vehicles in the RENAULT range.

7.2 **Geographical coverage:** The geographical coverage of the Anticorrosion Warranty is identical to that for the RENAULT New Vehicle Warranty.

### 7.3 Anticorrosion Warranty field of application

**7.3.1** In addition to the RENAULT New Vehicle Warranty, RENAULT guarantees the bodywork and sub frame of all RENAULT vehicles in the Schedule I from perforation from the interior, due to steel panel corrosion caused by a manufacturing, material or protective product application defect.

**7.3.2** This guarantee covers the repair or replacement of components with perforated steel panel work due to a manufacturing, material or protective product application defect, acknowledged by the Manufacturer.

**7.3.3** It is authorized RENAULT workshop's discretion to decide whether it is appropriate to repair or replace these components, and to inform the Customer.

**7.4 The Renault Anticorrosion Warranty does not cover:**

**7.4.1** any damage which is not covered by the RENAULT New Vehicle Warranty, as defined at the start of this booklet;

**7.4.2** Mechanical components which are not an integral part of the bodywork or sub-frame (wheel rims, exhaust system, etc.).

**7.5 Anticorrosion Warranty conditions of application**

**7.5.1** To obtain the Anticorrosion Warranty, the Customer must contact any member of the RENAULT authorized workshop network - only such members have authorization for operations of this sort.

**7.5.2** The Customer shall show the duly completed (delivery date and validation of anticorrosion test coupons) the Owner's Manual as proof of their warranty entitlement.

**7.5.3** Application of the RENAULT Anticorrosion Warranty is subject to the anticorrosion tests on the bodywork and sub-frame. Customer shall ensure that these tests are conducted at the mileage intervals stated in the Owner's Manual, and at least once in every two years. Scheduled maintenance services in the RENAULT authorized workshop network incorporate these tests.

**7.5.4** If the Customer requests to have the anticorrosion test conducted independently of the scheduled maintenance service, the same will be carried out at extra cost to the Customer.

**7.5.5** During these tests the Customer shall make sure that the professional carrying out the operation correctly completes the bodywork and sub frame test coupon, in order to validate the continuation of the Anticorrosion Warranty.

- 7.5.6 Repairs on any deterioration must be made as soon as possible.
- 7.5.7 The application of the RENAULT Anticorrosion Warranty is also subject to bodywork and sub-frame repairs being carried out in accordance with RENAULT recommendations.
- 7.5.8 The repair or replacement of components under the conditions described in the “field of application” (Paragraph 7.3), shall take into account the general condition of the vehicle with regard to its age, mileage and maintenance level.
- 7.5.9 Parts replaced under the Anticorrosion Warranty legally become the property of RENAULT.
- 7.5.10 Repairs and components fitted under the Anticorrosion Warranty are guaranteed until the end of the term of the original Anticorrosion Warranty.
- 7.5.11 Transferring ownership of the vehicle does not alter the application conditions of the Anticorrosion Warranty.

## 8 The RENAULT Paintwork Warranty

- 8.1 **Duration of the Paintwork Warranty:** RENAULT guarantees the bodywork paintwork and painted parts paintwork (door mirrors, bumpers) for 2 years or 50,000 kilometers (whichever is earlier) from the delivery date of the new vehicle, for vehicles in the RENAULT range.
- 8.2 **Geographical coverage:** The geographical coverage of the Paintwork Warranty is identical to that for the RENAULT New Vehicle Warranty.
- 8.3 **Paintwork Warranty field of application:**
  - 8.3.1 This warranty covers the free repair or replacement of components with paintwork defects (deterioration of lacquer or finishing varnish, due to any material, manufacturing or application defect) acknowledged by the Manufacturer, with the RENAULT authorized workshop carrying out the operation, keeping the Customer informed.
  - 8.3.2 This repair shall take into account the general condition of the vehicle with regard to its age, mileage and maintenance level.

#### **8.4 The RENAULT Paintwork Warranty does not cover:**

- 8.4.1** any damage which is not covered by The RENAULT New Vehicle Warranty, as defined at the start of this booklet;
- 8.4.2** damage due to force majeure events: lightning, fire, floods, earthquakes, war, riots and attacks;
- 8.4.3** Mechanical components which are not an integral part of the bodywork or sub-frame (wheel rims, exhaust system, etc.).
- 8.4.4** Damage due to action of road elements (sand, gravel, dust or road debris) which results in stone chipping of paint or glass.

#### **8.5 Paintwork Warranty conditions of application**

- 8.5.1** To obtain the Paintwork Warranty, the Customer must contact any member of the RENAULT authorized network - only such members have authorization for operations of this sort.
  - 8.5.2** The Customer shall show the duly completed (delivery date) Owner's Manual as proof of their entitlement to the warranty.
  - 8.5.3** By way of consideration for the parts supplied by RENAULT under the Paintwork Warranty, parts replaced under this warranty legally become the property of RENAULT.
  - 8.5.4** Repairs and components fitted under the Paintwork Warranty are guaranteed until the end of the term of the original Paintwork Warranty.
  - 8.5.5** Transferring ownership of the vehicle does not alter the application conditions of the Paintwork Warranty.
- 8.6** This warranty is the entire warranty given by RIPL and no dealer or its or his agent or employee is authorized to extend or enlarge this warranty and no dealer or its or his agent or employee is authorized to make any oral warranty on RIPL's behalf.
- 8.7** RIPL reserves the right to make any change in design or make any improvement on the vehicle at any time without any obligation to make the same change on vehicles previously sold.

8.8 Warranty service shall be provided only by RIPL's authorized dealers and Dealer Service Branch.

8.9 RIPL's decision is final and binding on the Owner of the vehicle in all warranty matters. RIPL reserves the right for the final decision on all warranty matters.

**9** All disputes arising out of this Warranty will be subject to the jurisdiction of Courts in Chennai only.

#### EXTENDED WARRANTY

Renault offers “ Renault Secure” Integrated Extended Warranty and Roadside Assistance Program on select models, in addition to the new vehicle warranty. Kindly Contact 1800 315 44 44 (Toll Free number) or your nearest Renault Dealer for more details.

Check for options and prices at <https://www.renault.co.in/renault-services/renault-secure.html>



# **MAINTENANCE APPENDIX**

## **INFORMATION ON THE MAINTENANCE PROGRAMME**

The maintenance program includes the RENAULT service and additional operations. To maintain the original quality of your RENAULT in terms of safety, comfort and performance, you must observe the maintenance program for your vehicle.

## **RENAULT SERVICE**

The RENAULT service applies to all RENAULT vehicles and always includes oil change, oil filter replacement, checks, top-ups and a check of your vehicle's electronic system. The RENAULT service is carried out at the service intervals specified in the maintenance program for your vehicle.

In addition to the service/oil change intervals set by RENAULT, the oil level should still be checked regularly. Your RENAULT dealer is at your disposal to carry out this operation and check other levels, safety parts and for any wear.

## **ADDITIONAL OPERATIONS**

The additional operations are customized to your vehicle: specific parts or fluids (in addition to the RENAULT service) will need to be replaced in accordance with the service intervals specified in the maintenance program for your vehicle. RENAULT reserves the right to modify its maintenance program at any time during the vehicle's life, within the framework of its vehicle development policy.

## **CERTAIN CONDITIONS OF USE**

RENAULT recommends that the frequency for replacing specific parts and fluids affected by certain conditions of use should be adapted accordingly.

Hereunder, the list of certain conditions of use and related new replacement frequency (replacement frequency means "when first of the two terms is reached").

- A) - At least 50% of journeys at an average speed less than 30 Km/h or with the engine running at idle speed (mainly urban use, taxis, driving school, door-to-door driving, etc),

- At least 30% of kilometers covered towing a trailer weighting more than 500 Kg,
- Driving in a dusty environment (building site, more than 1000 Km of trails per year,

<b>Operations</b>	<b>Frequency</b>
<b>Change engine oil, oil filter, air filter, fuel filter, cabin filter, belts and rollers (accessory and timing) <sup>(1) (2)</sup></b>	<b>Halve the kilometer frequency for recommended replacement in normal conditions of use,</b>
<p>For the following certain condition of use:            At least 50% of journeys with the engine running at idle speed, halve, as well, the time frequency replacement for oil and oil filter.</p>	

(1) The certain condition of use “driving in a dusty environment” does not modify the replacement frequency for belts (accessories and timing) as recommended replacement in normal condition of use.

(2) The damper pulleys for certain engines must be replaced during this operation. For more information, please consult your Renault representative.

- B) – Use of engine oil\* (for petrol and diesel engines without particles filter), which don’t correspond to RENAULT recommendations, (check maintenance pages),
- Prolonged use (+ 5000 Km / year) in temperatures bellow -15°C,
  - Use of fuels that don’t correspond to RENAULT recommendations, (See User Manual booklet).

**\* For diesel engines with Particles Filter, the use of an other engine oil than the one recommended by RENAULT may damage the Particles Filter**

<b>Operations</b>	<b>Frequency</b>
Change engine oil, oil filter	Halve the kilometer frequency for recommended replacement in normal conditions of use,

- C) – Four wheels drive vehicles (4WD): Prolonged use in rough driving conditions (trails, heavy rains...), in very



very humid areas or regular driving in water or mud,

<b>Operations</b>	<b>Frequency</b>
Change rear axle oil (4WD) Oil specification: TRANSELF UNIVERSAL FE 80W90	Every other engine oil change

## **RADIO FREQUENCY AND LOW FREQUENCY APPROVAL**

Any radio frequency or low frequency equipment fitted as standard in the RENAULT range complies with the essential requirements of the R & TTE Directive.

The countries that are covered by or agree to this directive are the countries of the European Union, the French overseas departments and territories, the French Southern and Antarctic Lands, the French territorial communities and:

Algeria, Andorra, Azerbaijan, Belarus, Bolivia, Colombia, Costa Rica, Ivory Cost, Cuba, Ecuador, Ethiopia, Georgia, Guatemala, the Republic of Guinea-Bissau, Guyana, Honduras, the Channel Islands, the Cayman Islands, the Canary Islands, the Comoros Islands, the Faroe Islands, the United States Virgin Islands, India, Ireland, Liberia, Liechtenstein, Macedonia, Mali, Monaco, Namibia, Nepal, Nicaragua, Niger, Norway, New Zealand, Uganda, Uzbekistan, Panama, Paraguay, Ceuta peninsula, the Czech Republic, Russia, Rwanda, San Marino, El Salvador, Sudan, Switzerland, Tanzania, Thailand, Turkmenistan, Turkey, Ukraine, Vatican City, Vietnam,



## THE FOLLOWING CHECKS MUST BE CARRIED OUT DURING EVERY SERVICE

Sl. No.	
1	Check the wiper blades and screen washer fluid levels
2	Check the condition of the windscreen and door mirrors
3	Check the operation of the instrument panel warning lights
4	Check the exhaust pipe
5	Check the levels, condition and sealing of the hydraulic power-assisted steering circuit (if fitted)
6	Check the levels, condition and sealing of the brake/clutch circuit
7	Check the presence of the wheel valve caps
8	Check the presence of the airbag and engine compartment labels
9	Check the signalling and exterior/interior lighting
10	Check the wear of the brake discs and pads
11	Check the condition and pressure of the tyres and road wheel security
12	Check the levels, condition and sealing of the cooling circuit
13	Check the levels, condition and sealing of the sequential gearbox circuits (if fitted)
14	Anti-corrosion check
15	Check the 12 V battery with the test tool
16	Check the computers with the diagnostic tool
17	Check the condition and sealing of the gaiters/rubber mountings/ball joints/shock absorbers
18	Check and lubricate the bonnet lock
19	Clean the sunroof system (if fitted)
20	Documentation and positioning of the maintenance label
21	Drain the water from the fuel filter
22	Engine oil change alert reinitialisation





Pre-Delivery inspection

## PDI

Registration number

Model

Date of Service

Mileage at Service

Authorised Dealer's Seal & Signature



Pre-Delivery inspection

## PDI

Model

Date of Delivery

Invoice number

Selling Dealer Name

Name of the Owner

VIN

Date of Service

Engine Number

Mileage at Service

Registration number

Authorised Dealer's Seal & Signature





RENAULT  
Passion for life

Preventive maintenance  
Service coupon

**I FREE SERVICE**

**2000 Km / 2 Months  
whichever is earlier**

Registration number

Model

Date of Service

Mileage at Service

Authorised Dealer's Seal & Signature



RENAULT  
Passion for life

Preventive maintenance  
Service coupon

**I FREE SERVICE**

Valid only at RENAULT authorised service station **2000 Km / 2 Months  
whichever is earlier**

Model

Date of Delivery

Invoice number

Selling Dealer Name

Name of the Owner

VIN

Date of Service

Engine Number

Mileage at Service

Registration number

Authorised Dealer's Seal & Signature

**I am satisfied with the condition of my vehicle  
and have taken delivery of the same.  
The dealer has explained the warranty terms,  
Maintenance schedule and policies  
to my satisfaction**

Owner's Signature

\* Only labour is free







Preventive maintenance  
Service coupon

**II FREE SERVICE**

**10 000 Km / 12 Months  
whichever is earlier**

Registration number

Model

Date of Service

Mileage at Service

Authorised Dealer's Seal & Signature



Preventive maintenance  
Service coupon

**II FREE SERVICE**

Valid only at RENAULT authorised service station **10 000 Km / 12 Months  
whichever is earlier**

Model

Date of Delivery

Invoice number

Selling Dealer Name

Name of the Owner

VIN

Date of Service

Engine Number

Mileage at Service

Registration number

Authorised Dealer's Seal & Signature

**I am satisfied with the condition of my vehicle  
and have taken delivery of the same.  
The dealer has explained the warranty terms,  
Maintenance schedule and policies  
to my satisfaction**

Owner's Signature

\* Only labour is free





RENAULT  
Désormais Est 2016

Preventive maintenance  
Service coupon

**III FREE SERVICE**

**20 000 Km / 24 Months  
whichever is earlier**

Registration number

Model

Date of Service

Mileage at Service

Authorised Dealer's Seal & Signature



RENAULT  
Désormais Est 2016

Preventive maintenance  
Service coupon

**III FREE SERVICE**

Valid only at RENAULT authorised service station **20 000 Km / 24 Months  
whichever is earlier**

Model

Date of Delivery

Invoice number

Selling Dealer Name

Name of the Owner

VIN

Date of Service

Engine Number

Mileage at Service

Registration number

Authorised Dealer's Seal & Signature

**I am satisfied with the condition of my vehicle  
and have taken delivery of the same.  
The dealer has explained the warranty terms,  
Maintenance schedule and policies  
to my satisfaction**

Owner's Signature

\* Only labour is free





# DELIVERY OF YOUR VEHICLE

Dealer Name  
Dealer Address

FIRST NAME..... SUR NAME.....

MODEL.....

VEHICLE DELIVERED ON.....BY.....

## PRESENTATION AND EXPLANATION

### 1 FRONT OF THE VEHICLE

Eg. Servicing details, Checking the levels,...

### 2 FRONT PASSENGER SIDE

Eg. Disconnecting the passenger airbag  
(to fit a child seat to the front seat), ...

### 3 REAR OF THE VEHICLE

Eg. Location of the spare wheel, tool kit, ...

### 4 REAR SEATS

Eg . Child safety (Isofix fixing point), Modularity of the seats,....

» Was your vehicle presented to you as stated above?

 YES NO

» Did your vehicle match your vehicle order?

 YES NO

### 5 DRIVING POSITION

Eg. Adjusting the driving position. Use of the instrument panel and controls. Specific points relating to your vehicle.

Eg: Programming the radio, blue tooth, automatic illumination of the headlights, etc,...

### 6 DEALER SERVICES / DEPARTMENTS

### 7 WARRANTY AND MAINTENANCE CONDITIONS

Eg. Warranty and maintenance documents (Service sheet or warranty & maintenance booklets), maintenance stamps...

### 8 ISSUED WITH

 Two set of keys / Smart access card Tool kit Spare tyre Vehicle invoice Insurance cover note Registration document Vehicle manual / Quick guide

COMMENTS:

.....

.....

.....

.....

Please note that **RENAULT** will not be responsible for any issues pertaining to **NON GENUINE** accessories fitted either by dealership or aftermarket.

Should you require any further details regarding the vehicle handover or if you have any questions relating to your vehicle, please do not hesitate to contact your Sales or Delivery Advisor.

ENJOY DRIVING YOUR NEW RENAULT!

CUSTOMER SIGNATURE

DELIVERY ADVISOR SIGNATURE

1<sup>st</sup> EXEMPLARY : CUSTOMER

2<sup>nd</sup> EXEMPLARY : DELIVERY ADVISOR



# DELIVERY OF YOUR VEHICLE

Dealer Name  
Dealer Address

FIRST NAME..... SUR NAME.....

MODEL.....

VEHICLE DELIVERED ON.....BY.....

## PRESENTATION AND EXPLANATION

### 1 FRONT OF THE VEHICLE

Eg. Servicing details, Checking the levels,...

### 2 FRONT PASSENGER SIDE

Eg. Disconnecting the passenger airbag  
(to fit a child seat to the front seat), ...

### 3 REAR OF THE VEHICLE

Eg. Location of the spare wheel, tool kit, ...

### 4 REAR SEATS

Eg . Child safety (Isofix fixing point), Modularity of the seats,....

» Was your vehicle presented to you as stated above?

YES  NO

» Did your vehicle match your vehicle order?

YES  NO

### 5 DRIVING POSITION

Eg. Adjusting the driving position. Use of the instrument panel and controls. Specific points relating to your vehicle.

Eg: Programming the radio, blue tooth, automatic illumination of the headlights, etc,...

### 6 DEALER SERVICES / DEPARTMENTS

### 7 WARRANTY AND MAINTENANCE CONDITIONS

Eg. Warranty and maintenance documents (Service sheet or warranty & maintenance booklets), maintenance stamps...

### 8 ISSUED WITH

- Two set of keys / Smart access card
- Tool kit
- Spare tyre
- Vehicle invoice
- Insurance cover note
- Registration document
- Vehicle manual / Quick guide

COMMENTS:

.....

.....

.....

.....

Please note that **RENAULT** will not be responsible for any issues pertaining to **NON GENUINE** accessories fitted either by dealership or aftermarket.

Should you require any further details regarding the vehicle handover or if you have any questions relating to your vehicle, please do not hesitate to contact your Sales or Delivery Advisor.

ENJOY DRIVING YOUR NEW RENAULT!

CUSTOMER SIGNATURE

DELIVERY ADVISOR SIGNATURE

1<sup>st</sup> EXEMPLARY : CUSTOMER

2<sup>nd</sup> EXEMPLARY : DELIVERY ADVISOR



RADIO CODE \_ \_ \_ \_ \_

**Vehicle Record Sheet**

MODEL	CHASSIS NO.	ENGINE NO.	KEY NO.	DATE OF DELIVERY	MILEAGE(KM)	BATTERY		TYRE					
						MAKE	SR NO./BATCH CODE	TYRE LOCATION	FR RH	FR LH	RR RH	RR LH	
								MAKE					
								BATCH NUMBER					
Owner's Name & Address								For any feedback please call us on 1800 315 44 44 or write to us at <a href="http://www.renault.co.in">www.renault.co.in</a>					
ADDRESS OF SELLING DEALER				SELLING DEALER CODE									
SHOWROOM													
								IMPORTANT INFORMATION TO CUSTOMER					
WORKSHOP													

RENAULT S.A.S. SOCIÉTÉ PAR ACTIONS SIMPLIFIÉE AU CAPITAL DE 533 941 113 € / 13-15, QUAI LE GALLO  
92100 BOULOGNE-BILLAN COURT R.C.S. NANTERRE 780 129 987 — SIRET 780 129 987 03591 / TÉL. : 0810 40 50 60  
NU 1404-1 – 99 91 089 31S – 08/2020 – Edition anglaise

