



**Hybrid
2010 Model
3rd Generation**
Emergency Response Guide



© 2009 Toyota Motor Corporation
All rights reserved. This document may not be
altered without the written permission of Toyota Motor Corporation.

10 Prius ERG REV – (09/21/09)

Foreword

In May 2000 and October 2003, Toyota introduced the 1st and 2nd generation Toyota Prius gasoline-electric hybrid vehicles in North America. To educate and assist emergency responders in the safe handling of Toyota Prius technology, Toyota published the 2000 and 2004 Toyota Prius Emergency Response Guides.

With the release of the 3rd generation Toyota Prius in May 2009, a new 2010 Toyota Prius Emergency Response Guide was published for emergency responders. While many features from the 1st and 2nd generation Prius models are similar, emergency responders should recognize and understand the new, updated features of the Prius covered in this guide.

High voltage electricity powers the electric motor, generator, air conditioning compressor and inverter/converter. All other automotive electrical devices such as the headlights, radio, and gauges are powered from a separate 12 Volt auxiliary battery. Numerous safeguards have been designed into the Prius to help ensure the high voltage, approximately 201.6 Volt, Nickel Metal Hydride (NiMH) Hybrid Vehicle (HV) battery pack is kept safe and secure in an accident.

The Prius utilizes the following electrical systems:

- Maximum 650 Volts AC
- Nominal 201.6 Volts DC
- Maximum 27 Volts DC
- Nominal 12 Volts DC

3rd generation Prius Features:

- Complete model change with a new exterior and interior design.
- A boost converter in the inverter/converter that boosts the available voltage to the electric motor to 650 Volts.
- A high voltage Hybrid Vehicle (HV) battery pack rated at 201.6 Volts.
- A high voltage motor driven Air Conditioning (A/C) compressor rated at 201.6 Volts and optional remote air conditioning system.
- An optional solar ventilation system rated at 27 Volts.

- A body electrical system rated at 12 Volts, negative chassis ground.
- Supplemental Restraint System (SRS) – dual stage frontal airbags, front seat mounted side airbags, side curtain airbags, front seatbelt pretensioners, and driver knee airbag.

High voltage electrical safety remains an important factor in the emergency handling of the Prius Hybrid Synergy Drive. It is important to recognize and understand the disabling procedures and warnings throughout the guide.

Additional topics in the guide include:

- Prius identification.
- Major Hybrid Synergy Drive component locations and descriptions.
- Extrication, fire, recovery, and additional emergency response information.
- Roadside assistance information.

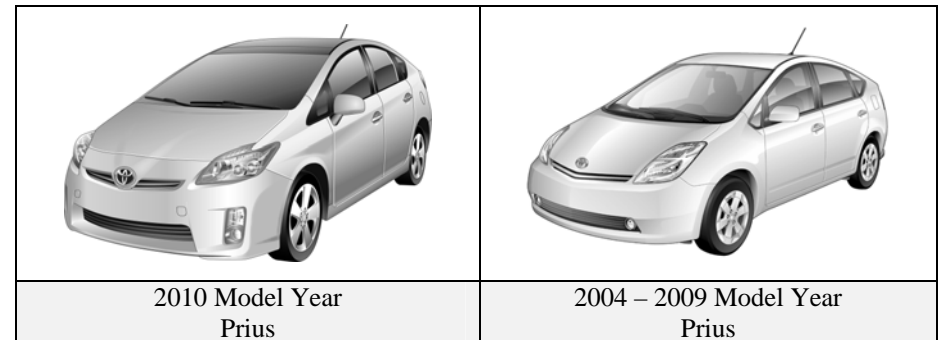

This guide is intended to assist emergency responders in the safe handling of a Prius vehicle during an incident.

NOTE:

Emergency Response Guides for Toyota hybrid and alternative fuel vehicles may be viewed at <http://techinfo.toyota.com>.

Table of Contents	Page
About the Prius	1
Prius Identification	2
Hybrid Synergy Drive Component Locations & Descriptions	5
Smart Key System	8
Electronic Gearshift Selector	10
Hybrid Synergy Drive Operation	11
Hybrid Vehicle (HV) Battery Pack	12
Solar Ventilation and Remote Air Conditioning Systems	13
Low Voltage Battery	15
High Voltage Safety	16
SRS Airbags & Seat Belt Pretensioners	17
Emergency Response	19
Extrication	19
Fire	28
Overhaul	29
Recovering/Recycling of NiMH HV Battery Pack	29
Spills	30
First Aid	30
Submersion	31
Roadside Assistance	32

About the Prius

The Prius continues into its 3rd generation as a gasoline-electric hybrid vehicle. Hybrid Synergy Drive means that the vehicle contains a gasoline engine and electric motor for power. The two hybrid power sources are stored on board the vehicle:

1. Gasoline stored in the fuel tank for the gasoline engine.
2. Electricity stored in a high voltage Hybrid Vehicle (HV) battery pack for the electric motor.

The result of combining these two power sources is improved fuel economy and reduced emissions. The gasoline engine also powers an electric generator to recharge the battery pack; unlike a pure all electric vehicle, the Prius never needs to be recharged from an external electric power source.

Depending on the driving conditions one or both sources are used to power the vehicle. The following illustration demonstrates how the Prius operates in various driving modes.

- ❶ During light acceleration at low speeds, the vehicle is powered by the electric motor. The gasoline engine is shut off.
- ❷ During normal driving, the vehicle is powered mainly by the gasoline engine. The gasoline engine also powers the generator to recharge the battery pack.

- ❸ During full acceleration, such as climbing a hill, both the gasoline engine and the electric motor power the vehicle.
- ❹ During deceleration, such as when braking, the vehicle regenerates kinetic energy from the front wheels to produce electricity that recharges the battery pack.
- ❺ While the vehicle is stopped, the gasoline engine and electric motor are off, however the vehicle remains on and operational.

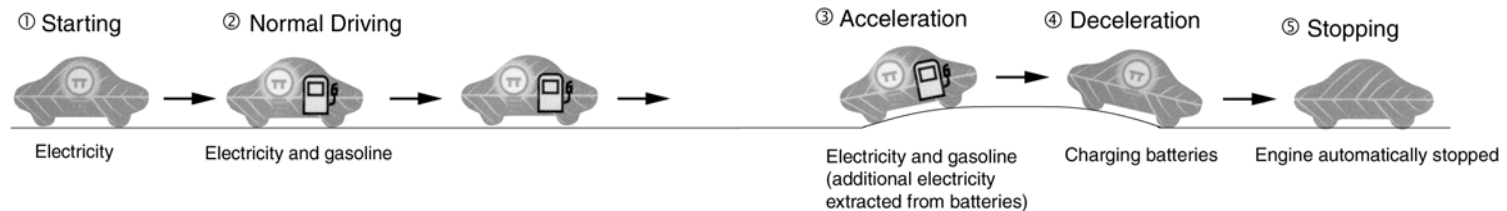

Prius Identification

In appearance, the 2010 model year Prius is a 5-door hatchback. Exterior, interior, and engine compartment illustrations are provided to assist in identification.

The alphanumeric 17 character Vehicle Identification Number (VIN) is provided in the front windshield cowl and on the driver door pillar.

Example VIN: JTDKN3DUA82020211

A Prius is identified by the first 8 alphanumeric characters **JTDKN3DU**.

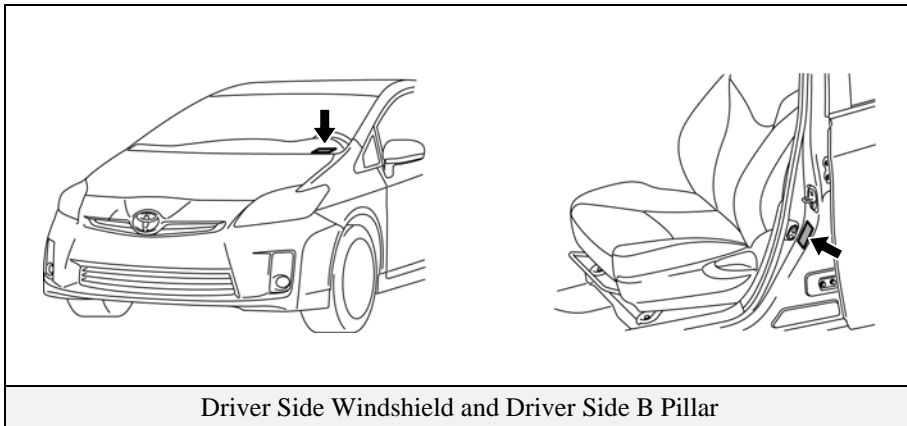

Exterior

- 1 **PRIUS** and  logos on the hatch.
- 2 Gasoline fuel filler door located on driver side rear quarter panel.

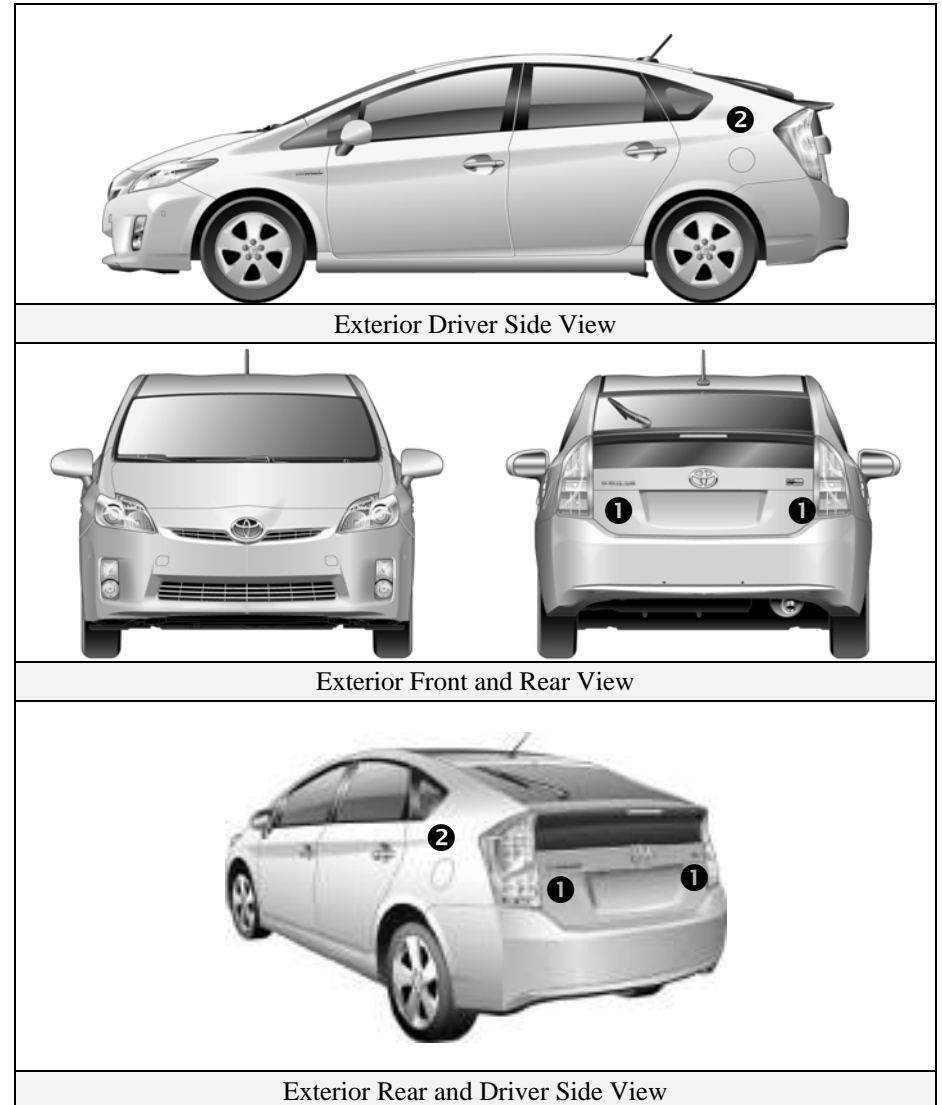

Prius Identification (Continued)

Interior

- ③ Instrument cluster (speedometer, **READY** light, shift position indicators, warning lights) located in center of the dash and near the base of the windshield.

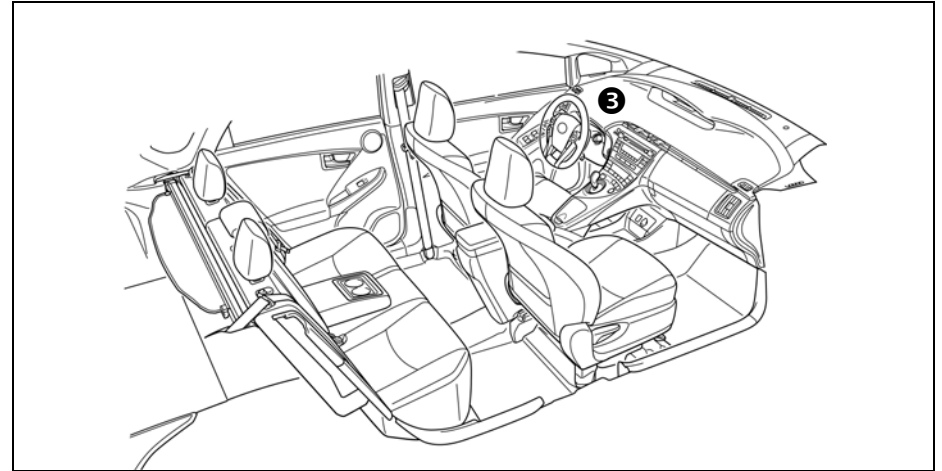

Interior View

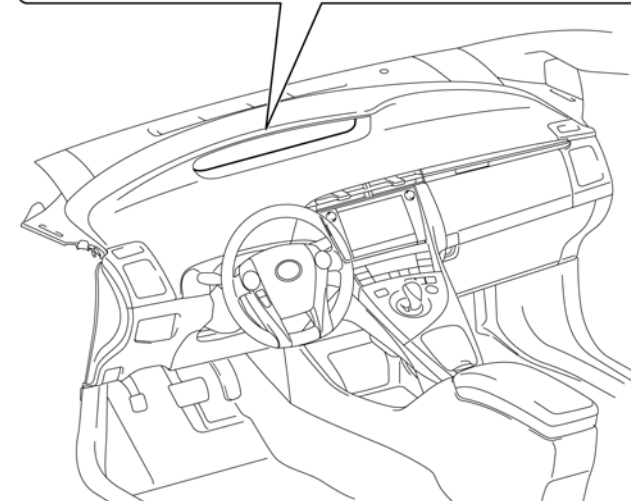
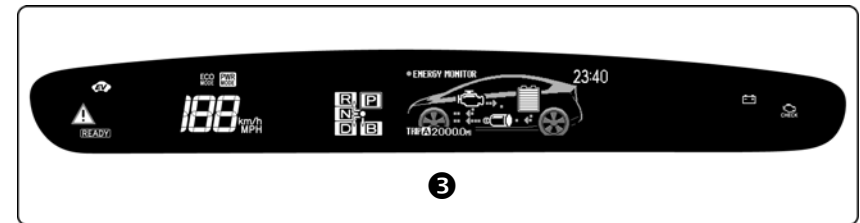

Instrument Cluster View

Prius Identification (Continued)

Engine Compartment

- ④ 1.8-liter aluminum alloy gasoline engine.
- ⑤ Logo on the plastic engine cover.

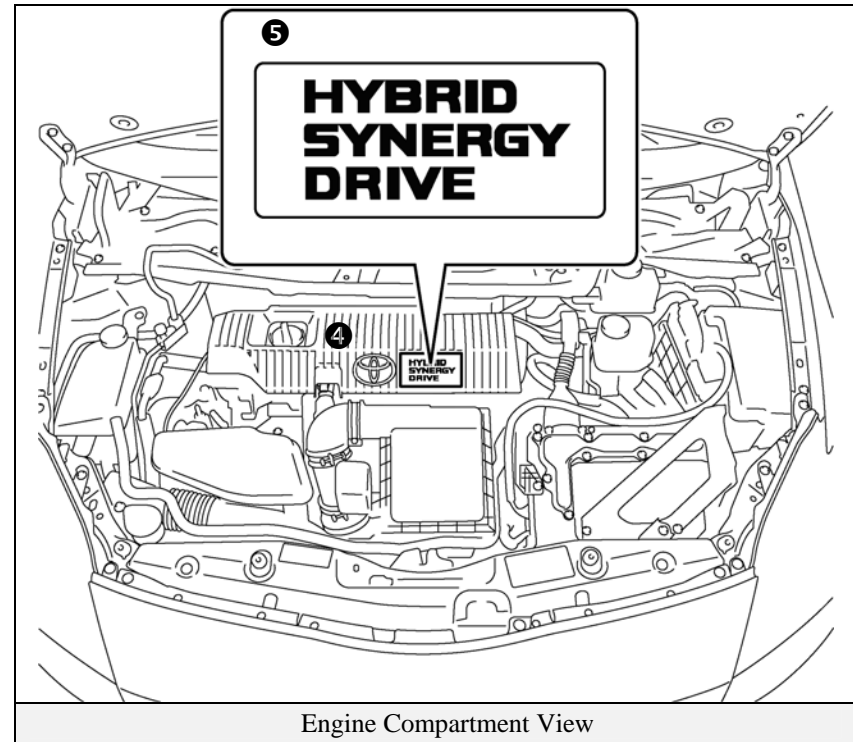

Hybrid Synergy Drive Component Locations & Descriptions

Component	Location	Description
12 Volt Auxiliary Battery ❶	Passenger Side of Cargo Area	A lead-acid battery that supplies power to the low voltage devices.
Hybrid Vehicle (HV) Battery Pack ❷	Cargo Area, Mounted to Cross Member behind Rear Seat	201.6 Volt Nickel Metal Hydride (NiMH) battery pack consisting of 28 low voltage (7.2 Volt) modules connected in series.
Power Cables ❸	Undercarriage and Engine Compartment	Orange colored power cables carry high voltage Direct Current (DC) between the HV battery pack, inverter/converter, and A/C compressor. These cables also carry 3-phase Alternating Current (AC) between the inverter/converter, electric motor, and generator.
Inverter/Converter ❹	Engine Compartment	Boosts and inverts the high voltage electricity from the HV battery pack to 3-phase AC electricity that drives the electric motor. The inverter/converter also converts AC electricity from the electric generator and electric motor (regenerative braking) to DC that recharges the HV battery pack.
Gasoline Engine ❺	Engine Compartment	Provides two functions: 1) Powers vehicle. 2) Powers generator to recharge the HV battery pack. The engine is started and stopped under control of the vehicle computer.
Electric Motor ❻	Engine Compartment	3-phase high voltage AC permanent magnet electric motor contained in the front transaxle. It is used to power the front wheels.
Electric Generator ❼	Engine Compartment	3-phase high voltage AC generator that is contained in the transaxle and recharges the HV battery pack.

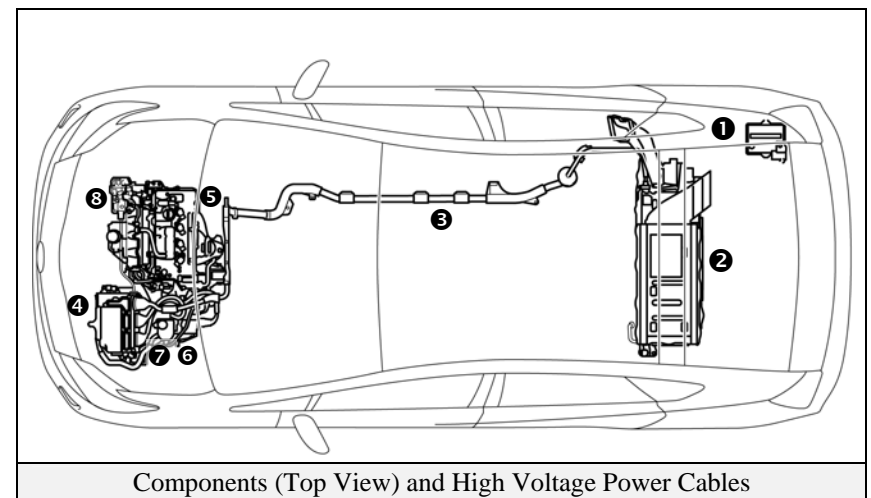
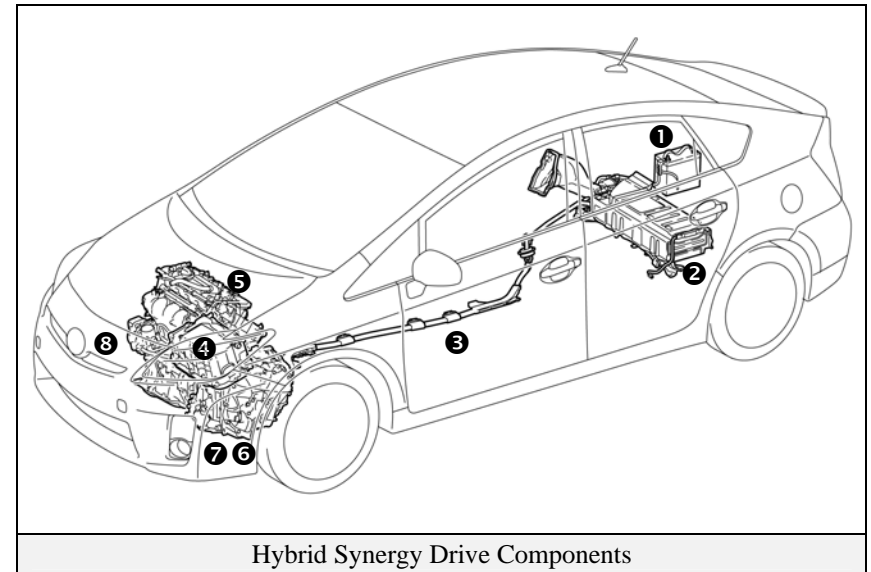

Hybrid Synergy Drive Component Locations & Descriptions (Continued)

Component	Location	Description
A/C Compressor (with Inverter) ⑧	Engine Compartment	3-phase high voltage AC electrically driven motor compressor.
Fuel Tank and Fuel Line ⑨	Undercarriage and Center	The fuel tank provides gasoline via a fuel line to the engine. The fuel line is routed under the center of vehicle.

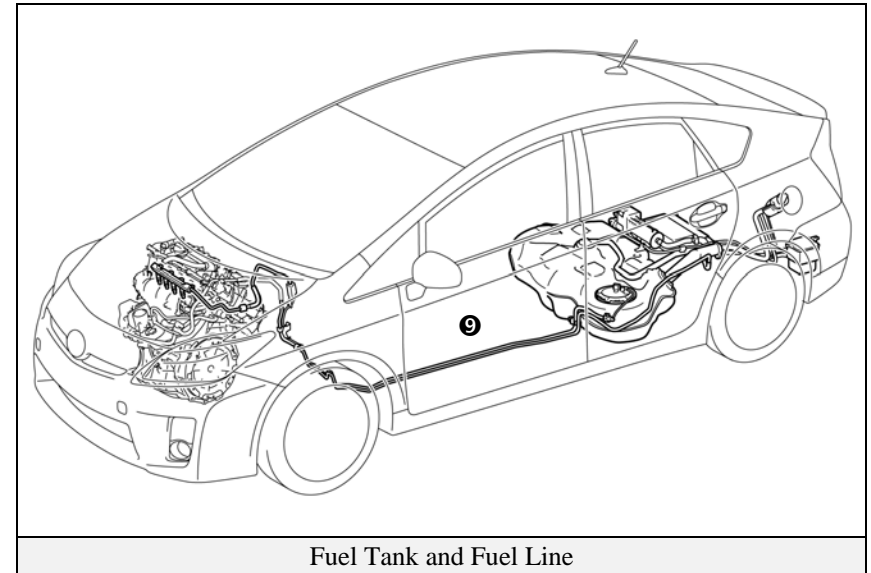

Hybrid Synergy Drive Component Locations & Descriptions (Continued)

Key Specifications:

Gasoline Engine:	98 hp (73 kW), 1.8-liter Aluminum Alloy Engine
Electric Motor:	80 hp (60 kW), Permanent Magnet Motor
Transmission:	Automatic Only (electrically controlled continuously variable transaxle)
HV Battery:	201.6 Volt Sealed NiMH-Battery
Curb Weight:	3,080 lbs/1,397 kg
Fuel Tank:	11.9 gals/45.0 liters
Fuel Economy Ratings:	51/48 (City/Hwy) miles/gal 4.7/4.8 (City/Hwy) liters/100 km
Frame Material:	Steel Unibody
Body Material:	Steel Panels except for Aluminum Hood and Hatch
Seating Capacity:	5 passenger

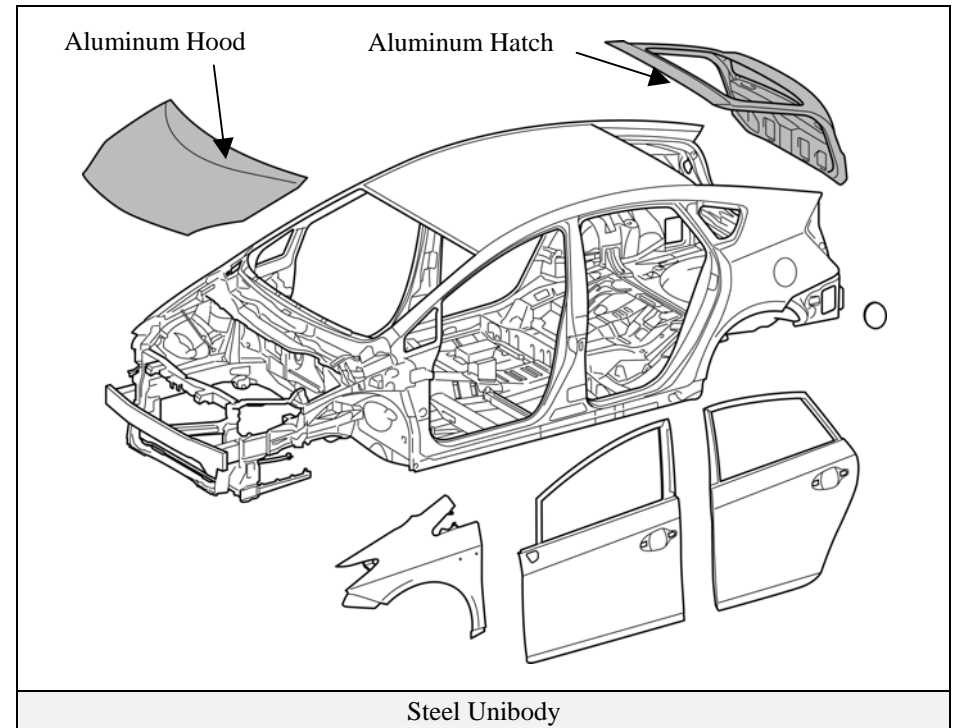

Smart Key System

The Prius smart key system consists of a smart key transceiver that communicates bi-directionally, enabling the vehicle to recognize the smart key in proximity to the vehicle. Once recognized, the smart key will allow the user to lock and unlock the doors without pushing smart key buttons, and start the vehicle without inserting it into an ignition switch.

Smart key features:

- Passive (remote) function to lock/unlock the doors and start the vehicle.
- Wireless transmitter buttons to lock/unlock all 5 doors.
- Hidden metal cut key to lock/unlock the doors.

Door (Lock/Unlock)

There are several methods available to lock/unlock the doors.

- Pushing the smart key lock button will lock all doors including the hatch. Pushing the smart key unlock button once unlocks the driver door, twice unlocks all doors.
- Touching the sensor on the backside of the driver door exterior handle, with the smart key in proximity to the vehicle, unlocks the driver door. Touching the sensor on the backside of the front passenger door exterior handle, with the smart key in proximity to the vehicle, unlocks all doors. Touching the lock sensor on either front door, or the lock button for the hatch will lock all doors.
- Inserting the hidden metal cut key in the driver door lock and turning clockwise once unlocks the driver door, twice unlocks all doors. To lock all doors turn the key counter clockwise once. Only the driver door contains an exterior door lock for the metal cut key.

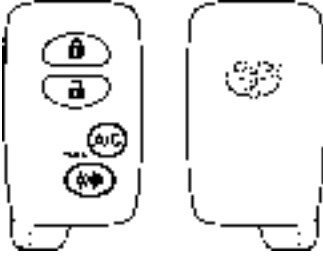
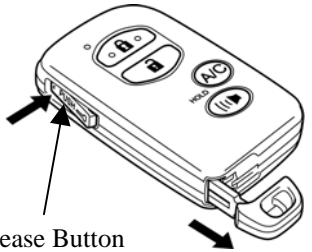
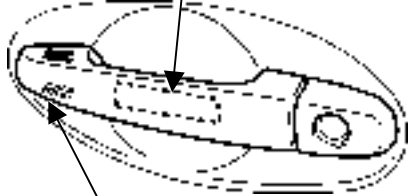
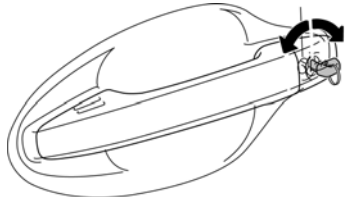
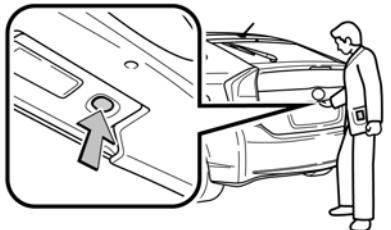
	 <p>Release Button</p>
<p>Smart Key (Fob)</p>	<p>Hidden Metal Cut Key for Door Lock</p>
 <p>Unlock Touch Sensor</p> <p>Lock Touch Sensor</p>	 <p>Use the Hidden Metal Cut Key</p>
<p>Driver Door Unlock Touch Sensor and Lock Touch Sensor</p>	<p>Front Driver Door Lock</p>
	<p>Optional Hatch Lock Button</p>

Smart Key System (Continued)

Vehicle Starting/Stopping

The smart key has replaced the conventional metal cut key, and the power button with an integral status indicator light has replaced the ignition switch. The smart key only needs to be in proximity to the vehicle to allow the system to function.

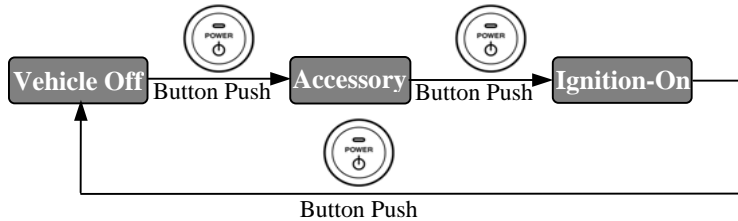

- With the brake pedal released, the first push of the power button operates the accessory mode, the second push operates the ignition-on mode, and the third push turns the ignition off again.

Ignition Mode Sequence (brake pedal released):

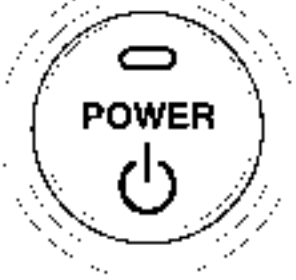

- Starting the vehicle takes priority over all other ignition modes and is accomplished by depressing the brake pedal and pushing the power button once. To verify the vehicle has started, check that the power button status indicator light is off and the **READY** light is illuminated in the instrument cluster.
- If the internal smart key battery is dead, use the following method to start the vehicle.
 - Touch the Toyota emblem side of the smart key to the power button.
 - Within the 5 seconds after the buzzer sounds, push the power button with the brake pedal depressed (the **READY** light will illuminate).
- Once the vehicle has started and is on and operational (**READY-ON**), the vehicle is shut off by bringing the vehicle to a complete stop and then depressing the power button once.
- To shut off the vehicle before coming to a stop in an emergency, push and hold down the power button for more than 3 seconds. This procedure may be useful at an accident scene in which the **READY** indicator is on, **Park** cannot be selected, and the drive wheels remain in motion.

Ignition Mode	Power Button Indicator Light
Off	Off
Accessory	Amber
Ignition-On	Amber
Brake Pedal Depressed	Green
Vehicle Started (READY-ON)	Off
Malfunction	Blinking Amber

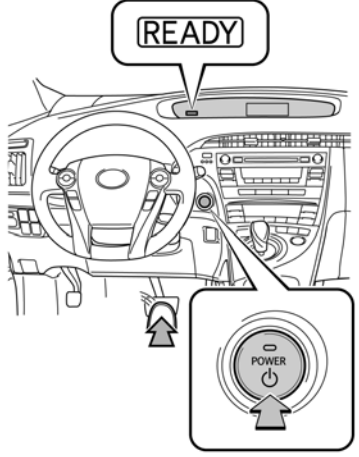
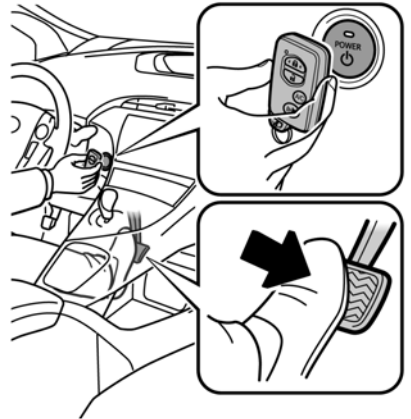
	
Power Button with Integral Status Indicator Light	Ignition Modes (Brake Pedal Released)
	
Starting Sequence (Brake Pedal Depressed)	Smart Key Recognition (When Smart Key Battery is Dead)

Electronic Gearshift Selector

The Prius electronic gearshift selector is a momentary select shift-by-wire system that engages the transaxle in **R**everse, **N**eutral, **D**rive, or engine **B**rake modes.

- These modes may only be engaged while the vehicle is on and operational (READY-on), except for Neutral which may also be engaged while in the ignition-on mode. After selecting the gear position R, N, D, or B the transaxle remains in that position, identified on the instrument cluster, but the shift selector returns to a default position. To select Neutral, it is necessary to hold the shift selector in the N position for approximately 0.5 seconds.
- Unlike a conventional vehicle, the electronic shift selector does not contain a park position. Instead, a separate **P** switch located above the shift selector engages the park (P) position.
- When the vehicle is stopped, regardless of shift selector position, the electro-mechanical parking pawl is engaged to lock the transaxle into park by either depressing the **P** switch or pushing the power button to shut off the vehicle.
- Being electronic, the gearshift selector and the park systems depend on the low voltage 12 Volt auxiliary battery for power. If the 12 Volt auxiliary battery is discharged or disconnected, the vehicle cannot be started and cannot be shifted out of park.

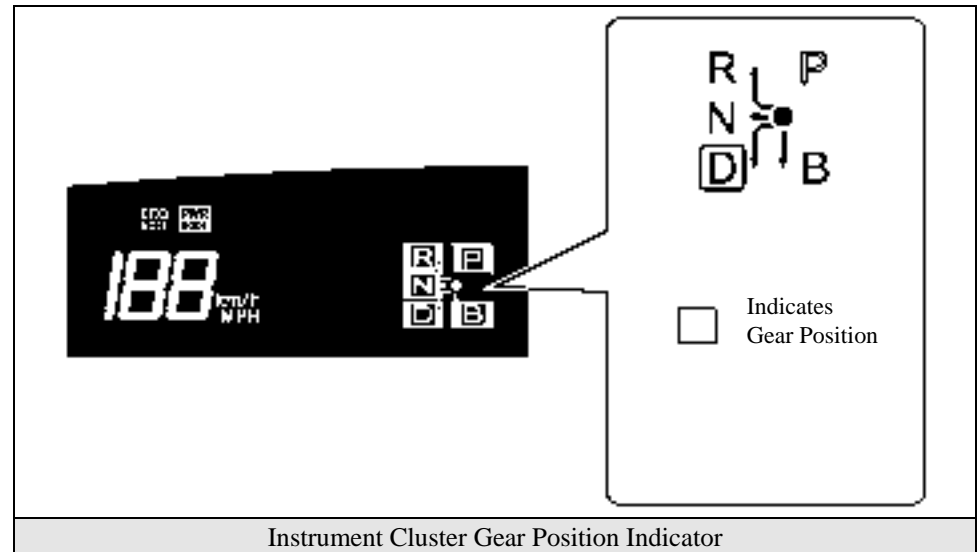
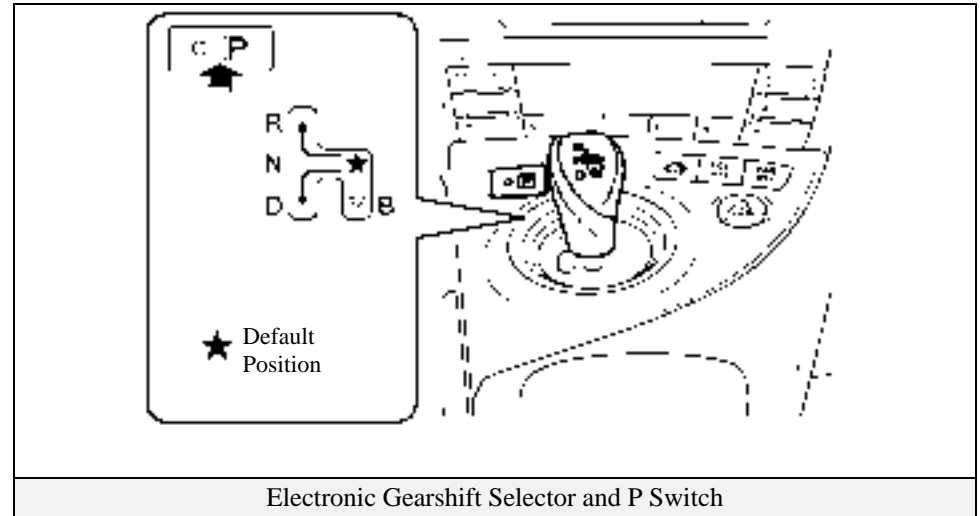

Hybrid Synergy Drive Operation

Once the **READY** indicator is illuminated in the instrument cluster, the vehicle may be driven. However, the gasoline engine does not idle like a typical automobile and will start and stop automatically. It is important to recognize and understand the **READY** indicator provided in the instrument cluster. When lit, it informs the driver that the vehicle is on and operational even though the gasoline engine may be off and the engine compartment is silent.

Vehicle Operation

- With the Prius, the gasoline engine may stop and start at any time while the **READY** indicator is on.
- Never assume that the vehicle is shut off just because the engine is off. Always look for the **READY** indicator status. The vehicle is shut off when the **READY** indicator and instrument cluster lights are off.
- The vehicle may be powered by:
 1. The electric motor only.
 2. The gasoline engine only.
 3. A combination of both the electric motor and the gasoline engine.
- The vehicle computer determines the mode in which the vehicle operates in order to improve fuel economy and reduce emissions. Three new features on the 2010 Prius are EV (Electric Vehicle) mode, Power mode and ECO (Economy) mode:
 1. EV Mode: When activated, and certain conditions have been met, the vehicle operates with the electric motor powered by the HV battery.
 2. ECO Mode: When activated, this mode helps enhance fuel economy on trips that involve frequent braking and acceleration.
 3. Power Mode: When activated, power mode optimizes acceleration feel by increasing the power output more quickly at the beginning of accelerator pedal operation.

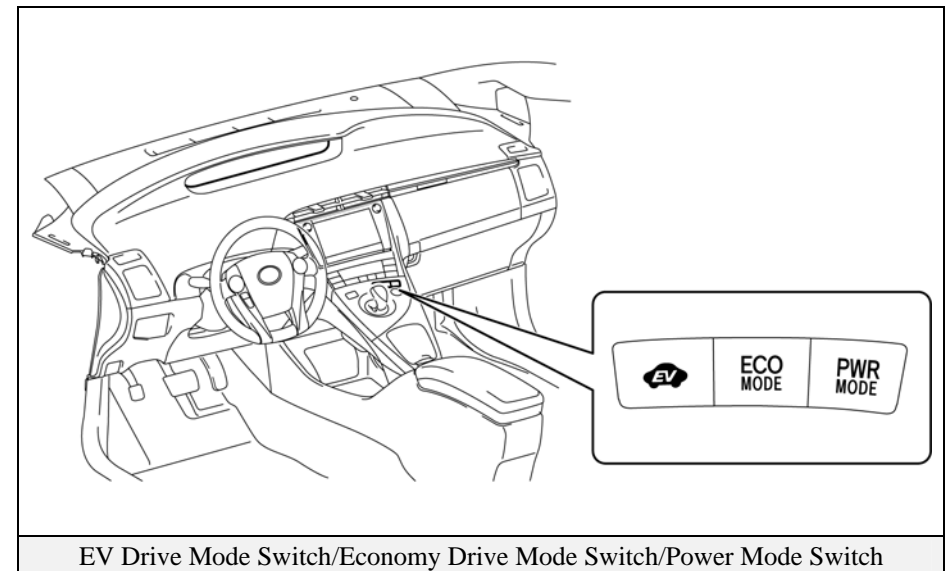
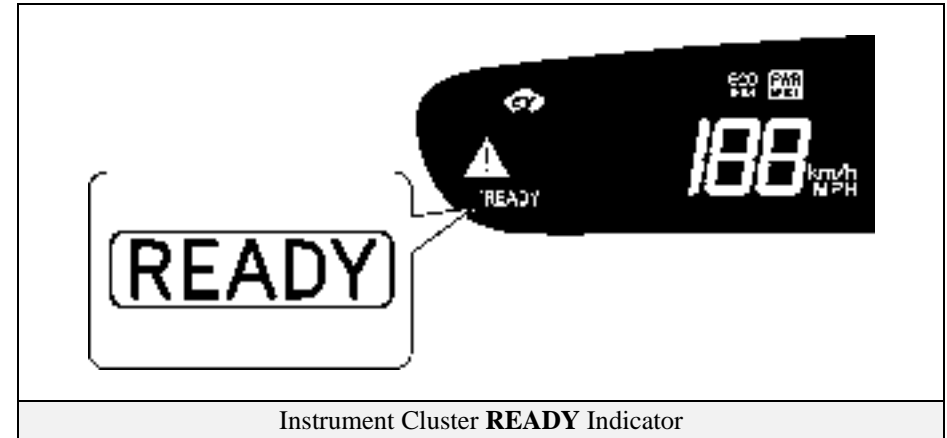

Hybrid Vehicle (HV) Battery Pack

The Prius features a high voltage Hybrid Vehicle (HV) battery pack that contains sealed Nickel Metal Hydride (NiMH) battery modules.

HV Battery Pack

- The HV battery pack is enclosed in a metal case and is rigidly mounted to the cargo area floor pan cross member behind the rear seat. The metal case is isolated from high voltage and concealed by carpet in the cabin area.
- The HV battery pack consists of 28 low voltage (7.2 Volt) NiMH battery modules connected in series to produce approximately 201.6 Volts. Each NiMH battery module is non-spillable and in a sealed case.
- The electrolyte used in the NiMH battery module is an alkaline mixture of potassium and sodium hydroxide. The electrolyte is absorbed into the battery cell plates and will not normally leak, even in a collision.

HV Battery Pack	
Battery pack voltage	201.6 V
Number of NiMH battery modules in the pack	28
NiMH battery module voltage	7.2 V
NiMH battery module dimensions	11.2 x 0.8 x 4.6 in (285 x 19.6 x 117.8 mm)
NiMH module weight	2.3 lbs (1.04 kg)
NiMH battery pack dimensions	11.7 x 23.2 x 0.42 in (297 x 590 x 10.7 mm)
NiMH battery pack weight	90 lbs (41 kg)

Components Powered by the HV Battery Pack

- Front Electric Motor
- Inverter/Converter
- Power Cables
- A/C Compressor
- Electric Generator

HV Battery Pack Recycling

- The HV battery pack is recyclable. Contact the nearest Toyota dealer or:

United States: (800) 331-4331

Canada: (888) TOYOTA 8 [(888) 869-6828]

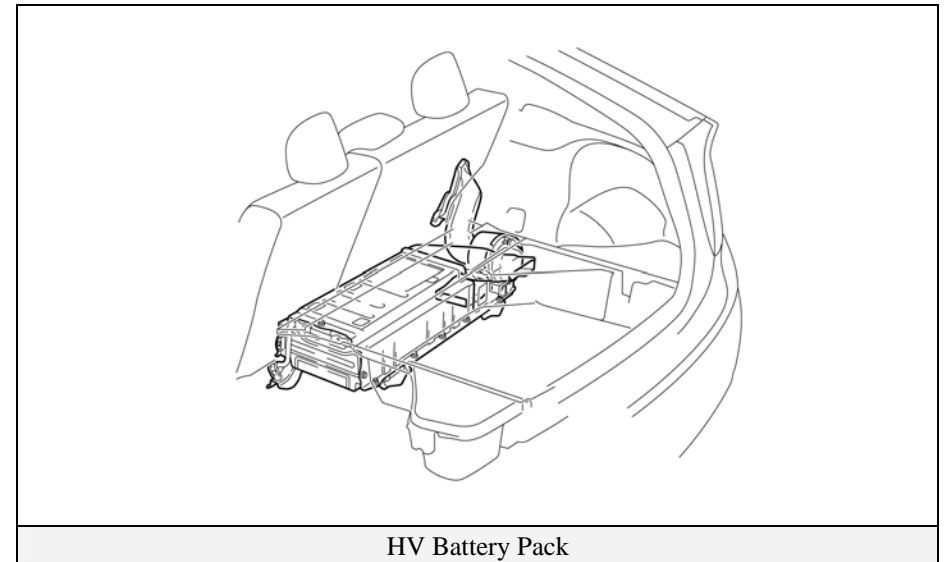

Solar Ventilation and Remote Air Conditioning Systems

Two newly available options on the 2010 Prius are the solar ventilation system and the remote air conditioning system. These systems are provided to enhance occupant comfort by lowering the inside cabin temperature while the vehicle is shut off and parked.

Solar Ventilation System

The solar ventilation system uses energy provided by a solar panel built into the roof to operate the blower fan contained within the air conditioning system. This allows ventilation of the vehicle interior when the vehicle is parked in direct sunlight.

The solar panel is located on the roof above the rear passenger space, as shown in the illustration. It consists of 36 poly crystalline silicon solar cells connected in series, and is primarily constructed from glass, potting material, silicon, silver and aluminum compounds, and a back sheet.

The solar panel generates a nominal 60 Watts of electricity, and although the voltage and current output vary by temperature and sunlight intensity, the panel does not produce high voltage. For example, the solar panel output is 22 Volts on an average sunny day (77°F, 25°C) and has a maximum output of 27 Volts in sub zero temperatures (-22°F, -30°C). The maximum current of 3.6 Amps occurs at full sunlight intensity.

Safety Concerns

The Prius solar panel is similar to the ones used in residential or commercial buildings except it does not operate at high voltage and does not use storage batteries.

Since voltage is generated when the solar panel is exposed to sunlight, the output wire may be energized even after the vehicle is shut off and the 12 Volt auxiliary battery is disconnected. Current will only flow if the solar ventilation blower fan circuit is turned on.

The solar panel output wire is not electrically connected to the 12 Volt auxiliary battery, SRS airbags, or the HV battery pack. The solar panel output will not back feed power to these circuits.

Breaking or cutting the solar panel is generally not a hazard except for injury that may occur from material fragments.

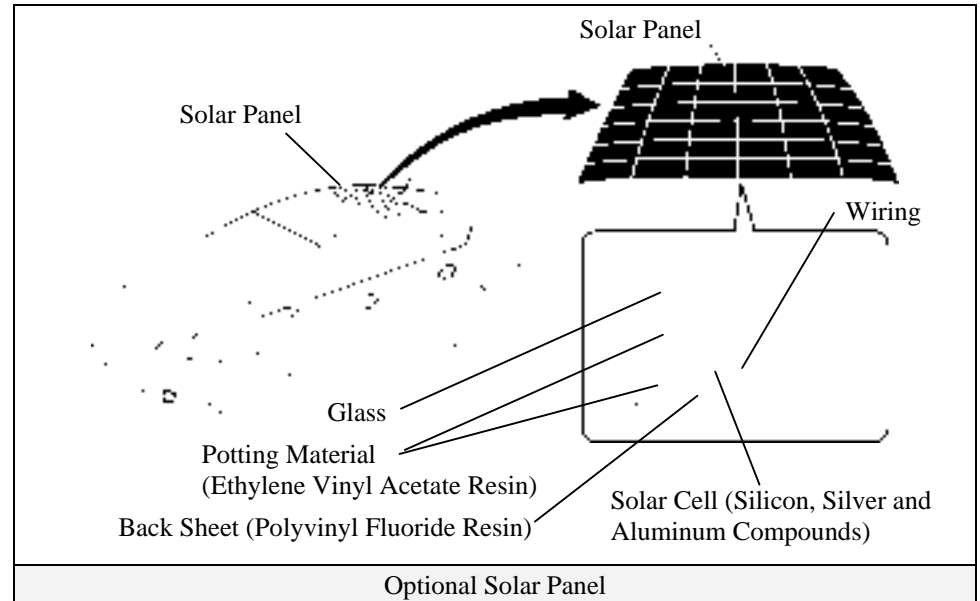

Solar Ventilation and Remote Air Conditioning Systems (Continued)

Optional Remote Air Conditioning System

The remote air conditioning system is similar to a remote engine start system used in a conventional gasoline vehicle to precondition the vehicle interior while the vehicle is parked. Unlike a conventional gasoline vehicle, the Prius does not start the gasoline engine. Instead it utilizes the energy stored in the High Voltage HV battery pack to operate the high voltage air conditioning compressor to cool the vehicle interior. The system is activated remotely by pushing the smart key A/C button and will operate for up to three minutes when certain conditions are met.

Safety Concerns

Since the operation of the remote air conditioning system allows high voltage electrical flow, it is important to recognize how the system is activated, deactivated, and disabled.

System Activation:

When the remote air conditioning system is activated, high voltage cables are energized and high voltage electricity flows from the HV battery pack to the air conditioning compressor. The system is operating when all of the following conditions occur:

- All doors are locked.
- The instrument cluster lights are on, but the **READY** indicator light is off.
- Air is flowing from the interior vehicle vents, and the blower fan noise may be heard.

System Deactivation:

When the system is deactivated, the high voltage cables are de-energized and high voltage electrical flow stops from the HV battery pack. The system is deactivated when any one of the following conditions occur:

- After about 3 minutes of operation.
- When the HV battery pack charge level is low.
- When a door is opened, the hood is opened, or the brake pedal is depressed.
- When the smart key A/C button is pushed twice within 3 seconds.
- When conditions for operation are not met.

System Disabling:

To disable the remote air conditioning system, first shut off the vehicle by pushing the power button if necessary and ensuring that the **READY** indicator and instrument cluster lights are off. Second, disconnect the 12 Volt auxiliary battery. After performing these two steps, the remote air conditioning system will be disabled and will not activate even if the smart key A/C button is pushed.

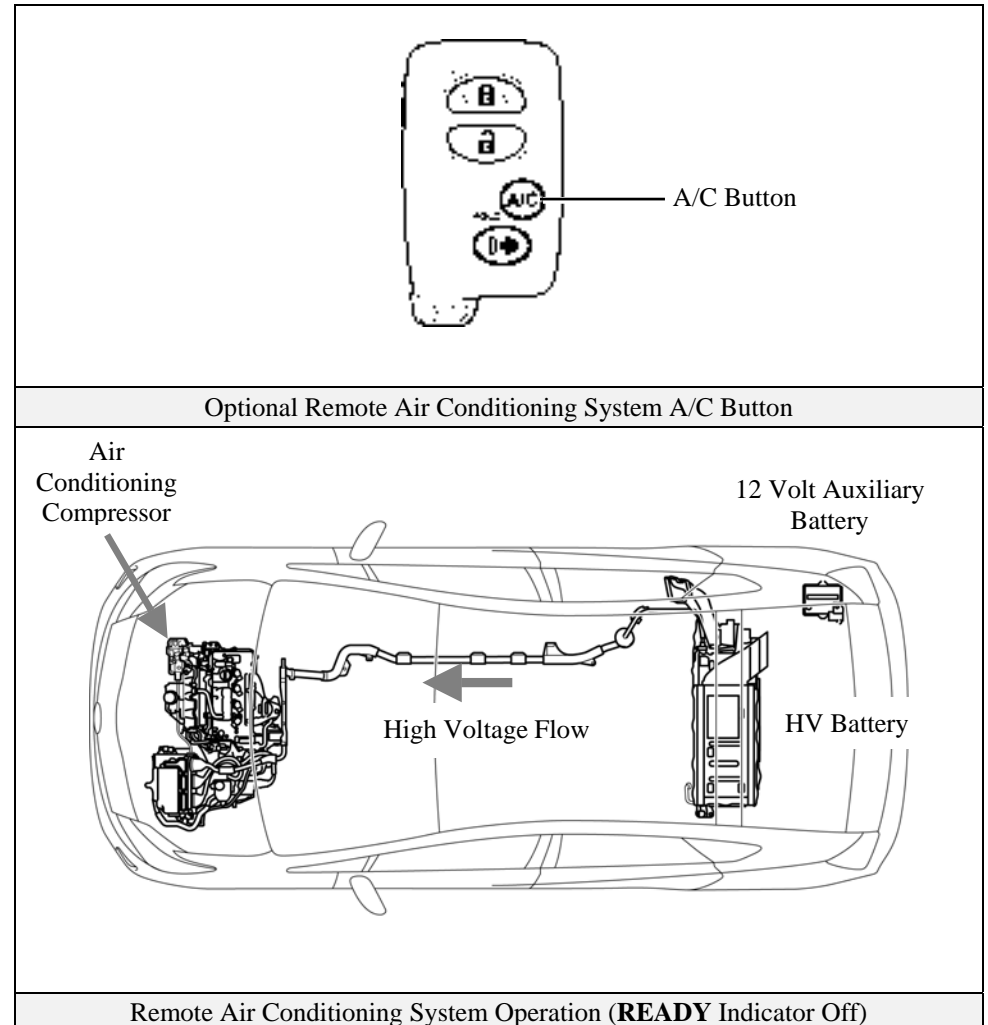

Low Voltage Battery

Auxiliary Battery

- The Prius contains a sealed lead-acid 12 Volt battery. The 12 Volt auxiliary battery powers the vehicle's electrical system similar to a conventional vehicle. As with conventional vehicles, the negative terminal of the auxiliary battery is grounded to the metal chassis of the vehicle.
- The auxiliary battery is located in the cargo area. It is concealed by a fabric cover on the passenger side in the rear quarter panel well.

NOTE:

An under hood label shows the location of the HV battery (traction battery) and 12 Volt auxiliary battery.

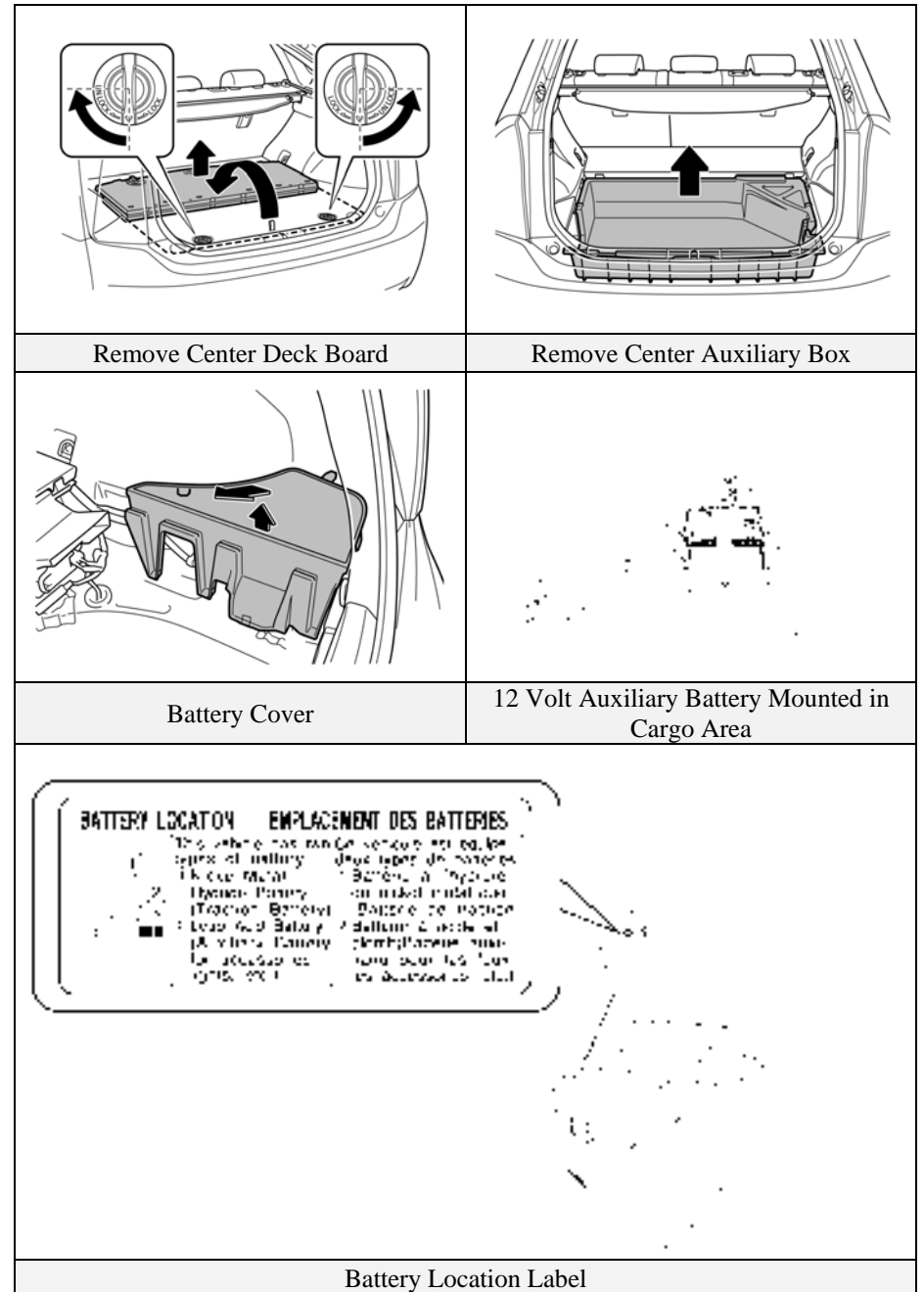

High Voltage Safety

The HV battery pack powers the high voltage electrical system with DC electricity. Positive and negative orange colored high voltage power cables are routed from the battery pack, under the vehicle floor pan, to the inverter/converter. The inverter/converter contains a circuit that boosts the HV battery voltage from 201.6 to 650 Volts DC. The inverter/converter creates 3-phase AC to power the motor. Power cables are routed from the inverter/converter to each high voltage motor (electric motor, electric generator, and A/C compressor). The following systems are intended to help keep occupants in the vehicle and emergency responders safe from high voltage electricity:

High Voltage Safety System

- A high voltage fuse ❶ provides short circuit protection in the HV battery pack.
- Positive and negative high voltage power cables ❷ connected to the HV battery pack are controlled by 12 Volt normally open relays ❸. When the vehicle is shut off, the relays stop electrical flow from leaving the HV battery pack.

⚠️WARNING:

The high voltage system may remain powered for up to 10 minutes after the vehicle is shut off or disabled. To prevent serious injury or death from severe burns or electric shock, avoid touching, cutting, or breaching any orange high voltage power cable or high voltage component.

- Both positive and negative power cables ❷ are insulated from the metal body. High voltage electricity flows through these cables and not through the metal vehicle body. The metal vehicle body is safe to touch because it is insulated from the high voltage components.

- A ground fault monitor ❹ continuously monitors for high voltage leakage to the metal chassis while the vehicle is running. If a malfunction is detected, the hybrid vehicle computer ❹ will illuminate the master warning light ⚠️ in the instrument cluster and indicate “Check Hybrid System” on the multi-information display.

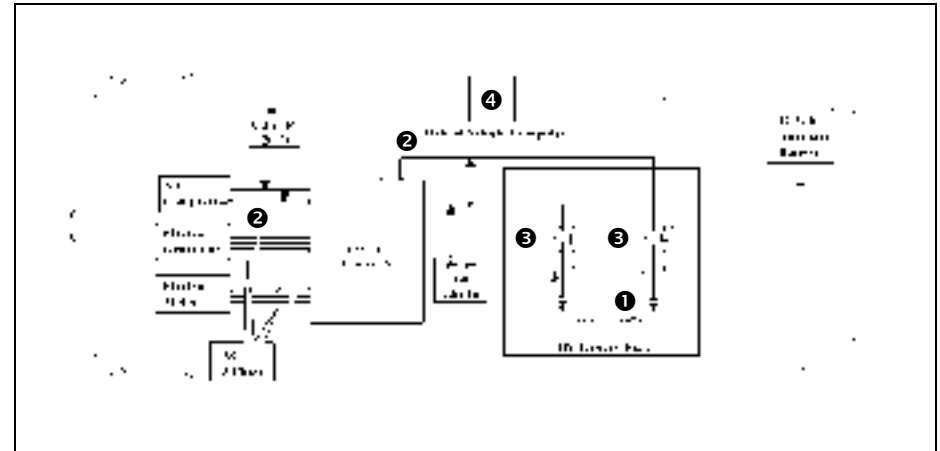

High Voltage Safety System – Vehicle Shut Off (READY-OFF)

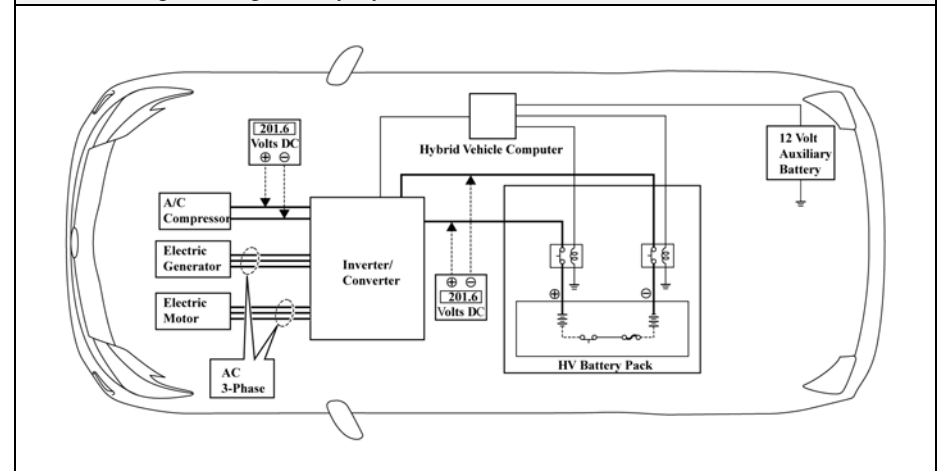

High Voltage Safety System – Vehicle On and Operational (READY-ON)

SRS Airbags & Seat Belt Pretensioners

Standard Equipment

- Electronic frontal impact sensors (2) are mounted in the engine compartment ① as illustrated.
- Front seat belt pretensioners are mounted near the base of the B-pillars ②.
- A frontal dual stage driver airbag ③ is mounted in the steering wheel hub.
- A frontal twin-chamber shaped dual stage passenger airbag ④ is integrated into the dashboard and deploys through the top of the dashboard.
- The SRS computer ⑤, which contains an impact sensor, is mounted on the floor pan underneath the instrument panel, forward of the shift lever.
- Front electronic side impact sensors (2) are mounted near the base of the B-pillars. ⑥
- Rear electronic side impact sensors (2) are mounted near the base of the C-pillars. ⑦
- Front seat side airbags ⑧ are mounted in the front seatbacks.
- Side curtain airbags ⑨ are mounted along the outer edge inside the roof rails.
- Driver knee airbag ⑩ is mounted on the lower portion of the dash.
- Active (mechanical non-pyrotechnic) front seat headrests (see description on page 27).

Optional Equipment

- The optional pre-collision safety system contains a radar sensory system, occupant seat sensor, and an electric motor-pyrotechnic pretensioner system. During a pre-collision event, an electric motor in the pretensioners retracts the front seatbelts. When conditions stabilize the electric motor will reverse itself. When the airbags deploy, the pyrotechnic pretensioners function normally.

WARNING:

The SRS may remain powered for up to 90 seconds after the vehicle is shut off or disabled. To prevent serious injury or death from unintentional SRS deployment, avoid breaching the SRS components.

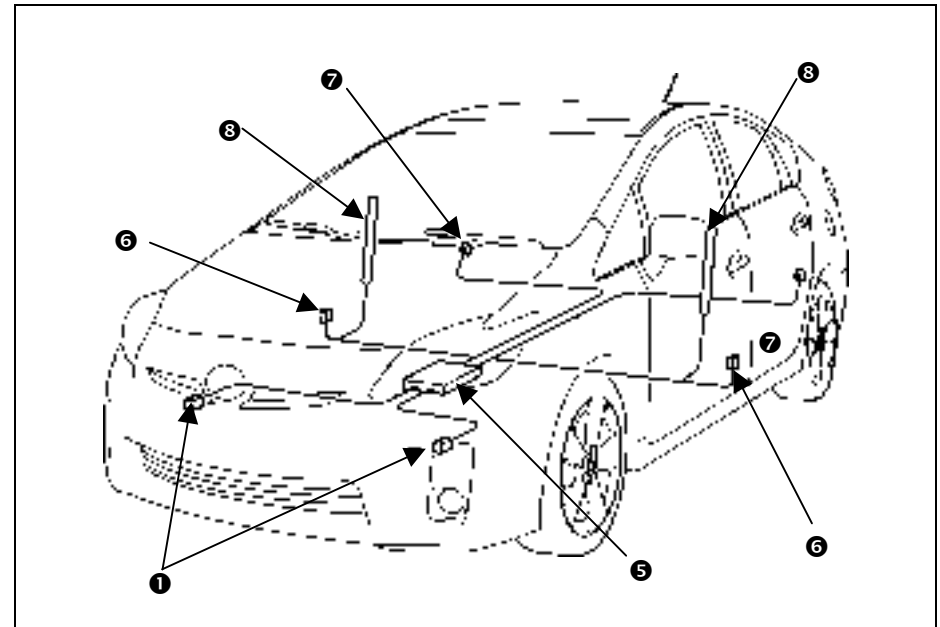

Electronic Impact Sensors and Side Airbags

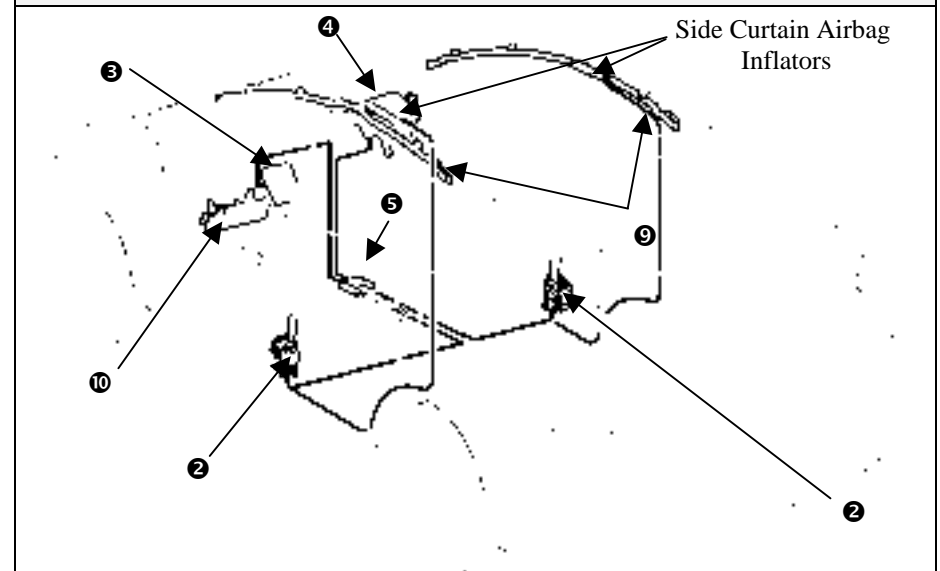

Standard Frontal Airbags, Seat Belt Pretensioners, Knee Airbag, Side Curtain Airbags

SRS Airbags & Seat Belt Pretensioners (Continued)

NOTE:

The front seatback mounted side airbags and the side curtain airbags may deploy independently of each other.

The knee airbag is designed to deploy simultaneously with the frontal airbag.

The Prius is equipped with a standard front passenger occupant classification system that may prohibit the deployment of the front passenger frontal airbag, front seatback mounted side airbag, and seat belt pretensioners. If the passenger occupant classification system prohibits deployment during an SRS event, the passenger SRS will not re-arm nor deploy.

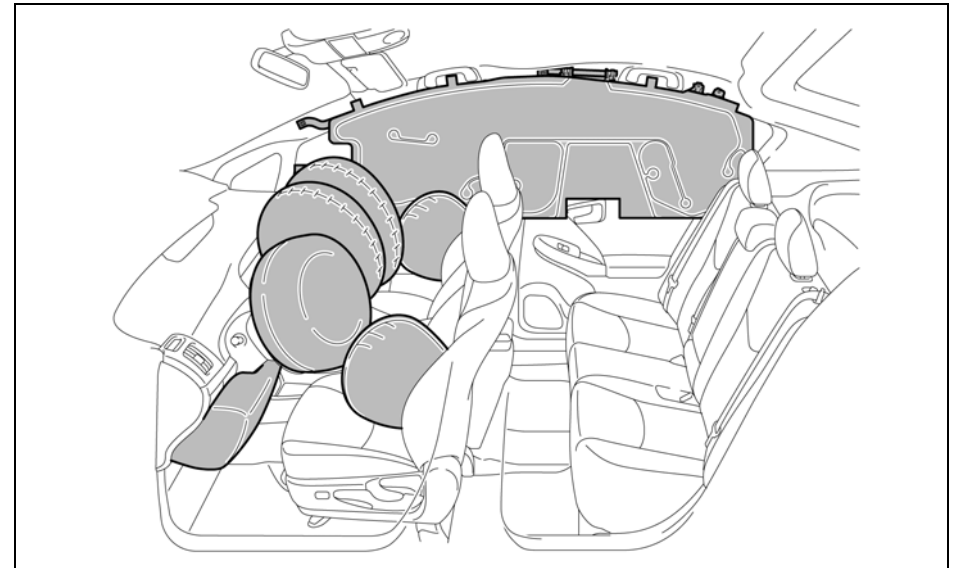
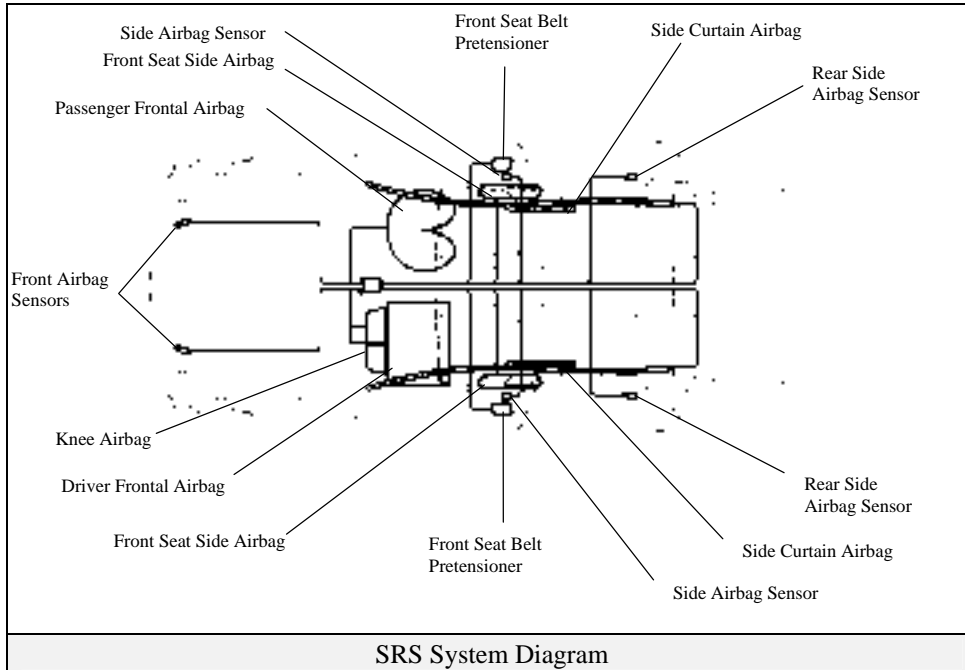

Frontal, Knee, Front Seatback Mounted Side, Side Curtain Airbags.

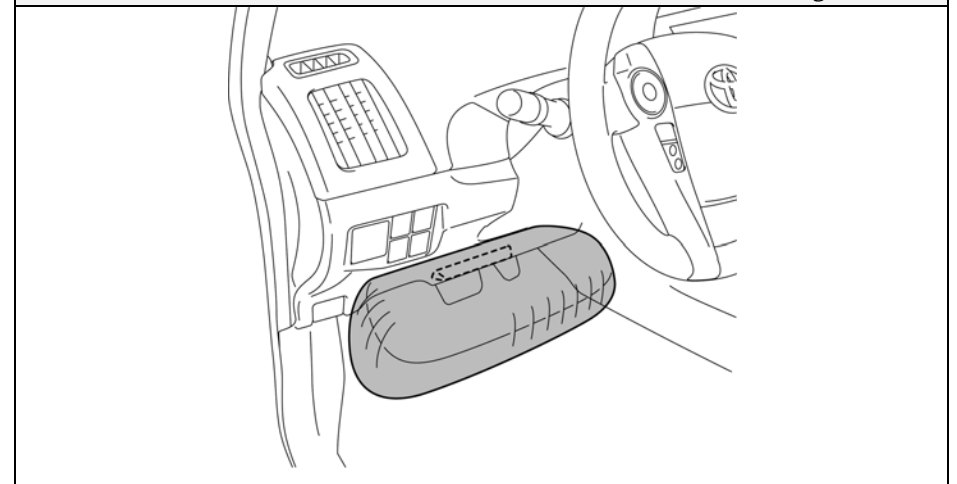

Driver Knee Airbag and Inflator

Emergency Response

On arrival, emergency responders should follow their standard operating procedures for vehicle incidents. Emergencies involving the Prius may be handled like other automobiles except as noted in these guidelines for Extrication, Fire, Overhaul, Recovery, Spills, First Aid, and Submersion.

WARNING:

- *Never assume the Prius is shut off simply because it is silent.*
- *Always observe the instrument cluster for the **READY** indicator status to verify whether the vehicle is on or shut off. The vehicle and optional remote air conditioning system are shut off when the **READY** indicator is off and the instrument cluster lights are out.*
- *Failure to shut off and disable the vehicle before emergency response procedures are performed may result in serious injury or death from the unintentional deployment of the SRS or severe burns and electric shock from the high voltage electrical system.*

Extrication

- **Immobilize Vehicle**
Chock wheels and set the parking brake.
Push the **P** switch to engage park.
- **Disable Vehicle**
Performing either of the following two procedures will shut the vehicle off and disable the HV battery pack, SRS, gasoline fuel pump, and optional remote air conditioning system.

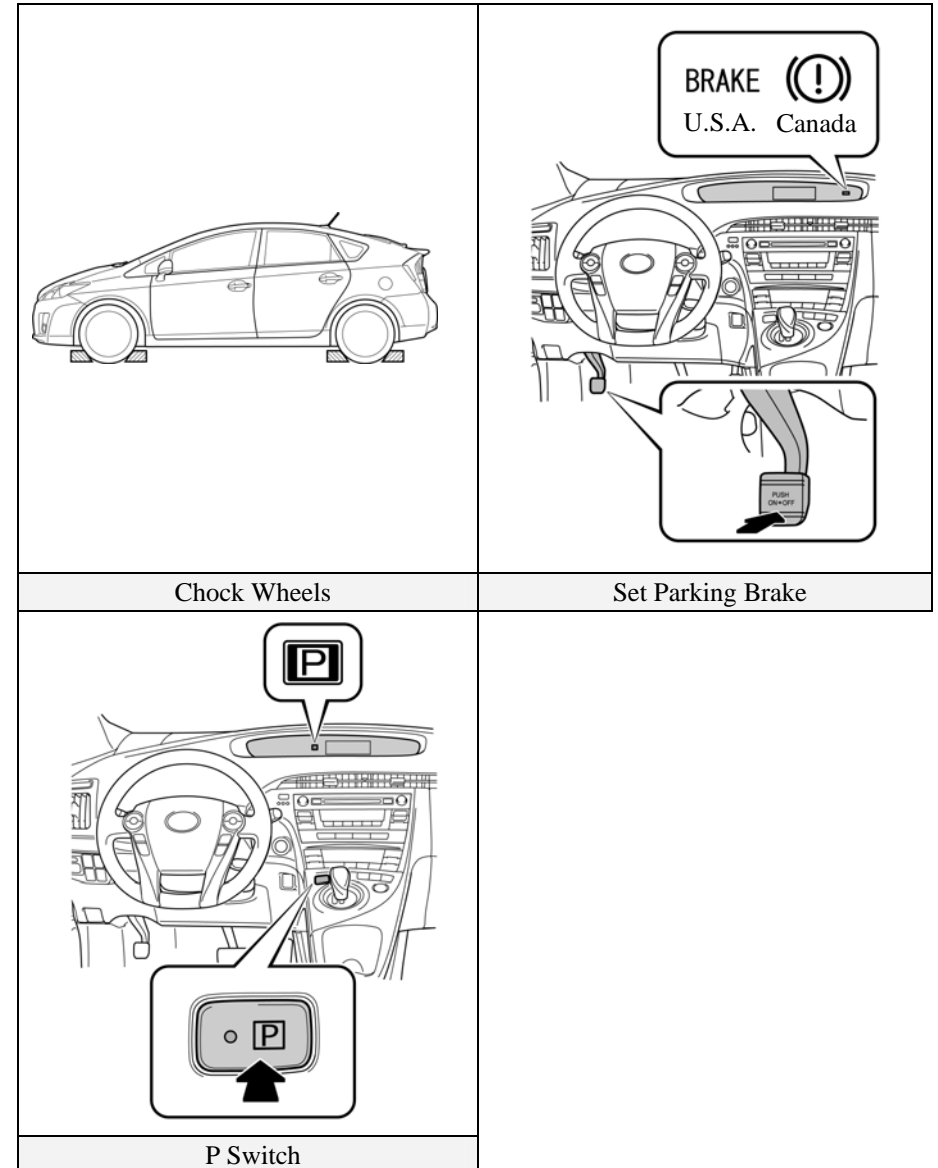

Emergency Response (Continued)

Extrication (Continued)

Procedure #1

1. Confirm the status of the **READY** indicator in the instrument cluster. If the **READY** indicator is illuminated, the vehicle is on and operational.
2. Shut off the vehicle by pushing the power button once.
3. The vehicle is already shut off if the instrument cluster lights are not illuminated. Do **not** push the power button because the vehicle may start.
4. If the smart key is easily accessible, keep it at least 16 feet (5 meters) away from the vehicle.
5. Disconnect the 12 Volt auxiliary battery under the cover in the cargo area to prevent accidental restarting of the vehicle and operation of the optional remote air conditioning system.

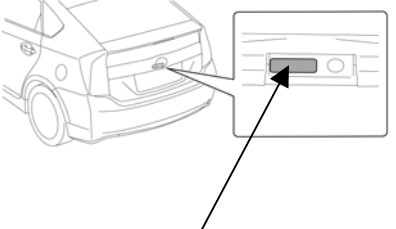
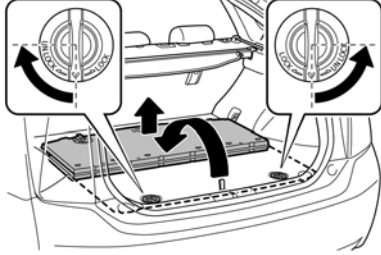
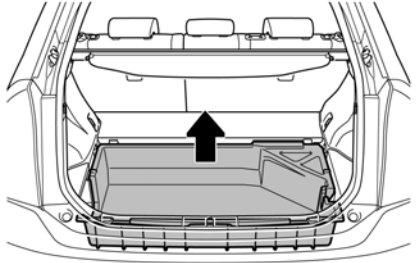
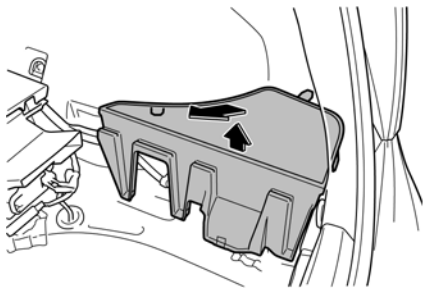
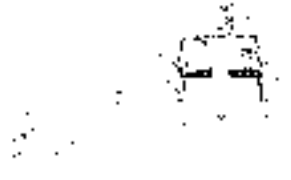
	 <p>Hatch Opener Switch</p>
<p>Shut Off Vehicle (READY-OFF)</p>	<p>Open Hatch Door</p>
	
<p>Remove Center Deck Board</p>	<p>Remove Center Auxiliary Box</p>
	
<p>Remove Auxiliary Battery Cover</p>	<p>12 Volt Auxiliary Battery in Cargo Area</p>

Emergency Response (Continued)

Extrication (Continued)

Procedure #2 (Alternate if power button is inaccessible)



1. Open the hood.
2. Remove the fuse box cover.
3. Remove the **IGCT** fuse (30A green colored) and **AM2** fuse (7.5A orange colored) in the engine compartment fuse box (refer to illustration). If the correct fuse cannot be recognized, pull all fuses in the fuse box.
4. Disconnect the 12 Volt auxiliary battery under the cover in the cargo area.

NOTE:

Before disconnecting the 12 Volt auxiliary battery, if necessary, lower the windows, unlock the doors and open the hatch as required. Once the 12 Volt auxiliary battery is disconnected, power controls will not operate.

⚠ WARNING:

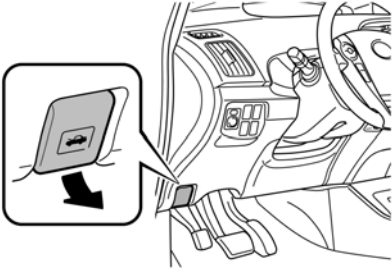
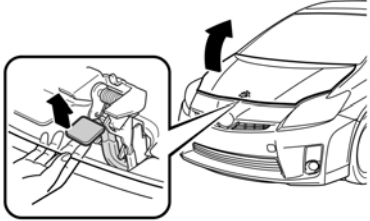
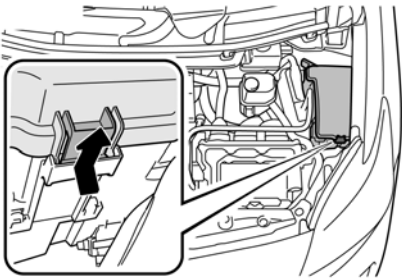
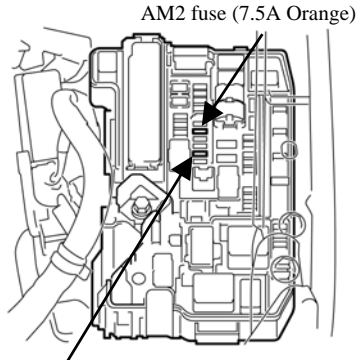
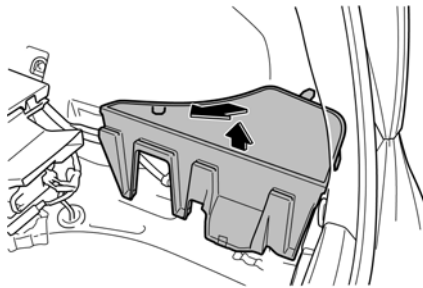
- *The high voltage system may remain powered for up to 10 minutes after the vehicle is shut off or disabled. To prevent serious injury or death from severe burns or electric shock, avoid touching, cutting, or breaching any orange high voltage power cable or high voltage component.*
- *The SRS may remain powered for up to 90 seconds after the vehicle is shut off or disabled. To prevent serious injury or death from unintentional SRS deployment, avoid breaching the SRS components.*
- *If none of the disabling procedures can be performed, proceed with caution as there is no assurance that the high voltage electrical system, SRS, fuel pump, or optional remote air conditioning system are disabled.*

	
Remote Hood Release	Hood Latch Release
	 <p>AM2 fuse (7.5A Orange)</p> <p>IGCT fuse (30A Green)</p>
Remove Fuse Box Cover	IGCT and AM2 Fuse Location in Engine Compartment Fuse Box
	
Remove Battery Cover	12 Volt Auxiliary Battery in Cargo Area

Emergency Response (Continued)

Extrication (Continued)

- Stabilize Vehicle

Crib at (4) points directly under the front and rear pillars.
Do not place cribbing under the high voltage power cables, exhaust system, or fuel system.

NOTE:

The Prius is equipped with a tire pressure warning system that by design prevents pulling the metal valve stem with integral transmitter from the wheel. Snapping the valve stem with pliers or removing the valve cap and Schrader valve will release the air in the tire.

- Access Patients

Glass Removal

Use normal glass removal procedures as required.

SRS Awareness

Responders need to be cautious when working in close proximity to undeployed airbags and seat belt pretensioners. Front dual stage airbags automatically ignite both stages within a fraction of a second.

Door Removal/Displacement

Doors can be removed by conventional rescue tools such as hand, electric, and hydraulic tools. In certain situations, it may be easier to pry back the vehicle body to expose and unbolt the hinges.

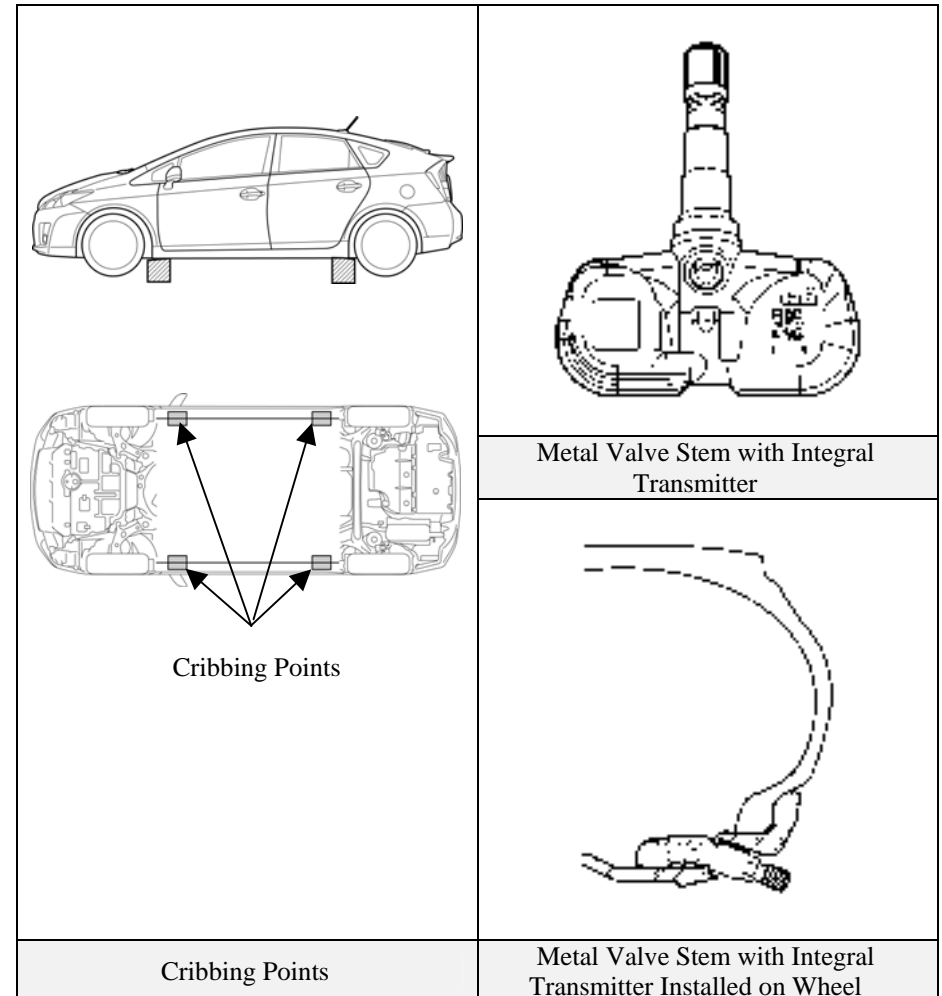

Emergency Response (Continued)

Extrication (Continued)

Roof Removal

The Prius is equipped with side curtain airbags. If the side curtain airbags are undeployed, total roof removal is not recommended. This is to avoid breaching the side curtain airbags, inflators, and wiring harness. Patient access through the roof can be performed by cutting the roof center section inboard of the roof rails as illustrated.

Prius models equipped with the optional solar panel have an output wire bundled with the side curtain airbag wire harness routed along the driver side C-pillar as shown in the illustration. This output wire is energized when the solar panel surface is exposed to light energy, and similar to a 12 Volt battery positive cable, it cannot be shut off or isolated until it reaches the control computer under the dashboard.

Cutting the roof center section may result in cutting into the optional solar panel and energized output wire. Wear personal protective equipment to prevent exposure to broken glass, material fragments, and dust.

NOTE:

The 27 Volt maximum solar panel output wire has a higher arc potential than 12 Volt wires.

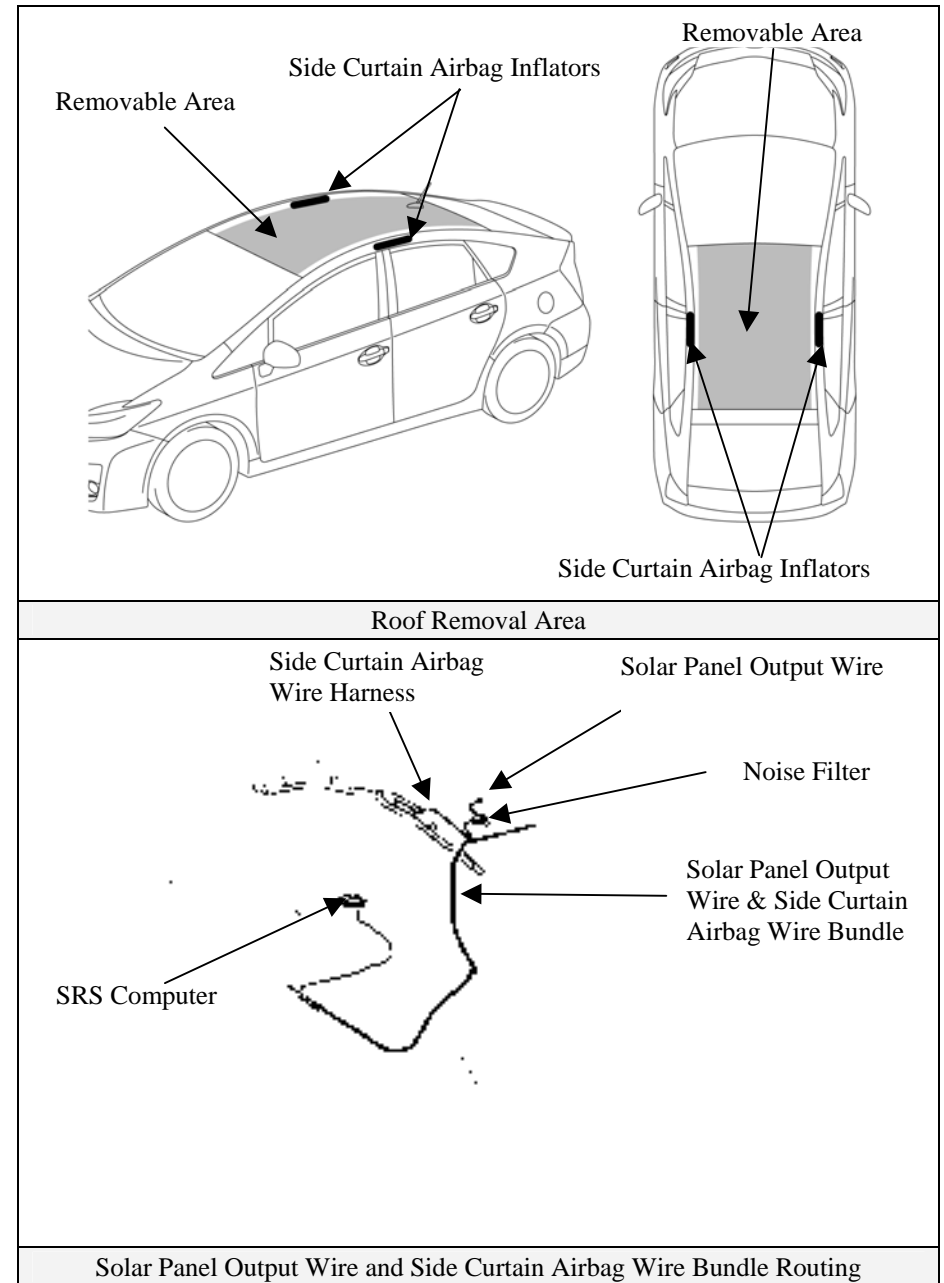

Emergency Response (Continued)

Extrication (Continued)

If the driver side curtain airbag is undeployed, avoid cutting the shaded area shown in the illustration. If this area is cut, there is a slight possibility of shorting the side curtain airbag harness and the solar panel energized output wire, resulting in airbag deployment. If cutting this area is unavoidable, manually disable the solar panel output wire using one or both of the following recommendations.

- Disable solar panel output by covering the entire panel with a material that blocks sunlight. Debris bags or salvage covers have been effective for disabling the solar panel output when two layers, either two separate layers, or one layer folded over the other, are used. Make sure the material is free of holes or tears that would allow sunlight through, and block the entire solar panel since even a small amount of sunlight will allow the solar panel to generate power.

NOTE:

Once the solar panel is disabled, the output in the energized wire drops immediately.

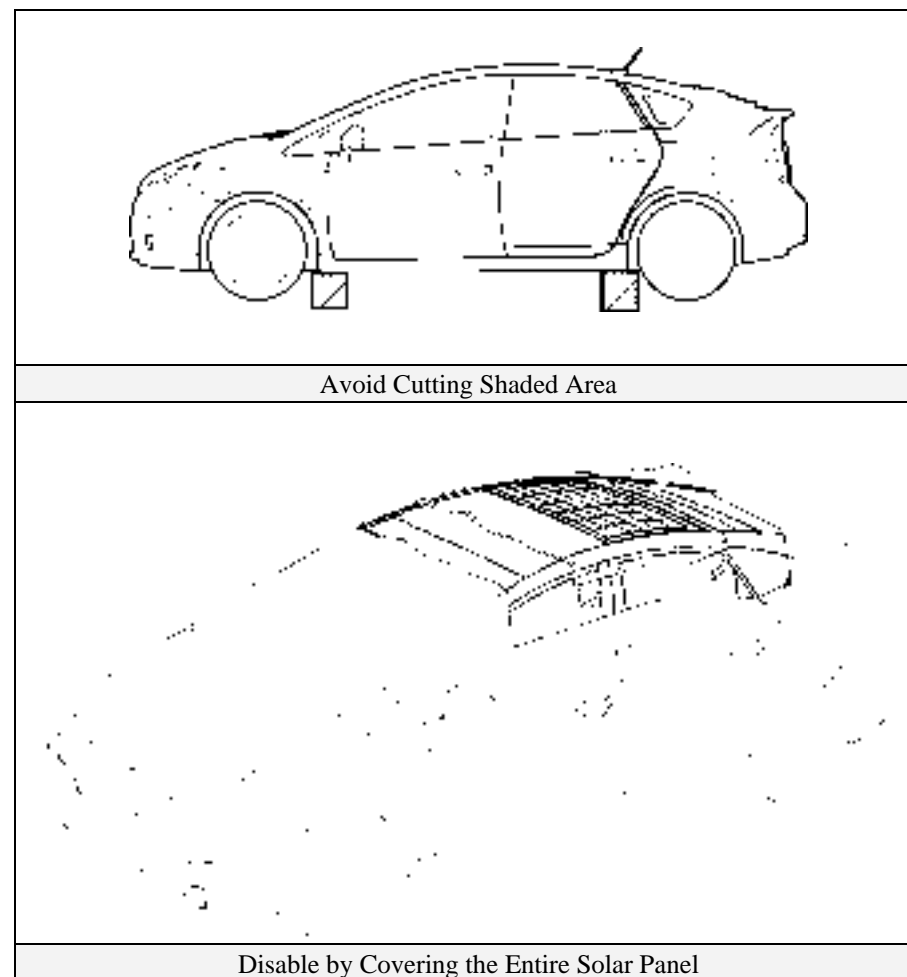

Emergency Response (Continued)

Extrication (Continued)

- Disable solar panel output by disconnecting or cutting the solar panel energized output wire. Remove the headliner above the driver side rear passenger area. Identify the red or blue output wire from under the solar panel as illustrated. Disconnect the connector or cut the red or blue wire to disable power output.

NOTE:

The 27 Volt maximum solar panel output wire has a higher arc potential than 12 Volt wires.

If neither of the above recommendations can be performed, keep away from the side curtain airbag deployment zone area along the driver and passenger side window as shown in the illustration.

Dash Displacement

The Prius is equipped with side curtain airbags. When undeployed, total roof removal is not recommended. This is to avoid breaching the side curtain airbags, inflators, SRS harnesses, and optional solar panel energized wire. As an alternative, dash displacement may be performed by using a Modified Dash Roll.

Disconnect/Cut Here (red or blue output wire):

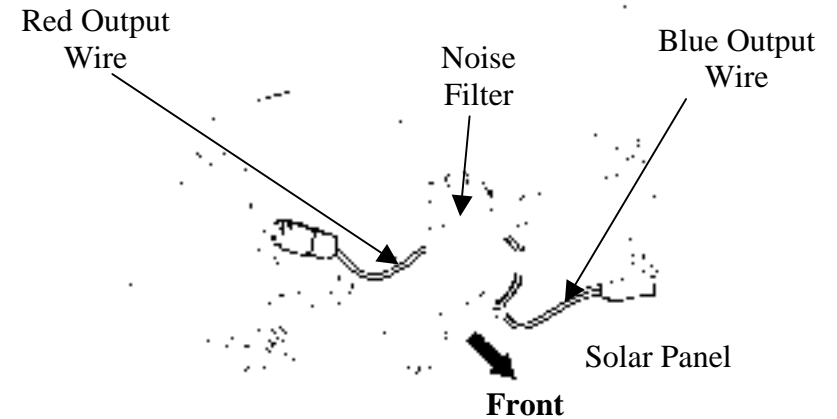

Disable Solar Panel Energized Output Wire (Headliner Removed)



Side Curtain Airbag Deployment Area

Emergency Response (Continued)

Extrication (Continued)

Rescue Lift Air Bags

Responders should not place cribbing or rescue lift air bags under the high voltage power cables, exhaust system, or fuel system.

Repositioning Steering Wheel and Front Seats

Telescopic steering wheel and seat controls are shown in the illustrations.

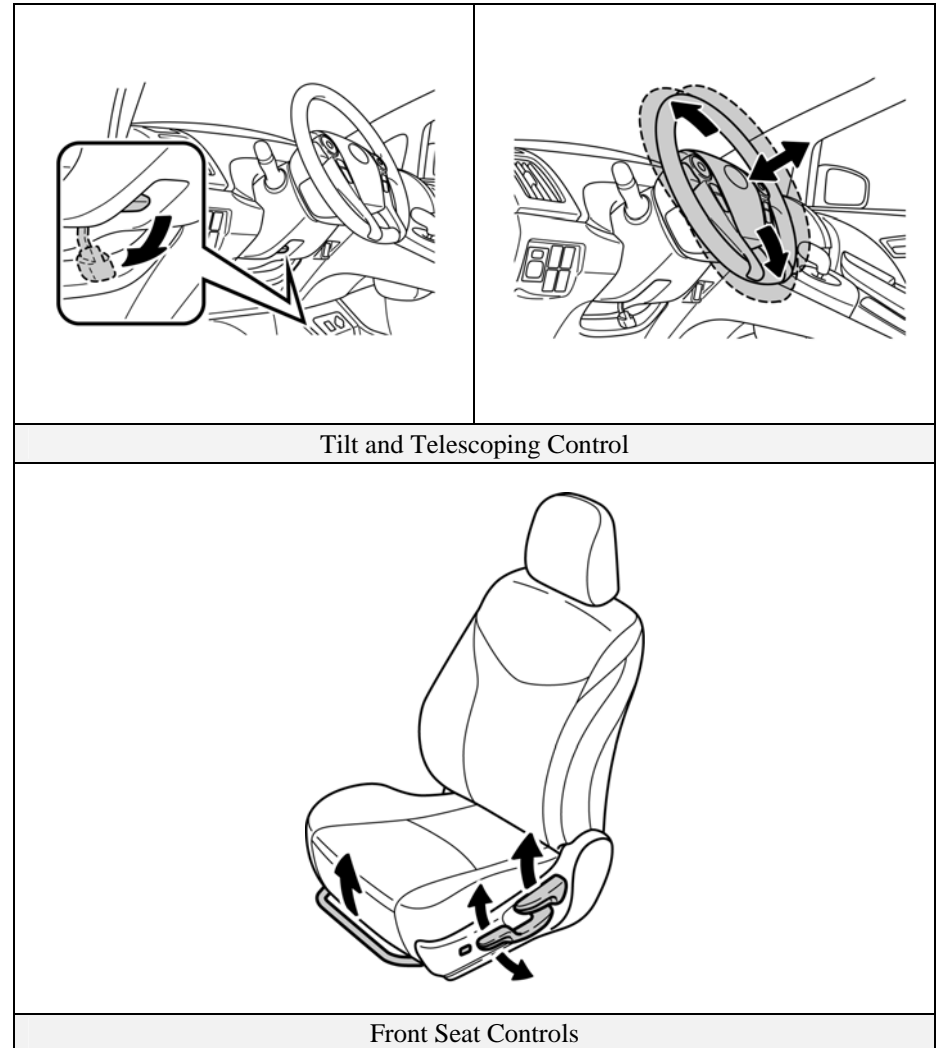

Emergency Response (Continued)

Extrication (Continued)

Active Headrest Removal

The Prius is equipped with active front headrests, located in both front seatbacks. The active headrests are mechanical non-pyrotechnic head supports that are designed to reduce neck injuries in the event of a rear collision.

No special methods are required to remove the headrests. Push the release button and lift to remove the headrest.

NOTE:

The Prius is equipped with an optional electrochromic auto dimming rear view mirror. The mirror contains a minimal amount of transparent gel sealed between two glass plates that will not normally leak.

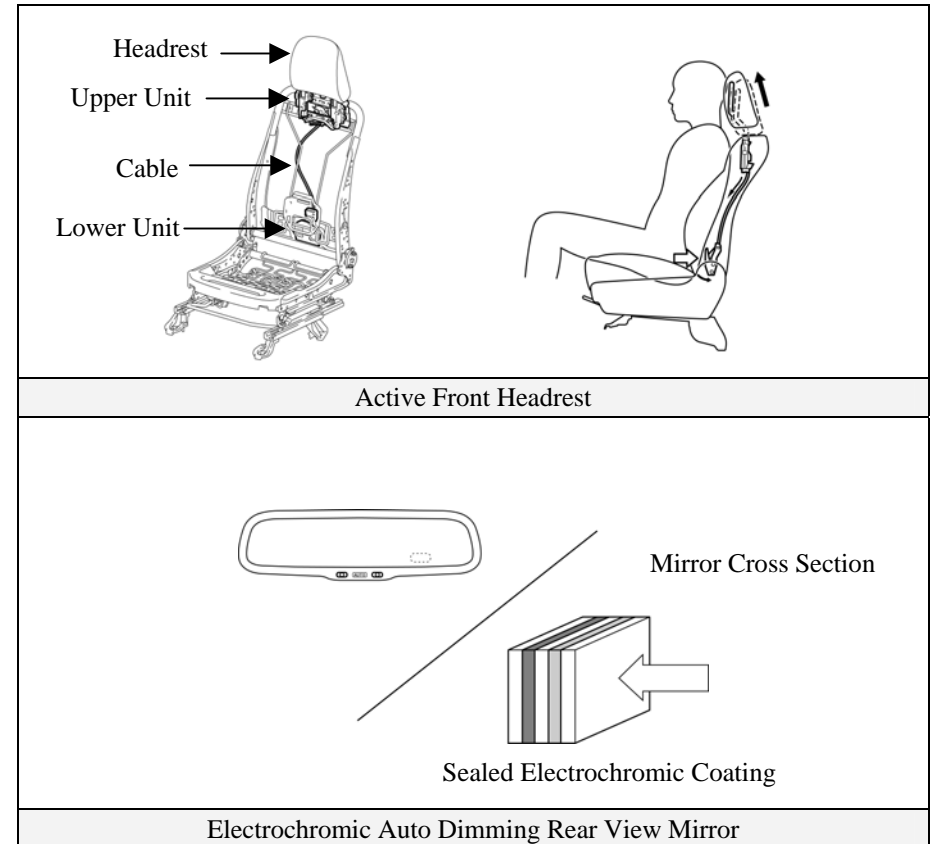

Emergency Response (Continued)

Fire

Approach and extinguish a fire using proper vehicle fire fighting practices as recommended by NFPA, IFSTA, or the National Fire Academy (USA).

- **Extinguishing Agent**
Water has been proven to be a suitable extinguishing agent.
- **Initial Fire Attack**
Perform a fast, aggressive fire attack.
Divert the runoff from entering watershed areas.
Attack teams may not be able to identify a Prius until the fire has been knocked down and overhaul operations have commenced.
- **Fire in the HV Battery Pack**
Should a fire occur in the NiMH HV battery pack, attack crews should utilize a water stream or fog pattern to extinguish any fire within the vehicle except for the HV battery pack.

WARNING:

- *The NiMH battery electrolyte is a caustic alkaline (pH 13.5) that is damaging to human tissues. To avoid injury by coming in contact with the electrolyte, wear proper personal protective equipment.*
- *The battery modules are contained within a metal case and accessibility is limited.*
- *To avoid serious injury or death from severe burns or electric shock, **never** breach or remove the high voltage battery pack cover under any circumstance including fire.*

When allowed to burn themselves out, the Prius NiMH battery modules burn rapidly and can quickly be reduced to ashes except for the metal.

Offensive Fire Attack

Normally, flooding an NiMH HV battery pack with copious amounts of water at a safe distance will effectively control the HV battery pack fire by cooling the adjacent NiMH battery modules to a point below their ignition temperature. The remaining modules on fire, if not extinguished by the water, will burn themselves out.

However, flooding the Prius HV battery pack is not recommended due to the battery case design and location preventing the responder from properly applying water through the available vent openings safely. Therefore, it is recommended that the incident commander allow the Prius HV battery pack to burn itself out.

Defensive Fire Attack

If the decision has been made to fight the fire using a defensive attack, the fire attack crew should pull back a safe distance and allow the NiMH battery modules to burn themselves out. During this defensive operation, fire crews may utilize a water stream or fog pattern to protect exposures or to control the path of smoke.

- **Fire involving the Optional Solar Panel**
The solar panel is constructed of materials commonly used in household electronic devices. Should a fire occur involving the solar roof panel, extinguish it using water.

Emergency Response (Continued)

Overhaul

During overhaul, immobilize and disable the vehicle if not already done. Refer to illustrations on page 19, 20, and 21. The HV battery cover should *never* be breached or removed under any circumstances including fire. Doing so may result in severe electrical burns, shock, or electrocution.

- Immobilize Vehicle
 - Chock wheels and set the parking brake.
 - Push the **P** switch to engage park.
- Disable Vehicle
 - Performing either of the following two procedures will shut the vehicle off and disable the HV battery pack, SRS, fuel pump and optional remote air conditioning.

Procedure #1

1. Confirm the status of the **READY** indicator in the instrument cluster. If the **READY** indicator is illuminated, the vehicle is on and operational.
2. Shut off the vehicle by pushing the power button once.
3. The vehicle is already shut off if the instrument cluster lights are not illuminated. Do **not** push the power button because the vehicle may start.
4. If the smart key is easily accessible, keep it at least 16 feet (5 meters) away from the vehicle.
5. Disconnect the 12 Volt auxiliary battery under the cover in the cargo area to prevent accidental restarting of the vehicle and operation of the optional remote air conditioning system.

Procedure #2 (Alternate if power button is inaccessible)

1. Open the hood and remove the fuse box cover.
2. Remove the **IGCT** fuse (30A green colored) and **AM2** fuse (7.5A orange colored) in the engine compartment fuse box as illustrated on page 21. If the correct fuse cannot be recognized, pull all fuses in the fuse box.
3. Disconnect the 12 Volt auxiliary battery under the cover in the cargo area.

NOTE:

Before disconnecting the 12 Volt auxiliary battery, if necessary, lower the windows, unlock the doors and open the hatch as required. Once the 12 Volt auxiliary battery is disconnected, power controls will not operate.

WARNING:

- *The high voltage system may remain powered for up to 10 minutes after the vehicle is shut off or disabled. To prevent serious injury or death from severe burns or electric shock, avoid touching, cutting, or breaching any orange high voltage power cable or high voltage component.*
- *The SRS may remain powered for up to 90 seconds after the vehicle is shut off or disabled. To prevent serious injury or death from unintentional SRS deployment, avoid breaching the SRS components.*
- *If none of the disabling procedures can be performed, proceed with caution as there is no assurance that the high voltage electrical system, SRS, fuel pump or optional remote air conditioning are disabled.*

Recovering/Recycling of NiMH HV Battery Pack

Clean up of the HV battery pack can be accomplished by the vehicle recovery crew without further concern of runoff or spillage. For information regarding recycling of the HV battery pack, contact the nearest Toyota dealer, or:

United States: (800) 331-4331

Canada: (888) TOYOTA 8 [(888) 869-6828]

Emergency Response (Continued)

Spills

The Prius contains the same common automotive fluids used in other non-hybrid Toyota vehicles, with the exception of the NiMH electrolyte used in the HV battery pack. The NiMH battery electrolyte is a caustic alkaline (pH 13.5) that is damaging to human tissues. The electrolyte, however, is absorbed in the cell plates and will not normally spill or leak out even if a battery module is cracked. A catastrophic crash that would breach both the metal battery pack case and a battery module would be a rare occurrence.

Similar to the use of baking soda to neutralize a lead-acid battery electrolyte spill, a dilute boric acid solution or vinegar can be used to neutralize a NiMH battery electrolyte spill.

NOTE:

Electrolyte leakage from the HV battery pack is unlikely due to its construction and the amount of available electrolyte contained within the NiMH modules. Any spillage would not warrant a declaration as a hazardous material incident. Responders should follow the recommendations as outlined in this emergency response guide.

In an emergency, manufacturer's Material Safety Data Sheets (MSDS) are available by contacting:

United States: CHEMTREC at (800) 424-9300

Canada: CANUTEC at *666 or (613) 996-6666 (collect)

- Handle NiMH electrolyte spills using the following Personal Protective Equipment (PPE):
 - Splash shield or safety goggles. Fold down helmet shields are not acceptable for acid or electrolyte spills.
 - Rubber, latex or nitrile gloves.
 - Apron suitable for alkaline.
 - Rubber boots.
- Neutralize NiMH Electrolyte
 - Use a boric acid solution or vinegar.
 - Boric acid solution - 800 grams boric acid to 20 liters water or 5.5 ounces boric acid to 1 gallon of water.

First Aid

Emergency responders may not be familiar with NiMH electrolyte exposure when rendering aid to a patient. Exposure to the electrolyte is unlikely except in a catastrophic crash or through improper handling. Utilize the following guidelines in the event of exposure.

WARNING:

The NiMH battery electrolyte is a caustic alkaline (pH 13.5) that is damaging to human tissues. To avoid injury by coming in contact with the electrolyte, wear proper personal protective equipment.

- Wear Personal Protective Equipment (PPE)
 - Splash shield or safety goggles. Fold down helmet shields are not acceptable for acid or electrolyte spills.
 - Rubber, latex or nitrile gloves.
 - Apron suitable for alkaline.
 - Rubber boots.
- Absorption
 - Perform gross decontamination by removing affected clothing and properly disposing of the garments.
 - Rinse the affected areas with water for 20 minutes.
 - Transport patients to the nearest emergency medical care facility.
- Inhalation in Non-Fire Situations
 - No toxic gases are emitted under normal conditions.
- Inhalation in Fire Situations
 - Toxic gases are given off as by-products of combustion. All responders in the Hot Zone should wear the proper PPE for fire fighting including SCBA.
 - Move a patient from the hazardous environment to a safe area and administer oxygen.
 - Transport patients to the nearest emergency medical care facility.
- Ingestion
 - If NiMH electrolyte is ingested, do not induce vomiting.
 - Allow the patient to drink large quantities of water to dilute the electrolyte (never give water to an unconscious person).

Emergency Response (Continued)

First Aid (Continued)

If vomiting occurs spontaneously, keep the patient's head lowered and forward to reduce the risk of asphyxiation.

Transport patients to the nearest emergency medical care facility.

The solar panel is constructed of glass, potting material, silicon, silver and aluminum compounds, and a back sheet. If the panel is compromised, wear personal protective equipment to prevent exposure to broken glass, material fragments and dust. In a fire, wear SCBA to prevent breathing toxic gases. Seek medical attention in the event of exposure to smoke from a burning solar roof panel.

Submersion

A submerged hybrid vehicle does not have high voltage potential on the metal vehicle body, and is safe to touch.

Access Patients

Responders can access the patient and perform normal extrication procedures. High voltage orange color coded power cables and high voltage components should never be touched, cut, or breached.

Vehicle Recovery

If a hybrid vehicle is fully or partially submerged in water, emergency responders may not be able to determine if the vehicle has been automatically disabled. The Prius may be handled by following these recommendations:

1. Remove the vehicle from the water.
2. Drain the water from the vehicle if possible.
3. Follow the immobilizing and disabling procedures on page 19, 20, and 21.

Roadside Assistance

The Prius utilizes an electronic gearshift selector and an electronic **P** position switch for park. If the 12 Volt auxiliary battery is discharged or disconnected, the vehicle cannot be started nor can it be shifted out of park. If discharged, the 12 Volt auxiliary battery can be jump started to allow vehicle starting and shifting out of park. Most other roadside assistance operations may be handled like conventional Toyota vehicles.

Towing

The Prius is a front wheel drive vehicle and it **must** be towed with the front wheels off the ground. Failure to do so may cause serious damage to Hybrid Synergy Drive components.

- The vehicle may be shifted out of **Park** into **Neutral** by turning the ignition-on and READY-on modes. To select **Neutral**, it is necessary to hold the shift selector in the N position for approximately 0.5 seconds.
- If the 12 Volt auxiliary battery is discharged, the vehicle will not start and shifting out of park is not possible. There is no manual override except to jump start the vehicle, refer to the Jump Starting on page 35.
- If a tow truck is not available, in an emergency the vehicle may be temporarily towed using a cable or chain secured to the emergency towing eyelet or rear tow hook. This should only be attempted on hard, paved roads for short distances at below 19 mph (30 km/h). The eyelet is located with the tools in the cargo area of the vehicle, refer to the illustration on page 34.

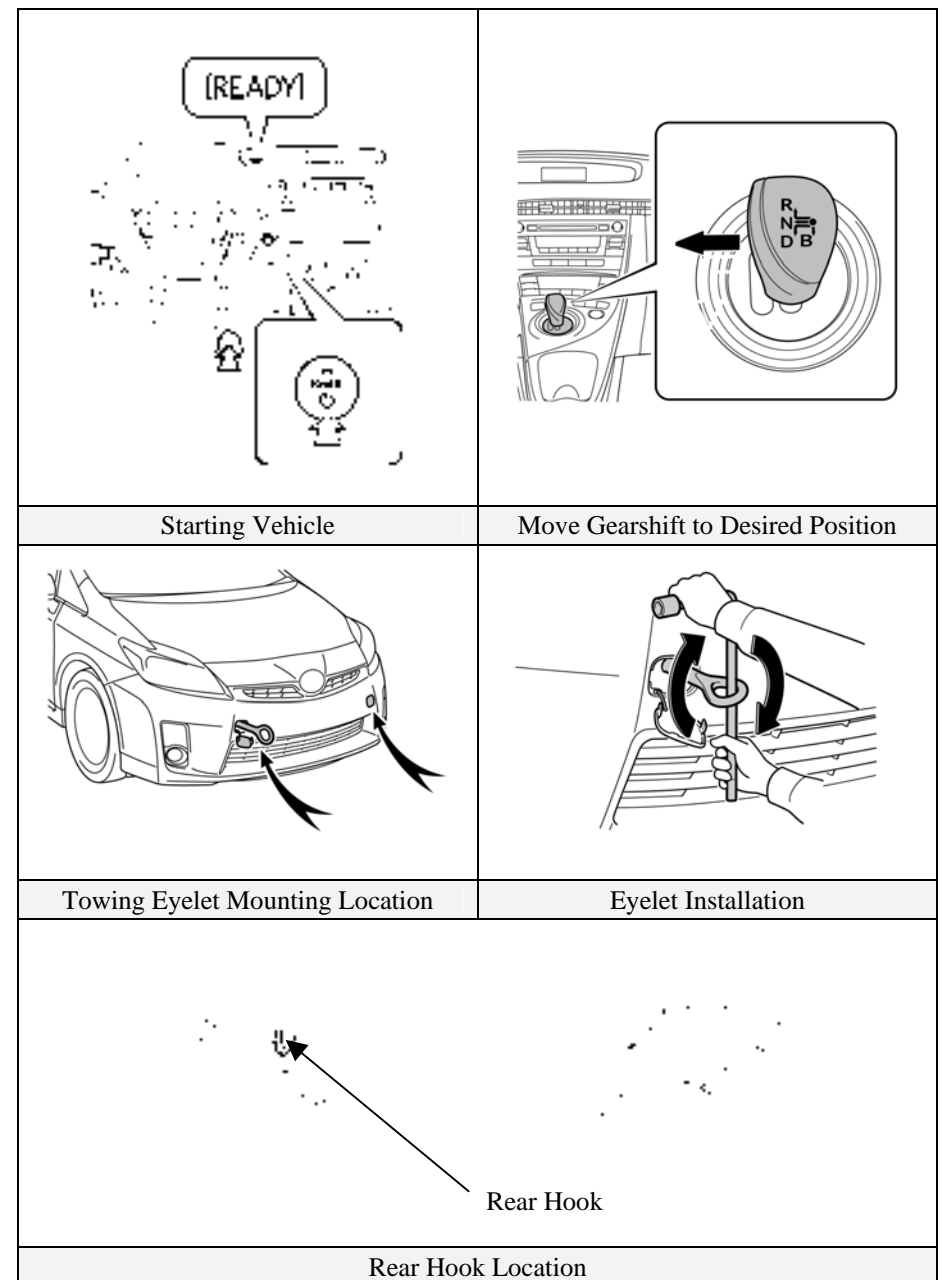

Roadside Assistance (Continued)

Electric Hatch Opener

The Prius is equipped with an electric hatch opener. In the event of 12 Volt power loss, the hatch cannot be opened from the outside of the vehicle.

The electric hatch can be opened manually using the release as shown in the illustration.

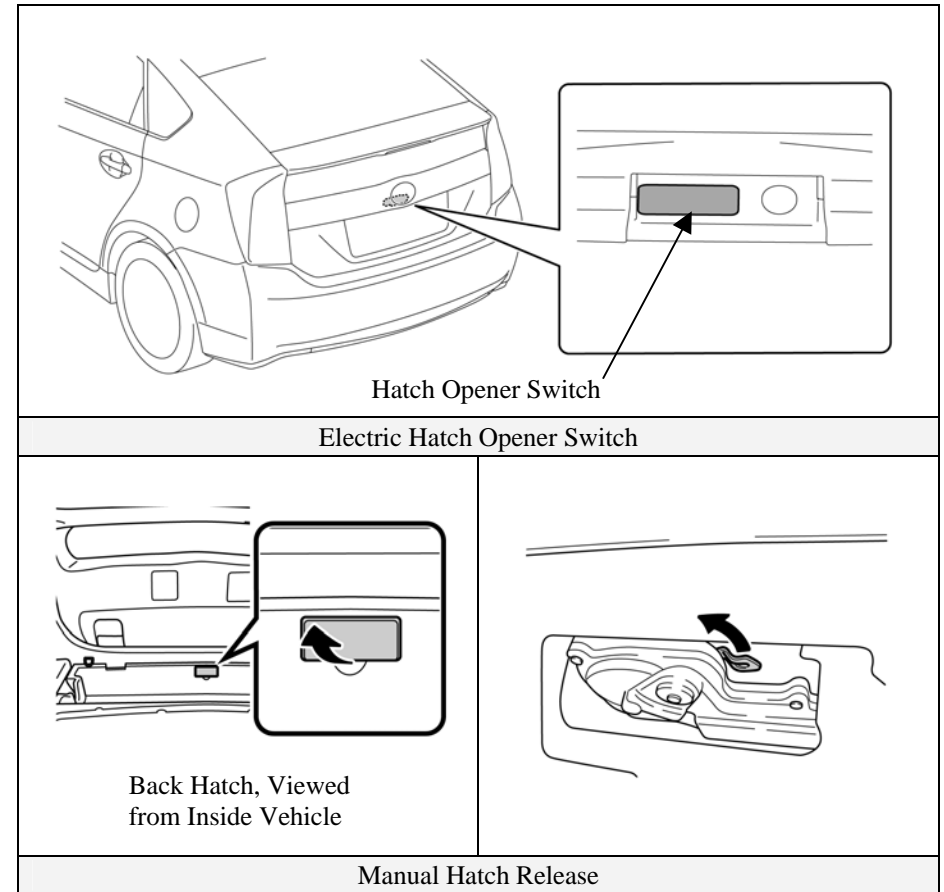

Roadside Assistance (Continued)

Spare Tire

The jack, tools, towing eyelet and spare tire are provided as shown.

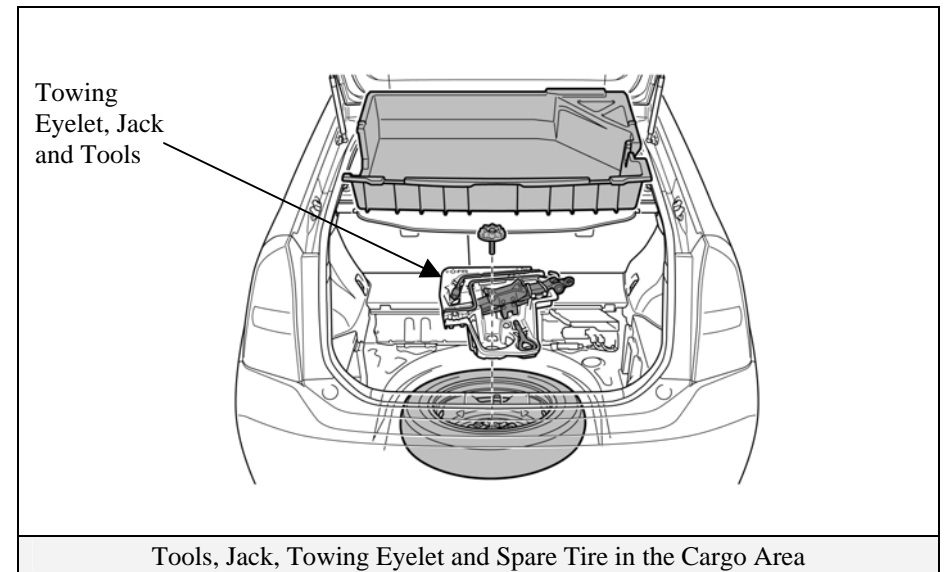

Roadside Assistance (Continued)

Jump Starting

The 12 Volt auxiliary battery may be jump started if the vehicle does not start and the instrument cluster gauges are dim or off after depressing the brake pedal and pushing the power button.

The 12 Volt auxiliary battery is located in the cargo area. If the 12 Volt auxiliary battery is discharged, the rear hatch cannot be opened. Instead, the vehicle can be jump started by accessing the remote positive 12 Volt auxiliary battery terminal in the engine compartment fuse box.

- Open the hood, remove the fuse box cover, and open the positive terminal cover.
- Connect the positive jumper cable to the positive terminal.
- Connect the negative jumper cable to a solid ground.
- Place the smart key in proximity to the interior of the vehicle, depress the brake pedal, and push the power button.

NOTE:

If the vehicle does not recognize the smart key after connecting the booster battery to the vehicle, open and close the driver door when the vehicle is shut off.

If the smart key internal battery is dead, touch the Toyota emblem side of the smart key to the power button during the start sequence. See the instructions and illustrations on page 9 for more details.

- The high voltage HV battery pack cannot be jump started.

Immobilizer

The Prius is equipped with a standard immobilizer system.

- The vehicle can be started only with a registered smart key.

