

Shaded portions show where cables are braided together in a protective sheathing.
Colours indicate coloured sleeveings on ends of leads.

NOTE.—S.S. 1. Open 4-Seater Model. The panel arrangement is slightly different from that shown above, but the wiring is the same.

Fig. 40.

WIRING DIAGRAMS

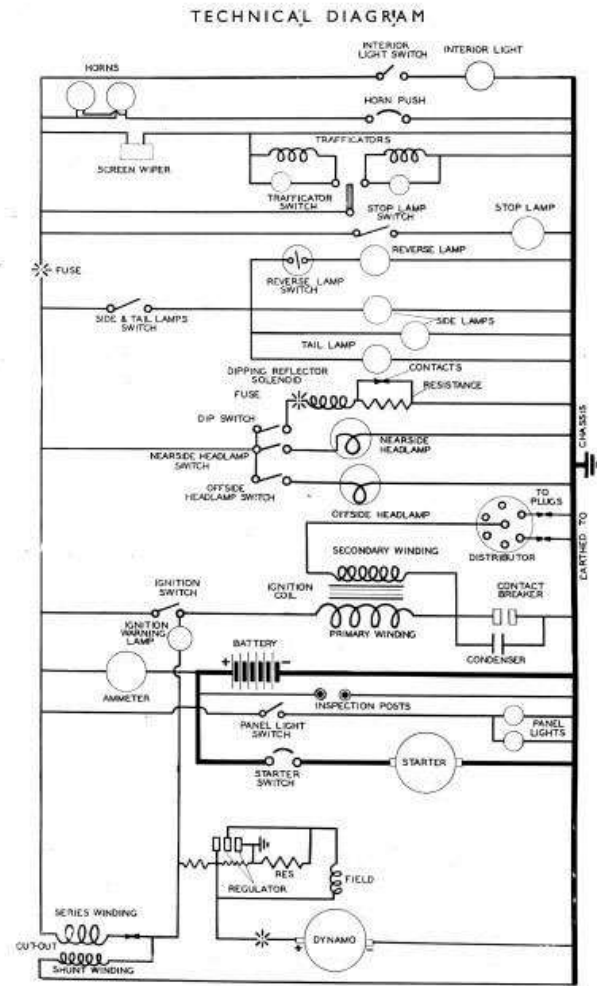

Fig. 41.