

# WORKSHOP MANUAL

## VEHICROSS (UGS)

### FOREWORD

This manual includes special notes, important points, service data, precautions, etc. that are needed for the maintenance, adjustments, service, removal and installation of vehicle components.

All information, illustrations and specifications contained in this manual are based on the latest product information available at the time of publication.

All rights are reserved to make changes at any time without notice.

Arrangement of the material is shown in the table of contents on the right-hand side of this page. A black spot on the first page of each section can be seen on the edge of the book below each section title. These point to a more detailed table of contents preceding each section.

*This manual applies to 2000 models.*

SECTION	TABLE OF CONTENTS
0A 0B	<b>GENERAL INFORMATION</b> General Information Maintenance and Lubrication
1A	<b>HEATING, VENTILATION AND AIR CONDITIONING</b> Compressor Overhaul
2A	<b>STEERING</b> Power-Assisted System
3C 3D 3E	<b>SUSPENSION</b> Front Suspension Rear Suspension Wheel and Tire System
4A1 4A2 4B2 4C 4D2	<b>DRIVELINE/AXLE</b> Differential Differential Driveline Control System (TOD) Drive Shaft System Transfer Case (TOD)
5A 5B 5C 5D	<b>BRAKE</b> Brake Control System Anti-Lock Brake System Power-Assisted Brake System Parking Brake System
6A 6B 6C 6D1 6D2 6D3 6E 6F 6G 6H 6J	<b>ENGINE</b> Engine Mechanical Engine Cooling Engine Fuel Engine Electrical Ignition System Starting and Charging System Driveability and Emissions Engine Exhaust Engine Lubrication Engine Speed Control System Induction
7A 7A1	<b>TRANSMISSION</b> Automatic Transmission Transmission Control System
8A 8B 8C 8D 8E 8F 8G 8H 8J	<b>BODY AND ACCESSORIES</b> Lighting System Wiper/Washer System Entertainment Wiring System Meter and Gauge Body Structure Seats Security and Locks Exterior/Interior Trim
9A 9J 9J1	<b>RESTRAINTS</b> Seat Belt System Supplemental Restraint System (Air Bag System) Restraint Control System
10A	<b>CONTROL SYSTEM</b> Cruise Control System

VEHICROSS

# GENERAL INFORMATION

## CONTENTS

General Information .....	0A
Maintenance and Lubrication .....	0B

# GENERAL INFORMATION

## CONTENTS

General Repair Instruction .....	0A-1	Lifting Instructions .....	0A-9
Illustration Arrows .....	0A-2	Standard Bolts Torque Specifications .....	0A-12
Identification .....	0A-3	Abbreviations Charts .....	0A-13
Theft Prevention Standard .....	0A-5	Service Parts Identification Plate .....	0A-14

### General Repair Instruction

- If a floor jack is used, the following precautions are recommended.  
Park vehicle on level ground, "block" front or rear wheels, set jack against the recommended lifting points (see "Lifting Instructions" in this section), raise vehicle and support with chassis stands and then perform the service operations.
- Before performing service operations, disconnect ground cable from the battery to reduce the chance of cable damage and burning due to short circuiting.
- Use a cover on body, seats and floor to protect them against damage and contamination.
- Brake fluid and anti-freeze solution must be handled with reasonable care, as they can cause paint damage.
- The use of proper tools and recommended essential and available tools, where specified, is important for efficient and reliable performance of service repairs.
- Use genuine Isuzu parts.
- Used cotter pins, plastic clips, gaskets, O-rings, oil seals, lock washers and self-locking nuts should be discarded and new ones should be installed, as normal function of the parts cannot be maintained if these parts are reused.
- To facilitate proper and smooth reassembly operation, keep disassembled parts neatly in groups. Keeping fixing bolts and nuts separate is very important, as they vary in hardness and design depending on position of installation.
- Clean the parts before inspection or reassembly. Also clean oil ports, etc. using compressed air, and make certain they are free from restrictions.
- Lubricate rotating and sliding faces of the parts with oil or grease before installation.
- When necessary, use a sealer on gaskets to prevent leakage.
- Carefully observe all specifications for bolt and nut torques.
- When removing or replacing parts that require refrigerant to be discharged from the air conditioning system, be sure to use the Vehicle Refrigerant Recovery and Recycling Equipment (VRRRE) to recover and recycle Refrigerant-134a.
- When a service operation is completed, make a final check to be sure the service has been done properly and the problem has been corrected.

### 15. SUPPLEMENTAL RESTRAINT SYSTEM

The vehicle is equipped with a Supplemental Restraint System. (SRS)—Air Bag.

This system is not to be serviced without consulting the appropriate service information.

Consult Sections 9J1 and 9J "SRS System" if work is to be done on the front of the vehicle such as bumper, sheet metal, seats, wiring, steering wheel or column.

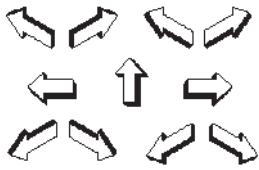






Also review SRS system information if any arc welding is to be done on the vehicle.








The SRS system equipped vehicle can be identified by:

- "AIR BAG" warning light on the instrument panel.
- A Code "J" for fifth digit of vehicle Identification Number.

### Illustration Arrows

Arrows are designed for specific purposes to aid your understanding of technical illustrations.

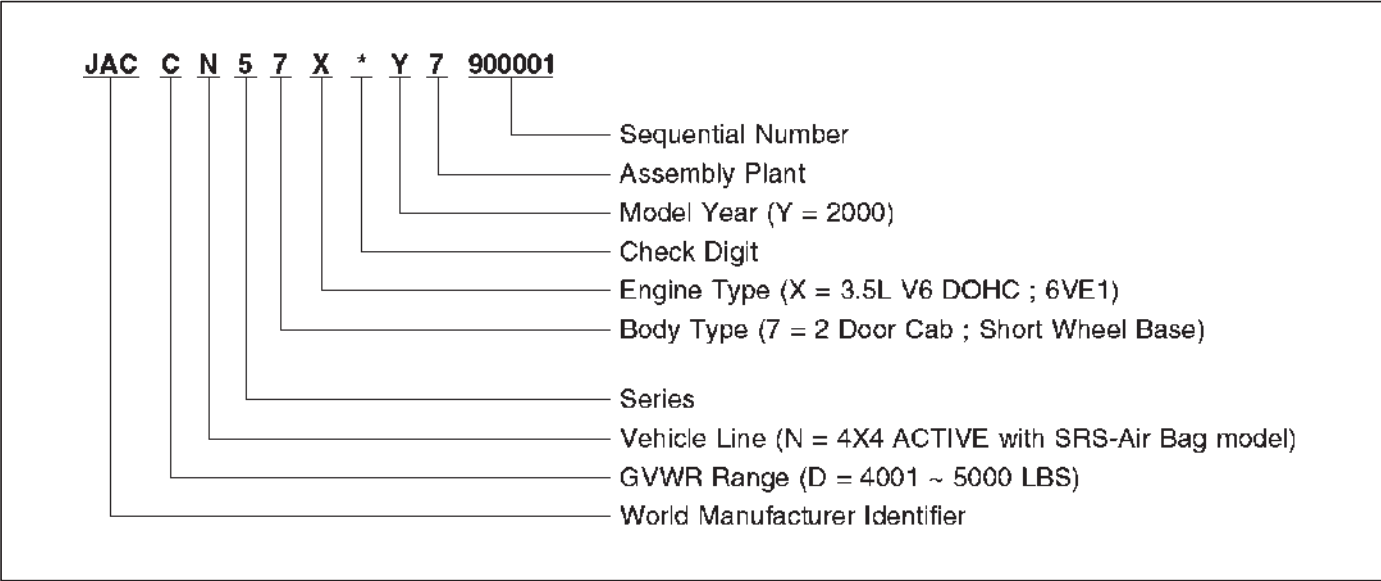
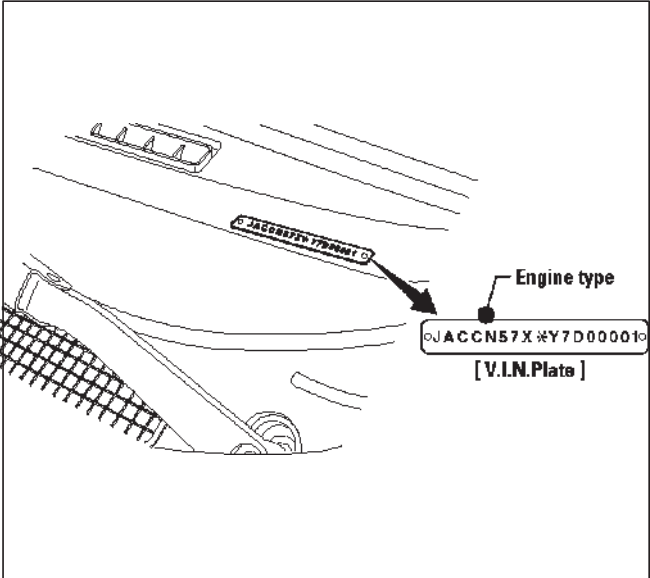
Arrow Type	Application
	Front of vehicle
	Up Side
	Task Related
	View Detail
	View Angle
	Dimension (1:2)
	Sectioning (1:3)

Arrow Type	Application
	<ul style="list-style-type: none"> <li>○ Ambient/Clean air flow</li> <li>○ Cool air flow</li> </ul>
	<ul style="list-style-type: none"> <li>○ Gas other than ambient air</li> <li>○ Hot air flow</li> </ul>
	<ul style="list-style-type: none"> <li>○ Ambient air mixed with another gas</li> <li>○ Can indicate temperature change</li> </ul>
	Motion or direction
	Lubrication point oil or fluid
	Lubrication point grease
	Lubrication point jelly

### Identification

#### Vehicle Identification Number (VIN)

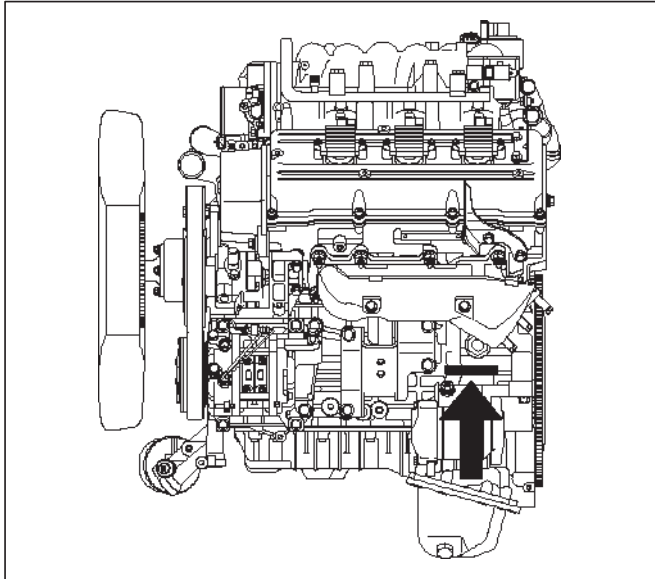
This is the legal identification of the vehicle. it is located on the left bottom of the windshield. It can be easily seen through the windshield from outside the vehicle.



## 0A-4 GENERAL INFORMATION

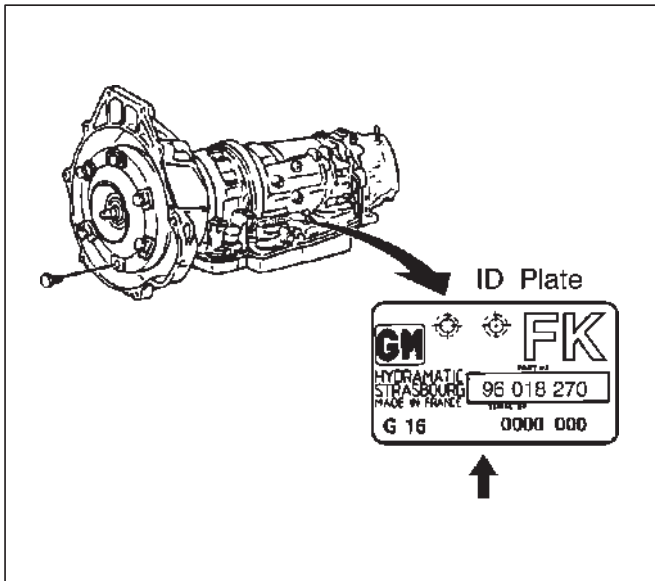
### Engine Serial Number

The gasoline engine serial number is stamped on the left rear lower area of the cylinder block above the starter.



F06RW001

Automatic : Stamped on the identification plate, located on the left side of the transmission above the mode switch.



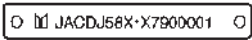



240RX009

### Theft Prevention Standard

The 11 major components listed below will be marked with 17 digit V.I.N. at the stage of production. In addition its service parts will be marked with manufacturer's trade mark, "R" mark and "DOT" mark.

Reference Figure No.	COMPONENT		INDICATION	
			PRODUCTION	SERVICE PARTS
0A-10	ENGINE	1- 6VE1	V.I.N. plate	"R M DOT" Mark stamping
0A-11	TRANSMISSION	2- Automatic transmission	V.I.N. plate	"R M DOT" Mark label
0A-11	BODY	3- Engine hood 4- Front door 5- Rear door 6- Fender 7- Rear Quarter panel 8- Front bumper 9- Back door left side 10- Back door right side 11- Rear bumper	V.I.N. label	"R M DOT" Mark label

### Anti Theft Stamping/Plate/Label

	STAMPING/PLATE	LABEL
PRODUCTION	Example 	Example 
SERVICE PARTS		

## 0A-6 GENERAL INFORMATION

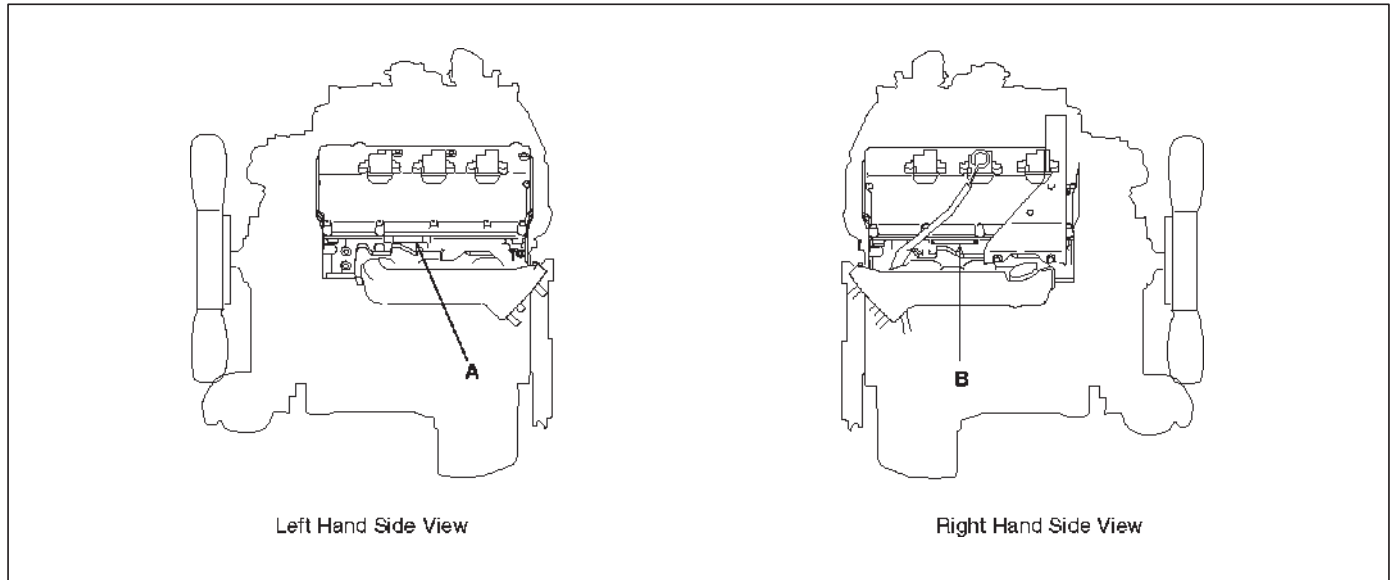
### Anti Theft Stamping/Label/Plate Location

The stamping, label and plate locations are indicated by arrows in the illustration below.

#### NOTE:

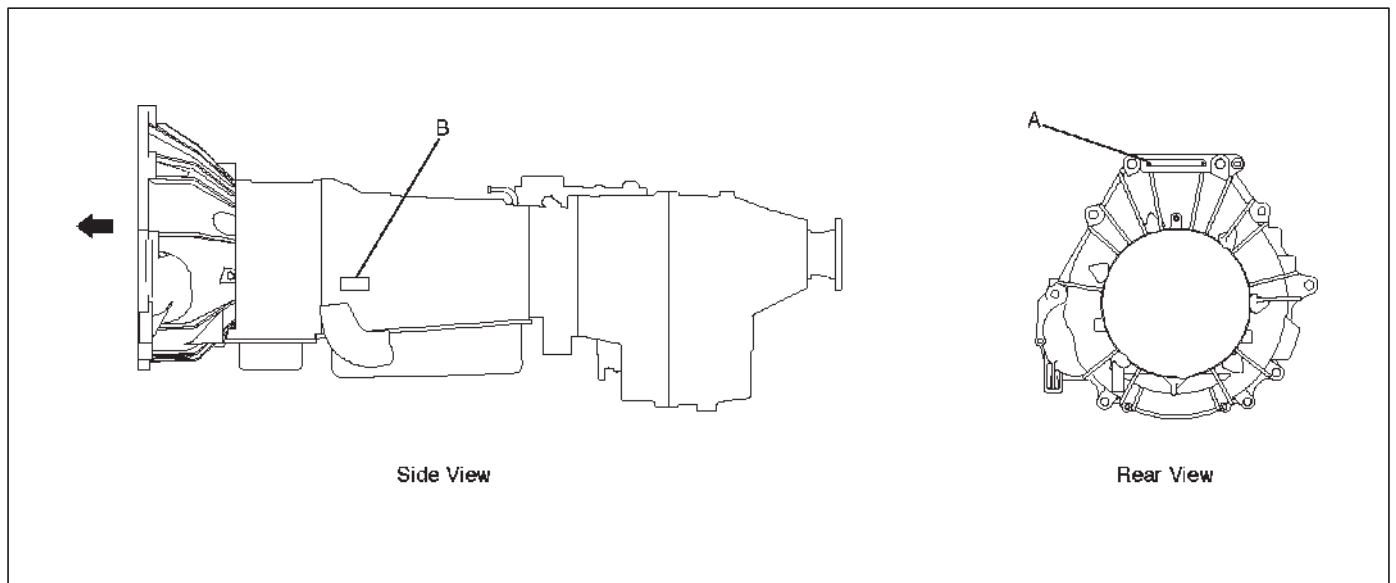
- A. VIN plate locations for production.
- B. Stamping locations for service parts.

#### Engine



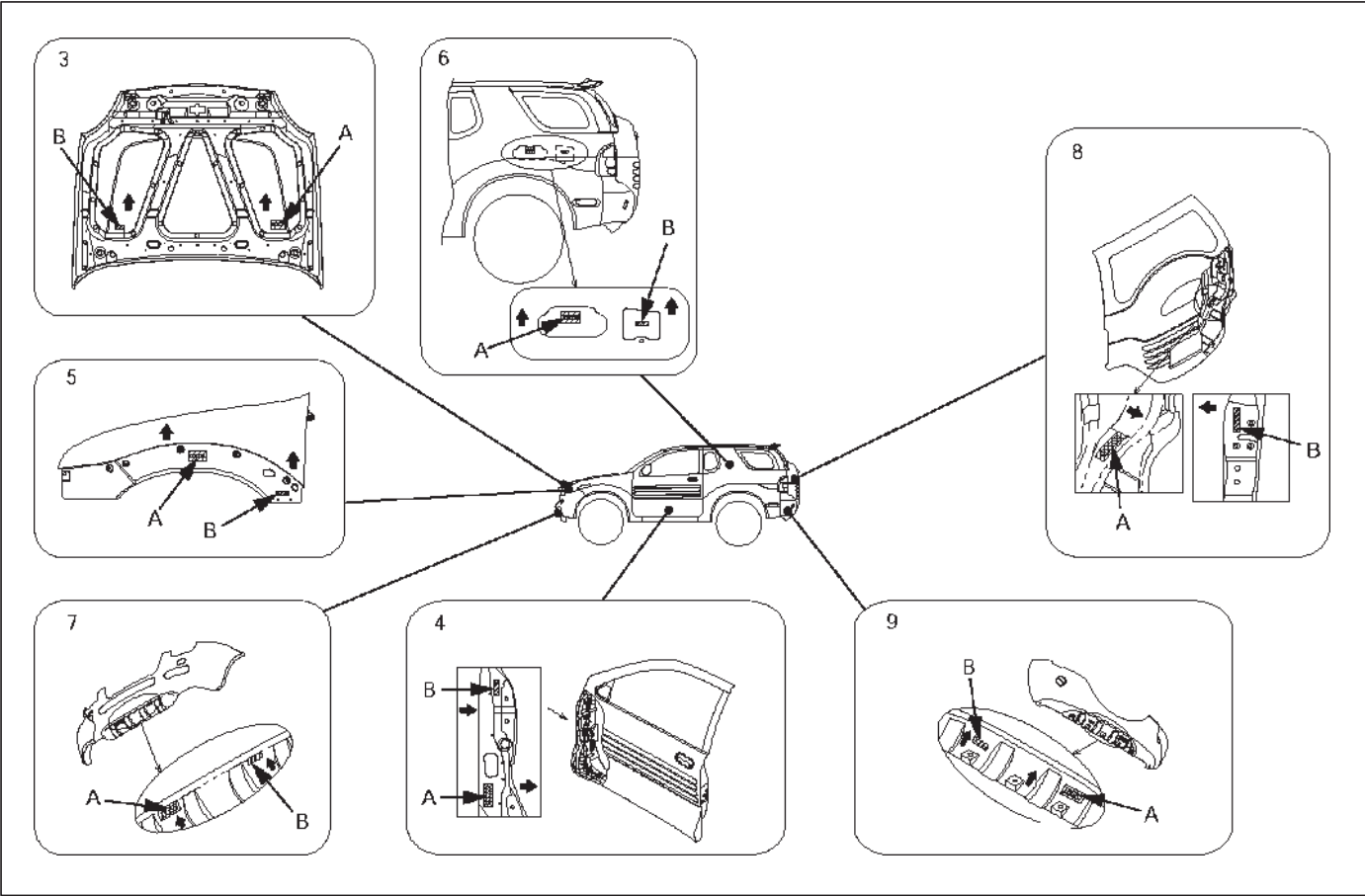
901RW195

#### Automatic Transmission (THM)



901RW197

Body



901RX070

Legend

- (3) Engine Hood
- (4) Front Door
- (5) Front Fender

- (6) Rear Quarter Panel
- (7) Front Bumper
- (8) Tail Gate
- (9) Rear Bumper

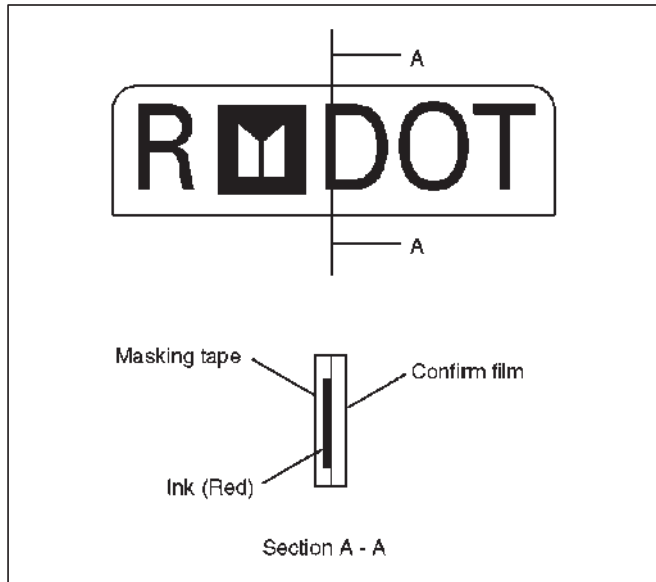


### Body Label Instructions

Do not peel off the masking tape until completion of paint work when replacing these parts, as the tape is affixed on the label attached to service parts for body of the anti-theft component.

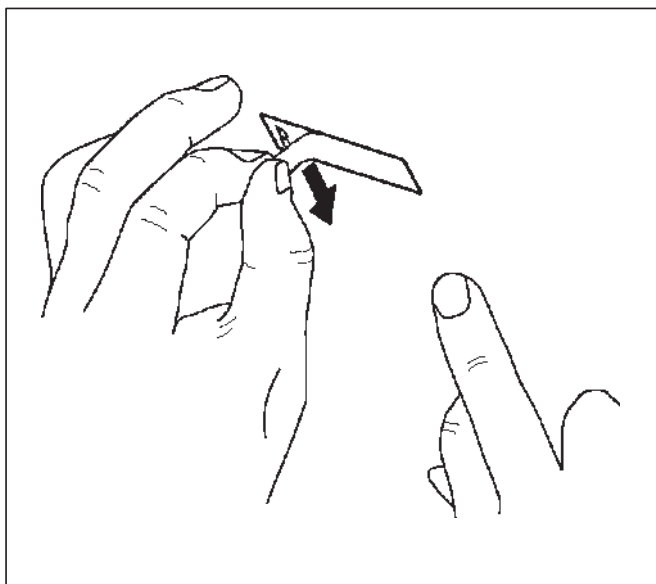
NOTE: Be sure to pull off the masking tape after paint work has been completed.

Do not attempt to remove this label for any reason.



### Precautions in pulling off the masking tape

1. Use only your finger nail or a similar blunt instrument to peel off the masking tape. Use of a sharp object will damage the underlying anti-theft label.
2. Be careful not to damage the paint around the label.

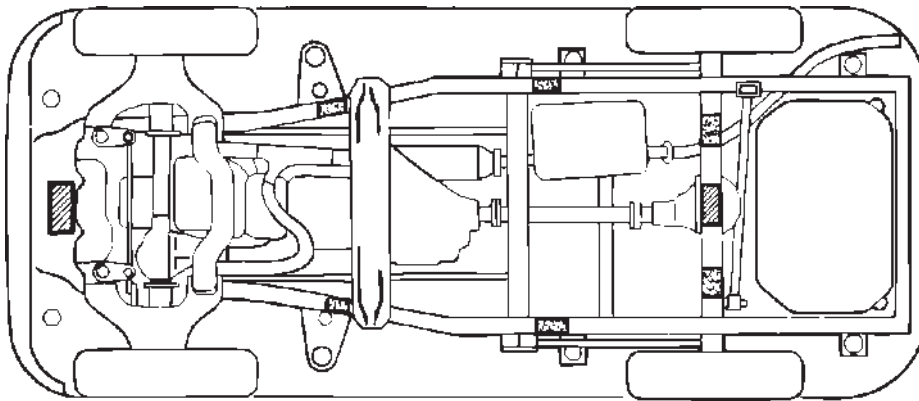


## Lifting Instructions

### CAUTION:

- If a lifting device other than the original jack is used, it is most important that the device be applied only to the correct lifting points. Raising the vehicle from any other point may result in serious damage.
- When jacking or lifting a vehicle at the frame side rail or other prescribed lift points, be certain that lift pads do not contact the catalytic converter, brake pipes or cables, or fuel lines. Such contact may result in damage or unsatisfactory vehicle performance.

### Lifting Points and Supportable Point Locations



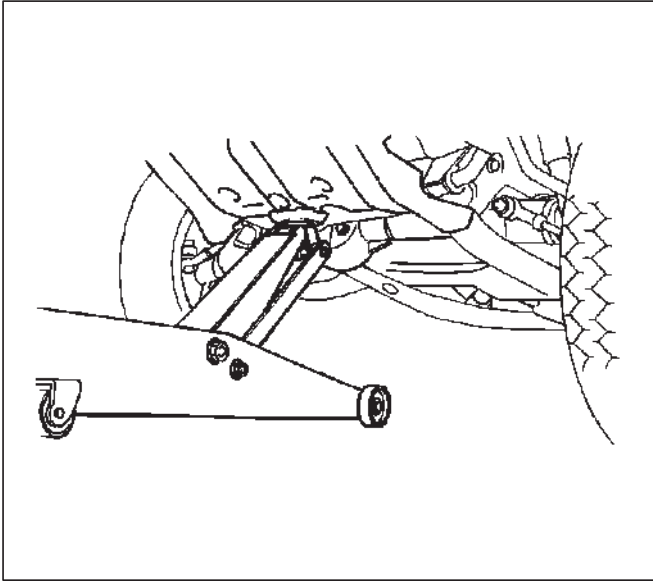
 Lifting point

 Supportable point

## 0A-10 GENERAL INFORMATION

### Lifting Point; Front

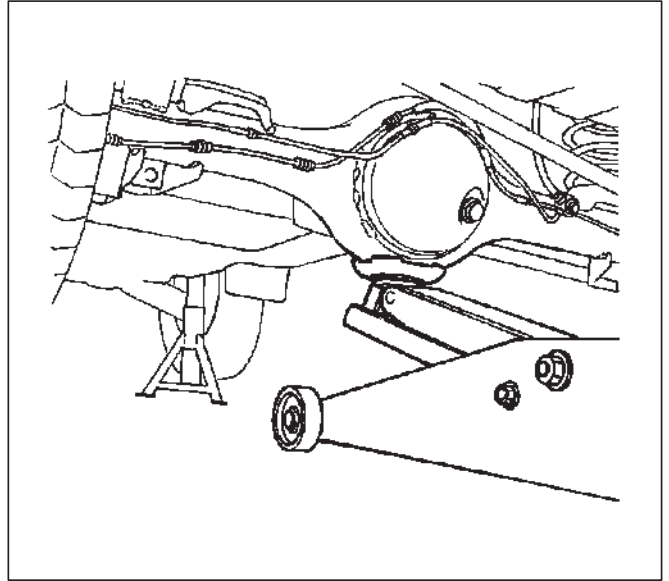
- When using a floor jack, lift on the center of the skid plate.



545RS001

### Lifting Point; Rear

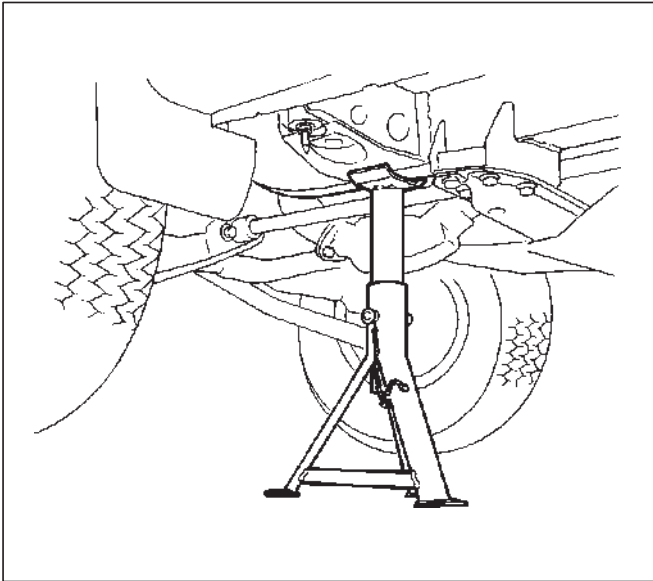
- Position the floor jack at the center of the rear axle case when lifting the vehicle.



420RS002

### Supportable Point; Front

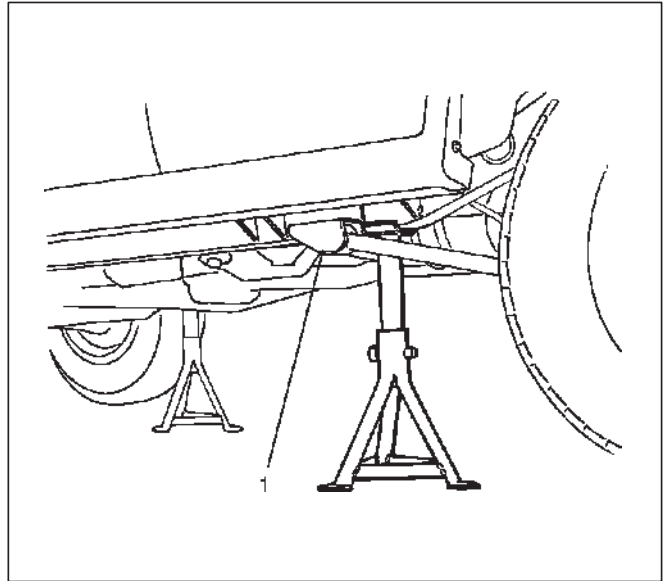
- Position the chassis stands at the bottom of the frame sidemember, behind the front wheel.



501RX020

### Supportable Point; Rear

- Position the chassis stands at the bottom of the frame sidemember, just behind the trailing link bracket.



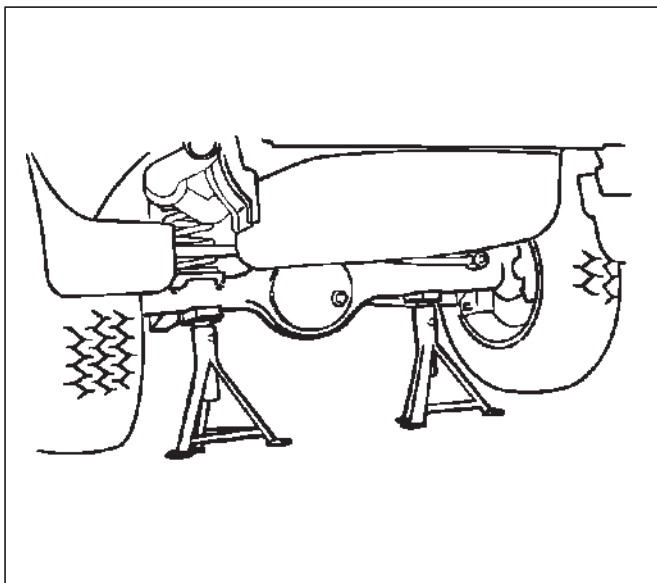
501RW002

### Legend

- (1) Trailing Link Bracket

**Supportable Point; Rear**





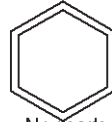



- Position the chassis stands at the bottom of the rear axle case.



420RS001

## Standard Bolts Torque Specifications

The torque values given in the following table should be applied where a particular torque is not specified.

Strength Class	4.8	8.8		9.8
		Refined	Non-Refined	
Bolt Identification				
	 No Mark			
Bolt Diameter × Pitch (mm)				
M 6X1.0	4 – 8 N·m (3 – 6 lb ft)	5 – 10 N·m (4 – 7 lb ft)		–
M 8X1.25	8 – 18 N·m (6 – 13 lb ft)	12 – 23 N·m (9 – 17 lb ft)		17 – 30 N·m (12 – 22 lb ft)
M 10X1.25	21 – 34 N·m (15 – 25 lb ft)	28 – 46 N·m (20 – 34 lb ft)		37 – 63 N·m (27 – 46 lb ft)
* M10X1.5	20 – 33 N·m (14 – 25 lb ft)	28 – 45 N·m (20 – 33 lb ft)		36 – 60 N·m (27 – 44 lb ft)
M12X1.25	49 – 74 N·m (36 – 54 lb ft)	61 – 91 N·m (45 – 67 lb ft)		76 – 114 N·m (56 – 84 lb ft)
* M12X1.75	45 – 69 N·m (33 – 51 lb ft)	57 – 84 N·m (42 – 62 lb ft)		72 – 107 N·m (53 – 79 lb ft)
M14X1.5	77 – 115 N·m (56 – 85 lb ft)	93 – 139 N·m (69 – 103 lb ft)		114 – 171 N·m (84 – 126 lb ft)
* M14X2.0	72 – 107 N·m (53 – 79 lb ft)	88 – 131 N·m (65 – 97 lb ft)		107 – 160 N·m (79 – 118 lb ft)
M16X1.5	104 – 157 N·m (77 – 116 lb ft)	135 – 204 N·m (100 – 150 lb ft)		160 – 240 N·m (118 – 177 lb ft)
* M16X2.0	100 – 149 N·m (74 – 110 lb ft)	130 – 194 N·m (95 – 143 lb ft)		153 – 230 N·m (113 – 169 lb ft)
M18X1.5	151 – 226 N·m (111 – 166 lb ft)	195 – 293 N·m (144 – 216 lb ft)		230 – 345 N·m (169 – 255 lb ft)
M20X1.5	206 – 310 N·m (152 – 229 lb ft)	270 – 405 N·m (199 – 299 lb ft)		317 – 476 N·m (234 – 351 lb ft)
M22X1.5	251 – 414 N·m (185 – 305 lb ft)	363 – 544 N·m (268 – 401 lb ft)		425 – 637 N·m (313 – 469 lb ft)
M24X2.0	359 – 539 N·m (265 – 398 lb ft)	431 – 711 N·m (318 – 524 lb ft)		554 – 831 N·m (409 – 613 lb ft)

The asterisk \* indicates that the bolts are used for female-threaded parts that are made of soft materials such as casting, etc.

## Abbreviations Charts

### List of automotive abbreviations which may be used in this manual

A — Ampere(s)	Exh — Exhaust
ABS — Antilock Brake System	° F — Degrees Fahrenheit
AC — Alternating Current	Fed — Federal (All States Except Calif.)
A/C — Air Conditioning	FF — Front Drive Front Engine
ACCEL — Accelerator	FL — Fusible Link
ACC — Accessory	FLW — Fusible Link Wire
ACL — Air Cleaner	FP — Fuel Pump
Adj — Adjust	FRT — Front
A/F — Air Fuel Ratio	ft — Foot
AIR — Secondary Air Injection System	FWD — Front Wheel Drive
Alt — Altitude	4WD — Four Wheel Drive
AMP — Ampere(s)	4 x 4 — Four Wheel Drive
ANT — Antenna	4 A/T — Four Speed Automatic Transmission/Transaxle
ASM — Assembly	Gal — Gallon
A/T — Automatic Transmission/Transaxle	GEN — Generator
ATDC — After Top Dead Center	GND — Ground
ATF — Automatic Transmission Fluid	Gov — Governor
Auth — Authority	g — Gram
Auto — Automatic	Harn — Harness
BARO — Barometric Pressure	HC — Hydrocarbons
Bat — Battery	HD — Heavy Duty
B+ — Battery Positive Voltage	Hg — Hydrargyrum (Mercury)
Bbl — Barrel	HiAlt — High Altitude
BHP — Brake Horsepower	HO2S — Heated Oxygen Sensor
BPT — Backpressure Transducer	HVAC — Heater-Vent-Air-Conditioning
BTDC — Before Top Dead Center	IAC — Idle Air Control
° C — Degrees Celsius	IAT — Intake Air Temperature
CAC — Charge Air Cooler	IC — Integrated Circuit / Ignition Control
Calif — California	ID — Identification / Inside Diameter
cc — Cubic Centimeter	IGN — Ignition
CID — Cubic Inch Displacement	INJ — Injection
CKP — Crankshaft Position	IP — Instrument Panel
CL — Closed Loop	IPC — Instrument Panel Cluster
CLCC — Closed Loop Carburetor Control	Int — Intake
CMP — Camshaft Position	ISC — Idle Speed Control
CO — Carbon Monoxide	J/B — Junction Block
Coax — Coaxial	kg — Kilograms
Conn — Connector	km — Kilometers
Conv — Converter	km/h — Kilometer per Hour
Crank — Crankshaft	kpa — Kilopascals
Cu. In. — Cubic Inch	kV — Kilovolts (thousands of volts)
CV — Constant Velocity	kW — Kilowatts
Cyl — Cylinder(s)	KS — Knock Sensor
DI — Distributor Ignition	L — Liter
Diff — Differential	lb ft — Foot Pounds
Dist — Distributor	lb in — Inch Pounds
DLC — Data Link Connector	LF — Left Front
DOHC — Double Overhead Camshaft	LH — Left Hand
DTC — Diagnostic Trouble Code	LR — Left Rear
DTM — Diagnostic Test Mode	LS — Left Side
DTT — Diagnostic Test Terminal	LWB — Long Wheel Base
DVM — Digital Voltmeter (10 meg.)	L-4 — In-Line Four Cylinder Engine
DVOM — Digital Volt Ohmmeter	MAF — Mass Air Flow
EBCM — Electronic Brake Control Module	MAN — Manual
ECM — Engine Control Module	MAP — Manifold Absolute Pressure
ECT — Engine Coolant Temperature	Max — Maximum
EEPROM — Electronically Erasable Programmable Read Only Memory	MC — Mixture Control
EGR — Exhaust Gas Recirculation	MFI — Multiport Fuel Injection
EI — Electronic Ignition	MIL — Malfunction Indicator Lamp
ETR — Electronically Tuned Receiver	Min — Minimum
EVAP — Evaporation Emission	mm — Millimeter
	MPG — Miles Per Gallon
	MPH — Miles Per Hour
	M/T — Manual Transmission/Transaxle
	MV — Millivolt

## 0A-14 GENERAL INFORMATION

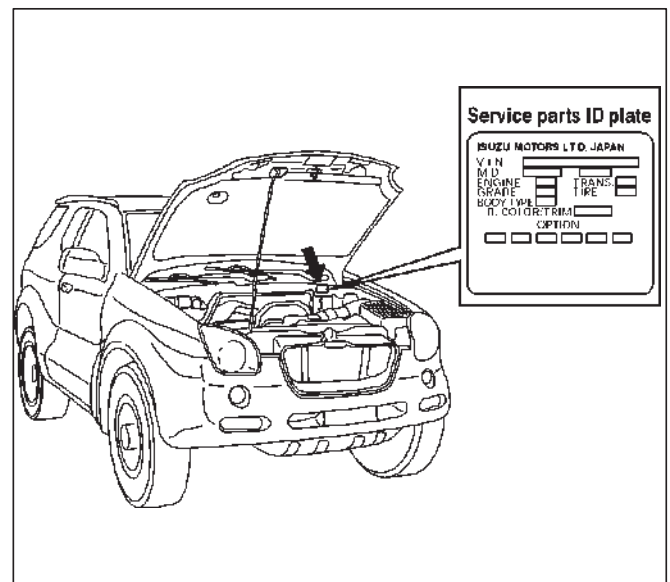
N — Newtons  
NA — Natural Aspirated  
NC — Normally Closed  
N-M — Newton Meters  
NO — Normally Open  
NOX — Nitrogen, Oxides of  
OBD — On-Board Diagnostic  
OD — Outside Diameter  
O/D — Over Drive  
OHC — Overhead Camshaft  
OL — Open Loop  
O<sub>2</sub> — Oxygen  
O<sub>2</sub>S — Oxygen Sensor  
PAIR — Pulsed Secondary Air Injection System  
P/B — Power Brakes  
PCM — Powertrain Control Module  
PCV — Positive Crankcase Ventilation  
PRESS — Pressure  
PROM — Programmable Read Only Memory  
PNP — Park/Neutral Position  
P/S — Power Steering  
PSI — Pounds per Square Inch  
PSP — Power Steering Pressure  
Pt. — Pint  
Pri — Primary  
PWM — Pulse Width Modulate  
Qt. — Quart  
REF — Reference  
RF — Right Front  
RFI — Radio Frequency Interference  
RH — Right Hand  
RPM — Revolutions Per Minute  
RPM Sensor — Engine Speed Sensor  
RPO — Regular Production Option  
RR — Right Rear  
RS — Right Side  
RTV — Room Temperature Vulcanizing  
RWAL — Rear Wheel Antilock Brake  
RWD — Rear Wheel Drive  
SAE — Society of Automotive Engineers  
Sec — Secondary  
SFI — Sequential Multiport Fuel Injection  
SI — System International  
SIR — Supplemental Inflatable Restraint System  
SOHC — Single Overhead Camshaft  
Sol — Solenoid  
SPEC — Specification  
Speedo — Speedometer  
SRS — Supplemental Restraint System  
ST — Start / Scan Tool  
Sw — Switch  
SWB — Short Wheel Base  
SYN — Synchronize  
Tach — Tachometer  
TB — Throttle Body  
TBI — Throttle Body Fuel Injection  
TCC — Torque Converter Clutch  
TCM — Transmission Control Module  
TDC — Top Dead Center  
Term — Terminal  
TEMP — Temperature  
TOD — Torque On Demand  
TP — Throttle Position  
TRANS — Transmission/Transaxle  
TURBO — Turbocharger

TVRS — Television & Radio Suppression  
TVV — Thermal Vacuum Valve  
TWC — Three Way Catalytic Converter  
3 A/T — Three Speed Automatic Transmission/Transaxle  
2WD — Two Wheel Drive  
4 x 2 — Two Wheel Drive  
U-joint — Universal Joint  
V — Volt(s)  
VAC — Vacuum  
VIN — Vehicle Identification Number  
VRRRE — Vehicle Refrigerant Recovery and Recycling Equipment  
V-ref — ECM Reference Voltage  
VSS — Vehicle Speed Sensor  
VSV — Vacuum Switch Valve  
V-6 — Six Cylinder "V" Engine  
V-8 — Eight Cylinder "V" Engine  
W — Watt(s)  
w/ — With  
w/b — Wheel Base  
w/o — Without  
WOT — Wide Open Throttle

## Service Parts Identification Plate

The Vehicle Information Plate (Service Parts ID plate) is provided on all vehicle models.

It is located on the center dash wall inside the engine compartment. The plate lists the VIN (Vehicle Identification Number), paint information and all production options and special equipment on the vehicle when it was shipped from the factory.



905RX005

VEHICROSS

# GENERAL INFORMATION

## MAINTENANCE AND LUBRICATION

### CONTENTS

Maintenance Schedule List .....	0B-1	Lubricant Viscosity Chart .....	0B-8
Explanation of Complete Vehicle		Recommended Liquid Gasket .....	0B-9
Maintenance Schedule .....	0B-4	Recommended Thread Locking Agents ...	0B-10
Recommended Fluids and Lubricants ....	0B-7	Maintenance Service Data .....	0B-11

### Maintenance Schedule List

#### Normal Vehicle Use

The maintenance instructions in this Maintenance Schedule are based on the assumption that the vehicle will be used as designed:

- to carry passengers and cargo within the limitations specified on the tire placard located on the inside of the glove compartment door;
- to be driven on reasonable road surfaces within legal operating limits;
- to be driven on a daily basis, as a general rule, for at least several miles/kilometers;
- to be driven on unleaded fuel

Unusual or severe operating conditions will require more frequent vehicle maintenance, as specified in the following sections.

#### Severe Driving Conditions

If the vehicle is usually operated under any of the severe driving conditions listed below, it is recommended that the applicable maintenance services be performed at the specified interval shown in the chart below.

##### Severe driving conditions:

- Towing a trailer, using a camper or car top carrier.
- Repeated short trips of less than 8 km (5 miles) with outside temperature remaining below freezing.
- Extensive idling and/or low speed driving for long distances, such as police, taxi or door-to-door delivery use.
- Operating on dusty, rough, muddy or salt spread roads.

ITEMS	INTERVAL
REPLACE TIMING BELT	Every 75,000 miles (120,000 km)
CHANGE ENGINE OIL AND OIL FILTER	Every 3,000 miles (4,800 km) or 3 months
CHANGE AUTOMATIC TRANSMISSION FLUID	Every 20,000 miles (32,000 km)
CHANGE FRONT AND REAR AXLE OIL	Every 30,000 miles (48,000 km) after changing at initial 15,000 miles (24,000 km) and 30,000 miles (48,000 km)
CHANGE POWER STEERING FLUID	Every 30,000 miles (48,000 km)



Mileage Only Items

**MILEAGE ONLY ITEMS**

MILEAGE ONLY ITEMS	IN THOUSANDS OF MILES (USE ODOMETER READING)										DESCRIPTION						
	7.5	15	22.5	30	37.5	45	52.5	60	67.5	75		82.5	90	97.5	105	112.5	120
1 CHANGE FRONT AND REAR AXLE OIL																	
2 CHANGE TRANSFER CASE OIL																	
3 REPLACE AIR CLEANER FILTER																	
4 REPLACE SPARK PLUGS																	
5 CHANGE ENGINE COOLANT																	
6 + REPLACE TIMING BELT	Replace every 100,000 miles.																
7 CHECK AND ADJUST VALVE CLEARANCE	Normal Condition																
8 ROTATE TIRES	Severe Condition																
9 REPACK FRONT WHEEL BEARINGS																	
10 CLEAN RADIATOR CORE AND AIR CONDITIONING CONDENSER																	

+ Replacement of the timing belt is recommended at every 100,000 miles (160,000 km). Failure to replace the timing belt may result in damage to the engine.

SHADED AREA INDICATES SERVICE TO BE PERFORMED.



## **Explanation of Complete Vehicle Maintenance Schedule**

Brief explanations of the services listed in the preceding Maintenance Scheduled are presented below.

Replace all questionable parts and note any necessary repairs as you perform these maintenance procedures.

### **Front and Rear Axle Lubricant Replacement**

Check the lubricant level after every 7,500 miles (12,000 km) of operation and add lubricant to level of filler hole if necessary.

Replace the front and rear axle lubricant at 15,000 miles (24,000 km) and 30,000 miles (48,000 km) and after every 30,000 miles (48,000 km) of operation thereafter.

### **Transfer Case Lubricant Replacement**

Check the lubricant level after every 7,500 miles (12,000 km) of operation and add lubricant to level of filler hole if necessary.

Replace the transfer case lubricant at 15,000 miles (24,000 km) and 30,000 miles (48,000 km) and after every 30,000 miles (48,000 km) of operation thereafter.

### **Air Cleaner Element Replacement**

Replace the air cleaner under normal operating conditions every 30,000 miles (48,000 km).

Operation of the vehicle in dusty areas will necessitate more frequent replacement.

### **Spark Plug Replacement**

Replace the plugs at 100,000 miles (160,000 km) intervals with the type specified at the end of this section.

### **Cooling System Service**

Drain, flush and refill system with new engine coolant. Refer to "Recommended Fluids and Lubricants" in this section, or ENGINE COOLING (SEC.6B).

### **Timing Belt Replacement**

Replacement of the timing belt is recommended at every 75,000 miles (120,000 km).

Failure to replace the timing belt may result in serious damage to the engine.

### **Valve Clearance Adjustment**

Incorrect valve clearance will result in increased engine noise and reduced engine output.

Retorque the camshaft bearing cap bolts before checking and adjusting the valve clearance.

Check and adjust the valve clearance every 60,000 miles (100,000 km).

### **Tire Rotation**

Rotate tires every 7,500 miles (12,000 km).

### **Power Steering Fluid Replacement**

Drain the power steering fluid and then refill the system to the proper level with power steering fluid.

### **Front Wheel Bearings Lubricant Replacement**

Clean and repack the front wheel bearings at 30,000 miles (48,000 km) intervals.

Refer to FRONT DRIVING AXLE (SEC. 4C).

### **Radiator Core and Air Conditioning Condenser Cleaning**

Clean the front of the radiator core and air conditioning condenser, at 60,000 miles (96,000 km) intervals.

### **Fluid Level Check**

**A fluid loss in any system (except windshield washer) may indicate a problem. Repair the system at once.**

#### **Engine oil level**

Check level and add if necessary. The best time to check the engine oil level is when the oil is warm. After stopping the engine with the vehicle on a level surface, wait a few minutes for the oil to drain back to the oil pan. Pull out the oil level indicator (dipstick). Wipe it clean and push the oil level indicator back down all the way. Pull out the oil level indicator, keeping the tip down, and look at the oil level on it.

Add oil, if needed, to keep the oil level above the "ADD" mark and between the "ADD" and "FULL" marks in the operating range area. Avoid overfilling the engine since this may cause engine damage. Push the oil level indicator back down all the way after taking the reading. If you check the oil level when the oil is cold, do not run the engine first. The cold oil will not drain back to the pan fast enough to give a true oil level.

#### **Engine coolant level and condition**

Check engine coolant level in the coolant reservoir and add engine coolant if necessary. Inspect the engine coolant and replace it if dirty or rusty.

#### **Windshield washer fluid level**

Check washer fluid level in the reservoir and add if necessary.

#### **Power steering system reservoir level**

Check and keep at the proper level.

#### **Brake master cylinder reservoir level**

Check fluid. Keep fluid at proper level. A low fluid level can indicate worn disc brake pads which may need to be serviced.

#### **Battery fluid level**

Check fluid level in the battery.

### **Fluid Leak Check**

Check for fuel, water, oil or other fluid leaks by looking at the surface beneath the vehicle after it has been parked for a while. Water dripping from the air conditioning system after use is normal. If you notice gasoline fumes or fluid at any time, locate the source and correct it at once.

## Engine Oil and Oil Filter Replacement

Always use API SE, SF, SG, SH or ILSAC GF-1 quality oils of the proper viscosity.

When choosing an oil, consider the range of temperatures the car will be operated in before the next oil change. Then, select the recommended oil viscosity from the chart.

Always change the oil and the oil filter as soon as possible after driving in a dust storm.

## Engine Cooling System Inspection

Inspect the coolant/anti-freeze. If the coolant is dirty or rusty, drain, flush and refill with new coolant. Keep coolant at the proper mixture for proper freeze protection, corrosion inhibitor level and best engine operating temperature. Inspect hoses and replace if cracked, swollen or deteriorated. Tighten the hose clamps if equipped with screw-type clamps. Clean outside of radiator and air conditioning condenser. Wash filler cap and neck. To help ensure proper operation, a pressure test of both the cooling system and the cap is also recommended.

## Exhaust System Inspection

Visually inspect the exhaust pipes, muffler, heat shields and hangers for cracks, deterioration, or damage.

Be alert to any changes in the sound of the exhaust system or any smell of fumes. These are signs the system may be leaking or overheating. Repair the system at once, if these conditions exist. (See also "Engine Exhaust Gas Safety" and "Three Way Catalytic Converter" in the Owner's manual.)

## Fuel Cap, Fuel Lines, and Fuel Tank Inspection

Inspect the fuel tank, the fuel cap and the fuel lines every 60,000 miles (96,000 km) for damage which could cause leakage.

Inspect the fuel cap and the gasket for correct sealing and physical damage. Replace any damaged parts.

## Drive Belt Inspection

Check the serpentine belt driving for cracks, fraying, wear, and correct tension every 30,000 miles (48,000 km). Replace as necessary.

## Wheel Alignment, Balance and Tires Operation

Uneven or abnormal tire wear, or a pull right or left on a straight and level road may show the need for a wheel alignment. A vibration of the steering wheel or seat at normal highway speeds means a wheel balancing is needed. Check tire pressure when the tires are "cold" (include the spare).

Maintain pressure as shown in the tire placard, which is located on the driver's door lock pillar.

## Steering System Operation

Be alert for any changes in steering action. An inspection or service is needed when the steering wheel is harder to turn or has too much free play, or if there are unusual sounds when turning or parking.

## Brake Systems Operation

Watch for the "BRAKE" light coming on. Other signs of possible brake trouble are such things as repeated pulling to one side when braking, unusual sounds when braking or between brake applications, or increased brake pedal travel. If you note one of these conditions, repair the system at once.

For convenience, the following should be done when wheels are removed for rotation: Inspect lines and hoses for proper hookup, bindings, leaks, crack, chafing etc. Inspect disc brake pads for wear and rotors for surface condition.

Inspect other brake parts, including parking brake drums, linings etc., at the same time. Check parking brake adjustment.

**Inspect the brakes more often if habit or conditions result in frequent braking.**

## Parking Brake and Transmission Park Mechanism Operation

Park on a fairly steep hill and hold the vehicle with the parking brake only. This checks holding ability. On automatic transmission vehicles, shifting from "P" position to the other positions cannot be made unless the brake pedal is depressed when the key switch is in the "ON" position or the engine is running.

**WARNING: BEFORE CHECKING THE STARTER SAFETY SWITCH OPERATION BELOW, BE SURE TO HAVE ENOUGH ROOM AROUND THE VEHICLE. THEN FIRMLY APPLY BOTH THE PARKING BRAKE AND THE REGULAR BRAKE. DO NOT USE THE ACCELERATOR PEDAL. IF THE ENGINE STARTS, BE READY TO TURN OFF THE KEY PROMPTLY. TAKE THESE PRECAUTIONS BECAUSE THE VEHICLE COULD MOVE WITHOUT WARNING AND POSSIBLY CAUSE PERSONAL INJURY OR PROPERTY DAMAGE.**

## Starter Safety Switch Operation

Check by trying to start the engine in each gear while setting the parking brake and the foot brake. The starter should crank only in "P" (Park) or "N" (Neutral).

## Accelerator Linkage Lubrication

Lubricate the accelerator pedal fulcrum pin with chassis grease.

## Steering and Suspension Inspection

Inspect the front and rear suspension and steering system for damaged, loose or missing parts or signs of wear. Inspect power steering lines and hoses for proper hookup, binding, leaks, cracks, chafing, etc.

### **Body and Chassis Lubrication**

Lubricate the key lock cylinders, the hood latch, the hood and door hinges, the door check link, the parking cable guides, the underbody contact points, and the linkage.

### **Propeller Shaft Inspection and Lubrication**

Rear propeller shaft yoke and universal joints with grease containing MOS2 (disulfide molybdenum type grease) at the interval shown in the Maintenance Schedule.

Check for play in normal direction of rotation of sliding yoke and universal joints. Also check the propeller shaft flange-to-pinion bolts for proper torque to 63 N•m (46 lb ft) for front transfer side and rear propeller shaft and proper torque to 43 N•m (32 lb ft) for front axle side.

### **Automatic Transmission Fluid Replacement**

Under harsh operating conditions, such as constant driving in heavy city traffic during hot weather, or in hilly or mountainous terrain, change the transmission fluid and service the sump filter after every 20,000 miles (32,000 km) of operation.

More over, the remaining life percentage of ATF can be estimated by using TECH-II as an auxiliary tool to judge the right time for ATF replacement.

The remaining life percentage is calculated from ATF'S heat history, when it is close to 0%, ATF replacement is recommended.

### **Auto Cruise Control Inspection**

Check to see if the clearance between cruise link and accelerator link is normal. Also check that the connected properly.

### **Accelerator Linkage Inspection**

Inspect for interference, binding, and damaged or missing parts. Check accelerator pedal for smooth operation and even pedal effort. Replace parts as needed.

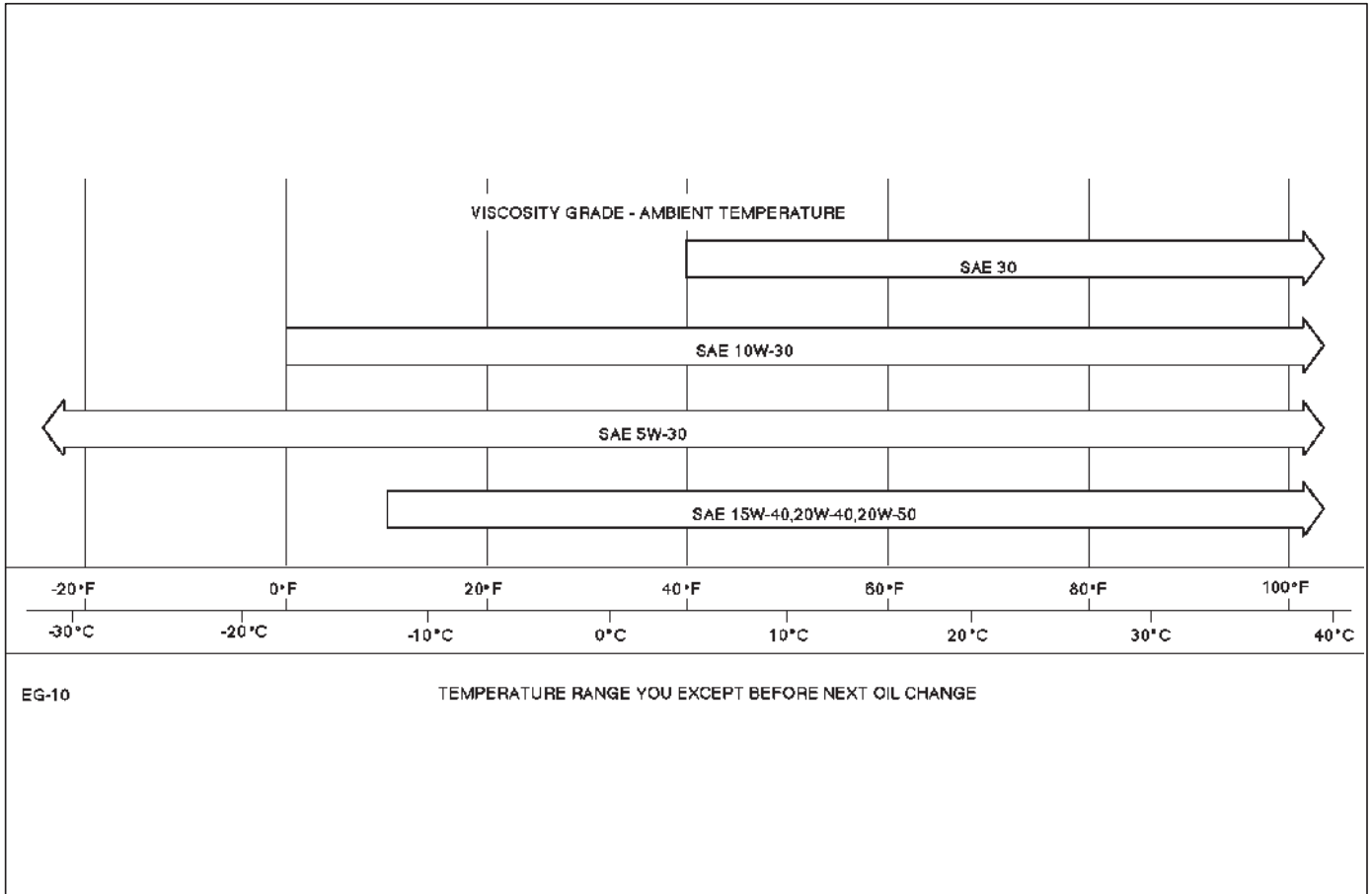
**Recommended Fluids and Lubricants**

USAGE	FLUID/LUBRICANT
Engine	API SE, SF, SG, SH or ILSAC GF-1 Engine oil (See oil chart on the following page for proper viscosity)
Engine coolant	Mixture of water and good quality ethylene glycol base type antifreeze.
Brake system	DOT-3 hydraulic brake fluid.
Power steering system	DEXRON® -III Automatic transmission fluid.
Automatic transmission	DEXRON® -III Automatic transmission fluid.
Rear axle and front axle	GL-5 gear lubricant (Standard differential) GL-5 Limited slip differential gear lubricant together with limited slip differential lubricant additive (Part No. 8-01052-358-0) or equivalent (If equipped with optional limited slip differential) (See oil chart in this section for proper viscosity)
Hood latch assembly a. Pivots and spring anchor b. Release pawl	Engine oil Chassis grease
Hood and door hinges	Engine oil
Chassis lubrication	Chassis grease
Parking brake cables	Chassis grease
Front wheel bearings	Wheel bearing grease
TOD system	DEXRON® -III Automatic transmission fluid.
Rear Propeller shafts Sliding yoke and Univeral joint	Grease containing MoS2 or multipurpose type grease NLGI No.2
Body door hinge pins and linkage, fuel door hinge, rear compartment lid hinges	Engine oil
Windshield washer solvent	Washer fluid
Key lock cylinder	Synthetic light weight engine oil (SAE 5W-30)
Accelerator linkage	Chassis grease

### Lubricant Viscosity Chart

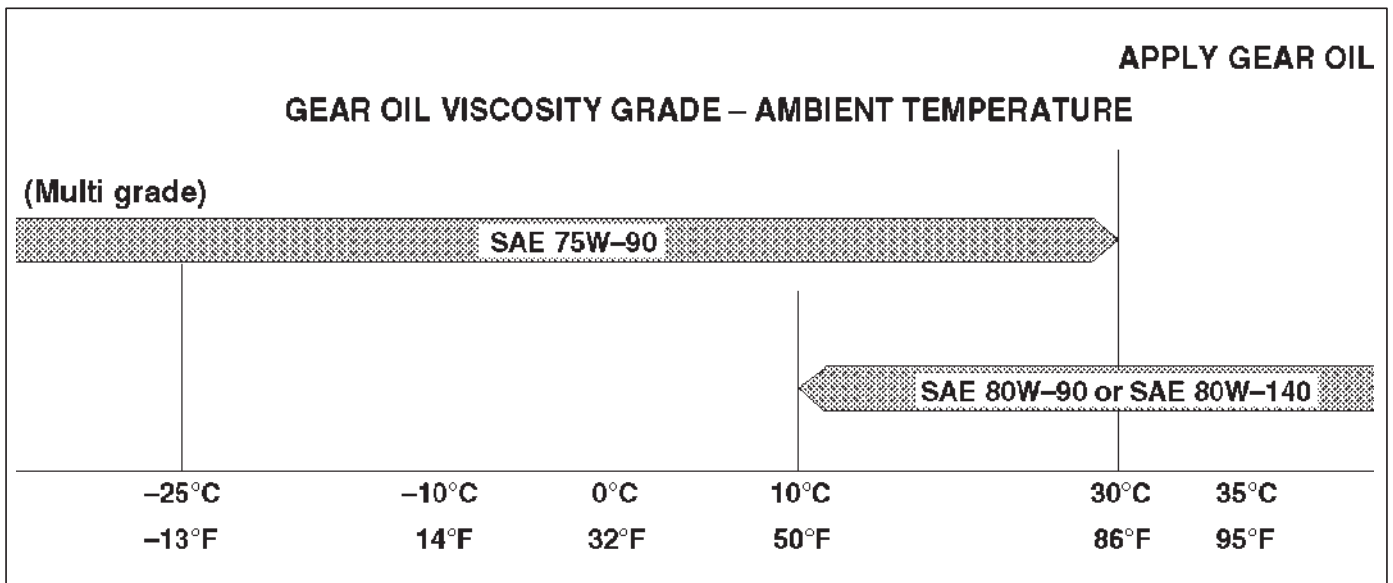
Lubricants should be carefully selected according to the lubrication chart. It is also important to select viscosity of lubricants according to the ambient temperature by referring to the following table.

#### Oil Viscosity Chart for Gasoline Engine



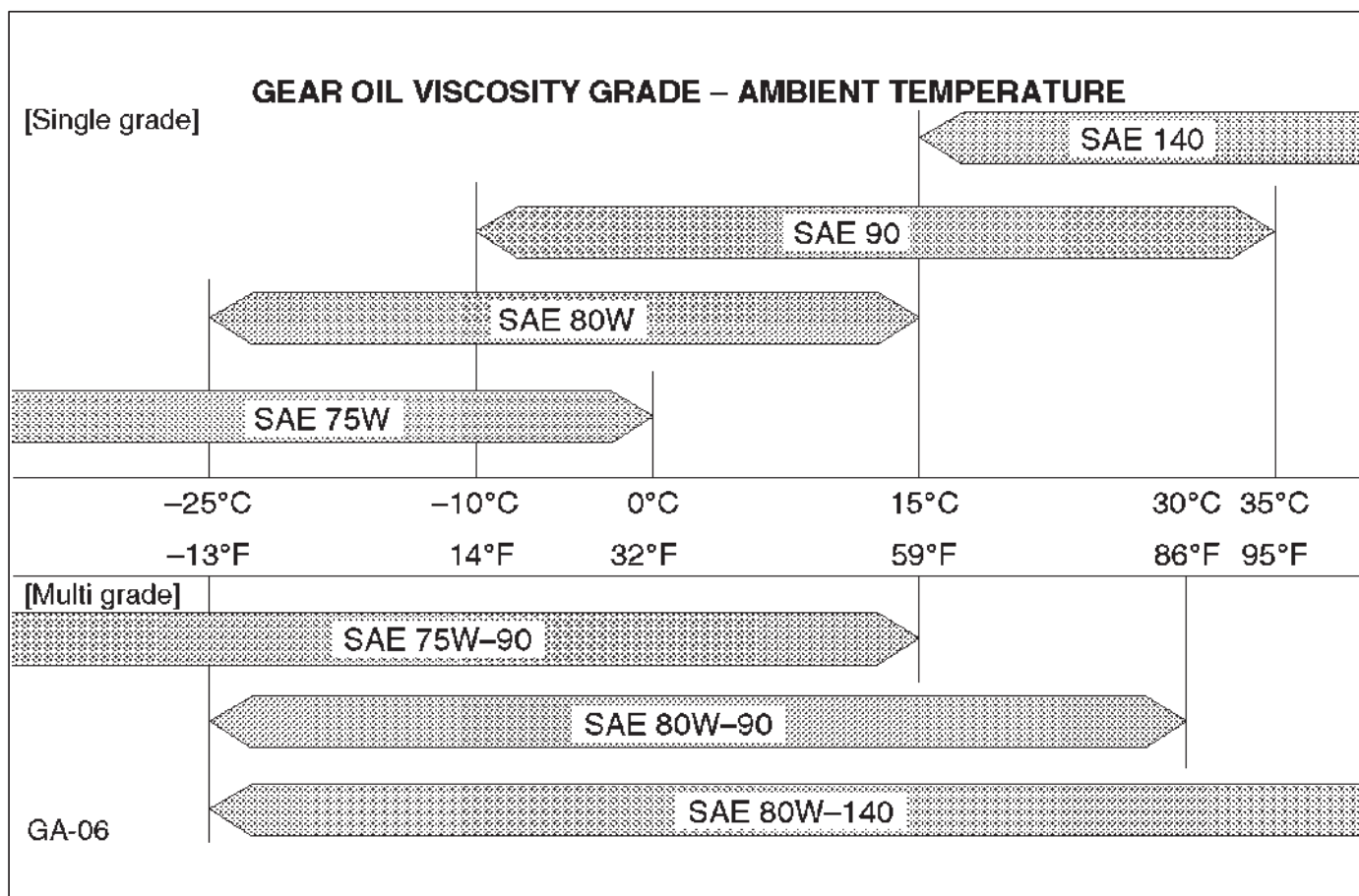
905RT011

#### Oil Viscosity Chart for Front Axle



800RW003

Oil Viscosity Chart for Rear Axle



B00RW004

Recommended Liquid Gasket

Type	Brand Name	Manufacturer	Remarks
RTV* Silicon Base	Three Bond 1207B	Three Bond	For Engine Repairs  For Axle Case Repairs. T/M Repairs. T/M
	Three Bond 1207C	Three Bond	
	Three Bond 1215	Three Bond	
	Three Bond 1280	Three Bond	
	Three Bond 1281	Three Bond	
Water Base	Three Bond 1141E	Three Bond	For Engine Repairs
Solvent	Three Bond 1104	Three Bond	For Engine Repairs
	Belco Bond 4	Isuzu	
	Belco Bond 401 Belco Bond 402	Isuzu Isuzu	
Anaerobic	LOCTITE 515	Loctite	All
	LOCTITE 518	Loctite	
	LOCTITE 17430	Loctite	

\* RTV: Room Temperature Vulcanizer

NOTE:

1. It is very important that the liquid gaskets listed above or their exact equivalent be used on the vehicle.
2. Be careful to use the specified amount of liquid gasket.  
Follow the manufacturer's instructions at all times.

3. Be absolutely sure to remove all lubricants and moisture from the connecting surfaces before applying the liquid gasket.  
The connecting surfaces must be perfectly dry.

4. Do not apply LOCTITE 17430, LOCTITE 515 and LOCTITE 518 between two metal surfaces having a clearance of greater than 0.25 mm (0.01 in). Poor adhesion will result.

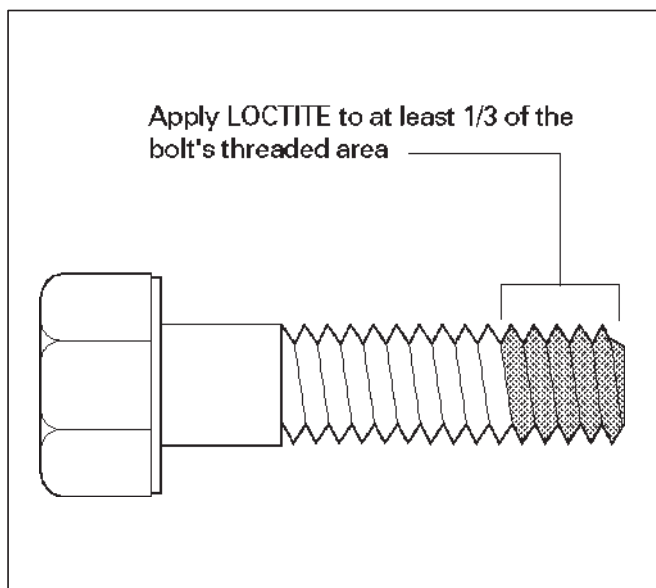


## Recommended Thread Locking Agents

LOCTITE Type	LOCTITE Color
LOCTITE 242	Blue
LOCTITE 262	Red
LOCTITE 271	Red

### Application Steps

1. Completely remove all lubricant and moisture from the bolts and the female-threaded surfaces of the parts to be joined.  
The surfaces must be perfectly dry.
2. Apply LOCTITE to the bolts.



3. Tighten the bolts to the specified torque.  
After tightening, be sure to keep the bolts free from vibration and torque for at least an hour until LOCTITE hardens.

**NOTE:** When the application procedures are specified in this manual, follow them.

**Maintenance Service Data**  
**Service Data and Specifications**

ENGINE	Valve clearance (cold)	Intake 0.28±0.05 mm Exhaust 0.3±0.05 mm
	Spark plug type	K16PR-P11/PK16PR11/RC10PYP4
	Spark plug gap	1.05 mm (0.04 in)
BRAKE	Brake pedal free play	6–10 mm (0.24–0.39 in)
	Parking brake travel	6–7 notches
WHEEL ALIGNMENT	Toe-in	0±2 mm (0±0.08 in)
	Camber	0°±30'
	Caster	2° 10'±45'
PROPELLER SHAFT	Flange torque	Front axle side propeller shaft. 43 N·m (32 lb ft)
WHEEL AND TIRES	Wheel nut torque	118 N·m (87 lb ft)
	* Tire inflation pressure (Front and Rear)	200 kpa (29 psi)
	* Tire inflation pressure (Spare)	420 kpa (60 psi)

\* Unless otherwise specified on tire information label on the vehicle.

**Approximate Capacities**

	Items	Metric Measure	U.S. Measure
Fuel tank		85 L	22.5 Gal.
* Crankcase	Oil Change with Filter	4.7 L	5.0 Qt
	Oil Change without Filter	4.0 L	4.3 Qt
Coolant		7.1 L	7.4 Qt
Transmission		8.6 L	9.1 Qt
Transfer		1.9 L	2.0 Qt
Axle	Rear	2.2 L	2.3 Qt
	Front	1.4 L	1.5 Qt
Power steering		1.0 L	1.1 Qt
Air conditioning (R-134a)		0.65 Kg	1.43 lbs

\*Crankcase capacities shown are approximate refill capacities. After refill, recheck oil level.

VEHICROSS

# HEATING, VENTILATION AND AIR CONDITIONING (HVAC)

## HVAC SYSTEMS

### CONTENTS

Service Precaution .....	1A-3	Control Lever Assembly, Control Cable and Associated Parts .....	1A-24
Heating and Ventilation System .....	1A-3	Removal .....	1A-25
General Description .....	1A-3	Installation .....	1A-26
Wiring Diagram .....	1A-7	Heater Bezel Illumination Bulb .....	1A-27
Diagnosis .....	1A-8	Heater Bezel Illumination Bulb and Associated Parts .....	1A-27
Individual Inspection .....	1A-12	Removal .....	1A-27
Heater Unit .....	1A-14	Installation .....	1A-27
Heater Unit and Associated Parts .....	1A-14	Resistor .....	1A-28
Removal .....	1A-14	Resistor and Associated Parts .....	1A-28
Installation .....	1A-15	Removal .....	1A-28
Heater Core and / or Mode Door .....	1A-15	Installation .....	1A-28
Disassembled View .....	1A-15	Air Conditioning System .....	1A-29
Removal .....	1A-16	General Description .....	1A-29
Inspection .....	1A-16	Air Conditioning Refrigerant Cycle Construction .....	1A-30
Installation .....	1A-16	Diagnosis .....	1A-43
Heater Mode Control Link Unit .....	1A-17	Individual Inspection .....	1A-53
Disassembled View .....	1A-17	General Repair Procedure .....	1A-54
Removal .....	1A-17	Leak Check .....	1A-57
Installation .....	1A-18	Compressor Assembly .....	1A-62
Heater Temperature Control Link Unit .....	1A-18	Compressor Assembly and Associated Parts .....	1A-62
Disassembled View .....	1A-18	Removal .....	1A-62
Removal .....	1A-18	Installation .....	1A-63
Installation .....	1A-18	New Compressor Installation .....	1A-63
Blower Assembly .....	1A-19	Condenser Assembly .....	1A-64
Blower Assembly and Associated Parts ..	1A-19	Condenser Assembly and Associated Parts	1A-64
Removal .....	1A-19	Removal .....	1A-64
Installation .....	1A-20	Installation .....	1A-64
Blower Link Unit and / or Mode door .....	1A-20	Condenser Fan Motor .....	1A-65
Disassembled View .....	1A-20	Condenser Fan Motor and Associated Parts	1A-65
Removal .....	1A-20	Removal .....	1A-66
Installation .....	1A-21	Installation .....	1A-66
Blower Motor .....	1A-22	Receiver / Drier .....	1A-66
Blower Motor and Associated Parts .....	1A-22	Receiver / Drier and Associated Parts ....	1A-66
Removal .....	1A-22	Removal .....	1A-66
Installation .....	1A-22	Installation .....	1A-66
Defroster Nozzle and Ventilation Duct .....	1A-23	Pressure Switch .....	1A-67
Defroster Nozzle, Ventilation Duct and Associated Parts .....	1A-23	Pressure Switch and Associated Parts ...	1A-67
Removal .....	1A-23	Removal .....	1A-67
Installation .....	1A-24		
Control Lever Assembly and / or Control Cable .....	1A-24		

## 1A-2 HEATING, VENTILATION AND AIR CONDITIONING (HVAC)

---

Installation .....	1A-67	Overview of Construction, Movement and Control of Major Parts of Automatic Air Conditioner System .....	1A-100
Evaporator Assembly .....	1A-68	Overview of Automatic Control of Automatic Air Conditioner .....	1A-104
Evaporator Assembly and Associated Parts	1A-68	Troubleshooting, Its Overview and Procedures .....	1A-108
Removal .....	1A-68	Auto Air Conditioner Control Unit Power Supply Diagnosis .....	1A-109
Installation .....	1A-69	Performance and Movement checklist for Automatic Air Conditioner Related Parts ...	1A-111
Electronic Thermostat, Evaporator Core and/or Expansion Valve .....	1A-69	Troubleshooting With Self-Diagnosis Function	1A-113
Disassembled View .....	1A-69	Inspection By Failed Location .....	1A-117
Removal .....	1A-70	Inspection of the Sensors .....	1A-117
Installation .....	1A-70	Inspection of the Intake Actuator System ..	1A-121
Refrigerant Line .....	1A-71	Inspection of the Mix Actuator System .....	1A-124
Refrigerant Line and Associated Parts ...	1A-71	Inspection of the Mode Actuator System ...	1A-127
Removal .....	1A-72	Inspection of the Fan Motor System .....	1A-130
Installation .....	1A-72	Inspection of the Magnetic Clutch System ..	1A-135
Main Data And Specifications .....	1A-73	Individual Inspection .....	1A-138
Compressor .....	1A-76	On-Vehicle Service .....	1A-141
Service Precaution .....	1A-76	Power Transistor .....	1A-141
General Description .....	1A-76	Removal .....	1A-141
Diagnosis .....	1A-77	Installation .....	1A-141
Magnetic Clutch Assembly (DKV-14D Type)	1A-78	Automatic Heater/Air Conditioner Control Unit .....	1A-141
Parts Location View .....	1A-78	Removal .....	1A-141
Removal .....	1A-78	Installation .....	1A-142
Inspection and Repair .....	1A-80	In Car Sensor .....	1A-142
Installation .....	1A-80	Removal .....	1A-142
Compressor Oil .....	1A-82	Installation .....	1A-142
Oil Specification .....	1A-82	Ambient Sensor .....	1A-142
Handling of Oil .....	1A-82	Removal .....	1A-142
Compressor Oil Check .....	1A-82	Installation .....	1A-142
Checking and Adjusting Oil Quantity for Used Compressor .....	1A-82	Sun Sensor .....	1A-143
Checking and Adjusting for Compressor Replacement .....	1A-83	Removal .....	1A-143
Contamination of Compressor Oil .....	1A-83	Installation .....	1A-143
Oil Return Operation .....	1A-83	Electronic Thermostat .....	1A-143
Replacement of Component Parts .....	1A-83	Removal .....	1A-143
Main Data and Specifications .....	1A-84	Installation .....	1A-143
Special Tools .....	1A-86	Mode Actuator .....	1A-144
Automatic Air Conditioning System .....	1A-87	Removal .....	1A-144
General Description .....	1A-87	Installation .....	1A-144
Full Automatic Air Conditioner Parts Configuration .....	1A-87	Mix Actuator .....	1A-144
Refrigerant Line and Associated Parts ...	1A-88	Removal .....	1A-144
Circuit Diagram .....	1A-89	Installation .....	1A-144
Functions and Features .....	1A-94	Intake Actuator .....	1A-145
Automatic Air Conditioner Block Diagram ...	1A-95	Removal .....	1A-145
Control Panel Layout .....	1A-96	Installation .....	1A-145
Air Control Functions .....	1A-97		
Operation and Functions of Control Panel Switches .....	1A-98		

## Service Precaution

**WARNING: THIS VEHICLE HAS A SUPPLEMENTAL RESTRAINT SYSTEM (SRS). REFER TO THE SRS COMPONENT AND WIRING LOCATION VIEW IN ORDER TO DETERMINE WHETHER YOU ARE PERFORMING SERVICE ON OR NEAR THE SRS COMPONENTS OR THE SRS WIRING. WHEN YOU ARE PERFORMING SERVICE ON OR NEAR THE SRS COMPONENTS OR THE SRS WIRING, REFER TO THE SRS SERVICE INFORMATION. FAILURE TO FOLLOW WARNINGS COULD RESULT IN POSSIBLE AIR BAG DEPLOYMENT, PERSONAL INJURY, OR OTHERWISE UNNEEDED SRS SYSTEM REPAIRS.**

**CAUTION:** Always use the correct fastener in the proper location. When you replace a fastener, use **ONLY** the exact part number for that application. ISUZU will call out those fasteners that require a replacement after removal. ISUZU will also call out the fasteners that require thread lockers or thread sealant. **UNLESS OTHERWISE SPECIFIED**, do not use supplemental coatings (Paints, greases, or other corrosion inhibitors) on threaded fasteners or fastener joint interfaces. Generally, such coatings adversely affect the fastener torque and the joint clamping force, and may damage the fastener. When you install fasteners, use the correct tightening sequence and specifications. Following these instructions can help you avoid damage to parts and systems.

## Heating and Ventilation System

### General Description

#### Heater

When the engine is warming up, the warmed engine coolant is sent out into the heater core. The heater system supplies warm air into the passenger compartment to warm it up.

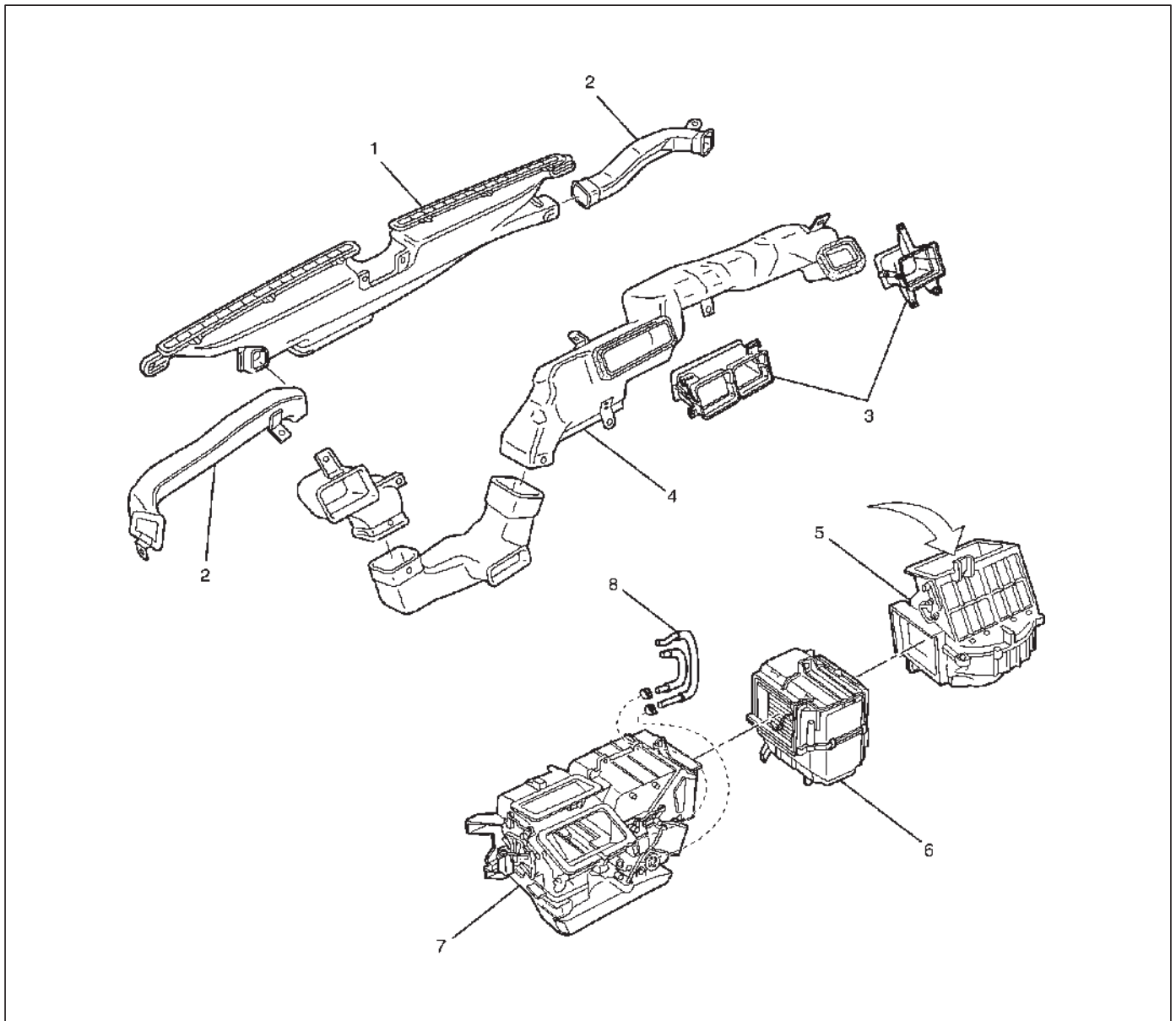
Outside air is circulated through the heater core of the heater unit and then back into the passenger compartment. By controlling the mixture of outside air and heater core air, the most comfortable passenger compartment temperature can be selected and maintained.

The temperature of warm air sent to the passenger compartment is controlled by the temperature control knob. This knob acts to open and close the air mix door, thus controlling the amount of air passed through the heater core.

The air selector knob, with its different modes, also allows you to select and maintain the most comfortable passenger compartment passenger compartment passenger compartment temperature.

The air source select lever is used to select either "FRESH" for the introduction of the outside air, or "CIRC" for the circulation of the inside air. When the lever is set to "FRESH", the outside air is always taken into the passenger compartment. When setting the lever to "CIRC" position, the circulation of air is restricted only to the inside air with no introduction of the outside air and the air in the passenger compartment gets warm quickly. However, the lever is normally set to "FRESH" to prevent the windshield from clouding.

## 1A-4 HEATING, VENTILATION AND AIR CONDITIONING (HVAC)



840RY00034

### Legend

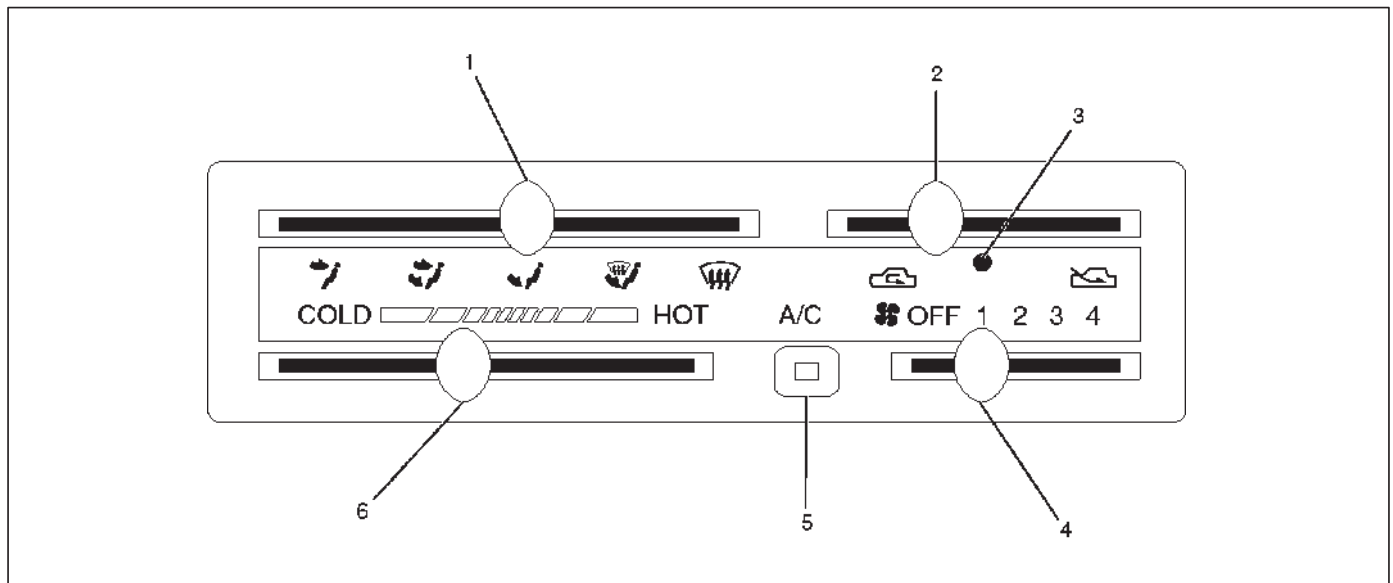
- (1) Defroster Nozzle
- (2) Side Defroster Duct
- (3) Air Outletvent Duct
- (4) Ventilation Duct

- (5) Blower Assembly
- (6) Evaporator Assembly
- (7) Heater Unit
- (8) Water Hose

### Control Lever Assembly

The vehicle has cable-control-type to control by cable the mode and temperature of the heater unit and the mode door for the air source of the blower assembly.

The fan control is used to control the amount of air sent out by the resistor at four levels from "LOW" to "HIGH".



#### Legend

- |                                  |                                   |
|----------------------------------|-----------------------------------|
| (1) Air Selector Lever           | (4) Fan Control Lever             |
| (2) Air Source Select Lever      | (5) Air Conditioning (A/C) Switch |
| (3) Partial Circulation Position | (6) Temperature Control Lever     |

### Ventilation

Set "AIR SOURCE SELECT LEVER" to "FRESH" position and turn on the blower fan. Heating can be done in this lever position, sending in fresh air from outside. The blower fan also serves to deliver fresh outside air to the vehicle interior to assure adequate ventilation.

#### Air Select Lever

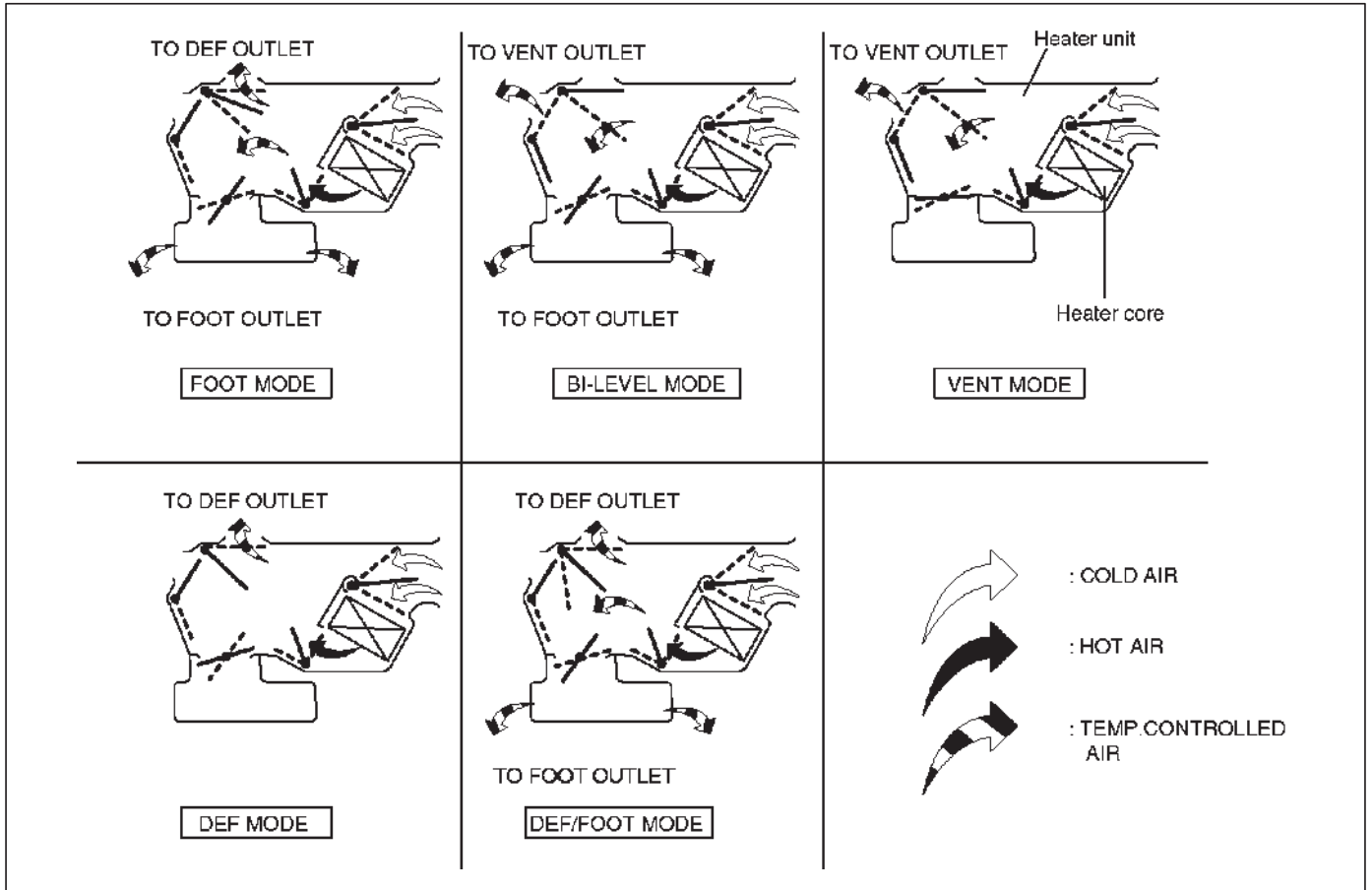
The air select knob allows you to direct heated air into the passenger compartment through different outlets.

1. **Vent** – In this position, air is discharged from the upper air outlet. Air quantity is controlled by the fan control lever.
2. **Bi-Level** – In this position, air flow is divided between the upper air outlets and the floor air outlets, with warmer air delivered to the floor outlets than the air delivered to the upper air outlets when the temp lever is in middle position.

3. **Foot** – In this position, air flow is delivered to the foot, while sending approx. A small amount of air to the wind shield.
4. **Def/Foot** – In this position, air flow is delivered to the foot, while sending approx. 40% of total amount of air to the windshield. Selecting this mode allows air conditioning system to work while the fan switch is turned to on position, even if the A/C switch is off.
5. **Defrost** – In this position, most of the air is delivered to the windshield and a small amount is delivered to the side windows. Selecting this mode allows air conditioning system to work while the fan switch is turned to on position, even if the A/C switch is off.

Moving the air source select lever to the "CIRC" position provides quickest heat delivery by closing the blower assembly mode door. In this position, outside air is not delivered to the passenger compartment.

## 1A-6 HEATING, VENTILATION AND AIR CONDITIONING (HVAC)



C01RX020

### Air Source Select Lever

The intake of outside air and the circulation of inside air are controlled by sliding this lever left or right.

### Fan Control Lever

This lever controls the blower motor speed to regulate the amount of air delivered to the defrost, foot, and ventilation ducts:

1. Low
2. Medium Low
3. Medium High
4. High

### Temperature Control Lever

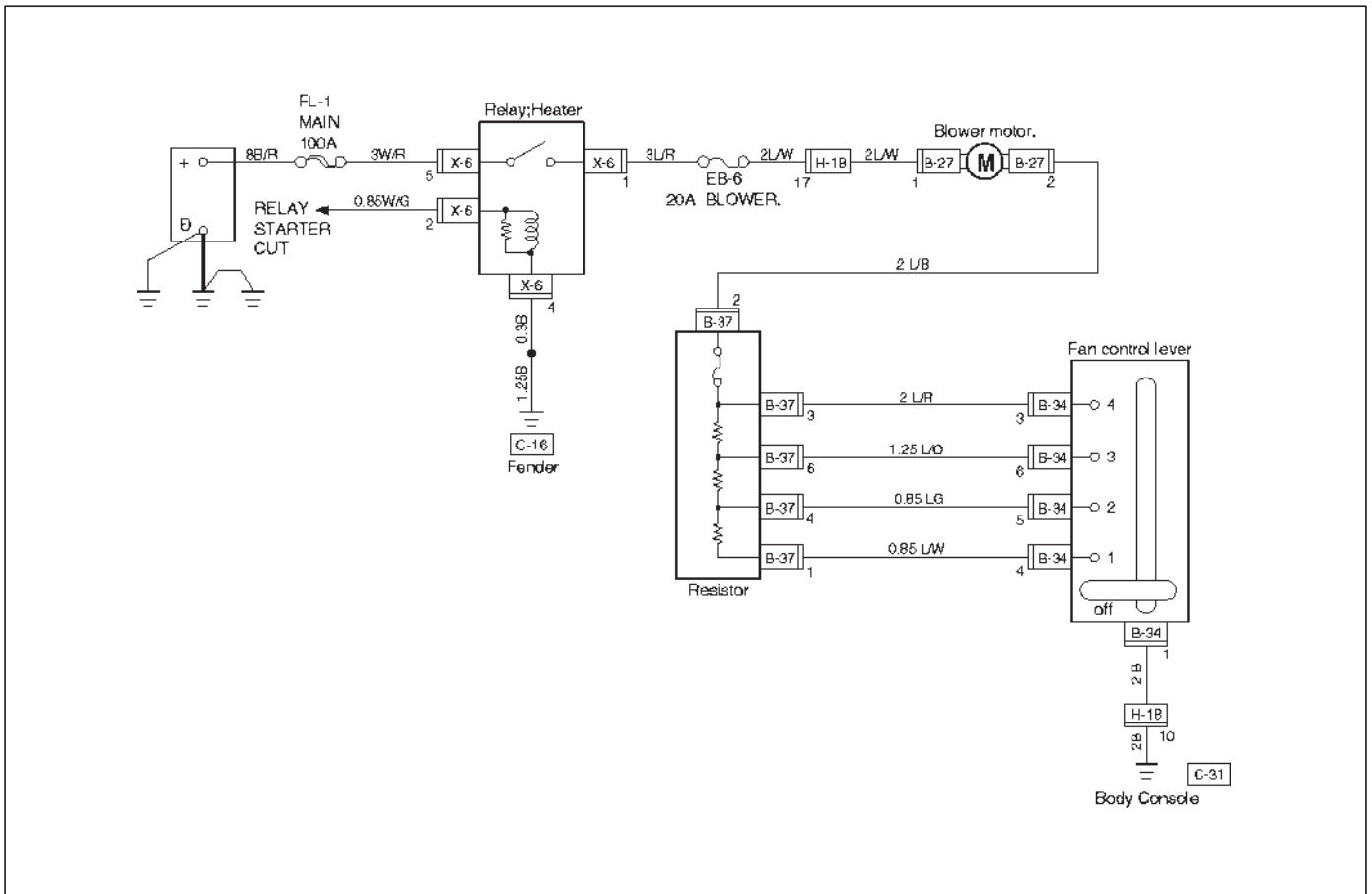
When the temperature control knob is in the "COLD" position, the air mix door closes to block the flow air to the heater core.

When the temperature control knob is in the "HOT" position, the air mix door opens to allow air to pass through the heater core and heat the passenger compartment.

Placing the knob in an intermediate position will cause a lesser or greater amount of air to reach the heater core. In this mode the passenger compartment temperature can be regulated.



Wiring Diagram



## 1A-8 HEATING, VENTILATION AND AIR CONDITIONING (HVAC)

### Diagnosis

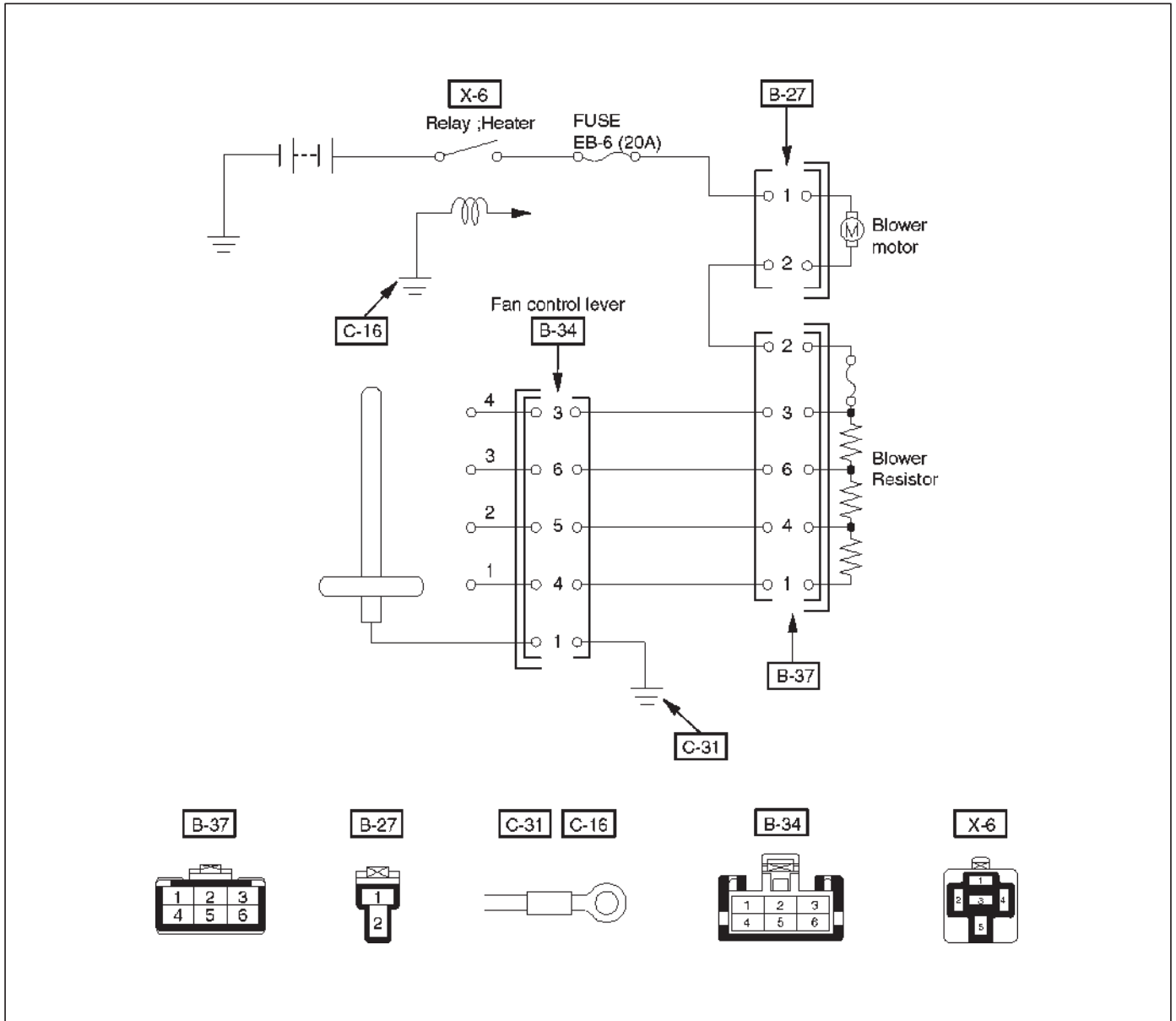
#### Heating Cycle diagnosis

Condition	Possible cause	Correction
No heating or insufficient heating.	Blower motor does not run or runs improperly.	Refer to "FAN CONTROL LEVER (FAN SWITCH) DIAGNOSIS".
	Engine coolant temperature is low.	Check the engine coolant temperature after warming up the engine and check the thermostat. Replace as necessary.
	Insufficient engine coolant.	Add engine coolant as required.
	Circulation volume of engine coolant is insufficient.	Check if the water hose to the heater core is clogged, collapsed or twisted. Repair or replace as necessary.
	Heater core clogged or collapsed.	Clean or replace as necessary.
	The heater cores is not provided with air sent from the blower motor.	Repair the temperature control link unit or mode doors.
	Duct connections defective or unsealing.	Repair or replace as necessary.
Control lever moves but mode door does not operate.	Cable attaching clip is not correct.	Repair
	Link unit of heater or blower assembly defective.	Repair
The mode door cannot be set to the mode selected.	Link unit of heater unit or blower assembly defective.	Repair.
	Control cable is not adjusted.	Adjust.

### Fan Control Lever (Fan Switch) Diagnosis

Current flows to the blower motor through the heater relay (X-6) to activate the rotation of the blower motor by turning "ON" the fan control knob (fan switch). Blower motor speed is controlled in stages by the resistor, by operating the switch from "LOW" to "HIGH".

For the inspection of the relays, switches and units in each table, refer to "INDIVIDUAL INSPECTION" in this section.



D08RX292

Condition	Possible cause	Correction
Blower motor does not run.	—	Refer to Chart A
Blower motor does not run in certain position (s).	—	Refer to Chart B, C, D and E
Blower motor does not stop at "OFF" position.	—	Refer to Chart F

## 1A-10 HEATING, VENTILATION AND AIR CONDITIONING (HVAC)

### Chart "A" Blower Motor Does Not Run

Step	Action	Yes	No
1	Is relay (X-6) OK?	Go to Step 2	Replace
2	Is fuse EB-6 (20A) OK?	Go to Step 3	Replace
3	Is resistor OK?	Go to Step 4	Replace
4	Is fan control lever OK?	Go to Step 5	Replace control lever assembly.
5	Is blower motor OK?	Go to Step 6	Replace
6	1. Turn the ignition switch "ON". 2. Turn fan control lever "ON". 3. Check to see if battery voltage is present at chassis side connector terminal No. B27-1  Is there a battery voltage?	Poor ground or open circuit either between chassis side connector terminal No. B27-2 and No. B37-2 or No. B-34-1 and body ground (No. C-31).	Open circuit between No. EB-6 (20A) fuse and No. B27-1.

### Chart "B" Blower Motor Does Not Run At Low Position

Step	Action	Yes	No
1	Is resistor OK?	Go to Step 2	Replace
2	Is fan control lever (Fan Switch) OK?	Open circuit between chassis side connector terminal No. B37-1 and No. B-34-4.	Replace control lever assembly.

### Chart "C" Blower Motor Does Not Run At Medium Low Position

Step	Action	Yes	No
1	Is resistor OK?	Go to Step 2	Replace
2	Is fan control lever (Fan Switch) OK?	Open circuit between the chassis side connector terminal No. B37-4 and No. B-34-5.	Replace control lever assembly.

### Chart "D" Blower Motor Does Not Run At Medium High Position

Step	Action	Yes	No
1	Is resistor OK?	Go to Step 2	Replace
2	Is fan control lever (Fan Switch) OK?	Open circuit between chassis side connector terminal No. B37-6 and No. B-34-6.	Replace control lever assembly.

**Chart “E” Blower Motor Does Not Run At High Position**

Step	Action	Yes	No
1	Is resistor OK?	Go to Step 2	Replace
2	Is fan control lever (Fan Switch) OK?	Open circuit between Chassis side connector terminal No. B37-3 and No. B-34-3.	Replace control lever assembly.

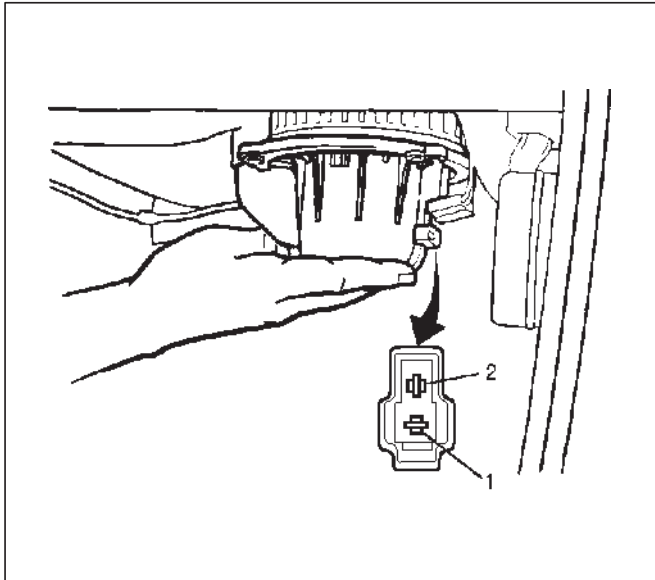
**Chart “F” Blower Motor Does Not Stop In The “OFF” Position**

Step	Action	Yes	No
1	Is the fan control lever (Fan Switch) OK?	Short circuit between chassis side connector terminal No. B27-2 and No. B37-2, No. B37-3 and No. B-34-3, No. B37-6 and No. B-34-6, No. B37-4 and No. B-34-5 or No. B37-1 and No. B34-4	Replace control lever assembly.

## Individual Inspection

### Blower Motor

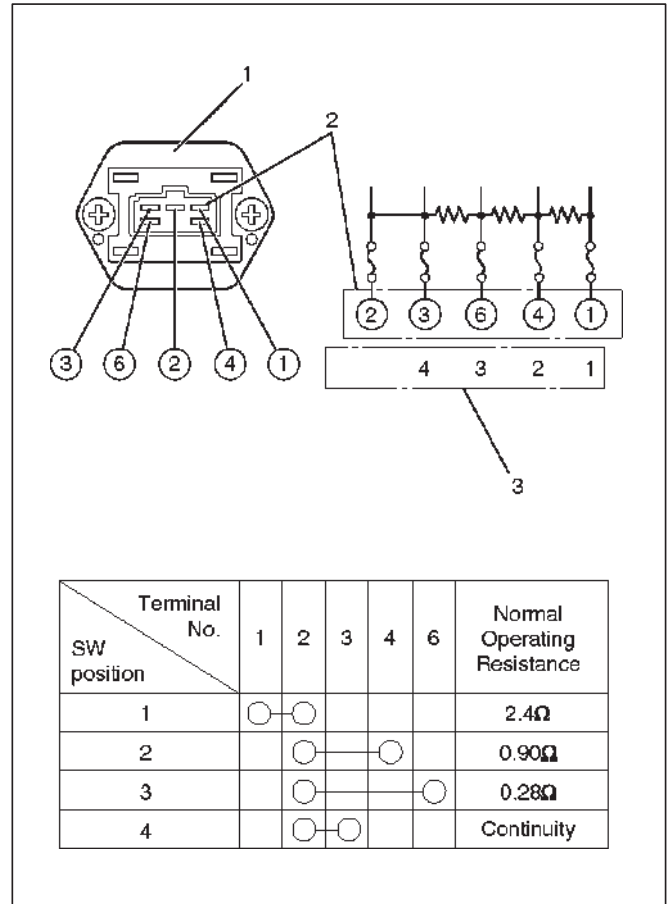
1. Disconnect the blower motor (B-27) connector from the blower motor.
2. Connect the battery positive terminal to the No. 1 terminal of the blower motor and negative to the No. 2.
3. Be sure to check to see if the blower motor operates correctly.



873RX004

### Resistor

1. Disconnect the resistor (B-37) connector.
2. Check for continuity and resistance between the terminals of the resistor.



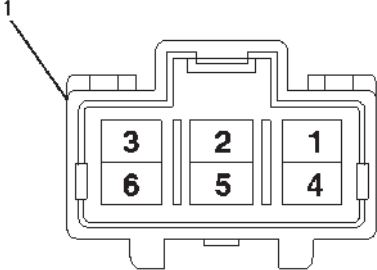
840RX013

### Legend

- (1) Resistor
- (2) Connector Terminal (Resistor Side)
- (3) Fan Switch Position

### Fan Control Lever (Fan Switch)

1. Check for continuity between the terminals of the fan control lever (1).

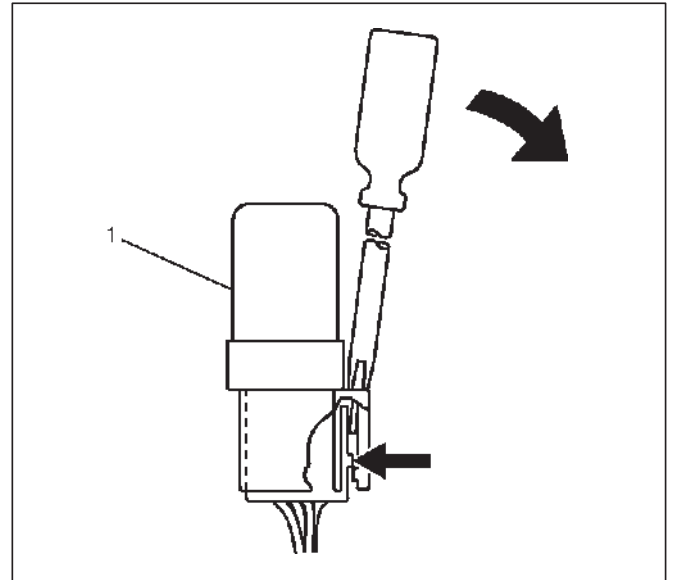


Connector No.		FAN SW.					
		B-34					
SW position		1	2	3	4	5	6
Blower motor	OFF						
	1	○			○		
	2	○				○	
	3	○					○
	4	○	○				

901RX065

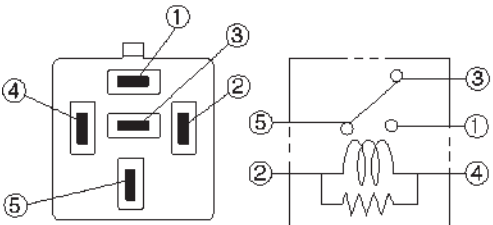
### Heater Relay

1. Disconnect heater relay (X-6).
  - When removing the connector for relay, unfasten the tongue lock of the connector by using a screwdriver, then pull the relay (1) out.



825RX046

2. Check for continuity between the terminals of heater relay.



③-⑤ ...Continuity  
 ①-⑤ ...No continuity

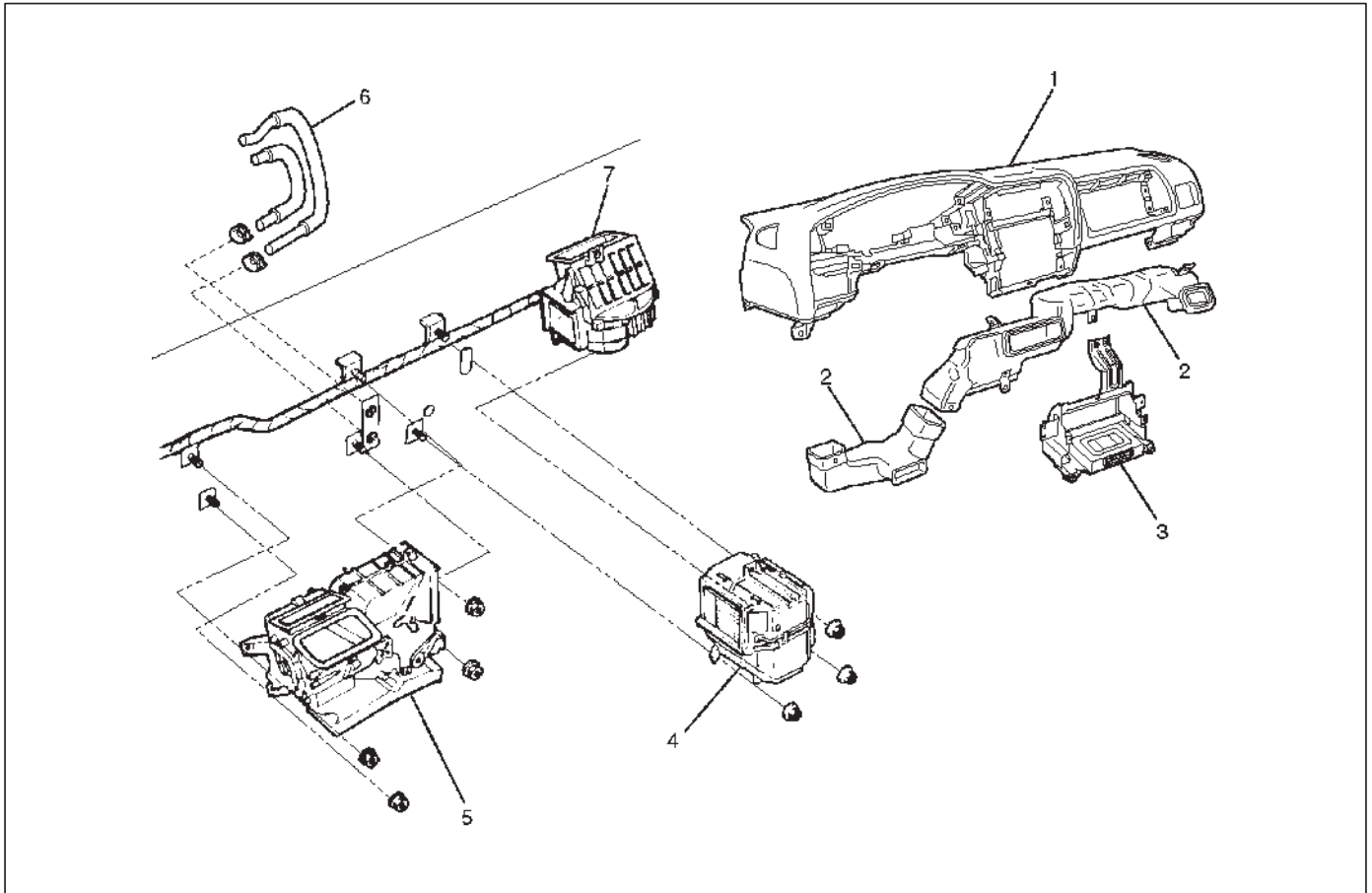
(When battery voltage is applied between ② and ④)

③-⑤ ...No continuity  
 ①-⑤ ...Continuity

901RX071

## Heater Unit

### Heater Unit and Associated Parts



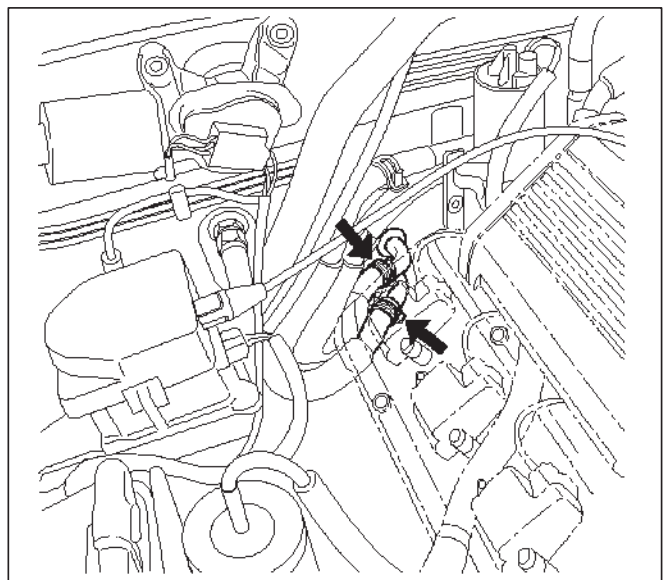
840RX011

#### Legend

- |                                     |                          |
|-------------------------------------|--------------------------|
| (1) Instrument Panel Assembly       | (4) Evaporator Assembly  |
| (2) Center & Lower Vent Duct        | (5) Heater Unit Assembly |
| (3) Instrument Panel Center Bracket | (6) Heater Hose          |
|                                     | (7) Blower Unit          |

### Removal

1. Disconnect the battery ground cable.
2. Drain the engine coolant.
3. Discharge and recover refrigerant (with air conditioning).
  - Refer to Refrigerant Recovery in this section.
4. Remove the Instrument panel assembly.
  - Refer to Instrument Panel Assembly in Body and Accessories section.
5. Remove instrument panel center bracket.
6. Remove blower unit.
7. Remove evaporator assembly.
  - Refer to Evaporator Assembly in this section.
8. Remove driver lap vent duct.
9. Remove Center & Lower vent duct.
10. Remove heater unit assembly.
  - Disconnect heater hoses at heater unit.



840RX006



## Installation

To install, follow the removal steps in the reverse order, noting the following points:

1. When handling the PCM and the control unit, be careful not to make any improper connection of the connectors.

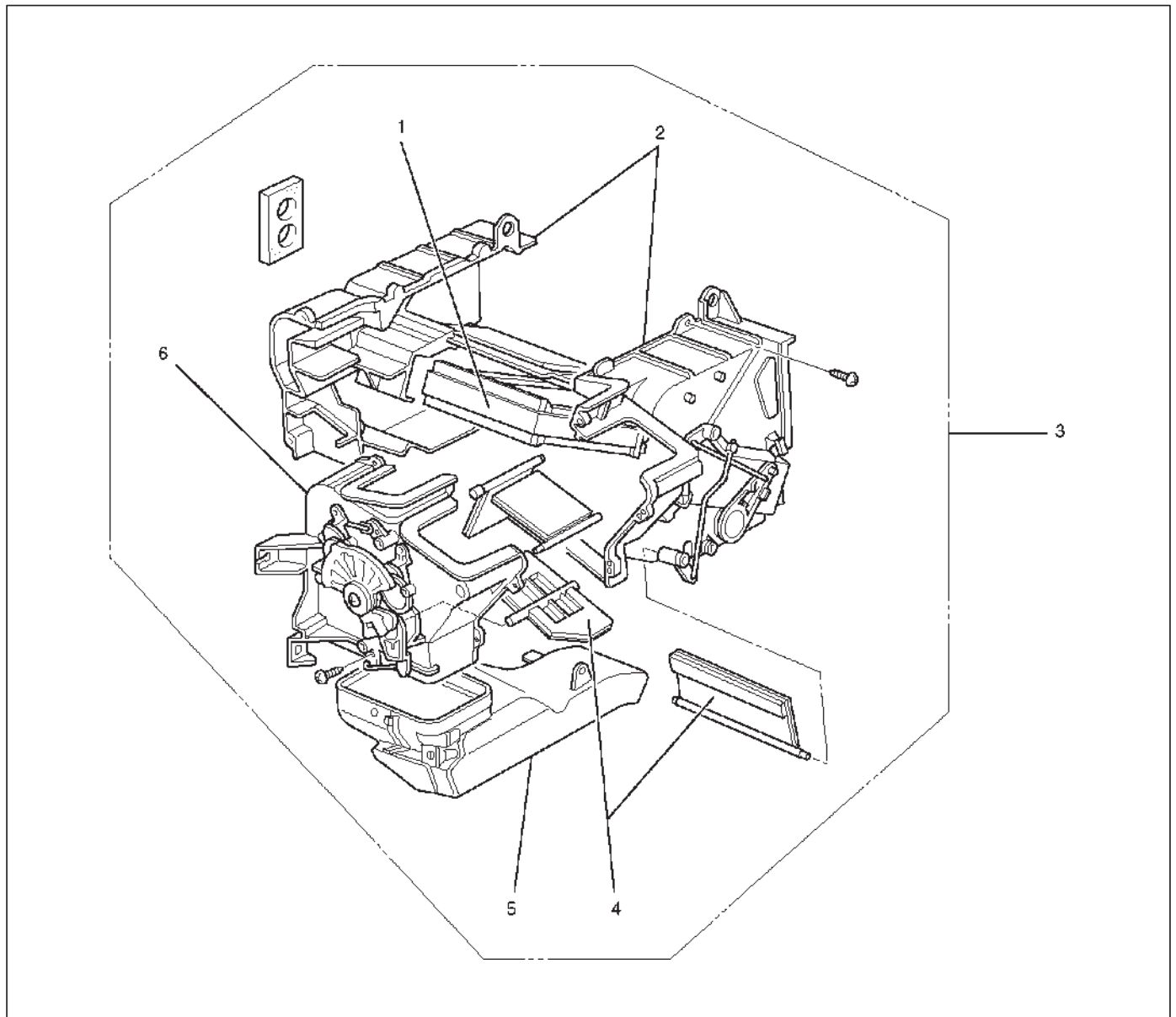
2. Adjust the control cables.

○Refer to Control Lever Assembly in this section.

3. When installing the heater unit, defroster nozzle and center vent duct, be sure that the proper seal is made, without any gap between them.

## Heater Core and / or Mode Door

### Disassembled View



### Legend

(1) Heater Core

(2) Case (Temperature Control)

(3) Heater Unit

(4) Mode Door

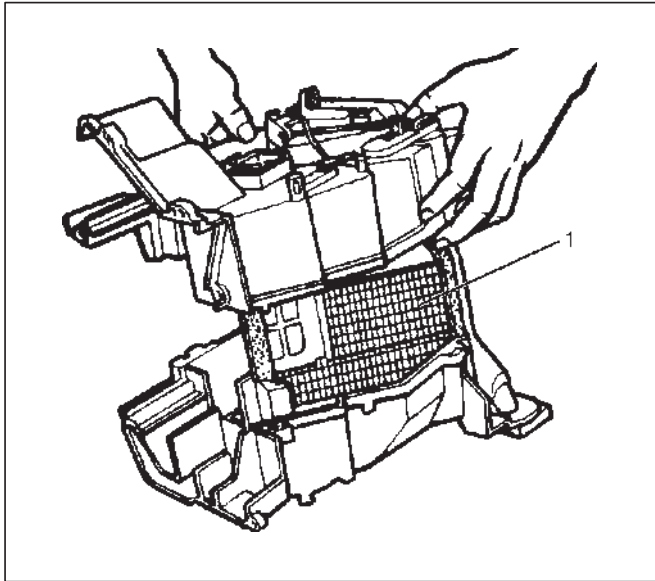
(5) Duct

(6) Case (Mode Control)

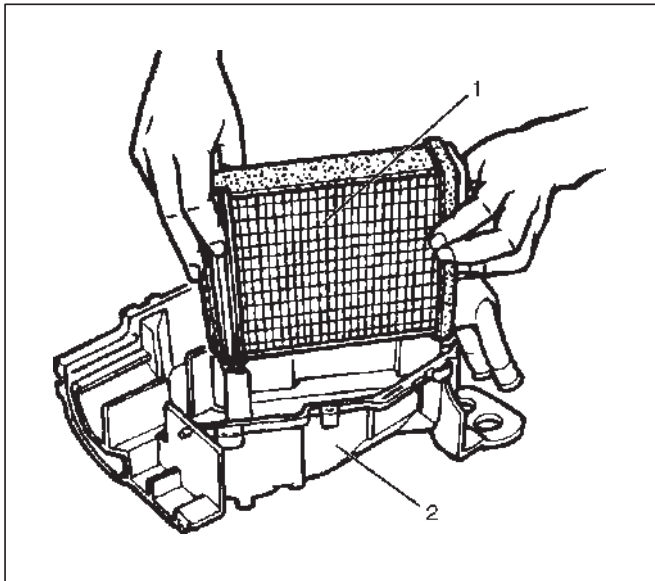
## 1A-16 HEATING, VENTILATION AND AIR CONDITIONING (HVAC)

### Removal

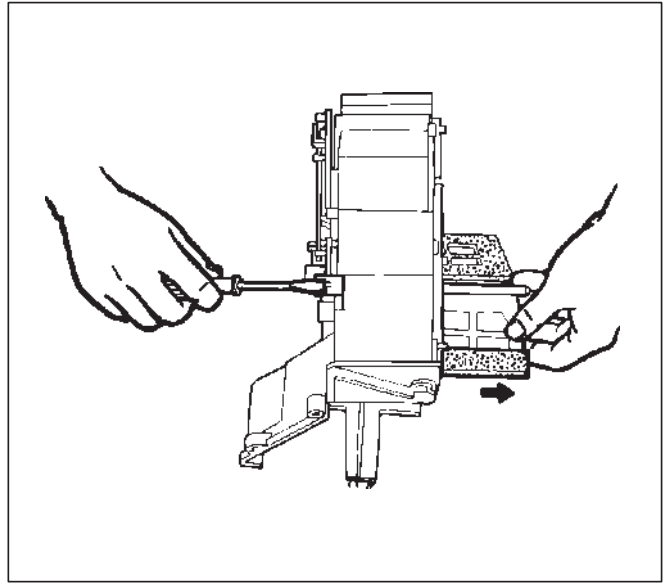
1. Disconnect the battery ground cable.
2. Drain the engine coolant.
3. Discharge and recover refrigerant (with air conditioning).
  - Refer to Refrigerant Recovery in this section.
4. Remove heater unit.
  - Refer to Heater Unit in this section.
5. Remove duct.
6. Remove case (Mode control) and do not remove link unit at this step.
7. Remove case (Temperature control) separate two halves of core case.



8. Remove heater core.



9. Pull out the mode door while raising up the catch of the door lever.



### Inspection

Check for foreign matter in the heater core, stain or the core fin defacement.

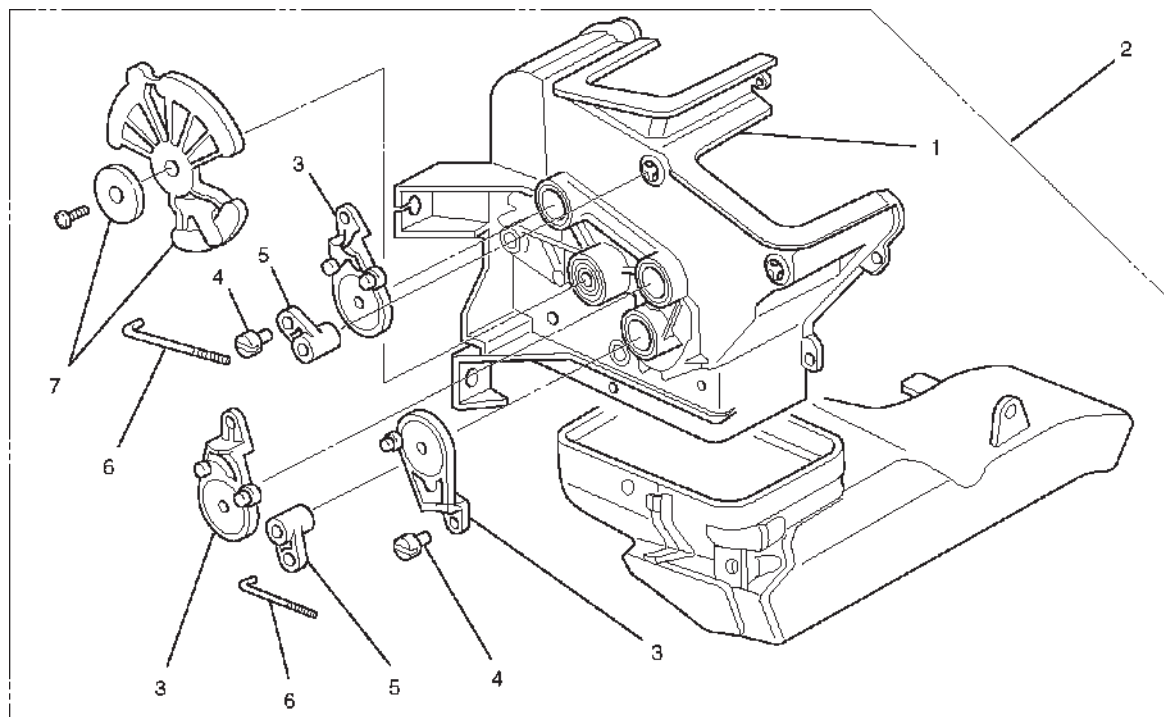
### Installation

To install, follow the removal steps in the reverse order, noting the following point:

1. Check that each door operates properly.

## Heater Mode Control Link Unit

### Disassembled View



860RX009

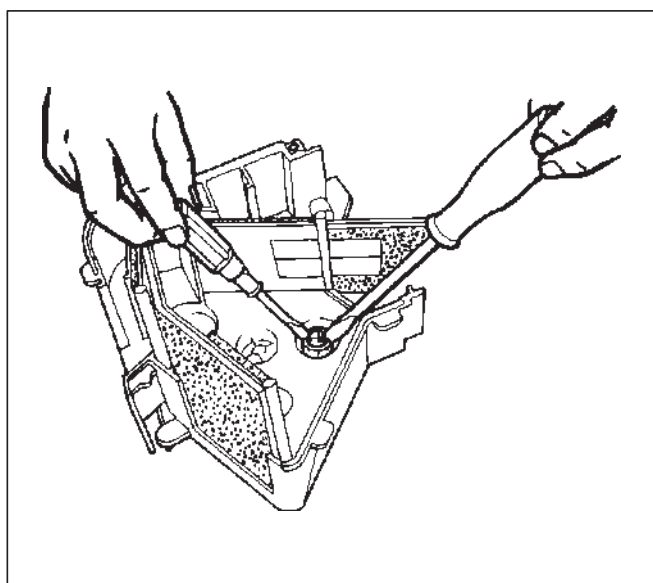
#### Legend

- (1) Case (Mode Control)
- (2) Heater Unit
- (3) Mode Sub-lever

- (4) Clip
- (5) Door Lever
- (6) Rod
- (7) Washer and Mode Main Lever

### Removal

1. Disconnect the battery ground cable.
2. Drain engine coolant.
3. Discharge and recover refrigerant (with air conditioning)
  - Refer to Refrigerant Recovery in this section.
4. Remove heater unit.
  - Refer to Heater Unit in this section.
5. Remove the case (Mode control) from heater unit.
6. Remove washer and the mode main lever.
7. Remove rod.
8. Press the tab of the sub-lever inward, and take out the sub-lever.
9. Pull out the door lever while raising up the catch of the door lever.
10. Remove clip.



860RX007

## 1A-18 HEATING, VENTILATION AND AIR CONDITIONING (HVAC)

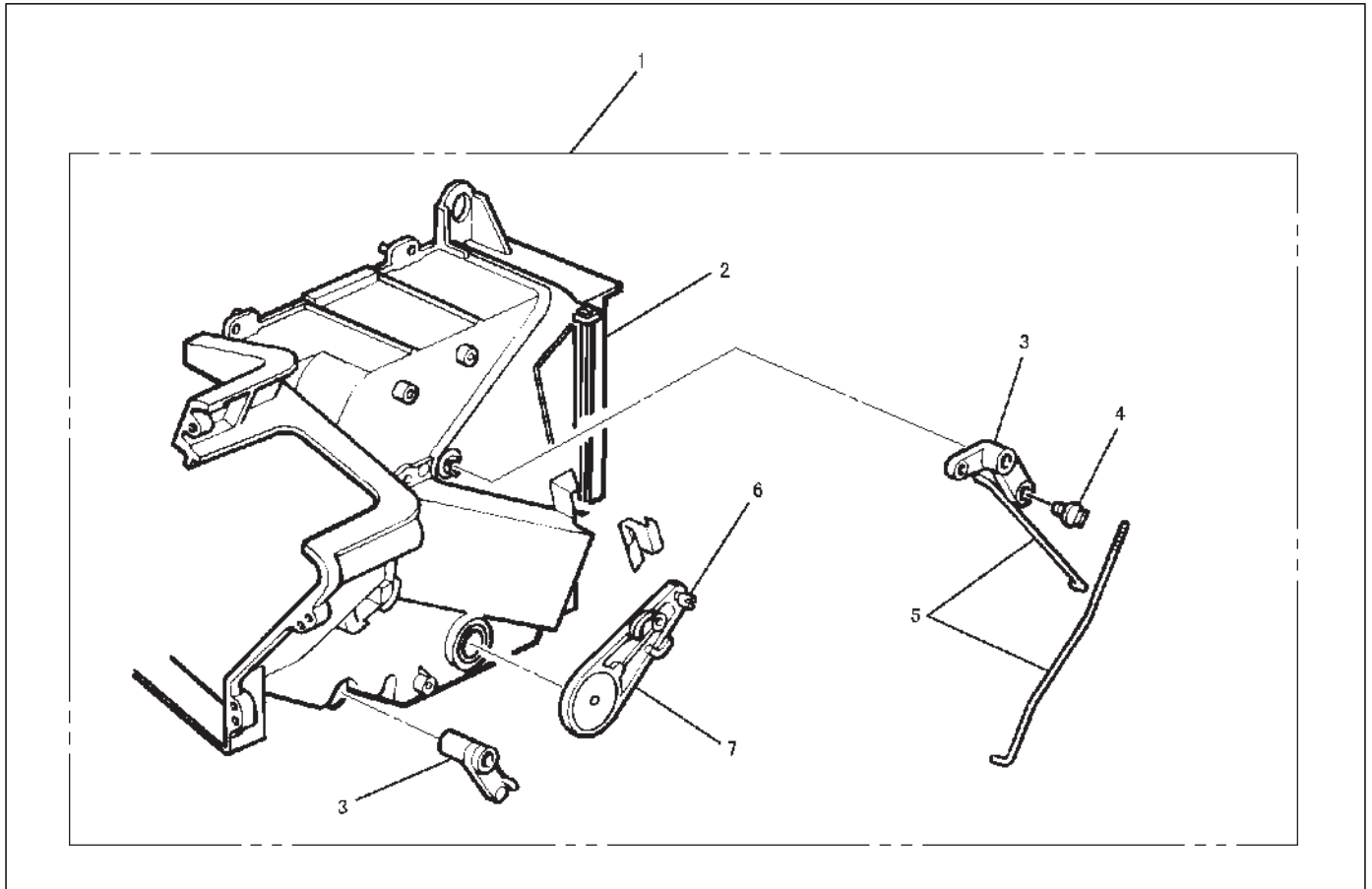
### Installation

To install, follow the remove steps in the reverse order, noting the following points:

1. Apply grease to the mode sub-lever and to the abrasive surface of the heater unit.
2. After installing the link unit, check to see if the link unit operates correctly.

## Heater Temperature Control Link Unit

### Disassembled View



#### Legend

- |                                |               |
|--------------------------------|---------------|
| (1) Heater Unit                | (4) Clip      |
| (2) Case (Temperature control) | (5) Rod       |
| (3) Door Lever                 | (6) Clip      |
|                                | (7) Sub-lever |

### Removal

1. Disconnect the battery ground cable.
2. Drain engine coolant.
3. Discharge and recover refrigerant (with air conditioning).
  - Refer to Refrigerant Recovery in this section.
4. Remove heater unit.
  - Refer to Heater Unit in this section.
5. Remove the case (Temperature control) from the heater unit.
6. Remove rod.
7. Remove sub-lever.
8. Pull out the door lever while raising up the catch of the door lever.

9. Remove clip.

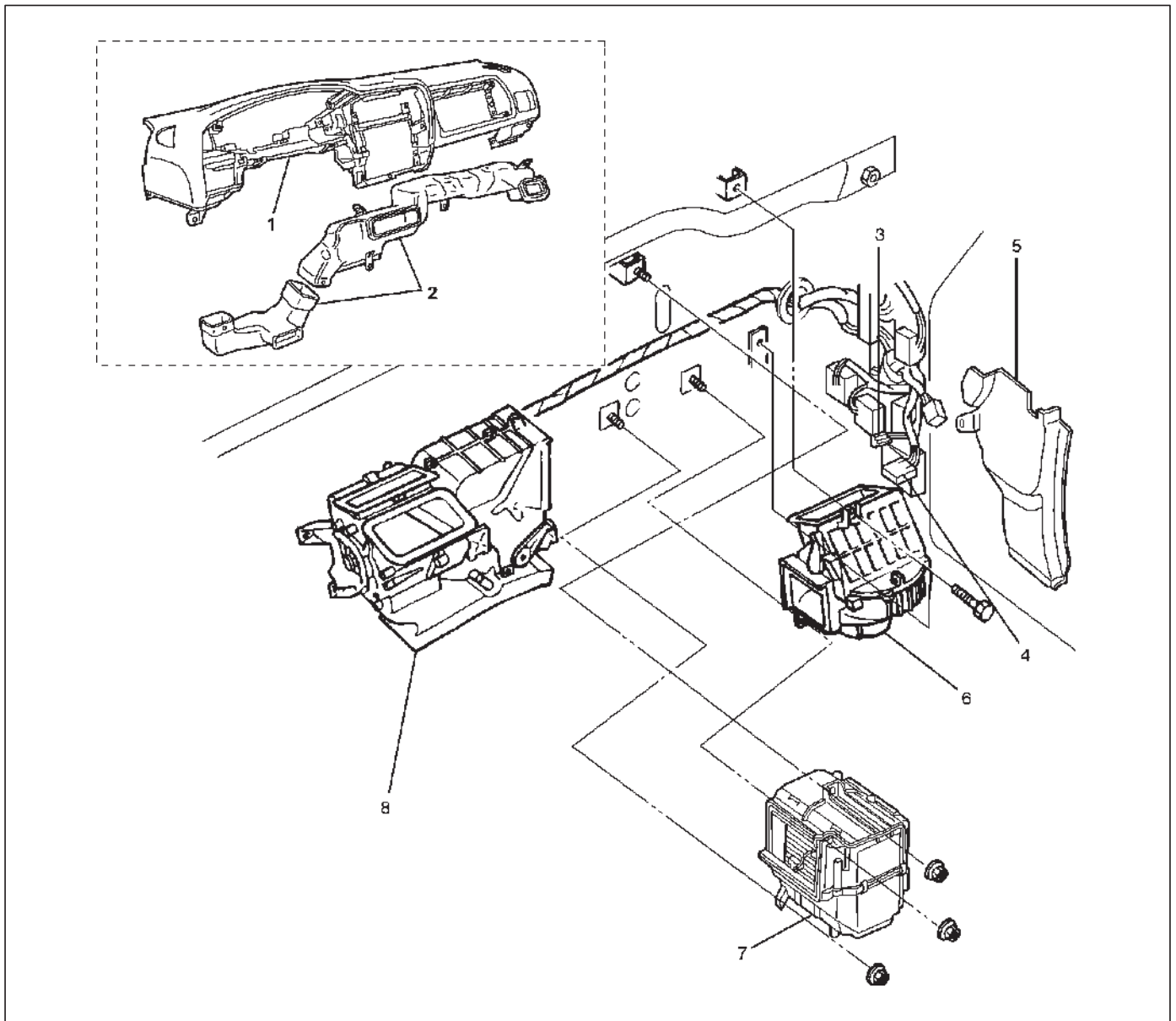
### Installation

To install, follow the removal steps in the reverse order, noting the following points:

1. Apply grease to the sub-lever and to the abrasive surface of the heater unit.
2. After installing the link unit, check to see if the link unit operates correctly.

## Blower Assembly

### Blower Assembly and Associated Parts



873RY00008

#### Legend

- |                               |                          |
|-------------------------------|--------------------------|
| (1) Instrument Panel Assembly | (5) Dash Side Trim Panel |
| (2) Center & Lower Vent Duct  | (6) Blower Assembly      |
| (3) Blower Motor Connector    | (7) Evaporator Assembly  |
| (4) Resistor Connector        | (8) Heater Unit          |

#### Removal

1. Disconnect the battery ground cable.
2. Discharge and recover refrigerant (with air conditioning).
  - Refer to Refrigerant Recovery in this section.
3. Remove instrument panel assembly.
  - Refer to Instrument Panel Assembly in Body and Accessories section.
4. Disconnect resistor connector.
5. Remove evaporator assembly.
  - Refer to Evaporator Assembly in this section.
6. Disconnect blower motor connector.
7. Remove blower assembly.

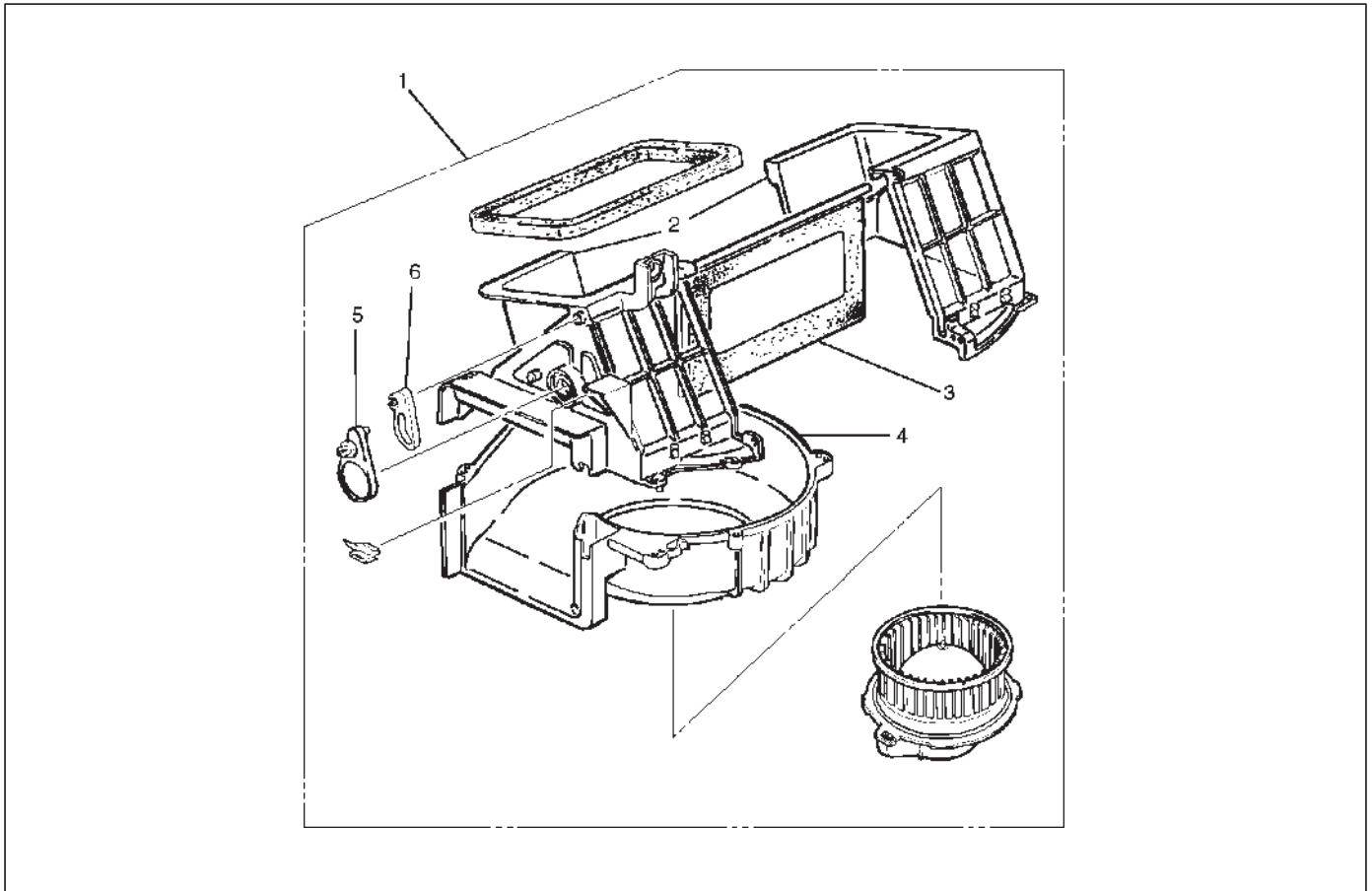
## Installation

To install, follow the removal steps in the reverse order, noting the following point:

1. Adjust the control cables.
  - Refer to Control Lever Assembly in this section.

## Blower Link Unit and / or Mode door

### Disassembled View



873RX003

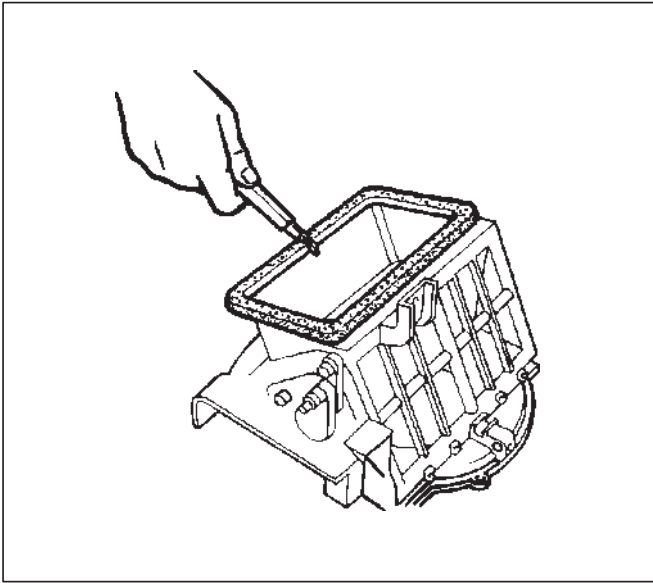
### Legend

- |                     |                |
|---------------------|----------------|
| (1) Blower Assembly | (4) Lower Case |
| (2) Upper Case      | (5) Sub Lever  |
| (3) Mode Door       | (6) Door Lever |

## Removal

1. Disconnect the battery ground cable.
2. Discharge and recover refrigerant (with air conditioning).
  - Refer to Refrigerant Recovery in this section.
3. Remove blower assembly.
  - Refer to Blower Assembly in this section.
4. Remove lower case.

5. After separating the upper case, slit the lining parting face with a knife.



6. Pull out the mode door while raising up the catch of door lever.
7. Remove sub-lever.
8. Remove door lever.

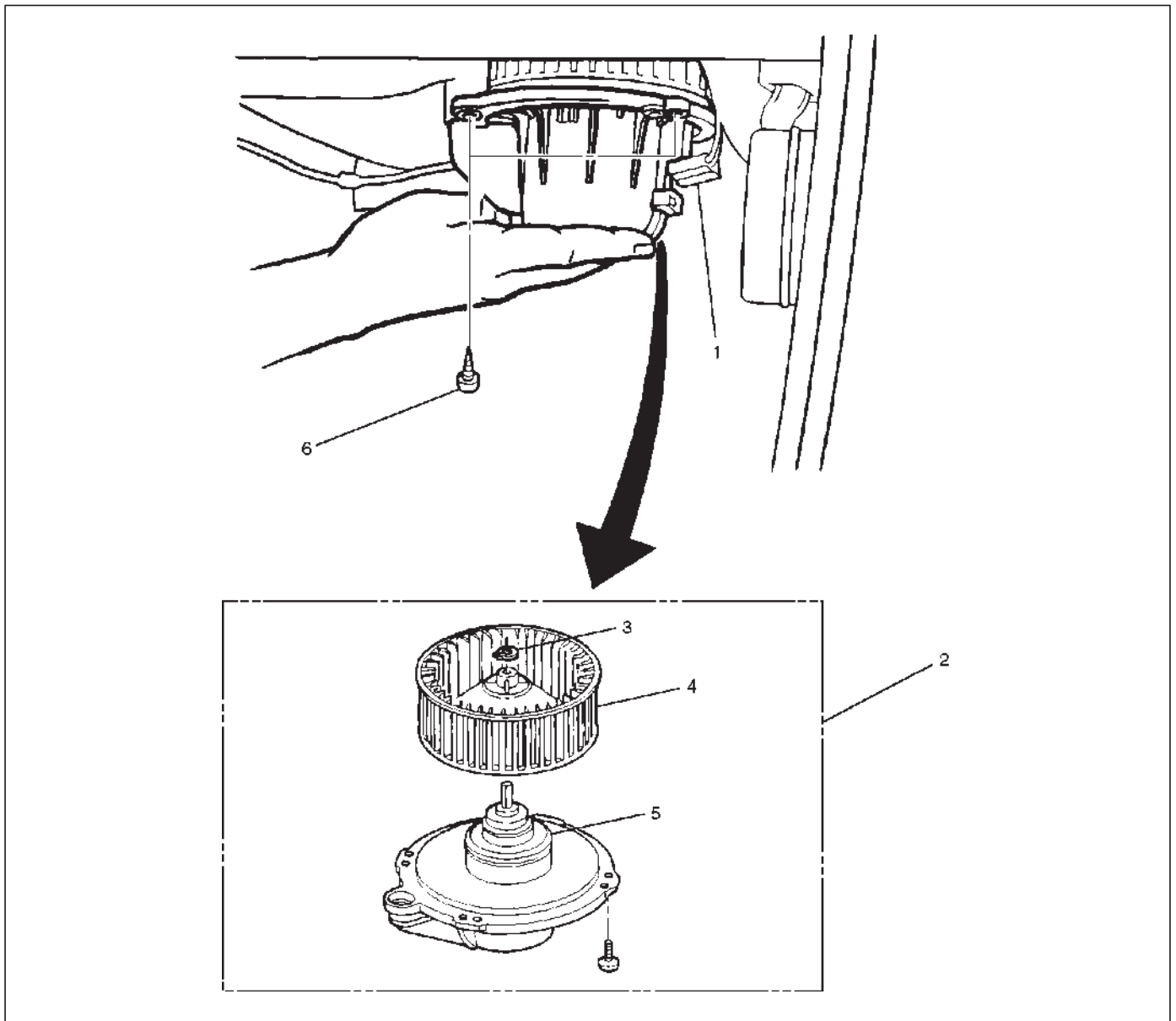
## Installation

To install, follow the removal steps in the reverse order, noting the following points:

1. Apply grease to the door lever and to the abrasive surface of the upper case.
2. Apply an adhesive to the parting face of the lining when assembling the upper case.

## Blower Motor

### Blower Motor and Associated Parts



873RS004

#### Legend

- |                            |                     |
|----------------------------|---------------------|
| (1) Blower Motor Connector | (4) Fan             |
| (2) Blower Motor Assembly  | (5) Blower Motor    |
| (3) Clip                   | (6) Attaching Screw |

### Removal

1. Disconnect the battery ground cable.
2. Remove blower motor connector.
3. Remove attaching screw.
4. Remove blower motor assembly.
5. Remove clip.
6. Remove fan.
7. Remove blower motor.

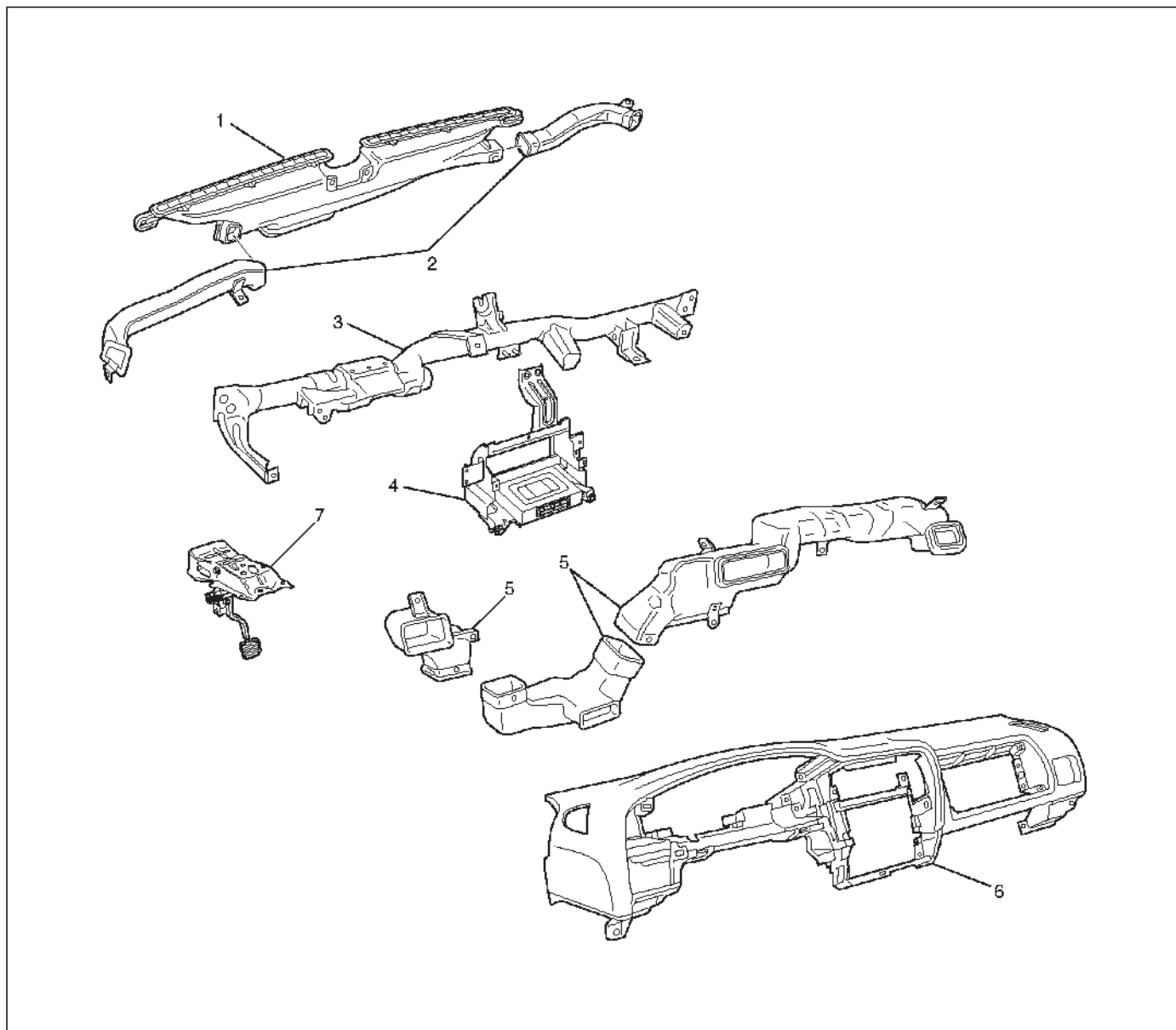
### Installation

To install, follow the removal steps in the reverse order.



## Defroster Nozzle and Ventilation Duct

### Defroster Nozzle, Ventilation Duct and Associated Parts



840RX009

#### Legend

- |                           |                                  |
|---------------------------|----------------------------------|
| (1) Defroster Nozzle      | (4) Center Bracket Assembly      |
| (2) Side Defroster Nozzle | (5) Vent Duct                    |
| (3) Cross Beam Assembly   | (6) Instrument Panel Assembly    |
|                           | (7) Brake Pedal Bracket Assembly |

#### Removal

1. Disconnect the battery ground cable.
2. Remove instrument panel assembly.
  - Refer to Instrument Panel Assembly in Body and Accessories section.
3. Remove vent duct.
  - Remove 5 clips and 2 screws.
4. Remove side defroster nozzle.
5. Remove cross beam assembly.
  - Refer to Cross Beam Assembly in Body and Accessories section.
6. Remove center bracket assembly.
7. Remove brake pedal bracket assembly.
8. Remove defroster nozzle.

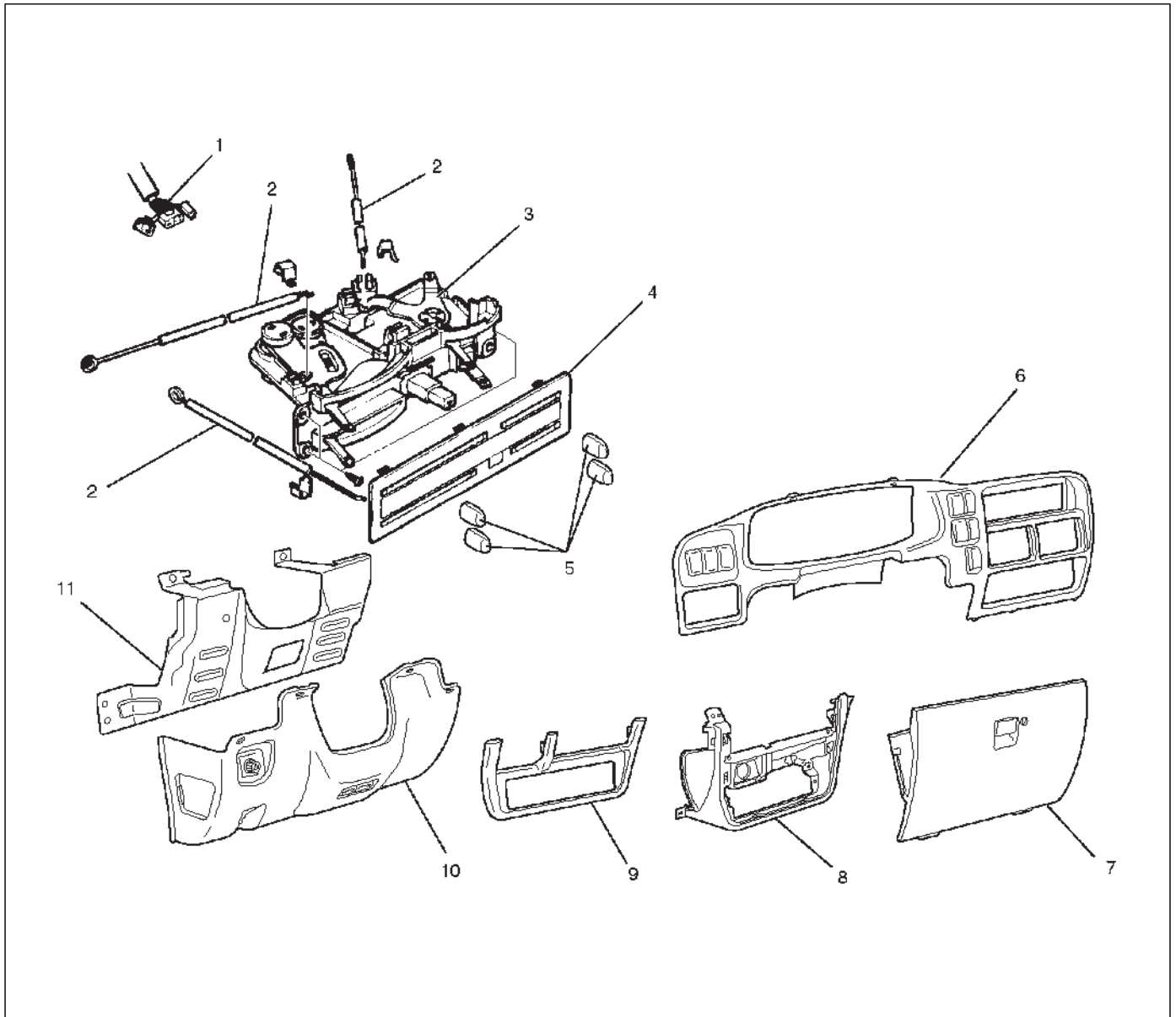
## Installation

To install, follow the removal steps in the reverse order, noting the following point:

1. Connect each duct and nozzle securely leaving no clearance between them and making no improper matching.

## Control Lever Assembly and / or Control Cable

### Control Lever Assembly, Control Cable and Associated Parts

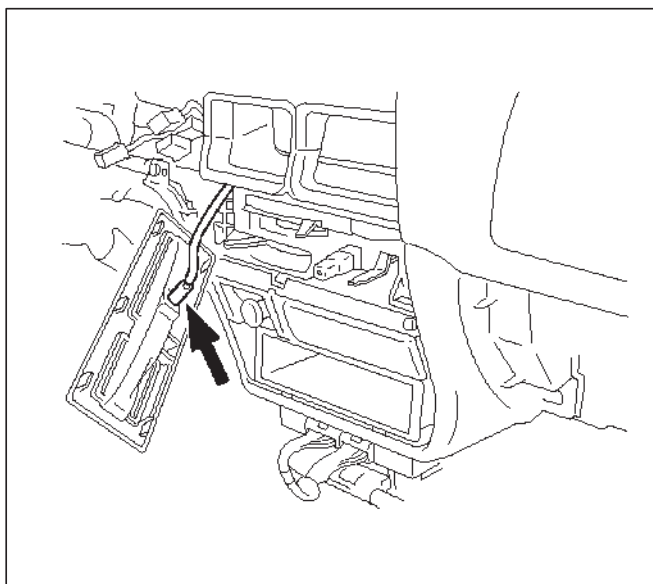


#### Legend

- |   |   |
|---|---|
| (1) Fan Control Lever and/or A/C Switch Connector | (7) Glove Box                                     |
| (2) Control Cable                                 | (8) Instrument Panel Lower Center Cover Assembly  |
| (3) Control Lever Assembly                        | (9) Lower Cluster Assembly                        |
| (4) Heater Bezel                                  | (10) Instrument Panel Driver Lower Cover Assembly |
| (5) Knobs   | (11) Knee Bolster Driver Panel Assembly           |
| (6) Meter Cluster Assembly                        |   |

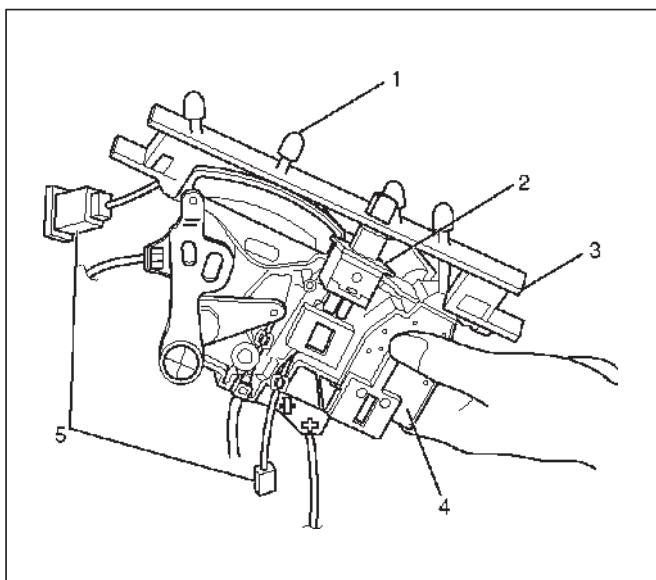
## Removal

1. Disconnect the battery ground cable.
2. Remove instrument panel driver lower cover assembly.
3. Remove knee Bolster Driver Panel Assembly.
4. Remove lower cluster assembly.
5. Remove meter cluster assembly.
  - Refer to Instrument Panel Assembly and Cross Beam Assembly in Body Structure section.
6. Remove instrument panel lower center cover assembly.
7. Remove glove box.
8. Remove the control lever attaching screws.
9. Pull the control lever assembly out and disconnect the fan switch and air conditioning switch connectors.



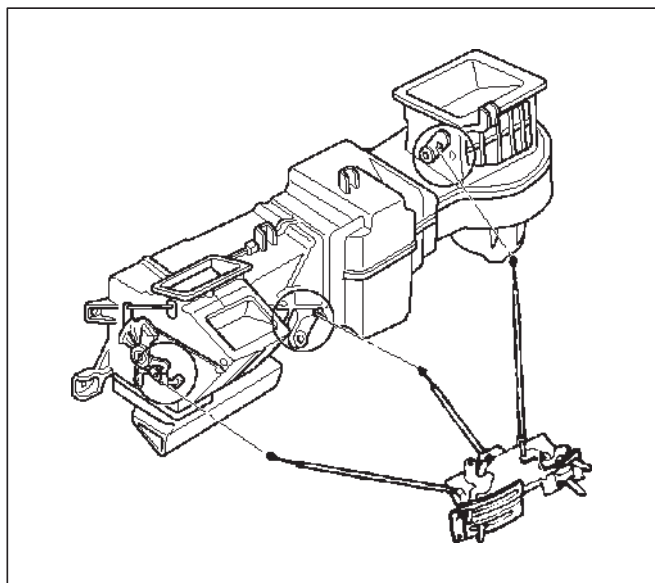
865RS015

10. Remove the illumination bulb holder.
11. Remove fan control lever and/or air conditioning (A/C) switch connector.
  - Pull the A/C switch out and disconnect the connectors.



865RX005

12. Remove control lever assembly.
13. Disconnect control cables at each unit side.



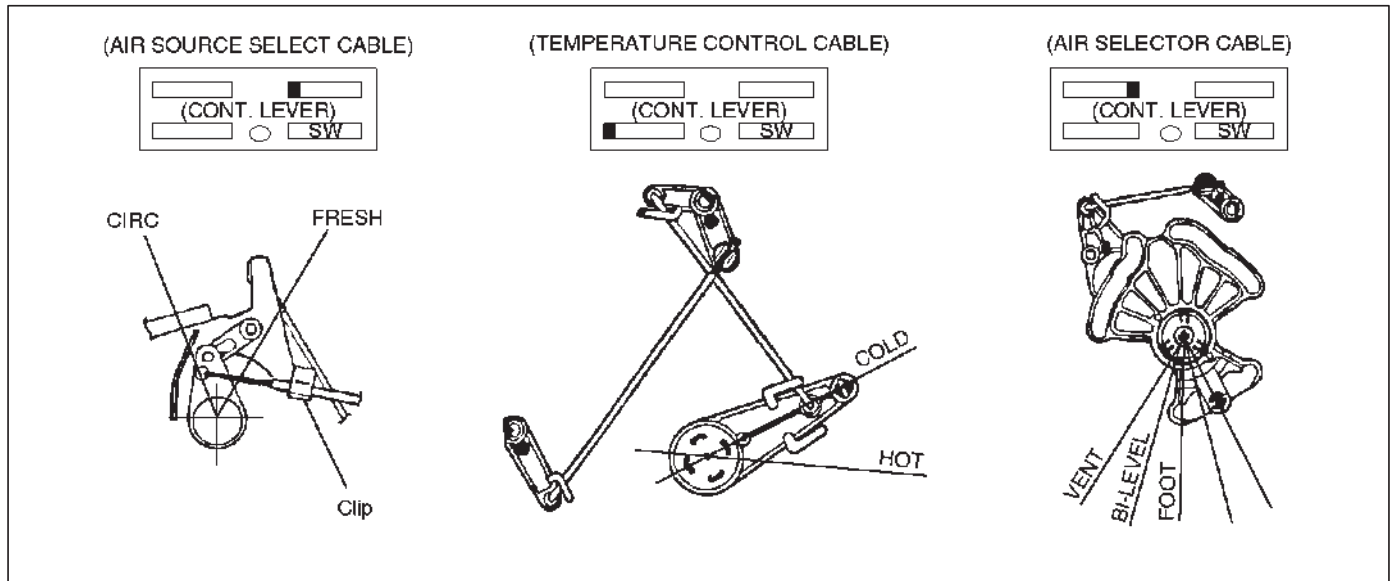
865RX002

## 1A-26 HEATING, VENTILATION AND AIR CONDITIONING (HVAC)

### Installation

To install, follow the removal steps in the reverse order, noting the following points:

1. Adjust the control cable.



865RX003

#### ○Air source control cable.

1. Slide the control lever to the left ("CIRC" position).
2. Connect the control cable at the "CIRC" position of the link unit of the blower assembly and secure it with the clip.

#### ○Temperature control cable.

1. Slide the control knob to the left ("MAX COLD" position).
2. Connect the control cable at the "COLD" position of the temperature control link of the heater unit and secure it with the clip.

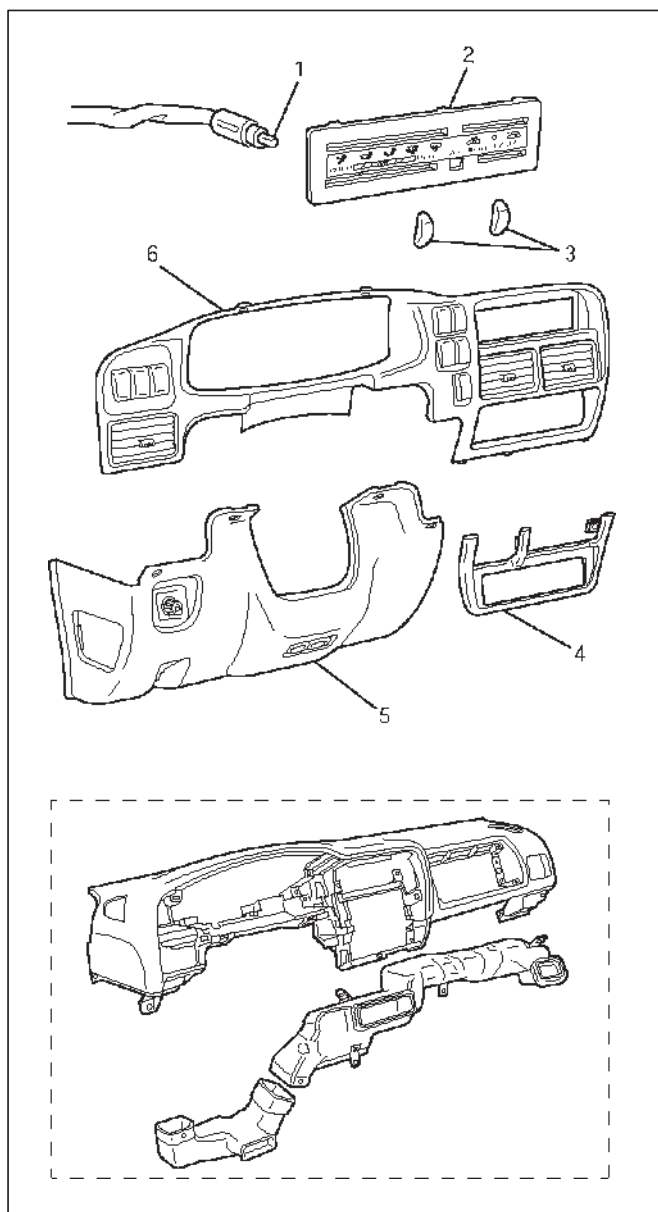
#### ○Air select control cable

1. Slide the control knob to the right ("DEFROST" position).
2. Connect the control cable at the "DEFROST" position of the mode control link of the heater unit and secure it with the clip.

2. Check the control cable operation.

## Heater Bezel Illumination Bulb

### Heater Bezel Illumination Bulb and Associated Parts



840RX012

### Removal

1. Disconnect the battery ground cable.
2. Remove instrument panel driver lower cover.
3. Remove lower cluster assembly.
4. Remove meter cluster assembly.
5. Remove knobs.
6. Remove heater bezel.
7. Remove illumination bulb.

### Installation

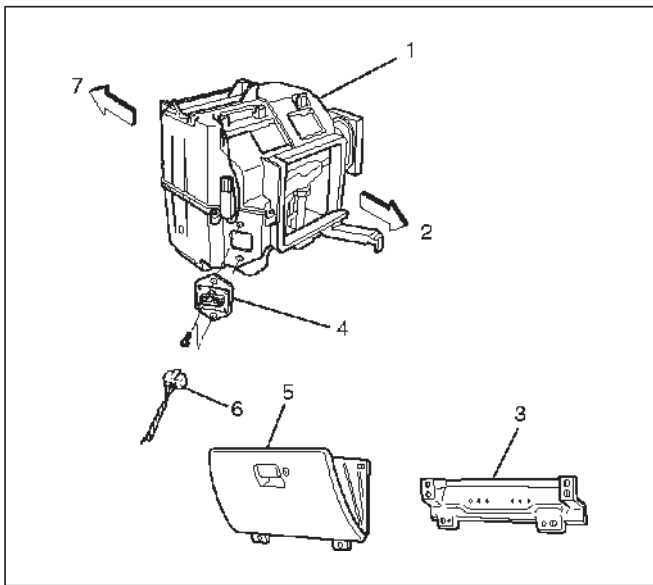
To install, follow the removal steps in the reverse order.

### Legend

- (1) Illumination Bulb
- (2) Heater Bezel
- (3) Knobs
- (4) Lower Cluster Assembly
- (5) Instrument Panel Driver Lower Cover
- (6) Meter Cluster Assembly

## Resistor

### Resistor and Associated Parts



874RX023

### Legend

- (1) Evaporator
- (2) To Blower Unit
- (3) Passenger Knee Bolster Reinforcement
- (4) Resistor
- (5) Glove Box
- (6) Resistor Connector
- (7) To Heater Unit

### Removal

1. Disconnect the battery ground cable.
2. Remove glove box.
3. Remove passenger knee bolster reinforcement.
4. Remove resistor connector.
5. Remove resistor.

### Installation

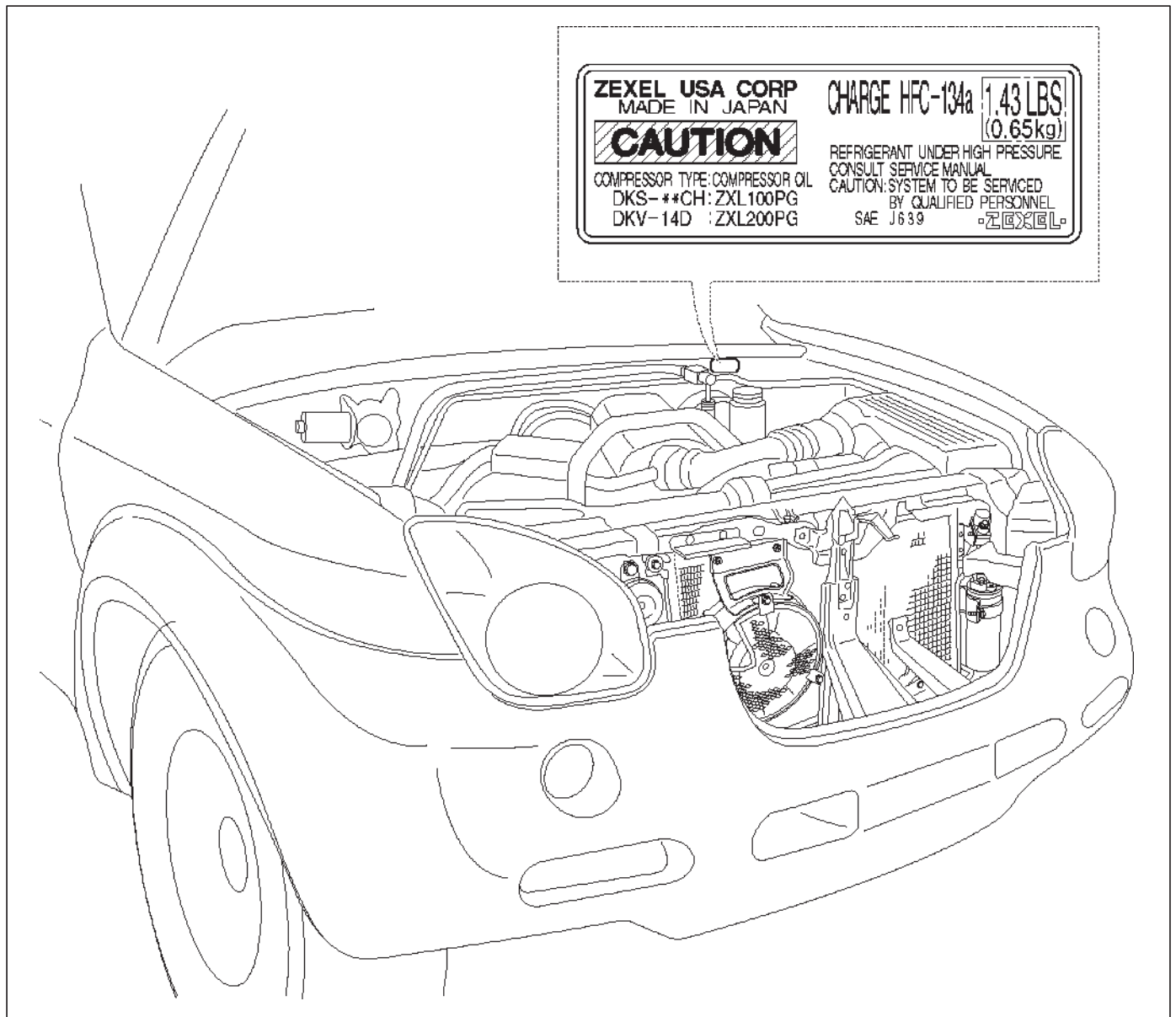
To install, follow the removal steps in the reverse order.

## Air Conditioning System

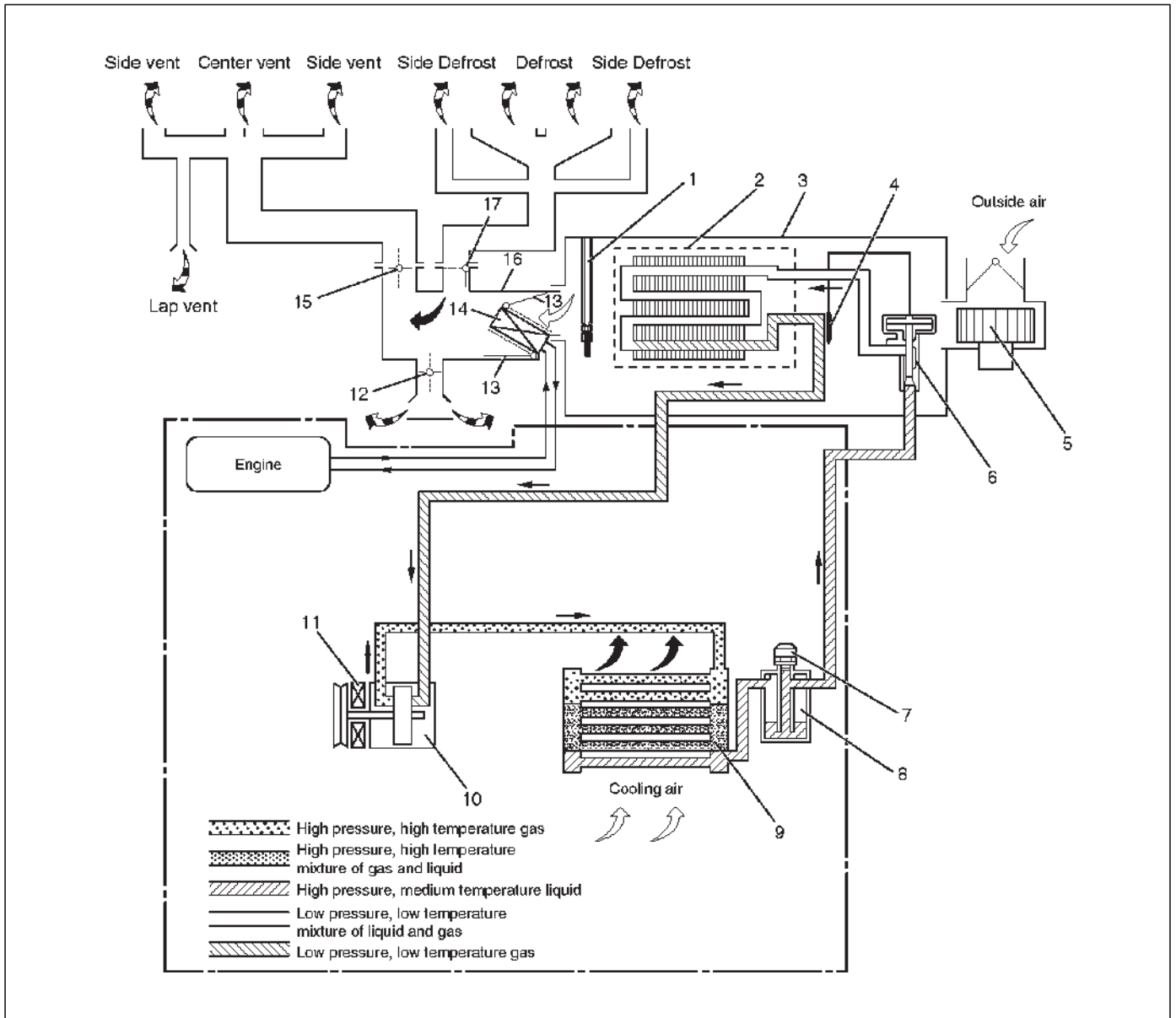
### General Description

**CAUTION:** Vehicle that use Refrigerant-134a (R-134a) in the air conditioning system have a caution plate fixed to the rear wall of the engine compartment. Also, components designed solely for use with R-134a are so marked, to distinguish them from components designed solely for use with

Refrigerant-12 (R-12) R-12 and R-134a systems require different types of lubricating oil. Components designed solely for use with one refrigerant and oil type must never be interchanged with components designed solely for use with another refrigerant and oil type.



## Air Conditioning Refrigerant Cycle Construction



C01RX004

### Legend

- |  |  |
|--|--|
| (1) Electronic Thermostat              | (9) Condenser                          |
| (2) Evaporator Core                    | (10) Compressor                        |
| (3) Evaporator Assembly                | (11) Magnetic Clutch                   |
| (4) Temperature Sensor                 | (12) Mode (HEAT) Control Door          |
| (5) Blower Motor                       | (13) Temp. Control Door (Air Mix Door) |
| (6) Expansion Valve                    | (14) Heater Core                       |
| (7) Pressure Switch or Pressure Sensor | (15) Mode (VENT) Control Door          |
| (8) Receiver/Drier                     | (16) Heater Unit                       |
|  | (17) Mode (DEF) Control Door           |

The refrigeration cycle includes the following four processes as the refrigerant changes repeatedly from liquid to gas and back to liquid while circulating.

### Evaporation

The refrigerant is changed from a liquid to a gas inside the evaporator. The refrigerant mist that enters the evaporator vaporizes readily. The liquid refrigerant removes the required quantity of heat (latent heat of

vaporization) from the air around the evaporator core cooling fins and rapidly vaporizes. Removing the heat cools the air, which is then radiated from the fins and lowers the temperature of the air inside the vehicle.

The refrigerant liquid sent from the expansion valve and the vaporized refrigerant gas are both present inside the evaporator as the liquid is converted to gas.



With this change from liquid to gas, the pressure inside the evaporator must be kept low enough for vaporization to occur at a lower temperature. Because of that, the vaporized refrigerant is sucked into the compressor.

### Compression

The refrigerant is compressed by the compressor until it is easily liquefied at normal temperature.

The vaporized refrigerant in the evaporator is sucked into the compressor. This action maintains the refrigerant inside the evaporator at a low pressure so that it can easily vaporize, even at low temperatures close to 0°C(32°F).

Also, the refrigerant sucked into the compressor is compressed inside the cylinder to increase the pressure and temperature to values such that the refrigerant can easily liquefy at normal ambient temperatures.

### Condensation

The refrigerant inside the condenser is cooled by the outside air and changes from gas to liquid.

The high temperature, high pressure gas coming from the compressor is cooled and liquefied by the condenser with outside air and accumulated in the receiver/drier. The heat radiated to the outside air by the high temperature, high pressure gas in the compressor is called heat of condensation. This is the total quantity of heat (heat of vaporization) the refrigerant removes from the vehicle interior via the evaporator and the work (calculated as the quantity of heat) performed for compression.

### Expansion

The expansion valve lowers the pressure of the refrigerant liquid so that it can easily vaporize.

The process of lowering the pressure to encourage vaporization before the liquefied refrigerant is sent to the evaporator is called expansion. In addition, the expansion valve controls the flow rate of the refrigerant liquid while decreasing the pressure.

That is, the quantity of refrigerant liquid vaporized inside the evaporator is determined by the quantity of heat which must be removed at a prescribed vaporization temperature. It is important that the quantity of refrigerant be controlled to exactly the right value.

### Compressor

The compressor performs two main functions:

It compresses low-pressure and low-temperature refrigerant vapor from the evaporator into high-pressure and high-temperature refrigerant vapor to the condenser. It pumps refrigerant and refrigerant oil through the air conditioning system.

This vehicle is equipped with a five-vane rotary compressor (3).

The thermo sensor (2) is installed to the front head of the compressor to protect it by stopping its operation when the temperature is abnormally high.

○ OFF — 160±5°C (320.0°±9.0°F)

○ ON — 135±5°C (275.0°±9.0°F)

The specified amount of the compressor oil is 150cc (5.0 fl. oz.).

The oil used in the HFC-134a system compressor differs from that used in R-12 systems.

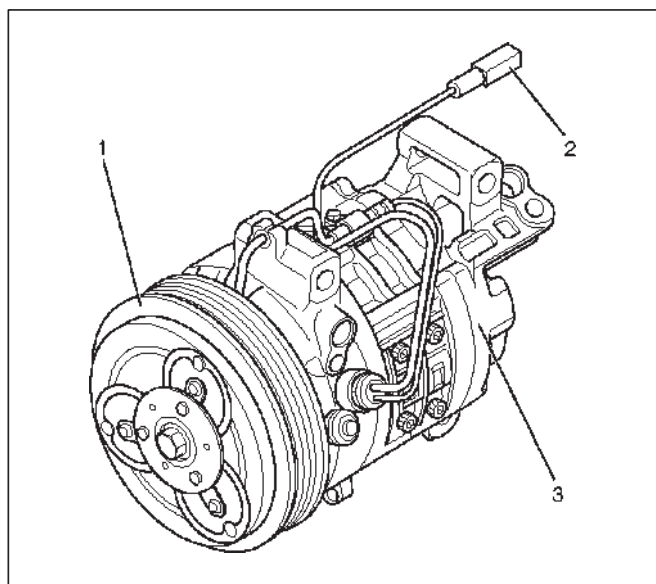
Also, compressor oil to be used varies according to the compressor model. Be sure to avoid mixing two or more different types of oil.

If the wrong oil is used, lubrication will be poor and the compressor will seize or malfunction.

The magnetic clutch connector is a waterproof type.

### Magnetic Clutch

The compressor is driven by the drive belt from the crank pulley of the engine. If the compressor is activated each time the engine is started, this causes too much load to the engine. The magnetic clutch (1) transmits the power from the engine to the compressor and activates it when the air conditioning is ON. Also, it cuts off the power from the engine to the compressor when the air conditioning is OFF. Refer to Compressor in this section for magnetic clutch repair procedure.



871RX009

### Condenser

The condenser assembly (6) is located in front of the radiator. It provides rapid heat transfer from the refrigerant to the cooling fins.

Also, it functions to cool and liquefy the high-pressure and high-temperature vapor sent from the compressor by the radiator fan or outside air.

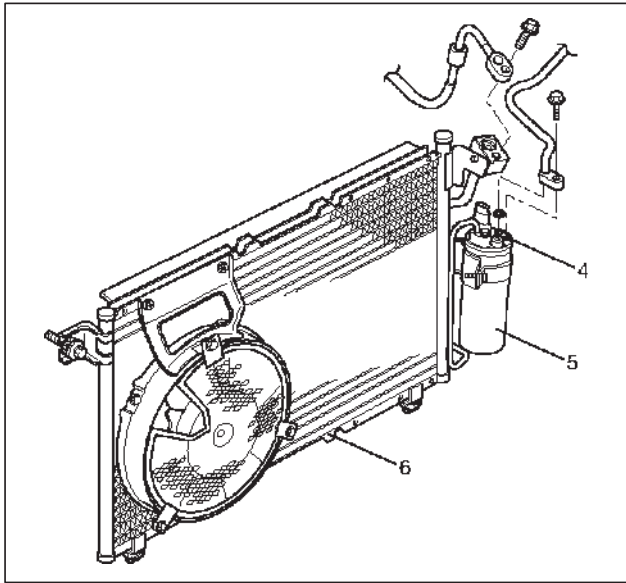
A condenser may malfunction in two ways: it may leak, or it may be restricted. A condenser restriction will result in excessive compressor discharge pressure. If a partial restriction is present, the refrigerant expands after passing through the restriction.

Thus, ice or frost may form immediately after the restriction. If air flow through the condenser or radiator is blocked, high discharge pressures will result. During normal condenser operation, the refrigerant outlet line will be slightly cooler than the inlet line.

The vehicle is equipped with the parallel flow type condenser. A larger thermal transmission area on the inner surface of the tube allows the radiant heat to increase and the ventilation resistance to decrease.

## 1A-32 HEATING, VENTILATION AND AIR CONDITIONING (HVAC)

The refrigerant line connection has a bolt at the block joint, for easy servicing.



852RX011

### Receiver / Dryer

The receiver/dryer (5) performs four functions:

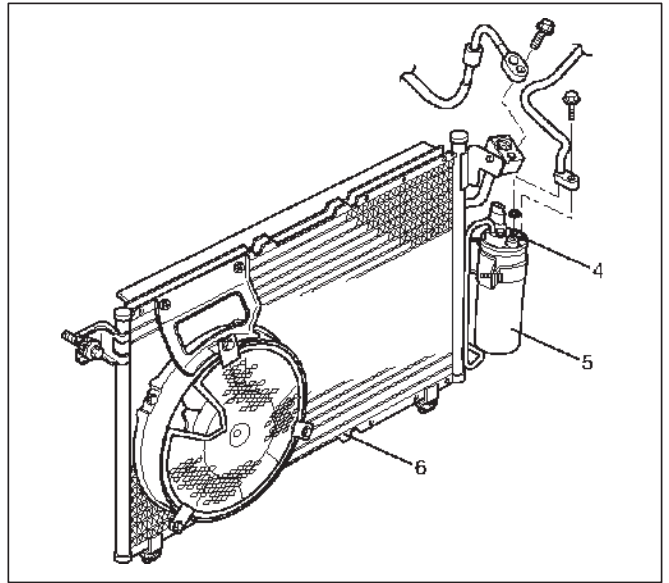
- As the quantity of refrigerant circulated varies depending on the refrigeration cycle conditions, sufficient refrigerant is stored for the refrigeration cycle to operate smoothly in accordance with fluctuations in the quantity circulated.
- The liquefied refrigerant from the condenser is mixed with refrigerant gas containing air bubbles. If refrigerant containing air bubbles is sent to the expansion valve, the cooling capacity will decrease considerably. Therefore, the liquid and air bubbles are separated and only the liquid is sent to the expansion valve.
- The receiver/dryer utilizes a filter and dryer to remove the dirt and water mixed in the cycling refrigerant.
- The sight glass, installed atop the receiver/dryer, show the state of the refrigerant.

A receiver/dryer may fail due to a restriction inside the body of the unit. A restriction at the inlet to the receiver/dryer will cause high pressure.

Outlet restrictions will be indicated by low pressure and little or no cooling. An excessively cold receiver/dryer outlet may indicate a restriction.

The receiver/dryer of this vehicle is made of aluminum with a smaller tank. It has a 300cc refrigerant capacity.

The refrigerant line connection has a bolt at the block joint, for easy servicing.



852RX011

### Triple Pressure Switch (V6, A/T)

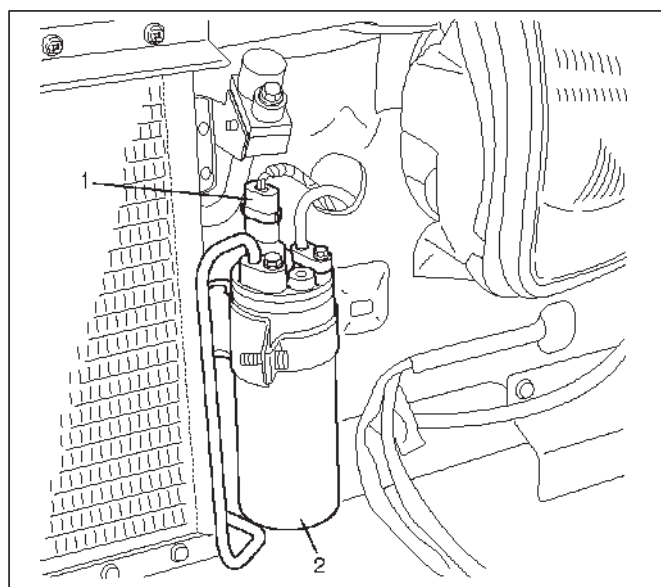
Triple pressure switch (1) is installed on the upper part of the receiver/dryer (2). This switch is constructed with a unitized type of two switches. One of them is a low and high pressure switch (Dual pressure switch) to switch "ON" or "OFF" the magnetic clutch as a result of irregularly high-pressure or low pressure of the refrigerant. The other one is a medium pressure switch (Cycling switch) to switch "ON" or "OFF" the condenser fan sensing the condenser high side pressure.

Compressor	ON (kpa/psi)	OFF (kpa/psi)
Low-pressure control	186.3±29.4 (27.0±4.3)	176.5±24.5 (25.6±3.6)
High-pressure control	2353.6±196.1 (341.3±28.4)	2942.0±196.1 (426.6±28.4)

Condenser fan	ON (kpa/psi)	OFF (kpa/psi)
Medium-pressure control	1471.0±98.1 (213.3±14.2)	1078.7±117.7 (156.4±17.1)

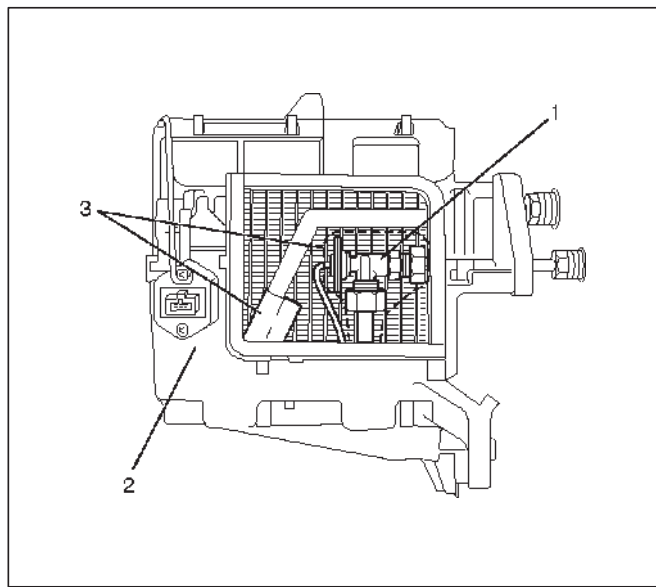
## Pressure Sensor

The pressure sensor (1) is installed on the upper part of the receiver/dryer (2). This sensor converts high pressure detection of refrigerant to an electrical voltage signal and supplies it to the PCM. The PCM controls switching compressor idle speed and cooling fan operation by the electrical voltage signal.



The calibration has been changed to match the characteristics of HFC-134a.

**CAUTION:** For the insulator (3) covers the expansion valve and the thermostat sensor as the prevention of noise and the heat insulator, use the new parts when removing it, in case of breaking down.



## Expansion Valve

This expansion valve (1) is an external pressure type and it is installed at the evaporator intake port.

The expansion valve converts the high pressure liquid refrigerant sent from the receiver/dryer to a low pressure liquid refrigerant by forcing it through a tiny port before sending it to the evaporator (2).

This type of expansion valve consists of a temperature sensor, diaphragm, ball valve, ball seat, spring adjustment screw, etc.

The temperature sensor contacts the evaporator outlet pipe, and converts changes in temperature to pressure. It then transmits these to the top chamber of the diaphragm.

The refrigerant pressure is transmitted to the diaphragm's bottom chamber through the external equalizing pressure tube.

The ball valve is connected to the diaphragm. The opening angle of the expansion valve is determined by the force acting on the diaphragm and the spring pressure.

The expansion valve regulates the flow rate of the refrigerant. Accordingly, when a malfunction occurs to this expansion valve, both discharge and suction pressure get low, resulting in insufficient cooling capacity of the evaporator.

## 1A-34 HEATING, VENTILATION AND AIR CONDITIONING (HVAC)

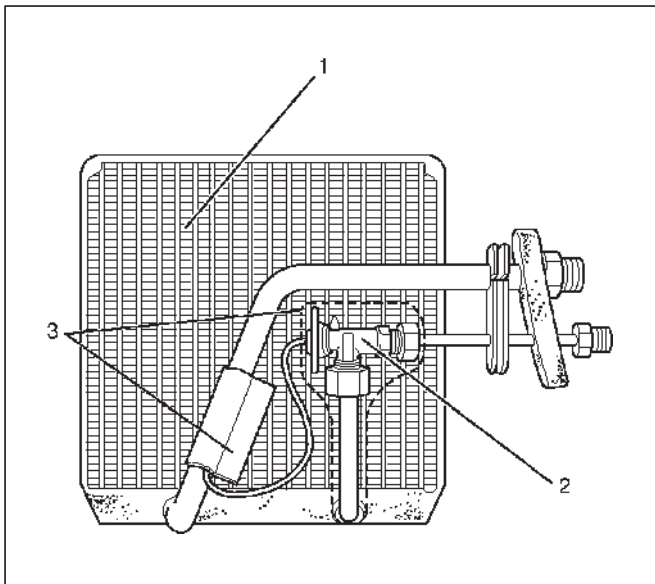
### Evaporator

The evaporator cools and dehumidifies the air before the air enters the passenger compartment. High-pressure liquid refrigerant flows through the expansion valve (2) into the low-pressure area of the evaporator. The heat in the air passing through the evaporator core (1) is lost to the cooler surface of the core, thereby cooling the air.

As heat is lost between the air and the evaporator core surface, moisture in the vehicle condenses on the outside surface of the evaporator core and is drained off as water. When the evaporator malfunctions, the trouble will show up as an inadequate supply of cool air. The cause is typically a partially plugged core due to dirt, or a malfunctioning blower motor.

The evaporator core with a laminate louver fin is a single-sided tank type where only one tank is provided under the core.

**CAUTION:** For the insulator (3) covers the expansion valve and the thermostat sensor as the prevention of noise and the heat insulator, use the new parts when removing it, in case of breaking down.



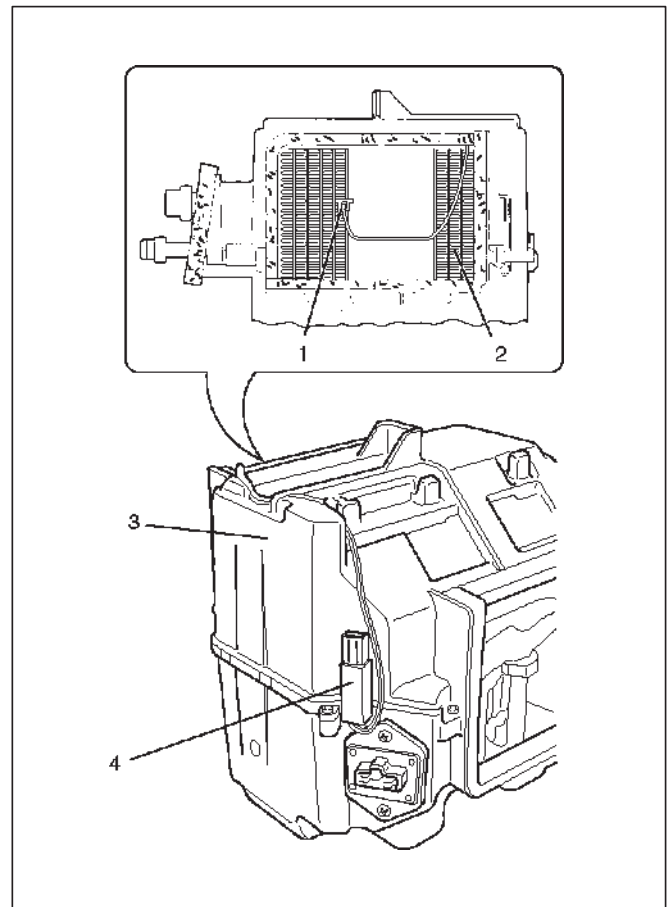
874RX029

### Electronic Thermostat

The electronic thermostat consists of the thermo sensor (1) and the thermostat unit (4) and functions electrically to reduce the noises being generated while the system is in operation.

The electronic thermo sensor (1) is mounted at the evaporator core (2) outlet and senses the temperature of the cool air from the evaporator (3). Temperature signals are input to the thermostat unit. This information is compared by the thermostat unit and results in the output to operate the A/C thermostat relay and turn the magnetic clutch ON or OFF to prevent evaporator freeze-up.

A characteristic of the thermo sensor is that the resistance decreases as the temperature increases and the resistance increases as the temperature decreases.



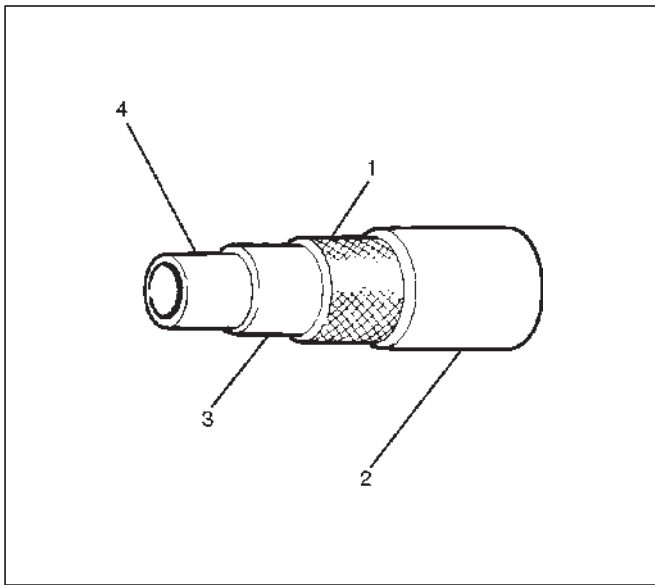
874RX022

## Refrigerant Line

Restriction in the refrigerant line will be indicated by:

1. Suction line — A restricted suction line will cause low suction pressure at the compressor, low discharge pressure and little or no cooling.
2. Discharge line — A restriction in the discharge line generally will cause the discharge line to leak.
3. Liquid line — A liquid line restriction will be evidenced by low discharge and suction pressure and insufficient cooling.

Refrigerant flexible hoses that have a low permeability to refrigerant and moisture are used. These low permeability hoses have a special nylon layer on the inside.

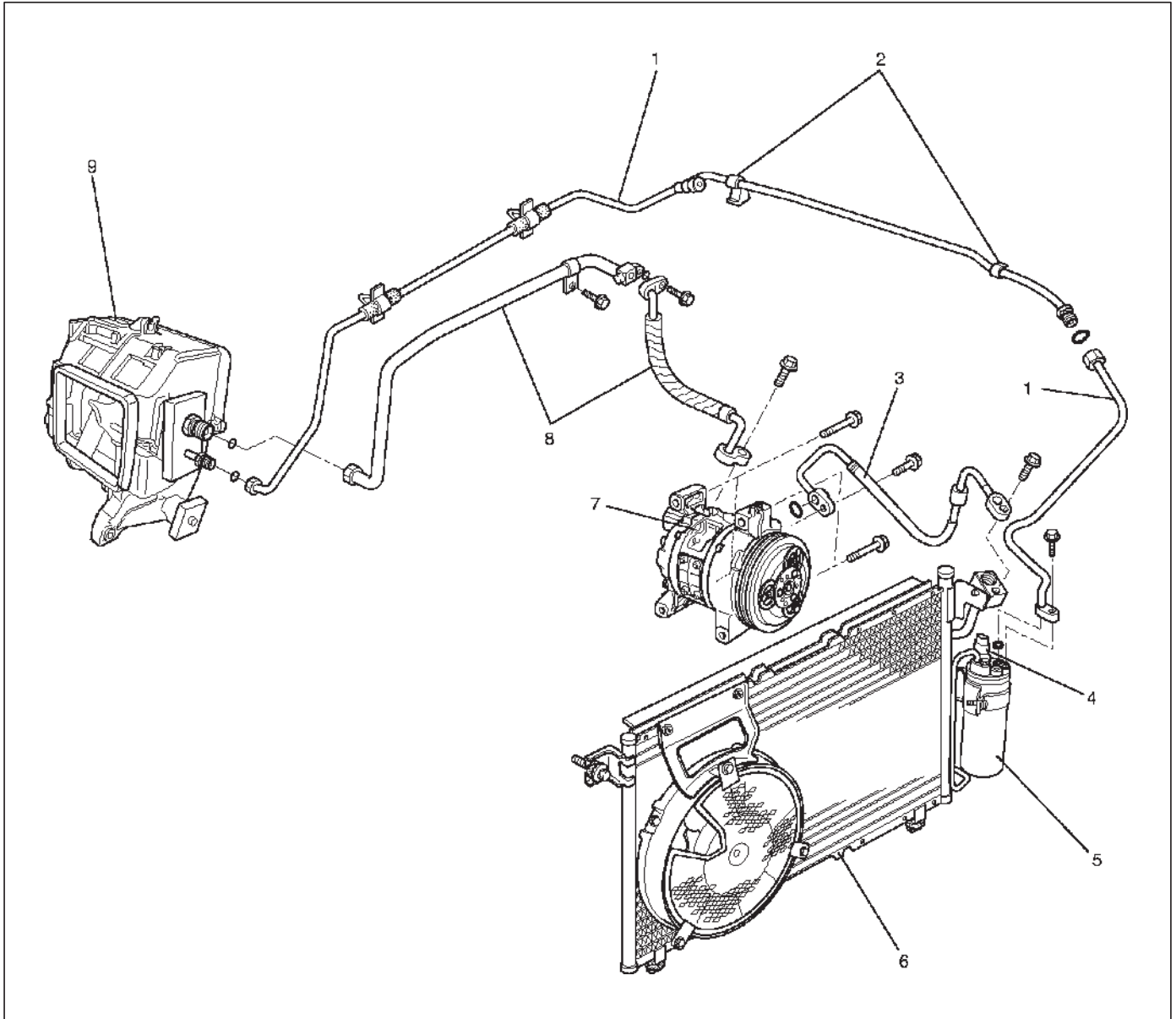


852RS001

### Legend

- (1) Reinforcement Layer (Polyester)
- (2) External Rubber Layer
- (3) Internal Rubber Layer
- (4) Resin Layer (Nylon)

Air Conditioning Parts

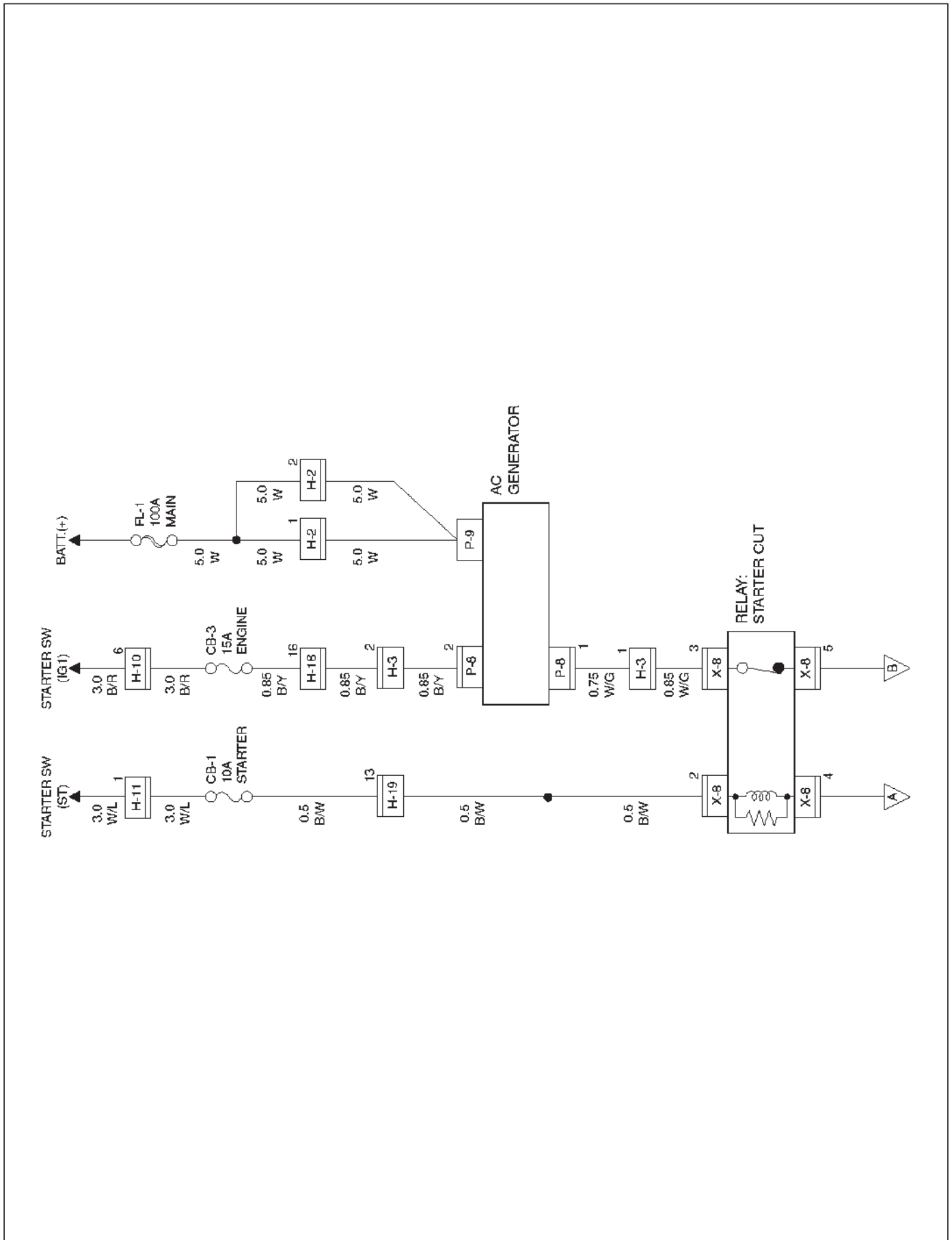


852RX006

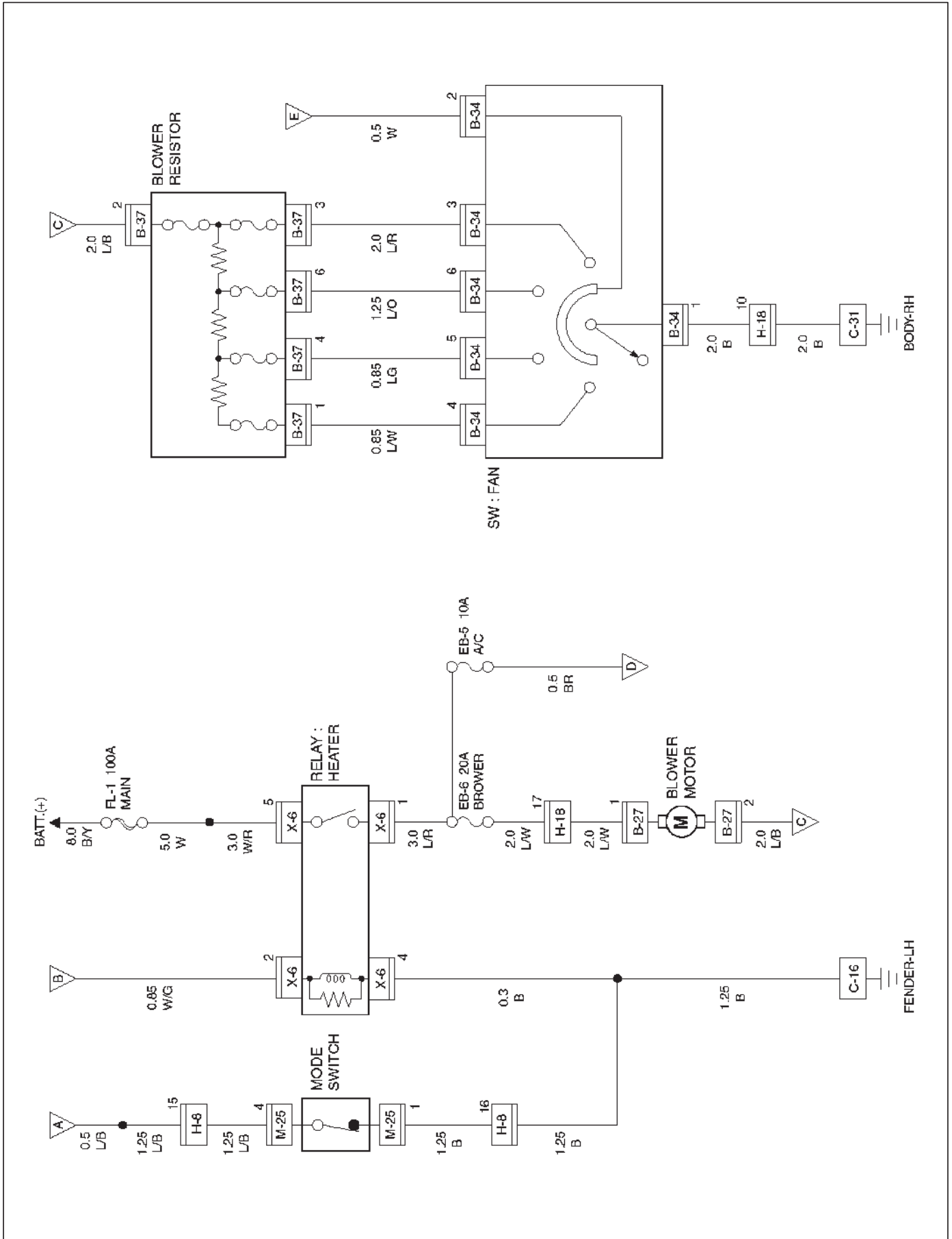
**Legend**

- |   |                                      |
|---|--------------------------------------|
| (1) Liquid Line (High-Pressure Pipe)    | (5) Receiver/Drier                   |
| (2) Clip                                | (6) Condenser Assembly               |
| (3) Discharge Line (High-Pressure Hose) | (7) Compressor                       |
| (4) Pressure Switch                     | (8) Suction Line (Low-Pressure Hose) |
|   | (9) Evaporator Assembly              |

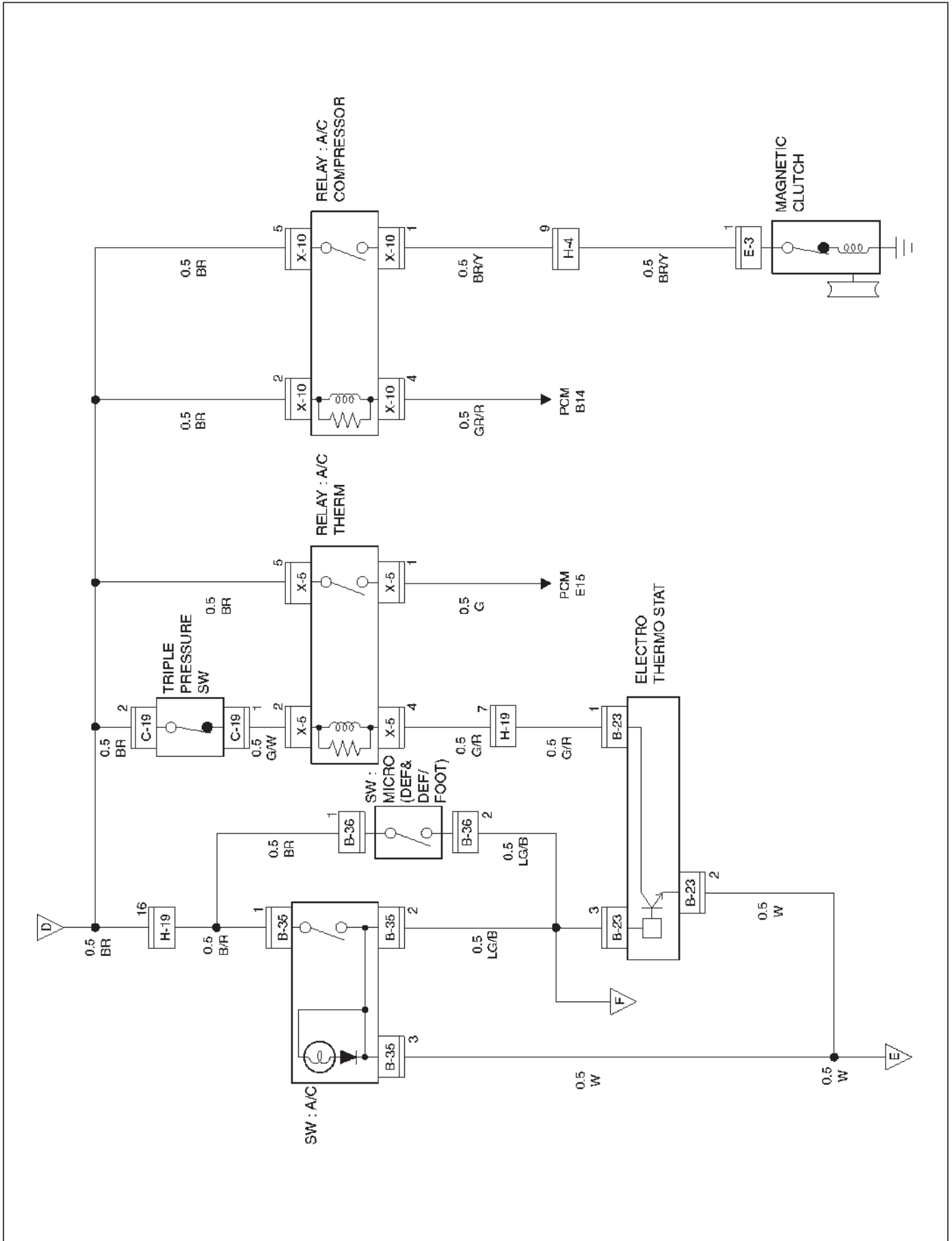
Wiring Diagram



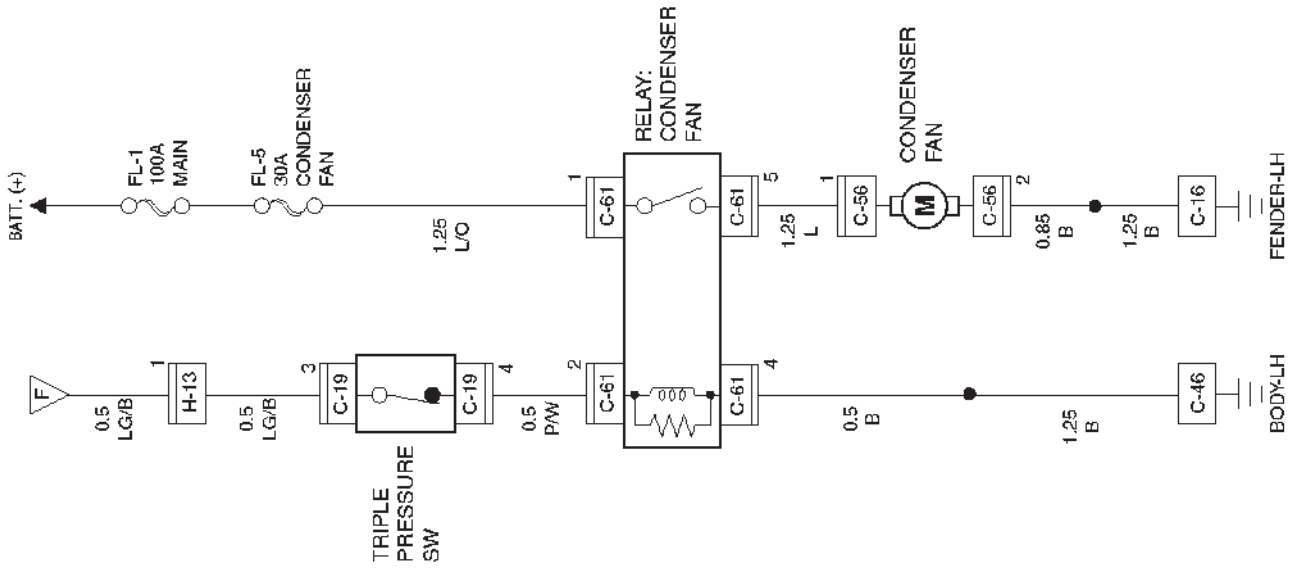
1A-38 HEATING, VENTILATION AND AIR CONDITIONING (HVAC)





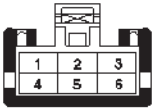

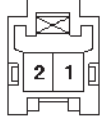
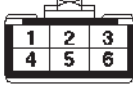
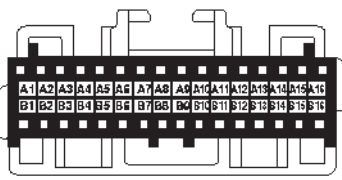
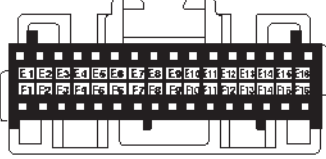
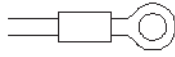



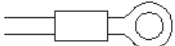
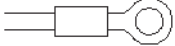
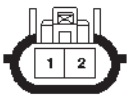




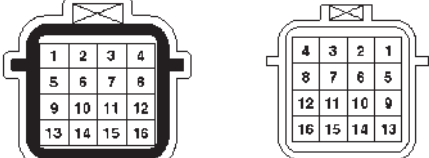


1A-40 HEATING, VENTILATION AND AIR CONDITIONING (HVAC)



Connector List

No.	Connector face
B-23	
B-27	
B-34	
B-35	
B-36	
B-37	
C-1	
C-3	
C-16	

No.	Connector face
C-19	
C-31	
C-46	
C-56	
C-61	
E-3	
H-2	
H-3	
H-4	

# 1A-42 HEATING, VENTILATION AND AIR CONDITIONING (HVAC)

No.	Connector face
H-8	
H-10	
H-11	
H-13	
H-18	
H-19	
M-25	
P-8	
P-9	

No.	Connector face
X-5	
X-6	
X-8	
X-10	

## Diagnosis

### Air Conditioning Cycle Diagnosis

Condition	Possible cause	Correction
No cooling or insufficient cooling.	Magnetic clutch does not run.	Refer to "Magnetic Clutch Diagnosis" in this section.
	Compressor is not rotating properly. Drive belt is loosened or broken.	Adjust the drive belt to the specified tension or replace the drive belt.
	Compressor is not rotating properly. Magnetic clutch face is not clean and slips.	Clean the magnetic clutch face or replace.
	Compressor is not rotating properly. Incorrect clearance between magnetic drive plate and pulley.	Adjust the clearance. Refer to Compressor in this section.
	Compressor is not rotating properly. Compressor oil leaks from the shaft seal or shell.	Replace the compressor
	Compressor is not rotating properly. Compressor is seized.	Replace the compressor
	Insufficient or excessive charge of refrigerant.	Discharge and recover the refrigerant. Recharge to the specified amount.
	Leaks in the refrigerant system.	Check the refrigerant system for leaks and repair as necessary. Discharge and recover the refrigerant. Recharge to the specified amount.
	Condenser is clogged or insufficient radiation.	Clean the condenser or replace as necessary.
	Temperature control link unit of the heat unit is defective.	Repair the link unit.
	Unsteady operation due to a foreign substance in the expansion valve.	Replace the expansion valve.
	Poor operation of the electronic thermostat.	Check the electronic thermostat and replace as necessary.
Insufficient velocity of cooling air.	Evaporator clogged or frosted.	Check the evaporator core and replace or clean the core.
	Air leaking from the cooling unit or air duct.	Check the evaporator and duct connection, then repair as necessary.
	Blower motor does not rotate properly.	Refer to Fan Control Lever (Fan Switch) Diagnosis in this section.

\*For the execution of the charging and discharging operation in the table above, refer to Recovery, Recycling, Evacuating and Charging in this section.

## 1A-44 HEATING, VENTILATION AND AIR CONDITIONING (HVAC)

---

### Checking The Refrigerant System With Manifold Gauge

Since Refrigerant-134a (HFC-134a) is used in the air conditioning system in this vehicle, be sure to use manifold gauges, charging hoses and other air conditioning service tools for HFC-134a when checking the refrigerant system.

#### Conditions:

- Run the engine at Idling
- Air conditioning switch is "ON"
- Run the blower motor at "HIGH" position
- Temperature control lever set to "MAX COLD"
- Air source selector lever at "CIRC"
- Open the engine hood
- Close all the doors

#### Normal Pressure:

- At ambient temperature: approx. 25–30°C (77–86°F).
- At low-pressure side: approx. 147.1–294.2 kpa (21.3–42.7 psi).
- At high-pressure side: approx. 1372.9–1863.3 kpa (199.1–270.2 psi).

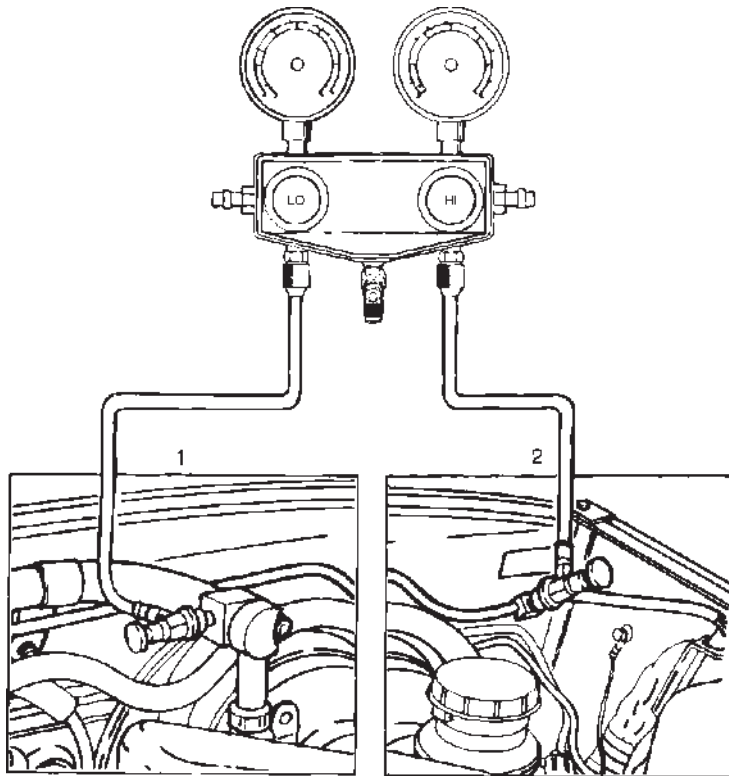
Refer to the table on the refrigerant pressure-temperature relationship.

Pressure		Temperature	
(kpa)	(psi)	(°C)	(°F)
36	5.3	-20	-4.4
67	9.7	-15	5
104	15	-10	14
147	21	-5	23
196	28	0	32
255	37	5	41
314	45	10	50
392	57	15	59
471	68	20	68
569	82	25	77
677	98	30	86
785	114	35	95
912	132	40	104
1059	154	45	113
1216	176	50	122

**Connect The Manifold Gauge**

Low-pressure hose (LOW) — Suction side

High pressure hose (HI) — Discharge side



901RS180

**Legend**

- (1) Low Side
- (2) High Side

## 1A-46 HEATING, VENTILATION AND AIR CONDITIONING (HVAC)

Condition	Possible cause	Correction
Discharge (High Gauge) Pressure Abnormally High	Condenser clogged or dirty.	Clean the condenser fins
	Cooling fan does not operate properly.	Check the cooling fan operation.
Discharge (High Gauge) Pressure Abnormally High. Insufficient cooling.	Excessive refrigerant in system.	Discharge and recover refrigerant. Recharge to specified amount.
Discharge (High Gauge) Pressure Abnormally High. High pressure gauge drop. (After stopping A/C, the pressure drops approx. 196 kpa (28 psi) quickly)	Air in system.	Evacuate and charge refrigerant system.
Discharge (High Gauge) Pressure Abnormally Low. Insufficient cooling	Insufficient refrigerant in system.	Check for leaks. Discharge and recover the refrigerant. Recharge to the specified amount.
Discharge (High Gauge) Pressure Abnormally Low. Low pressure gauge indicates vacuum.	Clogged or defective expansion valve.	Replace the expansion valve.
Discharge (High Gauge) Pressure Abnormally Low. Frost or dew on refrigerant line before and after the receiver/dryer or expansion valve, and low pressure gauge indicates vacuum.	Restriction caused by debris or moisture in the receiver/dryer.	Check system for restriction and replace the receiver/dryer.
Discharge (High Gauge) Pressure Abnormally Low. High and low pressure gauge balanced quickly. (After turned off A/C)	Compressor seal defective	Repair or replace the compressor.
	Poor compression due to a defective compressor gasket.	Repair or replace the compressor.
Suction (Low Gauge) Pressure Abnormally High. Low pressure gauge (Low pressure gauge is lowered after condenser is cooled by water.)	Excessive refrigerant in system.	Discharge and recover refrigerant Recharge to specified amount.
Suction (Low Gauge) Pressure Abnormally High. Low pressure hose temperature. (Low pressure hose temperature around the compressor refrigerant line connector is lower than around evaporator.)	Unsatisfactory valve operation due to defective temperature sensor of expansion valve.	Replace the expansion valve.
	Expansion valve opens too long.	Replace the expansion valve.
Suction (Low Gauge) Pressure Abnormally High. High and low pressure gauge balanced quickly. (After turned off A/C)	Compressor gasket is defective.	Repair or replace the compressor.
Suction (Low Gauge) Pressure Abnormally Low. Insufficient cooling.	Insufficient refrigerant in system.	Check for leaks. Discharge and recover the refrigerant. Recharge to specified amount.
Suction (Low Gauge) Pressure Abnormally Low. Frost on the expansion valve inlet line	Expansion valve clogged.	Replace the expansion valve.

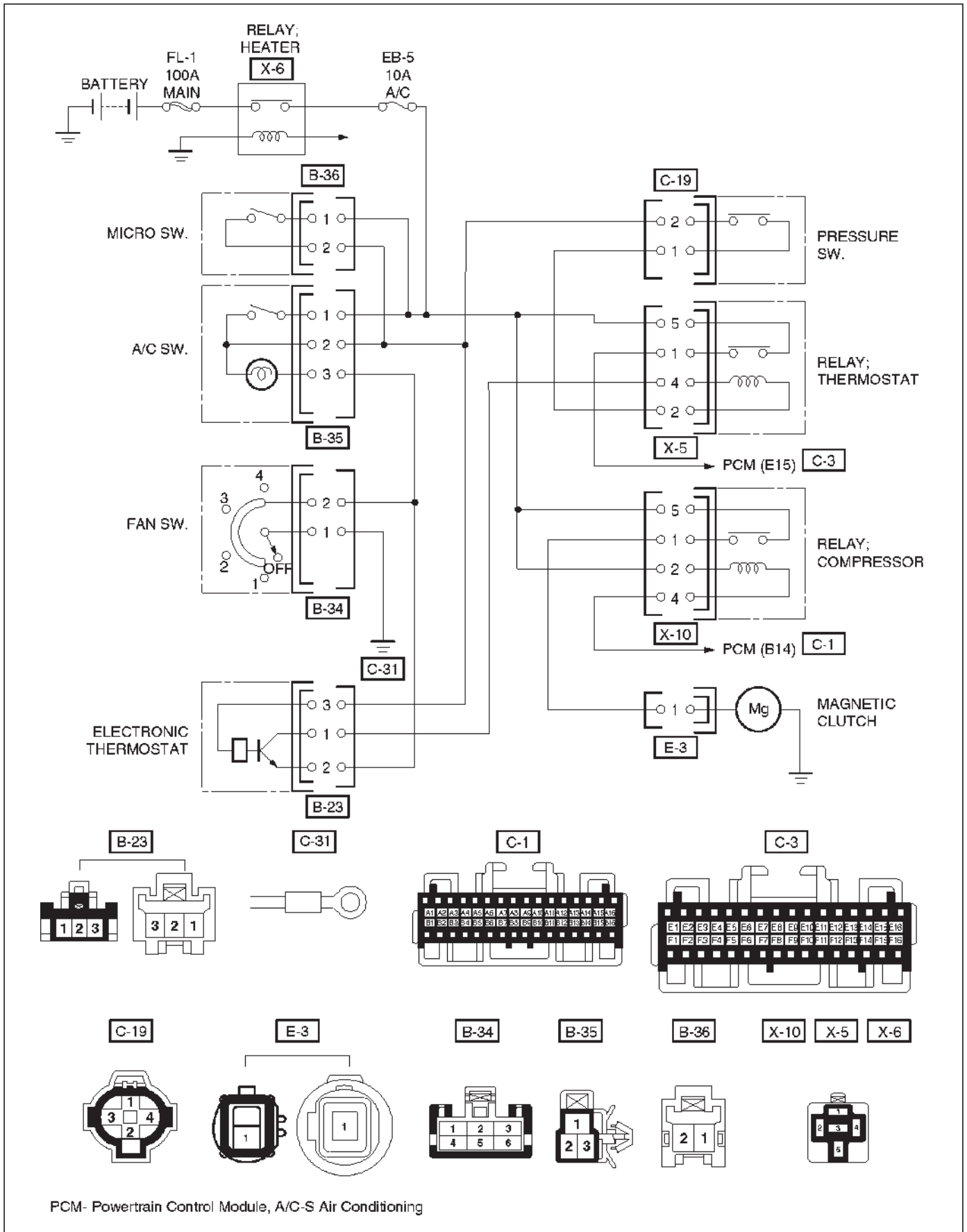


## HEATING, VENTILATION AND AIR CONDITIONING (HVAC) 1A-47

Condition	Possible cause	Correction
Suction (Low Gauge) Pressure Abnormally Low Receiver/dryer inlet and outlet refrigerant line temperature. (A distinct difference in temperature develops.)	Receiver/Drier clogged.	Replace the receiver/dryer.
Suction (Low Gauge) Pressure Abnormally Low. Expansion valve outlet refrigerant line. (Not cold and low pressure gauge indicates vacuum.)	Expansion valve temperature sensor is defective.	Replace the expansion valve.
Suction (Low Gauge) Pressure Abnormally Low. When the refrigerant line is clogged or blocked, the low pressure gauge reading will decrease, or a vacuum reading may be shown.	Clogged or blocked refrigerant line.	Replace refrigerant line.
Suction (Low Gauge) Pressure Abnormally Low. Evaporator core is frozen.	Thermo switch defective.	Replace thermo switch.
Suction (Low Gauge) and Discharge (High Gauge) Pressure Abnormally High. Insufficient cooling.	Excessive refrigerant in system.	Discharge and recover the refrigerant, the Recharge to the specified amount.
	Condenser clogged or dirty.	Clean the condenser fin.
Suction (Low Gauge) and Discharge (High Gauge) Pressure Abnormally High. Suction (Low) pressure hose (Not cold).	Air in system.	Evacuate and charge refrigerant.
Suction (Low Gauge) and Discharge (High Gauge) Pressure Abnormally Low. Insufficient cooling	Insufficient refrigerant in system.	Check for leaks. Discharge and recover refrigerant. Recharge to specified amount.

A/C — Air Conditioning

Magnetic Clutch Diagnosis



## HEATING, VENTILATION AND AIR CONDITIONING (HVAC) 1A-49

When the air conditioning switch and the fan control knob (fan switch) are turned on with the engine running, current flows through the compressor relay to activate the magnetic clutch.

The air conditioning can be stopped by turning of the air conditioning switch or the fan control knob (fan switch). However, even when the air conditioning is in operation, the electronic thermostat, the pressure switch or the

Powertrain Control Module (PCM) is used to stop the air conditioning temporarily by turning off the magnetic clutch in the prearranged conditions to reduce the engine load which is being caused by the rise in the engine coolant temperature, and the acceleration of the vehicle, etc. For the inspection of the relays, switches and units in the table, refer to "Individual Inspection" in this section.

### Magnetic Clutch Does Not Run

Step	Action	Yes	No
1	Is No. EB-5 (10A) fuse OK?	Go to Step 2	Replace
2	Are heater (X-6), thermostat (X-5), and compressor (X-10) relays OK?	Go to Step 3	Replace
3	Is pressure switch OK?	Go to Step 4	Switch defective or insufficient refrigerant.
4	Are air conditioning switch and fan control lever (Fan Switch) OK?	Go to Step 5	Replace
5	1. Turn the ignition switch "ON" (Engine is running). 2. Air conditioning switch and fan control lever (Fan Switch) "ON". 3. Check to see if battery voltage is present at chassis side connector terminal No. E3-1. Is there a battery voltage?	Go to Step 6	Go to Step 7
6	Check to see if there is continuity between compressor side connector terminal No. E3-1 and the magnetic clutch side connector terminal. Is there a continuity?	Magnetic clutch defective.	Compressor defective.
7	Check to see if battery voltage is present at chassis side connector terminal No.B35-1. Is there a battery voltage?	Go to Step 8	Open circuit between No.EB-5 (10A) fuse and No. B35-2.
8	Check to see if battery voltage is present at chassis side connector terminal No. C19-2 Is there a battery voltage?	Go to Step 9	Open circuit between No.B35-2 and No. C19-2.
9	1. Disconnect thermostat relay (X-5). 2. Check to see if battery voltage is present at the chassis side relay terminal NO. X5-5 Is there a battery voltage?	Go to Step 10	Open circuit between No. EB-5 (10A) fuse and No.X5-5.
10	Check to see if battery voltage (approx. 10V) is present between chassis side relay terminal No. X5-2 and No. X5-4. Is there a battery voltage?	Go to Step 11	Go to Step 17
11	1. Reconnect thermostat relay and disconnect compressor relay (X-10). 2. Check to see if battery voltage is present at the chassis side relay terminal No. X10-5. Is there a battery voltage?	Go to Step 12	Open circuit between No. EB-5 (10A) fuse and No. X10-5.
12	Check to see if there is continuity between chassis side relay terminal No. X10-1 and the chassis side connector terminal No. E3-1. Is there a continuity?	Go to Step 13	Open circuit.

## 1A-50 HEATING, VENTILATION AND AIR CONDITIONING (HVAC)

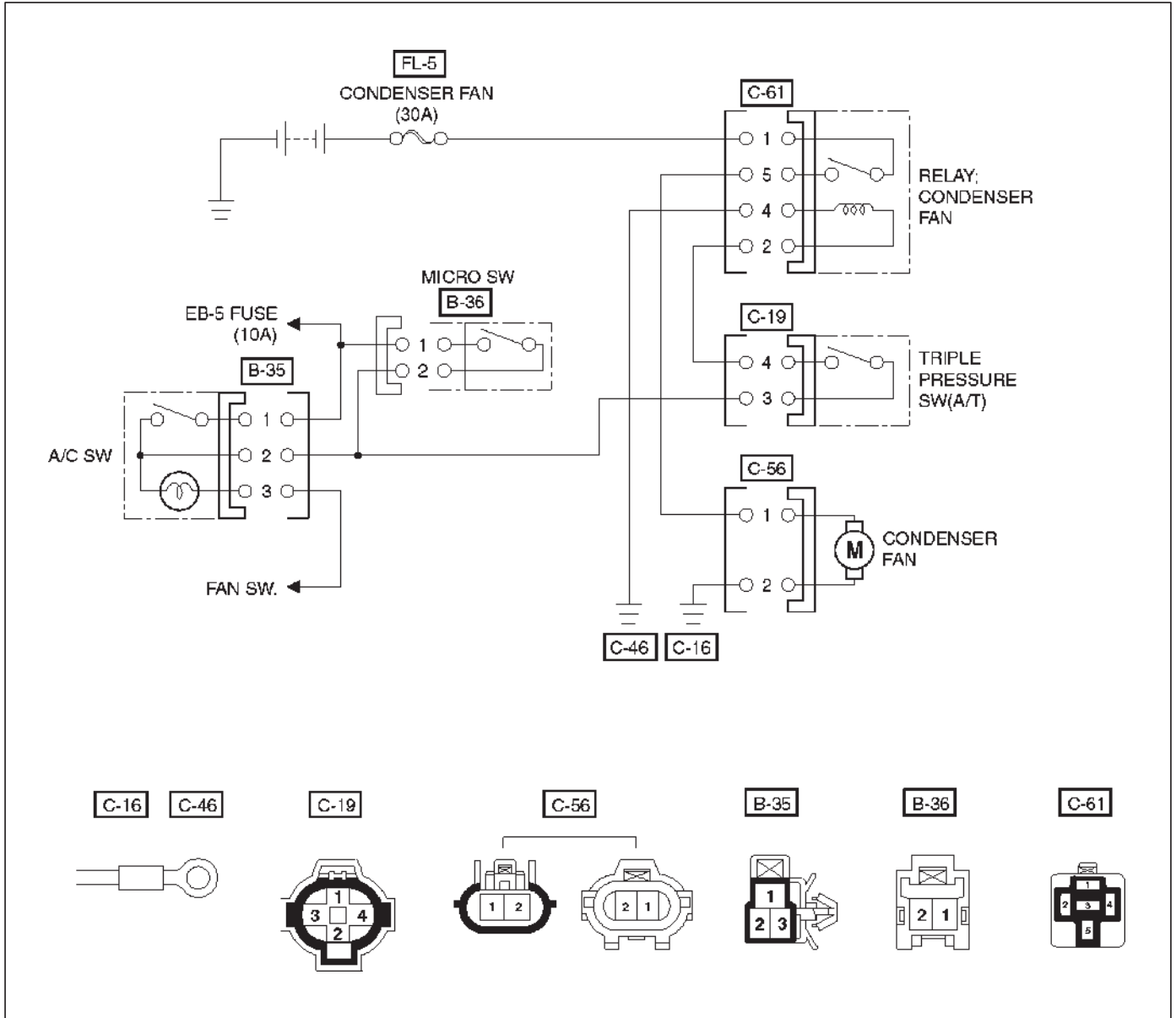
### Magnetic Clutch Does Not Run (Cont'd)

Step	Action	Yes	No
13	Check to see if battery voltage is present between chassis side relay terminal No. X10-2 and No. X10-4. Is there a battery voltage?	Go to Step 14	Go to Step 15
14	Check to see if battery voltage is present at chassis side relay terminal No. X10-2. Is there a battery voltage?	Go to Step 16	Open circuit between No. EB-5 (10A) fuse and No. X10-2.
15	Check to see if battery voltage is present at chassis side connector terminal No. C1-B14. Is there a battery voltage?	Power train control module (PCM) defective. Refer to Driveability and Emissions in Engine section.	Open circuit between No. X10-4 and No. C1-B14.
16	Check to see if there is continuity between chassis side relay terminal No. X5-1 and chassis side connector terminal No. C3-E15. Is there a continuity?	Power train control module (PCM) defective. Refer to Driveability and Emissions in Engine section.	Open circuit
17	Check to see if battery voltage is present at chassis side relay terminal No.X5-2. Is there a battery voltage?	Go to Step 18	Open circuit between No.X5-2 and C19-1.
18	1. Reconnect thermostat relay. 2. Check to see if battery voltage is present at chassis side connector terminal No.B23-3. Is there a battery voltage?	Go to Step 19	Open circuit between No.B35-2 and No.B23-3.
19	Check to see if battery voltage (approx 10V) is present at chassis side connector terminal No. B23-1. Is there a battery voltage?	Go to Step 20	Open circuit between No. X5-4 and No. B23-1.
20	Check to see if there is continuity between chassis side connector terminal No. B23-2 and No.B-34-2. Is there a continuity?	Electronic thermostat defective.	Open circuit between No. B23-2 and No.B34-6 or poor ground (Fan Switch Ground Circuit).

### Condenser Fan Diagnosis

While the air conditioning is ON, the cycling switch in the triple pressure switch senses the refrigerant pressure, and activates the condenser fan to improve the cooling capacity of the condenser when the refrigerant pressure

exceeds a set pressure value. The condenser fan stops when the air conditioning is turned "OFF" or when the pressure goes down below the set pressure value.



D08RX281

Condition	Possible cause	Correction
Condenser fan does not run.	-	Refer to "Chart A".
	-	Refer to "Chart B".

## 1A-52 HEATING, VENTILATION AND AIR CONDITIONING (HVAC)

### Chart "A" Condenser Fan Does Not Run

Step	Action	Yes	No
1	Is FL-5 (30A) OK?	Go to Step 2	Replace
2	Is relay (C-61) OK?	Go to Step 3	Replace
3	Is pressure switch OK?	Go to Step 4	Switch defective or insufficient refrigerant.
4	Is air conditioning switch OK?	Go to Step 5	Replace
5	Is fan motor OK?	Go to Step 6	Replace
6	1. Disconnect condenser fan relay (C61). 2. Check to see if battery voltage is present at the chassis side relay terminal NO. C61-1 Is there a battery voltage?	Go to Step 7	Open circuit between FL-5 (30A) and No.C-61-1.
7	1. Reconnect condenser fan relay (C61). 2. Air conditioning switch "ON". 3. Check to see if battery voltage is present at chassis side connector terminal No.C19-3. Is there a battery voltage?	Go to Step 8	Open circuit between B35-2 and C19-3.
8	1. Air conditioning switch "OFF". 2. Check to see if there is continuity between chassis side relay terminal No.C61-2 and the chassis side connector terminal No.C19-4. Is there a continuity?	Go to Step 9	Open circuit.
9	Check to see if there is continuity between chassis side connector terminal No. C56-1 and chassis side relay terminal No.C61-5. Is there a continuity?	Poor ground or open circuit between chassis side connector terminal No.C61-4 (or No.C56-2) and body ground (No.C16 or C46).	Open circuit.

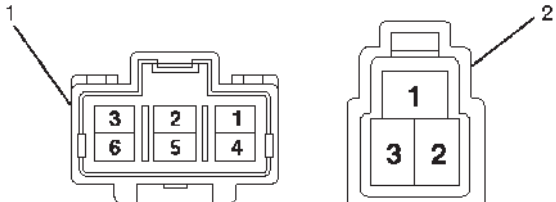
### Chart "B" Condenser Fan Does Not Stop

Step	Action	Yes	No
1	1. Air conditioning switch "OFF". Does condenser fan stop?	Triple pressure switch defective.	Condenser fan relay (C61) defective.

## Individual Inspection

### Fan Control Knob (Fan Switch) And Air Conditioning (A/C) Switch

1. Check for continuity between terminals of the fan switch (1) and air conditioning switch (2).



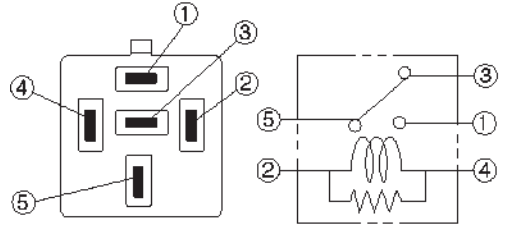
Connector No.	FAN SW B-34						A/C SW B-35		
	1	2	3	4	5	6	1	2	3
SW position									
Blower motor	OFF								
	1	○			○				
	2	○				○			
	3	○					○		
A/C	OFF							○	○
	ON						○	○	○

A/C-Air Conditioning

901RX054

### Compressor Relay

1. Check for continuity between terminals of the compressor relay.



③-⑤ ...Continuity  
①-⑤ ...No continuity

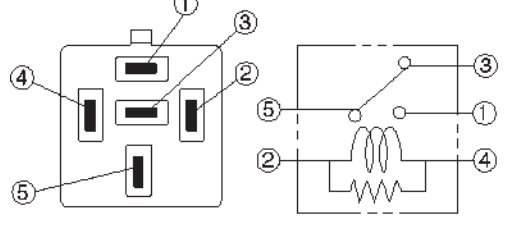
(When battery voltage is applied between ② and ④)

③-⑤ ...No continuity  
①-⑤ ...Continuity

901RX071

### Thermo Switch Relay and Condenser Fan Relay

1. Check for continuity between terminals of the thermo switch and condenser fan relay.



③-⑤ ...Continuity  
①-⑤ ...No continuity

(When battery voltage is applied between ② and ④)

③-⑤ ...No continuity  
①-⑤ ...Continuity

901RX071

## 1A-54 HEATING, VENTILATION AND AIR CONDITIONING (HVAC)

### Triple Pressure Switch (V6 A/T)

1. Disconnect the connector and check for continuity between pressure switch side connector terminals (1) and (2).
2. Reconnect the connector to activate the A/C switch, and check to see if there is continuity between the chassis side connector terminals and the fan operates.

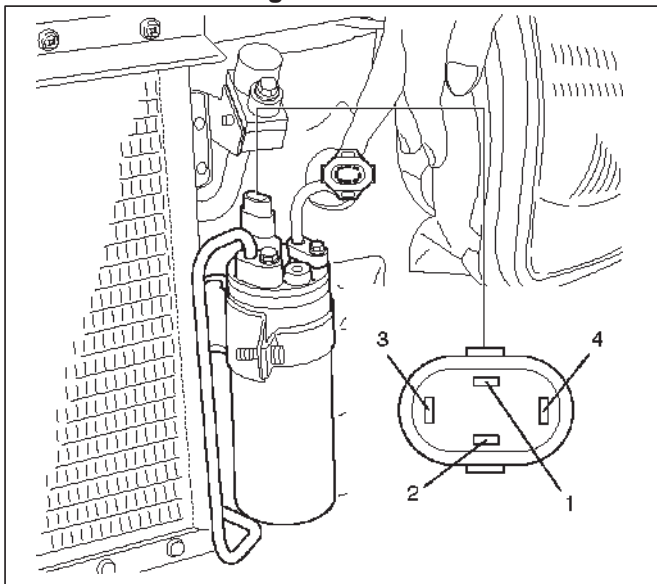
#### A/C OFF

Terminal No.	Control	Continuity
1—2	Magnetic Clutch	Continuity
3—4	Condenser Fan	No Continuity

#### A/C ON

Refrigerant Pressure	Terminal No.	Continuity	Fan
Below 1078±118 kpa	3—4	No Continuity	OFF
Above 1471±98 kpa/213±14 psi		Continuity	ON

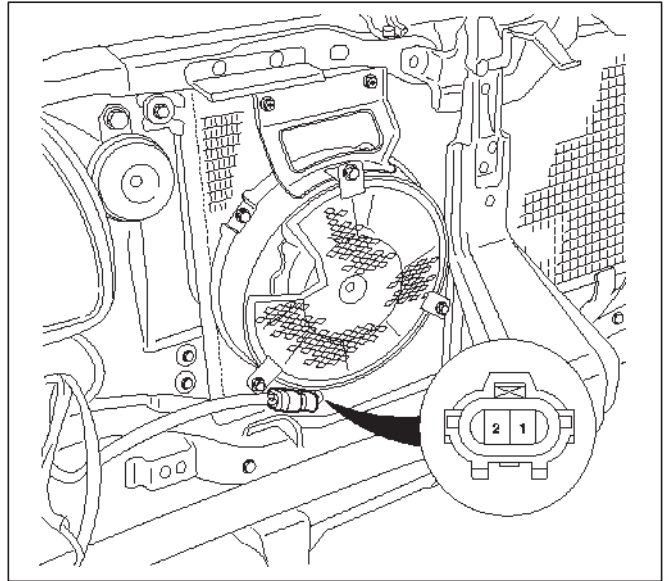
#### A/C - Air Conditioning



### Condenser Fan

1. Disconnect the condenser fan connector.
2. Connect the battery positive terminal to the condenser fan side connector terminal No.C-56-1 and negative to the No.C-56-2.

3. Check that condenser fan is rotating correctly.



901RX049

## General Repair Procedure

### Precautions For Replacement or Repair of Air Conditioning Parts

There are certain procedures, practices and precautions that should be followed when servicing air conditioning systems:

- Keep your work area clean.
- Always wear safety goggles and protective gloves when working on refrigerant systems.
- Beware of the danger of carbon monoxide fumes caused by running the engine.
- Beware of discharged refrigerant in enclosed or improperly ventilated garages.
- Always disconnect the negative battery cable and discharge and recover the refrigerant whenever repairing the air conditioning system.
- When discharging and recovering the refrigerant, do not allow refrigerant to discharge too fast; it will draw compressor oil out of the system.
- Keep moisture and contaminants out of the system. When disconnecting or removing any lines or parts, use plugs or caps to close the fittings immediately. Never remove the caps or plugs until the lines or parts are reconnected or installed.
- When disconnecting or reconnecting the lines, use two wrenches to support the line fitting, to prevent from twisting or other damage.
- Always install new O-rings whenever a connection is disassembled.
- Before connecting any hoses or lines, apply new specified compressor oil to the O-rings.



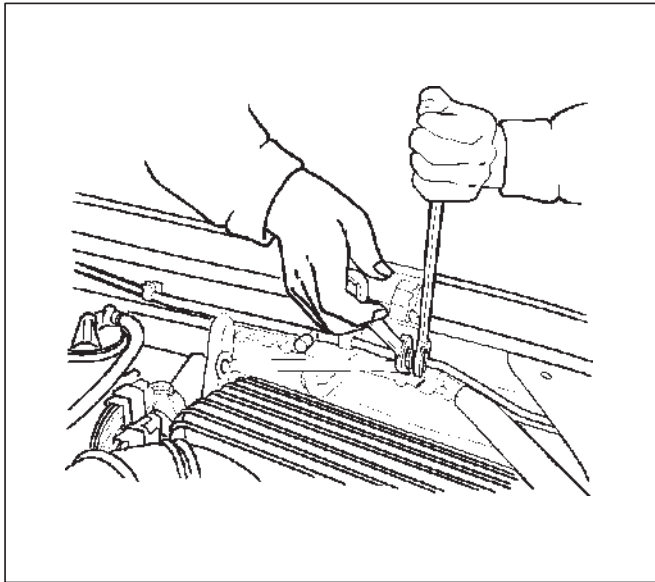
○ When removing and replacing any parts which require discharging the refrigerant circuit, the operations described in this section must be performed in the following sequence:

1. Use the J-39500 (ACR<sup>4</sup>: HFC-134a Refrigerant Recovery / Recycling / Recharging / System) or equivalent to thoroughly discharge and recover the refrigerant.
2. Remove and replace the defective part.
3. After evacuation, charge the air conditioning system and check for leaks.

## Repair Of Refrigerant Leaks

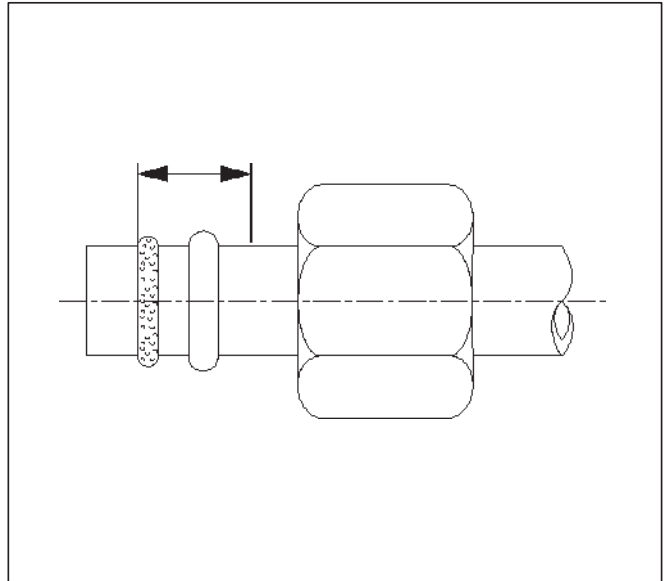
### Refrigerant Line Connections

Install new O-rings, if required. When disconnecting or connecting lines, use two wrenches to prevent the connecting portion from twisting or becoming damaged.

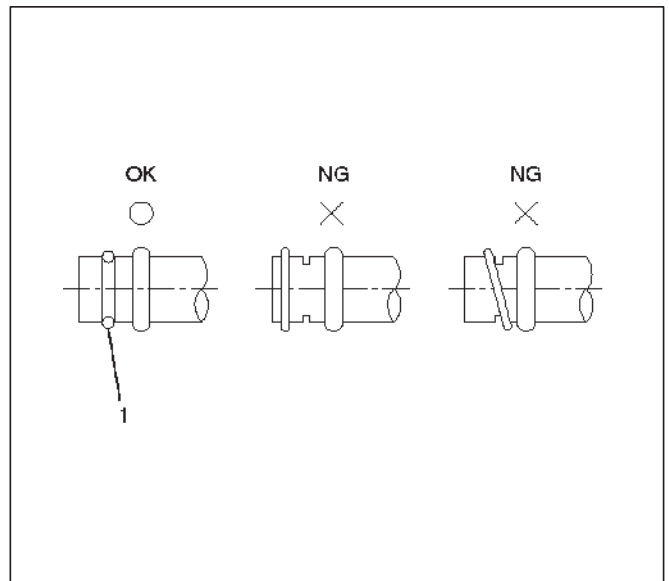


When connecting the refrigerant line at a block joint, securely insert the projecting portion of the joint portion into the connecting hole on the unit side and secure with a bolt. Apply the specified compressor oil to the O-rings prior to connecting.

**CAUTION: Compressor (PAG) oil to be used varies according to the compressor model. e sure to apply oil specified for the model of ompressor.**



O-rings (2) must be fitted in the groove (1) of refrigerant line.

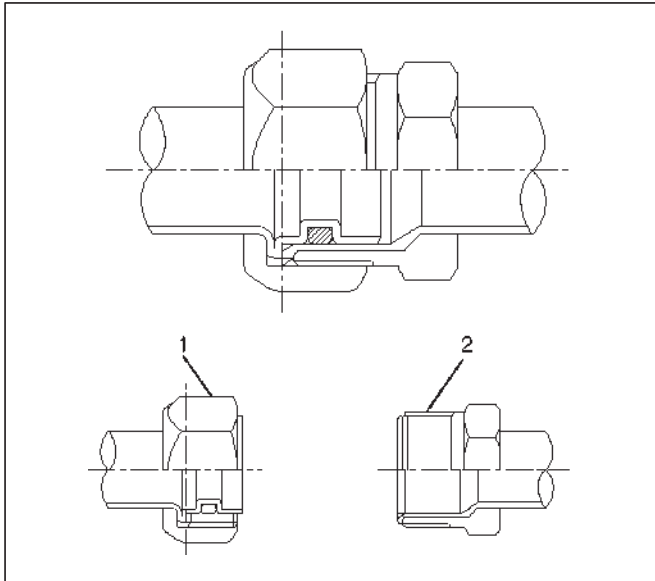


## 1A-56 HEATING, VENTILATION AND AIR CONDITIONING (HVAC)

---

Insert the nut into the union.

First, tighten the nut by hand as much as possible, then tighten the nut to the specified torque.



850RW004

## Leak Check

### Inspection of refrigerant leak

Refrigerant leak may cause an adverse effect not only on the performance and durability of each component of the air-conditioner, but also on the global atmosphere.

Therefore, it is most important to repair refrigerant leak when there is any leak found.

### Inspection flow of refrigerant leak

Step	Action	Yes	No
1	1. Evacuate the refrigerant system. 2. Charge the refrigerant.  Is there any refrigerant leak?	Repair refrigerant system.	Go to Step 2.
2	1. Operate the compressor for more than 5 minutes to raise the pressure on the high pressure side.  Is there any refrigerant leak at high pressure components?	Repair refrigerant system.	Compressor operation to be confirmed.

### Inspection Steps

Check the components of air-conditioner to see if there occurs any refrigerant leak along the flow of refrigerant.

NOTE:

- To avoid an error in the detection of refrigerant leak, make sure of there being no refrigerant vapor or cigarette smoke around the vehicle before conducting the inspection. Also, select a location where the refrigerant vapor will not get blown off with wind.
- Inspection should be conducted chiefly on the pipe connections and sections where a marked oil contamination is found. When refrigerant is leaking, oil inside is also leaking at the same time.
- It is possible to visually check the leak from inside the cooling unit. Follow the method below when checking. Remove the drain hose or resistor of the cooling unit, and insert a leak detector to see if there occurs any leak.

#### High Pressure Side

1. Discharger section of compressor.
2. Inlet/outlet section of condenser.
3. Inlet/outlet section of receiver driver.
4. Inlet section of cooling unit.

#### Low Pressure Side

1. Outlet section of cooling unit.
2. Intake section of compressor.

### Major Checking Points of Refrigerant Leak

#### Compressor

- Pipe connection
- Sealing section of shaft
- Mating section or cylinder

#### Condenser

- Pipe connection

- Welds of condenser body

#### Receiver driver

- Pipe connection
- Attaching section of pressure switch
- Section around the sight glass

#### Evaporator unit (cooling unit)

- Pipe connections
- Connections of expansion valve
- Brazed sections of evaporator

NOTE:

- The evaporator and expansion valve are contained in the case. Remove the drain hose or the resistor of the cooling unit and insert a leak detector when checking for any leak.

#### Flexible hose

- Pipe connection
- Caulking section of the hose
- Hose (cracks, pinholes, flaws)

#### Pipe

- Pipe connection
- Pipe (cracks, flaws)

#### Charge valve

NOTE:

- The charge valve, which is used to connect the gauge manifold, is normally provided with a resin cap. When the valve inside gets deteriorated, refrigerant will leak out.

### Leak at Refrigerant Line Connections

1. Check the torque on the refrigerant line fitting and, if too loose, tighten to the specified torque.
  - Use two wrenches to prevent twisting and damage to the line.
  - Do not over tighten.

## 1A-58 HEATING, VENTILATION AND AIR CONDITIONING (HVAC)

2. Perform a leak test on the refrigerant line fitting.
3. If the leak is still present, discharge and recover the refrigerant from the system.
4. Replace the O-rings.
  - O-rings cannot be reused. Always replace with new ones.
  - Be sure to apply the specified compressor oil to the new O-rings.
5. Retighten the refrigerant line fitting to the specified torque.
  - Use two wrenches to prevent twisting and damage to the line.
6. Evacuate, charge and retest the system.

### Leaks In The Hose

If the compressor inlet or outlet hose is leaking, the entire hose must be replaced. The refrigerant hose must not be cut or spliced for repair.

1. Locate the leak.
2. Discharge and recover the refrigerant.
3. Remove the hose assembly.
  - Cap the open connections at once.
4. Connect the new hose assembly.
  - Use two wrenches to prevent twisting or damage to the hose fitting.
  - Tighten the hose fitting to the specified torque.
5. Evacuate, charge and test the system.

### Compressor Leaks

If leaks are located around the compressor shaft seal or shell, replace or repair the compressor.

### Recovery, Recycling, Evacuation and Charging of HFC-134a

Air conditioning systems contain HFC-134a. This is a chemical mixture which requires special handling procedures to avoid personal injury.

- Always wear safety goggles and protective gloves.
- Always work in a well-ventilated area. Do not weld or steam clean on or near any vehicle-installed air conditioning lines or components.
- If HFC-134a should come in contact with any part of the body, flush the exposed area with cold water and immediately seek medical help.
- If it is necessary to transport or carry any container of HFC-134a in a vehicle, do not carry it in the passenger compartment.
- If it is necessary to fill a small HFC-134a container from a large one, never fill the container completely. Space should always be allowed above the liquid for expansion.
- HFC-134a and R-12 should never be mixed as their compositions are not the same.
- HFC-134a PAG oil tends to absorb moisture more quickly than R-12 mineral oil and, therefore, should be handled more carefully.
- Keep HFC-134a containers stored below 40°C (100°F).

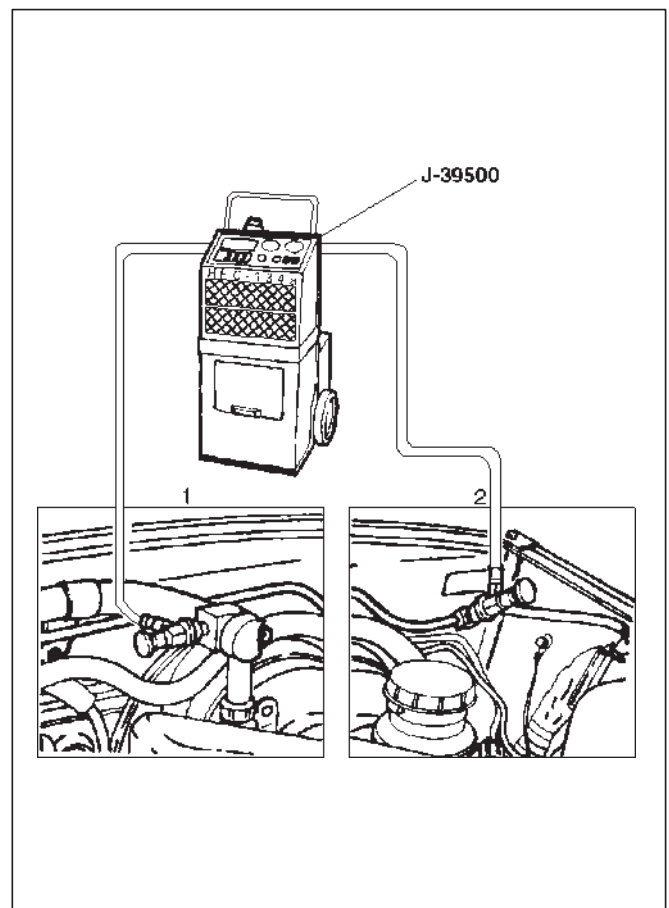
### WARNING:

- SHOULD HFC-134A CONTACT YOUR EYE(S), CONSULT A DOCTOR IMMEDIATELY.
- DO NOT RUB THE AFFECTED EYE(S). INSTEAD, SPLASH QUANTITIES OF FRESH COLD WATER OVER THE AFFECTED AREA TO GRADUALLY RAISE THE TEMPERATURE OF THE REFRIGERANT ABOVE THE FREEZING POINT.
- OBTAIN PROPER MEDICAL TREATMENT AS SOON AS POSSIBLE. SHOULD THE HFC-134A TOUCH THE SKIN, THE INJURY MUST BE TREATED THE SAME AS SKIN WHICH HAS BEEN FROSTBITTEN OR FROZEN.

### Refrigerant Recovery

The refrigerant must be discharged and recovered by using the J-39500 (ACR<sup>4</sup>:HFC-134a Refrigerant Recovery/Recycling/Recharging/System) or equivalent before removing or mounting air conditioning parts.

1. Connect the high and low charging hoses of the ACR<sup>4</sup>(or equivalent) as shown below.



### Legend

- (1) Low Side
- (2) High Side

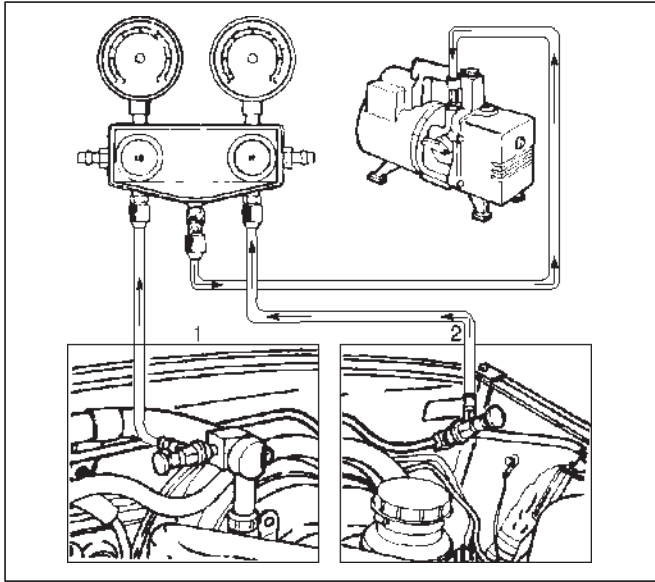
2. Recover the refrigerant by following the Manufacturer's Instructions.
3. When a part is removed, put a cap or a plug on the connecting portion so that dust, dirt or moisture cannot get into it.

## Refrigerant Recycling

Recycle the refrigerant recovered by J-39500 (ACR<sup>4</sup>:HFC-134a Refrigerant Recovery / Recycling / Recharging / System) or equivalent.

For the details of the actual operation, follow the steps in the ACR<sup>4</sup>(or equivalent) Manufacturer's Instructions.

## Evacuation of The Refrigerant System



901RS182

### Legend

- (1) Low Side
- (2) High Side

NOTE: Explained below is a method using a vacuum pump. Refer to the ACR<sup>4</sup>(or equivalent) manufacturer's instructions when evacuating the system with a ACR<sup>4</sup>(or equivalent).

Air and moisture in the refrigerant will cause problems in the air conditioning system. Therefore, before charging the refrigerant, be sure to evacuate air and moisture thoroughly from the system.

1. Connect the gauge manifold.
  - High-pressure valve (HI) — Discharge-side.
  - Low-pressure valve (LOW) — Suction-side.
2. Discharge and recover the refrigerant.
3. Connect the center hose of the gauge manifold set to the vacuum pump inlet.
4. Operate the vacuum pump, open shutoff valve and then open both hand valves.
5. When the low-pressure gauge indicates approximately 750 mmHg (30 inHg), continue the evacuation for 5 minutes or more.
6. Close both hand valves and stop the vacuum pump.
7. Check to ensure that the pressure does not change after 10 minutes or more.
  - If the pressure changes, check the system for leaks.
  - If leaks occur, retighten the refrigerant line connections and repeat the evacuation steps.

8. If no leaks are found, again operate the vacuum pump for 20 minutes or more. After confirming that the gauge manifold pressure is at 750 mmHg (30 inHg), close both hand valves.

9. Close positive shutoff valve. Stop the vacuum pump and disconnect the center hose from the vacuum pump.

## Charging The Refrigerant System

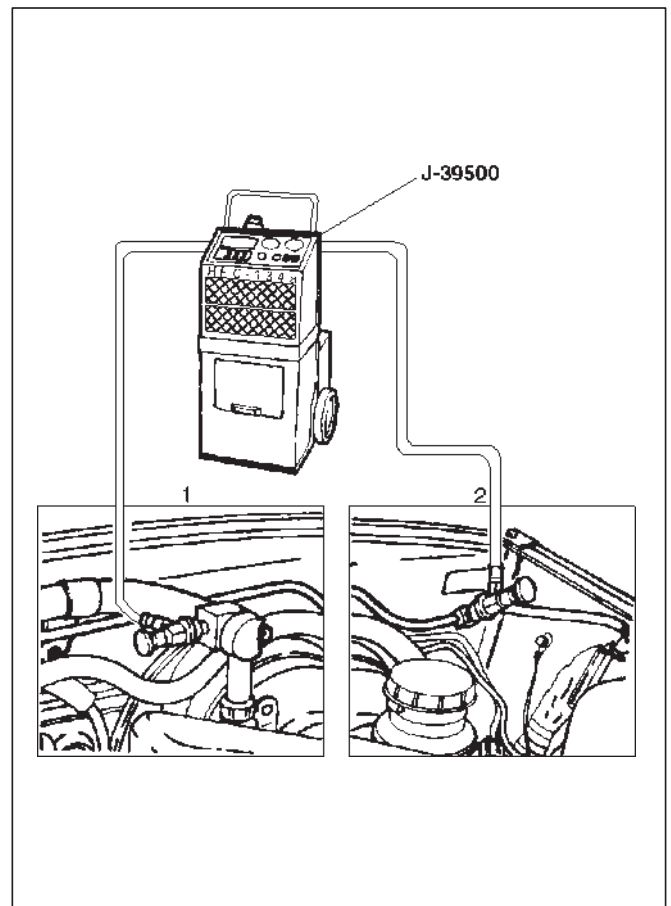
There are various methods of charging refrigerant into the air conditioning system.

These include using J-39500 (ACR<sup>4</sup>:HFC-134a Refrigerant Recovery/Recycling/Recharging/System) or equivalent and direct charging with a weight scale charging station.

### Charging Procedure

#### ○ ACR<sup>4</sup>(or equivalent) Method

For the charging of refrigerant recovered by ACR<sup>4</sup>(or equivalent), follow the manufacturer's instruction.



901RS183

### Legend

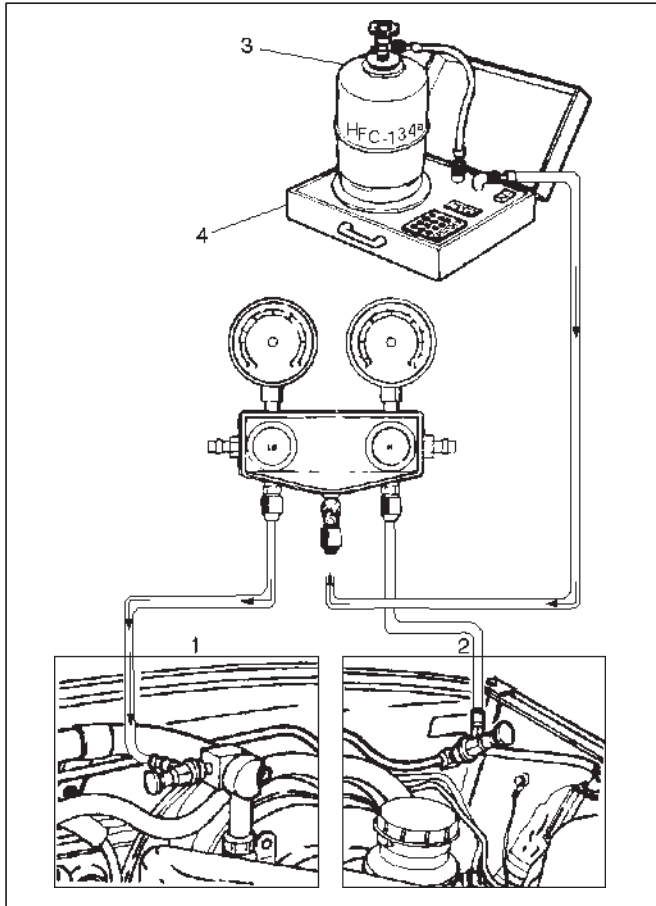
- (1) Low Side
- (2) High Side

#### ○ Direct charging with a weight scale charging station method

1. Make sure the evacuation process is correctly completed.
2. Connect the center hose of the manifold gauge to the weight scale.

## 1A-60 HEATING, VENTILATION AND AIR CONDITIONING (HVAC)

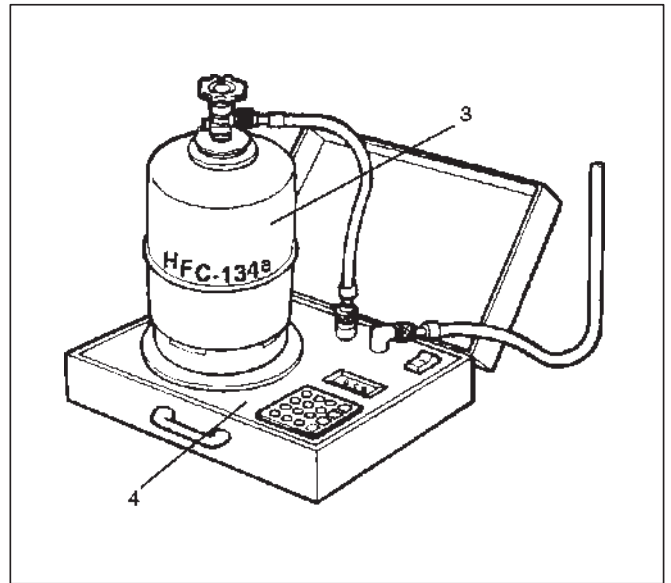
3. Connect the low pressure charging hose of the manifold gauge to the low pressure side service valve of the vehicle.
4. Connect the high pressure charging hose of the manifold gauge to the high pressure side service valve of the vehicle.



### Legend

- (1) Low Side
- (2) High Side
- (3) Refrigerant Container
- (4) Weight Scale

5. Place the refrigerant container(3) up right on a weight scale(4).  
Note the total weight before charging the refrigerant.
  - a. Open the refrigerant container valve.
  - b. Open the low side valve on the manifold gauge set. Refer to the manufacturer's instructions for a weight scale charging station.



6. Perform a system leak test:

- Charge the system with approximately 200 g (0.44 lbs) of HFC-134a.
- Make sure the high pressure valve of the manifold gauge is closed.
- Check to ensure that the degree of pressure does not change.
- Check for refrigerant leaks by using a HFC-134a leak detector.
- If a leak occurs, recover the refrigerant. Repair the leak and start all over again from the first step of evacuation.

7. If no leaks are found, continue charging refrigerant to the air conditioning system.

- Charge the refrigerant until the scale reading decreases by the amount of the charge specified.

### Specified amount: 650 g (1.43 lbs)

- If charging the system becomes difficult:

1. Run the engine at idle and close all the vehicle doors.
2. Turn A/C switch "ON".
3. Set the fan switch to its highest position.
4. Set the air source selector lever to "CIRC".
5. Slowly open the low side valve on the manifold gauge set.

**WARNING: BE ABSOLUTELY SURE NOT TO OPEN THE HIGH PRESSURE VALVE OF THE MANIFOLD GAUGE. SHOULD THE HIGH PRESSURE VALVE BE OPENED, THE HIGH PRESSURE REFRIGERANT WOULD FLOW BACKWARD, AND THIS MAY CAUSE THE REFRIGERANT CONTAINER TO BURST.**

8. When finished with the refrigerant charging, close the low pressure valve of the manifold gauge and container valve.

9. Check for refrigerant leaks.

**Checking The A/C System**

1. Run the engine and close all the vehicle doors.
2. Turn A/C switch "ON", set the fan switch to its highest position.
3. Set the air source lever to "CIRC", set the temperature lever to the full cool position.
4. Check the high and low pressure of the manifold gauge.
  - Immediately after charging refrigerant, both high and low pressures might be slightly high, but they settle down to the pressure guidelines shown below:
  - The ambient temperature should be between 25-30°C (77-86°F).
  - The pressure guideline for the high-pressure side is approximately 1372.9-1863.3 kpa (199.1-270.2 psi).
  - The pressure guideline for the low-pressure side is approximately 147.1-294.2 kpa (21.3-42.7 psi).
  - If an abnormal pressure is found, refer to Checking The Refrigerant System With Manifold Gauge in this section.
5. Put your hand in front of the air outlet and move the temperature control lever of the control panel to different positions. Check if the outlet temperature changes as selected by the control knob.

**Reading Sight Glass**

The sight glass provides accurate diagnosis only under the following conditions.

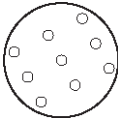
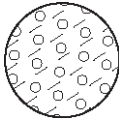
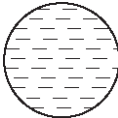
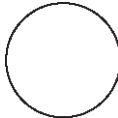
If the vehicle can be tested under these conditions, check the sight glass appearance and compare to the chart below.

- Engine speed idle
- A/C switch "ON"
- Blower fan operating at highest speed
- Air source selector lever at "RECIRC"
- Temperature control lever at coldest position
- Ambient temperature below 30°C (86°F) and humidity below 70% (See NOTE 1)
- High side pressure less than 1667.1 kpa (241.7 psi) (See NOTE 2)

NOTE: 1. If the vehicle cannot be moved to a testing location that meets these specifications, then the sight glass cannot be used for diagnosis. You must discharge and recover the refrigerant, then recharge the system with the specified amount of refrigerant.

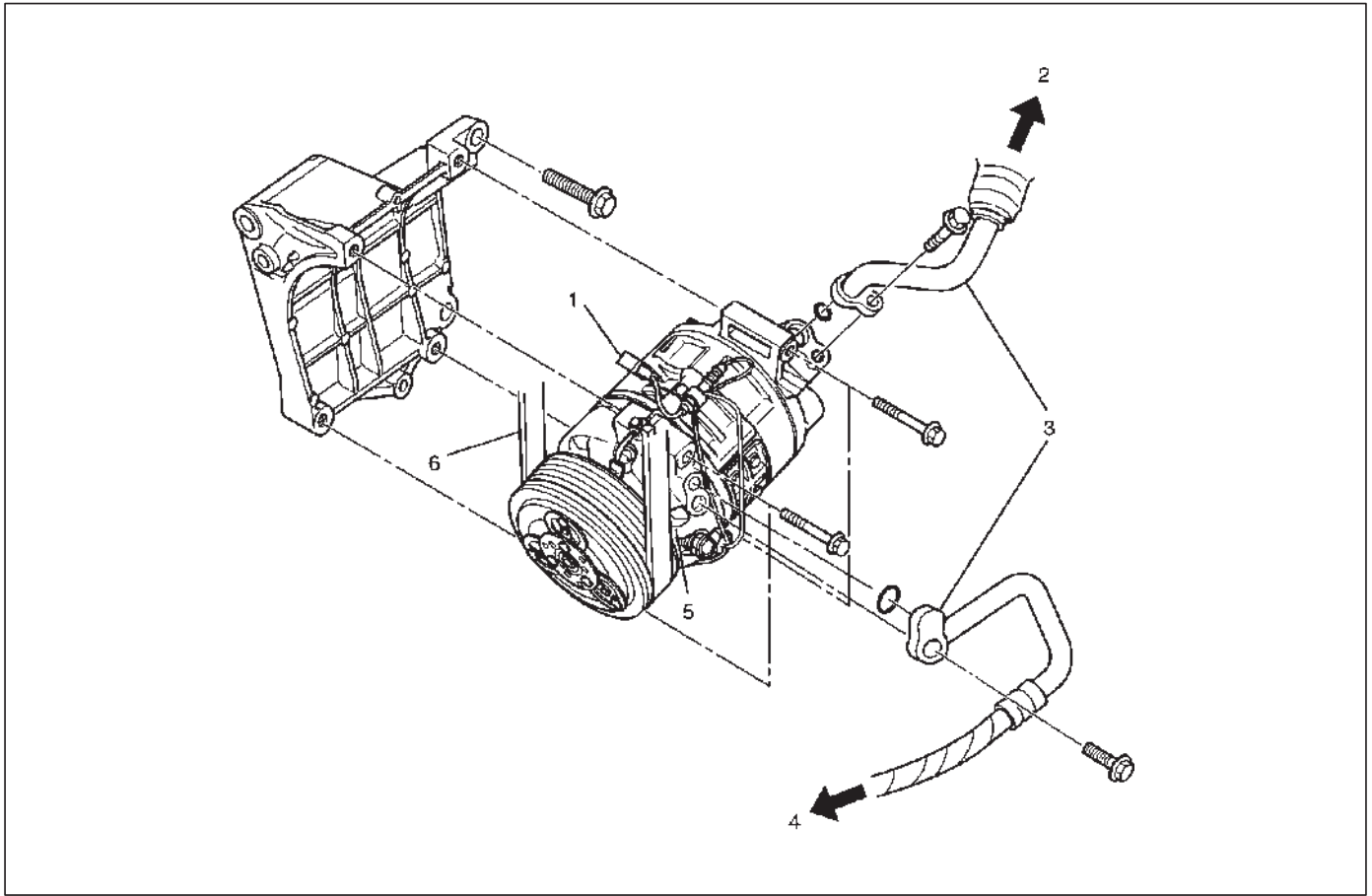
Then continue checking the system performance.

NOTE: 2. If the high side pressure is greater than stated, the sight glass cannot be used for diagnosis. You must discharge and recover the refrigerant, then recharge the system with the specified amount of refrigerant. Then continue checking system performance.

High and low pressure pipe temperature	The high pressure pipe is hot and the low pressure pipe is cold. There is a distinct difference in temperature between them.	The high pressure pipe is warm and the low pressure pipe is not so cold as usual. There is no great difference in temperature between them.	There is little difference in temperature between the high pressure pipe and the low pressure pipe.	The high pressure pipe is hot and the low pressure pipe is slightly warm. There is a difference in temperature between them.
Sight glass condition	Almost transparent. A flow of bubbles can be seen, but they disappear when the throttle is opened. 	A flow of bubbles always can be seen. It appears sometimes transparent, and sometimes frothy. 	Something like fog faintly can be seen. 	Even at idle with the fan at "HI" (with the window fully open) the bubbles cannot be seen. 
Air conditioning cycle condition	OK	NG (Not enough refrigerant)	NG (Almost no refrigerant)	NG (Too much refrigerant)

## Compressor Assembly

### Compressor Assembly and Associated Parts



871RY0036

#### Legend

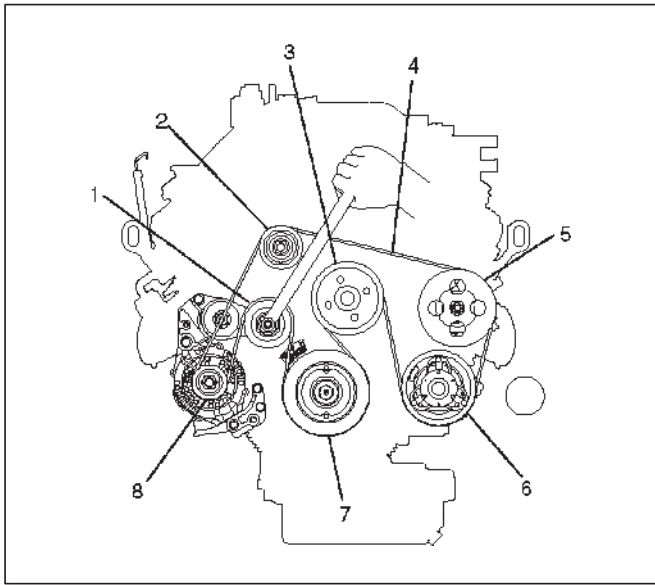
- |                                       |                     |
|---------------------------------------|---------------------|
| (1) Magnetic Clutch Harness Connector | (4) To Condenser    |
| (2) To Evaporator                     | (5) Compressor      |
| (3) Refrigerant Line Connector        | (6) Serpentine Belt |

### Removal

1. Disconnect the battery ground cable.
2. Discharge and recover refrigerant.
  - Refer to Refrigerant Recovery in this section.
3. Disconnect magnetic clutch harness connector.
4. Remove serpentine belt.



- Move serpentine belt tensioner to loose side using wrench then remove serpentine belt.



850RX003

**Legend**

- (1) Tensioner
- (2) Idle Pulley
- (3) Cooling Fan Pulley
- (4) Serpentine Belt
- (5) Power Steering Oil Pump
- (6) Air Conditioner Compressor
- (7) Crankshaft Pulley
- (8) Generator

- 5. Disconnect refrigerant line connector.
  - When removing the line connector, the connecting part should immediately be plugged or capped to prevent foreign matter from being mixed into the line.
- 6. Remove compressor.

**Installation**

- 1. Install compressor.
  - Tighten the compressor fixing bolts to the specified torque.

**Torque: 19 N•m (14 lb•ft)**

- 2. Connect refrigerant line connector.
  - Tighten the refrigerant line connector fixing bolts to the specified torque.

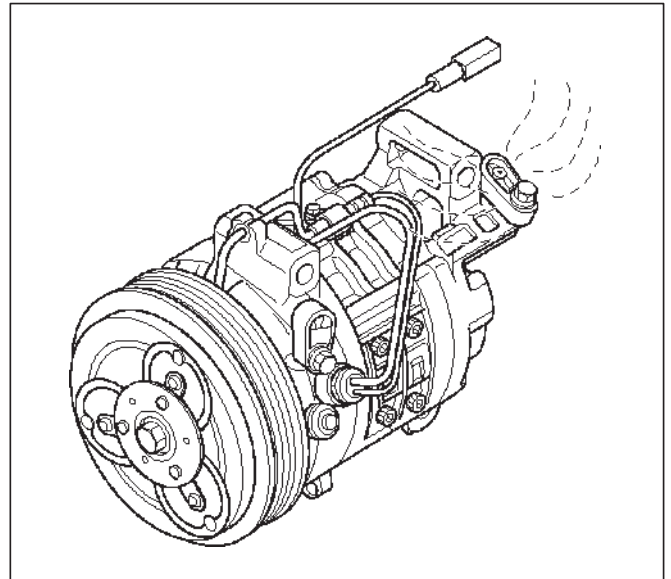
**Torque: 15 N•m (11 lb•ft)**

- O-rings cannot be reused. Always replace with new ones.
- Be sure to apply new compressor oil to the O-rings when connecting refrigerant lines.
- 3. Install serpentine belt.
  - Move serpentine belt tensioner to loose side using wrench, then install serpentine belt to normal position.
- 4. Connect magnetic clutch harness connector.

**New Compressor Installation**

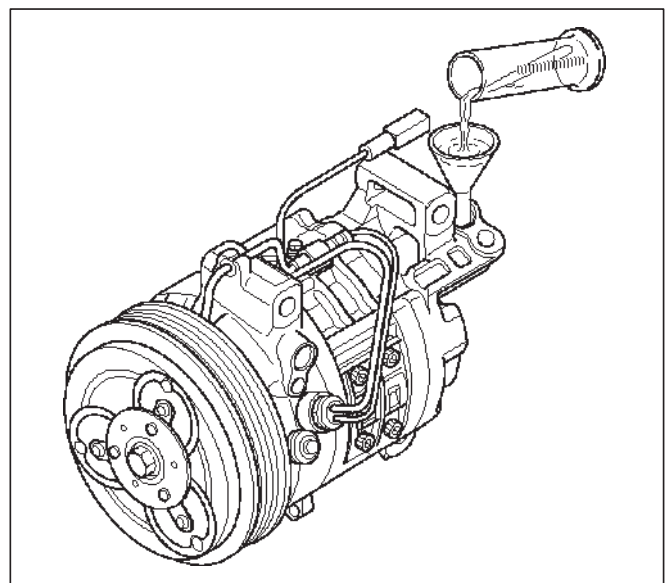
The new compressor is filled with 150cc (5.0fl.oz.)of compressor oil and nitrogen gas. When mounting the compressor on the vehicle, perform the following steps;

- 1. Gently release nitrogen gas from the new compressor.
  - Take care not to let the compressor oil flow out.
  - Inspect O-rings and replace if necessary.



871RX008

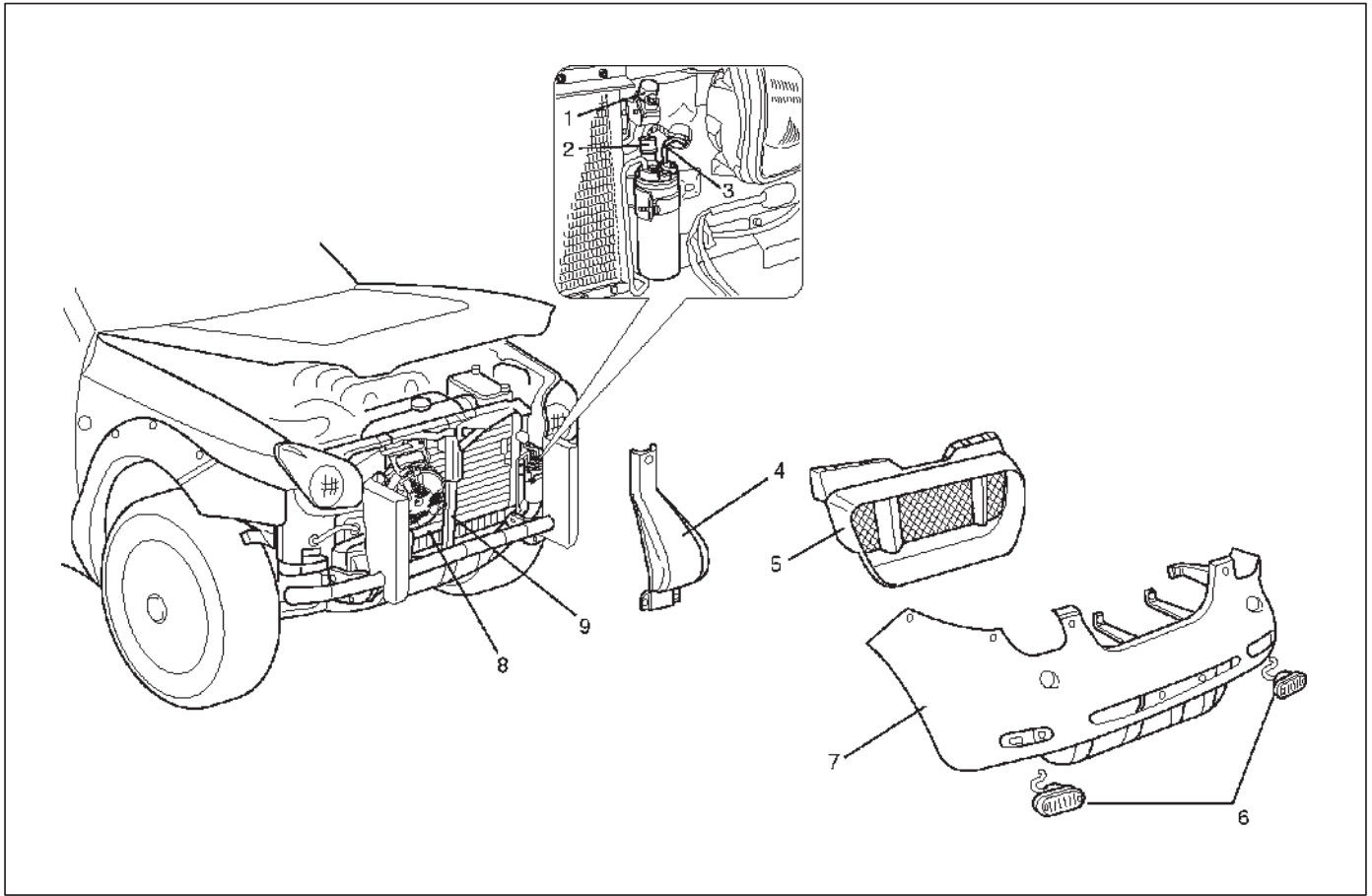
- 2. Turn the compressor several times by hand and release the compressor oil in the rotor.
- 3. When installing on a new system, the compressor should installed as it is. When installing on a used system, the compressor should be installed after adjusting the amount of compressor oil. (Refer to Compressor in this section)
- 4. When replacing the compressor, in advance, measure the amount of oil in the old compressor. Then drain the oil from the new compressor temporarily, and refill the new compressor with the same amount of oil in the old compressor.



871RX013

## Condenser Assembly

### Condenser Assembly and Associated Parts



875RX004

#### Legend

- |                                       |                                |
|---------------------------------------|--------------------------------|
| (1) Refrigerant Line                  | (5) Radiator Grille            |
| (2) Pressure Switch Connector         | (6) Front Turn Signal Light    |
| (3) Refrigerant Line                  | (7) Front Bumper Assembly      |
| (4) Front Bumper Lower Center Support | (8) Condenser Assembly         |
|                                       | (9) Engine Hood Front End Stay |

### Removal

1. Disconnect the battery ground cable.
2. Discharge and recover refrigerant.
  - Refer to Refrigerant Recovery in this section.
3. Remove radiator grille.
4. Remove front turn signal light.
5. Remove front bumper assembly.
6. Remove front bumper lower center support.
7. Remove engine hood front end stay.
  - Apply setting mark to the engine hood lock fixing position before removing it.
8. Disconnect pressure switch connector.
9. Disconnect refrigerant line.
  - When removing the line connector, the connecting part should immediately be plugged or capped to prevent foreign matter from being mixed into the line.

10. Remove condenser assembly.

- Handle with care to prevent damaging the condenser or radiator fin.

### Installation

1. Install condenser assembly.
  - If installing a new condenser, be sure to add 30cc (1.0 fl. oz.) of new compressor oil to a new one.
  - Tighten the condenser fixing bolts to the specified torque.

#### Torque: 6 N•m (52 lb in)

2. Connect refrigerant line.

- Tighten the inlet line connector fixing bolt to the specified torque.

#### Torque: 15 N•m (11 lb ft)

- Tighten the outlet line connector fixing bolt to the specified torque.

**Torque: 6 N•m (52 lb in)**

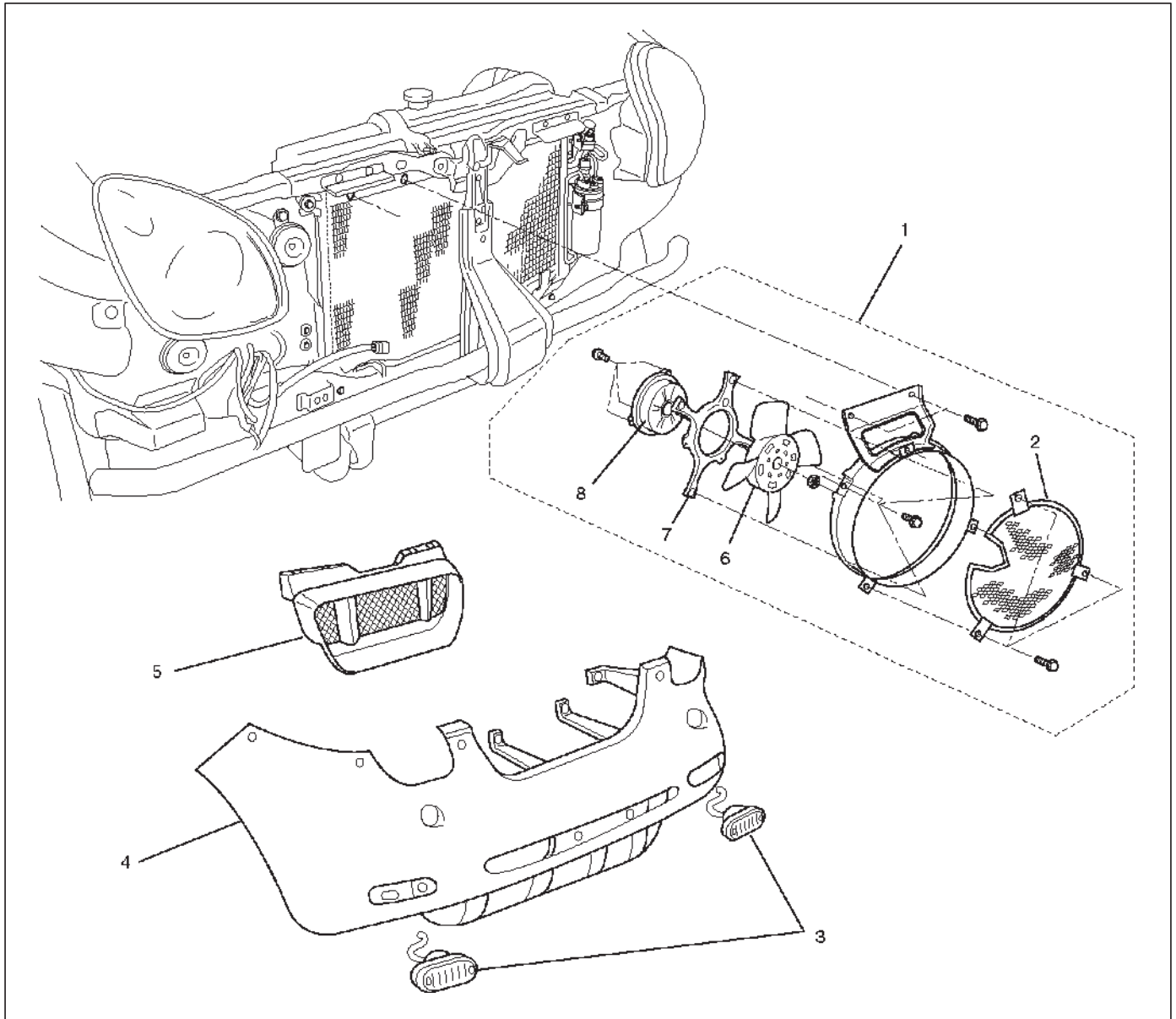
- O-rings cannot be reused. Always replace with new ones.
- Be sure to apply new compressor oil to the O-rings when connecting the refrigerant line.

3. Connect pressure switch connector.

- 4. Install engine hood front end stay.
- 5. Install front bumper lower center.
- 6. Install front bumper assembly.
- 7. Install front turn signal light.
- 8. Install radiator grille.

## Condenser Fan Motor

### Condenser Fan Motor and Associated Parts



875RX006

**Legend**

- (1) Condenser Fan Assembly
- (2) Shroud
- (3) Front Turn Signal Light
- (4) Front Bumper Assembly

- (5) Radiator Grille
- (6) Fan
- (7) Stay
- (8) Condenser Fan Motor

## 1A-66 HEATING, VENTILATION AND AIR CONDITIONING (HVAC)

### Removal

1. Disconnect the battery ground cable.
2. Discharge and recover refrigerant.
  - Refer to Refrigerant Recovery in this section.
3. Remove radiator grille.
4. Remove front turn signal light.
5. Remove front bumper assembly.
6. Remove condenser fan assembly.
  - Disconnect the fan motor connector and remove the 4 fixing bolts.
7. Remove shroud.
  - Remove the 3 fixing nuts.

- Loosen the condenser fixing nut and disconnect the fan motor connector from bracket.
8. Remove fan.
    - Remove the fan fixing C-ring and plate.
  9. Remove condenser fan motor.

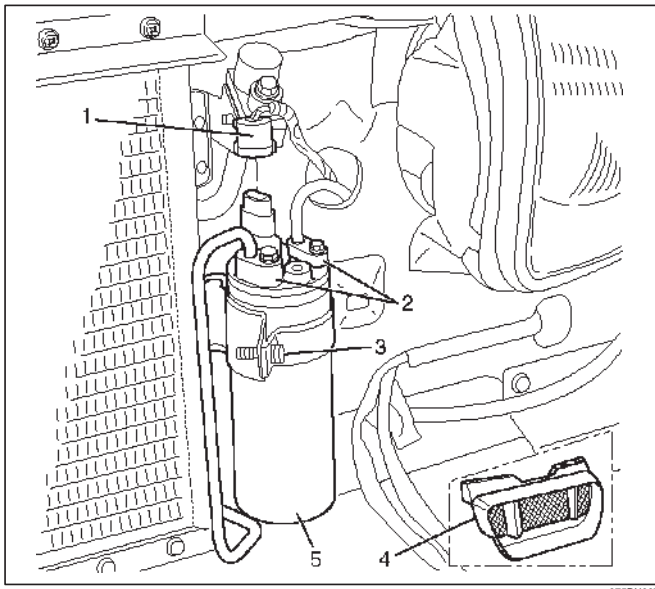
### Installation

To install, follow the removal steps in the reverse order, noting the following point.

1. Route the fan motor harness in its previous position, and fix it securely with clip and bracket.

## Receiver / Drier

### Receiver / Drier and Associated Parts



#### Legend

- (1) Pressure Switch Connector
- (2) Refrigerant Line
- (3) Bracket Bolt
- (4) Radiator Grille
- (5) Receiver / Drier

### Removal

1. Disconnect the battery ground cable.
2. Discharge and recover refrigerant.
  - Refer to Refrigerant Recovery in this section.
3. Remove radiator grille.
4. Disconnect pressure switch connector.

5. Disconnect refrigerant line.

○When removing the line connected part, the connecting part should immediately be plugged or capped to prevent foreign matter from being mixed into the line.

6. Remove bracket bolt.
7. Remove receiver/drier.

○Loosen the bolt, then, using care not to touch or bend the refrigerant line, carefully pull out the receiver/drier.

### Installation

To install, follow the removal steps in the reverse order, noting the following points:

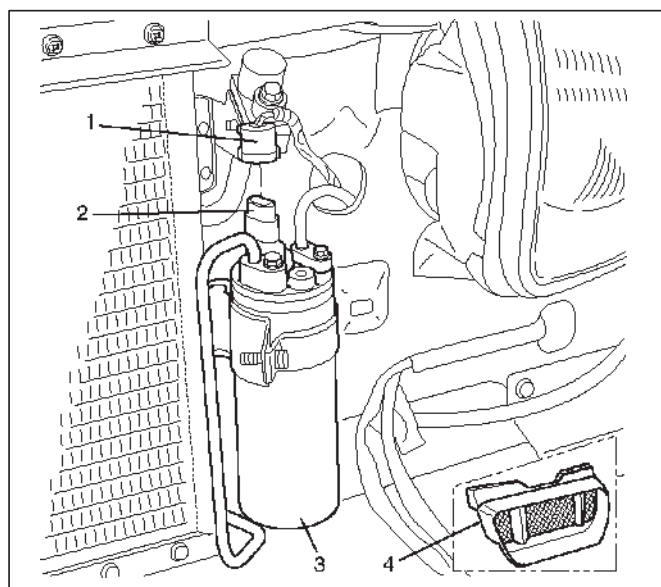
1. If installing a new receiver/drier, be sure to add 30cc (1.0 fl. oz.) of new compressor oil to a new one.
2. Put the receiver/drier in the bracket and connect with the refrigerant line. Check that no excessive force is imposed on the line. Fasten the bracket bolt to the receiver/drier.
3. Tighten the refrigerant line to the specified torque.

#### Torque: 6 N•m (52 lb in)

4. O-rings cannot be reused. Always replace with new ones.
5. Be sure to apply new compressor oil to the O-rings when connecting the refrigerant line.

## Pressure Switch

### Pressure Switch and Associated Parts



875RX005

#### Legend

- (1) Pressure Switch Connector
- (2) Pressure Switch
- (3) Receiver / Drier
- (4) Radiator Grille

### Installation

To install, follow the removal steps in the reverse order, noting the following point:

1. O-ring cannot be reused. Always replace with a new one.
2. Be sure to apply new compressor oil to the O-ring when connecting pressure switch.
3. Tighten the pressure switch to the specified torque.

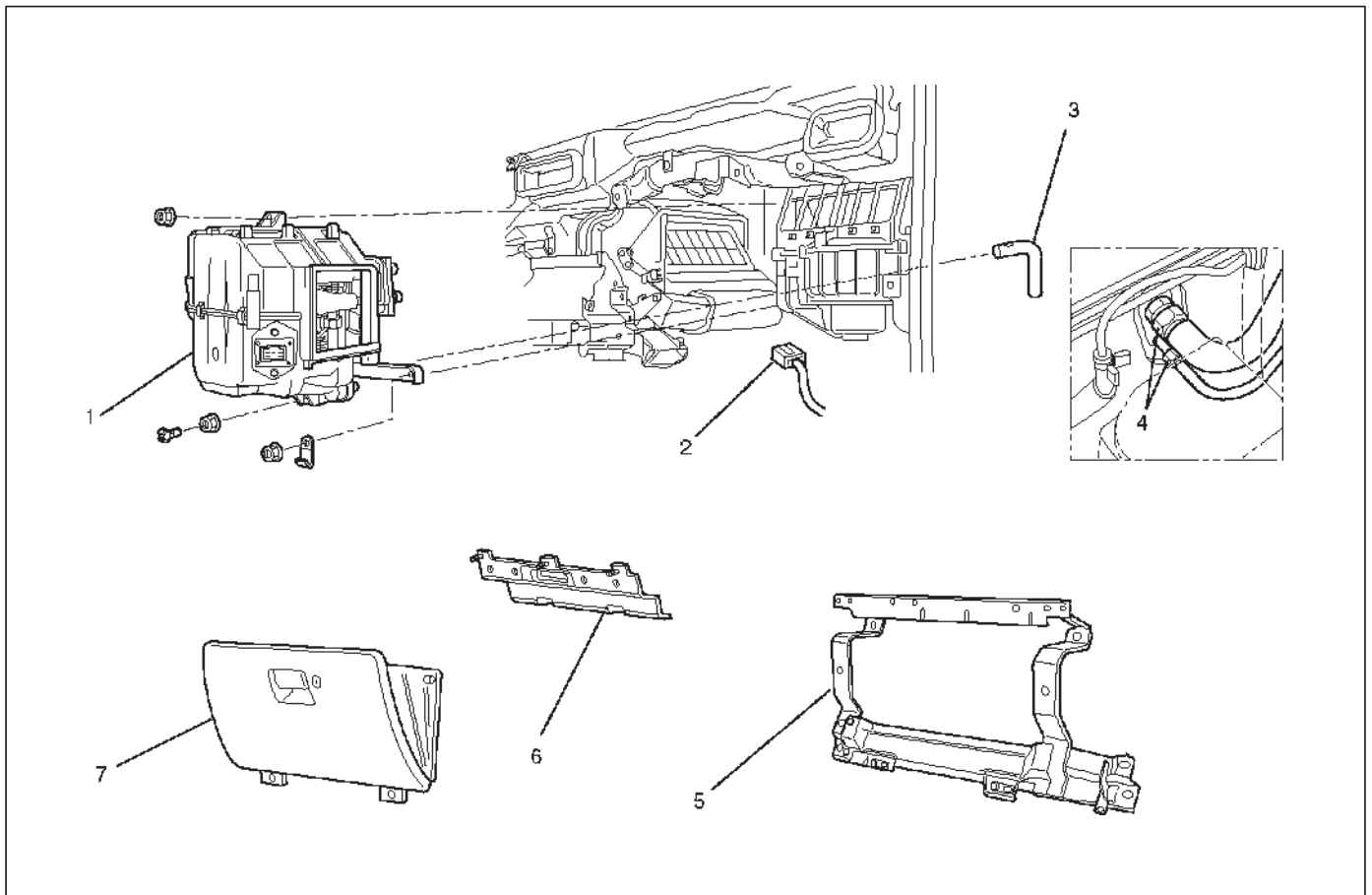
**Torque: 13 N•m (113 lb in)**

### Removal

1. Disconnect the battery ground cable.
2. Discharge and recover refrigerant.
  - Refer to "Refrigerant Recovery in this section.
3. Remove radiator grille.
4. Disconnect pressure switch connector.
5. Disconnect pressure switch.
  - When removing the switch connected part, the connecting part should immediately be plugged or capped to prevent foreign matter from being mixed into the line.

## Evaporator Assembly

### Evaporator Assembly and Associated Parts



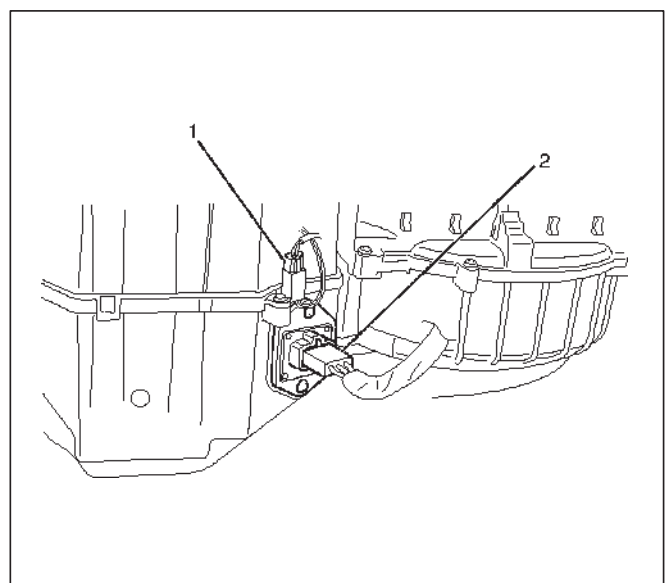
865RX004

#### Legend

- |  |                                    |
|--|------------------------------------|
| (1) Evaporator Assembly                          | (4) Refrigerant Line               |
| (2) Resistor and Electronic Thermostat Connector | (5) Instrument Panel Reinforcement |
| (3) Drain Hose                                   | (6) Glove Box Cover                |
|  | (7) Glove Box                      |

#### Removal

1. Disconnect the battery ground cable.
2. Discharge and recover refrigerant.
  - Refer to Refrigerant Recovery in this section.
3. Remove glove box.
4. Remove instrument panel asm.
  - Refer to Instrument Panel Asm and Cross Beam Asm in Body Structure section.
5. Disconnect resistor (2) and electronic thermostat connector (1).



865RX006

6. Disconnect drain hose.
7. Disconnect refrigerant line.
  - Use a back-up wrench when disconnecting and reconnecting the refrigerant lines.
  - When removing the refrigerant line connected part, the connecting part should immediately be plugged or capped to prevent foreign matter from being mixed into the line.
8. Remove evaporator assembly.

1. To install a new evaporator assembly, add 50cc (1.7 fl. oz.) of new compressor oil to the new core.
2. Tighten the refrigerant outlet line to the specified torque.

**Torque: 25 N•m (18 lb ft)**

3. Tighten the refrigerant inlet line to the specified torque.

**Torque: 15 N•m (11 lb ft)**

4. O-rings cannot be reused. Always replace with new ones.

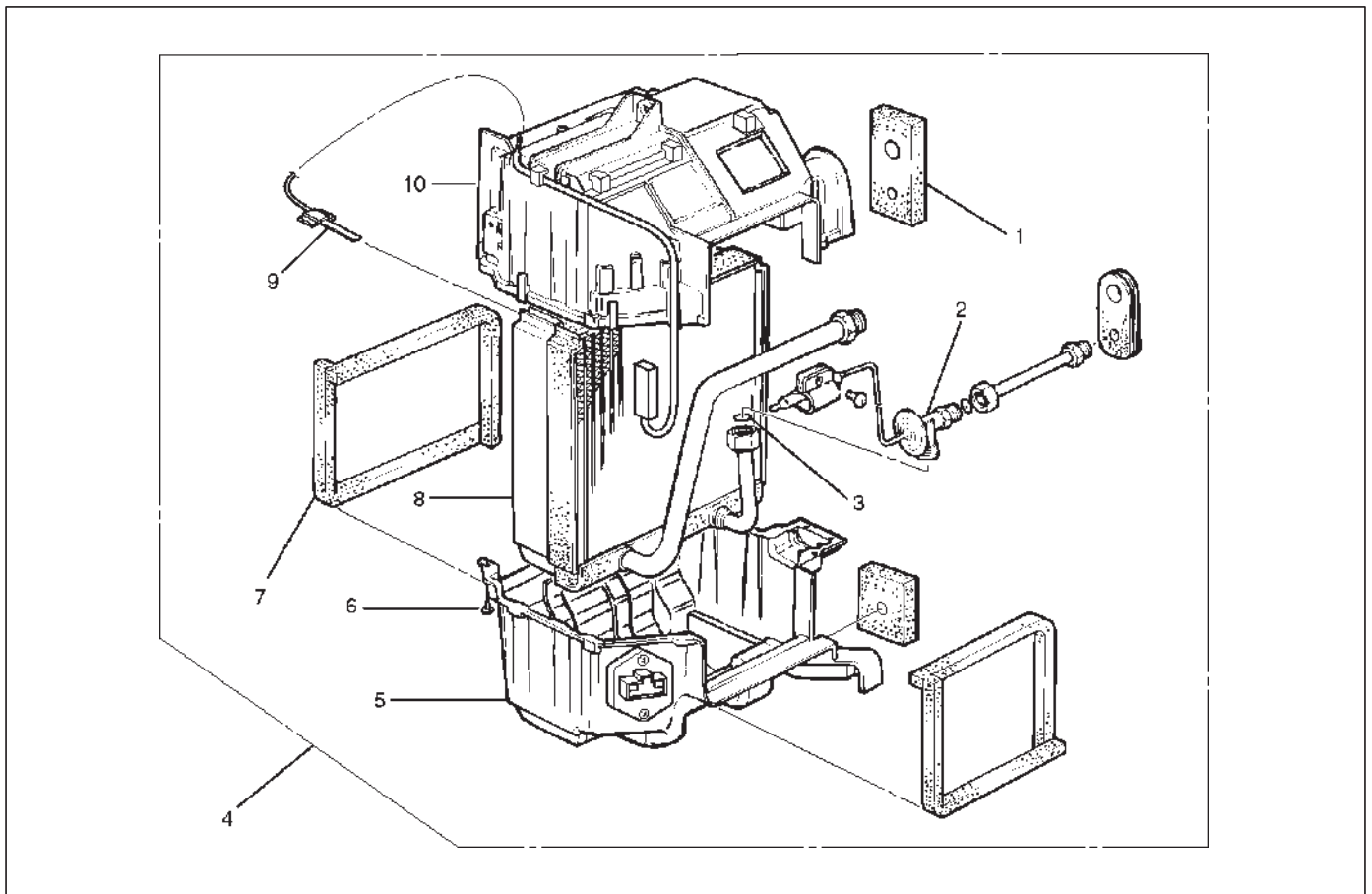
5. Be sure to apply new compressor oil to the O-rings when connecting lines.

## Installation

To install, follow the removal steps in the reverse order, noting the following points:

## Electronic Thermostat, Evaporator Core and/or Expansion Valve

### Disassembled View



874RX017

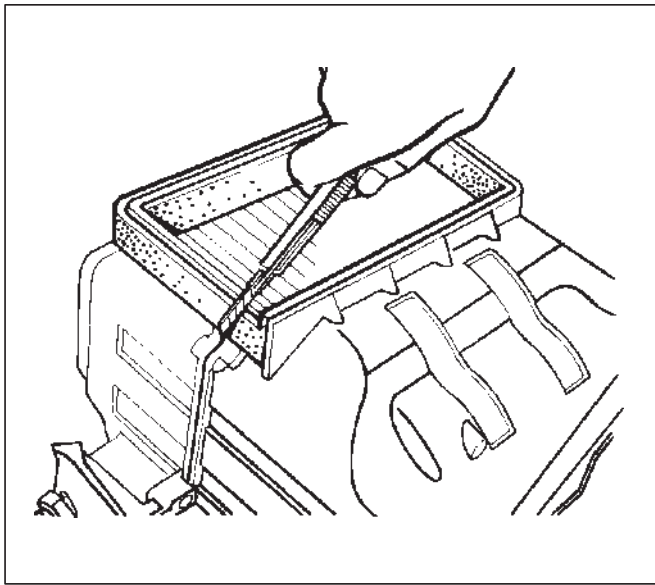
### Legend

- |                         |                           |
|-------------------------|---------------------------|
| (1) Lining              | (6) Attaching Screw       |
| (2) Expansion Valve     | (7) Lining                |
| (3) O-ring              | (8) Evaporator Core       |
| (4) Evaporator Assembly | (9) Electronic Thermostat |
| (5) Lower Case          | (10) Upper Case           |

## 1A-70 HEATING, VENTILATION AND AIR CONDITIONING (HVAC)

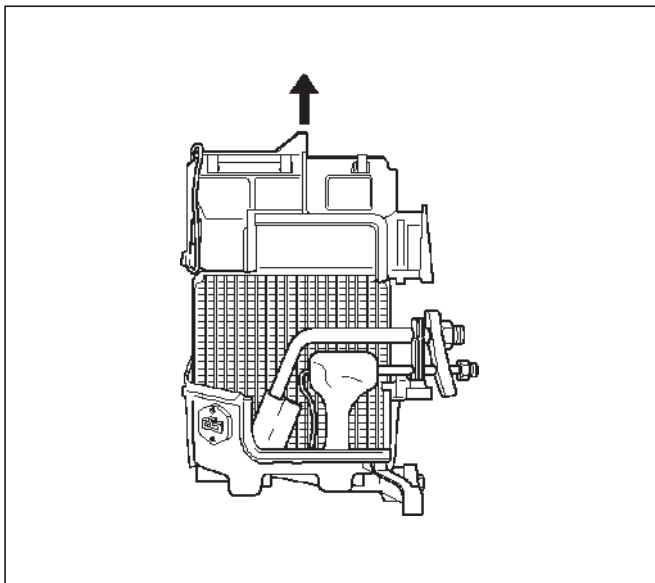
### Removal

1. Disconnect the battery ground cable.
2. Discharge and recover refrigerant.
  - Refer to Refrigerant Recovery in this section.
3. Remove evaporator assembly.
  - Refer to Evaporator Assembly in this section.
4. Pull the sensor from the evaporator assembly.
5. Remove attaching screw.
6. Remove upper case.
7. Remove lower case.
  - Slit the case parting face with a knife since the lining is separated when removing the evaporator.



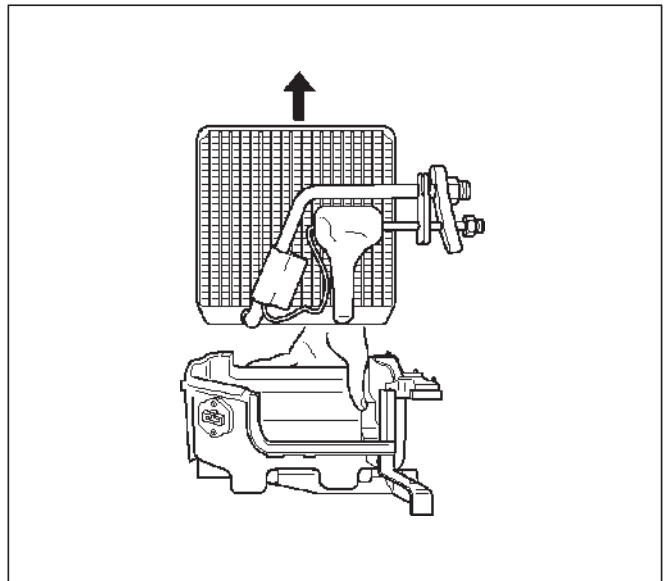
874RS006

- Lift to remove the upper case.



874RX018

8. Remove evaporator core.



874RX019

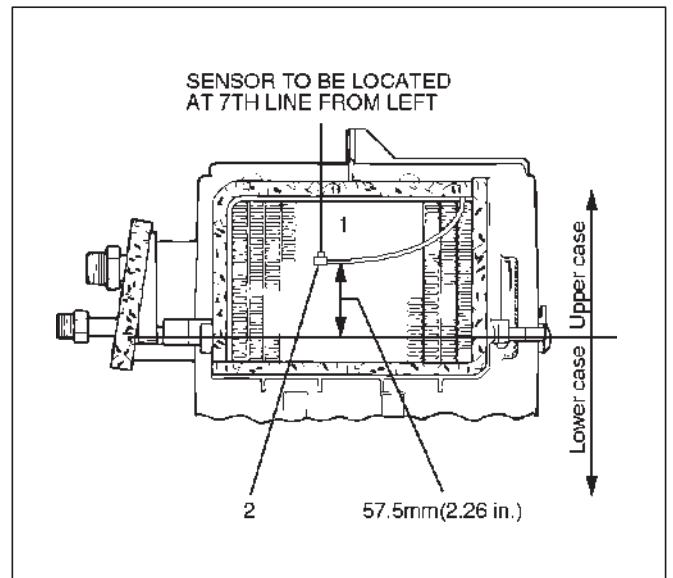
9. Remove expansion valve.

- Tear off the insulator carefully.
- Use a back-up wrench when disconnecting all refrigerant pipes.

### Installation

To install, follow the removal steps in the reverse order, noting the following points:

1. The sensor is installed on the core with the clip.
2. The sensor must not interfere with the evaporator core.
3. When installing the new evaporator core, install the thermo sensor (2) to the evaporator core (1) specified position with the clip in the illustration.



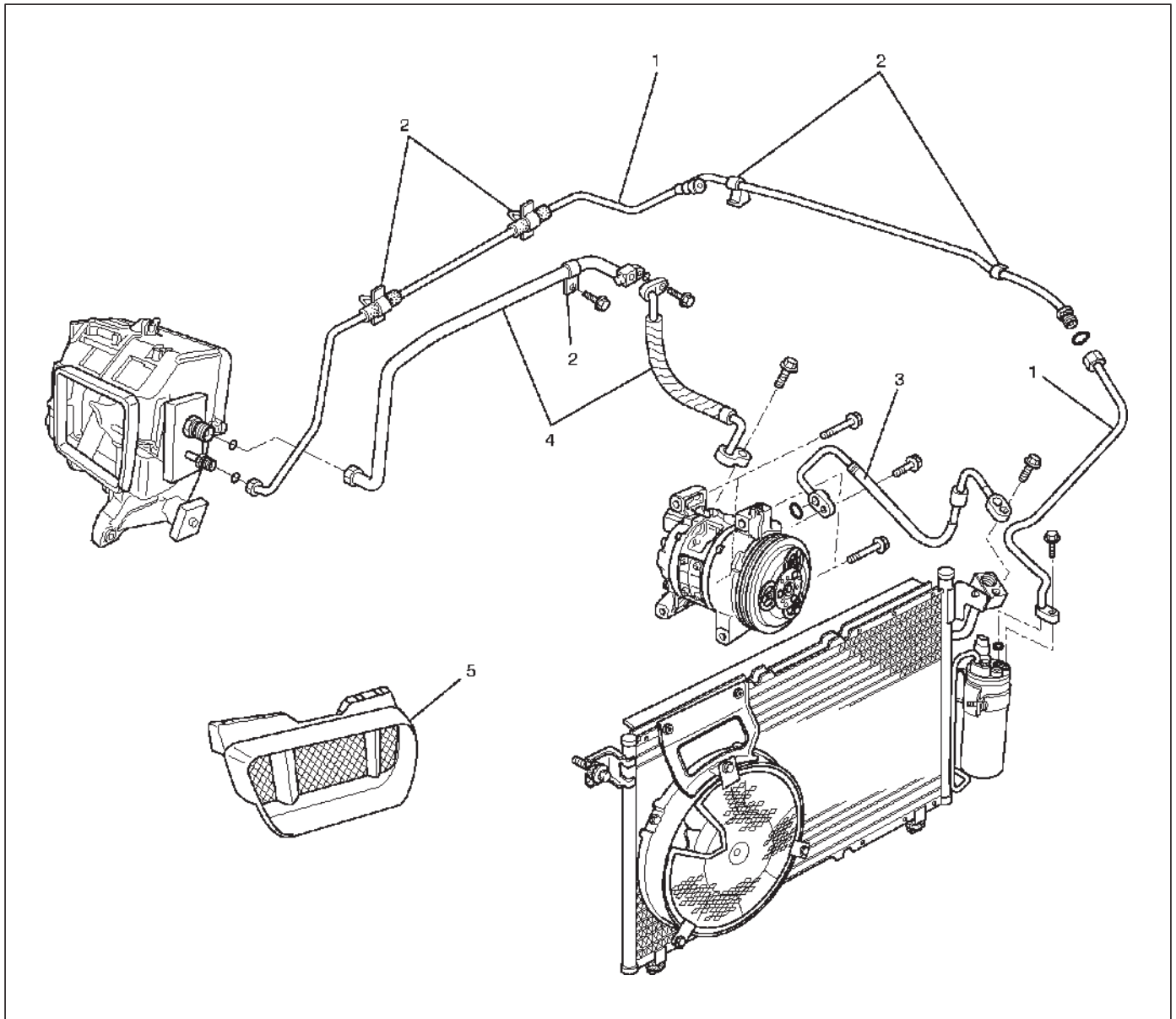
874RX021



4. O-rings cannot be reused. Always replace with new ones.
5. Be sure to apply new compressor oil to the O-rings when connecting lines.
6. Be sure to install the sensor and the insulator on the place where they were before.
7. To install a new evaporator core, add 50cc (1.7 fl. oz.) of new compressor oil to the new core.
8. Tighten the refrigerant lines to the specified torque. Refer to Main Data and Specifications for Torque Specifications in this section.
9. Apply an adhesive to the parting face of the lining when assembling the evaporator assembly.

## Refrigerant Line

### Refrigerant Line and Associated Parts



852RX010

#### Legend

- |                                      |   |
|--------------------------------------|---|
| (1) Liquid Line (High-Pressure Pipe) | (3) Discharge Line (High-Pressure Hose) |
| (2) Clip and Clamp                   | (4) Suction Line (Low-Pressure Pipe)    |
|                                      | (5) Radiator Grille                     |

### Removal

1. Disconnect the battery ground cable.
2. Discharge and recover refrigerant.
  - Refer to Refrigerant Recovery in this section.
3. Remove radiator grille.
4. Remove clip and clamp.
5. Disconnect liquid line (High-pressure pipe).
6. Disconnect suction line (Low-pressure pipe) using a back-up wrench.
7. Disconnect suction line (Low-pressure hose) using a back-up wrench.
8. Disconnect discharge line (High-pressure hose) using a back-up wrench.
  - Use a backup wrench when disconnecting and reconnecting the refrigerant lines.
  - When removing the refrigerant line connecting part, the connecting part should immediately be plugged or capped to prevent foreign matter from being mixed into the line.

### Installation

To install, follow the removal steps in the reverse order, noting the following point:

1. O-rings cannot be reused. Always replace with new ones.
2. Be sure to apply new compressor oil to the O-rings when connecting lines.
3. Tighten the refrigerant line to the specified torque.  
Refer to Main Data and Specifications for Torque Specifications in this section.

## Main Data And Specifications

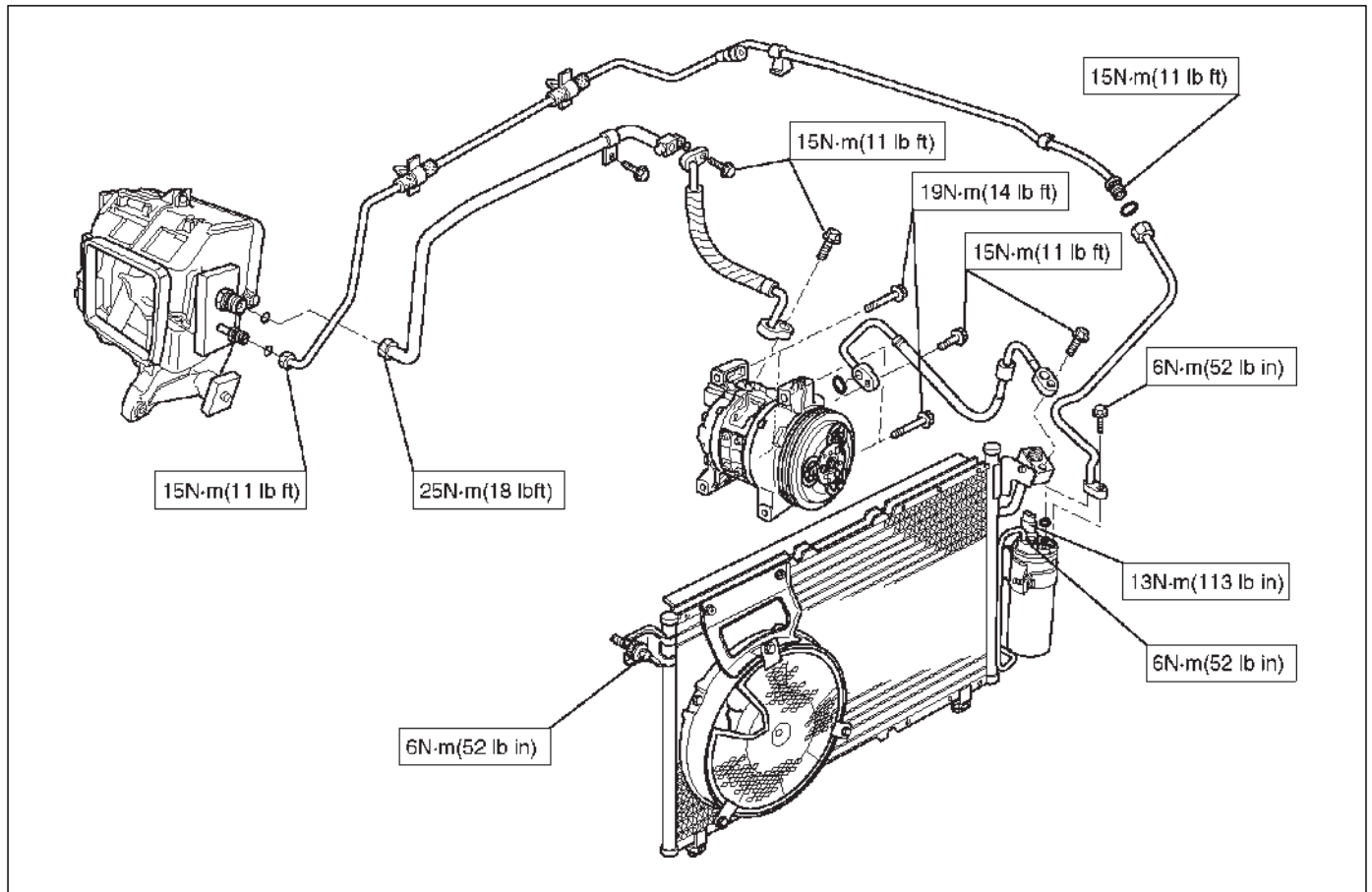
### General Specifications

<b>HEATER UNIT</b>	
Temperature control	Reheat air mix system
Capacity	4.3 kw (3,700 Kcal./hr.)
Air flow	280 m <sup>3</sup> /h
<b>HEATER CORE</b>	
Type	Plate and Corrugate - Fin type
Element dimension	171 mm (6.7 in.) × 161 mm (6.3 in.) × 25 mm (1.0 in.)
Radiating area	Approx. 0.75 m <sup>2</sup>
<b>EVAPORATOR ASSEMBLY</b>	
Capacity	4.9 kw (4,200 Kcal./hr.)
Air flow	470 m <sup>3</sup> /hr
<b>EVAPORATOR CORE</b>	
Type	Al-laminate louver fin type
Element dimension	235 mm (9.3 in.) × 225.3 mm (8.9 in.) × 60 mm (2.4 in.)
<b>EXPANSION VALVE</b>	
Type	Internal pressure equalizing type
<b>THERMOSTAT SWITCH</b>	
Type	Electronic thermostat OFF: Below 3.5 ± 0.5 °C (38.3 ± 0.9 °F) ON: Above 5.0 ± 0.5 °C (41.0 ± 0.9 °F)
<b>BLOWER MOTOR</b>	
Rated output	113 W
Rated electric current	14.5 A±10%
<b>CONDENSER</b>	
Type	Parallel flow type
Radiation performance	10.9 kw (9,400 Kcal./hr.)
<b>RECEIVER/DRIER</b>	
Type	Assembly includes sight glass with dual (triple) pressure switch
Internal volume	300 cc (10 fl.oz.)
<b>PRESSURE SWITCH</b>	
Type	Triple pressure switch
	Low pressure control ON: 196.3±29.4 kpa (27.0±4.3 psi) OFF: 176.5±19.6 kpa (25.6±2.8 psi)
	Medium pressure control ON: 1471.0±98.1 kpa (213.3±14.2 psi) OFF: 1078.7±117.7 kpa (156.4±17.7 psi)
	High pressure control ON: 2353.6±196.1 kpa (341.3±28.4 psi) OFF: 2942.0±196.1 kpa (426.6±28.4 psi)

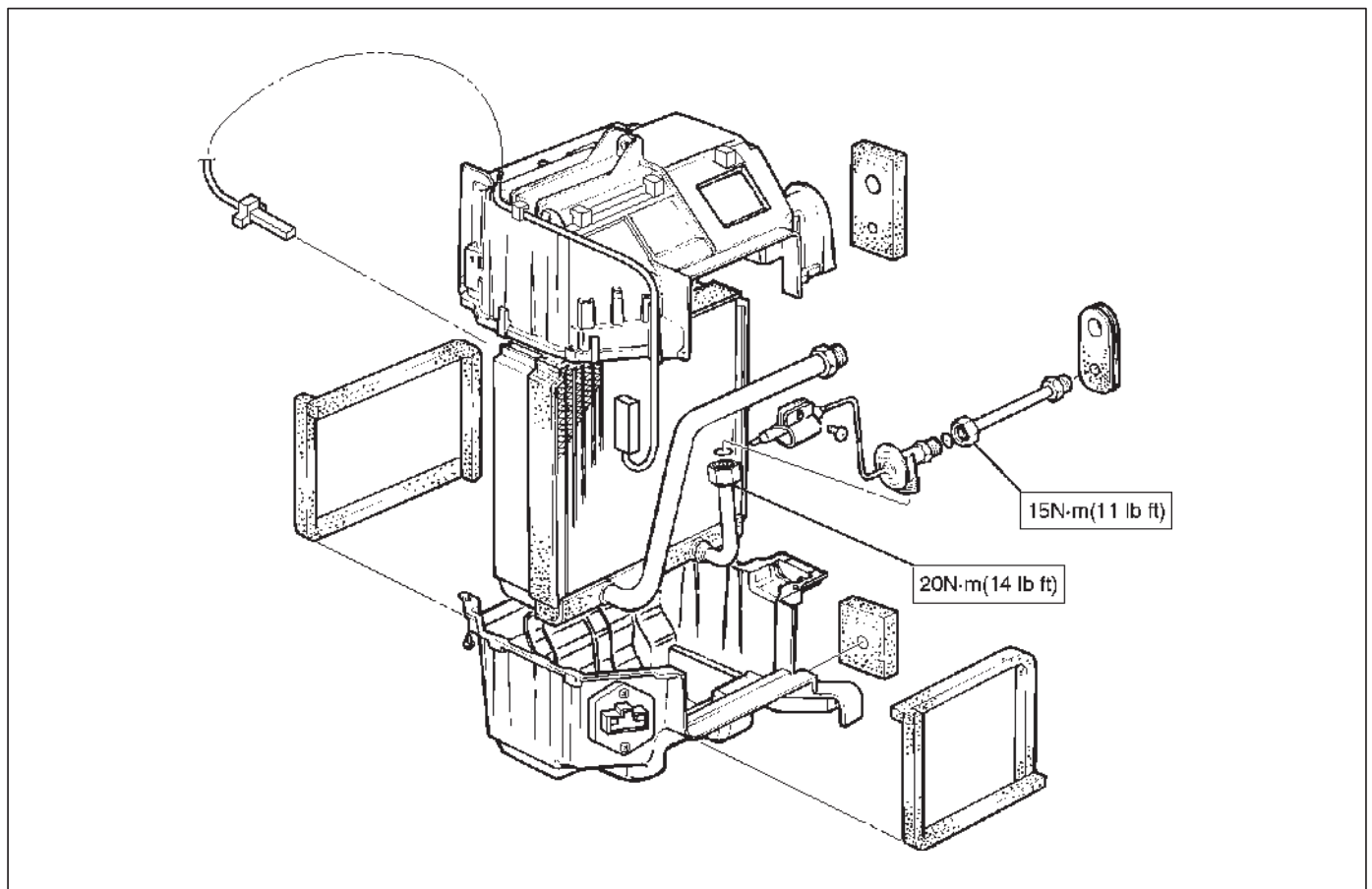
**1A-74 HEATING, VENTILATION AND AIR CONDITIONING (HVAC)**

<b>REFRIGERANT</b>	
Type	HFC-134a
Specified amount	600 g (1.32 lbs.)

Torque Specifications



852RX007



874RX016

## Compressor

### Service Precaution

**WARNING: THIS VEHICLE HAS A SUPPLEMENTAL RESTRAINT SYSTEM (SRS). REFER TO THE SRS COMPONENT LOCATION VIEW IN ORDER TO DETERMINE WHETHER YOU ARE PERFORMING SERVICE ON OR NEAR THE SRS COMPONENTS OR THE SRS WIRING. WHEN YOU ARE PERFORMING SERVICE ON OR NEAR THE SRS COMPONENTS OR THE SRS WIRING, REFER TO THE SRS ON-VEHICLE SERVICE INFORMATION. FAILURE TO FOLLOW CAUTIONS COULD RESULT IN POSSIBLE AIR BAG DEPLOYMENT, PERSONAL INJURY, OR OTHERWISE UNNEEDED SRS SYSTEM REPAIRS.**

**CAUTION: Always use the correct fastener in the proper location. When you replace a fastener, use ONLY the exact part number for that application. ISUZU will call out those fasteners that require a replacement after removal. ISUZU will also call out the fasteners that require thread lockers or thread sealant. UNLESS OTHERWISE SPECIFIED, do not use supplemental coatings (paints, greases, or other corrosion inhibitors) on threaded fasteners or fastener joint interfaces. Generally, such coatings adversely affect the fastener torque and the joint clamping force, and may damage the fastener. When you install fasteners, use the correct tightening sequence and specifications. Following these instructions can help you avoid damage to parts and systems.**

### General Description

When servicing the compressor, keep dirt or foreign material from getting on or into the compressor parts and system. Clean tools and a clean work area are important for proper service. The compressor connections and the outside of the compressor should be cleaned before any "On-Vehicle" repair, or before removal of the compressor. The parts must be kept clean at all times and any parts to be reassembled should be cleaned with Trichloroethane, naphtha, kerosene, or equivalent solvent, and dried with dry air. Use only lint free cloths to wipe parts.

The operations described below are based on bench overhaul with compressor removed from the vehicle, except as noted. They have been prepared in order of accessibility of the components. When the compressor is removed from the vehicle for servicing, the oil remaining in the compressor should be discarded and new compressor oil added to the compressor.

Compressor malfunction will appear in one of four ways: noise, seizure, leakage or low discharge pressure. Resonant compressor noises are not cause for alarm; however, irregular noise or rattles may indicate broken parts or excessive clearances due to wear. To check seizure, de-energize the magnetic clutch and check to see if the drive plate can be rotated. If rotation is impossible, the compressor is seized. Low discharge pressure may be due to a faulty internal seal of the compressor, or a restriction in the compressor. Low discharge pressure may also be due to an insufficient

refrigerant charge or a restriction elsewhere in the system. These possibilities should be checked prior to servicing the compressor. If the compressor is inoperative, but is not seized, check to see if current is being supplied to the magnetic clutch coil terminals.

The compressor oil used in the HFC-134a system compressor differs from that used in R-12 systems.

Concerning the types of compressor oil which are used for the vehicle, refer to "Main Data and Specifications".

Also, compressor oil to be used varies according to the compressor model. Be sure to avoid mixing two or more different types of oil.

If the wrong oil is used, lubrication will be poor and the compressor will seize or malfunction.

### DKV-14D Type Compressor

DKV-14D is equipped with five-vane rotary compressor. The compressor has vanes built into a rotor which is mounted on a shaft.

When the shaft rotates, the vanes built into the cylinder block assembly are operated by centrifugal force.

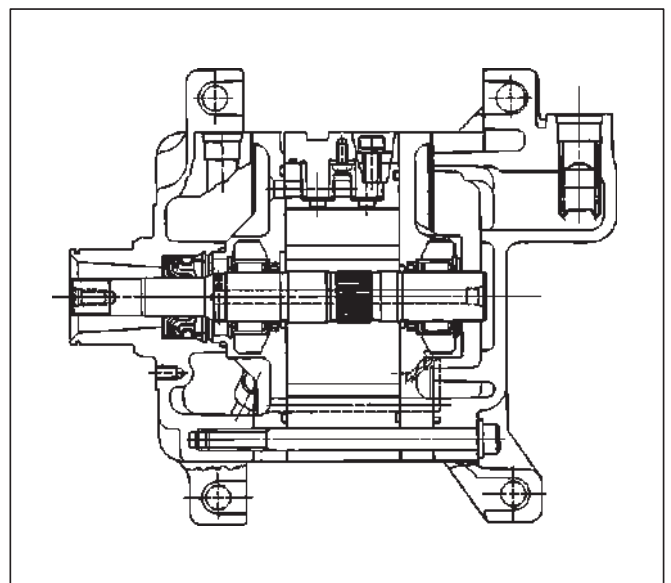
This changes the volume of the space formed by the rotor and cylinder, resulting in the intake and compression of the refrigerant gas. The discharge valve and the valve stopper, which protects the discharge valve, are built into the cylinder block assembly. There is no suction valve but a shaft seal is installed between the shaft and head; a trigger valve, which applies back pressure to the vanes, is installed in the cylinder block and a refrigerant gas temperature sensor is installed in the front head.

The specified quantity of compressor oil is contained in the compressor to lubricate the various parts using the refrigerant gas discharge pressure.

The thermo sensor is installed to the front head of the compressor to protect it by stopping its operation when the refrigerant gas is insufficient or when the temperature get abnormally high.

○ OFF:  $160 \pm 5$  °C ( $320.0 \pm 9.0$  °F)

○ ON:  $135 \pm 5$  °C ( $275.0 \pm 9.0$  °F)

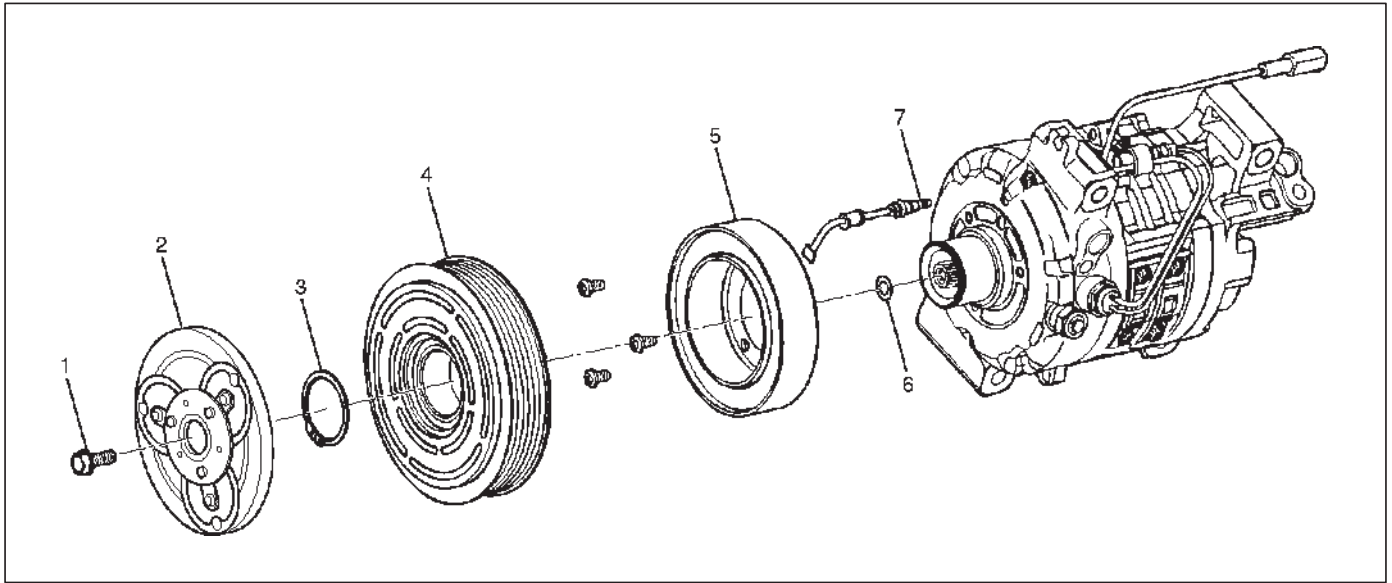


**Diagnosis**

<b>Condition</b>	<b>Possible cause</b>	<b>Correction</b>
Noise from compression	Defective rotor/piston	Replace compressor/cylinder and shaft assembly
	Defective shaft	Replace compressor/cylinder and shaft assembly
Noise from magnetic clutch	Defective bearing	Replace magnetic clutch
	Defective clutch	Replace magnetic clutch
	Clearance between drive plate and pulley not standard	Adjust the clearance or replace magnetic clutch
Insufficient cooling	Defective gasket	Replace compressor/gasket
	Defective rotor/reed valve	Replace compressor/valve plate
	Defective trigger valve/suction valve	Replace compressor/suction valve
Not rotating	Defective rotor/piston	Replace compressor/cylinder and shaft assembly
	Defective shaft	Replace compressor/cylinder and shaft assembly
	Rotating parts seized due to insufficient oil	Replace compressor
Oil and/or gas leakage	Defective seal	Replace compressor/shaft seal
	Defective O-ring	Replace

## Magnetic Clutch Assembly (DKV-14D Type)

### Parts Location View



871RX012

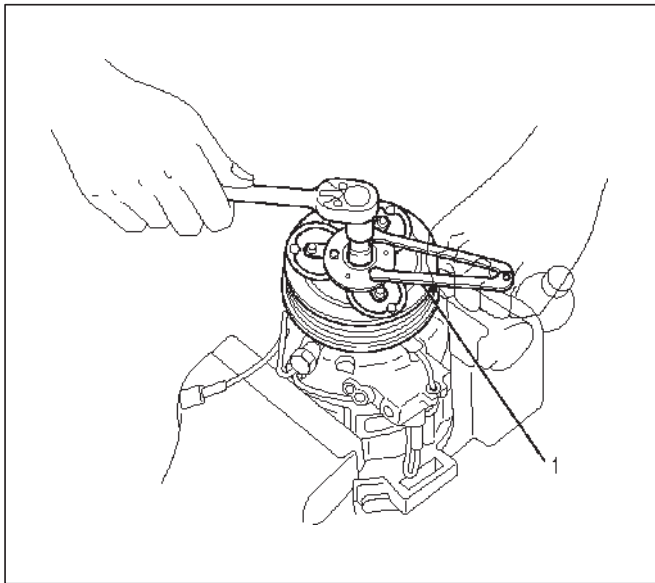
#### Legend

- (1) Drive Plate bolt
- (2) Drive Plate
- (3) Snap Ring

- (4) Pulley Assembly
- (5) Field Coil
- (6) Shim (s)
- (7) Lead Wire

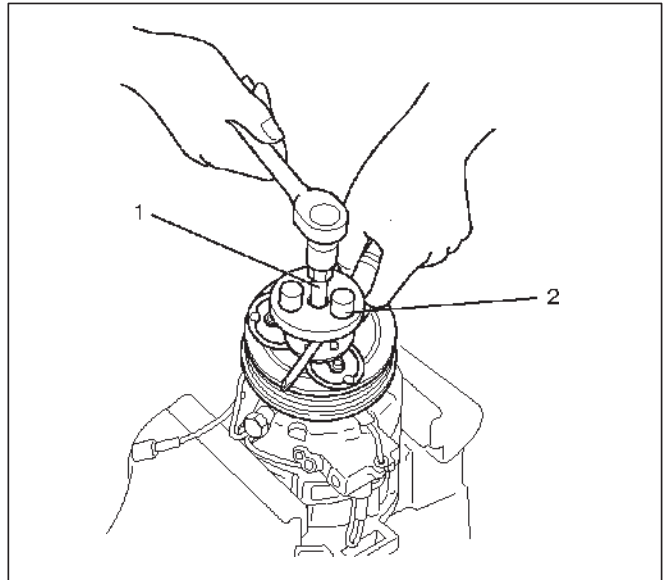
### Removal

1. Using drive plate holder J-7624 (1) to prevent the drive plate from rotating, then remove the drive plate bolt.



901RX065

2. Remove drive plate by using drive plate puller J-33944-A (2) and forcing screw J-33944-4 (1).

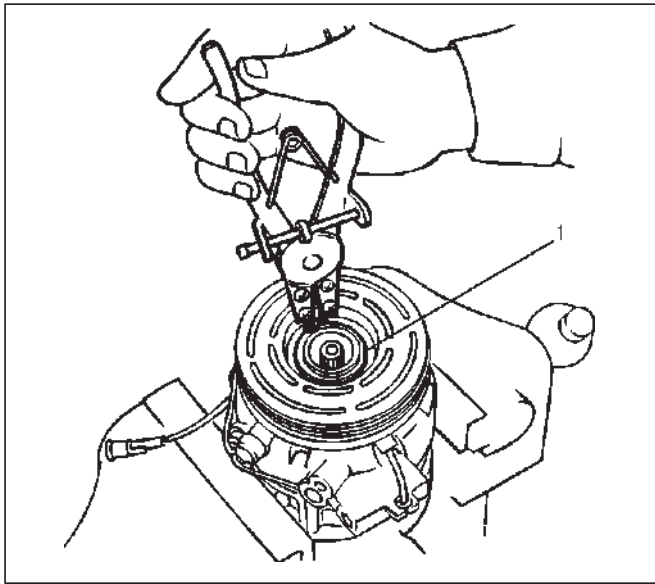


871RX016



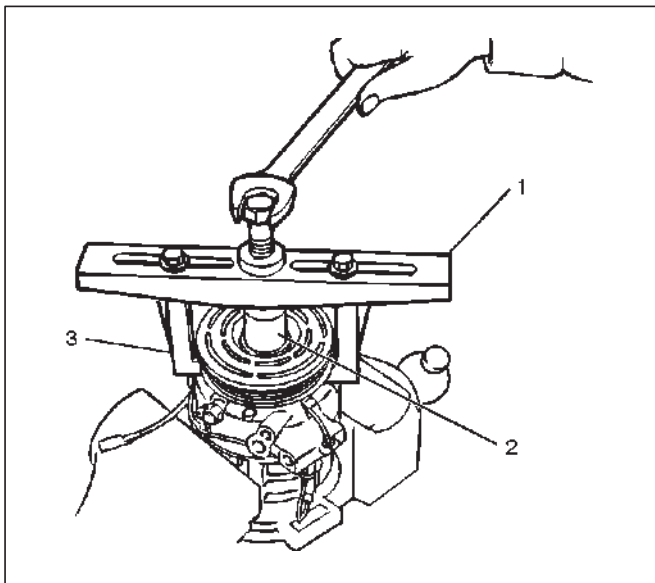
3. Remove shim (s).

4. Remove snap ring (1) by using snap ring pliers.



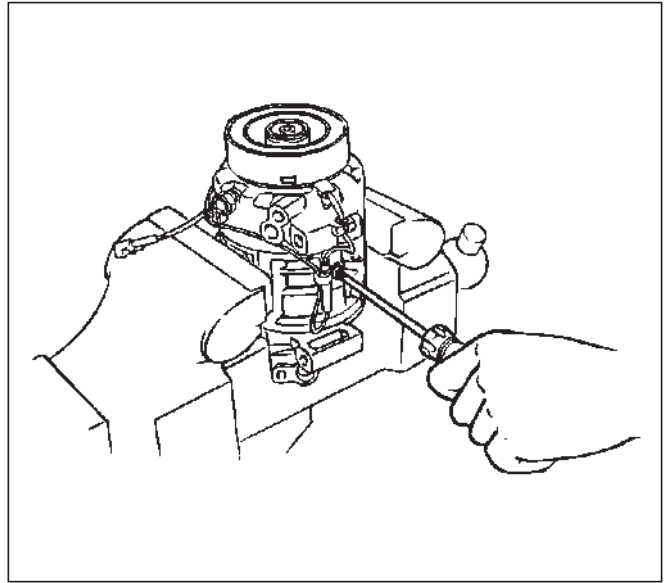
871RW016

5. Remove pulley assembly by using pulley puller pilot J-38424 (2), pulley puller J-8433 (1) and pulley puller leg J-24092-2 (3).



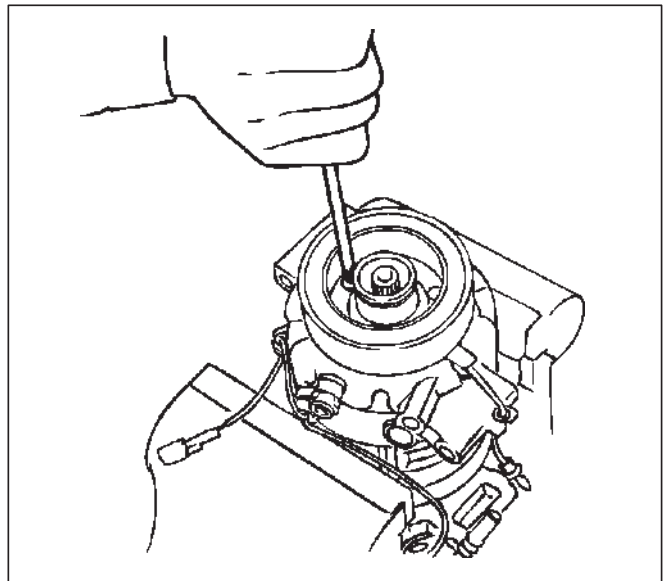
871RX031

6. Loosen screw and disconnect the coil lead wire connector.



871RS010

7. Loosen three screws and remove the field coil.



871RS011

## Inspection and Repair

### Drive Plate

If the frictional surface shows signs of damage due to excessive heat, the drive plate and pulley should be replaced.

### Pulley Assembly

Check the appearance of the pulley assembly. If the frictional surface of the pulley shows signs of excessive grooving due to slippage, both the pulley and drive plate should be replaced. The frictional surfaces of the pulley assembly should be cleaned with a suitable solvent before reinstallation.

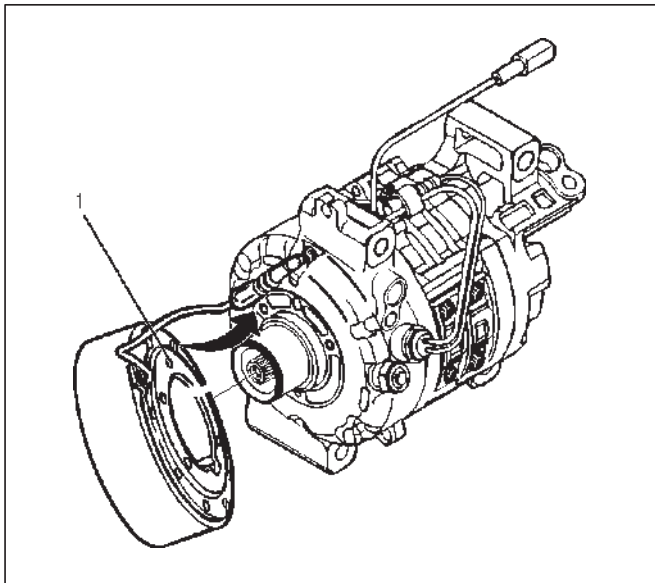
### Coil

Check coil for loose connector or cracked insulation.

## Installation

1. Install field coil.

- Align the located portion (1) of the field coil and compressor.

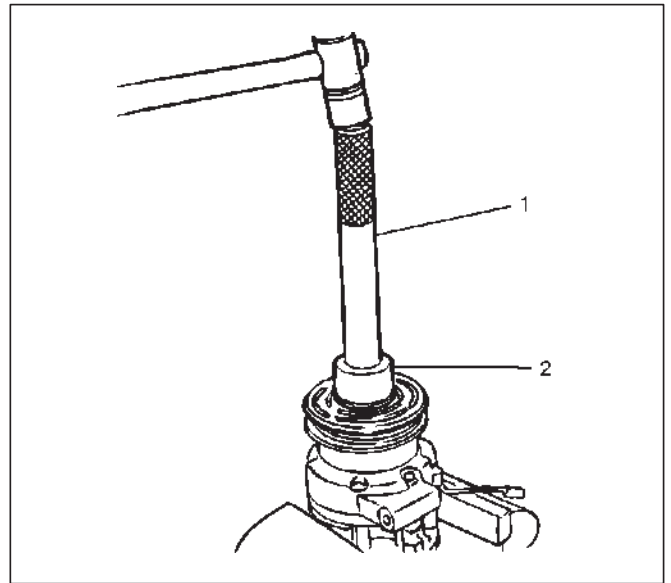


- Tighten the mounting screw to the specified torque.

**Torque: 5N·m (44 lb in)**

2. Connect the lead wire connector with the rubber hold and tighten the screw.

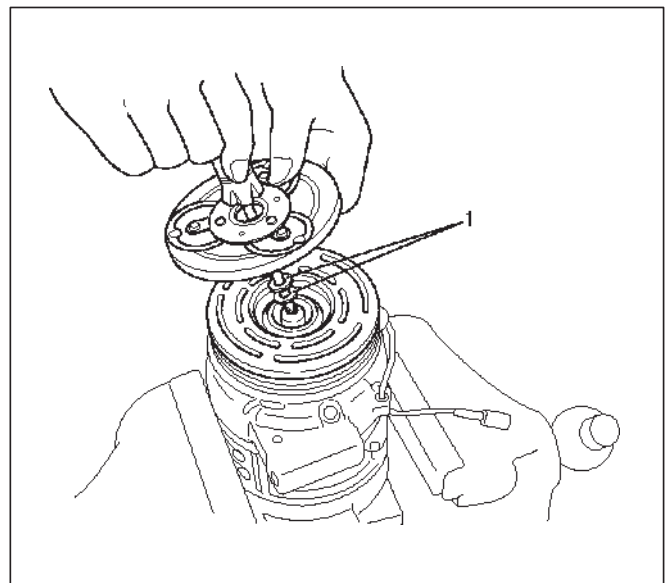
3. Install pulley assembly by using pulley installer J-33940-A (2) and drive handle J-8092 (1).



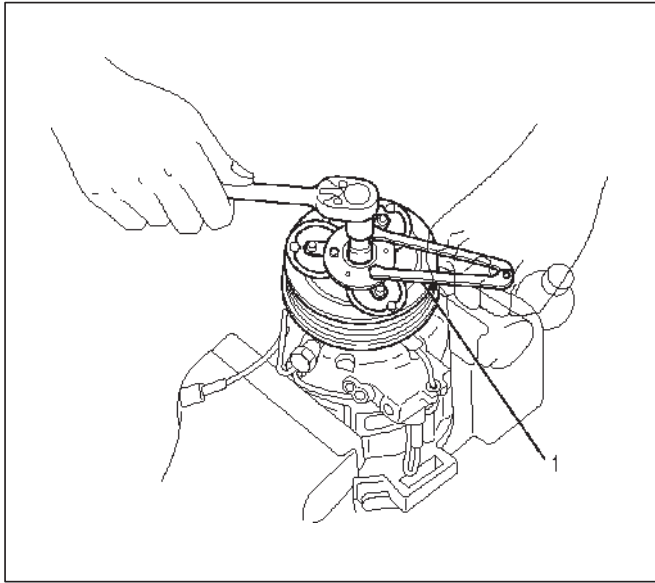
4. Install snap ring.

5. Install shim (s).

6. Install the drive plate to the compressor drive shaft together with the original shim(s)(1). Press the drive plate by hand.



7. Install drive plate bolt by using drive plate holder J-7624 (1) to prevent the drive plate from rotating.

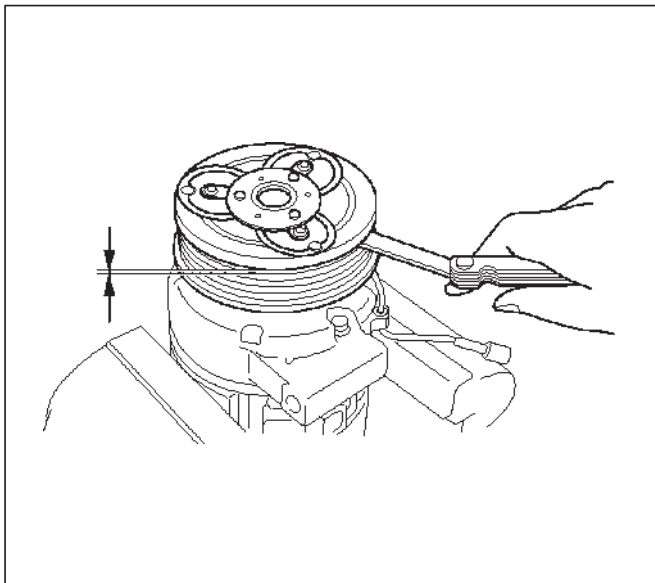


901RX065

- Tighten the drive plate bolt to the specified torque.

**Torque: 13 N·m (113 lb in)**

- After tightening the drive plate bolt, check to be sure the pulley rotates smoothly.
- Check to be sure that the clutch clearance is between 0.3-0.6 mm (0.01-0.02 in.)



871RX014

- If necessary, install adjusting shim(s).
- Adjusting shims are available in the following thickness.

**Thickness**

- 0.1 mm (0.0039 in.)
- 0.3 mm (0.0118 in.)
- 0.5 mm (0.0197 in.)

## Compressor Oil

### Oil Specification

- The HFC-134a system requires a synthetic (PAG) compressor oil.
- Compressor (PAG) oil varies according to compressor model. Be sure to use oil specified for the model of compressor.
- **Always use HFC-134a Vane Rotary Type Compressor Oil (AIPDN Part No.2-90188-301-0)**

### Handling of Oil

- The oil should be free from moisture, dust, metal powder, etc.
- Do not mix with other oil.
- The water content in the oil increases when exposed to the air. After use, seal oil from air immediately. (HFC-134a Vane Rotary Compressor Oil absorbs moisture very easily.)
- The compressor oil must be stored in steel containers, not in plastic containers.

### Compressor Oil Check

The oil used to lubricate the compressor is circulating with the refrigerant.

Whenever replacing any component of the system or a large amount of gas leakage occurs, add oil to maintain the original amount of oil.

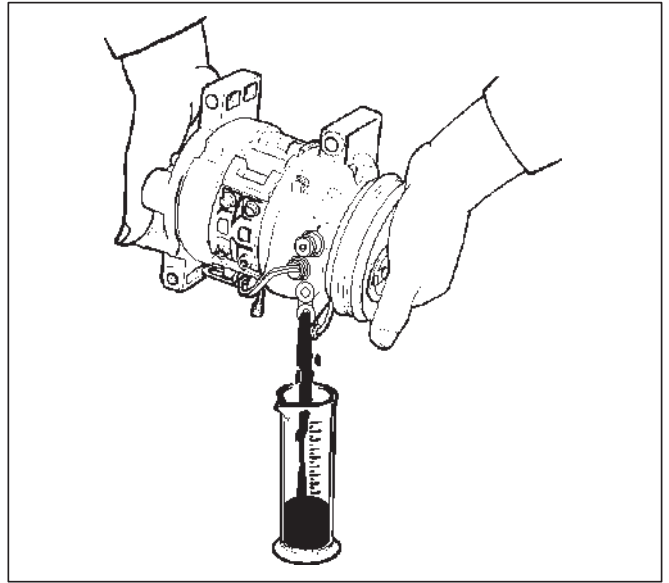
#### Oil Capacity

**Capacity total in system: 150cc (5.0 fl.oz)**

**Compressor (Service parts) charging amount: 150 cc (5.0 fl.oz)**

### Checking and Adjusting Oil Quantity for Used Compressor

1. Perform oil return operation. Refer to Oil Return Operation in this section.
2. Discharge and recover refrigerant and remove the compressor.
3. Drain the compressor oil and measure the extracted oil with a measuring cylinder.



4. If the amount of oil drained is much less than 90 cc (3.0 fl. oz.), some refrigerant may have leaked out. Conduct a leak tests on the connections of each system, and if necessary, repair or replace faulty parts.
5. Check the compressor oil contamination. (Refer to Contamination of Compressor Oil in this section.)
6. Adjust the oil level following the next procedure below.

(Charging Amount)	(Collected Amount)
more than 90cc (3.0 fl.oz)	same as collected amount
less than 90 cc (3.0 fl.oz)	90cc (3.0 fl.oz)

7. Install the compressor, then evacuate, charge and perform the oil return operation.
8. Check system operation.

**When it is impossible to preform oil return operation, the compressor oil should be checked in the following order:**

1. Discharge and recover refrigerant and remove the compressor.
2. Drain the compressor oil and measure the extracted oil with a measuring cylinder.
3. Check the oil for contamination.
4. If more than 90 cc (3.0 fl. oz.) of oil is extracted from the compressor, supply the same amount of oil to the compressor to be installed.
5. If the amount of oil extracted is less than 90 cc (3.0 fl. oz.), recheck the compressor oil in the following order.
6. Supply 90 cc (3.0 fl. oz.) of oil to the compressor and install it onto the vehicle.

7. Evacuate and recharge with the proper amount of refrigerant.
8. Perform the oil return operation.
9. Remove the compressor and recheck the amount of oil.
10. Adjust the compressor oil, if necessary.

(Collected Amount)	(Charging Amount)
more than 90 cc (3.0 fl.oz)	same as collected amount
less than 90 cc (3.0 fl.oz)	90 cc (3.0 fl.oz)

### Checking and Adjusting for Compressor Replacement

150 cc (5.0 fl.oz.) of oil is charged in compressor (service parts). So it is necessary to drain the proper amount of oil from the new compressor.

1. Perform oil return operation.
2. Discharge and recover the refrigerant and remove the compressor.
3. Drain the compressor oil and measure the extracted oil.
4. Check the compressor oil for contamination.
5. Adjust the oil level as required.

(Amount of oil drained from used compressor)	(Draining amount of oil from new compressor)
less than 90 cc (3.0 fl.oz)	Same as drained amount
more than 90 cc (3.0 fl.oz)	90 cc (3.0 fl.oz)

6. Evacuate, charge and perform the oil return operation.
7. Check the system operation.

### Contamination of Compressor Oil

Unlike engine oil, no cleaning agent is added to the compressor oil. Even if the compressor runs for a long period of time (approximately one season), the oil never becomes contaminated as long as there is nothing wrong with the compressor or its method of use.

**Inspect the extracted oil for any of the following conditions:**

- The capacity of the oil has increased.
- The oil has changed to red.
- Foreign substances, metal powder, etc., are present in the oil.

**If any of these conditions exists, the compressor oil is contaminated. Whenever contaminated compressor oil is discovered, the receiver/drier must be replaced.**

### Oil Return Operation

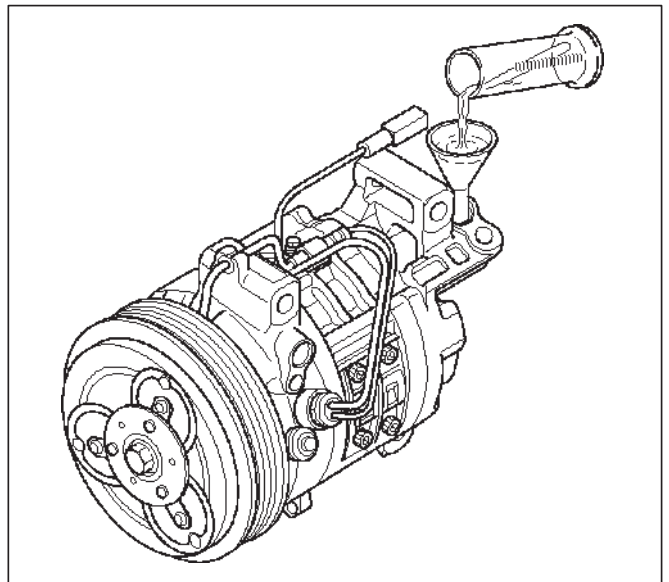
There is close affinity between the oil and the refrigerant. During normal operation, part of the oil recirculates with the refrigerant in the system. When checking the amount of oil in the system, or replacing any component of the system, the compressor must be run in advance for oil return operation. The procedure is as follows:

1. Open all the doors and the engine hood.
2. Start the engine and air conditioning switch to "ON" and set the fan control knob at its highest position.
3. Run the compressor for more than 20 minutes between 800 and 1,000 rpm in order to operate the system.
4. Stop the engine.

### Replacement of Component Parts

When replacing the system component parts, supply the following amount of oil to the component parts to be installed.

(Component parts to be installed)	(Amount of Oil)
Evaporator	50 cc (1.7 fl. oz.)
Condenser	30 cc (1.0 fl. oz.)
Receiver/dryer	30 cc (1.0 fl. oz.)
Refrigerant line (one piece)	10 cc (0.3 fl. oz.)



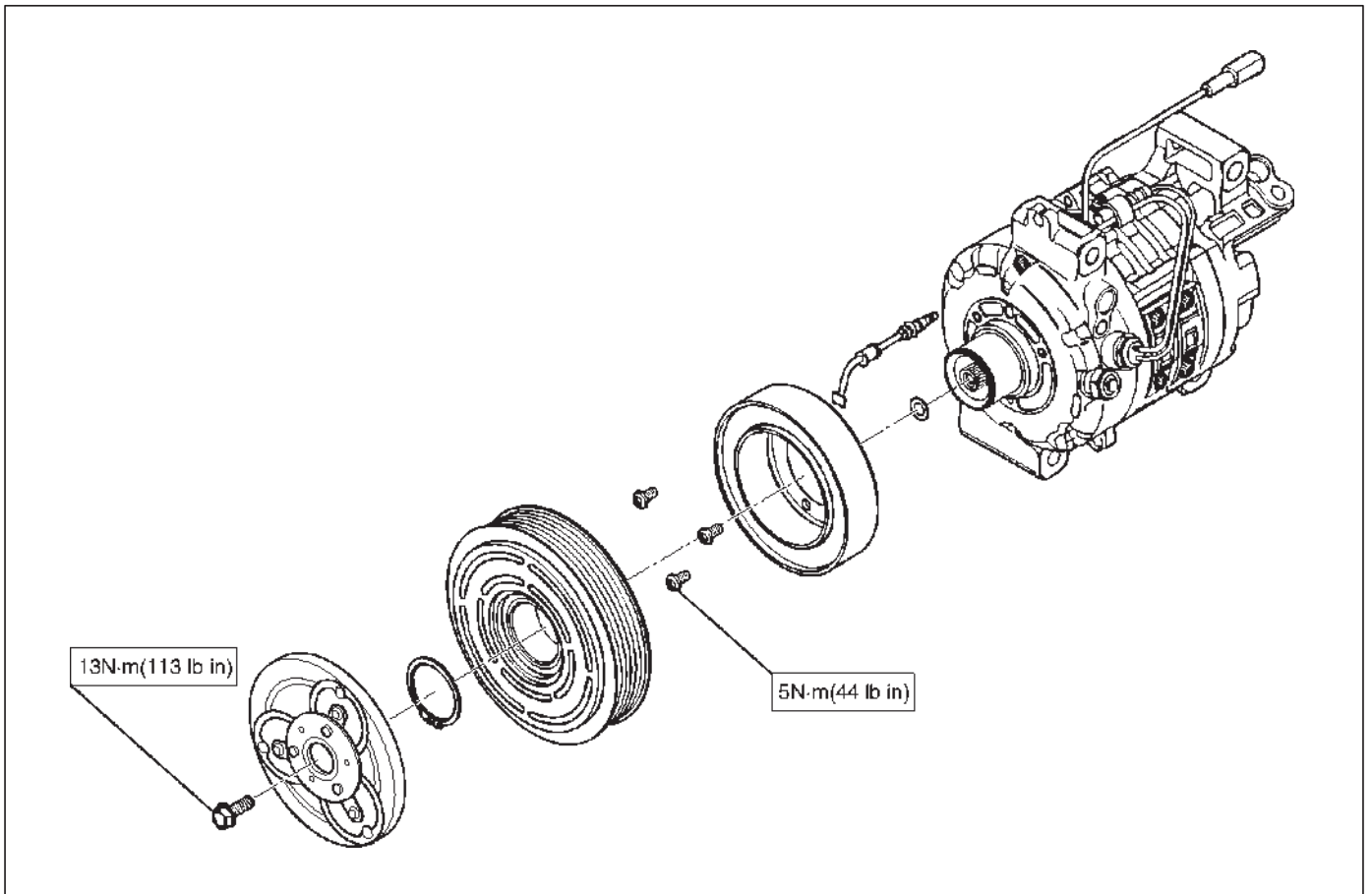
871RX013

## Main Data and Specifications

### General Specifications

<b>COMPRESSOR</b>	
Model	DKV-14D
Type	Vane rotary type
Number of vanes	5
Rotor diameter	64 mm (2.52 in.)
Stroke	8.75 mm (0.34 in.)
Displacement	140 cc (47.3 fl.oz.)
Maximum speed	7,000 rpm (up to 8,500 rpm)
Direction of rotation	Clockwise (Front-side view)
Lubrication system	Pressure differential type
Lubricant	R-134a Vane Rotary Type Compressor Oil (AIPDN Part No.2-90188-301-0) 150 cc (5.0 fl.oz.)
Refrigerant	Refrigerant-134a (R-134a), 650 g (1.43 lbs.)
Shaft seal	Lip type
Weight	3.6 kg (7.94 lbs.)
<b>MAGNETIC CLUTCH</b>	
Type	Electromagnetic single-plate dry clutch
Rated voltage	12 Volts D.C.
Current consumption	3.7 A
Starting torque	49 N·m (36 lb-ft)
Direction of rotation	Clockwise (Front-side view)
Weight	2.4 kg (5.3 lbs.)

Torque Specifications



**Special Tools**

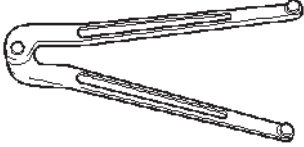
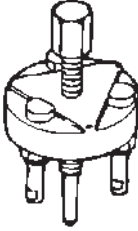

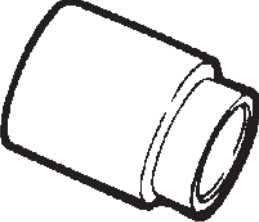
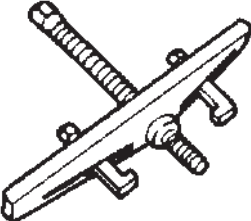
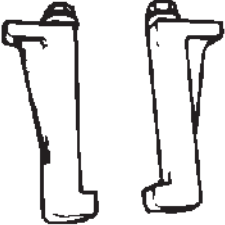
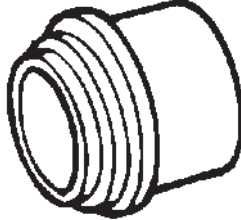
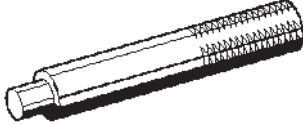
ILLUSTRATION	TOOL NO. TOOL NAME
 <p>901RS195</p>	<p><b>J-7624</b> Clutch plate holder</p>
 <p>901RS192</p>	<p><b>J-33944-A</b> Drive plate puller</p>
 <p>901RS193</p>	<p><b>J-33944-4</b> Forcing screw</p>
 <p>901RS194</p>	<p><b>J-38424</b> Pulley puller pilot</p>
 <p>901RS196</p>	<p><b>J-8433</b> Pulley puller</p>
 <p>901RS196</p>	<p><b>J-24092-2</b> Pulley puller leg</p>

ILLUSTRATION	TOOL NO. TOOL NAME
 <p>901RS197</p>	<p><b>J-33940-A</b> Pulley installer</p>
 <p>901RS218</p>	<p><b>J-8092</b> Drive handle</p>



## Automatic Air Conditioning System

### General Description

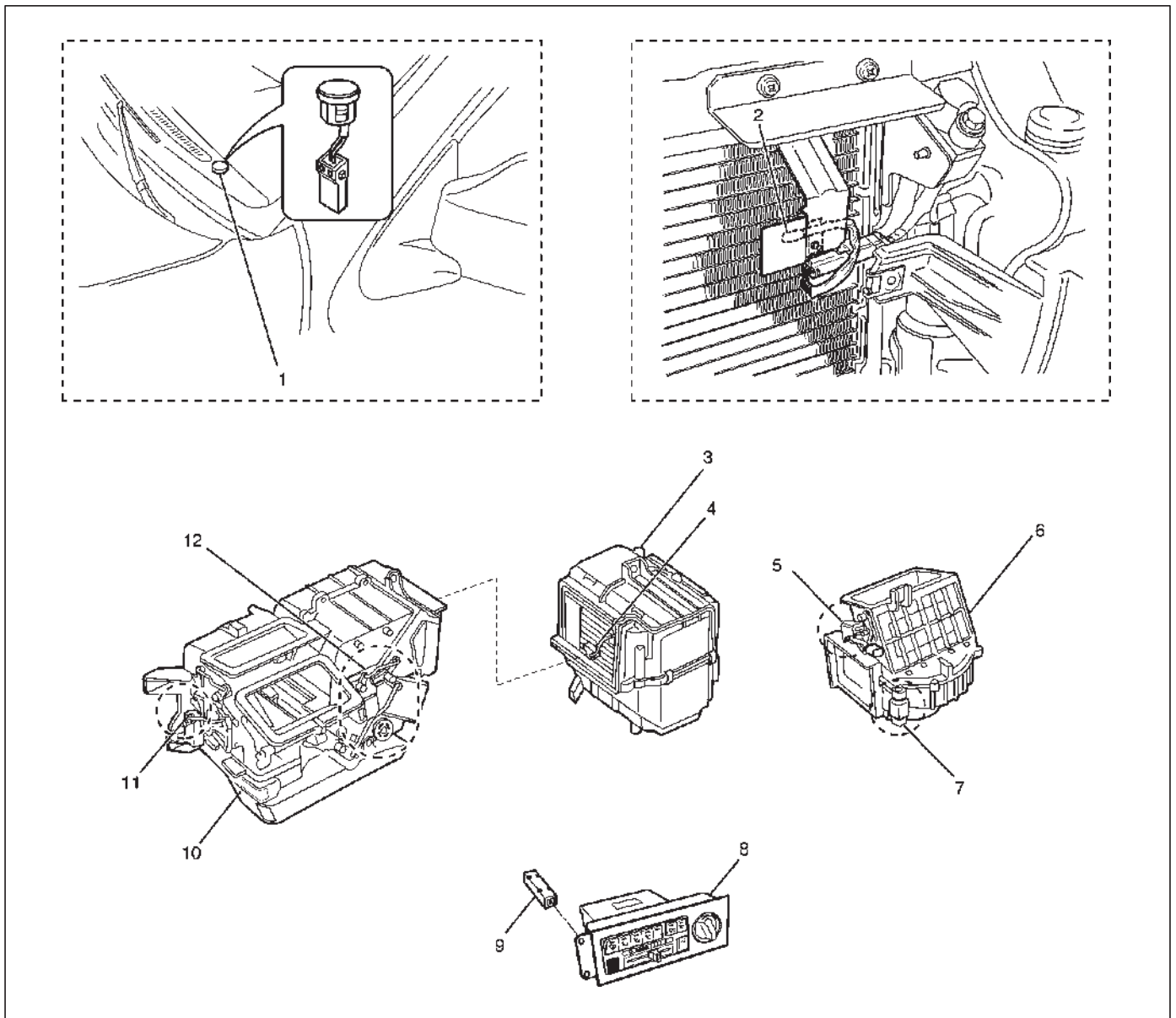
Using a variety of sensors, this automatic heater and air conditioner accurately senses outside air temperature, solar radiation quantity, evaporator's blowing temperature, and interior temperature, then enters these data to the automatic heater/air conditioner control unit (equipped with the built-in micro-computer). The data provided to the control unit enables to automatically control blow temperature and blow air quantity, turn on or

off the compressor and switch the blow port as well as switching between the fresh air intake and interior air circulation.

Resetting the automatic function allows you to switch to the manual control mode.

The self-diagnosis function of the automatic heater and air conditioner control unit (with the built-in micro-computer) allows the unit to access and diagnose a failed part easier and quicker.

### Full Automatic Air Conditioner Parts Configuration

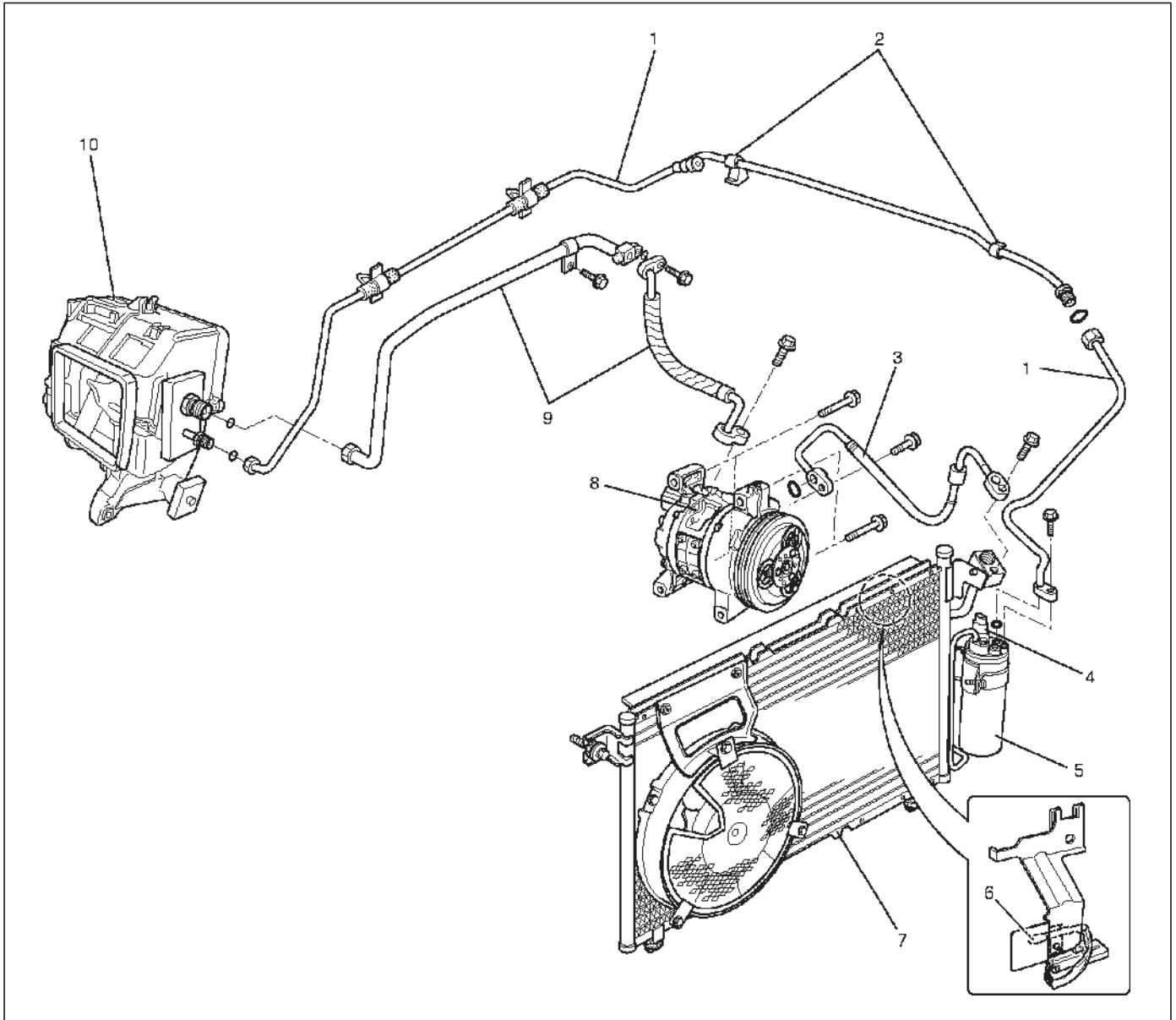


865RY00023

#### Legend

- |                         |  |
|-------------------------|--|
| (1) Sun Sensor          | (7) Max – High Relay                       |
| (2) Ambient Sensor      | (8) Automatic Air Conditioner Control Unit |
| (3) Evaporator Assembly | (9) In Car Sensor                          |
| (4) Duct Sensor         | (10) Heater Unit                           |
| (5) Intake Actuator     | (11) Mode Actuator                         |
| (6) Blower Unit         | (12) Mix Actuator                          |

## Refrigerant Line and Associated Parts

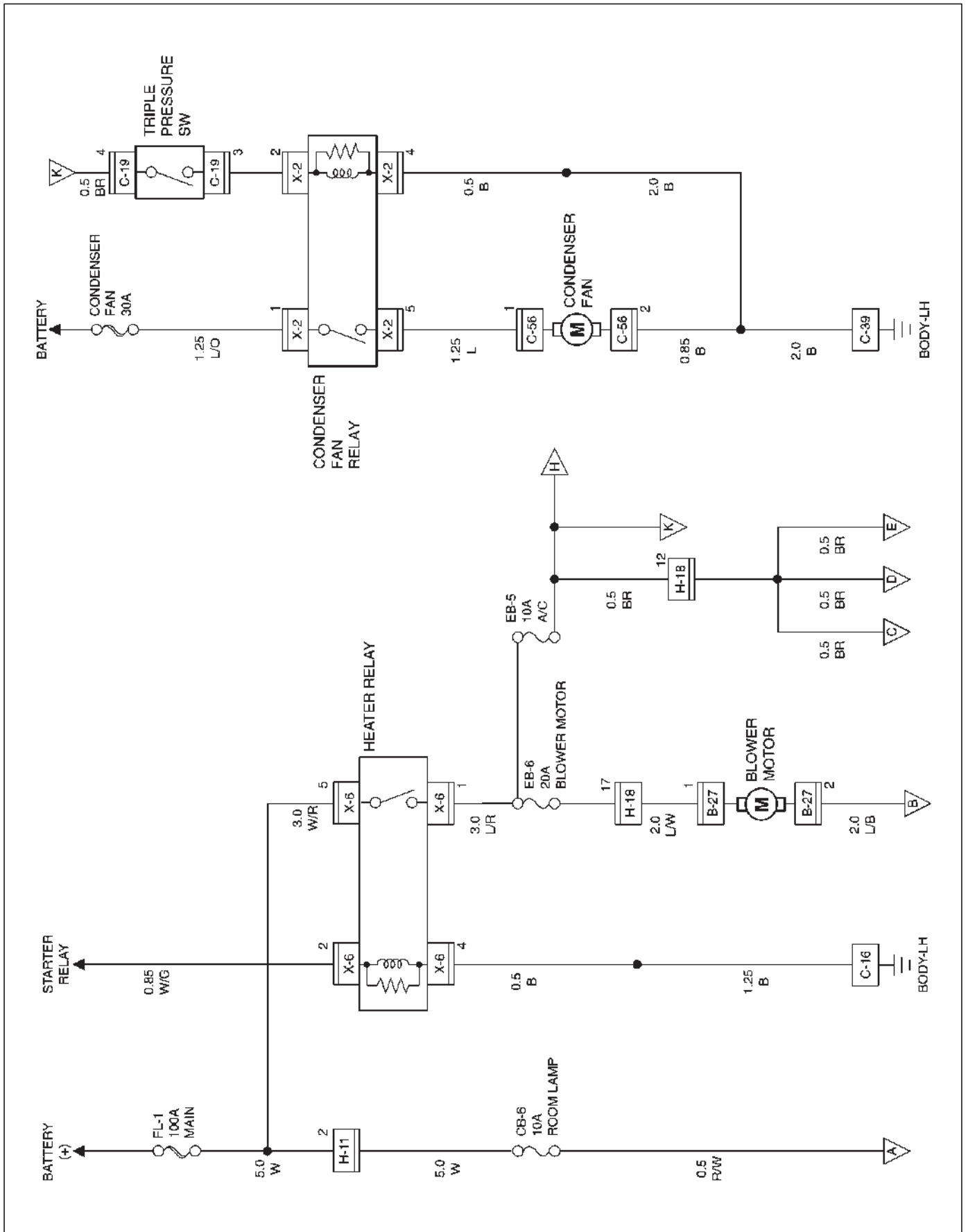


### Legend

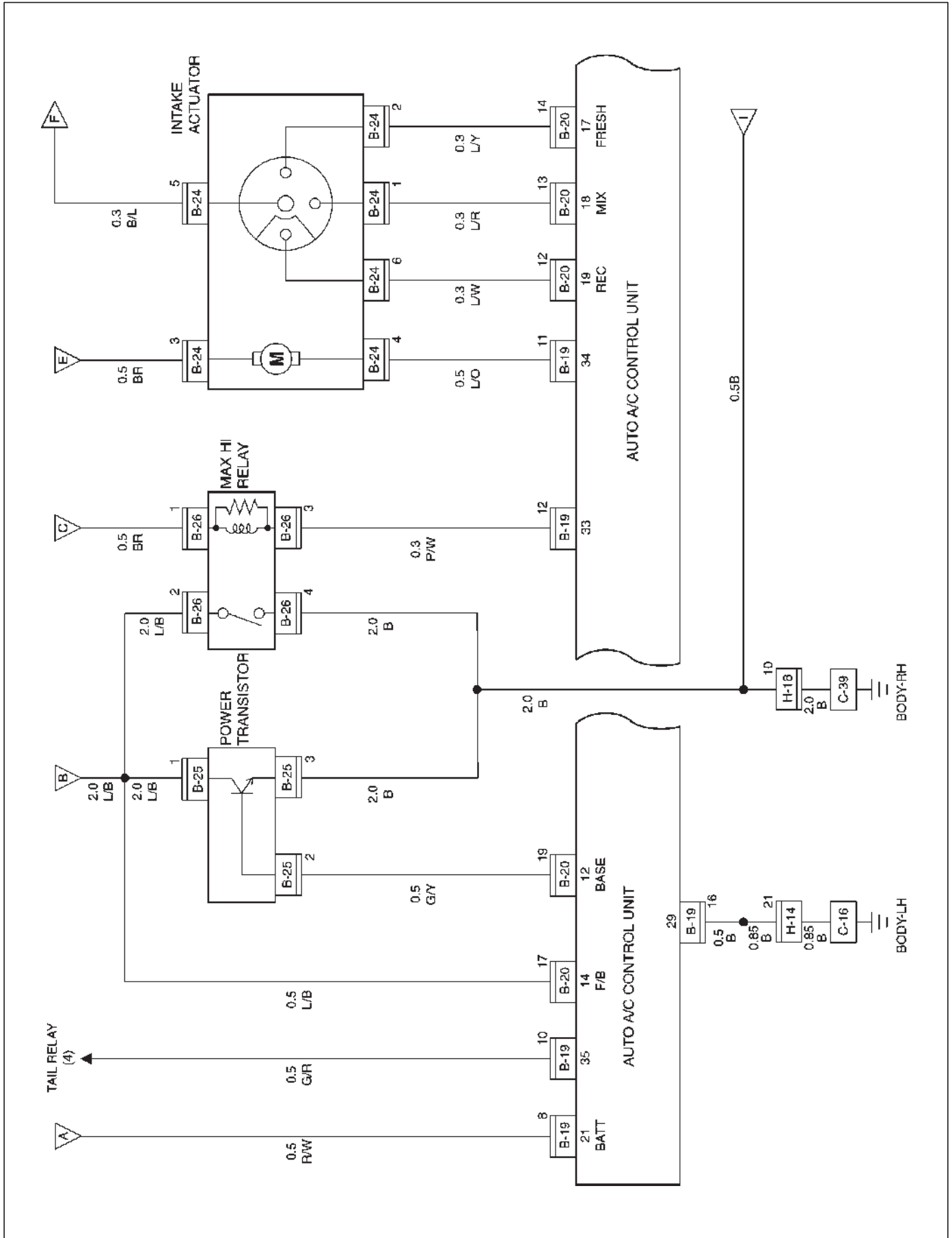
- |   |                                      |
|---|--------------------------------------|
| (1) Liquid Line (High Pressure Pipe)    | (6) Ambient Sensor                   |
| (2) Clip and Clamp                      | (7) Condenser Assembly               |
| (3) Discharge Line (High Pressure Hose) | (8) Compressor                       |
| (4) Pressure Switch                     | (9) Suction Line (Low-Pressure Hose) |
| (5) Receiver Drier                      | (10) Evaporator Assembly             |

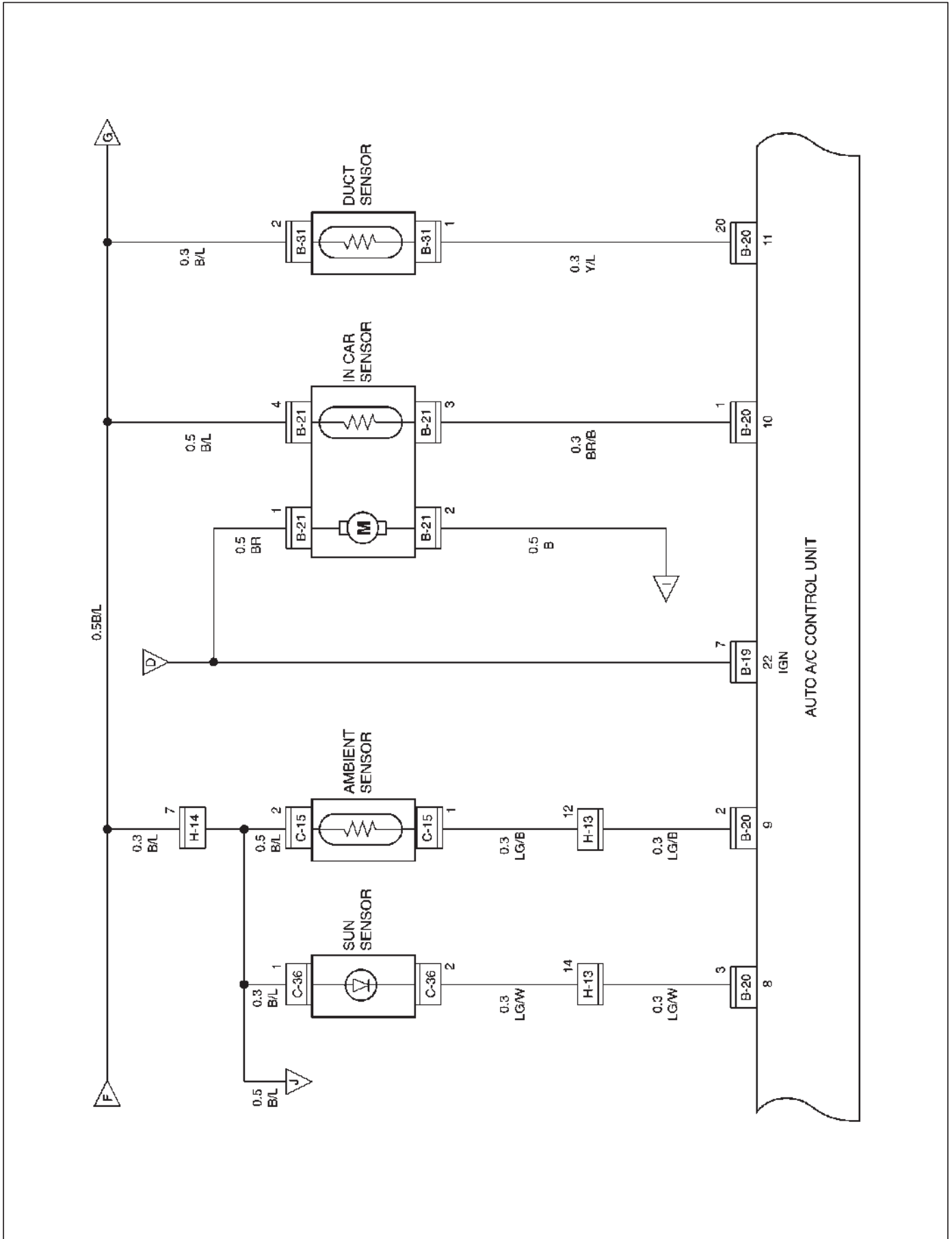
# Circuit Diagram

## 6VE1 Engine

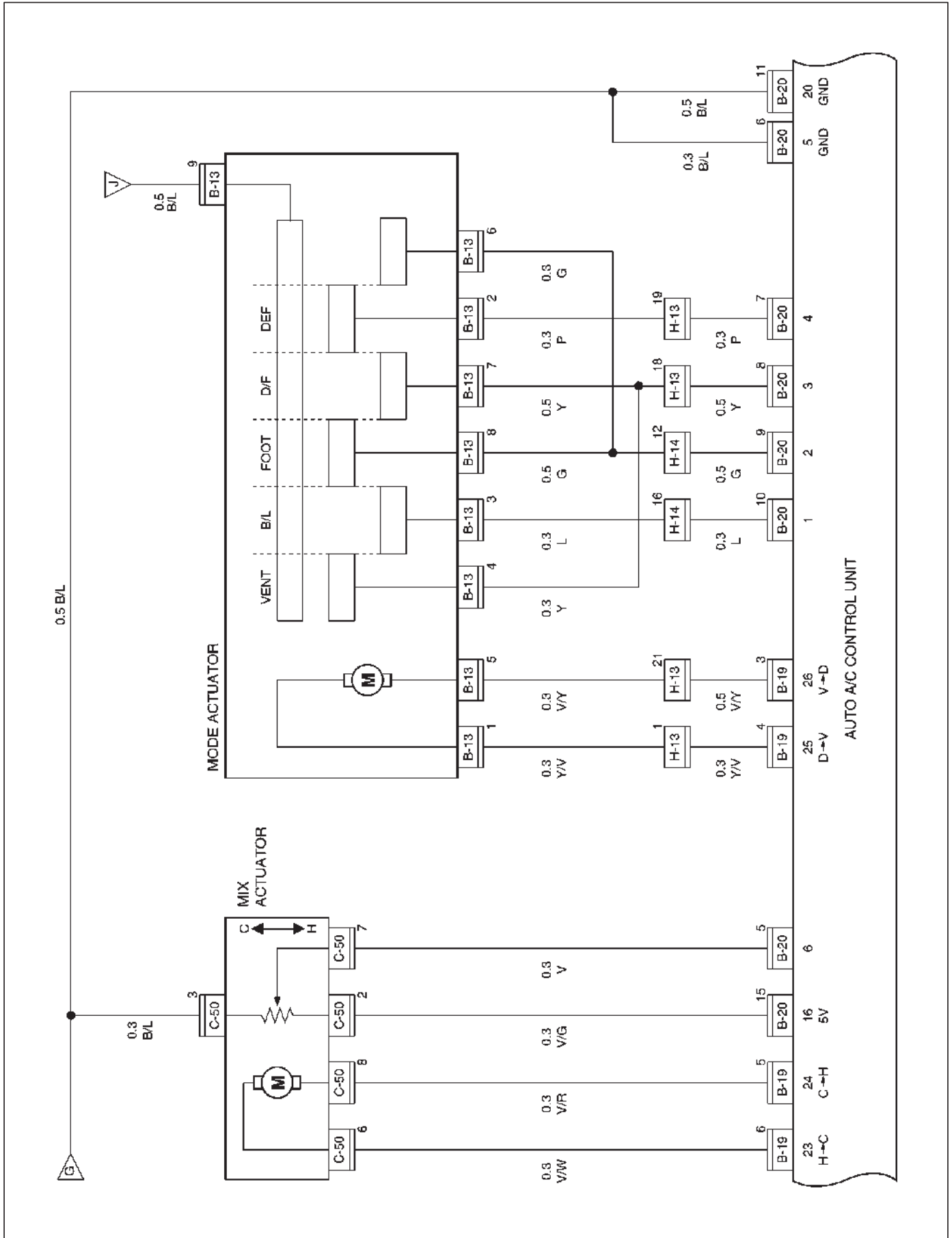


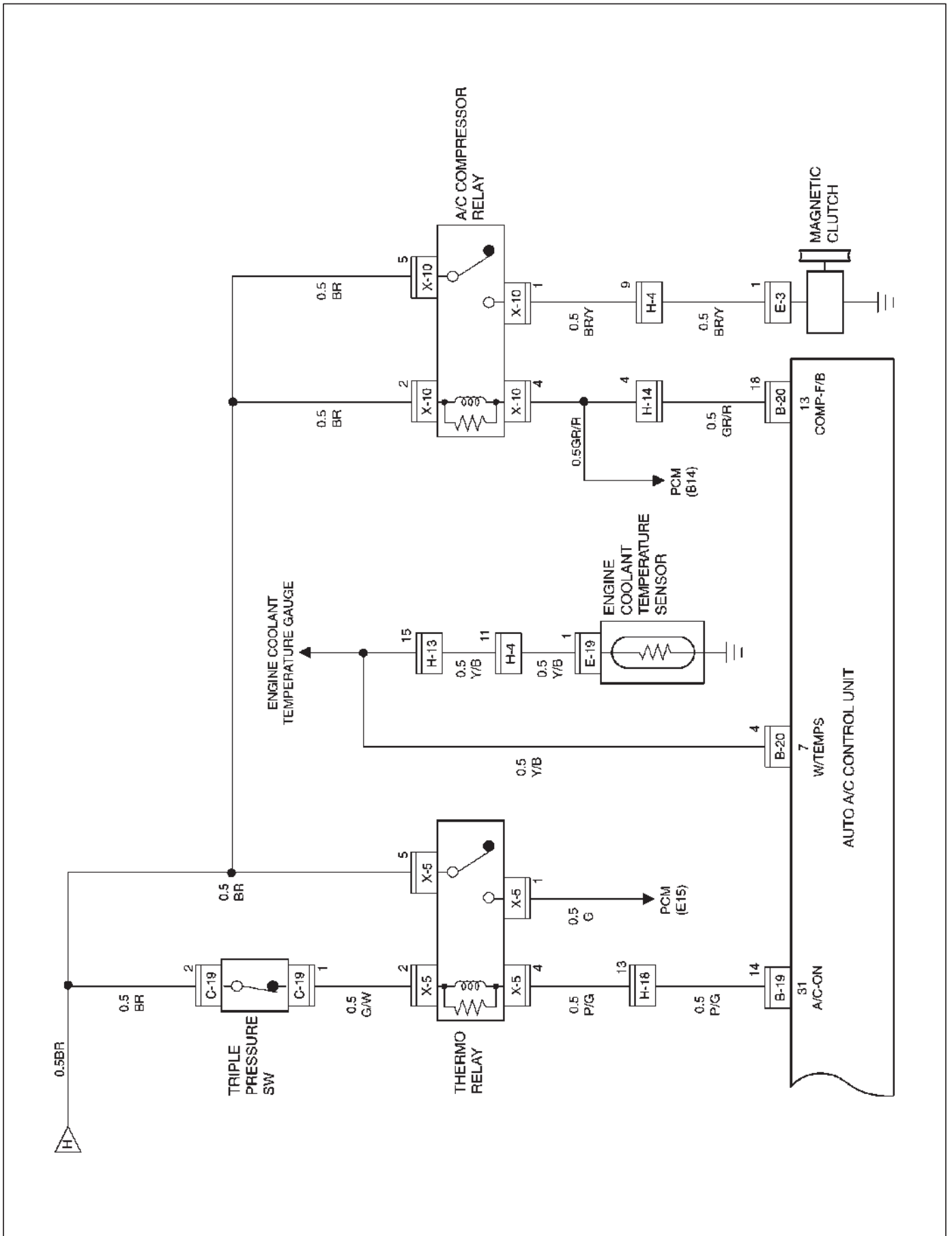
1A-90 HEATING, VENTILATION AND AIR CONDITIONING (HVAC)





1A-92 HEATING, VENTILATION AND AIR CONDITIONING (HVAC)





### Functions and Features

#### Automatic interior temperature control

This function enables to maintain the interior temperature at the level specified from the temperature control switch despite of changes in factors such as vehicle speeds, outside air temperature and number of passengers.

#### Maximum cooling and heating function

You can select FC (Full cool, namely maximum cooling temperature) or FH (Full heat, maximum heating temperature) from the temperature control lever.

#### Automatic air flow control

Air flow is automatically and consecutively fine tuned according to the specified interior temperature and changes in aperture of the heater unit mix door.

#### Mode (blow port) control

This function automatically selects either one of the VENT, BI-LEVEL, FOOT or DEF mode for the blow port according to changes of temperature on the blow port. Using the mode switch allows you to select a desired blow port manually.

#### Intake (switching between the fresh air intake and circulation of interior air) control

The intake (switching between fresh air intake and circulation of interior air) mode automatically selects either FRESH (fresh air intake), MIX or RECIRC (interior air circulation) according to changes of the blow port temperature. Using the intake switch allows you to select a desired intake port manually (in the manual operation, FRESH and RECIRC modes alone are available). Pressing the DEF (defrost) mode switch selects the FRESH (fresh air intake).

#### Cooler start-up timing control

This function is used for maintaining the air flow at "LOW" level until the evaporator is sufficiently cooled down. It is intended to prevent a large volume of hot air being blowing into inside of a vehicle when the cooler is turned on in hot summer season.

#### Heater start-up timing control

This function is used for maintained the air flow at "LOW" level and also for maintaining the defrost mode until temperature of coolant in the heater core is sufficiently heated. It is intended to prevent a large volume of cool air being blown into inside of a vehicle when the heater is turned on in cold winter season.

#### Solar radiation quantity offset control

The photodiode on the sun sensor determines solar radiation quantity accurately to offset interior temperature quickly.

#### Switch position storing function

This function is used for storing switch positions being selected in the immediately preceding operation, namely the last time the ignition has been turned off. It simplifies the setup procedures when restarting

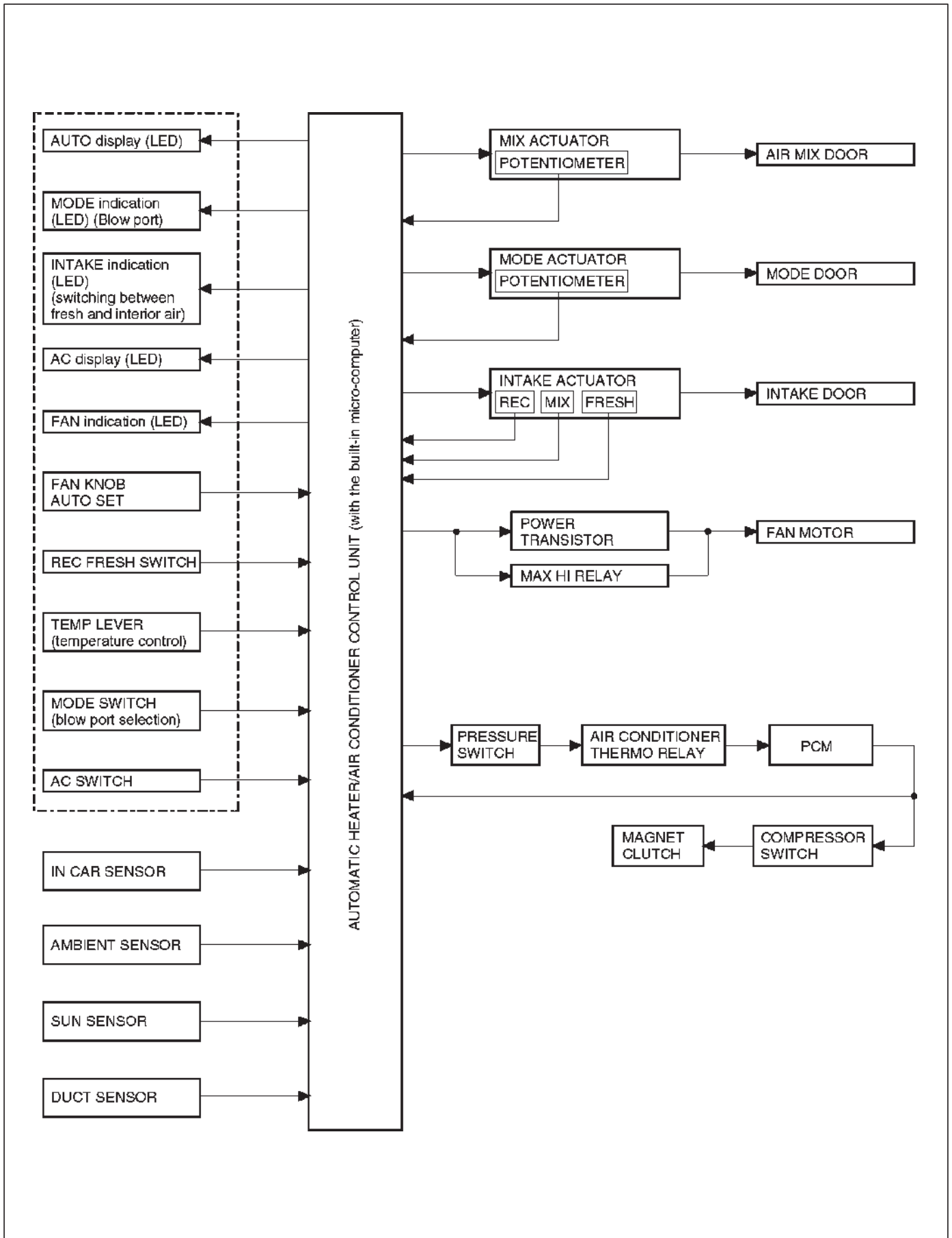
the system.

#### Self-diagnosis function

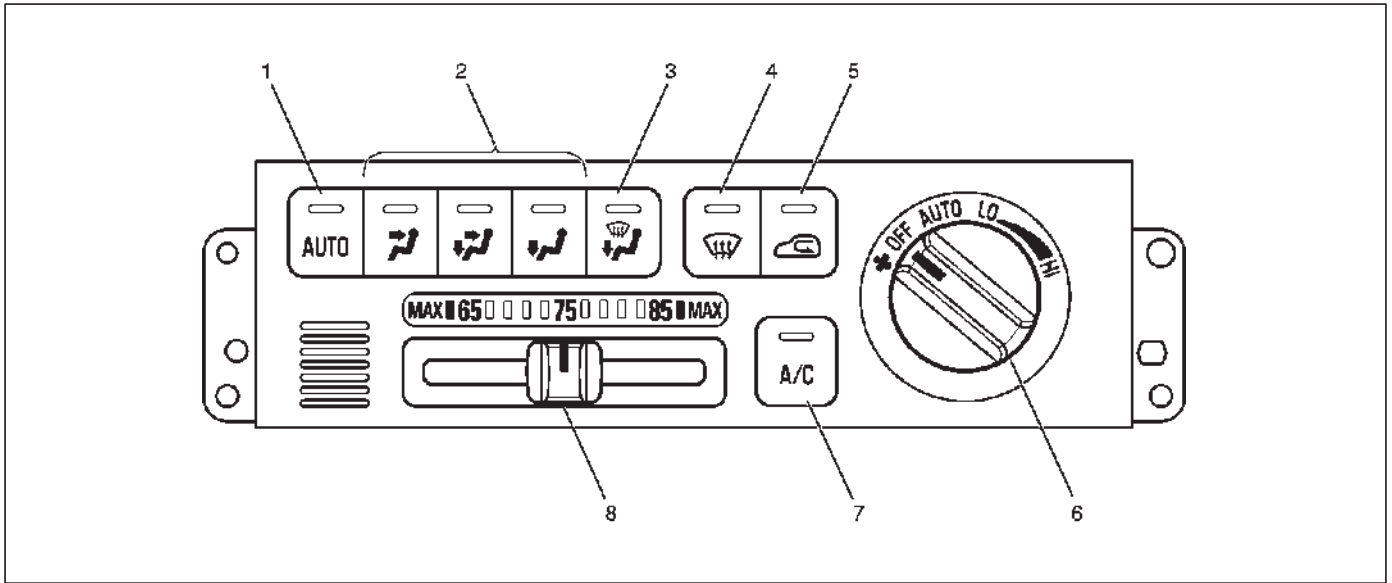
The self-diagnosis function turned on from the panel switch makes your troubleshooting easier (for detail of this function, refer to the section titled "Self-Diagnosis").



### Automatic Air Conditioner Block Diagram



## Control Panel Layout

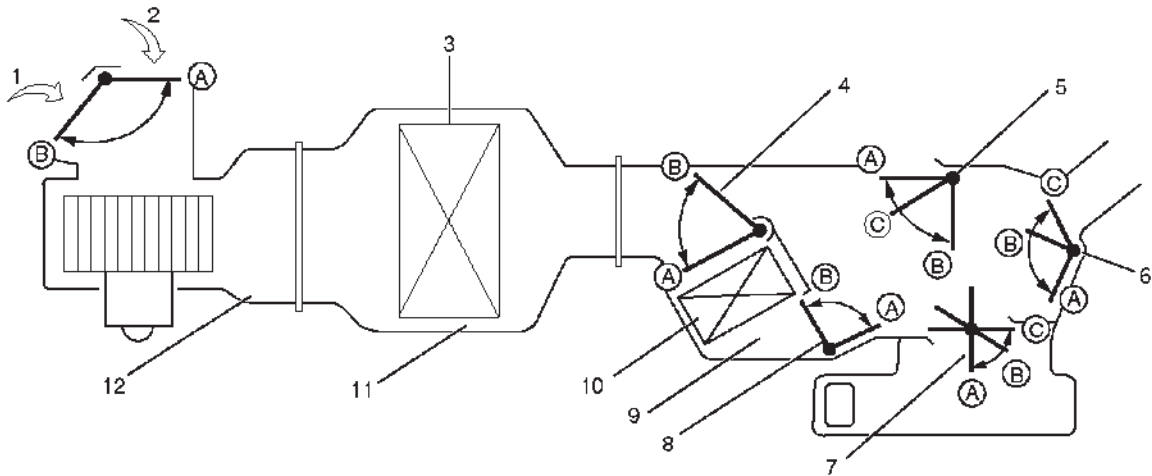


865RY00019

### Legend

- |                     |                              |
|---------------------|------------------------------|
| (1) Auto Switch     | (5) Intake Switch            |
| (2) Mode Switch     | (6) Fan Switch               |
| (3) DEF/FOOT Switch | (7) Air Conditioning Switch  |
| (4) DEF Switch      | (8) Temperature Control Knob |

**Air Control Functions**



	Mode Position					Display of Intake Status		Set Temperature		
	VENT	BI-LEVEL	FOOT	DEF/FOOT	DEF	 ON OFF		Blue	White	Red
								FULL COLD	65-85°C	FULL HOT
Vent Door	(A)	(B)	(C)	(C)	(C)	—	—	—	—	—
Foot Door	(C)	(B)	(A)	(B)	(C)	—	—	—	—	—
DEF Door	(A)	(A)	(A)	(C)	(B)	—	—	—	—	—
Intake Door	—	—	—	—	—	(A)	(B)	—	—	—
Air Mix Door	—	—	—	—	—	—	—	(A)	(A)~(B)	(B)
Sub Air Mix Door	—	—	—	—	—	—	—	(B)	(B)~(A)	(A)

C01RY00004

**Legend**

- (1) Interior Air Intake
- (2) Fresh Air Intake
- (3) Evaporator Core
- (4) Air Mix Door
- (5) DEF Door
- (6) VENT Door
- (7) FOOT Door
- (8) Sub Air Mix Door
- (9) Heater Unit
- (10) Heater Core
- (11) Evaporator Unit
- (12) Blower Unit

## Operation and Functions of Control Panel Switches

### Auto Switch

1. Pressing this switch turns on the automatic control mode. It resets all manual switches except that for the fan control. However, when the Manual REC is selected for the intake or the Manual Open is selected, the modes are maintained.
2. It causes the A/C (air conditioner) to the ON mode (this function, however, available only when the fan is turned on and also the compressor is turned on because of the given outside air temperature level).

#### Indication

- The AUTO LED is turned off.
- Currently selected mode for the Mode and Intake are respectively indicated.

### DEF Switch

Press this switch to select the DEF mode.

Blow port	Intake port	A/C	MIX
DEF	Auto FRESH *1	ON mode *2	Auto

- \*1: When the manual REC is selected for the Intake, the manual REC is maintained.  
 \*2: The ON mode is enabled only when the fan is turned on, and also the compressor is turned on because of the given outside air temperature level.

#### Indication

- The AUTO LED is turned off.

- The A/C LED remains turned on even if the compressor has been turned off because of the given outside air temperature level. Pressing the air conditioning switch in this state turns off the A/C LED.

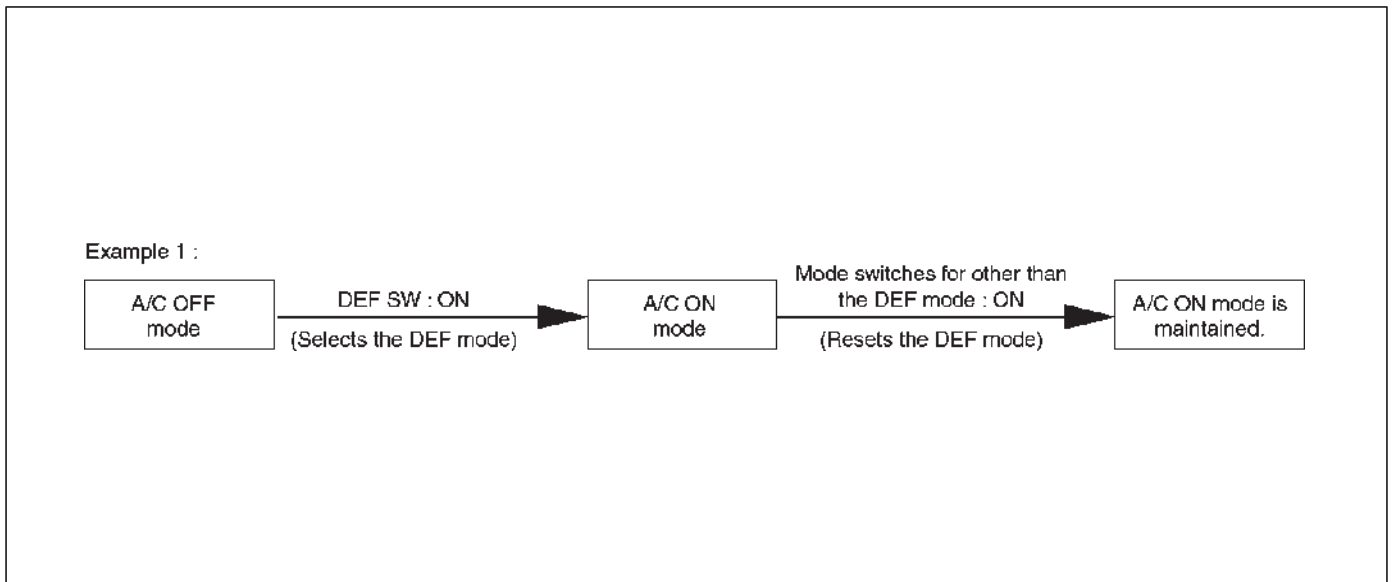
### Mode Switch

1. Pressing the VENT, B/L or FOOT switch selects the corresponding mode.
2. When the Auto is selected for the Mode and Intake, pressing the mode switch fixes the Intake to the immediately preceding status.

#### Indication

- The AUTO LED is turned off.
- Currently selected blow port is indicated.

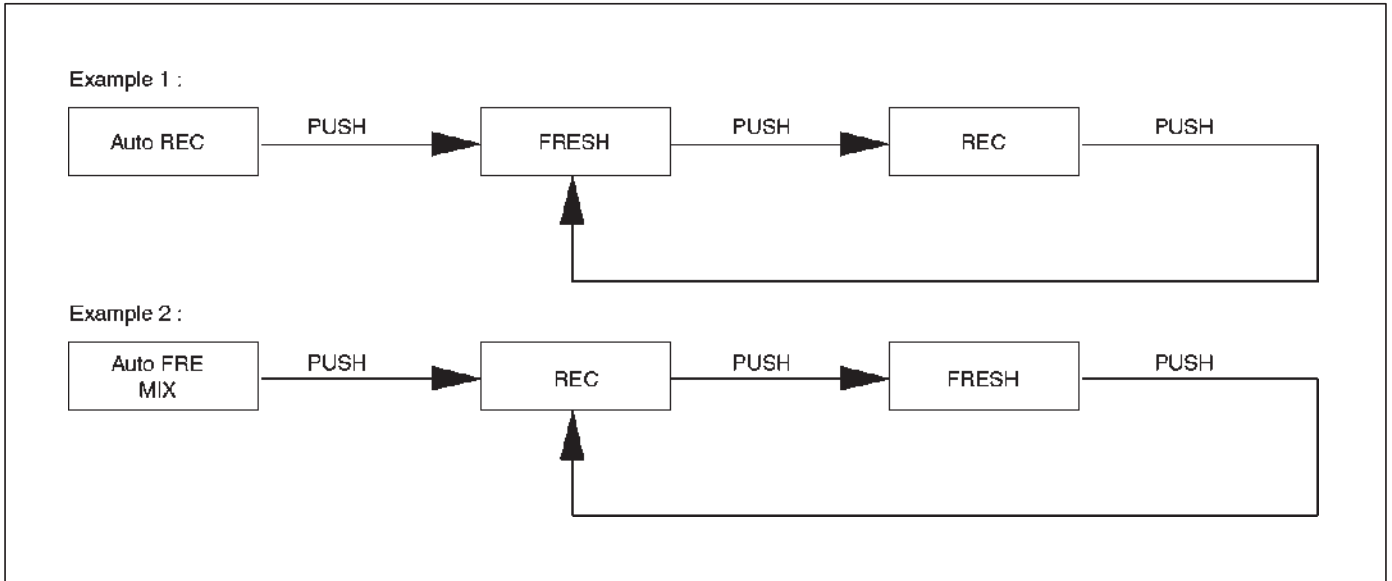
- The DEF LED and the A/C LED are turned on.
- The indication of the intake LED depends on the system condition.



F01RX006

### Intake Switch

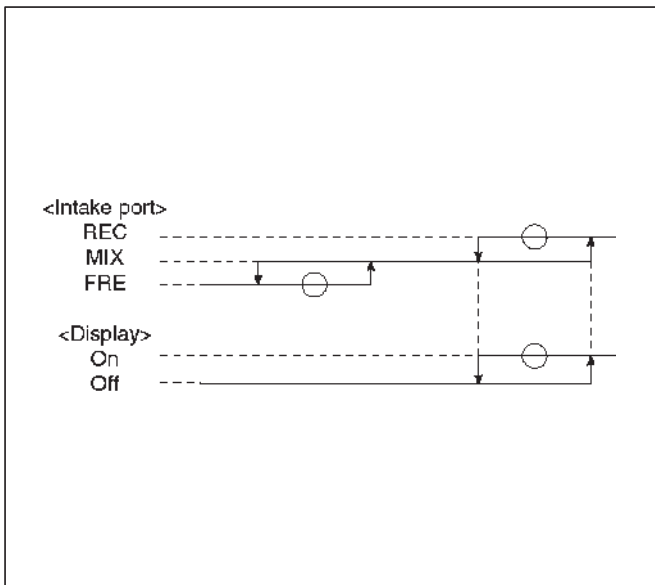
Pressing this switch sequentially selects a different intake port in the following order.



F01RY00010

**Indication**

- The Auto LED maintains unaffected.
- Currently selected intake port is indicated.



F01RX007

**Fan Switch**

1. Sets the fan to the specified mode.
2. Even when the fan switch is turned off, status display for the Mode, Intake is maintained.

**Temperature Control Knob**

1. This knob is operable only when the fan is turned on. It may be used for the MAX control of each block except the fan.
2. When the manual mode is selected for the fan control, this manual mode is maintained.

**MAX Control**

	Mix	Fan	Mode	Intake	A/C
MAX/COOL	Full cool	MAX/HI	VENT	REC*1 *2	Current status is maintained
MAX/HEAT	Full hot	MAX/HI	FOOT*3	FRESH *2	Current status is maintained

\*1: While the A/C system is off, "FRESH" is selected automatically.  
When the "DEF" or "D/F" switch is turned on, "FRESH" is selected automatically.

\*2: While the A/C system is on, the intake mode is selected by depending on the operation of the mode switch.

\*3: When the heating system is turned on, "DEF" is selected automatically.

## 1A-100 HEATING, VENTILATION AND AIR CONDITIONING (HVAC)

### Indication

- As long as the MAX control is selected, the immediately preceding indication shall be maintained for the AUTO.
- Status display is provided for others.

### Air Conditioning Switch

Pressing this switch turns on or off the A/C (air conditioning) control. (The compressor remains turned off if the fan is turned off and also the compressor has been turned off because of the given outside air temperature level.)

### Indication

1. The A/C LED remains turned on even if the compressor has been turned off because of the given outside air temperature level. In this case, however, the AUTO or DEF switch must be turned on and the A/C ON mode must also be turned on (by the MAX/C mode).
2. Pressing the A/C switch from the above state (1) turns off the A/C LED.

## Overview of Construction, Movement and Control of Major Parts of Automatic Air Conditioner System

### Automatic Heater/Air Conditioner Control Unit

Equipped with the built-in micro-computer, this control unit operates on signals from sensors and input signals from switches to offer total control of the blower fan, and actuators used for the mode door, intake door and air mix door.

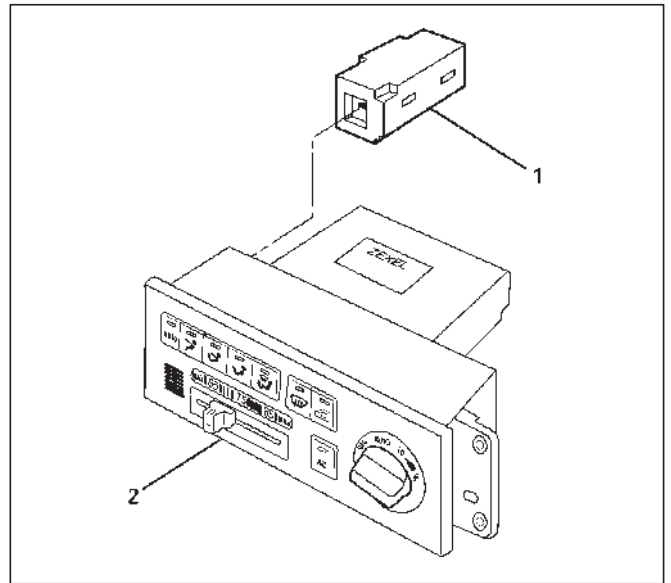
Its self-diagnosis function enables quicker access to a failed part and its more accurate troubleshooting.

### In Car Sensor

It is a sensor used for detecting room temperature of a vehicle. This sensor converts a given room temperature into a resistance value before entering the data to the automatic heater/air conditioner control unit.

This in car sensor unites the power driven aspirator and the motor fan so that a small amount of room air may be constantly fed to the sensor.

This sensor is provided on the control panel.



865RY00020

### Legend

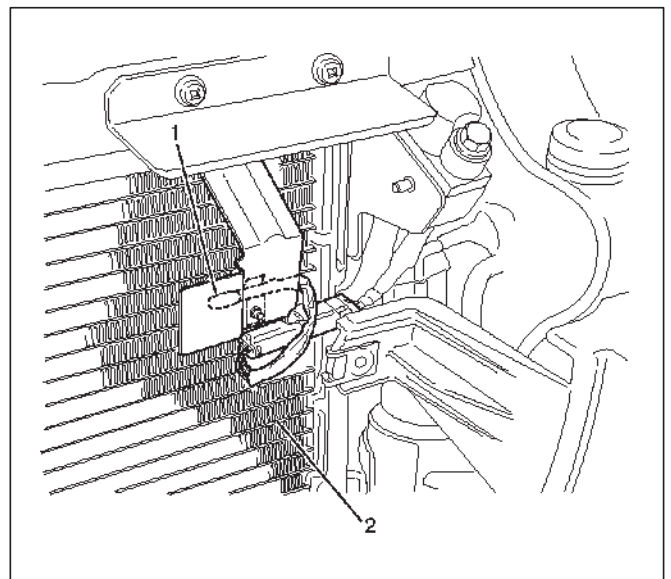
- (1) In Car Sensor
- (2) Automatic Air Conditioner Control Unit

### Ambient Sensor

This sensor is used for detecting temperature outside the vehicle. It converts a given outside air temperature into a resistance value before entering the data to the automatic heater/air conditioner control unit.

Thermal effects from the condenser and radiator during idling after a run can be measured and offset the automatic amplifier.

This sensor is provided on the side plate situated at upper right side of the condenser.



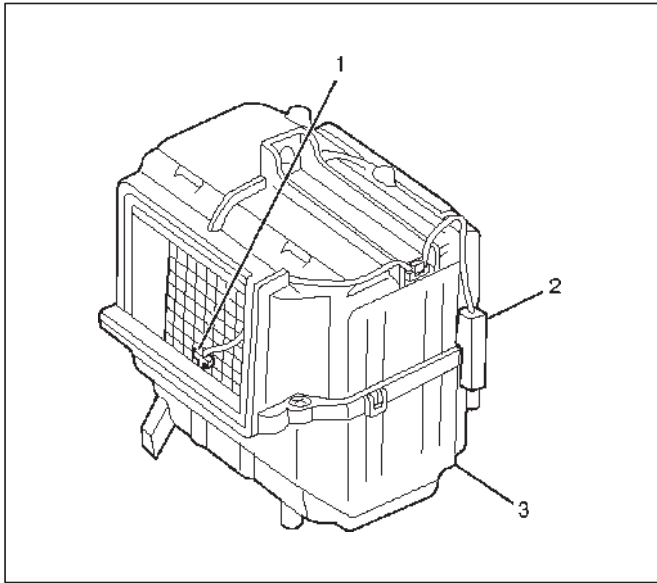
875RY00014

### Legend

- (1) Ambient Sensor
- (2) Condenser Assembly

**Duct Sensor**

The duct sensor is the sensor to detect temperature change of the side of evaporator blower coming by fresh recirculation of intake door or “on” “off” of compressor. The temperature is converted to resistant rate. And it works as thermostat to control to prevent freezing of evaporator. This sensor is installed in the upper case of evaporator.



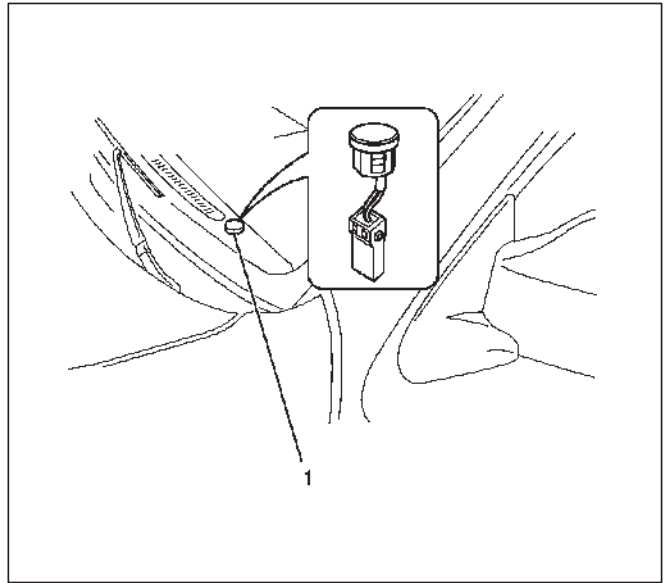
860RY0007

**Legend**

- (1) Duct Sensor
- (2) Electro Thermo
- (3) Evaporator

**Sun Sensor**

It is a photodiode used for detecting quantity of solar radiation. This sensor converts the offset signal generated by changes in the interior temperature (which results from fluctuations in solar radiation) into photoelectric current to enter into the automatic heater/air conditioner control unit. This sensor is provided at top of the defroster grill.



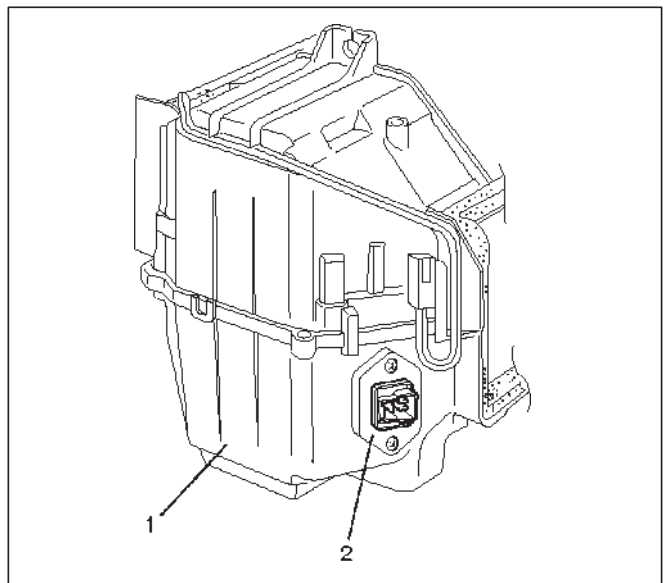
865RY00021

**Legend**

- (1) Sun Sensor

**Power Transistor**

Receiving base current from the automatic heater/air conditioner control unit, the power transistor implements stage-less speed change of the blower fan motor. This transistor is provided on the evaporator.



874RY00011

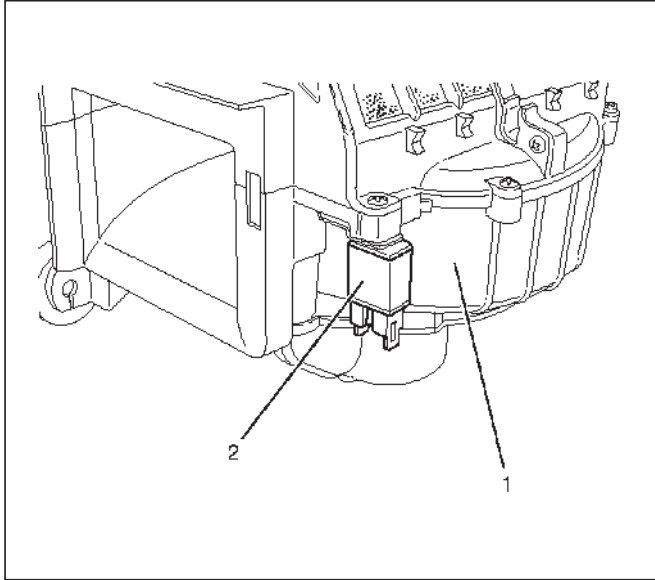
**Legend**

- (1) Evaporator Assembly
- (2) Power Transistor

## 1A-102 HEATING, VENTILATION AND AIR CONDITIONING (HVAC)

### Max Hi Relay

This relay turned on or off by the signal from the automatic heater/air conditioner control unit. As the Max Hi relay is turned on, supply voltage is directly fed to the blower fan motor to select the Max Hi mode.



873RY00005

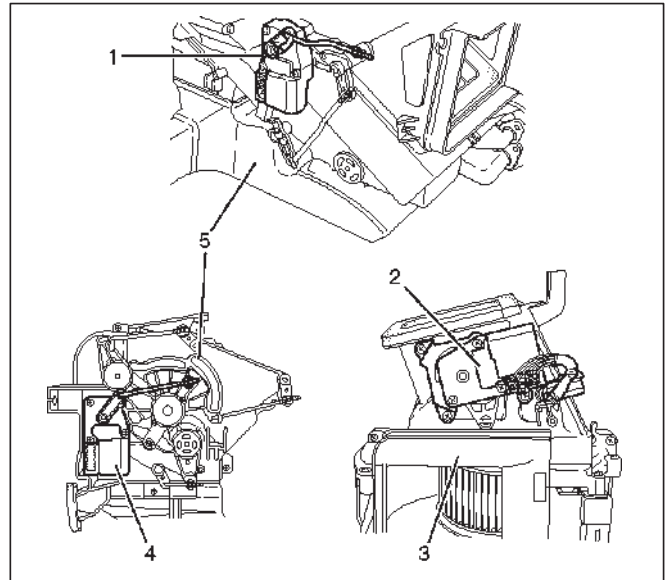
#### Legend

- (1) Blower Unit
- (2) Max High Relay

### Actuator

The actuators are power driven type containing a small motor. Receiving output current from the automatic heater/air conditioner control unit, actuators drive the heater and blower unit mode doors.

Actuators consist of the mode actuator used for switching the mode (blow port selection), the mix actuator used for changing aperture of the air mix door, the intake actuator used for switching the intake mode (fresh air/interior air) and the cold air bypassing actuator.



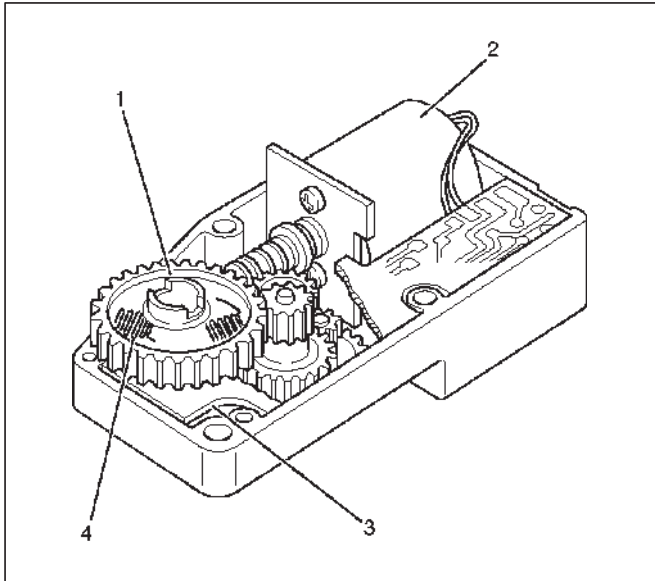
860RY00006

#### Legend

- (1) Mix Actuator
- (2) Intake Actuator
- (3) Blower Unit
- (4) Mode Actuator
- (5) Heater Unit



The actuator changes the motor speed using the gear and drives each door rotating the output axis united with the sliding contact.



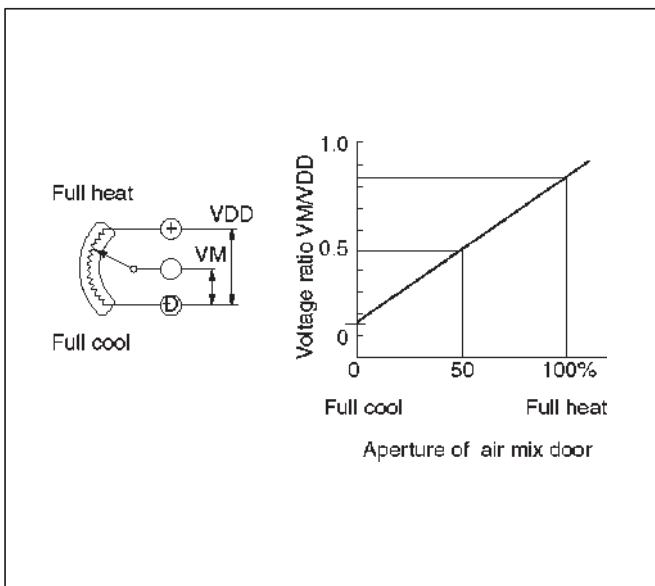
860RW026

**Legend**

- (1) Output Axis
- (2) Motor
- (3) Printed Circuit Board
- (4) Sliding Contact

The mode and mix actuators are common actuators with the built-in potentiometer. For the intake actuator, the contact switch type is selected.

The potentiometer is a register assembled to the printed circuit board of the mix and mode actuators. It detects the air mix door position specified by rotation of the output axis as a ratio of the variable terminal (VM) voltage against the reference voltage (VDD: 5V), then signals the value to the automatic heater/air conditioner control unit.



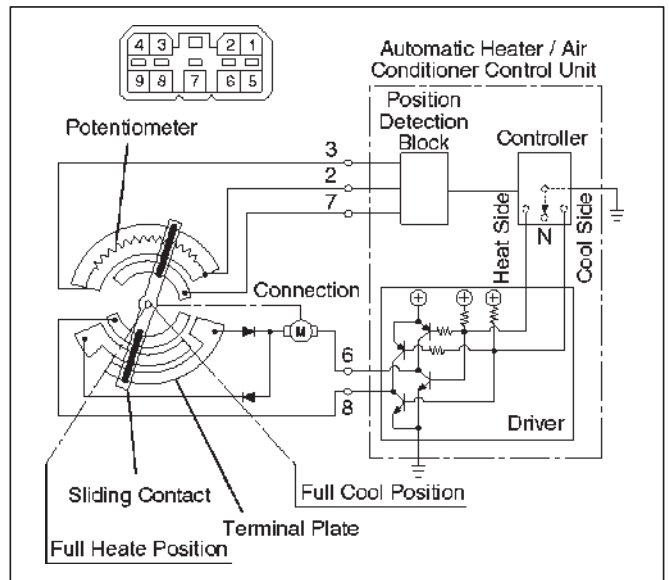
C01RX016

**Movement of Mix Actuator**

Position of the air mix door is determined by the controller on the automatic heater/air conditioner control unit.

As the heat or cool side of the controller is grounded, the transistor on the driver is activated and, thus, the motor rotation is turned on. The sliding contact connected to the motor sends the position detection signal from the potentiometer to the automatic heater/air conditioner control unit. As the set temperature and interior temperature are balanced, the controller returns to the neutral and the motor rotation is stopped.

I-45		Rotation direction	Remarks
(+) side	(-) side		
8	6	Clockwise	Full heat side
6	8	Counter clockwise	Full cool side



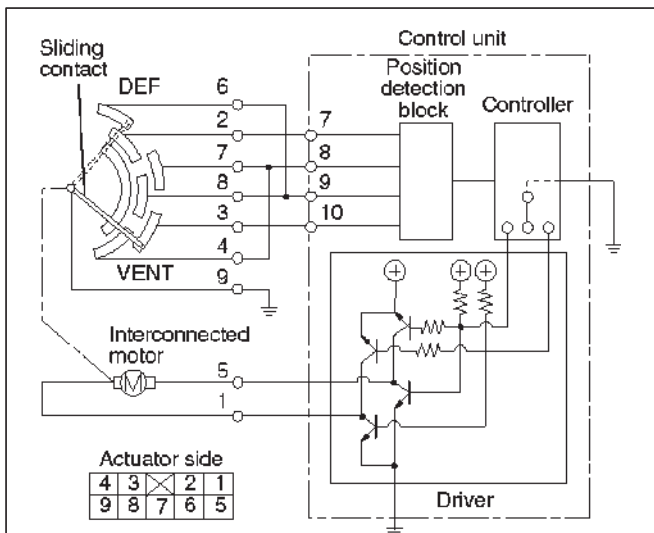
C01RX005

## 1A-104 HEATING, VENTILATION AND AIR CONDITIONING (HVAC)

### Movement of Mode Actuator

As target position of the mode door is decided on the controller of the control unit, the control unit reads the position detection signal from the actuator to select the clockwise or counter clockwise motor rotation direction. Grounding the controller VENT or DEF side after the direction selection activates the transistor on the driver, thus turning on the motor rotation. Accompanying the motor rotation, the sliding contact rotates, too. When the target position is reached, the controller on the control unit returns to the neutral and the motor stops.

Conduction pin		Rotation direction	Remarks
(+) side	(-) side		
5	1	Clockwise	VENT to DEF direction
1	5	Counter clockwise	DEF to VENT direction



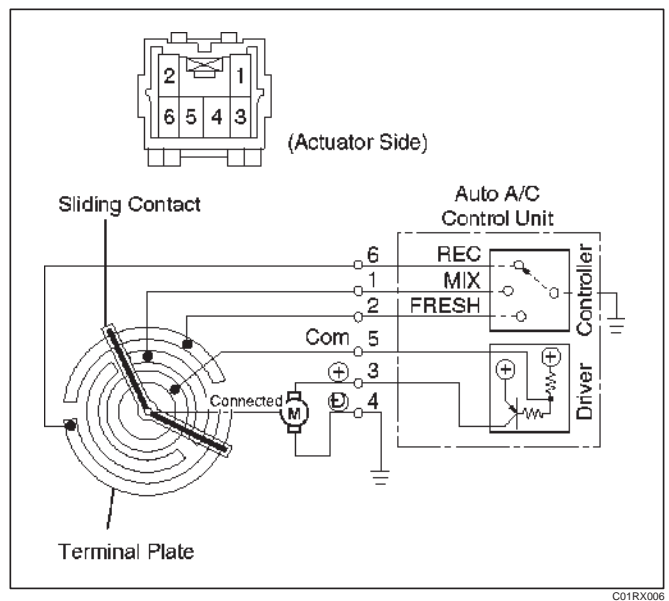
	7	8	9	10
VENT	H	L	H	L
Mid point between VENT - B/L	H	H	H	L
B/L	H	H	L	L
Mid point between B/L - FOOT	H	H	L	H
FOOT	H	L	L	H
Mid point between FOOT - D/F	H	L	H	H
D/F	L	L	H	H
Mid point between D/F - DEF	L	H	H	H
DEF	L	H	L	H

C01RX017

### Movement of Intake Actuator

The controller on the automatic heater/air conditioner control unit selects an intake mode to be used. As the Terminal No.5 I-49 is grounded via the sliding contact on the terminal plate, the transistor on the driver is activated, thus turning on the motor rotation. Then, accompanying move of the motor, the sliding contact rotates until grounding of the Terminal No.5 I-49 is removed, thus stopping the motor.

Grounding terminal	Rotation direction	Remarks
No.5 I-49	Clockwise	RE-CIRCULATION→MIX→FRESH



C01RX006

### Overview of Automatic Control of Automatic Air Conditioner

The full automatic heater and air conditioner on this vehicle has the following features:

- Interior temperature control.
- Air flow control.
- Mode (blow port) control.
- Intake (switching between fresh air and interior air) control.
- Heater start timing control.
- Cooler start timing control.
- Evaporator anti-freeze control.

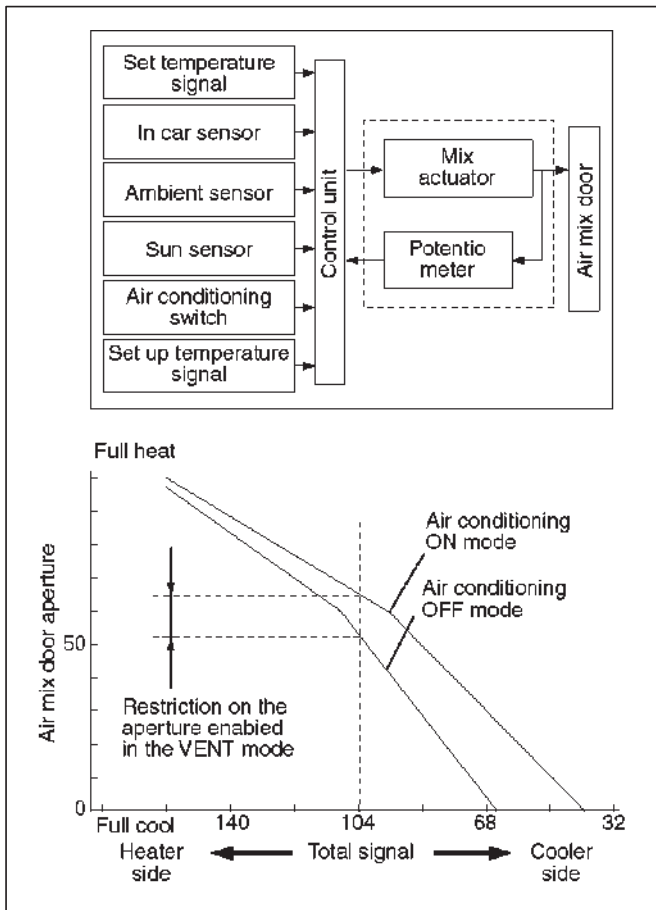
### Interior Temperature Control

The automatic heater/air conditioner control unit operates on the setup temperature signal from the temperature control switch and other sensor signals to derive the total signal. Then, the control unit compares this signal against the signal from the potentiometer to determine rotation direction of the mix actuator. The mix actuator moves the air mix door to the aperture specified by the total signal so that the specified interior temperature is achieved.

If the compressor is turned off in the A/C (air conditioning) mode, aperture of the air mix door is offset according to the outside air temperature or the specified interior temperature. This function removes the difference in the blowing temperature in this state and that of when the compressor is turned on.

When FH or FC is selected for the setup temperature, the air mix door is accordingly fixed to the Full Heat or Full Cool mode.

When the VENT mode is selected, aperture of the air mix door is controlled so that excessively heated air may not be blown from the VENT blow port.



C01RY00011

### Air Flow Control

#### In the Auto Mode

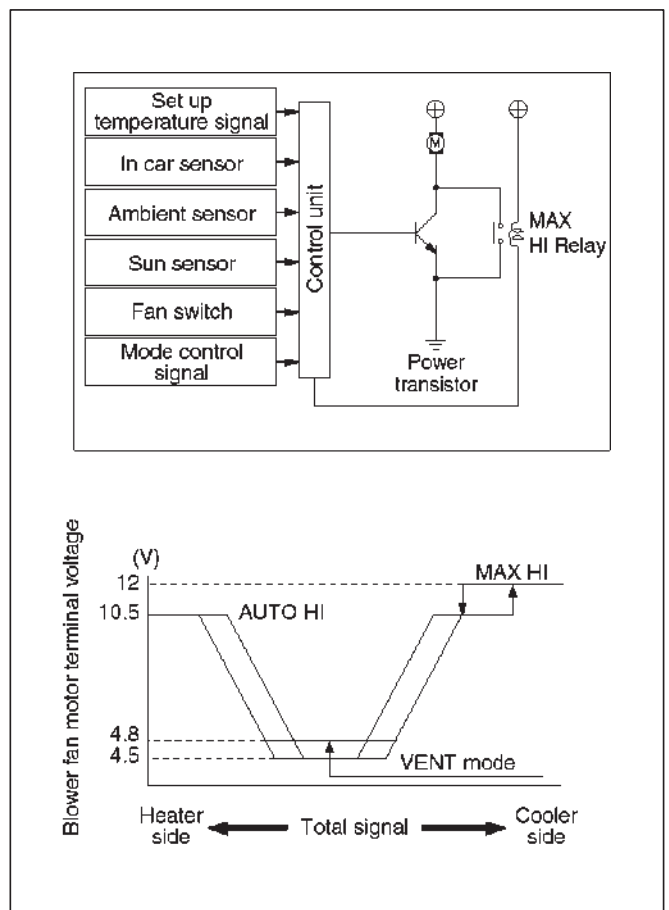
- The automatic heater/air conditioner control unit operates on the setup temperature signal and other sensor signals to derive the total signal. Then, the control unit adjusts base potential of the power transistor to match it to the voltage pattern of the target fan so that stage-less fan speed control can be achieved.

When solar radiation quantity is detected in the VENT or B/L mode, the control unit increases the minimum fan voltage to offset.

When FH or FC is selected from the temperature control switch, air flow is accordingly fixed to MAX HI or AUTO HI.

#### In the Manual Mode

- Air flow specified from the fan switch is entered to the automatic heater/air conditioner control unit as the manual signal. The signal modifies the air flow to the level specified from the fan switch so that the required fan voltage is attained.



C01RY00008

## 1A-106 HEATING, VENTILATION AND AIR CONDITIONING (HVAC)

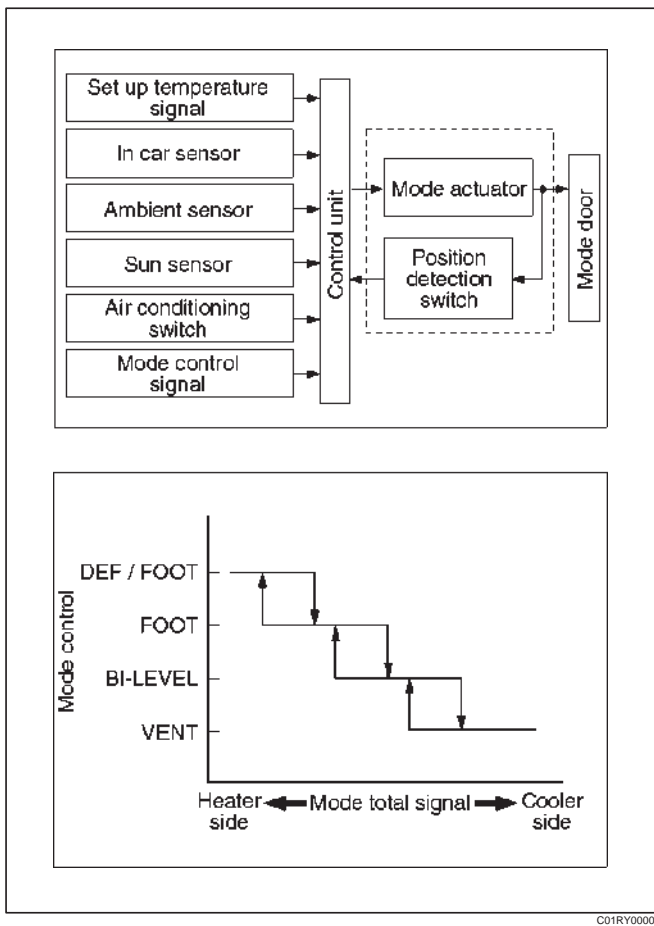
### Mode (Blow Port) Control

The automatic heater/air conditioner control unit operates on the setup temperature from the control switch, and temperature and solar radiation quantify from the sensors to determine the total mode control signal. According to the pattern specified by this signal, the control unit selects either one of the VENT, BI-LEVEL, FOOT or DEF/FOOT mode.

The mode actuator determines the rotation direction comparing the target position against the current position being determined by the position detection signal.

When FH or FC is selected for the temperature from the temperature control switch, mode is accordingly fixed to the VENT or FOOT.

- In the manual operation of the mode switch, you can select a desired blow port mode pressing the corresponding mode switch.
- Operating the DEF mode switch selects the DEF for the blow port mode.



C01RY0009

### Intake (Fresh air/interior air switching) Control

In the Full Auto mode, the automatic heater/air conditioner control unit operates on the setup temperature signal and other sensor input signals to derive the total signal. According to the pattern specified by this signal, the control unit provides the intake control. When the fan is turned off or the A/C (air conditioning) is turned off, the intake is fixed to the FRESH mode.

When FC or FH is selected from the control switch, the intake mode is accordingly fixed to the RECIRC or FRESH.

#### In the Manual Operation

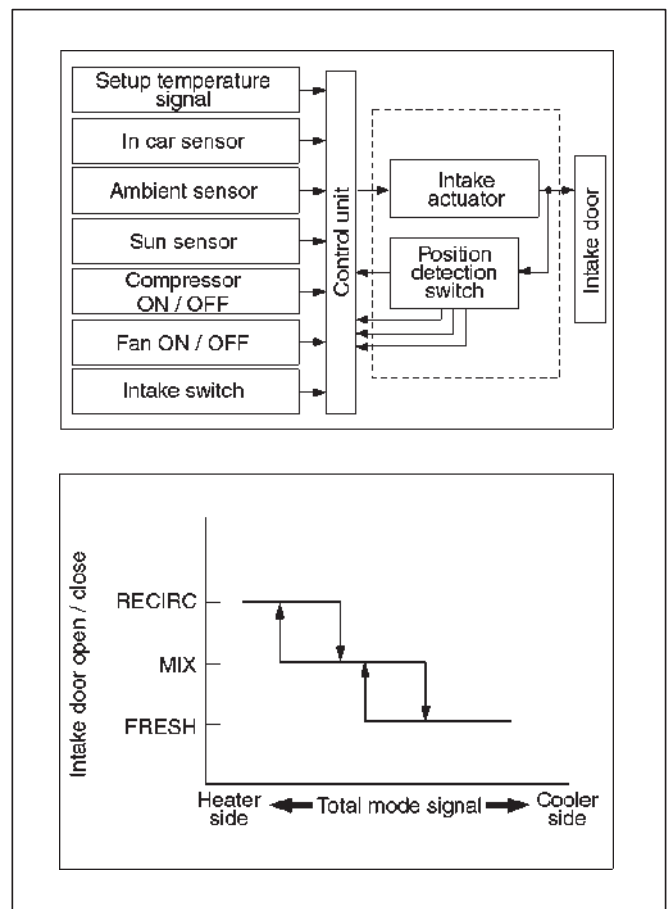
- Pressing the FRESH (fresh air intake) or the RECIRC (room air circulation) accordingly selects the FRESH or RECIRC mode.

#### When the DEF Mode Switch is depressed

- The intake mode is fixed to the FRESH. When the MANU REC is selected, however, the mode is fixed the RECIRC.

#### When the Mode Switch is depressed

- If the automatic intake control is selected, the intake is fixed to the currently selected mode.



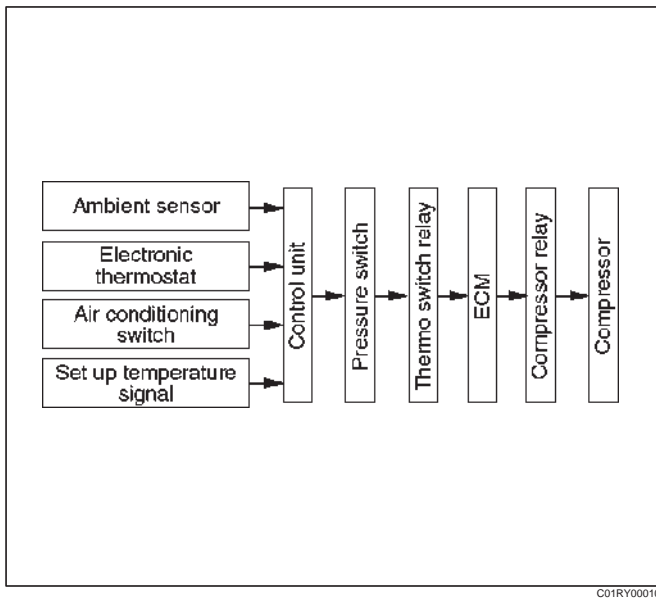
C01RY00012

### Compressor Control

In the automatic control mode, the automatic heater/air conditioner control unit turns on or off the compressor with the evaporator anti-freeze mechanism using the evaporation sensor. And, when outside air is detected to be low through the outside air temperature sensor signal, the control unit turns off the compressor using the compressor control function.

#### Manual Control

- In the automatic control mode, pressing the A/C (air conditioning) switch turns off the compressor.
- Pressing the DEF mode switch automatically turns on the compressor.



C01RY00010

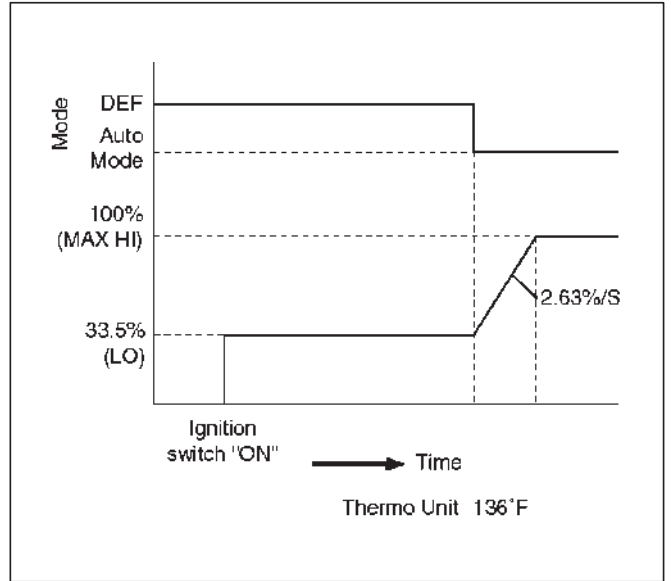
### Heating Start Timing Control

When the automatic heater/air conditioner is started, heating is turned on under following conditions.

- The detected temperature of thermo unit is 136°F or less.
- The temperature setting signal and the total signal by each sensor meet the condition of heating.

When the detected temperature by the coolant temperature sensor is 136°F or less, the blower fan motor is set to work at low speed and the “DEF” mode is selected.

When the detected temperature by the coolant temperature sensor is 77°F or more, the blow mode changes automatic control. And the blower fan speed is controlled to be lineally up from “LO” to “MAX HI”.



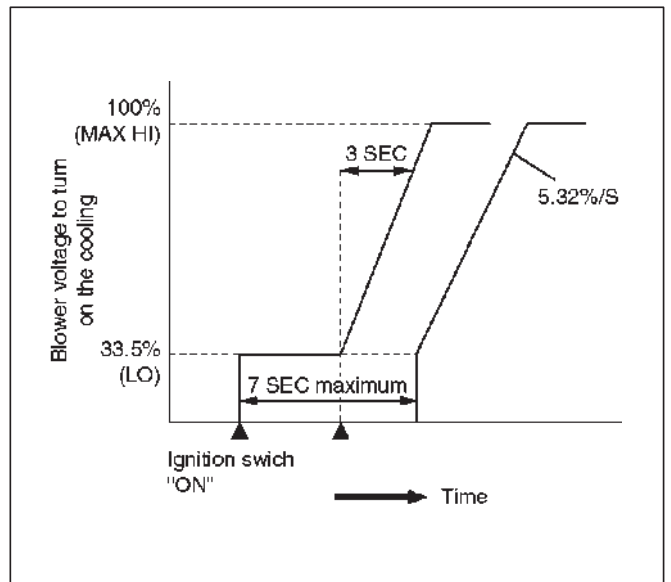
840RY00016

### Cooling Start Timing Control

When the automatic heater/air conditioner is started, cooling is turned on under following conditions.

- The in car sensor is 86°F or more.
- The temperature setting signal and the signals from each sensor meet the specified condition.

The blower fan speed is set to “LO” for maximum 7 seconds when cooling start conditions meet, and then, is controlled to be lineally up to “MAX HI” by 5.32%/S.



C06RY00001

## Troubleshooting, Its Overview and Procedures

The full automatic heater and air conditioner equips with the "Self-Diagnosis Function" to check its major components.

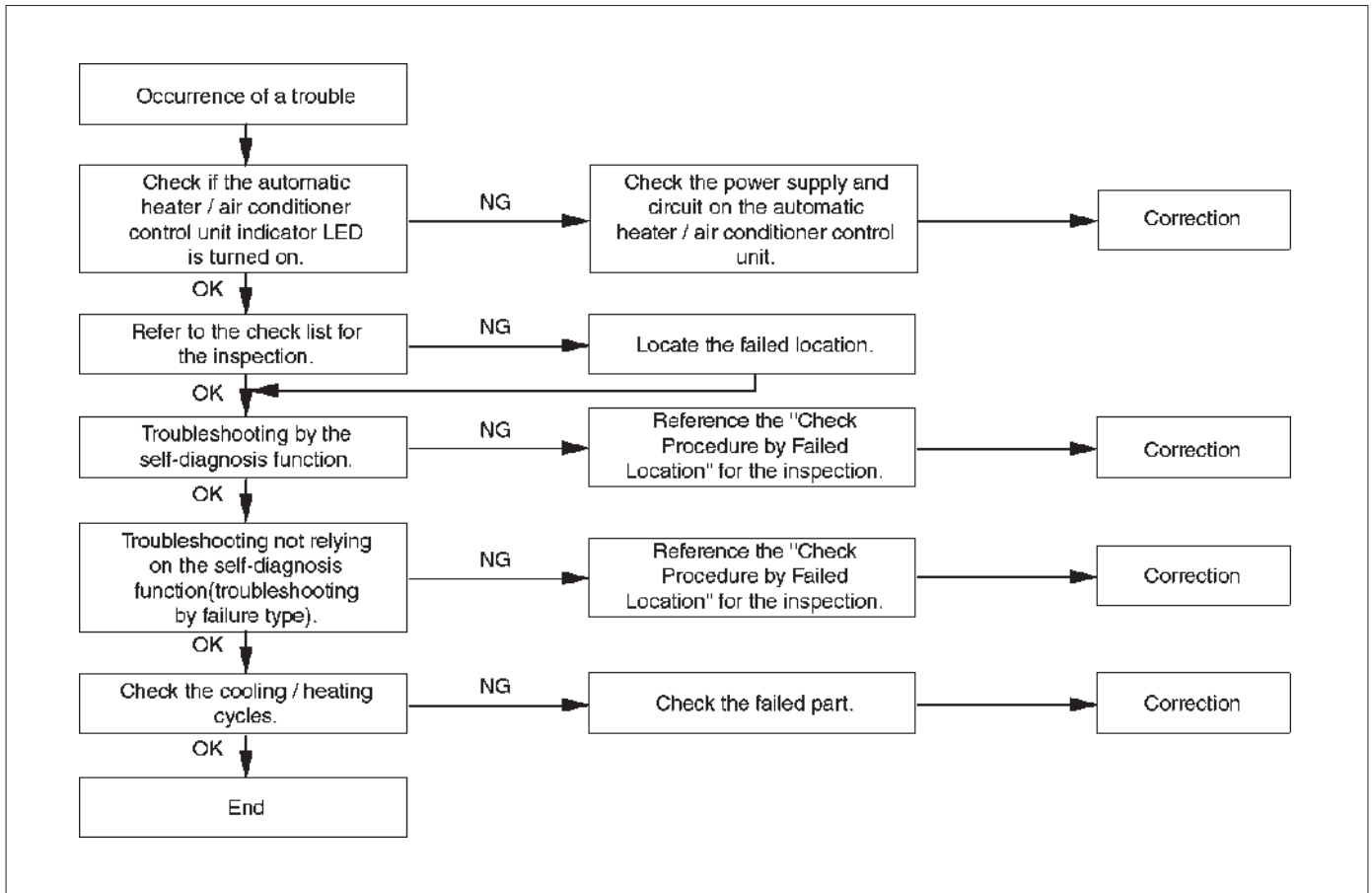
This function makes access to the sensors, actuators and blower fan motor system easier when checking them up and, when a failed part is located, this function restores its original performance.

When implementing the troubleshooting, this self-diagnosis function narrows the range to be searched

at the first step, then check relevant parts one by one according to the "Checking Procedures by Failed Location". As for a location this function is unappreciable, the system accurately determines characteristics of a given trouble and checks relevant parts according to the "Checking Procedures by Failed Location".

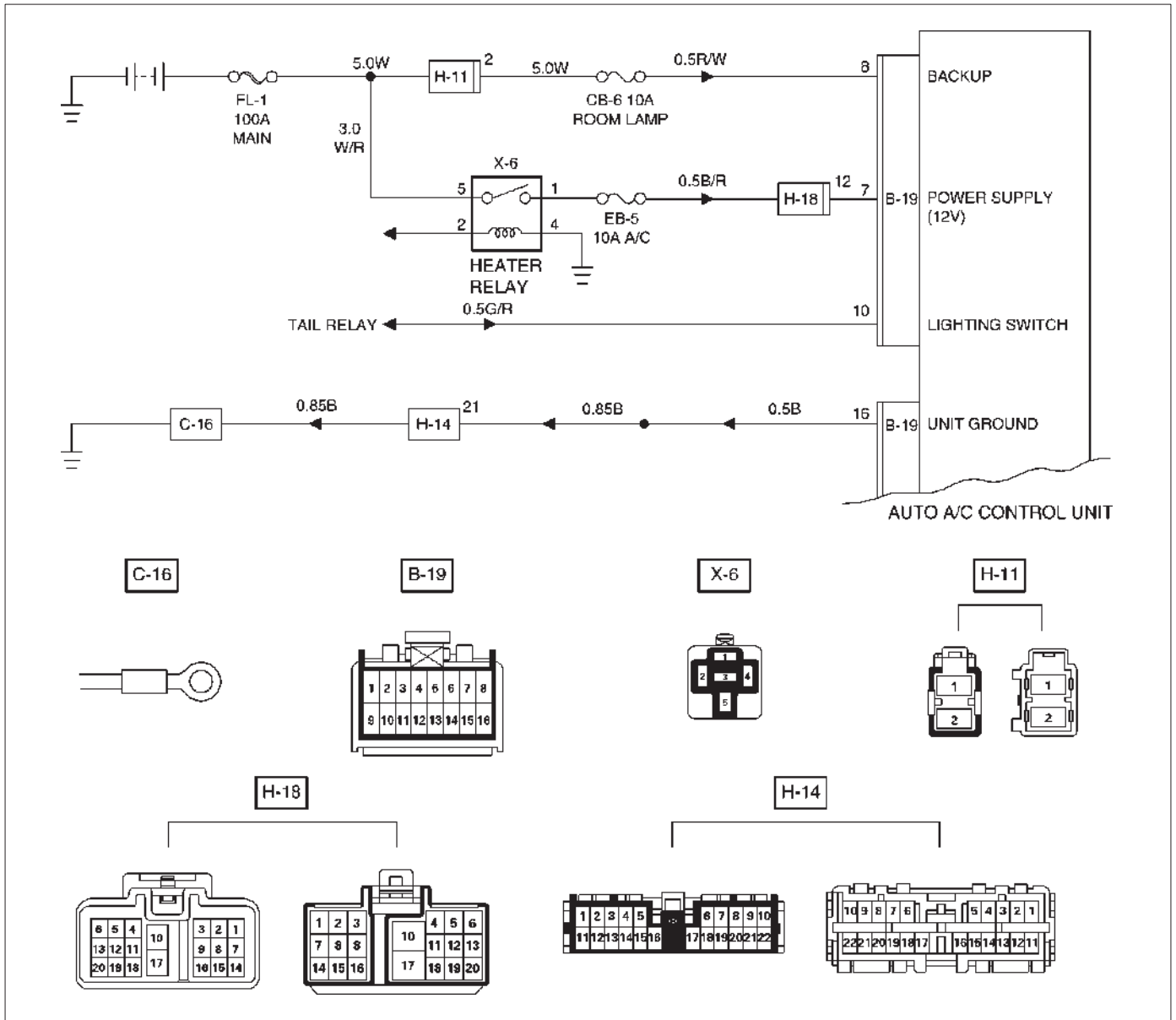
The following illustrates basic troubleshooting flow.

### Basic Troubleshooting Flow



## Auto Air Conditioner Control Unit Power Supply Diagnosis

This check is required because a trouble on the auto amplifier (control unit) power supply circuit or grounding circuit prevents accurate troubleshooting.



D08RY00644

Condition	Possible cause	Correction
Power source does not supply to auto air conditioner control unit.	—	Refer to Chart A

## 1A-110 HEATING, VENTILATION AND AIR CONDITIONING (HVAC)

### Chart "A": Check of Auto Amplifier Power Supply System

Step	Action	Value(s)	Yes	No
1	Is the fuse CB-6 normal?	—	Go to Step 2	Replace the fuse
2	Is the fuse EB-5 normal?	—	Go to Step 3	Replace the fuse
3	Disconnect the auto A/C control unit connector B-19. Is the battery voltage applied between the harness side connector terminal No.B19-8 and the ground?	Approx. 12V	Go to Step 5	Go to Step 4
4	Repair an open circuit between the fuse CB-6 and terminal No.B19-8. Is the action complete?	—	Go to Step 4	—
5	Is there continuity between the harness side connector terminal No.B19-16 and the ground?	—	Go to Step 7	Go to Step 6
6	Repair an open circuit between terminal No.B19-16 and the ground No.C-16. Is the action complete?	—	Go to Step 5	—
7	Turn the lighting switch on. Is the battery voltage applied between the harness side connector terminal No.B19-10 and the ground?	Approx. 12V	Go to Step 9	Go to Step 8
8	Repair an open circuit between the lighting switch and terminal No.B19-10. Is the action complete?	—	Go to Step 7	—
9	Turn the starter switch on. Is the battery voltage applied between the harness side connector terminal No.B19-7 and the ground?	Approx. 12V	—	Go to Step 10
10	Repair an open circuit between the fuse EB-5 and terminal No.B19-7. Is the action complete?	—	Verify repair	—



## Performance and Movement checklist for Automatic Air Conditioner Related Parts




Start the engine, and when the engine coolant reached 122°F check performance and movement of the related parts according the following checklist.

### Performance Check Using the Manual Switch

No.	Item	Checking Approach		Acceptance criteria
		Condition	Operation	
1	Blowing temperature (check movement of air mix door)	Auto switch must be turned on(FAN-AUTOMODE -AUTO)	<ol style="list-style-type: none"> <li>1. Select FC for the setup temperature.</li> <li>2. Select FH for the setup temperature.</li> </ol> → Then, select the MAX Control.	<ol style="list-style-type: none"> <li>1. Cold air shall be blown out.</li> <li>2. Hot air shall be blown out.</li> </ol>
2	Airflow volume(check movement of the mode door)	Set temperature to 77°F.	<ol style="list-style-type: none"> <li>1. Turn the fan knob off.</li> <li>2. Turn the fan knob from LOW to HI.</li> </ol>	<ol style="list-style-type: none"> <li>1. The fan shall be stopped, thus stopping air blow, too.</li> <li>2. Airflow volume shall change from LOW to HI.</li> </ol>
3	Blowing temperature(check movement of the mode door)	Set temperature to 77°F.Set the fan knob to HI.	Push the mode switch to change the blow port mode sequentially from the VENT through BI-LEVEL, FOOT up to DEF.	LED corresponding to each mode shall be turned on and the blow port mode shall be switched smoothly.
4	The interior/outside air switching mode (check movement of intake door)	Set temperature to 77°F.	Turn the LED off using the interior/outside air switch (this introduces the outside air intake mode). Then, the set fan knob to HI and press the interior/outside switch to turn on the LED.	The LED indication shall be switched from OFF to ON accompanying a change in air blowing sound.
5	Compressor	Set the temperature to 64.4°F (FC). (Outside air temperature is 32°F or above and interior temperature at ordinary temperature.)	Push the "OFF" switch. <ol style="list-style-type: none"> <li>1. Push the Auto switch.</li> <li>2. Push the Air Conditioner switch.</li> </ol>	<ol style="list-style-type: none"> <li>1. As the fan knob is set to the Auto position, the A/C switch LED shall come on and the compressor shall be turned on.</li> <li>2. As the A/C LED comes off, the compressor shall be turned off.</li> </ol>

1A-112 HEATING, VENTILATION AND AIR CONDITIONING (HVAC)

Check of Auto Function

No.	Item	Checking Approach		Acceptance criteria
		Condition	Operation	
1	Auto function	FAN KNOB "AUTO" MODE SW "AUTO"	Select FC for the temperature.	The LED shall come on. Cold air shall be blown out. The following LEDs shall come on: <input type="radio"/> Blow port mode:  <input type="radio"/> Intake mode <input type="radio"/> Fan speed: MAX Hi <input type="radio"/> A/C
			Change the temperature gradually starting with 68°F up to 86°F.	<p><b>The following phenomena shall be recognized.</b></p> <input type="radio"/> Temperature of blown air: Cold air is changed to hot air. <input type="radio"/> Change in the air flow volume. <input type="radio"/> The blow port mode LED indication changes in the following sequence:  (VENT) (BI-LEVEL) (FOOT)
			Select FH for the temperature.	Cold air shall be blown out. The following LEDs shall come on. <input type="radio"/> Blow port mode:  <input type="radio"/> Fan speed: Max Hi.

## Troubleshooting With Self-Diagnosis Function

### Overview of Self-Diagnosis Function

The self-diagnosis is implemented in 3 steps for each target. For detail of check procedure contained in each step, refer to the relevant section of "Check Procedure by Failed Location" listed in the Self-Diagnosis Operation Procedure.

For turning on the self-diagnosis function and switching of the check step, refer to the flow chart given below. You can reset the self-diagnosis function by turning the ignition switch off or turning the DEF switch on for 5 seconds.

### Self-Diagnosis Operation Procedure

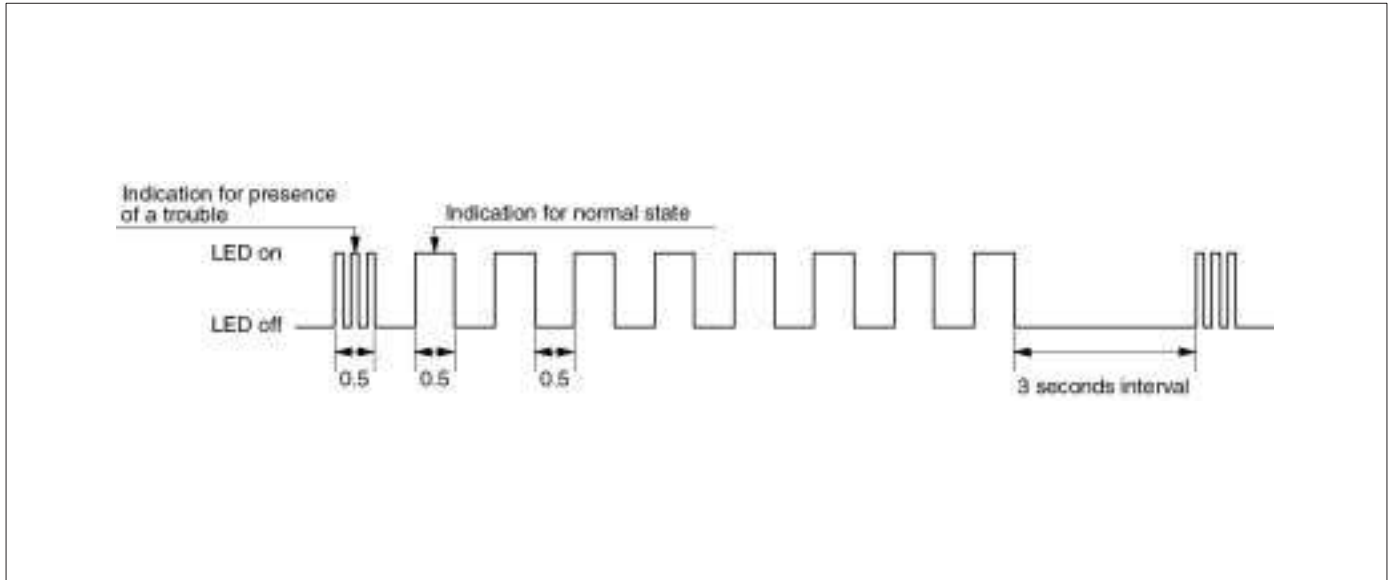
Step	Action	Value(s)	Yes	No
1	1. Set the IG to the OFF position. 2. Apply 60W bulb light to the sun sensor. 3. Set the temperature setting lever on the automatic heater/air conditioner panel to the center position (77°F). 4. Set the fan switch on the same panel to the Auto position. Is the action complete?	—	Go to Step 2	—
2	While pushing both the Auto switch and the DEF switch on the automatic heater/air conditioner panel, start the engine. Is the current trouble diagnosing function turned on approximately in 10 seconds?	—	Go to Step 3	—
3	Does the A/C LED flash every 0.5 second interval?	—	Go to Step 4	Refer to *1.
4	Push the A/C switch once. Does the A/C LED flash every 0.5 second interval?	—	Go to Step 5	Refer to *2.
5	Refer to *3 chart "Check of Output Equipment". Does each output equipment function normally according to operation of the temperature setting level?	—	Go to Step 6	Repair or replace the output equipment or repair the harness
6	Push the DEF switch for 5 seconds consecutively or turn on and off the IG. Is the action complete?	—	Go to Step 1	—

## 1A-114 HEATING, VENTILATION AND AIR CONDITIONING (HVAC)

### \*1 Displaying the Current Trouble Diagnosing Table

Start the engine while holding down both the Auto switch and the DEF switch on the control panel, and the table will appear in approximately 10 seconds to the indicator lamp (LED) of the air conditioning switch. Result of the diagnosis along the following 9 items will be shown one by one in 0.5 second interval irrespective of presence or absence of a trouble for a given item. When the display 9 items is completed, it is repeated with 3 seconds of interval in between. A failed item is indicated by flashing of the LED that is repeated 3 times within 0.5 seconds. If a trouble is indicated, you can locate the failed section by knowing when in the total sequence it has been displayed.

one in 0.5 second interval irrespective of presence or absence of a trouble for a given item. When the display 9 items is completed, it is repeated with 3 seconds of interval in between. A failed item is indicated by flashing of the LED that is repeated 3 times within 0.5 seconds. If a trouble is indicated, you can locate the failed section by knowing when in the total sequence it has been displayed.



F01RX010

### Item for Current Trouble Diagnosis

Display pattern	Failed part
	Normal pattern
	In car sensor
	Ambient sensor
	Sun sensor (Note 1)
	Duct sensor
	Temperature control lever (Note 2)
	Fan switch (Note 3)
	Mix actuator
	Mode (blow port) control
	Intake (fresh air/interior air switching) control

F01RY0008

## HEATING, VENTILATION AND AIR CONDITIONING (HVAC) 1A-115

As shown above, display of result along nine items is repeated with 3-second interval in between.

Note 1: When checking the sun sensor, apply sufficient light using a 60W bulb. Otherwise, it can be diagnosed as failed.

Note 2: If the temperature setting lever is set on both ends (one set to 64.4°F, blue scale = Full cool and the other to 87.8°F, red scale = Full hot), they can be diagnosed as failed.

Note 3: Likewise, the fan switch can be diagnosed as failed if set on both ends.

### \*2 Displaying the Past Trouble Diagnosing Table

The past trouble diagnosis displays only the items on which trouble has recurred 16 times in the past.

If you press the air conditioning switch once while the current trouble diagnosis is taking place, display of the

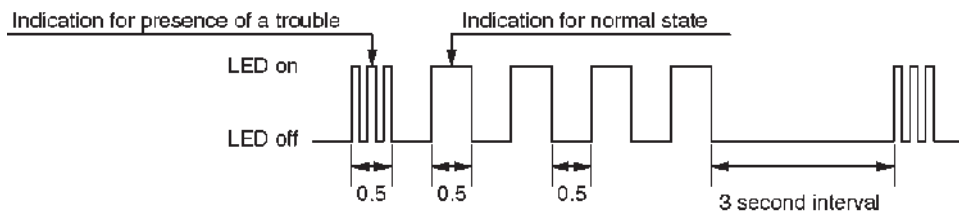
past trouble diagnosis will appear on the indicator lamp (LED) of the air conditioning switch.

Results of the diagnosis along the following five items are displayed one by one in 0.5 second interval irrespective of presence or absence of a trouble. A failed item is indicated by flashing of the LED that is repeated 3 times within 0.5 seconds. You can locate the failed section by counting in what sequence it has been displayed.

Past trouble code can be cleared by disconnecting one of the following sources for at least thirty (30) seconds.

NOTE: To prevent system damage, the ignition key must be "OFF" when disconnecting or reconnecting battery power.

- The No.16 fuse (Room lamp, Clock)
- The negative battery cable. (Disconnecting the negative battery cable will result in the loss of other on-board memory data, such as preset radio tuning).



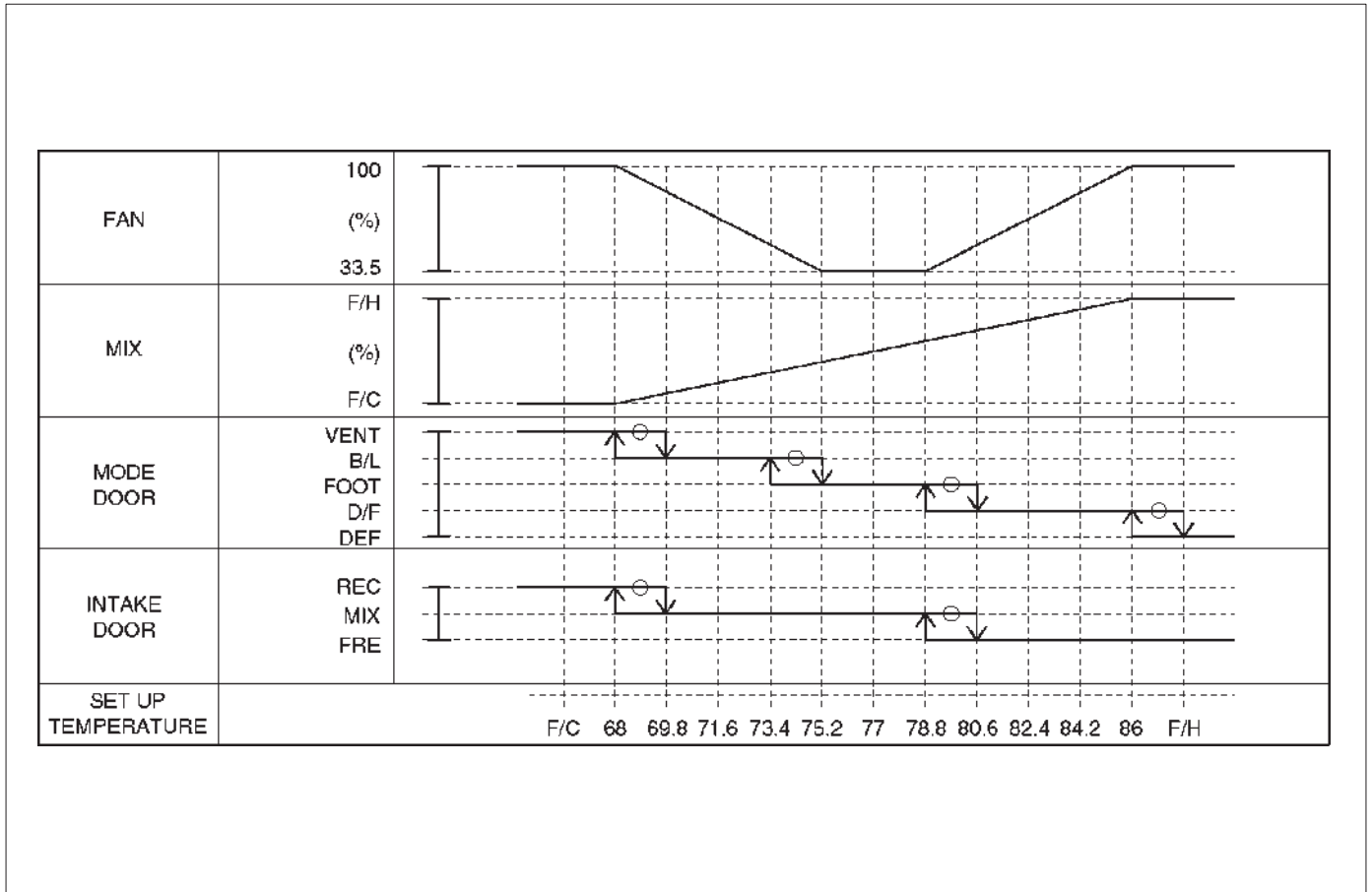
F01RX011

Display pattern	Failed part
<div style="display: flex; justify-content: space-between;"> <div style="text-align: left;"> <p>ON</p> <p>OFF</p> </div> </div>	Normal pattern
	In car sensor
	Ambient sensor
	Sun sensor
	Duct sensor
	Mix actuator

F01RY0007

1A-116 HEATING, VENTILATION AND AIR CONDITIONING (HVAC)

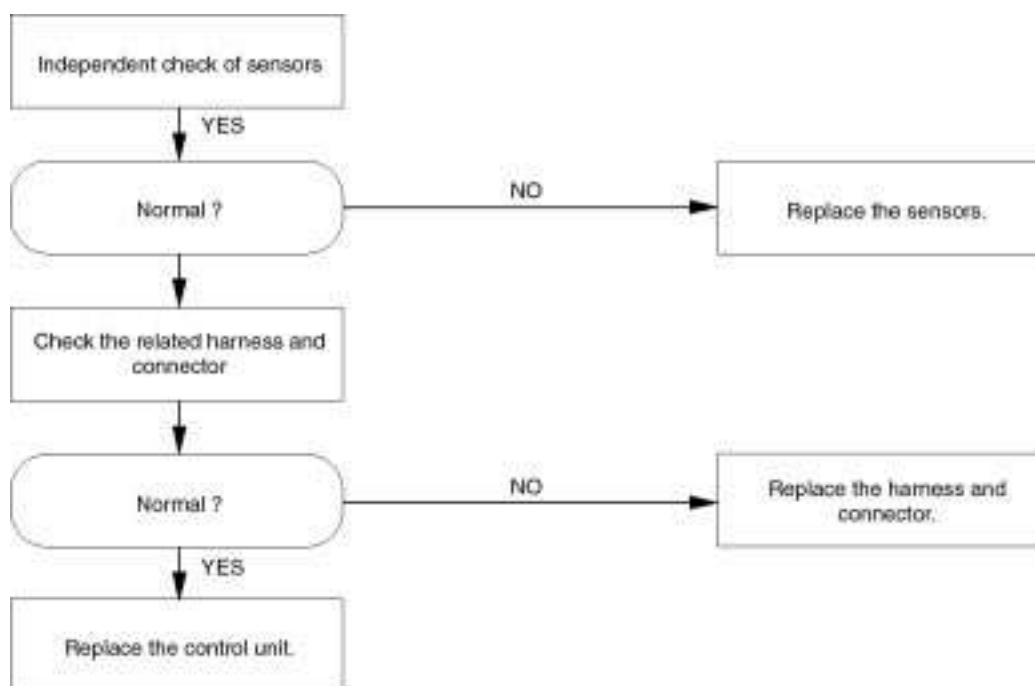
\*3Check of Output Equipment



## Inspection By Failed Location

### Inspection of the Sensors

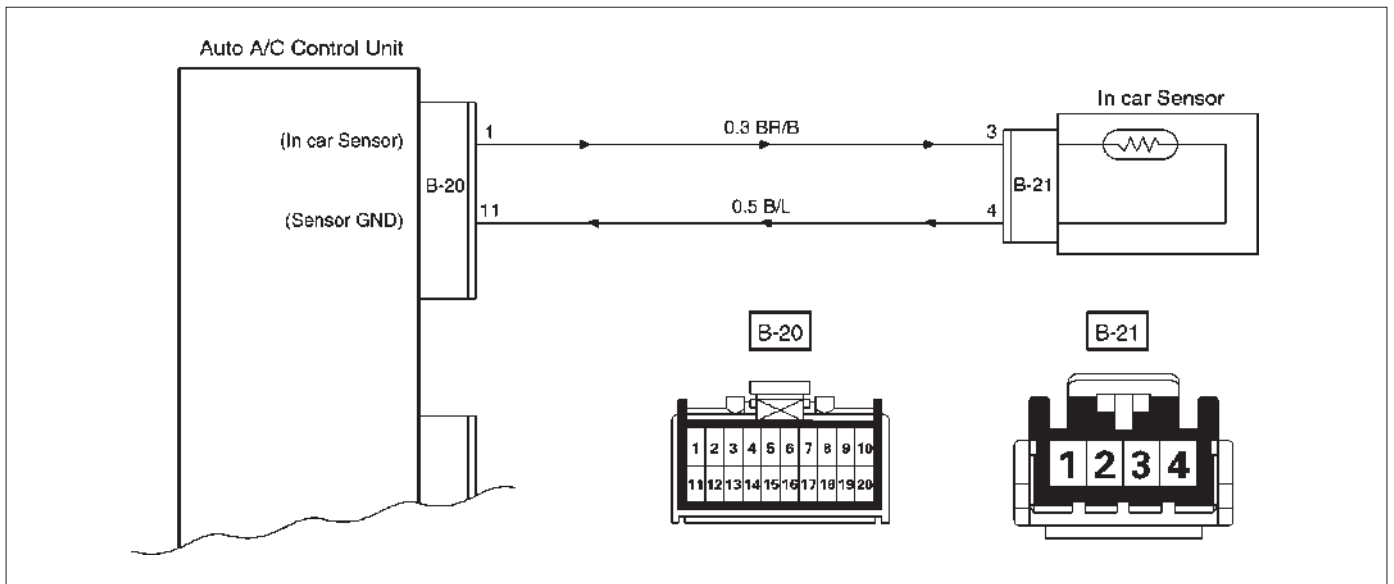
When the self-diagnosis function has determined that trouble is present on the sensors, check them according to the following flow chart.



Sensors	Allowable range	Check method
In car sensor	Refer to the sensor resistance curve.	Chart 1
Ambient sensor	Refer to the sensor resistance curve.	Chart 2
Sun sensor	100 ohms maximum in forward and 0.02 mA minimum when exposed to 60W incandescent lamp.	Chart 3

# 1A-118 HEATING, VENTILATION AND AIR CONDITIONING (HVAC)

## Chart 1: In Car Sensor

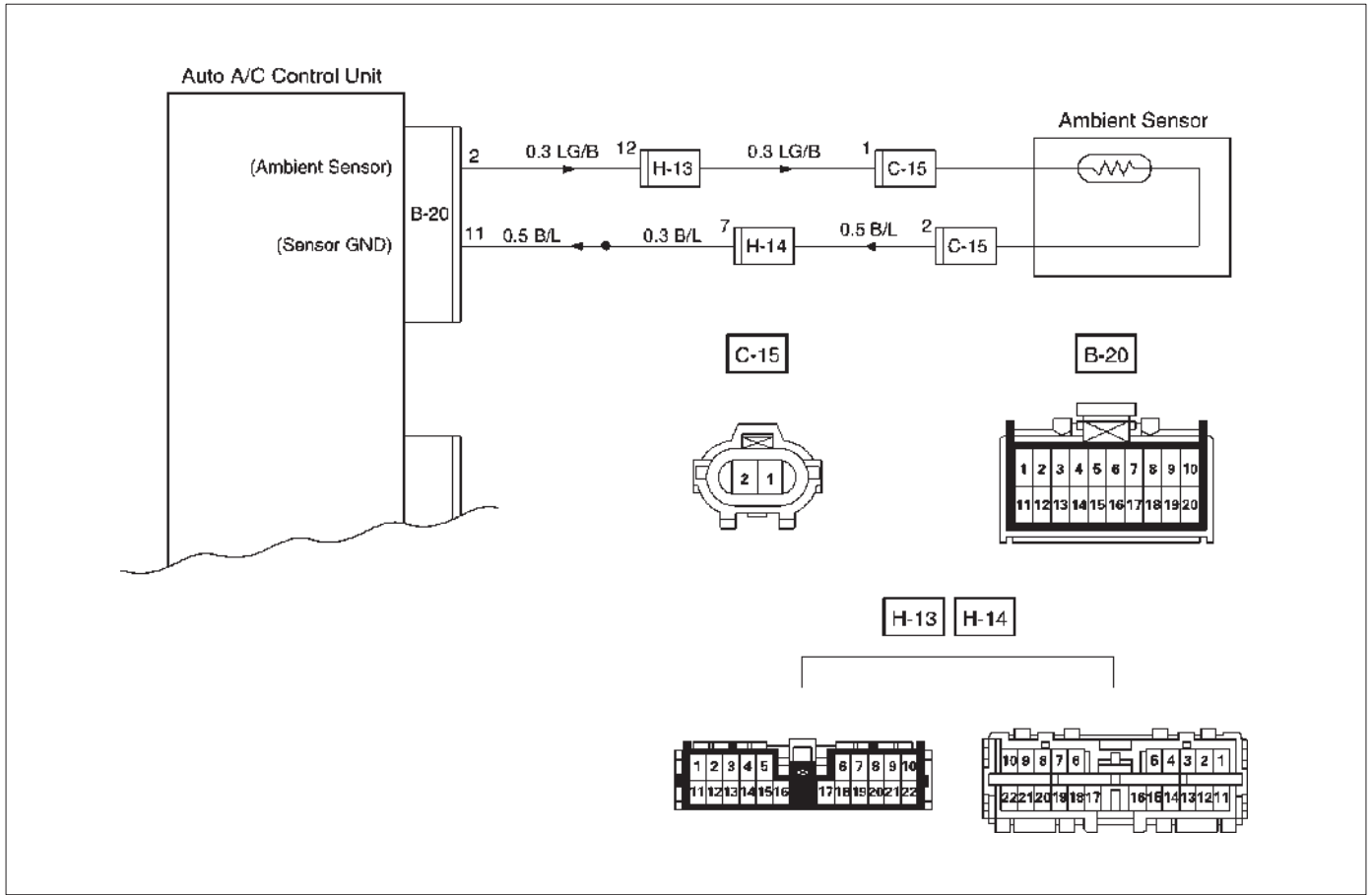


D08RY00651

Step	Action	Value(s)	Yes	No
1	Disconnect the in car sensor connector. (No.B-21) Is performance of the sensor normal? (Refer to the later section on "Individual Inspection")	—	Go to Step 2	Replace the in car sensor
2	Is there continuity between the harness side connector No.B20-1 and No.B21-3?	—	Go to Step 4	Go to Step 3
3	Repair an open circuit between terminal No.B20-1 and No.B21-3. Is the action complete?	—	Go to Step 2	—
4	Is there continuity between the harness side connector No.B20-11 and No.B21-4?	—	Go to Step 6	Go to Step 5
5	Replace the auto air conditioner control unit. Is the action complete?	—	Verify repair	—



Chart 2: Ambient Sensor

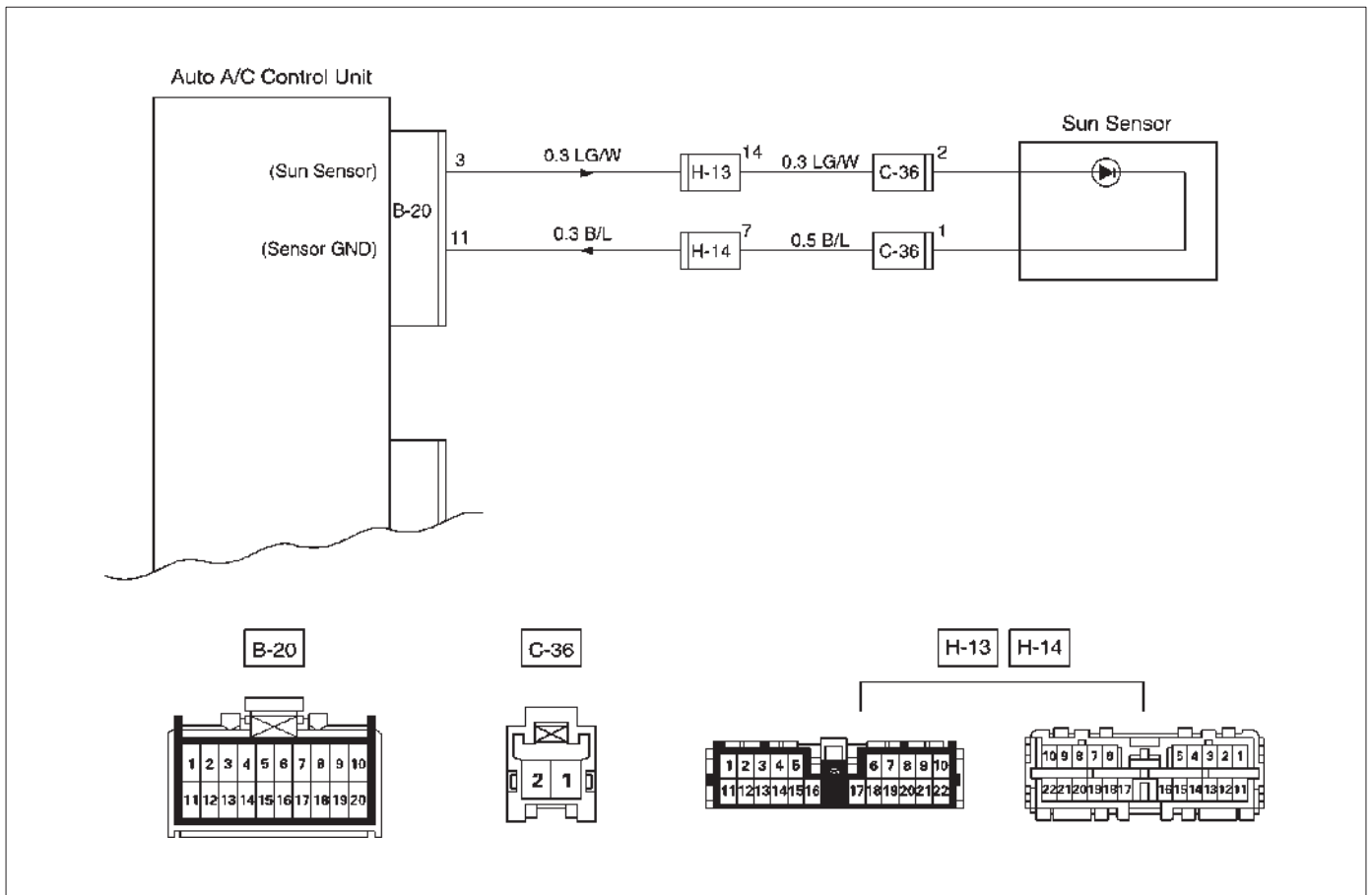


D08RY00652

Step	Action	Value(s)	Yes	No
1	Disconnect ambient sensor connector. (No.C-15) Is performance of the ambient sensor normal? (Refer to the later section on "Individual inspection")	—	Go to Step 2	Replace the ambient sensor
2	Connect the ambient sensor connector. Is resistance between the harness side connector No.B20-2 and No.B20-11 normal?	Refer to the later section on "Individual inspection"	Go to Step 4	Go to Step 3
3	Repair an open circuit between terminal No.B20-2 and No.C15-1 or No.B20-11 and No.C15-2. Is the action complete?	—	Verify repair	—
4	Replace the auto air conditioner control unit. Is the action complete?	—	Verify repair	—

# 1A-120 HEATING, VENTILATION AND AIR CONDITIONING (HVAC)

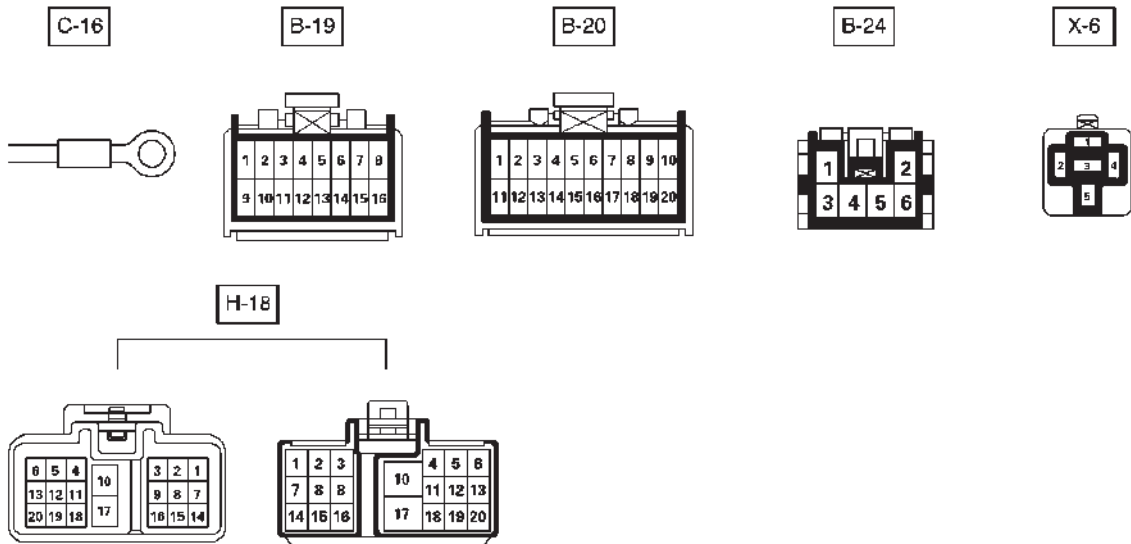
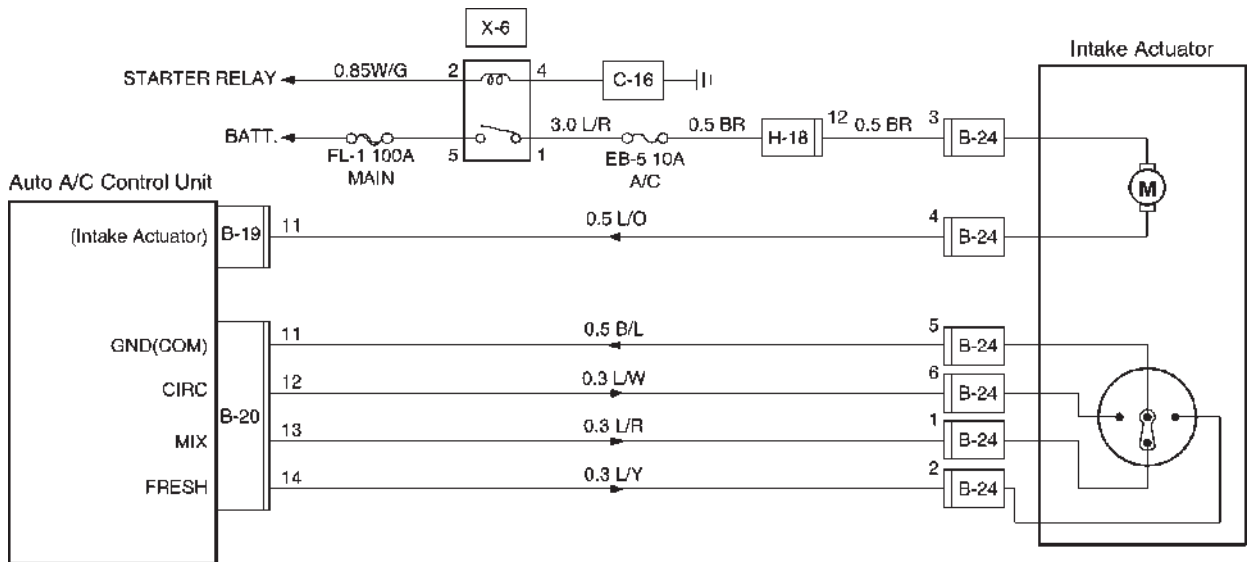
## Chart 3: Sun Sensor



D08RY00645

Step	Action	Value(s)	Yes	No
1	Disconnect the sun sensor connector. (No.C-36) Is performance of the sun sensor normal? (Refer to the later section on individual inspection)	—	Go to Step 2	Replace the sun sensor.
2	Is there continuity between the harness side connector terminal No.B20-3 and No.C36-2?	—	Go to Step 4	Go to Step 4
3	Repair an open circuit between terminal No.B20-3 and No.C36-2. Is the action complete?	—	Go to Step 2	—
4	Is there continuity between the harness side connector terminal No.B20-11 and No.C36-1?	—	Go to Step 6	Go to Step 5
5	Repair an open circuit between terminal No.B20-11 and C36-1. Is the action complete?	—	Go to Step 4	—
6	Replace the auto air conditioner control unit. Is the action complete?	—	Verify repair	—

## Inspection of the Intake Actuator System



## 1A-122 HEATING, VENTILATION AND AIR CONDITIONING (HVAC)

Condition	Possible cause	Correction
Does not work at all	—	Refer to Chart A
Control failure	—	Refer to Chart B

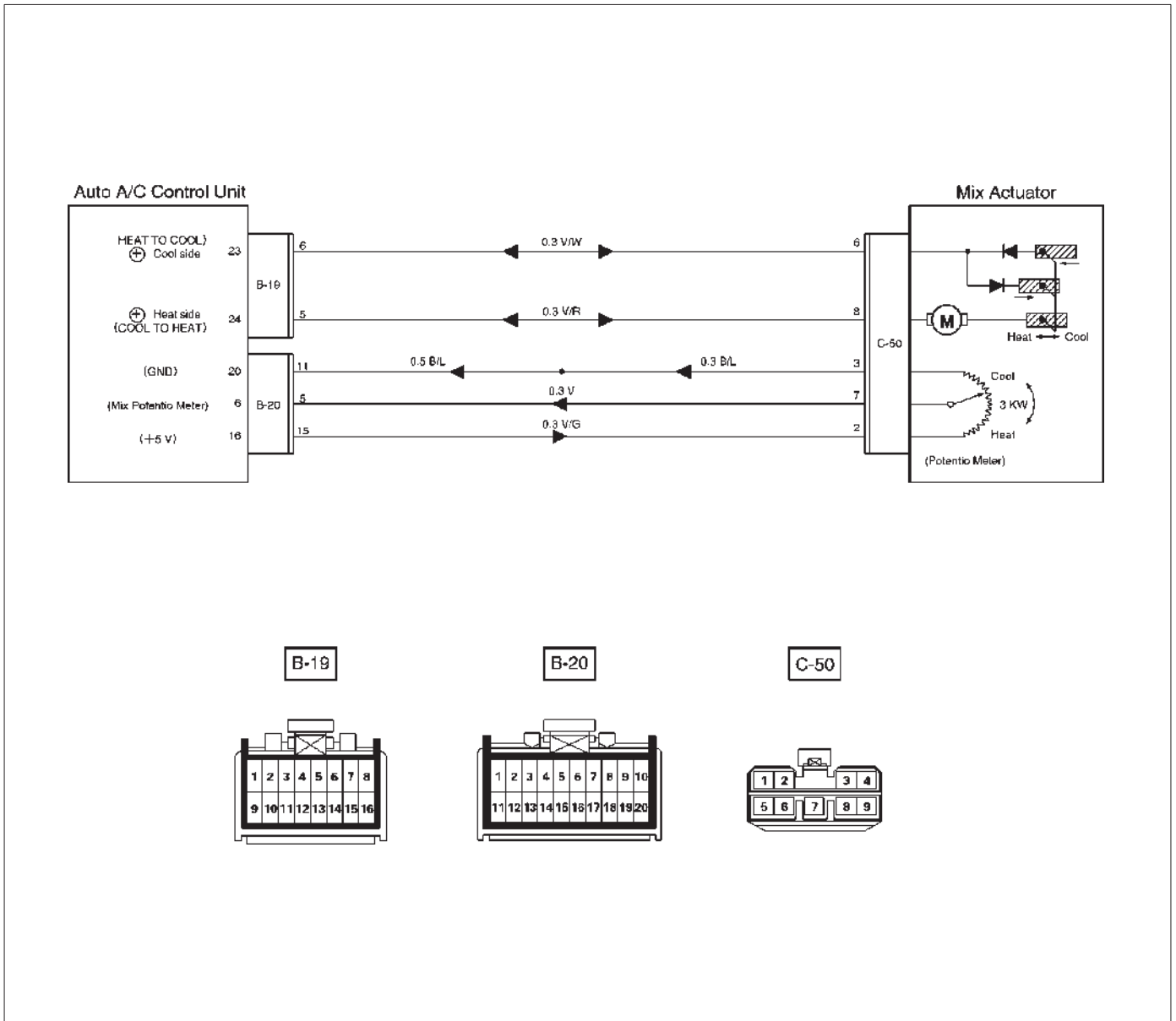
### Chart A: Does Not Work At All

Step	Action	Value(s)	Yes	No
1	Is the fuse FL-1 normal?	—	Go to Step 2	Replace the fuse
2	Is the fuse EB-5 normal?	—	Go to Step 3	Replace the fuse
3	Is the relay X-6 normal?	—	Go to Step 4	Replace the relay
4	Turn on the ignition switch. (the engine is run.) Is the battery voltage applied between the harness side connector terminal No.B24-3 and ground?	Approx 12V	Go to Step 6	Go to Step 5
5	Repair an open circuit between terminal No.B24-3 and No.X6-1. Is the action complete?	—	Go to Step 4	—
6	Is the battery voltage applied between the harness side connector terminal No.B24-4 and ground?	Approx 12V	Go to Step 8	Go to Step 7
7	Replace the intake actuator motor. Is the action complete?	—	Go to Step 6	—
8	Is there continuity between the harness side connector terminal No.B19-11 and No.B24-4?	—	Go to Step 10	Go to Step 9
9	Repair an open circuit between No.B19-11 and B24-4. Is the action complete?	—	Verify repair	—
10	Replace the auto air conditioner control unit. Is the action complete?	—	Verify repair	—

**Chart B: Failure on the Intake Control**

Step	Action	Value(s)	Yes	No
1	Is the fuse No.EB-5 normal?	—	Go to Step 2	Replace the fuse
2	Is the relay No.X-6 normal?	—	Go to Step 3	Replace the relay
3	Turn on the ignition switch. (the engine is run.) Is the intake actuator stopped?	—	Go to Step 5	Go to Step 4
4	Replace or repair the auto air conditioner control unit. Is the action complete?	—	Verify repair	—
5	Is there continuity between the harness side connector terminal No.B24-5 and No.B20-11?	—	Go to Step 7	Go to Step 6
6	Repair an open circuit between terminal No.B24-5 and No.B20-11. Is the action complete?	—	Go to Step 5	—
7	Is there continuity between the harness side connector terminal No.B24-6 and No.B20-12?	—	Go to Step 9	Go to Step 8
8	Repair an open circuit between terminal No.B24-6 and No.B20-12. Is the action complete?	—	Go to Step 7	—
9	Is there continuity between the harness side connector terminal No.B24-1 and No.B20-13?	—	Go to Step 11	Go to Step 10
10	Repair an open circuit between terminal No.B24-1 and B20-13. Is the action complete?	—	Go to Step 9	—
11	Is there continuity between the harness side connector terminal No.B24-2 and No.B20-14?	—	Go to Step 13	Go to Step 12
12	Repair an open circuit between harness No.B24-2 and No.B20-14. Is the action complete?	—	Go to Step 11	—
13	1. Disconnect the intake actuator connector No.B24. 2. Is the battery voltage applied between harness side connector terminal No.B24-6 and ground? No.B24-2 and ground? No.B24-1 and ground?	—	Go to Step 14	Go to Step 15
14	Replace or repair the intake actuator. Is the action complete?	—	Verify repair	—
15	Replace or repair the air conditioner control unit. Is the action complete?	—	Verify repair	—

## Inspection of the Mix Actuator System



D08RY00647

Condition	Possible cause	Correction
Does not work at all	—	Refer to Chart A
Control failure	—	Refer to Chart B

**Chart A: Does Not work At All**

Step	Action	Value(s)	Yes	No
1	1. Turn on the ignition switch (the engine is run). 2. Disconnect the mix actuator connector (C-50). 3. Short-circuit the chassis harness side connector terminal No.C50-3 and No.C50-7. 4. Using the temperature control lever, select FH for the temperature.  Is the battery voltage applied on a regular interval basis between the harness side connector terminal No.C50-6 (-) and No.C50-8 (+)?	—	Go to Step 3	Go to Step 2
2	Replace the auto air conditioner control unit.	—	Verify repair	—
3	Using the temperature control lever, select FC for the temperature.  Is the battery voltage applied on a regular interval basis between the harness side connector terminal No.C50-6 (+) and No.C50-8 (-)?	—	Go to Step 5	Go to Step 4
4	Replace the auto air conditioner control unit.	—	Verify repair	—
5	Is there continuity between the harness side connector terminal No.B19-6 and No.C50-6?	—	Go to Step 7	Go to Step 6
6	Repair an open circuit between terminal No.B19-6 and No.C50-6.  Is the action complete?	—	Go to Step 5	—
7	Is there continuity between the harness side connector terminal No.B19-5 and No.C50-8?	—	Go to Step 9	Go to Step 8
8	Repair an open circuit between terminal No.B19-5 and No.C50-8.  Is the action complete?	—	Verify repair	—
9	Replace the mix actuator.  Is the action complete?	—	Verify repair	—

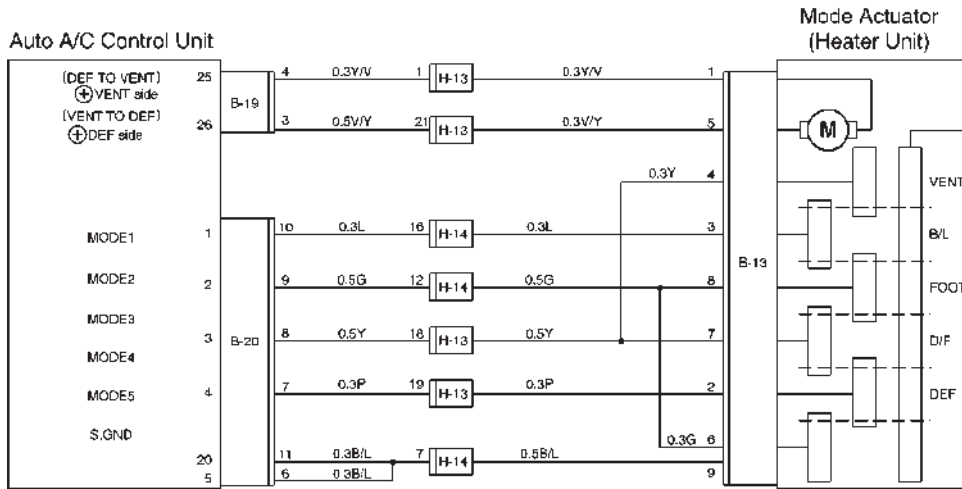
## 1A-126 HEATING, VENTILATION AND AIR CONDITIONING (HVAC)

### Chart B: Mix Actuator Control Failure

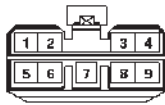
Step	Action	Value(s)	Yes	No
1	Turn the ignition switch (the engine is run). Dose the mix actuator fully stroke when FH and FC of the temperature control lever?	—	Go to Step 3	Go to Step 2
2	Repair or replace the air mix door or the link unit. Is the action complete?	—	Varify repair	—
3	Is there continuity between the harness side connector terminal No.C50-3 and No.B20-11?	—	Go to Step 5	Go to Step 4
4	Repair an open circuit between terminal No.C50-3 and No.B20-11. Is the action complete?	—	Go to Step 3	—
5	Is there continuity between harness side connector terminal No.C50-7 and No.B20-5?	—	Go to Step 7	Go to Step 6
6	Repair an open circuit between terminal No.C50-7 and No.B20-5. Is the action complete?	—	Go to Step 5	—
7	Is there continuity between the harness side connector terminal No.C50-2 and No.B20-15?	—	Go to Step 9	Go to Step 8
8	Repair an open circuit between terminal No.C50-2 and No.B20-15. Is the action complete?	—	Go to Step 7	—
9	Is sum of the voltage between the following chassis harness side connector terminals approximately 5V? No.B20-15 and No.B20-5, No.B20-5 and No.B20-11	—	Go to Step 11	Go to Step 10
10	Replace the actuator. Is the action complete?	—	Verify repair	—
11	Replace the auto air conditioner control unit. Is the action complete?	—	Verify repair	—



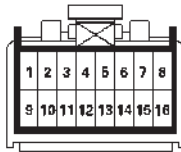
## Inspection of the Mode Actuator System



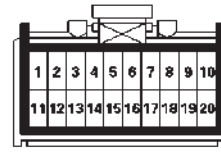
B-13



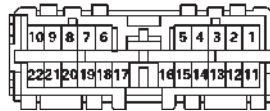
B-19



B-20



H-13 H-14



D08RY00648

Condition	Possible cause	Correction
Does not work at all	—	Refer to Chart A
Control failure	—	Refer to Chart B

## 1A-128 HEATING, VENTILATION AND AIR CONDITIONING (HVAC)

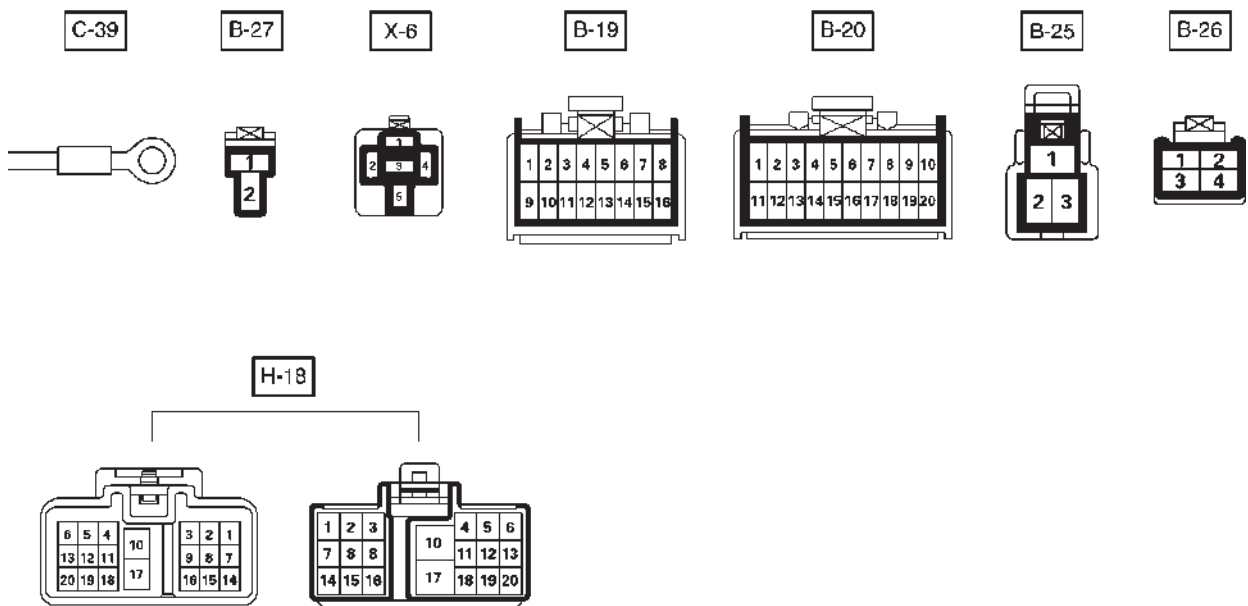
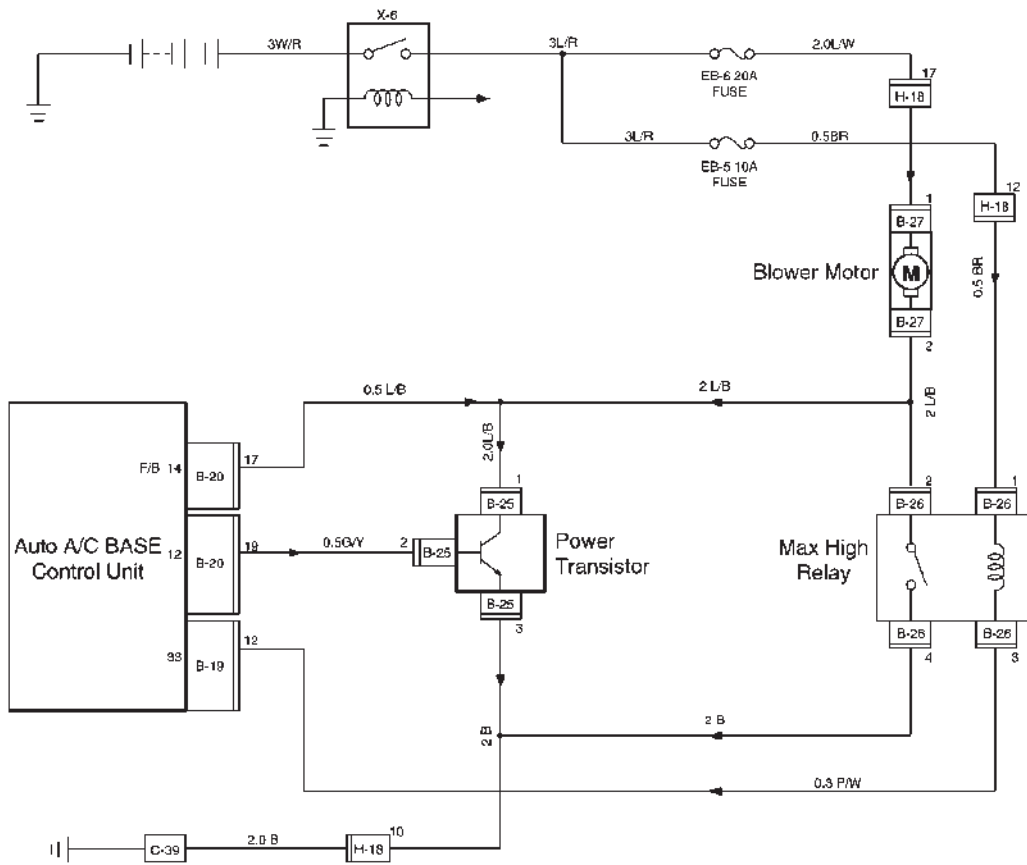
**Chart A: Does Not Work At All**

Step	Action	Value(s)	Yes	No
1	1. Turn on the ignition switch (the engine is run). 2. Disconnect the mode actuator connector (B-13) 3. Select VENT pressing the mode actuator. Is the battery voltage provided on a regular interval between the harness side connector terminal No.B13-1 (+) and No.B13-5 (-)?	—	Go to Step 3	Go to Step 2
2	Replace the auto air conditioner control unit. Is the action complete?	—	Verify repair	—
3	Turn on the DEF mode switch. Is the battery voltage provided on a regular interval between the chassis side connector terminal No.B13-5 (+) and No.B13-1 (-)?	—	Go to Step 5	Go to Step 4
4	Replace the auto air conditioner control unit.	—	Verify repair	—
5	Is there continuity between the harness side connector terminal No.B13-1 and No.B19-4?	—	Go to Step 7	Go to Step 6
6	Repair an open circuit between terminal No.B13-1 and No.B19-4. Is the action complete?	—	Go to Step 5	—
7	Is there continuity between the harness side connector terminal No.B13-5 and No.B19-3?	—	Go to Step 9	Go to Step 8
8	Repair an open circuit between terminal No.B13-5 and No.B19-3. Is the action complete?	—	Verify repair	—
9	Replace the mode actuator.	—	Verify repair	—

**Chart B: Mode Actuator Control Failure**

Step	Action	Value(s)	Yes	No
1	Turn on the ignition switch (the engine is run). Dose the mode actuator fully stroke when the defrost mode and the vent mode are selected?	—	Go to Step 3	Go to Step 2
2	Repair or replace the mode door or the link unit. Is the action complete?	—	Go to Step 1	—
3	Is there continuity between the harness side connector terminal No.B13-9 and No.B20-11?	—	Go to Step 5	Go to Step 4
4	Repair an open circuit between terminal No.B13-9 and No.B20-11. Is the action complete?	—	Go to Step 3	—
5	Is there continuity between the harness side connector terminal No.B13-3 and No.B20-10?	—	Go to Step 7	Go to Step 6
6	Repair an open circuit between terminal No.B13-3 and No.B20-10. Is the action complete?	—	Go to Step 5	—
7	Is there continuity between harness side connector terminal No.B13-4 and No.B20-8?	—	Go to Step 9	Go to Step 8
8	Repair an open circuit between terminal No.B13-4 and No.B20-8. Is the action complete?	—	Go to Step 7	—
9	Is sum of the voltage between the following harness side connector terminal approximately 5V? Voltage between No.B20-8 and No.B20-10 plus voltage between No.B20-8 and No.B20-11	5V	Go to Step 11	Go to Step 10
10	Replace the actuator. Is the action complete?	—	Verify repair	—
11	Dose the mode actuator work normally through manual operation?	—	Go to Step 13	Go to Step 12
12	Replace the sensor. Is the action complete?	—	Verify repair	—
13	Replace the auto air conditioner control unit. Is the action complete?	—	Verify repair	—

## Inspection of the Fan Motor System



## HEATING, VENTILATION AND AIR CONDITIONING (HVAC) 1A-131

Condition	Possible cause	Correction
The fan dose not rotate at all	—	Refer to Chart A
The fan dose not rotate in the MAX-HI mode	—	Refer to Chart B
The fan dose not rotate in any mode other than MAX-HI	—	Refer to Chart C
The fan dose not stop	—	Refer to Chart D

### Chart A: Fan Does Not Rotate At All

Step	Action	Value(s)	Yes	No
1	Are the fuse No.EB-6 and No.EB-5 normal?	—	Go to Step 2	Replace the fuse
2	Are the relay No.X-6 and No.B-26 normal?	—	Go to Step 3	Replace the relay
3	Turn on the ignition switch (the engine is run). Is the battery voltage applied between the harness side connector terminal No.B27-1 and ground?	—	Go to Step 5	Go to Step 4
4	Repair an open circuit between terminal No.B27-1 and No.EB-6 fuse. Is the action complete?	—	Go to Step 3	—
5	Is there continuity between the harness side connector terminal No.B27-2 and ground (No.C-39)?	—	Go to Step 7	Go to Step 6
6	Repair an open circuit between terminal No.B27-2 and ground. Is the action complete?	—	—	—
7	Is the battery voltage applied between the harness side connector terminal No.B27-2 and No.B27-1?	—	Go to Step 8	Go to Step 9
8	Replace the blower motor. Is the action complete?	—	Verify repair	—
9	Refer to chart B and C. Is the action complete?	—	Verify repair	—

## 1A-132 HEATING, VENTILATION AND AIR CONDITIONING (HVAC)

### Chart B: Fan Does Not Rotate in MAX HI Mode

Step	Action	Value(s)	Yes	No
1	Is the MAX-HI relay (B-26) normal?	—	Go to Step 2	Replace the relay
2	1. Turn on the ignition switch (the engine is run). 2. Set the fan switch to the MAX-HI. Is there continuity between the harness side connector terminal No.B27-2 and No.B26-2?	—	Go to Step 4	Go to Step 3
3	Repair an open circuit between terminal No.B27-2 and No.B26-2. Is the action complete?	—	Go to Step 3	—
4	Is there continuity between the harness side connector terminal No.B26-4 and ground (No.C-39)?	—	Go to Step 6	Go to Step 5
5	Repair an open circuit between terminal No.B26-4 and ground (No.C-39). Is the action complete?	—	Go to Step 4	—
6	Is the battery voltage applied between the harness side connector terminal No.B26-1 and ground?	—	Go to Step 8	Go to Step 7
7	Repair an open circuit between terminal No.B26-1 and No.EB-5 fuse. Is the action complete?	—	Go to Step 6	—
8	Is the battery voltage applied between the harness side connector terminal No.B19-12 and ground?	—	Go to Step 10	Go to Step 9
9	Repair an open circuit between terminal No.B26-3 and No.B19-12. Is the action complete?	—	Verify repair	—
10	Replace the auto air conditioner control unit. Is the action complete?	—	Verify repair	—

**Chart C: Fan Does Not Rotate In Any Mode Other Than MAX HI**

Step	Action	Value(s)	Yes	No
1	Is the power transistor performance normal? (Refer to the later section on "individual inspection")	—	Go to Step 2	Replace the power transistor
2	Is there continuity between the harness side connector terminal No.B27-2 and No.B25-1, No.B27-2 and No.B20-17?	—	Go to Step 4	Go to Step 3
3	Repair an open circuit between terminal. No.B27-2 and B25-1 No.B27-2 and B20-17	—	Go to Step 2	—
4	Is there continuity between the harness side connector terminal No.B25-3 and ground (No.C-39)?	—	Go to Step 6	Go to Step 5
5	Repair an open circuit between terminal No.B25-3 and ground. Is the action complete?	—	Go to Step 4	—
6	Is there continuity between the harness side connector terminal No.B25-2 and No.B20-19?	—	Go to Step 8	Go to Step 7
7	Repair an open circuit between terminal No.B25-2 and No.B20-19. Is the action complete?	—	Go to Step 6	—
8	Replace the auto air conditioner control unit. Is the action complete?	—	Verify repair	—

## 1A-134 HEATING, VENTILATION AND AIR CONDITIONING (HVAC)

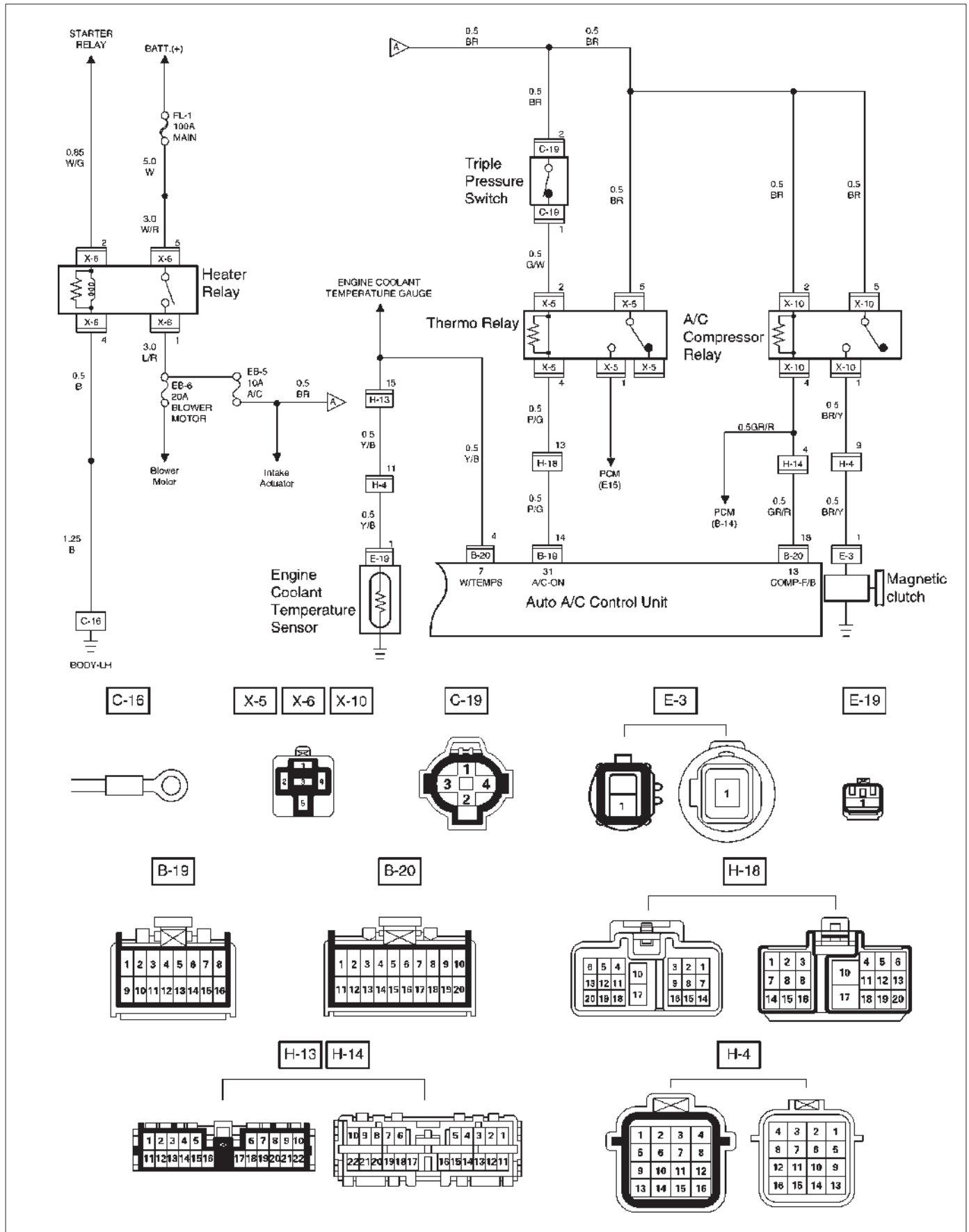
### Chart D: Fan Does Not Stop

Step	Action	Value(s)	Yes	No
1	1. Disconnect the max high relay, the power transistor connector B-25 and the auto A/C control unit connector B-20. 2. Turn on the ignition switch. Does the blower motor stop?	—	Go to Step 3	Go to Step 2
2	Repair a short circuit between connector No.B27-2 and No.B26-2, No.B27-2 and No.B25-1, or No.B27-2 and B20-17. Is the action complete?	—	Verify repair	—
3	Is the max high relay normal? (Refer to the later section on "individual inspection".)	—	Go to Step 4	Replace the relay
4	Reinstall the max high relay. Does the blower motor start operating?	—	Go to Step 6	Go to Step 5
5	Repair a short circuit between connector No.B26-3 and No.B19-12. Is the action complete?	—	Go to Step 4	—
6	Is the power transistor normal? (Refer to the later section on "individual inspection".)	—	Go to Step 7	Replace the power transistor
7	Reinstall the power transistor. Does the blower motor start operating?	—	Replace the auto A/C control unit	—



## Inspection of the Magnetic Clutch System

### 6VE1 Engine



## 1A-136 HEATING, VENTILATION AND AIR CONDITIONING (HVAC)

Condition	Possible cause	Correction
Magnetic clutch does not work	—	Refer to Chart A

**Chart A: Magnetic Clutch Does Not work**

Step	Action	Value(s)	Yes	No
1	Is the fuse No.EB-5 normal?	—	Go to Step 2	Replace the fuse
2	Is the relay No.X-10 (compressor relay) No.X-5 (A/C thermo relay) and No.X-6 (heater relay) normal?	—	Go to Step 3	Replace the fuse
3	Is the thermo unit normal?	—	Go to Step 4	Replace the thermo unit
4	Is the pressure switch normal?	—	Go to Step 5	Replace the pressure switch
5	1. Turn the ignition switch on. (the engine is run.) 2. Push the air conditioner switch on. Is the battery voltage applied between the harness side connector terminal No.E3-1 and the ground?	—	Go to Step 6	Go to Step 7
6	Repair or replace the magnetic clutch. Is the action complete?	—	Verify repair	—
7	Is there continuity between the harness side connector terminal No.X10-1 and No.E3-1?	—	Go to Step 9	Go to Step 8
8	Repair an open circuit between terminal No.X10-1 and No.E3-1. Is the action complete?	—	Go to Step 7	—
9	Is the battery voltage applied between the harness side connector terminal No.X10-5 and ground, No.X10-2 and ground?	—	Go to Step 11	Go to Step 10
10	Repair an open circuit between terminal No.X10-5 and fuse No.EB-5, No.X10-2 and fuse No.EB-5. Is the action complete?	—	Go to Step 9	—
11	Is the battery voltage applied between the harness side connector terminal No.B20-18 and ground?	—	Go to Step 13	Go to Step 12
12	Repair an open circuit between terminal No.B20-18 and No.X10-4. Is the action complete?	—	Go to Step 11	—
13	Is the battery voltage applied between the harness side connector terminal No.C19-2 and ground?	—	Go to Step 15	Go to Step 14
14	Repair an open circuit between terminal No.C19-2 and fuse No.EB-5. Is the action complete?	—	Go to Step 13	—
15	Is the battery voltage applied between the harness side connector terminal No.X5-2 and ground, No.X5-5 and ground?	—	Go to Step 17	Go to Step 16
16	Repair an open circuit between terminal No.X5-2 and No.C19-1, No.X5-5 and fuse No.EB-5. Is the action complete?	—	Go to Step 15	—
17	Is the battery voltage applied between the harness side connector terminal No.B19-14 and ground?	—	Go to Step 19	Go to Step 18

**Chart A: Magnetic Clutch Does Not work (Cont'd)**

Step	Action	Value(s)	Yes	No
18	Repair an open circuit between terminal No.X5-4 and B19-14. Is the action complete?	—	Go to Step 17	—
19	Is there continuity between the harness side connector terminal No.B20-4 and ground?	—	Go to Step 21	Go to Step 20
20	Repair an open circuit between terminal No.B20-4 and No.E19-1. Is the action complete?	—	Go to Step 20	—
21	Dose the thermo relay "ON" when connecting ground to the harness connector terminal No.H18-13?	—	Go to Step 23	Go to Step 22
22	Failure on the auto air conditioner control unit. Is the action complete?	—	Verify repair	—

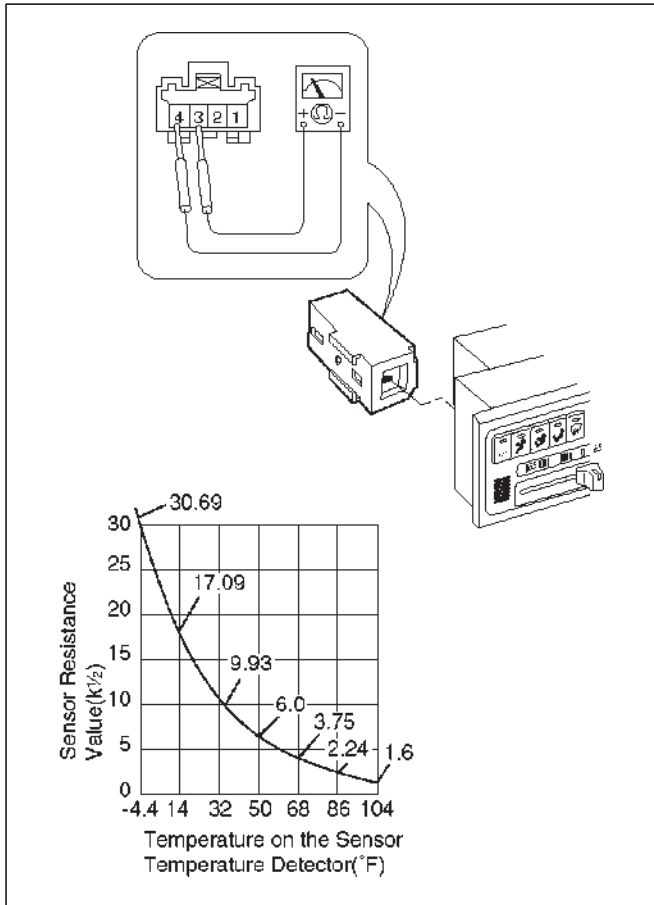
**CAUTION:** There are conditions which air conditioner system dose not operate except trouble as follows.

1. The throttle is griater than 90%.
2. The ignition voltage is below 10.5 volts.
3. The engine speed greater than 4500 RPM for 5 seconds or 5400 RPM.
4. The engine coolant temperature (ECT) is greater than 257 °F.
5. The intake air temperature (IAT) is less than 41 °F.
6. The power steering pressure switch signals a high pressure condition.

## Individual Inspection

### In Car Sensor

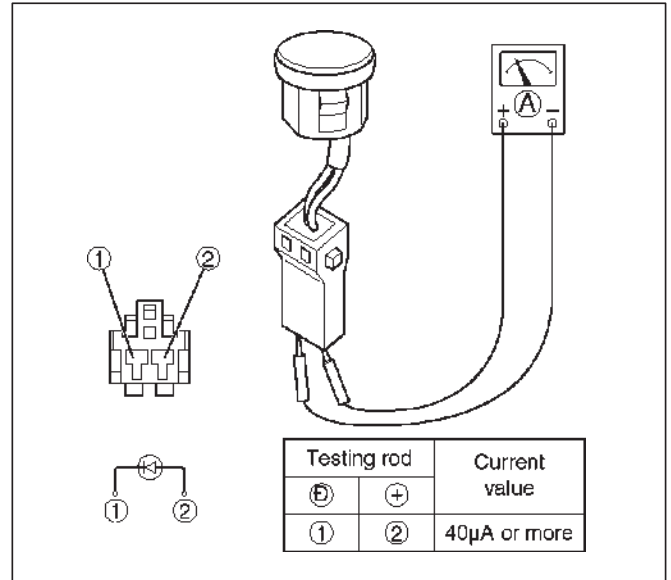
1. Disconnect the in car sensor connector (B-21).
2. Measure resistance between the in car sensor side terminal No.B21-3 and No.B21-4.



865RY00011

### Sun Sensor

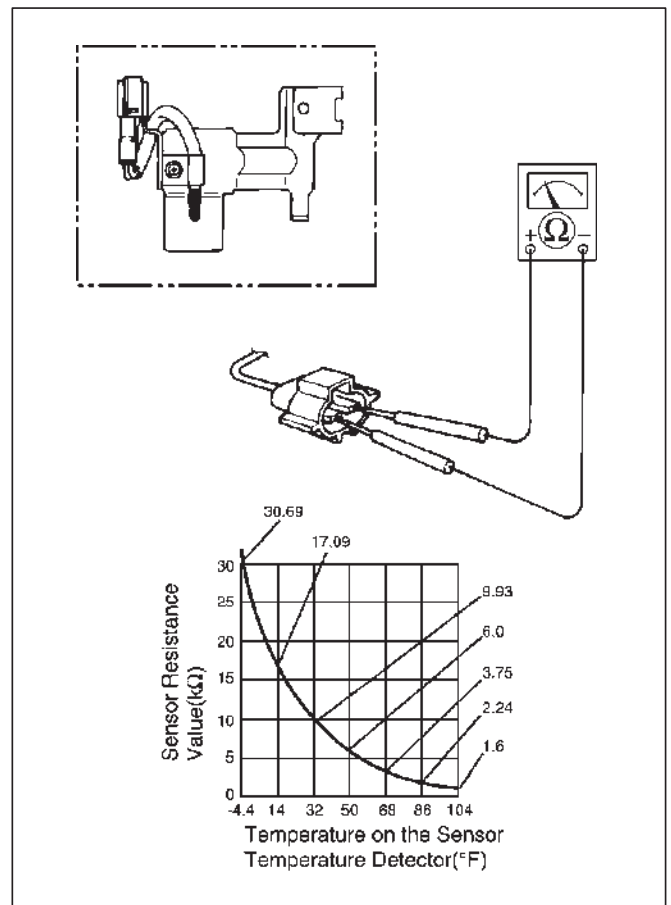
1. Disconnect the sun sensor connector (C-36).
2. Measure the current value on the sun sensor when placed it approximately 15 cm away from 60W incandescent lamp.



D06RY00001

### Ambient Sensor

1. Disconnect the connector (C-15) on the ambient sensor.
2. Measure resistance between the ambient sensor side terminals.



C01RY00014

**Power Transistor**

1. Remove the power transistor connector (B-25) from the evaporator assembly.
2. Check the conduction between the power transistor side terminals.

Terminal No.	1	2	3	Conduction
Testing rod	-	+		Conducted (50Ω maximum)
	-		+	Conducted (100Ω maximum)
	+	-		Not conducted
	+	-		Conducted (220Ω maximum)
		-	+	Not conducted

C01RY00002

**MAX HI Relay**

1. Remove the MAX – HI relay connector (B-26) from the blower assembly.
2. Check the conduction between the MAX – HI relay side terminals.

No continuity between terminals (2) and (4).

Continuity between terminal (2) and (4) when battery voltage is applied between (1) and (3).

C01RY00003

**In Car Sensor**

1. Turn on the ignition switch (the engine is started). Start the air conditioner in “Full Auto”.
2. Make sure that the in car sensor suctions cigarette smokes and such.

**In Car Sensor**

1. Dismount the in car sensor from the automatic heater/air conditioner control unit. Connect (+) end and (-) end of the battery to the aspirator motor side terminals No.B21-1 and No.B21-2, respectively, then check if the motor runs normally.

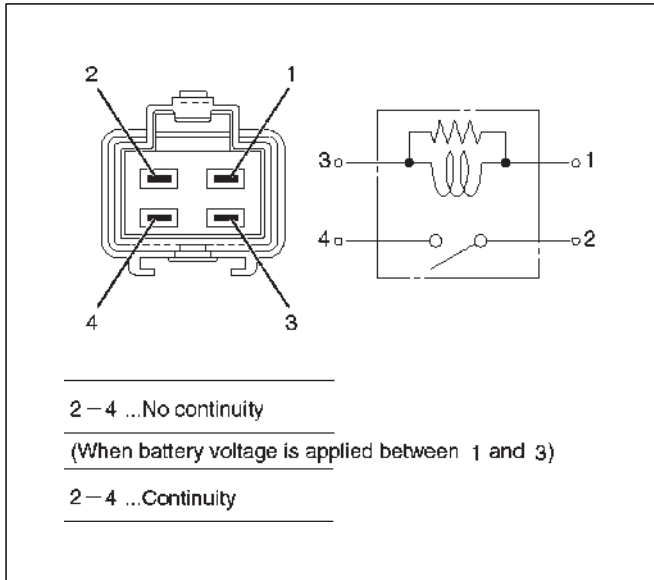
C01RY00005

## 1A-140 HEATING, VENTILATION AND AIR CONDITIONING (HVAC)

### Heater (X-6), Thermostat (X-5), And Compressor (X-10) Relay

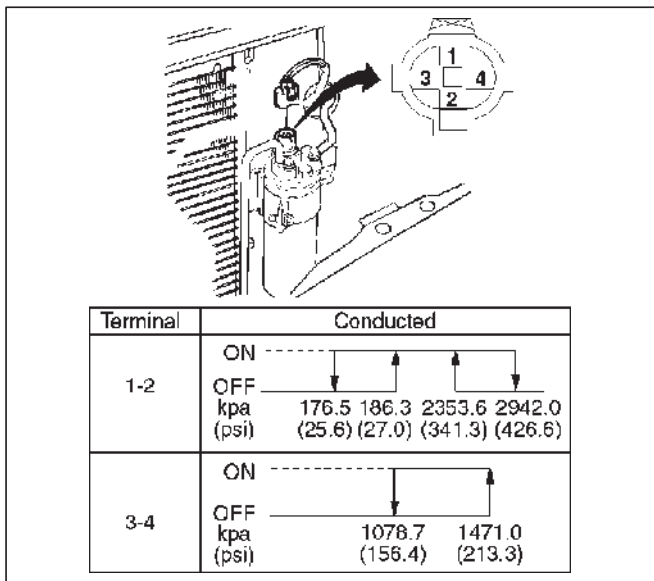
1. Disconnect relays and check for continuity and resistance between relay terminals.

○For handling of these relays, refer to Heater Relay in this section.



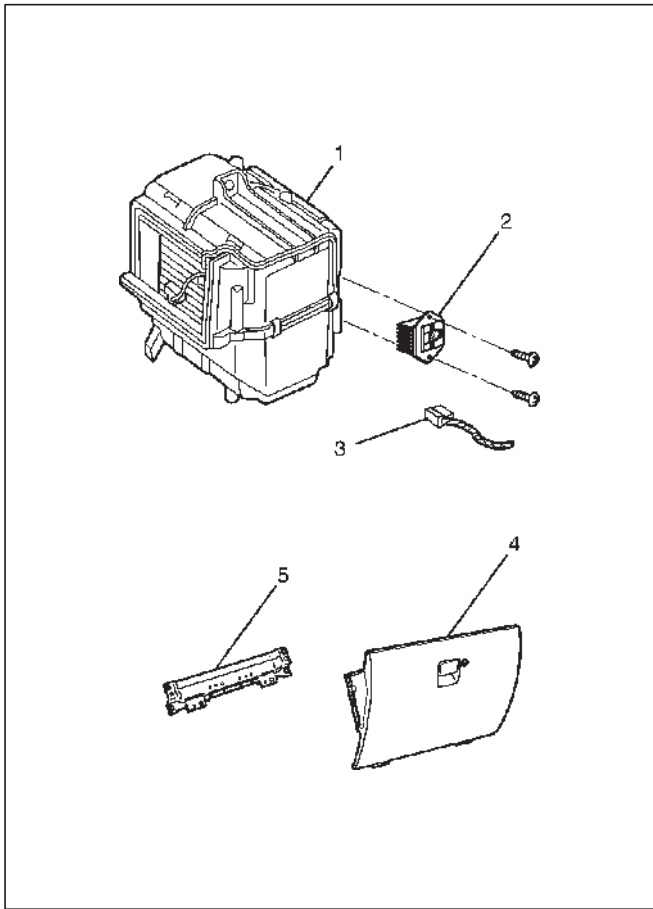
### Triple Pressure Switch (V6, A/T)

1. Disconnect the connector and check for continuity between pressure switch side connector terminals (1) and (2).
2. Reconnect the connector to activate the A/C switch, and check to see if there is continuity between the chassis side connector terminal (3) and (4) and the fan operates.



## On-Vehicle Service

### Power Transistor



874RY00020

#### Legend

- (1) Evaporator Assembly
- (2) Power Transistor
- (3) Power Transistor Connector
- (4) Glove Box
- (5) Passenger Knee Bolster Reinforcement

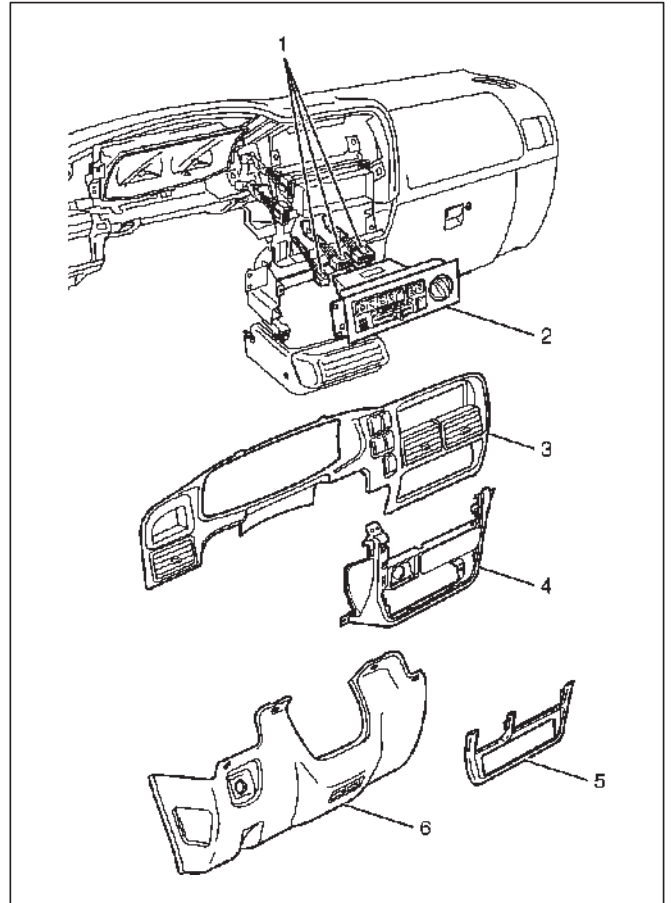
### Removal

1. Remove glove box.
2. Remove passenger knee bolster reinforcement.
3. Disconnect the power transistor connector.
4. Remove power transistor.

### Installation

To install, follow the removal step in the reverse order.

### Automatic Heater/Air Conditioner Control Unit



865RY00022

#### Legend

- (1) Connector
- (2) Automatic Heater/Air Conditioner Control Unit
- (3) Meter Cluster
- (4) Instrument Panel Lower Center Cover.
- (5) Lower Cluster
- (6) Instrument Panel Driver Lower Cover

### Removal

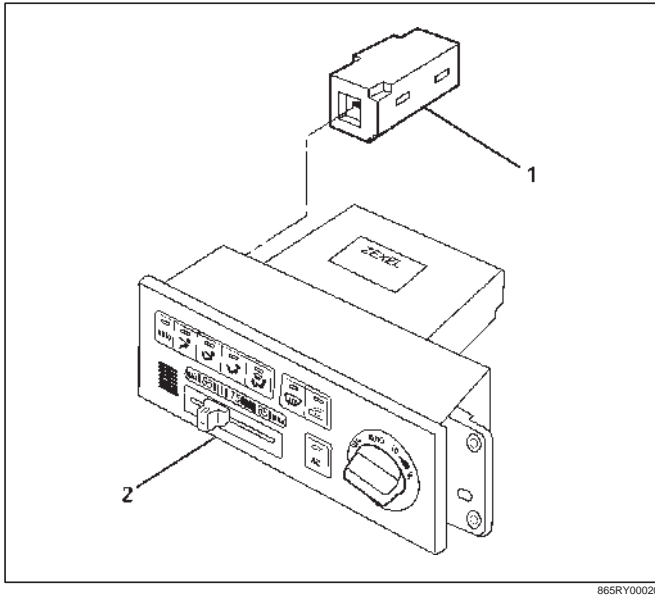
1. Disconnect the battery ground cable.
2. Remove instrument panel driver lower cover.
3. Remove lower cluster.
4. Remove meter cluster.
5. Remove instrument panel lower center cover.
  - Refer to Instrument Panel Assembly in Body Structure section.
6. Disconnect the automatic heater/air conditioner control unit connector.
  - Remove the control unit fixing screws, pull out the control unit and disconnect the connectors.
7. Remove automatic heater/air conditioner control unit.

## 1A-142 HEATING, VENTILATION AND AIR CONDITIONING (HVAC)

### Installation

To install, follow the removal step in the reverse order.

### In Car Sensor



#### Legend

- (1) In Car Sensor
- (2) Automatic Heater/Air Conditioner Control Unit

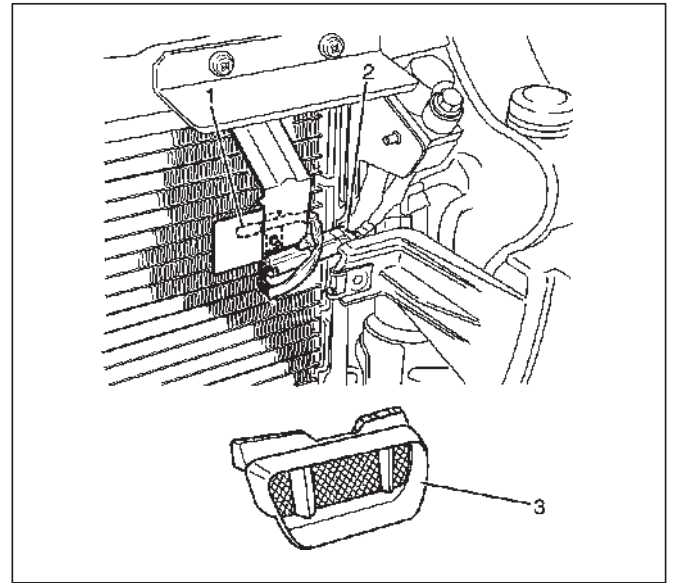
### Removal

1. Disconnect the battery ground cable.
2. Remove the automatic heater/air conditioner control unit.
  - Refer to the automatic heater/air conditioner control unit section.
3. Remove in car sensor.

### Installation

To install, follow the removal step in the reverse order.

### Ambient Sensor



#### Legend

- (1) Ambient Sensor
- (2) Sensor Connector
- (3) Radiator Grille

### Removal

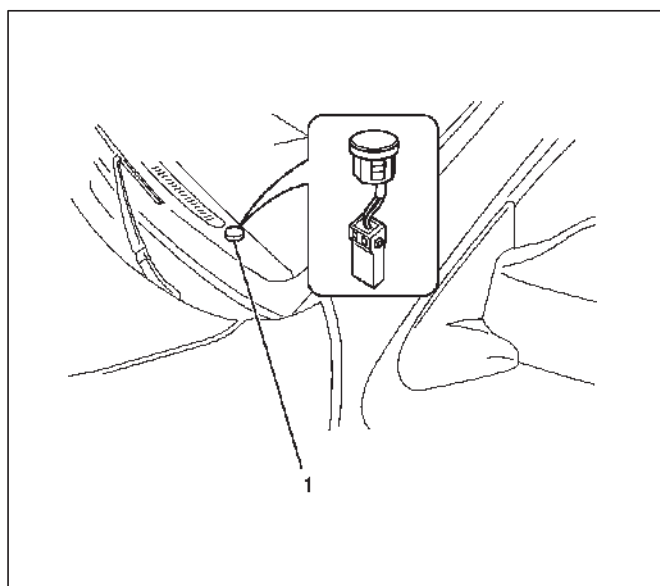
1. Disconnect the battery ground cable.
2. Remove radiator grille.
  - Refer to Radiator Grille in Body Structure section.
3. Disconnect the ambient sensor connector.
4. Remove the ambient sensor.

### Installation

To install, follow the removal step in the reverse order.



## Sun Sensor



865RY00021

### Legend

- (1) Sun Sensor

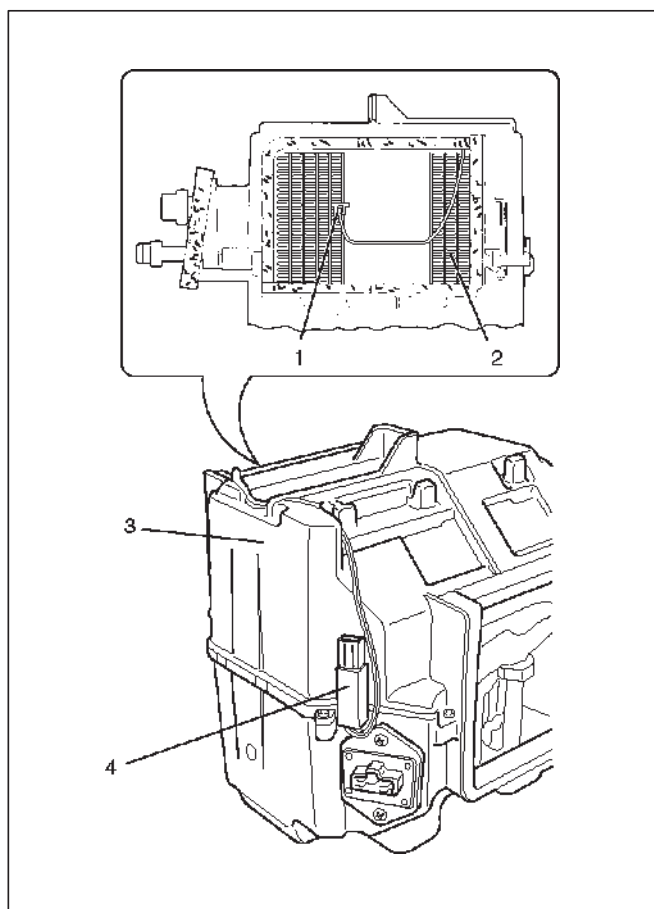
## Removal

1. Disconnect the battery ground cable.
2. Remove the sun sensor.
3. Disconnect the sun sensor connector.

## Installation

To install, follow the removal step in the reverse order.

## Electronic Thermostat



874RX022

### Legend

- (1) Duct Sensor
- (2) Evaporator Core
- (3) Evaporator Assembly
- (4) Thermostat Assembly

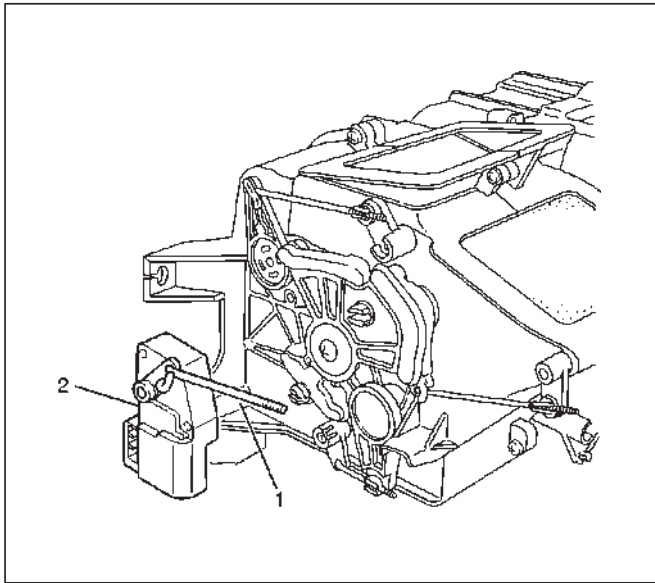
## Removal

1. Disconnect the battery ground cable.
2. Remove evaporator assembly.
  - Refer to evaporator assembly section.
3. Remove electronic thermostat.

## Installation

To install, follow the removal step in the reverse order.

## Mode Actuator



### Legend

- (1) Actuator Rod
- (2) Mode Actuator

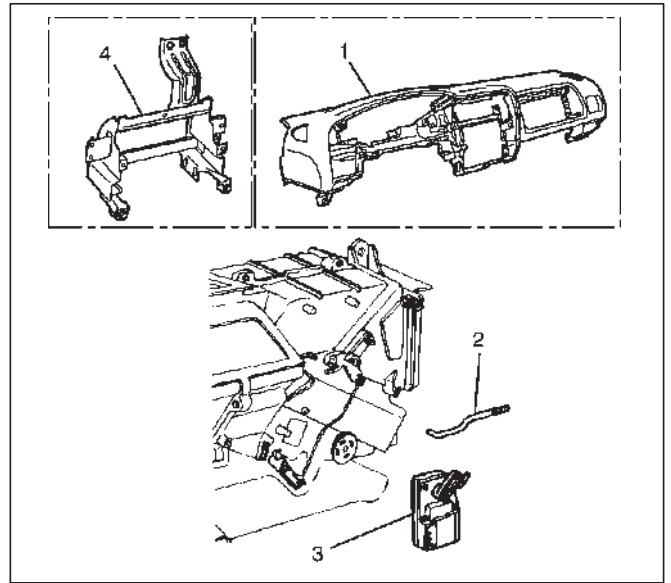
## Removal

1. Disconnect the battery ground cable.
2. Remove the actuator rod.
3. Remove the mode actuator.

## Installation

To install, follow the remove step in the reverse order.

## Mix Actuator



### Legend

- (1) Instrument Panel Assembly
- (2) Actuator Rod
- (3) Mix Actuator
- (4) Instrument Panel Center Bracket

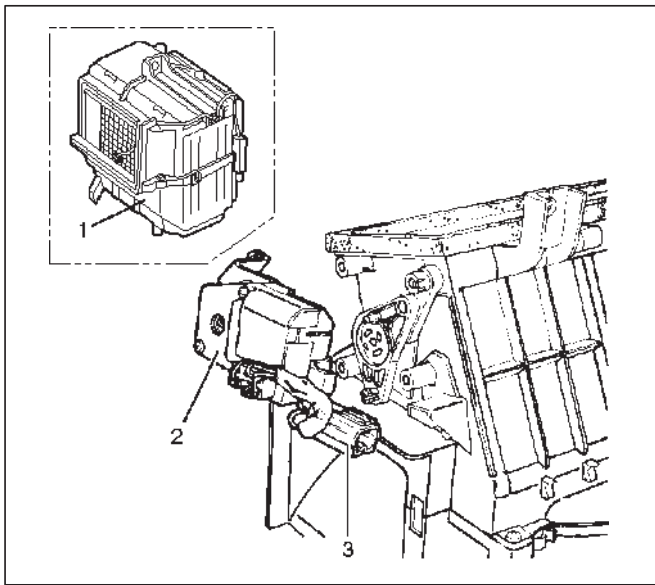
## Removal

1. Disconnect the battery ground cable.
2. Remove the instrument panel assembly.
  - Refer to the Instrument Panel Assembly in Body and Accessories section.
3. Remove the instrument panel center bracket.
4. Remove the actuator rod.
5. Remove the mix actuator.

## Installation

To install, follow the remove step in the reverse order.

## Intake Actuator



873RY00004

### Legend

- (1) Evaporator Assembly
- (2) Intake Actuator
- (3) Intake Actuator Connector

## Removal

1. Disconnect the battery ground cable.
2. Discharge and recover refrigerant.
  - Refer to Refrigerant Recovery in this section.
3. Remove the evaporator assembly.
  - Refer to Evaporator Assembly section.
4. Disconnect the intake actuator connector.
5. Remove the intake actuator.

## Installation

To install, follow the remove step in the reverse order.

VEHICROSS

# STEERING

## POWER ASSISTED SYSTEM

### CONTENTS

Service Precaution .....	2A-2	Inspection and Repair .....	2A-39
General Description .....	2A-2	Installation .....	2A-39
Diagnosis .....	2A-5	Relay Lever .....	2A-40
Power Steering System Test .....	2A-11	Relay Lever and Associated Parts .....	2A-40
Maintenance .....	2A-11	Removal .....	2A-40
Fluid Level .....	2A-12	Installation .....	2A-41
Bleeding The Power Steering System .....	2A-12	Steering Linkage and Associated Parts .....	2A-42
Bleeding Procedure .....	2A-12	Main Data and Specifications .....	2A-42
Flushing The Power Steering System .....	2A-12	Special Tools .....	2A-43
Steering Wheel Free Play Adjustment .....	2A-12	Supplemental Restraint System Steering	
Front End Alignment Inspection and		Wheel & Column .....	2A-44
Adjustment .....	2A-13	Service Precaution .....	2A-44
Main Data and Specifications .....	2A-18	SRS Connectors (3 pin) .....	2A-44
Special Tools .....	2A-19	SRS Connectors (2 pin) .....	2A-44
Power Steering Gear .....	2A-20	Inflator Module .....	2A-46
Power Steering Gear and Associated Parts	2A-20	Inflator Module and Associated Parts .....	2A-46
Removal .....	2A-20	Removal .....	2A-46
Installation .....	2A-21	Inspection and Repair .....	2A-47
Steering Gear Disassembled View .....	2A-22	Installation .....	2A-47
Disassembly .....	2A-22	Steering Wheel .....	2A-48
Inspection and Repair .....	2A-24	Steering Wheel and Associated Parts .....	2A-48
Reassembly .....	2A-25	Removal .....	2A-48
Main Data and Specifications .....	2A-27	Installation .....	2A-50
Special Tools .....	2A-28	Combination Switch .....	2A-51
Power Steering Pump .....	2A-29	Combination Switch and Associated Parts	2A-51
Power Steering Pump and Associated Parts	2A-29	Removal .....	2A-51
Removal .....	2A-29	Installation .....	2A-53
Installation .....	2A-30	Lock Cylinder .....	2A-55
Power Steering Pump Disassembled View	2A-31	Lock Cylinder and Associated Parts .....	2A-55
Disassembly .....	2A-31	Removal .....	2A-55
Inspection and Repair .....	2A-32	Installation .....	2A-57
Reassembly .....	2A-33	System Inspection .....	2A-58
Main Data and Specifications .....	2A-34	Steering Column .....	2A-59
Center Track Rod Assembly .....	2A-35	Steering Column and Associated Parts .....	2A-59
Center Track Rod Assembly and		Removal .....	2A-59
Associated Parts .....	2A-35	Inspection .....	2A-61
Removal .....	2A-35	Installation .....	2A-63
Inspection and Repair .....	2A-36	System Inspection .....	2A-64
Installation .....	2A-36	Supplemental Restraint System Steering	
Outer Track Rod Assembly .....	2A-37	Wheel & Column and Associated Parts .....	2A-65
Outer Track Rod Assembly and		Main Data and Specifications .....	2A-65
Associated Parts .....	2A-37	Special Tools .....	2A-66
Removal .....	2A-37		

## 2A-2 POWER-ASSISTED STEERING SYSTEM

### Service Precaution

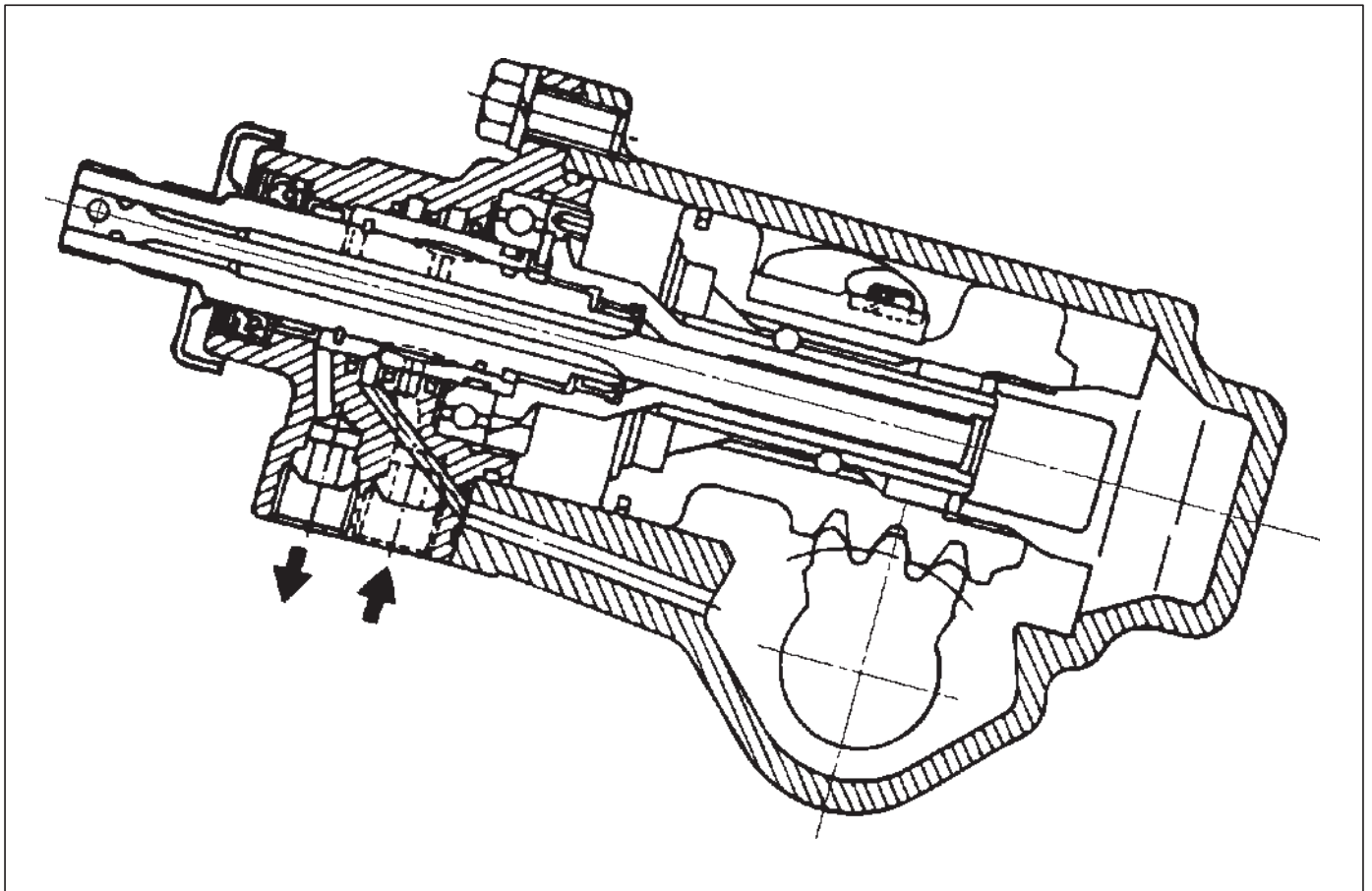
**WARNING:** THIS VEHICLE HAS A SUPPLEMENTAL RESTRAINT SYSTEM (SRS). REFER TO THE SRS COMPONENT AND WIRING LOCATION VIEW IN ORDER TO DETERMINE WHETHER YOU ARE PERFORMING SERVICE ON OR NEAR THE SRS COMPONENTS OR THE SRS WIRING. WHEN YOU ARE PERFORMING SERVICE ON OR NEAR THE SRS COMPONENTS OR THE SRS WIRING, REFER TO THE SRS SERVICE INFORMATION. FAILURE TO FOLLOW WARNINGS COULD RESULT IN POSSIBLE AIR BAG DEPLOYMENT, PERSONAL INJURY, OR OTHERWISE UNNEEDED SRS SYSTEM REPAIRS.

**CAUTION:** Always use the correct fastener in the proper location. When you replace a fastener, use **ONLY** the exact part number for that application. ISUZU will call out those fasteners that require a replacement after removal. ISUZU will also call out the fasteners that require thread lockers or thread sealant. **UNLESS OTHERWISE SPECIFIED**, do not use supplemental coatings (Paints, greases, or other corrosion inhibitors) on threaded fasteners or fastener joint interfaces. Generally, such coatings adversely affect the fastener torque and the joint clamping force, and may damage the fastener. When you install fasteners, use the correct tightening sequence and specifications. Following these instructions can help you avoid damage to parts and systems.

### General Description

The hydraulic power steering system consists of a pump, an oil reservoir, a steering gear, a pressure hose and a return hose.

### Power Steering Gear



A03RS001

The power steering gear has a recirculating ball system which acts as a rolling thread between the worm shaft and the rack piston. When the worm shaft is turned right, the rack piston moves up in gear.

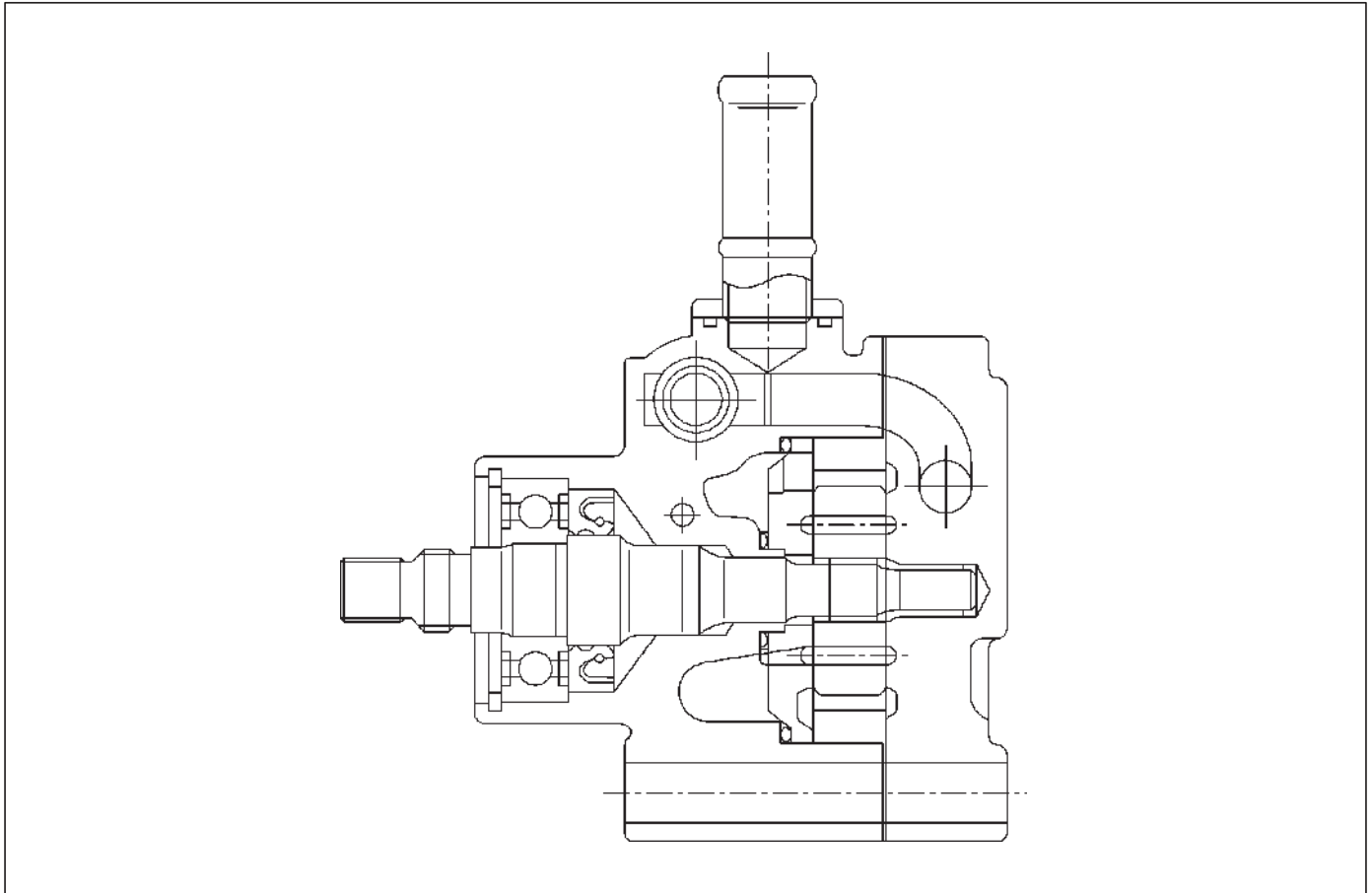
Turning the worm shaft left moves the rack piston down in gear. The rack piston teeth mesh with the sector gear, which is part of the sector shaft.

Turning the worm shaft turns the sector shaft, which turns the wheels through the steering linkage.

The control valve in the steering gear directs the power steering fluid to either side of the rack piston.

The rack piston converts the hydraulic pressure into a mechanical force. If the steering system becomes damaged and loses hydraulic pressure, the vehicle can be controlled manually.

## Hydraulic Pump



442RV006

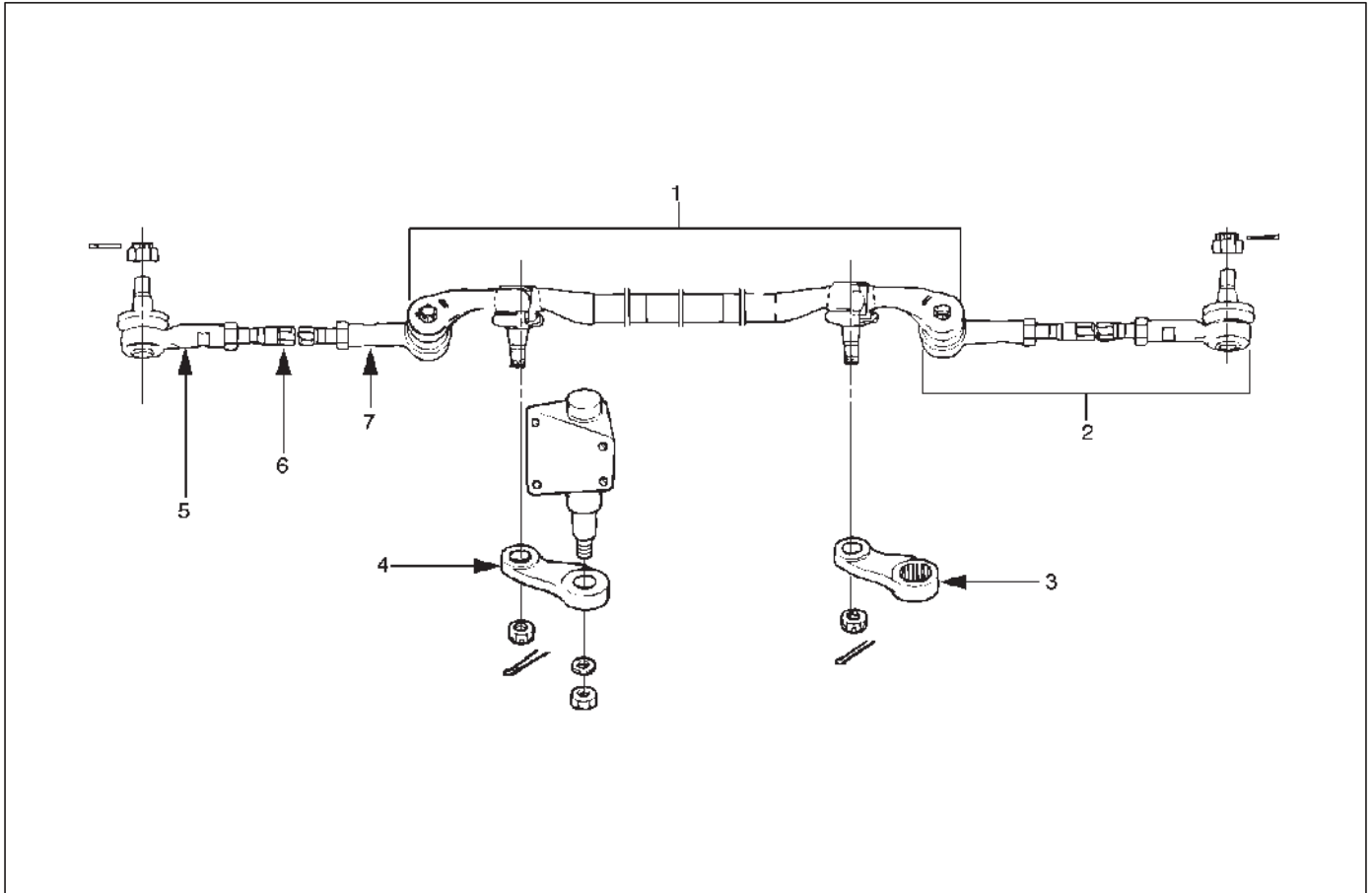
The hydraulic pump is a vane-type design. There are two openings at the rear of the pump housing. The larger opening contains the cam ring, pressure plate, thrust plate, rotor and vane assembly, and end plate. The smaller opening contains the pressure line union, flow control valve and spring.

### Pressure Switch

When hydraulic pressure reaches 3430 kPa (500 psi), the pressure switch closes causing the Engine Control Module (ECM) to actuate the idle air control valve, which increases the engine rpm to prevent the overload-induced engine speed slow down. The switch opens when hydraulic pressure drops to 2940 kPa (430 psi).

## 2A-4 POWER-ASSISTED STEERING SYSTEM

### Steering Linkage



433RS007

#### Legend

- |                               |                   |
|-------------------------------|-------------------|
| (1) Center Track Rod Assembly | (4) Relay Lever   |
| (2) Outer Track Rod Assembly  | (5) Rod End,Outer |
| (3) Pitman Arm                | (6) Track Rod     |
|                               | (7) Rod End,Inner |

The steering linkage consists of a pitman arm, relay lever, center track rod, and two adjustable outer track rods.

When the steering wheel is turned, the gear rotates the pitman arm which forces the center track rod to one side. The outer track rods, connected to the center track rod by ball studs, transfers the steering force to the wheels. The outer track rods are adjustable and are used for toe-in adjustments. The center track rod is supported by the pitman arm and relay lever. The relay lever pivots on a support attached to the frame.

The overall condition of the steering linkage affects steering performance. If parts are bent, damaged, worn or poorly lubricated, improper and possibly dangerous steering action will result.

Whenever any steering linkage components are repaired or replaced, check the steering geometry and front end alignment. Refer to Front End Alignment Inspection and Adjustment in this section.

## Steering Column

**WARNING: TO AVOID DEPLOYMENT WHEN TROUBLE-SHOOTING THE SRS SYSTEM, DO NOT USE ELECTRICAL TEST EQUIPMENT, SUCH AS BATTERY-POWERED OR A/C-POWERED VOLT-METER, OHMMETER, ETC., OR ANY TYPE OF ELECTRICAL EQUIPMENT OTHER THAN SPECIFIED IN THIS MANUAL. DO NOT USE A NON-POWERED PROBE-TYPE TESTER.**

**INSTRUCTION IN THIS MANUAL MUST BE FOLLOWED CAREFULLY, OTHERWISE PERSONAL INJURY MAY RESULT.**

When servicing a vehicle equipped with Supplemental Restraint System, pay close attention to all WARNINGS and CAUTIONS.

For detailed explanation about SRS, refer to Restraints section.

The steering column has three important features in addition to the steering function:

1. The column is energy absorbing, designed to compress in a front-end collision to minimize the possibility of injury to the driver of the vehicle.
2. The ignition switch and lock are mounted conveniently on the column.

3. With the column mounted lock, the ignition and steering operation can be locked to prevent theft of the vehicle.

The column can be disassembled and reassembled. However, to ensure the energy absorbing action, use only the specified screws, bolts and nuts as designated, and tighten them to the specified torque.

Handle the column with care when it is removed from the vehicle. A sharp blow on the end of steering shaft or shift lever, or dropping the assembly could shear or loosen the fasteners that maintain column rigidity.

## Diagnosis

Since the problems in steering, suspension, wheels and tires involve several systems, they must all be considered when diagnosing a complaint. To identify the symptom, always road test the vehicle first. Proceed with the following preliminary inspections and correct any defects which are found.

1. Inspect tires for proper pressure and uneven wear.
2. Raise vehicle on a hoist, then inspect front and rear suspension and steering linkage for loose or damaged parts.
3. Spin the front wheels. Inspect for out-of-round tires, out-of-balance tires, loose and/or rough wheel bearings.

## General Diagnosis

Condition	Possible cause	Correction
Vehicle Pulls	Mismatched or uneven tires.	Replace tire.
	Tires not adequately inflated.	Adjust tire pressure.
	Broken or sagging springs.	Replace spring.
	Radial tire lateral force.	Replace tire.
	Improper wheel alignment.	Adjust wheel alignment.
	Brake dragging in one wheel.	Repair brake.
	Loose, bent or broken front or rear suspension parts.	Tighten or replace the appropriate suspension part(s).
Abnormal or Excessive Tire Wear	Faulty shock absorbers.	Replace shock absorber.
	Sagging or broken spring.	Replace spring.
	Tire out of balance.	Balance or replace tire.
	Improper wheel alignment.	Check front end alignment.
	Faulty shock absorber.	Replace shock absorber.
	Hard driving.	Replace tire.
	Overloaded vehicle.	Replace tire and reduce load.
	Tires not rotated periodically.	Replace or rotate tire.
	Worn or loose road wheel bearings.	Replace wheel bearing.
	Wobbly wheel or tires.	Replace wheel or tire.
Tires not adequately inflated.	Adjust the pressure.	
Wheel Hop	Blister or bump on tire.	Replace tire.
	Improper shock absorber operation.	Replace shock absorber.



## 2A-6 POWER-ASSISTED STEERING SYSTEM

Condition	Possible cause	Correction
Shimmy, Shake or Vibration	Tire or wheel out of balance.	Balance wheels or replace tire/or wheel.
	Loose wheel bearings.	Replace wheel bearing.
	Worn steering linkage ball joints.	Replace ball joints.
	Worn upper or lower ball joints.	Replace ball joints
	Excessive wheel runout.	Repair or replace wheel and/or tire.
	Blister or bump on tire.	Replace tire.
	Excessive loaded radial runout of tire/wheel assembly.	Replace tire or wheel.
	Improper wheel alignment.	Check wheel alignment.
	Loose or worn steering linkage.	Tighten or replace steering linkage.
	Loose steering gear.	Tighten housing bolts.
	Tires not adequately inflated.	Adjust tire pressure.
	Loose, bent or broken front or rear suspension parts.	Tighten or replace the appropriate suspension parts.
	Faulty shock absorber.	Replace shock absorber.
	Hub bearing preload misadjustment.	Adjust preload.
Hard Steering	Bind in steering linkage ball studs, upper or lower ball joint.	Replace ball joint.
	Improper wheel alignment.	Check wheel alignment.
	Steering gear misadjustment.	Check and adjust pinion torque.
	Tire not adequately inflated.	Inflate tires to proper pressure.
	Bind in steering column or shaft.	Repair or replace.
	Improper power steering system operation.	Repair or replace. Refer to "Power steering system diagnosis"
Too Much Play In Steering	Wheel bearings worn.	Replace wheel bearings.
	Loose steering gear or linkage.	Retighten or repair.
	Steering gear misadjustment.	Inspect and adjust steering gear preload.
	Worn or loose steering shaft universal joint.	Retighten or replace steering shaft.
	Worn steering linkage ball joints.	Replace ball joints.
	Worn upper or lower ball joints.	Replace ball joints.
Poor Steering Wheel Returnability	Bind in steering linkage ball joints.	Replace ball joints.
	Bind in upper or lower ball joints.	Replace ball joints.
	Bind in steering column and shaft.	Repair or replace.
	Bind in steering gear.	Check and repair steering gear.
	Improper wheel alignment.	Adjust wheel alignment.
	Tires not adequately inflated.	Adjust tire pressure.
	Loose steering wheel nut.	Retighten.
Worn wheel bearing.	Replace.	

Condition	Possible cause	Correction
Abnormal Noise	Worn, sticky or loose upper or lower ball joint, steering linkage ball joints or drive axle joints.	Replace.
	Faulty shock absorbers.	Replace.
	Worn upper or lower control arm bushing.	Replace.
	Loose stabilizer bar.	Retighten bolts or replace bushings.
	Loose wheel nuts.	Tighten nuts. Check for elongated wheel nut holes. Replace wheel if required.
	Loose suspension bolts or nuts.	Retighten suspension bolts or nuts.
	Broken or otherwise damaged wheel bearings.	Replace wheel bearing.
	Broken suspension springs.	Replace spring.
	Loose steering gear.	Retighten mounting bolt.
	Faulty steering gear.	Check and adjust steering gear.
Wandering or Poor Steering Stability	Mismatched or unevenly worn tires.	Replace tire or inflate tires to proper pressure.
	Loose steering linkage ball joints.	Replace ball joints.
	Faulty shock absorbers.	Replace shock absorber.
	Loose stabilizer bar.	Tighten or replace stabilizer bar or bushings.
	Broken or sagging springs.	Replace spring (pairs).
	Steering gear misadjustment.	Check or adjust steering gear.
	Improper wheel alignment.	Adjust wheel alignment.
Erratic Steering When Braking	Worn wheel bearings.	Replace wheel bearings.
	Broken or sagging springs.	Replace spring (pairs).
	Leaking caliper.	Repair or replace caliper.
	Warped discs.	Replace brake disc.
	Badly worn brake pads.	Replace brake pads.
	Tires are inflated unequally.	Inflate tires to proper pressure.

## 2A-8 POWER-ASSISTED STEERING SYSTEM

### Power Steering System

There is some noise in all power steering systems. One of the most common is a hissing sound when the steering wheel is fully turned and the car is not moving. This noise will be most evident when the steering wheel is operated while the brakes are applied. There is no relationship be-

tween this noise and steering performance. Do not replace the valve unless the "hissing" noise is extremely objectionable. A replacement valve will also have a slight noise, and is not always a cure for the condition.

Condition	Possible cause	Correction
Rattle or Chucking Noise	Pressure hose touching other parts of vehicle.	Adjust hose position. Do not bend tubing by hand.
	Tie rod ends loose.	Tighten or replace tie rod end.
	Loose steering gear mounting.	Tighten steering gear mounting.
	Steering gear misadjustment.	Check and adjust steering gear preload.
Poor Return of Steering Wheel to Center	Improper front wheel alignment.	Adjust front wheel alignment.
	Wheel bearing worn.	Replace front wheel bearing.
	Tie rod end binding.	Replace tie rod end.
	Ball joint binding.	Replace ball joint.
	Tight or frozen steering shaft bearing.	Replace steering assembly.
	Steering gear misadjustment.	Adjust the steering gear.
	Sticky or plugged steering gear valve.	Repair or replace steering gear valve.
Entry of air in the power steering system.	Bleed the system.	
Momentary Increase In Effort When Turning Wheel Fast To Right or Left	High internal leakage.	Repair steering gear.
	Power steering fluid level low.	Replenish fluid.
Steering Wheel Surges or Jerks When Turning Especially During Parking	Insufficient pump pressure.	Repair pump assembly.
	Sticky steering gear valve.	Repair or replace steering gear.
	Power steering fluid level low.	Replenish fluid.
Excessive Wheel Kick Back or Loose Steering	Air in system.	Bleed hydraulic system.
	Tie rod end loose.	Tighten tie rod end.
	Wheel bearing worn.	Replace wheel bearing.
Hard Steering or Lack of Power Assist	Sticky steering gear valve.	Repair or replace steering gear valve.
	Insufficient pump pressure.	Repair pump assembly.
	Excessive internal pump leakage.	Repair pump assembly.
	Excessive internal steering gear leakage.	Repair steering gear.
	Power steering fluid level low.	Replenish fluid.
Unstable Engine Idling or Stalling When Turning	Pressure switch of the power steering pump or its harness is faulty.	Repair or replace.

### Power Steering Pump

Foaming milky power steering fluid, low fluid level, and possible low pressure can be caused by air in the fluid, or loss of fluid due to internal pump leakage. Check for leak and correct. Bleed the system. Extremely cold temperatures will cause air bubbles in the system if the fluid level

is low. If the fluid level is correct and the pump still foams, remove the pump from the vehicle and check the housing for cracks. If the housing is cracked, replace the pump housing.

Condition	Possible cause	Correction
Low Pressure Due to Steering Pump	Relief valve sticking or inoperative.	Replace relief valve.
	Side plate not flat against cam ring.	Replace side plate.
	Extreme wear of cam ring.	Replace cam ring.
	Scored side plate or rotor.	Replace side plate or rotor.
	Vanes sticking in rotor slots.	Repair or replace vanes and rotor.
	Cracked or broken side plate.	Replace side plate.
	High internal leakage.	Repair internal leakage.
Low Pressure Due to Steering Gear	Scored housing bore.	Replace housing.
Growling Noise In Steering Pump	Excessive back pressure in hoses or steering unit caused by restriction.	Repair steering unit or pump.
	Scored side plate or rotor.	Replace side plate or rotor.
	Worn cam ring.	Replace cam ring.
Groaning Noise In Steering Pump	Air in the fluid.	Bleed hydraulic system.
	Low fluid level.	Replenish fluid.
	Pump mounting loose.	Tighten mounting bolt.
Rattling Noise In Steering Pump	Vanes sticking in rotor slots.	Repair or replace vanes and rotor.
	Vane improperly installed.	Repair rotor and vane.
Swishing Noise In Steering Pump	Damaged relief valve.	Replace relief valve.
Whining Noise In Steering Pump	Scored side plate and vanes.	Replace side plate and vanes.

### Steering Column Lock System

Condition	Possible cause	Correction
Will Not Unlock	Damaged lock cylinder.	Replace lock cylinder.
	Damaged park lock cable.	Replace park lock cable.
Will Not Lock	Lock spring broken or worn.	Replace lock cylinder.
	Damaged lock cylinder.	Replace lock cylinder.
	Ignition switch stuck.	Repair or replace ignition switch.
	Park lock cable damaged.	Replace park lock cable.
Key Cannot be Removed in "OFF-LOCK"	Ignition switch is not set correctly.	Correct ignition switch.
	Damaged lock cylinder.	Replace lock cylinder.
	Faulty shift lock mechanism.	Repair or replace the shift lock mechanism.

### Column

Condition	Possible cause	Correction
Noise in Column	Universal joint loose.	Tighten joint.
	Shaft lock snap ring not seated.	Place snap ring in proper position.

## 2A-10 POWER-ASSISTED STEERING SYSTEM

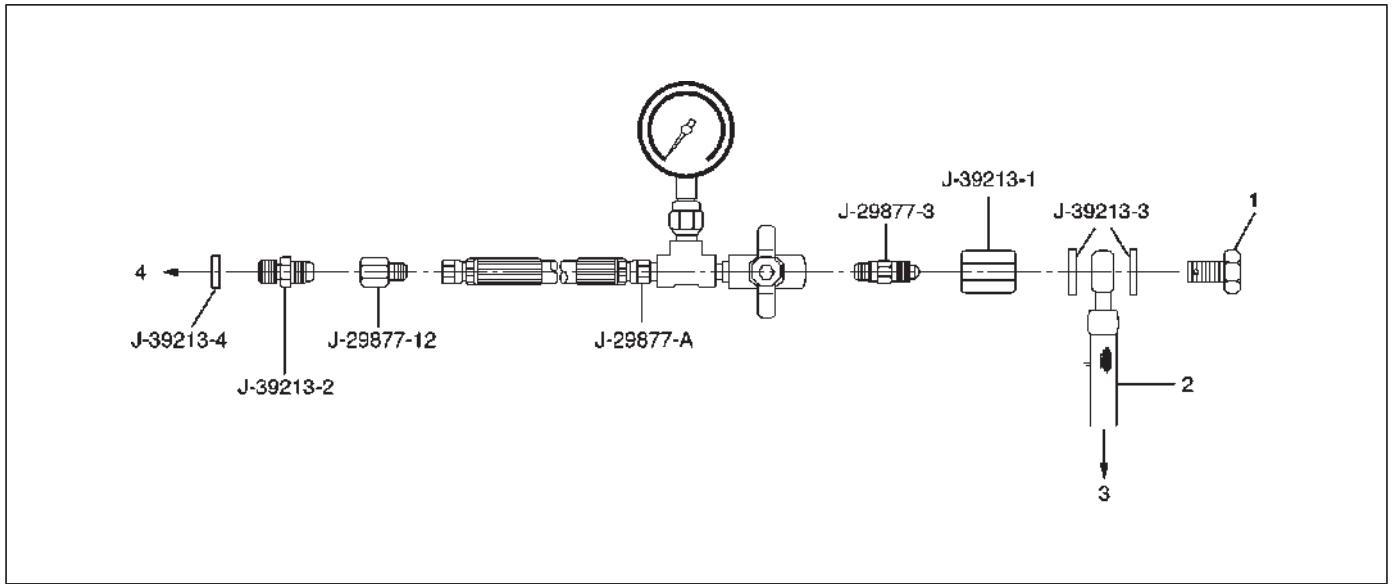
### Turn Signal Switch

This diagnosis covers mechanical problems only. Refer to Turn Signal Switch in Electrical section for electrical diagnosis.

Condition	Possible cause	Correction
Turn Signal Will Not Stay In Turn Position	Foreign material or loose parts preventing movement of yoke.	Repair or replace signal switch.
	Broken or missing detent or canceling spring.	Replace signal switch.
Turn Signal Will Not Cancel	Loose switch mounting screws.	Tighten mounting screws.
	Switch or anchor bosses broken.	Replace turn signal switch.
	Broken, missing or out of position detent, return or canceling spring.	Replace turn signal switch.
	Worn canceling cam.	Replace turn signal switch.
Turn Signal Difficult To Operate	Turn signal switch arm loose.	Tighten arm screw.
	Broken or distorted yoke.	Replace turn signal switch.
	Loose or misplaced springs.	Replace turn signal switch.
	Foreign parts and/or material.	Repair turn signal switch.
	Loose turn signal switch mounting screws.	Tighten mounting screws.
Turn Signal Will Not Indicate Lane Change	Broken lane change pressure pad or spring hanger.	Replace turn signal switch.
	Broken, missing or misplaced lane change spring.	Replace turn signal switch.
	Base of wire damaged.	Replace turn signal switch.
Hazard Switch Cannot Be Turned Off	Foreign material between hazard switch to turn signal switch body.	Repair or replace hazard switch.
No Turn Signal Lights	Electrical failure in chassis harness.	Refer to Electrical section.
	Inoperative turn signal flasher unit.	Replace flasher unit.
	Loose chassis harness connector.	Repair loose connector.
Front or Rear Turn Signal Lights Not Flashing	Burned-out or damaged turn signal bulb.	Replace bulb.
	High resistance connection to ground at bulb socket.	Repair bulb socket.
	Loose chassis harness connector.	Repair loose connector.

## Power Steering System Test

### Test Procedure



#### Legend

- (1) Bolt (M16 × 1.5)
- (2) Hose (Vehicle Side)

- (3) To Power Steering Gear
- (4) To Power Steering Pump

Test of fluid pressure in the power steering system is performed to determine whether or not the oil pump and power steering unit are functioning normally.

The power steering system test is the method used to identify and isolate hydraulic circuit difficulties. Prior to performing this test, the following inspections and corrections, if necessary, must be made.

- Inspect pump reservoir for proper fluid level.
- Inspect pump belt for proper tension.
- Inspect pump driver pulley condition.

1. Place a container under the pump to catch the fluid when disconnecting or connecting the hoses.
2. With the engine NOT running, disconnect the pressure hose at the power steering pump and install power steering tester J-29877-A. The gauge must be between the shutoff valve and pump. Open the shutoff valve.
3. Check the fluid level. Fill the reservoir with power steering fluid, to the "Full" mark. Start the engine, then turn the steering wheel and momentarily hold it against a stop (right or left). Turn the engine off and check the connections at tester for leakage.
4. Bleed the system. Refer to Bleeding the Power Steering System in this section.
5. Start the engine and check the pump fluid level. Add power steering fluid if required. When the engine is at normal operating temperature, increase engine speed to 1500 rpm.

**CAUTION: Do not leave shutoff valve fully closed for more than 5 seconds, as the pump could become damaged internally.**

6. Fully close the shutoff valve. Record the highest pressures.

- If the pressure recorded is within 9300–9800 kpa (1350–1420 psi), the pump is functioning within its specifications.
- If the pressure recorded is higher than 9800 kpa (1420 psi), the valve in the pump is defective.
- If the pressure recorded is lower than 9300 kpa (1350 psi), the valve or the rotating group in the pump is defective.

7. If the pump pressures are within specifications, leave the valve open and turn (or have someone else turn) the steering wheel fully in both directions. Record the highest pressures and compare with the maximum pump pressure recorded in step 6. If this pressure cannot be built in either side of the power steering gear, the power steering gear is leaking internally and must be disassembled and repaired.
8. Shut the engine off, remove the testing gauge.
9. Reconnect the pressure hose, check the fluid level and make the needed repairs.
10. If the problem still exists, the steering and front suspension must be thoroughly examined.

## Maintenance

The hydraulic system should be kept clean and fluid level in the reservoir should be checked at regular intervals and fluid added when required. Refer to Recommended Fluids and Lubricants in General Information section for the type of fluid to be used and the intervals for filling.

## 2A-12 POWER-ASSISTED STEERING SYSTEM

If the system contains some dirt, flush it as described in this section. If it is exceptionally dirty, both the pump and the gear must be completely disassembled before further usage.

All tubes, hoses, and fittings should be inspected for leakage at regular intervals. Fittings must be tight. Make sure the clips, clamps and supporting tubes and hoses are in place and properly secured.

Power steering hoses and lines must not be twisted, kinked or tightly bent. Air in the system will cause spongy action and noisy operation. When a hose is disconnected or when fluid is lost, for any reason, the system must be bled after refilling. Refer to Bleeding the Power Steering System in this section.

- Inspect belt for tightness.
- Inspect pulley for looseness or damage. The pulley should not wobble with the engine running.
- Inspect hoses so they are not touching any other parts of the vehicle.
- Inspect fluid level and fill to the proper level.

### Fluid Level

1. Run the engine until the power steering fluid reaches normal operating temperature, about 55°C (130°F), then shut the engine off.
2. Check the level of fluid in the reservoir.
3. If the fluid level is low, add power steering fluid as specified in General Information to the proper level and install the reservoir cap.
4. When checking the fluid level after the steering system has been serviced, air must be bled from the system. Refer to Bleeding the Power Steering System in this section.

### Bleeding The Power Steering System

When a power steering pump or gear has been installed, or an oil line has been disconnected, the air that has entered the system must be bled out before the vehicle is operated. If air is allowed to remain in the power steering fluid system, noisy and unsatisfactory operation of the system may result.

### Bleeding Procedure

When bleeding the system, and any time fluid is added to the power steering system, be sure to use only power steering fluid as specified in General Information.

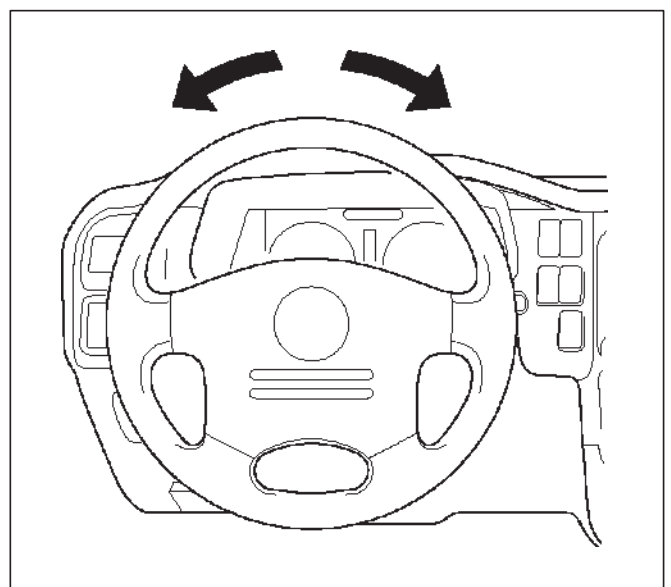
1. Fill the pump fluid reservoir to the proper level and let the fluid settle for at least two minutes.
2. Start the engine and let it run for a few seconds. Do not turn the steering wheel. Then turn the engine off.
3. Add fluid if necessary.
4. Repeat the above procedure until the fluid level remains constant after running the engine.
5. Raise and support the front end of the vehicle so that the wheels are off the ground.
6. Start the engine. Slowly turn the steering wheel right and left, lightly contacting the wheel stops.

7. Add power steering fluid if necessary.
8. Lower the vehicle, set the steering wheel at the straight forward position after turning it to its full steer positions 2 or 3 times, and stop the engine.
9. Check the fluid level and refill as required.
10. If the fluid is extremely foamy, allow the vehicle to set a few minutes, then repeat the above procedure.

### Flushing The Power Steering System

1. Raise and support the front end of the vehicle off the ground until the wheels are free to turn.
2. Remove the fluid return line at the pump inlet connector and plug the connector port on the pump. Position the line toward a large container to catch the draining fluid.
3. While running the engine at idle, fill the reservoir with new power steering fluid. Turn the steering wheel in both directions. Do not contact or hold the steering wheel to the wheel stops. This will cause the pump to go to pressure relief mode, which may cause a sudden fluid overflow at the reservoir.
4. Install all the lines and hoses. Fill the system with new power steering fluid and bleed the system as described in Bleeding The Power Steering System. Operate the engine for about 15 minutes. Remove the pump return line at the pump inlet and plug the connection on the pump. While refilling the reservoir, check the draining fluid for contamination. If foreign material is still evident, replace all lines, disassemble and clean or replace the power steering system components. Do not re-use any drained power steering fluid.

### Steering Wheel Free Play Adjustment Inspection



430RX006

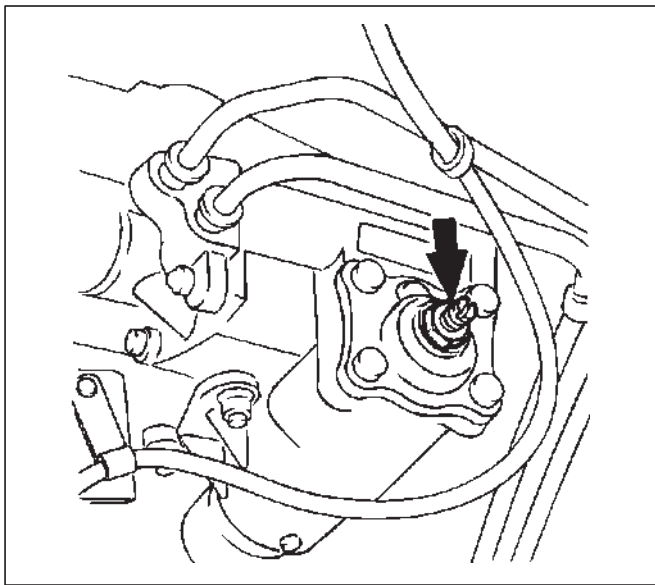
1. With the tires in the straight-ahead position, check the amount of steering wheel play by turning the wheel in both directions until the tires begin to move.

NOTE: The wheel free play should be checked with the engine running.

**Free play: 10 – 30 mm (0.39 – 1.18 in)**

2. Also check the steering wheel for play and looseness in the mount by moving it back and forth and sideways. When test driving, check for hard steering, steering shimmy and tendency to pull to one side.

### Adjustment



1. Align the front wheels properly in the straight ahead position.
2. Loosen the lock nut on the adjusting screw of the steering gear.
3. Turn the adjust screw clockwise to decrease free play or counter-clockwise to increase.
4. After check of specified free play, tighten the lock nut to specified torque.

**Torque: 41 N·m (30 lb ft)**

## Front End Alignment Inspection and Adjustment

### General Description

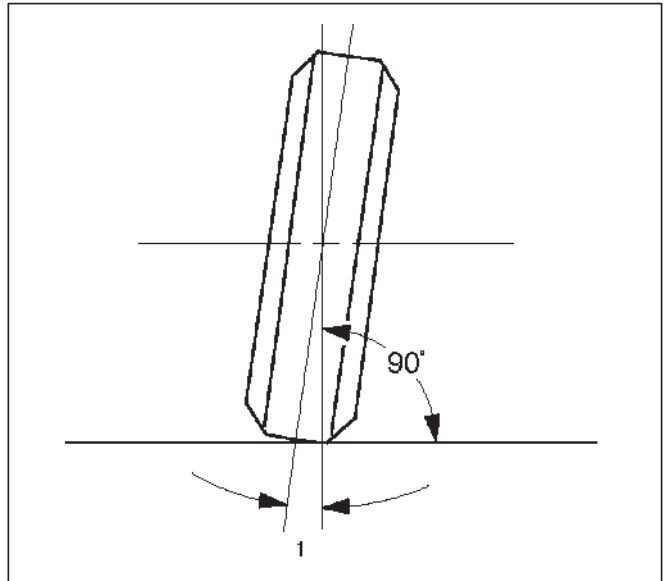
“Front End Alignment” refers to the angular relationship between the front wheels, the front suspension attaching parts and the ground.

Proper front end alignment must be maintained in order to insure efficient steering, good directional stability and to prevent abnormal tire wear.

The most important factors of front end alignment are wheel toe-in, wheel camber and axle caster.

### Camber:

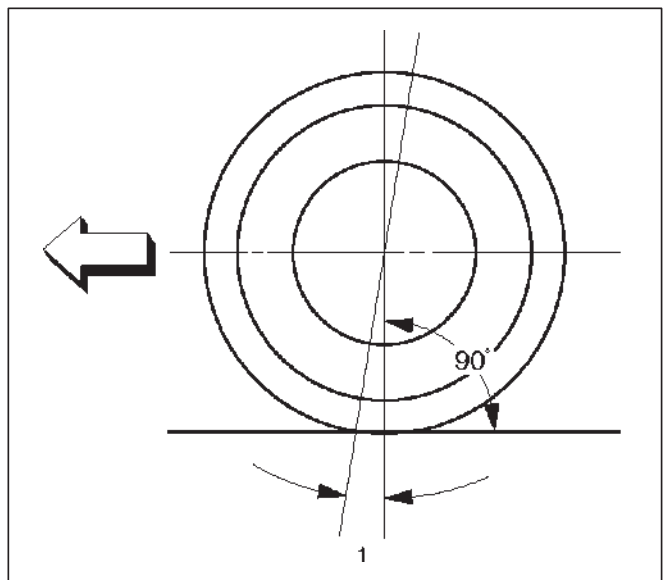
This illustration is viewed from the front of the vehicle.



Camber is the vertical tilting inward or outward of the front wheels. When the wheels tilt outward at the top, the camber is positive (+). When the wheels tilt inward at the top, the camber is negative (-). The amount of tilt measured in degrees from the vertical is called the camber angle (1). If camber is extreme or unequal between the wheels, improper steering and excessive tire wear will result. Negative camber causes wear on the inside of the tire, while positive camber causes wear to the outside.

### Caster:

This illustration is viewed from the side of the vehicle.



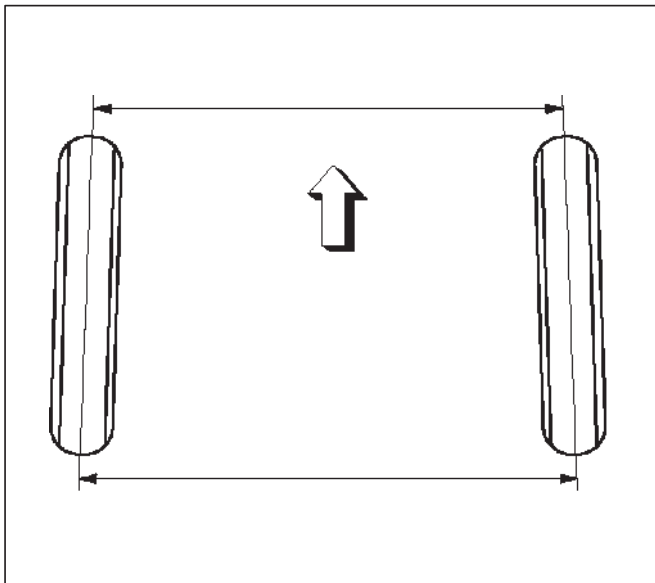


## 2A-14 POWER-ASSISTED STEERING SYSTEM

Caster(1) is the vertical tilting of the wheel axis either forward or backward (when viewed from the side of the vehicle). A backward tilt is positive(+) and a forward tilt is negative (-). On the short and long arm type suspension you cannot see a caster angle without a special instrument, but if you look straight down from the top of the upper control arm to the ground, the ball joints do not line up (fore and aft) when a caster angle other than 0 degree is present. With a positive angle, the lower ball joint would be slightly ahead (toward the front of the vehicle) of the upper ball joint center line.

### Toe-in:

This illustration is viewed from the top of the vehicle.



Toe-in is the measured amount the front wheels are turned in. The actual amount of toe-in is normally a fraction of a degree. Toe-in is measured from the center of the tire treads or from the inside of the tires. The purpose of toe-in is to insure parallel rolling of the front wheels and to offset any small deflections of the wheel support system which occurs when the vehicle is rolling forward. Incorrect toe-in results in excessive toe-in and unstable steering. Toe-in is the last alignment to be set in the front end alignment procedure.

### Inspection

Before making any adjustments affecting caster, camber or toe-in, the following front end inspection should be made.

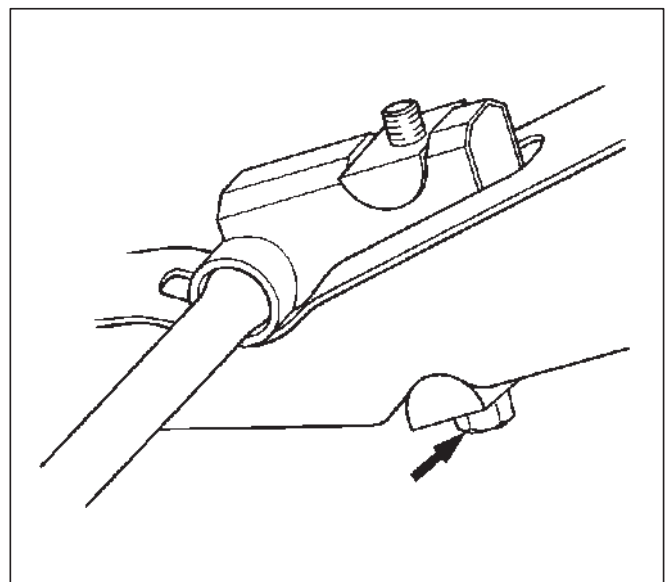
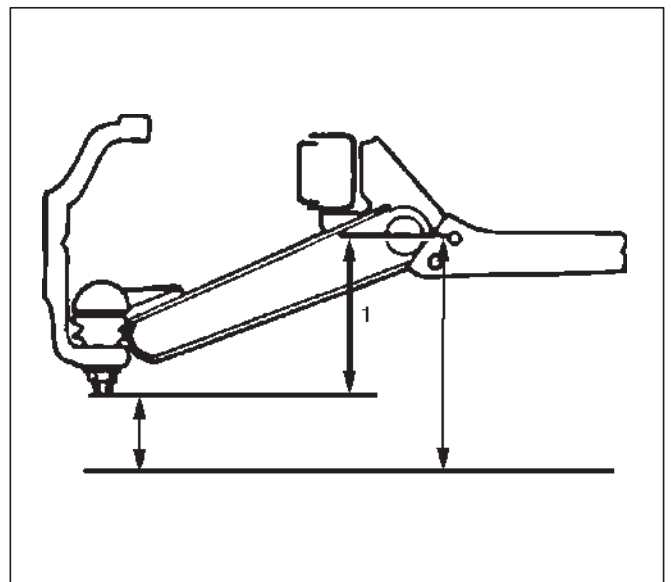
1. Inspect the tires for proper inflation pressure. Refer to Main Data and Specifications in Wheel and Tire System section.
2. Make sure that the vehicle is unladen condition (With no passenger or loading).
3. Make sure that the spare tire is installed at the normal position.
4. Inspect the front wheel bearings for proper adjustment. Refer to Front Hub and Disc Overhaul in Suspension section.
5. Inspect the ball joints, tie rod ends and relay rods. If excessive looseness is noted, correct before adjusting. Refer to Steering Linkage in this section.

6. Inspect the wheels and tires for run-out. Refer to Wheel Replacement in Wheel and Tire System section.
7. Inspect the trim height. If not within specifications, the correction must be made before adjusting caster.
8. Inspect the steering gear for looseness at the frame.
9. Inspect the shock absorbers for leaks or any noticeable noise. Refer to Shock Absorber Replacement in Suspension section.
10. Inspect the control arms or stabilizer bar attachment for looseness. Refer to Suspension section .
11. Inspect the front end alignment using alignment equipment. Follow the manufacturer's instructions.
12. Park the vehicle must be on a level surface.

### Trim Height Adjustment

Adjust the trim height(1) by means of the adjusting bolt on the height control arms.

**CAUTION:** When adjusting front end alignment, be sure to begin with trim height first, as it may change other adjusted alignments.



1. Check and adjust the tire inflation pressures.
2. Park the vehicle on a level ground and move the front of the vehicle up and down several times to settle the suspension.
3. Make necessary adjustment with the adjusting bolt on the height control arms.

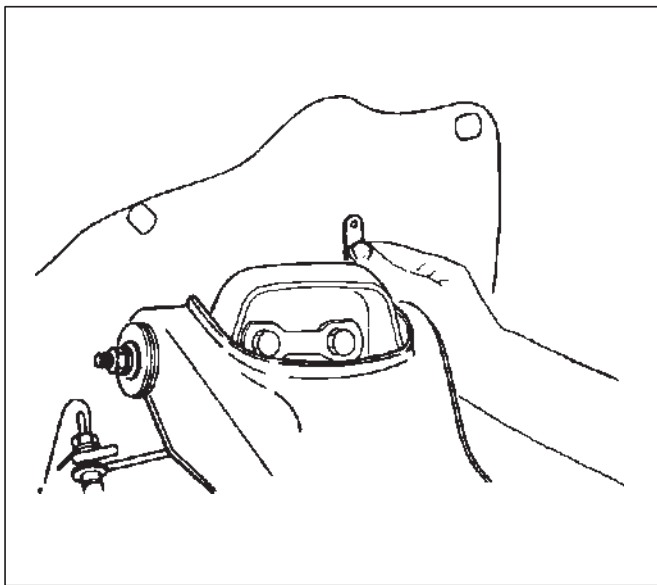
**Trim height: 119 mm (4.69 in)**

### Caster Adjustment

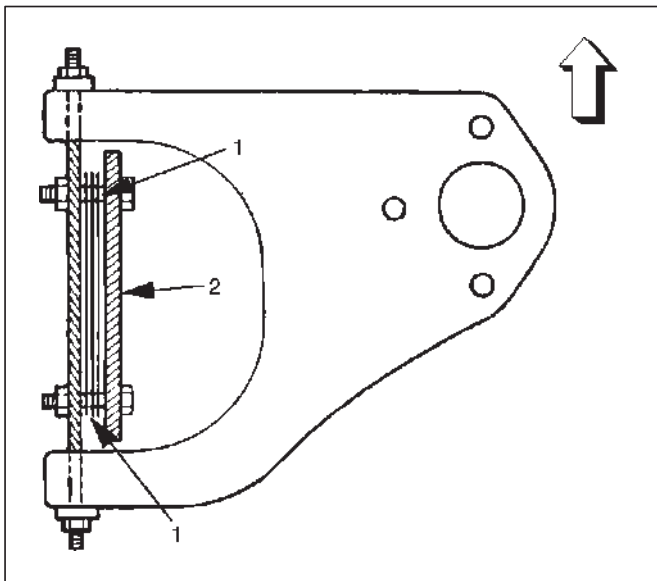
The caster angle can be adjusted by means of the caster shims(1) installed between the chassis frame(2) and fulcrum pins.

**Caster angle:  $2^{\circ}05' \pm 45'$**

**CAUTION: Left and right side must be equal within 30'.**



450RS001



450RS002

**NOTE:** Difference of the caster shim front/rear thickness should be 3.6 mm (0.142 in) or less. Overall thickness of caster shim and camber shim should be 10.8 mm (0.425 in) or less.

Tighten the fulcrum pin bolt to the specified torque.

**Torque: 152 N-m (112 lb ft)**

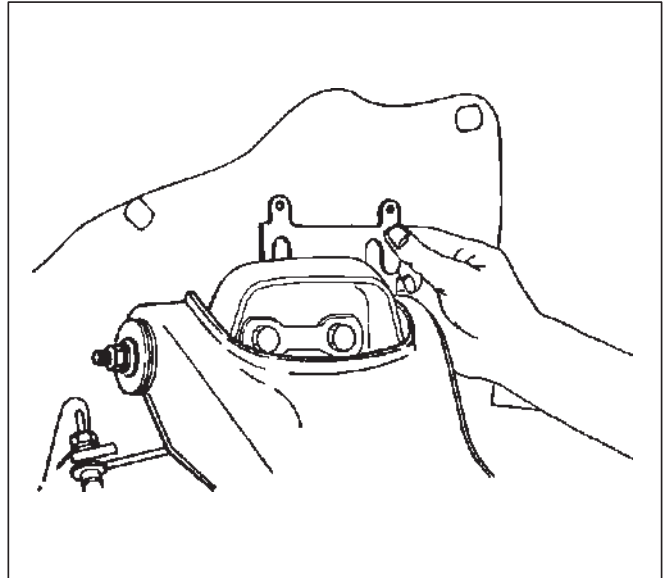
### Camber Adjustment

The camber angle can be adjusted by means of the camber shims(2) installed in position between the chassis frame(1) and fulcrum pins

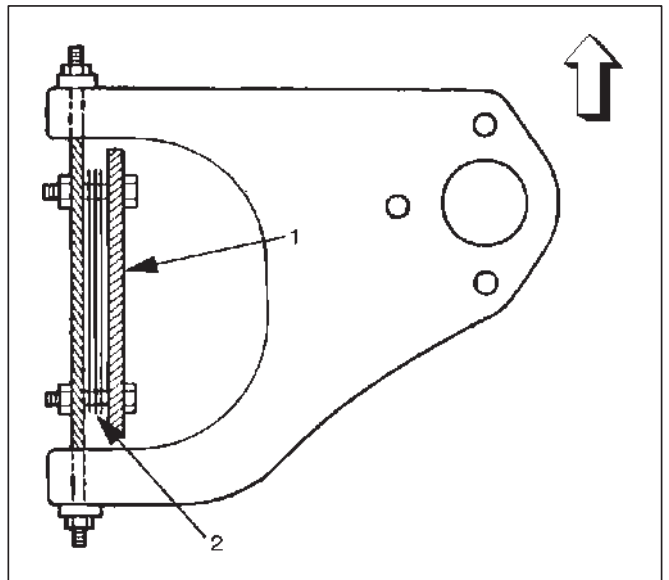
**Camber angle:  $0^{\circ} \pm 30'$**

**King pin inclination:  $12^{\circ}30' \pm 30'$**

**CAUTION: Left and right side must be equal within 30'.**



450RS004



450RS005

**NOTE:** Overall thickness of caster shim and camber shim should be 10.8 mm (0.425 in) or less.

Tighten the fulcrum pin bolt to the specified torque.

**Torque: 152 N-m (112 lb ft)**

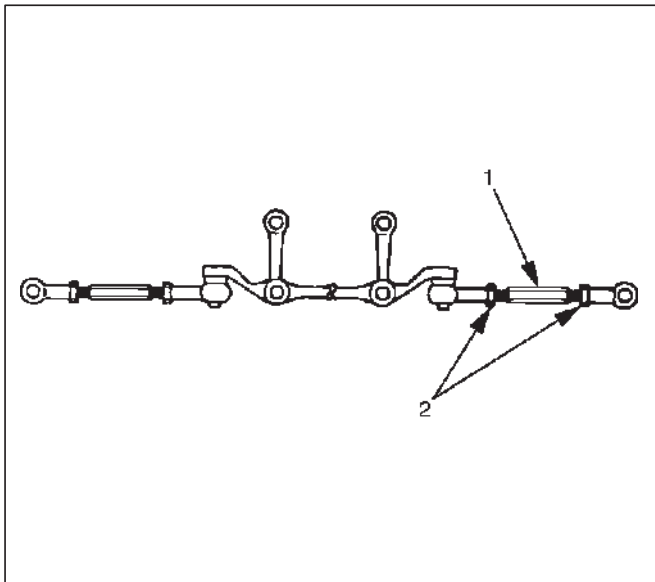
## 2A-16 POWER-ASSISTED STEERING SYSTEM

	Position of shims		Camber angle	Caster angle
	Front side	Rear side		
Caster shim	When added	When removed	Decreases	Decreases
	When removed	When added	Increases	Increases
	—	When removed	Unchanged	Decreases
	—	When added	Unchanged	Increases
Camber shim	When added		Decreases	Unchanged
	When removed		Increases	Unchanged

### Toe-in Adjustment

1. To adjust the toe-in angle, loosen the lock nuts(2) on the outer track rods(1) and turn the outer track rods. Turn both rods the same amount, to keep the steering wheel centered .

**Toe-in:  $0 \pm 2$  mm ( $0 \pm 0.08$  in)**

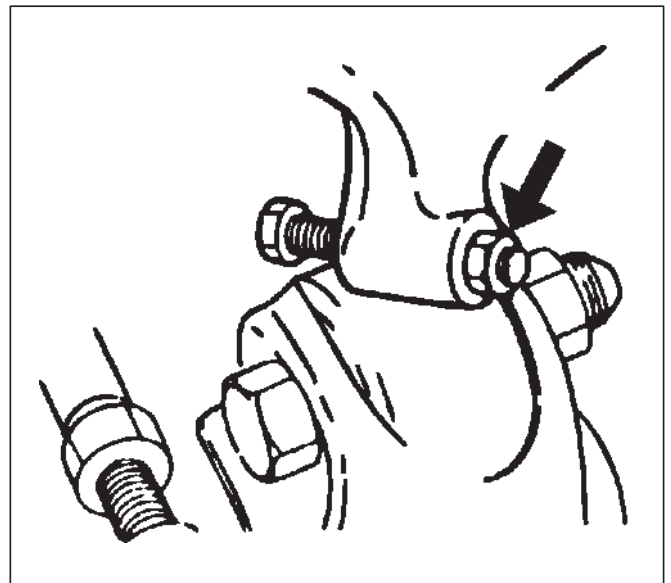


2. Tighten the lock nut to the specified torque.

**Torque: 118 N-m (87 lb ft)**

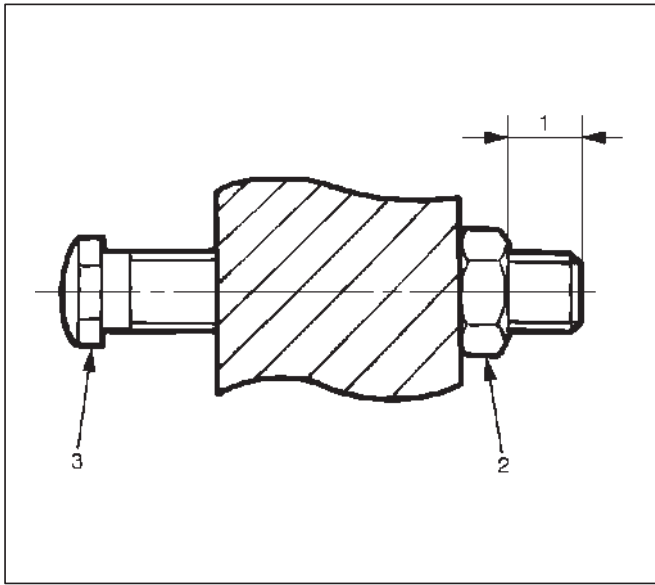
### Maximum Steering Angle Adjustment

The maximum steering angle of the front wheels can be adjusted with the stop bolts under the frame side members.



1. Position each front wheel on the turning radius gauge in a straight-ahead position.
2. Set the parking brake firmly.
3. Adjust the inside wheel angle of each side with the stop bolts.

NOTE: The maximum protruding length(1) of stop bolt(3) from the lock nut(2) should be 10 mm or less



433RS003

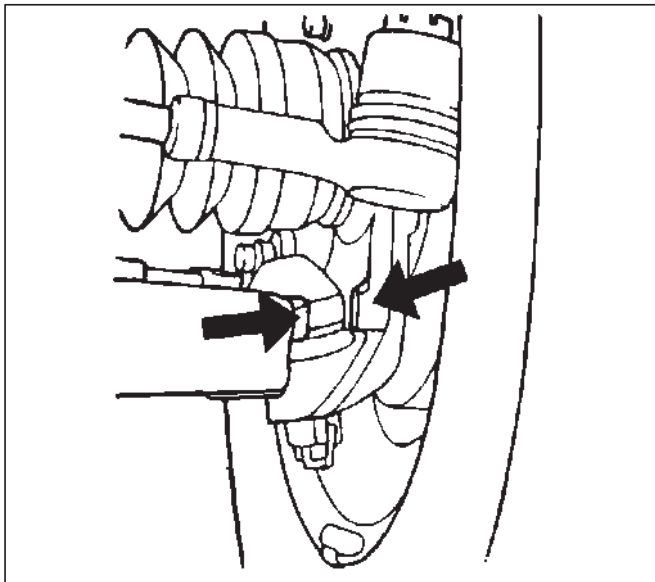
4. Similarly adjust the inside wheel angle of the other side with stop bolt.

**Inside wheel: 33° (+0° to -3°)**

**Outside wheel: 31°**

NOTE: Maximum steering angles should be set after adjusting front wheel alignment.

5. If the stop between the lower link end and the knuckle comes ahead of the stop bolt, adjust the stop bolt so that inner stop bolt touches the drop arm (relay lever).



433RS004

6. Tighten the lock nut to the specified torque.

**Torque: 23 N·m (17 lb ft)**

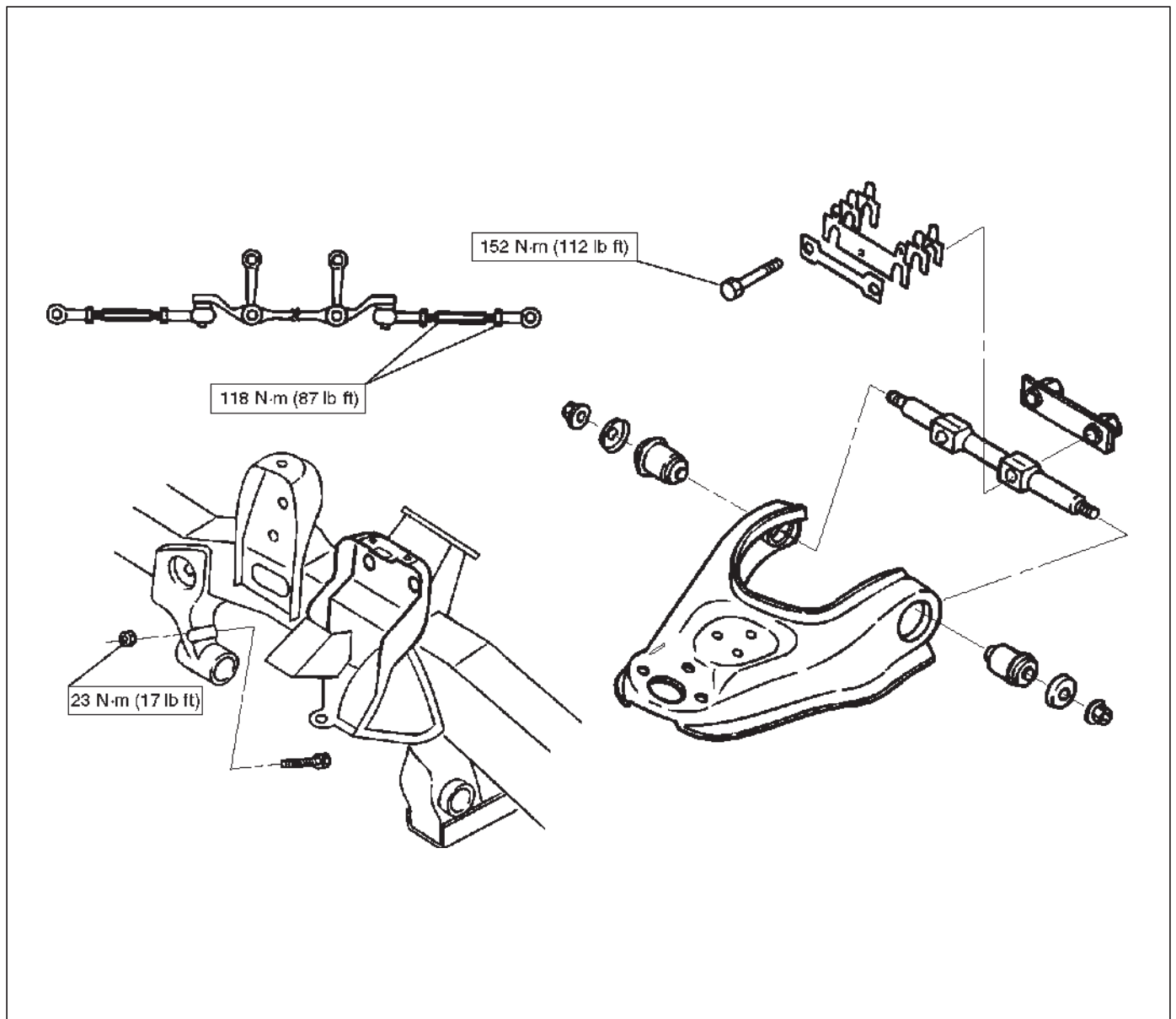
## 2A-18 POWER-ASSISTED STEERING SYSTEM

### Main Data and Specifications


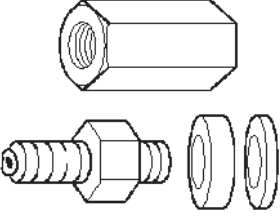
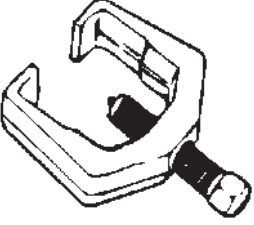
#### General Specification

Caster		$2^{\circ}05' \pm 45'$
Camber		$0^{\circ} \pm 30'$
King pin inclination		$12^{\circ}30' \pm 30'$
Toe-in		$0 \pm 2 \text{ mm } (0 \pm 0.08 \text{ in})$
Max. steering angle	inside	$33^{\circ} (+0^{\circ} \text{ to } -3^{\circ})$
	outside	$31^{\circ}$

#### Torque Specification

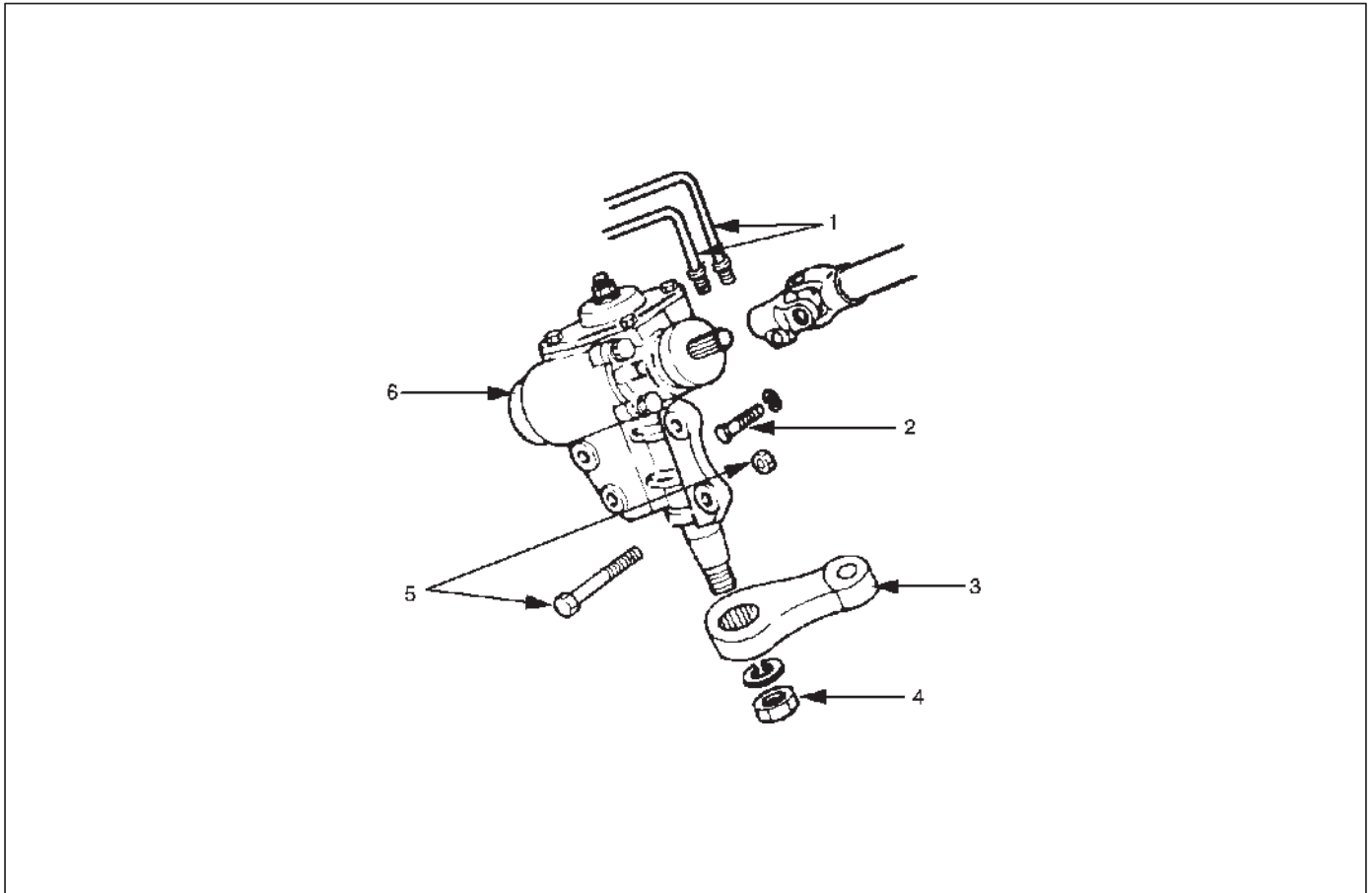


**Special Tools**

ILLUSTRATION	TOOL NO. TOOL NAME
 <p style="text-align: right; font-size: small;">901R5276</p>	<p style="text-align: center;"><b>J-29877-A</b> Tester: Power steering</p>
 <p style="text-align: right; font-size: small;">901R5278</p>	<p style="text-align: center;"><b>J-39213</b> Adapter: Power steering tester</p>
 <p style="text-align: right; font-size: small;">901R5279</p>	<p style="text-align: center;"><b>J-29107</b> Remover: Pitman arm</p>

## Power Steering Gear

### Power Steering Gear and Associated Parts



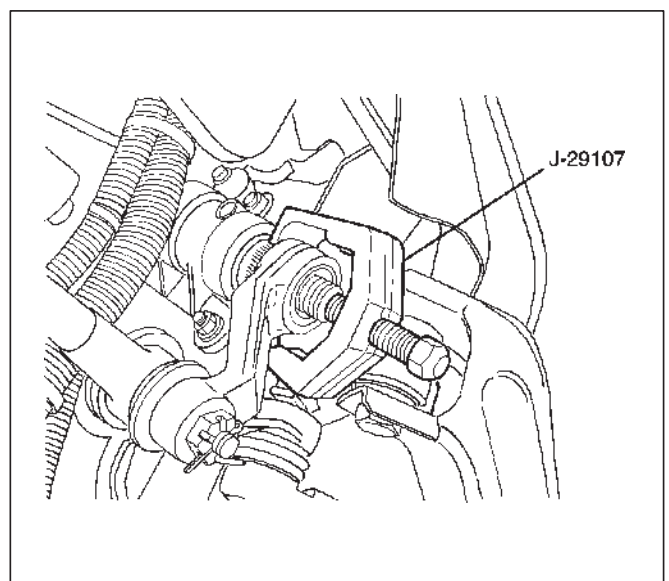
431RX016

#### Legend

- |                          |                                    |
|--------------------------|------------------------------------|
| (1) Pipe                 | (4) Nut                            |
| (2) Universal Joint Bolt | (5) Gear Box Mounting Bolt and Nut |
| (3) Pitman Arm           | (6) Gear Box                       |

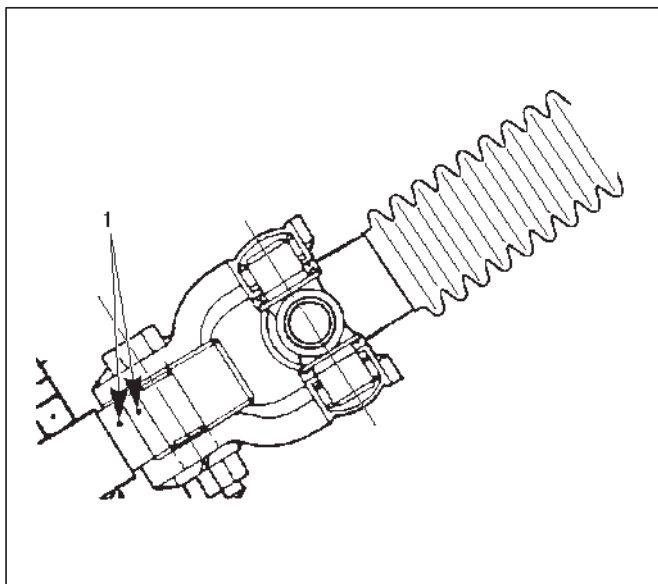
### Removal

1. Remove the stone guard.
2. Remove the lower fan shroud. Refer to Radiator in Engine section.
3. Disconnect stabilizer bar at the stabilizer links. Loosen stabilizer bracket fixing nuts.
4. Remove pipe.
5. Remove nut.
6. Use Pitman arm remover J-29107 to remove pitman arm.



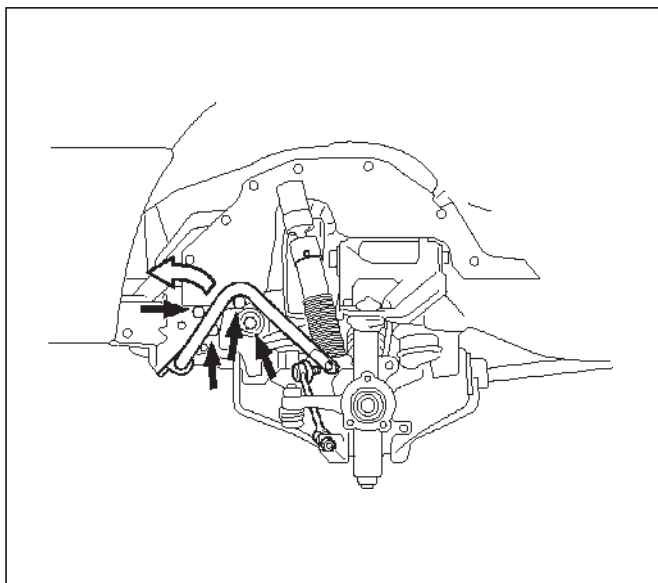
433RS005

7. Make a setting mark(1) across the coupling flange and worm shaft to ensure reassembly of the parts in the original position, then remove universal joint bolt.



431RW004

8. Push the stabilizer bar aside and remove the gear box mounting bolts and nuts.

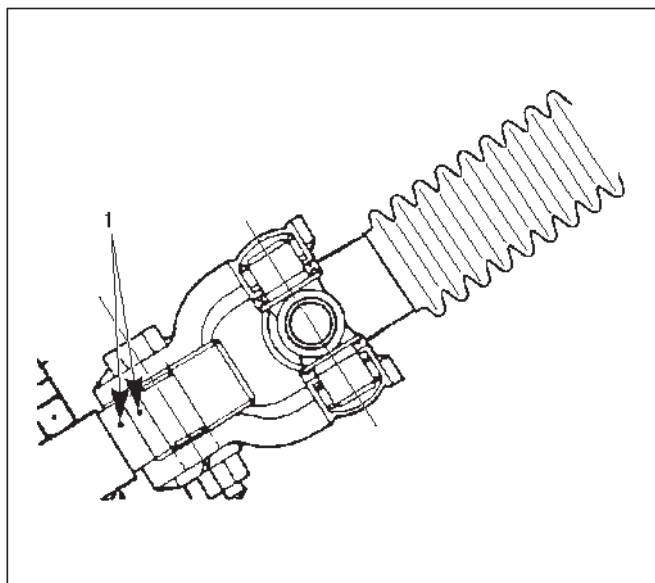


433RX002

9. Remove gear box.

## Installation

1. Align the setting marks(1) made at removal, then install gear box.



431RW004

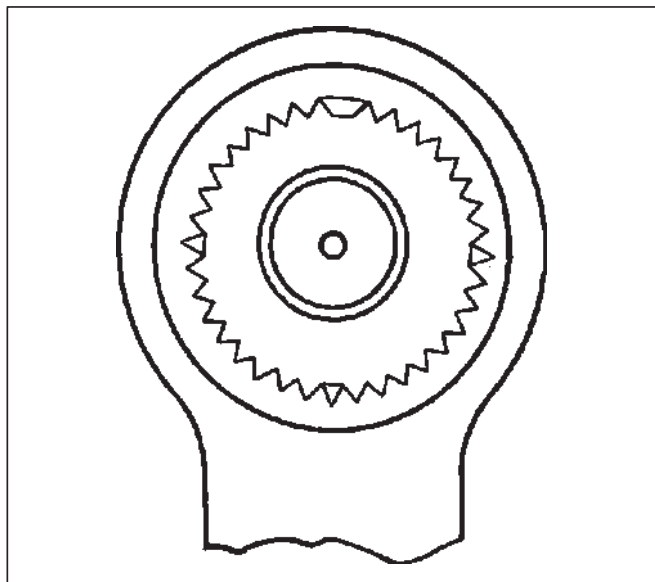
2. Tighten gear box mounting bolt and nut to specified torque.

**Torque: 44 N-m (33 lb ft)**

3. Tighten gear universal joint bolt to specified torque.

**Torque: 25 N-m (18 lb ft)**

4. Align the notched tooth and install pitman arm.



433RS006

5. Install nut and tighten Nut to specified torque.

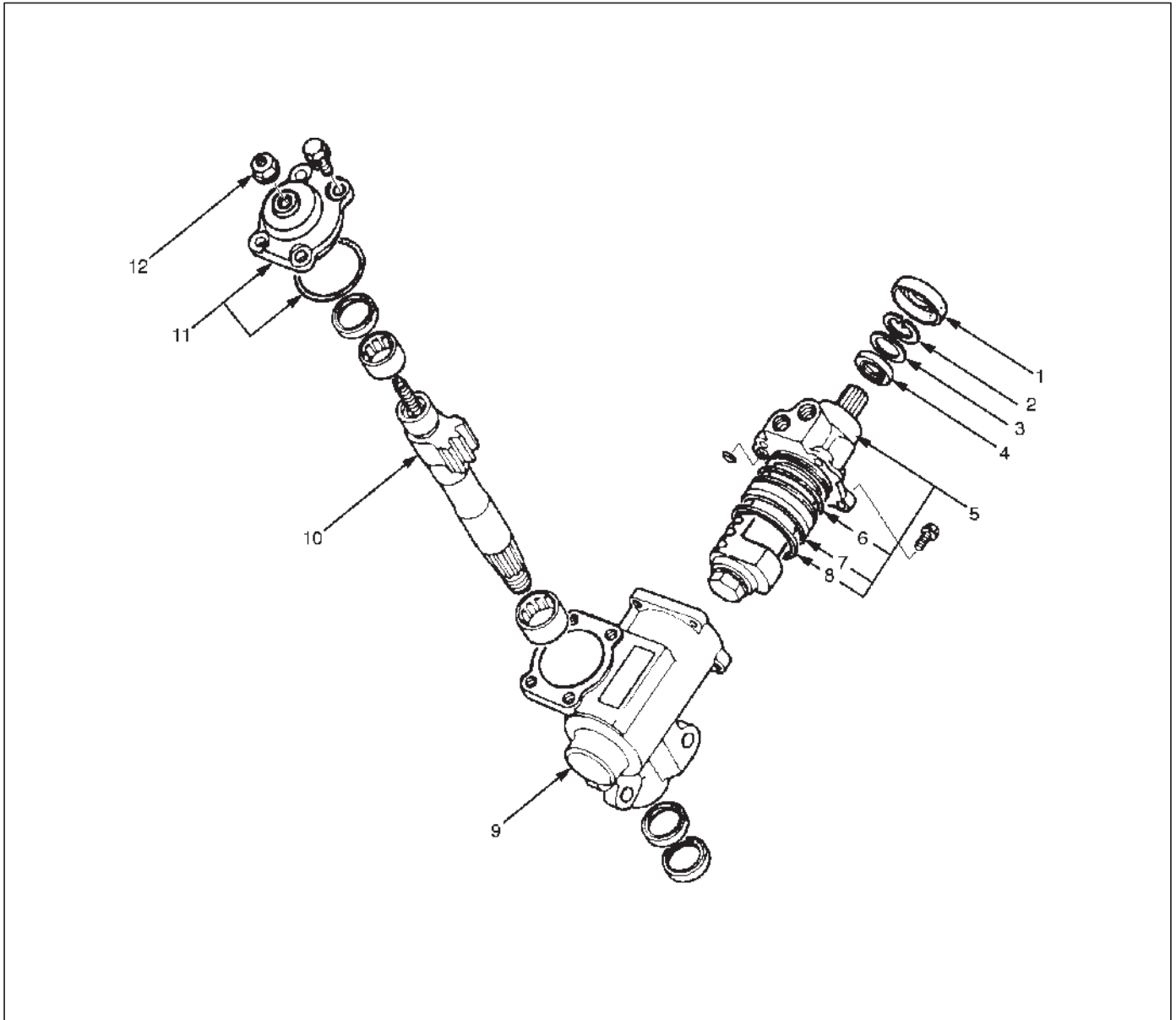
**Torque: 216 N-m (159 lb ft)**

6. Install Pipe and tighten to specified torque.

**Torque: 44 N-m (33 lb ft)**



## Steering Gear Disassembled View



440RS001

### Legend

- |   |                         |
|---|-------------------------|
| (1) Dust Cover                          | (7) Seal Ring           |
| (2) Retaining Ring                      | (8) O-ring              |
| (3) Back Up Ring                        | (9) Gear Box            |
| (4) Oil Seal                            | (10) Sector Shaft       |
| (5) Ball-nut and Valve Housing Assembly | (11) Top Cover Assembly |
| (6) O-ring                              | (12) Lock Nut           |

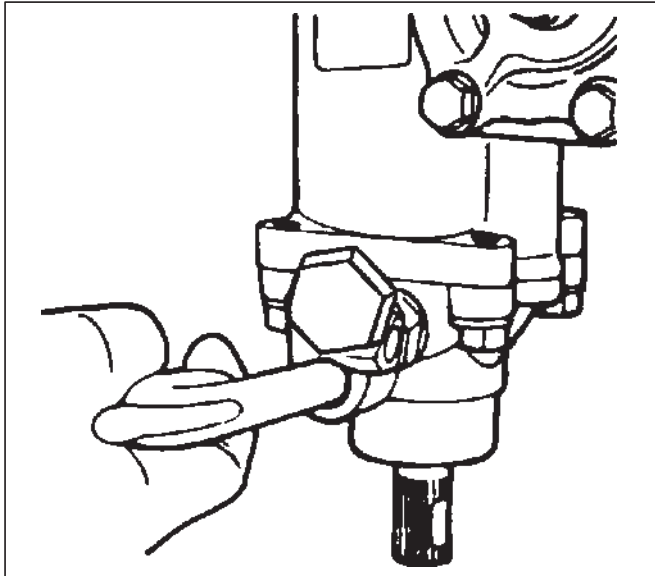
## Disassembly

**CAUTION:** Do not clamp the steering gear assembly in a vise by the power cylinder housing.

1. Remove dust cover.
2. Remove retaining ring.
3. Remove back up ring.

4. Remove oil seal.

- Clean the faces of the extended stub shaft.
- Plug the hose fitting on the inlet side.
- Remove the oil seal by blowing compressed air through the hole in the outlet side.

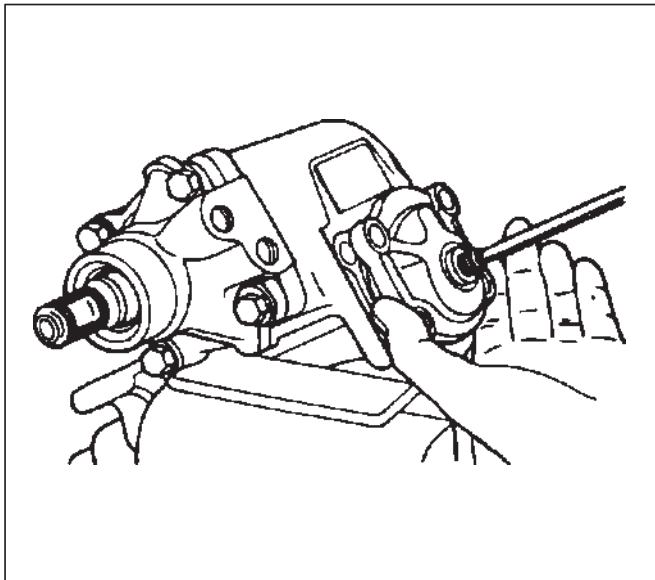


440RS002

5. Remove lock nut.

- Remove the adjusting screw lock nut and turn the adjusting screw counter-clockwise to remove the preload between the sector gear and the rack piston.

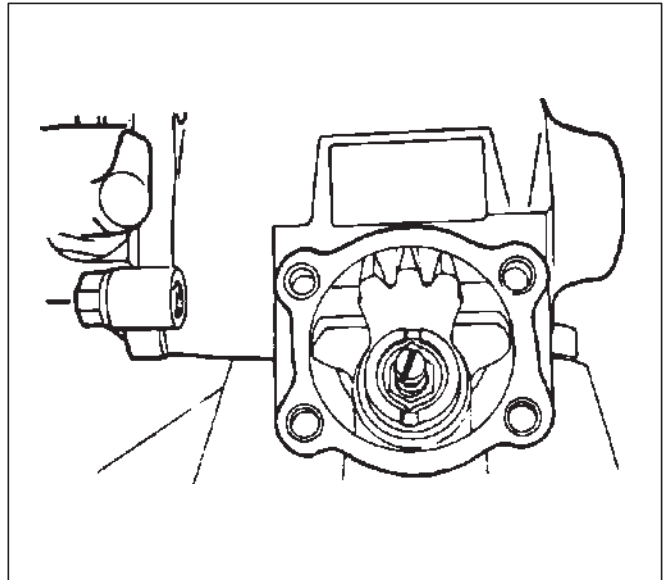
6. Remove the top cover bolts and the top cover assembly.



440RS003

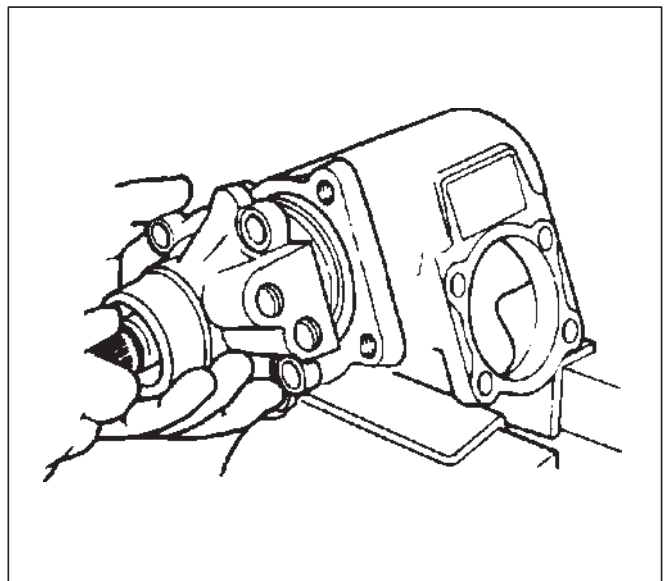
- Holding the top cover stationary, turn the adjusting screw clockwise to raise and free to cover, then remove the cover with O-ring.

7. Bring the stub shaft into straight-ahead position. Do not force the sector shaft off the gear box with a hammer or other impact tools then remove sector shaft.



440RS004

8. Remove ball-nut and valve housing assembly.



440RS005

- Always keep the ball nut and valve housing assembly in a horizontal position to prevent them from traveling to the end of the worm shaft and damaging the ball tubes.

- 9. Remove O-ring.
- 10. Remove seal ring.
- 11. Remove O-ring.
- 12. Remove gear box.

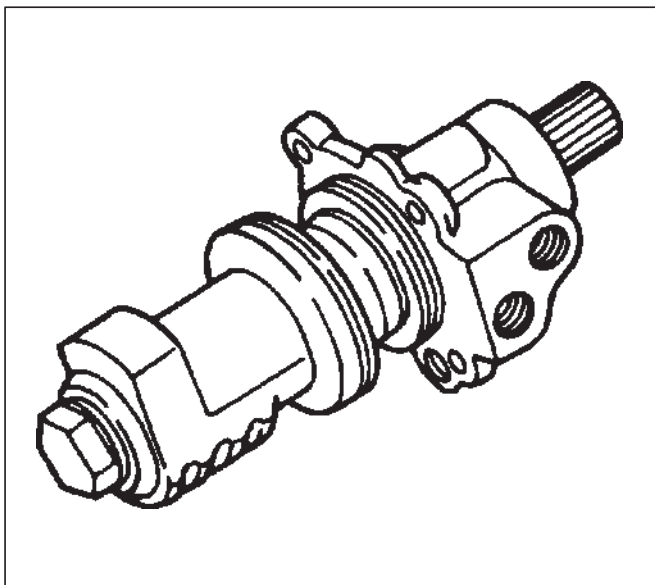
## 2A-24 POWER-ASSISTED STEERING SYSTEM

### Inspection and Repair

Inspect the following parts for wear, damage or any other abnormal conditions.

- Bearing
- Ball-nut and valve housing
- Sector shaft
- Top cover
- Gear box
- Needle bearing
- Dust seal
- Seal ring
- Gasket

### Ball-nut Rotation

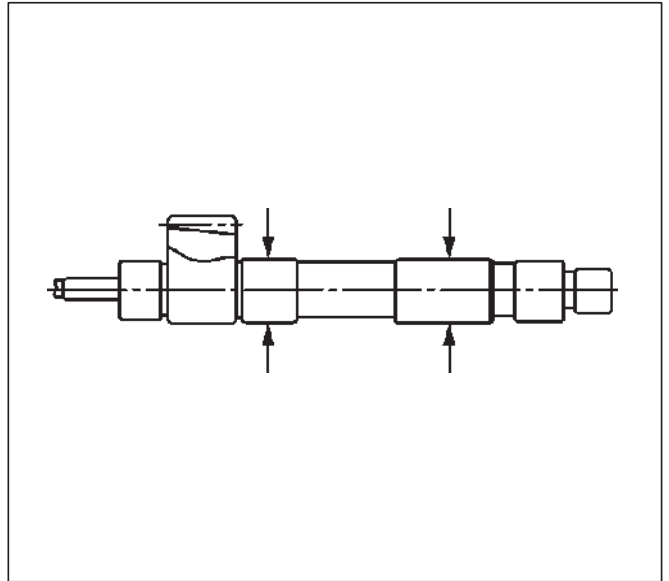


Hold the ball nut and valve housing assembly vertically and see if the ball-nut lowers by turning smoothly. If the ball-nut does not lower smoothly, check the worm shaft for bending and foreign matter.

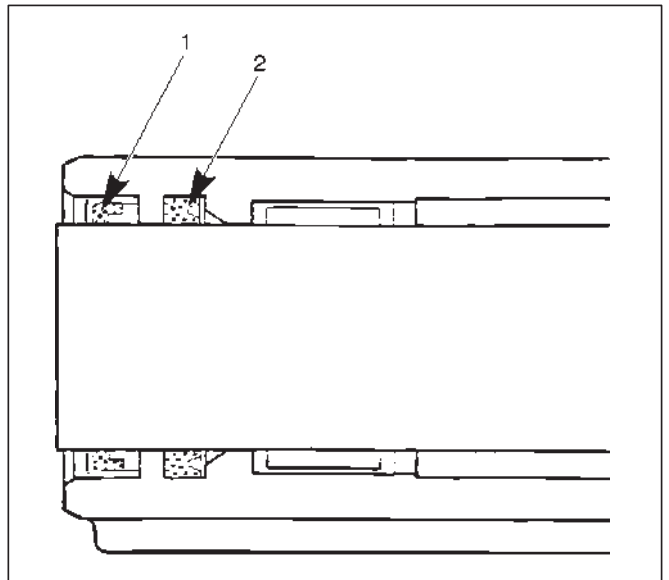
**NOTE:** When testing the ball nut and valve housing assembly, do not let it travel all the way to the end of worm shaft, or damage to the ball tubes will result.

- Check sector shaft outside diameter.

**Limit: 31.7 mm (1.25 in)**

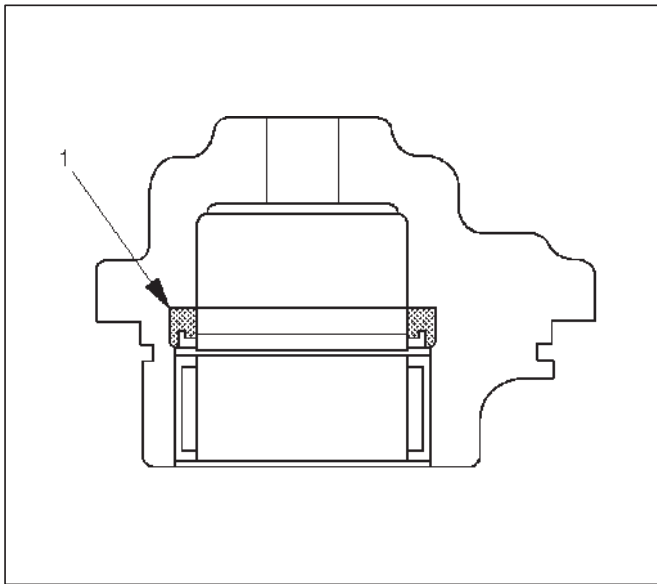


### Dust Seal and Seal Ring Setting



- Note the dust seal (1) and the seal ring(2) installation direction. Always install a new part.
- Apply a thin coat of power steering fluid to lip of each part.

### Gasket Setting

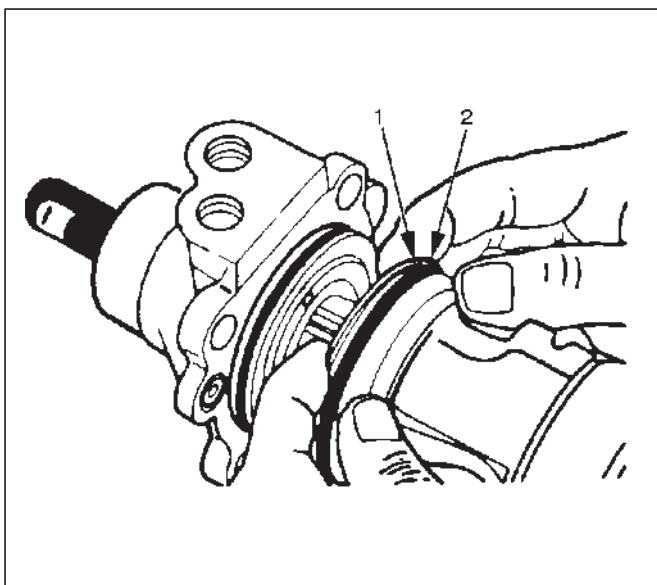


440RW002

- Note the gasket(1) installation direction.
- Apply a thin coat of power steering fluid to lip of each part.

### Reassembly

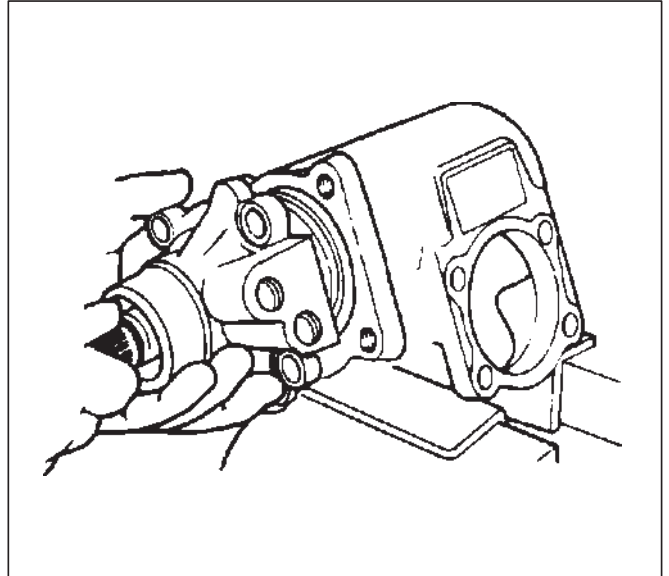
1. Install gear box.
2. Apply a thin coat of power steering fluid to the new O-ring(2) and be sure to discard used part, then install o-ring.
3. Apply a thin coat of power steering fluid to the new seal ring(1) and be sure to discard used part, then install seal ring.
4. Apply a thin coat of power steering fluid to the new O-ring and be sure to discard used part, then install o-ring.



440RS010

5. Install ball-nut and valve housing assembly.

- Always keep the ball screw and valve housing assembly in a horizontal position (avoid holding it vertically), or the rack piston will fall off onto the end of the worm, causing the rack piston to slip out of the worm shaft and ball to fall out.



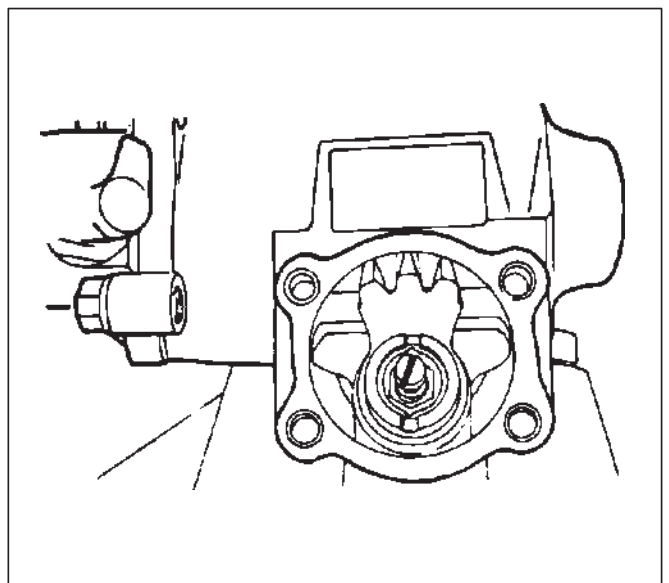
440RS005

- Be careful not to drop the O-ring into the valve housing.
- Tighten the valve housing bolts to the specified torque.

**Torque: 47 N-m (35 lb ft)**

6. Install sector shaft.

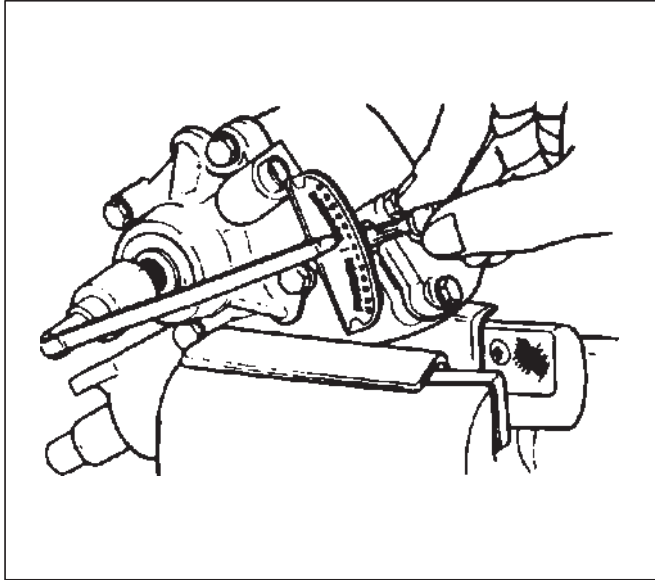
- Tape the sector shaft serrations to protect the seal ring from damage.
- Align the center tooth of ball nut with that of the sector shaft.



440RS004

## 2A-26 POWER-ASSISTED STEERING SYSTEM

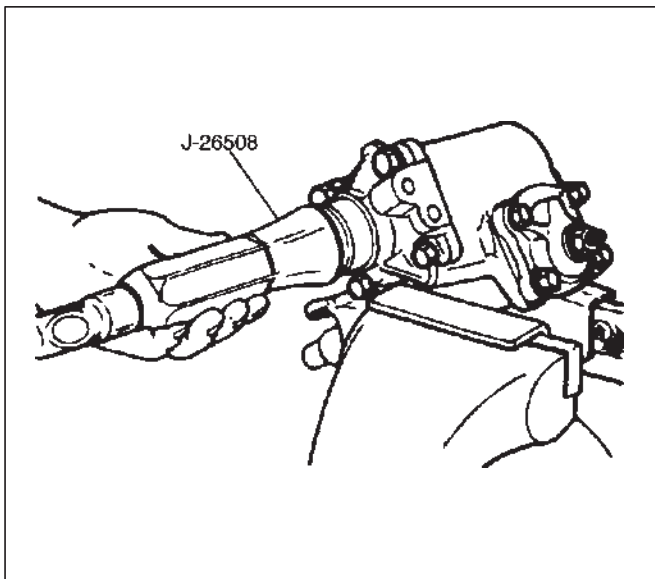
7. Install O-ring.
8. Install top cover assembly and tighten the fixing bolts to specified torque.  
**Torque: 47 N·m (35 lb ft)**
9. Adjust the backlash between the worm gear and the ball nut.



- With the worm gear rotating, set it to the straight ahead position.
- Set the worm shaft preload to below 10kg·cm with the sector shaft adjusting screw.
- Measure the worm shaft preload with the worm gear turned 450° both to the right and to the left. The worm gear preload in these positions should be 0.4–0.6 N·m (4–6 kg·cm) lower than in the straight ahead position.
- Lock the sector shaft adjusting screw with the lock nut.

**Lock nut torque: 41 N·m (30 lb ft)**

10. Apply a thin coat of power steering fluid to oil seal lip of each part, then use installer J-26508 to install oil seal.

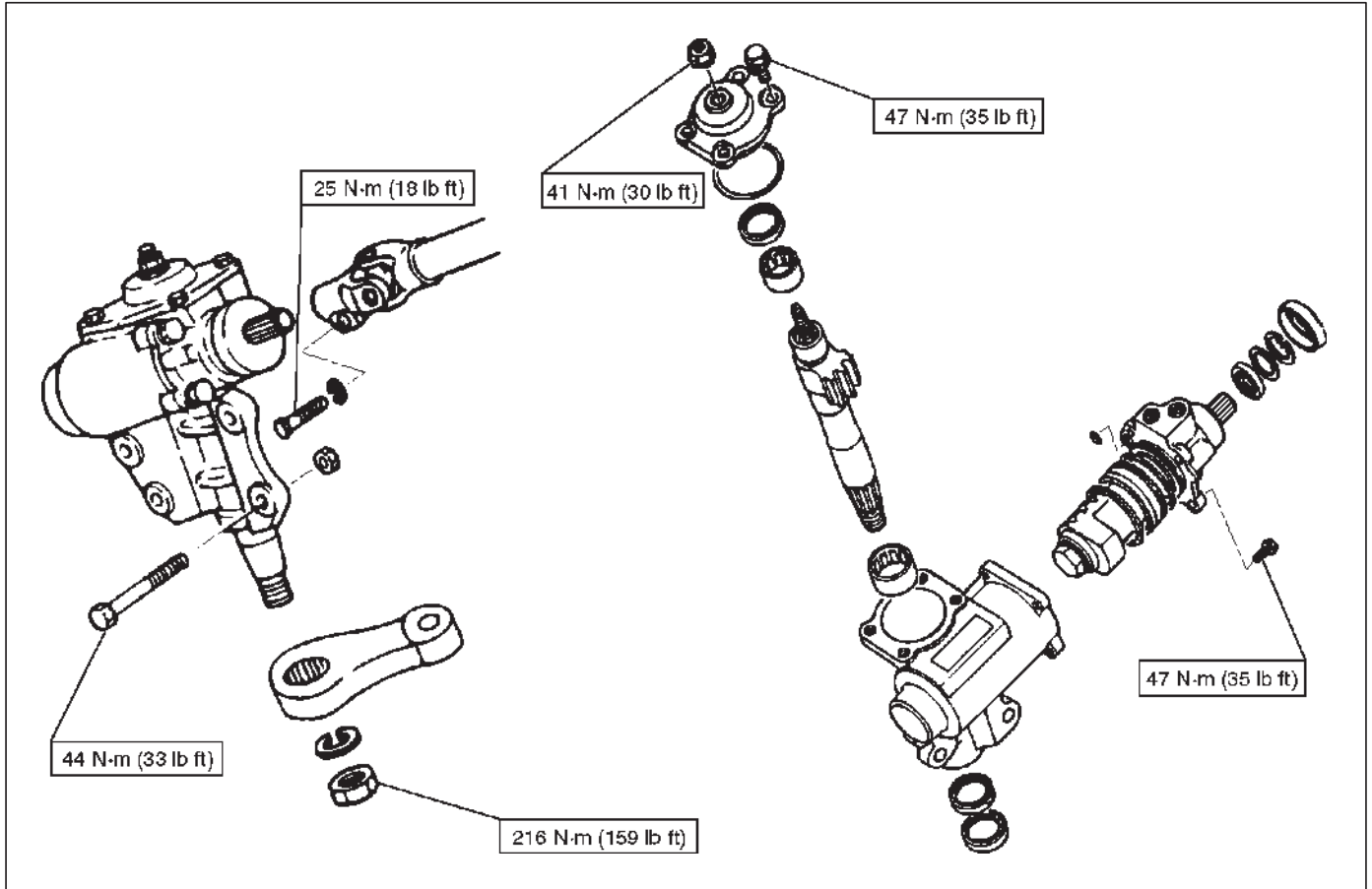


## Main Data and Specifications

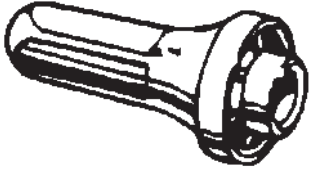
### General Specifications

Steering unit	Type	Integral, ball screw
	Gear ratio	16.3 : 1

### Torque Specifications

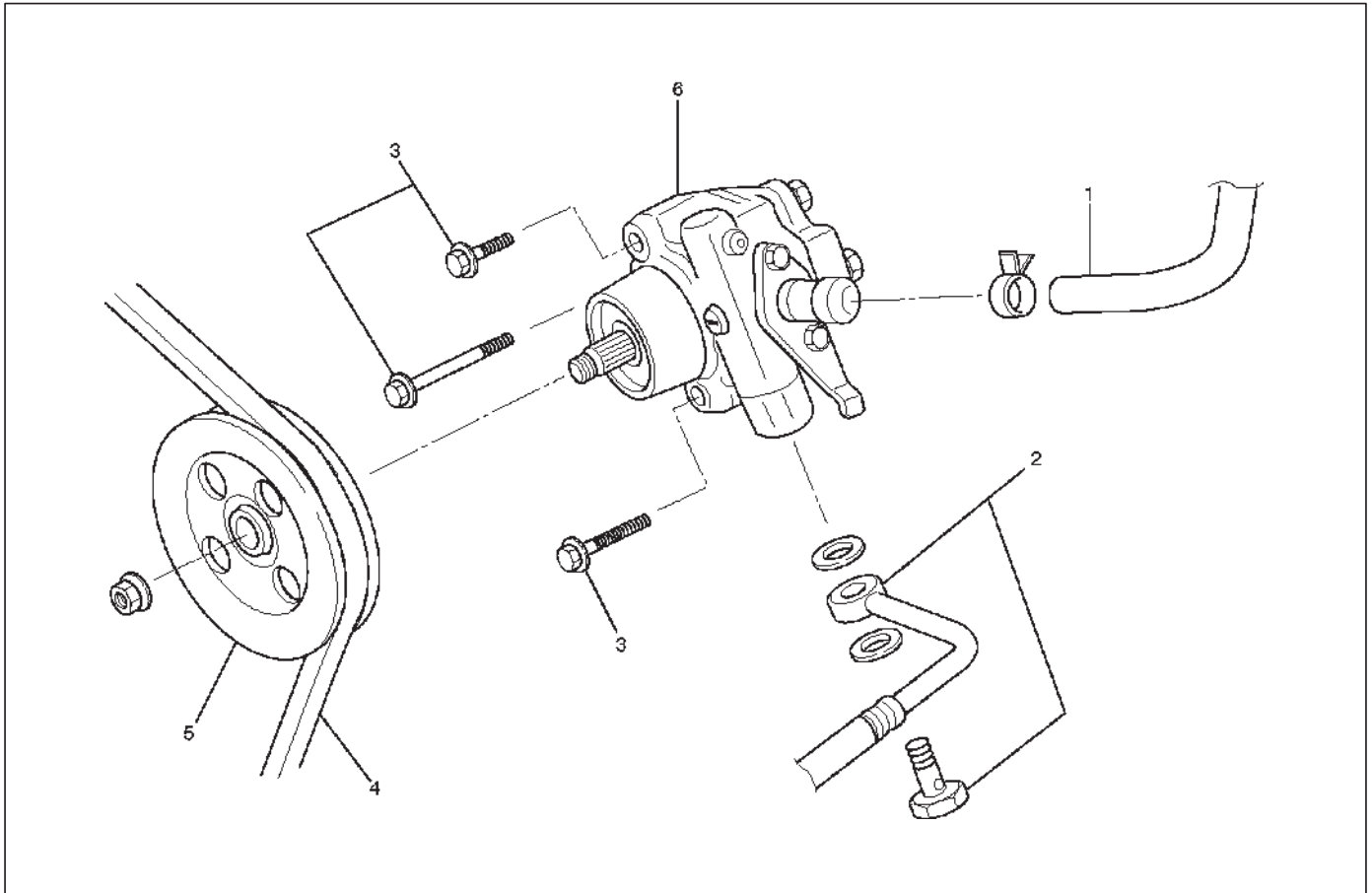


### Special Tools

ILLUSTRATION	TOOL NO. TOOL NAME
 <small>921RS28Z</small>	<p><b>J-26508</b> Installer: Extension housing oil seal</p>

## Power Steering Pump

### Power Steering Pump and Associated Parts



436RW003

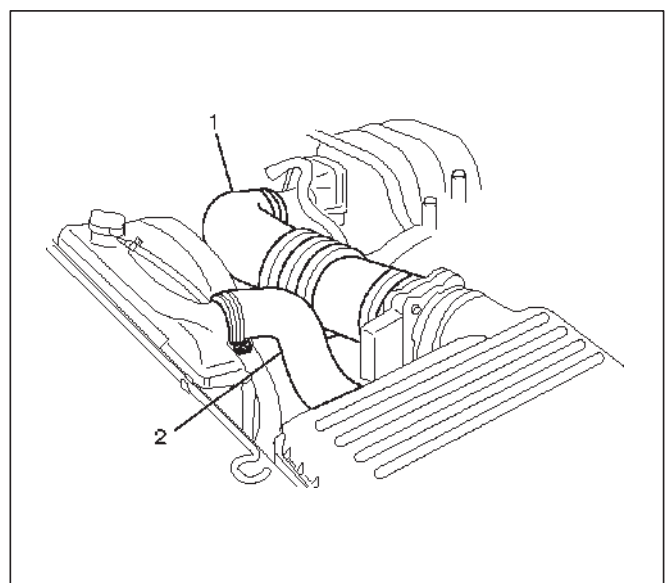
#### Legend

- (1) Hose, Suction
- (2) Hose, Flexible
- (3) Bolt

- (4) Belt
- (5) Pulley
- (6) Pump Assembly

### Removal

1. Drain the engine coolant.
2. Place a drain pan below the pump.
3. Remove the air cleaner duct (1) and the radiator upper hose (2).



436RX002



## 2A-30 POWER-ASSISTED STEERING SYSTEM

---

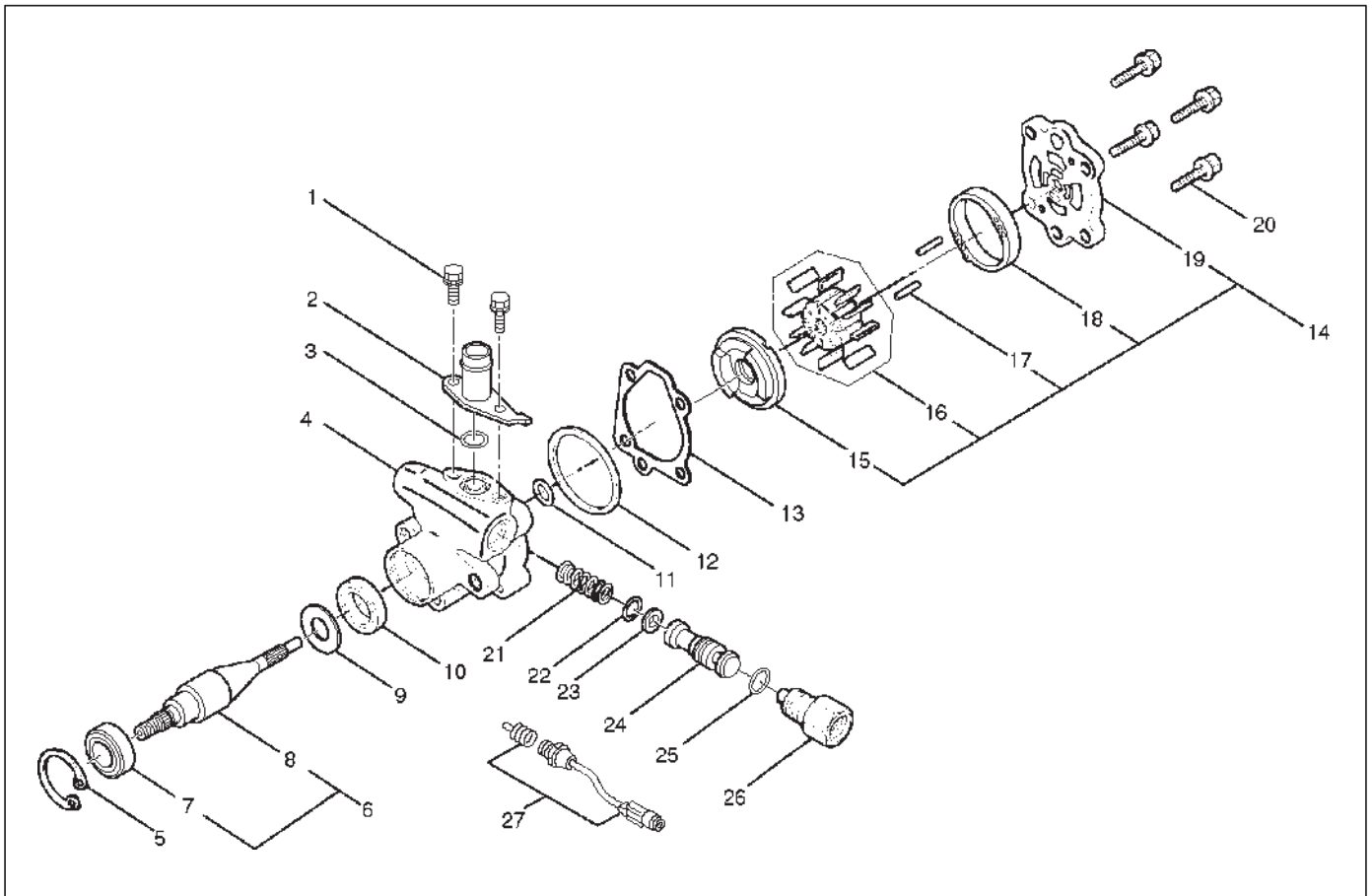
4. Remove the drive belt.
5. Remove the pulley from the power steering pump.
6. Disconnect the suction hose.
7. Disconnect the flexible hose.
8. Remove the power steering pump fixing bolt.
9. Remove the pump assembly.

**CAUTION:** When removing the pump assembly, be careful not to damage the wiring harness under the pump housing.

### Installation

1. Install the adjust plate and tighten the mounting bolts to the specified torque.  
**Torque: 56 N·m (41 lb ft)**
2. Install the pump assembly. Connect the harness under the pump housing.
3. Tighten the fixing bolt to the specified torque.  
**Torque: 46 N·m (34 lb ft)**
4. Connect the flexible hose, then tighten the eye bolt to specified torque.  
**Torque: 54 N·m (40 lb ft)**
5. Connect the suction hose.
6. Install the pulley onto the power steering pump and tighten the nut to the specified torque.  
**Torque: 78 N·m (58 lb ft)**
7. Install the air cleaner duct and the radiator upper hose.
8. Refill the engine coolant.
9. Fill and bleed the power steering system. Refer to Bleeding the Power Steering System in this section.

## Power Steering Pump Disassembled View



412RX005

**Legend**

- |                    |   |
|--------------------|---|
| (1) Bolt           | (14) Rear Housing Assembly and Pump Cartridge |
| (2) Suction Pipe   | (15) Side Plate                               |
| (3) O-ring         | (16) Rotor and Vane                           |
| (4) Front Housing  | (17) Pin                                      |
| (5) Snap Ring      | (18) Cam                                      |
| (6) Shaft Assembly | (19) Rear Housing                             |
| (7) Bearing        | (20) Bolt                                     |
| (8) Shaft          | (21) Spring                                   |
| (9) Retaining Ring | (22) Retaining Ring                           |
| (10) Oil Seal      | (23) Filter                                   |
| (11) O-ring        | (24) Valve                                    |
| (12) O-ring        | (25) O-ring                                   |
| (13) Gasket        | (26) Connector                                |
|                    | (27) Pressure Switch                          |

**Disassembly**

1. Clean the oil pump with solvent (plug the discharge and suction ports to prevent the entry of solvent). Be careful not to expose the oil seal of shaft assembly to solvent.
2. Remove the bolt.
3. Remove the suction pipe.
4. Remove the O-ring.
5. Remove the connector.
6. Remove the O-ring.
7. Remove the valve.
8. Remove the retaining ring.
9. Remove the filter.
10. Remove the spring.
11. Remove the snap ring.
12. Remove the shaft assembly.
13. Remove the retaining ring.
14. Remove the oil seal.

**CAUTION: When removing the oil seal, be careful not to damage the housing.**

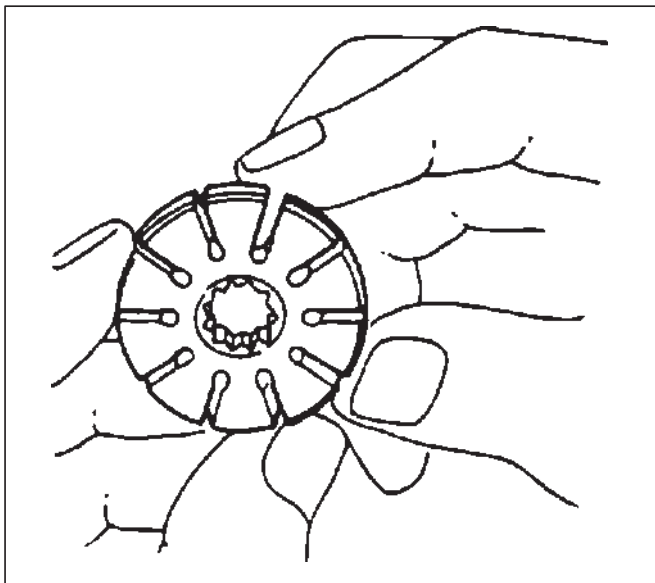
## 2A-32 POWER-ASSISTED STEERING SYSTEM

15. Remove the bolt.
16. Remove the rear housing assembly and the pump cartridge.
17. Remove the gasket.
18. Remove the O-ring.
19. Remove the O-ring.
20. Remove the front housing.
21. Remove the side plate.
22. Remove the rotor and vane.
23. Remove the cam.
24. Remove the pin.
25. Remove the rear housing.
26. Remove the pressure switch.

### Inspection and Repair

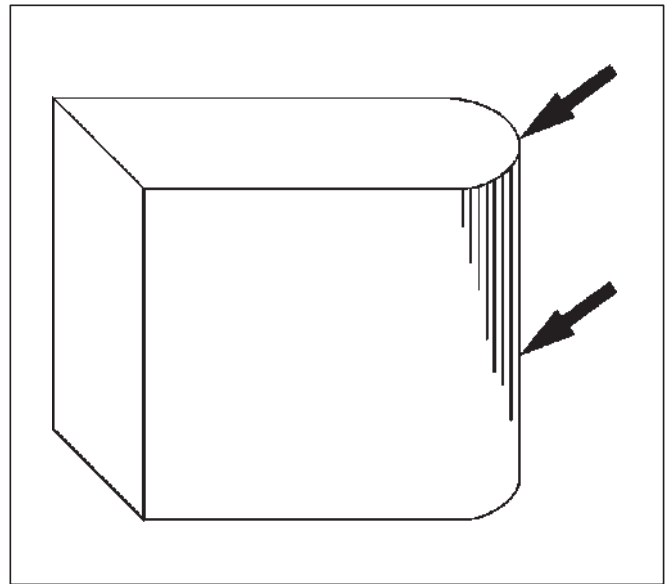
Make all necessary adjustments, repairs, and part replacements if wear, damage, or other problems are discovered during inspection.

#### Rotor



Check that the groove in the vane is free from excessive wear and that the vane slides smoothly. When part replacement becomes necessary, the pump cartridge should be replaced as a subassembly.

#### Vane



Sliding faces of the vane should be free from wear. (Particularly the curved face at the tip that contact with the cam should be free from wear and distortion). When part replacement becomes necessary, the pump cartridge should be replaced as a subassembly.

#### Cam

The inner face of the arm should have a uniform contact pattern without a sign of step wear. When part replacement becomes necessary, the pump cartridge should be replaced as a subassembly.

#### Side Plate

The sliding faces of parts must be free from step wear (more than 0.01 mm), which can be felt by the finger nail. The parts with minor scores may be reused after lapping the face.

#### Valve

The sliding face of the valve must be free from burrs and damage. The parts with minor scores may be reused after smoothing with emery cloth (#800 or finer).

#### Shaft

Oil seal sliding faces must be free from a step wear which can be felt by the finger nail. Needle bearing fitting face must be free from damage and wear.

#### O-ring, Oil Seal, Retaining Ring

Be sure to discard used parts, and always use new parts for installation. Prior to installation, lubricate all seals and rings with power steering fluid.

#### Pressure Switch

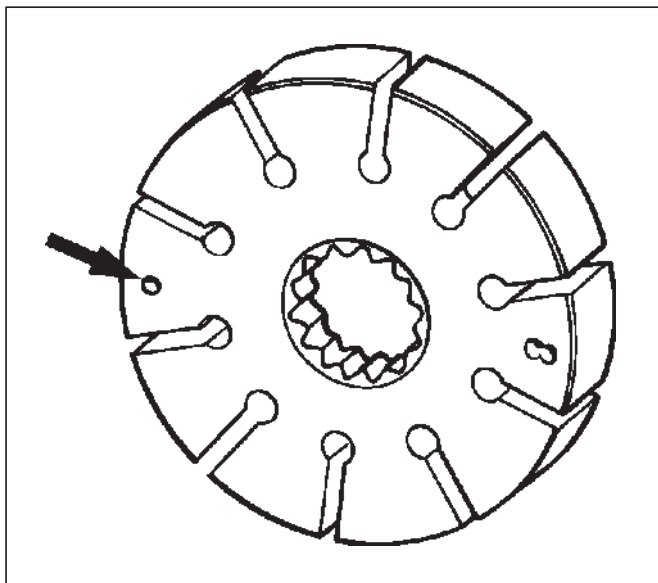
Check the switch operation as follows:

With engine idling and A/C on, turn the steering wheel fully to the left; compressor should interrupt and engine idle speed will increase. Shut off A/C and again turn

steering fully to the left; engine idle will increase. If system fails to function properly, disconnect connector at the pressure switch and repeat system check while testing continuity across disconnected SW connector.

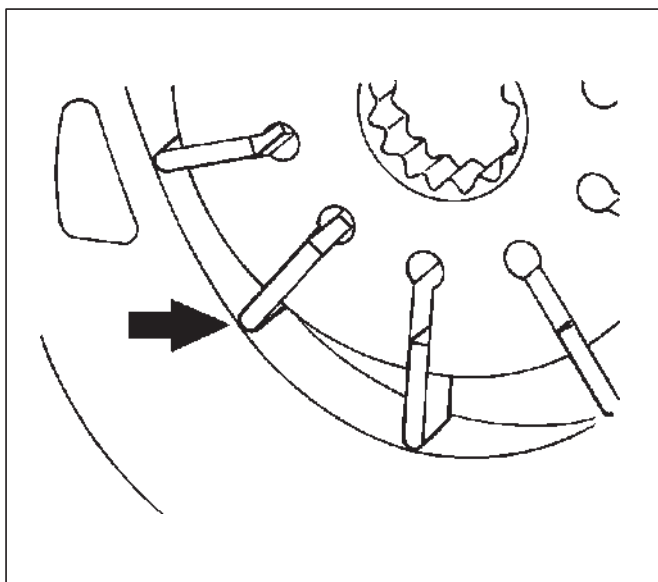
## Reassembly

1. Install rear housing.
2. Install pin.
3. Install cam.
4. Install the rotor with punch mark facing the front housing.



442RS004

5. Install the vanes with curved face in contact with the inner wall of the cam.



442RS005

6. Install side plate.

**CAUTION:** When installing side plate, be careful not to damage its inner surface. Damaged side plate may cause poor pump performance, pump seizure or oil leakage.

7. Install front housing.
8. Install a new o-ring and be sure to discard used parts.
9. Install a new o-ring and be sure to discard used parts.
10. Install a new gasket and be sure to discard used parts.
11. Install rear housing and pump cartridge.
12. Install bolt and tighten it to the specified torque.

**Torque: 17.6 N·m (12.8 lb ft)**

13. Install a new oil seal and be sure to discard used parts.

**CAUTION:** When installing the oil seal, be careful not to damage the oil seal contacting surface of the housing.

14. Install shaft assembly.
15. Install snap ring.
16. Install spring.
17. Install retaining ring.
18. Install filter.
19. Install valve.
20. Install retaining ring.
21. Install a new o-ring and be sure to discard used parts.
22. Install connector and tighten it to the specified torque.

**Torque: 19.6 N·m (14.3 lb ft)**

23. Install a new o-ring and be sure to discard used parts.
24. Install suction pipe.
25. Install bolt and tighten it to the specified torque.

**Torque: 15.7 N·m (11.5 lb ft)**

26. Install pressure switch and tighten it to the specified torque.

**Torque: 20 N·m (14 lb ft)**

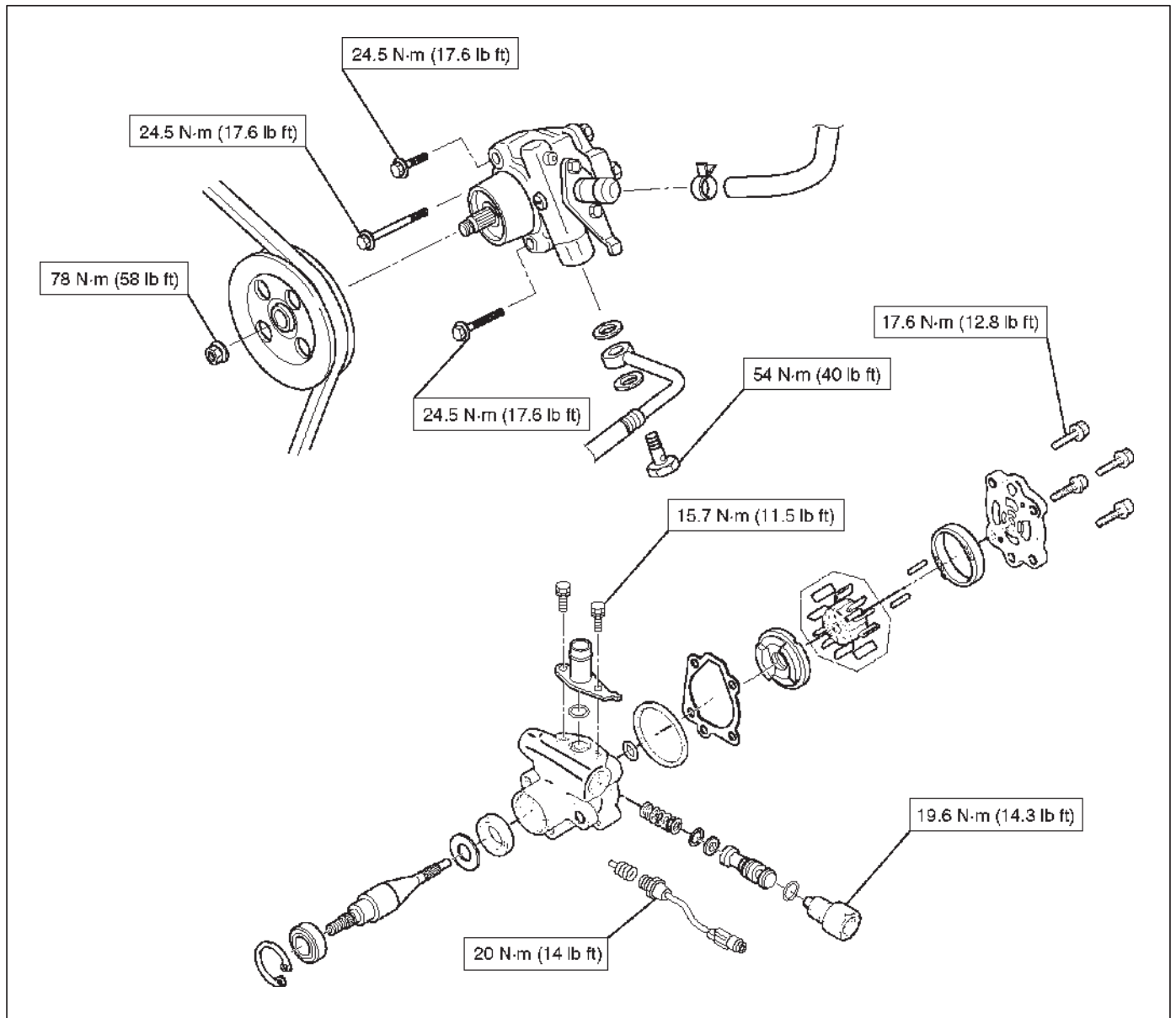
## 2A-34 POWER-ASSISTED STEERING SYSTEM

### Main Data and Specifications

#### General Specifications

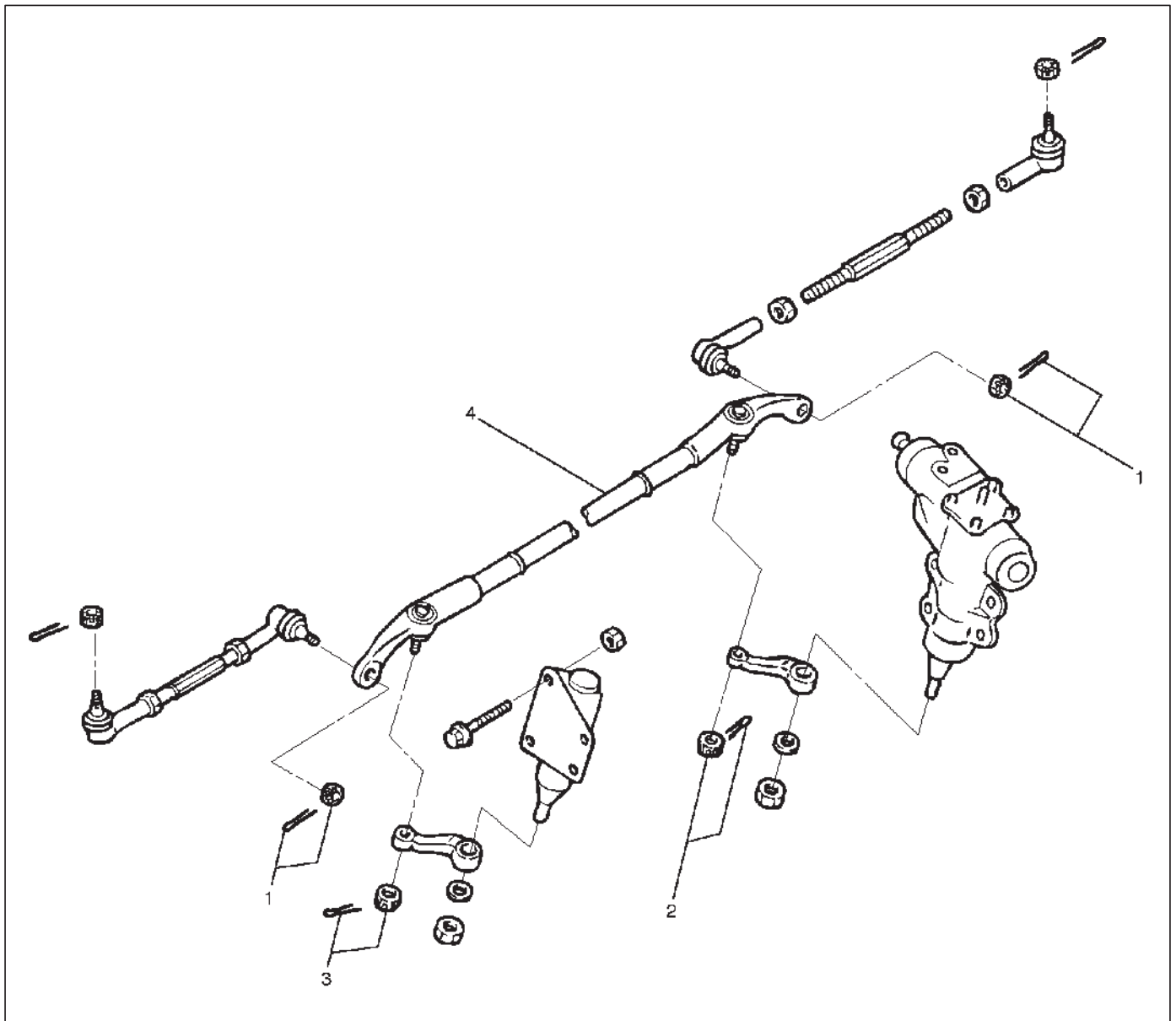
Oil pump	Type	Vane
	Operating fluid	ATF DEXRON®-III

#### Torque Specifications



## Center Track Rod Assembly

### Center Track Rod Assembly and Associated Parts



433RW001

#### Legend

- |                                    |                                     |
|------------------------------------|-------------------------------------|
| (1) Nut and Cotter Pin             | (3) Nut and Cotter Pin, Relay Lever |
| (2) Nut and Cotter Pin, Pitman Arm | (4) Center Track Rod Assembly       |

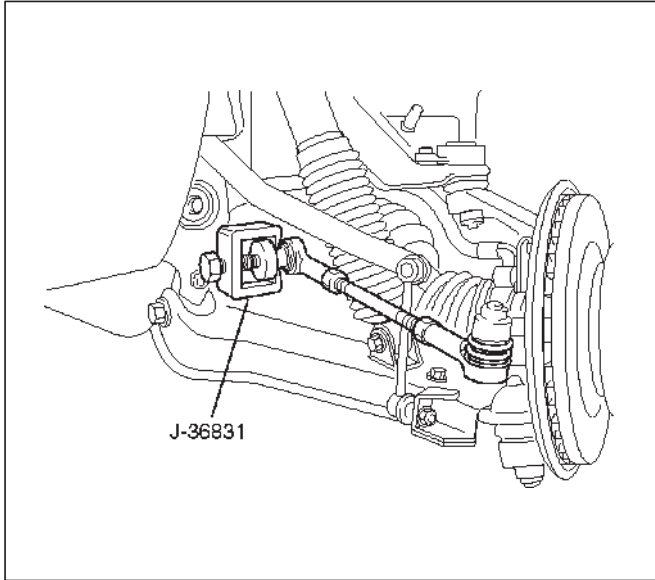
### Removal

1. Raise the vehicle and support the frame with suitable safety stands.

## 2A-36 POWER-ASSISTED STEERING SYSTEM

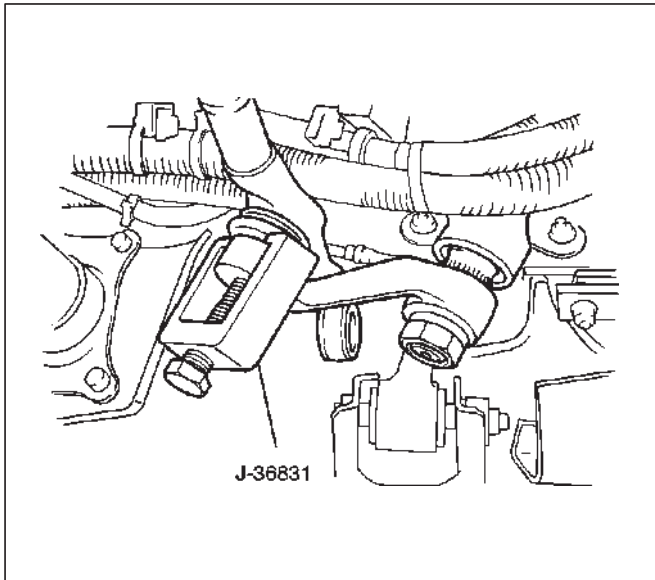
2. Remove nut and cotter pin, then use remover J-36831 to disconnect outer track rod assembly from the center track rod.

**CAUTION:** Be careful not to damage the ball joint boot.



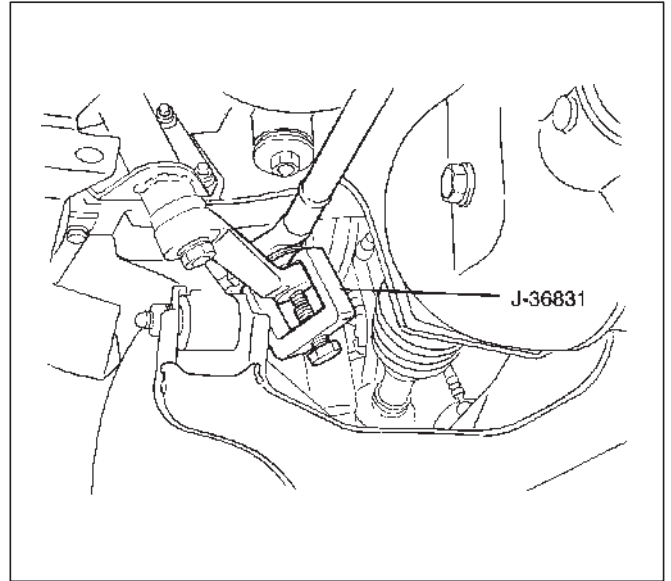
3. Remove nut and cotter pin then use remover J-36831 to remove pitman arm from the center track rod.

**CAUTION:** Be careful not to damage the ball joint boot.



4. Remove nut and cotter pin then use remover J-36831 to remove relay lever from the center track rod.

**CAUTION:** Be careful not to damage the ball joint boot.



5. Remove center track rod assembly.

## Inspection and Repair

Make necessary correction or parts replacement if wear, damage, corrosion, bending, deteriorations or any other abnormal condition are found through inspection. Check the ball joint (Boot, screws and tapered surfaces).

## Installation

1. Install center track rod assembly.
2. Install nut, cotter pin and relay lever, then tighten the nut to the specified torque, with just enough additional torque to align cotter pin holes. Install new cotter pin.

**Torque: 59 N-m (43 lb ft)**

3. Install nut, cotter pins and pitman arm, then tighten the nut to the specified torque, with just enough additional torque to align cotter pin holes. Install new cotter pin.

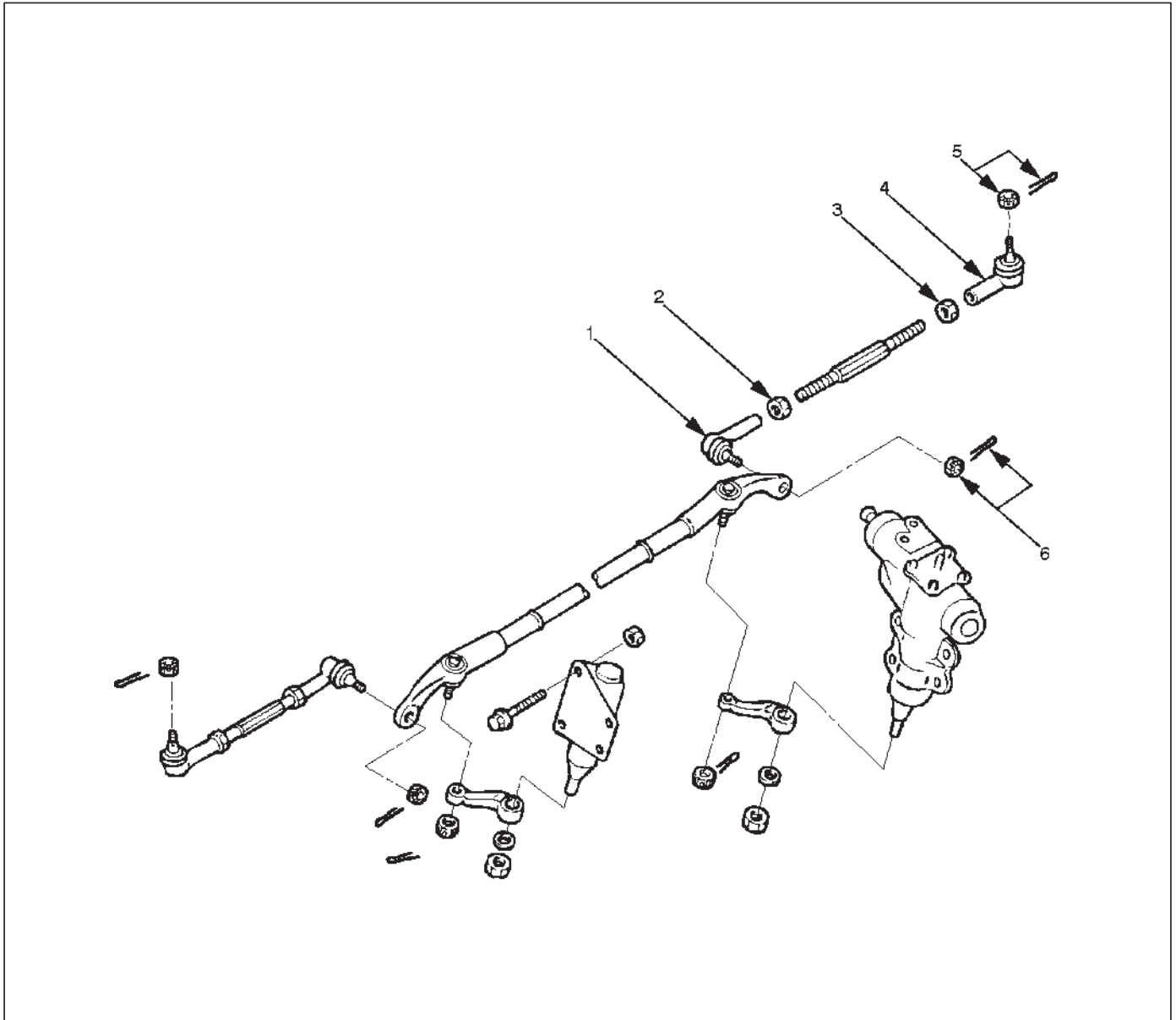
**Torque: 98 N-m (72 lb ft)**

4. Install nut and cotter pin, then tighten the nut to the specified torque, with just enough additional torque to align cotter pin holes. Install new cotter pin.

**Torque: 98 N-m (72 lb ft)**

## Outer Track Rod Assembly

### Outer Track Rod Assembly and Associated Parts



433RS012

#### Legend

- |   |  |
|---|--|
| (1) Rod End Assembly, Inner             | (4) Rod End Assembly, Outer              |
| (2) Lock Nut, Inner (Left-hand threads) | (5) Nut and Cotter Pin, Knuckle Arm      |
| (3) Lock Nut, Outer                     | (6) Nut and Cotter Pin, Center Track Rod |

#### Removal

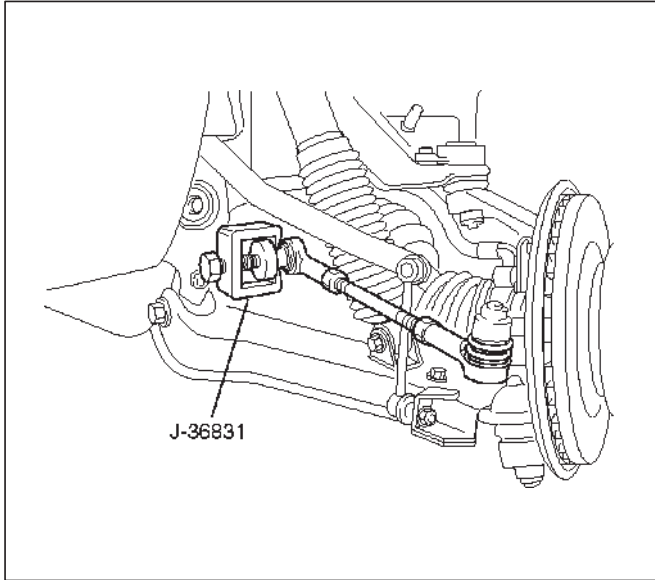
1. Remove wheel and tire assembly. Refer to Wheel Replacement in Suspension section.



## 2A-38 POWER-ASSISTED STEERING SYSTEM

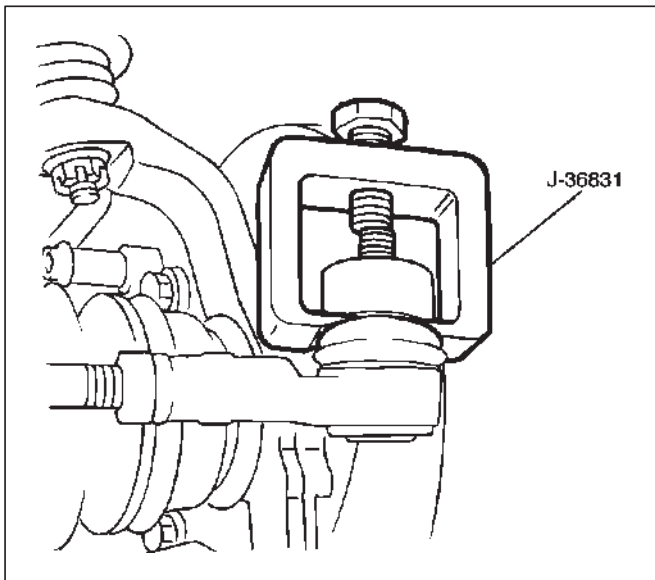
2. Remove nut and cotter pin, then use remover J-36831 to disconnect outer track rod assembly at the center track rod.

**CAUTION:** Be careful not to damage the ball joint boot.



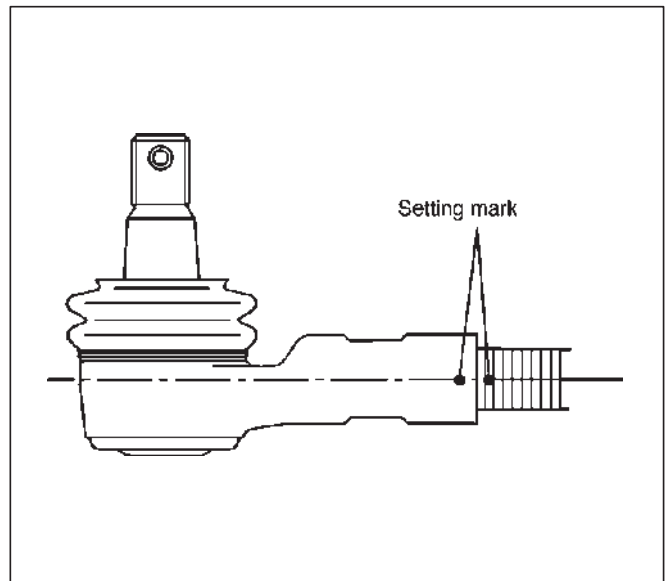
3. Remove nut and cotter pin then use remover J-36831 to remove outer track rod assembly from the knuckle arm.

**CAUTION:** Be careful not to damage the ball joint boot.



4. Remove outer lock nut.

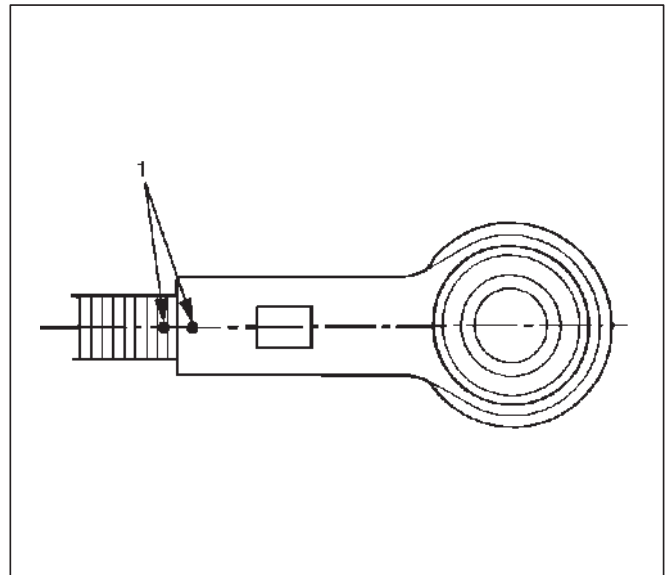
5. Apply setting marks (1) to ensure reassembly of the parts in their original position, then remove outer rod end assembly.



6. Remove inner lock nut.

**NOTE:** For either outer rod, the screw on the right side of the vehicle is threaded counterclockwise.

7. Apply setting marks (1) to ensure reassembly of the parts in their original position, then remove inner rod end.



## Inspection and Repair

Make necessary correction or parts replacement if wear, damage, corrosion, bending, deteriorations or any other abnormal condition are found through inspection.

Check the following parts:

- Rod end assembly
- Ball joint (Boot, screws and tapered surfaces)

## Installation

1. Install inner rod end and align the setting marks applied during disassembly.
2. Tighten the inner lock nut to specified torque.

**Torque: 118 N·m (87 lb ft)**

NOTE: For either outer rod, the screw on the right side of the vehicle is threaded counterclockwise.

3. Install outer rod end assembly and align the setting marks applied during disassembly.
4. Tighten the outer lock nut to specified torque.

**Torque: 118 N·m (87 lb ft)**

5. Install knuckle arm nut and cotter pin then tighten the nut to the specified torque, with just enough additional torque to align cotter pin holes. Install new cotter pin.

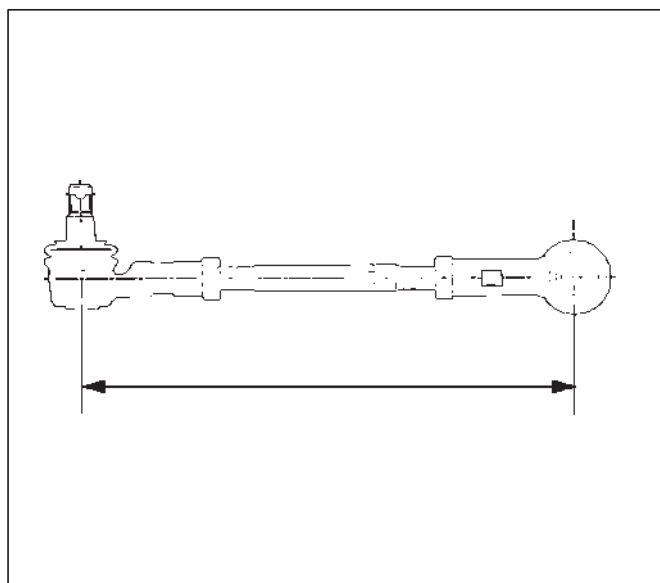
**Torque: 98 N·m (72 lb ft)**

6. Install center track rod and nut and cotter pin then tighten the nut to the specified torque, with just enough additional torque to align cotter pin holes. Install new cotter pin.

**Torque: 98 N·m (72 lb ft)**

NOTE: If replacing the track rod, adjust the new track rod length.

**Rod length: 328.3 mm (12.93 in)**

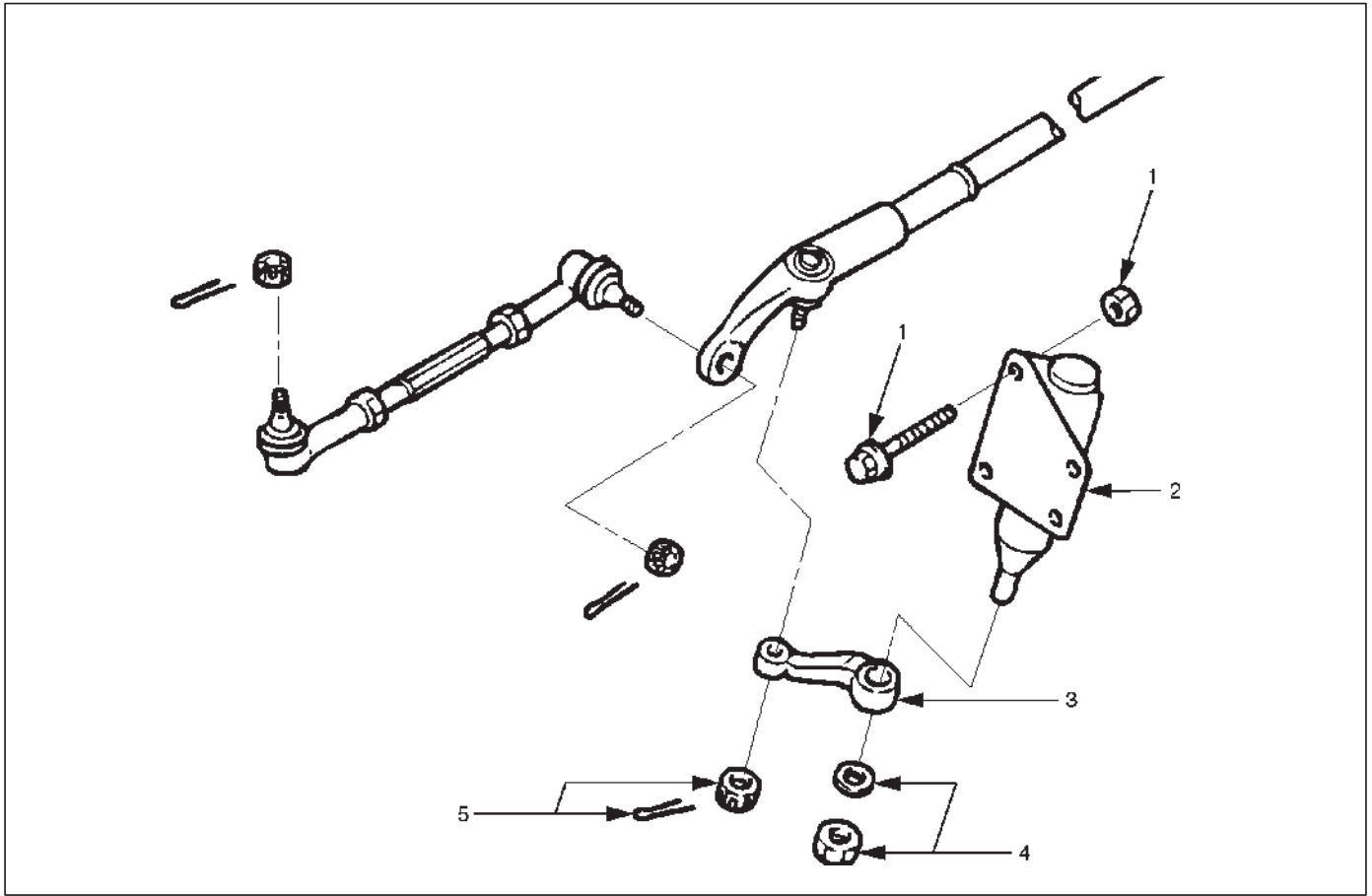


433RS016

NOTE: Adjust the toe-in. Refer to Front End Alignment Inspection and Adjustment in this section.

## Relay Lever

### Relay Lever and Associated Parts



433RX003

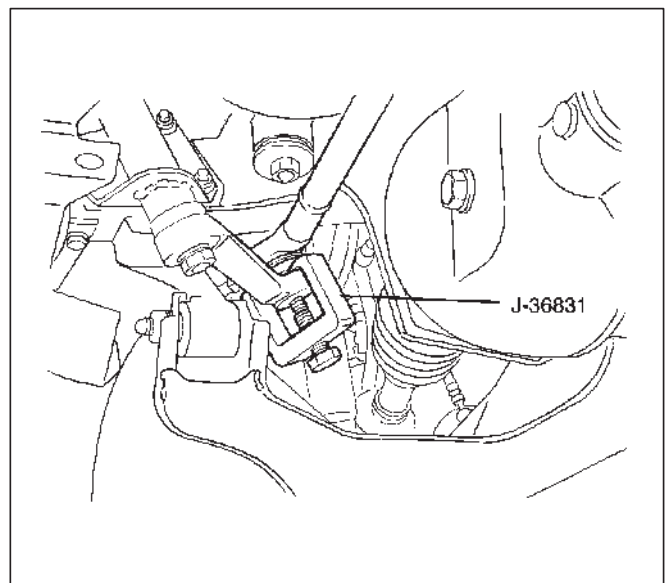
#### Legend

- (1) Bolt and Nut
- (2) Bracket

- (3) Relay Lever
- (4) Nut and Washer
- (5) Nut and Cotter Pin

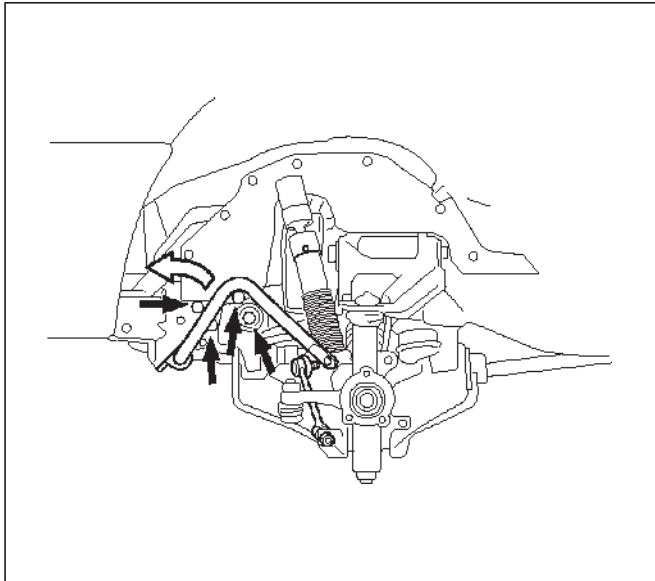
### Removal

1. Raise the vehicle and support the frame with suitable safety stands.
2. Remove nut and cotter pin then use remover J-36831 to disconnect relay lever at the center track rod.



433RS011

3. Remove stabilizer bar bolt and nut and push the stabilizer bar aside, then remove the relay lever bolts and nuts.

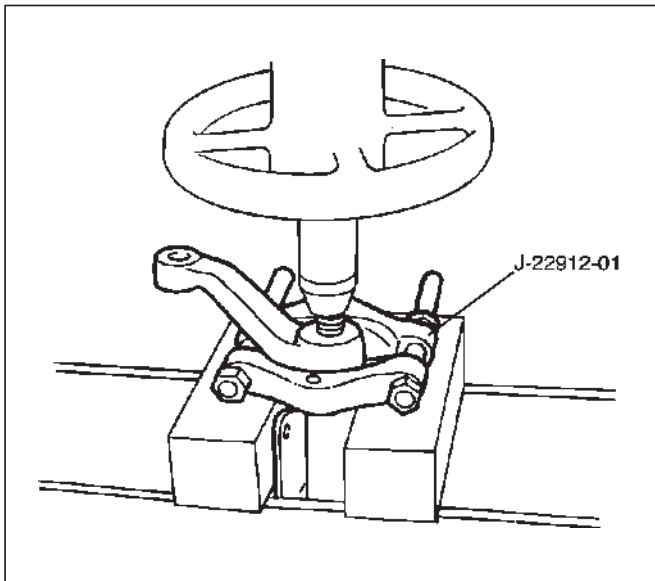


433RX002

6. Install nut and cotter pin and tighten the nut to the specified torque, with just enough additional torque to align cotter pin holes. Install new cotter pin.

**Torque: 59 N·m (43 lb ft)**

4. Remove relay lever and bracket.
5. Remove relay lever nut and washer.
6. Remove relay lever, use remover J-22912-01 to remove relay lever from the bracket.



433RS019

7. Remove bracket.

## Installation

1. Install bracket.
2. Install relay lever.
3. Install nut and washer and tighten the nut to the specified torque.

**Torque: 118 N·m (87 lb ft)**

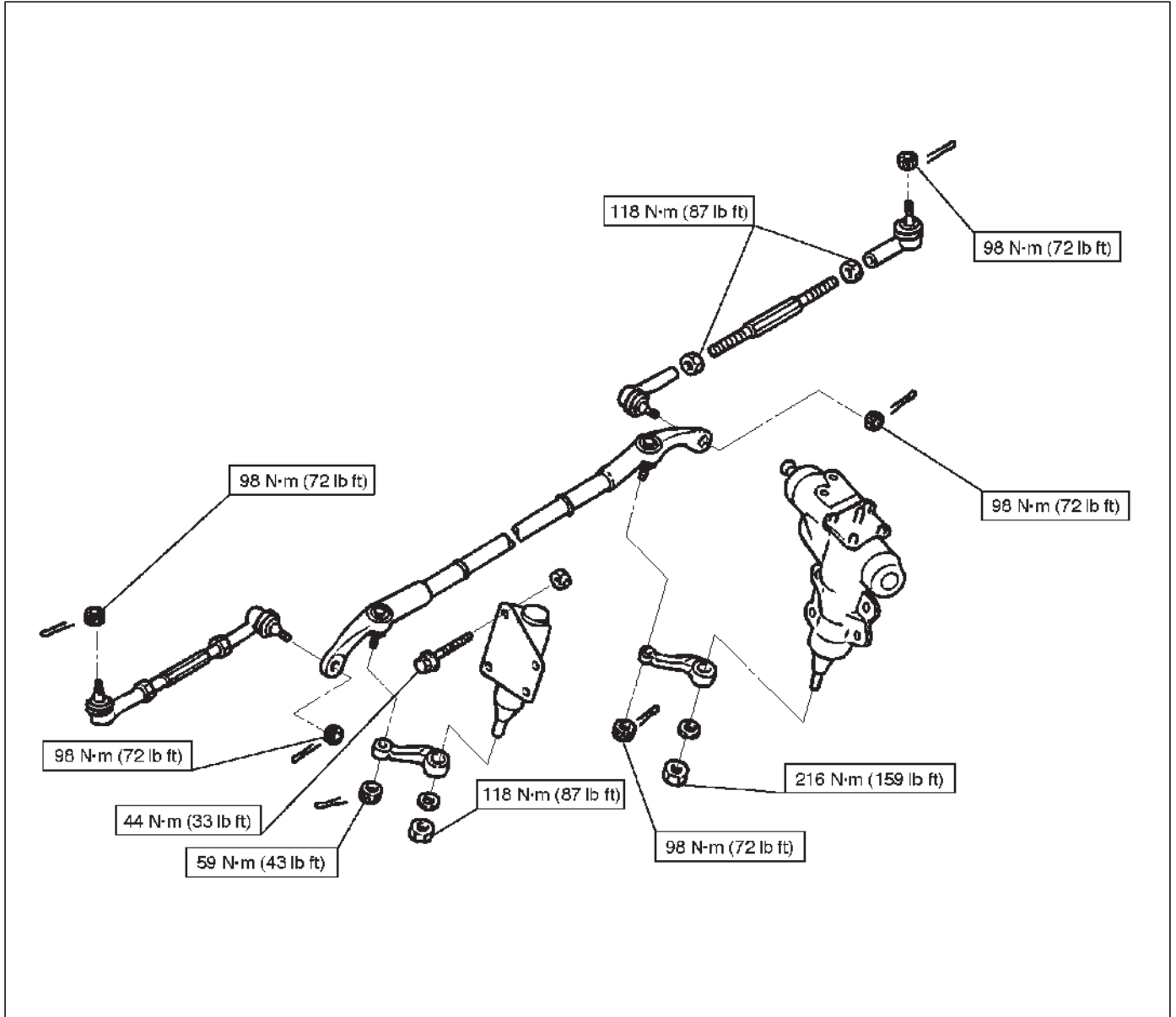
4. Install relay lever and bracket.
5. Install bolt and nut and tighten it to the specified torque.

**Torque: 44 N·m (33 lb ft)**

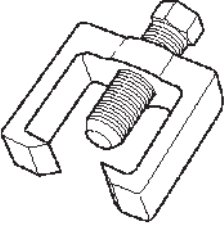
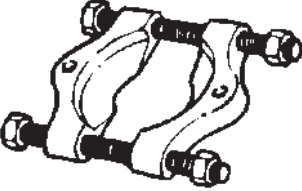
## Steering Linkage and Associated Parts

### Main Data and Specifications

#### Torque Specifications



**Special Tools**

ILLUSTRATION	TOOL NO. TOOL NAME
 <small>901RS261</small>	<p><b>J-36831</b> Tie rod end remover</p>
 <small>901RS262</small>	<p><b>J-22912-01</b> Relay lever remover</p>

## Supplemental Restraint System Steering Wheel & Column

### Service Precaution

This steering wheel and column repair section covers the Supplemental Restraint System (SRS) steering column. The following repair procedures are specific to SRS components. When servicing a vehicle equipped with Supplemental Restraint System, pay close attention to all WARNINGS and CAUTIONS.

For detailed explanation about SRS, refer to Restraints section.

**WARNING: THIS VEHICLE HAS A SUPPLEMENTAL RESTRAINT SYSTEM (SRS). REFER TO THE SRS COMPONENT AND WIRING LOCATION VIEW IN ORDER TO DETERMINE WHETHER YOU ARE PERFORMING SERVICE ON OR NEAR THE SRS COMPONENTS OR THE SRS WIRING. WHEN YOU ARE PERFORMING SERVICE ON OR NEAR THE SRS COMPONENTS OR THE SRS WIRING, REFER TO THE SRS SERVICE INFORMATION. FAILURE TO FOLLOW WARNINGS COULD RESULT IN POSSIBLE AIR BAG DEPLOYMENT, PERSONAL INJURY, OR OTHERWISE UNNEEDED SRS SYSTEM REPAIRS.**

**SAFE HANDLING OF INFLATOR MODULES REQUIRES FOLLOWING THE PROCEDURES DESCRIBED BELOW FOR BOTH LIVE AND DEPLOYED MODULES.**

**SAFETY PRECAUTIONS MUST BE FOLLOWED WHEN HANDLING A DEPLOYED AIR BAG ASSEMBLY (AIR BAG). AFTER DEPLOYMENT, THE AIR BAG ASSEMBLY (AIR BAG) SURFACE MAY CONTAIN A SMALL AMOUNT OF SODIUM HYDROXIDE, A BY-PRODUCT OF THE DEPLOYMENT REACTION, THAT IS IRRITATING TO THE SKIN AND EYES. MOST OF THE POWDER ON THE AIR BAG ASSEMBLY (AIR BAG) IS HARMLESS. AS A PRECAUTION, WEAR GLOVES AND SAFETY GLASSES WHEN HANDLING A DEPLOYED AIR BAG ASSEMBLY, AND WASH YOUR HANDS WITH MILD SOAP AND WATER AFTERWARDS.**

**WHEN CARRYING A LIVE AIR BAG ASSEMBLY, MAKE SURE THE BAG AND TRIM COVER ARE POINTED AWAY FROM YOU. NEVER CARRY AN AIR BAG ASSEMBLY BY THE WIRES OR CONNECTOR ON THE UNDERSIDE OF MODULE. IN THE CASE OF AN ACCIDENTAL DEPLOYMENT, THE BAG WILL THEN DEPLOY WITH MINIMAL CHANCE OF INJURY. WHEN PLACING A LIVE AIR BAG ASSEMBLY ON A BENCH OR OTHER SURFACE, ALWAYS FACE THE BAG AND TRIM COVER UP, AWAY FROM THE SURFACE.**

**NEVER REST A STEERING COLUMN ASSEMBLY ON THE STEERING WHEEL WITH THE AIR BAG ASSEMBLY FACE DOWN AND COLUMN VERTICAL. THIS IS NECESSARY SO THAT A FREE SPACE IS PROVIDED TO ALLOW THE AIR BAG ASSEMBLY TO EXPAND IN THE UNLIKELY EVENT OF ACCIDENTAL DEPLOYMENT. OTHERWISE, PERSONAL INJURY COULD RESULT.**

**TO AVOID DEPLOYMENT WHEN TROUBLE SHOOTING THE SRS SYSTEM, DO NOT USE ELECTRICAL TEST EQUIPMENT, SUCH AS BATTERY-POWERED OR A/C-POWERED VOLT-METER, OHMMETER, ETC., OR ANY TYPE OF ELECTRICAL EQUIPMENT OTHER THAN SPECIFIED IN THIS MANUAL. DO NOT USE A NON-POWERED PROBE-TYPE TESTER.**

**INSTRUCTIONS IN THIS MANUAL MUST BE FOLLOWED CAREFULLY, OTHERWISE PERSONAL INJURY MAY RESULT.**

**CAUTION:**

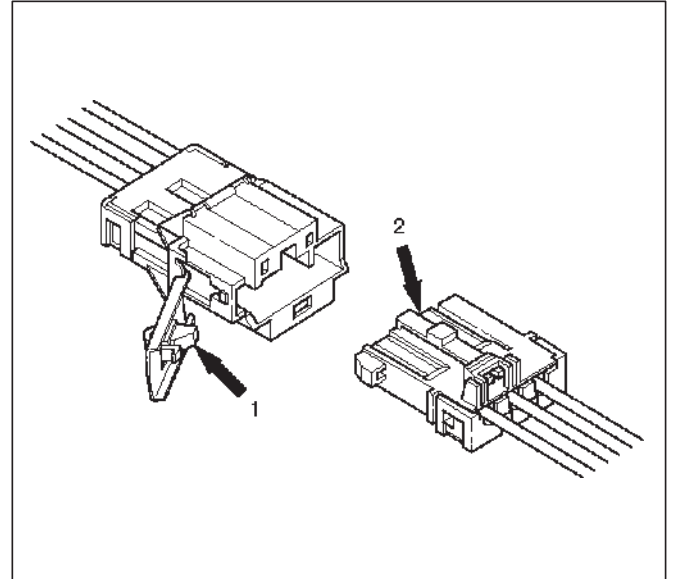
- Never use the air bag assembly from another vehicle. Use only the air bag assembly for "VX".

### SRS Connectors (3 pin)

**CAUTION: Double-lock type yellow color connectors are used for supplemental restraint system-air bag circuit.**

When removing the cable harness, disconnect the connector by unlocking at two places, outside (1) and inside (2). In such a case, do not pull the wires. Otherwise, wire disconnection may occur.

When connect the double lock type SRS connector, insert the connector completely and lock at outside. Imperfect locking may cause malfunction of SRS circuit.



827RW001

### SRS Connectors (2 pin)

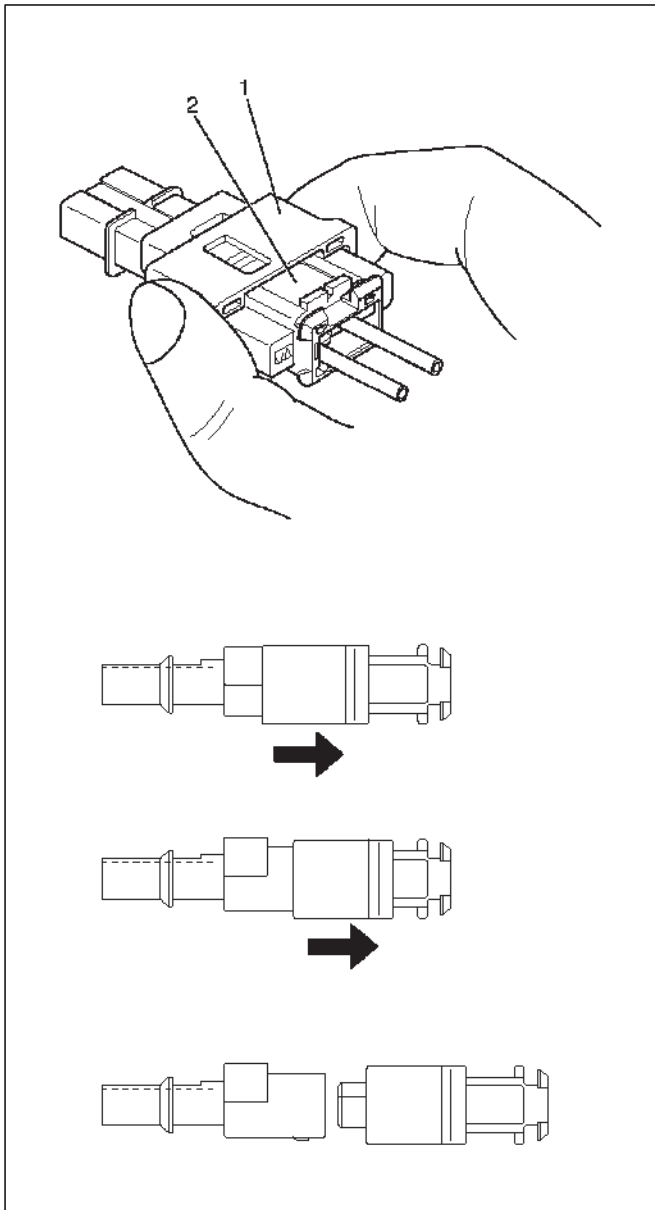
**CAUTION: The special yellow color connectors are used for supplemental restraint system-air bag circuit.**

When removing the cable harness, do not pull the cables. Otherwise, cable disconnection may occur.

When connect the SRS connector, insert the connector completely. Imperfect locking may cause malfunction of SRS circuit.

**Removal**

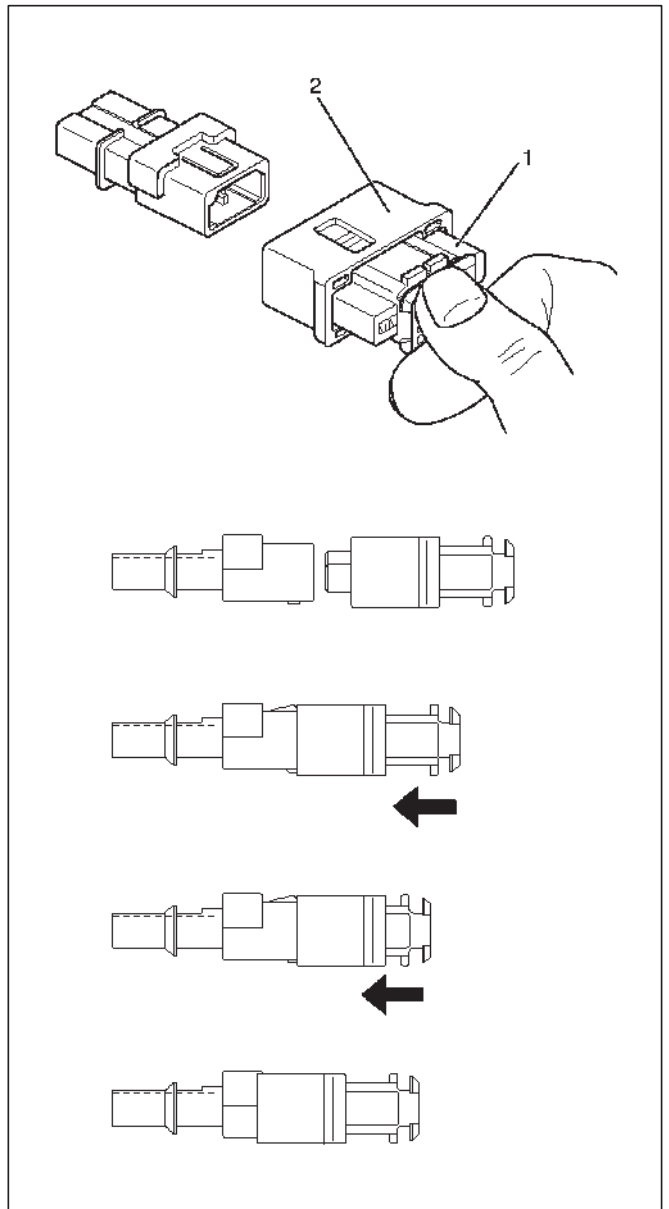
To remove the connector, hold the cover insulator(1) and pull it. The cover insulator slides and lock will be released. Do not hold the socket insulator(2).



827RW026

**Installation**

To install the connector, hold the socket insulator(1) and insert it. The cover insulator slides and connector will be locked. Do not hold the cover insulator(2).

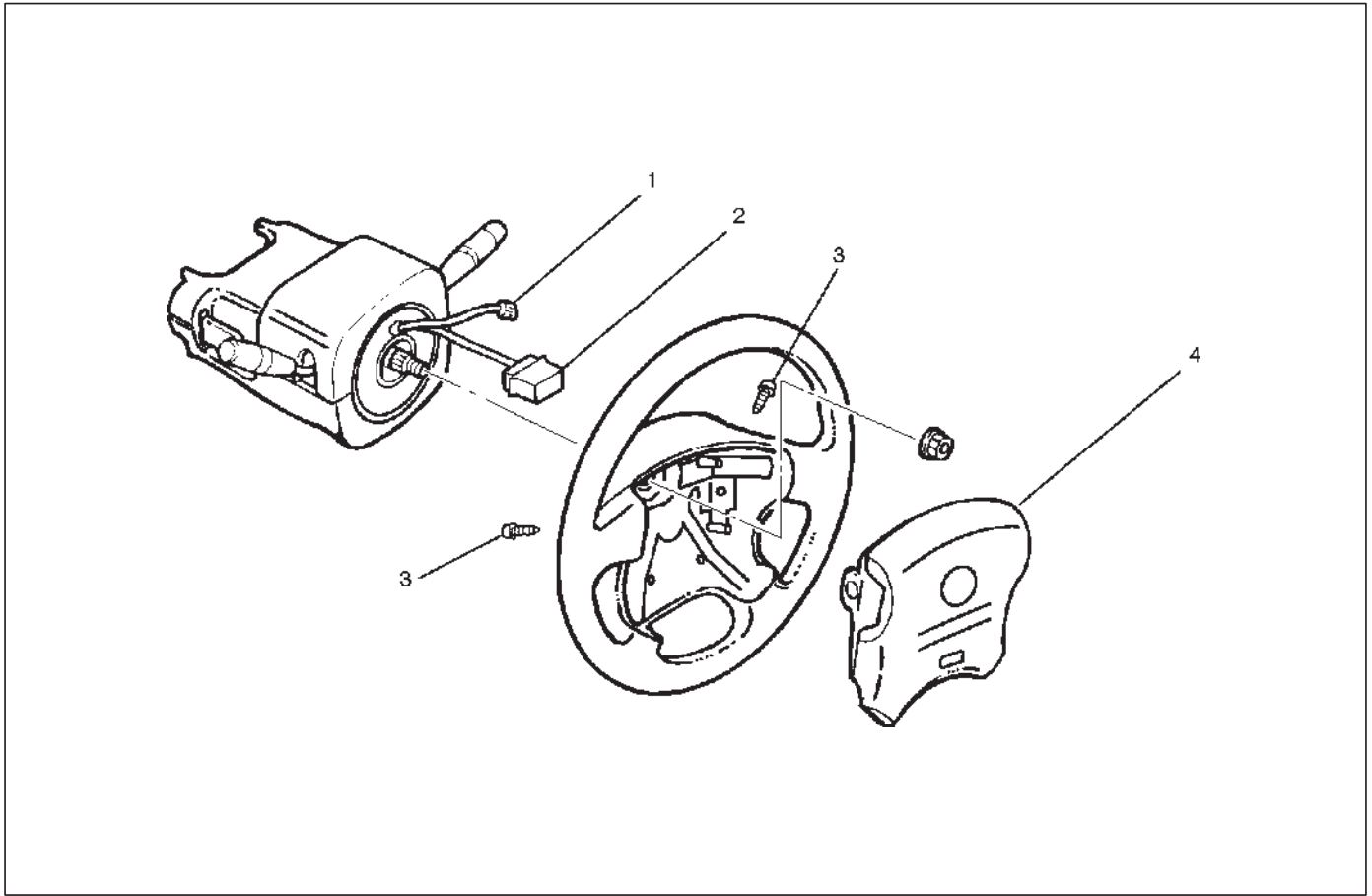


827RW027



## Inflator Module

### Inflator Module and Associated Parts



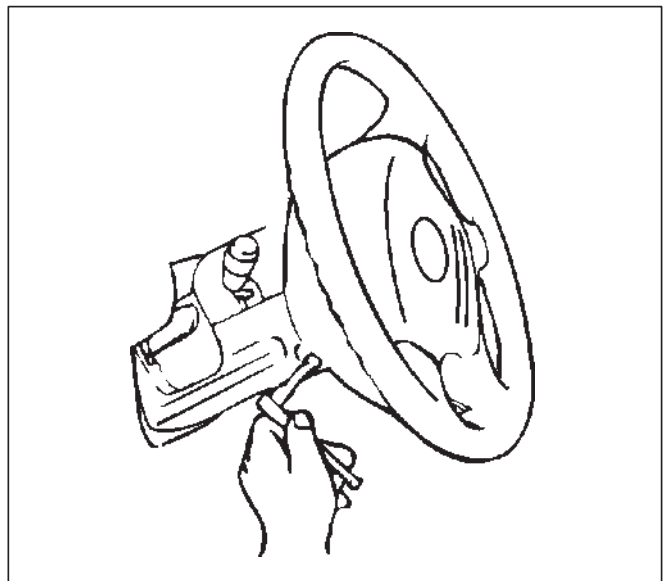
827RW071-1

#### Legend

- |                   |                     |
|-------------------|---------------------|
| (1) Horn Lead     | (3) Fixing Bolt     |
| (2) SRS Connector | (4) Inflator Module |

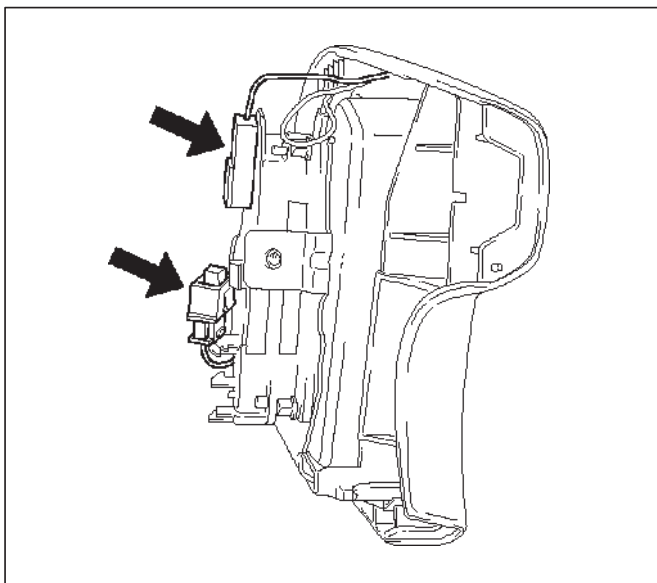
### Removal

1. Turn the steering wheel so that the vehicle's wheels are pointing straight ahead.
2. Turn the ignition switch to "LOCK".
3. Disconnect the battery "-" terminal cable, and wait at least 5 minutes.
4. Disconnect the yellow 3-way SRS connector located under the steering column.
5. Loosen the inflator module fixing bolt from behind the steering wheel assembly using a TORX® driver or equivalent until the inflator module can be released from steering assembly .



827RW070

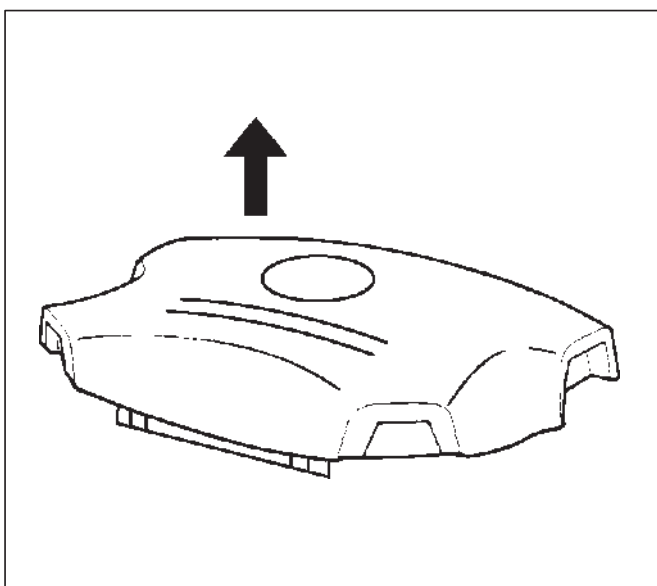
6. Disconnect the yellow 2-way SRS connector and horn lead located behind the inflator module.



7. Remove inflator module.

## Inspection and Repair

**WARNING: THE INFLATOR MODULE SHOULD ALWAYS BE CARRIED WITH THE URETHANE COVER AWAY FROM YOUR BODY AND SHOULD ALWAYS BE LAID ON A FLAT SURFACE WITH THE URETHANE SIDE UP. THIS IS NECESSARY BECAUSE A FREE SPACE IS PROVIDED TO ALLOW THE AIR CUSHION TO EXPAND IN THE UNLIKELY EVENT OF ACCIDENTAL DEPLOYMENT. OTHERWISE, PERSONAL INJURY MAY RESULT .**



The inflator module consists of a cover, air bag, inflator, and retainer. Inspect the inflator module mainly for the following:

- Check for holes, cracks, severe blemishes and deformation on the cover.
- Check that the retainer is not deformed.

- Check for defects such as damage and breakage in the lead wire for the igniter.

If an abnormality is found as the result of the inspection, replace the inflator module with a new one.

## Installation

1. Support the module and carefully connect the module connector and horn lead.

**CAUTION: Never use the air bag assembly from another vehicle. Use only the air bag assembly for "VX".**

**NOTE:** Pass the lead wire through the tabs on the plastic cover (wire protector) of inflator to prevent lead wire from being pinched.

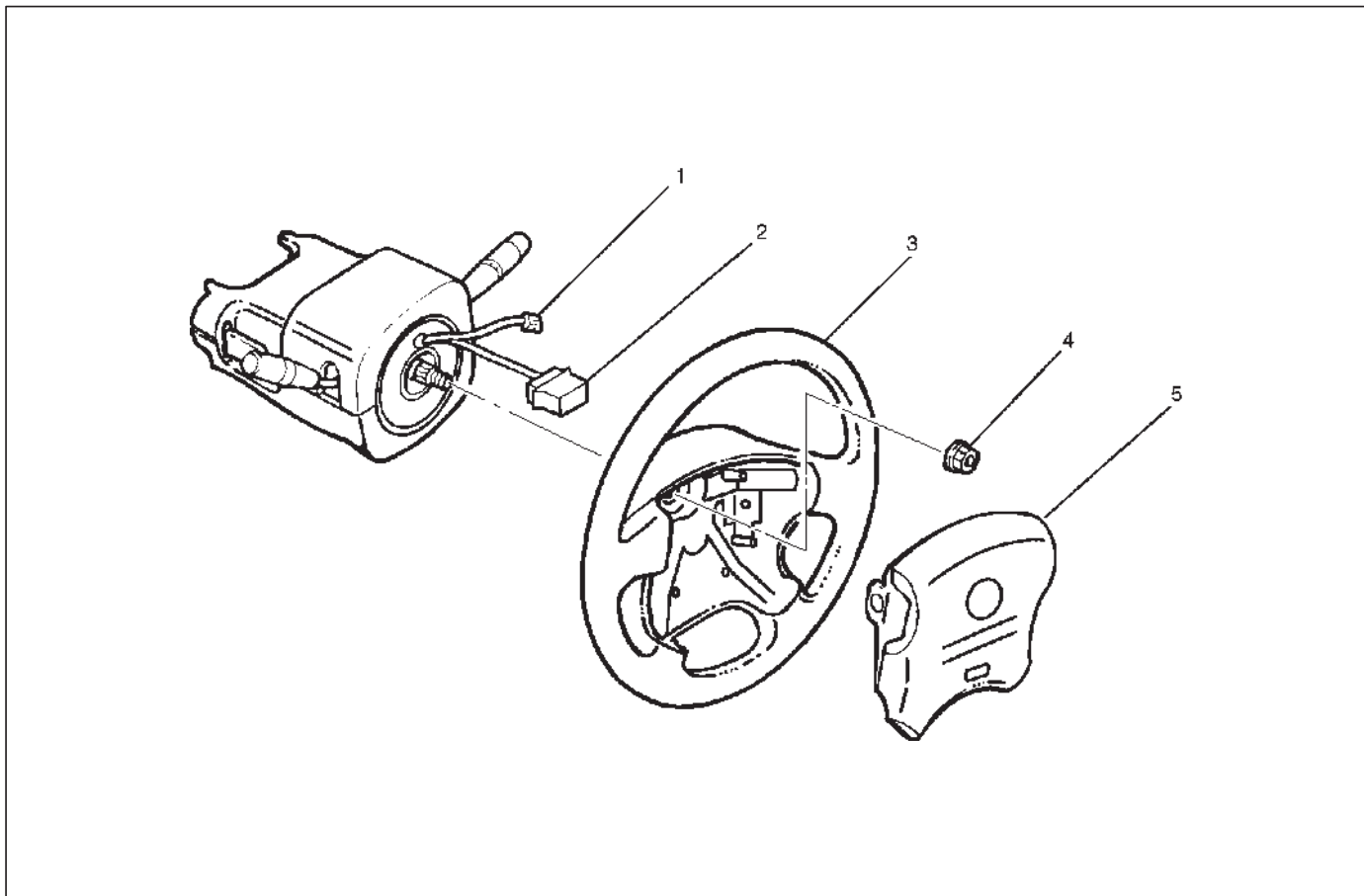
2. Tighten bolts to specified torque.

**Torque: 8.8 N-m (78 lb in)**

3. Connect the yellow 3-way SRS connector located under the steering column.
4. Connect the battery "–" terminal cable.
5. Set ignition to "ON" while watching warning light. Light should flash 7 times and then go off. If lamp does not operate correctly, refer to Restraints section.

## Steering Wheel

### Steering Wheel and Associated Parts



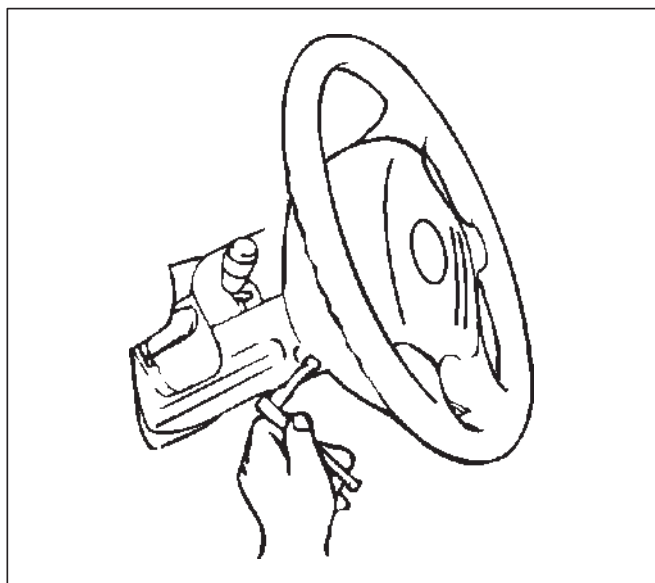
827RW069

#### Legend

- |                   |                               |
|-------------------|-------------------------------|
| (1) Horn Lead     | (3) Steering Wheel            |
| (2) SRS Connector | (4) Steering Wheel Fixing Nut |
|                   | (5) Inflator Module           |

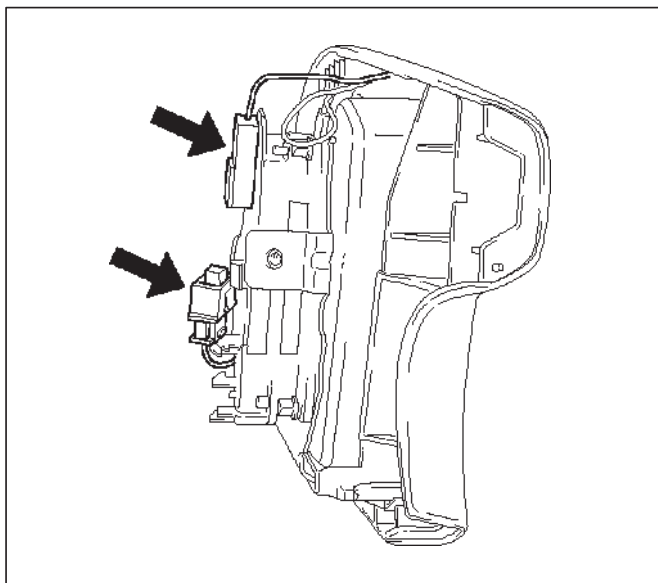
### Removal

1. Turn the steering wheel so that the vehicle's wheels are pointing straight ahead.
2. Turn the ignition switch to "LOCK".
3. Disconnect the battery "-" terminal cable, and wait at least 5 minutes.
4. Disconnect the yellow 3-way SRS connector located under the steering column.
5. Loosen the inflator module fixing bolt from behind the steering wheel assembly using a TORX® driver or equivalent until the inflator module can be released from steering assembly.



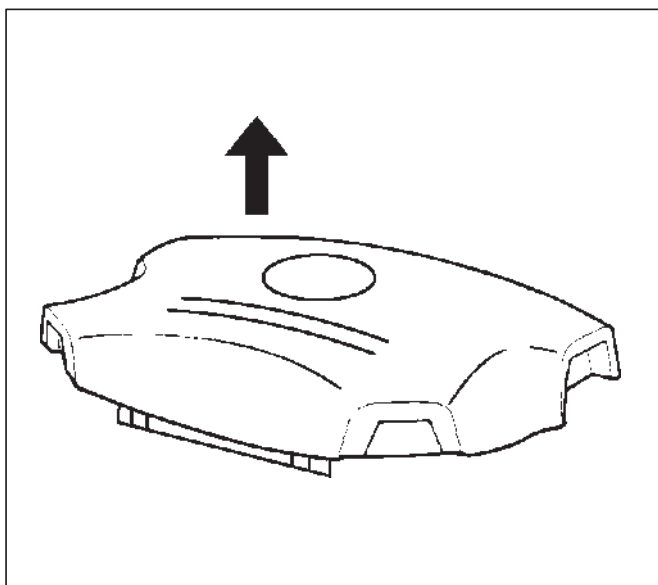
827RW070

6. Disconnect the yellow 2-way SRS connector located behind the inflator module.



827RW073

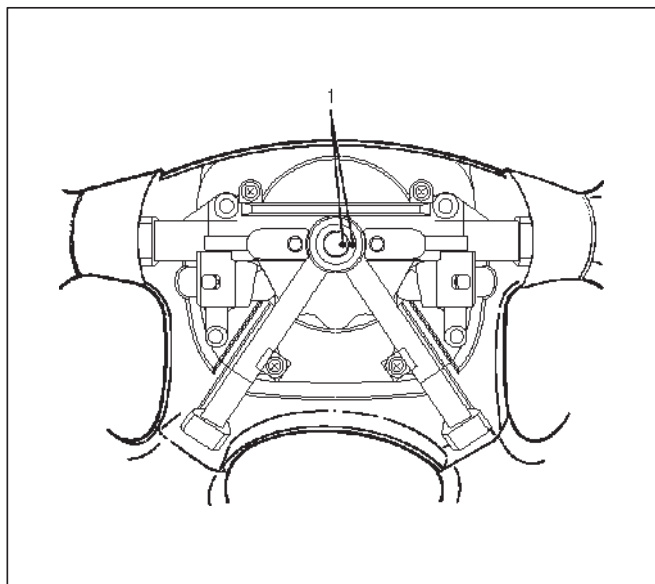
**WARNING: THE INFLATOR MODULE SHOULD ALWAYS BE CARRIED WITH THE URETHANE COVER AWAY FROM YOUR BODY AND SHOULD ALWAYS BE LAID ON A FLAT SURFACE WITH THE URETHANE SIDE UP. THIS IS NECESSARY BECAUSE A FREE SPACE IS PROVIDED TO ALLOW THE AIR CUSHION TO EXPAND IN THE UNLIKELY EVENT OF ACCIDENTAL DEPLOYMENT. OTHERWISE, PERSONAL INJURY MAY RESULT.**



827RW072

7. Remove steering wheel fixing nut.

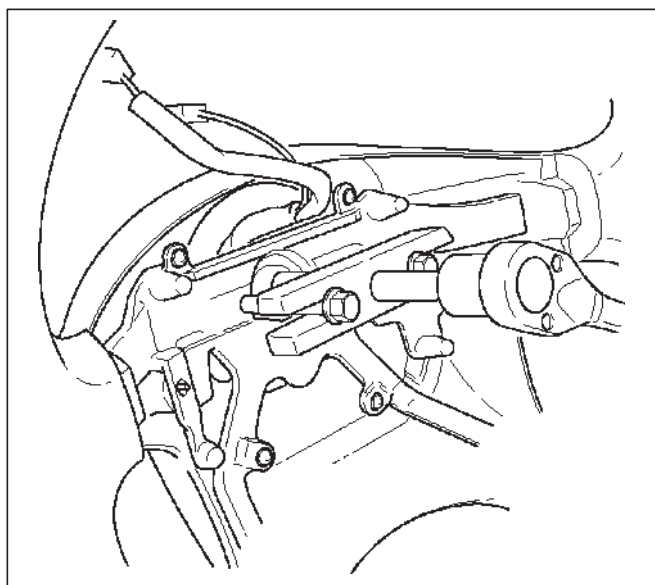
8. Apply a setting mark (1) across the steering wheel and shaft so parts can be reassembled in their original position, then remove steering wheel.



430RW021

9. Move the front wheels to the straight ahead position, then use steering wheel remover J-29752 to remove the steering wheel.

**CAUTION: Never apply force to the steering wheel in direction of the shaft by using a hammer or other impact tools in an attempt to remove the steering wheel. The steering shaft is designed as an energy absorbing unit.**



430RX005

## 2A-50 POWER-ASSISTED STEERING SYSTEM

---

### Installation

1. Install steering wheel by aligning the setting marks made when removing.

**CAUTION: Never apply force to the steering wheel in direction of the shaft by using a hammer or other impact tools in an attempt to remove the steering wheel. The steering shaft is designed as an energy absorbing unit.**

2. Tighten the steering wheel fixing nut to the specified torque.

**Torque: 34 N·m (25 lb ft)**

3. Connect horn lead.
4. Support the module and carefully connect the module connector.

**CAUTION: Never use the air bag assembly from another vehicle. Use only the air bag assembly for "VX".**

**NOTE:** Pass the lead wire through the tabs on the plastic cover (wire protector) of inflator to prevent lead wire from being pinches.

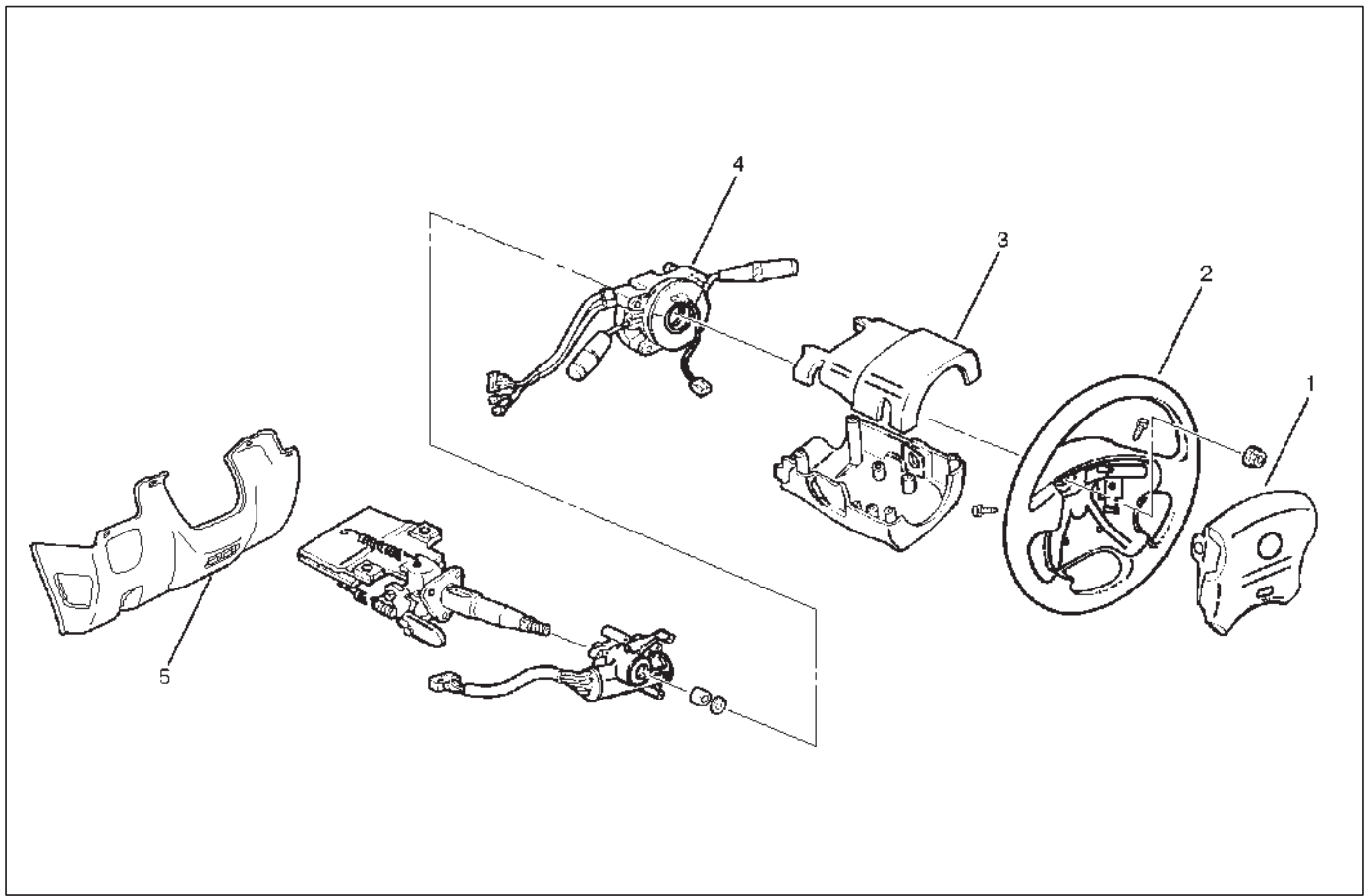
5. Tighten bolts to specified sequence as illustrated.

**Torque: 8.8 N·m (78 lb in)**

6. Connect the yellow 3-way SRS connector located under the steering column.
7. Connect the battery "-" terminal cable.
8. Turn the ignition switch to "ON" while watching warning light. Light should flash 7 times and then go off. If lamp does not operate correctly, refer to Restraints section.

## Combination Switch

### Combination Switch and Associated Parts



431RX008

#### Legend

- |                     |  |
|---------------------|--|
| (1) Inflator Module | (3) Steering Column Cover                    |
| (2) Steering Wheel  | (4) Combination Switch and SRS Coil Assembly |
|                     | (5) Instrument Panel Lower Cover             |

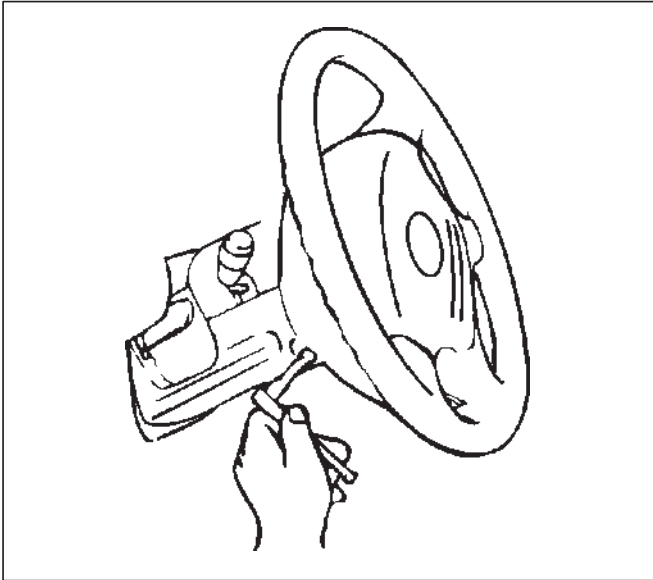
### Removal

1. Turn the steering wheel so that the vehicle's wheels are pointing straight ahead.
2. Turn the ignition switch to "LOCK".
3. Disconnect the battery "-" terminal cable, and wait at least 5 minutes.
4. Disconnect the yellow 3-way SRS connector located under the steering column.

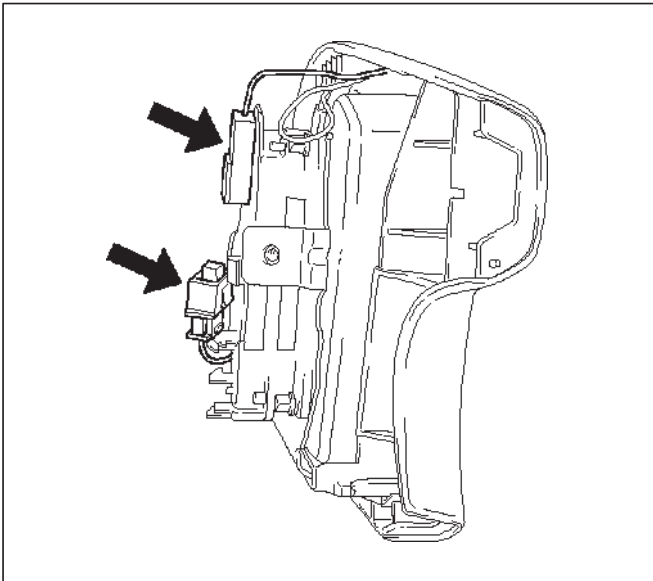
**CAUTION:** The wheels of the vehicle must be straight ahead and the steering column in the "LOCK" position before disconnecting the steering wheel. Failure to do so will cause the coil assembly to become uncentered which will cause damage to the coil assembly.

## 2A-52 POWER-ASSISTED STEERING SYSTEM

5. Remove the engine hood opening lever, then remove instrument panel lower cover.
6. Loosen the inflator module fixing bolt from behind the steering wheel assembly using a TORX® driver or equivalent until the inflator module can be released from steering assembly. Disconnect the yellow 2-way SRS connector and horn lead located behind the inflator module, then remove inflator module.



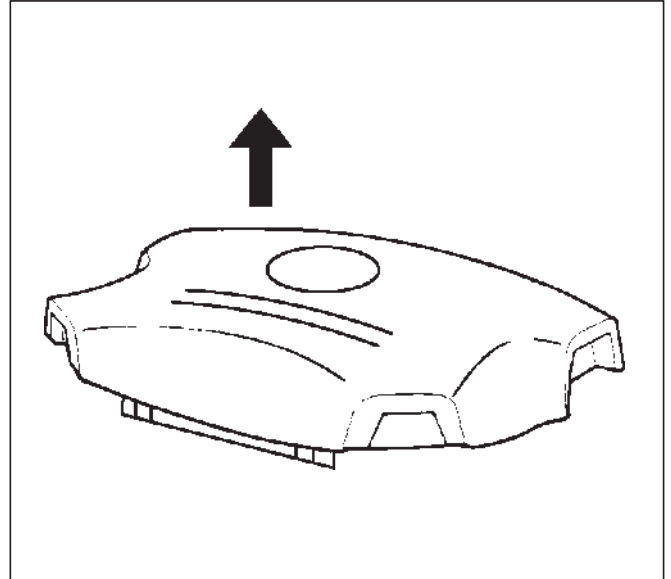
827RW070



827RW073

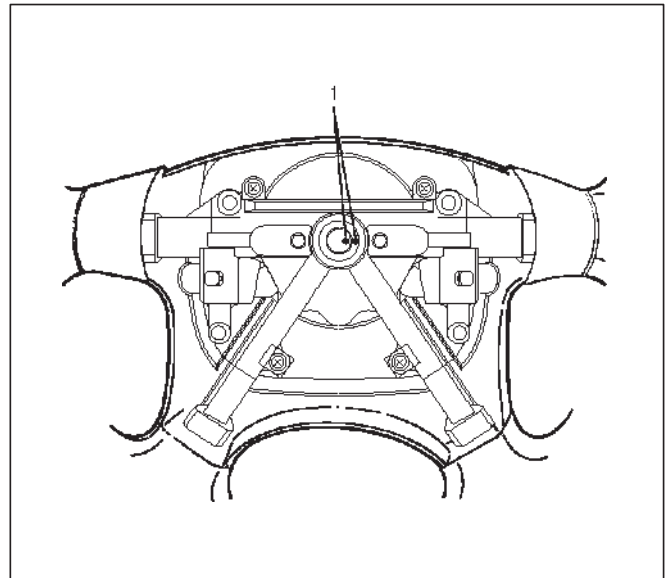
7. Remove the steering wheel fixing nut.

**WARNING: THE INFLATOR MODULE SHOULD ALWAYS BE CARRIED WITH THE URETHANE COVER AWAY FROM YOUR BODY AND SHOULD ALWAYS BE LAID ON A FLAT SURFACE WITH THE URETHANE SIDE UP. THIS IS NECESSARY BECAUSE A FREE SPACE IS PROVIDED TO ALLOW THE AIR CUSHION TO EXPAND IN THE UNLIKELY EVENT OF ACCIDENTAL DEPLOYMENT. OTHERWISE, PERSONAL INJURY MAY RESULT.**



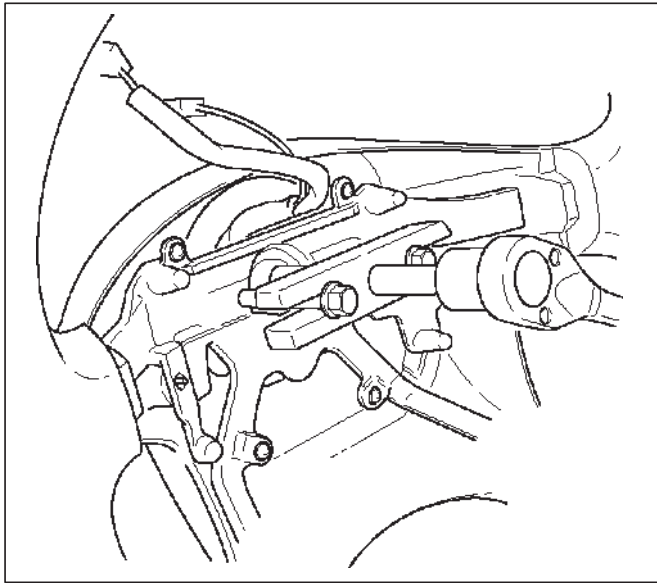
827RW072

8. Apply a setting mark (1) across the steering wheel and shaft so parts can be reassembled in their original position. Move the front wheels to the straight ahead position, then use steering wheel remover J-29752 to remove the steering wheel.



430RW021

**CAUTION:** Never apply force to the steering wheel in direction of the shaft by using a hammer or other impact tools in an attempt to remove the steering wheel. The steering shaft is designed as an energy absorbing unit.

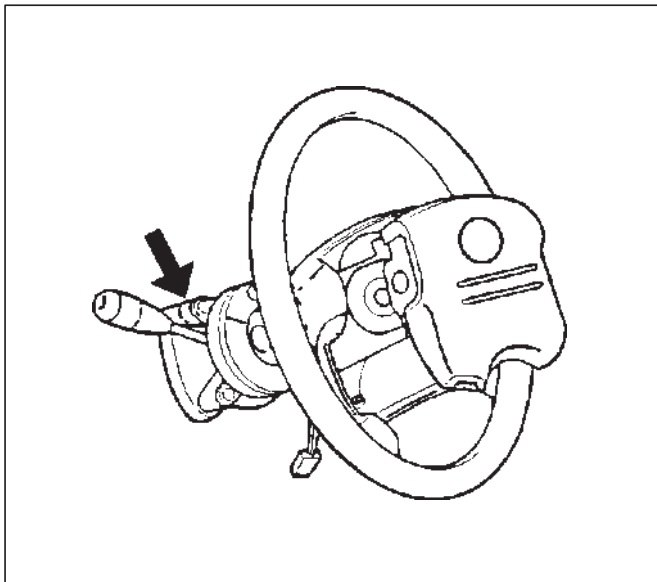


430RX005

9. Remove steering column cover.

10. Disconnect the wiring harness connectors located under the steering column, then remove combination switch and SRS coil assembly.

**NOTE:** The SRS coil is a part of the combination switch assembly, which can not be replaced separately. Therefore, be sure not to remove the SRS coil from the combination switch assembly.

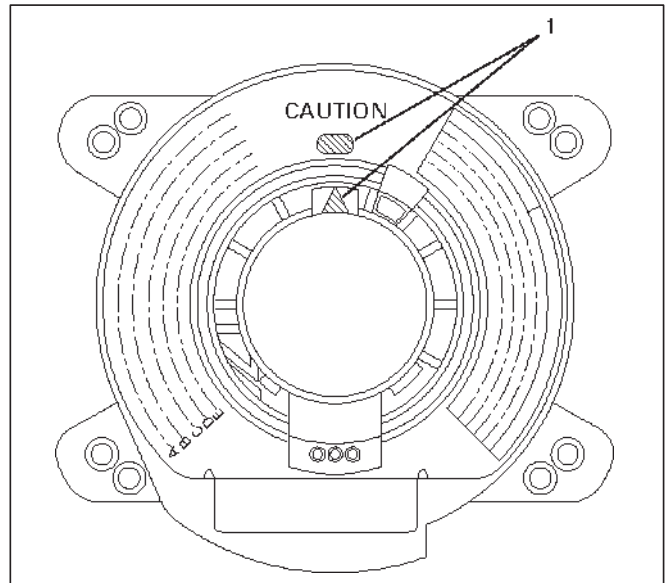


825RW288

## Installation

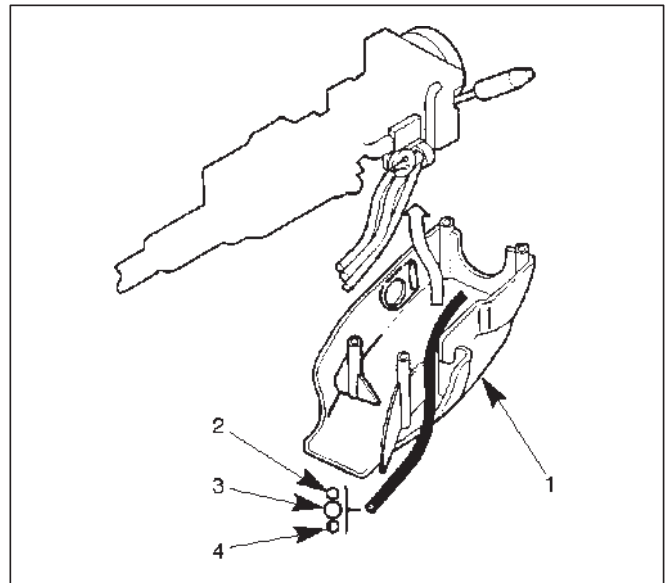
1. Install combination switch and SRS coil assembly. After installation of combination switch assembly, connect the combination switch wiring harness connector. Then turn the SRS coil counterclockwise to full, return about 3 turns and align the neutral mark.

**CAUTION:** When turning the SRS coil counterclockwise to full, stop turning if resistance is felt. Forced further turning may damage to the cable in the SRS coil.



825RX027

2. When installing the steering column cover, be sure to route each wire harness as illustrated so that the harnesses do not catch on any moving parts.



825RW017

### Legend

- (1) Steering Column Cover
- (2) Starter Switch Harness
- (3) Combination Switch Harness
- (4) Inflator Module Harness

3. Align the setting marks made when removing then install steering wheel.

**CAUTION:** Never apply force to the steering wheel in direction of the shaft by using a hammer or other impact tools in an attempt to remove the steering wheel. The steering shaft is designed as an energy absorbing unit.



## 2A-54 POWER-ASSISTED STEERING SYSTEM

---

4. Tighten the steering wheel fixing nut to the specified torque.

**Torque: 34 N·m (25 lb ft)**

5. Support the inflator module and carefully connect the module connector and horn lead.

**CAUTION: Never use the air bag assembly from another vehicle. Use only the air bag assembly for "VX".**

NOTE: Pass the lead wire through the tabs on the plastic cover (wire protector) of inflator to prevent lead wire from being pinched.

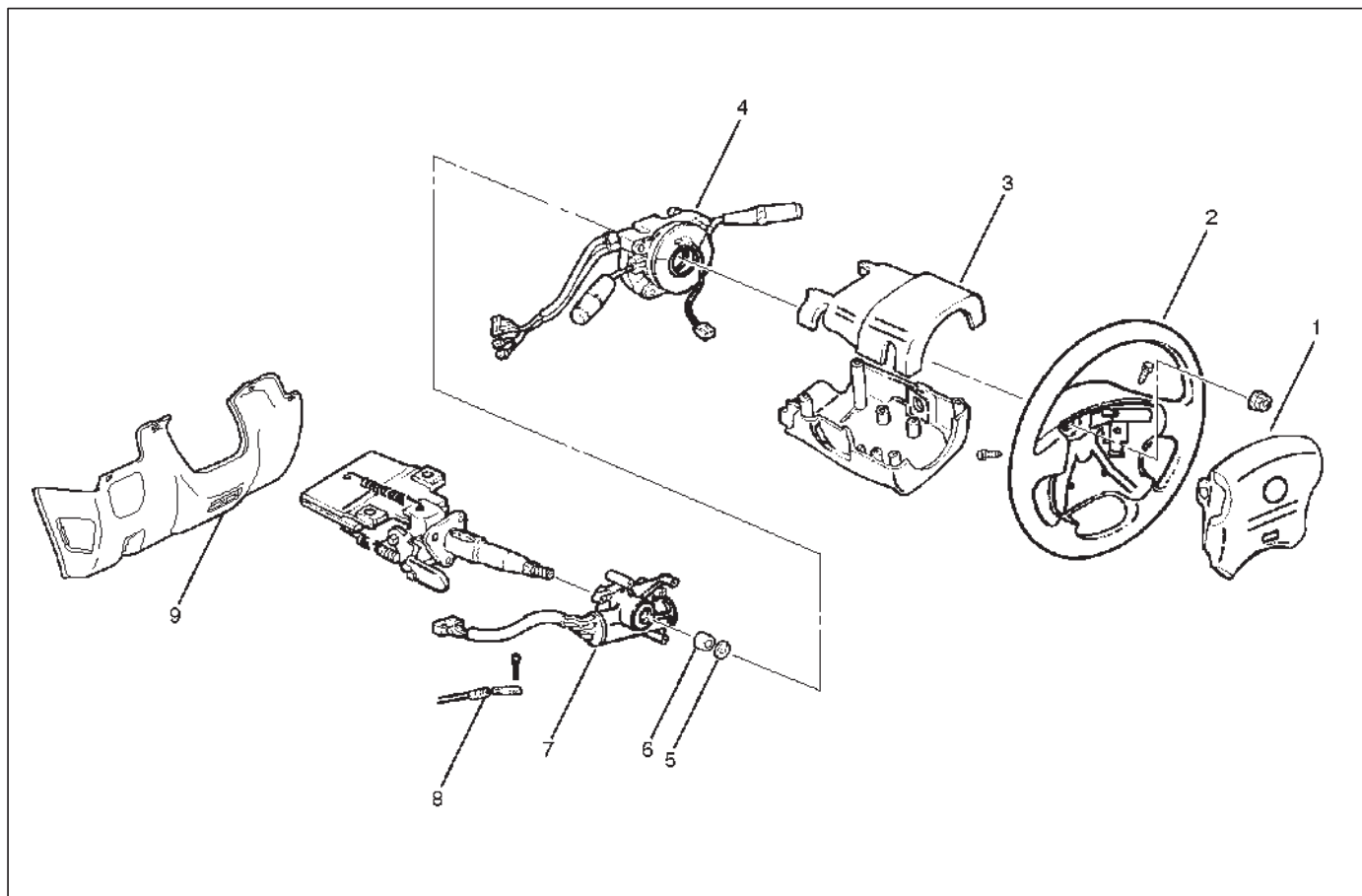
6. Tighten bolts to specified torque.

**Torque: 8.8 N·m (78 lb in)**

7. Install instrument panel lower cover then install the engine hood opening lever.
8. Connect the yellow 3-way SRS connector located under the steering column.
9. Connect the battery "-" terminal cable.
10. Turn the ignition switch to "ON" while watching warning light and check the light should flash 7 times and then go off. If lamp does not operate correctly, refer to Restraints section.

## Lock Cylinder

### Lock Cylinder and Associated Parts



431RX009

#### Legend

- |  |                                  |
|--|----------------------------------|
| (1) Inflator Module                          | (5) Snap Ring                    |
| (2) Steering Wheel                           | (6) Cushion Rubber               |
| (3) Steering Column Cover                    | (7) Lock Cylinder Assembly       |
| (4) Combination Switch and SRS Coil Assembly | (8) Shift Lock Cable             |
|  | (9) Instrument Panel Lower Cover |

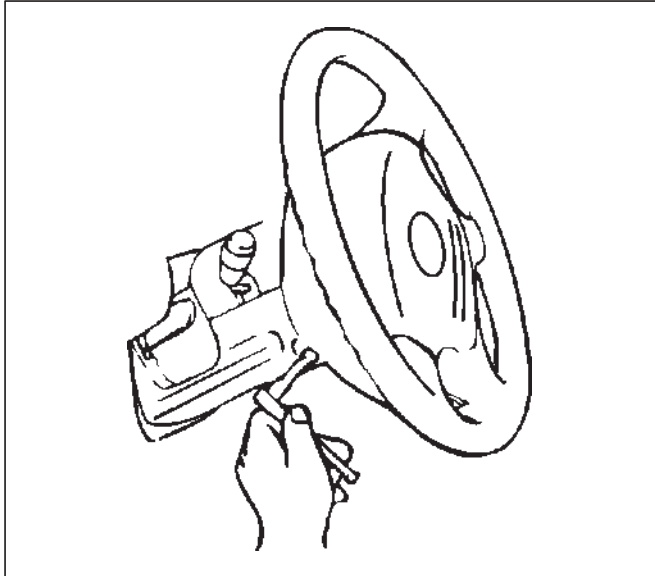
### Removal

1. Turn the steering wheel so that the vehicle's wheels are pointing straight ahead.
2. Turn the ignition switch to "LOCK".
3. Disconnect the battery "-" terminal cable, and wait at least 5 minutes.
4. Disconnect the yellow 3-way SRS connector located under the steering column.

**CAUTION:** The wheels of the vehicle must be straight ahead and the steering column in the "LOCK" position before disconnecting the steering wheel. Failure to do so will cause the coil assembly to become uncentered which will cause damage to the coil assembly.

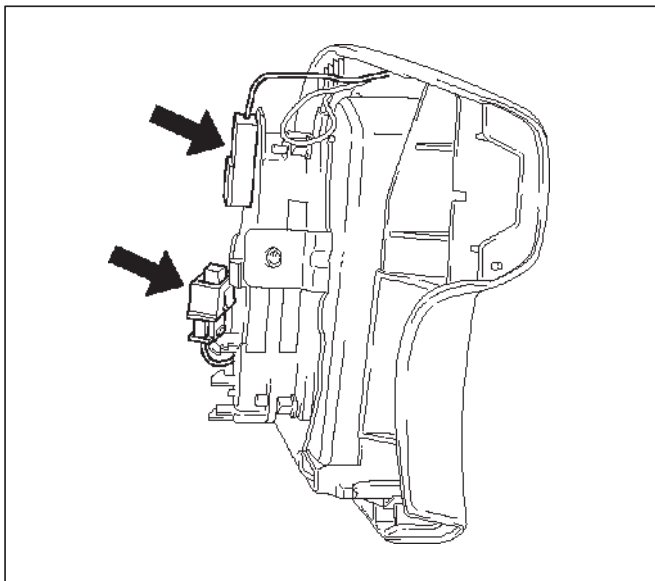
## 2A-56 POWER-ASSISTED STEERING SYSTEM

5. Remove the engine hood opening lever and instrument panel lower cover.
6. Loosen the inflator module fixing bolt from behind the steering wheel assembly using a TORX® driver or equivalent until the inflator module can be released from steering assembly.



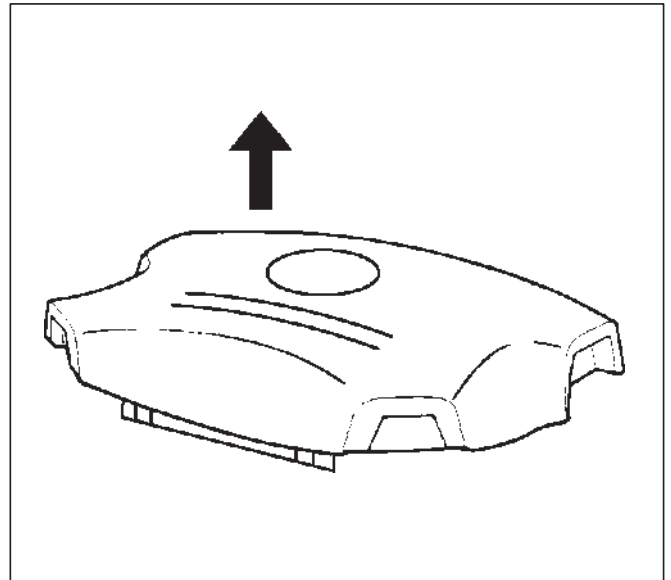
827RW070

7. Disconnect the yellow 2-way SRS connector and horn lead located behind the inflator module then remove the inflator module.



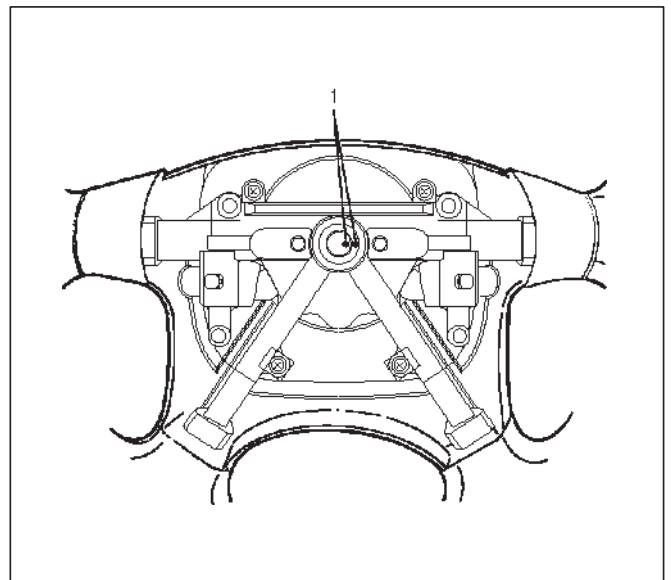
827RW073

**WARNING: THE INFLATOR MODULE SHOULD ALWAYS BE CARRIED WITH THE URETHANE COVER AWAY FROM YOUR BODY AND SHOULD ALWAYS BE LAID ON A FALT SURFACE WITH THE URETHANE SIDE UP. THIS IS NECESSARY BECAUSE A FREE SPACE IS PROVIDED TO ALLOW THE AIR CUSHION TO EXPAND IN THE UNLIKELY EVENT OF ACCIDENTAL DEPLOYMENT. OTHERWISE, PERSONAL INJURY MAY RESULT.**



827RW072

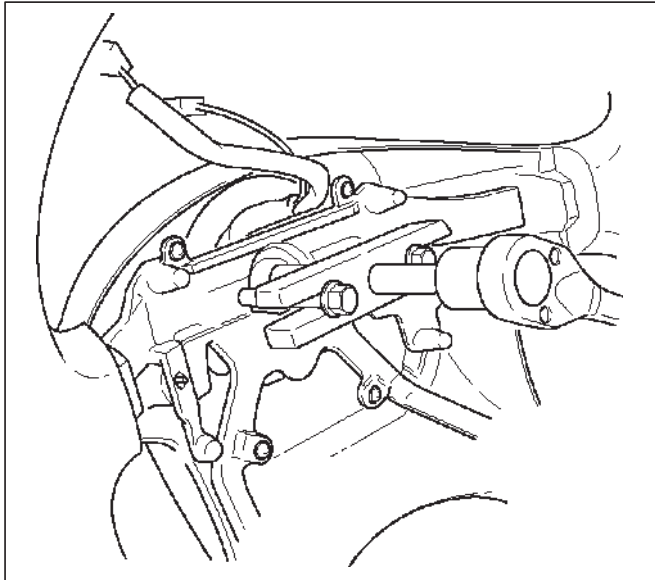
8. Remove the steering wheel fixing nut.
9. Apply a setting mark (1) across the steering wheel and shaft so parts can be reassembled in their original position.



430RW021

10. Move the front wheels to the straight ahead position, then use steering wheel remover J-29752 to remove the steering wheel.

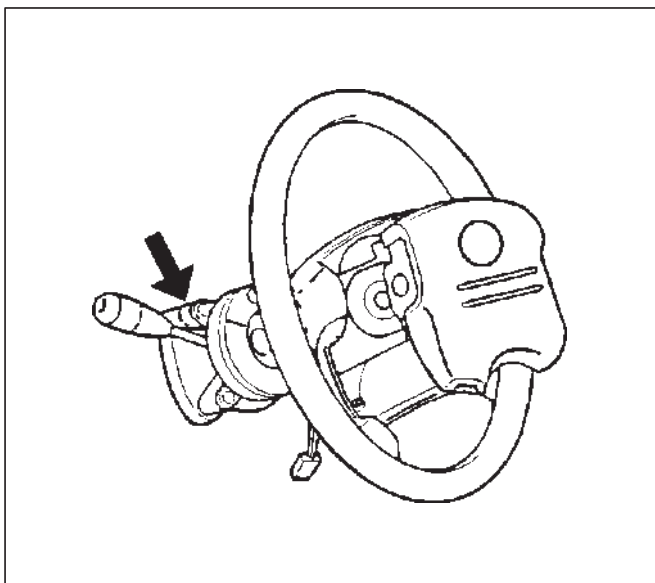
**CAUTION:** Never apply force to the steering wheel in direction of the shaft by using a hammer or other impact tools in an attempt to remove the steering wheel. The steering shaft is designed as an energy absorbing unit.



439RX005

11. Remove steering column cover.
12. Disconnect the wiring harness connectors located under the steering column.
13. Remove the combination switch assembly with SRS coil.

**NOTE:** The SRS coil is a part of the combination switch assembly, which can not be replaced separately. Therefore, be sure not to remove the SRS coil from the combination switch assembly.



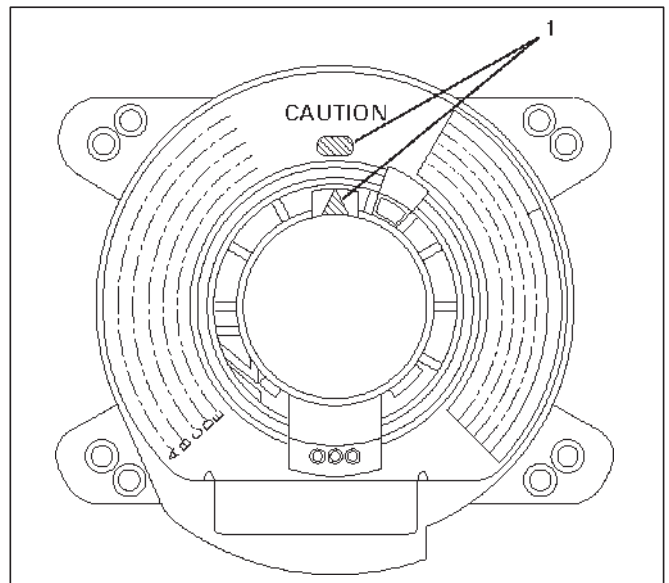
825RW288

14. Remove snap ring.
15. Remove cushion rubber.
16. Remove shift lock cable.
17. Disconnect the starter switch harness connector located under the steering column, then remove lock cylinder assembly.

## Installation

1. Install lock cylinder assembly.
2. Install shift lock cable.
3. Install cushion rubber.
4. Install snap ring.
5. Install Combination switch and SRS coil assembly. After installation of combination switch assembly, connect the combination switch wiring harness connector located under the steering column.
6. Turn the SRS coil counterclockwise to full, return about 3 turns and align the neutral mark.

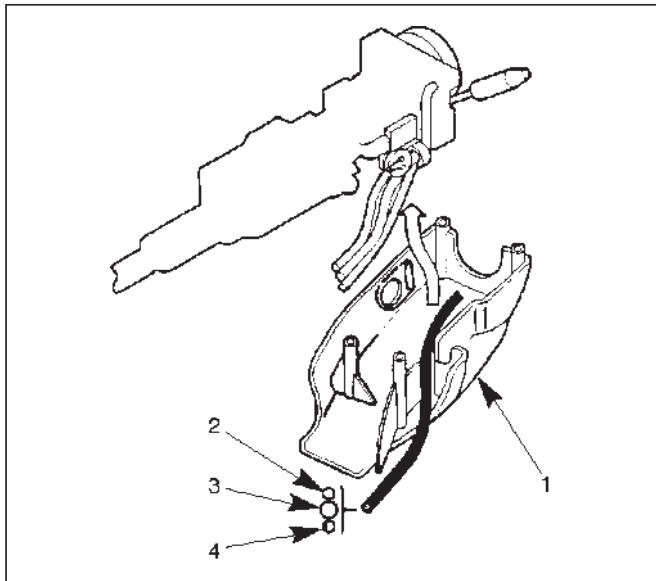
**CAUTION:** When turning the SRS coil counterclockwise to full, stop turning if resistance is felt. Forced further turning may damage to the cable in the SRS coil.



825RX027

## 2A-58 POWER-ASSISTED STEERING SYSTEM

- When installing the steering column cover, be sure to route each wire harness as illustrated so that the harnesses do not catch on any moving parts.



### Legend

- Steering Column Cover
- Starter Switch Harness
- Combination Switch Harness
- Inflator Module Harness

- Install steering wheel by aligning the setting marks made during removal.

**CAUTION:** Never apply force to the steering wheel in direction of the shaft by using a hammer or other impact tools in an attempt to remove the steering wheel. The steering shaft is designed as an energy absorbing unit.

- Tighten the steering wheel fixing nut to the specified torque.

**Torque: 34 N·m (25 lb ft)**

- Support inflator module and carefully connect the module connector and horn lead, then install inflator module.

**CAUTION:** Never use the air bag assembly from another vehicle. Use only the air bag assembly for "VX".

**NOTE:** Pass the lead wire through the tabs on the plastic cover (wire protector) of inflator to prevent lead wire from being pinched.

- Tighten fixing bolts to specified torque.

**Torque: 8.8 N·m (78 lb in)**

- Install instrument panel lower cover, then install the engine hood opening lever.

- Connect the yellow 3-way SRS connector located under the steering column.

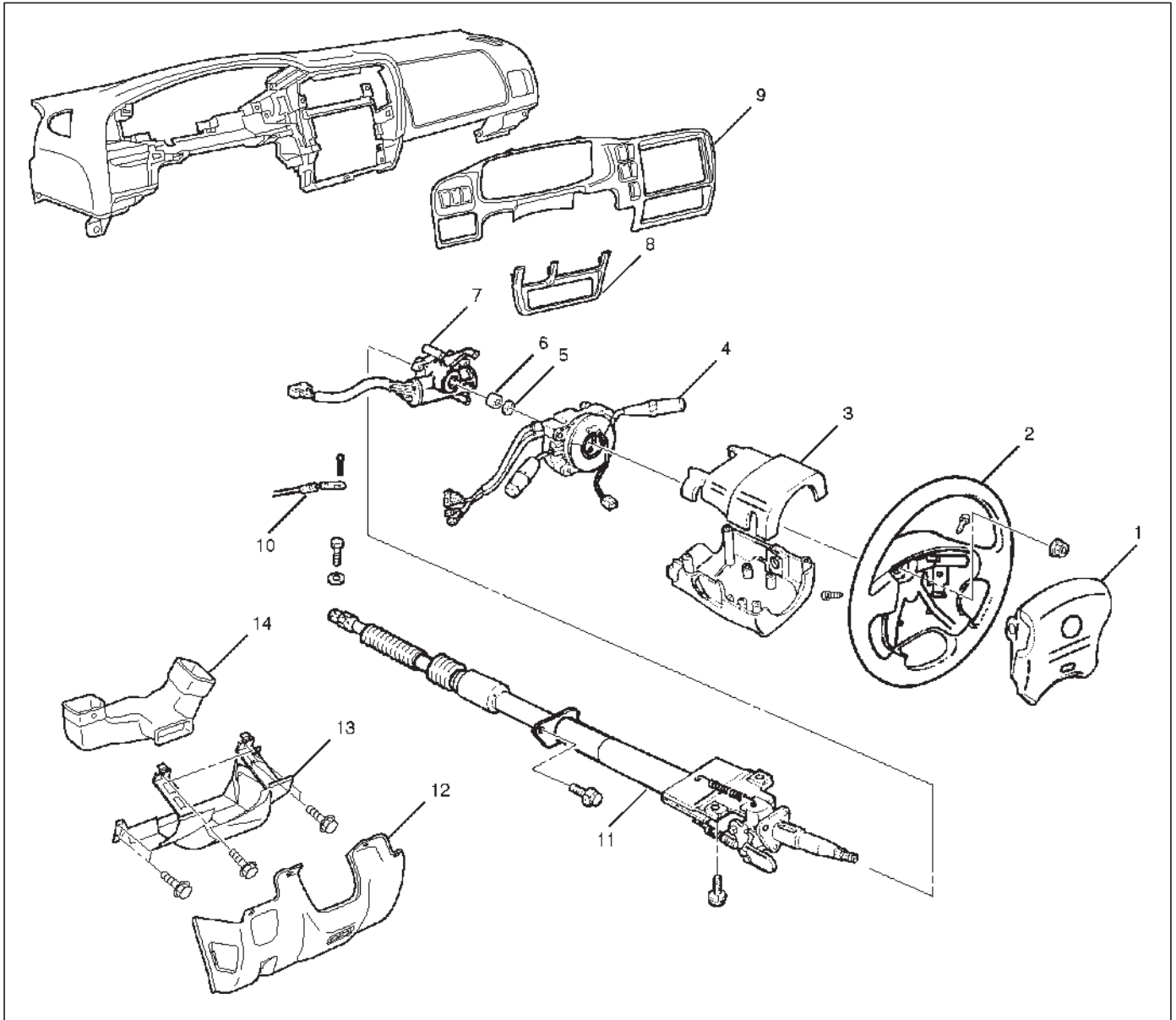
- Connect the battery "–" terminal cable.

## System Inspection

Turn the ignition switch to "ON" while watching warning light. The light should flash 7 times and then go off. If lamp does not operate correctly, refer to Restraints section .

## Steering Column

### Steering Column and Associated Parts



431RX007

#### Legend

- |  |  |
|--|--|
| (1) Inflator Module                          | (8) Lower Cluster Assembly               |
| (2) Steering Wheel                           | (9) Meter Cluster Assembly               |
| (3) Steering Column Cover                    | (10) Shift Lock Cable                    |
| (4) Combination Switch and SRS Coil Assembly | (11) Steering Column Assembly            |
| (5) Snap Ring                                | (12) Instrument Panel Lower Cover        |
| (6) Cushion Rubber                           | (13) Driver Knee Bolster (reinforcement) |
| (7) Lock Cylinder Assembly                   | (14) Duct                                |

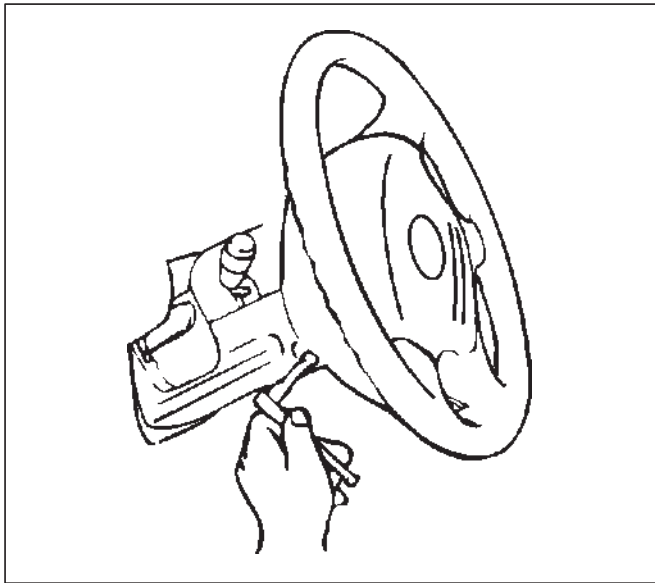
#### Removal

1. Turn the steering wheel so that the vehicle's wheels are pointing straight ahead.
2. Turn the ignition switch to "LOCK".
3. Disconnect the battery "-" terminal cable, and wait at least 5 minutes.
4. Disconnect the yellow 3-way SRS connector located under the steering column.

## 2A-60 POWER-ASSISTED STEERING SYSTEM

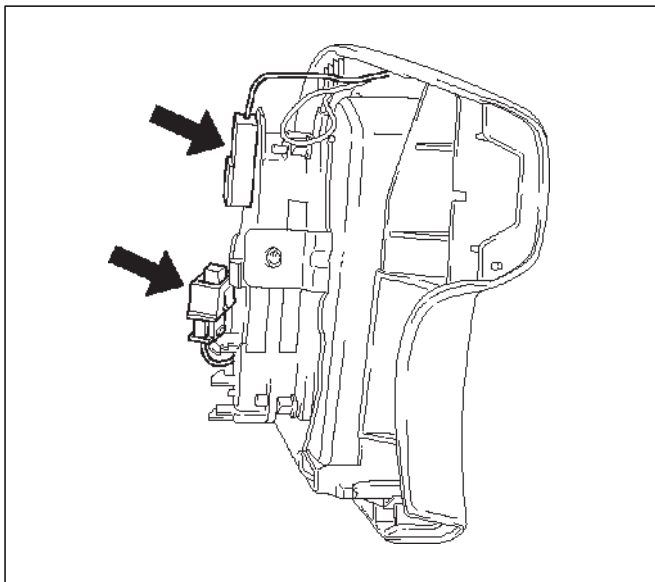
**CAUTION:** The wheel of the vehicle must be straight ahead and the steering column in the “LOCK” position before disconnecting the steering column from the steering gear. Failure to do so will cause the SRS coil assembly to become uncentered which will cause damage to the SRS coil assembly.

5. Loosen the inflator module fixing bolt from behind the steering wheel assembly using a TORX® driver or equivalent until the inflator module can be released from steering assembly.



827RW070

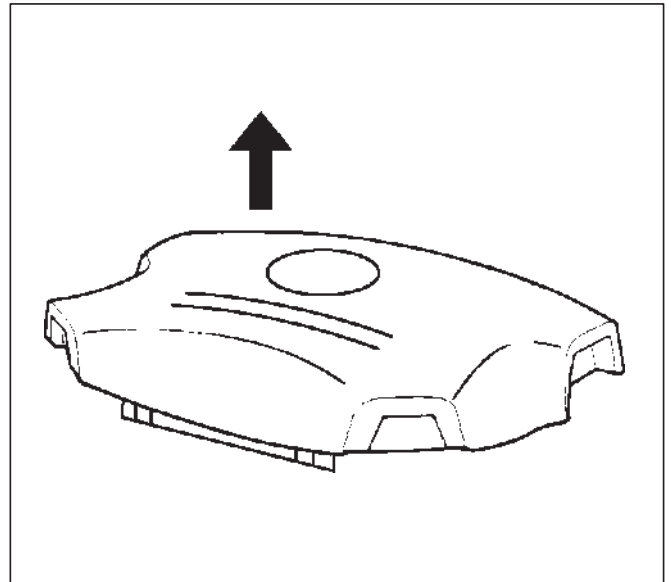
6. Disconnect the yellow 2-way SRS connector and horn lead located behind the inflator module.



827RW073

7. Remove inflator module.

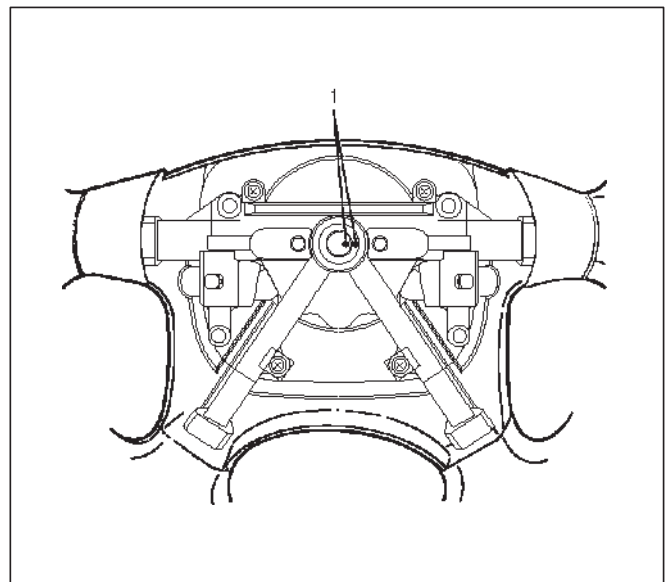
**WARNING:** THE INFLATOR MODULE SHOULD ALWAYS BE CARRIED WITH THE URETHANE COVER AWAY FROM YOUR BODY AND SHOULD ALWAYS BE LAID ON A FLAT SURFACE WITH THE URETHANE SIDE UP. THIS IS NECESSARY BECAUSE A FREE SPACE IS PROVIDED TO ALLOW THE AIR CUSHION TO EXPAND IN THE UNLIKELY EVENT OF ACCIDENTAL DEPLOYMENT. OTHERWISE, PERSONAL INJURY MAY RESULT.



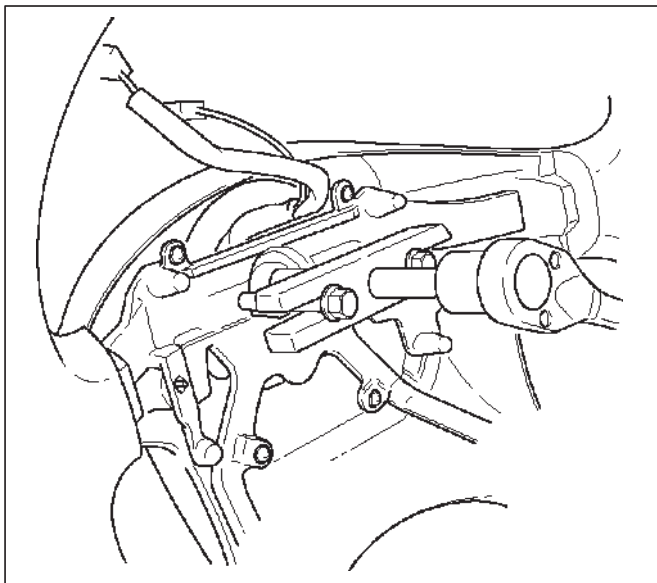
827RW072

8. Remove the steering wheel fixing nut.

9. Apply a setting mark (1) across the steering wheel and shaft so parts can be reassembled in their original position. Move the front wheels to the straight ahead position, then use steering wheel remover J-29752 to remove the steering wheel.



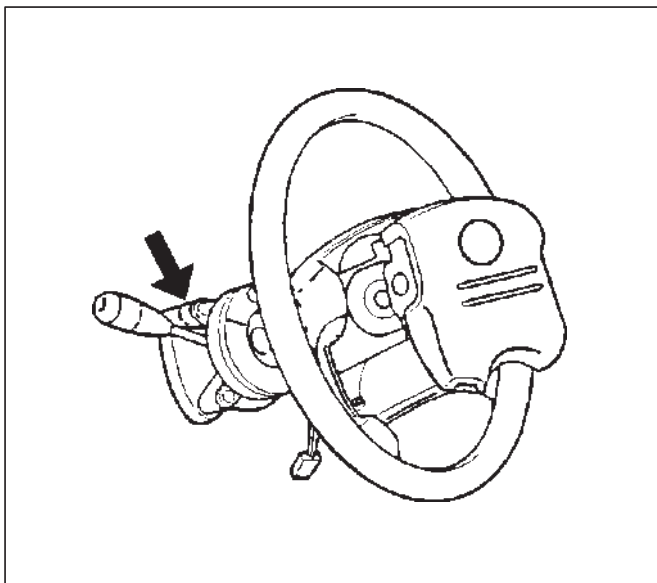
430RW021



430RX005

10. Remove the engine hood opening lever, then remove the instrument panel lower cover.
11. Remove lower cluster assembly.
12. Remove meter cluster assembly.
13. Remove driver knee bolster (reinforcement).
14. Remove duct.
15. Remove steering column cover.
16. Disconnect the wiring harness connectors located under the steering column.
17. Remove the combination switch assembly with SRS coil.

NOTE: SRS coil is a part of combination switch assembly, which can not be replaced singly. Therefore, be sure not to remove the SRS coil from the combination switch assembly.

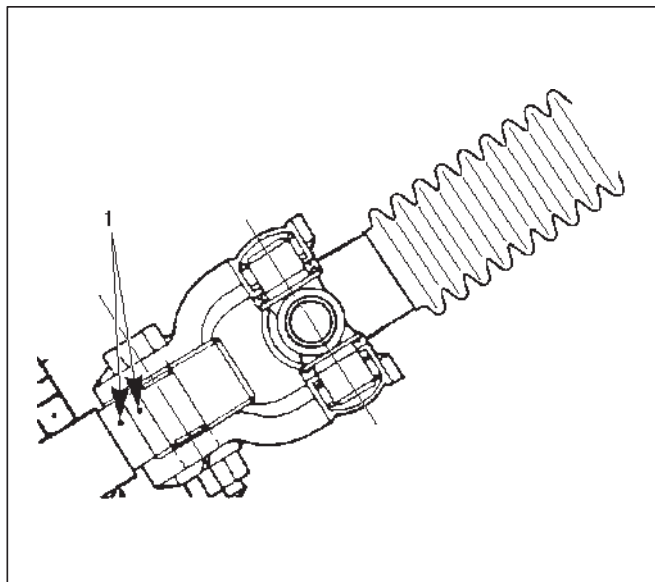


825RW288

18. Remove snap ring.
19. Remove cushion rubber.
20. Remove shift lock cable.

21. Disconnect the starter switch harness connector located under the steering column, then remove lock cylinder assembly.
22. Apply a setting mark (1) across the universal joint and steering shaft to reassemble the parts in their original position, then remove steering column assembly.

NOTE: A setting mark can be easily made if the shaft is withdrawn a little by loosening the steering shaft universal joint.



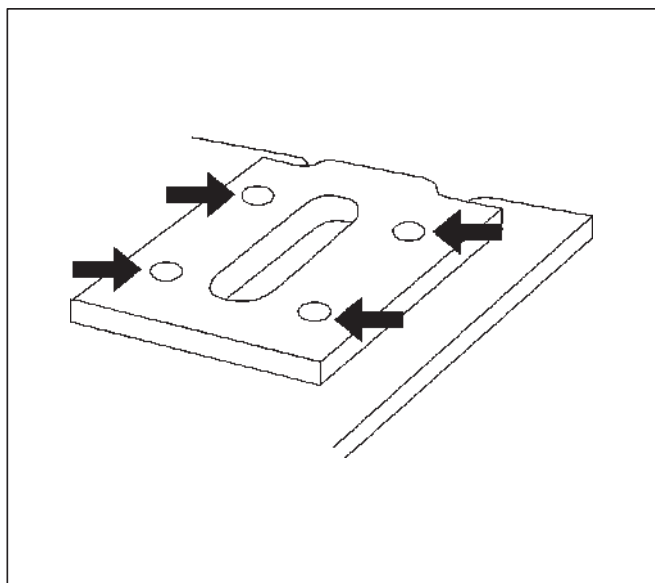
431RW004

### Inspection

If the abnormal conditions are found through inspection, replace the steering column assembly.

### Column Capsule

Check capsules on steering column bracket assembly; all must be securely seated in bracket slots and checked for any loose conditions when pushed or pulled by hand.

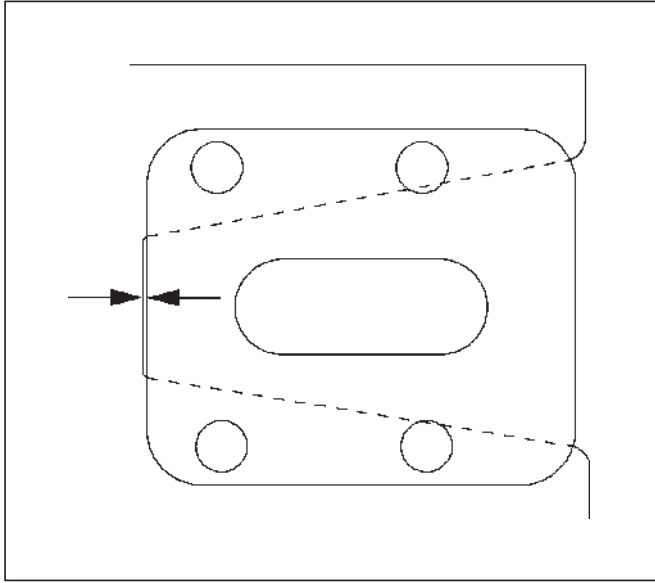


431RW030



## 2A-62 POWER-ASSISTED STEERING SYSTEM

Check clearance between capsule and bracket. It must be within 1 mm (0.039 in).

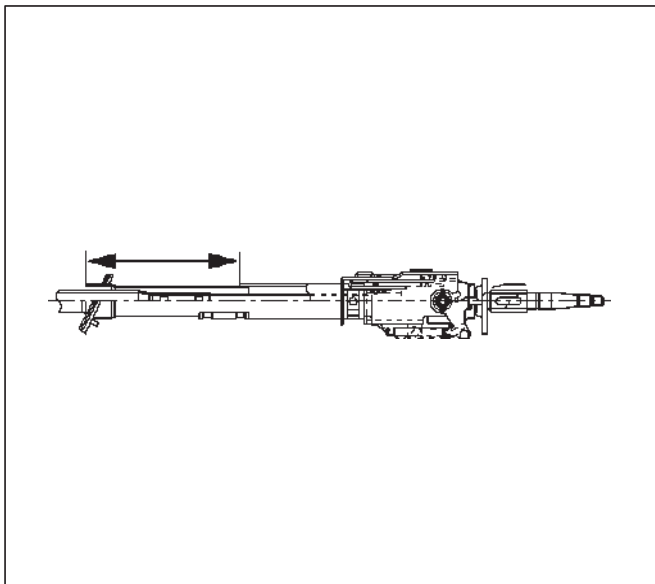


431RW031

### Column Tube

Check for collapse by measuring the distance as shown in the figure.

**Standard distance: 162.2–165.8 mm (6.386–6.528 in)**



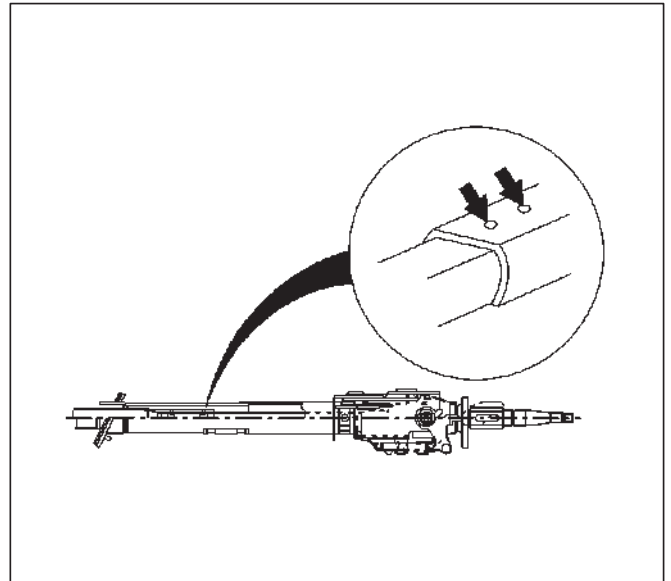
431RW032

### Column Universal Joint for Tilt Mechanism

If the resistance is felt when checked by rotate the joint, replace the steering column assembly.

### Sheared Injected Plastic Pin

Check the sheared injected plastic pins for any loose conditions or damage.

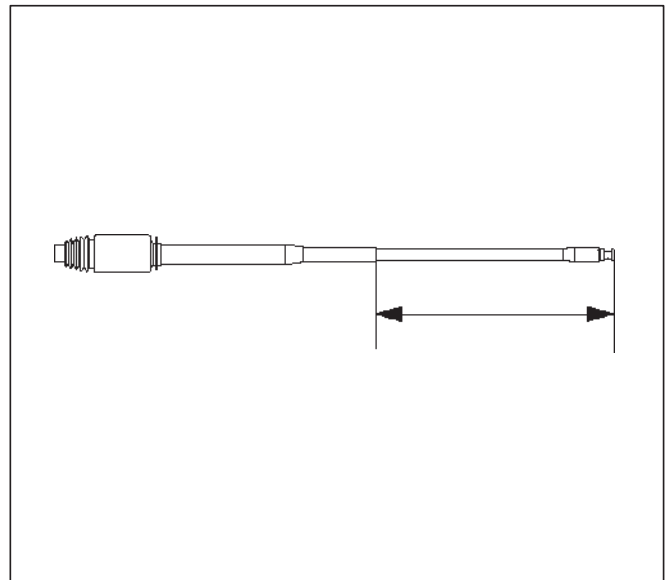


431RW033

### Shaft Length

Check the shaft length from the upper end of the slide joint to the end of the shaft. If column length is not in specifications, steering column should be replaced.

**Standard length: 271.2–273.2 mm (10.677–10.756 in)**



431RX003

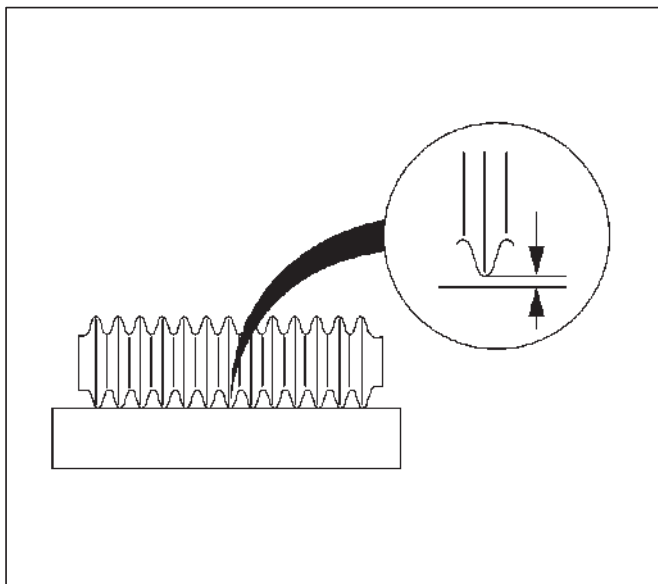
### Shaft Universal Joint (Lower End)

If the resistance is felt when checked by rotate the joint, replace the steering column assembly.

### Shaft Bellows Pipe

Check the shaft bellows pipe for bend by using straight edge. Measure the clearance between the bellows pipe and the straight edge (at center of the bellows pipe).

**Standard: Less than 1 mm (0.039 in)**



431RW035

### Tilt Mechanism

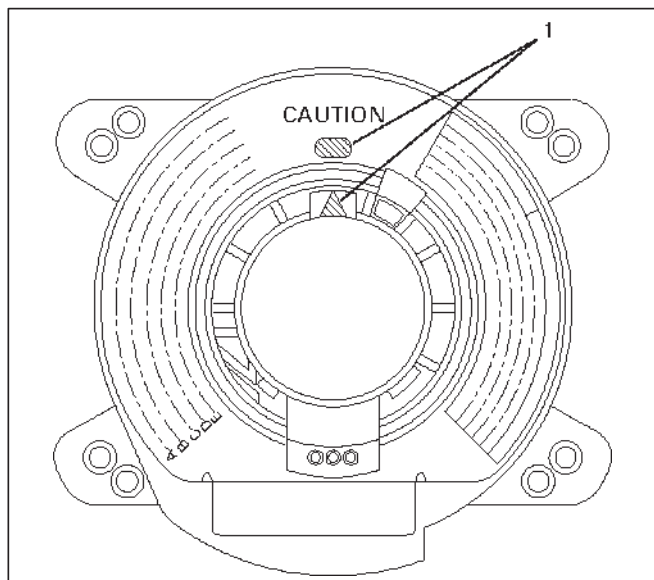
Tilt mechanism should moves smoothly. While locked the tilt mechanism, be sure the steering column latch securely by pushing the steering wheel upward and downward.

### Installation

1. Install steering column assembly.
2. Align the setting marks on the universal joint and steering shaft made during removal.
3. Tighten the steering column fixing bolt (dash panel) to the specified torque.  
**Torque: 19 N·m (14 lb ft)**
4. Tighten the steering column fixing bolt (pedal bracket) to the specified torque.  
**Torque: 17 N·m (13 lb ft)**
5. Tighten the universal joint to the specified torque.  
**Torque: 25 N·m (18 lb ft)**
6. Install lock cylinder assembly.
7. Install shift lock cable.
8. Install cushion rubber.
9. Install snap ring.
10. Install Combination switch and SRS coil assembly. After installation of combination switch assembly, connect the combination switch wiring harness connector located under the steering column.

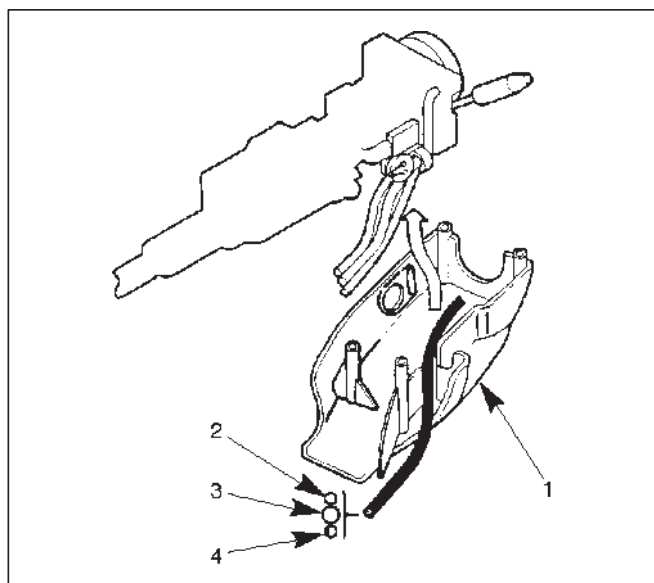
11. Turn the SRS coil counterclockwise to full, return about 3 turns and align the neutral mark.

**CAUTION: When turning the SRS coil counterclockwise to full, stop turning if resistance is felt. Forced further turning may damage to the cable in the SRS coil.**



825RX027

12. When installing the steering column cover, be sure to route each wire harness as illustrated so that the harnesses do not catch any moving parts.



825RW017

### Legend

- (1) Steering Column Cover
- (2) Starter Switch Harness
- (3) Combination Switch Harness
- (4) Inflator Module Harness

## 2A-64 POWER-ASSISTED STEERING SYSTEM

---

13. Install duct.
14. Install driver knee bolster (reinforcement).
15. Install meter cluster assembly.
16. Install lower cluster assembly.
17. Install instrument panel lower cover, then install engine hood opening lever.
18. Install steering wheel and align the setting marks made when removing.

**CAUTION: Never apply force to the steering wheel in direction of the shaft by using a hammer or other impact tools in an attempt to remove the steering wheel. The steering shaft is designed as an energy absorbing unit.**

19. Tighten the steering wheel fixing nut to the specified torque.

**Torque: 34 N·m (25 lb ft)**

20. Support the module and carefully connect the module connector and horn lead then install inflator module.

**CAUTION: Never use the air bag assembly from another vehicle. Use only the air bag assembly for "VX".**

NOTE: Pass the lead wire through the tabs on the plastic cover (wire protector) of inflator to prevent lead wire from being pinched.

21. Tighten bolts to specified torque.

**Torque: 8.8 N·m (78 lb in)**

22. Connect the yellow 3-way SRS connector located under the steering column.
23. Connect the battery "–" terminal cable.

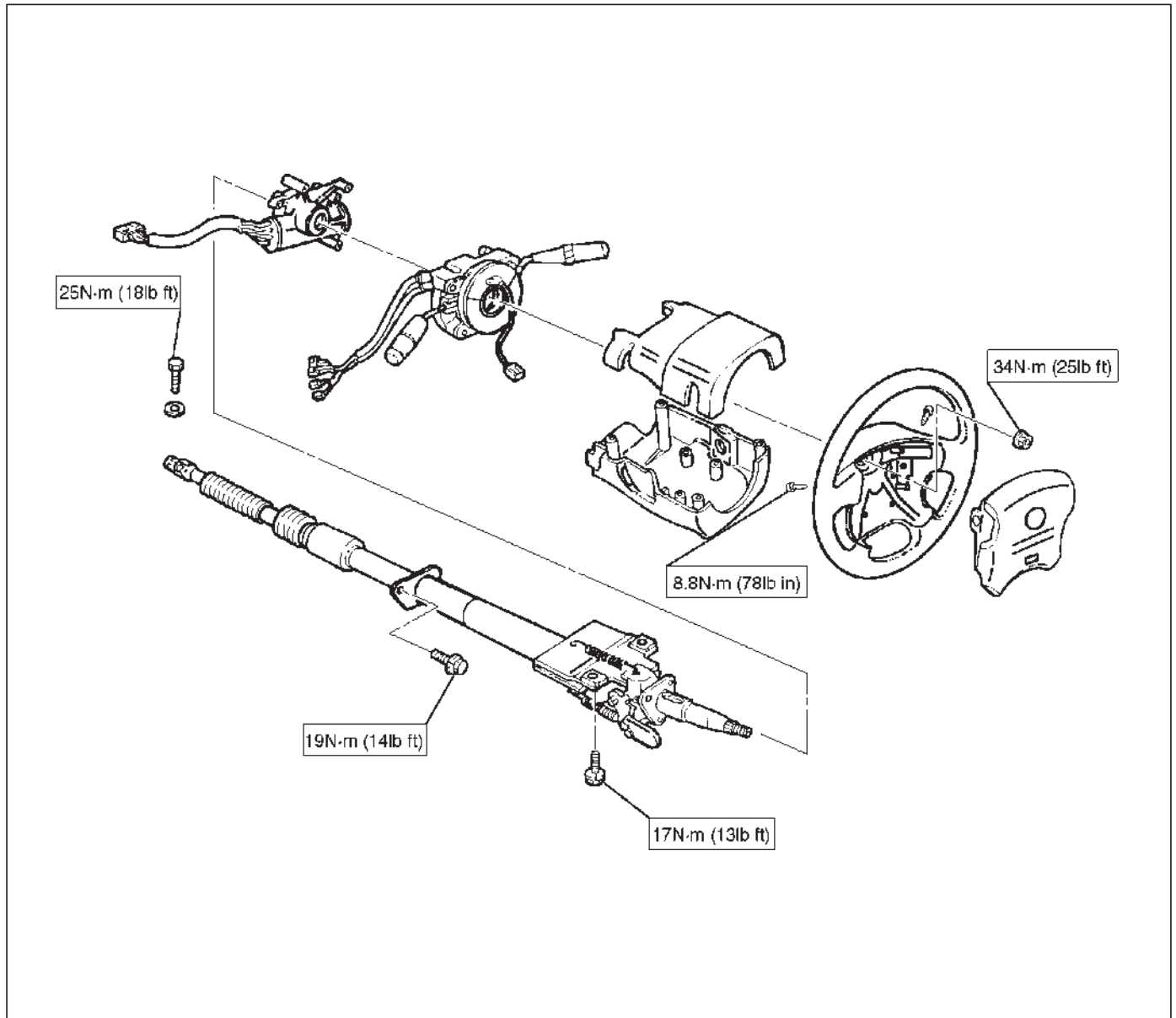
### System Inspection

Turn the ignition switch "ON" while watching warning light. The light should flash 7 times and then go off. If lamp does not operate correctly, refer to Restraints section.

# Supplemental Restraint System Steering Wheel & Column and Associated Parts

## Main Data and Specifications

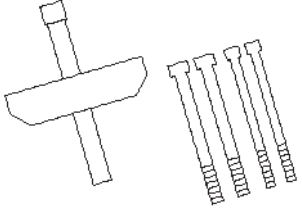
### Torque Specifications



## 2A-66 POWER-ASSISTED STEERING SYSTEM

---

### Special Tools

ILLUSTRATION	TOOL NO. TOOL NAME
 <p>901R5294</p>	<p><b>J-29752</b> Steering wheel remover</p>

VEHICROSS

# SUSPENSION

## CONTENTS

Front Suspension .....	3C
Rear Suspension .....	3D
Wheel and Tire System .....	3E

## FRONT SUSPENSION

### CONTENTS

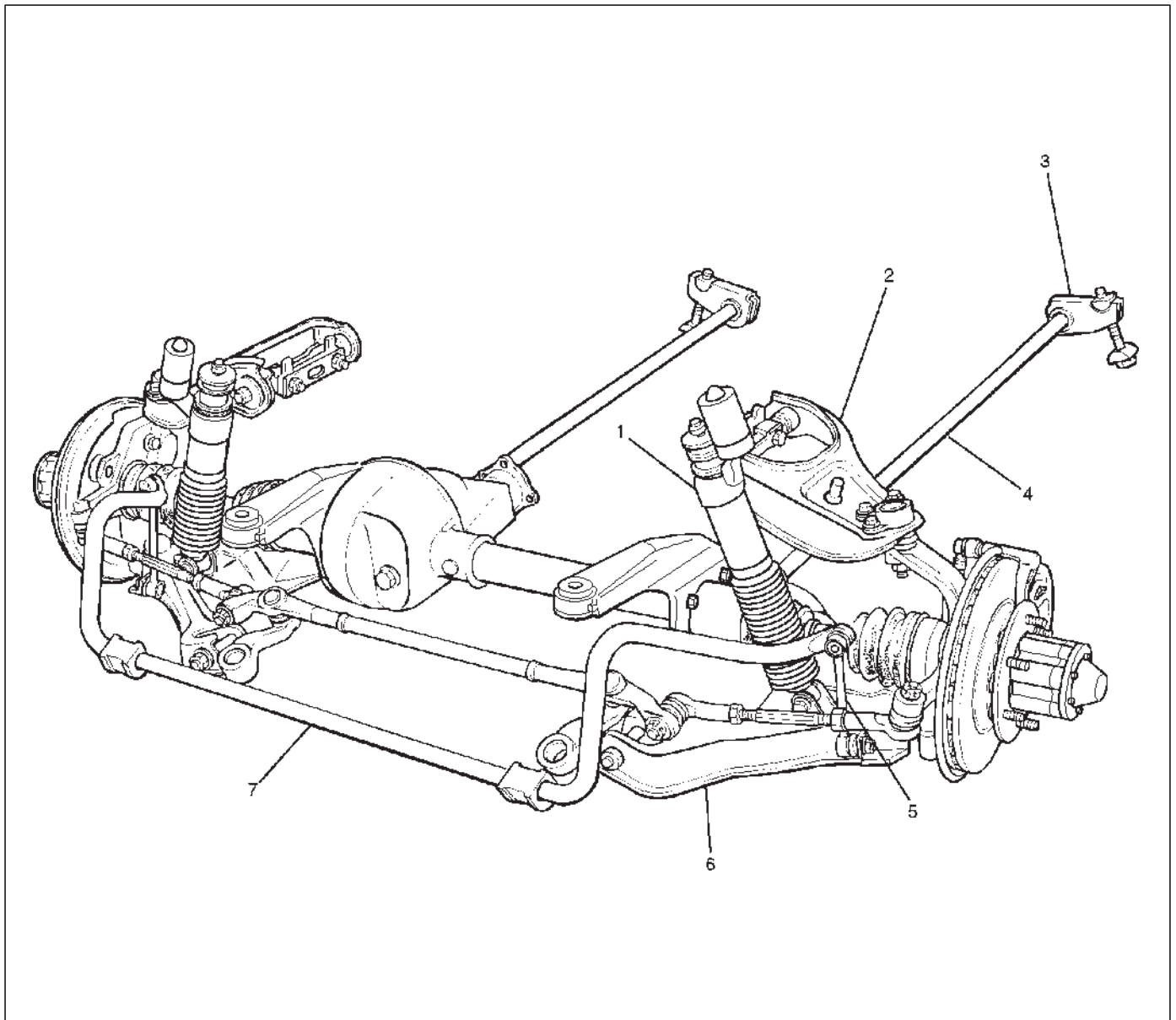
Service Precaution .....	3C-1	Upper Control Arm .....	3C-15
General Description .....	3C-2	Upper Control Arm and Associated Parts .	3C-15
General Diagnosis .....	3C-3	Removal .....	3C-15
Shock Absorber .....	3C-6	Inspection and Repair .....	3C-16
Shock Absorber and Associated Parts ....	3C-6	Installation .....	3C-17
Removal .....	3C-6	Lower Control Arm .....	3C-19
Inspection and Repair .....	3C-7	Lower Control Arm and Associated Parts .	3C-19
Installation .....	3C-7	Removal .....	3C-19
Stabilizer Bar .....	3C-8	Inspection and Repair .....	3C-20
Stabilizer Bar and Associated Parts ....	3C-8	Installation .....	3C-21
Removal .....	3C-8	Upper Ball Joint .....	3C-22
Inspection and Repair .....	3C-8	Upper Ball Joint and Associated Parts ....	3C-22
Installation .....	3C-8	Removal .....	3C-22
Torsion Bar .....	3C-9	Inspection and Repair .....	3C-23
Torsion Bar and Associated Parts ....	3C-9	Installation .....	3C-23
Removal .....	3C-9	Lower Ball Joint .....	3C-24
Inspection and Repair .....	3C-10	Lower Ball Joint and Associated Parts ....	3C-24
Installation .....	3C-10	Removal .....	3C-24
Knuckle .....	3C-12	Inspection and Repair .....	3C-25
Knuckle and Associated Parts .....	3C-12	Installation .....	3C-25
Removal .....	3C-12	Main Data and Specifications .....	3C-26
Inspection and Repair .....	3C-13	Special Tools .....	3C-27
Installation .....	3C-13		

### Service Precaution

**WARNING: THIS VEHICLE HAS A SUPPLEMENTAL RESTRAINT SYSTEM (SRS). REFER TO THE SRS COMPONENT AND WIRING LOCATION VIEW IN ORDER TO DETERMINE WHETHER YOU ARE PERFORMING SERVICE ON OR NEAR THE SRS COMPONENTS OR THE SRS WIRING. WHEN YOU ARE PERFORMING SERVICE ON OR NEAR THE SRS COMPONENTS OR THE SRS WIRING, REFER TO THE SRS SERVICE INFORMATION. FAILURE TO FOLLOW WARNING COULD RESULT IN POSSIBLE AIR BAG DEPLOYMENT, PERSONAL INJURY, OR OTHERWISE UNNEEDED SRS SYSTEM REPAIRS.**

**CAUTION: Always use the correct fastener in the proper location. When you replace a fastener, use ONLY the exact part number for that application. ISUZU will call out those fasteners that require a replacement after removal. ISUZU will also call out the fasteners that require thread lockers or thread sealant. UNLESS OTHERWISE SPECIFIED, do not use supplemental coatings (Paints, greases, or other corrosion inhibitors) on threaded fasteners or fastener joint interfaces. Generally, such coatings adversely affect the fastener torque and the joint clamping force, and may damage the fastener. When you install fasteners, use the correct tightening sequence and specifications. Following these instructions can help you avoid damage to parts and systems.**

## General Description



C03RX001

### Legend

- |                        |                       |
|------------------------|-----------------------|
| (1) Shock Absorber     | (4) Torsion Bar       |
| (2) Upper Control Arm  | (5) Link              |
| (3) Height Control Arm | (6) Lower Control Arm |
|                        | (7) Stabilizer Bar    |

The front suspension is designed to allow each wheel to compensate for changes in the road surface level without greatly affecting the opposite wheel. Each wheel is independently connected to the frame by a steering knuckle, ball joint assemblies, and upper and lower control arms. The front wheels are held in proper relationship to each other by two outer track rods which are connected to steering arms on the knuckles, and to a center track rod.

All models have a front suspension system consisting of control arms, stabilizer bar, shock absorbers and torsion bars. The front end of the torsion bar is attached to the lower control arm. The rear of the torsion bar is mounted

into a height control arm at the crossmember. Vehicle trim height is controlled by adjusting this arm.

The shock absorber is gas-sealed type and it has reservoir tank.

Shock absorbers are mounted between the brackets on the frame and the lower control arms. The lower portion of each shock absorber is attached to the lower control arm. The upper portion of each shock absorber extends through a frame bracket and is secured with two rubber bushings, four retainers and nuts.

Ball joint assemblies are bolted to the outer end of the upper and lower control arm and are attached to the steering knuckle.

The inner ends of the upper control arm have pressed in bushings. Bolts, passing through the bushing, attach the control arm to the frame. The inner ends of the lower control arm are attached to the frame by bolts passing through the bushings, which are pressed in the frame.

Side roll of the front suspension is controlled by a spring steel stabilizer bar. It is mounted in rubber bushings, which are held to the crossmember by brackets. The ends of the stabilizer bar are connected to the lower control arms by links.

### General Diagnosis

Condition	Possible cause	Correction
Vehicle Pulls	Mismatched or uneven tires.	Replace tire.
	Tires not adequately inflated.	Adjust tire pressure.
	Broken or sagging springs.	Replace springs.
	Radial tire lateral force.	Replace tire.
	Improper wheel alignment.	Adjust wheel alignment.
	Brake dragging in one wheel.	Repair brake.
	Loose, bent or broken front or rear suspension parts.	Tighten or replace the appropriate suspension part(s).
	Faulty shock absorbers.	Replace shock absorbers.
Abnormal or Excessive Tire Wear	Sagging or broken spring.	Replace spring.
	Tire out of balance.	Balance or replace tire.
	Improper wheel alignment.	Check front end alignment.
	Faulty shock absorber.	Replace shock absorber.
	Hard driving.	Replace tire.
	Overloaded vehicle.	Replace tire and reduce load.
	Tires not rotated periodically.	Replace or rotate tire.
	Worn or loose road wheel bearings.	Replace wheel bearing.
	Wobbly wheel or tires.	Replace wheel or tire.
	Tires not adequately inflated.	Adjust the pressure.
Wheel Hop	Blister or bump on tire.	Replace tire.
	Improper shock absorber operation.	Replace shock absorber.
Shimmy, Shake or Vibration	Tire or wheel out of balance.	Balance wheels or replace tire/or wheel.
	Loose wheel bearings.	Replace wheel bearing.
	Worn steering linkage ball joints.	Replace ball joints.
	Worn upper or lower ball joints.	Replace ball joints.
	Excessive wheel runout.	Repair or replace wheel and/or tire.
	Blister or bump on tire.	Replace tire.
	Excessive loaded radial runout of tire/wheel assembly.	Replace tire or wheel.
	Improper wheel alignment.	Check wheel alignment.
	Loose or worn steering linkage.	Tighten or replace steering linkage.
	Loose steering gear.	Tighten housing bolts.
	Tires not adequately inflated.	Adjust tire pressure.
	Loose, bent or broken front or rear suspension parts.	Tighten or replace the appropriate suspension parts.
	Faulty shock absorber.	Replace shock absorber.
Hub bearing preload misadjustment.	Adjust preload.	



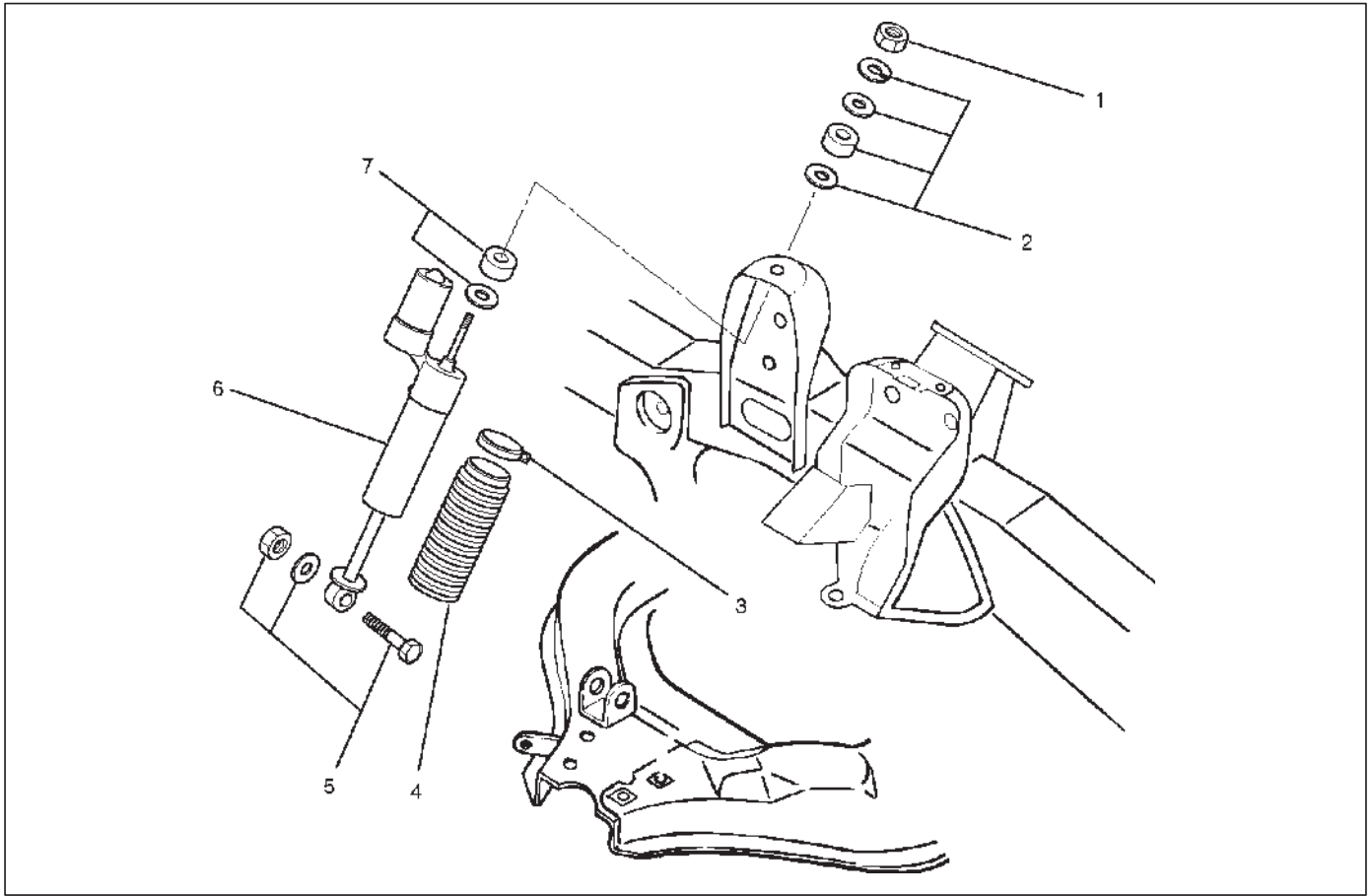
**3C-4 FRONT SUSPENSION**

Condition	Possible cause	Correction
Hard Steering	Bind in steering linkage ball studs, upper or lower ball joint.	Replace ball joint.
	Improper wheel alignment.	Check wheel alignment.
	Steering gear misadjustment.	Check and adjust pinion torque.
	Tire not adequately inflated.	Inflate tires to proper pressure.
	Bind in steering column or shaft.	Repair or replace.
	Improper power steering system operation.	Repair or replace. Refer to Steering section.
Too Much Play In Steering	Wheel bearings worn.	Replace wheel bearings.
	Loose steering gear or linkage.	Retighten or repair.
	Steering gear misadjustment.	Inspect and adjust steering gear preload.
	Worn or loose steering shaft universal joint.	Retighten or replace steering shaft.
	Worn steering linkage ball joints.	Replace ball joints.
	Worn upper or lower end ball joints.	Replace ball joints.
Poor Steering Wheel Returnability	Bind in steering linkage ball joints.	Replace ball joints.
	Bind in upper or lower ball joints.	Replace ball joints.
	Bind in steering column and shaft.	Repair or replace.
	Bind in steering gear.	Check and repair steering gear.
	Improper wheel alignment.	Adjust wheel alignment.
	Tires not adequately inflated.	Adjust tire pressure.
	Loose steering wheel nut.	Retighten.
	Worn wheel bearing.	Replace.
Abnormal Noise	Worn, sticky or loose upper or lower ball joint, steering linkage ball joints or drive axle joints.	Replace.
	Faulty shock absorbers.	Replace.
	Worn upper or lower control arm bushing.	Replace.
	Loose stabilizer bar.	Retighten bolts or replace bushings.
	Loose wheel nuts.	Tighten nuts. Check for elongated wheel nut holes. Replace wheel if required.
	Loose suspension bolts or nuts.	Retighten suspension bolts or nuts.
	Broken or otherwise damaged wheel bearings.	Replace wheel bearing.
	Broken suspension springs.	Replace spring.
	Loose steering gear.	Retighten mounting bolt.
	Faulty steering gear.	Check and adjust steering gear.

Condition	Possible cause	Correction
Wandering or Poor Steering Stability	Mismatched or unevenly worn tires.	Replace tire or inflate tires to proper pressure.
	Loose steering linkage ball joints.	Replace ball joints.
	Faulty shock absorbers.	Replace shock absorber.
	Loose stabilizer bar.	Tighten or replace stabilizer bar or bushings.
	Broken or sagging springs.	Replace spring (pairs).
	Steering gear misadjustment.	Check or adjust steering gear.
	Improper wheel alignment.	Adjust wheel alignment.
Erratic Steering When Braking	Worn wheel bearings.	Replace wheel bearings.
	Broken or sagging springs.	Replace spring (pairs).
	Leaking caliper.	Repair or replace caliper.
	Warped discs.	Replace brake disc.
	Badly worn brake pads.	Replace brake pads.
	Tires are inflated unequally.	Inflate tires to proper pressure.
Low or Uneven Trim Height	Broken or sagging springs.	Replace springs (In pairs).
	Vehicle overloaded.	Reduce load.
	Incorrect springs.	Adjust or replace torsion bar.
Suspension Bottoms	Vehicle overloaded.	Reduce load.
	Faulty shock absorber.	Replace shock absorber.
	Incorrect, broken or sagging springs.	Replace springs.
Body Leans	Loose stabilizer bar.	Tighten stabilizer bar bolts or replace bushings.
	Faulty shock absorber, struts or mounting.	Replace shock absorber.
	Broken or sagging springs.	Replace springs (In pairs).
	Vehicle overloaded.	Reduce load.
Cupped Tires	Worn wheel bearings.	Replace wheel bearing.
	Excessive tire or wheel run out.	Replace tire or wheel.
	Worn ball joints.	Replace ball joints.
	Tire out of balance.	Adjust tire balance.

## Shock Absorber

### Shock Absorber and Associated Parts



450RX004

#### Legend

- |                               |                               |
|-------------------------------|-------------------------------|
| (1) Nut                       | (4) Boot                      |
| (2) Rubber Bushing and Washer | (5) Bolt, Nut and Washer      |
| (3) Boot Band                 | (6) Shock Absorber            |
|                               | (7) Rubber Bushing and Washer |

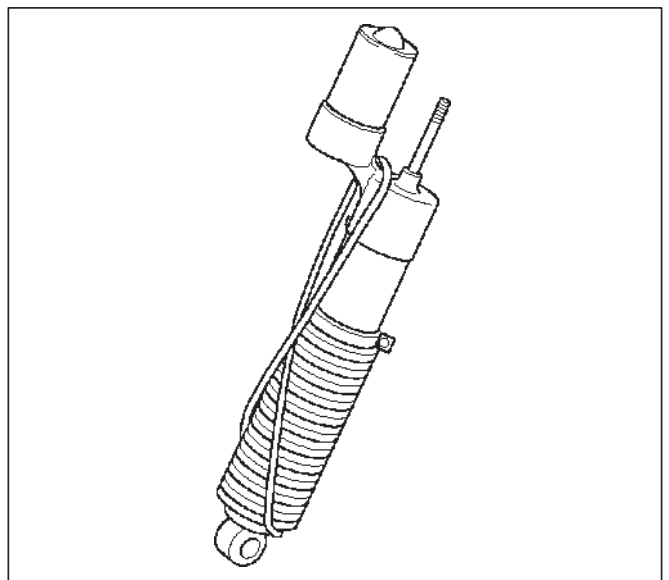
### Removal

#### CAUTION:

- This shock absorber is sealed with high pressure gas, so it is hard to compress and it expands very fast.
- This shock absorber has aluminum body. Never insert bar between shock absorber and its bracket to avoid damage.

1. Raise the vehicle and support it with suitable safety stands.
2. Remove wheel and tire assembly. Refer to Wheel Replacement in this section.
3. Compress shock absorber by jacking up lower control arm.
4. Fix the compressed shock absorber with strong plastic band or cable.

**CAUTION:** Do not use metal chain or wire. Because aluminum body of the shock absorber may be damaged. Use plastic band or cable.



450RX002

5. Remove the fixing nut, rubber bushing and washer (Upper side).
6. Lower the control arm slowly until the stud of the shock absorber can be pulled out from bracket.

**CAUTION:** During the work, be sure that the plastic band is not come off or broken. Be careful not to pinched your hand with the expanding shock absorber and bracket.

7. Remove fixing bolt, nut and washer (Lower side), then remove the shock absorber.
8. Remove rubber bushing and washer.
9. Hold the shock absorber with a press, remove the plastic band, then expand shock absorber.
10. Remove boot band and boot.

### Inspection and Repair

Make necessary correction or parts replacement if wear, damage, corrosion or any other abnormal conditions are found through inspection.

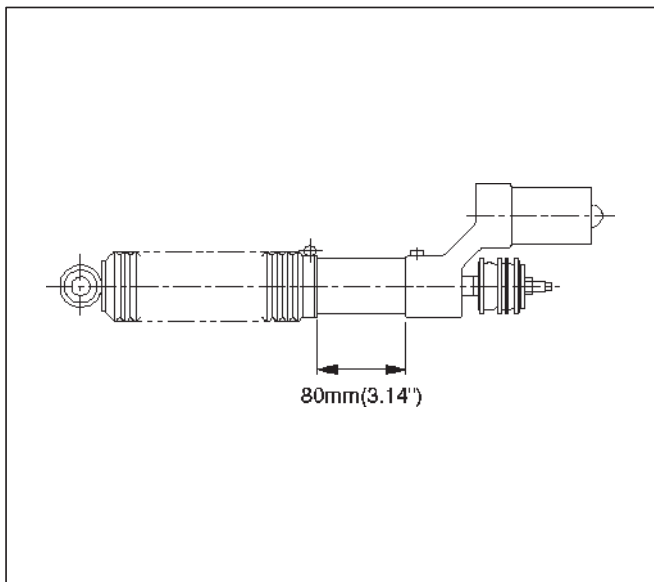
Check the following parts:

- Shock absorber
- Rubber bushing
- Boot
- Boot band

**CAUTION:** If the boot is deformed, replace it even if it has no crack or damage.

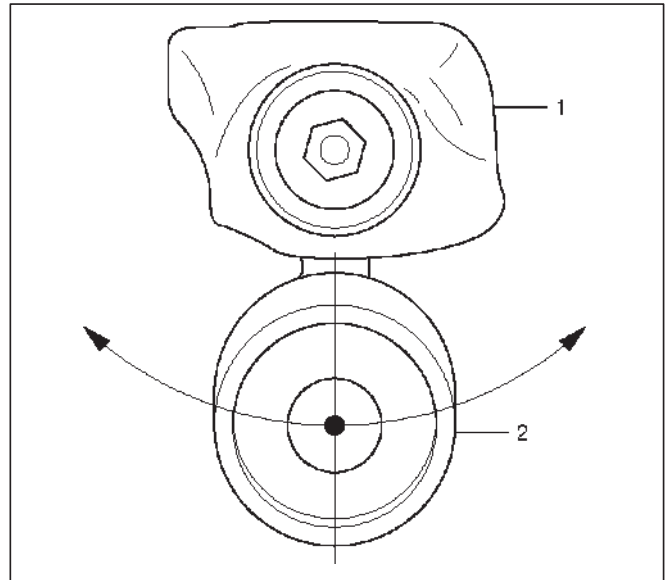
### Installation

1. Install boot and boot band to specified position.



2. Compress the shock absorber with a press, fix the compressed shock absorber with strong plastic band or cable.
3. Install rubber bushing and washer.
4. Install shock absorber.

**CAUTION:** The position of reservoir tank(2) must be center of frame bracket(1).



5. Install fixing bolt, nut and washer (Lower side), then tighten the bolt and nut finger-tight.
6. Remove the plastic band from shock absorber.
7. Install rubber bushing, washer and fixing nut (Upper side). Tighten the nut finger-tight.
8. Install wheel and tire assembly.
9. Retighten the fixing bolt and nut to specified torque after the vehicle is at curb height.

**Torque:**

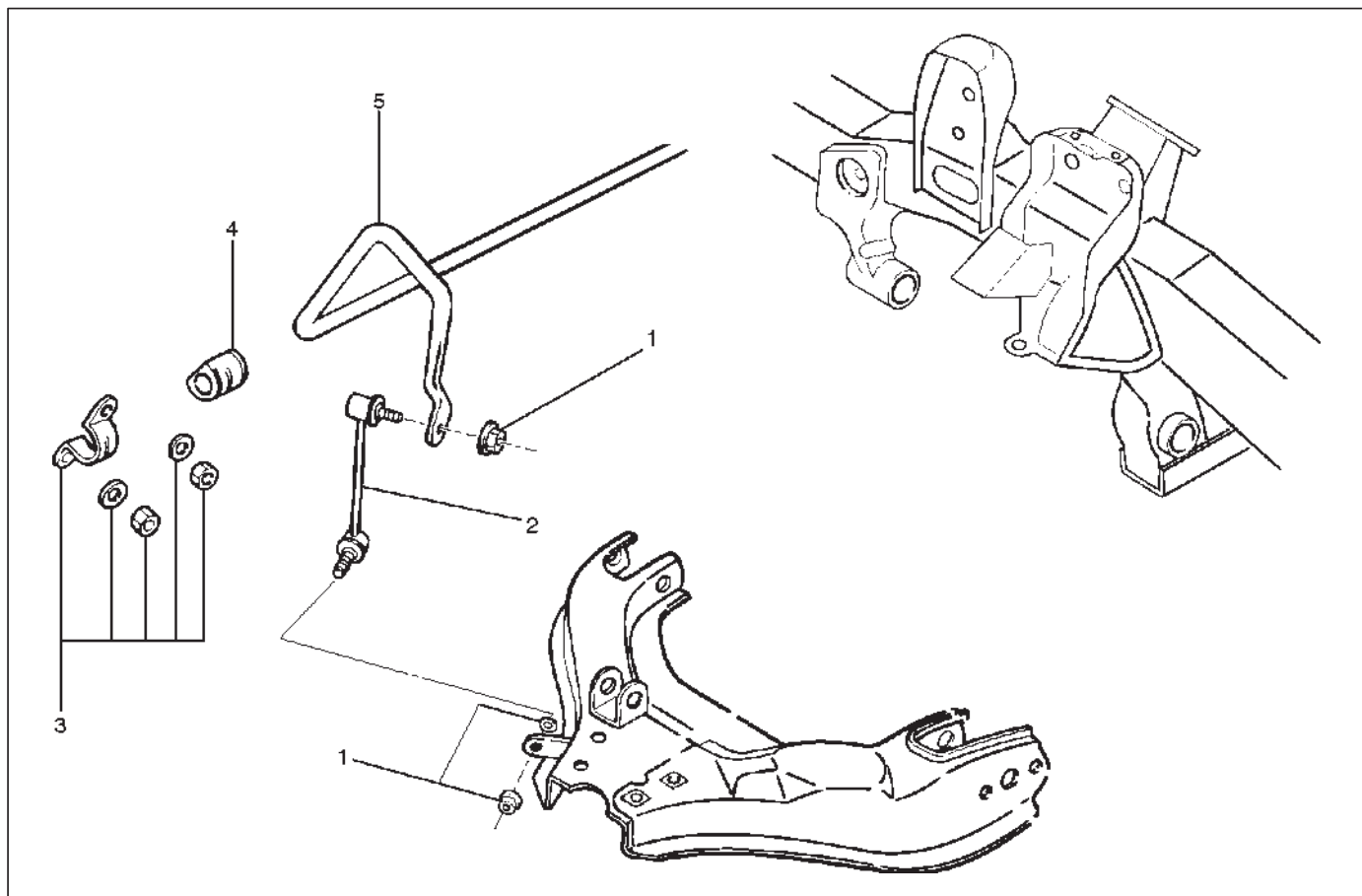
**Upper nut: 20 N·m (14 lb ft)**

**Lower bolt and nut: 82 N·m (61 lb ft)**

**CAUTION:** Be sure that the boot is installed without deformation.

## Stabilizer Bar

### Stabilizer Bar and Associated Parts



410RS002

#### Legend

- (1) Nut and Washer
- (2) Link

- (3) Bracket
- (4) Rubber Bushing
- (5) Stabilizer Bar

### Removal

1. Raise the vehicle and support the frame with suitable safety stands.
2. Remove the stone guard.
3. Remove wheel and tire assembly. Refer to Wheel Replacement in this section.
4. Remove nut and washer.

**CAUTION: Be careful not to break the ball joint boot.**

5. Remove link.
6. Remove bracket.
7. Remove stabilizer bar.
8. Remove rubber bushing.

### Inspection and Repair

Make necessary correction or parts replacement if wear, damage, corrosion or any other abnormal conditions are found through inspection.

Check the following parts:

- Stabilizer bar
- Rubber bushing
- Link ball joint

### Installation

1. Install rubber bushing.
2. Install stabilizer bar.
3. Install bracket, then tighten it to the specified torque.

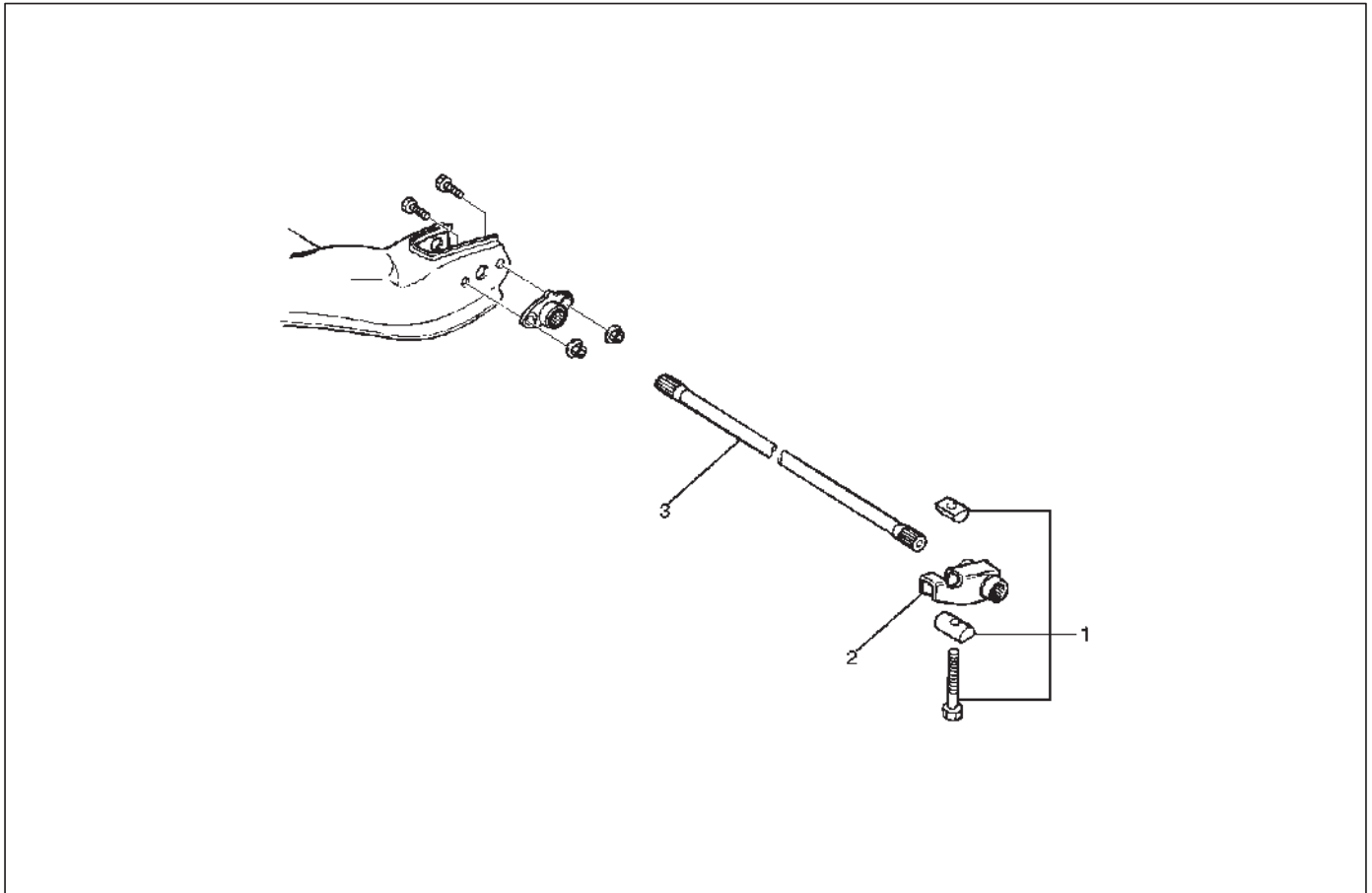
**Torque: 22 N·m (16 lb ft)**

4. Install link.
5. Install nut and washer, then tighten the nut to the specified torque.

**Torque: 50 N·m (37 lb ft)**

## Torsion Bar

### Torsion Bar and Associated Parts



410RS003

#### Legend

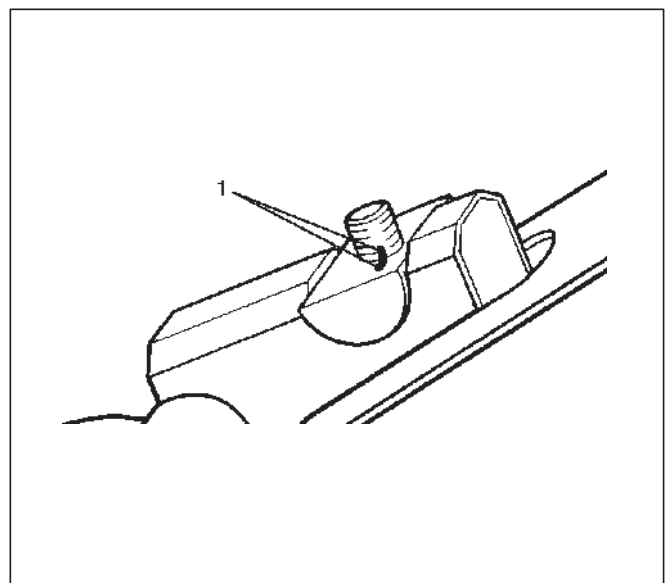
(1) Adjust Bolt, End Piece and Seat

(2) Height Control Arm

(3) Torsion Bar

### Removal

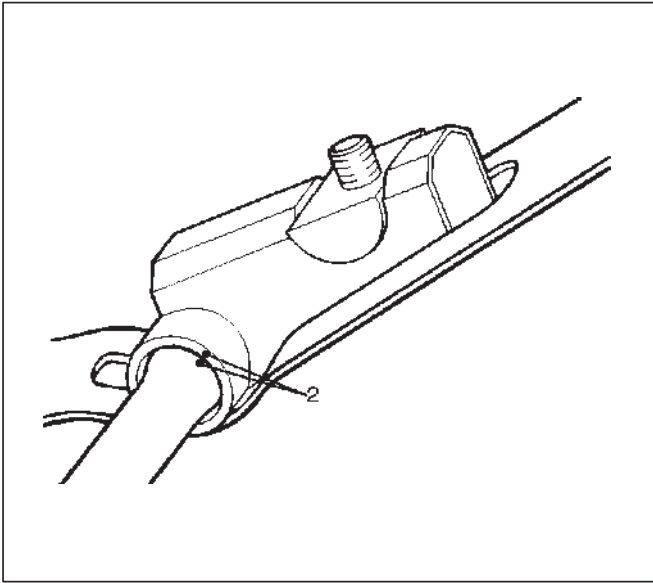
1. Raise the vehicle and support the frame with suitable safety stands.
2. Apply the setting marks(1) to the adjust bolt and end piece, then remove adjust bolt, end piece and seat.



410RS004

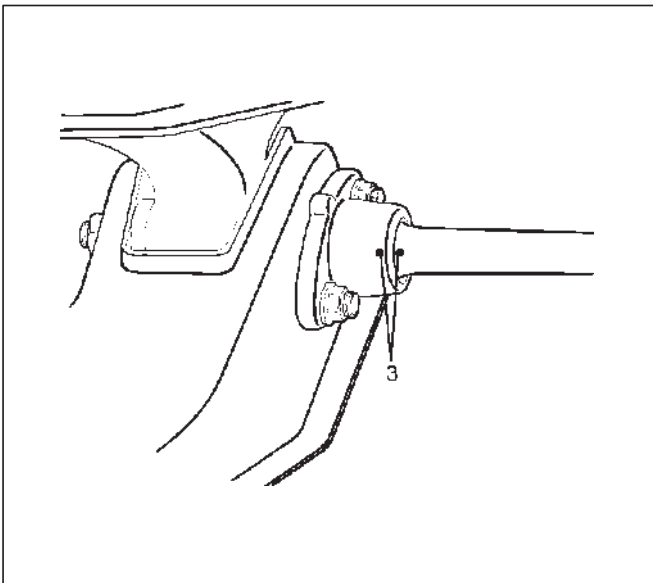
## 3C-10 FRONT SUSPENSION

3. Apply the setting marks(2) to the height control arm and torsion bar, then remove height control arm.



410RS005

4. Apply the setting marks(3) to the torsion bar and lower control arm, then remove torsion bar.

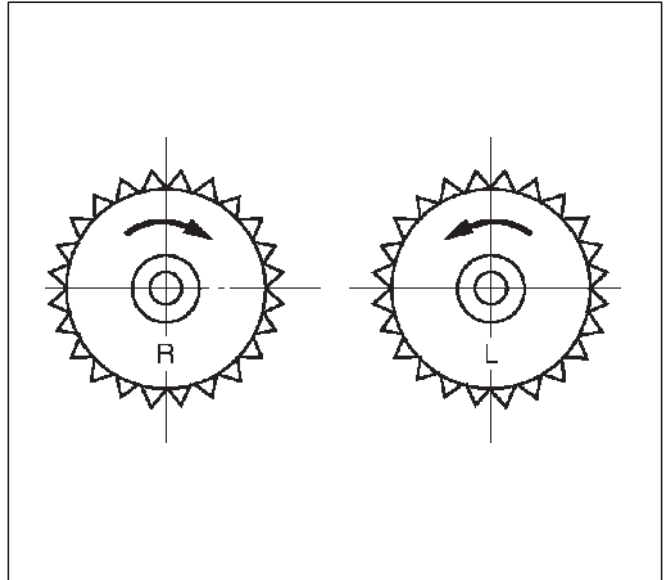


410RS006

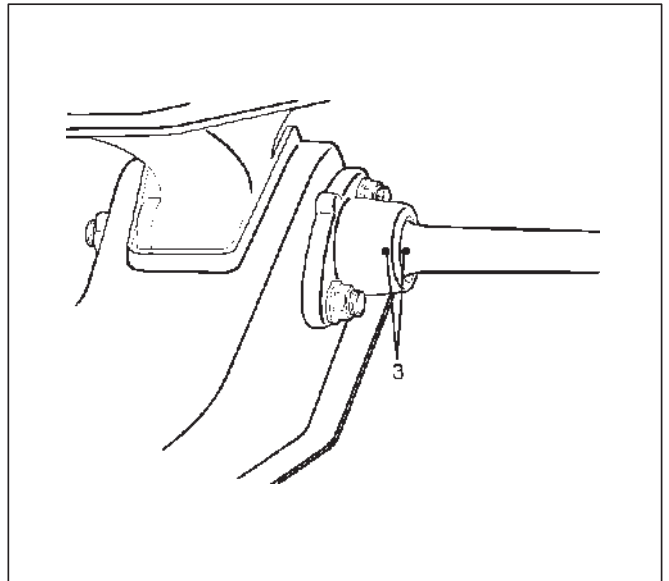
- Torsion bar
- Height control arm
- Adjust bolt

### Installation

1. Apply grease to the serrated portions, then install torsion bar. Make sure the bars are on their correct respective sides and align the setting marks(3).



410RS007



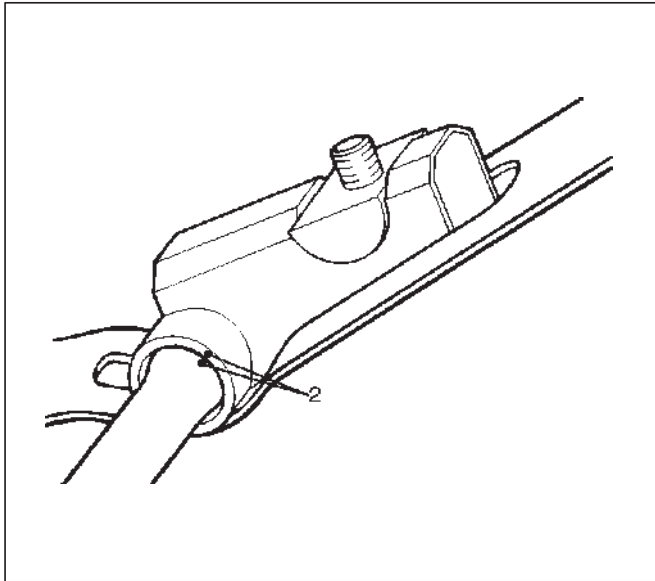
410RS006

### Inspection and Repair

Make necessary correction or parts replacement if wear, damage, corrosion or any other abnormal conditions are found through inspection.

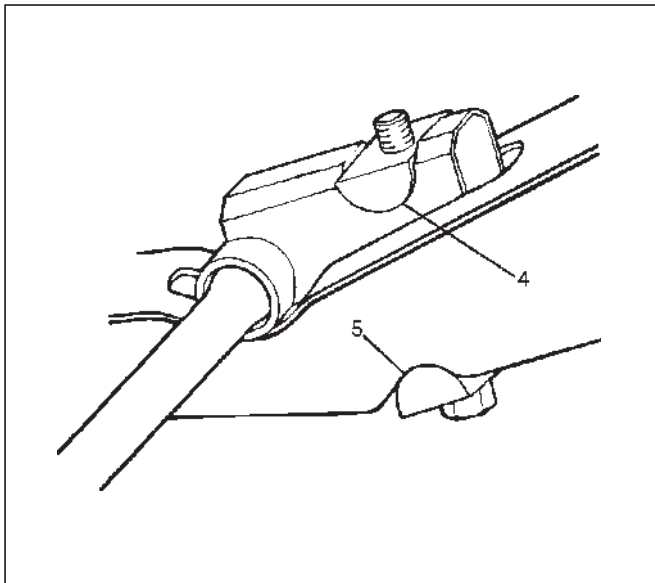
Check the following parts:

2. Apply grease to the portion that fits into the bracket then install height control arm and align the setting marks(2).



410RS005

3. Apply grease to the bolt portion of the end piece(4). Apply grease to the portion of the seat(5) that fits into the bracket.

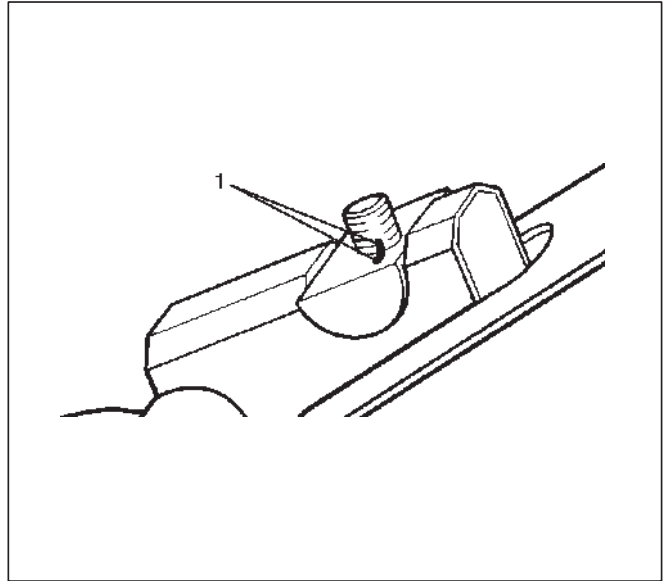


410RS006

4. Apply grease to the serrated portions.

5. Install adjust bolt and seat, then turn the adjust bolt to the setting mark(1) applied during disassembly.

NOTE: Adjust the trim height. Refer to Front End Alignment Inspection and Adjustment in Steering section.

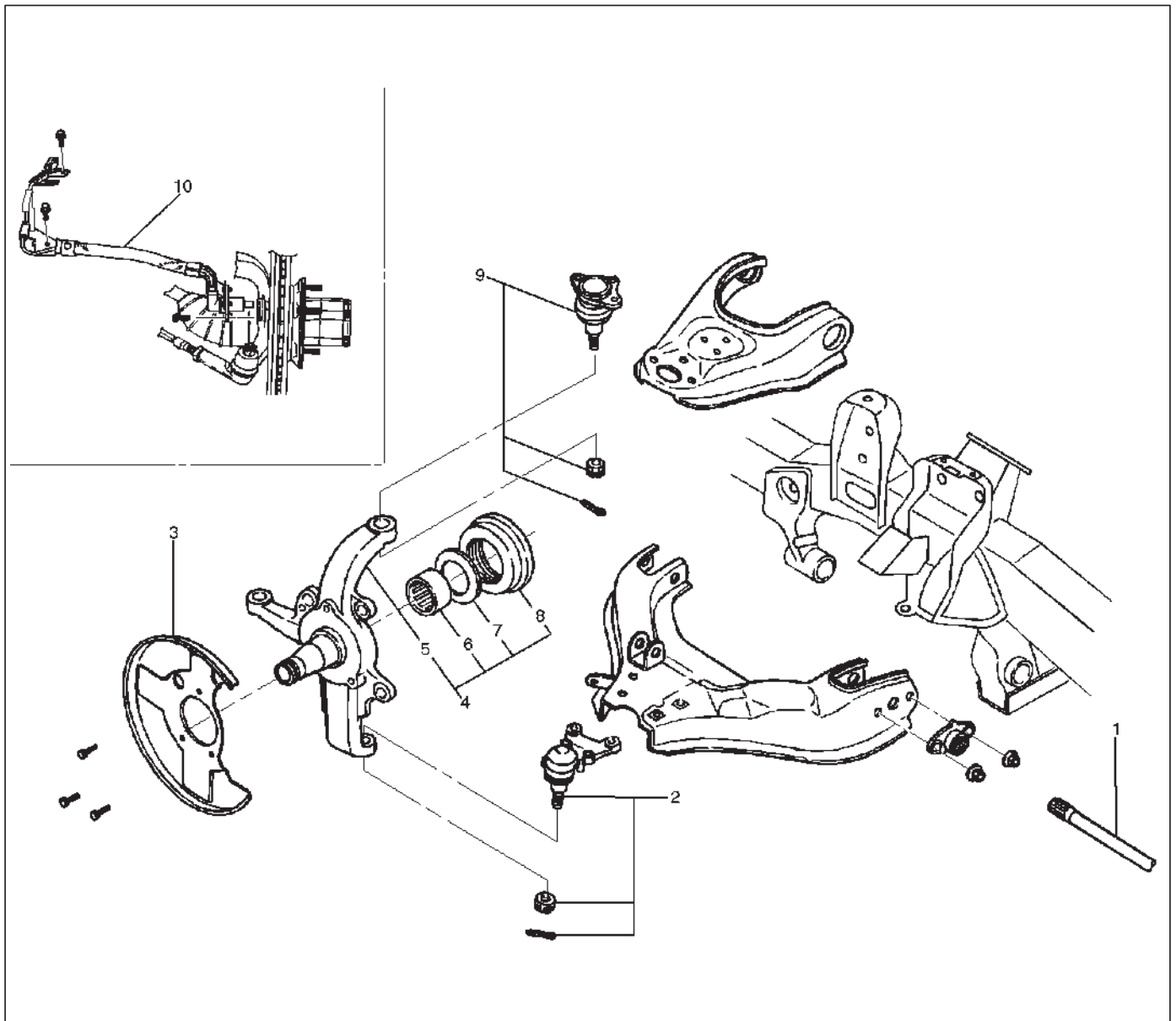


410RS004



## Knuckle

### Knuckle and Associated Parts



410RW001

#### Legend

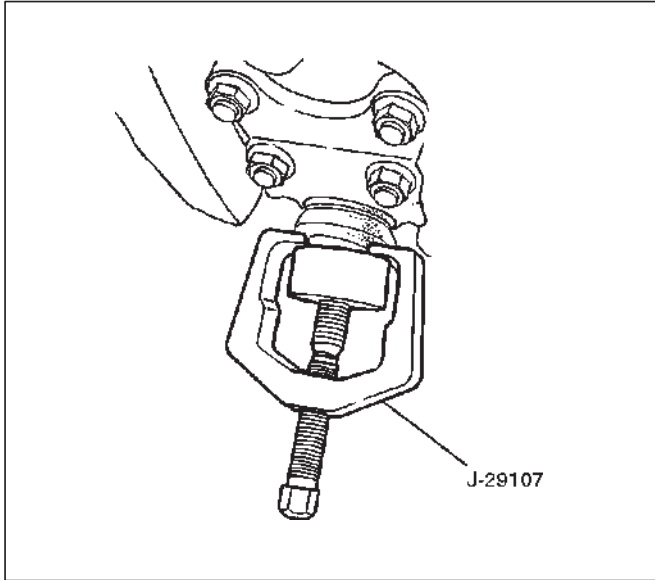
- |                      |                         |
|----------------------|-------------------------|
| (1) Torsion Bar      | (6) Needle Bearing      |
| (2) Lower Ball Joint | (7) Thrust Washer       |
| (3) Back Plate       | (8) Oil Seal            |
| (4) Knuckle Assembly | (9) Upper Ball Joint    |
| (5) Knuckle          | (10) Wheel Speed Sensor |

### Removal

1. Raise the vehicle and support the frame with suitable safety stands.
2. Remove wheel and tire assembly. Refer to Wheel Replacement in this section.
3. Remove the brake caliper. Refer to Disc Brakes in Brake section.
4. Remove the hub assembly. Refer to Front Hub and Disk in Driveline/Axle section.
5. Remove outer track rod from the knuckle. Refer to Outer Track Rod Assembly Replacement in Steering section.
6. Remove the speed sensor from the knuckle.
7. Loosen torsion bar by height control arm adjust bolt, then remove torsion bar. Refer to Torsion Bar Replacement in this section.

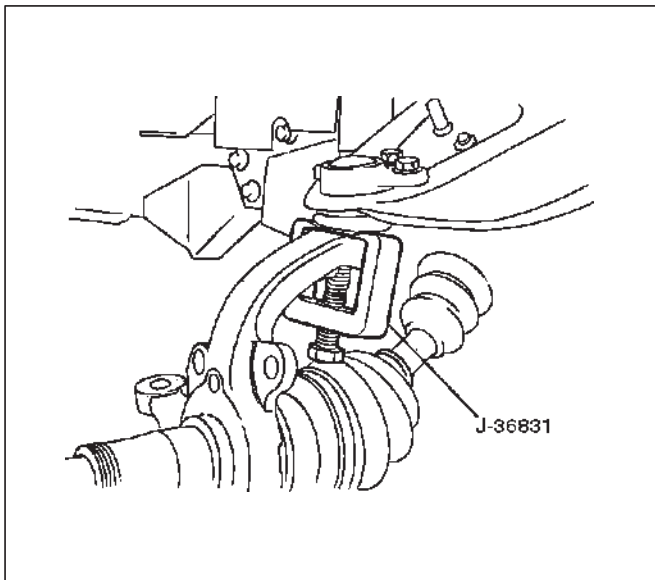
- 8. Remove wheel speed sensor.
- 9. Remove back plate.
- 10. Remove lower ball joint by using remover J-29107.

**CAUTION: Be careful not to damage the ball joint boot.**



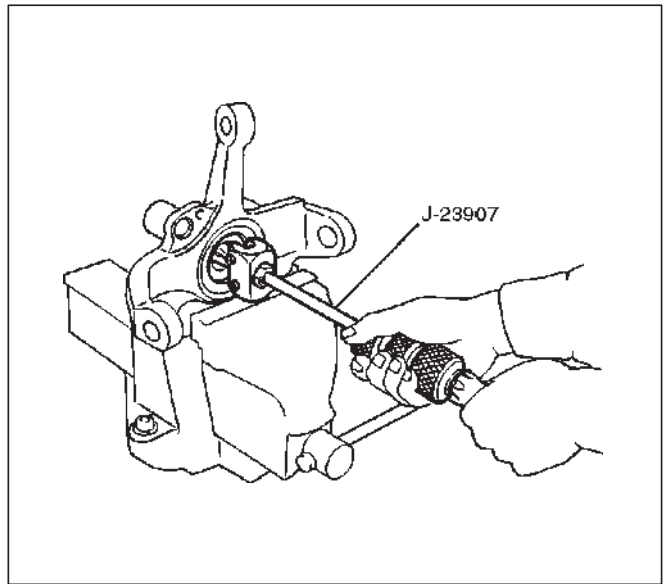
- 11. Remove upper ball joint by using remover J-36831.

**CAUTION: Be careful not to damage the ball joint boot.**



- 12. Remove knuckle assembly.
- 13. Remove oil seal.
- 14. Remove washer.

- 15. Remove needle bearing by using remover J-23907.



### Inspection and Repair

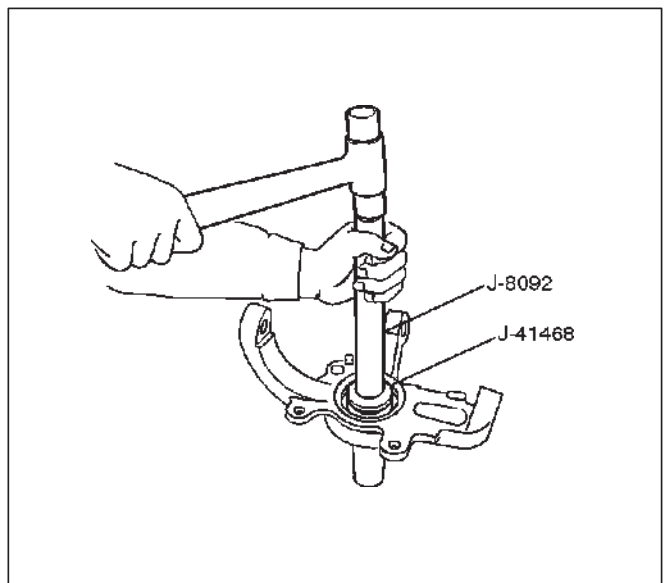
Make necessary correction or parts replacement if wear, damage, corrosion or any other abnormal conditions are found through inspection.

Check the following parts:

- Knuckle
- Knuckle arm
- Needle bearing
- Thrust washer

### Installation

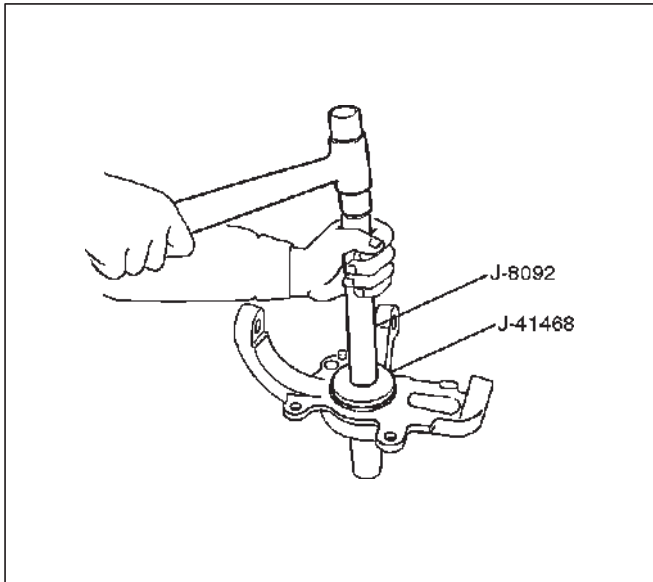
- 1. Apply appropriate amount of multi-purpose type grease to the new bearing (Approx. 5 g) and install needle bearing by using installer J-36838 and J-8092.



### 3C-14 FRONT SUSPENSION

---

2. Apply multi-purpose type grease to the thrust washer, and install washer with chamfered side facing knuckle.
3. Use a new oil seal, and apply multi-purpose type grease to the area surrounded by the lip (approx. 2 g). Then use installer J-41468 and J-8092 to install oil seal. After fitting the oil seal to the installer, drive it to the knuckle using a hammer or bench press until the tool front face contacts with the thrust washer.



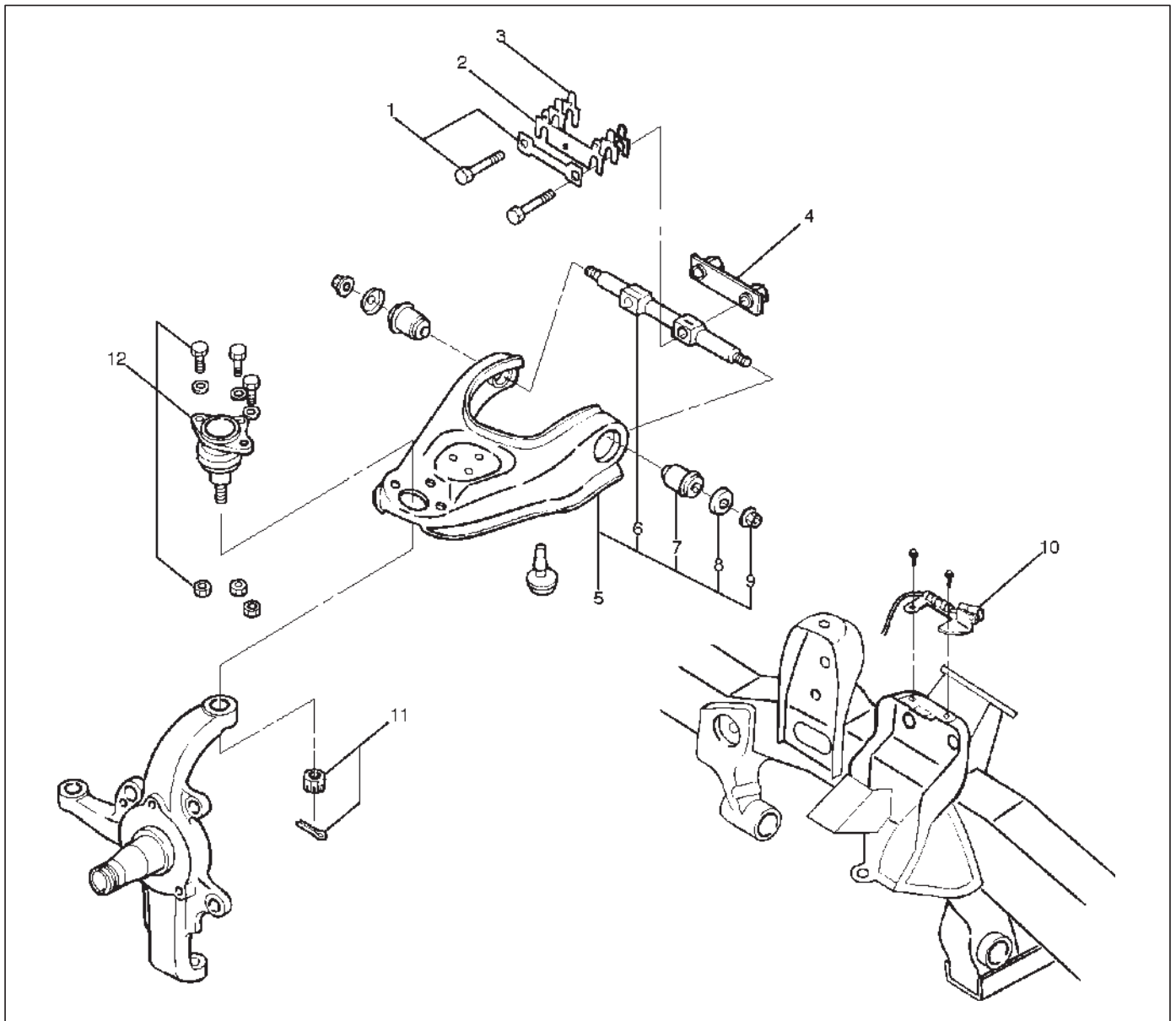
901RW046

4. Install knuckle assembly.
5. Install upper ball joint and tighten the nut to the specified torque, with just enough additional torque to align cotter pin holes. Install new cotter pin.  
**Torque: 98 N·m (72 lb ft)**
6. Install lower ball joint and tighten the nut to the specified torque, with just enough additional torque to align cotter pin holes. Install new cotter pin.  
**Torque: 147 N·m (108 lb ft)**
7. Install back plate.
8. Install wheel speed sensor.
9. Install torsion bar, refer to Torsion Bar Replacement in this section.

**NOTE:** Adjust the trim height. Refer to Front End Alignment Inspection and Adjustment in Steering section.

## Upper Control Arm

### Upper Control Arm and Associated Parts



450RS007

#### Legend

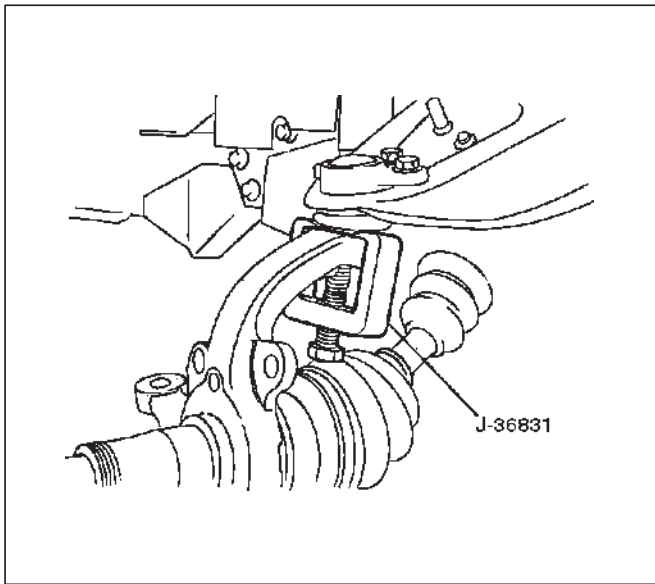
- |                                |                         |
|--------------------------------|-------------------------|
| (1) Bolt and Plate             | (7) Bushing             |
| (2) Camber Shims               | (8) Plate               |
| (3) Caster Shims               | (9) Nut                 |
| (4) Nut Assembly               | (10) Speed Sensor Cable |
| (5) Upper Control Arm Assembly | (11) Nut and Cotter Pin |
| (6) Fulcrum Pin                | (12) Upper Ball Joint   |

#### Removal

1. Raise the vehicle and support the frame with suitable safety stands.
2. Remove wheel and tire assembly. Refer to Wheel Replacement in this section.
3. Remove the brake caliper and disconnect brake pipe. Refer to Disc Brakes in Brake section.
4. Support lower control arm with a jack.
5. Remove speed sensor cable.
6. Remove nut and cotter pin then use remover J-36831.

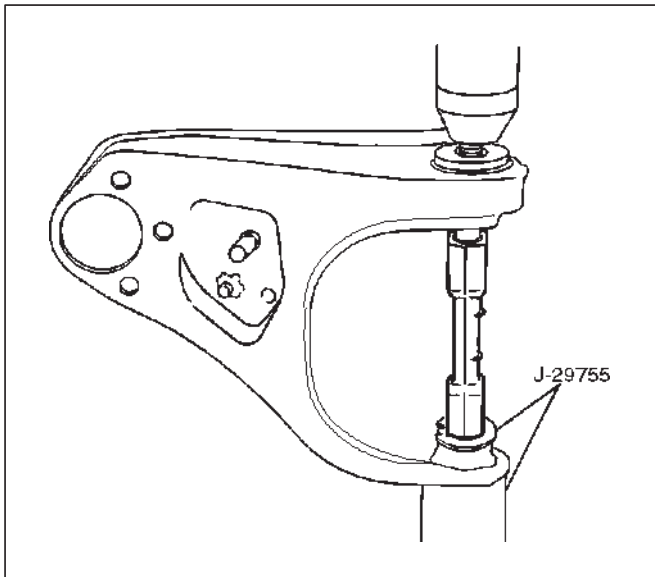
## 3C-16 FRONT SUSPENSION

**CAUTION:** Be careful not to break the ball joint boot.

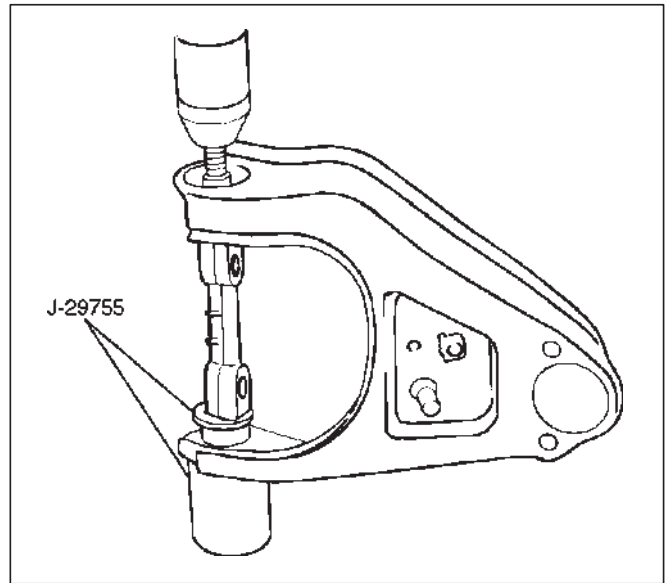


901RW043

7. Remove upper ball joint.
8. Remove bolt and plate.
9. Remove nut assembly.
10. Remove camber shims and note the positions and number of shims.
11. Remove caster shims and note the positions and number of shims.
12. Remove upper control arm assembly.
13. Remove nut.
14. Remove plate.
15. Remove bushing by using remover J-29755.



901RW047



901RW046

16. Remove fulcrum pin.

### Inspection and Repair

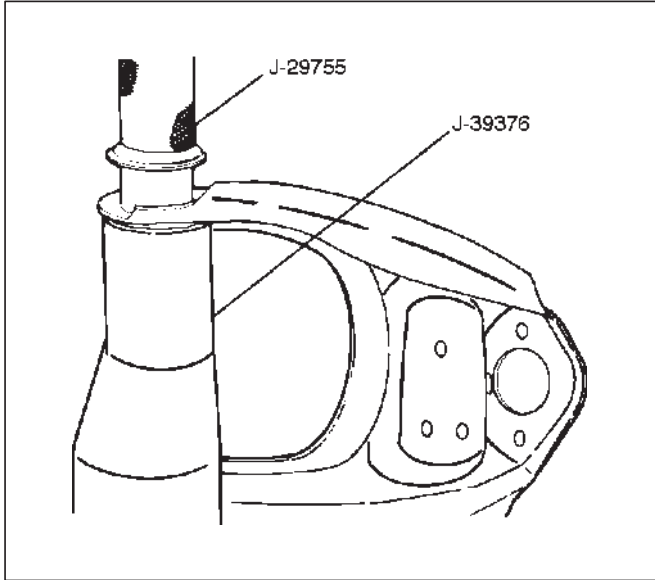
Make necessary parts replacement if wear, damage, corrosion or any other abnormal conditions are found through inspection.

Check the following parts:

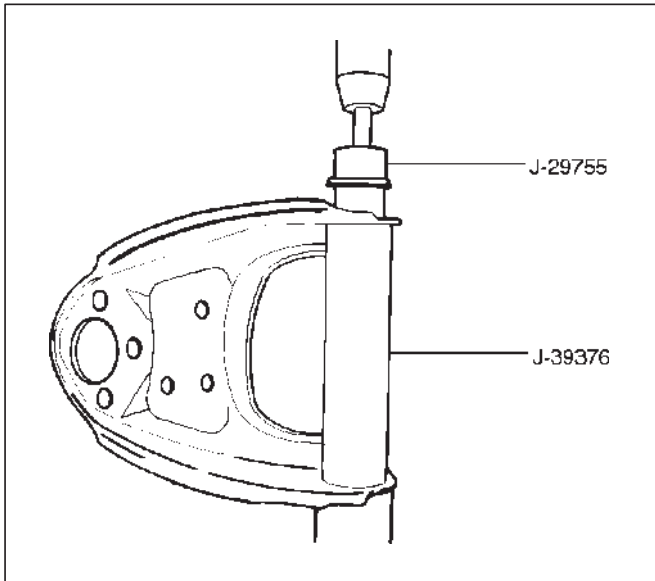
- Upper control arm
- Bushing
- Fulcrum pin

## Installation

1. Install fulcrum pin.
2. Install bushing by using installer J-29755 and J-39376.



901RW049

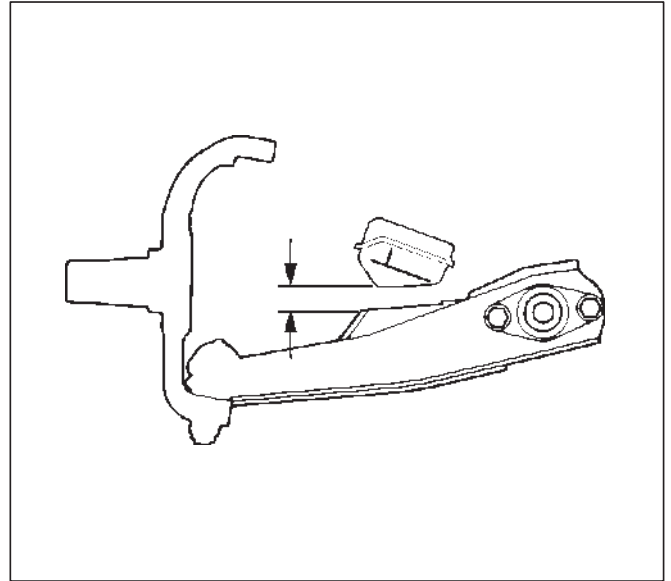


901RW050

3. Install plate.
4. Install nut and tighten fulcrum pin nut finger-tight.

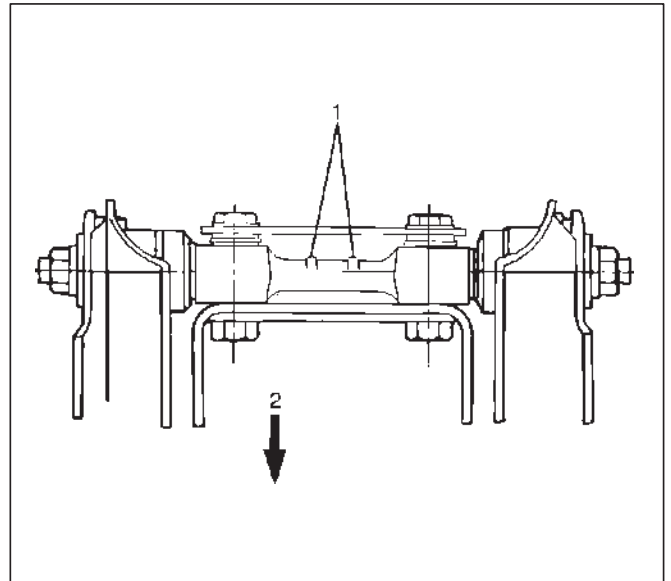
NOTE: Torque fulcrum pin nut after adjusting buffer clearance.

**Buffer clearance: 17 mm (0.67 in)**  
**Torque: 108 N·m (80 lb ft)**



450RS012

5. Install upper control arm assembly with the fulcrum pin projections turned inward.



450RS013

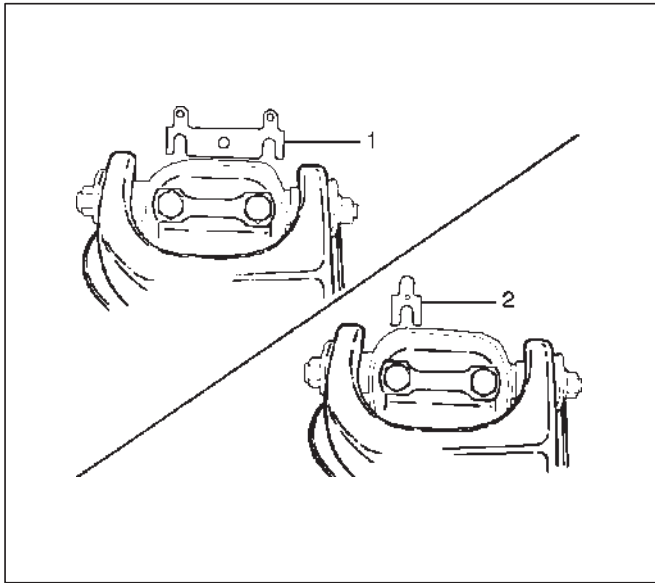
### Legend

- (1) Projection
- (2) Outward

## 3C-18 FRONT SUSPENSION

---

6. Install the caster shims(2) between the chassis frame and fulcrum pin.
7. Install the camber shims(1) between the chassis frame and fulcrum pin.

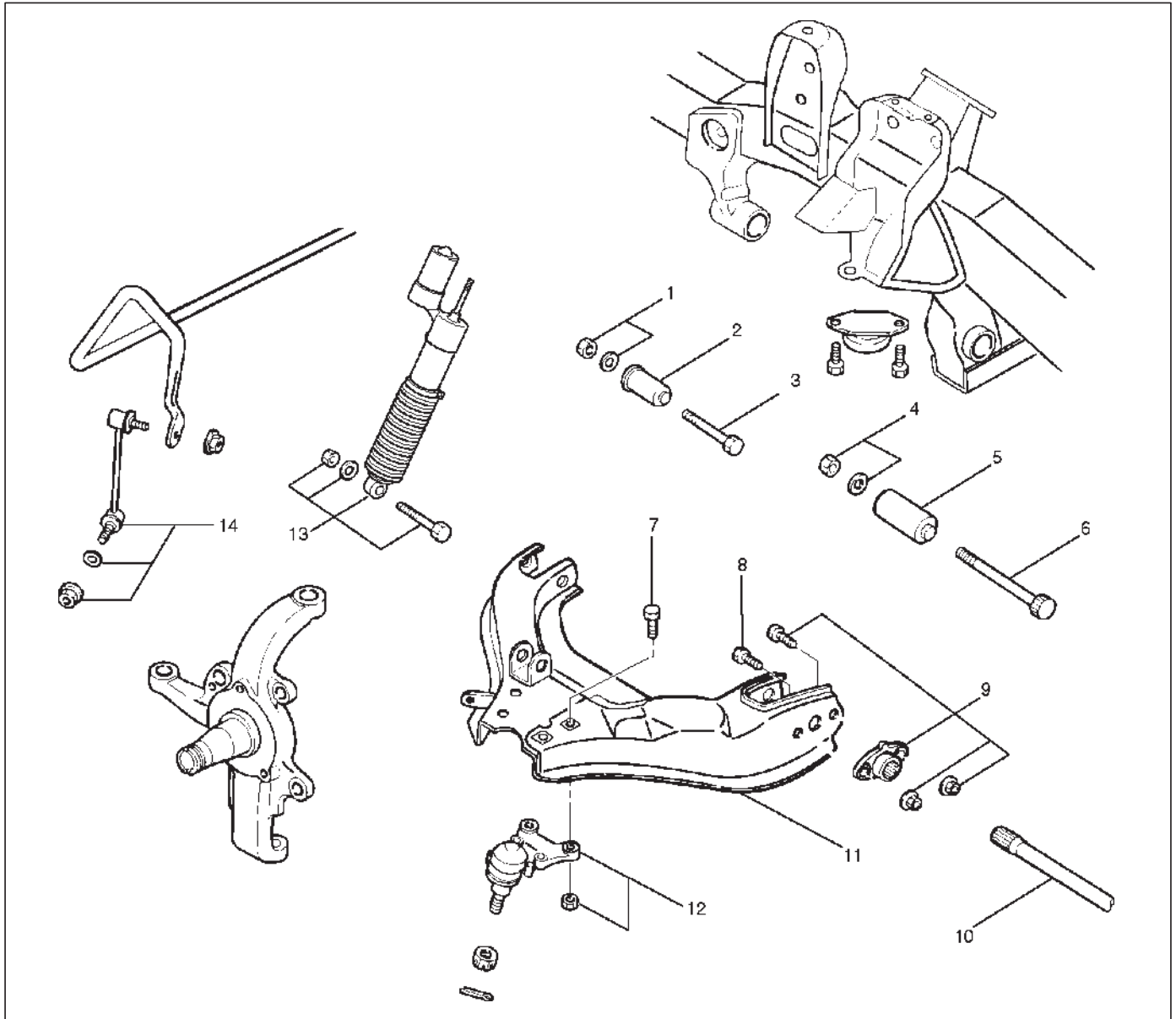


450RS014

8. Install nut assembly.
9. Install bolt and plate, then tighten the bolt to the specified torque.  
**Torque: 152 N·m (112 lb ft)**
10. Install upper ball joint and tighten it to the specified torque.  
**Torque: 57 N·m (42 lb ft)**
11. Install nut and cotter pin then tighten the nut to the specified torque, with just enough additional torque to align cotter pin holes. Install new cotter pin.  
**Torque: 98 N·m (72 lb ft)**
12. Install speed sensor cable.

## Lower Control Arm

### Lower Control Arm and Associated Parts



450RX001

#### Legend

- |                                 |                             |
|---------------------------------|-----------------------------|
| (1) Nut and Washer (Front Side) | (8) Torsion Bar Arm Bolt    |
| (2) Bush (Front Side)           | (9) Torsion Bar Arm Bracket |
| (3) Bolt (Front Side)           | (10) Torsion Bar            |
| (4) Nut and Washer (Rear Side)  | (11) Lower Control Arm      |
| (5) Bush (Rear Side)            | (12) Lower Ball Joint       |
| (6) Bolt (Rear Side)            | (13) Shock Absorber         |
| (7) Lower Ball Joint Bolt       | (14) Stabilizer Link        |

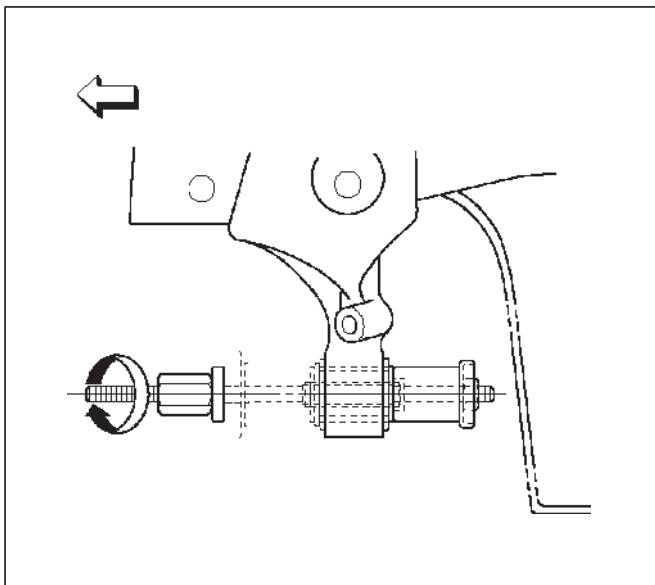
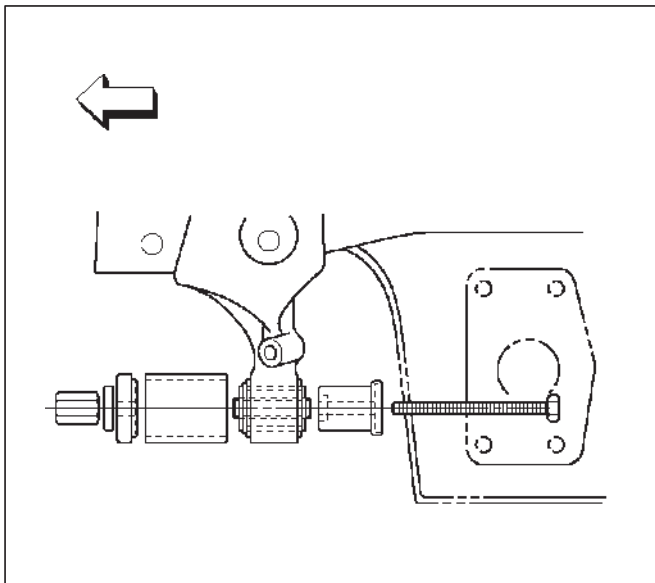
#### Removal

1. Raise the vehicle and support the frame with suitable safety stands.
2. Remove wheel and tire assembly. Refer to Wheel Replacement in this section.
3. Remove the outer track rod from the knuckle. Refer to Steering Linkage in Steering section.
4. Remove the retaining ring from the front axle driving shaft to release the shaft from hub. Refer to Front Hub and Disc in Driveline/Axle section.
5. Support lower control arm with a jack.
6. Remove front nut and washer.

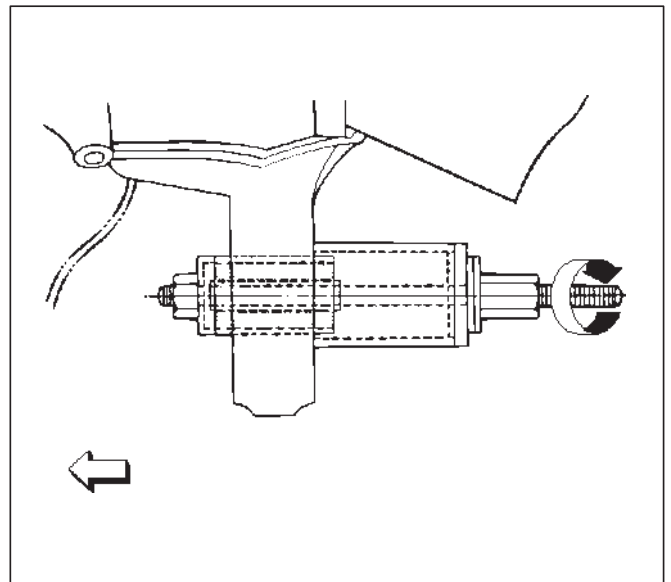
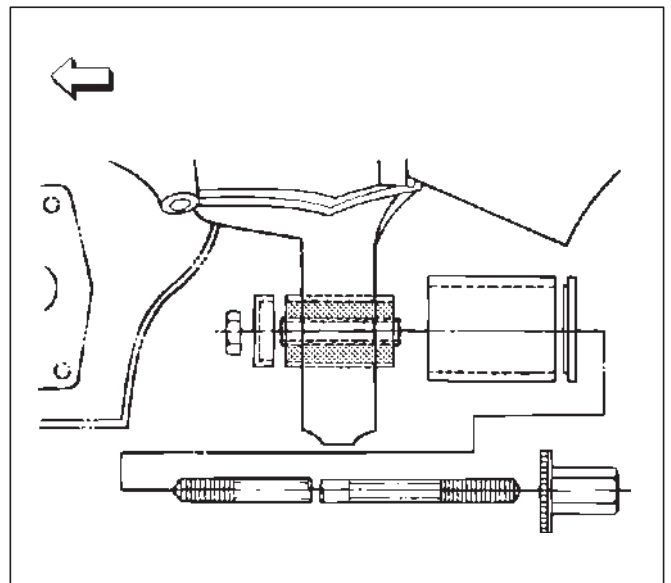


## 3C-20 FRONT SUSPENSION

7. Remove rear nut and washer.
8. Remove torsion bar, refer to Torsion Bar Replacement in this section.
9. Remove torsion bar arm bracket.
10. Disconnect the stabilizer link at the lower control arm.
11. Remove the shock absorber lower end from the lower control arm.
12. Remove the lower ball joint from the lower control arm.
13. Remove front bolt.
14. Remove rear bolt.
15. Remove lower control arm.
16. Remove torsion bar arm bolt.
17. Remove lower ball joint bolt.
18. Remove front bushing by using remover J-36833.



19. Remove rear bushing by using remover J-36834.



### Inspection and Repair

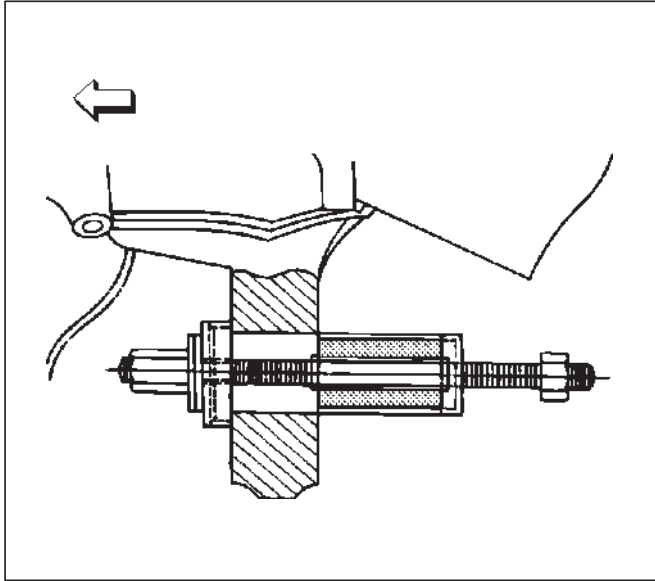
Make necessary correction or parts replacement if wear, damage, corrosion or any other abnormal conditions are found through inspection.

Check the following parts:

- Lower control arm
- Bushing

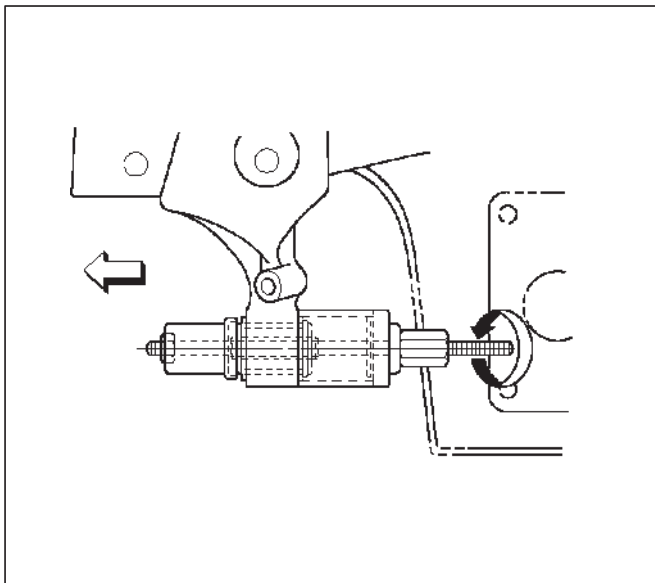
## Installation

1. Install rear bushing by using installer J-36834.



901RW053

2. Install front bushing by using installer J-36833.



901RW036

3. Install lower ball joint bolt.
4. Install torsion bar arm bolt.
5. Install lower control arm.
6. Install rear bolt.
7. Install front bolt.

8. Install lower ball joint and tighten it to the specified torque.

**Torque: 103 N·m (76 lb ft)**

9. Install shock absorber and tighten it to the specified torque.

**Torque: 82 N·m (61 lb ft)**

10. Install stabilizer link and tighten it to the specified torque.

**Torque: 50 N·m (37 lb ft)**

11. Install torsion bar arm bracket and tighten it to the specified torque.

**Torque: 116 N·m (85 lb ft)**

12. Install Torsion bar, refer to Torsion Bar Replacement in this section.

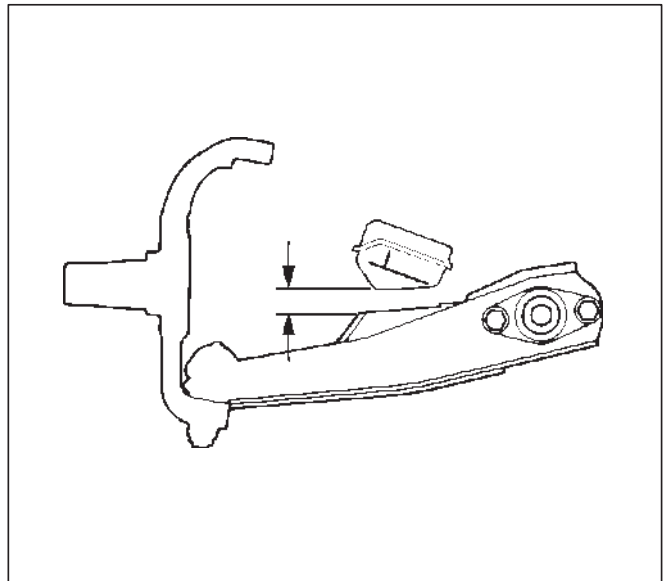
13. Install rear nut and washer and tighten lower link nut finger-tight.

14. Install front nut and washer then tighten lower link nut finger-tight.

NOTE: Torque lower control arm nut after adjusting buffer clearance .

15. Adjust the trim height. Refer to Front End Alignment Inspection and Adjustment in Steering section.

**Buffer clearance: 17 mm (0.67 in)**



450RS012

16. Tighten lower link nut to specified torque.

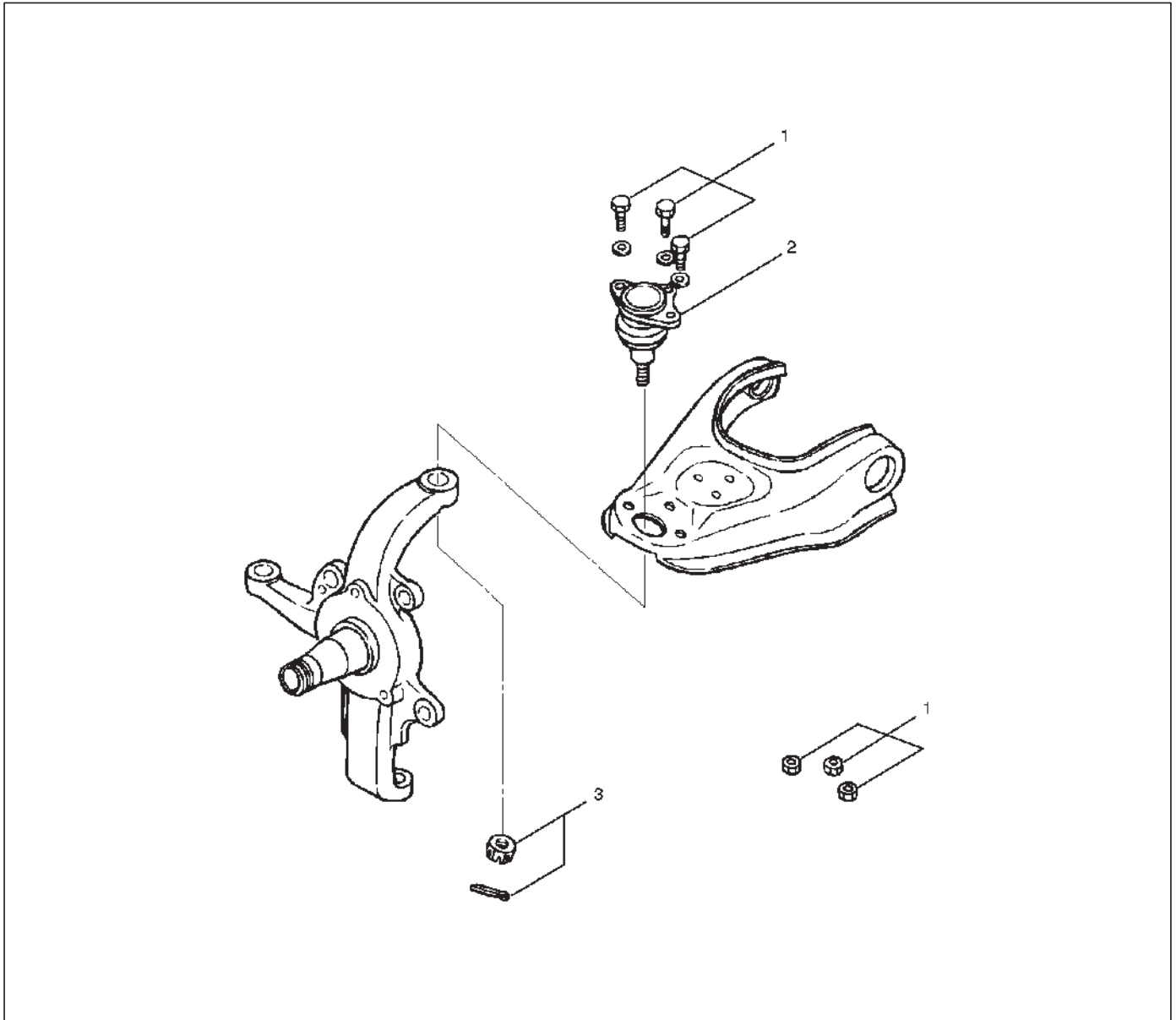
**Torque:**

**Front: 157 N·m (116 lb ft)**

**Rear: 196 N·m (145 lb ft)**

## Upper Ball Joint

### Upper Ball Joint and Associated Parts



450RS022

#### Legend

(1) Bolt, Nut and Washer

(2) Upper Ball Joint

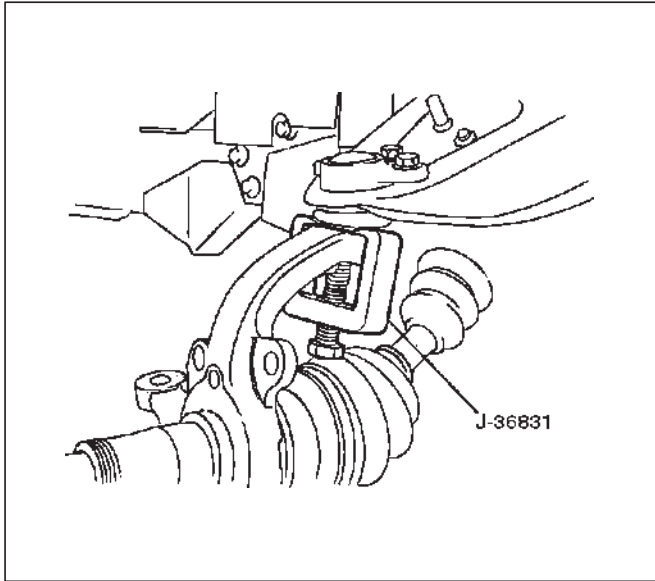
(3) Nut and Cotter Pin

### Removal

1. Raise the vehicle and support the frame with suitable safety stands.
2. Remove the speed sensor from the knuckle.

3. Remove upper ball joint nut and cotter pin, then use remover J-36831 to remove the upper ball joint from the knuckle.

**CAUTION:** Be careful not to break the ball joint boot.

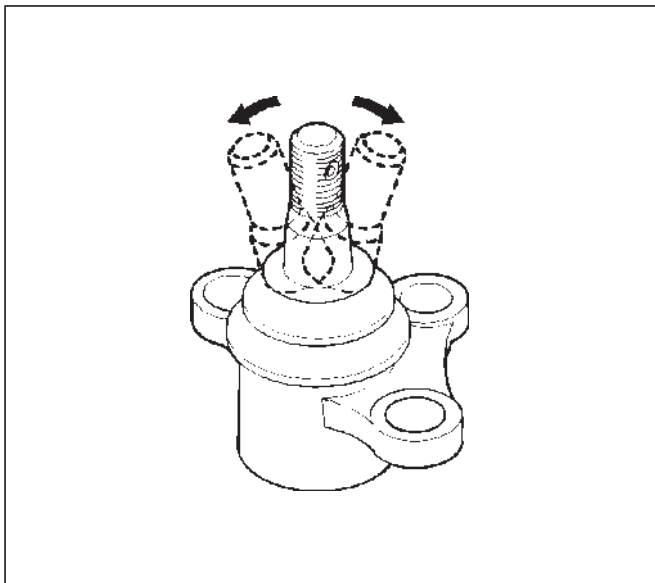


- 4. Remove bolt and washer.
- 5. Remove upper ball joint.

### Inspection and Repair

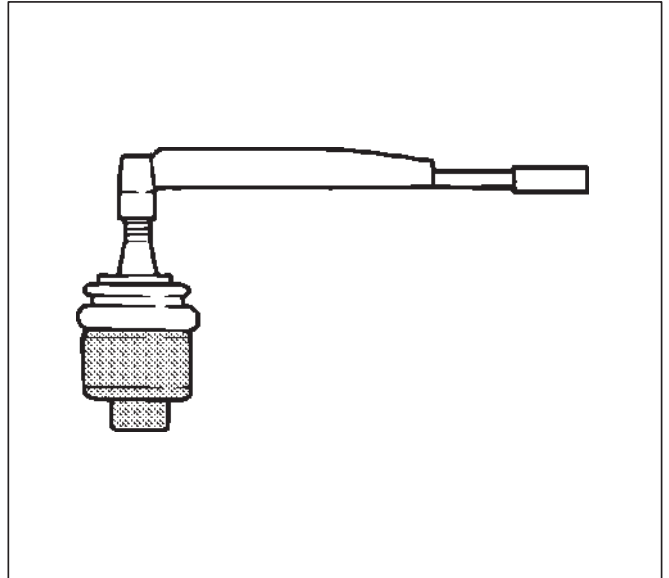
Make necessary parts replacement if wear, damage, corrosion or any other abnormal conditions are found through inspection.

- Inspect the lower end boot for damage or grease leak.  
Move the ball joint as shown in the figure to confirm its normal movement.
- Inspect screw/taper area of ball for damage.
- If any defects are found by the above inspections, replace the ball joint assembly with new one.



- After moving the ball joint 4 or 5 times, attach nut then measure the preload.

**Starting torque: 0.5 –3.2 N·m (0.4–2.4 lb ft)**



If the above limits specified are exceeded, replace the ball joint assembly.

### Installation

- 1. Install upper ball joint.
- 2. Install bolt and nut, then tighten them to the specified torque.

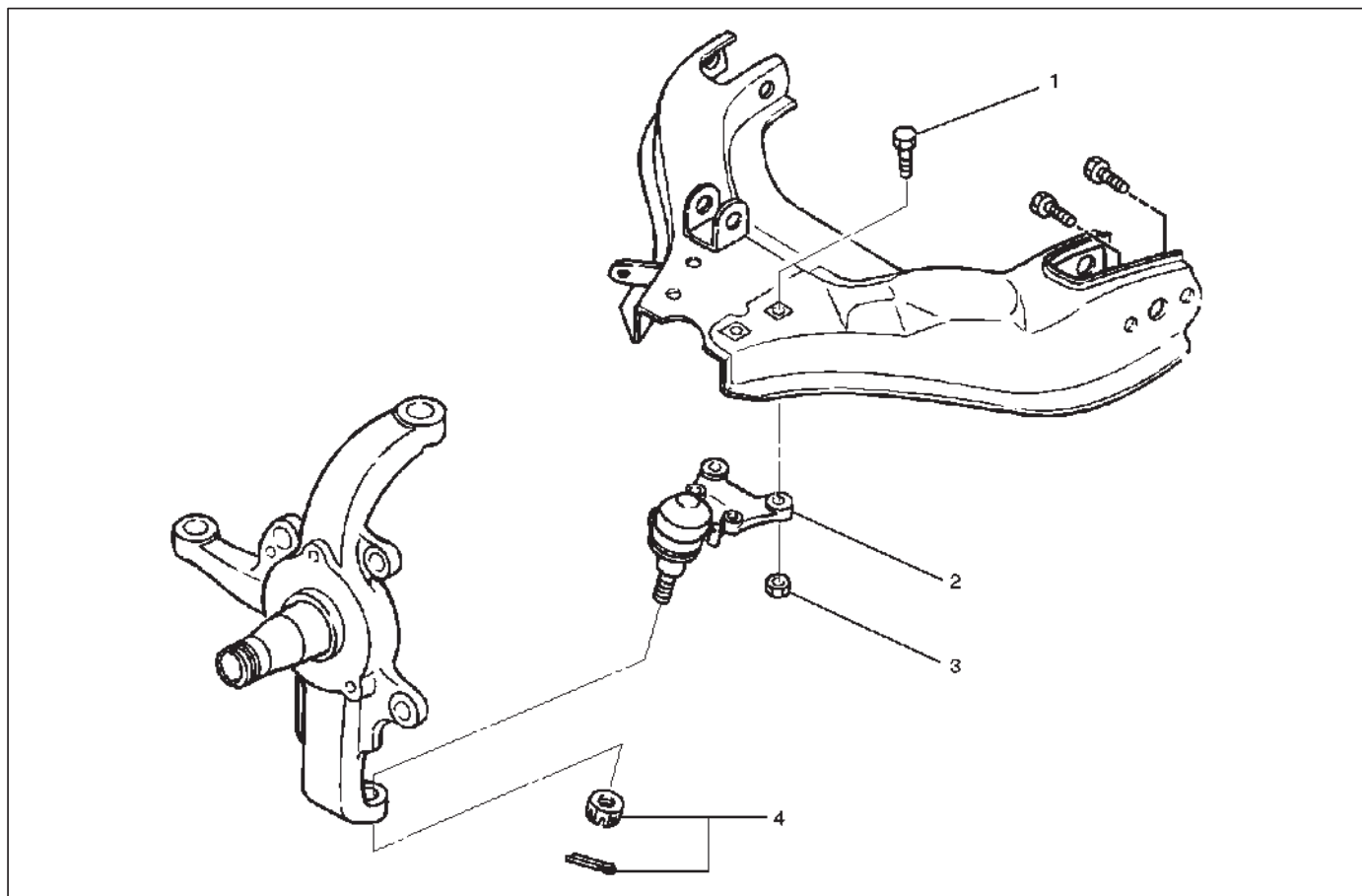
**Torque: 57 N·m (42 lb ft)**

- 3. Install nut and cotter pin, then tighten the nut to the specified torque with just enough additional torque to align cotter pin holes. Install new cotter pin.

**Torque: 98 N·m (72 lb ft)**

## Lower Ball Joint

### Lower Ball Joint and Associated Parts



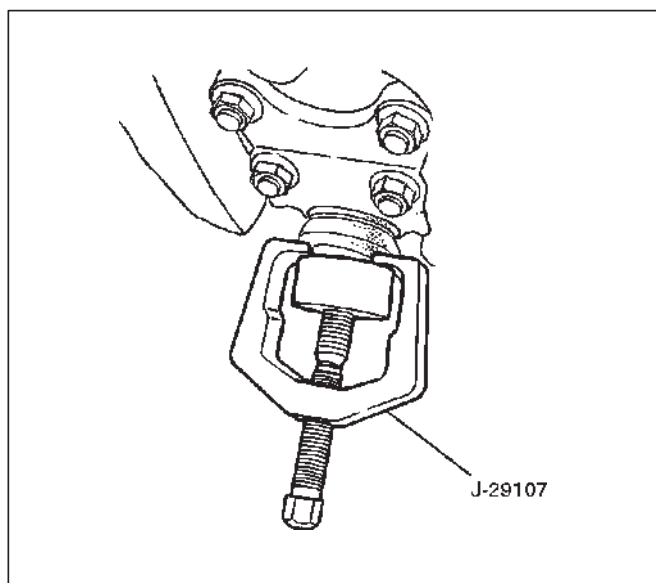
#### Legend

- |                      |                        |
|----------------------|------------------------|
| (1) Bolt             | (3) Nut                |
| (2) Lower Ball Joint | (4) Nut and Cotter Pin |

### Removal

1. Raise the vehicle and support the frame with suitable safety stands.
2. Remove wheel and tire assembly. Refer to Wheel Replacement in this section.
3. Remove the outer track rod from the knuckle. Refer to Steering Linkage in Steering section.
4. Remove the retaining ring from the front axle driving shaft to release the shaft from hub. Refer to Front Hub and Disc in Driveline/Axle section.
5. Support lower control arm with a jack.
6. Remove lower ball joint nut and cotter pin, then use remover J-29107 to remove the lower ball joint from the knuckle.

**CAUTION:** Be careful not to damage the ball joint boot.

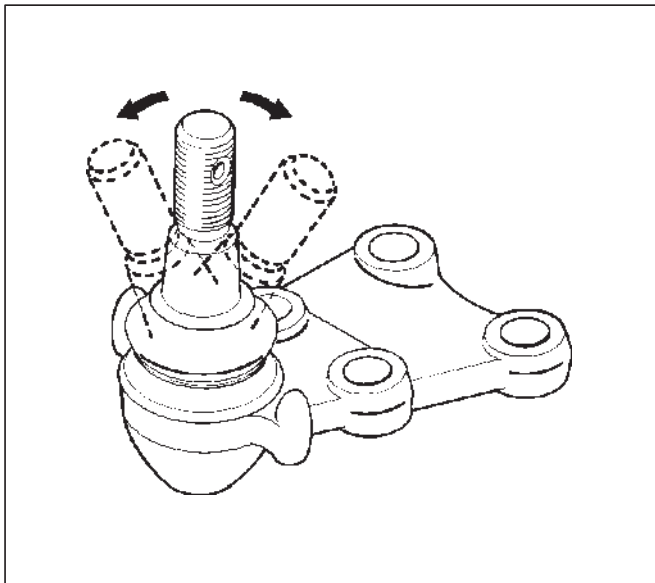


7. Remove nut.
8. Remove lower ball joint.
9. Remove bolt.

### Inspection and Repair

Make necessary parts replacement if wear, damage, corrosion or any other abnormal conditions are found through inspection.

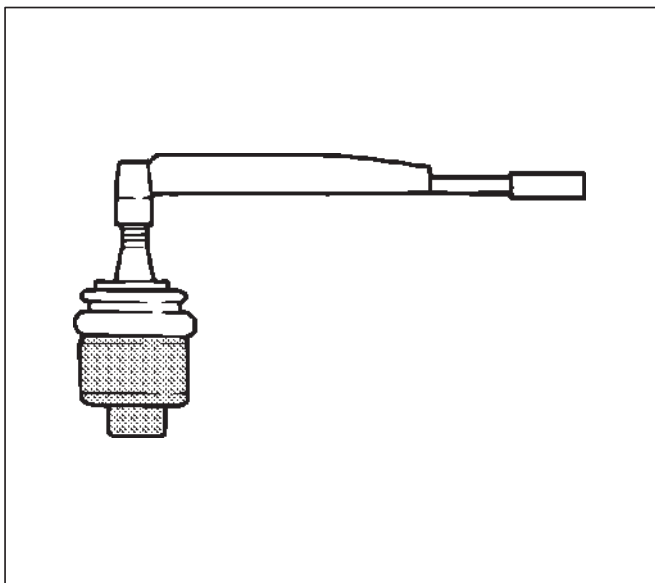
- Inspect the lower end boot for damage or grease leak. Move the ball joint as shown in the figure to confirm its normal movement .
- Inspect screw/taper area of ball for damage.
- If any defects are found by the above inspections, replace the ball joint assembly with new one.



450RS026

- After moving the ball joint 4 or 5 times, attach nut the measure the preload.

**Starting torque: 0.5–6.4 N·m (0.4–4.7 lb ft)**



450RS024

- If the above limits specified are exceeded, replace the ball joint assembly.

### Installation

1. Install bolt.
2. Install lower ball joint.
3. Install nut and tighten it to the specified torque.

**Torque: 103 N·m (76 lb ft)**

4. Install nut, then tighten it to the specified torque with just enough additional torque to align cotter pin holes. Install new cotter pin.

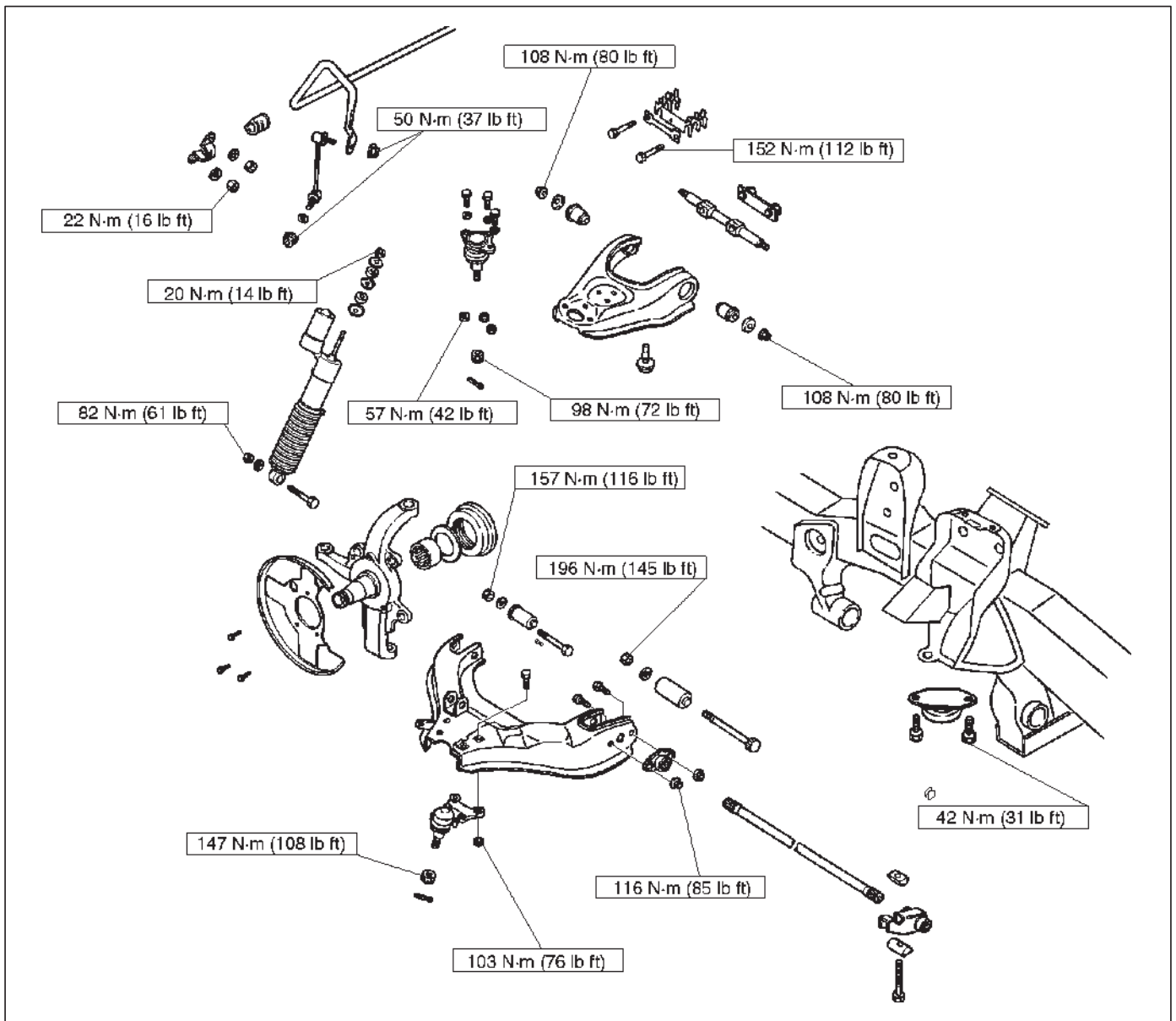
**Torque: 147 N·m (108 lb ft)**

## Main Data and Specifications

### General Specifications

Front suspension	Type	Independent wishbone arms, torsion bar spring with stabilizer bar.
Torsion bar spring	Length	1217 mm (47.9 in)
	Diameter	29.0 mm (1.14 in)
Front shock absorber	Type	Gas filled single tube shock absorber
	Piston diameter	46.0 mm (1.81 in)
	Stroke	130.0 mm (5.12 in)
	Compressed length	390.0 mm (15.35 in)
	Extended length	260.0 mm (10.24 in)
Stabilizer bar	Diameter	28.0 mm (1.10 in)

### Torque Specifications



Special Tools


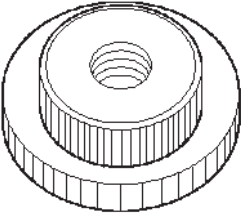
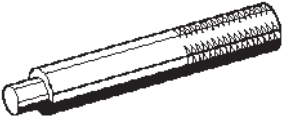
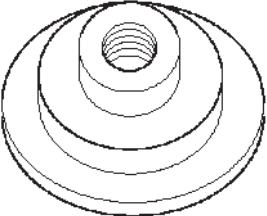
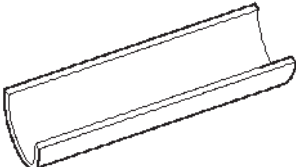
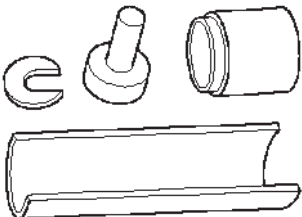
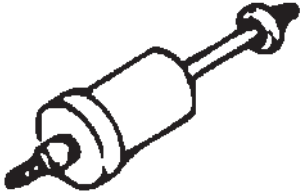
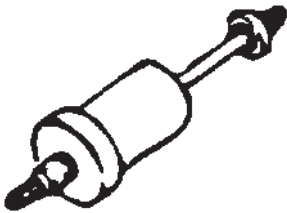
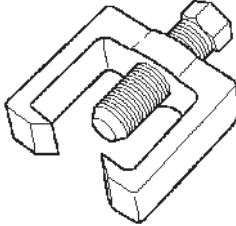
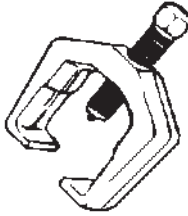
ILLUSTRATION	TOOL NO. TOOL NAME
 <p style="text-align: right; font-size: small;">901RS283</p>	<p style="text-align: center;"><b>J-23907</b> Remover; Needle bearing</p>
 <p style="text-align: right; font-size: small;">901RS284</p>	<p style="text-align: center;"><b>J-36838</b> Installer; Needle bearing</p>
 <p style="text-align: right; font-size: small;">901RS285</p>	<p style="text-align: center;"><b>J-8092</b> Grip</p>
 <p style="text-align: right; font-size: small;">901RS162</p>	<p style="text-align: center;"><b>J-41468</b> Installer; Oil seal</p>
 <p style="text-align: right; font-size: small;">901RS286</p>	<p style="text-align: center;"><b>J-39376</b> Installer; Upper arm bushing</p>
 <p style="text-align: right; font-size: small;">901RS287</p>	<p style="text-align: center;"><b>J-29755</b> Remover and Installer Upper arm bushing</p>

ILLUSTRATION	TOOL NO. TOOL NAME
 <p style="text-align: right; font-size: small;">901RS288</p>	<p style="text-align: center;"><b>J-36833</b> Remover and Installer kit; Lower arm front bushing</p>
 <p style="text-align: right; font-size: small;">901RS289</p>	<p style="text-align: center;"><b>J-36834</b> Remover and Installer kit; Lower arm rear bushing</p>
 <p style="text-align: right; font-size: small;">901RS290</p>	<p style="text-align: center;"><b>J-36831</b> Tie rod end remover</p>
 <p style="text-align: right; font-size: small;">901RS279</p>	<p style="text-align: center;"><b>J-29107</b> Lower end remover</p>



VEHICROSS

# SUSPENSION

## REAR SUSPENSION

### CONTENTS

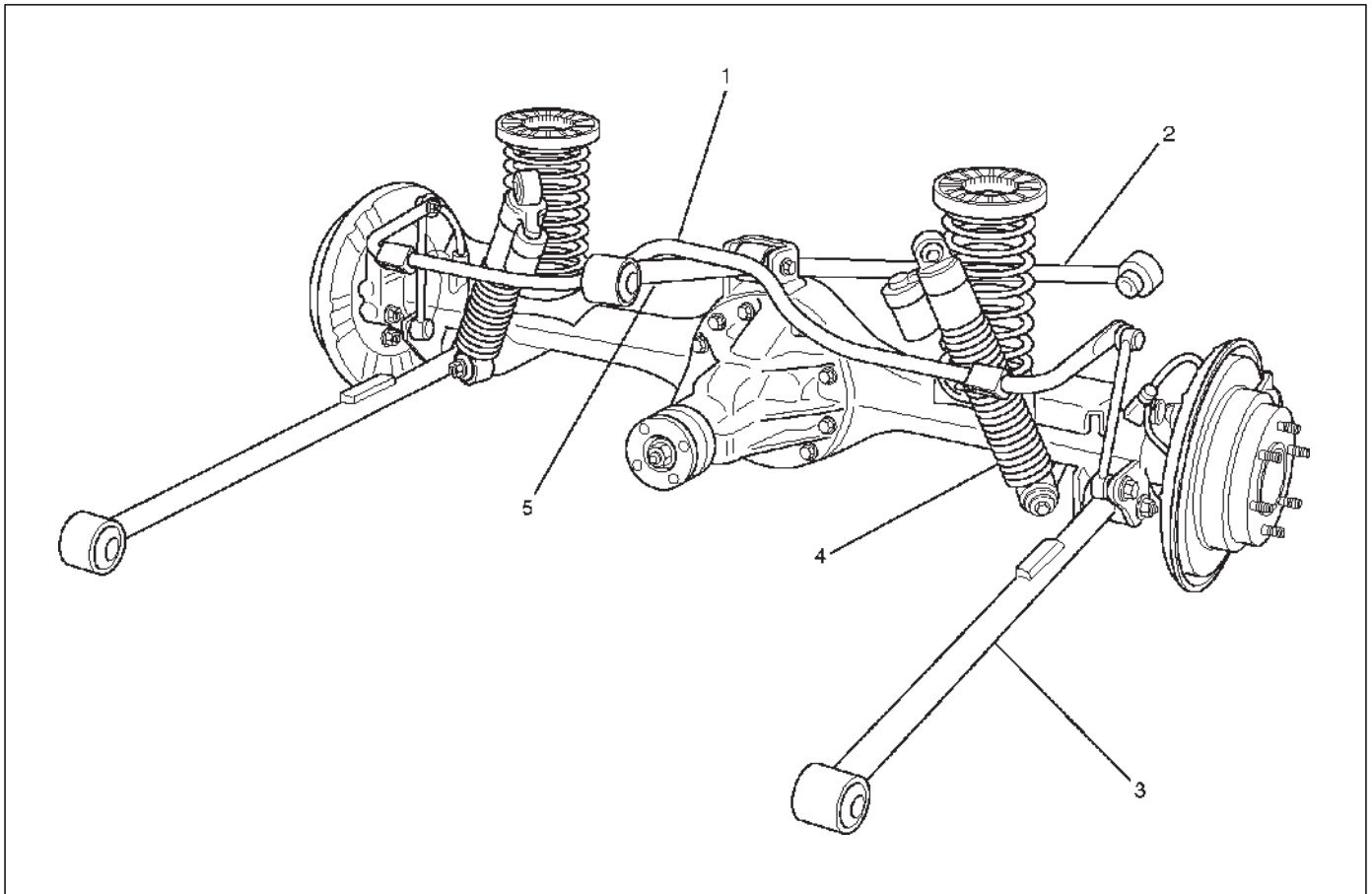
Service Precaution .....	3D-1	Center Link .....	3D-9
General Description .....	3D-2	Center Link and Associated Parts .....	3D-9
Coil Spring .....	3D-3	Removal .....	3D-9
Coil Spring and Associated Parts .....	3D-3	Inspection and Repair .....	3D-9
Removal .....	3D-3	Installation .....	3D-10
Inspection and Repair .....	3D-4	Lateral Rod .....	3D-11
Installation .....	3D-4	Lateral Rod and Associated Parts .....	3D-11
Shock Absorber .....	3D-5	Removal .....	3D-11
Shock Absorber and Associated Parts .....	3D-5	Inspection and Repair .....	3D-11
Removal .....	3D-5	Installation .....	3D-12
Inspection and Repair .....	3D-5	Stabilizer Bar .....	3D-13
Installation .....	3D-6	Stabilizer Bar and Associated Parts .....	3D-13
Trailing Link .....	3D-7	Removal .....	3D-13
Trailing Link and Associated Parts .....	3D-7	Inspection and Repair .....	3D-13
Removal .....	3D-7	Installation .....	3D-14
Inspection and Repair .....	3D-7	Main Data and Specifications .....	3D-15
Installation .....	3D-8	Special Tools .....	3D-17

### Service Precaution

**WARNING: THIS VEHICLE HAS A SUPPLEMENTAL RESTRAINT SYSTEM (SRS). REFER TO THE SRS COMPONENT AND WIRING LOCATION VIEW IN ORDER TO DETERMINE WHETHER YOU ARE PERFORMING SERVICE ON OR NEAR THE SRS COMPONENTS OR THE SRS WIRING. WHEN YOU ARE PERFORMING SERVICE ON OR NEAR THE SRS COMPONENTS OR THE SRS WIRING, REFER TO THE SRS SERVICE INFORMATION. FAILURE TO FOLLOW WARNINGS COULD RESULT IN POSSIBLE AIR BAG DEPLOYMENT, PERSONAL INJURY, OR OTHERWISE UNNEEDED SRS SYSTEM REPAIRS.**

**CAUTION: Always use the correct fastener in the proper location. When you replace a fastener, use ONLY the exact part number for that application. ISUZU will call out those fasteners that require a replacement after removal. ISUZU will also call out the fasteners that require thread lockers or thread sealant. UNLESS OTHERWISE SPECIFIED, do not use supplemental coatings (Paints, greases, or other corrosion inhibitors) on threaded fasteners or fastener joint interfaces. Generally, such coatings adversely affect the fastener torque and the joint clamping force, and may damage the fastener. When you install fasteners, use the correct tightening sequence and specifications. Following these instructions can help you avoid damage to parts and systems.**

## General Description



C03RX002

### Legend

- (1) Stabilizer Bar
- (2) Lateral Rod

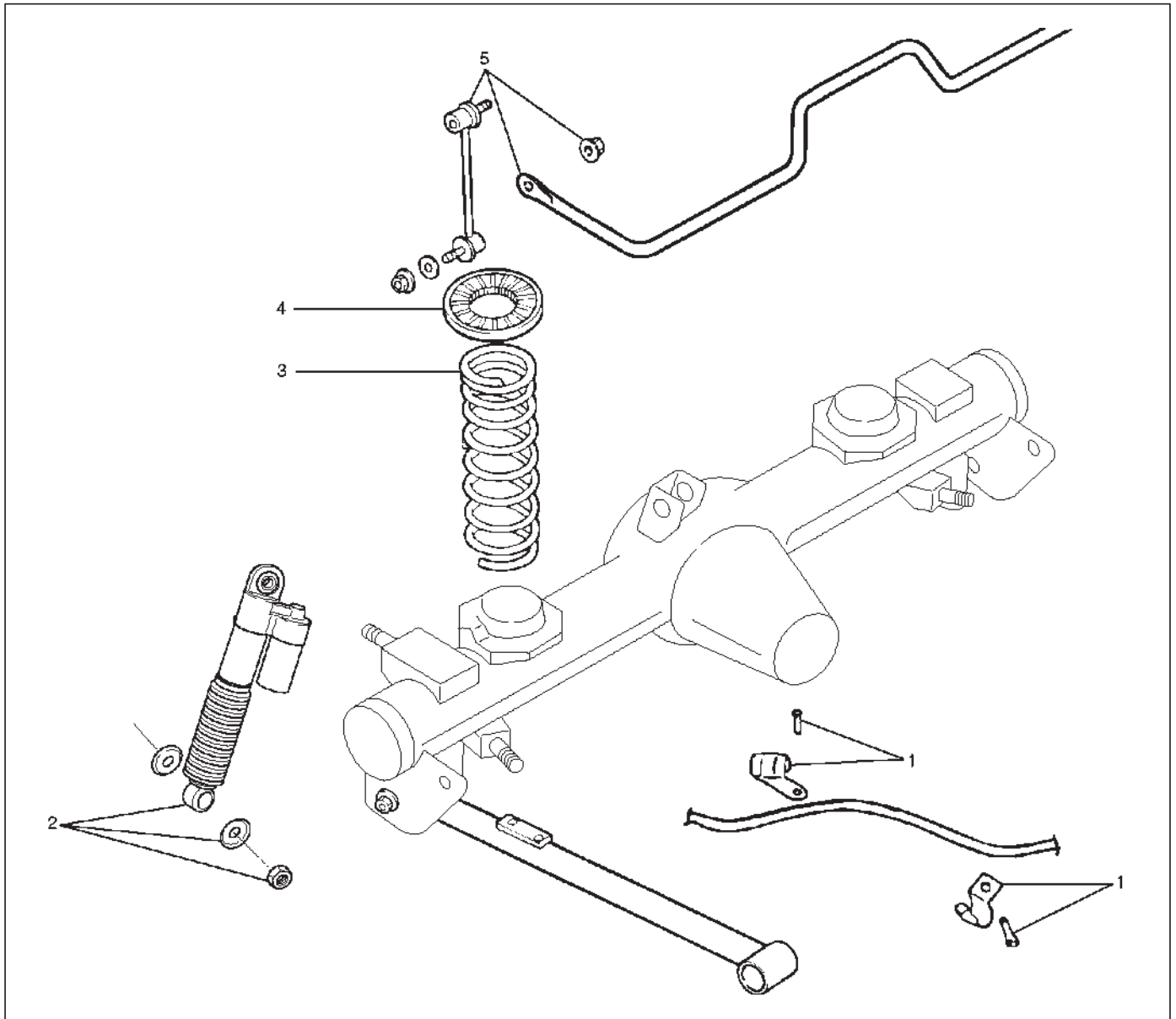
- (3) Trailing Link
- (4) Shock Absorber
- (5) Center Link

The rear suspension is a 4-link, coil spring type suspension with a stabilizer bar, consisting of two trailing links, center link, lateral rod, shock absorber, and stabilizer. In this suspension, the links are specially arranged to enable the rear axle to move freely, thereby expanding suspension stroke, reducing friction, and improving lateral rigidity and roll control. All these result in improved stability, riding comfort, and rough road maneuverability.

Each link connects to the axle housing with the frame through a runner bushing. The axle housing is supported by the trailing links and center link longitudinally and by the lateral rod latitudinally.

## Coil Spring

### Coil Spring and Associated Parts



460RX007

#### Legend

- (1) Parking Brake Cable Bracket
- (2) Shock Absorber

- (3) Coil Spring
- (4) Insulator
- (5) Stabilizer Bar

### Removal

1. Raise the vehicle and support the frame with suitable safety stands.
2. Support the rear axle case with a jack.
3. Remove the parking brake cable bracket from the trailing link.
4. Disconnect the stabilizer bar at the stabilizer link.
5. Remove the shock absorber from the axle case.
6. Remove spring insulator.
7. Remove the lower insulator and coil spring while lowering the rear axle case.

**CAUTION:** Be sure not to let the brake hose, parking brake cable, and breather hose extend to their full length.

## Inspection and Repair

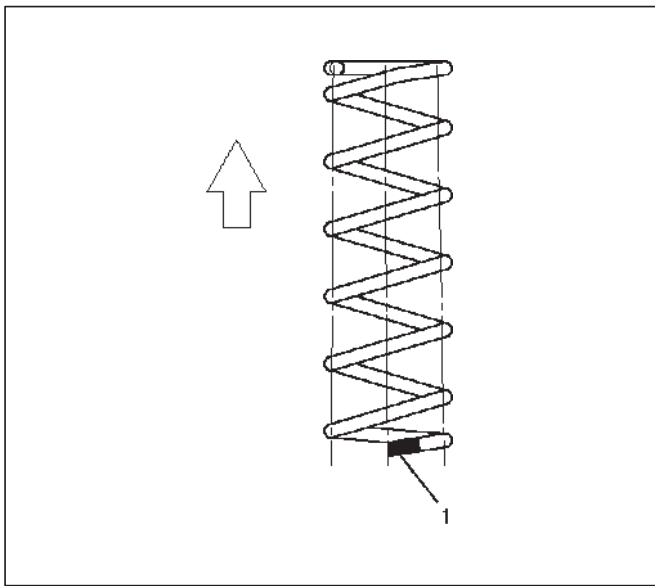
Make necessary correction or parts replacement if wear, damage, corrosion or any other abnormal conditions are found through inspection.

Check the following parts:

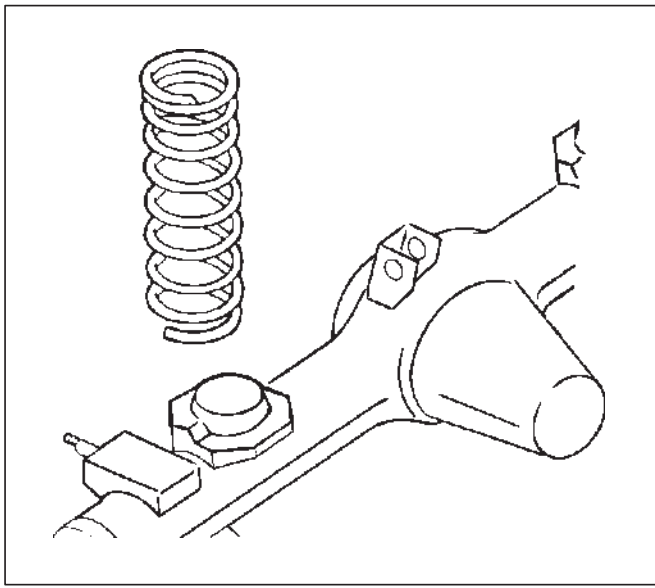
- Coil spring
- Insulator

## Installation

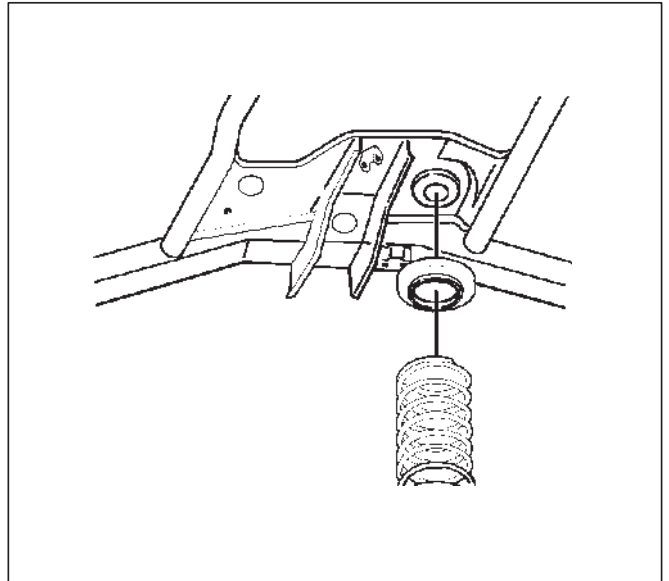
1. Install coil spring and make sure that the coil spring is installed in the proper position. Paint mark(1) should be downward.



2. Fit the end of the coil spring to the coil spring seat and mount the coil spring on the rear axle case.



3. Install the insulator on the coil spring. Jack up the axle case gently with the top of the coil spring set to the spring seat on the frame side.



4. Install shock absorber and tighten the nut lightly, then retighten it to the specified torque after the vehicle is at curb height.

NOTE: When mounting shock absorber, be sure not to use grease on bushings or any other nearby part.

**Torque: 78 N-m (58 lb ft)**

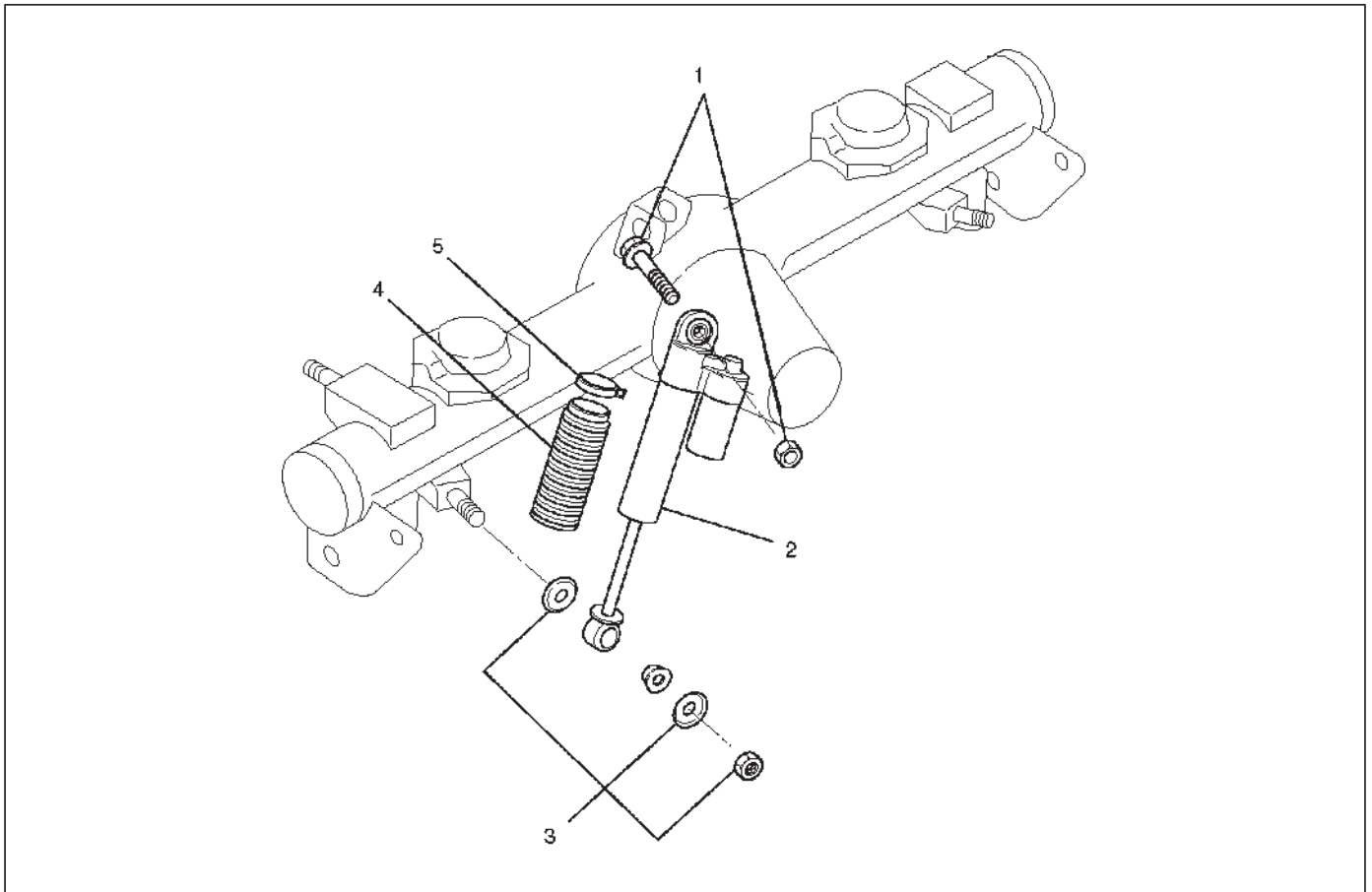
5. Install stabilizer bar.

**Torque: 50 N-m (37 lb ft)**

6. Install parking brake cable bracket.

## Shock Absorber

### Shock Absorber and Associated Parts



460RX004

#### Legend

- |                    |                    |
|--------------------|--------------------|
| (1) Bolt and Nut   | (3) Nut and Washer |
| (2) Shock Absorber | (4) Boot           |
|                    | (5) Boot Band      |

### Removal

#### CAUTION:

- **This shock absorber is sealed with high pressure gas, so it is hard to compress and it expands very fast.**
- **This shock absorber has aluminum body. Never insert bar between shock absorber and its bracket to avoid damage.**

1. Raise the vehicle and support it with suitable safety stands.
2. Remove nut and washer (Lower side).
3. Remove bolt and nut (Upper side).
4. Remove shock absorber.
5. Remove boot band and boot.

### Inspection and Repair

Make necessary correction or parts replacement if wear, damage, corrosion or any other abnormal conditions are found through inspection.

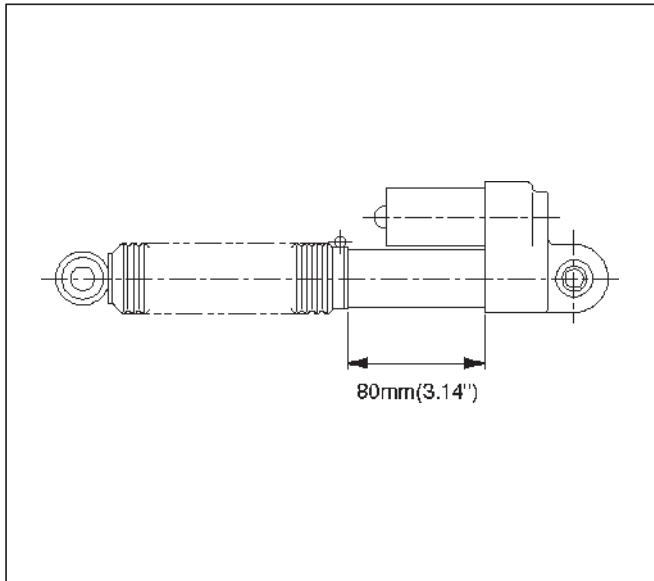
Check the following parts:

- Shock absorber
- Rubber bushing
- Boot
- Boot band

**CAUTION: If the boot is deformed, replace it even if it has no clack or damage.**

## Installation

1. Install boot and boot band to specified position.



460RX008

2. Install shock absorber.

**CAUTION: Do not apply grease to shock absorber or its bracket.**

3. Install bolt and nut (Upper side), then tighten the bolt and nut finger-tight.
4. Install nut and washer (Lower side), then tighten the bolt and nut finger-tight.
5. Retighten the fixing bolt and nut to specified torque after the vehicle is at curb height.

**Torque:**

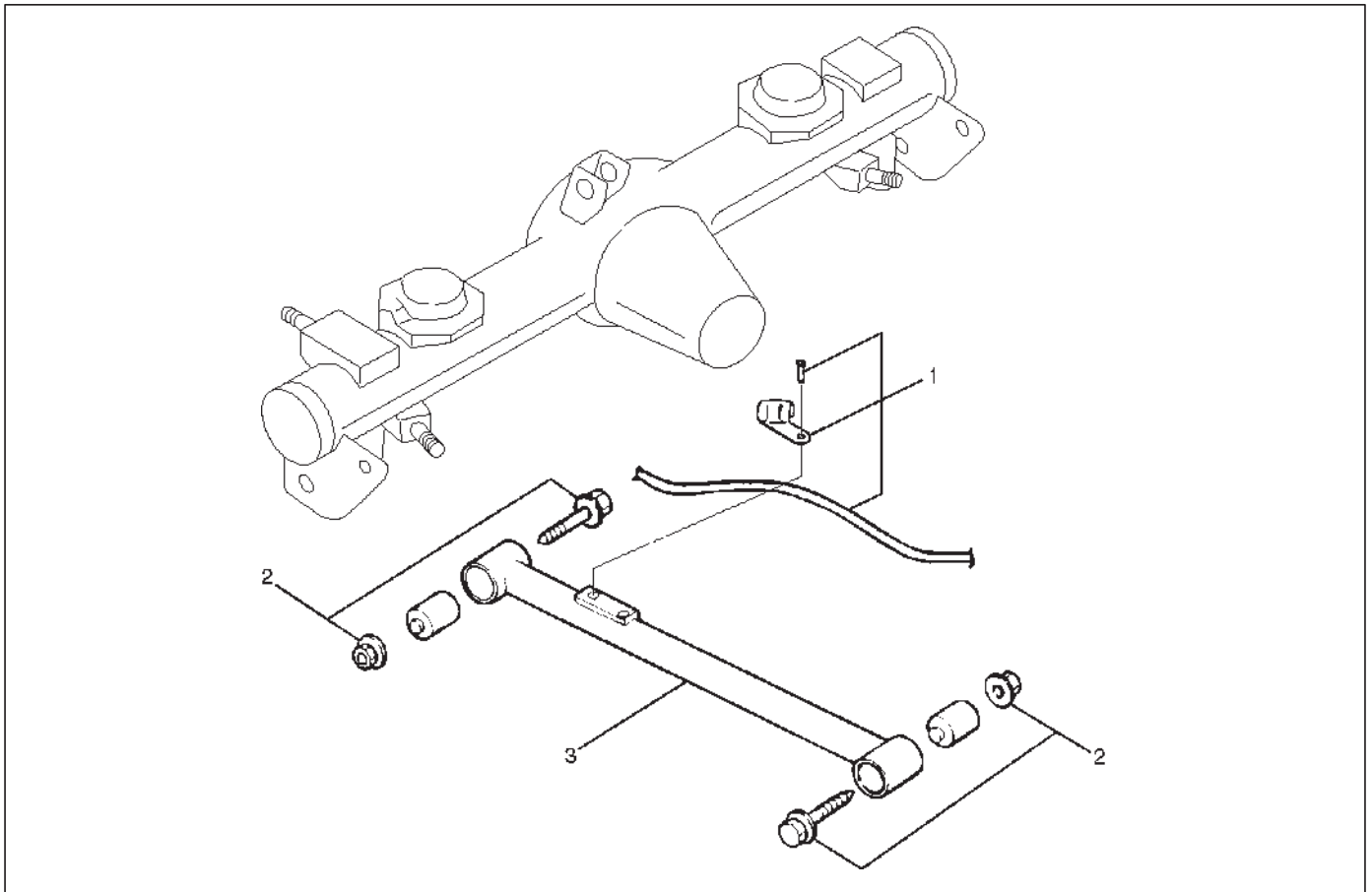
**Upper bolt and nut: 95 N·m (70 lb ft)**

**Lower nut: 78 N·m (58 lb ft)**

**CAUTION: Be sure that the boot is installed without deformation**

## Trailing Link

### Trailing Link and Associated Parts



460RX006

#### Legend

(1) Parking Brake Cable

(2) Bolt and Nut

(3) Trailing Link

### Removal

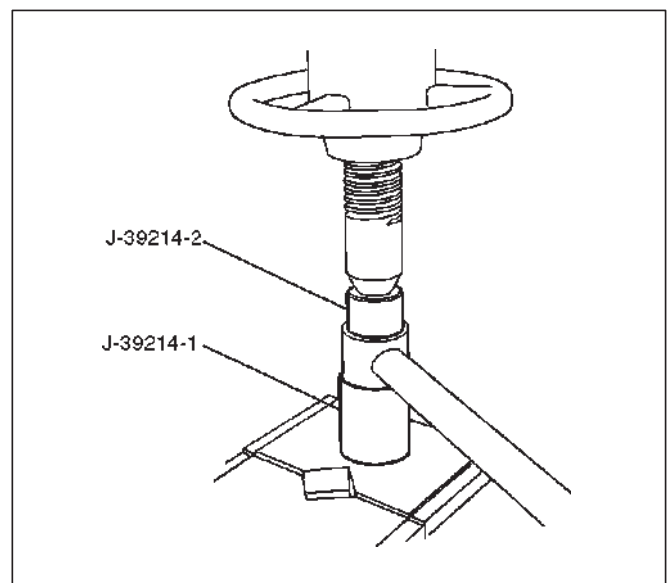
1. Remove the parking brake cable from the trailing link.
2. Remove the trailing link fixing bolt and nut.
3. Remove trailing link.

### Inspection and Repair

Make necessary correction or parts replacement if wear, damage, corrosion or any other abnormal conditions are found through inspection.

1. Trailing link
2. Rubber bushing

○Remove the rubber bushing by using remover J-39214.

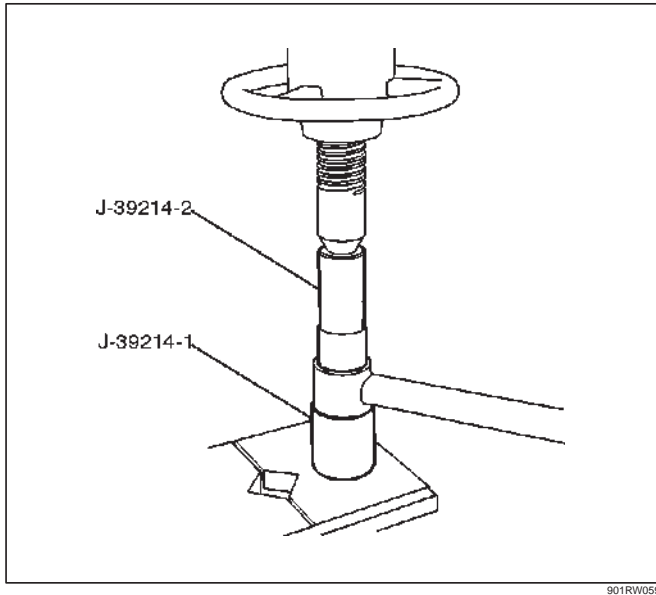


901RW056

## 3D-8 REAR SUSPENSION

- Install the rubber bushing by using installer J-39214.

NOTE: When mounting rubber bushings, be sure not to use grease on bushings or any other nearby part.

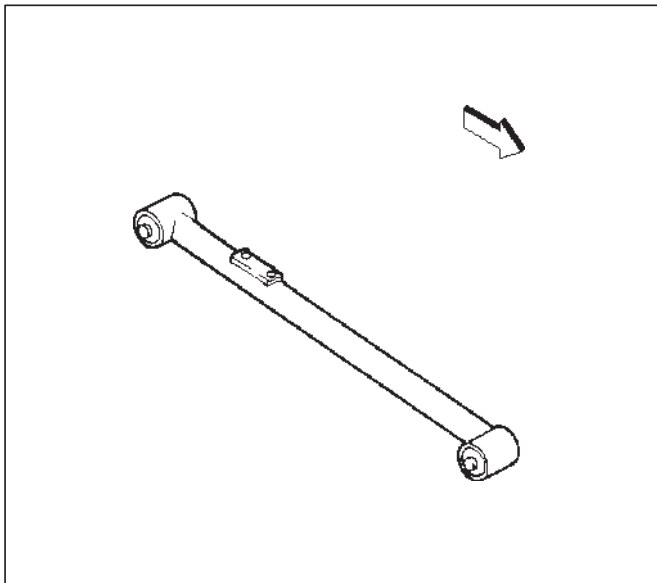


901RW059

## Installation

1. Install trailing link. Make sure that the trailing link is in its correct position.

NOTE: When mounting trailing link, be sure not to use grease on bushings or any other nearby part.



460RS008

2. Install bolt and nut. Tighten the bolts and nuts lightly, then retighten them to the specified torque after the vehicle is at curb height.

**Torque: 137 N·m (101 lb ft)**

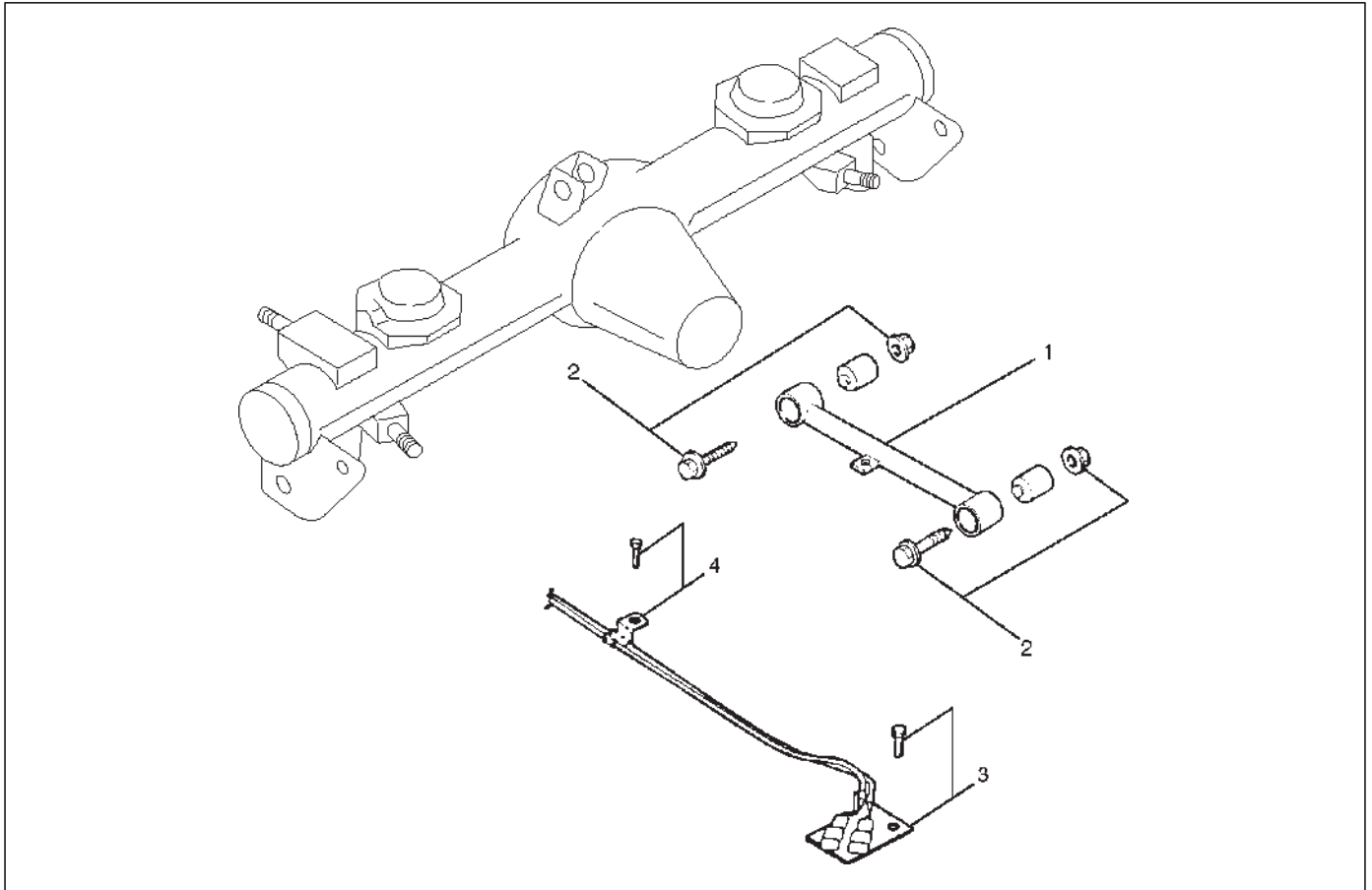
3. Install parking brake cable.

**CAUTION: The parking brake cable should not be overstrained or slackened.**



## Center Link

### Center Link and Associated Parts



460RX002

#### Legend

- (1) Center Link
- (2) Bolt and Nut

- (3) Speed Sensor Cable Bracket
- (4) Speed Sensor Cable

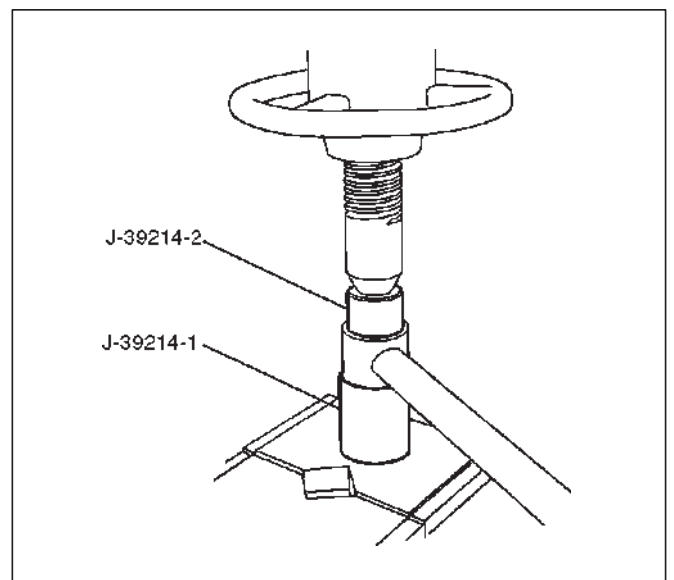
### Removal

1. Remove the speed sensor cable from the center link.
2. Remove the speed sensor cable bracket from the frame.
3. Remove bolt and nut.
4. Remove center link.

### Inspection and Repair

Make necessary correction or parts replacement if wear, damage, corrosion or any other abnormal conditions are found through inspection.

1. Center link
2. Rubber bushing
  - Remove the rubber bushing by using remover J-39214.

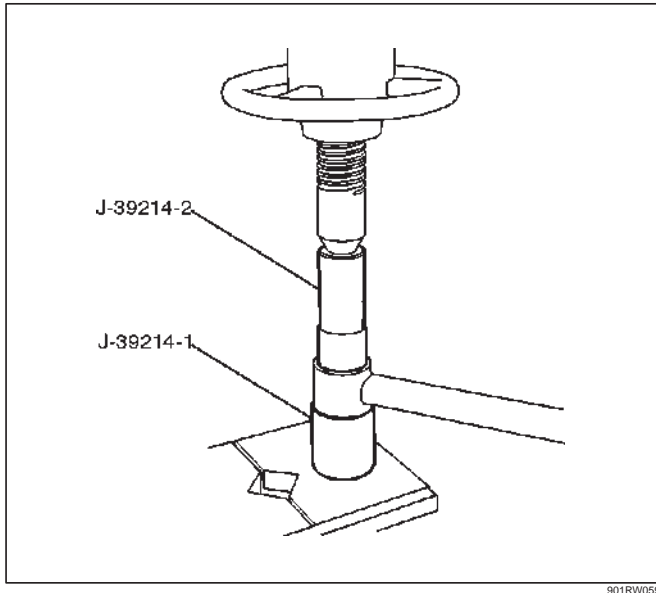


901RW058

## 3D-10 REAR SUSPENSION

- Install the rubber bushing by using to installer J-39214.

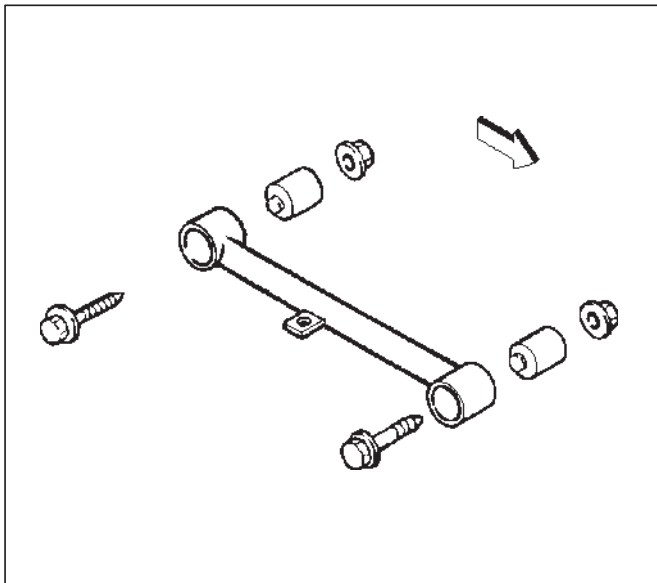
NOTE: When mounting rubber bushings, be sure not to use grease on bushings or any other nearby part.



## Installation

1. Install center link. Make sure that the center link is in its correct position.

NOTE: When mounting center link, be sure not to use grease bushings or any other nearby part.



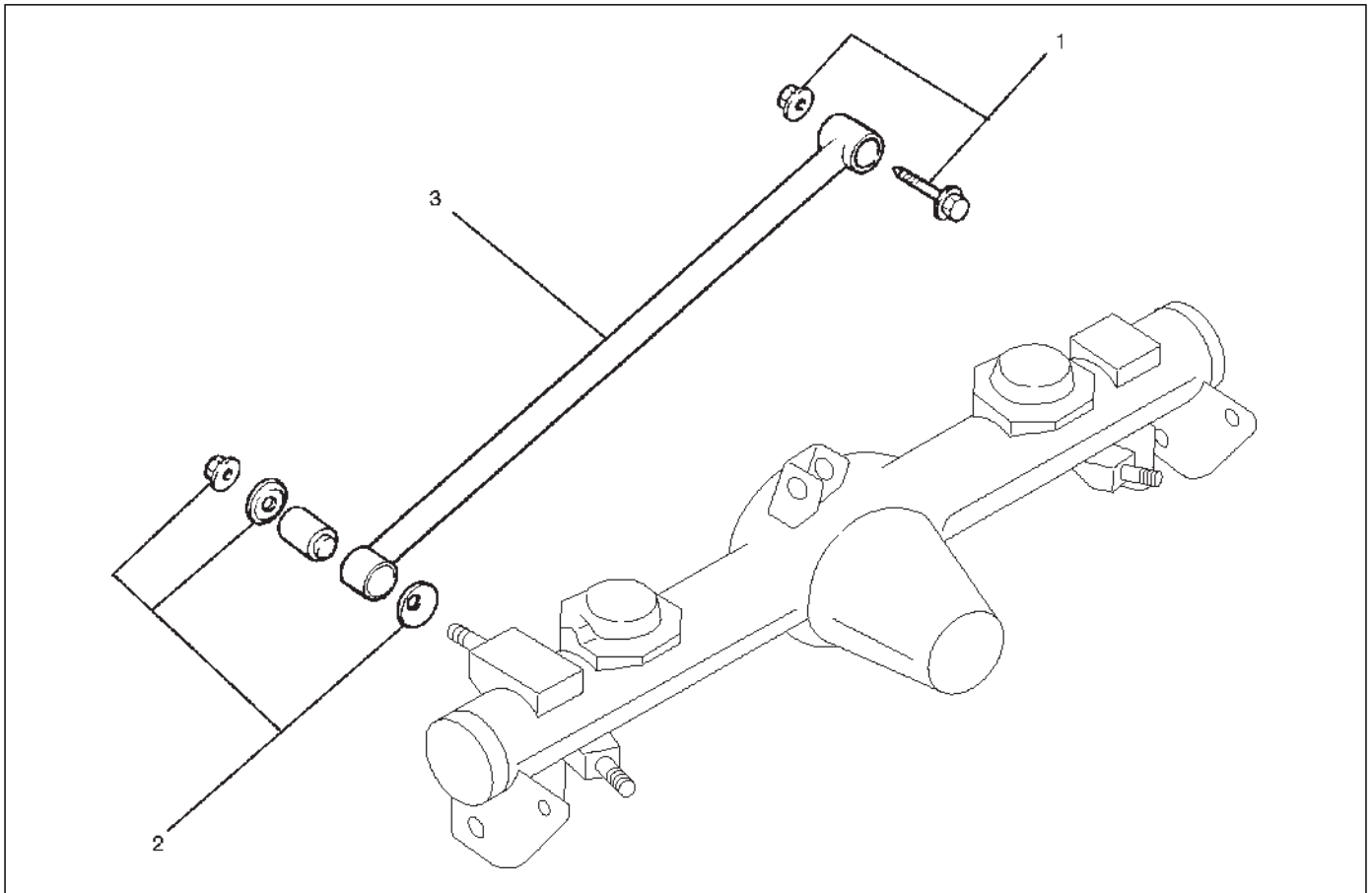
2. Install bolt and nut. Tighten the bolts and nuts lightly, then retighten them to the specified torque after the vehicle is at curb height.

**Torque: 137 N·m (101 lb ft)**

3. Install speed sensor cable bracket.
4. Install speed sensor cable.

## Lateral Rod

### Lateral Rod and Associated Parts



460RX003

#### Legend

(1) Bolt and Nut

(2) Nut and Washer

(3) Lateral Rod

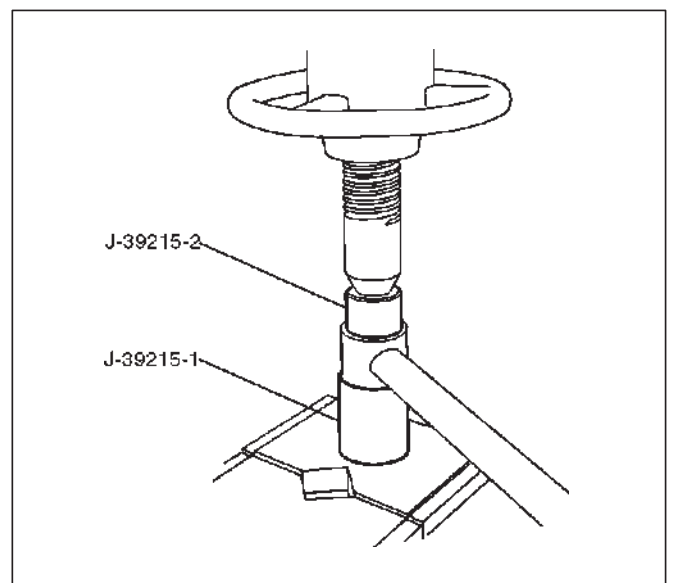
### Removal

1. Remove nut and washer.
2. Remove bolt and nut.
3. Remove lateral rod.

### Inspection and Repair

Make necessary correction or parts replacement if wear, damage, corrosion or any other abnormal condition are found through inspection.

1. Lateral rod
2. Rubber bushing (Frame side)
  - Remove the rubber bushing (Frame side) by using remover J-39214.

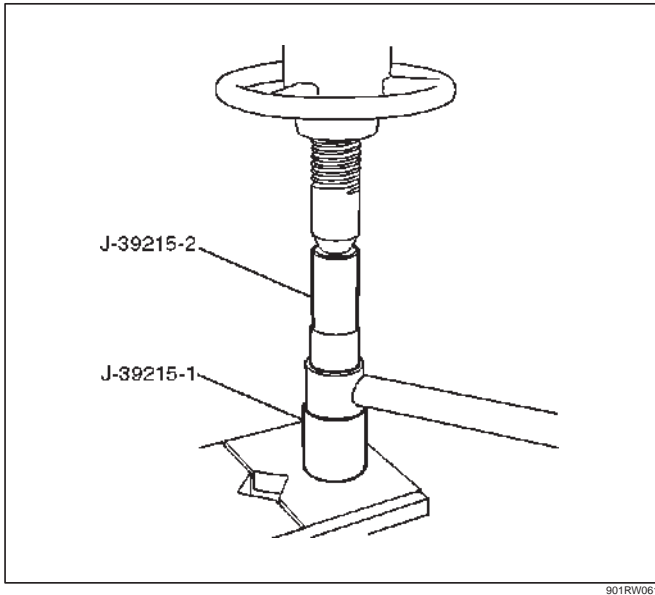


901RW060

## 3D-12 REAR SUSPENSION

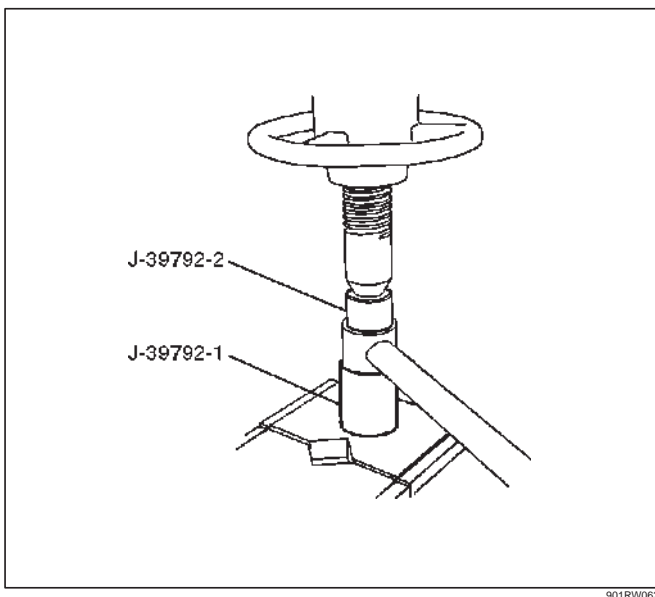
○ Install the rubber bushing (Frame side) by using Installer J-39215.

NOTE: When mounting rubber bushings, do not use grease on bushings or any other nearby parts.

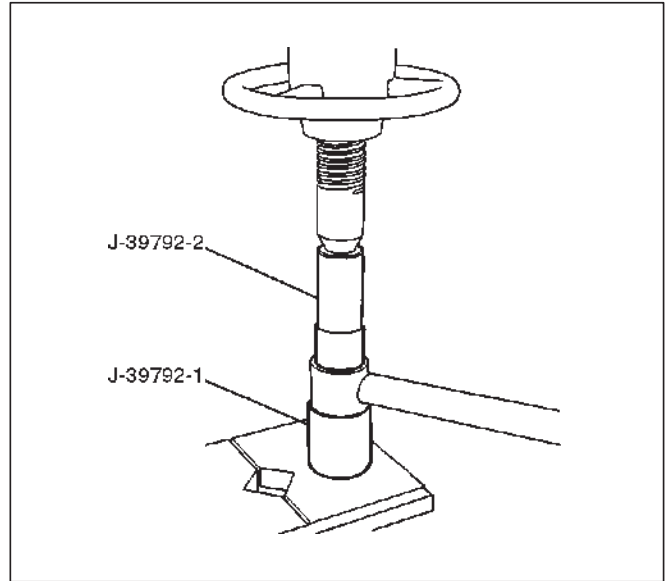


### 3. Rubber bushing (Axle side)

○ Remove the rubber bushing (Axle side) by using remover J-39792.



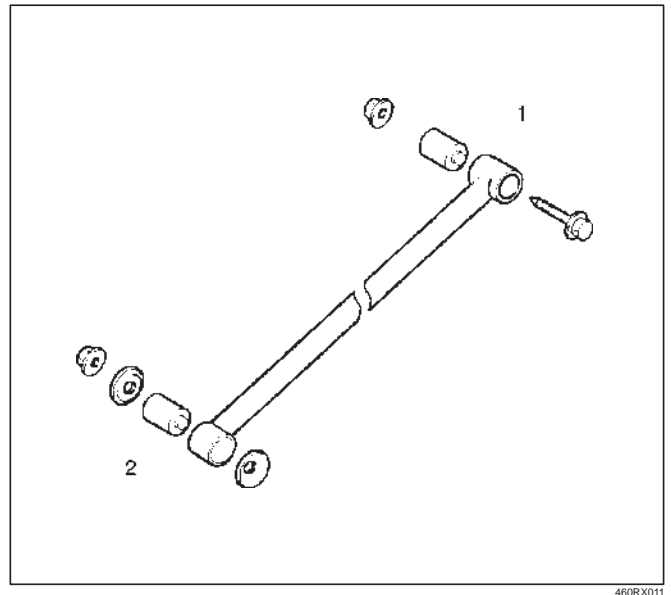
○ Install the rubber bushing (Axle side) by using installer J-39792.



## Installation

1. Install lateral rod and make sure that the lateral rod is in its correct position.

NOTE: When mounting lateral rod, be sure not to use grease on bushings or any other nearby part.



### Legend

- (1) Frame Side
- (2) Axle Side

2. Install bolt and nut. Tighten the bolt and nut lightly, then retighten them to the specified torque after the vehicle is at curb height.

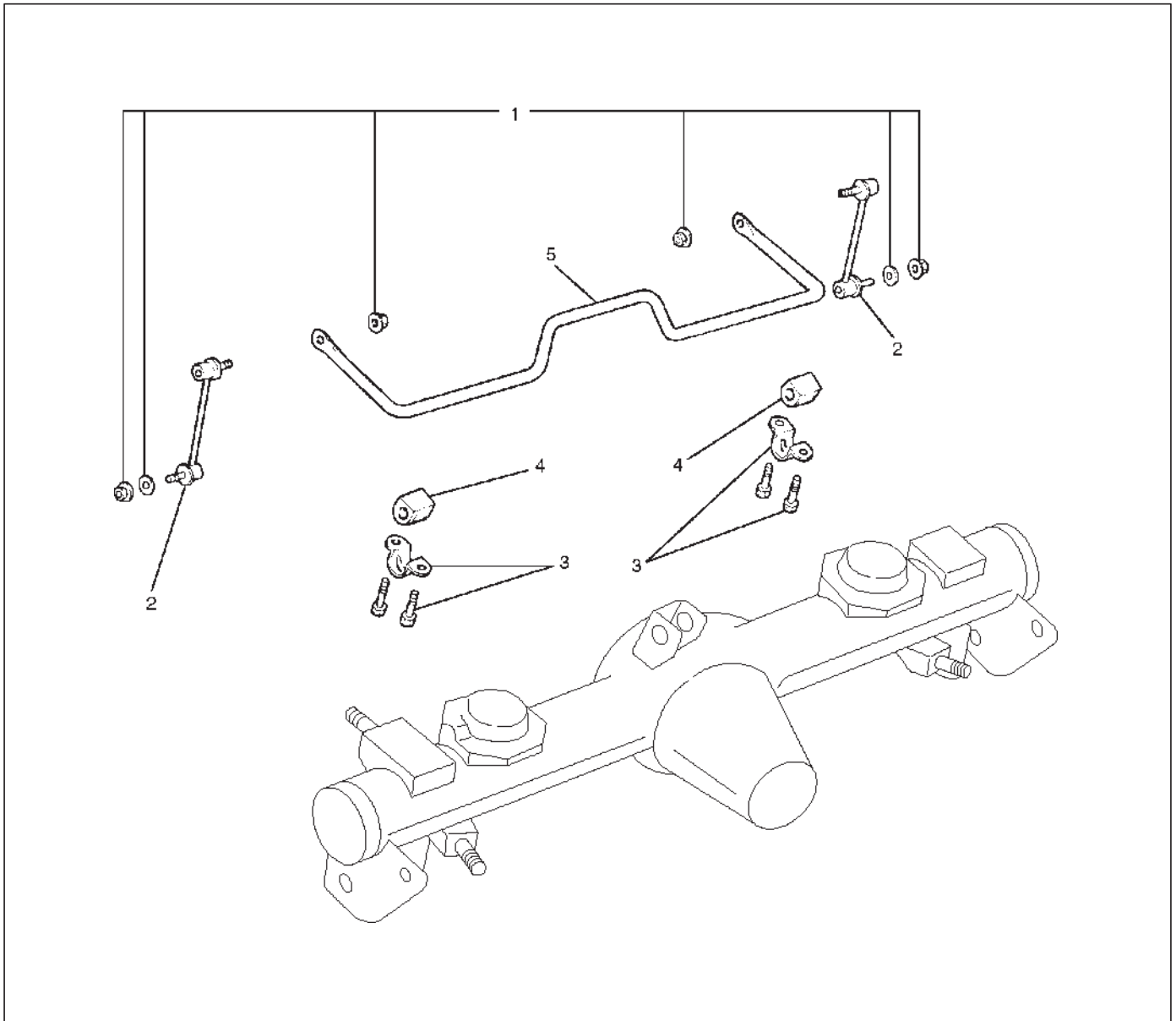
**Torque: 137 N·m (101 lb ft)**

3. Install nut and washer. Tighten the nut lightly, then retighten the nut to the specified torque after the vehicle is at curb height.

**Torque: 78 N·m (58 lb ft)**

## Stabilizer Bar

### Stabilizer Bar and Associated Parts



460RX005

#### Legend

- (1) Nut and Washer
- (2) Link

- (3) Bracket
- (4) Rubber Bushing
- (5) Stabilizer Bar

### Removal

1. Raise the vehicle and support the frame with suitable safety stands.
2. Remove wheel and tire assembly. Refer to Wheel Replacement in this section.
3. Remove nut and washer.
4. Remove link.

**CAUTION:** Be careful not to damage the ball joint boot.

5. Remove bracket.

6. Remove rubber bushing.

7. Remove stabilizer bar.

### Inspection and Repair

Make necessary correction or parts replacement if wear, damage, corrosion or any other abnormal conditions are found through inspection.

Check the following parts:

- Stabilizer bar
- Rubber bushing

## 3D-14 REAR SUSPENSION

---

○ Link ball joint

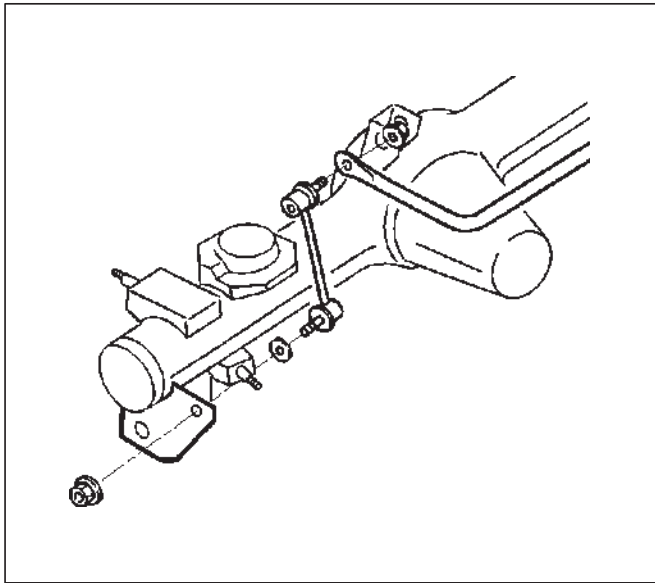
### Installation

1. Install stabilizer bar.
2. Install rubber bushing.
3. Install bracket and tighten to the specified torque.

**Torque: 22 N·m (16 lb ft)**

4. Install link.
5. Install nut and washer, then tighten the nut to the specified torque.

**Torque: 50 N·m (37 lb ft)**



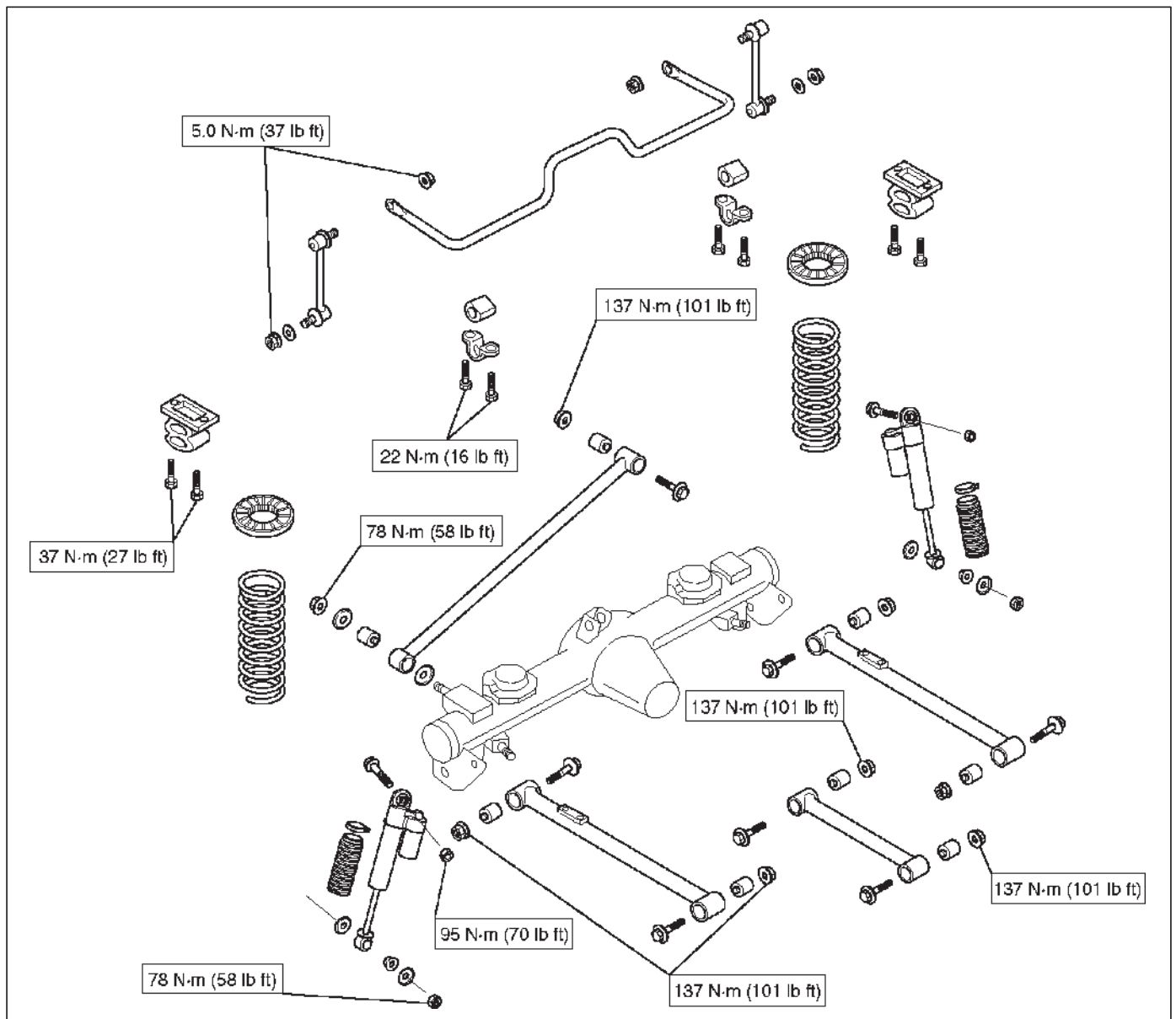
460RS016

## Main Data and Specifications

### General Specifications

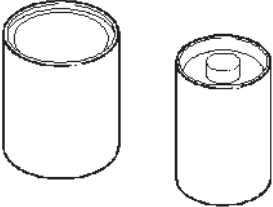
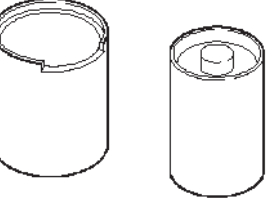
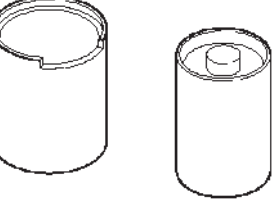
Rear suspension	Type	4-Link, coil spring type with stabilizer bar.
Coil spring	Free length	402mm (15.83in)
	Spring diameter	13.4mm (0.53in)
	Coil diameter (inner)	105mm (4.13in)
	Effective No. of turns	9.18
	Total No. of turns	10.68
Shock absorber	Type	Gas filled single tube shock absorber
	Piston diameter	46.0mm (1.81in)
	Stroke	170mm (6.69in)
	Extended length	489mm (19.25in)
	Compressed length	319mm (12.56in)
Stabilizer bar	Diameter	19.0mm (0.75in)

Torque Specifications





**Special Tools**

ILLUSTRATION	TOOL NO. TOOL NAME
 <p style="text-align: right; font-size: small;">901RS201</p>	<p style="text-align: center;"><b>J-39214</b> Remover and Installer; Trailing center link bushing</p>
 <p style="text-align: right; font-size: small;">901RS202</p>	<p style="text-align: center;"><b>J-39792</b> Remover and Installer; Lateral rod bushing (axle side)</p>
 <p style="text-align: right; font-size: small;">901RS203</p>	<p style="text-align: center;"><b>J-39215</b> Remover and Installer; Lateral rod bushing</p>

# SUSPENSION

## WHEEL AND TIRE SYSTEM

### CONTENTS

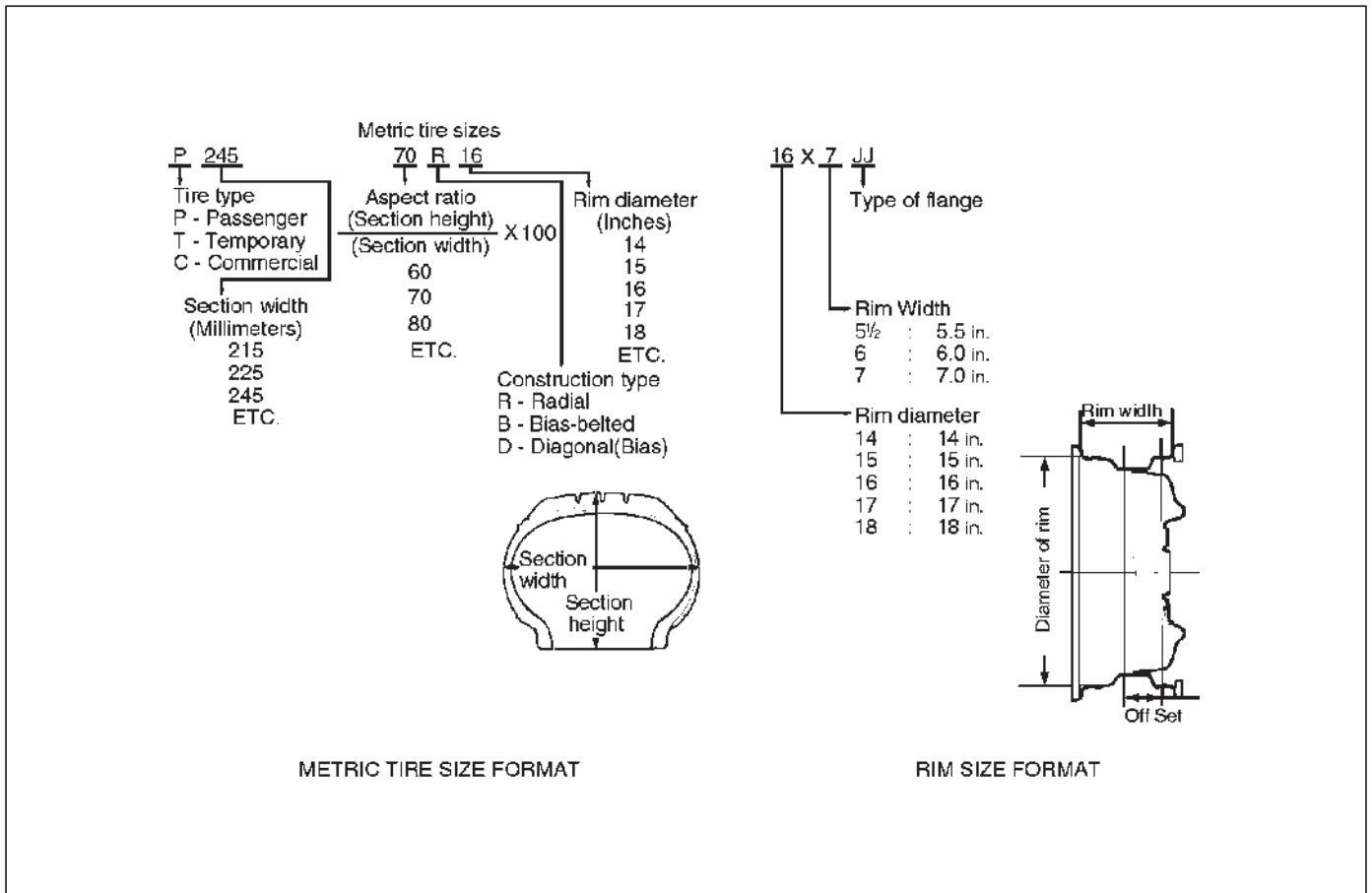
Service Precaution .....	3E-1	Tire .....	3E-10
General Description .....	3E-2	Tire Replacement .....	3E-10
Diagnosis .....	3E-3	Temporary Spare Tire .....	3E-10
Wheel .....	3E-9	General Balance Procedure .....	3E-10
Wheel and Associated Parts .....	3E-9	Balancing Wheel and Tire .....	3E-11
Removal .....	3E-9	Main Data and Specifications .....	3E-12
Installation .....	3E-9		

### Service Precaution

**WARNING: THIS VEHICLE HAS A SUPPLEMENTAL RESTRAINT SYSTEM (SRS). REFER TO THE SRS COMPONENT AND WIRING LOCATION VIEW IN ORDER TO DETERMINE WHETHER YOU ARE PERFORMING SERVICE ON OR NEAR THE SRS COMPONENTS OR THE SRS WIRING. WHEN YOU ARE PERFORMING SERVICE ON OR NEAR THE SRS COMPONENTS OR THE SRS WIRING, REFER TO THE SRS SERVICE INFORMATION. FAILURE TO FOLLOW WARNING COULD RESULT IN POSSIBLE AIR BAG DEPLOYMENT, PERSONAL INJURY, OR OTHERWISE UNNEEDED SRS SYSTEM REPAIRS.**

**CAUTION: Always use the correct fastener in the proper location. When you replace a fastener, use ONLY the exact part number for that application. ISUZU will call out those fasteners that require a replacement after removal. ISUZU will also call out the fasteners that require thread lockers or thread sealant. UNLESS OTHERWISE SPECIFIED, do not use supplemental coatings (Paints, greases, or other corrosion inhibitors) on threaded fasteners or fastener joint interfaces. Generally, such coatings adversely affect the fastener torque and the joint clamping force, and may damage the fastener. When you install fasteners, use the correct tightening sequence and specifications. Following these instructions can help you avoid damage to parts and systems.**

General Description

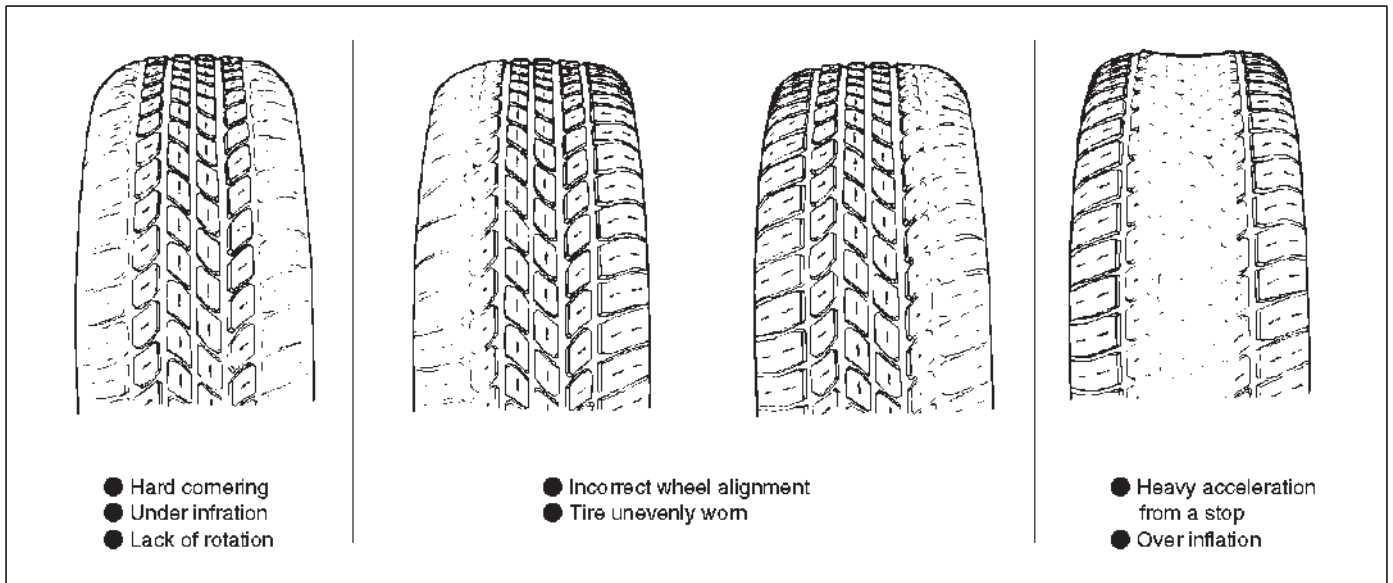


480RY00019

Replacement wheels or tires must be equivalent to the originals in load capacity, specified dimension and mounting configuration. Improper size or type may affect bearing life, brake performance, speedometer/odometer calibration, vehicle ground clearance and tire clearance to the body and chassis. All model are equipped with

metric sized tubeless steel belted radial tires. Correct tire pressures and driving habits have an important influence on tire life. Heavy cornering, excessively rapid acceleration and unnecessary sharp braking increase premature and uneven wear.

## Diagnosis



480RS001

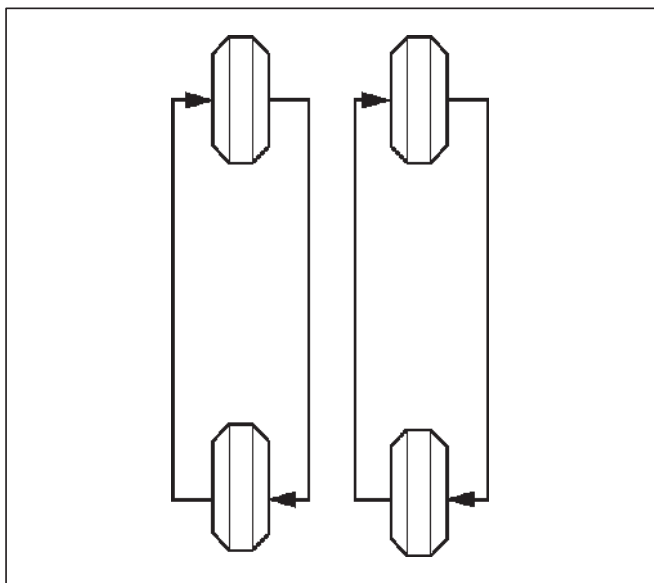
### Irregular and Premature Wear

Irregular and/or premature wear has many causes. Some of them are incorrect inflation pressures, lack of tire rotation, poor driving habits or improper wheel alignment. Incorrect inflation is common cause of tire premature wear.

NOTE: Due to their design, radial tires tend to wear faster in the shoulder area, particularly on the front tires. This makes regular rotation especially necessary. After rotation, be sure to check wheel nut torque, and set tire pressures.

### Tire Rotation

Tire rotation is recommended to equalize wear for longer tire life.



480RX006

If the following conditions are noted, rotate the tires:

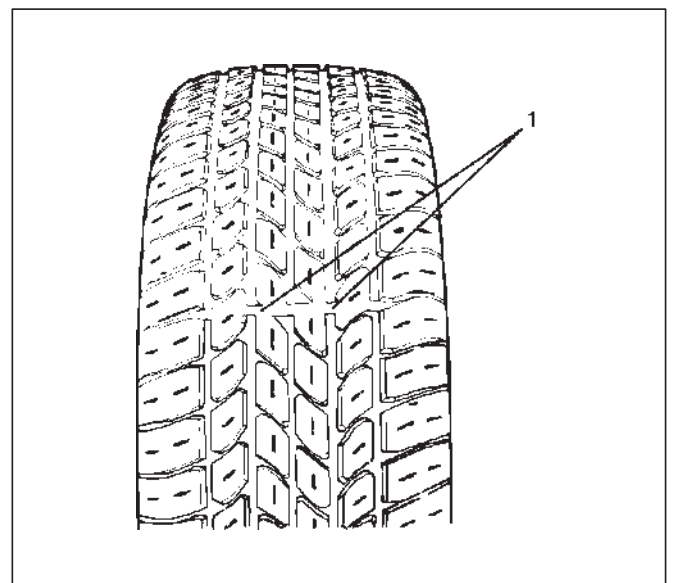
- Front tire wear is different from rear.
- Uneven wear exists across the tread of any tire.
- Left and right front tire wear is unequal.
- Left and right rear tire wear is unequal.

Check wheel alignment if the following conditions are noted:

- Left and right front tire wear is unequal.
- Wear is uneven across the tread of any front tire.
- Front tire treads have a scuffed appearance with "feather" edges on one side of the tread ribs or blocks.

NOTE: Do not include temporary spare tire assembly in rotation.

### Tread Wear Indicators

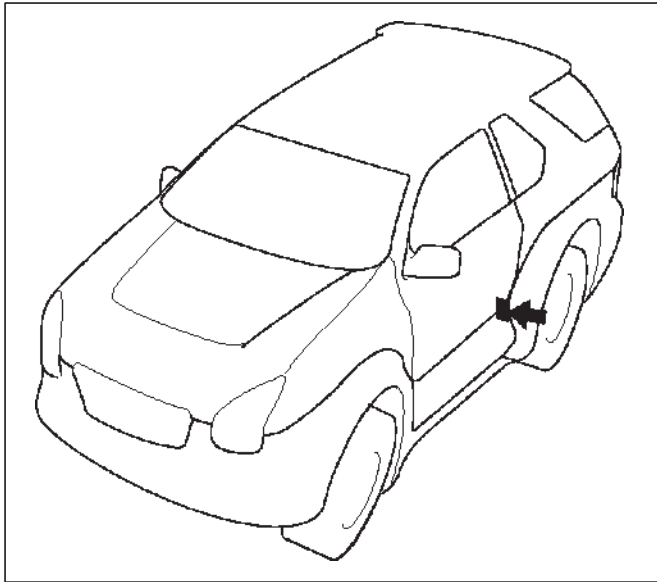


480RS006

## 3E-4 WHEEL AND TIRE SYSTEM

The original equipment tires have built-in tread wear indicators(1) to show when tires need replacement. These indicators may appear as wide bands. When the indicators appear in two or more grooves at three locations, tire replacement is recommended.

### Inflation of Tires



Tire pressure, in cold condition (after vehicle has set for three hours or more, and driven less than one mile), should be checked monthly or before any extended trip. Tire pressure increases approximately 15% when the tires become hot during driving. Tire pressure specification is shown on the label located on the left door lock pillar.

NOTE: Check the tire pressure whenever irregular wear is found. Tire inflation greatly affects tire wear. If the alignment check does not reveal any alignment problems, check the condition of the shock absorbers and wheel/tire balance.

### Diagnosis List

If the following conditions are noted, rotation is required.

1. Front tire wear is different from rear.
2. Uneven wear exists across the tread of any tire.
3. Left and right front tire wear is unequal.
4. Left and right rear tire wear is unequal.

If the following conditions are noted, check the wheel alignment.

1. Left and right front tire wear is unequal.
2. Uneven wear exists across the tread of any tire.
3. Front tire treads have scuffed appearance with "feather" edges on one side of tread ribs or blocks.
4. There is cupping, flat spotting etc.

Higher than recommended pressure can cause:

1. Hard ride.
2. Poor steering stability.
3. Rapid and uneven wear at center of the tread.

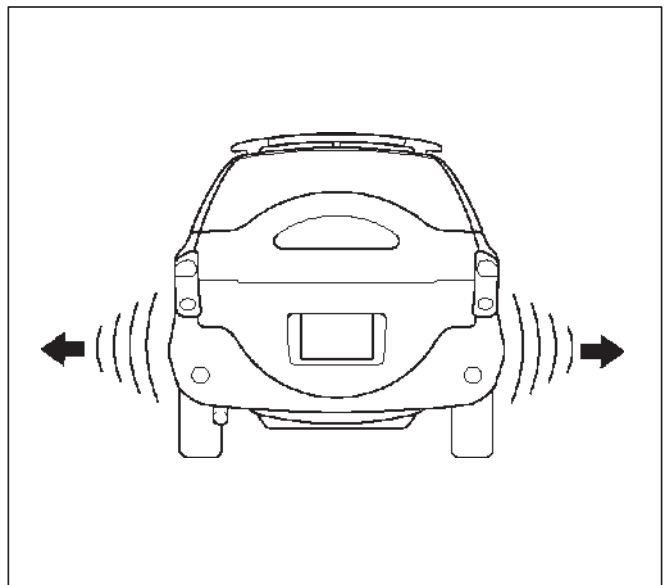
Lower than recommended pressure can cause:

1. Tire squeal on turns.
2. Hard steering.
3. Rapid and uneven wear on the edges of the tread.
4. Tire rim bruises and rupture.
5. Tire cord breakage.
6. High tire temperatures.
7. Reduced handling.
8. Reduced fuel economy.

Unequal pressure on same axle can cause:

1. Uneven braking.
2. Steering lead.
3. Reduced handling.
4. Swerve on acceleration.

### Radial Tire Waddle



Waddle is side-to-side movement at the front and/or rear of the car. It can be caused by the steel belt not being straight within the tire, or by excessive lateral runout of the tire or wheel. It is most noticeable at low speed, about 8 to 48 km/h (5 to 30 mph). It may also cause rough ride at 80 to 113 km/h (50 to 70 mph).

The car can be road tested to see which end of the car has the faulty tire. If the tire causing the waddle is on the rear, the rear end of the car will "waddle". From the driver's seat, it feels as if someone is pushing on the side of the car.

If the faulty tire is on the front, the waddle is more easily seen. The front sheet metal appears to be moving back and forth. It feels as if the driver's seat is the pivot point in the car.

Another more time-consuming method of determining the faulty tire is substituting tire and wheel assemblies that are known to be good. Follow these steps:

1. Drive the car to determine if the waddle is coming from the front or rear.

2. Install tire and wheel assemblies known to be good (from a similar car) in place of those on the end of the car which is waddling. If the waddle cannot be isolated to front or rear, start with the rear tires.
3. Road test again. If improvement is noted, install the original tire and wheel assemblies one at a time until the faulty tire is found. If no improvement is noted, install tires known to be good in place of all four. Then, install the originals one at a time until the faulty tire is found.

### **Radial Tire Lead/Pull**

“Lead/Pull” is vehicle deviation from a straight path, on a level road with no pressure on the steering wheel.

Lead is usually caused by:

1. Poorly manufactured radial tires.
2. Uneven brake adjustment.
3. Wheel alignment.

The way in which a tire is built can produce lead in a car. An example of this is placement of the belt. Off-center belts on radial tires can cause the tire to develop a side force while rolling straight down the road and the tire will tend to roll like a cone.

The “Radial Tire Lead/Pull Correction” chart should be used to make sure that front wheel alignment is not mistaken for tire lead.

Rear tires will not cause lead/pull.

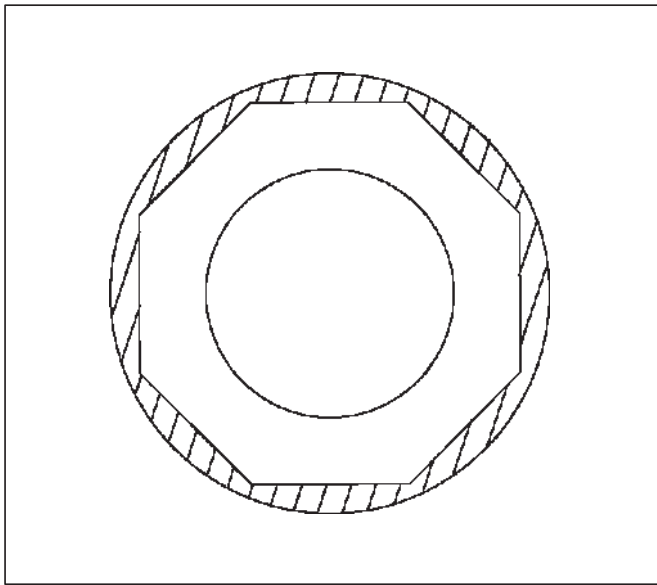
Radial Tire Lead/Pull Correction Chart

Step	Action	Yes	No
1	1. Inflate tires to recommended pressure. 2. Road test vehicle on level uncrowned road. Was a problem corrected?	End	Go to Step 2
2	Switch front tires side to side and road test again. Was a problem corrected?	If roughness results, replace tires	Go to Step 3
3	Did the vehicle lead in same direction?	Go to Step 4	Go to Step 5
4	Put tires back in original position and check alignment. Was a problem corrected?	End	Go to Step 5
5	Install known good tire on one front side. Was a problem corrected?	Replace tire	Install a known good tire in place of other front tire If lead corrected, replace tire

Typical examples of abnormal tire ahead wear and major causes:

**CAUTION: Similar wear patterns can be caused by worn suspension parts, misalignment of wheels and tires, and other suspension related problems.**

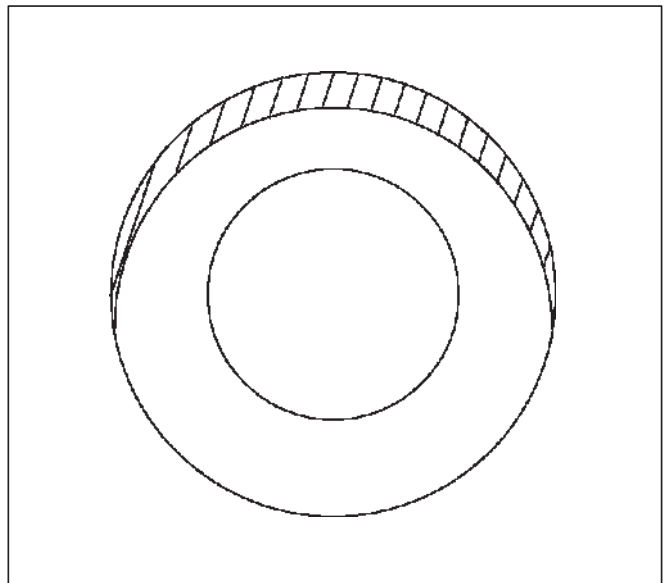
Spotty wear – wear localized on shoulder sections, and in an extreme cases, the tire becomes polygonal in shape.



480RW002

1. Tire or wheel out of round or distorted.
2. Hub or knuckle out of round or distorted.
3. Play in hub bearings or ball joint.
4. Rotating parts out of balance.

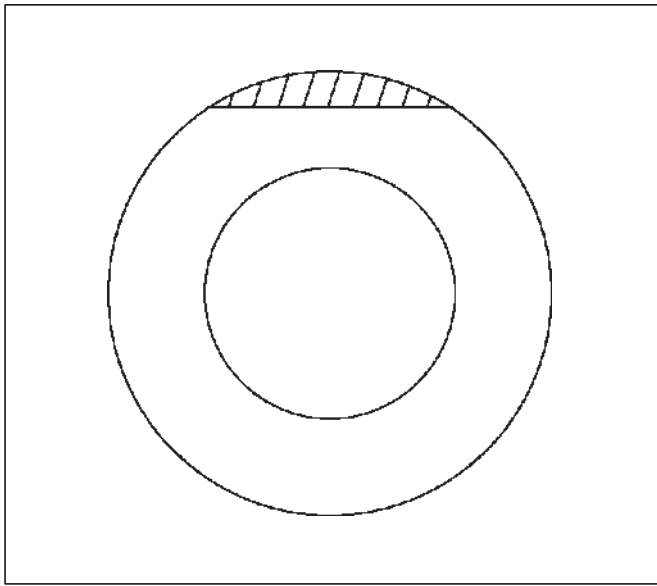
Tread wear one-sided.



480RW003

1. Rotating parts out of balance.
2. Tire or wheel out of round.
3. Hub or knuckle out of round or distorted.

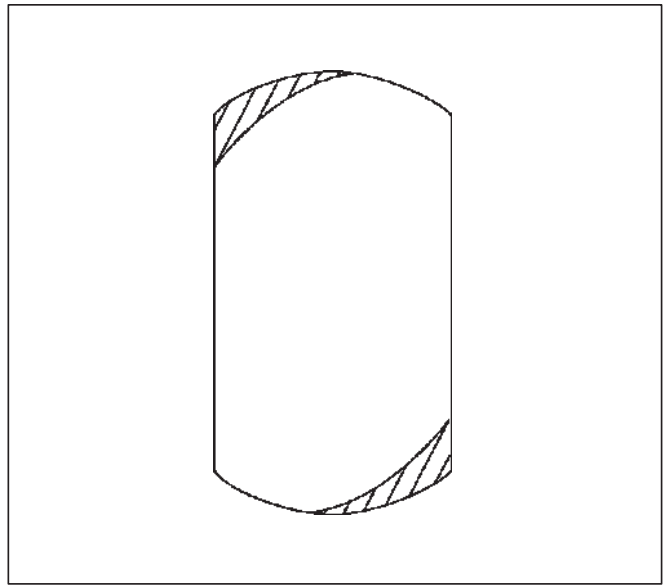
Localized tread wear.



480RW004

1. Once spotty wear develops in tread due to hard braking, localized wear tends to be promoted.

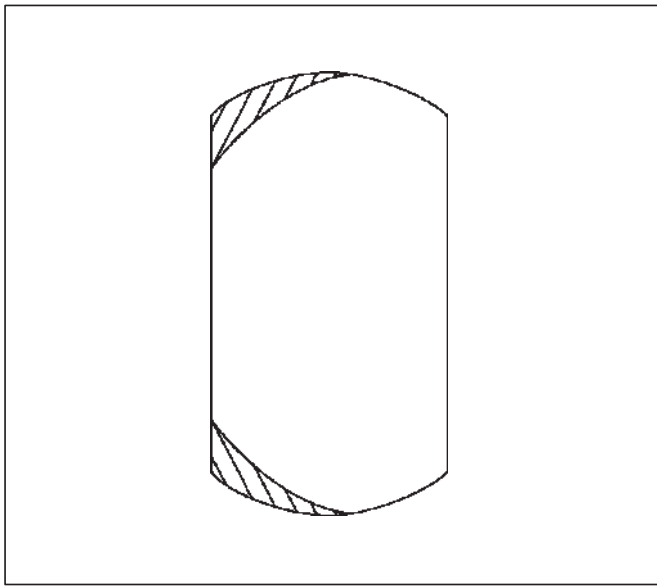
Wear in shoulders at points opposed to each other.



480RW006

1. Tire or wheel out of round or distorted.
2. Play in bearings or ball joint.

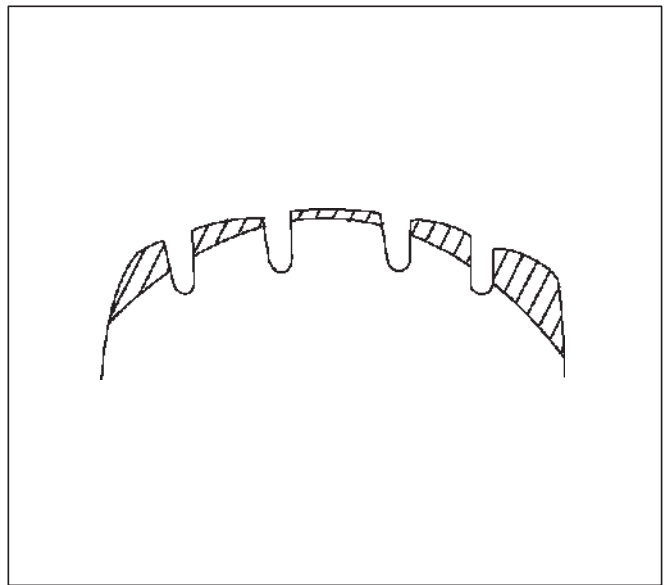
Shoulder wear (generally wear develops in outer shoulder):



480RW005

1. Camber or toe-in incorrect.
2. Shoulder wear caused by repeated hard-cornering.

Premature wear in shoulders.



480RW007

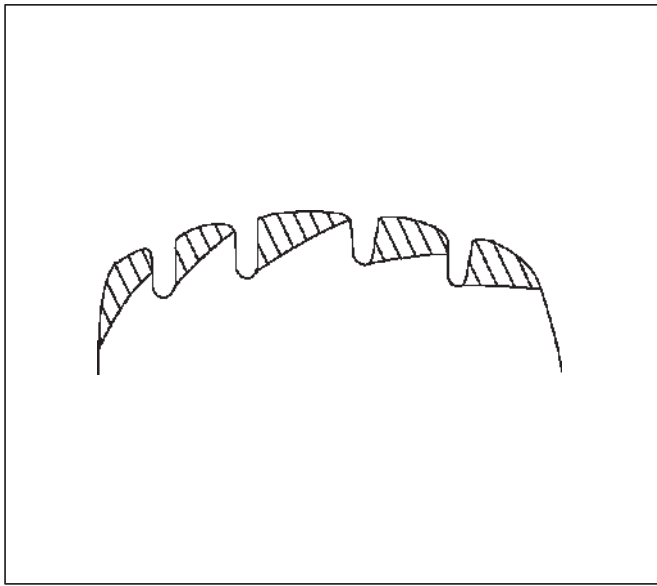
1. Flexing of tire excessive due to under-inflation.



## 3E-8 WHEEL AND TIRE SYSTEM

---

One sided feather edging.

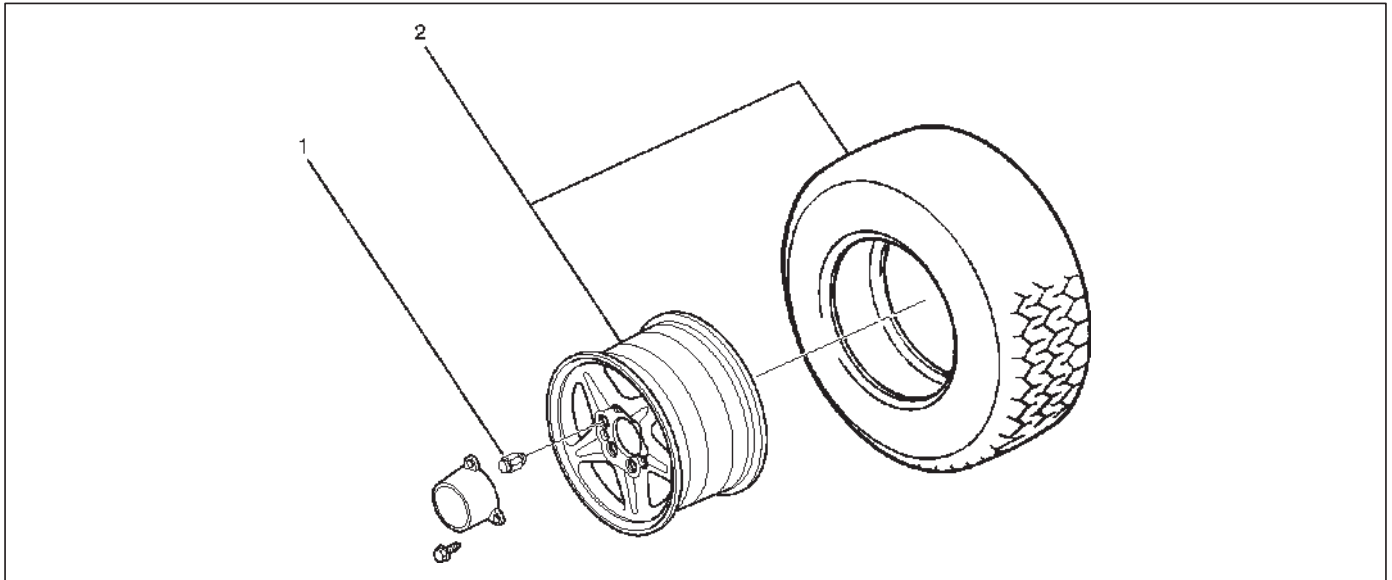


480RW008

1. Wear caused by repeated hard-cornering.
2. Camber or toe-in incorrect.

## Wheel

### Wheel and Associated Parts



480RX004

#### Legend

- (1) Wheel Lug Nut
- (2) Wheel and Tire

### Removal

1. Loosen wheel lug nut by approximately 180° (half a rotation), then raise the vehicle and remove the nuts.
2. Remove wheel and tire.

**NOTE:** Never use heat to loosen a tight wheel lug nut. The application of heat to the hub can shorten the life of the wheel and may cause damage to wheel bearings.

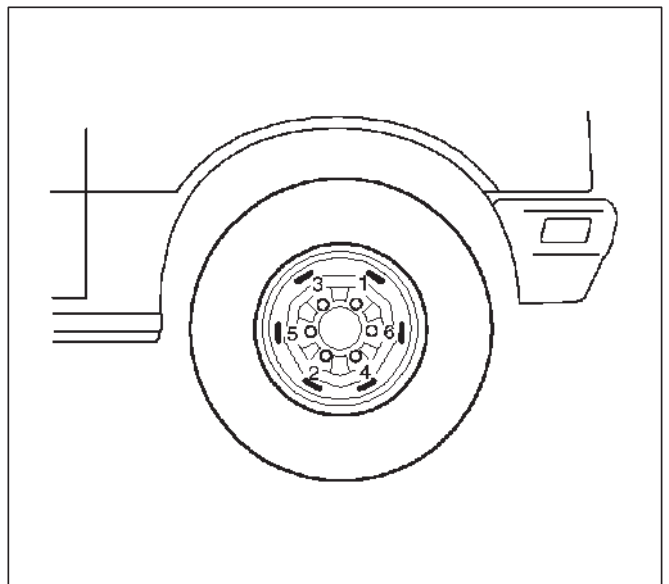
### Installation

1. Install wheel and tire.
2. Install wheel lug nut, and lower the vehicle. Tighten the wheel lug nuts to the specified torque in numerical order.

**Torque: 118 N·m (87 lb ft)**

**CAUTION:** Before installing wheels, remove any build-up of corrosion on the wheel mounting surface and brake disc mounting surface by scraping and wire brushing. Installing wheels without good metal-to-metal contact at mounting surfaces can cause wheel nuts to loosen, which can later allow a wheel to come off while the vehicle is moving.

**NOTE:** Valve caps should be on the valve stems to keep dust and water out.



480RS020

## Tire

### Tire Replacement

When replacement is necessary, the original metric tire size should be used. Most metric tire sizes do not have exact corresponding alphanumeric tire sizes. It is recommended that new tires be installed in pairs on the same axle. If necessary to replace only one tire, it should be paired with a tire having the most tread, to equalize braking traction.

**CAUTION: Do not mix different types of tires such as radial, bias and bias-belted tires except in emergencies, because vehicle handling may be seriously affected and may result in loss of control.**

### Tire Dismounting

Remove valve cap on valve stem and deflate the tire. Then use a tire changing machine to mount or dismount tires. Follow the equipment manufacturer's instruction. Do not use hand tools or tire lever alone to change tires as they may damage the tire beads or wheel rim.

### Tire Mounting

Rim bead seats should be cleaned with a wire brush or coarse steel wool to remove lubricants, and light rust. Before mounting a tire, the bead area should be well lubricated with an approved tire lubricant.

After mounting, inflate the tire to 196kpa (28 psi) so that beads are completely seated. Inflate the air to specified pressure and install valve cap to the stem.

**WARNING: NEVER STAND OVER TIRE WHEN INFLATING. BEAD MAY BREAK WHEN BEAD SNAPS OVER RIM'S SAFETY HUMP AND CAUSE SERIOUS PERSONAL INJURY.**

**NEVER EXCEED 240 KPA (35 PSI) PRESSURE WHEN INFLATING. IF 240 KPA (35 PSI) PRESSURE WILL NOT SEAT BEADS, DEFLATE, RE-LUBRICATE AND RE-INFLATE. OVER INFLATION MAY CAUSE THE BEAD TO BREAK AND CAUSE SERIOUS PERSONAL INJURY.**

### Tire Repair

There are many different materials on the market used to repair tires.

Manufacturers have published detailed instructions on how and when to repair tires. These instructions can be obtained from the tire manufacturer if they are not included with the repair kit.

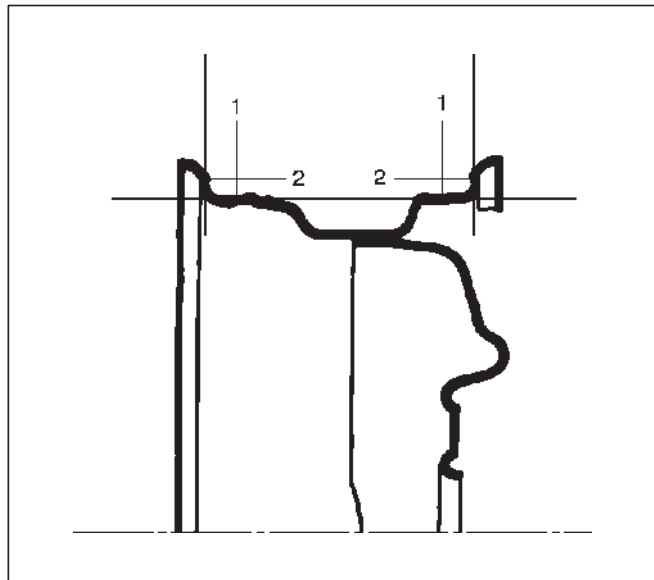
### Wheel Inspection

Damaged wheels and wheels with excessive run-out must be replaced.

Wheel run out at rim (Base on hub Bore):

**Vertical play(1): Less than 0.7mm (0.028 in)**

**Horizontal play(2): Less than 0.7mm (0.028 in)**



### Temporary Spare Tire

This vehicle is equipped with a temporary spare tire. When using this spare tire, observe the following notice.

NOTE:

- Do not use this temporary spare tire for another vehicle.
- This spare tire is for temporary use only. Repair and reinstall the standard wheel and tire assembly as soon as possible.
- This spare tire should be used with the specified inflation pressure (420 kpa/60 psi).
- Do not attempt to use tire chains on this spare tire.
- For other information, refer to the caution label and owner's manual.

### General Balance Procedure

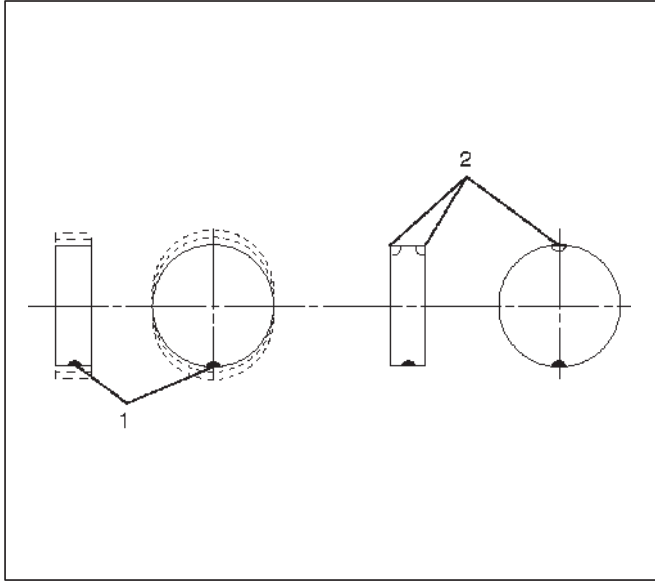
Deposits of mud, etc. must be cleaned from the inside of the rim.

The tire should be inspected for the following: match mount paint marks, bent rims, bulges, irregular tire wear, proper wheel size and inflation pressure. Then balance according to the equipment manufacturer's recommendations.

There are two types of wheel and tire balance.

Static balance is the equal distribution of weight around the wheel.

Assemblies that are statically unbalanced cause a bouncing action called tramp. This condition will eventually cause uneven tire wear.

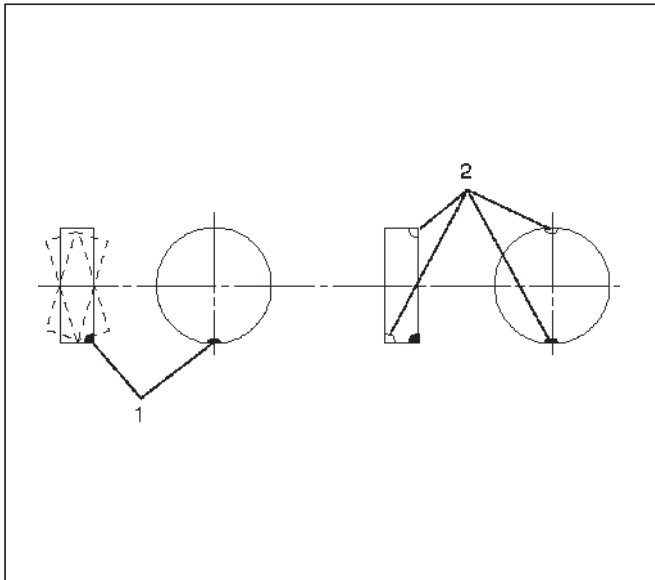


480RS014

**Legend**

- (1) Heavy Spot Wheel Hop
- (2) Add Balance Weights Here

Dynamic balance is the equal distribution of weight on each side of the wheel center-line so that when the tire spins there is no tendency for the assembly to move from side to side. Assemblies that are dynamically unbalanced may cause shimmy.



480RS013

**Legend**

- (1) Heavy Spot Wheel Shimmy
- (2) Add Balance Weights Here

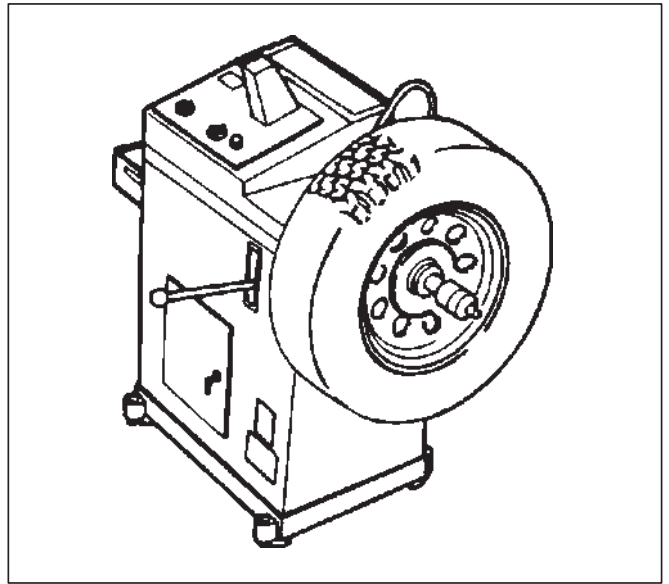
**Balancing Wheel and Tire**

**On-vehicle Balancing**

On-Vehicle balancing methods vary with equipment and tool manufacturers. Be sure to follow each manufacturer's instructions during balancing operation.

**Off-vehicle Balancing**

Most electronic off-vehicle balancers are more accurate than the on-vehicle spin balancers. They are easy to use and give a dynamic balance. Although they do not correct for drum or disc unbalance (as on-vehicle spin balancing does), they are very accurate.



480RS015

**WARNING: STONES SHOULD BE REMOVED FROM THE TREAD TO AVOID OPERATOR INJURY DURING SPIN BALANCING AND TO OBTAIN A GOOD BALANCE.**

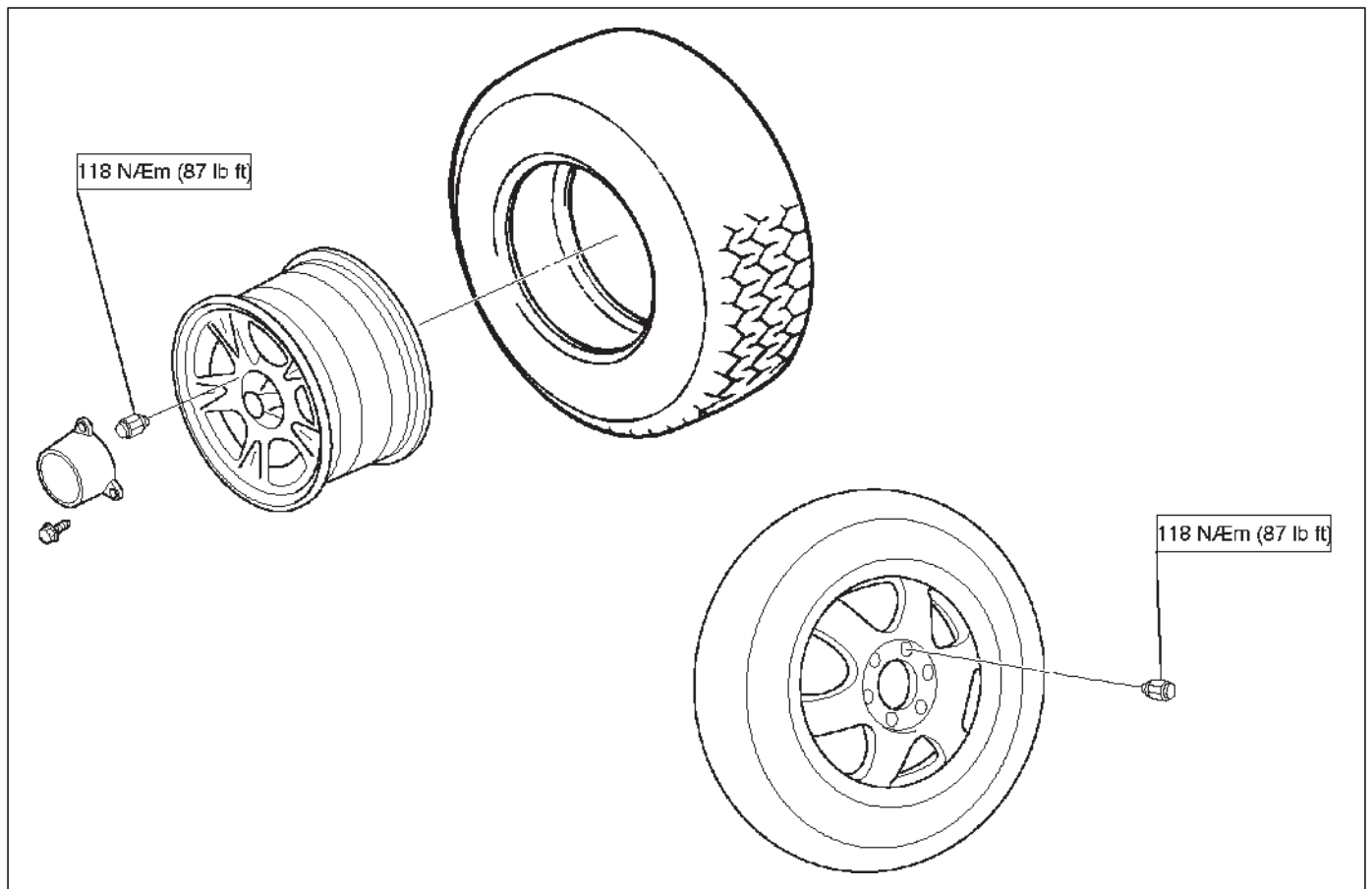
## 3E-12 WHEEL AND TIRE SYSTEM

### Main Data and Specifications

#### General Specifications

Wheels	Size	18 x 7JJ
	Offset	38.0 mm (1.50 in)
	P.C.D., wheel studs	139.7 mm (5.50 in)
Standard tire	Size	P245/60R18 106S
	Pressure	200 kpa (29 psi)
Spare wheel	Size	17 x 4T
	Offset	38.0 mm (1.50 in)
	P.C.D., wheel studs	139.7 mm (5.50 in)
Spare tire	Size	T165/90 D17 105M
	Pressure	420 kpa (60 psi)

#### Torque Specifications



VEHICROSS

# DRIVELINE/AXLE

## CONTENTS

Differential (Front) .....	4A1	Drive Shaft System .....	4C
Differential (Rear) .....	4A2	Transfer Case (TOD) .....	4D2
Driveline Control System .....	4B2		

## DIFFERENTIAL (FRONT)

### CONTENTS

Service Precaution .....	4A1-1	Installation .....	4A1-6
Front Drive Axle .....	4A1-2	Differential Assembly .....	4A1-8
Diagnosis .....	4A1-2	Disassembled View .....	4A1-8
Pinion Shaft Oil Seal .....	4A1-3	Disassembly .....	4A1-9
Pinion Shaft Oil Seal and Associated Parts	4A1-3	Reassembly .....	4A1-11
Removal .....	4A1-3	Differential Cage Assembly .....	4A1-20
Inspection and Repair .....	4A1-4	Disassembled View .....	4A1-20
Installation .....	4A1-4	Disassembly .....	4A1-20
Front Drive Axle Assembly .....	4A1-5	Inspection and Repair .....	4A1-21
Front Drive Axle Assembly and		Reassembly .....	4A1-22
Associated Parts .....	4A1-5	Main Data and Specifications .....	4A1-24
Removal .....	4A1-5	Special Tools .....	4A1-26

### Service Precaution

**WARNING: THIS VEHICLE HAS A SUPPLEMENTAL RESTRAINT SYSTEM (SRS). REFER TO THE SRS COMPONENT AND WIRING LOCATION VIEW IN ORDER TO DETERMINE WHETHER YOU ARE PERFORMING SERVICE ON OR NEAR THE SRS COMPONENTS OR THE SRS WIRING. WHEN YOU ARE PERFORMING SERVICE ON OR NEAR THE SRS COMPONENTS OR THE SRS WIRING, REFER TO THE SRS SERVICE INFORMATION. FAILURE TO FOLLOW WARNINGS COULD RESULT IN POSSIBLE AIR BAG DEPLOYMENT, PERSONAL INJURY, OR OTHERWISE UNNEEDED SRS SYSTEM REPAIRS.**

**CAUTION:** Always use the correct fastener in the proper location. When you replace a fastener, use **ONLY** the exact part number for that application. ISUZU will call out those fasteners that require a replacement after removal. ISUZU will also call out the fasteners that require thread lockers or thread sealant. **UNLESS OTHERWISE SPECIFIED**, do not use supplemental coatings (Paints, greases, or other corrosion inhibitors) on threaded fasteners or fastener joint interfaces. Generally, such coatings adversely affect the fastener torque and the joint clamping force, and may damage the fastener. When you install fasteners, use the correct tightening sequence and specification. Following these instructions can help you avoid damage to parts and systems.

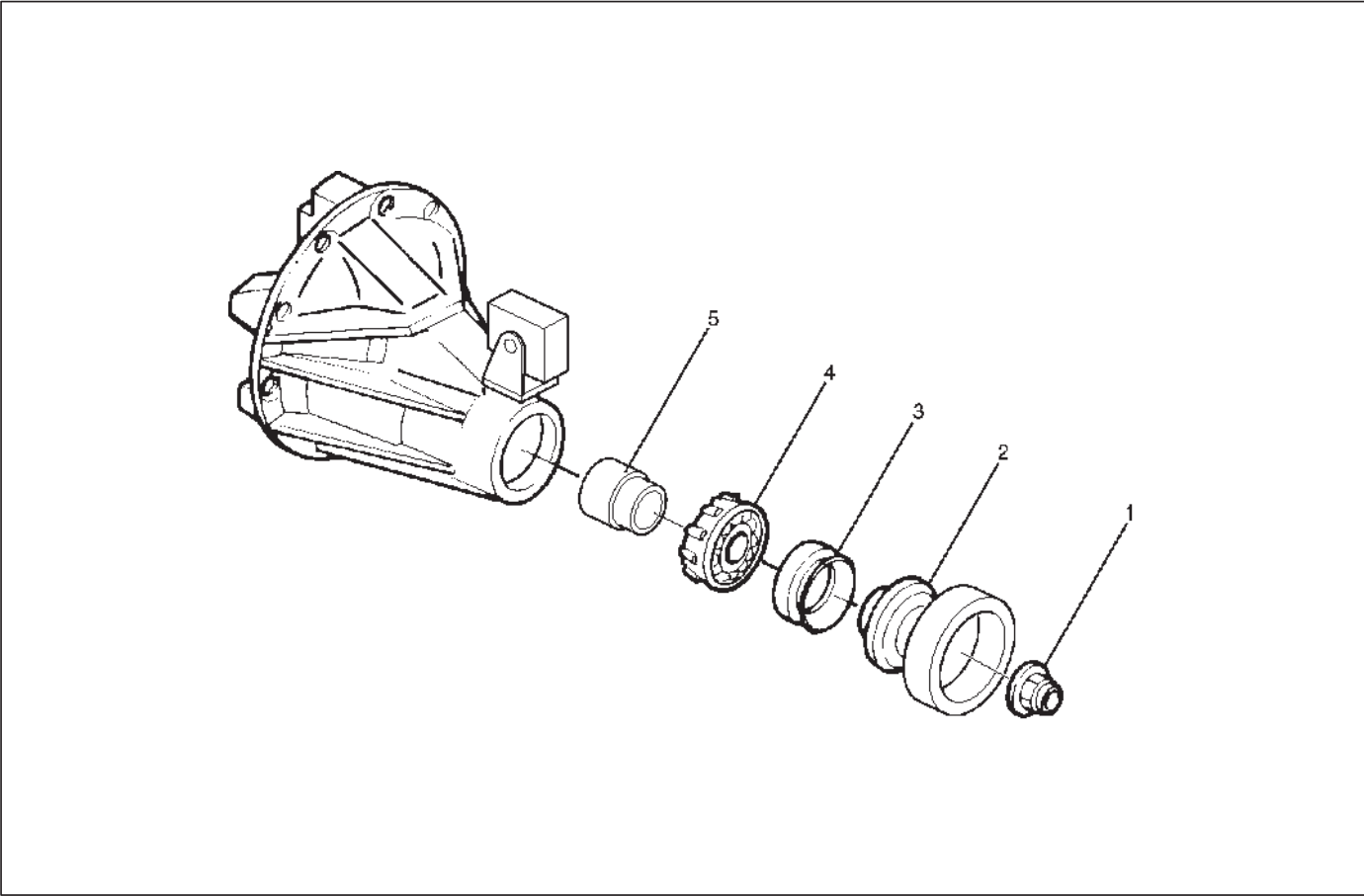
## Front Drive Axle

### Diagnosis

Condition	Possible cause	Correction
Oil Leak At Front Axle	Worn or defective oil seal.	Replace the oil seal.
	Front axle housing cracked.	Repair or replace.
Oil Leak At Pinion Shaft	Too much gear oil.	Correct the oil level.
	Oil seal worn or defective.	Replace the oil seal.
	Pinion flange loose or damaged.	Tighten or replace.
Noises In Front Axle Drive Shaft Joint	Broken or worn drive shaft joints and bellows (BJ and DOJ).	Replace the drive shaft joints and bellows.
"Clank" When Accelerating From "Coast"	Loose drive shaft joint to output shaft bolts.	Tighten.
	Damaged inner drive shaft joint.	Replace.
Shudder or Vibration During Acceleration	Excessive drive shaft joint angle.	Repair.
	Worn or damaged drive shaft joints.	Replace.
	Sticking spider assembly (inner drive shaft joint).	Lubricate or replace.
	Sticking joint assembly (outer drive shaft joint).	Lubricate or replace.
Vibration At Highway Speeds	Out of balance or out of round tires.	Balance or replace.
	Front end out of alignment.	Align.
Noises in Front Axle	Insufficient gear oil.	Replenish the gear oil.
	Wrong or poor grade gear oil.	Replace the gear oil.
	Drive pinion to ring gear backlash incorrect.	Adjust the backlash.
	Worn or chipped ring gear, pinion gear or side gear.	Replace the ring gear, pinion gear or side gear.
	Pinion shaft bearing worn.	Replace the pinion shaft bearing.
	Wheel bearing worn.	Replace the wheel bearing.
	Differential bearing loose or worn.	Tighten or replace.
Wanders and Pulls	Wheel bearing preload too tight.	Adjust the wheel bearing preload.
	Incorrect front alignment.	Adjust the front alignment.
	Steering linkage loose or worn.	Tighten or replace.
	Steering gear out of adjustment.	Adjust or replace the steering gear.
	Tire worn or improperly inflated.	Adjust the inflation or replace.
	Front or rear suspension parts loose or broken.	Tighten or replace.
Front Wheel Shimmy	Wheel bearing worn or improperly adjusted.	Adjust or replace.
	Incorrect front alignment.	Adjust the front alignment.
	Worn ball joint or bush.	Replace the ball joint or bush.
	Steering linkage loose or worn.	Tighten or replace.
	Steering gear out of adjustment.	Tighten or replace.
	Tire worn or improperly inflated.	Replace or adjust the inflation.
	Shock absorber worn.	Replace the shock absorber.

# Pinion Shaft Oil Seal

## Pinion Shaft Oil Seal and Associated Parts



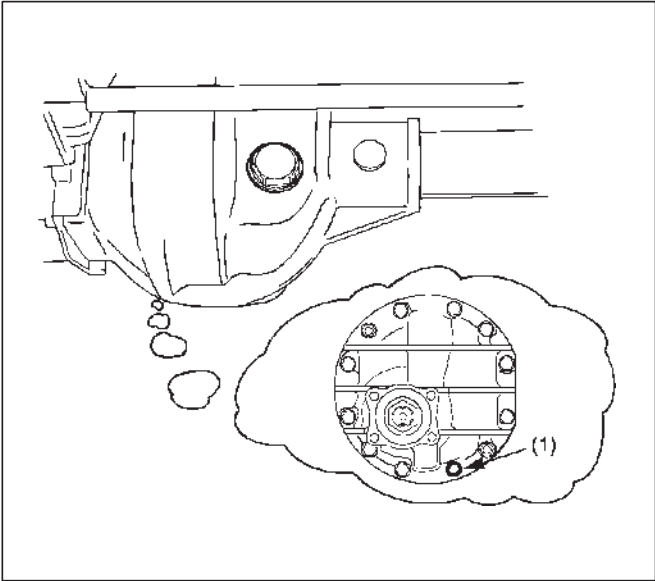
415RX002

**Legend**

- (1) Flange Nut
- (2) Flange
- (3) Oil Seal
- (4) Outer Bearing
- (5) Collapsible Spacer

### Removal

1. Raise the vehicle and support it at the frame.  
The hoist must remain under the front axle housing.
2. Drain the front axle oil by loosening the drain plug(1).

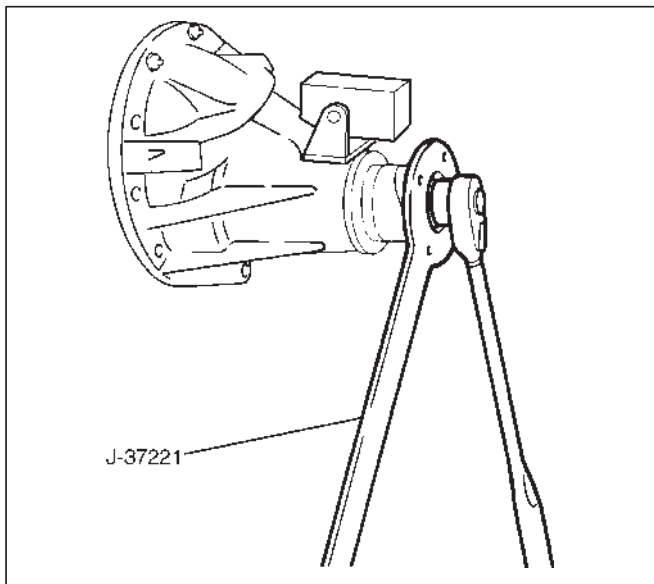


412RS001

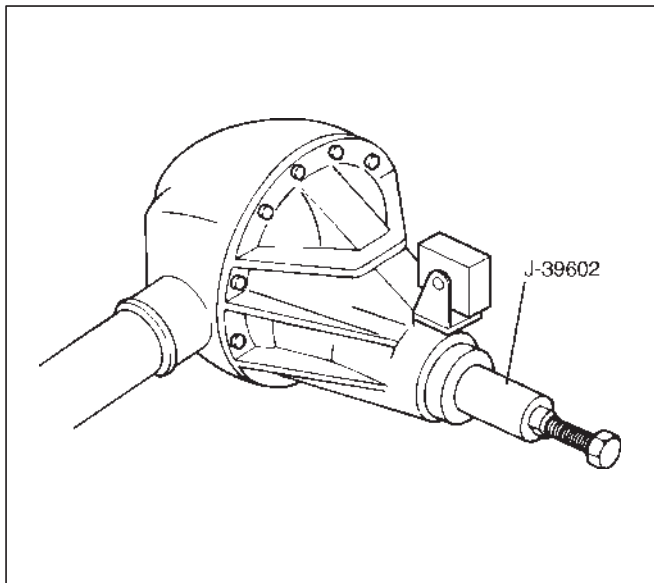


## 4A1-4 DIFFERENTIAL (FRONT)

3. Remove the front propeller shaft. Refer to Front Propeller Shaft in this section.
4. Remove flange nut by using pinion flange holder J-37221.



5. Remove flange.
6. Remove oil seal.
7. Remove outer bearing by using remover J-39602.



8. Remove collapsible spacer.

## Inspection and Repair

Make necessary correction or parts replacement if wear, damage, corrosion or any other abnormal conditions are found through inspection.

Check the following parts:

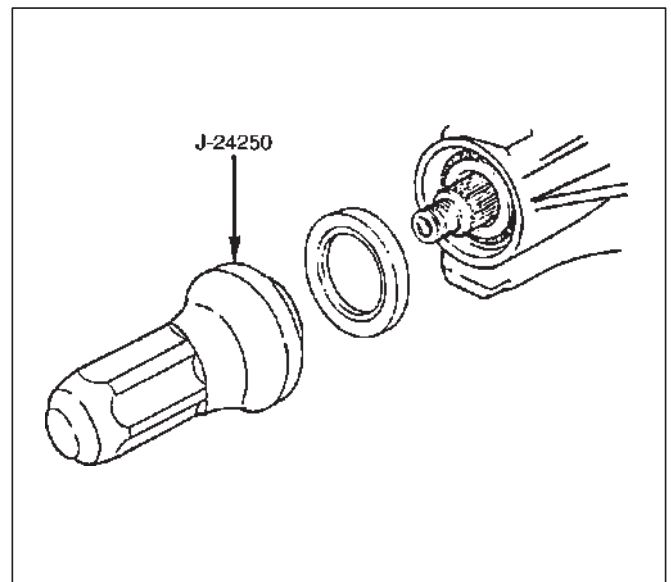
1. Seal surface of the pinion.
2. Cage bore for burns.

## Installation

1. Install collapsible spacer. Discard the used collapsible spacer and install a new one.
2. Install outer bearing.

NOTE: Do not drive in, but just temporarily set in the outer bearing by hand, which should be indirectly pressed in finally by tightening the flange nut.

3. Install oil seal, use oil seal installer J-24250 to install a new oil seal that has been soaked in axle lubricant.

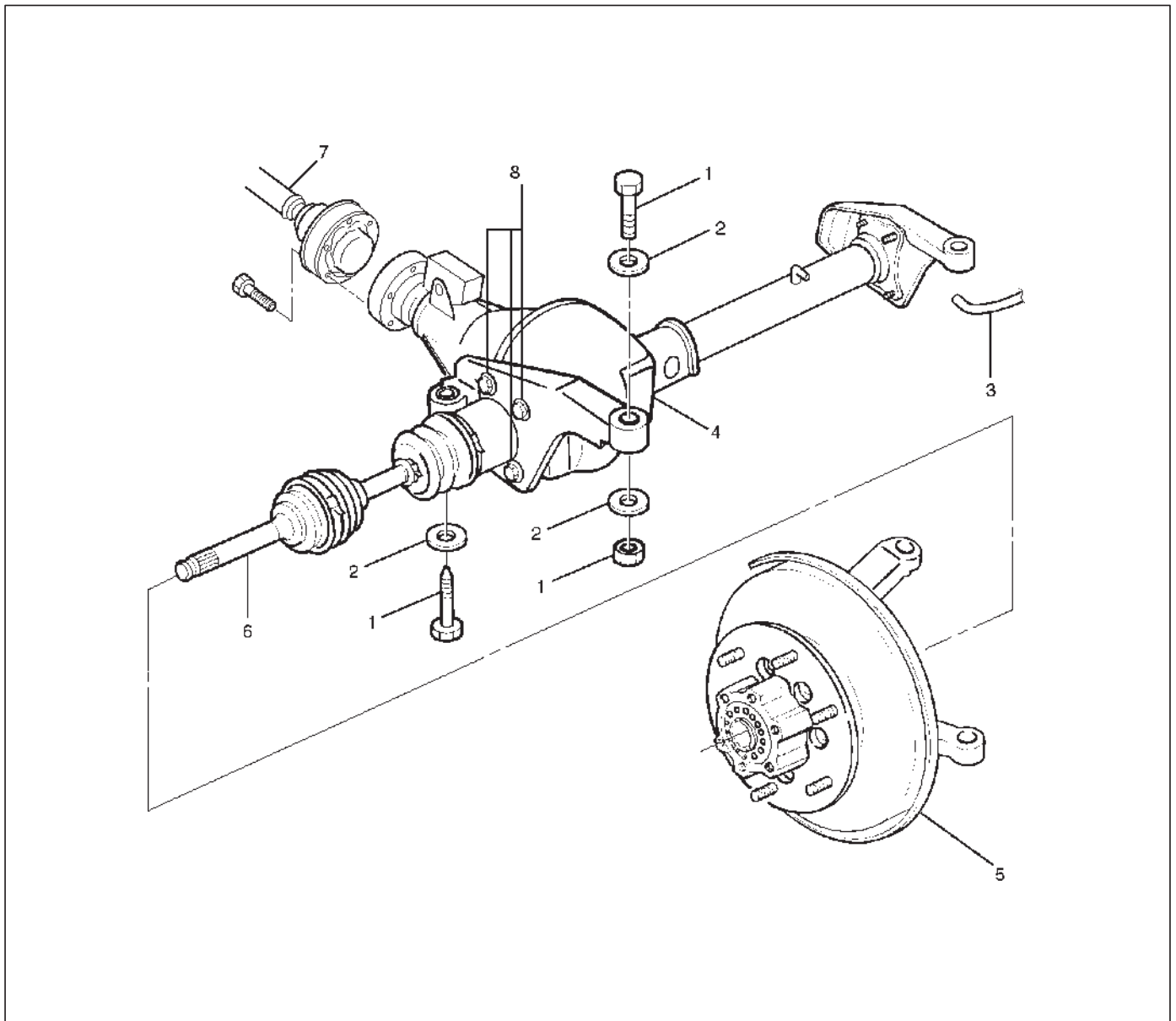


4. Install flange.
5. Install flange nut, refer to Differential Assembly Overhaul for flange nut reassembly in this section.

NOTE: Discard the used nut and install a new one.

## Front Drive Axle Assembly

### Front Drive Axle Assembly and Associated Parts



412RX006

#### Legend

- |   |   |
|---|---|
| (1) Mounting Bolt and Nut   | (5) Hub Assembly (Disc, Back Plate and Knuckle) |
| (2) Washer and Spacer   | (6) Front Drive Shaft Assembly (RH side)        |
| (3) Breather Hose   | (7) Propeller Shaft                             |
| (4) Front Axle Case Assembly and Front Drive Shaft Assembly (LH side) | (8) Bolt  |

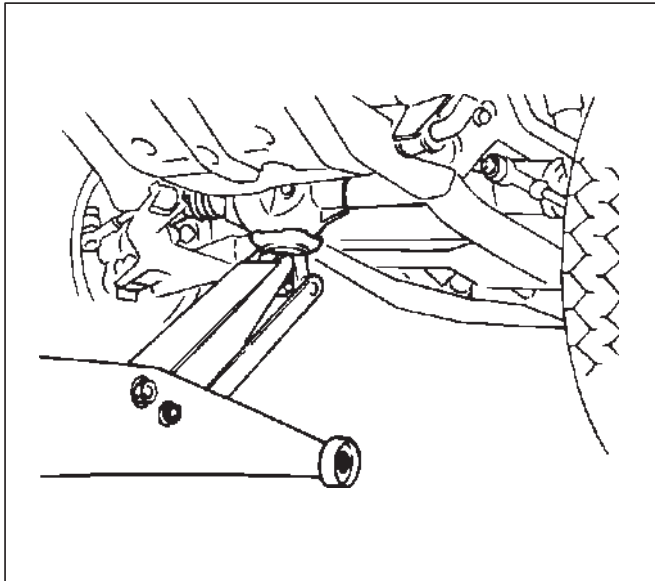
#### Removal

1. Jack up the vehicle and support it using jack stands.
2. Remove the tire and wheel.
3. Remove the drain bolt to drain differential oil.

## 4A1-6 DIFFERENTIAL (FRONT)

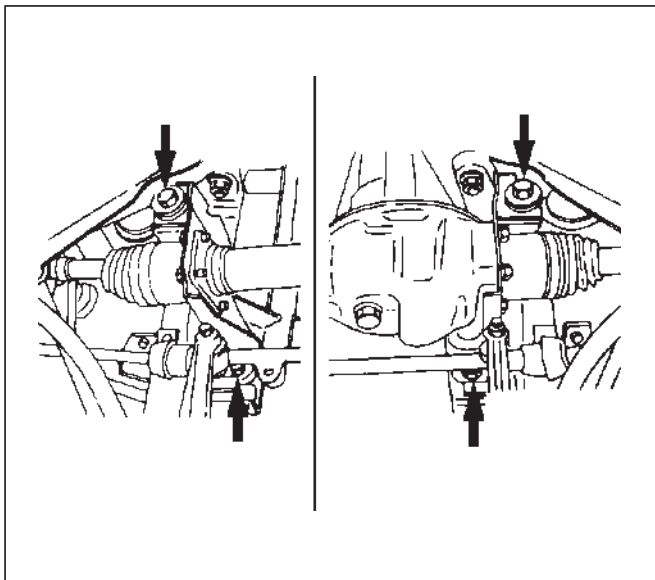
### NOTE:

- a. During the work, be sure that the diff case is supported by the jack.



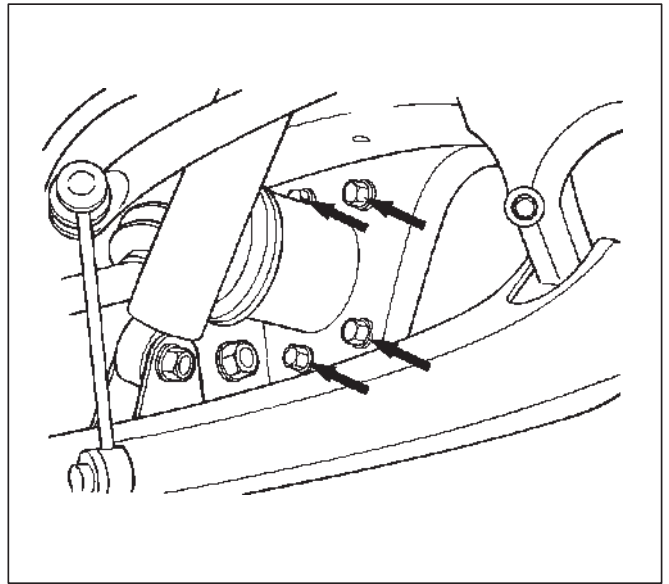
412RS003

- b. Remove the brake caliper fixing bolt and hang the caliper. Refer to Disc Brakes in Brake section.
- c. Remove the antilock brake system speed sensor. Refer to Front Wheel Speed Sensor in Brake section.
4. Remove the hub assembly (Disc, back plate and knuckle), refer to Front Hub and Disc in this section.
5. Disconnect the knuckle and the suspension arm. Refer to Suspension section.
6. Remove steering link and arm assembly, refer to Steering Linkage in Steering section.
7. Remove suspension crossmember.
8. Remove propeller shaft, refer to Front Propeller Shaft in this section.
9. Disconnect breather hose.
10. Remove the hose clip.
11. Remove mounting bolt and nut.



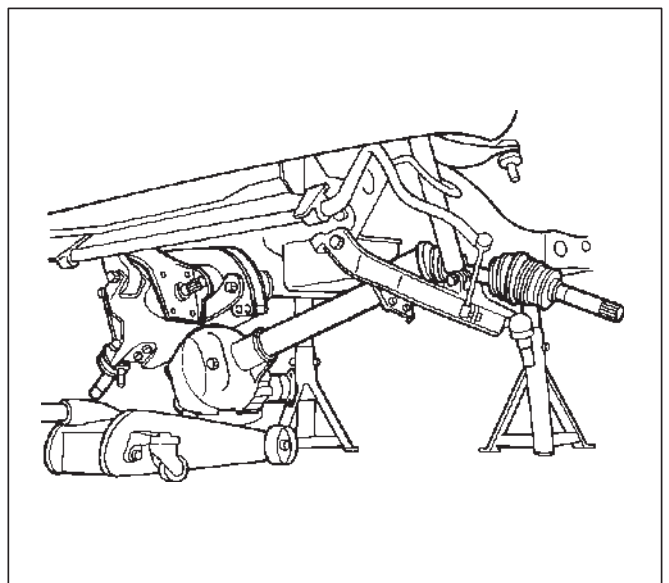
412RS004

12. Remove washer and spacer.
13. Remove the mounting bracket fixing bolt.



412RS005

14. Lower the vehicle and disconnect the RH front drive shaft assembly, then remove the front axle case assembly and front drive shaft assembly (LH).



412RS006

15. Remove front drive shaft assembly (RH).

## Installation

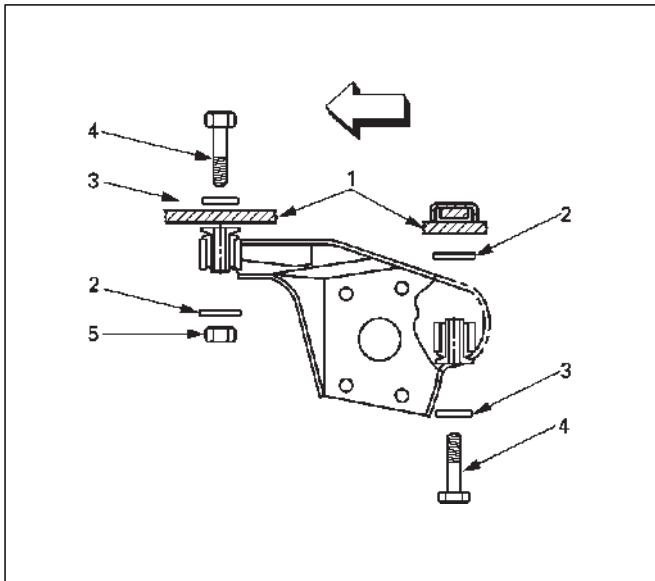
1. Install front drive shaft assembly (RH) and lay the assembly on the lower arm.
2. Install front axle case assembly and front drive shaft assembly (LH) and place the axle case on the jack, connect to the front drive shaft assembly (RH) before installing to the vehicle.
3. Install bolt and tighten the mounting bracket fixing bolt to the specified torque.

**Torque: 116 N·m (85lb ft)**

4. Install washer and spacer.

5. Tighten the mounting bolt and nut to the specified torque.

**Torque: 152 N·m (112lb ft)**



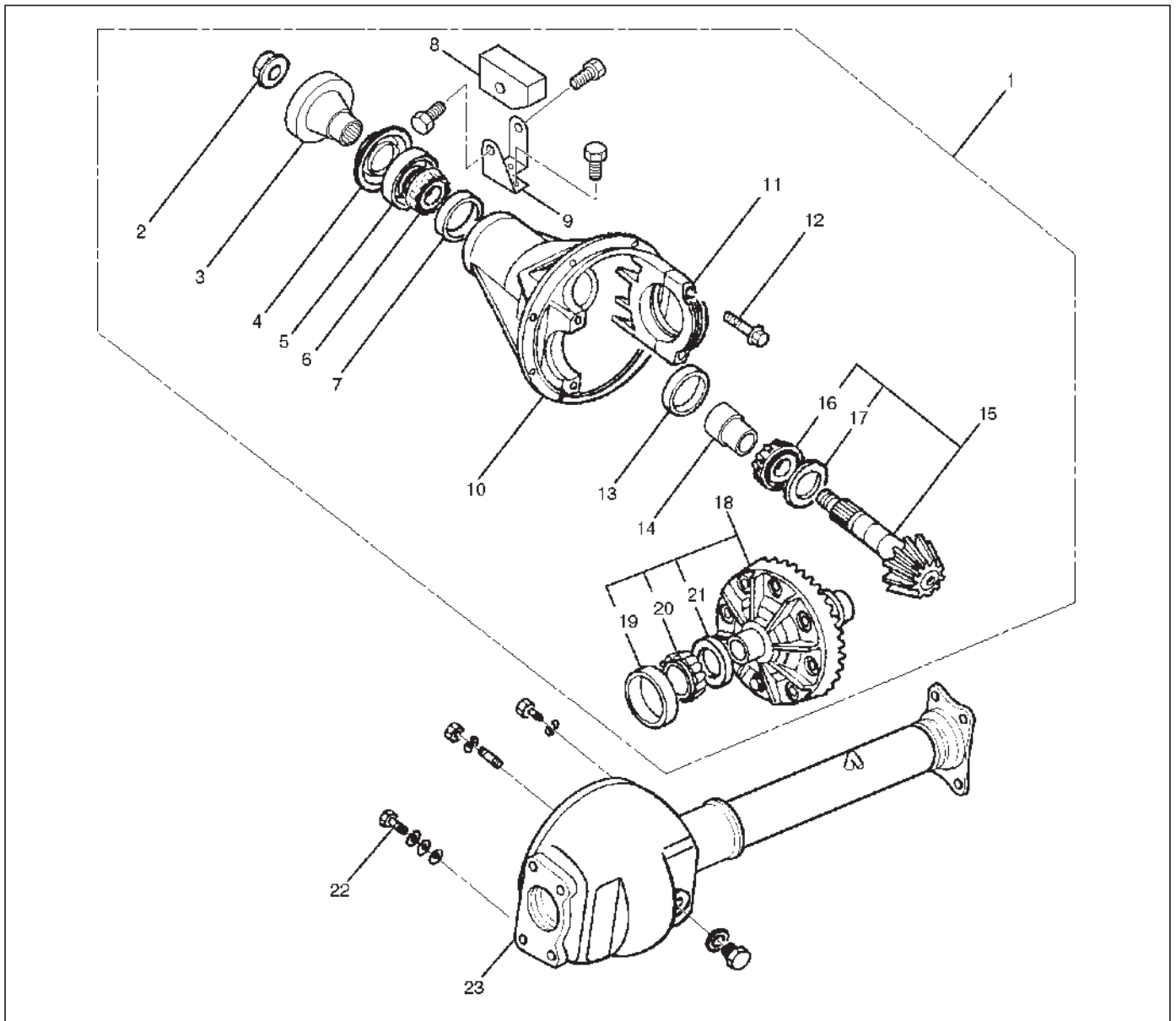
412RW005

#### Legend

- (1) Frame
  - (2) Spacer
  - (3) Washer
  - (4) Bolt
  - (5) Nut
- 
6. Connect breather hose and install the hose clip.
7. Install propeller shaft, refer to Front Propeller Shaft in this section.
8. Install suspension crossmember.
9. Steering link and arm assembly, refer to Steering Linkage in Steering section.
10. Install hub assembly (Disc, back plate and knuckle), refer to Front Hub and Disc in this section.

## Differential Assembly

### Disassembled View



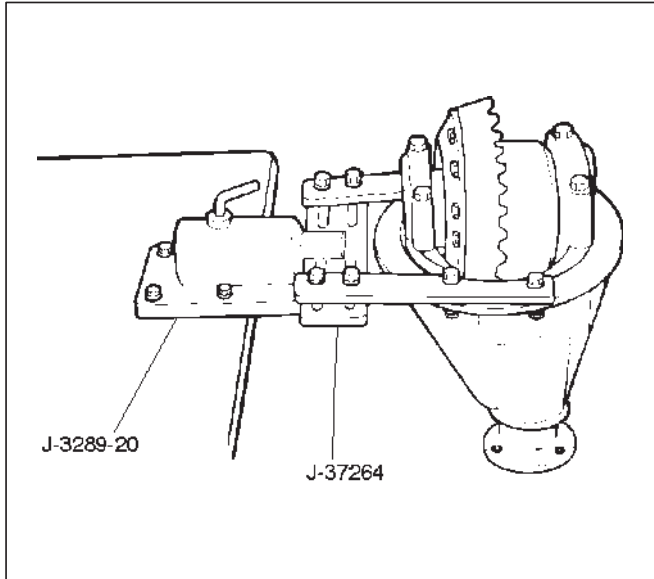
415RX001

#### Legend

- |                              |                               |
|------------------------------|-------------------------------|
| (1) Differential Assembly    | (12) Bolt                     |
| (2) Flange Nut               | (13) Inner Bearing Outer Race |
| (3) Flange                   | (14) Collapsible Spacer       |
| (4) Dust Cover               | (15) Pinion Gear              |
| (5) Oil Seal                 | (16) Inner Bearing            |
| (6) Outer Bearing            | (17) Adjust Shim              |
| (7) Outer Bearing Outer Race | (18) Diff Cage Assembly       |
| (8) Damper                   | (19) Side Bearing Outer Race  |
| (9) Bracket                  | (20) Side Bearing             |
| (10) Differential Carrier    | (21) Adjust Shim              |
| (11) Bearing Cap             | (22) Bolt                     |
|                              | (23) Axle Case                |

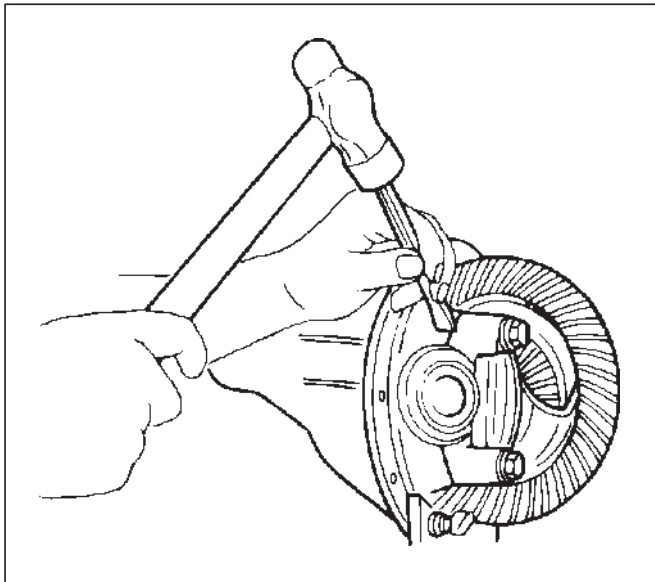
## Disassembly

1. Remove differential carrier fixing bolt.
2. Remove differential assembly.
3. Using holding fixture J-37264 and holding fixture base J-3289-20, fix the differential assembly to the bench.



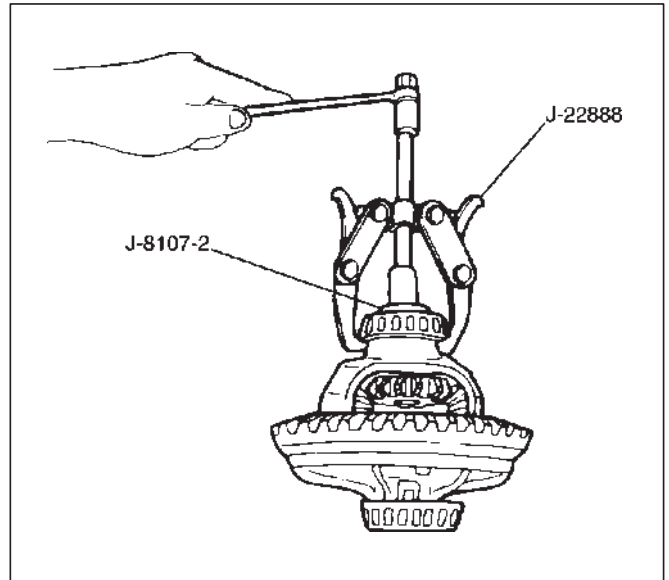
425RS008

4. Remove bearing cap bolt.
5. Apply a setting mark to the side bearing cap and the differential carrier then remove bearing cap.



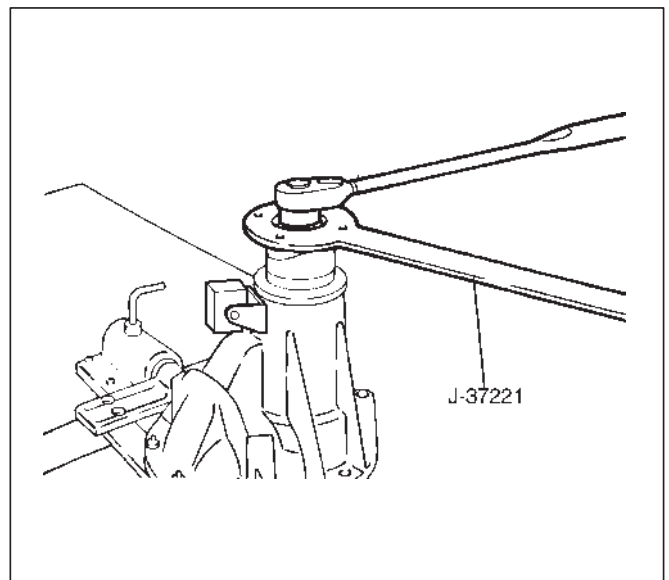
425RS009

6. Remove differential cage assembly.
7. Remove side bearing outer race, after removal, keep the right and left hand side bearing assemblies separate to maintain inner and outer race combinations.
8. Remove side bearing, using remover J-22888 and adapter J-8107-2.



415RS005

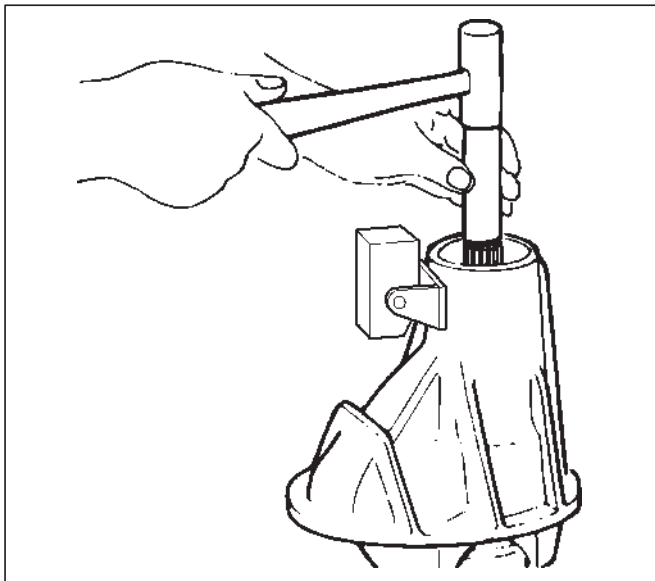
9. Remove adjust shim, note the thickness and position of the shims removed.
10. Remove the flange nut using holding wrench J-37221 after raising up its staked parts completely.



425RW040

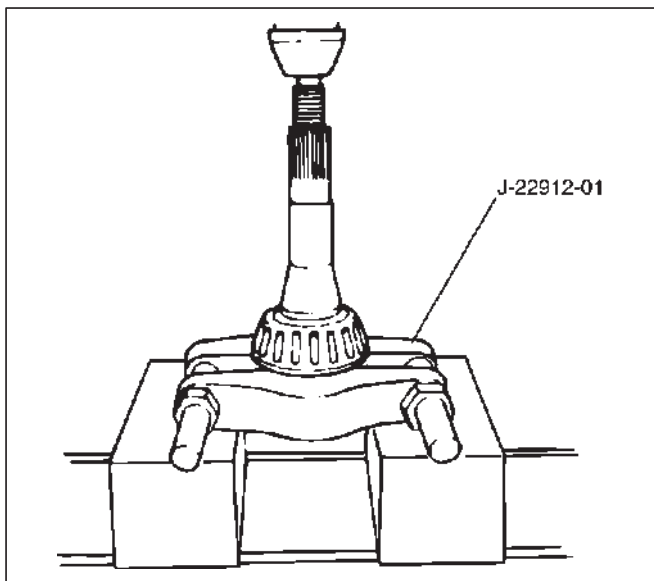
## 4A1-10 DIFFERENTIAL (FRONT)

11. Remove flange.
12. Remove dust cover.
13. Remove the drive pinion assembly using a soft metal rod and a hammer.



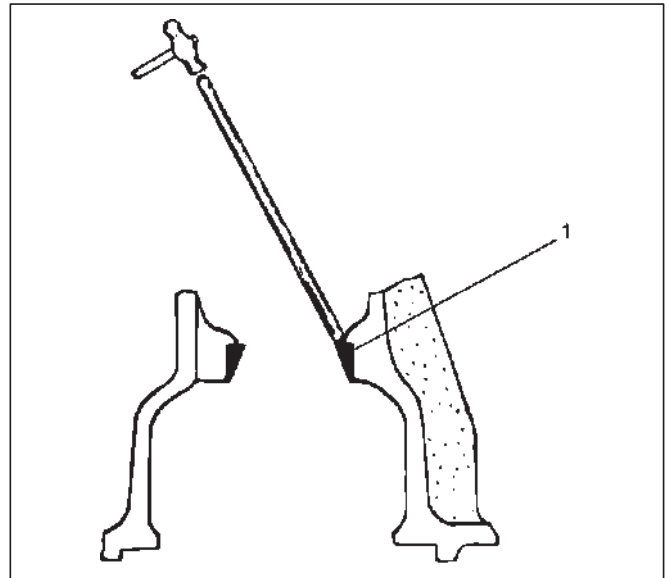
425RW041

14. Remove collapsible spacer.
15. Remove the inner bearing using a separator J-22912-01 and a press.

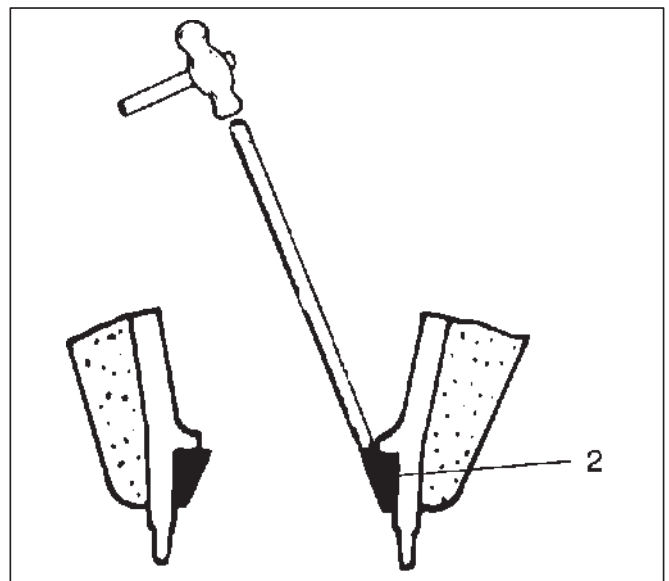


415RS006

16. Remove adjust shim.
17. Remove inner bearing outer race.
18. Remove oil seal.
19. Remove outer bearing.
20. Remove the inner bearing outer race (1) and the outer bearing outer race (2) by using a brass bar and a hammer.

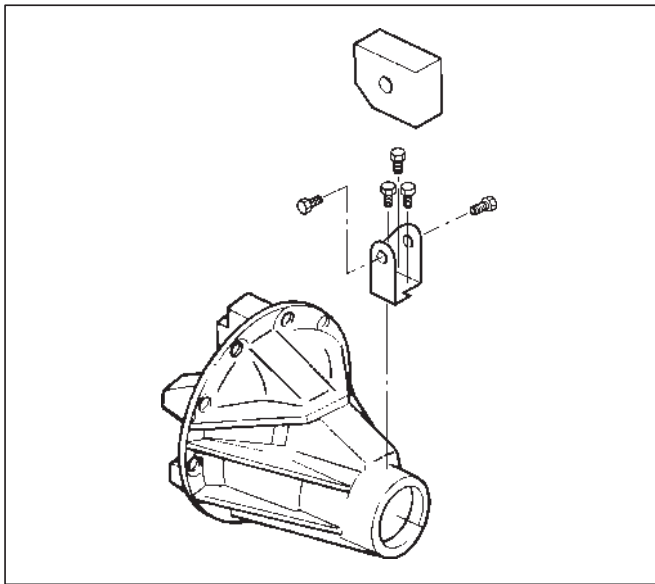


425RS014



425RS015

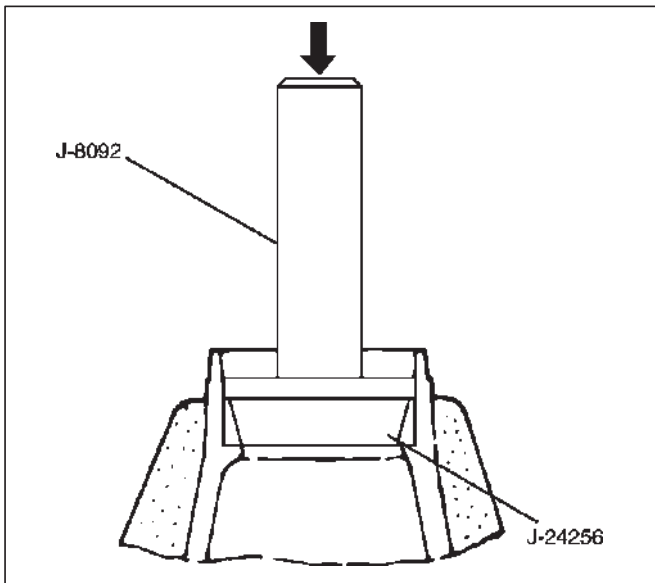
21. Remove damper and bracket.



425RW042

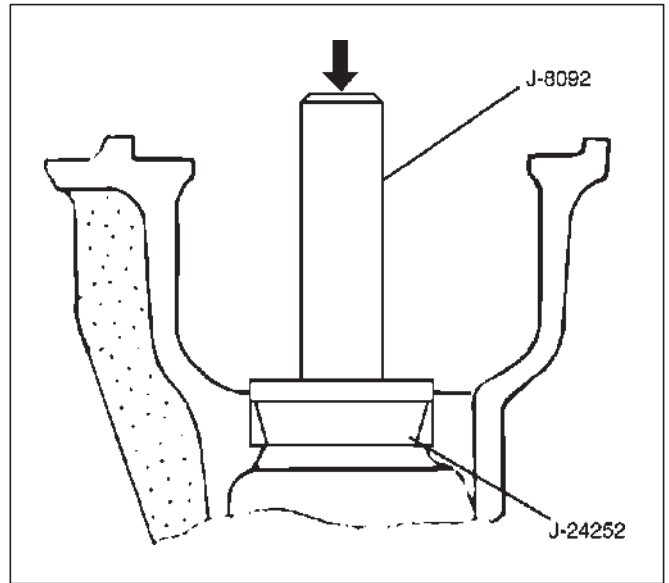
**Reassembly**

1. Using installer J-24256 and grip J-8092, install outer bearing outer race.



415RS007

2. Using installer J-24252 and grip J-8092, install Inner bearing outer race.



415RS008

3. Install adjust shim and adjust drive pinion mounting distance

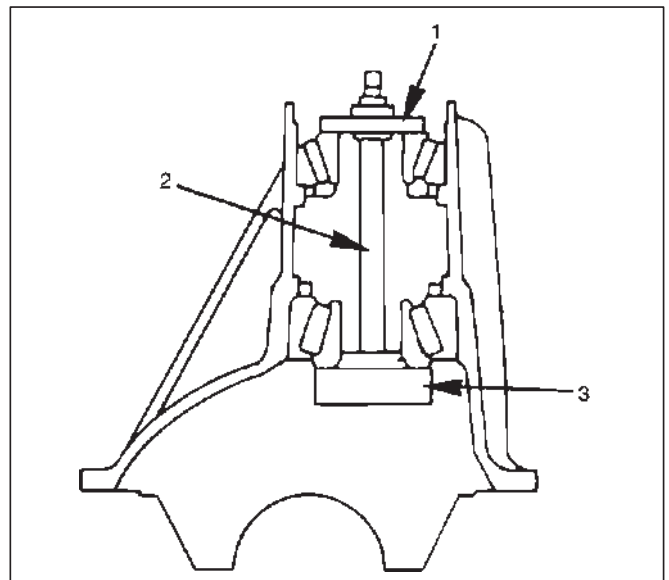
1. Apply gear oil to the inner and outer drive pinion bearing.

Clean the pinion setting gauge set.

Then install the gauge set together with the inner and outer bearings.

2. Tighten the nut to the specified torque.

**Torque: 2.3 N·m (20 lb in)**



415RS009

**Legend**

(1) Pilot : J-21777-42

(2) Nut and Bolt : J-23597-9

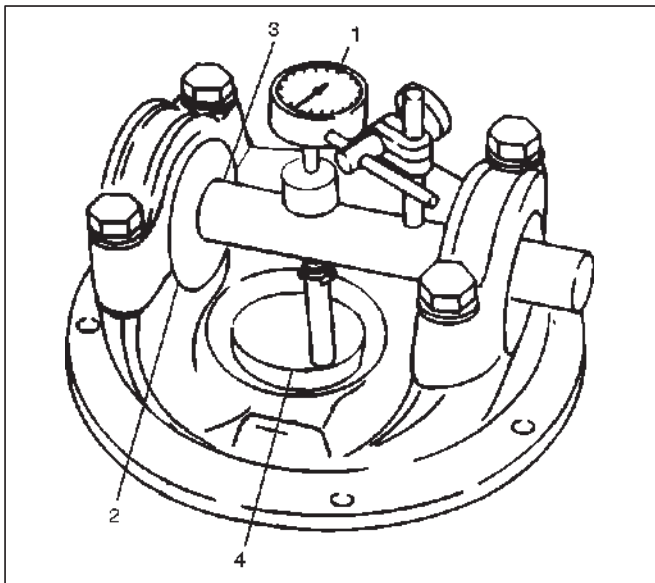
(3) Gauge Plate : J-23597-7



## 4A1-12 DIFFERENTIAL (FRONT)

3. Clean the side bearing bores. Install the dial indicator with the discs and arbor. Install and tighten the bearing caps to the specified torque.

**Torque: 98 N·m (72 lb ft)**

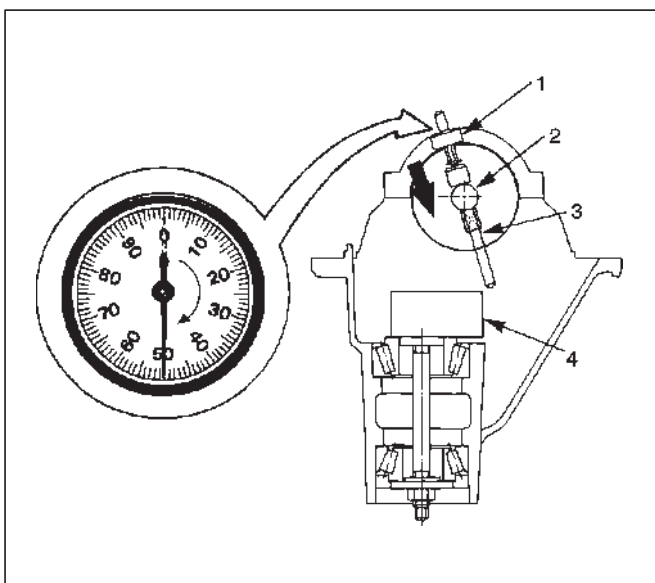


415RS010

### Legend

- (1) Dial Indicator: J-8001
- (2) Disc (2 pcs.): J-23597-8
- (3) Arbor: J-23597-1
- (4) Gauge Plate: J-23597-42

4. Set the dial indicator to "0". Place it on the mounting post of the gauging arbor with the contact button touching the indicator pad. Force the dial indicator downward until the needle has made a half turn clockwise. Tighten down the dial indicator in this position.



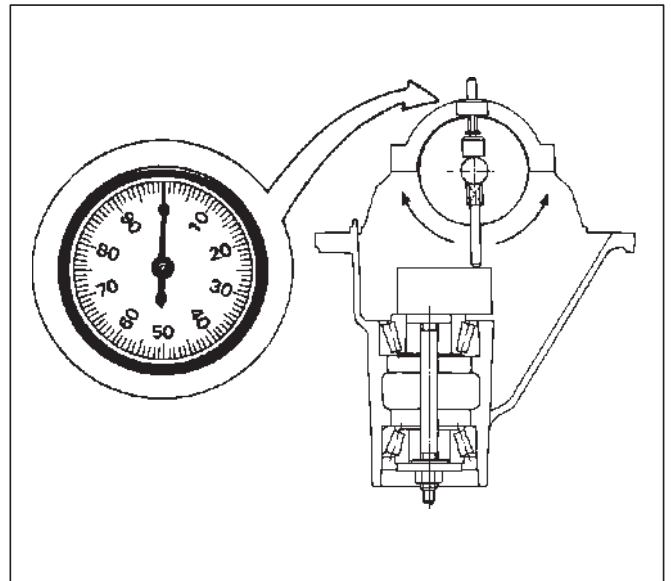
425RS020

### Legend

- (1) Dial Indicator
- (2) Gauging Arbor
- (3) Plunger
- (4) Gauge Plate

5. Position the plunger on the gauge plate. Move the gauging arbor slowly back and forth and locate the position at which the dial indicator shows the greatest deflection. At this point, once again set the dial indicator to "0".

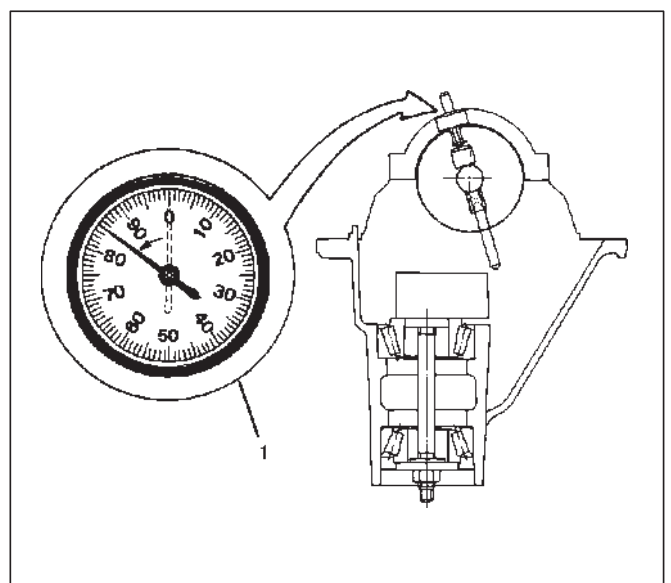
Repeat the procedure to verify the "0" setting.



425RS021

6. After the ZERO setting is obtained, rotate the gauging arbor until the dial indicator rod does not touch the gauging plate.

Record the number the dial indicator needle points to.



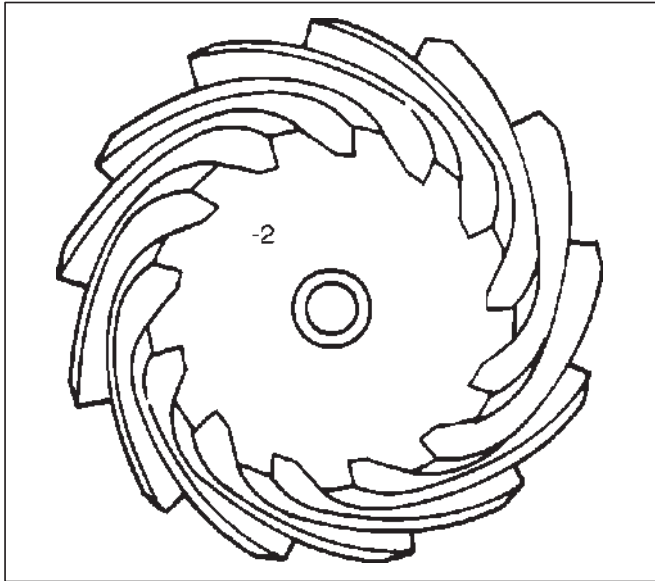
425RS022

### Legend

- (1) Example=Dial indicator reading of 0.085

- Record the pinion depth code on the head of the drive pinion.

The number indicates a necessary change in the pinion mounting distance. A plus number indicates the need for a greater mounting distance (which can be achieved by decreasing the shim thickness). A minus number indicates the need for a smaller mounting distance (which can be achieved by increasing the shim thickness). If examination reveals pinion depth code "0", the pinion is "nominal".



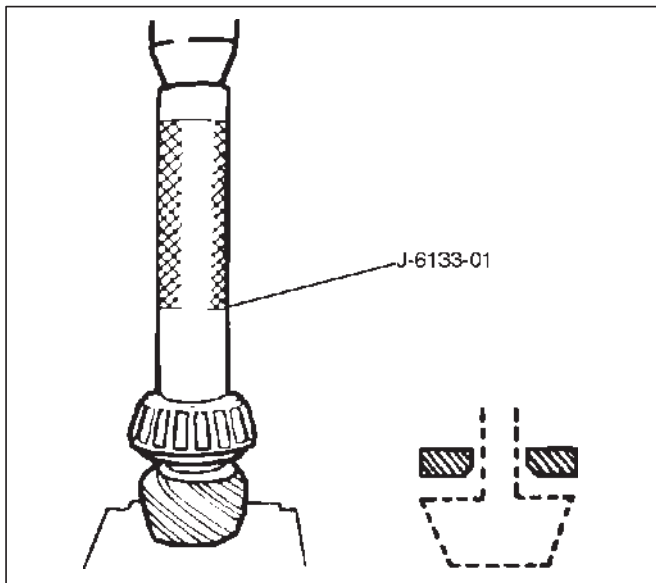
425RS023



NOTE: When ordering shims, find the part number in the parts catalog by using the thickness of shims listed in the above table.

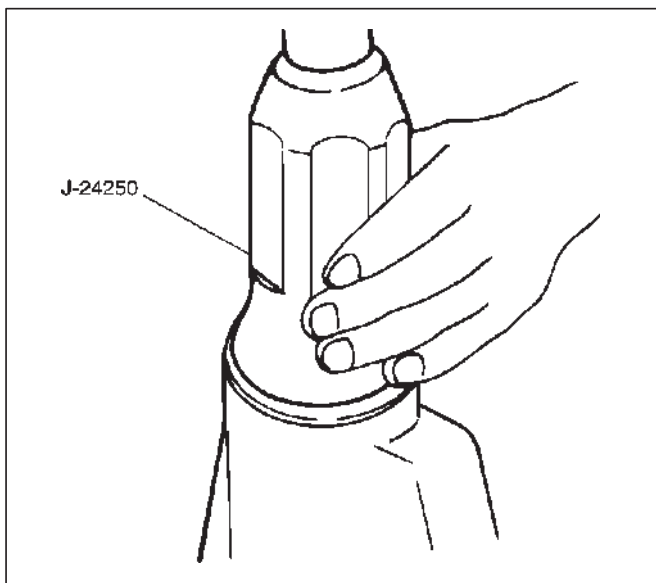
4. Place the shim on the drive pinion, with the chamfered side turned towards the pinion head then install the inner bearing onto the pinion using an installer J-6133-01 and a press.

NOTE: Do not apply pressure to the roller cage and apply pressure only to the inner race.



5. Discard the used collapsible spacer and install a new one.
6. Install pinion gear.
7. Install outer bearing.
8. Use oil seal installer J-24250 to install a new oil seal that has been soaked in rear axle lubricant.

NOTE: Take care to use a front differential oil seal, NOT the rear differential oil seal.



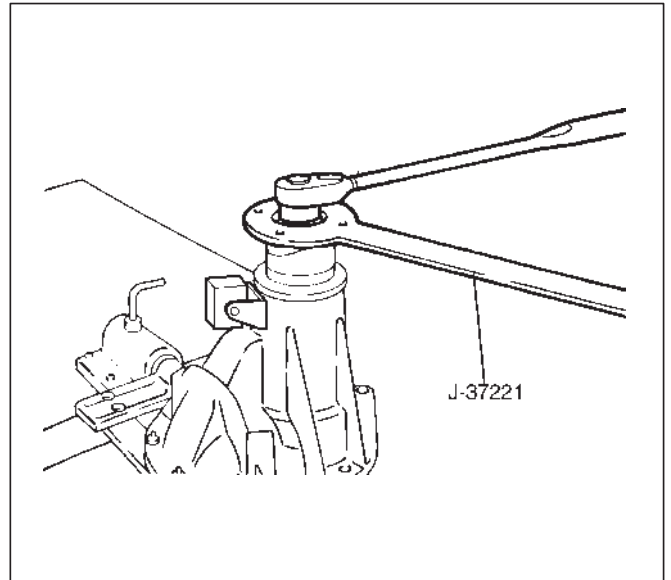
9. Install dust cover.
10. Install flange.

11. Install flange nut.

1. Apply lubricant to the pinion threads.
2. Tighten the nut to the specified torque using the pinion flange holder J-37221.

**Torque: 177-275N·m (130-203 lb ft)**

NOTE: Discard used flange nut and install new one and do not over tighten the flange nut.

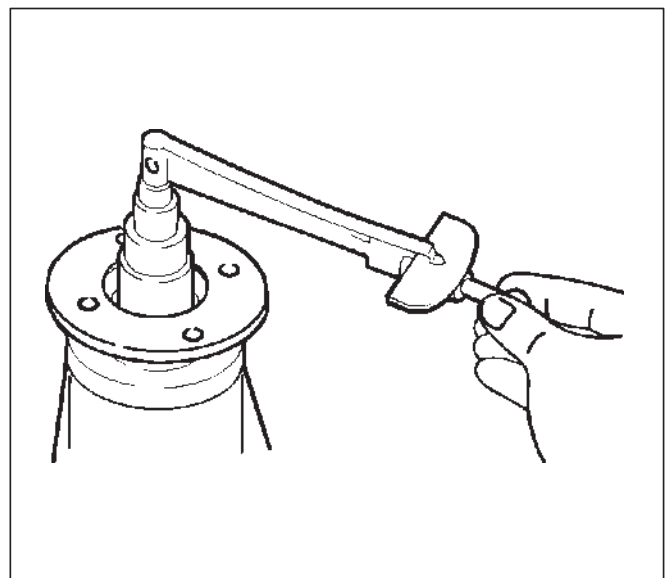


3. Adjust pinion bearing preload.
  - a. Measure the bearing preload by using a torque meter. Note the scale reading required to rotate the flange.
  - b. Continue tightening flange nut until the specified starting torque is obtained.

**Starting torque:**

**New bearing 0.7-1.1 N·m(5.64-9.98 lb in)**

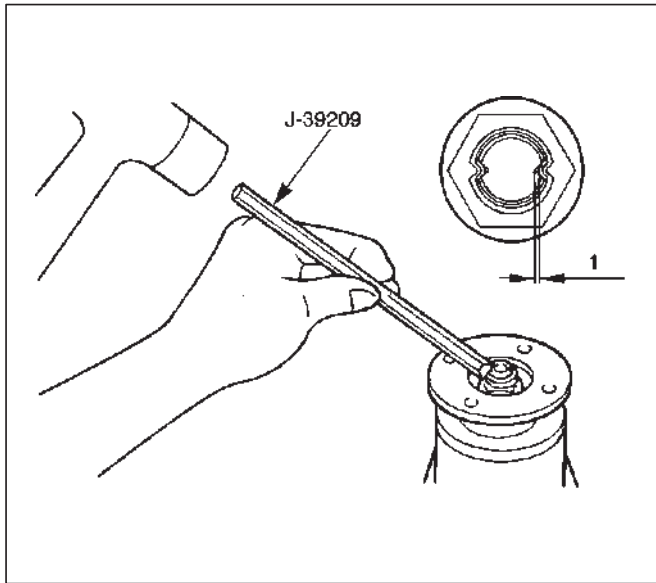
**Used bearing 0.4-0.5N·m(2.86-4.94lb in)**



4. Using punch J-39209, stake the flange nut at two points.

## 4A1-16 DIFFERENTIAL (FRONT)

NOTE: When staking, be sure to turn the nut to insure that there is no change in bearing preload. Make sure of preload again as instructed in 3).

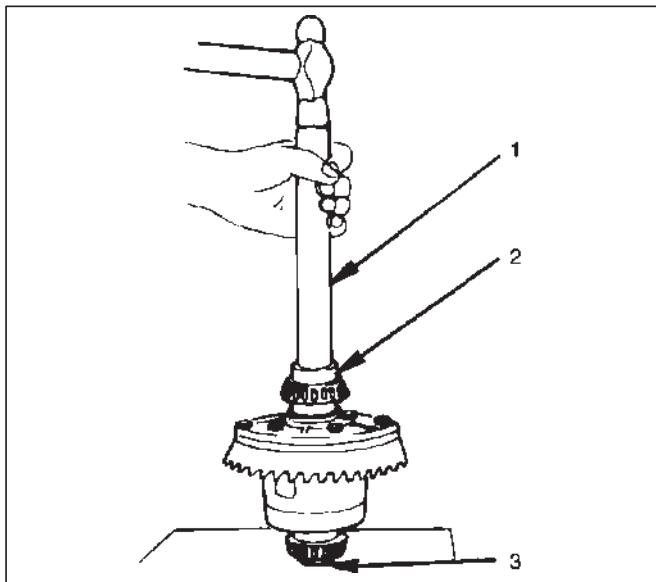


### Legend

- (1) 1.3mm or less

### 12. Install adjust shim.

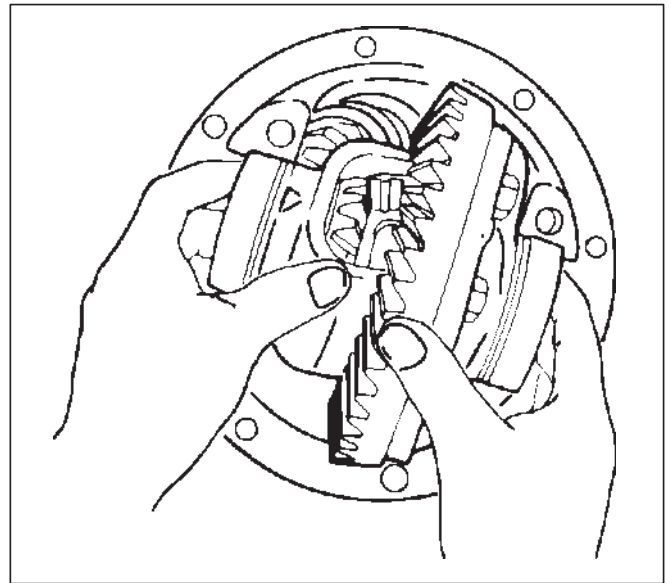
1. Attach the side bearing to the differential assembly without shims. Support the opposite side using a pilot to prevent bearing damage.



### Legend

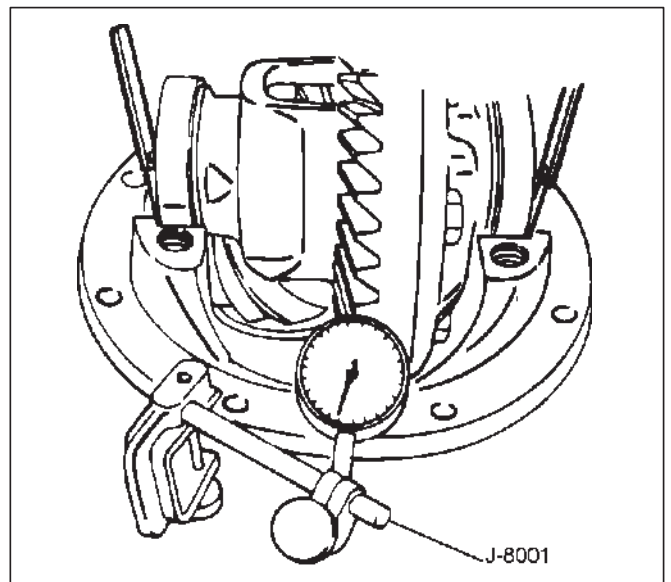
- (1) Drive handle: J-8092  
(2) Installer: J-24244  
(3) Pilot: J-8107-2

2. Insert the differential cage assembly with bearing outer races into the side bearing bores of the carrier.



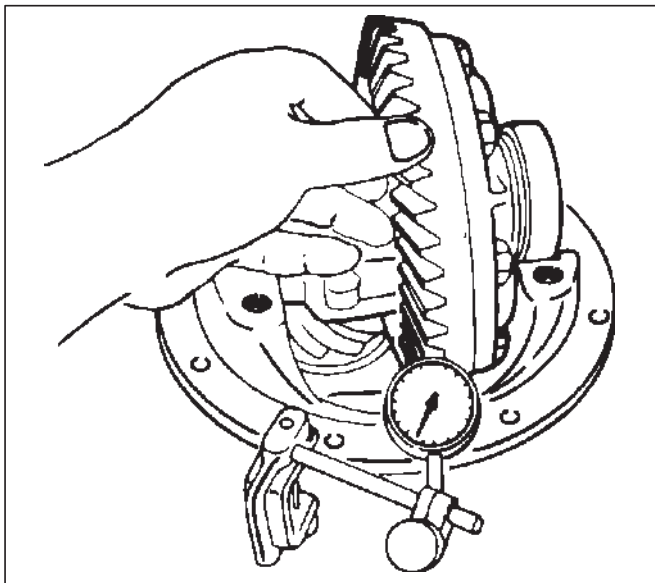
3. Using two sets of feeler gauges, insert a feeler stock of sufficient thickness between each bearing outer race and the carrier to remove all end play. Make certain the feeler stock is pushed to the bottom of the bearing bores.

Mount the dial indicator J-8001 on the carrier so that the indicator stem is at right angles to a tooth on the ring gear.



- Adjust feeler gauge thickness from side to side until ring gear backlash is in the specified range.

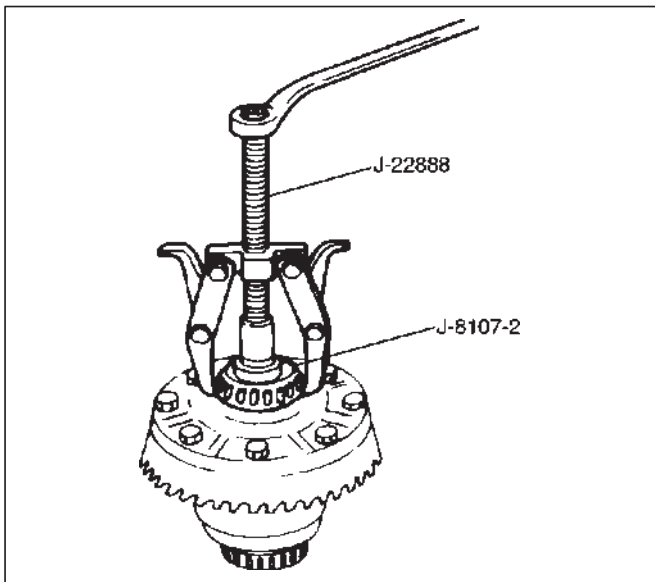
**Backlash: 0.13–0.18 mm(0.005 –0.007 in)**



425RS032

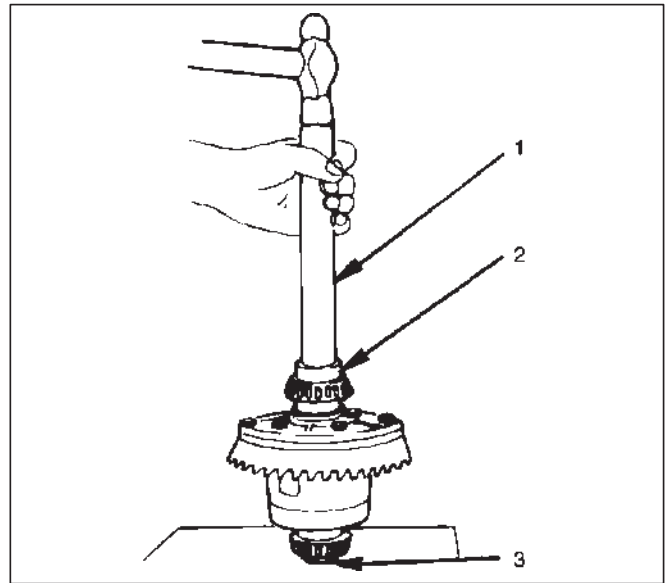
With zero end play and correct backlash established, remove the feeler gauge packs, determine the thickness of the shims required and add 0.05 mm (0.002 in) to each shim pack to provide side bearing preload. Always use new shims.

- Use bearing remover J-22888 and pilot J-8107-2 to remove side bearing.



415RS013

- Install the side bearings together with the selected shims.

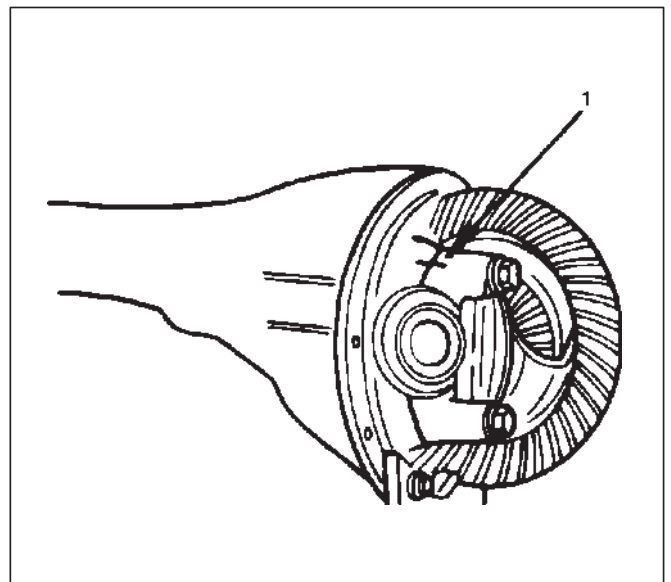


425RS029

**Legend**

- (1) Drive Handle: J-8092
- (2) Installer: J-24244
- (3) Pilot: J-8107-2

- Install side bearing outer race.
- Install differential cage assembly.
- Install bearing cap then align the setting marks(1) applied at disassembly.

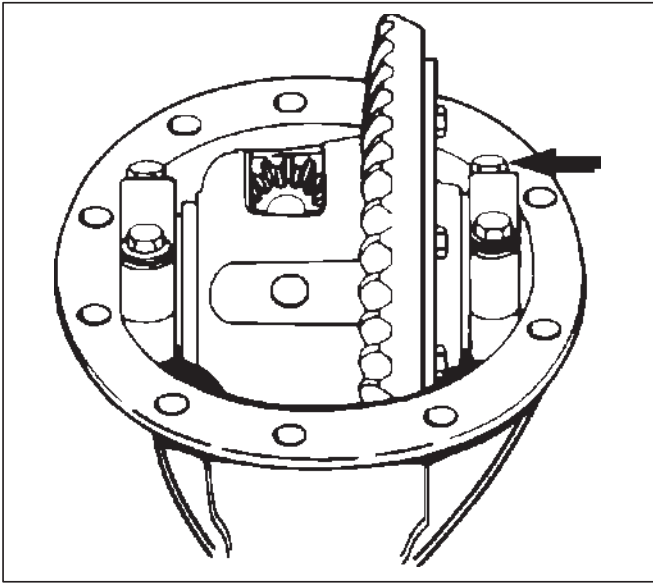


425RS035

## 4A1-18 DIFFERENTIAL (FRONT)

17. Tighten the cap bolt to the specified torque.

**Torque: 98 N·m (72 lb ft)**

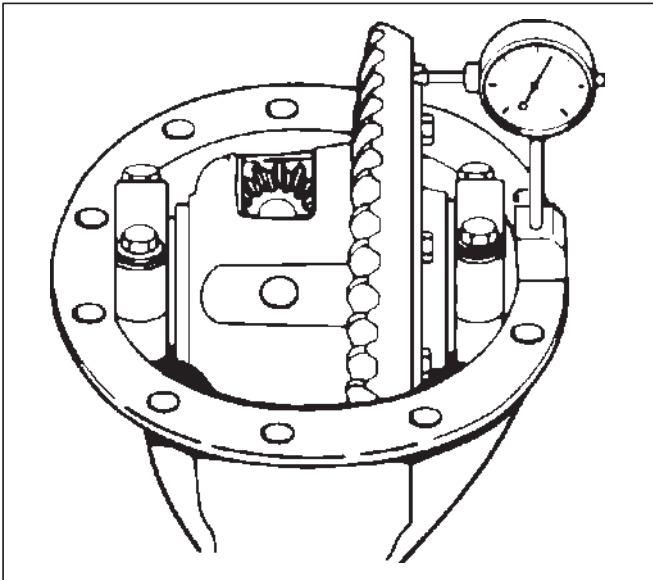


425RS036

1. Measure the amount of run-out of the ring gear at its rear face.

**Standard: 0.02 mm ( 0.001 in)**

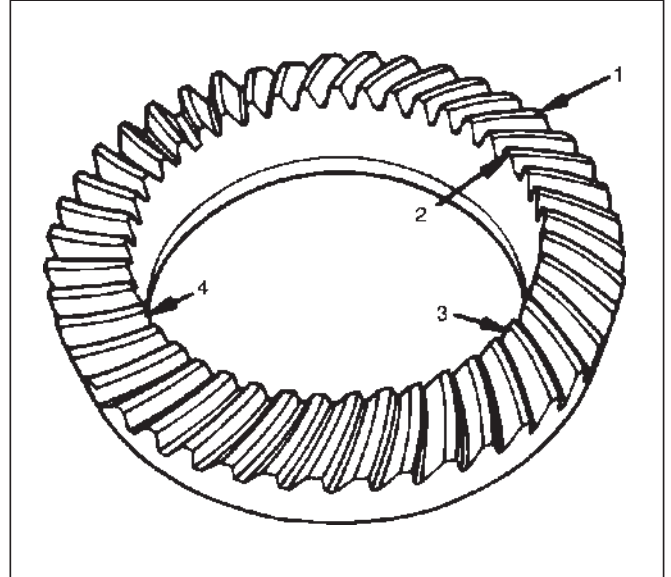
**Limit: 0.05 mm ( 0.002 in)**



425RS037

## Gear Tooth Contact Pattern Check and Adjustment

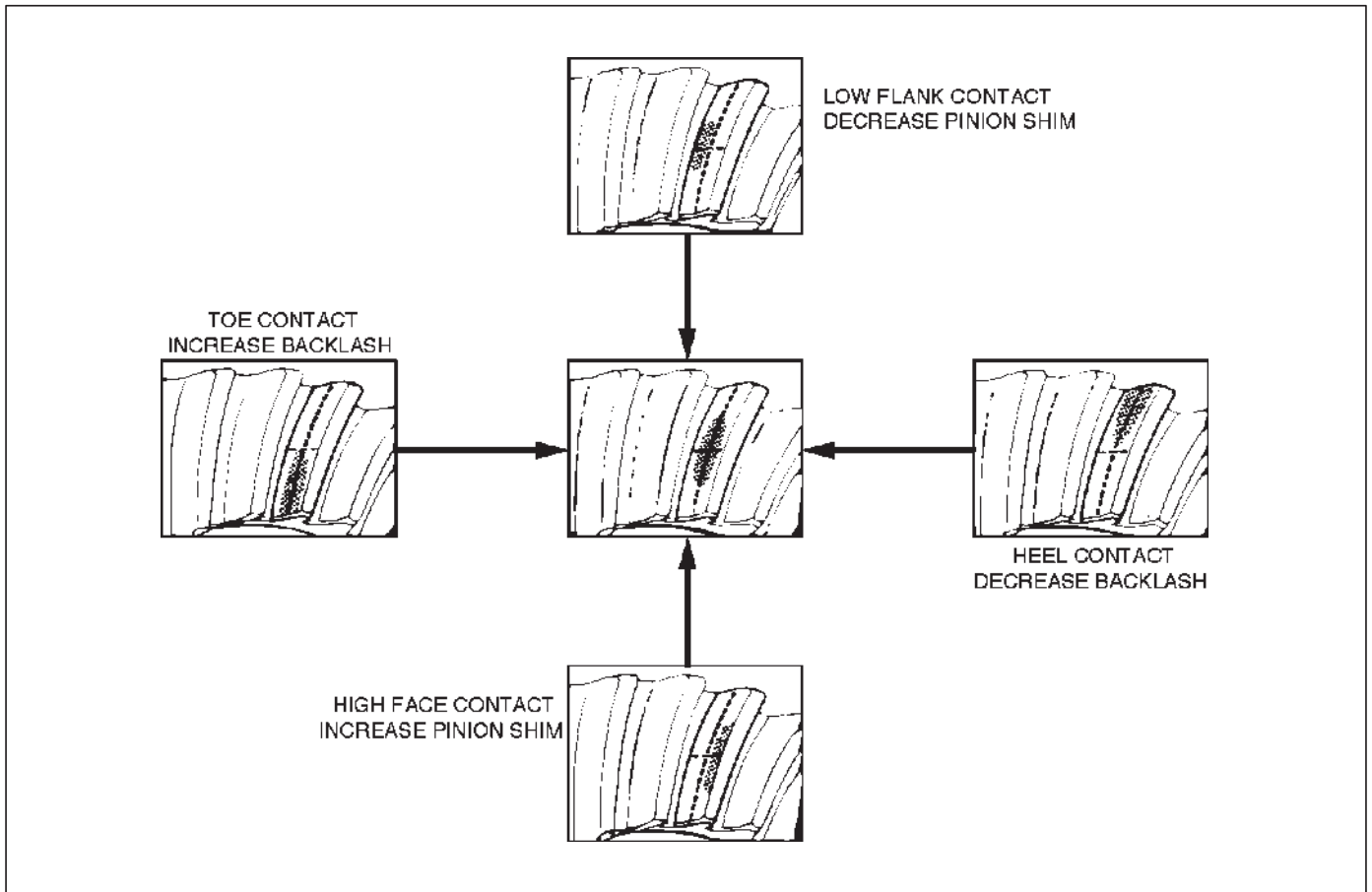
1. Apply a thin coat of prussian blue or equivalent to the faces of the 7-8 teeth of the ring gear. Check the impression of contact on the ring gear teeth and make necessary adjustment as described in illustration if the contact is abnormal.



425RS038

### Legend

- (1) Heel
- (2) Toe
- (3) Concave Side (Coast)
- (4) Convex Side (Drive)

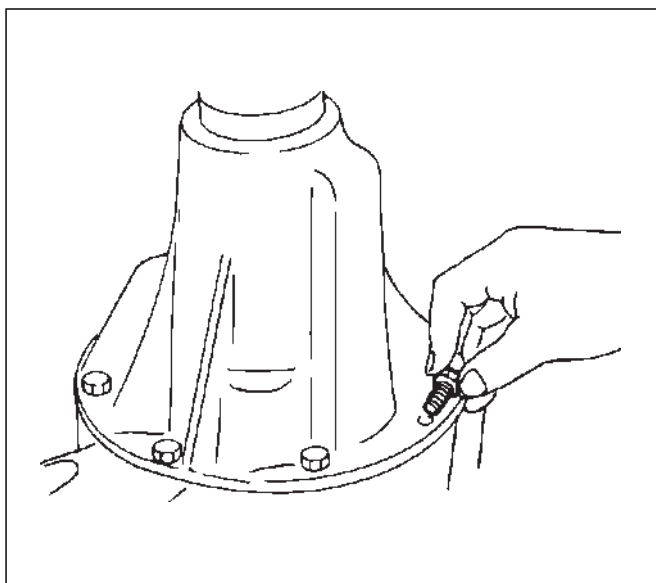


425RS039

18. Install differential assembly.

1. Clean the faces of the front axle case and differential carrier.  
Apply Three Bond TB1215 or equivalent to the sealing side of the axle case and the carrier.
2. Attach the differential case and the carrier assembly to the front axle case and tighten the nuts and bolts.

**Torque: 25 N·m (19 lb ft)**



415RS014

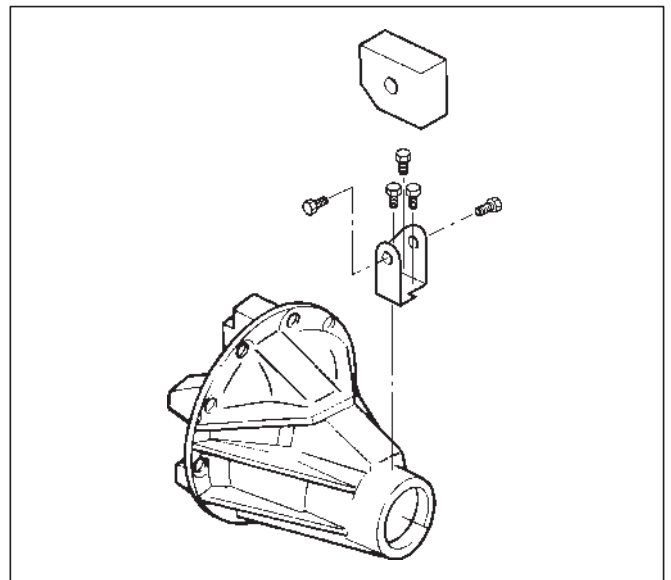
3. Fill the axle case with hypoid gear lubricant, to just below the filler hole.

**Lubricant capacity: 1.4 liter(1.5 US qt)**

19. Install damper.

1. Clean the faces and bolt thread hole of differential carrier.
2. Install the bracket with new bolts.
3. Install the damper to the bracket with new bolts.

**Torque: 25 N·m (19 lb ft)**

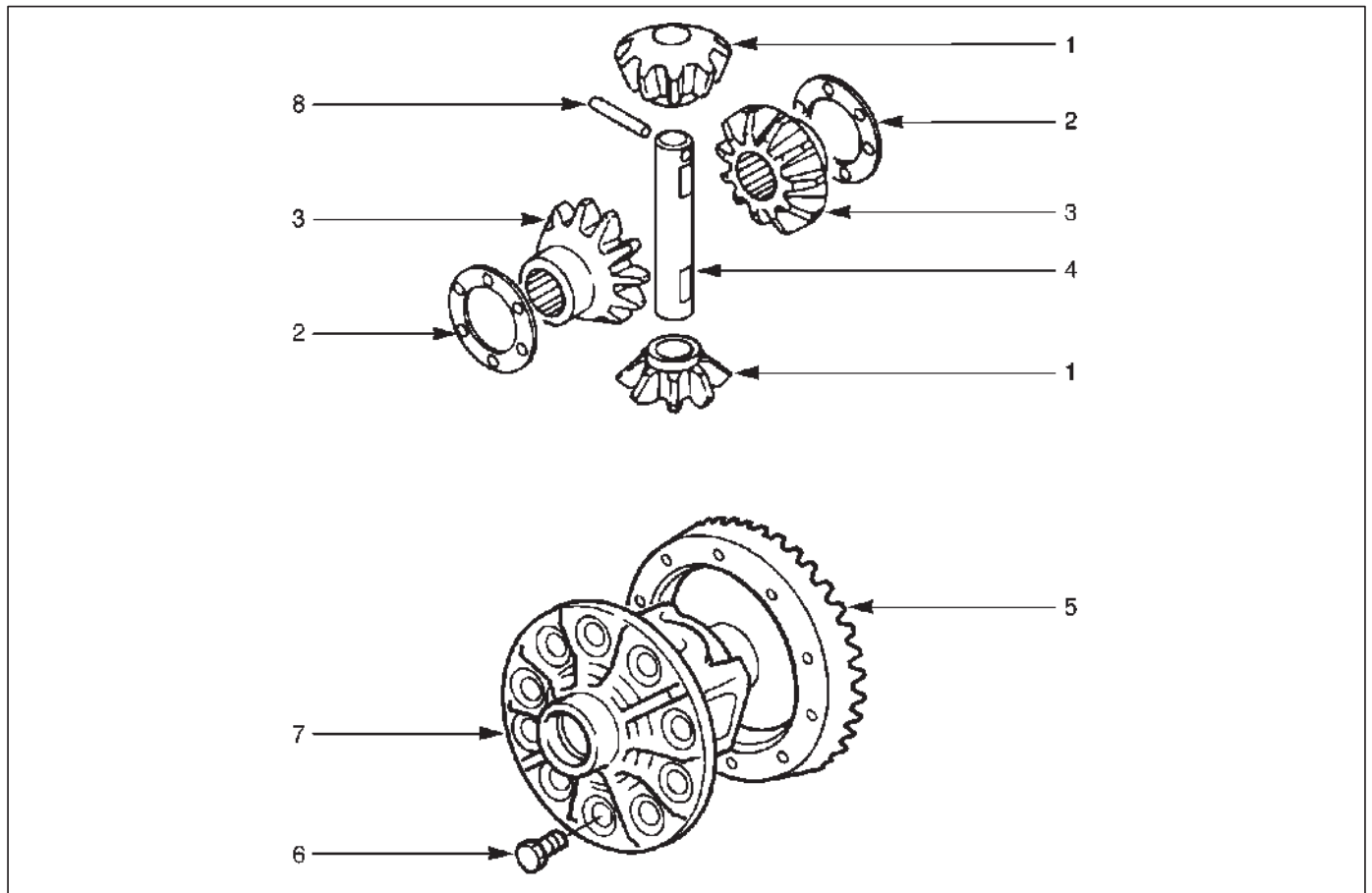


425RW042



## Differential Cage Assembly

### Disassembled View



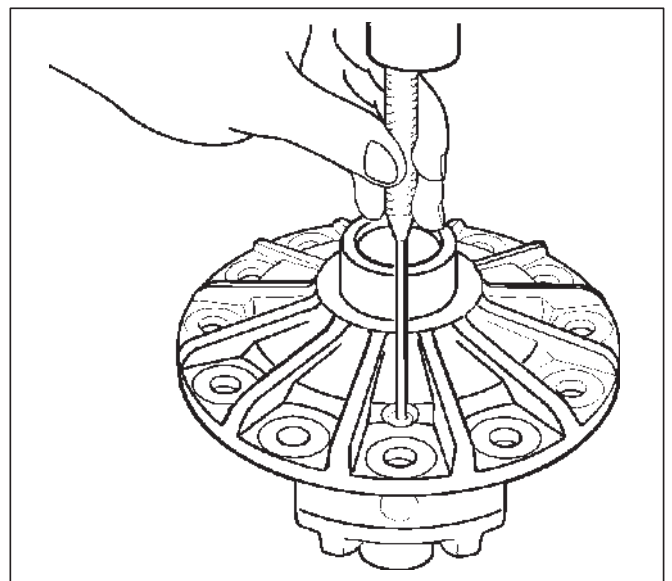
415RS015

#### Legend

- |                   |                       |
|-------------------|-----------------------|
| (1) Pinion Gear   | (5) Ring Gear         |
| (2) Thrust Washer | (6) Bolt              |
| (3) Side Gear     | (7) Differential Cage |
| (4) Cross Pin     | (8) Lock Pin          |

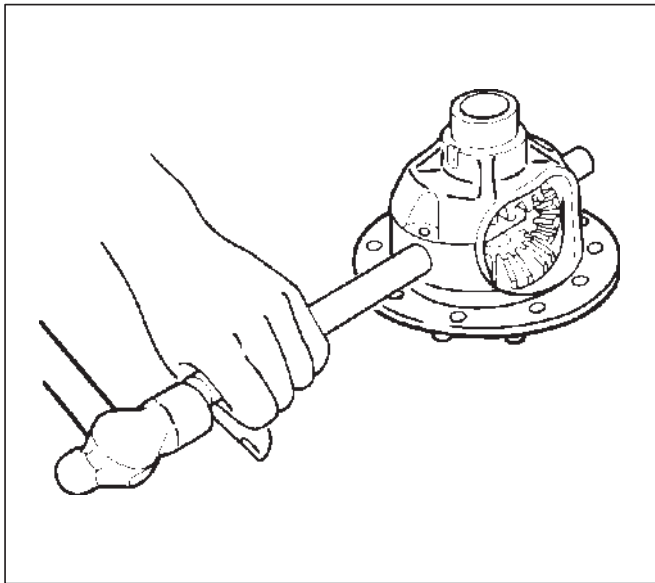
### Disassembly

1. Remove bolt.
2. Remove ring gear.
3. Remove lock pin, break staking on the lock pin, using a 5 mm (0.20 in) diameter drill.



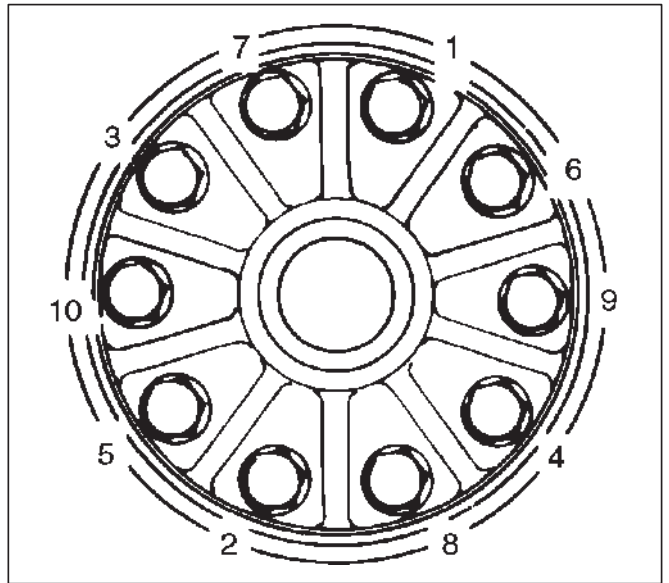
425RS042

4. Remove the cross pin, using a soft metal rod and a hammer.



425RS043

5. Tighten the fixing bolts in a diagonal sequence as illustrated.



415RS016

- 5. Remove pinion gear.
- 6. Remove side gear.
- 7. Remove thrust washer.

### Inspection and Repair

Make necessary correction or parts replacement if wear, damage, corrosion or any other abnormal conditions are found through inspection.

Check the following parts:

- 1. Ring gear, pinion gear
- 2. Bearing
- 3. Side gear, pinion gear, cross pin
- 4. Differential cage, carrier
- 5. Thrust washer
- 6. Oil seal

### Ring gear replacement:

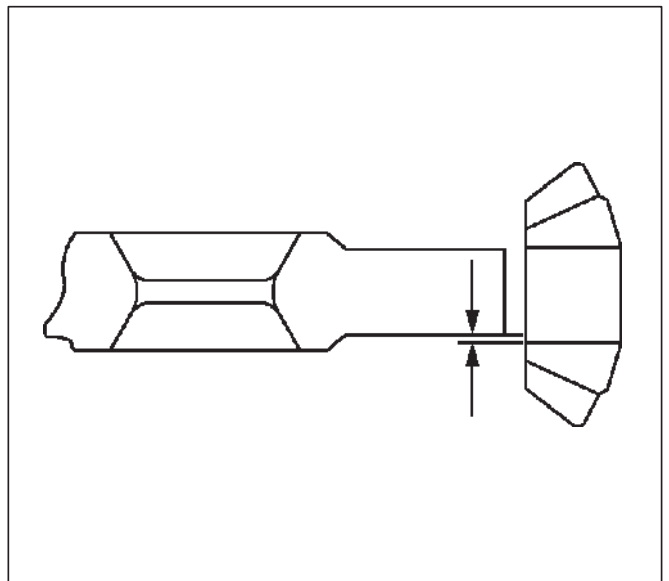
- 1. The ring gear should always be replaced with the drive pinion as a set.
- 2. Clean the ring gear threaded holes to remove the locking agent.
- 3. When installing the ring gear, apply LOCTITE 271 or equivalent to all the threaded area and half of the unthreaded area of the bolt.
- 4. Discard used bolts and install new ones.

**Torque: 108 N-m (80 lb ft)**

### Clearance between the differential pinion and the cross pin measurement:

**Standard: 0.06 – 0.12 mm (0.002–0.005 in)**

**Limit: 0.2 mm (0.008 in)**



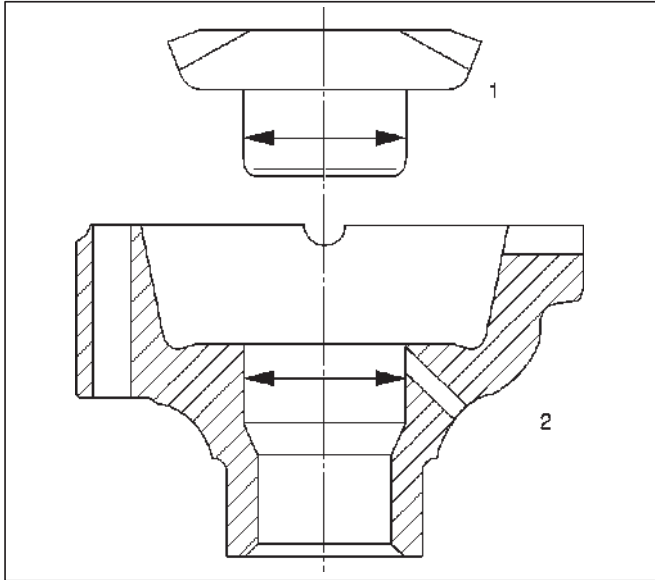
425RS045

## 4A1-22 DIFFERENTIAL (FRONT)

### Clearance between the side gear and the differential box:

Standard: 0.03–0.10 mm (0.001–0.004 in)

Limit: 0.15 mm(0.006 in)



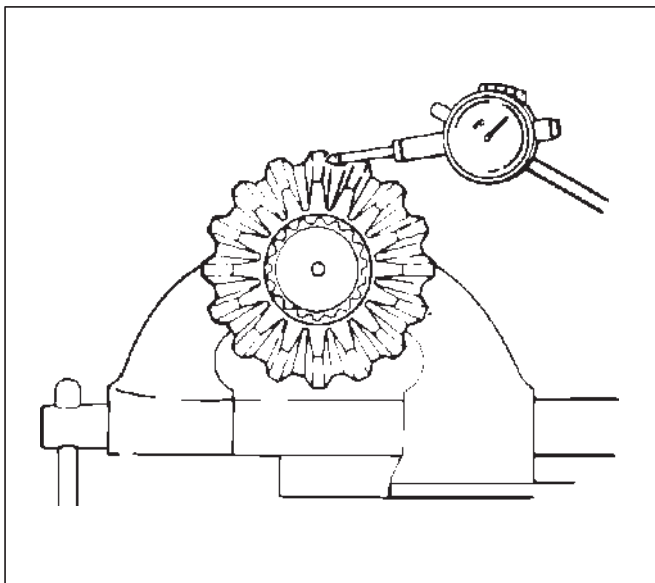
#### Legend

- (1) Side Gear
- (2) Differential Box

### Play in splines between the side gear and the axle shaft:

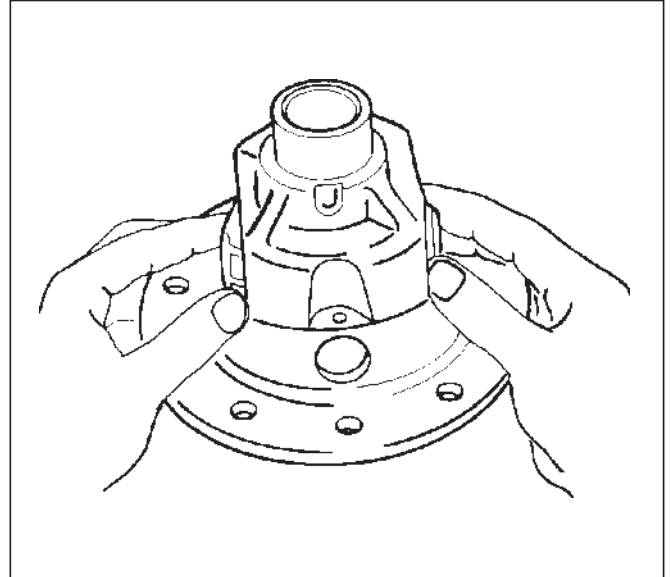
Standard: 0.08–0.36 mm(0.003 –0.014 in)

Limit:0.5m (0.02 in)



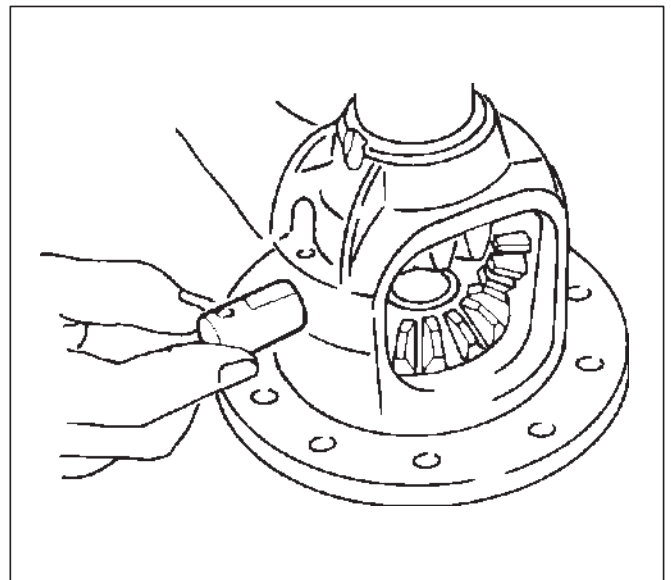
### Reassembly

1. Install thrust washer.
2. Install side gear.
3. Install the pinion gear by engaging it with the side gears while turning both pinion gears simultaneously in the same direction.



4. Install cross pin.

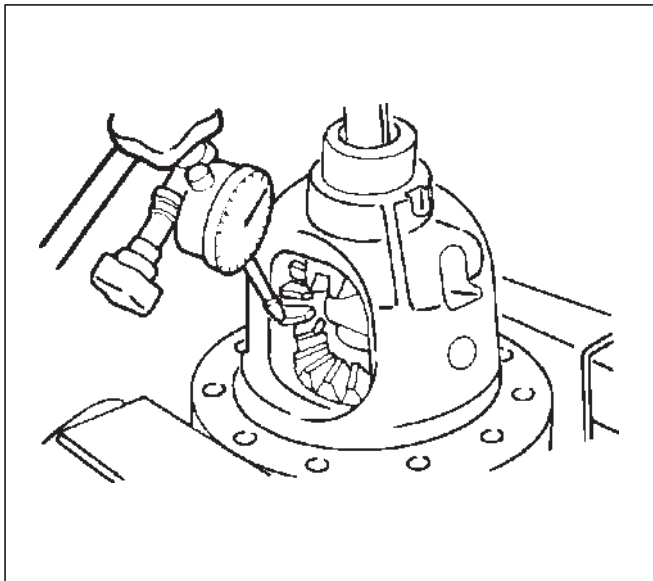
1. Be sure to install the cross pin so that it is in alignment with the lock pin hole in the differential cage.



2. Adjust the backlash between the side gear and the pinion gear.

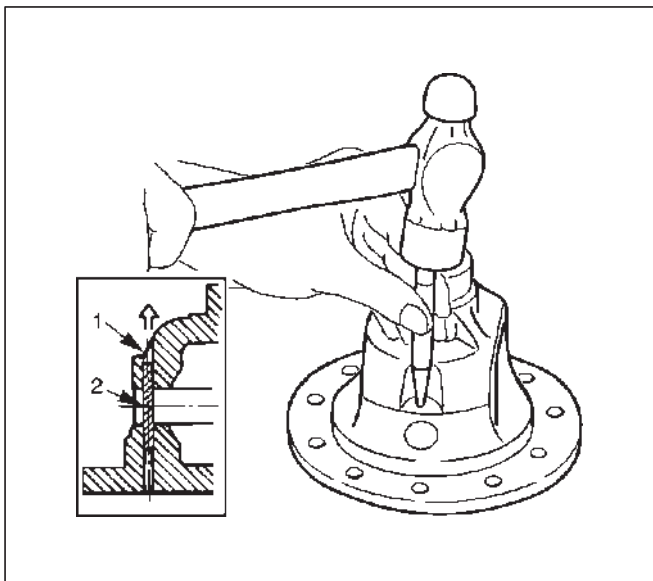
**Backlash:0.03 – 0.08 mm (0.001– 0.003 in)**

**Thickness of thrust washers available:**  
**1.00 mm, 1.05 mm, 1.10 mm (0.039 in, 0.041 in, 0.043 in)**



425RS050

5. Install lock pin. After lock pin installation, stake the cage to secure the lock pin.



425RS051

**Legend**

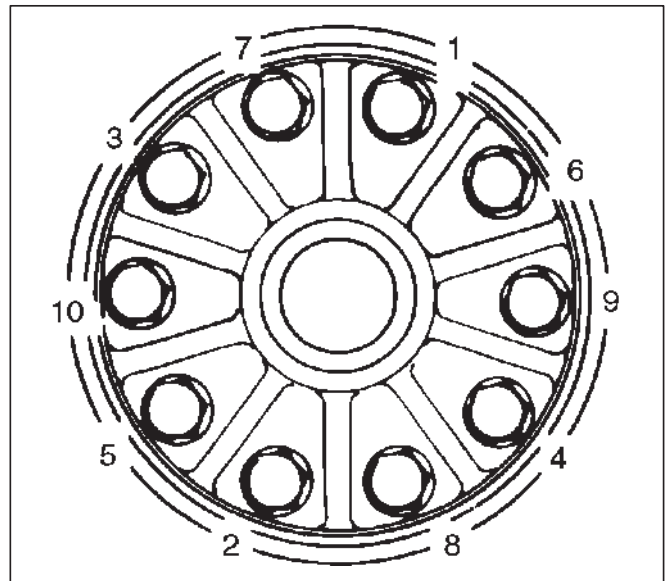
- (1) Staked Portion
- (2) Lock Pin

6. Clean the ring gear threaded holes to remove the locking agent. When installing the ring gear, apply LOCTITE 271 or equivalent to all the threaded area and half of the unthreaded area of the bolt.

7. Tighten the bolts in diagonal sequence as illustrated.

**Torque: 108 N·m (80 lb ft)**

NOTE: Discard used bolts and install new ones.



415RS016

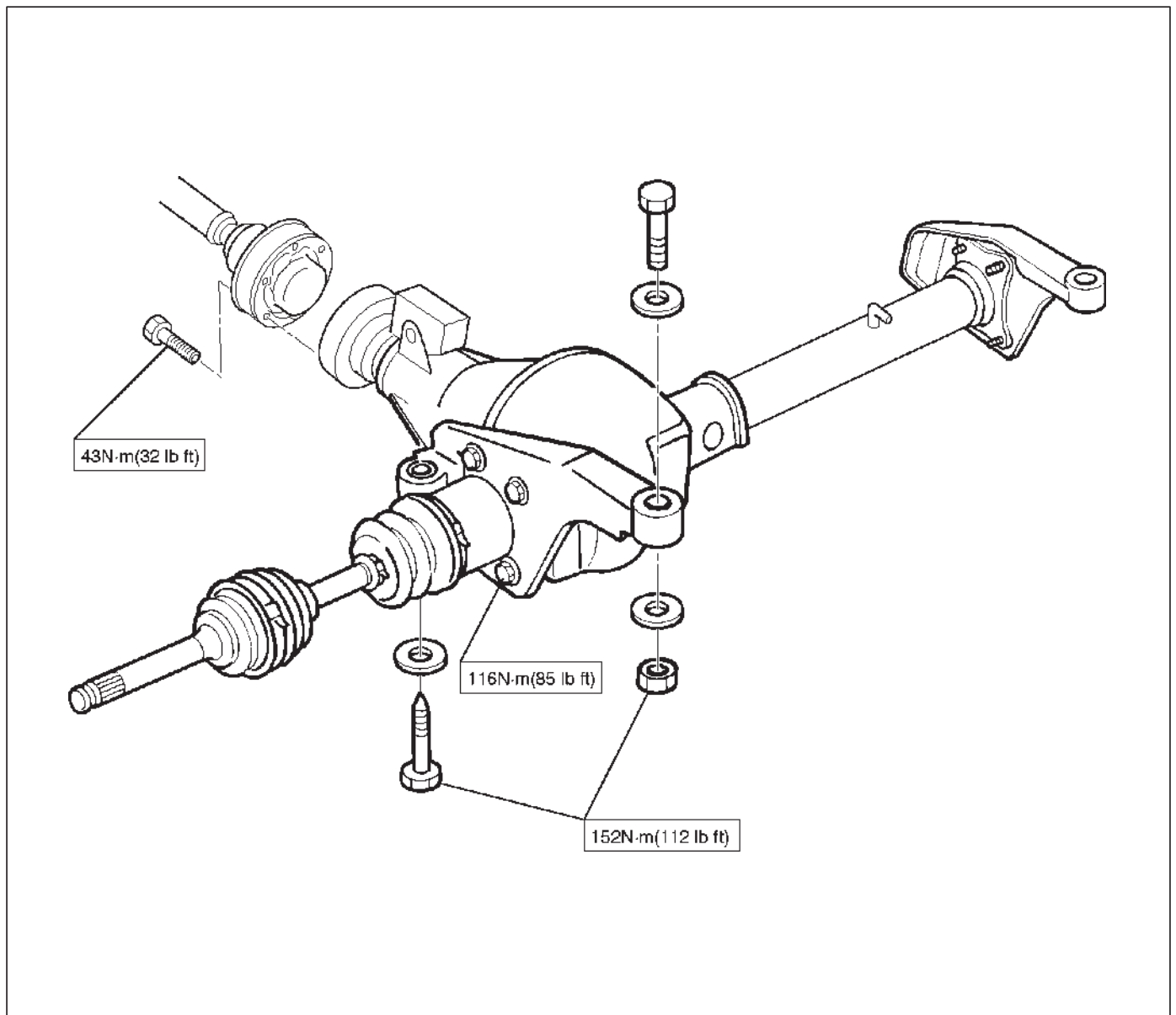
## 4A1-24 DIFFERENTIAL (FRONT)

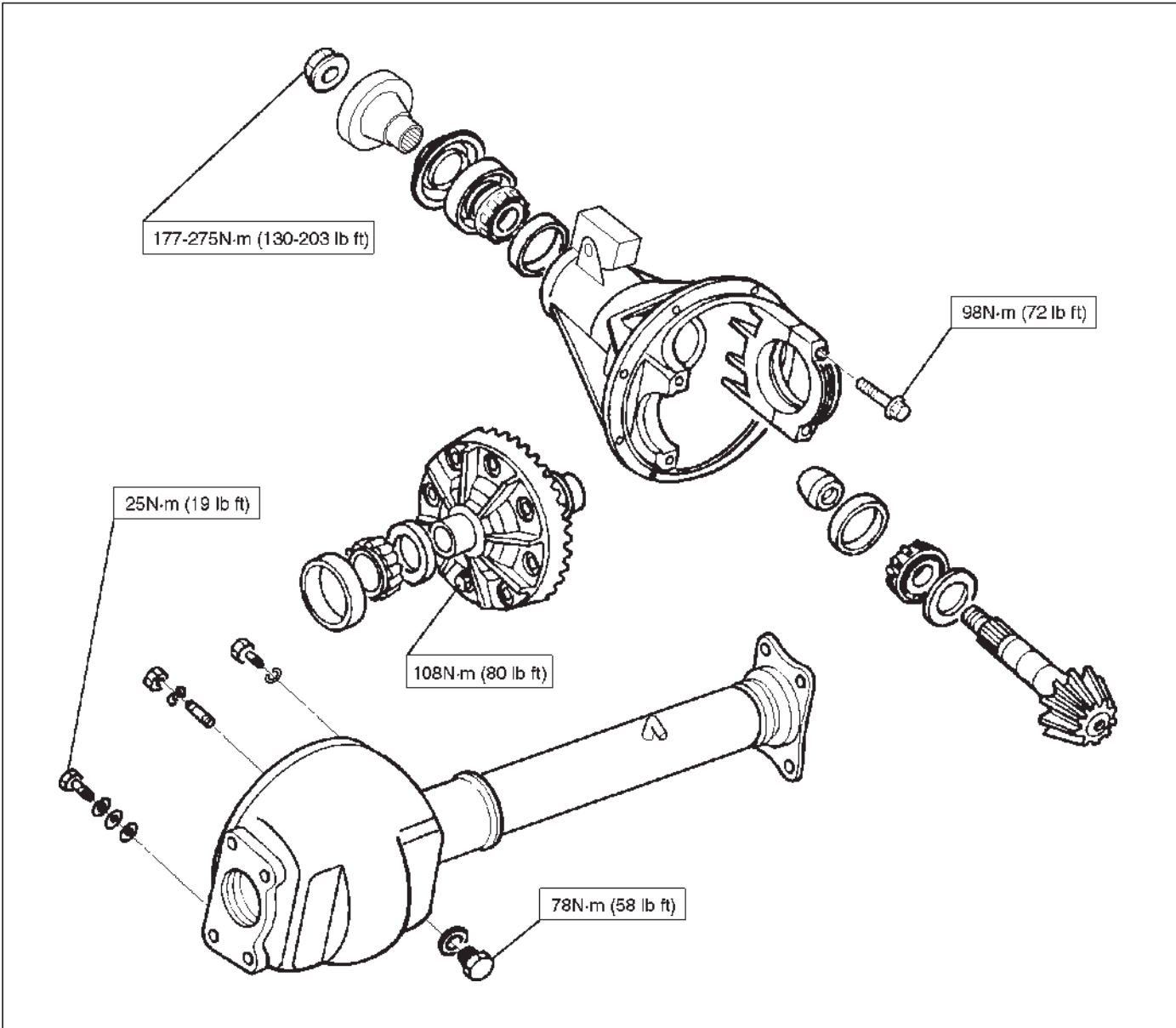
### Main Data and Specifications

#### General Specifications

Axle tube Type	It consists of the duct, a cast iron housing and the axle tube.	
Gear type	Hypoid	
Gear ratio	(to 1)	4.300
Differential type	Two pinion	
Oil capacity	liter (US qt)	1.4 (1.5)
Type of lubricant	GL-5 (Multi grade type) Refer to General Information	
Axle shaft type	Constant velocity joint (Birfield joint type and double offset joint)	
Hub locking Type	Rigid	


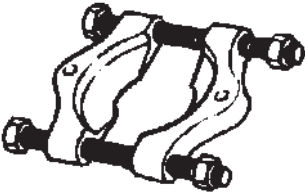
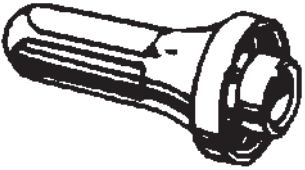
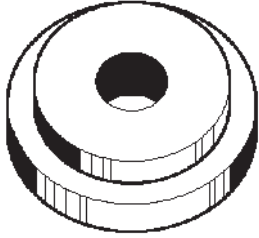
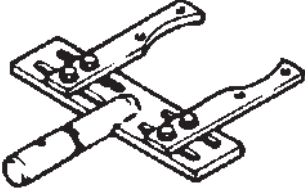
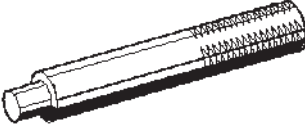
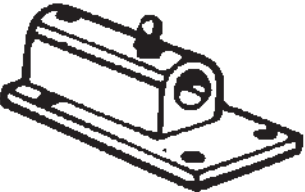
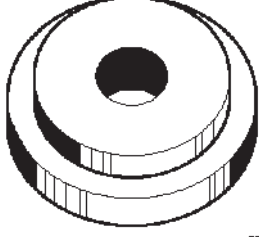
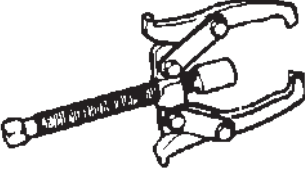
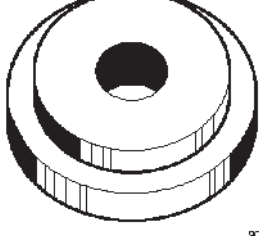
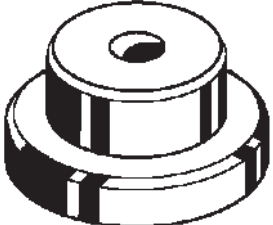
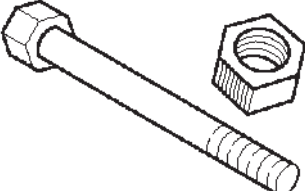
#### Torque Specifications





## 4A1-26 DIFFERENTIAL (FRONT)

### Special Tools

ILLUSTRATION	TOOL NO. TOOL NAME	ILLUSTRATION	TOOL NO. TOOL NAME
 <p style="text-align: right; font-size: small;">901RS210</p>	<p style="text-align: center;"><b>J-37221</b> Holder; Pinion flange</p>	 <p style="text-align: right; font-size: small;">901RS226</p>	<p style="text-align: center;"><b>J-22912-01</b> Separator</p>
 <p style="text-align: right; font-size: small;">901RS232</p>	<p style="text-align: center;"><b>J-24250</b> Installer; Oil seal</p>	 <p style="text-align: right; font-size: small;">901RS246</p>	<p style="text-align: center;"><b>J-24256</b> Installer; Outer bearing outer race</p>
 <p style="text-align: right; font-size: small;">901RS212</p>	<p style="text-align: center;"><b>J-37264</b> Differential holding fixture (Use with J-3289-20 base)</p>	 <p style="text-align: right; font-size: small;">901RS24</p>	<p style="text-align: center;"><b>J-8092</b> Driver handle</p>
 <p style="text-align: right; font-size: small;">901RS213</p>	<p style="text-align: center;"><b>J-3289-20</b> Holding fixture base</p>	 <p style="text-align: right; font-size: small;">901RS246</p>	<p style="text-align: center;"><b>J-24252</b> Installer; Inner bearing outer race</p>
 <p style="text-align: right; font-size: small;">901RS214</p>	<p style="text-align: center;"><b>J-22888</b> Puller; Side bearing</p>	 <p style="text-align: right; font-size: small;">901RS223</p>	<p style="text-align: center;"><b>J-21777-42</b> Pilot</p>
 <p style="text-align: right; font-size: small;">901RS238</p>	<p style="text-align: center;"><b>J-8107-2</b> Adapter; Side bearing plug</p>	 <p style="text-align: right; font-size: small;">901RS242</p>	<p style="text-align: center;"><b>J-23597-9</b> Nut and bolt</p>

**DIFFERENTIAL (FRONT) 4A1-27**

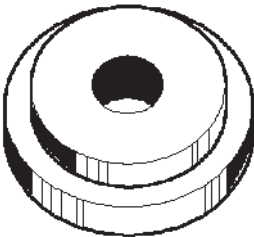
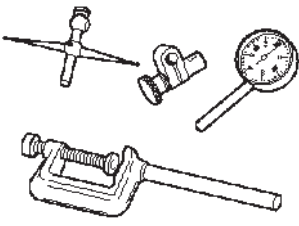

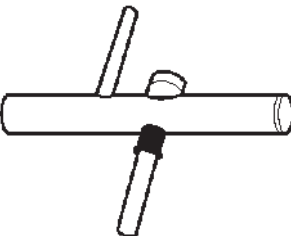
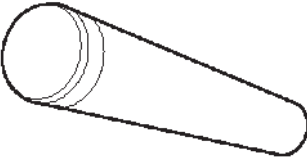
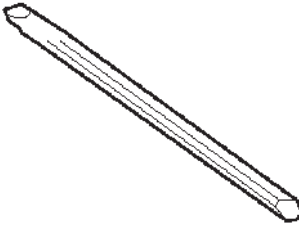
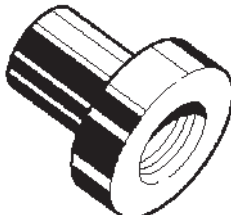
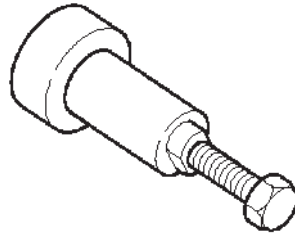
ILLUSTRATION	TOOL NO. TOOL NAME
 <p style="text-align: right; font-size: small;">901RS243</p>	<p style="text-align: center;"><b>J-23597-7</b> Gauge plate</p>
 <p style="text-align: right; font-size: small;">901RS224</p>	<p style="text-align: center;"><b>J-8001</b> Dial indicator</p>
 <p style="text-align: right; font-size: small;">901RS244</p>	<p style="text-align: center;"><b>J-23597-8</b> Disc</p>
 <p style="text-align: right; font-size: small;">901RS226</p>	<p style="text-align: center;"><b>J-23597-1</b> Arbor</p>
 <p style="text-align: right; font-size: small;">901RS227</p>	<p style="text-align: center;"><b>J-6133-01</b> Installer; Pinion bearing</p>
 <p style="text-align: right; font-size: small;">901RS228</p>	<p style="text-align: center;"><b>J-39209</b> Punch; End nut lock</p>

ILLUSTRATION	TOOL NO. TOOL NAME
 <p style="text-align: right; font-size: small;">901RS245</p>	<p style="text-align: center;"><b>J-24244</b> Installer; Side bearing</p>
 <p style="text-align: right; font-size: small;">901RS230</p>	<p style="text-align: center;"><b>J-39602</b> Remover; Outer bearing</p>



VEHICROSS

# DRIVELINE/AXLE

## DIFFERENTIAL (REAR)

### CONTENTS

Service Precaution .....	4A2-1	Differential Assembly and Associated Parts	4A2-8
General Description .....	4A2-2	Removal .....	4A2-8
Diagnosis .....	4A2-3	Installation .....	4A2-9
Axle Housing .....	4A2-4	Disassembled View .....	4A2-10
Axle Housing and Associated Parts .....	4A2-4	Disassembly .....	4A2-11
Removal .....	4A2-4	Reassembly .....	4A2-13
Oil Seal Replacement .....	4A2-5	Limited Slip Differential .....	4A2-21
Installation .....	4A2-5	Disassembled View .....	4A2-21
Pinion Oil Seal .....	4A2-6	Disassembly .....	4A2-22
Pinion Oil Seal and Associated Parts .....	4A2-6	Inspection and Repair .....	4A2-22
Removal .....	4A2-6	Reassembly .....	4A2-24
Inspection and Repair .....	4A2-7	Main Data and Specifications .....	4A2-27
Installation .....	4A2-7	Special Tools .....	4A2-28
Differential Assembly .....	4A2-8		

### Service Precaution

**WARNING: IF SO EQUIPPED WITH A SUPPLEMENTAL RESTRAINT SYSTEM (SRS), REFER TO THE SRS COMPONENT AND WIRING LOCATION VIEW IN ORDER TO DETERMINE WHETHER YOU ARE PERFORMING SERVICE ON OR NEAR THE SRS COMPONENTS OR THE SRS WIRING. WHEN YOU ARE PERFORMING SERVICE ON OR NEAR THE SRS COMPONENTS OR THE SRS WIRING, REFER TO THE SRS SERVICE INFORMATION. FAILURE TO FOLLOW WARNINGS COULD RESULT IN POSSIBLE AIR BAG DEPLOYMENT, PERSONAL INJURY, OR OTHERWISE UNNEEDED SRS SYSTEM REPAIRS.**

**CAUTION: Always use the correct fastener in the proper location. When you replace a fastener, use ONLY the exact part number for that application. ISUZU will call out those fasteners that require a replacement after removal. ISUZU will also call out the fasteners that require thread lockers or thread sealant. UNLESS OTHERWISE SPECIFIED, do not use supplemental coatings (Paints, greases, or other corrosion inhibitors) on threaded fasteners or fastener joint interfaces. Generally, such coatings adversely affect the fastener torque and the joint clamping force, and may damage the fastener. When you install fasteners, use the correct tightening sequence and specification. Following these instructions can help you avoid damage to parts and systems.**

## 4A2-2 DIFFERENTIAL (REAR)

### General Description

The rear axle assembly is of the semi-floating type in which the vehicle weight is carried on the axle housing. The center line of the pinion gear is below the center line of the ring gear (hypoid drive).

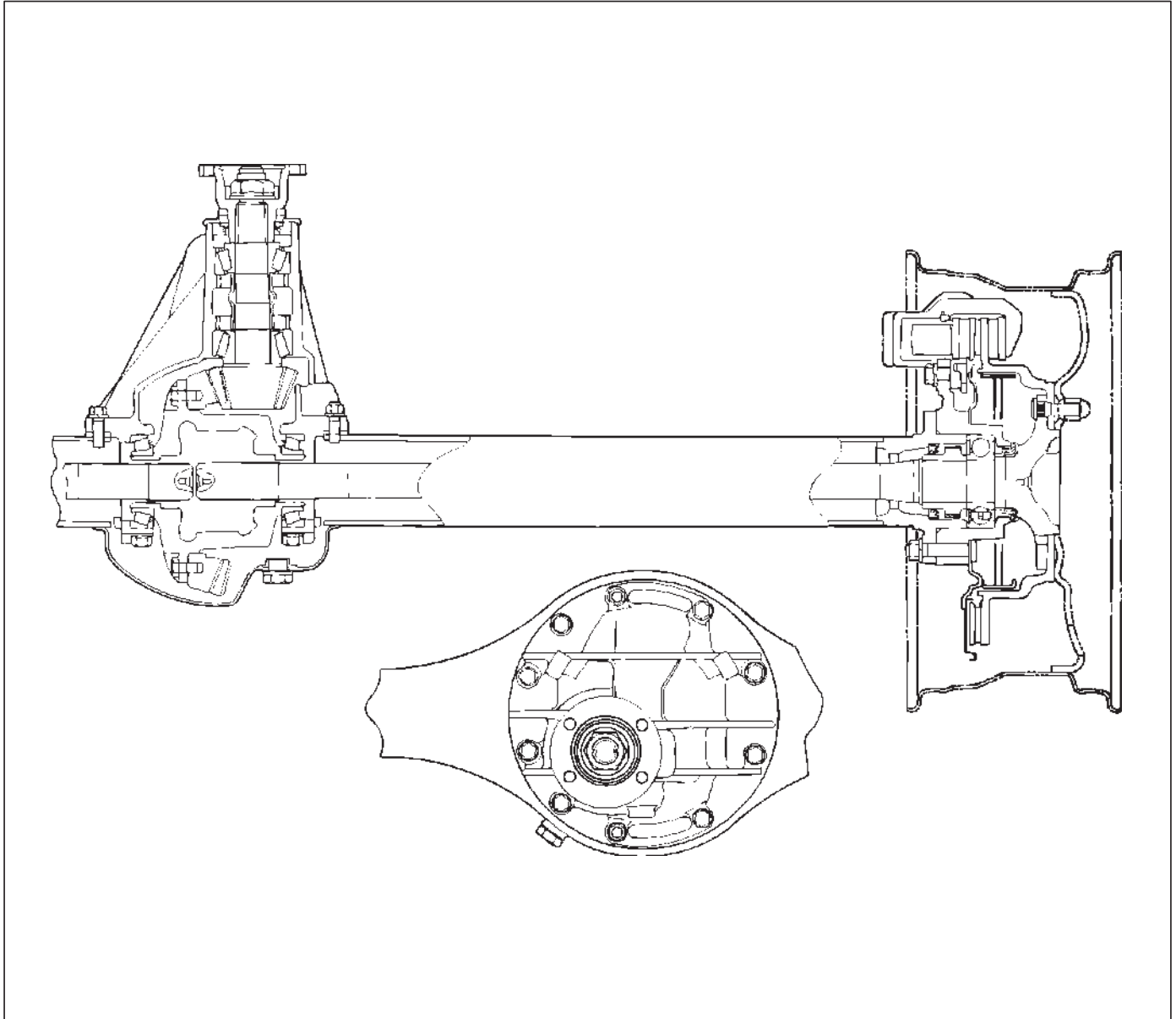
All parts necessary to transmit power from the propeller shaft to the rear wheels are enclosed in a banjo type axle housing.

The 8.7 inch ring gear rear axle uses a conventional ring and pinion gear set to transmit the driving force of the engine to the rear wheels. This gear set transfers this

driving force at a 90 degree angle from the propeller shaft to the drive shafts.

The axle shafts are supported at the wheel end of the shaft by a roller bearing.

The pinion gear is supported by two tapered roller bearings. The pinion depth is set by a shim pack located between the gear end of the pinion and the roller bearing that is pressed onto the pinion. The pinion bearing preload is set by crushing a collapsible spacer between the bearings in the axle housing.



The ring gear is bolted onto the differential cage with 12 bolts.

The differential cage is supported in the axle housing by two tapered roller bearings. The differential and ring gear are located in relationship to the pinion by using selective shims and spacers between the bearing and the axle housing. To move the ring gear, shims are deleted from one side and an equal amount are added to the other side. These shims are also used to preload the bearings which

are pressed onto the differential cage. Two bearing caps are used to hold the differential into the rear axle housing. The differential is used to allow the wheels to turn at different rates of speed while the rear axle continues to transmit the driving force. This prevents tire scuffing when going around corners and prevents premature wear on internal axle parts.

The rear axle is sealed with a pinion seal, a seal at each axle shaft end, and by a liquid gasket between the differential carrier and the axle housing.

## Diagnosis

Many noises that seem to come from the rear axle actually originate from other sources such as tires, road surface, wheel bearings, engine, transmission, muffler, or body drumming. Investigate to find the source of the noise before disassembling the rear axle. Rear axles, like any other mechanical device, are not absolutely quiet but should be considered quiet unless some abnormal noise is present.

To make a systematic check for axle noise, observe the following:

1. Select a level asphalt road to reduce tire noise and body drumming.
2. Check rear axle lubricant level to assure correct level, and then drive the vehicle far enough to thoroughly warm up the rear axle lubricant.
3. Note the speed at which noise occurs. Stop the vehicle and put the transmission in neutral. Run the engine speed slowly up and down to determine if the noise is caused by exhaust, muffler noise, or other engine conditions.
4. Tire noise changes with different road surfaces; axle noises do not. Temporarily inflate all tires to 344 kpa (3.5kg/cm<sup>2</sup>, 50 psi) (for test purposes only). This will change noise caused by tires but will not affect noise caused by the rear axle.

Rear axle noise usually stops when coasting at speeds under 48 km/h (30 mph); however, tire noise continues with a lower tone. Rear axle noise usually changes when comparing pull and coast, but tire noise stays about the same.

Distinguish between tire noise and rear axle noise by noting if the noise changes with various speeds or sudden acceleration and deceleration. Exhaust and axle noise vary under these conditions, while tire noise remains constant and is more pronounced at speeds of 32 to 48 km/h (20 to 30 mph). Further check for tire noise by driving the vehicle over smooth pavements or dirt roads (not gravel) with the tires at normal pressure. If the noise is caused by tires, it will change noticeably with changes in road surface.

5. Loose or rough front wheel bearings will cause noise which may be confused with rear axle noise; however, front wheel bearing noise does not change when comparing drive and coast. Light application of the brake while holding vehicle speed steady will often cause wheel bearing noise to diminish. Front wheel bearings may be checked for noise by jacking up the wheels and spinning them or by shaking the wheels to determine if bearings are loose.
6. Rear suspension rubber bushings and spring insulators dampen out rear axle noise when correctly installed. Check to see that there is no link or rod loosened or metal-to-metal contact.
7. Make sure that there is no metal-to-metal contact between the floor and the frame.

After the noise has been determined to be in the axle, the type of axle noise should be determined, in order to make any necessary repairs.

## Gear Noise

Gear noise (whine) is audible from 32 to 89 km/h (20 to 55 mph) under four driving conditions.

1. Driving under acceleration or heavy pull.
2. Driving under load or under constant speed.
3. When using enough throttle to keep the vehicle from driving the engine while the vehicle slows down gradually (engine still pulls slightly).
4. When coasting with the vehicle in gear and the throttle closed. The gear noise is usually more noticeable between 48 and 64 km/h (30 and 40 mph) and 80 and 89 km/h (50 and 55 mph).

## Bearing Noise

Bad bearings generally produce a rough growl or grating sound, rather than the whine typical of gear noise. Bearing noise frequently "wow-wows" at bearing rpm, indicating a bad pinion or rear axle side bearing. This noise can be confused with rear wheel bearing noise.

## Rear Wheel Bearing Noise

Rear wheel bearing noise continues to be heard while coasting at low speed with transmission in neutral. Noise may diminish by gentle braking. Jack up the rear wheels, spin them by hand and listen for noise at the hubs. Replace any faulty wheel bearings.

## Knock At Low Speeds

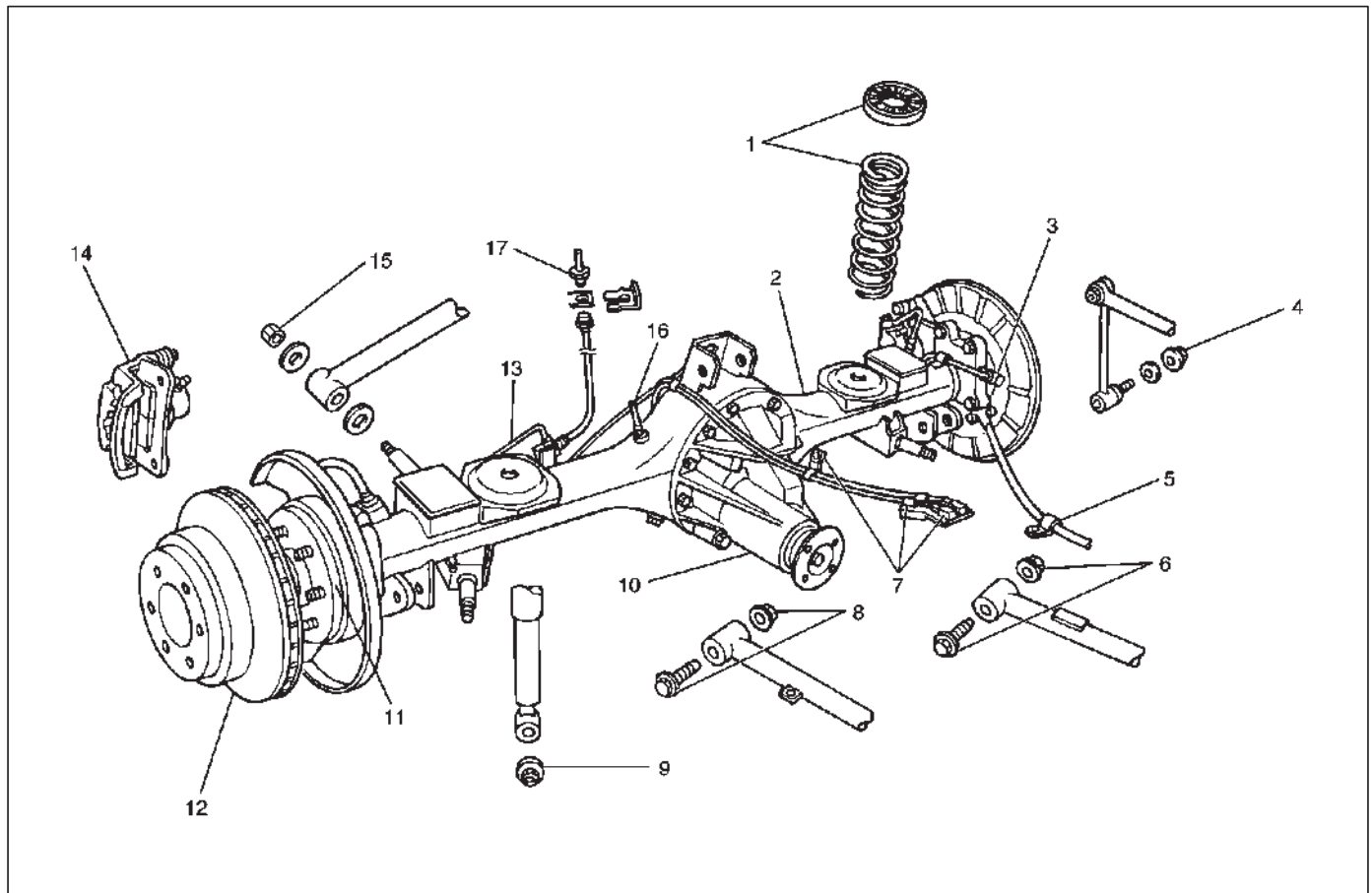
Low speed knock can be caused by worn universal joints or a side gear hub counter bore in the cage that is worn oversize. Inspect and replace universal joints or cage and side gears as required.

## Backlash Clunk

Excessive clunk on acceleration and deceleration can be caused by a worn rear axle pinion shaft, a worn cage, excessive clearance between the axle and the side gear splines, excessive clearance between the side gear hub and the counterbore in the cage, worn pinion and side gear teeth, worn thrust washers, or excessive drive pinion and ring gear backlash. Remove worn parts and replace as required. Select close-fitting parts when possible. Adjust pinion and ring gear backlash.

## Axle Housing

### Axle Housing and Associated Parts



420RW022

#### Legend

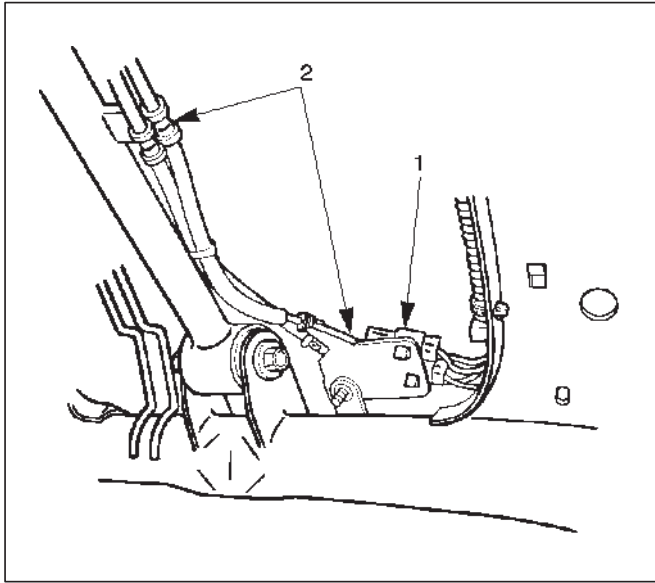
- |   |                            |
|---|----------------------------|
| (1) Coil Spring and Insulator                         | (9) Nut                    |
| (2) Axle Housing Assembly                             | (10) Differential Assembly |
| (3) ABS Speed Sensor and Harness                      | (11) Axle Shaft Assembly   |
| (4) Nut   | (12) Brake Disc            |
| (5) Parking Brake Cable                               | (13) Brake Line            |
| (6) Bolt and Nut                                      | (14) Brake Caliper         |
| (7) Antilock Brake System (ABS) Connector and Bracket | (15) Nut                   |
| (8) Bolt and Nut                                      | (16) Breather Hose         |
|   | (17) Flare Nut             |

#### Removal

1. Raise the vehicle and support it with suitable safety stands.  
The hoist must remain under the rear axle housing.
2. Drain brake fluid. Refer to Hydraulic Brakes in Brake section.
3. Remove rear wheels and tires. Refer to Wheel in Suspension section.
4. Remove propeller shaft. Refer to Rear Propeller Shaft in this section.
5. Drain the rear axle oil into a proper container.

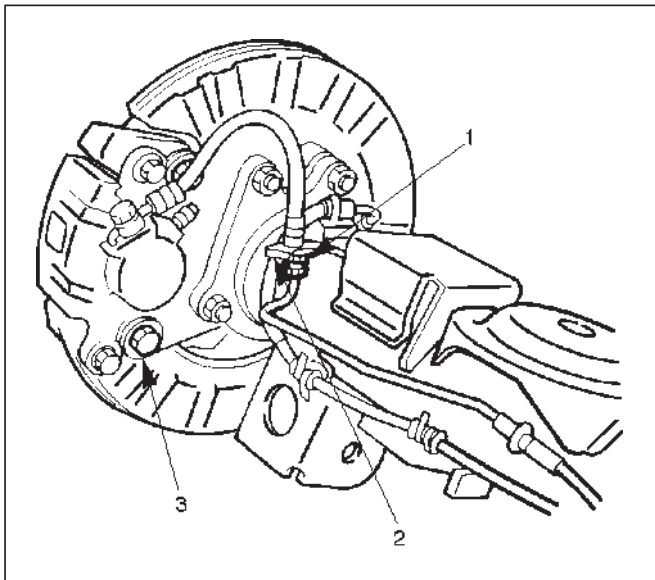
6. Remove parking brake cable, release the connection between the cable fixing clip equalizer. Refer to Parking Brakes in Brake section.
7. Move the clip aside and pull out the breather hose.

8. Disconnect the ABS connectors (1) and remove the brackets (2) attached to the frame and center link.



350RS001

9. Loosen the brake tube flare nut, remove the clip and take out the brake tube.
10. Remove the shock absorber fixing nut from the axle housing.
11. Remove the stabilizer linkage mounting nut from the axle housing.
12. Remove the lateral rod fixing nut from the axle housing.
13. Remove the center link mounting bolt and nut from the axle housing.
14. Remove the trailing link fixing bolt and nut from the axle housing.
15. Lower the jack and remove the coil spring and insulator.
16. Axle housing assembly can be separated from the vehicle on completion of steps 1 – 11.
17. Remove the brake caliper fixing bolt (3), loosen the flare nut (1), release the clip (2) and take out the brake caliper together with the flexible hose.

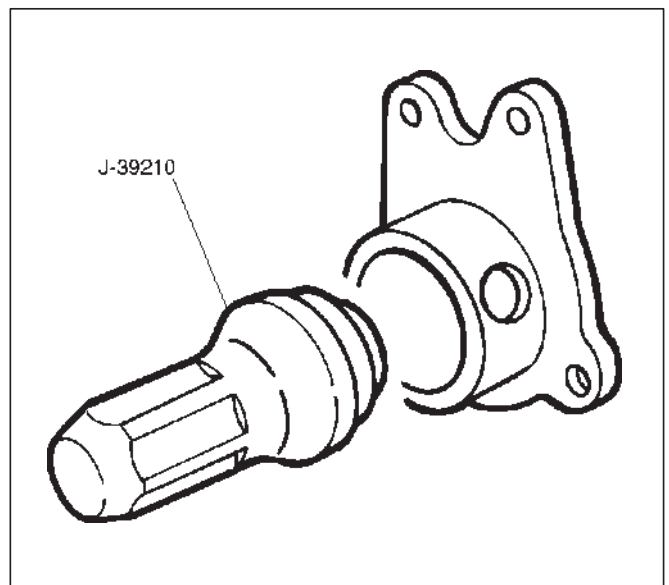


306RS001

18. Remove brake disc.
19. Remove antilock brake system speed sensor fixing bolt and the clip and bracket on the axle housing.
20. Remove the brake line clip and fixing bolt on the axle housing and take out the brake pipe.
21. Remove the bearing holder fixing nut and take out the axle shaft assembly, be sure not to damage the oil seal by the spline of the shaft, Refer to Axle Shaft in this section.
22. Remove differential assembly, refer to Differential Assembly in this section.

## Oil Seal Replacement

Remove the oil seal, carefully not to damage the housing, and mount new oil seal using oil seal installer J-39210.



420RS004

## Installation

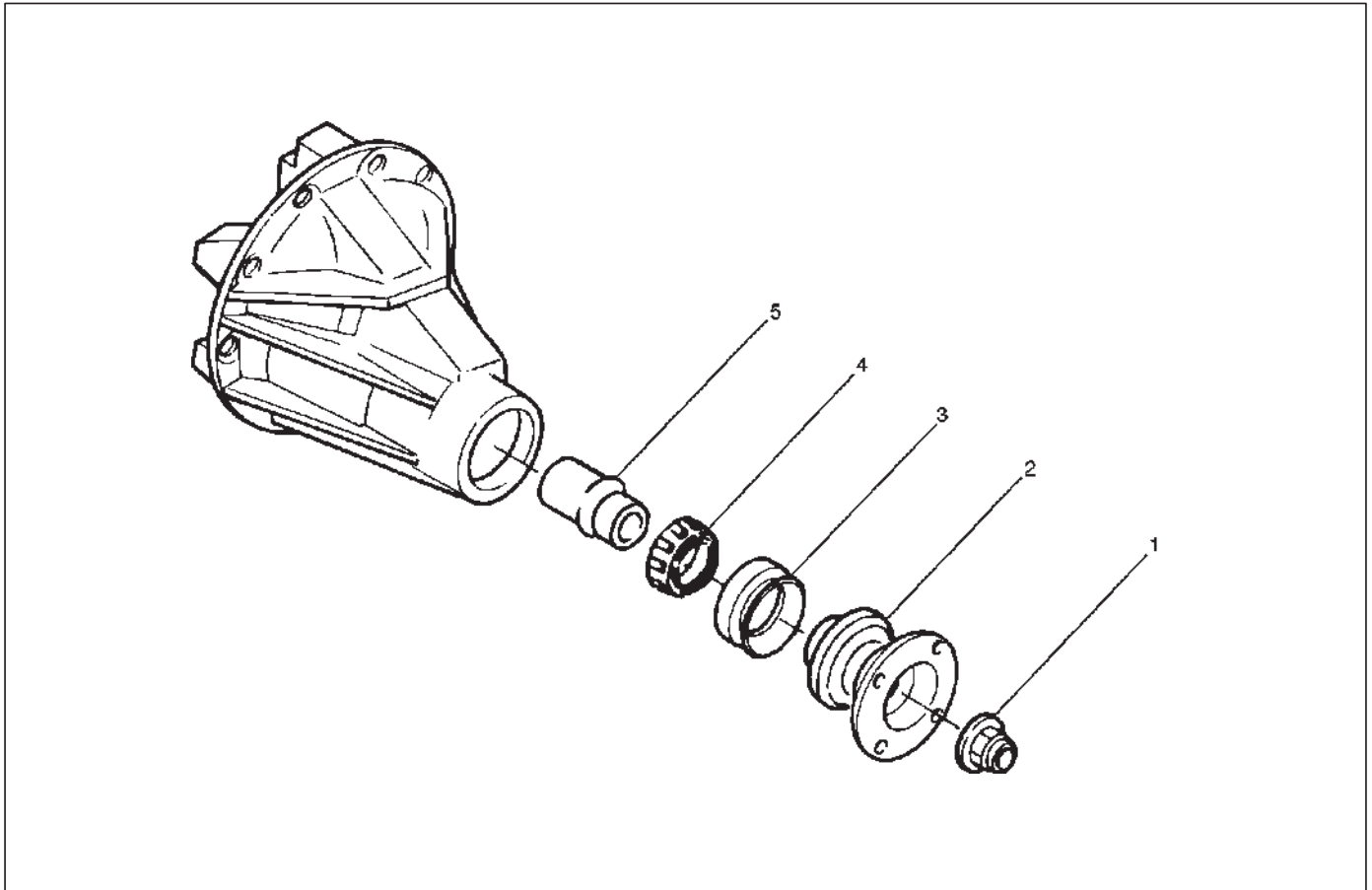
1. Install differential assembly, refer to Differential Assembly in this section.
2. Install axle shaft assembly then tighten the bearing holder mounting nut to the specified torque. Be sure not to damage the oil seal by the spline of the shaft.
- Torque: 74N·m (54lb ft)**
3. Install brake line.
4. Connect antilock brake system (ABS) speed sensor and harness, refer to Anti-Lock Brake System (ABS) in Brake section.
5. Install brake disc.
6. Install brake caliper. Refer to Disk Brakes in Brake section.
7. Install axle housing assembly.
8. Install coil spring and insulator.
9. Install the trailing link fixing bolt and nut to the axle housing. For the procedures in items 9–13, refer to Suspension section.
10. Install the center link bolt and nut to the axle housing.
11. Install the lateral rod fixing nut to the axle housing.

## 4A2-6 DIFFERENTIAL (REAR)

12. Install the stabilizer linkage mounting nut to the axle housing.
13. Install the shock absorber fixing nut to the axle housing.
14. Install brake tube flare nut, Refer to Disk Brakes in Brake section.
15. Install ABS connector and bracket.
16. Connect breather hose.
17. Install parking brake cable, Refer to Parking Brakes in Brake section.
18. Bleed brakes. Refer to Hydraulic Brakes in Brake section.

## Pinion Oil Seal

### Pinion Oil Seal and Associated Parts



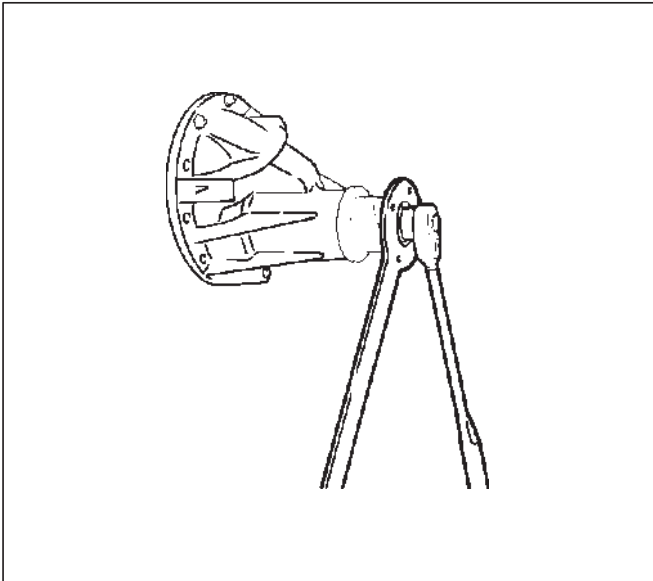
#### Legend

- |                           |                        |
|---------------------------|------------------------|
| (1) Flange Nut and Washer | (3) Oil Seal           |
| (2) Flange                | (4) Outer Bearing      |
|                           | (5) Collapsible Spacer |

### Removal

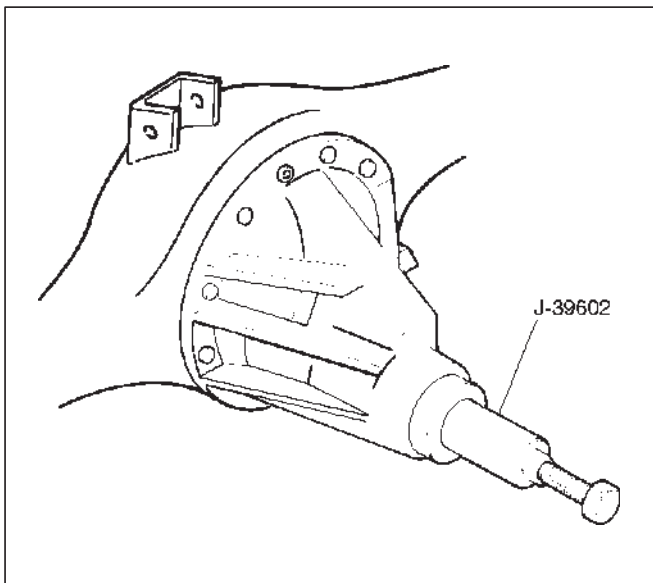
1. Remove the rear propeller shaft. Refer to Rear Propeller Shaft in this section.
2. Drain the rear axle oil.

3. Remove flange nut and washer by using pinion flange holder J-37221 after raising up its staked parts completely.



425RS002

4. Remove flange.  
5. Remove oil seal.  
6. Remove outer bearing by using remover J-39602.



425RS003

7. Remove collapsible spacer.

## Inspection and Repair

Make necessary correction or parts replacement if wear, damage, corrosion or any other abnormal conditions are found through inspection.

Check the following parts:

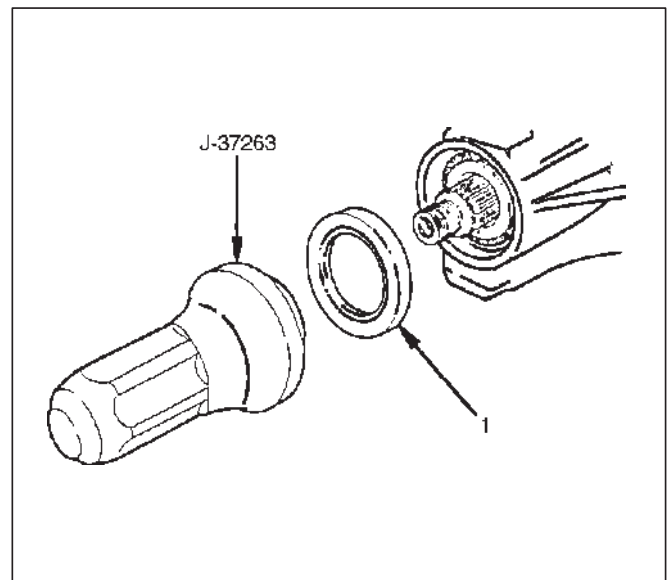
1. Seal surface of the pinion.
2. Cage bore for burns.

## Installation

1. Install collapsible spacer, discard the used collapsible spacer and install a new one.
2. Install outer bearing.

NOTE: Do not drive in, but just temporarily set in the outer bearing by hand, which should be indirectly pressed in finally by tightening the flange nut.

3. By using the seal installer J-37263, install a new oil seal (1) that has grease on seal lip.



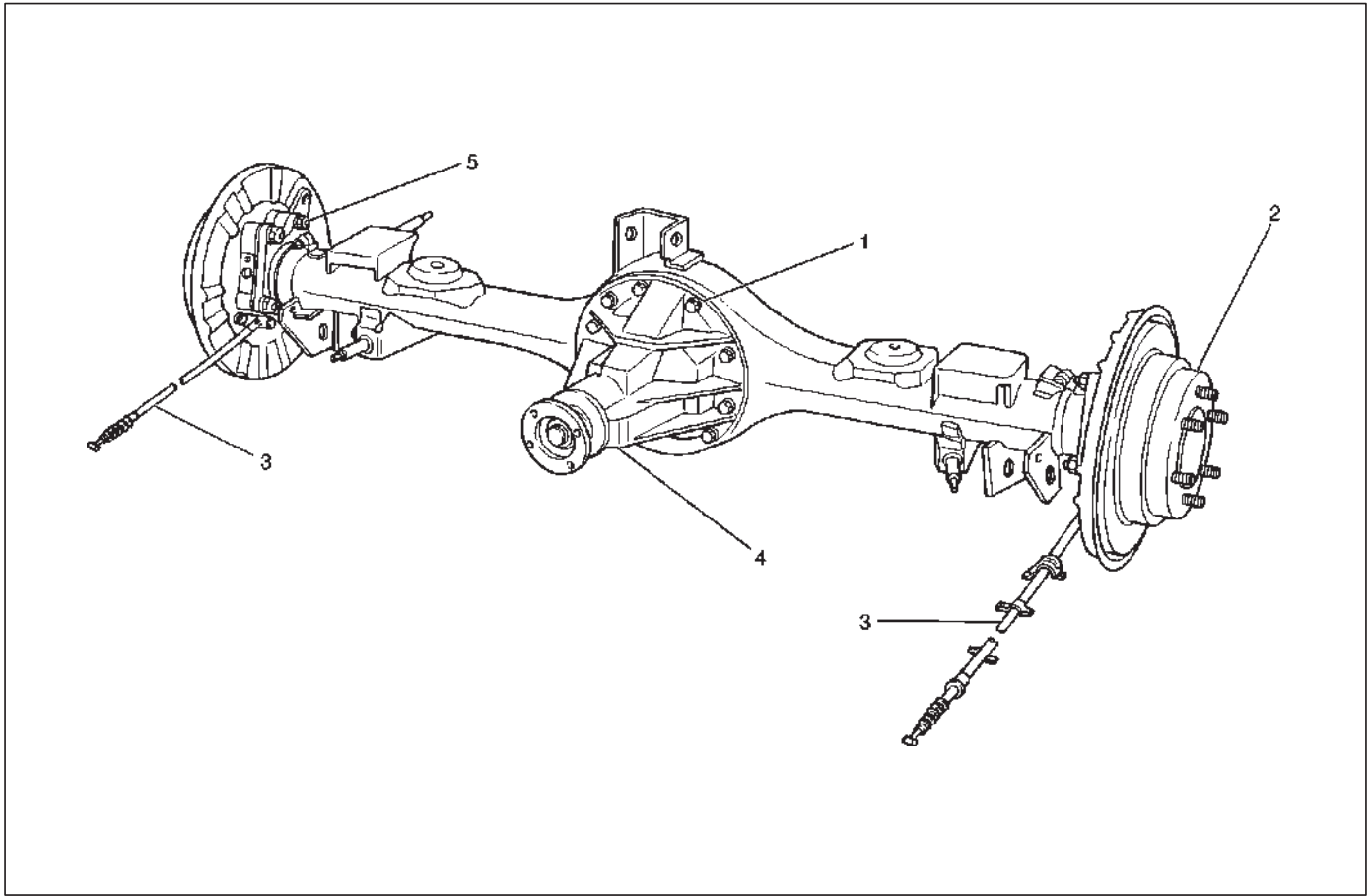
425RS004

4. Install flange.
5. Install flange nut and washer. Refer to Differential Assembly in this section for flange nut reassembly.

NOTE: Discard the used nut and install a new one.

## Differential Assembly

### Differential Assembly and Associated Parts



425RW055

#### Legend

- |                         |                           |
|-------------------------|---------------------------|
| (1) Bolt and Nut        | (3) Parking Brake Cable   |
| (2) Axle Shaft Assembly | (4) Differential Assembly |
|                         | (5) Nut                   |

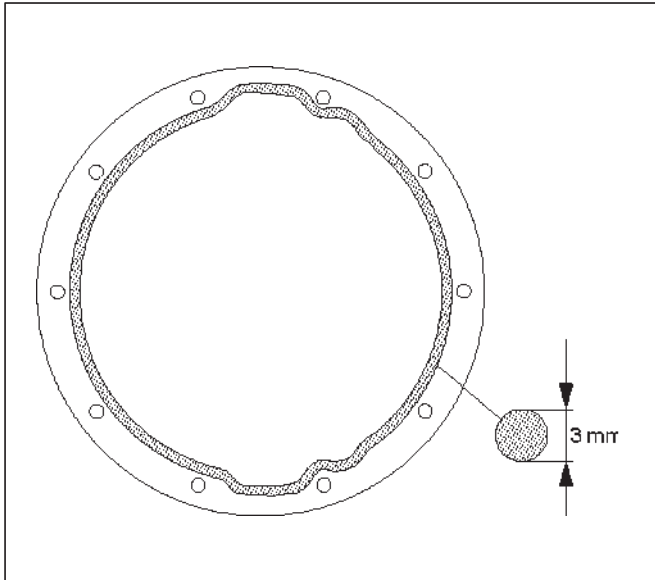
#### Removal

1. Jack up and support the frame with stands.
2. Remove the wheel and tire. Refer to Wheel in Steering section.
3. Drain the differential oil.
4. Remove the propeller shaft. Refer to Rear Propeller Shaft in this section.
5. Remove the ABS speed sensor. Refer to Anti-lock Brake System (ABS) in Brake section.
6. Remove the parking brake cable fastening clip and disconnect the equalizer section. Refer to Parking Brakes in Brake section.
7. Remove the bearing holder fixing nuts.
8. Remove axle shaft assembly, be sure not to damage the oil seal by axle shaft.
9. Remove differential carrier mounting bolts and nuts.
10. Remove differential assembly.



## Installation

1. Clean the contact surfaces of the axle and differential carrier. As shown in the drawing, apply Three Bond TB1215 or equivalent then install differential assembly.



2. Install bolt and nut. Tighten the differential carrier mounting bolts and nuts to the specified torque.

**Torque:Nuts 44N·m (33lb ft)**

**Bolts 66N·m (48lb ft)**

3. Install axle shaft assembly. Be sure not to damage the oil seal by axle shaft.
4. Install nut, refer to Axle Shaft in this section.
5. Install parking brake cable, refer to Parking Brakes in Brake section.

NOTE: After completing the assembling work, fill the prescribed gear oil to the filler hole.

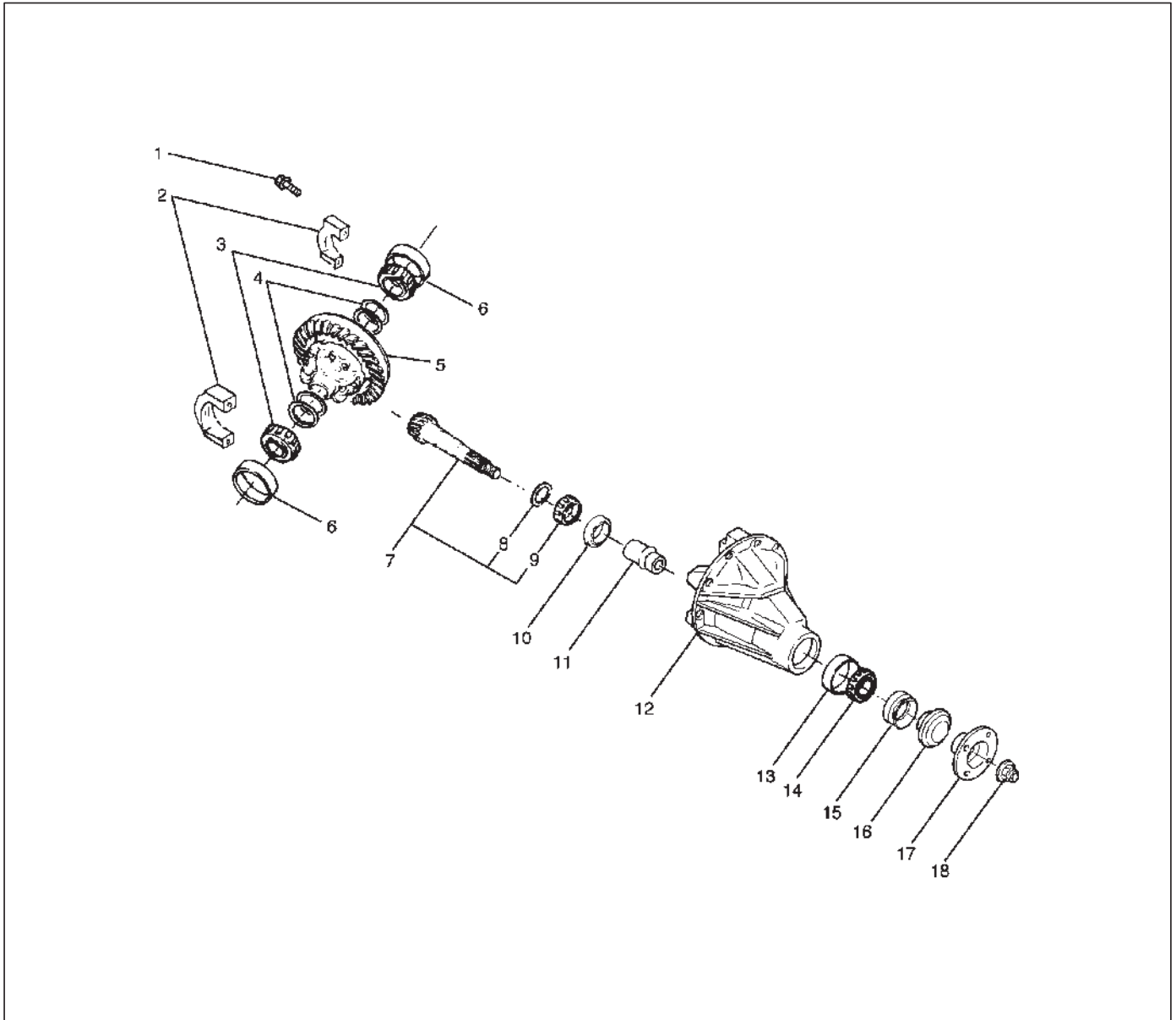
**Lubricant capacity: 1.8 liter (1.9US qt)**

6. Tighten the oil filler plug to the specified torque.

**Torque: 78N·m (58lb ft)**

## 4A2-10 DIFFERENTIAL (REAR)

### Disassembled View



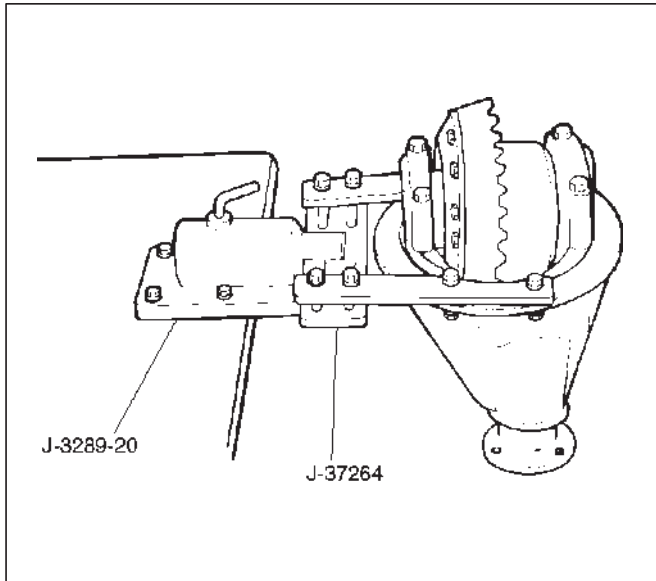
415RW035

#### Legend

- |                             |                               |
|-----------------------------|-------------------------------|
| (1) Bolt                    | (10) Inner Bearing Outer Race |
| (2) Bearing Cap             | (11) Collapsible Spacer       |
| (3) Side Bearing            | (12) Differential Carrier     |
| (4) Adjust Shim             | (13) Outer Bearing Outer Race |
| (5) Diff Cage Assembly      | (14) Outer Bearing            |
| (6) Side Bearing Outer Race | (15) Oil Seal                 |
| (7) Pinion Gear             | (16) Dust Cover               |
| (8) Adjust Shim             | (17) Flange                   |
| (9) Inner Bearing           | (18) Flange Nut               |

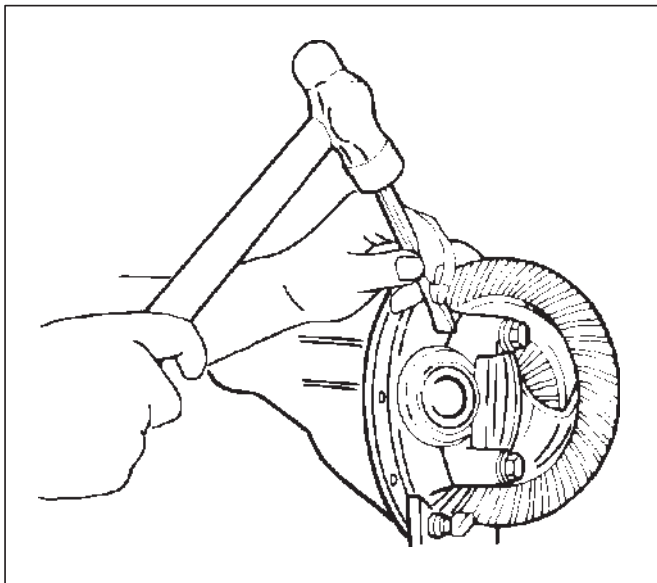
## Disassembly

- Using holding fixture J-37264 and holding fixture base J-3289-20, fix the differential assembly to the bench.



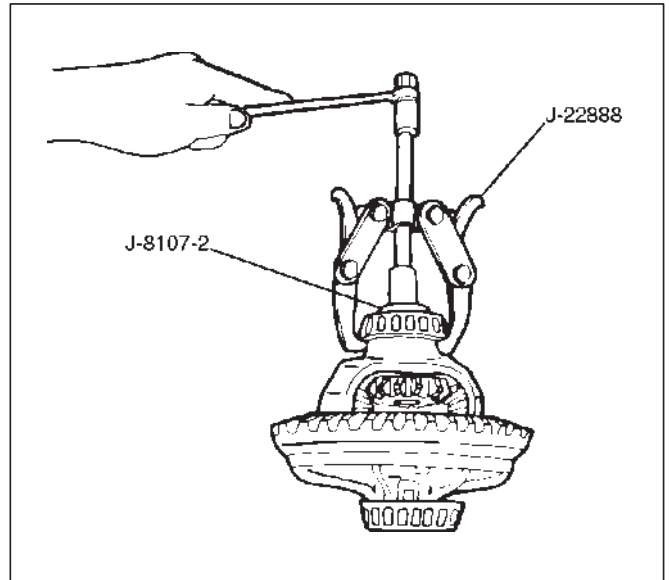
425RS008

- Remove bearing cap bolt.
- Apply a setting mark to the side bearing cap and the differential carrier then remove bearing cap.



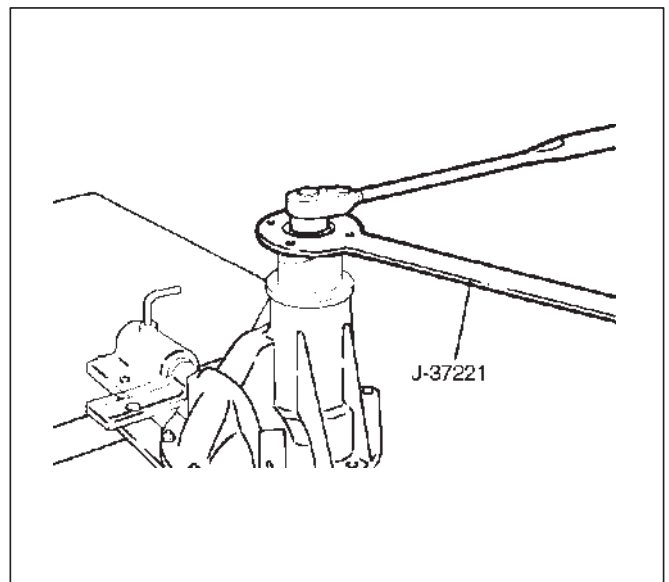
425RS009

- Remove differential cage assembly.
- Remove side bearing outer race, after removal, keep the right and left hand side bearing assemblies separate to maintain inner and outer race combinations.
- Remove side bearing, using remover J-22888 and adapter J-8107-2.



415RS005

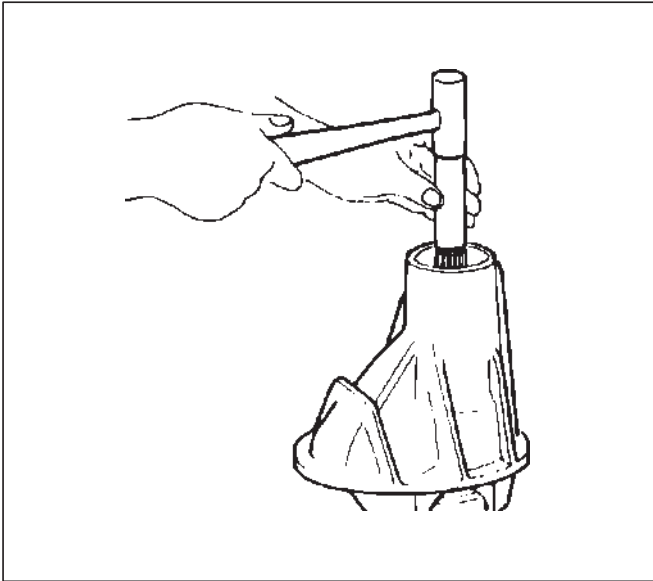
- Remove adjust shim, note the thickness and position of the shims removed.
- Remove the flange nut using holding wrench J-37221 after raising up its staked parts completely.



425RX002

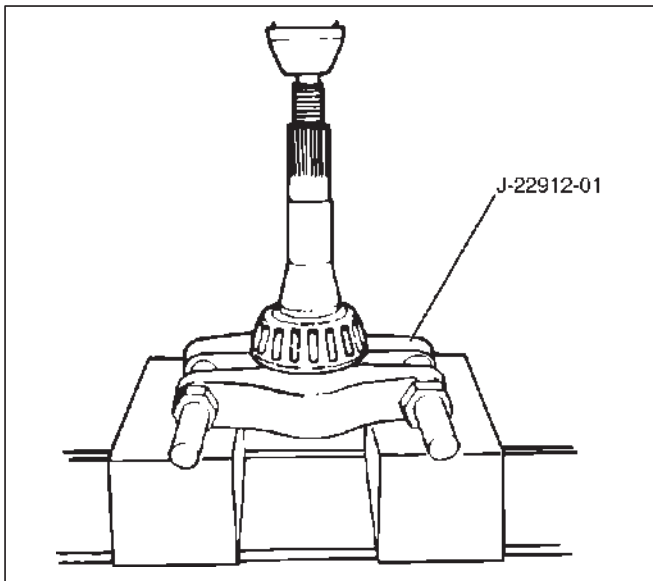
## 4A2-12 DIFFERENTIAL (REAR)

9. Remove flange.
10. Remove dust cover.
11. Remove the drive pinion assembly using a soft metal rod and a hammer.



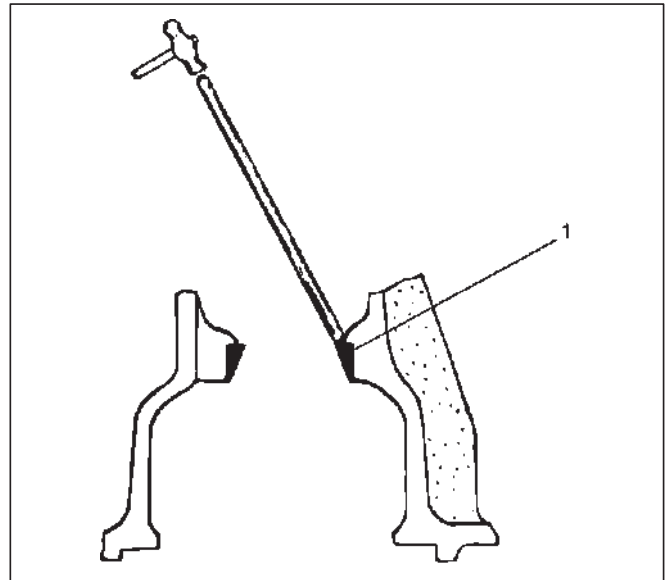
425RW056

12. Remove collapsible spacer.
13. Remove the inner bearing using a separator J-22912-01 and a press.

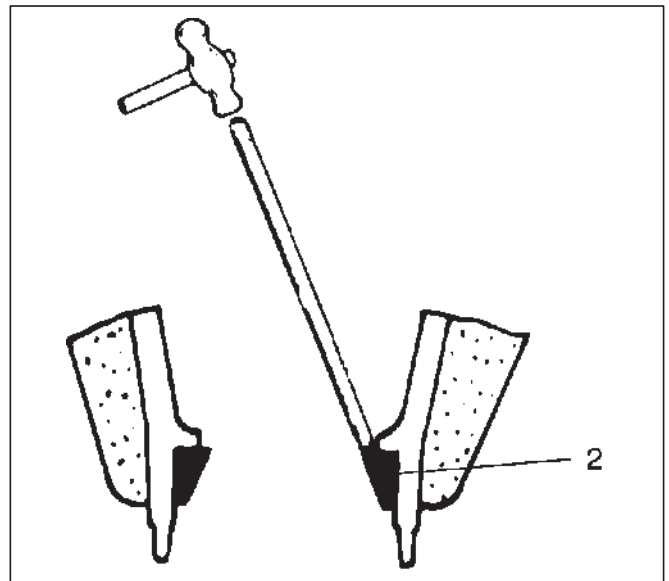


415RS006

14. Remove adjust shim.
15. Remove inner bearing outer race.
16. Remove oil seal.
17. Remove outer bearing.
18. Remove the inner bearing outer race (1) and the outer bearing outer race (2) by using a brass bar and a hammer.



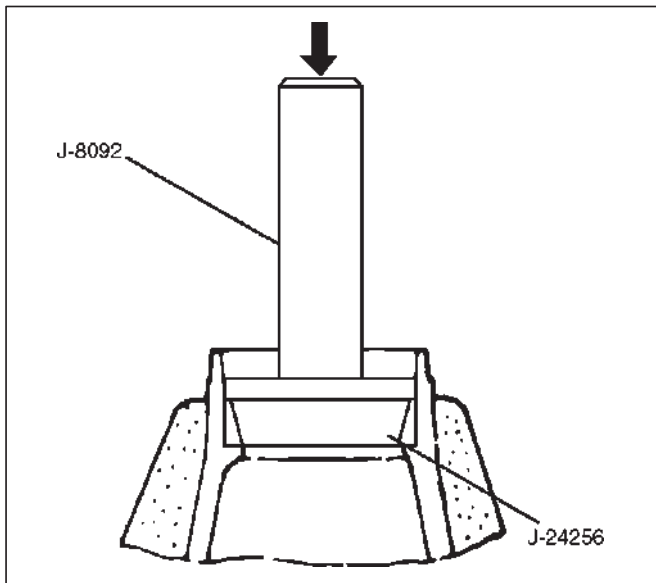
425RS014



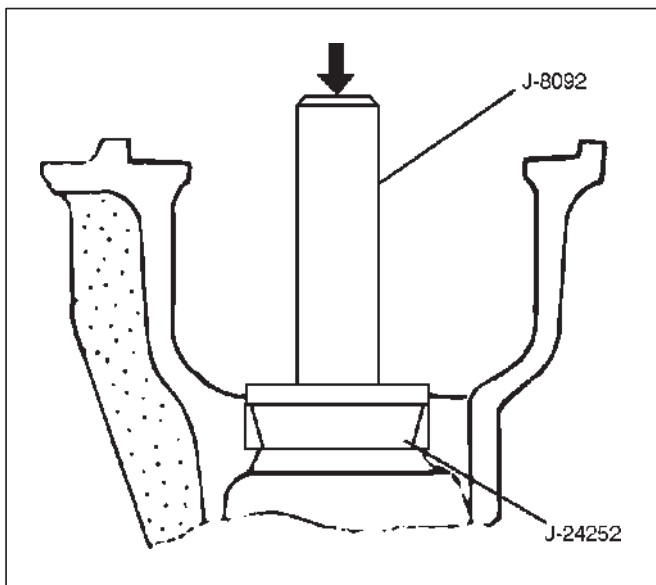
425RS015

## Reassembly

1. Using installer J-24256 and grip J-8092, install outer bearing outer race.



2. Using installer J-24252 and grip J-8092, install Inner bearing outer race.

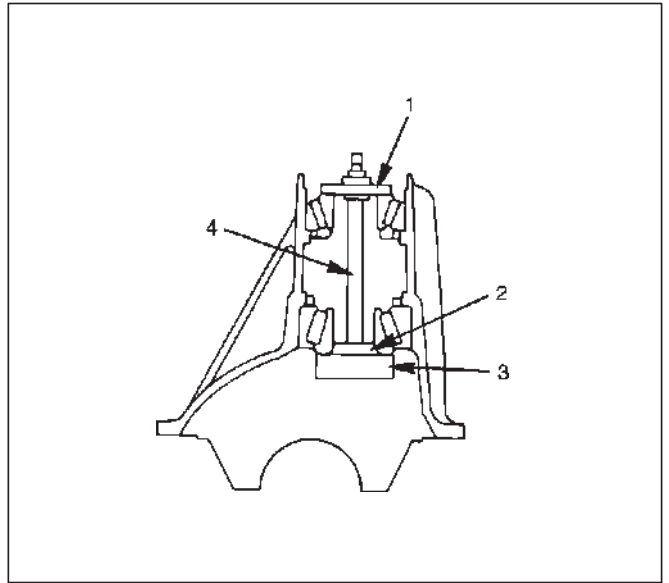


3. Install adjust shim and adjust drive pinion mounting distance

1. Apply gear oil to the inner and outer drive pinion bearing.  
Clean the pinion setting gauge set.  
Then install the gauge set together with the inner and outer bearings.

2. Tighten the nut to the specified torque.

**Torque: 2.3 N-m (20 lb in)**

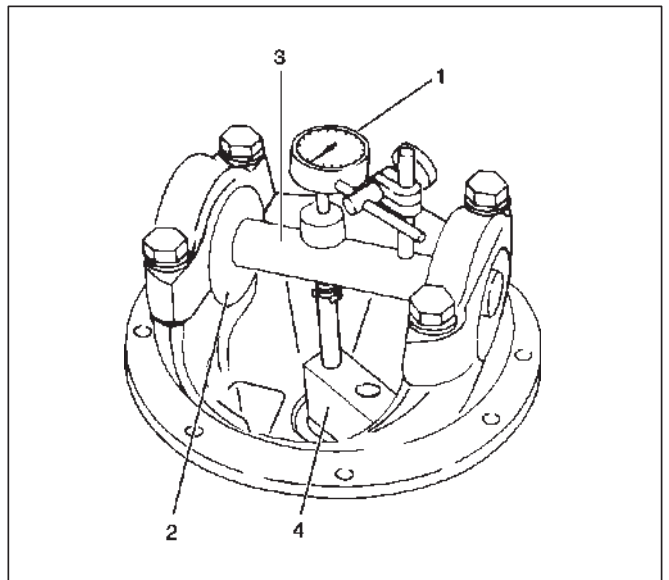


### Legend

- (1) Front Pilot: J-21777-42
- (2) Rear Pilot: J-23597-12
- (3) Gauge Plate: J-23597-7
- (4) Bolt and Nut: J-23597-9

3. Clean the side bearing bores. Install the dial indicator with the discs and arbor. Install and tighten the bearing caps to the specified torque.

**Torque: 108 N-m (80 lb ft)**

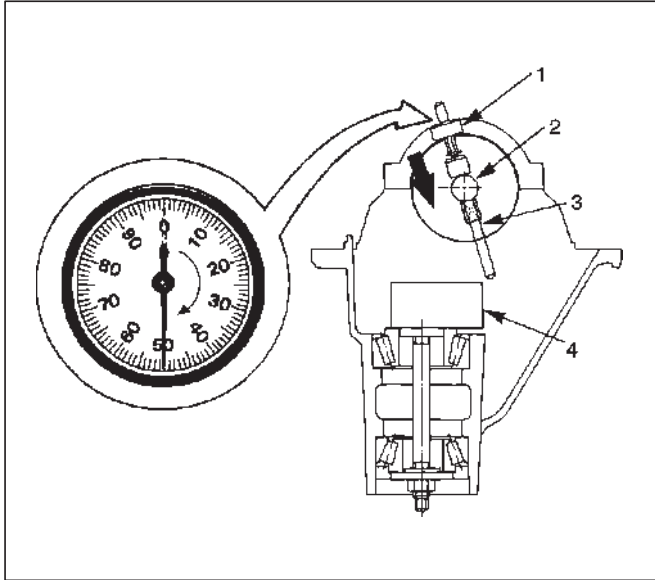


### Legend

- (1) Dial Indicator: J-8001
- (2) Disc (2 pcs.): J-23597-8
- (3) Arbor: J-23597-1
- (4) Gauge Plate: J-23597-7

## 4A2-14 DIFFERENTIAL (REAR)

- Set the dial indicator to "0". Place it on the mounting post of the gauging arbor with the contact button touching the indicator pad. Force the dial indicator downward until the needle has made a half turn clockwise. Tighten down the dial indicator in this position.



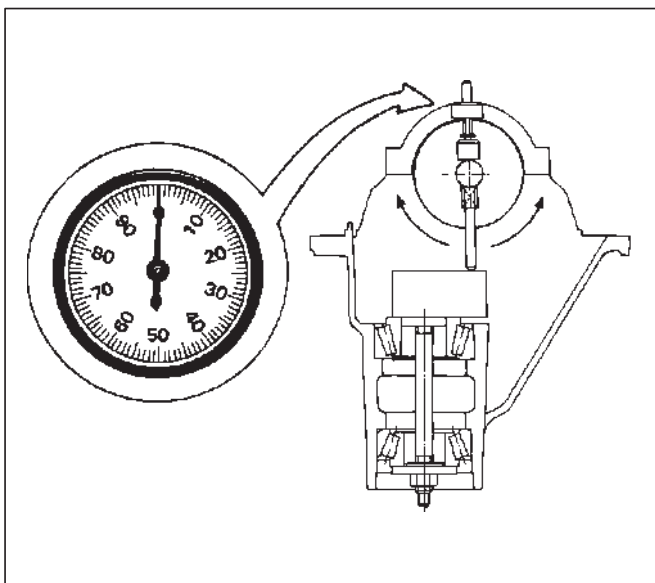
425RS020

### Legend

- Dial Indicator
- Gauging Arbor
- Plunger
- Gauge Plate

- Position the plunger on the gauge plate. Move the gauging arbor slowly back and forth and locate the position at which the dial indicator shows the greatest deflection. At this point, once again set the dial indicator to "0".

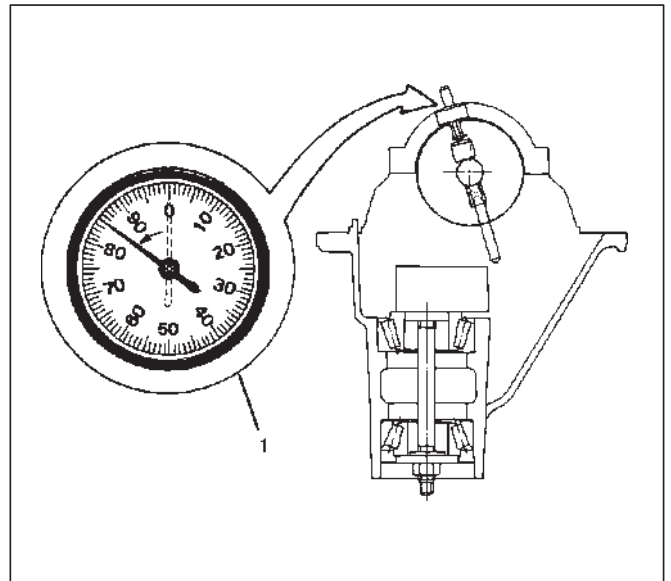
Repeat the procedure to verify the "0" setting.



425RS021

- After the ZERO setting is obtained, rotate the gauging arbor until the dial indicator rod does not touch the gauging plate.

Record the number the dial indicator needle points to.



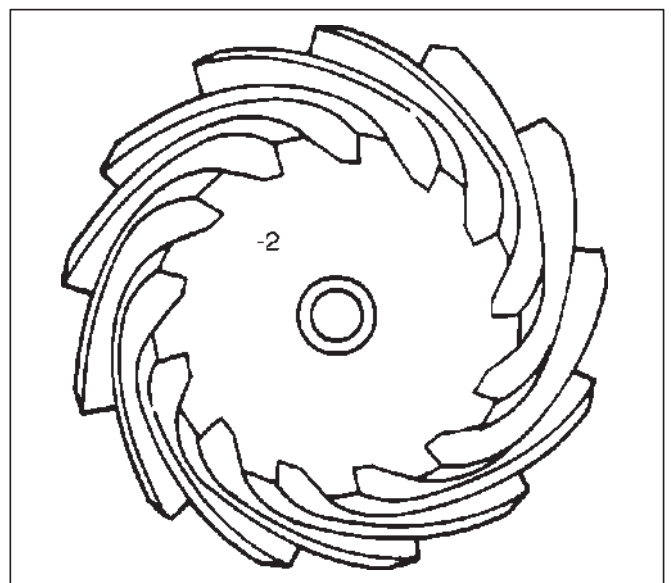
425RS022

### Legend

- Example=Dial indicator reading of 0.085

- Record the pinion depth code on the head of the drive pinion.

The number indicates a necessary change in the pinion mounting distance. A plus number indicates the need for a greater mounting distance (which can be achieved by decreasing the shim thickness). A minus number indicates the need for a smaller mounting distance (which can be achieved by increasing the shim thickness). If examination reveals pinion depth code "0", the pinion is "nominal".



425RS023

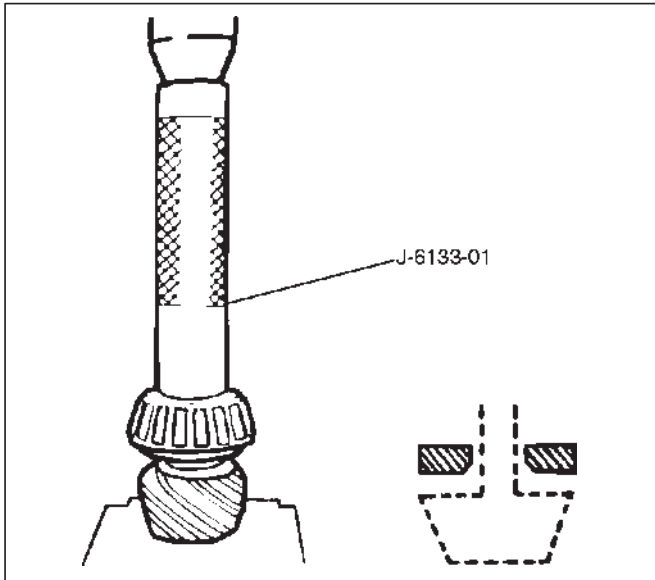


## 4A2-16 DIFFERENTIAL (REAR)

NOTE: When ordering shims, find the part number in the parts catalog by using the thickness of shims listed in the above table.

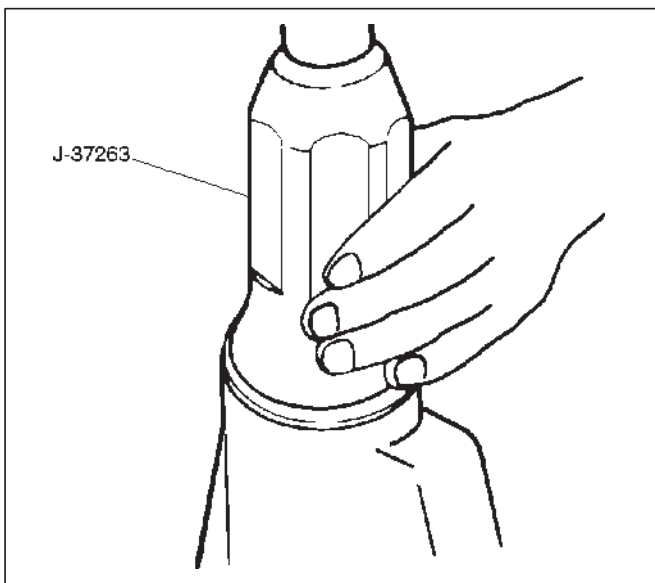
- Place the shim on the drive pinion, with the chamfered side turned towards the pinion head then install the inner bearing onto the pinion using an installer J-6133-01 and a press.

NOTE: Do not apply pressure to the roller cage and apply pressure only to the inner race.



- Discard the used collapsible spacer and install a new one.
- Install pinion gear.
- Install outer bearing.
- Use oil seal installer J-37263 to install a new oil seal that has been soaked in rear axle lubricant.

NOTE: Take care to use a front differential oil seal, NOT the rear differential oil seal.



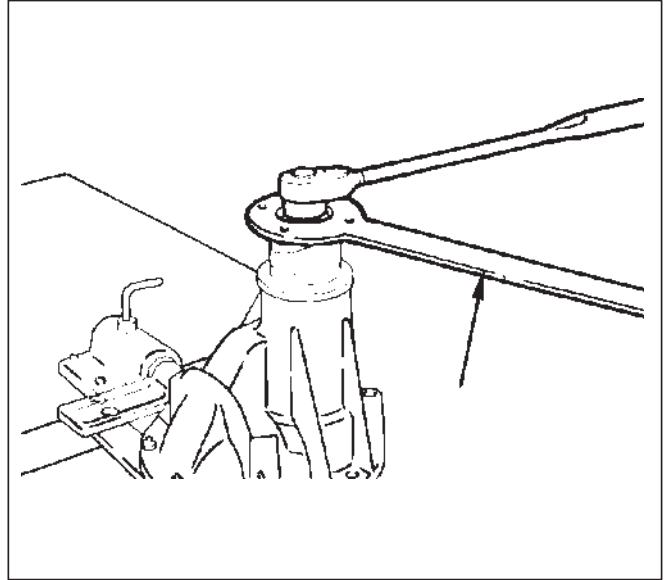
- Install dust cover.
- Install flange.

- Install flange nut.

- Apply lubricant to the pinion threads.
- Tighten the nut to the specified torque using the pinion flange holder J-37221.

**Torque: 245–294N·m (181–217 lb ft)**

NOTE: Discard used flange nut and install new one and do not over tighten the flange nut.

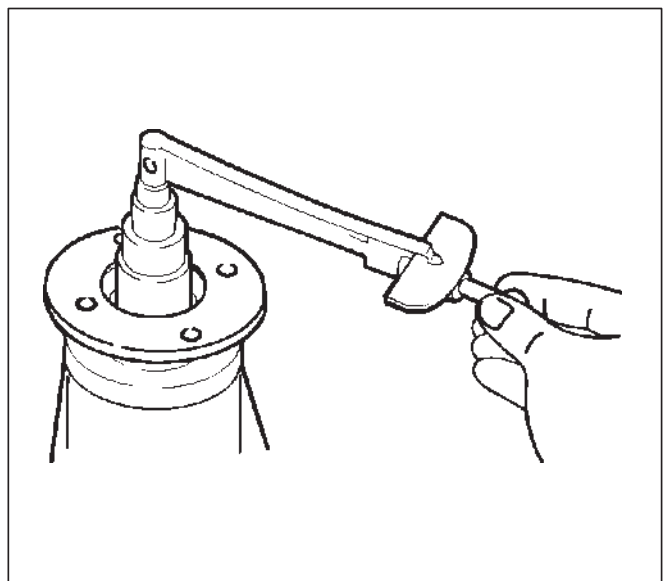


- Adjust pinion bearing preload.
  - Measure the bearing preload by using a torque meter. Note the scale reading required to rotate the flange.
  - Continue tightening flange nut until the specified starting torque is obtained.

**Starting torque:**

**New bearing 0.7–1.3 N·m(6.08–11.28 lb in)**

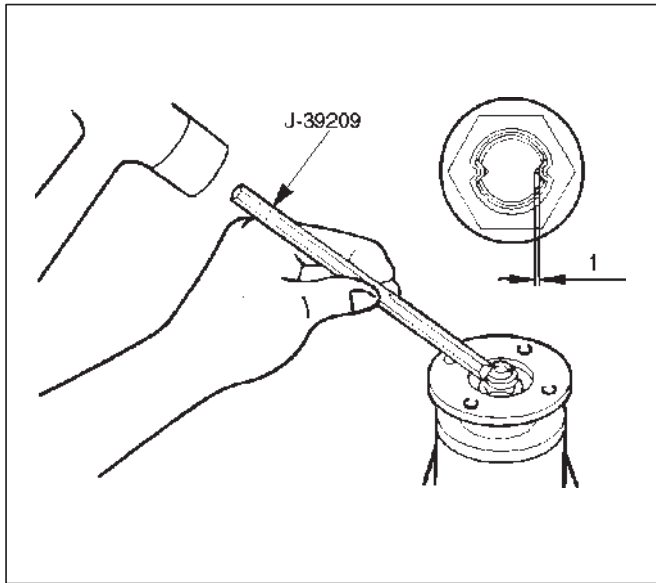
**Used bearing 0.4–0.6N·m(3.04-5.64 lb in)**



- Using punch J-39209, stake the flange nut at two points.



NOTE: When staking, be sure to turn the nut to insure that there is no change in bearing preload. Make sure of preload again as instructed in 3).



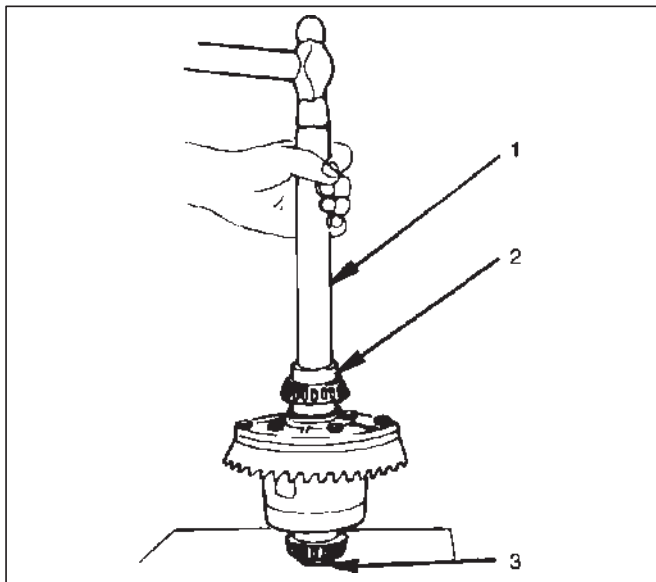
415RS012

**Legend**

- (1) 1.5mm or less

12. Install adjust shim.

1. Attach the side bearing to the differential assembly without shims. Support the opposite side using a pilot to prevent bearing damage.

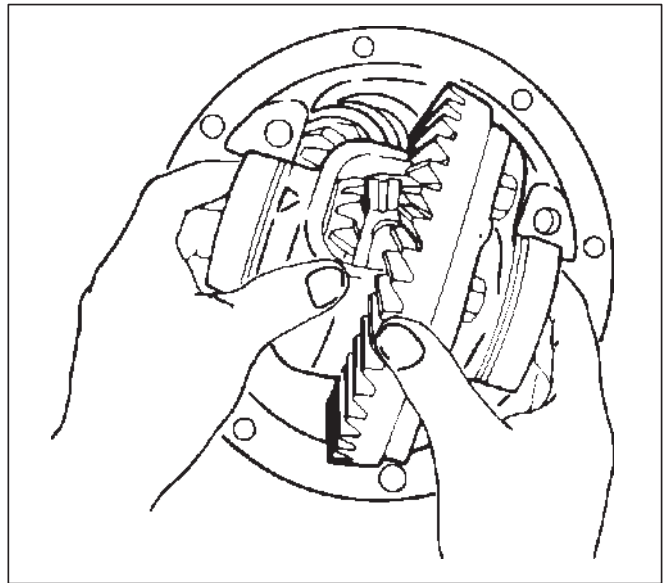


425RS029

**Legend**

- (1) Drive handle: J-8092
- (2) Installer: J-24244
- (3) Pilot: J-8107-2

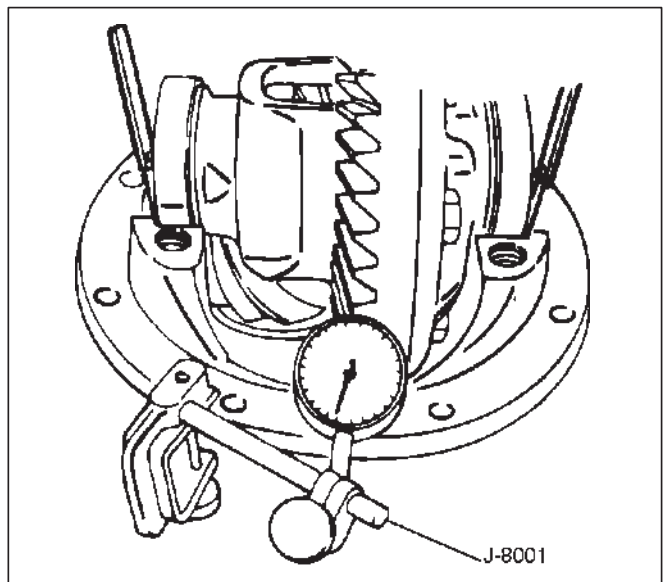
2. Insert the differential cage assembly with bearing outer races into the side bearing bores of the carrier.



425RS030

3. Using two sets of feeler gauges, insert a feeler stock of sufficient thickness between each bearing outer race and the carrier to remove all end play. Make certain the feeler stock is pushed to the bottom of the bearing bores.

Mount the dial indicator J-8001 on the carrier so that the indicator stem is at right angles to a tooth on the ring gear.

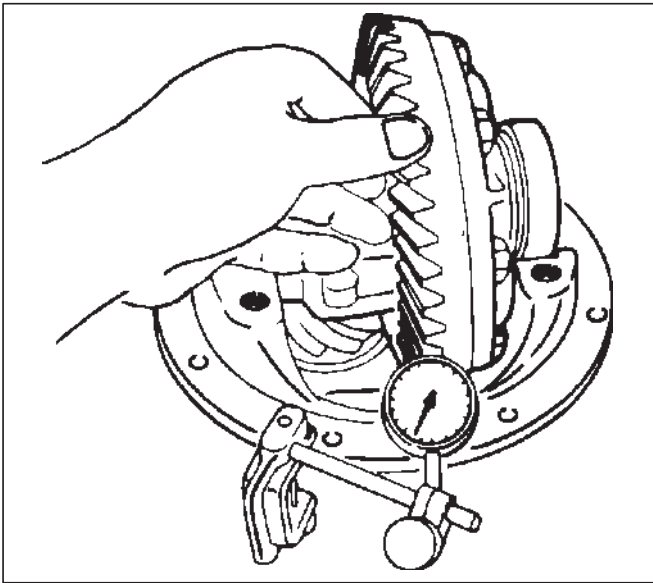


425RS031

## 4A2-18 DIFFERENTIAL (REAR)

- Adjust feeler gauge thickness from side to side until ring gear backlash is in the specified range.

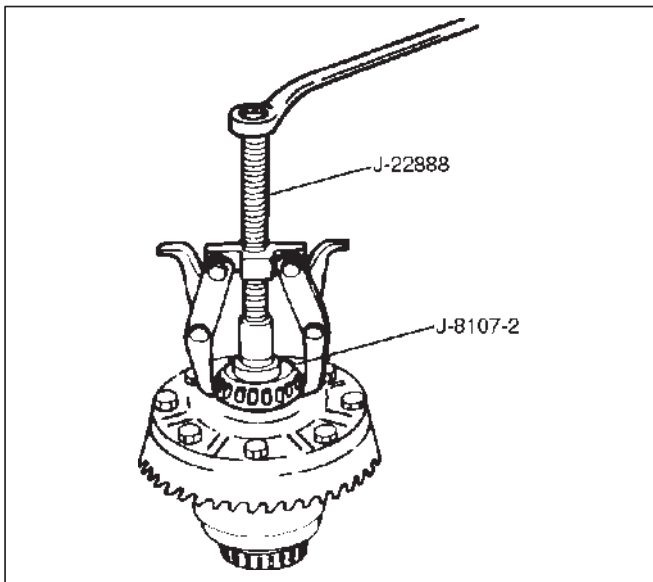
**Backlash: 0.15–0.2 mm(0.006 –0.008 in)**



425RS032

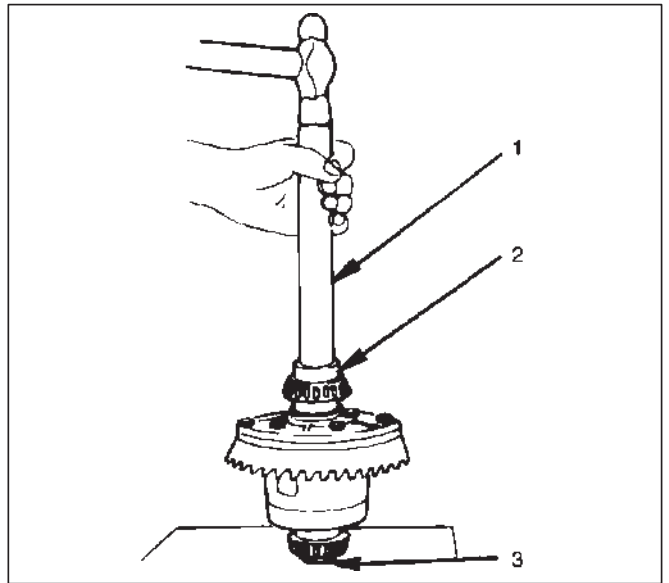
With zero end play and correct backlash established, remove the feeler gauge packs, determine the thickness of the shims required and add 0.05 mm (0.002 in) to each shim pack to provide side bearing preload. Always use new shims.

- Use bearing remover J-22888 and pilot J-8107-2 to remove side bearing.



415RS013

- Install the side bearings together with the selected shims.

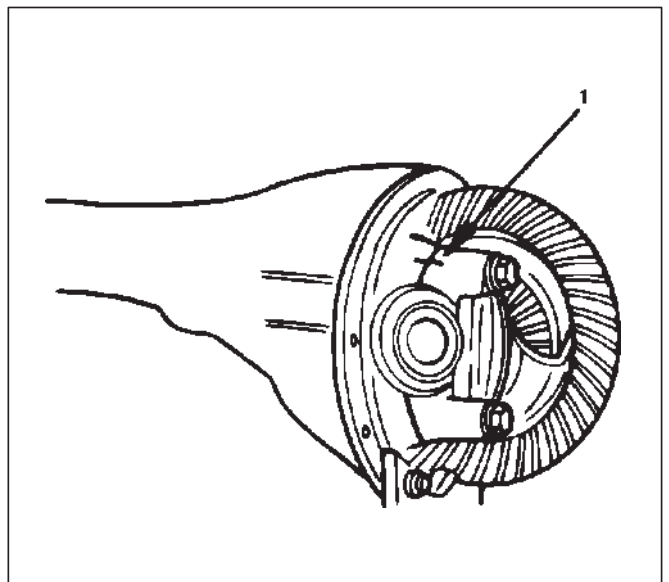


425RS029

### Legend

- Drive Handle: J-8092
- Installer: J-24244
- Pilot: J-8107-2

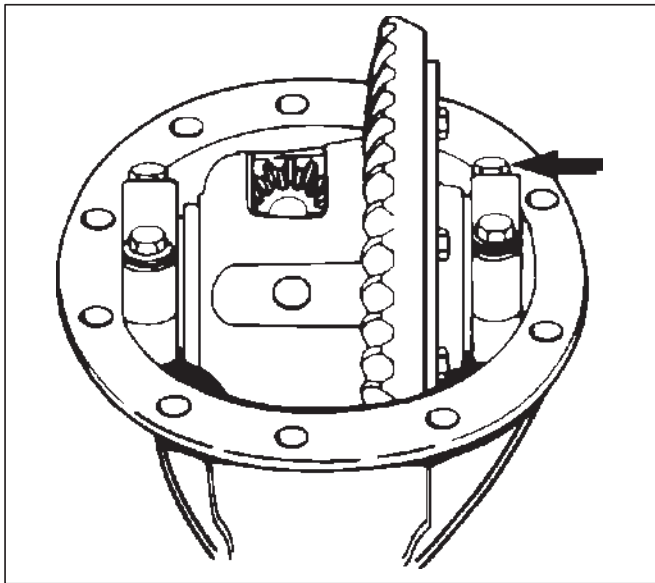
- Install side bearing outer race.
- Install differential cage assembly.
- Install bearing cap then align the setting marks(1) applied at disassembly.



425RS035

17. Tighten the cap bolt to the specified torque.

**Torque: 108 N-m (80 lb ft)**

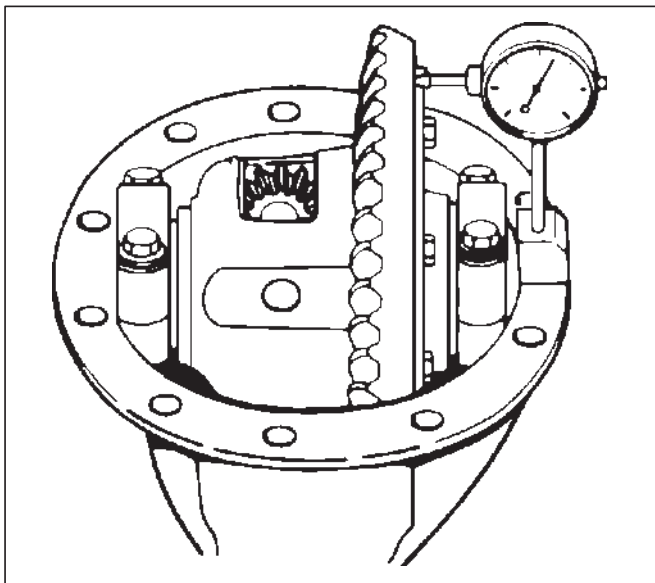


425RS036

1. Measure the amount of run-out of the ring gear at its rear face.

**Standard: 0.02 mm ( 0.001 in)**

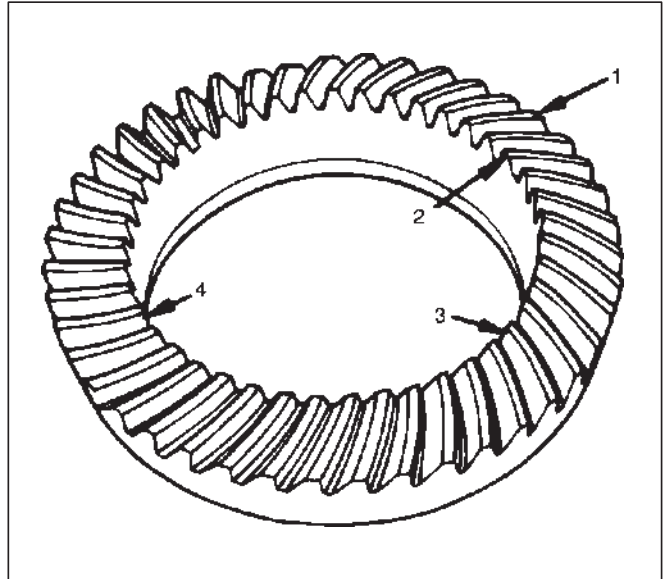
**Limit: 0.05 mm ( 0.002 in)**



425RS037

**Gear Tooth Contact Pattern Check and Adjustment**

1. Apply a thin coat of prussian blue or equivalent to the faces of the 7-8 teeth of the ring gear. Check the impression of contact on the ring gear teeth and make necessary adjustment as described in illustration if the contact is abnormal.

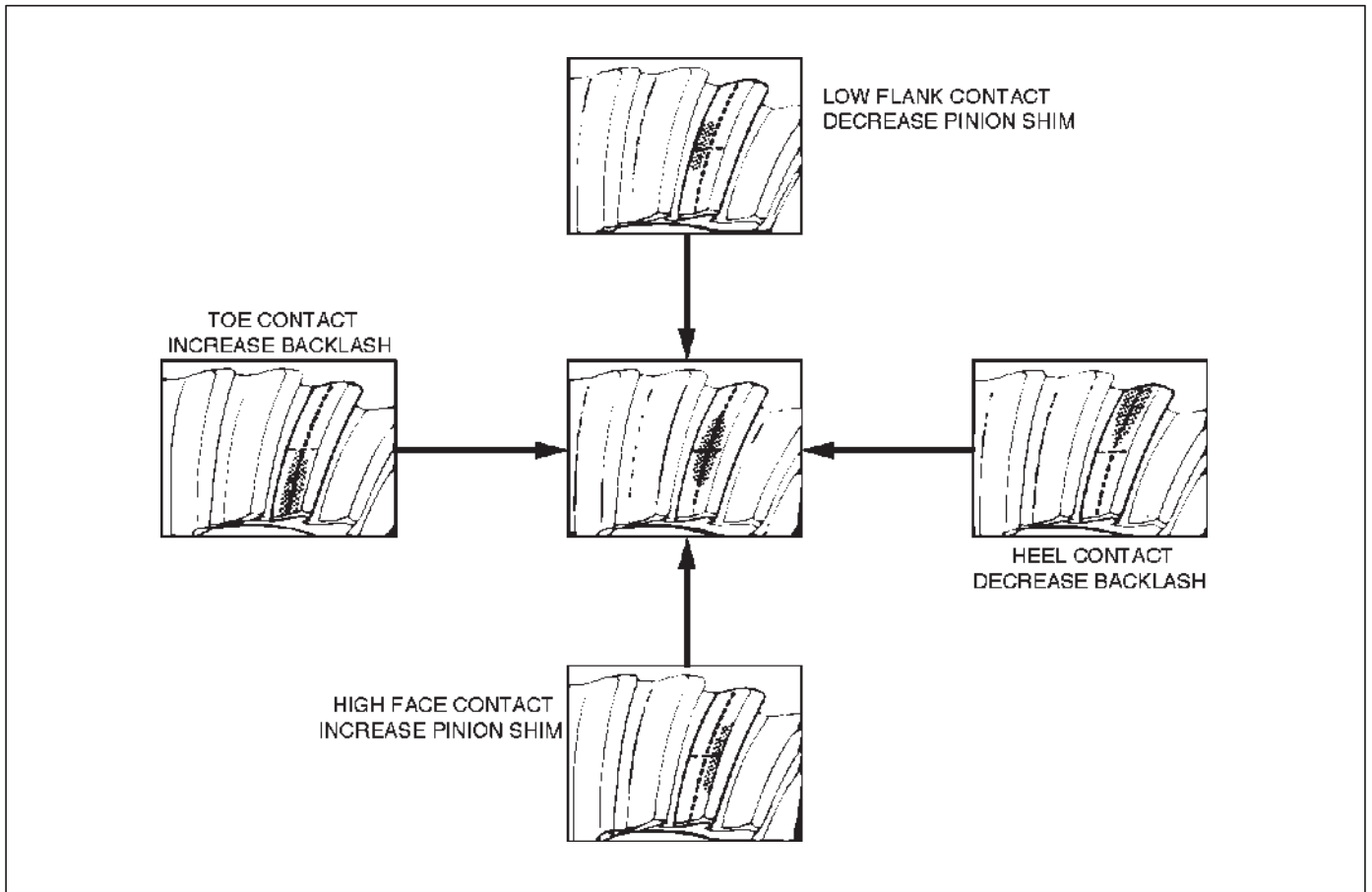


425RS038

**Legend**

- (1) Heel
- (2) Toe
- (3) Concave Side (Coast)
- (4) Convex Side (Drive)

## 4A2-20 DIFFERENTIAL (REAR)



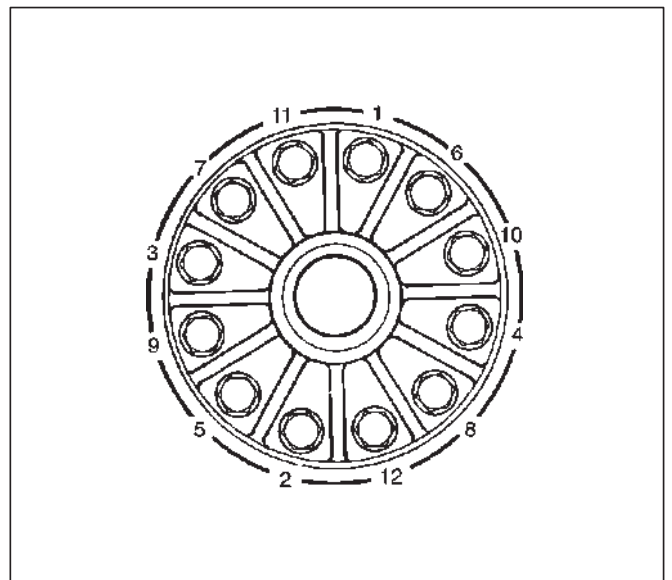
426RS036

### Ring gear replacement:

1. The ring gear should always be replaced with the drive pinion as a set.
2. Clean the ring gear threaded holes to remove the locking agent.
3. When installing the ring gear, apply LOCTITE 271 or equivalent to all the threaded area and half of the unthreaded area of the bolt.
4. Discard used bolts and install new ones.

**Torque: 108 N·m (80 lb ft)**

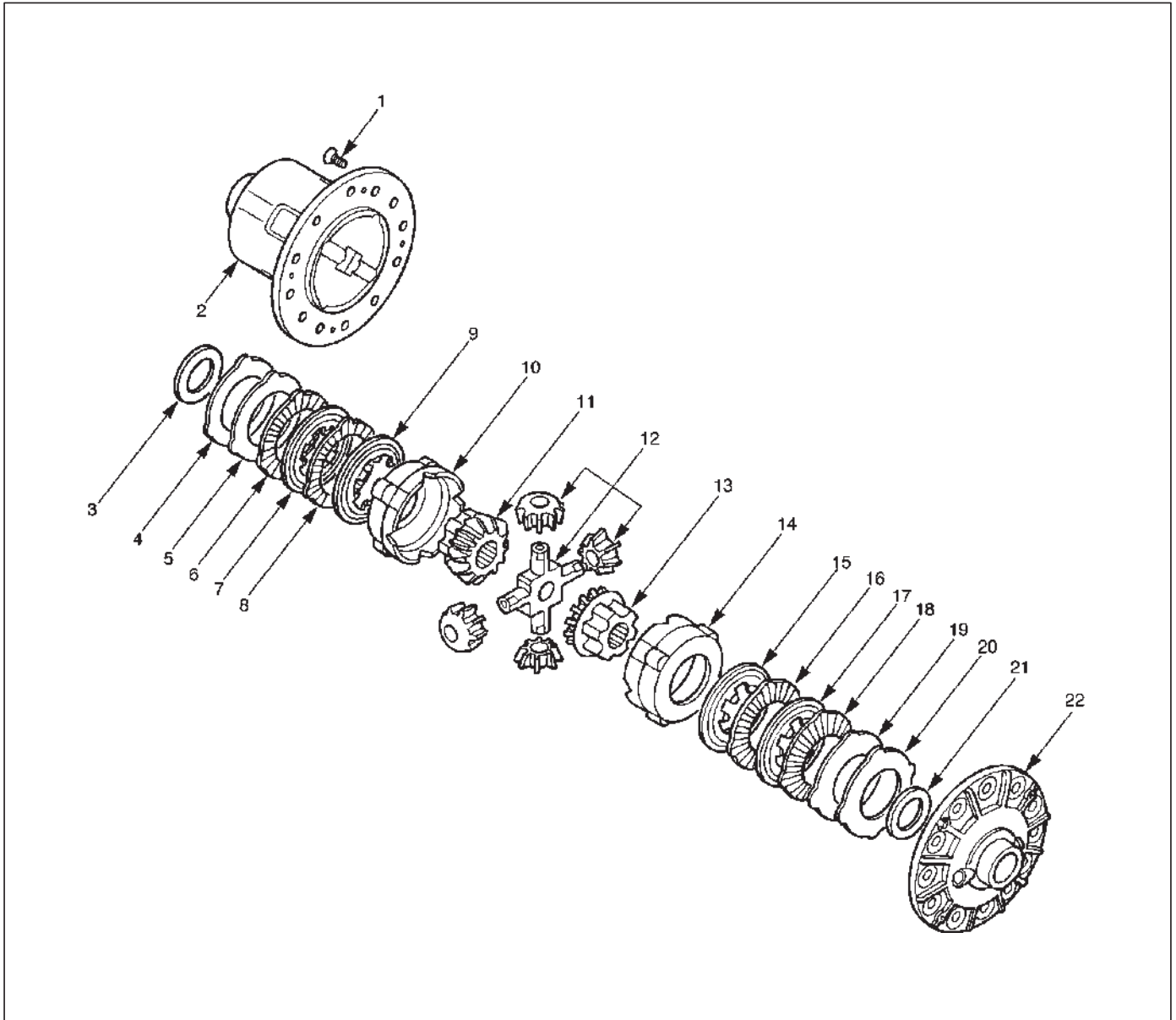
5. Tighten the fixing bolts in a diagonal sequence as illustrated.



415RW036

## Limited Slip Differential

### Disassembled View



425RS053

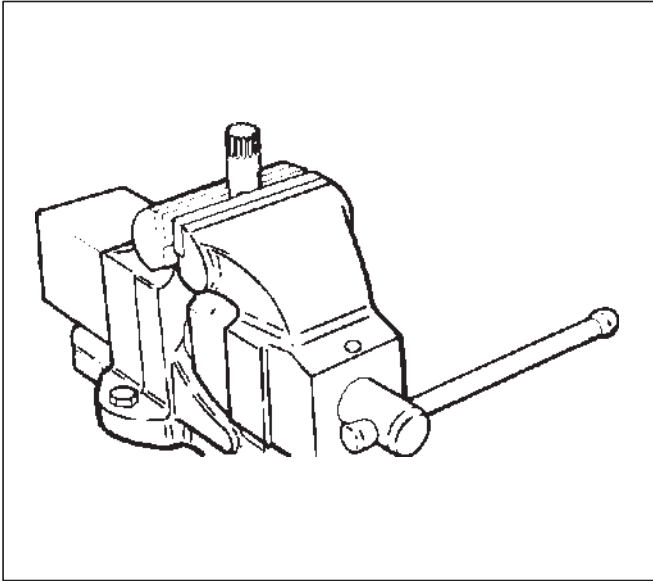
#### Legend

- |                         |                              |
|-------------------------|------------------------------|
| (1) Screw               | (12) Pinion and pinion shaft |
| (2) Differential cage A | (13) Side gear               |
| (3) Thrust washer       | (14) Pressure ring           |
| (4) Spring disc         | (15) Friction disc           |
| (5) Spring disc         | (16) Friction plate          |
| (6) Friction plate      | (17) Friction disc           |
| (7) Friction disc       | (18) Friction plate          |
| (8) Friction plate      | (19) Spring disc             |
| (9) Friction disc       | (20) Spring disc             |
| (10) Pressure ring      | (21) Thrust washer           |
| (11) Side gear          | (22) Differential cage B     |

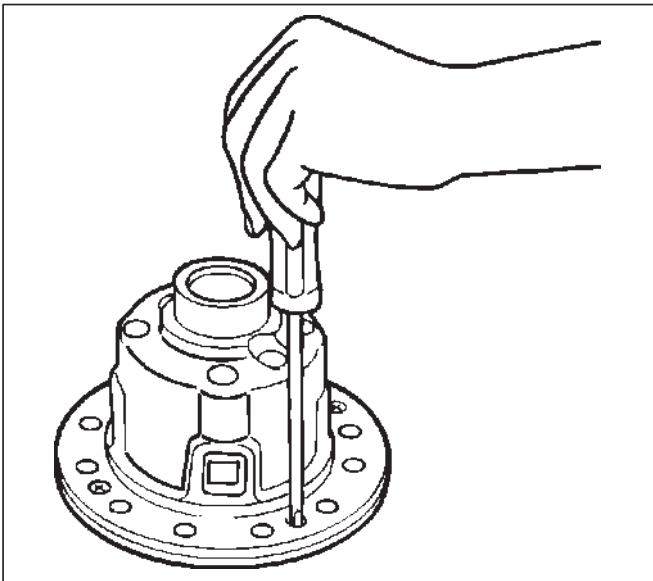
## 4A2-22 DIFFERENTIAL (REAR)

### Disassembly

1. Using special tool, J-41033, grip it with a vice, and set the differential.



2. Gradually and evenly loosen the 4 fixing screws of the differential cages A and B.



3. Remove Differential cage A.
4. Remove Thrust washer.
5. Remove Spring disc.

NOTE: When removing the spring disc, friction disc, and friction plate, place them in order for clear distinction of left and right use.

6. Remove Spring disc.
7. Remove Friction plate.

8. Remove Friction disc.
9. Remove Friction plate.
10. Remove Friction disc.
11. Remove Pressure ring.
12. Remove Side gear.
13. Remove Pinion and pinion shaft.
14. Remove Side gear.
15. Remove Pressure ring.
16. Remove Friction disc.
17. Remove Friction plate.
18. Remove Friction disc.
19. Remove Friction plate.
20. Remove Spring disc.
21. Remove Spring disc.
22. Remove Thrust washer.
23. Remove Differential cage B.

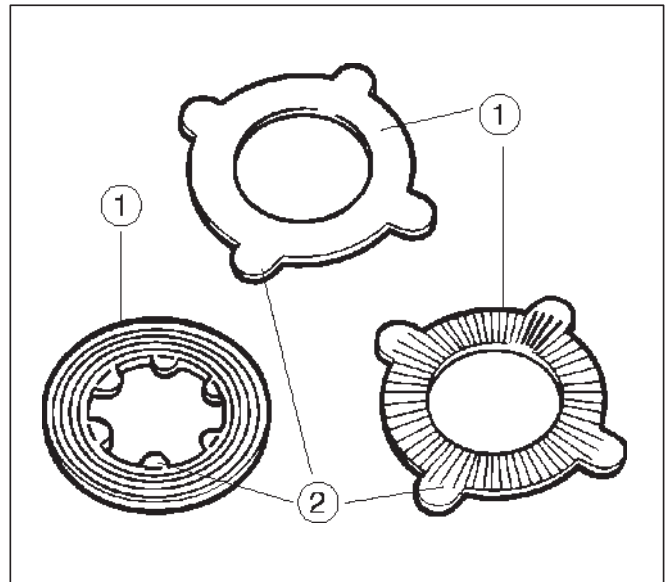
### Inspection and Repair

Make necessary correction or parts replacement if wear, damage, corrosion or any other abnormal condition is found through inspection.

#### Visual check

Check the following parts for wear, damage, noise or any other abnormal conditions.

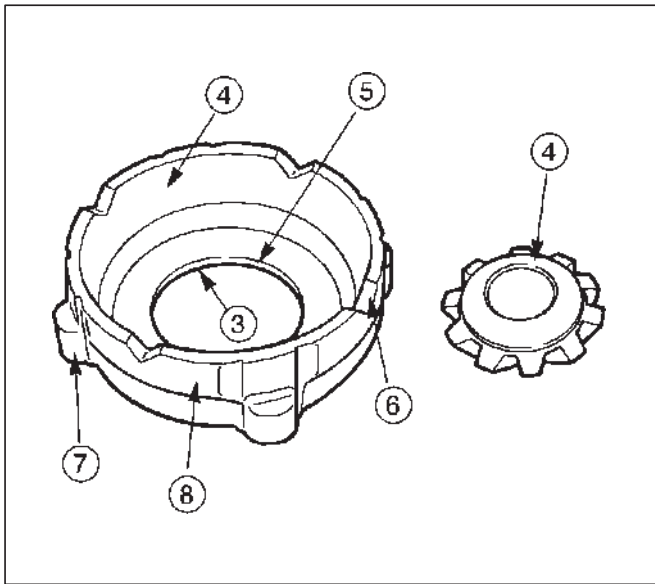
- Friction disc, friction plate and spring disc



#### Legend

- (1) Sliding surfaces
- (2) Projections

○ Pressure ring

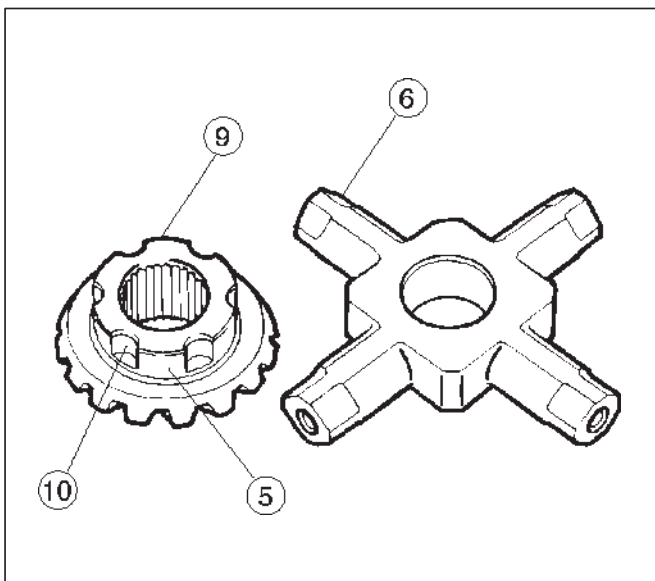


425RS057

**Legend**

- (3) Sliding surface with the friction disc. When nicks or scratches are found, polish with an oil stone and repair on a level block using a compound.
- (4) Sliding spherical surface with the pinion gear.
- (5) Sliding surface with the side gear.
- (6) V-shaped groove of the pressure ring and V-shaped section of the pinion shaft.
- (7) Fitting section with the case.
- (8) Face contacting the inner surface of the differential case. Repair burrs and nicks using an oil stone.

○ Thrust washer

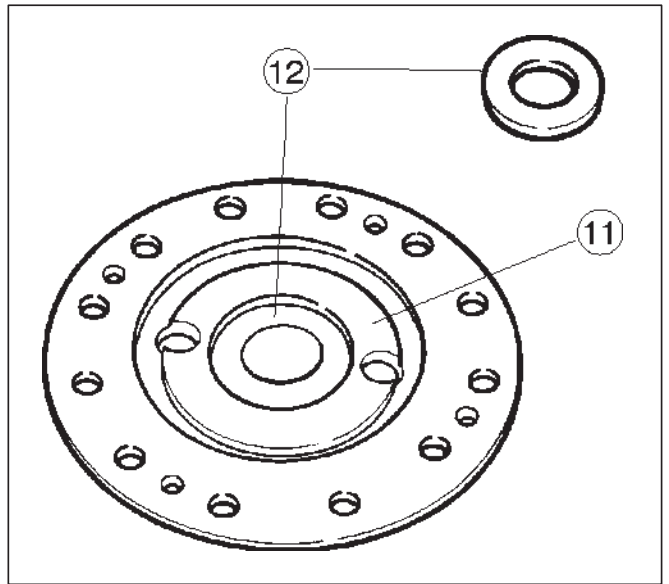


425RS068

**Legend**

- (9) Sliding surface with the side gear or case.
  - (10) Peripheral groove of the side gear.
- Repair light nicks and burrs using an oil stone.

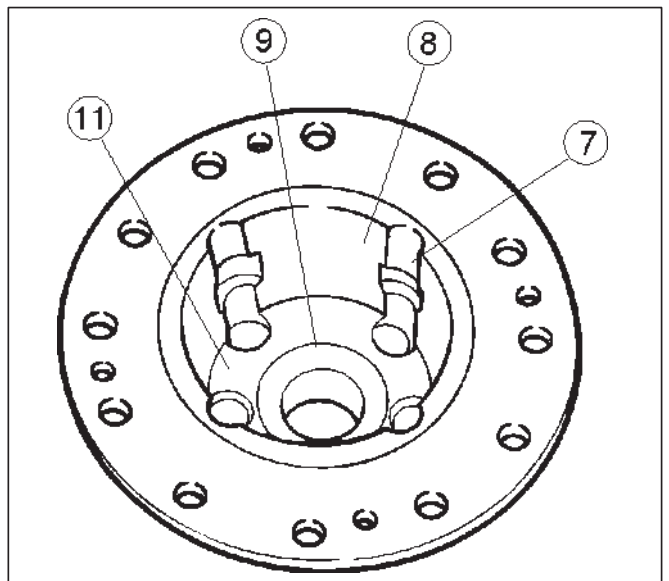
○ Case



425RS059

**Legend**

- (11) Contact surface with the spring disc.
  - (12) Inner groove of the differential cage B.
- Repair light nicks and burrs using an oil stone.



425RS060

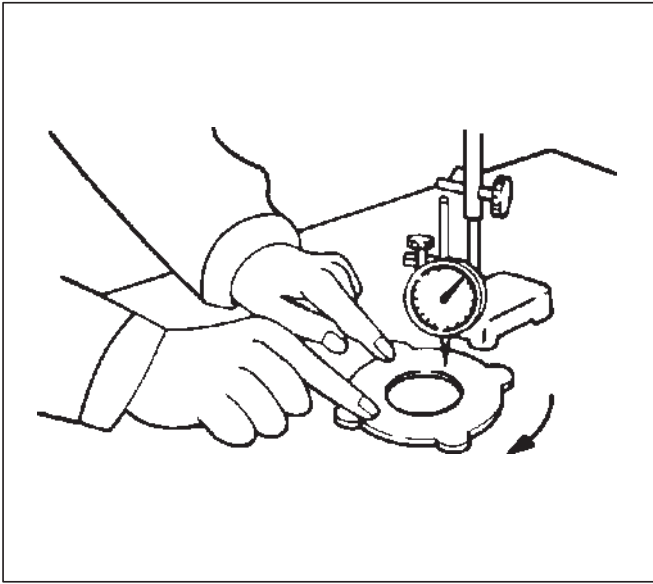
**Legend**

- (7) Fitting section with the case.
  - (8) Face contacting the inner surface of the differential case.
  - (9) Sliding surface with the side gear or case.
  - (11) Contact surface with spring disc.
- Repair burrs and nicks using an oil stone.

## 4A2-24 DIFFERENTIAL (REAR)

Measure the Deformation of the friction disc & plate.

**Limit: 0.08 mm (0.003 in)**



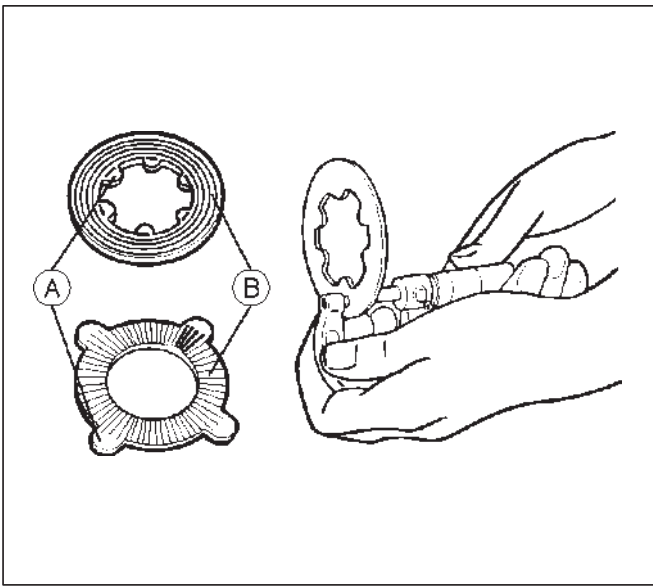
Measure the wear of the friction plate & disc

**Limit(A-B): 0.1 mm (0.004 in)**

**Remarks:**

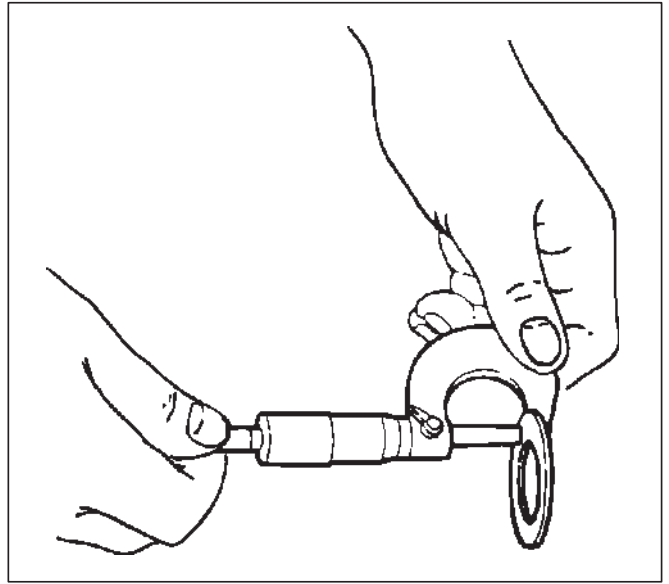
**A=Inner or outer projections**

**B=Sliding surface subjected to abrasion**



Measure the wear of the thrust washer

**Limit: 1.3 mm (0.05 in)**



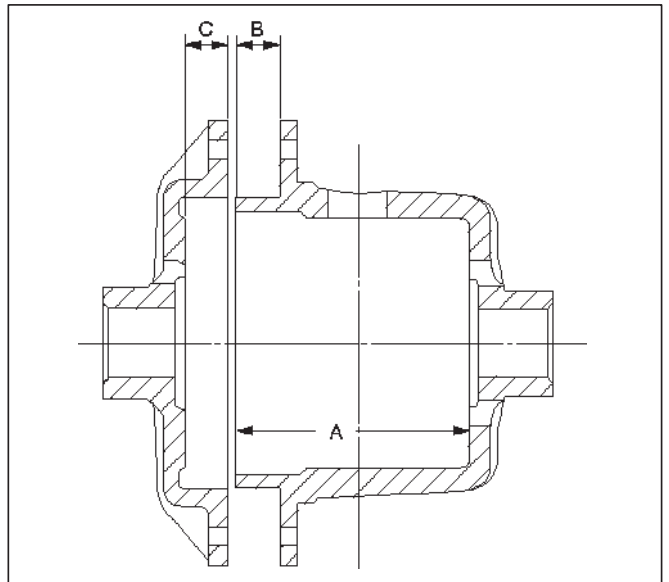
## Reassembly

Adjust the clearance between the friction disc and plate.

1. Measuring the depth of the differential cage.

**Standard (A-B): 80.58 mm (3.17 in)**

**(C): 10.58 mm (0.41 in)**

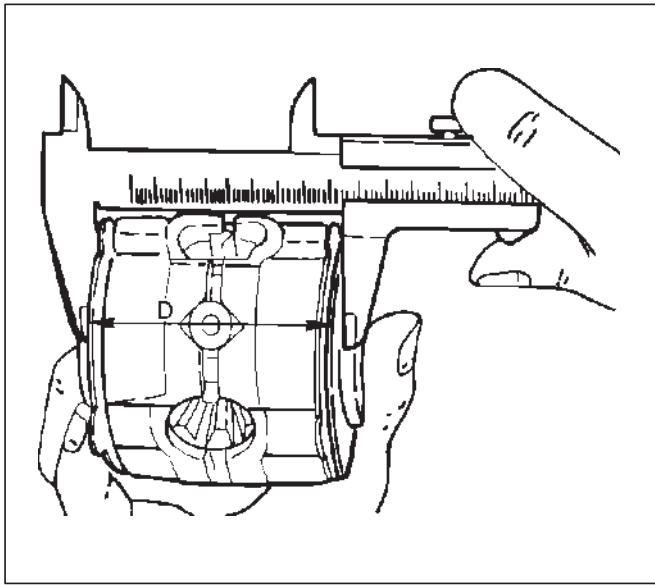


2. Measuring the overall length of the pressure ring, friction disc and friction plate.

○ Mount the pinion shaft in the pressure ring and then install the friction disc & plate.



- Measure the length between the plates over the V-groove. (D)



425RS065

- 3. After measuring dimensions A, B, C and D, make adjustment in the following manner:

- Measure the thickness (E) of the spring disc.  
1.75mm (0.069in) × 4 discs

- 4. Select the friction disc & plate so as to satisfy the following equation:

$$\{(A-B)+C\}-(D+E)=0.06-0.20\text{mm (0.002-0.008in)}$$

Also, the total size difference of the friction disc & plate and spring disc should be 0.05mm (0.02in) or less.

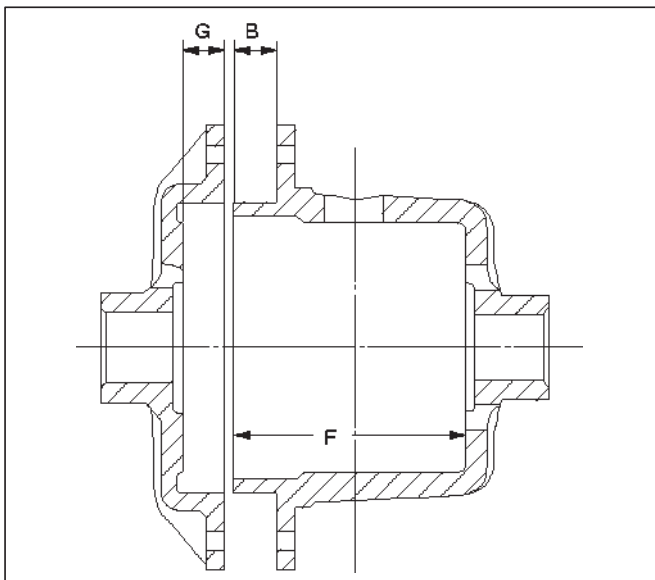
**Thickness : 1.75–1.85mm(0.069–0.073 in)**

### Backlash adjustment of the side gear in the direction of the shaft

- 1. Measuring the depth of the differential cage.

**(F-B): 82.03 mm (3.23 in)**

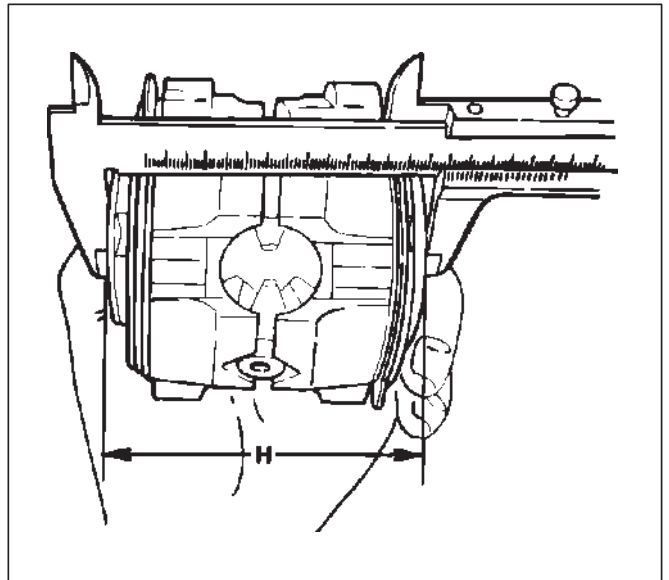
**(G): 12.03 mm (0.47 in)**



425RS066

- 2. Measuring the dimension between the thrust washers at both ends.

- Assemble the side gear, pinion, pinion shaft, pressure ring and thrust washer, and pressing the pressure ring to the pinion shaft in the direction of the shaft to make the clearance 0.
- Have the side gear contact to the pinion to make the backlash 0.
- Measure the dimension (H) between thrust washers at both ends.



425RS067

- 3. After measuring dimensions of each of the above sections, proceed with the adjustment in the following manner:

Adjust the clearance to satisfy the equation below.

$$\{(F - B) + G - H\}=0.05 - 0.20 \text{ mm}$$

Also, select the thrust washers so that the dimensional difference between the back surfaces of the left and right pressure rings to the thrust washers is 0.05mm or less.

**Thickness : 1.5mm (0.059 in)**

**1.6 mm(0.063 in)**

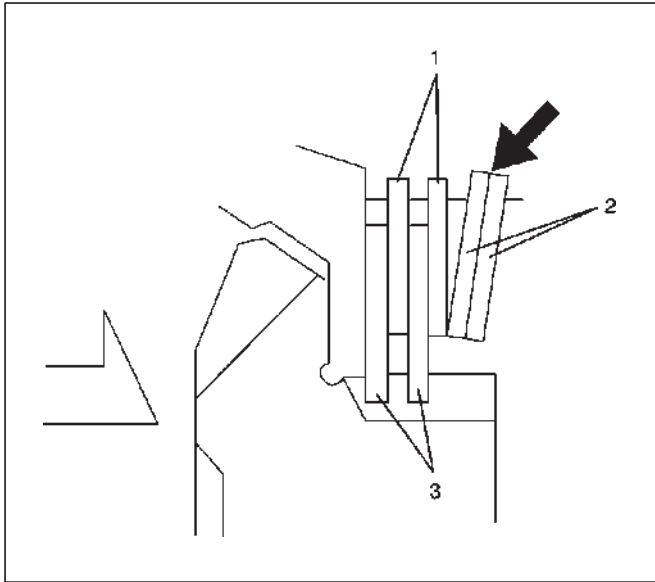
**1.7 mm(0.067 in)**

## 4A2-26 DIFFERENTIAL (REAR)

NOTE: When assembling the parts, apply recommended gear oil sufficiently to each of the parts, especially, to the contact surfaces and sliding surfaces.

1. Install differential cage B.
2. Install thrust washer.
3. Install spring disc.

○When assembling the spring disc, make sure the mounting direction is correct as shown in figure.



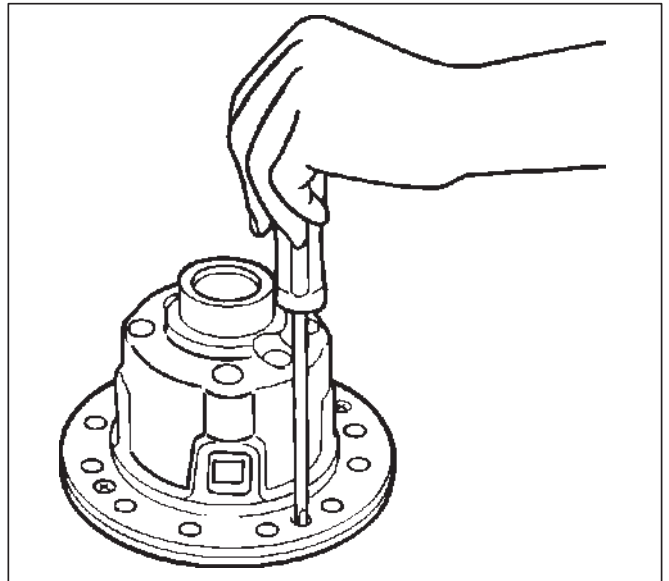
### Legend

- (1) Friction Plate
- (2) Spring Disc
- (3) Friction Disc

4. Install spring disc.
5. Install friction plate.
6. Install friction disc.
7. Install friction plate.
8. Install friction disc.
9. Install pressure ring.
10. Install side gear.
11. Install pinion and pinion shaft.
12. Install side gear.
13. Install pressure ring.
14. Install friction disc.
15. Install friction plate.
16. Install friction disc.
17. Install friction plate.
18. Install spring disc.  
○When assembling the spring disc, make sure the mounting direction is correct.
19. Install spring disc.
20. Install thrust washer.
21. Install differential cage A.

22. Install screw.

○Matching the guide marks of the differential cages A and B, tighten the screws evenly in the diagonal order.

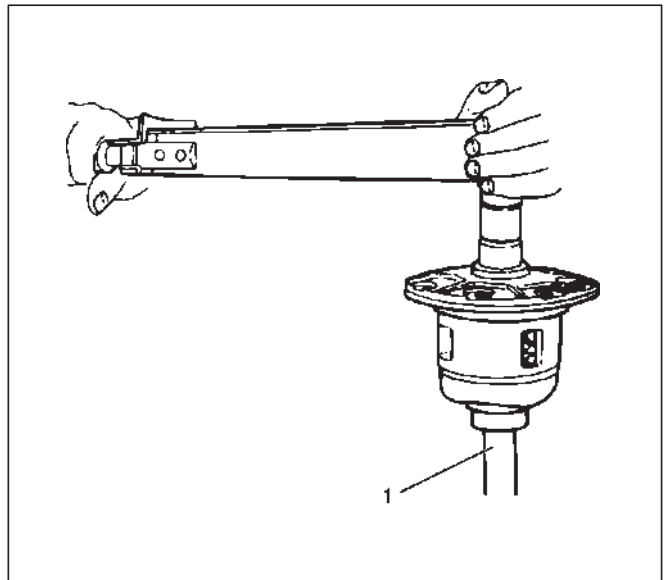


23. Check the operation.

○Measure the starting torque using the side gear holder.

### Starting torque:

**64 – 98 N·m (47 – 72lb ft)**



### Legend

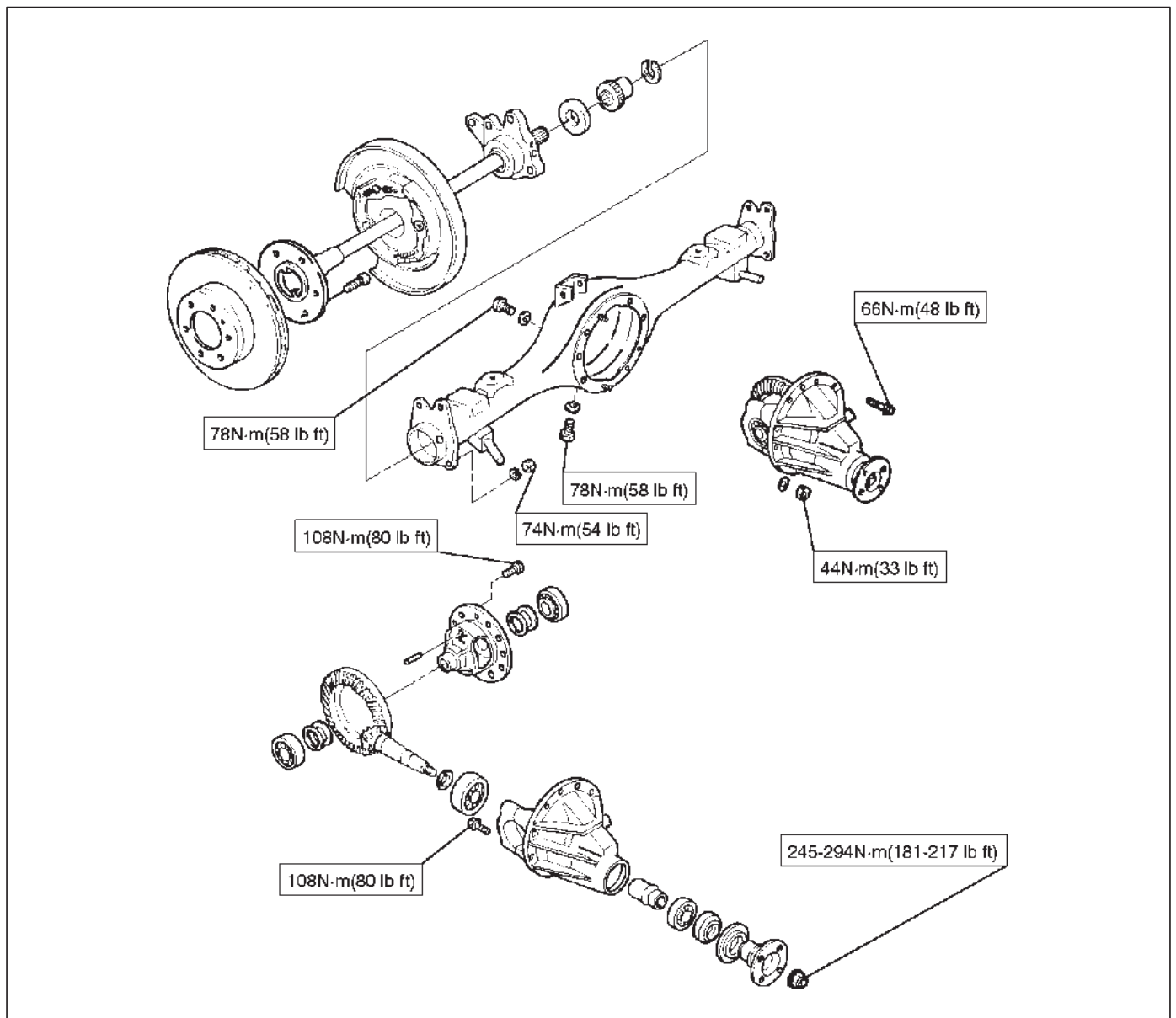
- (1) Side Gear Holder : J-41033

## Main Data and Specifications

### General Specifications


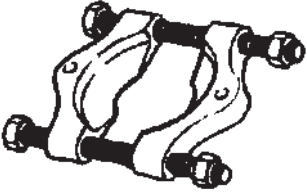
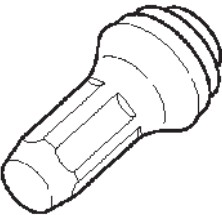
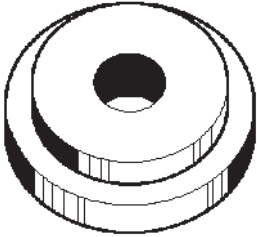
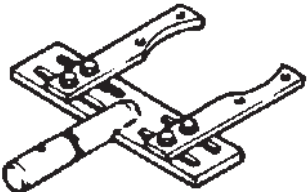
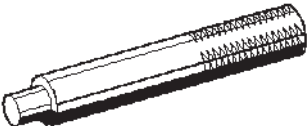
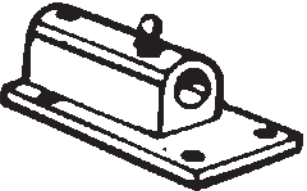
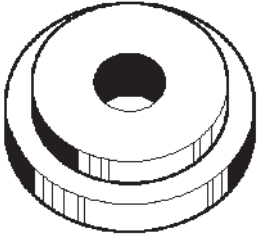
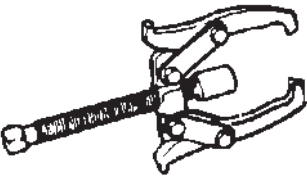
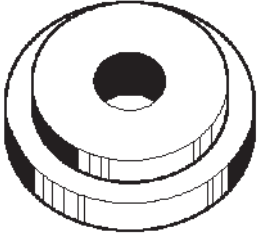
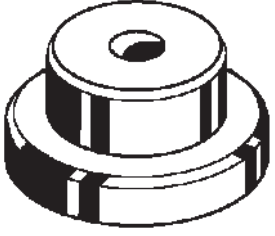
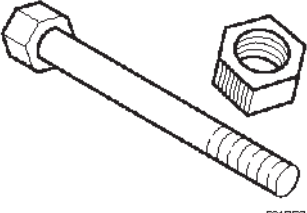
Rear axle	
Type	Banjo, Semi-floating
Rear axle Size	220mm(8.66in)
Gear type	Hypoid
Gear ratio (to 1)	4.300
Differential type	Four pinion
Type of Lubricant	GL-5 Limited slip differential gear lubricant together with limited slip differential lubricant additive (Refer to General Information)
Capacity	2.2liter(2.3 US qt)

### Torque Specifications



4A2-28 DIFFERENTIAL (REAR)

Special Tools

ILLUSTRATION	TOOL NO. TOOL NAME	ILLUSTRATION	TOOL NO. TOOL NAME
 <p style="text-align: right; font-size: small;">901RS210</p>	<p style="text-align: center;"><b>J-37221</b> Holder; Pinion flange</p>	 <p style="text-align: right; font-size: small;">901RS226</p>	<p style="text-align: center;"><b>J-22912-01</b> Separator</p>
 <p style="text-align: right; font-size: small;">901RS206</p>	<p style="text-align: center;"><b>J-39210</b> Installer; Oil seal</p>	 <p style="text-align: right; font-size: small;">901RS240</p>	<p style="text-align: center;"><b>J-24256</b> Installer; Outer bearing outer race</p>
 <p style="text-align: right; font-size: small;">901RS212</p>	<p style="text-align: center;"><b>J-37264</b> Differential holding fixture (Use with 5-8840-0003-0)</p>	 <p style="text-align: right; font-size: small;">901RS24</p>	<p style="text-align: center;"><b>J-8092</b> Driver handle</p>
 <p style="text-align: right; font-size: small;">901RS213</p>	<p style="text-align: center;"><b>J-3289-20</b> Holding fixture base</p>	 <p style="text-align: right; font-size: small;">901RS240</p>	<p style="text-align: center;"><b>J-24252</b> Installer; Inner bearing outer race</p>
 <p style="text-align: right; font-size: small;">901RS214</p>	<p style="text-align: center;"><b>J-22888</b> Puller; Side bearing</p>	 <p style="text-align: right; font-size: small;">901RS220</p>	<p style="text-align: center;"><b>J-21777-42</b> Front Pilot</p>
 <p style="text-align: right; font-size: small;">901RS232</p>	<p style="text-align: center;"><b>J-8107-2</b> Adapter; Side bearing plug</p>	 <p style="text-align: right; font-size: small;">901RS243</p>	<p style="text-align: center;"><b>J-23597-9</b> Nut and bolt</p>

**DIFFERENTIAL (REAR) 4A2-29**

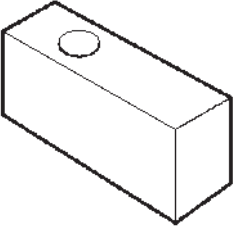
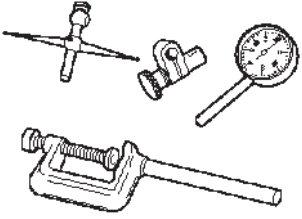
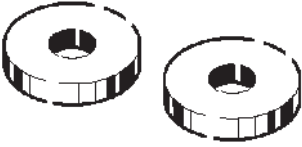
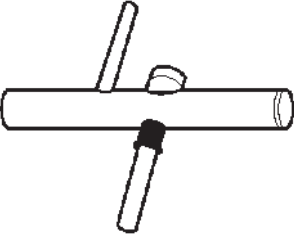
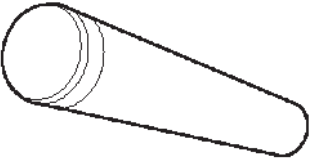
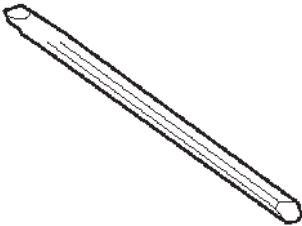
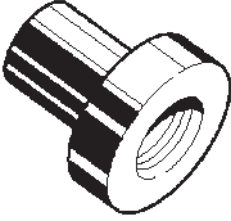
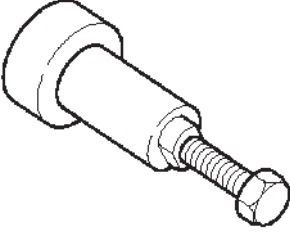
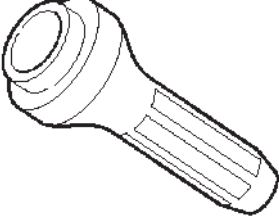
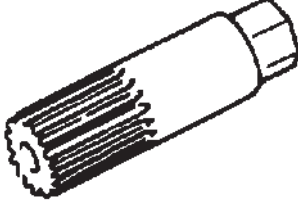
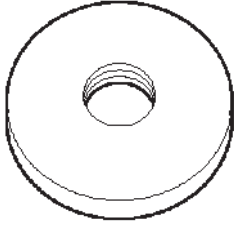
ILLUSTRATION	TOOL NO. TOOL NAME
 <p style="text-align: right; font-size: small;">901RS223</p>	<p style="text-align: center;"><b>J-23597-7</b> Gauge plate</p>
 <p style="text-align: right; font-size: small;">901RS224</p>	<p style="text-align: center;"><b>J-8001</b> Dial indicator</p>
 <p style="text-align: right; font-size: small;">901RS244</p>	<p style="text-align: center;"><b>J-23597-8</b> Disc</p>
 <p style="text-align: right; font-size: small;">901RS226</p>	<p style="text-align: center;"><b>J-23597-1</b> Arbor</p>
 <p style="text-align: right; font-size: small;">901RS227</p>	<p style="text-align: center;"><b>J-6133-01</b> Installer; Pinion bearing</p>
 <p style="text-align: right; font-size: small;">901RS228</p>	<p style="text-align: center;"><b>J-39209</b> Punch; End nut lock</p>

ILLUSTRATION	TOOL NO. TOOL NAME
 <p style="text-align: right; font-size: small;">901RS245</p>	<p style="text-align: center;"><b>J-24244</b> Installer; Side bearing</p>
 <p style="text-align: right; font-size: small;">901RS236</p>	<p style="text-align: center;"><b>J-39602</b> Remover; Outer bearing</p>
 <p style="text-align: right; font-size: small;">901RS211</p>	<p style="text-align: center;"><b>J-37263</b> Installer; Pinion oil seal</p>
 <p style="text-align: right; font-size: small;">901RW230</p>	<p style="text-align: center;"><b>J-41033</b> Holder; Side gear</p>
 <p style="text-align: right; font-size: small;">901RS222</p>	<p style="text-align: center;"><b>J-23597-12</b> Rear pilot</p>

# DRIVELINE/AXLE

## DRIVELINE CONTROL SYSTEM (TOD)

### CONTENTS

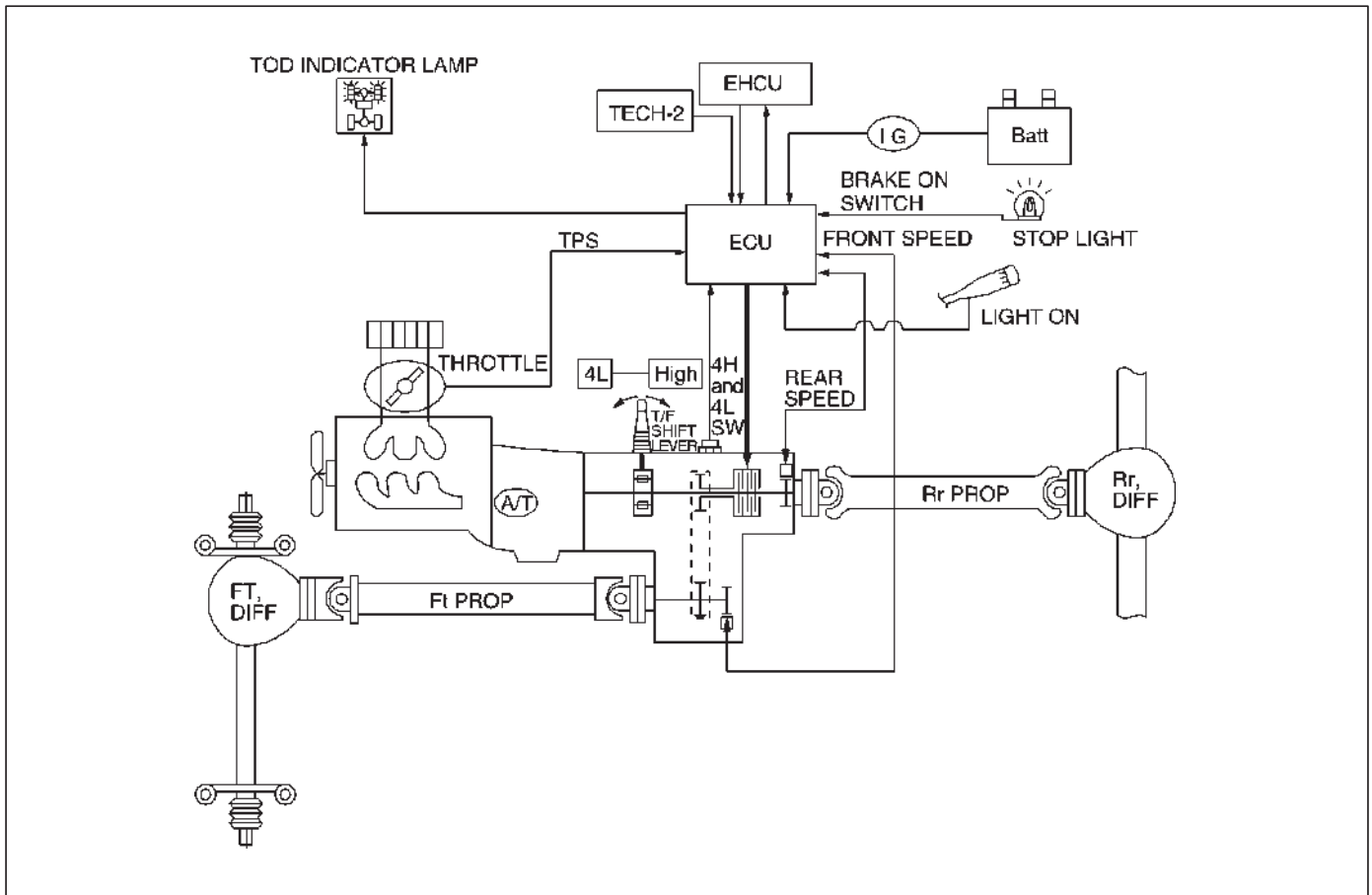
Service Precaution .....	4B2-1	Connector List .....	4B2-20
General Description .....	4B2-2	Checking Failed Pin .....	4B2-21
System Components .....	4B2-4	Checking Failed TOD Control Unit Pin .....	4B2-24
Parts Location .....	4B2-4	Tech 2 Scan Tool .....	4B2-25
Functions of Indicator Lamp .....	4B2-8	Diagnostic Trouble Codes .....	4B2-28
Diagnosis .....	4B2-12	Diagnosis from Trouble Codes .....	4B2-29
Basic Diagnostic Flow Chart .....	4B2-15	Trouble Diagnosis Depending on The Status of TOD Indicator .....	4B2-46
Parts Location .....	4B2-16	Diagnosis from Symptom .....	4B2-65
Circuit Diagram .....	4B2-17		

### Service Precaution

**WARNING: THIS VEHICLE HAS A SUPPLEMENTAL RESTRAINT SYSTEM (SRS). REFER TO THE SRS COMPONENT AND WIRING LOCATION VIEW IN ORDER TO DETERMINE WHETHER YOU ARE PERFORMING SERVICE ON OR NEAR THE SRS COMPONENTS OR THE SRS WIRING. WHEN YOU ARE PERFORMING SERVICE ON OR NEAR THE SRS COMPONENTS OR THE SRS WIRING, REFER TO THE SRS SERVICE INFORMATION. FAILURE TO FOLLOW WARNINGS COULD RESULT IN POSSIBLE AIR BAG DEPLOYMENT, PERSONAL INJURY, OR OTHERWISE UNNEEDED SRS SYSTEM REPAIRS.**

**CAUTION: Always use the correct fastener in the proper location. When you replace a fastener, use ONLY the exact part number for that application. ISUZU will call out those fasteners that require a replacement after removal. ISUZU will also call out the fasteners that require thread lockers or thread sealant. UNLESS OTHERWISE SPECIFIED, do not use supplemental coatings (Paints, greases, or other corrosion inhibitors) on threaded fasteners or fastener joint interfaces. Generally, such coatings adversely affect the fastener torque and the joint clamping force, and may damage the fastener. When you install fasteners, use the correct tightening sequence and specifications. Following these instructions can help you avoid damage to parts and systems.**

## General Description



TOD (Torque on Demand) system is traction control system of vehicle.

### Transfer Position and Drive Mode

Two drive modes can be selected through operation of transfer lever.

Transfer Position	Mode	Drive mode
HIGH	TOD	Electronically controlled torque split four wheel drive
4L	4L	Low-speed mechanical lock-up four wheel drive

The electronic control unit (ECU) judges the signals from the transfer lever and controls the transfer drive mode.

### TOD Control

The TOD position usually drives the rear wheels, and transmits the torque to the front wheels with the help of an electronically controlled torque split mechanism according to running conditions encountered. This force is split by the transfer and delivered to the front wheels. The magnitude of the torque transmitted to the front wheels is controlled by changing the pressing force of the electromagnetic multi plate disk clutch built in the transfer unit. The pressing force of the clutch is controlled by changing the voltage to the electromagnetic coil mounted to the rear of the clutch. When the clutch is completely disengaged, the rear wheels are driven. When the clutch

is completely engaged, a rigid four wheel drive mode is obtained. The torque split status is controlled continuously between the rear wheel and four wheel drive modes. This system includes front and rear propeller shaft speed sensors, and throttle position sensor that monitors the engine output.

The control unit receives signals from these sensors and changes the pressing force of the electromagnetic multi plate disk clutch to determine the torque distribution on the front and rear wheels. Therefore, when the slip of the rear wheels is increased against the current torque level in the normal rear wheel drive mode, the control unit detects the slip condition, determines the optimum torque based on the feedback control logic, and increases the torque to the front wheels.

The control unit uses the signal from the throttle position sensor to predict the future vehicle condition and the intention of the driver with respect to acceleration and deceleration, and determines the initial torque distribution using this data and the information from the speed sensors.

In case of small circle turning in the parking lot, for example, the control unit minimizes the clutch pressing force to allow differential operation to prevent wheel hop. When the ABS becomes active, the control unit optimizes the clutch pressing force to ensure stable braking.

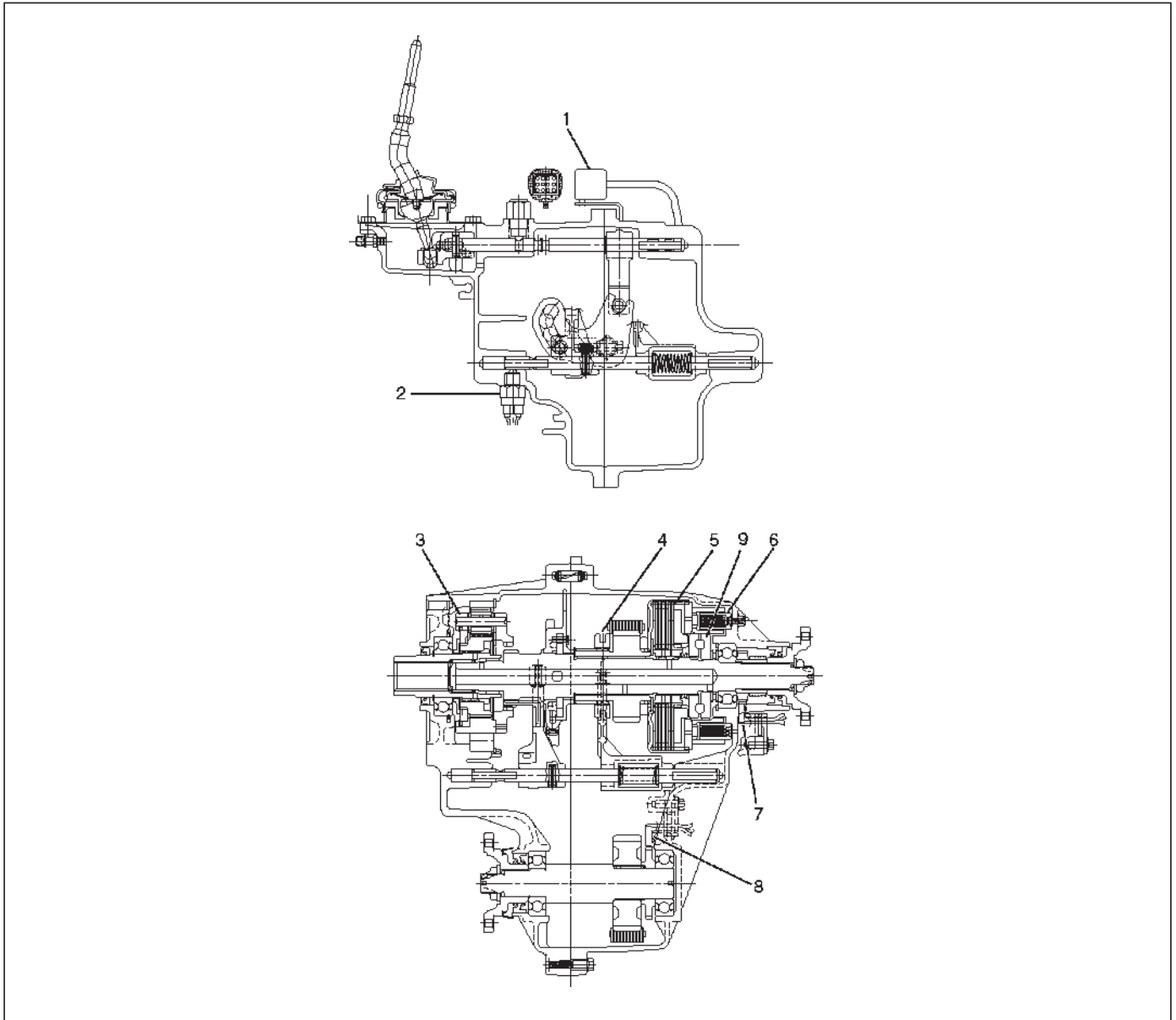
### **TOD Indicator Control**

The TOD indicator on the instrument panel informs the driver of the current working status of the transfer unit. The information consists of two items: the drive mode (TOD, 4L, transition) and the torque split status of the TOD (torque distribution level). The indicator can display occasional errors and corresponding error codes.



## System Components

### Parts Location



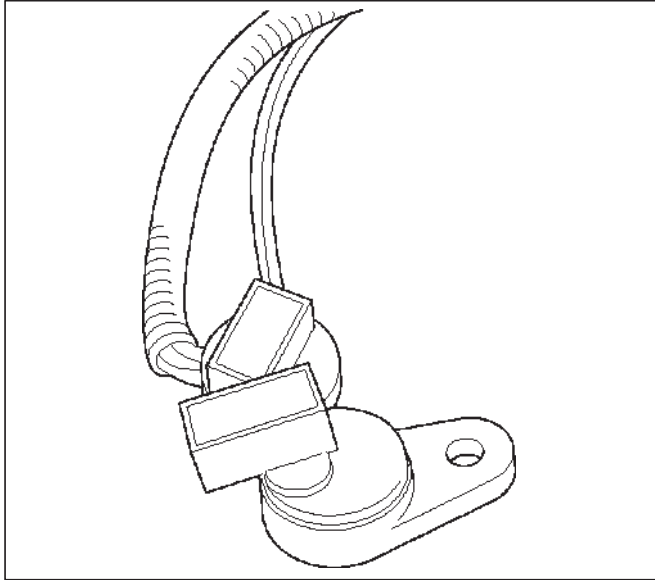
A07RX003-1

#### Legend

- |                                 |                                  |
|---------------------------------|----------------------------------|
| (1) T/F Connector               | (5) Multi Plate Disk Clutch Pack |
| (2) 4H and 4L Switch            | (6) Electromagnetic Coil         |
| (3) High-Low Planetary Gear Set | (7) Rear Speed Sensor            |
| (4) Mechanical Lock             | (8) Front Speed Sensor           |
|                                 | (9) Ball and Ramp Cam            |

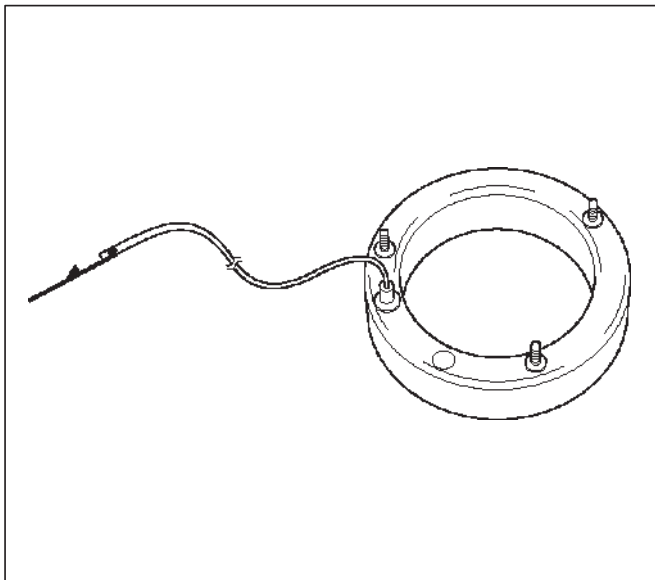
### Front and Rear Speed Sensors

The sensors are mounted to the transfer case, detect the rotation of rotors directly coupled to the propeller shafts. Thirty rectangular pulses are output per one rotation of the propeller shaft.



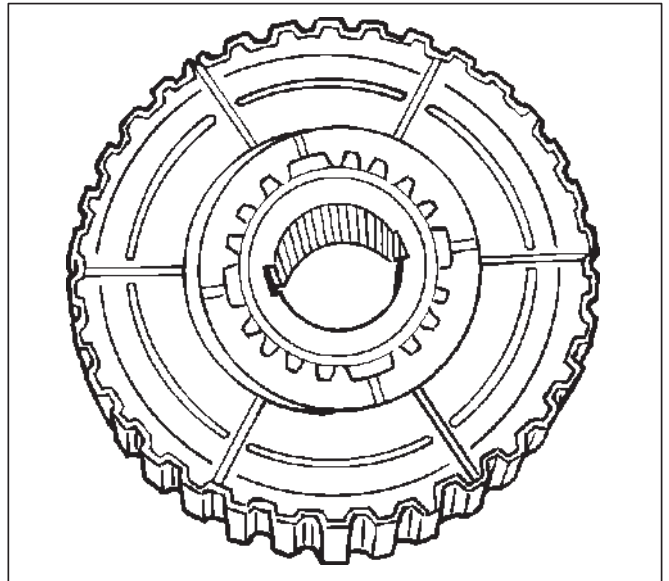
### Electromagnetic Coil

Receives the duty signals from the TOD control unit and controls the pressing force of the clutch pressure cam.



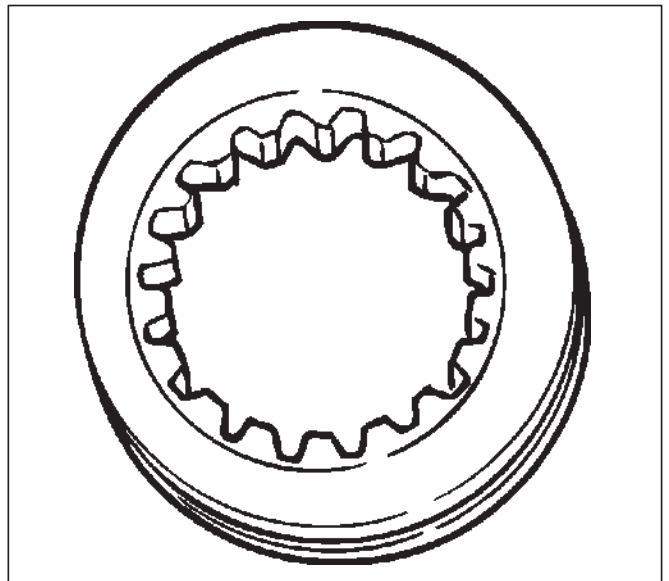
### Multi Plate Disk Clutch Pack

Transmits the torque determined by the clutch pressing force to the front propeller shaft via the front drive chain.



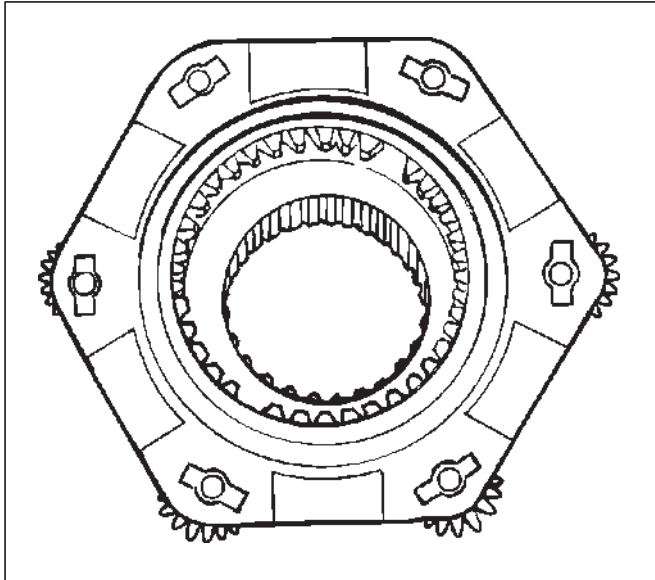
### Mechanical Lock Sleeve

Couples the front and rear propeller shaft mechanically when the transfer shaft is in the 4L position.



### High-Low Planetary Gear Set

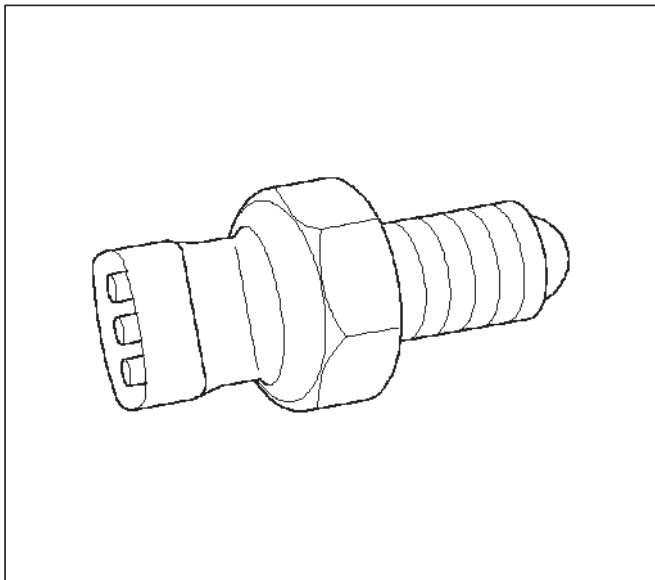
Establishes an auxiliary transmission mechanism. When the transfer shift lever is set to the TOD position, the reduction gear ratio is 1.000 and the corresponding driving force is generated. When the transfer shift lever is set to the 4L position, the reduction gear ratio is 2.480 and the corresponding driving force is generated.



262RW030

### 4H and 4L Switch

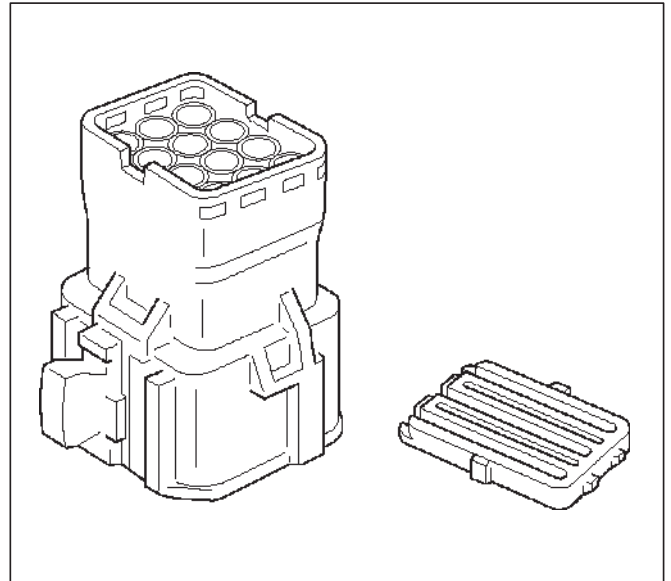
Detects the shift position of the transfer from the movement of the transfer lever and outputs signals to the TOD control unit.



261RW002

### Transfer Connector

Transmits the input and output signals of the speed sensors, electromagnetic coil, and 4H and 4L switch to the vehicle harness. A waterproof 12-pin type is used.

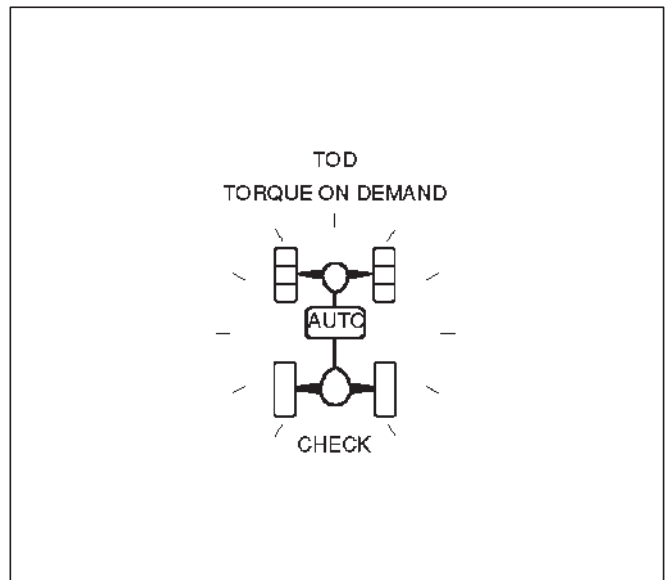


261RW046

### TOD Indicator Lamps (on the instrument panel)

Inform the following items.

- Bulb check
- Drive mode
- ABS IN status
- BRAKE ON status

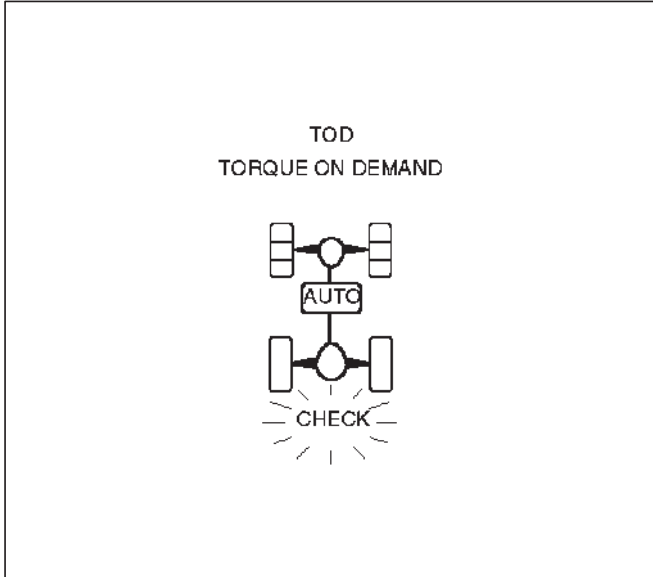


821RW049

## Check Lamp

Inform the following items.

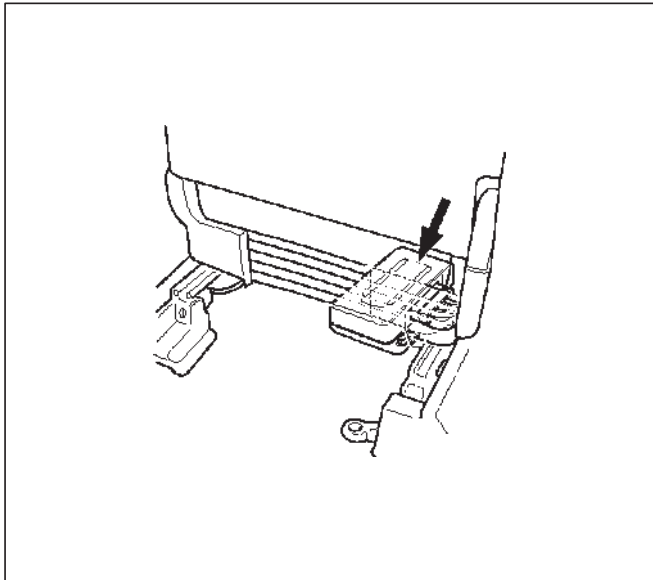
- Bulb check
- Fail (fail alarm)
- Trouble code



821RW076

## TOD ECU


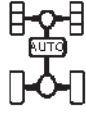
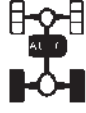



This control unit is mounted to the front right hand seat via a special bracket.



F07RV014

## Functions of Indicator Lamp

### TOD Indicator Lamps

Output condition					Indicator indicate state	Remark	Each sw state	
ECU Terminal No.							4H SW	4L SW
25	26	27	28	29				
0	0	0	1	0	 4L Mode		OFF	ON
1	1	1	1	1	 N Mode		ON	ON
1	1	1	0	0	 TOD Mode1	Traction distribution about 0:100	OFF	OFF
1	1	0	0	0	 TOD Mode2	Traction distribution about 15:85		
1	0	0	0	0	 TOD Mode3	Traction distribution about 30:70		
0	0	0	0	0	 TOD Mode4	Traction distribution about 50:50		

1=12V 0=GND

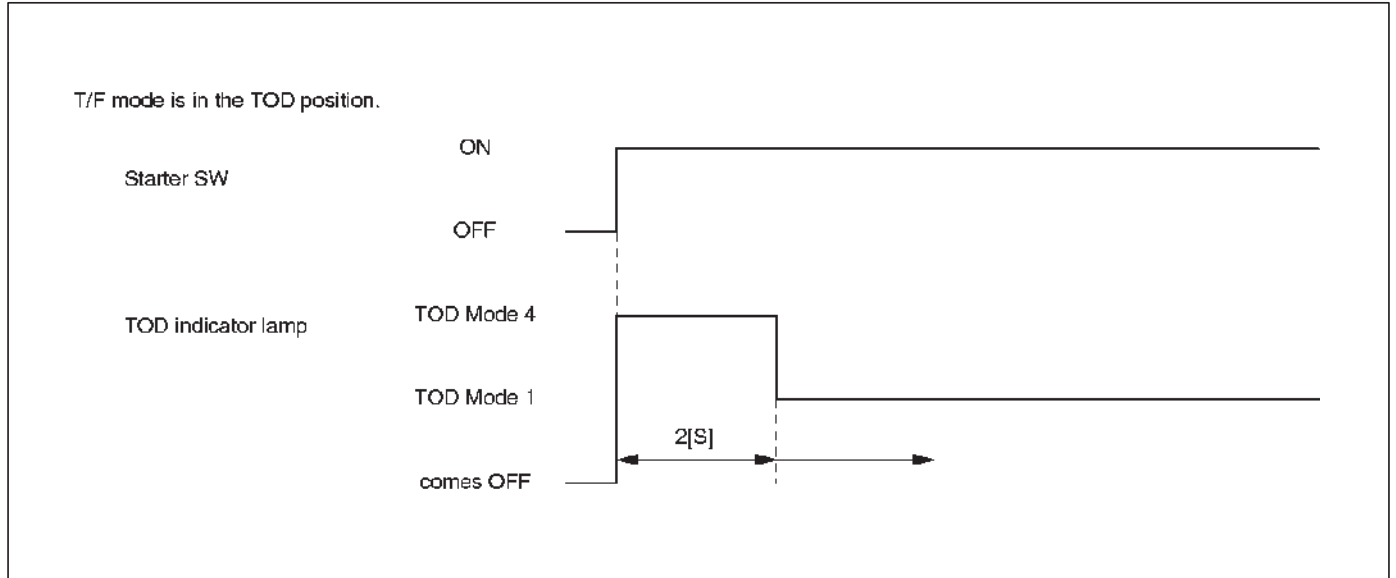
#### Indication of Drive Mode

The transfer lever position signals are transmitted to the TOD control unit according to the condition listed above.

**Bulb Check**

When the starter switch is turned on, the TOD indicator lamps go on as shown below.

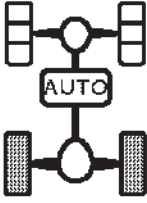
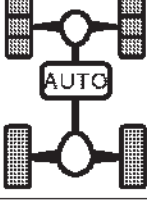
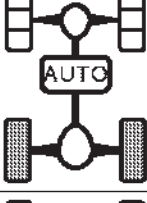
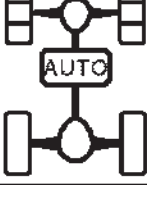
NOTE: Once the starter switch is turned on, all the TOD indicator lamps are lit for two seconds, even if the transfer lever is in any position.



## 4B2-10 DRIVE LINE CONTROL SYSTEM (TOD)

### Simplified checking method of ABS INPUT and BRAKE ON signals:

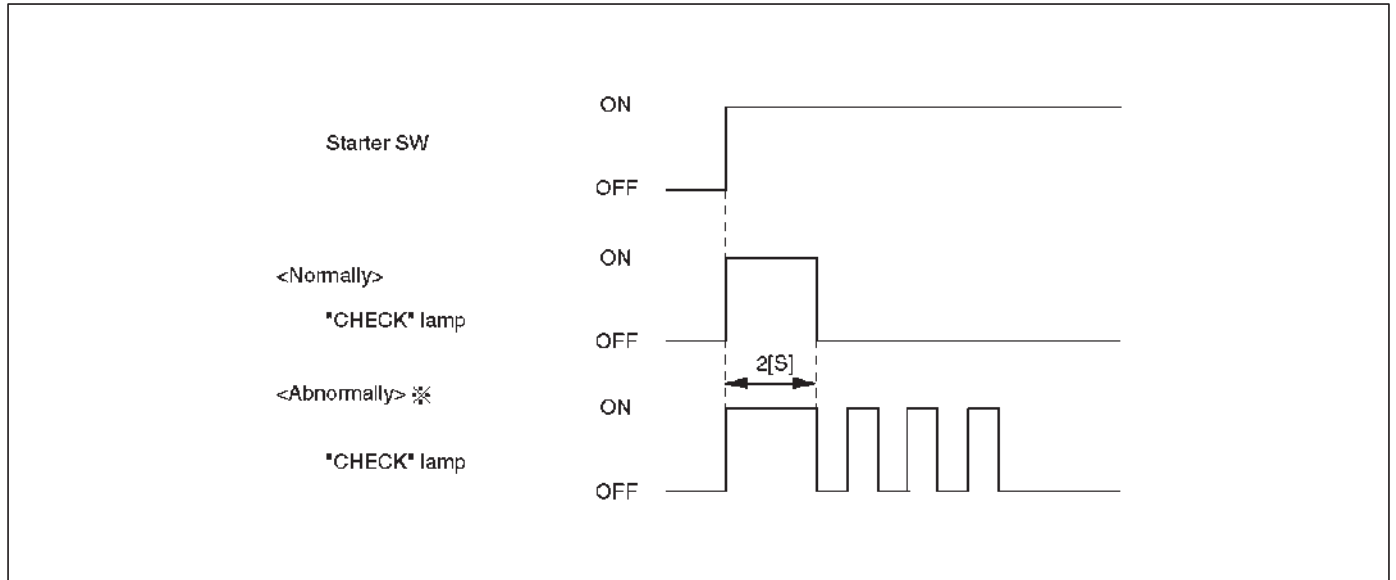
In the event that any of the signal inputs listed below are observed while the self-diagnostic code is being displayed (the self-diagnostic connector is short-circuited to GND), you can simply check the ABS INPUT and BRAKE ON signals as shown in the figures below.

1		<ul style="list-style-type: none"><li>• In case of ABS signal being inputted, TOD indicator will light as illustrated.</li></ul>
2		<ul style="list-style-type: none"><li>• In case of BRAKE ON signal being inputted, TOD indicator will light as illustrated.</li></ul>
3		<ul style="list-style-type: none"><li>• When both the ABS and BRAKE ON signals are inputted simultaneously, ABS signal is indicated.</li></ul>
4		<ul style="list-style-type: none"><li>• In cases other than "1, 2, 3", the indication is always as illustrated. (This is light-off mode)</li><li>• TOD indicator light returns to usual control (mode) at 12 km/h or more.</li></ul>

## Check Lamp

### Check Lamp Bulb Check

When the starter switch is turned on in the normal state, the control unit turns on the CHECK lamp to check the bulb.





## Diagnosis

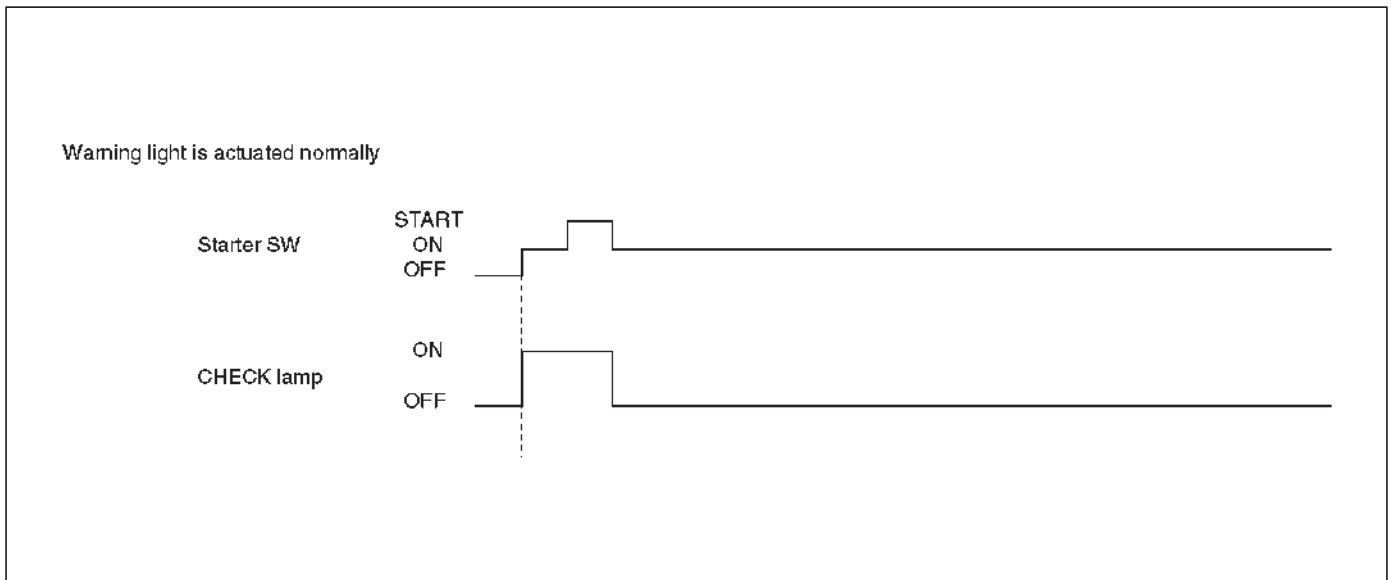
### General Information Diagnosis

The troubles on TOD are classified into the group that can be identified by the lighting status of the TOD indicator lamps and those that can be recognized as abnormal phenomena of the vehicle by the driver.

The troubles that can be identified by the lighting status of the TOD indicator lamps are examined by the procedures "Diagnosis from Trouble Codes" and "Trouble Diagnosis Depending on The Status of TOD Indicator". The troubles that can be recognized as abnormal phenomena of the vehicle by the driver are examined by the procedure "Diagnosis from symptom".

### Self-diagnosis

The control unit has a function of self-diagnosis. If a trouble occurs in the course of system startup, the control unit blinks the CHECK lamp and saves the trouble code.



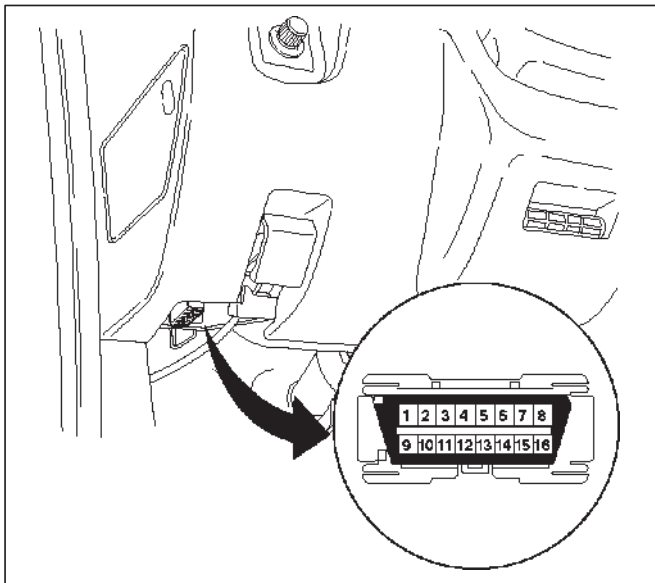
C07RW021

NOTE: If an intermittent fault occurs, the control unit stops blinking upon removal of the fault. The trouble code is saved to the control unit.

**Indication Method of Trouble Code**

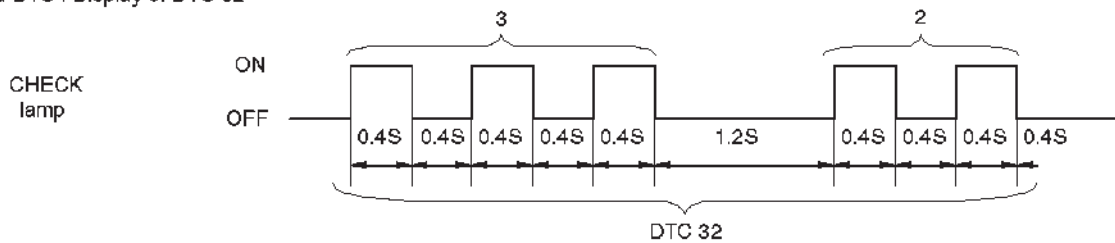
- Short-circuit terminal 8 of the self-diagnostic connector to GND to display the trouble code on the CHECK lamp.

- If no trouble codes exist, code "12" is displayed continuously.
- If trouble codes exist, code "12" is displayed three times, and the trouble codes, starting from the smaller code number, are displayed three times respectively.

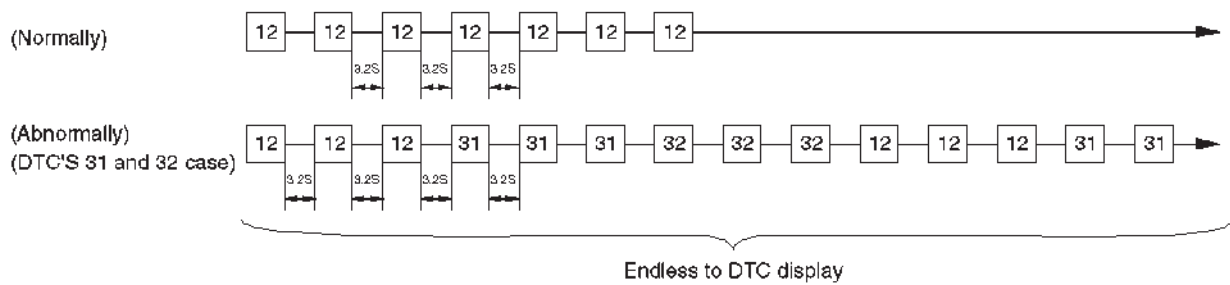


821RX029

How to read DTC : Display of DTC 32



An example of DTC display

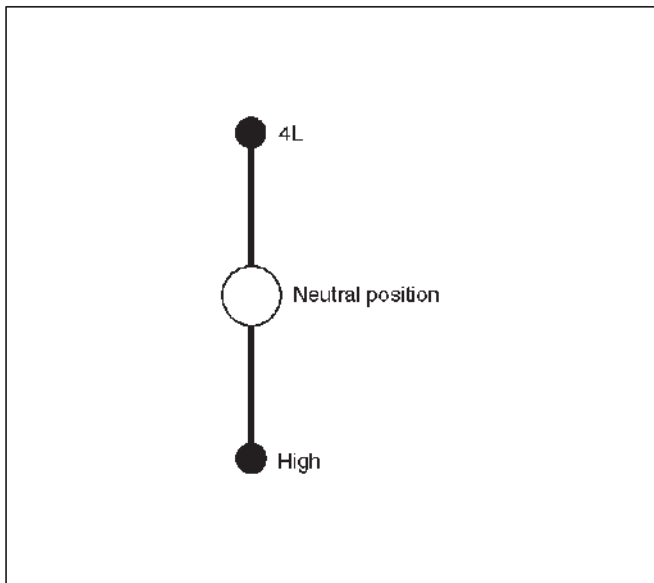


**How to Clear The Trouble Code**

The trouble codes saved to the control unit can be deleted by the following procedure if the starter switch is being in the OFF position.

1. Block wheels.  
Shift the transfer lever to the neutral position between HIGH and 4L, and short-circuit the self-diagnostic connector.

NOTE: The neutral position between HIGH and 4L refers to the point that turns off the TOD indicator lamps. (However, be sure to check the position before short-circuiting the self-diagnostic connector.)



C07RW011

2. Turn on the starter switch while maintaining the state of step 1, and step on the brake pedal five times within five seconds from the first step on. (Note that "five times" includes the first step on). (The TOD indicator lamps display the 4L mode whenever the brake pedal is stepped on.)
3. If the conditions shown in steps 1 and 2 are met, clear the trouble codes saved to the control unit. (After the codes are completely deleted, the code 12 indicates the normal condition)

**Precautions on Diagnosis****Replacement of Control Unit**

The control unit itself rarely fails. In most cases, the harnesses have failed (i.e. short-circuit). Before replacing the control unit, check the connector joints and whether the specified current flows to the control unit.

**Trouble Intermittently Observed**

Troubles intermittently observed are mostly attributable to temporary imperfect connection of harnesses and connectors.

When such troubles are found, check the associated circuit according to the following procedure.

1. Check whether connectors are plugged in or connector terminals are completely engaged.
2. Check whether the terminals are deformed or damaged. If yes, remove the deformation or damage and connect the terminals securely.

3. In examination of failed harness circuit, shake the harness to check for poor connections. Do not put unnecessary stress on the harness.

**System Check of Failed TOD Vehicle**

If the TOD indicator lamps experienced faulty operation even once in the past, the failed portion can be identified by use of the procedure "Diagnosis from Trouble Codes" or "Trouble Diagnosis Depending on The Status of TOD Indicator". If the troubles that are only recognized as abnormal phenomena of the vehicle by the driver are observed, conduct the test outlined in the following procedure to reproduce the faulty phenomena and diagnose the fault for each phenomenon.

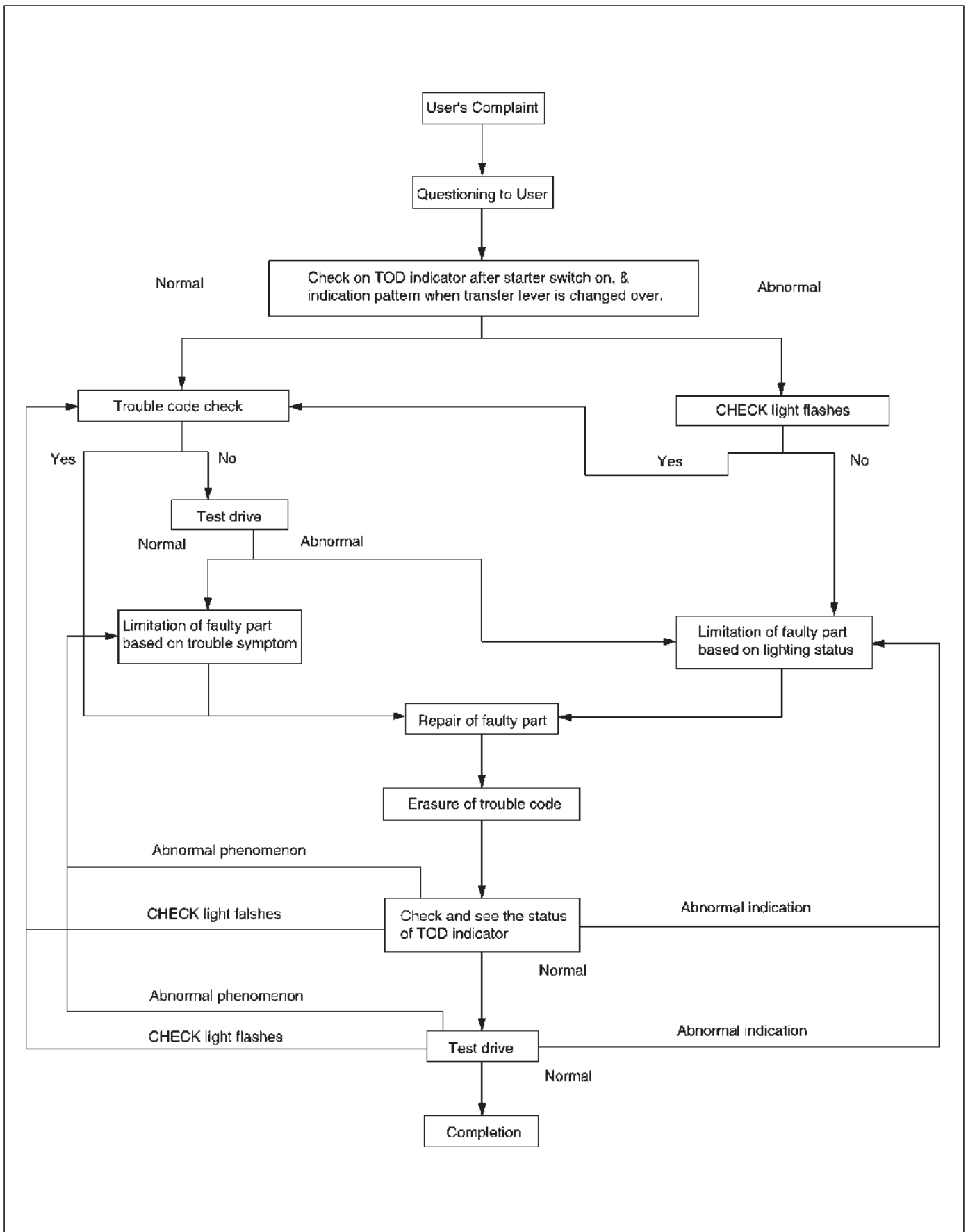
1. Start the engine, and check that the TOD indicator lamps are turned on for about two seconds for initial check; the CHECK lamp goes off; and the TOD indicator lamps display the specified drive mode. (If the CHECK lamp starts blinking, read the trouble codes and identify the failed portion.)
2. While keeping the vehicle at a standstill, shift the transfer lever to change the modes: TOD mode→4L mode→TOD mode. Check that the TOD indicator lamps correctly display the status whenever the mode is changed. If the transition status is displayed during the shift operation, run the vehicle a little to complete shifting.
3. Start the vehicle in the TOD mode, and slowly accelerate to at least 40 km/h (25 MPH) and maintain the speed for about two minutes. Apply the brake to completely stop the vehicle. Repeat this test pattern at least three times.
4. Turn the steering fully to the right (or left) in the TOD mode, and slowly drive the vehicle in a circle five times.
5. Start the vehicle in the TOD mode, and slowly accelerate to at least 40 km/h (25 MPH). Apply the brake strongly so that the ABS works, and completely stop the vehicle.
6. Start the vehicle in the 4L mode, and slowly accelerate to at least 20 km/h (13 MPH). Apply the brake and completely stop the vehicle.

If the CHECK lamp starts blinking during the test run, read the trouble codes and give appropriate maintenance according to the diagnostic procedure. If the TOD indicator lamps are lit abnormally during the run, check the lighting condition and give appropriate maintenance according to the diagnostic procedure. Even if the phenomena are not observed, try to reproduce the abnormal state reported by the customer.

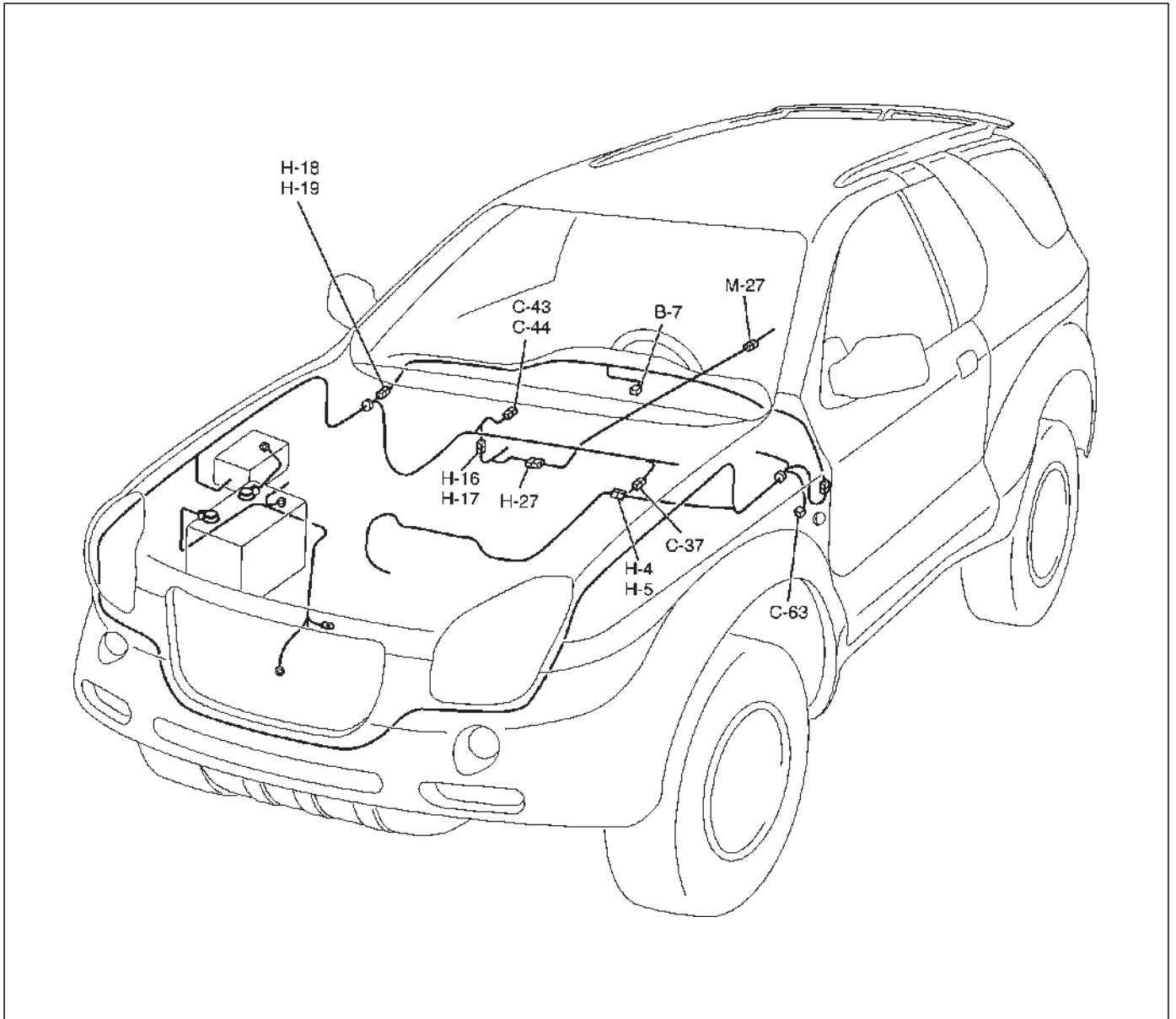
**Post-Repair Check**

As long as the starter switch is not turned off, the TOD indicator lamps continue blinking even after the failed control unit is repaired. Therefore, upon completion of repair, be sure to turn off the starter switch once and then turn it on to conduct the test run sequence specified in steps 1 through 6 above and check that the TOD indicator lamps no longer show any faulty status.

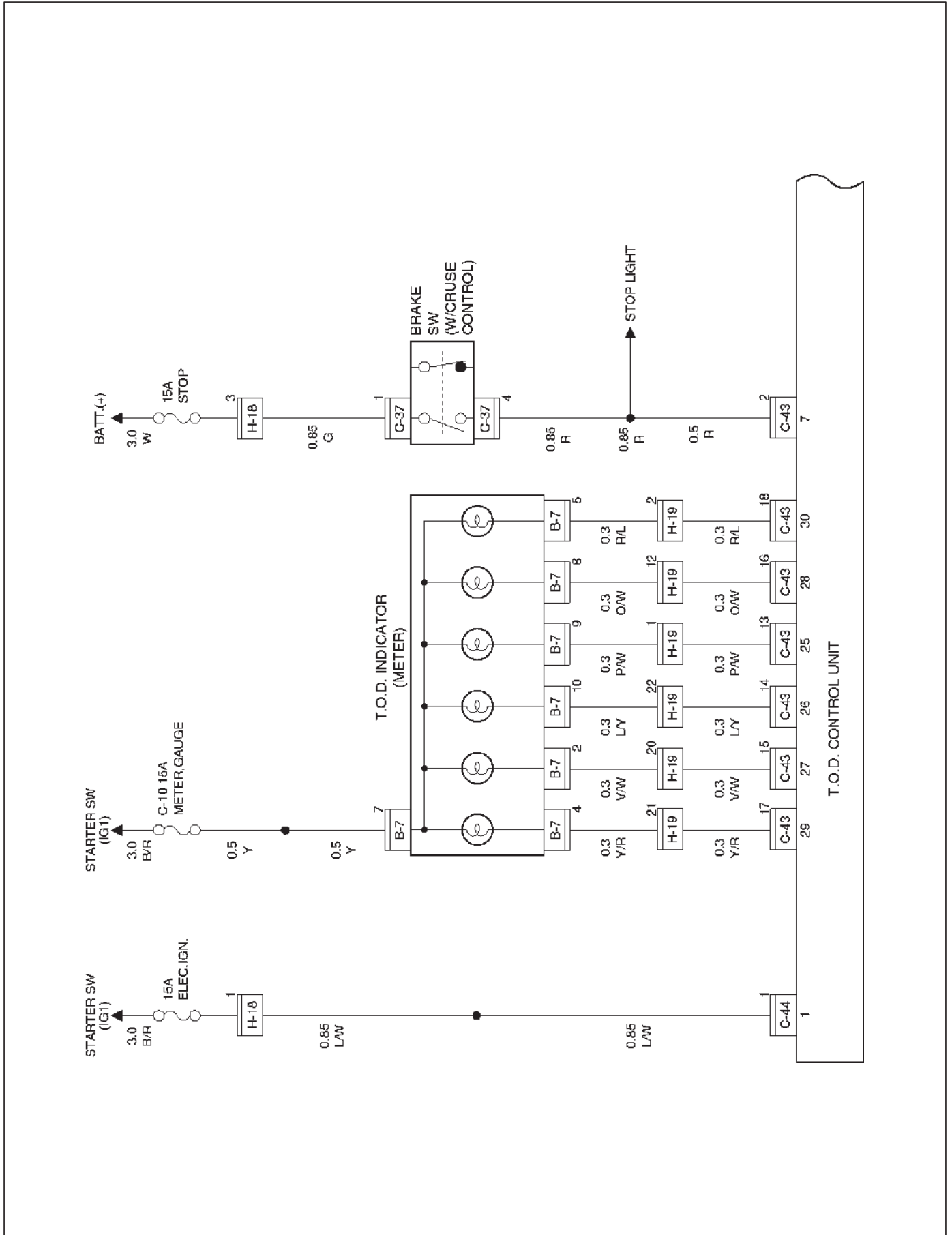
### Basic Diagnostic Flow Chart

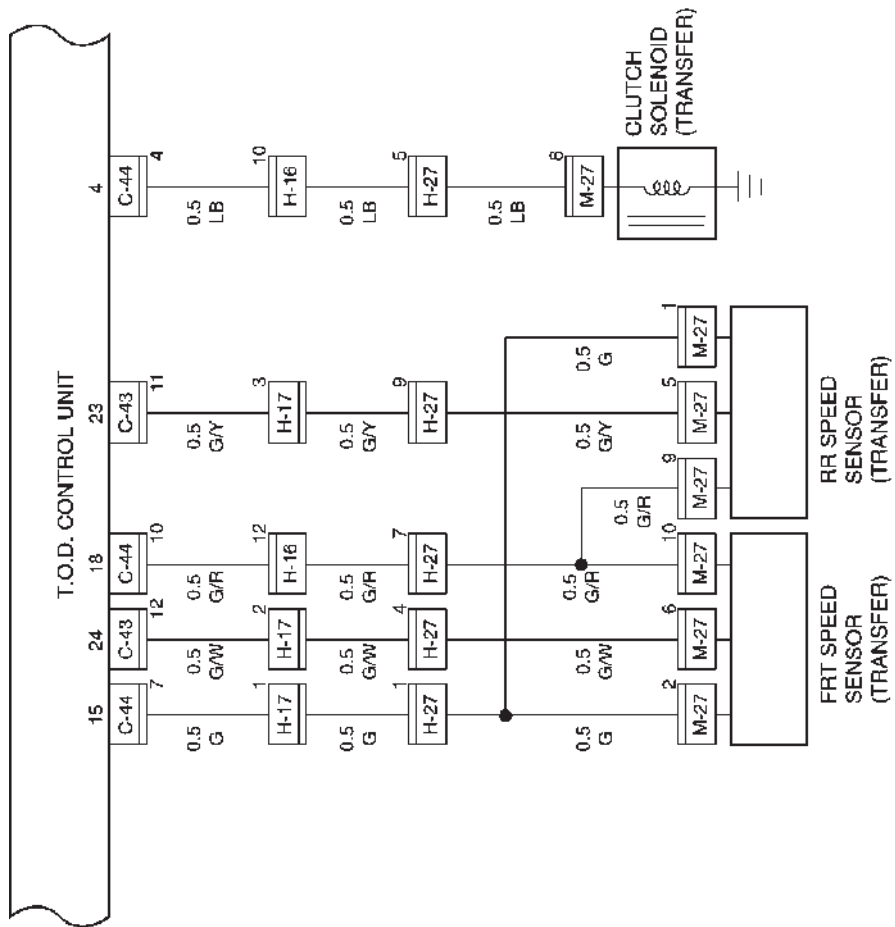


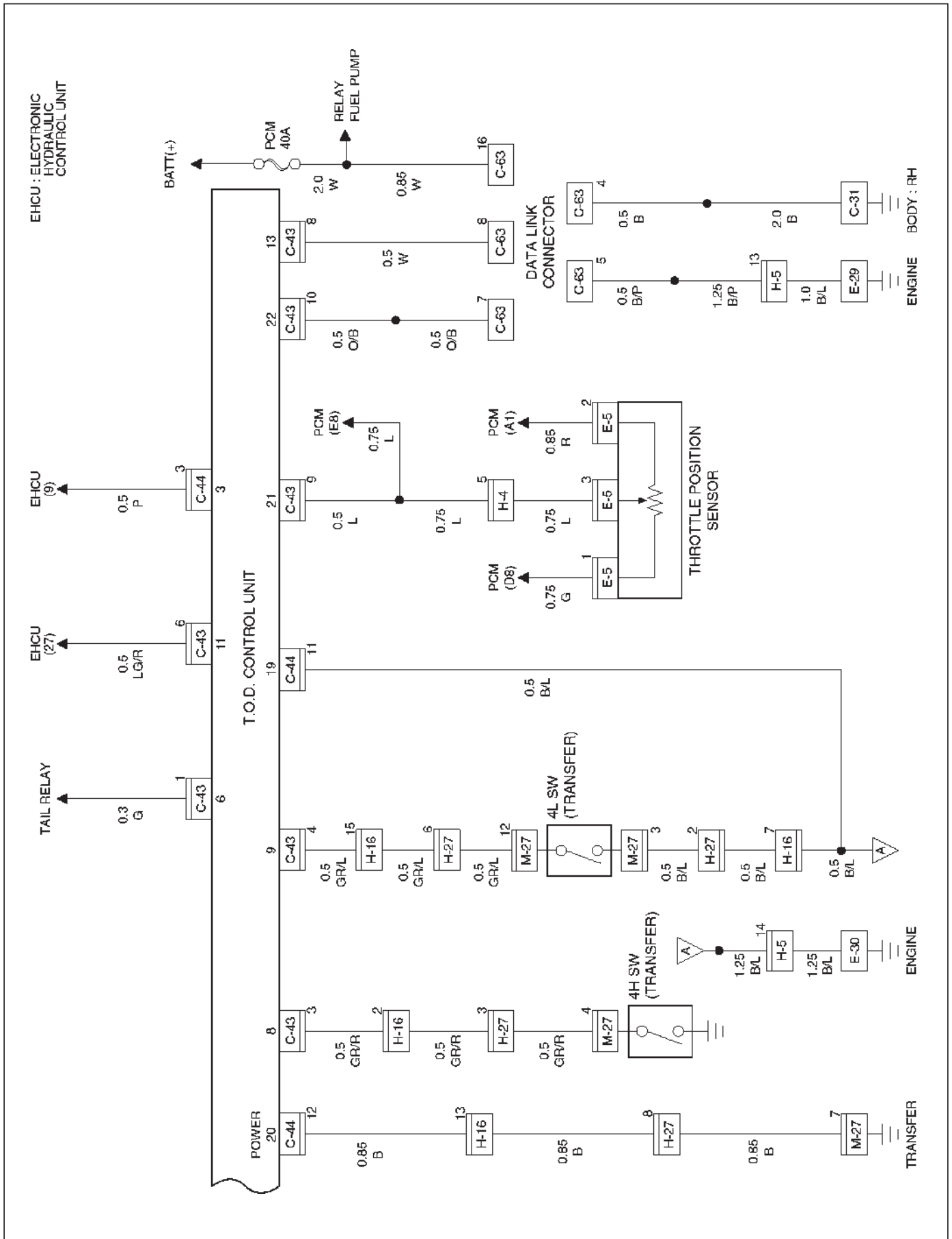
Parts Location



Circuit Diagram


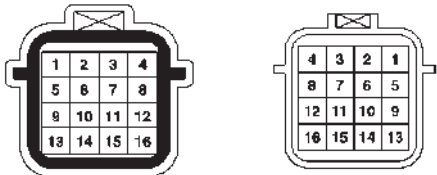

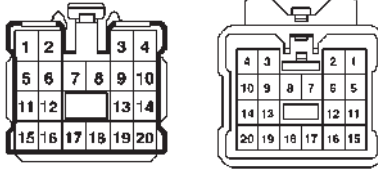


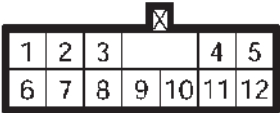
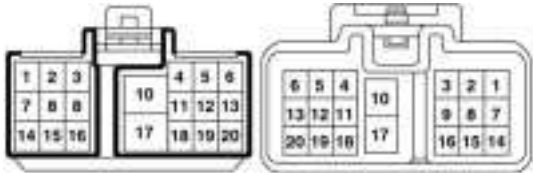

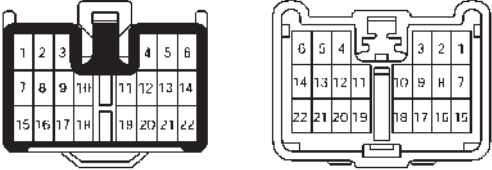
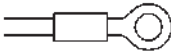

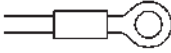

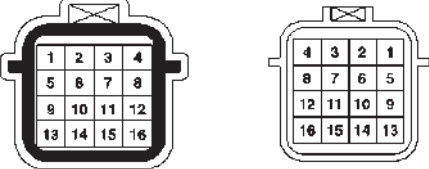








Connector List

No.	Connector face	No.	Connector face
B-7		H-5	
C-37		H-16	
C-43		H-17	
C-44		H-18	
C-63		H-19	
E-29		H-27	
E-30		M-27	
H-4			

## Checking Failed Pin Connector Pin Assignment

ECU pin assignment

NOTE: Connector C-43 and C-44 are connected.

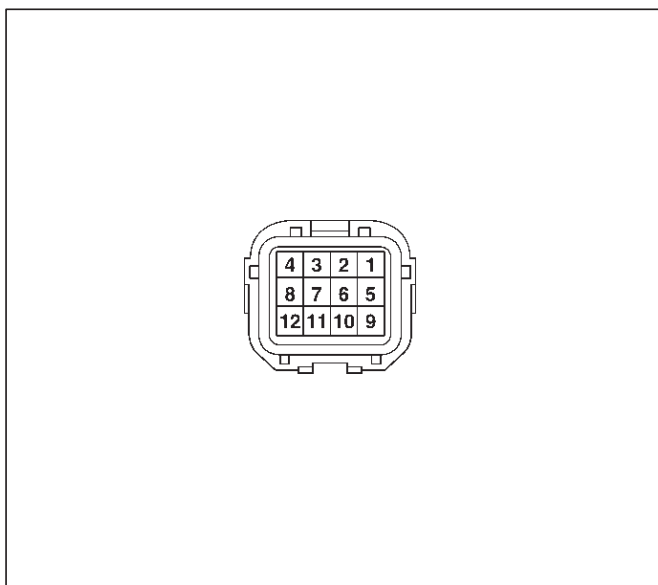
	13	12	11	10	X		9	8	7	6	5	4	X		3	2	1	
	30	29	28	27	26	25	24	23	22	21	20	19	18	17	16	15	14	

**4B2-22 DRIVE LINE CONTROL SYSTEM (TOD)**

No.	NAME	CONTENTS
1	VIG	Power supply (IG)
2	N.C.	Not used
3	4WD OUT	4WD signal output
4	SOL (+)	Electromagnetic solenoid
5	N.C.	Not used
6	LIGHTING SW	Lighting SW input
7	BRAKE	Brake SW input
8	4H SW	4H SW input
9	4L SW	4L SW input
10	N.C.	Not used
11	ABS IN	Operation signal input
12	N.C.	Not used
13	DIAG	Self-diagnosis input
14	N.C.	Not used
15	Ref.	Vehicle speed sensor supply
16	N.C.	Not used
17	N.C.	Not used
18	COM (-)	Vehicle speed sensor GND
19	S-GND	Sensor GND
20	P-GND	Power GND
21	TPS	Throttle position sensor
22	TECH 2	TECH 2 output
23	Rer. Sig	Rear vehicle speed sensor input
24	Fr. Sig	Front vehicle speed sensor input
25	IND.a	4WD display signal a
26	IND.b	4WD display signal b
27	IND.c	4WD display signal c
28	IND.AUTO	AUTO display output
29	IND Rr	Rear display output
30	CHECK	TOD warning lamp

**Reference**

- Transfer connector pin assignment (connector on the transfer case)  
for inspection of transfer pins.



No.	NAME	CONTENTS	COLOR CODING
1	Ref. (Rer. )	Rear speed sensor reference output	LG
2	Ref. (Frt. )	Front speed sensor reference output	LG
3	SW GND	SW GND	B
4	4H SW (+)	4H SW plus terminal	R
5	Rer. (+)	Rear speed sensor plus	B/LG
6	Frt. (+)	Front speed sensor plus	LB
7	POWER GND	Power GND	B
8	SOL (+)	Electromagnetic solenoid	Y
9	COM (-) (Rer. )	Rear speed sensor GND	GR/R
10	COM (-) (Frt. )	Front speed sensor GND	GR/R
11	NC	Not used	—
12	4L SW (+)	4L SW plus terminal	Y

As for the color coding, refer to Wiring - Wire Color Coding in Wiring System section.

## 4B2-24 DRIVE LINE CONTROL SYSTEM (TOD)

### Checking Failed TOD Control Unit Pin

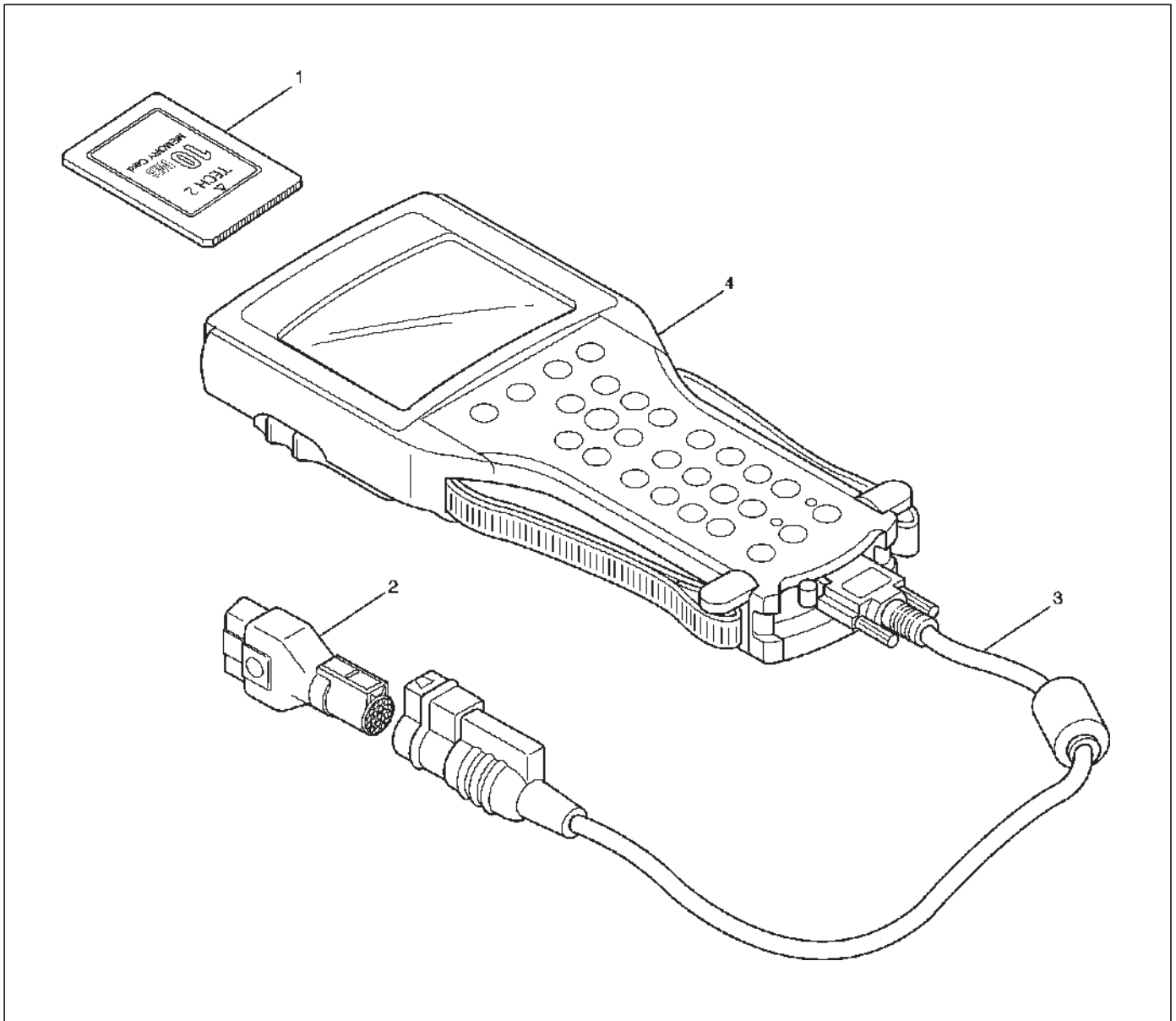
NOTE:

1. Unplug the ECU connector and the pins, unless otherwise specified.
2. Before removing the ECU, turn off the ignition switch.
3. If the standard values are not observed, check the pins with other testers.

Check Pin No.	Circuit to be tested	Ignition Switch Position	Engine State	Multimeter Scale/Range	Measure between Pin Number	Standard Value	Note
20	P-GND	OFF	STOP	$\Phi$	20, 19	Continuity : OK	
19	GND	OFF	STOP	$\Phi$	19, GND	Continuity : OK	
8	4H SW	OFF	STOP	$\Phi$	8, 19	No continuity (high, 4L) and continuity (N) : OK	
9	4L SW	OFF	STOP	$\Phi$	9, 19	No continuity (high) and continuity (4L, N) : OK	
13	DIAG	OFF	STOP	$\Phi$	13 (TOD), 8 (DLC Connector)	Continuity : OK	DLC connector terminal 8
25	IND.a	ON	STOP	DCV	25 (+), 19 (-)	8.0 ~14.5 V	SW ON: 0V SW OFF: 8.0-14.5V
26	IND.b	ON	STOP	DCV	26 (+), 19 (-)	8.0 ~14.5 V	
27	IND.c	ON	STOP	DCV	27 (+), 19 (-)	8.0 ~14.5 V	
30	CHECK LAMP	ON	STOP	DCV	30 (+), 19 (-)	8.0 ~14.5 V	
11	ABS IN	ON	STOP	DCV	11 (+), 19 (-)	11.5 ~14.5 V	
15	Ref.	ON	STOP	DCV	15 (+), 19 (-)	5 ~9 V	Connect ECU
24	Ft.(+)	ON	STOP	DCV	24 (+), 19 (-)	0.7 ~6 V	Connect ECU (off one tooth of speed sensor ring) and move the vehicle making sure of voltage change.
23	Rr.(+)	ON	STOP	DCV	23 (+), 19 (-)	0.7 ~6 V	Connect ECU (off one tooth of speed sensor ring) and move the vehicle making sure of voltage change.
18	COM(-)	ON	STOP	DCV	18 (+), 19 (-)	0V	Connect ECU
1	Vig	ON	STOP	DCV	1 (+), 19 (-)	8 ~14.5 V	
7	BRAKE	OFF	STOP	DCV	7 (+), 19 (-)	8 ~14.5 V	Press brake pedal
21	TPS	ON	STOP	DCV	21 (+), 19 (-)	0.2 ~4.6 V	Step on the accelerator pedal and make sure that voltage changes.
3	4WD OUT	OFF	STOP	$\Phi$	3, 19	7 ~12 k $\Phi$	Disconnect battery GND terminal
4	SOL(+)	OFF	STOP	$\Phi$	4, 19	1.0 ~5.0 $\Phi$	Disconnect battery GND terminal
6	LIGHTING	ON	STOP	DCV	6 (+), 19 (-)	SW OFF : 8.0 ~14.5 V SW ON : 0 V	
28	AUTO INDI	ON	STOP	DCV	28 (+), 19 (-)	TOD : 0 V 4L : 8.0 ~14.5 V	ON: 0V OFF: 8.0 - 14.5V
29	RR INDI	ON	STOP	DCV	29 (+), 19 (-)	0 V	

### Tech 2 Scan Tool

From 98 MY, Isuzu dealer service departments are recommended to use Tech 2. Please refer to Tech 2 scan tool user guide.



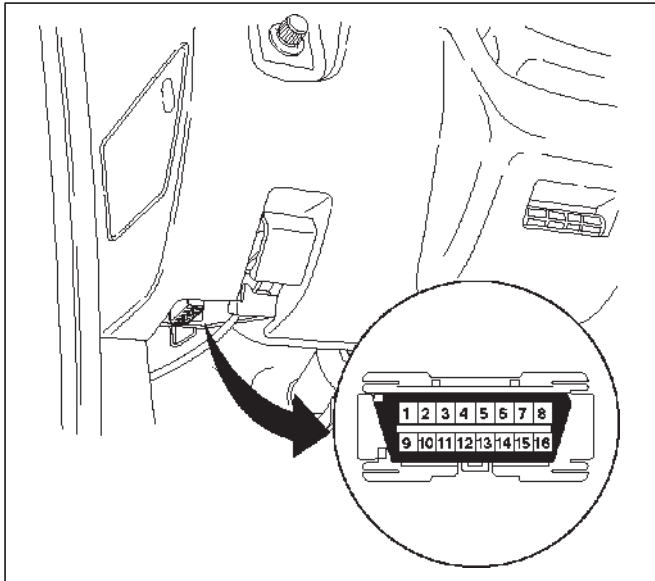
#### Legend

- (1) PCMCIA Card
- (2) SAE 16/19 Adaptor

- (3) DLC Cable
- (4) Tech 2

### Getting Started

- Before operating the Isuzu PCMCIA card with the Tech 2, the following steps must be performed:
- 1. The Isuzu 98 System PCMCIA card (1) inserts into the Tech 2 (4).
- 2. Connect the SAE 16/19 adapter (2) to the DLC cable (4).
- 3. Connect the DLC cable to the Tech 2 (4)
- 4. Make sure the vehicle ignition is off.
- 5. Connect the Tech 2 SAE 16/19 adapter to the vehicle DLC connector.



821RX029

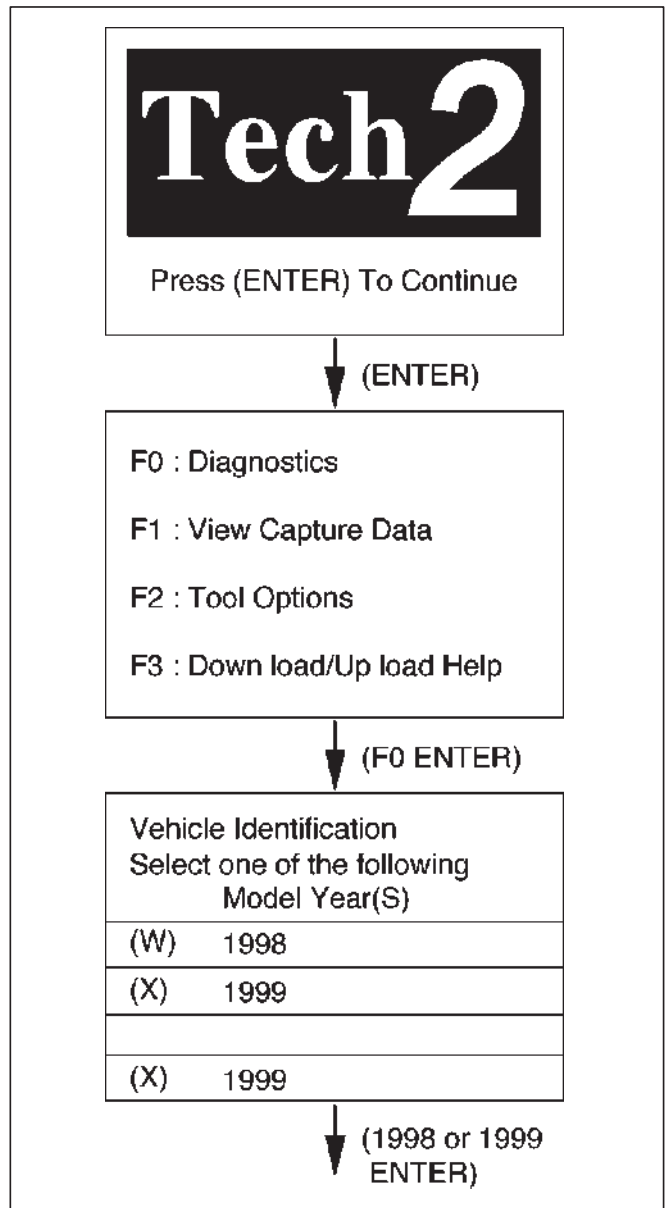
- 6. Turn the ignition on.
- 7. Power up the Tech 2.
- 8. Verify the Tech 2 power up display.



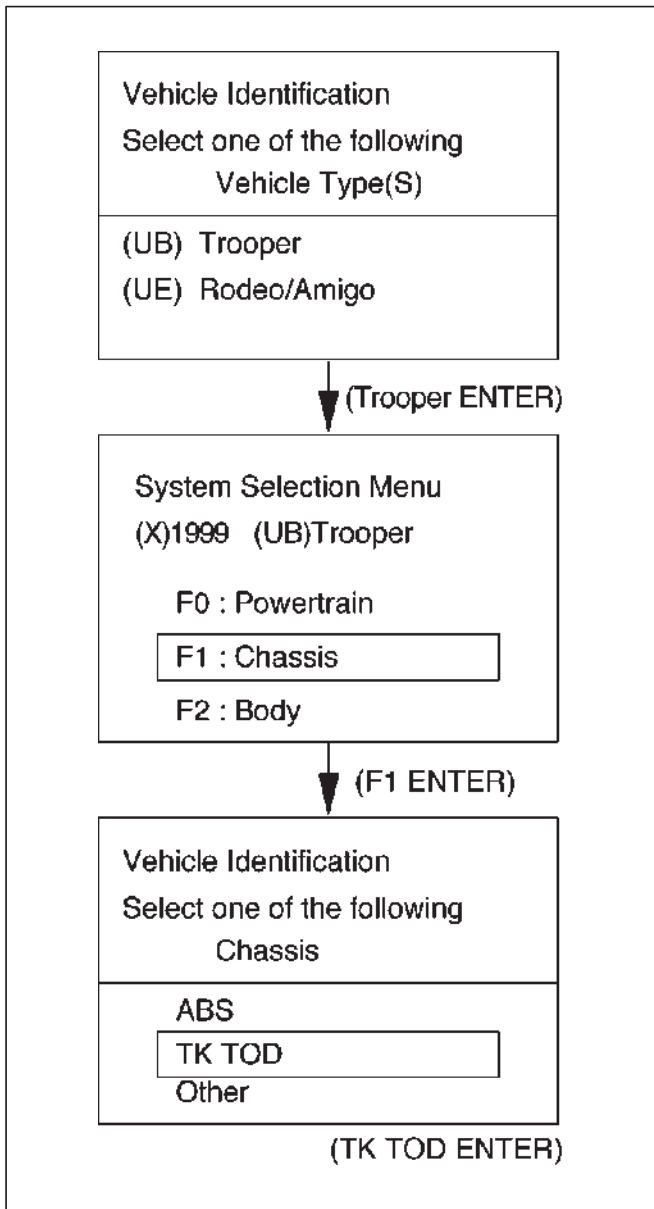
060RW009

### Operating Procedure

The power up screen is displayed when you power up the tester with the Isuzu systems PCMCIA card. Follow the operating procedure below.



060RX065



060RX062



**4B2-28 DRIVE LINE CONTROL SYSTEM (TOD)****Diagnostic Trouble Codes**

Code	Item	Diagnosis	Check flow No.
12	Start code	Normal	—
13	Ref	Shorted GND	6
14	Front speed sensor	Input abnormality (open, sig or com)	2
15	Ref	Shorted VB	6
16	Front speed sensor	Input abnormality	3
21	TPS	Shorted or disconnected wiring, abnormality in input	7
23	ECU	CPU abnormality	1
24	Rear speed sensor	Input abnormality (open, sig or com)	5
26	EMC (+)	Shorted GND	10
27	Rear speed sensor	Input abnormality	4
31	EMC (+)	Shorted or disconnected coil/wiring	9
36	ECU	CPU abnormality	1
37	ECU	CPU abnormality	1
38	ECU	CPU abnormality	1

TPS : Throttle Position Sensor  
EMC : Electromagnetic coil

## Diagnosis from Trouble Codes

- Diagnose TOD based on the fault that has been saved to the control unit according to the system self-diagnostic function.

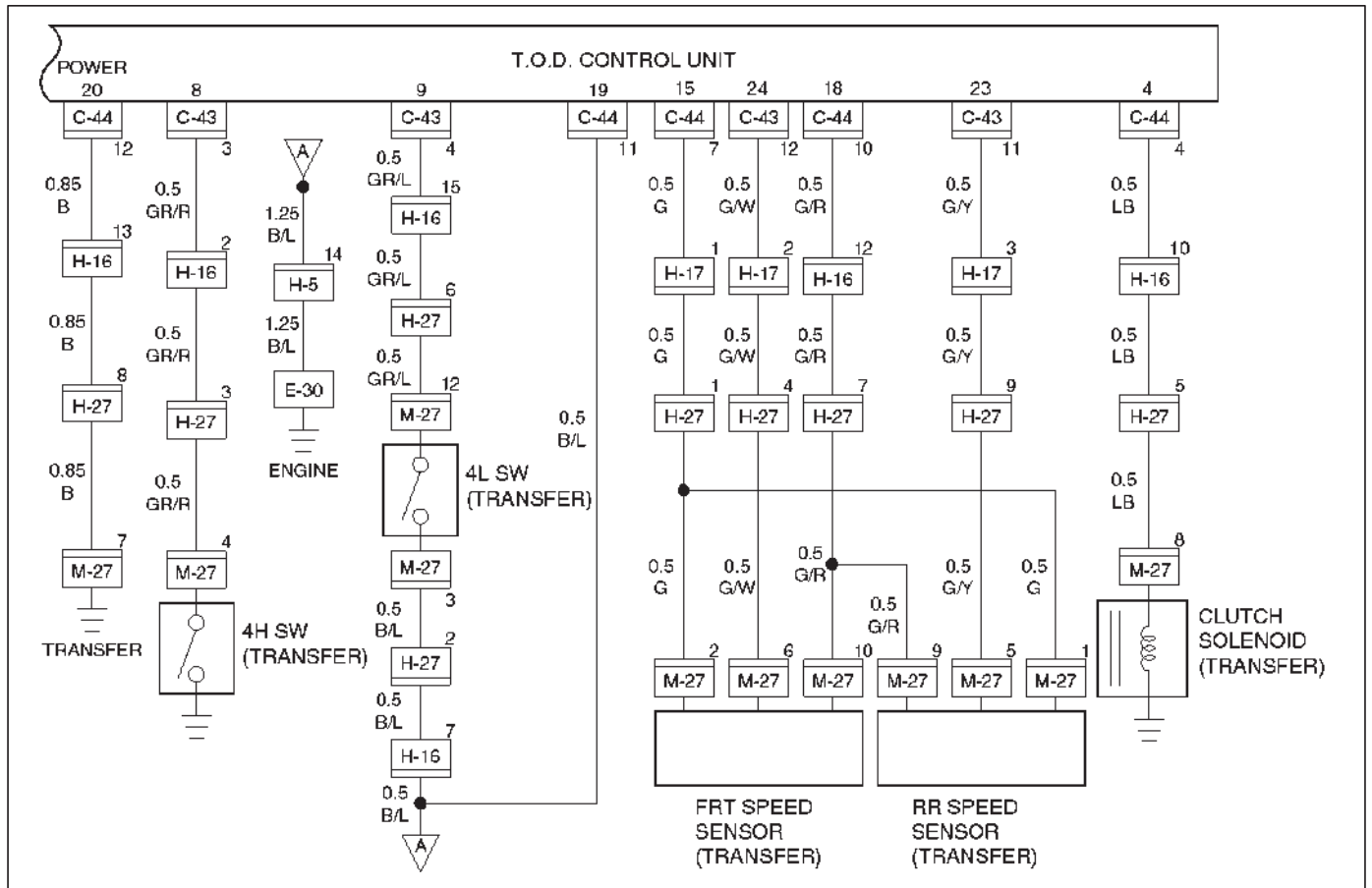
Check flow	Trouble code	Phenomenon	Standard
1	23, 36, 37, 38	The ECU is failed.	—

Step	Action	Yes	No
1	Turn on the starter switch. Is the trouble reproduced?	Replace the ECU and conduct the test run. Go to Step 3	Go to Step 2
2	1. Clear the trouble codes. 2. Conduct the test run. Is the trouble reproduced during the test run?	Replace the ECU and conduct the test run. Go to Step 3	The trouble is not reproduced. Refer to "Troubles intermittently observed". Go to Step 3
3	1. Check that all the parts are mounted. 2. Clear the trouble codes. Is this step complete?	Repeat the "Diagnosis Flow".	Return to Step 3

## 4B2-30 DRIVE LINE CONTROL SYSTEM (TOD)

Check flow	Trouble code	Phenomenon	Standard
2	14	Front speed sensor signal open or GND short, speed sensor com open.	0.3 > sensor voltage

NOTE: The following procedure shows the case that the front or rear sensor reference or common grounding line is broken.



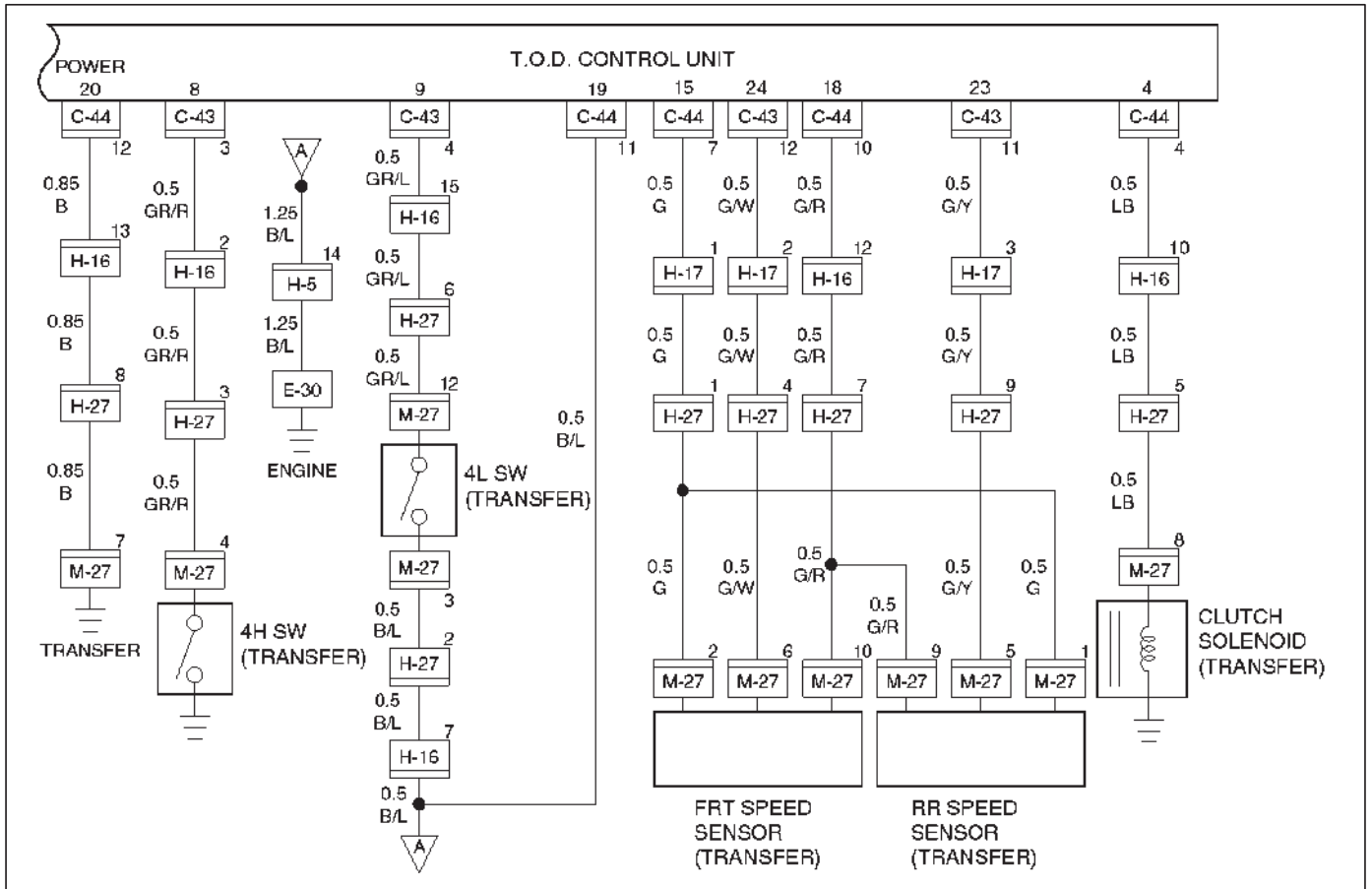
**DRIVE LINE CONTROL SYSTEM (TOD) 4B2-31**

Step	Action	Yes	No
1	1. Start the engine. 2. Select 4H (TOD) mode.  Is the memory except DTC 14?	Go to Step 3	Go to Step 2
2	Is the continuity between harness of terminal 24 and GND(vehicle side terminal of the front speed sensor)?	Replace front speed sensor. Go to Step 6	Repair the circuit. Go to Step 6
3	Is the memory DTC 24?	Go to Step 4	Refer to other trouble check flow. Go to Step 2
4	Is the continuity between harness of terminal 23, and 24 (vehicle side terminal of the front and rear speed sensor)?	Go to Step 5	Repair the circuit. Go to Step 6
5	Is the continuity between harness of terminal 18, and 15 (vehicle side terminal of the speed sensor COM and ref)?	Replace front and rear speed sensor. Go to Step 6	Repair the circuit. Go to Step 6
6	1. Check that all the parts are mounted. 2. Clear the trouble code.  Is the step complete?	Repeat the "Diagnosis Flow".	The trouble is not reproduced. Refer to "Troubles intermittently observed". Return to Step 6

## 4B2-32 DRIVE LINE CONTROL SYSTEM (TOD)

Check flow	Trouble code	Phenomenon	Standard
3	16	The front speed sensor no pulse.	Hi level : 4.5 ~ 6.0 V Lo level : 0.7 ~ 2.0 V Frequency (F) = 832 Hz (at 50 km/h /31 MPH)

NOTE: Find the trouble in which the pulse corresponding to the running speed is not input.



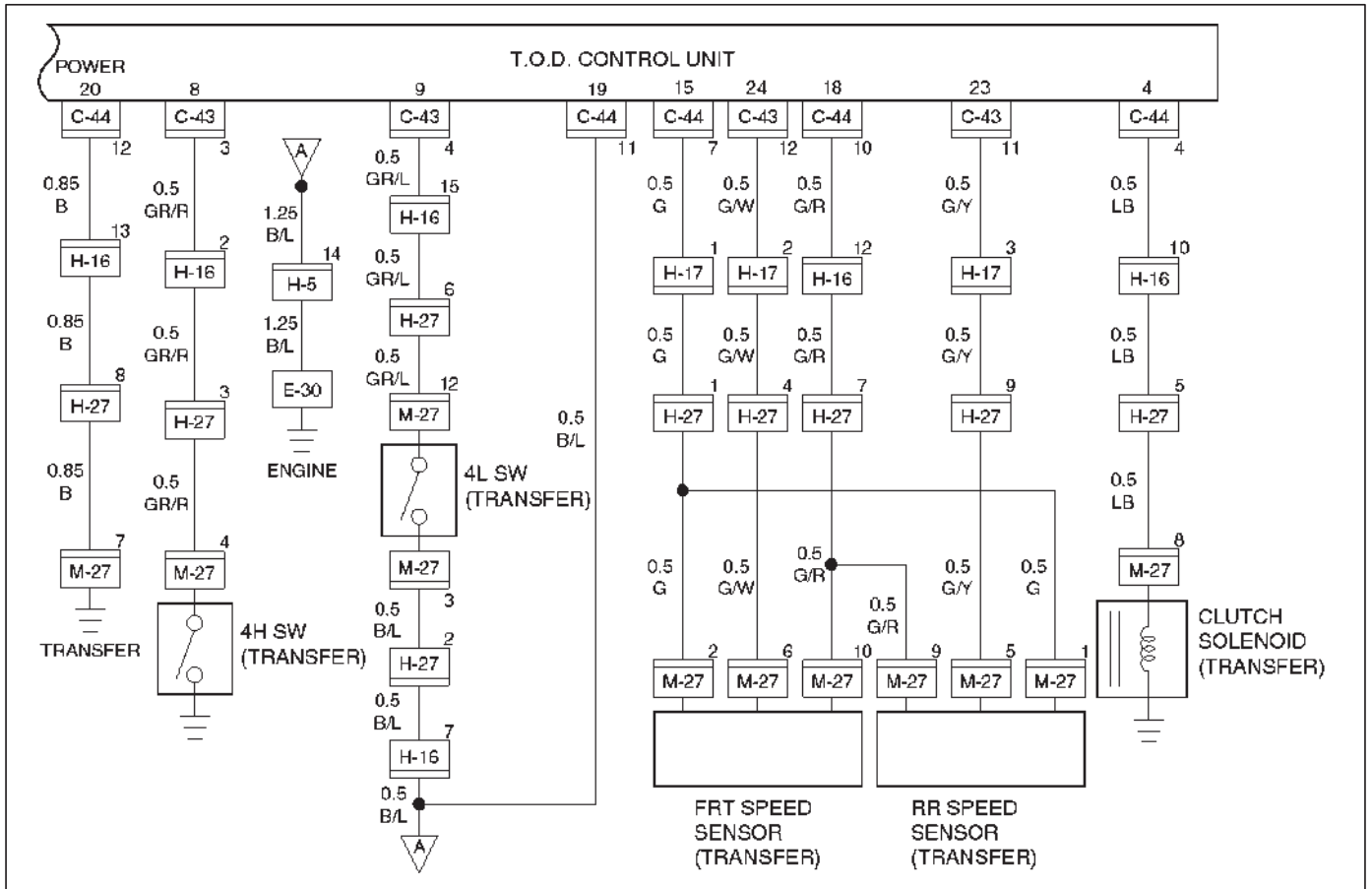
**DRIVE LINE CONTROL SYSTEM (TOD) 4B2-33**

Step	Action	Yes	No
1	1. Connect TECH 2. While running in TOD mode, does TECH-2's front speed sensor indication change with vehicle speed?	Go to Step 2	Inspect and repair front speed sensor tone wheel. Go to Step 4
2	Is the continuity harness of terminal 24 (vehicle side terminal of the front speed sensor)?	Replace speed sensor. Go to Step 3	Repair the circuit. Go to Step 3
3	1. Clear the trouble code. While running at 40 kph in TOD mode for 30 consecutive sec, is trouble code reissued?	Replace ECU. Go to Step 4	Go to Step 4
4	1. Check that all the parts are mounted. 2. Clear the trouble code. Is this step complete?	Repeat the "Diagnosis Flow".	The trouble is not reproduced. Refer to "Troubles intermittently observed". Return to Step 4

## 4B2-34 DRIVE LINE CONTROL SYSTEM (TOD)

Check flow	Trouble code	Phenomenon	Standard
4	27	The rear speed sensor no pulse.	Hi level : 4.5 ~ 6.0 V Lo level : 0.7 ~ 2.0 V Frequency (F) = 832 Hz (at 50 km/h /31 MPH)

NOTE: Find the trouble in which the pulse corresponding to the running speed is not input.



**DRIVE LINE CONTROL SYSTEM (TOD) 4B2-35**

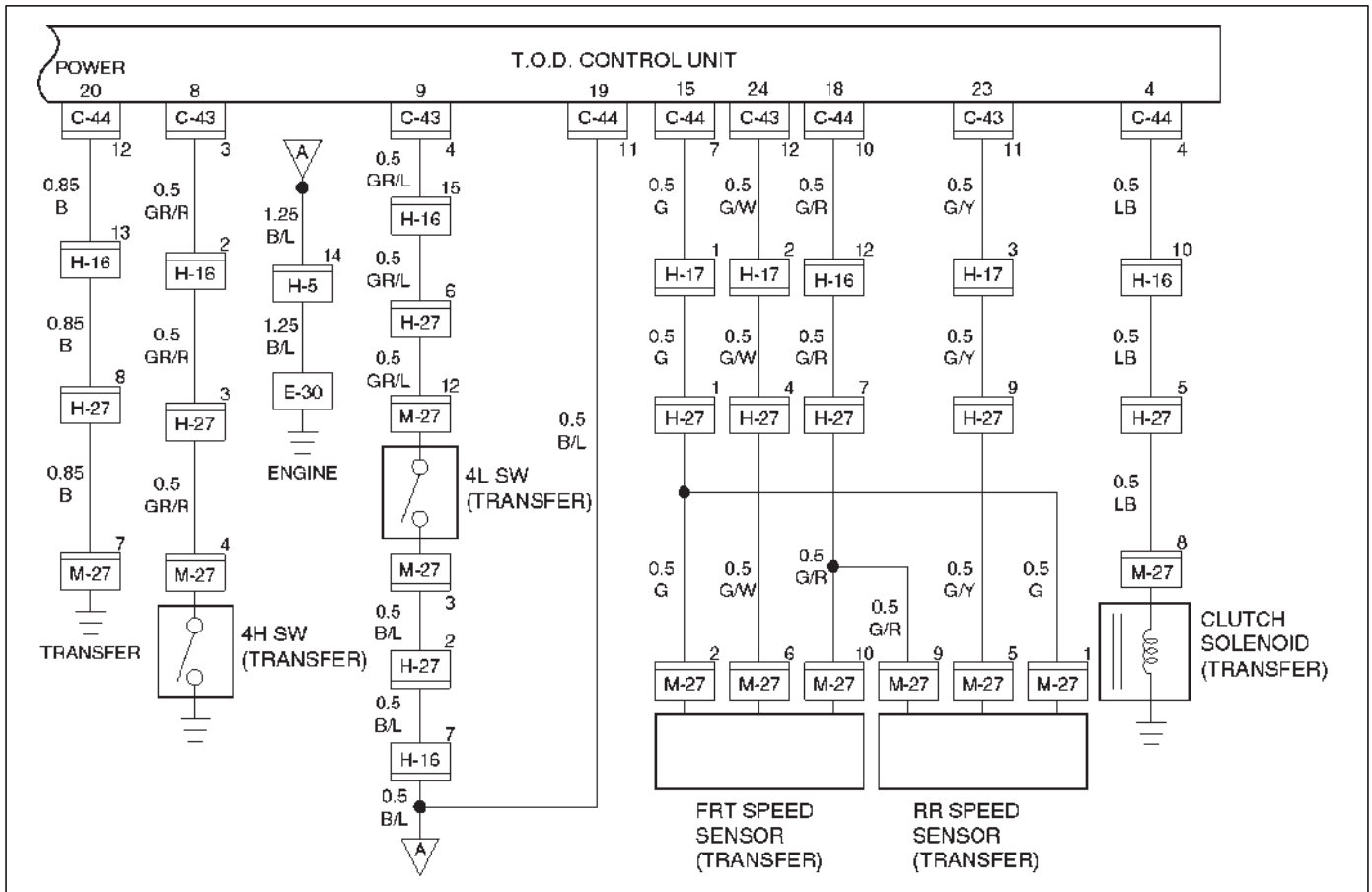
<b>Step</b>	<b>Action</b>	<b>Yes</b>	<b>No</b>
1	1. Connect TECH 2. While running in TOD mode, does TECH-2's rear speed sensor indication change with vehicle speed?	Go to Step 2	Inspect and repair front speed sensor tone wheel. Go to Step 4
2	Is the continuity harness of terminal 23 (vehicle side terminal of the rear speed sensor)?	Replace rear speed sensor. Go to Step 3	Repair the circuit. Go to Step 3
3	1. Clear the trouble code. While running at 40 kph (25 MPH) in TOD mode for 30 consecutive sec, is trouble code reissued?	Replace EUC. Go to Step 4	Go to Step 4
4	1. Check that all the parts are mounted. 2. Clear the trouble code. Is this step complete?	Repeat the "Diagnosis Flow".	The trouble is not reproduced. Refer to "Troubles intermittently observed". Return to Step 4



**4B2-36 DRIVE LINE CONTROL SYSTEM (TOD)**

Check flow	Trouble code	Phenomenon	Standard
5	24	Rear speed sensor signal open or GND short, speed sensor COM open.	0.3 > sensor voltage

NOTE: The following procedure shows the case that the front or rear sensor reference or common grounding line is broken.



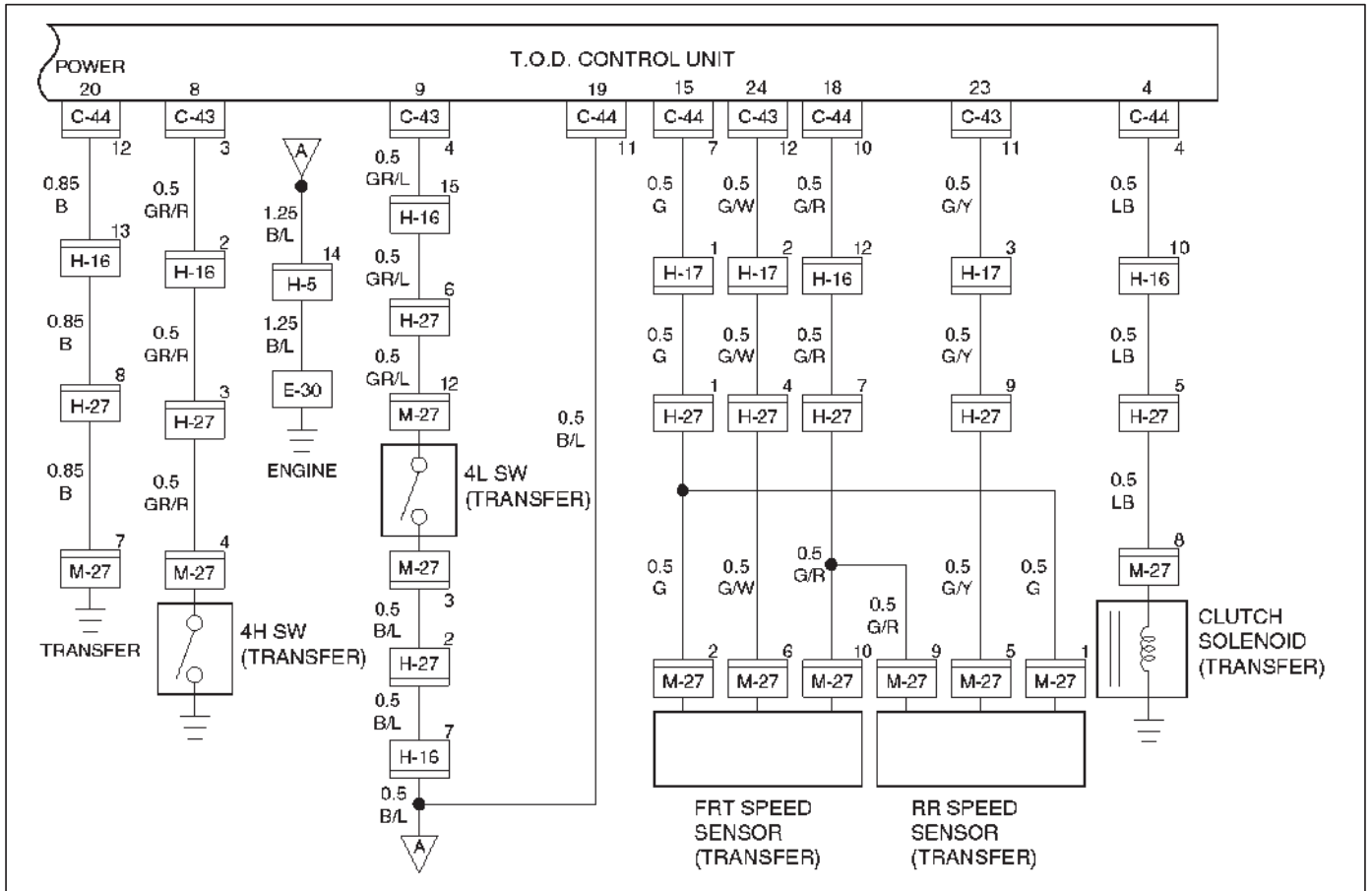
**DRIVE LINE CONTROL SYSTEM (TOD) 4B2-37**

Step	Action	Yes	No
1	1. Start the engine. 2. Select 4H (TOD) mode.  Is the memory except DTC 24?	Go to Step 3	Go to Step 2
2	Is the continuity between harness of terminal 23 and GND(vehicle side terminal of the rear speed sensor)?	Replace rear speed sensor. Go to Step 6	Repair the circuit. Go to Step 6
3	Is the memory DTC 14?	Go to Step 4	Refer to other trouble check flow. Go to Step 2
4	Is the continuity between harness of terminal 23, and 24 (vehicle side terminal of the front and rear speed sensor)?	Go to Step 5	Repair the circuit Go to Step 6
5	Is the continuity between harness of terminal 15, and 18 (vehicle side terminal of the speed sensor COM and ref)?	Replace front and rear speed sensor. Go to Step 6	Repair the circuit. Go to Step 6
6	1. Check that all the parts are mounted. 2. Clear the trouble code.  Is the step complete?	Repeat the "Diagnosis Flow".	The trouble is not reproduced. Refer to "Troubles intermittently observed". Return to Step 6

## 4B2-38 DRIVE LINE CONTROL SYSTEM (TOD)

Check flow	Trouble code	Phenomenon	Standard
6	13	The reference is short-circuited to GND.	Reference ~ 5 V
	15	The reference is short-circuited to Vb.	

If the reference wire (15) is short-circuited to GND, the speed signal is not generated. If the wire is short-circuited to the battery voltage, the signal level becomes faulty.

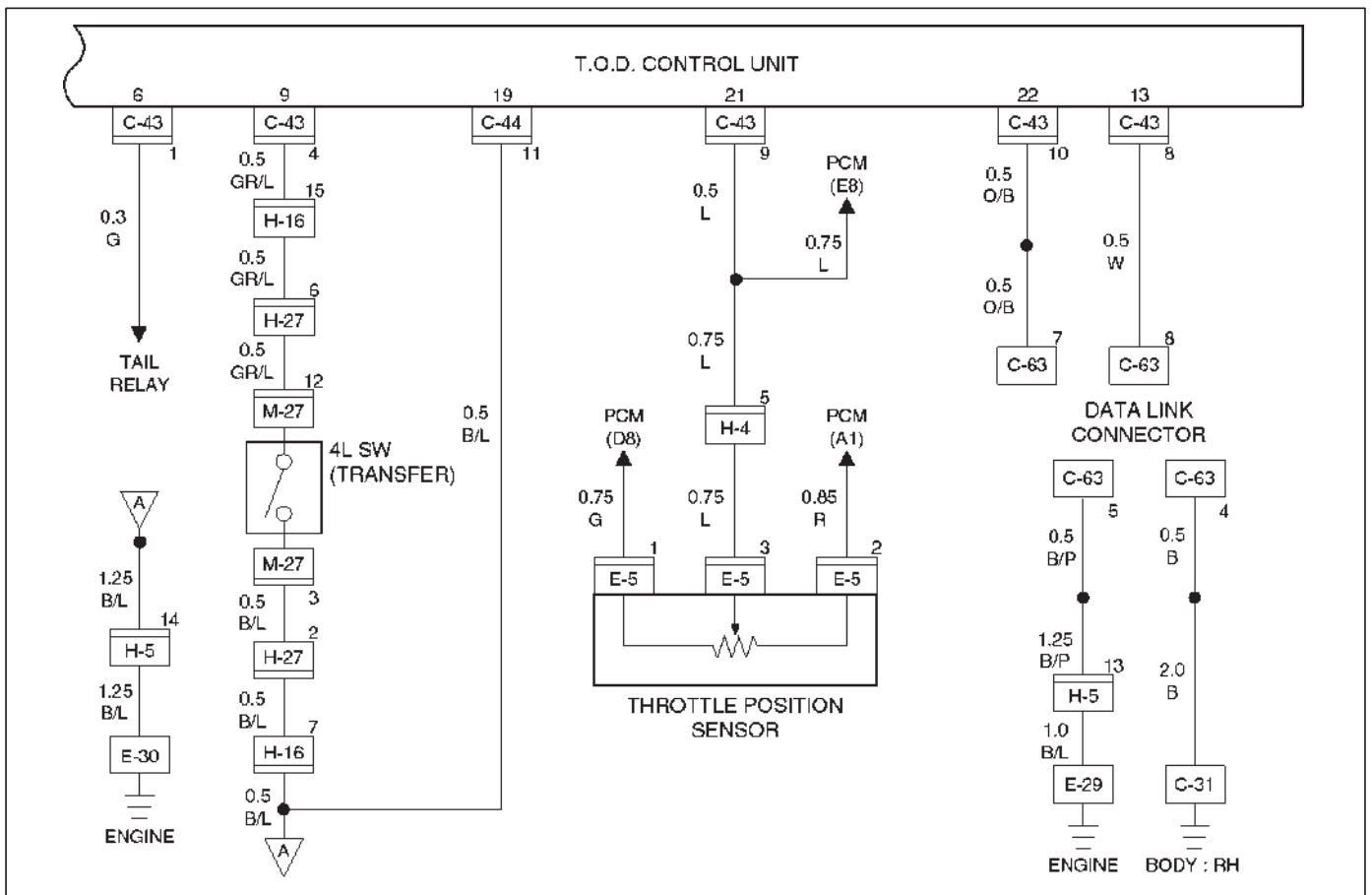


Step	Action	Yes	No
1	1. Start the engine. Does the voltage between terminals 15 and 19 meet the standard 5V?	Go to Step 8	Go to Step 2
2	Is the voltage below the standard?	Go to Step 3	Go to Step 7
3	1. Turn off the starter switch. 2. Disconnect the ECU connector. Is the continuity established between vehicle harness terminals (C-44)7 and (C-44)11?	Go to Step 4	The ECU is failed. Replace the ECU. Go to Step 8
4	1. Disconnect the H-17 connector. Is the continuity established between floor harness connector terminals (H-27)1 and (H-27)8?	Go to Step 5	Go to Step 6
5	1. Disconnect the M-27 connector. Is the continuity established between transfer harness connector terminals (M-27)2 and (M-27)7?	Replace the front speed sensor. Go to Step 8	The reference harness for the front speed sensor is short-circuited to GND. Repair the circuit. Go to Step 8
6	1. Disconnect the M-27 connector. Is the continuity established between transfer harness connector terminals (M-27)1 and (M-27)7?	Replace the rear speed sensor. Go to Step 8	The reference harness for the rear speed sensor is short-circuited to GND. Repair the circuit. Go to Step 8
7	1. Turn off the starter switch. 2. Disconnect the ECU connector. 3. Turn on the starter switch. Is the battery voltage observed between harness connector terminals (C-44)7 and (C-44)11?	Repair the harness circuit. Go to Step 8	The ECU has failed. Replace the ECU. Go to Step 8
8	1. Check that all the parts are mounted. 2. Clear the trouble code. Is this step complete?	Repeat the "Diagnosis Flow"	Go to Step 8

## 4B2-40 DRIVE LINE CONTROL SYSTEM (TOD)

Check flow	Trouble code	Phenomenon	Standard						
7	21	The voltage of the throttle position sensor (TPS) is faulty.	<table border="1"> <thead> <tr> <th></th> <th>V</th> </tr> </thead> <tbody> <tr> <td>Idling</td> <td>0.44 ~ 0.87</td> </tr> <tr> <td>Wide open throttle (WOT)</td> <td>3.7 ~ 4.6</td> </tr> </tbody> </table>		V	Idling	0.44 ~ 0.87	Wide open throttle (WOT)	3.7 ~ 4.6
	V								
Idling	0.44 ~ 0.87								
Wide open throttle (WOT)	3.7 ~ 4.6								

The signal voltage from the TPS deviates from the standard range.

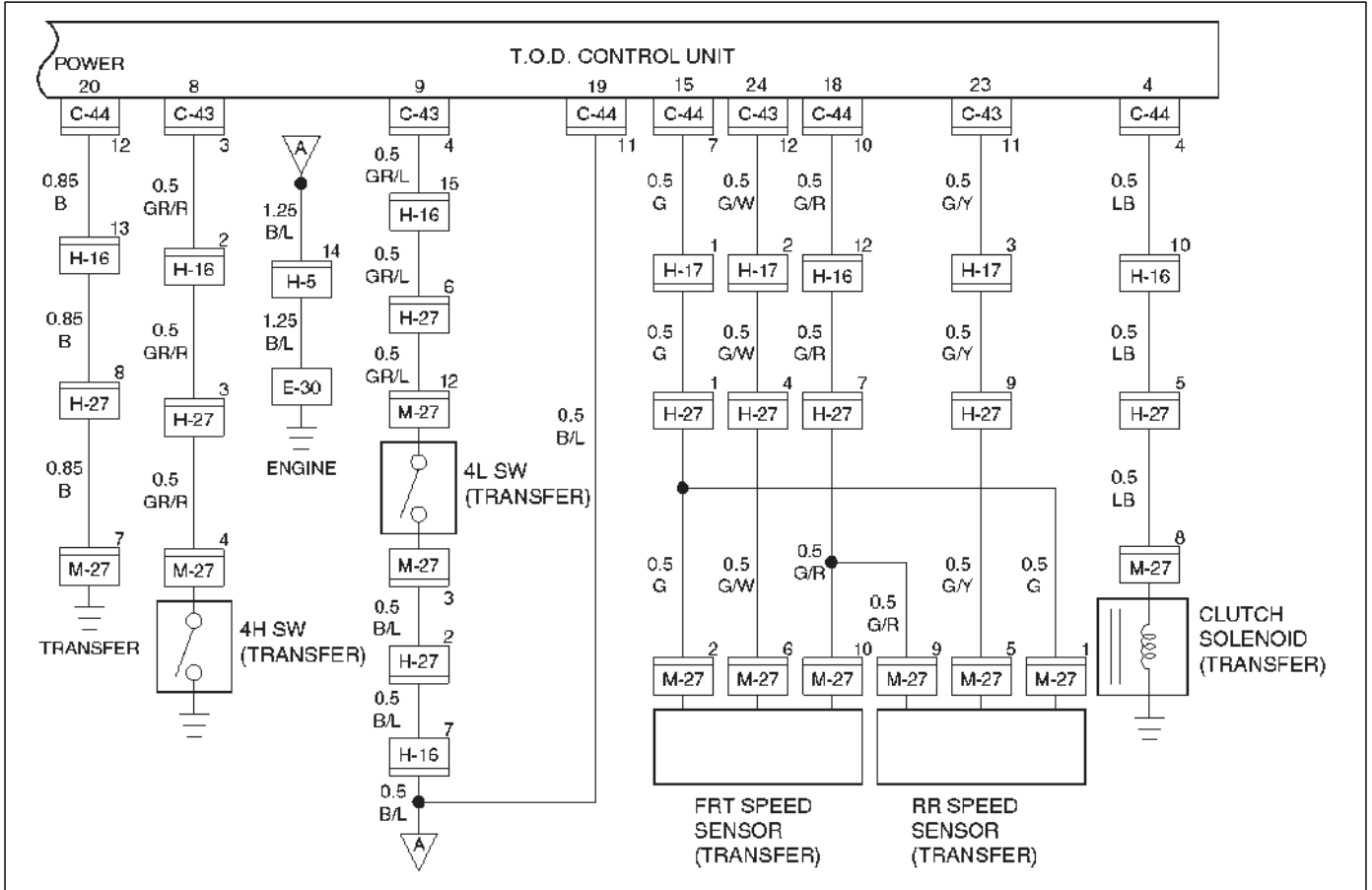


**DRIVE LINE CONTROL SYSTEM (TOD) 4B2-41**

Step	Action	Yes	No
1	1. Turn off the starter switch. Is the battery voltage normal?	Go to Step 2	Charge or replace the battery. Go to Step 6
2	1. Turn on the starter switch. Does the voltage between terminals 21 and 19 fall within the standard range above?	Go to Step 6	Go to Step 3
3	1. Turn off the starter switch. 2. Disconnect the ECU connector. 3. Turn on the starter switch. Does the voltage between terminals (C-43)9 and (C-44)11 fall within the standard range above?	The ECU has failed. Replace the ECU. Go to Step 6	Go to Step 4
4	Is the harness healthy?	Go to Step 5	Repair the harness. Go to Step 6
5	Is the TPS healthy?	Go to Step 6	Replace the TPS. Go to Step 6
6	1. Check that all the parts are mounted. 2. Clear the trouble code. Is this step complete?	Repeat the "Diagnosis Flow".	Go to Step 6

**4B2-42 DRIVE LINE CONTROL SYSTEM (TOD)**

Check flow	Trouble code	Phenomenon	Standard
9	31	The electromagnetic coil is broken.	—

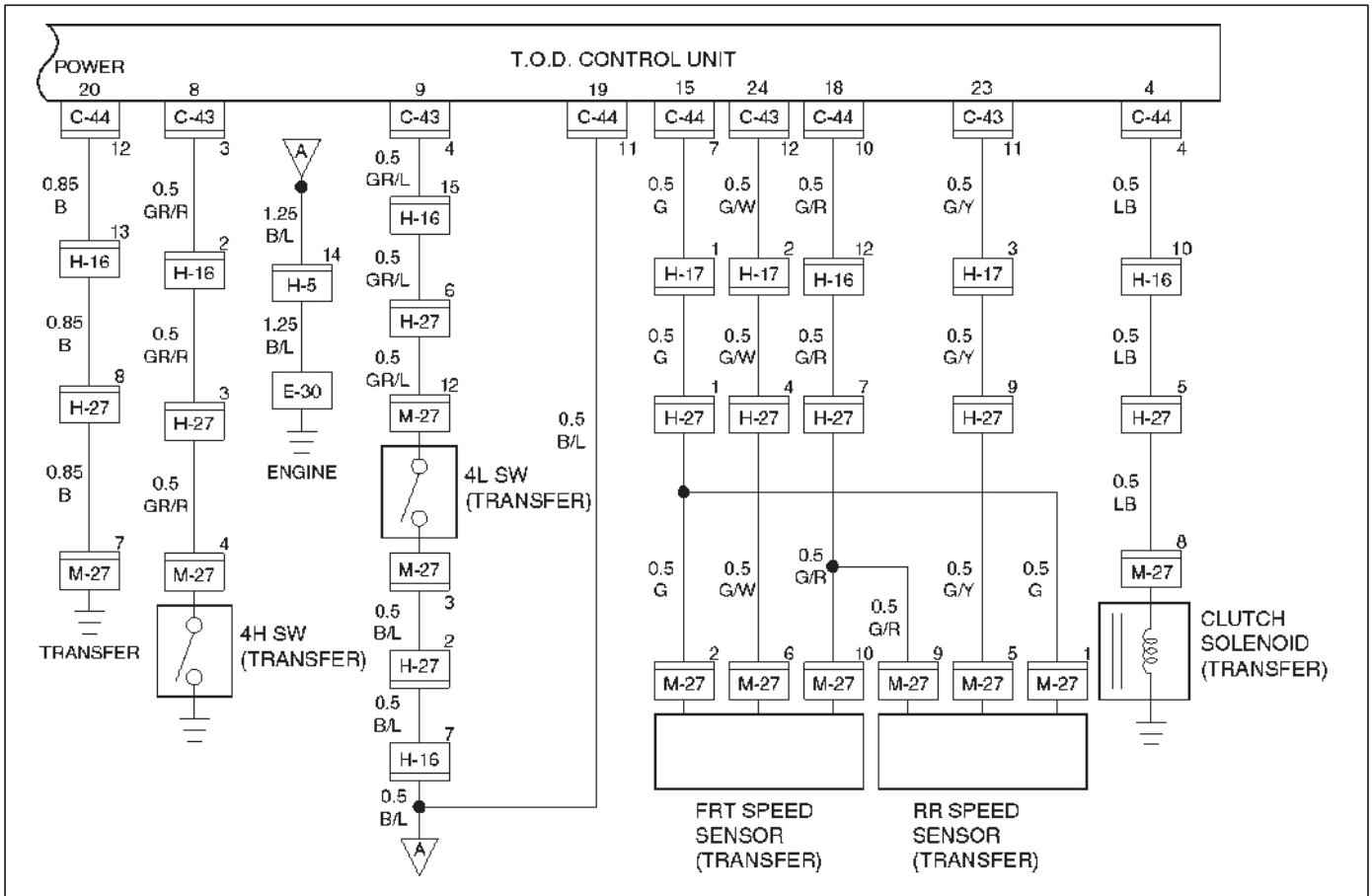


Step	Action	Yes	No
1	<p>1. Turn off the starter switch. 2. Disconnect the ECU connector from ECU.</p> <p>Is the continuity established between terminals (C-44)4 and (C-44)12?</p>	Go to Step 2	Go to Step 4
2	<p>1. Connect the ECU connector. 2. Start the engine. 3. Set the TOD mode.</p> <p>Does the voltage between terminals 4 and 20 indicate at least 0.4V?</p>	Go to Step 3	<p>The ECU has failed. Replace the ECU. Go to Step 5</p>
3	<p>Is the battery voltage always observed between terminals 4 and 20?</p>	<p>The harness is short-circuited on the battery. Repair the circuit. Go to Step 5</p>	<p>The phenomenon is not reproduced. Refer to "Troubles intermittently observed". Go to Step 5</p>
4	<p>1. Disconnect the M-27 connector.</p> <p>Is the continuity established between transfer connector terminals (M-27)8 and (M-27)7?</p>	<p>The harness is broken. Repair the circuit. Go to Step 5</p>	<p>Replace the transfer electromagnetic coil (solenoid clutch). Go to Step 5</p>
5	<p>1. Check that all the parts are mounted. 2. Clear the trouble code.</p> <p>Is this step complete?</p>	<p>Repeat the "Diagnosis Flow".</p>	Return to Step 5



# 4B2-44 DRIVE LINE CONTROL SYSTEM (TOD)

Check flow	Trouble code	Phenomenon	Standard
10	26	The electromagnetic coil GND is short-circuited.	Resistance: 1.0 to 5.0 ohm (at ordinary temperature)




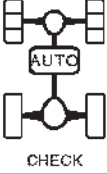
**DRIVE LINE CONTROL SYSTEM (TOD) 4B2-45**

Step	Action	Yes	No
1	1. Turn off the starter switch. 2. Disconnect the ECU connector from ECU.  Does the resistance between terminals (C-44)4 and (C-44)12 indicate 1.0 to 5.0 ohm?	Go to Step 2	Go to Step 3
2	1. Connect the ECU connector. 2. Start the engine. 3. Set the TOD mode.  When the throttle is operated between full close and full open positions, does the voltage between terminals 4 and 20 indicate at least 0.1 to 1.0 V?	The phenomenon is not reproduced. Refer to "Troubles intermittently observed". Go to Step 4	The ECU has failed. Replace the ECU. Go to Step 4
3	Does the resistance between transfer connector terminals (M-27)8 and (M-27)7 indicate 1.0 to 5.0ohm?	The harness is broken. Repair the circuit. Go to Step 4	Replace the transfer electromagnetic coil. Go to Step 4
4	1. Check that all the parts are mounted. 2. Clear the trouble code.  Is this step complete?	Repeat the "Diagnosis Flow".	Return to Step 4

## Trouble Diagnosis Depending on The Status of TOD Indicator


Functional check with TOD indicator light is conducted prior to check on Charts A-H.

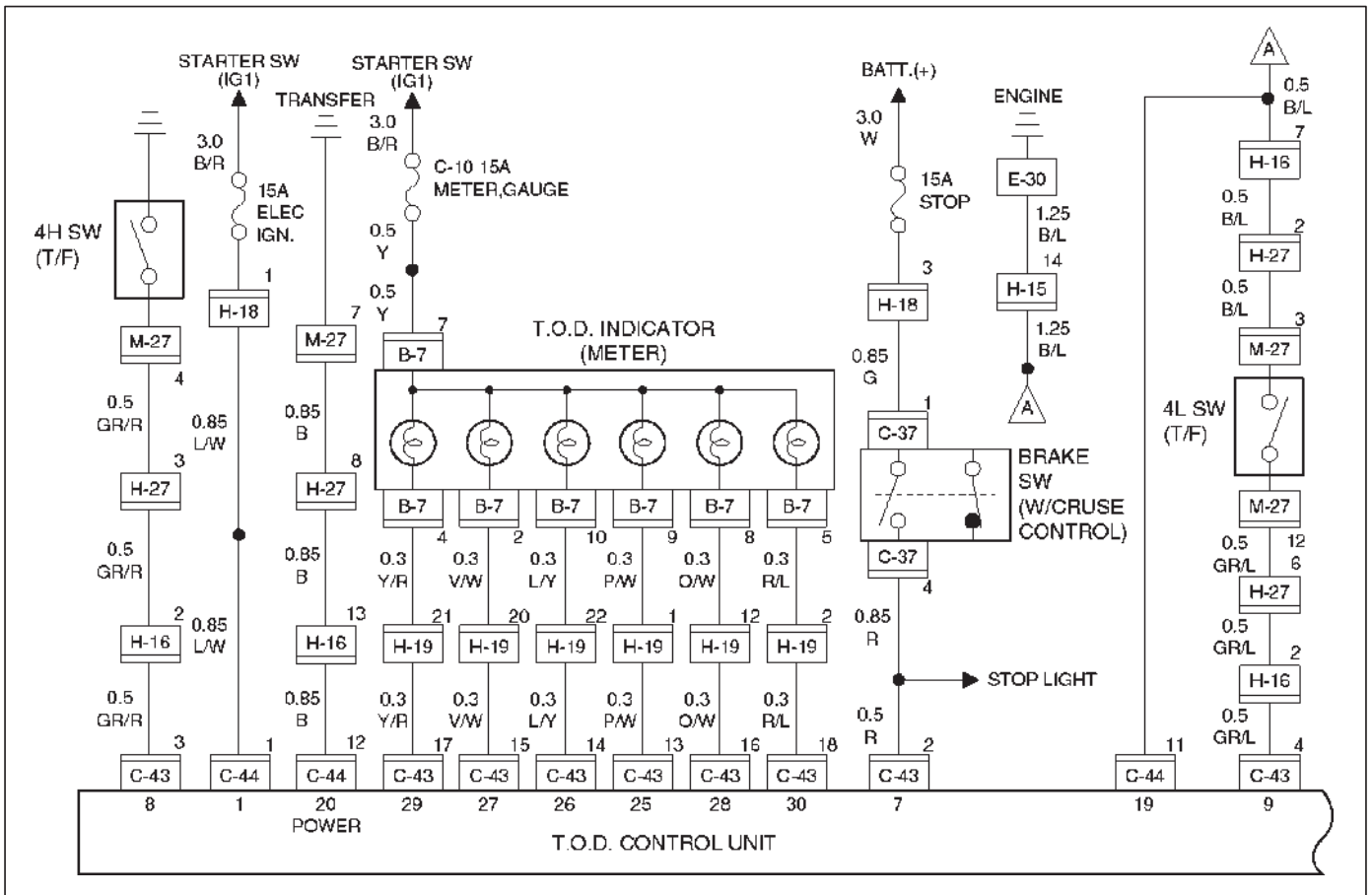
- After the starter is switched on, check and see if the status has become as tabulated below.

Is the continuity established between ECU terminal :					TOD Indicator indicate state
25 and 20	26 and 20	27 and 20	28 and 20	29 and 20	
Yes	Yes	Yes	Yes	Yes	
No	No	No	No	No	

C07RW012-1

- If the status is as tabulated above, there is no problem. If not as tabulated above, inspect the harness.

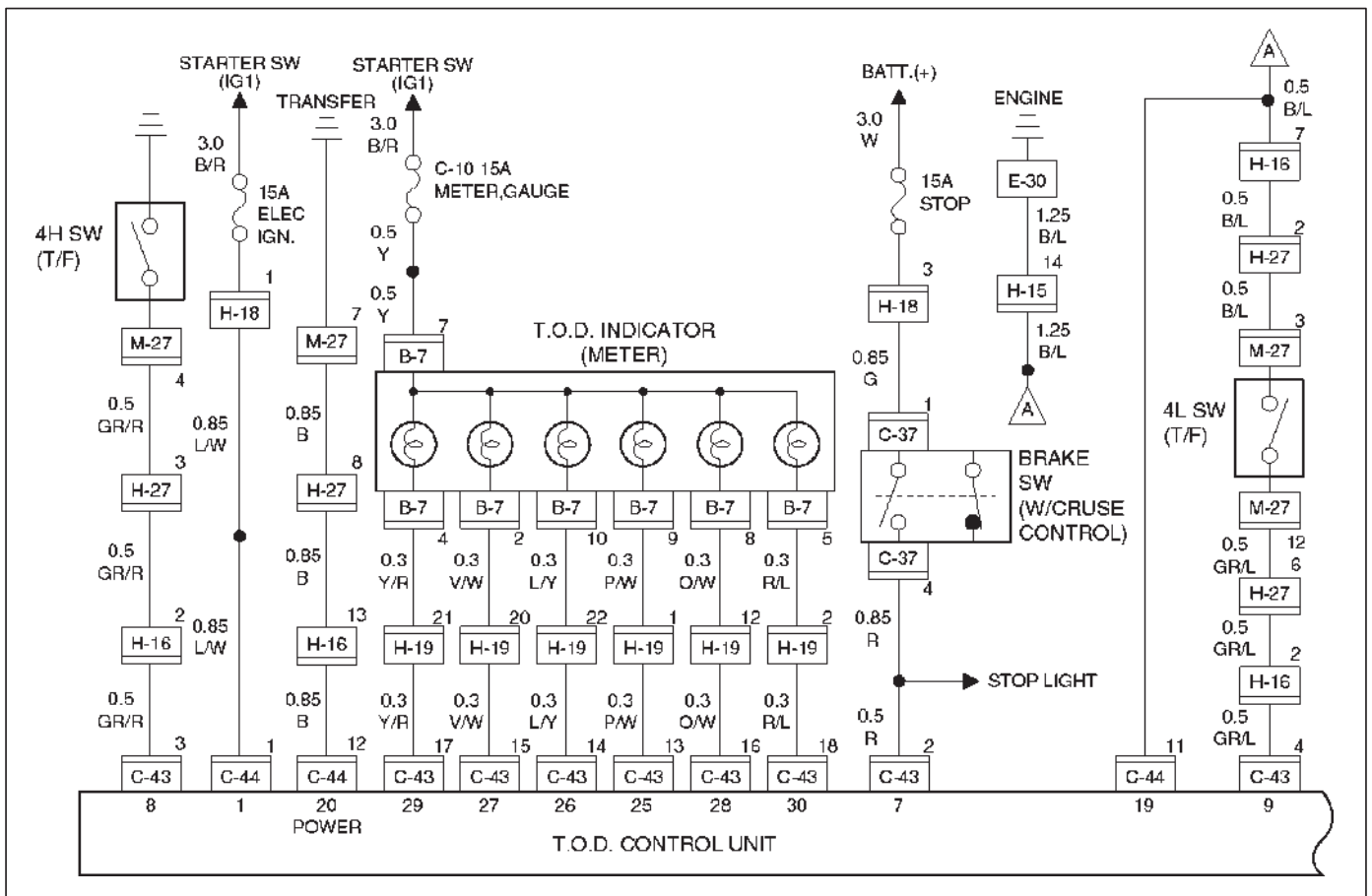
Chart A	Indicator drive circuit	
Function of circuit	The circuit informs the indicator of the working condition of the ECU.	
Fail condition	All the TOD indicator lamps and CHECK lamp are lit, and go off momentarily at an interval of about two seconds.	
Indicator lamp status		—
Transfer position	TOD, 4L	—



**4B2-48 DRIVE LINE CONTROL SYSTEM (TOD)**

<b>Step</b>	<b>Action</b>	<b>Yes</b>	<b>No</b>
1	Turn on the starter switch. Is the battery voltage observed between terminals 1 and 19?	The ECU has failed. Replace the ECU. Go to Step 2	Check the battery circuit. Go to Step 2
2	Check that all the parts are mounted. Is this step complete?	Repeat the "Diagnosis Flow".	Return to Step 2

Chart C-1	4H switch circuit wires are broken or the battery is short-circuited.
Function of circuit	—
Fail condition	When the lever is shifted from 4L to TOD, the 4L mode remains on the indicator and the TOD mode is displayed without turning off the previous mode.
Indicator lamp status	
Transfer position	4L <—> Neutral <—> TOD



**4B2-50 DRIVE LINE CONTROL SYSTEM (TOD)**

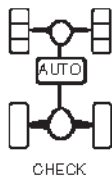
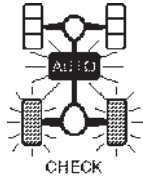
Step	Action	Yes	No
1	1. Turn on the starter switch. When the transfer lever is shifted to the high position, is 5V observed between terminals 8 and 19 (4H switch)?	Go to Step 2	Go to Step 4
2	When the transfer lever is shifted to the 4L position, is 5V observed between terminals 8 and 19 (4H switch)?	Go to Step 3	Go to Step 4
3	When the transfer lever is shifted to the neutral position, is 0V observed between terminals 8 and 19 (4H switch)?	Replace the ECU. Go to Step 4	Go to Step 4
4	1. Turn off the starter switch. 2. Disconnect the ECU connector. 3. Turn on the starter switch. When the transfer lever is shifted to the high position, is 12V observed between terminals 8 and 19 (4H switch)?	Go to Step 5	Go to Step 7
5	When the transfer lever is shifted to the neutral position, is 0V observed between terminals 8 and 19 (4H switch)?	Go to Step 6	Go to Step 7
6	When the transfer lever is shifted to the 4L position, is 12V observed between terminals 8 and 19 (4H switch)?	The 4H switch circuit battery is short-circuited between ECU and transfer. Repair the circuit. Go to Step 14	Go to Step 7
7	Turn off the starter switch. When the transfer lever is shifted to the neutral position, is the continuity established between terminals 8 and 19 (4H switch)?	Go to Step 8	Go to Step 10
8	When the transfer lever is shifted to the high position, is the continuity established between terminals 8 and 19?	Go to Step 10	Go to Step 9
9	When the transfer lever is shifted to the 4L position, is the continuity established between terminals 8 and 19?	Go to Step 14	The phenomenon is not reproduced. Refer to "Troubles intermittently observed". Go to Step 10
10	When the transfer lever is shifted to the neutral position, is the continuity established between terminals (M-27)4 and (M-27)7?	Go to Step 11	Repair the transfer assembly. Go to Step 14
11	When the transfer lever is shifted to the high position, is the continuity established between transfer connector terminals (M-27)4 and (M-27)7?	Repair the transfer assembly. Go to Step 14	Go to Step 12
12	When the transfer lever is shifted to the 4L position, is the continuity established between transfer connector terminals (C-43)3 and (M-27)4?	Repair the transfer assembly. Go to Step 14	Go to Step 13

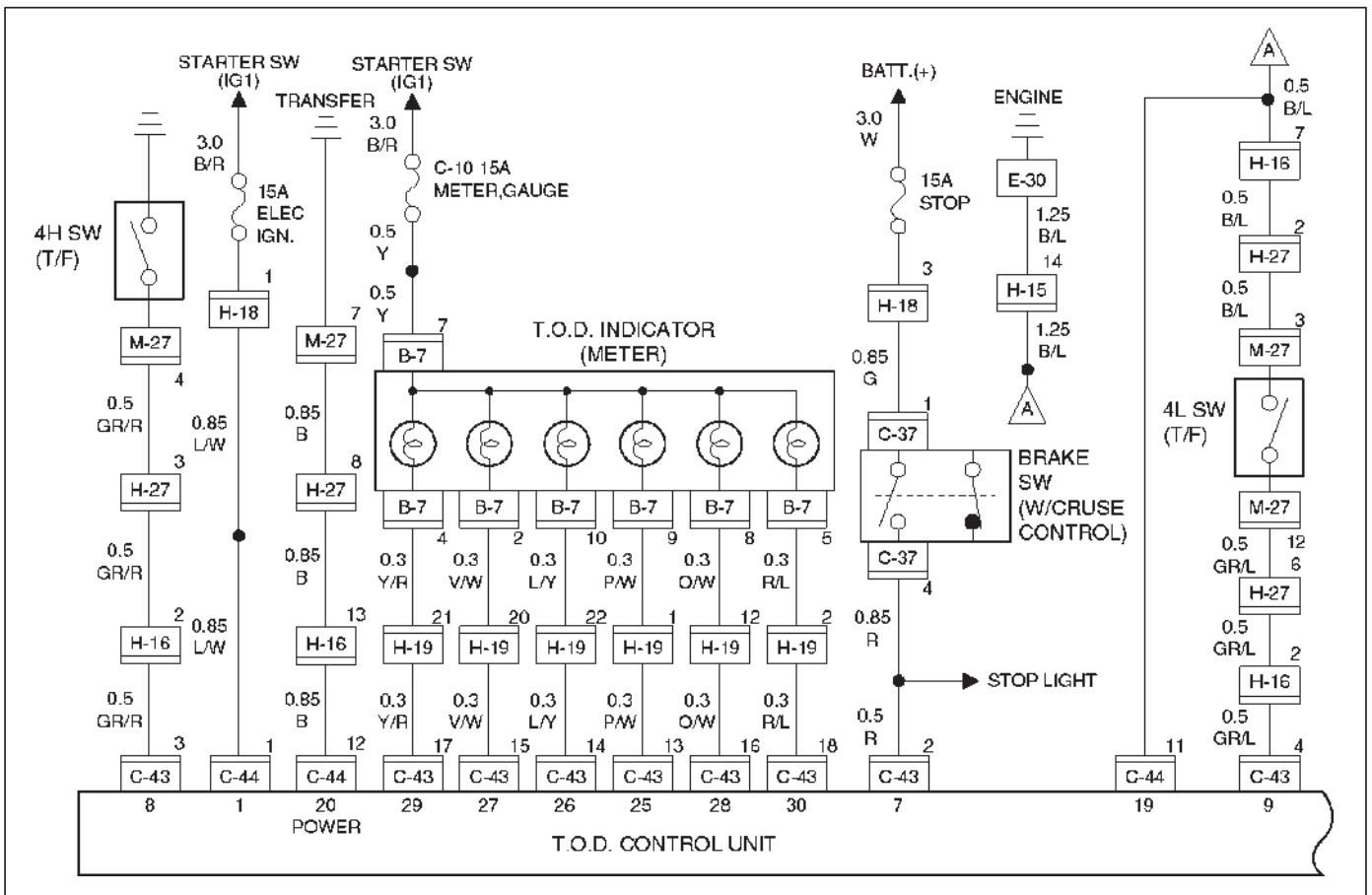
**DRIVE LINE CONTROL SYSTEM (TOD) 4B2-51**

<b>Step</b>	<b>Action</b>	<b>Yes</b>	<b>No</b>
13	Is the continuity established between transfer terminals (M-27)4 and body?	The ECU has failed. Replace the ECU. Go to Step 14	The harness is broken between terminal (M-27)4 and GND. Repair the circuit. Go to Step 14
14	Check that all the parts are mounted. Is this step complete?	Repeat the "Diagnosis Flow".	Return to Step 14



**4B2-52 DRIVE LINE CONTROL SYSTEM (TOD)**

Chart C-2	The 4H switch circuit is short-circuited to GND.	
Function of circuit	—	
Fail condition	When the transfer lever is shifted to 4L, the indicator lamp status is not changed. When the transfer lever is shifted to High, the indicator lamp blinks at TOD mode.	
Indicator lamp status	 <p>CHECK</p>	 <p>CHECK</p> <p>Blinking</p>
Transfer position	4L	High (TOD)

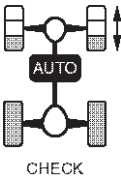
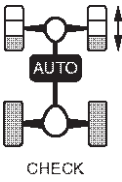


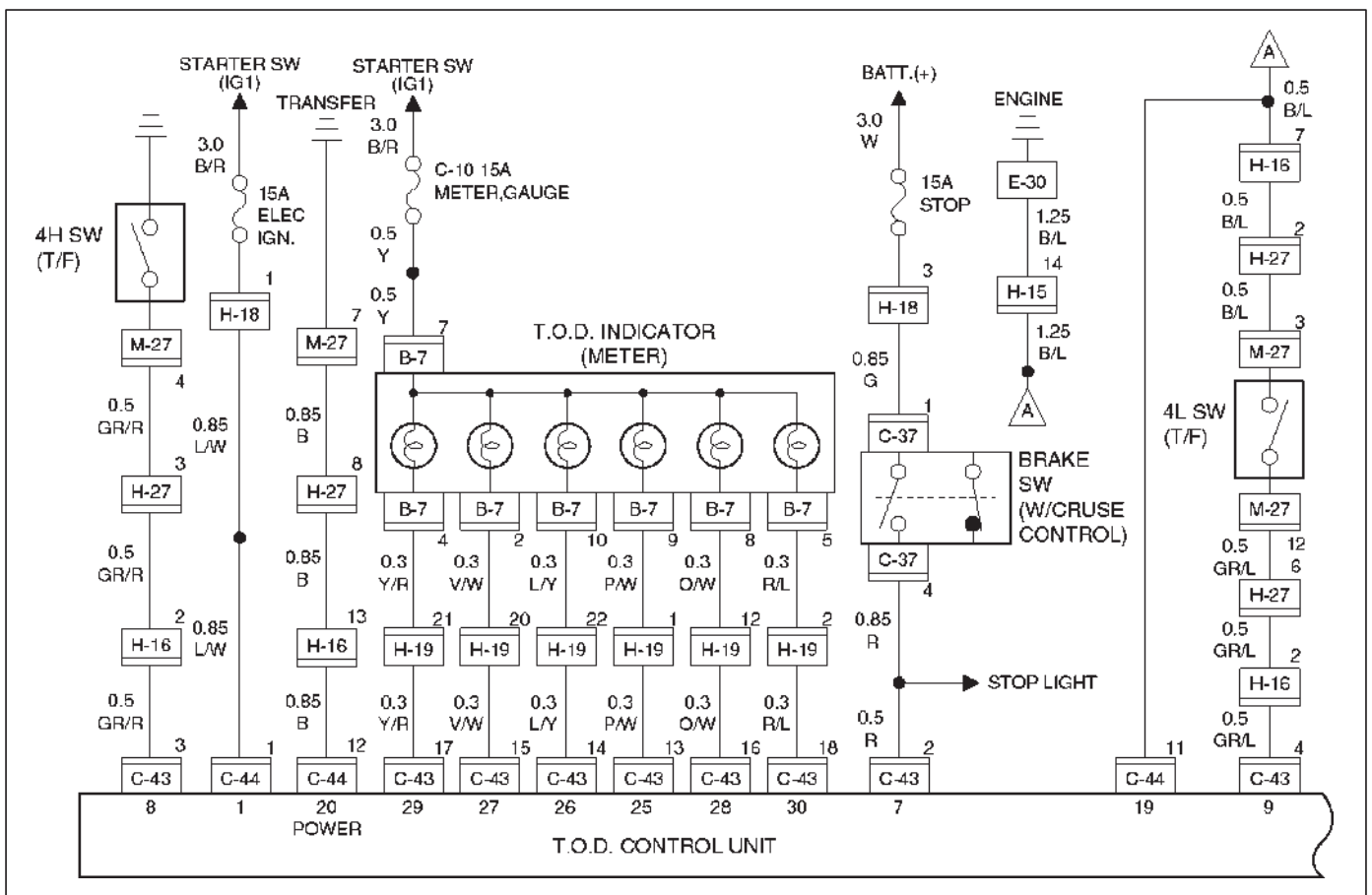
**DRIVE LINE CONTROL SYSTEM (TOD) 4B2-53**

<b>Step</b>	<b>Action</b>	<b>Yes</b>	<b>No</b>
1	When the transfer lever is shifted to the High position, is 5V observed between terminals 8 and 19 (4H switch)?	Go to Step 2	Go to Step 14
2	When the transfer lever is shifted to the neutral position, is 0V observed between terminals 8 and 19 (4H switch)?	Go to Step 3	Go to Step 14
3	When the transfer lever is shifted to the 4L position, is 5V observed between terminals 8 and 19 (4H switch)?	Go to Step 4	Go to Step 14
4	1. Turn off the starter switch. Is the continuity established between terminals 1 and 25?	Go to Step 5	Replace TOD indicator lamp bulb. Go to Step 23
5	Is the continuity established between terminals 1 and 26?	Go to Step 6	Replace TOD indicator lamp bulb. Go to Step 23
6	Is the continuity established between terminals 1 and 27?	Go to Step 7	Replace TOD indicator lamp bulb. Go to Step 23
7	Is the continuity established between terminals 1 and 28?	Go to Step 8	Replace TOD indicator lamp bulb. Go to Step 23
8	Is the continuity established between terminals 1 and 29?	Go to Step 9	Replace TOD indicator lamp bulb. Go to Step 23
9	1. Turn on the starter switch. 2. Shift the transfer lever is shifted to the 4L position. Is 0 V observed between terminals 25 and 20?	Go to Step 10	The ECU has failed. Replace the ECU. Go to Step 23
10	Is 0 V observed between terminals 26 and 20?	Go to Step 11	The ECU has failed. Replace the ECU. Go to Step 23
11	Is 0 V observed between terminals 27 and 20?	Go to Step 12	The ECU has failed. Replace the ECU. Go to Step 23
12	Is 12 V observed between terminals 28 and 20?	Go to Step 13	The ECU has failed. Replace the ECU. Go to Step 23
13	Is 0 V observed between terminals 29 and 20?	The phenomenon is not reproduced. Refer to "Troubles intermittently observed". Go to Step 23	The ECU has failed. Replace the ECU. Go to Step 23

**4B2-54 DRIVE LINE CONTROL SYSTEM (TOD)**

Step	Action	Yes	No
14	1. Turn off the starter switch. 2. Disconnect the ECU connector.  When the transfer lever is shifted to the neutral position, is the continuity established between terminals (C-43)3 and (C-44)11 (4H switch)?	Go to Step 15	Go to Step 17
15	When the transfer lever is shifted to the high position, is the continuity established between terminals (C-43)3 and (C-44)11?	Go to Step 17	Go to Step 16
16	When the transfer lever is shifted to the 4L position, is the continuity established between terminals (C-43)3 and (C-44)11?	The ECU has failed. Replace the ECU. Go to Step 23	Go to Step 17
17	1. Disconnect the H-27 connector.  When the transfer lever is shifted to the neutral position between high and 4L, is the continuity established between terminals (H-27)3 and (C-43)3?	Go to Step 18	Go to Step 20
18	When the transfer lever is shifted to the high position, is the continuity established between transfer connector terminals (H-27)3 and (C-43)3?	Go to Step 20	Go to Step 19
19	When the transfer lever is shifted to the 4L position, is the continuity established between transfer connector terminals (H-27)3 and (C-43)3?	Go to Step 20	GND is short-circuited between terminals (C-43)3 and (H-27)3. Repair the circuit. Go to Step 23
20	1. Disconnect the M-27 connector.  When the transfer lever is shifted to the neutral position between high and 4L, is the continuity established between terminals (M-27)4 and (C-43)3?	Go to Step 21	Repair the transfer assembly. Go to Step 23
21	When the transfer lever is shifted to the high position, is the continuity established between terminals (M-27)4 and (C-43)3?	Repair the transfer assembly. Go to Step 23	Go to Step 22
22	When the transfer lever is shifted to the 4L position, is the continuity established between terminals (M-27)4 and (C-43)3?	Repair the transfer assembly. Go to Step 23	GND is short-circuited between terminals (C-43)3 and (M-27)4. Repair the circuit. Go to Step 23
23	Check that all the parts are mounted. Is this step complete?	Repeat the "Diagnosis Flow".	Return to Step 23

Chart D-1	4L switch circuit wires are broken or the battery is short-circuited.	
Function of circuit	—	
Fail condition	The TOD mode is displayed in the neutral position between high and 4L. When the lever is shifted to the 4L position, the TOD mode is displayed.	
Indicator lamp status		
Transfer position	4L	Neutral



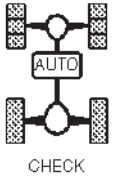
**4B2-56 DRIVE LINE CONTROL SYSTEM (TOD)**

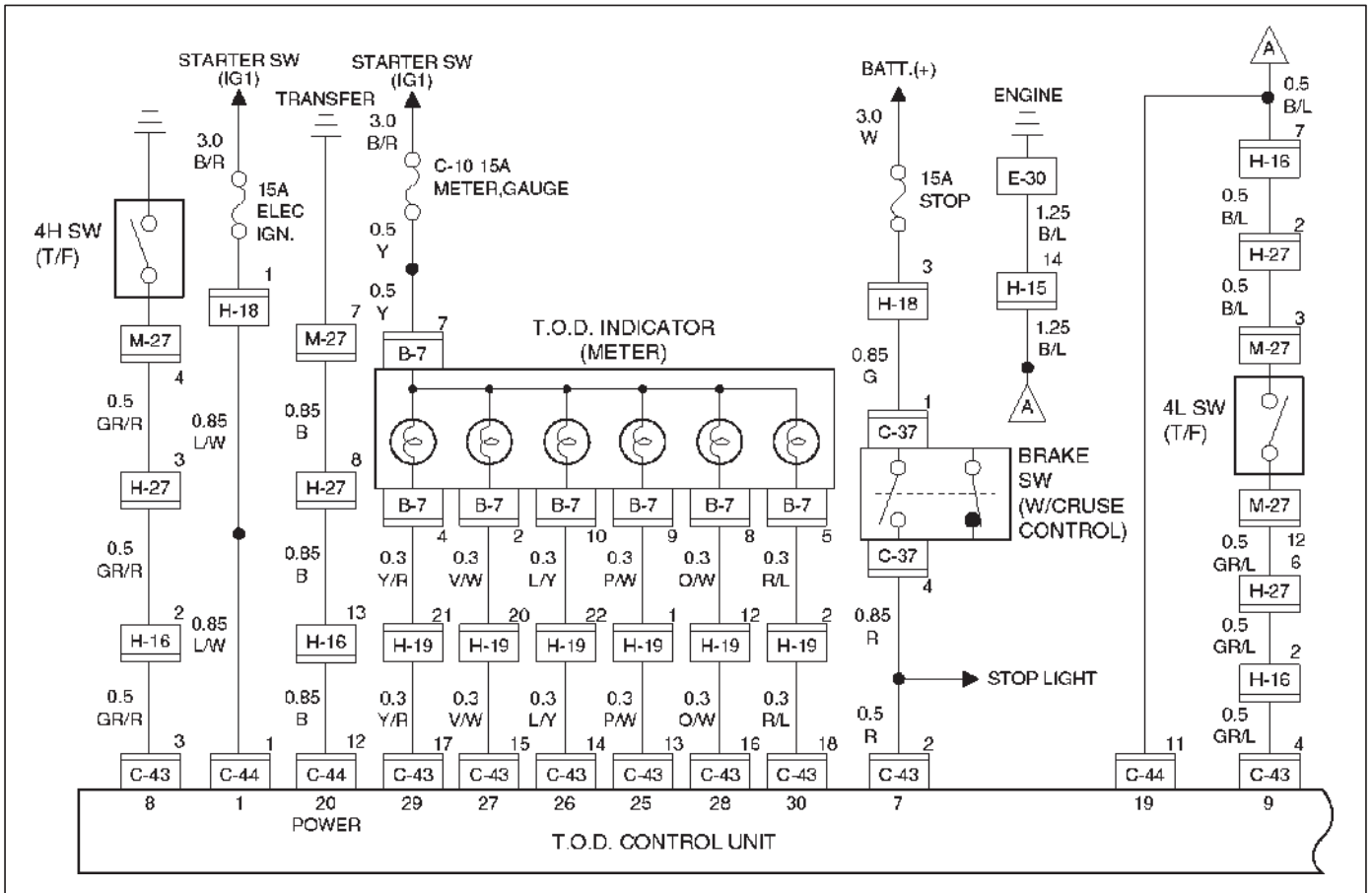
Step	Action	Yes	No
1	Turn on the starter switch. When the transfer lever is shifted to the high position, is 5V observed between terminals 9 and 19 (4L switch)?	Go to Step 2	Go to Step 4
2	When the transfer lever is shifted to the neutral position, is 0V observed between terminals 9 and 19 (4L switch)?	Go to Step 3	Go to Step 4
3	When the transfer lever is shifted to the 4L position, is 0V observed between terminals 9 and 19 (4L switch)?	The ECU has failed. Replace the ECU. Go to Step 4	Go to Step 4
4	1. Turn off the starter switch. 2. Disconnect the ECU connector. 3. Turn on the starter switch. When the transfer lever is shifted to the high position, is 12V observed between terminals (C-43)4 and (C-44)11 (4L switch)?	Go to Step 5	Go to Step 7
5	When the transfer lever is shifted to the neutral position, is 0V observed between terminals (C-43)4 and (C-44)11 (4L switch)?	Go to Step 6	Go to Step 7
6	When the transfer lever is shifted to the 4L position, is 0V observed between terminals (C-43)4 and (C-44)11 (4L switch)?	The 4L switch circuit battery is short-circuited between ECU and transfer. Repair the circuit Go to Step 13	Go to Step 7
7	Turn off the starter switch. When the transfer lever is shifted to the high position, is the continuity established between terminals (C-43)3 and (C-44)11 (4H switch)?	Go to Step 10	Go to Step 8
8	When the transfer lever is shifted to the neutral position between high and 4L, is the continuity established between terminals (C-43)4 and (C-44)11 (4L switch)?	Go to Step 9	Go to Step 10
9	When the transfer lever is shifted to the 4L position, is the continuity established between terminals (C-43)4 and (C-44)11 (4L switch)?	The phenomenon is not reproduced. Refer to "Troubles intermittently observed". Go to Step 13	Go to Step 10
10	1. Disconnect the M-27 connector. When the transfer lever is shifted to the neutral position between high and 4L, is the continuity established between transfer connector terminals (M-27)12 and GND?	Wires are broken between transfer connector (M-27) and floor connector (H-27). Repair the circuit. Go to Step 11	Repair the transfer assembly. Go to Step 13
11	When the transfer lever is shifted to the 4L position, is the continuity established between transfer connector terminals (M-27)12 and GND?	Go to Step 12	Repair the transfer assembly. Go to Step 13

**DRIVE LINE CONTROL SYSTEM (TOD) 4B2-57**

<b>Step</b>	<b>Action</b>	<b>Yes</b>	<b>No</b>
12	When the transfer lever is shifted to the high position, is the continuity established between transfer connector terminals (M-27)12 and GND?	Repair the transfer assembly. Go to Step 13	Go to Step 13
13	Check that all the parts are mounted. Is this step complete?	Repeat the "Diagnosis Flow".	Return to Step 13

**4B2-58 DRIVE LINE CONTROL SYSTEM (TOD)**

Chart D-2	The 4L switch circuit is short-circuited to GND.
Function of circuit	—
Fail condition	The 4L mode is displayed even in the TOD.
Indicator lamp status	 <p style="text-align: center;">CHECK</p>
Transfer position	High (TOD)



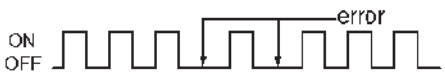
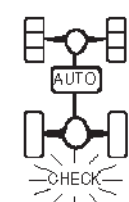
**DRIVE LINE CONTROL SYSTEM (TOD) 4B2-59**

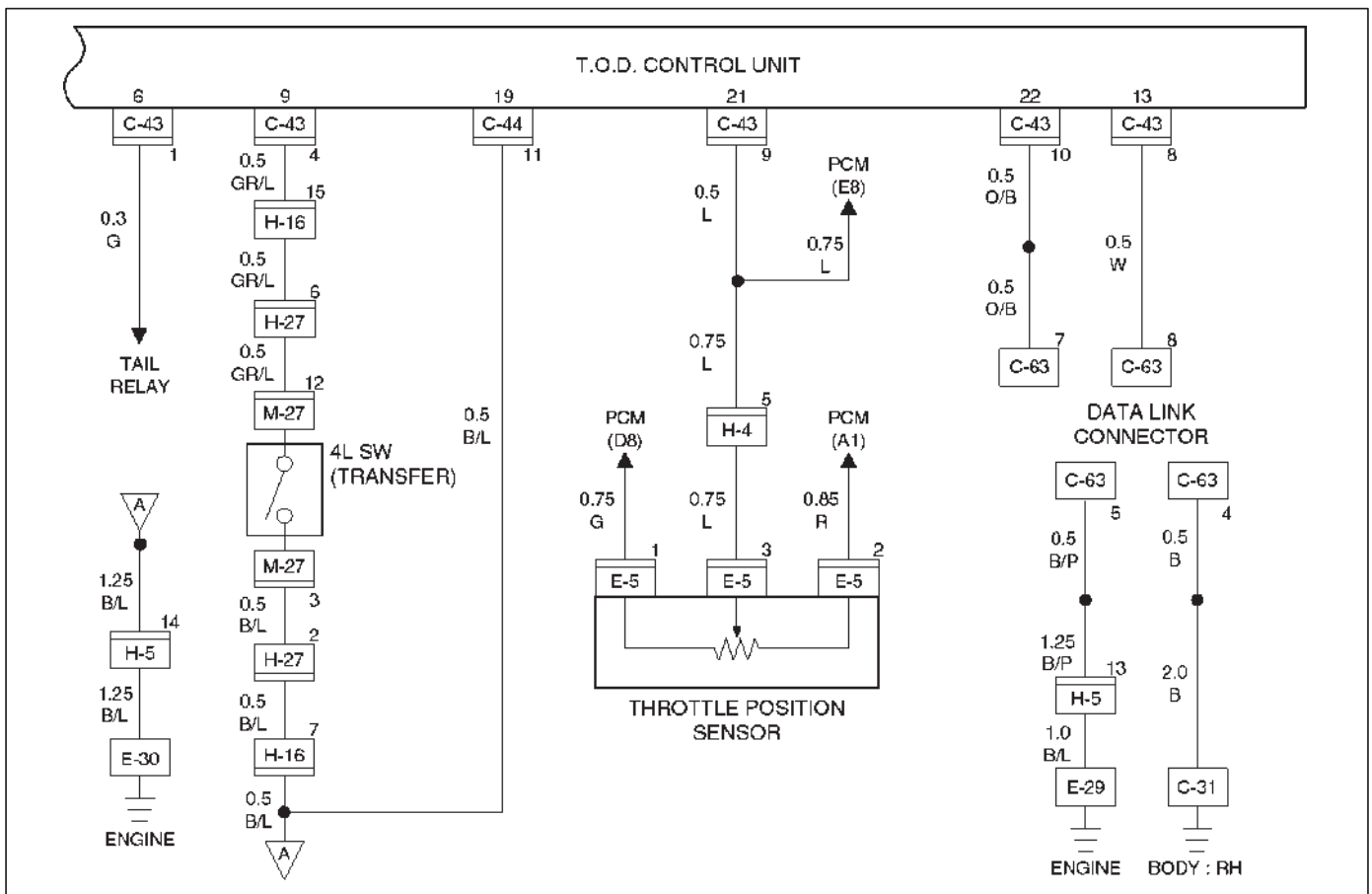
Step	Action	Yes	No
1	When the transfer lever is shifted to the high position, is 5V observed between terminals 9 and 19 (4L switch)?	Go to Step 2	Go to Step 7
2	When the transfer lever is shifted to the neutral position, is 0V observed between terminals 9 and 19 (4L switch)?	Go to Step 3	Go to Step 7
3	When the transfer lever is shifted to the 4L position, is 0V observed between terminals 9 and 19 (4L switch)?	Go to Step 4	Go to Step 7
4	1. Shift the Transfer lever to the neutral position. Is 12V observed between terminals 25 and 19?	Go to Step 5	The ECU has failed. Replace the ECU. Go to Step 16
5	Is 12V observed between terminals 26 and 19?	Go to Step 6	The ECU has failed. Replace the ECU. Go to Step 16
6	Is 12V observed between terminals 27 and 19?	The phenomenon is not reproduced. Refer to "Troubles intermittently observed". Go to Step 16	The ECU has failed. Replace the ECU. Go to Step 16
7	1. Turn off the starter switch. 2. Disconnect the ECU connector.  When the transfer lever is shifted to the neutral position between High and 4L, is the continuity established between terminals (C-43)4 and (C-44)11?	Go to Step 8	Go to Step 10
8	When the transfer lever is shifted to the 4L position, is the continuity established between terminals (C-43)4 and (C-44)11?	Go to Step 9	Go to Step 10
9	When the transfer lever is shifted to the high position, is the continuity established between terminals (C-43)4 and (C-44)11?	Go to Step 10	The ECU has failed. Replace the ECU. Go to Step 16
10	1. Disconnect the H-27 connector.  When the transfer lever is shifted to the neutral position between high and 4L, is the continuity established between terminals (H-27)6 and (C-44)11?	Go to Step 11	Go to Step 13
11	When the transfer lever is shifted to the 4L position, is the continuity established between transfer connector terminals (H-27)6 and (C-44)11?	Go to Step 12	Go to Step 13
12	When the transfer lever is shifted to the high position, is the continuity established between terminals (H-27)6 and (C-44)11?	Go to Step 13	GND is short-circuited between terminals (C-43)4 and (H-27)6. Repair the circuit. Go to Step 16
13	1. Disconnect the M-27 connector.  When the transfer lever is shifted to the neutral position between high and 4L, is the continuity established between terminals (M-27)12 and GND?	Go to Step 14	Repair the transfer assembly. Go to Step 16



**4B2-60 DRIVE LINE CONTROL SYSTEM (TOD)**

<b>Step</b>	<b>Action</b>	<b>Yes</b>	<b>No</b>
14	When the transfer lever is shifted to the 4L position, is the continuity established between terminals (M-27)12 and GND?	Go to Step 15	Repair the transfer assembly. Go to Step 16
15	When the transfer lever is shifted to the high position, is the continuity established between terminals (H-27)6 and GND?	Repair the transfer assembly. Go to Step 16	GND is short-circuited between terminals (H-27)6 and (M-27)12. Repair the circuit. Go to Step 16
16	Check that all the parts are mounted. Is this step complete?	Repeat the "Diagnosis Flow".	Return to Step 16

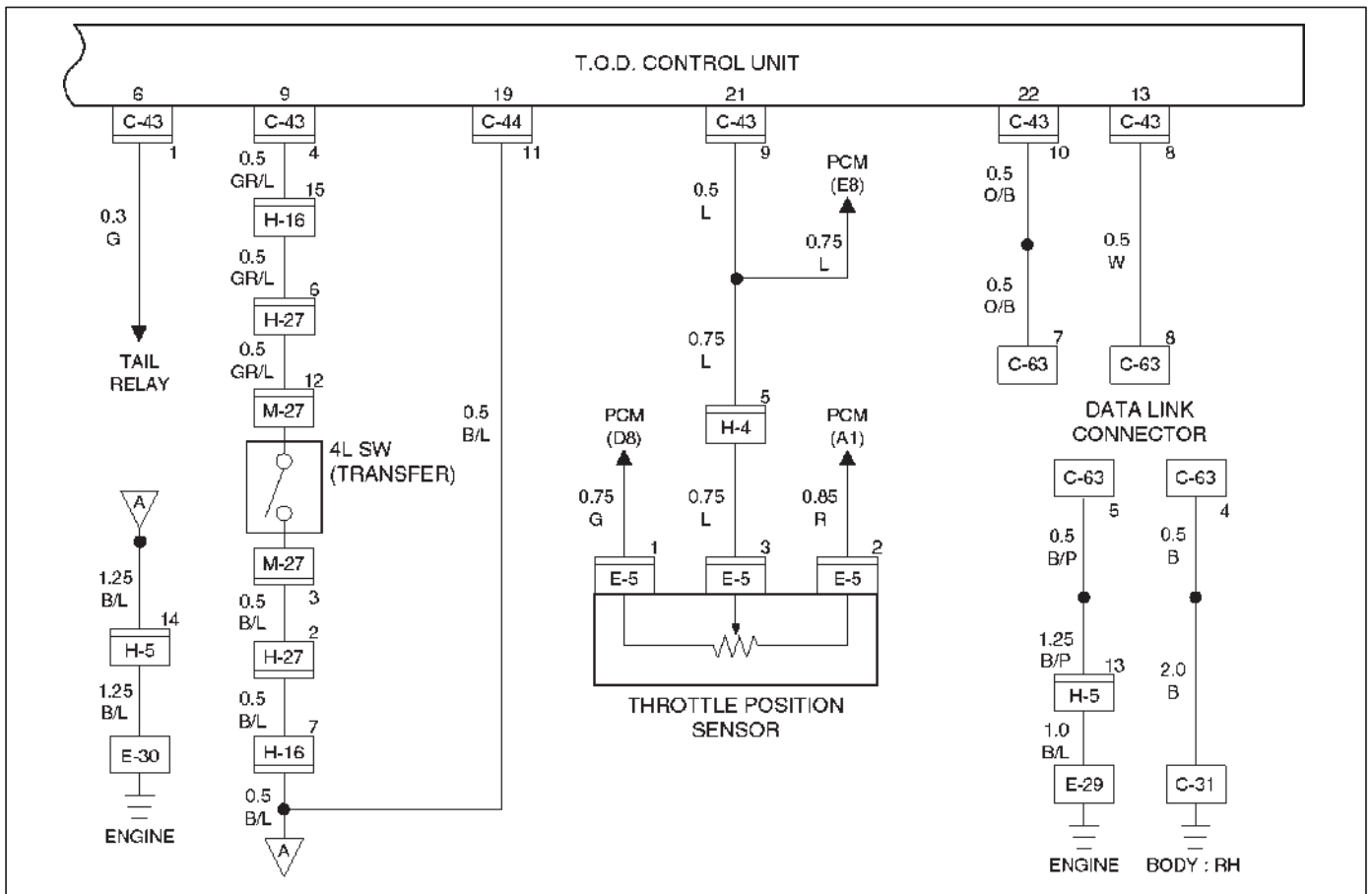
Chart G	The trouble codes are displayed.
Function of circuit	—
Fail condition	The CHECK lamp continues blinking irregularly. 
Indicator lamp status	
Transfer position	—



**4B2-62 DRIVE LINE CONTROL SYSTEM (TOD)**

<b>Step</b>	<b>Action</b>	<b>Yes</b>	<b>No</b>
1	Disconnect the ECU connector from ECU. Is the continuity established between terminals (C-43)8 and (C-44)11?	Go to Step 2	The ECU has failed. Replace the ECU. Go to Step 3
2	Is the self-diagnostic connector short-circuited?	Go to Step 3	Repair the self-diagnostic connector. Go to Step 3
3	1. Check that all the parts are mounted. 2. Clear the trouble codes. Is this step complete?	Repeat the "Diagnosis Flow".	Go to Step 3

Chart H	lighting switch circuit
Function of circuit	Reads in the status of lighting switch, and reduces the indicator brightness at night.
Fail condition	Even if the lighting switch is pressed on and off, brightness does not change.
Indicator lamp status	
Transfer position	All position (example TOD mode)



**4B2-64 DRIVE LINE CONTROL SYSTEM (TOD)**

Step	Action	Yes	No
1	1. Disconnect ECU terminal. 2. Turn on the starter switch.  Is battery voltage observed between ECU terminals (C-43)1 and (C-44)11?	Go to Step 2	Wirers are broken lighting SW circuit. Repair the circuit.  Go to Step 4
2	Turn lighting SW "ON".  Is 0 V observed between ECU terminal (C-43)1 and (C-44)11?	Go to Step 3	Lighting SW circuit battery short. Repair the circuit.  Go to Step 4
3	Connect ECU terminal.  While the lighting switch is pressed on and off, does the brightness of the indicator change?	The phenomenon is not reproduced. Refer to "Troubles intermittently observed" Go to Step 4	The ECU has failed. Replace the ECU.  Go to Step 4
4	Check that all the parts are mounted.  Is this step complete?	Repeat the "Diagnosis Flow".	Return to Step 4

## Diagnosis from Symptom

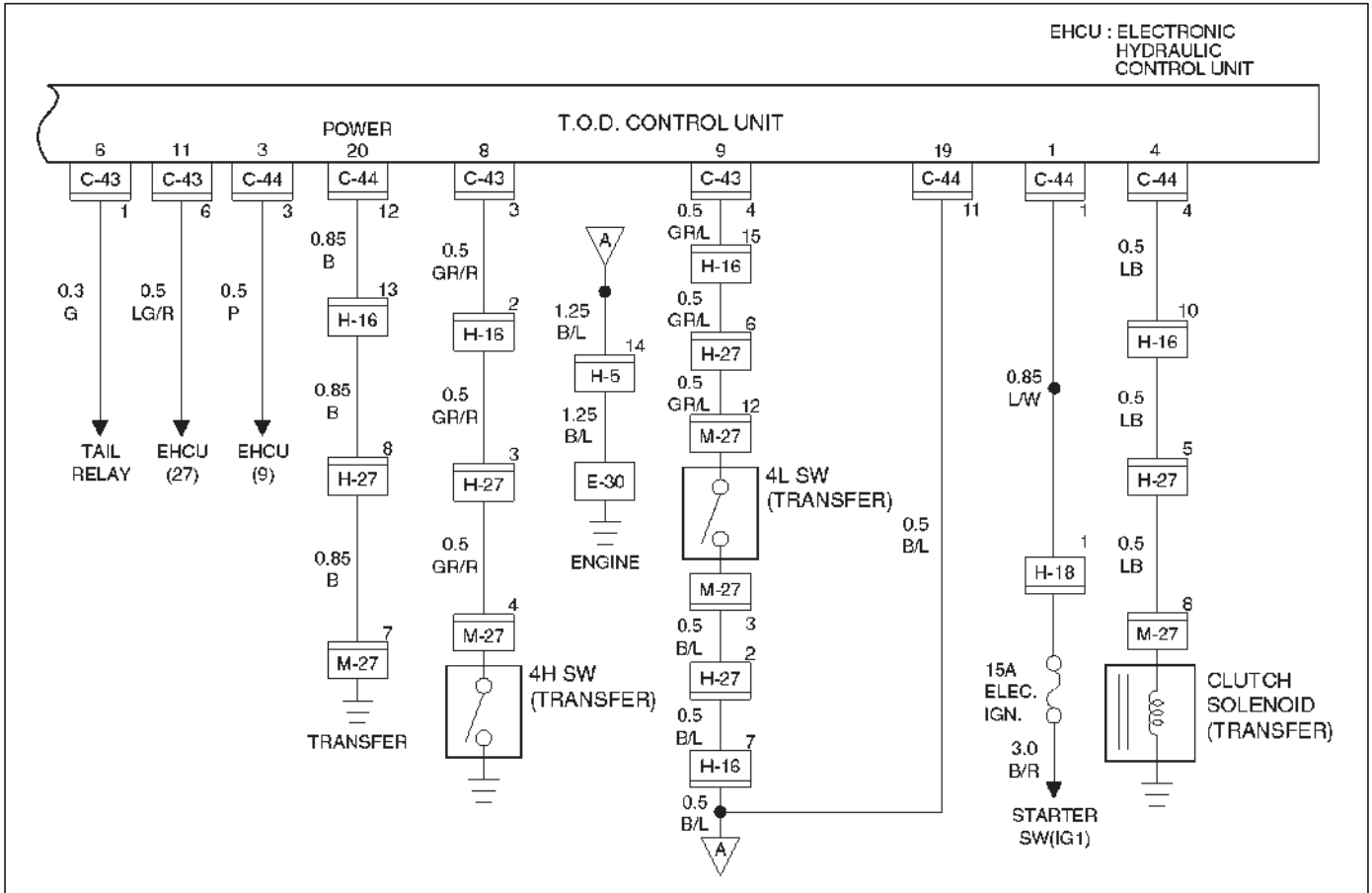
Troubles that are not indicated by the warning lamp are listed in the table below. These troubles are caused by the faults that cannot be detected by the self-diagnostic function of the control unit.

If this type of trouble is observed, interview the customer and conduct test runs to reproduce the trouble, cross-check the reported trouble with the listed phenomena, and diagnose and analyze the trouble on the item by item basis.

	Phenomena	Major cause	Corrective action
1	The tight corner braking is observed when the vehicle is subject to full steering.	<input type="radio"/> The standard tires are not used. <input type="radio"/> The tire pressure is incorrect. <input type="radio"/> The tires are worn in uniformity. <input type="radio"/> The transfer or wiring is imperfect. <input type="radio"/> The limited slip differential is failed.	Check and recondition the vehicle according to Chart 1.
2	The 4WD mode is not active, resulting in remarkable rear wheel spin.	<input type="radio"/> The transfer or wiring is imperfect.	Check and recondition the vehicle according to Chart 2.
3	<input type="radio"/> The drive resistance of the 4WD system is too large to get sufficient running speed. <input type="radio"/> Noised drive line.	<input type="radio"/> The standard tires are not used. <input type="radio"/> The tire pressure is incorrect. <input type="radio"/> The tires are worn in uniformity. <input type="radio"/> The transfer or wiring is imperfect. <input type="radio"/> The limited slip differential is imperfect.	Check and recondition the vehicle according to Chart 1.
4	The braking distance gets long even when the ABS is active.	<input type="radio"/> The wiring is imperfect. <input type="radio"/> The ABS is failed.	Check and recondition the vehicle according to Chart 4.

**4B2-66 DRIVE LINE CONTROL SYSTEM (TOD)**

Chart 1	The tight corner braking is observed.
Function of circuit	—
Fail condition	When the vehicle is subject to full steering in the TOD mode, the drive resistance gets large or the judder occurs. Otherwise, the above phenomenon is observed only when the brake is applied.



**DRIVE LINE CONTROL SYSTEM (TOD) 4B2-67**

Step	Action	Yes	No
1	Are the front and rear tires in specified size?	Go to Step 2	Replace the tires with specified ones, and service the new tires. Go to Step 14
2	Is the tire pressure correct?	Go to Step 3	Replace the tires with specified ones, and service the new tires. Go to Step 14
3	Are the tires free from abnormal wear?	Go to Step 4	Replace the tires with specified ones, and service the new tires. Go to Step 14
4	Are different types of tires used?	Go to Step 5	Replace the tires with specified ones, and service the new tires. Go to Step 14
5	1. Start the engine. 2. Shift the transfer lever to the high (TOD) position. 3. Fully turn the steering to the left (or right) end, and select the D range and start the creep run.  Does the tight corner braking occur? Is the judder with chug-chug sound observed? * Use caution on the operation.	Go to Step 6	Go to Step 10
6	Is an LSD mounted to the rear differential?	Go to Step 7	Go to Step 8
7	Is the genuine LSD oil used in the rear differential?	Go to Step 8	Replace the differential oil. Go to Step 14
8	Does the engine output the power correctly?	Go to Step 13	Check the engine. Go to Step 14
9	Do the speed sensors work correctly? (Check trouble codes.)	The ECU has failed. Replace the ECU. Go to Step 14	Replace the speed sensors. Go to Step 14
10	Is the tight corner braking observed only when the brake is applied?	Go to Step 11	Conduct full steering under WOT. Go to Step 5
11	1. Turn off the starter switch. 2. Disconnect the ECU connector.  Is the battery voltage observed between terminals (C-43)6 and (C-49)11?	Go to Step 12	Repair the circuit of terminal 6 (ABS IN). Go to Step 14
12	1. Apply the brake and fully turn the steering to the left (or right) end, and start the creep run.  Does the voltage between terminals 4 and 20 range between 0.1 and 1.0V?	Repair the transfer assembly. Go to Step 14	The ECU has failed. Replace the ECU. Go to Step 14

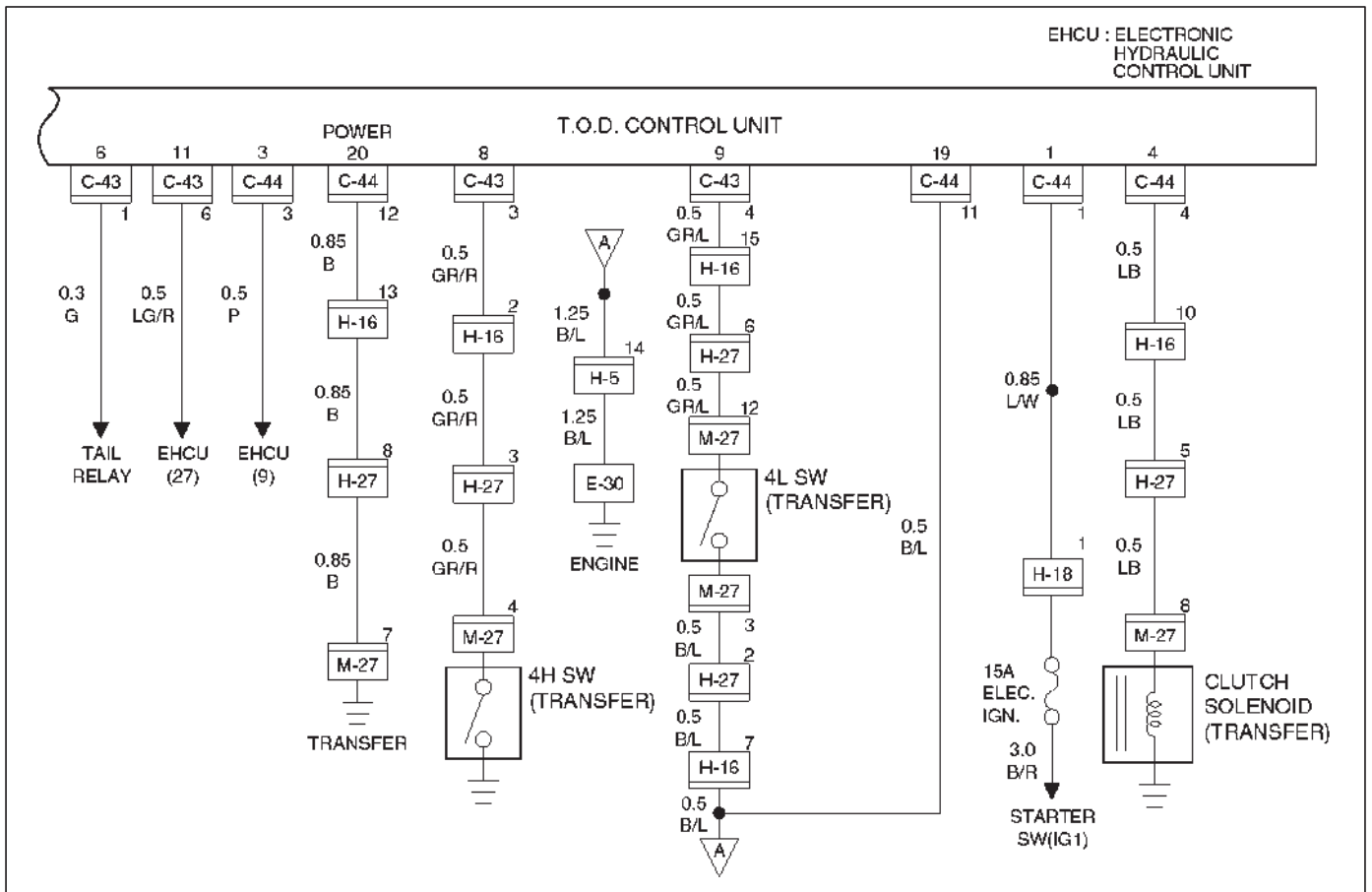


**4B2-68 DRIVE LINE CONTROL SYSTEM (TOD)**

<b>Step</b>	<b>Action</b>	<b>Yes</b>	<b>No</b>
13	1. Shift the transfer lever to the high (TOD) position. 2. Fully turn the steering to the left (or right) end, and select the D range and start the creep run.  Does the voltage between terminals 4 and 20 range between 0.1 and 1.0V?	Repair the transfer assembly. Go to Step 14	Go to Step 9
14	Check that all the parts are mounted.  Is this step complete?	Repeat the "Diagnosis Flow".	Return to Step 14

\*NOTE: Before checking this item, run the vehicle more than 10 meters with the steering wheel in straight position so that the 4L mechanical lock sleeve can be released certainly.

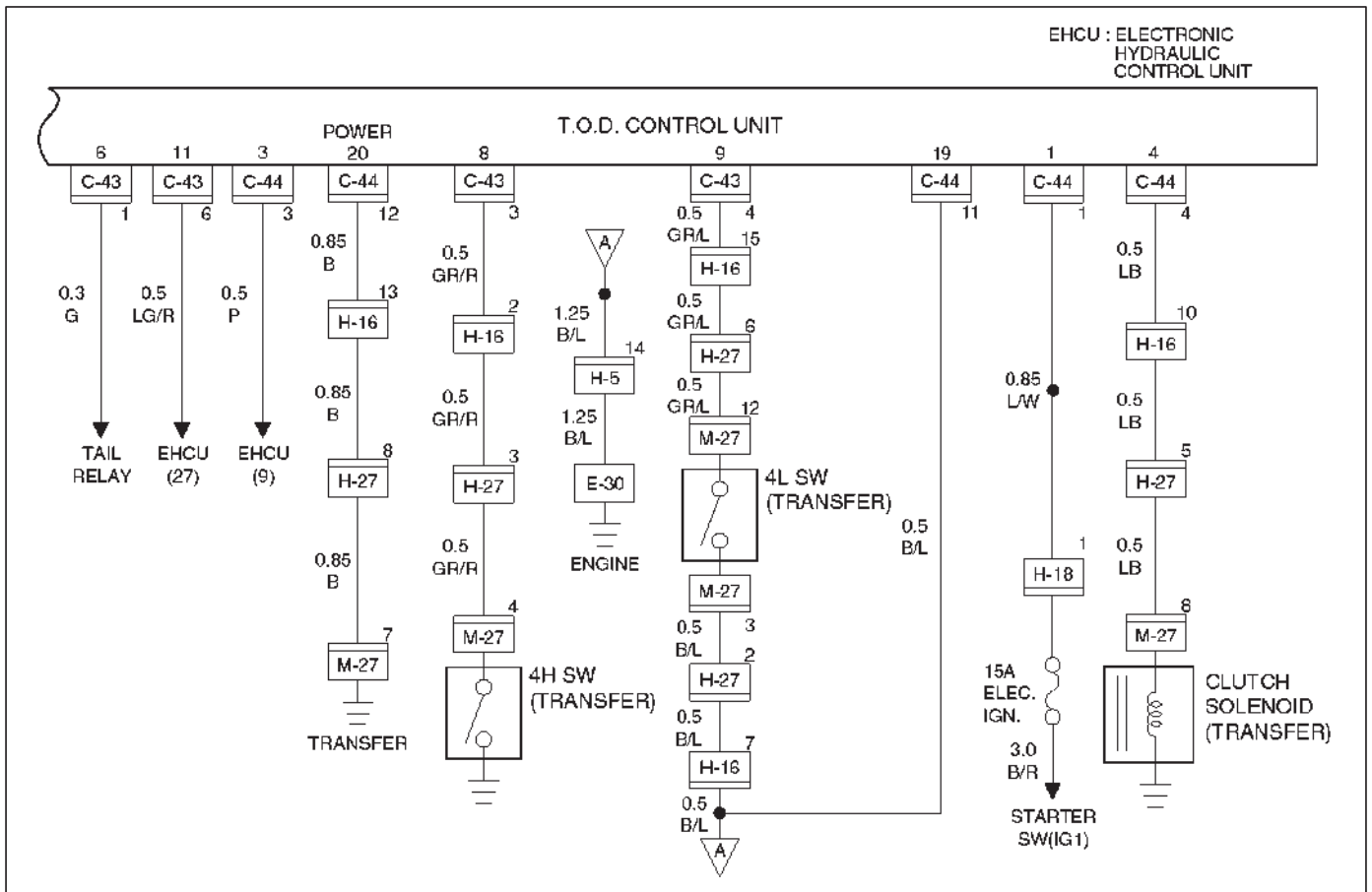
Chart 2	The 4WD mode is not active.
Function of circuit	—
Fail condition	The rear wheels spin in the TOD mode, so the driving torque is not transmitted to the front wheels. The indicator lamps will not show the 4L and TOD status.



**4B2-70 DRIVE LINE CONTROL SYSTEM (TOD)**

Step	Action	Yes	No
1	Is the trouble code 31 or 26 recorded?	Examine the trouble based on "Diagnosis from Trouble Codes". Go to Step 6	Go to Step 2
2	When the transfer lever is in the specified position, do the TOD indicator lamps show the correct status?	Go to Step 3	Examine the trouble based on "Trouble Diagnosis Depending on the Status of TOD Indicator". Go to Step 6
3	Shift the transfer lever to the 4L position, fully turn the steering to the left (or right) end, and start the creep run. Does the tight corner braking occur?	Go to Step 4	Repair the transfer assembly. Go to Step 6
4	1. Shift the transfer lever to the high (TOD) position. 2. Turn on the starter switch.  Does the voltage between terminals 4 and 20 indicate at least 0.1V while the throttle is completely open?	Go to Step 5	The ECU has failed. Replace the ECU. Go to Step 6
5	Does the voltage between terminals 4 and 20 indicate at least 3V while the throttle is completely closed?	The TOD clutch is worn. Repair the transfer assembly. Go to Step 6	The ECU has failed. Replace the ECU. Go to Step 6
6	Check that all the parts are mounted.  Is this step complete?	Repeat the "Diagnosis Flow".	Return to Step 6

Chart 4	The braking distance gets long even when the ABS is active.
Function of circuit	—
Fail condition	Enough deceleration is not obtained and the braking distance gets long even when the ABS is active in the TOD mode.



**4B2-72 DRIVE LINE CONTROL SYSTEM (TOD)**

<b>Step</b>	<b>Action</b>	<b>Yes</b>	<b>No</b>
1	Are the brake and ABS systems healthy?	Go to Step 2	Repair the brake and ABS. Go to Step 4
2	Turn on the starter switch. Is the battery voltage observed between terminals 1 and 20?	Go to Step 3	Repair the battery system. Go to Step 4
3	1. The voltage between terminals 3 and 19 range between 7.5 and 16V (0.24 seconds make a cycle)  Does the voltage within the range specified?	Examine the trouble based on "Diagnosis from Trouble Codes". Go to Step 4	The ECU has failed. Replace the ECU. Go to Step 4
4	Check that all the parts are mounted. Is this step complete?	Repeat the "Diagnosis Flow".	Return to Step 4

VEHICROSS

# DRIVELINE/AXLE

## DRIVE SHAFT SYSTEM

### CONTENTS

Service Precaution .....	4C-1	Front Propeller Shaft .....	4C-16
General Description .....	4C-1	General Description .....	4C-16
Diagnosis .....	4C-2	Front Propeller Shaft and Associated Parts	4C-16
Front Hub and Disc .....	4C-3	Removal .....	4C-17
Disassembled View .....	4C-3	Installation .....	4C-17
Disassembly .....	4C-3	Inspection and Repair .....	4C-18
Inspection and Repair .....	4C-4	Main Data and Specifications .....	4C-20
Reassembly .....	4C-5	Rear Propeller Shaft .....	4C-21
Main Data and Specifications .....	4C-8	General Description .....	4C-21
Special Tools .....	4C-9	Rear Propeller Shaft and Associated Parts	4C-21
Front Drive Shaft Joint .....	4C-10	Removal .....	4C-22
Front Drive Shaft Joints Replacement ....	4C-10	Installation .....	4C-22
Front Axle Drive Shaft .....	4C-11	Disassembly .....	4C-23
Front Axle Drive Shaft and Associated		Universal Joint Disassembly .....	4C-24
Parts .....	4C-11	Inspection and Repair .....	4C-25
Disassembly .....	4C-12	Universal Joint Reassembly .....	4C-26
Inspection and Repair .....	4C-13	Reassembly .....	4C-27
Bushing Replacement .....	4C-13	Main Data and Specifications .....	4C-28
Reassembly .....	4C-14		

### Service Precaution

**WARNING: THIS VEHICLE HAS A SUPPLEMENTAL RESTRAINT SYSTEM(SRS). REFER TO THE SRS COMPONENT AND WIRING LOCATION VIEW IN ORDER TO DETERMINE WHETHER YOU ARE PERFORMING SERVICE ON OR NEAR THE SRS COMPONENTS OR THE SRS WIRING. WHEN YOU ARE PERFORMING SERVICE ON OR NEAR THE SRS COMPONENTS OR THE SRS WIRING, REFER TO THE SRS SERVICE INFORMATION. FAILURE TO FOLLOW WARNINGS COULD RESULT IN POSSIBLE AIR BAG DEPLOYMENT, PERSONAL INJURY, OR OTHERWISE UNNEEDED SRS SYSTEM REPAIRS.**

**CAUTION:** Always use the correct fastener in the proper location. When you replace a fastener, use ONLY the exact part number for that application. ISUZU will call out those fasteners that require a replacement after removal. ISUZU will also call out the fasteners that require thread lockers or thread sealant. UNLESS OTHERWISE SPECIFIED, do not use supplemental coatings (Paints, greases, or other corrosion inhibitors) on threaded fasteners or fastener joint interfaces. Generally, such coatings adversely affect the fastener torque and the joint clamping force, and may damage the fastener. When you install fasteners, use the correct tightening sequence and specifications. Following these instructions can help you avoid damage to parts and systems.

### General Description

This publication contains essential removal, installation, adjustment and maintenance procedures.

The drive axles are completely flexible assemblies, consisting of inner and outer constant velocity (CV) drive shaft joints connected by an axle shaft.

For description of front propeller shaft and universal joint, refer to Front Propeller Shaft in this section.

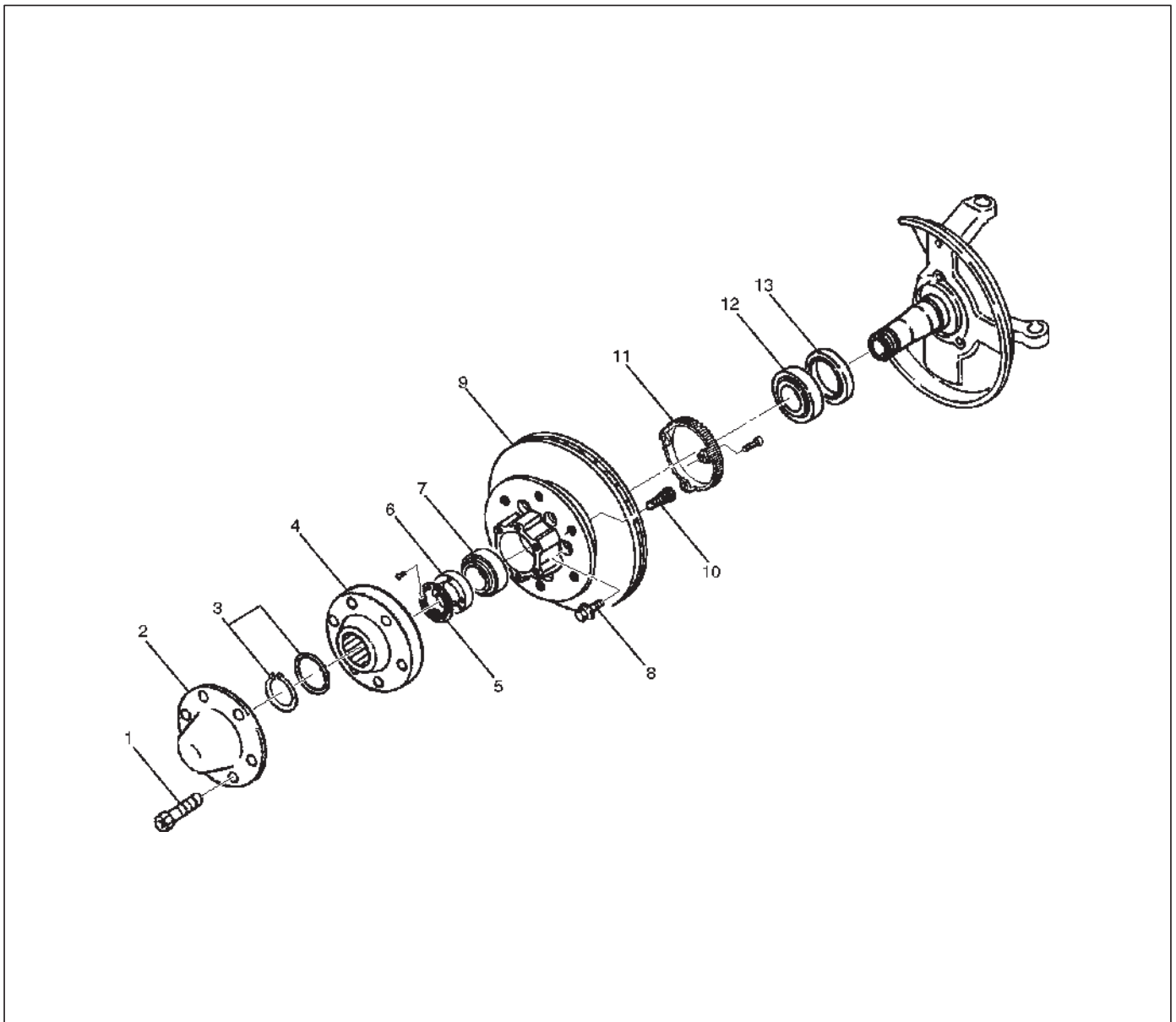
## 4C-2 DRIVE SHAFT SYSTEM

### Diagnosis

Condition	Possible cause	Correction
Oil Leak At Front Axle	Worn or defective oil seal.	Replace the oil seal.
	Front axle housing cracked.	Repair or replace.
Oil Leak At Pinion Shaft	Too much gear oil.	Correct the oil level.
	Oil seal worn or defective.	Replace the oil seal.
	Pinion flange loose or damaged.	Tighten or replace.
Noises In Front Axle Drive Shaft Joint	Broken or worn drive shaft joints and bellows (BJ and DOJ).	Replace the drive shaft joints and bellows.
"Clank" When Accelerating From "Coast"	Loose drive shaft joint to output shaft bolts.	Tighten.
	Damaged inner drive shaft joint.	Replace.
Shudder or Vibration During Acceleration	Excessive drive shaft joint angle.	Repair.
	Worn or damaged drive shaft joints.	Replace.
	Sticking spider assembly (inner drive shaft joint).	Lubricate or replace.
	Sticking joint assembly (outer drive shaft joint).	Lubricate or replace.
Vibration At Highway Speeds	Out of balance or out of round tires.	Balance or replace.
	Front end out of alignment.	Align.
Noises in Front Axle	Insufficient gear oil.	Replenish the gear oil.
	Wrong or poor grade gear oil.	Replace the gear oil.
	Drive pinion to ring gear backlash incorrect.	Adjust the backlash.
	Worn or chipped ring gear, pinion gear or side gear.	Replace the ring gear, pinion gear or side gear.
	Pinion shaft bearing worn.	Replace the pinion shaft bearing.
	Wheel bearing worn.	Replace the wheel bearing.
	Differential bearing loose or worn.	Tighten or replace.
Wanders and Pulls	Wheel bearing preload too tight.	Adjust the wheel bearing preload.
	Incorrect front alignment.	Adjust the front alignment.
	Steering linkage loose or worn.	Tighten or replace.
	Steering gear out of adjustment.	Adjust or replace the steering gear.
	Tire worn or improperly inflated.	Adjust the inflation or replace.
	Front or rear suspension parts loose or broken.	Tighten or replace.
Front Wheel Shimmy	Wheel bearing worn or improperly adjusted.	Adjust or replace.
	Incorrect front alignment.	Adjust the front alignment.
	Worn ball joint or bush.	Replace the ball joint or bush.
	Steering linkage loose or worn.	Tighten or replace.
	Steering gear out of adjustment.	Tighten or replace.
	Tire worn or improperly inflated.	Replace or adjust the inflation.
	Shock absorber worn.	Replace the shock absorber.

## Front Hub and Disc

### Disassembled View



411RW001

#### Legend

- |                                |                           |
|--------------------------------|---------------------------|
| (1) Bolt                       | (7) Outer Bearing         |
| (2) Cap                        | (8) Bolt                  |
| (3) Snap Ring and Shim         | (9) Hub and Disc Assembly |
| (4) Hub Flange                 | (10) Wheel Pin            |
| (5) Lock Washer and Lock Screw | (11) ABS Sensor Ring      |
| (6) Hub Nut                    | (12) Inner Bearing        |
|                                | (13) Oil Seal             |

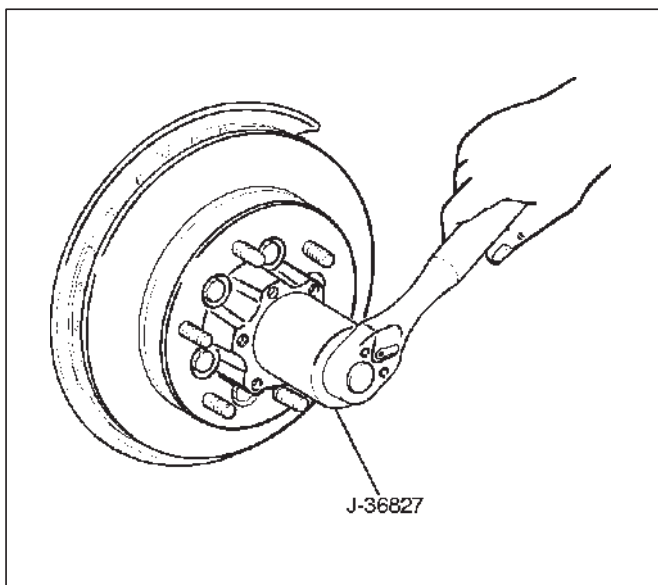
### Disassembly

1. Jack up the front of vehicle and support frame with jack stands.
2. Remove the disc brake caliper assembly and hang it on the frame with wires. Refer to Disk Brakes in Brake section.
3. Remove bolt.
4. Remove cap.
5. Remove snap ring and shim.
6. Remove hub flange.
7. Remove lock washer and lock screw.



## 4C-4 DRIVE SHAFT SYSTEM

8. Use wrench J-36827, remove hub nut.



9. Remove hub and disc assembly.

10. Remove ABS sensor ring.

11. Remove outer bearing.

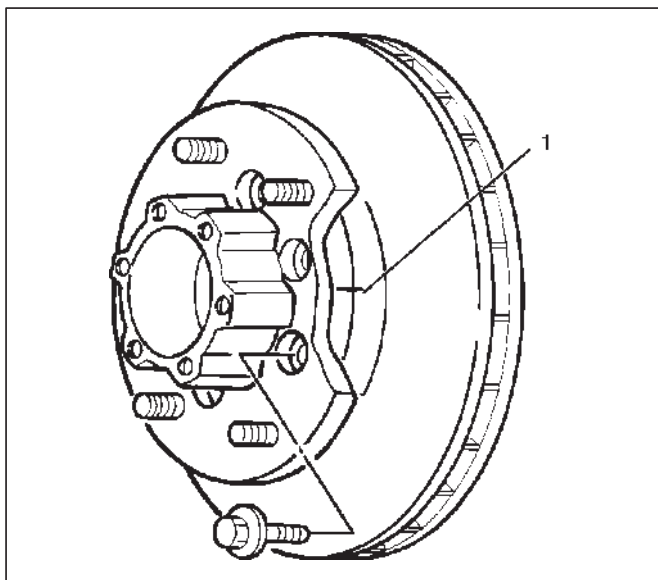
12. Remove oil seal.

13. Remove inner bearing.

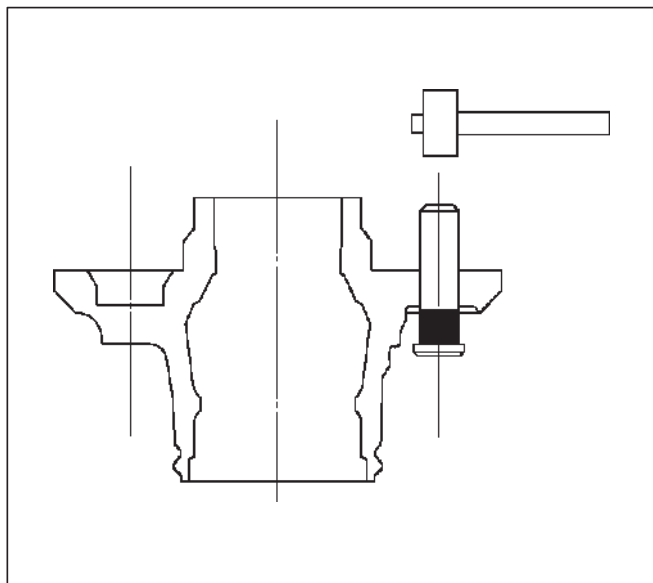
14. Remove bolt, if necessary, replace the wheel pin in the following manner.

○Apply a scribe mark(1) to disc to hub.

○Clamp the hub and disc assembly in a vise, using protective pads. Remove the 6 disc-to-hub retaining bolts.



○Place hub on a suitable work surface and remove the studs by using a hammer.



## Inspection and Repair

Make necessary correction or parts replacement if wear, damage, corrosion or any other abnormal conditions are found through inspection.

Check the following parts:

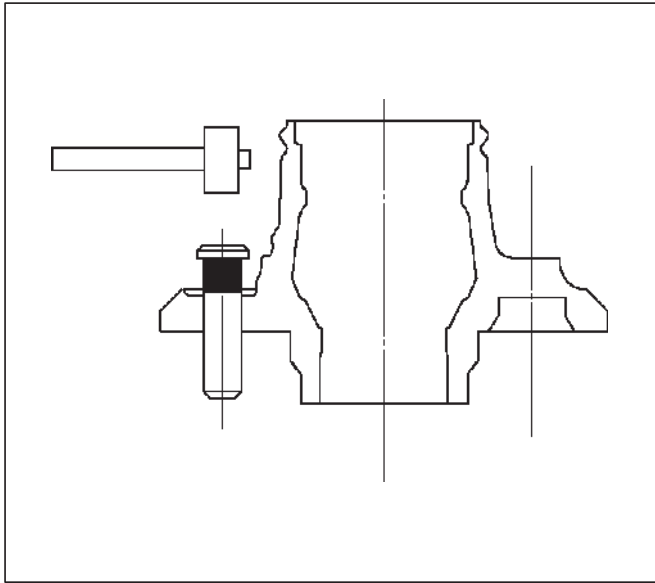
- Hub
- Hub bearing oil seal
- Knuckle spindle
- Disc
- Caliper
- Shift on the fly system parts (Cap, Hub flange, Shim, Snap ring)
- ABS sensor ring

For inspection and servicing of disc caliper and related parts, refer to Disc Brakes in Brake section.

## Reassembly

1. Install wheel pin.

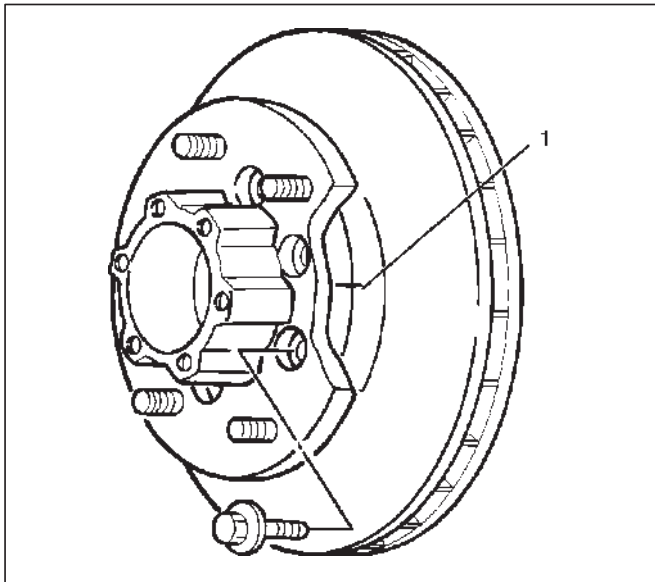
- Place the hub on a wood workbench or a block of wood approx. 6" by 6" to protect the wheel stud ends and threads.
  - Insert a wheel stud using a hammer.
- Be sure the wheel stud is started squarely and seats completely.



411RS005

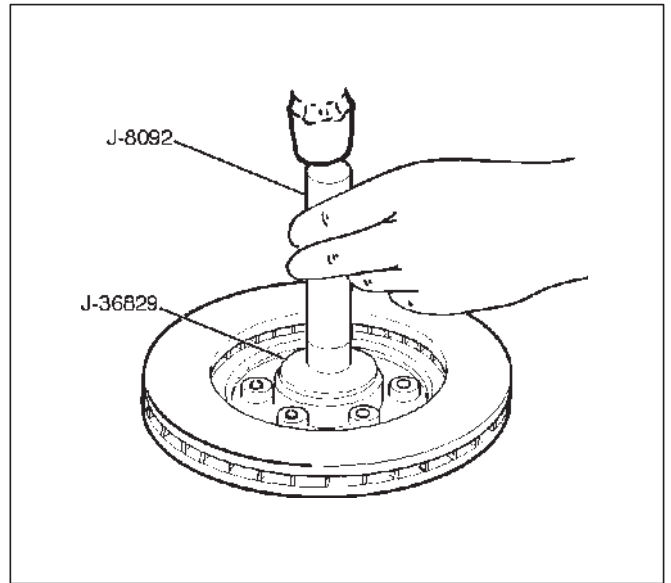
2. Align scribe marks(1) and attach the hub to the disc, then tighten the bolts to the specified torque.

**Torque: 103 N-m (76 lb ft)**



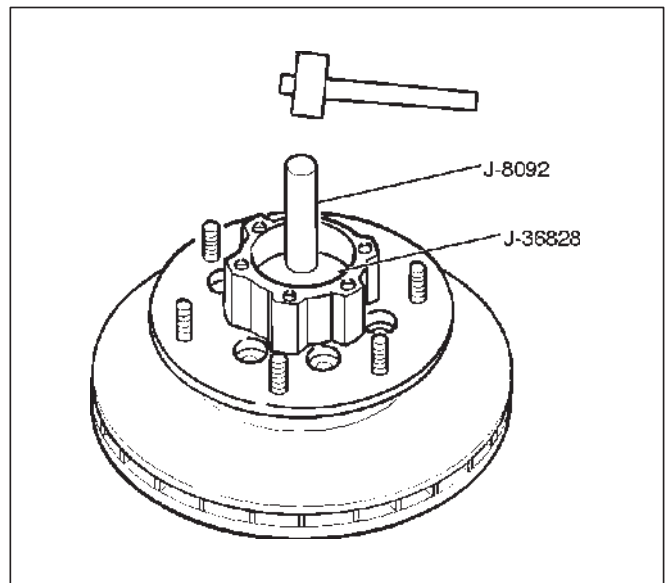
411RS003

3. Use installer J-36829 and grip J-8092, then install the inner bearing by driving it into the hub.



901RW055

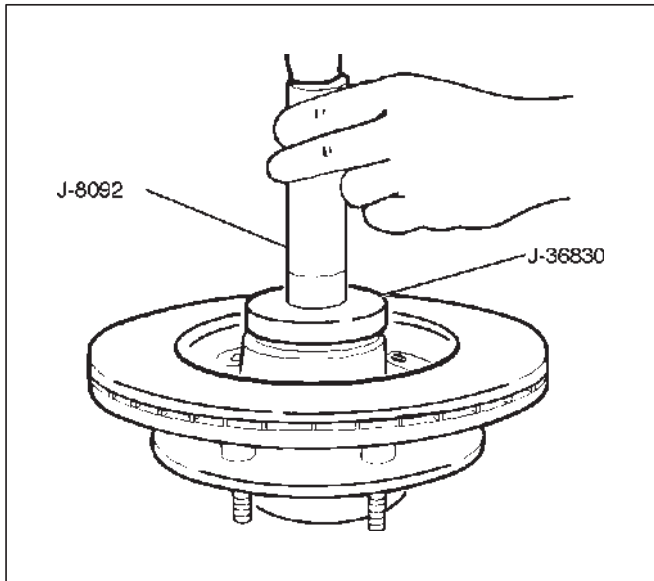
4. Use installer J-36828 and grip J-8092, then install the outer bearing by driving it into the hub.



901RW056

## 4C-6 DRIVE SHAFT SYSTEM

5. Apply grease (NLGI No.2 or equivalent) to the lip portion, then install oil seal by using installer J-36830 and grip J-8092.



6. Install ABS sensor ring, then tighten the bolts to the specified torque.

**Torque: 18 N·m (13 lb ft)**

7. Install hub and disc assembly.

○Apply grease in the hub.

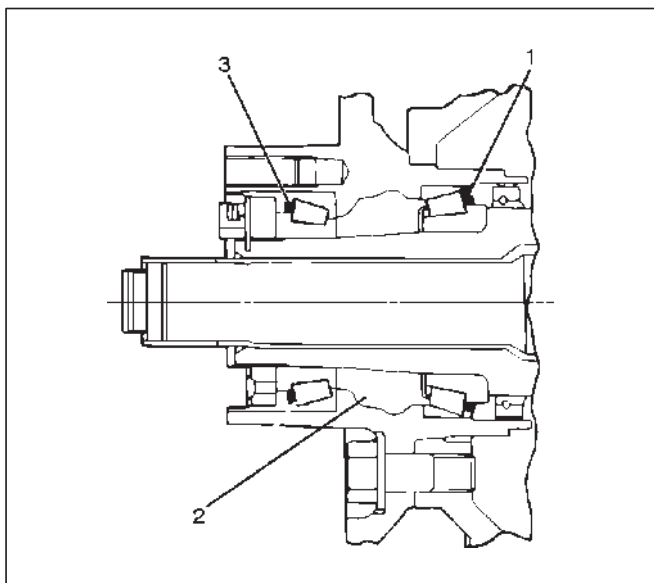
○Apply wheel bearing type grease NLGI No. 2 or equivalent to the outer and inner bearing.

### Grease Amount

**Hub: 35 g (1.23 oz)**

**Outer bearing: 10 g (0.35 oz)**

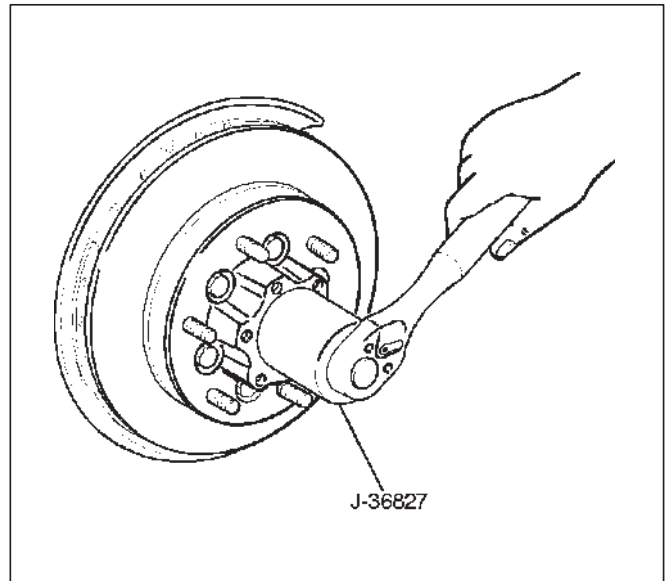
**Inner bearing: 15 g (0.53 oz)**



### Legend

- (1) Inner Bearing
- (2) Hub
- (3) Outer Bearing

8. Install hub nut. Turn to the place where there is a chamfer in the tapped hole to the outer side, then attach the nut by using front hub nut wrench J-36827.



### Preload Adjustment

1. Tighten the hub nut to 29 N·m (22 lb ft), then fully loosen the nut.
2. Tighten the hub nut to the value given below, using a spring scale on the wheel pin.

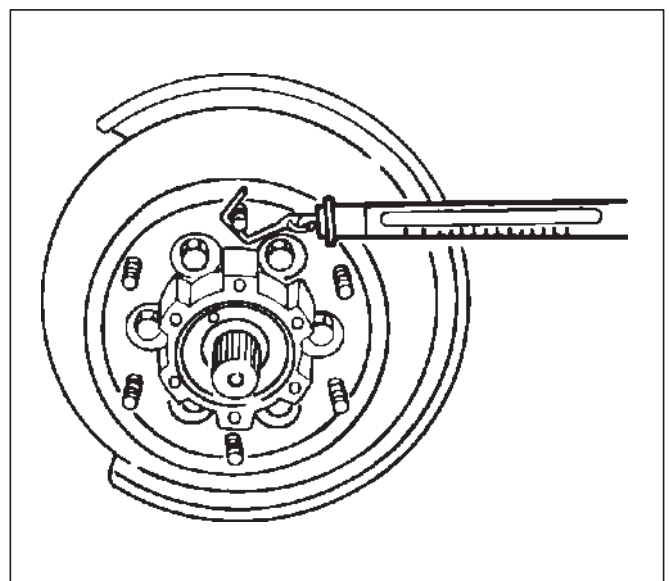
### New bearing and New oil seal

**Bearing Preload: 20 N – 25 N (4.4 lb – 5.5 lb)**

### Used bearing and New oil seal

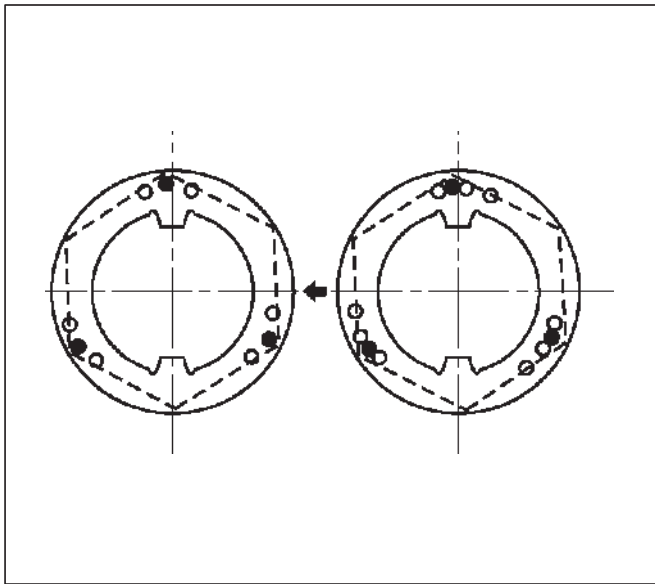
**Bearing Preload: 12 N – 18 N (2.6 lb – 4.0 lb)**

If the measured bearing preload is outside the specifications, adjust it by loosening or tightening the bearing nut.



9. Install lock washer and lock screw in the following manner.

- Turn the side with larger diameter of the tapered bore to the vehicle outer side, then attach the washer.
- If the bolt holes in the lock plate are not aligned with the corresponding holes in the nut, reverse the lock plate.
- If the bolt holes are still out of alignment, turn in the nut just enough to obtain alignment.
- Screw is to be fastened tightly so its head may come lower than the surface of the washer.



411RS012

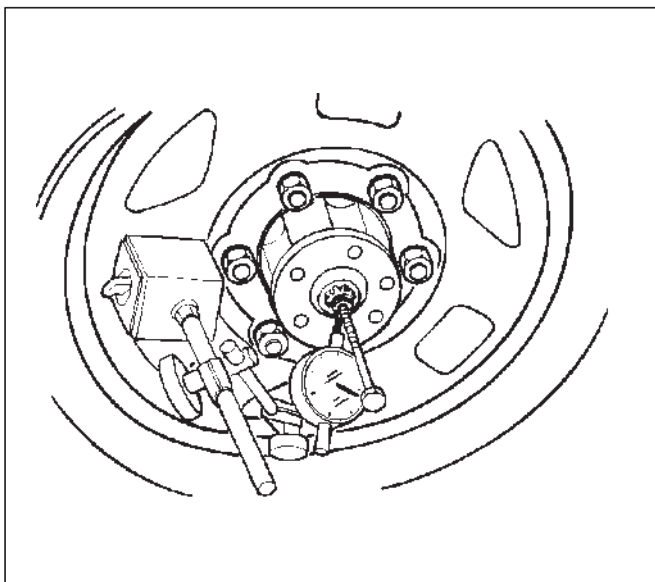
10. Apply adhesive (LOCTITE 515 or equivalent) to both joining flange faces then install hub flange.

11. Install snap ring and shim.

- Adjust the clearance between the free wheeling hub body and the snap ring.

**Clearance: 0 mm–0.3 mm (0 in–0.012 in)**

**Shims Available: 0.2 mm, 0.3 mm, 0.5 mm, 1.0 mm (0.008 in, 0.012 in, 0.020 in, 0.039 in)**



411RW002

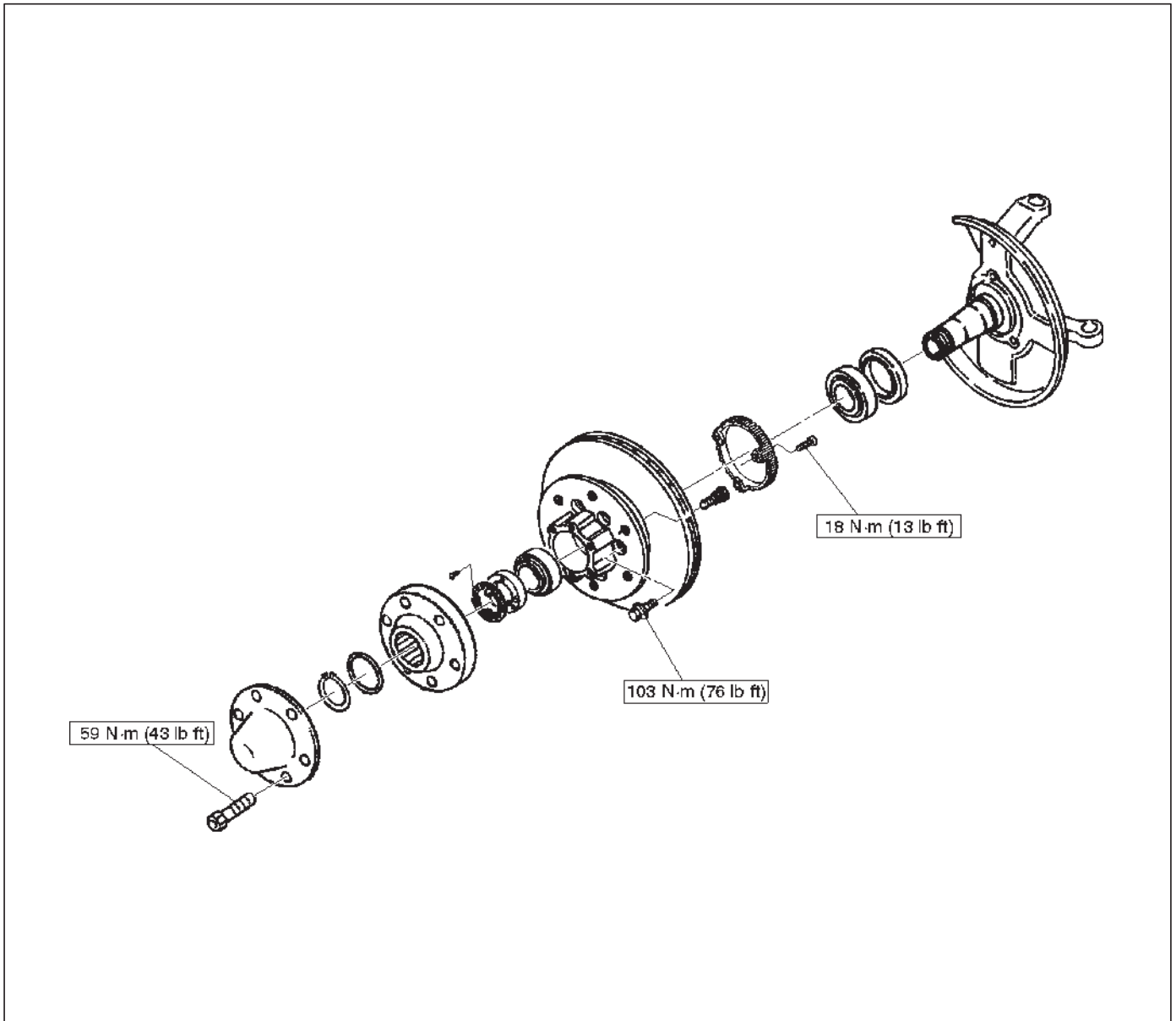
12. Install hub cap.

13. Tighten the bolts to the specified torque.

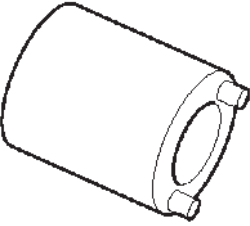
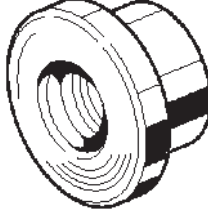
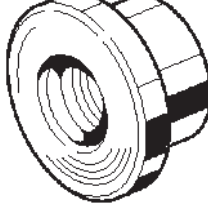
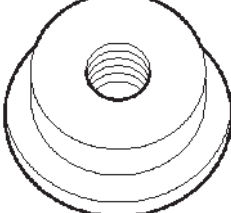
**Torque: 59 N·m (43 lb ft)**

## Main Data and Specifications

### Torque Specifications



**Special Tools**

ILLUSTRATION	TOOL NO. TOOL NAME
 <small>901RS246</small>	<b>J-36827</b> Wrench; Hub nut
 <small>901RS247</small>	<b>J-36829</b> Installer; Inner bearing
 <small>901RS248</small>	<b>J-36828</b> Installer; Outer bearing
 <small>901RS249</small>	<b>J-36830</b> Installer; Oil seal

## Front Drive Shaft Joint

### Front Drive Shaft Joints Replacement

- Refer to Front Axle Drive Shaft in this section, and refer to Front Hub and Disc in this section.

### Front Hub Bearing Preload Check

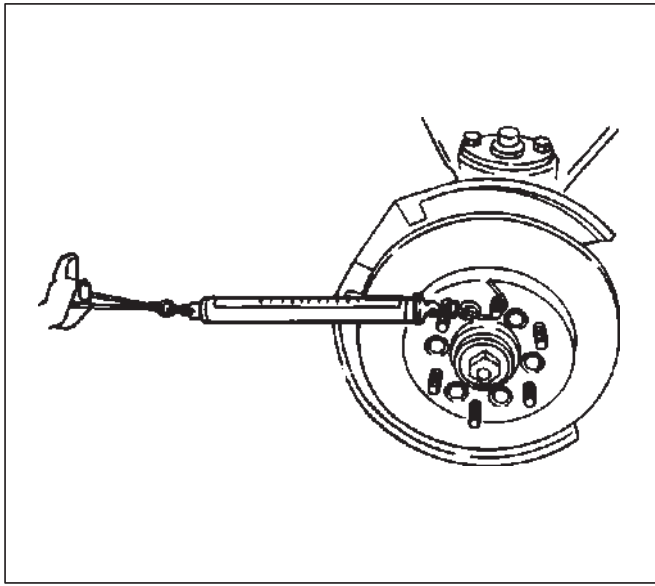
Check the hub bearing preload at the wheel pin.

**New bearing and new oil seal:**

**19.6 – 24.5 N (4.4 – 5.5 lb)**

**Used bearing and new oil seal:**

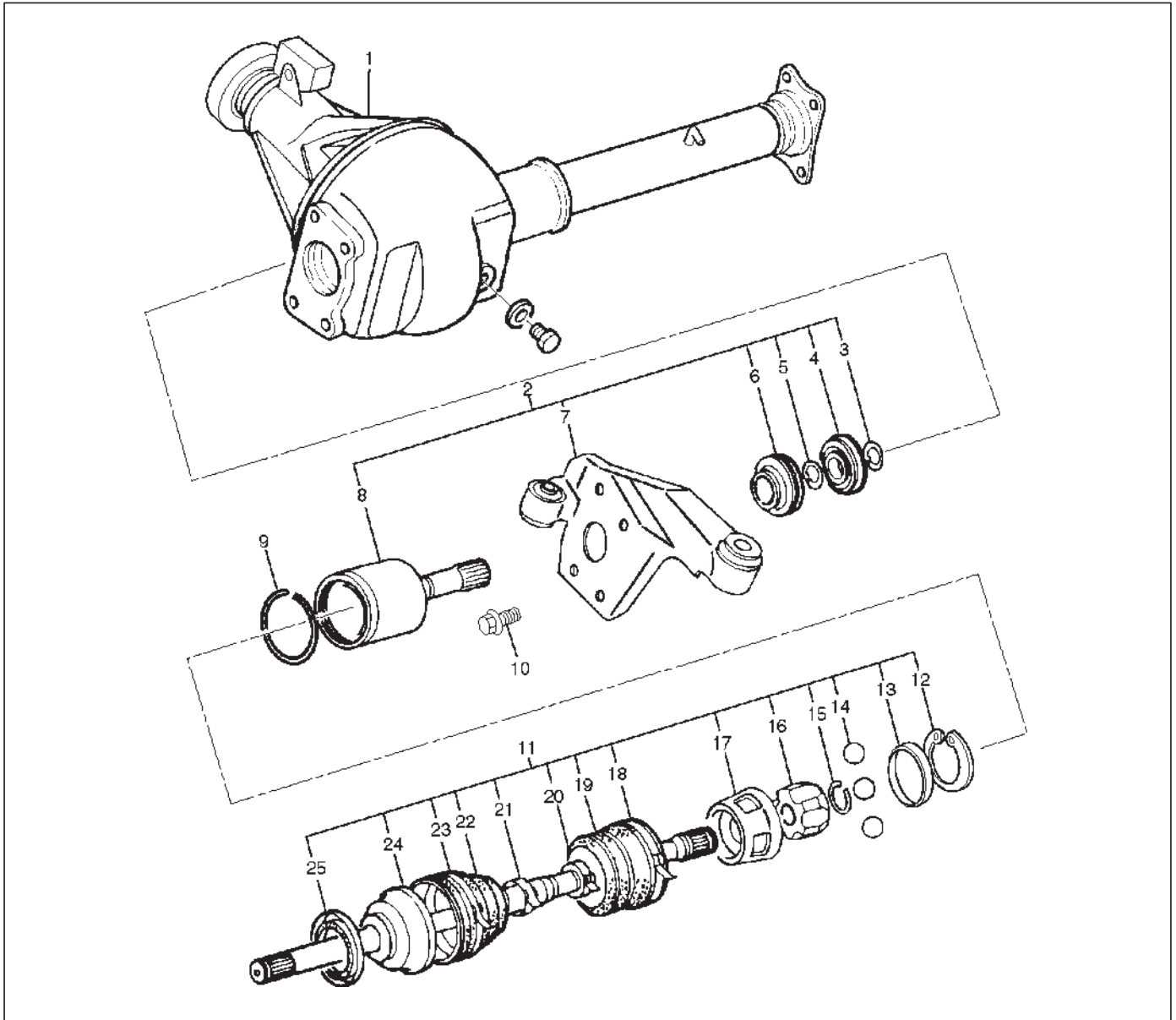
**11.8– 17.7 N (2.6 – 4.0 lb)**



411RS001

## Front Axle Drive Shaft

### Front Axle Drive Shaft and Associated Parts



412RX007

#### Legend

- |                                 |                    |
|---------------------------------|--------------------|
| (1) Axle Case and Differential  | (13) Spacer        |
| (2) DOJ Case Assembly           | (14) Ball          |
| (3) Snap Ring                   | (15) Snap Ring     |
| (4) Bearing                     | (16) Ball Retainer |
| (5) Snap Ring                   | (17) Ball Guide    |
| (6) Oil Seal                    | (18) Band          |
| (7) Bracket                     | (19) Bellows       |
| (8) DOJ Case                    | (20) Band          |
| (9) Circlip                     | (21) Band          |
| (10) Bolt                       | (22) Bellows       |
| (11) Drive Shaft Joint Assembly | (23) Band          |
| (12) Snap Ring                  | (24) BJ Shaft      |
|                                 | (25) Dust Seal     |

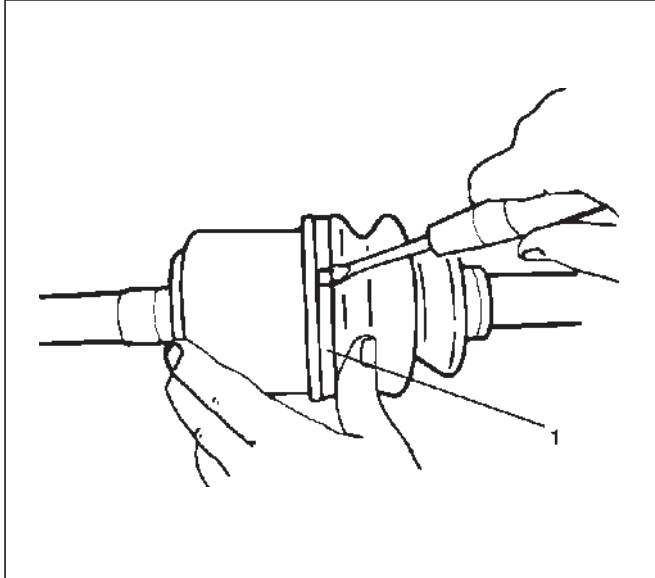


## 4C-12 DRIVE SHAFT SYSTEM

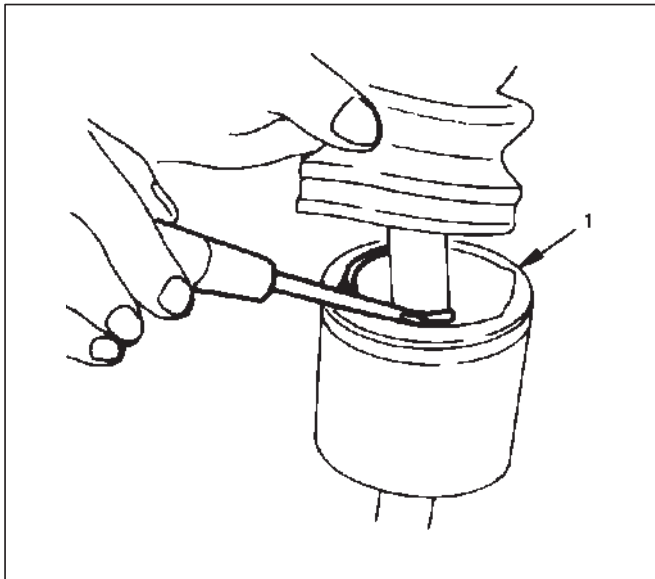
### Disassembly

NOTE: For the left side, follow the same steps as right side.

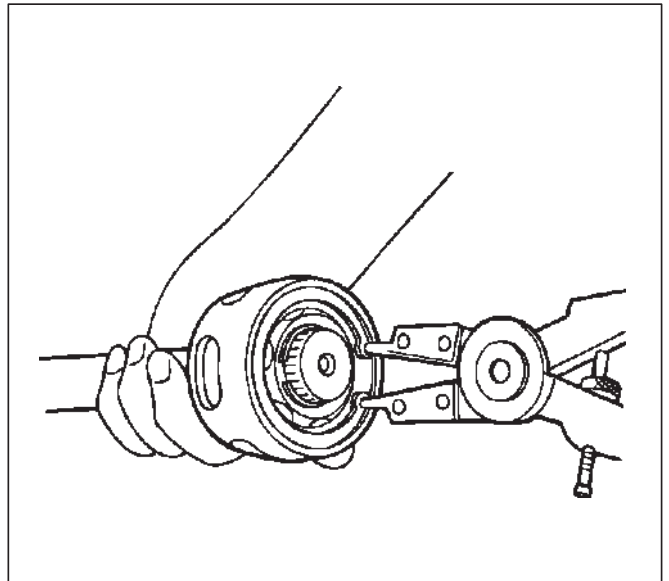
1. Raise the hooked end of the band (1) with a screwdriver or equivalent.



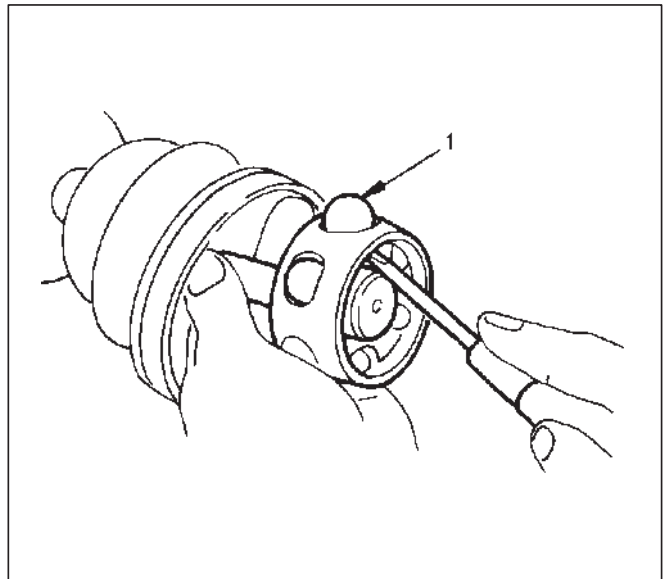
2. Remove band.
3. Pry off circlip (1) with a screwdriver or equivalent.



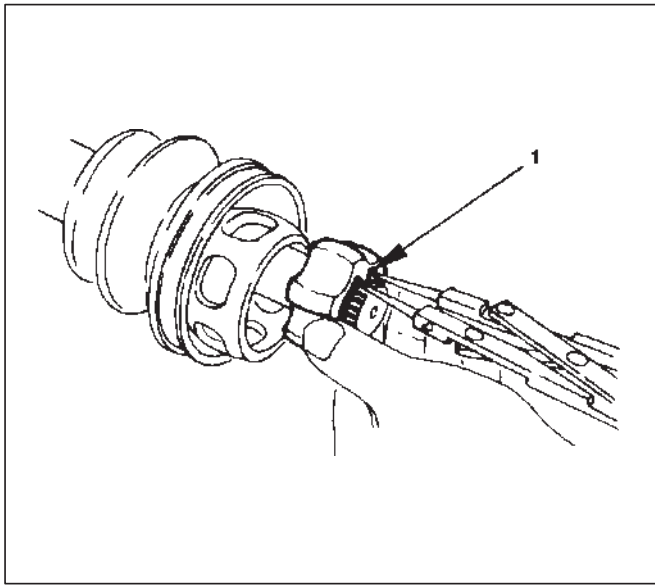
4. Remove drive shaft joint assembly.
5. Using snap ring pliers, remove the snap ring.



6. Remove spacer.
7. Remove the six balls (1) with a screwdriver or equivalent.



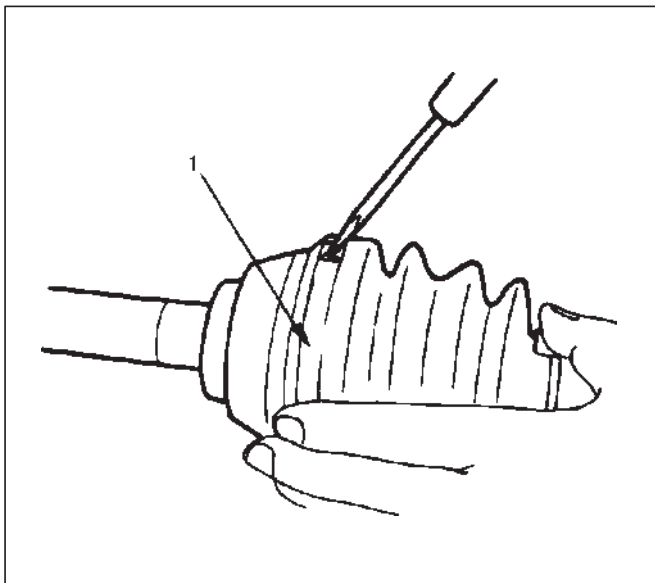
8. Using snap ring pliers, remove the snap ring (1) fastening the ball retainer to the center shaft.



412RS013

9. Remove ball retainer, ball guide and bellows.

10. Raise the hooked end of the band (1) with a screwdriver or equivalent.



412RS014

11. Remove band.
12. Remove bellows.
13. Remove dust seal.
14. Remove BJ shaft assembly.
15. Remove the mounting bracket fixing bolts, and then remove DOJ case assembly from the axle case.
16. Remove snap ring and bearing.
17. Remove snap ring and oil seal.
18. Remove bracket.

## Inspection and Repair

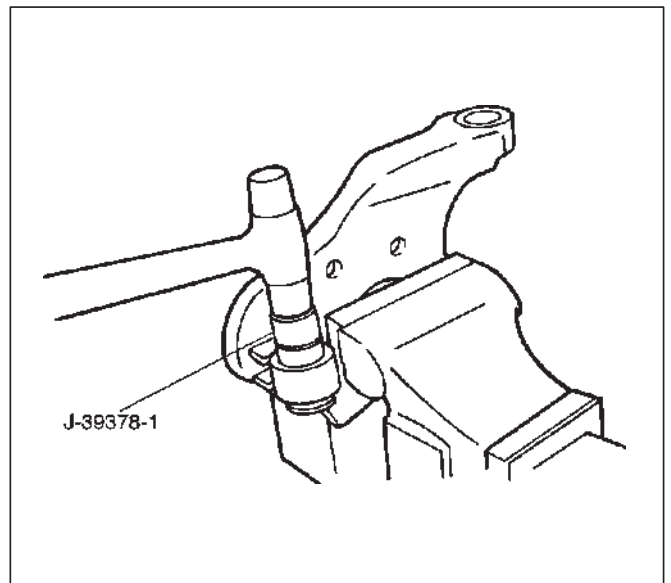
Make necessary correction or parts replacement if wear, damage, corrosion or any other abnormal conditions are found through inspection.

Check the following parts:

1. Drive shaft joint assembly
2. DOJ case, ball, ball guide, ball retainer
3. Bellows
4. Bearing
5. Dust seal, oil seal

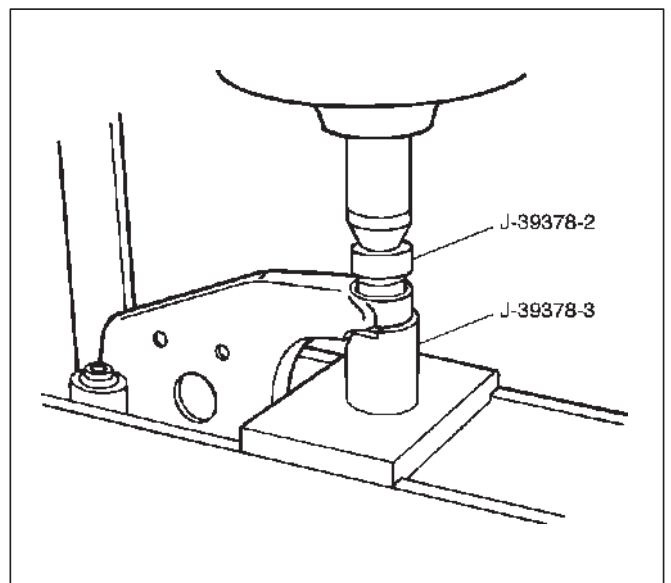
## Bushing Replacement

- Remove the bushings using a remover J-39378-1 and hammer.



412RS015

- By using installer J-39378-2 and base J-39378-3, press fit the bushings into the bracket.



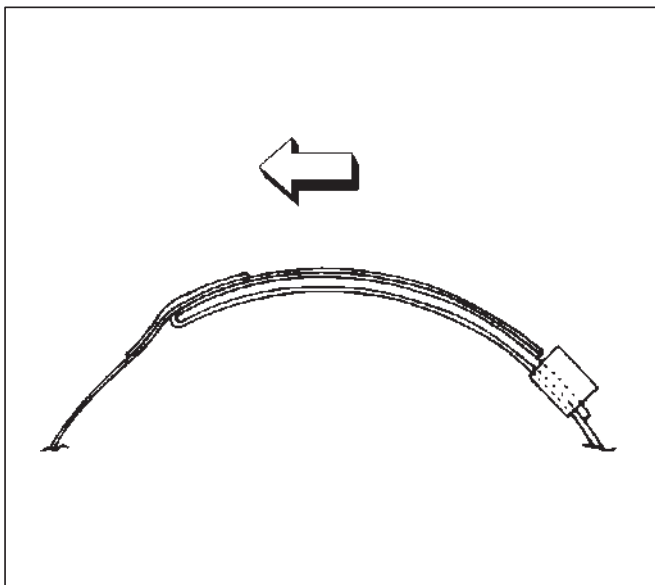
412RS016

## Reassembly

1. Install DOJ case to bracket.
2. Install oil seal and fix snap ring.
3. Install bearing and fix snap ring.
4. Install bracket to axle case. Tighten the bracket bolt to the specified torque.

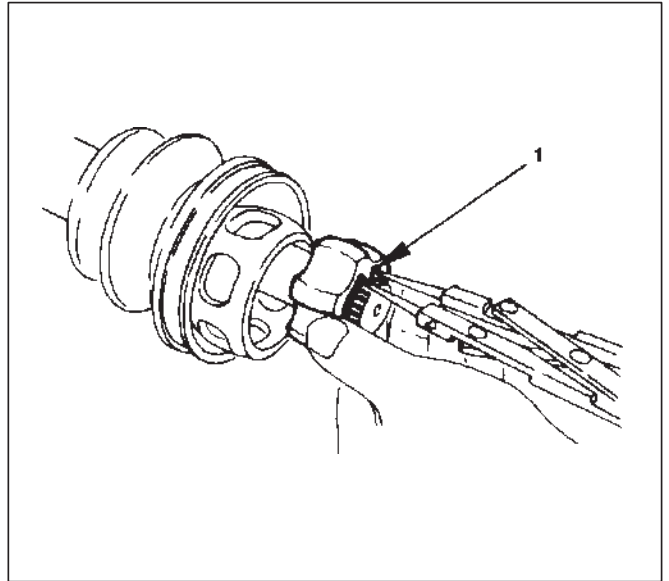
**Torque: 116 N·m (85 lb ft)**

5. Apply 150g of the specified grease in BJ .
6. Install dust seal .
7. Apply a thin coat of grease to the shaft for smooth installation then install bellows.
8. Install band. Note the setting direction. After installation, check that the bellows is free from distortion.

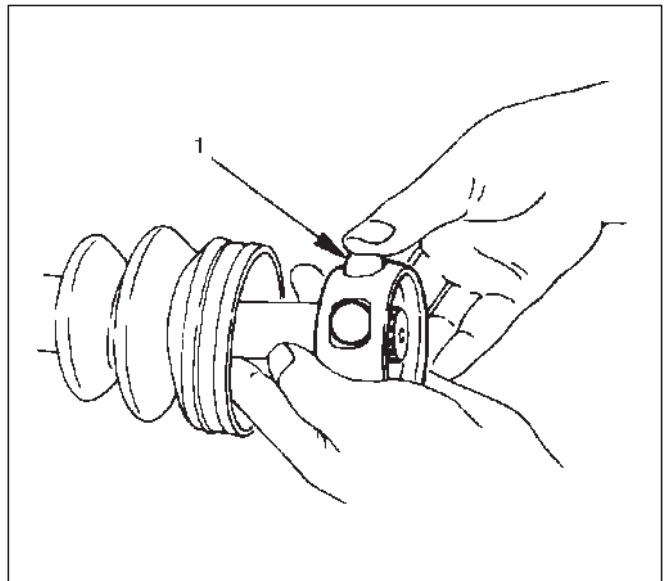


9. Install another bellows and fix band.
10. Install the ball guide with the smaller diameter side ahead onto the shaft.
11. Install ball retainer.

12. Using snap ring pliers, install the snap ring (1) securing the ball retainer to the shaft.

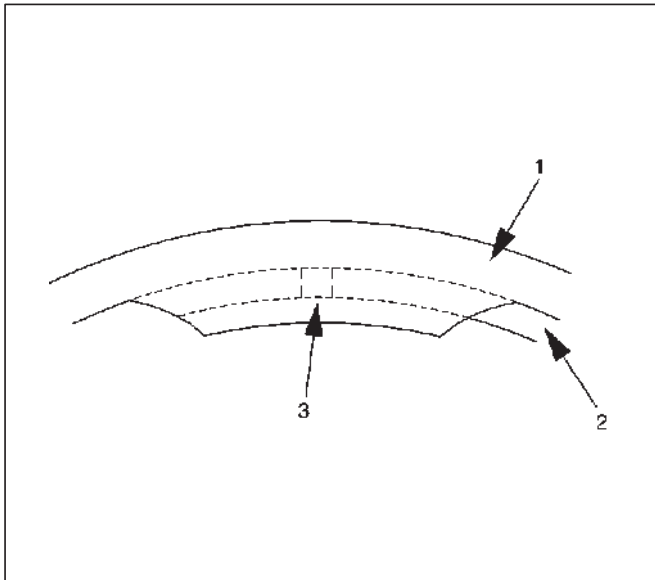
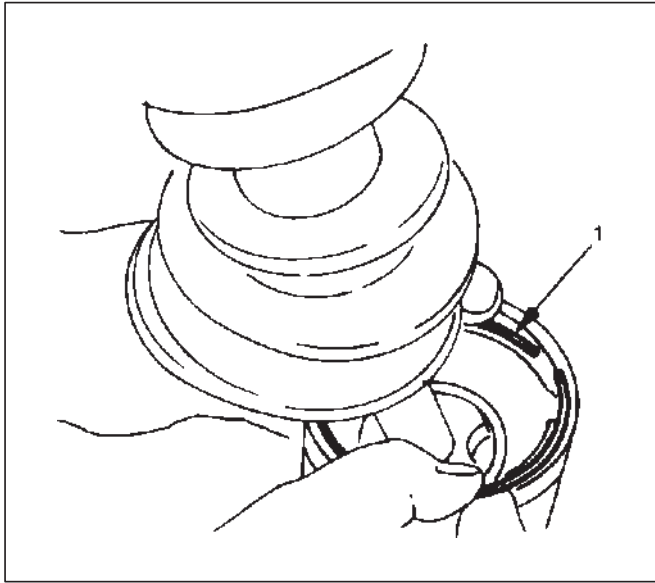


13. Align the track on the ball (1) retainer with the window in the cage, and install the six balls into position.



14. Install spacer.
15. Install snap ring.
16. Enclose 150g of the specified grease in DOJ case, then install drive shaft joint assembly. After reassembly, move the DOJ longitudinally several times to get to fit.

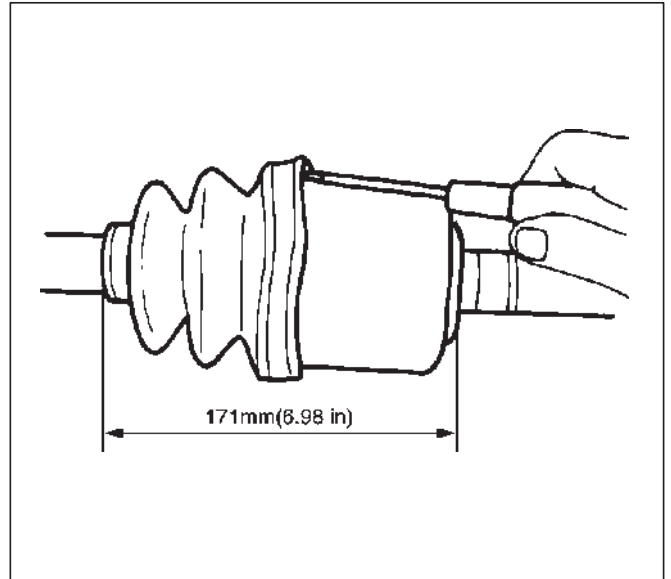
17. Install the circlip (1) so that open ends are positioned away from the ball groove.



**Legend**

- (1) Outer Case
- (2) Circlip
- (3) Open Ends

18. Install bellows. Adjust the air pressure within the bellows by inserting a screwdriver or equivalent, so that it equals atmospheric pressure.



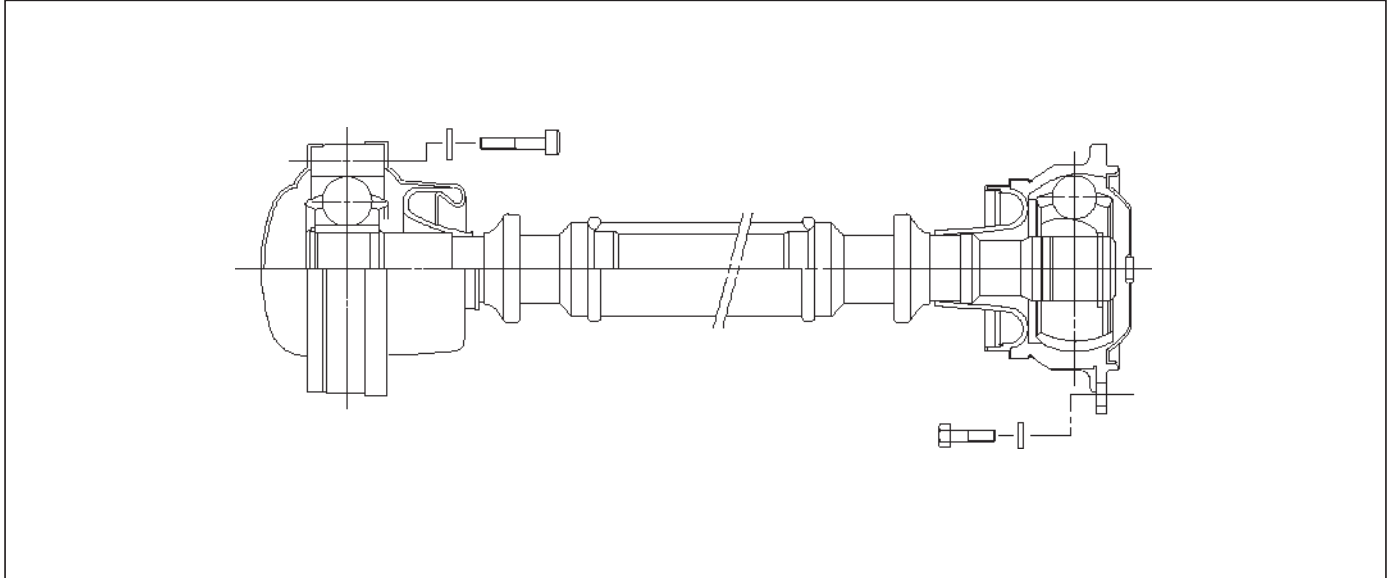
19. Install Band. After installation, check that the bellows is free from distortion.

## Front Propeller Shaft

### General Description

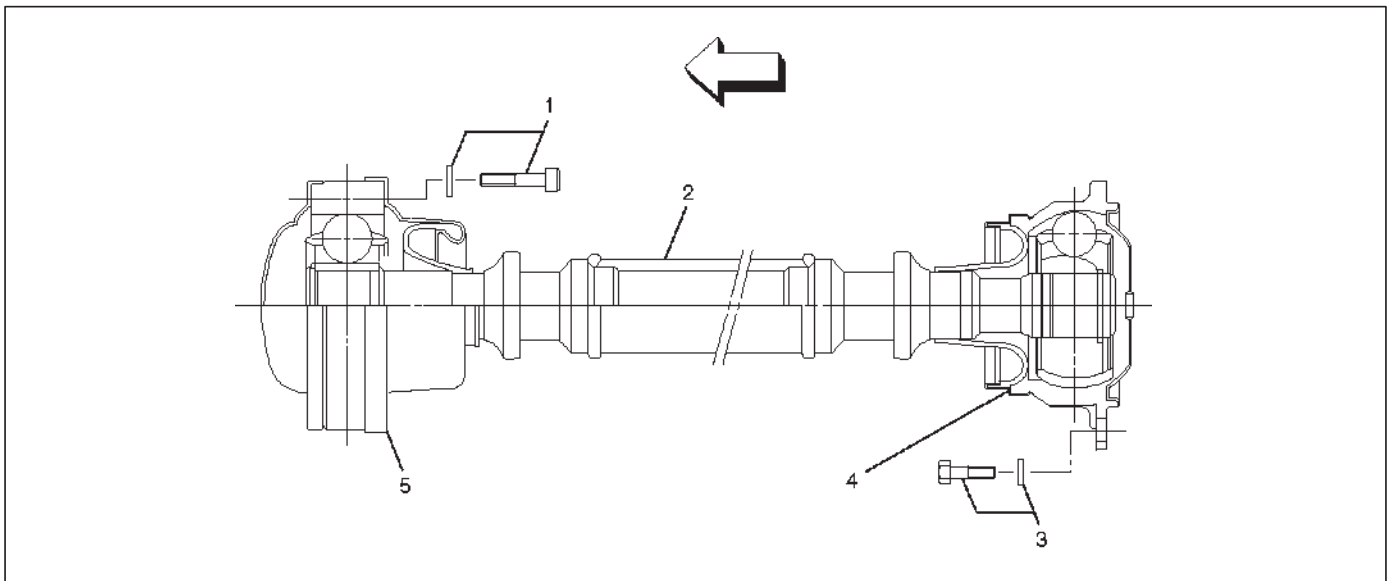
Since the propeller shaft is carefully balanced, welding or any other modifications are not permitted.

Alignment marks should be applied to each propeller shaft before removal.



401RX016

### Front Propeller Shaft and Associated Parts



401RX017

#### Legend

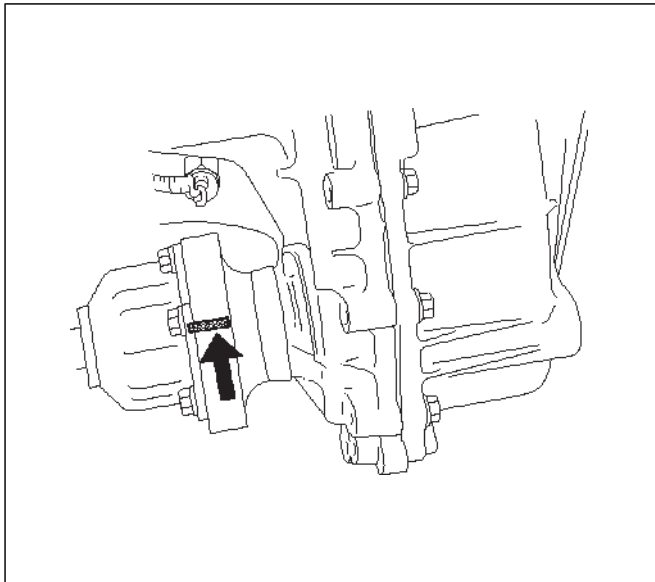
- (1) Bolt and Lock Washer (Front Axle Side)
- (2) Front Propeller Shaft

- (3) Bolt and Washer (Transfer Side)
- (4) BJ Constant Velocity Joint
- (5) LJ Constant Velocity Joint

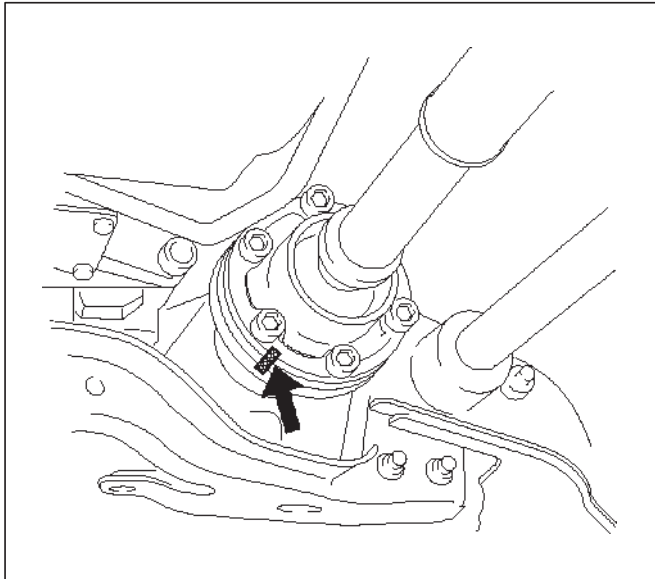
## Removal

1. Jack up the vehicle and support it on the chassis stands.
2. Gear shift lever should be placed in neutral position and parking brake released.
3. Remove the exhaust and transfer protectors.

NOTE: Apply alignment marks on the flange at the front propeller shaft both front and rear side.



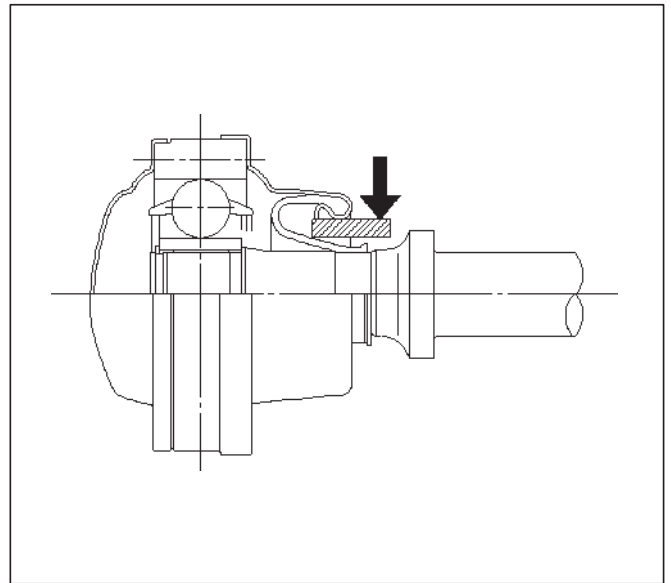
401RX016



401RW052

4. Remove bolt and lock washer (Front axle side).
5. Remove bolt and washer (Transfer side).
6. Remove front propeller shaft.

NOTE: When removing, installing or carrying for front propeller shaft, be sure to wind a piece of cloth around the part of the boot with which fittings may interfere so that the boot can be protected. The boot may be damaged if bending force is applied to the constant velocity joint of the shaft.



401RW051

## Installation

NOTE: Never install the shaft assembly backwards. Completely remove the black paint from the connecting surface of flange coupling on each end of propeller shaft. Clean so that no foreign matter will be caught in between.

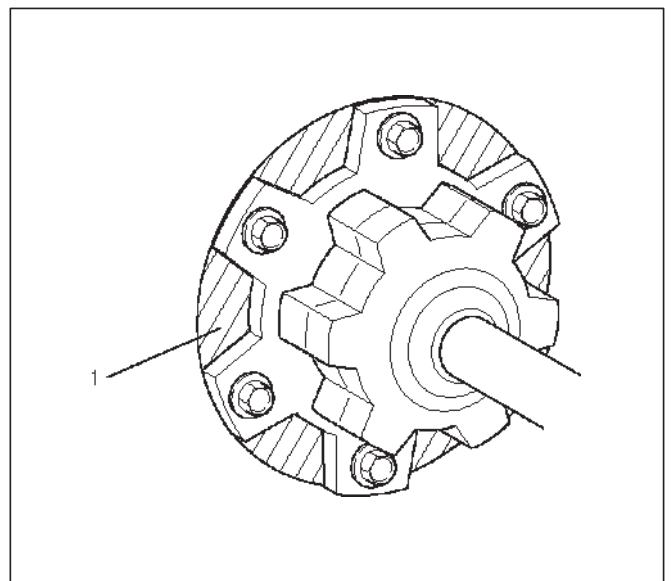
1. Align the mark which was applied at removal. Install front propeller shaft and tighten the bolts to the specified torque.

### Torque:

**Front axle side: 43 N·m (32 lb ft)**

**Transfer side: 63 N·m (46 lb ft)**

2. Install the exhaust and transfer protectors.
3. After installing the propeller shaft, be sure to apply black paint (1) to exposed area (other than connecting surface) of the entire surface of flange coupling (Transfer side only).



401RX011

### Inspection and Repair

Make necessary correction or parts replacement if wear, damage, corrosion or any other abnormal condition is found through inspection.

Check the following parts for wear, damage, noise or any other abnormal conditions:

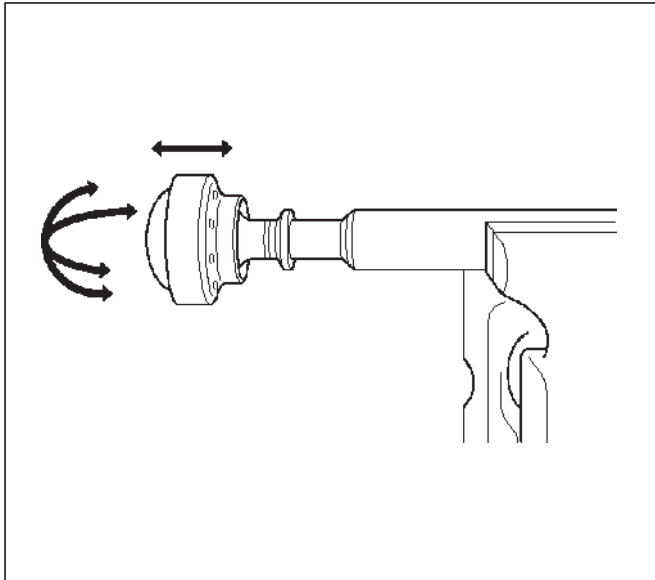
- Constant velocity joint

### Constant Velocity Joint

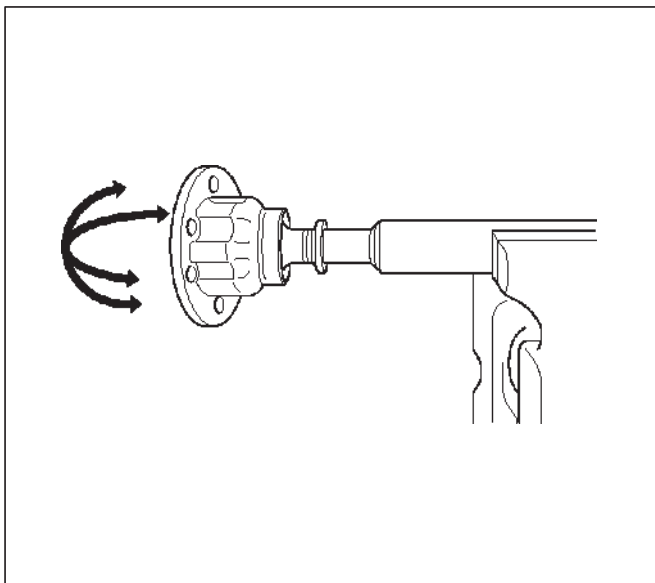
NOTE: LJ and BJ constant velocity joints are unremovable types. Check the joint for play and the boot for damage, wear, and leak of grease. If abnormality is found, replace propeller shaft as an assembly.

### Play in Constant Velocity Joint

Fix the shaft in a vise between pieces of wood, and try to move the joint vertically, right and left, and back and forth to make sure of smooth motions and no remarkable play.



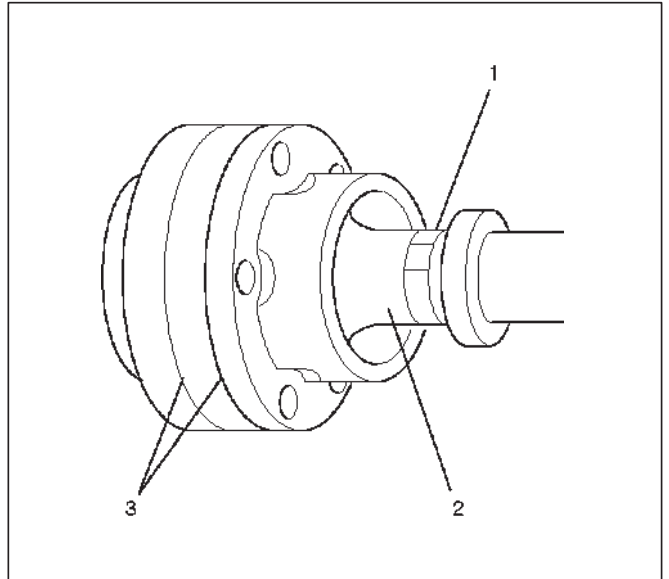
401RW050



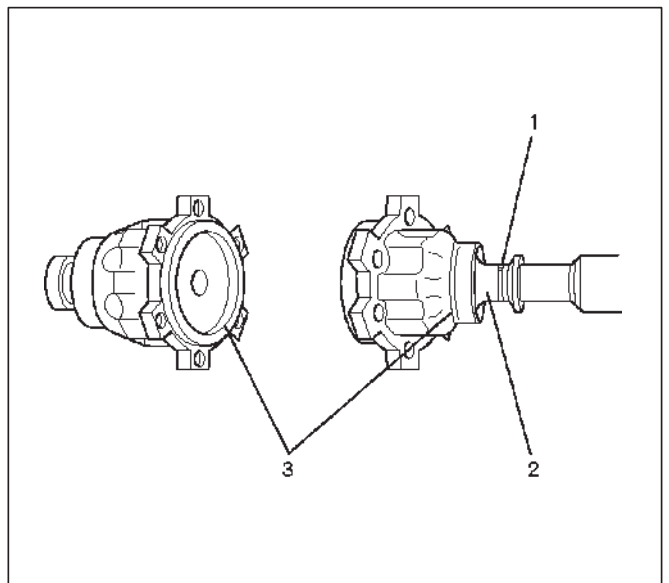
401RW049

### Boot of Constant Velocity Joint

Check the boot (2) for crack, damage and grease leak, and the boot band (1) for loosening and damage. Check the both sides of the joint and make sure that there is no leak of grease from the cover press-in parts(3).



401RX019

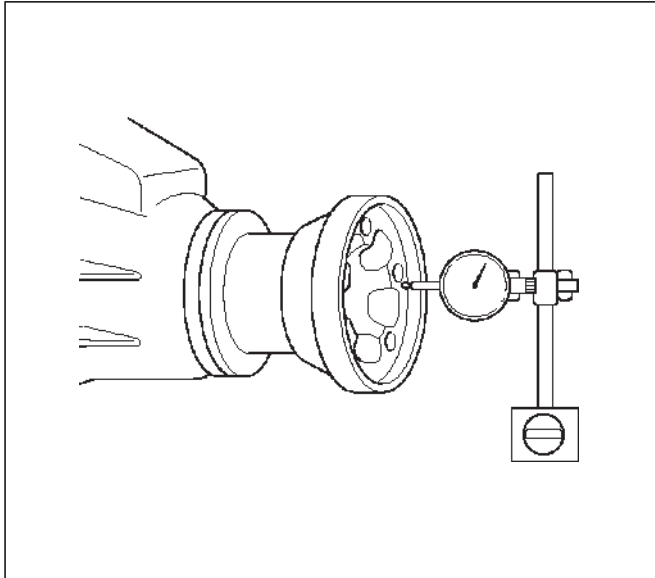


401RX021

**Front Axle Flange Run-out**

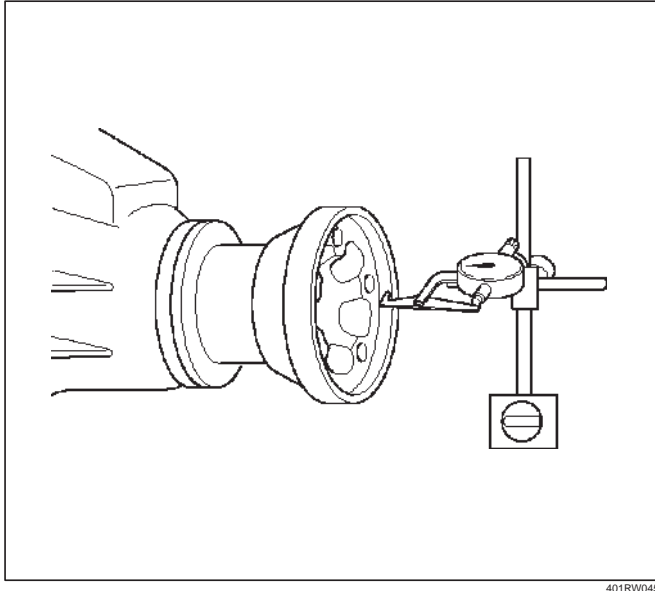
1. Set a dial gage at right angle near the outer circumference of the flange face and check the run-out of the flange face.

**Limit: 0.15 mm (0.006 in)**

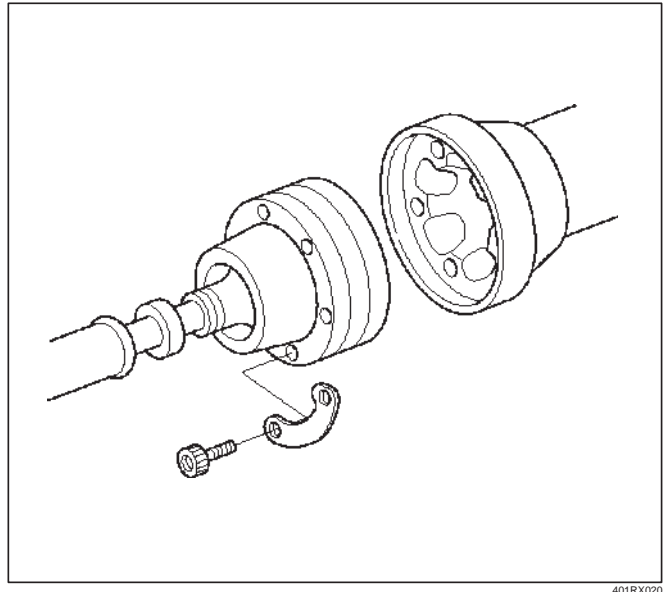


2. Set a dial gage at right angle near the inner circumference of the flange and check the run-out of the flange.

**Limit: 0.15 mm (0.006 in)**



3. If vibration is felt during the TOD drive, disconnect the propeller shaft at the front axle. Reinstall the propeller shaft at 60°, 120°, 180°, 240°, and 300° and conduct test drive in each position and check if there is vibration.





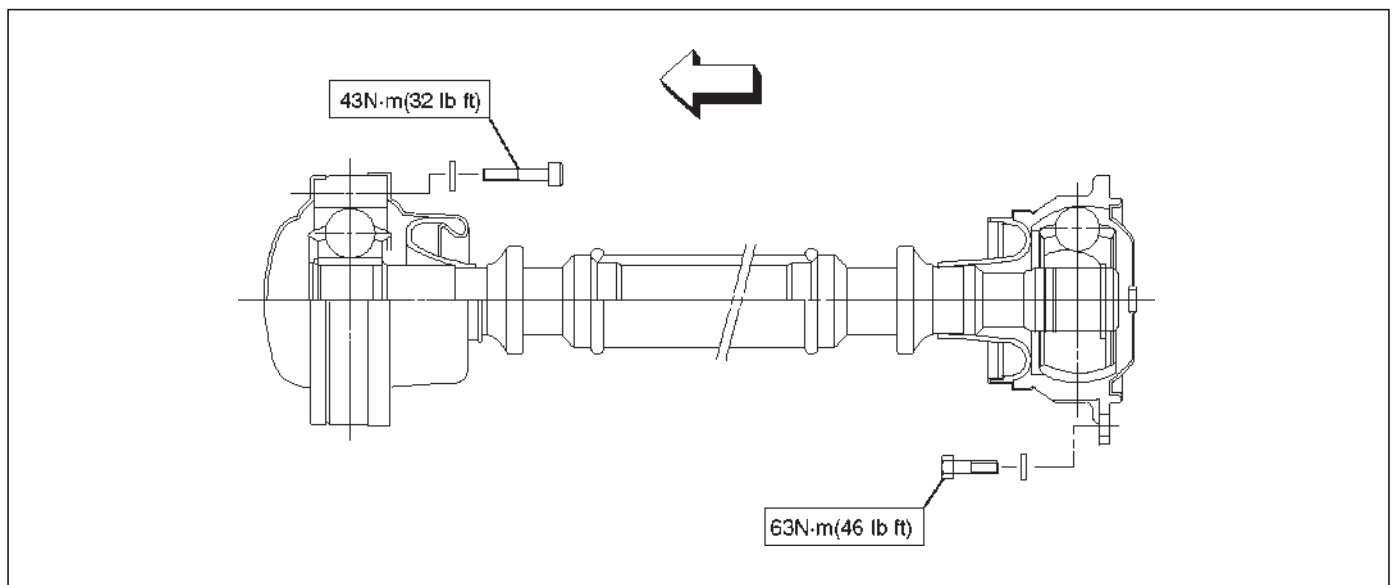
## 4C-20 DRIVE SHAFT SYSTEM

### Main Data and Specifications

#### General Specifications

Engine	6VE1(3.5 L)
Transmission	A/T with TOD
Construction	Hollow steel tube with constant velocity joints.
Outside diameter	40.0 mm (1.57 in)
Length	577 mm (22.72 in)

#### Torque Specifications

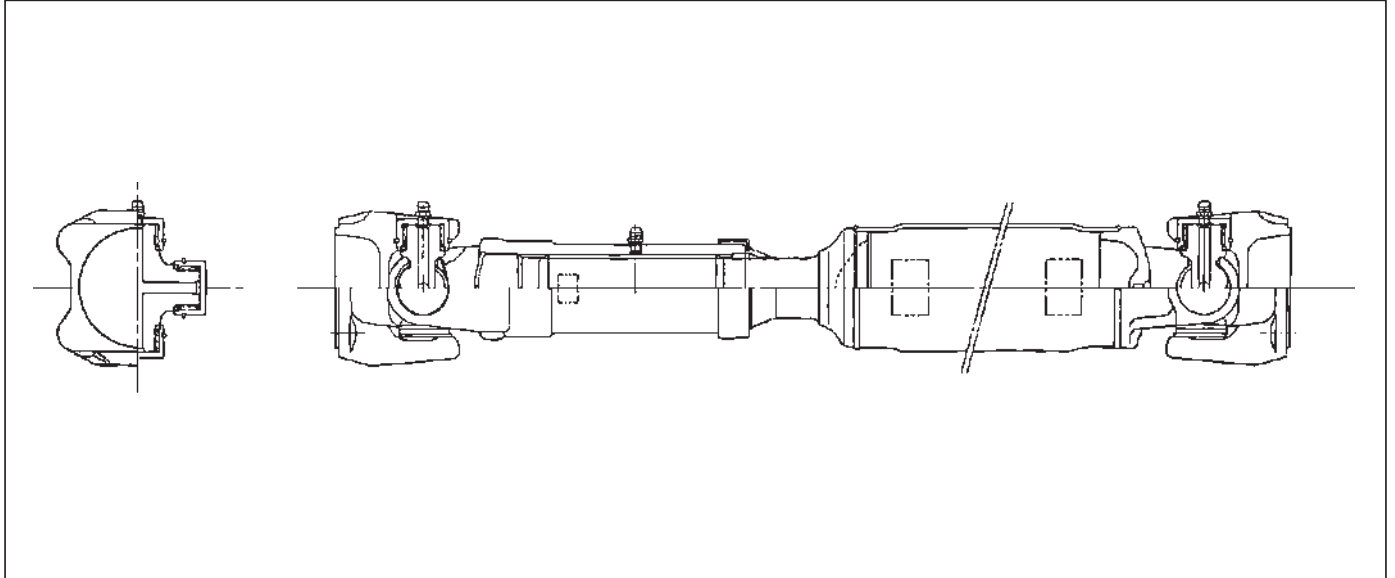


## Rear Propeller Shaft

### General Description

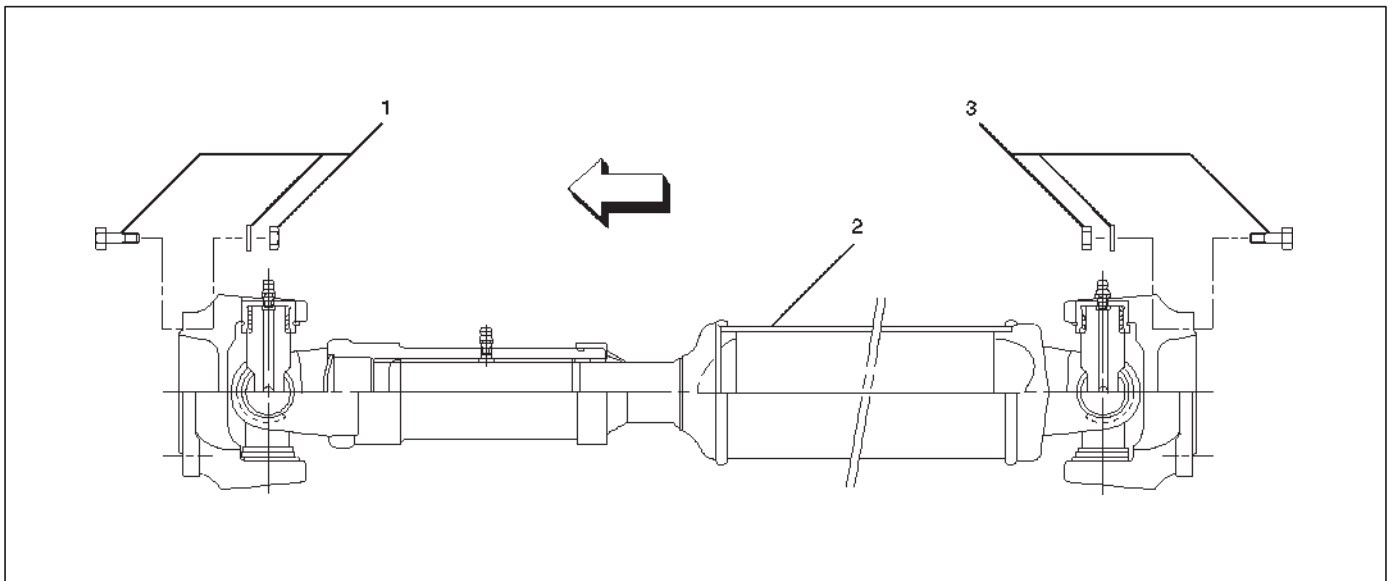
Since the propeller shaft is carefully balanced, welding or any other modifications are not permitted.

Alignment marks should be applied to each propeller shaft before removal.



401RW003

### Rear Propeller Shaft and Associated Parts



401RW059

#### Legend

(1) Bolt, Nut and Washer

(2) Rear Propeller Shaft

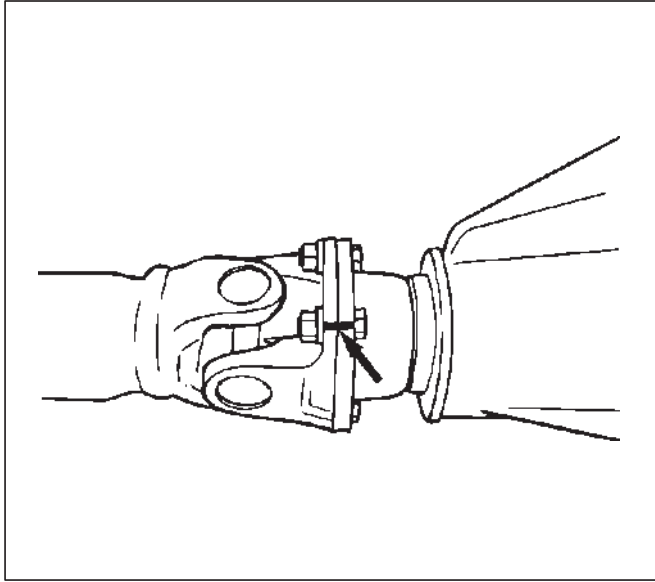
(3) Bolt, Nut and Washer

## 4C-22 DRIVE SHAFT SYSTEM

### Removal

1. Jack up the vehicle and support it on the chassis stands.
2. Gear shift lever should be placed in neutral position and parking brake released.

NOTE: Apply alignment marks on the flange at the rear propeller shaft both front and rear side.



3. Remove bolt, nut and washer (Rear axle side).
4. Remove bolt, nut and washer (Transfer side).
5. Remove rear propeller shaft.

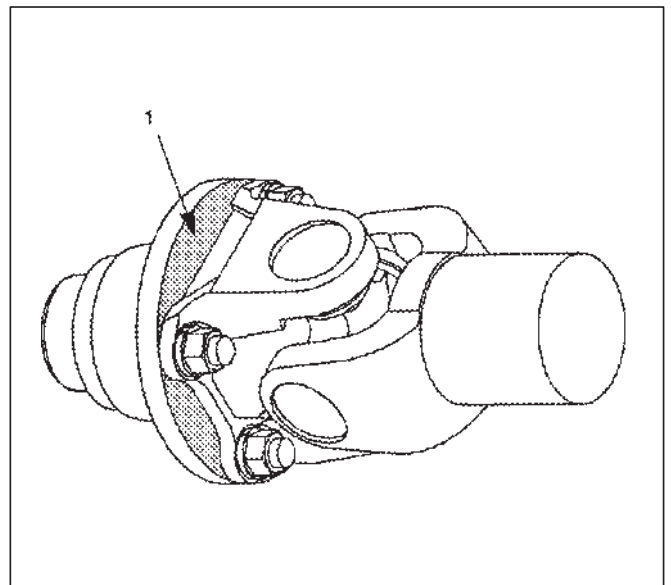
### Installation

NOTE: Never install the shaft assembly backwards.

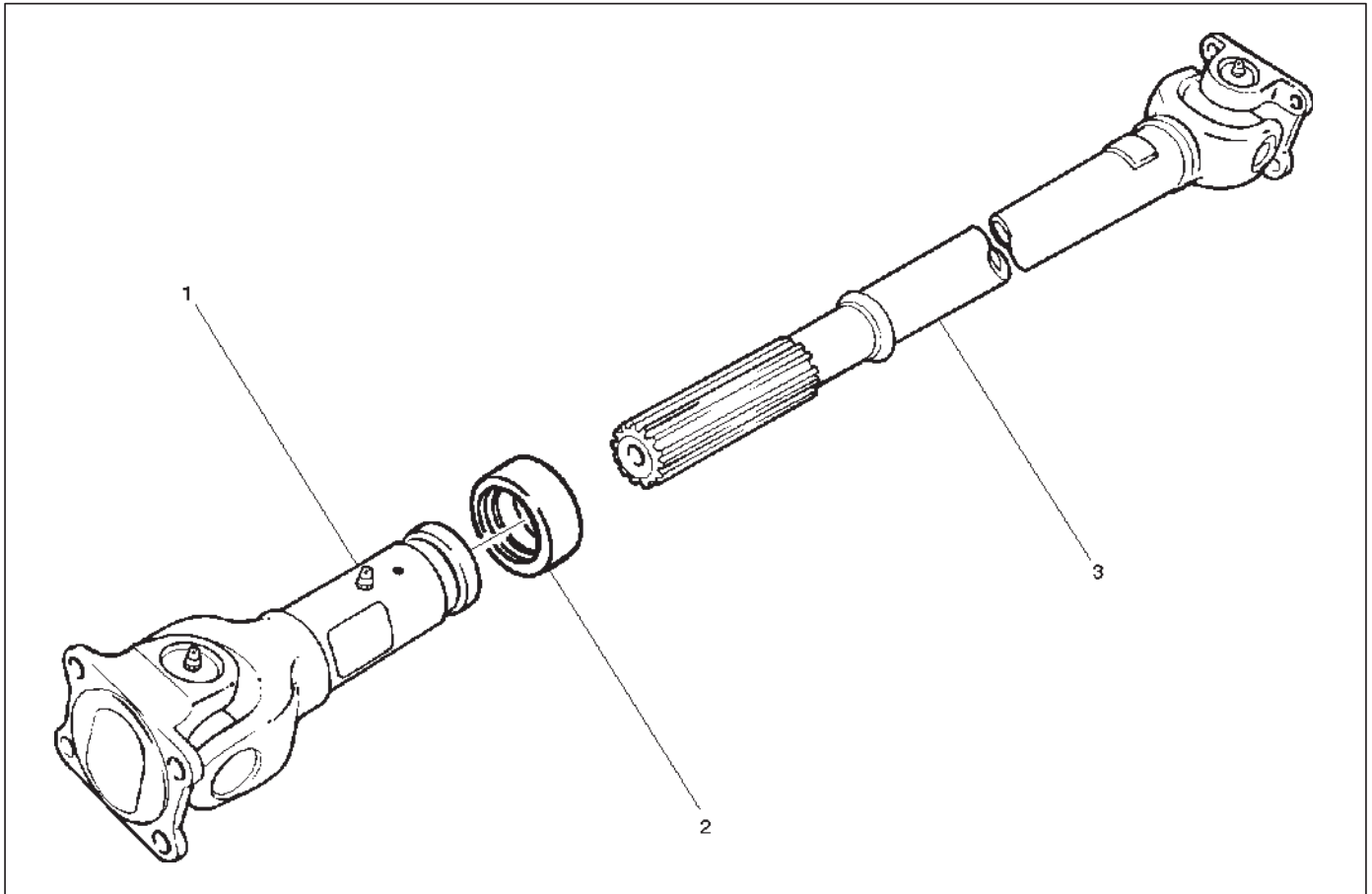
1. Completely remove the black paint from the connecting surface of flange coupling on each end of propeller shaft. Clean so that no foreign matter will be caught in between.
2. Align the mark which is applied at removal .  
Install rear propeller shaft and tighten the bolts to the specified torque.

**Torque: 63 N·m (46 lb ft)**

3. After installing the propeller shaft, be sure to apply black paint (1) to exposed area (other than connecting surface) of the entire surface of flange coupling .



**Disassembly**



401RW057

**Legend**

(1) Sleeve Yoke

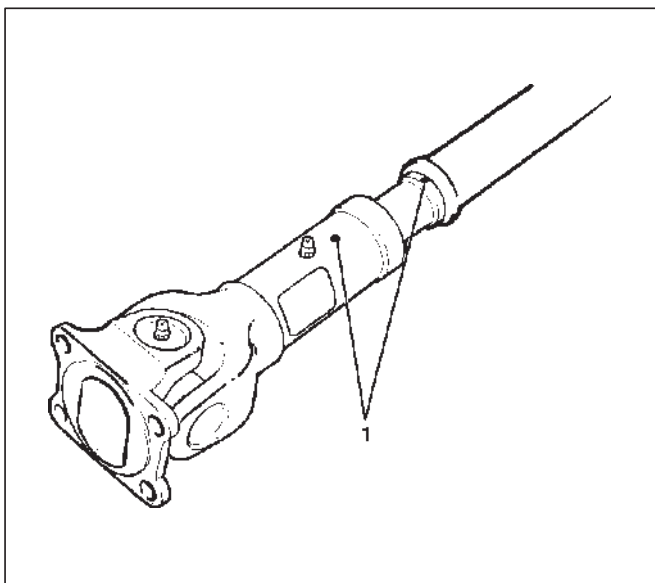
(2) Seal

(3) Tube Assembly

1. Apply alignment marks (1) on the sleeve yoke and tube assembly then remove sleeve yoke.

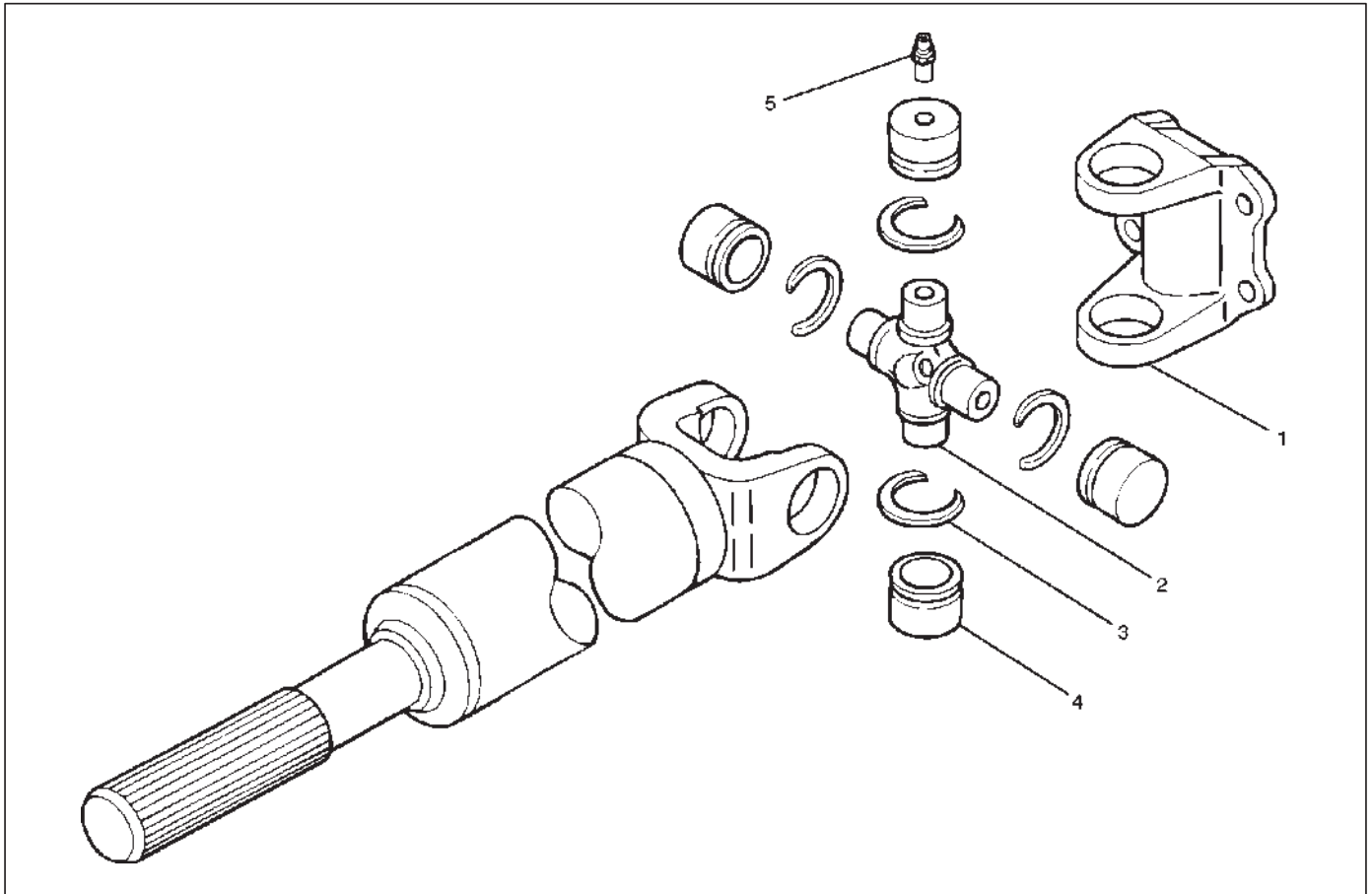
2. Remove seal.

3. Remove tube assembly.



401RW056

### Universal Joint Disassembly

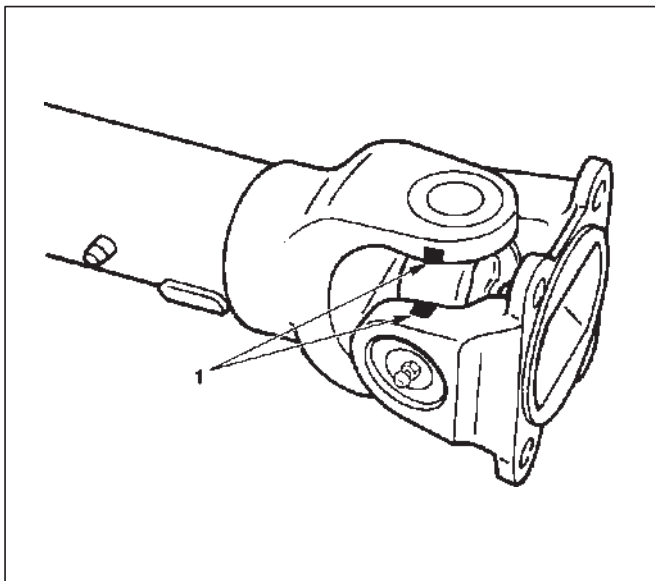


401RW054

#### Legend

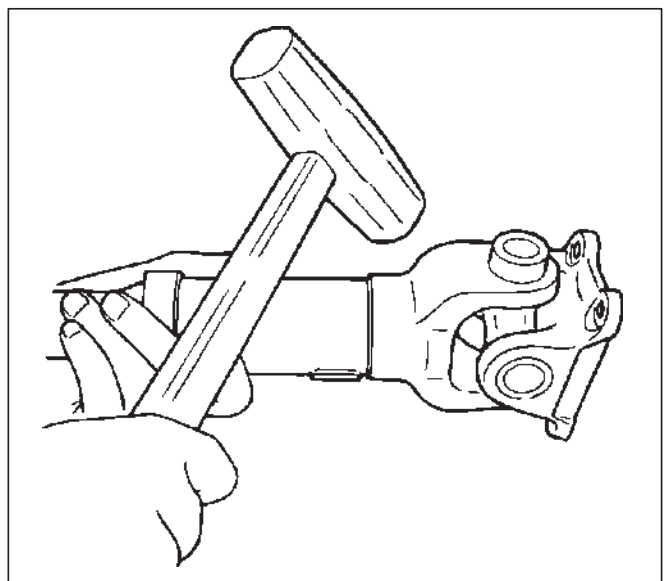
- (1) Flange Yoke
- (2) Spider with Grease Fitting
- (3) Snap Ring
- (4) Needle Roller Bearing
- (5) Grease Fitting

1. Apply alignment marks (1) on the yokes of the universal joint, then remove snap ring.



401RS028

2. Tap out the needle roller bearing by gently striking the shoulder of the yoke, using a mallet or a brass hammer.



401RS006

3. Make sure of proper position for reinstallation by applying setting marks, then remove spider with grease fitting.

### Inspection and Repair

Make necessary correction or parts replacement if wear, damage, corrosion or any other abnormal condition is found through inspection.

NOTE: When any part of the journal assembly (spider, needle roller bearing, grease fitting) requires replacement, be sure to replace the entire assembly.

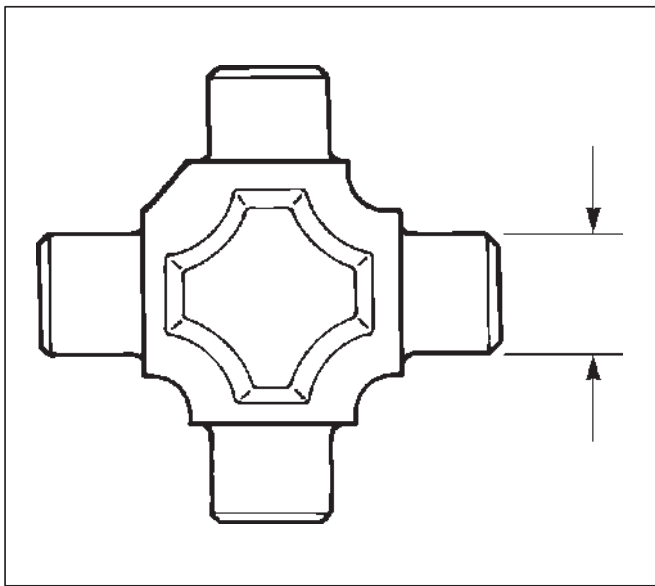
Check the following parts for wear, damage, noise or any other abnormal conditions:

1. Spider
2. Needle roller bearing
3. Yoke
4. Flange

### Outside Diameter of Spider Pin

**Standard: 17.00 mm (0.669 in)**

**Limit: 16.90 mm (0.665 in)**

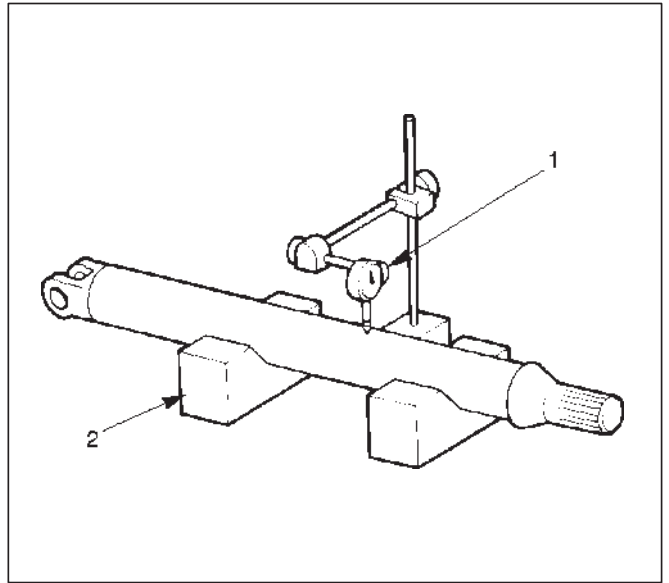


### Propeller Shaft Run-out

Support the ends of the propeller shaft on V-blocks (2) and check for run-out by holding the probe of a dial indicator (1) in contact with the center part of the shaft. If the amount of run-out is beyond the standard value for assembly, correct with a bench press or replace the shaft with a new propeller shaft assembly .

**Standard: 0.3 mm (0.012 in)**

**Limit: 0.5 mm (0.02 in)**

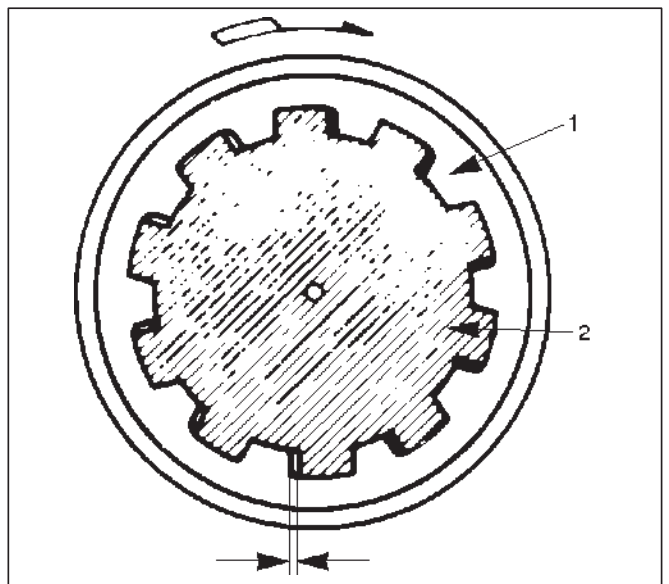


### Play in Splines in Normal Direction of Rotation

Check the amount of play between the sleeve yoke (1) and the propeller shaft spline (2) in the direction of rotation, using a pointed feeler gauge.

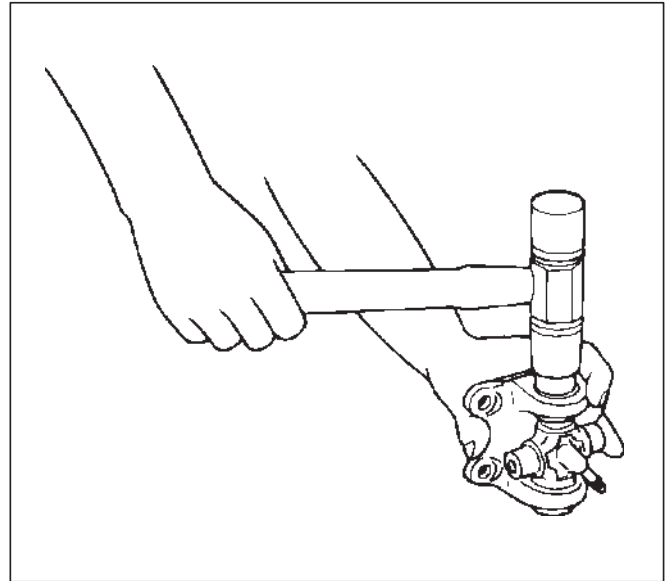
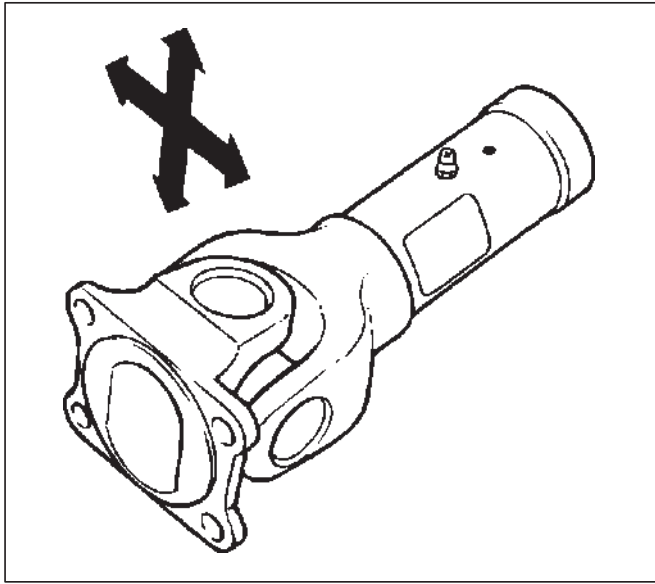
**Standard: 0.073 – 0.156 mm (0.003 – 0.006 in)**

**Limit: 0.3 mm (0.012 in)**



### Play in Universal Joint

Limit: Less than 0.1 mm (0.004 in)



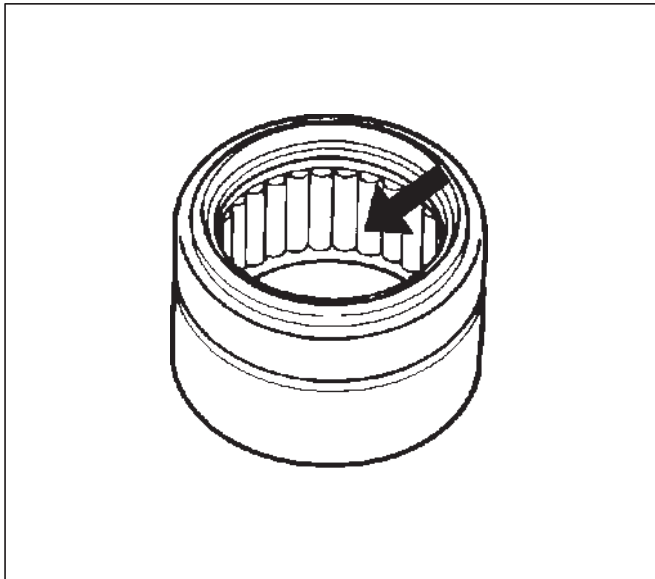
4. Align setting marks (1) and join the yokes.

NOTE: Assemble the spider and spline yoke so that their grease fittings are arranged on the same side.

### Universal Joint Reassembly

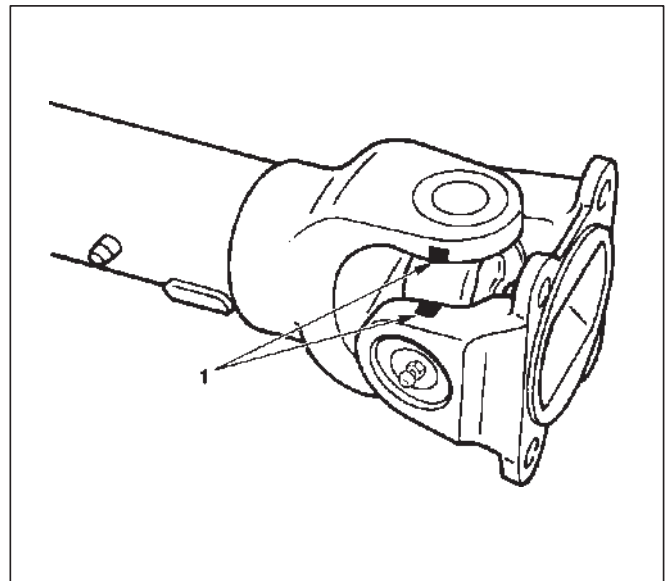
1. Install spider to flange yoke. Be sure to install the spider by aligning the setting marks made during disassembly.
2. Before installing needle roller bearing, apply a molybdenum-disulfide grease or a multi-purpose type grease NLGI No. 2 to inside of the bearing cap.

Grease Amount: Approx. 1.2 g (0.042 oz)



3. Using either a mallet (or brass hammer) or a press, install the needle roller bearing into the yoke so that the snap ring can be installed in its groove.

**CAUTION:** The needle roller bearing cannot be installed smoothly if it is set at an incorrect angle with the flange and excessive hammering will damage the needle roller bearing.



5. Install snap ring.

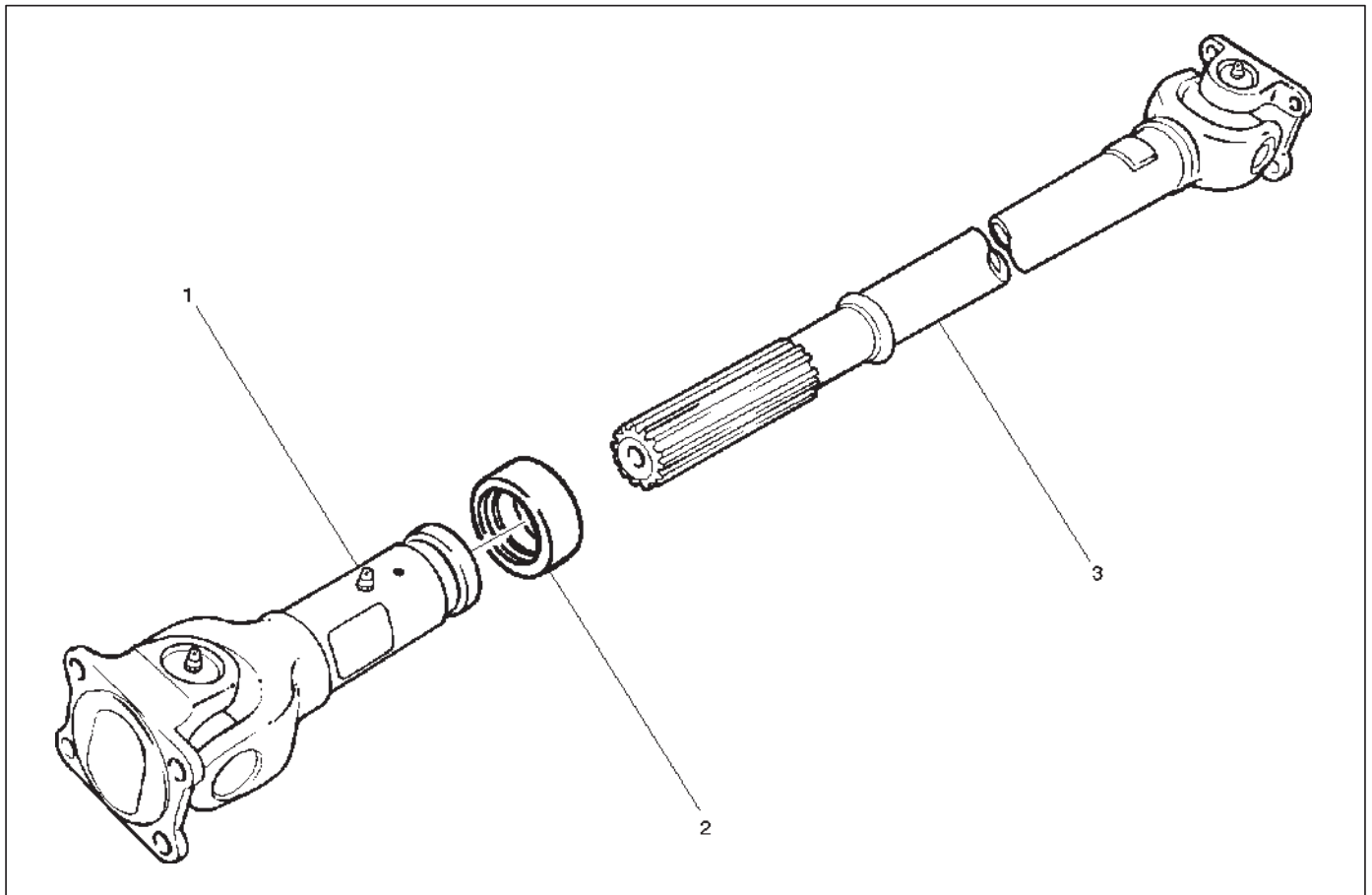
NOTE: Discard used snap rings and install new ones. When the bearing cap is in position, select and attach a snap ring of suitable thickness so that the end play of the spider pin is held within 0.1 mm (0.004 in).

#### Snap ring thickness and identification color

- 1.5 mm (0.059 in): Blue
- 1.545 mm (0.061 in): White
- 1.59 mm (0.063 in): Yellow
- 1.635 mm (0.064 in): Green
- 1.68 mm (0.066 in): Not colored

NOTE: Be sure to use snap rings of the same thickness on both sides.

## Reassembly



401RW057

### Legend

(1) Sleeve Yoke

(2) Seal

(3) Tube Assembly

1. Discard used seal and install new one.
2. Align the alignment marks and install tube assembly to sleeve yoke.



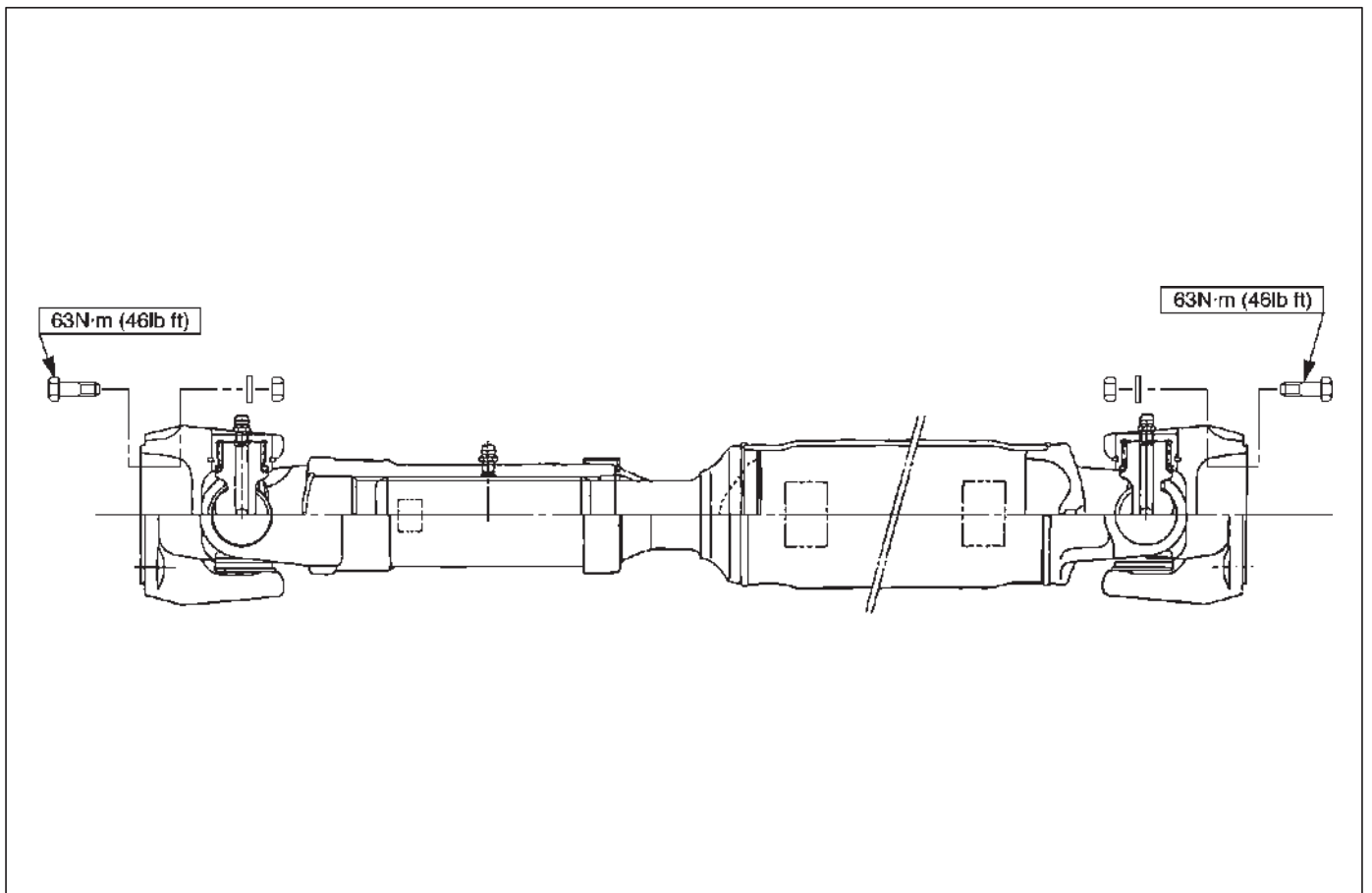
## 4C-28 DRIVE SHAFT SYSTEM

### Main Data and Specifications

#### General Specifications

Engine	6VE1(3.5 L)
Transmission	A/T with TOD
Construction	Hollow steel tube with yoke and spider type universal joints.
Outside diameter	68.9 mm (2.71 in)
Length	654 mm (25.75 in)

#### Torque Specifications



E04RW006

# DRIVELINE/AXLE

## TRANSFER CASE (TOD)

### CONTENTS

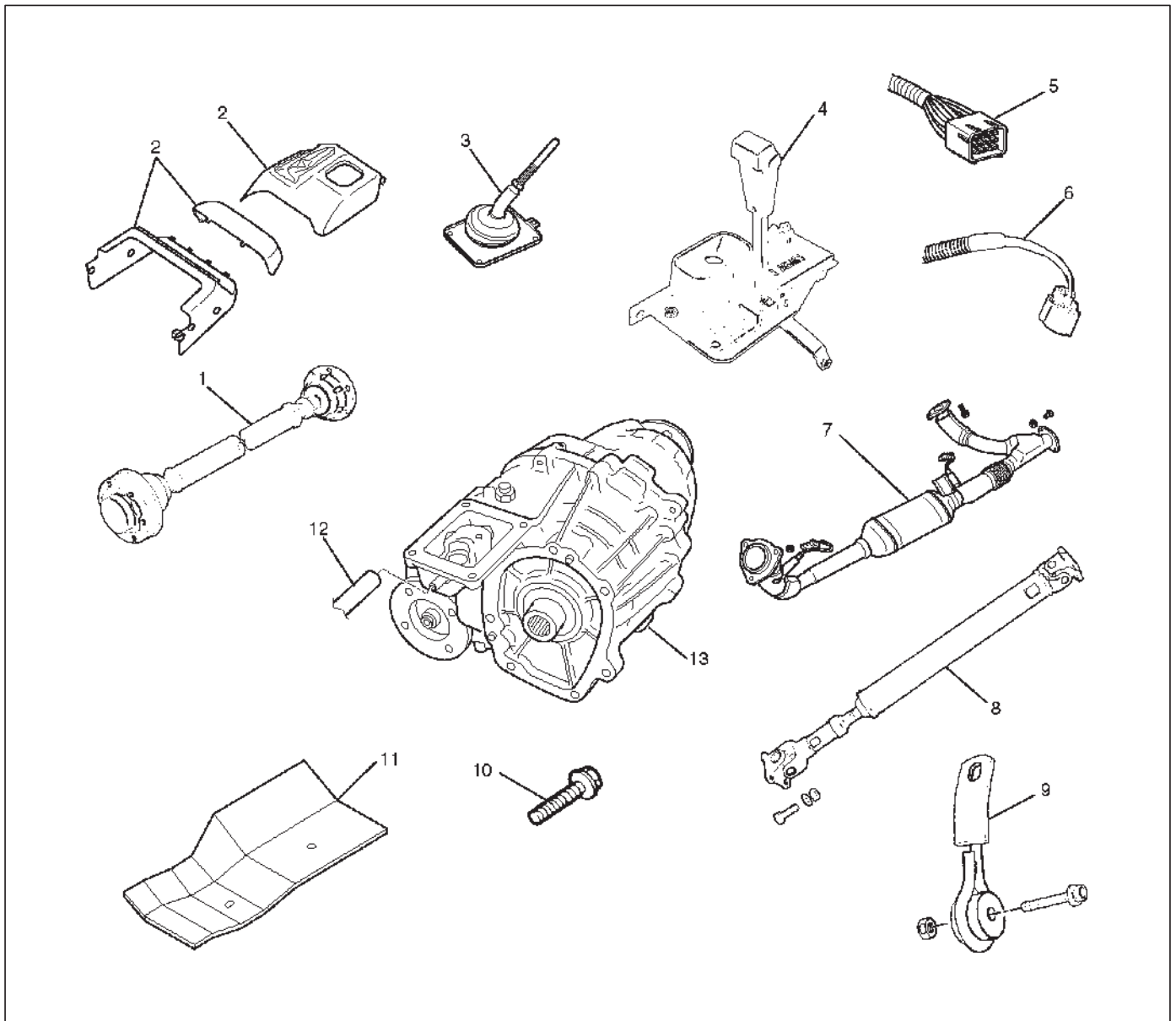
Service Precaution .....	4D2-1	Disassembly .....	4D2-16
Transfer Case Assembly .....	4D2-2	Sprocket and Mechanical Lock .....	4D2-18
Removal .....	4D2-3	Disassembled View .....	4D2-18
Installation .....	4D2-3	Disassembly .....	4D2-18
Transfer Rear Oil Seal .....	4D2-5	Output Shafts and Shift Control Shaft .....	4D2-20
Transfer Rear Oil Seal and Associated		Disassembled View .....	4D2-20
Parts .....	4D2-5	Disassembly .....	4D2-21
Removal .....	4D2-5	Transfer Case .....	4D2-23
Installation .....	4D2-5	Disassembled View .....	4D2-23
TOD ECU .....	4D2-7	Disassembly .....	4D2-24
Removal .....	4D2-7	Inspection and Repair .....	4D2-26
Installation .....	4D2-7	Transfer Case .....	4D2-30
Unit Repair .....	4D2-8	Disassembled View .....	4D2-30
Inspection .....	4D2-8	Reassembly .....	4D2-30
Transfer Case .....	4D2-9	Output Shafts and Shift Control Shaft .....	4D2-34
Disassembled View .....	4D2-9	Disassembled View .....	4D2-34
Disassembly .....	4D2-9	Reassembly .....	4D2-34
Reassembly .....	4D2-10	Sprocket and Mechanical Lock .....	4D2-37
Transfer Cover Assembly .....	4D2-12	Disassembled View .....	4D2-37
Disassembled View .....	4D2-12	Reassembly .....	4D2-37
Disassembly .....	4D2-12	Clutch Pack and Clutch Cam .....	4D2-39
Reassembly .....	4D2-14	Disassembled View .....	4D2-39
Transfer Case Assembly Clutch Pack and		Reassembly .....	4D2-39
Clutch Cam .....	4D2-16	Main Data and Specifications .....	4D2-41
Disassembled View .....	4D2-16	Special Tools .....	4D2-43

### Service Precaution

**WARNING: THIS VEHICLE HAS A SUPPLEMENTAL RESTRAINT SYSTEM (SRS). REFER TO THE SRS COMPONENT AND WIRING LOCATION VIEW IN ORDER TO DETERMINE WHETHER YOU ARE PERFORMING SERVICE ON OR NEAR THE SRS COMPONENTS OR THE SRS WIRING. WHEN YOU ARE PERFORMING SERVICE ON OR NEAR THE SRS COMPONENTS OR THE SRS WIRING, REFER TO THE SRS SERVICE INFORMATION. FAILURE TO FOLLOW WARNINGS COULD RESULT IN POSSIBLE AIR BAG DEPLOYMENT, PERSONAL INJURY, OR OTHERWISE UNNEEDED SRS SYSTEM REPAIRS.**

**CAUTION: Always use the correct fastener in the proper location. When you replace a fastener, use ONLY the exact part number for that application. ISUZU will call out those fasteners that require a replacement after removal. ISUZU will also call out the fasteners that require thread lockers or thread sealant. UNLESS OTHERWISE SPECIFIED, do not use supplemental coatings (Paints, greases, or other corrosion inhibitors) on threaded fasteners or fastener joint interfaces. Generally, such coatings adversely affect the fastener torque and the joint clamping force, and may damage the fastener. When you install fasteners, use the correct tightening sequence and specifications. Following these instructions can help you avoid damage to parts and systems.**

## Transfer Case Assembly



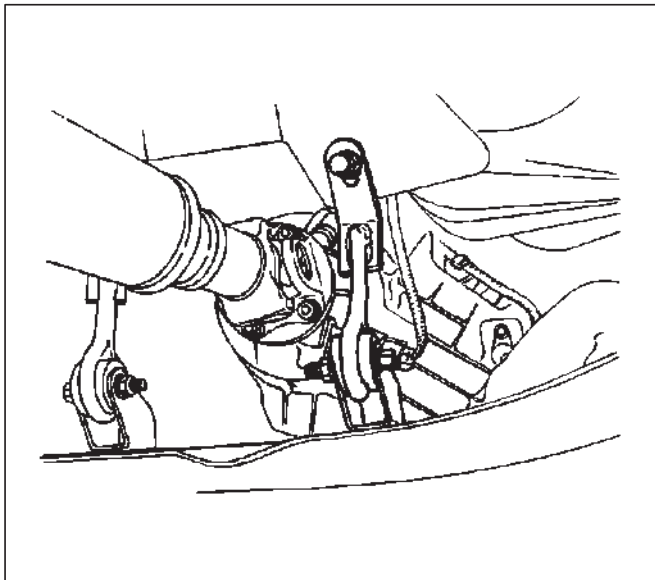
F07RX004

### Legend

- |                                  |                             |
|----------------------------------|-----------------------------|
| (1) Front Propeller Shaft        | (7) Left Exhaust Pipe       |
| (2) PCM Cover and Center Console | (8) Rear Propeller Shaft    |
| (3) Transfer Control Lever       | (9) Seat Belt Tension Rod   |
| (4) Selector Lever Assembly      | (10) Transfer Case Bolt     |
| (5) Transfer Connector           | (11) Air Scoop              |
| (6) Speed Sensor Connector       | (12) Breather Hose          |
|                                  | (13) Transfer Case Assembly |

## Removal

1. Disconnect the ground cable (-).
2. Remove the air scoop.
3. Remove the rear propeller shaft from the transfer case.
4. Remove the front propeller shaft.
5. Remove the shift control rod from the selector lever assembly.
6. Disconnect the harness connector and rear console and remove the center console.
7. Disconnect the shift lock cable and remove the selector lever assembly and put it aside.
8. Remove the transfer control lever.
9. Disconnect breather hose.
10. Remove the left front exhaust pipe set bolts and nuts, and put the pipe aside.
11. Remove the silencer.
12. Remove the left seat belt tension rod and put the propeller shaft aside.

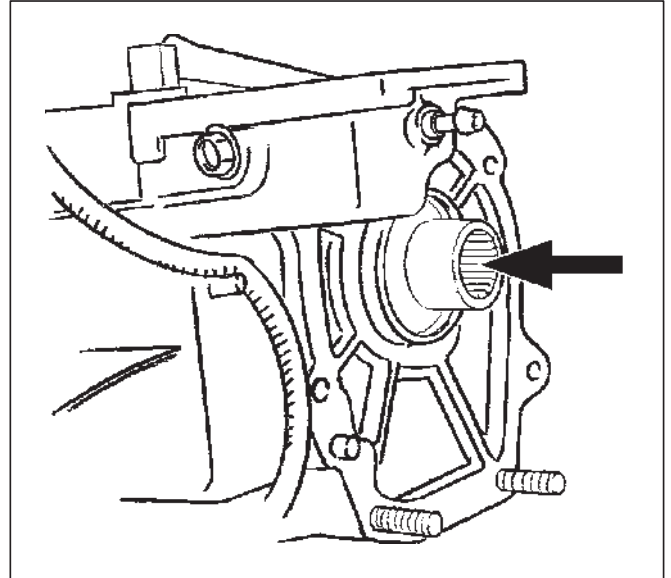


13. Disconnect the transfer connector from the top of the transfer case.
14. Disconnect the speed sensor harness connector.
15. Remove the fuse pipe clamp bolt on the transfer case assembly.
16. Support the transmission with a jack.
17. Remove the seven bolts from the transfer case.
18. Remove transfer case assembly.

## Installation

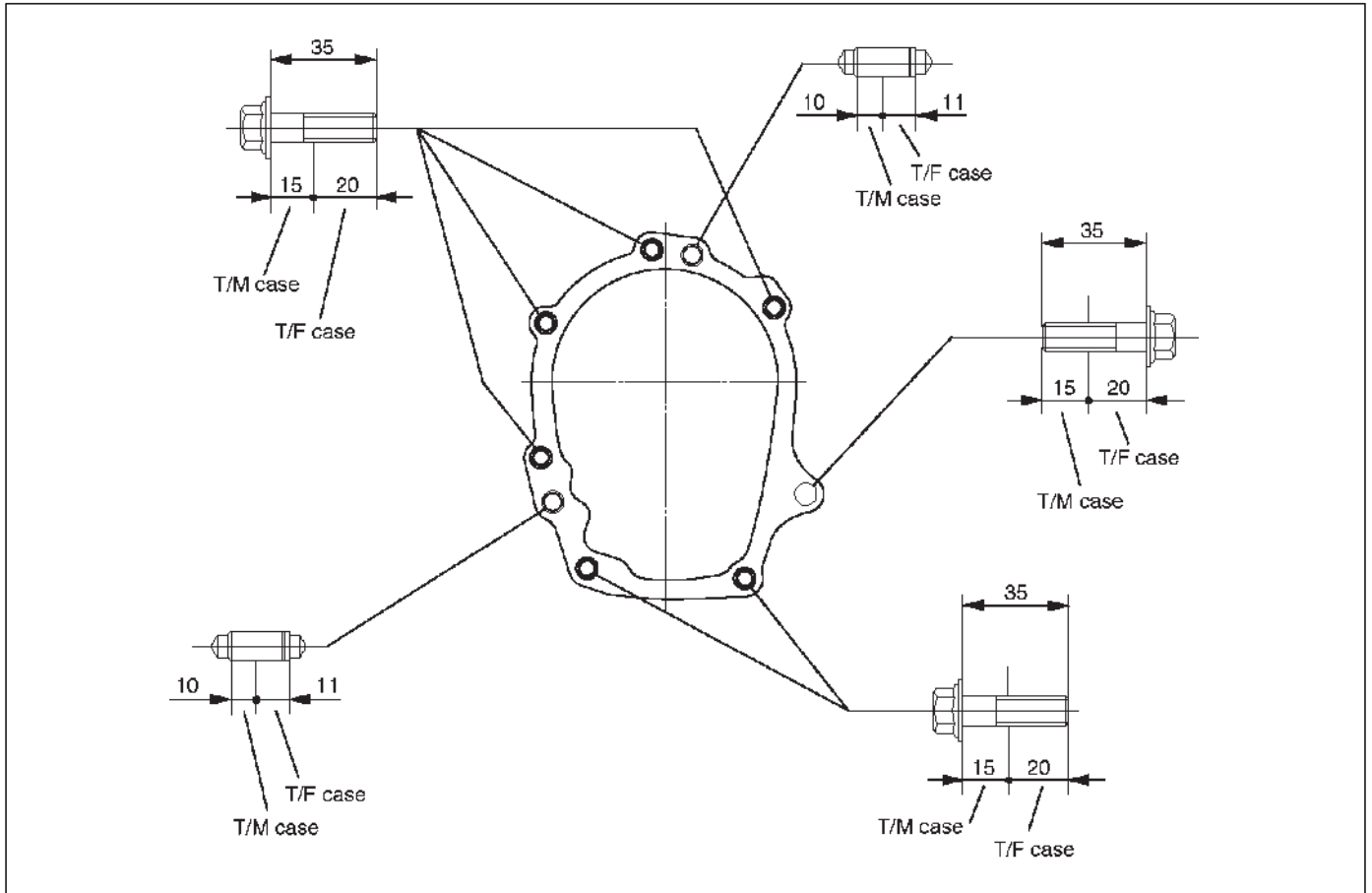
To install, follow the removal steps in the reverse order, noting the following points:

1. Apply a thin coat of grease (Besco L2) or equivalent to the input shaft spline.



2. Mount the transfer case.
3. Tighten the transfer case bolts (see the figure below).  
**Torque : 46 N·m (34 lb ft)**

## 4D2-4 TRANSFER CASE (TOD)

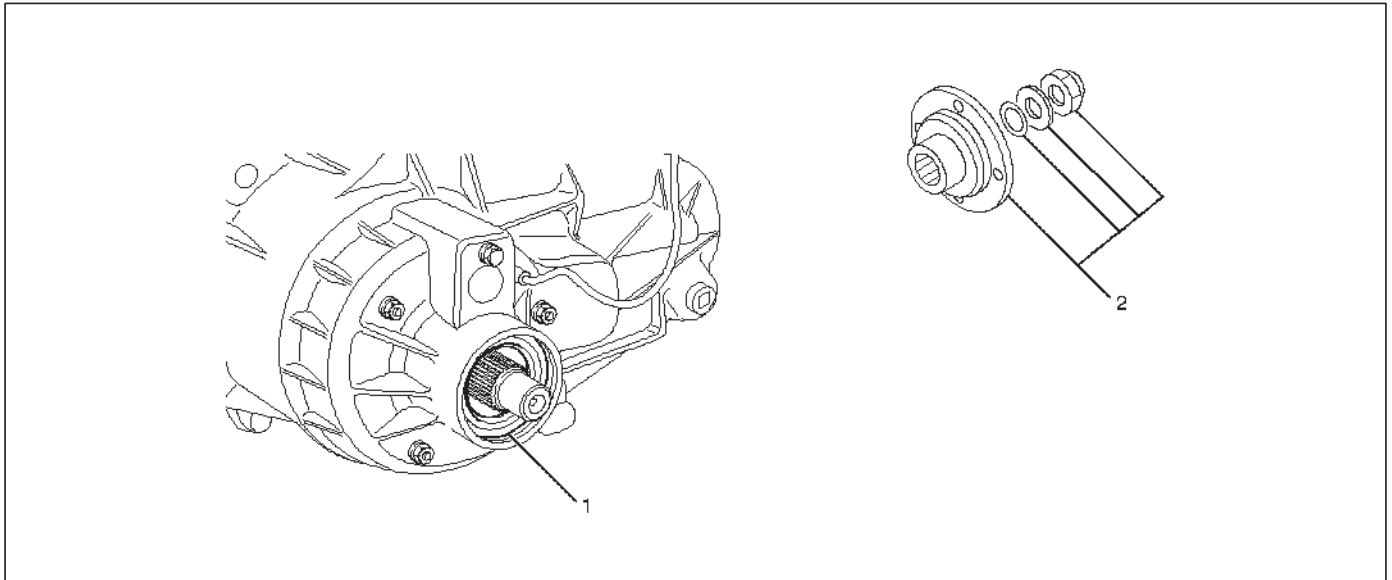


261RW004-1

4. Tighten the propeller shaft bolt.  
**Torque : 63 N·m (46 lb ft)**

## Transfer Rear Oil Seal

### Transfer Rear Oil Seal and Associated Parts



261RW005

#### Legend

- (1) Oil Seal
- (2) End Nut and Rear Companion Flange

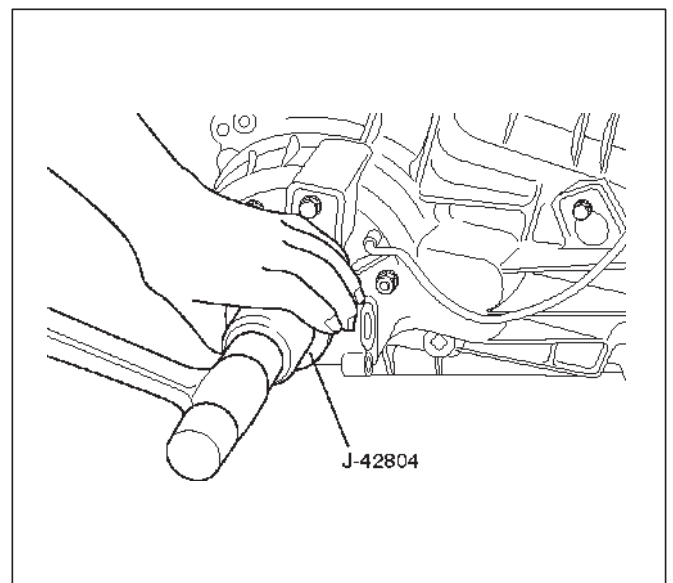
### Removal

1. Remove the rear propeller shaft from the transfer case.
2. Using the flange holder J-8614-11, remove the end nut.
3. Using the universal puller, remove the rear companion flange, washer and O-ring.
4. Remove the oil seal from the transfer rear case.

### Installation

1. Apply ATF to the circumference of the oil seal. Fill the oil seal lip with grease (Besco L2).
2. Using the oil seal installer J-42804, install the oil seal.

NOTE: When attaching the oil seal, pay attention to the direction.



261RW035

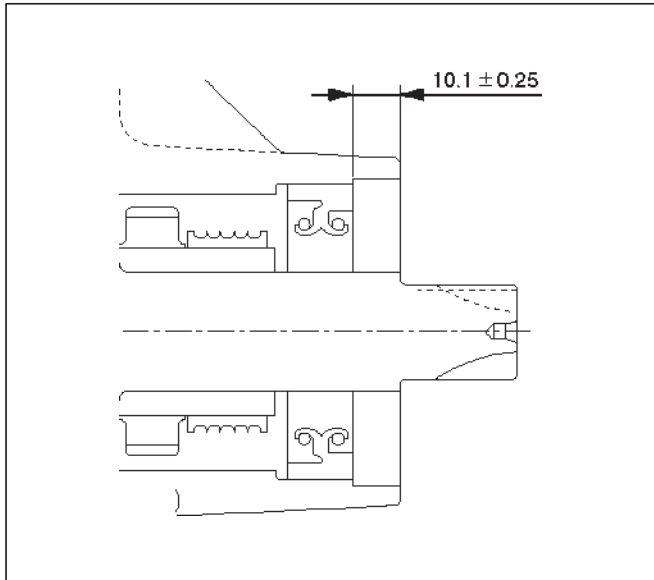
## 4D2-6 TRANSFER CASE (TOD)

### Rear Output Shaft Oil Seal

Distance between the transfer case end and oil seal.

NOTE: When installing the oil seal to the specified dimension, be careful not to damage it.

**Distance : 9.85 — 10.35mm (0.39 — 0.41 in)**



A04RW004

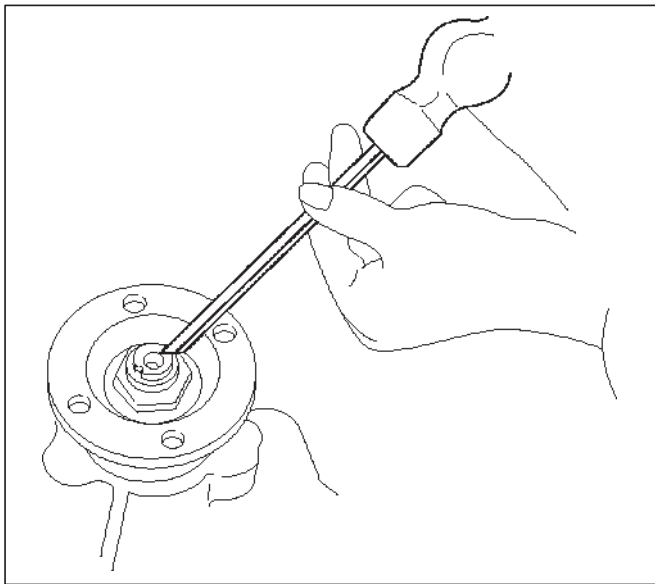
3. Mount the rear companion flange, O-ring , washer, and nut to the transfer in this order.

4. Using the flange holder J-8614-11, install a new end nut.

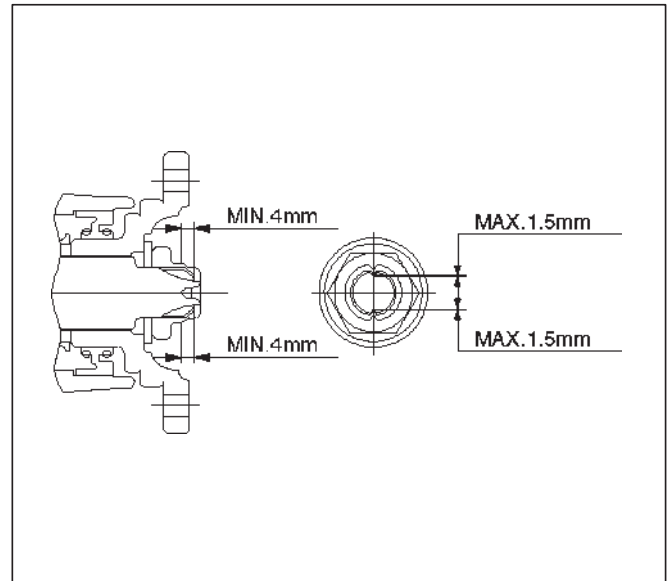
**Torque : 167 N-m (123 lb ft)**

5. Using the punch J-39209, stake the end nut at two spots.

NOTE: Check the staked end nut is free from cracks.



266RW020



260RW007

6. Install the rear propeller shaft to the transfer case and tighten to the specified torque.

**Torque : 63 N-m 46 (lb ft)**

## TOD ECU

### Removal

1. Disconnect the battery ground cable (-).
2. Remove the passenger seat.
3. Disconnect the connector from the ECU.
4. Remove the set bolts and detach the ECU from the bracket.

### Installation

1. Perform the removal steps in reverse order.



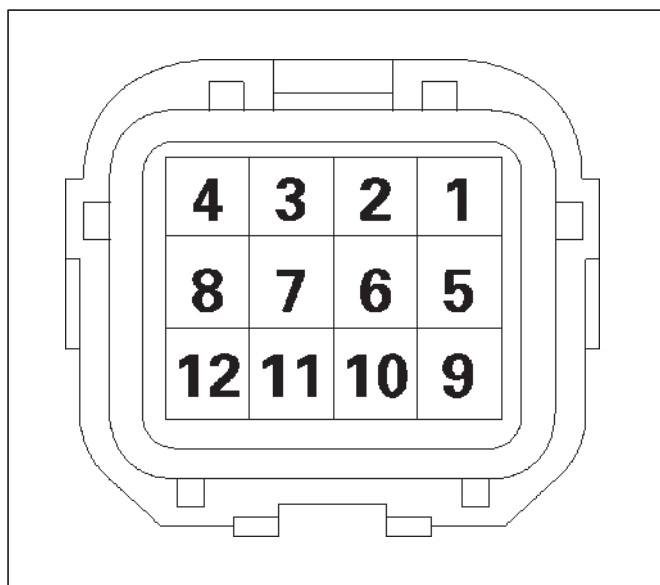
## Unit Repair

### Inspection

Before disassembling and after assembling, check the following items on the transfer connector terminals.

No .	NAME	CONTENTS	COLOR COD-ING
1	Ref . (Ref . )	Rear speed sensor reference output	LG
2	Ref . (Frt . )	Front speed sensor reference output	LG
3	SW GND	SW GND	B
4	4H SW (+)	4H SW plus terminal	R
5	Rer . (+)	Rear speed sensor plus	B/LG
6	Frt . (+)	Front speed sensor plus	LB
7	POWER GND	Power GND	B
8	SOL (+)	Electromagnetic solenoid	Y
9	COM (-) (Ref .)	Rear speed sensor GND	GR/R
10	COM (-) (Frt .)	Front speed sensor GND	GR/R
11	NC		—
12	4L SW (+)	4L SW plus terminal	Y

As for the color coding, refer to Wring-Wire Color Coding in Wiring System section.



810RW002

### 4H and 4L switch

Check whether the 4H (terminals 4 and 7) and 4L switch (terminals 12 and 3) work as specified in the table below. If yes, the continuity is established on these switch. If not, check the switch, shift rails, transfer case, and rear cover, and replace the failed parts.

Position	High	Neutral	4L
4H SW (4 to 7)	OFF	ON	OFF
4L SW (3 to 12)	OFF	ON	ON

### Power GND

Check that there is a continuity between the power GND pin (terminal 7) and transfer case. If not, replace the grounding wire.

### Resistance of electromagnetic coil

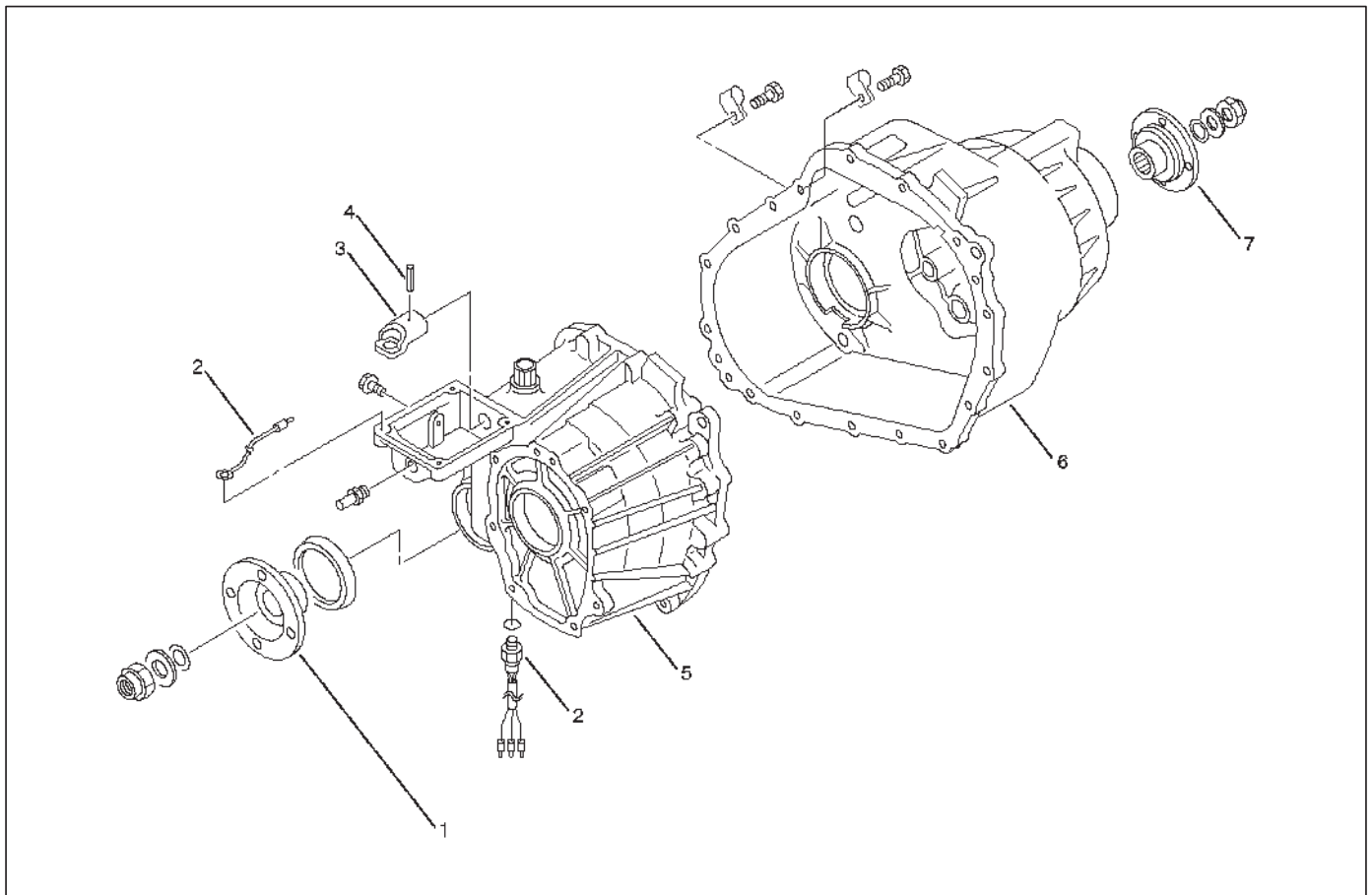
Check the resistance between electromagnetic clutch solenoid (terminal 8) and power GND (terminal 7). If not, replace the electromagnetic coil.

**Standard : 1.4 ~ 2.0Ω**

**Allowable : 1.0 ~ 5.0Ω**

## Transfer Case

### Disassembled View



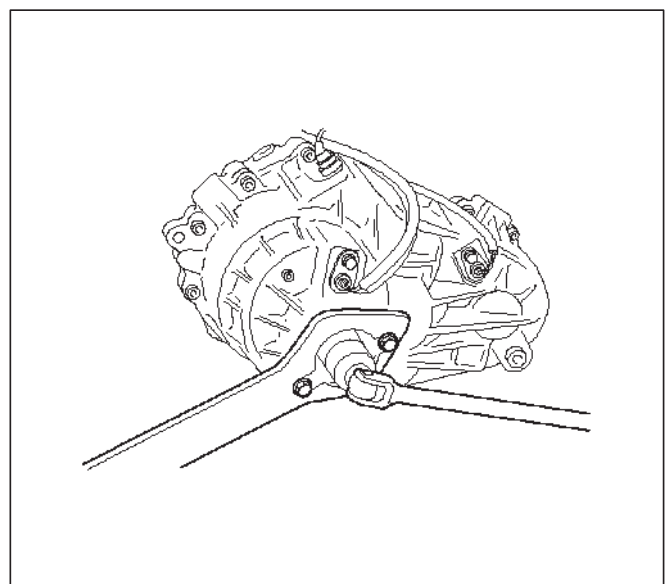
266RW004

#### Legend

- |   |                             |
|---|-----------------------------|
| (1) Front Companion Flange                                  | (4) Spring Pin              |
| (2) 4H and 4L Switch, Grounding Cable, and Center Connector | (5) Transfer Case Assembly  |
| (3) Offset Lever  | (6) Transfer Cover Assembly |
|   | (7) Rear Companion Flange   |

### Disassembly

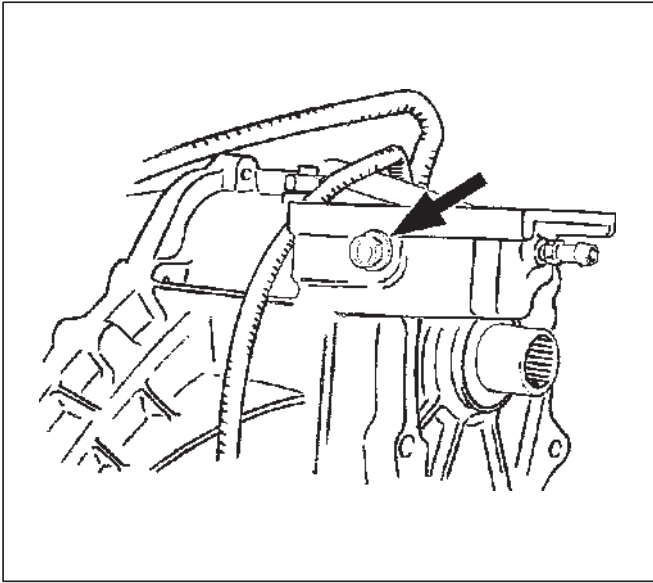
1. Remove the drain plug from the transfer case and drain the oil.
2. Disconnect the 4H and 4L switch and grounding cable.
3. Remove the clip fixing the harness.
4. Using the flange holder J-8614-11, remove the flange nut and front companion flange.
5. Using the flange holder J-8614-11, remove the flange nut and rear companion flange.



266RW005

## 4D2-10 TRANSFER CASE (TOD)

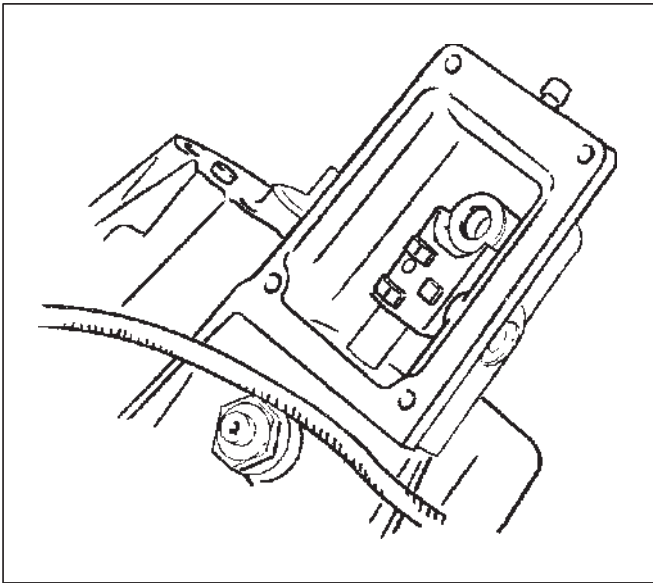
6. Remove the offset lever set bolt on the right side.



261RW015

7. Remove the offset lever lock spring pin.

8. Remove the offset lever.



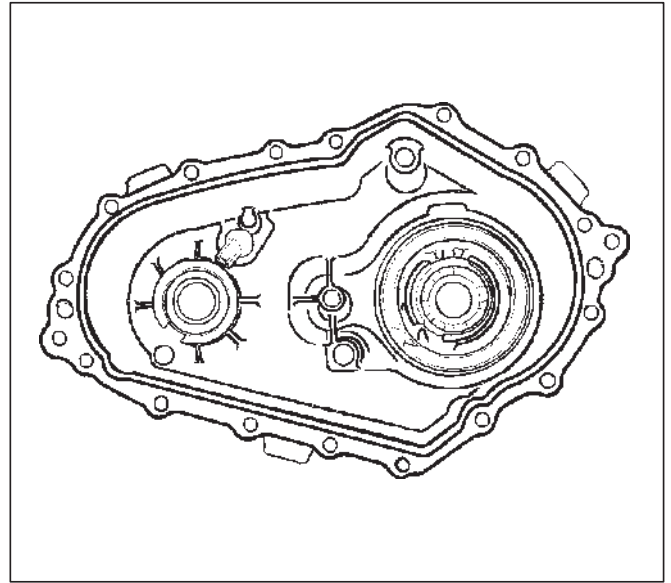
261RW017

9. Remove the sixteen bolts and detach the transfer cover assembly from the transfer case assembly.

**NOTE:** When removing the transfer cover assembly, be careful not to damage the oil seal.

### Reassembly

1. Apply liquid gasket (Loctite 598 or equivalent) uniformly to the mating face that contacts the transfer case.



261RW023

2. Tighten the sixteen bolts to the specified torque.

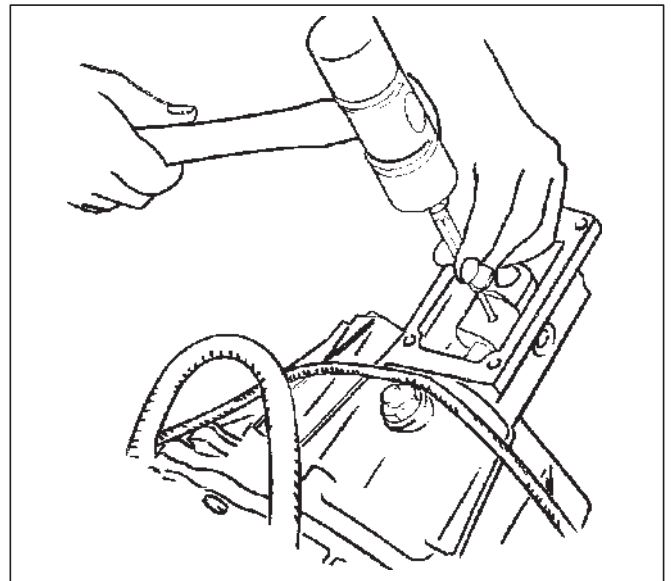
**Torque : 31 N-m (23 lb ft)**

3. Wind the sealing tape around the drain plug thread and tighten the plug with the specified torque.

**Torque : 25 N-m (18 lb ft)**

4. Install offset lever.

5. Mount the offset lever to the transfer shift rod and install the spring pin.



261RW016

6. Install rear and front companion flange.

7. Attach the O-ring and washer to the companion flange.

**NOTE:** Securely push the O-ring to the hollow of the companion flange, and then attach the washer.

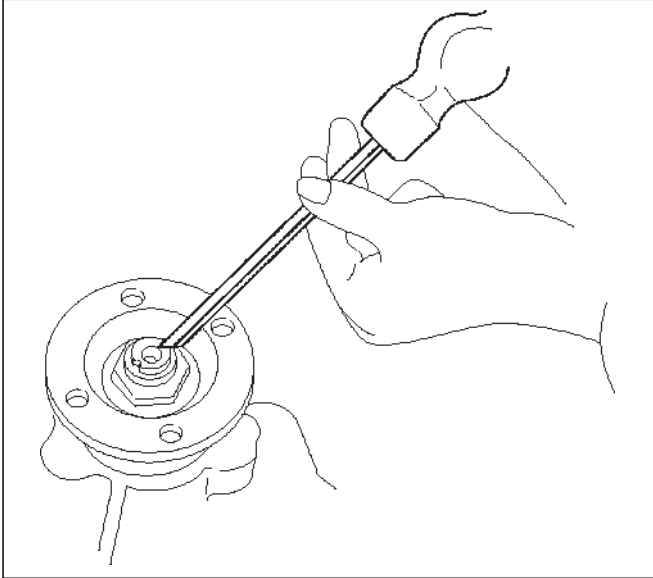
8. Use the flange holder J-8614-11 to tighten the flange nuts to transfer case.

9. Tighten the flange nuts to the specified torque.

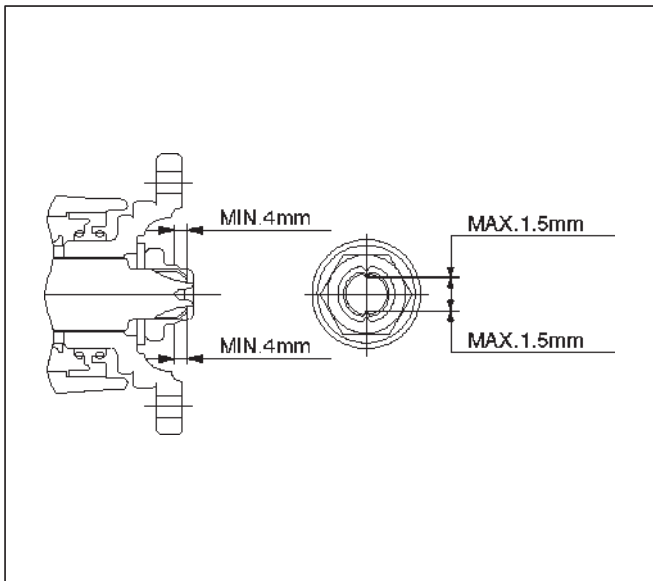
**Torque : 167 N·m (123 lb ft)**

10. Using the punch J-39209, securely stake each flange nut at two spots.

NOTE: Check the staked flange nuts are free from cracks.



266RW020



260RW007

11. Fix the harness with the clip.

12. Tighten the 4L and 4H switch to the specified torque.

**Torque : 24 N·m (17 lb ft)**

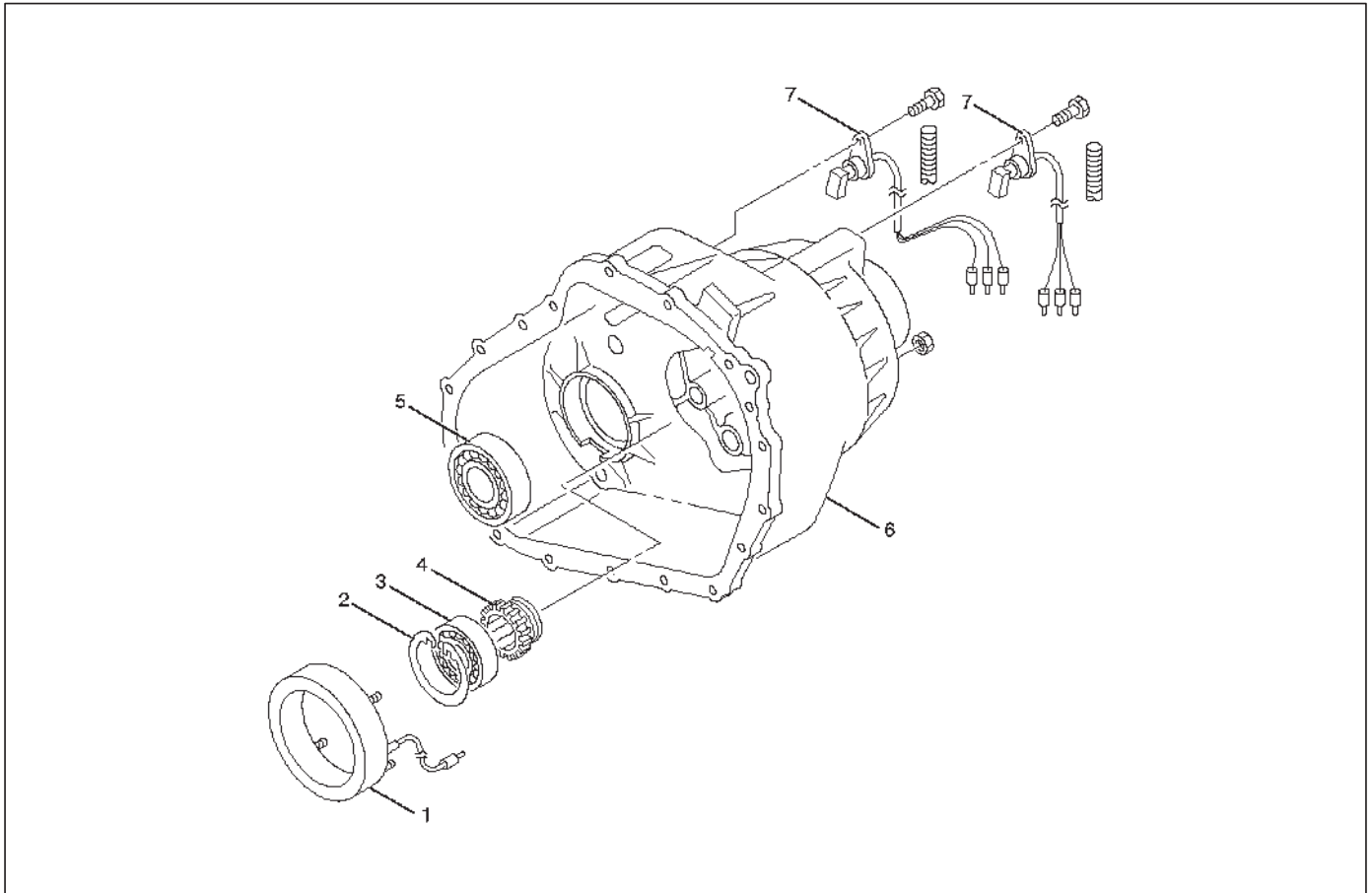
13. Fill the transfer case with ATF II or III (1.9 liters).

14. Wind the sealing tape around the filler plug thread and tighten the plug to the specified torque.

**Torque : 25 N·m (18 lb ft)**

## Transfer Cover Assembly

### Disassembled View



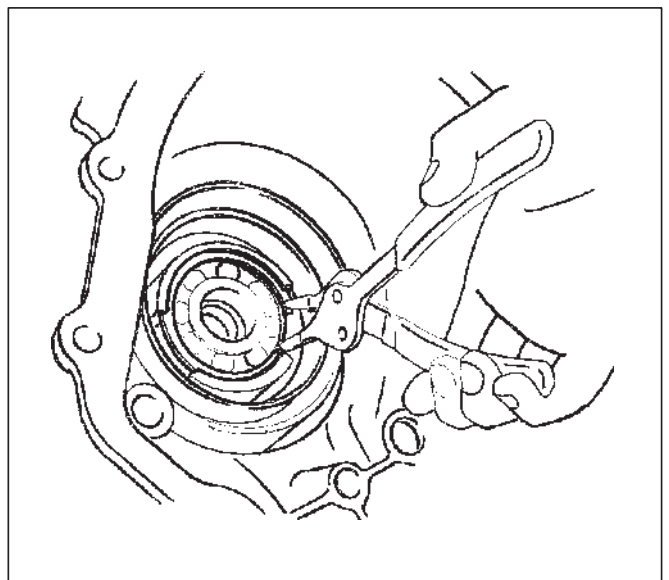
261RW007

#### Legend

- |                   |                                  |
|-------------------|----------------------------------|
| (1) Coil Assembly | (4) Speed Gear and Tone Wheel    |
| (2) Snap Ring     | (5) Ball Bearing                 |
| (3) Ball Bearing  | (6) Transfer Cover Assembly      |
|                   | (7) Front and Rear Speed Sensors |

### Disassembly

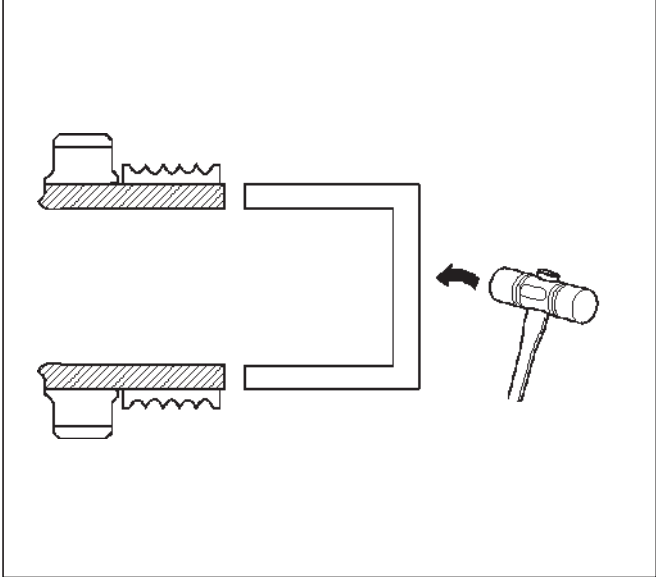
1. Using snap ring pliers, remove the snap ring.



261RW047

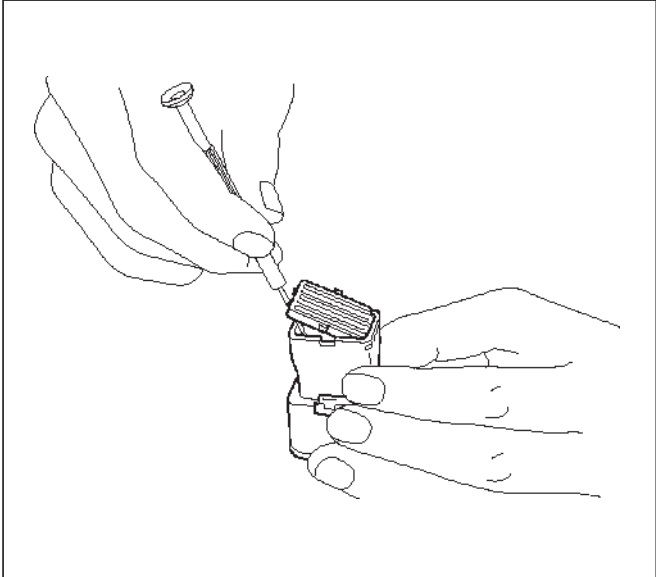
2. Strike the speed gear and tone wheel with a rod or other appropriate tool from the outside of the transfer cover assembly, and remove the ball bearing and speed gear and tone wheel.

NOTE: Pay attention not to damage the speed gear teeth.



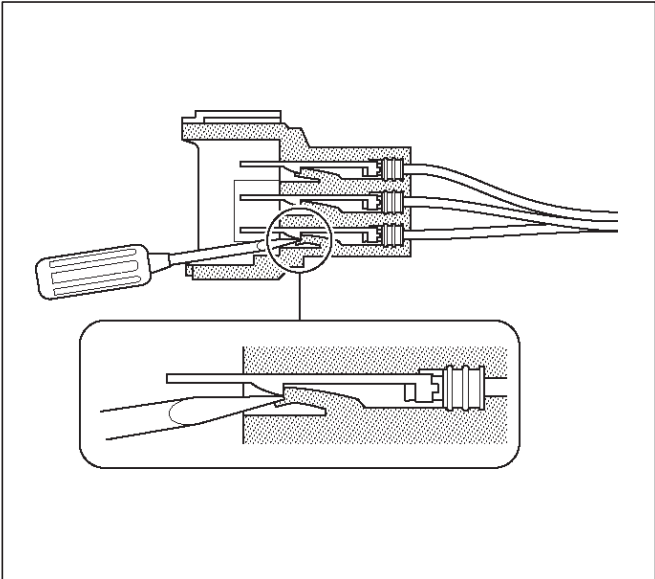
3. Remove the stopper plate on the back with a precision screwdriver or other appropriate tool starting from the small lock of the plate.

NOTE: Pay attention not to damage the stopper plate during the work.

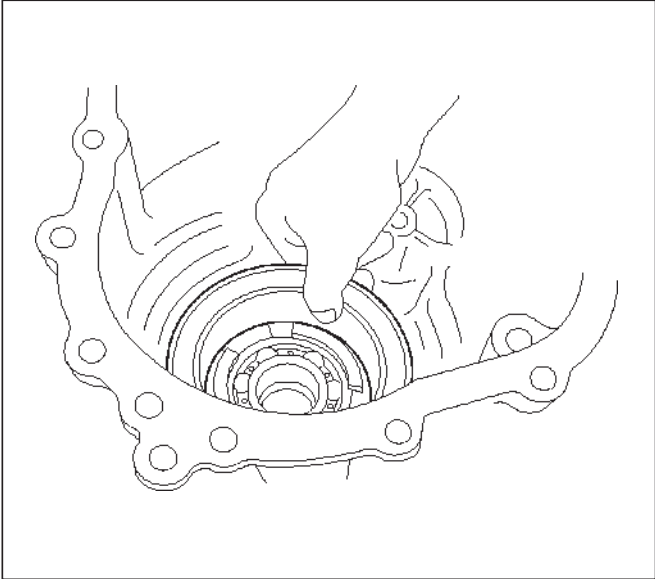


4. Using a terminal pull-out tool or an equivalent tool, push down the lock to unlatch the terminal for the coil assembly, and pull the terminal out.

NOTE: Pay attention not to damage other terminals.

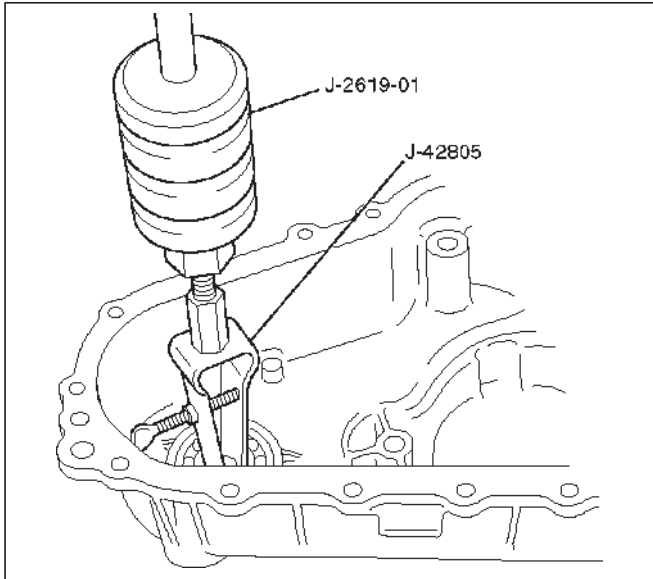


5. Remove the fixing nuts of the coil assembly from the outside of the transfer cover assembly. Remove the coil assembly from the transfer cover.



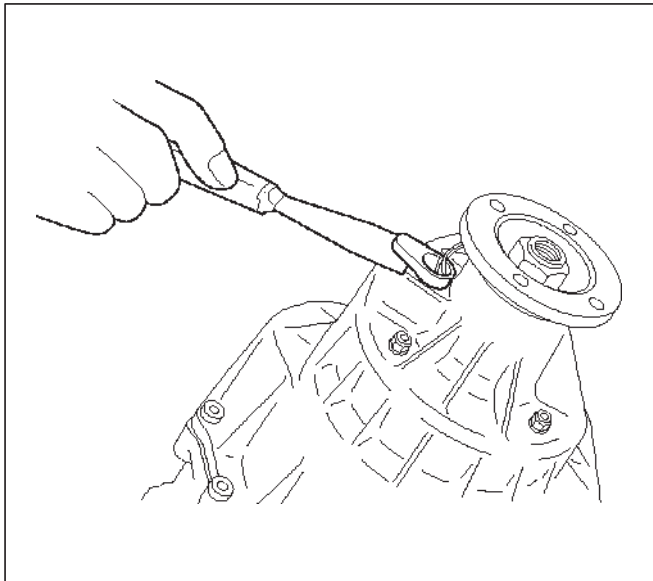
## 4D2-14 TRANSFER CASE (TOD)

- Using the bearing remover J-42805 and slide hammer J-2619-01, remove the ball bearing for the front output shaft.



- Remove the bolts and front and rear speed sensors.

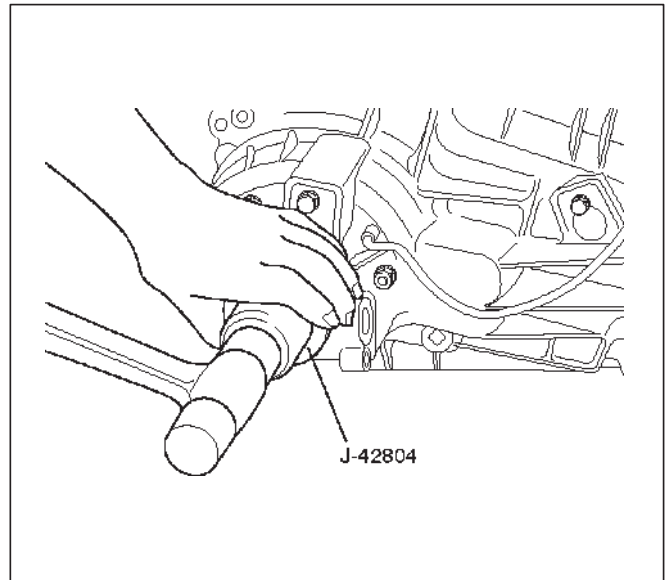
**NOTE:** Pay attention not to damage the speed sensors during the work.



## Reassembly

- Remove the oil seal from the transfer cover assembly.
- Apply oil to the circumference of the new oil seal and fill the lip with grease (Besco L2 or equivalent).

- Using the oil seal installer J-42804, attach the oil seal to the transfer cover assembly.

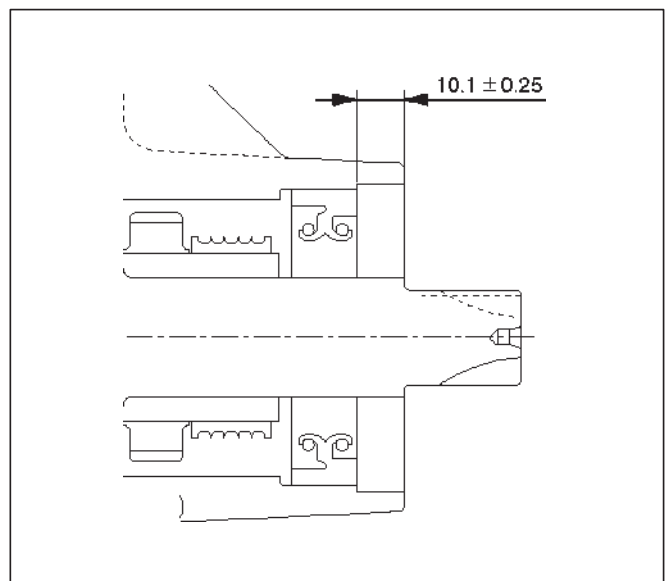


## Rear Output Shaft Oil Seal

Distance between the transfer case end and oil seal.

**NOTE:** When installing the oil seal to the specified dimension, be careful not to damage it.

**Dimension : 9.85 — 10.35mm (0.39 — 0.41 in)**

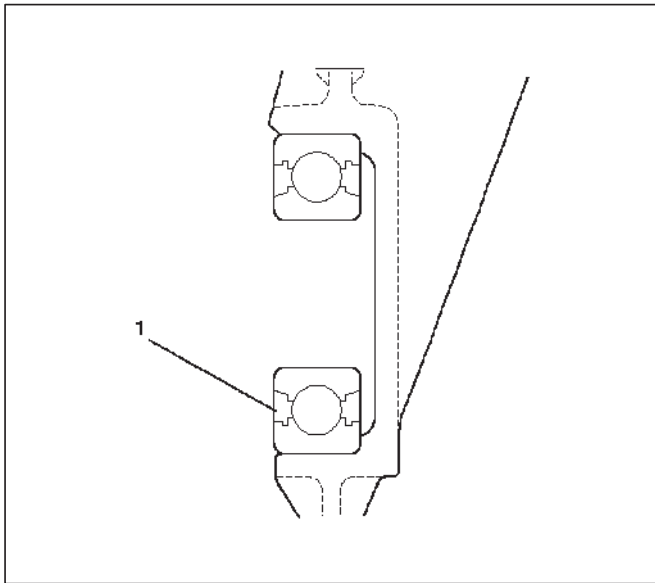


- Apply grease to the seal ring of each front and rear speed sensor, and mount the sensors carefully.
- Tighten the bolt with the specified torque.

**Torque : 5 N·m (43 lb in)**

**NOTE:** Pay attention not to mount the front (or rear) sensor to the rear (or front) sensor position.

6. Mount the ball bearing (1) for the front output shaft flat as shown in the figure.



261RW008

7. Mount the coil assembly and tighten the set nuts with the specified torque.

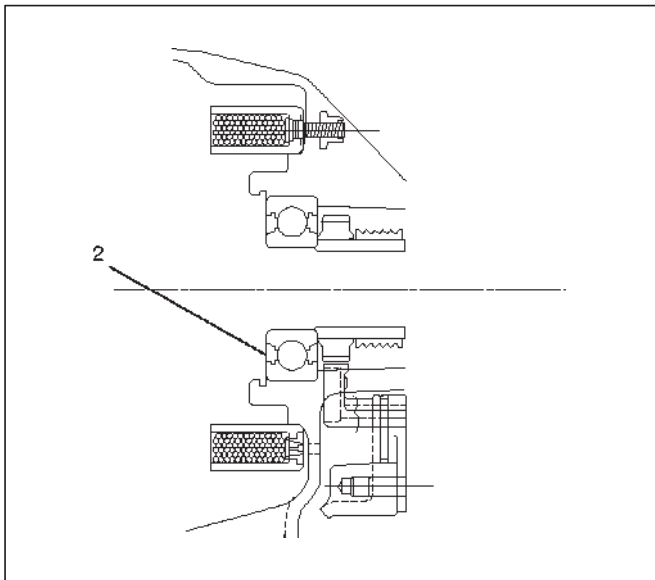
**Torque : 10 N·m (87 lb in)**

8. Connect the terminal in the central connector.

NOTE: Be careful not to damage other terminals.

9. Set speed gear and tone wheel.

10. Mount the ball bearing (2) flat as shown in the figure.



261RW009-1

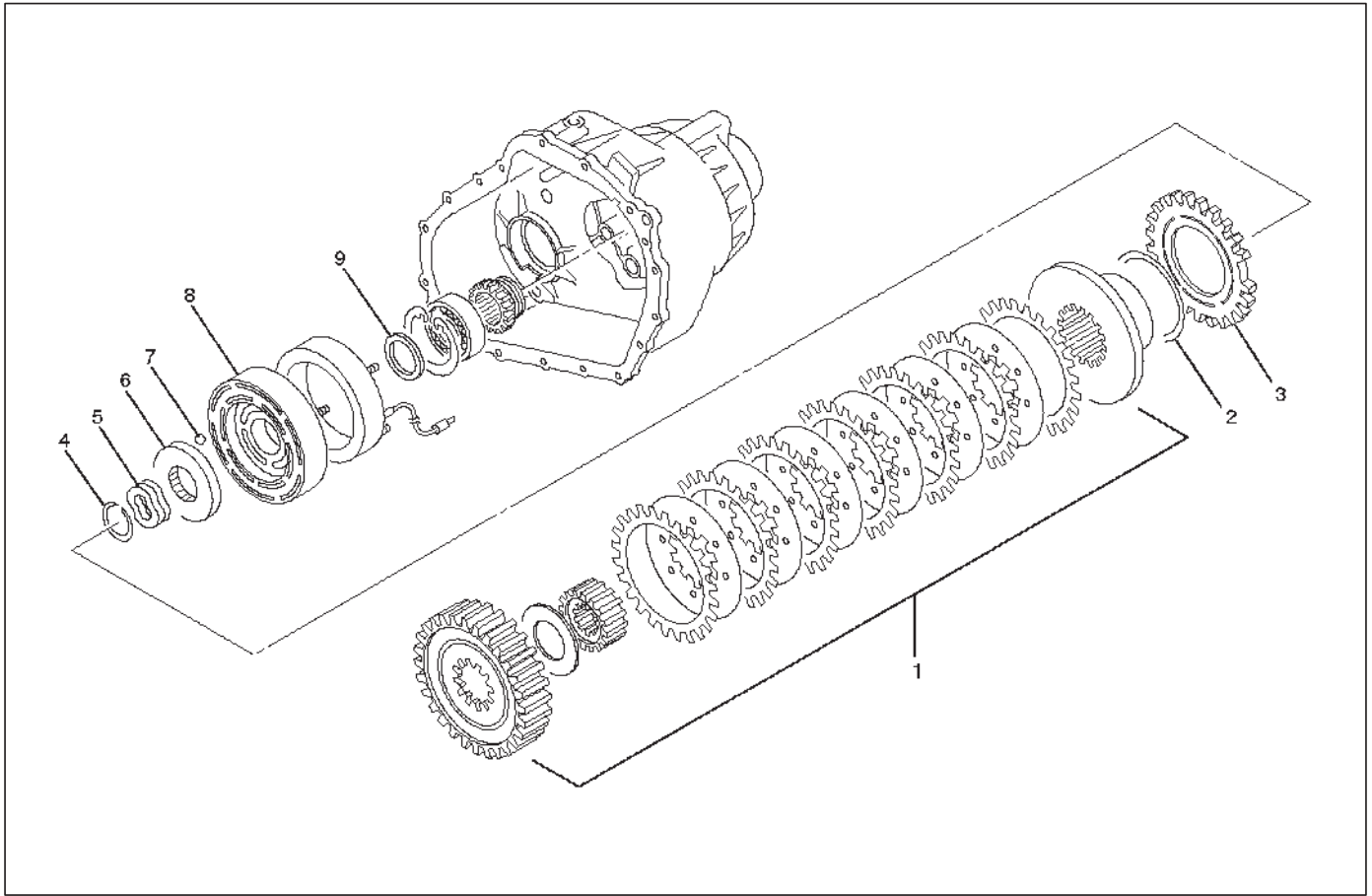
11. Using snap ring pliers, install the snap ring to the transfer cover assembly.

NOTE: Securely mount the snap ring to the groove of the transfer cover assembly.



## Transfer Case Assembly Clutch Pack and Clutch Cam

### Disassembled View



266RW006

#### Legend

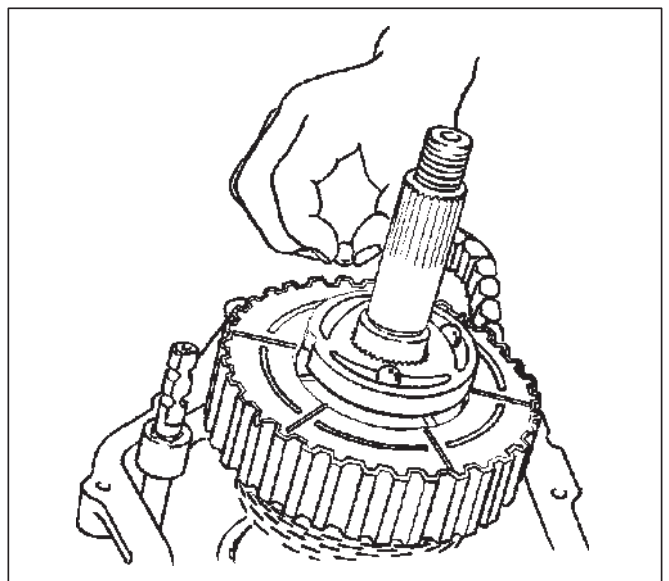
- |                          |                          |
|--------------------------|--------------------------|
| (1) Clutch Pack Assembly | (5) Wave Spring          |
| (2) Insulator Washer     | (6) Cam Pulley           |
| (3) Armature Plate       | (7) Cam Ball             |
| (4) Snap Ring            | (8) Cam and Coil Housing |
|                          | (9) Thrust Bearing       |

### Disassembly

1. Remove the thrust bearing.
2. Remove the cam and coil housing.

NOTE: When the cam and coil housing is removed, the cam balls may be detached together with the housing. Be careful not to lose the ball.

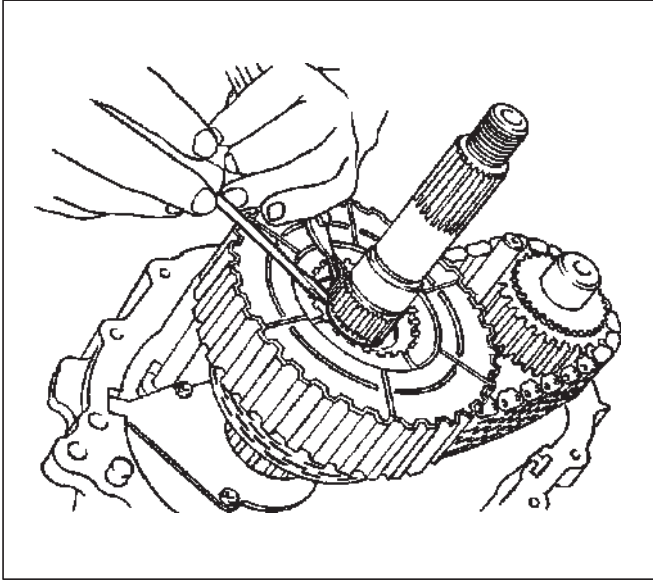
3. Remove the cam ball.



266RW013

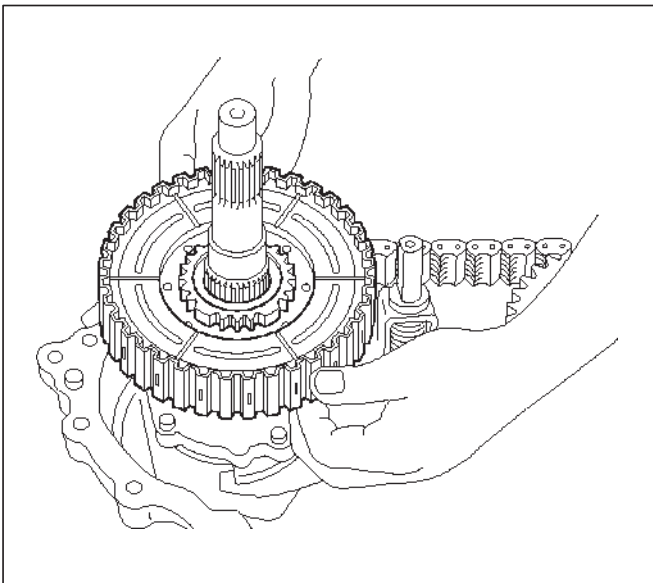
4. Remove the cam pulley.
5. Remove the wave spring.
6. Using snap ring pliers, remove the snap ring.

NOTE: Be careful not to damage the snap ring.



266RW009

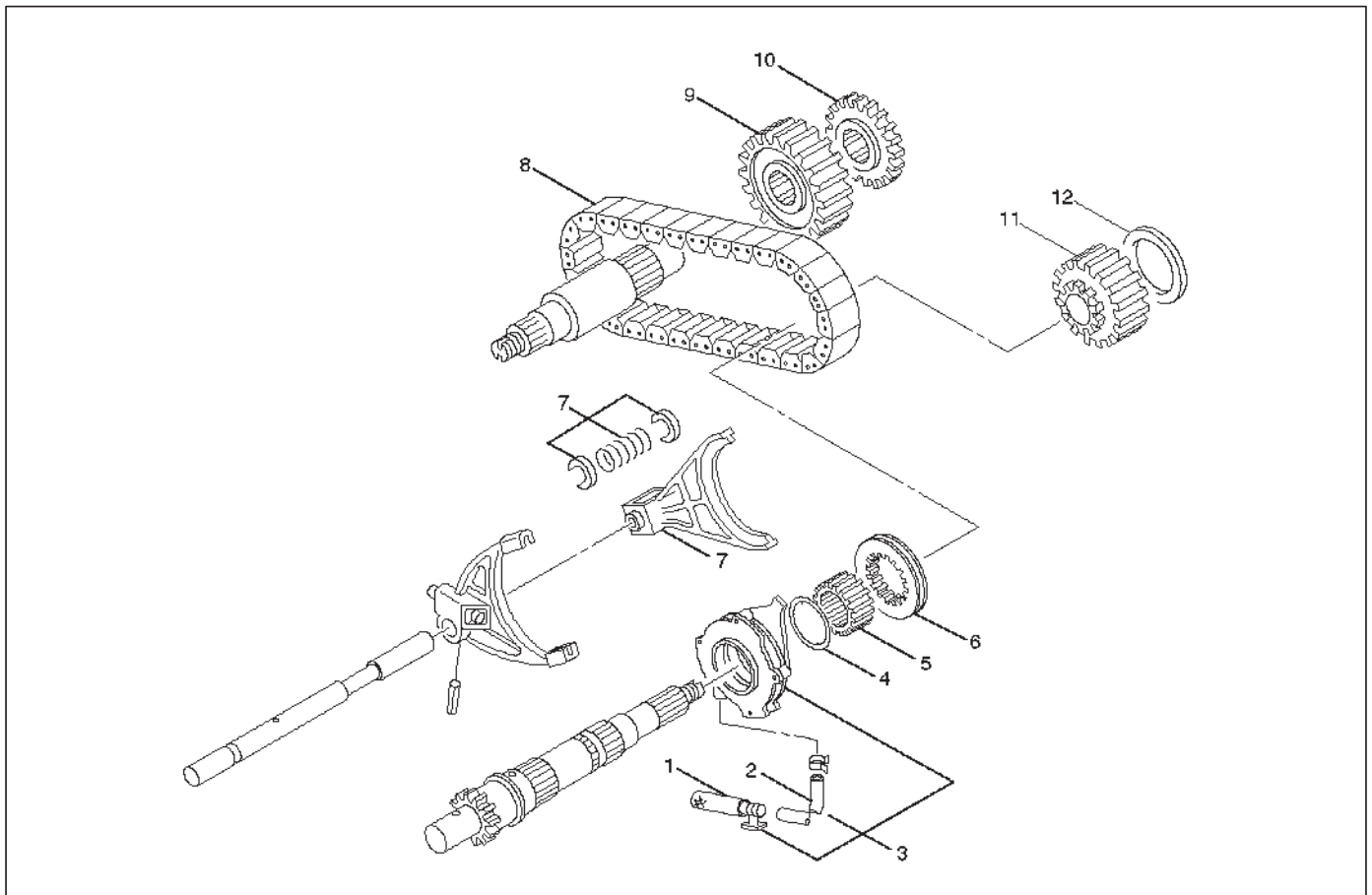
7. Remove the armature plate.
8. Remove the insulator washer.
9. Remove the clutch pack assembly as a package.



266RW017

## Sprocket and Mechanical Lock

### Disassembled View



266RW008

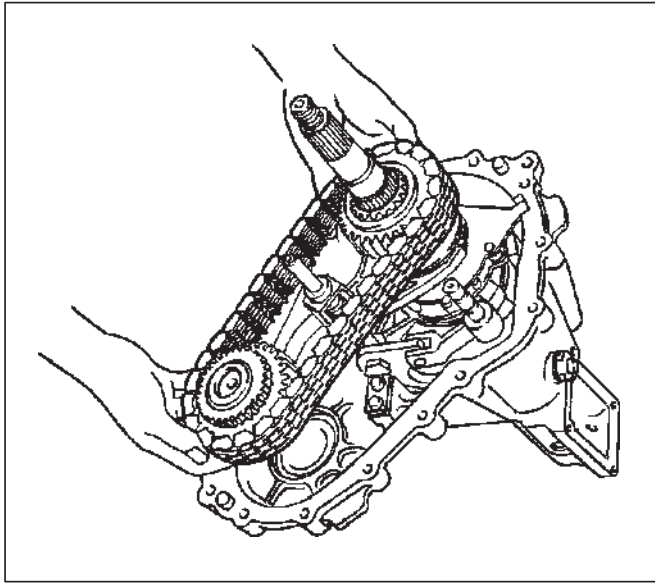
#### Legend

- |                         |                          |
|-------------------------|--------------------------|
| (1) Strainer            | (7) Lock-up Fork         |
| (2) Hose                | (8) Chain                |
| (3) Oil Pump Assembly   | (9) Lower Drive Sprocket |
| (4) Thrust Washer       | (10) Front Tone Wheel    |
| (5) Mechanical Lock Hub | (11) Drive Sprocket      |
| (6) Lock-up Sleeve      | (12) Sprocket Spacer     |

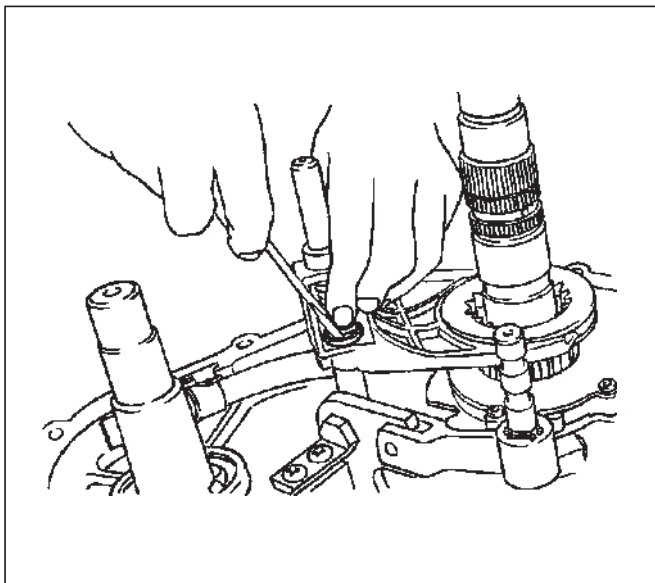
### Disassembly

1. Remove the sprocket spacer.
2. Remove the front tone wheel.

3. Remove the drive sprocket, lower drive sprocket, and chain together from the front and rear output shafts.



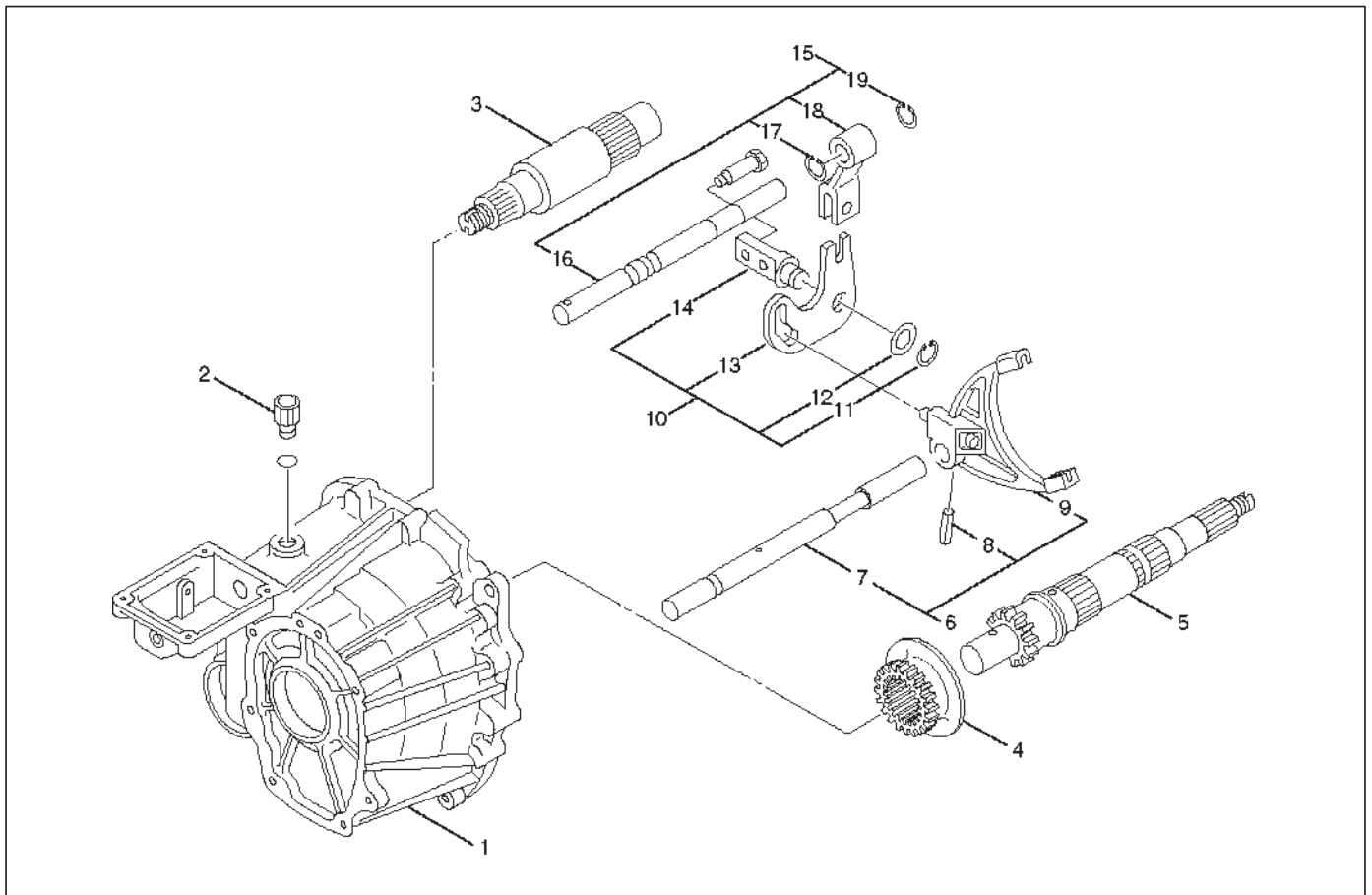
4. Remove the mechanical lock hub.
5. Remove the spring retainer from the connection between lock-up shaft and lock-up fork.



6. Remove the lock-up fork and lock-up sleeve.
7. Remove the thrust washer.
8. Remove the magnet from the strainer set position together with the oil pump assembly.
9. Remove the strainer from the oil pump assembly.
10. Remove the hose from the oil pump assembly.

## Output Shafts and Shift Control Shaft

### Disassembled View



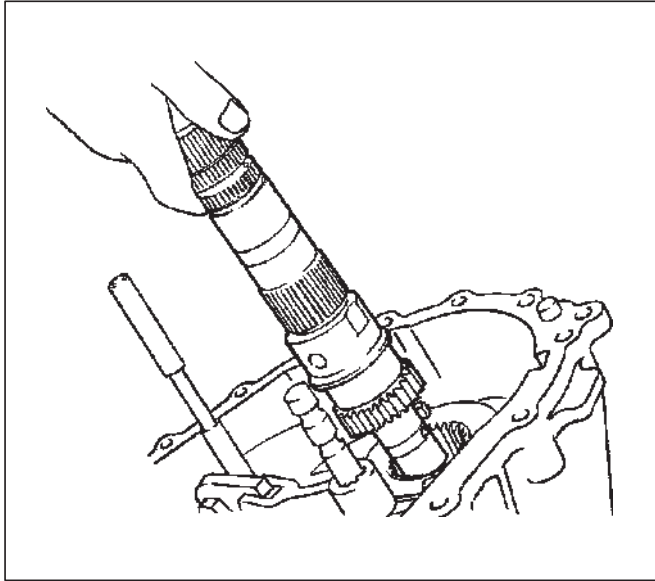
261RW010-1

#### Legend

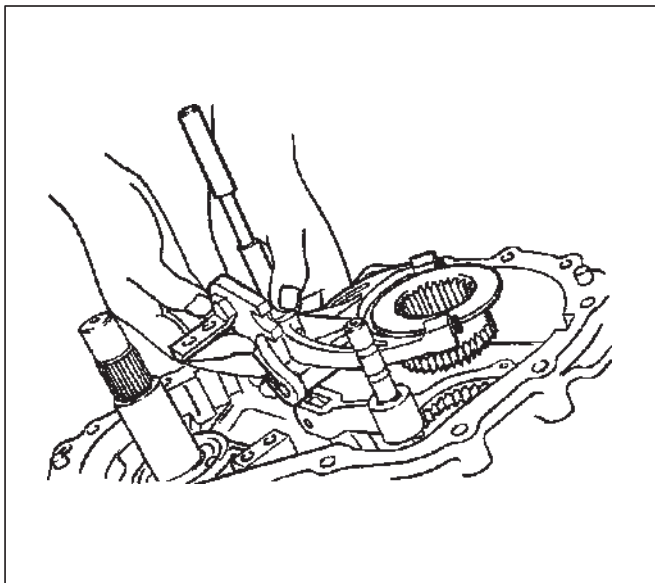
- |                             |                               |
|-----------------------------|-------------------------------|
| (1) Transfer Case Assembly  | (10) Cam Assembly             |
| (2) Detent Spring           | (11) Snap Ring                |
| (3) Front Output Shaft      | (12) Washer                   |
| (4) Reduction Hub           | (13) Cam                      |
| (5) Output Shaft            | (14) Cam Pilot Block          |
| (6) Reduction Fork Assembly | (15) Shifter Shaft Assembly   |
| (7) Lock-up Shaft           | (16) Shifter Lever Shaft      |
| (8) Spring Pin              | (17) Snap Ring                |
| (9) Reduction Fork          | (18) Reduction Lever Assembly |
|                             | (19) Snap Ring                |

## Disassembly

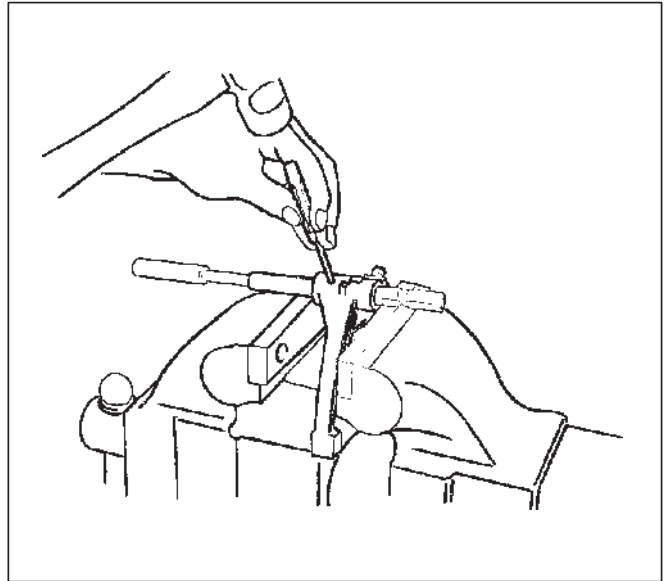
1. Remove the output shaft.



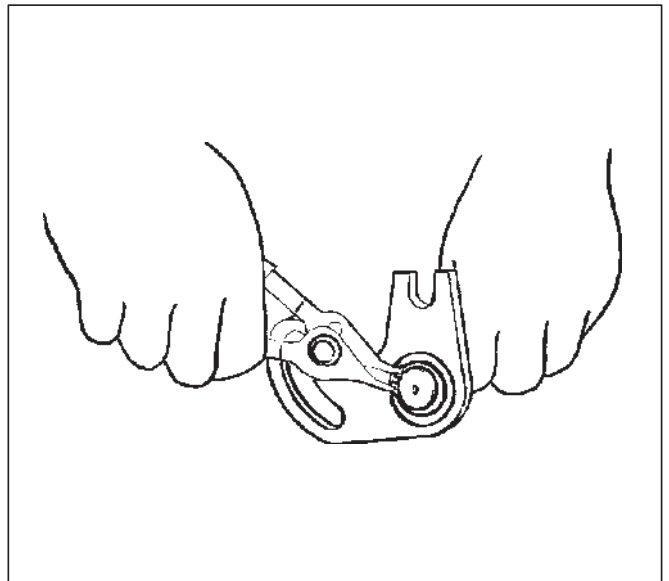
2. Remove the detent spring.
3. Remove the cam pilot block set bolts.
4. Remove the reduction fork assembly and cam assembly together with the reduction hub.



5. Remove the spring pin that fixes the reduction fork to the lock-up shaft.



6. Remove the reduction fork.
7. Remove the lock-up shaft.
8. Using snap ring pliers, remove the snap ring from the cam pilot block.

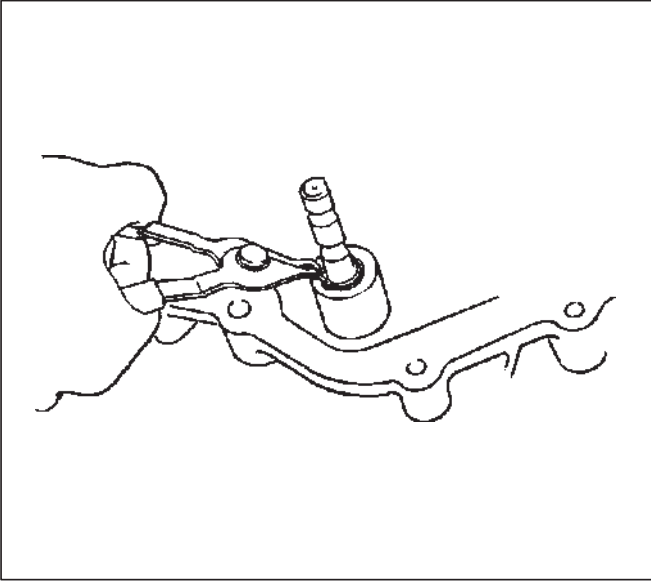


9. Remove the washer.
10. Remove the cam.
11. Remove the cam pilot block.

## 4D2-22 TRANSFER CASE (TOD)

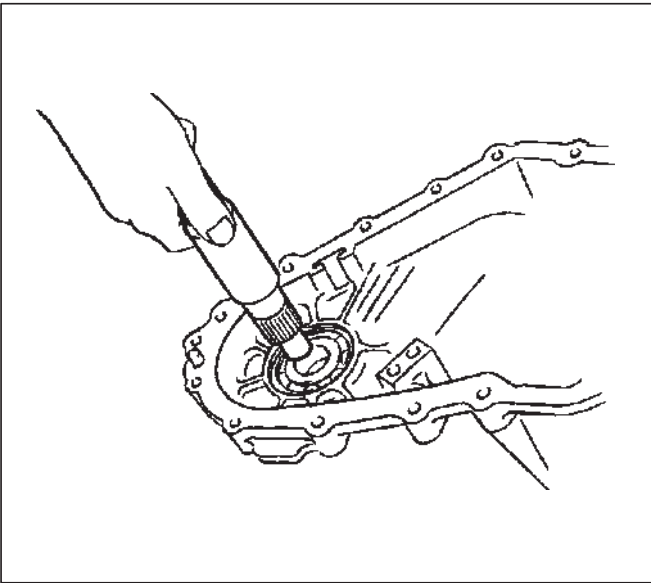
---

12. Using snap ring pliers, remove the snap ring from the shift lever shaft.



261RW021

13. Remove the reduction lever assembly.  
14. Remove the snap ring.  
15. Remove the shifter lever shaft.  
16. Remove the front output shaft.

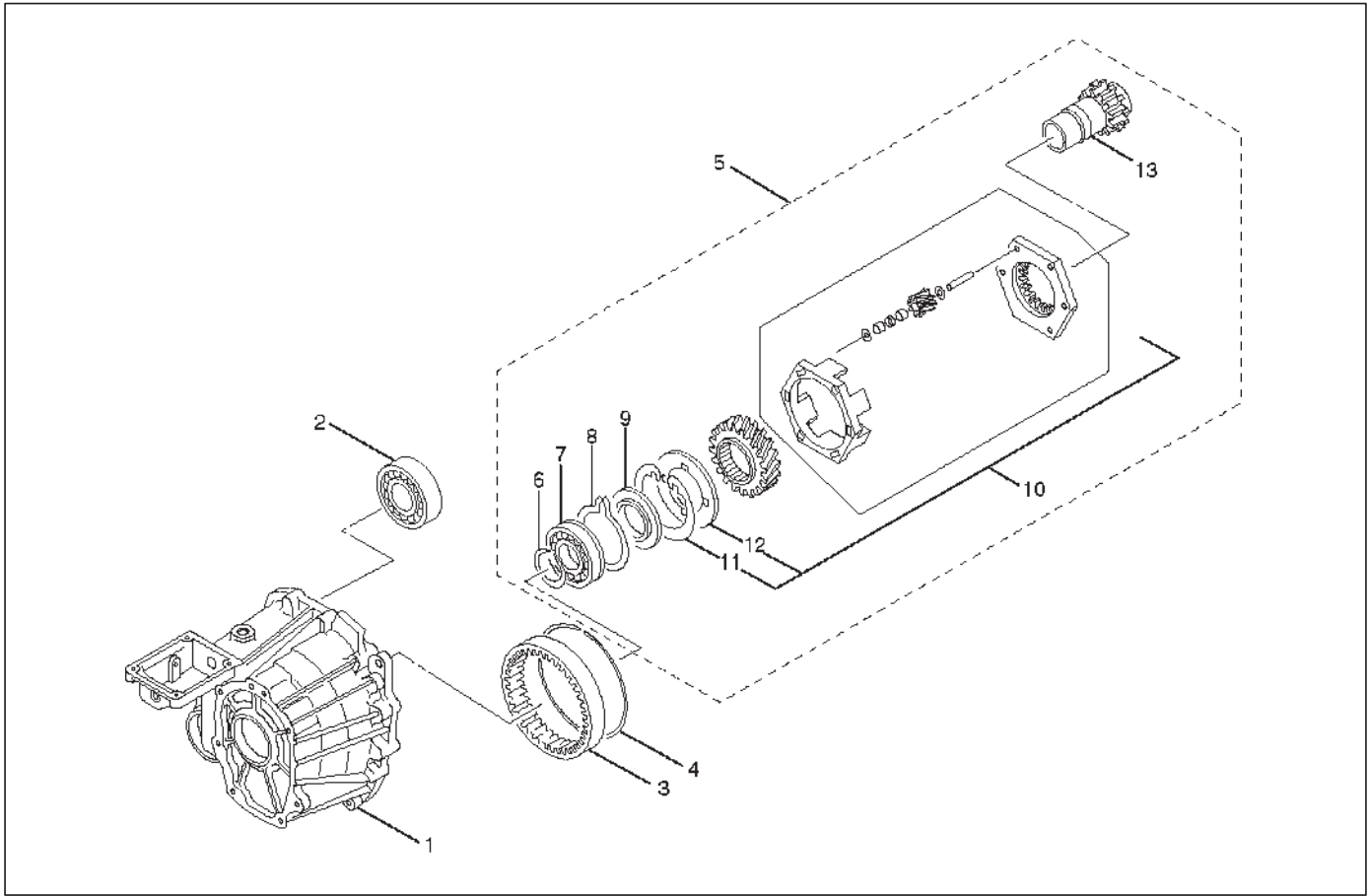


266RW012

17. Remove the transfer case assembly.

# Transfer Case

## Disassembled View



265RW015

### Legend

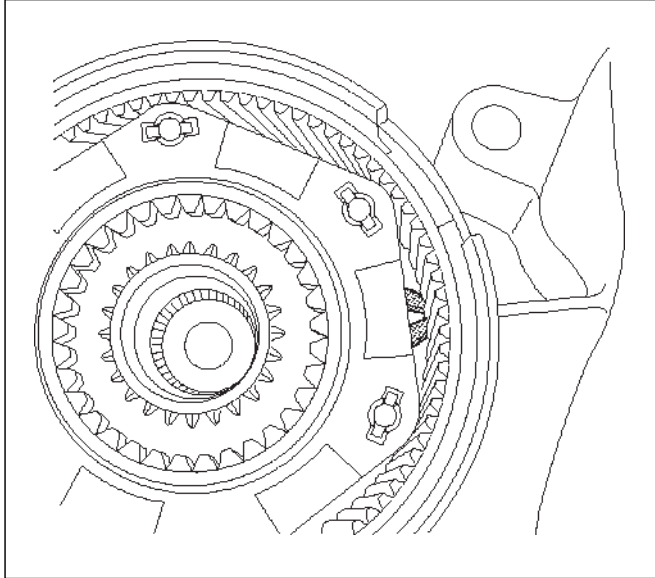
- (1) Transfer Case
- (2) Ball Bearing
- (3) Ring Gear
- (4) Snap Ring
- (5) Input Shaft and Carrier Assembly
- (6) Snap Ring
- (7) Ball Bearing
- (8) Snap Ring
- (9) Thrust Plate
- (10) Carrier Assembly
- (11) Snap Ring
- (12) Circular Hub
- (13) Input Shaft



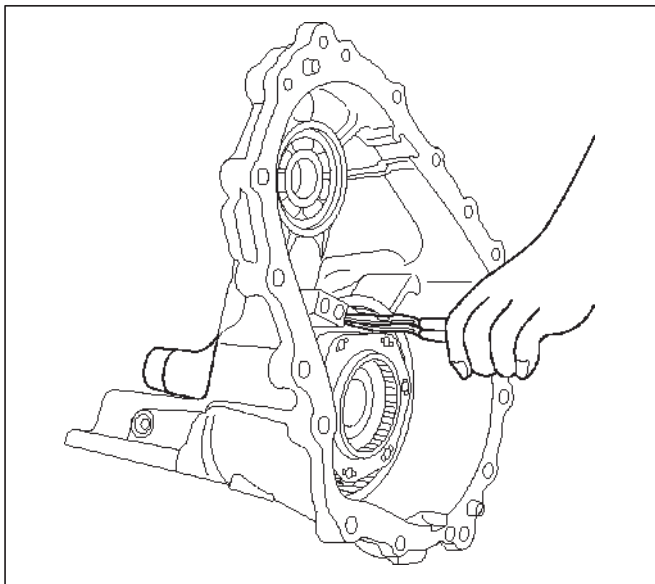
## 4D2-24 TRANSFER CASE (TOD)

### Disassembly

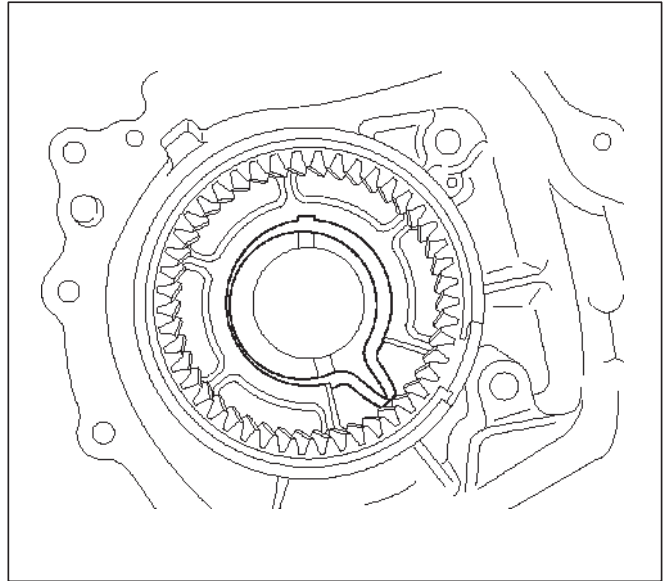
1. Remove the ball bearing (for front output shaft).
2. Using snap ring pliers, expand the snap ring through the opening between the ring gear and carrier assembly.



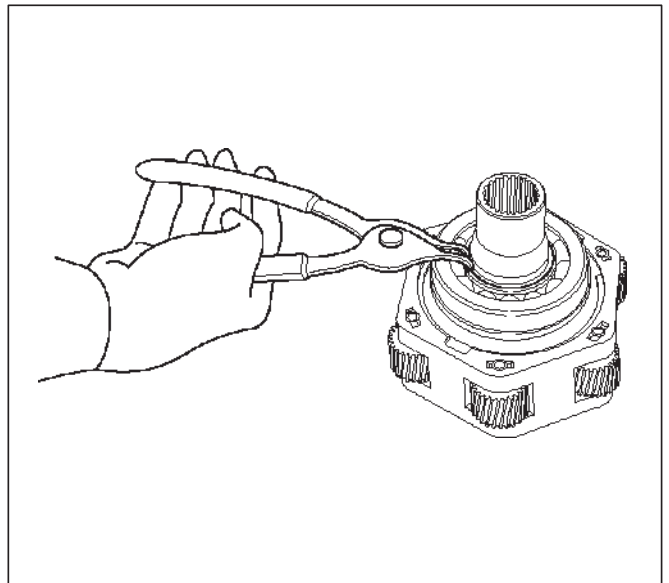
3. While expanding the snap ring, remove the input shaft, ball bearing, carrier assembly, and thrust plate from the transfer case.



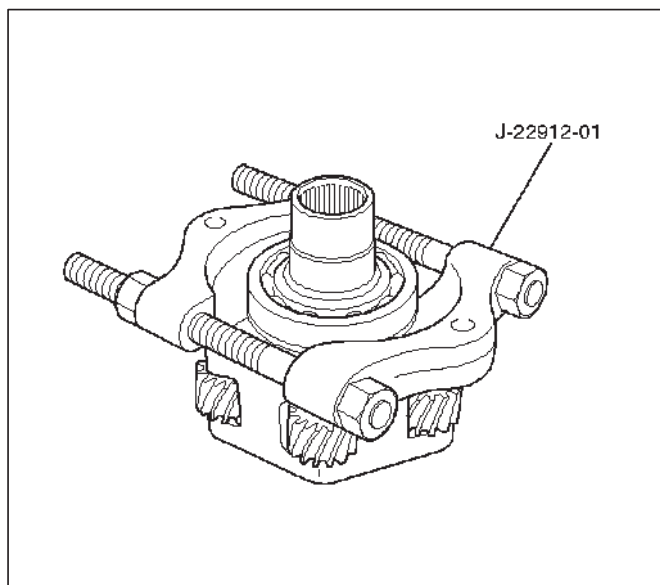
4. Remove the snap ring from the transfer case.



5. Using snap ring pliers, remove the snap ring before the ball bearing.

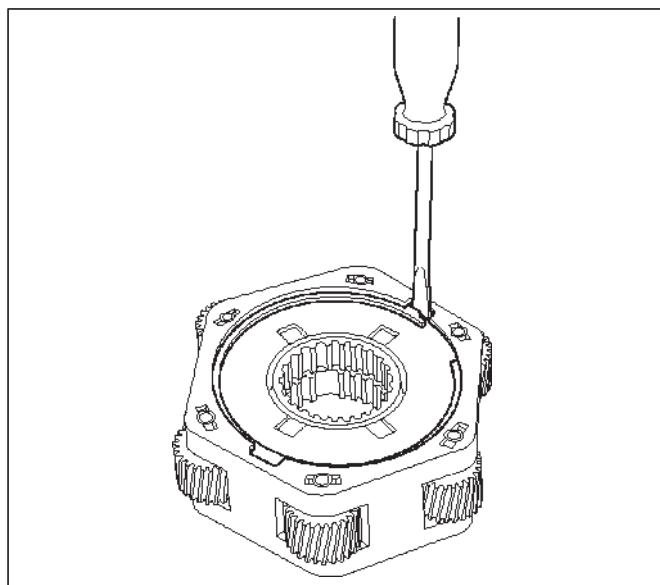


6. Using the bearing remover J-22912-01, remove the ball bearing from the input shaft.



265RW004

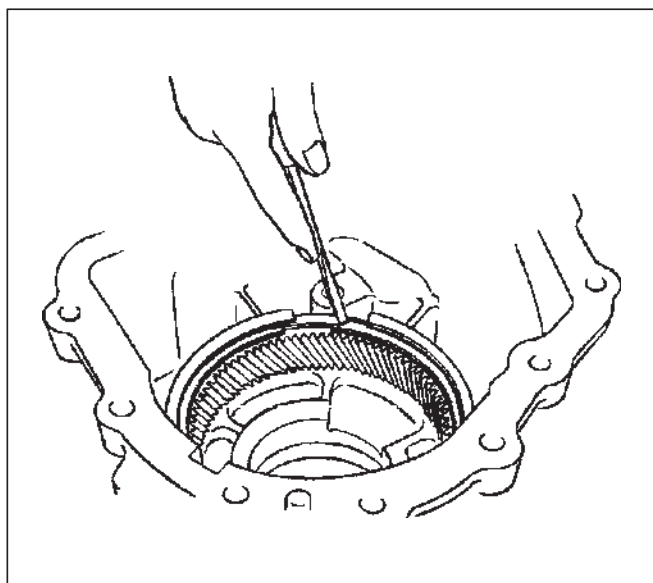
- 7. Remove the thrust plate.
- 8. Remove the carrier assembly.
- 9. Remove the snap ring from the carrier assembly.



265RW006

10. Remove the circular hub.

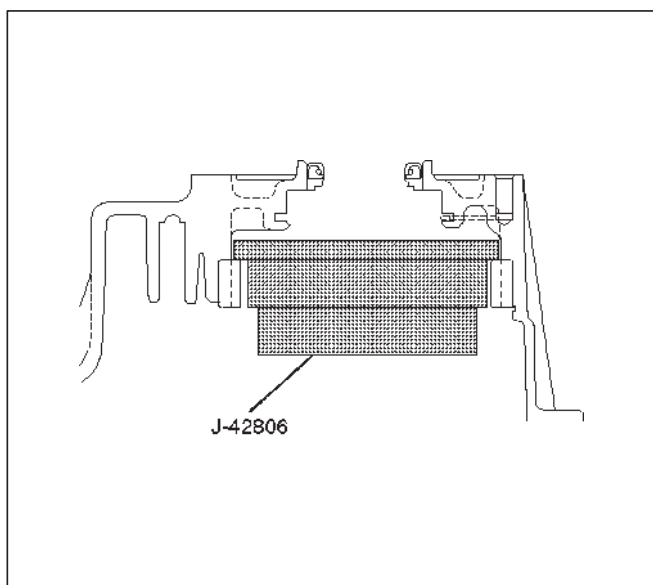
11. Remove the snap ring before the ring gear.



261RW025

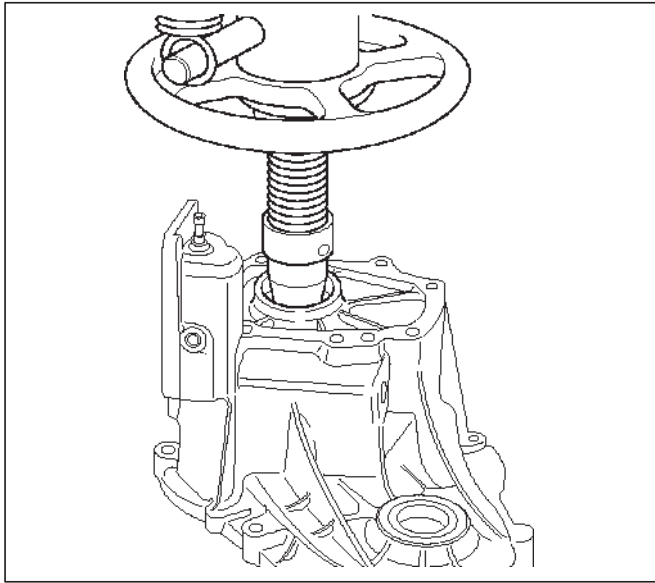
12. Using the special tool J-42806, remove the ring gear.

NOTE: Removing the ring gear needs a high-load press. This means the transfer case may be damaged. To remove and replace the ring gear, it is recommended that the transfer case assembly should be replaced.



261RW011

## 4D2-26 TRANSFER CASE (TOD)



### Inspection and Repair

When wear, damage, or any other defects are observed during the inspection, the part or parts must be repaired or replaced. Wash all the parts with clean solvent, and check that old oil, metallic particles, dirt, or foreign materials are completely removed. Blow the air into oil holes and grooves to remove foreign materials or residual solvent.

#### Chain

- Check whether the face that contacts the sprocket is free from excessive wear or damage. If defects are observed, replace the part.
- If the chain interference mark is found on the inside wall of the transfer cover or the chain is so slack that a skipped engagement occurs between the chain and sprocket, replace the chain.

#### Sprocket

- Check whether the sprocket tooth surface is excessively worn or damaged, and there is evidence of burrs, chipping, wear, or damage on the gear spline. Remove minor flaws or scratches with oil stone. If excessive wear or damage is observed, replace the part.
- If excessive wear or damage is observed on the sprocket inside sliding surface, replace the part.

#### Gear

Check whether the gear tooth surface is excessively worn or damaged, and there is evidence of burrs, chipping, wear, or damage on the gear spline. Remove minor flaws or scratches with oil stone. If excessive wear or damage is observed, replace the part.

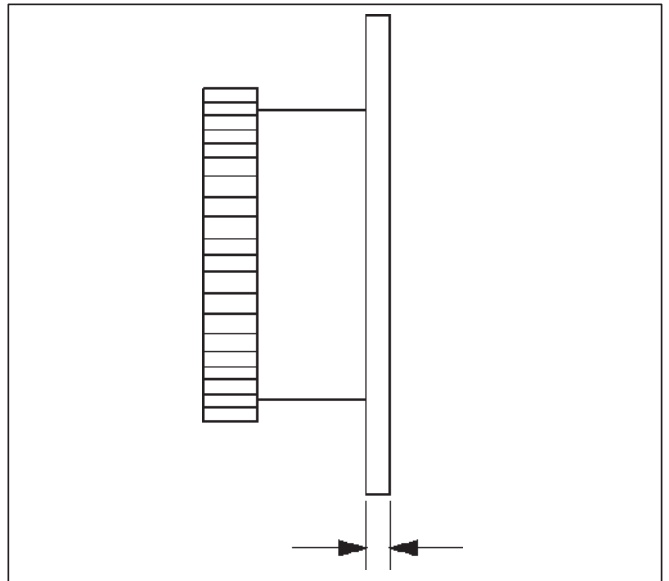
#### Thickness of Reduction Hub

- Measure the thickness with a micrometer.

- If the measurement exceeds the limit, replace the reduction hub.

**Standard : 3.05-3.30 mm (0.120-0.130 in)**

**Allowable limit : 2.5 mm (0.098 in)**



#### Lock-up Sleeve

Mount the mechanical lock hub, drive sprocket assembly, and lock-up sleeve to the output shaft.

If the lock-up sleeve does not move smoothly, replace the sleeve.

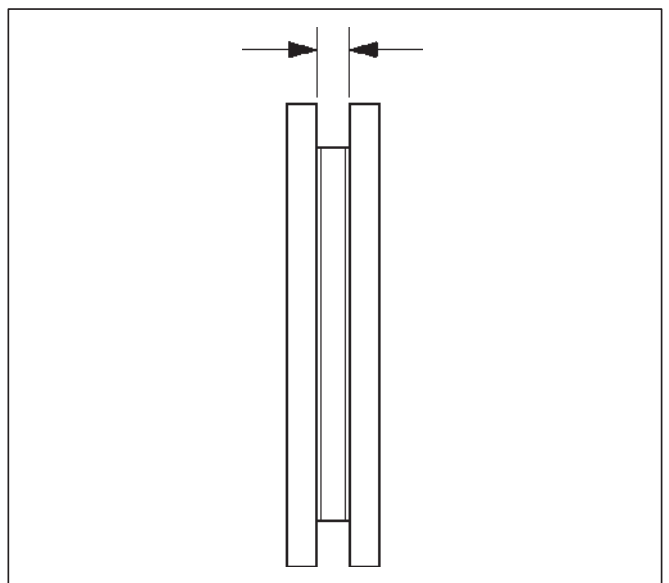
NOTE: Apply ATF to the area engaging the gear.

#### Thickness of Lock-up Sleeve

- If the measurement exceeds the limit, replace the lock-up sleeve.

**Standard : 7.16-7.32 mm (0.282-0.288 in)**

**Allowable limit : 7.9 mm (0.311 in)**



### Reduction Fork

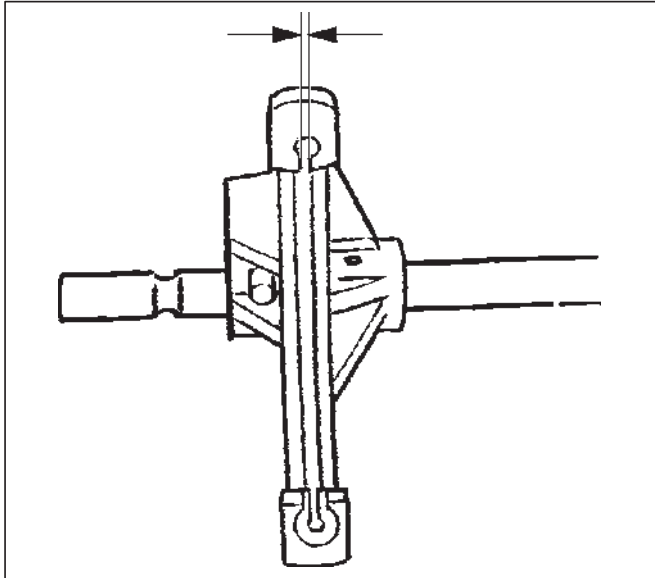
Check the reduction fork and shaft for wear, distortion, and scratches. If defects are observed, replace the parts.

#### Thickness of Reduction Fork

- If the measurement exceeds the limit, replace the reduction fork.

**Standard : 3.41-3.79 mm (0.134-0.149 in)**

**Allowable limit : 4.4 mm (0.173 in)**



261RW026

### Lock-up Fork

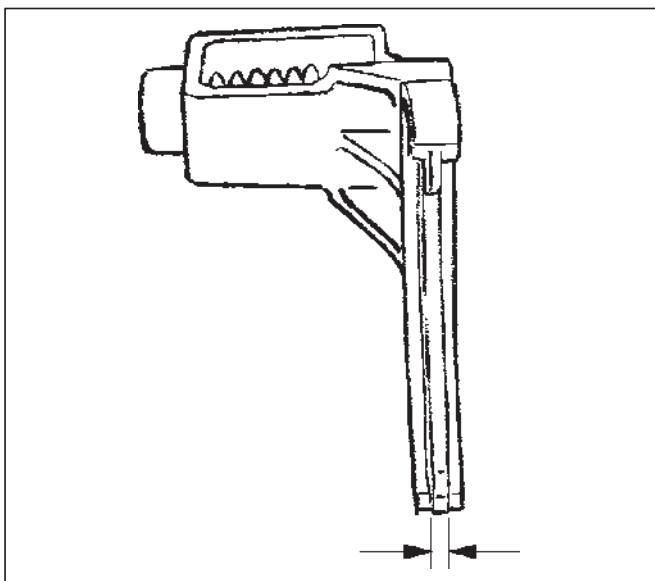
- Check the lock-up fork and shaft for wear, distortion, and scratches. If defects are observed, replace the parts.

#### Thickness of Lock-up Fork

If the measurement exceeds the limit, replace the lock-up fork.

**Standard : 6.99-7.09 mm (0.275-0.279 in)**

**Allowable limit : 6.3 mm (0.248 in)**



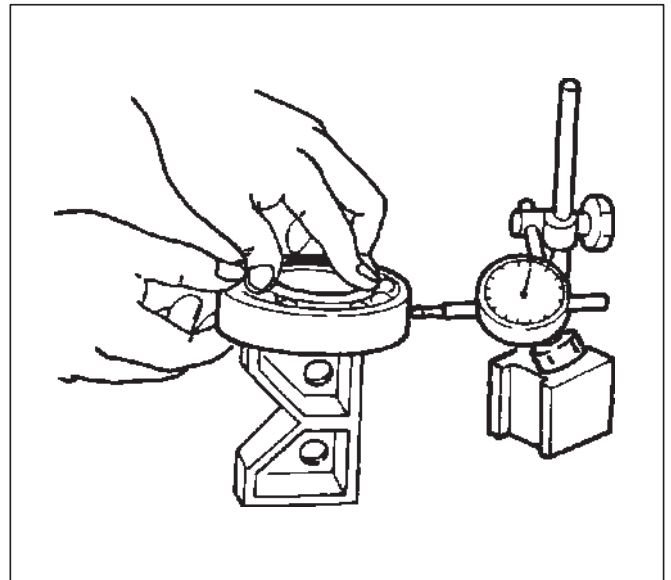
261RW027

### Bearing

Check the profile of the needle, roller, ball, and thrust bearings. Wash the bearings with clean solvent completely, and dry with air.

NOTE: If the bearing is rotated excessively, the balls may be damaged. So, rotate the bearing slowly with your hand. Apply grease to the bearing, and check the smoothness of the bearing while slowly rotating the race with your hand.

**Allowable limit : 0.23 mm (0.009 in)**



226RW143

### Lock-up Fork Spring

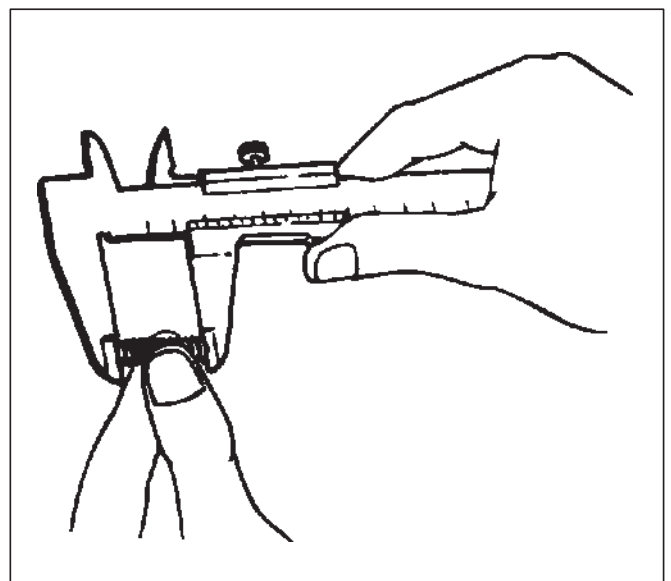
Check the lock-up fork spring for distortion, cracking, and wear. If defects are observed, replace the part.

#### Free Length of the Lock-up Fork Spring

- If the measurement exceeds the limit, replace the spring.

**Standard : 60.96 mm (2.40 in)**

**Allowable limit : 55.0 mm (2.17 in)**



220RW045

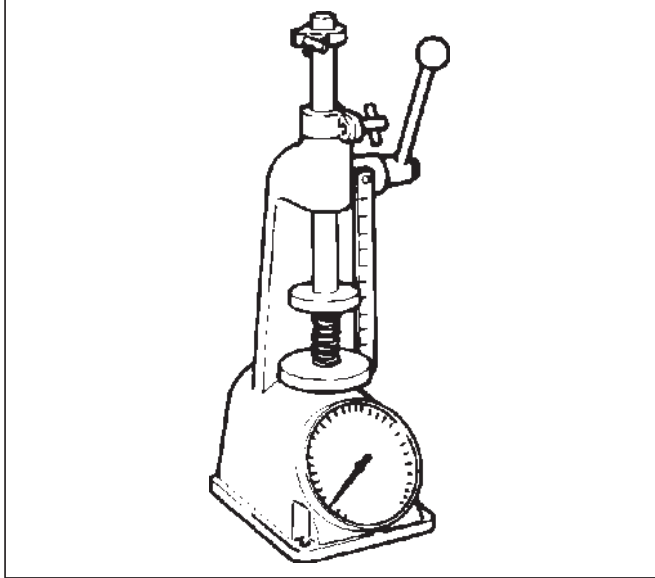
## 4D2-28 TRANSFER CASE (TOD)

### Tension of Lock-up Fork Spring

- If the measurement exceeds the limit, replace the spring. (When compressed to 41.4 mm)

**Standard : 27.1-33.8 N {2.76-3.45 kg}**

**Allowable limit : 24.5 N {2.5 kg}**



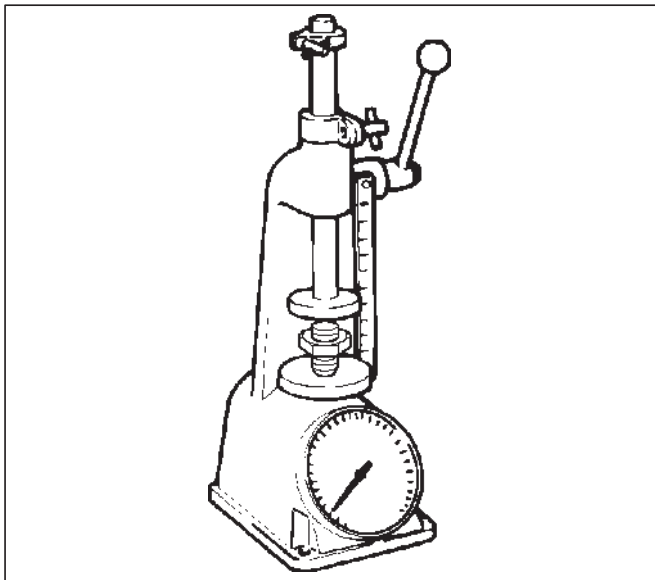
014RW048

### Tension of Detent Spring Assembly

- If the measurement exceeds the limit, replace the spring. N {kg} (When compressed by 3 mm from the free length)

**Standard : 139 N -203 {14.2-20.7 kg}**

**Allowable limit : 130 N {13.3 kg}**



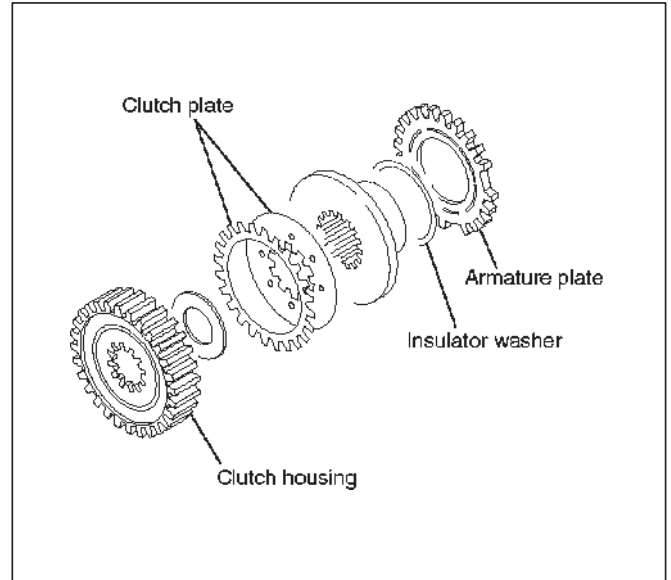
261RW041

### Oil Pump

- Remove foreign materials from the strainer. If the strainer is damaged, replace it.
- If the area into which the shaft is inserted is excessively worn or damaged, replace the pump.

### Multi Plate Disk Clutch

- If the burned, mirror-surfaced clutch facing, or scraping is observed on the clutch plates, clutch housing, armature plate, and insulator washer, replace the part or parts.



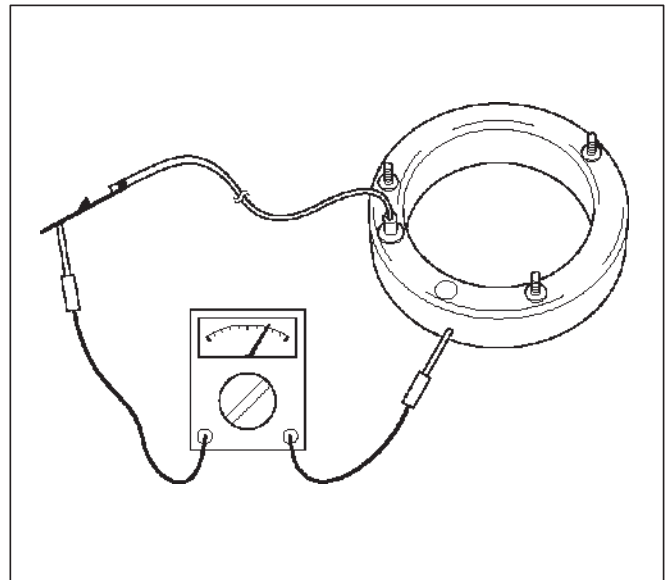
266RW031

### Coil Assembly

- Check the resistance of the coil with a tester. If defects are observed, replace the assembly.  
\* (ordinary temperature)

**Standard : 1.4-2.0 Ω**

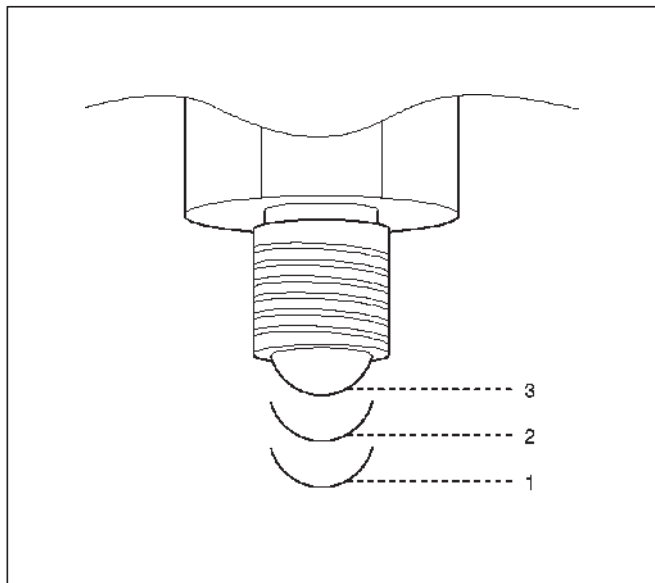
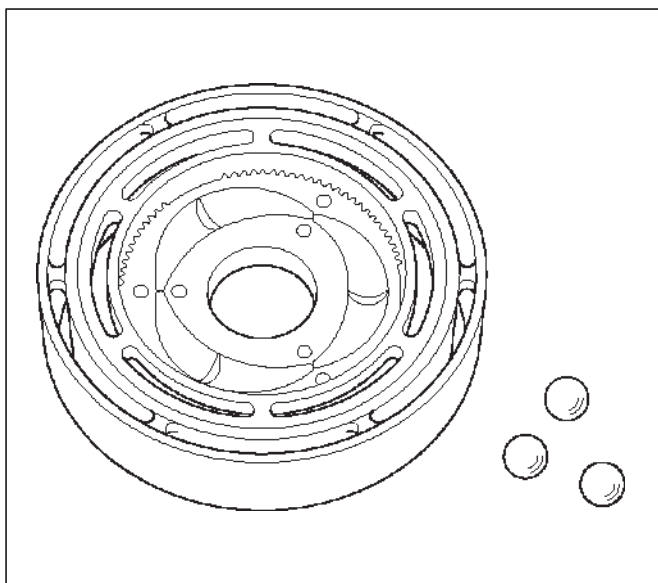
**Allowable limit : 1.0-5.0 Ω**



261RW031

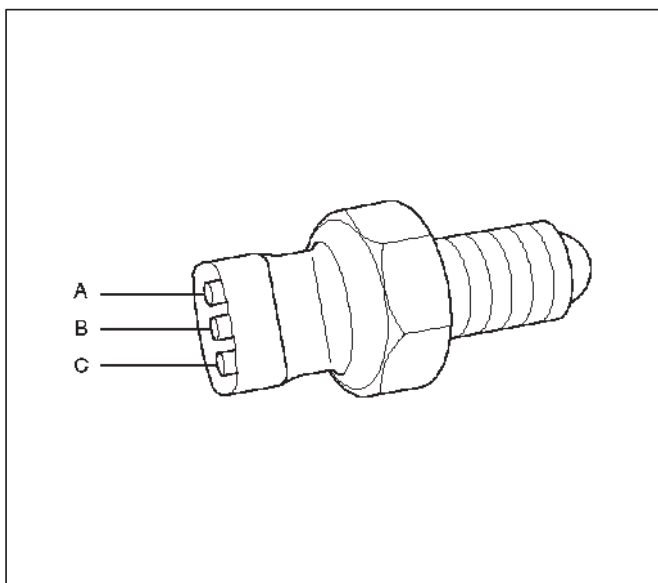
### Cam Pulley, Cam Ball, and Cam&Coil Housing

- Check the cam balls and cam for excessive wear or damage. If defective, replace the parts.



### 4H and 4L Switch

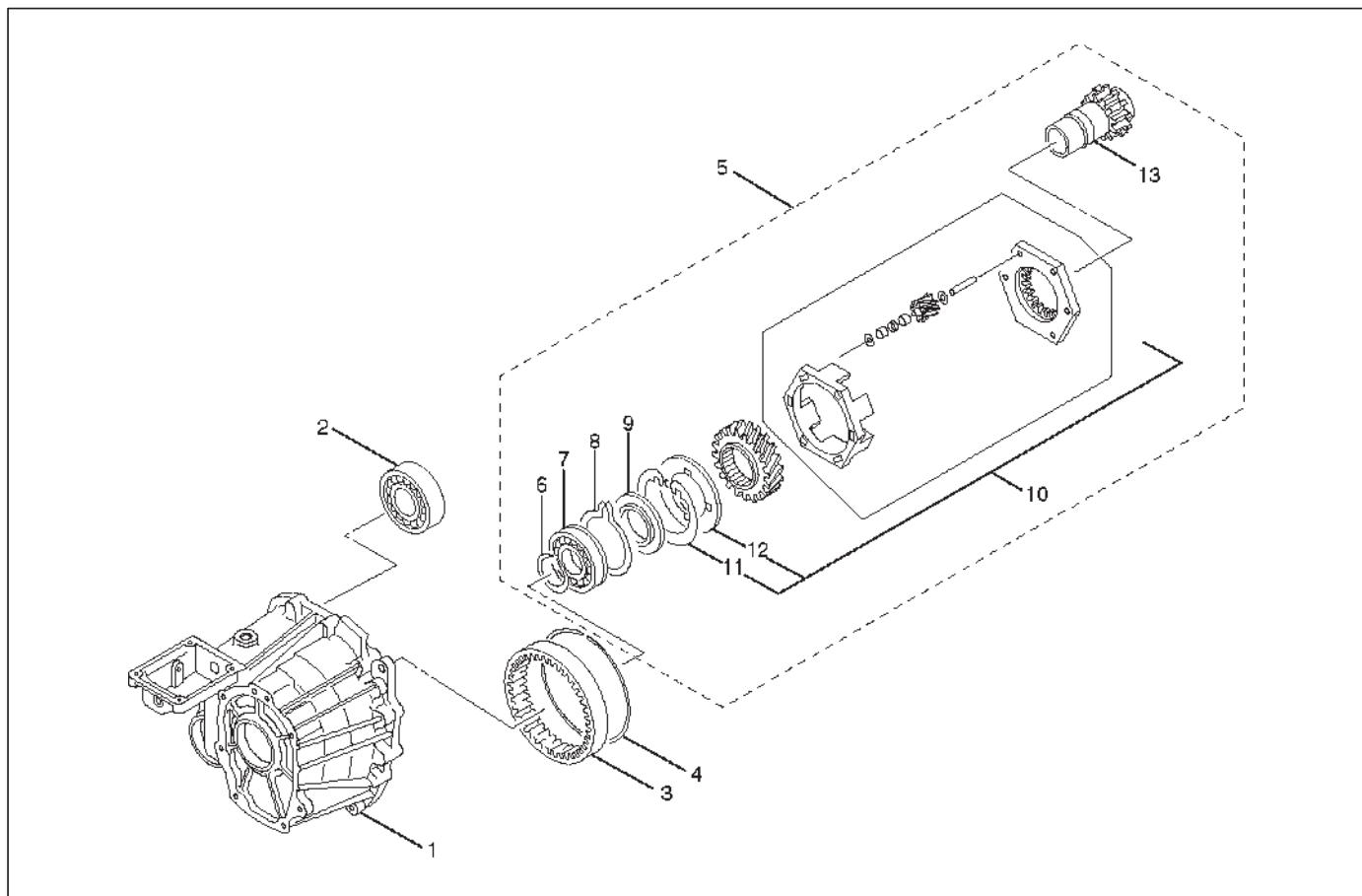
- Check the continuity of 4H and 4L switch.



Switch Stroke	4H Switch Signal	4L Switch Signal	The corresponding position of transfer lever
	B to Switch Body	A to C	
1	Open	Open	High
2	Open	Close	4L
3	Close	Close	Neutral

## Transfer Case

### Disassembled View



265RW015

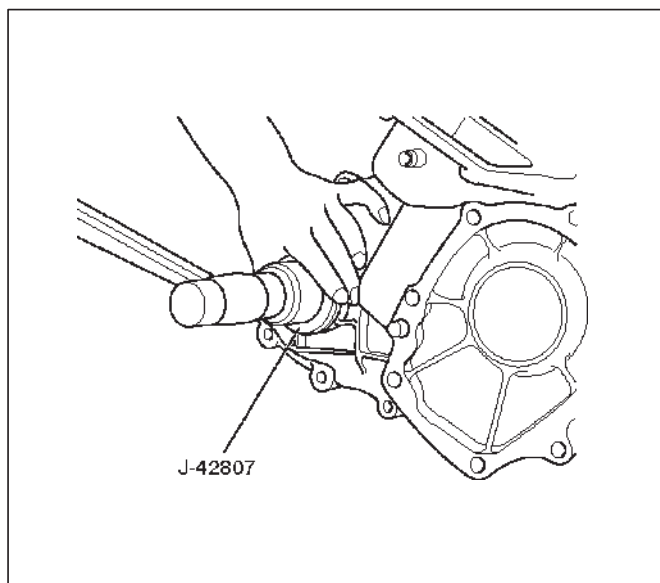
#### Legend

- |                                      |                       |
|--------------------------------------|-----------------------|
| (1) Transfer Case                    | (7) Ball Bearing      |
| (2) Ball Bearing                     | (8) Snap Ring         |
| (3) Ring Gear                        | (9) Thrust Plate      |
| (4) Snap Ring                        | (10) Carrier Assembly |
| (5) Input Shaft and Carrier Assembly | (11) Snap Ring        |
| (6) Snap Ring                        | (12) Circular Hub     |
|                                      | (13) Input Shaft      |

### Reassembly

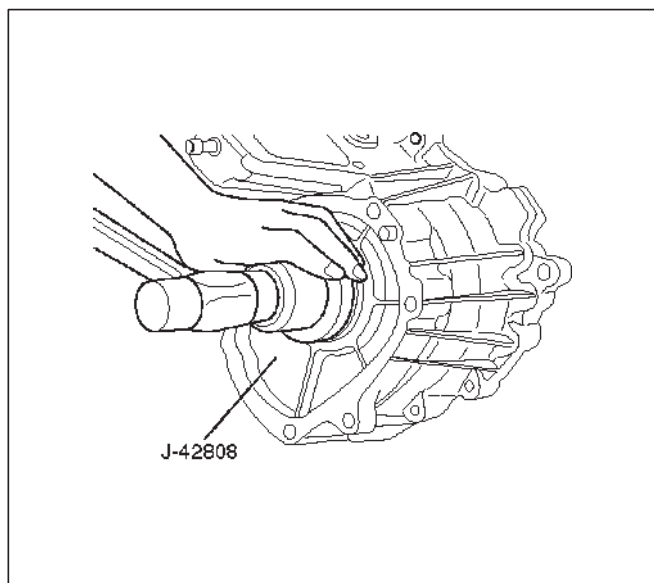
1. Remove the oil seals from the transfer case.
2. Apply ATF to the circumference of the new oil seal and fill the lip with grease (Besco L2 or equivalent).

3. Using the front output shaft oil seal installer J-42807, install the oil seal to the transfer case.



261RW014

4. Using the input shaft oil seal installer J-42808, install the oil seal to the transfer case.



261RW012

### Front Output Shaft Oil Seal

Distance between the transfer case end and oil seal.

NOTE: When installing the oil seal to the specified dimension, be careful not to damage it.

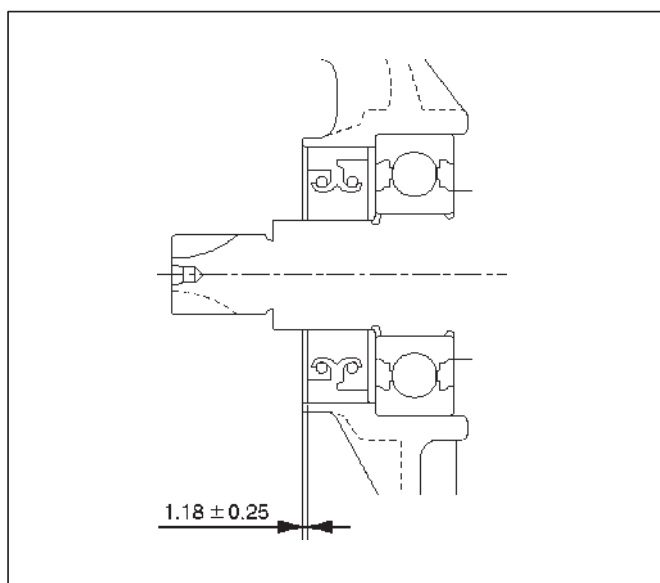
**Distance : 0.93 — 1.43mm (0.037 — 0.056 in)**

### Input Shaft Oil Seal

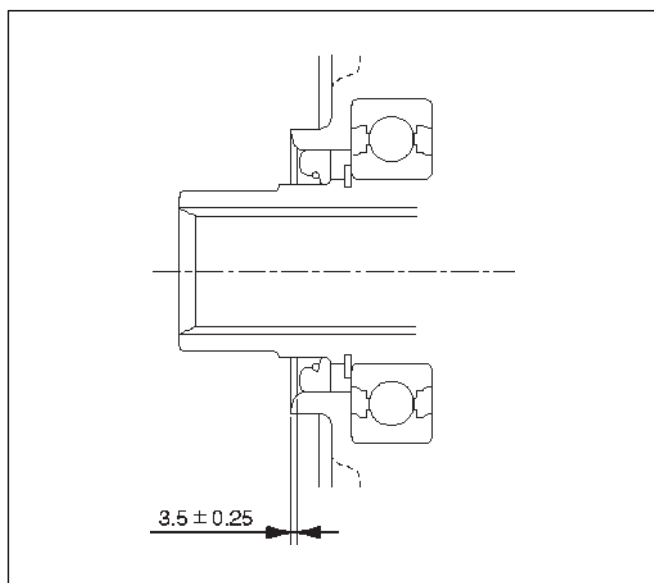
Distance between the transfer case end and oil seal.

NOTE: When installing the oil seal to the specified dimension, be careful not to damage it.

**Distance : 3.25 — 3.75mm (0.13 — 0.15 in)**



A04RW003



A04RW002

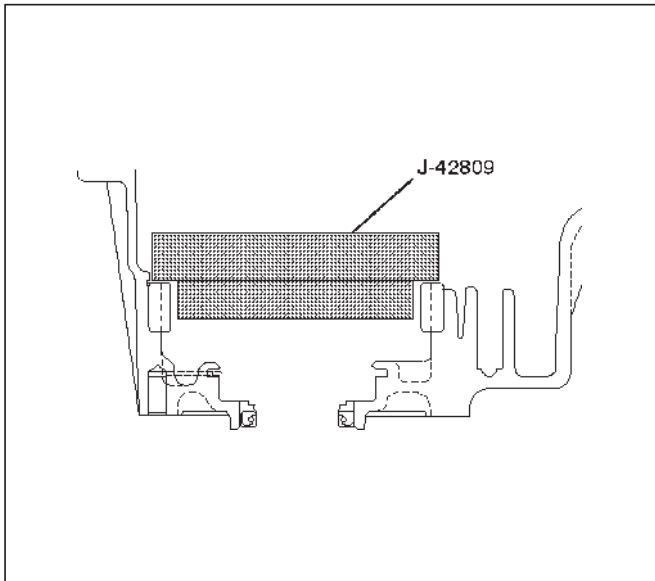


## 4D2-32 TRANSFER CASE (TOD)

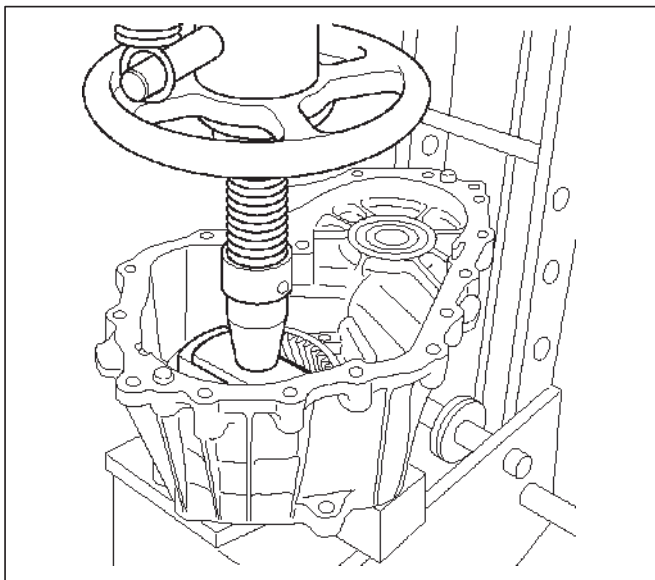
5. Using the special tool J-42809, press-fit the ring gear.

**Pay attention to the following points.**

- Identify the correct direction of gear.
- Do not damage the gear.
- Do not press-fit the ring gear slantingly.
- Press-fit the ring gear to the innermost.
- Remove burrs generated by press-fitting.
- If the transfer case has serration's, match them with those of the gear and press-fit the gear.



261RW013



261RW034

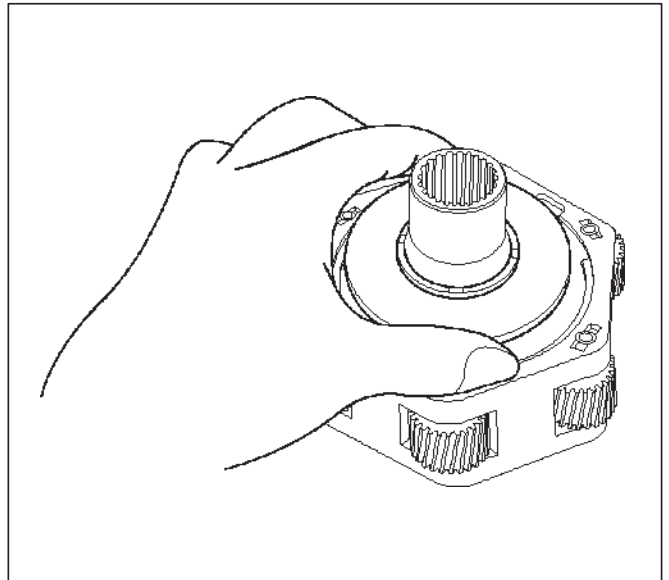
6. Install snap ring to the transfer case.

7. Install the circular hub to the carrier.

8. Install the snap ring to the carrier.

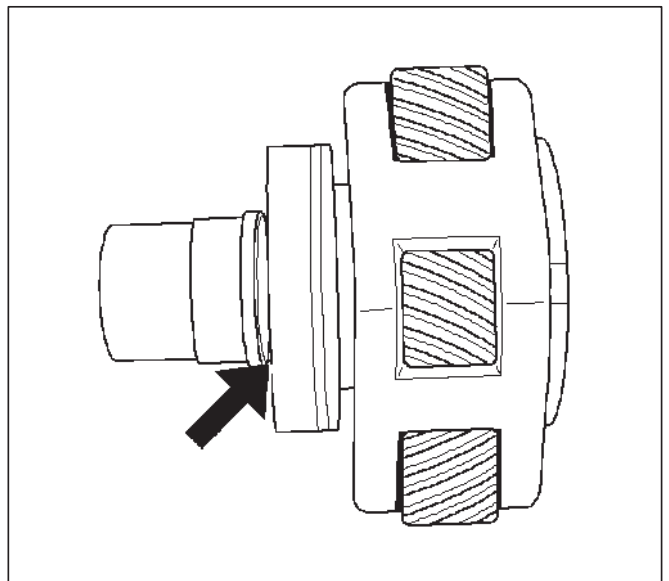
9. Mount the carrier assembly to the input shaft.

10. Check the direction of thrust plate and mount it to the input shaft.



265RW008

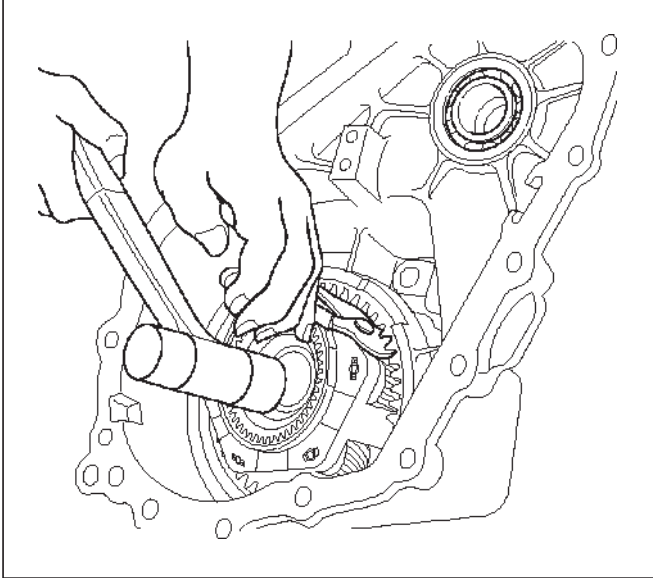
11. Mount the ball bearing to the input shaft so that the snap ring will be installed to the input shaft.



265RW003

12. Install the snap ring to the input shaft.

13. Set the snap ring to the transfer case.
14. Using the snap ring pliers, expand the snap ring through the opening between the ring gear and carrier assembly, and install the input shaft and carrier assembly to the transfer case. Securely install the snap ring to the input shaft and carrier assembly.

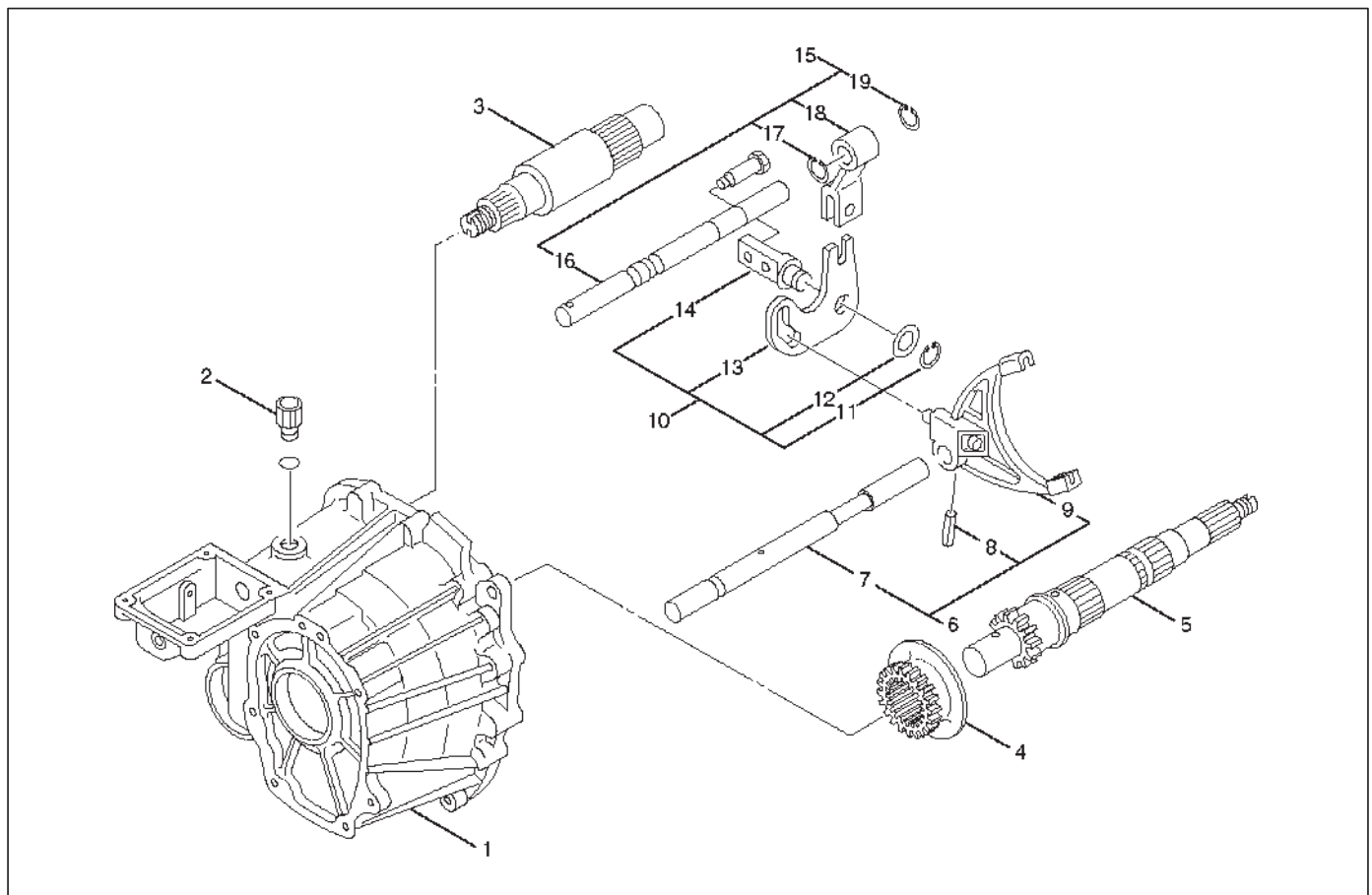


261RW038

15. Install ball bearing (for front output shaft).

## Output Shafts and Shift Control Shaft

### Disassembled View



261RW010-1

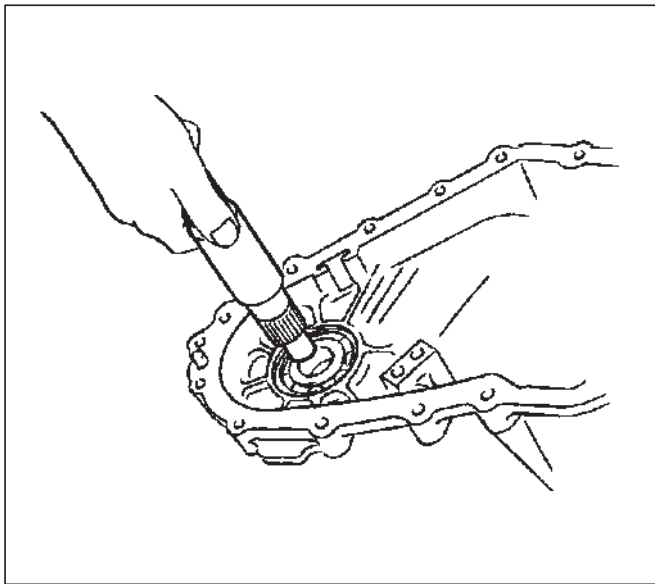
#### Legend

- |                             |                               |
|-----------------------------|-------------------------------|
| (1) Transfer Case Assembly  | (10) Cam Assembly             |
| (2) Detent Spring           | (11) Snap Ring                |
| (3) Front Output Shaft      | (12) Washer                   |
| (4) Reduction Hub           | (13) Cam                      |
| (5) Output Shaft            | (14) Cam Pilot Block          |
| (6) Reduction Fork Assembly | (15) Shifter Shaft Assembly   |
| (7) Lock-up shaft           | (16) Shifter Lever Shaft      |
| (8) Spring Pin              | (17) Snap Ring                |
| (9) Reduction Fork          | (18) Reduction Lever Assembly |
|                             | (19) Snap Ring                |

### Reassembly

1. Apply ATF to the inside of the ball bearing for the front output shaft.

2. Mount the front output shaft to the transfer case.

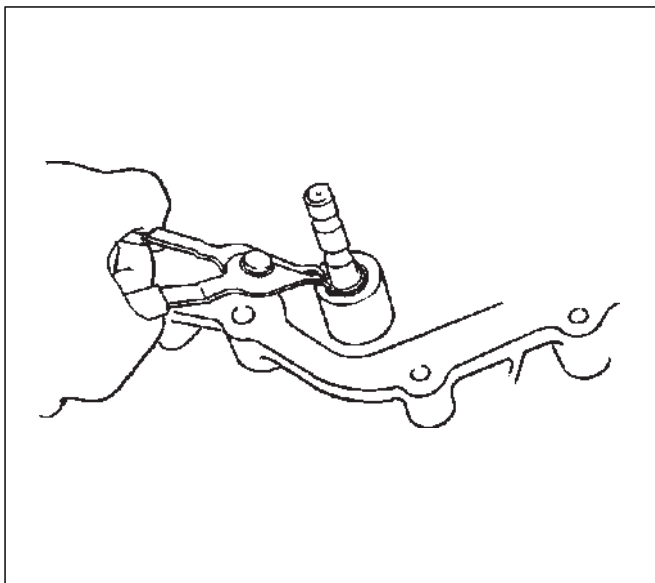


266RW012

3. Install the shifter lever shaft.

4. Install the snap ring.

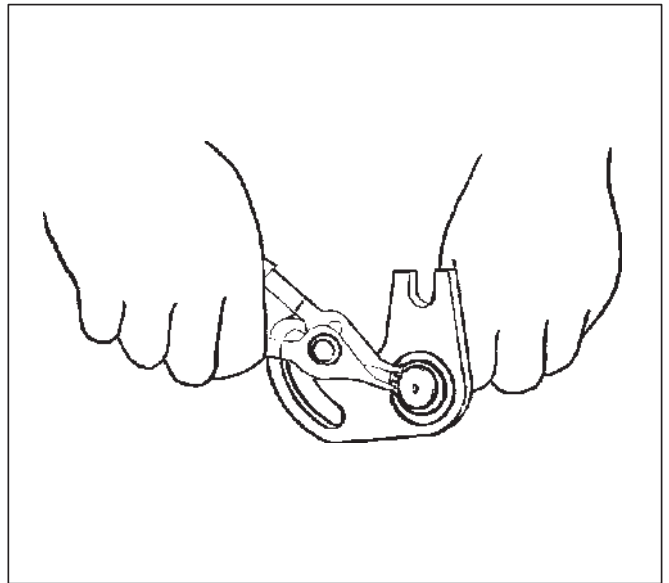
5. Install the reduction lever assembly to the shifter lever shaft and fix the assembly with the snap ring.



261RW021

6. Install the cam to the cam pilot block.

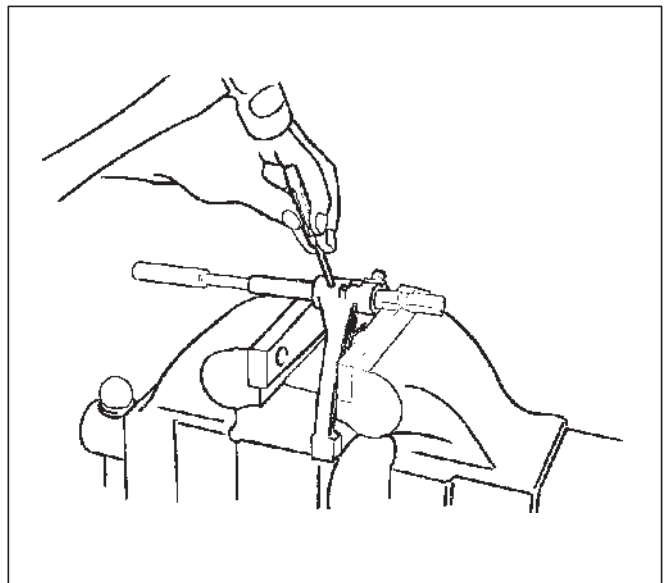
7. Attach the washer to the cam pilot block and fix the washer with the snap ring.



261RW029

8. Mount the reduction fork to the lock-up shaft.

9. Install the spring pin to the reduction fork and lock-up shaft.



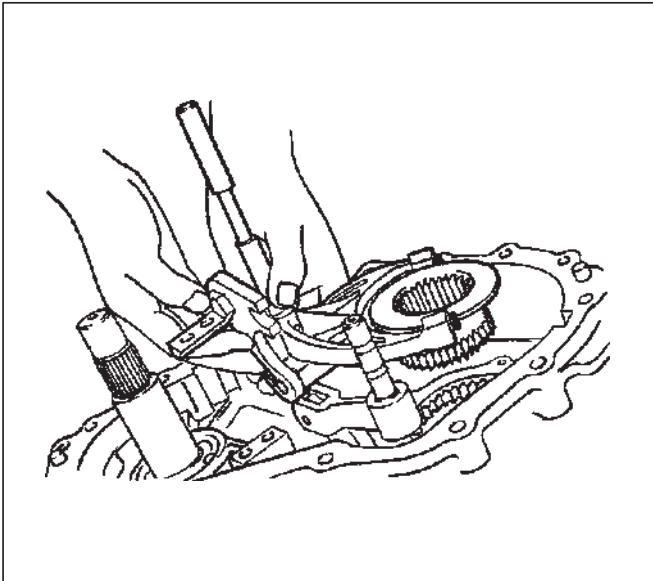
261RW020

10. Install the shifter shaft assembly.

## 4D2-36 TRANSFER CASE (TOD)

---

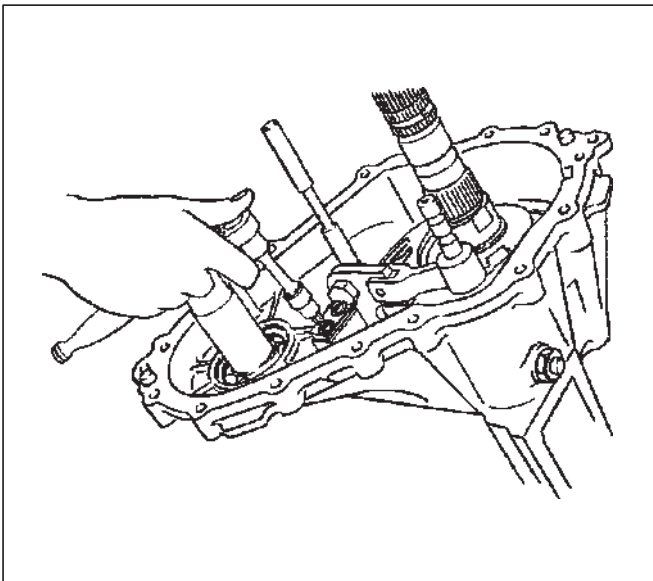
11. Install the reduction fork assembly together with the reduction hub and cam assembly to the transfer case assembly.



261RW019

12. Tighten the cam pilot block set bolts to the specified torque.

**Torque : 12 N·m (104 lb in)**



261RW022

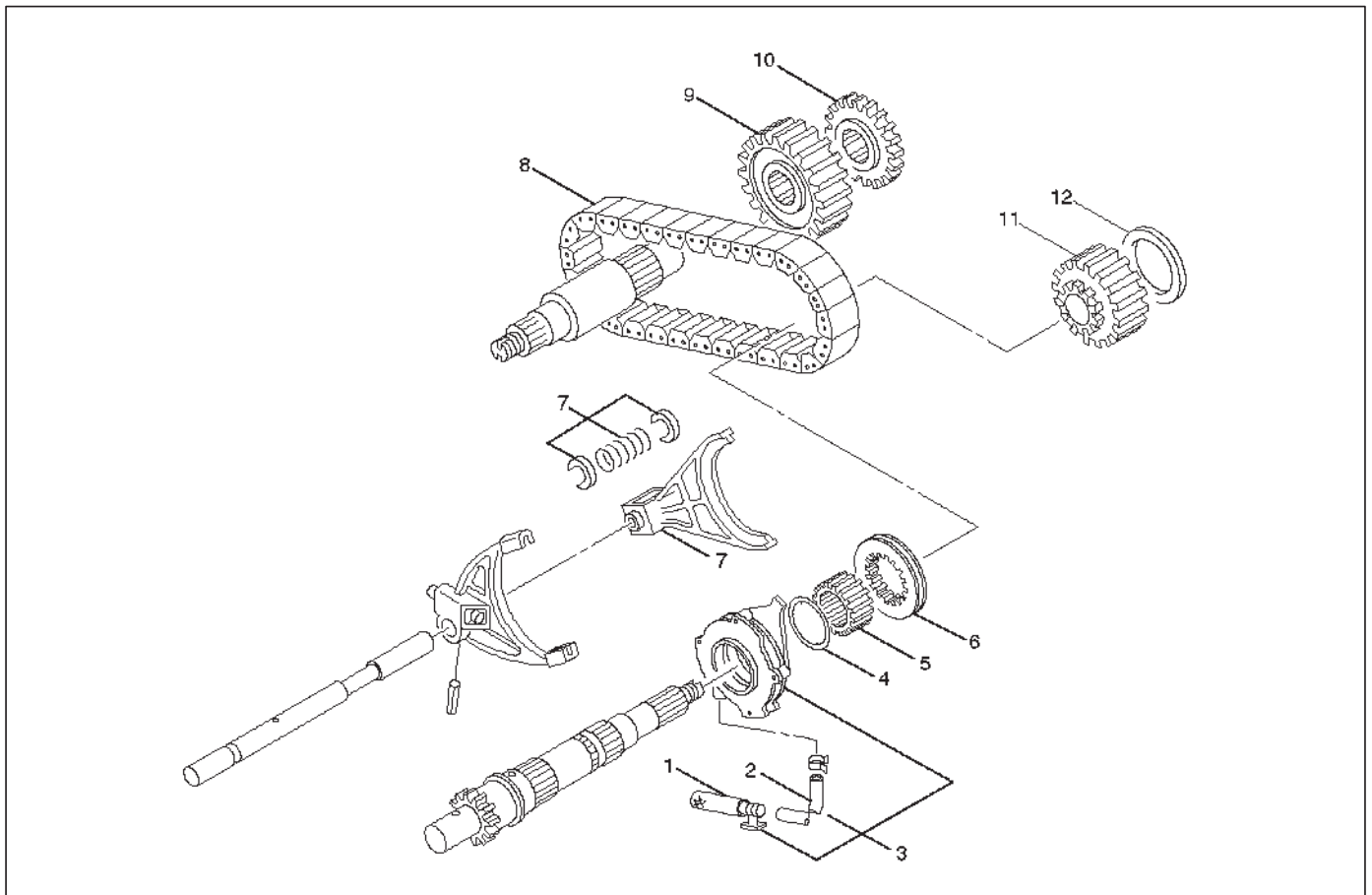
13. Tighten the detent spring to the specified torque.

**Torque : 24 N·m (17 lb ft)**

14. Apply ATF to the needle bearing inside the input shaft assembly.
15. Install the output shaft to the transfer case.

## Sprocket and Mechanical Lock

### Disassembled View



266RW008

#### Legend

- |                         |                          |
|-------------------------|--------------------------|
| (1) Strainer            | (7) Lock-up Fork         |
| (2) Hose                | (8) Chain                |
| (3) Oil Pump Assembly   | (9) Lower Drive Sprocket |
| (4) Thrust Washer       | (10) Front Tone Wheel    |
| (5) Mechanical Lock Hub | (11) Drive Sprocket      |
| (6) Lock-up Sleeve      | (12) Sprocket Spacer     |

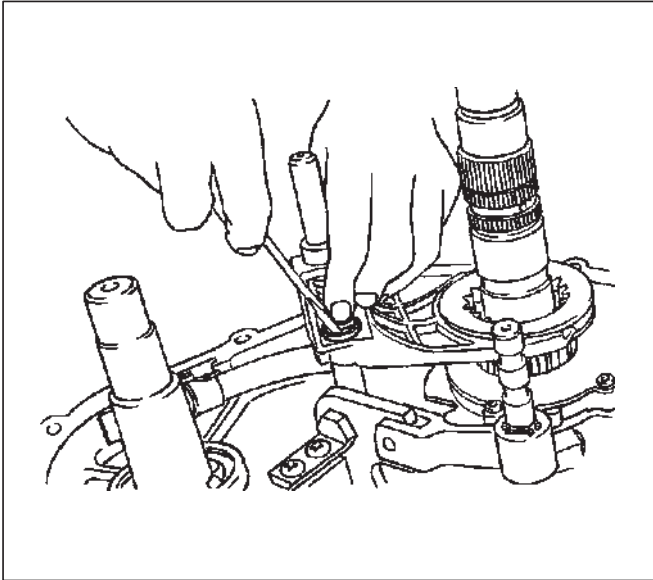
### Reassembly

1. Connect the hose and strainer to the oil pump.
2. Install the oil pump assembly to the output shaft and attach the magnet to the strainer set position.
3. Install thrust washer.

## 4D2-38 TRANSFER CASE (TOD)

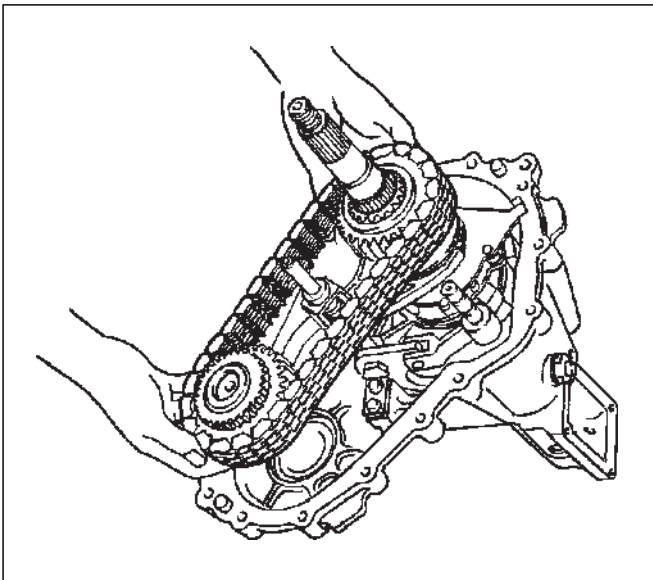
---

4. Install the spring to the lock-up fork.
5. install the lock-up sleeve together with the lock-up fork to the output shaft and reduction fork assembly each other.
6. Install the spring retainers to the lock-up fork.



261RW018

7. Install the mechanical lock hub.
8. Apply ATF to the chain.
9. Engage the chain to both sprockets.
10. Install the chain and sprocket assembly to both output shafts.

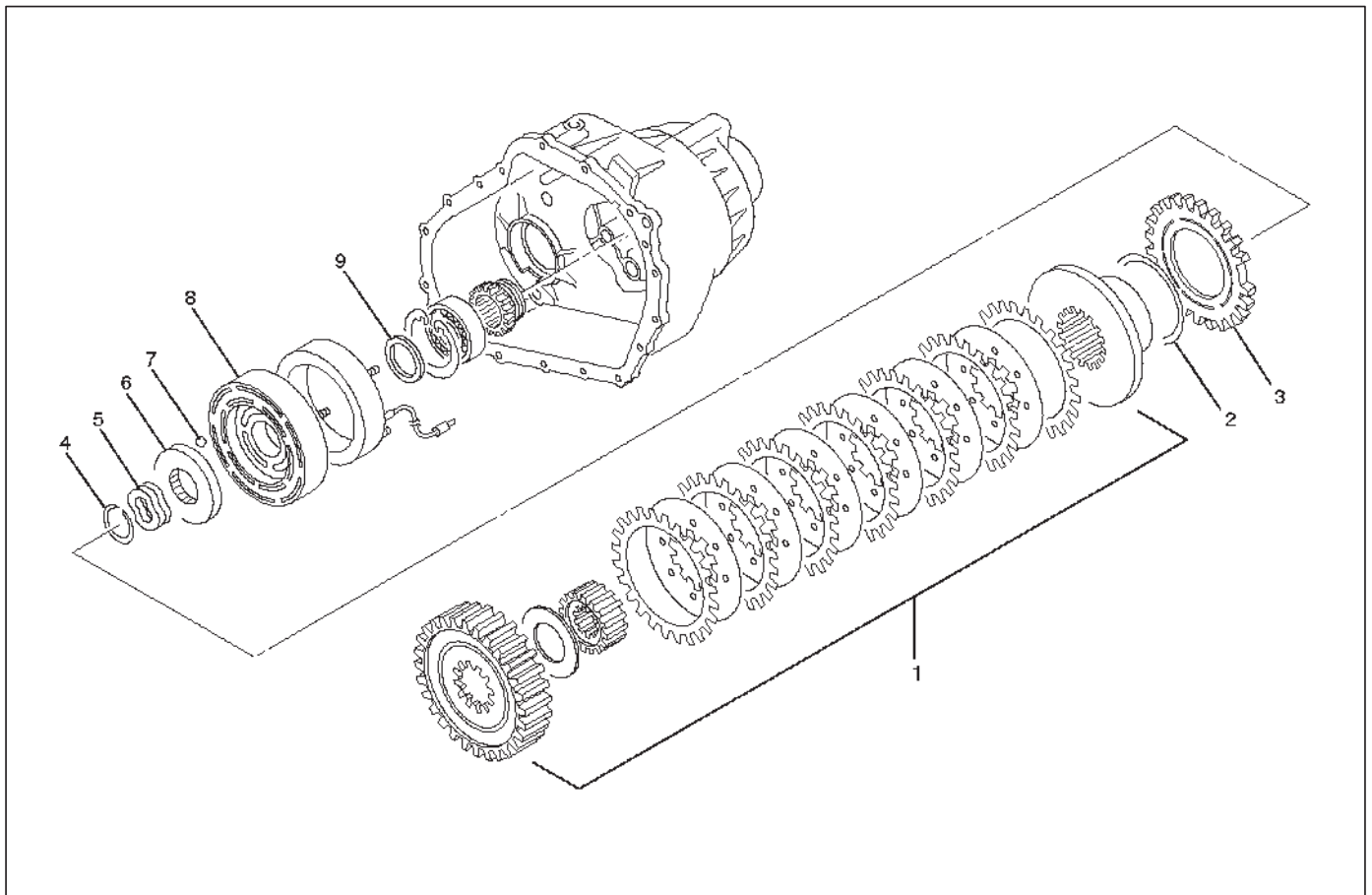


266RW010

11. Install the front tone wheel and sprocket spacer.

## Clutch Pack and Clutch Cam

### Disassembled View



266RW006

#### Legend

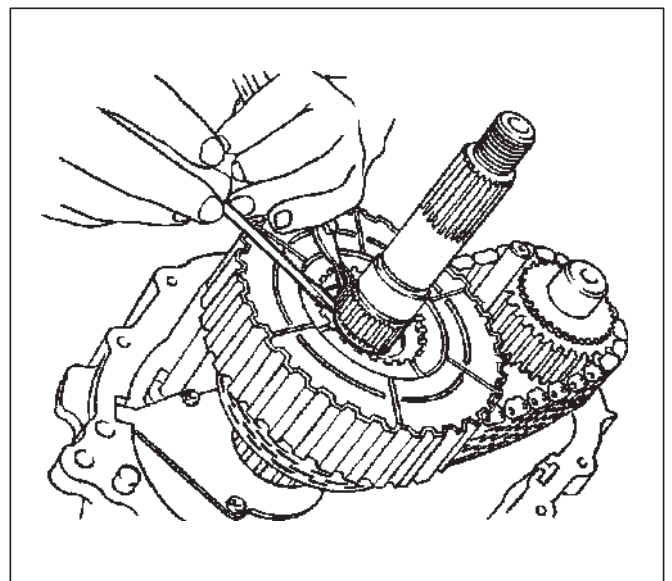
- |                          |                          |
|--------------------------|--------------------------|
| (1) Clutch Pack Assembly | (5) Wave Spring          |
| (2) Insulator Washer     | (6) Cam Pulley           |
| (3) Armature Plate       | (7) Cam Ball             |
| (4) Snap Ring            | (8) Cam and Coil Housing |
|                          | (9) Thrust Bearing       |

### Reassembly

1. Mount the clutch pack assembly to which the multi plate disk clutch is already installed to the output shaft.

NOTE: Mount the clutch pack assembly while adjusting the phase of both the clutch housing and drive sprocket.

2. Install the insulator washer.
3. Install the armature plate.
4. Using snap ring pliers, install the snap ring.



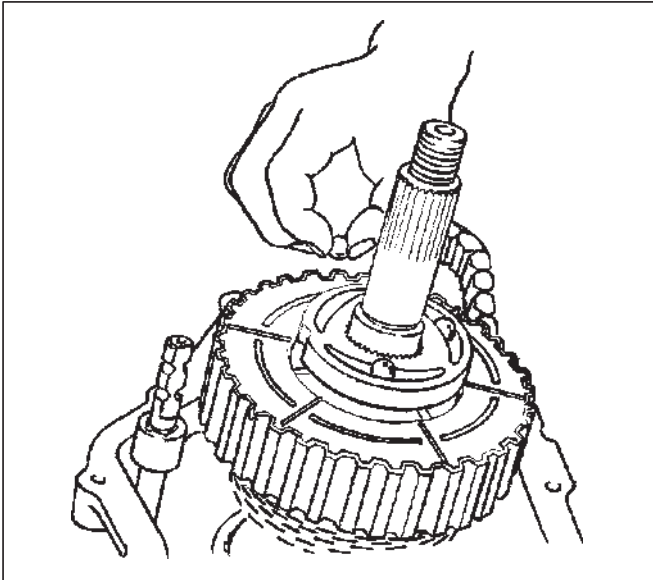
266RW009



## 4D2-40 TRANSFER CASE (TOD)

---

5. Install the wave spring.
6. Install the cam pulley.
7. Place a ball on each groove of the cam pulley.



266RW013

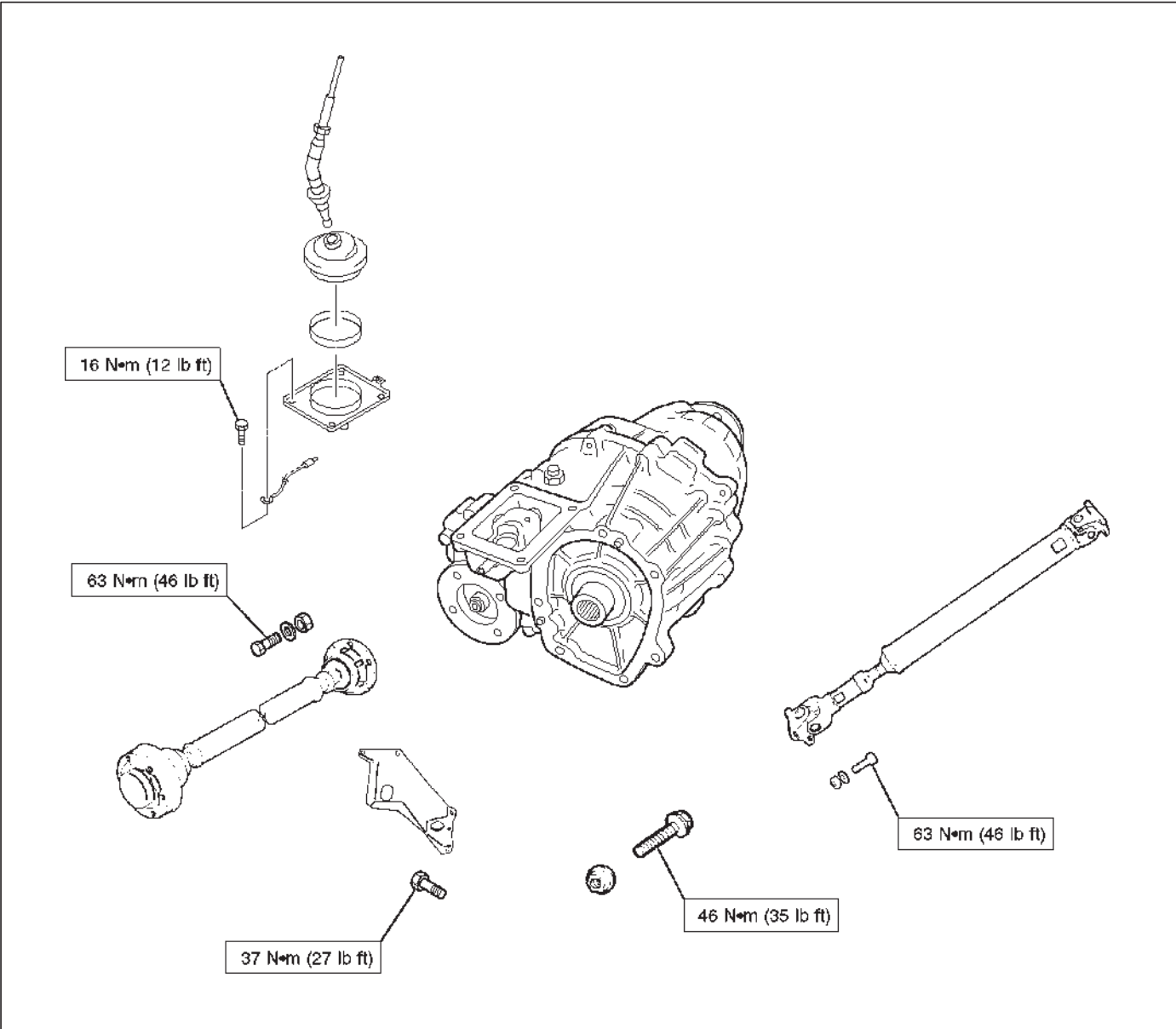
8. Install the cam and coil housing.
9. Install the thrust bearing.

### Main Data and Specifications

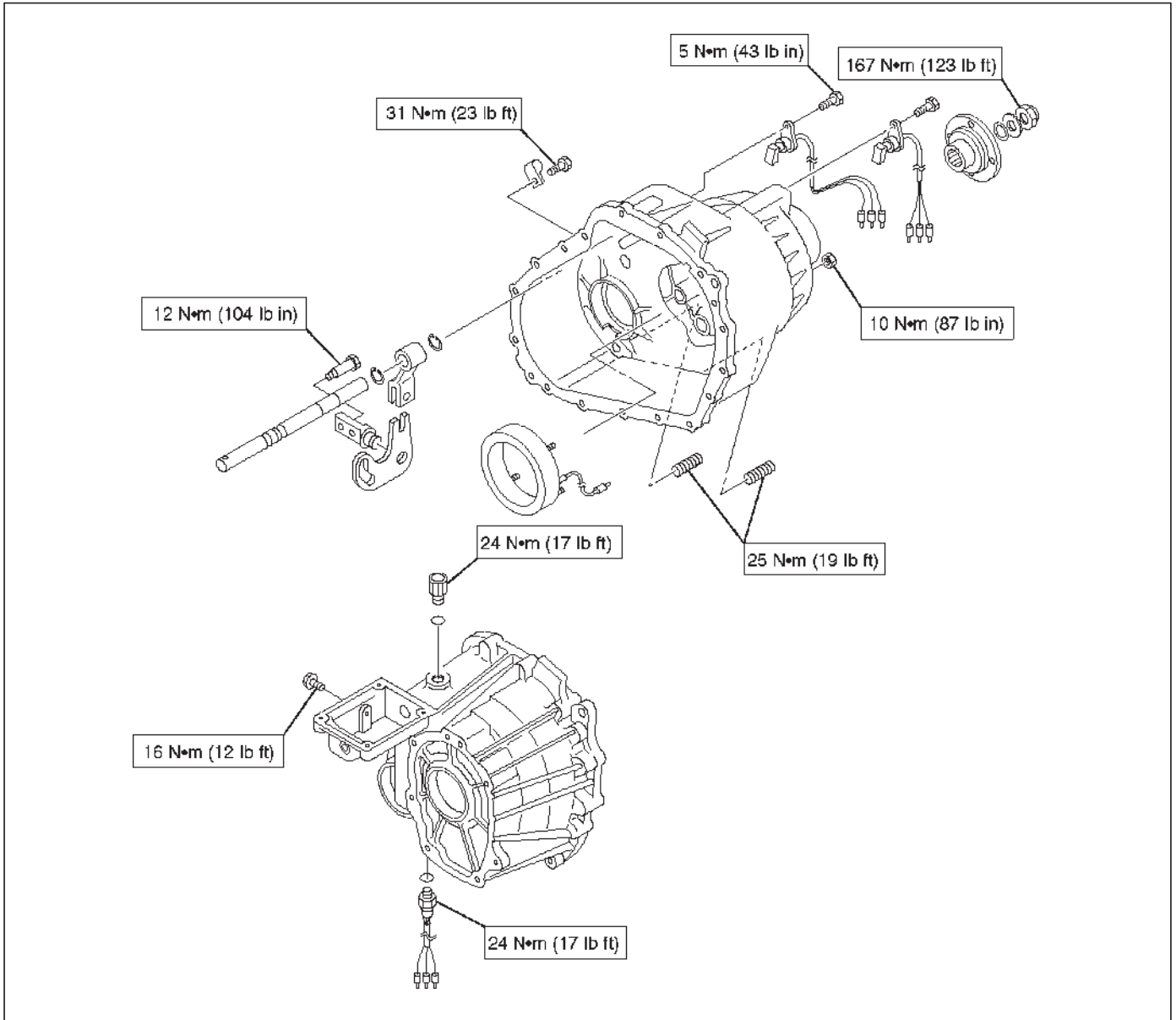
#### Leading Particulars

Type	TOD 4L	Transfer case with low range reduction mechanism Electronically controlled torque split four wheel drive Low-speed mechanical lock-up four wheel drive
Control system		Floor direct control
Gear ratio	H L	1.000 2.480
Oil quantity, Lit		1.9
Oil		ATF DEXRON®-IIE or ATF DEXRON®-III

#### Torque Specifications



# 4D2-42 TRANSFER CASE (TOD)



Special Tools

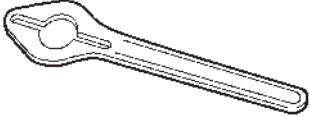
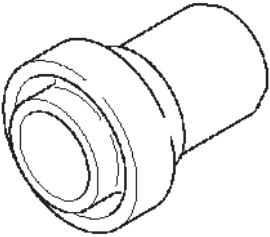

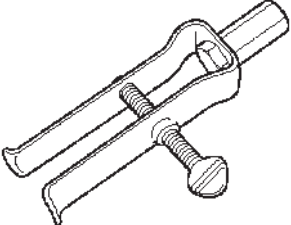
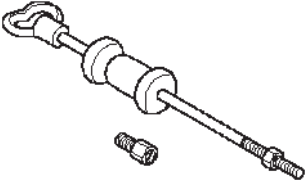
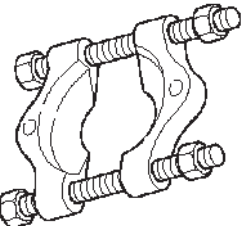

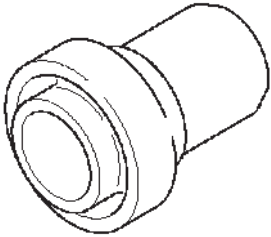
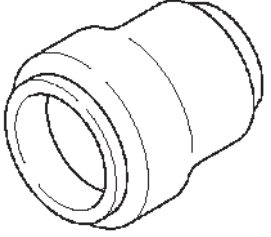
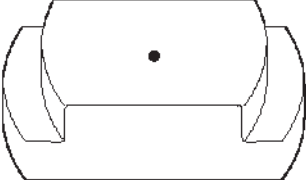
ILLUSTRATION	TOOL NO. TOOL NAME
 <p style="text-align: right; font-size: small;">901RW071</p>	<p style="text-align: center;"><b>J-8614-11</b> Flange Holder</p>
 <p style="text-align: right; font-size: small;">901RW095</p>	<p style="text-align: center;"><b>J-42804</b> Rear Oil Seal Installer</p>
 <p style="text-align: right; font-size: small;">901RW089</p>	<p style="text-align: center;"><b>J-39209</b> Punch</p>
 <p style="text-align: right; font-size: small;">901RW094</p>	<p style="text-align: center;"><b>J-42805</b> Bearing Remover</p>
 <p style="text-align: right; font-size: small;">901RW096</p>	<p style="text-align: center;"><b>J-2619-01</b> Slide Hammer</p>
 <p style="text-align: right; font-size: small;">901RW091</p>	<p style="text-align: center;"><b>J-22912-01</b> Bearing Remover</p>

ILLUSTRATION	TOOL NO. TOOL NAME
 <p style="text-align: right; font-size: small;">901RW092</p>	<p style="text-align: center;"><b>J-42806</b> Ring Gear Replacer</p>
 <p style="text-align: right; font-size: small;">901RW095</p>	<p style="text-align: center;"><b>J-42807</b> Front Out Oil Seal Installer</p>
 <p style="text-align: right; font-size: small;">901RW097</p>	<p style="text-align: center;"><b>J-42808</b> Input Shaft Oil Seal Installer</p>
 <p style="text-align: right; font-size: small;">901RW093</p>	<p style="text-align: center;"><b>J-42809</b> Ring Gear Installer</p>

VEHICROSS

# BRAKES

## BRAKE CONTROL SYSTEM

### CONTENTS

Service Precaution .....	5A-2	Chart B-3 Power Voltage Drop (DTC 15) ..	5A-30
General Description .....	5A-3	Chart B-4 CLASS-2 Communication Line Abnormality (DTC 16) .....	5A-30
System Components .....	5A-4	Chart B-5 G-Sensor Circuit (DTC 21) .....	5A-31
Electronic Hydraulic Control Unit (EHCU) .	5A-4	Chart B-6 Abnormal Transmission Input (DTC 23) .....	5A-32
ABS Warning Light .....	5A-4	Chart B-7 Transfer Monitor (DTC 24) .....	5A-32
Wheel Speed Sensor .....	5A-4	Chart B-8 EHCUC Pump Motor And Motor Relay Circuit (DTC 32) .....	5A-33
G-Sensor .....	5A-4	Chart B-9 EHCUC Pump Valve And Valve Relay Circuit (DTC 35) .....	5A-33
Normal and Anti-lock Braking .....	5A-4	Chart B-10 FL Isolation Solenoid Valve Abnormality (DTC 41) .....	5A-33
Brake Pedal Travel .....	5A-4	Chart B-11 FL Dump Solenoid Valve Abnormality (DTC 42) .....	5A-34
Acronyms and Abbreviations .....	5A-4	Chart B-12 FR Isolation Solenoid Valve Abnormality (DTC 43) .....	5A-34
General Diagnosis .....	5A-5	Chart B-13 FR Dump Solenoid Valve Abnormality (DTC 44) .....	5A-34
General Information .....	5A-5	Chart B-14 Rear Isolation Solenoid Valve Abnormality (DTC 45) .....	5A-35
ABS Service Precautions .....	5A-5	Chart B-15 Rear Dump Solenoid Valve Abnormality (DTC 46) .....	5A-35
Computer System Service Precautions ...	5A-5	Chart B-16 FL Speed Sensor Disconnection (DTC 51) .....	5A-35
General Service Precautions .....	5A-5	Chart B-17 FR Speed Sensor Disconnection (DTC 52) .....	5A-36
Note on Intermittents .....	5A-5	Chart B-18 RL Speed Sensor Disconnection (DTC 53) .....	5A-36
Test Driving ABS Complaint Vehicles .....	5A-6	Chart B-19 RR Speed Sensor Disconnection (DTC 54) .....	5A-37
“ABS” Warning Light .....	5A-6	Chart B-20 FL Speed Sensor Short Circuit (DTC 61) .....	5A-38
Normal Operation .....	5A-6	Chart B-21 FR Speed Sensor Short Circuit (DTC 62) .....	5A-39
Basic Diagnostic Flow Chart .....	5A-6	Chart B-22 RL Speed Sensor Short Circuit (DTC 63) .....	5A-40
Basic Inspection Procedure .....	5A-7	Chart B-23 RR Speed Sensor Short Circuit (DTC 64) .....	5A-41
Tech 2 Scan Tool .....	5A-8	Chart B-24 Sensor Signal Input Abnormality (DTC 65) .....	5A-42
Getting Started .....	5A-9	Sensor Signal Abnormality Criteria using TECH 2 .....	5A-42
Operating Procedure .....	5A-9	Unit Inspection Procedure .....	5A-43
Data List .....	5A-11	Chart C-1-1 FL Sensor Output Inspection Procedure .....	5A-43
EHCUC Connector Pin-out Checks .....	5A-12	Chart C-1-2 FR Sensor Output Inspection Procedure .....	5A-44
Circuit Diagram .....	5A-13	Chart C-1-3 RL Sensor Output Inspection Procedure .....	5A-44
Connector List .....	5A-15	Chart C-1-4 RR Sensor Output Inspection Procedure .....	5A-45
Part Location .....	5A-17	Chart TC-1 Sensor Output Inspection Procedure (Use TECH 2) .....	5A-45
Symptom Diagnosis .....	5A-18	Chart C-2 Transmission Input Inspection Procedure .....	5A-46
Chart A-1 ABS Works Frequently But Vehicle Does Not Decelerate .....	5A-19		
Chart TA-1 ABS Works Frequently But Vehicle Does Not Decelerate (Use TECH 2) .....	5A-20		
Chart A-2 Uneven Braking Occurs While ABS Works .....	5A-20		
Chart A-3, TA-3 The Wheels Are Locked .	5A-21		
Chart A-4 Brake Pedal Feed Is Abnormal .	5A-22		
Chart A-5, TA-5 Braking Sound (From EHCUC) Is Heard While Not Braking .....	5A-23		
Diagnostic Trouble Codes .....	5A-24		
Diagnosis By “ABS” Warning Light			
Illumination Pattern .....	5A-25		
Diagnostic Trouble Codes (DTCs) .....	5A-26		
Chart B-1 With the key in the ON position (Before starting the engine). Warning light (W/L) is not activated. ....	5A-29		
Chart B-2 EHCUC Abnormality (DTC 14) ...	5A-29		

## 5A-2 BRAKE CONTROL SYSTEM

---

Chart TC-2 Transmission Input Inspection Procedure (Use TECH 2) .....	5A-46
Special Tools .....	5A-47

### Service Precaution

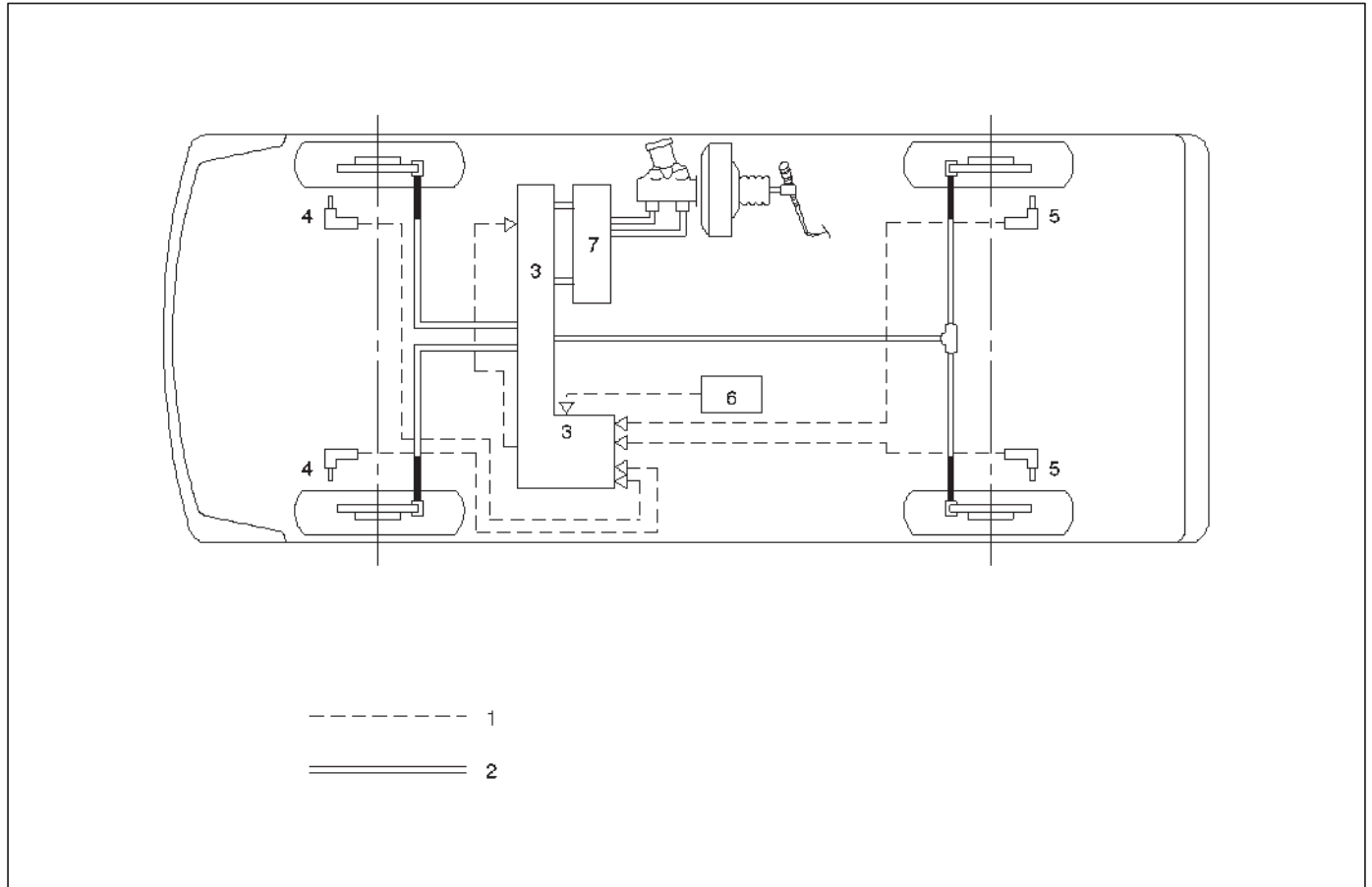
**WARNING: THIS VEHICLE HAS A SUPPLEMENTAL RESTRAINT SYSTEM (SRS). REFER TO THE SRS COMPONENT AND WIRING LOCATION VIEW IN ORDER TO DETERMINE WHETHER YOU ARE PERFORMING SERVICE ON OR NEAR THE SRS COMPONENTS OR THE SRS WIRING. WHEN YOU ARE PERFORMING SERVICE ON OR NEAR THE SRS COMPONENTS OR THE SRS WIRING, REFER TO THE SRS SERVICE INFORMATION. FAILURE TO FOLLOW WARNINGS COULD RESULT IN POSSIBLE AIR BAG DEPLOYMENT, PERSONAL INJURY, OR OTHERWISE UNNEEDED SRS SYSTEM REPAIRS.**

**CAUTION: Always use the correct fastener in the proper location. When you replace a fastener, use ONLY the exact part number for that application. ISUZU will call out those fasteners that require a replacement after removal. ISUZU will also call out the fasteners that require thread lockers or thread sealant. UNLESS OTHERWISE SPECIFIED, do not use supplemental coatings (Paints, greases, or other corrosion inhibitors) on threaded fasteners or fastener joint interfaces. Generally, such coatings adversely affect the fastener torque and the joint clamping force, and may damage the fastener. When you install fasteners, use the correct tightening sequence and specifications. Following these instructions can help you avoid damage to parts and systems.**

## General Description

The Anti-lock Brake System (ABS) works on all four wheels. A combination of wheel speed sensor and Electronic Hydraulic Control Unit (EHCU) can determine when a wheel is about to stop turning and adjust brake pressure to maintain best braking.

This system helps the driver maintain greater control of the vehicle under heavy braking conditions.



C05RW002

### Legend

- |  |  |
|--|--|
| (1) Electronic                               | (4) Front Wheel Speed Sensor             |
| (2) Hydraulic                                | (5) Rear Wheel Speed Sensor              |
| (3) Electronic Hydraulic Control Unit (EHCU) | (6) G-Sensor                             |
|  | (7) Proportioning and Bypass (P&B) Valve |

## System Components

Electronic Hydraulic Control Unit (EHCU), four Wheel Speed Sensors, Warning Light, and G-sensor.

### Electronic Hydraulic Control Unit (EHCU)

The EHCU consists of ABS control circuits, fault detector, and a fail-safe. It drives the hydraulic unit according to the signal from each sensor, cancelling ABS to return to normal braking when a malfunction has occurred in the ABS.

The EHCU has a self-diagnosing function which can indicate faulty circuits during diagnosis.

The EHCU is mounted on the engine compartment front right side. It consists of a Motor, Plunger Pump, Solenoid Valves and Check Valve.

On the outside, the relay box containing a motor relay and a valve relay is installed.

**Solenoid Valves:** Reduces or holds the caliper fluid pressure for each front disc brake or both rear disc brakes according to the signal sent from the EHCU.

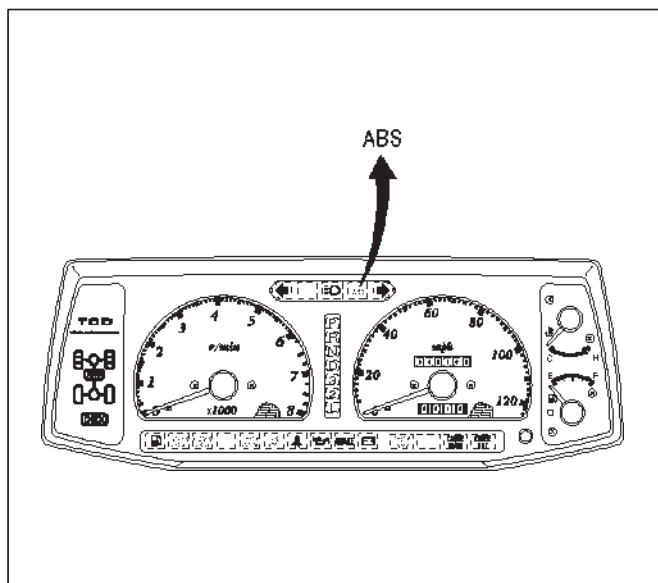
**Reservoir:** Temporarily holds the brake fluid that returns from the front and rear disc brake caliper so that pressure of front disc brake caliper can be reduced smoothly.

**Plunger Pump:** Feeds the brake fluid held in the reservoir to the master cylinder.

**Motor:** Drives the pump according to the signal from EHCU.

**Check Valve:** Controls the brake fluid flow.

### ABS Warning Light



Vehicles equipped with the Anti-lock Brake System have an amber "ABS" warning light in the instrument panel. The "ABS" warning light will illuminate if a malfunction in the Anti-lock Brake System is detected by the Electronic Hydraulic Control Unit (EHCU). In case of an electronic malfunction, the EHCU will turn "ON" the "ABS" warning light and disable the Anti-lock braking function.

The "ABS" light will turn "ON" for approximately three seconds after the ignition switch is to the "ON" position. If the "ABS" light stays "ON" after the ignition switch is the "ON" position, or comes "ON" and stays "ON" while

driving, the Anti-lock Brake System should be inspected for a malfunction according to the diagnosis procedure.

### Wheel Speed Sensor

It consists of a sensor and a rotor. The sensor is attached to the knuckle on the front wheels and to the axle shaft bearing holder on the rear wheels.

The rotor is press-fit in the axle shaft.

The flux generated from electrodes magnetized by a magnet in the sensor varies due to rotation of the rotor, and the electromagnetic induction generates alternating voltage in the coil. This voltage draws a "sine curve" with the frequency proportional to rotor speed and it allows detection of wheel speed.

### G-Sensor

The G-sensor installed inside the center console detects the vehicle deceleration speed and sends a signal to the EHCU. In 4WD operation, all four wheels may be decelerated in almost the same phase, since all wheels are connected mechanically.

This tendency is noticeable particularly on roads with low friction coefficient, and the ABS control is adversely affected.

The G-sensor judges whether the friction coefficient of road surface is low or high, and changes the EHCU's operating system to ensure ABS control.

### Normal and Anti-lock Braking

Under normal driving conditions, the Anti-lock Brake System functions the same as a standard power assisted brake system. However, with the detection of wheel lock-up, a slight bump or kick-back will be felt in the brake pedal. This pedal "bump" will be followed by a series of short pedal pulsations which occurs in rapid succession. The brake pedal pulsation will continue until there is no longer a need for the anti-lock function or until the vehicle is stopped. A slight ticking or popping noise may be heard during brake applications when the Anti-lock features is being used.

When the Anti-lock feature is being used, the brake pedal may rise even as the brakes are being applied. This is also normal. Maintaining a constant force on the pedal will provide the shortest stopping distance.

### Brake Pedal Travel

Vehicles equipped with the Anti-lock Brake System may be stopped by applying normal force to the brake pedal. Although there is no need to push the pedal beyond the point where it stops or holds the vehicle, by applying more force the pedal will continue to travel toward the floor. This extra brake pedal travel is normal.

### Acronyms and Abbreviations

Several acronyms and abbreviations are commonly used throughout this section:

**ABS**  
Anti-lock Brake System

**CKT**  
Circuit



**DLC**

Data Link Connector

**EHCUC**

Electronic Hydraulic Control Unit

**FL**

Front Left

**FR**

Front Right

**GEN**

Generator

**MV**

Millivolts

**RL**

Rear Left

**RR**

Rear Right

**RPS**

Revolution per Second

**VDC**

Volts DC

**VAC**

Volts AC

**W/L**

Warning Light

**WSS**

Wheel Speed Sensor

## General Diagnosis

### General Information

ABS malfunction can be classified into two types, those which can be detected by the ABS warning light and those which can be detected as a vehicle abnormality by the driver.

In either case, locate the fault in accordance with the "BASIC DIAGNOSTIC FLOWCHART" and repair.

Please refer to Section 5C for the diagnosis of mechanical troubles such as brake noise, brake judder (brake pedal or vehicle vibration felt when braking), uneven braking, and parking brake trouble.

### ABS Service Precautions

Required Tools and Items:

- Box Wrench
- Brake Fluid
- Special Tool

Some diagnosis procedures in this section require the installation of a special tool.

#### J-39200 High Impedance Multimeter

When circuit measurements are requested, use a circuit tester with high impedance.

### Computer System Service Precautions

The Anti-lock Brake System interfaces directly with the Electronic Hydraulic Control Unit (EHCUC) which is a control computer that is similar in some regards to the

Powertrain Control Module. These modules are designed to withstand normal current draws associated with vehicle operation. However, care must be taken to avoid overloading any of the EHCUC circuits. In testing for opens or shorts, do not ground or apply voltage to any of the circuits unless instructed to do so by the appropriate diagnostic procedure. These circuits should only be tested with a high impedance multimeter (J-39200) or special tools as described in this section. Power should never be removed or applied to any control module with the ignition in the "ON" position.

Before removing or connecting battery cables, fuses or connectors, always turn the ignition switch to the "OFF" position.

### General Service Precautions

The following are general precautions which should be observed when servicing and diagnosing the Anti-lock Brake System and/or other vehicle systems. Failure to observe these precautions may result in Anti-lock Brake System damage.

- If welding work is to be performed on the vehicle using an electric arc welder, the EHCUC and valve block connectors should be disconnected before the welding operation begins.
- The EHCUC and valve block connectors should never be connected or disconnected with the ignition "ON".
- EHCUC of the Anti-lock Brake System are not separately serviceable and must be replaced as assemblies. Do not disassemble any component which is designated as non-serviceable in this Section.
- If only rear wheels are rotated using jacks or drum tester, the system will diagnose a speed sensor malfunction and the "ABS" warning light will illuminate. But actually no trouble exists. After inspection stop the engine once and re-start it, then make sure that the "ABS" warning light does not illuminate.

#### If the battery has been discharged

The engine may stall if the battery has been completely discharged and the engine is started via jumper cables. This is because the Anti-lock Brake System (ABS) requires a large quantity of electricity. In this case, wait until the battery is recharged, or set the ABS to a non-operative state by removing the fuse for the ABS (40A). After the battery has been recharged, stop the engine and install the ABS fuse. Start the engine again, and confirm that the ABS warning light does not light.

### Note on Intermittents

As with virtually any electronic system, it is difficult to identify an intermittent failure. In such a case duplicating the system malfunction during a test drive or a good description of vehicle behavior from the customer may be helpful in locating a "most likely" failed component or circuit. The symptom diagnosis chart may also be useful in isolating the failure. Most intermittent problems are caused by faulty electrical connections or wiring. When an intermittent failure is encountered, check suspect circuits for:

- Suspected harness damage.

## 5A-6 BRAKE CONTROL SYSTEM

- Poor mating of connector halves or terminals not fully seated in the connector body (backed out).
- Improperly formed or damaged terminals.

### Test Driving ABS Complaint Vehicles

In case that there has been an malfunction in the lighting pattern of "ABS" warning light, the fault can be located in accordance with the "DIAGNOSIS BY "ABS" WARNING LIGHT ILLUMINATION PATTERN" . In case of such trouble as can be detected by the driver as a vehicle symptom, however, it is necessary to give a test drive following the test procedure mentioned below, thereby reproducing the symptom for trouble diagnosis on a symptom basis:

1. Start the engine and make sure that the "ABS" W/L goes OFF. If the W/L remains ON, it means that the Diagnostic Trouble Code (DTC) is stored. Therefore, read the code and locate the fault.
2. Start the vehicle and accelerate to about 30 km/h (19 mph) or more.
3. Slowly brake and stop the vehicle completely.
4. Then restart the vehicle and accelerate to about 40 km/h (25 mph) or more.
5. Brake at a time so as to actuate the ABS and stop the vehicle.
6. Be cautious of abnormality during the test. If the W/L is actuated while driving, read the DTC and locate the fault.
7. If the abnormality is not reproduced by the test, make best efforts to reproduce the situation reported by the customer.

8. If the abnormality has been detected, repair in accordance with the "SYMPTOM DIAGNOSIS" .

#### NOTE:

- Be sure to give a test drive on a wide, even road with little traffic.
- If an abnormality is detected, be sure to suspend the test and start trouble diagnosis at once.

### "ABS" Warning Light

When ABS trouble occurs and actuates when possible the "ABS" warning light, the trouble code corresponding to the trouble is stored in the EHCUC. Only the ordinary brake system is available when the ABS is turned off. When the "ABS" warning light is actuated, if the starter switch is set ON after setting it OFF once, the EHCUC checks up on the entire system and, if there is no abnormality, judges ABS to work currently and the warning light works normally even though the trouble code is stored.

NOTE: Illumination of the "ABS" warning light indicates that anti-lock braking is no longer available. Power assisted braking without anti-lock control is still available.

### Normal Operation

#### "ABS" Warning Light

When the ignition is first moved from "OFF" to "ON" , the amber "ABS" warning light will turn "ON" . The "ABS" warning light will turn "ON" during engine starting and will usually stay "ON" for approximately three seconds after the ignition switch is returned to the "ON" position. The warning light should remain "OFF" at all other times.

### Basic Diagnostic Flow Chart

Step	Action	Yes	No
1	1. Customer complaint. 2. Questioning to customer. 3. Basic inspection (Refer to "Basic inspection procedure") Using TECH 2?	Go to Step 2	Go to Step 4
2	Make sure of DTC by mode "F0 : Diagnostic Trouble Codes". Is EHCUC including DTC?	Go to Step 3	Go to Step 5
3	1. Repair of faulty part. 2. Elimination of DTC. 3. Inspection of "ABS" W/L Illumination pattern with ignition SW "ON". 4. Test drive. Dose repeat trouble?	Repeat the diagnosis if the symptom or DTC appears again Go to Step 1	Go to Step 5
4	Check if the DTC is stored. Is EHCUC including DTC?	Go to Step 3	Trouble diagnosis based on symptom (Refer to "SYMPTOM DIAGNOSIS") Go to Step 3
5	1. Reconnect all components and ensure all component are properly mounted. 2. Clear diagnostic trouble code. Was this step finished?	Finished	Go to Step 5

## Basic Inspection Procedure

### 1. Basic Inspection of System Brake

Step	Action	Yes	No
1	Is the fluid level normal?	Go to Step 2	Replenish with fluid. Go to Step 2
2	Does fluid leak?	Repair. Go to Step 3	Go to Step 3
3	Is the booster functioning normal?	Go to Step 4	Repair. Go to Step 4
4	Is the pad and rotor normal?	Go to Step 5	Repair. Go to Step 5
5	Reconnect all components and ensure all component are properly mounted. Was this step finished?	Finished	Go to Step 5

### 2. Inspection of Front Axle Switch

Step	Action	Yes	No
1	Turn the key switch on and shift to 4WD position by pressing the 4WD switch. Does the 4WD light come on?	Go to Step 2	Repair. Go to Step 2
2	Reconnect all components and ensure all components are properly mounted. Was this step finished?	Finished	Go to Step 2

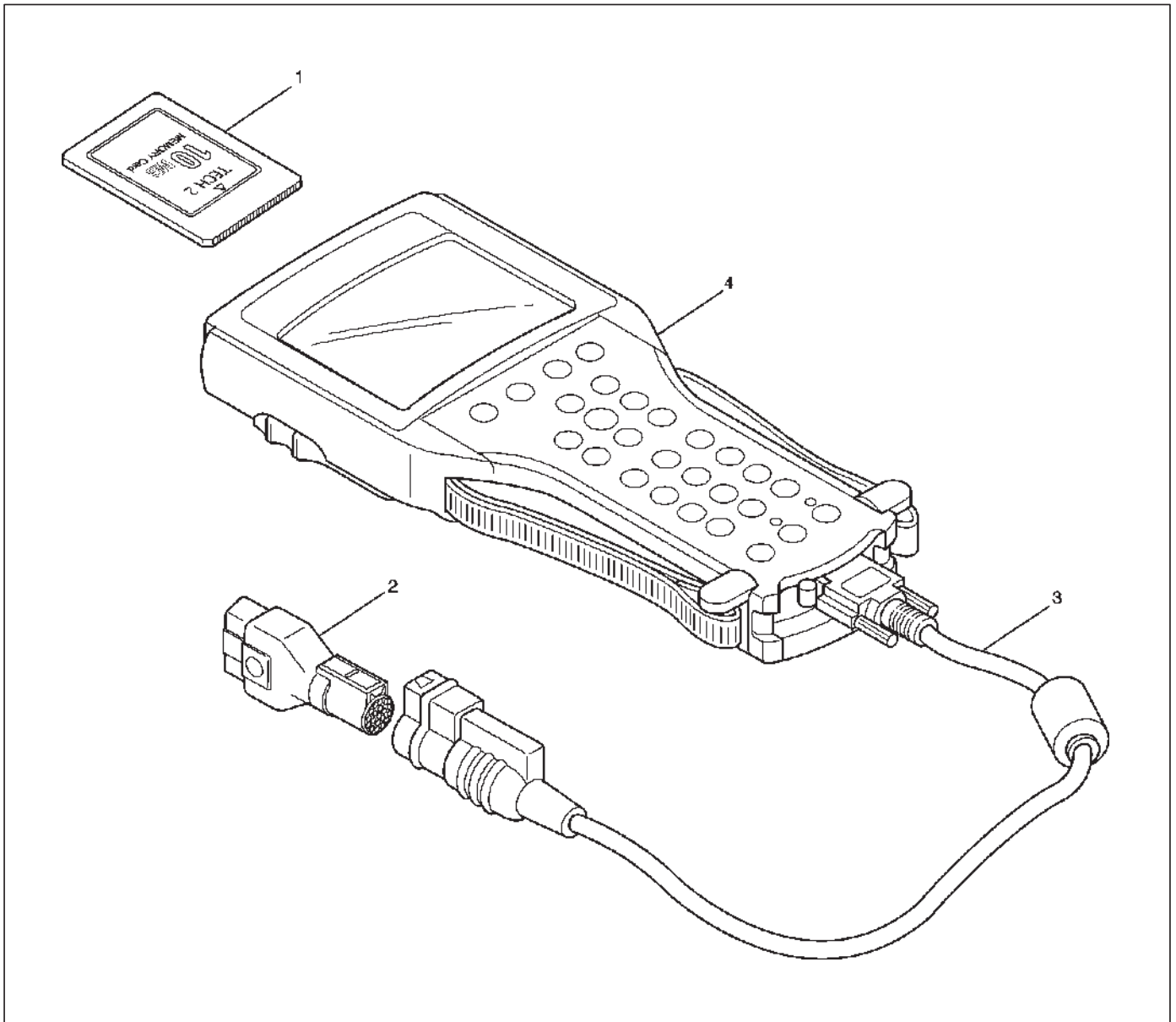
### 3. Ground Inspection

Step	Action	Yes	No
1	Are ABS—related ground points ok?	Go to Step 2	Repair. Go to Step 2
2	Reconnect all components and ensure all components are properly mounted. Was this step finished?	Finished	Go to Step 2

## 5A-8 BRAKE CONTROL SYSTEM

### Tech 2 Scan Tool

From 98 MY, Isuzu dealer service departments are recommended to use Tech 2. Please refer to Tech 2 scan tool user guide.



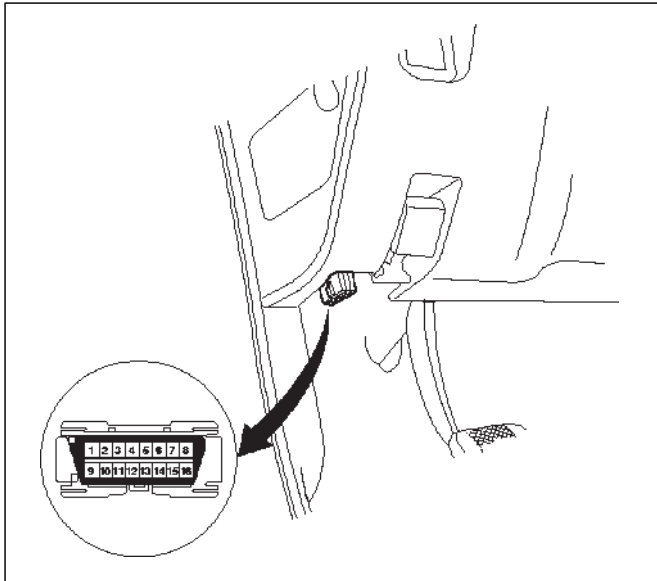
#### Legend

- (1) PCMCIA Card
- (2) SAE 16/19 Adaptor

- (3) DLC Cable
- (4) Tech-2

## Getting Started

- Before operating the Isuzu PCMCIA card with the Tech 2, the following steps must be performed:
  1. The Isuzu 98 System PCMCIA card (1) inserts into the Tech 2 (4).
  2. Connect the SAE 16/19 adapter (2) to the DLC cable (3).
  3. Connect the DLC cable to the Tech 2 (4).
  4. Make sure the vehicle ignition is off.
  5. Connect the Tech 2 SAE 16/19 adapter to the vehicle DLC connector.



826RX016

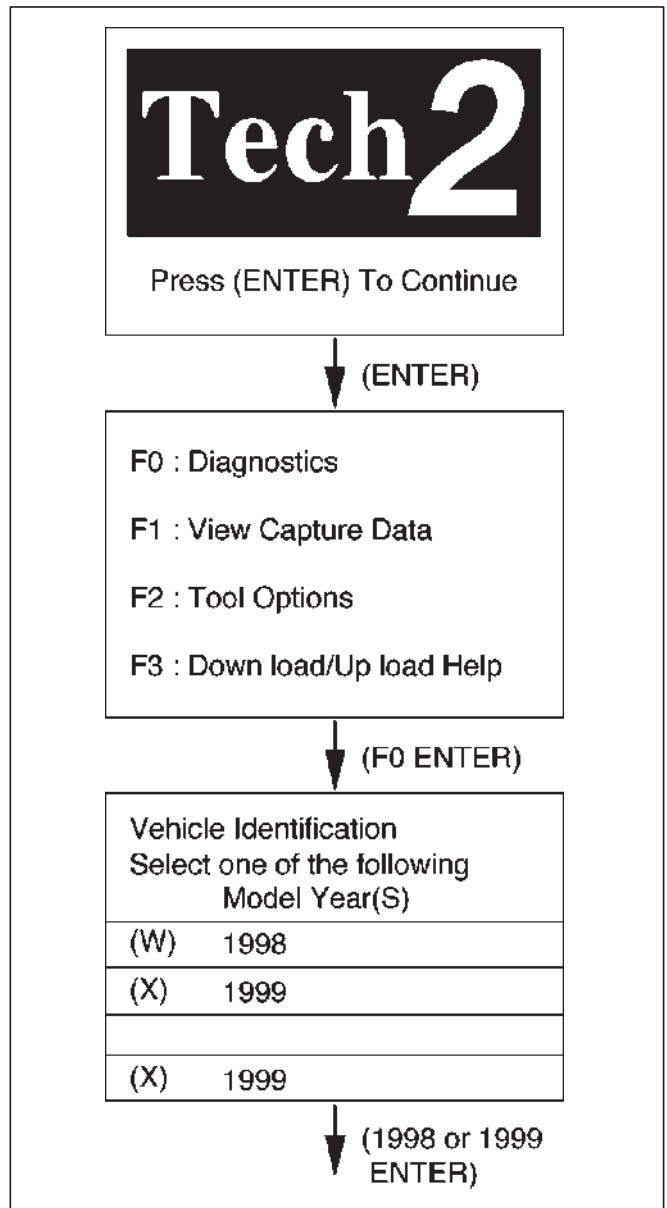
6. The vehicle ignition turns on.
7. Power up the Tech 2.
8. Verify the Tech 2 power up display.



060RW009

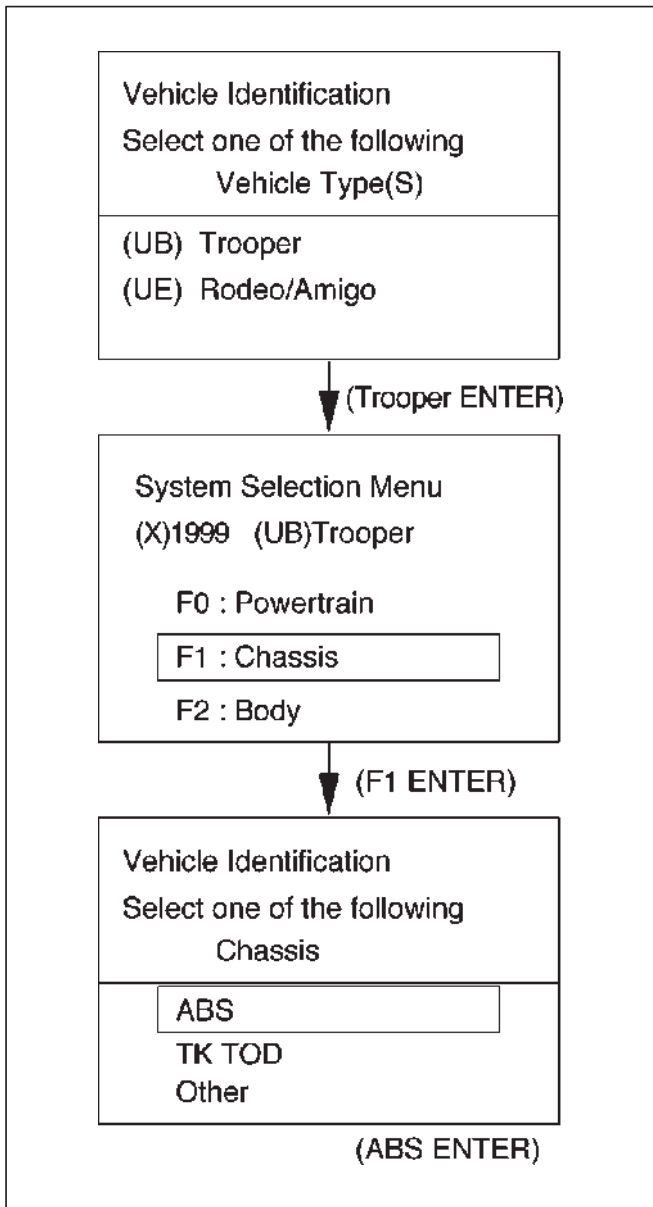
## Operating Procedure

The power up screen is displayed when you power up the tester with the Isuzu systems PCMCIA card. Follow the operating procedure below.



060RX065

## 5A-10 BRAKE CONTROL SYSTEM



060RX064

**Data List**

Display	Content	OK/NG Criteria for Data
Battery Voltage	Voltage	Between 10–16.9V
Brake Light Switch	Open/Close	Open(0V) when pedal is released
		Closed(12V) when pedal is depressed.
Front Left Wheel Speed Front Right Wheel Speed Rear Left Wheel Speed Rear Right Wheel Speed	MPH(km/h)	Start the vehicle and make sure of linear change in each wheel speed.
		Turn each wheel by hand and make sure that each speed data change.
Wheel Sensor Status	OK/NG	To be OK usually
G-sensor	Low/High	To be Low usually
Transfer Monitor(TOD)	4 Wheel Drive	To be 4 Wheel Drive usually
Off-Road Switch (Transmission Input)	Active/Inactive	When shift lever position is L and R : Active
Valve Relay	Active/Inactive	To be Active usually
ABS State	ON/OFF	To be OFF usually
ABS Relay	Active/Inactive	To be Active usually
Return Pump Relay	Active/Inactive	To be Inactive usually
Front Left Isolation Valve	Active/Inactive	To be Inactive usually
Front Left Dump Valve		
Front Right Isolation Valve		
Front Right Dump Valve		
Rear Isolation Valve		
Rear Dump Valve		
ABS Warning Lamp	ON/OFF	To be ON usually (while engine stopped)

## 5A-12 BRAKE CONTROL SYSTEM

### EHCU Connector Pin-out Checks

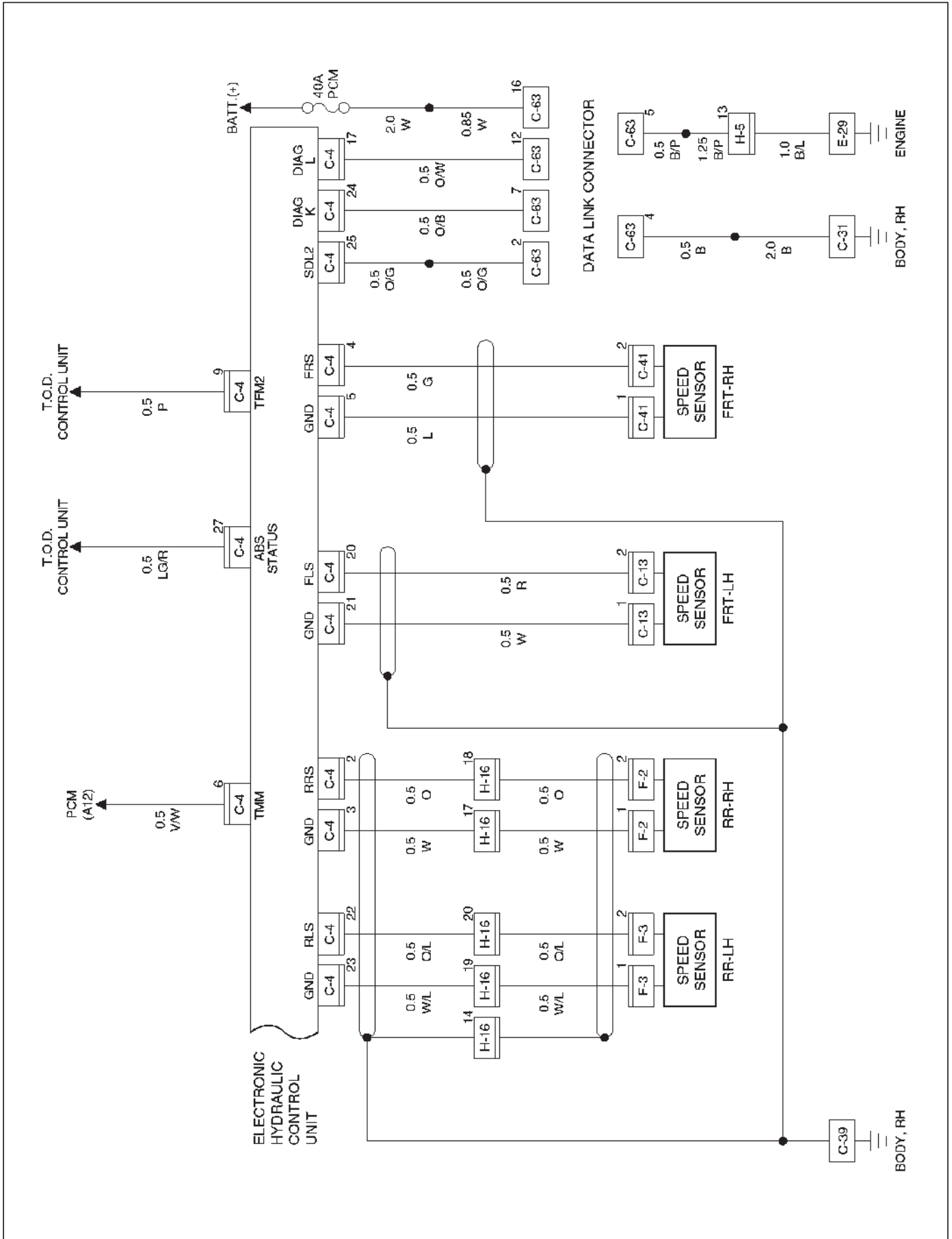
- Disconnect Electronic Brake Control Module.
- Perform checks with high impedance digital multimeter J-39200 or equivalent.

No.	Circuit to be Tested	Ignition Switch Position	Multimeter Scale/Range	Measure between Pin Number	Nominal Value	Note
1	Ignition enable	OFF	20DCV	8 (+), 15 (-)	0V to 0.1V	
		ON	20DCV	8 (+), 15 (-)	11.5V to 14.5V	
2	Stop light switch	OFF	20DCV	10, 15	10.5V to 14.5V	Press brake pedal
3	Ground connection	OFF	200 $\Phi$	12, Ground 15, Ground	Less than 2 $\Phi$	
4	FL speed sensor	OFF	2k $\Phi$	20, 21	1.3k to 1.9k $\Phi$	Internal Resistance
		OFF	200k $\Phi$	20, 15	more than 100k $\Phi$	Insulation Resistance
		OFF	200mACV	20, 21	more than 200mV	Turn wheel at 1RPS
5	FR speed sensor	OFF	2k $\Phi$	4, 5	1.3k to 1.9k $\Phi$	Internal Resistance
		OFF	200k $\Phi$	4, 15	more than 100k $\Phi$	Insulation Resistance
		OFF	200mACV	4, 5	more than 200mV	Turn wheel at 1RPS
6	RL speed sensor	OFF	2k $\Phi$	22, 23	1.3k to 1.9k $\Phi$	Insulation Resistance
		OFF	200k $\Phi$	22, 15	more than 100k $\Phi$	Internal Resistance
		OFF	200mACV	22, 23	more than 200mV	Turn wheel at 1RPS
7	RR speed sensor	OFF	2k $\Phi$	2, 3	1.3k to 1.9k $\Phi$	Internal Resistance
		OFF	200k $\Phi$	2, 15	more than 100k $\Phi$	Insulation Resistance
		OFF	200mACV	2, 3	more than 200mV	Turn wheel at 1RPS
8	G-sensor	ON		26, 8	1k to 2k $\Phi$	Horizontal vehicle
9	Transmission Input	ON	20DCV	6 (+), 15 (-)	Less than 6V (shift lever position – L, R) 6.6 to 9.0V (other shift position)	Battery voltage 12V








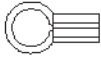
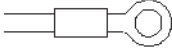
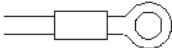
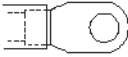
5A-14 BRAKE CONTROL SYSTEM



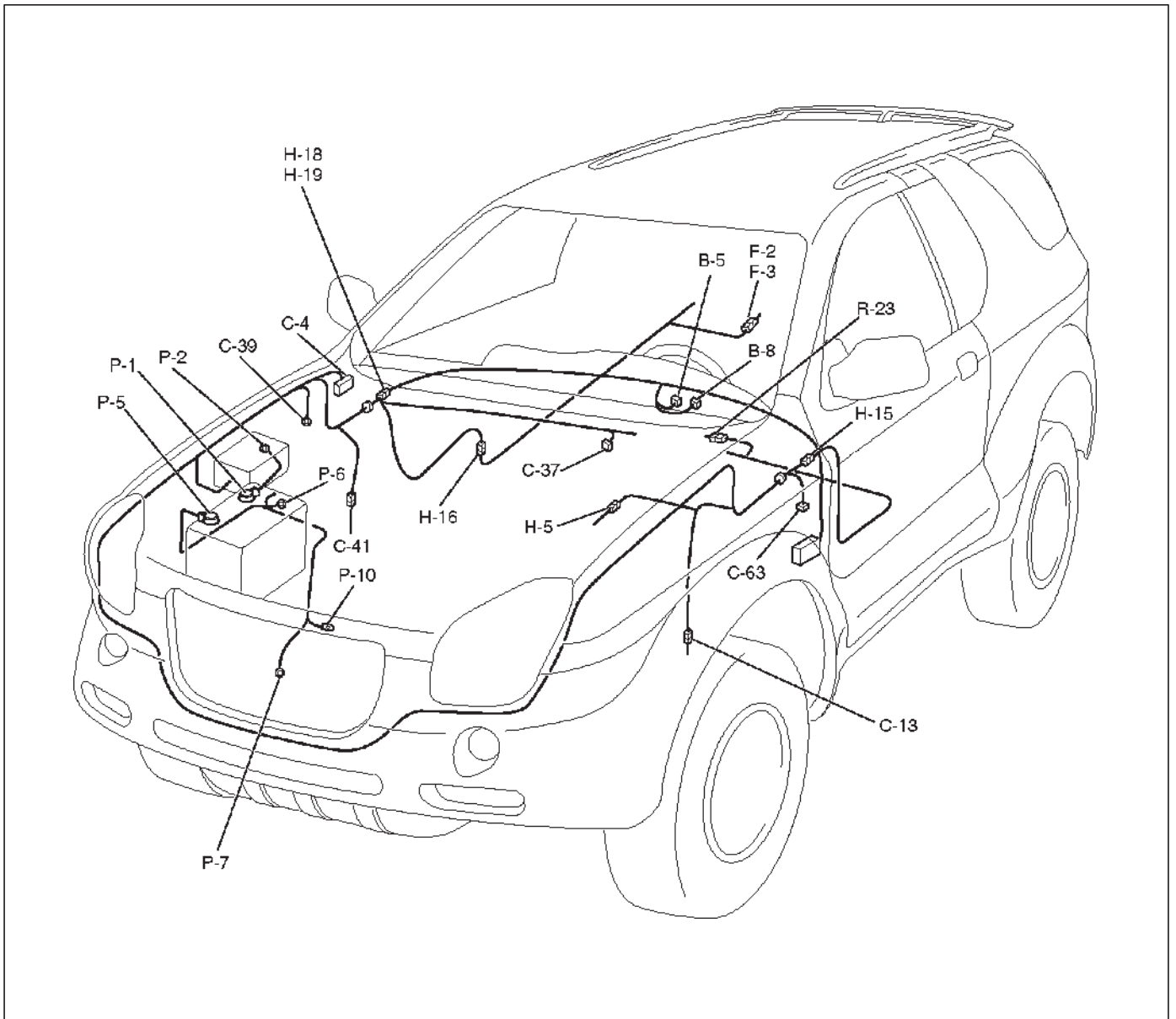
Connector List

No.	Connector face	No.	Connector face
B-5		C-63	
B-8		E-29	
C-4		F-2	
C-13		F-3	
C-31		H-5	
C-37		H-15	
C-39		H-16	
C-41		H-18	
H-19			

**5A-16 BRAKE CONTROL SYSTEM**

No.	Connector face	No.	Connector face
R-23			
P-1			
P-2			
P-5			
P-6			
P-7			
P-10			

Part Location



## 5A-18 BRAKE CONTROL SYSTEM

---

### Symptom Diagnosis

The symptoms that cannot be indicated by the warning light can be divided in the following five categories:

1. ABS works frequently but vehicle does not decelerate.
2. Uneven braking occurs while ABS works.
3. The wheels lock during braking.
4. Brake pedal feel is abnormal.
5. Braking sound (from EHCUC) is heard while not braking.

These are all attributable to problems which cannot be detected by EHCUC self-diagnosis. Use the customer complaint and a test to determine which symptom is present. Then follow the appropriate flow chart listed below.

No.	Symptom	Diagnostic Flow Charts	
		Without TECH 2	With TECH 2
1	ABS works frequently but vehicle does not decelerate.	Chart A-1	Chart TA-1
2	Uneven braking occurs while ABS works.	Chart A-2	—
3	The wheels are locked.	Chart A-3	Chart TA-3
4	Brake pedal feel is abnormal.	Chart A-4	—
5	Braking sound (from EHCUC) is heard while not braking.	Chart A-5	Chart TA-5

**Chart A-1 ABS Works Frequently But Vehicle Does Not Decelerate**

Step	Action	Yes	No
1	1. Turn key off. 2. G Sensor connector and EHCUC connector disconnected. Is there continuity between EHCUC terminals 26 and 8?	Go to Step 2	Go to Step 3
2	Connect EHCUC connector. Is there continuity between the G sensor and the EHCUC?	Go to Step 3	Repair circuit. Go to Step 1
3	Is the G sensor normal? (Refer to chart B-5)	Go to Step 4	Replace G sensor. Go to Step 11
4	Is braking force distribution normal between the front and rear of the vehicle?	Go to Step 5	Repair brake parts. Go to Step 11
5	Are axle parts installed normally?	Go to Step 6	Repair axle parts. Go to Step 11
6	Is there play in each wheel speed sensor?	Repair wheel speed sensor. Go to Step 11	Go to Step 7
7	Is there damage, or powered iron sticking to each wheel speed sensor/sensor ring?	Replace sensor or sensor ring. Go to Step 11	Go to Step 8
8	Is the output of each wheel speed sensor normal? (Refer to chart C-1 or TC-1)	Go to Step 9	Replace wheel speed sensor or repair harness. Go to Step 11
9	Is the input of transmission normal? (Refer to chart C-2 or TC-2)	Go to Step 10	Replace switch or repair harness. Go to Step 11
10	Is the input of TOD controller normal?	Go to Step 11	Replace controller or repair harness. Go to Step 11
11	Reconnect all components and ensure all components are properly mounted. Was this step finished?	Repeat the "Basic diagnostic flow chart."	Go to Step 11

**5A-20 BRAKE CONTROL SYSTEM****Chart TA-1 ABS Works Frequently But Vehicle Does Not Decelerate (Use TECH 2)**

<b>Step</b>	<b>Action</b>	<b>Yes</b>	<b>No</b>
1	1. Connect TECH 2. 2. Make sure of the output conditions of each wheel speed sensor by mode "F1: Data Display". Is the output of each sensor normal?	Go to Step 2	Replace wheel speed sensor. Go to Step 3
2	Return to Chart A-1. Was the Chart A-1 finished?	Go to Step 3	Go to Step 2
3	Reconnect all components, ensure all components are properly mounted. Was this step finished?	Repeat the "Basic diagnostic flow chart."	Go to Step 3

**Chart A-2 Uneven Braking Occurs While ABS Works**

<b>Step</b>	<b>Action</b>	<b>Yes</b>	<b>No</b>
1	Is there play in each sensor?	Repair. Go to Step 5	Go to Step 2
2	Is there damage or powdered iron sticking to each sensor/sensor ring?	Repair. Go to Step 5	Go to Step 3
3	Is the output of each sensor normal? (Refer to chart C-1 or TC-1)	Go to Step 4	Replace sensor or repair harness. Go to Step 5
4	Is brake pipe connecting order correct?	Replace EHCU. Go to Step 5	Reconnect brake pipe correctly. Go to Step 5
5	Reconnect all components, ensure all components are properly mounted. Was this step finished?	Repeat the "Basic diagnostic flow chart."	Go to Step 5



Chart A-3, TA-3 The Wheels Are Locked

Step	Action	Yes	No
1	Is ABS working?	Go to Step 2	Go to Step 6
2	Is vehicle speed under 10 km/h (6mph)?	Normal.	Go to Step 3
3	Is sensor output normal? (Chart C-1 or TC-1)	Go to Step 4	Replace sensor or repair harness. Go to Step 9
4	Is transmission input normal? (Chart C-2 or TC-2)	Go to Step 5	Replace SW or repair harness. Go to Step 9
5	Is TOD controller normal?	Replace EHCU. Go to Step 9	Replace TOD controller or repair harness. Go to Step 9
6	Is transmission input normal? (Chart C-2 or TC-2)	Go to Step 7	Replace SW or repair harness Go to Step 9
7	Is TOD controller normal?	Go to Step 8	Replace TOD controller or repair harness. Go to Step 9
8	Is hydraulic unit grounded properly?	Replace EHCU. Go to Step 9	Correct. Go to Step 9
9	Reconnect all components, ensure all components are properly mounted. Was this step finished?	Repeat the "Basic diagnostic flow chart."	Go to Step 9

**5A-22 BRAKE CONTROL SYSTEM**

**Chart A-4 Brake Pedal Feed Is Abnormal**

<b>Step</b>	<b>Action</b>	<b>Yes</b>	<b>No</b>
1	Is the stop light actuated when the brake pedal is depressed?	Go to Step 2	Go to Step 3
2	1. Turn the ignition switch off. 2. Disconnect EHCUC connector. 3. Measure voltage between the EHCUC connector terminal 10 and 15 when brake pedal is depressed. Is the voltage equal to the battery voltage?	Go to Step 4	Harness NG between brake SW and EHCUC. Go to Step 7
3	Is stop light fuse C-14 normal?	Go to Step 5	Replace fuse C-14. Go to Step 7
4	Is there continuity between EHCUC connector terminals, 12 and 15 to body ground?	Go to Step 6	Repair body grounded harness. Go to Step 7
5	Is the brake SW normal?	Repair stop light harness. Go to Step 7	Replace brake SW. Go to Step 7
6	Is the check harness/connector for suspended disconnection?	Hydraulic system leakage or air entry (Refer to servicing "Leakage or brake fluid" ) Go to Step 7	Repair harness. Go to Step 7
7	Reconnect all components and ensure all components are properly mounted. Was this step finished?	Repeat the "Basic diagnostic flow chart."	Go to Step 7

Chart A-5,TA-5 Braking Sound (From EHCU) Is Heard While Not Braking

Step	Action	Yes	No
1	Is this the first time the vehicle is being driven after starting the engine?	It is self checking sound. Normal.	Go to Step 2
2	Is vehicle speed under 10 km/h (6 mph)?	It is self checking sound. Normal.	Go to Step 3
3	Check for the following condition: <input type="radio"/> At the time of shift down or clutch operation. <input type="radio"/> At the time of low $\Phi$ drive (ice or snow road) or rough road drive. <input type="radio"/> At the time of high-speed turn. <input type="radio"/> At the time of passing curb. <input type="radio"/> At the time of operating electrical equipment switches. <input type="radio"/> At the time of racing the engine (over 5000 rpm). Did it occur under any one condition above?	ABS may sometime be actuated even when brake pedal is not applied.	Go to Step 4
4	Is there play in each sensor/wheel speed sensor rings?	Go to Step 5	Repair. Go to Step 7
5	Damage or powdered iron sticking to each sensor/wheel speed sensor ring?	Go to Step 6	Repair. Go to Step 7
6	Is each sensor output normal?(Refer to chart C-1 or TC-1).	Check harness/connector for suspected disconnection. If no disconnection is found, replace EHCU. Go to Step 7	Repair. Go to Step 7
7	Reconnect all components, ensure all components are properly mounted. Was this step finished?	Repeat the "Basic diagnostic flow chart."	Go to Step 7

## 5A-24 BRAKE CONTROL SYSTEM

### Diagnostic Trouble Codes

Choose and trace an appropriate flowchart by the numbers listed below to find fault and repair.

Code	Item	Diagnosis	Chart No.
12	Start Code	Normal	—
14	EHCU Function	Abnormality in input/output, operational and control circuits	B-2
15	Power Voltage Drop		B-3
16	CLASS-2 Communication Line Abnormality		B-4
21	G-sensor	Wiring disconnection	B-5
23	Transmission Input	Input abnormality	B-6
24	Transfer Monitor		B-7
32	Motor & Motor Relay	Shorted or disconnected coil	B-8
35	Valve Relay	Shorted or disconnected coil/wiring	B-9
41	FL Holding Solenoid Valve	Shorted or disconnected coil/wiring	B-10
42	FL Decompression Solenoid Valve	Shorted or disconnected coil/wiring	B-11
43	FR Holding Solenoid Valve	Shorted or disconnected coil/wiring	B-12
44	FR Decompression Solenoid Valve	Shorted or disconnected coil/wiring	B-13
45	Rear Holding Solenoid Valve	Shorted or disconnected coil/wiring	B-14
46	Rear Decompression Solenoid Valve	Shorted or disconnected coil/wiring	B-15
51	FL Wheel Speed Sensor	Disconnected coil/wiring	B-16
52	FR Wheel Speed Sensor	Disconnected coil/wiring	B-17
53	RL Wheel Speed Sensor	Disconnected coil/wiring	B-18
54	RR Wheel Speed Sensor	Disconnected coil/wiring	B-19
61	FL Wheel Speed Sensor	Shorted coil/wiring	B-20
62	FR Wheel Speed Sensor	Shorted coil/wiring	B-21
63	RL Wheel Speed Sensor	Shorted coil/wiring	B-22
64	RR Wheel Speed Sensor	Shorted coil/wiring	B-23
65	Sensor Signal Input	Wrong number of teeth	B-24

## Diagnosis By “ABS” Warning Light Illumination Pattern

In the event that there is abnormality in the “ABS” warning light illumination pattern while the key is in the ON position or if the warning light is actuated during driving, trouble should be diagnosed on a illumination pattern basis as follows:

No.	Condition	“ABS” Warning Light Illumination Pattern	Diagnostic
1	Warning light is actuated normally	<p>Warning light ON OFF</p> <p>Starter SW ON OFF</p> <p>Still not lit during driving</p>	Normal
2	Warning light is not lit	<p>Warning light ON OFF</p> <p>Starter SW ON OFF</p>	Warning light lighting circuit trouble→Go to Chart B-1
3	Warning light remains ON	<p>Warning light ON OFF</p> <p>Starter SW ON OFF</p>	Diagnostic trouble codes are stored. Display diagnostic trouble codes and diagnose on a code basis according to the flow charts.
4	Warning light is actuated while driving	<p>Warning light ON OFF</p> <p>Starter SW ON OFF</p> <p>During driving</p>	Diagnostic trouble codes are stored. Display diagnostic trouble codes and diagnose on a code basis according to the flow charts.

## 5A-26 BRAKE CONTROL SYSTEM

### Diagnostic Trouble Codes (DTCs)

When the warning light in the meter remains ON, the EHCU stores the fault identification and disables the ABS.

1. How to display and erase DTCs:

#### NOTE:

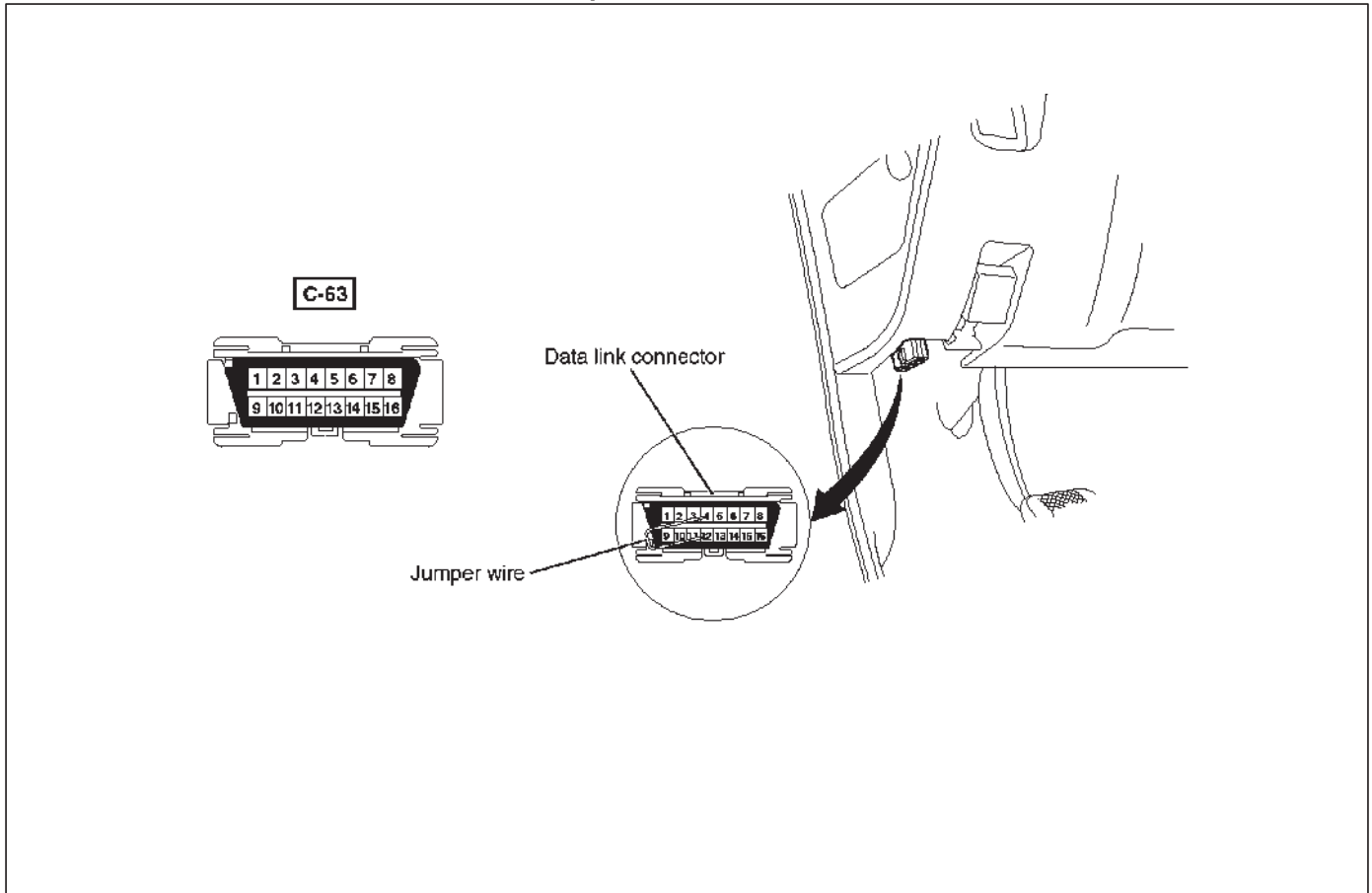
- If DTCs are not displayed, harness C-4 connector terminal 30 and I-10 connector terminal 2 may be disconnected. Repair the harness and try DTC display again.

- DTCs can be displayed also by TECH 2. Select mode "F0: Diagnostic Trouble Codes" from Application Menu.

#### 1. How to start DTC display:

- Confirm that the vehicle has come to a complete stop (with the wheels standing still) and that the brake pedal is not depressed. (Unless these two conditions are satisfied, DTC display cannot be started.)
- With IGN OFF, connect #12 terminal with #4 terminal or #5 terminal (GND). Then turn IGN ON.

#### The DLC is located behind the driver side kick panel



826RX015

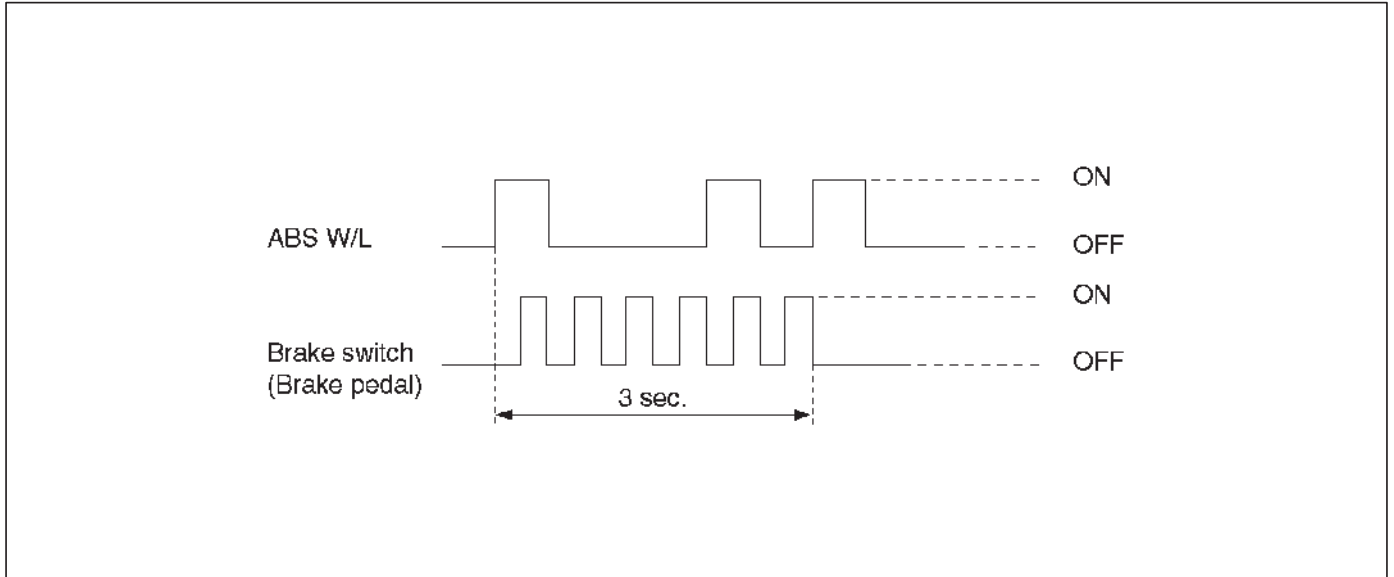
- Keep #12 terminal connected with #4 terminal or #5 terminal (GND) during DTC display. (If #12 terminal is separated from #4 terminal or #5 terminal (GND) during display, display will stop.)

#### 2. DTC display:

- DTC is displayed by blinking warning light.
- Double-digit display.
- First, normal DTC 12 is displayed three times and then any other DTCs are displayed three times. (If no other DTCs have been stored, the display of DTC 12 will be repeated.)

## 3. How to erase code:

- Conduct brake switch ON/OFF operation 6 or more times within 3 seconds of self-diagnosis startup.
- The code cannot be erased if more than 3 seconds have passed since self-diagnosis startup, or if self-diagnosis has started with brake switched on (brake pedal depressed).



B05RW005

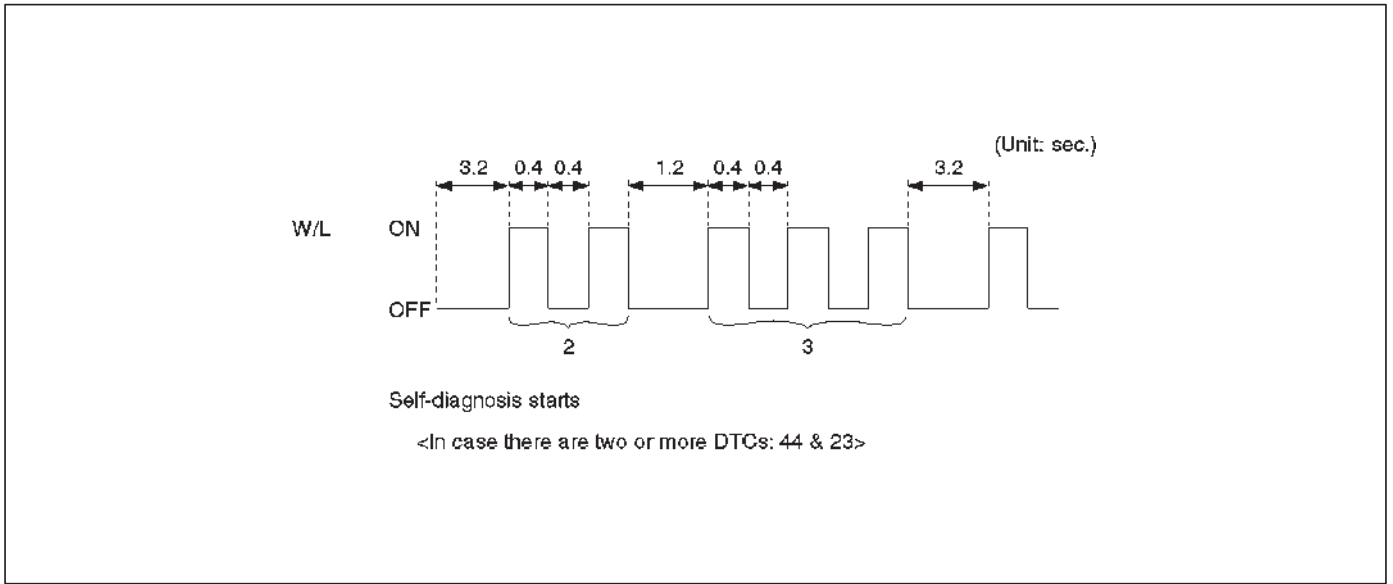
## 4. Notes

- If the following should occur during Diagnostic Trouble Code (DTC) display the display will be discontinued. After initial check, the status that is under the control of ABS will be returned :
  - The vehicle starts (The wheels turn) or the brake pedal is depressed.
- Up to 3 different codes can be stored.
- If the ABS should turn OFF due to an intermittent defect, the system will be restored at the next key cycle, if the initial check finds no abnormality (when IGN is switched from OFF to ON).

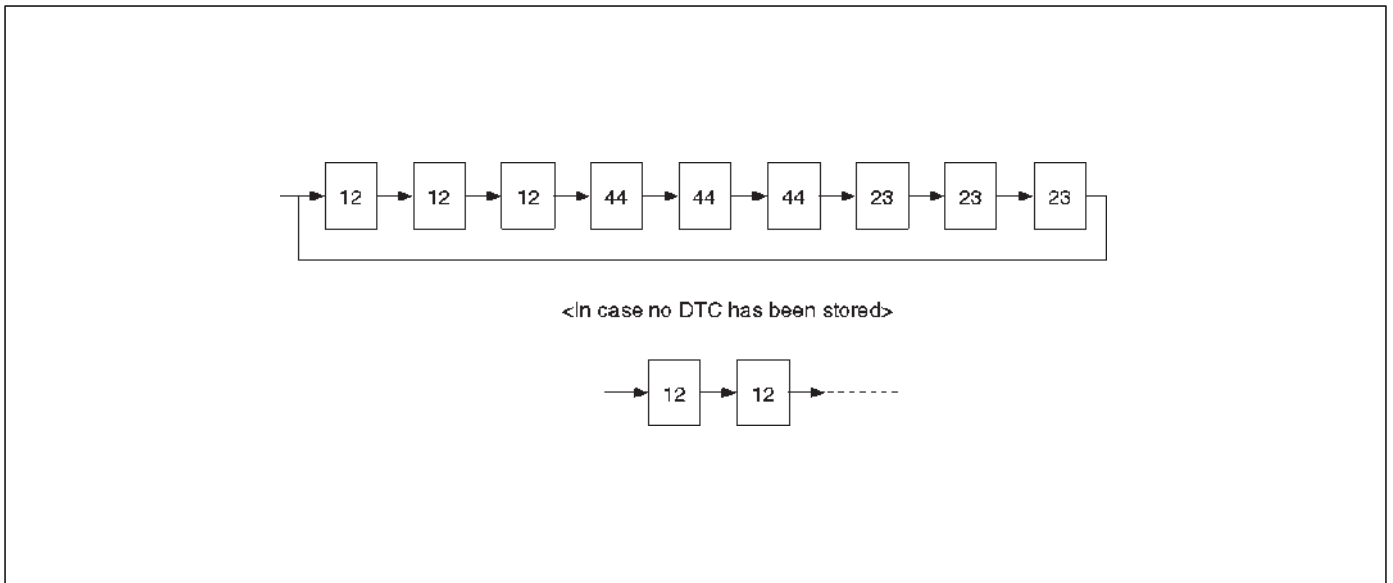
## 5A-28 BRAKE CONTROL SYSTEM

### 5. An example of DTC display

#### Display of DTC 23



After displaying DTC 12 three times, one DTC after another is displayed, starting with the most recent one. (However, display is discontinued after about 5 minutes.)



The DTC 12 is displayed repeatedly. (display is discontinued after about 5 minutes)



**Chart B-1 With the key in the ON position (Before starting the engine). Warning light (W/L) is not activated.**

Step	Action	Yes	No
1	Is W/L fuse C-10 disconnected?	Replace fuse. Go to Step 5	Go to Step 2
2	Is W/L burnt out?	Replace W/L bulb. Go to Step 5	Go to Step 3
3	1. Turn the key off. 2. Disconnect EHCUC connector. 3. Turn the key ON. 4. Measure the voltage between EHCUC connector terminal 16 and 15.  Is the voltage equal to the battery voltage?	Go to Step 4	Repair harness and connector. Go to Step 5
4	Is there continuity between EHCUC connector terminals, 12 and 15 and body ground.	Check harness for suspected disconnection.  No fault found: Replace EHCUC. Go to Step 5	Repair harness and connector. Go to Step 5
5	Reconnect all components, ensure all components are properly mounted.  Was this step finished?	Repeat the "Basic diagnostic flow chart."	Go to Step 5

**Chart B-2 EHCUC Abnormality (DTC 14)**

Step	Action	Yes	No
1	1. Turn the key off. 2. Disconnect the EHCUC connector. 3. Inspect EHCUC ground.  Is there resistance between the EHCUC connector terminals, 12 and 15 and body ground?	Go to Step 2	Repair the body ground harness. Go to Step 3
2	1. Turn the key off, connect the EHCUC. 2. Erase the trouble code. 3. Turn Ignition off, then on, to perform system self-check. 4. If warning light remains on, display trouble codes once again.  Is the check trouble code 14?	Replace EHCUC. Go to Step 3	Inspect in accordance with the DTC displayed.
3	1. Reconnect all components and ensure all components are properly mounted. 2. Clear diagnostic trouble code.  Was this step finished?	Repeat the "Basic diagnostic flow chart."	Go to Step 3

**5A-30 BRAKE CONTROL SYSTEM**

**Chart B-3 Power Voltage Drop (DTC 15)**

<b>Step</b>	<b>Action</b>	<b>Yes</b>	<b>No</b>
1	Is the battery voltage normal? (Battery capacity check)	Go to Step 2	Charge or replace battery. Go to Step 2
2	1. Turn the key off. 2. Disconnect EHCU connector. 3. Turn the key on.  Is the voltage between EHCU connector terminals 8 and 15, higher than 10V?	Check harness connector for suspected disconnection. Fault found: Repair, and perform system self-check. No fault found: replace EHCU. Go to Step 3	Repair harness or connector. Go to Step 3
3	1. Reconnect all components, ensure all components are properly mounted. 2. Clear diagnostic trouble code.  Was this step finished?	Repeat the "Basic diagnostic flow chart."	Go to Step 3

**Chart B-4 CLASS-2 Communication Line Abnormality (DTC 16)**

<b>Step</b>	<b>Action</b>	<b>Yes</b>	<b>No</b>
1	1. Turn the key off. 2. Disconnect EHCU and PCM connector.  Is there continuity between EHCU connector terminals 25 and ground?	Go to Step 2	Repair harness or connector. Go to Step 3
2	1. Connect EHCU connector. 2. Clear diagnostic trouble code. 3. Turn the key on.  Is the diagnostic trouble code 16 shown on the displayed?	Check the PCM harness. Refer to 6E section. Go to Step 3	Replace EHCU. Go to Step 3
3	1. Reconnect all components, ensure all components are properly mounted. 2. Clear diagnostic trouble code.  Was this step finished?	Repeat the "Basic diagnostic flow chart."	Go to Step 3

Chart B-5 G-Sensor Circuit (DTC 21)

Step	Action	Yes	No
1	Vehicle placed horizontal. Is the resistance between the G sensor connector terminals 1 and 2 within 4.0-6.0 k $\Omega$ ?	Check harness connector for short. Fault found : Repair , and perform system self-check. No fault found : replace EHCU. Go to Step 3	Go to Step 2
2	Is the bracket installed horizontally?	Go to Step 4	Repair or replace bracket. Go to Step 4
3	Remove G sensor. Is the resistance between the G sensor connector terminals 1 and 2 within 1.0-2.0 k $\Omega$ when G sensor is horizontal?	Go to Step 4	Replace G sensor. Go to Step 5
4	Measure resistance between G sensor connector terminals 1 and 2 within 4.0-6.0 k $\Omega$ when G sensor tilted to 30° or more?	Harness between EHCU and G sensor is faulty and short. Repair the harness Go to Step 5	Replace G sensor. Go to Step 5
5	1. Reconnect all components and ensure all components are properly mounted. 2. Clear diagnostic trouble code. Was this step finished?	Repeat the "Basic diagnostic flow chart."	Go to Step 5

**5A-32 BRAKE CONTROL SYSTEM**

**Chart B-6 Abnormal Transmission Input (DTC 23)**

Step	Action	Yes	No
1	1. Turn the key off. 2. Disconnect EHCUC connector.  Is there continuity between EHCUC connector terminal 6 to 15 (Gear position-P)?	Shorted switch harness. Repair switch or harness. Go to Step 4	Go to Step 2
2	Turn the key on and measure the voltage between EHCUC connector terminal 6 and 15.  Is the 6V under when the gear position is L, and R(Battery voltage 12V)?	Go to Step 3	Transmission SW trouble. Disconnected harness. Repair SW and harness. Go to Step 4
3	Is there 6.6 to 9.0V when the gear position is 2,3,D,N and P (Battery voltage 12V)?	Suspected harness/connector short power source/GND. Suspected shorted transmission SW. Fault found: repair, and perform system self-check. No fault found: replace EHCUC. Go to Step 4	Transmission SW trouble. Disconnected harness. Repair SW and harness. Go to Step 4
4	1. Reconnect all components, ensure all components are properly mounted. 2. Clear diagnostic trouble code.  Was this step finished?	Repeat the "Basic diagnostic flow chart."	Go to Step 4

**Chart B-7 Transfer Monitor (DTC 24)**

Step	Action	Yes	No
1	1. Turn the key off. 2. Disconnect EHCUC connector.  Is the EHCUC connector terminal 9 line normally?	Go to Step 2	Repair Go to Step 3
2	Is the TOD ECU normal?	Replace EHCUC. Go to Step 3	Repair or replace TOD ECU. Go to Step 3
3	1. Reconnect all components, ensure all components are properly mounted. 2. Clear diagnostic trouble code.  Was this step finished?	Repeat the "Basic diagnostic flow chart."	Go to Step 3

**Chart B-8 EHCUC Pump Motor And Motor Relay Circuit (DTC 32)**

Step	Action	Yes	No
1	1. Turn the key off. 2. Disconnect EHCUC connector. 3. Measure voltage between EHCUC connector terminal 13 and body ground.  Is the voltage equal to battery voltage?	Go to Step 2	Repair fuse/harness between battery and EHCUC connector terminal 13. Go to Step 3
2	Is there continuity between EHCUC connector terminal 12 and ground?	Go to Step 3	Repair between EHCUC connector terminal 12 and ground. Go to Step 3
3	1. Reconnect all components and ensure all components are properly mounted. 2. Clear diagnostic trouble code.  Was this step finished?	Repeat the "Basic diagnostic flow chart."	Go to Step 3

**Chart B-9 EHCUC Pump Valve And Valve Relay Circuit (DTC 35)**

Step	Action	Yes	No
1	1. Turn the key off. 2. Disconnect EHCUC connector. 3. Measure voltage between EHCUC connector terminal 14 and body ground.  Is the voltage equal to battery voltage?	Replace EHCUC. Go to Step 2	Repair fuse and harness EHCUC connector terminal 14 and battery. Go to Step 2
2	1. Reconnect all components and ensure all components are properly mounted. 2. Clear diagnostic trouble code.  Was this step finished?	Repeat the "Basic diagnostic flow chart."	Go to Step 2

**Chart B-10 FL Isolation Solenoid Valve Abnormality (DTC 41)**

Step	Action	Yes	No
1	Was the "EHCUC Connector Pin-out Checks" performed?	Go to Step 2	Go to "EHCUC Connector Pin-out Checks".
2	Is the EHCUC connector free from damage or corrosion?	Go to Step 3	Repair the connector. Repeat the "Basic Diagnostic Flow Chart".
3	1. Replace the EHCUC. 2. Reconnect all component, ensure all component are properly mounted.  Was this step finished?	Repeat the "Basic Diagnostic Flow Chart".	Go to Step 3

## 5A-34 BRAKE CONTROL SYSTEM

### Chart B-11 FL Dump Solenoid Valve Abnormality (DTC 42)

Step	Action	Yes	No
1	Was the "EHCUC Connector Pin-out Checks" performed?	Go to Step 2	Go to "EHCUC Connector Pin-out Checks".
2	Is the EHCUC connector free from damage or corrosion?	Go to Step 3	Repair the connector. Repeat the "Basic Diagnostic Flow Chart".
3	1. Replace the EHCUC. 2. Reconnect all component, ensure all component are properly mounted. Was this step finished?	Repeat the "Basic Diagnostic Flow Chart".	Go to Step 3

### Chart B-12 FR Isolation Solenoid Valve Abnormality (DTC 43)

Step	Action	Yes	No
1	Was the "EHCUC Connector Pin-out Checks" performed?	Go to Step 2	Go to "EHCUC Connector Pin-out Checks".
2	Is the EHCUC connector free from damage or corrosion?	Go to Step 3	Repair the connector. Repeat the "Basic Diagnostic Flow Chart".
3	1. Replace the EHCUC. 2. Reconnect all component, ensure all component are properly mounted. Was this step finished?	Repeat the "Basic Diagnostic Flow Chart".	Go to Step 3

### Chart B-13 FR Dump Solenoid Valve Abnormality (DTC 44)

Step	Action	Yes	No
1	Was the "EHCUC Connector Pin-out Checks" performed?	Go to Step 2	Go to "EHCUC Connector Pin-out Checks".
2	Is the EHCUC connector free from damage or corrosion?	Go to Step 3	Repair the connector. Repeat the "Basic Diagnostic Flow Chart".
3	1. Replace the EHCUC. 2. Reconnect all component, ensure all component are properly mounted. Was this step finished?	Repeat the "Basic Diagnostic Flow Chart".	Go to Step 3

**Chart B-14 Rear Isolation Solenoid Valve Abnormality (DTC 45)**

Step	Action	Yes	No
1	Was the "EHCUC Connector Pin-out Checks" performed?	Go to Step 2	Go to "EHCUC Connector Pin-out Checks".
2	Is the EHCUC connector free from damage or corrosion?	Go to Step 3	Repair the connector. Repeat the "Basic Diagnostic Flow Chart".
3	1. Replace the EHCUC. 2. Reconnect all component, ensure all component are properly mounted. Was this step finished?	Repeat the "Basic Diagnostic Flow Chart".	Go to Step 3

**Chart B-15 Rear Dump Solenoid Valve Abnormality (DTC 46)**

Step	Action	Yes	No
1	Was the "EHCUC Connector Pin-out Checks" performed?	Go to Step 2	Go to "EHCUC Connector Pin-out Checks".
2	Is the EHCUC connector free from damage or corrosion?	Go to Step 3	Repair the connector. Repeat the "Basic Diagnostic Flow Chart".
3	1. Replace the EHCUC. 2. Reconnect all component, ensure all component are properly mounted. Was this step finished?	Repeat the "Basic Diagnostic Flow Chart".	Go to Step 3

**Chart B-16 FL Speed Sensor Disconnection (DTC 51)**

Step	Action	Yes	No
1	1. Turn the key off. 2. Disconnect EHCUC connector. 3. Measure the resistance between EHCUC connector terminals 20 and 21. Is the resistance between 1.3k and 1.9k ohms?	Check for faults in harness between speed sensor and EHCUC. Fault found: Repair, and perform system self-check. No fault found: Replace EHCUC. Go to Step 3	Go to Step 2
2	Measure the FL speed sensor resistance at the sensor connector. Is the resistance between 1.3k and 1.9k ohms?	Repair harness abnormality between sensors and EHCUC. Go to Step 3	Replace sensor. Go to Step 3
3	1. Reconnect all components, ensure all components are properly mounted. 2. Clear diagnostic trouble code. Was this step finished?	Repeat the "Basic diagnostic flow chart."	Go to Step 3

**5A-36 BRAKE CONTROL SYSTEM**

**Chart B-17 FR Speed Sensor Disconnection (DTC 52)**

Step	Action	Yes	No
1	1. Turn the key off. 2. Disconnect EHCUC connector. 3. Measure the resistance between EHCUC connector terminals 4 and 5.  Is the resistance between 1.3k and 1.9k ohms?	Check for faults in harness between speed sensor and EHCUC.  Fault found: Repair, and perform system self-check.  No fault found: Replace EHCUC. Go to Step 3	Go to Step 2
2	Measure the FR speed sensor resistance at the sensor connector.  Is the resistance between 1.3k and 1.9k ohms?	Repair harness abnormality between sensors and EHCUC. Go to Step 3	Replace sensor. Go to Step 3
3	1. Reconnect all components and ensure all components are properly mounted. 2. Clear diagnostic trouble code.  Was this step finished?	Repeat the "Basic diagnostic flow chart."	Go to Step 3

**Chart B-18 RL Speed Sensor Disconnection (DTC 53)**

Step	Action	Yes	No
1	1. Turn the key off. 2. Disconnect EHCUC connector. 3. Measure the resistance between EHCUC connector terminals 22 and 23.  Is the resistance between 1.3k and 1.9k ohms?	Check for faults in harness between speed sensor and EHCUC.  Fault found: Repair, and perform system self-check.  No fault found: Replace EHCUC. Go to Step 3	Go to Step 2
2	Measure the RL speed sensor resistance at the sensor connector.  Is the resistance between 1.3k and 1.9k ohms?	Repair harness abnormality between sensors and EHCUC. Go to Step 3	Replace sensor. Go to Step 3
3	1. Reconnect all components and ensure all components are properly mounted. 2. Clear diagnostic trouble code.  Was this step finished?	Repeat the "Basic diagnostic flow chart."	Go to Step 3



Chart B-19 RR Speed Sensor Disconnection (DTC 54)

Step	Action	Yes	No
1	1. Turn the key off. 2. Disconnect EHCUC connector. 3. Measure the resistance between EHCUC connector terminals 2 and 3.  Is the resistance between 1.3K and 1.9k ohms?	Check for faults in harness between speed sensor and EHCUC.  Fault found: Repair, and perform system self-check.  No fault found: Replace EHCUC. Go to Step 3.	Go to Step 2
2	Measure the RR speed sensor resistance at the sensor connector.  Is the sensor resistance between 1.3k and 1.9k ohms?	Repair harness abnormality between sensors and EHCUC. Go to Step 3	Replace sensor. Go to Step 3
3	1. Reconnect all components and ensure all components are properly mounted. 2. Clear diagnostic trouble code.  Was this step finished?	Repeat the "Basic diagnostic flow chart."	Go to Step 3

**5A-38 BRAKE CONTROL SYSTEM**

**Chart B-20 FL Speed Sensor Short Circuit (DTC 61)**

Step	Action	Yes	No
1	1. Turn the key off. 2. Disconnect EHCUC connector 3. Measure the FL speed sensor resistance between EHCUC connector terminals 20 and 21.  Is the resistance between 1.3k and 1.9k ohms?	Go to Step 2	Go to Step 3
2	Is there play in the sensor/sensor rotor?	Go to Step 4	Repair. Go to Step 6
3	Measure the FL speed sensor resistance at the sensor connector.  Is the resistance between 1.3k and 1.9k ohms?	Repair harness abnormality between sensors and EHCUC. Go to Step 6	Replace sensor. Go to Step 6
4	Damage and powdered iron sticking to sensor/sensor ring?	Go to Step 5	Repair. Go to Step 6
5	Is sensor output normal? (Chart C-2 or TC-2)	Check for faults in harness between speed sensor and EHCUC.  Fault found: repair, and perform system self-check.  No fault found: replace EHCUC. Go to Step 6	Replace sensor. Go to Step 6
6	1. Reconnect all components and ensure all components are properly mounted. 2. Clear diagnostic trouble code.  Was this step finished?	Repeat the "Basic diagnostic flow chart."	Go to Step 6

NOTE: Even after repairing the faulty part the warning light (W/L) does not go out if the vehicle is at a stop. Turn the ignition switch to the ON position and drive the vehicle at 12 km/h or higher to make sure that the warning light goes out.

Chart B-21 FR Speed Sensor Short Circuit (DTC 62)

Step	Action	Yes	No
1	1. Turn the key off. 2. Disconnect EHCUC connector. 3. Measure the FR speed sensor resistance between EHCUC connector terminals 4 and 5.  Is the resistance between 1.3k and 1.9k ohms?	Go to Step 2	Go to Step 3
2	Is there play in the sensor/sensor rotor?	Go to Step 4	Repair. Go to Step 6
3	Measure the FR speed sensor resistance at the sensor connector.  Is the resistance between 1.3k and 1.9k ohms?	Repair harness abnormality between sensors and EHCUC. Go to Step 6	Replace sensor. Go to Step 6
4	Damage and powdered iron sticking to sensor/sensor ring?	Go to Step 5	Repair. Go to Step 6
5	Is sensor output normal? (Chart C-2 or TC-2)	Check for faults in harness between speed sensor and EHCUC.  Fault found: repair, and perform system self-check.  No fault found: replace EHCUC. Go to Step 6	Replace sensor. Go to Step 6
6	1. Reconnect all components and ensure all components are properly mounted. 2. Clear diagnostic trouble code.  Was this step finished?	Repeat "Basic diagnostic flow chart."	Go to Step 6

NOTE: Even after repairing the faulty part the warning light (W/L) does not go out if the vehicle is at a stop. Turn the ignition switch to the ON position and drive the vehicle at 12 km/h or higher to make sure that the warning light goes out.

**5A-40 BRAKE CONTROL SYSTEM**

**Chart B-22 RL Speed Sensor Short Circuit (DTC 63)**

Step	Action	Yes	No
1	1. Turn the key off. 2. Disconnect EHCUC connector 3. Measure the RL speed sensor resistance between EHCUC connector terminals 22 and 23.  Is the resistance between 1.3k and 1.9k ohms?	Go to Step 2	Go to Step 3
2	Is there play in the sensor/sensor rotor?	Go to Step 4	Repair. Go to Step 6
3	Measure the RL speed sensor resistance at the sensor connector.  Is the resistance between 1.3k and 1.9k ohms?	Repair harness abnormality between sensors and EHCUC. Go to Step 6	Replace sensor. Go to Step 6
4	Damage and powdered iron sticking to sensor/sensor ring?	Go to Step 5	Repair. Go to Step 6
5	Is sensor output normal? (Chart C-2 or TC-2)?	Check for faults in harness between speed sensor and EHCUC.  Fault found: repair, and perform system self-check.  No fault found: replace EHCUC. Go to Step 6	Replace sensor. Go to Step 6
6	1. Reconnect all components and ensure all components are properly mounted. 2. Clear diagnostic trouble code.  Was this step finished?	Repeat the "Basic diagnostic flow chart."	Go to Step 6

NOTE: Even after repairing the faulty part the warning light (W/L) does not go out if the vehicle is at a stop. Turn the ignition switch to the ON position and drive the vehicle at 12 km/h or higher to make sure that the warning light goes out.

Chart B-23 RR Speed Sensor Short Circuit (DTC 64)

Step	Action	Yes	No
1	1. Turn the key off. 2. Disconnect EHCUC connector. 3. Measure the RR speed sensor resistance between EHCUC connector terminals 2 and 3.  Is the resistance between 1.3k and 1.9k ohms?	Go to Step 2	Go to Step 3
2	Is there play in the sensor/sensor rotor?	Go to Step 4	Repair. Go to Step 6
3	Measure the RR speed sensor resistance at the sensor connector.  Is the resistance between 1.3k and 1.9k ohms?	Repair harness abnormality between sensors and EHCUC. Go to Step 6	Replace sensor. Go to Step 6
4	Damage and powdered iron sticking to sensor/sensor ring?	Go to Step 5	Repair. Go to Step 6
5	Is sensor output normal? (Chart C-2 or TC-2)	Check for faults in harness between speed sensor and EHCUC.  Fault found: repair, and perform system self-check.  No fault found: replace EHCUC. Go to Step 6	Replace sensor. Go to Step 6
6	1. Reconnect all components and ensure all components are properly mounted. 2. Clear diagnostic trouble code.  Was this step finished?	Repeat "Basic diagnostic flow chart."	Go to Step 6

NOTE: Even after repairing the faulty part the warning light (W/L) does not go out if the vehicle is at a stop. Turn the ignition switch to the ON position and drive the vehicle at 12 km/h or higher to make sure that the warning light goes out.

## 5A-42 BRAKE CONTROL SYSTEM

**Chart B-24 Sensor Signal Input Abnormality (DTC 65)**

Step	Action	Yes	No
1	Using TECH 2?	Go to Step 2	Go to Step 3
2	1. Connect TECH 2. 2. Select Snap shot manual trigger. 3. With wheel speed data displayed, run the vehicle when speed has arrived at 30 km/h (18 mph). 4. Check speed data on each wheel (refer to the criterion given below). *1  Is the abnormal sensor condition found?	Replace. Go to Step 8	Go to Step 3 All the sensors should follow the following flowchart (without using TECH 2).
3	Is there play in sensor/sensor ring?	Repair. Go to Step 8	Go to Step 4
4	Is there powdered iron sticking to sensor/sensor ring?	Repair. Go to Step 8	Go to Step 5
5	Is there a broken tooth or indentation in sensor ring?	Replace sensor ring. Go to Step 8	Go to Step 6
6	Is there play in wheel bearing?	Adjust or repair. Go to Step 8	Go to Step 7
7	Is the check wiring between sensor and EHCUC normal?	Replace EHCUC. Go to Step 8	Repair, and perform system self-check. Go to Step 8
8	1. Reconnect all components, ensure all components are properly mounted. 2. Clear diagnostic trouble code.  Was this step finished?	Repeat "Basic diagnostic flow chart."	Go to Step 8

### Sensor Signal Abnormality Criteria using TECH 2

1. While driving, the speed of one or two wheels 25% or more higher than that of the other wheels.
2. The speed of one or two wheels is 10 km/h (6 mph) or more higher than that of the other wheels.
3. During steady driving, wheel speed changes abruptly.

\*1 The vehicle must run on a level paved road.

NOTE: Even after repairing the faulty part the warning light (W/L) does not go out if the vehicle is at a stop.

Turn the ignition switch to the ON position and drive the vehicle at 12 km/h or higher to make sure that the warning light goes out.

It is important to verify that the correct tires are installed on vehicle.

## Unit Inspection Procedure

This section describes the following inspection procedures referred to during "SYMPTOM DIAGNOSIS" and "DIAGNOSIS BY 'ABS' WARNING LIGHT ILLUMINATION PATTERN":

	without TECH 2	with TECH 2
Wheel Speed Sensor Output Inspection	Chart C-1-1 to C-1-4	Chart TC-1
Transmission SW Inspection	Chart C-2	Chart TC-2

### Chart C-1-1 FL Sensor Output Inspection Procedure

Step	Action	Yes	No
1	1. Turn the key off. 2. Disconnect EHCUC connector. 3. Jack up the vehicle, With all four wheels off the ground. Measure the AC voltage between EHCUC connector terminals while turning FL wheel at a speed of 1 RPS:  Is voltage between EHCUC connector terminals 20 and 21 under 200 mV?	Go to Step 2	Ok. Go to Step 3
2	1. Disconnect the wheel speed sensor. 2. Measure resistance between the wheel speed sensor connector terminals 1 and 2.  Is resistance between connector (C-13) terminals 1 and 2 within 1.3k - 1.9k ohms?	Connector is faulty, or open or short circuit in harness between wheel speed sensor connector and EHCUC. Inspect and correct the connector or harness Go to Step 3	Wheel speed sensor is faulty. Replace the wheel speed sensor. Go to Step 3
3	Reconnect all components and ensure all components are properly mounted.  Was this step finished?	Repeat the "Basic diagnostic flow chart."	Go to Step 3

## 5A-44 BRAKE CONTROL SYSTEM

### Chart C-1-2 FR Sensor Output Inspection Procedure

Step	Action	Yes	No
1	1. Turn the key off. 2. Disconnect EHCUC connector. 3. Jack up the vehicle with all four wheels off the ground. Measure the AC voltage between EHCUC connector terminals while turning FR wheel at a speed of 1 RPS:  Is voltage between EHCUC connector terminals 4 and 5 under 200 mV?	Go to Step 2	Ok. Go to Step 3
2	1. Disconnect the wheel speed sensor. 2. Measure resistance between the wheel speed sensor connector terminals 1 and 2.  Is resistance between connector (C-41) terminals 1 and 2 within 1.3k - 1.9k ohms?	Connector is faulty, or open or short circuit of harness between wheel speed sensor connector and EHCUC. Inspect and correct the connector or harness Go to Step 3	Wheel speed sensor is faulty. Replace the wheel speed sensor. Go to Step 3
3	Reconnect all components and ensure all components are properly mounted.  Was this step finished?	Repeat the "Basic diagnostic flow chart."	Go to Step 3

### Chart C-1-3 RL Sensor Output Inspection Procedure

Step	Action	Yes	No
1	1. Turn the key off. 2. Disconnect EHCUC connector. 3. Jack up the vehicle with all four wheels off the ground. Measure the AC voltage between EHCUC connector terminals while turning RL wheel at a speed of 1 RPS:  Is voltage between EHCUC connector terminals 22 and 23 under 200 mV?	Go to Step 2	Ok. Go to Step 3
2	1. Disconnect the wheel speed sensor. 2. Measure resistance between the wheel speed sensor connector terminals 1 and 2.  Is resistance between connector (F-3) terminals 1 and 2 within 1.3k - 1.9k ohms?	Connector is faulty, or open or short circuit of harness between wheel speed sensor connector and EHCUC. Inspect and correct the connector or harness Go to Step 3	Wheel speed sensor is faulty. Replace the wheel speed sensor. Go to Step 3
3	Reconnect all components and ensure all components are properly mounted.  Was this step finished?	Repeat the "Basic diagnostic flow chart."	Go to Step 3



Chart C-1-4 RR Sensor Output Inspection Procedure

Step	Action	Yes	No
1	1. Turn the key off. 2. Disconnect EHCUC connector. 3. Jack up the vehicle with all four wheels off the ground. Measure the AC voltage between EHCUC connector terminals while turning RR wheel at a speed of 1 RPS:  Is voltage between EHCUC connector terminals 2 and 3 under 200 mV?	Go to Step 2	Ok. Go to Step 3
2	1. Disconnect the wheel speed sensor. 2. Measure resistance between the wheel speed sensor connector terminals 1 and 2.  Is resistance between connector (F-2) terminals 1 and 2 within 1.3k - 1.9k ohms?	Connector is faulty, or open or short circuit of harness between wheel speed sensor connector and EHCUC. Inspect and correct the connector or harness Go to Step 3	Wheel speed sensor is faulty. Replace the wheel speed sensor. Go to Step 3
3	Reconnect all components and ensure all components are properly mounted.  Was this step finished?	Repeat the "Basic diagnostic flow chart."	Go to Step 3

Chart TC-1 Sensor Output Inspection Procedure (Use TECH 2)

Step	Action	Yes	No
1	1. Connect TECH 2. 2. While driving the vehicle, check the wheel speed of each sensor by Data List.  Is the vehicle speed value is normal?	Go to Step 6	Go to Step 2
2	Check the sensor harness for suspected disconnection (Check while shaking harness/connector).  Is the sensor harness connection normal?	Replace speed sensor. Go to Step 3	Repair. Go to Step 6
3	While driving the vehicle, check the wheel speed of each sensor by Data List.  Is the vehicle speed value is normal?	Go to Step 6	Go to Step 4
4	Check sensor roter.  Is the sensor roter normal?	Go to Step 6	Replace sensor roter. Go to Step 5
5	While driving the vehicle, check the wheel speed of each sensor by Data List.  Is the vehicle speed value is normal?	Go to Step 6	Repair harness or connector between EHCUC and speed sensor. Go to Step 6
6	Reconnect all components, ensure all components are properly mounted.  Was this step finished?	Repeat the "Basic diagnostic flow chart."	Go to Step 6

**5A-46 BRAKE CONTROL SYSTEM**


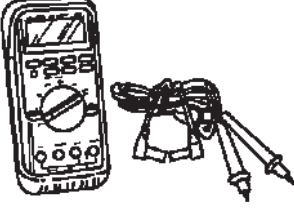
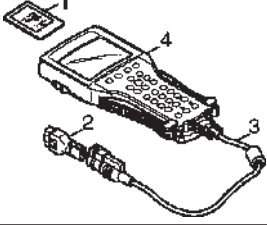
**Chart C-2 Transmission Input Inspection Procedure**

Step	Action	Yes	No
1	1. Turn the key off. 2. Disconnect EHCU connector.  Is there continuity between EHCU connector terminals 6 and 15 (Gear position-P)?	Shorted switch harness. Repair switch or harness. Go to Step 4	Go to Step 2
2	Turn the key on and measure voltage between EHCU connector terminals 6 and 15.  Is there less than 6V when the gear position is L, and R(Battery voltage 12V)?	Go to Step 3	Transmission SW trouble. Disconnected harness. Repair SW and harness. Go to Step 4
3	Measure the voltage between EHCU connector terminals 6 and 15.  Is there 6.6 to 9.0V when the gear position is 2,3,D,N and P (Battery voltage 12V)?	Go to Step 4	Transmission SW trouble. Disconnected harness. Repair SW and harness. Go to Step 4
4	1. Reconnect all components and ensure all components are properly mounted. 2. Clear diagnostic trouble code.  Was this step finished?	Repeat the "Basic diagnostic flow chart."	Go to Step 4

**Chart TC-2 Transmission Input Inspection Procedure (Use TECH 2)**

Step	Action	Yes	No
1	1. Connect TECH 2. 2. Select Data List.  Is "Off-Road Switch(Transmission Input): Active" when the shift lever is the L and R?	Go to Step 2	Go to Step 3
2	Is "Off-Road Switch(Transmission Input): Inactive" when the shift lever is other than the L and R?	Go to Step 4	Go to Step 3
3	1. Abnormal inhibitor SW or harness. 2. Repair inhibitor SW or harness.  Is the inhibitor SW or harness repaired?	Go to Step 4	Go to Step 3
4	Reconnect all components, ensure all components are properly mounted.  Was this step finished?	Repeat the "Basic diagnostic flow chart."	Go to Step 4

## Special Tools

ILLUSTRATION	TOOL NO. TOOL NAME
 <p>901RW074</p>	<p><b>J-35616</b> Connector test adapter kit</p>
 <p>901RS153</p>	<p><b>J-39200</b> High impedance multimeter</p>
	<p><b>7000086-ISU</b> Tech 2 Set (1) PCMCIA Card (2) SAE 16/19 Adapter (3) DLC Cable (4) Tech-2</p>

# BRAKES

## ANTI-LOCK BRAKE SYSTEM

### CONTENTS

Service Precaution .....	5B-1	Front Wheel Speed Sensor and Associated Parts .....	5B-4
Electronic Hydraulic Control Unit .....	5B-2	Removal .....	5B-4
Electronic Hydraulic Control Unit and Associated Parts .....	5B-2	Inspection and Repair .....	5B-5
Removal .....	5B-2	Installation .....	5B-5
Installation .....	5B-2	Rear Wheel Speed Sensor .....	5B-6
G-Sensor .....	5B-3	Rear Wheel Speed Sensor and Associated Parts .....	5B-6
Removal .....	5B-3	Removal .....	5B-6
Inspection and Repair .....	5B-3	Inspection and Repair .....	5B-6
Installation .....	5B-3	Installation .....	5B-6
Front Wheel Speed Sensor .....	5B-4		

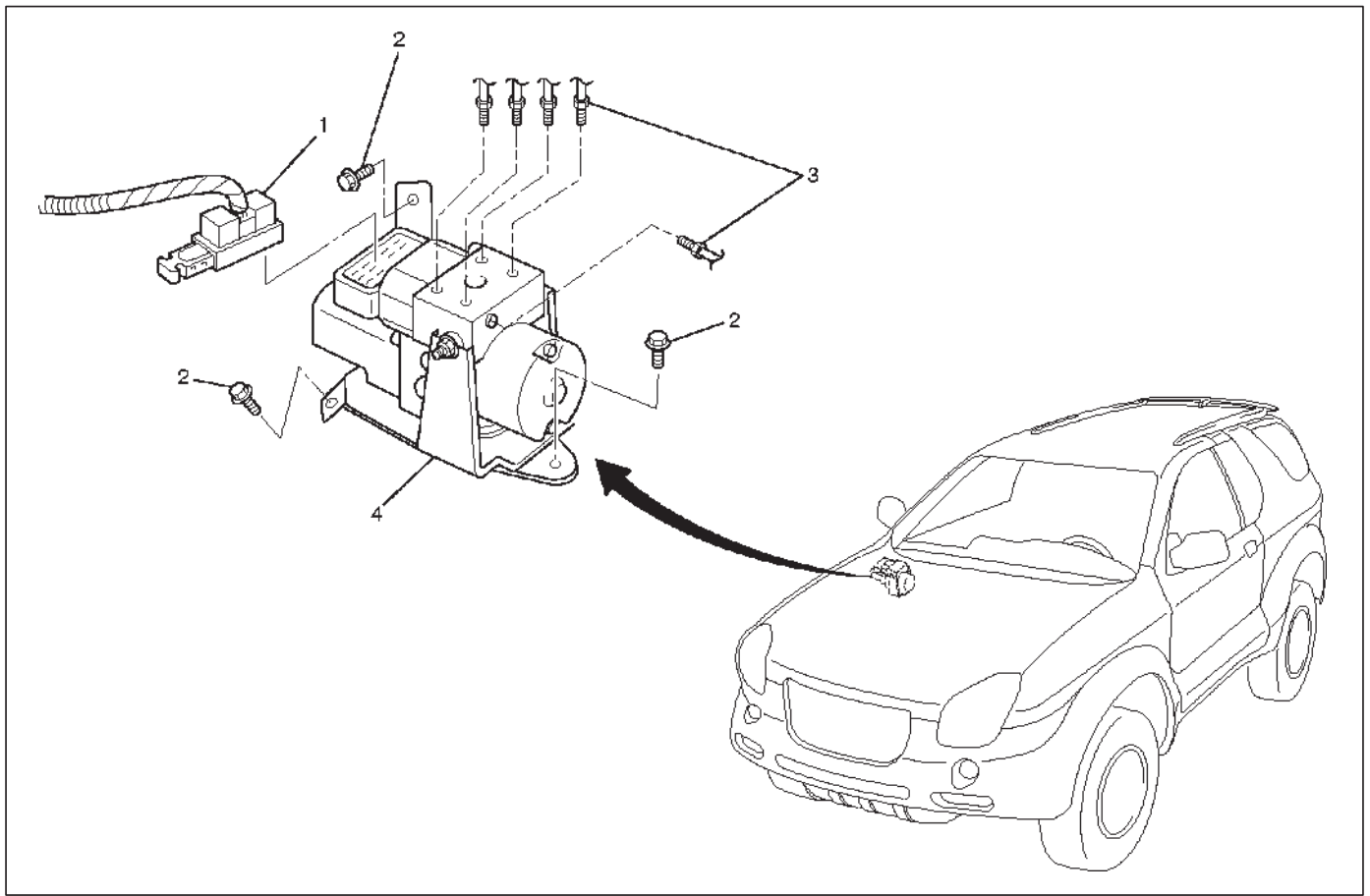
### Service Precaution

**WARNING: THIS VEHICLE HAS A SUPPLEMENTAL RESTRAINT SYSTEM (SRS). REFER TO THE SRS COMPONENT AND WIRING LOCATION VIEW IN ORDER TO DETERMINE WHETHER YOU ARE PERFORMING SERVICE ON OR NEAR THE SRS COMPONENTS OR THE SRS WIRING. WHEN YOU ARE PERFORMING SERVICE ON OR NEAR THE SRS COMPONENTS OR THE SRS WIRING, REFER TO THE SRS SERVICE INFORMATION. FAILURE TO FOLLOW WARNINGS COULD RESULT IN POSSIBLE AIR BAG DEPLOYMENT, PERSONAL INJURY, OR OTHERWISE UNNEEDED SRS SYSTEM REPAIRS.**

**CAUTION: Always use the correct fastener in the proper location. When you replace a fastener, use ONLY the exact part number for that application. ISUZU will call out those fasteners that require a replacement after removal. ISUZU will also call out the fasteners that require thread lockers or thread sealant. UNLESS OTHERWISE SPECIFIED, do not use supplemental coatings (Paints, greases, or other corrosion inhibitors) on threaded fasteners or fastener joint interfaces. Generally, such coatings adversely affect the fastener torque and the joint clamping force, and may damage the fastener. When you install fasteners, use the correct tightening sequence and specifications. Following these instructions can help you avoid damage to parts and systems.**

## Electronic Hydraulic Control Unit

### Electronic Hydraulic Control Unit and Associated Parts



350RX004

#### Legend

- (1) Connector
- (2) Bolts

- (3) Brake Pipes
- (4) EHC Unit Assembly

### Removal

1. Remove harness connector.
  - To remove the connector, release lock by pulling knob.
2. Remove brake pipes.
  - After disconnecting brake pipe, cap or tape the openings of the brake pipe to prevent the entry of foreign matters.
3. Remove EHC fixing bolts.
4. Remove EHC Unit Assembly.

### Installation

To install, follow the removal steps in the reverse order, noting the following points:

#### Torque

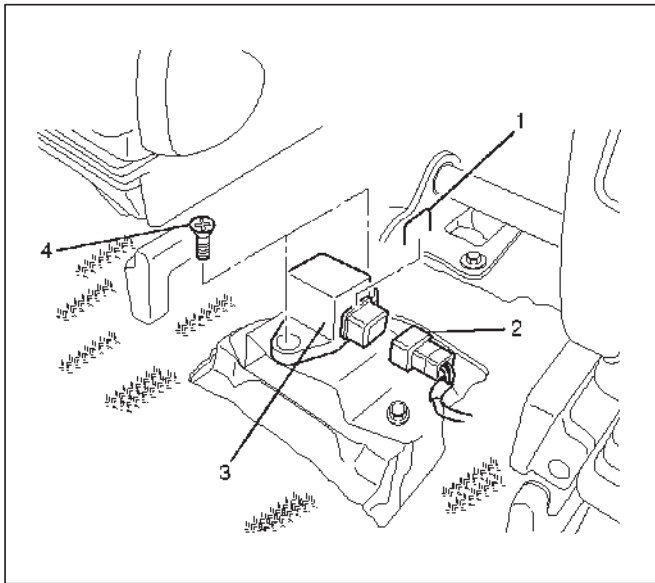
**EHC Unit fixing bolts : 24 N·m (17 lb ft)**

**Brake pipe (joint bolts) : 16 N·m (12 lb ft)**

- After installing the hydraulic unit, bleed brakes completely. Refer to Bleeding Brake Hydraulic System in this section.

## G-Sensor

### Removal



350RX005

1. Remove center console.
  - Refer to Consoles in Body and Accessories section.
2. Remove clip (1) from G-sensor connector (2), then disconnect connector.
3. Remove G-sensor fixing screw (4).
4. Remove G-sensor (3).

### Inspection and Repair

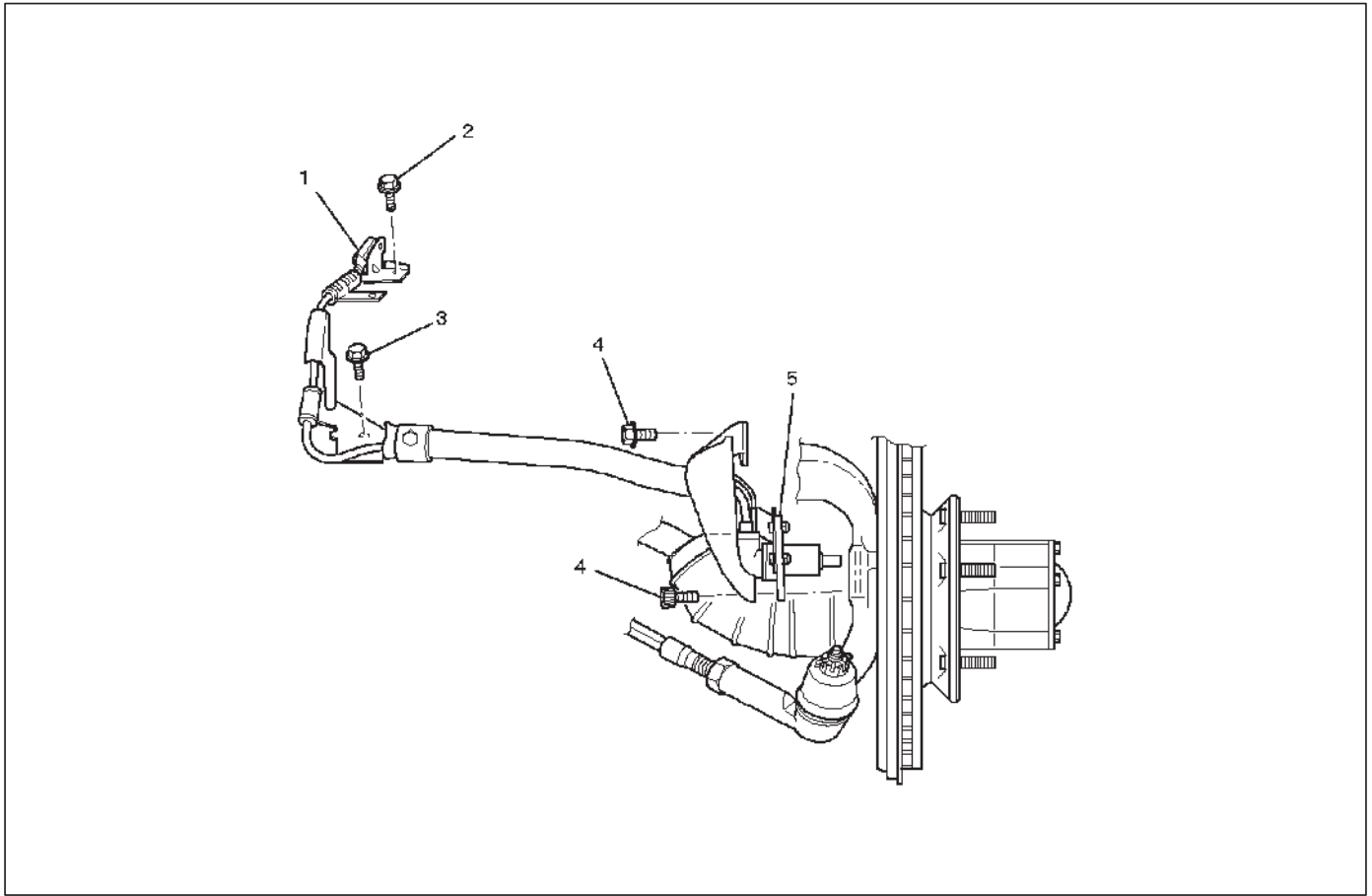
Refer to "Chart B-5" in this Section.

### Installation

1. Install G-sensor assembly (3).
    - Care should be taken so that the G-sensor is not installed in the wrong direction.
  2. Install G-sensor assembly fixing screw (4).
    - Tighten the fixing screw to the specified torque.
- Torque : 6 N·m (52 lb in)**
3. Install G-sensor wiring connector (2) and clip (1).
  4. Install center console.
    - Refer to Consoles in Body and Accessories section.

## Front Wheel Speed Sensor

### Front Wheel Speed Sensor and Associated Parts

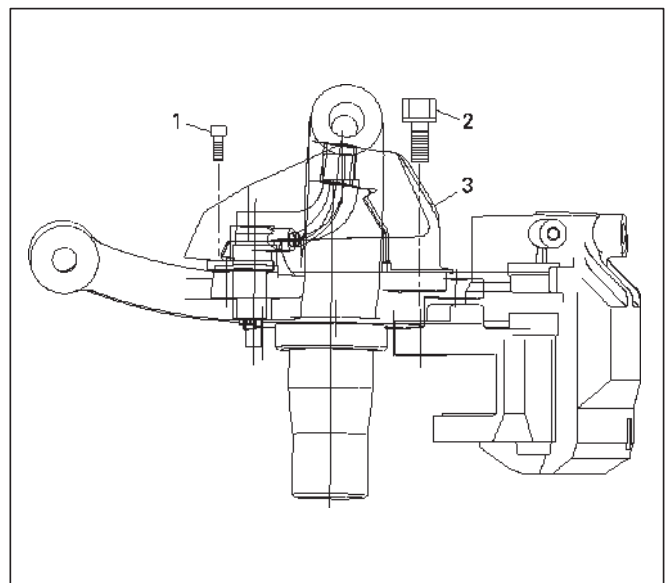


#### Legend

- |   |  |
|---|--|
| (1) Speed Sensor Connector                | (3) Sensor Cable Fixing Bolt (Lower side)  |
| (2) Sensor Cable Fixing Bolt (Upper side) | (4) Sensor Cable Fixing Bolt (Sensor side) |
|   | (5) Speed Sensor                           |

#### Removal

1. Remove speed sensor connector.
2. Remove sensor cable fixing bolt (Upper side).
3. Remove sensor cable fixing bolt (Lower side).
4. Remove the speed sensor cable fixing bolts (1) and caliper fixing bolt (2) from caliper side speed sensor cable bracket (3).



5. Remove speed sensor.

## Inspection and Repair

1. Check the speed sensor pole piece for presence of foreign materials; remove any dirt, etc.
2. Check the pole piece for damage; replace speed sensor if necessary.
3. Check the speed sensor cable for short or open circuit, and replace with a new one if necessary.  
To check for cable short or open, bend or stretch the cable while checking for continuity.
4. Check the sensor ring for damage including tooth chipping, and if damaged, replace the sensor ring assembly. Refer to removal of the sensor ring in Section 4C "Front hub and disc".

3. Install speed sensor cable fixing bolt (Lower side) and tighten the fixing bolt to the specified torque.

**Torque : 24 N·m (18 lb ft)**

4. Install speed sensor cable fixing bolt (Upper side) and tighten the fixing bolt to the specified torque.

**Torque : 6 N·m (52 lb ft)**

NOTE: Confirm that a white line marked on the cable is not twisted when connecting the speed sensor cable.

5. Install speed sensor connector.

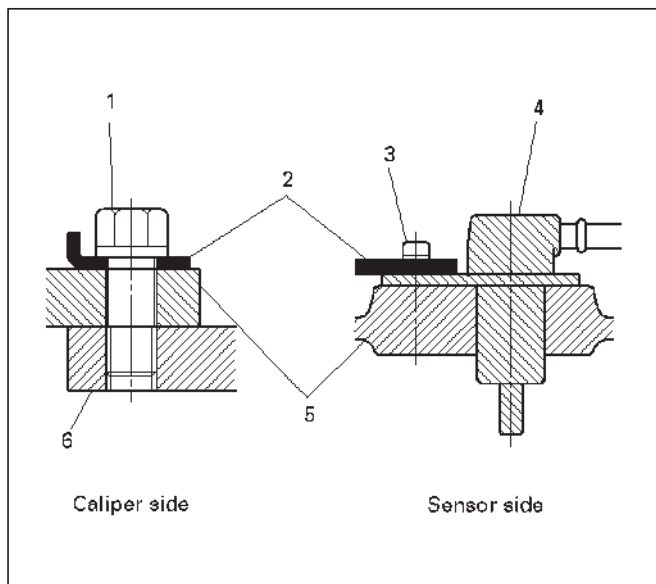
## Installation

1. Install speed sensor and take care not to hit the speed sensor pole piece during installation.
2. Install speed sensor fixing bolt and tighten the fixing bolt to the specified torque.

### Torque

**Sensor side : 8 N·m (69 lb in)**

**Caliper side : 155 N·m (115 lb ft)**



350RW011

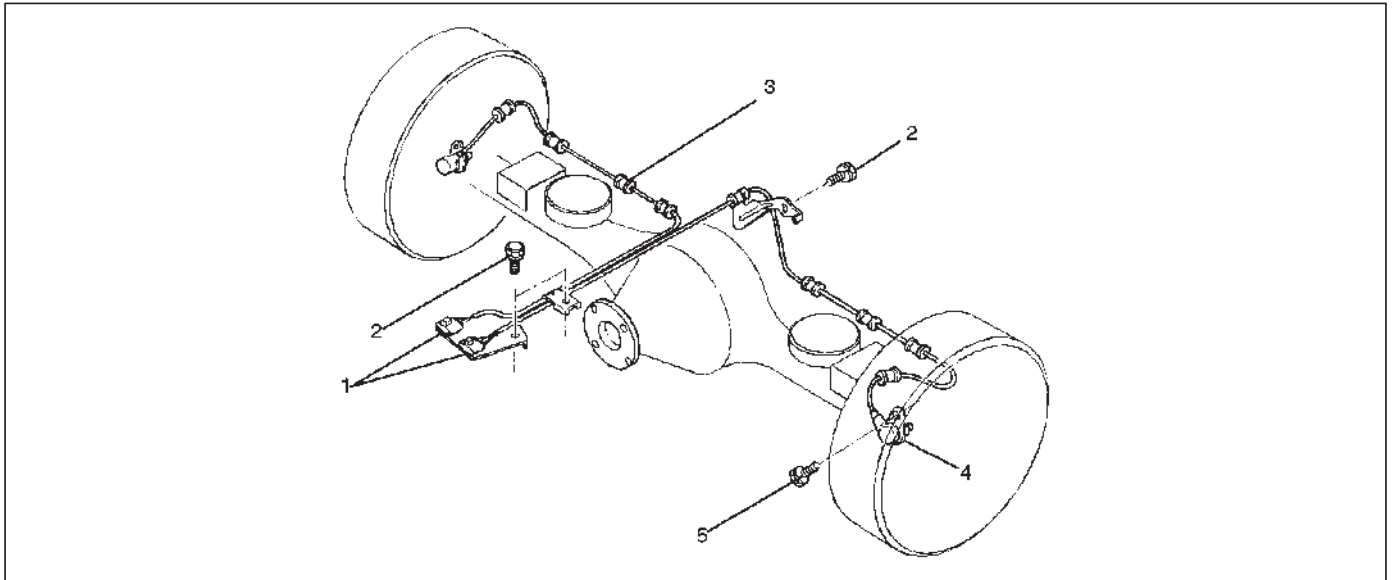
### Legend

- (1) Caliper Fixing Bolt
- (2) Bracket
- (3) Sensor Fixing Bolt
- (4) Sensor
- (5) Knuckle
- (6) Brake Caliper



## Rear Wheel Speed Sensor

### Rear Wheel Speed Sensor and Associated Parts



350RW008

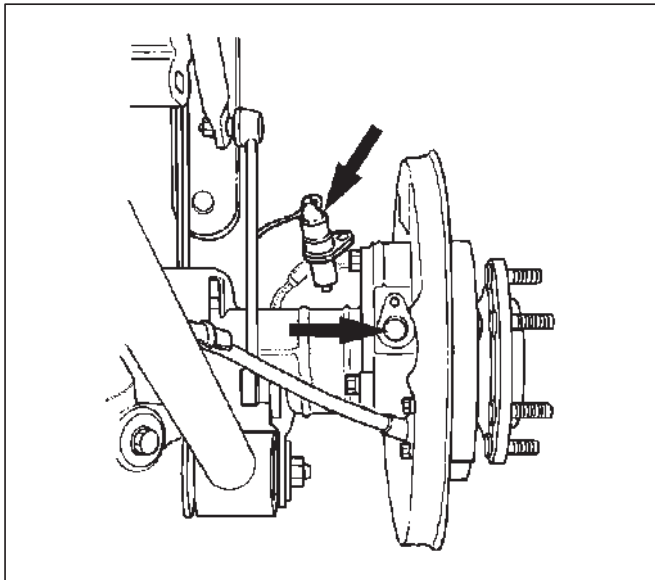
#### Legend

- (1) Speed Sensor Connector
- (2) Sensor Cable Fixing Bolt

- (3) Clip (11 pieces)
- (4) Speed Sensor
- (5) Sensor Fixing Bolt

### Removal

1. Remove speed sensor connector.
2. Remove clip.
3. Remove sensor cable fixing bolt.
4. Remove sensor fixing bolt.
5. Remove speed sensor.



350RS035

### Inspection and Repair

1. Check the speed sensor pole piece for presence of foreign materials; remove any dirt, etc.
2. Check the pole piece for damage, and replace the speed sensor if necessary.
3. Check the speed sensor cable for a short or an open, and replace with a new one if necessary. To check for cable short or open, bend or stretch the cable while checking for continuity.
4. Check the sensor ring for damage including tooth chipping. If damaged replace the axle shaft assembly. Refer to removal of the sensor ring in Section 4B "Rear Axle".

### Installation

1. Install the speed sensor and take care not to hit the speed sensor pole piece during installation.
2. Install the sensor fixing bolt and tighten it to the specified torque.  
**Torque : 18 N-m (13 lb ft)**
3. Install the sensor cable fixing bolt and tighten it to the specified torque.  
**Torque : 24 N-m (18 lb ft)**

NOTE: Confirm that the cable is not twisted when connecting the speed sensor cable.

4. Install clip.
5. Install speed sensor connector.

VEHICROSS

# BRAKES

## POWER-ASSISTED BRAKE SYSTEM

### CONTENTS

Service Precaution .....	5C-2	Master Cylinder Assembly and Associated Parts .....	5C-21
General Description .....	5C-2	Removal .....	5C-21
Diagnosis .....	5C-5	Inspection and Repair .....	5C-21
General Diagnosis .....	5C-6	Installation .....	5C-22
Hydraulic Brakes .....	5C-9	Main Data and Specifications .....	5C-23
Filling Master Cylinder Reservoir .....	5C-9	Special Tools .....	5C-24
Deterioration of Brake Fluid .....	5C-9	Vacuum Booster Assembly .....	5C-25
Leakage of Brake Fluid .....	5C-9	Vacuum Booster Assembly and Associated Parts .....	5C-25
Bleeding Brake Hydraulic System .....	5C-9	Removal .....	5C-25
Flushing Brake Hydraulic System .....	5C-10	Inspection and Repair .....	5C-25
Brake Pipes and Hoses .....	5C-10	Installation .....	5C-26
Brake Hose Inspection .....	5C-10	Exterior Components .....	5C-28
Front / Rear Caliper Brake Hose .....	5C-11	Exterior Components and Associated Parts .....	5C-28
Front / Rear Caliper Brake Hose and Associated Parts .....	5C-11	Removal .....	5C-28
Removal .....	5C-11	Inspection and Repair .....	5C-29
Installation .....	5C-11	Installation .....	5C-29
Rear Axle Brake Hose .....	5C-12	Vacuum Booster Overhaul .....	5C-29
Rear Axle Brake Hose and Associated Parts .....	5C-12	Vacuum Booster .....	5C-29
Removal .....	5C-12	Main Data and Specifications .....	5C-30
Installation .....	5C-12	Special Tools .....	5C-31
Brake Pipe .....	5C-13	Front Disc Brake Pads .....	5C-32
Removal .....	5C-13	Front Disc Brake Pads Inspection .....	5C-32
Installation .....	5C-13	Front Disc Brake Pads and Associated Parts .....	5C-32
P & B (Proportioning and Bypass) Valve .....	5C-14	Removal .....	5C-33
Removal .....	5C-14	Installation .....	5C-33
Installation .....	5C-14	Front Disc Brake Rotor .....	5C-35
Main Data and Specifications .....	5C-15	Inspection .....	5C-35
Brake Pedal .....	5C-16	Replacing Brake Rotors .....	5C-35
Checking Pedal Height .....	5C-16	Refinishing Brake Rotors .....	5C-35
Checking Pedal Travel .....	5C-16	Front Disc Brake Caliper Assembly .....	5C-37
Brake Pedal and Associated Parts .....	5C-17	Front Disc Brake Caliper Assembly and Associated Parts .....	5C-37
Removal .....	5C-17	Removal .....	5C-37
Installation .....	5C-17	Installation .....	5C-38
Stoplight Switch .....	5C-18	Front Disc Brake Caliper .....	5C-40
Removal .....	5C-18	Front Disc Brake Caliper Disassembled View .....	5C-40
Installation .....	5C-18	Disassembly .....	5C-40
Main Data and Specifications .....	5C-19	Inspection and Repair .....	5C-41
Fluid Reservoir Tank .....	5C-20	Reassembly .....	5C-41
Fluid Reservoir Tank and Associated Parts .....	5C-20	Main Data and Specifications .....	5C-43
Removal .....	5C-20	Rear Disc Brake Pads .....	5C-44
Installation .....	5C-20		
Master Cylinder Assembly .....	5C-21		

## 5C-2 POWER ASSISTED BRAKE SYSTEM

Brake Pads Inspection .....	5C-44	Rear Disc Brake Caliper Assembly and Associated Parts .....	5C-49
Brake Pads and Associated Parts .....	5C-44	Removal .....	5C-49
Removal .....	5C-45	Installation .....	5C-50
Installation .....	5C-45	Rear Disc Brake Caliper .....	5C-52
Rear Disc Brake Rotor .....	5C-47	Rear Disc Brake Caliper Disassembled View .....	5C-52
Inspection .....	5C-47	Disassembly .....	5C-52
Replacing Brake Rotors .....	5C-47	Inspection and Repair .....	5C-53
Refinishing Brake Rotors .....	5C-47	Reassembly .....	5C-53
Rear Drum (In Disc) Inside Diameter Check	5C-48	Main Data and Specifications .....	5C-55
Rear Disc Brake Caliper Assembly .....	5C-49		

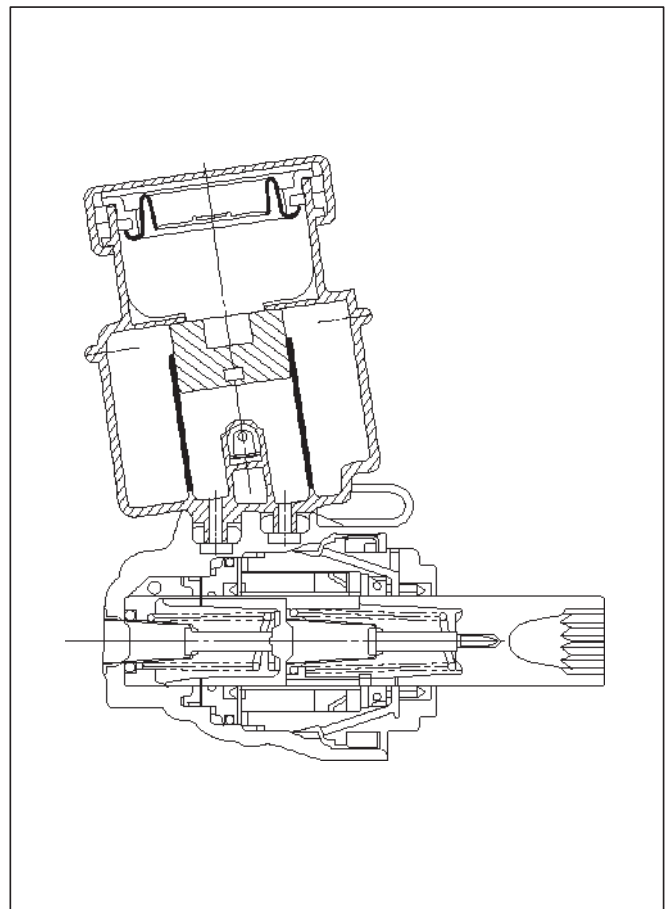
### Service Precaution

**WARNING:** THIS VEHICLE HAS A SUPPLEMENTAL RESTRAINT SYSTEM (SRS). REFER TO THE SRS COMPONENT AND WIRING LOCATION VIEW IN ORDER TO DETERMINE WHETHER YOU ARE PERFORMING SERVICE ON OR NEAR THE SRS COMPONENTS OR THE SRS WIRING. WHEN YOU ARE PERFORMING SERVICE ON OR NEAR THE SRS COMPONENTS OR THE SRS WIRING, REFER TO THE SRS SERVICE INFORMATION. FAILURE TO FOLLOW WARNINGS COULD RESULT IN POSSIBLE AIR BAG DEPLOYMENT, PERSONAL INJURY, OR OTHERWISE UNNEEDED SRS SYSTEM REPAIRS.

**CAUTION:** Always use the correct fastener in the proper location. When you replace a fastener, use ONLY the exact part number for that application. ISUZU will call out those fasteners that require a replacement after removal. ISUZU will also call out the fasteners that require thread lockers or thread sealant. UNLESS OTHERWISE SPECIFIED, do not use supplemental coatings (Paints, greases, or other corrosion inhibitors) on threaded fasteners or fastener joint interfaces. Generally, such coatings adversely affect the fastener torque and the joint clamping force, and may damage the fastener. When you install fasteners, use the correct tightening sequence and specifications. Following these instructions can help you avoid damage to parts and systems.

### General Description

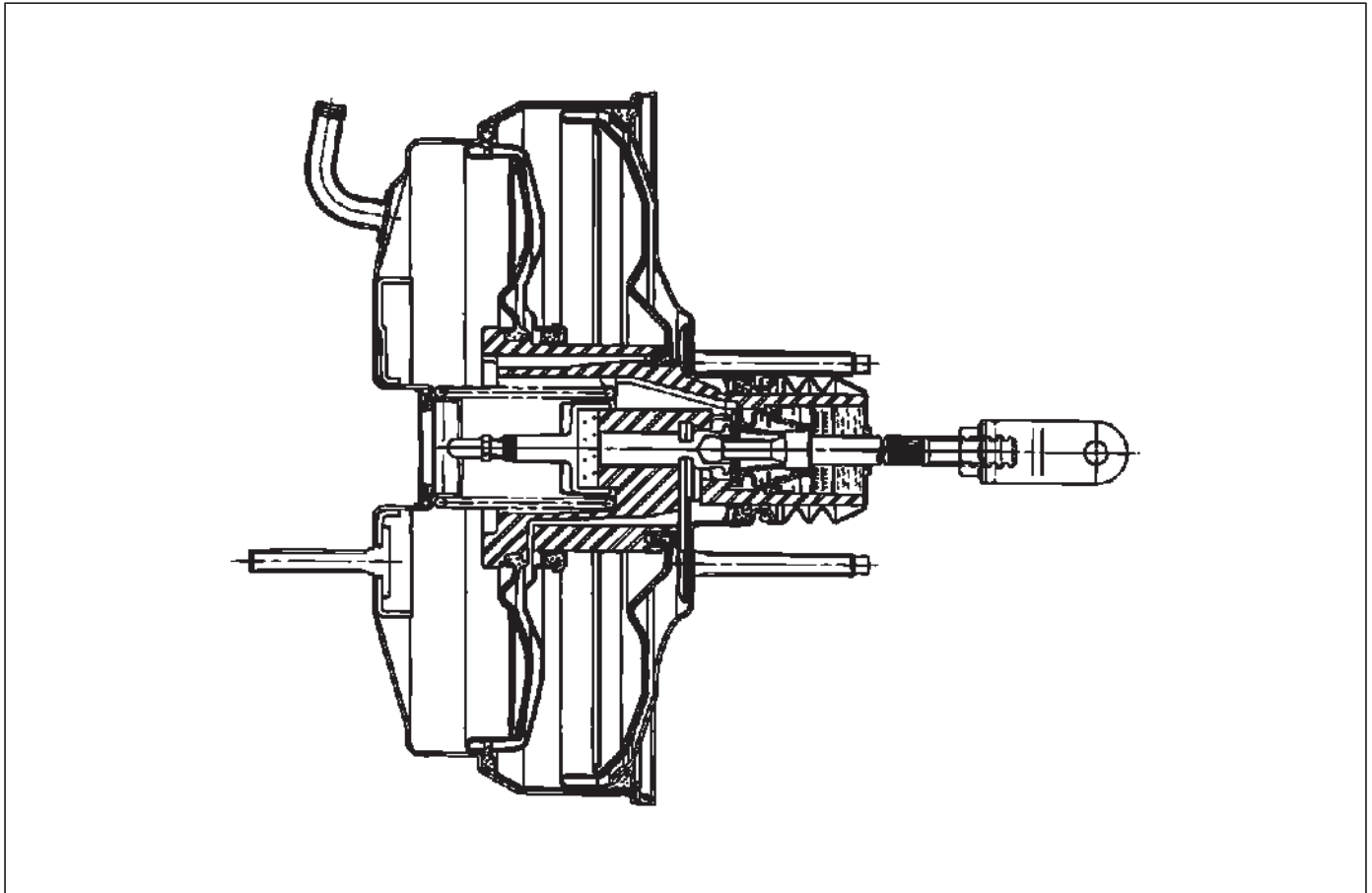
#### Master Cylinder Assembly



The master cylinder contains two pistons that supply the hydraulic pressure for a dual-circuit braking system. The primary piston provides the fluid pressure to the front brakes, while the secondary piston provides the fluid pressure to the rear brakes. If the pressure is lost from either system, the remaining system will function to stop the vehicle.

**CAUTION:**

1. The master cylinder is not repairable. If found defective, it must be replaced as a complete assembly.
2. If any hydraulic component is removed or disconnected, it may be necessary to bleed all or part of the brake system. (Refer to "On-Vehicle Service" in this section.)

**Brake Booster**

This booster is a tandem vacuum unit with a diaphragm effective diameter 205mm + 230mm. In normal operating mode, with the service brakes in the released position, the tandem vacuum booster operates with vacuum on both sides of its diaphragms. When the brakes are applied, air at atmospheric pressure is admitted to one side of each diaphragm to provide the power assist. When the service brake is released, the atmospheric air is shut off from the one side of each diaphragm. The air is then drawn from the booster through the vacuum check valve to the vacuum source.

**CAUTION:**

1. If any hydraulic component is removed or disconnected, it may be necessary to bleed all or part of the brake system.
2. The torque values specified are for dry, unlubricated fasteners.
3. The vacuum booster is not repairable and must be replaced as a complete assembly.

3. The torque values specified are for dry, un-lubricated fasteners.
4. Perform service operations on a clean bench free from all mineral oil materials.

**Disc Brake**

The disc brake assembly consists of a caliper, piston, rotor, pad assembly and support bracket. The caliper assembly has a single bore and is mounted to the support bracket with two mounting bolts. The support bracket allows the caliper to move laterally against the rotor. The caliper is a one-piece casting with the inboard side containing the piston bore. A square cut rubber seal is located in a groove in the piston bore which provides the hydraulic seal between the piston and the cylinder wall.

**NOTE:**

1. Replace all components included in repair kits used to service this caliper.
2. Lubricate rubber parts with clean brake fluid to ease assembly.
3. If any hydraulic component is removed or disconnected, it may be necessary to bleed all or part of the brake system.
4. Replace pads in axle sets only.

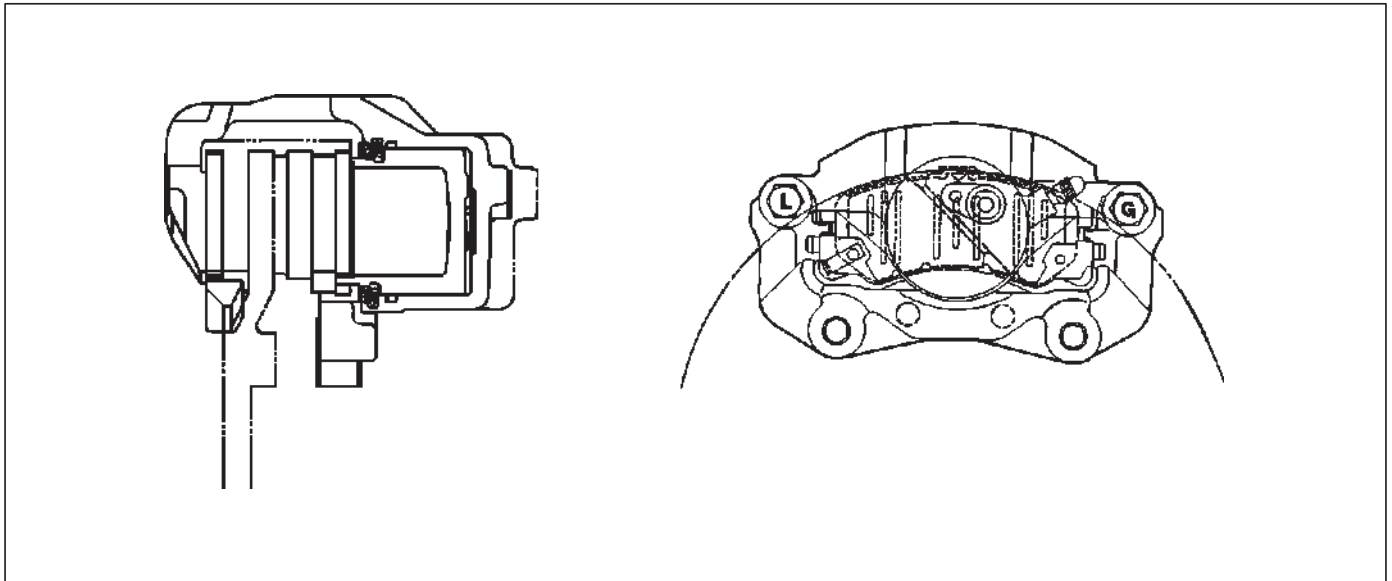
## 5C-4 POWER ASSISTED BRAKE SYSTEM

5. The torque values specified are for dry, unlubricated fasteners.

6. Perform the service operation on a clean bench free from all mineral oil materials.

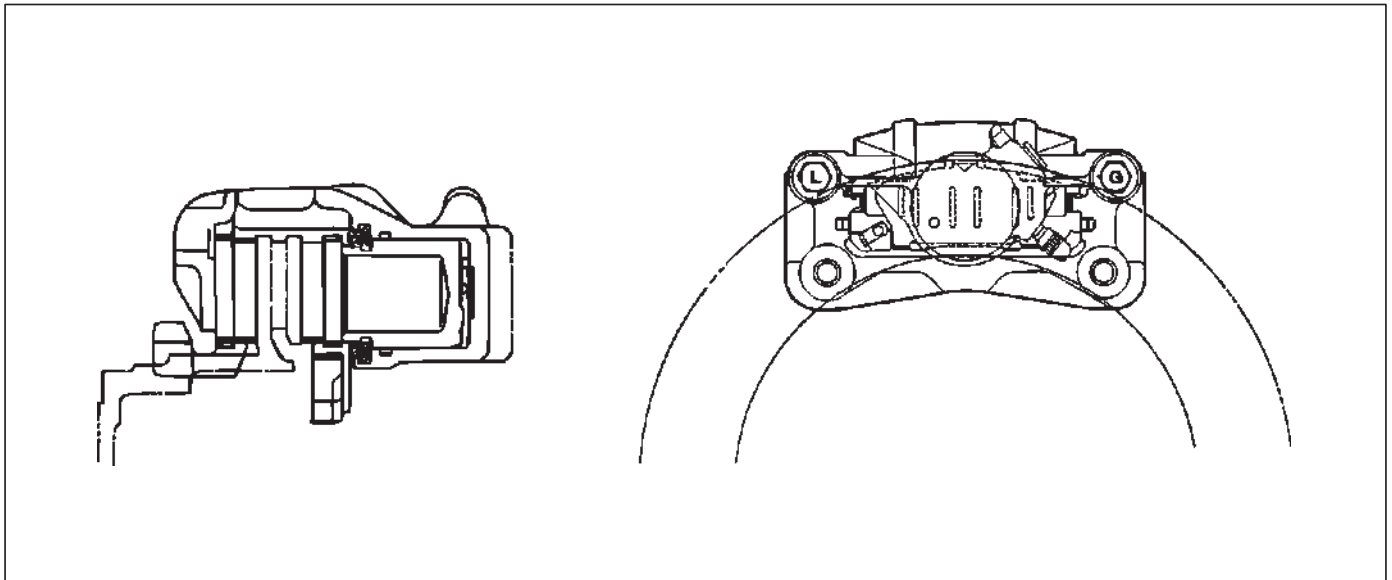
### Operation

#### Front Disc Brake



A05RW001

#### Rear Disc Brake



A05RW002

Hydraulic pressure, created by applying the brake pedal, is converted by the caliper to a stopping force. This force acts equally against the piston and the bottom of the caliper bore to move the piston outward and to move (slide) the caliper inward resulting in a clamping action on the rotor. This clamping action forces the linings against the rotor, creating friction to stop the vehicle.

## Diagnosis

### Road Testing The Brakes

#### Brake Test

Brakes should be tested on a dry, clean, reasonably smooth and level roadway. A true test of brake performance cannot be made if the roadway is wet, greasy or covered with loose dirt so that all tires do not grip the road equally. Testing will also be adversely affected if the roadway is crowned so as to throw the weight of the vehicle toward wheels on one side or if the roadway is so rough that wheels tend to bounce. Test the brakes at different vehicle speeds with both light and heavy pedal pressure; however, avoid locking the wheels and sliding the tires. Locked wheels and sliding tires do not indicate brake efficiency, since heavily braked but turning wheels will stop the vehicle in less distance than locked wheels. More tire-to-road friction is present with a heavily braked turning tire than with a sliding tire.

The standard brake system is designed and balanced to avoid locking the wheels except at very high deceleration levels.

It is designed this way because the shortest stopping distance and best control is achieved without brake lock-up.

Because of high deceleration capability, a firmer pedal may be felt at higher deceleration levels.

#### External Conditions That Affect Brake Performance

1. Tires: Tires having unequal contact and grip on the road will cause unequal braking. Tires must be equally inflated, identical in size, and the thread pattern of right and left tires must be approximately equal.
2. Vehicle Loading: A heavily loaded vehicle requires more braking effort.

3. Wheel Alignment: Misalignment of the wheels, particularly in regard to excessive camber and caster, will cause the brakes to pull to one side.

#### Brake Fluid Leaks

With engine running at idle and the transmission in "Neutral", depress the brake pedal and hold a constant foot pressure on the pedal. If pedal gradually falls away with the constant pressure, the hydraulic system may be leaking.

Check the master cylinder fluid level. While a slight drop in the reservoir level will result from normal lining wear, an abnormally low level in reservoir indicates a leak in the system. The hydraulic system may be leaking internally as well as externally. Refer to "Master Cylinder Inspection". Also, the system may appear to pass this test but still have slight leakage. If fluid level is normal, check the vacuum booster push rod length. If an incorrect length push rod is found, adjust or replace the push rod. Check the brake pedal travel and the parking brake adjustment. When checking the fluid level, the master cylinder fluid level may be low from the "MAX" mark if the front and rear linings are worn. This is normal.

#### Warning Light Operation

When the ignition switch is in the START position, the "BRAKE" warning light should turn on and go off when the ignition switch returns to the ON position.

The following conditions will turn on the "BRAKE" light:

1. Parking brake applied. The light should be on whenever the parking brake is applied and the ignition switch is on.
2. Low fluid level. A low fluid level in the master cylinder will turn the "BRAKE" light on.
3. During engine cranking the "BRAKE" light should remain on. This notifies the driver that the warning circuit is operating properly.

## General Diagnosis

Condition	Possible cause	Correction
Brake Pull	Tire inflation pressure is unequal.	Adjust
	Front wheel alignment is incorrect.	Adjust
	Unmatched tires on same axle.	Tires with approx. the same amount of tread should be used on the same axle.
	Restricted brake pipes or hoses.	Check for soft hoses and damaged lines. Replace with new hoses and new double-walled steel brake piping.
	Water or oil on the brake pads.	Clean or replace.
	Brake pads hardened.	Replace
	Brake pads worn excessively.	Replace
	Brake rotor worn or scored.	Grind or replace.
	Disc brake caliper malfunctioning.	Clean or replace.
	Front hub bearing preload incorrect.	Adjust or replace.
	Loose suspension parts.	Check all suspension mountings.
	Loose calipers.	Check and tighten the bolts to specifications.
Brake Roughness or Chatter (Pulsates)	Excessive lateral runout.	Check per instructions. If not within specifications, replace or machine the rotor.
	Parallelism not within specifications.	Check per instructions. If not within specifications, replace or machine the rotor.
	Wheel bearings not adjusted.	Adjust wheel bearings to correct specifications
	Pad reversed (steel against iron).	Replace the brake pad and machine rotor to within specifications.
Excessive Pedal Effort	Malfunctioning vacuum booster.	Check the vacuum booster operation and repair, if necessary.
	Partial system failure.	Check the front and rear brake system for failure and repair. Also, check the brake warning light. If a failed system is found, the light should indicate failure.
	Excessively worn pad.	Check and replace pads in sets.
	Piston in caliper stuck or sluggish.	Remove caliper and rebuild.
	Fading brakes due to incorrect pad.	Remove and replace with original equipment pad or equivalent.
	Vacuum leak to vacuum booster.	Check for ruptured or loose hose.
	Check the direction of check valve within vacuum hose.	Correct vacuum hose direction.
	Grease on the brake pads.	Replace or clean.

Condition	Possible cause	Correction
Excessive Brake Pedal Travel	Air in hydraulic circuit.	Bleed the hydraulic circuit.
	Level of brake fluid in the reservoir too low.	Replenish brake fluid reservoir to specified level and bleed hydraulic circuit as necessary.
	Master cylinder push rod clearance excessive.	Adjust
	Leakage in hydraulic system.	Correct or replace defective parts.
Brake Drag	Master cylinder pistons not returning correctly.	Adjust the stop light switch and vacuum booster push rod. If necessary, rebuild.
	Restricted brake pipes or hoses.	Check for soft hoses or damaged pipes, and replace with new hoses and new double-walled steel brake piping.
	Parking brake misadjusted.	Adjust
	Parking brake lining clearance insufficient.	Adjust
	Brake pedal free play insufficient.	Adjust the brake pedal height or power cylinder operating rod.
	Piston in the master cylinder sticking.	Replace
	Piston in the disc brake caliper sticking.	Replace piston seals.
	Brake pads sticking in caliper.	Clean
	Return spring weakened.	Replace
	Parking brake binding.	Overhaul the parking brakes and correct.
	Front hub bearing preload incorrect.	Adjust or replace.
	Parking brake shoes not returning.	Correct or replace the brake back plate and brake shoe as necessary.
	Obstructions in hydraulic circuit.	Clean
	Brake disc warped excessively.	Grind or replace.
	Rear brake drum distorted.	Grind or replace.
Parking cable sticking.	Grind or replace.	
Grabbing or Uneven Braking Action (All conditions listed under "Pulls")	Malfunctioning vacuum booster.	Check operation and correct as necessary.
	Binding brake pedal mechanism.	Check and lubricate, if necessary.
	Corroded caliper assembly.	Clean and lubricate.
Brake Noisy	Brake pads are worn.	Replace
	Brake pads are hardened.	Replace
	Brake pads are in poor contact with rotor.	Correct
	Brake disc(s) warped, worn or damaged.	Grind or replace.
	Disc brake anti-squeak shims fatigued.	Replace
	Front hub bearings are loose or preload is incorrect.	Adjust or replace.
	Brake disc is rusted.	Grind or replace.



**5C-8 POWER ASSISTED BRAKE SYSTEM**

<b>Condition</b>	<b>Possible cause</b>	<b>Correction</b>
Poor Brake Action	Master cylinder faulty.	Correct or replace.
	Vacuum booster faulty.	Correct or replace.
	Level of brake fluid in reservoir too low.	Replenish and bleed.
	Air in hydraulic circuit.	Bleed
	Disc brake caliper faulty.	Clean or replace.
	Water or oil on brake pads.	Clean or replace.
	Brake pads in poor contact with the brake disc.	Correct
	Brake pads worn.	Replace
	Brake disc rusted.	Grind or replace.
	Check valve in vacuum hose faulty.	Correct or replace.

## Hydraulic Brakes

### Filling Master Cylinder Reservoir

**CAUTION:** Use only specified brake fluid. Do not use any fluid which contains a petroleum base. Do not use a container which has been used for petroleum based fluids or a container which is wet with water. Petroleum based fluid will cause swelling and distortion of rubber parts in the hydraulic brake system. Water mixed with brake fluid lowers the fluid boiling point. Keep all fluid containers capped to prevent contamination.

Always fill the master cylinder reservoir when the engine is cold.

Never allow the brake fluid to come in contact with the painted surfaces.

The master cylinder reservoir must be kept properly filled to ensure adequate reserve and to prevent air and moisture from entering the hydraulic system. However, because of expansion due to heat absorbed from the brakes and the engine, the reservoir must not be overfilled. The brake fluid reservoir is on the master cylinder, which is located under the hood on the left side of the cowl. Thoroughly clean reservoir cap before removal to avoid getting dirt into reservoir. Remove cup and diaphragm. Add fluid as required to bring level to the "MAX" mark on the reservoir tank. Use "DOT 3" Hydraulic Brake Fluid. If the fluid cap diaphragm is stretched, return it to the original position before installing.

### Deterioration of Brake Fluid

Using any other brake fluid than specified or brake fluid with mineral oil or water mixed in will drop the boiling point of brake fluid. It may, in turn, result in vapor lock or deteriorated rubber parts of the hydraulic system. Be sure to change the brake fluid at specified intervals.

If the rubber parts are deteriorated, remove all the system parts and clean them with alcohol. Prior to reassembly, dry the cleaned parts with air to remove the alcohol. Replace all the hoses and rubber parts of the system.

### Leakage of Brake Fluid

With engine idling, set shift lever in the neutral position and continue to depress brake pedal at a constant pedal application force.

Should the pedal stroke become deeper gradually, a leakage from the hydraulic pressure system is possible. Make sure by visual check that there is no leak.

### Bleeding Brake Hydraulic System

A bleeding operation is necessary to remove air from the hydraulic brake system whenever air is introduced into the hydraulic system. It may be necessary to bleed the hydraulic system at all four brakes if air has been introduced through a low fluid level or by disconnecting brake pipes at the master cylinder. If a brake pipe is disconnected at one wheel, only that wheel cylinder/caliper needs to be bled. If the pipes are disconnected at any fitting located between the master

cylinder and brakes, then the brake system served by the disconnected pipe must be bled.

1. For 4-Wheel Antilock Brake System (ABS) equipped vehicle, be sure to remove the ABS main fuse 40A located at the relay and fuse box before bleeding air. If you attempt to bleed air without removing the main fuse, air cannot be let out thoroughly, and this may cause damage to the hydraulic unit. After bleeding air, be sure to replace the ABS main fuse back to its original position.
2. Set the parking brake completely, then start the engine.

NOTE: The vacuum booster will be damaged if the bleeding operation is performed with the engine off.

3. Remove the master cylinder reservoir cap.
4. Fill the master cylinder reservoir with brake fluid. Keep the reservoir at least half full during the air bleeding operation
5. Always use new brake fluid for replenishment.
6. In replenishing brake fluid, take care that air bubbles do not enter the brake fluid.  
When the master cylinder is replaced or overhauled, first bleed the air from the master cylinder, then from each wheel cylinder and caliper following the procedures described below.

### Bleeding the Master Cylinder

7. Disconnect the rear wheel brake pipe (1) from the master cylinder.  
Check the fluid level and replenish as necessary. If replenished, leave the system for at least one minute.
8. Depress the brake pedal slowly once and hold it depressed.
9. Completely seal the delivery port of the master cylinder with your finger, where the pipe was disconnected then release the brake pedal slowly.
10. Release your finger from the delivery port when the brake pedal returns completely.
11. Repeat steps 7 through 9 until the brake fluid comes out of the delivery port during step 7.

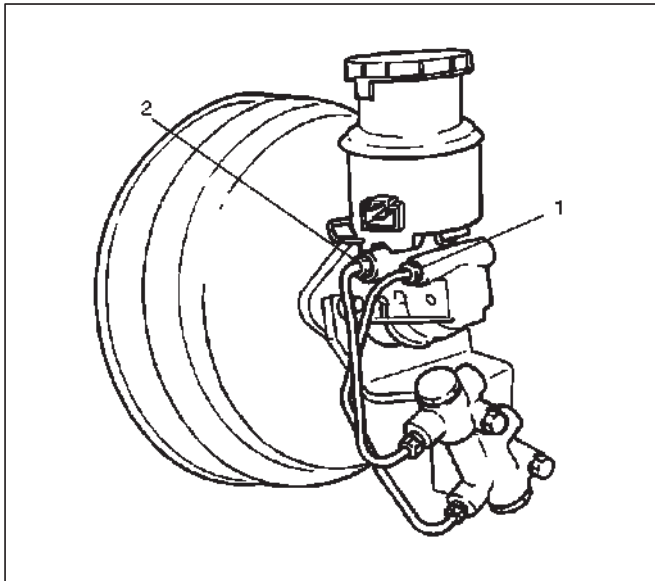
NOTE: Do not allow the fluid level in the reservoir to go below the half-way mark.

12. Reconnect the brake pipe (1) to the master cylinder and tighten the pipe.
13. Depress the brake pedal slowly once and hold it depressed.
14. Loosen the rear wheel brake pipe (1) at the master cylinder.
15. Retighten the brake pipe, then release the brake pedal slowly.

## 5C-10 POWER ASSISTED BRAKE SYSTEM

16. Repeat steps 13 through 15 until no air comes out of the port when the brake pipe is loosened

NOTE: Be very careful not to allow the brake fluid to come in contact with painted surfaces.



17. Bleed the air from the front wheel brake pipe connection (2) by repeating steps 7 through 16.

### Bleeding the Caliper

18. Bleed the air from each wheel in the order listed below:

- Right rear caliper
- Left rear caliper
- Right front caliper
- Left front caliper

Conduct air bleeding from the wheels in the above order. If no brake fluid comes out, it suggests that air is mixed in the master cylinder. In this case, bleed air from the master cylinder in accordance with steps 7 through 17, and then bleed air from the caliper.

19. Place the proper size box end wrench over the bleeder screw.

20. Cover the bleeder screw with a transparent tube, and submerge the free end of the transparent tube in a transparent container containing brake fluid.

21. Pump the brake pedal slowly three (3) times (once/sec), then hold it depressed.

22. Loosen the bleeder screw until fluid flows through the tube.

23. Retighten the bleeder screw.

24. Release the brake pedal slowly.

25. Repeat steps 21 through 24 until the air is completely removed.

It may be necessary to repeat the bleeding procedure 10 or more times for front wheels and 15 or more times for rear wheels.

26. Go to the next wheel in the sequence after each wheel is bled.

Be sure to monitor reservoir fluid level.

27. Depress the brake pedal to check if you feel “sponginess” after the air has been removed from all wheel cylinders and calipers.

If the pedal feels “spongy”, the entire bleeding procedure must be repeated.

28. After the bleeding operation is completed on the each individual wheel, check the level of the brake fluid in the reservoir and replenish up to the “MAX” level as necessary.

29. Attach the reservoir cap.

If the diaphragm inside the cap is deformed, reform it and install.

30. Stop the engine.

## Flushing Brake Hydraulic System

It is recommended that the entire hydraulic system be thoroughly flushed with clean brake fluid whenever new parts are installed in the hydraulic system. Approximately one quart of fluid is required to flush the hydraulic system. The system must be flushed if there is any doubt as to the grade of fluid in the system or if fluid has been used when it contains the slightest trace of mineral oil. All rubber parts that have been subjected to a contaminated fluid must be replaced.

## Brake Pipes and Hoses

The hydraulic brake system components are interconnected by special steel piping and flexible hoses. Flexible hoses are used between the frame and the front calipers, the frame and rear axle case and the rear axle and the rear calipers.

When the hydraulic pipes have been disconnected for any reason, the brake system must be bled after reconnecting the pipe. Refer to “Bleeding the Brake Hydraulic System” in this section.

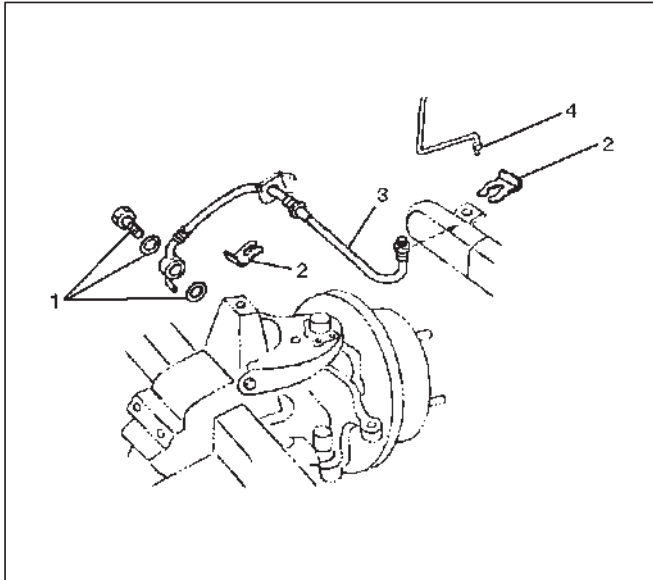
## Brake Hose Inspection

The brake hose should be inspected at least twice a year. The brake hose assembly should be checked for road hazard, cracks and chafing of the outer cover, and for leaks and blisters. Inspect for proper routing and mounting of the hose. A brake hose that rubs on suspension components will wear and eventually fail. A light and mirror may be needed for an adequate inspection. If any of the above conditions are observed on the brake hose, adjust or replace the hose as necessary.

**CAUTION: Never allow brake components such as calipers to hang from the brake hoses, as damage to the hoses may occur.**

## Front / Rear Caliper Brake Hose

### Front / Rear Caliper Brake Hose and Associated Parts



352RW001

#### Legend

- (1) Bolt and Gasket
- (2) Clip
- (3) Hose
- (4) Brake Pipe

### Installation

To install, follow the removal steps in the reverse order, noting the following points:

1. Tighten the brake pipes to the specified torque

**Torque: 16 N·m (12 lb ft)**

2. Tighten the bolt to the specified torque.

**Torque: 35 N·m (26 lb ft)**

**NOTE:** Always use new gaskets and be sure to put the hooked edge of the flexible hose end into the anti-rotation cavity.

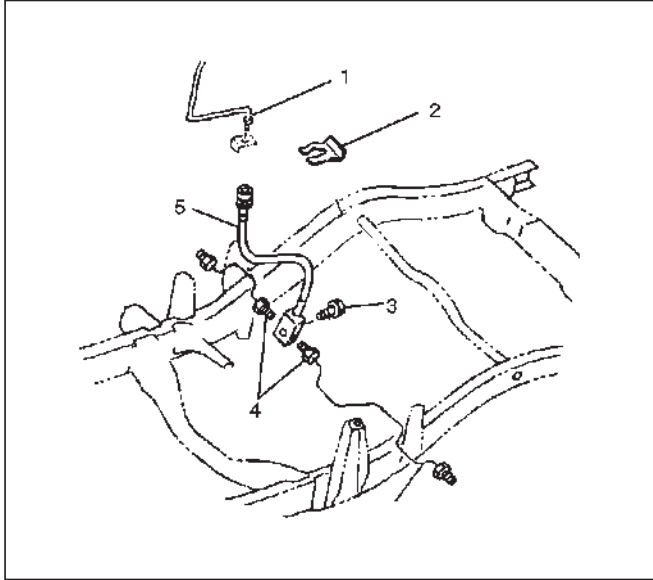
After installing the brake hoses, bleed the brakes as described in this section.

### Removal

1. Raise the vehicle and support it with suitable safety stands.
2. Remove the wheel and tire assembly.
3. Clean dirt, grease, and other foreign material off the hose fittings at both ends.
4. Disconnect brake pipe.
5. Remove clip.
6. Remove bolt and gasket.
7. Remove hose.

## Rear Axle Brake Hose

### Rear Axle Brake Hose and Associated Parts



#### Legend

- (1) Brake Pipe
- (2) Clip
- (3) Bolt
- (4) Brake Pipe
- (5) Hose

### Installation

To install, follow the removal steps in the reverse order, noting the following points:

1. Tighten the brake pipes to the specified torque

**Torque: 16 N·m (12 lb ft)**

2. Tighten the bolt to the specified torque.

**Torque: 15 N·m (11 lb ft)**

After installing the brake hoses, bleed the brakes as described in this section.

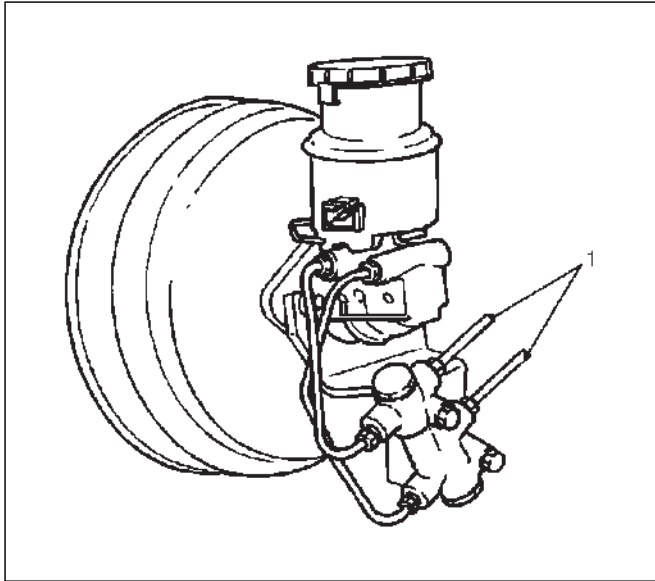
### Removal

1. Raise the vehicle and support it with suitable safety stands.
2. Remove wheel and tire assembly.
3. Clean dirt, grease, and other foreign material off the hose fittings at both ends.
4. Disconnect brake pipe.
5. Remove clip.
6. Remove brake pipe.
7. Remove bolt.
8. Remove hose.

## Brake Pipe

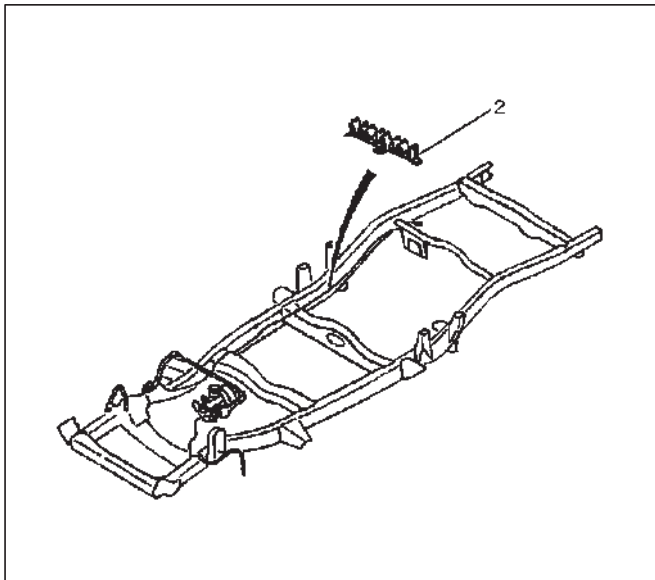
### Removal

1. Raise the vehicle and support it with suitable safety stands.
2. Remove wheel and tire assembly as necessary.
3. Clean dirt, grease, and other foreign material off the pipe fittings at both ends.
4. Remove brake pipe (1).



330RW001

5. Remove plastic clip (2).



330RW002

### Installation

To install, follow the removal steps in the reverse order, noting the following points:

1. Tighten the brake pipes to the specified torque.

#### Master cylinder side

**Torque: 12 N·m (104 lb in)**

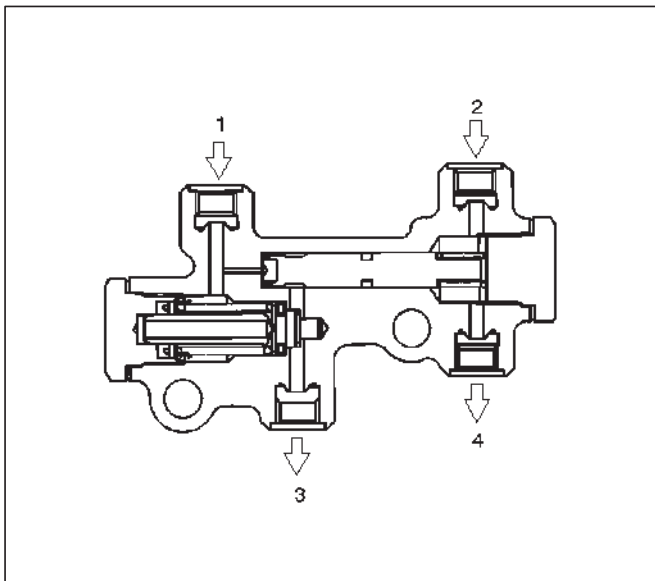
#### Other

**Torque: 16 N·m (12 lb ft)**

After installing the brake pipes, bleed the brakes as described in this section.

## P & B (Proportioning and Bypass) Valve

### P & B (Proportioning and Bypass) Valve Sectional View



#### Legend

- (1) Master Cylinder (Secondary)
- (2) Master Cylinder (Primary)
- (3) Rear Brake
- (4) Front Brake

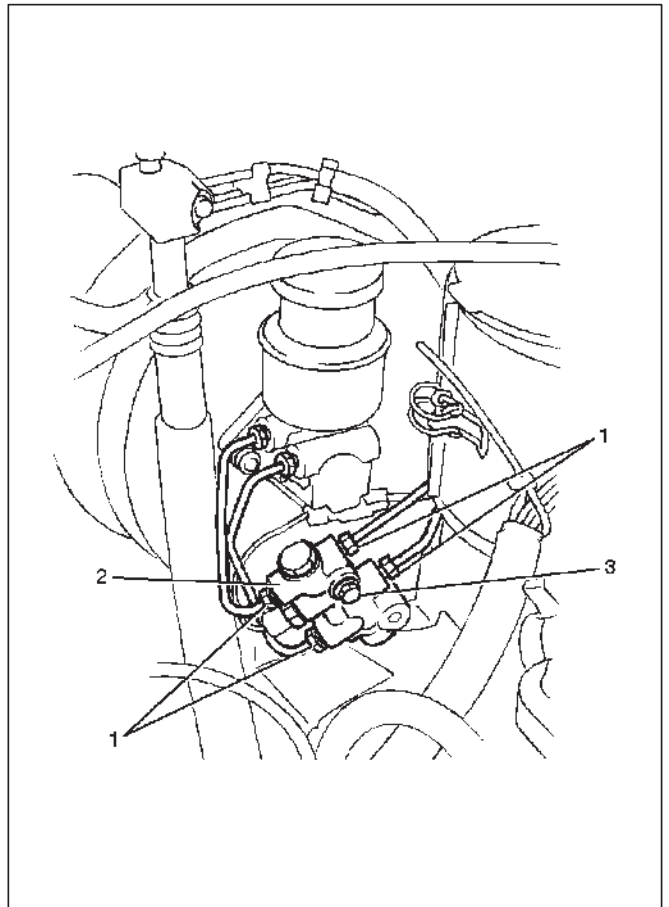
The P&B valve contains two sections, each serving a different function.

The proportioning section of the P&B valve proportions outlet pressure to the rear brakes after a predetermined rear input pressure has been reached. This is done to prevent rear wheel lock up on the vehicles with light rear wheel loads. The valve has a pass feature which assures full system pressure to the rear brakes in the event of front brake system malfunction. Also full front pressure is retained in the event of rear brake malfunction.

The combination valve has a pressure differential warning switch which is designed to constantly compare front and rear brake pressure from the master cylinder and turn on the brake system warning light on the instrument panel in the event of a front or rear system malfunction. The valve and switch are so designed that the switch will latch in the warning position once a malfunction has occurred. The only way the light can be turned off is to repair the malfunction and apply a pedal force required to developed line pressure. The P&B valve is not repairable and must be replaced as a complete assembly.

### Removal

1. The P&B valve is not repairable and must be replaced as a complete assembly. Care must be taken to prevent brake fluid from contacting any painted surface.
2. Remove hydraulic pipes (1) and plug (1) the pipes to prevent the loss of fluid or the entrance of dirt.
3. Remove bolt (3).
4. Remove P&B valve (2).

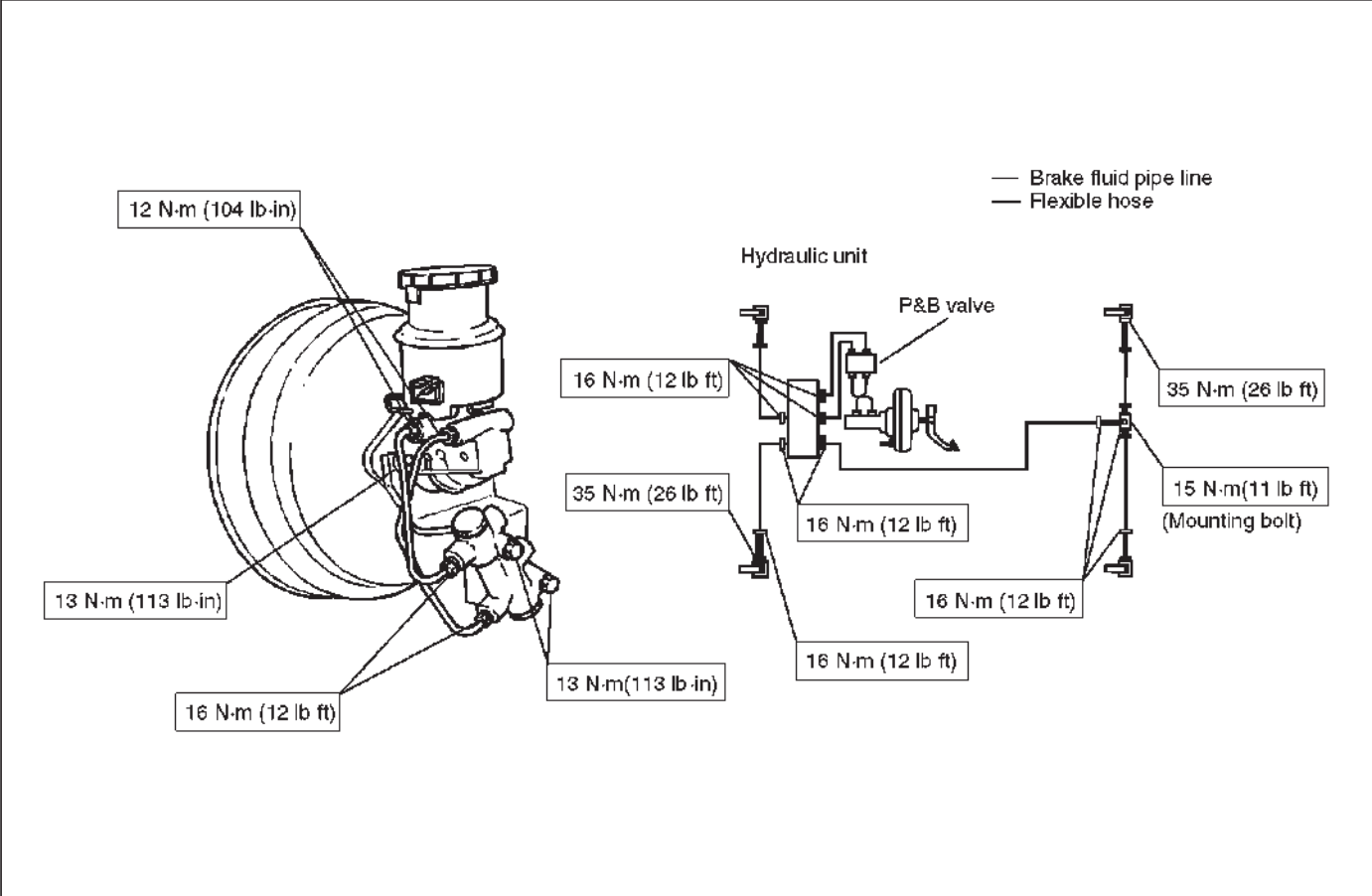


### Installation

1. Install P&B valve (2).
2. Install bolt (3) and tighten the bolt to the specified torque.  
**Torque: 13 N-m (113 lb in)**
3. Install hydraulic pipes (1) and tighten the bolt to the specified torque.  
**Torque: 16 N-m (12 lb ft)**
4. After installing the brake pipes, bleed the brakes referring to "Bleeding Brake Hydraulic System" in this section.

Main Data and Specifications

Torque Specifications



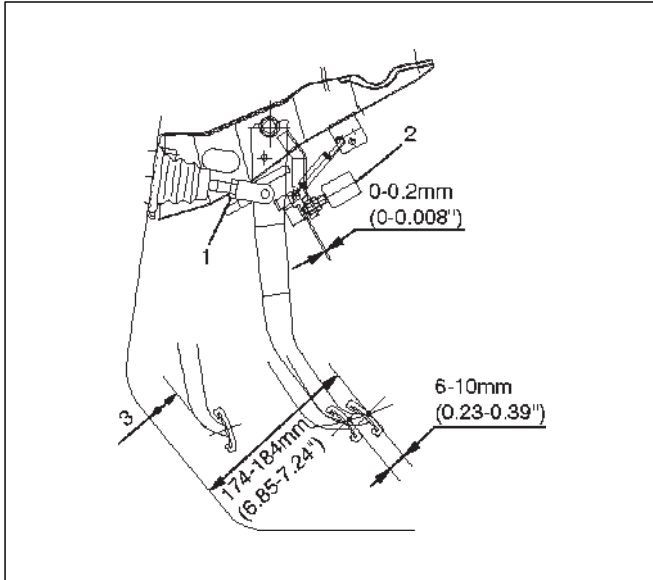


## Brake Pedal

### Checking Pedal Height

The push rod serves as the brake pedal stopper when the pedal is fully released. Brake pedal height adjustment should be performed as follows:

#### Adjust Brake Pedal



350RX006

1. Measure the brake pedal height after making sure the pedal is fully returned by the pedal return spring. Pedal height must be measured after starting the engine and receiving it several times.

**Pedal Free Play : 6-10 mm (0.23-0.39 in)**

**Pedal Free Play : 174-184 mm (6.85-7.24 in)**

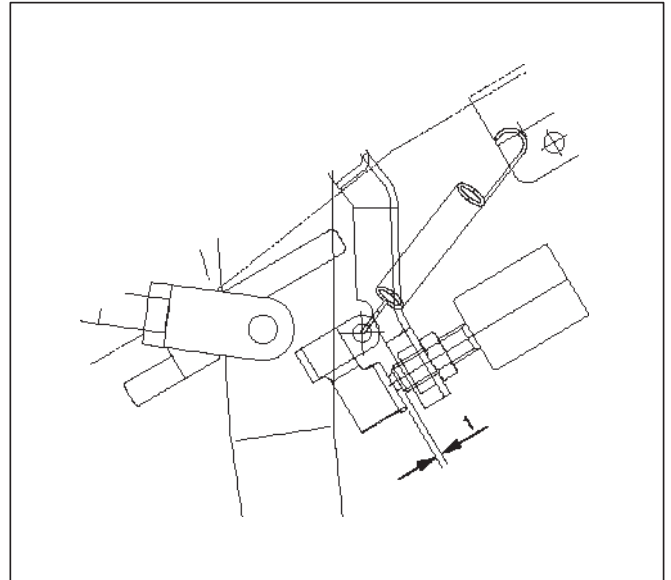
NOTE: Pedal free play must be measured after turning off the engine and stepping on the brake pedal firmly five times or more.

2. If the measured value is not within the above range, adjust the brake pedal as follows:
  - a. Disconnect the stoplight switch connector.
  - b. Loosen the stoplight switch lock nut (1).
  - c. Rotate the stoplight switch so that it moves away from the brake pedal.
  - d. Loosen the lock nut on the push rod.
  - e. Adjust the brake pedal to the specified height by rotating the push rod in the appropriate direction.
  - f. Tighten the lock nut to the specified torque.

**Torque: 20 N-m (15 lb ft)**

- g. Adjust the stoplight switch to the specified clearance (between the switch housing and the brake pedal) by rotating the switch housing.

**Clearance : 0-0.2 mm (0-0.008 in)**

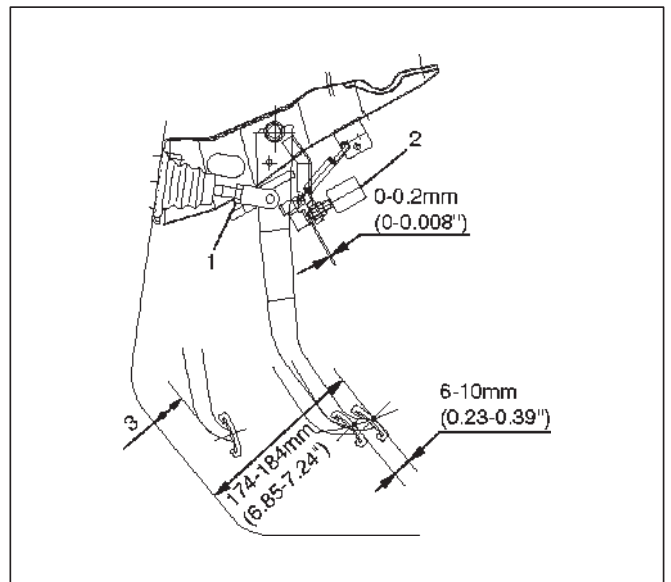


310RW002

NOTE: While adjusting the stoplight switch, make sure that the threaded part of the stoplight switch does not push the brake pedal.

- h. Tighten the stoplight switch lock nut.
- i. Connect the stoplight switch connector.

### Checking Pedal Travel



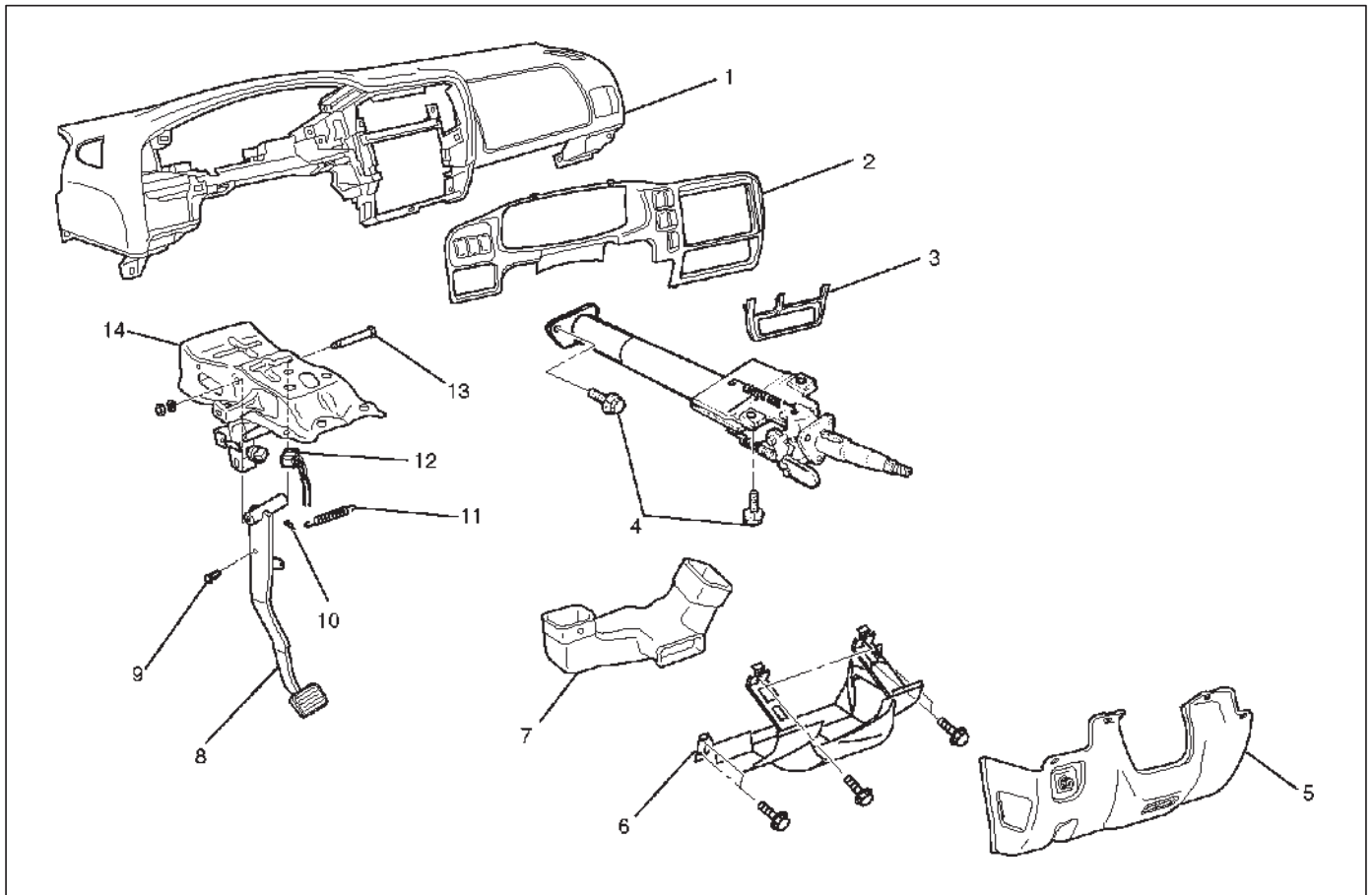
350RX006

1. Pedal height (3) must be measured after starting the engine and revving it several times to apply vacuum to the vacuum booster fully.

NOTE: Pedal height (3) must be 55 mm (2.2 in) or more when about 50 kg (110.25 lb) of stepping force is applied.

2. If the measured value is lower than the above range, air existing in the hydraulic system is suspected. Perform the bleeding procedure.

## Brake Pedal and Associated Parts



310RX005

### Legend

- |   |                                   |
|---|-----------------------------------|
| (1) Instrument Panel                    | (8) Brake Pedal                   |
| (2) Meter Cluster Assembly              | (9) Pin                           |
| (3) Lower Cluster Assembly              | (10) Snap Pin                     |
| (4) Steering Column fixing bolts        | (11) Return Spring                |
| (5) Instrument Panel Lower Cover        | (12) Stoplight Switch Connector   |
| (6) Driver Knee Bolster (reinforcement) | (13) Fulcrum Pin                  |
| (7) Duct                                | (14) Brake Pedal Bracket Assembly |

### Removal

- To remove or install the steering column fixing bolts, refer to Steering Column in Steering section.
1. Remove engine hood opener, then remove instrument panel lower cover.
  2. Remove lower cluster.
  3. Remove meter cluster.
  4. Remove driver knee bolster (reinforcement).
  5. Remove duct.
  6. Remove stoplight switch connector.
  7. Remove snap pin.
  8. Remove pin.
  9. Remove steering column fixing bolts.
  10. Remove brake pedal bracket assembly.
  11. Remove return spring.

12. Remove fulcrum pin.
13. Remove brake pedal.

### Installation

1. Install brake pedal to pedal bracket.
  2. Apply grease to the entire circumference of the fulcrum pin and install it to bracket. Install nut and tighten to specified torque.
- Torque: 33 N·m (24 lb ft)**
3. Install return spring.

## 5C-18 POWER ASSISTED BRAKE SYSTEM

4. Install brake pedal bracket assembly and tighten bolts and nuts to specified torque.

**Torque:**

**Bolts: 15 N·m (11 lb ft)**

**Nuts: 21 N·m (15 lb ft)**

5. Install steering column fixing bolts and tighten to specified torque.

**Torque:**

**Upper: 17 N·m (12 lb ft)**

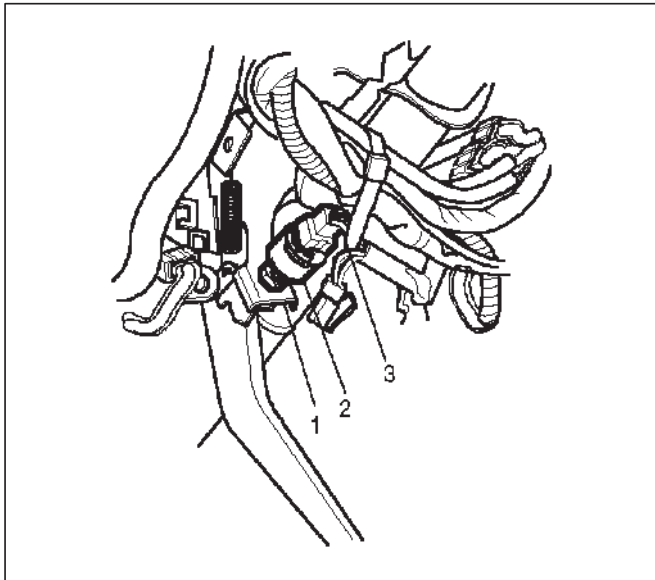
**Lower: 19 N·m (14 lb ft)**

6. Apply grease to pin and install it to brake pedal.
7. Install snap pin and adjust the pedal free travel. Refer to "Brake Pedal Adjustment" previously in this manual.
8. Install stoplight switch connector.
9. Install duct.
10. Install driver knee bolster (reinforcement).
11. Install meter cluster.
12. Install lower cluster.
13. Install instrument panel lower cover.

## Stoplight Switch

### Removal

1. Remove shift knob.
2. Remove front console assembly.
3. Remove lower cluster assembly.
4. Remove instrument panel driver lower cover.
5. Remove driver knee bolster assembly.
6. Remove stoplight switch connector (3).
7. Remove lock nut (1).
8. Remove switch (2).

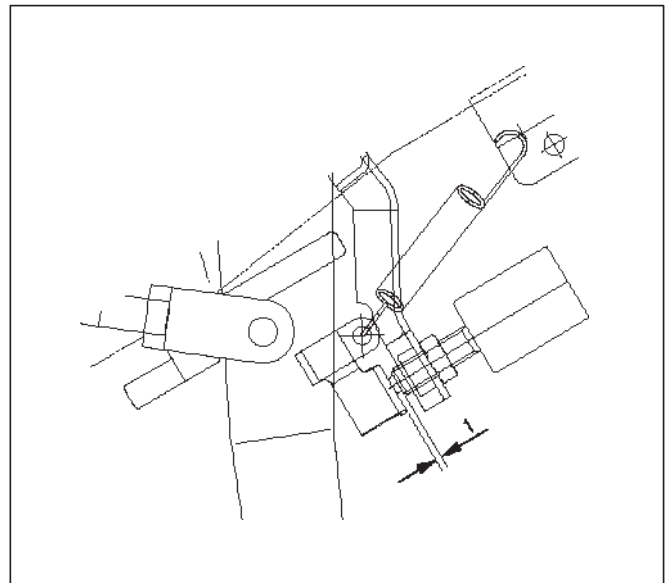


### Installation

1. Install switch and adjust the stoplight switch to the specified clearance (between the switch housing and the brake pedal) by rotating the switch housing.

**Clearance (1): 0-0.2 mm (0-0.009 in)**

NOTE: While adjusting the installation of the stoplight switch, make sure that the threaded part of the stoplight switch does not push the brake pedal.



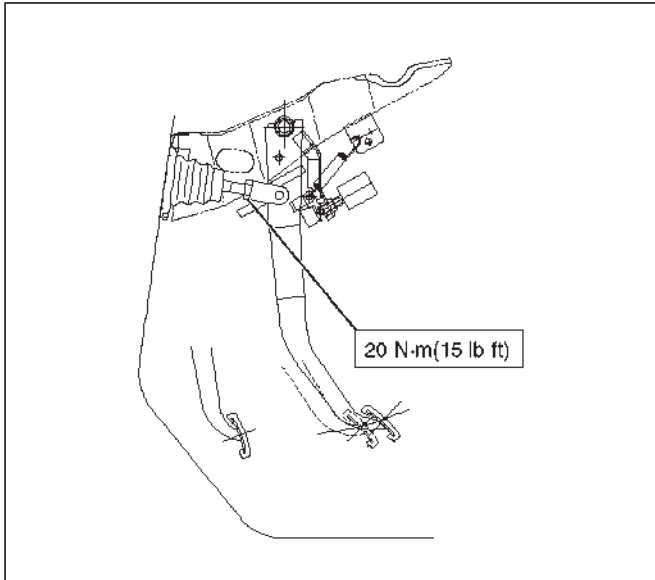
2. Install lock nut.
3. Connect stoplight switch connector.
4. Install driver knee bolster assembly.
5. Install instrument panel driver lower cover.
6. Install lower cluster assembly.
7. Install front console assembly.
8. Install shift knob.

## Main Data and Specifications

### General Specifications

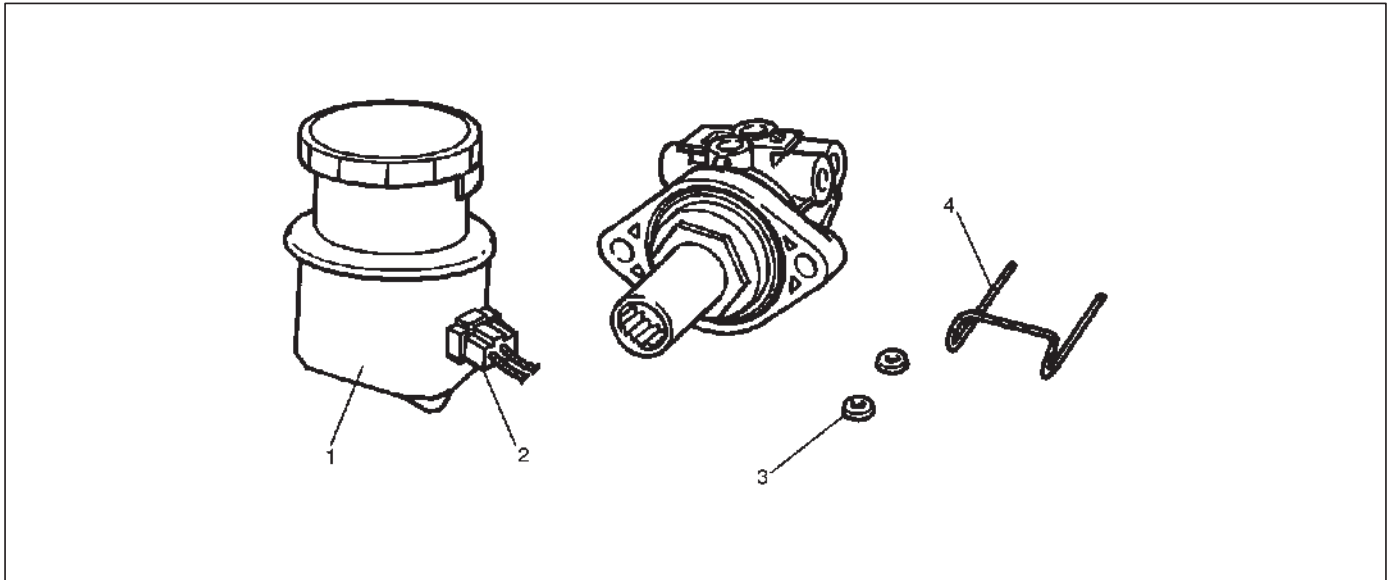
Pedal free play	6–10 mm (0.23 –0.39 in)
Pedal Height	173–185 mm (6.81–7.28 in)

### Torque Specifications



## Fluid Reservoir Tank

### Fluid Reservoir Tank and Associated Parts



330RW003

#### Legend

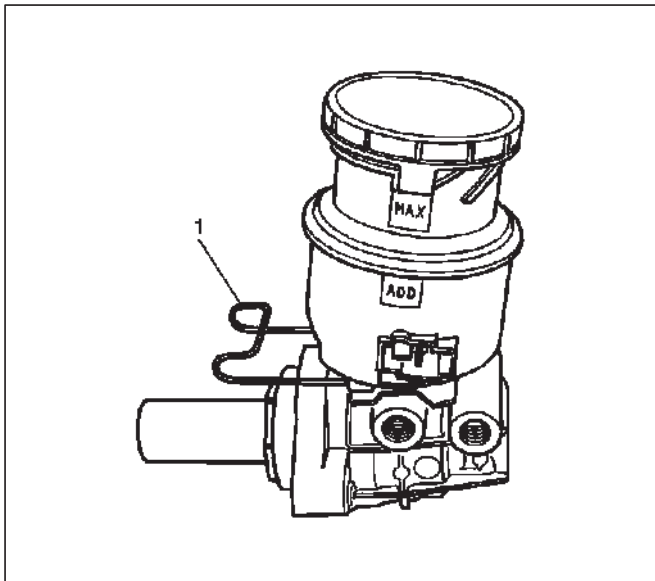
- (1) Fluid Reservoir
- (2) Electrical Connector

- (3) O-ring
- (4) Retainer

### Removal

NOTE: Before removing the fluid reservoir, remove the brake fluid from the fluid reservoir.

1. Disconnect electrical connector.
2. Remove retainer (1).



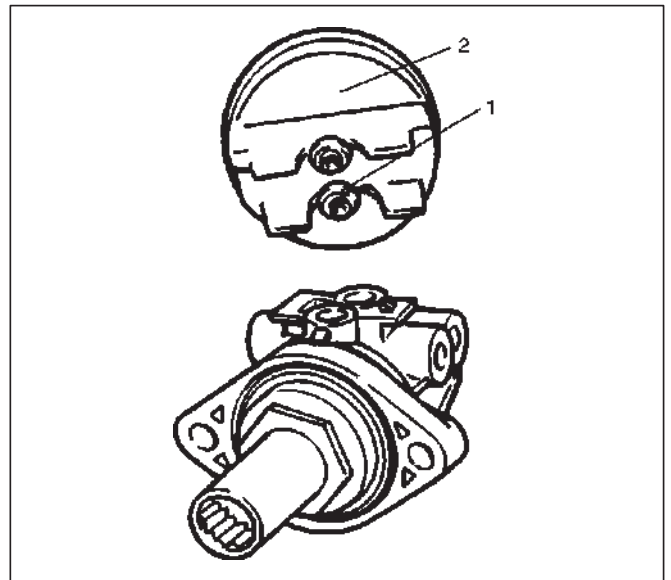
330RW004

3. Remove fluid reservoir and the fluid level sensor built into the fluid reservoir. The fluid level sensor cannot be removed for servicing.
4. Remove O-ring.

### Installation

To install, follow the removal steps in the reverse order, noting the following points:

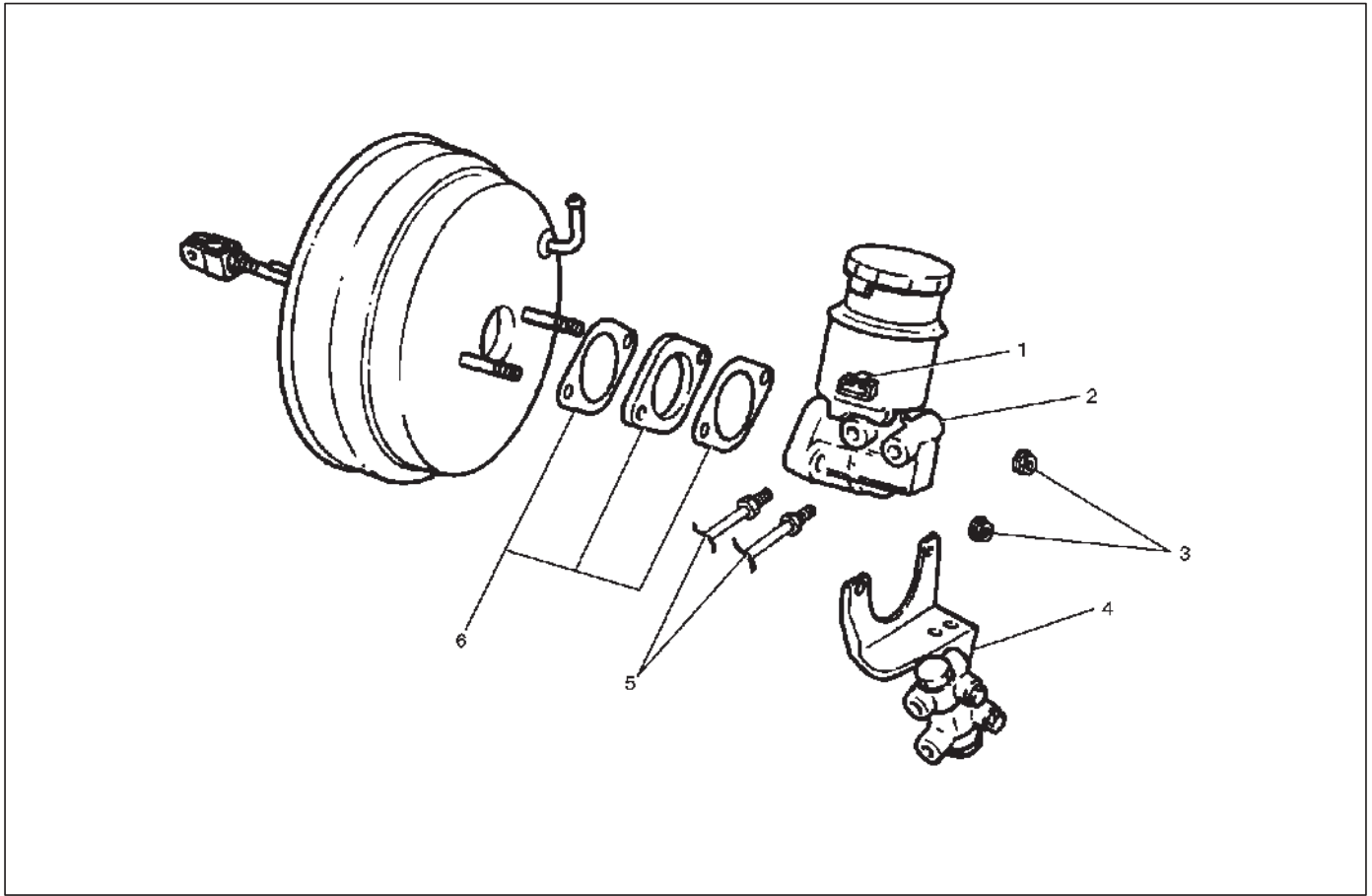
1. O-ring (1) must be set onto the fluid reservoir (2), before installing fluid reservoir.



330RW005

## Master Cylinder Assembly

### Master Cylinder Assembly and Associated Parts



330RW006

#### Legend

- |                          |                           |
|--------------------------|---------------------------|
| (1) Electrical Connector | (4) P&B Valve and Bracket |
| (2) Master Cylinder      | (5) Brake Pipes           |
| (3) 2 attaching Nuts     | (6) Spacer and 2 gaskets  |

### Removal

**CAUTION:** When removing the master cylinder from the vacuum booster, be sure to get rid of the internal negative pressure of the vacuum booster (for instance, disconnecting the vacuum hose) in advance.

If any negative pressure remains in the vacuum booster, the piston may possibly come out when the master cylinder is being removed, letting the brake fluid run out.

While removing the master cylinder, further, do not hold the piston as it can be easily pulled out.

Outside surface of the piston is the surface on which seals are to slide. Care should be taken to keep the surface free of cuts and dents.

1. Disconnect electrical connector.
2. Remove brake pipes after disconnecting the brake pipe, cap or tape the openings of the brake pipe to prevent the entry of foreign matter.
3. Remove 2 attaching nuts.

4. Remove P&B valve and bracket.
5. Remove master cylinder.
6. Remove spacer and the 2 gaskets.

### Inspection and Repair

#### Master Cylinder

The master cylinder is not repairable and must be replaced as a complete assembly if found defective.

#### Inspection

Excessive brake pedal travel, malfunction or dragging brake suggests that the master cylinder is defective. In such cases perform the following visual check.

#### Visual Check

Make parts replacement as required if wear, distortion, nicks, cuts, corrosion, or other abnormal conditions are found through the following parts inspection:

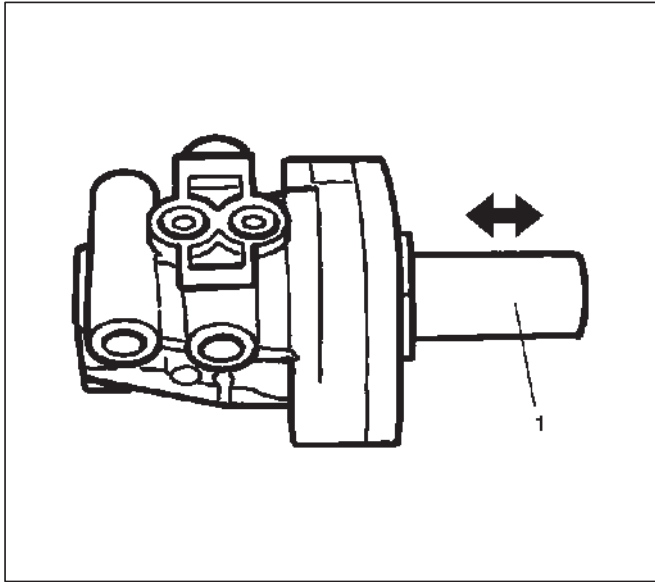
- Master cylinder body
- Fluid reservoir

## 5C-22 POWER ASSISTED BRAKE SYSTEM

- O-ring

### Functional Inspection of Master Cylinder Piston

Push the primary piston (1) with your fingers to check that it travels smoothly. If the motion is questionable, replace the master cylinder as a complete assembly.

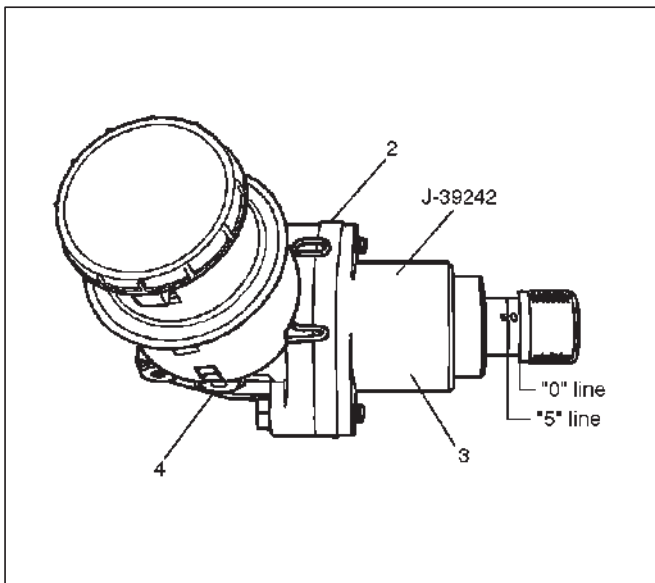


330RW007

### Functional Inspection of Master Cylinder

Inspect the master cylinder for function as follows. If any abnormal function is found, replace with a new one. (including the master cylinder attachment and master cylinder plug (7))

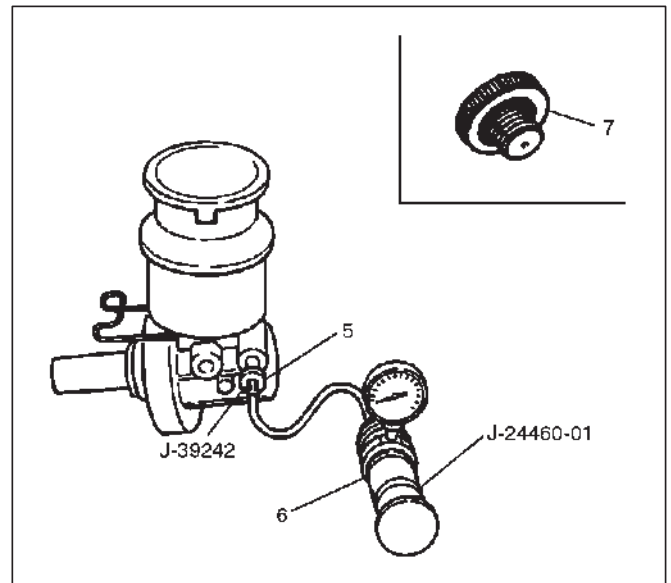
Install the primary piston holder (3) J-39242 onto the master cylinder (4). Make sure the spacer (2) (2 bolts) with its adjusting bolt is screwed in up to the "0" line



330RW008

Connect the master cylinder attachment (5) J-39242 with the end of the radiator cap tester (6) J-24460-01, and apply air pressure with the cap tester. Make sure there is no rise in pressure and that with the adjusting bolt further screwed in 5 mm (align the adjusting bolt to the "5" line).

There should be a pressure increase of 0.5 kg/cm<sup>2</sup> or more.



330RW009

NOTE: When checking the front (or primary) side, be sure to mount the master cylinder plug in the rear (or secondary) port.

	"0" Line	"5" Line
Apply air pressure to the front and rear ports	No pressure rise.	Pressure increase of 0.5 kg/cm <sup>2</sup> or more
Remarks	Checks port into the atmospheric pressure chamber	Checks air tightness of the pressure chamber

NOTE:

1. Do not use an air compressor, as the air from the compressor is mixed with compressor oil.
2. When installing the master cylinder onto the vacuum booster, always adjust the vacuum booster push rod. (Refer to "Vacuum Booster" in this section).
3. After the master cylinder is installed onto the vehicle, check for leakage, pedal travel and pedal free play.

### Installation

1. Install spacer and the 2 gaskets.
2. Install master cylinder, when replacing the master cylinder or vacuum booster or both, always measure the vacuum booster push rod protrusion and adjust it as necessary (Refer to "Vacuum Booster" in section).
3. Install P&B valve and bracket.
4. Install 2 attaching nuts and tighten the attaching nuts to the specified torque.

**Torque: 13 N·m (113 lb in)**

5. Install brake pipes and tighten the brake pipe to the specified torque.

**Master cylinder side**

**Torque: 12 N·m (104 lb in)**

**Others**

**Torque: 16 N·m (12 lb ft)**

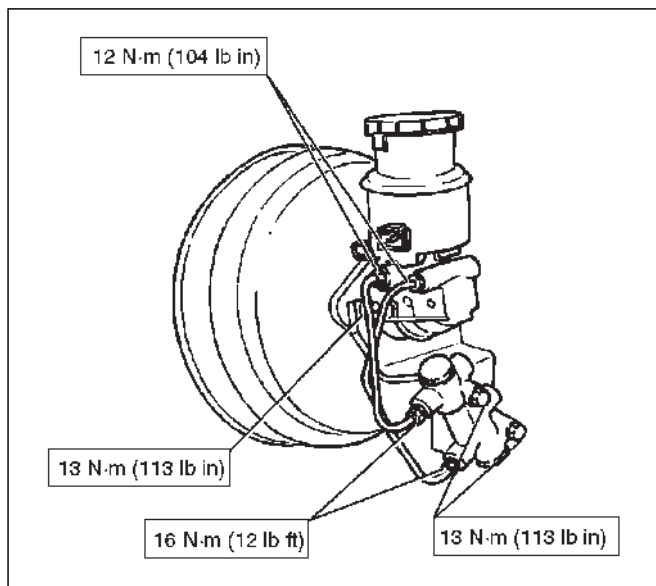
6. Connect electrical connector.

**Main Data and Specifications**

**General Specifications**

Type	Dual-circuit
Piston bore diameter	25.4 mm (1.000 in)

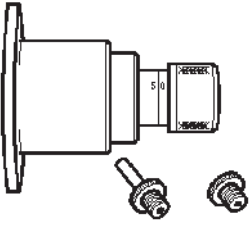
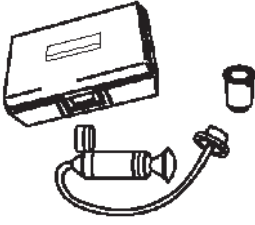
**Torque Specifications**



E05RW003

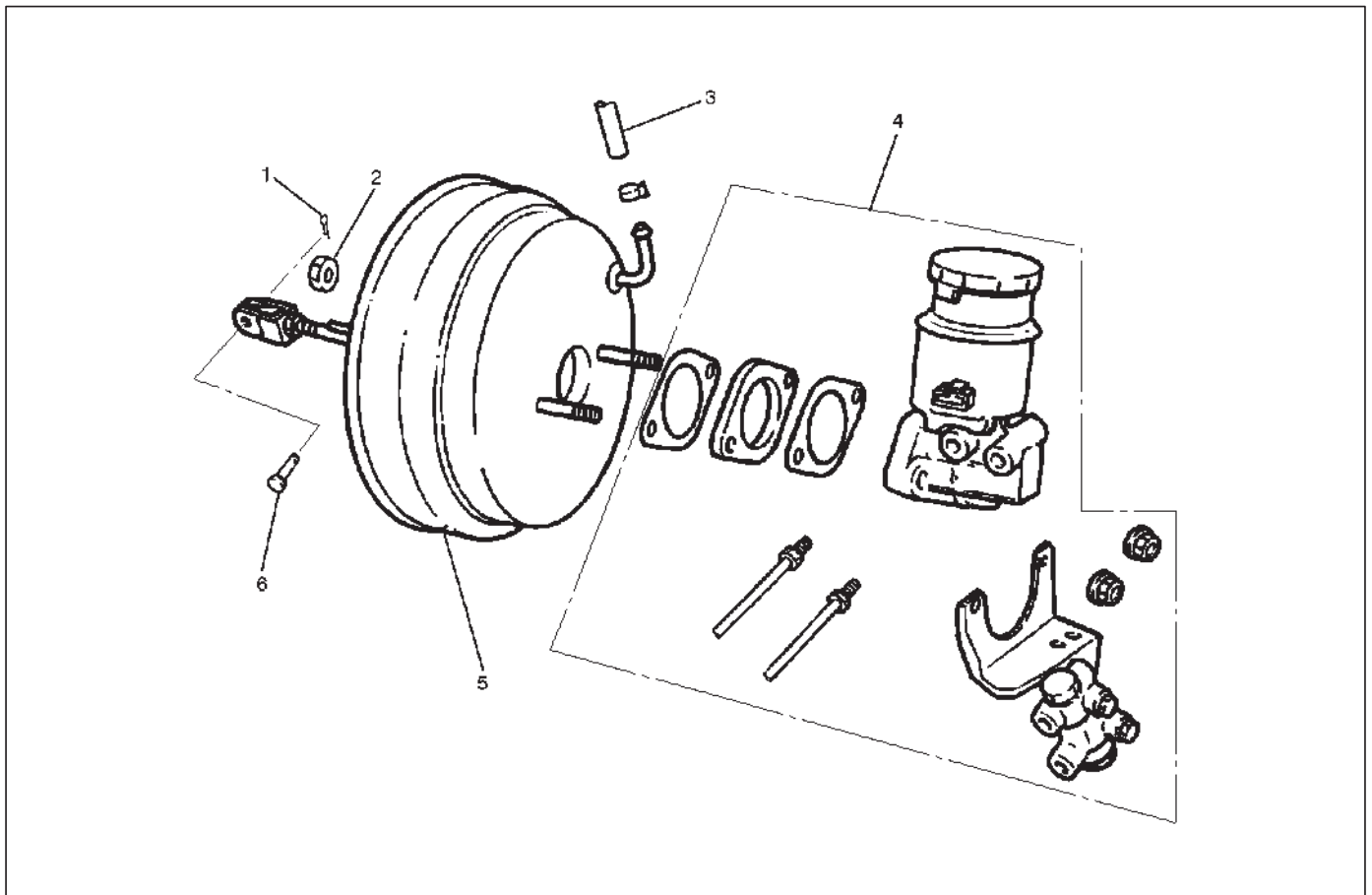


**Special Tools**

ILLUSTRATION	TOOL NO. TOOL NAME
 <p>901RS200</p>	<p>J-39242 Primary Piston Holder (including master cylinder attachment and master cylinder plug)</p>
 <p>901RS201</p>	<p>J-24460-01 Radiator Cap Tester</p>

## Vacuum Booster Assembly

### Vacuum Booster Assembly and Associated Parts



331RW001

#### Legend

- |                               |                     |
|-------------------------------|---------------------|
| (1) Pin                       | (4) Master Cylinder |
| (2) Vacuum Booster Fixing Nut | (5) Vacuum Booster  |
| (3) Vacuum Hose               | (6) Snap Pin        |

### Removal

1. Before removing the vacuum booster assembly, disconnect and remove the brake pipes.
2. Remove master cylinder, refer to "Master Cylinder Removal" in this section.

**CAUTION:** When removing the master cylinder from the vacuum booster, be sure to get rid of the internal negative pressure of the vacuum booster (by, for instance, disconnecting the vacuum hose) in advance.

If any negative pressure remains in the vacuum booster, the piston may possibly come out when the master cylinder is being removed, letting the brake fluid run out.

While removing the master cylinder, further, do not hold the piston as it can be easily pulled out.

Outside surface of the piston is the surface on which seals are to slide. Care should be taken to keep the surface free of cuts and dents.

3. Remove vacuum hose.
4. Disconnect the yoke clevis from the brake pedal.
5. Remove vacuum booster fixing nut.
6. Remove vacuum booster.

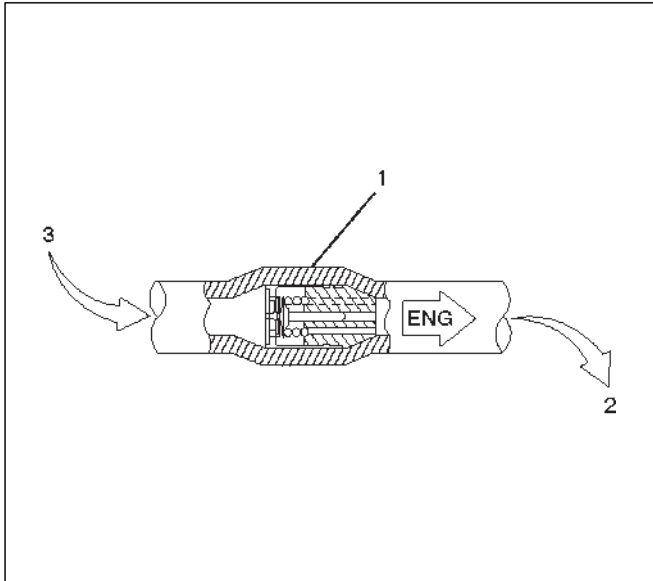
### Inspection and Repair

#### Vacuum Hose

1. Inspect the check valve (1), which is installed inside the vacuum hose.
2. Air should pass freely from the vacuum booster (3) to the engine (2).

## 5C-26 POWER ASSISTED BRAKE SYSTEM

3. Air should not pass from the engine (2) to the vacuum booster (3). If it does, the check valve is inoperative and the vacuum hose must be replaced.



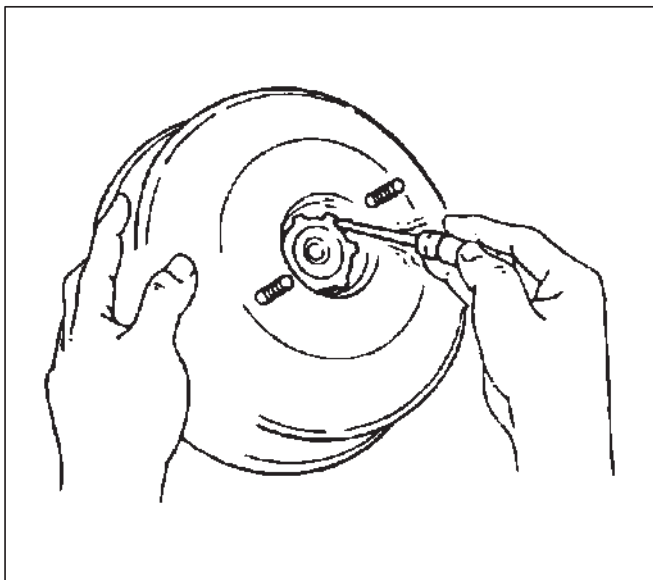
360RX001

### Installation

1. Install vacuum booster and vacuum booster push rod adjustment.

**NOTE:** When replacing either the master cylinder or vacuum booster, be sure to measure push rod, and adjust if required.

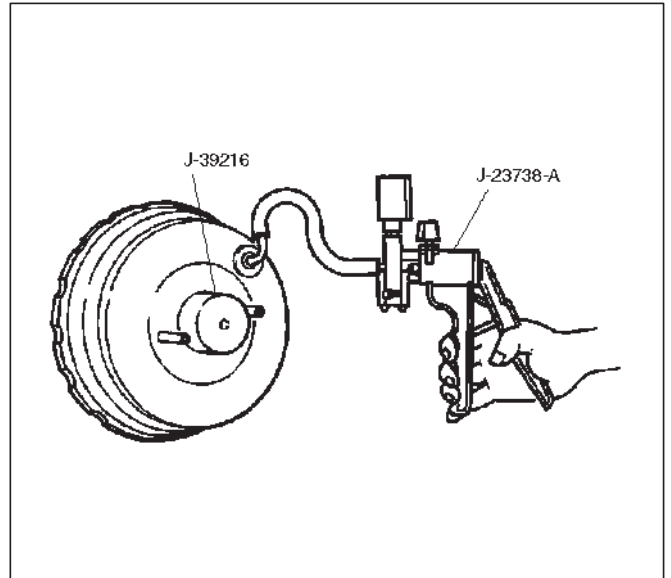
2. Remove retainer from vacuum booster front shell using a small screwdriver. Then gently draw plate and seal assembly out of the shell inside.



331RS003

3. Set push rod gauge J-39216 on vacuum booster, and apply negative pressure by means of vacuum pump J-23738-A so that the pressure in the vacuum booster becomes 500 mm Hg.

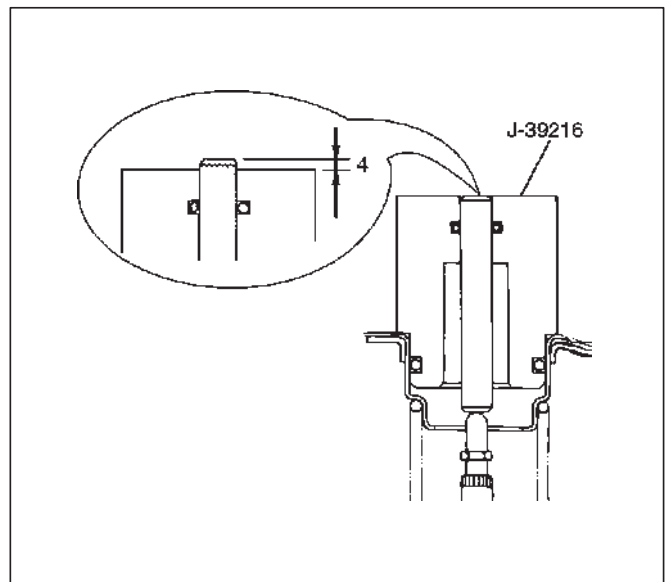
**NOTE:** Be sure to apply **NEGATIVE** pressure after installing a push rod gauge on the vacuum booster.



331RS004

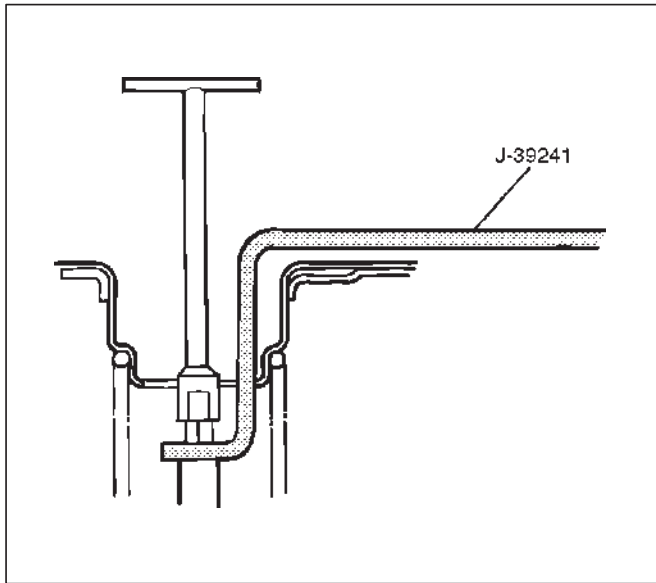
4. Measure dimension (4).

**Dimension (4) (Standard):**  $-0.1-0.1$  mm  
( $-0.0039-0.0039$  in)



331RW002

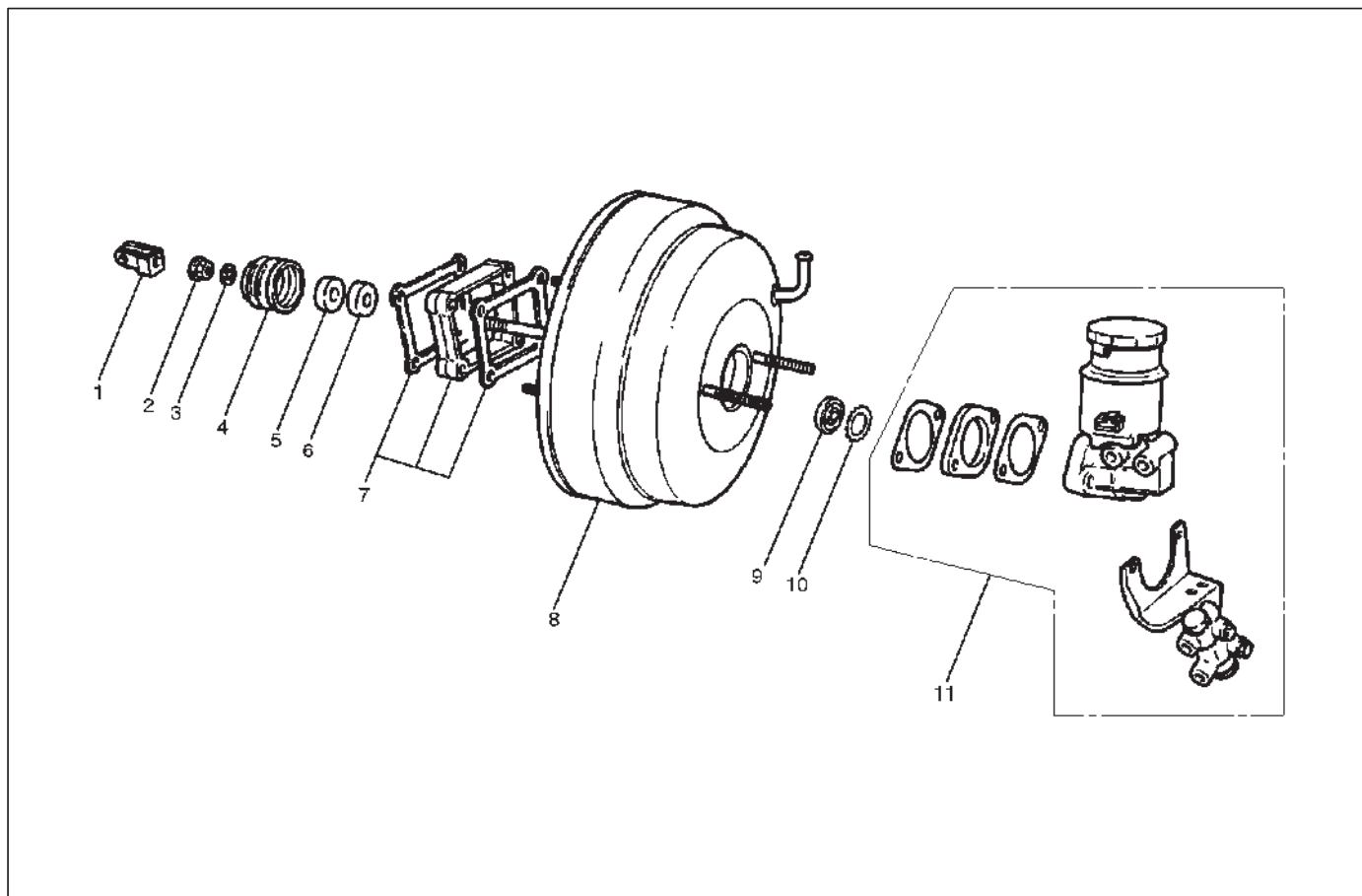
5. If dimension (4) is out of the standard range, adjust push rod using the Push Rod Support J-39241.



6. Mount plate and seal assembly in vacuum booster front shell. Then install the retainer.
7. Install vacuum booster fixing nut and tighten the specified torque.
- Torque: 21 N·m (16 lb ft)**
8. Install yoke clevis.
9. Connect vacuum hose and make sure that the arrow on the hose points in the direction of the engine.
10. Install master cylinder, refer to "Master Cylinder Installation" in this section.

## Exterior Components

### Exterior Components and Associated Parts



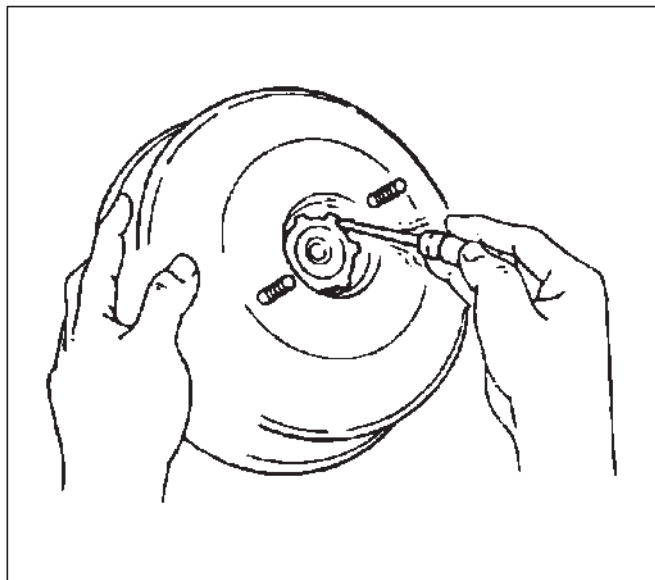
331RW004

#### Legend

- |                      |                              |
|----------------------|------------------------------|
| (1) Yoke Clevis      | (6) Filter                   |
| (2) Lock Nut         | (7) 2 Gaskets and Spacer     |
| (3) Retaining Clip   | (8) Vacuum Booster           |
| (4) Valve Body Guard | (9) Retainer                 |
| (5) Silencer         | (10) Plate and Seal Assembly |
|                      | (11) Master Cylinder         |

#### Removal

1. Remove master cylinder, refer to "Master Cylinder" in this section.
2. Remove vacuum booster, refer to "Vacuum Booster" in this section.
3. Remove yoke clevis.
4. Remove lock nut.
5. Remove retaining clip.
6. Remove valve body guard.
7. Remove silencer.
8. Remove filter.
9. Remove 2 gaskets and spacer.
10. Remove retainer, use a small screwdriver to pry out the retainer. Gently pull out the plate and seal assembly from the shell.



331RS003

11. Remove plate and seal assembly.

## Inspection and Repair

### Visual Check

Make necessary parts replacement if cuts, nicks, excessive wear, or other abnormal conditions are found through inspection. Check the following parts:

- Yoke clevis
- Valve body guard
- Silencer
- Filter plate and seal assembly

### Installation

1. Install plate and seal assembly.

2. Install retainer.

3. Install 2 gaskets and spacer.

4. Install filter.

5. Install silencer.

6. Install valve body guard.

7. Install retainer.

8. Install lock nut and tighten to the specified torque.

**Torque: 20 N·m (15 lb ft)**

9. Install yoke clevis.

10. Install vacuum booster, refer to "Vacuum Booster" in this section.

11. Install master cylinder, refer to "Master Cylinder" in this section and after installation, perform brake pedal check and adjustment. Refer to "Brake Pedal" in this section.

## Vacuum Booster Overhaul

### Vacuum Booster

The vacuum booster cannot be disassembled for repair. Replace a defective vacuum booster with a new one.

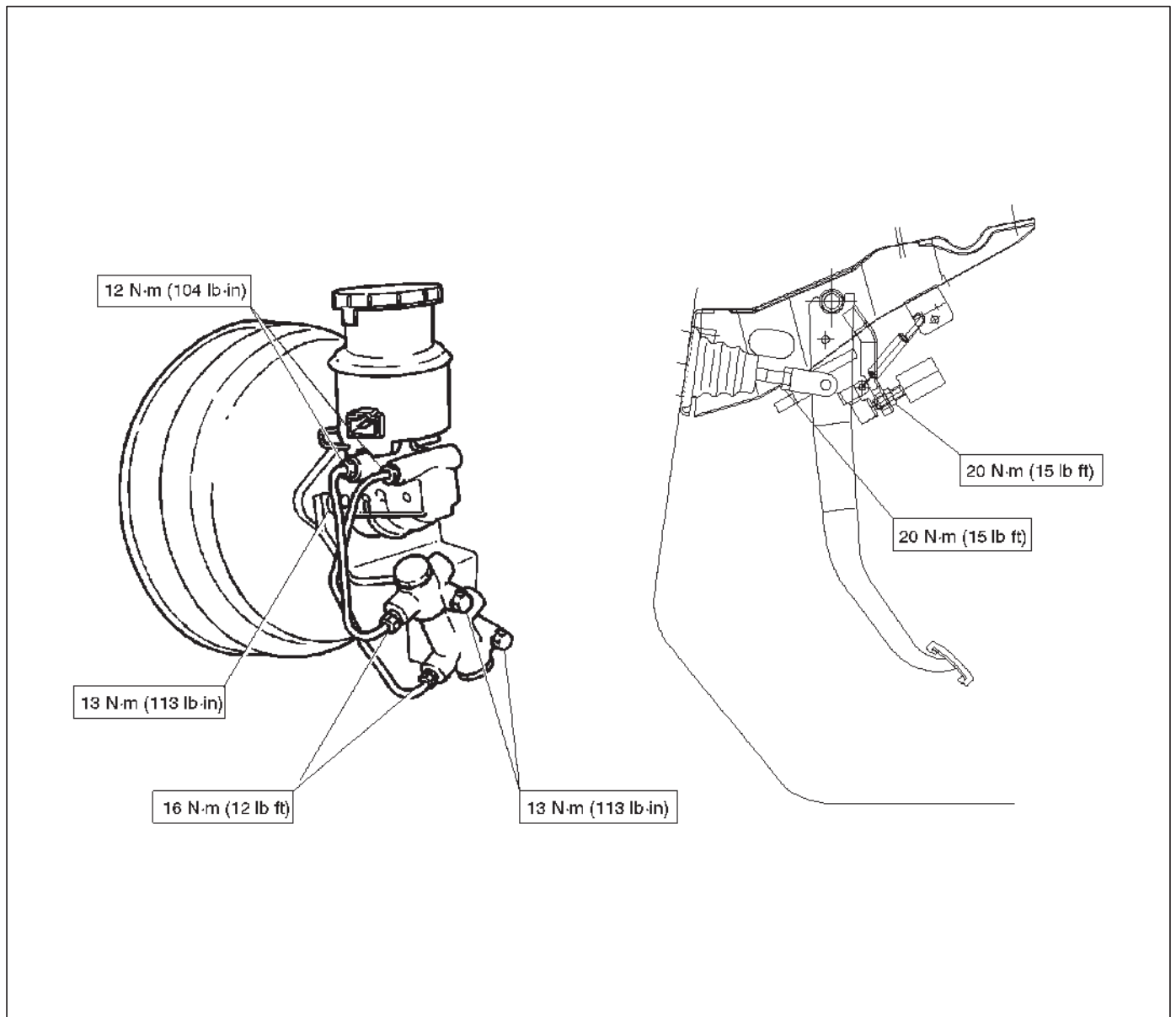
## 5C-30 POWER ASSISTED BRAKE SYSTEM

### Main Data and Specifications

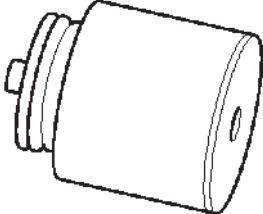
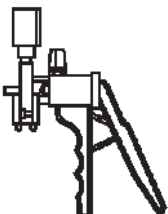

#### General Specifications

Vacuum booster diaphragm diameter (Front)	205 mm (8.07 in)
Vacuum booster diaphragm diameter (Rear)	230 mm (9.06 in)
Push rod stroke	More than 32.0 mm (1.26 in)
Plunger diameter	10.25 mm (0.40 in)
Push rod diameter	27.4 mm (1.08 in)

#### Torque Specifications



Special Tools

ILLUSTRATION	TOOL NO. TOOL NAME
 <small>901RS202</small>	<p>J-39216 Push Rod Gauge</p>
 <small>901RS203</small>	<p>J-23738-A Vacuum Pump</p>
 <small>901RS204</small>	<p>J-39241 Push Rod Support</p>



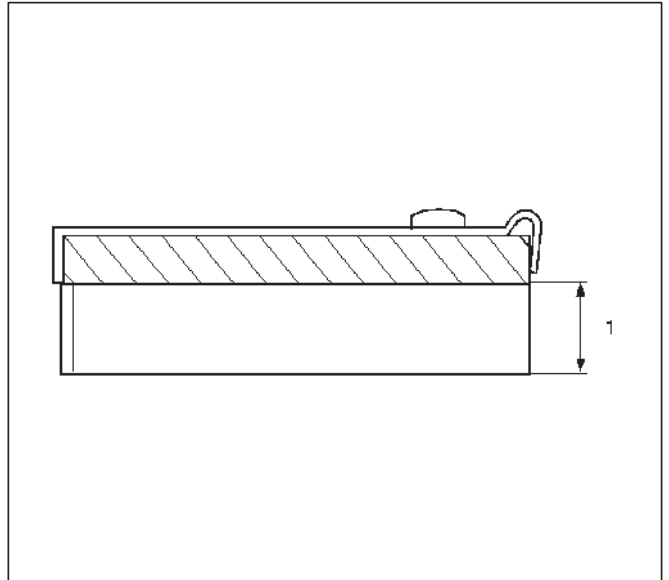
## Front Disc Brake Pads

### Front Disc Brake Pads Inspection

Check the outer pad by looking at each caliper from above. Check the thickness on the inner pad by looking down through the inspection hole in the top of the caliper. Whenever the pad is worn to about the thickness of the pad base, the pad should be removed for further measurements. The pad should be replaced anytime the pad thickness (1) is worn to within 1.00 mm (0.039 in) of the pad itself.

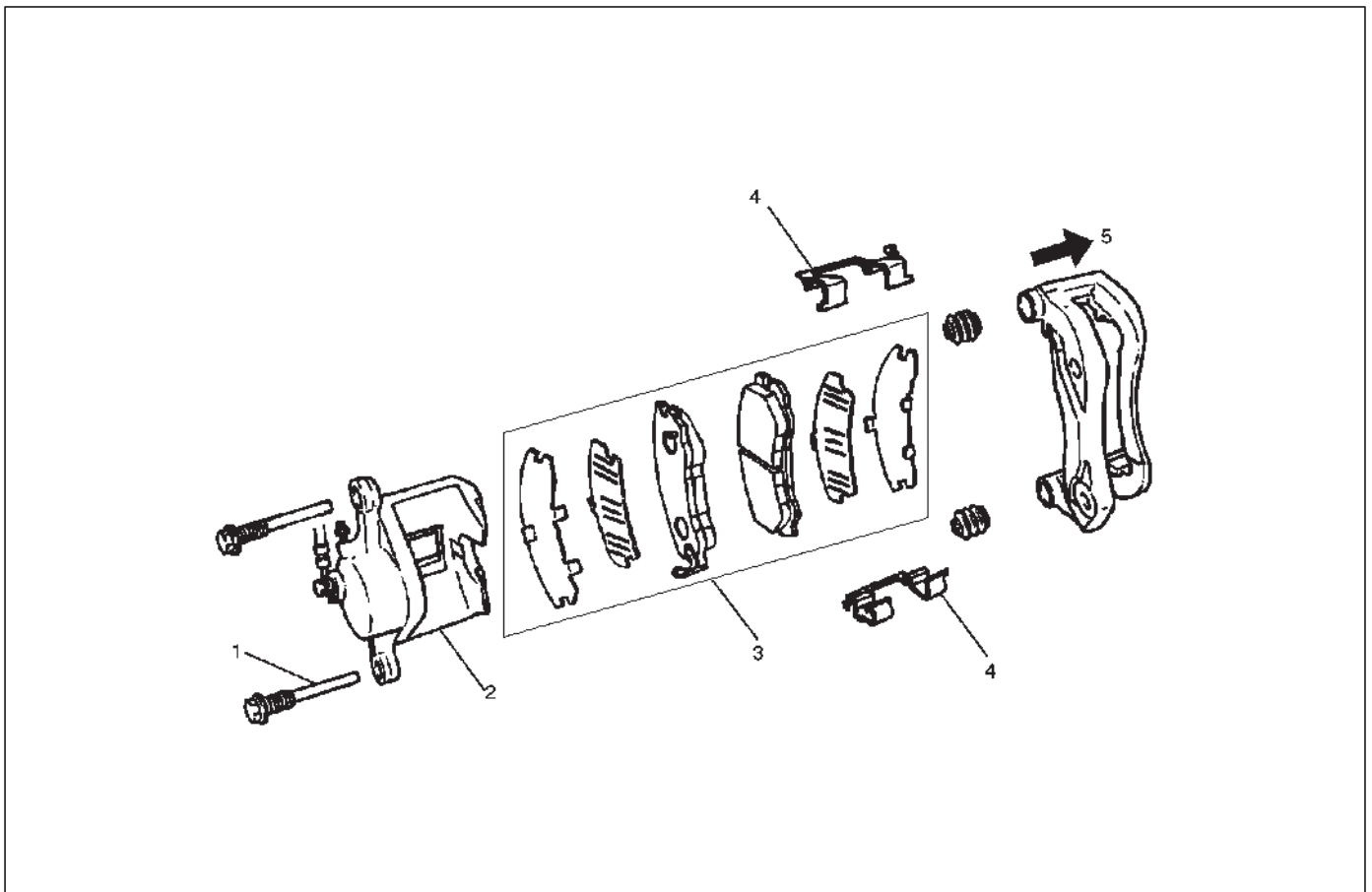
The disc pads have a wear indicator that makes a noise when the pad wears to where replacement is required.

**Minimum limit (1): 1.0 mm (0.039 in)**



302RS002

### Front Disc Brake Pads and Associated Parts



302RW003

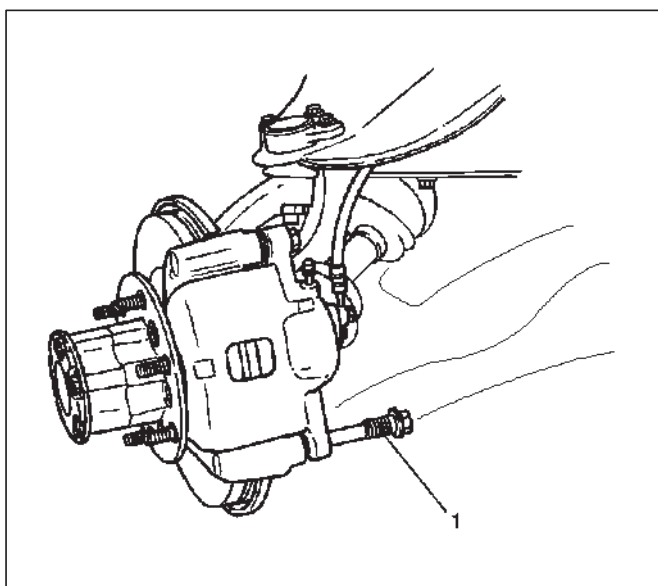
#### Legend

- |                      |                  |
|----------------------|------------------|
| (1) Lock Bolt        | (3) Pad Assembly |
| (2) Caliper Assembly | (4) Clip         |
|                      | (5) Outer Side   |

## Removal

NOTE: If a squealing noise occurs from the front brake while driving, check the pad wear indicator plate. If the indicator plate contacts the rotor, the disc pad assembly should be replaced.

- Draw out two-thirds of the brake fluid from the reservoir.
  - Raise the vehicle and support it with suitable safety stands.
1. Remove wheel and tire assembly, refer to "Wheels and Tires System" in Section 3E.
  2. Remove lock bolt (1).

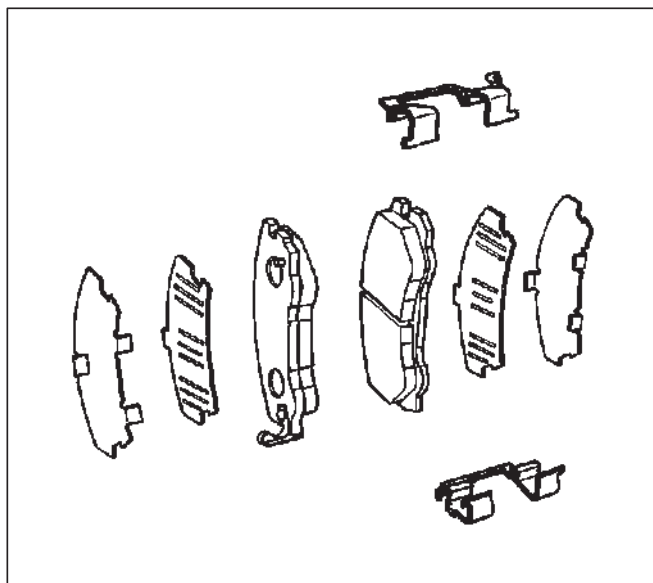


302RW004

3. Remove caliper assembly and support the caliper assembly so that the brake hose is not stretched or damaged.
4. Remove pad assembly with shim.
5. Remove Clip.

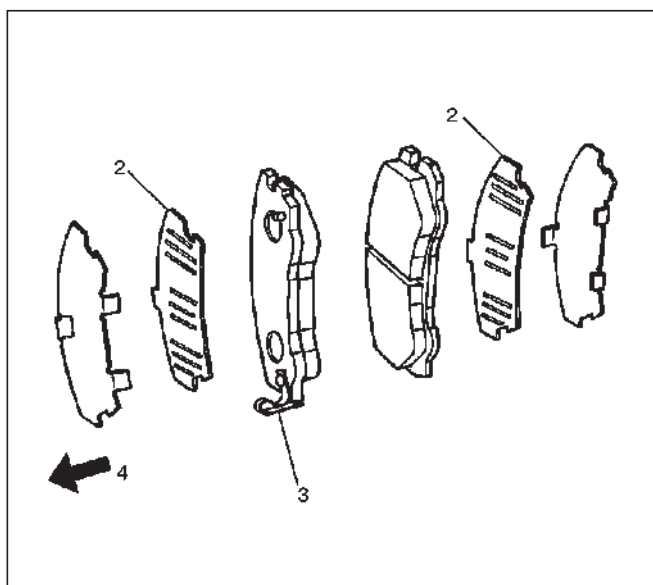
## Installation

1. Install clip.



302RS005

2. Install pad assembly with shim and apply special grease (approximately 0.2 g) to both contacting surfaces of the inner shims (2). Wipe off extruded grease after installing.

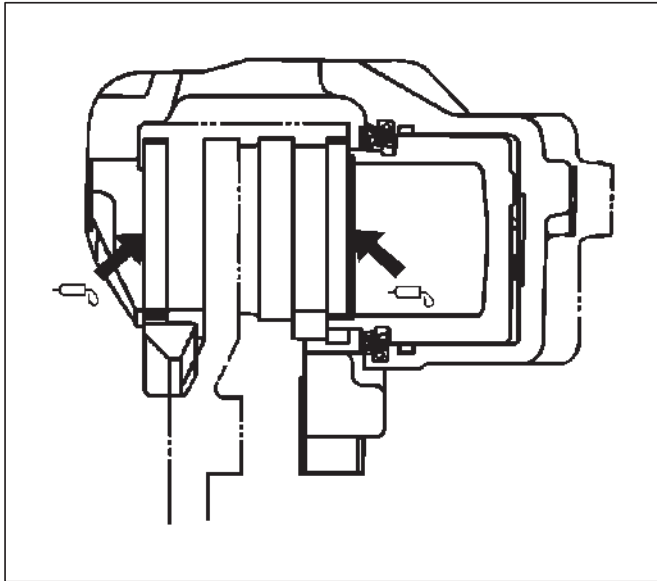


302RW005

### Legend

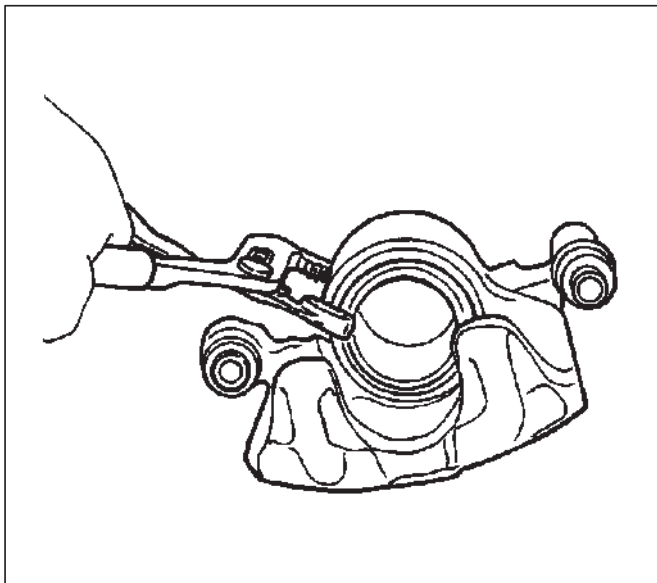
- (2) Inner Shim
- (3) Wear Indicator
- (4) Inner Side

## 5C-34 POWER ASSISTED BRAKE SYSTEM



302RW006

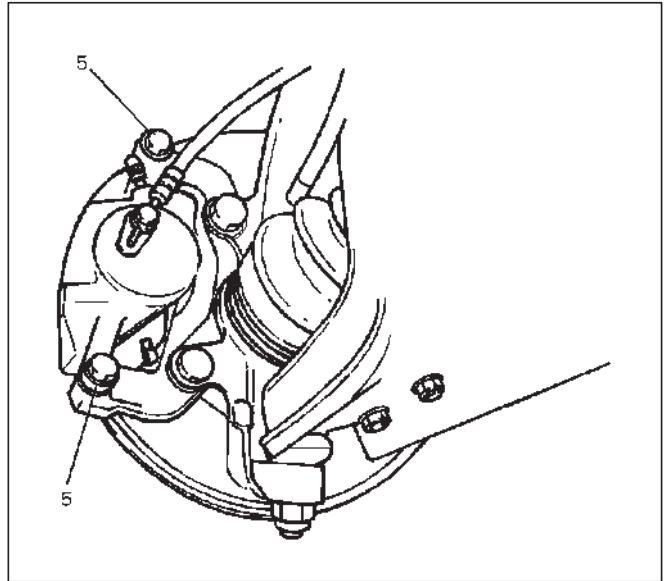
3. Install caliper assembly, use adjustable pliers to bottom the piston into the caliper bore.  
Be careful do not damage the piston boot and do not damage the flexible hose by twisting or pulling it.



302RS006

4. Install lock bolt (5) and tighten the bolt to the specified torque.

**Torque: 74 N·m (54 lb ft)**



302RW007

5. Install wheel and tire assembly, refer to "Wheels and Tires System" in Section 3E.
6. Pump the brake pedal several times to make sure that the pedal is firm. Check the brake fluid level in the reservoir after pumping the brakes.

## Front Disc Brake Rotor

### Inspection

In the manufacturing of the brake rotor, all the tolerances regarding surface finish, parallelism and lateral runout are held very closely. Maintaining these tolerances provides the surface necessary to assure smooth brake operation.

### Lateral Runout

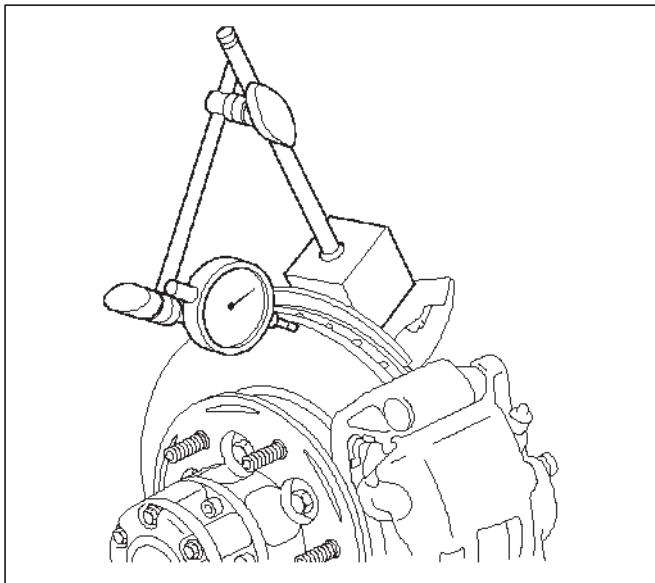
Lateral runout is the movement of the rotor from side to side as it rotates on the spindle. This could also be referred to as "rotor wobble".

This movement causes the piston to be knocked back into its bore. This results in additional pedal travel and a vibration during braking.

### Checking Lateral Runout

1. Adjust the wheel bearing correctly, refer to "Differential" in Section 4A.
2. Attach a dial indicator to some portion of the suspension so that the stem contacts the rotor face about 29 mm (1.14 in) from the rotor edge.
3. Move the rotor one complete rotation and the lateral runout should not exceed 0.13 mm (0.005 in).

**Maximum runout: 0.13 mm (0.005 in)**



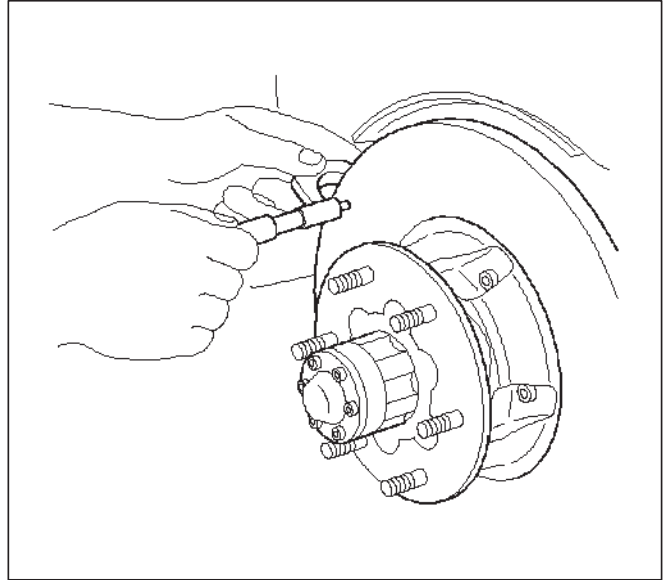
411RS019

### Parallelism

Parallelism is the measurement of thickness of the rotor at four or more points around the circumference of the rotor. All measurements must be made 29 mm (1.14 in) from the edge of the rotor.

The rotor thickness must not vary more than 0.010 mm (0.0004 in) from point to point.

**Maximum runout: 0.010 mm (0.0004 in)**



411RS018

### Replacing Brake Rotors

When installing new brake rotors, do not refinish the surfaces. These parts are at the correct level of surface finish.

### Refinishing Brake Rotors

Accurate control of the rotor tolerances is necessary for proper performance of the disc brakes. Machining of the rotor should be done only with precision equipment. All brake rotors have a minimum thickness dimension cast into them. This dimension is the minimum wear dimension and not a refinish dimension. The minimum wear dimension is 24.60 mm (0.969 in). The minimum refinish dimension is 24.97 mm (0.983 in).

When refinishing rotors, always use sharp cutting tools or bits. Dull or worn tools leave a poor surface finish which will affect initial braking performance. Vibration dampening attachments should always be used when refinishing braking surfaces. These attachments eliminate tool chatter and will result in better surface finish.

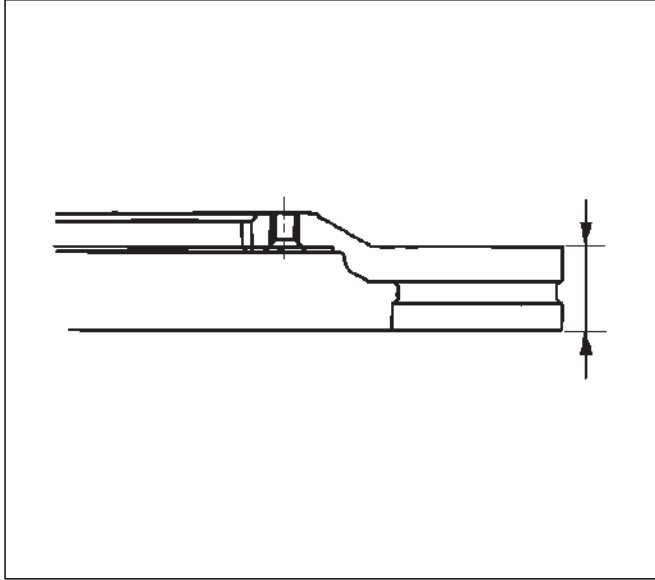
## 5C-36 POWER ASSISTED BRAKE SYSTEM

---

After refinishing, replace any rotor that does not meet the minimum thickness of 24.97 mm (0.983 in). Do not use a brake rotor that will not meet the specification.

**Minimum wear dimension: 24.60 mm (0.969 in)**

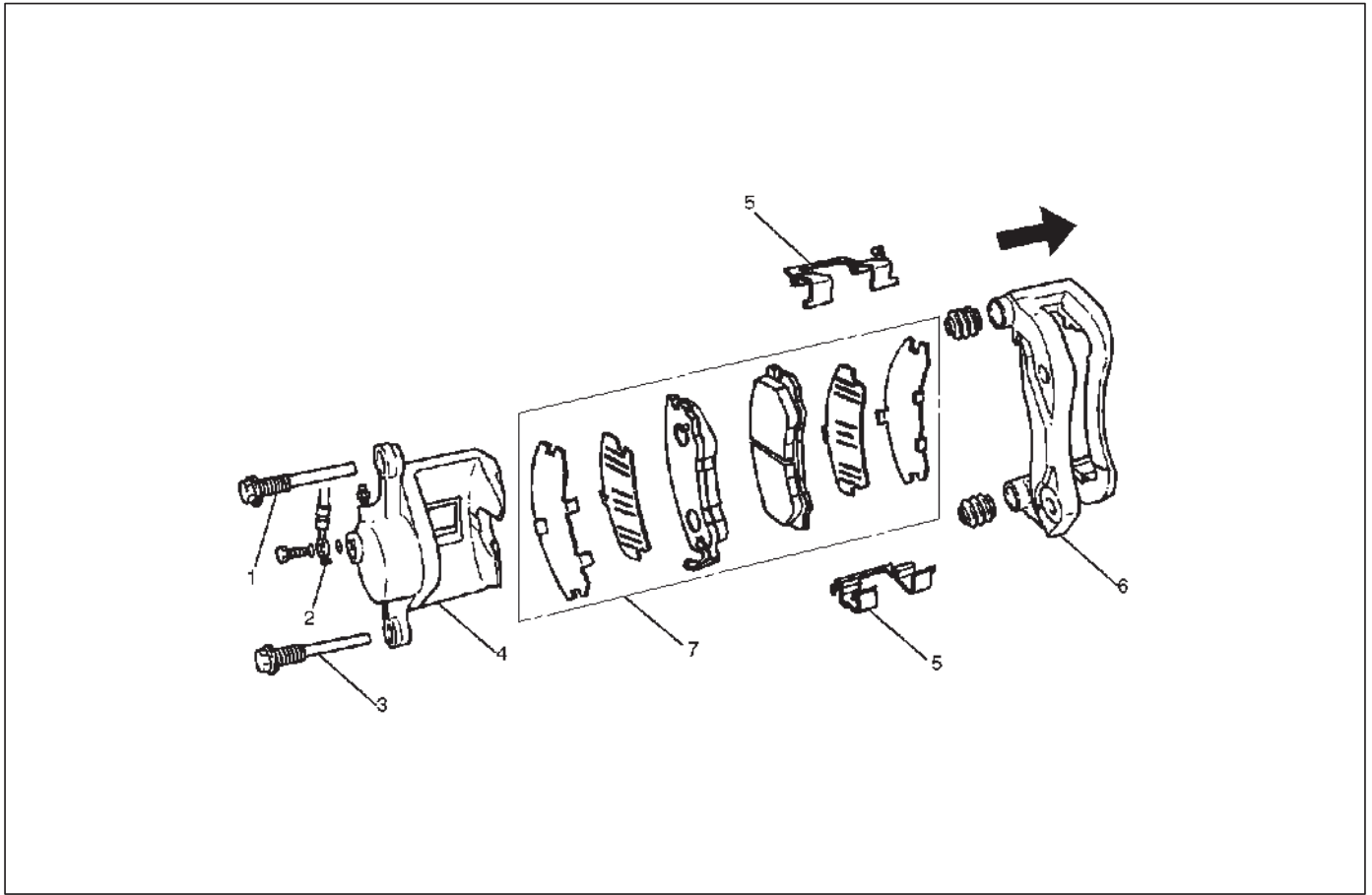
**Refinish dimension: 24.97 mm (0.983 in)**



411RW003

## Front Disc Brake Caliper Assembly

### Front Disc Brake Caliper Assembly and Associated Parts



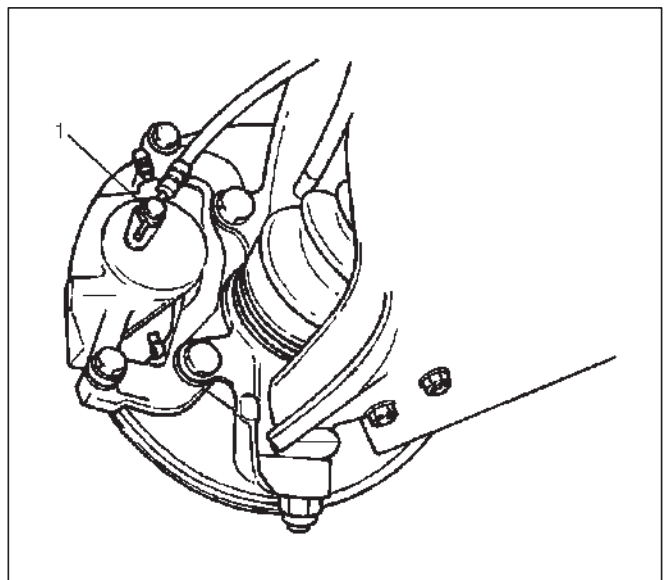
302RW006

#### Legend

- |                         |                      |
|-------------------------|----------------------|
| (1) Guide Bolt          | (4) Caliper Assembly |
| (2) Brake Flexible Hose | (5) Clip             |
| (3) Lock Bolt           | (6) Support Bracket  |
|                         | (7) Pad Assembly     |

### Removal

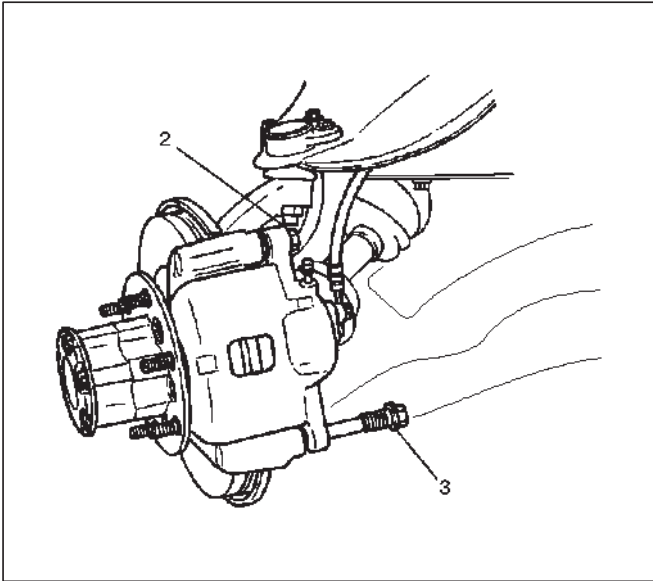
1. Raise the vehicle and support with suitable safety stands.
2. Wheel and tire assembly, refer to "Wheels and Tires System" in Section 3E.
3. Remove the bolt and gaskets, then disconnect the flexible hose from the caliper and after disconnecting the flexible hose (1), cap or tape the openings to prevent entry of foreign material.



302RW006

## 5C-38 POWER ASSISTED BRAKE SYSTEM

4. Since the brake fluid flows out from the connecting coupler, place a drain pan under the vehicle.
5. Remove guide bolt (2).
6. Remove lock bolt (3).

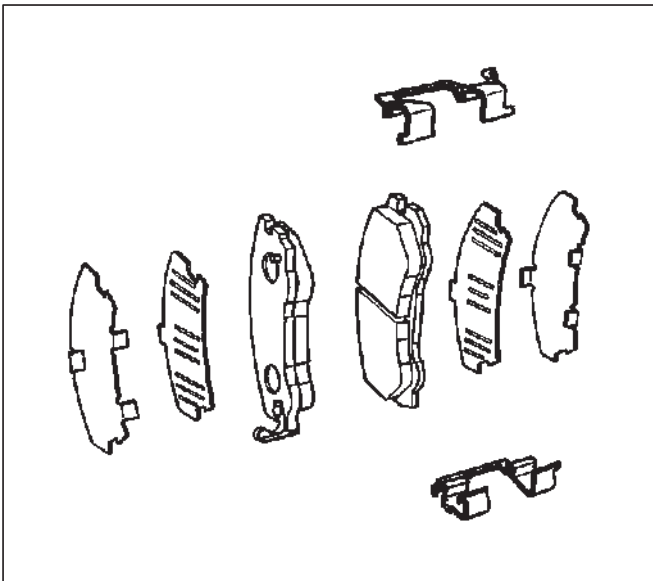


302RW010

7. Remove caliper assembly.
8. Remove support bracket with pad assembly and take care not to damage the flexible brake hose when removing the support bracket.
9. Remove pad assembly with shim and mark the lining locations if they are to be reinstalled.
10. Remove clip.

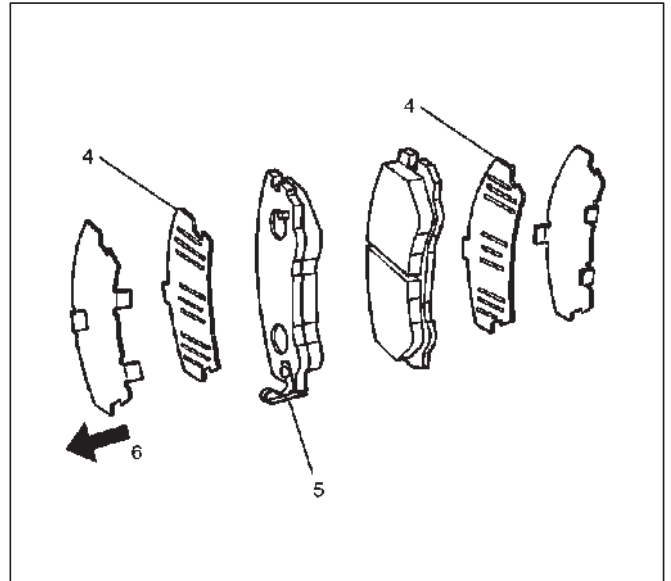
### Installation

1. Install clip.



302RS005

2. Install pad assembly with shim and apply special grease (approximately 0.2 g) to both contacting surfaces of the inner shims (6). Wipe off extruded grease after installing.



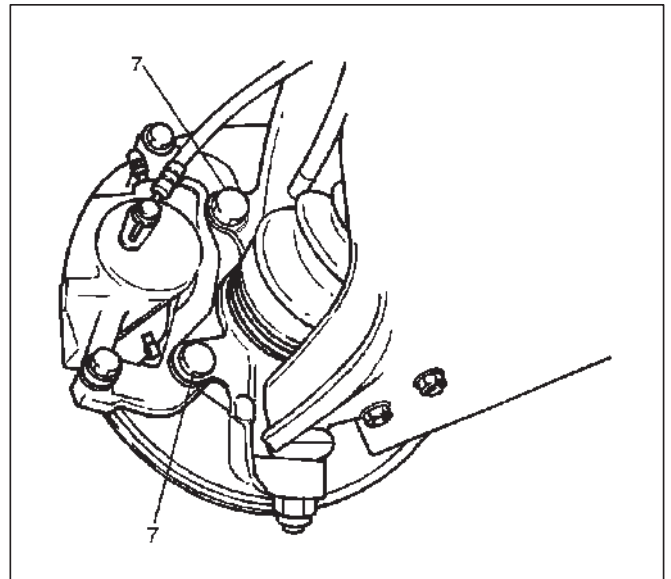
302RW011

### Legend

- (4) Inner Shim
- (5) Wear Indicator
- (6) Inner Side

3. Install support bracket and tighten the bolt (7) to the specified torque.

**Torque: 155 N·m (115 lb ft)**

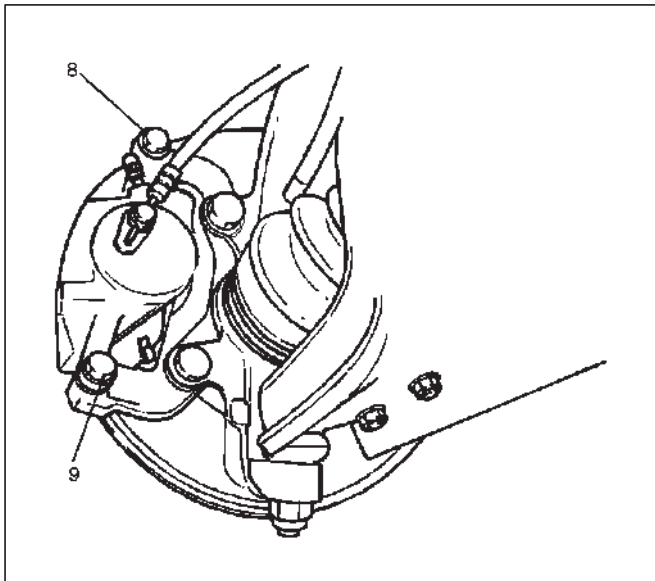


302RW012

4. Install caliper assembly.

5. Install lock bolt (9) and guide bolt (8) and tighten the bolt to the specified torque.

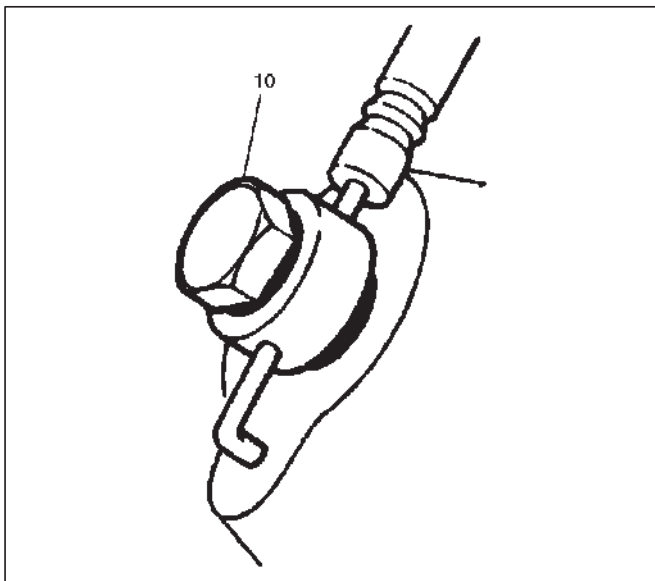
**Torque: 74 N·m (54 lb ft)**



302RW013

6. Install brake flexible hose, always use new gaskets and be sure to put the hooked edge of the flexible hose end into the anti-rotation cavity then tighten the I-bolt (10) to the specified torque.

**Torque: 35 N·m (26 lb ft)**



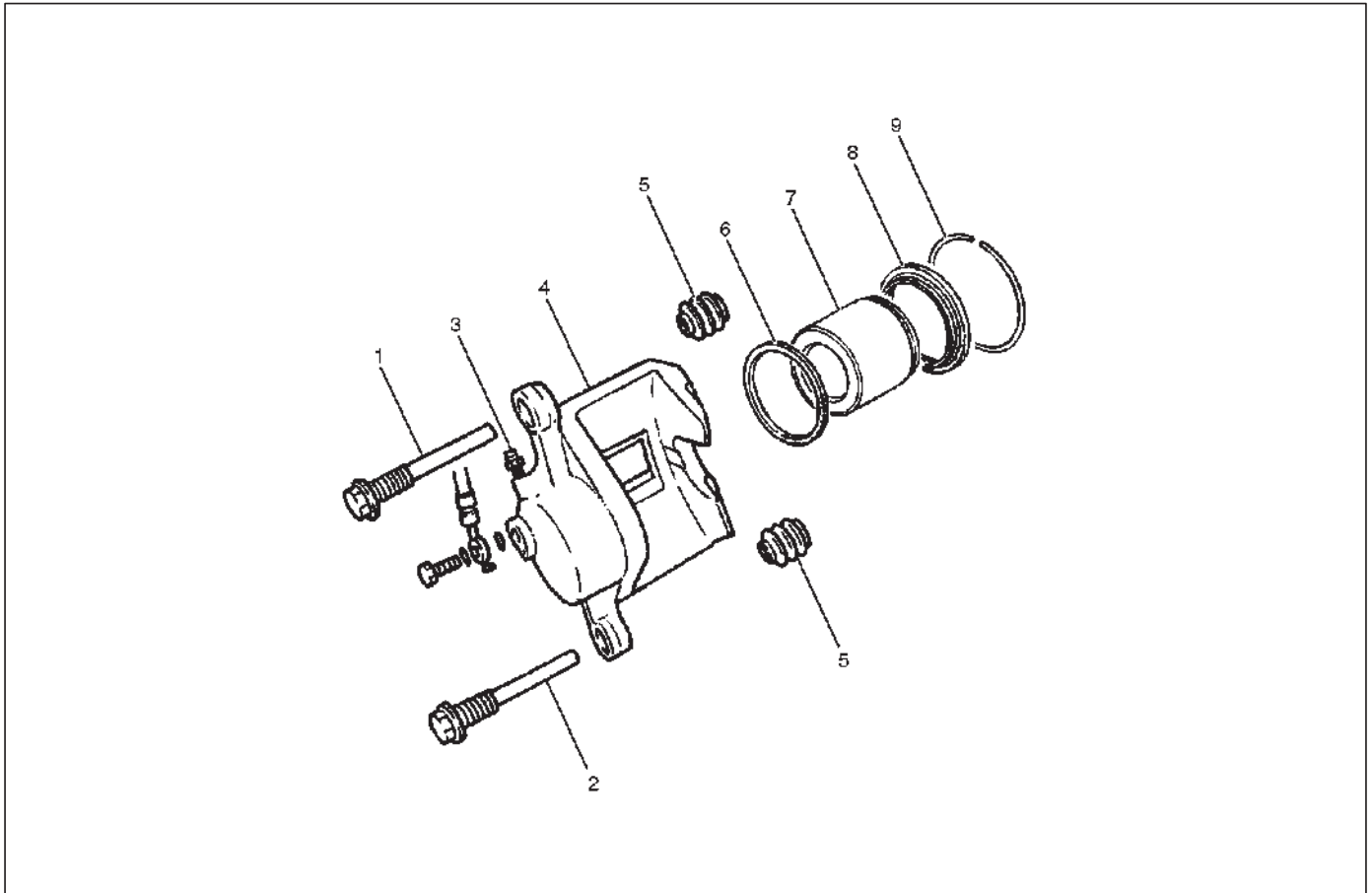
302RW014

7. Install wheel and tire assembly, refer to "Wheels and Tires System" in Section 3E.
8. Bleed brakes. Refer to "Hydraulic Brakes" in this section.



## Front Disc Brake Caliper

### Front Disc Brake Caliper Disassembled View



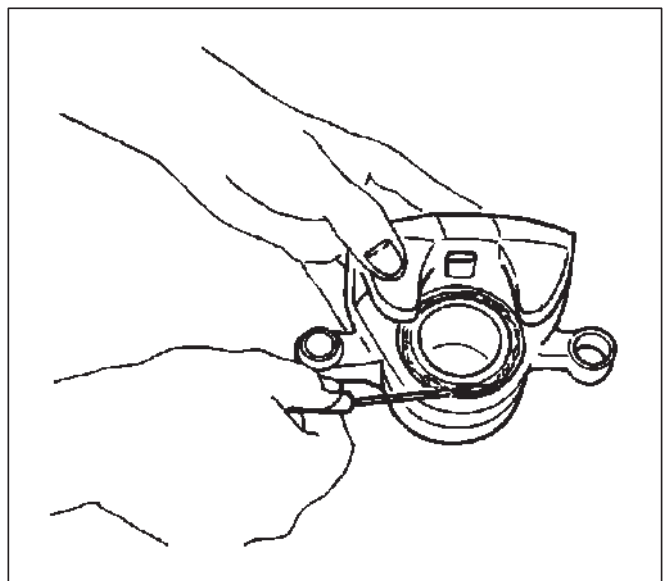
302RW015

#### Legend

- |                      |   |
|----------------------|---|
| (1) Guide Bolt       | (5) Dust Boot: Guide Bolt and Lock Bolt |
| (2) Lock Bolt        | (6) Piston Seal                         |
| (3) Bleeder with Cap | (7) Piston                              |
| (4) Caliper Body     | (8) Dust Boot: Piston                   |
|                      | (9) Dust Boot Ring                      |

### Disassembly

1. Remove guide bolt.
2. Remove lock bolt.
3. Remove dust boot: guide bolt and lock bolt.
4. Remove dust boot ring, using a small screwdriver, remove the dust boot ring.

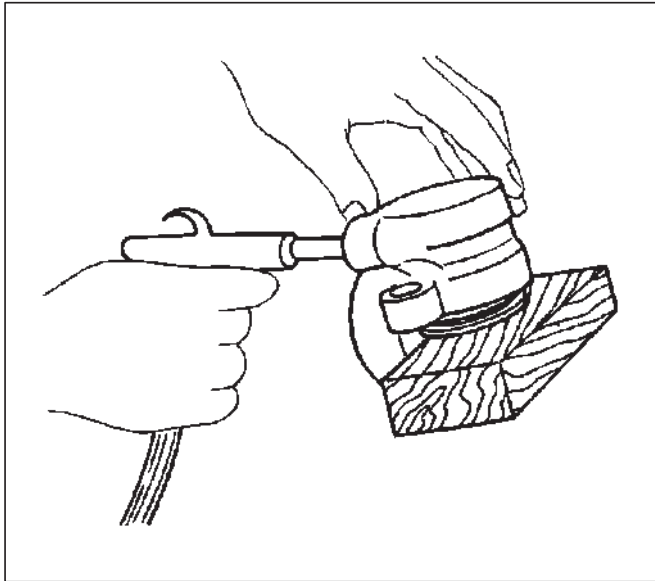


302RS016

5. Insert a block of wood into the caliper and force out the piston by blowing compressed air into the caliper at the flexible hose attachment. This procedure must be done prior to removal of the dust boot.

**WARNING: DO NOT PLACE YOUR FINGERS IN FRONT OF THE PISTON IN AN ATTEMPT TO CATCH OR PROTECT IT WHEN APPLYING COMPRESSED AIR. THIS COULD RESULT IN PERSONAL INJURY.**

**CAUTION: Use just enough air to ease the piston out of the bore. If the piston is blown out, it may be damaged.**



302RS017

6. Remove dust boot: piston.
7. Remove piston seal.
8. Remove bleeder with cap.
9. Remove caliper body.

## Inspection and Repair

Make necessary parts replacement, if wear, damage, corrosion or any other abnormal conditions are found through inspection.

Check the following parts:

- Rotor
- Cylinder body
- Cylinder bore
- Piston
- Guide bolt, lock bolt
- Support bracket

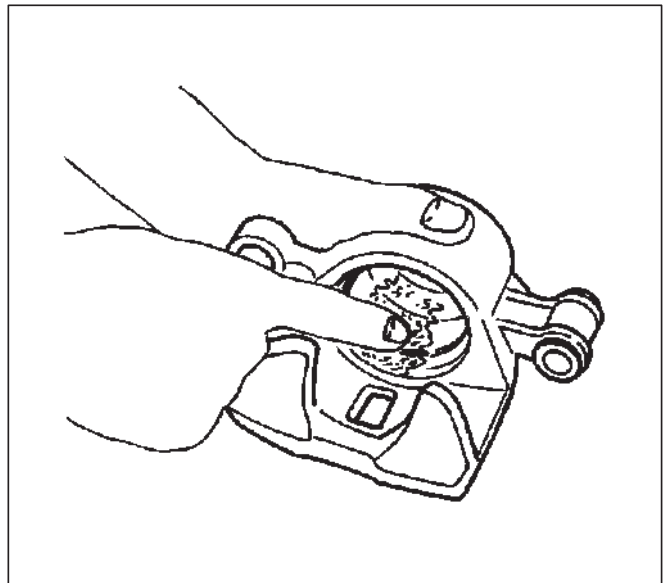
**NOTE:** The piston seal, boot ring and dust boot are to be replaced each time the caliper is overhauled. Discard these used rubber parts and replace them with new ones.

## Reassembly

1. Install caliper body.
2. Install bleeder with cap and tighten the cap to the specified torque.

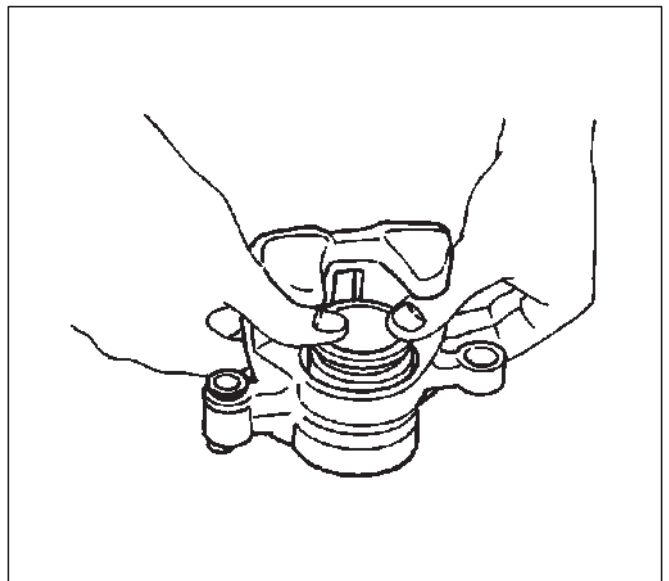
**Torque: 8 N·m (69 lb in)**

3. Install piston seal and apply special rubber grease to the piston seal and cylinder wall, then insert the piston seal into the cylinder. The special rubber grease is included in the repair kit.



302RS018

4. Install piston.
5. Install piston dust boot; when inserting the piston into the cylinder, use finger pressure only and do not use a mallet or other impact tool, since damage to the cylinder wall or piston seal can result.

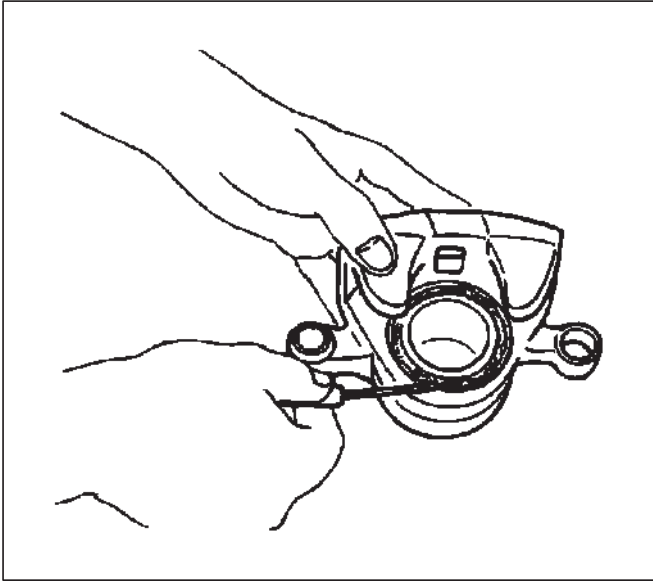


302RS019

## 5C-42 POWER ASSISTED BRAKE SYSTEM

---

6. Install dust boot ring and apply special grease (approximately 1 g) to the piston and attach the dust boot to the piston and caliper. Insert the dust boot ring into the dust boot.

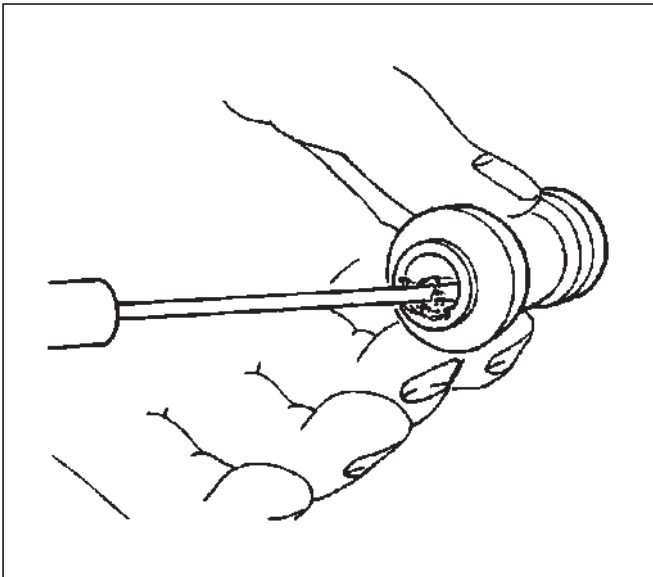


302RS020

7. Install guide bolt and lock bolt dust boot.
8. Install lock bolt and guide bolt and tighten the bolt to the specified torque.

**Torque: 74 N·m (54 lb ft)**

9. Install the dust boot on the support bracket after applying special grease (approximately 1 g) onto the dust boot inner surface. Apply special grease onto the lock bolt and guide bolt setting hole of the support bracket.



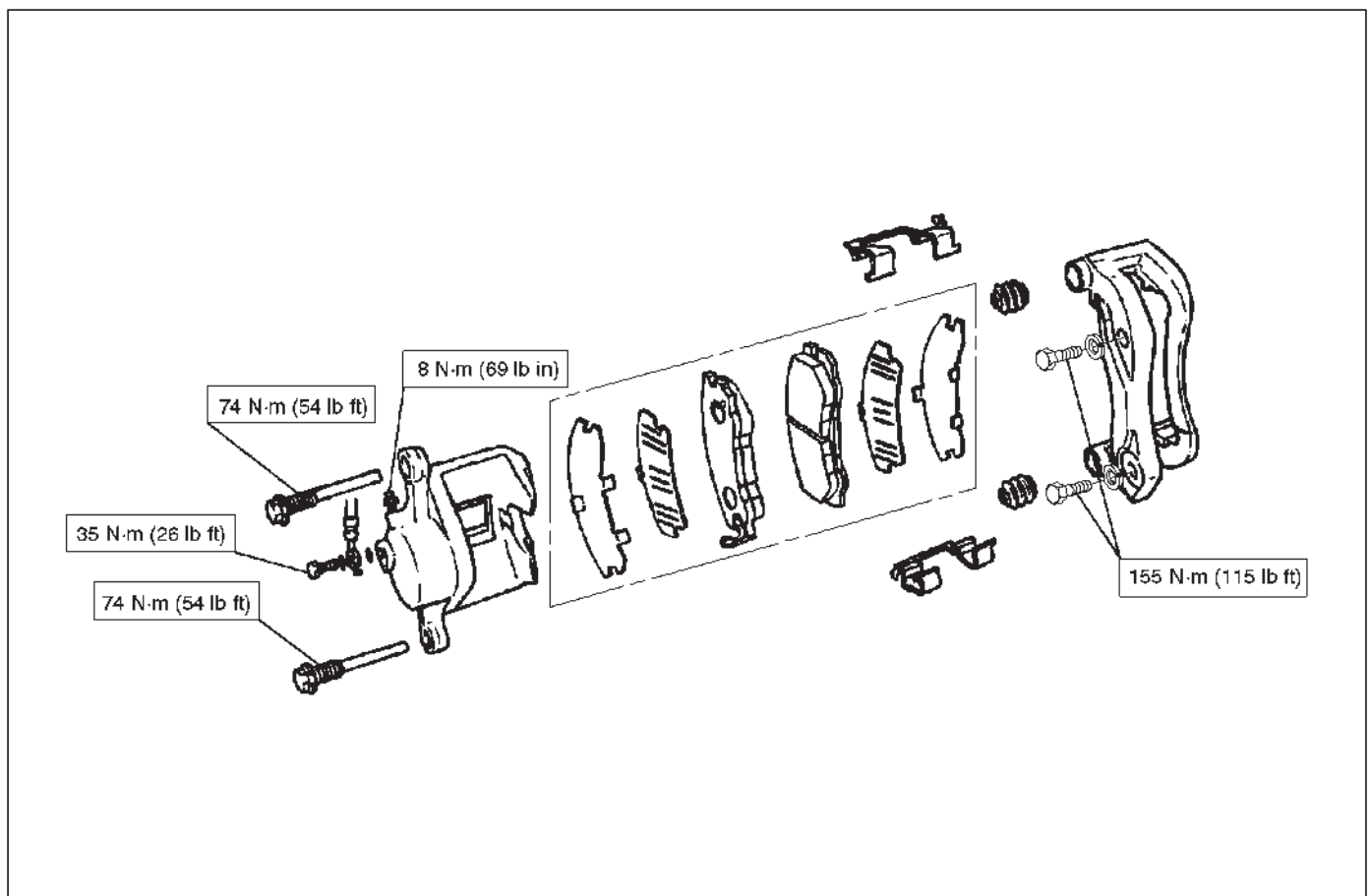
302RS021

## Main Data and Specifications

### General Specifications

Type	Floating, pin slide
Pad dimension	55 cm <sup>2</sup> (8.52 in <sup>2</sup> )
Adjusting method	Self-adjusting
Piston diameter	60.33 mm (2.38 in)
Disc type	Ventilated
Disc thickness	26 mm (1.02 in)
Disc effective diameter	222 mm (8.74 in)

### Torque Specifications



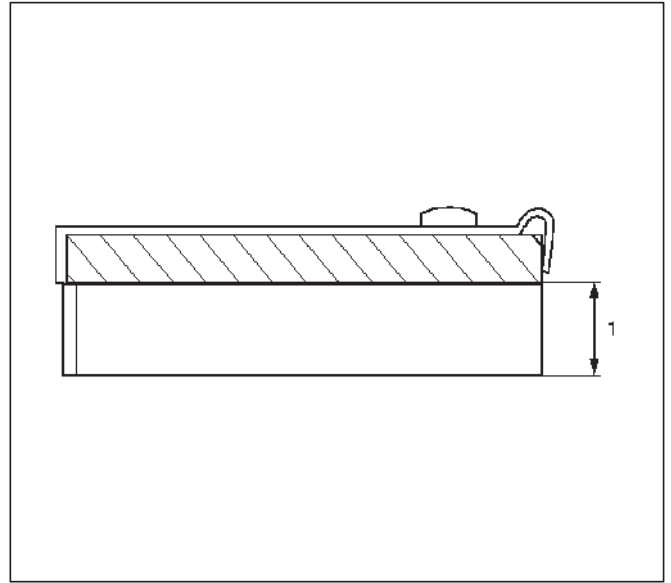
## Rear Disc Brake Pads

### Brake Pads Inspection

Check the outer pads by looking at each caliper from above. Check the thickness on the inner pad by looking down through the inspection hole in the top of the caliper. Whenever the pad is worn to about the thickness of the pad base, the pad should be removed for further measurements. The pad should be replaced anytime the pad thickness (1) is worn to within 1.0 mm (0.039 in) of the pad itself.

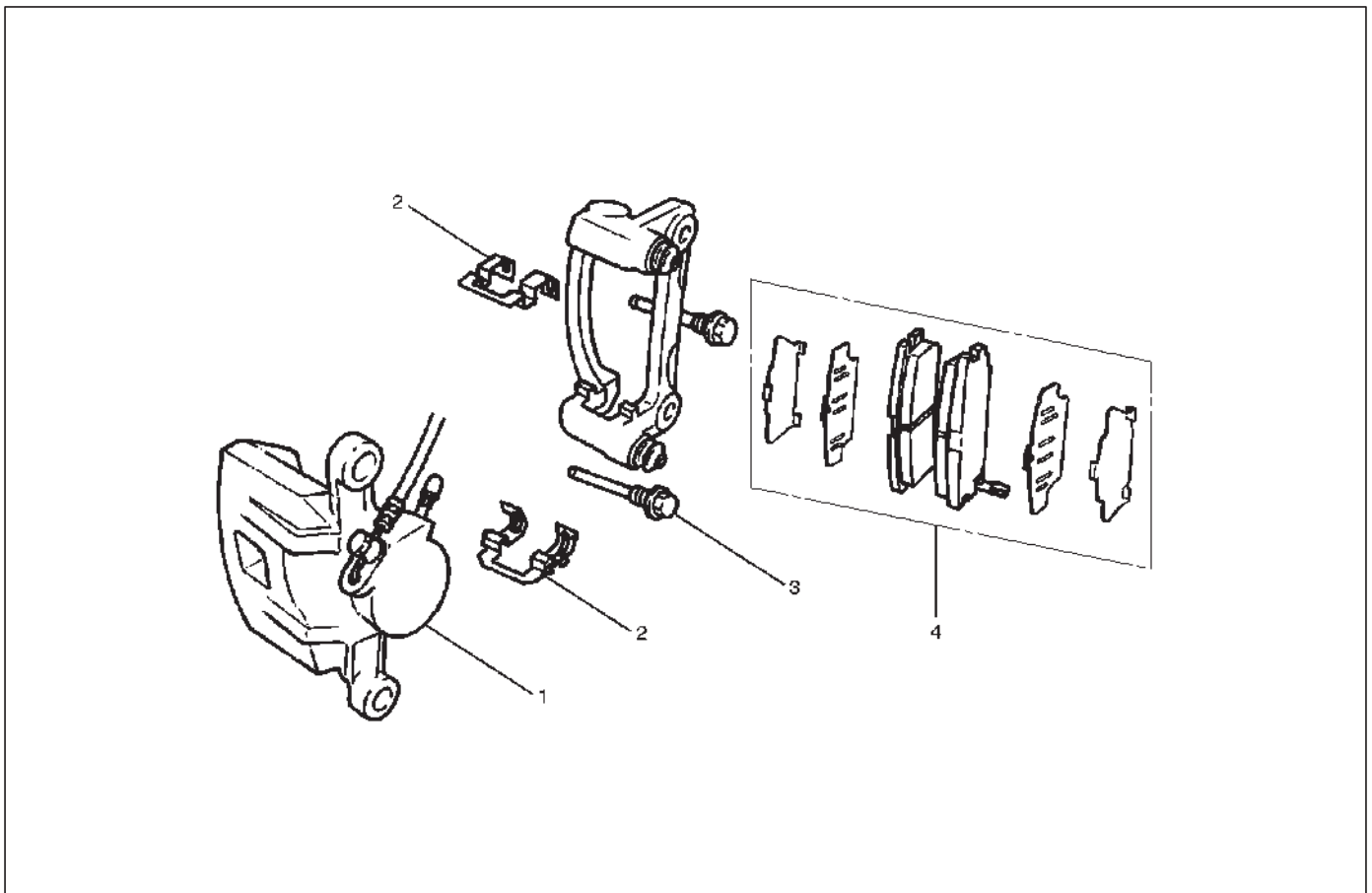
The disc pads have a wear indicator that makes a noise when the pad wears to where replacement is required.

**Minimum limit (1): 1.0 mm (0.039 in)**



302RW016

### Brake Pads and Associated Parts



306RW001

#### Legend

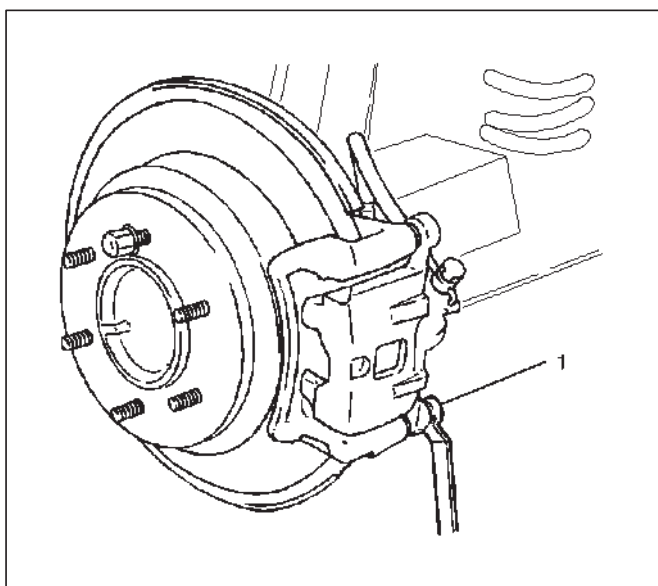
- (1) Caliper Assembly
- (2) Clip

- (3) Lock Bolt
- (4) Pad Assembly

## Removal

NOTE: If a squealing noise occurs from the rear brake while driving, check the pad wear indicator plate. If the indicator plate contacts the rotor, the disc pad assembly should be replaced.

- Draw out two-thirds of the brake fluid from the reservoir.
  - Raise the vehicle and support it with suitable safety stands.
1. Remove wheel and tire assembly, refer to "Wheels and Tires System" in Section 3E.
  2. Remove lock bolt (1)

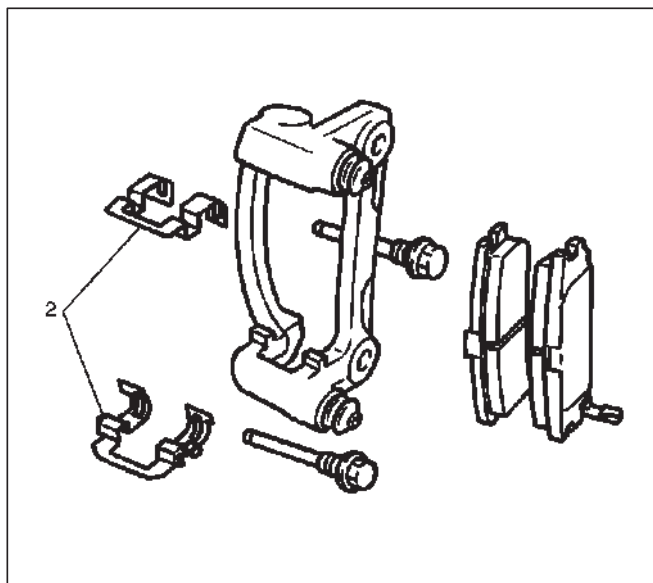


306RW002

3. Remove caliper assembly and support the caliper assembly so that the brake hose is not stretched or damaged.
4. Remove pad assembly with shim.
5. Remove clip.

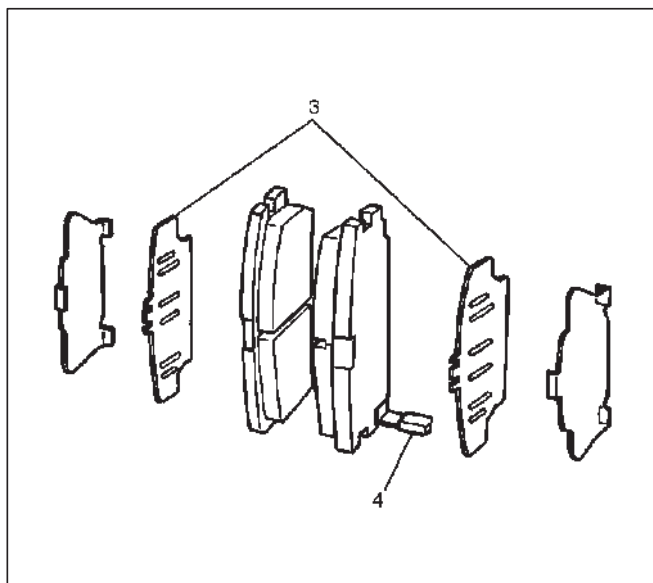
## Installation

1. Install clip (2).



306RW003

2. Install pad assembly with shim and apply special grease (approximately 0.2 g) to both contacting surfaces of the inner shims. Wipe off extruded grease after installing.

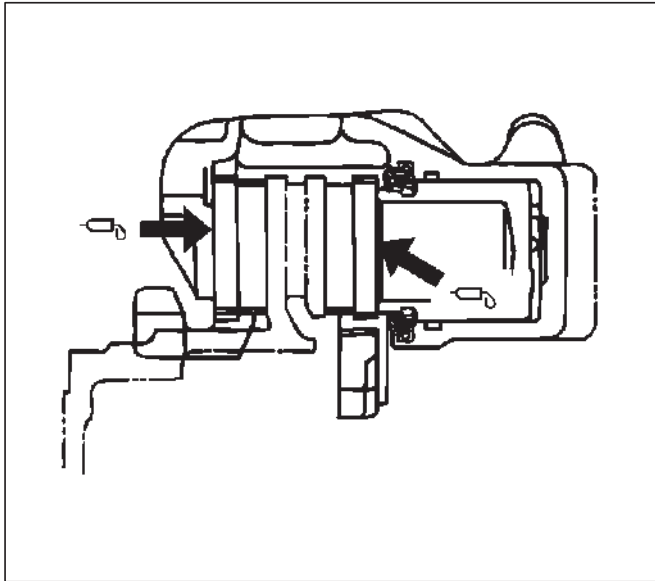


306RW004

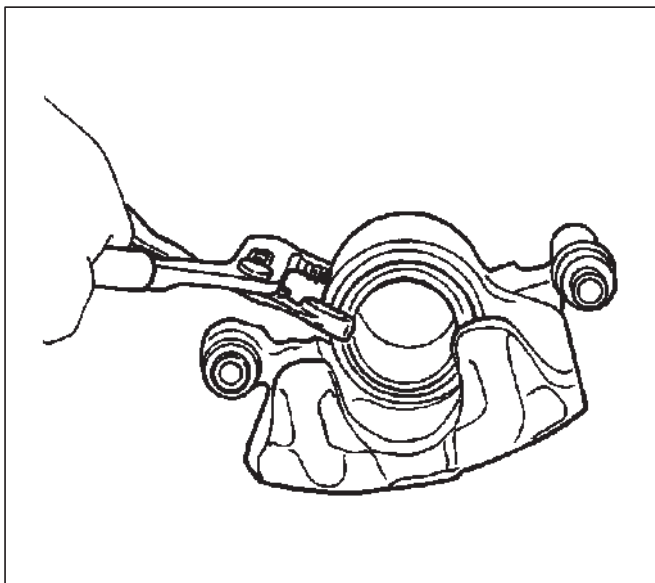
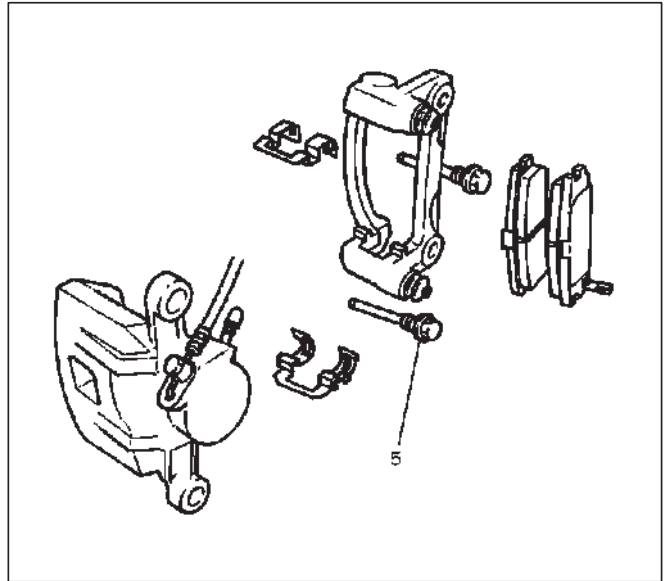
### Legend

- (3) Inner Shim
- (4) Wear Indicator

## 5C-46 POWER ASSISTED BRAKE SYSTEM



3. Install caliper assembly, use adjustable pliers to bottom the piston into the caliper bore. Be careful not to damage the piston dust boot and do not damage the flexible hose by twisting or pulling it.



4. Install lock bolt (5) and tighten the bolt to the specified torque.

**Torque: 44 N·m (32 lb ft)**

5. Install wheel and tire assembly, refer to "Wheels and Tires System" in Section 3E.
6. Pump the brake pedal several times to make sure that the pedal is firm. Check the brake fluid level in the reservoir after pumping the brakes.

## Rear Disc Brake Rotor

### Inspection

In the manufacturing of the brake rotor, all the tolerances regarding surface finish, parallelism and lateral runout are held very closely. Maintaining these tolerances provides the surface necessary to assure smooth brake operation.

### Lateral Runout

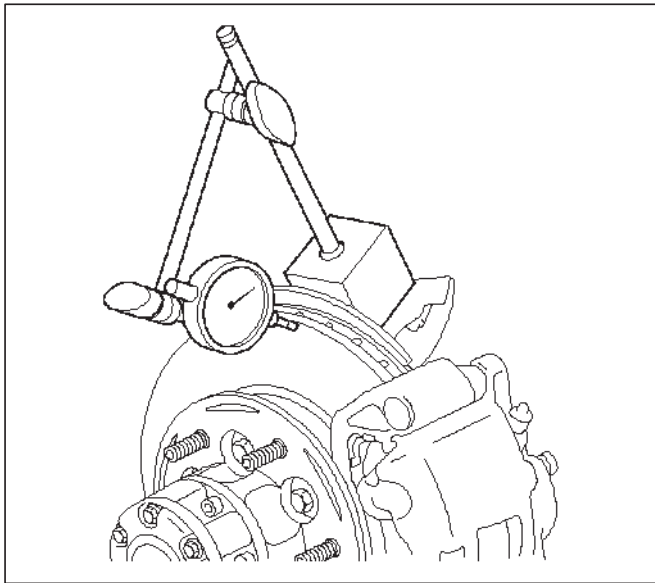
Lateral runout is the movement of the rotor from side to side as it rotates on the spindle. This could also be referred to as "rotor wobble".

This movement causes the piston to be knocked back into its bore. This results in additional pedal travel and a vibration during braking.

### Checking Lateral Runout

1. Adjust the wheel bearing correctly, refer to "Differential" in Section 4A.
2. Attach a dial indicator to some portion of the suspension so that the stem contacts the rotor face about 29 mm (1.14 in) from the rotor edge.
3. Move the rotor one complete rotation.
  1. The lateral runout should not exceed 0.13 mm (0.005 in)

**Maximum runout: 0.13 mm (0.005 in)**

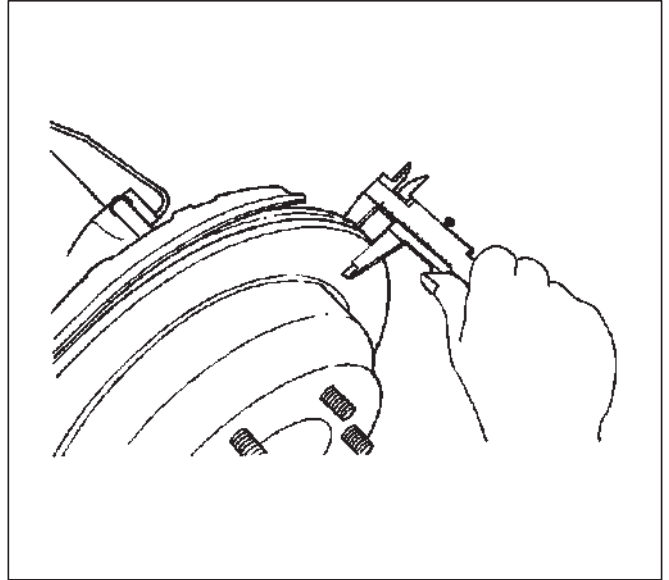


### Parallelism

Parallelism is the measurement of thickness of the rotor at four or more points around the circumference of the rotor. All measurements must be made 22 mm (0.87 in) from the edge of the rotor.

The rotor thickness must not vary more than 0.010 mm (0.0004 in) from point to point.

**Maximum parallelism: 0.001 mm (0.0004 in)**



### Replacing Brake Rotors

When installing new brake rotors, do not refinish the surfaces. These parts are at the correct level of surface finish.

### Refinishing Brake Rotors

Accurate control of the rotor tolerances is necessary for proper performance of the disc brakes. Machining of the rotor should be done only with precision equipment. All brake rotors have a minimum thickness dimension cast into them. This dimension is the minimum wear dimension and not a refinish dimension. The minimum wear dimension is 16.6 mm (0.654 in). The minimum refinish dimension is 16.97 mm (0.668 in).

When refinishing rotors, always use sharp cutting tools or bits. Dull or worn tools leave a poor surface finish which will affect initial braking performance. Vibration dampening attachments should always be used when refinishing braking surfaces. These attachments eliminate tool chatter and will result in better surface finish.



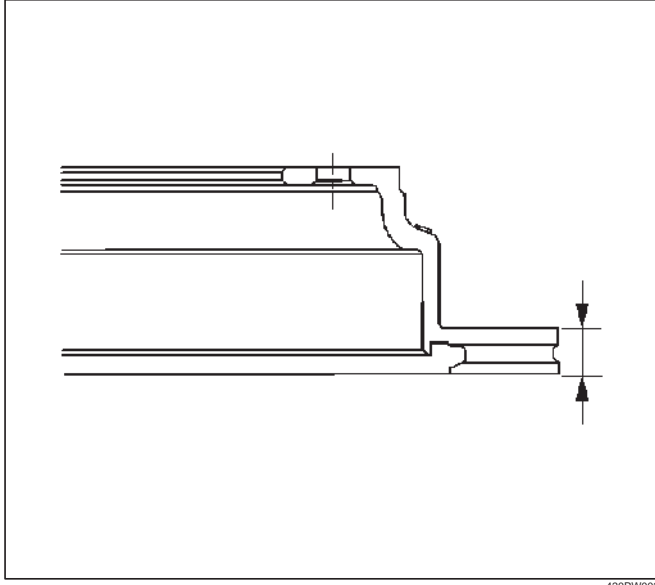
## 5C-48 POWER ASSISTED BRAKE SYSTEM

---

After refinishing, replace any rotor that does not meet the minimum thickness of 16.97 mm (0.668 in). Do not use a brake rotor that will not meet the specification.

**Minimum wear dimension: 16.6 mm (0.654 in)**

**Refinish dimension: 16.97 mm (0.668 in)**



420RW002

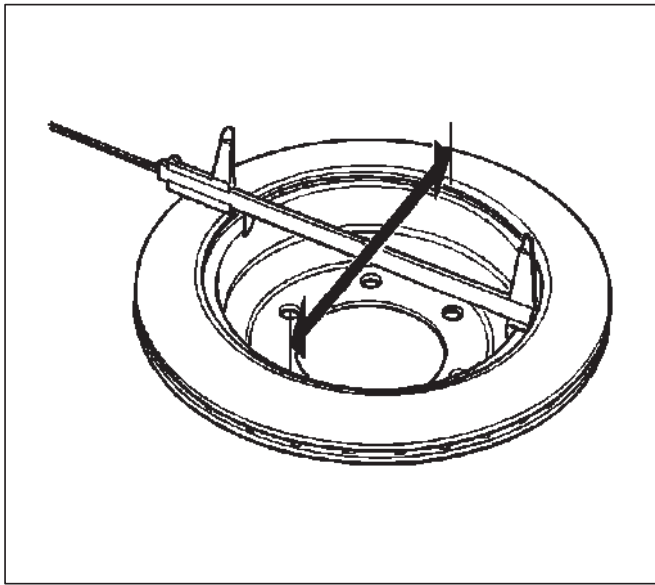
### Rear Drum (In Disc) Inside Diameter Check

Check the rear drum inside diameter by measuring at more than two portions as shown in the illustration.

If the inside diameter is greater than the limit, replace the rear rotor.

**Standard: 210.0 mm (8.27 in)**

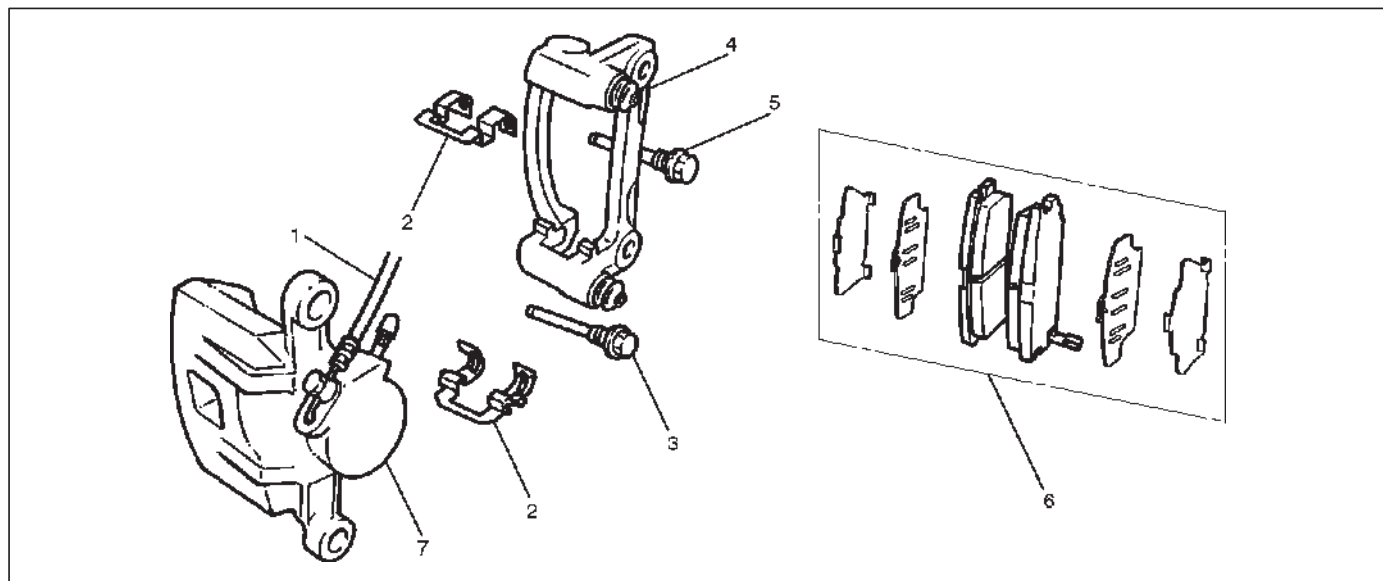
**Limit: 211.4 mm (8.32 in)**



420RS035

## Rear Disc Brake Caliper Assembly

### Rear Disc Brake Caliper Assembly and Associated Parts



306RW007

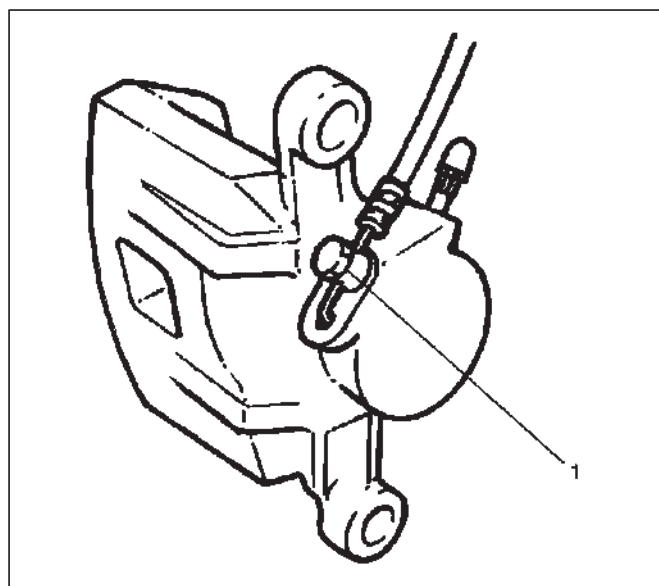
#### Legend

- |                         |                            |
|-------------------------|----------------------------|
| (1) Brake Flexible Hose | (4) Support Bracket        |
| (2) Clip                | (5) Guide Bolt             |
| (3) Lock Bolt           | (6) Pad Assembly with Shim |
|                         | (7) Caliper Assembly       |

### Removal

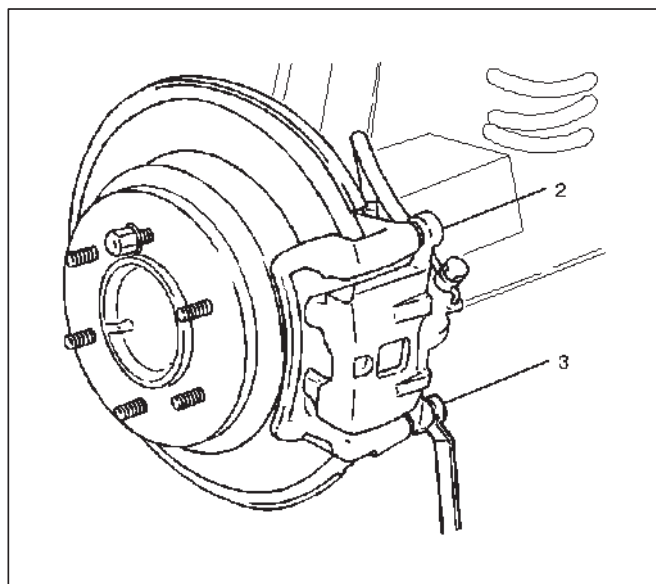
1. Raise the vehicle and support with suitable safety stands.
2. Remove wheel and tire assembly, refer to "Wheels and Tires System" in Section 3E.
3. Remove the bolt and gaskets, then disconnect the flexible hose from the caliper and after disconnecting the flexible hose (1), cap or tape the openings to prevent entry of foreign material.

5. Remove lock bolt (2).
6. Remove guide bolt (3).



306RW008

4. Since the brake fluid flows out from the connecting coupler, place a drain pan under the vehicle.



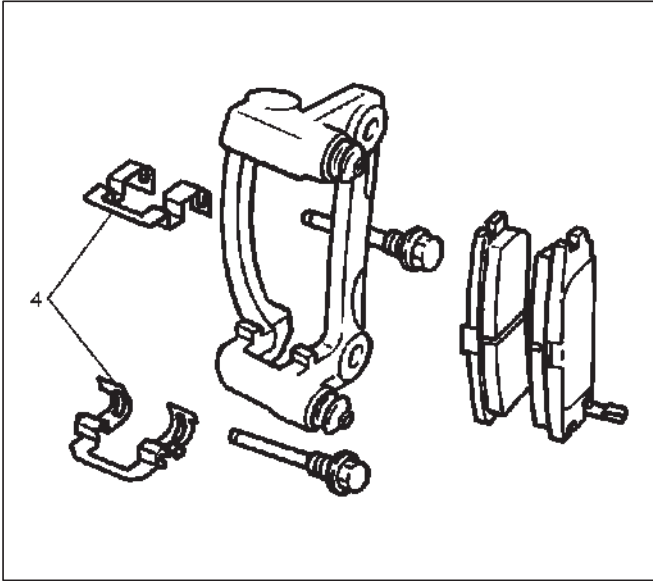
306RW009

7. Remove caliper assembly.
8. Remove support bracket with pad assembly and take care not to damage the flexible brake hose when removing the support bracket.
9. Remove pad assembly (with shim) and mark the lining locations if they are to be reinstalled.
10. Remove clip.

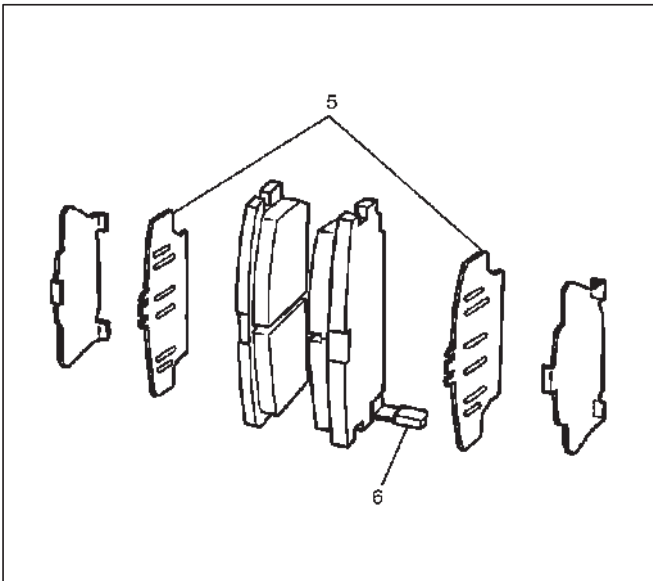
## 5C-50 POWER ASSISTED BRAKE SYSTEM

### Installation

1. Install clip (4).



2. Install pad assembly (with shim) and apply special grease (approximately 0.2 g) to both contacting surfaces of the inner shims (5). Wipe off extruded grease after installing.

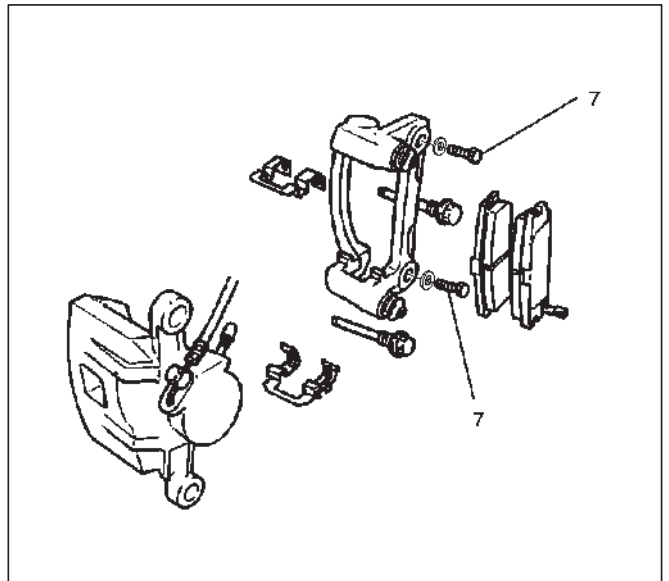


#### Legend

- (5) Inner Shim
- (6) Wear indicator

3. Install support bracket and tighten the bolt (7) to the specified torque.

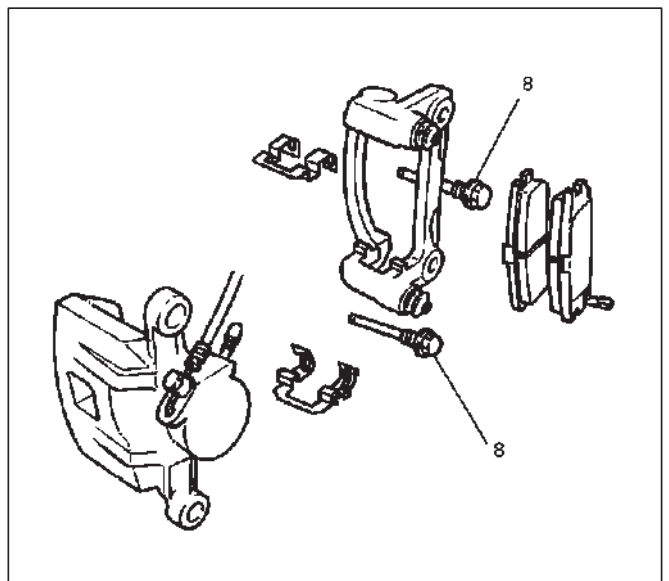
**Torque: 103 N·m (76 lb ft)**



4. Install caliper assembly.

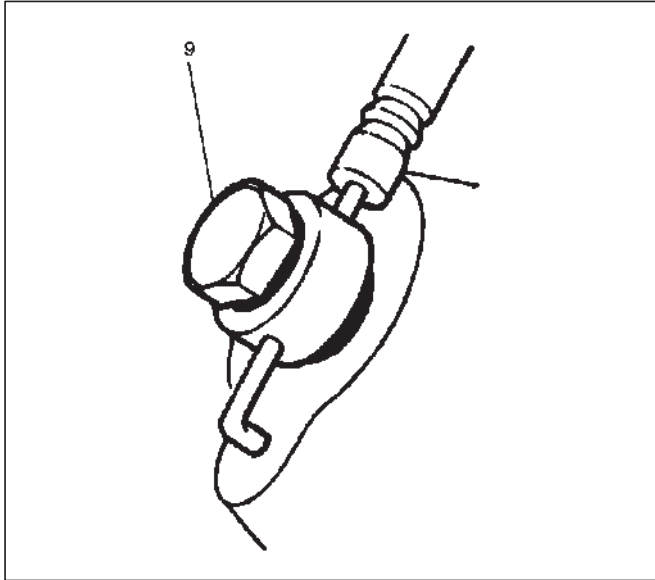
5. Install lock bolt and guide bolt (8) and tighten the bolt to the specified torque.

**Torque: 44 N·m (32 lb ft)**



6. Install brake flexible hose, always use new gaskets and be sure to put the hooked edge of the flexible hose end into the anti-rotation cavity then tighten the I-bolt (9) to the specified torque.

**Torque: 35 N·m (26 lb ft)**

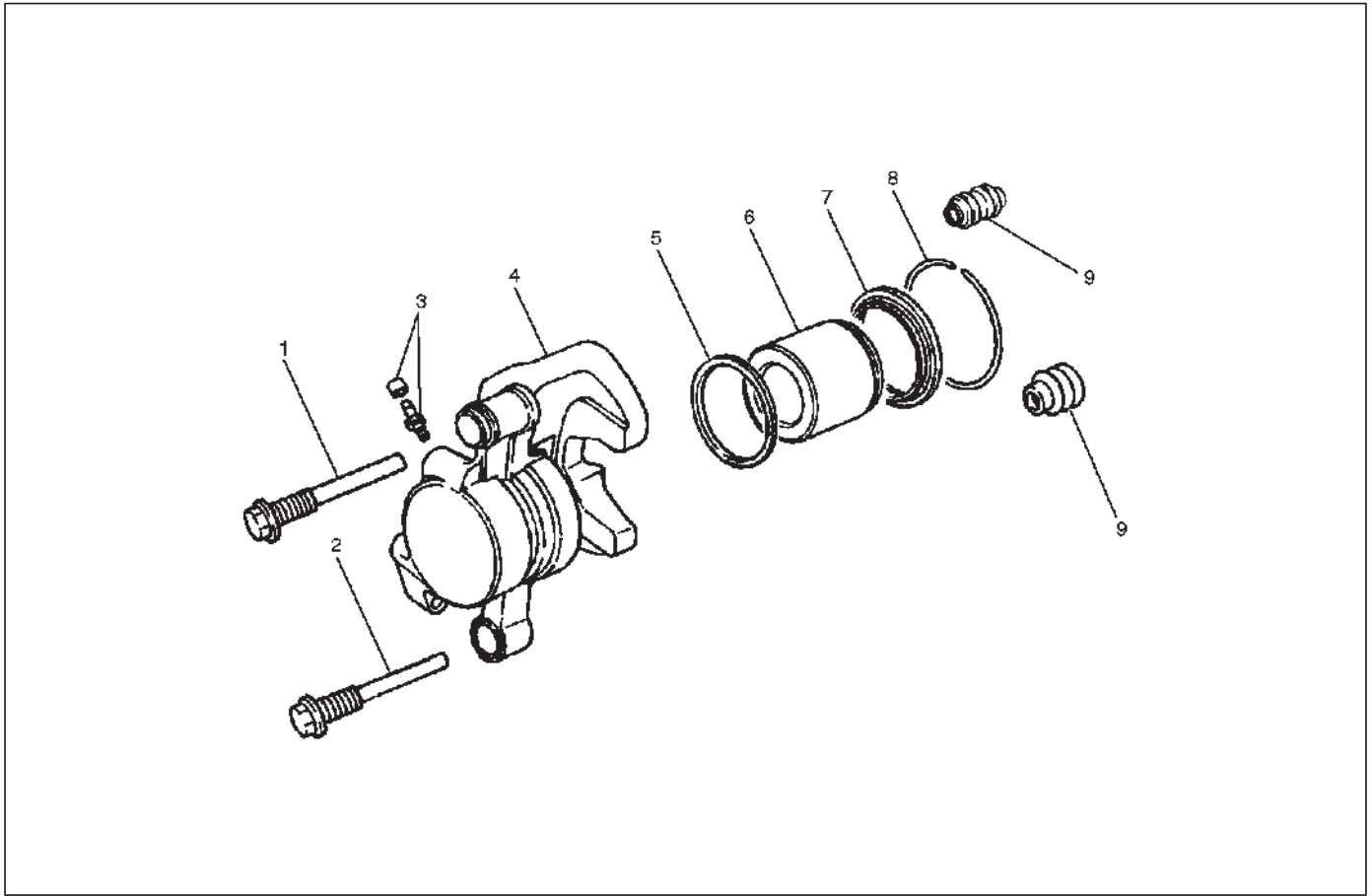


302RW017

7. Install the wheel and tire assembly, refer to “Wheels and Tires System” in Section 3E.
8. Bleed brakes. Refer to “Hydraulic Brakes” in this section.

## Rear Disc Brake Caliper

### Rear Disc Brake Caliper Disassembled View



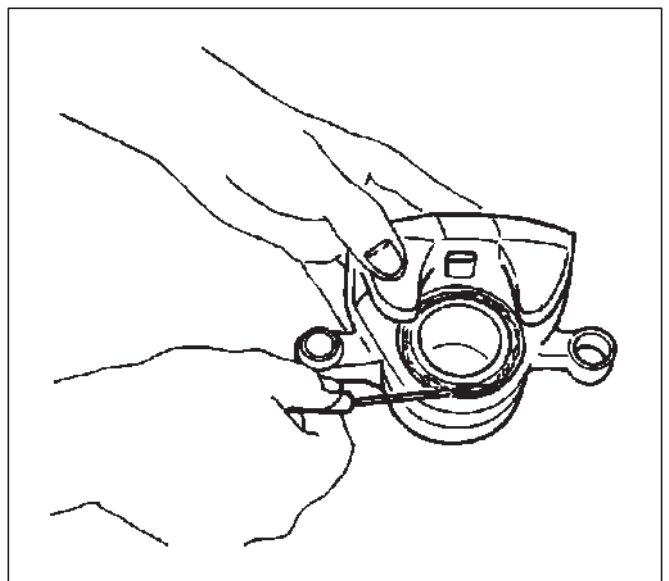
306RW014

#### Legend

- |                      |   |
|----------------------|---|
| (1) Guide Bolt       | (5) Piston Seal                         |
| (2) Lock Bolt        | (6) Piston                              |
| (3) Bleeder with Cap | (7) Dust Boot: Piston                   |
| (4) Caliper Body     | (8) Dust Boot Ring                      |
|                      | (9) Dust Boot: Guide Bolt and Lock Bolt |

### Disassembly

1. Remove guide bolt.
2. Remove lock bolt.
3. Remove dust boot; guide bolt and lock bolt.
4. Remove the dust boot ring using a small screwdriver.

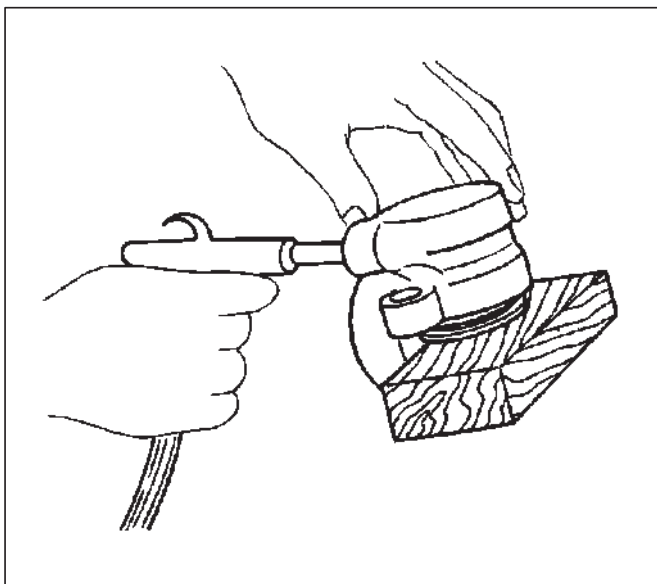


302RS016

5. Insert a block of wood into the caliper and force out the piston by blowing compressed air into the caliper at the flexible hose attachment. This procedure must be done prior to removal of the dust boot.

**WARNING: DO NOT PLACE YOUR FINGERS IN FRONT OF THE PISTON IN AN ATTEMPT TO CATCH OR PROTECT IT WHEN APPLYING COMPRESSED AIR. THIS COULD RESULT IN PERSONAL INJURY.**

**CAUTION: Use just enough air to ease the piston out of the bore. If the piston is blown out, it may be damaged.**



302RS017

6. Remove dust boot: piston.
7. Remove piston seal.
8. Remove bleeder with cap.
9. Remove caliper body.

## Inspection and Repair

Make necessary parts replacement, if wear, damage, corrosion or any other abnormal conditions are found through inspection.

Check the following parts:

- Rotor
- Cylinder body
- Cylinder bore
- Piston
- Guide bolt, lock bolt
- Support bracket

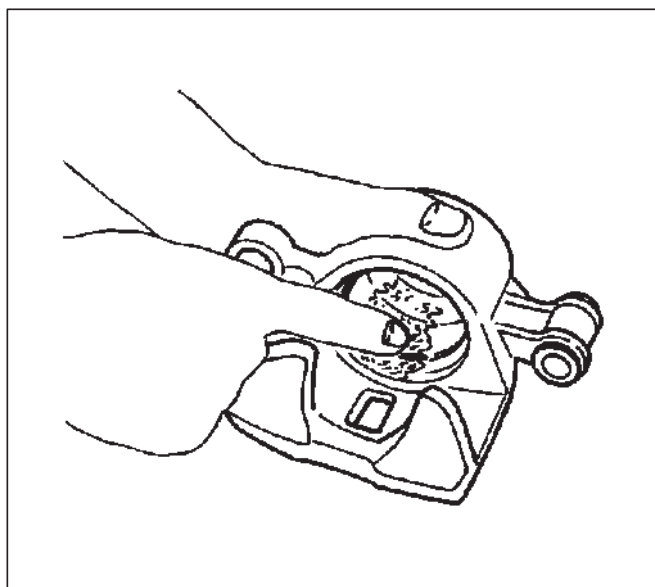
**NOTE:** The piston dust seal and dust boot are to be replaced each time the caliper is overhauled. Discard these used rubber parts and replace with new ones.

## Reassembly

1. Install caliper body.
2. Install bleeder with cap and tighten the cap to the specified torque.

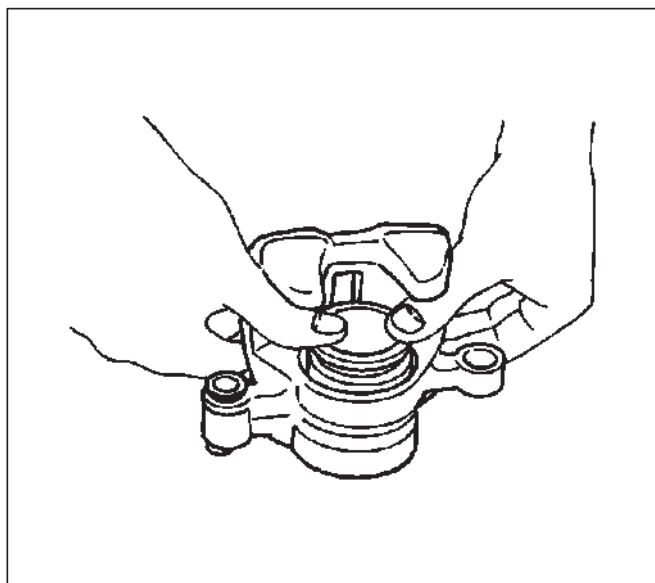
**Torque: 8 N·m (69 lb ft)**

3. Install piston seal and apply special rubber grease to the piston seal and cylinder wall, then insert the piston seal into the cylinder. The special rubber grease is included in the repair kit.



302RS018

4. Install piston.
5. Install piston dust boot; when inserting the piston into the cylinder, use finger pressure only and do not use a mallet or other impact tool, since damage to the cylinder wall or piston seal can result.

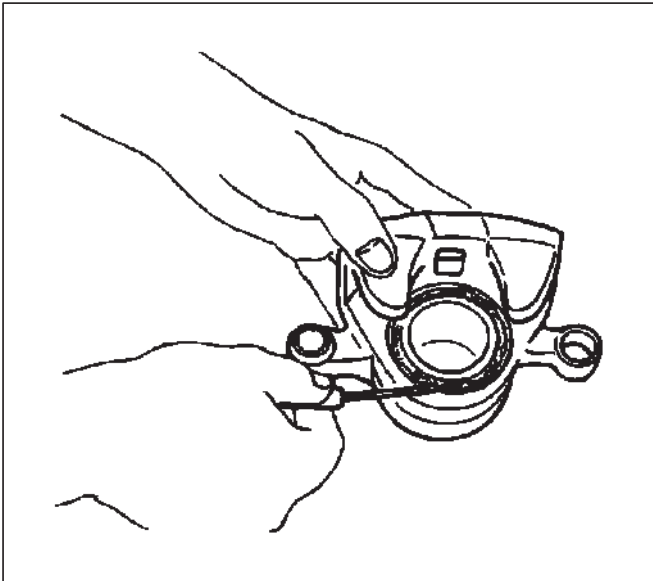


302RS019

## 5C-54 POWER ASSISTED BRAKE SYSTEM

---

6. Install dust boot ring and apply special grease (approximately 1g) to the piston and attach the dust boot to the piston and caliper. Insert the dust boot ring into the dust boot.

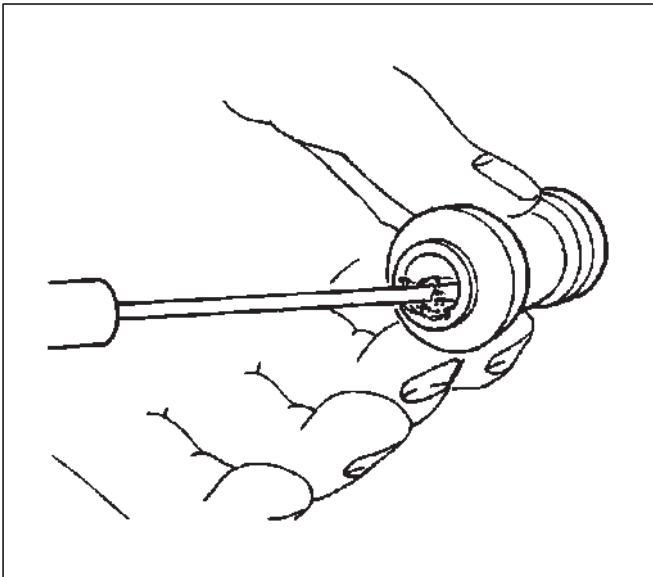


302RS020

7. Install guide bolt and lock bolt dust boot.
8. Install lock bolt and guide bolt and tighten the bolt to the specified torque.

**Torque: 74 N·m (54 lb ft)**

9. Install the dust boot on the support bracket after applying special grease (Approx. 1g) onto the dust boot inner surface. Also apply special grease onto the lock bolt and guide bolt setting hole of the support bracket.



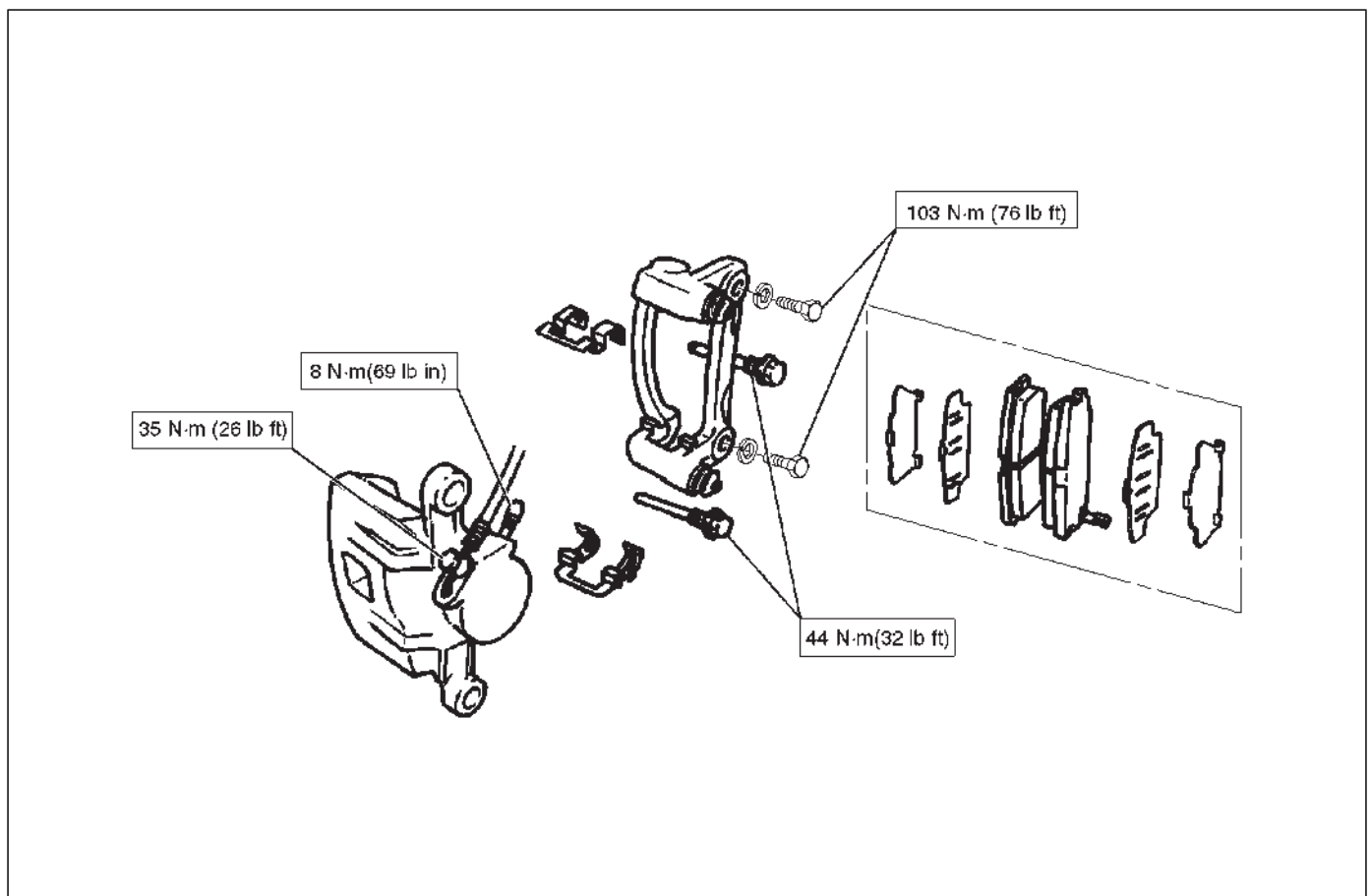
302RS021

## Main Data and Specifications

### General Specifications

Type	Floating, pin slide
Pad dimension	33 cm <sup>2</sup> (5.11 in <sup>2</sup> )
Adjusting method	Self-adjusting
Piston diameter	41.3 mm (1.63 in)
Disc type	Ventilated
Disc thickness	18 mm (0.71 in)
Disc effective diameter	269.2 mm (10.60 in)

### Torque Specifications





# BRAKES

## PARKING BRAKE SYSTEM

### CONTENTS

Service Precaution .....	5D-1	Parking Brake Rear Cable .....	5D-5
General Description .....	5D-1	Parking Brake Rear Cable and	
Operation .....	5D-2	Associated Parts .....	5D-5
Parking Brake Lever and Front Cable .....	5D-3	Removal .....	5D-5
Parking Brake Lever, Front Cable and		Installation .....	5D-6
Associated Parts .....	5D-3	Inspection and Repair .....	5D-7
Removal .....	5D-3	Parking Brake Adjustment .....	5D-7
Installation .....	5D-4	Main Data and Specifications .....	5D-8

### Service Precaution

**WARNING: THIS VEHICLE HAS A SUPPLEMENTAL RESTRAINT SYSTEM (SRS). REFER TO THE SRS COMPONENT AND WIRING LOCATION VIEW IN ORDER TO DETERMINE WHETHER YOU ARE PERFORMING SERVICE ON OR NEAR THE SRS COMPONENTS OR THE SRS WIRING. WHEN YOU ARE PERFORMING SERVICE ON OR NEAR THE SRS COMPONENTS OR THE SRS WIRING, REFER TO THE SRS SERVICE INFORMATION. FAILURE TO FOLLOW WARNINGS COULD RESULT IN POSSIBLE AIR BAG DEPLOYMENT, PERSONAL INJURY, OR OTHERWISE UNNEEDED SRS SYSTEM REPAIRS.**

**CAUTION: Always use the correct fastener in the proper location. When you replace a fastener, use ONLY the exact part number for that application. ISUZU will call out those fasteners that require a replacement after removal. ISUZU will also call out the fasteners that require thread lockers or thread sealant. UNLESS OTHERWISE SPECIFIED, do not use supplemental coatings (Paints, greases, or other corrosion inhibitors) on threaded fasteners or fastener joint interfaces. Generally, such coatings adversely affect the fastener torque and the joint clamping force, and may damage the fastener. When you install fasteners, use the correct tightening sequence and specifications. Following these instructions can help you avoid damage to parts and systems.**

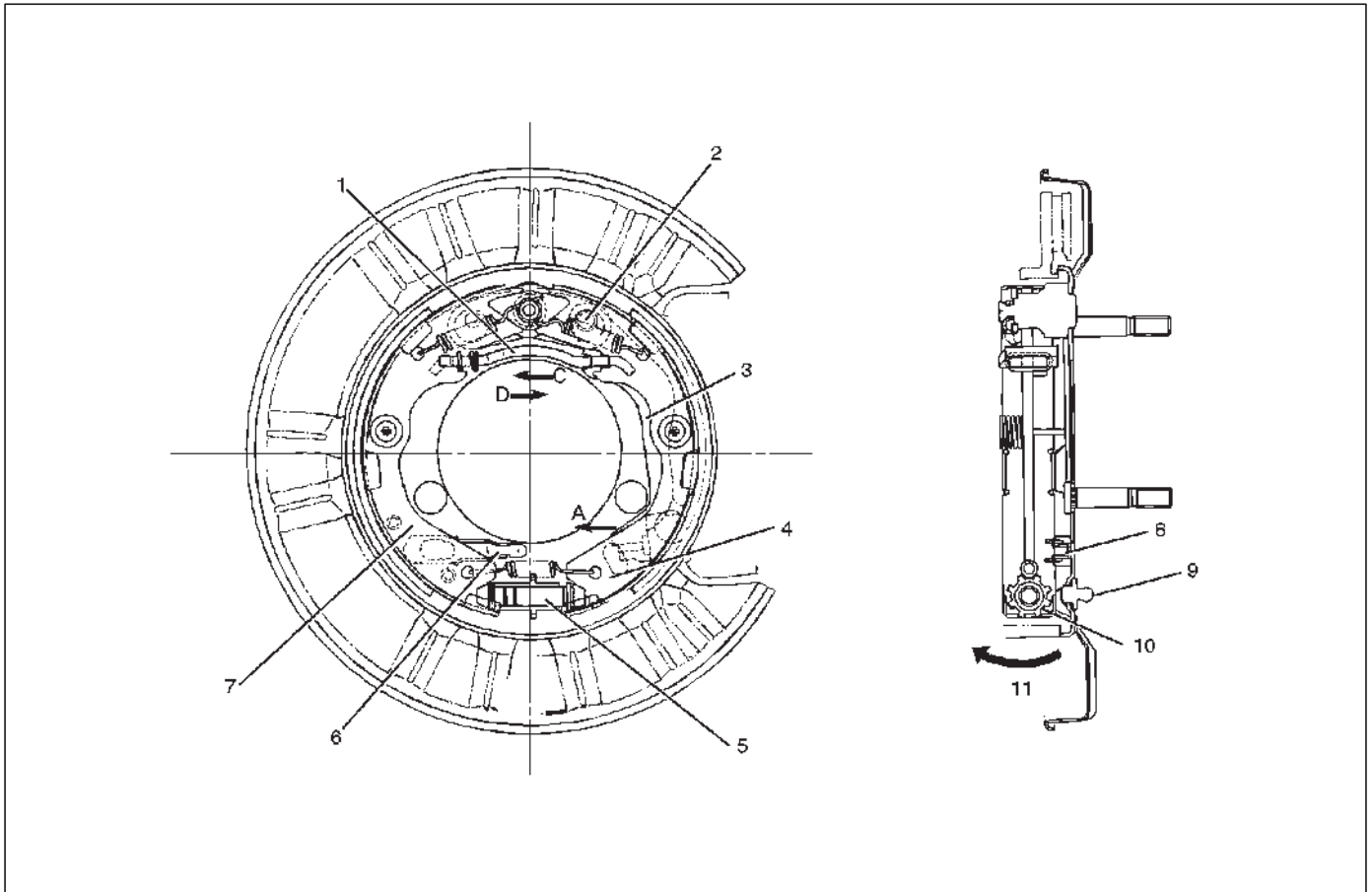
### General Description

Pulling up the parking brake lever by hand will set the parking brake. Once pulled up, the lever is held by a ratchet-type lock until it is released. The position of the lever is transmitted through cable/lever systems to the rear wheels. These parts are designed in order to obtain sufficient braking force when parking on slopes. When the parking brake is set, or when the ignition switch is in the "ON" position, the brake warning light illuminates.

The rear wheel parking brake is a duo-servo brake (mechanical inside expansion type) built into the rear disc brake. Parking brake adjustment is made through the adjusting hole bored through the back plate. Adjust the parking brake lever stroke to six or seven notches. Refer to "Parking Brake Adjustment" in this Section.

## 5D-2 PARKING BRAKE

### Operation



C05RW003

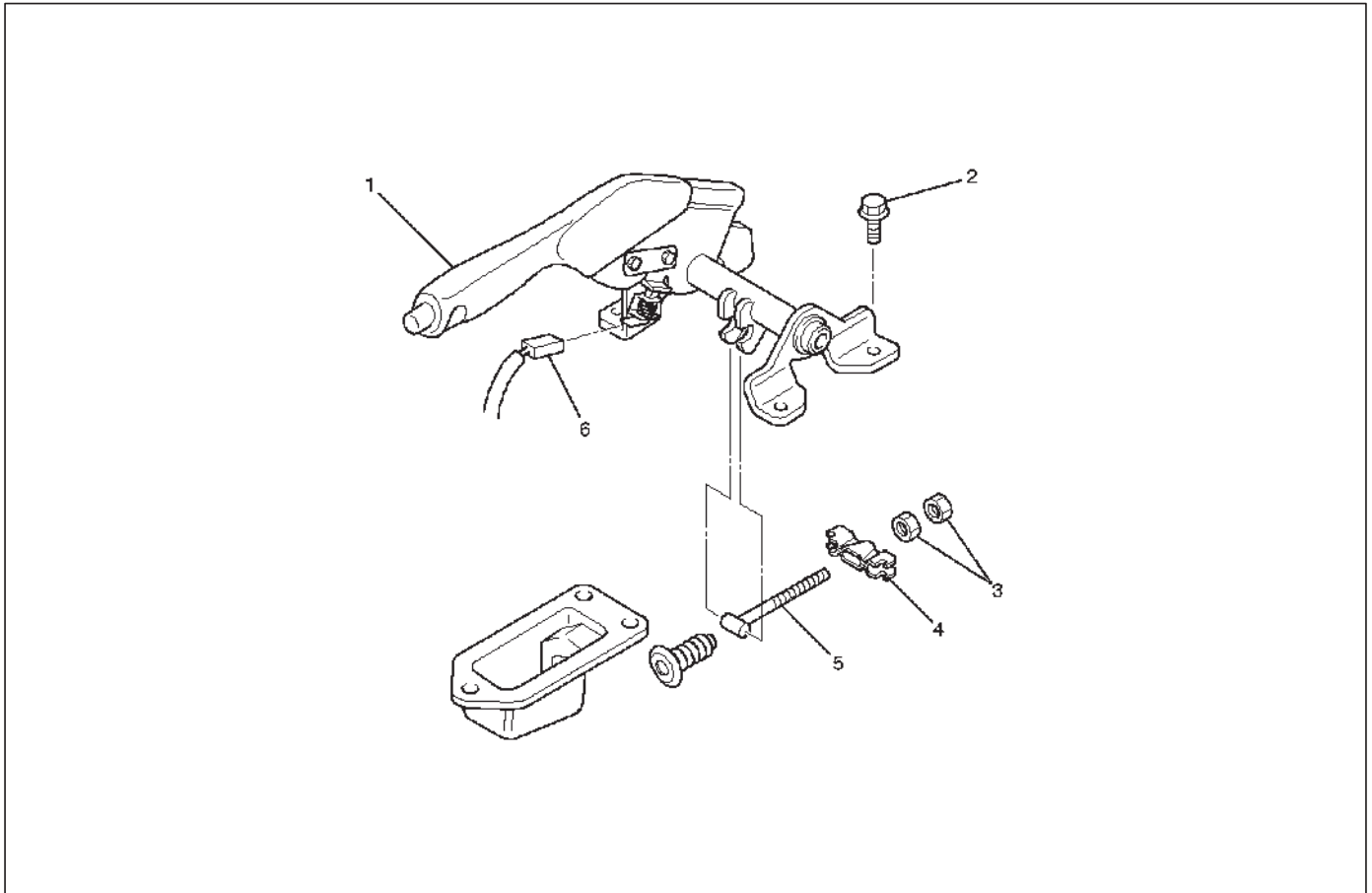
#### Legend

- |                           |                               |
|---------------------------|-------------------------------|
| (1) Strut                 | (6) Parking Cable Guide       |
| (2) Fulcrum B             | (7) Primary Shoe              |
| (3) Parking Lever         | (8) Parking Brake Cable Guide |
| (4) Secondary Shoe        | (9) Adjusting Hole Plug       |
| (5) Adjusting Screw Notch | (10) Adjusting Screw Notch    |
|                           | (11) Shoe Expanding Direction |

When pulled in the direction "A", the parking lever presses the secondary shoe against the brake drum using the lever/shoe joint "B" as a fulcrum and pushes the strut in the direction "C". The strut, in turn, presses the primary shoe against the brake drum. Counter force "D" to the primary shoe is transmitted again to the secondary shoe through the fulcrum "B". The secondary shoe contacts the drum thereby producing braking effect. Clearance which may result from worn parking brake shoe lining can be adjusted by turning the adjusting screw. Refer to "Parking Brake Adjustment" in this Section.

## Parking Brake Lever and Front Cable

### Parking Brake Lever, Front Cable and Associated Parts



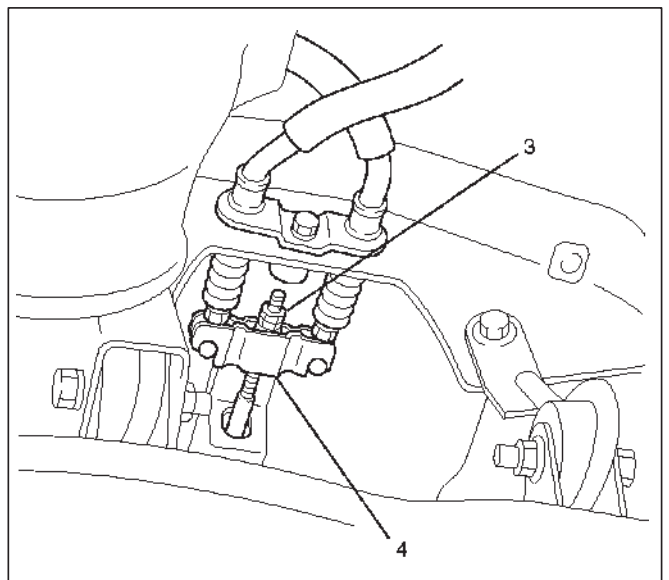
311RW001

#### Legend

- |                         |                               |
|-------------------------|-------------------------------|
| (1) Parking Brake Lever | (4) Equalizer                 |
| (2) Bolt                | (5) Parking Brake Front Cable |
| (3) Adjusting Nut       | (6) Switch Connector          |

#### Removal

1. Remove adjusting nut (3).
2. Remove equalizer (4).



311RW002

## 5D-4 PARKING BRAKE

---

3. Remove center console.  
(Refer to Section 10 "Body".)
4. Remove bolts.
5. Disconnect switch connector.
6. Remove parking brake lever.
7. Remove parking brake front cable.

### Installation

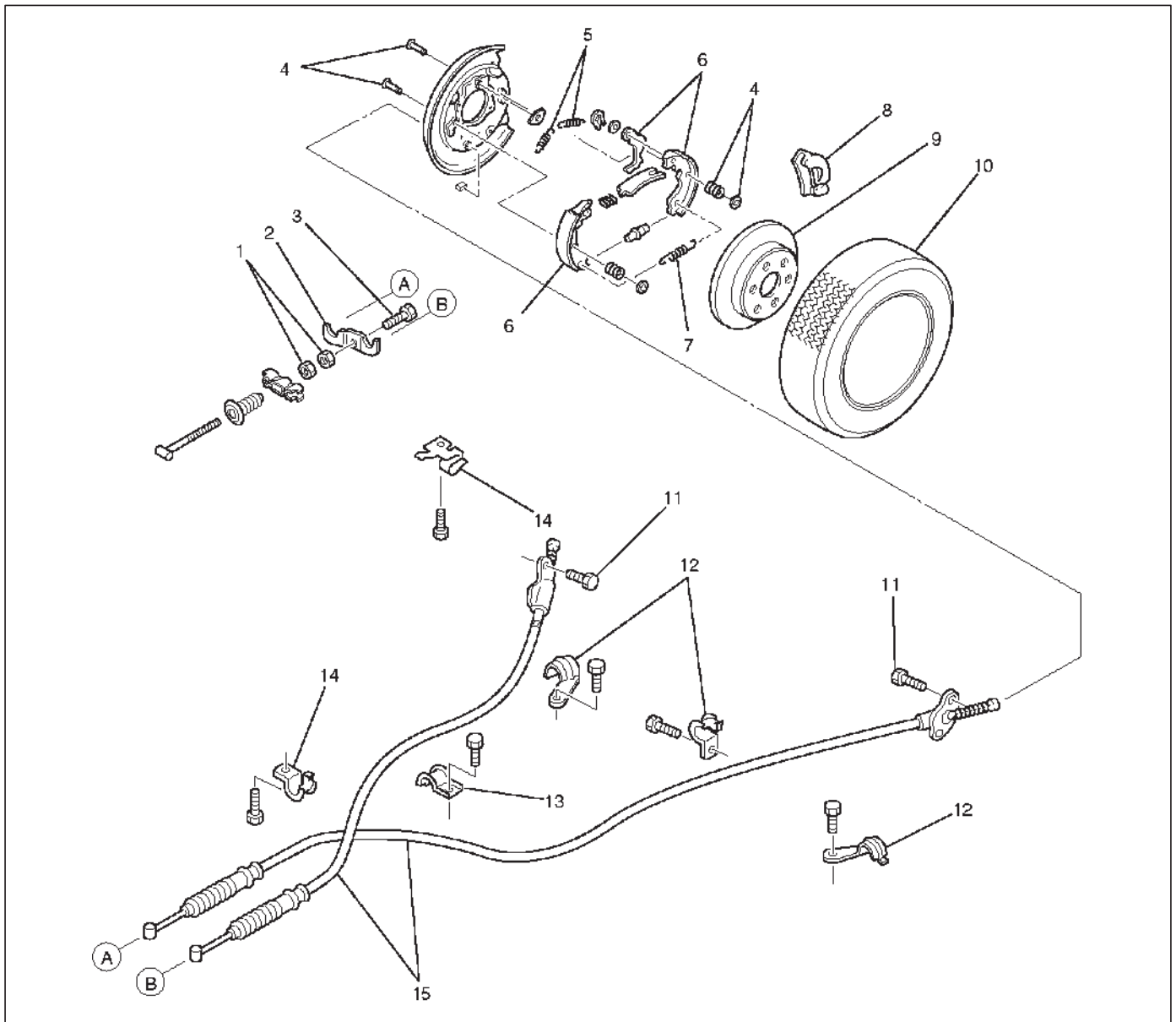
1. Install parking brake front cable.
2. Install parking brake lever and apply grease (BESCO L-2 or equivalent) to front cable contact point.
3. Reconnect switch connector.
4. Install bolts and tighten the parking brake lever fixing bolt to the specified torque.

**Torque : 15 N·m (11 lb ft)**

5. Install center console.  
(Refer to Section 10 "Body".)
6. Install equalizer.
7. Install adjusting nut and adjust the parking brake lever. (See "Parking Brake Adjustment" in this section.)

## Parking Brake Rear Cable

### Parking Brake Rear Cable and Associated Parts



311RX002

#### Legend

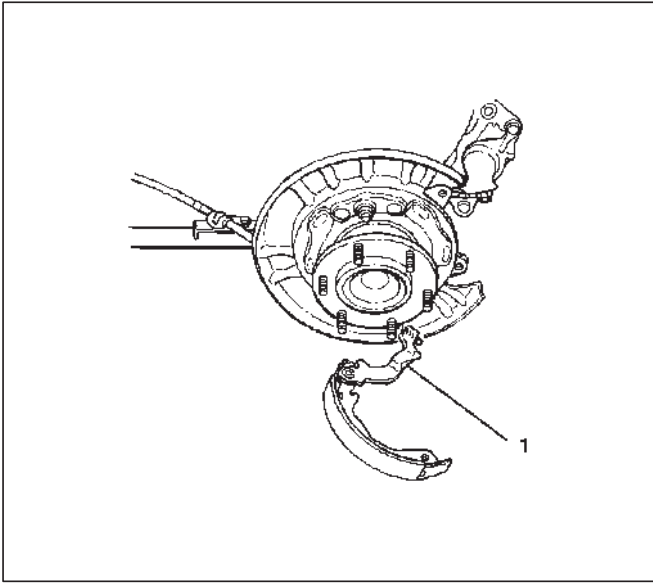
- |                          |                        |
|--------------------------|------------------------|
| (1) Adjust Nut           | (8) Caliper Assembly   |
| (2) Back Plate           | (9) Rotor (Drum)       |
| (3) Bolt                 | (10) Rear Wheels       |
| (4) Holding Spring       | (11) Cable Fixing Bolt |
| (5) Return Spring; Upper | (12) Clip              |
| (6) Shoe Assembly        | (13) Clip              |
| (7) Return Spring; Lower | (14) Clip              |
|                          | (15) Rear Cable        |

#### Removal

1. Remove adjusting nut.
2. Remove rear wheels.
3. Remove caliper assembly, remove two bolts to remove the caliper assembly from the support bracket. (Refer to "Rear Disc Brakes in Disc Brakes" in Section 5C). Temporarily hang the caliper with a wire in order to avoid stretching the brake hose.
4. Remove rotor (drum).
5. Remove clip (floor side).

## 5D-6 PARKING BRAKE

6. Remove bolt.
7. Remove back plate.
8. Remove clip (frame side).
9. Remove clip (suspension side).
10. Remove holding spring.
11. Remove return spring; upper.
12. Remove return spring; lower.
13. Remove the brake shoe assembly. Then remove the parking brake cable from the parking brake lever (1).



308RW001

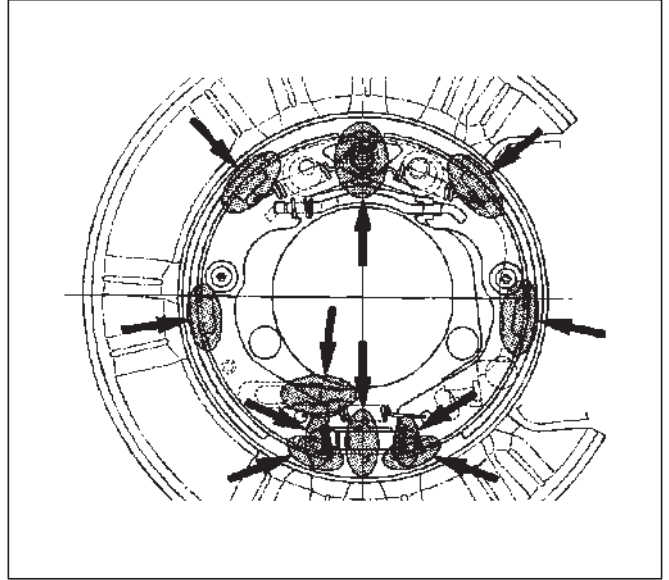
14. Remove cable fixing bolt.
15. Remove rear cable.

## Installation

1. Install rear cable and apply grease (BESCO L-2 or equivalent) to the connecting portion of the rear cable and the equalizer.
2. Install cable fixing bolt and tighten the cable fixing bolt to the specified torque.

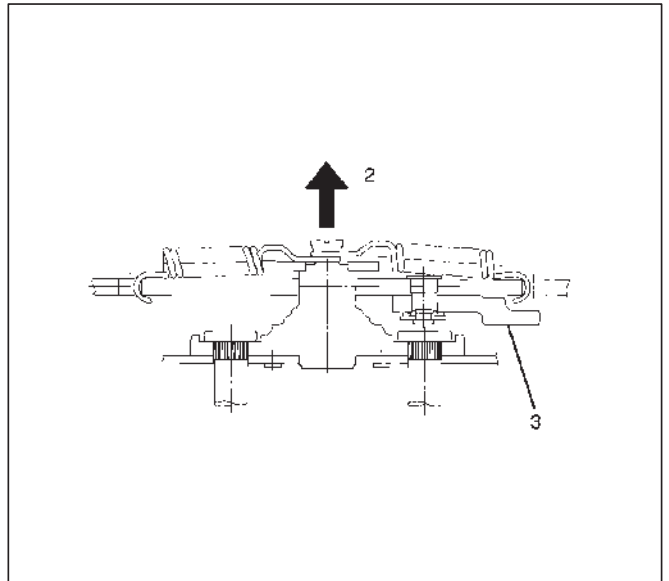
**Torque: 6 N·m (52 lb in)**

3. Install shoe assembly and after installation of the shoe and cable assembly, apply the special grease included in the repair kit to the portions indicated in the illustration.



308RS002

4. Install return spring; lower.
5. Install return spring; upper and the parking brake lever (3) side (secondary side) return spring must be installed on the outer side (2) of the primary side return spring.



308RW002

6. Install holding spring.
7. Install clip (suspension side) and tighten the bolt to the specified torque.  
**Torque: 7.8 N·m (68 lb in)**
8. Install clip (frame side) and tighten the bolt to the specified torque.  
**Torque: 15 N·m (11 lb in)**
9. Install back plate.
10. Install bolt and tighten the bolt to the specified torque.  
**Torque: 6 N·m (52 lb in)**
11. Install clip (floor side) and tighten the bolt to the specified torque.  
**Torque: 15 N·m (11 lb in)**
12. Install rotor.
13. Install caliper assembly.
14. Install rear wheels.
15. Install adjusting nut and apply grease (BESCO L-2 or equivalent) to front cable contact point.
16. Tighten the adjusting nut to the specified torque and to adjust the parking brake, refer to "Parking Brake Adjustment" in this section.  
**Torque: 6 N·m (52 lb in)**

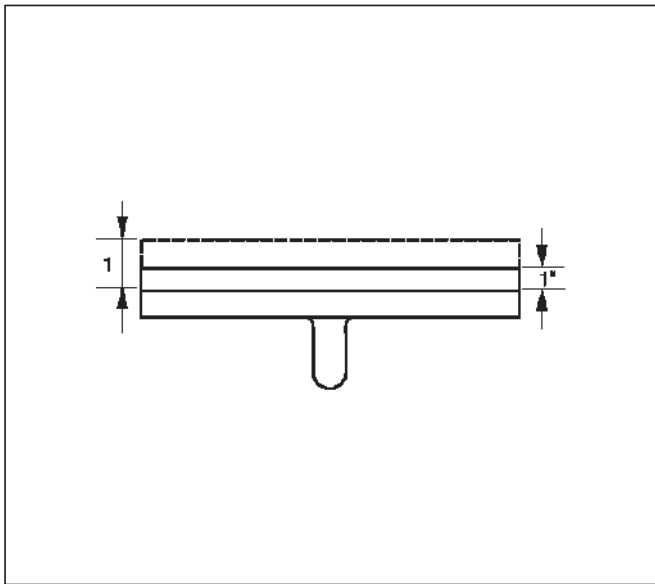
## Inspection and Repair

### Parking Brake Lining Inspection

Check the shoe assemblies for wear by removing the brake drum rotor.

Replace the shoe assemblies if the lining thickness is less than 1.0 mm (0.039 in).

**Minimum limit: 1.0 mm (0.039 in)**



308RW003

### Parking Brake Rotor (Drum) Inspection

Refer to "Rear Disc Brakes" in Section 5A2 for the inspection procedure of the rotor (drum).

## Parking Brake Adjustment

### 1. Adjustment of parking brake assembly

○Prior to lever stroke adjustment, adjust the rear brake shoe/rotor (drum) gap. Perform this procedure by loosening the adjusting nut of the equalizer.

a. Remove the adjusting hole plug (rubber) and turn the shoe adjusting screw downward using a small screwdriver so that the shoes will expand until they get into close contact with the rotor. (Turn down the adjusting screw notch by notch until the rotor does not turn.)

b. Turn the adjusting screw in the opposite direction (upward) until the rotor can be turned lightly. Standard number of notches to turn upward: 7 or 8. Turn the rotor in order to ensure that there is no brake dragging.

### 2. Adjustment of parking brake cable

a. Turn the equalizer nut so that the parking brake lever travels 6 or 7 notches when pulled up with a force of 30 kg (66 lb).

b. Make sure that there is no brake dragging and tighten the cable lock nut.

**Torque : 6 N·m (52 lb in)**

### 3. Break-in of parking brake shoe

○When poor braking is felt, or just after replacement of parking brake shoes, be sure to conduct the break-in procedure by driving the vehicle as follows:

a. Forward 50 km/h (30 mph) × 400 m (about 30 seconds) with a lever pull force of 15 kg (33 lb).

b. Backward 10 km/h (6 mph) × 50 m (about 18 seconds) with a lever pull force of 15 kg (33 lb).

NOTE: Break-in procedures must be performed under safe conditions and traffic rules.

○If the braking effect remains poor after the break-in, wait for some time until parking brake shoe cools down and repeat procedures a. and b. noted above.

○On completion of break-in, inspect the parking brake lever stroke, and if the lever does not come within the specified number of notches when pulled up, readjust.

○Excessive break-in may cause premature wear of the parking brake lining.

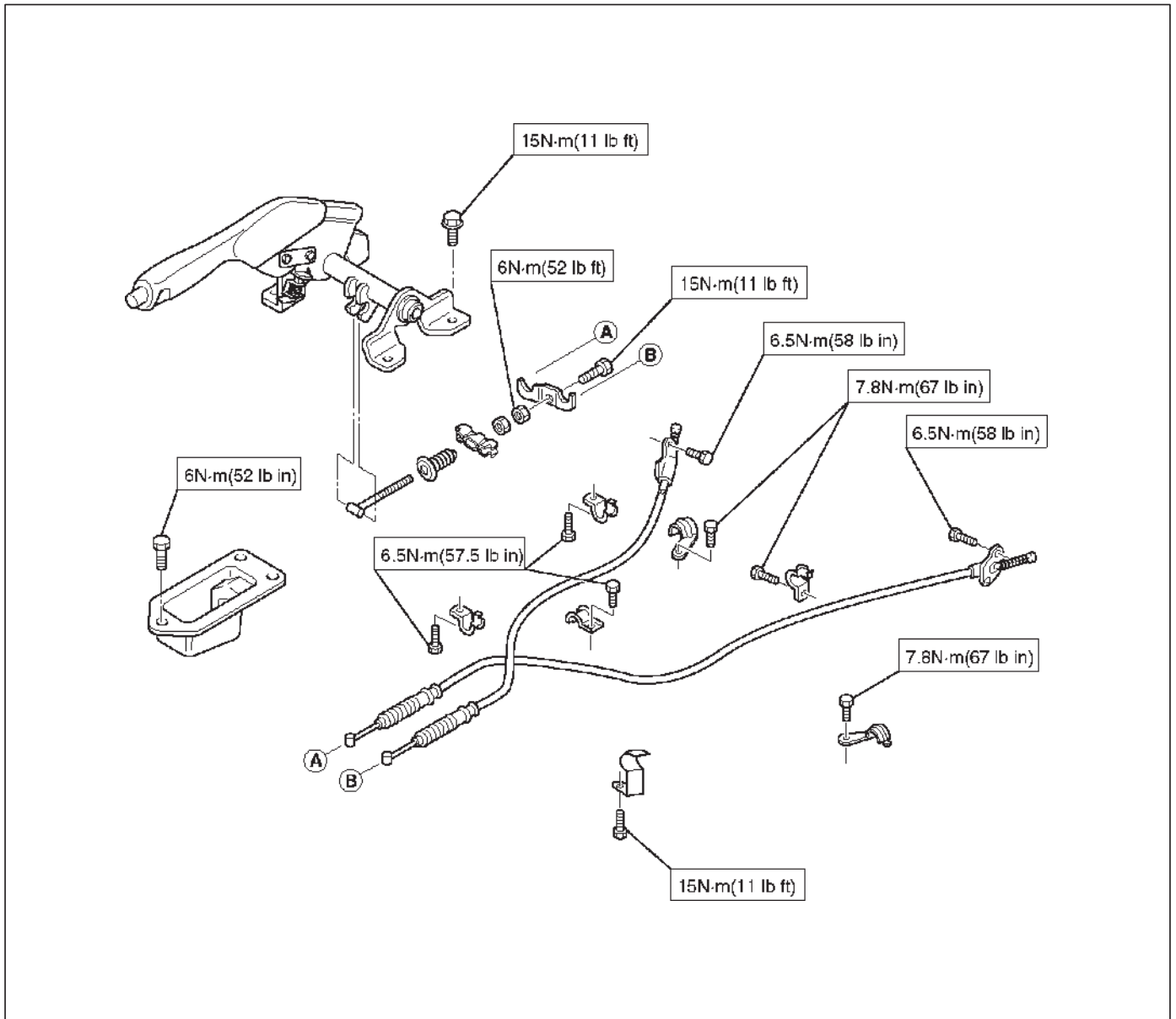
## 5D-8 PARKING BRAKE

### Main Data and Specifications

#### General Specifications

Rear parking brake	
Type	Duo-servo
Lining Dimension	121.2 cm <sup>2</sup> (18.79 in <sup>2</sup> )
Adjusting Method	Manual adjusting
Rotor (Drum) Inside Diameter	210 mm (8.27 in)
Parking Brake Lever Stroke	6-7 notches When pulled with a force of 30 kg (66 lb)

#### Torque Specifications





VEHICROSS

# ENGINE

## CONTENTS

Engine Mechanical .....	6A	Driveability and Emissions .....	6E
Engine Cooling .....	6B	Engine Exhaust .....	6F
Engine Fuel .....	6C	Engine Lubrication .....	6G
Engine Electrical .....	6D1	Engine Speed Control System .....	6H
Ignition System .....	6D2	Inducton .....	6J
Starting and Charging System .....	6D3		

# ENGINE MECHANICAL

## CONTENTS

Service Precaution .....	6A-2	Removal .....	6A-41
General Description .....	6A-3	Installation .....	6A-42
Engine Diagnosis .....	6A-4	Crankshaft and Main Bearings .....	6A-43
Cylinder Head Cover LH .....	6A-18	Removal .....	6A-43
Removal .....	6A-18	Installation .....	6A-44
Installation .....	6A-19	Rear Oil Seal .....	6A-48
Cylinder Head Cover RH .....	6A-21	Removal .....	6A-48
Removal .....	6A-21	Installation .....	6A-48
Installation .....	6A-22	Engine Assembly .....	6A-49
Common Chamber .....	6A-24	Removal .....	6A-49
Removal .....	6A-24	Installation .....	6A-49
Installation .....	6A-24	Cylinder Head .....	6A-52
Exhaust Manifold LH .....	6A-26	Cylinder Head and Associated Parts .....	6A-52
Removal .....	6A-26	Disassembly .....	6A-52
Installation .....	6A-26	Clean .....	6A-53
Exhaust Manifold RH .....	6A-28	Inspection and Repair .....	6A-53
Removal .....	6A-28	Reassembly .....	6A-53
Installation .....	6A-29	Valve Spring, Oil Controller, Valve, Valve Guide .....	6A-56
Crankshaft Pulley .....	6A-30	Valve Spring, Oil Controller, Valve, Valve Guide and Associated Parts .....	6A-56
Removal .....	6A-30	Disassembly .....	6A-56
Installation .....	6A-30	Inspection and Repair .....	6A-57
Timing Belt .....	6A-31	Reassembly .....	6A-60
Removal .....	6A-31	Valve Clearance Adjustments .....	6A-61
Installation .....	6A-32	Camshaft .....	6A-63
Camshaft .....	6A-35	Camshaft and Associated Parts .....	6A-63
Removal .....	6A-35	Disassembly .....	6A-63
Installation .....	6A-35	Inspection and Repair .....	6A-64
Cylinder Head .....	6A-38	Reassembly .....	6A-66
Removal .....	6A-38	Crankshaft .....	6A-69
Installation .....	6A-38	Crankshaft and Associated Parts .....	6A-69
Valve Stem Oil Controller , Valve Spring and Valve Guide .....	6A-40	Disassembly .....	6A-69
Removal .....	6A-40	Inspection and Repair .....	6A-70
Installation .....	6A-40	Inspection and Repair .....	6A-71
Piston, Piston Ring and Connecting Rod ...	6A-41	Reassembly .....	6A-73

## 6A-2 ENGINE MECHANICAL

---

Piston and Connecting Rod .....	6A-77
Piston, Connecting Rod and Associate Parts .....	6A-77
Disassembly .....	6A-77
Inspection and Repair .....	6A-78
Reassembly .....	6A-82
Cylinder Block .....	6A-85
Cylinder Block and Associated Parts .....	6A-85
Disassembly .....	6A-85
Inspection and Repair .....	6A-86
Reassembly .....	6A-87
Main Data and Specification .....	6A-90
Special Tool .....	6A-96

### Service Precaution

**WARNING: THIS VEHICLE HAS A SUPPLEMENTAL RESTRAINT SYSTEM (SRS). REFER TO THE SRS COMPONENT AND WIRING LOCATION VIEW IN ORDER TO DETERMINE WHETHER YOU ARE PERFORMING SERVICE ON OR NEAR THE SRS COMPONENTS OR THE SRS WIRING. WHEN YOU ARE PERFORMING SERVICE ON OR NEAR THE SRS COMPONENTS OR THE SRS WIRING, REFER TO THE SRS SERVICE INFORMATION. FAILURE TO FOLLOW WARNINGS COULD RESULT IN POSSIBLE AIR BAG DEPLOYMENT, PERSONAL INJURY, OR OTHERWISE UNNEEDED SRS SYSTEM REPAIRS.**

**CAUTION: Always use the correct fastener in the proper location. When you replace a fastener, use ONLY the exact part number for that application. ISUZU will call out those fasteners that require a replacement after removal. ISUZU will also call out the fasteners that require thread lockers or thread sealant. UNLESS OTHERWISE SPECIFIED, do not use supplemental coatings (Paints, greases, or other corrosion inhibitors) on threaded fasteners or fastener joint interfaces. Generally, such coatings adversely affect the fastener torque and the joint clamping force, and may damage the fastener. When you install fasteners, use the correct tightening sequence and specifications. Following these instructions can help you avoid damage to parts and systems.**

## General Description

### Engine Cleanliness And Care

An automobile engine is a combination of many machined, honed, polished and lapped surfaces with tolerances that are measured in the thousandths of a millimeter (ten thousandths of an inch). Accordingly, when any internal engine parts are serviced, care and cleanliness are important. Throughout this section, it should be understood that proper cleaning and protection of machined surfaces and friction areas is part of the repair procedure. This is considered standard shop practice even if not specifically stated.

- A liberal coating of engine oil should be applied to all friction areas during assembly to protect and lubricate the surfaces on initial operation.
- Whenever valve train components, pistons, piston rings, connecting rods, rod bearings, and crankshaft journal bearings are removed for service, they should be retained in order.
- At the time of installation, they should be installed in the same locations and with the same mating surfaces as when removed.
- Battery cables should be disconnected before any major work is performed on the engine. Failure to disconnect cables may result in damage to wire harness or other electrical parts.
- The six cylinders of this engine are identified by numbers; Right side cylinders 1, 3 and 5, Left side cylinders 2, 4 and 6, as counted from crankshaft pulley side to flywheel side.

### General Information on Engine Service

The following information on engine service should be noted carefully, as it is important in preventing damage and contributing to reliable engine performance:

- When raising or supporting the engine for any reason, do not use a jack under the oil pan. Due to the small clearance between the oil pan and the oil pump strainer, jacking against the oil pan may cause damage to the oil pick-up unit.
- The 12-volt electrical system is capable of damaging circuits. When performing any work where electrical terminals could possibly be grounded, the ground cable of the battery should be disconnected at the battery.
- Any time the intake air duct or air cleaner is removed, the intake opening should be covered. This will protect against accidental entrance of foreign material into the cylinder which could cause extensive damage when the engine is started.

### Cylinder Block

The cylinder block is made of aluminum die-cast casting for 75° V-type six cylinders. It has a rear plate integrated structure and employs a deep skirt. The cylinder liner is cast and the liner inner diameter and crankshaft journal diameter are classified into grades. The crankshaft is supported by four bearings of which width of No.3 bearing on the body side is different in order to support the thrust bearing. The bearing cap is made of nodular cast iron and each bearing cap uses four bolts and two side bolts.

### Cylinder Head

The cylinder head, made of aluminum alloy casting employs a pent-roof type combustion chamber with a spark plug in the center. The intake and exhaust valves are placed in V-type design. The ports are cross-flow type.

### Valve Train

Intake and exhaust camshaft on the both side of banks are driven through an camshaft drive gear by timing belt. The valves are operated by the camshaft and the valve clearance is adjusted to select suitable thickness shim.

### Intake Manifold

The intake manifold system is composed of the aluminum cast common chamber and intake manifold attached with six fuel injectors.

### Exhaust Manifold

The exhaust manifold is made of nodular cast iron.

### Pistons and Connecting Rods

Aluminum pistons are used after selecting the grade that meets the cylinder bore diameter. Each piston has two compression rings and one oil ring. The piston pin is made of chromium steel is offset 1mm toward the thrust side, and the thrust pressure of piston to the cylinder wall varies gradually as the piston travels. The connecting rods are made of forged steel. The connecting rod bearings are graded for correct size selection.

### Crankshaft and Bearings

The crankshaft is made of Ductile cast-iron. Pins and journals are graded for correct size selection for their bearing.

### Engine Lubrication

The oil discharged by a trochoid-type oil pump driven by the crankshaft and is fed through full-flow oil filter and to the oil gallery provided under the crankshaft bearing cap. The oil is then led to the crankshaft journals and cylinder head. The crank pins are lubricated with oil from crankshaft journals through oil holes. Also, an oil jet is fed to each cylinder from crankshaft journals on the connecting rod for piston cleaning. The oil pan flange is sealed with liquid packing only; do not deform or damage the flange surface during removal or installation.

## Engine Diagnosis

### Hard Starting

#### 1. Starting Motor Does Not Turn Over

##### Troubleshooting Procedure

Turn on headlights and starter switch.

Condition	Possible cause	Correction
Headlights go out or dim considerably	Battery run down or under charged	Recharge or replace battery
	Terminals poorly connected	Clean battery posts and terminals and connect properly
	Starting motor coil circuit shorted	Overhaul or replace
	Starting motor defective	Overhaul or replace

#### 2. Ignition Trouble — Starting Motor Turns Over But Engine Does Not Start

##### Spark Test

Disconnect an igniton coil from any spark plug. Connect the spark plug tester J-26792 (ST-125), start the engine, and check if a spark is generated in the spark plug tester.

Before starting the engine, make sure that the spark plug tester is properly grounded. To avoid electrical shock, do not touch the part where the insulation of the igniton coil is broken while the engine is running.

Condition	Possible cause	Correction
Spark jumps across gap	Spark plug defective	Clean, adjust spark gap or replace
	Ignition timing incorrect	Refer to Ignition System
	Fuel not reaching fuel injector(s) or engine	Refer to item 3 (Trouble in fuel system)
	Valve timing incorrect	Adjust
	Engine lacks compression	Refer to item 4 (Engine lacks compression)
No sparking takes place	Ignition coil disconnected or broken	Connect properly or replace
	Electronic Ignition System with module	Replace
	Poor connections in engine harness	Correct
	Powertrain Control Module cable disconnected or defective	Correct or replace

#### 3. Trouble In Fuel System

Condition	Possible cause	Correction
Starting motor turns over and spark occurs but engine does not start.	Fuel tank empty	Fill
	Water in fuel system	Clean
	Fuel filter clogged	Replace filter
	Fuel pipe clogged	Clean or replace
	Fuel pump defective	Replace
	Fuel pump circuit open	Correct or replace
	Evaporative Emission Control System circuit clogged	Correct or replace
	Multipoint Fuel Injection System faulty	Refer to "Electronic Fuel Injection" section

#### 4. Engine Lacks Compression

Condition	Possible cause	Correction
Engine lacks compression	Spark plug loosely fitted or spark plug gasket defective	Tighten to specified torque or replace gasket
	Valve timing incorrect	Adjust
	Cylinder head gasket defective	Replace gasket
	Valve incorrectly seated	Lap valve
	Valve stem seized	Replace valve and valve guide
	Valve spring weakened or broken	Replace
	Cylinder or piston rings worn	Overhaul engine
	Piston ring seized	Overhaul engine.

#### Engine Compression Test Procedure

1. Start and run the engine until the engine reaches normal operating temperature.
2. Turn the engine off.
3. Remove all the spark plugs.
4. Remove ignition coil fuse (15A) and disable the ignition system.
5. Remove the fuel pump relay from the relay and fuse box.
6. Engage the starter and check that the cranking speed is approximately 300 rpm.
7. Install cylinder compression gauge into spark plug hole.
8. With the throttle valve opened fully, keep the starter engaged until the compression gage needle reaches the maximum level. Note the reading.
9. Repeat the test with each cylinder.  
If the compression pressure obtained in any cylinder falls below the limit, engine overhaul is necessary.

**Limit; 1000 kpa (145 psi)**

**Rough Engine Idling or Engine Stalling**

Condition	Possible cause	Correction
Trouble in fuel injection system	Idle air control valve defective	Replace
	Throttle shutting off incomplete	Correct or replace
	Throttle position sensor circuit open or shorted	Correct or replace
	Fuel injector circuits open or shorted	Correct or replace
	Fuel injectors damaged	Replace
	Fuel pump relay defective	Replace
	Mass Air flow (MAF) Sensor circuit open or poor connections	Correct or replace
	MAF Sensor defective	Replace
	Manifold Absolute Pressure (MAP) Sensor circuit open or poor connections	Correct or replace
	MAP Sensor defective	Replace
	Engine Coolant Temperature (ECT) Sensor circuit open or poor connections	Correct or replace
	ECT Sensor defective	Replace
	Intake Air Temperature (IAT) sensor circuit open or poor connections	Correct or replace
	IAT sensor defective	Replace
	Knock Sensor (KS) cable broken or poor connections	Correct or replace
	KS defective	Replace
	KS Module circuits open or ground	Correct or replace
	KS Module defective	Replace
Vehicle Speed Sensor (VSS) circuit open or shorted	Correct or replace	
VSS defective	Replace	
Trouble in emission control system	Powertrain Control Module defective	Replace
	Exhaust Gas Recirculation (EGR) Valve circuit open or poor connections	Correct or replace
	EGR Valve faulty	Replace
	Canister purge valve circuit open or poor connections	Correct or replace
	Canister purge valve defective	Replace
	Evaporative Emission Canister Purge control valve defective	Replace
	Trouble in ignition system	Refer to "Hard Start"

<b>Condition</b>	<b>Possible cause</b>	<b>Correction</b>
Others	Engine lacks compression	Refer to "Hard Start"
	Valve incorrectly seated	Lap valve
	Air Cleaner Filter clogged	Replace filter element
	Valve timing incorrect	Readjust
	Idle air control valve broken	Replace
	Fast idle solenoid defective	Replace
	Positive Crankcase Ventilation valve defective or clogged	Replace

**Rough Engine Running**

<b>Condition</b>	<b>Possible cause</b>	<b>Correction</b>
Engine misfires periodically	Ignition coil layer shorted	Replace
	Spark plugs fouling	Clean or install hotter type plug
	Spark plug(s) insulator nose leaking	Replace
	Fuel injector(s) defective	Replace
	Powertrain control module faulty	Replace
Engine knocks periodically	Spark plugs running too hot	Install colder type spark plugs
	Powertrain control module faulty	Replace
Engine lacks power	Spark plugs fouled	Clean
	Fuel injectors defective	Replace
	Mass Air flow Sensor or Intake Airflow Sensor circuit defective	Correct or replace
	Manifold Absolute Pressure (MAP) Sensor or Manifold Absolute Pressure Sensor circuit defective	Correct or replace
	Engine Coolant Temperature (ECT) Sensor or ECT Sensor circuit defective	Correct or replace
	Powertrain Control Module faulty	Replace
	Intake Air Temperature (IAT) Sensor or IAT Sensor circuit defective	Correct or replace
	Throttle Position Sensor (TPS) or TPS circuit defective	Correct or replace
	Knock Sensor (KS) or KS circuits defective	Correct or replace
	KS Module or KS Module circuits defective	Correct or replace

**Hesitation**

Condition	Possible cause	Correction
Hesitation on acceleration	Throttle Position Sensor (TPS) adjustment incorrect	Replace throttle valve assembly
	TPS circuit open or shorted	Correct or replace
	Excessive play in accelerator linkage	Adjust or replace
	Mass Air flow (MAF) Sensor circuit open or poor connections	Correct or replace
	MAF Sensor defective	Replace
	Manifold Absolute Pressure (MAP) Sensor circuit open or shorted	Correct or replace
	MAP Sensor defective	Replace
	Intake Air Temperature (IAT) Sensor circuit open or shorted	Correct or replace
	IAT Sensor defective	Replace
	Knock Sensor (KS) Circuit open or poor connections	Correct or replace
	KS defective	Replace
	KS Module circuits open or shorted	Correct or replace
	KS Module defective	Replace
Hesitation at high speeds (Fuel pressure too low)	Fuel tank strainer clogged	Clean or replace
	Fuel pipe clogged	Clean or replace
	Fuel filter clogged	Replace
	Defective fuel pump system	Check and replace
	Fuel Pressure Control Valve leaking	Replace
Hesitation at high speeds (Fuel injector not working normally)	Power supply or ground circuit for Multiport Fuel Injection System shorted or open	Check and correct or replace
	Fuel Injector defective	Replace
	Cable of Multiport Fuel Injection System circuit open or poor connections	Correct or replace



Condition	Possible cause	Correction
Hesitation at high speeds	Powertrain Control Module defective	Replace
	Throttle Position Sensor (TPS) cable broken or poor connections	Correct or replace
	TPS defective	Replace
	Engine Coolant Temperature (ECT) Sensor circuit open or shorted	Correct or replace
	ECT Sensor defective	Replace
	Mass Air flow (MAF) Sensor circuit open or poor connections	Correct or replace
	MAF Sensor defective	Replace
	MAP Sensor cable broken or poor connections	Correct or replace
	MAP Sensor defective	Replace
	IAT Sensor circuit open or poor connections	Correct or replace
	IAT Sensor defective	Replace
	KS circuit open or poor connections	Correct or replace
	KS defective	Replace
	KS Module circuit open or shorted	Correct or replace
	KS Module defective	Replace
	Throttle valve not fully opened	Check and correct or replace
Air Cleaner Filter clogged	Replace filter element	
Power supply voltage too low	Check and correct or replace	

## 6A-10 ENGINE MECHANICAL

### Engine Lacks Power

Condition	Possible cause	Correction
Trouble in fuel system	Fuel Pressure Control Valve not working normally	Replace
	Fuel injector clogged	Clean or replace
	Fuel pipe clogged	Clean
	Fuel filter clogged or fouled	Replace
	Fuel pump drive circuit not working normally	Correct or replace
	Fuel tank not sufficiently breathing due to clogged Evaporative Emission Control System circuit	Clean or replace
	Water in fuel system	Clean
	Inferior quality fuel in fuel system	Use fuel of specified octane rating
	Powertrain Control Module supplied poor voltage	Correct circuit
	Throttle Position Sensor cable broken or poor connections	Correct or replace
	Throttle Position Sensor defective	Replace
	Mass Air flow Sensor not working normally	Replace
	Manifold Absolute Pressure Sensor not working normally	Replace
	Intake Air Temperature Sensor not working normally	Replace
	Engine Coolant Temperature (ECT) Sensor circuit open or shorted	Correct or replace
	ECT Sensor defective	Replace
Powertrain Control Module defective	Replace	
Trouble in intake or exhaust system	Air Cleaner Filter clogged	Replace filter element
	Air duct kinked or flattened	Correct or replace
Ignition failure	_____	Refer to Hard Start Troubleshooting Guide
	Heat range of spark plug inadequate	Install spark plugs of adequate heat range
	Ignition coil defective	Replace

<b>Condition</b>	<b>Possible cause</b>	<b>Correction</b>
Engine overheating	Level of Engine Coolant too low	Replenish
	Fan clutch defective	Replace
	Incorrect fan installed	Replace
	Thermostat defective	Replace
	Engine Coolant pump defective	Correct or replace
	Radiator clogged	Clean or replace
	Radiator filler cap defective	Replace
	Level of oil in engine crankcase too low or wrong engine oil	Change or replenish
	Resistance in exhaust system increased	Clean exhaust system or replace defective parts
	Throttle Position Sensor (TPS) adjustment incorrect	Replace with Throttle Valve ASM
	TPS circuit open or shorted	Correct or replace
Cylinder head gasket damaged	Replace	
Engine overcooling	Thermostat defective	Replace (Use a thermostat set to open at 82°C (180°F))
Engine lacks compression	—————	Refer to Hard Start
Others	Tire inflation pressure abnormal	Adjust to recommended pressures
	Brake drag	Adjust
	Level of oil in engine crankcase too high	Correct level of engine oil
	Exhaust Gas Recirculation Valve defective	Replace

**Engine Noisy**

Abnormal engine noise often consists of various noises originating in rotating parts, sliding parts and other moving parts of the engine. It is, therefore, advisable to locate the source of noise systematically.

<b>Condition</b>	<b>Possible cause</b>	<b>Correction</b>
Noise from crank journals or from crank bearings (Faulty crank journals and crank bearings usually make dull noise that becomes more evident when accelerating)	Oil clearance increased due to worn crank journals or crank bearings	Replace crank bearings and crankshaft or regrind crankshaft and install the undersize bearing
	Crankshaft out of round	Replace crank bearings and crankshaft or regrind crankshaft and install the undersize bearing
	Crank bearing seized	Crank bearing seized. Replace crank bearings and crankshaft or regrind crankshaft and install the undersize bearing

## 6A-12 ENGINE MECHANICAL

### Troubleshooting Procedure

Disconnect each spark plug in sequence using insulated spark plug wire removers. Locate cylinder with defective

bearing by listening for abnormal noise that stops when spark plug is disconnected.

Condition	Possible cause	Correction
Noise from connecting rods or from connecting rod bearings (Faulty connecting rods or connecting rod bearings usually make an abnormal noise slightly higher than the crank bearing noise, which becomes more evident when engine is accelerated)	Bearing or crankshaft pin worn	Replace connecting rod bearings and crankshaft or regrind crankshaft pin and install the undersize bearing
	Crankpin out of round	Replace connecting rod bearings and crankshaft or regrind crankshaft pin and install the undersize bearing
	Connecting rod bent	Correct or replace
	Connecting rod bearing seized	Replace connecting rod bearings and crankshaft or regrind crankshaft pin and install the undersize bearing

### Troubleshooting Procedure

Abnormal noise stops when the spark plug on the cylinder with defective part is disconnected.

Condition	Possible cause	Correction
Piston and cylinder noise (Faulty piston or cylinder usually makes a combined mechanical thumping noise which increases when engine is suddenly accelerated but diminishes gradually as the engine warms up)	Piston clearance increased due to cylinder wear	Replace pistons and crank bearings or connecting rods or cylinder body.
	Piston seized	Replace pistons and crank bearings or connecting rods or cylinder body.
	Piston ring broken	Replace pistons and crank bearings or connecting rods or cylinder body.
	Piston defective	Replace pistons and others

### Troubleshooting Procedure

Disconnect each spark plug and listen for change in engine noise.

Condition	Possible cause	Correction
Piston pin noise (Piston makes noise each time it goes up and down)	Piston pin or piston pin hole worn	Replace piston, piston pin and connecting rod assy

### Troubleshooting Procedure

The slapping sound stops when spark plug on bad cylinder is disconnected.

Condition	Possible cause	Correction
Timing belt noise	Timing belt tension is incorrect	Replace pusher or adjust the tension pulley or replace timing belt
	Tensioner bearing defective	Replace
	Timing belt defective	Replace
	Timing pulley defective	Replace
	Timing belt comes in contact with timing cover	Replace timing belt and timing cover
Valve noise	Valve clearance incorrect	Replace adjusting shim
	Valve and valve guide seized	Replace valve and valve guide
	Valve spring broken or weakened	Replace
	Valve seat off-positioned	Correct
	Camshaft worn out	Replace

<b>Condition</b>	<b>Possible cause</b>	<b>Correction</b>
Crankshaft noise	Crankshaft end play excessive (noise occurs when clutch is engaged)	Replace thrust bearing
Engine knocking	Preignition due to use of spark plugs of inadequate heat range	Install Spark Plugs of adequate heat range
	Carbon deposits in combustion chambers	Clean
	Fuel too low in octane rating	Replace fuel
	Wide Open Throttle enrichment system failure	Refer to Section 6E
	Selection of transmission gear incorrect	Caution operator of incorrect gear selection
	Engine overheating	Refer to "Engine Lacks Power"
Others	Water pump defective	Replace
	Drive belt slipping	Replace auto tensioner or drive belt

**Abnormal Combustion**

<b>Condition</b>	<b>Possible cause</b>	<b>Correction</b>
Trouble in fuel system	Fuel pressure control valve defective	Replace
	Fuel filter clogged	Replace
	Fuel pump clogged	Clean or replace
	Fuel tank or fuel pipe clogged	Clean or replace
	Fuel injector clogged	Clean or replace
	Fuel pump relay defective	Replace
	Power supply cable for fuel pump broken or poor connections	Reconnect, correct or replace
	Mass Air flow (MAF) sensor circuit open or defective	Correct or replace
	MAF Sensor defective	Replace
	Manifold Absolute Pressure (MAP) Sensor circuit open or shorted	Correct or replace
	MAP Sensor defective	Replace
	Engine Coolant Temperature (ECT) Sensor circuit open or shorted	Correct or replace
	ECT Sensor defective	Replace
	TPS defective	Replace
	TPS connector poor connections	Reconnect
	Vehicle Speed Sensor (VSS) cable poor connections or defective	Correct or replace
	VSS loosely fixed	Fix tightly
	VSS in wrong contact or defective	Replace
Powertrain Control Module cable poor connections or defective	Correct or replace	

## 6A-14 ENGINE MECHANICAL

Condition	Possible cause	Correction
Trouble in emission control system	Heated Oxygen (O <sub>2</sub> ) Sensor circuit open	Correct or replace
	O <sub>2</sub> Sensor defective	Replace
	Signal vacuum hose loosely fitted or defective	Correct or replace
	Exhaust Gas Recirculation (EGR) Valve circuit open or shorted	Correct or replace
	EGR Valve defective	Replace
	Engine Coolant Temperature (ECT) Sensor circuit open or shorted	Correct or replace
	Canister Purge Valve circuit open or shorted	Correct or replace
	Canister Purge Valve defective	Replace
	ECT Sensor defective	Replace
	Positive Crankcase Ventilation (PCV) valve and hose clogged	Correct or replace
	Evaporator system	Refer to Section 6E
Trouble in ignition system	—————	Refer to "Engine Lacks Power"
Trouble in cylinder head parts	Carbon deposits in combustion chamber	Remove carbon
	Carbon deposit on valve, valve seat and valve guide	Remove carbon

## Engine Oil Consumption Excessive

Condition	Possible cause	Correction
Oil leaking	Oil pan drain plug loose	Retighten or replace gasket
	Crankcase fixing bolts loosened	Retighten
	Oil pan setting bolts loosened	Retighten
	Oil pan gasket broken	Replace gasket
	Front cover retaining bolts loose or gasket broken	Retighten or replace gasket
	Head cover fixing bolts loose or gasket broken	Retighten or replace gasket
	Oil cooler adapter cracked	Replace
	Oil cooler center bolt loose	Retighten
	Oil cooler O-ring broken	Replace
	Oil cooler piping loose or broken	Retighten or replace
	Oil filter adapter cracked	Replace
	Oil filter attaching bolt loose or rubber gasket broken	Retighten or replace oil filter
	Oil cooler broken	Replace
	Crankshaft front or rear oil seal defective	Replace oil seal
	Oil pressure unit loose or broken	Retighten or replace
	Blow-by gas hose broken	Replace hose
Positive Crankcase Ventilation Valve clogged	Clean	
Engine/Transmission coupling failed	Replace oil seal	
Oil leaking into combustion chambers due to poor seal in valve system	Valve stem oil seal defective	Replace
	Valve stem or valve guide worn	Replace valve and valve guide
Oil leaking into combustion chambers due to poor seal in cylinder parts	Cylinders and pistons worn excessively	Replace cylinder body assembly and pistons
	Piston ring gaps incorrectly positioned	Correct
	Piston rings set with wrong side up	Correct
	Piston ring sticking	Replace cylinder body assembly and pistons
	Piston ring and ring groove worn	Replace pistons and others
	Return ports in oil rings clogged	Clean piston and replace rings
Positive Crankcase Ventilation System malfunctioning	Positive Crankcase Ventilation Valve clogged	Clean
Others	Improper oil viscosity	Use oil of recommended S.A.E. viscosity
	Continuous high speed driving and/or severe usage such as trailer towing	Continuous high speed operation and/or severe usage will normally cause increased oil consumption

**Fuel Consumption Excessive**

Condition	Possible cause	Correction
Trouble in fuel system	Mixture too rich or too lean due to trouble in fuel injection system	Refer to "Abnormal Combustion"
	Fuel cut function does not work	Refer to "Abnormal Combustion"
Trouble in ignition system	Misfiring or abnormal combustion due to trouble in ignition system	Refer to "Hard Start" or "Abnormal Combustion"
Others	Engine idle speed too high	Reset Idle Air Control Valve
	Returning of accelerator control sluggish	Correct
	Fuel system leakage	Correct or replace
	Brake drag	Correct
	Selection of transmission gear incorrect	Caution operator of incorrect gear selection
	Excessive Exhaust Gas Recirculation (EGR) flow due to trouble in EGR system	Refer to "Abnormal Combustion"

**Lubrication Problems**

Condition	Possible cause	Correction
Oil pressure too low	Wrong oil in use	Replace with correct engine oil
	Relief valve sticking	Replace
	Oil pump not operating properly	Correct or replace
	Oil pump strainer clogged	Clean or replace strainer
	Oil pump worn	Replace
	Oil pressure gauge defective	Correct or replace
	Crankshaft bearing or connecting rod bearing worn	Replace
Oil contamination	Wrong oil in use	Replace with correct engine oil
	Oil filter clogged	Replace oil filter
	Cylinder head gasket damage	Replace gasket
	Burned gases leaking	Replace piston and piston rings or cylinder body assembly
Oil not reaching valve system	Oil passage in cylinder head or cylinder body clogged	Clean or correct

**Engine Oil Pressure Check**

1. Check for dirt, gasoline or water in the engine oil.
  - a. Check the viscosity of the oil.
  - b. Change the oil if the viscosity is outside the specified standard.
  - c. Refer to the "Maintenance and Lubrication" section of this manual.
2. Check the engine oil level.  
 The level should fall somewhere between the "ADD" and the "FULL" marks on the oil level dipstick.  
 If the oil level does not reach the "ADD" mark on the oil level dipstick, engine oil must be added.
3. Remove the oil pressure unit.
4. Install an oil pressure gauge.
5. Start the engine and allow the engine to reach normal operating temperature (About 80°C).
6. Measure the oil pressure.  
**Oil pressure should be:  
 392-550 kpa (56.9-80.4 psi) at 3000 rpm.**
7. Stop the engine.
8. Remove the oil pressure gauge.
9. Install the oil pressure unit.
10. Start the engine and check for leaks.



**Malfunction Indicator Lamp**

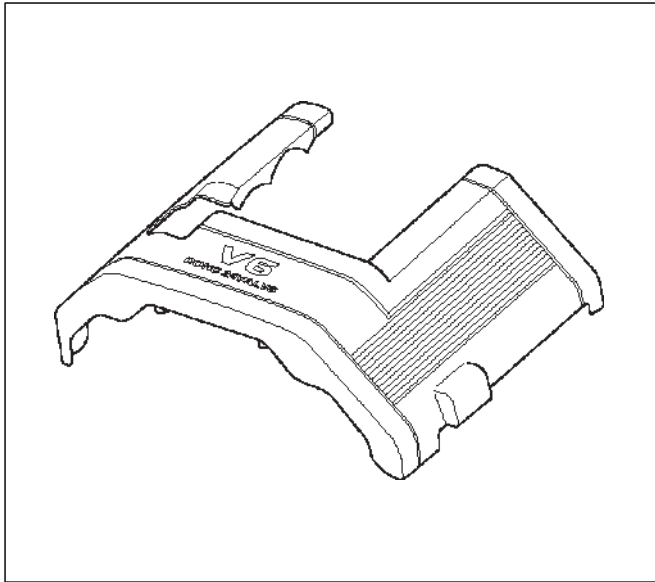
The instrument panel "CHECK ENGINE" Malfunction Indicator Lamp (MIL) illuminates by self diagnostic system when the system checks the starting of engine, or senses malfunctions.

<b>Condition</b>	<b>Possible cause</b>	<b>Correction</b>
"CHECK ENGINE" MIL does not illuminate at the starting of engine	Bulb defective	Replace
	MIL circuit open	Correct or replace
	Command signal circuit to operate self diagnostic system shorted	Correct or replace
	Powertrain Control Module (PCM) cable loosely connected, disconnected or defective	Correct or replace
	PCM defective	Replace
"CHECK ENGINE" MIL illuminates, and stays on	Deterioration of heated oxygen sensor internal element	Replace
	Heated oxygen (O <sub>2</sub> ) sensor connector terminal improper contact	Reconnect properly
	O <sub>2</sub> sensor lead wire shorted	Correct
	O <sub>2</sub> sensor circuit open	Correct or replace
	Deterioration of Engine Coolant Temperature (ECT) sensor internal element	Replace
	ECT sensor connector terminal improper contact	Reconnect properly
	ECT sensor lead wire shorted	Correct
	ECT sensor circuit open	Correct or replace
	Throttle position sensor open or shorted circuits	Correct or replace
	Deterioration of crankshaft position sensor	Replace
	Crankshaft position sensor circuit open or shorted	Correct or replace
	Vehicle speed sensor circuit open	Correct or replace
	Manifold absolute pressure sensor circuit open or shorted	Correct or replace
	Intake air temperature sensor circuit open or shorted	Correct or replace
	Fuel injector circuit open or shorted	Correct or replace
	PCM driver transistor defective	Replace PCM
	Malfunctioning of PCM RAM (Random Access Memory) or ROM (Read Only Memory)	Replace PCM

## Cylinder Head Cover LH

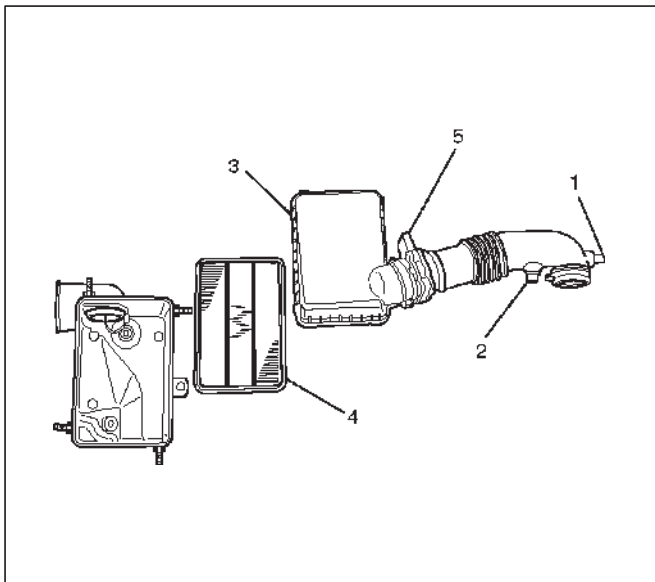
### Removal

1. Disconnect battery ground cable.
2. Drain engine coolant from faucet bottom of radiator.
3. Remove engine cover from the dowels on the common chamber.



F06RW018

4. Remove air cleaner duct assembly (3) and air cleaner element (4).



130RW001

### Legend

- (1) Positive Crankcase Ventilation Hose Connector
- (2) Intake Air Temperature Sensor
- (3) Air Cleaner Duct Assembly
- (4) Air Cleaner Element
- (5) Mass Air Flow Sensor

NOTE: Disconnect the mass air flow (MAF) sensor connector, intake air temperature (IAT) sensor connector, and positive crankcase ventilation (PCV) hose before hand the air cleaner duct assembly is removed.

5. Disconnect following wiring connectors and bonding cable:

- Manifold Absolute Pressure (MAP) sensor
- Vacuum Switching Valve (VSV) for Induction Air Control Valve (IACV) actuator
- Ignition coils for left bank
- Fuel injectors for left bank
- Idle air control (IAC) valve
- Throttle position sensor (TPS)
- Ground cable
- Others as necessitated

6. Disconnect following vacuum hoses:

- Brake master VAC
- Canister
- VSV for IACV actuator
- Duty solenoid valve
- PCV

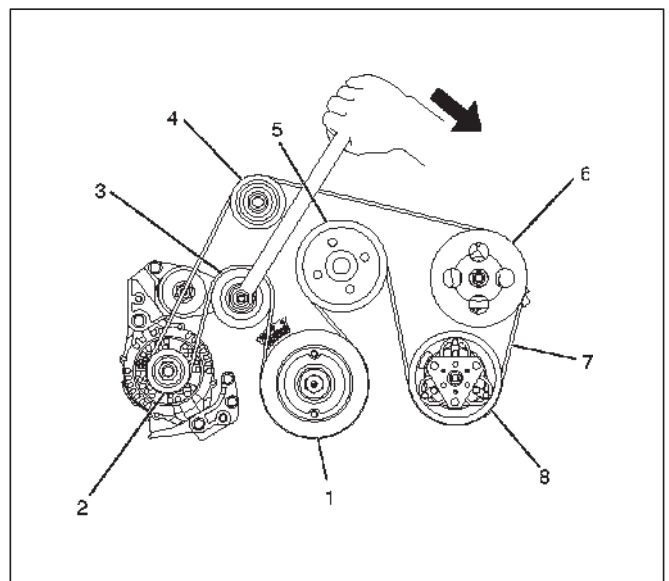
7. Disconnect radiator upper and lower hoses

8. Remove engine harness from the cylinder head cover.

9. Remove the upper fan guide.

10. Remove cooling fan and clutch assembly.

11. Remove drive belt by pushing down the auto tensioner using spanner as illustrated.

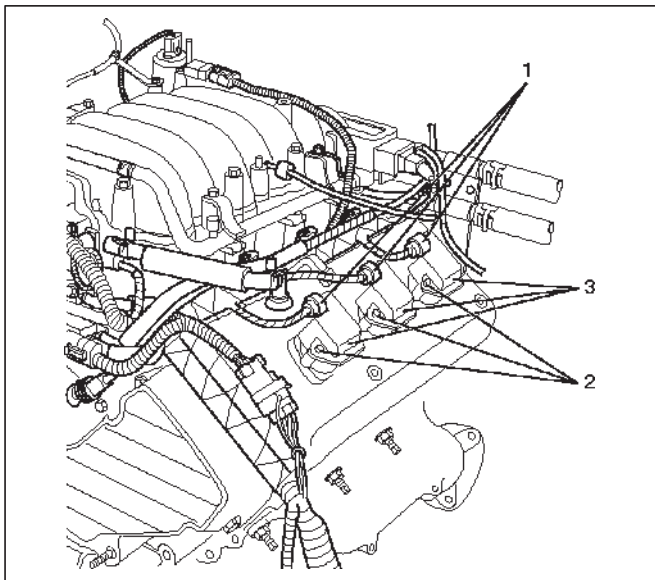


F06RW019

**Legend**

- (1) Crankshaft Pulley
- (2) Generator
- (3) Auto Tensioner
- (4) Idle Pulley
- (5) Cooling Fan Pulley
- (6) Power Steering Oil Pump
- (7) Drive Belt
- (8) Air Conditioner Compressor

- 12. Remove power steering oil pump pulley.
- 13. Remove fan pulley and bracket assembly.
- 14. Remove idle pulley assembly.
- 15. Remove auto tensioner assembly.
- 16. Remove crankshaft pulley using J-8614-01 crankshaft holder.
- 17. Remove timing belt covers from the right bank side to the left bank side in order.
- 18. Remove ignition coil assemblies for the left side bank.



060RW018

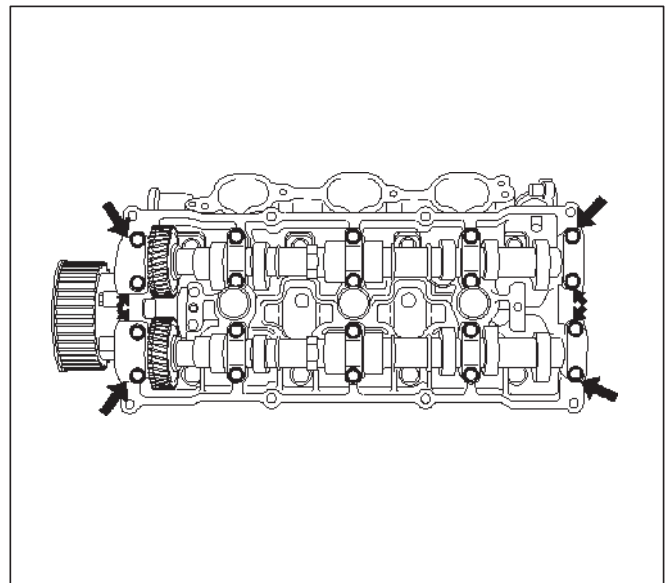
**Legend**

- (1) Ignition Coil Connectors
- (2) Bolts
- (3) Ignition Coil Assemblies

- 19. Remove cylinder head cover assembly.
- NOTE: As the inmost left side bolt in the cylinder head cover is not easy to remove, follow the undermentioned procedure for removing the bolt.
- 20. Remove the left side front tire.
  - 21. Remove the exhaust manifold heat shield on the front exhaust pipe through the wheel house.
  - 22. Remove the engine hanger through the wheel house.
  - 23. Remove Air Conditioning (A/C) high pressure pipe fixing clip from the engine compartment and put it away to facilitate the work.
  - 24. Remove the inmost left side bolt from the engine compartment.

**Installation**

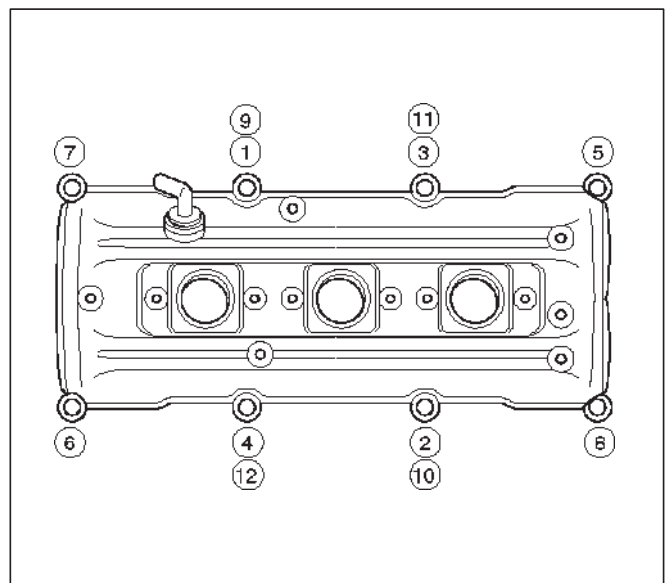
- 1. Install cylinder head cover and gasket.
  - Clean the sealing surface of cylinder head and cylinder head cover to remove oil and sealing materials completely.
  - Apply sealant (TB-1207B or equivalent) of bead diameter 2-3 mm at eight place of arched area of camshaft bracket on front and rear sides.
  - The cylinder head cover must be installed within 5 minutes after sealant application to prevent premature hardening of sealant.



014RW144

○Tighten bolts to the specified torque.

**Torque : 9 N-m (80 lb in)**



010RW006

- 2. Install ignition coil assemblies and tighten the fixing bolts to the specified torque.

**Torque : 4 N-m (35.4 lb in)**

## 6A-20 ENGINE MECHANICAL

---

3. Install timing belt covers from left bank side to right bank side, and tighten the fixing bolts and nut to the specified torque.

**Torque : 19 N·m (14 lb ft)**

4. Install crankshaft pulley and tighten the fixing bolt using J-8614-01 crankshaft holder to the specified torque.

**Torque : 167 N·m (123 lb ft)**

5. Install auto tensioner assembly and tighten the fixing bolts to the specified torque.

**Torque :**

**Shorter Bolt : 20 N·m (14.8 lb ft)**

**Longer Bolt : 39 N·m (28.8 lb ft)**

6. Install idle pulley and bracket assembly and tighten the fixing bolt to the specified torque.

**Torque : 52 N·m (38.4 lb ft)**

7. Install fan pulley and bracket assembly and tighten the fixing bolts and nut to the specified torque.

**Torque : 22 N·m (16.2 lb ft)**

8. Install power steering oil pump pulley and tighten the fixing bolt to the specified torque.

**Torque : 78 N·m (57.5 lb ft)**

9. Install drive belt by pushing down the auto tensioner using a spanner as shown in the removal step of drive belt.

10. Install cooling fan and clutch assembly and tighten the fixing bolts to the specified torque.

**Torque : 10 N·m (88.5 lb in)**

11. Install upper fan guide and clip both side and tighten the fixing bolts to the specified torque.

**Torque : 4 N·m (35.4 lb in)**

12. Install engine harness and tighten the fixing bolts of the retaining clip and bracket to the specified torque.

**Torque : 4 N·m (35.4 lb in)**

13. Connect radiator upper and lower hoses and clip them securely.

14. Connect vacuum hoses of those which were disconnected in the removal step.

15. Connect wiring connectors and ground cable of those which were disconnected in the removal step.

16. Install air cleaner element and air cleaner duct assembly, and clip both end securely.

17. Connect Mass Air Flow (MAF) sensor connector, Intake Air Temperature (IAT) sensor connector and PCV hose.

18. Install engine cover mating with the dowels.

19. Install the Air Conditioning (A/C) high pressure pipe fixing clip.

20. Install the engine hanger through the wheel house.

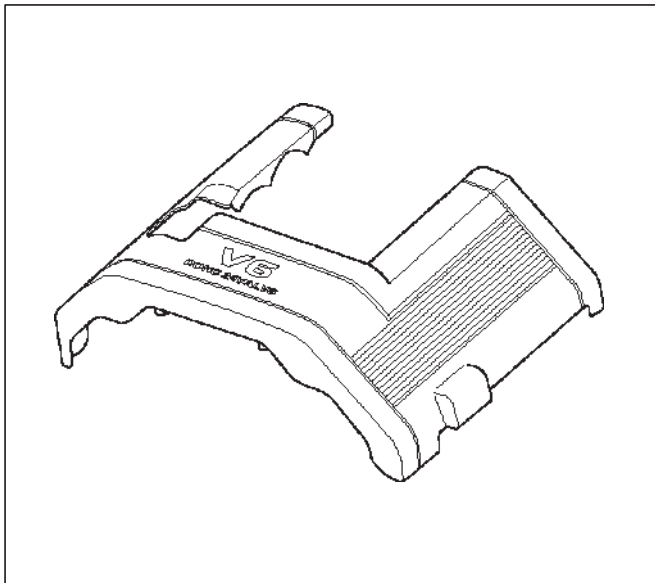
21. Install the exhaust manifold heat shield through the wheel house.

22. Install the tire.

## Cylinder Head Cover RH

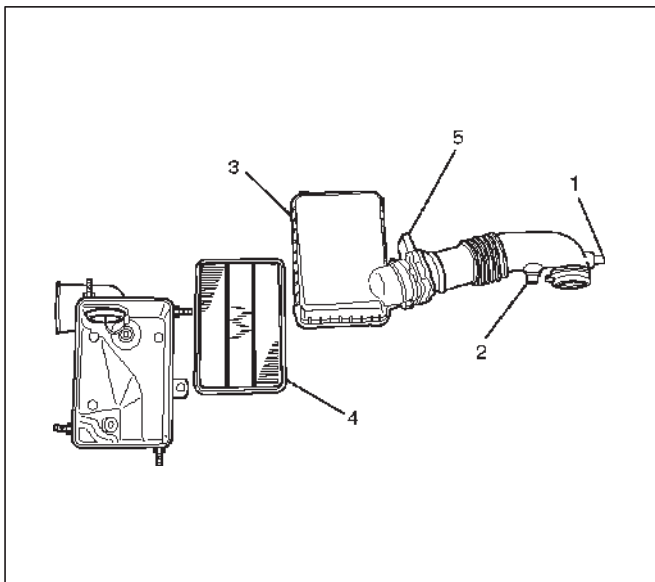
### Removal

1. Disconnect battery ground cable.
2. Remove battery from the vehicle.
3. Drain engine coolant from faucet bottom of radiator.
4. Remove engine cover from the dowels on the common chamber.



F06RW016

5. Remove air cleaner duct assembly (3) and air cleaner element (4).



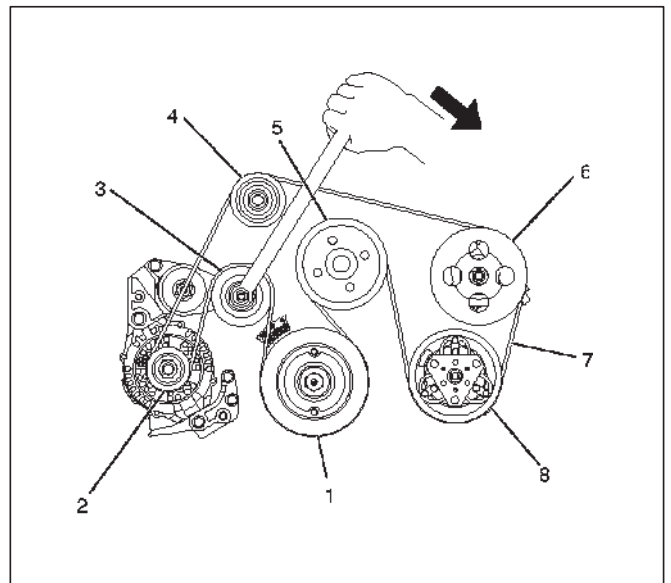
130RW001

### Legend

- (1) Positive Crankcase Ventilation Hose Connector
- (2) Intake Air Temperature Sensor
- (3) Air Cleaner Duct Assembly
- (4) Air Cleaner Element
- (5) Mass Air Flow Sensor

NOTE: Disconnect the mass air flow (MAF) sensor connector, intake air temperature (IAT) sensor connector, and positive crankcase ventilation (PCV) hose before hand the air cleaner duct assembly is removed.

6. Disconnect following wiring connectors and ground cable:
  - Exhaust Gas Recirculation (EGR) valve
  - Fuel injectors for right bank
  - Ignition coils for right bank
  - Ground cable
  - Others as necessitated
7. Disconnect radiator upper and lower hoses.
8. Remove engine harness from the cylinder head cover.
9. Remove the upper fan guide.
10. Remove cooling fan and clutch assembly.
11. Remove drive belt by pushing down the auto tensioner using spanner as illustrated.



F06RW019

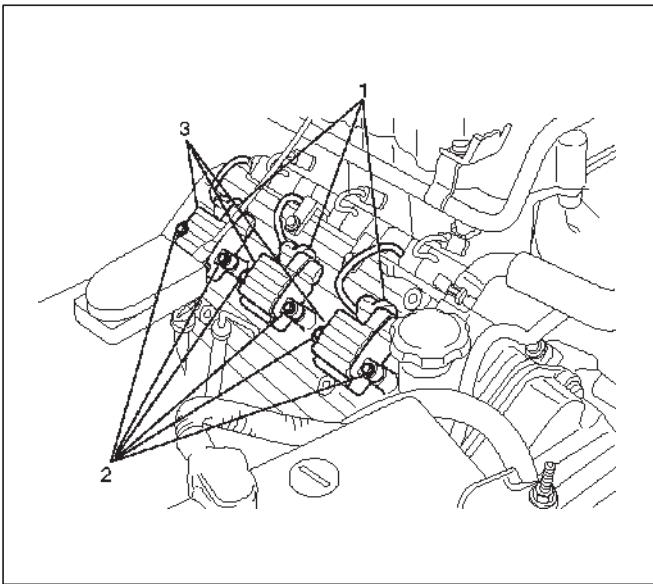
### Legend

- (1) Crankshaft Pulley
- (2) Generator
- (3) Auto Tensioner
- (4) Idle Pulley
- (5) Cooling Fan Pulley
- (6) Power Steering Oil Pump
- (7) Drive Belt
- (8) Air Conditioner Compressor

12. Remove fan pulley and bracket assembly.
13. Remove idle pulley assembly.
14. Remove auto tensioner assembly.
15. Remove crankshaft pulley using J-8614-01 crankshaft holder.
16. Remove timing belt covers for right side.

## 6A-22 ENGINE MECHANICAL

17. Remove ignition coil assemblies for the right side.



### Legend

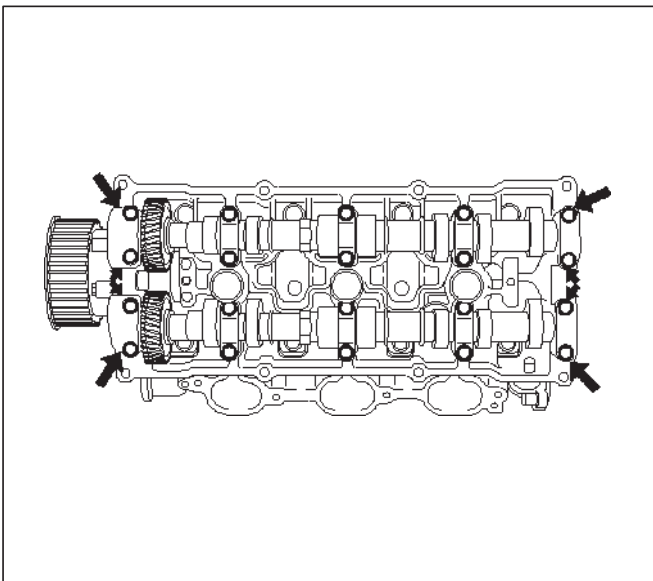
- (1) Ignition Coil Connectors
- (2) Bolts
- (3) Ignition Coil Assemblies

18. Remove cylinder head cover assembly.

## Installation

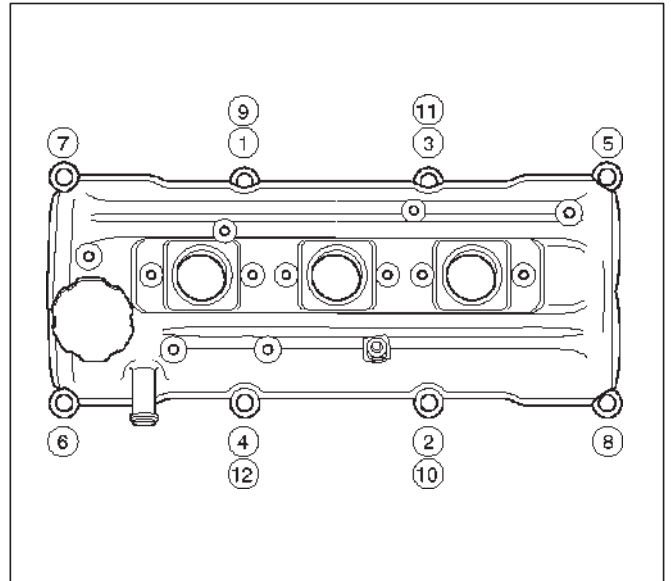
1. Install cylinder head cover.

- Clean the sealing surface of cylinder head and cylinder head cover to remove oil and sealing materials completely.
- Apply sealant (TB-1207B or equivalent) of bead diameter 2-3 mm at arched area of the camshaft bracket on the front and rear sides.
- The cylinder head cover must be installed within 5 minutes after sealant application before the sealant hardens.



○ Tighten bolts in turn to the specified torque.

**Torque : 8.8 N-m (77.9 lb in)**



2. Install ignition coil assemblies and tighten the fixing bolts to the specified torque.

**Torque : 4 N-m (35.4 lb in)**

3. Install timing belt cover and tighten the fixing bolts and nut to the specified torque.

**Torque : 19 N-m (14 lb ft)**

4. Install crankshaft pulley and tighten the fixing bolt using J-8614-01 crankshaft holder to the specified torque.

**Torque : 167 N-m (123 lb ft)**

5. Install auto tensioner assembly and tighten the fixing bolts to the specified torque.

**Torque :**

**Shorter Bolt : 20 N-m (14.8 lb ft)**

**Longer Bolt : 39 N-m (28.8 lb ft)**

6. Install idle pulley assembly and tighten the fixing bolt to the specified torque.

**Torque : 52 N-m (38.4 lb ft)**

7. Install fan pulley and bracket assembly and tighten the fixing bolts and nut to the specified torque.

**Torque : 22 N-m (16.2 lb ft)**

8. Install drive belt by pushing down the auto tensioner using spanner as shown in the removal step of drive belt.

9. Install cooling fan clutch assembly and tighten the fixing bolts to the specified torque.

**Torque : 10 N-m (88.5 lb in)**

10. Install upper fan guide and clip both side and tighten the fixing bolts to the specified torque.

**Torque : 4 N-m (35.4 lb in)**

11. Install engine harness and tighten the fixing bolts of the retaining clip and brackets to the specified torque.

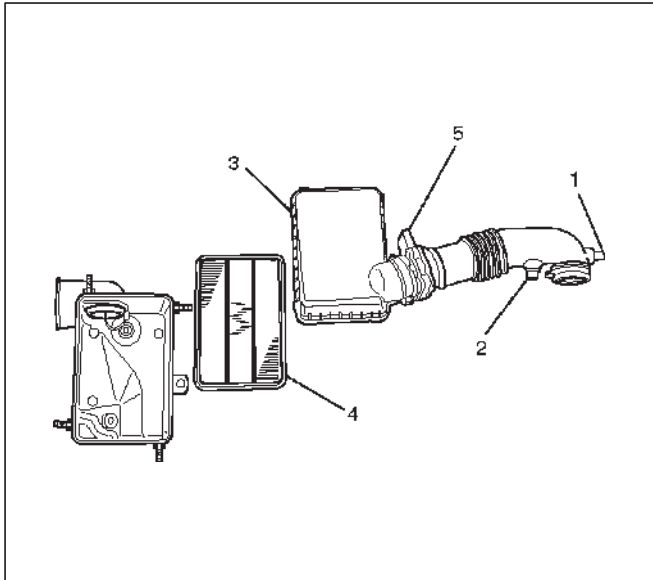
**Torque : 4 N-m (35.4 lb in)**

12. Connect upper and lower radiator hoses and clip them securely.
13. Connect wiring connectors and ground cable of those which were disconnected in the removal step.
14. Install air cleaner element and air cleaner duct assembly, and the clip both end securely.
15. Connect Mass Air Flow (MAF) sensor connector, Intake Air Temperature (IAT) sensor connector and Positive Crankcase Ventilation (PCV) hose.
16. Install engine cover mating with the dowels.

## Common Chamber

### Removal

1. Disconnect battery ground cable.
2. Disconnect Intake Air Temperature (IAT) sensor and Mass Air Flow sensor (MAF).
3. Remove air cleaner duct assembly.



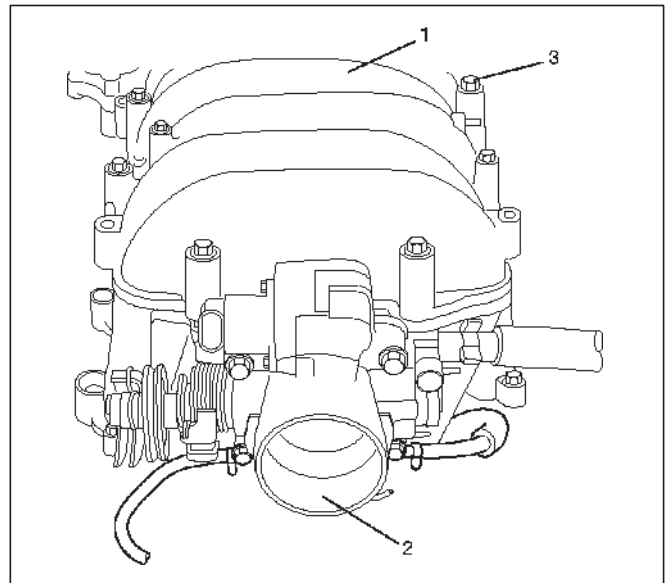
130RW001

#### Legend

- (1) Positive Crankcase Ventilation Hose Connector
- (2) Intake Air Temperature Sensor
- (3) Air Cleaner Duct Assembly
- (4) Air Cleaner Element
- (5) Mass Air Flow Sensor

4. Disconnect accelerator pedal cable and automatic Cruise Control Cable from throttle body and cable bracket.
5. Disconnect vacuum booster hose from common chamber.
6. Disconnect connector from manifold absolute pressure sensor, idle air control valve, throttle position sensor, solenoid valve, electric vacuum sensing valve, and Exhaust Gas Recirculation (EGR) valve.
7. Disconnect vacuum hose on canister Vacuum Switching Valve (VSV) and positive crankcase ventilation hose, fuel rail assembly with pressure control valve bracket.
8. Remove ventilation hose from throttle valve and intake duct.
9. Remove the four throttle body fixing bolts.
10. Remove EGR valve assembly fixing bolt and nut on common chamber and remove EGR valve assembly.
11. Remove two bolts from the common chamber rear side and remove fuel hose bracket.

12. Remove the common chamber four bolts and four nuts then remove the common chamber.



025RW001

#### Legend

- (1) Common Chamber
- (2) Throttle Valve Assembly
- (3) Bolt

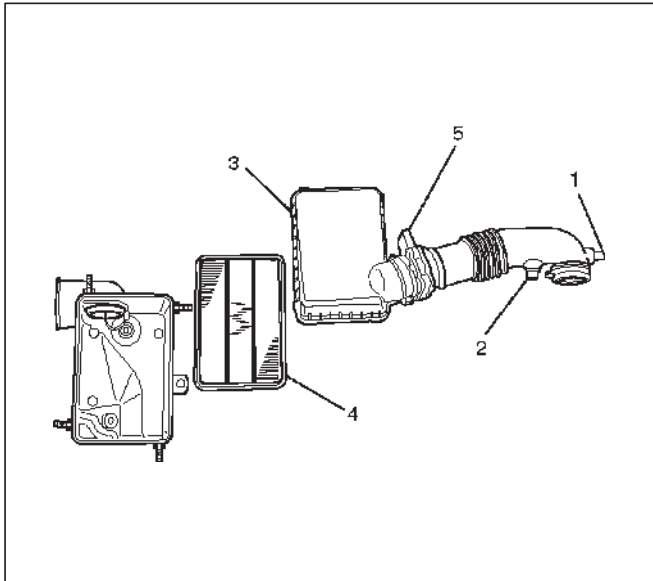
### Installation

1. Install common chamber and tighten bolts and nuts to the specified torque.  
**Torque :**  
**Bolt : 25 N·m (18 lb ft)**  
**Nut : 25 N·m (18 lb ft)**
2. Install fuel hose bracket and tighten bolts to specified torque.  
**Torque : 10 N·m (89 lb in)**
3. Install EGR valve assembly and tighten bolt and nut to the specified torque.  
**Torque : 25 N·m (18 lb ft)**
4. Install throttle body and tighten bolts to the specified torque.  
**Torque : 25 N·m (18 lb ft)**
5. Install ventilating hose to throttle valve and intake duct.
6. Connect vacuum hoses on canister VSV and positive crankcase ventilation hose. Tighten bolts for fuel rail assembly with pressure control valve bracket.  
**Torque : 25 N·m (18 lb ft)**
7. Connect each connector without fail.
8. Connect vacuum booster hose.



9. Connect accelerator pedal cable and Cruise Control Cable.

10. Install air cleaner duct assembly.



**Legend**

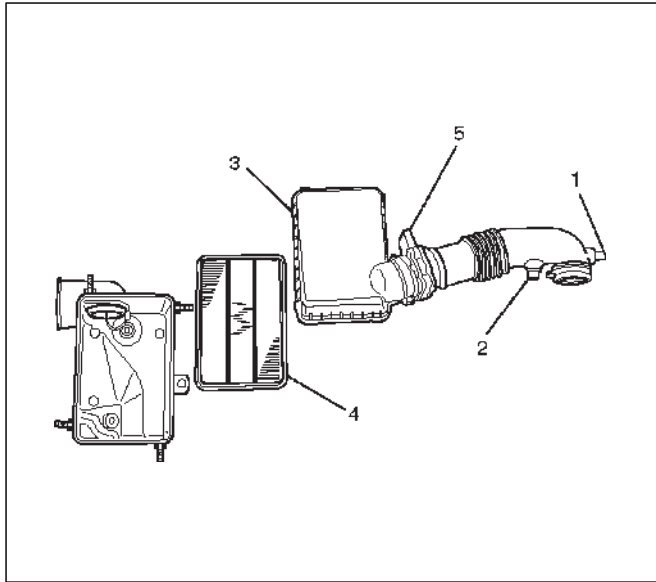
- (1) Positive Crankcase Ventilation Hose Connector
- (2) Intake Air Temperature Sensor
- (3) Air Cleaner Duct Assembly
- (4) Air Cleaner Element.
- (5) Mass Air Flow Sensor

11. Reconnect IAT sensor and MAF sensor connectors.

## Exhaust Manifold LH

### Removal

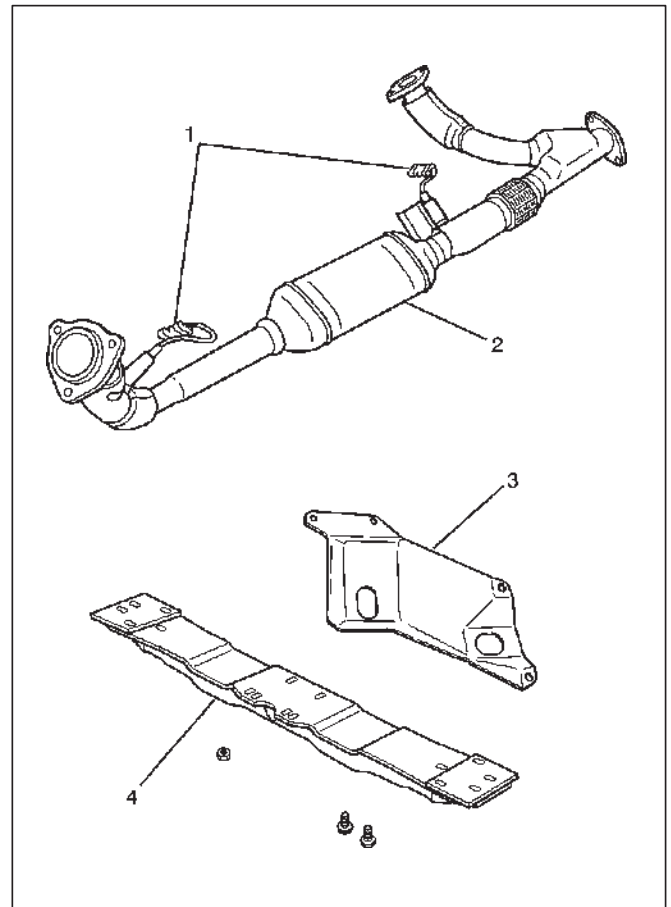
1. Disconnect battery ground cable.
2. Disconnect Intake Air Temperature (IAT) sensor and Mass Air Flow (MAF) sensor.
3. Remove air cleaner duct assembly.



#### Legend

- (1) Positive Crankcase Ventilation Hose Connector
- (2) Intake Air Temperature Sensor
- (3) Air Cleaner Duct Assembly
- (4) Air Cleaner Element
- (5) Mass Air Flow Sensor

4. Remove transfer under cover.
5. Remove 3rd crossmember.
6. Disconnect Heated oxygen (O<sub>2</sub>) sensor connector.
7. Remove the three stud nuts from the front exhaust pipe flange and two nuts from the rear exhaust pipe flange.



#### Legend

- (1) O<sub>2</sub> Sensors
- (2) Exhaust Front Pipe LH
- (3) Transfer Under Cover
- (4) 3rd Crossmember

8. Remove heat protector two fixing bolts and remove unit.
9. Remove a bolt on engine LH side for air conditioner (A/C) compressor bracket and loosen two bolts for A/C compressor then move A/C compressor to front side.
10. Remove exhaust manifold eight fixing nuts and remove exhaust manifold from the engine.

### Installation

1. Install exhaust manifold and gasket and tighten exhaust manifold fixing nuts to the specified torque with new nuts.

**Torque: 52 N-m (38 lb ft)**

2. Install heat protector.

3. Install exhaust front pipe's three stud nuts and rear pipe's two nuts to the specified torque.

**Torque :**

**Stud nuts: 67 N-m (49 lb ft)**

**Nuts: 43 N-m (32 lb ft)**

4. Set A/C compressor to normal position and tighten two bolts to the specified torque.

**Torque : 40 N·m (30 lb ft)**

5. Reconnect O<sub>2</sub> sensor connectors.

6. Install 3rd crossmember.

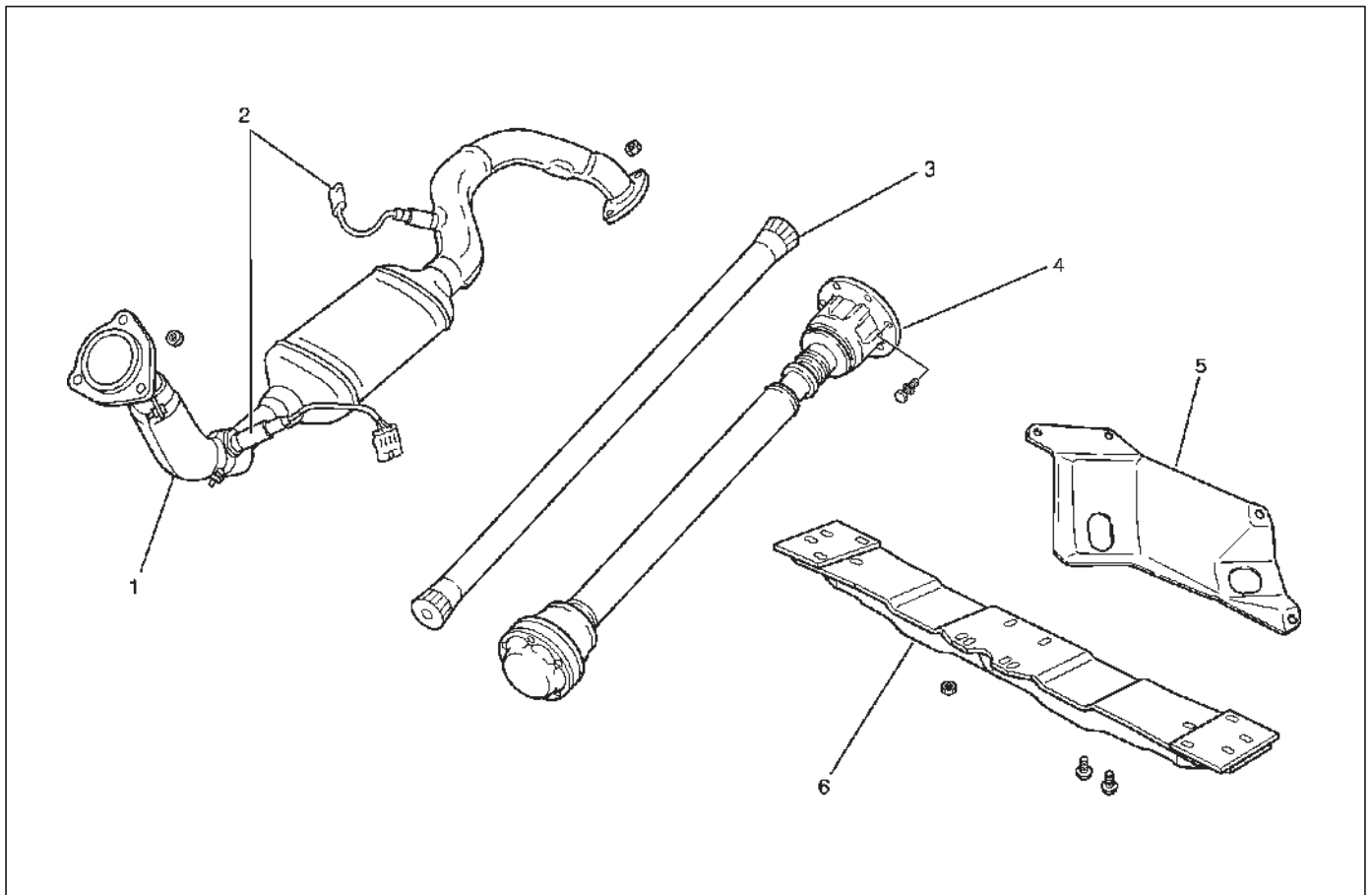
7. Install transfer under cover.

8. Install air cleaner duct assembly.

9. Reconnect IAT sensor and MAF sensor connectors.

## Exhaust Manifold RH

### Removal



035RX016

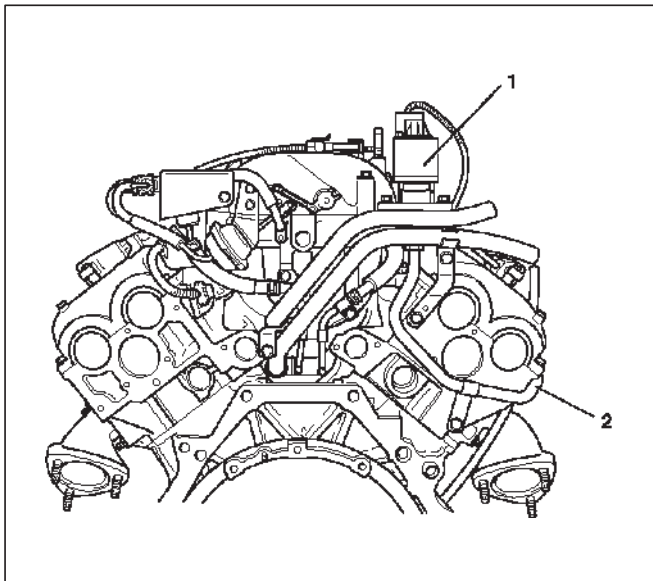
#### Legend

- |                            |                           |
|----------------------------|---------------------------|
| (1) Exhaust Front Pipe RH  | (4) Front Propeller Shaft |
| (2) O <sub>2</sub> Sensors | (5) Transfer Under Cover  |
| (3) Torsion Bar            | (6) 3rd Crossmember       |

1. Disconnect battery ground cable.
2. Remove transfer under cover.
3. Remove 3rd crossmember.
4. Remove torsion bar and front propeller shaft. Refer to removal procedure in Front Suspension section.
5. Disconnect front Heated oxygen (O<sub>2</sub>) sensor connectors.
6. Remove front exhaust flange pipe three stud nuts and two rear flange nuts then disconnect exhaust pipe.
7. Remove heat protector two fixing bolts and remove unit.

8. Remove Exhaust Gas Recirculation (EGR) pipe fixing bolt and nut from exhaust manifold, remove a nut from EGR valve and a bolt from the rear side of the cylinder head for the EGR pipe bracket then remove the EGR pipe.

8. Install 3rd crossmember.
9. Install transfer under cover.



056RW001

**Legend**

- (1) EGR Valve
- (2) EGR Pipe

9. Remove exhaust manifolds eight fixing nuts and the exhaust manifold.

**Installation**

1. Install exhaust manifold and tighten bolts to the specified torque.

**Torque : 52 N·m (38 lb ft)**

2. Install the EGR pipe, tighten bolt and nut on exhaust manifold to the specified torque.

**Torque : 28 N·m (21 lb ft)**

Tighten nut on EGR valve to the specified torque.

**Torque : 44 N·m (33 lb ft)**

Tighten the bolt for EGR pipe bracket to specified torque.

**Torque : 25 N·m (18 lb ft)**

3. Install heat protector
4. Install front exhaust flange pipe and tighten three stud nuts and rear two nuts to the specified torque.

**Torque:**

**Stud nuts: 67 N·m (49 lb ft)**

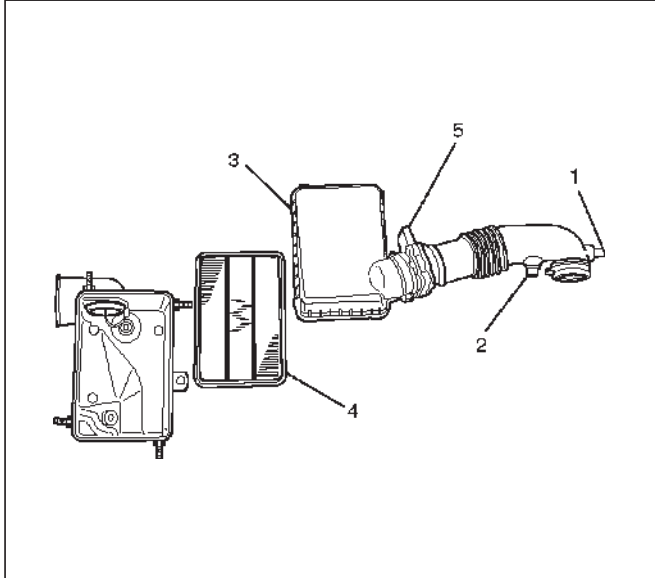
**Nuts: 43 N·m (32 lb ft)**

5. Reconnect O2 Sensor harness connector.
6. Install the torsion bar and readjust the vehicle height. Refer to installation and vehicle height adjustment procedure for Front Suspension.
7. Install front propeller shaft. Refer to installation procedue in Front suspension section.

## Crankshaft Pulley

### Removal

1. Disconnect battery ground cable.
2. Remove air cleaner assembly.

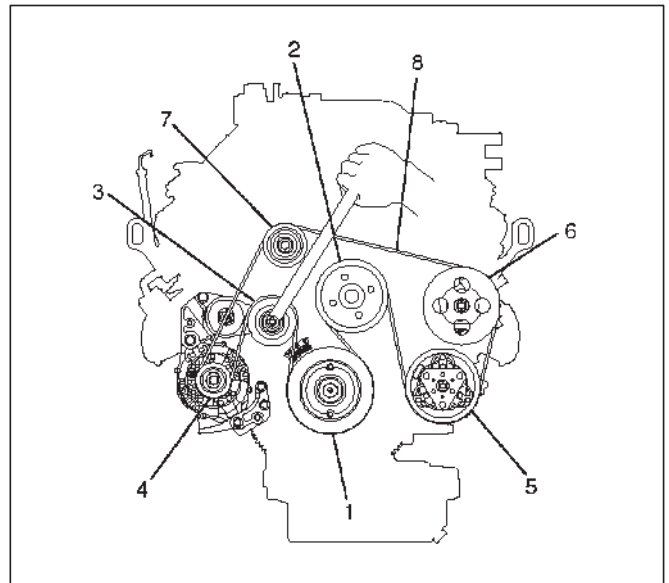


#### Legend

- (1) Positive Crankcase Ventilation Hose Connector
- (2) Intake Air Temperature Sensor
- (3) Air Cleaner Duct Assembly
- (4) Air Cleaner Element
- (5) Mass Air Flow Sensor

3. Remove radiator upper fan shroud from radiator.

4. Move Drive belt tensioner to loose side using wrench then remove serpentine belt.



#### Legend

- (1) Crankshaft Pulley
- (2) Cooling Fan Pulley
- (3) Auto Tensioner
- (4) Generator
- (5) Air Conditioner Compressor
- (6) Power Steering Oil Pump
- (7) Idle Pulley
- (8) Drive Belt

5. Remove cooling fan assembly four fixing nuts, then the cooling fan assembly.
6. Remove crankshaft pulley assembly using J-8614-01 crankshaft holder, hold crankshaft pulley then remove center bolt and pulley.

### Installation

1. Install crankshaft pulley using J-8614-01 crankshaft holder, hold the crankshaft pulley and tighten center bolt to the specified torque.

**Torque : 167 N-m (123 lb ft)**

2. Install cooling fan assembly and tighten bolts/nuts to the specified torque.

**Torque : 22 N-m (16 lb ft) for fan pulley and fan bracket.**

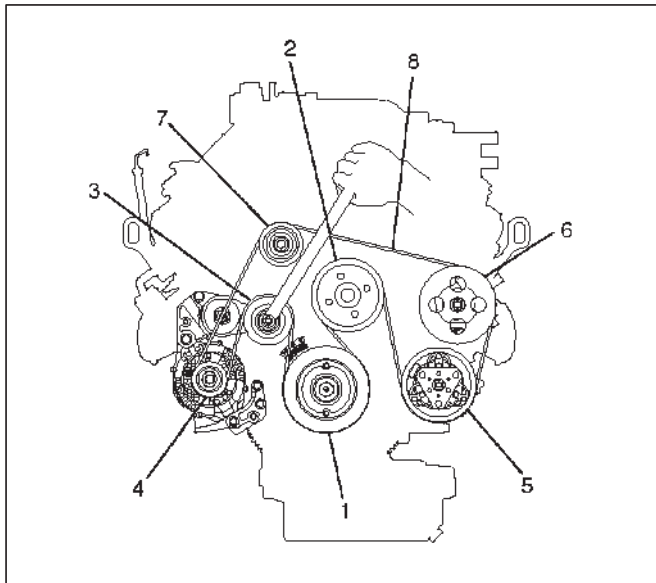
**Torque : 10 N-m (88.5 lb in) for fan and clutch assembly.**

3. Move Drive belt tensioner to loose side using wrench, then install serpentine belt to normal position.
4. Install radiator upper fan shroud.
5. Install air cleaner assembly.

## Timing Belt

### Removal

1. Disconnect battery ground cable.
2. Remove air cleaner assembly.
3. Remove radiator upper fan shroud from radiator.
4. Move drive belt tensioner to loose side using wrench then remove drive belt.



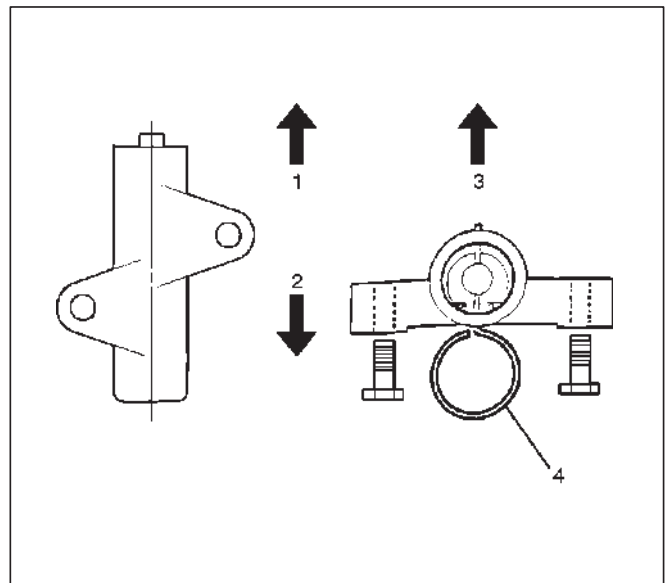
#### Legend

- (1) Crankshaft Pulley
- (2) Cooling Fan Pulley
- (3) Auto Tensioner
- (4) Generator
- (5) Air Conditioner Compressor
- (6) Power Steering Oil Pump
- (7) Idle Pulley
- (8) Drive Belt

5. Remove cooling fan assembly four nuts, then the cooling fan assembly.
6. Remove cooling fan drive pulley assembly.
7. Remove idle pulley assembly.
8. Remove serpentine belt tensioner assembly.
9. Remove power steering pump assembly.
10. Remove crankshaft pulley assembly using J-8614-01 crankshaft holder, hold crankshaft pulley remove center bolt, then the pulley.

11. Remove right side timing belt cover then left side timing belt cover.
12. Remove lower timing belt cover
13. Remove pusher.

**CAUTION:** The pusher prevents air from entering the oil chamber. Its rod must always be facing upward.



#### Legend

- (1) Up Side
- (2) Down Side
- (3) Direction For Installation
- (4) Locking Pin

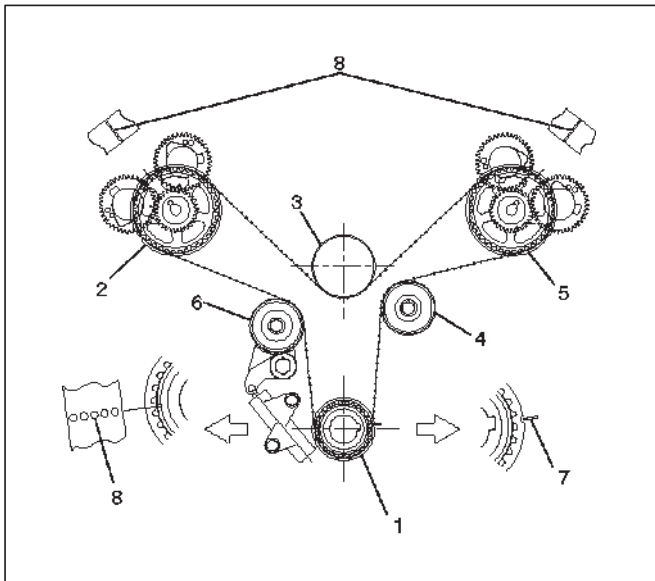
14. Remove timing belt.

#### CAUTION:

1. Do not bend or twist the belt, otherwise its core could be damaged. The belt should not be bent at a radius less than 30 mm.
2. Do not allow oil or other chemical substances to come in contact with the belt. They will shorten the life.
3. Do not attempt to pry or stretch the belt with a screw driver or any other tool during installation.
4. Store timing belt in a cool and dark place. Never expose the belt direct sunlight or heat.

## Installation

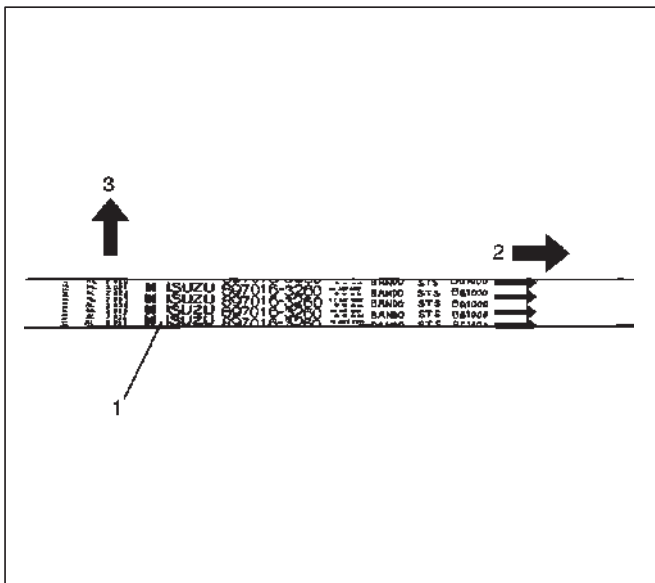
NOTE: For correct belt installation, the letter on the belt must be able to be read as viewed from the front of the vehicle.



014RW005

### Legend

- (1) Crankshaft Timing Pulley
- (2) RH Bank Camshaft Drive Gear Pulley
- (3) Water Pump Pulley
- (4) Idle Pulley
- (5) LH Bank Camshaft Drive Gear Pulley
- (6) Tension Pulley
- (7) Alignment Mark on Oil Pump.
- (8) Alignment Mark on Timing Belt



014RW006

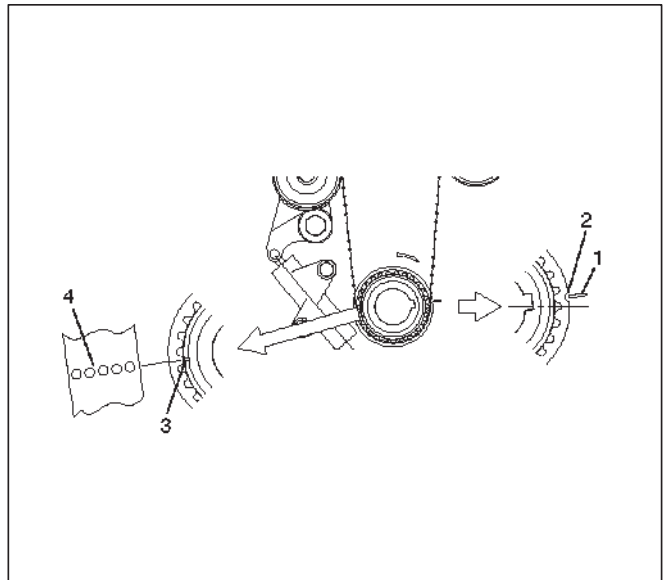
### Legend

- (1) Timing Belt
- (2) Engine Rotation Direction
- (3) Cylinder Head Side

### 1. Install timing belt.

1. Align groove of crankshaft timing pulley with mark on oil pump.  
Align the mark on the crankshaft timing pulley with alignment mark (white dots line) on the timing belt.  
Secure the belt with a double clip.

NOTE: When timing marks are aligned, No.2 piston will be on Top Dead Center.

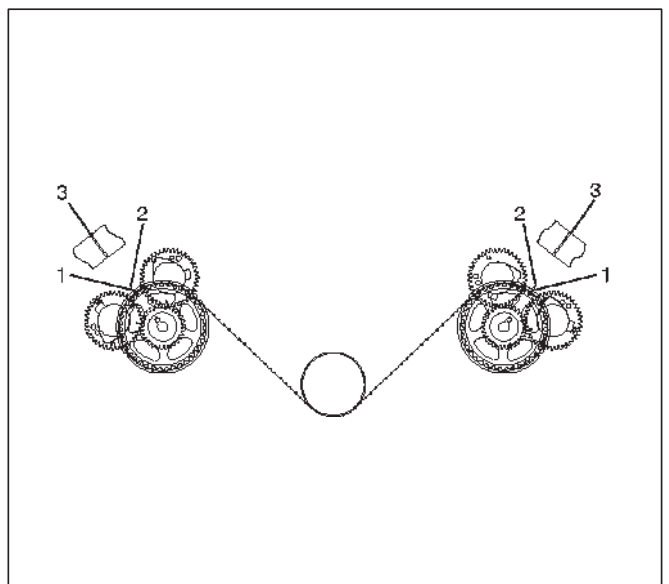


014RW003

### Legend

- (1) Alignment Mark on Oil Pump
- (2) Groove on Crankshaft Timing Pulley
- (3) Alignment Mark on Crankshaft Timing Pulley
- (4) Alignment Mark on Timing Belt

2. Align the marks on the camshaft drive gear pulleys with the corresponding alignment marks on the cylinder head covers.



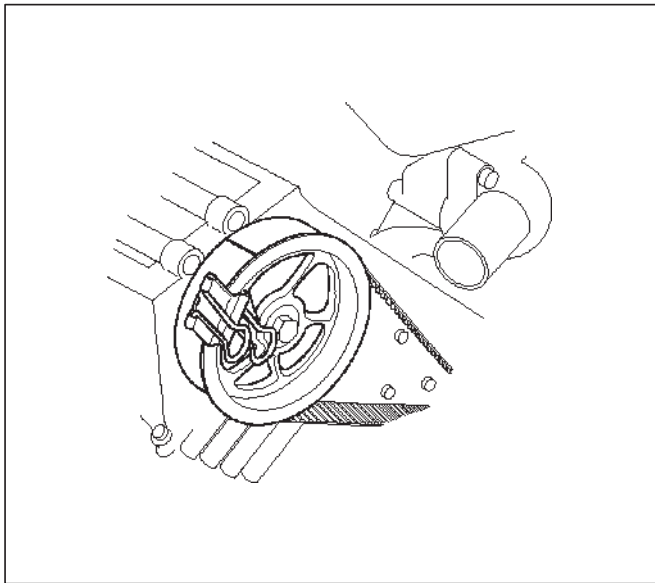
014RW004



**Legend**

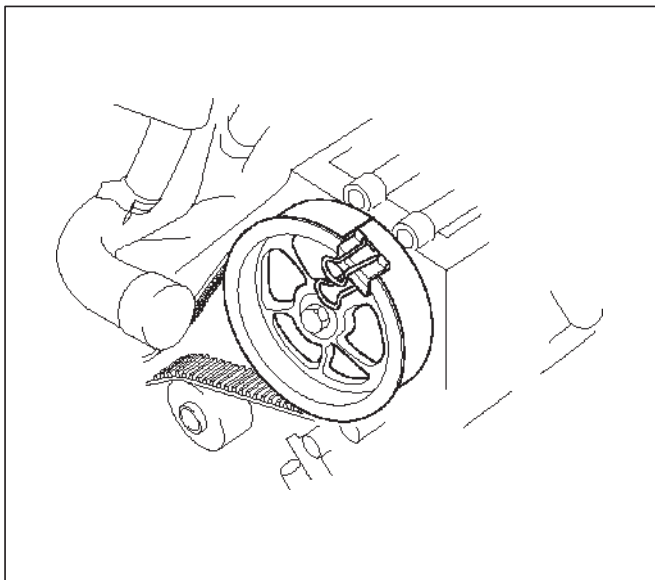
- (1) Alignment Mark on Camshaft Drive Gear Pulley
- (2) Alignment Mark on Cylinder Head Cover.
- (3) Alignment Mark on Timing Belt (White Line)

- 3. Align the alignment mark (white line) on the timing belt with alignment mark on the RH bank camshaft drive gear pulley (on the left side as viewed from the front of the vehicle).  
Secure the belt with a double clip.



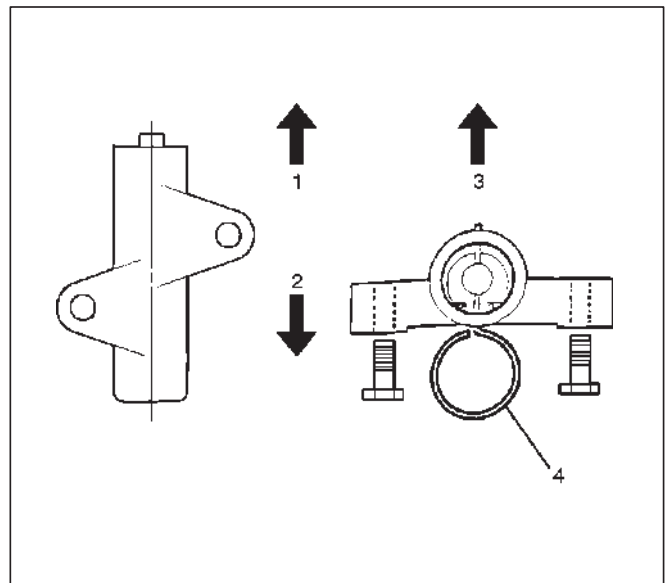
- 4. Align the alignment mark (white line) on the timing belt with the alignment mark on the LH bank camshaft drive gear pulley.  
When aligning the timing marks, use a wrench to turn the camshaft drive gear pulley, then set the timing mark between timing belt and camshaft drive gear pulley.  
Secure the belt with a double clip.

**NOTE:** It is recommended for easy installation that the belt be secured with a double clip after it is installed to each pulley.



- 5. Install crankshaft pulley temporarily and tighten center bolt by hand (do not use a wrench).  
Turn the crankshaft pulley clockwise to give some belt slack between the crankshaft timing pulley and the RH bank camshaft drive gear pulley.
- 2. Install pusher and tighten bolt to the specified torque.
  - 1. Install the pusher while pushing the tension pulley to the belt.
  - 2. Pull out pin from the pusher.

**NOTE:** When reusing the pusher, press the pusher with approximately 100Kg to retract the rod, and insert a pin (1.4 mm piano wire).



**Legend**

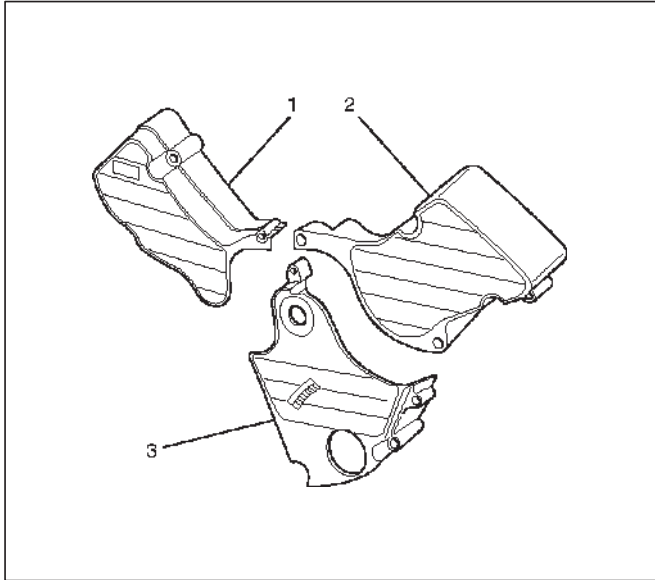
- (1) Up Side
- (2) Down Side
- (3) Direction for Installation
- (4) Locking Pin

- 3. Remove double clips from timing belt pulleys.  
Turn the crankshaft pulley clockwise by two turns.  
**Torque : 25 N-m (18 lb ft)**

## 6A-34 ENGINE MECHANICAL

3. Install timing belt cover.  
Remove crankshaft pulley that was installed in step 1 item 5.  
Tighten bolts to the specified torque.

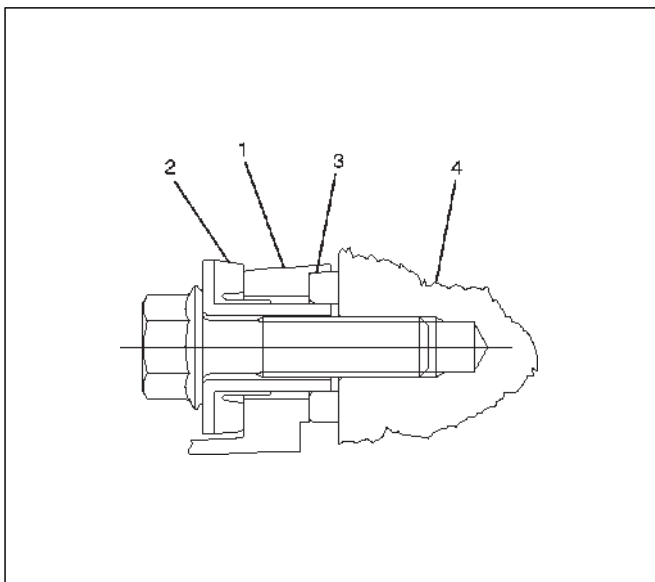
**Torque: 19 N-m (14 lb ft)**



020RW004

### Legend

- (1) Timing Belt Cover RH
- (2) Timing Belt Cover LH
- (3) Timing Belt Cover Lower



020RW003

### Legend

- (1) Timing Belt Cover
- (2) Rubber Bushing
- (3) Sealing Rubber
- (4) Cylinder Body

4. Install crankshaft pulley using J-8614-01, hold the crankshaft pulley and tighten center bolt to the specified torque.

**Torque : 167 N-m (123 lb ft)**

5. Install fan pulley bracket and tighten fixing bolts to the specified torque.

**Torque : 22 N-m (16 lb ft)**

6. Install power steering pump assembly and tighten to the specified torque.

**Torque :**

**M8 bolt : 22 N-m (16 lb ft)**

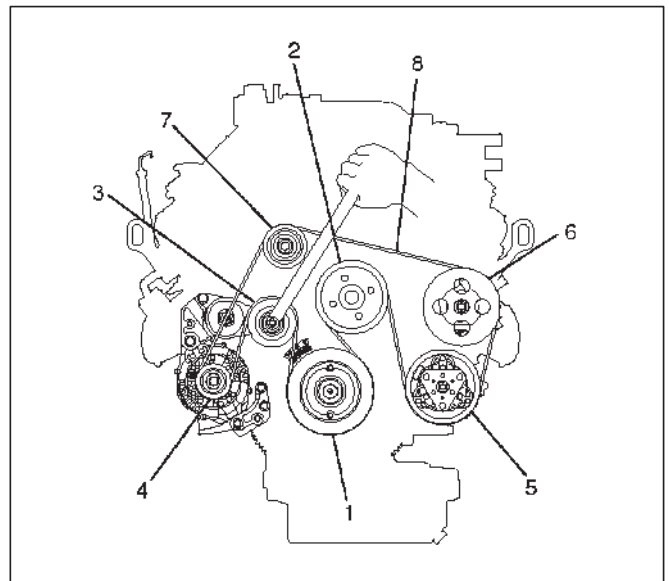
**M10 bolt : 46 N-m (34 lb ft)**

7. Install cooling fan assembly and tighten bolts/nuts to the specified torque.

**Torque : 22 N-m (16 lb ft) for fan pulley and fan bracket.**

**Torque : 10 N-m (88.5 lb in) for fan and clutch assembly.**

8. Move drive belt tensioner to loose side using wrench, then install drive belt to normal position.



850RW001

### Legend

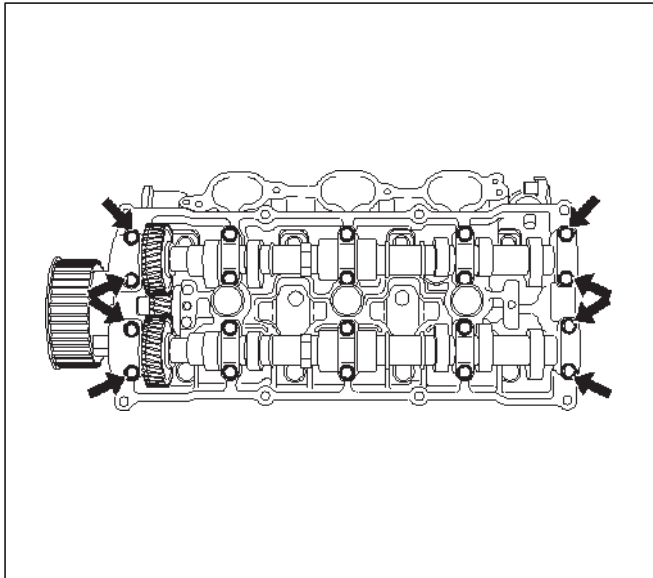
- (1) Crankshaft Pulley
- (2) Cooling Fan Pulley
- (3) Auto Tensioner
- (4) Generator
- (5) Air Conditioner Compressor
- (6) Power Steering Oil Pump
- (7) Idle Pulley
- (8) Drive Belt

9. Install radiator upper fan shroud.
10. Install air cleaner assembly.

## Camshaft

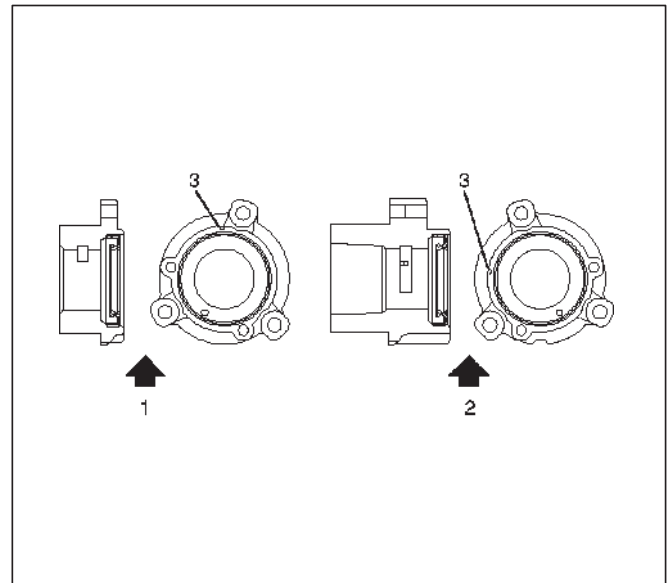
### Removal

1. Disconnect battery ground cable.
2. Remove crankshaft pulley.
  - Refer to removal procedure for Crankshaft Pulley in this manual.
3. Remove timing belt.
  - Refer to removal procedure for Timing Belt in this manual.
4. Remove cylinder head cover LH.
  - Refer to removal procedure for Cylinder Head Cover LH in this manual.
5. Remove cylinder head cover RH.
  - Refer to removal procedure for Cylinder Head Cover RH in this manual.
6. Remove twenty fixing bolts from inlet and exhaust camshaft bracket on one side bank, then camshaft brackets.



7. Remove camshaft assembly.
8. Remove fixing bolt for camshaft drive gear pulley.

9. Remove three fixing bolts from camshaft drive gear retainer, then camshaft drive gear assembly.



### Legend

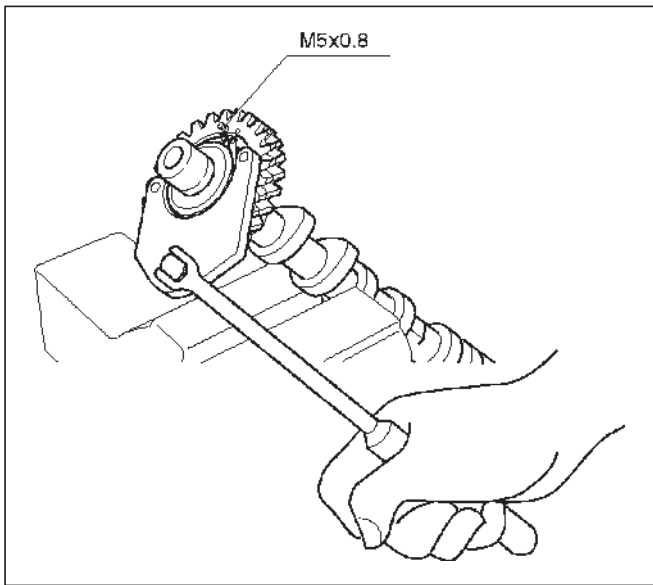
- (1) Right Bank
- (2) Left Bank
- (3) Timing Mark on Retainer

### Installation

1. Install camshaft drive gear assembly and tighten three bolts to the specified torque.
  - Torque : 10 N·m (89 lb in)**
2. Tighten bolt for camshaft drive gear assembly pulley to the specified torque.
  - Torque : 98 N·m (72 lb ft)**
3. Tighten sub gear setting bolt.
  1. Use the J-42686 gear spring lever to turn sub gear to right direction until it aligns with the M5 bolt hole between camshaft driven gear and sub gear.

## 6A-36 ENGINE MECHANICAL

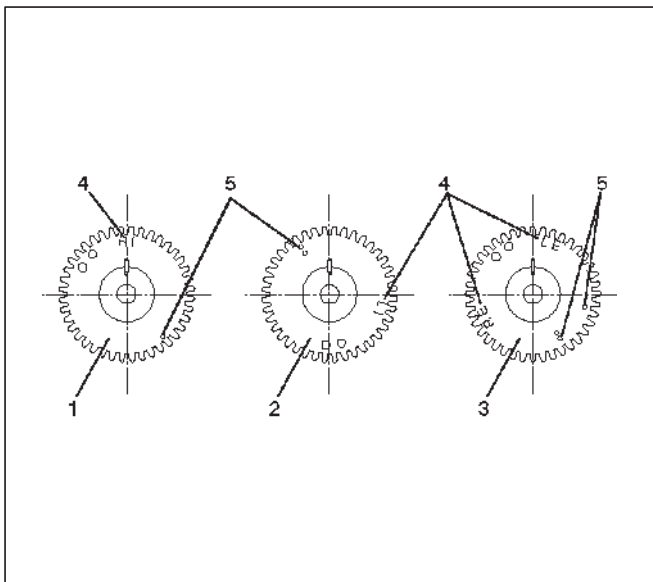
- Tighten the M5 bolt to a suitable torque to prevent the sub gear from moving.



014RW041

- Install camshaft assembly and camshaft brackets, tighten twenty bolts on one side bank to the specified torque.

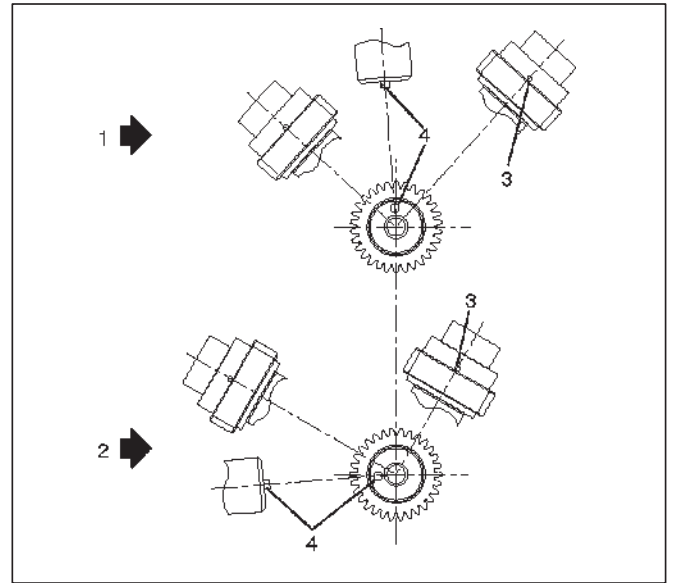
- Apply engine oil to camshaft journal and bearing surface of camshaft bracket.
- Align timing mark on intake camshaft (one dot for right bank, two dot for left bank) and exhaust camshaft (one dot for right bank, two dots for left bank) to timing mark on camshaft drive gear (one dot).



014RW020

### Legend

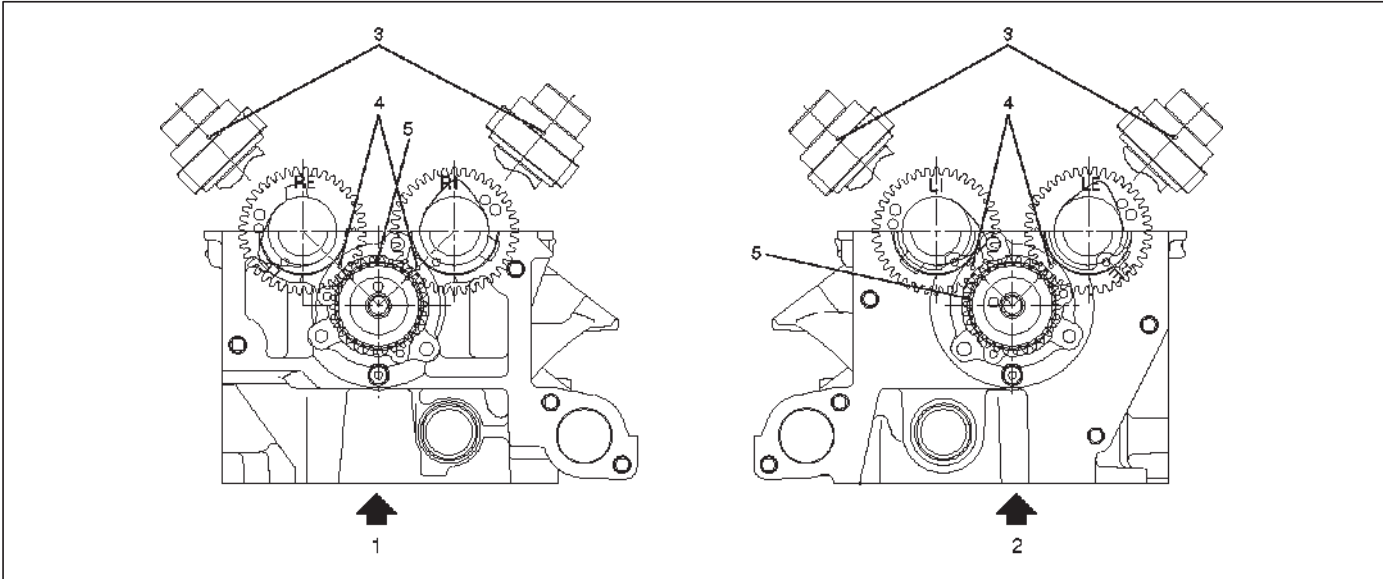
- Intake Camshaft Timing Gear for Right Bank
- Intake Camshaft Timing Gear for Left Bank
- Exhaust Camshaft Timing Gear
- Discrimination Mark  
(LI: Left bank intake, RI: Right bank intake)  
(LE: Left bank exhaust, RE: Right bank exhaust)



014RW023

### Legend

- Right Bank Camshaft Drive Gear
- Left Bank Camshaft Drive Gear
- Timing Mark on Drive Gear
- Dowel Pin



014RW024

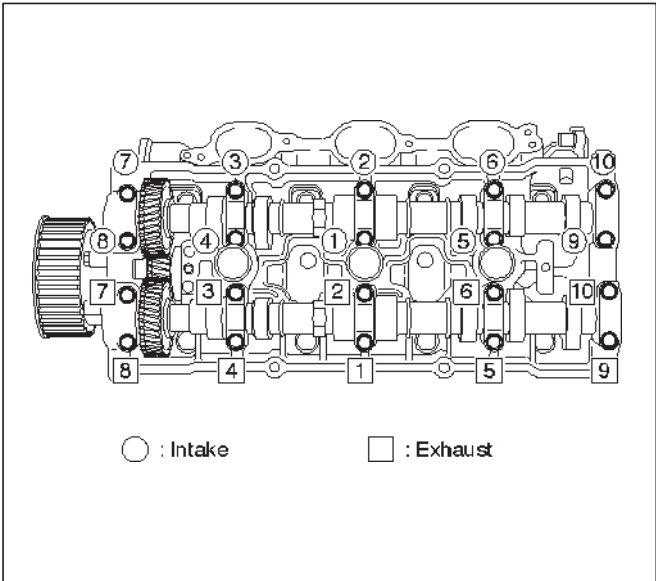
**Legend**

- (1) Right Bank
- (2) Left Bank

- (3) Alignment Mark on Camshaft Drive Gear
- (4) Alignment Mark on Camshaft
- (5) Alignment Mark on Retainer

3. Tighten twenty bolts on numerical order an one side bank as shown in the illustration.

**Torque : 10 N·m (89 lb in)**



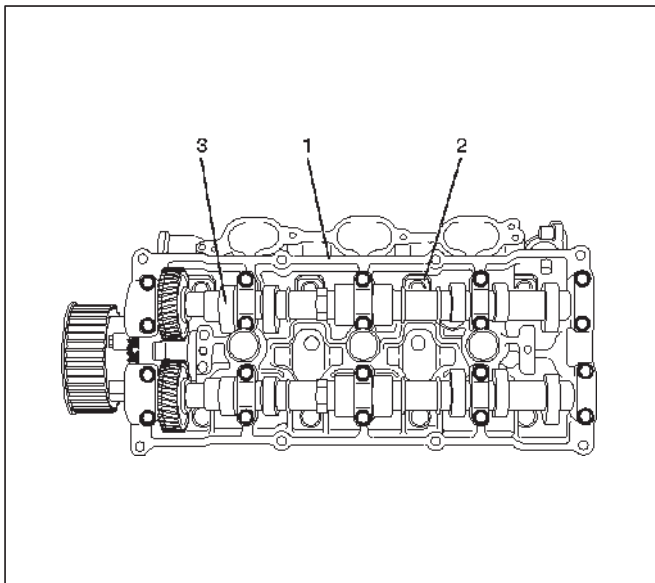
014RW031

- 5. Install cylinder head cover RH.
  - Refer to installation procedure for CYLINDER HEAD COVER RH in this manual.
- 6. Install cylinder head cover LH.
  - Refer to installation procedure for CYLINDER HEAD COVER LH in this manual.
- 7. Install the new timing belt.
  - Refer to installation procedure for TIMING BELT in this manual.
- 8. Install crankshaft pulley.
  - Refer to installation procedure for CRANKSHAFT PULLEY in this manual.

## Cylinder Head

### Removal

1. Remove engine hood.
2. Disconnect battery ground cable.
3. Drain radiator coolant.
4. Drain engine oil.
5. Remove crankshaft pulley.
  - Refer to removal procedure for Crankshaft Pulley in this manual.
6. Remove timing belt.
  - Refer to removal procedure for Timing Belt in this manual.
7. Remove cylinder head cover LH.
  - Refer to removal procedure for Cylinder Head Cover LH in this manual.
8. Remove cylinder head cover RH.
  - Refer to removal procedure for Cylinder Head Cover RH in this manual.
9. Remove common chamber.
  - Refer to removal procedure for Common Chamber in this manual.
10. Remove cylinder head assembly.
  1. Loosen eights bolts for tight cylinder head.
  2. Remove cylinder head assembly.



014RW028

#### Legend

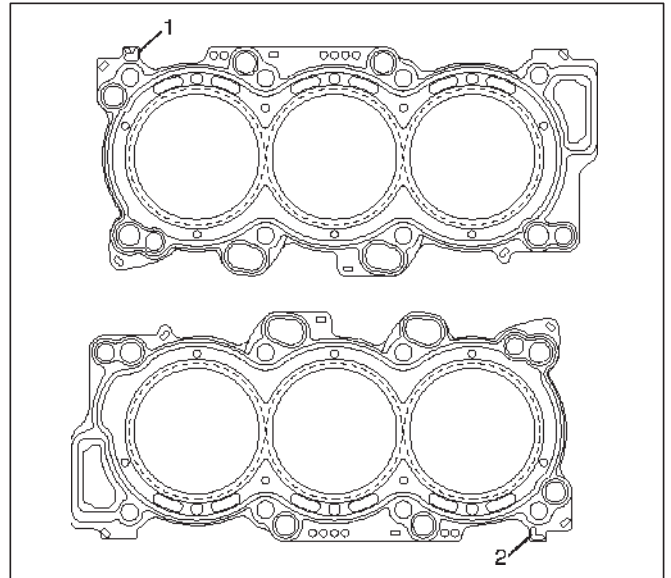
- (1) Cylinder Head
- (2) Cylinder Head Bolt
- (3) Camshaft

### Installation

1. Install cylinder head assembly to cylinder block.
  1. Put cylinder head gasket on the cylinder block.

NOTE: There is discrimination mark "R" for right bank and "L" for left bank on the cylinder head gasket as shown in the illustration.

Do not reuse cylinder head gasket.



011RW005

2. Align dowel pin hole to dowel pin on the cylinder block.
3. Tighten two bolts temporarily by hand to prevent the cylinder head assembly from moving.
4. Using J-24239-01 cylinder head bolt wrench, tighten bolts in numerical order as shown in the illustration to the specified torque.

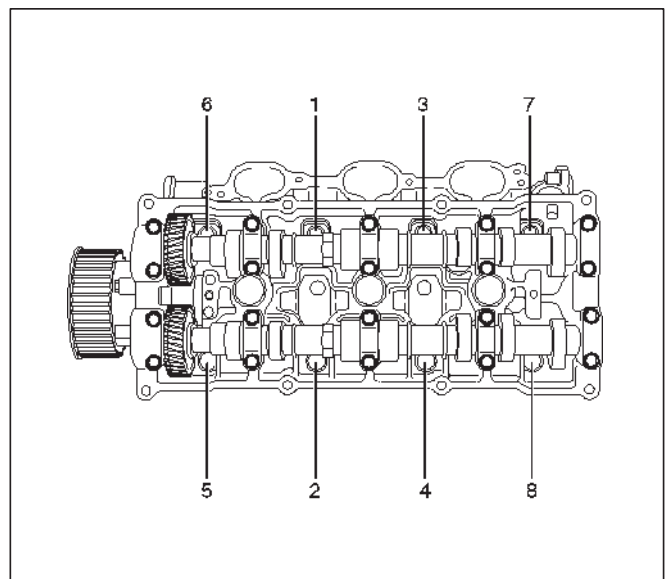
NOTE: Do not reuse cylinder head bolts.

Do not apply any lubricant to the cylinder head bolts.

#### Torque :

**1st step : 29 N·m (21 lb ft)**

**Final : 64 N·m (47 lb ft)**



014RW029

2. Install common chamber.
  - Refer to installation procedure for Common Chamber in this manual.
3. Install cylinder head cover RH.
  - Refer to installation procedure for Cylinder Head Cover RH in this manual.
4. Install cylinder head cover LH.
  - Refer to installation procedure for Cylinder Head Cover LH in this manual.
5. Install timing belt.
  - Refer to installation procedure for Timing Belt in this manual.
6. Install crankshaft pulley.
  - Refer to installation procedure for Crankshaft Pulley in this manual.

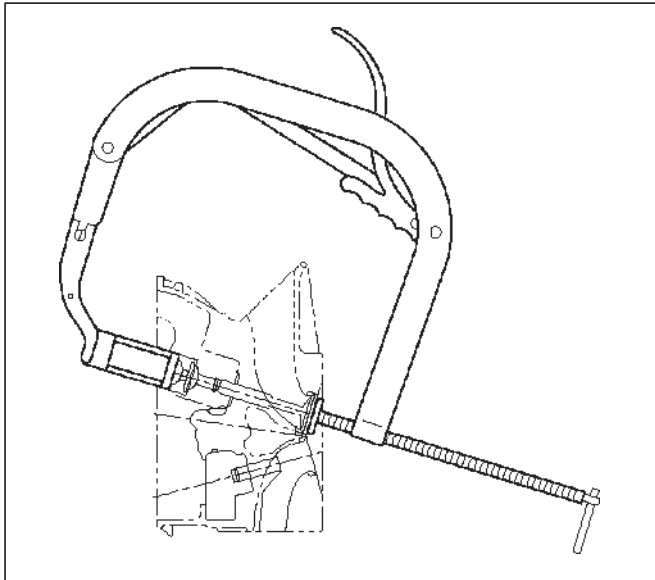
## Valve Stem Oil Controller , Valve Spring and Valve Guide

### Removal

1. Disconnect battery ground cable.
2. Drain engine oil.
  - Drain engine coolant.
3. Remove cylinder head assembly.
  - Refer to removal procedure for Cylinder Head in this manual.
4. Remove camshaft.
  - Refer to removal procedure for Camshaft in this manual.
5. Remove tappets with shim.

NOTE: Do not damage shim surface.

6. Remove valve springs using J-8062 valve spring compressor and J-42898 valve spring compressor adapter then remove upper valve spring seat and lower seat.



7. Remove oil controller using J-37281 oil controller remover, remove each valve stem oil controller.
8. Remove valve guide using J-37985 valve guide replacer.

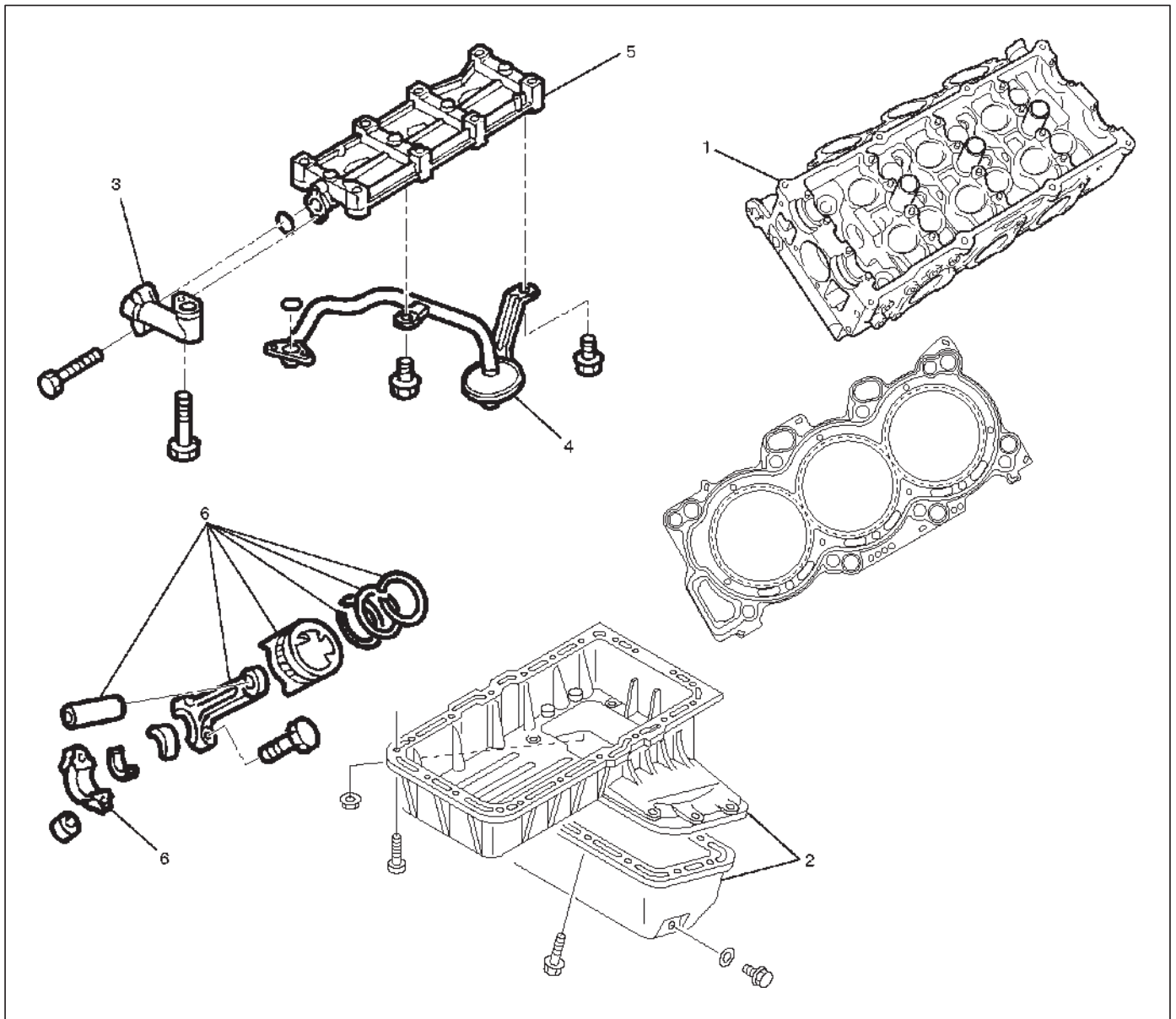
### Installation

1. Install valve guide using J-42899 valve guide installer.
2. Install oil controller using J-38537 oil controller installer.
3. Install lower valve spring seat, valve spring and upper valve spring seat then put split collars on the upper spring seat, using J-8062 valve spring compressor and J-42898 valve spring compressor adapter to install the split collars.
4. Install tappet with shim.
5. Install camshaft assembly.
  - Refer to installation procedure for Camshaft in this manual.
6. Install cylinder head assembly.
  - Refer to installation procedure for Cylinder Head in this manual.
7. Refile engine oil until full level.
8. Refile engine coolant.



## Piston, Piston Ring and Connecting Rod

### Removal



#### Legend

- (1) Cylinder Head
- (2) Crankcase with Oil Pan
- (3) Oil Pipe

- (4) Oil Strainer
- (5) Oil Gallery
- (6) Piston with Connecting Rod Assembly

1. Remove cylinder head assembly.

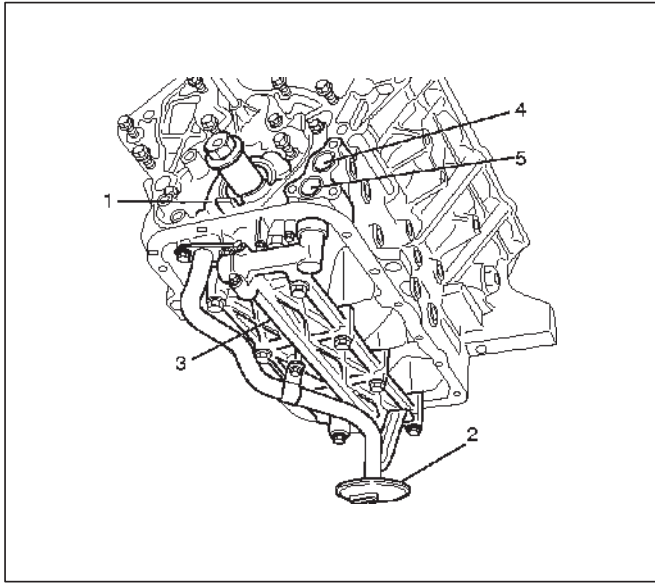
○Refer to removal procedure for Cylinder Head in this manual.

2. Remove crankcase with Oil Pan.

○Refer to removal procedure for Oil Pan and Crankcase in this manual.

## 6A-42 ENGINE MECHANICAL

3. Remove oil strainer fixing bolts, remove oil strainer assembly with O-ring.



050RW002

### Legend

- (1) Oil Pump
- (2) Oil Strainer
- (3) Oil Gallery
- (4) From Oil Filter
- (5) To Oil Filter

4. Remove three fixing bolts, oil pipe with O-ring.
5. Remove eight fixing bolts, oil gallery.
6. Remove piston with connecting rod assembly, before removing the bearing cap, remove carbon on the top of cylinder bore and push piston with connecting rod out from the top of cylinder bore.

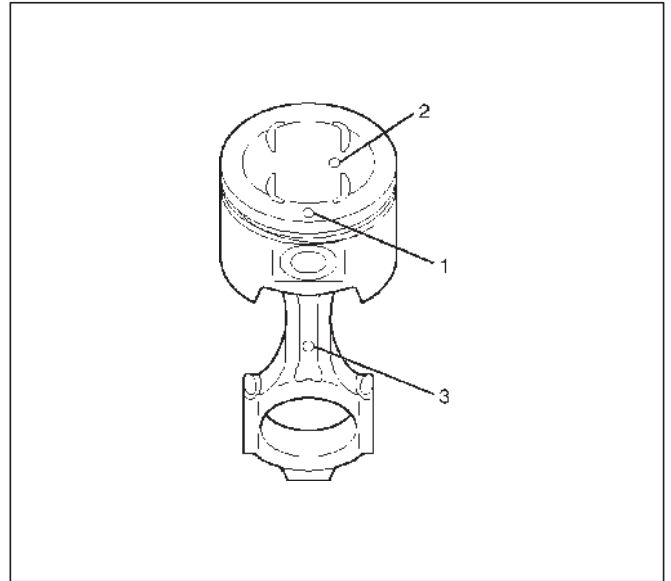
## Installation

1. Install piston with connecting rod assembly.
  - Apply engine oil to cylinder bore, connecting rod bearing and crank pin.  
When installing the piston, its front mark must face the engine front side.
  - The bearing cap number must be the same as connecting rod number.
  - Apply engine oil to the thread and seating surface of each nut.
  - Tighten nuts to the specified torque.

**Torque : 54 N·m (40 lb ft)**

- After tightening the nuts, make sure that the crankshaft rotates smoothly.

**NOTE:** Do not apply engine oil to the bearing back faces and connecting rod bearing fitting surfaces.



015RW003

### Legend

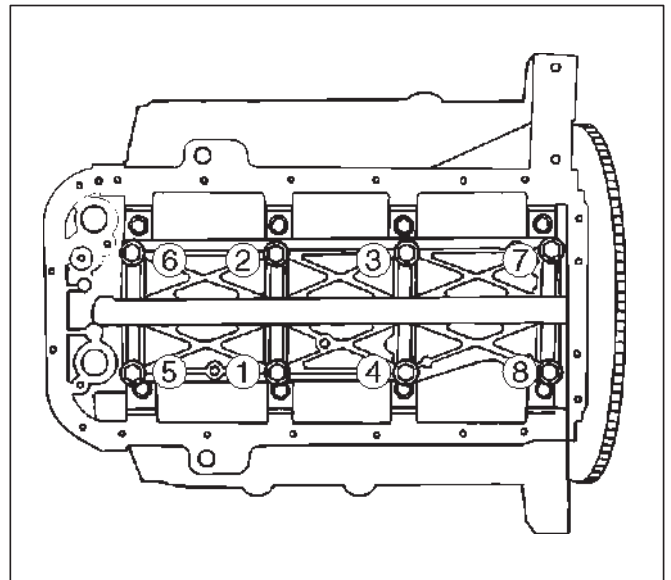
- (1) Piston Front Mark
- (2) Piston Grade
- (3) Connecting Rod Front Mark

2. Install oil gallery and tighten the bolts in two steps, in the order shown in illustration.

### Torque :

**1st step : 29 N·m (21 lb ft)**

**2nd step : 55°-65°**



051RS009

3. Install oil pipe with O-ring.

**Torque : 10 N·m (89 lb in)**

4. Install oil strainer assembly with O-ring.

**Torque : 25 N·m (18 lb ft)**

5. Install crankcase with Oil Pan.

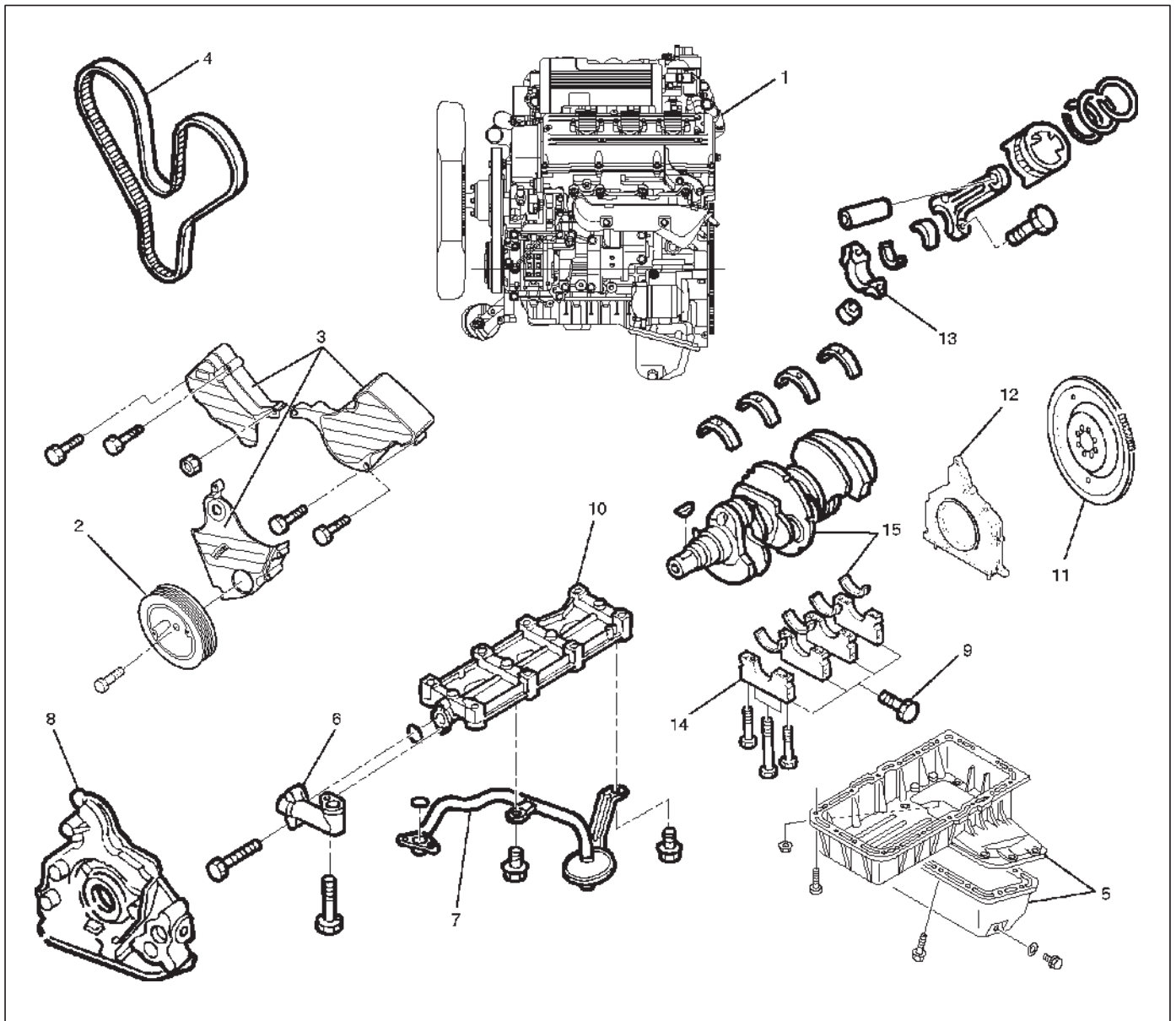
- Refer to installation procedure for Oil Pan and Crankcase in this manual.

6. Install cylinder head assembly.

- Refer to installation procedure for Cylinder Head in this manual.

## Crankshaft and Main Bearings

### Removal



#### Legend

- |                            |                                  |
|----------------------------|----------------------------------|
| (1) Engine Assembly        | (8) Oil Pump Assembly            |
| (2) Crankshaft Pulley      | (9) Cylinder Body Side Bolt      |
| (3) Timing Belt Cover      | (10) Oil Gallery                 |
| (4) Timing Belt            | (11) Flywheel                    |
| (5) Crankcase with Oil Pan | (12) Rear Oil Seal Retainer      |
| (6) Oil Pipe               | (13) Connecting Rod Cap          |
| (7) Oil Strainer           | (14) Crankshaft Main Bearing Cap |
|                            | (15) Crankshaft and Main Bearing |

1. Remove engine assembly.

○Refer to removal procedure for Engine Assembly in this manual.

2. Remove timing belt.

○Refer to removal procedure for Timing Belt in this manual.

3. Remove oil pan and crankcase.

○Refer to removal procedure for Oil Pan and Crankcase in this manual.

4. Remove oil pipe with O-ring.

5. Remove oil strainer assembly with O-ring.

## 6A-44 ENGINE MECHANICAL

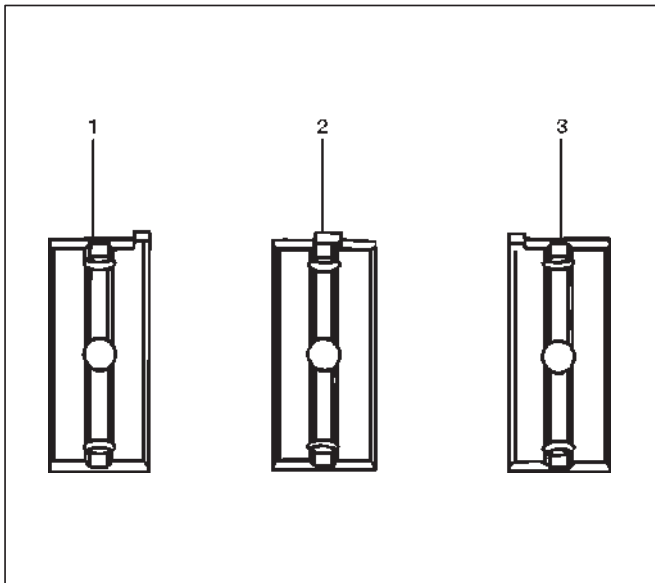
6. Remove oil pump assembly.
  - Refer to removal procedure for Oil Pump in this manual.
7. Remove cylinder body side bolts.
8. Remove oil gallery.
9. Remove flywheel.
10. Remove rear oil seal retainer.
  - Refer to removal procedure for Rear Oil Seal in this manual.
11. Remove connecting rod caps.
12. Remove crankshaft main bearing caps.
13. Remove crankshaft and main bearings.

### Installation

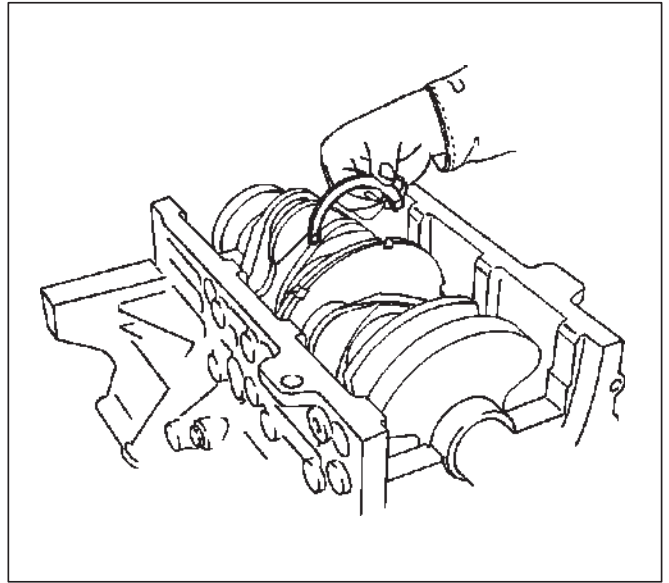
1. Install crankshaft and main bearings.
  - Install main bearings in the cylinder block and main bearing caps respectively.  
Apply new engine oil to upper and lower main bearings.

#### NOTE:

- Do not apply engine oil to the bearing back faces.
- Make sure that main bearings are in correct position.
- Install crankshaft with care.
- Apply engine oil to the thrust washer.
- Install thrust washer on No.3 journal.
- Oil grooves in thrust washer must face the crankshaft.



015RS012



015RS013

2. Install crankshaft main bearing caps.
  - Apply engine oil to the thread and seating surface of each bearing cap fixing bolt.

#### NOTE:

- Do not apply engine oil to the bearing back faces.
- Install bearing caps in the order of numbers, starting with cylinder block front side.
- Tighten main bearing fixing bolts to the specified torque.

#### **Torque : 39 N·m (29 lb ft)**

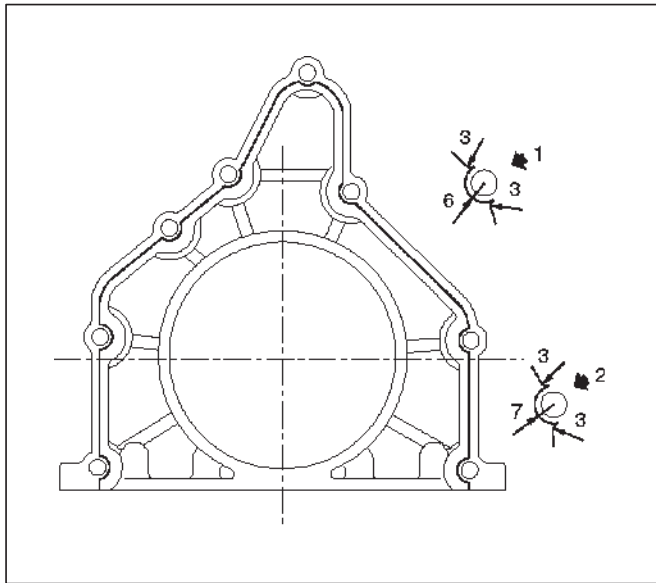
- After tightening the bolts, make sure that the crankshaft rotates smoothly.
3. Install connecting rod caps.

- The cap number must be same as connecting rod number.
- Apply engine oil to the thread and seating surface of each nut.
- Tighten nuts to the specified torque.

#### **Torque : 54 N·m (40 lb ft)**

- After tightening the nuts, make sure that the crankshaft rotates smoothly.
4. Install rear oil seal retainer.
    - Remove oil on cylinder block and retainer fitting surface.
    - Apply sealant (TB1207B or equivalent) to retainer fitting surface as shown in illustration.

- The oil seal retainer must be installed within 5 minutes after sealant application before the sealant hardens.



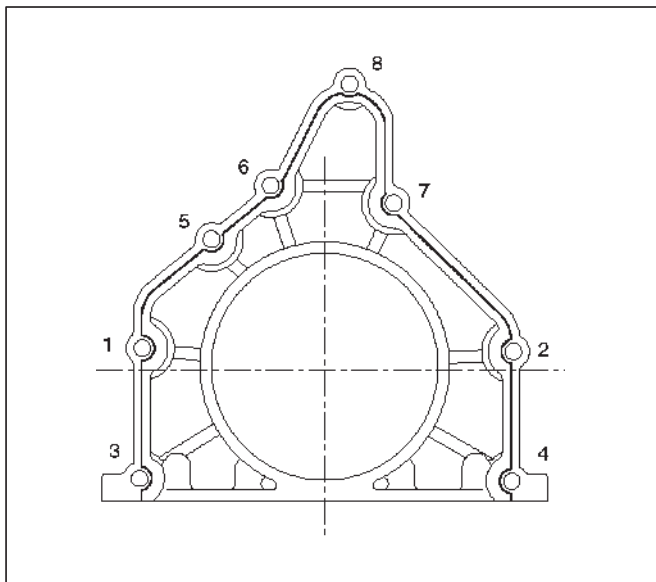
015RW002

**Legend**

- (1) Around Bolt Holes
- (2) Around Dowel Pin

- Apply engine oil to oil seal lip and align a dowel pin hole in the cylinder block with that in the retainer.
- Tighten retainer fixing bolts to the specified torque.

**Torque : 18 N·m (13 lb ft)**



015RW001

**5. Install flywheel.**

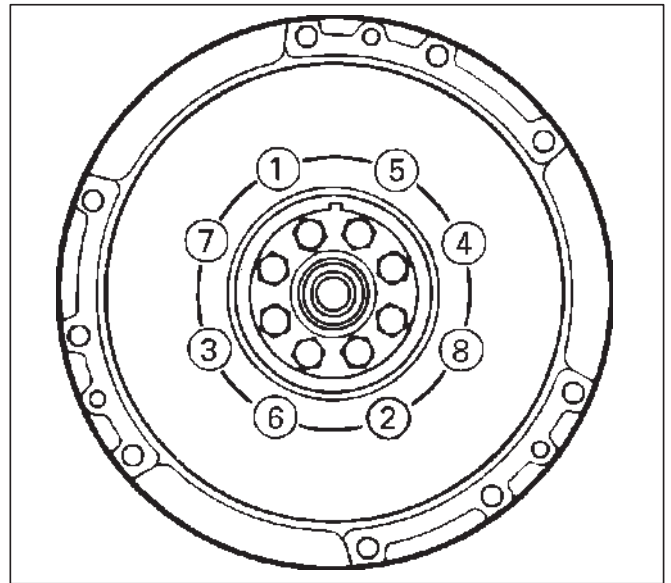
- Clean tapped holes in the crankshaft.
- Remove oil on crankshaft and flywheel fitting surface.

**NOTE:**

- Do not reuse the bolts.
- Do not apply oil or thread lock to the bolts.

- Tighten fixing bolts to the specified torque.

**Torque : 54 N·m (40 lb ft)**



015RS018

**6. Install oil gallery.**

- Clean contact surface of oil gallery and main bearing cap.  
Apply engine oil to oil gallery fixing bolts and tighten the bolts in two steps, in the order shown in illustration.

**Torque :**

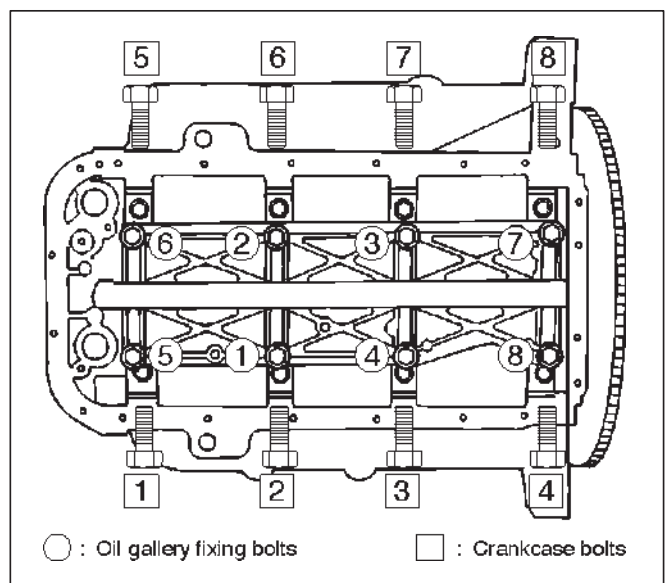
**1st step : 29 N·m (21 lb ft)**

**2nd step : 55°-65°**

- 7. Install cylinder body side bolts and tighten bolts in order to the specified torque.

**Torque : 39 N·m (29 lb ft)**

**NOTE:** Do not apply the oil to the bolts.



- : Oil gallery fixing bolts
- : Crankcase bolts

012RS007

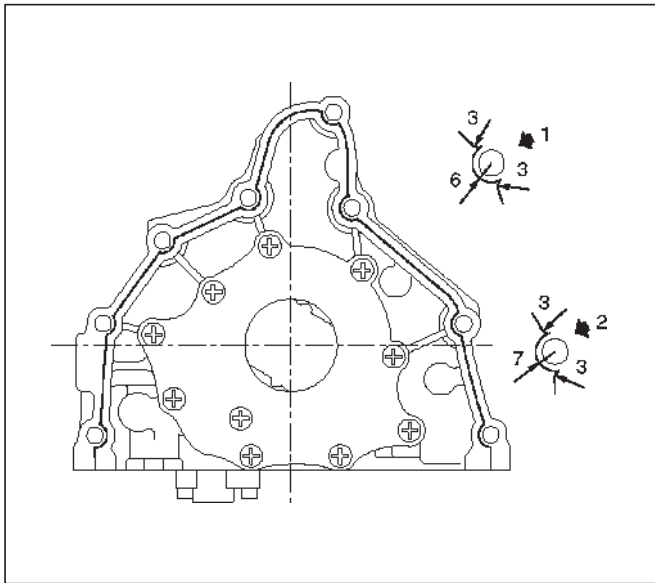
**8. Install oil pump assembly.**

- Remove oil on cylinder block and oil pump mounting surface.

## 6A-46 ENGINE MECHANICAL

- Apply sealant (TB1207B or equivalent) to the oil pump mounting surface.
- The oil pump assembly must be installed within 5 minutes after sealant application before the sealant hardens.
- Apply engine oil to oil seal lip.
- Install oil pump in the cylinder block and tighten fixing bolts to the specified torque.

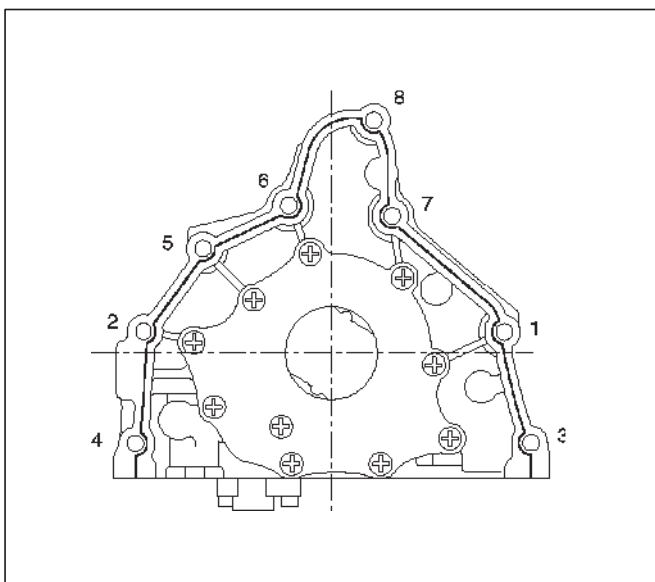
**Torque : 25 N·m (18 lb ft)**



051RW002

### Legend

- (1) Around Bolt Holes
- (2) Around Dowel Pin



051RW001

9. Install oil strainer with O-ring, tighten to the specified torque.

**Torque : 25 N·m (18 lb ft)**

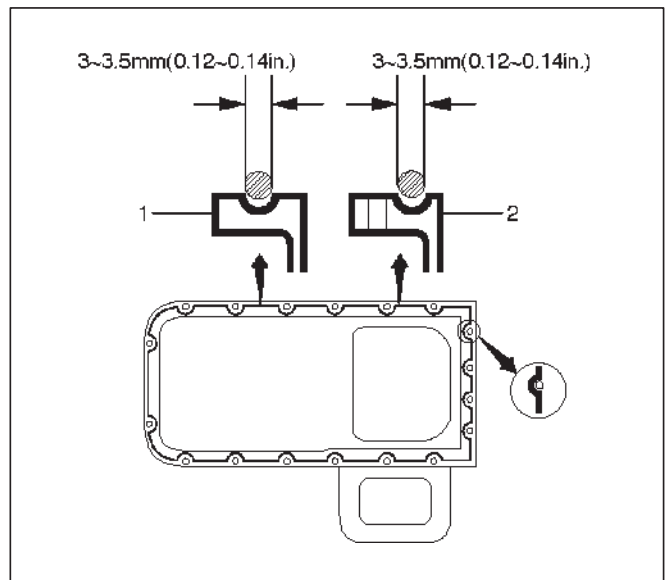
10. Install oil pipe with O-ring, tighten fixing bolts to the specified torque.

**Torque : 25 N·m (18 lb ft)**

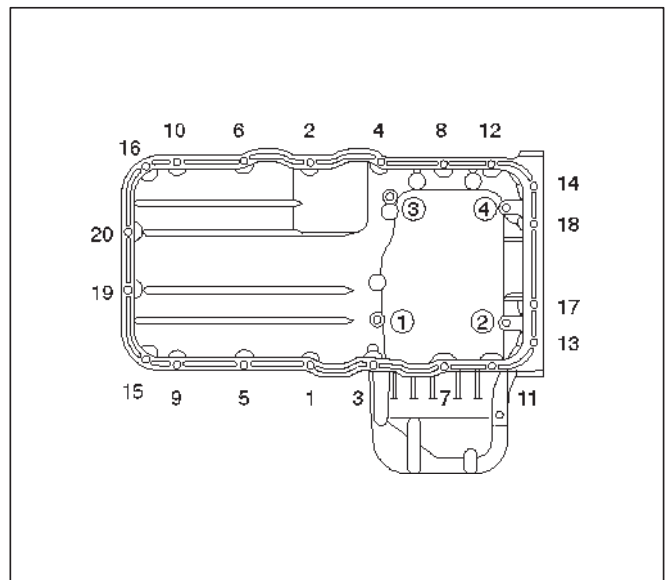
11. Install crankcase.

- Remove oil on crankcase mounting surface and dry the surface.
- Properly apply a 4.5 mm (0.7 in) wide bead of sealant (TB1207C or equivalent) to the crankcase mounting surface. The bead must be continuous.
- The crankcase must be installed within 5 minutes after sealant application before the sealant hardens.
- Tighten fixing bolts to the specified torque.

**Torque : 10 N·m (89 lb in)**



013RW010



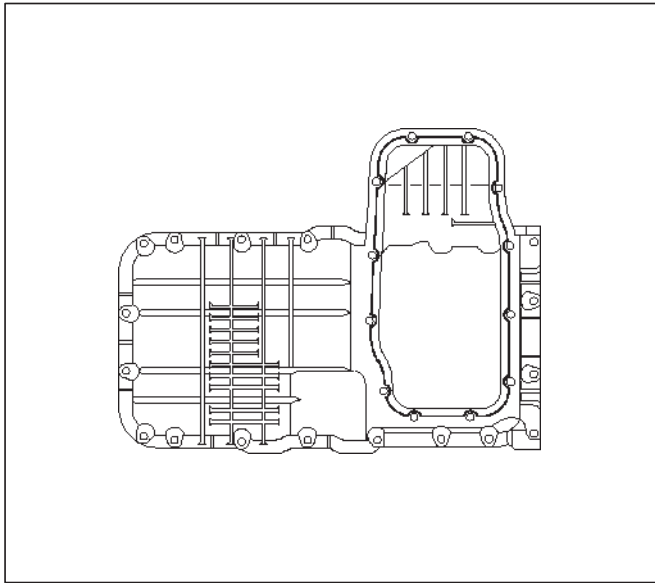
013RW004

12. Install oil pan

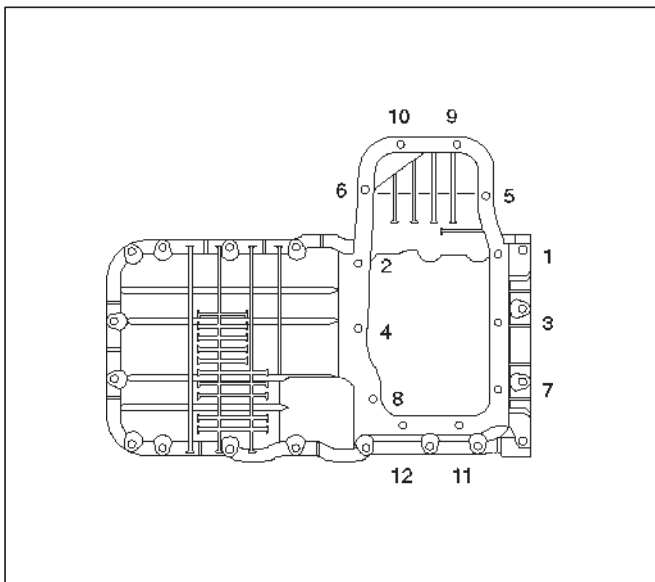
- Remove oil on oil pan mounting surface and dry the surface.
- Properly apply a 4.5 mm (0.7 in) wide bead of sealant (TB1207C or equivalent) to the oil pan mounting surface. The bead must be continuous.
- The oil pan must be installed within 5 minutes after sealant application to prevent premature hardening of sealant.

○Tighten fixing bolts to the specified torque.

**Torque : 25 N·m (18 lb ft)**



013RW003



013RW002

13. Install timing belt.

○Refer to installation procedure for Timing Belt in this manual.

14. Install engine assembly.

○Refer to installation procedure for Engine in this manual.

## Rear Oil Seal

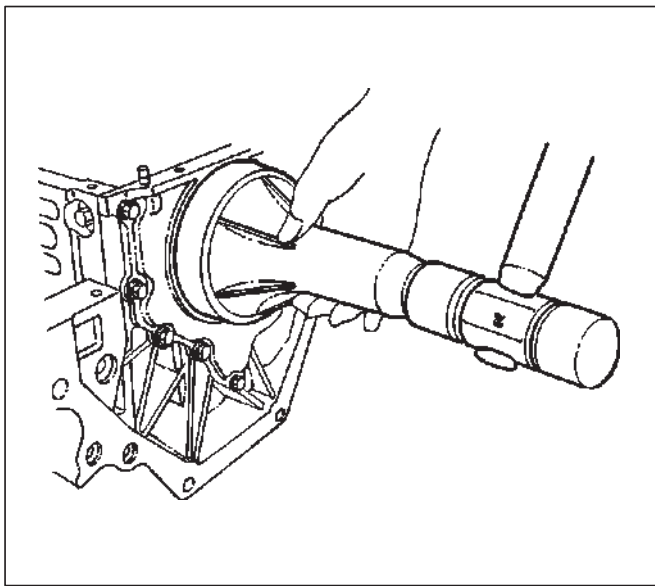
### Removal

1. Remove transmission assembly.
  - Refer to removal procedure for Transmission section in this manual.
2. Remove flywheel.
3. Remove rear oil seal using a seal remover.

NOTE: Take care not to damage the crankshaft or oil seal retainer when removing oil seal.

### Installation

1. Apply engine oil to oil seal lip and install oil seal using J-39201.

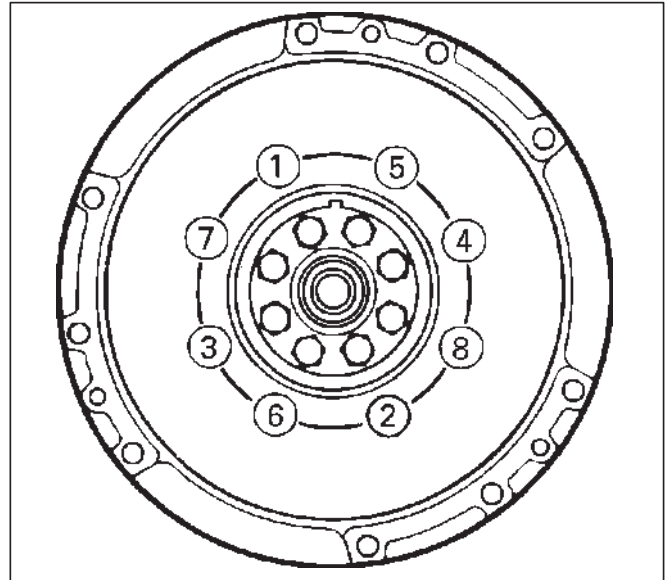


015RS017

2. Install flywheel.
  - Clean tapped holes in the crankshaft.
  - Remove oil on the crankshaft and flywheel mounting surface.
  - Tighten fixing bolts to the specified torque.

NOTE: Do not reuse the bolts and do not apply oil or thread lock to the bolts.

**Torque : 54 N·m (40 lb ft)**

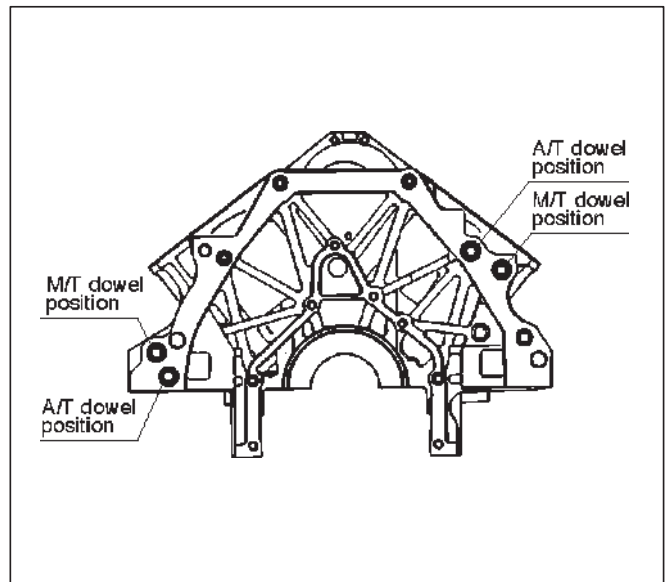


015RS018

3. Install transmission.
  - See Transmission section in this manual.

**CAUTION:** When assembling the engine and transmission, confirm that dowels have been mounted in the specified positions at the engine side. Take care that dowel positions are different between the manual transmission and the automatic transmission.

Otherwise, the transmission may be damaged.

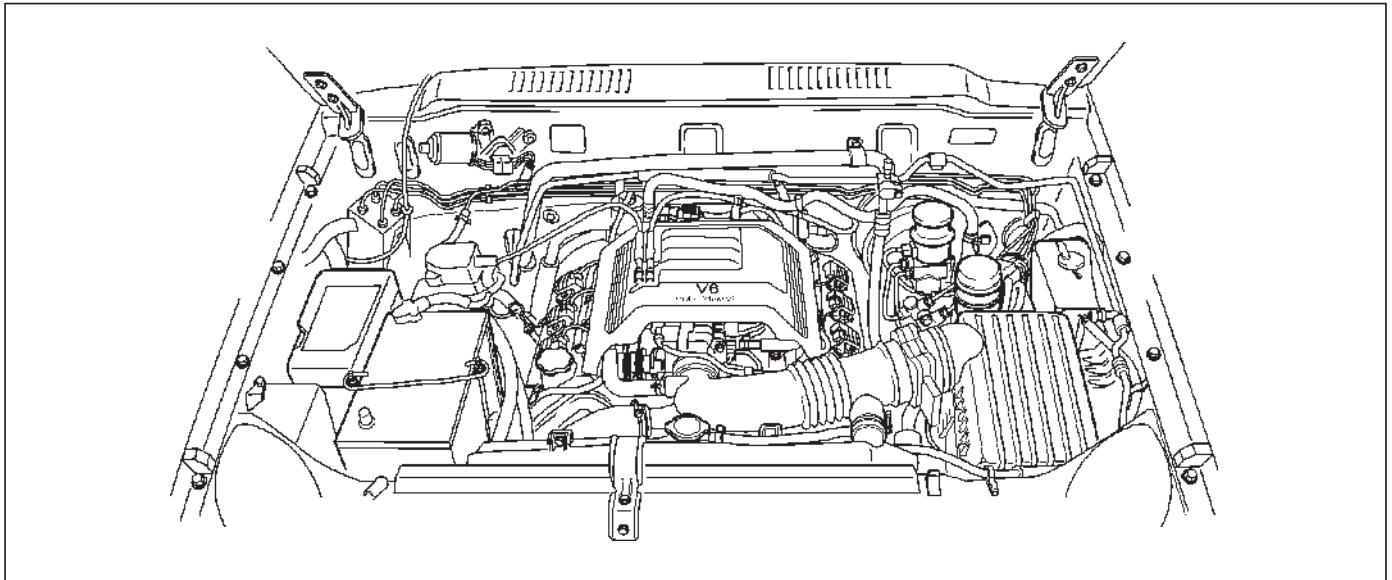


012RS009



## Engine Assembly

### Removal



035RX005

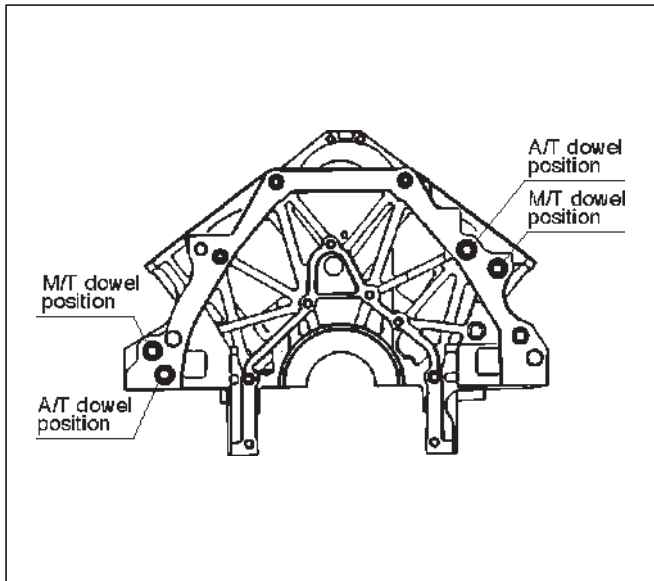
1. Disconnect battery ground and positive cable.
  2. Remove battery.
  3. Make alignment mark on the engine hood and hinges before removal in order to return the hood to original position exactly.
  4. Remove engine hood.
  5. Drain radiator coolant.
  6. Disconnect accelerator cable and automatic cruise control cable from throttle valve on common chamber.
  7. Disconnect air duct with air cleaner cover.
  8. Remove air cleaner assembly.
  9. Disconnect canister vacuum hose.
  10. Disconnect vacuum booster hose.
  11. Disconnect three engine harness connectors.
  12. Disconnect harness connector to transmission (left front side of engine compartment), disconnect shift on the fly harness connector from front side of front axle and remove transmission harness bracket from engine left side.
  13. Disconnect ground cable between engine and frame.
  14. Disconnect ground cable connector on the back of the right dash panel.
  15. Disconnect ground cable terminal on the left bank.
  16. Disconnect starter harness connector from starter.
  17. Disconnect generator harness connector from generator.
  18. Disconnect coolant reserve tank hose from radiator.
  19. Remove radiator upper and lower hoses.
  20. Remove upper fan shroud.
  21. Remove cooling fan assembly four fixing nuts, then the cooling fan assembly.
  22. Move drive belt tensioner to loose side using wrench then remove drive belt.
  23. Remove power steering pump fixing bolts, then power steering pump. Place the power steering pump along with piping on the body side.
  24. Remove air conditioning compressor fixing bolts from bracket and place the compressor along with piping on the body side.
  25. Remove four Heated Oxygen (O<sub>2</sub>) sensor harness connectors (two each bank) from exhaust front pipe.
  26. Remove three exhaust pipe fixing nuts from each bank.
  27. Remove two exhaust pipe fixing nuts from each exhaust pipe, then move exhaust pipe to rear side of vehicle.
  28. Remove flywheel dust covers.
  29. Disconnect two heater hoses from engine.
  30. Disconnect fuel hoses from right side of transmission.
- CAUTION: Plug fuel pipes on engine side and fuel hoses from fuel tank.**
31. Remove transmission assembly. Refer to Transmission section in this manual.
  32. Support the engine by engine hoist.
  33. Remove two left side engine mount fixing bolts from engine mount on chassis side.
  34. Remove two right side engine mount fixing bolts from engine mount on chassis side.
  35. Remove engine assembly.

### Installation

**CAUTION: When assembling the engine and transmission, confirm that dowels have been mounted in the specified positions at the engine side. Take care that dowel positions are different between the manual transmission and the automatic transmission.**

## 6A-50 ENGINE MECHANICAL

If the engine is assembled in the condition that the dowels have not been mounted in the specified positions, the transmission may be damaged the transmission.



1. Install engine assembly. Tighten engine mount fixing bolts to frame to the specified torque.

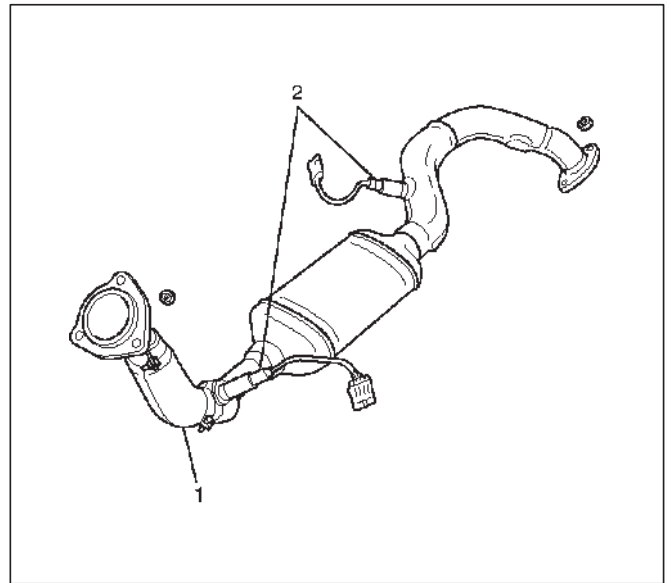
**Torque: 41 N·m (30 lb ft)**

2. Reconnect fuel hose to fuel pipe on engine.
3. Install transmission assembly. Refer to Transmission section in this manual.
4. Reconnect two heater hoses to engine.
5. Install flywheel dust covers.
6. Install exhaust pipe and temporarily tighten two (each bank) rear exhaust flange nuts then tighten three stud nuts (each bank) between exhaust manifold and exhaust pipe, finally tighten rear side nuts to the specified torque.

**Torque:**

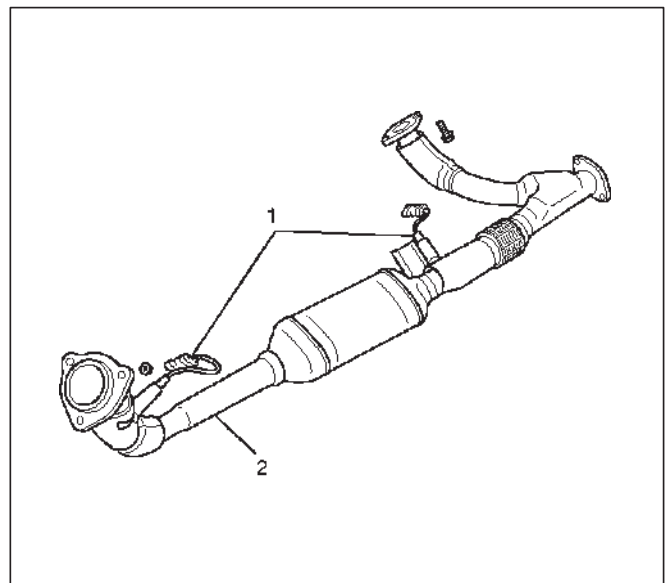
**Nuts: 43 N·m (32 lb ft)**

**Stud nuts: 67 N·m (49 lb ft)**



### Legend

- (1) Exhaust Front Pipe RH
- (2) Heated Oxygen (O<sub>2</sub>) Sensor



### Legend

- (1) O<sub>2</sub> Sensor
- (2) Exhaust Front Pipe LH

7. Reconnect O<sub>2</sub> sensor connector.
8. Install cooling fan assembly and tighten bolts/nuts to the specified torque.

**Torque : 22 N·m (16 lb ft) for fan pulley and fan bracket.**

**Torque : 10 N·m (88.5 lb in) for fan and clutch assembly.**

9. Install air conditioner compressor to engine and tighten to the specified torque.

**Torque :**

**M8 bolts : 22 N·m (16 lb ft)**

**M10 bolts : 43 N·m (32 lb ft)**

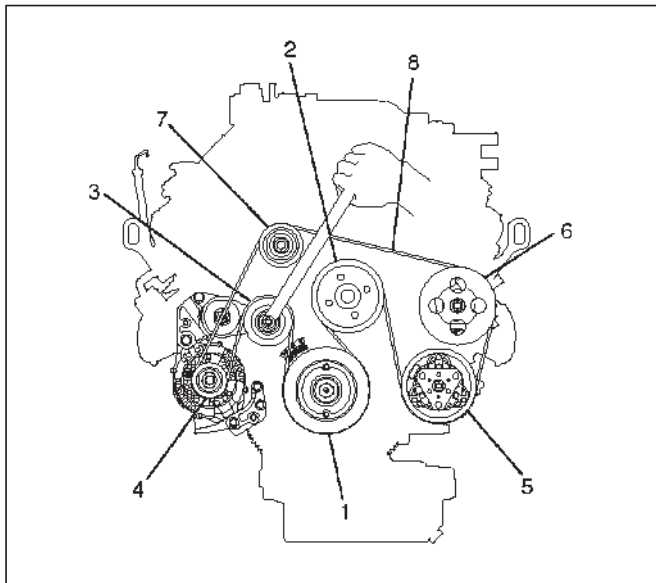
10. Install power steering pump, tighten fixing bolt to the specified torque.

**Torque :**

**M8 bolts : 22N·m (16 lb ft)**

**M10 bolts : 46 N·m (34 lb ft)**

11. Move drive belt tensioner to loose side using wrench, then install drive belt to normal position.



**Legend**

- (1) Crankshaft Pulley
- (2) Cooling Fan Pulley
- (3) Tensioner
- (4) Generator
- (5) Air Conditioner Compressor
- (6) Power Steering Oil Pump
- (7) Drive Belt

12. Install upper fan shroud.

13. Reconnect radiator upper and lower hoses.

14. Reconnect coolant reserve tank hose to radiator.

15. Reconnect generator harness connector.

16. Reconnect starter harness connector.

17. Reconnect ground cable terminal on left bank

18. Reconnect ground cable terminal on the back of right dash panel.

19. Reconnect ground cable between engine and chassis.

20. Reconnect harness connector to transmission and install transmission harness bracket on engine left side.

21. Reconnect three engine harness connectors.

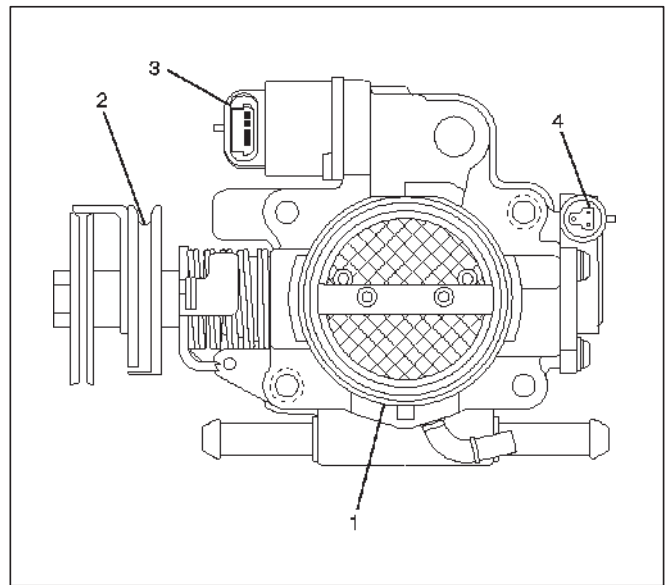
22. Reconnect vacuum booster hose.

23. Reconnect canister vacuum hose.

24. Install air cleaner assembly.

25. Reconnect air duct.

26. Reconnect accelerator cable and automatic cruise control cable to throttle valve on common chamber.



**Legend**

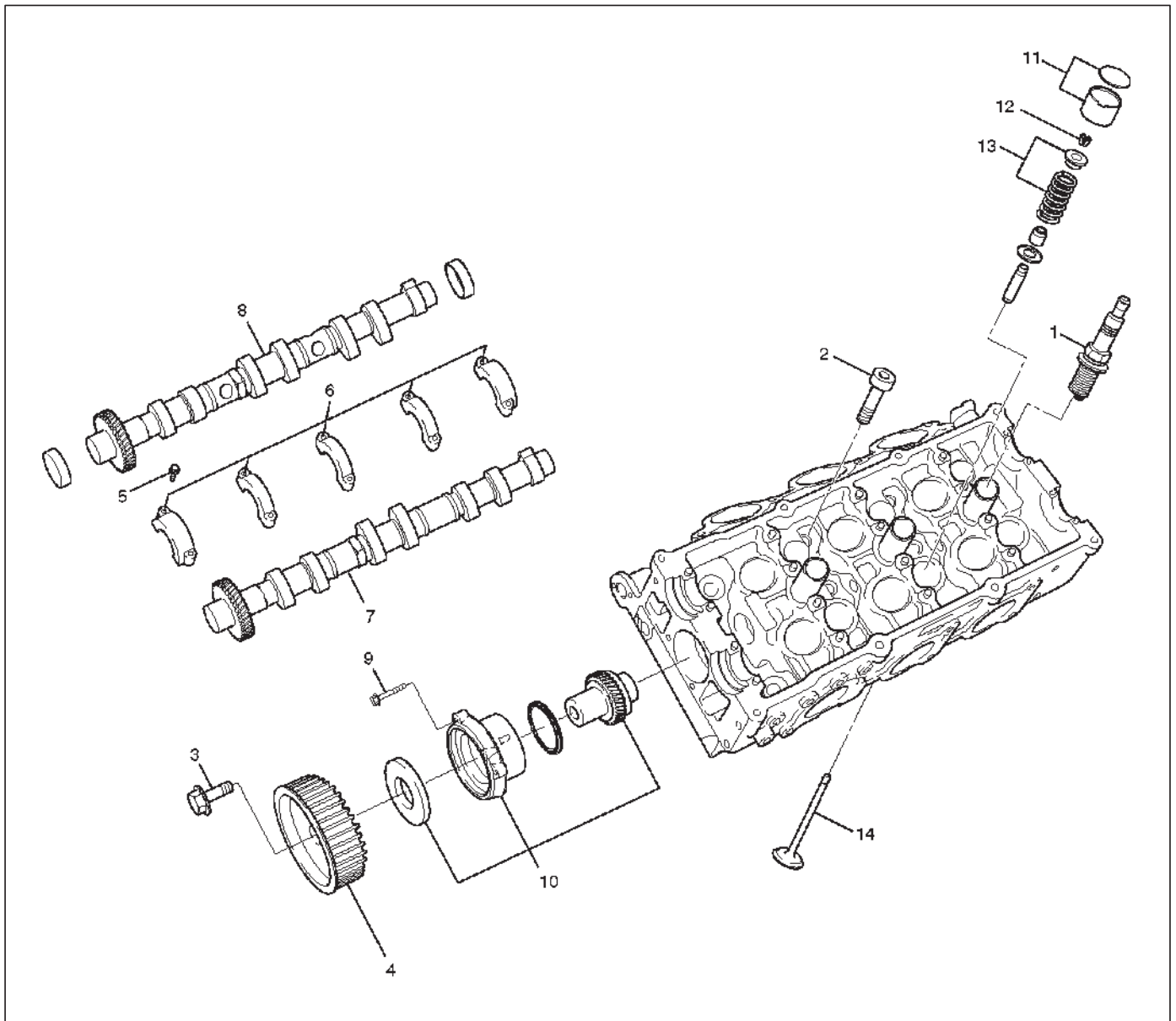
- (1) Throttle Valve Assembly
- (2) Throttle Lever
- (3) Idle Air Control Valve
- (4) Throttle Position Sensor

27. Install engine hood to the original position.

○Refer to installation procedure for Body section in this manual.

## Cylinder Head

### Cylinder Head and Associated Parts



011RW008

#### Legend

- |  |   |
|--|---|
| (1) Spark Plug                             | (8) Camshaft Intake                     |
| (2) Cylinder Head Bolt                     | (9) Retainer Fixing Bolt                |
| (3) Camshaft Drive Gear Pulley Fixing Bolt | (10) Retainer Assembly                  |
| (4) Camshaft Drive Gear Pulley             | (11) Tappet with Shim                   |
| (5) Camshaft Bracket Fixing Bolt           | (12) Split Collar                       |
| (6) Camshaft Bracket                       | (13) Valve Spring and Spring Upper Seat |
| (7) Camshaft Exhaust                       | (14) Valve                              |

### Disassembly

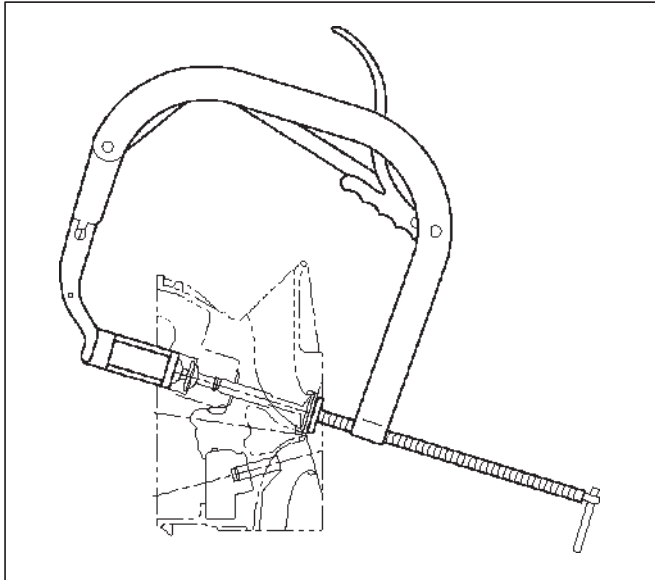
#### NOTE:

- During disassembly, be sure that the valve train components are kept together and identified so that they can be reinstalled in their original locations.

- Before removing the cylinder head from the engine and before disassembling the valve mechanism, perform a compression test and note the results.

1. Remove camshaft drive gear pulley fixing bolt (3), then pulley (4).

2. Remove camshaft bracket fixing bolt (5), camshaft bracket (6), then camshaft exhaust (7), and intake side (8).
3. Remove tappet with shim (11).
4. Use the J-8062 valve spring compressor and J-42898 valve spring compressor adapter to remove the split collar (12), valve spring with upper seat (13) and valve (14).



014RW042

5. Remove spark plug (1).

**CAUTION:** Do not remove the spark plugs when the head and plugs are hot. Clean dirt and debris from spark plug recess areas before removal.

## Clean

### Cylinder head

Carefully remove all varnish, soot and carbon from the bare metal. Do not use a motorized wire brush on any gasket sealing surface.

## Inspection and Repair

1. Examine cylinder head gasket and mating surfaces for leaks, corrosion and blow-by. If the gasket has failed, determine the cause.
  - Insufficient torque on head bolts.
  - Improper installation
  - Loose or warped cylinder head
  - Missing dowel pins
  - Warped case surface
2. Cylinder head for cracks, especially between valve seats and in the exhaust ports.

3. Cylinder head deck for corrosion, sand particles in head and porosity.

### CAUTION:

- Do not attempt to weld the cylinder head. Replace it.
  - Do not reuse cylinder head bolts.
4. Examine cylinder head deck, common chamber and exhaust manifold mating surfaces for flatness. These surfaces may be reconditioned by milling. If the surfaces are "out of flat" by more than specification, the surface should be ground to within specifications. Replace the head if it requires machining beyond the repairable limit.

#### Head surface and manifold surface

**Standard: 0.05 mm (0.002 in) or less**

**Warpage limit: 0.2 mm (0.0079 in)**

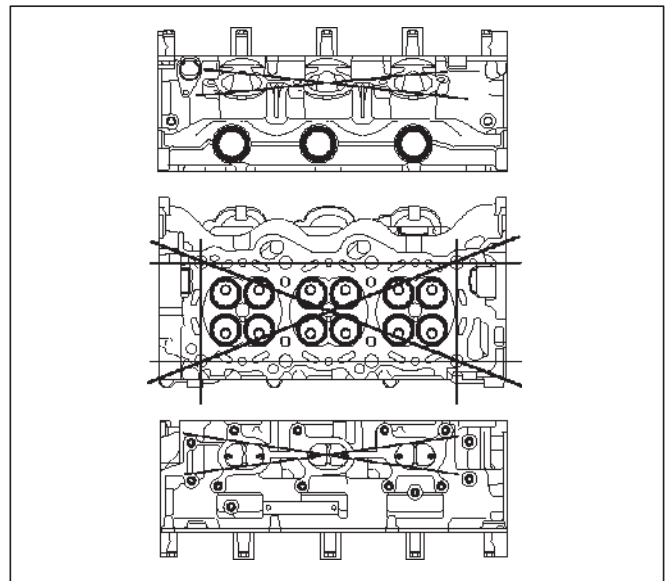
**Maximum Repairable limit: 0.2 mm (0.0079 in)**

#### Head height

**Standard height : 133.2 mm (5.2441 in)**

**Warpage limit : 0.2 mm (0.0079 in)**

**Maximum Repairable limit : 133.0 mm (5.2362 in)**



011RW019

5. Water jacket sealing plugs seating surfaces.

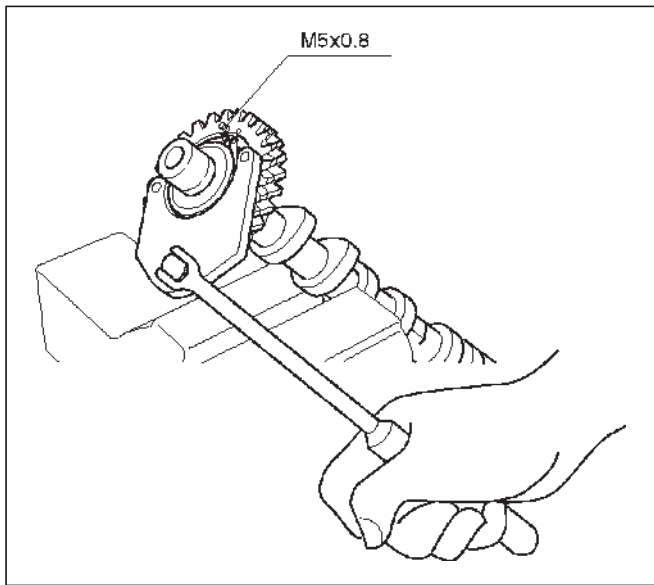
## Reassembly

1. Install Spark plug and tighten all the spark plugs to specified torque.
 

**Torque: 18 N·m (13 lb ft)**
2. Tighten sub gear setting bolt.
  1. Use J-42686 (gear spring lever) to turn sub gear to right direction until the M5 bolt aligns with the hole between camshaft driven gear and sub gear.

## 6A-54 ENGINE MECHANICAL

- Tighten the M5 bolt to a suitable torque to prevent the sub gear from moving .



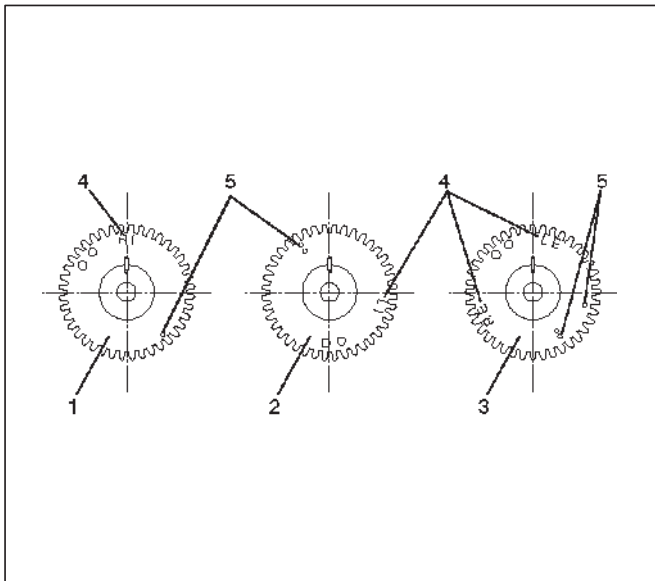
014RW025

- Install camshaft drive gear assembly and tighten three bolts to the specified torque.

**Torque: 10 N·m (7.4 lb ft)**

- Install camshaft assembly and camshaft brackets, tighten twenty bolts on one side bank to the specified torque.

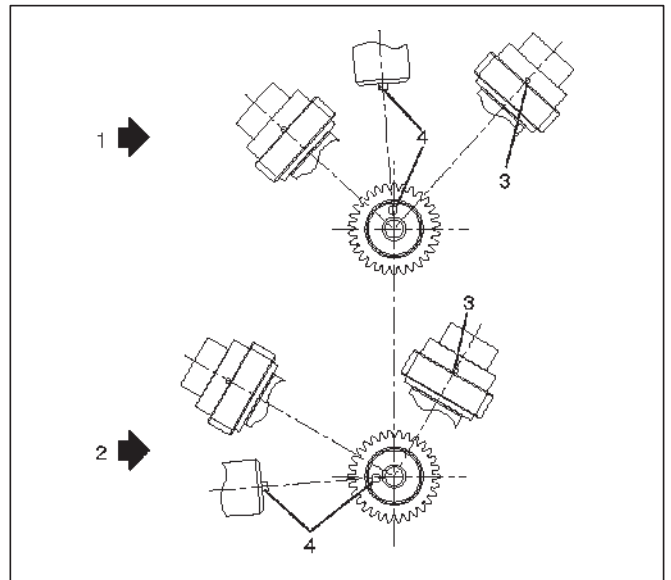
- Apply engine oil to camshaft journal and bearing surface of camshaft bracket.
- Align timing mark on intake camshaft (one dot for right bank, two dots for left bank) and exhaust camshaft (one dot for right bank, two dots for left bank) to timing mark on camshaft drive gear (one dot).



014RW020

### Legend

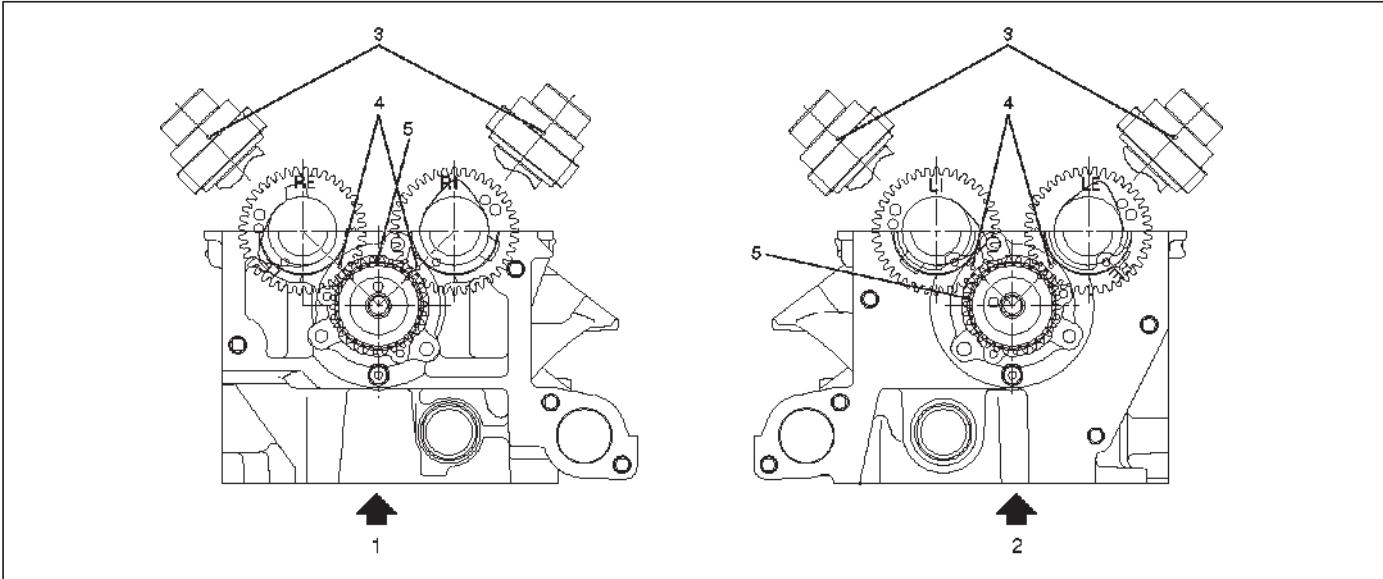
- (1) Intake Camshaft Timing Gear for Right Bank
- (2) Intake Camshaft Timing Gear for Left Bank
- (3) Exhaust Camshaft Timing Gear
- (4) Discrimination Mark
- LI: Left Bank Intake
- RI: Right Bank Intake
- LE: Left Bank Exhaust
- RE: Right Bank Exhaust



014RW023

### Legend

- (1) Right Bank Camshaft Drive Gear
- (2) Left Bank Camshaft Drive Gear
- (3) Timing Mark on Drive Gear
- (4) Dowel Pin



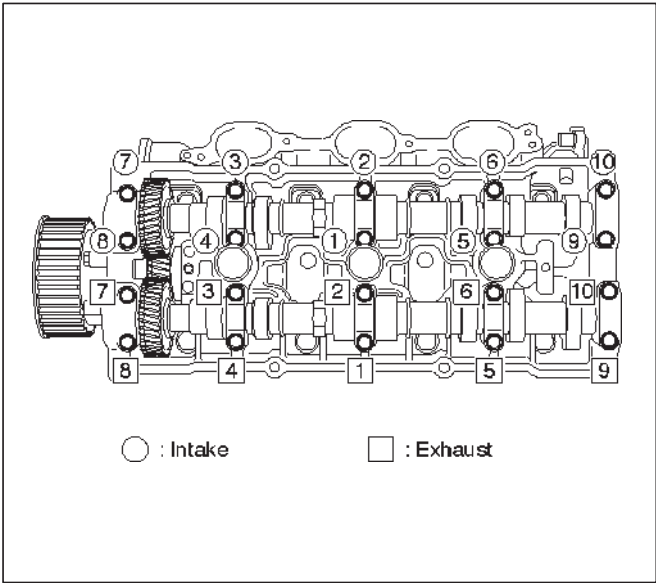
014RW024

**Legend**

- (1) Right Bank
- (2) Left Bank
- (3) Alignment Mark on Camshaft Drive Gear
- (4) Alignment Mark on Camshaft
- (5) Alignment Mark on Retainer

3. Tighten twenty bolts in numerical order on one side bank as shown in the illustration.

**Torque: 10 N-m (89 lb in)**



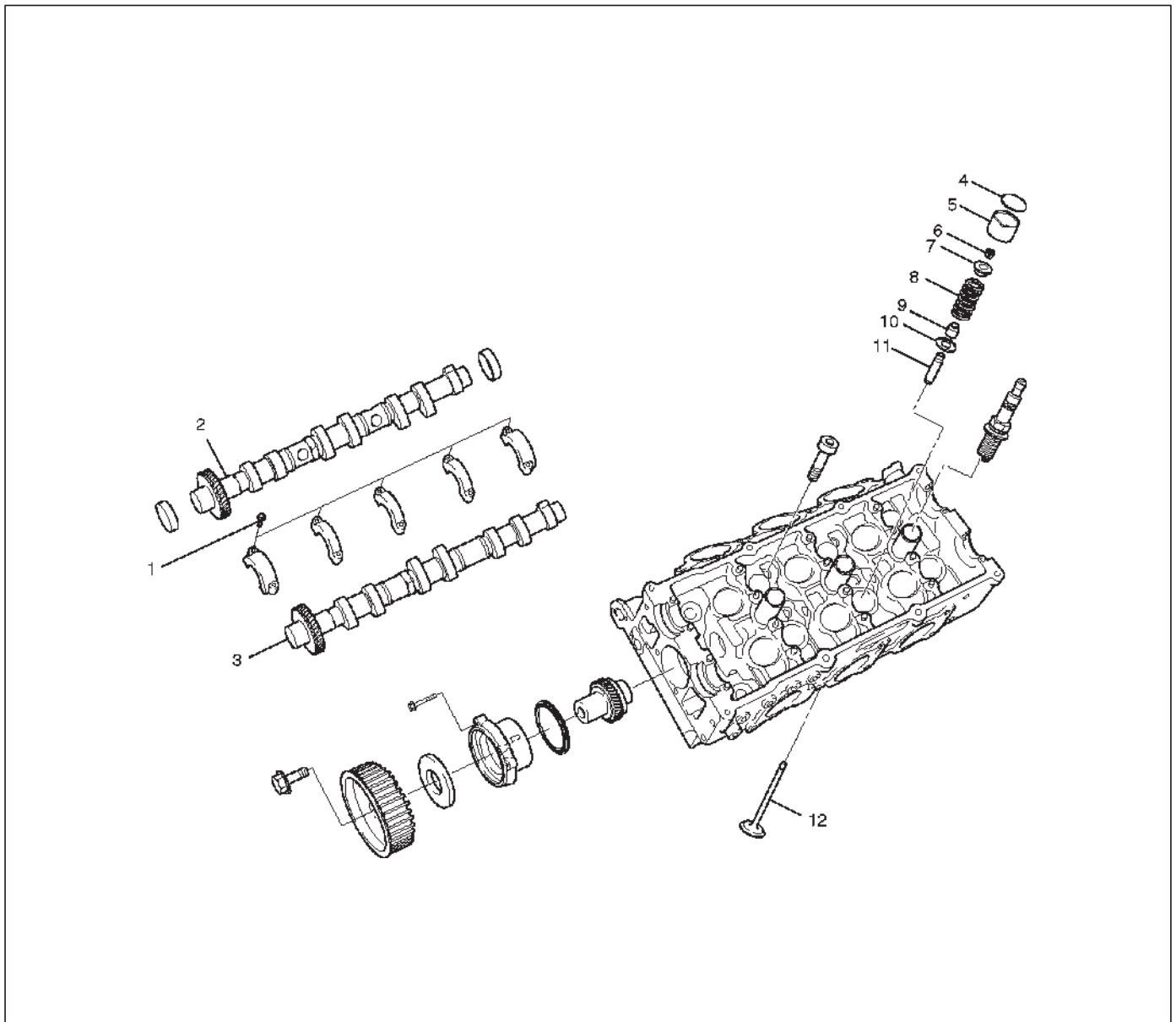
014RW031

5. Tighten bolt for camshaft drive gear assembly pulley to the specified torque.

**Torque: 98 N-m (72 lb ft)**

## Valve Spring, Oil Controller, Valve, Valve Guide

### Valve Spring, Oil Controller, Valve, Valve Guide and Associated Parts



#### Legend

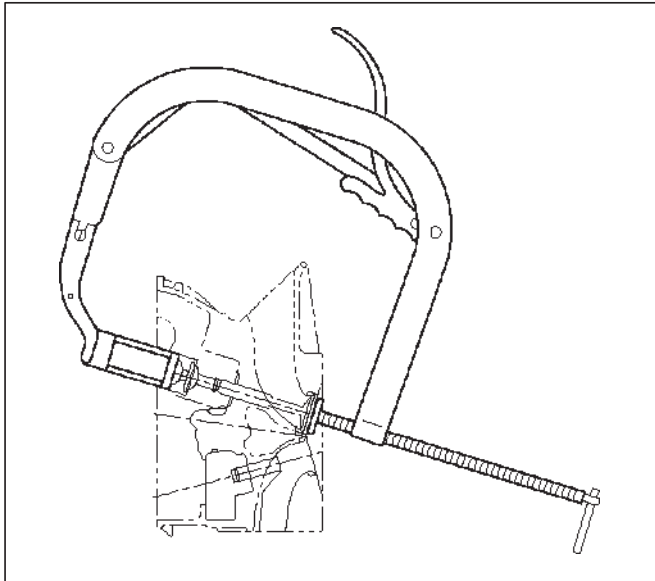
- |                                   |                        |
|-----------------------------------|------------------------|
| (1) Camshaft Bracket Fixing Bolts | (7) Spring Upper Seat  |
| (2) Camshaft Assembly Inlet       | (8) Valve Spring       |
| (3) Camshaft Assembly Exhaust     | (9) Oil Controller     |
| (4) Shim                          | (10) Spring Lower Seat |
| (5) Tappet                        | (11) Valve Guide       |
| (6) Split Collar                  | (12) Valve             |

#### Disassembly

1. Remove camshaft bracket fixing bolts (1).
2. Remove camshaft assembly (intake).
  - Refer to removal procedure for Camshaft Assembly in this manual.
3. Remove camshaft assembly (Exhaust side).
  - Refer to removal procedure for Camshaft Assembly in this manual.
4. Remove shim (4) and tappet (5).



5. Use J-8062 valve spring compressor and J-42898 valve spring compressor adapter to remove split collar.



014RW042

6. Remove valve spring.
7. Remove valve.
8. Remove oil controller and spring lower seat.
9. Remove the valve guide using the J-42899 valve guide replacer.

## Inspection and Repair

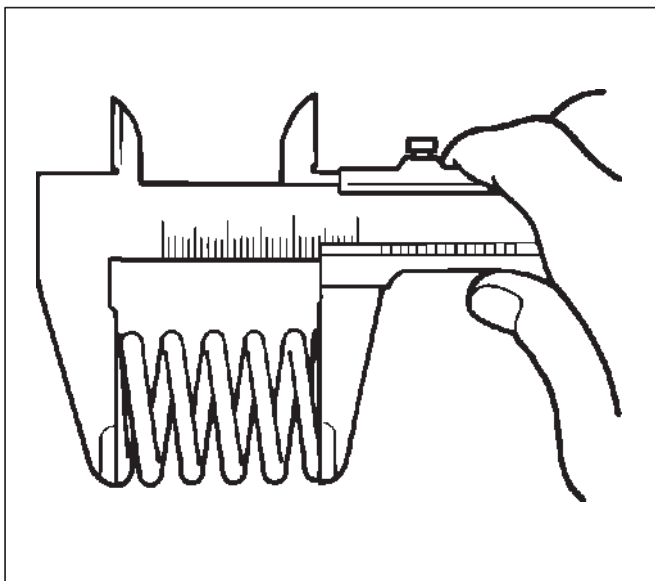
### Valve Spring

**CAUTION:** Visually inspect the valve springs and replace them if damage or abnormal wear is evident.

1. Measure the free height of the springs. The springs must be replaced if the free height is below the specified limit.

**Standard :** 44.6 mm (1.7559 in)

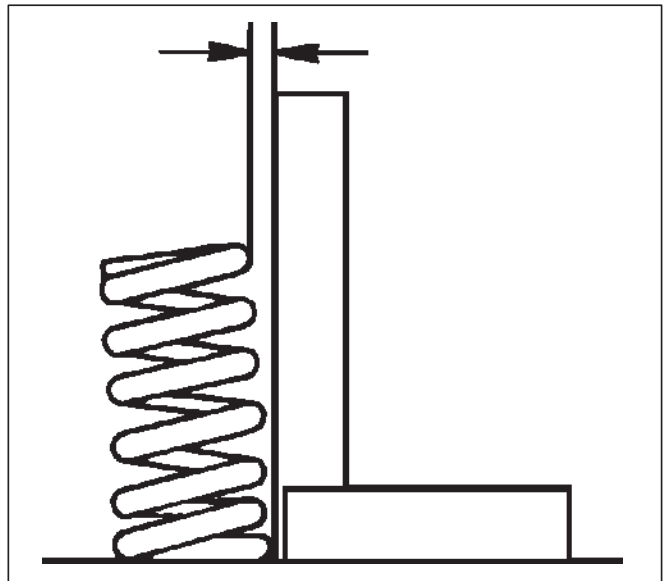
**Limit :** 43.6 mm (1.7165 in)



014RS004

2. Measure the valve spring squareness with a steel square and replace the valve springs if the measured value exceeds the specified limit.

**Limit :** 2 mm (0.0787 in)



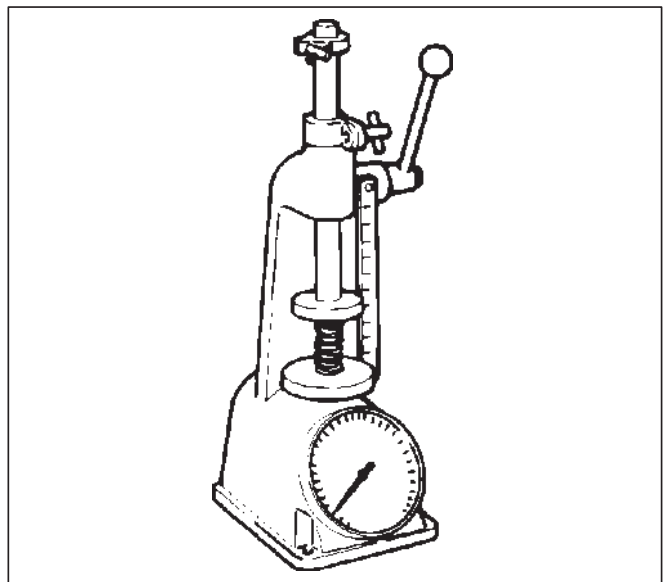
014RS005

3. Using a spring tester to compress the springs to the installed height, measure the compressed spring tension, and replace the springs if the measured tension is below the specified limit.

**At installed height:** 35.0 mm (1.38 in)

**Standard:** 196 N (44 lb)

**Limit:** Less than 181 N (41 lb)



014RS006

### Valve Guide

**CAUTION:** Take care not to damage the valve seat contact surface, when removing carbon adhering to the valve head. Carefully inspect the valve stem for scratches or abnormal wear. If these conditions are present, the valve and the valve guide must be replaced as a set.

## 6A-58 ENGINE MECHANICAL

1. Measure the valve stem diameter with a micrometer. If the valve stem diameter is less than the specified limit, the valve and the valve guide must be replaced as a set.

### Diameter of Valve Stem

#### Intake

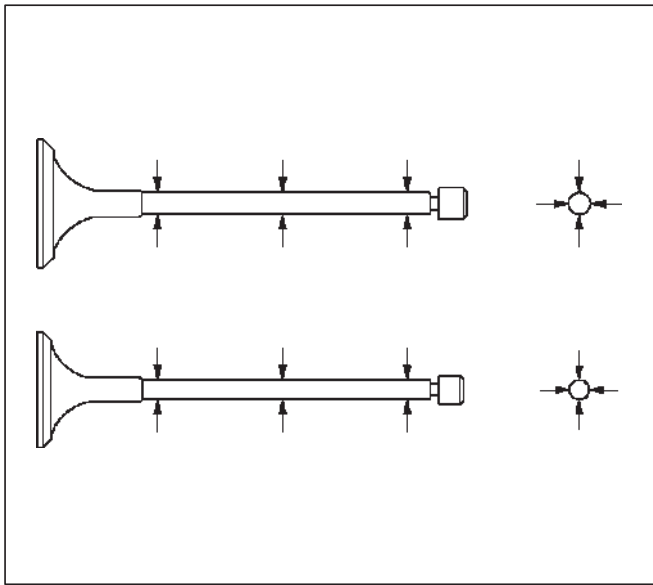
**Standard : 5.977 mm–5.959 mm**  
**(0.2353 in–0.2346 in)**

**Limit : 5.90 mm (0.2323 in)**

#### Exhaust

**Standard : 5.952 mm–5.970 mm**  
**(0.2343 in–0.2350 in)**

**Limit : 5.90 mm (0.2323 in)**



2. Measure the inside diameter of the valve guide with a micrometer. Subtract the measured outer diameter of the valve stem from the measured inner diameter of the valve guide. If the value exceeds the specified limit, the valve and the valve guide must be replaced as a set.

### Inside Diameter of the Valve Guide

#### Inlet clearance

**Standard : 0.023 mm–0.056 mm**  
**(0.0009 in–0.0002 in)**

**Limit : 0.20 mm (0.00787 in)**

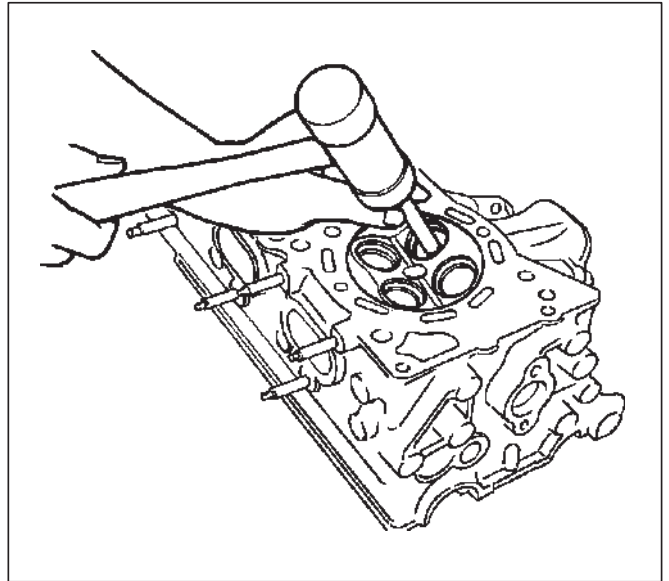
#### Exhaust clearance

**Standard : 0.030 mm–0.063 mm**  
**(0.0012 in–0.0025 in)**

**Limit : 0.20 mm (0.00787 in)**

## Valve Guide Replacement

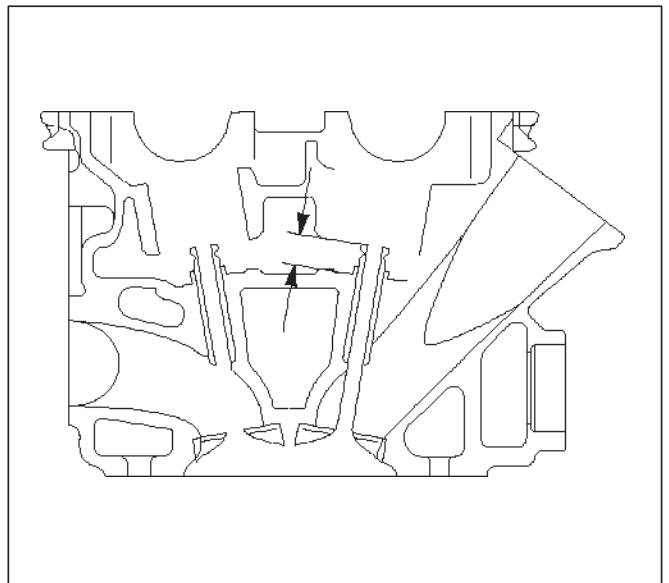
1. Using Valve guide replacer: J-42899, drive out the valve guide from the combustion chamber side.



2. Apply engine oil to the outside of the valve guide. Using valve guide replacer J-42899, drive in a new valve guide from the camshaft side, and check the valve guide height.

**Valve guide upper end height: 13.0 mm (0.5118 in)**

**(Measured from the cylinder head upper face)**



3. Check the clearance. If the clearance is less than the specified value, ream the inside diameter of valve guide. Using a sharp 6 mm reamer, ream the valve guide to obtain the specified clearance.

## Valve Seat

1. Measure the protrusion of the valve stem when a new valve is installed in the cylinder head. If the protrusion of the valve stem exceeds the limit, replace the valve seat insert or the cylinder head assembly.

### Protrusion of valve stem

#### Intake

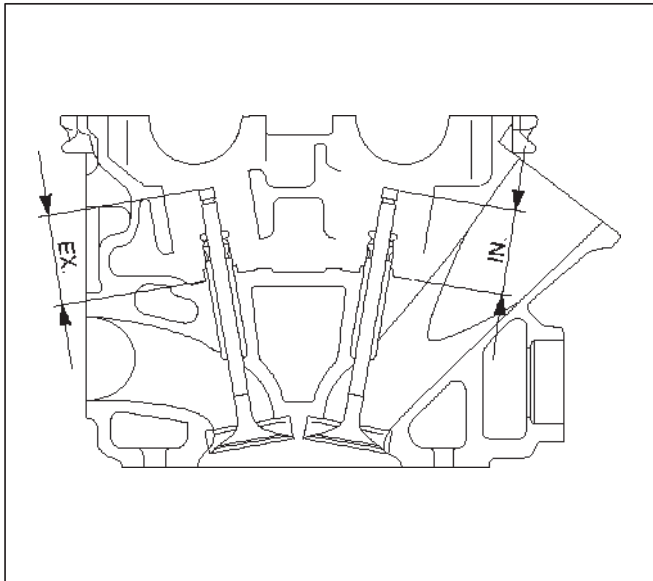
**Standard: 39.32 mm (1.5480 in)**

Limit: 39.47 mm (1.5539 in)

Exhaust

Standard: 39.30 mm (1.5472 in)

Limit: 39.45 mm (1.5531 in)



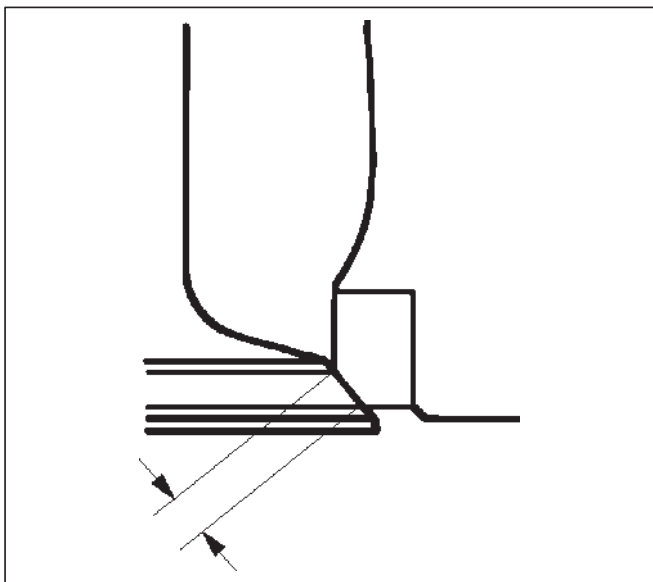
014RW047

2. Measure the valve seat contact width. Make the necessary corrections if the seat contact surface is damaged or rough or if the contact width wear exceeds the limit.

**Valve seat contact width**

Standard: 1.1 mm (0.0433 in)

Limit: 1.7 mm (0.0669 in)

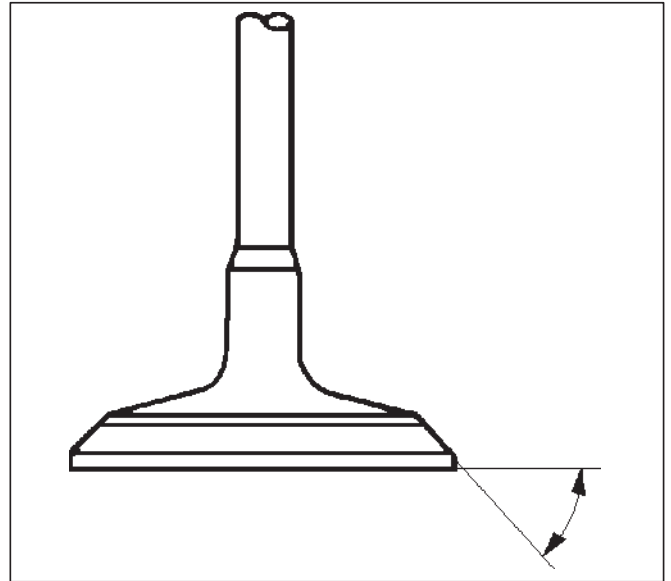


014RS011

### Contact Surface Angle on Valve Seat on Valve

1. Measure contact surface angle on valve seat.
2. If the measured value exceeds the limit, replace valve, valve guide and valve seat as a set.

**Valve contact surface angle: 45°**

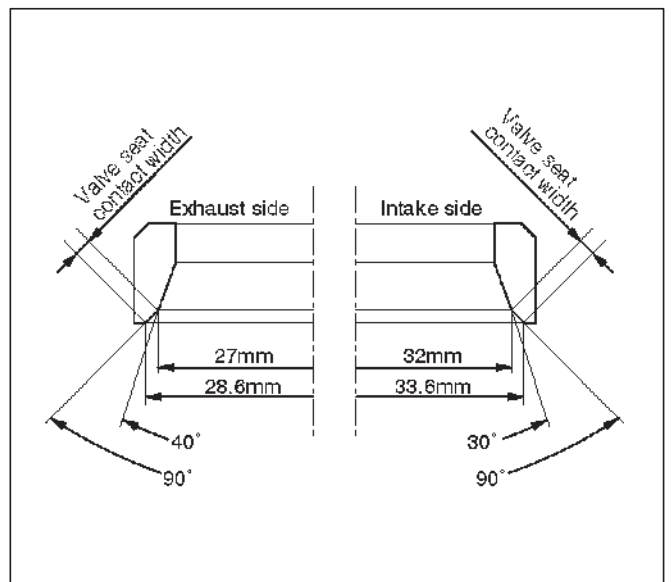


014RS012

### Valve Seat Insert Correction

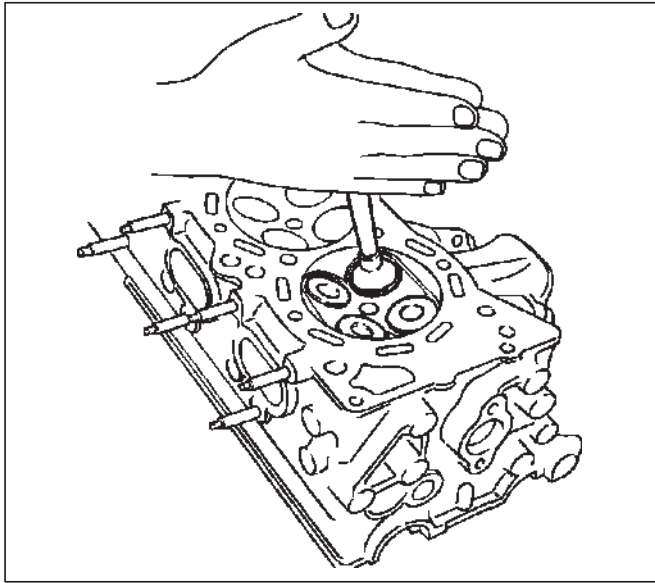
1. Remove the carbon from the valve seat insert surface.
2. Use a valve cutter to minimize scratches and other rough areas. This will bring the contact width back to the standard value. Remove only the scratches and rough areas. Do not cut away too much. Take care not to cut away unblemished areas of the valve seat surface.

**Valve seat angle degree: 90°**



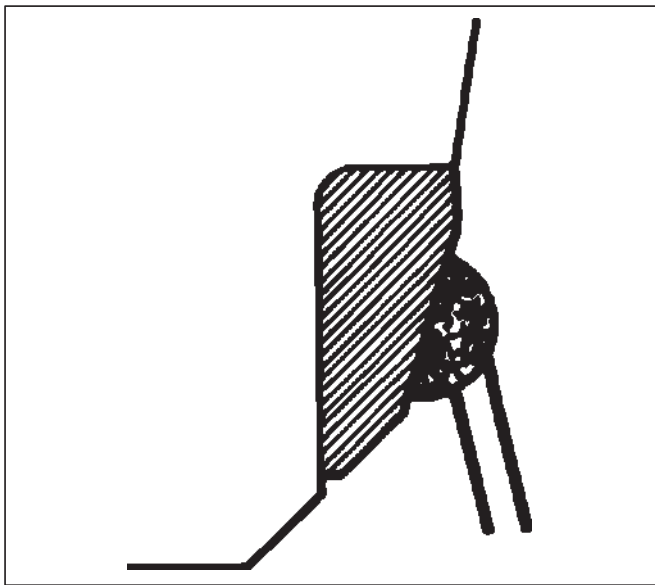
014RW059

3. Apply abrasive compound to the valve seat insert surface.
4. Insert the valve into the valve guide.
5. Turn the valve while lapping it to fit the valve seat insert.
6. Check that the valve contact width is correct.
7. Check that the valve seat insert surface is in contact with the entire circumference of the valve.



### Valve Seat Insert Replacement

1. Arc weld the rod at several points. Be careful not to damage the aluminum section.
2. Allow the rod to cool for a few minutes. This will cause the valve seat to shrink.
3. Strike the rod and pull it out.



4. Carefully clean the valve seat press-fit section on the cylinder head side.
5. Heat the press-fit section with steam or some other means to cause expansion. Cool the valve seat with dry ice or some other means.
6. Insert the press-fit section into the valve seat horizontally.

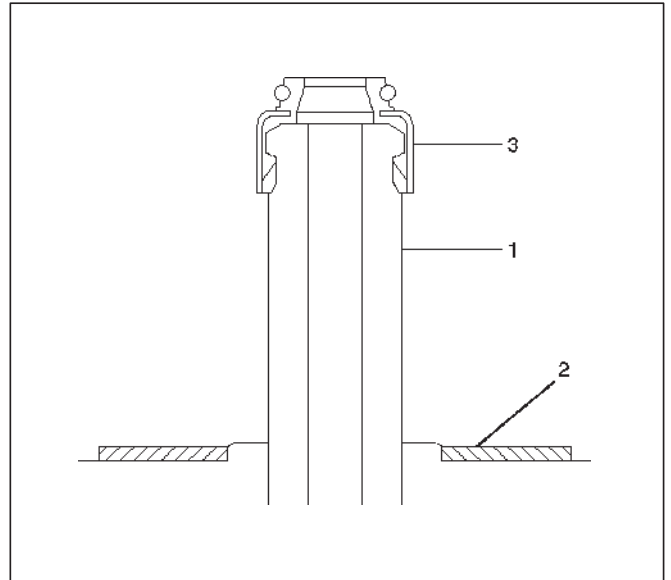
**Standard fitting interference: 0.14 mm–0.09 mm (0.0055 in–0.0035 in)**

7. After insertion, use a seat grinder to grind finish the seating face. Carefully note the seating angle, the contact width, and the depression.

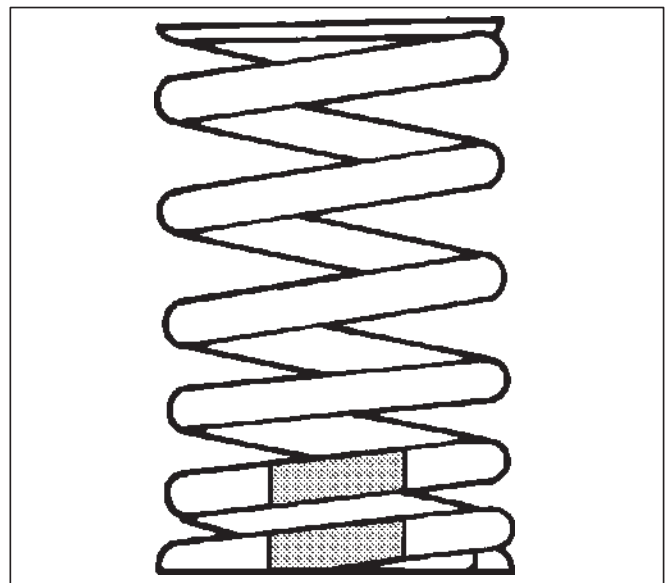
8. Lap the valve and the seat.

### Reassembly

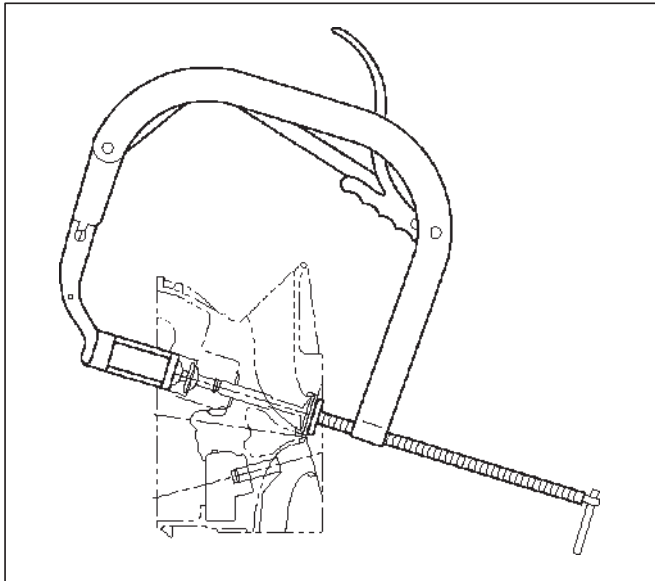
1. Install valve guide (1) to cylinder head. Apply engine oil to the outside of the valve guide. Using valve guide replacer J-42899, drive in a new valve guide from the camshaft side.
2. Install oil controller (3) and spring lower seat (2). Using oil controller replacer J-37281, drive in a new oil controller.



3. Install valve to valve guide. Before install valve guide apply engine oil to the outside of the valve stem.
4. Install valve spring to cylinder head. Attach the valve spring to the lower spring seat. The painted area of the valve spring should be facing downward.



5. Install lower valve spring seat, valve spring and upper valve spring seat then put split collars on the upper spring seat, using the J-8062 valve spring compressor and J-42898 valve spring compressor adapter to install the split collars.



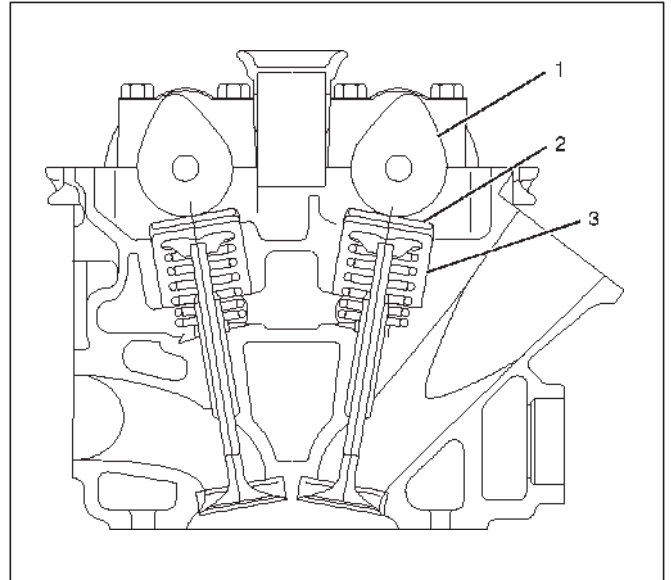
6. Install tappet with shim.

7. Install camshaft assembly.

○Refer to installation procedure for Camshaft in this manual.

## Valve Clearance Adjustments

NOTE: To adjust valve clearance, apply engine oil to the cam as well as to the adjusting shim (2) with the cylinder head built on the cylinder block, give a few turns to the camshaft by means of timing pulley tightening bolt, and measure valve clearance when the nose of cam is just opposite to maximum cam lift (1) as shown in illustration below.



### Legend

- (1) Cam
- (2) Shim
- (3) Tappet

### Valve Clearance Standard Value (cold)

**Intake: 0.23 mm–0.33 mm**  
(0.0091 in–0.0130 in)

**Exhaust: 0.25 mm–0.35 mm**  
(0.0098 in–0.0138 in)

### Selection of Adjusting Shim

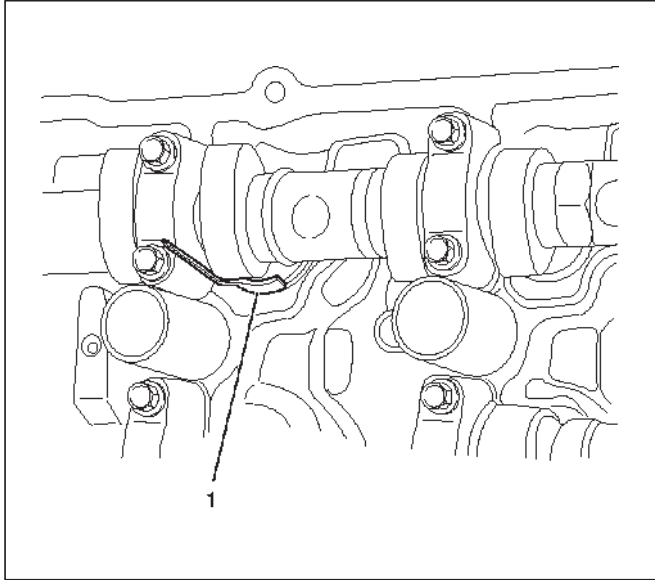
Shim to be selected = (Thickness of removed shim) + (Valve clearance measurement – Standard valve)

Based on the above formula, the best suited shim should be selected from 41 sorts of shim (Thickness at 0.02mm (0.0008 in) intervals from 2.40mm (0.0946 in) through 3.2mm (0.1260 in) thick). Install the shim and check valve clearance.

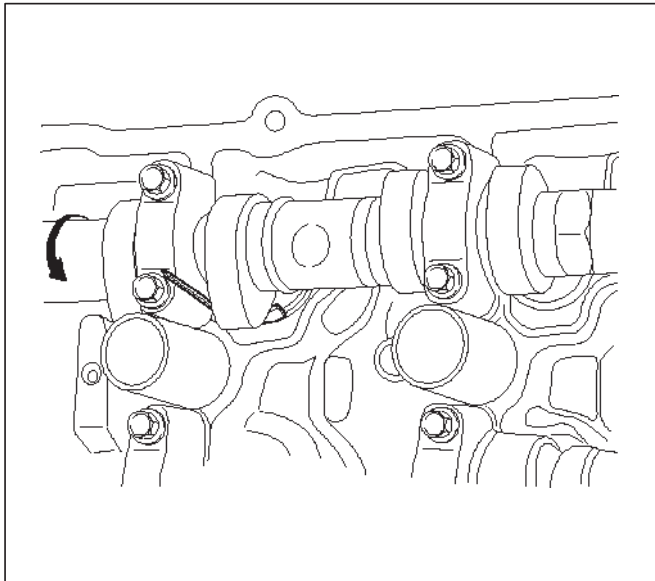
## 6A-62 ENGINE MECHANICAL

### Replacement of Shim

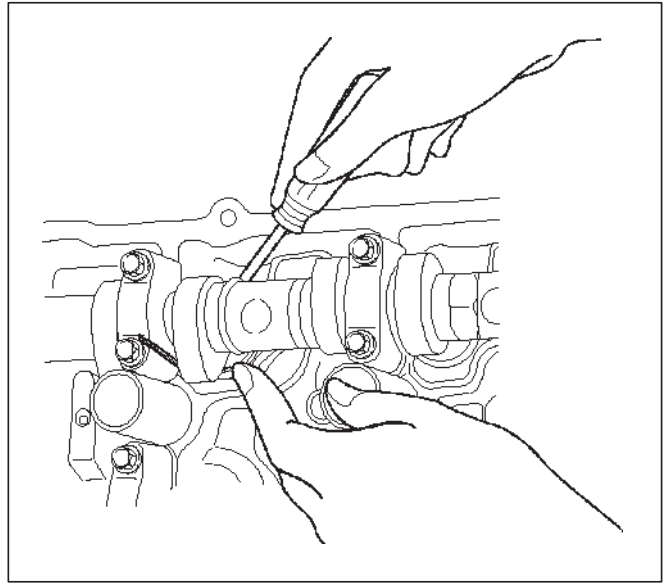
Let the cam push down the edge of tappet by using J-42689 valve clearance adjusting tool and push out the shim with a flat blade screw driver as shown in illustrations below.



014RW082



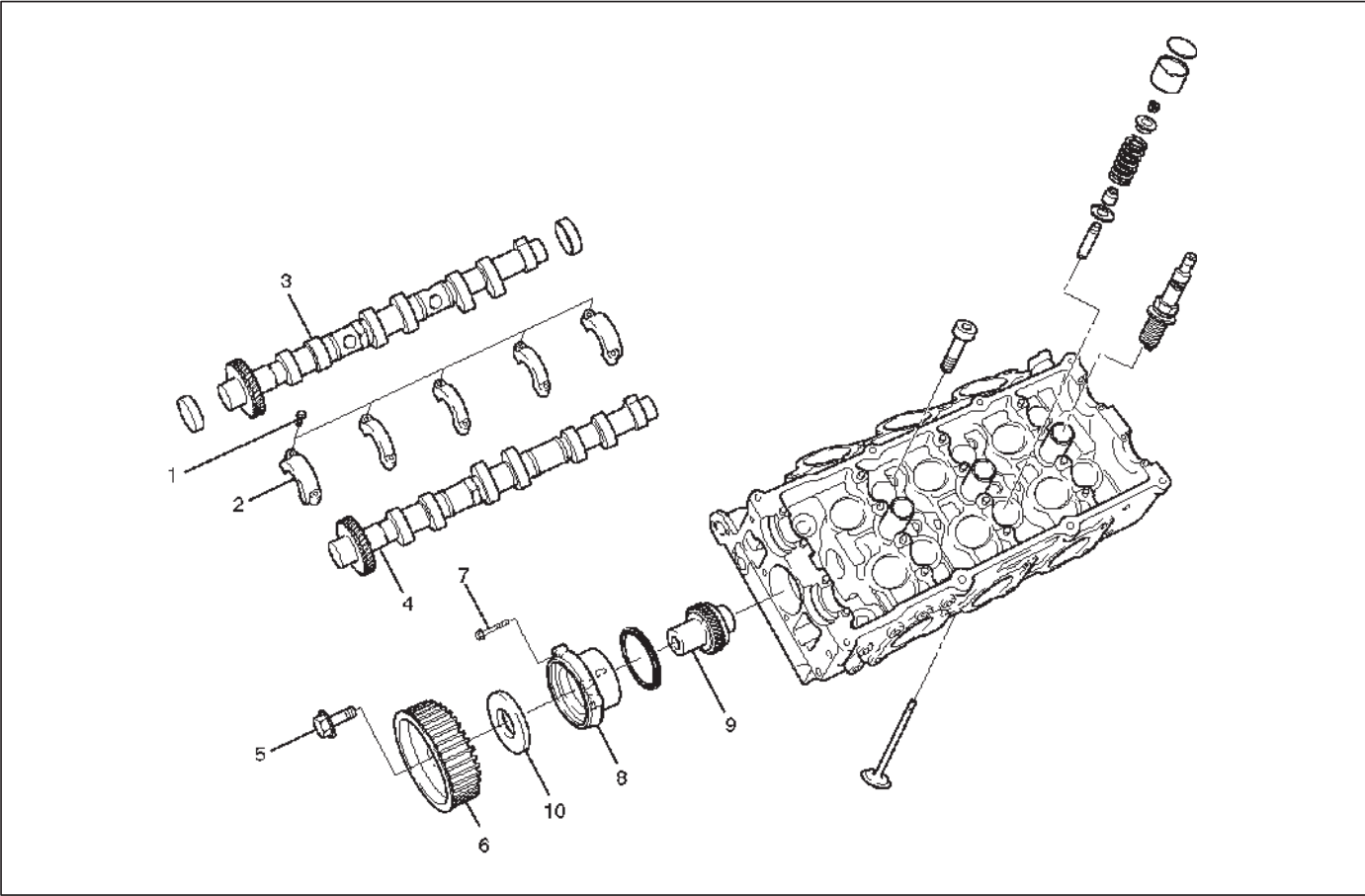
014RW083



014RW084

# Camshaft

## Camshaft and Associated Parts



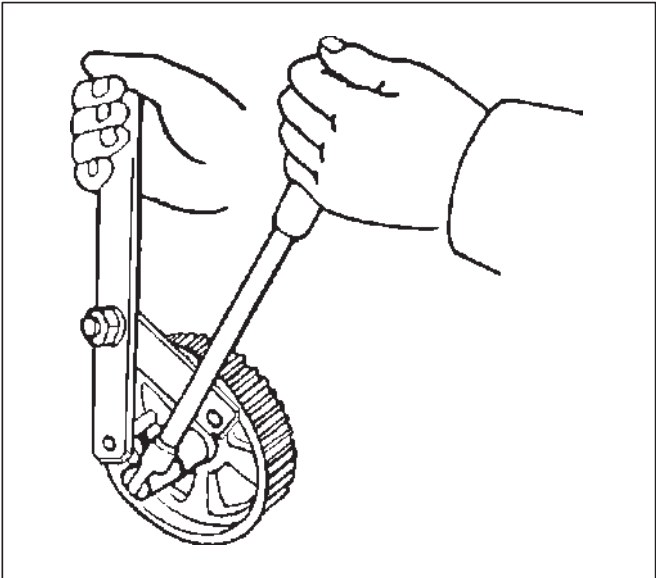
014RW040

### Legend

- (1) Camshaft Bracket Fixing Bolt
- (2) Camshaft Bracket
- (3) Camshaft Assembly Intake
- (4) Camshaft Assembly Exhaust
- (5) Pulley Fixing Bolt
- (6) Camshaft Drive Gear Pulley
- (7) Retainer Fixing Bolt
- (8) Retainer
- (9) Camshaft Drive Gear
- (10) Oil Seal

## Disassembly

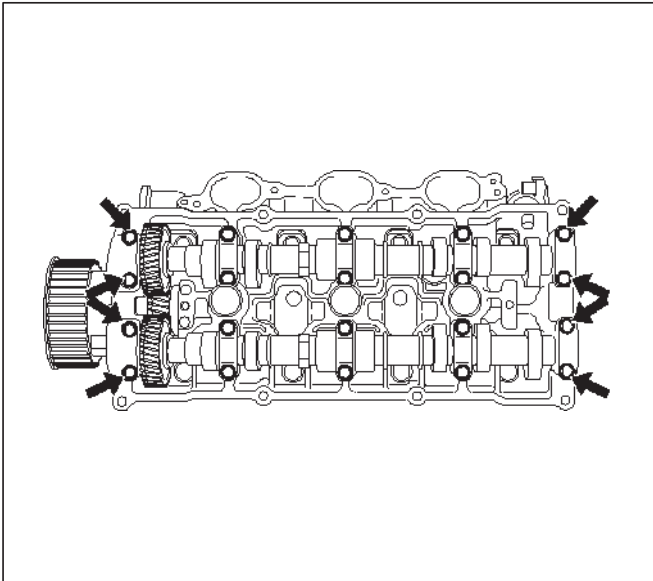
1. Remove fixing bolt (5) for camshaft drive gear pulley using the J-43041 universal holder.



014RW060

## 6A-64 ENGINE MECHANICAL

2. Remove twenty fixing bolts from inlet and exhaust camshaft bracket on one side bank, then camshaft brackets (2).



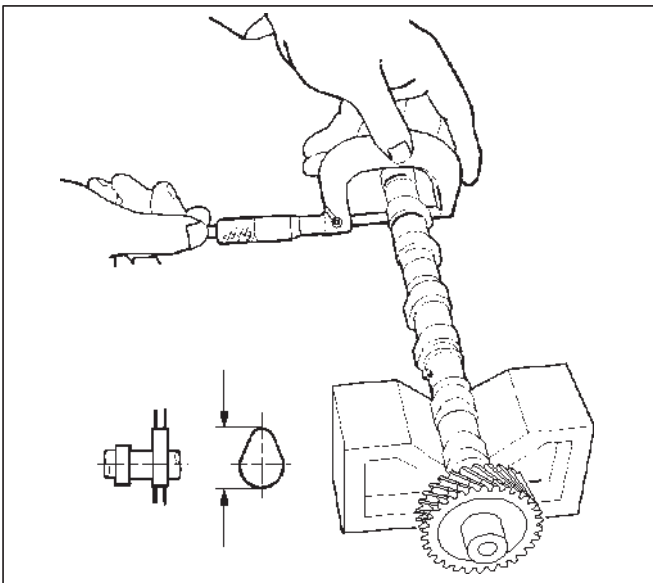
014RW027

3. Remove camshaft assembly (3), (4).
4. Remove three fixing bolts (7) from camshaft drive gear retainer (8), then camshaft drive gear assembly.

### Inspection and Repair

1. Use a micrometer to measure the cam lobe height and uneven wear. Replace the camshaft if either the lobe height or the uneven wear exceeds the specified limit.

**Lobe height : 44.709 mm (1.7602 in)**  
**Uneven wear : 0.05 mm (0.0020 in)**



014RW043

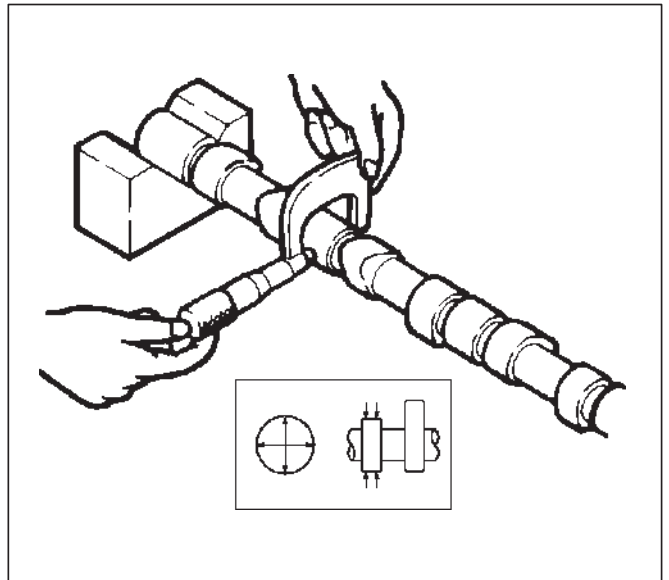
2. Use a micrometer to measure the diameter and the uneven wear of the camshaft journals. Replace the camshaft if the diameter or the uneven wear exceeds the specified limit.

#### Journal Diameter

**Standard : 25.972 mm–25.993 mm**  
**(1.0225 in–1.0233 in)**

**Limit : 25.8 mm (1.0157 in)**

**Uneven wear : 0.05 mm (0.0020 in)**

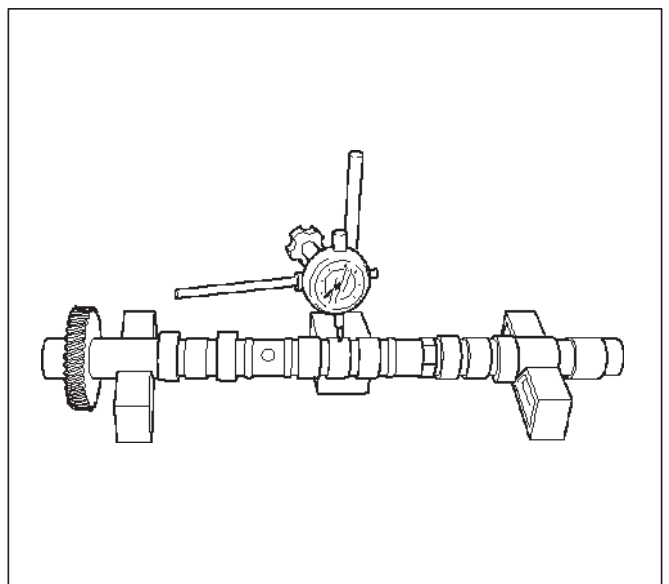


014RS023

3. Place the camshaft on V-blocks. Slowly rotate the camshaft and measure the runout with a dial indicator. Replace the camshaft if the runout exceeds the specified limit.

#### Runout

**Limit : 0.1 mm (0.0039 in)**



014RW044

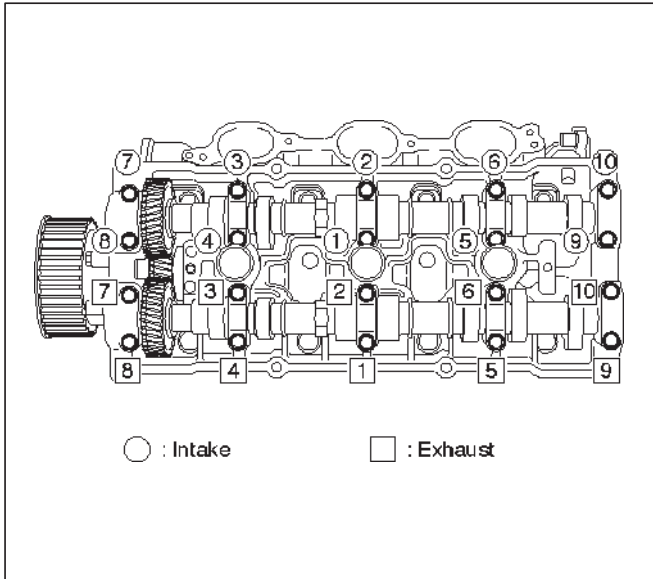


4. Measure the camshaft journal oil clearance.

1. Measure the camshaft bracket housing inside diameter.

NOTE: Tighten camshaft bracket (2) to specified torque before measuring the camshaft bracket inside diameter.

**Torque : 10 N·m (89 lb in)**

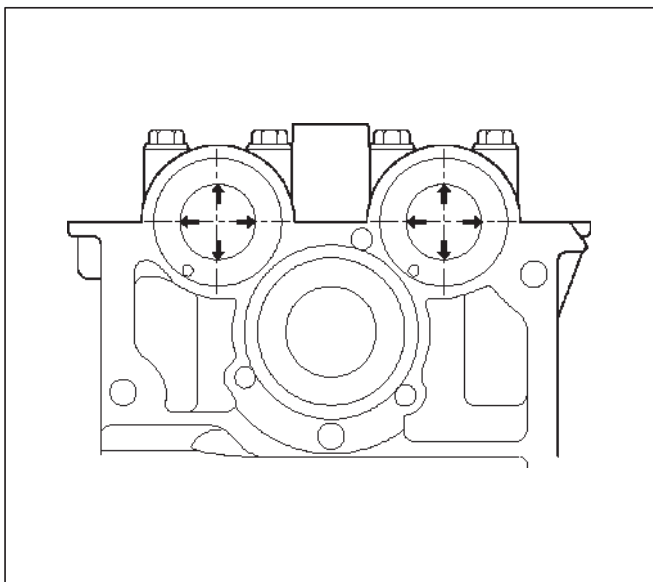


2. Subtract the camshaft outside diameter from the camshaft bracket housing inside diameter.

**Oil Clearance**

**Standard : 0.027 mm–0.078 mm  
(0.0011 in–0.0031 in)**

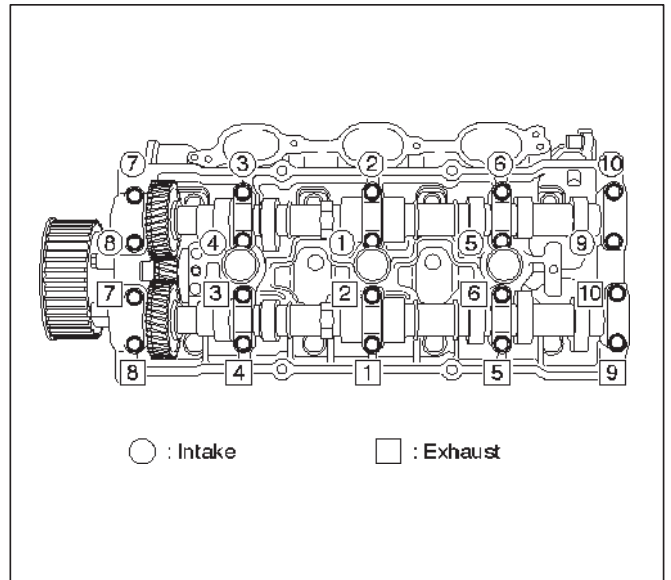
**Limit : 0.11 mm (0.0043 in)**



5. Replace the cylinder head and/or camshaft if the measured oil clearance exceeds the specified limit.

1. Carefully clean the camshaft journal, the camshaft bracket, and the cylinder head.
2. Install camshaft assembly and camshaft brackets (2), tighten twenty bolts (1) on one side bank to the specified torque.

**Torque: 10 N·m (89 lb in)**

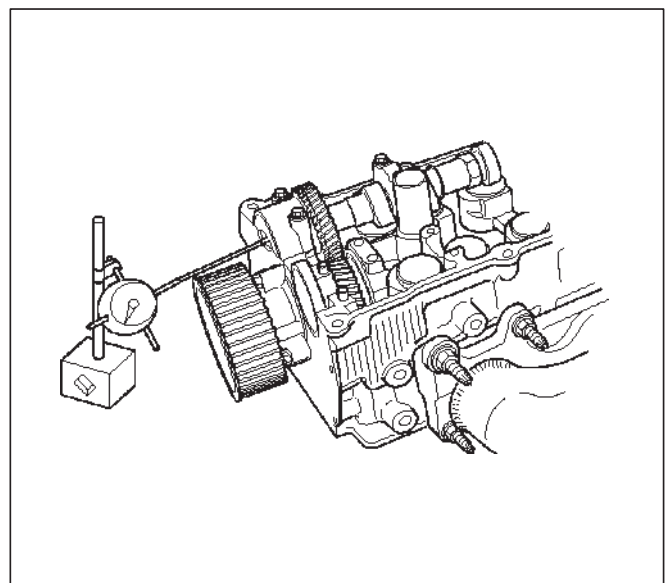


3. Measure the camshaft thrust clearance with a dial indicator. Replace the camshaft and/or the cylinder head if the camshaft thrust clearance exceeds the specified limit.

**Camshaft thrust Clearance**

**Standard : 0.03 mm–0.08 mm  
(0.0012 in.–0.0031 in.)**

**Limit : 0.12 mm (0.0047 mm)**

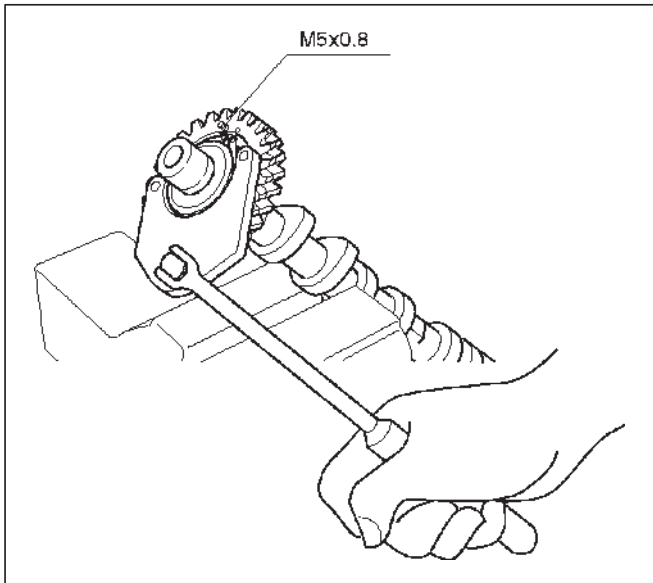


## Reassembly

1. Install camshaft drive gear assembly and tighten three bolts to specified torque.

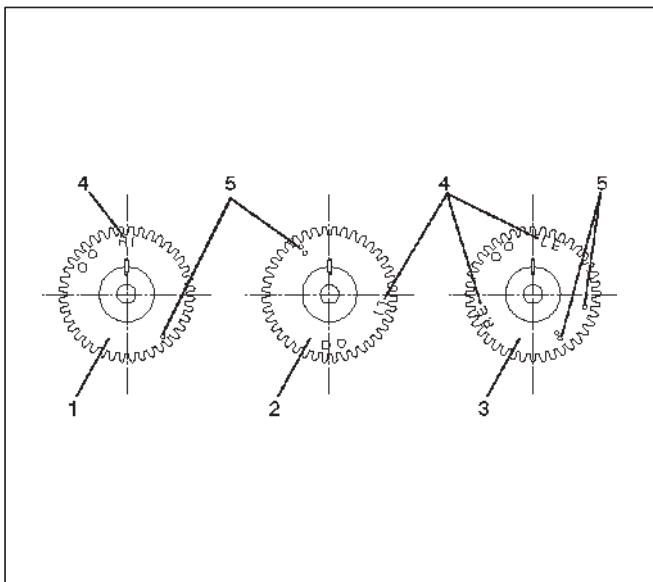
**Torque: 10 N·m (89 lb in)**

2. Tighten sub gear setting bolt.
  1. Use J-42686 to turn sub gear to right direction until the M5 bolt hole aligns between camshaft driven gear and sub gear.
  2. Tighten M5 bolt suitable torque for prevent moving the sub gear.



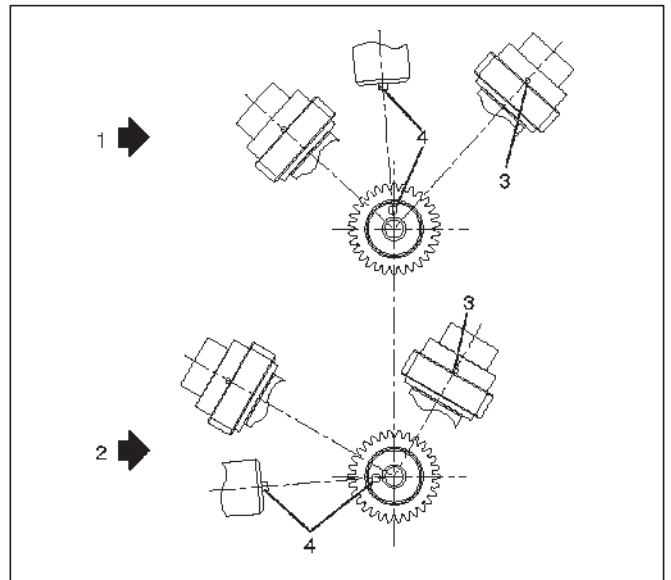
3. Install camshaft assembly and camshaft brackets, tighten twenty bolts on one side bank to the specified torque.

1. Apply engine oil to camshaft journal and bearing surface of camshaft bracket.
2. Align timing mark on intake camshaft (one dot for right bank, two dots for left bank) and exhaust camshaft (one dot for right bank, two dots for left bank) to timing mark on camshaft drive gear (one dot).



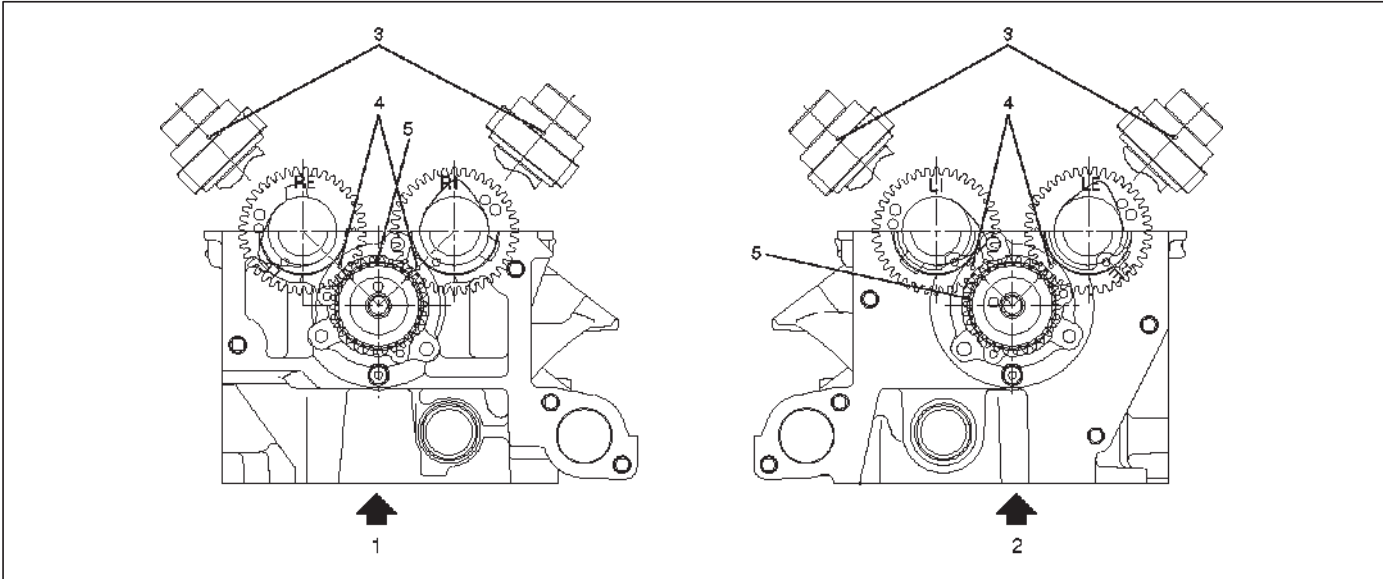
## Legend

- (1) Intake Camshaft Timing Gear for Right Bank
- (2) Intake Camshaft Timing Gear for Left Bank
- (3) Exhaust Camshaft Timing Gear
- (4) Discerning Mark
- LI: Left Bank Intake
- RI: Right Bank Intake
- LE: Left Bank Exhaust
- RE: Right Bank Exhaust



## Legend

- (1) Right Bank Camshaft Drive Gear
- (2) Left Bank Camshaft Drive Gear
- (3) Timing Mark on Drive Gear
- (4) Dowel Pin



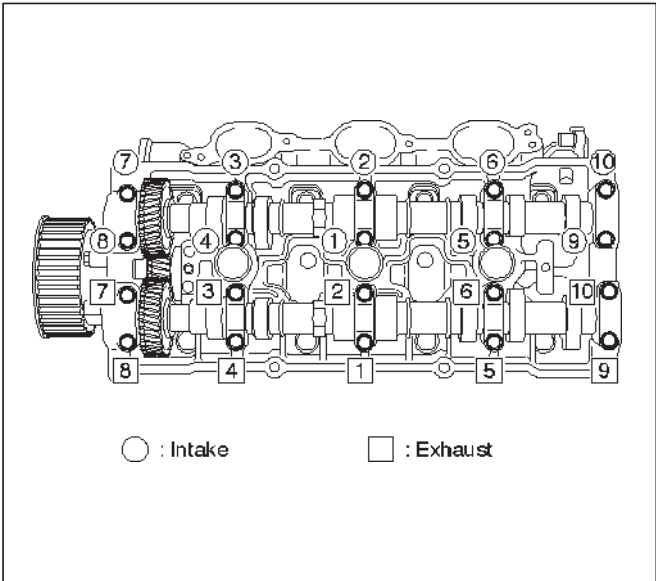
014RW024

**Legend**

- (1) Right Bank
- (2) Left Bank
- (3) Alignment Mark on Camshaft Drive Gear
- (4) Alignment Mark on Camshaft
- (5) Alignment Mark on Retainer

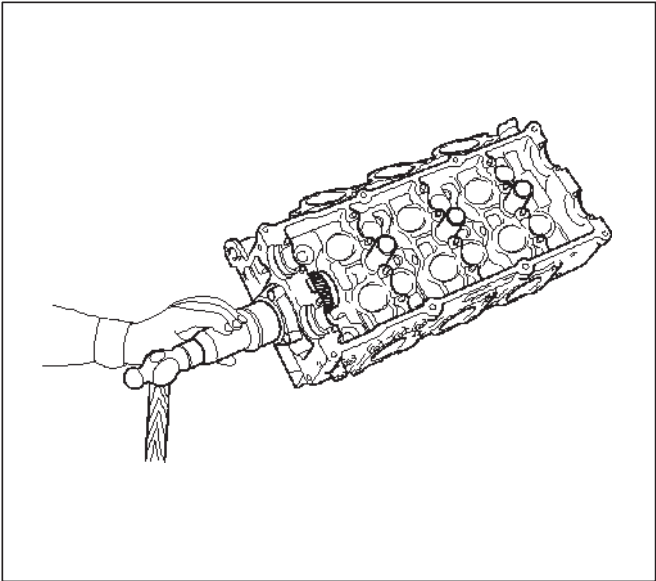
3. Tighten twenty bolts in numerical order on one side bank as shown in the illustration.

**Torque: 10 N-m (89 lb in)**



014RW031

4. If the oil seal requires replacement, use the J-42985 to install the oil seal.



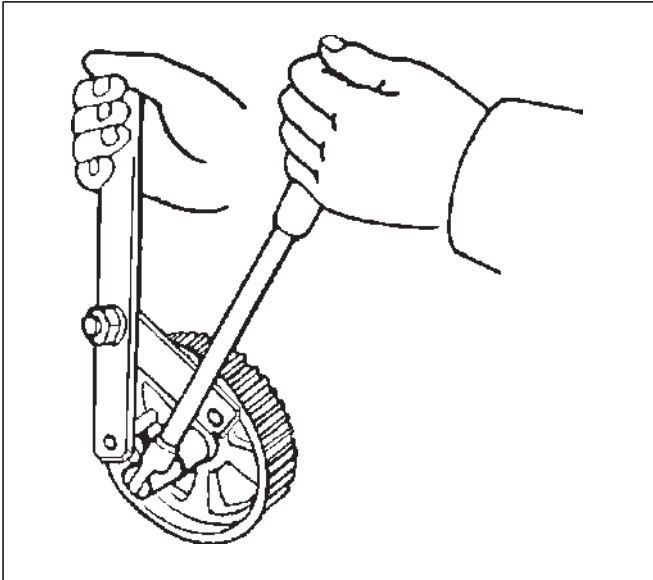
014RW034

## 6A-68 ENGINE MECHANICAL

---

5. Tighten bolt for camshaft drive gear pulley to the specified torque using the J-43041 universal holder.

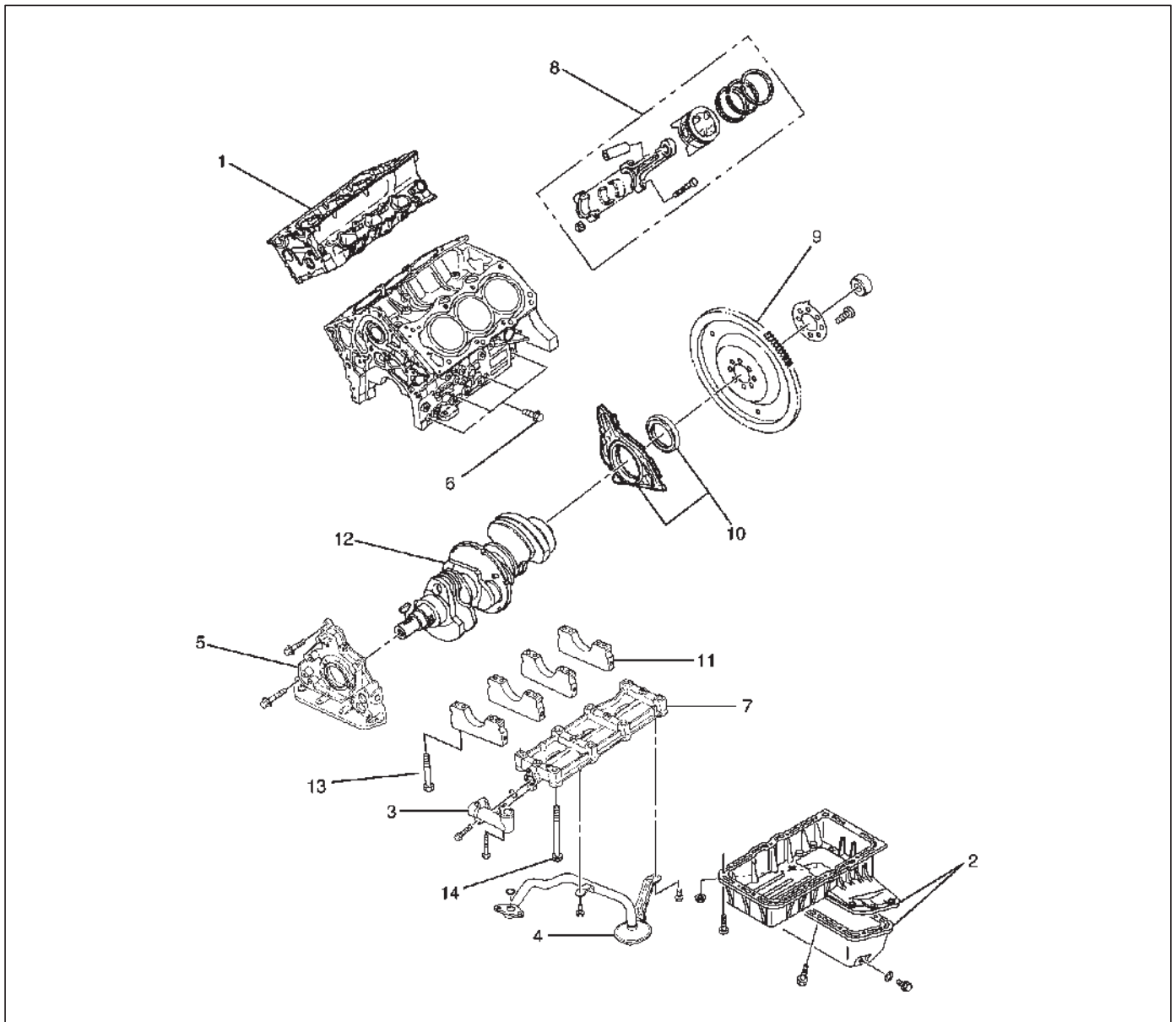
**Torque: 98 N·m (72 lb ft)**



014RW060

## Crankshaft

### Crankshaft and Associated Parts



012RX001

#### Legend

- |                               |  |
|-------------------------------|--|
| (1) Cylinder Head Assembly    | (8) Piston and Connecting Rod Assembly   |
| (2) Crankcase with Oil Pan    | (9) Flywheel                             |
| (3) Oil Pipe and O-Ring       | (10) Rear Oil Seal Retainer and Oil Seal |
| (4) Oil Strainer and O-Ring   | (11) Main Bearing Cap                    |
| (5) Oil Pump Assembly         | (12) Crankshaft                          |
| (6) Cylinder Block Side Bolts | (13) Main Bearing Cap Fixing Bolts       |
| (7) Oil Gallery               | (14) Oil Gallery Fixing Bolts            |

### Disassembly

1. Remove cylinder head assembly (1). Refer to "Cylinder Head" in this manual.
2. Remove crankcase with oil pan (2). Refer to "Oil Pan and Crankcase" in this manual.

**CAUTION:** Take care not to damage or deform the sealing flange surface of crankcase.

3. Remove oil pipe and O-ring (3).
4. Remove oil strainer and O-ring (4).
5. Remove oil pump assembly (5).
6. Remove crankcase side bolts (6).

## 6A-70 ENGINE MECHANICAL

7. Remove oil gallery (7).
8. Remove piston and connecting rod assembly (8). Refer to "Piston, Piston Ring and Connecting Rod" in this manual.
9. Remove flywheel (9).
10. Remove rear oil seal retainer (10).
11. Remove main bearing cap (11).
12. Remove crankshaft (12).

### Inspection and Repair

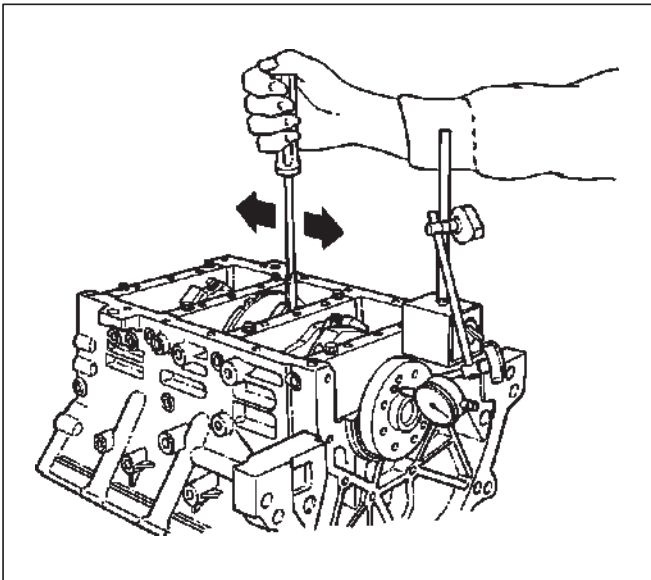
#### 1. Crankshaft

Set the dial indicator as shown in the illustration and measure the crankshaft thrust clearance. If the thrust clearance exceeds the specified limit, replace the thrust bearings as a set.

#### Thrust Clearance

**Standard : 0.06 mm–0.24 mm  
(0.0024 in–0.0094 in)**

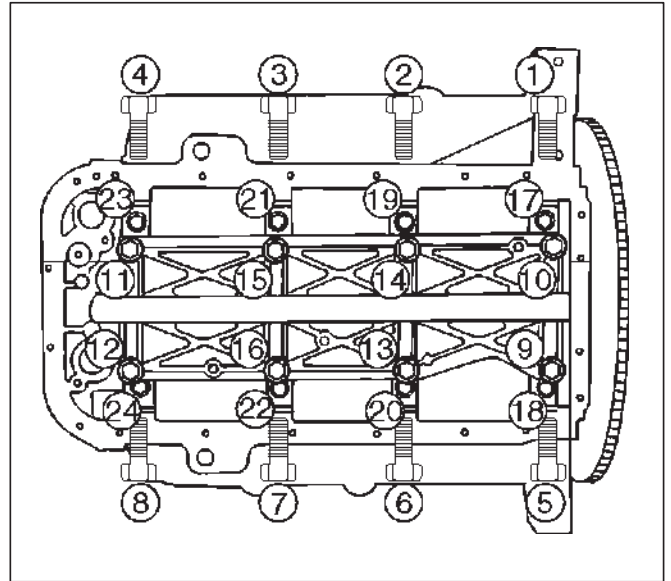
**Limit : 0.30 mm (0.0118 in)**



015RS003

### Main Bearing Clearance

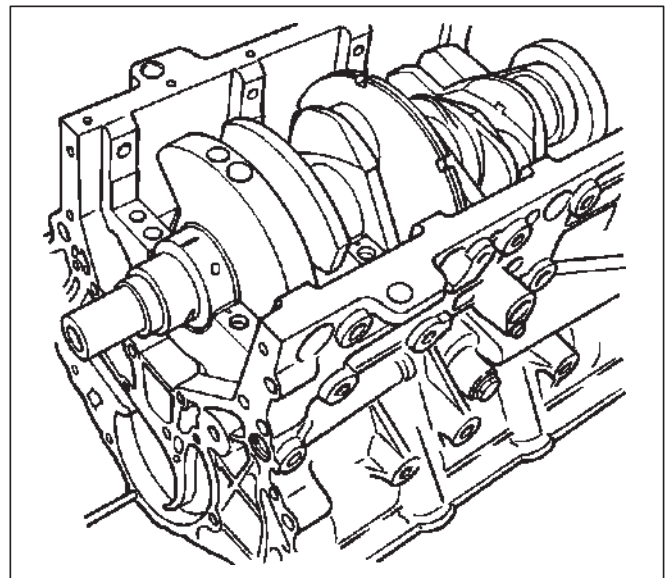
1. Remove the bearing caps and measure the oil clearance.
2. Remove the main bearing cap fixing bolts in the sequence shown in the illustration. Arrange the removed main bearing caps in the cylinder number order. Remove the main bearings.



015RS004

3. Remove the crankshaft.  
Remove the main bearings.
4. Clean the upper and lower bearings as well as the crankshaft main journal.
5. Check the bearings for damage or excessive wear. The bearings must be replaced as a set if damage or excessive wear is discovered during inspection.
6. Set the upper bearings and the thrust washers to their original positions.  
Carefully install the crankshaft.
7. Set the lower bearings to the bearing cap original position.
8. Apply plastigage to the crankshaft journal unit as shown in the illustration.

NOTE: Do not set the plastigage on the oil hole.



015RS005

9. Install main bearing caps, oil gallery and crank case bolts in the order shown, and tighten each bolt to the specified torque.

NOTE: Do not apply engine oil to the crank case side bolts.

**Main bearing cap bolts.**

**Torque: 39 N·m (29lb ft)**

**Oil gallery fixing bolts.**

**Torque:**

**1st step: 29 N·m (21 lb ft)**

**2nd step 55° ~ 65°**

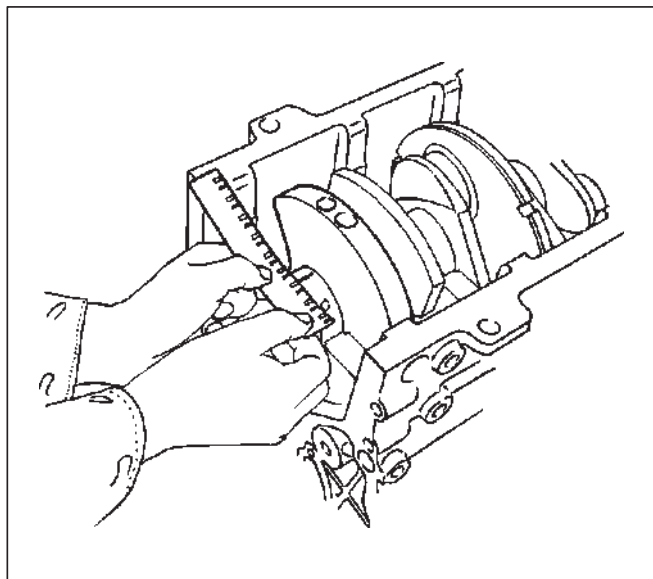
**Crank case side bolts**

**Torque : 39 N·m (29lb ft)**

NOTE: Do not allow the crankshaft to rotate.

**Standard : 0.019 mm–0.043 mm  
(0.0007 in–0.0017 in)**

**Limit : 0.08 mm (0.0031 in)**



015RS008

12. Clean the plastigage from the bearings and the crankshaft.

Remove the crankshaft and the bearings.

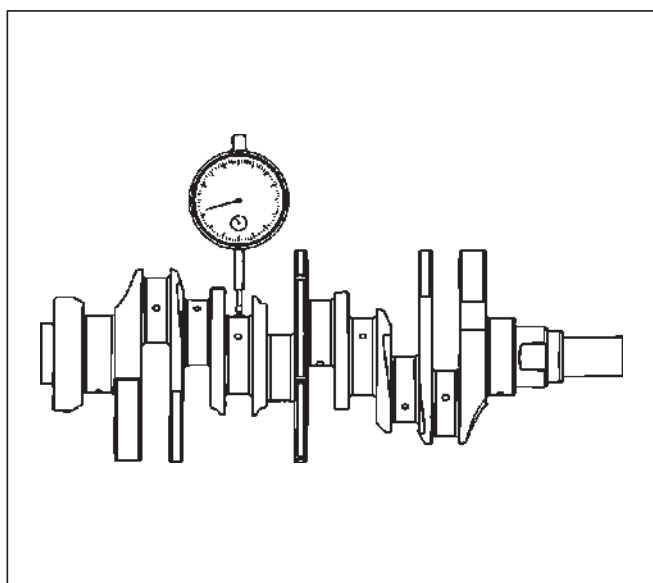
**Crankshaft (12) Inspection**

Inspect the surface of the crankshaft journal and crank pins for excessive wear and damage. Inspect the oil seal fitting surfaces for excessive wear and damage. Inspect the oil ports for obstructions.

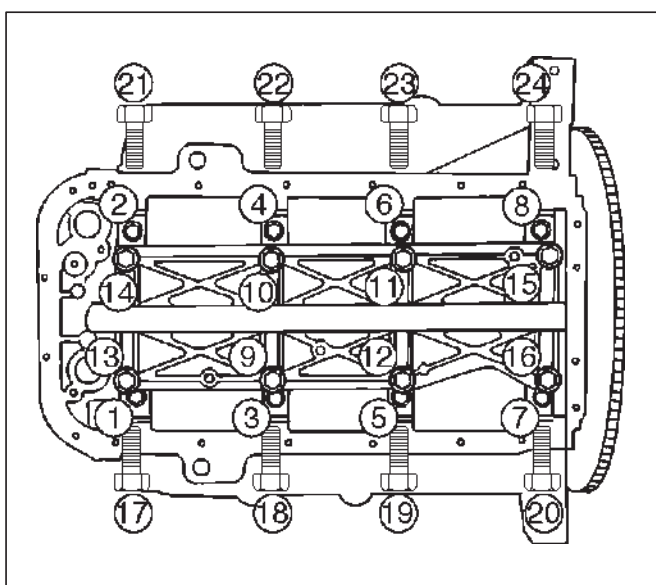
**Inspection and Repair**

1. Carefully set the crankshaft on the V-blocks. Slowly rotate the crankshaft and measure the runout. If the crankshaft runout exceeds the specified limit, the crankshaft must be replaced.

**Runout : 0.04 mm (0.0016 in)**

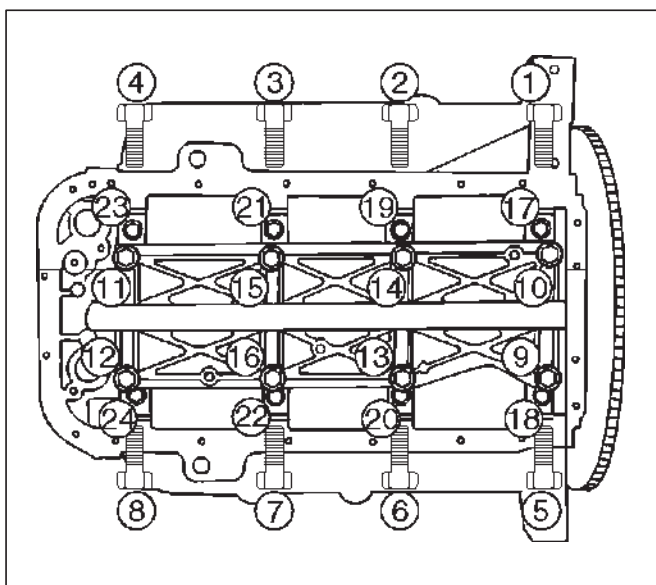


015RS007



015RS006

10. Remove the main bearing caps in the sequence shown in the illustration.



015RS004

11. Measure the plastigage width and determine the oil clearance. If the oil clearance exceeds the specified limit, replace the main bearings as a set and/or replace the crankshaft.

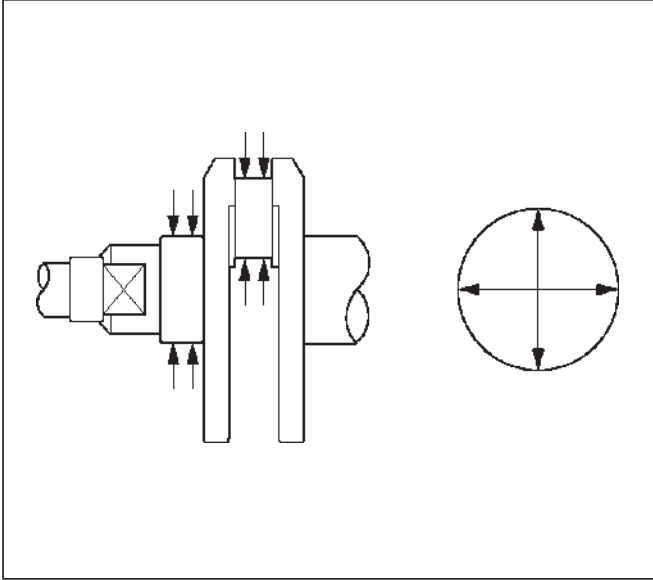
## 6A-72 ENGINE MECHANICAL

2. Measure the diameter and the uneven wear of main journal and crank pin. If the crankshaft wear exceeds the specified limit, crankshaft must be replaced.

**Main journal diameter : 63.918 mm–63.933 mm  
(2.5165 in–2.5170 in)**

**Crank pin diameter : 53.922 mm–53.937 mm  
(2.1229 in.–2.1235 in.)**

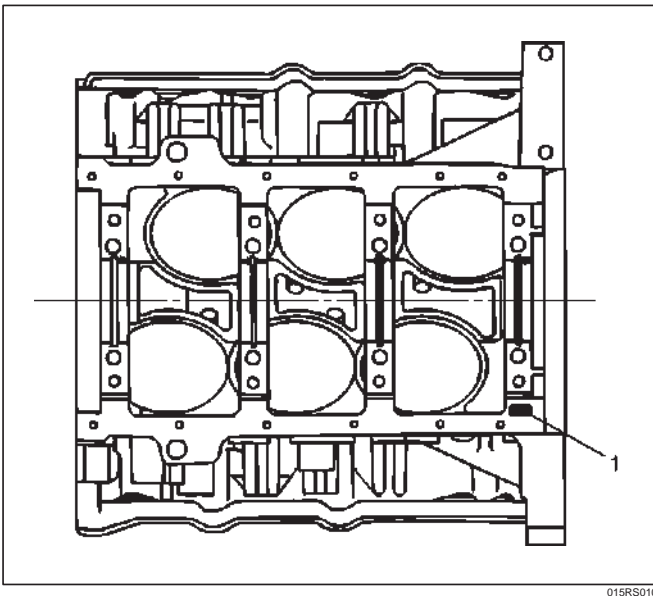
**Uneven wear limit : 0.005 mm (0.0002 in)**



### Crankshaft Bearing Selection

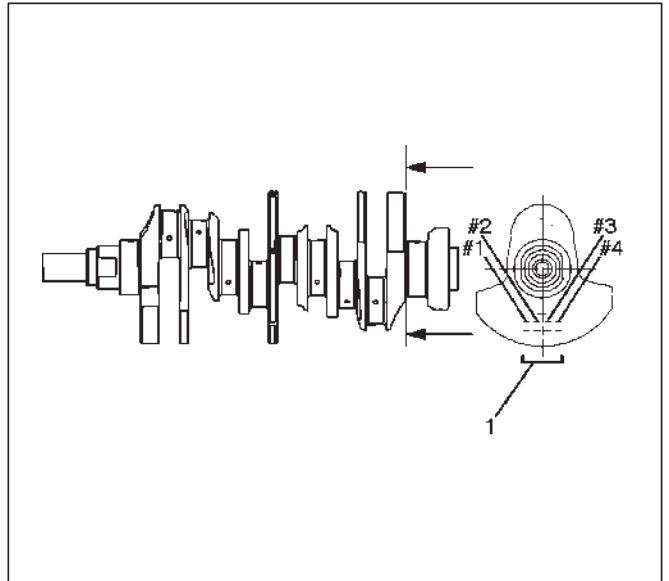
When installing new crankshaft bearings or replacing bearings, refer to the selection table below. Select and install the new crankshaft bearings, paying close attention to the cylinder block journal hole.

1. Diameter size mark (1) and the crankshaft journal.

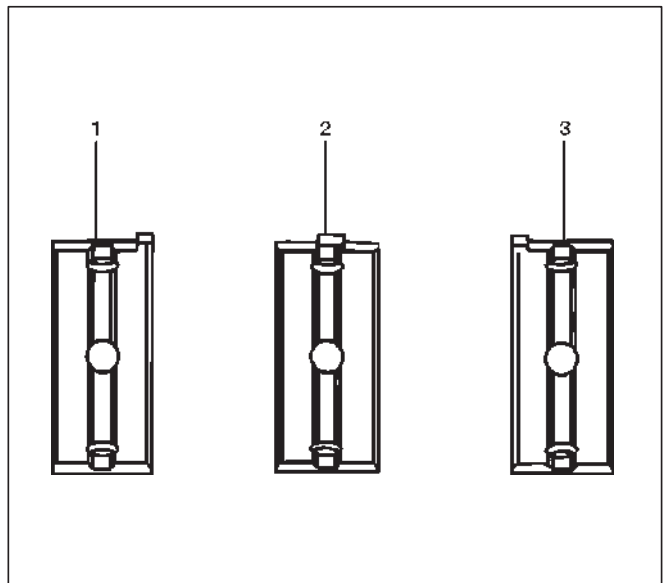


2. Diameter size mark (1).

The diameter size marks are stamped on the No.1 crankshaft balancer as shown in the illustration.



NOTE: Take care to ensure the bearings are positioned correctly.



### Legend

- (1) Number 1 and 4 main bearing upper and lower
- (2) Number 2 and 3 main bearing upper
- (3) Number 2 and 3 main bearing lower



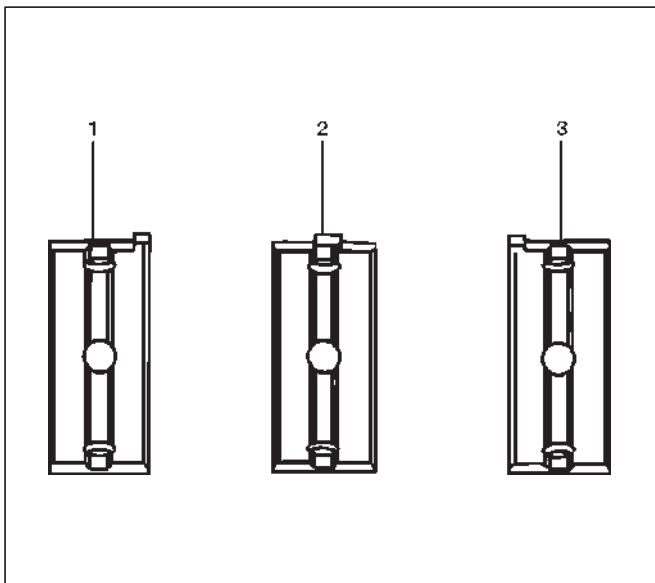
1 Size Mark	Main Bearing Bore Diameter mm (in)	Crank Shaft Main Journal Diameter mm (in)	2 Size Mark	Crank Shaft Bearing Size Mark (Upper Side)	Crank Shaft Bearing Size Mark (Lower Side)	Oil Clearance (Reference) mm (in)
1	68.994-69.000 (2.7163-2.7165)	63.918-63.925 (2.5165-2.5167)	2	Blue	Blue	0.030-0.049 (0.0012-0.0019)
		63.926-63.933 (2.5168-2.5170)	1	Brown	Brown	0.028-0.047 (0.0011-0.0019)
2	68.987-68.993 (2.7160-2.7163)	63.918-63.925 (2.5165-2.5167)	2			Green
		63.926-63.933 (2.5168-2.5170)	1	0.027-0.046 (0.0011-0.0018)		
3	68.980-68.986 (2.7157-2.7160)	63.918-63.925 (2.5165-2.5167)	2	Yellow	Yellow	0.028-0.047 (0.0011-0.0019)
		63.926-63.933 (2.5168-2.5170)	1			0.026-0.045 (0.0010-0.0018)

## Reassembly

### 1. Crankshaft (12)

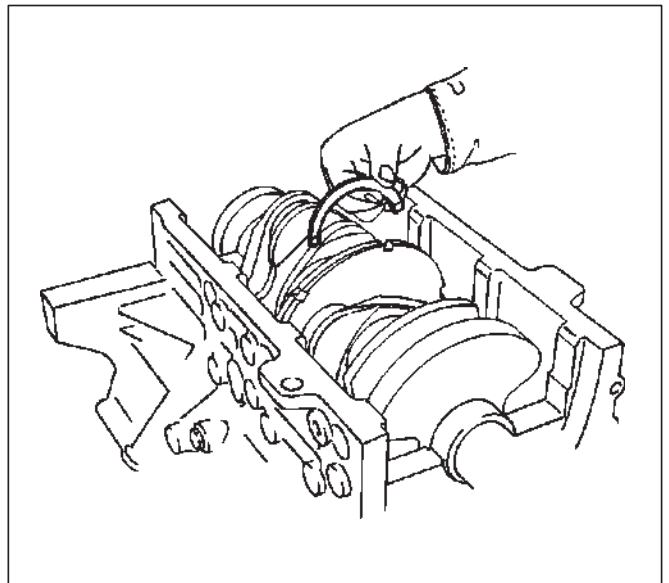
- Install the main bearings to the cylinder block and the main bearing caps.
- Be sure that they are positioned correctly.
- Apply new engine oil to the upper and lower main bearing faces.

NOTE: Do not apply engine oil to the main bearing back faces.



015RS012

- Carefully mount the crankshaft.
- Apply engine oil to the thrust washer.
- Assemble the thrust washer to the No.3 bearing journal. The oil grooves must face the crankshaft.

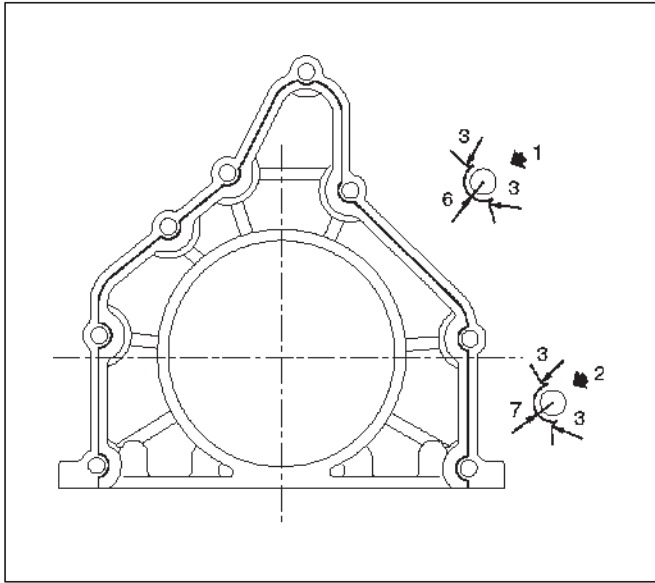


015RS013

### 2. Rear oil seal (10)

- Remove the oil from the cylinder block and the retainer mounting surface.
- Apply sealant (TB-1207B or equivalent) to the retainer mounting surface, following the pattern shown in the illustration.

The retainer must be installed within 5 minutes after sealant application before the sealant hardens.



015RW002

**Legend**

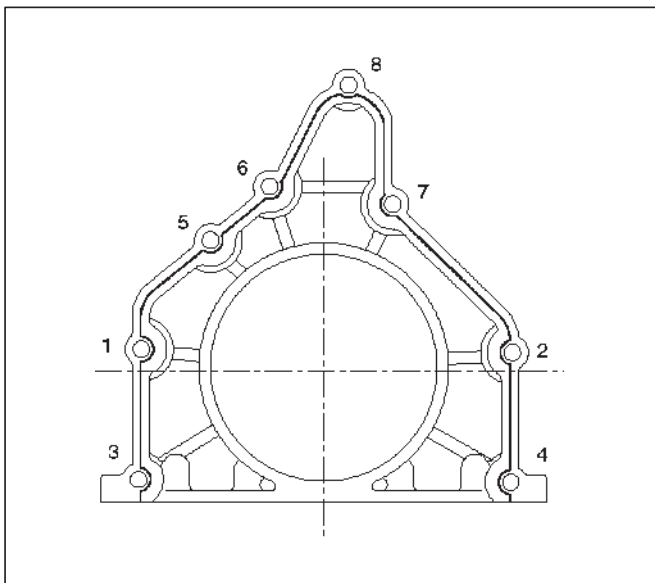
- (1) Around Bolt Holes
- (2) Around Dowel Pin

- Apply engine oil to the oil seal lip.
- Align the cylinder block dowel pin holes with the rear retainer dowel pins.
- Tighten the rear retainer fixing bolts. New bolts should be used when installing rear retainer.

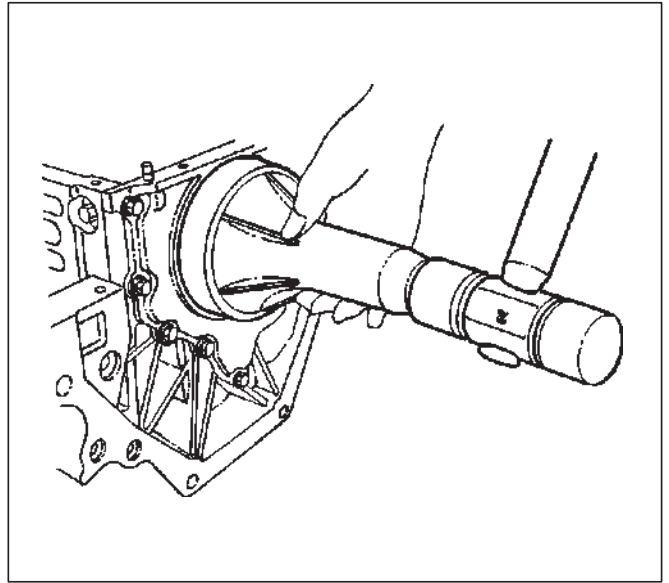
**Torque: 18 N-m (13 lb ft)**

**NOTE:** Be very careful not to disengage the oil seal garter spring during installation of the rear retainer.

If the seal was removed from retainer for replacement, apply engine oil to the oil seal lip and install the oil seal using J-39201 oil seal installer.



015RW001



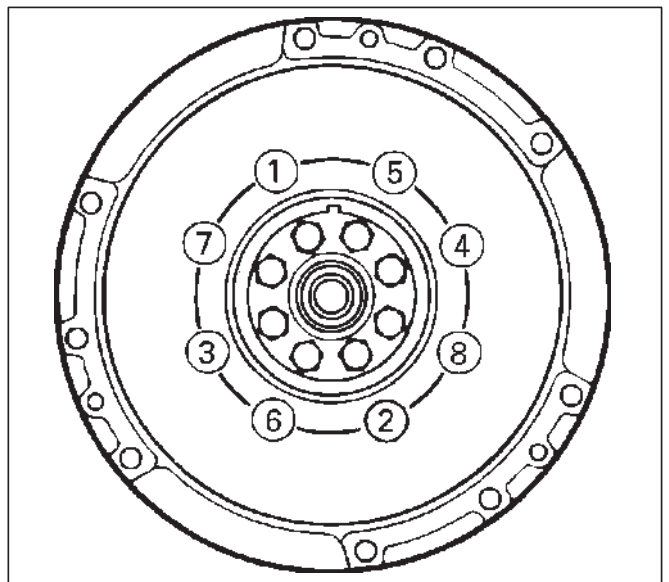
015RS017

**3. Flywheel (9)**

1. Thoroughly clean and remove the oil from the threads of crankshaft.
2. Remove the oil from the crankshaft and flywheel mounting faces.
3. Mount the flywheel on the crankshaft and then install the washer.
4. Hold the crankshaft to prevent from rotating then install the bolts in the order shown to the specified torque.

**Torque: 54 N-m (40 lb ft)**

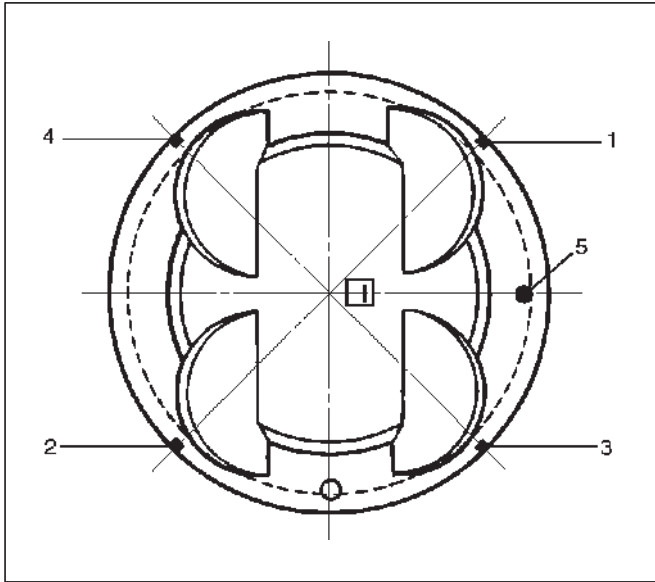
**NOTE:** Do not reuse the bolt and do not apply oil or thread lock to the bolt.



015RS018

4. Piston and connecting rod assembly (8)

- Apply engine oil to the cylinder bores, the connecting rod bearings and the crankshaft pins. Check to see that the piston ring end gaps are correctly positioned.



015RS019

**Legend**

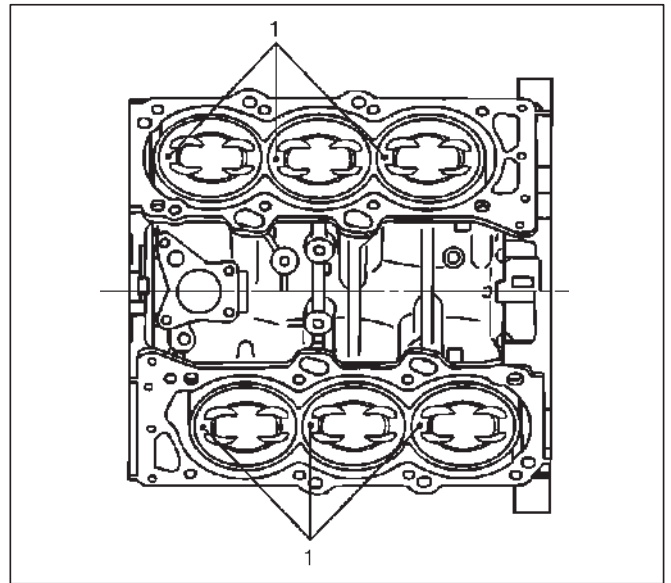
- (1) No.1 Compression Ring
- (2) No.2 Compression Ring
- (3) Oil Ring Side Rail Upper
- (4) Oil Ring Side Rail Lower
- (5) Piston Front Mark

- Insert the piston/connecting rod assemblies into each cylinder with the piston ring compressor. The front marks must be facing the front of the engine.
- Match the numbered caps with the numbers on the connecting rods. Align the punched marks on the connecting rods and caps.
- Apply engine oil to the threads and seating faces of the nuts.
- Tighten the nuts.

**Torque: 54 N·m (40 lb ft)**

After tightening the cap nuts, check to see that the crankshaft rotates smoothly.

NOTE: Do not apply engine oil to the bearing back faces.

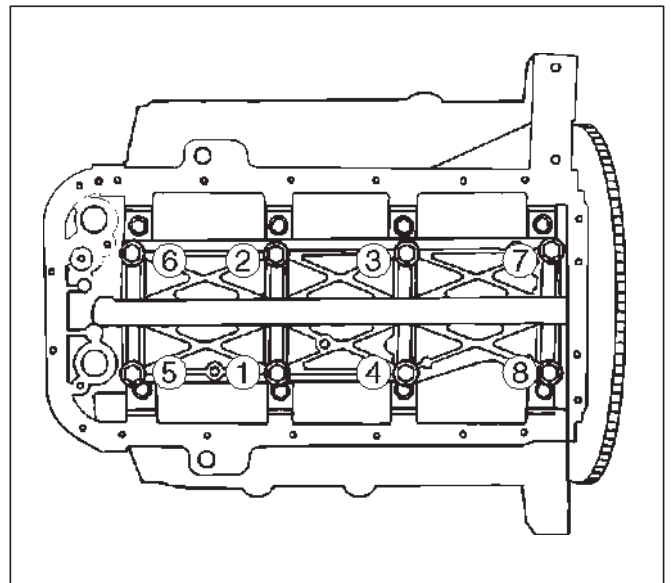


015RS020

- 5. Install oil gallery (7) and tighten the bolts in 2 steps, in the order shown.

**1st step: 29 N·m (22 lb ft)**

**2nd step: 55° ~ 65°**



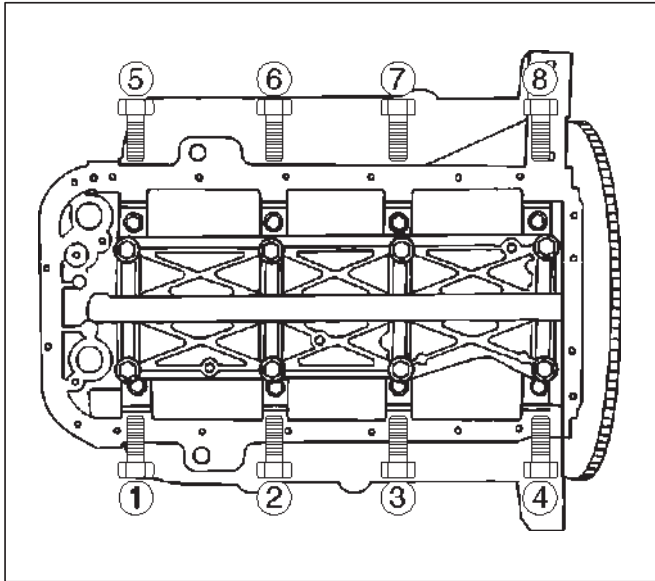
051RS009

- 6. Cylinder block side bolts (6)

- Tighten all the bolts to the specified torque in the order shown.

NOTE: Do not apply engine oil to the crank case side bolts.

**Torque: 39 N·m (29 lb ft)**



012RS001

7. Install oil pump assembly (5), refer to “Oil pump” in this manual.

8. Install oil strainer and O-ring (4).

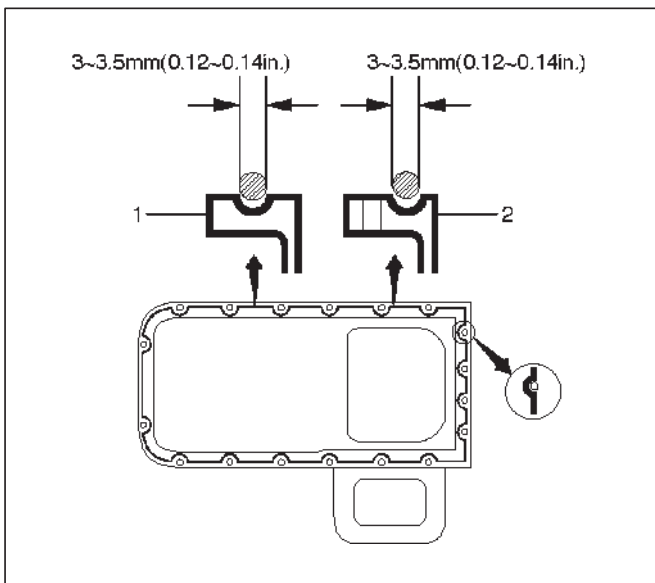
9. Install oil pipe and O-ring (3) and tighten the bolts.

**Torque: 25 N·m (18 lb ft)**

10. Install crankcase oil pan (2).

1. Completely remove all residual sealant, lubricant and moisture from the sealing surfaces. The surfaces must be perfectly dry.
2. Apply a correct width bead of sealant (TB—1207C or its equivalent) to the contact surfaces of the oil pan. There must be no gaps in the bead.
3. The crankcase assembly must be installed within 5 minutes after sealant application to prevent premature hardening of the sealant.
4. Tighten the bolts and nuts to the specified torque.

**Torque : 10 N·m (89 lb in)**



013RW010

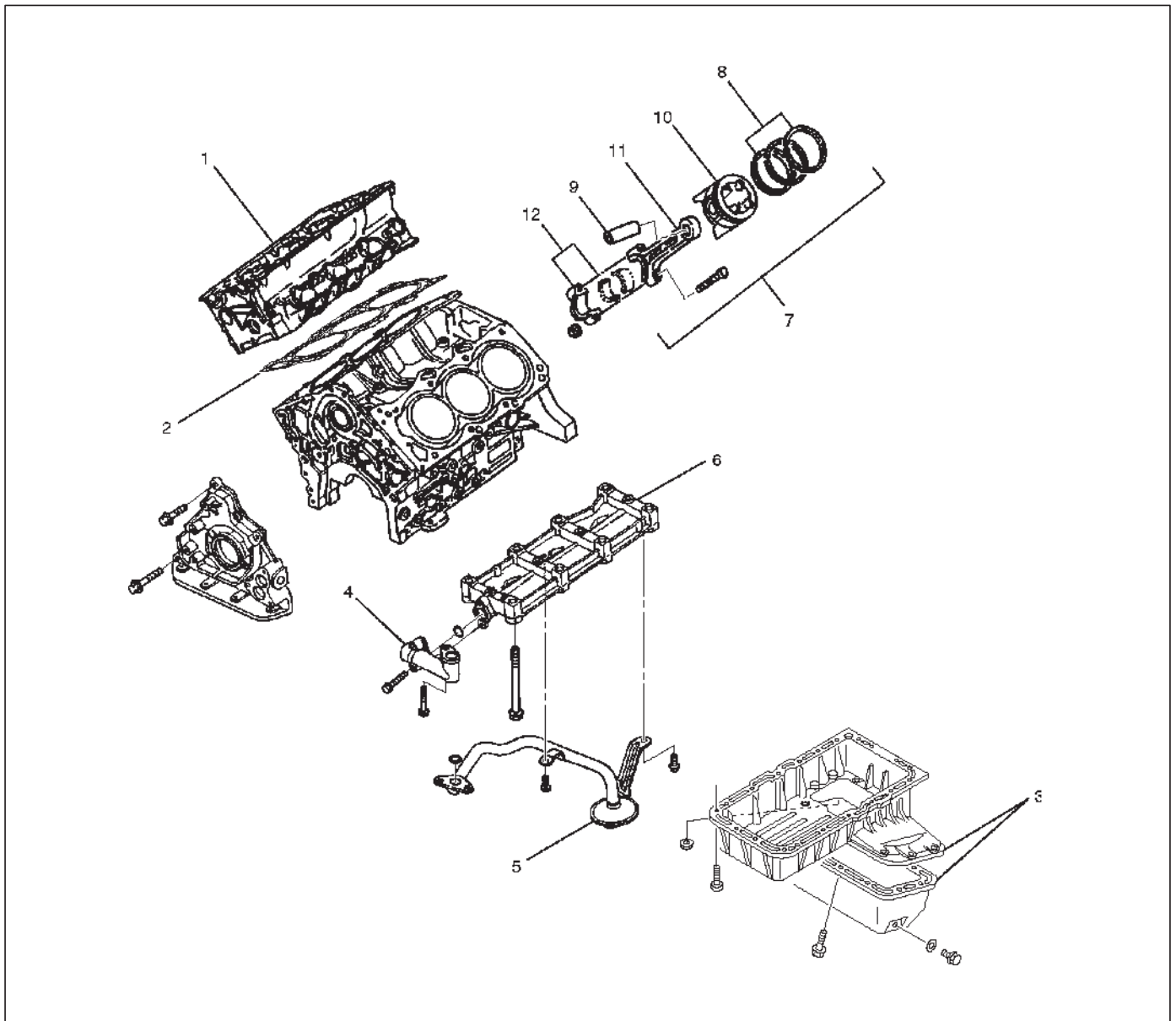
**Legend**

- (1) Portion Between Bolt Holes
- (2) Bolt Hole Portion

11. Install cylinder head assembly, refer to “Cylinder head” in this manual.

## Piston and Connecting Rod

### Piston, Connecting Rod and Associate Parts



#### Legend

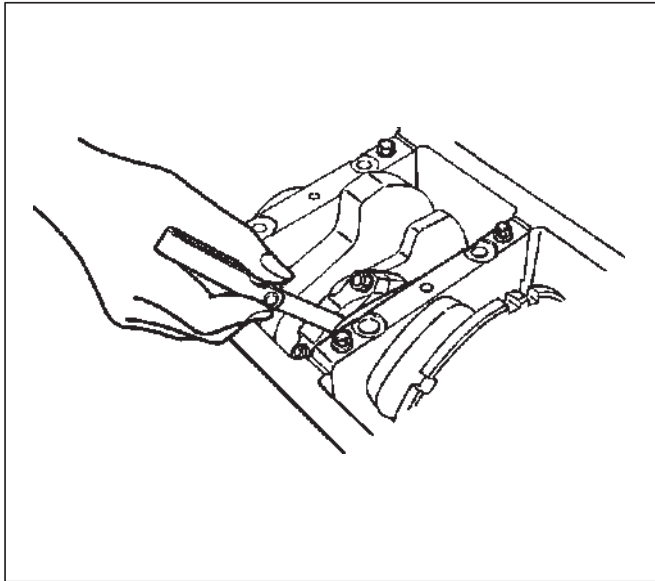
- |                             |  |
|-----------------------------|--|
| (1) Cylinder Head Assembly  | (7) Piston and Connecting Rod Assembly |
| (2) Cylinder Head Gasket    | (8) Piston Ring                        |
| (3) Crankcase with Oil Pan  | (9) Piston Pin                         |
| (4) Oil Pipe and O-Ring     | (10) Piston                            |
| (5) Oil Strainer and O-Ring | (11) Connecting Rod                    |
| (6) Oil Gallery             | (12) Connecting Rod Cap                |

#### Disassembly

1. Remove cylinder head assembly (1). Refer to "Cylinder Head Removal" in this manual.
2. Remove cylinder head gasket (2).
3. Remove crankcase with oil pan (3). Refer to "Oil Pan and Crankcase" in this manual.
4. Remove oil pipe and O-ring (4).

5. Remove oil strainer and O-ring (5).
6. Remove oil gallery (6).
7. Remove connecting rod cap with connecting rod lower bearing (12).
8. Remove piston and connecting rod assembly (7).

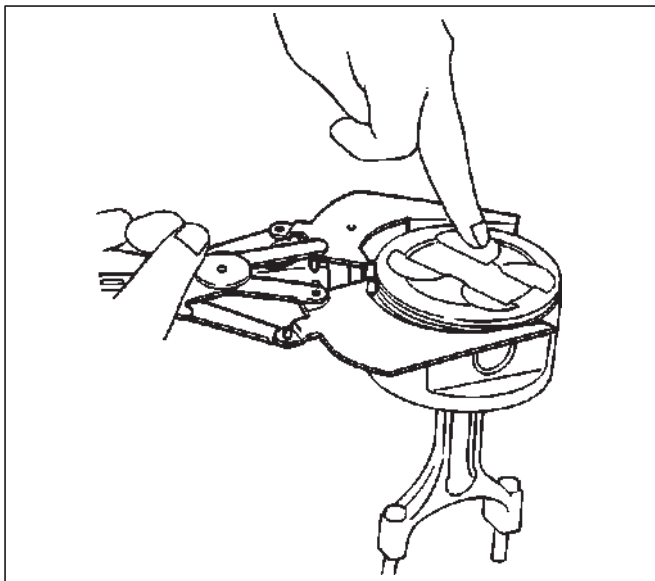
NOTE: Before removing piston and connecting rod assembly, measure thrust clearance.



015RS031

○Remove any ridge or carbon build up from the top end of the cylinder.

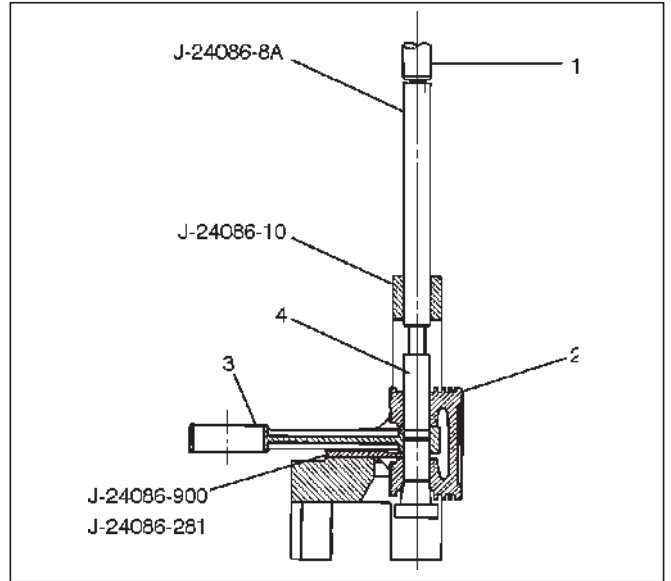
9. Remove the piston rings (8) with a piston ring expander. Arrange the removed piston rings in the cylinder number order.



015RS022

10. Remove the piston pin (9) using J-24086-C piston pin service set and piston support with a press.

NOTE: Keep the parts removed from each cylinder separate. All parts must be reinstalled in their original positions. Heating the connecting rod will permit easy removal of the piston pin.



015RS023

**Legend**

- (1) Press Ram
- (2) Piston
- (3) Connecting Rod
- (4) Piston Pin

- 11. Piston (10)
- 12. Connecting rod (11)

**Inspection and Repair**

**Pistons (10)**

Carefully clean away all the carbon adhering to the piston head and the piston ring grooves.

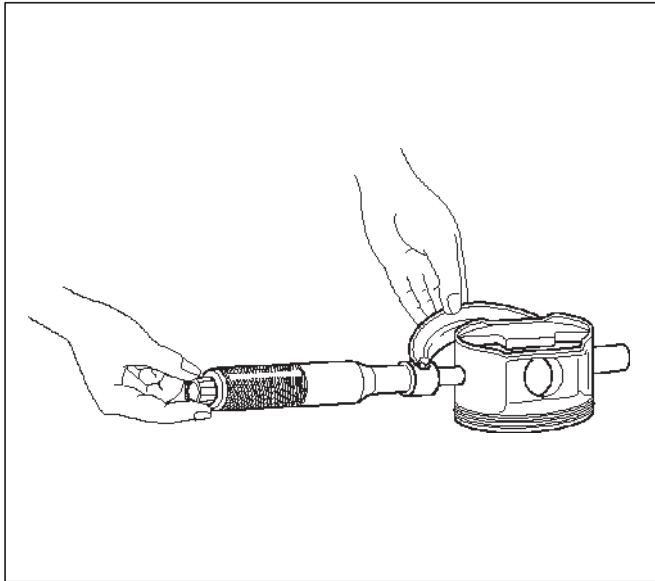
NOTE: Never use a wire brush to clean the pistons. Damage will result. Visually check each piston for cracking, scoring, and other signs of excessive wear. If any of the above conditions are found, the piston must be replaced.

**Piston Diameter**

- 1. Measure the piston outside diameter with micrometer at the piston grading position and a right angle to the piston pin.

Piston grading position (from piston head)

**Piston grading position : 43.0 mm (1.6929 in)**



015RV014

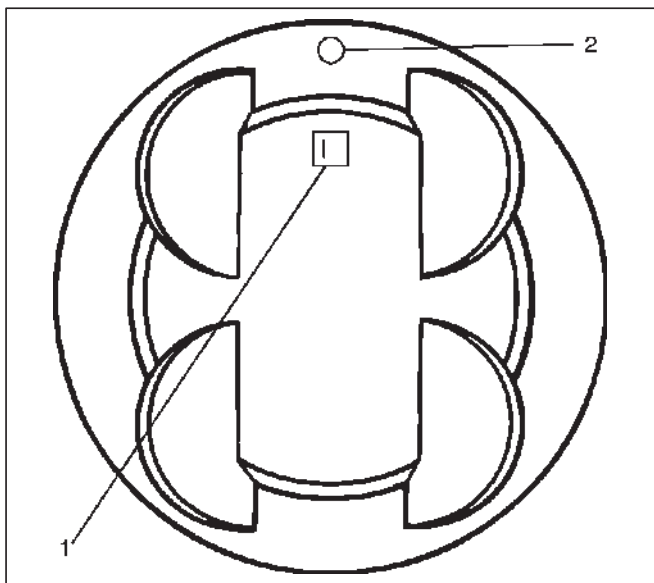
The size mark (1) for piston outside diameter is represented as shown in illustration below.

#### Outside Diameter

**Size Mark A : 93.360 mm–93.370 mm  
(3.6756 in–3.6760 in)**

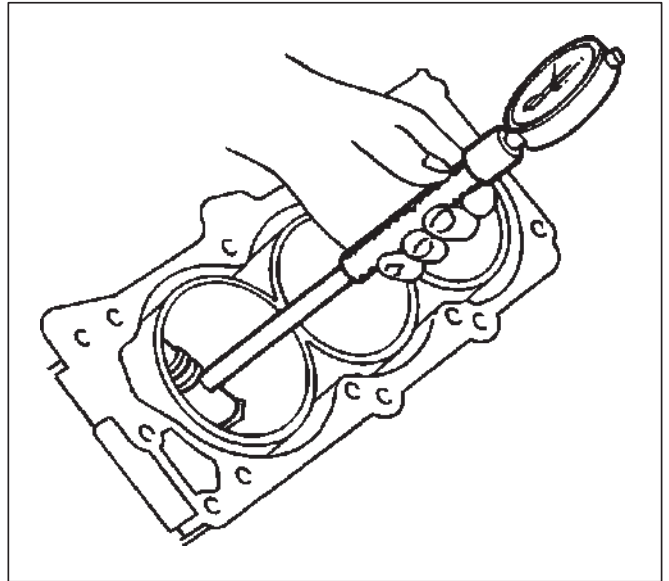
**Size Mark B : 93.371 mm–93.380 mm  
(3.6760 in–3.6764 in)**

**Size Mark C : 93.381 mm–93.390 mm  
(3.6764 in–3.6768 in)**



015RS025

Measure the cylinder bore inside diameter (refer to “Cylinder Block” in this manual).



012RS002

### Piston Rings (8)

Any worn or damaged part discovered during engine overhaul must be replaced with a new one.

#### 1. Ring end gap measurement

- Insert the piston ring into the bore.
- Push the ring by the piston, at a right angle to the wall, into the point at which the cylinder bore diameter is the smallest.
- Measure the ring end gap.

#### Compression Ring

##### 1st ring

**Standard: 0.300 mm–0.400 mm  
(0.0118 in–0.0157 in)**

**Limit: 1.0 mm (0.0394 in)**

##### 2nd ring

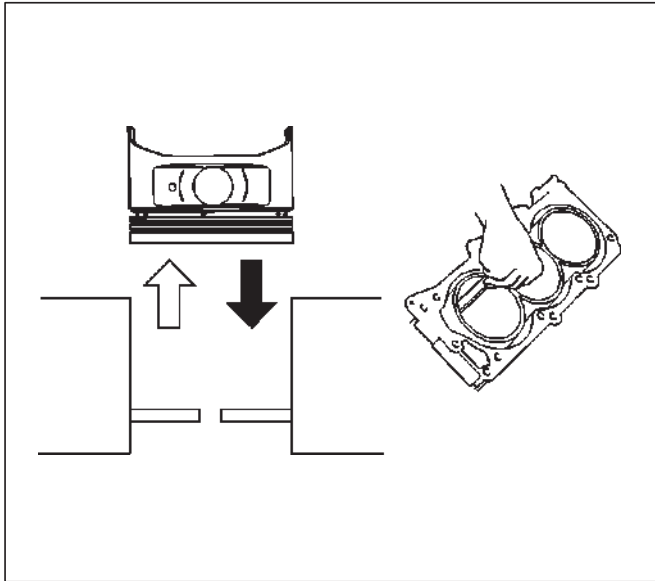
**Standard: 0.450 mm–0.600 mm  
(0.0177 in–0.0236 in)**

**Limit: 1.2 mm (0.0472 in)**

##### Oil ring

**Standard: 0.150 mm–0.450 mm  
(0.0059 in–0.0177 in)**

**Limit: 1.05 mm (0.0413 in)**

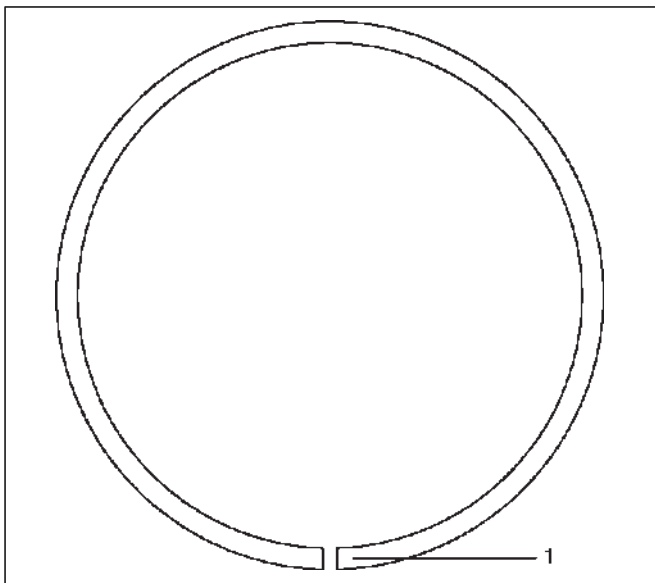


015RS026

○Positioning mark (1) is painted as shown in the illustration.

**Marked T : No.1 Compression ring**

**Marked T2 : No.2 Compression ring**



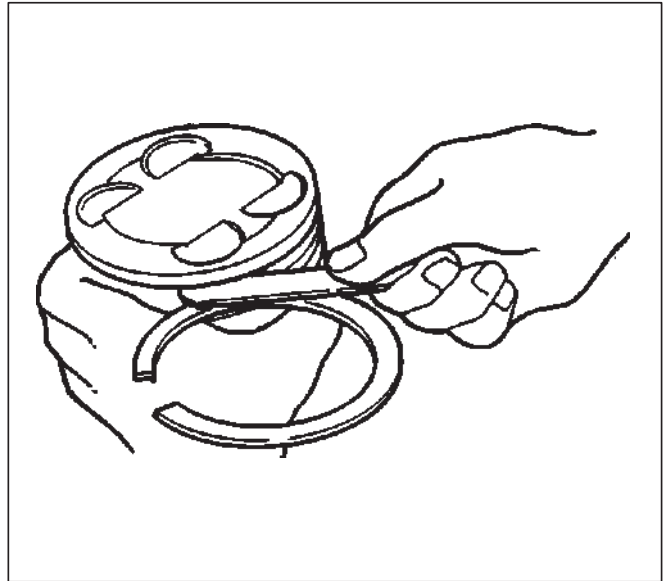
015RS027

2. Measure the clearance between the piston ring groove and the piston ring with a feeler gauge. If the piston ring groove / piston ring clearance exceeds the specified limit, the piston must be replaced.

**Compression Ring Clearance**

**Standard : 0.016 mm–0.038 mm  
(0.0006 in.–0.0015 in)**

**Limit : 0.15mm (0.0059 in)**



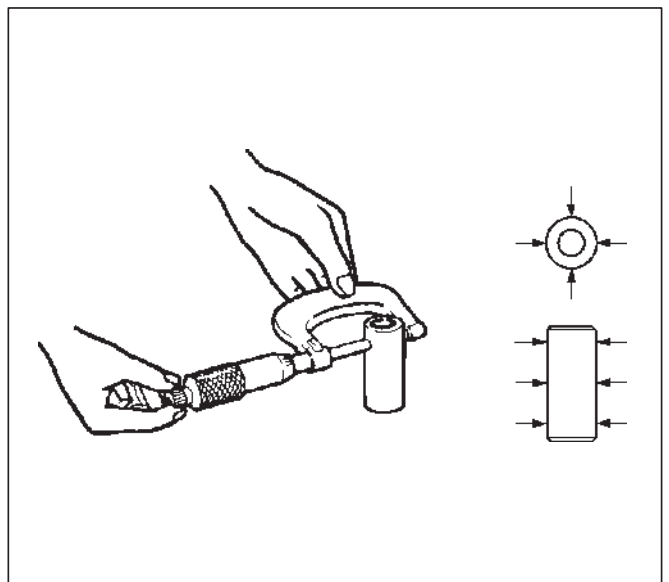
015RS028

### Piston Pin (9)

NOTE: Do not reuse the old piston pin.

1. Use a micrometer to measure the new piston pin outside diameter in both directions at three different positions.
2. Measure the inside diameter of the connecting rod small end. If the fitting interference between the small end and pin does not conform to the specified value, the connecting rod must be replaced.

**Standard : 0.023 mm–0.038 mm (0.0009 in–0.0015 in)**



015RS029

3. Insert the new pin into the piston and rotate it. If the pin rotates smoothly with no backlash, the clearance is normal. If there is backlash or roughness, measure the clearance. If the clearance exceeds the specified limit, the piston must be replaced.

**Clearance**

**Standard : 0.010 mm–0.017 mm  
(0.0004 in.–0.0007 in)**

**Limit : 0.040 mm (0.0016 in)**



## Connecting Rods (11)

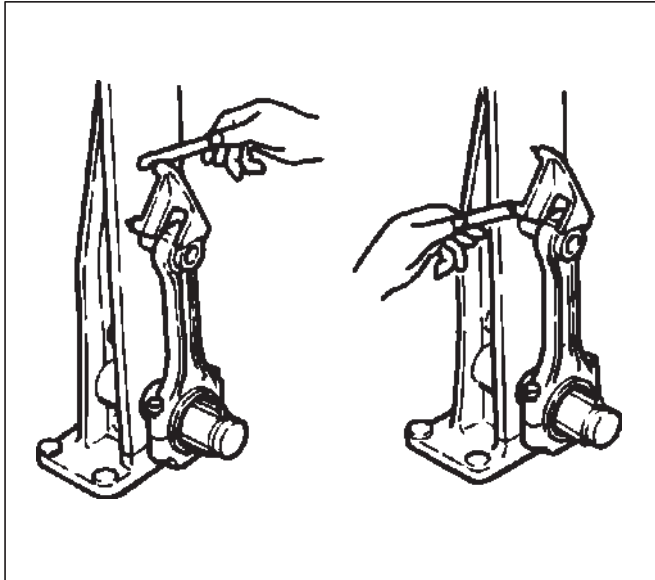
1. Check the connecting rod alignment. If either the bend or the twist exceeds the specified limit, the connecting rod must be replaced.

**Bend per 100 mm (3.937 in)**

**Limit: 0.15 (0.0059)**

**Twist per 100 mm (3.937 in)**

**Limit: 0.20 (0.0078)**

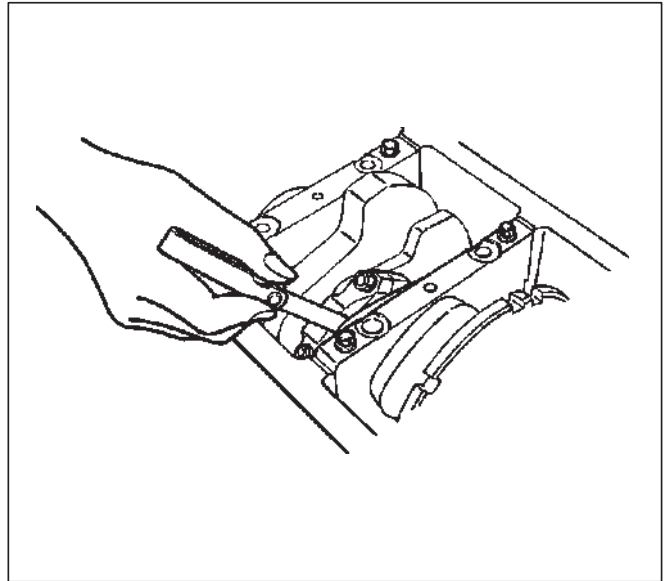


2. Measure the connecting rod thrust clearance. Use a feeler gauge to measure the thrust clearance at the large end of the connecting rod. If the clearance exceeds the specified limit, the connecting rod must be replaced.

**Standard : 0.16 mm–0.35 mm**

**(0.0063 in.–0.0138 in)**

**Limit : 0.40 mm (0.0157 in)**



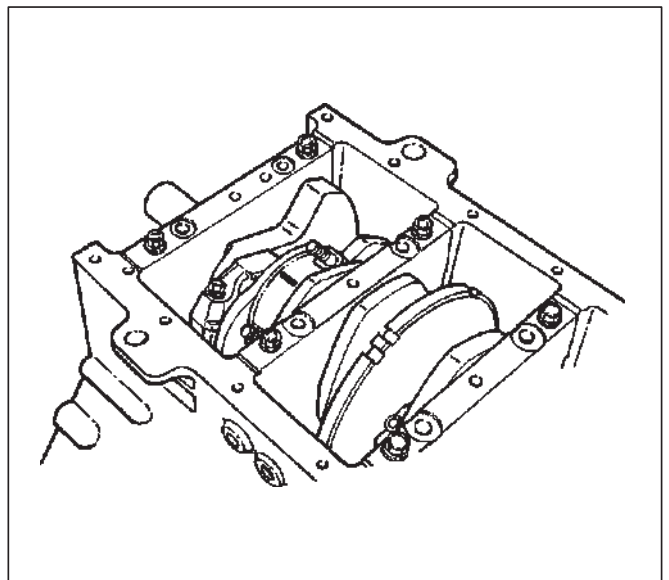
3. Measure the oil clearance between the connecting rod and the crankshaft.

1. Remove the connecting rod cap nuts and the rod caps (12).

Arrange the removed rod caps in the cylinder number order.

2. Clean the rod bearings and the crankshaft pins.

3. Carefully check the rod bearings. If even one bearing is found to be damaged or badly worn, the entire bearing assembly must be replaced as a set. Reinstall the bearings in their original positions. Apply plastigage to the crank pin.



## 6A-82 ENGINE MECHANICAL

- Reinstall the rod caps (12) to their original positions.  
Tighten the rod cap nuts.

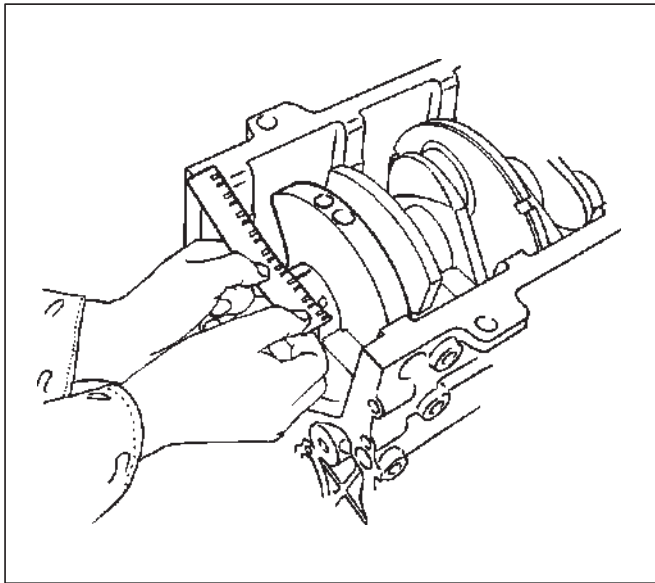
**Torque: 54 N·m (40 lb ft)**

NOTE: Do not allow the crankshaft to rotate.

- Remove the rod caps.
- Measure the width of the plastigage and determine the oil clearance. If the oil clearance exceeds the limit, replace the rod bearing as a set.

**Standard : 0.019 mm–0.043 mm  
(0.0007 in–0.0017 in)**

**Limit : 0.08 mm (0.003 in)**



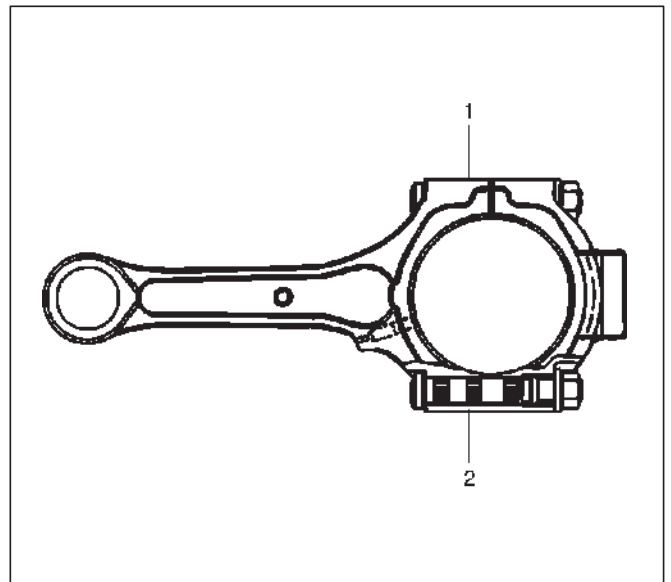
015RS008

- Clean the plastigage from the bearings and the crankshaft pins.

### Con-rod Bearing Selection

Select and install the new connecting rod bearings, paying close attention to the connecting rod big end diameter size mark (1).

NOTE: Take care not to confuse the alignment mark (2) and the size mark (1) during the installation procedure.



015RS034

1 Size Mark	Big end Bore Diameter mm (in)	Crankshaft Pin Diameter	Connecting Rod Bearing Thickness (Reference) mm (in)	Color of Size Mark	Oil Clearance (Reference) mm (in)
A	56.994-57.000 (2.2439-2.2441)	53.922-53.937 (2.1229-2.1235)	1.512-1.516 (0.0595-0.0597)	Yellow	0.025-0.054 (0.0010-0.0021)
B	56.988-56.994 (2.2436-2.2439)		1.508-1.512 (0.0594-0.0595)	Green	0.027-0.056 (0.0011-0.0022)
C	56.982-56.988 (2.2434-2.2436)		1.504-1.508 (0.0592-0.0594)	Pink	0.029-0.058 (0.0011-0.0023)

### Reassembly

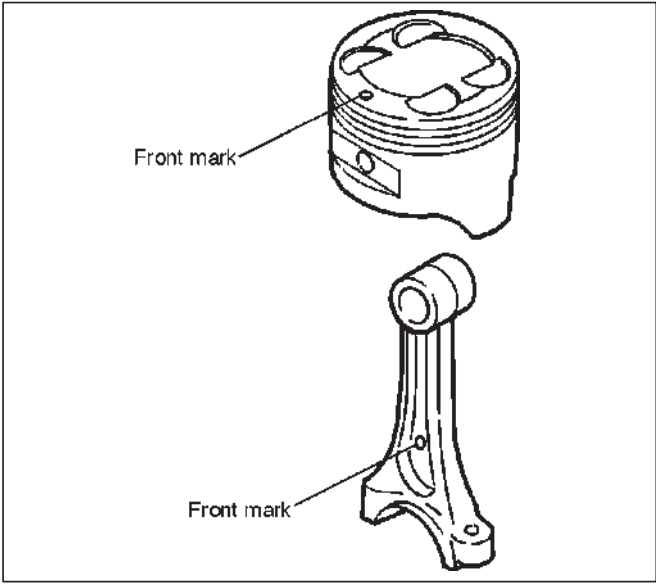
- Install connecting rod
- Install piston

- Install piston pin

○Apply a thin coat of engine oil to the piston pin. Try to insert the piston pin into the piston pin hole with normal finger pressure.

NOTE: When changing piston / connecting rod combinations, do not change the piston / piston pin combination and do not reuse the old piston pin.

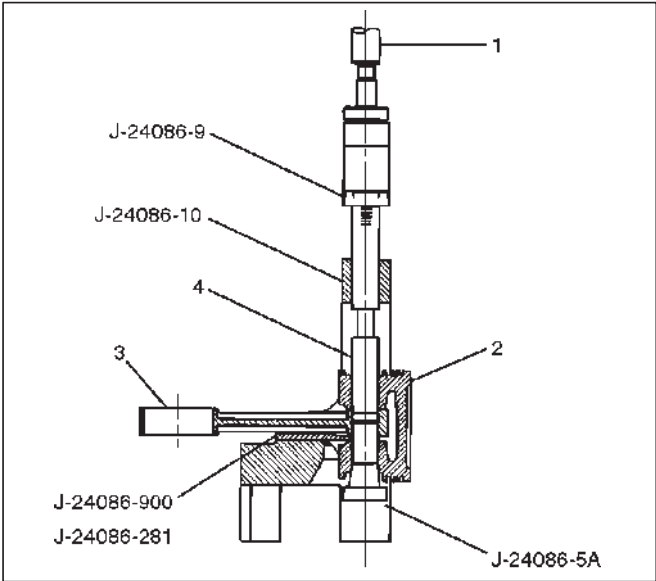
○Attach the piston to the connecting rod with the piston front mark and the connecting rod front mark on the same side.



015RS036

○With J-24086-C Piston pin service set and a press, press fit the piston pin.

NOTE: Heat the connecting rod small end to a suitable temperature to ensure smooth installation.



015RS037

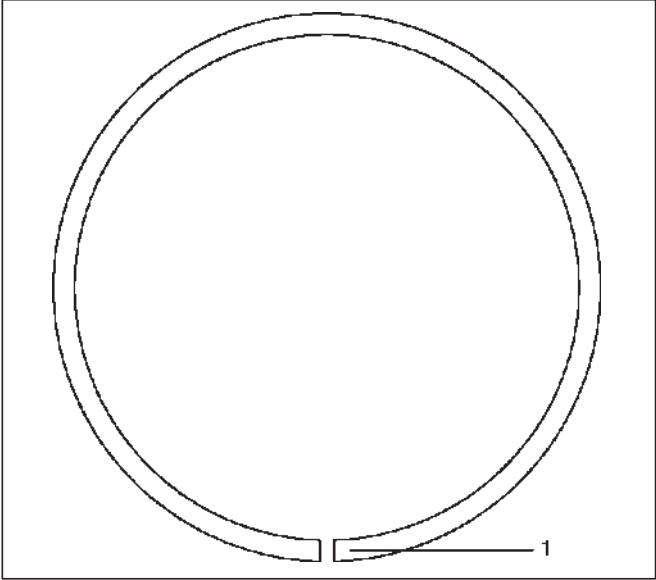
**Legend**

- (1) Press Ram
- (2) Piston
- (3) Connecting Rod
- (4) Piston Pin

4. Install piston ring with the piston ring expander. The compression ring must be set with the T mark (1) facing up.

**Marked T : No.1 Compression ring**

**Marked T2 : No.2 Compression ring**



015RS027

○Install piston rings in the following sequence.

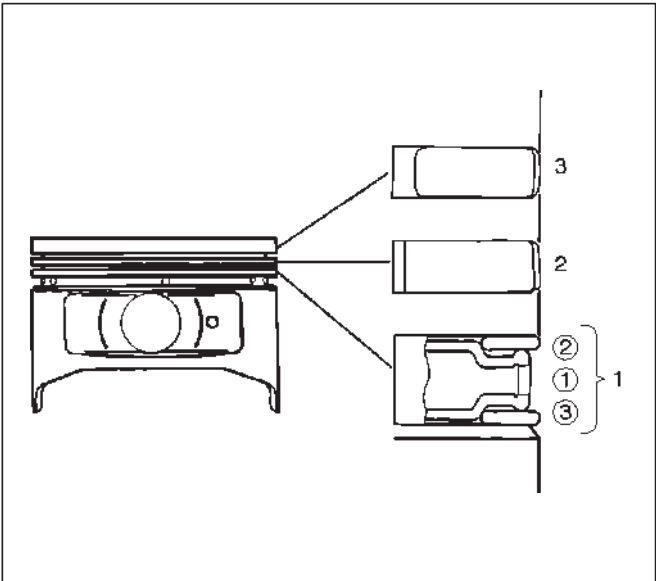
1. Oil ring
  1. Expander ring
  2. Upper side rail
  3. Lower side rail
2. 2nd compression ring
3. 1st compression ring

○The compression rings must be set with the T or T2 mark facing up.

**Marked T : No.1 Compression ring**

**Marked T2 : No.2 Compression ring**

○After installation, apply engine oil to the entire circumference of the piston rings. Check to see that all the rings rotate smoothly.



015RS038

5. Install piston and connecting rod assembly.

○Insert the bearings into the connecting rods and caps. Apply new engine oil to the bearing faces and nuts.

## 6A-84 ENGINE MECHANICAL

---

○Tighten the connecting rod cap nuts

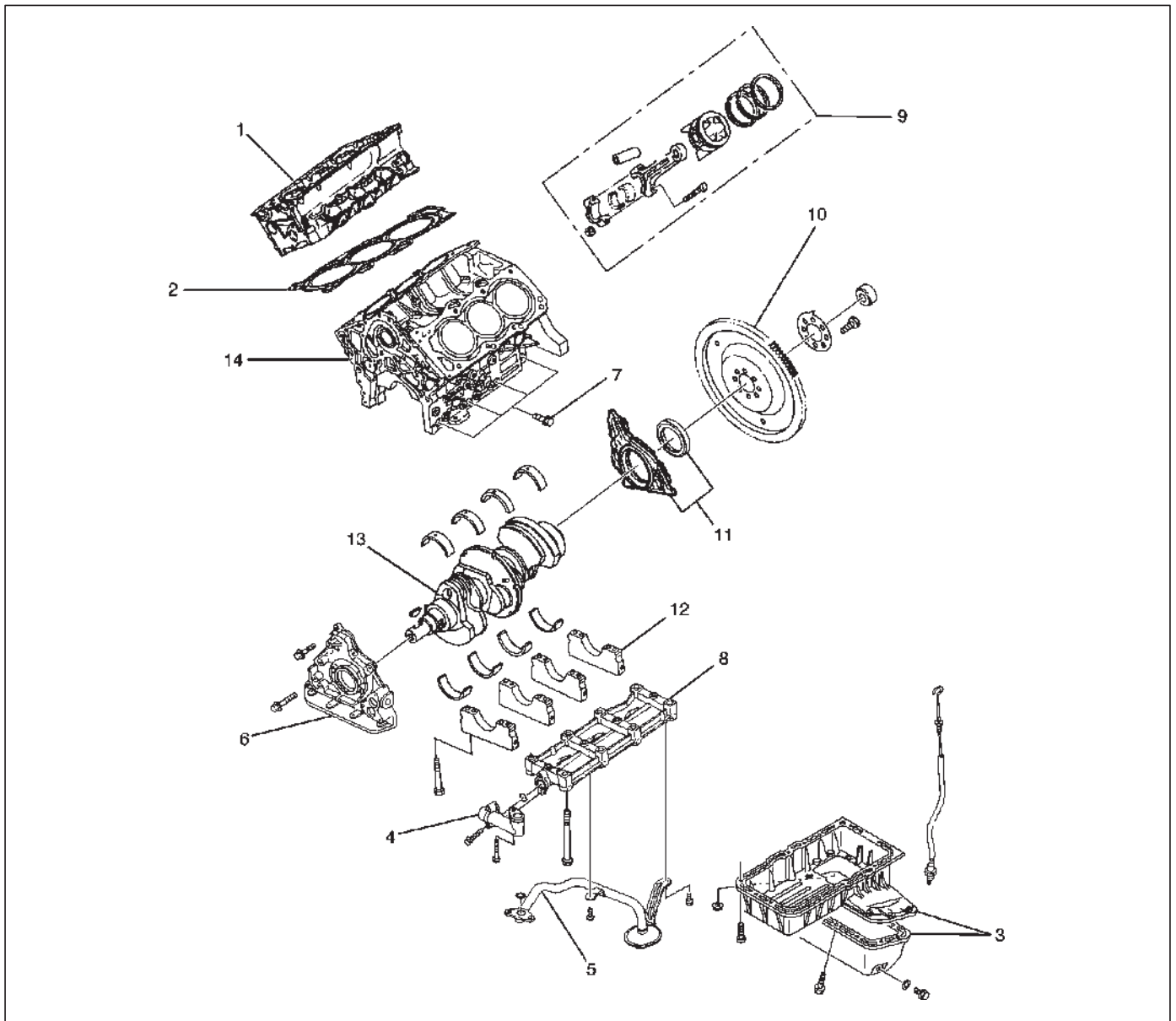
**Torque : 54 N·m (40 lb ft)**

NOTE: Do not apply engine oil to the bearing back faces.

6. Oil gallery, refer to “Crankshaft and main bearing” in this manual.
7. Oil strainer and O-ring.
8. Oil pipe and O-ring.
9. Install crankcase with oil pan, refer to “Oil pan and Crankcase” in this manual.
10. Install cylinder head gasket.
11. Install Cylinder head assembly.
  - Refer to “Cylinder head” in this manual.

## Cylinder Block

### Cylinder Block and Associated Parts



012RX002

#### Legend

- |                               |  |
|-------------------------------|--|
| (1) Cylinder Head Assembly    | (8) Oil Gallery                        |
| (2) Cylinder Head Gasket      | (9) Piston and Connecting Rod Assembly |
| (3) Crankcase with Oil Pan    | (10) Flywheel                          |
| (4) Oil Pipe and O-Ring       | (11) Rear Oil Seal Retainer Assembly   |
| (5) Oil Strainer and O-Ring   | (12) Main Bearing Cap                  |
| (6) Oil Pump Assembly         | (13) Crankshaft                        |
| (7) Cylinder Block Side Bolts | (14) Cylinder Block                    |

#### Disassembly

1. Remove cylinder head assembly.
2. Remove cylinder head gasket.
3. Remove crankcase with oil pan.
4. Remove oil pipe and O-ring.
5. Remove oil strainer and O-ring.
6. Remove oil pump assembly.
7. Remove crankcase side bolts.
8. Remove oil gallery.
9. Remove piston and connecting rod assembly.
10. Remove flywheel.

11. Remove rear oil seal retainer assembly.
12. Remove main bearing cap.
13. Remove crankshaft.
14. Remove cylinder block.

## Inspection and Repair

1. Remove the cylinder head gasket and any other material adhering to the upper surface of the cylinder block. Be very careful not to allow any material to accidentally drop into the cylinder block. Be very careful not to scratch the cylinder block.
2. Carefully remove the oil pump, rear oil seal retainer, and crankcase assembly installation surface seal.
3. Wipe the cylinder block clean.
4. Visually inspect the cylinder block. If necessary, use a flaw detector to perform a dye penetrate and hydraulic (or air pressure) test. If cracking or other damage is discovered, the cylinder block must either be repaired or replaced.

### Flatness

1. Using a straight-edge and feeler gauge, check that the upper surface of the cylinder block is not warped.

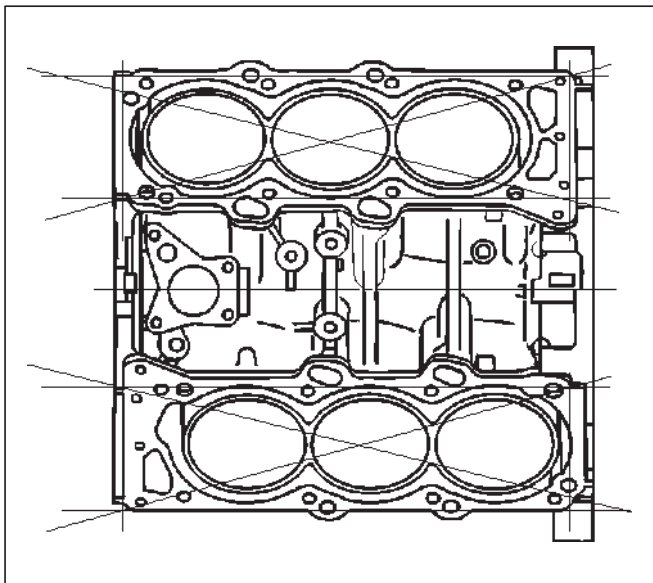
**CAUTION:** Be very careful not to allow any material to accidentally drop into the upper surface of the cylinder block. Be very careful not to scratch the upper surface of the cylinder block.

2. The cylinder block must be reground or replaced if the warpage exceeds the limit.

### Warpage

**Limit : 0.15 mm (0.0059 in)**

**Maximum repairable limit: 0.15 mm (0.0059 in)**



## Cylinder Bore

Use a cylinder gauge to measure the cylinder bore diameter in both the axial and thrust directions. Each measurement should be made at six points.

**CAUTION:** Be very careful not to allow any material to accidentally drop into the upper surface of the cylinder block. Be very careful not to scratch the upper surface of the cylinder block.

### Cylinder Bore Inside Diameter

**Limit : 93.530 (3.6823)**

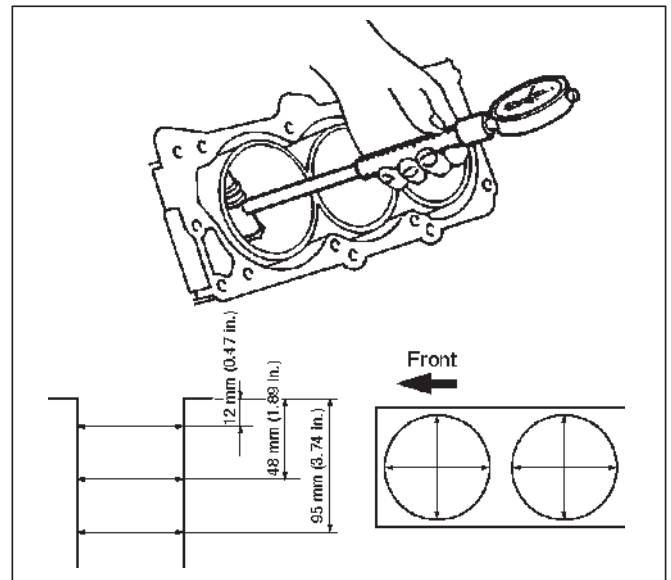
If the measurement exceed the specified limit, the cylinder block must be replaced.

### Diameter

**Grade A : 93.400 mm–93.410 mm  
(3.6772 in–3.6776 in)**

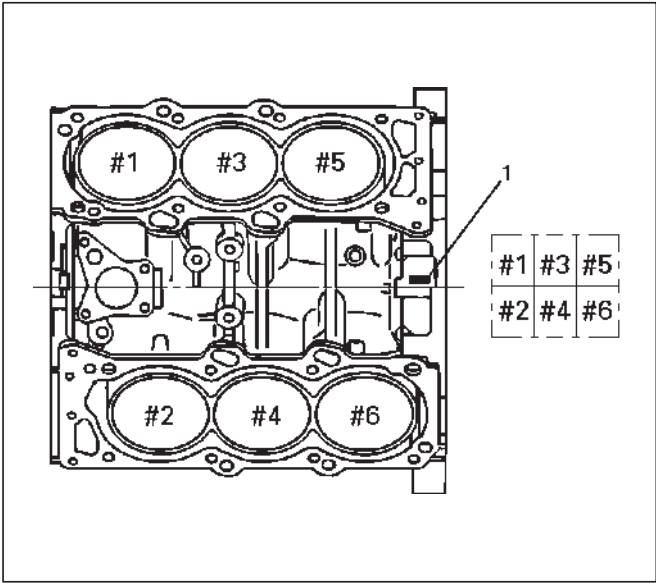
**Grade B : 93.411 mm–93.420 mm  
(3.6776 in–3.6779 in)**

**Grade C : 93.421 mm–93.430 mm  
(3.6780 in–3.6783 in)**



**NOTE:** For information on piston diameter, please refer to the section "Inspection of the Piston and Connecting Rod Assembly" in this manual.

- The "Grade" mark (1) is stamped at the position illustrated.

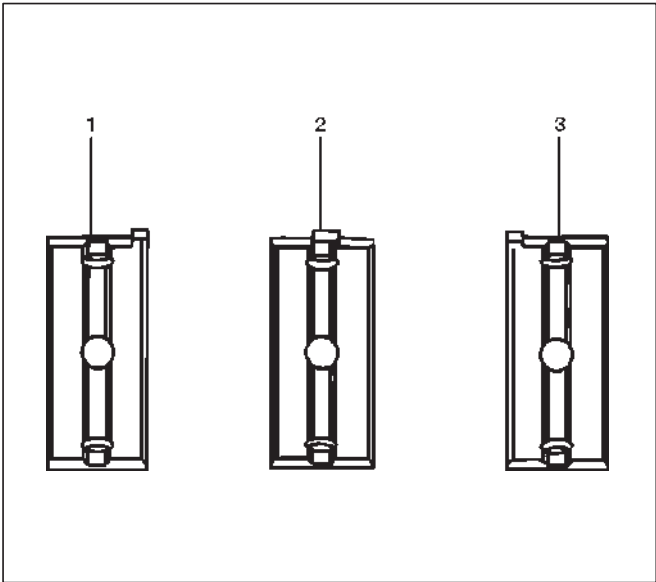


012RS006

**Reassembly**

1. Install cylinder block.
2. Install crankshaft.
  - Install the main bearings to the cylinder block and the main bearing caps.
  - Be sure that they are positioned correctly.
  - Apply new engine oil to the upper and lower main bearing faces.

NOTE: Do not apply engine oil to the bearing back faces.

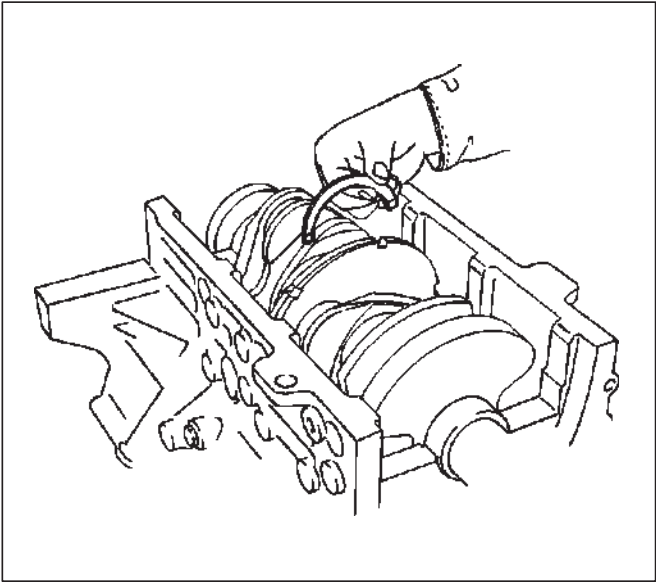


015RS012

**Legend**

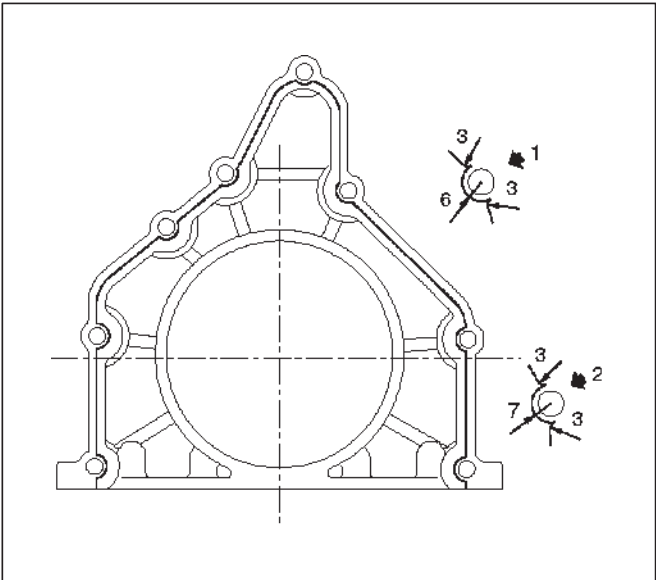
- (1) Number 1 and 4 main bearing upper and lower.
- (2) Number 2 and 3 main bearing upper.
- (3) Number 2 and 3 main bearing lower.

- Carefully mount the crankshaft.
- Apply engine oil to the thrust washer.
- Assemble the thrust washer to the No. 3 bearing journal. The oil grooves must face the crankshaft.



015RS013

3. Install rear oil seal retainer.
  - Remove oil on cylinder block and retainer fitting surface.
  - Apply sealant (TB1207B or equivalent) to retainer fitting surface as shown in illustration.
  - The oil seal retainer must be installed within 5 minutes after sealant application before the sealant hardens.



015RW002

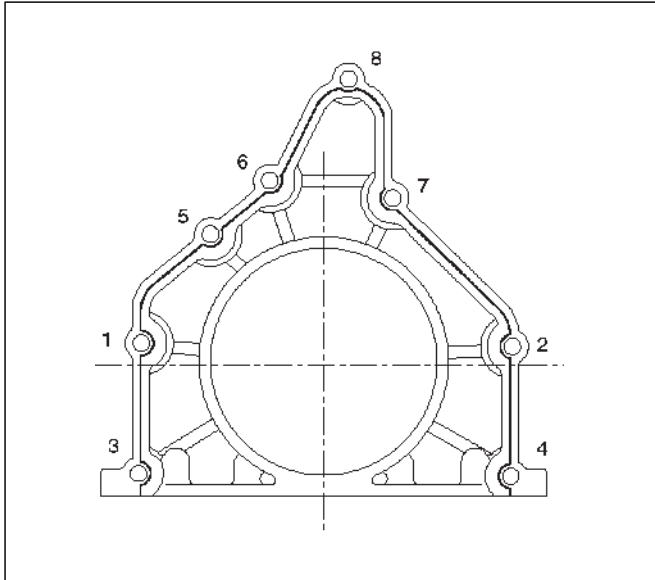
**Legend**

- (1) Around Bolt Holes
- (2) Around Dowel Pin

## 6A-88 ENGINE MECHANICAL

- Apply engine oil to oil seal lip and align a dowel pin hole in the cylinder block with that in the retainer.
- Tighten retainer fixing bolts to the specified torque.

**Torque: 25 N·m (18.4 lb ft)**



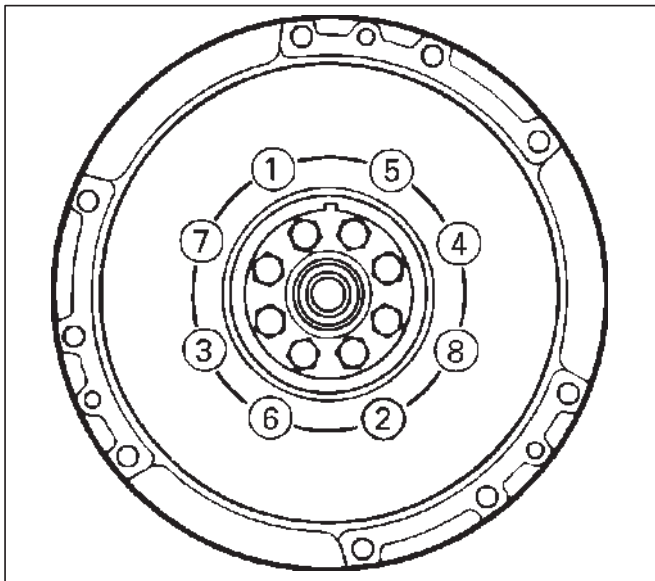
015RW001

### 4. Install flywheel

1. Thoroughly clean and remove the oil from the threads of crankshaft.
2. Remove the oil from the crankshaft and flywheel mounting faces.
3. Mount the flywheel on the crankshaft and then install the washer.
4. Holding the crankshaft stationary, tighten the flywheel bolts in the order shown.

**Torque: 54 N·m (40 lb ft)**

NOTE: Do not reuse the bolts and do not apply oil or thread lock to the bolts.



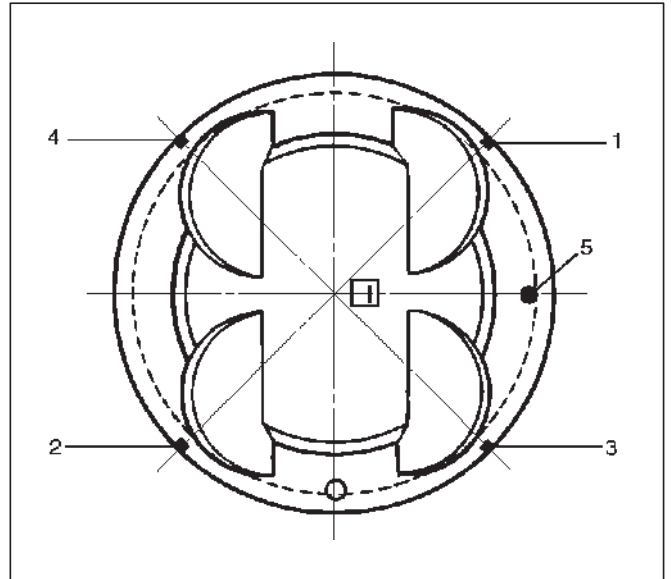
015RS018

### 5. Install piston and connecting rod assembly.

- Apply engine oil to the cylinder bores, the connecting rod bearings and the crankshaft pins.

NOTE: Do not apply engine oil to the bearing back faces.

- Check to see that the piston ring end gaps are correctly positioned.



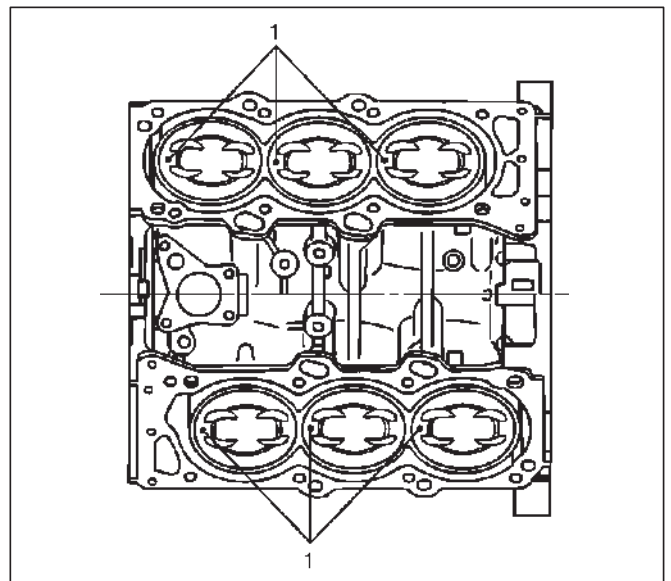
015RS019

### Legend

- (1) No.1 Compression Ring
- (2) No.2 Compression Ring
- (3) Oil Ring Side Rail Upper
- (4) Oil Ring Side Rail Lower
- (5) Piston Front Mark

- Insert the piston/connecting rod assemblies into each cylinder with the piston ring compressor.

- The front marks (1) must be facing the front of the engine.



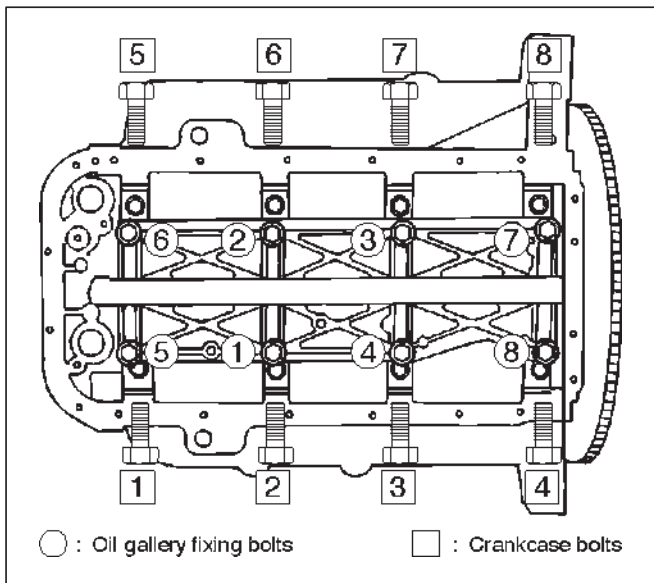
015RS020



6. Install oil gallery and tighten the bolts in 2 steps in the order shown.

**1st step : 29 N-m (22 lb ft)**

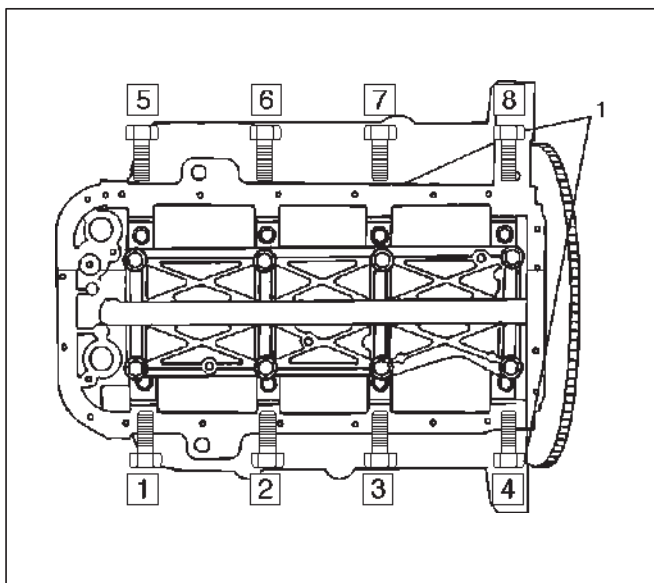
**2nd step : 55° ~ 65°**



012RS007

7. Install cylinder block side bolts (1) and tighten crankcase bolts in sequence shown in the illustration to specified torque.

**Torque : 39 N-m (29 lb ft)**



012RW005

8. Install oil pump assembly. Refer to "Oil Pump" in this manual.

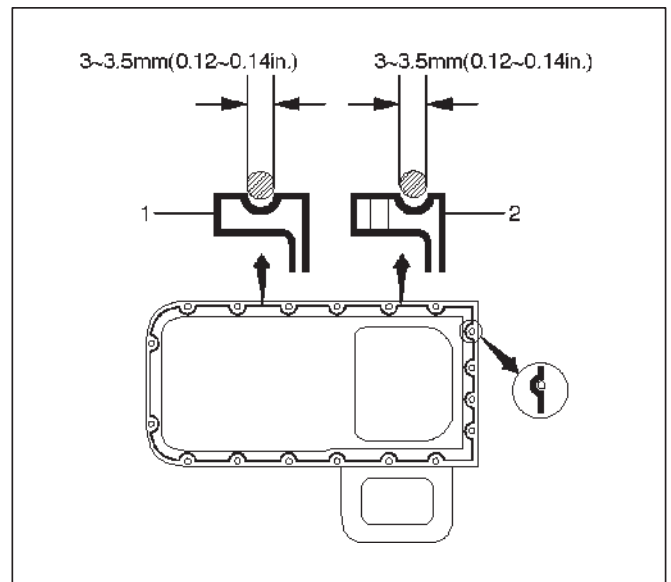
9. Install oil strainer and O-ring.

10. Install oil pipe and O-ring.

11. Install crankcase with oil pan.

1. Completely remove all residual sealant, lubricant and moisture from the sealing surfaces. The surfaces must be perfectly dry.
2. Apply a correct width bead of sealant (TB-1207C or its equivalent) to the contact surfaces of the crankcase. There must be no gaps in the bead.
3. The oil pan must be installed within 5 minutes after sealant application to prevent premature hardening of sealant.
4. Tighten the bolts and nuts to the specified torque.

**Torque : 10 N-m (89 lb in)**



013RW010

**Legend**

- (1) Portion Between Both Holes
- (2) Bolt Hole Portions

12. Install cylinder head gasket.

13. Install cylinder head assembly. Refer to "Cylinder Head" in this manual.

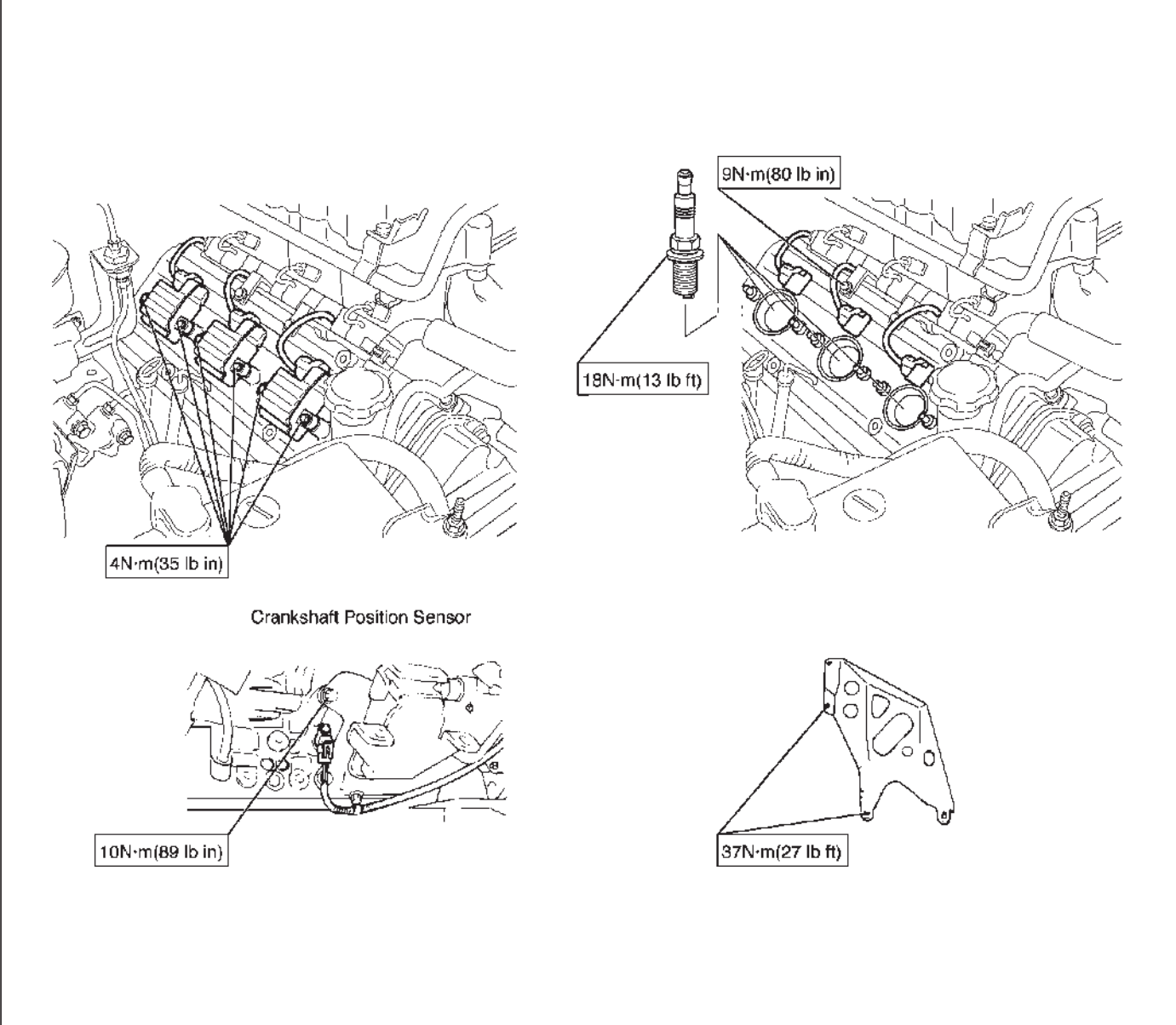
## Main Data and Specification

### General Specification

Item	Specifications
	6VE1
Engine type, number of cylinders and arrangement	Water cooled, four cycle V6
Form of combustion chamber	Pent roof type
Valve mechanism	4-Cams, 4-Valves, DOHC Gear & Belt Drive
Cylinder liner type	Casted in cylinder drive
Total piston displacement	3494 cc
Cylinder bore x stroke	93.4mm x 85.0mm (3.677 in x 3.346 in)
Compression ratio	9.1 : 1
Compression pressure at 300rpm	14.0 Kg/cm <sup>2</sup>
Engine idling speed rpm	Non adjustable (750)
Valve clearance	Intake: 0.28 mm (0.11 in)
	Exhaust: 0.30mm (0.12in)
Oil capacity	5.3 liters
Ignition timing	Non adjustable (20° BTDC at idle rpm)
Spark plug	K16PR-P11, PK16PR11, RC10PYP4
Plug gap	1.0 mm-1.1 mm(0.0394 in - 0.0433 in)

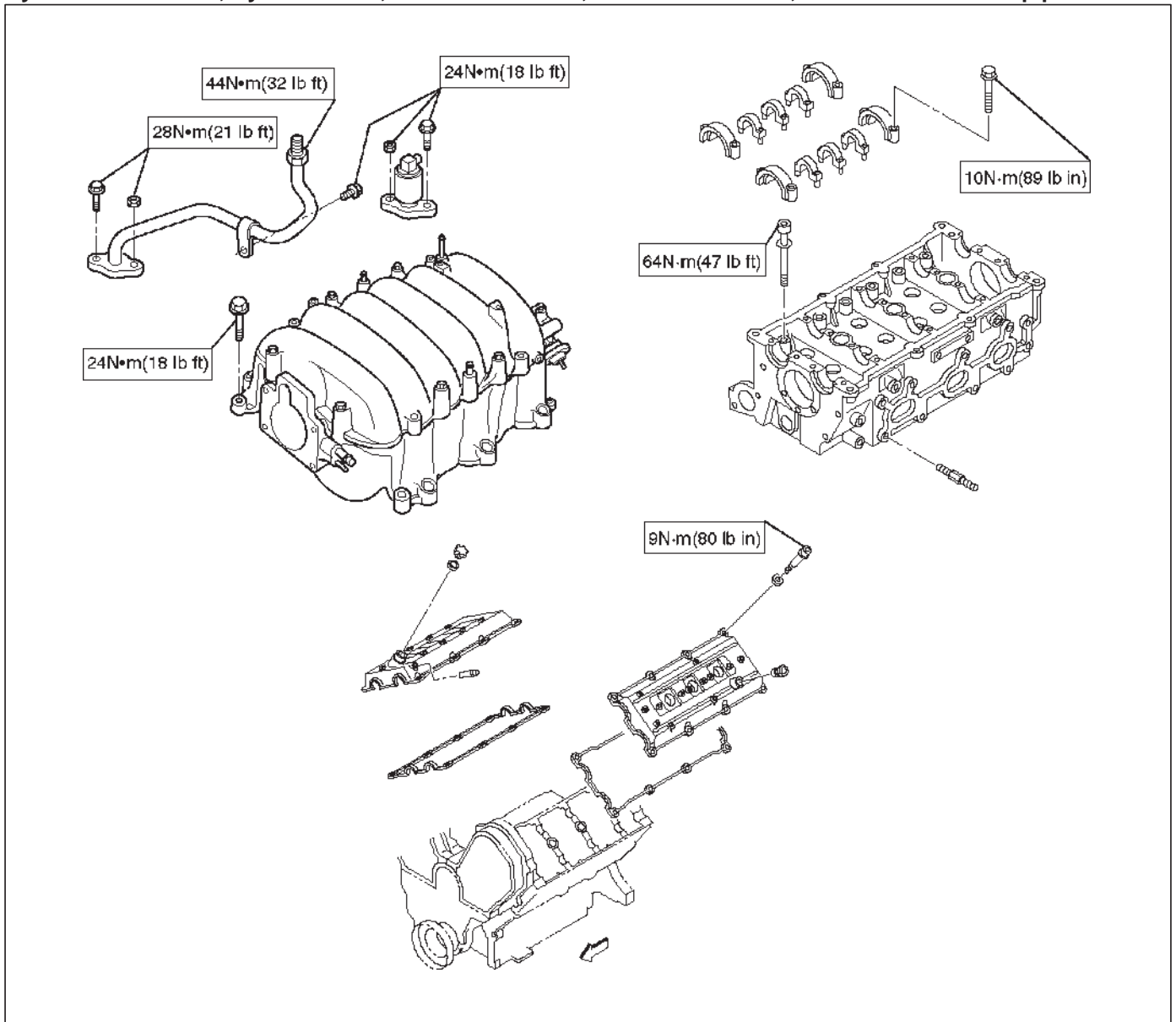
**Torque Specifications**

Ignition coil, Spark plug, Crankshaft Position sensor and Under cover

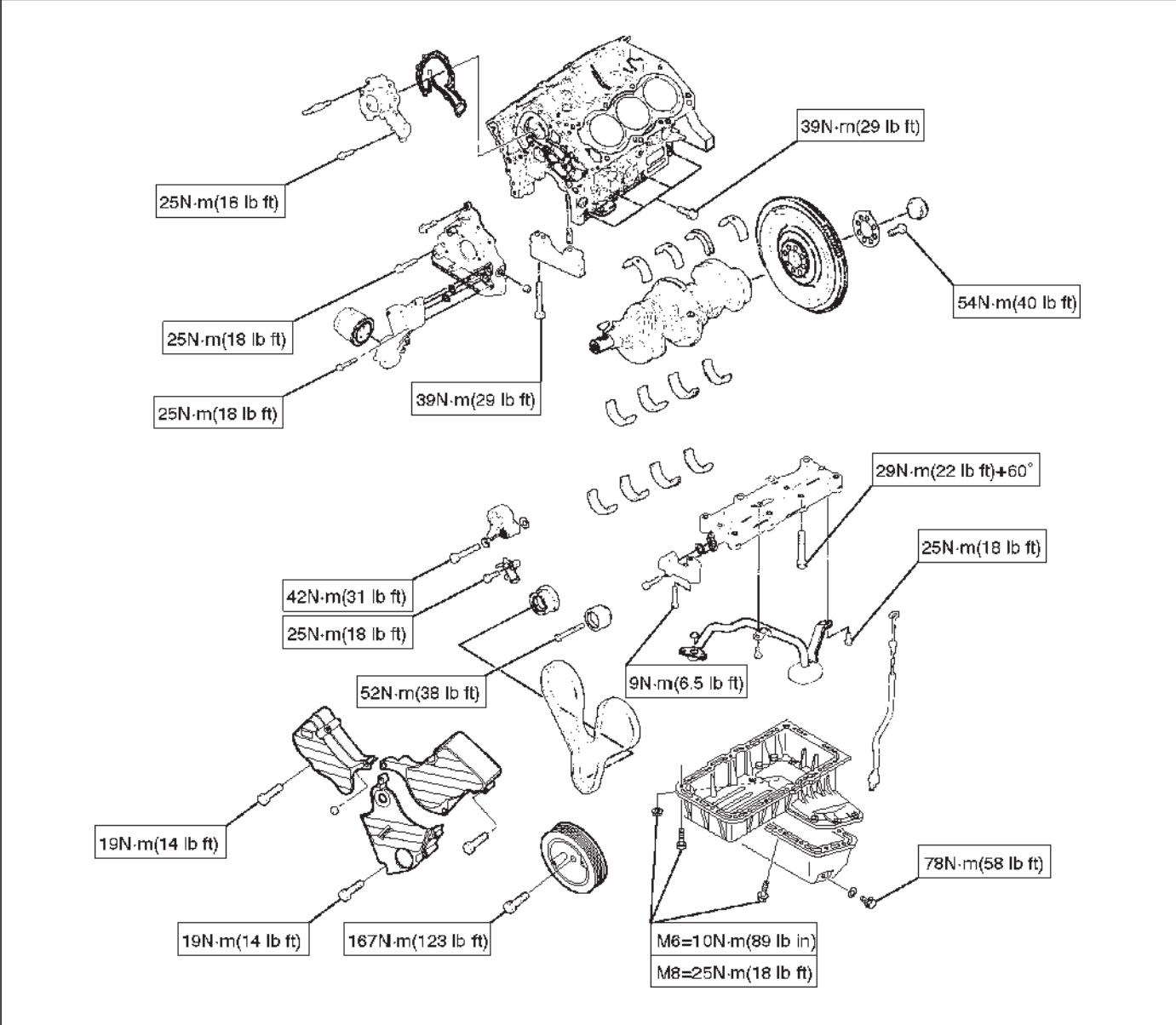


6A-92 ENGINE MECHANICAL

Cylinder head cover, Cylinder head, Camshaft bracket, Common chamber, EGR valve and EGR pipe

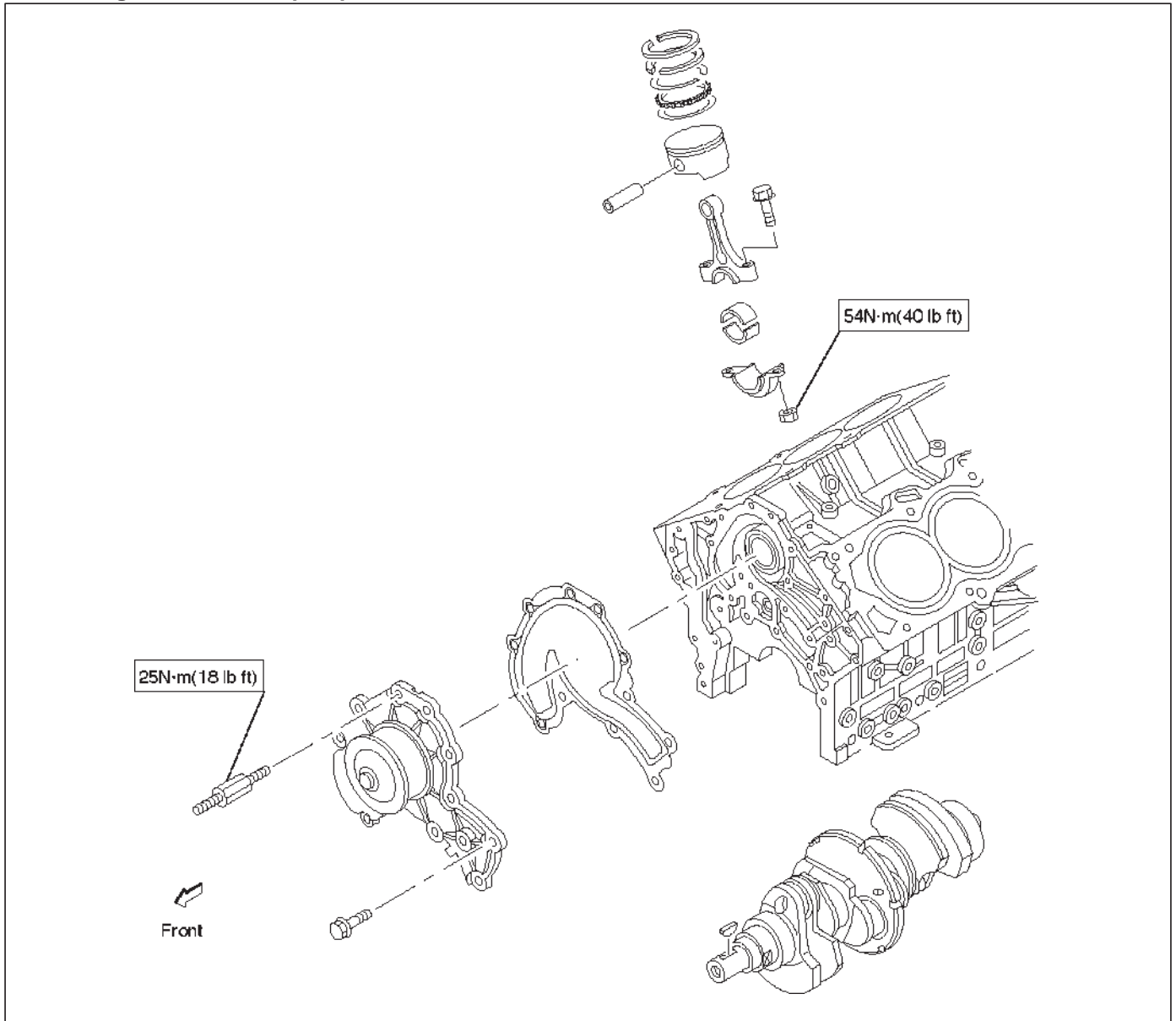


Crankshaft main bearing, Flywheel, Crankcase, Oil pan, Timing belt tensioner, Timing pulley, Timing belt cover, Oil pump, Oil gallery, Oil strainer and Water pump

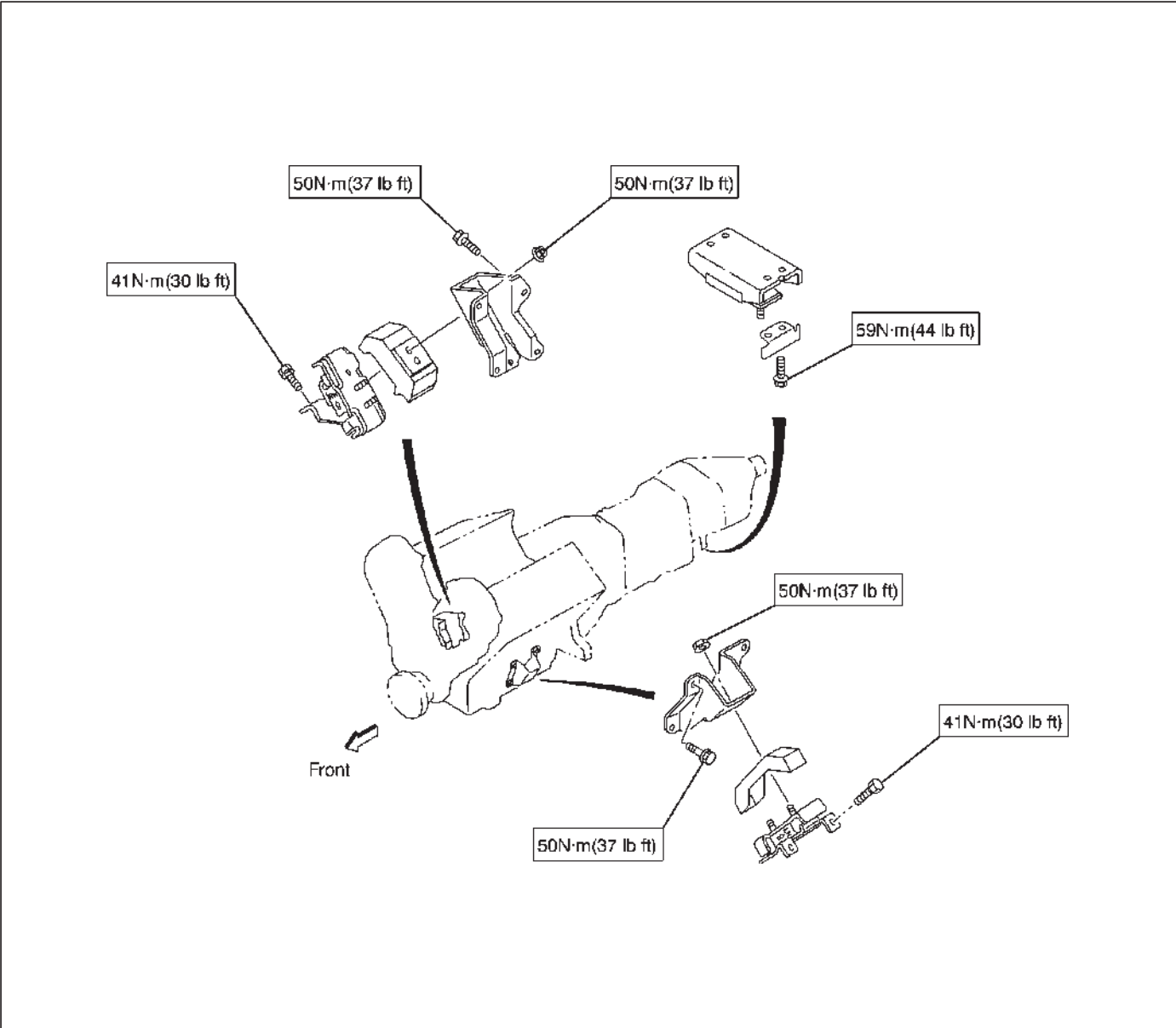


# 6A-94 ENGINE MECHANICAL

## Connecting rod and Water pump



Engine mount



Special Tool

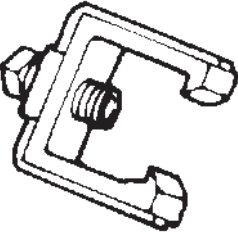
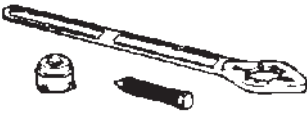
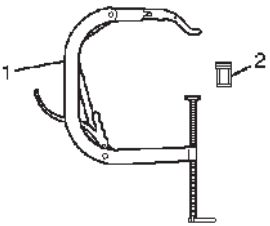
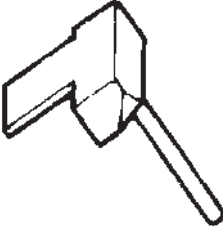
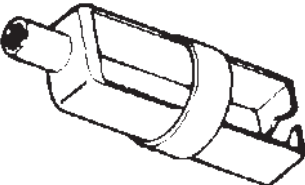
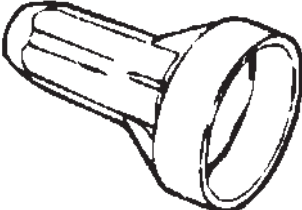


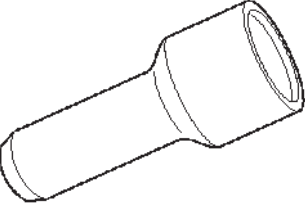
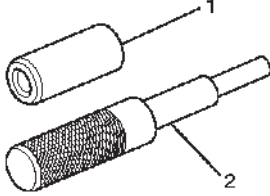
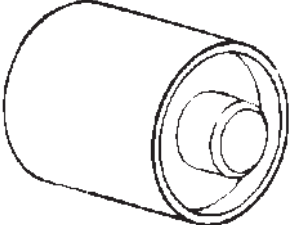
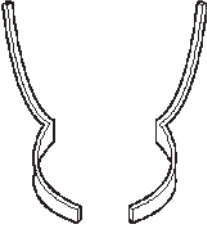
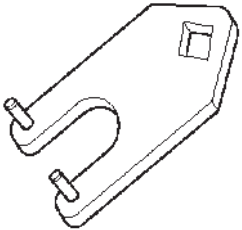
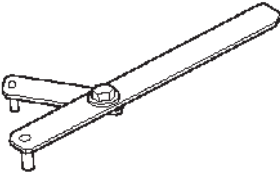
ILLUSTRATION	TOOL NO. TOOL NAME	ILLUSTRATION	TOOL NO. TOOL NAME
 <p>901RT033</p>	<p><b>J-21687-02</b> Remover; tie rod end</p>	 <p>901RT041</p>	<p><b>J-8614-01</b> Holder; Crankshaft</p>
 <p>F06RW002</p>	<p><b>J-8062</b> Compressor; Valve spring (1) <b>J-42898</b> Adapter; Compressor, Valve spring (2)</p>	 <p>901RT042</p>	<p><b>J-37228</b> Seal cutter</p>
 <p>901RT036</p>	<p><b>J-37281</b> Remover; Oil controller</p>	 <p>901RT043</p>	<p><b>J-39201</b> Installer; Real oil seal</p>
 <p>901RT037</p>	<p><b>J-38537</b> Installer; Oil controller</p>	 <p>901RT046</p>	<p><b>J-24239-1</b> Cylinder head bolt wrench</p>
 <p>901RW171</p>	<p><b>J-42985</b> Installer; Camshaft oil seal</p>	 <p>901RW182</p>	<p><b>J-42899</b> Replacer; Valve guide (1, 2) <b>J-42687</b> Installer; Valve guide (1) <b>J-37985-1</b> Remover; Valve guide (2)</p>
 <p>901RT040</p>	<p><b>J-39206</b> Installer; Pilot bearing</p>	 <p>901RW108</p>	<p><b>J-42689</b> Adjusting Tool: Valve clearance</p>



ILLUSTRATION	TOOL NO. TOOL NAME
 <p>901RW110</p>	<p><b>J-42686</b> Lever; Gear spring</p>
 <p>901RW116</p>	<p><b>J-43041</b> Holder; Universal</p>

# ENGINE

## ENGINE COOLING

### CONTENTS

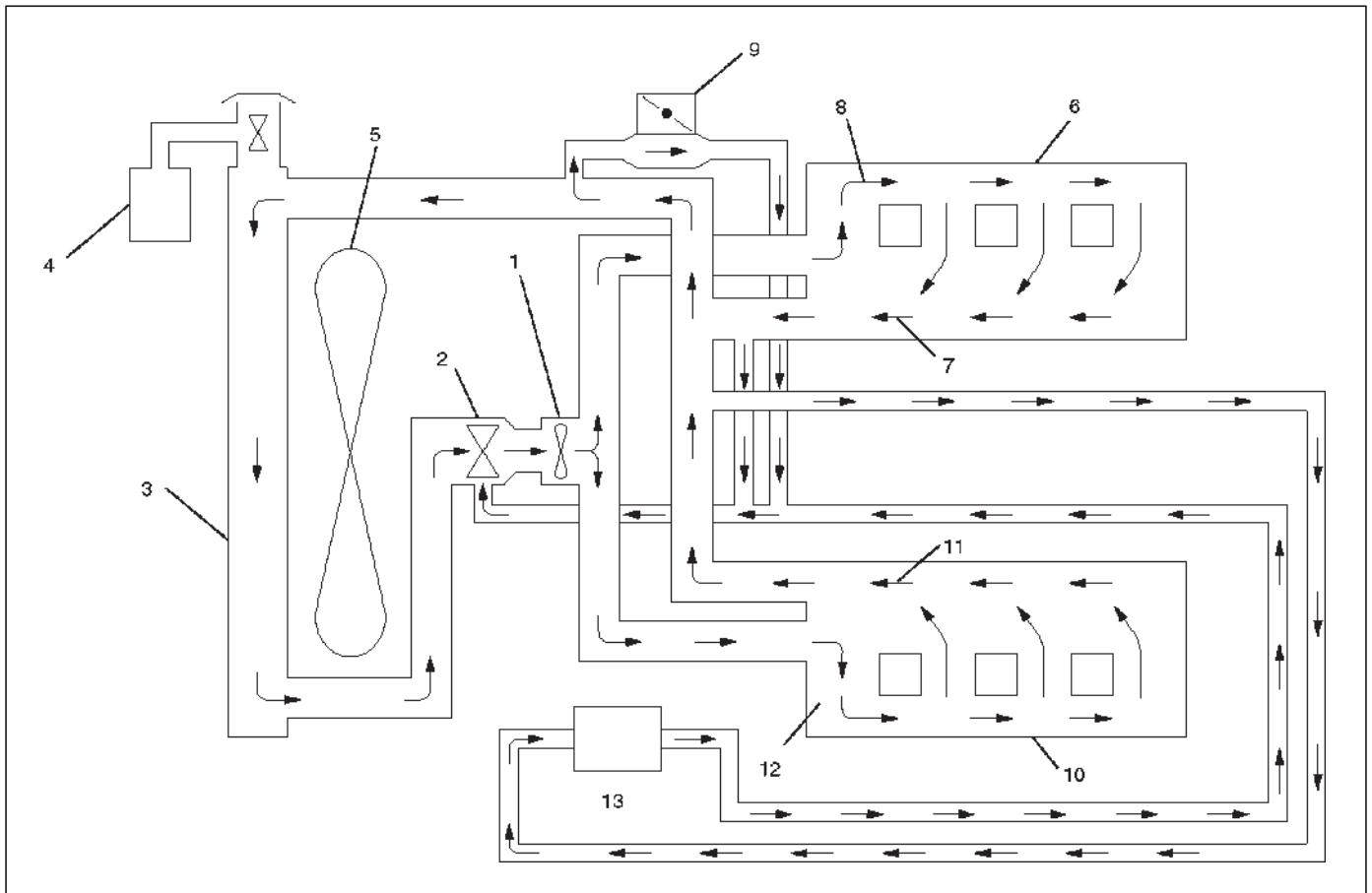
Service Precaution .....	6B-1	Inspection .....	6B-8
General Description .....	6B-2	Installation .....	6B-8
Diagnosis .....	6B-5	Radiator .....	6B-9
Draining and Refilling Cooling System .....	6B-6	Radiator and Associated Parts .....	6B-9
Engine coolant change .....	6B-6	Removal .....	6B-9
Water Pump .....	6B-7	Inspection .....	6B-10
Water Pump and Associated Parts .....	6B-7	Installation .....	6B-11
Removal .....	6B-7	Drive Belt and Cooling Fan .....	6B-12
Inspection .....	6B-7	Drive Belt and Associated Parts .....	6B-12
Installation .....	6B-7	Inspection .....	6B-12
Thermostat .....	6B-8	Installation .....	6B-12
Thermostat and Associated Parts .....	6B-8	Main Data and Specifications .....	6B-13
Removal .....	6B-8	Special Tool .....	6B-14

### Service Precaution

**WARNING: THIS VEHICLE HAS A SUPPLEMENTAL RESTRAINT SYSTEM (SRS). REFER TO THE SRS COMPONENT AND WIRING LOCATION VIEW IN ORDER TO DETERMINE WHETHER YOU ARE PERFORMING SERVICE ON OR NEAR THE SRS COMPONENTS OR THE SRS WIRING. WHEN YOU ARE PERFORMING SERVICE ON OR NEAR THE SRS COMPONENTS OR THE SRS WIRING, REFER TO THE SRS SERVICE INFORMATION. FAILURE TO FOLLOW WARNINGS COULD RESULT IN POSSIBLE AIR BAG DEPLOYMENT, PERSONAL INJURY, OR OTHERWISE UNNEEDED SRS SYSTEM REPAIRS.**

**CAUTION:** Always use the correct fastener in the proper location. When you replace a fastener, use **ONLY** the exact part number for that application. ISUZU will call out those fasteners that require a replacement after removal. ISUZU will also call out the fasteners that require thread lockers or thread sealant. **UNLESS OTHERWISE SPECIFIED**, do not use supplemental coatings (Paints, greases, or other corrosion inhibitors) on threaded fasteners or fastener joint interfaces. Generally, such coatings adversely affect the fastener torque and the joint clamping force, and may damage the fastener. When you install fasteners, use the correct tightening sequence and specifications. Following these instructions can help you avoid damage to parts and systems.

**General Description**



030RW001

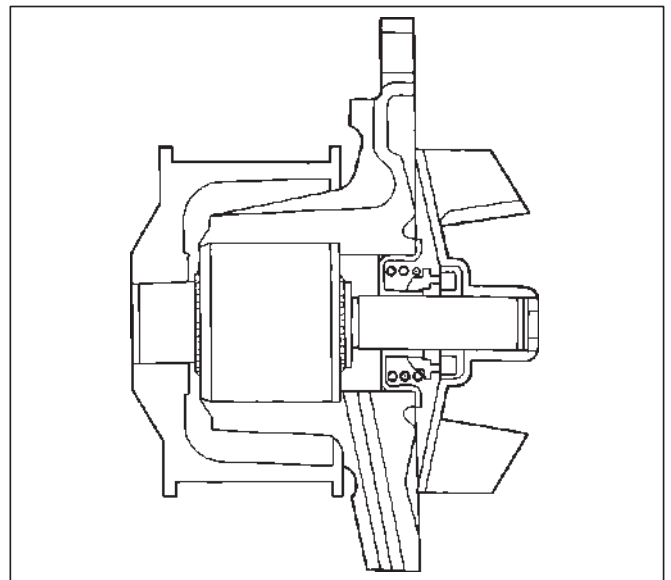
**Legend**

- |                    |                     |
|--------------------|---------------------|
| (1) Water Pump     | (7) Cylinder Head   |
| (2) Thermostat     | (8) Right Bank      |
| (3) Radiator       | (9) Throttle Body   |
| (4) Reserve Tank   | (10) Cylinder Block |
| (5) Cooling Fan    | (11) Cylinder Head  |
| (6) Cylinder Block | (12) Left Bank      |
|                    | (13) Heater         |

The cooling system is a pressurized Engine Coolant (EC) forced circulation type which consists of a water pump, thermostat cooling fan, radiator and other components. The automatic transmission fluid is cooled by the EC in radiator.

**Water Pump**

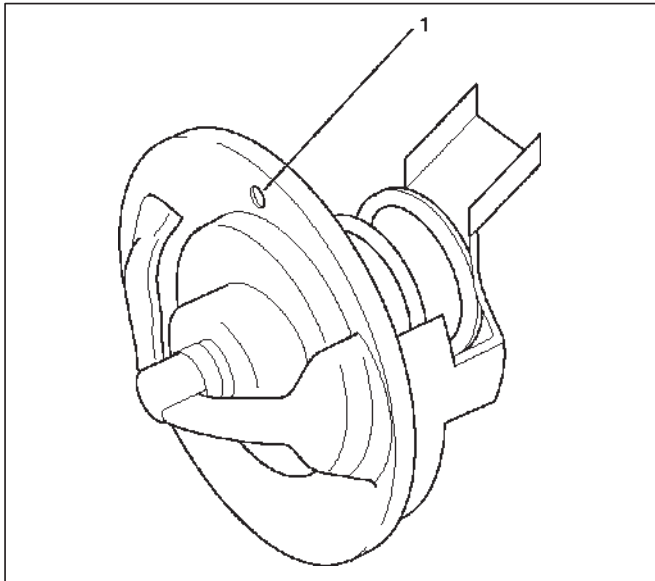
The EC pump is a centrifugal impeller type and is driven by a timing belt.



030RS001

### Thermostat

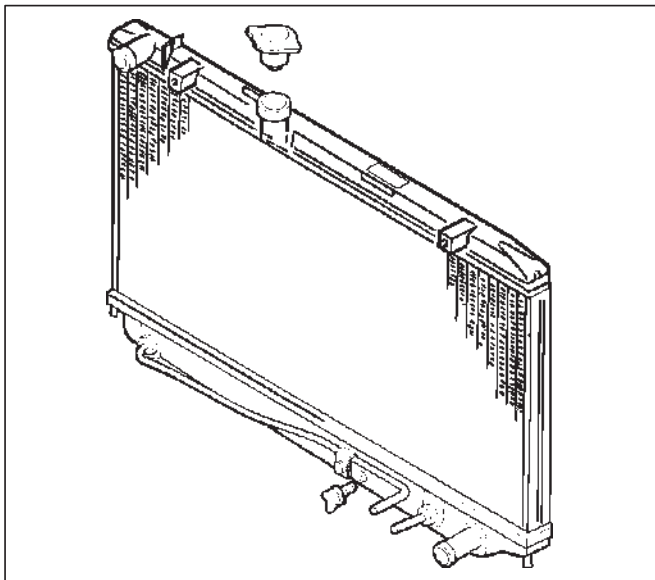
The thermostat is a wax pellet type with a air hole(1) and is installed in the thermostat housing.



031RW002

### Radiator

The radiator is a tube type with corrugated fins. In order to raise the boiling point of the coolant, the radiator is fitted with a cap in which the valve is operated at 88~ 118 kpa (12.8 ~ 17.1 psi) pressure.



110RS001

### Anti Freeze Solution

- Relation between the mixing ratio and freezing temperature of the Engine Coolant varies with the ratio of anti-freeze solution in water. Proper mixing ratio can be determined by referring to the chart. Supplemental inhibitors or additives claiming to increase cooling capability that have not been specifically approved by Isuzu are not recommended for addition to the cooling system.
- Calculating mixing ratio

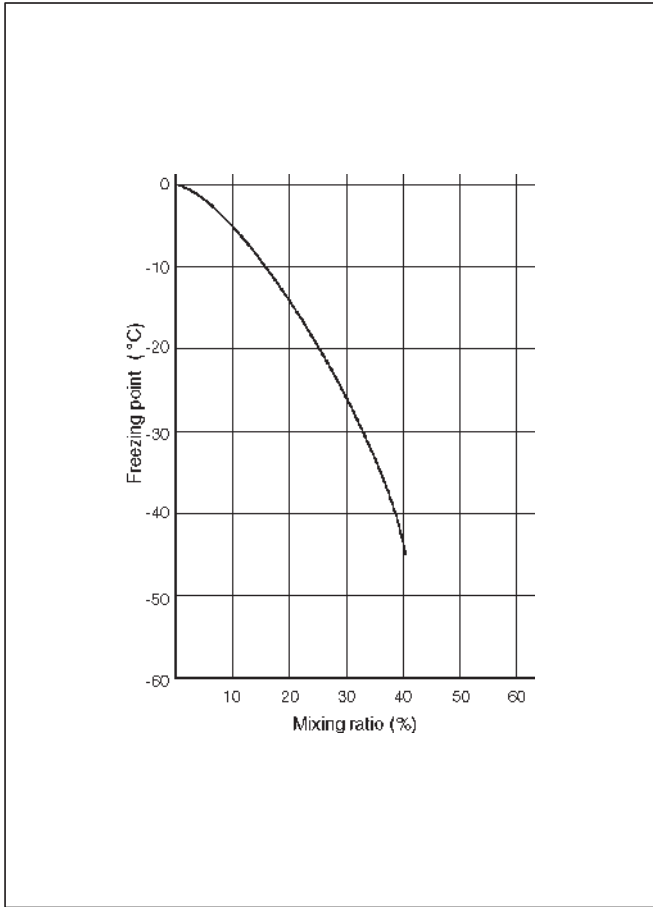
$$\text{Mixing ratio} = \frac{\text{Anti freeze solution (Lit/gal.)}}{\text{Anti freeze solution (Lit/gal.)} + \text{Water (Lit/gal.)}}$$

F06RW005

## 6B-4 ENGINE COOLING

NOTE: Antifreeze solution + Water = Total cooling system capacity.

- Total Cooling System Capacity
- 8.8Lit (2.32Us gal)



B06RW002

### ○ Mixing ratio

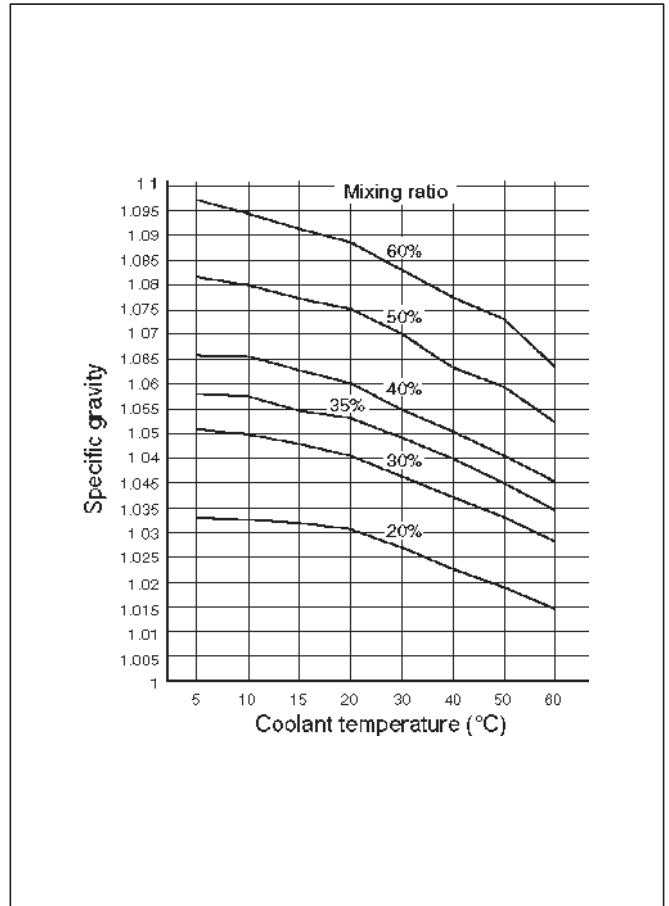
Check the specific gravity of engine coolant in the cooling system temperature ranges from 0°C to 50°C using a suction type hydrometer, then determine the density of the engine coolant by referring to the table.

NOTE:

1. Even in the areas where the atmospheric temperature is higher than 0°C, be sure not to use antifreeze solution at a mixing ratio lower than 20% so that the inside of the engine may not be corroded.

2. If antifreeze solution is used at a mixing ratio higher than 60%, the specific heat of the coolant falls and the engine may be overheated. Moreover, antifreeze performance drop and the coolant may be frozen. The density of the solution must be adjusted as occasion calls.

Antifreeze solution lower than 20% may not have sufficient anticorrosive performance, and therefore, please never fail to adjust as occasion demands within the range of 20% to 60%.



B06RW003

## Diagnosis

### Engine Cooling Trouble

Condition	Possible cause	Correction
Engine overheating	Low Engine Coolant level	Replenish
	Incorrect fan installed	Replace
	Thermo meter unit faulty	Replace
	Faulty thermostat	Replace
	Faulty Engine Coolant temperature sensor	Repair or replace
	Clogged radiator	Clean or replace
	Faulty radiator cap	Replace
	Low engine oil level or use of improper engine oil	Replenish or change oil
	Clogged exhaust system	Clean exhaust system or replace faulty parts
	Faulty Throttle Position sensor	Replace throttle valve assembly
	Open or shorted Throttle Position sensor circuit	Repair or replace
Damaged cylinder head gasket	Replace	
Engine overcooling	Faulty thermostat	Replace
Engine slow to warm-up	Faulty thermostat	Replace
	Thermo unit faulty	Replace

## Draining and Refilling Cooling System

Before draining the cooling system, inspect the system and perform any necessary service to ensure that it is clean, does not leak and is in proper working order. The engine coolant (EC) level should be between the "MIN" and "MAX" lines of reserve tank when the engine is cold. If low, check for leakage and add EC up to the "MAX" line. There should not be any excessive deposit of rust or scales around the radiator cap or radiator filler hole, and the EC should also be free from oil. Replace the EC if excessively dirty.

### Engine coolant change

1. To change engine coolant, make sure that the engine is cool.

**WARNING: WHEN THE COOLANT IS HEATED TO A HIGH TEMPERATURE, BE SURE NOT TO LOOSEN OR REMOVE THE RADIATOR CAP. OTHERWISE YOU MIGHT GET SCALDED BY HOT VAPOR OR BOILING WATER. TO OPEN THE RADIATOR CAP, PUT A PIECE OF THICK CLOTH ON THE CAP AND LOOSEN THE CAP SLOWLY TO REDUCE THE PRESSURE WHEN THE COOLANT HAS BECOME COOLER.**

2. Open radiator cap and drain the cooling system by loosening the drain valve on the radiator and on the cylinder body.

NOTE: For best result it is suggested that the engine cooling system be flushed at least once a year. It is advisable to flash the interior of the cooling system including the radiator before using anti-freeze (ethylene-glycol based).

Replace damaged rubber hoses as the engine anti-freeze coolant is liable to leak out even minor cracks.

Isuzu recommends to use Isuzu genuine anti-freeze (ethylene-glycol based) or equivalent, for the cooling system and not add any inhibitors or additives.

**CAUTION: A failure to correctly fill the engine cooling system in changing or topping up coolant may sometimes cause the coolant to overflow from the filler neck even before the engine and radiator are completely full.**

**If the engine runs under this condition, shortage of coolant may possibly result in engine overheating. To avoid such trouble, the following precautions should be taken in filling the system.**

3. To refill engine coolant, pour coolant up to filler neck using a filling hose which is smaller in outside diameter of the filler neck. Otherwise air between the filler neck and the filling hose will block entry, preventing the system from completely filling up.
4. Keep a filling rate of 9 liter/min. or less. Filling over this maximum rate may force air inside the engine and radiator.

And also, the coolant overflow will increase, making it difficult to determine whether or not the system is completely full.

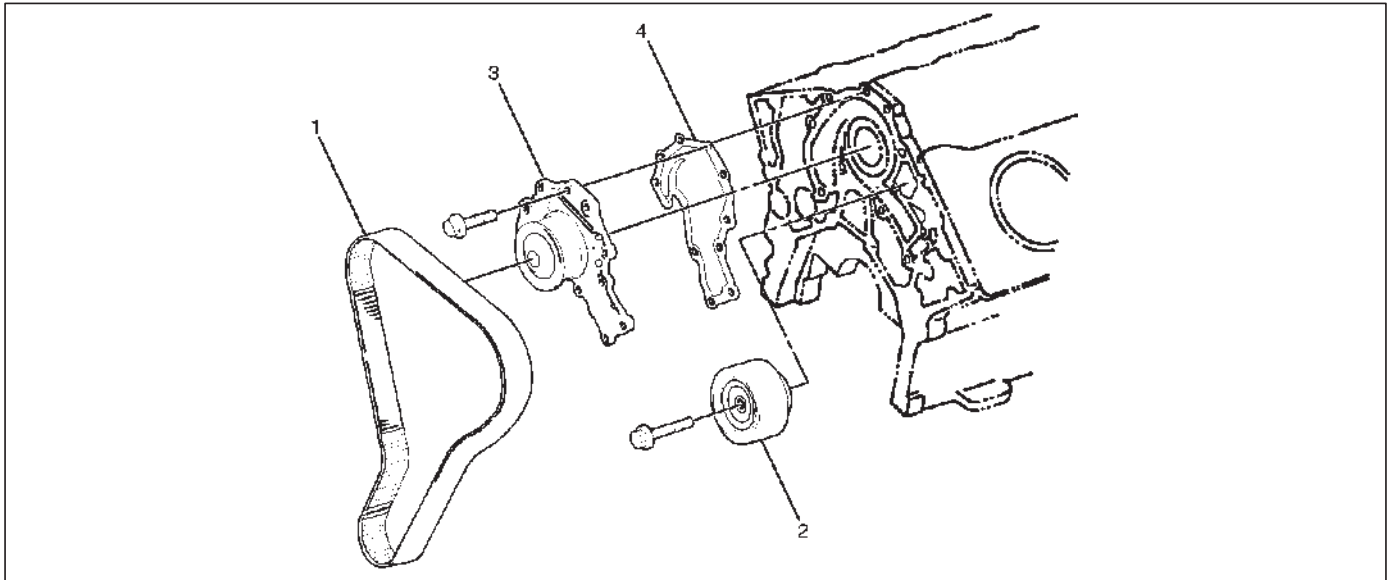
5. After filling the system to the full, pull out the filling hose and check to see if air trapped in the system is dislodged and the coolant level goes down. Should the coolant level go down, repeat topping-up until there is no more drop in the coolant level.
6. After directly filling the radiator, fill the reservoir to the maximum level.
7. Install and tighten radiator cap and start the engine. After idling for 2 to 3 minutes, stop the engine and reopen radiator cap. If the water level is lower, replenish.

**WARNING: WHEN THE COOLANT IS HEATED TO A HIGH TEMPERATURE, BE SURE NOT TO LOOSEN OR REMOVE THE RADIATOR CAP. OTHERWISE YOU MIGHT GET SCALDED BY HOT VAPOR OR BOILING WATER. TO OPEN THE RADIATOR CAP, PUT A PIECE OF THICK CLOTH ON THE CAP AND LOOSEN THE CAP SLOWLY TO REDUCE THE PRESSURE WHEN THE COOLANT HAS BECOME COOLER.**

8. After tightening radiator cap, warm up the engine at about 2,000 rpm.  
Set heater adjustment to the highest temperature position, and let the coolant circulate also into heater water system.
9. Check to see the thermostat has opened through the needle position of water thermometer, conduct a 5-minute idling again and stop the engine.
10. When the engine has been cooled, check filler neck for water level and replenish if required. Should extreme shortage of coolant is found, check the coolant system and reservoir tank hose for leakage.
11. Fill the coolant into the reservoir tank up to "MAX" line.

## Water Pump

### Water Pump and Associated Parts



030RS002

#### Legend

- (1) Timing Belt
- (2) Idle Pulley

- (3) Water Pump Assembly
- (4) Gasket

### Removal

1. Disconnect battery ground cable.
2. Drain coolant.
3. Radiator hose (on inlet pipe side).
4. Remove timing belt. Refer to "Timing Belt" in this manual.
5. Remove Idle pulley.
6. Remove water pump assembly.
7. Remove gasket.

2. Install water pump assembly and tighten bolts to the specified torque.

**Torque: 25 N·m (18 lb ft)**

○ Tightening order is in the illustration.

**NOTE:** To prevent the oil leakage, apply the LOCTITE 262 or an equivalent, to the arrow marked fixing bolt thread.

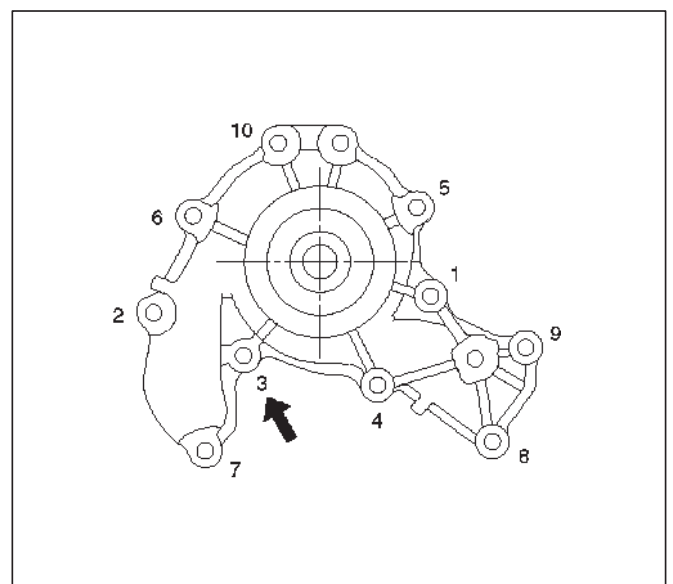
### Inspection

Make necessary repair and parts replacement if extreme wear or damage is found during inspection. Should any of the following problems occur, the entire water pump assembly must be replaced:

- Crack in the water pump body
- Engine Coolant leakage from the seal unit
- Play or abnormal noise in the bearing
- Cracks or corrosion in the impeller.

### Installation

1. Install gasket, clean the mating surface of gasket before installation.



030RW008



## 6B-8 ENGINE COOLING

### 3. Idle pulley

- Install idle pulley and tighten bolt to the specified torque.

**Torque: 52 N·m (38 lb ft)**

### 4. Timing belt

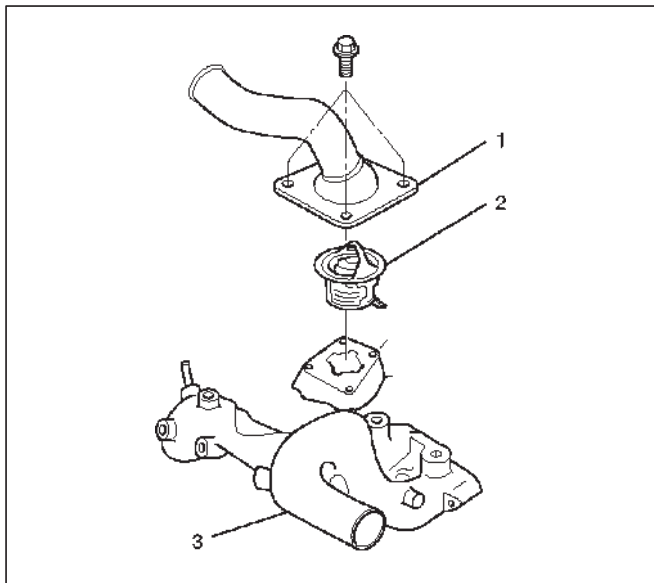
- Install a new timing belt. Refer to timing belt installation step in "Timing Belt" in this manual.

- 5. Connect radiator inlet hose and replenish Engine Coolant (EC).

- 6. Connect battery ground cable.

## Thermostat

### Thermostat and Associated Parts



#### Legend

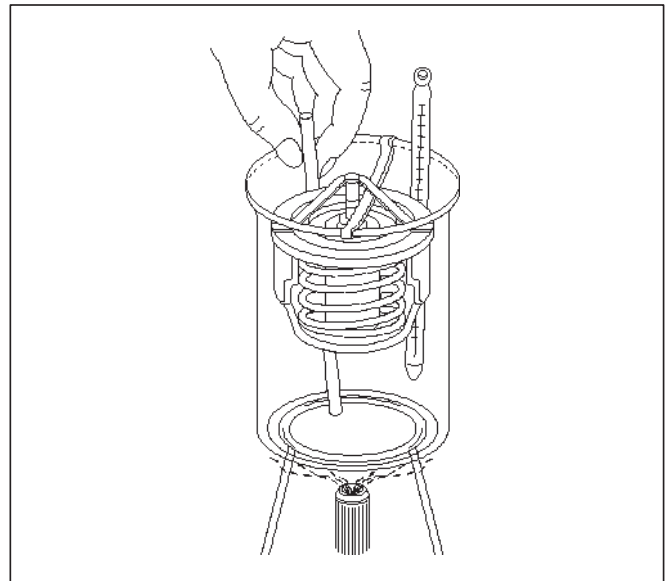
- (1) Thermostat Housing
- (2) Thermostat
- (3) Outlet Pipe

### Removal

1. Disconnect battery ground cable.
2. Drain engine coolant from the radiator and engine.
3. Disconnect radiator hose from the inlet pipe.
4. Remove thermostat housing.
5. Remove thermostat(2).

### Inspection

Suspend the thermostat in a water-filled container using thin wire. Place a thermometer next to the thermostat. Do not directly heat the thermostat. Gradually increase the water temperature. Stir the water so that the entire water is same temperature.



Confirm the temperature when the valve first begins to open.

**Valve opening temperature 74.5°C ~ 78.5°C  
(166.1°F ~ 173.3°F)**

Confirm the temperature when the valve is fully opened.

**Valve full open temperature and lift More than  
8.5mm (0.33 in) at 90°C (194°F)**

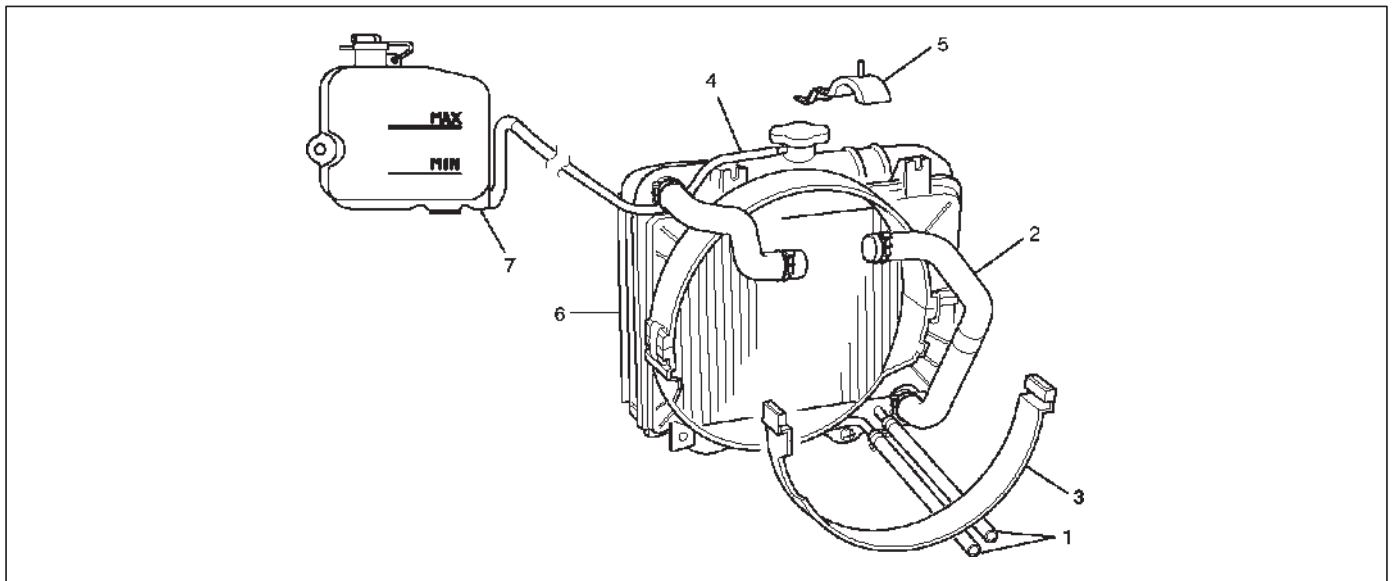
Make necessary repair and parts replacement if extreme wear or damage is found during inspection.

### Installation

1. Install thermostat into the outlet pipe(4) making sure that the air hole is in the up position.
2. Install thermostat housing and tighten bolts to the specified torque.  
**Torque: 25 N·m (18 lb ft)**
3. Installation rubber hose.
4. Replenish EC.
5. Start engine and check for EC leakage.

## Radiator

### Radiator and Associated Parts



110RW003

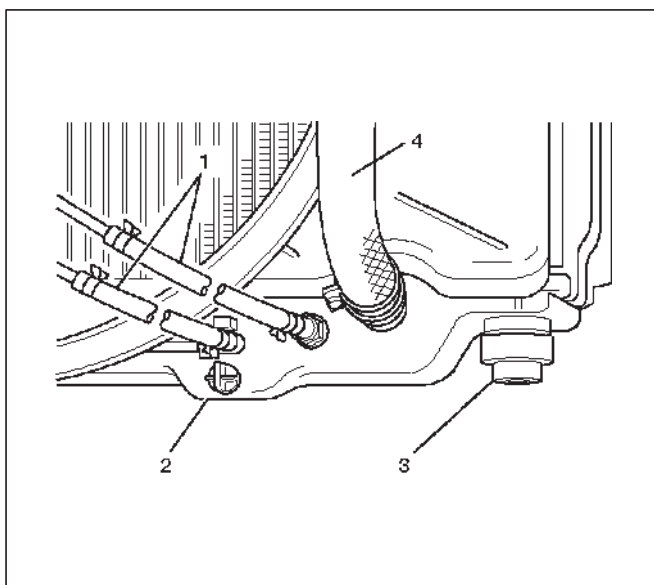
#### Legend

- |  |                       |
|--|-----------------------|
| (1) Oil Cooler Hose For Automatic Transmission | (4) Reserve Tank Hose |
| (2) Radiator Hose                              | (5) Bracket           |
| (3) Fan Guide, Lower                           | (6) Radiator Assembly |
|  | (7) Reserve Tank      |

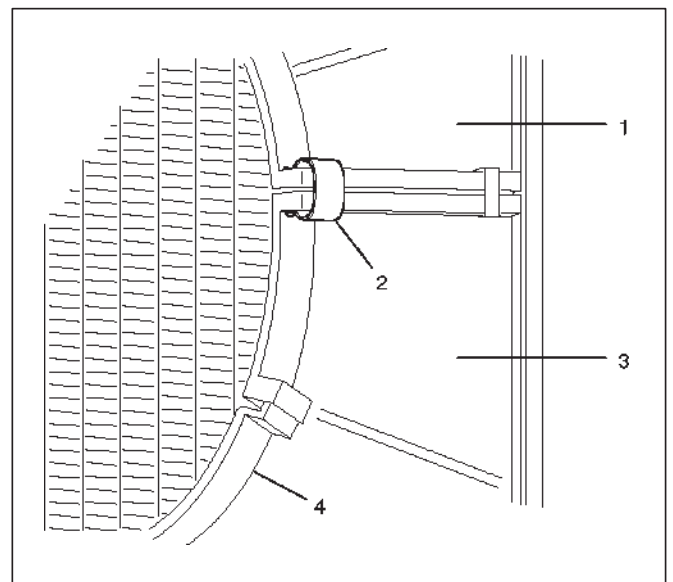
### Removal

1. Disconnect battery ground cable.
2. Loosen a drain plug(2) to drain Engine Coolant (EC).
3. Disconnect oil cooler hose (1).
4. Disconnect radiator inlet hose and outlet hose from the engine.

5. Remove fan guide(1), clips(3) on both sides and the bottom lock, then remove lower fan guide(3) with fan shroud(4).



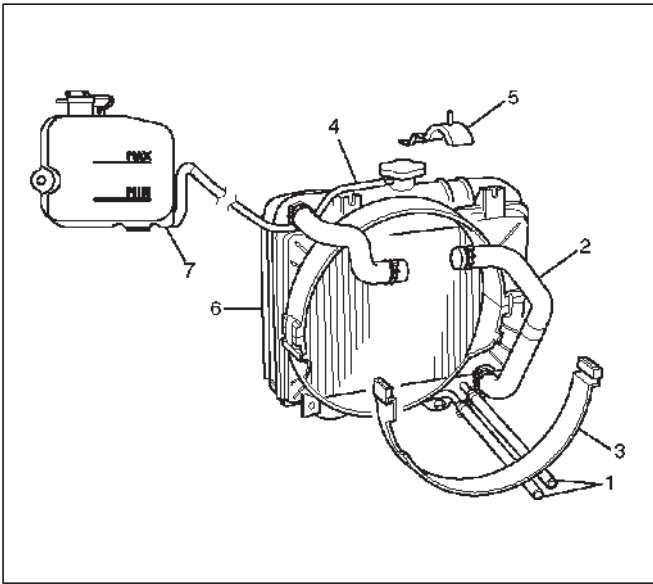
110RW002



110RW001

## 6B-10 ENGINE COOLING

6. Disconnect the reserve tank hose(4) from radiator.
7. Remove bracket(5).



110RW004

8. Lift up and remove the radiator assembly with hose, taking care not to damage the radiator core with a fan blade.
9. Remove rubber cushions on both sides at the bottom.

## Inspection

### Radiator Cap

Measure the valve opening pressure of the pressurizing valve with a radiator filler cap tester. Replace the cap if the valve opening pressure is outside the standard range.

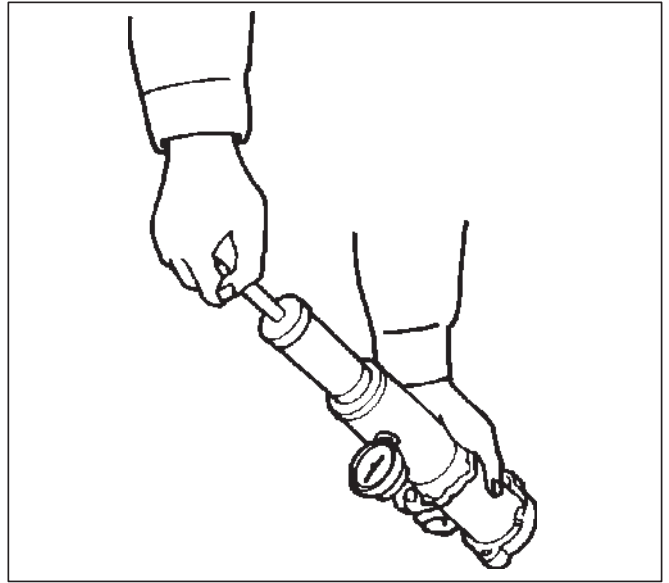
**Valve opening pressure kpa (psi) 88 ~ 118 (12.8 ~ 17.1)**

Cap tester: J-24460-01

Adapter: J-33984-A

Check the condition of the vacuum valve in the center of the valve seat side of the cap. If considerable rust or dirt is found, or if the valve seat cannot be moved by hand, clean or replace the cap.

**Valve opening vacuum kpa (psi) 1.96 ~ 4.91 (0.28 ~ 0.71)**



110RS006

### Radiator Core

1. A bent fin may result in reduced ventilation and overheating may occur. All bent fins must be straightened. Pay close attention to the base of the fin when it is being straightened.
2. Remove all dust, bugs and other foreign material.

### Flushing the Radiator

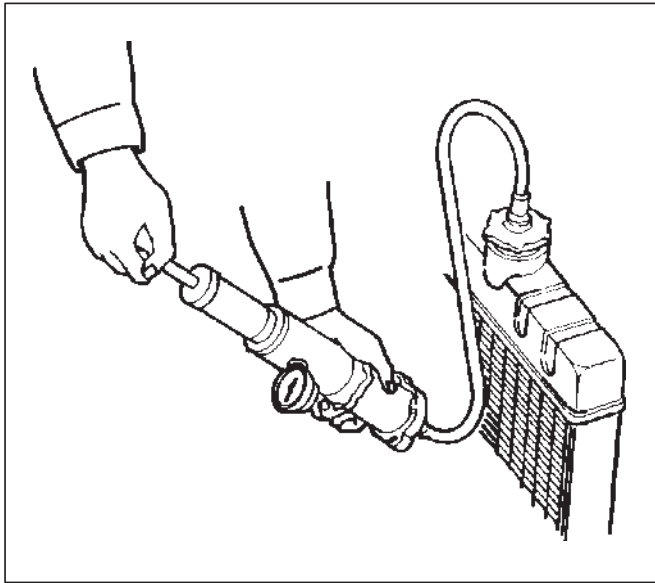
Thoroughly wash the inside of the radiator and the engine coolant passages with cold water and mild detergent. Remove all signs of scale and rust.

### Cooling System Leakage Check

Use a radiator cap tester to force air into the radiator through the filler neck at the specified pressure of 196 kpa (28.5 psi) with a cap tester:

- Leakage from the radiator
- Leakage from the coolant pump
- Leakage from the water hoses
- Check the rubber hoses for swelling.

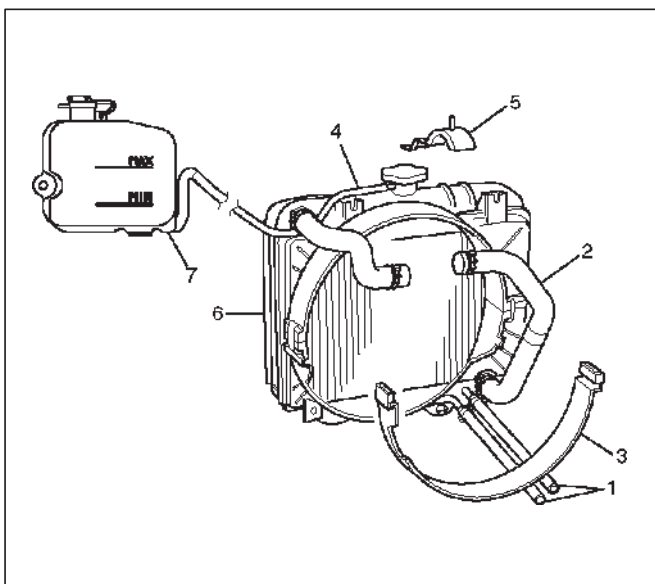
Cap tester: J-24460-01  
 Adapter: J-33984-A



110RS005

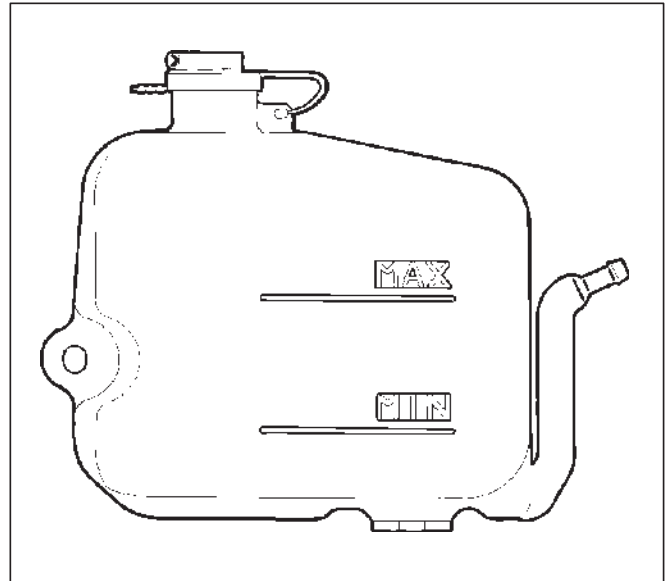
### Installation

1. Install rubber cushions on both sides of radiator bottom.
2. Install radiator assembly with hose, taking care not to damage the radiator core with a fan blade.
3. Install bracket (6) and support the radiator upper tank with the bracket (5) and secure the radiator.
4. Connect reserve tank hose (4).
5. Install lower fan guide (3).
6. Connect radiator inlet hose and outlet hose to the engine.
7. Connect oil cooler hose (1) to automatic transmission.



110RW004

8. Connect battery ground cable.
9. Pour engine coolant up to filler neck of radiator, and up to MAX mark of reserve tank.



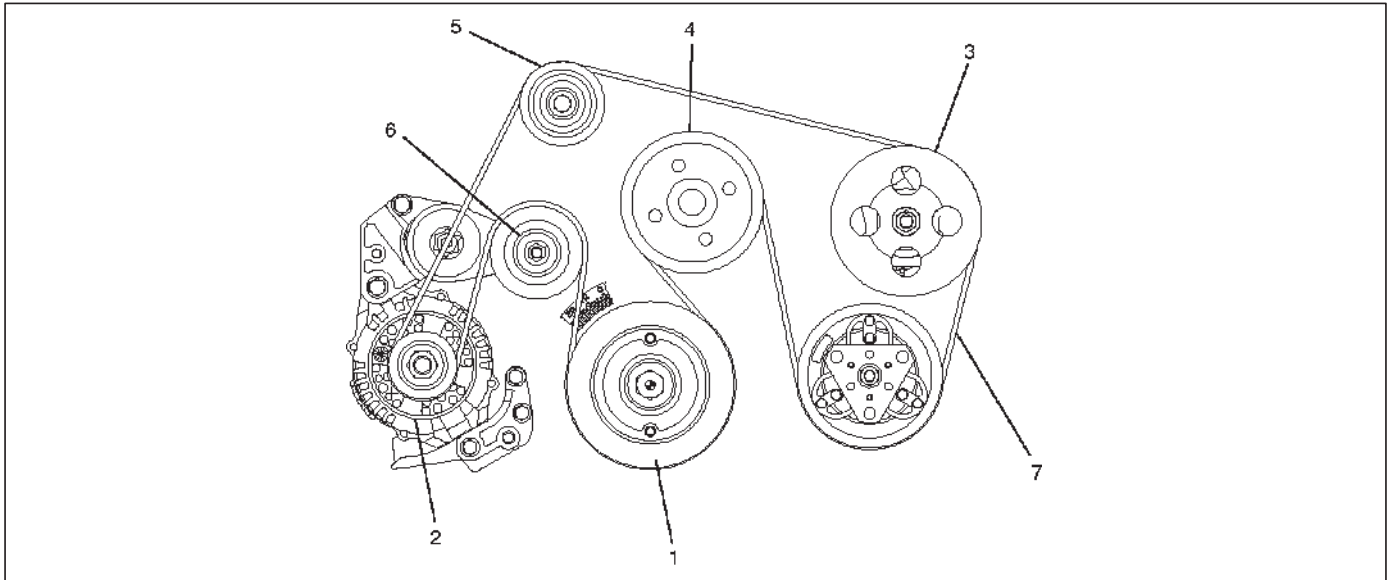
111RS001

Important operation (in case of 100% engine coolant change) procedure for filling with engine coolant.

- Remove radiator cap.
- Fill with engine coolant (EC) to the radiator filler neck.
- Fill with EC to the "MAX" line on the reservoir.
- Start the engine with the radiator cap removed and bring to operating temperature by running engine at 2,500 ~ 3,000 rpm for 2 to 3 minutes.
- By EC temperature gauge reading make sure that the thermostat is open.
- If air bubbles come up to the radiator filler neck, replenish with EC repeat until the EC level does not drop any further. Install the radiator cap and stop the engine.
- Replenish EC to the "MAX" line on the reservoir and leave as it is until the engine gets cool.
- After the engine gets cool, start the engine and make sure there is no water running noise heard from the heater core while the engine runs at 3,000 rpm.
- Should water running noise be heard, repeat the same procedure from the beginning.

## Drive Belt and Cooling Fan

### Drive Belt and Associated Parts



015RW005

#### Legend

- |                         |                                       |
|-------------------------|---------------------------------------|
| (1) Crankshaft Pulley   | (4) Water Pump and Cooling Fan Pulley |
| (2) Generator           | (5) Idle Pulley                       |
| (3) Power Steering Pump | (6) Auto Tensioner                    |
|                         | (7) Drive Belt                        |

The drive belt adjustment is not required with this automatic drive belt tensioner system.

### Inspection

Check drive belt for wear or damage, and replace with a new one as necessary.

### Installation

Install cooling fan assembly and tighten bolts/nuts to the specified torque.

**Torque : 22 N·m (16 lb ft) for fan pulley and fan bracket.**

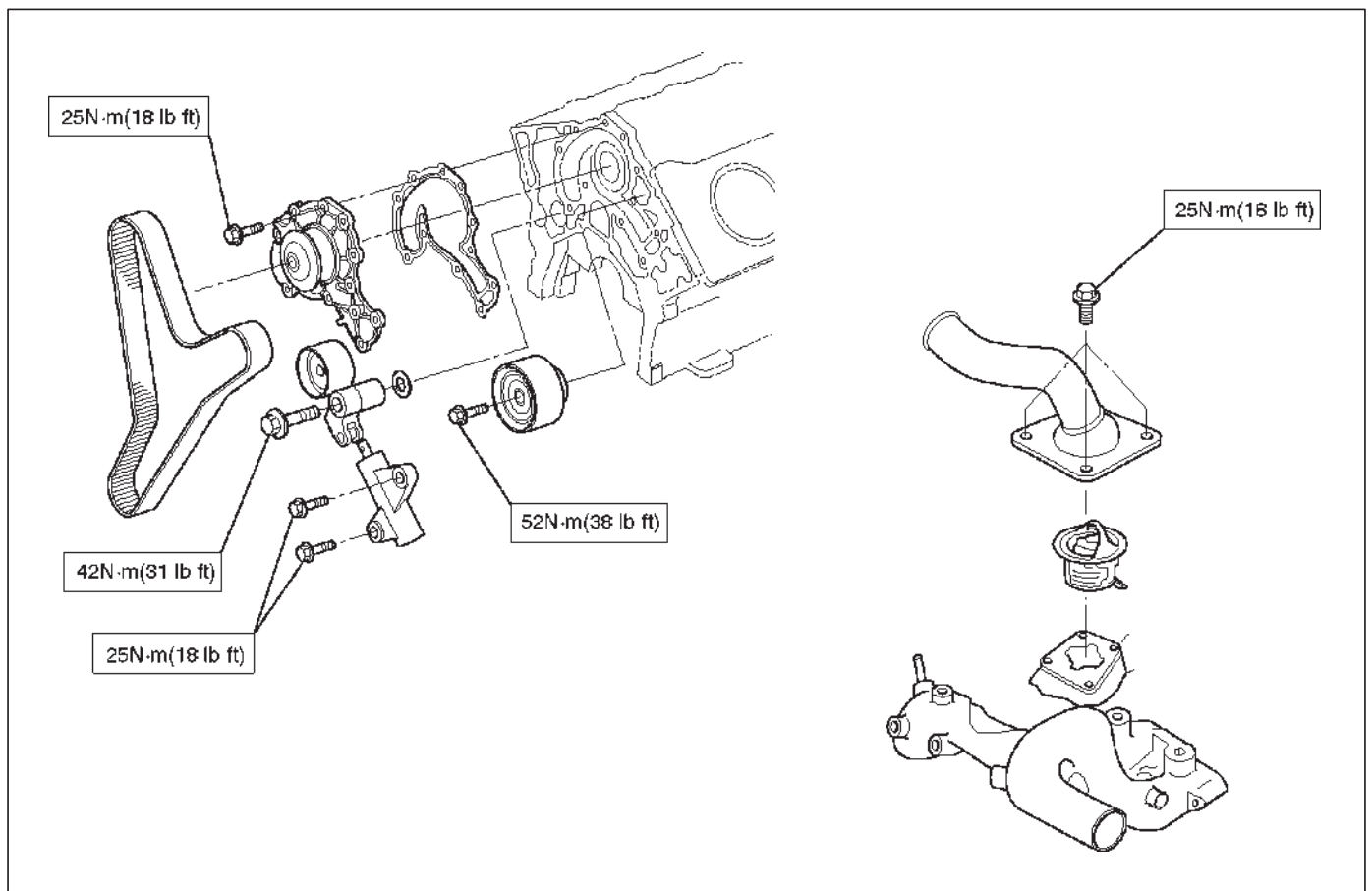
**Torque : 10 N·m (88.5 lb in) for fan and clutch assembly.**

## Main Data and Specifications

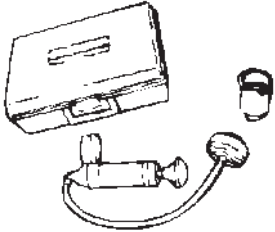
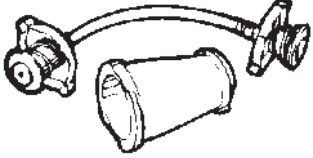
### General Specifications

	Specifications
Cooling system	Engine coolant forced circulation
Radiator	(1 tube in row) Tube type corrugated (2 tube in row)
Heat radiation capacity	71,300 kcal/h
Heat radiation area	13.26m <sup>2</sup> (1.23ft <sup>2</sup> )
Radiator front area	0.263m <sup>2</sup> (0.024ft <sup>2</sup> )
Radiator dry weight	46.8N (10.5lb)
Radiator cap valve opening pressure	88 ~ 118kpa (12.8 ~ 17.1psi)
Engine coolant capacity	2.4lit (16.3U.S q.t.)
Engine coolant pump	Centrifugal impeller type
Delivery	300 (317) or more
Pump speed	5000 ± 50 rpm
Thermostat	Wax pellet type with air hole
Valve opening temperature	74.5 ~ 78.5°C (166.1 ~ 173.3°F)
Engine coolant total capacity	8.8lit (2.32U.S gal)

### Torque Specifications



### Special Tool

ILLUSTRATION	TOOL NO. TOOL NAME
 <p>901RW0.72</p>	<p><b>J-24460-01</b> Tester; radiator cap</p>
 <p>901RW0.73</p>	<p><b>J-33984-A</b> Adapter; radiator cap</p>

VEHICROSS

# ENGINE

## ENGINE FUEL

### CONTENTS

Service Precaution .....	6C-1	Fuel Tank and Associated Parts .....	6C-7
General Description .....	6C-2	Removal .....	6C-8
Fuel Metering .....	6C-3	Installation .....	6C-8
Fuel Filter .....	6C-4	Fuel Tube / Quick – Connect Fittings .....	6C-8
Fuel Filter and Associated Parts .....	6C-4	Precautions .....	6C-8
Removal .....	6C-4	Cautions During Work .....	6C-8
Inspection .....	6C-4	Removal .....	6C-8
Installation .....	6C-4	Reuse of Quick–Connector .....	6C-10
Inspection .....	6C-5	Assembling Advice .....	6C-10
In–Tank Fuel Filter .....	6C-5	Fuel Gauge Unit .....	6C-11
Fuel Pump Flow Test .....	6C-5	Fuel Gauge Unit and Associated Parts ...	6C-11
Fuel Pump .....	6C-6	Removal .....	6C-11
Fuel Pump and Associated Parts .....	6C-6	Installation .....	6C-11
Removal .....	6C-6	Fuel Filler Cap .....	6C-12
Installation .....	6C-6	General Description .....	6C-12
Fuel Pump Relay .....	6C-7	Inspection .....	6C-12
General Description .....	6C-7	Main Data and Specifications .....	6C-12
Fuel Tank .....	6C-7		

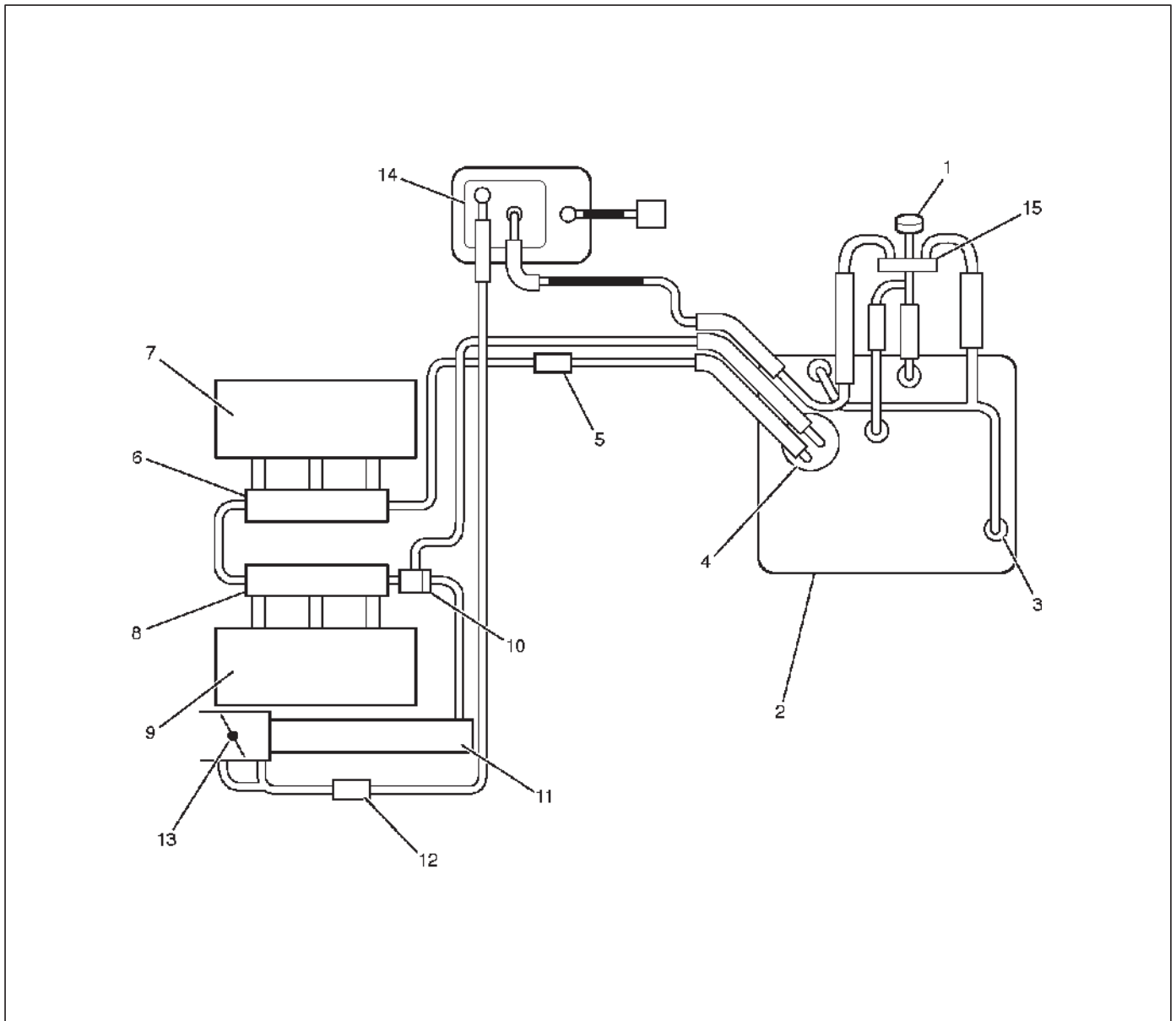
### Service Precaution

**WARNING: THIS VEHICLE HAS A SUPPLEMENTAL RESTRAINT SYSTEM (SRS). REFER TO THE SRS COMPONENT AND WIRING LOCATION VIEW IN ORDER TO DETERMINE WHETHER YOU ARE PERFORMING SERVICE ON OR NEAR THE SRS COMPONENTS OR THE SRS WIRING. WHEN YOU ARE PERFORMING SERVICE ON OR NEAR THE SRS COMPONENTS OR THE SRS WIRING, REFER TO THE SRS SERVICE INFORMATION. FAILURE TO FOLLOW WARNINGS COULD RESULT IN POSSIBLE AIR BAG DEPLOYMENT, PERSONAL INJURY, OR OTHERWISE UNNEEDED SRS SYSTEM REPAIRS.**

**CAUTION: Always use the correct fastener in the proper location. When you replace a fastener, use ONLY the exact part number for that application. ISUZU will call out those fasteners that require a replacement after removal. ISUZU will also call out the fasteners that require thread lockers or thread sealant. UNLESS OTHERWISE SPECIFIED, do not use supplemental coatings (Paints, greases, or other corrosion inhibitors) on threaded fasteners or fastener joint interfaces. Generally, such coatings adversely affect the fastener torque and the joint clamping force, and may damage the fastener. When you install fasteners, use the correct tightening sequence and specifications. Following these instructions can help you avoid damage to parts and systems.**



## General Description



140RW020

### Legend

- |                     |                                  |
|---------------------|----------------------------------|
| (1) Fuel Filler Cap | (8) Fuel Rail Left               |
| (2) Fuel Tank       | (9) Left Bank                    |
| (3) Rollover Valve  | (10) Fuel Pressure Control Valve |
| (4) Fuel Pump       | (11) Common Chamber              |
| (5) Fuel Filter     | (12) Duty Solenoid Valve         |
| (6) Fuel Rail Right | (13) Throttle Valve              |
| (7) Right Bank      | (14) Canister                    |
|                     | (15) Evaporation Shut Off Valve  |

When working on the fuel system, there are several things to keep in mind:

- Any time the fuel system is being worked on, disconnect the negative battery cable except for those tests where battery voltage is required.
- Always keep a dry chemical (Class B) fire extinguisher near the work area.
- Replace all pipes with the same pipe and fittings that were removed.
- Clean and inspect "O" rings. Replace if required.
- Always relieve the line pressure before servicing any fuel system components.
- Do not attempt repairs on the fuel system until you have read the instructions and checked the pictures relating to that repair.

- Adhere to all Notices and Cautions.

All gasoline engines are designed to use only unleaded gasoline. Unleaded gasoline must be used for proper emission control system operation.

Its use will also minimize spark plug fouling and extend engine oil life. Using leaded gasoline can damage the emission control system and could result in loss of emission warranty coverage.

All cars are equipped with an Evaporative Emission Control System. The purpose of the system is to minimize the escape of fuel vapors to the atmosphere.

## Fuel Metering

The Powertrain Control Module (PCM) is in complete control of this fuel delivery system during normal driving conditions.

The intake manifold function, like that of a diesel, is used only to let air into the engine. The fuel is injected by separate injectors that are mounted over the intake manifold.

The Manifold Absolute Pressure (MAP) sensor measures the changes in the intake manifold pressure which result from engine load and speed changes, which the MAP sensor converts to a voltage output.

This sensor generates the voltage to change corresponding to the flow of the air drawn into the engine. The changing voltage is transformed into an electric signal and provided to the PCM.

With receipt of the signals sent from the MAP sensor, Intake Air Temperature sensor and others, the PCM determines an appropriate fuel injection pulse width feeding such information to the fuel injector valves to effect an appropriate air/fuel ratio.

The Multiport Fuel Injection system utilizes an injection system where the injectors turn on at every crankshaft revolution. The PCM controls the injector on time so that the correct amount of fuel is metered depending on driving conditions.

Two interchangeable "O" rings are used on the injector that must be replaced when the injectors are removed.

The fuel rail is attached to the top of the intake manifold and supplies fuel to all the injectors.

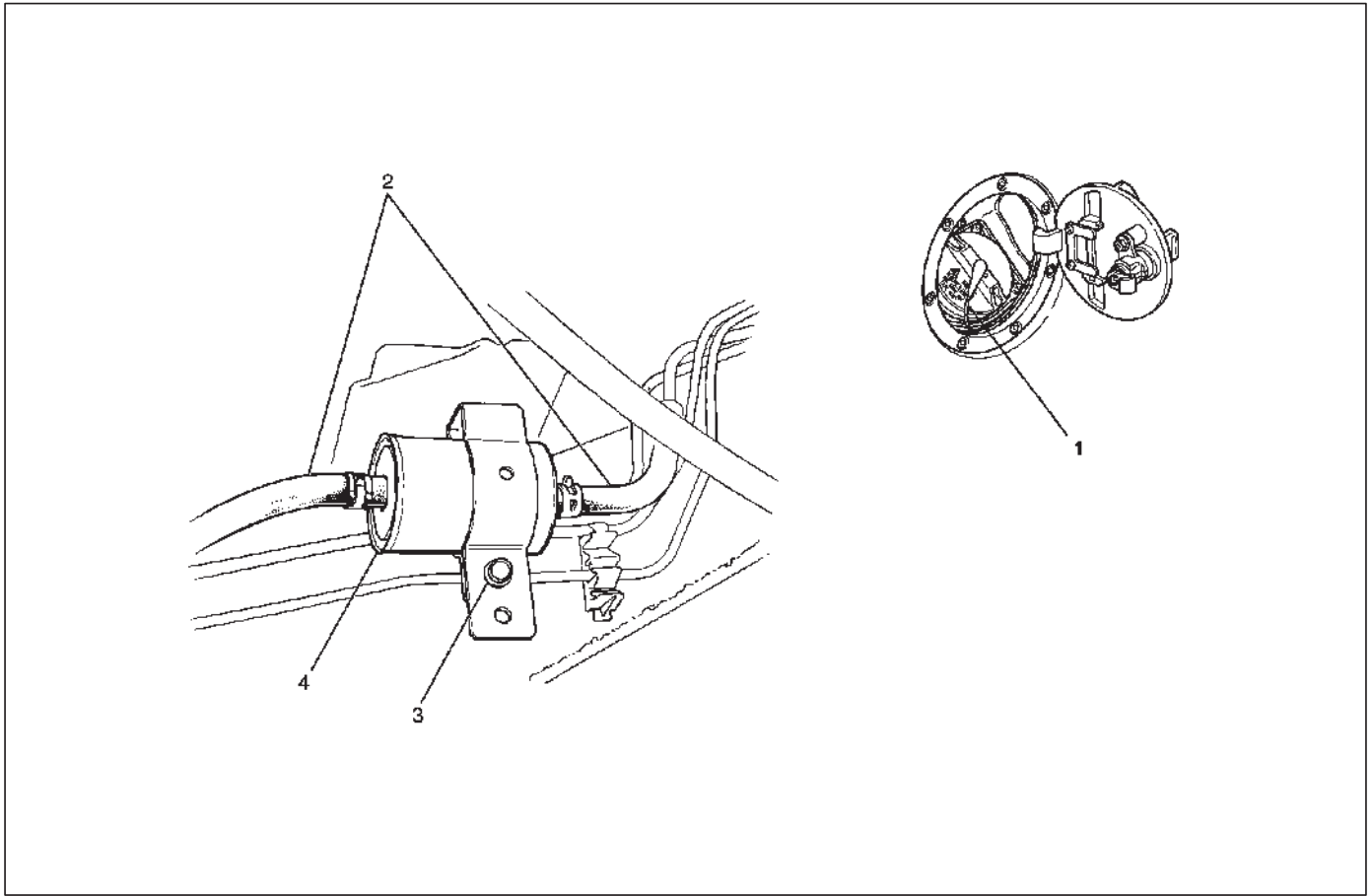
Fuel is recirculated through the rail continually while the engine is running. This removes air and vapors from the fuel as well as keeping the fuel cool during hot weather operation.

The fuel pressure control valve that is mounted on the fuel rail maintains a pressure differential across the injectors under all operating conditions. It is accomplished by controlling the amount of fuel that is recirculated back to the fuel tank based on engine demand.

See Section "Driveability and Emission" for more information and diagnosis.

## Fuel Filter

### Fuel Filter and Associated Parts



041RX008

#### Legend

- |                     |                             |
|---------------------|-----------------------------|
| (1) Fuel Filler Cap | (3) Fuel Filter Fixing Bolt |
| (2) Fuel Hose       | (4) Fuel Filter             |

### Removal

**CAUTION:** When repair to the fuel system has been completed, start engine and check the fuel system for loose connection or leakage. For the fuel system diagnosis, see Section "Driveability and Emission".

1. Disconnect battery ground cable.
2. Remove Fuel filler cap(1).
3. Disconnect fuel hoses(2) from fuel filter on both engine side and fuel tank side.
4. Remove fuel filter fixing bolt(3).
5. Remove fuel filter(4).

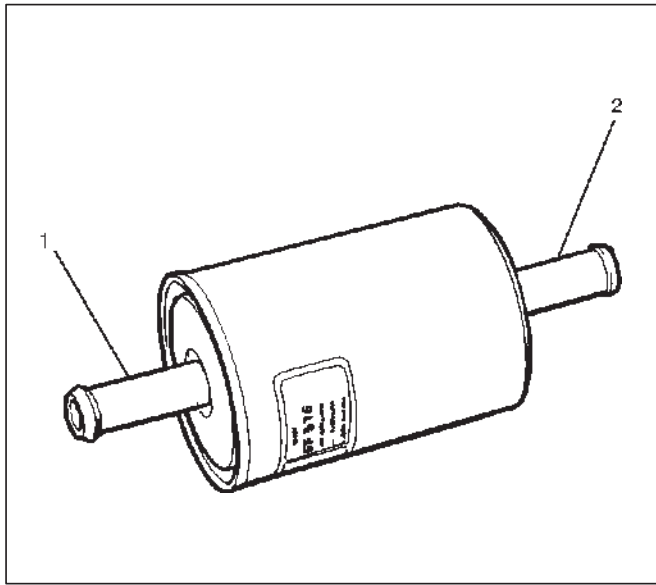
### Inspection

1. Replace the fuel filter if the fuel leaks from fuel filter body or if the fuel filter body itself is damaged.
2. Replace the filter if it is clogged with dirt or sediment.
3. Check the drain of receive and if it is clogged with dust, clean it up with air.

### Installation

1. Install the fuel filter in the proper direction.
2. Install fuel filter holder fixing bolt.

3. Connect fuel hoses on engine side(1) and fuel tank side(2).



4. Install fuel filler cap
5. Connect the battery ground cable.

### Inspection

After installation, start engine and check for fuel leakage.

### In-Tank Fuel Filter

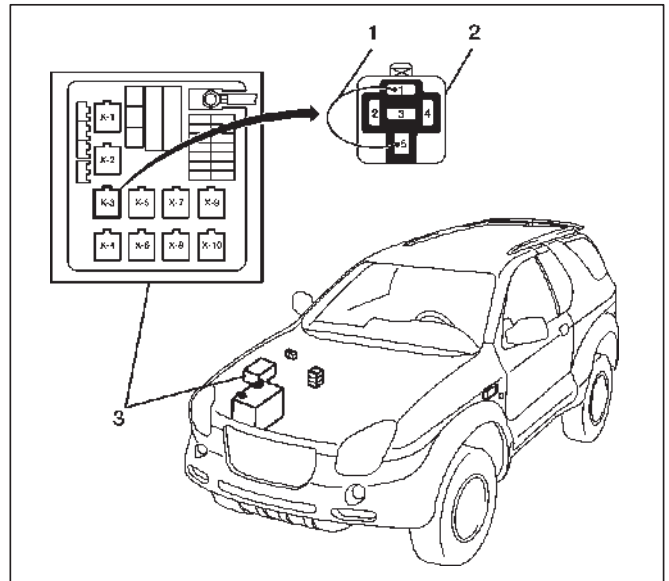
The filter is located on the lower end of fuel pickup tube in the fuel tank. It prevents dirt from entering the fuel pipe and also stops water unless the filter is completely submerged in the water. It is a self cleaning type, not requiring scheduled maintenance. Excess water and sediment in the tank restricts fuel supply to the engine, resulting in engine stoppage. In such a case, the tank must be cleaned thoroughly.

### Fuel Pump Flow Test

If reduction of fuel supply is suspected, perform the following checks:

1. Make sure that there is fuel in the tank.
2. With the engine running, check the fuel feed pipe and hose from fuel tank to injector for evidence of leakage. Retighten, if pipe or hose connection is loose. Also, check pipes and hoses for squashing or clogging.
3. Insert the hose from fuel feed pipe into a clean container, and check for fuel pump flow rate.

4. Connect the pump relay terminals with a jumper wire(1) as shown and start the fuel pump to measure delivery.



**CAUTION:** Never generate sparks when connecting a jumper wire.

Delivery	Delivery
15 seconds	0.38 liters minimum

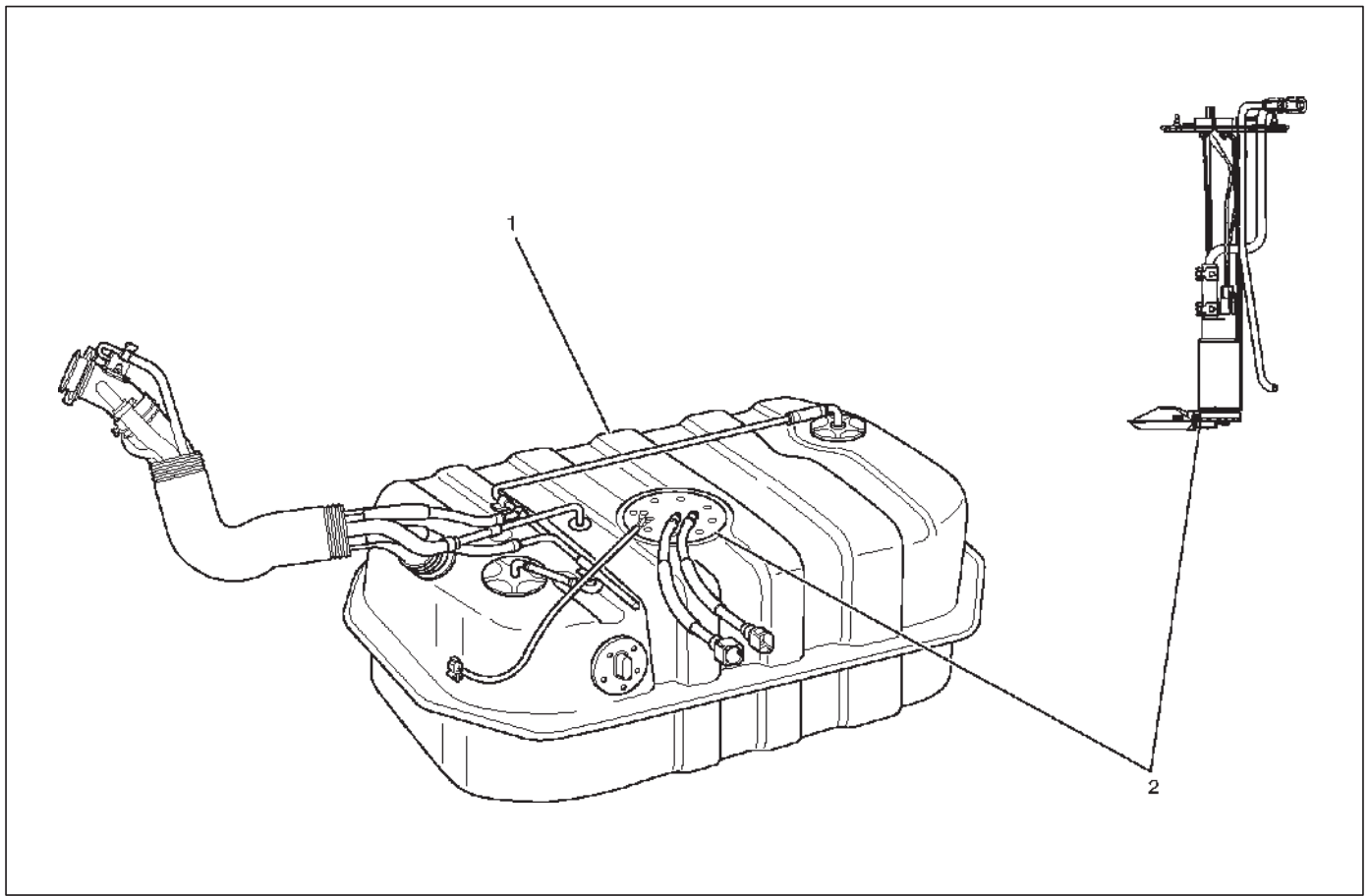
If the measure value is out of standard, conduct the pressure test.

### Pressure test

For the pressure test to the fuel system, see Section 6E "Fuel Control System".

## Fuel Pump

### Fuel Pump and Associated Parts



035RW030

### Removal

**CAUTION:** When repair to the fuel system has been completed, start engine and check the fuel system for loose connection or leakage. For the fuel system diagnosis, see Section “Driveability and Emission”.

1. Disconnect battery ground cable.
2. Loosen fuel filler cap.
3. Drain fuel.  
Tighten drain plug to the specified torque after draining fuel.

**Torque: 20 N·m (14 lb ft) — M8**

4. Remove fuel tank assembly(1). Refer to “Fuel Tank Removal” in this section.
5. Remove fuel pump assembly(2) fixing screws and remove the Fuel Pump assembly.

**NOTE:** After removing Fuel Pump, cover fuel tank to prevent any dust entering.

### Installation

1. Install Fuel Pump assembly(2).
2. Install fuel tank assembly(1). Refer to “Fuel Tank Installation”.
3. Fill the tank with fuel and tighten fuel filler cap.
4. Connect battery ground cable.

## Fuel Pump Relay

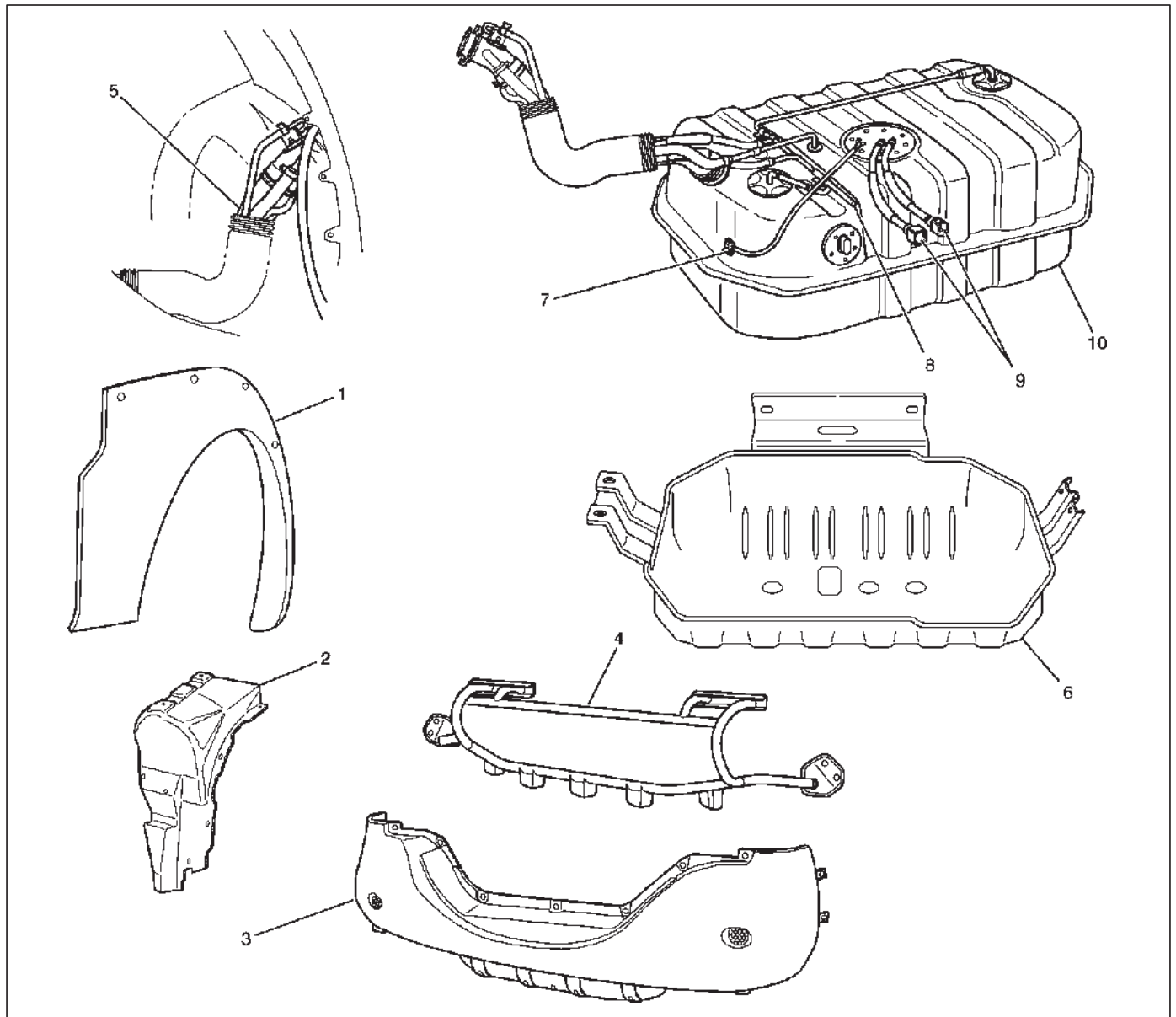
### General Description

In order to control the Fuel Pump operation, the Fuel Pump relay is provided. When the starter switch is turned to "ON" position, the Fuel Pump relay operates the Fuel Pump for 2 seconds.

When it is turned to "START" position, the Power Train Control Module (PCM) receives the reference pulse from the Ignition Control Module and it operates the relay, again causing the Fuel Pump to feed fuel.

## Fuel Tank

### Fuel Tank and Associated Parts



#### Legend

- |   |  |
|---|--|
| (1) Rear Fender Protector                                 | (6) Undercover   |
| (2) Fender Liner  | (7) Fuel Tank Wiring Connector                                 |
| (3) Rear Bumper ASM                                       | (8) Evapo Fuel Hose  |
| (4) Rear Bumper Reinforcement                             | (9) Fuel Feed Tube and Fuel Return Tube/Quick-Connect Fittings |
| (5) Fuel Filler Hose and Air Breather Hose and Evapo Hose | (10) Fuel Tank   |

## Removal

**CAUTION:** When repair to the fuel system has been completed, start engine and check the fuel system for loose connection or leakage. For the fuel system diagnosis, see Section “Driveability and Emission”.

1. Disconnect battery ground cable.
2. Loosen fuel filler cap.
3. Drain fuel.  
Tighten drain plug to the specified torque after draining fuel.

**Torque: 20 N·m (14 lb ft) — M8**

4. Remove rear fender protector (1).
5. Remove rear bumper (3).
6. Remove reared bumper reinforcement (4).
7. Remove fender liner (2) of wheel well on rear right side.
8. Disconnect evapo fuel hose(8).
9. Disconnect fuel filler hose, air breather hose and evapo hose (5).
10. Remove undercover fixing bolts on both sides and remove under cover(6).
11. Disconnect two fuel tank wiring connectors(7) on front right side of tank.
12. Disconnect fuel feed tube and fuel return tube(9).

**NOTE:** Handling of the fuel tube, be sure to refer “Fuel Tube/Quick-Connect Fittings” in this section.

13. Remove fuel tank fixing bolts on both sides and remove fuel tank(10).

## Installation

1. Install fuel tank(10).
  - Place a flange on right side of tank on the bracket.
  - Install a flange on left side on the bracket from the bottom, and tighten bolts to the specified torque.

**Torque: 36 N·m (27 lb ft)**

2. Connect fuel feed tube and fuel return tube(9).
3. Connect fuel tank wiring connector(7).
4. Install undercover(6).
5. Connect fuel filler hose, air breather hose and evapo hose(5).
6. Connect evapo fuel hose(8).
7. Install fender liner(2).
8. Install rear bumper reinforcement (4).
9. Install rear bumper (3).
10. Install rear fender protector (1).
  - Mount fender liner to the wheel well.
  - Fill the tank with fuel and tighten fuel filler cap.
  - Connect battery ground cable.

## Fuel Tube / Quick – Connect Fittings

### Precautions

- Lighting of Fires Prohibited.
- Keep flames away from your work area to prevent the inflammable from catching fire.
- Disconnect the battery negative cable to prevent shorting during work.
- When welding or conducting other heat-generating work on other parts, be sure to provide pretreatment to protect the piping system from thermal damage or spattering.

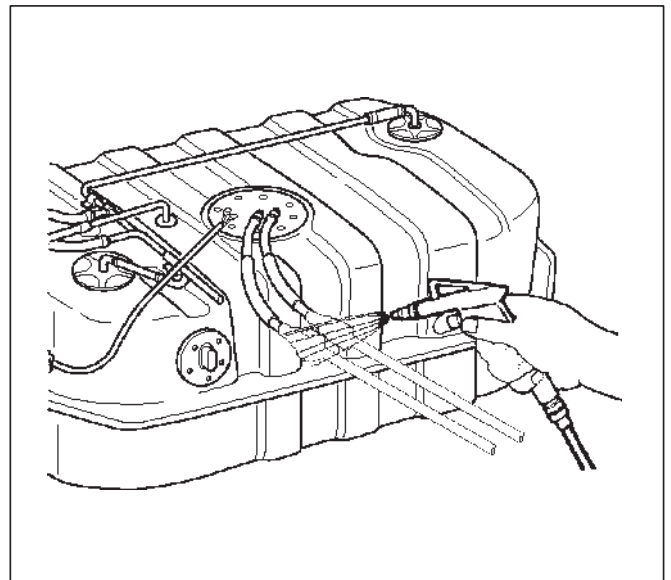
### Cautions During Work

Do not expose the assembly to battery electrolyte or do not wipe the assembly with a cloth used to wipe off spilt battery electorolyte.

The piping wet with battery electrolyte cannot be used. Be careful not to give a bending or twisting force to the piping during the work. If deformed, replace with a new piping.

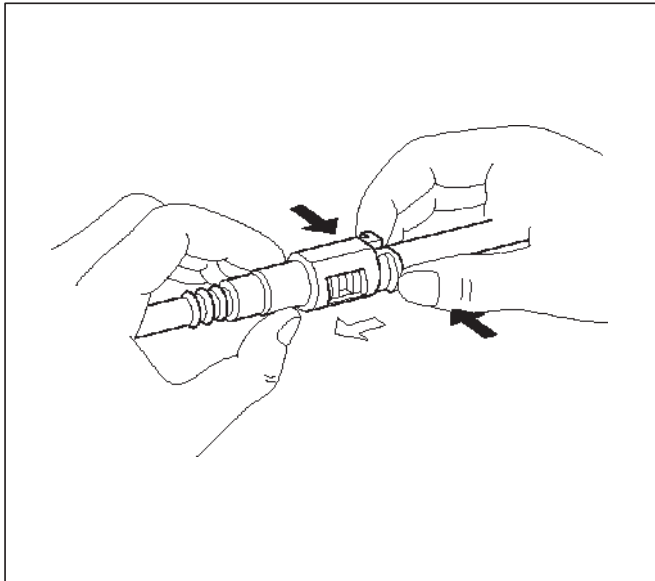
### Removal

1. Open the fuel cap to relieve the fuel pressure in the tank.  
If the fuel quick-connect fittings are dusty, clean with an air blower, etc. and then remove it.



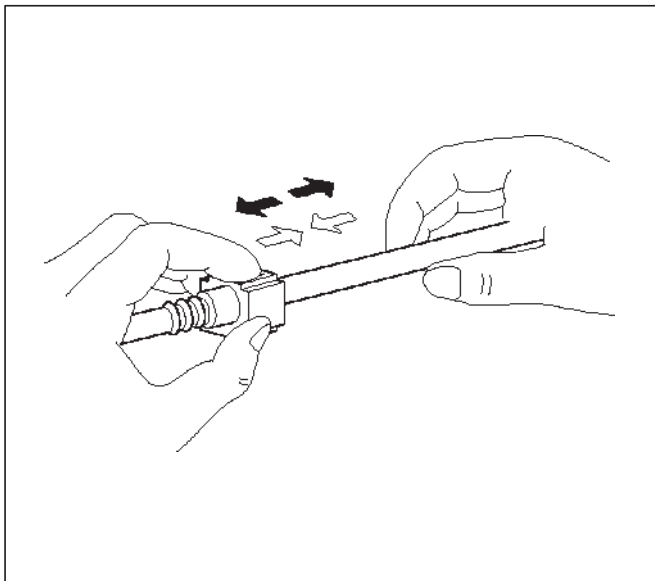
As some pressure may remain in the piping, cover the connector with a cloth, etc. to prevent the splashing of fuel in the first disconnection of the piping.

2. For removal of the delivery pipe (feeding fuel to the engine), hold the connector in one hand, and hold the retainer tab with the other hand and pull out the connector, as illustrated. The pipe can be removed with the retainer attached.



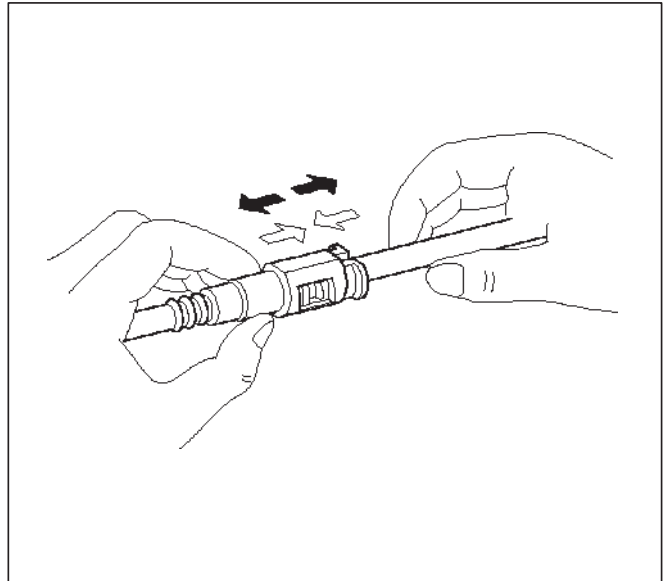
141RW019

3. For removal of the return pipe (returning fuel to the tank), hold the pipe in one hand, and pull out the connector with the other hand while pressing the square relieve button of the retainer, as illustrated.



141RW020

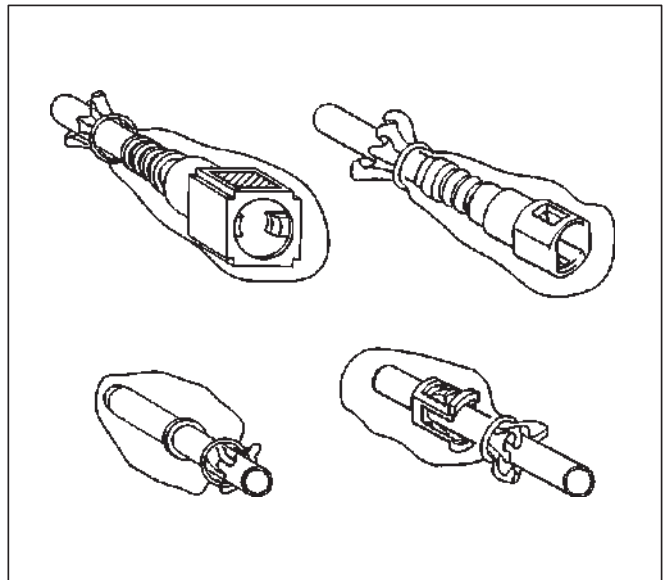
NOTE: This work should be done by hands. Do not use any tools. Should the pipe can hardly be removed from the connector, use a lubricant (light oil) and/or push and pull the connector longitudinally until the pipe is removed.



141RW021

When reusing the delivery pipe retainer, reuse without removing the retainer from the pipe. If the retainer is damaged or deformed, however, replace with a new retainer.

Cover the connectors removed with a plastic bag, etc. to prevent the entry of dust or rain water.



141RW022

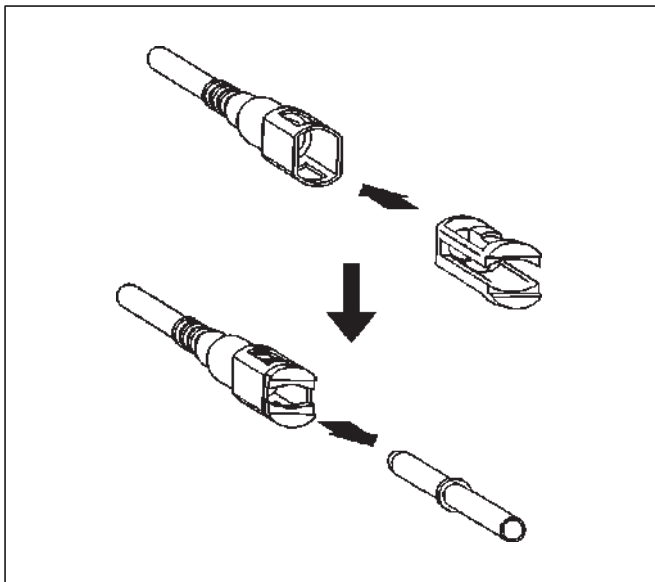


## Reuse of Quick-Connector

### (Delivery Pipe)

- Replace the pipe and connector if scratch, dent or crack is found.
- Remove mud and dust from the pipe and make sure that the end including spool is free of defects, such as scratch, rust, and dent, which may cause poor sealability. If defective, replace with a new pipe.
- If the retainer removed according to the removal step above is attached to the pipe, clean and insert it straight into the quick-connector till it clicks. After it clicks, try pulling it out to make sure that it is not drawn and is securely locked.

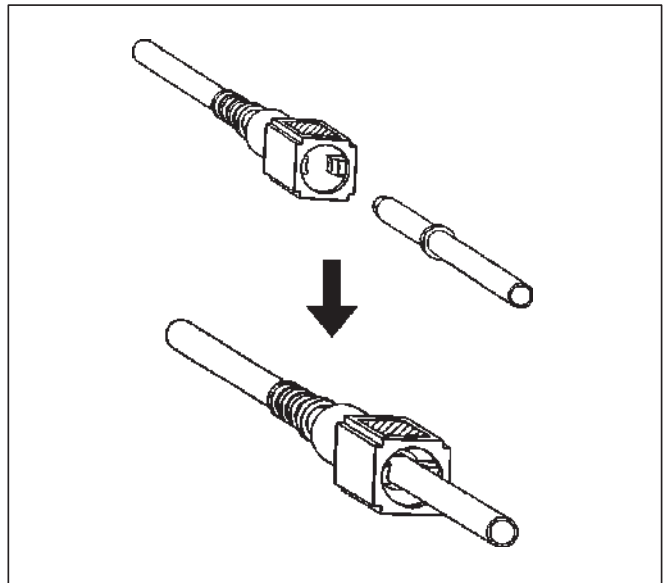
NOTE: The retainer, once removed from the pipe, cannot be reused. Just replace with a new retainer. Insert the new retainer into the connector side until it clicks, and connect the pipe as inserting it into the retainer until it clicks.



### (Return Pipe)

- Replace the pipe and connector if scratch, dent or crack is found.
- Remove mud or dust from the pipe and make sure that the end including spool is free from defects, such as scratch, rust, and dent, which may cause poor sealability. If defective, replace with a new pipe.

- After cleaning the pipe, insert it straight into the connector until it clicks. After it clicks, try pulling it out to make sure that it is not drawn and is securely locked.



## Assembling Advice

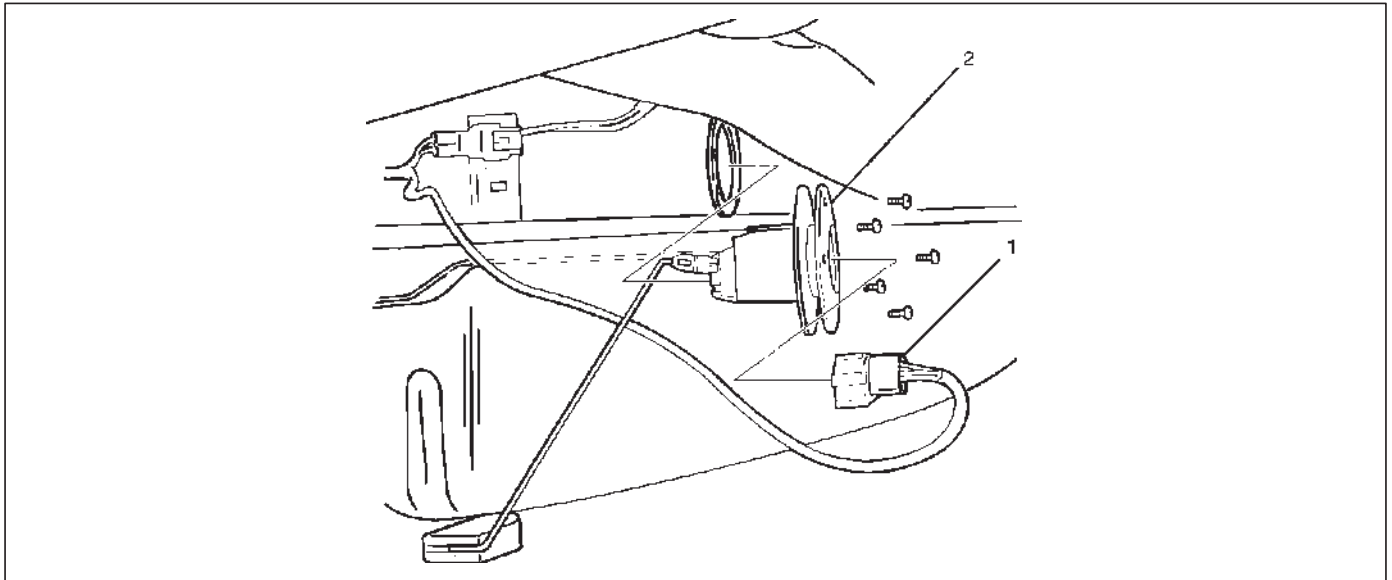
Application of engine oil or light oil to the pipe facilitates a good connection. The work should be started immediately after lubrication, since dust may stick to the pipe surface to cause poor sealability if a long time passes after lubrication.

### Test/Inspection After Assembling

1. Reconnect the battery negative cable.
2. Turn the ignition key to the "ON" position and check pump startup sound. As the pump is actuated to raise fuel pressure, check and see fuel leak from the piping system.
3. Make sure of no fuel leakage by conducting the above fuel leak check a few times.
4. Start the engine and make sure of stable idling speed and normal vehicle run. The entry of dust during the work may sometimes affect the fuel injection system.

## Fuel Gauge Unit

### Fuel Gauge Unit and Associated Parts



140RS004

#### Legend

- (1) Wiring Connector
- (2) Fuel Gauge Unit

### Removal

**CAUTION:** When repair to the fuel system has been completed, start engine and check the fuel system for loose connection or leakage. For the fuel system diagnosis, see Section "Driveability and Emission".

1. Disconnect battery ground cable.
2. Loosen fuel filler cap.
3. Drain fuel.  
Tighten drain plug to the specified torque after draining fuel.

**Torque: 20 N·m (14 lb ft) — M8**

4. Wiring connector
  - Disconnect wiring connector(1) from the unit.
5. Fuel gauge unit
  - Remove the fixing screws, then the fuel gauge unit(2).

**NOTE:** After removing fuel gauge unit, cover fuel tank to prevent any dust entering

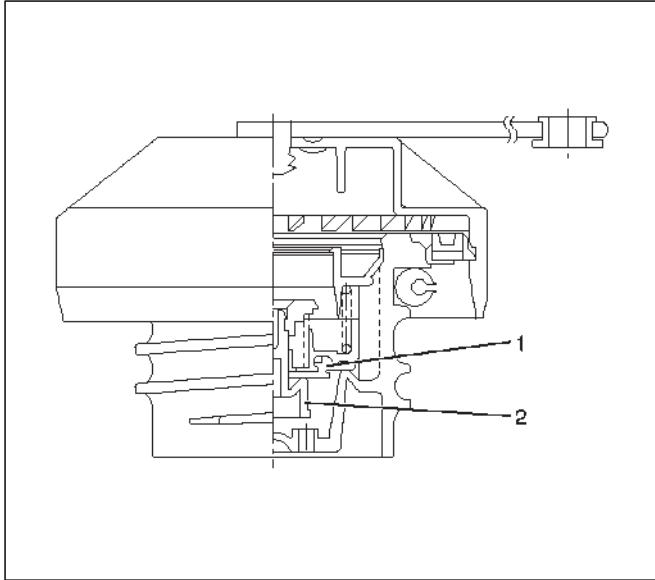
### Installation

1. Fuel gauge unit(2).
2. Wiring connector(1).
  - Connect the wiring connector to the fuel gauge unit.
  - Fill the tank with fuel and tighten fuel filler cap.
  - Connect battery ground cable.

## Fuel Filler Cap

### General Description

Fuel filler cap includes vacuum valve and pressure valve. In case any high vacuum and any high pressure happen in tank, each valve works to adjust the pressure to prevent the tank from being damaged.



### Legend

- (1) Vacuum Valve
- (2) Pressure Valve

### Inspection

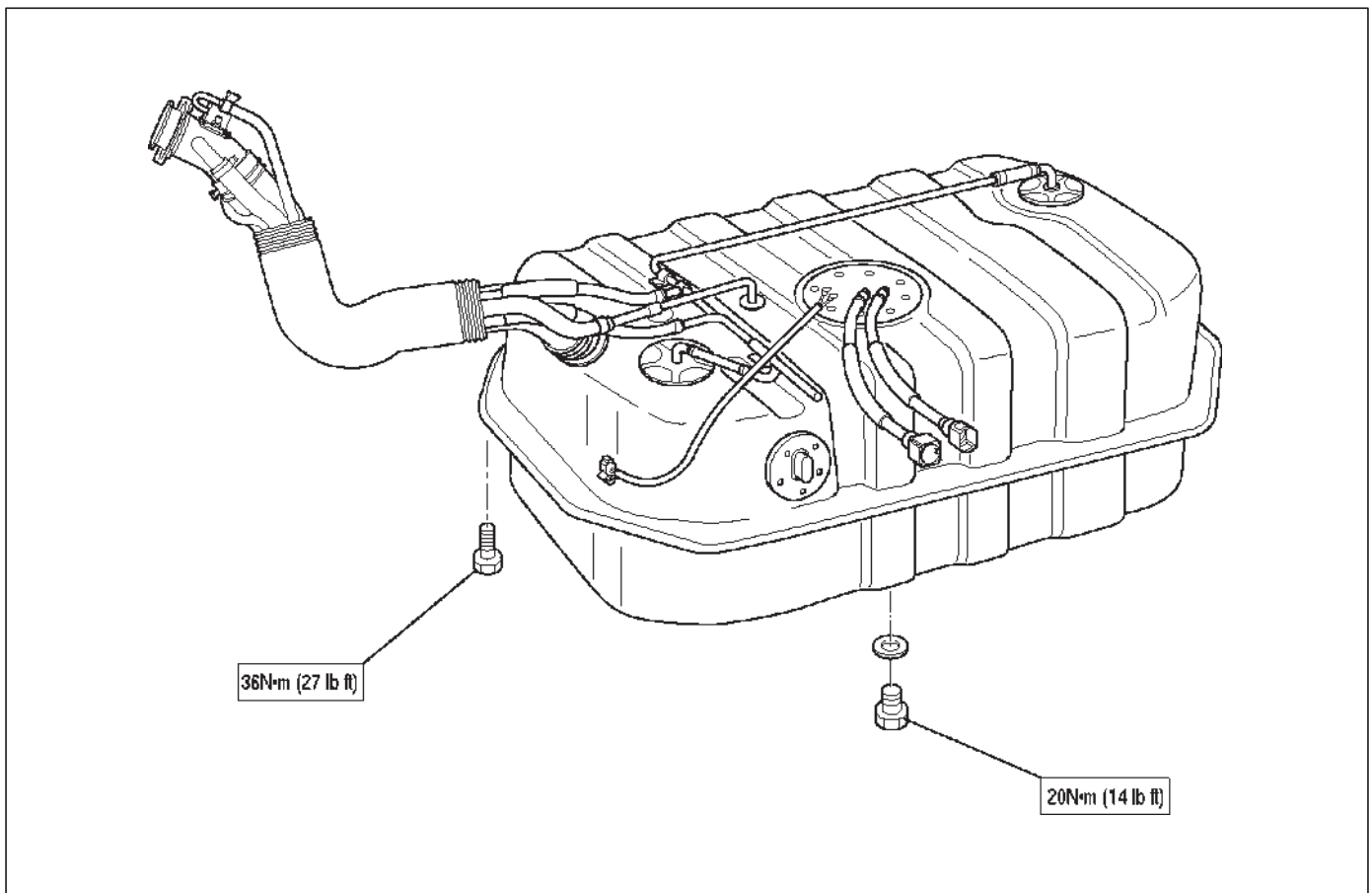
Check the seal ring in the filler cap for presence of any abnormality and for seal condition. Replace the filler cap, if abnormal.

**CAUTION: The fuel filler cap valves have characteristics.**

**A defective valve, no valve at all or a valve with the wrong characteristics will do a lot of harm to engine operating characteristics; be sure to use the same fuel filler cap as installed in this vehicle.**

### Main Data and Specifications

#### Torque Specification



# ENGINE

## ENGINE ELECTRICAL

### CONTENTS

Battery .....	6D1-1	Jump Starting .....	6D1-2
General Description .....	6D1-1	Battery Removal .....	6D1-3
Diagnosis .....	6D1-1	Battery Installation .....	6D1-3
Battery Charging .....	6D1-2	Main Data and Specifications .....	6D1-4

## Battery

### General Description

There are six battery fluid caps on top of the battery. These are covered by a paper label. The battery is completely sealed except for the six small vent holes on the side. These vent holes permit the escape of small amounts of gas generated by the battery. This type of battery has the following advantages over conventional batteries:

1. There is no need to add water during the entire service life of the battery.
2. The battery protects itself against overcharging. The battery will refuse to accept an extensive charge. (A conventional battery will accept an excessive charge, resulting in gassing and loss of battery fluid.)
3. The battery is much less vulnerable to self discharge than a conventional type battery.

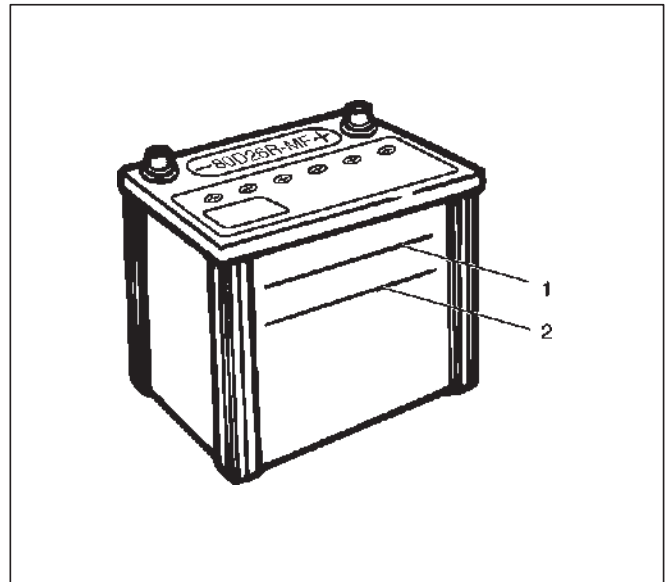
### Diagnosis

#### 1. Visual Inspection

Inspect the battery for obvious physical damage, such as a cracked or broken case, which would permit electrolyte loss.

Replace the battery if obvious physical damage is discovered during inspection.

Check for any other physical damage and correct it as necessary.



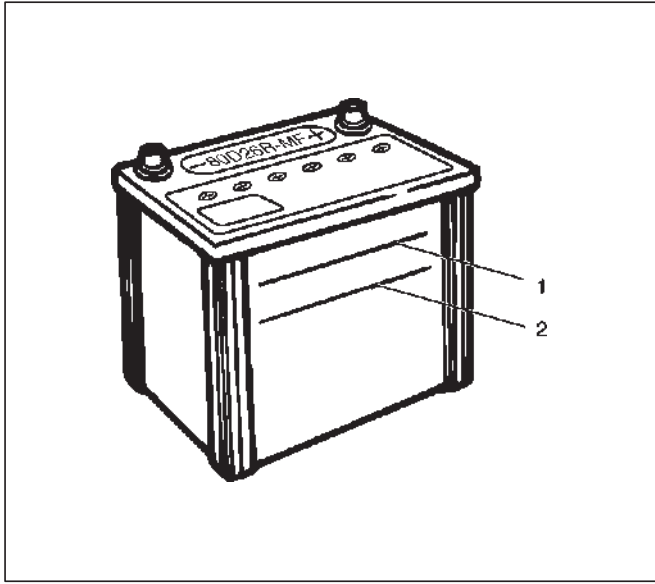
061RX003

## 6D1-2 ENGINE ELECTRICAL

### 2. Fluid Level Check

The fluid level should be between the upper level line(1) and lower level line(2) on side of battery.

- a. CORRECT FLUID LEVEL – Charge the battery.
- b. BELOW LOWER LEVEL – Replace battery.



061RX003

### 3. Voltage Check

1. Put voltmeter test leads to battery terminals.
  - a. VOLTAGE IS 12.4V OR ABOVE – Go to Step 4.
  - b. VOLTAGE IS UNDER 12.4V – Go to procedure (2) below.
2. Determine fast charge amperage from specification. (See Main Data and Specifications in this section).

Fast charge battery for 30 minutes at amperage rate no higher than specified value.

Take voltage and amperage readings after charge.

  - a. VOLTAGE IS ABOVE 16V AT BELOW 1/3 OF AMPERAGE RATE – Replace battery.
  - b. VOLTAGE IS ABOVE 16V AT ABOVE 1/3 OF AMPERAGE RATE – Drop charging voltage to 15V and charge for 10 – 15 hours. Then go to Step 5.
  - c. VOLTAGE IS BETWEEN 12V AND 16V – Continue charging at the same rate for an additional 3–1/2 hours. Then go to Step 4.
  - d. VOLTAGE BELOW 12V – Replace Battery.

### 4. Load Test

1. Connect a voltmeter and a battery load tester across the battery terminals.
2. Apply 300 ampere load for 15 seconds to remove surface charge from the battery. Remove load.
3. Wait 15 seconds to let battery recover. Then apply specified load from specifications (See Main Data and Specifications in this section).

Read voltage after 15 seconds, then remove load.

- a. VOLTAGE DOES NOT DROP BELOW THE MINIMUM LISTED IN THE TABLE – The battery is good and should be returned to service.
- b. VOLTAGE IS LESS THAN MINIMUM LISTED – Replace battery.

ESTIMATED TEMPERATURE		MINIMUM VOLTAGE
°F	°C	V
70	21	9.6
60	16	9.5
50	10	9.4
40	4	9.3
30	-1	9.1
20	-7	8.9
10	-12	8.7
0	-18	8.5

The battery temperature must be estimated by feel and by the temperature the battery has been exposed to for the preceding few hours.

### Battery Charging

Observe the following safety precautions when charging the battery:

1. Never attempt to charge the battery when the fluid level is below the lower level line on the side of the battery. In this case, the battery must be replaced.
2. Pay close attention to the battery during charging procedure.

Battery charging should be discontinued or the rate of charge reduced if the battery feels hot to the touch.

Battery charging should be discontinued or the rate of charge reduced if the battery begins to gas or spew electrolyte from the vent holes.
3. Battery temperature can have a great effect on battery charging capacity.
4. The sealed battery used on this vehicle may be either quick charged or slow charged in the same manner as other batteries.

Whichever method you decide to use, be sure that you completely charge the battery. Never partially charge the battery.

### Jump Starting

#### Jump Starting with an Auxiliary (Booster) Battery

**CAUTION: Never push or tow the vehicle in an attempt to start it. Serious damage to the emission system as well as other vehicle parts will result.**

Treat both the discharged battery and the booster battery with great care when using jumper cables. Carefully follow the jump starting procedure, being careful at all times to avoid sparking.

**WARNING: FAILURE TO CAREFULLY FOLLOW THE JUMP STARTING PROCEDURE COULD RESULT IN THE FOLLOWING:**

1. Serious personal injury, particularly to your eyes.
2. Property damage from a battery explosion, battery acid, or an electrical fire.
3. Damage to the electronic components of one or both vehicles particularly.

Never expose the battery to an open flame or electrical spark. Gas generated by the battery may catch fire or explode.

Remove any rings, watches, or other jewelry before working around the battery. Protect your eyes by wearing an approved set of goggles.

Never allow battery fluid to come in contact with your eyes or skin.

Never allow battery fluid to come in contact with fabrics or painted surfaces.

Battery fluid is a highly corrosive acid.

Should battery fluid come in contact with your eyes, skin, fabric, or a painted surface, immediately and thoroughly rinse the affected area with clean tap water.

Never allow metal tools or jumper cables to come in contact with the positive battery terminal, or any other metal surface of the vehicle. This will protect against a short circuit.

Always keep batteries out of reach of young children.

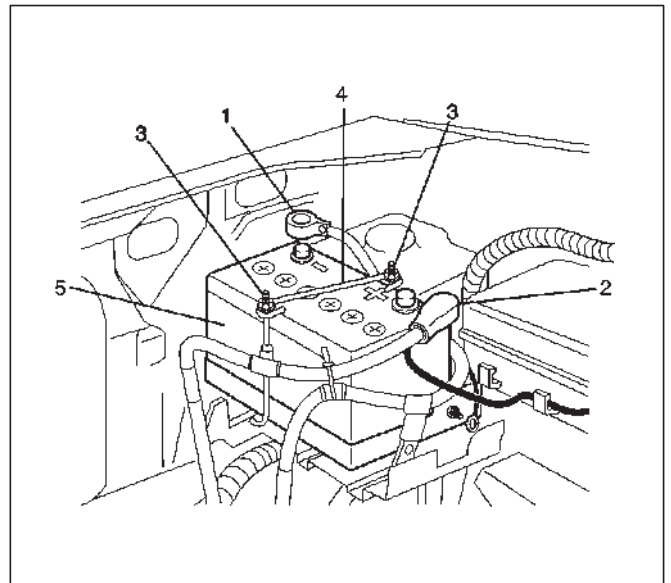
## Jump Starting Procedure

1. Set the vehicle parking brake.
  - If the vehicle is equipped with an automatic transmission, place the selector level in the "PARK" position.
  - Turn "OFF" the ignition.
  - Turn "OFF" all lights and any other accessory requiring electrical power.
2. Attach the end of one jumper cable to the positive terminal of the booster battery.
  - Attach the other end of the same cable to the positive terminal of the discharged battery.
  - Do not allow the vehicles to touch each other. This will cause a ground connection, effectively neutralizing the charging procedure.
  - Be sure that the booster battery has a 12 volt rating.
3. Attach one end of the remaining cable to the negative terminal of the booster battery.
  - Attach the other end of the same cable to a solid engine ground (such as the air conditioning compressor bracket or the generator mounting bracket) of the vehicle with the discharged battery.
  - The ground connection must be at least 450 mm (18 in.) from the battery of the vehicle whose battery is being charged.

**WARNING: NEVER ATTACH THE END OF THE JUMPER CABLE DIRECTLY TO THE NEGATIVE TERMINAL OF THE DEAD BATTERY.**

4. Start the engine of the vehicle with the good battery.
  - Make sure that all unnecessary electrical accessories have been turned "OFF".
5. Start the engine of the vehicle with the dead battery.
6. To remove the jumper cables, follow the above directions in reverse order.
  - Be sure to first disconnect the negative cable from the vehicle with the discharged battery.

## Battery Removal



061RX004

1. Remove negative cable (1).
2. Remove positive cable (2).
3. Remove retainer screw and rods (3).
4. Remove retainer (4).
5. Remove battery (5).

## Battery Installation

1. Install battery (5).
2. Install retainer (4).
3. Install retainer screw and rods (3).

**NOTE:** Make sure that the rod is hooked on the body side.

4. Install positive cable (2).
5. Install negative cable (1).

## 6D1-4 ENGINE ELECTRICAL

---

### Main Data and Specifications

#### General Specifications

Model (JIS)	80D26R-MF
Voltage (V)	12
Cold Cranking Performance (Amp)	582
Reserve Capacity (Min)	133
Load Test (Amp)	290
Fast Charge Maximum Amperage (Amp)	20
BCI Group No.	24

VEHICROSS

# ENGINE

## IGNITION SYSTEM

### CONTENTS

Service Precaution .....	6D2-1	Inspection and Repair .....	6D2-6
General Description .....	6D2-2	Burning Electrodes .....	6D2-6
Diagnosis .....	6D2-5	Measuring Insulation Resistance .....	6D2-6
Ignition Coil .....	6D2-5	Cleaning Spark Plugs .....	6D2-6
Removal .....	6D2-5	Installation .....	6D2-6
Inspection and Repair .....	6D2-5	Crankshaft Position Sensor .....	6D2-7
Installation .....	6D2-5	Removal .....	6D2-7
Spark Plug .....	6D2-6	Installation .....	6D2-7
Removal .....	6D2-6	Main Data and Specifications .....	6D2-8

### Service Precaution

**WARNING: THIS VEHICLE HAS A SUPPLEMENTAL RESTRAINT SYSTEM (SRS). REFER TO THE SRS COMPONENT AND WIRING LOCATION VIEW IN ORDER TO DETERMINE WHETHER YOU ARE PERFORMING SERVICE ON OR NEAR THE SRS COMPONENTS OR THE SRS WIRING. WHEN YOU ARE PERFORMING SERVICE ON OR NEAR THE SRS COMPONENTS OR THE SRS WIRING, REFER TO THE SRS SERVICE INFORMATION. FAILURE TO FOLLOW WARNINGS COULD RESULT IN POSSIBLE AIR BAG DEPLOYMENT, PERSONAL INJURY, OR OTHERWISE UNNEEDED SRS SYSTEM REPAIRS.**

**CAUTION: Always use the correct fastener in the proper location. When you replace a fastener, use ONLY the exact part number for that application. ISUZU will call out those fasteners that require a replacement after removal. ISUZU will also call out the fasteners that require thread lockers or thread sealant. UNLESS OTHERWISE SPECIFIED, do not use supplemental coatings (Paints, greases, or other corrosion inhibitors) on threaded fasteners or fastener joint interfaces. Generally, such coatings adversely affect the fastener torque and the joint clamping force, and may damage the fastener. When you install fasteners, use the correct tightening sequence and specifications. Following these instructions can help you avoid damage to parts and systems.**



### General Description

Ignition is done by the electronic ignition (EI) that directly fires the spark plugs from ignition coils through spark plug wires without using a distributor. A pair of ignition coils for the cylinders having different phases by 360° (No.1 and No.4, No.2 and No.5, No.3 and No.6) are fired simultaneously.

Since the cylinder on exhaust stroke requires less energy to fire its ignition plug, energy from the ignition coils can be utilized to fire the mating cylinder on compression stroke. After additional 360° rotation, respective cylinder strokes are reversed.

The EI consists of six ignition coils, ignition control module, crank angle sensor, powertrain control module (PCM) and other components.

The ignition coils are connected with the PCM by means of a 32 pin connector.

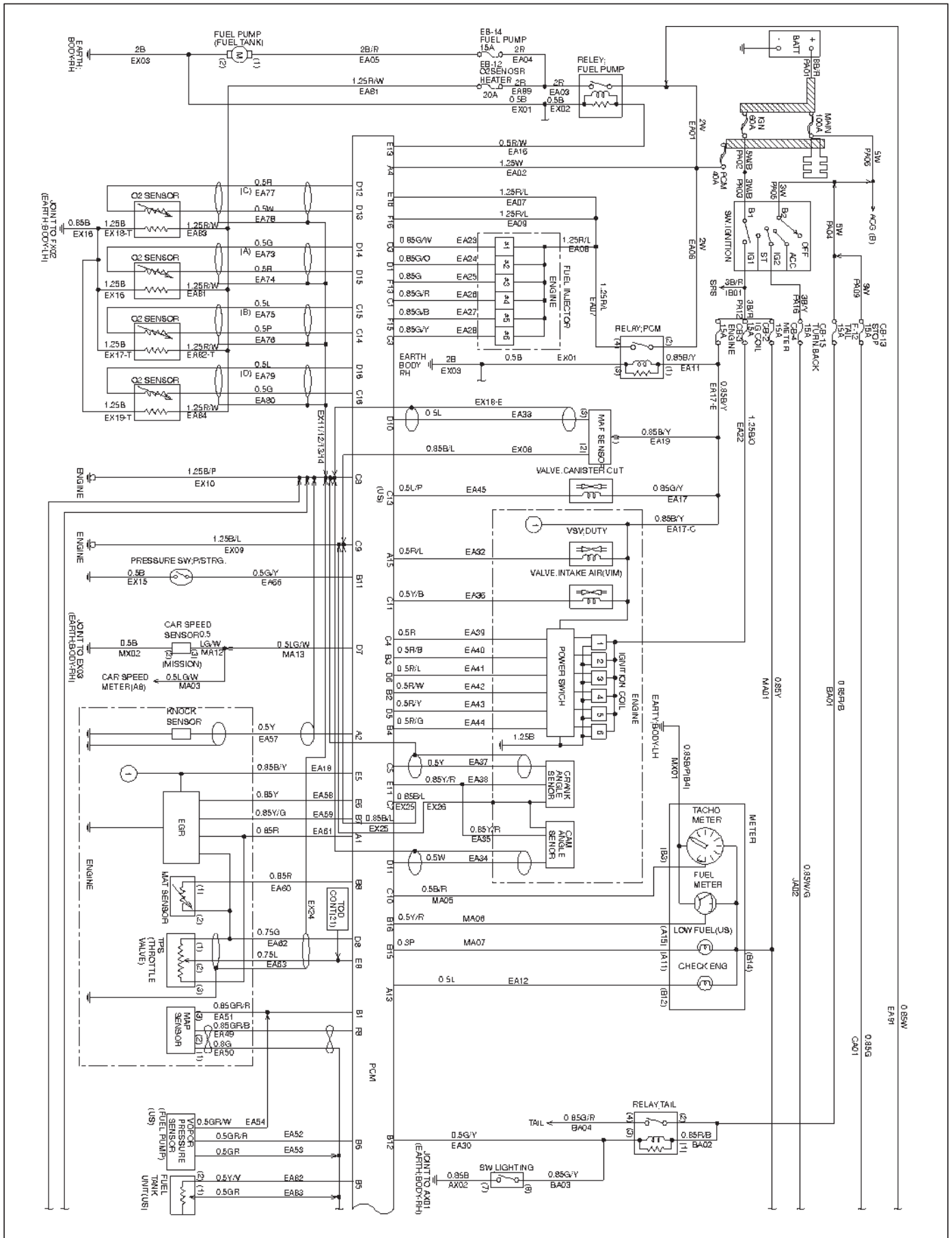
The ignition control module turns on/off the primary circuit of ignition coils, and also it controls the ignition timing at the engine speed below 538 rpm.

A notch in the timing disc on the crankshaft activates the crank position sensor which then sends information such as firing order and starting timing of each ignition coil to the PCM.

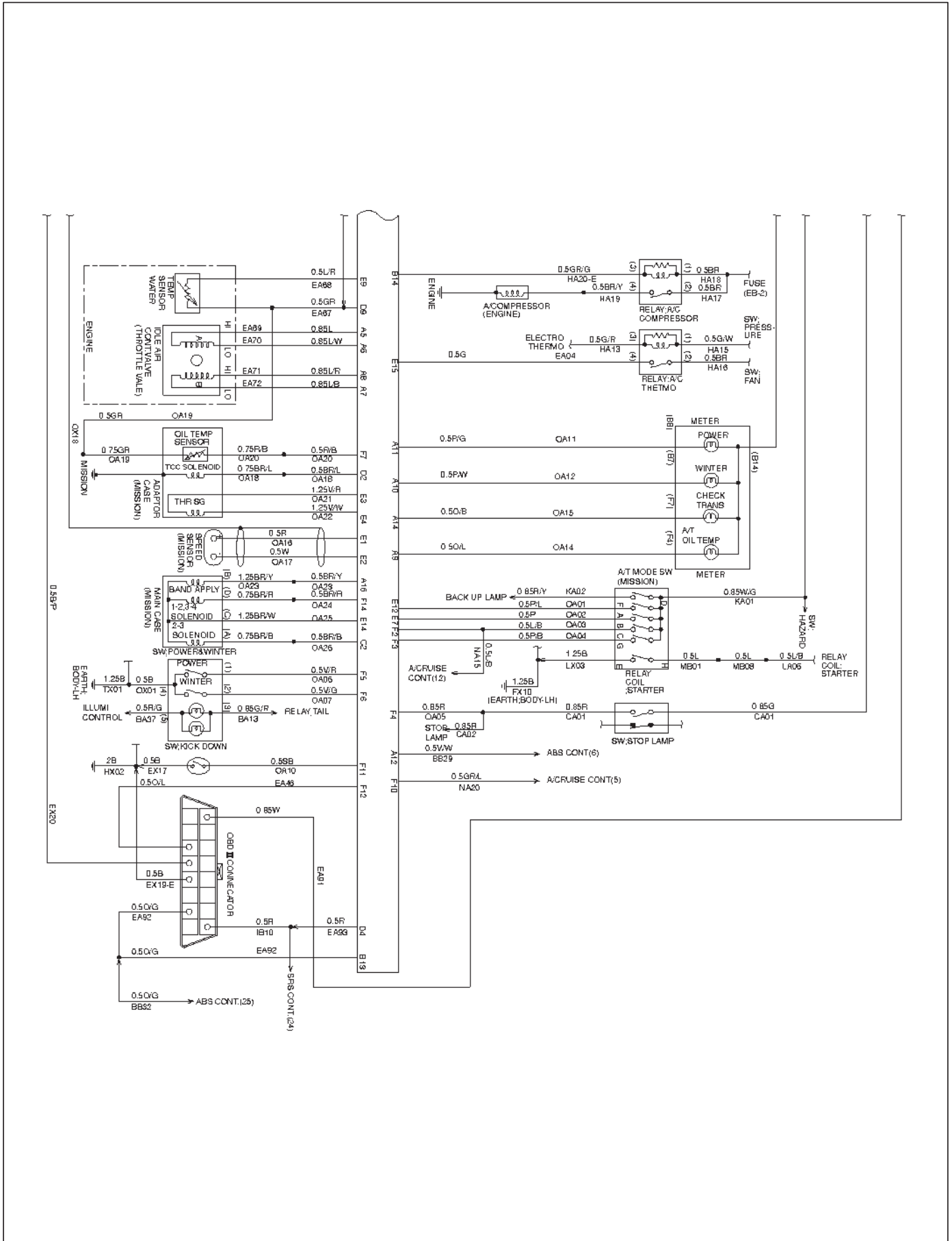
Further, the EI employs ignition control (IC) to control similar to a distributor system.

By receiving signals such as crank position, engine speed, water temperature and Manifold Absolute Pressure (MAP), the PCM controls the ignition timing.

# IGNITION SYSTEM 6D2-3



# 6D2-4 IGNITION SYSTEM



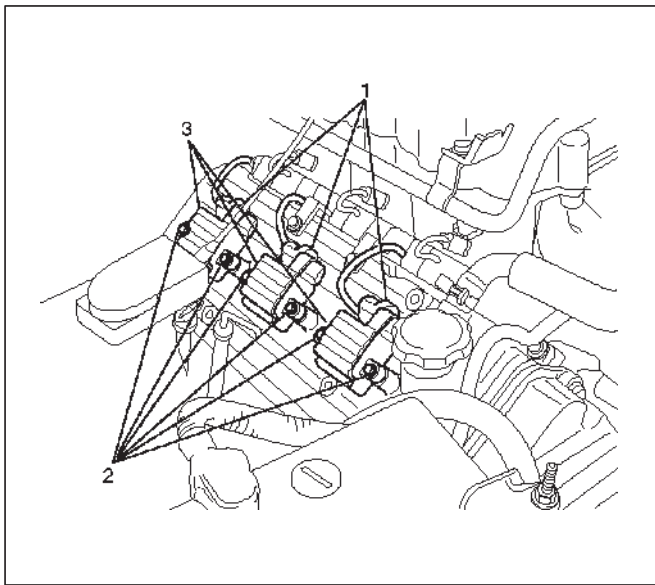
## Diagnosis

Refer to Section Drivability and Emissions for the diagnosis to electronic ignition system (EI system).

## Ignition Coil

### Removal

1. Disconnect battery ground cable.
2. Remove ignition coil connector and ignition coil.
  - Disconnect the connector from ignition coil.
  - Remove harness bracket bolt on cylinder head covers.
  - Remove fixing bolts on ignition coil.



#### Legend

- (1) Ignition Coil Connector
- (2) Bolt
- (3) Ignition Coil Assembly

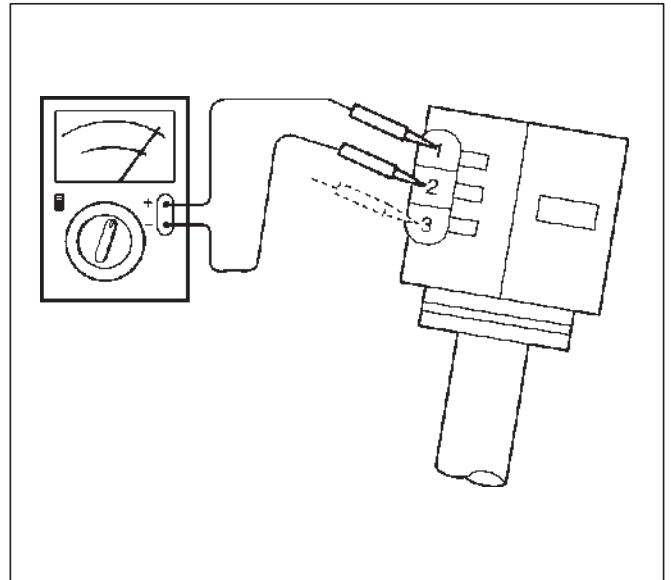
### Inspection and Repair

Check the ignition coil assembly for insulation. Check terminals for corrosion or damage, and replace as necessary.

Measuring resistance of ignition coil assembly.

Terminal No.	Limit
1 to 2	Without 0 ohm or infinity maximum ohm.
1 to 3	Same as above
2 to 3	Same as above

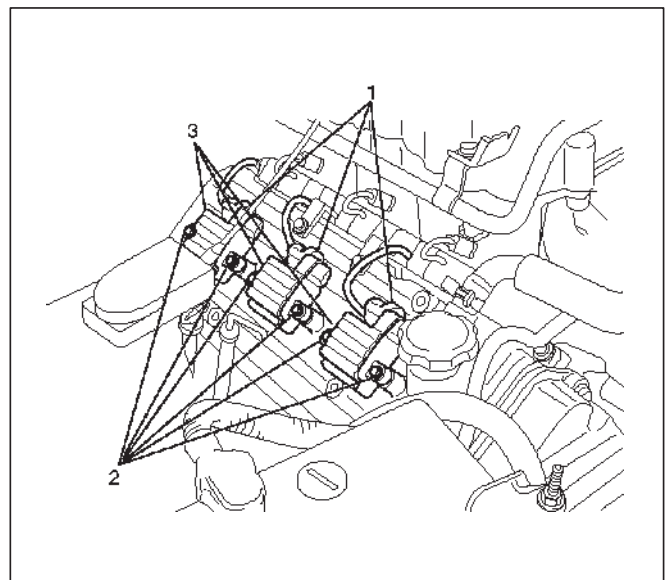
Measure resistance of ignition coil assembly, and replace the ignition coil assembly if its value exceeds the standard.



### Installation

1. Install the ignition coil assembly (3).  
Connect ignition coil connector (1) and ignition coil (3), then tighten bolt (2) to the specified torque.

**Torque: 4 N·m (35 lb in)**



2. Connect battery ground cable.

## Spark Plug

### Removal

1. Remove ignition coil assembly.
2. Remove spark plugs.

### Inspection and Repair

The spark plug affects entire engine performance and therefore its inspection is very important.

- Check electrode and insulator for presence of cracks, and replace if any.
- Check electrode for wear, and replace if necessary.
- Check gasket for damage, and replace if necessary.
- Measure insulation resistance with an ohmmeter, and replace if faulty.
- Adjust spark plug gap to 1.0 mm (0.04 in) ~ 1.1 mm (0.043 in).
- Check fuel and electrical systems if spark plug is extremely dirty.
- Use spark plugs having low heat value (hot type plug) if fuel and electrical systems are normal.
- Use spark plugs having high heat value (cold type plug) if insulator and electrode are extremely burned.

### Sooty Spark Plugs

Heavy deposit of carbon or oil on the electrode and insulator of spark plug reduces the engine performance.

#### Possible causes:

- Overly mixture
- Presence of oil in combustion chamber
- Incorrectly adjusted spark plug gap

### Burning Electrodes

This fault is characterized by scorched or heavily oxidized electrode or blistered insulator nose.

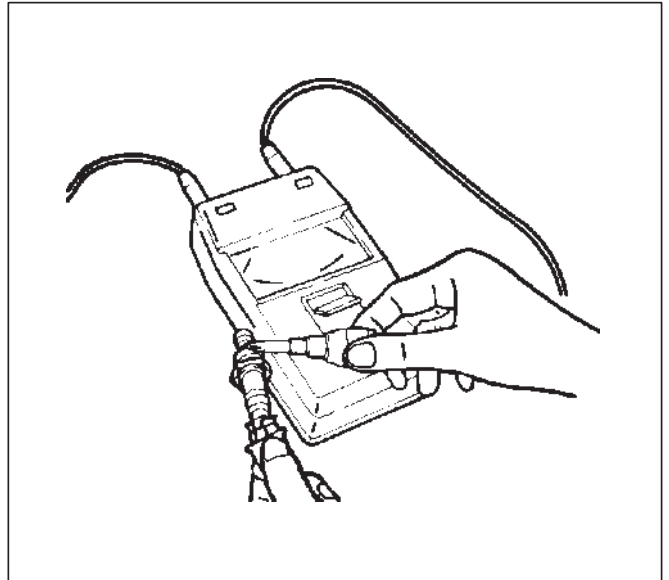
#### Possible causes:

- Overly mixture
- Improper heat value

### Measuring Insulation Resistance

- Measure insulation resistance using a 500 volt megaohm meter.
- Replace spark plugs if measured value is out of standard.

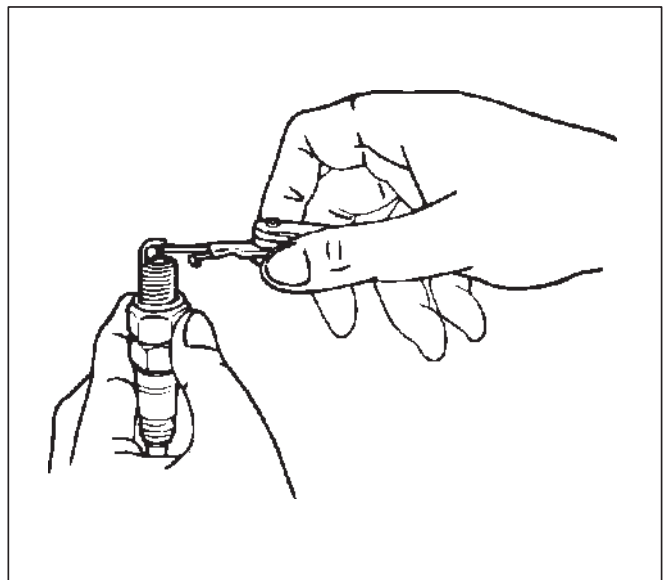
**Insulation resistance: 50 MΩ or more**



011RS010

### Cleaning Spark Plugs

- Clean spark plugs with a spark plug cleaner.
- Raise the ground electrode to an angle of 45 to 60 degrees. If electrode is wet, dry it before cleaning.
- After spark plug is thoroughly cleaned, check insulator for presence of cracks.
- Clean threads and metal body with a wire brush.
- File the electrode tip if electrode is extremely worn.
- Bend the ground electrode to adjust the spark plug gap.



011RS011

### Installation

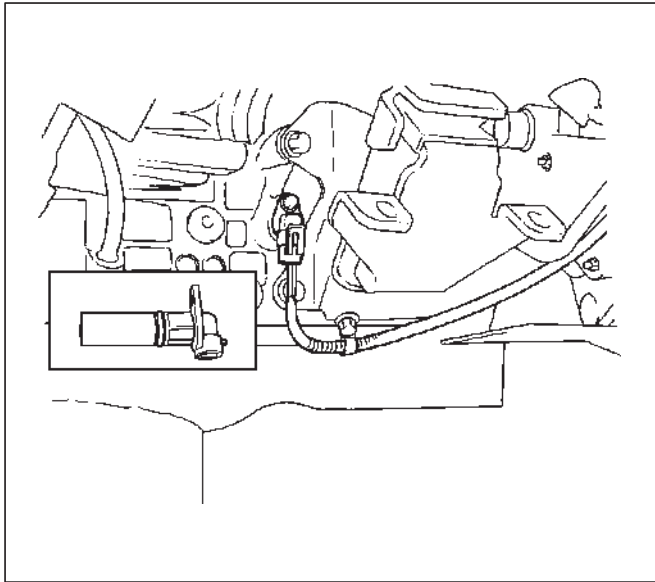
1. Spark plugs
  - Tighten spark plugs to the specified torque.

**Torque: 18 N·m (13 lb ft)**
2. Install the ignition coil assembly.

## Crankshaft Position Sensor

### Removal

1. Disconnect battery ground cable
2. Wiring connector from crankshaft position sensor.
3. Remove crankshaft position sensor from cylinder block.



012RS008

### Installation

1. Install crankshaft position sensor into the cylinder block.  
Before installation, apply small amount of engine oil to the O-ring.

**Torque: 10 N·m (89 lb in)**

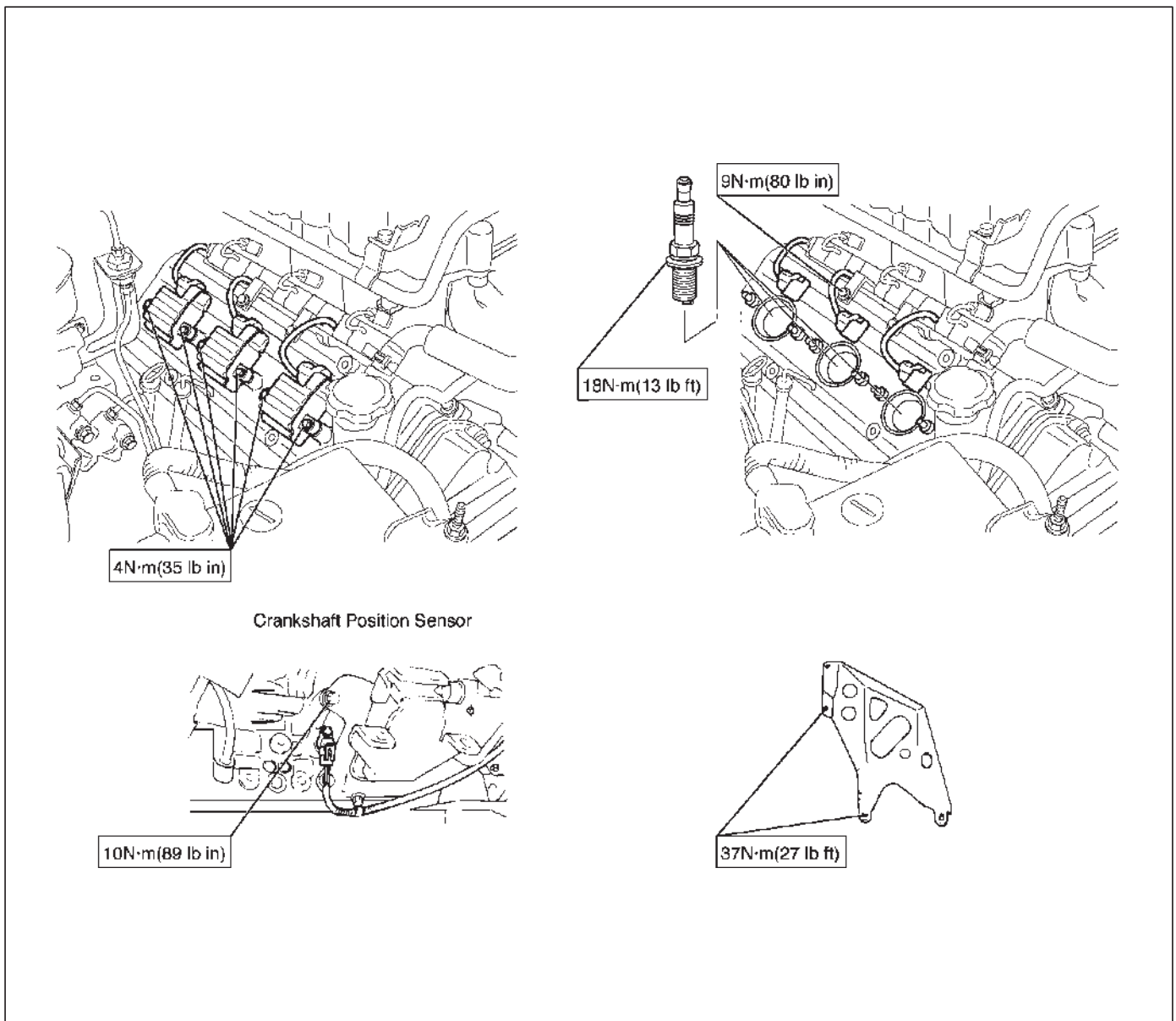
2. Reconnect wiring connector to crankshaft position sensor.

## Main Data and Specifications

### General Specifications

Ignition System	
Ignition Form	Electronic Ignition System (EI system) with Crankshaft position Sensor
Spark Plug	
Type	K16PR-P11 RC10PYP4 PK16PR11
Plug gap	1.0 mm (0.04 in) – 1.1 mm (0.043 in)
Torque	18 N·m (13 lb ft)

### Torque Specifications



VEHICROSS

# ENGINE

## STARTING AND CHARGING SYSTEM

### CONTENTS

Service Precaution .....	6D3-1	General Description .....	6D3-18
Starting System .....	6D3-2	General On-Vehicle Inspection .....	6D3-18
General Description .....	6D3-2	Generator .....	6D3-19
Diagnosis .....	6D3-4	Removal .....	6D3-19
Starter .....	6D3-5	Inspection .....	6D3-19
Removal .....	6D3-5	Installation .....	6D3-19
Installation .....	6D3-5	Disassembled View .....	6D3-20
Disassembled View .....	6D3-6	Disassembly .....	6D3-21
Disassembly .....	6D3-7	Inspection and Repair .....	6D3-23
Inspection and Repair .....	6D3-9	Reassembly .....	6D3-25
Reassembly .....	6D3-13	Bench Test .....	6D3-25
Main Data and Specifications .....	6D3-15	Main Data and Specifications .....	6D3-26
Charging System .....	6D3-18		

### Service Precaution

**WARNING: THIS VEHICLE HAS A SUPPLEMENTAL RESTRAINT SYSTEM (SRS). REFER TO THE SRS COMPONENT AND WIRING LOCATION VIEW IN ORDER TO DETERMINE WHETHER YOU ARE PERFORMING SERVICE ON OR NEAR THE SRS COMPONENTS OR THE SRS WIRING. WHEN YOU ARE PERFORMING SERVICE ON OR NEAR THE SRS COMPONENTS OR THE SRS WIRING, REFER TO THE SRS SERVICE INFORMATION. FAILURE TO FOLLOW WARNINGS COULD RESULT IN POSSIBLE AIR BAG DEPLOYMENT, PERSONAL INJURY, OR OTHERWISE UNNEEDED SRS SYSTEM REPAIRS.**

**CAUTION: Always use the correct fastener in the proper location. When you replace a fastener, use ONLY the exact part number for that application. ISUZU will call out those fasteners that require a replacement after removal. ISUZU will also call out the fasteners that require thread lockers or thread sealant. UNLESS OTHERWISE SPECIFIED, do not use supplemental coatings (Paints, greases, or other corrosion inhibitors) on threaded fasteners or fastener joint interfaces. Generally, such coatings adversely affect the fastener torque and the joint clamping force, and may damage the fastener. When you install fasteners, use the correct tightening sequence and specifications. Following these instructions can help you avoid damage to parts and systems.**



## Starting System

### General Description

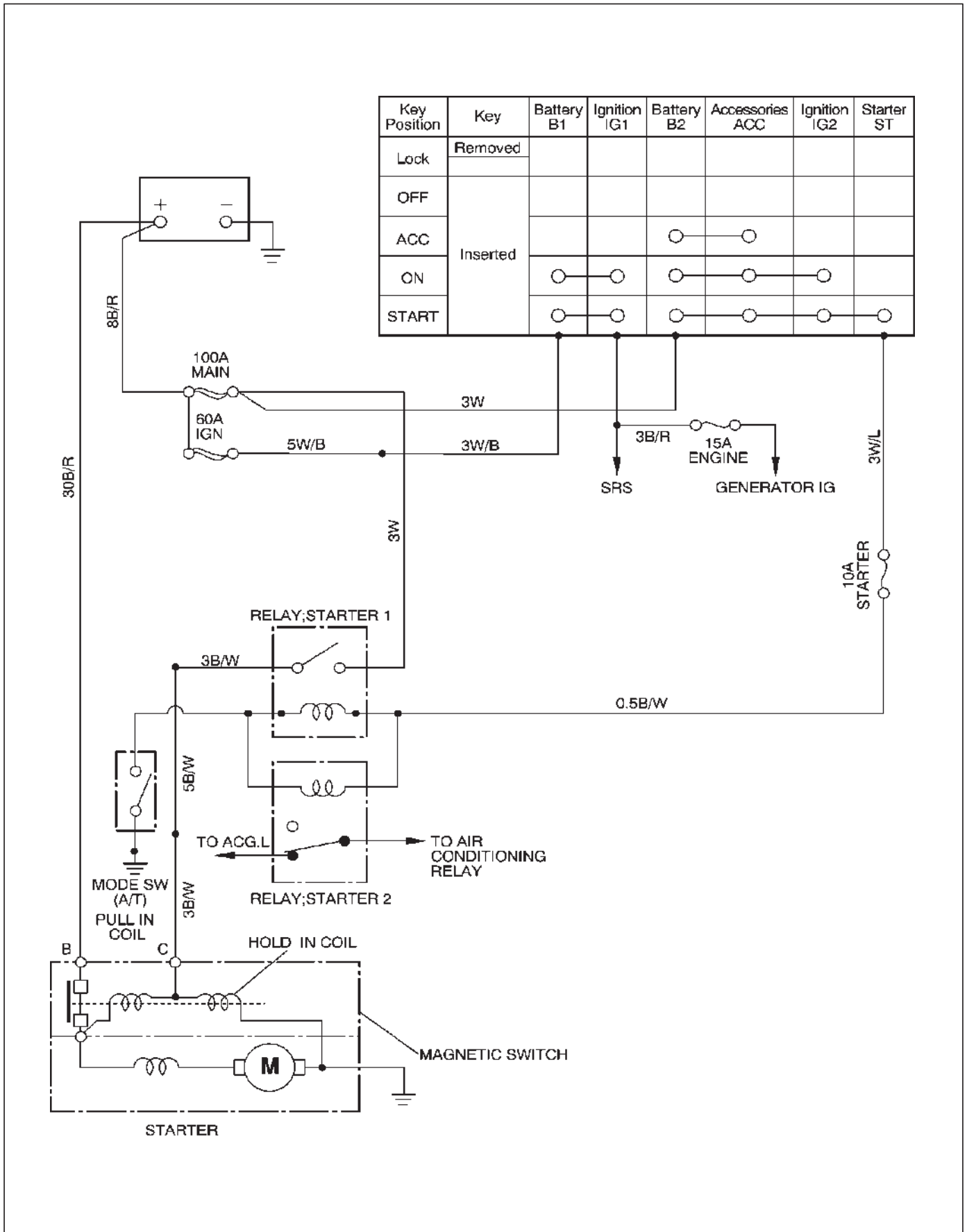
#### Cranking Circuit

The cranking system consists of a battery, starter, starter switch, starter relay, etc. These main components are connected.

#### Starter

The cranking system employs a magnetic type reduction starter in which the motor shaft is also used as a pinion shaft. When the starter switch is turned on, the contacts of the magnetic switch are closed, and the armature rotates. At the same time, the plunger is attracted, and the pinion is pushed forward by the shift lever to mesh with the ring gear.

Then, the ring gear runs to start the engine. When the engine starts and the starter switch is turned off, the plunger returns, the pinion is disengaged from the ring gear, and the armature stops rotation. When the engine speed is higher than the pinion, the pinion idles, so that the armature is not driven.



## 6D3-4 STARTING AND CHARGING SYSTEM

---

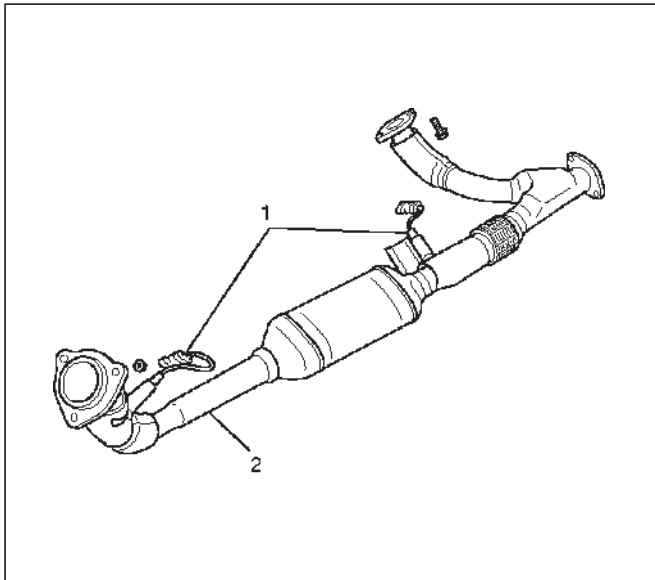
### Diagnosis

Condition	Possible cause	Correction
Starter does not run	Charging failure	Repair charging system
	Battery Failure	Replace Battery
	Terminal connection failure	Repair or replace terminal connector and/or wiring harness
	Starter switch failure	Repair or replace starter switch
	Starter failure	Repair or replace starter

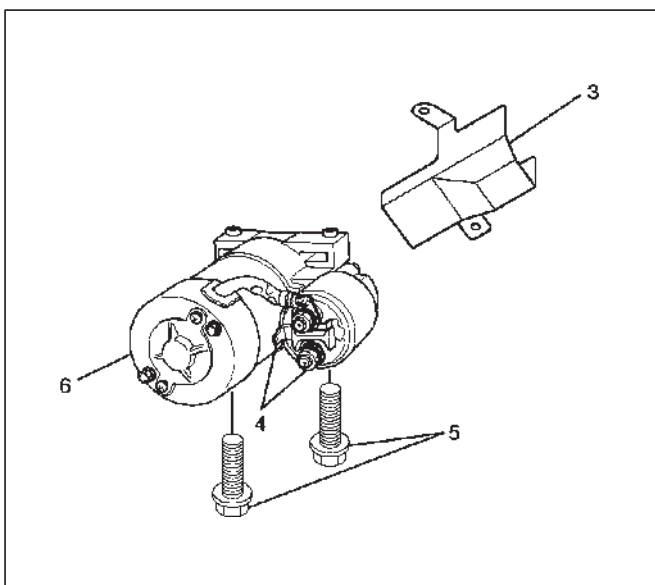
## Starter

### Removal

1. Battery ground cable.
2. Disconnect Heated Heated Oxygen (O<sub>2</sub>) Sensor connectors (1).
3. Remove exhaust front left pipe(2).  
Refer to Removal procedure for "Engine Exhaust" in this manual.



4. Remove heat protector(3).
5. Disconnect starter wiring connector from terminals "B" and "S"(4).
6. Remove starter assembly mounting bolts on inside and outside(5).
7. Remove starter assembly toward the bottom of engine(6).



### Installation

1. Install starter assembly(6).

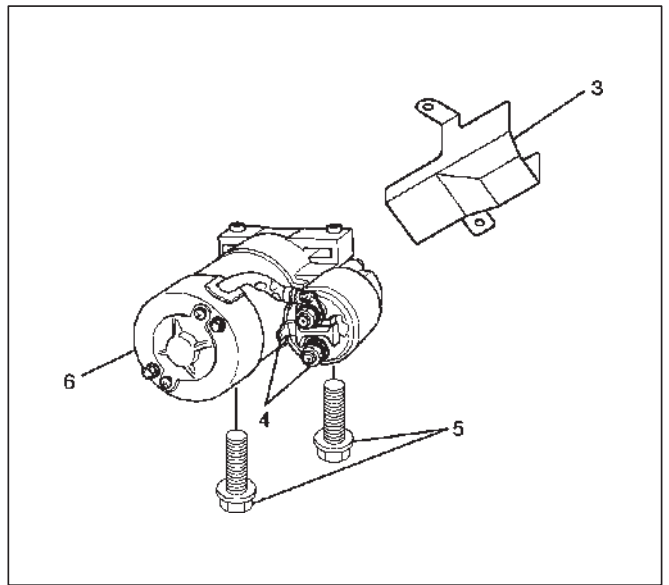
2. Install mounting bolts and tighten bolts to specified torque(5).

**Torque: 40 N·m (30 lb ft)**

3. Reconnect the connectors to terminals "B" and "S" and tighten Terminals "B" to specified torque.

**Torque: 9 N·m (80 lb in)**

4. Install heat protector(3).



5. Install exhaust front left pipe and tighten bolts and nuts to specified torque(2).

Refer to Install procedure for "Engine Exhaust" in this manual.

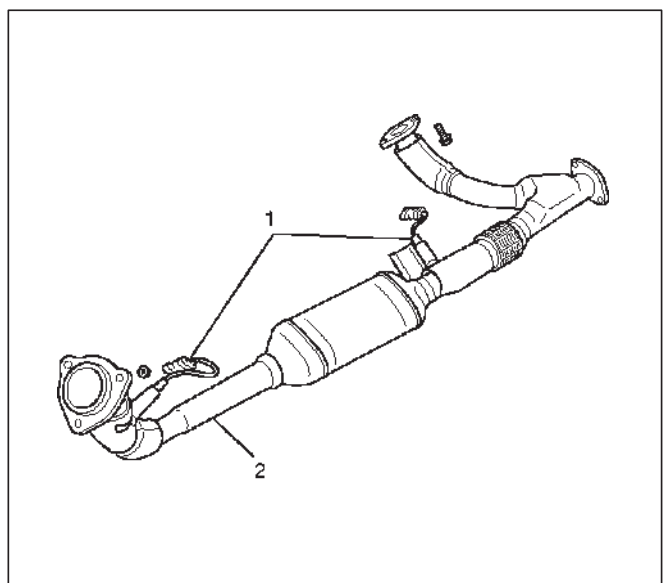
#### Stud Nuts

**Torque: 67 N·m (49 lb ft)**

#### Nuts

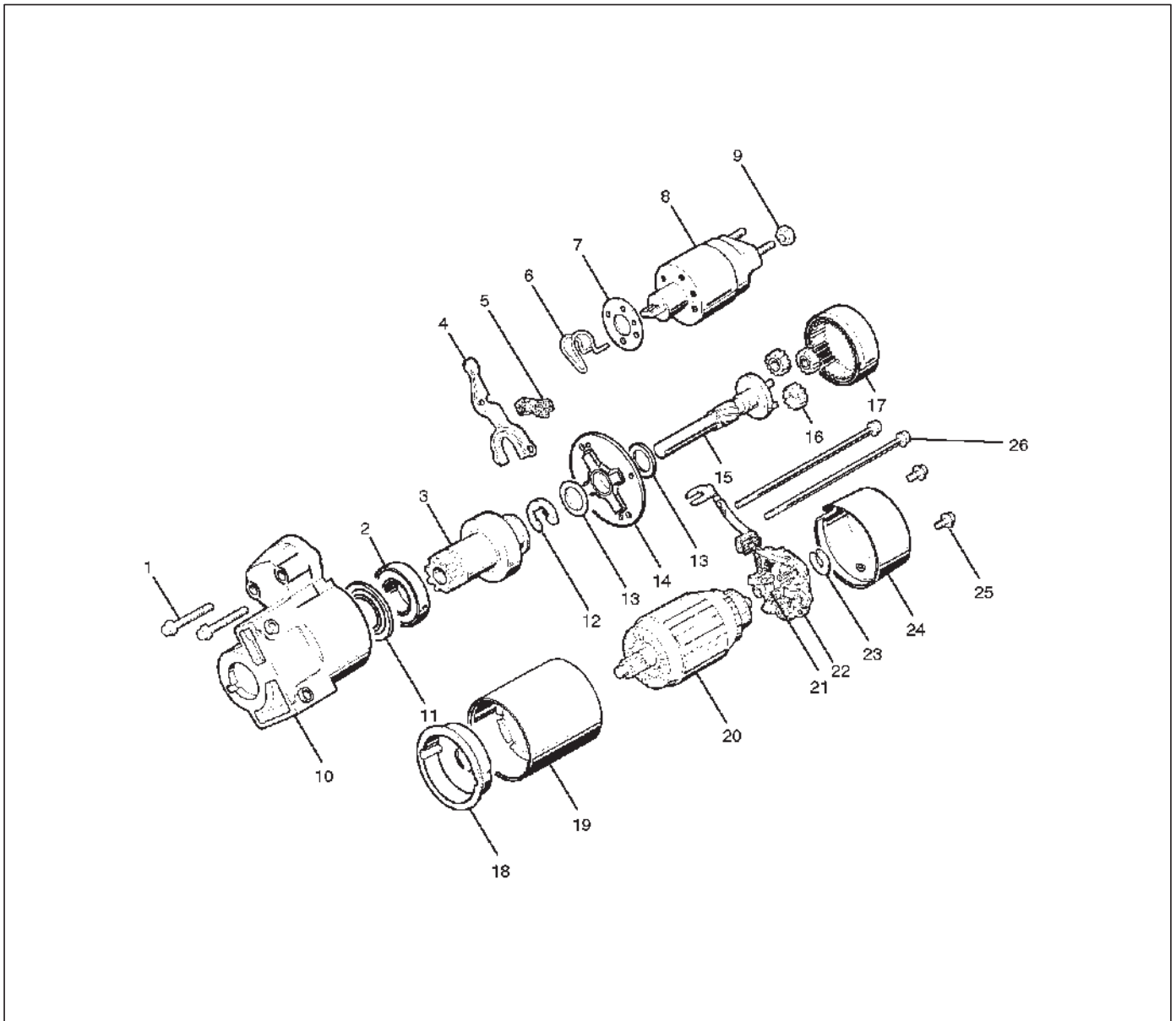
**Torque: 43 N·m (32 lb ft)**

6. Connect O<sub>2</sub> Sensor connectors (1).



7. Reconnect the battery ground cable.

Disassembled View



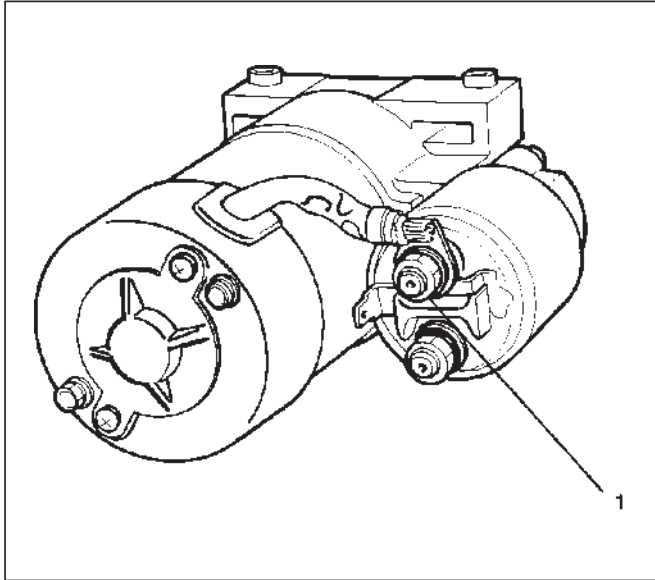
065RW002

**Legend**

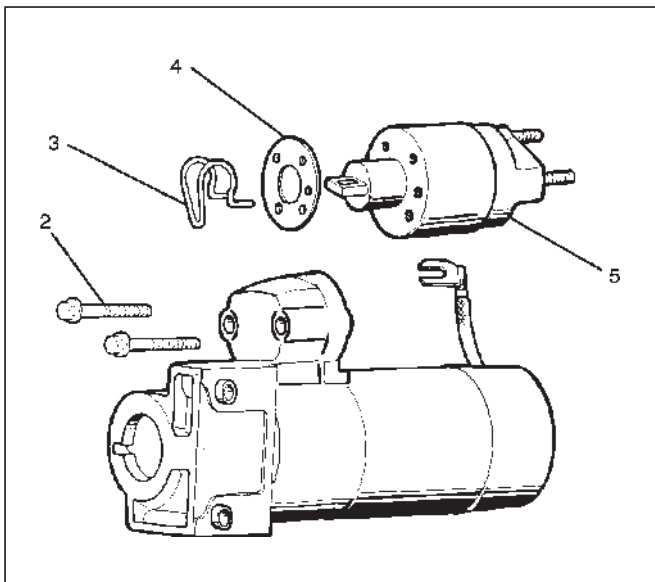
- |                        |                           |
|------------------------|---------------------------|
| (1) Bolt (2 pcs)       | (14) Center Bracket       |
| (2) Ball Bearing       | (15) Pinion Shaft         |
| (3) Pinion             | (16) Planet Gear (3)      |
| (4) Shift Lever        | (17) Internal Gear        |
| (5) Dust Cover         | (18) Center Bracket (A)   |
| (6) Torsion Spring     | (19) Yoke Assembly        |
| (7) Dust Cover         | (20) Armature             |
| (8) Magnetic Switch    | (21) Brush                |
| (9) Nut                | (22) Brush Holder         |
| (10) Gear Case         | (23) Thrust Washer        |
| (11) Bearing Cover     | (24) Rear Cover           |
| (12) E-Ring            | (25) Screw (2 pcs)        |
| (13) Thrust Washer (2) | (26) Through Bolt (2 pcs) |

## Disassembly

1. Loosen the nut(1) on terminal "M" of magnetic switch and disconnect the connector cable.
2. Remove bolt (2 pcs) (2).

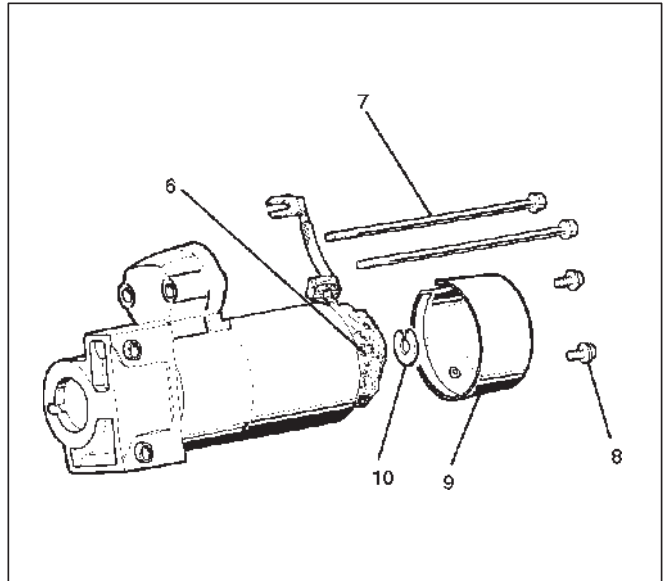


3. Remove magnetic switch(5).
4. Remove dust cover(4).
5. Remove torsion spring bolts, then the magnetic switch assembly.
6. Remove torsion spring(3) from magnetic switch assembly(5).

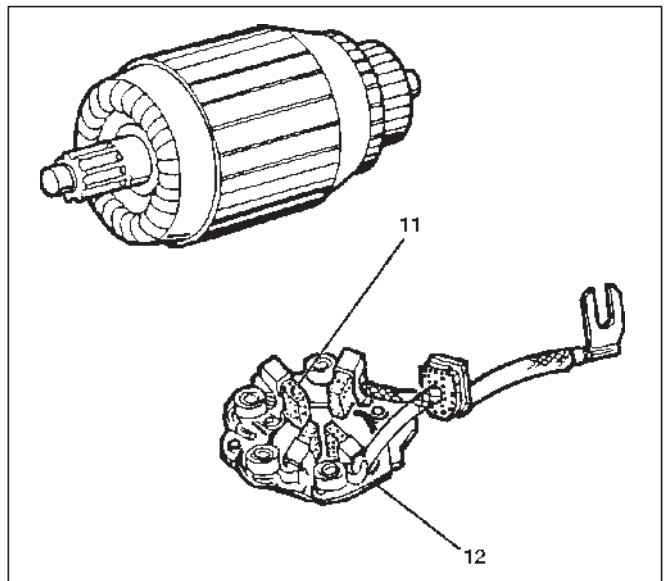


7. Remove screw (2 pcs) (8).
8. Remove through bolt (2 pcs) (7).

9. Remove screws and through bolts, then the rear cover(9) then remove thrust washer(10).
10. Remove brush holder(6).



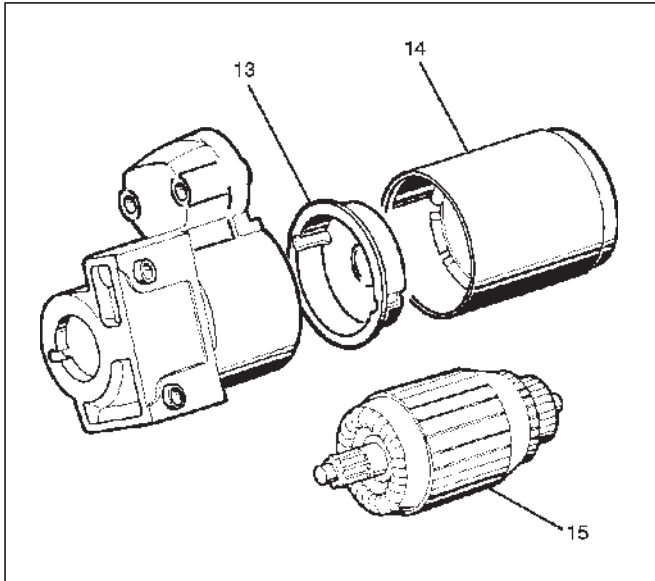
11. Raise a brush spring to detach brushes (4 pcs) from the commutator face and pull off the brush holder(12) and brush(11).



12. Remove yoke assembly(14).
13. Remove armature(15).
14. Pull off the yoke assembly, then remove armature, washer and center bracket.(A) (13).

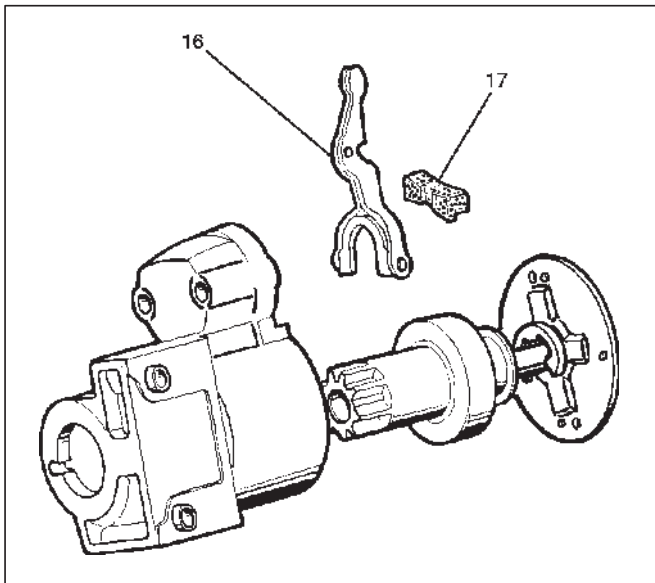
## 6D3-8 STARTING AND CHARGING SYSTEM

NOTE: In disassembling the yoke assembly, hold the armature and pull off slowly the yoke assembly. Because of strong magnetic force, avoid placing a metallic part near armature.



15. Remove dust cover(17).

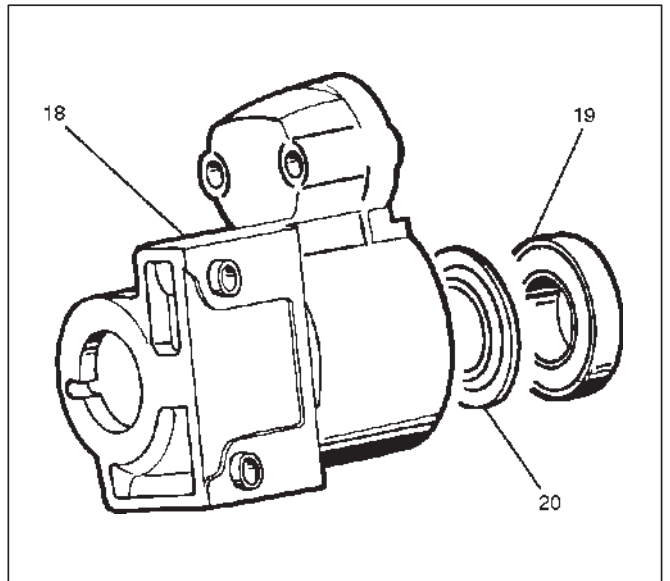
16. Remove a dust cover and shift lever(16) from the gear case.



17. Remove ball bearing(19).

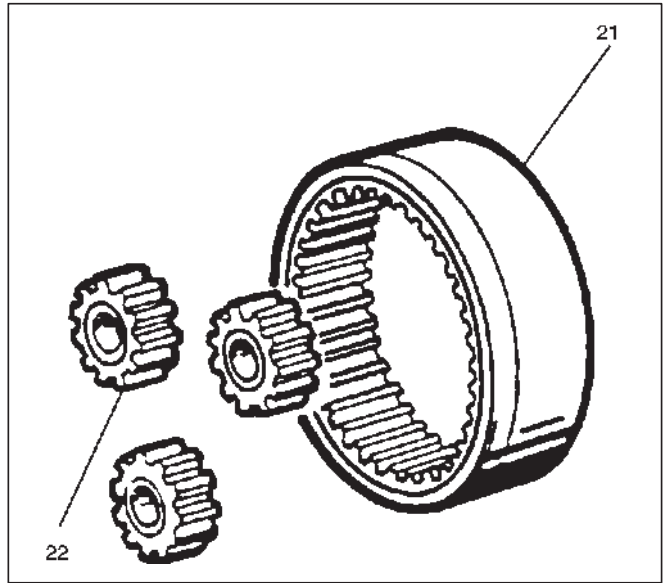
18. Remove bearing cover(20).

19. Remove a ball bearing and bearing cover from the gear case(18).

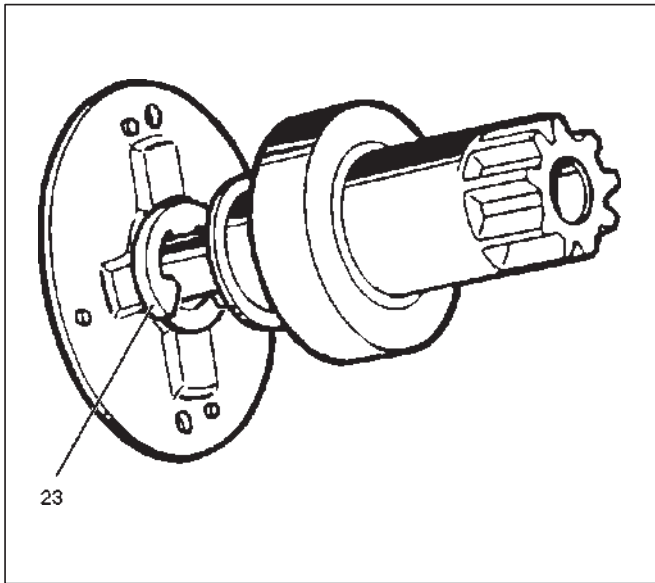


20. Internal gear(21).

21. Remove internal gear and planet gear(3) (22).



22. Remove an E-ring(23) from the pinion shaft using a flat blade screwdriver.

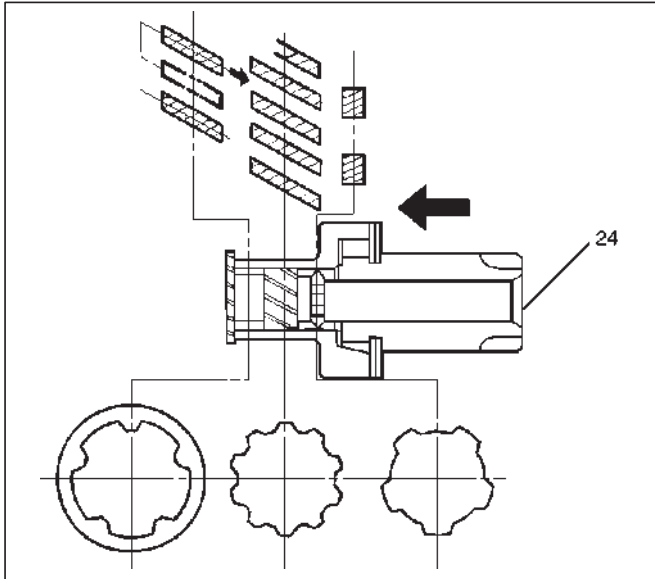


23. Holding the pinion shaft, push pinion toward the center bracket, and turn the pinion clockwise or counterclockwise by one tooth of spline, then pull off the pinion.

24. Remove thrust washer(24).

25. Remove center bracket

26. Remove pinion shaft.



## Inspection and Repair

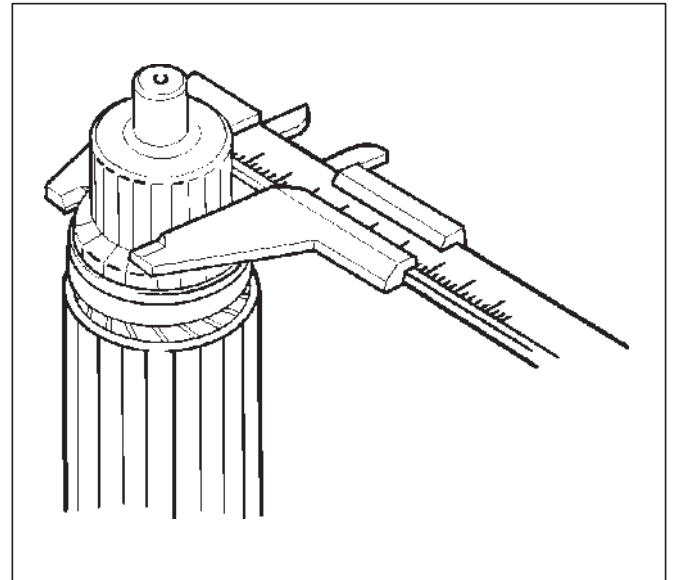
Repair or replace necessary parts if extreme wear or damage is found during inspection.

### Armature

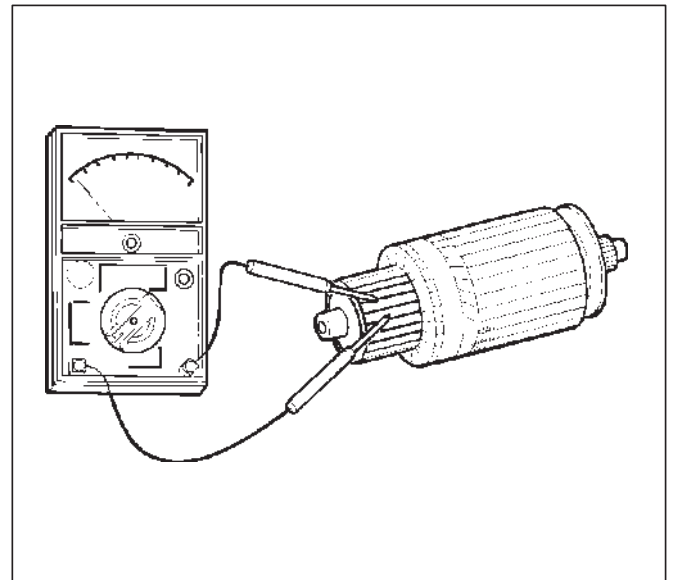
Measure the outer diameter of commutator, and replace with a new one if it is out of the limit.

**Standard: 33.0 mm (1.30 in)**

**Limit: 32.0 mm (1.26 in)**



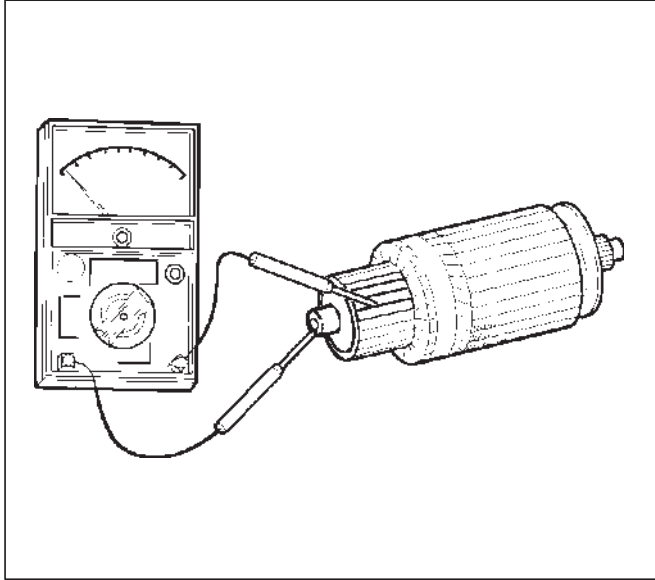
Check for continuity between commutator and segment. Replace commutator if there is no continuity (i.e., disconnected).





## 6D3-10 STARTING AND CHARGING SYSTEM

Check for continuity between commutator and shaft. Also, check for continuity between commutator and armature core, armature core and shaft. Replace commutator if there is continuity (i.e., internally grounded).



065RS016

Measure runout of armature core and commutator with a dial gauge. Repair or replace, if it exceeds the limit.

### Armature

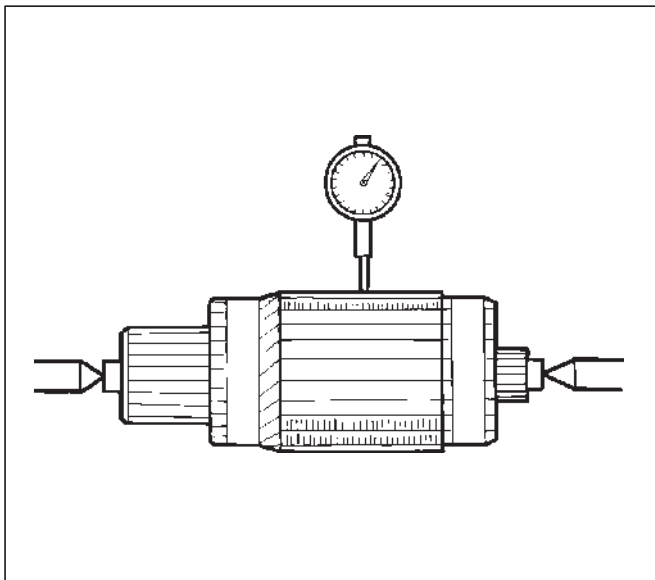
**Standard: 0.05 mm (0.002 in) Max.**

**Limit: 0.10 mm (0.004 in)**

### Commutator

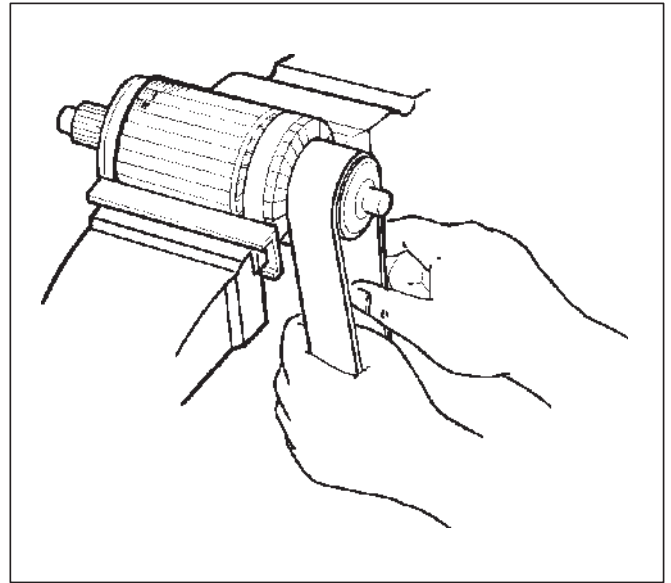
**Standard: 0.05 mm (0.002 in) Max.**

**Limit: 0.10 mm (0.004 in)**



065RS017

Polish the commutator surface with sandpaper #500 to #600 if it is rough.

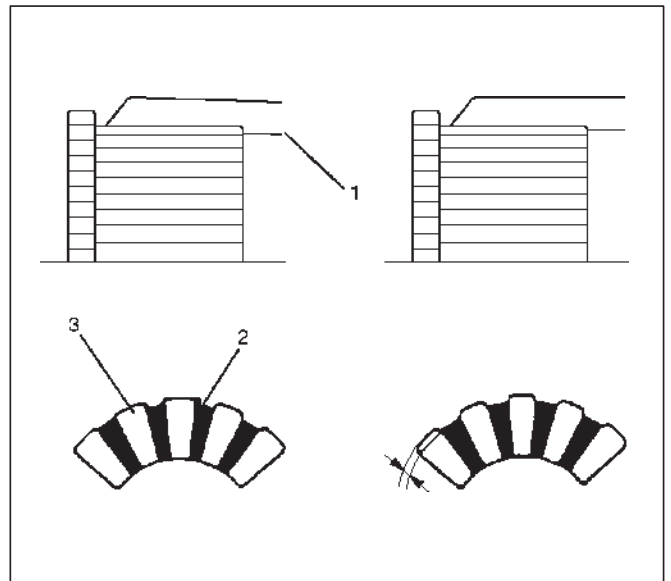


065RW012

Measure the depth of insulator in commutator. Repair, if it is below the limit.

**Standard: 0.05 mm to 0.8 mm (0.02 in to 0.03 in)**

**Limit: 0.2 mm (0.008 in)**



065RW013

### Legend

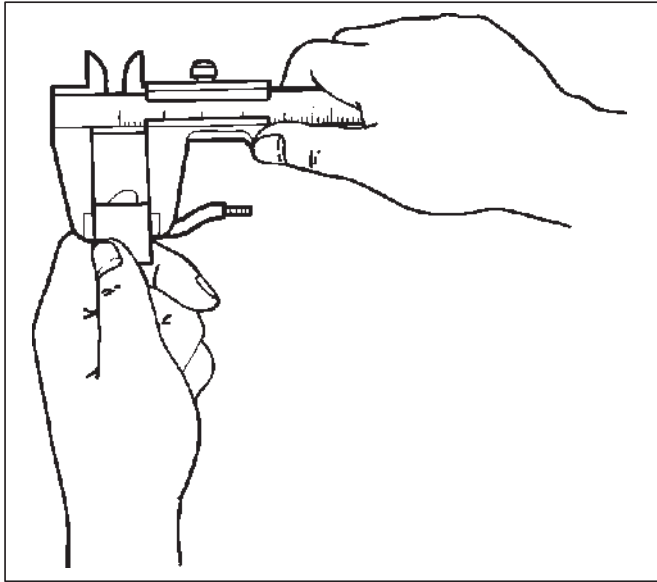
- (1) Steel Saw
- (2) Insulator
- (3) Commutator Segments

**Brush**

Measure the length of brush.  
 Replace with a new one, if it is below the limit.

**Standard: 16 mm (0.63 in)**

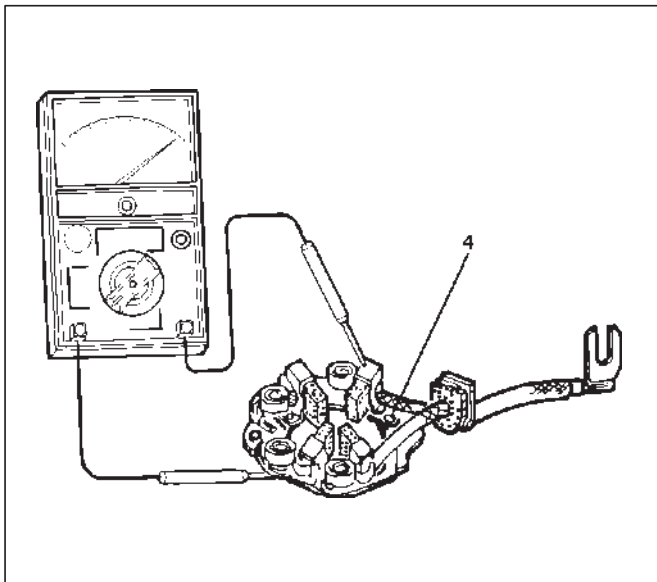
**Limit: 11 mm (0.43 in)**



065RW014

**Brush Holder**

Check for continuity between brush holder (+) (4) and base (-). Replace, if there is continuity (i.e., insulation is broken).

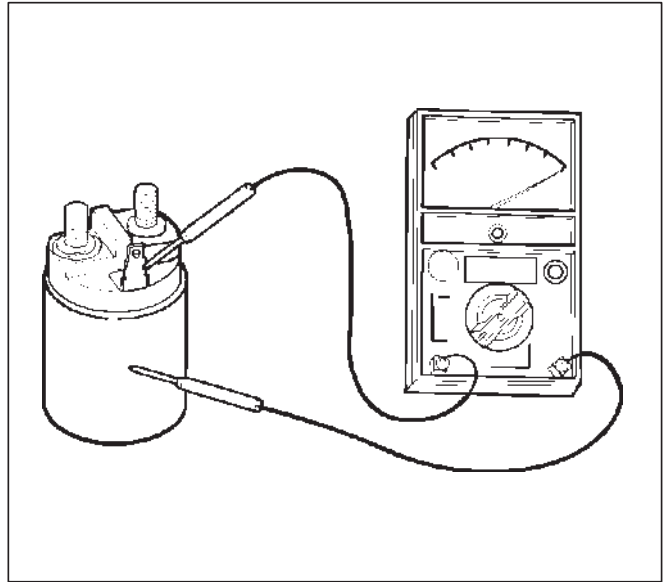


065RW015

**Magnetic Switch**

Check for continuity of shunt coil between terminals S and M.

Replace, if there is no continuity (i.e., coil is disconnected).

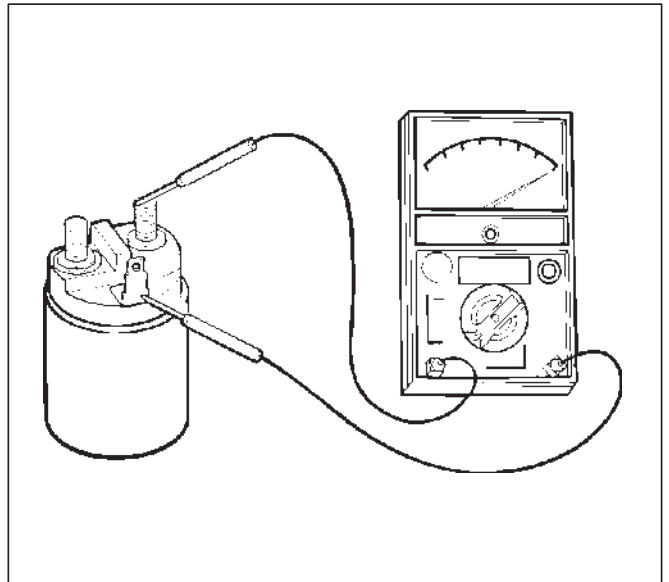


065RW016

**Continuity of Series Coil**

Check for continuity between terminals S and M.

Replace, if there is no continuity (i.e., coil is disconnected).

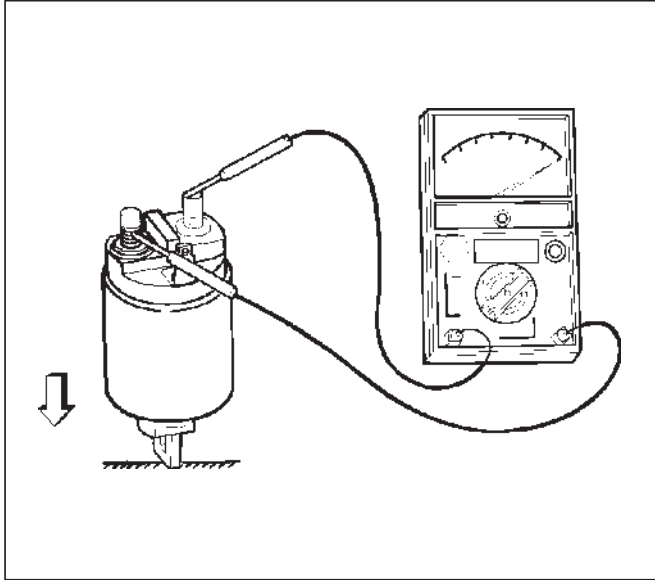


065RW017

## 6D3-12 STARTING AND CHARGING SYSTEM

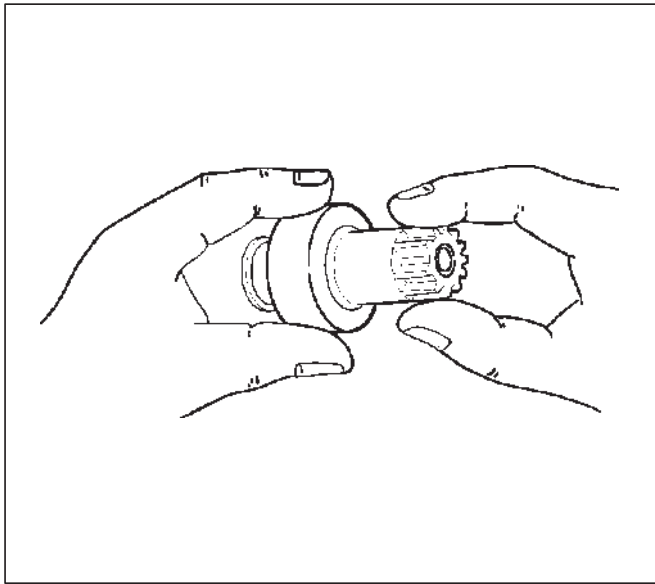
### Continuity of Contacts

With the plunger faced downward, push down the magnetic switch. In this state, check for continuity between terminals B and M. Replace, if there is no continuity (i.e., contacts are faulty).



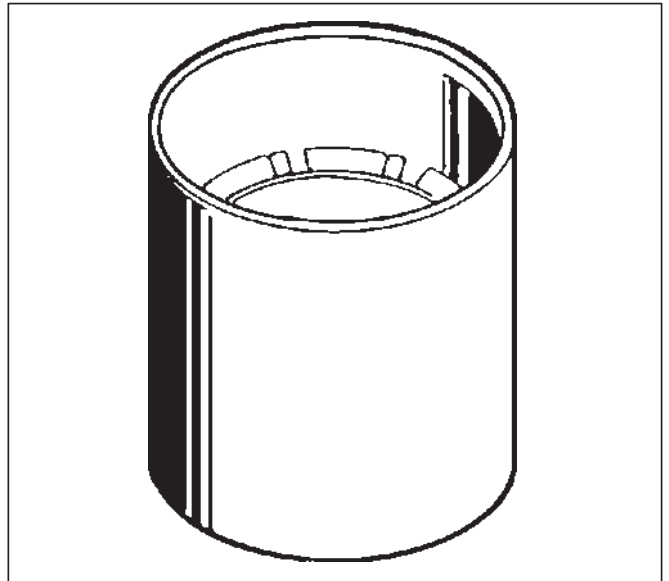
### Pinion

Check if the pinion rotates smoothly in drive direction by hand, or if it is locked when it is rotated in reverse. If not, replace the pinion.



### Yoke Assembly

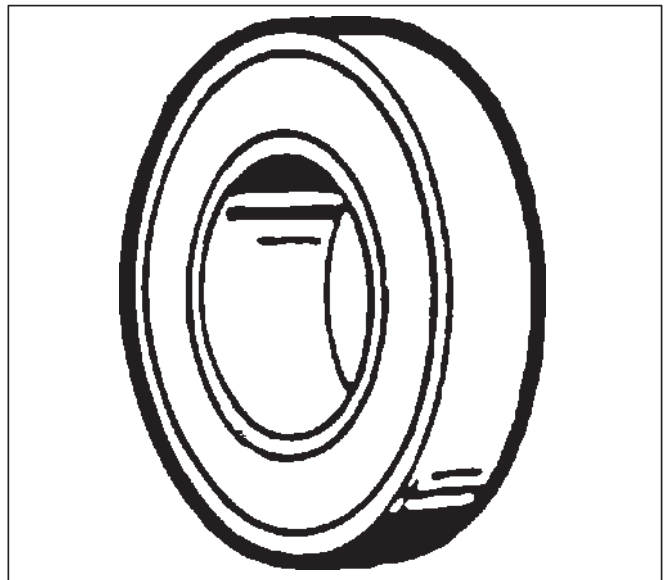
Check a magnet inside the yoke. Replace the yoke assembly if it is broken.



### Ball Bearing

Clamp the inner race of the ball bearing with your finger, and check for sticking or play when rotating the outer race.

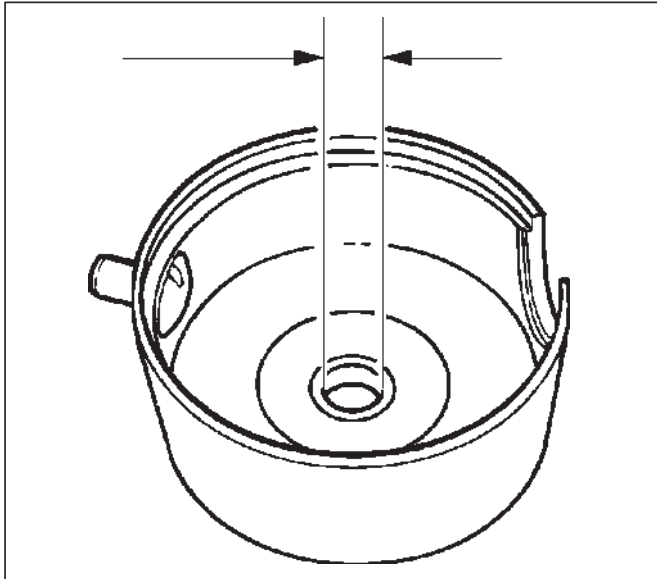
Replace, if abnormality is found.



Measure inner diameter of bushing in the rear cover, and replace if it exceeds the limit.

**Standard: 12.50 mm to 12.527 mm (0.492 in to 0.4932 in)**

**Limit: 12.60 mm (0.4961 in)**

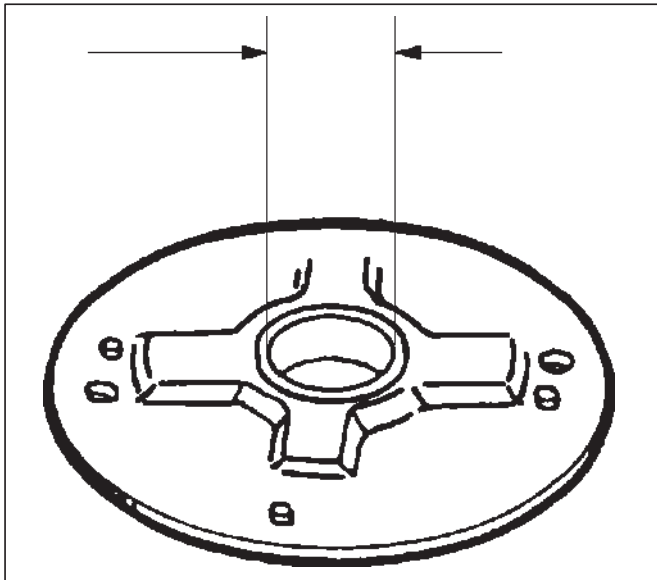


069RS028

Measure inner diameter of bushing in the center bracket (P), and replace if it exceeds the limit.

**Standard: 18.01 mm to 18.127 mm (0.7091 in to 0.7137 in)**

**Limit: 18.15 mm (0.7146 in)**



069RS029

## Reassembly

To install, follow the removal steps in the reverse order, noting the following points:

### Grease application places

- Bushing in rear cover and center bracket
- Gears in reduction gear
- Shift lever operating portion
- Sliding portion of pinion
- Plunger sliding portion of magnetic switch

### Reassembling Yoke Assembly

Before reassembly, make sure that no metallic parts attach to the yoke assembly. Because of strong magnetic force, hold the yoke assembly and insert it slowly into the armature.

### Torque

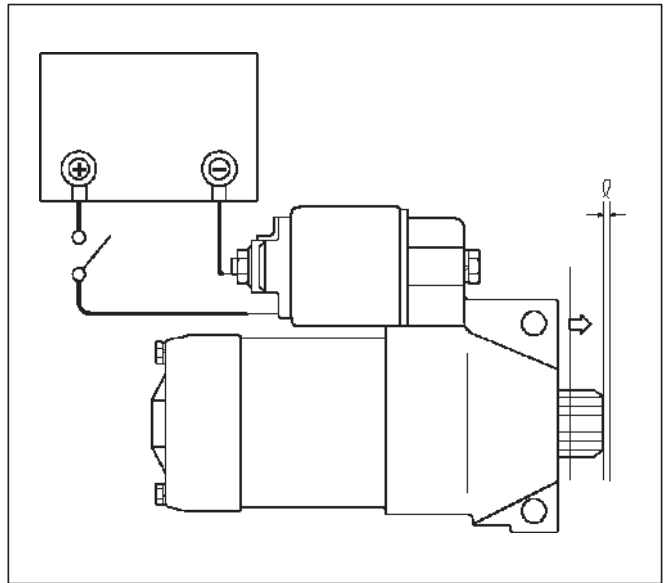
Torque for each part (See Torque Specifications in this section)

### Pinion Jump-out Dimension

Connect the “+” cable of battery to terminal S and the “-” cable to terminal M. Turn the switch on, and measure pinion travel dimension in thrust direction from the jump-out position.

In measuring the dimension, pull the pinion out a little in the arrow direction.

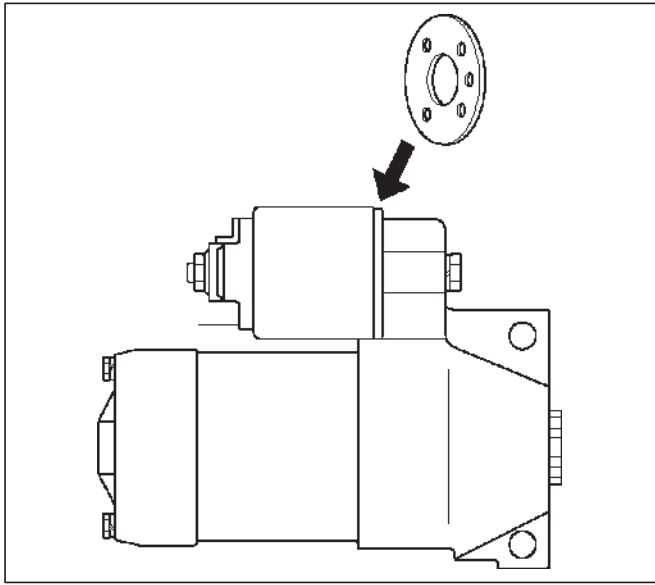
**Dimension(L): 0.05 mm to 1.5 mm (0.002 in to 0.06 in)**



069RS030

## 6D3-14 STARTING AND CHARGING SYSTEM

If the measured value is out of standard, insert dust cover, or disassemble and adjust.



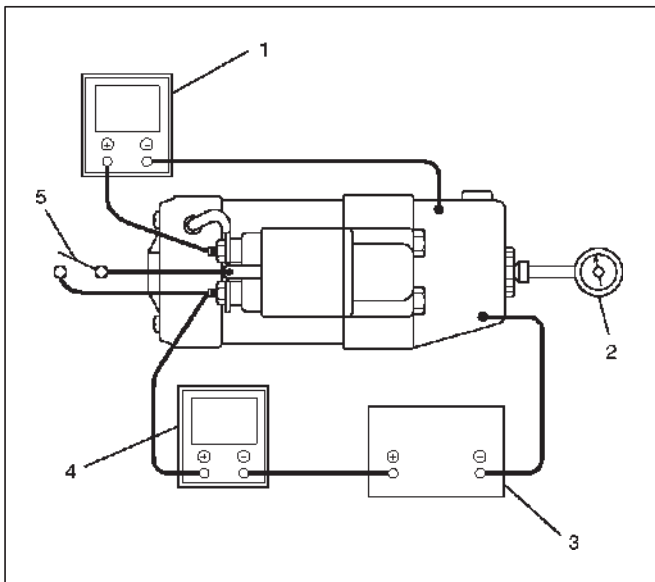
065RW019

### Characteristic Test

For easily confirming the characteristics, conduct the no load test as follows:

Rating as short as 30 seconds requires rapid testing.

Fix the starter on the test bench, and wire as shown in illustration. When the switch is closed, the current flows and the starter runs under no load. At this time, measure current, voltage and speed to check if they satisfy the standard.



065RW020

### Legend

- (1) Volt Meter
- (2) Tachometer
- (3) Battery
- (4) Ammeter
- (5) Switch

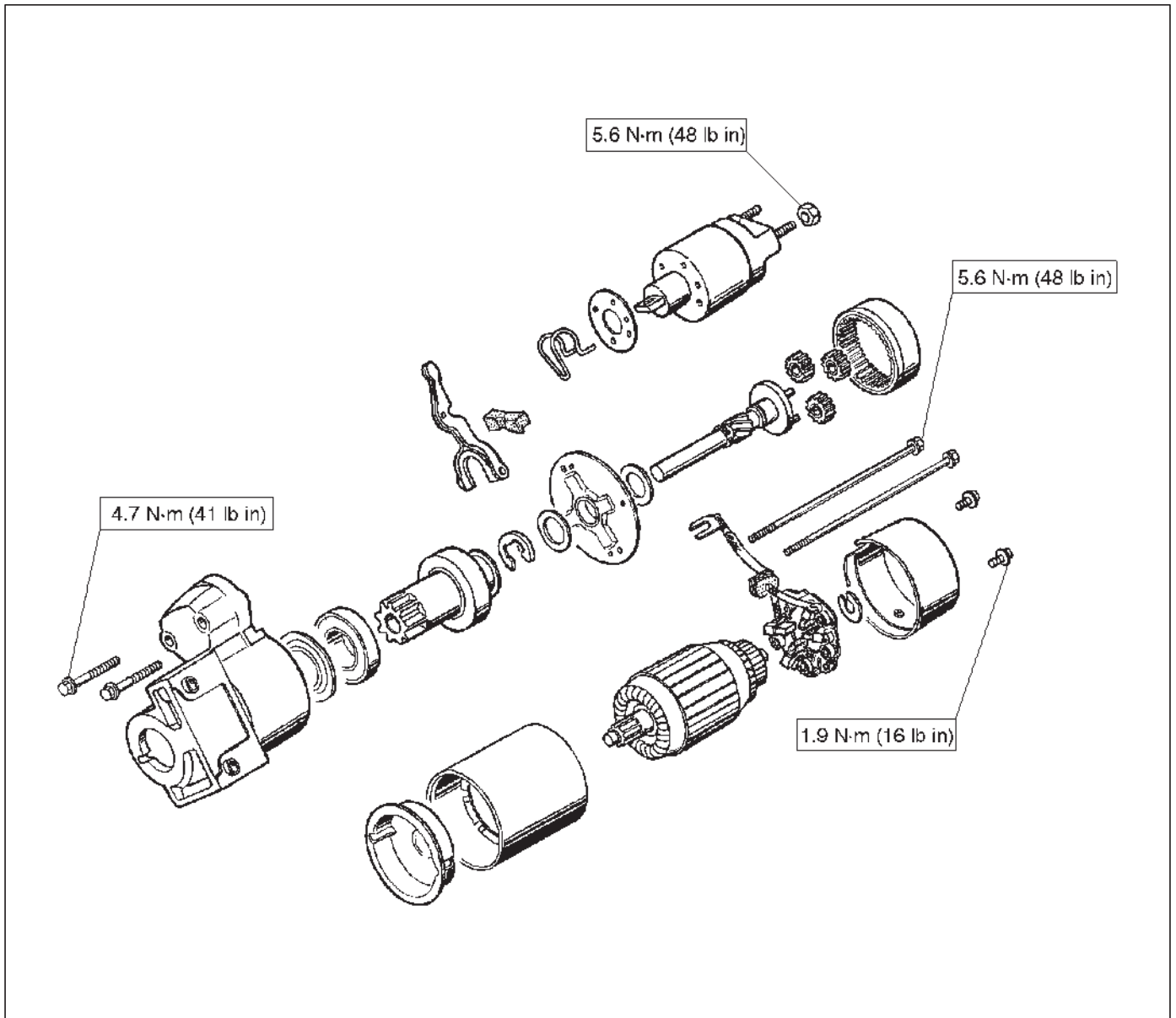
## Main Data and Specifications

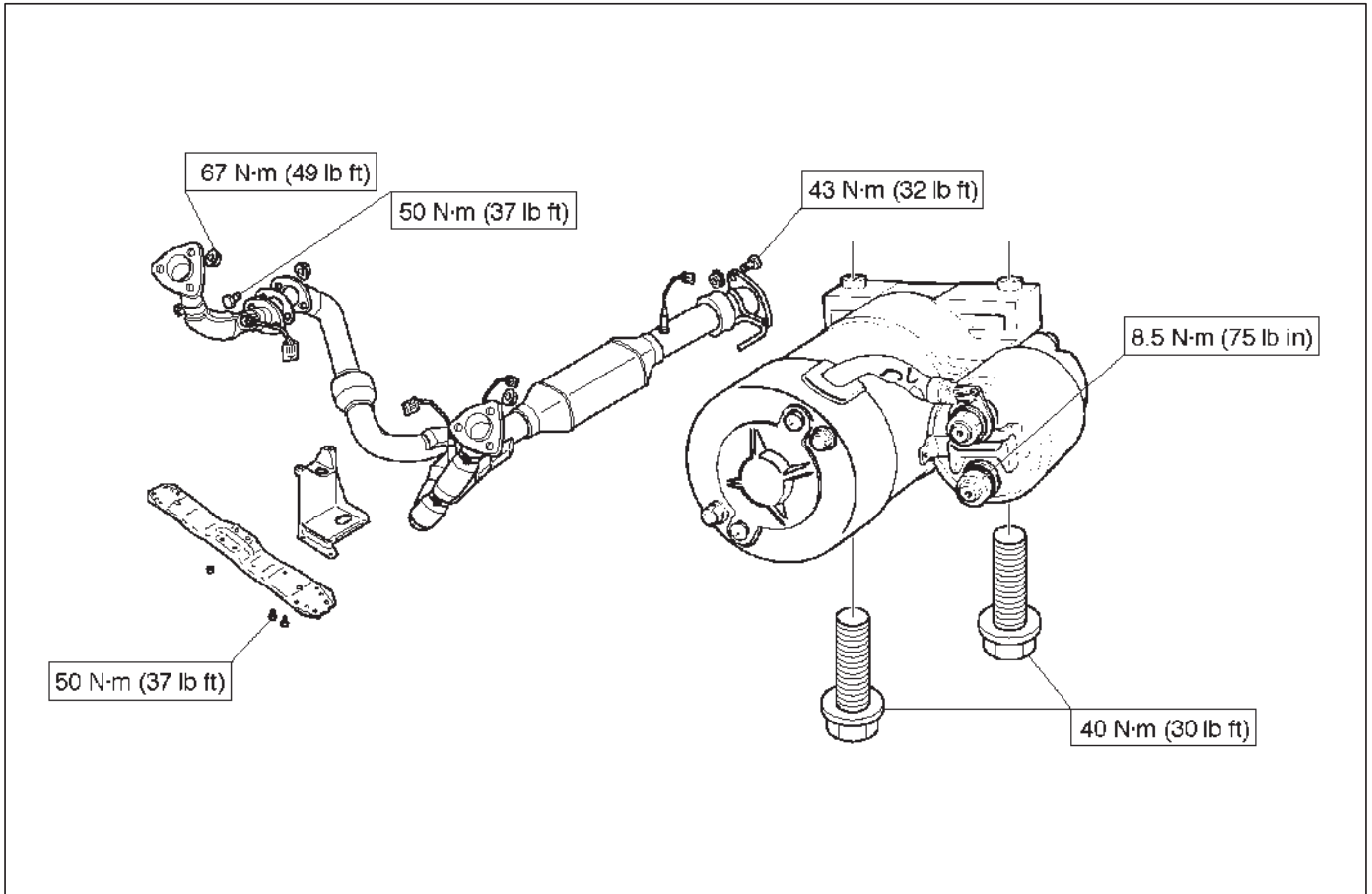
### General Specifications

Model	Specifications
Rating	
Voltage	12 V
Output	1.4 Kw
Time	30 sec
Number of teeth of pinion	9
Rotating direction(as viewed from pinion)	Clockwise
Weight(approx.)	37 N
No load characteristics	
Voltage /Current	11.5V/90A or less
Speed	3000rpm or more
Load characteristics	
Voltage/current	8.5V/350A
Torque	13.2N·m(9.7lb·in.) or more
Speed	1000rpm or more
Locking characteristics	
Voltage/current	2.4V/500A or less
Torque	11.8N·m(8.7lb·in) or more

## 6D3-16 STARTING AND CHARGING SYSTEM

### Torque Specifications







## Charging System

### General Description

The IC integral regulator charging system and its main components are connected as shown in the illustration.

The regulator is a solid state type and it is mounted along with the brush holder assembly inside the generator installed on the rear end cover.

The generator does not require particular maintenance such as voltage adjustment.

The rectifier connected to the stator coil has eight diodes to transform AC voltage into DC voltage.

This DC voltage is connected to the output terminal of generator.

### General On-Vehicle Inspection

The operating condition of charging system is indicated by the charge warning lamp. The warning lamp comes on when the starter switch is turned to "ON" position. The charging system operates normally if the lamp goes off when the engine starts.

If the warning lamp shows abnormality or if undercharged or overcharged battery condition is suspected, perform diagnosis by checking the charging system as follows:

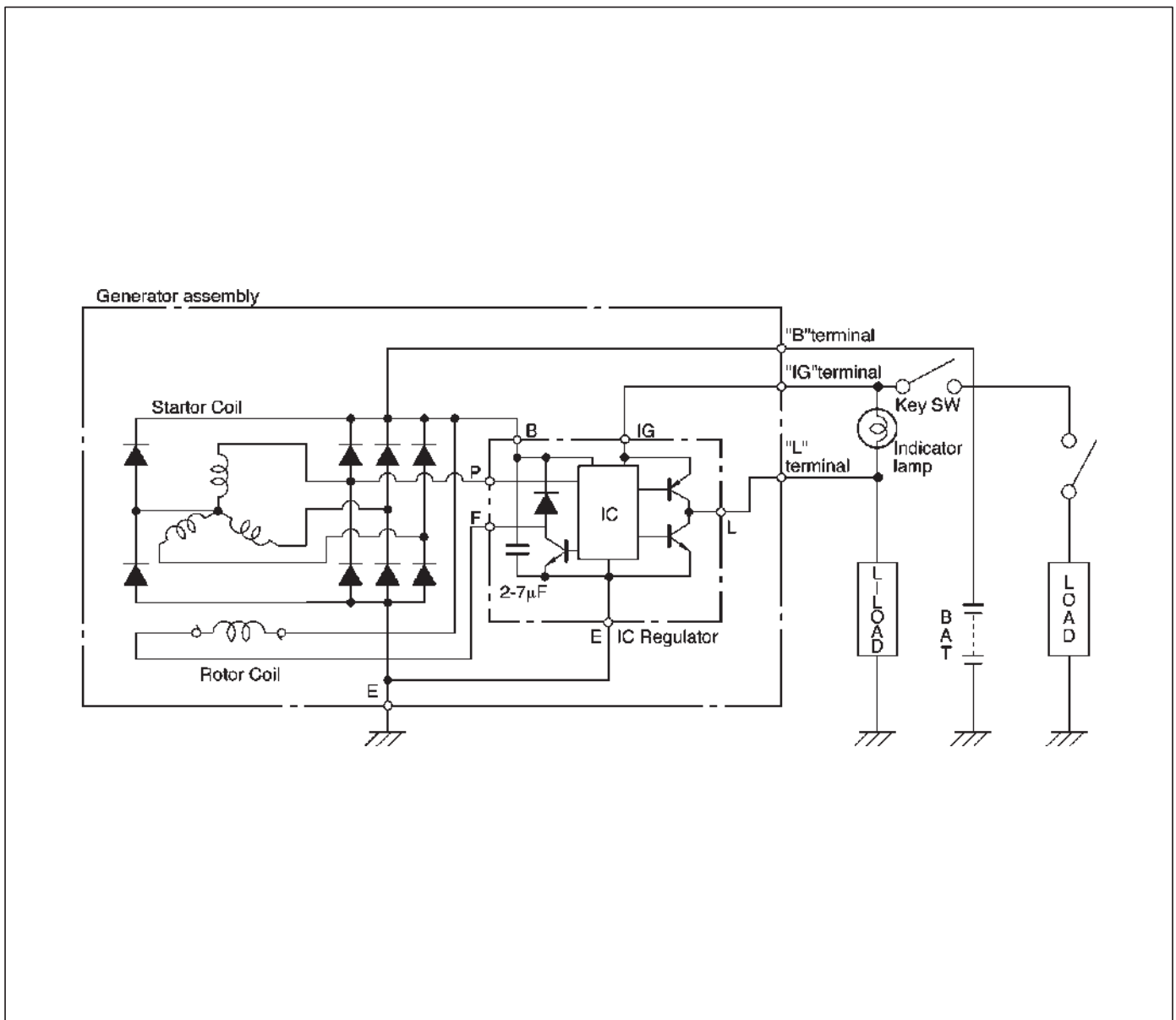
1. Check visually the belt and wiring connector.
2. With the engine stopped, turn the stator switch to "ON" position and observe the warning lamp.

If lamp does not come on:

Disconnect wiring connector from generator, and ground the terminal "L" on connector side.

If lamp comes on:

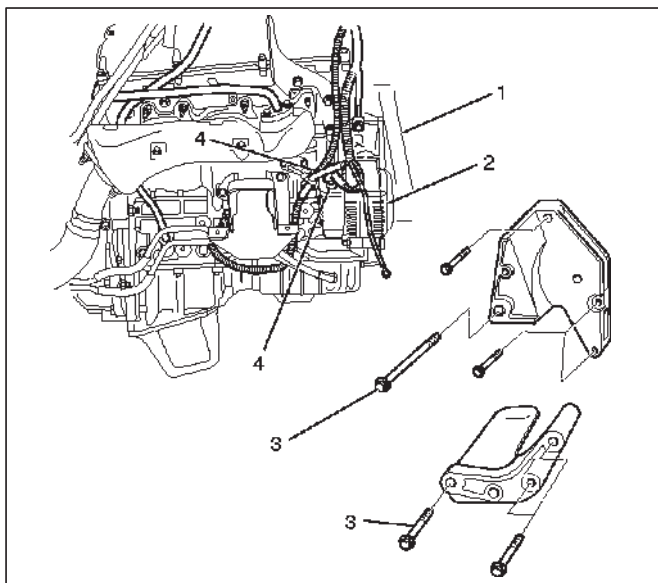
Repair or replace the generator.



## Generator

### Removal

1. Disconnect battery ground cable.
2. Move drive belt tensioner to loose side using wrench then remove drive belt (1).
3. Disconnect the wire from terminal "B" and disconnect the connector (4).
4. Remove generator fixing bolt (3).
5. Remove generator assembly (2).



060RW002

3. Reconnect the wiring connector to the generator, run the engine at middle speed, and turn off all electrical devices other than engine.
4. Measure battery voltage. If it exceeds 16V, repair or replace the generator.
5. Connect an ammeter to output terminal of generator, and measure output current under load by turning on the other electrical devices (eg., head lights). At this time, the voltage must not be less than 13V.

### Installation

1. Install generator assembly to the position to be installed.
2. Install generator assembly and tighten the fixing bolts to the specified torque.

#### Torque:

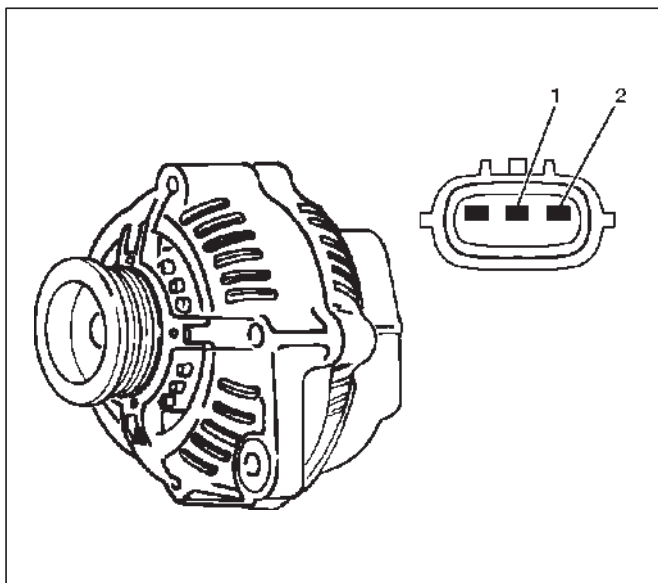
**M10 bolt: 41 N·m (30 lb ft)**

**M8 bolt: 21 N·m (15 lb ft)**

3. Connect wiring harness connector and direct terminal "B".
4. Move drive belt tensioner to loose side using wrench, then install drive belt to normal position.
5. Reconnect battery ground cable.

### Inspection

1. Disconnect the wiring connector from generator.
2. With the engine stopped, turn starter switch to "ON" and connect a voltmeter between connector terminal L (2) and ground or between terminal IG (1) and ground.

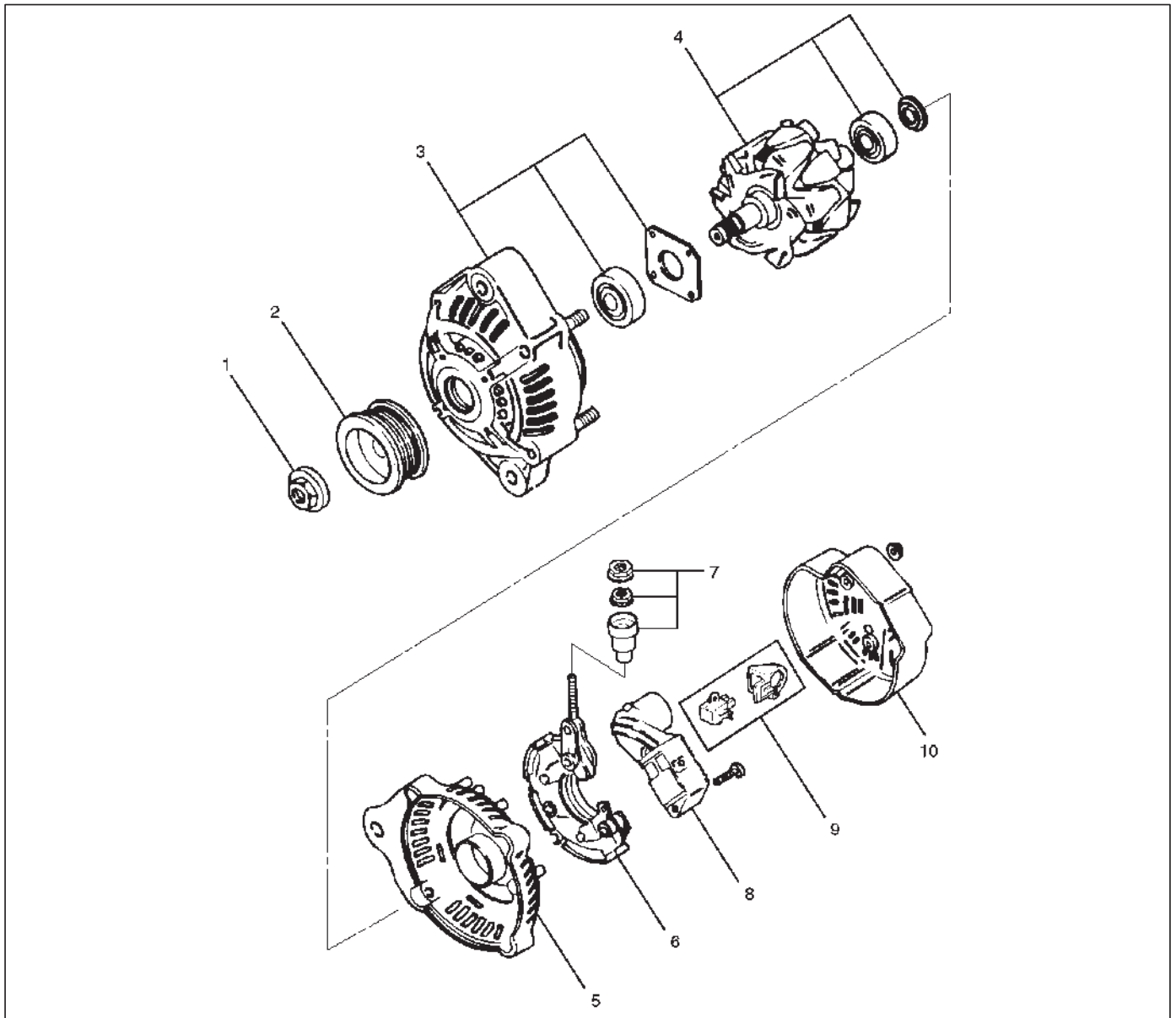


066RW001

If voltage is not present, the line between battery and connector is disconnected and so requires repair.

## 6D3-20 STARTING AND CHARGING SYSTEM

### Disassembled View

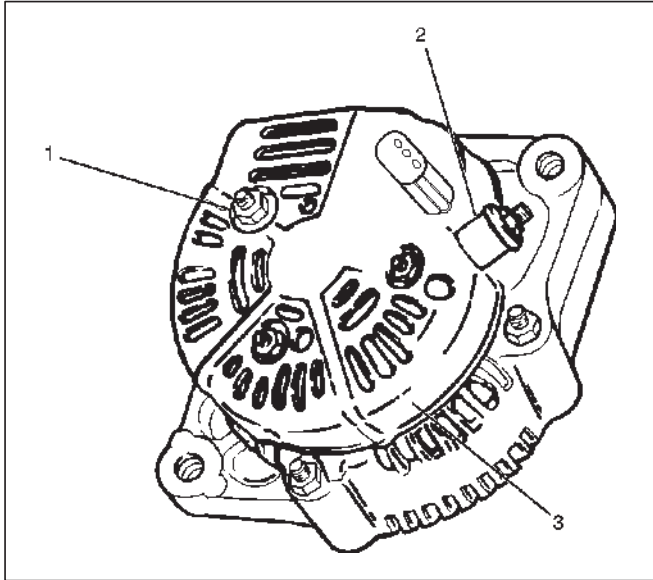


#### Legend

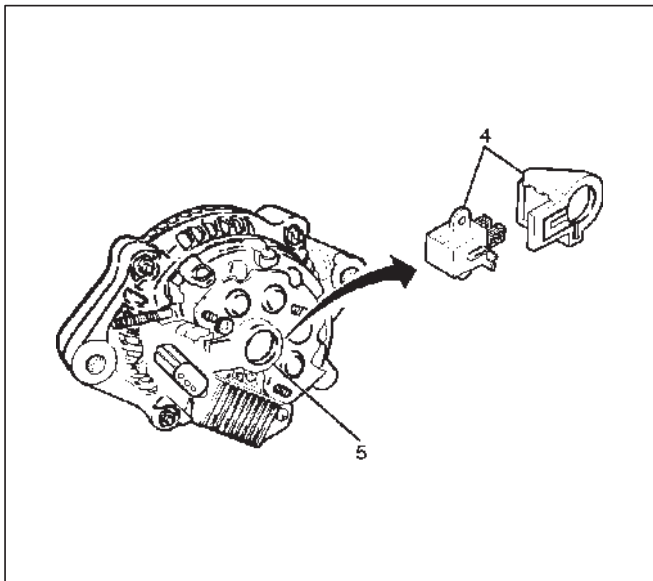
- |                          |                                |
|--------------------------|--------------------------------|
| (1) Pulley Nut           | (6) Rectifier                  |
| (2) Pulley               | (7) Terminal Insulator and Nut |
| (3) Front Cover Assembly | (8) Regulator Assembly         |
| (4) Rotor Assembly       | (9) Brush Holder Assembly      |
| (5) Rear End Cover       | (10) Rear Cover                |

## Disassembly

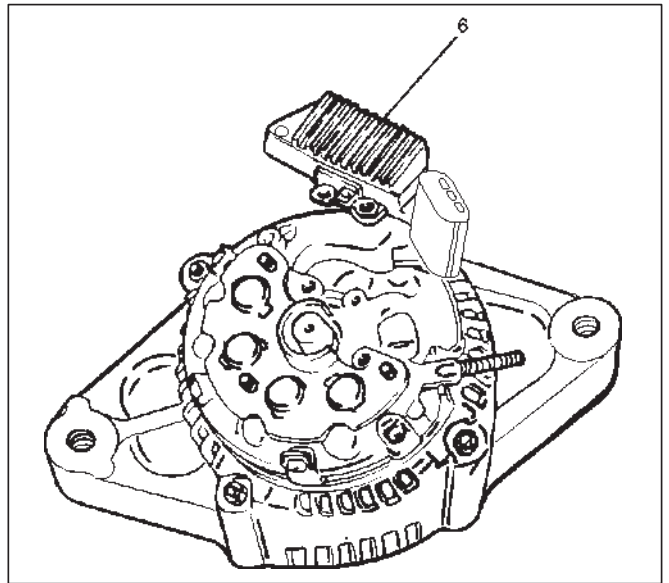
1. Terminal insulator and nut(2).
2. Remove three nuts(1) on the rear cover and a nut on terminal B and insulator, then remove the rear cover(3).



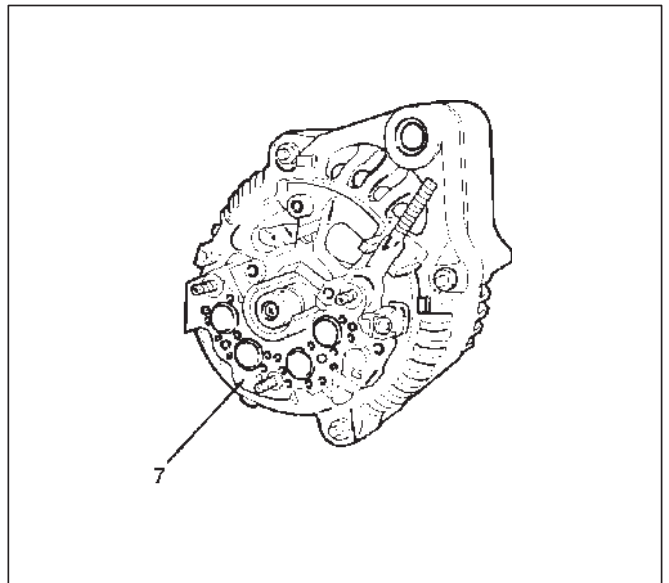
3. Remove two screws that fix the brush holder(5) and rectifier, then remove the brush holder assembly(4).



4. Remove three screws on the IC regulator, then the IC regulator assembly(6).

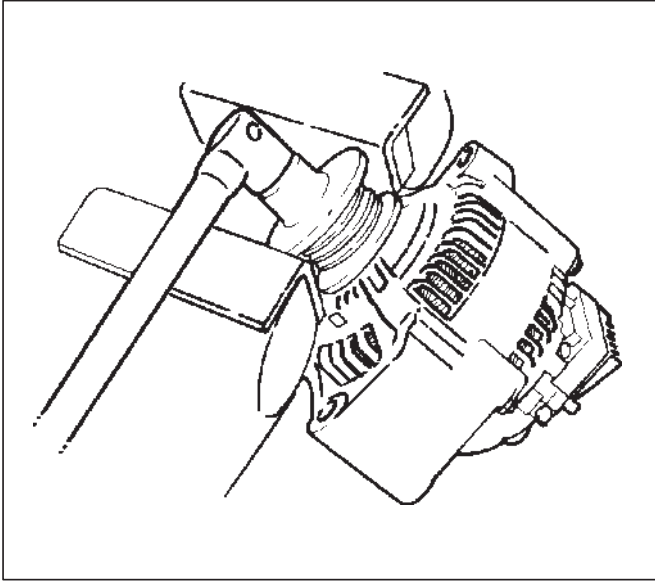


5. Remove four screws that fix rectifier(7) and stator lead wires.



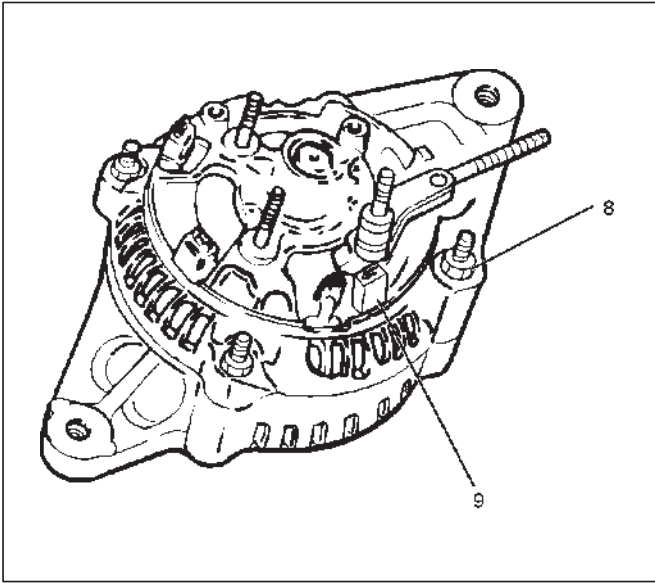
## 6D3-22 STARTING AND CHARGING SYSTEM

6. Secure the pulley directly in the vise between two copper plates, and remove the nut and pulley.



066RS010

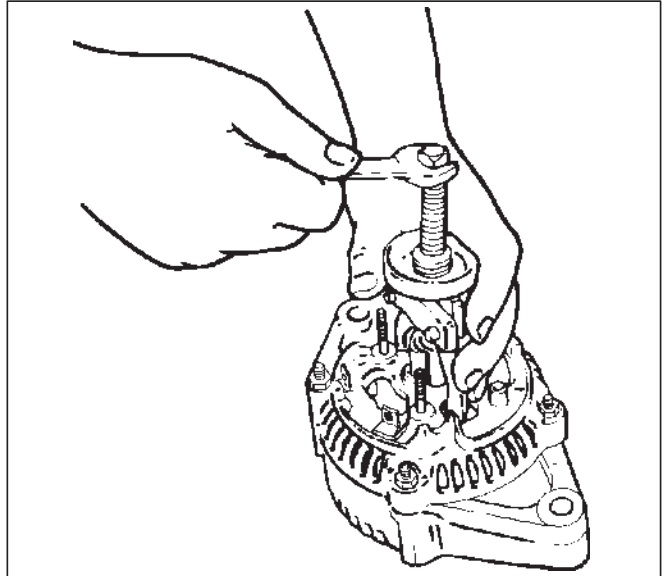
7. Remove four nuts(8) that secure the front cover assembly and rear end cover, and an insulator(9).



066RW005

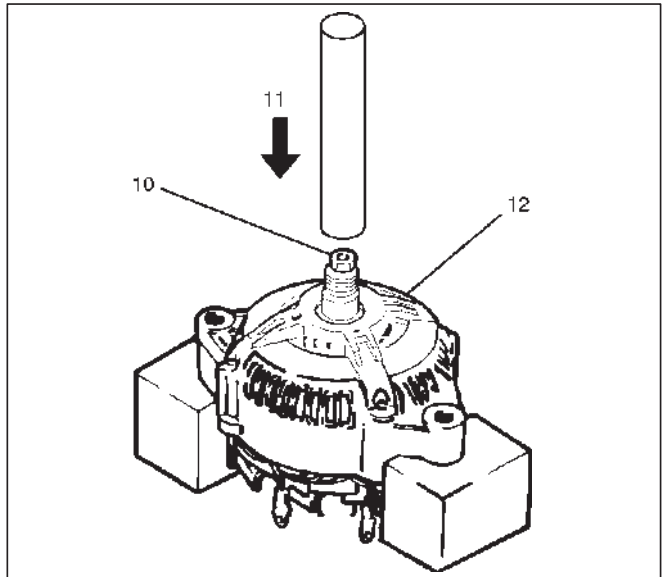
8. Use the puller to remove the rear end cover.

9. Rotor assembly



066RS012

10. Pull the rotor assembly(10) off the front cover assembly(12) using a bench press(11).



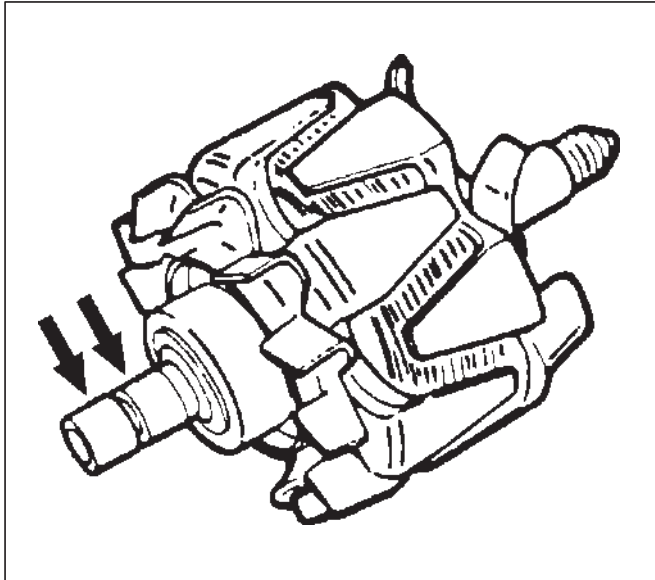
066RW006

## Inspection and Repair

Repair or replace necessary parts if extreme wear or damage is found during inspection.

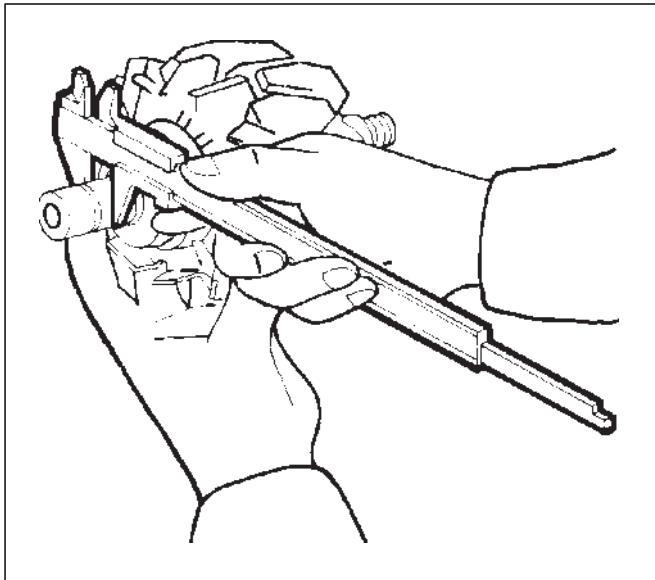
### Rotor Assembly

1. Check the rotor slip ring surfaces for contamination and roughness. If rough, polish with #500—600 sandpaper.



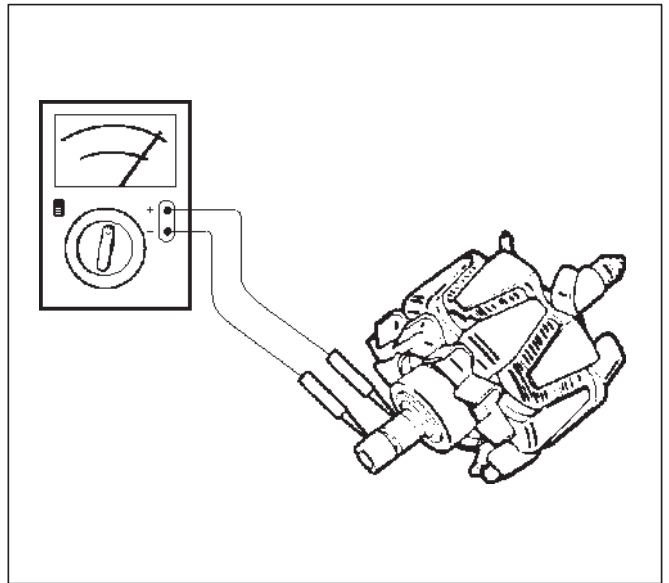
066RS014

2. Measure the slip ring diameter, and replace if it exceeds the limit.



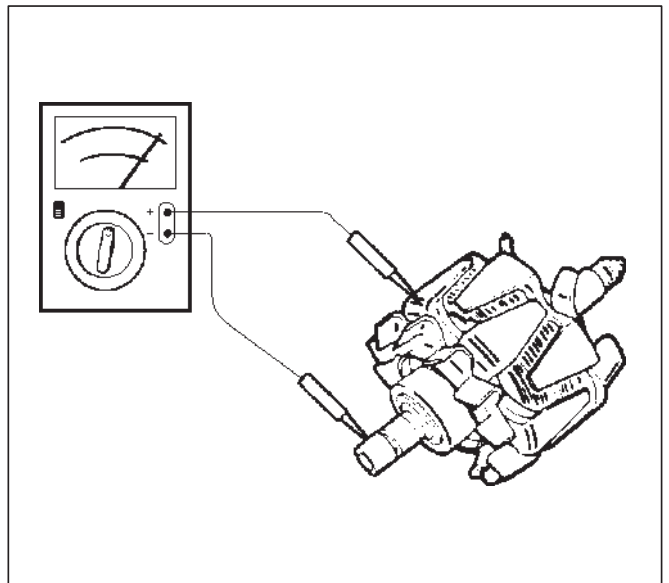
066RS015

3. Check resistance between slip rings, and replace if there is no continuity.



066RS016

4. Check for continuity between slip ring and rotor core. In case of continuity, replace the rotor assembly.

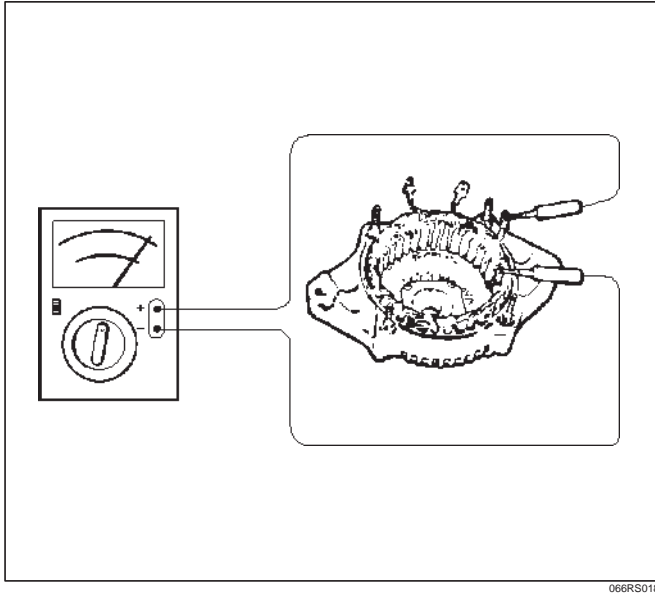


066RS017

## 6D3-24 STARTING AND CHARGING SYSTEM

### Stator Coil

1. Measure resistance between respective phases.
2. Measure insulation resistance between stator coil and core with a mega-ohmmeter.  
If less than standard, replace the coil.

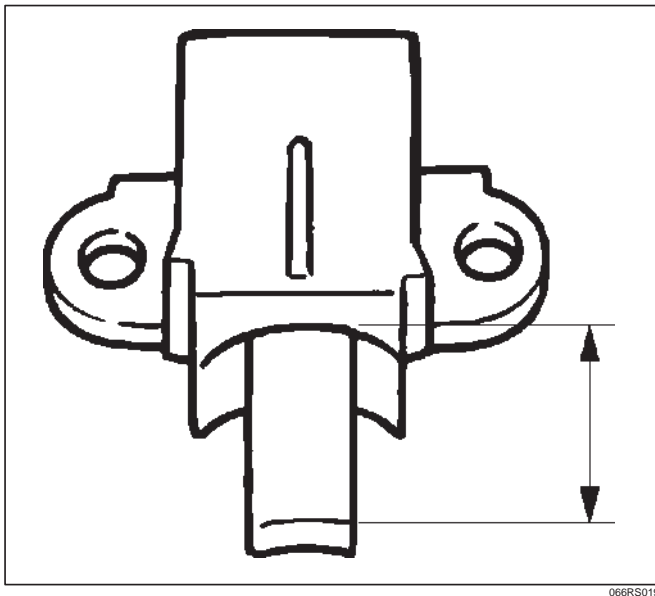


### Brush

Measure the brush length.  
If more than limit, replace the brush.

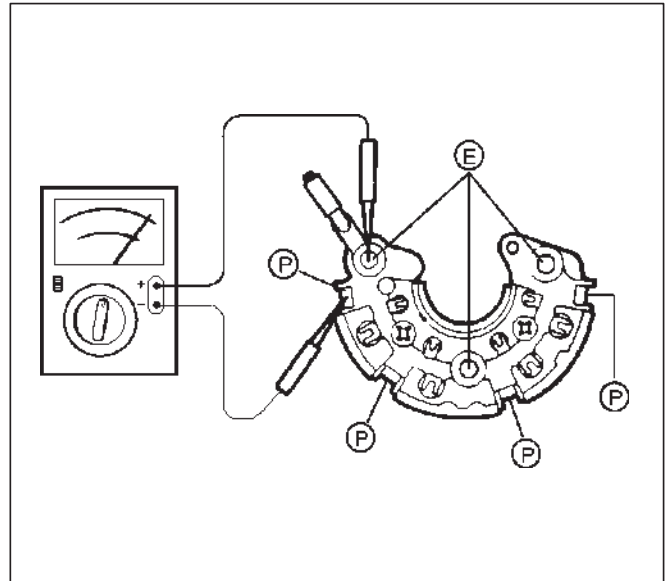
**Standard: 10.mm (0.4134 in)**

**Limit: 8.4.mm (0.3307 in)**



### Rectifier Assembly

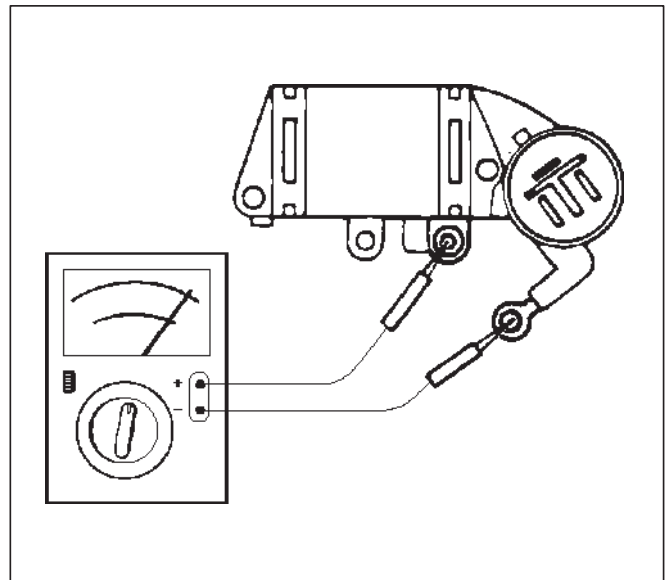
Check for continuity across "P" and "E" in the  $\times 100W$  range of multimeter.



Change polarity, and make sure that there is continuity in one direction, and not in the reverse direction. In case of continuity in both directions, replace the rectifier assembly.

### IC Regulator Assembly

Check for continuity across "B" and "F" in the  $\times 100W$  range of multimeter.

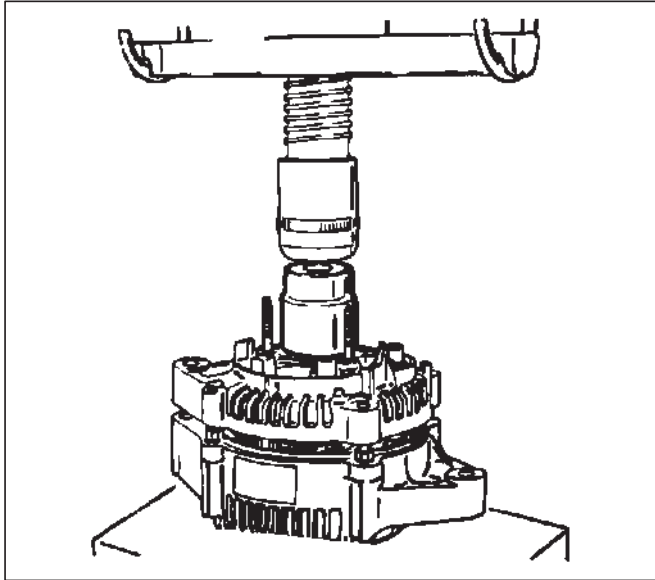


Change polarity, and make sure that there is continuity in one direction, and not in the reverse direction. In case of continuity in both directions, replace the IC regulator assembly.

## Reassembly

To reassemble, follow the disassembly steps in the reverse order, noting the following points:

1. Using a press with a socket wrench attached, reassemble rotor and rear end cover assembly in the front cover.

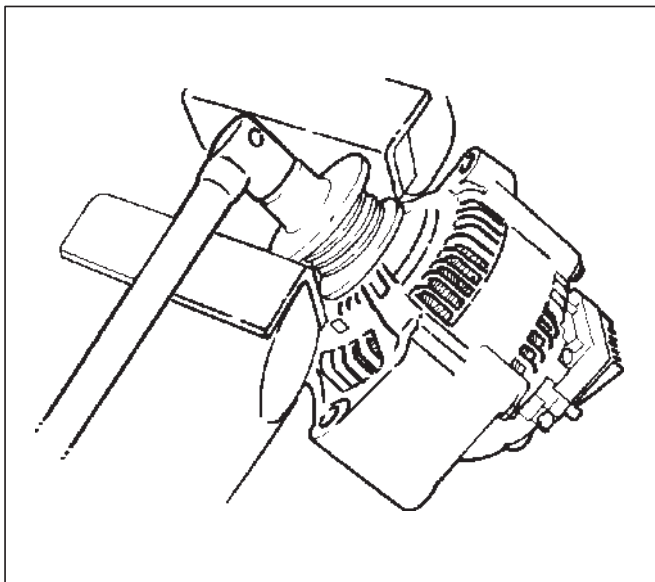


066RS022

2. Install pulley on the rotor.

Secure the pulley directly in the vise between two copper plates, and tighten nut to the specified torque.

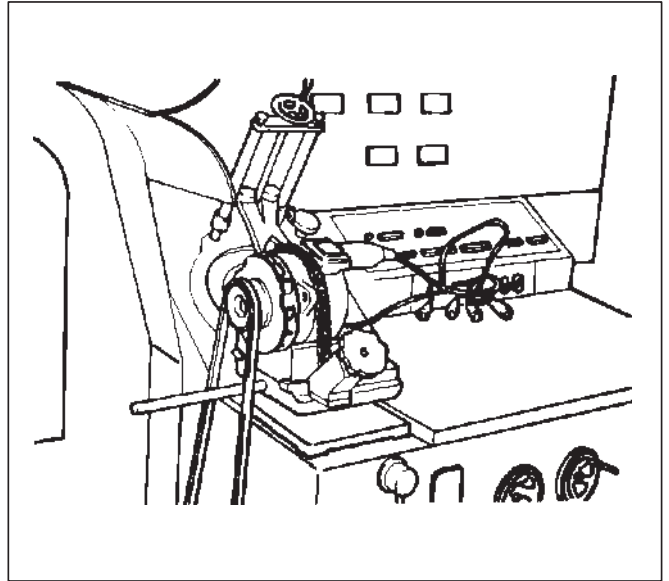
**Torque: 111 N·m (82 lb ft)**



066RS010

## Bench Test

Conduct a bench test of the generator.

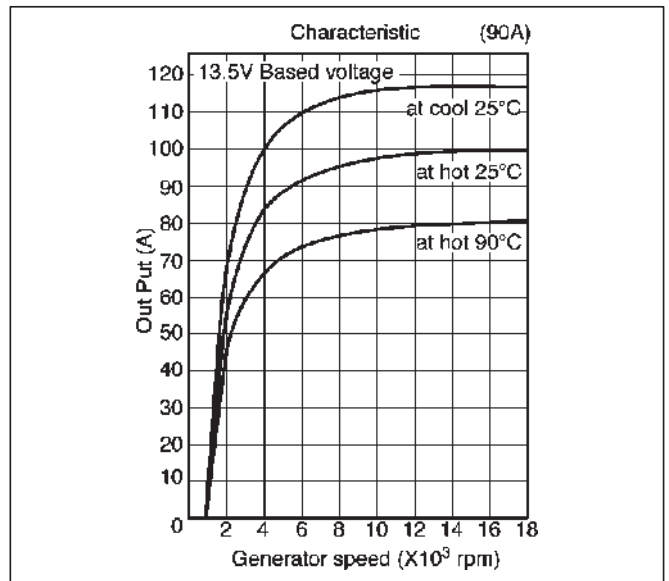


066RS023

### Preparation

Remove generator from the vehicle (see "Generator removal").

1. Secure generator to the bench test equipment and connect wires.
  - Terminal "IG" for energization
  - Terminal "L" for neutral (warning lamp)
  - Terminal "B" for output
2. Conduct the generator characteristic test.
  - Characteristics of generator are shown in illustration.
  - Repair or replace the generator if its outputs are abnormal.



B06RX002



## 6D3-26 STARTING AND CHARGING SYSTEM

---

### Main Data and Specifications

#### General Specifications

Parts Number (Nippon denso)	102211—1740
Model	ACJV74
Rated voltage	12 V
Rated output	90 A
Rotating direction (As viewed from pulled)	Clockwise
Pulley effective diameter	50 mm (1.97 in)
Weight	49.7 N (11.2 lb)

VEHICROSS

# ENGINE

## 6VE1 3.5L ENGINE DRIVEABILITY AND EMISSIONS

### CONTENTS

Specifications .....	6E-5	Serial Data Communications .....	6E-29
Tightening Specifications .....	6E-5	Class II Serial Data Communications .....	6E-29
Diagrams and Schematics .....	6E-6	On-Board Diagnostic (OBD) II .....	6E-29
PCM Wiring Diagram (1 of 8) .....	6E-6	On-Board Diagnostic Tests .....	6E-29
PCM Wiring Diagram (2 of 8) .....	6E-7	Comprehensive Component Monitor	
PCM Wiring Diagram (3 of 8) .....	6E-8	Diagnostic Operation .....	6E-29
PCM Wiring Diagram (4 of 8) .....	6E-9	System Status and Drive Cycle for	
PCM Wiring Diagram (5 of 8) .....	6E-10	Satisfying Federal Inspection	
PCM Wiring Diagram (6 of 8) .....	6E-11	/Maintenance (I/M 240) Regulations .....	6E-30
PCM Wiring Diagram (7 of 8) .....	6E-12	Common OBD II Terms .....	6E-30
PCM Wiring Diagram (8 of 8) .....	6E-13	The Diagnostic Executive .....	6E-30
PCM Pinouts .....	6E-14	DTC Types .....	6E-31
PCM Pinout Table, 32-Way Red		Decimal/Binary/Hexadecimal Conversions	6E-33
Connector – Row “A” .....	6E-14	Verifying Vehicle Repair .....	6E-33
PCM Pinout Table, 32-Way Red		Reading Diagnostic Trouble Codes Using	
Connector – Row “B” .....	6E-16	The Tech 2 Scan Tool .....	6E-33
PCM Pinout Table, 32-Way White		Tech 2 .....	6E-34
Connector – Row “C” .....	6E-17	Tech 2 Features .....	6E-34
PCM Pinout Table, 32-Way White		Getting Started .....	6E-35
Connector – Row “D” .....	6E-18	Operating Procedure (For Example) .....	6E-35
PCM Pinout Table, 32-Way Blue		DTC Modes .....	6E-36
Connector – Row “E” .....	6E-20	DTC Information Mode .....	6E-37
PCM Pinout Table, 32-Way Blue		Miscellaneous Test .....	6E-37
Connector – Row “F” .....	6E-21	Lamps Test .....	6E-38
Component Locators .....	6E-22	Relays Test .....	6E-39
Engine Component Locator .....	6E-22	EVAP Test .....	6E-40
Engine Component Locator Table .....	6E-22	Idle Air Control (IAC) System Test .....	6E-41
Undercarriage Component Locator .....	6E-23	Fuel System Test .....	6E-43
Undercarriage Component Locator Table .....	6E-23	EGR Control Test .....	6E-44
Fuse and Relay Panel (Underhood		Variable Intake Manifold Solenoid Test ...	6E-45
Electrical Center) .....	6E-24	Injector Balance Test .....	6E-46
Sensors and Miscellaneous Component		Plotting Snapshot Graph .....	6E-47
Locators .....	6E-25	Plotting Graph Flow Chart (Plotting graph	
Diagnosis .....	6E-27	after obtaining vehicle information) .....	6E-48
Strategy-Based Diagnostics .....	6E-27	Flow Chart for Snapshot Replay	
Strategy-Based Diagnostics .....	6E-27	(Plotting Graph) .....	6E-49
DTC Stored .....	6E-27	Primary System-Based Diagnostic .....	6E-50
No DTC .....	6E-27	Primary System-Based Diagnostic .....	6E-50
No Matching Symptom .....	6E-27	Fuel Control Heated Oxygen Sensor .....	6E-50
Intermittents .....	6E-27	HO2S Heater .....	6E-50
No Trouble Found .....	6E-27	Catalyst Monitor Heated Oxygen Sensors	
Verifying Vehicle Repair .....	6E-27	and Diagnostic Operation .....	6E-50
General Service Information .....	6E-27	Misfire Monitor Diagnostic Operation .....	6E-51
OBD II Serviceability Issues .....	6E-27	Misfire Monitor Diagnostic Operation .....	6E-51
Emissions Control Information Label .....	6E-28	Misfire Counters .....	6E-51
Maintenance Schedule .....	6E-28		
Visual / Physical Engine Compartment			
Inspection .....	6E-28		
Basic Knowledge of Tools Required .....	6E-29		

Fuel Trim System Monitor Diagnostic Operation .....	6E-52	DTC P0103 – MAF Sensor Circuit High Frequency .....	6E-122
Fuel Trim System Monitor Diagnostic Operation .....	6E-52	DTC P0106 – MAP System Performance ..	6E-124
Fuel Trim Cell Diagnostic Weights .....	6E-52	DTC P0107 – MAP Sensor Circuit Low Voltage .....	6E-127
On-Board Diagnostic (OBD II) System Check .....	6E-53	DTC P0108 – MAP Sensor Circuit High Voltage .....	6E-130
Circuit Description .....	6E-53	DTC P0112 – IAT Sensor Circuit Low Voltage .....	6E-134
Diagnostic Aids .....	6E-53	DTC P0113 – IAT Sensor Circuit High Voltage .....	6E-136
On-Board Diagnostic (OBD II) System Check .....	6E-54	DTC P0117 – ECT Sensor Low Voltage ...	6E-140
A/C Clutch Control Circuit Diagnosis .....	6E-56	DTC P0118 – ECT Sensor Circuit High Voltage .....	6E-142
Circuit Description .....	6E-56	DTC P0121 – TP System Performance ....	6E-145
Diagnostic Aids .....	6E-56	DTC P0122 – TP Sensor Circuit Low Voltage .....	6E-148
A/C Clutch Diagnosis .....	6E-57	DTC P0123 – TP Sensor Circuit High Voltage .....	6E-151
A/C Clutch Control Circuit Diagnosis .....	6E-57	DTC P0125 – ECT Excessive Time to Closed Loop Fuel Control .....	6E-154
Electronic Ignition System Diagnosis .....	6E-62	DTC P0131 – HO2S Circuit Low Voltage Bank 1 Sensor 1 .....	6E-157
Visual Check of The Evaporative Emission Canister .....	6E-62	DTC P0132 – HO2S Circuit High Voltage Bank 1 Sensor 1 .....	6E-160
Fuel Metering System Check .....	6E-62	DTC P0133 – HO2S Slow Response Bank 1 Sensor 1 .....	6E-164
Idle Air Control (IAC) Valve .....	6E-62	DTC P0134 – HO2S Circuit Insufficient Activity Bank 1 Sensor 1 .....	6E-167
Fuel System Pressure Test .....	6E-62	DTC P0135 – HO2S Heater Circuit Bank 1 Sensor 1 .....	6E-170
Fuel Injector Coil Test Procedure and Fuel Injector Balance Test Procedure .....	6E-62	DTC P0137 – HO2S Circuit Low Voltage Bank 1 Sensor 2 .....	6E-173
Knock Sensor Diagnosis .....	6E-67	DTC P0138 – HO2S Circuit High Voltage Bank 1 Sensor 2 .....	6E-176
Powertrain Control Module (PCM) Diagnosis .....	6E-67	DTC P0140 – HO2S Circuit Insufficient Activity BANK 1 SENSOR 2 .....	6E-179
Multiple PCM Information Sensor DTCS Set .....	6E-67	DTC P0141 – HO2S Heater Circuit Bank 1 Sensor 2 .....	6E-182
Exhaust Gas Recirculation (EGR) Diagnosis .....	6E-70	DTC P0151 – HO2S Circuit Low Voltage Bank 2 Sensor 1 .....	6E-185
Engine Tech 2 Data Definitions and Ranges .....	6E-70	DTC P0152 – HO2S Circuit High Voltage Bank 2 Sensor 1 .....	6E-188
Typical Scan Data Values .....	6E-73	DTC P0153 – HO2S Slow Response Bank 2 Sensor 1 .....	6E-192
No Malfunction Indicator Lamp (MIL) .....	6E-79	DTC P0154 – HO2S Circuit Insufficient Activity Bank 2 Sensor 1 .....	6E-195
Malfunction Indicator Lamp (MIL) “ON” Steady .....	6E-82	DTC P0155 – HO2S Heater Circuit Bank 2 Sensor 1 .....	6E-198
Malfunction Indicator Lamp (MIL) “ON” Steady .....	6E-83	DTC P0157 – HO2S Circuit Low Voltage Bank 2 Sensor 2 .....	6E-201
Engine Cranks But Will Not Run .....	6E-84	DTC P0158 – HO2S Circuit High Voltage Bank 2 Sensor 2 .....	6E-204
Engine Cranks But Will Not Run .....	6E-86	DTC P0160 – HO2S Circuit Insufficient Activity Bank 2 Sensor 2 .....	6E-207
Fuel System Electrical Test .....	6E-90	DTC P0161 – HO2S Heater Circuit Bank 2 Sensor 2 .....	6E-210
Fuel System Electrical Test .....	6E-91	DTC P0171 – Fuel Trim System Lean Bank 1 .....	6E-214
Fuel System Diagnosis .....	6E-93	DTC P0172 – Fuel Trim System Rich Bank 1 .....	6E-217
Fuel System Diagnosis .....	6E-95	DTC P0174 – Fuel Trim System Lean Bank 2 .....	6E-222
Idle Air Control (IAC) System Check .....	6E-98	DTC P0175 – Fuel Trim System Rich Bank 2 .....	6E-225
Idle Air Control (IAC) System Check .....	6E-99	DTC P0201 – Injector 1 Control Circuit ....	6E-229
Knock Sensor (KS) System Check (Engine Knock, Poor Performance, or Poor Economy) .....	6E-101	DTC P0202 – Injector 2 Control Circuit ....	6E-232
Exhaust Gas Recirculation (EGR) System Check .....	6E-103		
Manifold Absolute Pressure (MAP) Output Check .....	6E-105		
Evaporative (EVAP) Emissions Canister Purge Valve Check .....	6E-107		
PCM Diagnostic Trouble Codes .....	6E-110		
DTC P0101 – MAF System Performance ..	6E-115		
DTC P0102 – MAF Sensor Circuit Low Frequency .....	6E-118		

DTC P0203 – Injector 3 Control Circuit	6E-235	Poor Fuel Economy Symptom	6E-424
DTC P0204 – Injector 4 Control Circuit	6E-238	Excessive Exhaust Emissions or Odors Symptom	6E-426
DTC P0205 – Injector 5 Control Circuit	6E-241	Dieseling, Run-On Symptom	6E-428
DTC P0206 – Injector 6 Control Circuit	6E-244	Backfire Symptom	6E-429
DTC P0300 – Engine Misfire Detected	6E-247	Cuts Out, Misses Symptom	6E-431
DTC P0301 – Cylinder Misfire Detected	6E-250	Hesitation, Sag, Stumble Symptom	6E-434
DTC P0302 – Cylinder Misfire Detected	6E-252	Bank 1 Restricted Exhaust System Check	6E-436
DTC P0303 – Cylinder Misfire Detected	6E-254	Bank 2 Restricted Exhaust System Check	6E-437
DTC P0304 – Cylinder Misfire Detected	6E-256	Default Matrix Table	6E-438
DTC P0305 – Cylinder Misfire Detected	6E-258	Default Matrix Table	6E-438
DTC P0306 – Cylinder Misfire Detected	6E-260	On-Vehicle ServiceCamshaft Position (CMP) Sensor	6E-441
DTC P0325 – KS Module Circuit	6E-263	Crankshaft Position (CKP) Sensor	6E-441
DTC P0327 – KS Sensor Circuit	6E-265	Engine Coolant Temperature (ECT) Sensor	6E-442
DTC P0336 – 58X Reference Signal Circuit	6E-269	Heated Oxygen Sensor (HO2S)	6E-443
DTC P0337 – CKP Sensor Circuit Low Frequency	6E-271	Intake Air Temperature (IAT) Sensor	6E-445
DTC P0341 – CMP Sensor Circuit Performance	6E-275	Knock Sensor (KS)	6E-446
DTC P0342 – CMP Sensor Circuit Low	6E-278	Mass Air Flow (MAF) Sensor	6E-447
DTC P0351 – Ignition 1 Control Circuit	6E-282	Manifold Absolute Pressure (MAP) Sensor	6E-448
DTC P0352 – Ignition 2 Control Circuit	6E-285	Malfunction Indicator Lamp (MIL)	6E-449
DTC P0353 – Ignition 3 Control Circuit	6E-288	Powertrain Control Module (PCM) Service Precaution	6E-449
DTC P0354 – Ignition 4 Control Circuit	6E-291	Removal Procedure	6E-449
DTC P0355 – Ignition 5 Control Circuit	6E-294	Installation Procedure	6E-450
DTC P0356 – Ignition 6 Control Circuit	6E-297	EEPROM	6E-450
DTC P0401 – EGR Flow Insufficient	6E-301	Throttle Position (TP) Sensor	6E-450
DTC P0402 – EGR Pintle Position Error	6E-303	Vehicle Speed Sensor (VSS)	6E-451
DTC P0502 – VSS Circuit Low Input	6E-338	Air Cleaner/Air Filter	6E-452
DTC P1122 – TP Circuit Intermittent Low Voltage	6E-368	Idle Air Control (IAC) Valve	6E-453
DTC P1133 – HO2S Insufficient Switching Bank 1 Sensor 1	6E-370	Common Chamber	6E-454
DTC P1134 – HO2S Transition Time Ratio Bank 1 Sensor 1	6E-374	Accelerator Cable Assembly	6E-454
DTC P1153 – HO2S Insufficient Switching Bank 2 Sensor 1	6E-378	Inspection Procedure	6E-455
DTC P1154 – HO2S Transition Time Ratio Bank 2 Sensor 1	6E-382	Accelerator Pedal Replacement	6E-457
DTC P1171 – Fuel System Lean During Acceleration	6E-387	Fuel Filter Cap	6E-459
DTC P1380 – ABS Rough Road ABS System Fault	6E-389	Fuel Filter	6E-459
DTC P1381 – ABS Rough Road Class 2 Serial Link Error	6E-390	Fuel Gauge Unit	6E-461
DTC P1404 – EGR Stuck Closed	6E-392	Fuel Injectors	6E-462
DTC P1441 – EVAP System Flow During Non-Purge	6E-395	Fuel Pressure Regulator	6E-464
DTC P1508 – IAC System Low RPM	6E-398	Disassembly Procedure	6E-464
DTC P1509 – IAC System High RPM	6E-401	Assembly Procedure	6E-465
DTC P1618 – Serial Peripheral Interface (SPI) PCM Interprocessor Communication Error	6E-403	Fuel Metering System	6E-466
DTC P1625 – PCM Unexpected Reset	6E-404	Fuel Pump Assembly	6E-466
DTC P1640 – Driver-1-Output Circuit Fault (ODM)	6E-406	Fuel Pump Relay	6E-467
DTC P1650 – Quad Driver Module (QDM) "A" Fault	6E-409	Fuel Rail Assembly	6E-467
Symptom Diagnosis	6E-411	Fuel Tank	6E-468
Hard Start Symptom	6E-412	Throttle Body (TB)	6E-470
Surges and/or Chuggles Symptom	6E-414	Electronic Ignition System	6E-472
Lack of Power, Sluggish or Spongy Symptom	6E-417	Catalytic Converter	6E-473
Detonation/Spark Knock Symptom	6E-419	Air Conditioning Relay	6E-473
Rough, Unstable, or Incorrect Idle, Stalling Symptom	6E-421	EVAP Canister Hoses	6E-474
		EVAP Canister	6E-474
		EVAP Canister Vent Solenoid	6E-475
		Fuel Tank Pressure Sensor	6E-476
		EVAP Canister Purge Solenoid	6E-476

**6E-4 6VE1 3.5L ENGINE DRIVEABILITY AND EMISSIONS**

Fuel Tank Vent Valve .....	6E-477	Engine Speed/Fuel Disable Mode .....	6E-491
Linear Exhaust Gas Recirculation (EGR) Valve .....	6E-477	Fuel Cutoff Mode .....	6E-491
Positive Crankcase Ventilation (PCV) Valve ..	6E-478	Fuel Injector .....	6E-491
Wiring and Connectors .....	6E-479	Fuel Metering System Components .....	6E-492
PCM Connectors and Terminals .....	6E-479	Fuel Metering System Purpose .....	6E-492
Wire Harness Repair: Twisted Shielded Cable .....	6E-479	Fuel Pressure Regulator .....	6E-492
Twisted Leads .....	6E-480	Fuel Pump Electrical Circuit .....	6E-492
Weather-Pack Connector .....	6E-482	Fuel Rail .....	6E-492
Com-Pack III .....	6E-483	Idle Air Control (IAC) Valve .....	6E-493
Metri-Pack .....	6E-483	Run Mode .....	6E-493
General Description (PCM and Sensors) ...	6E-484	Starting Mode .....	6E-493
58X Reference PCM Input .....	6E-484	Throttle Body Unit .....	6E-494
A/C Request Signal .....	6E-484	General Description (Electronic Ignition System) .....	6E-494
Crankshaft Position (CKP) Sensor .....	6E-484	Camshaft Position (CMP) Sensor .....	6E-494
Camshaft Position (CMP) Sensor and Signal .....	6E-484	Crankshaft Position (CKP) Sensor .....	6E-494
Engine Coolant Temperature (ECT) Sensor	6E-484	Electronic Ignition .....	6E-495
Electrically Erasable Programmable Read Only Memory (EEPROM) .....	6E-485	Ignition Coils .....	6E-495
Fuel Control Heated Oxygen Sensors .....	6E-485	Ignition Control .....	6E-495
Catalyst Monitor Heated Oxygen Sensors	6E-485	Knock Sensor (KS) PCM Input .....	6E-496
Intake Air Temperature (IAT) Sensor .....	6E-486	Powertrain Control Module (PCM) .....	6E-496
Knock Sensor .....	6E-486	Spark Plug .....	6E-496
Linear Exhaust Gas Recirculation (EGR) Control .....	6E-487	A/C Clutch Diagnosis .....	6E-498
Mass Air Flow (MAF) Sensor .....	6E-487	A/C Clutch Circuit Operation .....	6E-498
Manifold Absolute Pressure (MAP) Sensor	6E-487	A/C Clutch Circuit Purpose .....	6E-498
Powertrain Control Module (PCM) .....	6E-488	A/C Request Signal .....	6E-498
PCM Function .....	6E-488	General Description (Evaporative (EVAP) Emission System) .....	6E-499
PCM Components .....	6E-488	EVAP Emission Control System Purpose ..	6E-499
PCM Voltage Description .....	6E-488	EVAP Emission Control System Operation	6E-499
PCM Input/Outputs .....	6E-488	Enhanced Evaporative Emission Control System .....	6E-500
PCM Service Precautions .....	6E-489	General Description (Exhaust Gas Recirculation (EGR) System) .....	6E-503
Reprogramming The PCM .....	6E-489	EGR Purpose .....	6E-503
Throttle Position (TP) Sensor .....	6E-489	Linear EGR Valve .....	6E-503
Transmission Fluid Temperature (TFT) Sensor .....	6E-489	Linear EGR Control .....	6E-503
Transmission Range Switch .....	6E-489	Linear EGR Valve Operation and Results of Incorrect Operation .....	6E-503
Vehicle Speed Sensor (VSS) .....	6E-490	EGR Pintle Position Sensor .....	6E-503
Use of Circuit Testing Tools .....	6E-490	General Description (Positive Crankcase Ventilation (PCV) System) .....	6E-504
Aftermarket Electrical and Vacuum Equipment .....	6E-490	Crankcase Ventilation System Purpose ...	6E-504
Electrostatic Discharge Damage .....	6E-490	Crankcase Ventilation System Operation ..	6E-504
General Description (Air Induction) .....	6E-491	Special Tools .....	6E-505
Air Induction System .....	6E-491		
General Description (Fuel Metering) .....	6E-491		
Acceleration Mode .....	6E-491		
Accelerator Controls .....	6E-491		
Battery Voltage Correction Mode .....	6E-491		
CMP Signal .....	6E-491		
Clear Flood Mode .....	6E-491		
Deceleration Mode .....	6E-491		

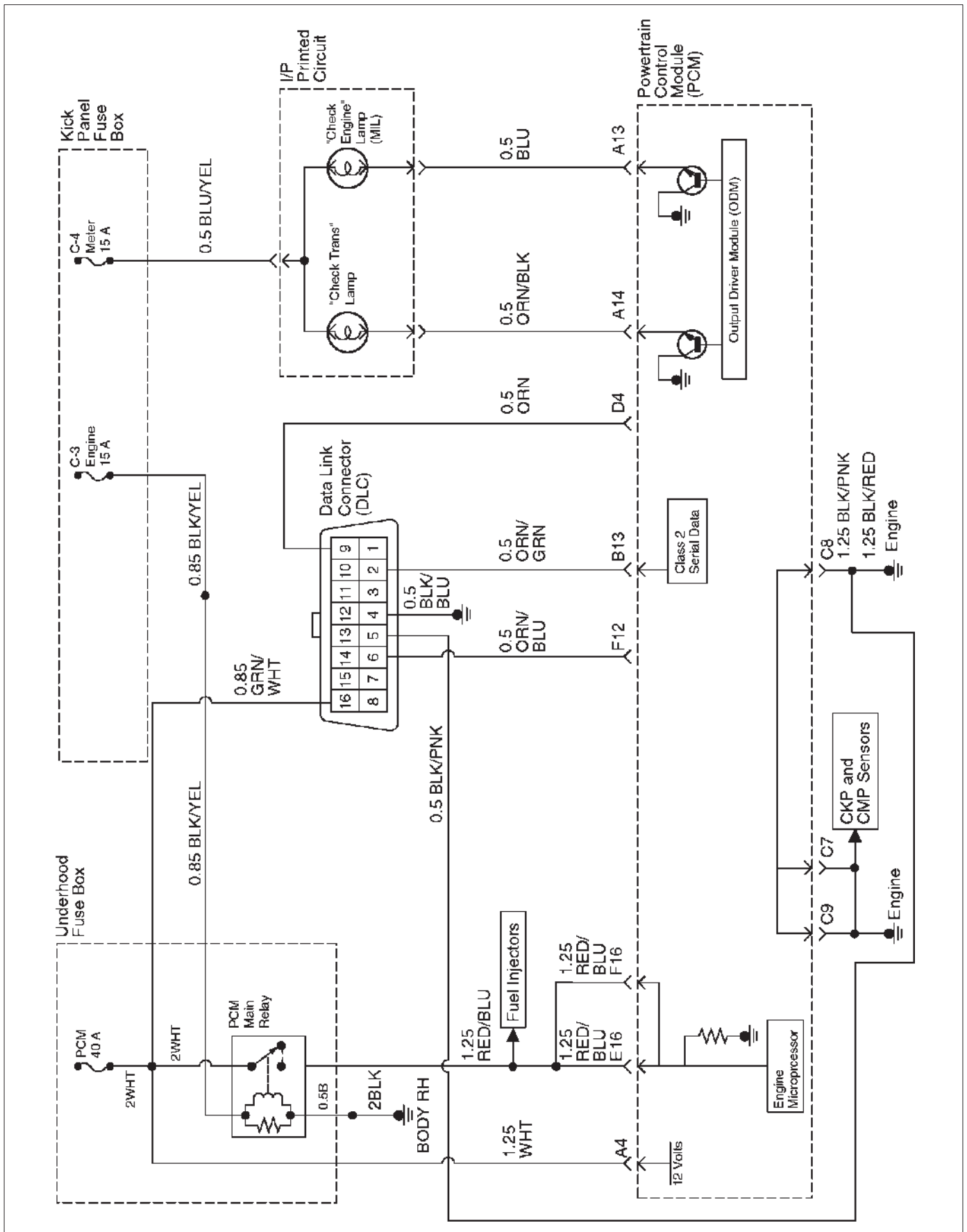
## Specifications

### Tightening Specifications

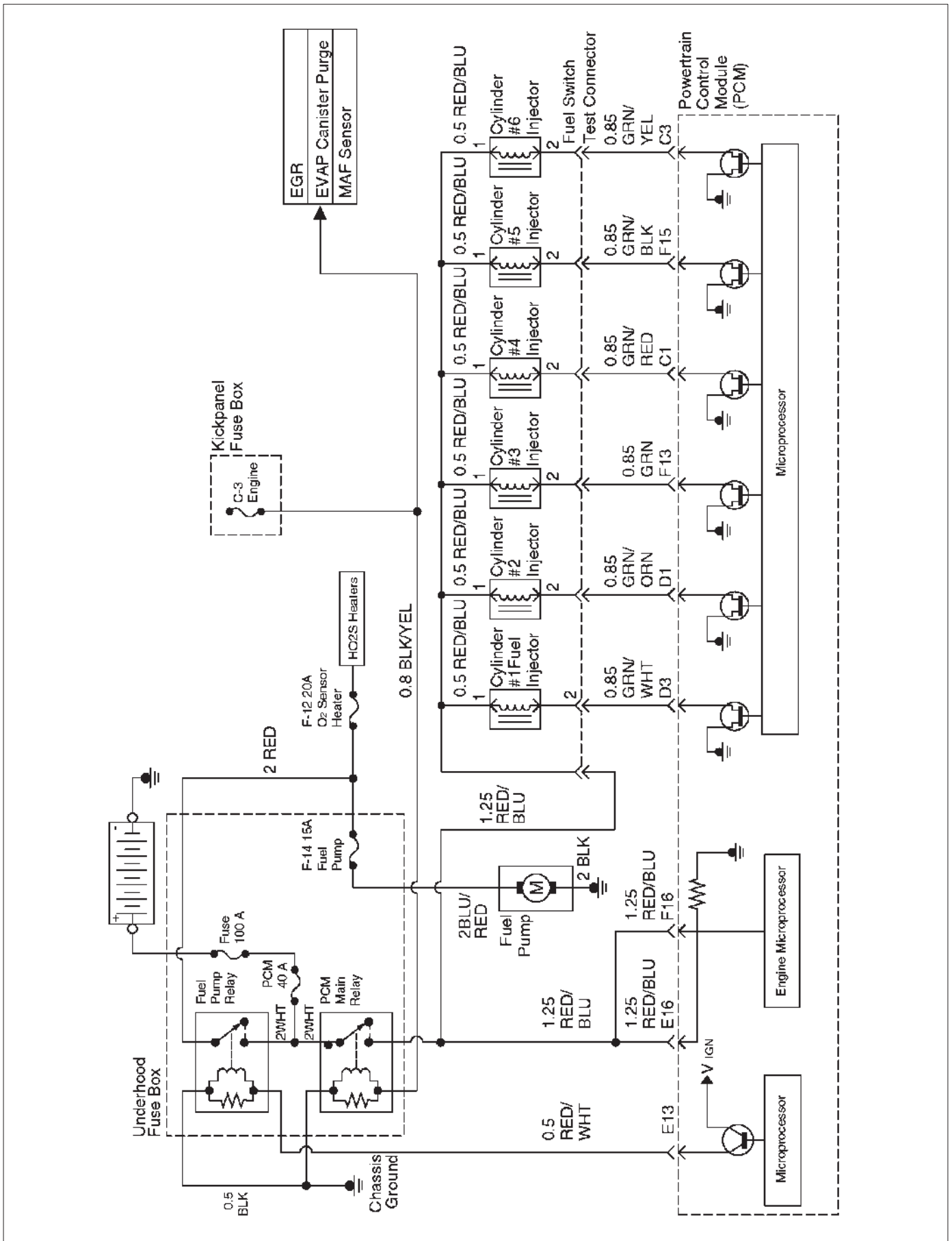
Application	N-m	Lb Ft.	Lb In.
Camshaft Position Sensor Retaining Screw	9	—	78
Crankshaft Position Sensor Mounting Bolt	10	—	87
EGR Bolt	28	21	—
EGR Nut	28	21	—
Engine Coolant Temperature Sensor	20	7.7	—
Fuel Drain Plug	29	22	—
Fuel Pressure Regulator Attaching Screw	6.5	—	60
Fuel Rail Bolts	25	18	—
Fuel Tank Undercover Retaining Bolts	36	27	—
Heated Oxygen Sensor	42	31	—
Lower Intake Manifold to Engine Block Bolts	25	18	—
Lower Intake Manifold to Engine Block Nuts	25	18	—
Spark Plugs	18	13	—
Throttle Body Mounting Bolts	25	18	—
Upper Intake Manifold to Lower Intake Manifold Bolts	25	18	—
VSS Retaining Bolt	13	—	120

### Diagrams and Schematics

#### PCM Wiring Diagram (1 of 8)

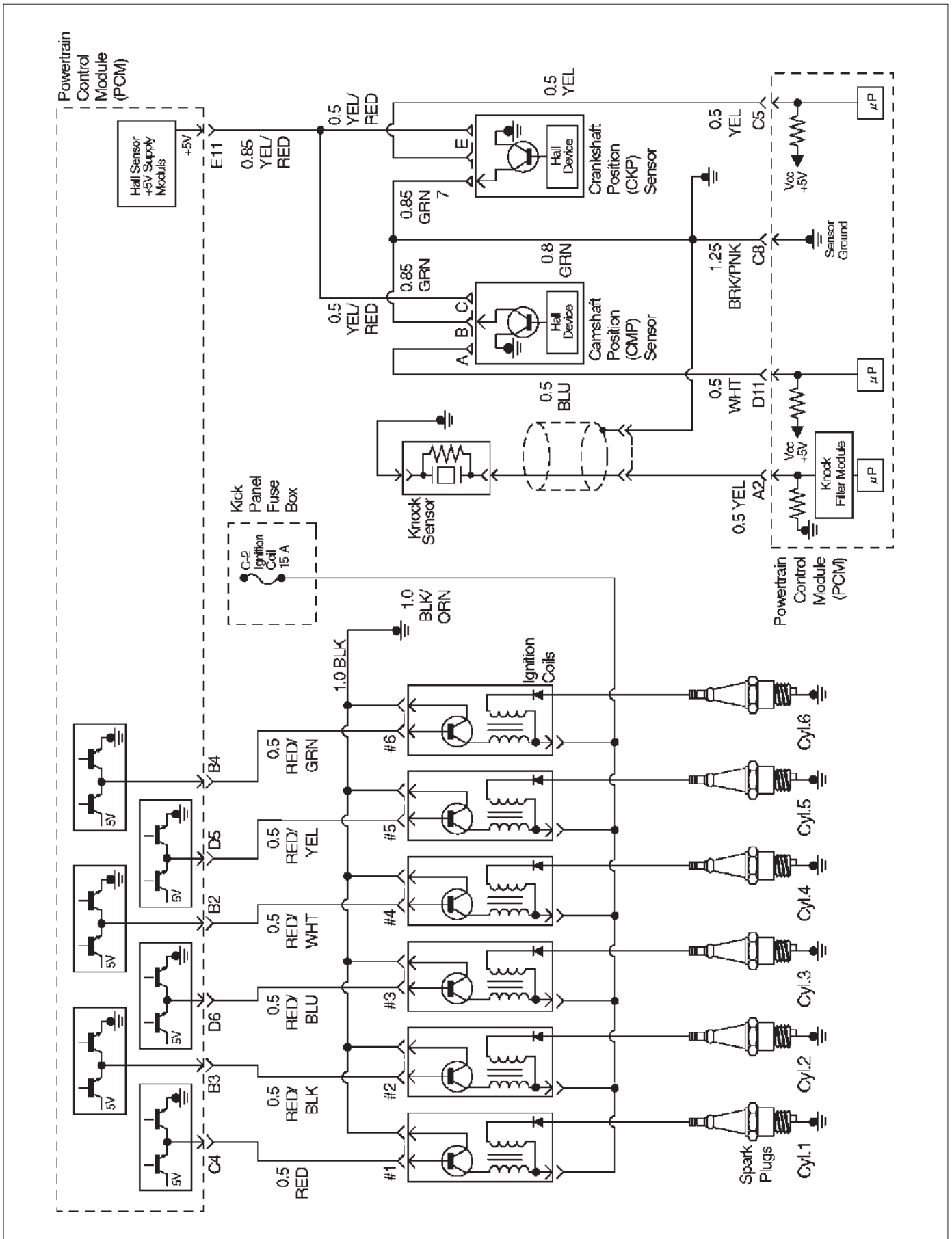


PCM Wiring Diagram (2 of 8)

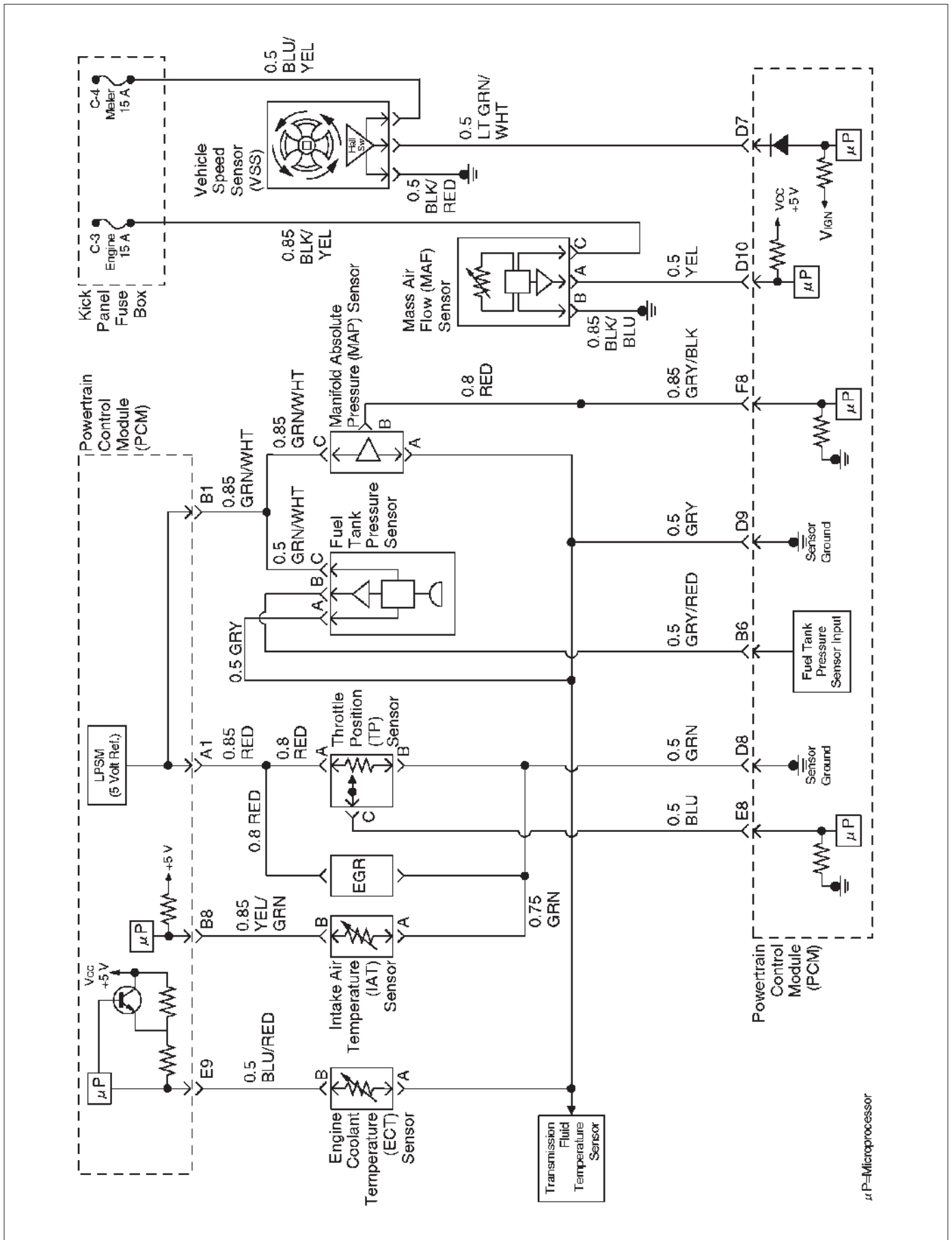




PCM Wiring Diagram (3 of 8)

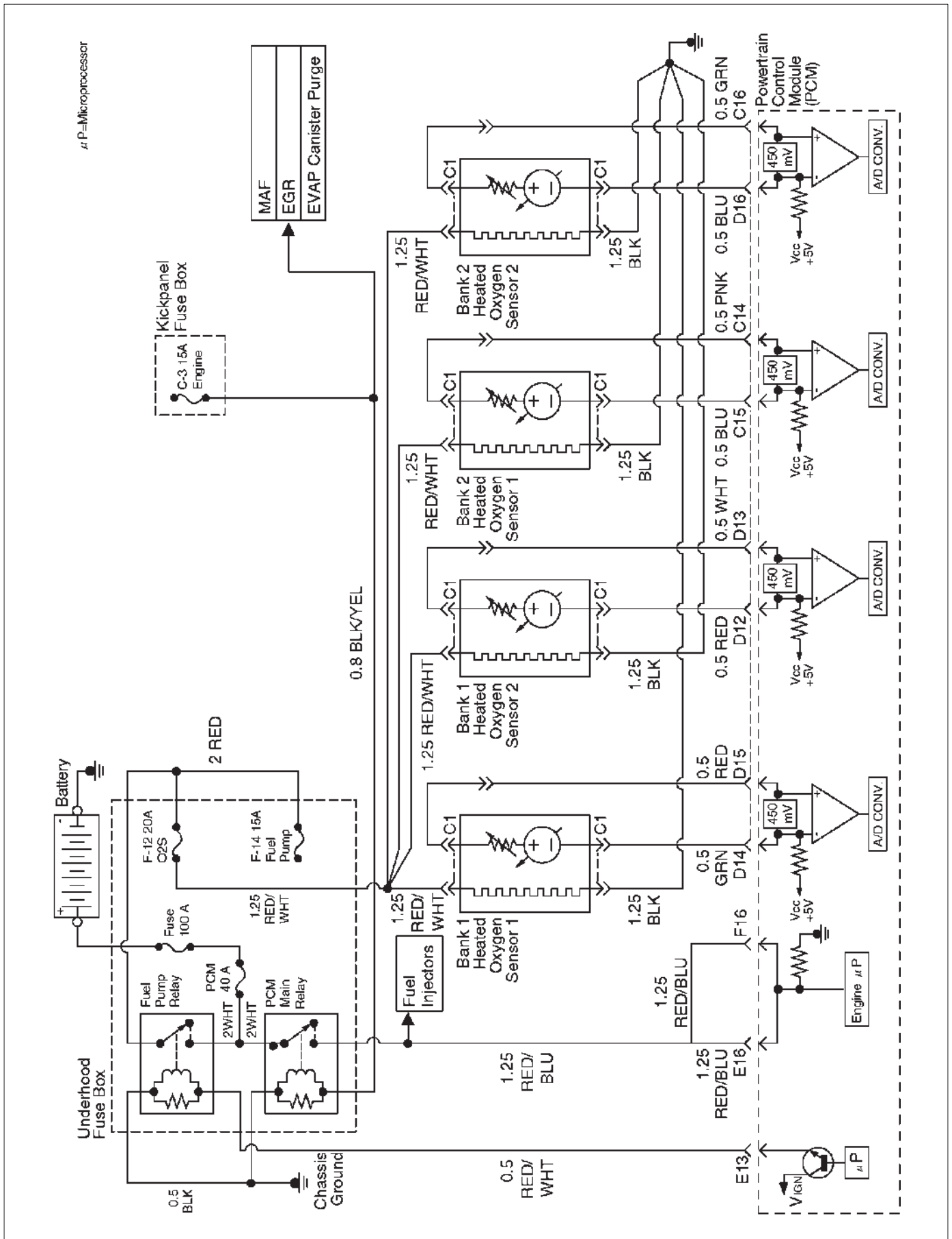


PCM Wiring Diagram (4 of 8)

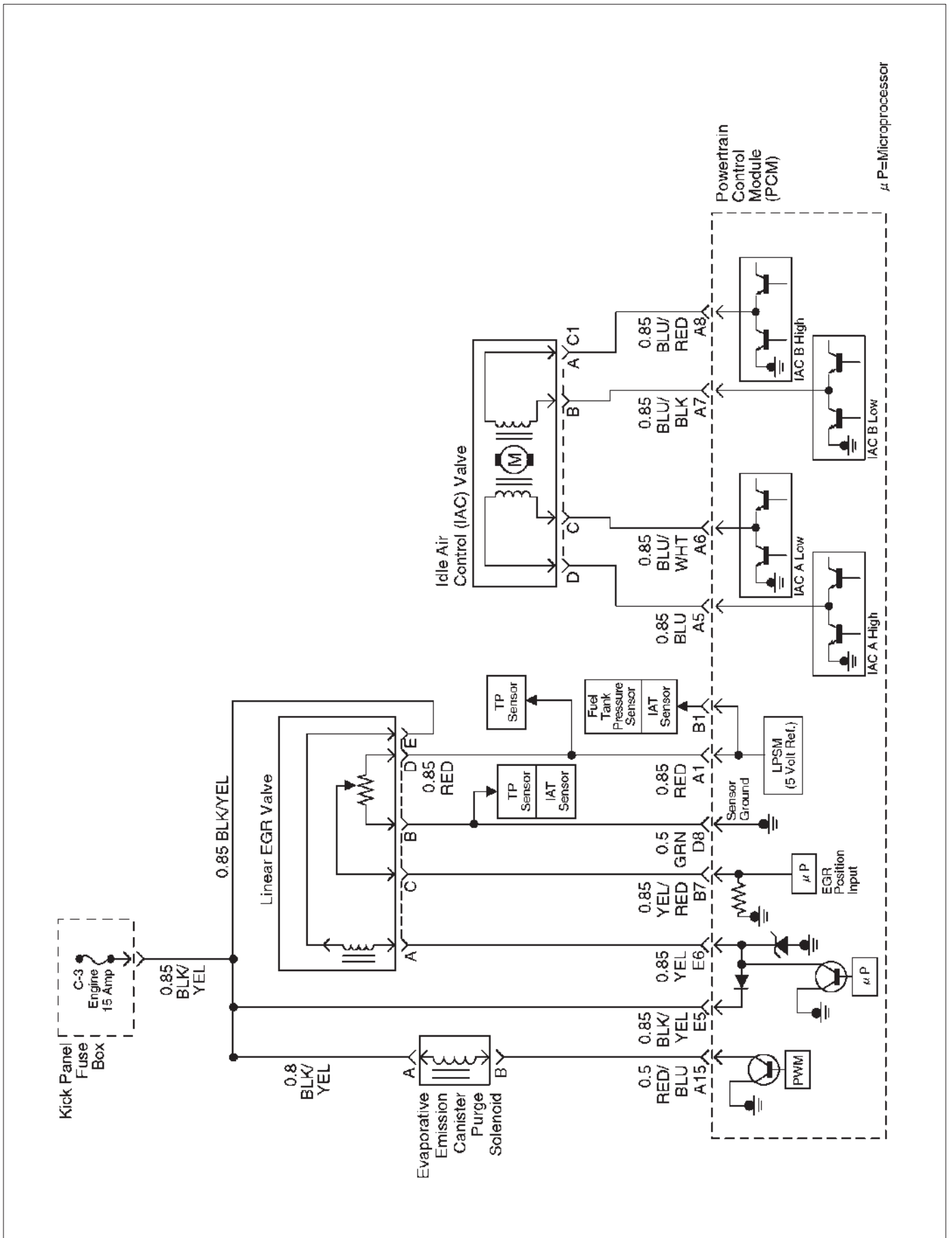


$\mu P$  = Microprocessor

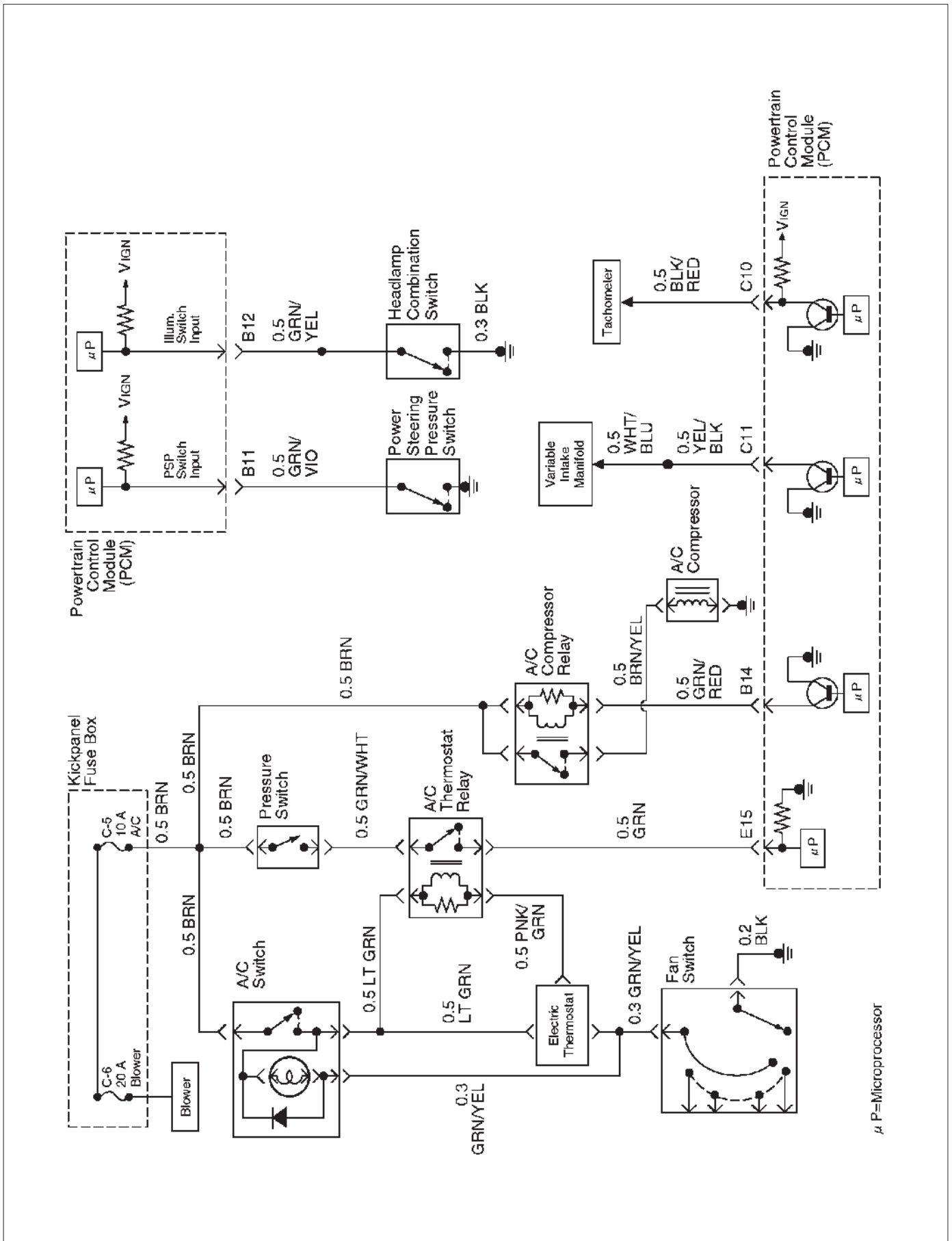
PCM Wiring Diagram (5 of 8)



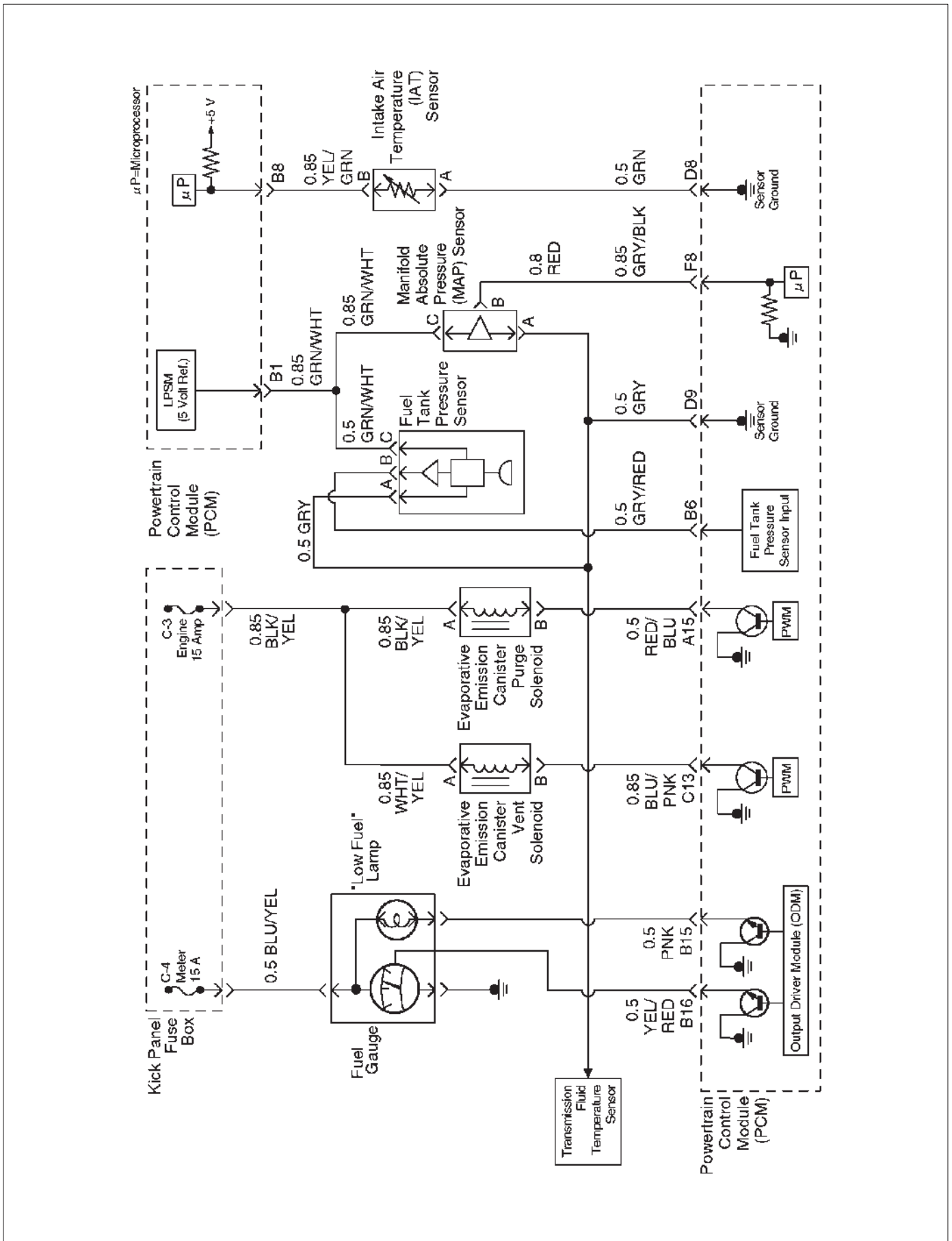
PCM Wiring Diagram (6 of 8)



PCM Wiring Diagram (7 of 8)

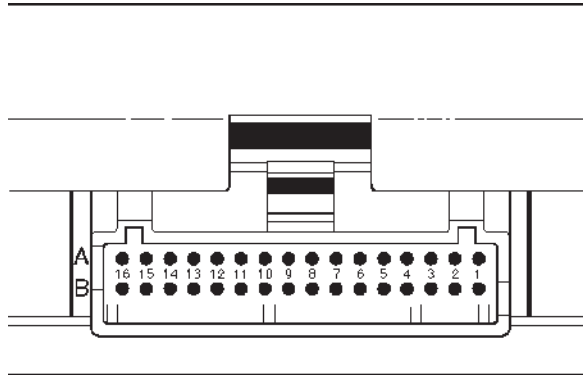


PCM Wiring Diagram (8 of 8)



## PCM Pinouts

### PCM Pinout Table, 32-Way Red Connector – Row “A”



TS23344

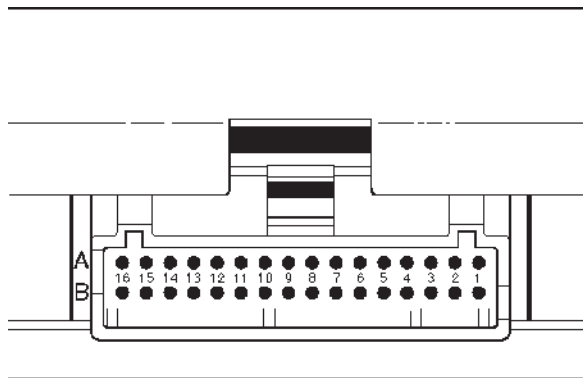
PIN	PIN Function	Wire Color	IGN ON	ENG RUN	Refer To
A1	5 Volt Reference "A"	RED	5.0 V	5.0 V	Appropriate Sensor
A2	Knock Sensor	YEL	0.0 V DC 2mV AC	0.0 V DC 18mV AC (at idle)	General Description and Operation, Knock Sensor
A3	Not Used	—	—	—	
A4	Battery Feed	WHT	B+	B+	Chassis Electrical
A5	Idle Air Control (IAC) "A" High	BLU	B+/0.8 V	B+/0.8 V	General Description and Operation, IAC
A6	IAC "A" Low	BLU/WHT	B+/0.8 V	B+/0.8 V	General Description and Operation, IAC
A7	IAC "B" Low	BLU/BLK	B+/0.8 V	B+/0.8 V	General Description and Operation, IAC
A8	IAC "B" High	BLU/RED	B+/0.8 V	B+/0.8 V	General Description and Operation, IAC
A9	Automatic Transmission Fluid (ATF) Lamp	ORN/BLU	B+	B+	Automatic Transmission (4L30E)
A10	Winter Lamp	PNK/WHT	B+	B+	Automatic Transmission (4L30E)
A11	Power Lamp	PNK/GRN	B+	B+	Automatic Transmission (4L30E)
A12	Antilock Brake System (ABS)	VIO/WHT	B+	B+	Antilock Brake System
A13	Malfunction Indicator (Check Engine or MIL) Lamp	BLU	0.0 V	B+	Chassis Electrical
A14	"Check Transmission" Lamp Driver	ORN/BLK	B+	B+	Chassis Electrical

**6VE1 3.5L ENGINE DRIVEABILITY AND EMISSIONS 6E-15**

<b>PIN</b>	<b>PIN Function</b>	<b>Wire Color</b>	<b>IGN ON</b>	<b>ENG RUN</b>	<b>Refer To</b>
A15	EVAP Canister Purge Solenoid	RED/BLU	B+	5.7 V	General Description and Operation, EVAP Emission Control System
A16	Band Apply	BRN/YEL	B+	B+	Automatic Transmission (4L30E)



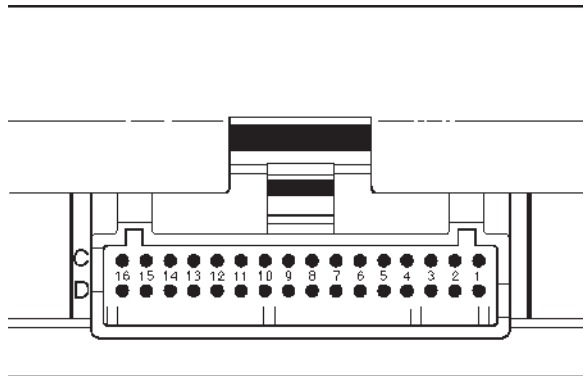
PCM Pinout Table, 32-Way Red Connector – Row “B”



TS23344

PIN	PIN Function	Wire Color	IGN ON	ENG RUN	Refer To
B1	5 Volt Reference “B”	GRN/WHT	5.0 V	5.0 V	Appropriate Sensor
B2	Ignition coil	RED/WHT	0.0 V	0.1 V	General Description and Operation
B3	Ignition coil	RED/BLK	0.0 V	0.1 V	General Description and Operation
B4	Ignition coil	RED/GRN	0.0 V	0.1 V	General Description and Operation
B5	Fuel Tank Level Sensor	YEL/VIO	0.5-4.9V	0.5-4.9V	—
B6	Tank Pressure Sensor	GRY/RED	0.2-4.8V	0.2-4.8V	—
B7	Exhaust Gas Recirculation (EGR)	YEL/RED	0.6 V	0.6 V	General Description and Operation, Linear EGR Control
B8	Intake Air Temperature (IAT) Sensor	YEL/GRN	0.5-4.9 V (depends on temperature)	0.5-4.9 V (depends on temperature)	General Description and Operation, IAT
B9	Not Used	—	—	—	—
B10	Not Used	—	—	—	—
B11	Power Steering Pressure (PSP) Switch	GRN/VIO	B+	B+	General Description and Operation, PSP
B12	Illuminated Switch	GRN/YEL	B+	B+	Chassis Electrical
B13	Class 2 Data	ORN/GRN	0.0 V	0.0 V	Diagnosis, Class 2 Serial Data
B14	A/C Clutch	GRN/RED	B+ (A/C OFF)	B+ (A/C OFF)	General Description and Operation, A/C Clutch Circuit Operation
B15	Low Fuel	PNK	B+	B+	—
B16	Fuel Gauge Control	YEL/RED	6.0V (Tank empty)	5.7V (Tank empty)	—

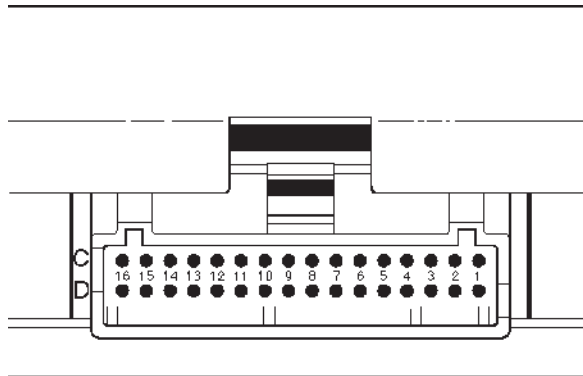
## PCM Pinout Table, 32-Way White Connector – Row “C”



TS23345

PIN	PIN Function	Wire Color	IGN ON	ENG RUN	Refer To
C1	Injector Cylinder #4	GRN/RED	B+	B+	General Description and Operation, Fuel Injector
C2	Shift “B” Solenoid	BRN/BLK	0.0 V	0.0 V	Automatic Transmission (4L30E)
C3	Injector Cylinder #6	GRN/YEL	B+	B+	General Description and Operation, Fuel Injector
C4	Ignition Control (IC) Cylinder #1	RED	0.0 V	0.1 V	General Description and Operation, Fuel Injector
C5	Crankshaft Position Sensor, “A” Circuit	YEL	0.3 V	2.2 V	General Description and Operation, Crankshaft Position Sensor
C6	Not Used	—	—	—	—
C7	PCM Ground	BLK/BLU	0.0 V	0.0 V	Chassis Electrical
C8	PCM Ground	BLK/RED	0.0 V	0.0 V	Chassis Electrical
C9	PCM Ground	BLK/BLU	0.0 V	0.0 V	Chassis Electrical
C10	Tachometer	BLK/RED	8.8 V	10.0 V (at idle)	Chassis Electrical
C11	Variable Intake Manifold	YEL/BLK	0.0 V	B+ (rpm 3600 over)	—
C12	Not Used	—	—	—	—
C13	EVAP VENT Solenoid	BLU/PNK	B+	B+	General Description
C14	Bank 2 HO2S 1 High	PNK	0.4 V	0.1-0.9 V	General Description and Operation, Fuel HO2S 1
C15	Bank 2 HO2S 1 Low	BLU	0.0 V	0.1 V	General Description and Operation, Fuel HO2S 1
C16	Bank 2 HO2S 2 High	GRN	0.4 V	0.1-0.9 V	General Description and Operation, Catalyst HO2S 2

## PCM Pinout Table, 32-Way White Connector – Row “D”



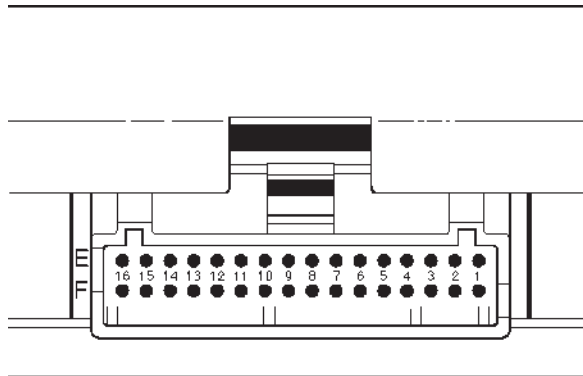
TS23345

PIN	PIN Function	Wire Color	IGN ON	ENG RUN	Refer To
D1	Injector Cylinder #2	GRN/ORN	B+	B+	General Description and Operation, Fuel Injector
D2	Torque Converter Clutch (TCC)	BRN/BLU	0.0 V	0.0 V	On-Vehicle Service, Torque Converter Clutch
D3	Injector Cylinder #1	GRN/WHT	B+	B+	General Description and Operation, Fuel Injector
D4	Serial Data (8192)	RED	5.0 V	5.0 V	Chassis Electrical
D5	Ignition Control, Cylinder #5	RED/YEL	0.0 V	0.1 V	General Description and Operation, Ignition Control Module
D6	Ignition Control, Cylinder #3	RED/BLUE	0.0 V	0.0 V	General Description and Operation, ICM
D7	VSS Input	LIGHT GRN/WHT	0.0 V	0.1 V (at rest)	Chassis Electrical
D8	Sensor Ground 5V Reference A Return	GRN	0.0 V	0.0 V	Appropriate Sensor
D9	Sensor Ground 5 V Reference B Return	GRY	0.0 V	0.0 V	Appropriate Sensor
D10	Mass Air Flow (MAF)	YEL	4.9 V	4.2 V	General Description, Mass Air Flow Sensor
D11	Camshaft Position Sensor	WHT	5.0 V or less than 1.0 V	4.6 V	General Description and Operation, Camshaft Position Sensor
D12	Bank 1 HO2S 2 Low	RED	0.0 V	0.1 V	General Description and Operation, Catalyst Monitor HO2S 2
D13	Bank 1 HO2S 2 High	WHT	0.3 V	0.1-0.9 V	General Description and Operation, Catalyst Monitor HO2S 2
D14	Bank 1 HO2S 1 Low	GRN	0.0 V	0.1 V	General Description and Operation, Fuel HO2S 1

**6VE1 3.5L ENGINE DRIVEABILITY AND EMISSIONS 6E-19**

<b>PIN</b>	<b>PIN Function</b>	<b>Wire Color</b>	<b>IGN ON</b>	<b>ENG RUN</b>	<b>Refer To</b>
D15	Bank 1 HO2S 1 Signal	RED	0.4 V	0.1-0.9 V	General Description and Operation, Fuel HO2S 1
D16	Bank 2 HO2S 2 Low	BLU	0.0 V	0.1 V	General Description and Operation, Catalyst HO2S 2

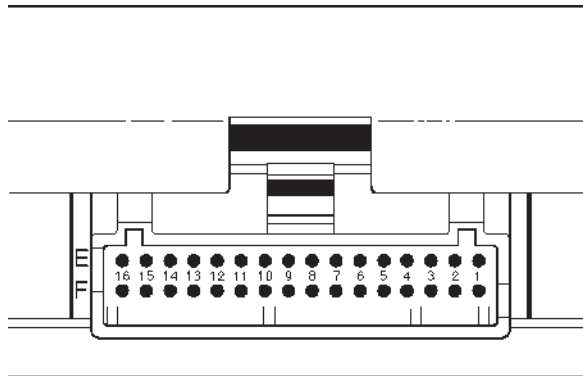
## PCM Pinout Table, 32-Way Blue Connector – Row “E”



TS23346

PIN	PIN Function	Wire Color	IGN ON	ENG RUN	Refer To
E1	Transmission Output Shaft Sensor (TOSS) High	WHT	0.0 V	0.1 V	Automatic Transmission (4L30E)
E2	Transmission Output Shaft Sensor (TOSS) Low	BLK	0.0 V	0.0 V	Automatic Transmission (4L30E)
E3	Pressure Control Solenoid Low	VIO/RED	0.0 V	1.1 V	Automatic Transmission (4L30E)
E4	Pressure Control Solenoid High	VIO/WHT	0.0 V	4.9 V	Automatic Transmission (4L30E)
E5	Exhaust Gas Recirculation (EGR) Control High	BLK/YEL	B+	B+	General Description and Operation, EGR Control
E6	EGR Control Low	YEL	B+	B+	General Description and Operation, EGR Control
E7	Transmission Range Signal “B”	DNK	0.0 V	0.0 V	Automatic Transmission (4L30E)
E8	Throttle Position (TP) Sensor	BLU	0.5-0.8 V	0.5-0.8 V (at idle)	General Description and Operation, Throttle Position Sensor
E9	Engine Coolant Temperature (ECT) Sensor	BLU/RED	0.5-4.9 V (depends on temperature)	0.5-4.9 V (depends on temperature)	General Description and Operation, Engine Coolant Temperature (ECT) Sensor
E10	Not Used	—	—	—	—
E11	Crankshaft Position (CKP) Sensor +5 Volt Reference	YEL/RED	less than 1.0 V	5.0 V	General Description and Operation, Crankshaft Position Sensor
E12	Transmission Range Signal “A”	DNK/BLU	B+	B+	Automatic Transmission (4L30E)
E13	Fuel Pump (FP) Relay	RED/WHT	0.0 V	B+	On-Vehicle Service, Fuel Pump Relay
E14	Shift High (BAND APPLY)	BRN/WHT	B+	B+	Automatic Transmission (4L30E)
E15	A/C Request	GRN	0.0 V	0.0 V	Electric Cooling Fans
E16	Ignition Feed (1 of 2 F16)	RED/BLU	B+	B+	—

## PCM Pinout Table, 32-Way Blue Connector – Row “F”

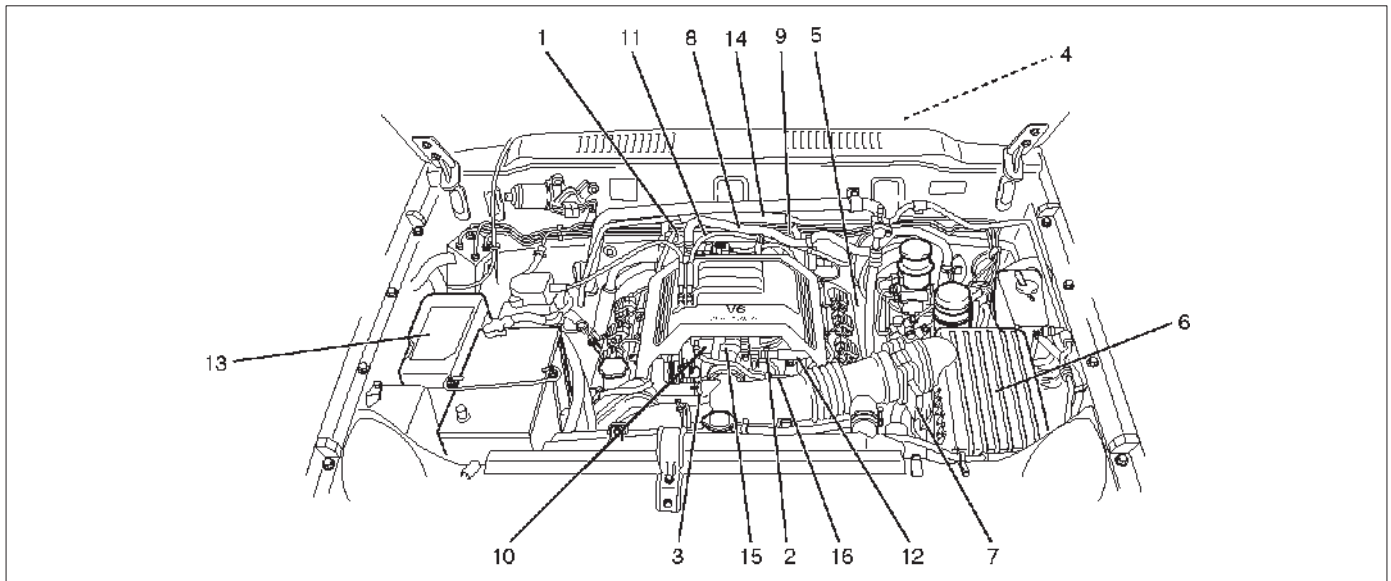


TS23346

PIN	PIN Function	Wire Color	IGN ON	ENG RUN	Refer To
F1	Not Used	—	—	—	—
F2	Transmission Range Signal “C”	RED	0.0 V	0.0 V	Automatic Transmission (4L30E)
F3	Transmission Range Signal “P”	DNK/BLK	B+	0.0 V	Automatic transmission (4L30E)
F4	Brake Switch	RED	0.0 V	0.0 V	Automatic transmission (4L30E)
F5	Power Switch	VIO/RED	B+	B+	Automatic Transmission (4L30E)
F6	Winter Switch	VIO/GRN	B+	B+	Automatic Transmission (4L30E)
F7	Transmission Fluid Temperature	RED/BLK	0.5-4.9 V (depends on temperature)	0.5-4.9 V (depends on temperature)	Automatic Transmission (4L30E)
F8	Manifold Absolute Pressure (MAP)	GRY/BLK	3.5-4.9 V (depends on altitude and barometric pressure)	0.6-1.3 V	General Description and Operation, Manifold Absolute Pressure
F9	Not Used	—	—	—	—
F10	Cruise Control	GRY/BLU	B+	B+	Automatic transmission (4L30E)
F11	Kickdown Switch	SKY BLU	B+	B+	Automatic Transmission (4L30E)
F12	DIAG	ORN/BLU	B+	B+	—
F13	Injector “C” Cylinder #3	GRN	B+	B+	General Description and Operation, Fuel Injector
F14	Shift “A” Solenoid	BRN/RED	B+	B+	Automatic Transmission (4L30E)
F15	Injector Cylinder #5	GRN/BLK	B+	B+	General Description and Operation, Fuel Injector
F16	Ignition Feed (1 of 2 E16)	RED/BLU	B+	B+	—

## Component Locators

### Engine Component Locator

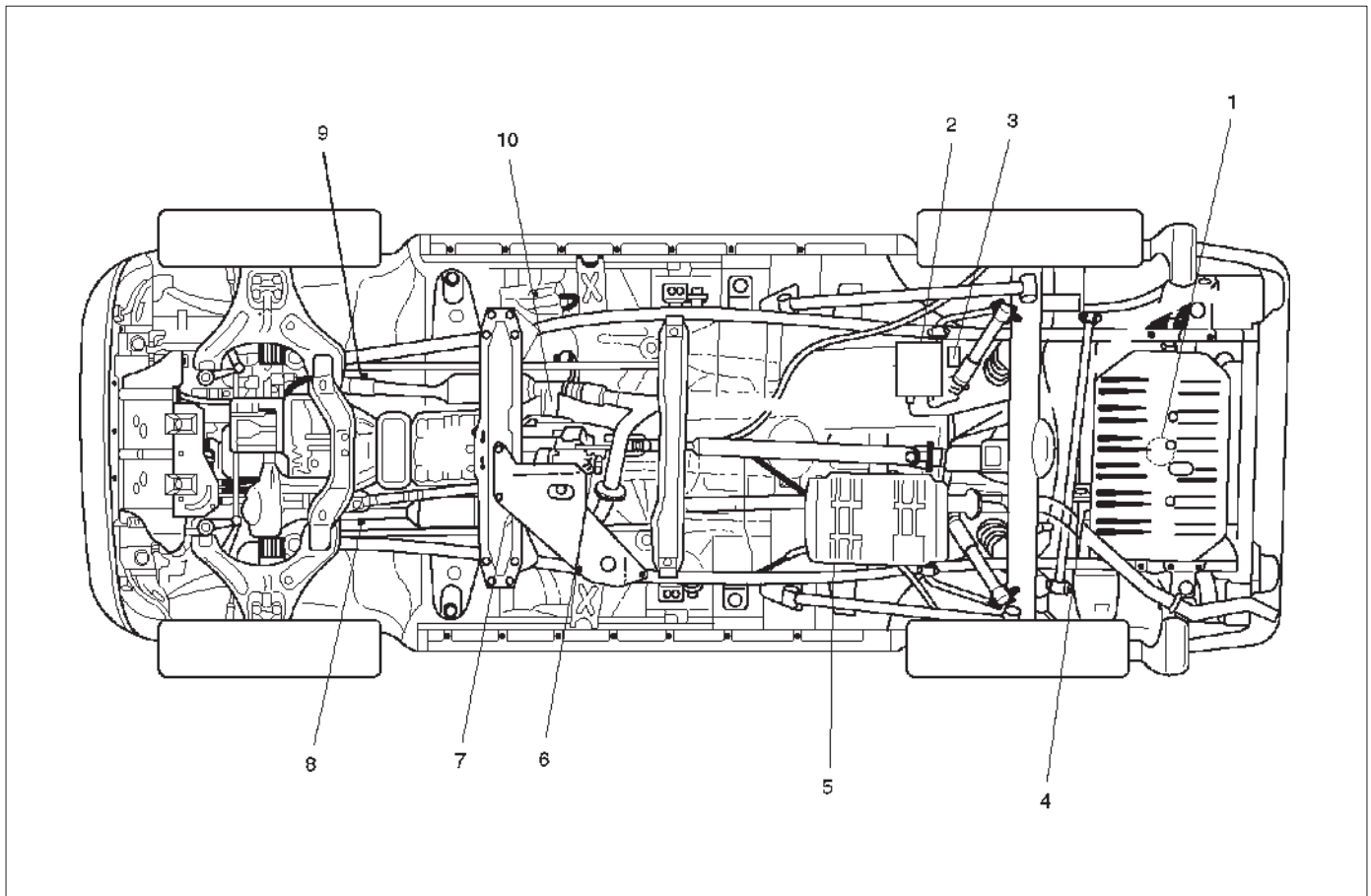


035RX013

**Engine Component Locator Table**

Number	Name	Location
1	Linear Exhaust Gas Recirculation (EGR) Valve	Rear right side of the engine
2	Throttle Position (TP) Sensor	On the rear of the throttle body
3	Intake Air Temperature (IAT) Sensor	On the intake air duct near the throttle body
4	Check Engine (MIL) Light	On the instrument panel beneath the tachometer
5	Positive Crankcase Ventilation (PCV) Valve	On the left of the cylinder head cover
6	Air Cleaner	Left front of the engine bay
7	Mass Air Flow (MAF) Sensor	Attached to the air filter box
8	Camshaft Position (CMP) Sensor	On the rear right side of the left cylinder head cover
9	Fuel Pressure Regulator	Rear right side of the engine
10	Idle Air Control (IAC) Valve	On the left of the throttle body
11	Upper Intake Manifold	Top of the engine
12	EVAP Canister Purge Valve	Bolted to the front of the coolant pipe
13	Fuse/Relay Box	Along the inside of the right fender
14	Manifold Absolute Pressure (MAP) Sensor	Bolted to the top of the upper intake manifold
15	Throttle Body	Between the intake air duct and the upper intake manifold
16	Engine Coolant Temperature Sensor	On the coolant crossover pipe at the front of the engine, near the throttle body

### Undercarriage Component Locator



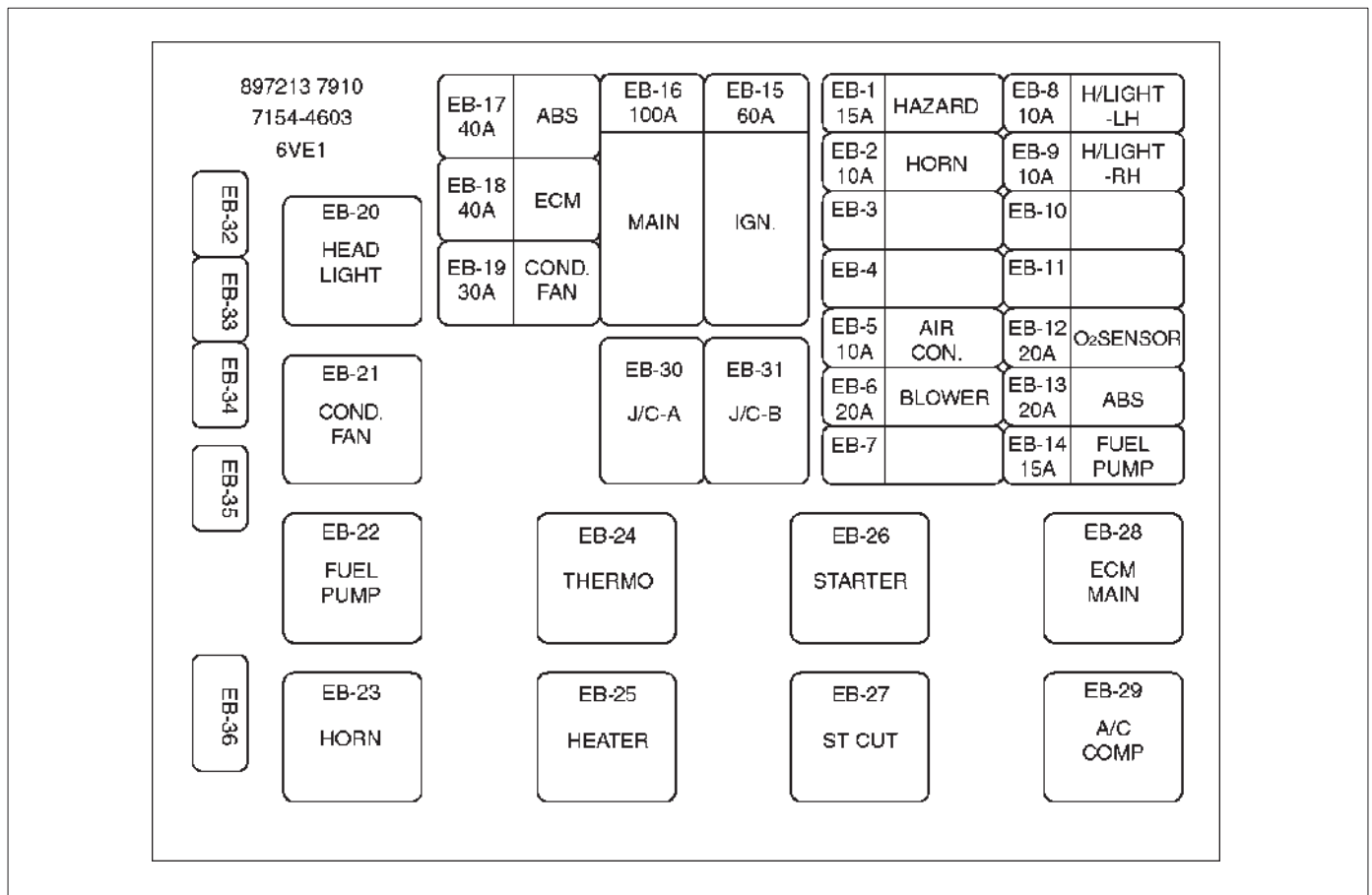
FO0RW032

**Undercarriage Component Locator Table**

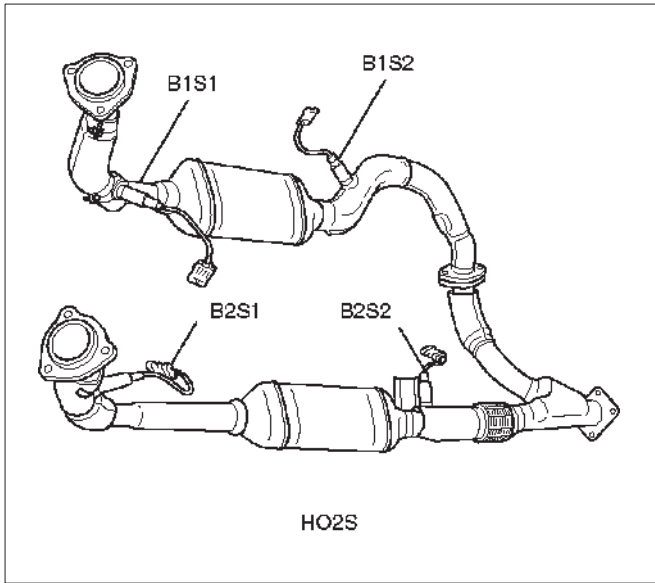
Number	Name	Location
1	Fuel Pump Assembly	Installed in the top of the fuel tank
2	EVAP Canister	On the top of the bracket that is located behind of the cross member
3	EVAP Canister Vent Solenoid	On the top of the bracket that is located behind of the cross member
4	Fuel Gauge Unit	Installed in the front edge of the fuel tank, on the right side
5	Fuel Filter	Located along the inside of the right frame rail, ahead of the rear axle
6	Vehicle Speed Sensor (VSS)	Protrudes from the rear output shaft housing of the transfer case.
7	Heated Oxygen Sensor (Bank 1, HO2S 2)	Threaded into the exhaust pipe behind the right-hand catalytic converter
8	Heated Oxygen Sensor (Bank 1, HO2S 1)	Threaded into the exhaust pipe ahead of the right-hand catalytic converter
9	Heated Oxygen Sensor (Bank 2, HO2S 1)	Threaded into the exhaust pipe ahead the left-hand catalytic converter
10	Heated Oxygen Sensor (Bank 2, HO2S 2)	Threaded into the exhaust pipe behind the left-hand catalytic converter



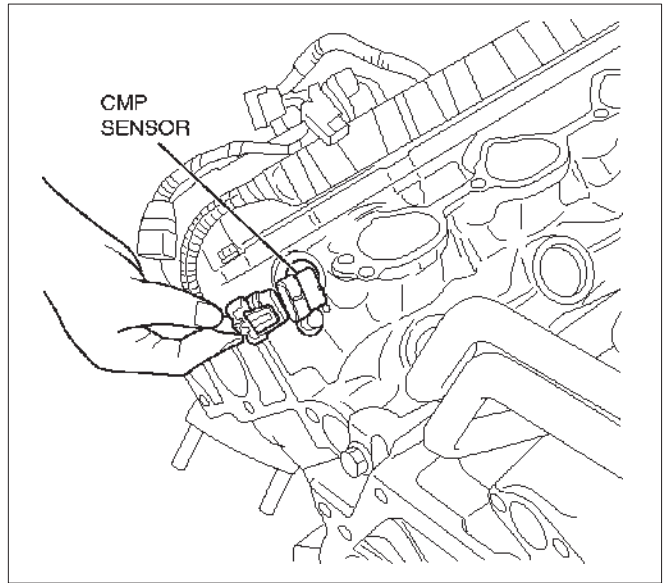
Fuse and Relay Panel (Underhood Electrical Center)



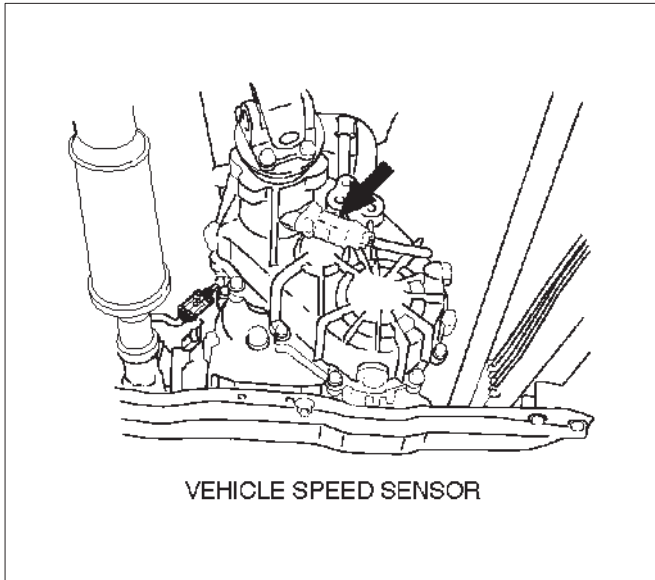
Sensors and Miscellaneous Component Locators



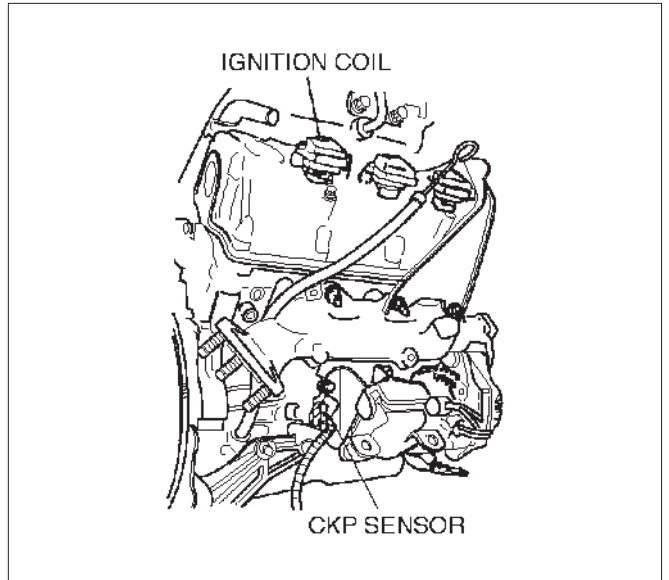
014RX058



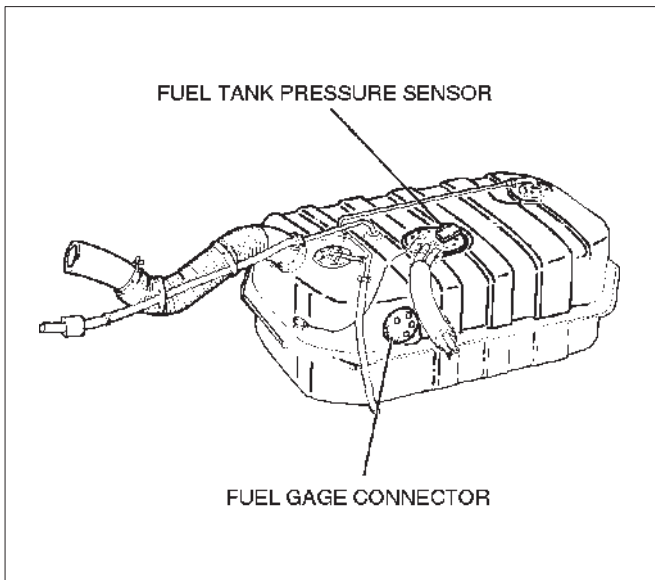
014RX059



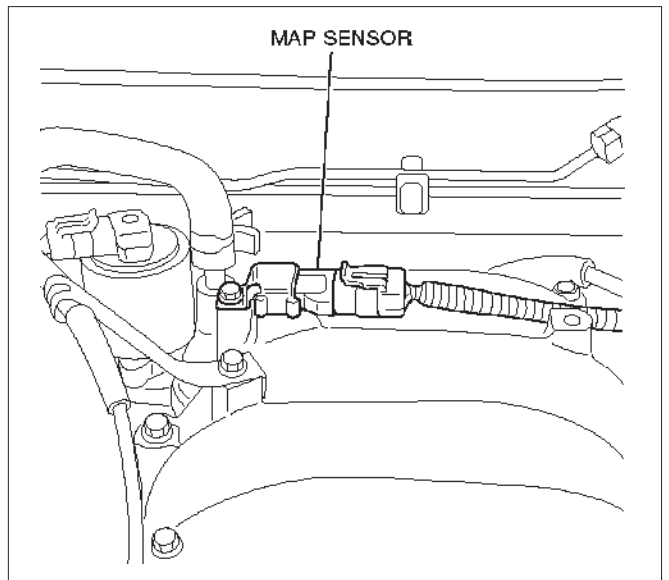
T321067



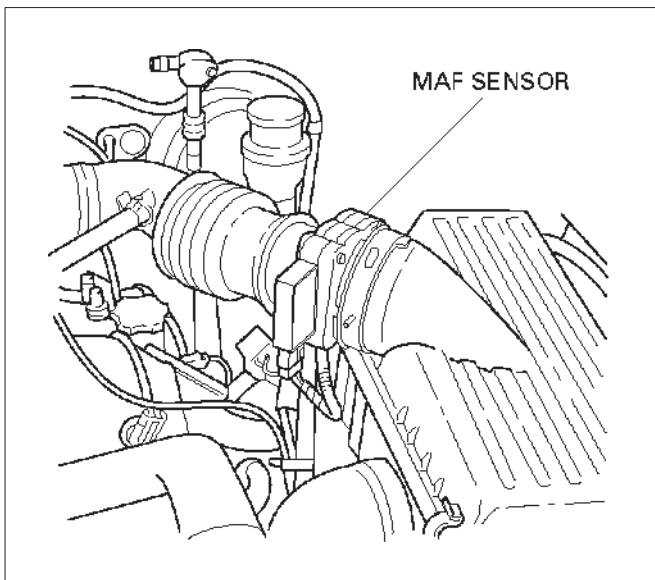
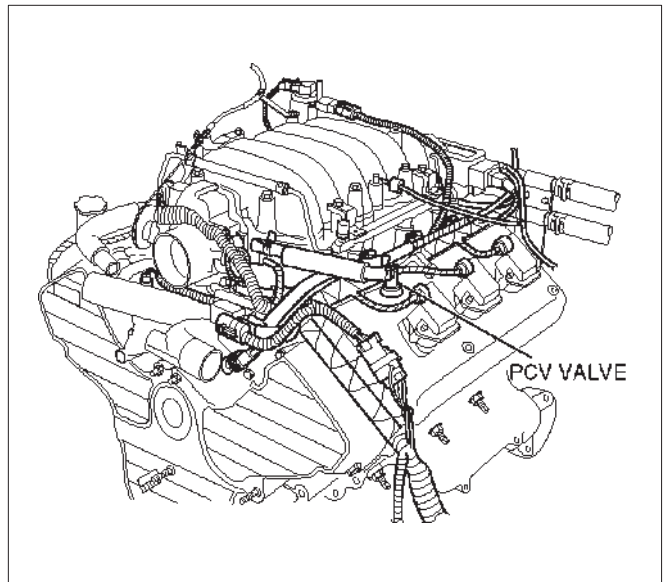
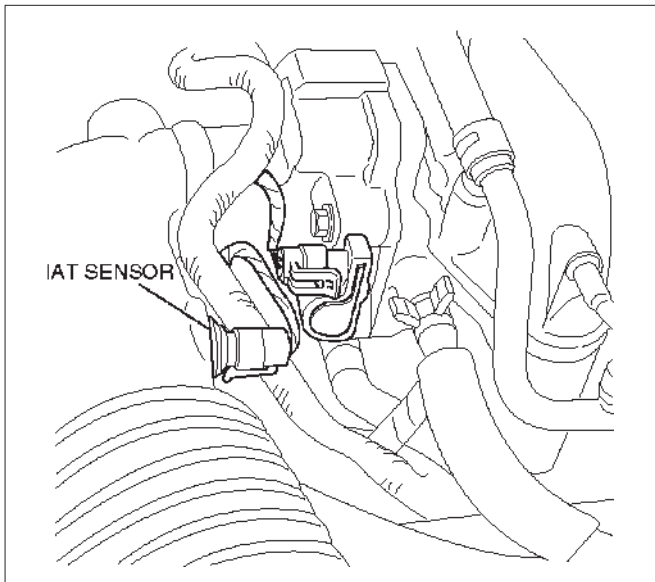
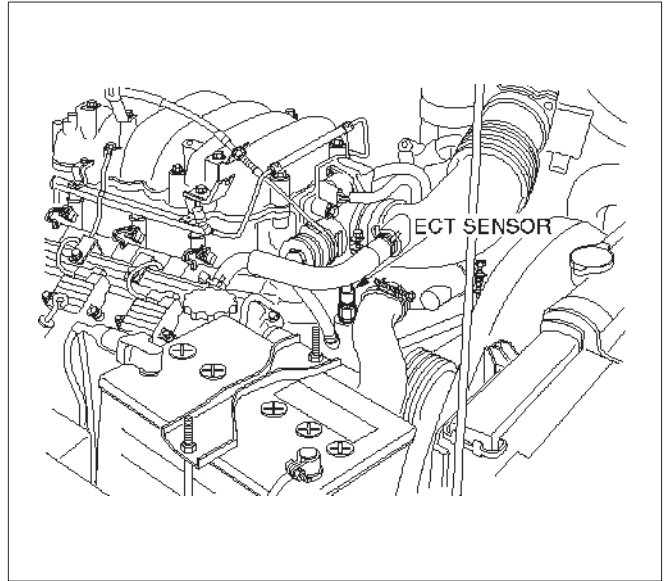
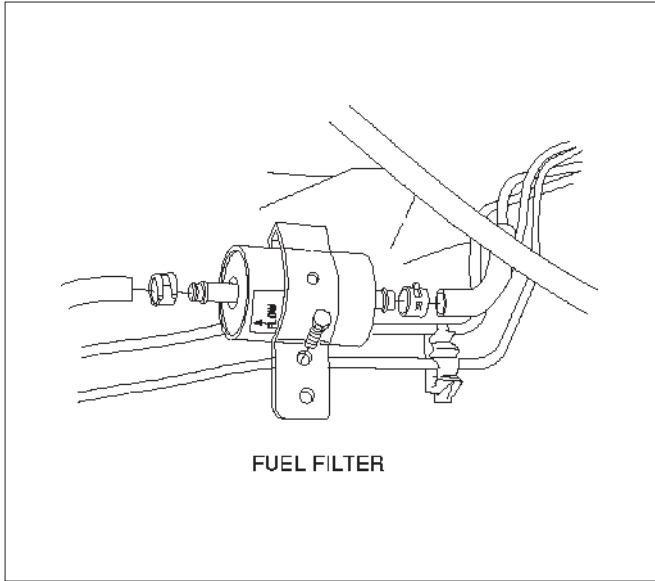
T321070



014RX060



055RW003



## Diagnosis

### Strategy-Based Diagnostics

#### Strategy-Based Diagnostics

The strategy-based diagnostic is a uniform approach to repair all Electrical/Electronic (E/E) systems. The diagnostic flow can always be used to resolve an E/E system problem and is a starting point when repairs are necessary. The following steps will instruct the technician how to proceed with a diagnosis:

1. Verify the customer complaint.
  - To verify the customer complaint, the technician should know the normal operation of the system.
2. Perform preliminary checks.
  - Conduct a thorough visual inspection.
  - Review the service history.
  - Detect unusual sounds or odors.
  - Gather diagnostic trouble code information to achieve an effective repair.
3. Check bulletins and other service information.
  - This includes videos, newsletters, etc.
4. Refer to service information (manual) system check(s).
  - "System checks" contain information on a system that may not be supported by one or more DTCs. System checks verify proper operation of the system. This will lead the technician in an organized approach to diagnostics.
5. Refer to service diagnostics.

#### DTC Stored

Follow the designated DTC chart exactly to make an effective repair.

#### No DTC

Select the symptom from the symptom tables. Follow the diagnostic paths or suggestions to complete the repair. You may refer to the applicable component/system check in the system checks.

#### No Matching Symptom

1. Analyze the complaint.
2. Develop a plan for diagnostics.
3. Utilize the wiring diagrams and the theory of operation.

Combine technician knowledge with efficient use of the available service information.

#### Intermittents

Conditions that are not always present are called intermittents. To resolve intermittents, perform the following steps:

1. Observe history DTCs, DTC modes, and freeze frame data.
2. Evaluate the symptoms and the conditions described by the customer.

3. Use a check sheet or other method to identify the circuit or electrical system component.
4. Follow the suggestions for intermittent diagnosis found in the service documentation.

Most Scan Tool, such as the Tech 2, have data-capturing capabilities that can assist in detecting intermittents.

#### No Trouble Found

This condition exists when the vehicle is found to operate normally. The condition described by the customer may be normal. Verify the customer complaint against another vehicle that is operating normally. The condition may be intermittent. Verify the complaint under the conditions described by the customer before releasing the vehicle.

1. Re-examine the complaint.
  - When the Complaint cannot be successfully found or isolated, a re-evaluation is necessary. The complaint should be re-verified and could be intermittent as defined in *Intermittents*, or could be normal.
2. Repair and verify.
  - After isolating the cause, the repairs should be made. Validate for proper operation and verify that the symptom has been corrected. This may involve road testing or other methods to verify that the complaint has been resolved under the following conditions:
    - Conditions noted by the customer.
    - If a DTC was diagnosed, verify a repair by duplicating conditions present when the DTC was set as noted in the Failure Records or Freeze Frame data.

#### Verifying Vehicle Repair

Verification of the vehicle repair will be more comprehensive for vehicles with OBD II system diagnostics. Following a repair, the technician should perform the following steps:

**IMPORTANT:** Follow the steps below when you verify repairs on OBD II systems. Failure to follow these steps could result in unnecessary repairs.

1. Review and record the Failure Records and the Freeze Frame data for the DTC which has been diagnosed (Freeze Frame data will only be stored for an A or B type diagnostic and only if the MIL ("Check Engine" lamp) has been requested).
2. Clear the DTC(S).
3. Operate the vehicle within conditions noted in the Failure Records and Freeze Frame data.
4. Monitor the DTC status information for the DTC which has been diagnosed until the diagnostic test associated with that DTC runs.

## General Service Information

#### OBD II Serviceability Issues

With the introduction of OBD II diagnostics across the entire passenger car and light-duty truck market in 1996, illumination of the MIL ("Check Engine" lamp) due to a non-vehicle fault could lead to misdiagnosis of the vehicle, increased warranty expense and customer

dissatisfaction. The following list of non-vehicle faults does not include every possible fault and may not apply equally to all product lines.

### **Fuel Quality**

Fuel quality is not a new issue for the automotive industry, but its potential for turning on the MIL (“Check Engine” lamp) with OBD II systems is new.

Fuel additives such as “dry gas” and “octane enhancers” may affect the performance of the fuel. If this results in an incomplete combustion or a partial burn, it will show up as a Misfire DTC P0300. The Reid Vapor Pressure of the fuel can also create problems in the fuel system, especially during the spring and fall months when severe ambient temperature swings occur. A high Reid Vapor Pressure could show up as a Fuel Trim DTC due to excessive canister loading. High vapor pressures generated in the fuel tank can also affect the Evaporative Emission diagnostic as well.

Using fuel with the wrong octane rating for the vehicle may cause driveability problems. Many of the major fuel companies advertise that using “premium” gasoline will improve the performance of the vehicle. Most premium fuels use alcohol to increase the octane rating of the fuel. Although alcohol-enhanced fuels may raise the octane rating, the fuel’s ability to turn into vapor in cold temperatures deteriorates. This may affect the starting ability and cold driveability of the engine.

Low fuel levels can lead to fuel starvation, lean engine operation, and eventually engine misfire.

### **Non-OEM Parts**

All of the OBD II diagnostics have been calibrated to run with OEM parts. Something as simple as a high-performance exhaust system that affects exhaust system back pressure could potentially interfere with the operation of the EGR valve and thereby turn on the MIL (“Check Engine” lamp). Small leaks in the exhaust system near the post catalyst oxygen sensor can also cause the MIL (“Check Engine” lamp) to turn on.

Aftermarket electronics, such as transceiver, stereos, and anti-theft devices, may radiate EMI into the control system if they are improperly installed. This may cause a false sensor reading and turn on the MIL (“Check Engine” lamp).

### **Environment**

Temporary environmental conditions, such as localized flooding, will have an effect on the vehicle ignition system. If the ignition system is rain-soaked, it can temporarily cause engine misfire and turn on the MIL (“Check Engine” lamp).

### **Refueling**

A new OBD II diagnostic was introduced in 1996 on some vehicles. This diagnostic checks the integrity of the entire evaporative emission system. If the vehicle is restarted after refueling and the fuel cap is not secured correctly, the on-board diagnostic system will sense this as a system fault and turn on the MIL (“Check Engine” lamp) with a DTC P0440.

### **Vehicle Marshaling**

The transportation of new vehicles from the assembly plant to the dealership can involve as many as 60 key cycles within 2 to 3 miles of driving. This type of operation contributes to the fuel fouling of the spark plugs and will turn on the MIL (“Check Engine” lamp) with a P0300 Misfire DTC.

### **Poor Vehicle Maintenance**

The sensitivity of OBD II diagnostics will cause the MIL (“Check Engine” lamp) to turn on if the vehicle is not maintained properly. Restricted air filters, fuel filters, and crankcase deposits due to lack of oil changes or improper oil viscosity can trigger actual vehicle faults that were not previously monitored prior to OBD II. Poor vehicle maintenance can’t be classified as a “non-vehicle fault”, but with the sensitivity of OBD II diagnostics, vehicle maintenance schedules must be more closely followed.

### **Severe Vibration**

The Misfire diagnostic measures small changes in the rotational speed of the crankshaft. Severe driveline vibrations in the vehicle, such as caused by an excessive amount of mud on the wheels, can have the same effect on crankshaft speed as misfire and therefore may set a Misfire DTC P0300.

### **Related System Faults**

Many of the OBD II system diagnostics will not run if the PCM detects a fault on a related system or component. One example would be that if the PCM detected a Misfire fault, the diagnostics on the catalytic converter would be suspended until Misfire fault was repaired. If the Misfire fault was severe enough, the catalytic converter could be damaged due to overheating and would never set a Catalyst DTC until the Misfire fault was repaired and the Catalyst diagnostic was allowed to run to completion. If this happens, the customer may have to make two trips to the dealership in order to repair the vehicle.

### **Emissions Control Information Label**

The engine compartment “Vehicle Emissions Control Information Label” contains important emission specifications and setting procedures. In the upper left corner is exhaust emission information. This identifies the emission standard (Federal, California, or Canada) of the engine, the displacement of the engine in liters, the class of the vehicle, and the type of fuel metering system. There is also an illustrated emission components and vacuum hose schematic.

This label is located in the engine compartment of every vehicle. If the label has been removed it should be replaced. It can be ordered from Isuzu Dealership.

### **Maintenance Schedule**

Refer to the *Maintenance Schedule*.

### **Visual / Physical Engine Compartment Inspection**

Perform a careful visual and physical engine compartment inspection when performing any diagnostic procedure or diagnosing the cause of an emission test failure. This can often lead to repairing a problem without

further steps. Use the following guidelines when performing a visual/physical inspection:

- Inspect all vacuum hoses for pinches, cuts, disconnections, and proper routing.
- Inspect hoses that are difficult to see behind other components.
- Inspect all wires in the engine compartment for proper connections, burned or chafed spots, pinched wires, contact with sharp edges or contact with hot exhaust manifolds or pipes.

## Basic Knowledge of Tools Required

NOTE: Lack of basic knowledge of this powertrain when performing diagnostic procedures could result in an incorrect diagnosis or damage to powertrain components. Do not attempt to diagnose a powertrain problem without this basic knowledge.

A basic understanding of hand tools is necessary to effectively use this section of the Service Manual.

## Serial Data Communications

### Class II Serial Data Communications

Government regulations require that all vehicle manufacturers establish a common communication system. This vehicle utilizes the "Class II" communication system. Each bit of information can have one of two lengths: long or short. This allows vehicle wiring to be reduced by transmitting and receiving multiple signals over a single wire. The messages carried on Class II data streams are also prioritized. If two messages attempt to establish communications on the data line at the same time, only the message with higher priority will continue. The device with the lower priority message must wait. The most significant result of this regulation is that it provides Tech 2 manufacturers with the capability to access data from any make or model vehicle that is sold.

The data displayed on the other Tech 2 will appear the same, with some exceptions. Some Tech 2 will only be able to display certain vehicle parameters as values that are a coded representation of the true or actual value. For more information on this system of coding, refer to *Decimal/Binary/Hexadecimal Conversions*. On this vehicle the Tech 2 displays the actual values for vehicle parameters. It will not be necessary to perform any conversions from coded values to actual values.

## On-Board Diagnostic (OBD) II

### On-Board Diagnostic Tests

A diagnostic test is a series of steps, the result of which is a pass or fail reported to the diagnostic executive. When a diagnostic test reports a pass result, the diagnostic executive records the following data:

- The diagnostic test has been completed since the last ignition cycle.
- The diagnostic test has passed during the current ignition cycle.

- The fault identified by the diagnostic test is not currently active.

When a diagnostic test reports a fail result, the diagnostic executive records the following data:

- The diagnostic test has been completed since the last ignition cycle.
- The fault identified by the diagnostic test is currently active.
- The fault has been active during this ignition cycle.
- The operating conditions at the time of the failure.

Remember, a fuel trim DTC may be triggered by a list of vehicle faults. Make use of all information available (other DTCs stored, rich or lean condition, etc.) when diagnosing a fuel trim fault.

## Comprehensive Component Monitor Diagnostic Operation

Comprehensive component monitoring diagnostics are required to monitor emissions-related input and output powertrain components. The *OBD II Comprehensive Component Monitoring List Of Components Intended To illuminate MIL* is a list of components, features or functions that could fall under this requirement.

### Input Components:

Input components are monitored for circuit continuity and out-of-range values. This includes rationality checking. Rationality checking refers to indicating a fault when the signal from a sensor does not seem reasonable, i.e. Throttle Position (TP) sensor that indicates high throttle position at low engine loads or MAP voltage. Input components may include, but are not limited to the following sensors:

- Vehicle Speed Sensor (VSS)
- Crankshaft Position (CKP) sensor
- Knock Sensor (KS)
- Throttle Position (TP) sensor
- Engine Coolant Temperature (ECT) sensor
- Camshaft Position (CMP) sensor
- Manifold Absolute Pressure (MAP) sensor
- Mass Air Flow (MAF) sensor

In addition to the circuit continuity and rationality check, the ECT sensor is monitored for its ability to achieve a steady state temperature to enable closed loop fuel control.

### Output Components:

Output components are diagnosed for proper response to control module commands. Components where functional monitoring is not feasible will be monitored for circuit continuity and out-of-range values if applicable. Output components to be monitored include, but are not limited to, the following circuits:

- Idle Air Control (IAC) Motor
- Control module controlled EVAP Canister Purge Valve
- Electronic Transmission controls
- A/C relays
- Cooling fan relay
- VSS output

- MIL control
- Cruise control inhibit

Refer to PCM and Sensors in General Descriptions.

### Passive and Active Diagnostic Tests

A passive test is a diagnostic test which simply monitors a vehicle system or component. Conversely, an active test, actually takes some sort of action when performing diagnostic functions, often in response to a failed passive test. For example, the EGR diagnostic active test will force the EGR valve open during closed throttle decel and/or force the EGR valve closed during a steady state. Either action should result in a change in manifold pressure.

### Intrusive Diagnostic Tests

This is any on-board test run by the Diagnostic Management System which may have an effect on vehicle performance or emission levels.

### Warm-Up Cycle

A warm-up cycle means that engine at temperature must reach a minimum of 70°C (160°F) and rise at least 22°C (40°F) over the course of a trip.

### Freeze Frame

Freeze Frame is an element of the Diagnostic Management System which stores various vehicle information at the moment an emissions-related fault is stored in memory and when the MIL is commanded on. These data can help to identify the cause of a fault. Refer to *Storing And Erasing Freeze Frame Data* for more detailed information.

### Failure Records

Failure Records data is an enhancement of the OBD II Freeze Frame feature. Failure Records store the same vehicle information as does Freeze Frame, but it will store that information for any fault which is stored in on-board memory, while Freeze Frame stores information only for emission-related faults that command the MIL on.

## System Status and Drive Cycle for Satisfying Federal Inspection/Maintenance (I/M 240) Regulations

I/M Ready Status means a signal or flag for each emission system test that had been set in the PCM. I/M Ready Status indicates that the vehicle on-board emissions diagnostics have been run. I/M Ready Status is not concerned whether the emission system passed or failed the test, only that on-board diagnosis is complete. Not all vehicle use all possible I/M flags.

## Common OBD II Terms

### Diagnostic

When used as a noun, the word diagnostic refers to any on-board test run by the vehicle's Diagnostic Management System. A diagnostic is simply a test run on a system or component to determine if the system or component is operating according to specification. There are many diagnostics, shown in the following list:

- Misfire
- Oxygen sensors

- Oxygen sensor heaters
- EGR
- Catalyst monitoring

### Enable Criteria

The term "enable criteria" is engineering language for the conditions necessary for a given diagnostic test to run. Each diagnostic has a specific list of conditions which must be met before the diagnostic will run. "Enable criteria" is another way of saying "conditions required". The enable criteria for each diagnostic is listed on the first page of the DTC description in Section 6E under the heading "Conditions for Setting the DTC". Enable criteria varies with each diagnostic, and typically includes, but is not limited to the following items:

- engine speed
- vehicle speed
- ECT
- MAF/MAP
- barometric pressure
- IAT
- TP
- high canister purge
- fuel trim
- TCC enabled
- A/C on

### Trip

Technically, a trip is a key on-run-key off cycle in which all the enable criteria for a given diagnostic are met, allowing the diagnostic to run. Unfortunately, this concept is not quite that simple. A trip is official when all the enable criteria for a given diagnostic are met. But because the enable criteria vary from one diagnostic to another, the definition of trip varies as well. Some diagnostic are run when the vehicle is at operating temperature, some when the vehicle first starts up; some require that the vehicle be cruising at a steady highway speed, some run only when the vehicle is idle; some diagnostics function with the TCC disables. Some run only immediately following a cold engine start-up.

A trip then, is defined as a key on-run-key off cycle in which the vehicle was operated in such a way as to satisfy the enabling criteria for a given diagnostic, and this diagnostic will consider this cycle to be one trip. However, another diagnostic with a different set of enable criteria (which were not met) during this driving event, would not consider it a trip. No trip will occur for that particular diagnostic until the vehicle is driven in such a way as to meet all the enable criteria.

## The Diagnostic Executive

The Diagnostic Executive is a unique segment of software which is designed to coordinate and prioritize the diagnostic procedures as well as define the protocol for recording and displaying their results. The main responsibilities of the Diagnostic Executive are listed as follows:

- Commanding the MIL ("Check Engine" lamp) on and off

- DTC logging and clearing
- Freeze Frame data for the first emission related DTC recorded
- Non-emission related Service Lamp (future)
- Operating conditions Failure Records buffer, (the number of records will vary)
- Current status information on each diagnostic
- System Status (I/M ready)

The Diagnostic Executive records DTCs and turns on the MIL when emission-related faults occur. It can also turn off the MIL if the conditions cease which caused the DTC to set.

### Diagnostic Information

The diagnostic charts and functional checks are designed to locate a faulty circuit or component through a process of logical decisions. The charts are prepared with the requirement that the vehicle functioned correctly at the time of assembly and that there are no multiple faults present.

There is a continuous self-diagnosis on certain control functions. This diagnostic capability is complemented by the diagnostic procedures contained in this manual. The language of communicating the source of the malfunction is a system of diagnostic trouble codes. When a malfunction is detected by the control module, a diagnostic trouble code is set and the Malfunction Indicator Lamp (MIL) ("Check Engine" lamp) is illuminated.

### Malfunction Indicator Lamp (MIL)

The Malfunction Indicator Lamp (MIL) looks the same as the MIL you are already familiar with ("Check Engine" lamp). However, OBD II requires that it illuminate under a strict set of guide lines.

Basically, the MIL is turned on when the PCM detects a DTC that will impact the vehicle emissions.

The MIL is under the control of the Diagnostic Executive. The MIL will be turned on if an emissions-related diagnostic test indicates a malfunction has occurred. It will stay on until the system or component passes the same test, for three consecutive trips, with no emissions related faults.

If the vehicle is experiencing a misfire malfunction which may cause damage to the Three-Way Catalytic Converter (TWC), the MIL will flash once per second. This will continue until the vehicle is outside of speed and load conditions which could cause possible catalyst damage, and the MIL will stop flashing and remain on steady.

### Extinguishing the MIL

When the MIL is on, the Diagnostic Executive will turn off the MIL after *three(3) consecutive* trips that a "test passed" has been reported for the diagnostic test that originally caused the MIL to illuminate.

Although the MIL has been turned off, the DTC will remain in the PCM memory (both Freeze Frame and Failure Records) until *forty(40) warm-up cycles after no faults* have been completed.

If the MIL was set by either a fuel trim or misfire-related DTC, additional requirements must be met. In addition to the requirements stated in the previous paragraph, these requirements are as follows:

- The diagnostic tests that are passed must occur with 375 RPM of the RPM data stored at the time the last test failed.
- Plus or minus ten (10) percent of the engine load that was stored at the time the last failed.
- Similar engine temperature conditions (warmed up or warming up ) as those stored at the time the last test failed.

Meeting these requirements ensures that the fault which turned on the MIL has been corrected.

The MIL ("Check Engine" lamp) is on the instrument panel and has the following function:

- It informs the driver that a fault affects vehicle emission levels has occurred and that the vehicle should be taken for service as soon as possible.
- As a bulb and system check, the MIL will come "ON" with the key "ON" and the engine not running. When the engine is started, the MIL will turn "OFF."
- When the MIL remains "ON" while the engine is running, or when a malfunction is suspected due to a driveability or emissions problem, a Powertrain On-Board Diagnostic (OBD II) System Check must be performed. The procedures for these checks are given in On-Board Diagnostic (OBD) System Check. These checks will expose faults which may not be detected if other diagnostics are performed first.

### DTC Types

Each DTC is directly related to a diagnostic test. The Diagnostic Management System sets DTC based on the failure of the tests during a trip or trips. Certain tests must fail two (2) consecutive trips before the DTC is set. The following are the four (4) types of DTCs and the characteristics of those codes:

- Type A
  - Emissions related
  - Requests illumination of the MIL of the first trip with a fail
  - Stores a History DTC on the first trip with a fail
  - Stores a Freeze Frame (if empty)
  - Stores a Fail Record
  - Updates the Fail Record each time the diagnostic test fails
- Type B
  - Emissions related
  - "Armed" after one (1) trip with a fail
  - "Disarmed" after one (1) trip with a pass
  - Requests illumination of the MIL on the *second consecutive trip* with a fail
  - Stores a History DTC on the second consecutive trip with a fail (The DTC will be armed after the first fail)
  - Stores a Freeze Frame on the second consecutive trip with a fail (if empty)



- Stores a Fail Record when the first test fails (not dependent on *consecutive trip* fails)
- Updates the Fail Record each time the diagnostic test fails

(Some special conditions apply to misfire and fuel trim DTCs)

- Type C (if the vehicle is so equipped)
  - Non-Emissions related
  - Requests illumination of the Service Lamp or the service message on the Drive Information Center (DIC) on the *first trip* with a fail
  - Stores a History DTC on the *first trip* with a fail
  - Does not* store a Freeze Frame
  - Stores Fail Record when test fails
  - Updates the Fail Record each time the diagnostic test fails
- Type D (*Type D* non-emissions related are not utilized on certain vehicle applications).
  - Non-Emissions related
  - Does not request illumination of any lamp
  - Stores a History DTC on the *first trip* with a fail
  - Does not* store a Freeze Frame
  - Stores Fail Record when test fails
  - Updates the Fail Record each time the diagnostic test fails

**IMPORTANT:** Only four Fail Records can be stored. Each Fail Record is for a different DTC. It is possible that there will not be Fail Records for every DTC if multiple DTCs are set.

### Special Cases of Type B Diagnostic Tests

Unique to the misfire diagnostic, the Diagnostic Executive has the capability of alerting the vehicle operator to potentially damaging levels of misfire. If a misfire condition exists that could potentially damage the catalytic converter as a result of high misfire levels, the Diagnostic Executive will command the MIL to “flash” at a rate of once per seconds during those the time that the catalyst damaging misfire condition is present.

Fuel trim and misfire are special cases of *Type B* diagnostics. Each time a fuel trim or misfire malfunction is detected, engine load, engine speed, and engine coolant temperature are recorded.

When the ignition is turned off, the last reported set of conditions remain stored. During subsequent ignition cycles, the stored conditions are used as reference for similar conditions. If a malfunction occurs during two consecutive trips, the Diagnostic Executive treats the failure as a normal *Type B* diagnostic, and does not use the stored conditions. However, if a malfunction occurs on two non-consecutive trips, the stored conditions are compared with the current conditions. The MIL will then illuminate under the following conditions:

- When the engine load conditions are within 10% of the previous test that failed.

- Engine speed is within 375 rpm, of the previous test that failed.
- Engine coolant temperature is in the same range as the previous test that failed.

### Storing and Erasing Freeze Frame Data and Failure Records

Government regulations require that engine operating conditions be captured whenever the MIL is illuminated. The data captured is called Freeze Frame data. The Freeze Frame data is very similar to a single record of operating conditions. Whenever the MIL is illuminated, the corresponding record of operating conditions is recorded to the Freeze Frame buffer.

Freeze Frame data can only be overwritten with data associated with a misfire or fuel trim malfunction. Data from these faults take precedence over data associated with any other fault. The Freeze Frame data will not be erased unless the associated history DTC is cleared.

Each time a diagnostic test reports a failure, the current engine operating conditions are recorded in the *Failure Records* buffer. A subsequent failure will update the recorded operating conditions. The following operating conditions for the diagnostic test which failed *typically* include the following parameters:

- Air Fuel Ratio
- Air Flow Rate
- Fuel Trim
- Engine Speed
- Engine Load
- Engine Coolant Temperature
- Vehicle Speed
- TP
- MAP/BARO
- Injector Base Pulse Width
- Loop Status

### Intermittent Malfunction Indicator Lamp

In the case of an “intermittent” fault, the MIL (“Check Engine” lamp) may illuminate and then (after three trips) go “OFF”. However, the corresponding diagnostic trouble code will be stored in the memory. When unexpected diagnostic trouble codes appear, check for an intermittent malfunction.

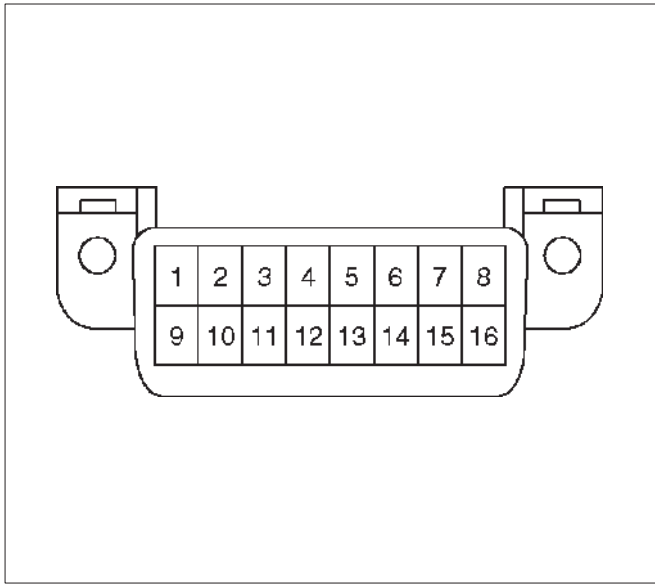
A diagnostic trouble code may reset. Consult the “Diagnostic Aids” associated with the diagnostic trouble code. A physical inspection of the applicable sub-system most often will resolve the problem.

### Data Link Connector (DLC)

The provision for communication with the control module is the Data Link Connector (DLC). It is located at the lower left of the instrument panel behind a small square cover. The DLC is used to connect to the Tech 2, Scan Tool. Some common uses of the Tech 2 are listed below:

- Identifying stored Diagnostic Trouble Codes (DTCs).
- Clearing DTCs.
- Performing output control tests.

- Reading serial data.



TS24064

## Decimal/Binary/Hexadecimal Conversions

Beginning in 1996, Federal Regulations require that all auto manufacturer selling vehicles in the United States provide Scan Tool manufacturers with software information to display vehicle operating parameters. All Scan Tool manufacturers will display a variety of vehicle information which will aid in repairing the vehicle. Some Scan Tools will display encoded messages which will aid in determining the nature of the concern. The method of encoding involves the use of a two additional numbering systems: Binary and Hexadecimal.

The binary number system has a base of two numbers. Each digit is either a 0 or a 1. A binary number is an eight digit number and is read from right to left. Each digit has a position number with the farthest right being the 0 position and the farthest left being the 7 position. The 0 position, when displayed by a 1, indicates 1 in decimal. Each position to the left is double the previous position and added to any other position values marked as a 1.

A hexadecimal system is composed of 16 different alpha numeric characters. The alpha numeric characters used are numbers 0 through 9 and letters A through F. The hexadecimal system is the most natural and common approach for Scan Tool manufacturers to display data represented by binary numbers and digital code.

## Verifying Vehicle Repair

Verification of vehicle repair will be more comprehensive for vehicles with OBD II system diagnostic. Following a repair, the technician should perform the following steps:

1. Review and record the Fail Records and/or Freeze Frame data for the DTC which has been diagnosed (Freeze Frame data will only be stored for an A or B type diagnostic and only if the MIL has been requested).
2. Clear DTC(s).
3. Operate the vehicle within conditions noted in the Fail Records and/or Freeze Frame data.

4. Monitor the DTC status information for the DTC which has been diagnosed until the diagnostic test associated with that DTC runs.

*Following these steps are very important in verifying repairs on OBD II systems. Failure to follow these steps could result in unnecessary repairs.*

## Reading Diagnostic Trouble Codes Using The Tech 2 Scan Tool

The procedure for reading diagnostic trouble code(s) is to use a diagnostic Scan Tool. When reading DTC(s), follow instructions supplied by tool manufacturer.

### Clearing Diagnostic Trouble Codes

**IMPORTANT:** Do not clear DTCs unless directed to do so by the service information provided for each diagnostic procedure. When DTCs are cleared, the Freeze Frame and Failure Record data which may help diagnose an intermittent fault will also be erased from memory.

If the fault that caused the DTC to be stored into memory has been corrected, the Diagnostic Executive will begin to count the "warm-up" cycles with no further faults detected, the DTC will automatically be cleared from the PCM memory.

To clear Diagnostic Trouble Codes (DTCs), use the diagnostic Scan Tool "clear DTCs" or "clear information" function. When clearing DTCs follow instructions supplied by the tool manufacturer.

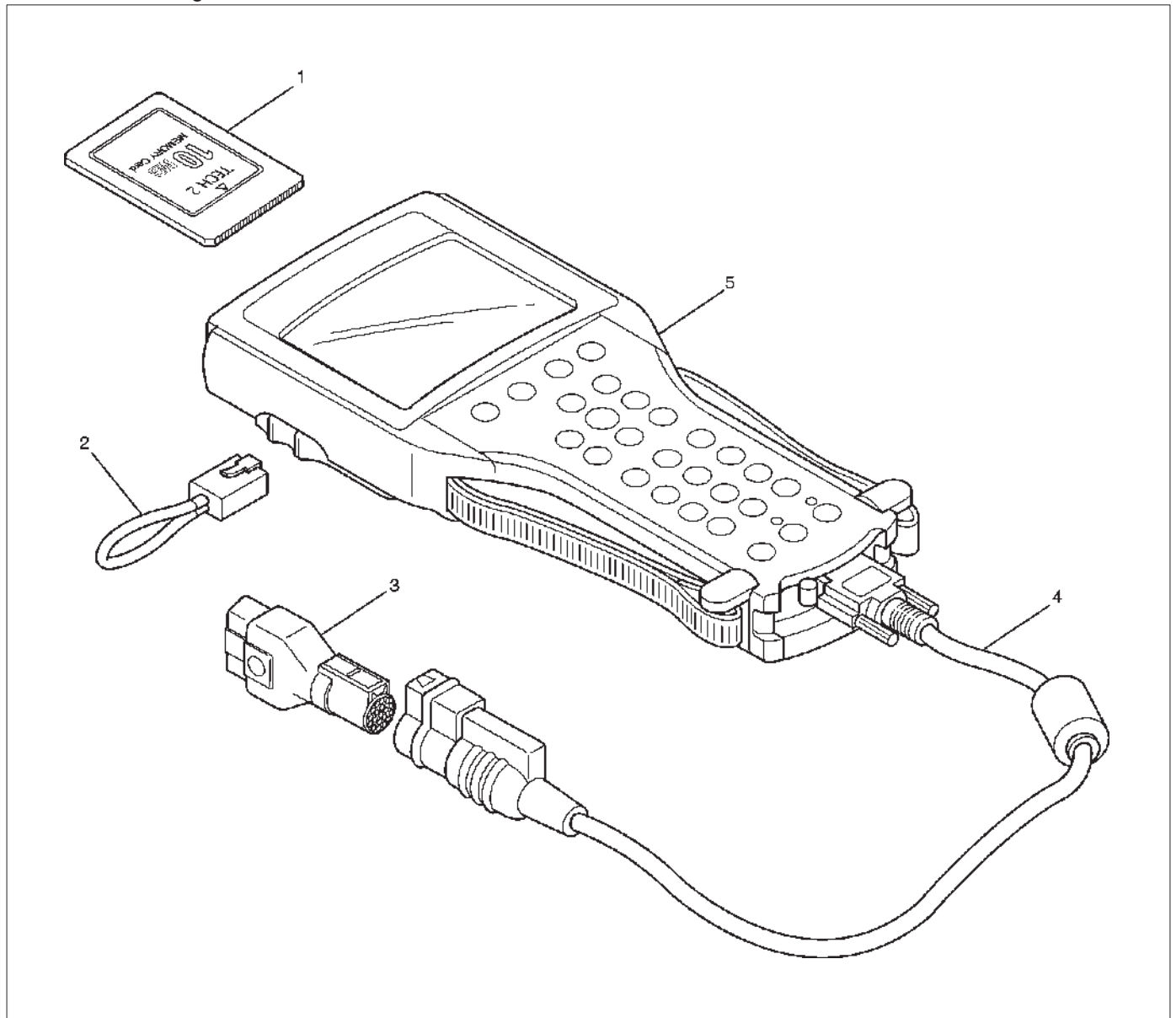
When a Scan Tool is not available, DTCs can also be cleared by disconnecting *one* of the following sources for at least thirty (30) seconds.

**NOTE:** To prevent system damage, the ignition key must be "OFF" when disconnecting or reconnecting battery power.

- The power source to the control module. Examples: fuse, pigtail at battery PCM connectors etc.
- The negative battery cable. (Disconnecting the negative battery cable will result in the loss of other on-board memory data, such as preset radio tuning).

## Tech 2

From 98 MY, Isuzu dealer service departments are recommended to use the Tech 2, Scan Tool. Please refer to the Tech 2 user guide.



### Legend

- |                                |                       |
|--------------------------------|-----------------------|
| (1) PCMCIA Card                | (3) SAE 16/19 Adaptor |
| (2) RS 232 Loop Back Connector | (4) DLC Cable         |
|                                | (5) Tech-2            |

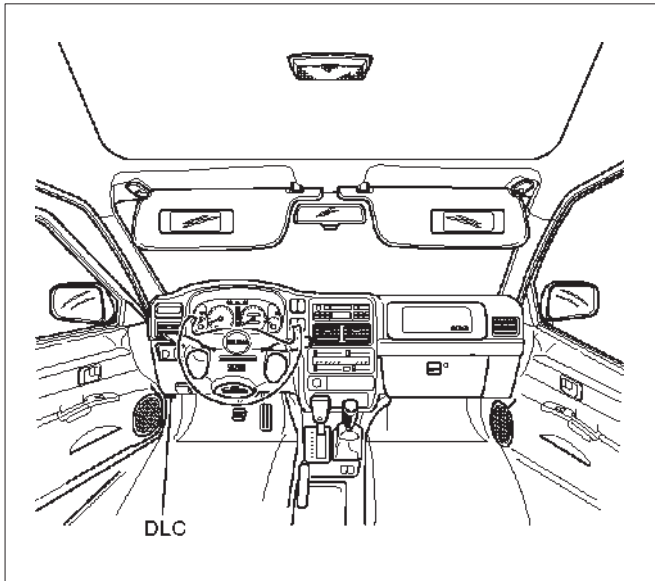
## Tech 2 Features

1. Tech 2 is a 12 volt system. Do not apply 24 volt.
2. After connecting and/or installing the Vehicle Communications Interface (VCI) module, PCMCIA card and DLC connector to the Tech 2, connect the tool to the vehicle DLC.
3. Make sure the Tech 2 is powered OFF when removing or installing the PCMCIA card.
4. The PCMCIA card has a capacity of 10 Megabytes which is 10 times greater than the memory of the Tech 1 Mass Storage Cartridge.
5. The Tech 2 has the capability of two snapshots.
6. The PCMCIA card is sensitive to magnetism and static electricity, so care should be taken in the handling of the card.
7. The Tech 2 can plot a graph when replaying a snapshot.
8. Always return to the Main Menu by pressing the EXIT key several times before shutting down.

9. To clear Diagnostic Trouble Codes (DTCs), open Application Menu and press "F1: Clear DTC Info".

**Getting Started**

- Before operating the Isuzu PCMCIA card with the Tech 2, the following steps must be performed:
- 1. The Isuzu 98 System PCMCIA card (1) inserts into the Tech 2 (5).
- 2. Connect the SAE 16/19 adapter (3) to the DLC cable (4).
- 3. Connect the DLC cable to the Tech 2 (5)
- 4. Make sure the vehicle ignition is off.
- 5. Connect the Tech 2 SAE 16/19 adapter to the vehicle DLC.



740RX060

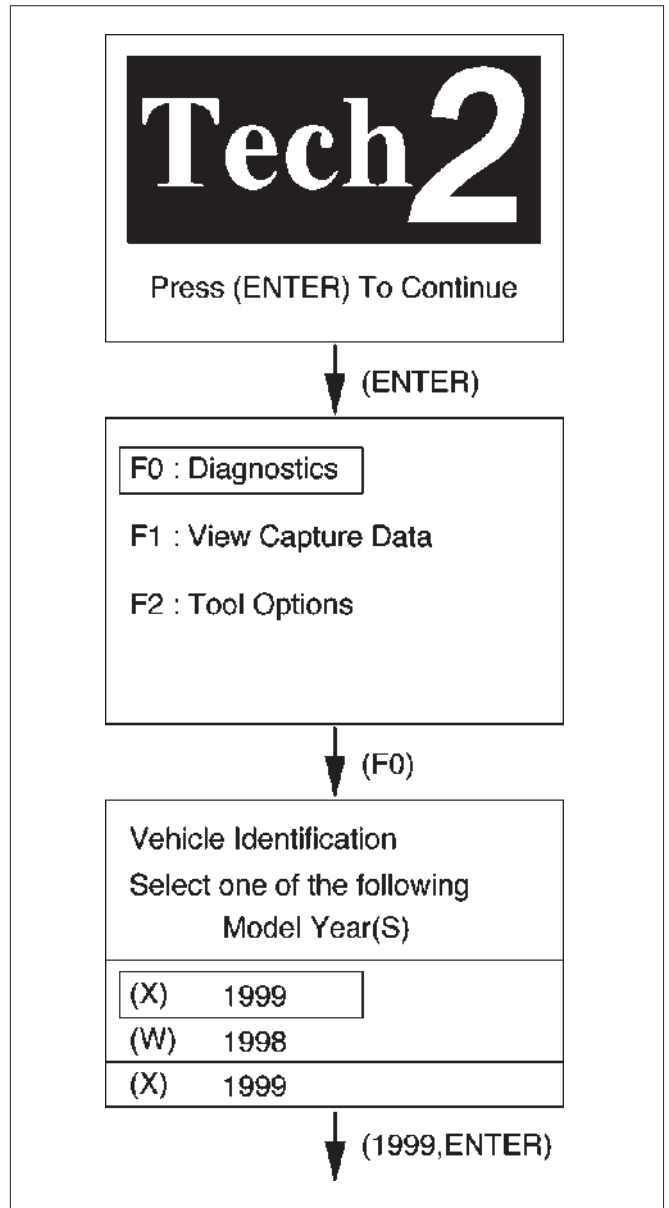
- 6. Turn on the vehicle ignition.
- 7. Power the Tech 2 ON and verify the Tech 2 power up display.



060RW009

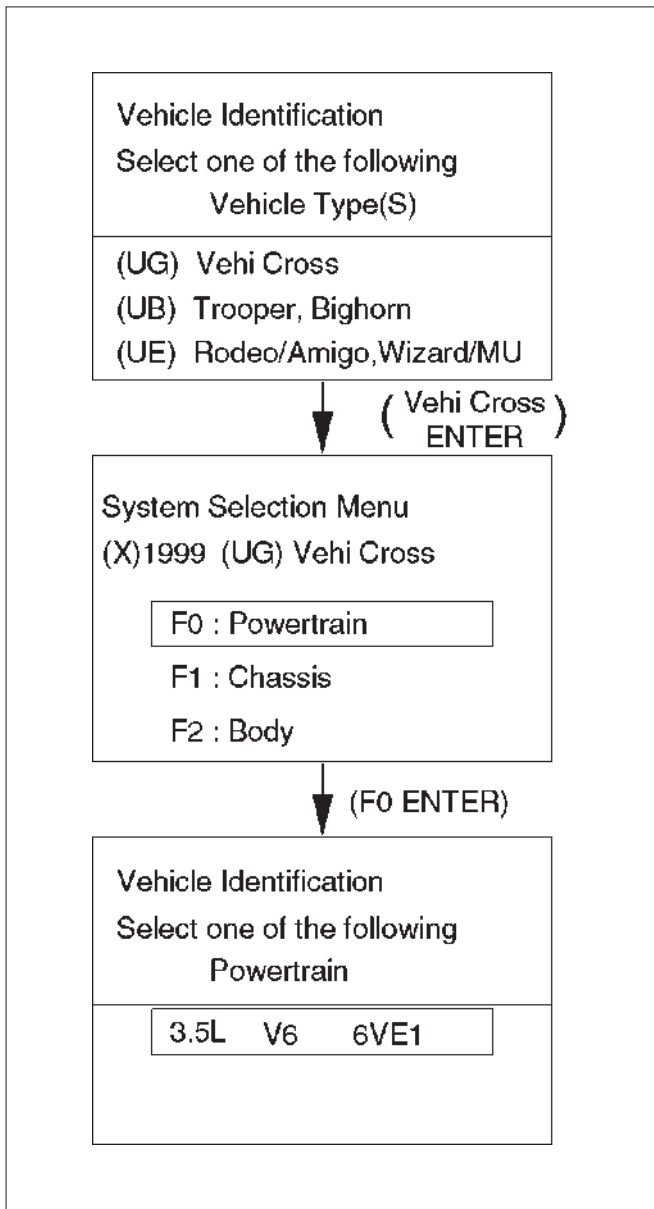
**Operating Procedure (For Example)**

The power up screen is displayed when you power up the tester with the Isuzu systems PCMCIA card. Follow the operating procedure below.



060RX060

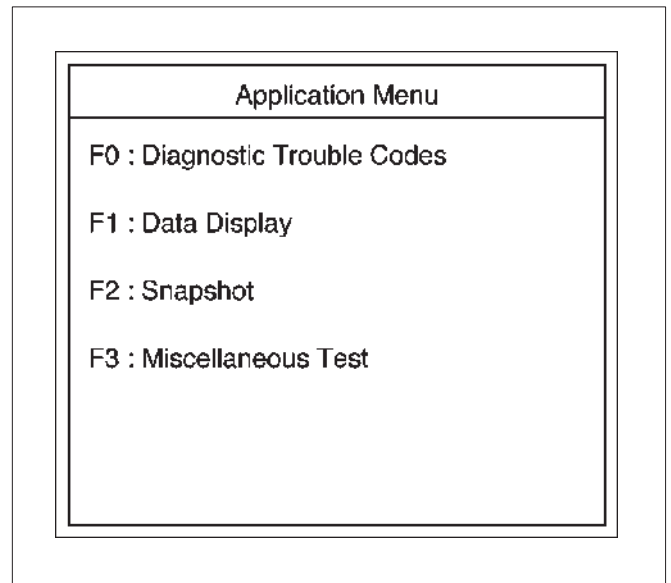
NOTE: The RS232 Loop back connector is only use for diagnosis of Tech 2. Refer to user guide of the Tech 2.



060RX081

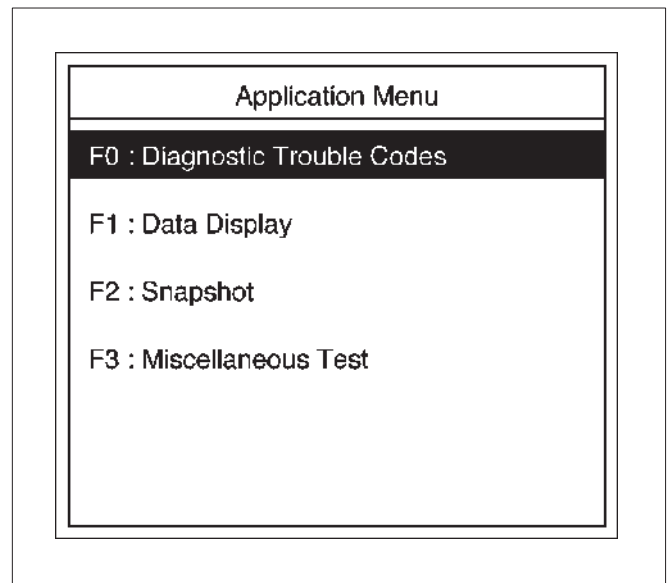
**Menu**

- The following table shows which functions are used for the available equipment versions.



060RW224

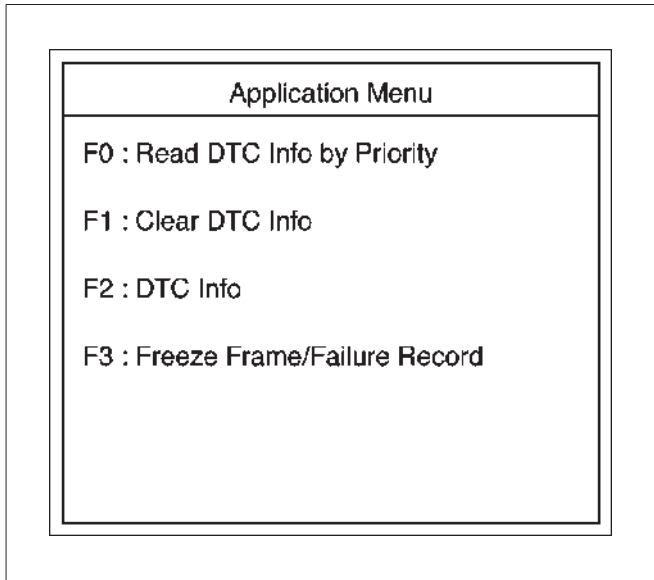
**DTC Modes**



060RW229

On OBD II vehicles there are five options available in Tech 2 DTC mode to display the enhanced information available. After selecting DTC, the following menu appears:

- DTC Info
- Freeze Frame
- Fail Records (not all applications)
- Clear Info

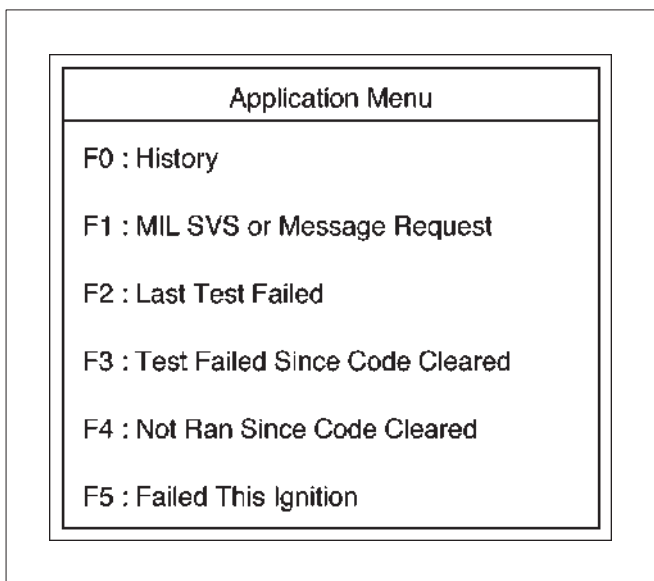


060RW223

The following is a brief description of each of the sub menus in DTC Info and DTC. The order in which they appear here is alphabetical and not necessarily the way they will appear on the Tech 2.

**DTC Information Mode**

Use the DTC info mode to search for a specific type of stored DTC information. There are six choices. The service manual may instruct the technician to test for DTCs in a certain manner. Always follow published service procedures.



060RW221

**DTC Status**

This selection will display any DTCs that have not run during the current ignition cycle or have reported a test failure during this ignition up to a maximum of 33 DTCs. DTC tests which run and pass will cause that DTC number to be removed from Tech 2 screen.

**Fail This Ignition**

This selection will display all DTCs that have failed during the present ignition cycle.

**History**

This selection will display only DTCs that are stored in the PCM's history memory. It will display all type A and B DTCs that have requested the MIL and have failed within the last 40 warm-up cycles. In addition, it will display all type C and type D DTCs that have failed within the last 40 warm-up cycles.

**Last Test Failed**

This selection will display only DTCs that have failed the last time the test run. The last test may have run during a previous ignition cycle if a type A or type B DTC is displayed. For type C and type D DTCs, the last failure must have occurred during the current ignition cycle to appear as Last Test Fail.

**MILSVC or Message Request**

This selection will display only DTCs that are requesting the MIL. Type C and type D DTCs cannot be displayed using this option. This selection will report type B DTCs only after the MIL has been requested.

**Not Run Since Code Cleared**

This option will display up to 33 DTCs that have not run since the DTCs were last cleared. Since any displayed DTCs have not run, their condition (passing or failing) is unknown.

**Test Failed Since Code Cleared**

This selection will display all active and history DTCs that have reported a test failure since the last time DTCs were cleared. DTCs that last failed more than 40 warm-up cycles before this option is selected will not be displayed.

**Miscellaneous Test**

This test consists of eight menus-Lights, Relays, EVAP, IAC System, Fuel System, EGR Control, Variable Intake Manifold Solenoid, and Injector Balance Tests.

In these tests, Tech 2 sends operating signals to the systems to confirm their operations thereby to judge the normality of electric circuits.

To judge intermittent trouble,

1. Confirm DTC freeze frame data, and match the freeze frame data as test conditions with the data list displayed by Miscellaneous Test.
2. Confirm DTC setting conditions, and match the setting conditions as test conditions with the data list displayed by Miscellaneous Test.
3. Refer to the latest Service Bulletin.

Check to see if the Latest software is released or not. And then Down Load the LATEST PROGRAMMED SOFTWARE to the replacement PCM.

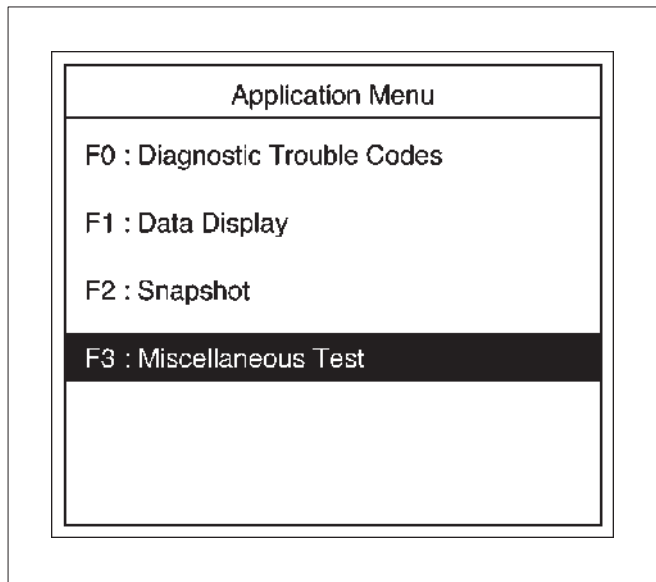
### Lamps Test

This test is conducted check MIL and Low Fuel Lamp for its working.

Tech2 must be used for this test.

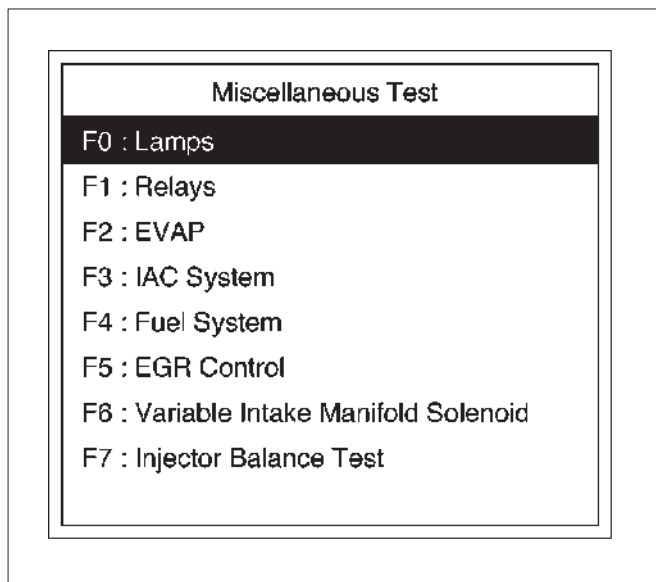
Test Procedure:

1. Connect Tech 2 to the vehicle DLC.
2. Run the Engine at idle.
3. Select F3: Miscellaneous Test in the Application Menu.



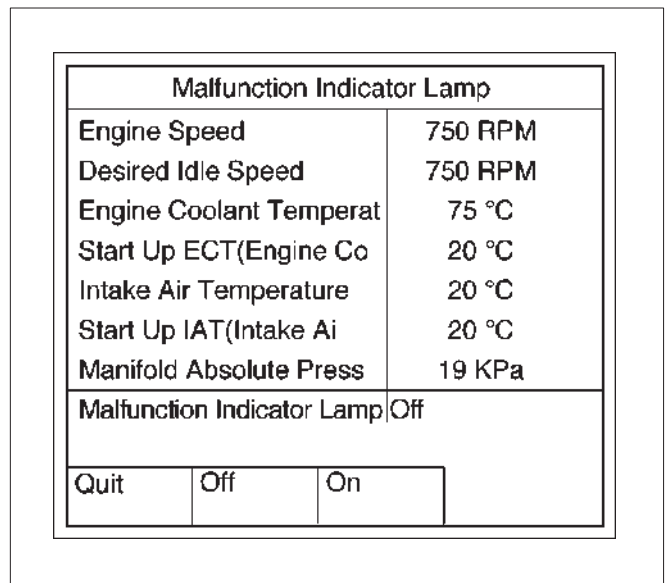
060RW228

4. Select F0:Lamps Test in the Miscellaneous Test.



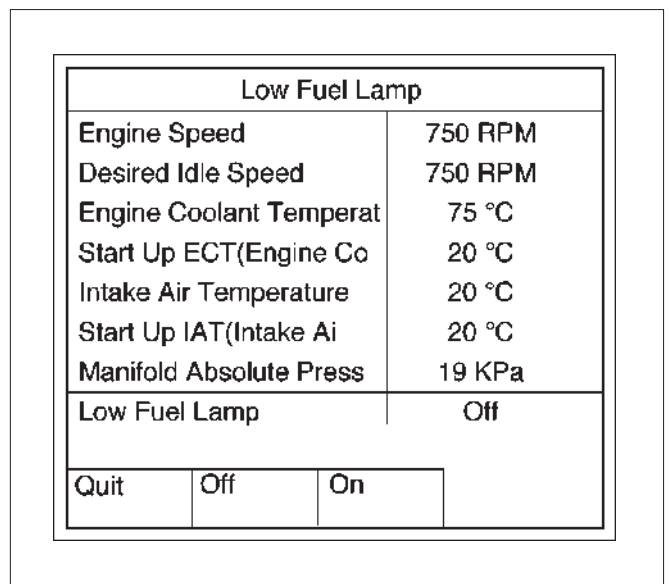
060RX035

5. Select F0:Malfunction Indicator Lamp.



060RX019

6. Push "On" soft key.
7. Make sure Lamp illuminates.
8. If lamp illuminates, the Lamp is operating correctly.
9. Select F1:Low Fuel Lamp



060RX020

10. Push "On" soft key.
11. Make sure Lamp illuminates.
12. If Lamp illuminates, the Lamp is operating correctly.

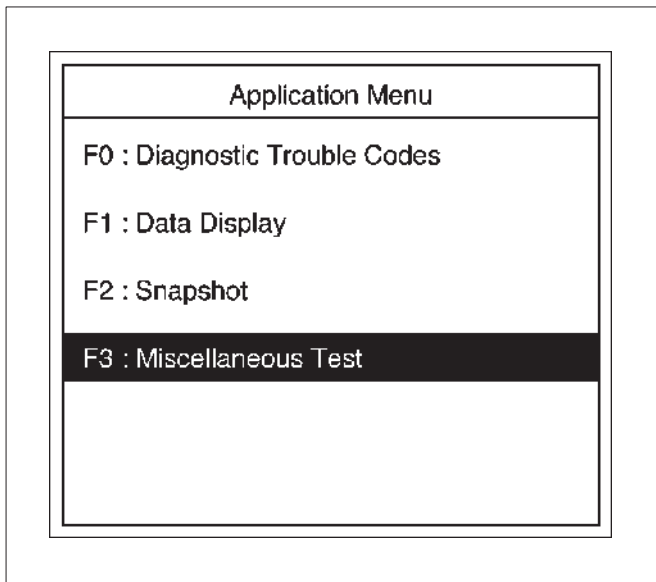
**Relays Test**

This test is conducted to check Fuel Pump Relay and A/C Clutch for proper operation.

Tech 2 must be used for this test.

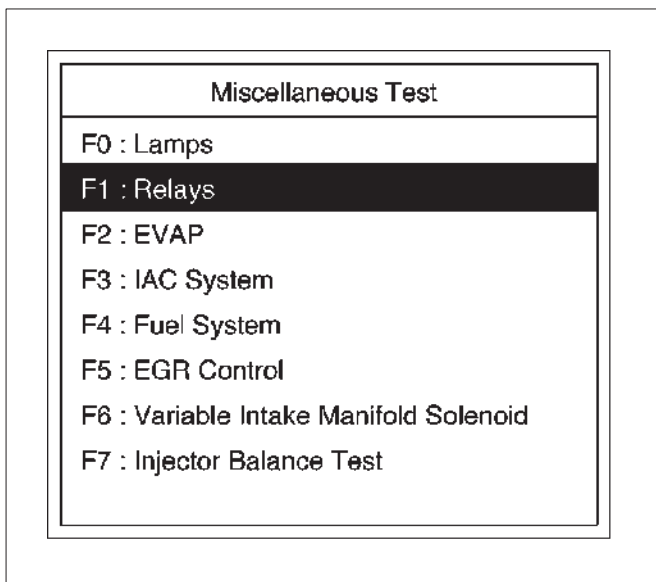
Test Procedure:

1. Connect Tech 2 to the vehicle DLC.
2. Ignition SW is "On".
3. Select F3: Miscellaneous Test in the Application Menu.



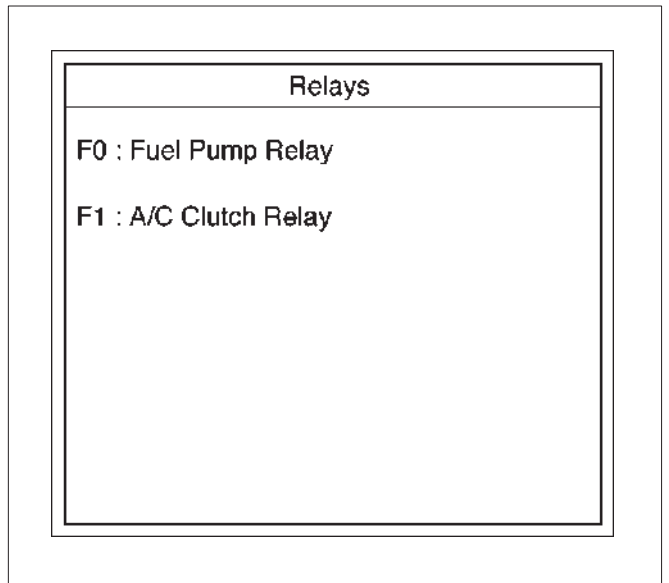
060RW228

4. Select F1:Relay Test in the Miscellaneous Test.



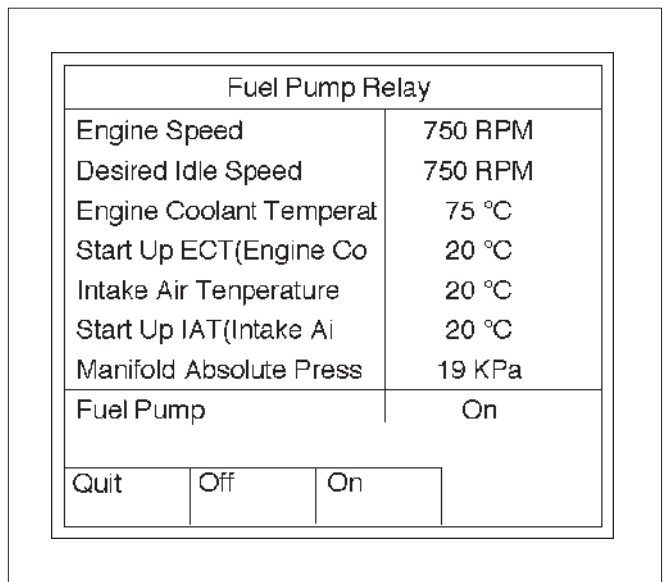
060RX034

5. Select F0:Fuel Pump Relay.



060RX021

6. Push "On" soft key.



060RX022

7. Control Fuel Pump Relay and check data list.

8. If the data list changes, the Fuel Pump Relay is normal.

9. Select F1:A/C Clutch Relay.

10. Run the Engine at idle.



11. Turn on Air Conditioning.



060RX023

- 12. Push "On" and "Off" soft keys.
- 13. Control A/C Clutch Relay and check data list.
- 14. If the data list changes, the A/C Clutch Relay is normal.

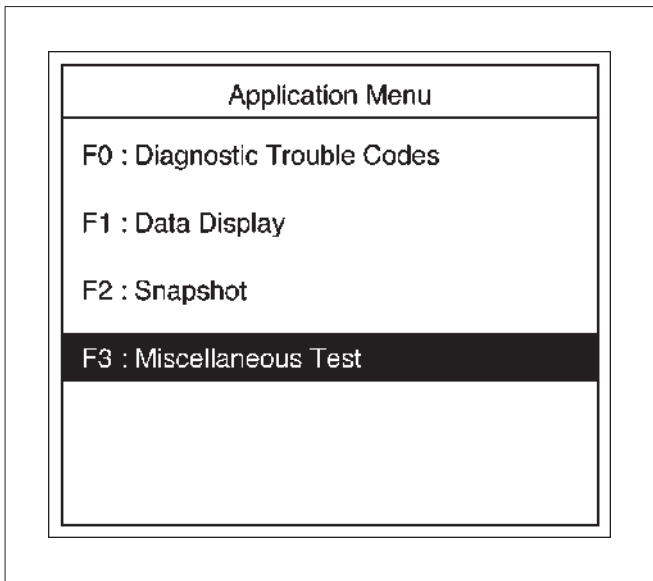
**EVAP Test**

This test is conducted to check EVAP system for its power operation.

Tech 2 must be used for this test.

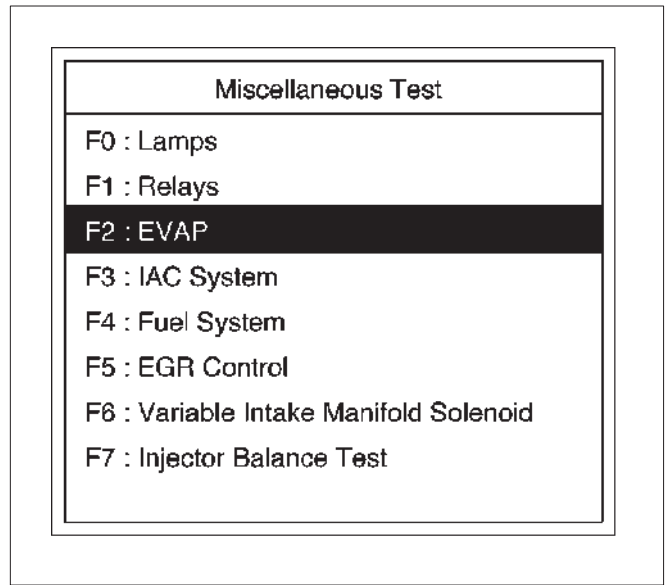
Test Procedure:

- 1. Connect Tech 2 to the vehicle DLC.
- 2. Run the Engine at idle.
- 3. Select F3: Miscellaneous Test in the Application Menu.



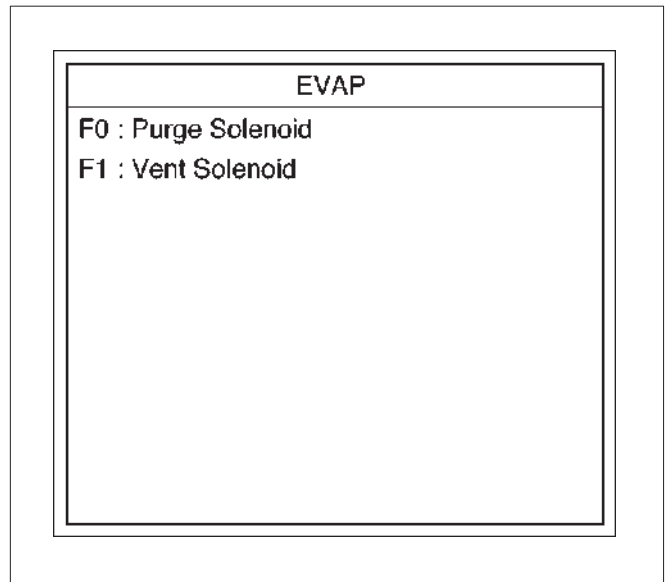
060RW228

4. Select F2:EVAP Test in the Miscellaneous Test.



060RX036

5. Select F0: Purge Solenoid.



060RX025

6. Push “Decrease” or “Increase” soft key.

Purge Solenoid	
Engine Speed	750 RPM
Desired Idle Speed	750 RPM
Engine Coolant Temperat	75 °C
Start Up ECT(Engine Co	20 °C
Intake Air Temperature	20 °C
Start Up IAT(Intake Ai	20 °C
Manifold Absolute Press	19 KPa
EVAP Purge Solenoid	60%
Quit	Decrease Increase

060RX026

7. Control EVAP Purge Solenoid and check a data list.
8. If the data list changes, the Purge Solenoid is normal.
9. Turn engine off, turn ignition SW “On”.
10. Select F1:Vent Solenoid.

EVAP
F0 : Purge Solenoid
F1 : Vent Solenoid

060RX025

11. Push “On” or “Off” soft key.

Vent Solenoid	
Engine Speed	750 RPM
Desired Idle Speed	750 RPM
Engine Coolant Temperat	75 °C
Start Up ECT(Engine Co	20 °C
Intake Air Temperature	20 °C
Start Up IAT(Intake Ai	20 °C
Manifold Absolute Press	19 KPa
EVAP Vent Solenoid	OFF
Quit	Off On

060RX027

12. Control EVAP Vent Solenoid and check data list.
13. If the data list changes, the EVAP Vent Solenoid is normal.

### Idle Air Control (IAC) System Test

This test is conducted to check IAC system for proper operation.

Tech 2 must be used for this test.

Test Procedure:

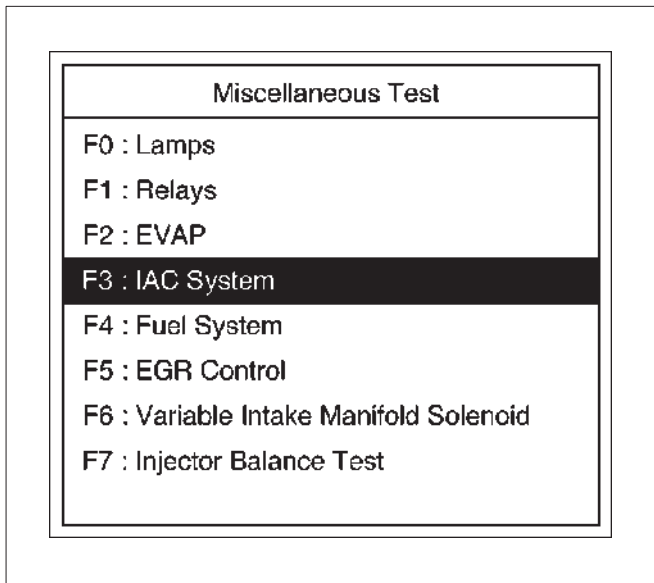
1. Connect Tech 2 to the vehicle DLC.
2. Run the Engine at idle.
3. Select F3: Miscellaneous Test in the Application Menu.

Application Menu
F0 : Diagnostic Trouble Codes
F1 : Data Display
F2 : Snapshot
F3 : Miscellaneous Test

060RW228

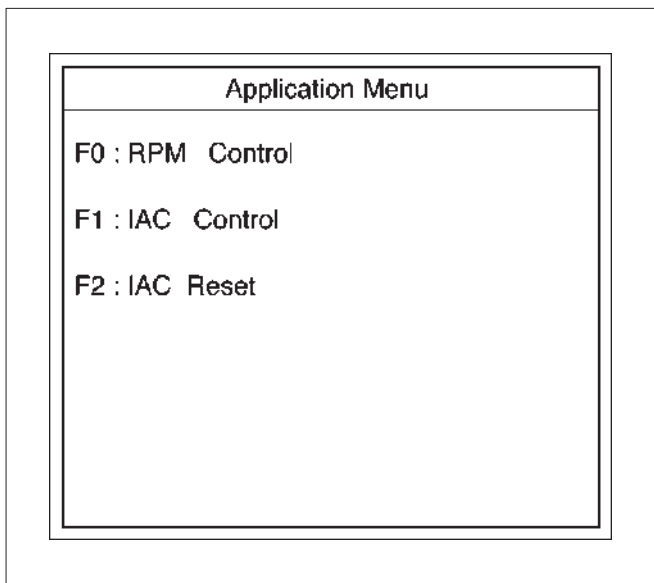
## 6E-42 6VE1 3.5L ENGINE DRIVEABILITY AND EMISSIONS

4. Select F3: IAC System Test in the Miscellaneous Test.



060RX007

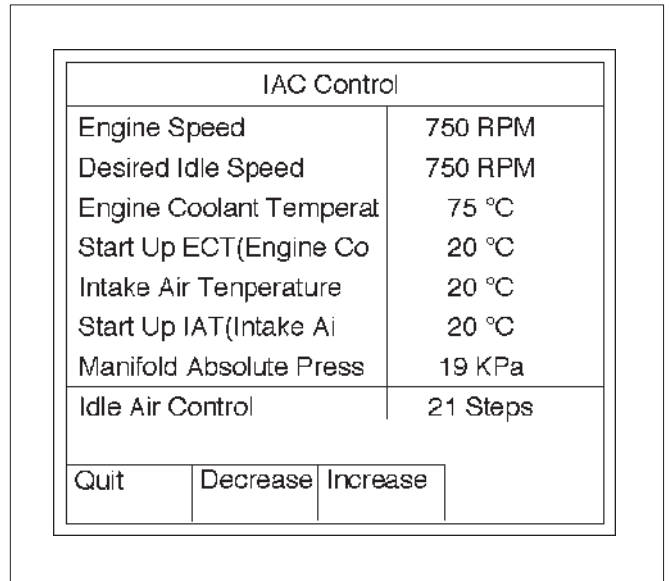
5. Select F1: IAC Control Test.



060RW235

6. Push "Increase" or "Decrease" soft key.

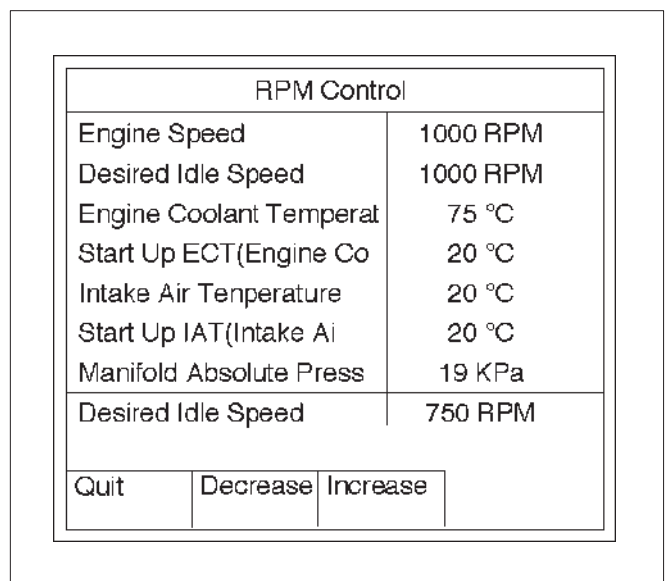
7. Control IAC system and check data list.



060RX015

8. If the data list changes, the IAC Control is normal.

9. Select F0: RPM Control Test.



060RX016

10. Push "Increase" or "Decrease" soft key.

11. Control RPM and check data list.

12. If the data list changes, the RPM control is normal.

13. Select F2: IAC Reset.

14. Push "Reset IAC" soft key.

15. Control IAC Reset and check data list.

16. If data list changes, the IAC has been Reset.

IAC Reset	
Engine Speed	750 RPM
Desired Idle Speed	750 RPM
Engine Coolant Temperat	75 °C
Start Up ECT(Engine Co	20 °C
Intake Air Temperature	20 °C
Start Up IAT(Intake Ai	20 °C
Manifold Absolute Press	19 KPa
Idle Air Control	21 Steps
Quit	Reset IAC

060RW231-1

4. Select F4: Fuel System in the Miscellaneous Menu.

Miscellaneous Test
F0 : Lamps
F1 : Relays
F2 : EVAP
F3 : IAC System
<b>F4 : Fuel System</b>
F5 : EGR Control
F6 : Variable Intake Manifold Solenoid
F7 : Injector Balance Test

060RX032

### Fuel System Test

This test is conducted check Fuel Level Gauge for proper operation.

Tech 2 must be used for this test.

Test Procedure:

1. Connect Tech 2 to the vehicle DLC.
2. Ignition SW is "On".
3. Select F3: Miscellaneous Test in the Application Menu.

5. Select F1: Fuel Gauge Level

Fuel System
F0 : Fuel Trim Reset
F1 : Fuel Gauge Level

060RX028

Application Menu
F0 : Diagnostic Trouble Codes
F1 : Data Display
F2 : Snapshot
<b>F3 : Miscellaneous Test</b>

060RW228

## 6E-44 6VE1 3.5L ENGINE DRIVEABILITY AND EMISSIONS

6. Push "Decrease" or "Increase" soft key.

Fuel Gauge Level	
Engine Speed	750 RPM
Desired Idle Speed	750 RPM
Engine Coolant Temperat	75 °C
Start Up ECT(Engine Co	20 °C
Intake Air Temperature	20 °C
Start Up IAT(Intake Ai	20 °C
Manifold Absolute Press	19 KPa
Fuel Level	50%
Quit	Decrease Increase

060RX030

7. Control Fuel Level and check data list.

8. If data list changes, the Fuel Gauge Level is normal.

9. Select F0: Fuel Trim Reset.

Fuel System
F0 : Fuel Trim Reset
F1 : Fuel Gauge Level

060RX028

10. Push "Reset" of soft key.

Fuel Trim Reset	
Engine Speed	750 RPM
Desired Idle Speed	750 RPM
Engine Coolant Temperat	75 °C
Start Up ECT(Engine Co	20 °C
Intake Air Temperature	20 °C
Start Up IAT(Intake Ai	20 °C
Manifold Absolute Press	19 KPa
Fuel Trim	
Quit	Reset

060RX029

### EGR Control Test

This test is conducted check EGR valve for proper operation.

Tech 2 must be used for this test.

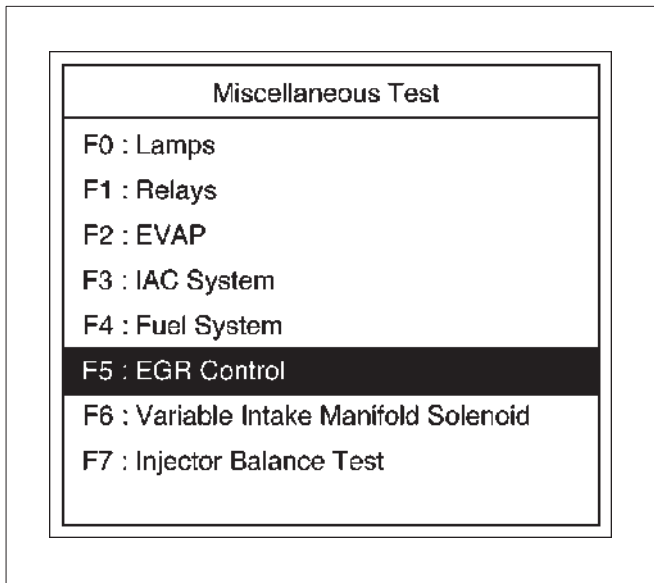
Test Procedure:

1. Connect Tech 2 to the vehicle DLC.
2. Run the Engine at idle.
3. Select F3: Miscellaneous Test in the Application Menu.

Application Menu
F0 : Diagnostic Trouble Codes
F1 : Data Display
F2 : Snapshot
<b>F3 : Miscellaneous Test</b>

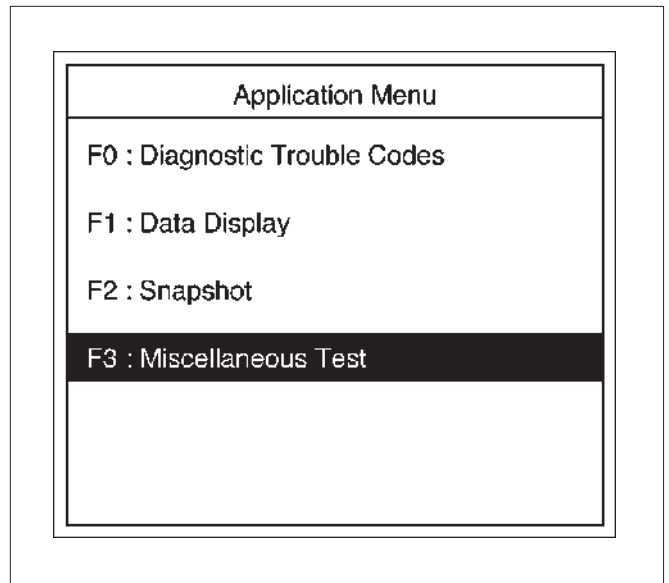
060RW228

4. Select F5: EGR Control Test in the Miscellaneous Test.



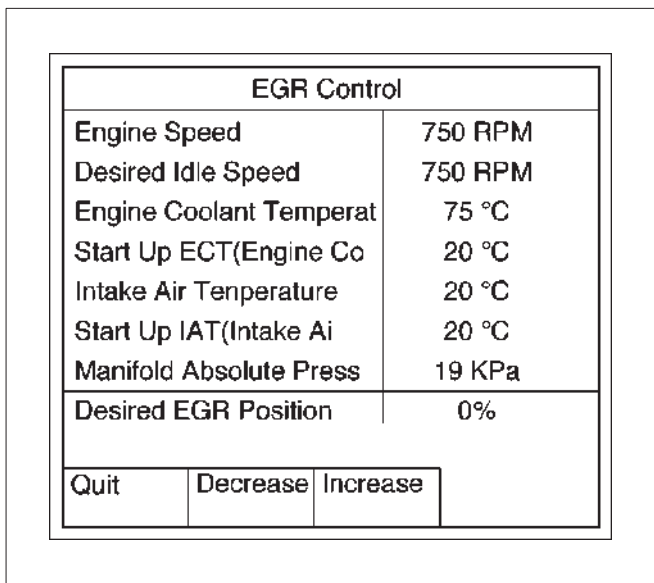
060RX008

3. Select F3: Miscellaneous Test in the Application Menu.



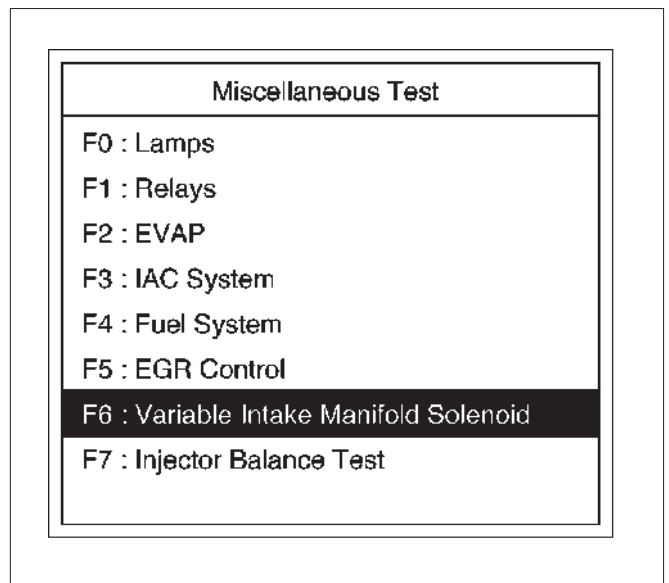
060RW228

5. Control EGR Valve and check data list.



060RX017

4. Select F6: Variable Intake Manifold (VIM) Solenoid Test.



060RX033

6. If data list changes, the EGR Control is normal.

### Variable Intake Manifold Solenoid Test

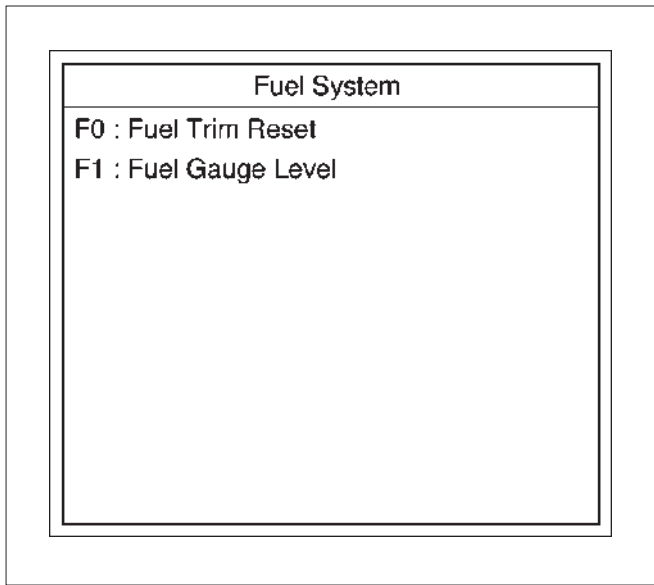
This test is conducted check VIM Solenoid for proper operation.

Tech 2 must be used for this test.

Test Procedure:

1. Connect Tech 2 to the vehicle DLC.
2. Ignition SW is "On".

5. Push "On" or "Off" of soft key.



060RX028

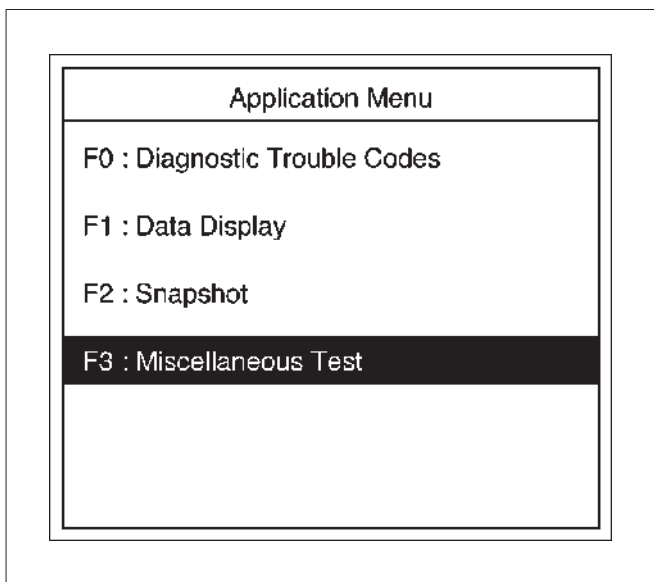
- 6. Control VIM Solenoid check data list.
- 7. If data list changes, the VIM Solenoid is normal.

### Injector Balance Test

This test is conducted to make sure the appropriate electric signals are being sent to injectors Nos. 1-6. Tech 2 must be used for this test.

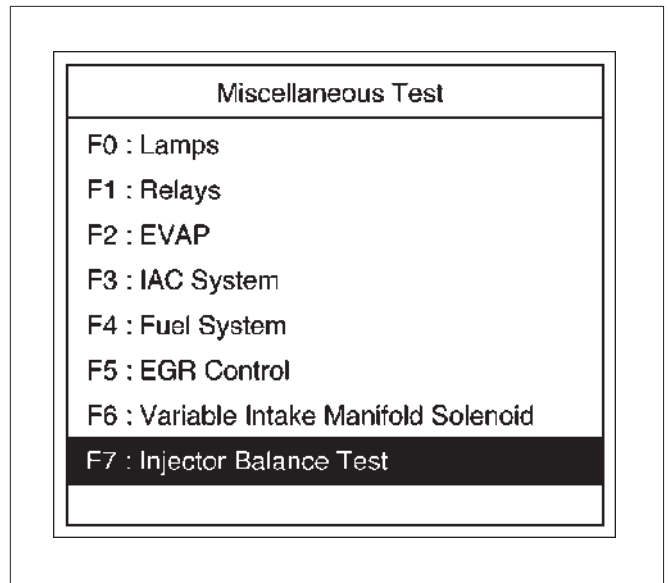
Test Procedure:

1. Connect Tech 2 to the vehicle DLC.
2. Run the Engine at idle.
3. Select F3: Miscellaneous Test in the Application Menu.



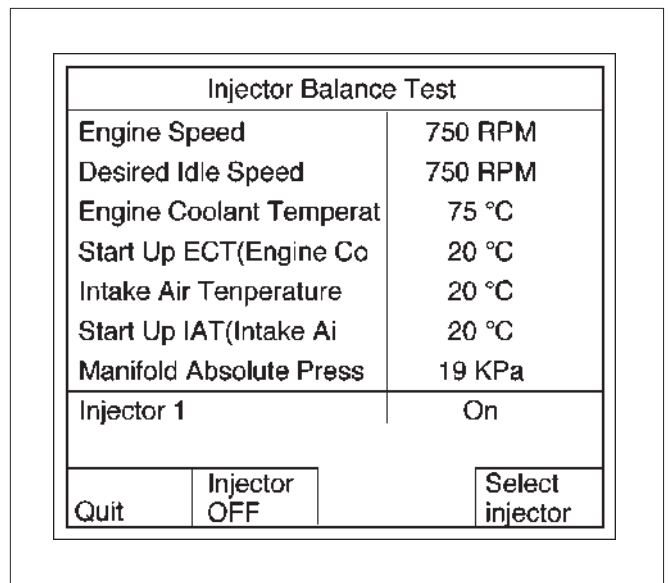
060RW228

4. Select F7: Injector Balance Test in the Miscellaneous Test.



060RX006

5. Select injector number and push "injector off" soft key.

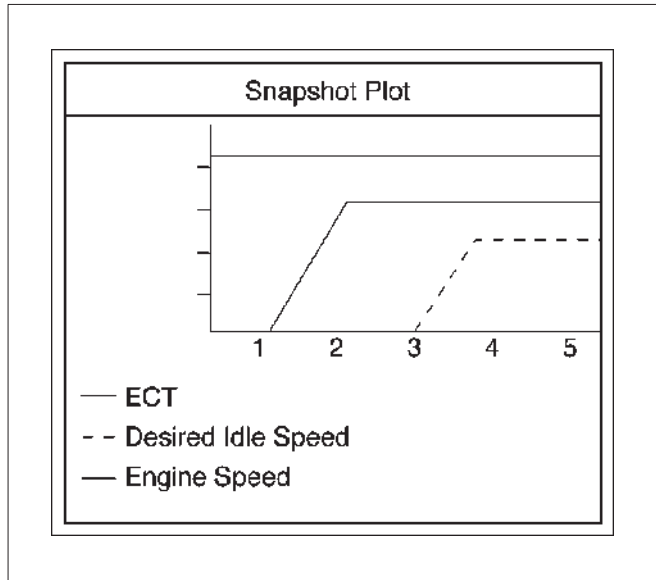


060RW230-1

- 6. Make sure of engine speed change.
- 7. If engine speed changes, the injector electric circuit is normal.  
If engine speed does not change, the injector electric circuit or the injector itself is not normal.

## Plotting Snapshot Graph

This test selects several necessary items from the data list to plot graphs and makes data comparison on a long term basis. It is an effective test particularly in emission related evaluations.



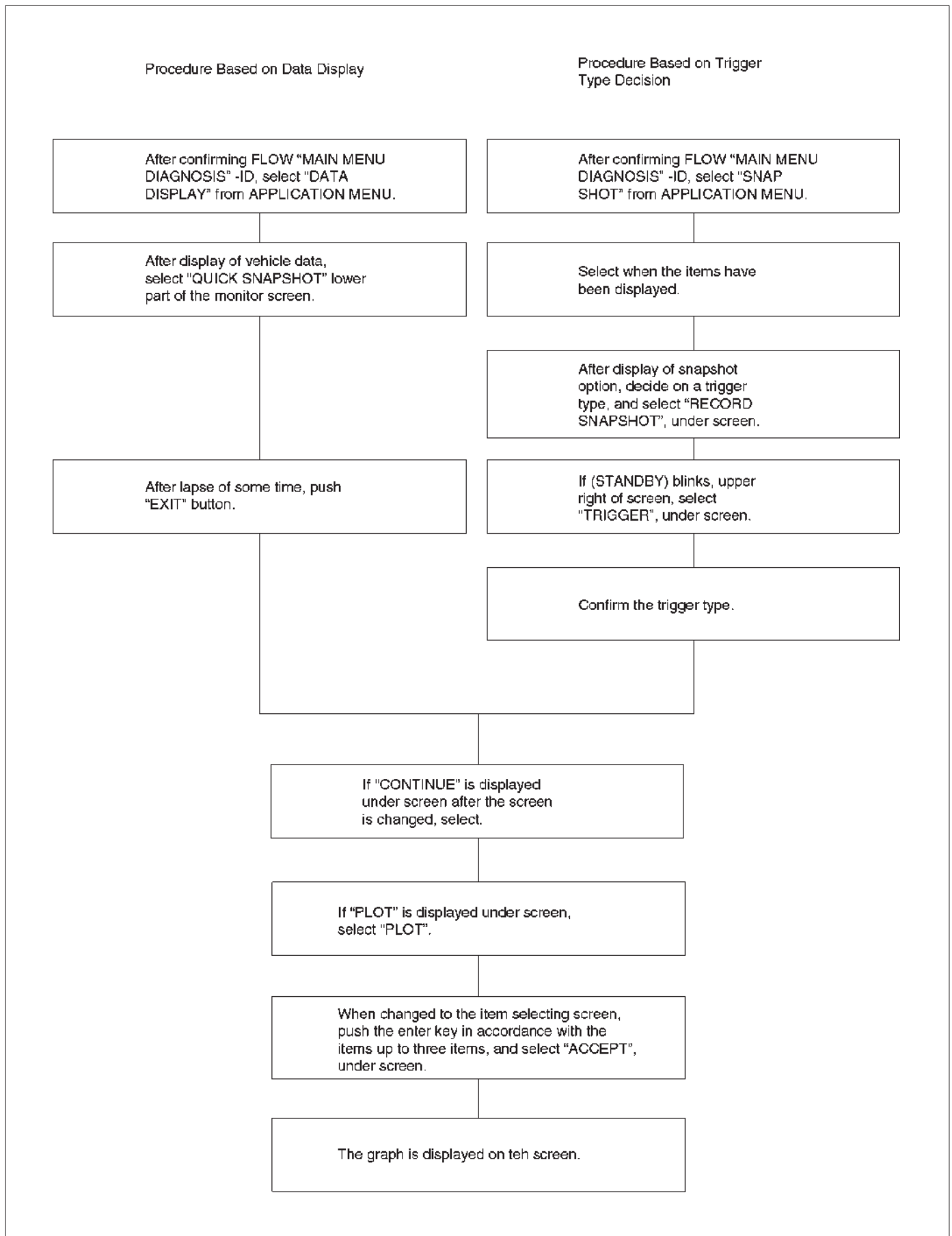
060RX037

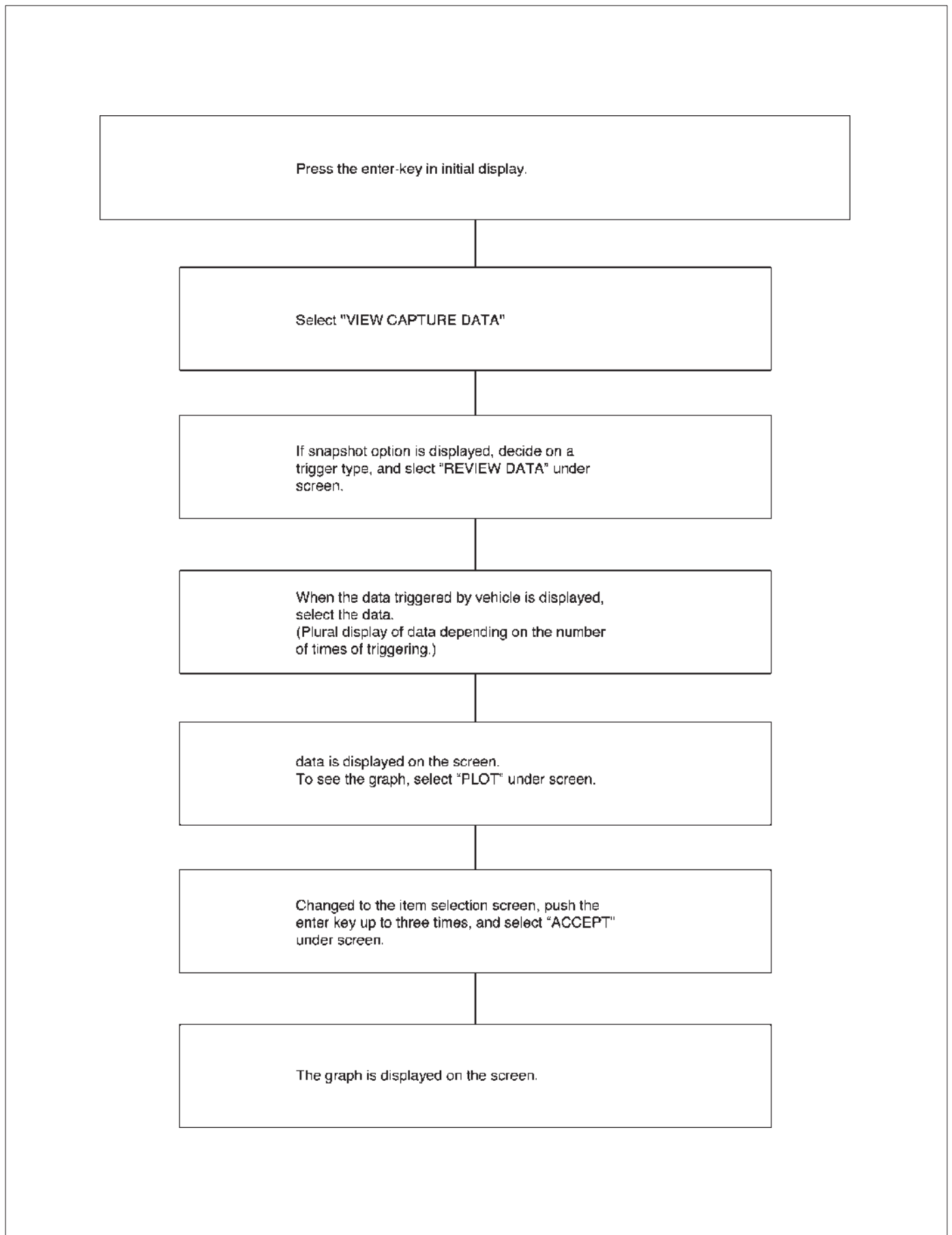
For trouble diagnosis, you can collect graphic data (snapshot) directly from the vehicle.

You can replay the snapshot data as needed. Therefore, accurate diagnosis is possible, even though the vehicle is not available.



## Plotting Graph Flow Chart (Plotting graph after obtaining vehicle information)



**Flow Chart for Snapshot Replay (Plotting Graph)**

## Primary System-Based Diagnostic

### Primary System-Based Diagnostic

There are primary system-based diagnostics which evaluate system operation and its effect on vehicle emissions. The primary system-based diagnostics are listed below with a brief description of the diagnostic function:

#### Heated Oxygen Sensor (HO2S) Diagnosis

The fuel control heated oxygen sensors (Bank 1 HO2S 1 and Bank 2 HO2S 1) are diagnosed for the following conditions:

- Heater performance (time to activity on cold start)
- Slow response
- Response time (time to switch R/L or L/R)
- Inactive signal (output steady at bias voltage – approx. 450 mV)
- Signal fixed high
- Signal fixed low

The catalyst monitor heated oxygen sensors (Bank 1 HO2S 2 and Bank 2 HO2S 2) are diagnosed for the following conditions:

- Heater performance (time to activity on cold start).
- Signal fixed low during steady state conditions or power enrichment (hard acceleration when a rich mixture should be indicated).
- Signal fixed high during steady state conditions or deceleration mode (deceleration when a lean mixture should be indicated).
- Inactive sensor (output steady at approx. 438 mV).

If the oxygen sensor pigtail wiring, connector or terminal are damaged, the entire oxygen sensor assembly must be replaced. Do not attempt to repair the wiring, connector or terminals. In order for the sensor to function properly, it must have clean reference air provided to it. This clean air reference is obtained by way of the oxygen sensor wire(s). Any attempt to repair the wires, connector or terminals could result in the obstruction of the reference air and degrade oxygen sensor performance. Refer to *On-Vehicle Service, Heated Oxygen Sensors*.

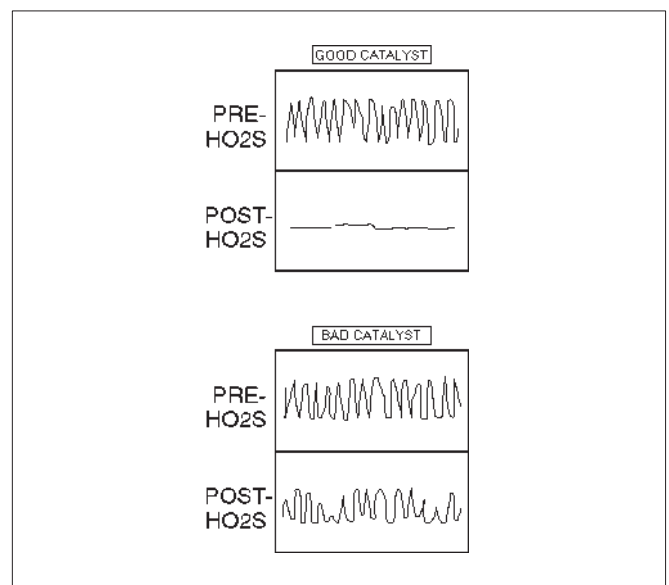
### Fuel Control Heated Oxygen Sensor

The main function of the fuel control heated oxygen sensors is to provide the control module with exhaust stream oxygen content information to allow proper fueling and maintain emissions within mandated levels. After it reaches operating temperature, the sensor will generate a voltage, inversely proportional to the amount of oxygen present in the exhaust gases. The control module uses the signal voltage from the fuel control heated oxygen sensors while in closed loop to adjust fuel injector pulse width. While in closed loop, the PCM can adjust fuel delivery to maintain an air/fuel ratio which allows the best combination of emission control and driveability. The fuel control heated oxygen sensors are also used to determine catalyst efficiency.

### HO2S Heater

Heated oxygen sensors are used to minimize the amount of time required for closed loop fuel control to begin operation and to allow accurate catalyst monitoring. The oxygen sensor heater greatly decreases the amount of time required for fuel control sensors (Bank 1 HO2S 1 and Bank 2 HO2S 1) to become active. Oxygen sensor heaters are required by catalyst monitor and sensor (Bank 1 HO2S 2 and Bank 2 HO2S 2) to maintain a sufficiently high temperature which allows accurate exhaust oxygen content readings further away from the engine.

### Catalyst Monitor Heated Oxygen Sensors and Diagnostic Operation



TS24067

To control emissions of hydrocarbons (HC), carbon monoxide (CO), and oxides of nitrogen (NO<sub>x</sub>), a three-way catalytic converter is used. The catalyst within the converter promotes a chemical reaction which oxidizes the HC and CO present in the exhaust gas, converting them into harmless water vapor and carbon dioxide. The catalyst also reduces NO<sub>x</sub>, converting it to nitrogen. The PCM has the ability to monitor this process using the pre-catalyst and post-catalyst heated oxygen sensors. The pre-catalyst sensor produces an output signal which indicates the amount of oxygen present in the exhaust gas entering the three-way catalytic converter. The post-catalyst sensor produces an output signal which indicates the oxygen storage capacity of the catalyst; this in turn indicates the catalyst's ability to convert exhaust gases efficiently. If the catalyst is operating efficiently, the pre-catalyst signal will be far more active than that produced by the post-catalyst sensor.

In addition to catalyst monitoring, the heated oxygen sensors have a limited role in controlling fuel delivery. If the sensor signal indicates a high or low oxygen content for an extended period of time while in closed loop, the PCM will adjust the fuel delivery slightly to compensate.

- The pre-catalyst sensors are designated Bank 1 HO2S 1 and Bank 2 HO2S 1. The post-catalyst sensors are Bank 1 HO2S 2 and Bank 2 HO2S 2.

### Catalyst Monitor Outputs

The catalyst monitor diagnostic is sensitive to the following conditions:

- Exhaust leaks
- HO2S contamination
- Alternate fuels

Exhaust system leaks may cause the following:

- Preventing a degraded catalyst from failing the diagnostic.
- Causing a false failure for a normally functioning catalyst.
- Preventing the diagnostic from running.

Some of the contaminants that may be encountered are phosphorus, lead, silica, and sulfur. The presence of these contaminants will prevent the TWC diagnostic from functioning properly.

### Three-Way Catalyst Oxygen Storage Capacity

The Three-Way catalyst (TWC) must be monitored for efficiency. To accomplish this, the control module monitors the pre-catalyst HO2S and post-catalyst HO2S oxygen sensors. When the TWC is operating properly, the post-catalyst oxygen sensor will have significantly less activity than the pre-catalyst oxygen sensor. The TWC stores and releases oxygen as needed during its normal reduction and oxidation process. The control module will calculate the oxygen storage capacity using the difference between the pre-catalyst and post catalyst oxygen sensor's voltage levels. If the activity of the post-catalyst oxygen sensor approaches that of the pre-catalyst oxygen sensor, the catalyst's efficiency is degraded.

Stepped or staged testing level allow the control module to statistically filter test information. This prevents falsely passing or falsely failing the oxygen storage capacity test. The calculations performed by the on-board diagnostic system are very complex. For this reason, post catalyst oxygen sensor activity should not be used to determine oxygen storage capacity unless directed by the service manual.

Two stages are used to monitor catalyst efficiency. Failure of the first stage will indicate that the catalyst requires further testing to determine catalyst efficiency. The second stage then looks at the inputs for the pre and post catalyst HO2S sensors more closely before determining if the catalyst is indeed degraded. This further statistical processing is done to increase the accuracy of oxygen storage capacity type monitoring. Failing the first (stage 1) test does not indicate a failed catalyst. The catalyst may be marginal or the fuel sulfur content could be very high.

Aftermarket HO2S characteristics may be different from the original equipment manufacturer sensor. This may lead to a false pass or a false fail of the catalyst monitor diagnostic. Similarly, if an aftermarket catalyst does not contain the same amount of cerium as the original part, the correlation between oxygen storage and conversion efficiency may be altered enough to set a false DTC.

## Misfire Monitor Diagnostic Operation

### Misfire Monitor Diagnostic Operation

The misfire monitor diagnostic is based on crankshaft rotational velocity (reference period) variations. The PCM determines crankshaft rotational velocity using the crankshaft position sensor and camshaft position sensor. When a cylinder misfires, the crankshaft slows down momentarily. By monitoring the crankshaft and camshaft position sensor signals, the PCM can calculate when a misfire occurs.

For a non-catalyst damaging misfire, the diagnostic will be required to monitor a misfire present for between 1000-3200 engine revolutions.

For catalyst-damaging misfire, the diagnostic will respond to misfire within 200 engine revolutions.

Rough roads may cause false misfire detection. A rough road will cause torque to be applied to the drive wheels and drive train. This torque intermittently decreases the crankshaft rotational velocity. This may be falsely detected as a misfire.

### Misfire Counters

Whenever a cylinder misfires, the misfire diagnostic counts the misfire and notes the crankshaft position at the time the misfire occurred. These "misfire counters" are basically a file on each engine cylinder. A current and a history misfire counter are maintained for each cylinder. The misfire current counters (Misfire #1-6) indicate the number of firing events out of the last 200 cylinder firing events which were misfires. The misfire current counter will display real time data without a misfire DTC stored. The misfire history counters (Misfire #1-6) indicate the total number of cylinder firing events which were misfires. The misfire history counters will display 0 until the misfire diagnostic has failed and a DTC P0300 is set. Once the misfire DTC P0300 is set, the misfire history counters will be updated every 200 cylinder firing events. A misfire counter is maintained for each cylinder.

If the misfire diagnostic reports a failure, the diagnostic executive reviews all of the misfire counters before reporting DTC. This way, the diagnostic executive reports the most current information.

When crankshaft rotation is erratic, a misfire condition will be detected. Because of this erratic condition, the data that is collected by the diagnostic can sometimes incorrectly identify which cylinder is misfiring. Misfires are counted from more than one cylinder. Cylinder #1 has the majority of counted misfires. In this case, the Misfire Counters would identify cylinder #1 as the misfiring cylinder. The misfires in the other counters were just background noise caused by the erratic misfire rotation of the crankshaft. If the number of accumulated misfires is sufficient for the diagnostic to identify a true misfire, the diagnostic will set DTC P0300 – Misfire Detected.

Use diagnostic equipment to monitor misfire counter data on OBD II-compliant vehicles. Knowing which specific cylinder(s) misfired can lead to the root cause, even when dealing with a multiple cylinder misfire. Using the information in the misfire counters, identify which cylinders are misfiring. If the counter indicates cylinders

numbers 1 and 4 misfired, look for a circuit or component common to both cylinders number 1 and 4.

Misfire counter information is located in the "Specific Eng." menu, "Misfire Data" sub-menu of the data list.

The misfire diagnostic may indicate a fault due to a temporary fault not necessarily caused by a vehicle emission system malfunction. Examples include the following items:

- Contaminated fuel
- Low fuel
- Fuel-fouled spark plugs
- Basic engine fault

## **Fuel Trim System Monitor Diagnostic Operation**

### **Fuel Trim System Monitor Diagnostic Operation**

This system monitors the averages of short-term and long-term fuel trim values. If these fuel trim values stay at their limits for a calibrated period of time, a malfunction is indicated. The fuel trim diagnostic compares the averages of short-term fuel trim values and long-term fuel trim values to rich and lean thresholds. If either value is within the thresholds, a pass is recorded. If both values are outside their thresholds, a rich or lean DTC will be recorded.

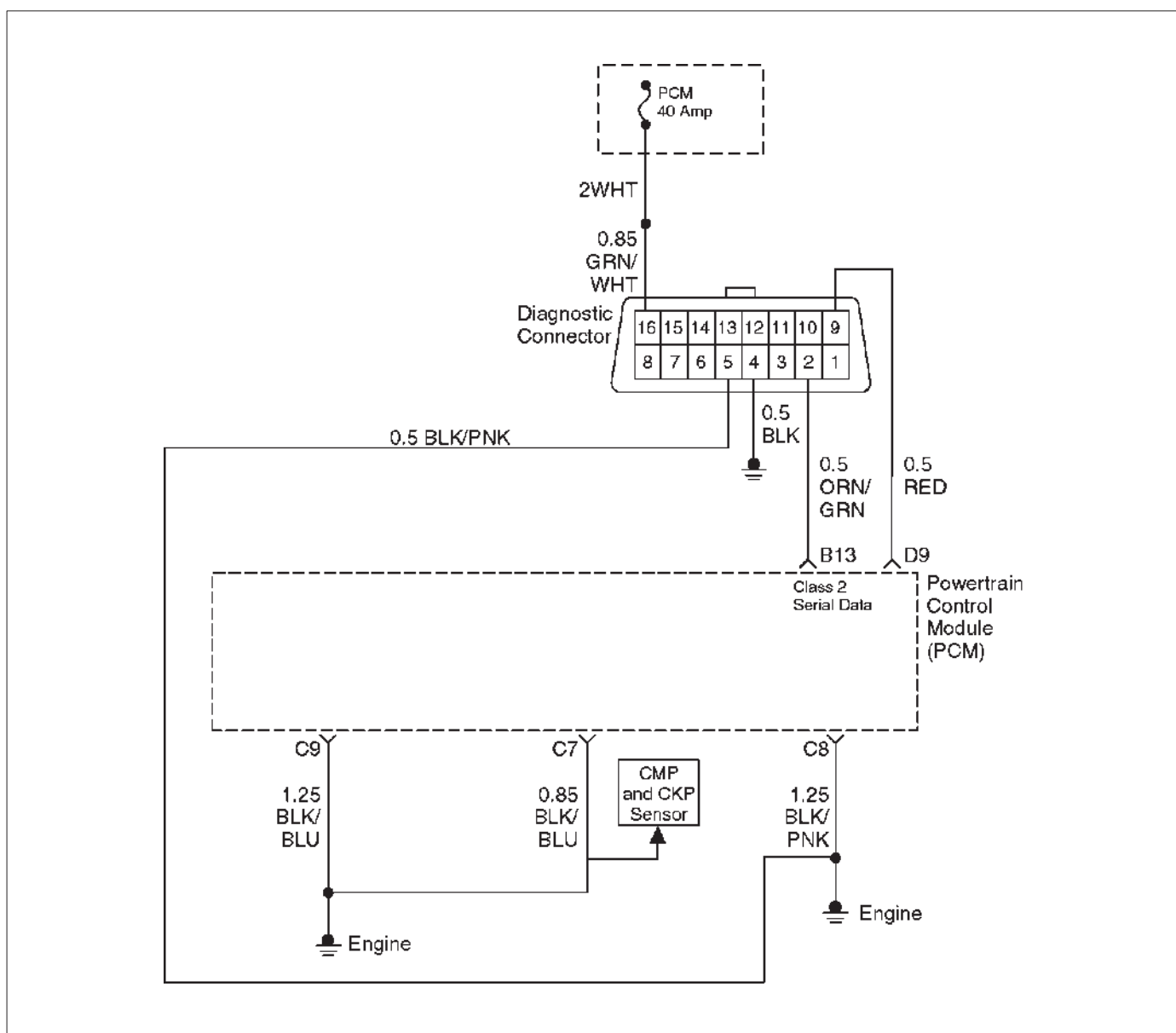
The fuel trim system diagnostic also conducts an intrusive test. This test determines if a rich condition is being caused by excessive fuel vapor from the EVAP canister. In order to meet OBD II requirements, the control module uses weighted fuel trim cells to determine the need to set a fuel trim DTC. A fuel trim DTC can only be set if fuel trim counts in the weighted fuel trim cells exceed specifications. This means that the vehicle could have a fuel trim problem which is causing a problem under certain conditions (i.e., engine idle high due to a small vacuum leak or rough idle due to a large vacuum leak) while it operates fine at other times. No fuel trim DTC would set (although an engine idle speed DTC or HO2S DTC may set). Use the Tech 2 to observe fuel trim counts while the problem is occurring.

A fuel trim DTC may be triggered by a number of vehicle faults. Make use of all information available (other DTCs stored, rich or lean condition, etc.) when diagnosing a fuel trim fault.

### **Fuel Trim Cell Diagnostic Weights**

No fuel trim DTC will set regardless of the fuel trim counts in cell 0 unless the fuel trim counts in the weighted cells are also outside specifications. This means that the vehicle could have a fuel trim problem which is causing a problem under certain conditions (i.e. engine idle high due to a small vacuum leak or rough due to a large vacuum leak) while it operates fine at other times. No fuel trim DTC would set (although an engine idle speed DTC or HO2S DTC may set). Use the Tech 2 to observe fuel trim counts while the problem is occurring.

## On-Board Diagnostic (OBD II) System Check



D06RX069

### Circuit Description

The on-board diagnostic system check is the starting point for any driveability complaint diagnosis. Before using this procedure, perform a careful visual/physical check of the PCM and engine grounds for cleanliness and tightness.

The on-board diagnostic system check is an organized approach to identifying a problem created by an electronic engine control system malfunction.

### Diagnostic Aids

An intermittent may be caused by a poor connection, rubbed-through wire insulation or a wire broken inside the insulation. Check for poor connections or a damaged harness. Inspect the PCM harness and connector for improper mating, broken locks, improperly formed or damaged terminals, poor terminal-to-wire connection, and damaged harness.

### Test Description

Number(s) below refer to the step number(s) on the Diagnostic Chart:

1. The MIL ("Check Engine" lamp) should be "ON" steady with the ignition "ON"/engine "OFF." If not, the "No MIL" chart should be used to isolate the malfunction.
2. Checks the Class 2 data circuit and ensures that the PCM is able to transmit serial data.
3. This test ensures that the PCM is capable of controlling the MIL ("Check Engine" lamp) and the MIL ("Check Engine" lamp) driver circuit is not shorted to ground.
4. If the engine will not start, the *Cranks But Will Not Run* chart should be used to diagnose the condition.
7. A Tech 2 parameter which is not within the typical range may help to isolate the area which is causing the problem.

10. This vehicle is equipped with a PCM which utilizes an electrically erasable programmable read only memory (EEPROM). When the PCM is replaced, the new PCM must be programmed. *Refer to PCM Replacement and Programming Procedures in Powertrain Control Module (PCM) and Sensors.*

### On-Board Diagnostic (OBD II) System Check

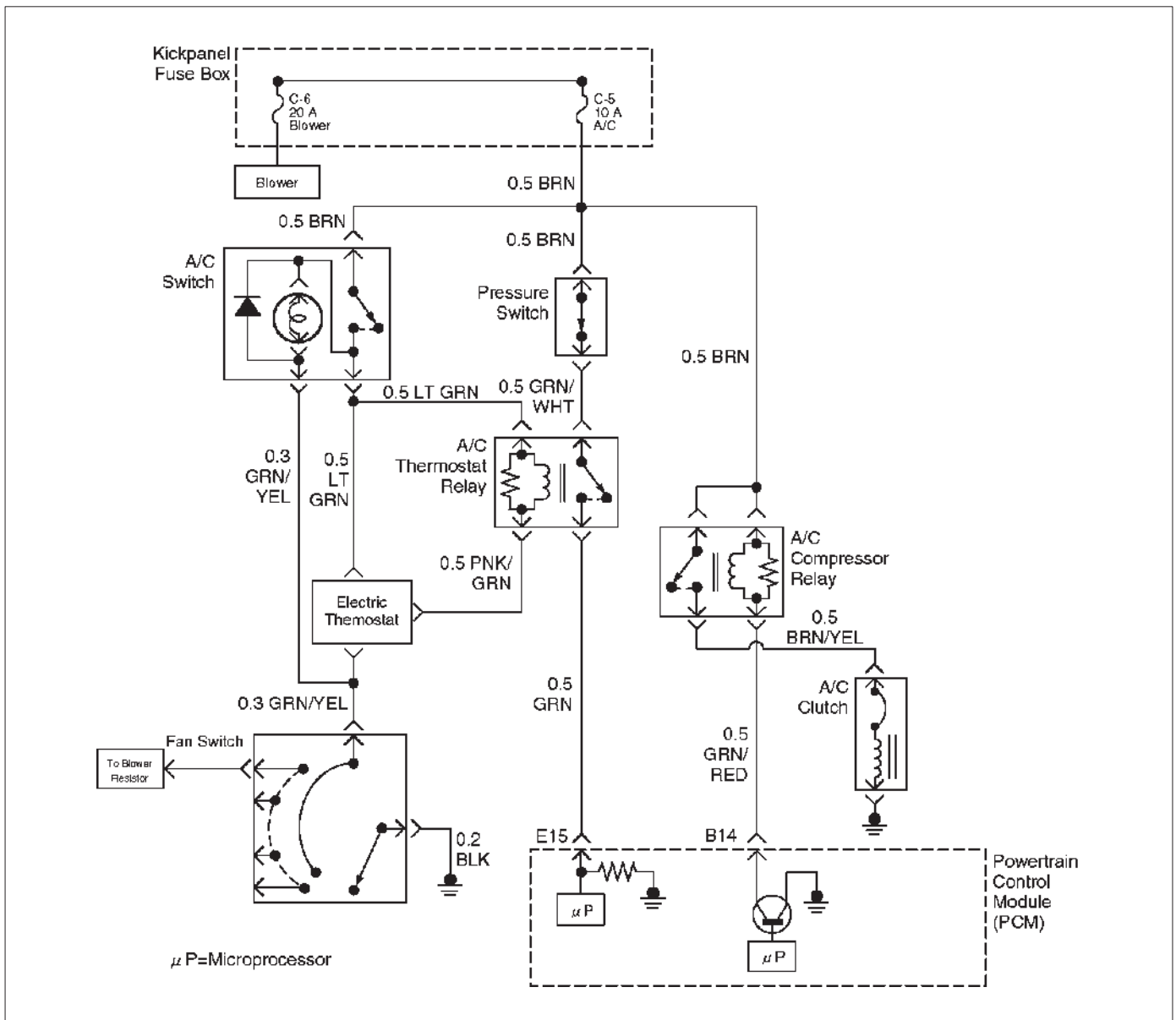
Step	Action	Value(s)	Yes	No
1	1. Ignition "ON," engine "OFF." 2. Observe the malfunction indicator lamp (MIL or "Check Engine lamp"). Is the MIL ("Check Engine" lamp) "ON?"	—	Go to Step 2	Go to No MIL ("Check Engine" lamp)
2	1. Ignition "OFF." 2. Install Tech 2. 3. Ignition "ON." 4. Attempt to display PCM engine data with the Tech 2. Does the Tech 2 display PCM data?	—	Go to Step 3	Go to Step 8
3	1. Using the Tech 2 output tests function, select MIL ("Check Engine lamp") dash lamp control and command the MIL ("Check Engine" lamp) "OFF." 2. Observe the MIL ("Check Engine lamp"). Did the MIL ("Check Engine" lamp) turn "OFF?"	—	Go to Step 4	Go to MIL ("Check Engine" lamp) On Steady
4	Attempt to start the engine. Did the engine start and continue to run?	—	Go to Step 5	Go to Cranks But Will Not Run
5	Select "Display DTCs" with the Tech 2. Are any DTCs stored?	—	Go to Step 6	Go to Step 7
6	Are two or more of the following DTCs stored? P0107, P0108, P0113, P0118, P0122, P0123, P0712?	—	Go to "Multiple PCM Information Sensor DTCs Set"	Go to applicable DTC table
7	Compare PCM data values displayed on the Tech 2 to the typical engine scan data values. Are the displayed values normal or close to the typical values?	—	Go to Symptom	Refer to indicated Component System Checks
8	1. Ignition "OFF," disconnect the PCM. 2. Ignition "ON," engine "OFF." 3. Check the Class 2 data circuit for an open, short to ground, or short to voltage. Also, check the DLC ignition feed circuit for an open or short to ground and the DLC ground circuit for an open. 4. If a problem is found, repair as necessary. Was a problem found?	—	Go to Step 2	Go to Step 9

### On-Board Diagnostic (OBD II) System Check (Cont'd)

Step	Action	Value(s)	Yes	No
9	1. Attempt to reprogram the PCM. Refer to <i>Powertrain Control Module (PCM) in On-Vehicle Service</i> . 2. Attempt to display PCM data with the Tech 2. Does the Tech 2 display PCM engine data?	—	Go to <i>Step 2</i>	Go to <i>Step 10</i>
10	Replace the PCM. <b>IMPORTANT:</b> The replacement PCM must be programmed. Refer to <i>Powertrain Control Module (PCM) in On-Vehicle Service</i> . And also refer to latest Service Bulletin. Check to see if the Latest software is released or not. And then Down Load the LATEST PROGRAMMED SOFTWARE to the replacement PCM. Is the action complete?	—	Go to <i>Step 2</i>	—



## A/C Clutch Control Circuit Diagnosis



### Circuit Description

When air conditioning and blower fan are selected, and if the system has a sufficient refrigerant charge, a 12-volt signal is supplied to the A/C request input of the powertrain control module (PCM). The A/C request signal may be temporarily canceled during system operation by the electronic thermostat in the evaporator case. The electronic thermostat may intermittently remove the control circuit ground for the A/C thermostat relay to prevent the evaporator from forming ice. When the A/C request signal is received by the PCM, the PCM supplies a ground from the compressor clutch relay if the engine operating conditions are within acceptable ranges. With the A/C compressor relay energized, voltage is supplied to the compressor clutch coil. The PCM will enable the compressor clutch to engage whenever A/C has been selected with the engine running, unless any of the following conditions are present:

- The throttle is greater than 90%.
- The ignition voltage is below 10.5 volts.
- The engine speed is greater than 4500 RPM for 5 seconds or 5400 RPM.
- The engine coolant temperature (ECT) is greater than 125 °C (257 °F).
- The intake air temperature (IAT) is less than 5 °C (41 °F).
- The power steering pressure switch signals a high pressure condition.

### Diagnostic Aids

To diagnose an intermittent fault, check for following conditions:

- Poor connection at the PCM—Inspect connections for backed-out terminals, improper mating, broken locks, improperly formed or damaged terminals, and poor terminal-to-wire connection.

- Damaged harness—Inspect the wiring harness for damage. If the harness appears to OK, observe the A/C clutch while moving connectors and wiring harnesses related to the A/C. A sudden clutch malfunction will indicate the source of the intermittent fault.

**A/C Clutch Diagnosis**

This chart should be used for diagnosing the electrical portion of the A/C compressor clutch circuit. A Tech 2 will be used in diagnosing the system. The Tech 2 has the ability to read the A/C request input to the PCM. The Tech 2 can display when the PCM has commanded the A/C clutch “ON.” The Tech 2 should have the ability to override the A/C request signal and energize the A/C compressor relay.

**Test Description**

**IMPORTANT:** Do not engage the A/C compressor clutch with the engine running if an A/C mode is not selected at the A/C control switch.

The numbers below refer to the step numbers on the Diagnostic Chart:

3. This a test determine is the problem is with the refrigerant system. If the switch is open, A/C pressure gauges will be used to determine if the pressure switch is faulty or if the system is partially discharged or empty.
4. Although the normal complaint will be the A/C clutch failing to engage, it is possible for a short circuit to cause the clutch to run when A/C has not been selected. This step is a test for that condition.
7. There is an extremely low probability that both relays will fail at the same time, so the substitution process is one way to check the A/C Thermostat relay. Use a known good relay to do a substitution check.
9. The blower system furnishes a ground for the A/C control circuit, and it also shares a power source through the Heater and A/C Relay. The blower must be “ON” in order to test the A/C system.

**A/C Clutch Control Circuit Diagnosis**

Step	Action	Value(s)	Yes	No
1	Was the “On-Board Diagnostic (OBD) System Check” performed?	—	Go to Step 2	Go to OBD System Check
2	Are any other DTCs stored?	—	Go to the other DTC chart(s) first	Go to Step 3
3	1. Disconnect the electrical connector at the pressure switch located on the receiver/drier. 2. Use an ohmmeter to check continuity across the pressure switch. Is the pressure switch open?	—	Go to Air Conditioning to diagnose the cause of the open pressure switch	Go to Step 4
4	<b>IMPORTANT:</b> Before continuing with the diagnosis, the following conditions must be met: ○ The intake air temperature must be greater than 15°C. (60°F). ○ The engine coolant temperature must be less than 119°C (246°F). 1. A/C “OFF.” 2. Start the engine and idle for 1 minute. 3. Observe the A/C compressor. Is the A/C compressor clutch engaged even though A/C has not been requested?	—	Go to Step 45	Go to Step 5
5	1. Idle the engine. 2. A/C “ON”. 3. Blower “ON”. 4. Observe the A/C compressor. Is the A/C compressor magnetic clutch engaged?	—	Refer to Diagnostic Aids	Go to Step 6

### A/C Clutch Control Circuit Diagnosis (Cont'd)

Step	Action	Value(s)	Yes	No
6	1. Engine idling. 2. A/C "ON". 3. Blower "ON". 4. Observe the "A/C Request" display on the Tech 2. (Refer to the Miscellaneous test) Does the tool "A/C Request" display indicate "Yes?"	—	Go to <i>Step 34</i>	Go to <i>Step 7</i>
7	Temporarily substitute the A/C compressor relay in place of the A/C thermostat relay, then repeat Step 5. Did the "A/C Request" display indicate "Yes?"	—	Go to <i>Step 8</i>	Go to <i>Step 9</i>
8	Replace the original A/C thermostat relay. Is the action complete?	—	Verify repair	—
9	Does the blower operate?	—	Go to <i>Step 10</i>	Go to <i>Step 11</i>
10	Repair the blower. Is the action complete?	—	Verify repair	—
11	Check for a faulty 10A A/C fuse in the underdash fuse panel. Was the 10A fuse OK?	—	Go to <i>Step 13</i>	Go to <i>Step 12</i>
12	Check for short circuit and make repairs if necessary. Replace the 10A A/C fuse. Is the action complete?	—	Verify repair	—
13	1. Ignition "ON." 2. Use a DVM to check voltage at the positive A/C switch wire (BRN). Was voltage equal to the specified value?	+B	Go to <i>Step 15</i>	Go to <i>Step 14</i>
14	Repair the open wire (BRN) between the A/C switch and the A/C fuse. Is the action complete?	—	Verify repair	—
15	1. Remove the glove box to gain access to the A/C thermostat. 2. Disconnect the thermostat connector. 3. Attach a fused jumper between ground and the PNK/GRN wire at the thermostat. 4. A/C "ON." 5. Blower "ON." Does A/C request indicate "YES" on the Tech 2?	—	Go to <i>Step 16</i>	Go to <i>Step 23</i>
16	1. Ignition "ON." 2. Use a DVM to check voltage at the electronic A/C thermostat. Was voltage equal to the specified value?	+B	Go to <i>Step 20</i>	Go to <i>Step 17</i>
17	Check for an open (LT GRN) between the thermostat and the A/C switch. Was the wire open?	—	Go to <i>Step 18</i>	Go to <i>Step 19</i>
18	Repair the open wire (LT GRN) between the thermostat and the A/C switch. Is the action complete?	—	Verify repair	—

### A/C Clutch Control Circuit Diagnosis (Cont'd)

Step	Action	Value(s)	Yes	No
19	Replace the A/C switch. Is the action complete?	—	Verify repair	—
20	Use an ohmmeter to check continuity between the electronic A/C thermostat and the blower switch. Was there an open circuit?	—	Go to <i>Step 21</i>	Go to <i>Step 22</i>
21	Repair the open wire (GRN/YEL) between the thermostat and the blower switch. Is the action complete?	—	Verify repair	—
22	Replace the electronic A/C thermostat. Is the an action complete?	—	Verify repair	—
23	Check for an open circuit between A/C thermostat relay and PCM A/C request terminal (E-15). Was there an open circuit?	—	Go to <i>Step 24</i>	Go to <i>Step 25</i>
24	Repair the open circuit between the PCM and A/C thermostat relay. Is the action complete?	—	Verify repair	—
25	Check for an open circuit between the A/C switch (LT GRN) and the A/C thermostat relay (LT GRN). Was there an open circuit?	—	Go to <i>Step 26</i>	Go to <i>Step 27</i>
26	Repair the open circuit between the A/C switch and the A/C thermostat relay. Is the action complete?	—	Verify repair	—
27	1. Ignition "ON." 2. Use a DVM to check voltage at the A/C pressure switch (BRN). Was voltage equal to the specified value?	+B	Go to <i>Step 29</i>	Go to <i>Step 28</i>
28	Repair the open circuit between the 10A A/C fuse and the pressure switch. Is the action complete?	—	Verify repair	—
29	Use an ohmmeter to check continuity between the pressure switch (GRN/WHT) and the A/C thermostat relay (GRN/WHT). Was the circuit open?	—	Go to <i>Step 30</i>	Go to <i>Step 31</i>
30	Repair the open circuit between the pressure switch and the A/C thermostat relay. Is the action complete?	—	Verify repair	—
31	Check for damaged pin or terminal at E-15 of the PCM. Was a damaged pin or terminal found?	—	Go to <i>Step 32</i>	Go to <i>Step 33</i>
32	Repair the damaged pin or terminal. Is the action complete?	—	Verify repair	—

### A/C Clutch Control Circuit Diagnosis (Cont'd)

Step	Action	Value(s)	Yes	No
33	<p>Replace the PCM.</p> <p><b>IMPORTANT:</b> The replacement PCM must be programmed. Refer to <i>On-Vehicle Service</i> in <i>Powertrain Control Module Sensors</i> for procedures.</p> <p>And also refer to latest Service Bulletin.</p> <p>Check to see if the Latest software is released or not. And then Down Load the LATEST PROGRAMMED SOFTWARE to the replacement PCM.</p> <p>Is the action complete?</p>	—	Verify repair	—
34	<ol style="list-style-type: none"> <li>1. Remove the A/C compressor relay.</li> <li>2. Ignition "ON."</li> <li>3. Use a DVM to check voltage at both of the BRN wires at the A/C compressor relay socket.</li> </ol> <p>Is the voltage equal to the specified value?</p>	+B	Go to <i>Step 36</i>	Go to <i>Step 35</i>
35	<p>Repair the faulty BRN wire between the A/C fuse and the A/C compressor relay .</p> <p>Is the action complete?</p>	—	Verify repair	—
36	<ol style="list-style-type: none"> <li>1. A/C compressor relay removed.</li> <li>2. Engine idling.</li> <li>3. A/C "ON."</li> <li>4. Blower "ON."</li> <li>5. Use a DVM to measure voltage between the GRN/BLK wire at the A/C compressor relay socket and battery±.</li> </ol> <p>Did the DVM indicate the specified value?</p>	+B	Go to <i>Step 40</i>	Go to <i>Step 37</i>
37	<p>Check for an open GRN/BLK wire between PCM terminal B-14 and the A/C compressor relay.</p> <p>Was the wire open?</p>	—	Go to <i>Step 38</i>	Go to <i>Step 39</i>
38	<p>Repair the open GRN/BLK wire between the PCM and the A/C compressor relay.</p> <p>Is the action complete?</p>	—	Verify repair	—
39	<p>Check for a damaged pin or terminal at B-14 of the PCM.</p> <p>Was a damaged pin or a terminal found?</p>	—	Go to <i>Step 32</i>	Go to <i>Step 33</i>
40	<ol style="list-style-type: none"> <li>1. A/C compressor relay removed.</li> <li>2. Connect a fused jumper at the A/C compressor relay socket between either BRN wire and the BRN/YEL wire.</li> <li>3. Engine idling.</li> <li>4. A/C "ON."</li> <li>5. Blower "ON."</li> </ol> <p>Did the compressor magnetic clutch engage?</p>	—	Go to <i>Step 41</i>	Go to <i>Step 42</i>
41	<p>Repair the A/C compressor relay.</p> <p>Is the action complete?</p>	—	Verify repair	—
42	<p>Check for an open circuit between the A/C compressor relay and the A/C clutch.</p> <p>Was an open circuit found?</p>	—	Go to <i>Step 43</i>	Go to <i>Step 44</i>

**A/C Clutch Control Circuit Diagnosis (Cont'd)**

Step	Action	Value(s)	Yes	No
43	Repair the open circuit between the compressor Clutch and the A/C compressor relay. Is the action complete?	—	Verify repair	—
44	Service the compressor clutch or replace the compressor due to a faulty internal overheat switch. Is the action complete?	—	Verify repair	—
45	1. Remove the A/C compressor relay. 2. Idle the engine. Is the compressor clutch still engaged when A/C is not selected?	—	Go to <i>Step 46</i>	Go to <i>Step 47</i>
46	Repair the short to voltage between the A/C clutch and A/C compressor relay. Is the action complete?	—	Verify repair	—
47	1. Reinstall the A/C compressor relay. 2. Remove the A/C thermostat relay. 3. Engine idling. Is the compressor clutch still engaged when A/C is not selected?	—	Go to <i>Step 48</i>	Go to <i>Step 50</i>
48	Use a DVM to check for a short to ground between the A/C compressor relay and B-14 of the PCM. Was a short detected?	—	Go to <i>Step 49</i>	Go to <i>Step 33</i>
49	Repair the short to ground between the PCM and A/C compressor relay. Is the action complete?	—	Verify repair	—
50	Repair the short to ground between the A/C thermostat relay and the electronic thermostat. Is the action complete?	—	Verify repair	—

## Electronic Ignition System Diagnosis

If the engine cranks but will not run or immediately stalls, the Engine Cranks But Will Not Start chart must be used to determine if the failure is the ignition system or the fuel system. If DTC P0300 through P306, P0341, or P0336 is set, the appropriate diagnostic trouble code chart must be used for diagnosis.

If a misfire is being experienced with no DTC set, refer to the *Symptoms* section for diagnosis.

## Visual Check of The Evaporative Emission Canister

- If the canister is cracked or damaged, replace the canister.
- If fuel is leaking from the canister, replace the canister and check hoses and hose routing.

## Fuel Metering System Check

Some failures of the fuel metering system will result in an "Engine Cranks But Will Not Run" symptom. If this condition exists, refer to the *Cranks But Will Not Run* chart. This chart will determine if the problem is caused by the ignition system, the PCM, or the fuel pump electrical circuit.

Refer to *Fuel System Electrical Test* for the fuel system wiring schematic.

If there is a fuel delivery problem, refer to *Fuel System Diagnosis*, which diagnoses the fuel injectors, the fuel pressure regulator, and the fuel pump. If a malfunction occurs in the fuel metering system, it usually results in either a rich HO<sub>2</sub>S signal or a lean HO<sub>2</sub>S signal. This condition is indicated by the HO<sub>2</sub>S voltage, which causes the PCM to change the fuel calculation (fuel injector pulse width) based on the HO<sub>2</sub>S reading. Changes made to the fuel calculation will be indicated by a change in the long term fuel trim values which can be monitored with a Tech 2. Ideal long term fuel trim values are around 0%; for a lean HO<sub>2</sub>S signal, the PCM will add fuel, resulting in a fuel trim value above 0%. Some variations in fuel trim values are normal because all engines are not exactly the same. If the evaporative emission canister purge is "ON," the fuel trim may be as low as -38%. If the fuel trim values are greater than +23%, refer to *DTC P0131, DTC P0151, DTC P0171, and DTC 1171* for items which can cause a lean HO<sub>2</sub>S signal.

## Idle Air Control (IAC) Valve

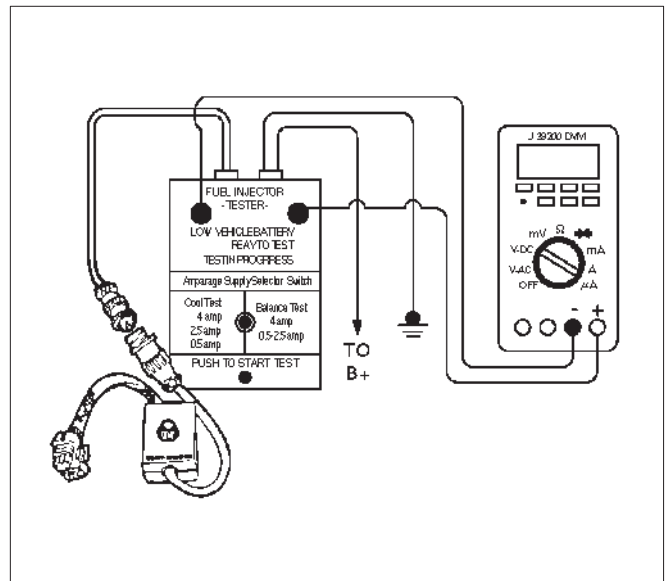
The Tech 2 displays the IAC pintle position in counts. A count of "0" indicates the PCM is commanding the IAC pintle to be driven all the way into a fully-seated position. This is usually caused by a large vacuum leak.

The higher the number of counts, the more air is being commanded to bypass the throttle blade. Refer to IAC System Check in order to diagnose the IAC system. Refer to *Rough, Unstable, or Incorrect Idle, Stalling in Symptoms* for other possible causes of idle problems.

## Fuel System Pressure Test

A fuel system pressure test is part of several of the diagnostic charts and symptom checks. To perform this test, refer to *Fuel Systems Diagnosis*.

## Fuel Injector Coil Test Procedure and Fuel Injector Balance Test Procedure



T32003

## Test Description

Number(s) below refer to the step number(s) on the Diagnostic Chart:

2. Relieve the fuel pressure by connecting the J 34730-1 Fuel Pressure Gauge to the fuel pressure connection on the fuel rail.

**CAUTION:** In order to reduce the risk of fire and personal injury, wrap a shop towel around the fuel pressure connection. The towel will absorb any fuel leakage that occurs during the connection of the fuel pressure gauge. Place the towel in an approved container when the connection of the fuel pressure gauge is complete.

Place the fuel pressure gauge bleed hose in an approved gasoline container.

With the ignition switch "OFF," open the valve on the fuel pressure gauge.

3. Record the lowest voltage displayed by the DVM after the first second of the test. (During the first second, voltage displayed by the DVM may be inaccurate due to the initial current surge.)

Injector Specifications:

Resistance Ohms	Voltage Specification at 10°C-35°C (50°F-95°F)
11.8 – 12.6	5.7 – 6.6

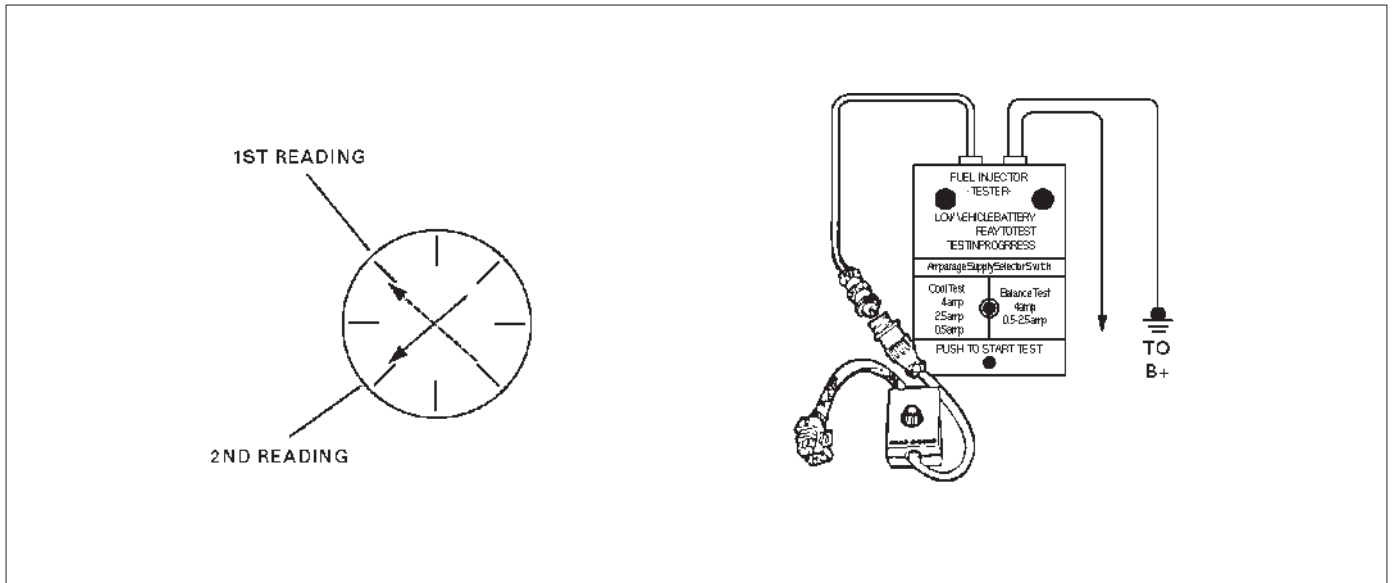
- The voltage displayed by the DVM should be within the specified range.
- The voltage displayed by the DVM may increase throughout the test as the fuel injector windings warm and the resistance of the fuel injector windings changes.
- An erratic voltage reading (large fluctuations in voltage that do not stabilize) indicates an intermittent connection within the fuel injector.

5. Injector Specifications:

Highest Acceptable Voltage Reading Above/Below 35°C/10°C (95°F/50°F)	Acceptable Subtracted Value
9.5 Volts	0.6 Volts

7. The Fuel Injector Balance Test portion of this chart (Step 7 through Step 11) checks the mechanical (fuel delivery) portion of the fuel injector. An engine cool-down period of 10 minutes is necessary in order to avoid irregular fuel pressure readings due to "Hot Soak" fuel boiling.

**Injector Coil Test Procedure (Steps 1-6) and Injector Balance Test Procedure (Steps 7-11)**



R262001

CYLINDER	1	2	3	4	5	6
1st Reading (1)	296 kpa (43 psi)	296 kpa (43 psi)	296 kpa (43 psi)	296 kpa (43 psi)	296 kpa (43 psi)	296 kpa (43 psi)
2nd Reading (2)	131 kpa (19 psi)	117 kpa (17 psi)	124 kpa (18 psi)	145 kpa (21 psi)	131 kpa (19 psi)	130 kpa (19 psi)
Amount of Drop (1st Reading-2nd Reading)	165 kpa (24 psi)	179 kpa (26 psi)	172 kpa (25 psi)	151 kpa (22 psi)	165 kpa (24 psi)	166 kpa (24 psi)
Av.drop = 166 kpa/24 psi ± 10 kpa/1.5 psi = 156 - 176 kpa or 22.5 - 25.5 psi	OK	Faulty, Rich (Too Much Fuel Drop)	OK	Faulty, Lean (Too Little Fuel Drop)	OK	OK

NOTE: These figures are examples only.



## Injector Coil Test Procedure (Steps 1-6) and Injector Balance Test Procedure (Steps 7-11)

Step	Action	Value(s)	Yes	No
1	Was the "On-Board Diagnostic (OBD) System Check" performed?	—	Go to Step 2	Go to <i>OBD System Check</i>
2	<p>1. Turn the engine "OFF."</p> <p>NOTE: In order to prevent flooding of a single cylinder and possible engine damage, relieve the fuel pressure before performing the fuel injector coil test procedure.</p> <p>2. Relieve the fuel pressure. Refer to <i>Test Description Number 2</i>.</p> <p>3. Connect the J 39021-5V Fuel Injector Tester to B+ and ground, and to the J 39021-90 Injector Switch Box.</p> <p>4. Connect the injector switch box to the grey fuel injector harness connector located on the front of the EVAP canister bracket.</p> <p>5. Set the amperage supply selector switch on the fuel injector tester to the "Coil Test" 0.5 amp position.</p> <p>6. Connect the leads from the J 39200 Digital Voltmeter (DVM) to the injector tester. Refer to the illustrations associated with the test description.</p> <p>7. Set the DVM to the tenths scale (0.0).</p> <p>8. Observe the engine coolant temperature.</p> <p>Is the engine coolant temperature within the specified values?</p>	10°C (50°F) to 35°C (95°F)	Go to Step 3	Go to Step 5
3	<p>1. Set injector switch box injector #1.</p> <p>2. Press the "Push to Start Test" button on the fuel injector tester.</p> <p>3. Observe the voltage reading on the DVM.</p> <p><b>IMPORTANT:</b> The voltage reading may rise during the test.</p> <p>4. Record the lowest voltage observed after the first second of the test.</p> <p>5. Set the injector switch box to the next injector and repeat steps 2, 3, and 4.</p> <p>Did any fuel injector have an erratic voltage reading (large fluctuations in voltage that did not stabilize) or a voltage reading outside of the specified values?</p>	5.7-6.6 V	Go to Step 4	Go to Step 7
4	<p>Replace the faulty fuel injector(s). Refer to <i>Fuel Injector</i>.</p> <p>Is the action complete?</p>	—	Go to Step 7	—

## Injector Coil Test Procedure (Steps 1-6) and Injector Balance Test Procedure (Steps 7-11) (Cont'd)

Step	Action	Value(s)	Yes	No
5	1. Set injector switch box injector #1. 2. Press the "Push to Start Test" button on the fuel injector tester. 3. Observe the voltage reading on the DVM. <b>IMPORTANT:</b> The voltage reading may rise during the test. 4. Record the lowest voltage observed after the first second of the test. 5. Set the injector switch box to the next injector and repeat steps 2, 3, and 4.  Did any fuel injector have an erratic voltage reading (large fluctuations in voltage that did not stabilize) or a voltage reading above the specified value?	9.5 V	Go to Step 4	Go to Step 6
6	1. Identify the highest voltage reading recorded (other than those above 9.5 V). 2. Subtract the voltage reading of each injector from the highest voltage selected in step 1. Repeat until you have a subtracted value for each injector.  For any injector, is the subtracted Value in step 2 greater than the specified value?	0.6 V	Go to Step 4	Go to Step 7
7	<b>CAUTION: In order to reduce the risk of fire and personal injury, wrap a shop towel around the fuel pressure connection. The towel will absorb any fuel leakage that occurs during the connection of the fuel pressure gauge. Place the towel in an approved container when the connection of the fuel pressure gauge is complete.</b>  1. Connect the J 34730-1 Fuel Pressure Gauge to the fuel pressure test port. 2. Energize the fuel pump using the Tech 2. 3. Place the bleed hose of the fuel pressure gauge into an approved gasoline container. 4. Bleed the air out of the fuel pressure gauge. 5. With the fuel pump running, observe the reading on the fuel pressure gauge.  Is the fuel pressure within the specified values?	296-376 kpa (43-55 psi)	Go to Step 8	Go to Fuel System Diagnosis
8	Turn the fuel pump "OFF."  Does the fuel pressure remain constant?	—	Go to Step 9	Go to Fuel System Diagnosis

## Injector Coil Test Procedure (Steps 1-6) and Injector Balance Test Procedure (Steps 7-11) (Cont'd)

Step	Action	Value(s)	Yes	No
9	<ol style="list-style-type: none"> <li>1. Connect the J 39021-5V Fuel Injector Tester and J 39021-90 Injector Switch Box the fuel injector harness connector.</li> <li>2. Set the amperage supply selector switch on the fuel injector tester to the "Balance Test" 0.5–2.5 amp position.</li> <li>3. Using the Tech 2 turn the fuel pump "ON" then "OFF" in order to pressurize the fuel system.</li> <li>4. Record the fuel pressure indicated by the fuel pressure gauge after the fuel pressure stabilizes. This is the first pressure reading.</li> <li>5. Energize the fuel injector by depressing the "Push to Start Test" button on the fuel injector tester.</li> <li>6. Record the fuel pressure indicated by the fuel pressure gauge after the fuel pressure gauge needle has stopped moving. This is the second pressure reading.</li> <li>7. Repeat steps 1 through 6 for each fuel injector.</li> <li>8. Subtract the second pressure reading from the first pressure reading for one fuel injector. The result is the pressure drop value.</li> <li>9. Obtain a pressure drop value for each fuel injector.</li> <li>10. Add all of the individual pressure drop values. This is the total pressure drop.</li> <li>11. Divide the total pressure drop by the number of fuel injectors. This is the average pressure drop.</li> </ol> <p>Does any fuel injector have a pressure drop value that is either higher than the average pressure drop or lower than the average pressure drop by the specified value?</p>	10 kpa (1.5 psi)	Go to Step 10	Go to <i>OBD System Check</i>
10	<p>Re-test any fuel injector that does not meet the specification. Refer to the procedure in step 9.</p> <p>NOTE: Do not repeat any portion of this test before running the engine in order to prevent the engine from flooding.</p> <p>Does any fuel injector still have a pressure drop value that is either higher than the average pressure drop or lower than the average pressure drop by the specified value?</p>	10 kpa (1.5 psi)	Go to Step 11	Go to <i>Symptoms</i>
11	<p>Replace the faulty fuel injector(s). Refer to <i>Fuel Injector</i>.</p> <p>Is the action complete?</p>	—	Verify repair	—

## Knock Sensor Diagnosis

The Tech 2 has two data displays available for diagnosing the knock sensor (KS) system. The two displays are described as follows:

- “Knock Retard” indicates the number of degrees that the spark timing is being retarded due to a knock condition.
- “KS Noise Channel” indicates the current voltage level being monitored on the noise channel.

DTCs P0325 and P0327 are designed to diagnose the KS module, the knock sensor, and the related wiring. The problems encountered with the KS system should set a DTC. However, if no DTC was set but the KS system is suspect because of a detonation complaint, refer to *Detonation/Spark Knock in Symptoms*.

## Powertrain Control Module (PCM) Diagnosis

To read and clear diagnostic trouble codes, use a Tech 2.

**IMPORTANT:** Use of a Tech 2 is recommended to clear diagnostic trouble codes from the PCM memory. Diagnostic trouble codes can also be cleared by turning the ignition “OFF” and disconnecting the battery power from the PCM for 30 seconds. Turning off the ignition and disconnecting the battery power from the PCM will cause all diagnostic information in the PCM memory to be cleared. Therefore, all the diagnostic tests will have to be re-run.

Since the PCM can have a failure which may affect only one circuit, following the diagnostic procedures in this section will determine which circuit has a problem and where it is.

If a diagnostic chart indicates that the PCM connections or the PCM is the cause of a problem, and the PCM is replaced, but this does not correct the problem, one of the following may be the reason:

- There is a problem with the PCM terminal connections. The terminals may have to be removed from the connector in order to check them properly.
- EEPROM program is not correct for the application. Incorrect components or reprogramming the PCM with the wrong EEPROM program may cause a malfunction and may or may not set a DTC.
- The problem is intermittent. This means that the problem is not present at the time the system is being checked. In this case, refer to the *Symptoms* portion of the manual and make a careful physical inspection of all component and wiring associated with the affected system.
- There is a shorted solenoid, relay coil, or harness. Solenoids and relays are turned “ON” and “OFF” by the PCM using internal electronic switches called drivers. A shorted solenoid, relay coil, or harness will not damage the PCM but will cause the solenoid or relay to be inoperative.

## Multiple PCM Information Sensor DTCS Set

### Circuit Description

The powertrain control module (PCM) monitors various sensors to determine the engine operating conditions. The PCM controls fuel delivery, spark advance, transmission operation, and emission control device operation based on the sensor inputs.

The PCM provides a sensor ground to all of the sensors. The PCM applies 5 volts through a pull-up resistor, and determines the status of the following sensors by monitoring the voltage present between the 5-volt supply and the resistor:

- The engine coolant temperature (ETC) sensor
- The intake air temperature (IAT) sensor
- The transmission fluid temperature (TFT) sensor

The PCM provides the following sensors with a 5-volt reference and a sensor ground signal:

- The exhaust gas recirculating (EGR) pintle position sensor
- The throttle position (TP) sensor
- The manifold absolute pressure (MAP) sensor

The PCM monitors the separate feedback signals from these sensors in order to determine their operating status.

### Diagnostic Aids

**IMPORTANT:** Be sure to inspect PCM and engine grounds for being secure and clean.

A short to voltage in one of the sensor input circuits may cause one or more of the following DTCs to be set:

- P0108/P1106
- P0113/P1111
- P0118/P1115
- P0123/P1121
- P0712

**IMPORTANT:** If a sensor input circuit has been shorted to voltage, ensure that the sensor is not damaged. A damaged sensor will continue to indicate a high or low voltage after the affected circuit has been repaired. If the sensor has been damaged, replace it.

An open in the sensor ground circuit between the PCM and the splice will cause one or more of the following DTCs to be set:

- P0108/P1106
- P0113/P1111
- P0118/P1115
- P0123/P1121
- P0712

A short to ground in the 5-volt reference A or B circuit will cause one or more of the following DTCs to be set:

- P0107/P1107
- P0122/P1122

The 5-volt reference circuit A, between the PCM and the splice, will cause one or more of the following DTCs to be set:

- P0122/P1122

The 5-volt reference circuit B, between the PCM and the splice, will cause one or more of the following DTCs to be set:

- P0107/P1107/P0452

Check for the following conditions:

- Poor connection at PCM.** Inspect the harness connectors for backed-out terminals, improper mating, broken locks, improperly formed or damaged terminals, and a poor terminal-to-wire connection.

- Damaged harness.** Inspect the wiring harness for damage. If the harness is not damaged, observe an affected sensor's displayed value on the Tech 2 with the ignition "ON" and the engine "OFF" while you move the connectors and the wiring harnesses related to the following sensors:

- IAT
- ECT
- TP
- MAP
- EGR
- TFT

### Multiple PCM Information Sensor DTCs Set

Step	Action	Value(s)	Yes	No
1	Was the "On-Board Diagnostic (OBD) System Check" performed?	—	Go to Step 2	Go to OBD System Check
2	1. Turn the ignition "OFF," disconnect the PCM. 2. Turn the ignition "ON," check the 5 volt reference A circuit for the following conditions: <ul style="list-style-type: none"> <li><input type="radio"/> A poor connection at the PCM.</li> <li><input type="radio"/> An open between the PCM connector and the splice.</li> <li><input type="radio"/> A short to ground.</li> <li><input type="radio"/> A short to voltage.</li> </ul> Is there an open or short?	—	Go to Step 3	Go to Step 4
3	Repair the open or short. Is the action complete?	—	Verify repair	—
4	Check the sensor ground circuit for the following conditions: <ul style="list-style-type: none"> <li><input type="radio"/> A poor connection at the PCM or the affected sensors.</li> <li><input type="radio"/> An open between the PCM connector and the affected sensors.</li> </ul> Is there an open or a poor connection?	—	Go to Step 5	Go to Step 6
5	Repair the open or the poor connection. Is the action complete?	—	Verify repair	—
6	Measure the voltage between the EGR pintle position sensor signal circuit at the PCM harness connector and ground. Does the voltage measure near the specified value?	0 V	Go to Step 7	Go to Step 12
7	Measure the voltage between the MAP sensor signal circuit at the PCM harness connector and ground. Does the voltage measure near the specified value?	0 V	Go to Step 8	Go to Step 15
8	Measure the voltage between the TP sensor signal circuit at the PCM harness connector and ground. Does the voltage measure near the specified value?	0 V	Go to Step 9	Go to Step 16

### Multiple PCM Information Sensor DTCs Set (Cont'd)

Step	Action	Value(s)	Yes	No
9	Measure the voltage between the IAT sensor signal circuit at the PCM harness connector and ground. Does the voltage measure near the specified value?	0 V	Go to <i>Step 10</i>	Go to <i>Step 17</i>
10	Measure the voltage between the ECT sensor signal circuit at the PCM harness connector and ground. Does the voltage measure near the specified value?	0 V	Go to <i>Step 11</i>	Go to <i>Step 18</i>
11	1. Disconnect the EGR valve. 2. Measure the voltage between the EGR pintle position sensor signal circuit at the PCM harness connector and ground. Does the voltage measure near the specified value?	0 V	Go to <i>Step 13</i>	Go to <i>Step 18</i>
12	Measure the voltage between the TFT sensor signal circuit at the PCM harness connector and ground. Does the voltage measure near the specified value?	0 V	Go to <i>Step 20</i>	Go to <i>Step 19</i>
13	Replace the EGR valve. Is the action complete?	—	Verify repair	—
14	Locate and repair the short to voltage in the MAP sensor signal circuit. Is the action complete?	—	Verify repair	—
15	Locate and repair the short to voltage in the TP sensor signal circuit. Is the action complete?	—	Verify repair	—
16	Locate and repair the short to voltage in the IAT sensor signal circuit. Is the action complete?	—	Verify repair	—
17	Locate and repair the short to voltage in the ECT sensor signal circuit. Is the action complete?	—	Verify repair	—
18	Locate and repair the short to voltage in the EGR pintle position sensor signal circuit. Is the action complete?	—	Verify repair	—
19	Locate and repair the short to voltage in the TFT sensor signal circuit. Is the action complete?	—	Verify repair	—
20	Replace the PCM. <b>IMPORTANT:</b> The replacement PCM must be programmed. Refer to <i>On-Vehicle Service in Powertrain Control Module and Sensors for procedures</i> . And also refer to latest Service Bulletin. Check to see if the Latest software is released or not. And then Down Load the LATEST PROGRAMMED SOFTWARE to the replacement PCM. Is the action complete?	—	Go to <i>OBD System Check</i>	—

## Exhaust Gas Recirculation (EGR) Diagnosis

An EGR flow check diagnosis of the linear EGR system is covered by DTC P0401. Pintle position error diagnosis is covered by DTC P0402, P0404, P1404, P0405, P0406. If EGR diagnostic trouble codes P0401 and/or P0402, P0404, P1404, P0405, P0406 are encountered, refer to the DTC charts.

## Engine Tech 2 Data Definitions and Ranges

### A/C CLUTCH – Tech 2 Displays ON or OFF –

Indicates whether the PCM has commanded the A/C clutch ON. Used in A/C system diagnostic.

### A/C REQUEST — Tech 2 Displays YES or NO —

Indicates the state of the A/C request input circuit from the HVAC controls. The PCM uses the A/C request signal to determine whether A/C compressor operation is being requested.

### AIR/FUEL RATIO — Tech 2 Range 0.0-25.5 —

Air/fuel ratio indicates the PCM commanded value. In closed loop, the air/fuel ratio should normally be displayed around “14.2-14.7.” A lower air/fuel ratio indicates a richer commanded mixture, which may be seen during power enrichment or TWC protection modes. A higher air/fuel ratio indicates a leaner commanded mixture. This can be seen during deceleration fuel mode.

### BAROMETRIC PRESSURE — Tech 2 Range 10-105 kpa/0.00-5.00 Volts —

The barometric pressure reading is determined from the MAP sensor signal monitored during key up and wide open throttle (WOT) conditions. The barometric pressure is used to compensate for altitude differences and is normally displayed around “61-104” depending on altitude and barometric pressure.

### CHECK TRANS LAMP — AUTO TRANSMISSION —

Indicates the need to check for a DTC with the Tech 2 when the lamp is flashing 0.2 seconds ON and 0.2 seconds OFF.

### CMP ACT. COUNTER – Cam Position Activity DECEL FUEL MODE — Tech 2 Display ACTIVE or INACTIVE —

“ACTIVE” displayed indicates that the PCM has detected conditions appropriate to operate in deceleration fuel mode. The PCM will command the deceleration fuel mode when it detects a closed throttle position while the vehicle is traveling over 20 mph. While in the deceleration fuel delivered by entering open loop and decreasing the injector pulse width.

### DESIRED EGR POS. — Tech 2 Range 0%-100% —

Represents the EGR pintle position that the PCM is commanding.

### DESIRED IDLE — Tech 2 Range 0-3187 RPM —

The idle speed that the PCM is commanding. The PCM will compensate for various engine loads based on engine coolant temperature, to keep the engine at the desired speed.

### ECT — (Engine Coolant Temperature) Tech 2 Range –40°C to 151°C (–40°F to 304°F) —

The engine coolant temperature (ECT) is mounted in the coolant stream and sends engine temperature information to the PCM. The PCM applies 5 volts to the ECT sensor circuit. The sensor is a thermistor which changes internal resistance as temperature changes. When the sensor is cold (high resistance), the PCM monitors a high signal voltage and interprets that as a cold engine. As the sensor warms (decreasing resistance), the voltage signal will decrease and the PCM will interpret the lower voltage as a warm engine.

### EGR DUTY CYCLE — Tech 2 Range 0%-100% —

Represents the EGR valve driver PWM signal from the PCM. A duty cycle of 0% indicates that no EGR flow is being commanded; a 100% duty cycle indicates maximum EGR flow commanded.

### EGR FEEDBACK — Tech 2 Range 0.00-5.00 Volts —

Indicates the EGR pintle position sensor signal voltage being monitored by the PCM. A low voltage indicates a fully extended pintle (closed valve); a voltage near 5 volts indicates a retracted pintle (open valve).

### ENGINE LOAD — Tech 2 Range 0%-100% —

Engine load is calculated by the PCM from engine speed and MAF sensor readings. Engine load should increase with an increase in RPM or air flow.

### ENGINE RUN TIME — Tech 2 Range 00:00:00-99:99:99 Hrs:Min:Sec —

Indicates the time elapsed since the engine was started. If the engine is stopped, engine run time will be reset to 00:00:00.

### ENGINE SPEED — Range 0-9999 RPM —

Engine speed is computed by the PCM from the 58X reference input. It should remain close to desired idle under various engine loads with engine idling.

### EVAP PURGE PWM — Tech 2 Range 0%-100% —

Represents the PCM commanded PWM duty cycle of the EVAP purge solenoid valve. “0%” displayed indicates no purge; “100%” displayed indicates full purge.

### FUEL PUMP — Tech 2 Displays ON or OFF —

Indicates the PCM commanded state of the fuel pump relay driver circuit.

### FUEL TRIM CELL — Tech 2 Range 0-21 —

The fuel trim cell is dependent upon engine speed and MAF sensor readings. A plot of RPM vs. MAF is divided into 22 cells. Fuel trim cell indicates which cell is currently active.

### FUEL TRIM LEARN

#### — Tech 2 Displays NO or YES —

When conditions are appropriate for enabling long term fuel trim corrections, fuel trim learn will display “YES.” This indicates that the long term fuel trim is responding to the short term fuel trim. If the fuel trim learn displays “NO,” then long term fuel trim will not respond to changes in short term fuel trim.

**HO2S BANK 1, SEN. 1****— Tech 2 Range 0-1132 mV —**

Represents the fuel control exhaust oxygen sensor output voltage. Should fluctuate constantly within a range between 10 mV (lean exhaust) and 1000 mV (rich exhaust) while operating in closed loop.

**HO2S BANK 1, SEN. 2****— Tech 2 Range 0-1000mV —**

Monitors the exhaust oxygen sensor output voltage. The PCM monitors the operating efficiency of catalytic converter by comparing the output voltages of sensor 1 and sensor 2 in this bank. If the catalytic converter is operating efficiently, the output voltage of sensor 1 will give a greater fluctuation than that of sensor 2. If the PCM detects an abnormal level of voltage fluctuation from sensor 2, a DTC P0420 will be set, indicating that the catalytic converter for this bank is no longer operating efficiently.

**HO2S BANK2, SEN. 1—Tech 2 Range 0-1132 mV—**

Represents the fuel control exhaust oxygen sensor output voltage. Should fluctuate constantly within a range between 10mV (lean exhaust) and 1000 mV (rich exhaust) while operating in closed loop.

**HO2S BANK 2, SEN. 2 —Tech 2 Range 0-1000 mV—**

Monitors the exhaust oxygen sensor output voltage. The PCM monitors the operating efficiency of catalytic converter by comparing the output voltages of sensor 1 and sensor 2 in this bank. If the catalytic converter is operating efficiently, the output voltage of sensor 1 will have a greater fluctuation than that of sensor 2. If the PCM detects an abnormal level of voltage fluctuation from sensor 2, a DTC P0430 will be set, indicating that the catalytic converter for this bank is no longer operating efficiently.

**HO2S BANK 1, SEN. 1—Tech 2 Displays NOT READY or READY—**

Indicates the status of the exhaust oxygen sensor. The Tech 2 will indicate that the exhaust oxygen sensor is ready when the PCM detects a fluctuating HO2S voltage sufficient to allow closed loop operation. This will not occur unless the exhaust oxygen sensor is warmed up.

**HO2S BANK 2, SEN. 1 — Tech 2 Displays NOT READY or READY —**

Indicates the status of the exhaust oxygen sensor. The Tech 2 will indicate that the exhaust oxygen sensor is ready when the PCM detects a fluctuating HO2S voltage sufficient to allow closed loop operation. This will not occur unless the exhaust oxygen sensor is warmed up.

**HO2S WARM UP TIME BANK 1, SEN. 1/BANK 1, SEN 2 BANK 2 SEN. 1/BANK 2 SEN. 2 — Tech 2 Range 00:00:00-99:99:99 HRS:MIN:SEC —**

Indicates warm-up time for each HO2S. The HO2S warm-up time is used for the HO2S heater test. The PCM will run the heater test only after a cold start (determined by engine coolant and intake air temperature at the time of start-up) and only once during an ignition cycle. When the engine is started the PCM will monitor the HO2S voltage. When the HO2S voltage indicates a sufficiently active sensor, the PCM looks at how much time has elapsed since start-up. If the PCM determines that too much time was required for the HO2S to become active, a DTC will set. If the engine was warm when started, HO2S warm-up will the display "00:00:00".

**IAC Idle Air Control POSITION — Tech 2 Range 0-255 Counts —**

Displays the commanded position of the idle air control pintle in counts. A larger number of counts means that more air is being commanded through the idle air passage. Idle air control should respond fairly quickly to changes in engine load to maintain desired idle RPM.

**IAT (INTAKE AIR TEMPERATURE) — Tech 2 Range -40° C to 151° C (-40° F to 304° F) —**

The PCM converts the resistance of the intake air temperature sensor to degrees. Intake air temperature (IAT) is used by the PCM to adjust fuel delivery and spark timing according to incoming air density.

**IGNITION 1 — Tech 2 Range 0-25.5 Volts —**

This represents the system voltage measured by the PCM at its ignition feed.

**INJ. PULSE BANK 1/INJ. PULSE BANK 2 — Tech 2 Range 0-1000 msec. —**

Indicates the amount of time the PCM is commanding each injector "ON" during each engine cycle. A longer injector pulse width will cause more fuel to be delivered. Injector pulse width should increase with increased engine load.

**KS NOISE CHANNEL (Knock Sensor) —**

Indicates the output from the KS noise channel. There is always some electrical noise in an engine compartment and to avoid mistaking this as engine knock, the output from the knock sensor is compared to the output from the noise channel. A knock condition is not set unless the knock sensor output is greater than the noise channel output.



**LONG TERM FUEL TRIM BANK 1/BANK 2 —**

The long term fuel trim is derived from the short term fuel trim values and represents a long term correction of fuel delivery for the bank in question. A value of 0% indicates that fuel delivery requires no compensation to maintain the PCM commanded air/fuel ratio. A negative value significantly below 0% indicates that the fuel system is rich and fuel delivery is being reduced (decreased injector pulse width). A positive value significantly greater than 0% indicates that a lean condition exists and the PCM is compensating by adding fuel (increased injector pulse width). Because long term fuel trim tends to follow short term fuel trim, a value in the negative range due to canister purge at idle should not be considered unusual. Fuel trim values at maximum authority may indicate an excessively rich or lean system.

**LOOP STATUS — Tech 2 Displays OPEN or CLOSED —**

“CLOSED” indicates that the PCM is controlling fuel delivery according to oxygen sensor voltage. In “OPEN” the PCM ignores the oxygen sensor voltage and bases the amount of fuel to be delivered on TP sensor, engine coolant, and MAF sensor inputs only.

**MAF — Tech 2 Range 0.0-512 gm/s —**

MAF (mass air flow) is the MAF input frequency converted to grams of air per second. This indicates the amount of air entering the engine.

**MAP — Tech 2 Range 10-105 kpa (0.00-4.97 Volts)**

The manifold absolute pressure (MAP) sensor measures the change in the intake manifold pressure from engine load, EGR flow, and speed changes. As intake manifold pressure increases, intake vacuum decreases, resulting in a higher MAP sensor voltage and kpa reading. The MAP sensor signal is used to monitor intake manifold pressure changes during the EGR flow test, to update the BARO reading, and as an enabling factor for several of the diagnostics.

**MIL (Malfunction Indicator Lamp) — Tech 2 Displays ON or OFF —**

Indicates the PCM commanded state of the malfunction indicator lamp.

**MISFIRE CUR. CYL. #1 /#2 /#3 /#4 / #5 / #6 — Tech 2 Range 0-255 Counts —**

The misfire current counters increase at a rate according to the number of the possible misfires being detected on each cylinder. The counters may normally display some activity, but the activity should be nearly equal for all the cylinders.

**MISFIRE CUR. CYL. #1 /#2 /#3 /#4 / #5 / #6 — Tech 2 Range 0-65535 Counts —**

The misfire history counters display the relative level of misfire that has been detected on each cylinder. The misfire history counters will not update or show any activity until a misfire DTC (P0300) has become active.

**MISFIRE FAILURES SINCE FIRST FAIL — Tech 2 Range 0-65535 Counts —**

Indicates the number of 200 crankshaft revolution sample periods during which the level of misfire was sufficiently high to report a fail.

**MISFIRE PASSES SINCE FIRST FAIL — Tech 2 Range 0-65535 Counts —**

Indicates the number of 200 crankshaft revolution sample periods during which the level of misfire was sufficiently low to report a pass.

**POWER ENRICHMENT — Tech 2 Displays ACTIVE or INACTIVE —**

“ACTIVE” displayed indicates that the PCM has detected conditions appropriate to operate in power enrichment mode. The PCM will command power enrichment mode when a large increase in throttle position and load is detected. While in power enrichment mode, the PCM will increase the amount of fuel delivered by entering open loop and increasing the injector pulse width. This is done to prevent a possible sag or hesitation from occurring during acceleration.

**SPARK — Tech 2 Range -64° to 64° —**

Displays the amount of spark advance being commanded by the PCM on the IC circuit.

**START-UP ECT — Tech 2 Range -40° C to 151° C (-40° F to 304° F) —**

Indicates the engine coolant temperature at the time that the vehicle was started. Used by the HO2S diagnostic to determine if the last start-up was a cold start.

**START-UP IAT — Tech 2 Range -40° C to 151° C (-40° F to 304° F) —**

Indicates the intake air temperature at the time that the vehicle was started. Used by the HO2S diagnostic to determine if the last start-up was a cold start.

**TOTAL MISFIRE CURRENT COUNT — Tech 2 Range 0-255 —**

Indicates the total number of cylinder firing events that were detected as being misfires during the last 200 crankshaft revolution sample period.

**TP — Tech 2 Range 0%-100% —**

TP (throttle position) angle is computed by the PCM from the TP sensor voltage. TP angle should display “0%” at idle and “100%” at wide open throttle.

**TP SENSOR — Tech 2 Range 0.00-5.00 Volts —**

The voltage being monitored by the PCM on the TP sensor signal circuit.

**CATALYST PROTECTION MODE — Tech 2 Displays YES or NO —**

“YES” displayed indicates that the PCM has detected conditions appropriate to operate in TWC protection mode. The PCM will decrease the air/fuel ratio to a value that depends on mass air flow (higher mass air flow = lower air/fuel ratio).

**WEAK CYLINDER — Tech 2 Displays Cylinder Number —**

This indicates that the PCM has detected crankshaft speed variations that indicate 2% or more cylinder firing events are misfires.

---

## Typical Scan Data Values

Use the Typical Scan Data Values Table only after the On-Board Diagnostic System Check has been completed, no DTC(s) were noted, and you have determined that the on-board diagnostics are functioning properly. Tech 2 values from a properly-running engine may be used for comparison with the engine you are diagnosing. The typical scan data values represent values that would be seen on a normally-running engine.

NOTE: A Tech 2 that displays faulty data should not be used, and the problem should be reported to the Tech 2 manufacturer. Use of a faulty Tech 2 can result in misdiagnosis and unnecessary replacement of parts.

Only the parameters listed below are referred to in this service manual for use in diagnosis. For further information on using the Tech 2 to diagnose the PCM and related sensors, refer to the applicable reference section listed below. If all values are within the typical range described below, refer to the *Symptoms* section for diagnosis.

**Test Conditions**

Engine running, lower radiator hose hot, transmission in park or neutral, closed loop, accessories off, brake not applied and air conditioning off.

**3.5L V-6 Engine**

Tech 2 Parameter	Data List	Units Displayed	Typical Data Values (IDLE)	Typical Data Values (2500 RPM)
Engine Speed	Engine	RPM	Within -50 to +100 of "Desired Idle"	Actual engine speed
Desired Idle Speed	Engine	RPM	750	800
Engine Coolant Temperature	Engine	°C or °F	80 – 100 (176 – 212 °F)	80 – 100 (176 – 212 °F)
Start Up ECT (Engine Coolant Temperature)	Engine	°C or °F	—	—
Intake Air Temperature	Engine	°C or °F	0 – 100, depends on underhood	0 – 80, depends on underhood
Start Up IAT (Intake Air Temperature)	Engine	°C or °F	—	—
Manifold Absolute Pressure	Engine	kpa	23 – 40	19 – 32
Manifold Absolute Pressure	Engine	V	0.65 – 1.32	0.46 – 1.10
Barometric Pressure	Engine	kpa	61 – 104 (depends on altitude and barometric)	61 – 104 (depends on altitude and barometric)
Throttle Position	Engine	%	0	3 – 5
Throttle Position Sensor	Engine	V	0.35 – 0.39	0.55 – 0.59
Mass Air Flow	Engine	g/s	2.85 – 6.65	9.5 – 16.5
Air Fuel Ratio	Engine	Ratio:_to1	14.7:1	14.7:1
Injection Pulse Bank 1	Engine	ms	2.0 – 4.0	2.5 – 4.0
Injection Pulse Bank 2	Engine	ms	2.0 – 4.0	2.5 – 4.0
Spark Advance	Engine	°CA	15 – 22	34 – 44
EGR Duty Cycle	Engine	%	0	0
Desired EGR Position	Engine	%	0	0
EGR Normalized	Engine	%	0	0
EGR Feedback	Engine	V	0.45 – 0.80	0.45 – 0.80
EGR Closed Pintle Position	Engine	Steps	20 – 40	20 – 40
Catalyst Protection Mode	Engine	Yes/No	No	No
Knock Present	Engine	Yes/No	No	No
Knock Sensor Noise Channel	Engine	V	0.10 – 0.40	0.50 – 1.75
Knock Retard	Engine	°CA	—	—
A/C Clutch Relay	Engine	On/Off	Off	—
A/C Request	Engine	Yes/No	No	—
Camshaft Activity	Engine	Counts	0 – 255 always increasing	0 – 255 always increasing
EVAP Purge Solenoid (Evaporative Emission)	Engine	On/Off	Off	Off
EVAP Vent Valve (Evaporative Emission)	Engine	On/Off	On	On
Low Fuel Lamp	Engine	On/Off	—	—
Fuel Level	Engine	%	—	—

**6VE1 3.5L ENGINE DRIVEABILITY AND EMISSIONS 6E-75**

<b>Tech 2 Parameter</b>	<b>Data List</b>	<b>Units Displayed</b>	<b>Typical Data Values (IDLE)</b>	<b>Typical Data Values (2500 RPM)</b>
Fuel Level Sensor	Engine	V	—	—
Fuel Pump	Engine	On/Off	On	On
Fuel Tank Pressure Sensor	Engine	V	1.47 – 1.53	1.65 – 1.71
Idle Air Control	Engine	Steps	—	—
Transmission Check Light	Engine	On/Off	Off	Off
Park/Neutral Position	Engine	P-N/R-D-3-2-L	P-N	P-N
TCC Engaged	Engine	Yes/No	No	No
Vehicle Speed	Engine	MPH or km/h	0	0
Ignition Voltage	Engine	V	12.8 – 14.1	12.8 – 14.1
Fuel system Status	Engine	Closed Loop /Open Loop	Closed Loop	Closed Loop
Power Enrichment	Engine	Yes/No	No	No
Engine Load	Engine	%	2.0 – 5.5	8.0 – 16.0
Time From Start	Engine	—:—:—	—:—:—	—:—:—
Deceleration Fuel Cutoff	Engine	Inactive/Active	Inactive	Inactive
Malfunction Indicator Lamp	Engine	On/Off	Off	Off
Upshift Lamp	Engine	On/Off	Off	Off
VIM solenoid (Variable Intake Manifold)	Engine	On/Off	On	On
Security Wait Time	Engine	Inactive/Active	Inactive	Inactive

Tech 2 Parameter	Data List	Units Displayed	Typical Data Values (IDLE)	Typical Data Values (2500 RPM)
Engine Speed	Misfire	RPM	Within -50 to +100 of "Desired Idle"	Actual engine speed
Desired Idle Speed	Misfire	RPM	750	800
Engine Coolant Temperature	Misfire	°C or °F	80 – 100 (176 – 212 °F)	80 – 100 (176 – 212 °F)
Start Up ECT (Engine Coolant Temperature)	Misfire	°C or °F	—	—
Intake Air Temperature	Misfire	°C or °F	0 – 100, depends on underhood temp	0 – 80, depends on underhood temp
Start Up IAT (Intake Air Temperature)	Misfire	°C or °F	—	—
Manifold Absolute Pressure	Misfire	kpa	23 – 40	19 – 32
Barometric Pressure	Misfire	kpa	61 – 104 (depends on altitude and barometric)	61 – 104 (depends on altitude and barometric)
Throttle Position	Misfire	%	0	3 – 5
Throttle Position Sensor	Misfire	V	0.35 – 0.39	0.55 – 0.59
Mass Air Flow	Misfire	g/s	2.85 – 6.65	9.5 – 16.5
Misfire Current Cyl.#1	Misfire	Counts	0-2	0-2
Misfire Current Cyl.#2	Misfire	Counts	0-2	0-2
Misfire Current Cyl.#3	Misfire	Counts	0-2	0-2
Misfire Current Cyl.#4	Misfire	Counts	0-2	0-2
Misfire Current Cyl.#5	Misfire	Counts	0-2	0-2
Misfire Current Cyl.#6	Misfire	Counts	0-2	0-2
Misfire History Cyl.#1	Misfire	Counts	0	0
Misfire History Cyl.#2	Misfire	Counts	0	0
Misfire History Cyl.#3	Misfire	Counts	0	0
Misfire History Cyl.#4	Misfire	Counts	0	0
Misfire History Cyl.#5	Misfire	Counts	0	0
Misfire History Cyl.#6	Misfire	Counts	0	0
Misfire Failure Since First Fail	Misfire	Counts	0	0
Misfire Passes Since First Fail	Misfire	Counts	0	0
Total Misfire	Misfire	Counts	0-5	0-5
Weak Cylinder	Misfire	Cylinder #	—	—
Misfire Delay Counter	Misfire	Counts	0	0
ABS Rough Road	Misfire	Value	0	0
ABS Rough Road Counts	Misfire	Counts	0	0
Engine Load	Misfire	%	2.0 – 5.5	8.0 – 16.0
Vehicle Speed	Misfire	MPH or km/h	0	0
Time From Start	Misfire	_:.:_	_:.:_	_:.:_

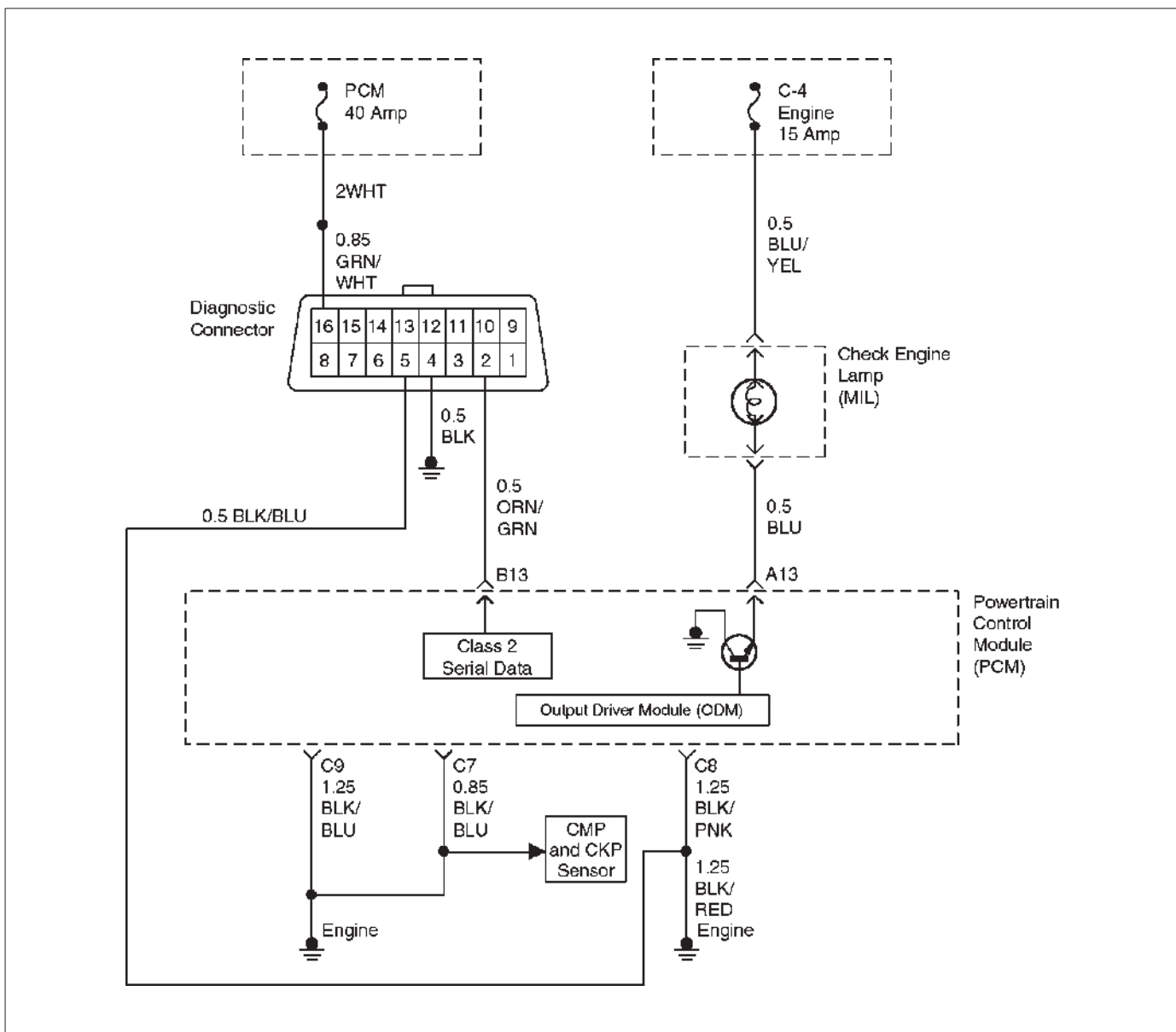
**6VE1 3.5L ENGINE DRIVEABILITY AND EMISSIONS 6E-77**

<b>Tech 2 Parameter</b>	<b>Data List</b>	<b>Units Displayed</b>	<b>Typical Data Values (IDLE)</b>	<b>Typical Data Values (2500 RPM)</b>
Engine Speed	O2 Sensor	RPM	Within -50 to +100 of "Desired Idle"	Actual engine speed
Desired Idle Speed	O2 Sensor	RPM	750	800
Engine Coolant Temperature	O2 Sensor	°C or °F	80 – 100 (176 – 212 °F)	80 – 100 (176 – 212 °F)
Start Up ECT (Engine Coolant Temperature)	O2 Sensor	°C or °F	—	—
Intake Air Temperature	O2 Sensor	°C or °F	0 – 100, depends on underhood temp	0 – 80, depends on underhood temp
Start Up IAT (Intake Air Temperature)	O2 Sensor	°C or °F	—	—
Manifold Absolute Pressure	O2 Sensor	kpa	23 – 40	19 – 32
Barometric Pressure	O2 Sensor	kpa	61 – 104 (depends on altitude and barometric)	61 – 104 (depends on altitude and barometric)
Throttle Position	O2 Sensor	%	0	3 – 5
Throttle Position Sensor	O2 Sensor	V	0.35 – 0.39	0.55 – 0.59
Mass Air Flow	O2 Sensor	g/s	2.85 – 6.65	9.5 – 16.5
Air Fuel Ratio	O2 Sensor	g/s	2.85 – 6.65	9.5 – 16.5
B1 S1 O2 Sensor (Bank 1 Sensor 1)	O2 Sensor	mV	50 – 950 always changing quickly	50 – 950 always changing quickly
B1 S2 O2 Sensor (Bank 1 Sensor 2)	O2 Sensor	mV	200 – 700	250 – 650
B2 S1 O2 Sensor (Bank 2 Sensor 1)	O2 Sensor	mV	50 – 950 always changing quickly	50 – 950 always changing quickly
B2 S2 O2 Sensor (Bank 2 Sensor 2)	O2 Sensor	mV	200 – 700	250 – 650
B1 O2S Ready (Bank 1)	O2 Sensor	Yes/No	Yes	Yes
B2 O2S Ready (Bank 2)	O2 Sensor	Yes/No	Yes	Yes
B1 S1 O2S Warm Up Time (Bank1 Sensor 1)	O2 Sensor	seconds	24 – 45	24 – 45
B1 S2 O2S Warm Up Time (Bank1 Sensor 2)	O2 Sensor	seconds	60 – 100	60 – 100
B2 S1 O2S Warm Up Time (Bank2 Sensor 1)	O2 Sensor	seconds	24 – 45	24 – 45
B2 S2 O2S Warm Up Time (Bank2 Sensor 2)	O2 Sensor	seconds	60 – 100	60 – 100
B1 Long Term Fuel Trim (Bank1)	O2 Sensor	%	—	—
B2 Long Term Fuel Trim (Bank2)	O2 Sensor	%	—	—
B1 Short Term Fuel Trim (Bank1)	O2 Sensor	%	—	—

**6E-78 6VE1 3.5L ENGINE DRIVEABILITY AND EMISSIONS**

<b>Tech 2 Parameter</b>	<b>Data List</b>	<b>Units Displayed</b>	<b>Typical Data Values (IDLE)</b>	<b>Typical Data Values (2500 RPM)</b>
B2 Short Term Fuel Trim (Bank2)	O2 Sensor	%	—	—
Fuel Trim Cell	O2 Sensor	Cell No.	20	2 or 6
Fuel Trim Learned	O2 Sensor	Yes/No	Yes	Yes
B1 S1 Status (Bank 1 Sensor 1)	O2 Sensor	Rich/Lean	—	—
B2 S1 Status (Bank 2 Sensor 1)	O2 Sensor	Rich/Lean	—	—
Engine Load	O2 Sensor	%	2.0 – 5.5	8.0 – 16.0

## No Malfunction Indicator Lamp (MIL)



D06RX071

### Circuit Description

The "Check Engine" lamp (MIL) should always be illuminated and steady with the ignition "ON" and the engine stopped. Ignition feed voltage is supplied to the MIL bulb through the meter fuse. The powertrain control module (PCM) turns the MIL "ON" by grounding the MIL driver circuit.

### Diagnostic Aids

An intermittent MIL may be caused by a poor connection, rubbed-through wire insulation, or a wire broken inside the insulation. Check for the following items:

- Inspect the PCM harness and connections for improper mating, broken locks, improperly formed or damaged terminals, poor terminal-to-wire connection, and damaged harness.
- If the engine runs OK, check for a faulty light bulb, an open in the MIL driver circuit, or an open in the instrument cluster ignition feed.

- If the engine cranks but will not run, check for an open PCM ignition or battery feed, or a poor PCM to engine ground.

### Test Description

Number(s) below refer to the step number(s) on the Diagnostic Chart.

2. A "No MIL" condition accompanied by a no-start condition suggests a faulty PCM ignition feed or battery feed circuit.
9. Using a test light connected to B+, probe each of the PCM ground terminals to ensure that a good ground is present. Refer to *PCM Terminal End View* for terminal locations of the PCM ground circuits.
12. In this step, temporarily substitute a known good relay for the PCM relay. The horn relay is nearby, and it can be verified as "good" simply by honking the horn. Replace the horn relay after completing this step.



17. This vehicle is equipped with a PCM which utilizes an electrically erasable programmable read only memory (EEPROM). When the PCM is replaced, the new PCM must be programmed. Refer to *PCM Replacement and Programming Procedures* in *Powertrain Control Module (PCM) and Sensors*.

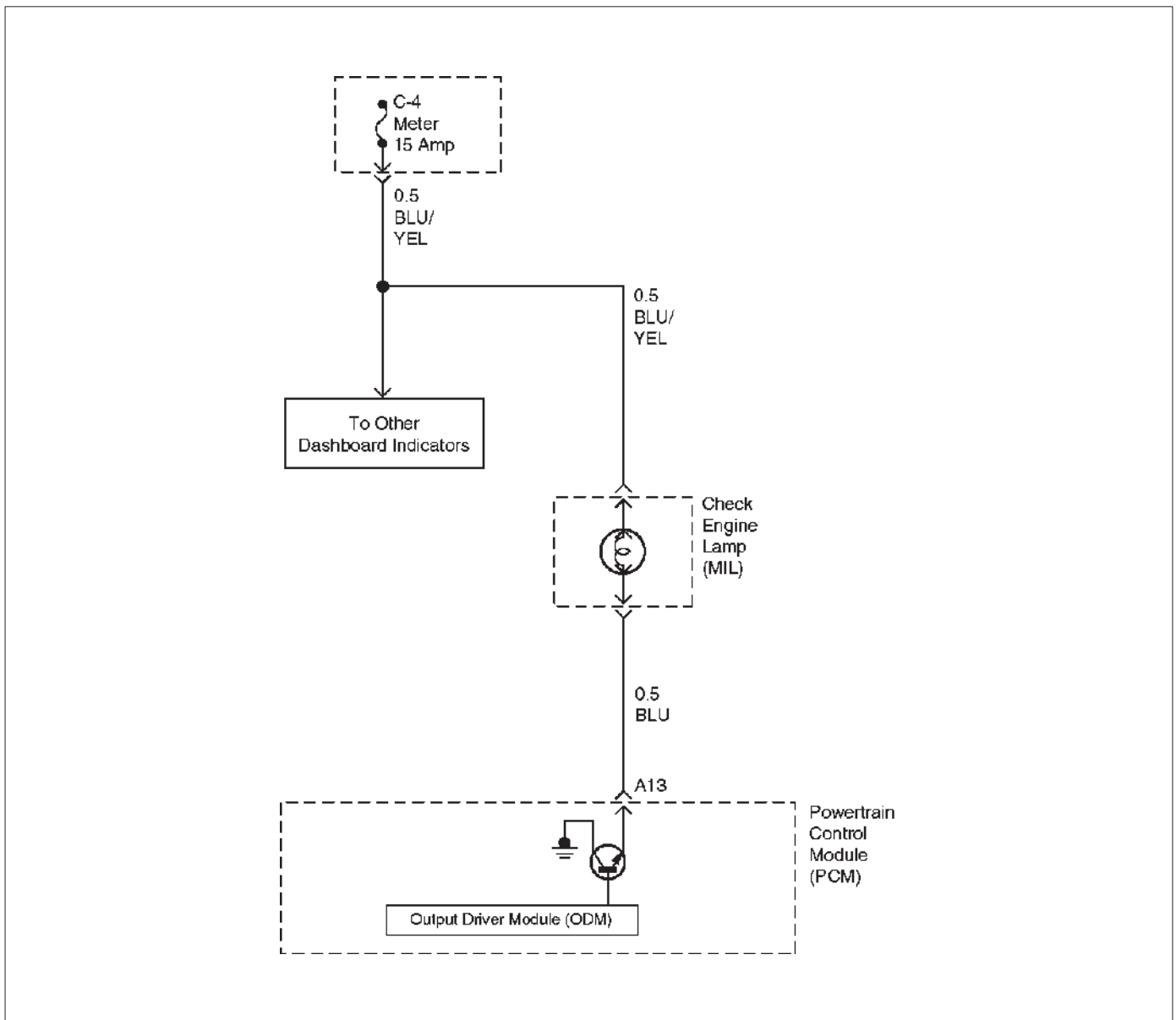
### No Malfunction Indicator Lamp (MIL)

Step	Action	Value(s)	Yes	No
1	Was the "On-Board Diagnostic (OBD) System Check" performed?	—	Go to Step 2	Go to <i>OBD System Check</i>
2	Attempt to start the engine. Does the engine start?	—	Go to Step 3	Go to Step 6
3	Check the meter fuse for the instrument cluster ignition feed circuit. Is the fuse OK?	—	Go to Step 4	Go to Step 16
4	Ignition "ON," probe the ignition feed circuit at the cluster connector with a test light to ground. Is the test light "ON?"	—	Go to Step 5	Go to Step 13
5	1. Ignition "OFF." 2. Disconnect the PCM. 3. Jumper the MIL driver circuit at the PCM connector to ground. 4. Ignition "ON." Is the MIL "ON?"	—	Go to Step 10	Go to Step 11
6	Check the PCM ignition feed and battery feed fuses (15 A engine fuse and 15 A PCM fuse). Are both fuses OK?	—	Go to Step 7	Go to Step 15
7	1. Ignition "OFF." 2. Disconnect the PCM. 3. Ignition "ON." 4. Probe the ignition feed circuit at the PCM harness connector with a test light to ground. Is the test light "ON?"	—	Go to Step 8	Go to Step 12
8	Probe the battery feed circuit at the PCM harness connector with a test light to ground. Is the test light "ON?"	—	Go to Step 9	Go to Step 14
9	Check for a faulty PCM ground connection. Was a problem found?	—	Verify repair	Go to Step 10
10	Check for damaged terminals at the PCM. Was a problem found?	—	Verify repair	Go to Step 17
11	Check for an open MIL driver circuit between the PCM and the MIL. Was a problem found?	—	Verify repair	Go to Step 18
12	Substitute a known "good" relay for the PCM main relay. Was the malfunction fixed?	—	Verify repair	Go to Step 13

### No Malfunction Indicator Lamp (MIL) (Cont'd)

Step	Action	Value(s)	Yes	No
13	Repair the open in the ignition feed circuit. Is the action complete?	—	Verify repair	—
14	Locate and repair the open PCM battery feed circuit. Is the action complete?	—	Verify repair	—
15	Locate and repair the short to ground in the PCM ignition feed circuit or PCM battery feed circuit. Is the action complete?	—	Verify repair	—
16	Locate and repair the short to ground in the ignition feed circuit to the instrument cluster, and replace the fuse. Is the action complete?	—	Verify repair	—
17	Replace the PCM. <b>IMPORTANT:</b> The replacement PCM must be programmed. Refer to <i>PCM</i> in <i>ON-Vehicle Service</i> for procedures. And also refer to latest Service Bulletin. Check to see if the Latest software is released or not. And then Down Load the LATEST PROGRAMMED SOFTWARE to the replacement PCM. Is the action complete?	—	Verify repair	—
18	Check the MIL driver circuit for a poor connection at the instrument panel connector. Was a problem found?	—	Verify repair	Go to <i>Instrument Panel</i> in <i>Electrical Diagnosis</i>

## Malfunction Indicator Lamp (MIL) "ON" Steady



D06RX072

### Circuit description

The malfunction indicator lamp (MIL) should always be illuminated and steady with ignition "ON" and the engine stopped. Ignition feed voltage is supplied directly to the MIL indicator. The powertrain control module (PCM) turns the MIL "ON" by grounding the MIL driver circuit. The MIL should not remain "ON" with the engine running and no DTC(s) set. A steady MIL with the engine running and no DTC(s) suggests a short to ground in the MIL driver circuit.

### Diagnostic Aids

An intermittent may be caused by a poor connection, rubbed-through wire insulation, or a wire broken inside the insulation. Check for the following items:

- Poor connection or damaged harness – Inspect the PCM harness and connectors for improper mating, broken locks, improperly formed or damaged terminals, poor terminal-to-wire connection, and damaged harness.

### Test Description

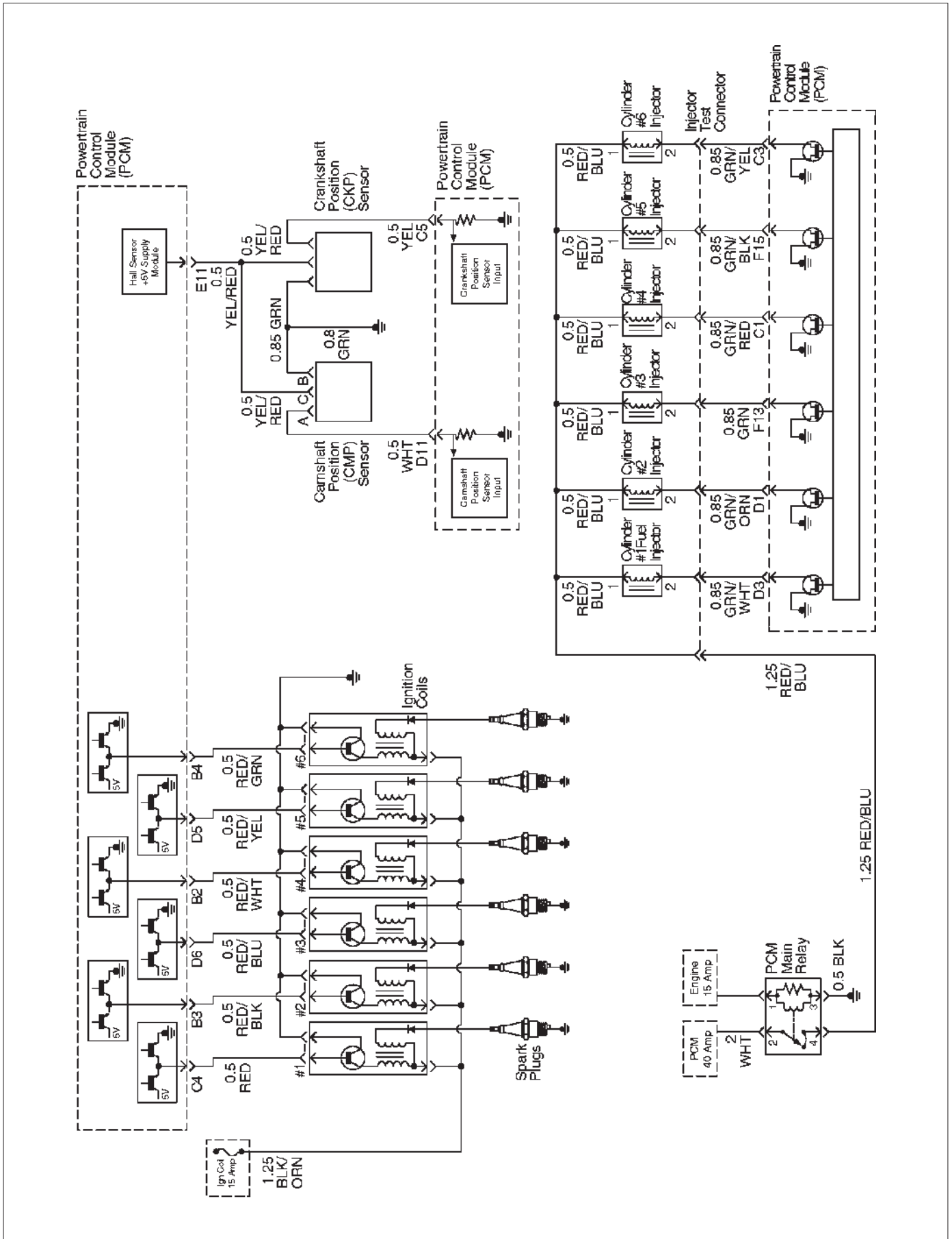
Number(s) below refer to the step number(s) on the Diagnostic Chart.

2. If the MIL does not remain "ON" when the PCM is disconnected, the MIL driver wiring is not faulty.
3. If the MIL driver circuit is OK, the instrument panel cluster is faulty.
6. This vehicle is equipped with a PCM which utilizes an electrically erasable programmable read only memory (EEPROM). When the PCM is replaced, the new PCM must be programmed. Refer to *PCM Replacement and Programming Procedures in Powertrain Control Module (PCM) and Sensors*.

### Malfunction Indicator Lamp (MIL) "ON" Steady

Step	Action	Value(s)	Yes	No
1	Was the "On-Board diagnostic (OBD) System Check" performed?	—	Go to Step 2	Go to <i>OBD System Check</i>
2	1. Ignition "OFF," disconnect PCM. 2. Ignition "ON," observe the MIL (Service Engine Soon lamp). Is the MIL "ON?"	—	Go to Step 3	Go to Step 5
3	1. Ignition "OFF," disconnect the instrument panel cluster. 2. Check the MIL driver circuit between the PCM and the instrument panel cluster for a short to ground. 3. If a problem is found, repair as necessary. Was the MIL driver circuit shorted to ground?	—	Go to <i>OBD System Check</i>	Go to Step 4
4	Replace the instrument panel cluster. Is the action complete?	—	Go to <i>OBD System Check</i>	—
5	1. Ignition "OFF," reconnect the PCM. 2. Ignition "ON," reprogram the EEPROM. Refer to <i>On-Vehicle Service</i> in <i>Powertrain Control Module and Sensors</i> for procedures. 3. Using the Tech 2 output controls function, select MIL dash lamp control and command the MIL "OFF." (Refer to the Miscellaneous test) Did the MIL turn "OFF?"	—	Go to <i>OBD System Check</i>	Go to Step 6
6	Replace the PCM. <b>IMPORTANT:</b> The replacement PCM must be programmed. Refer to <i>On-Vehicle Service</i> in <i>Powertrain Control Module and Sensors</i> for procedures. And also refer to latest Service Bulletin. Check to see if the Latest software is released or not. And then Down Load the LATEST PROGRAMMED SOFTWARE to the replacement PCM. Is the action complete?	—	Go to <i>OBD System Check</i>	—

### Engine Cranks But Will Not Run



## Circuit Description

The electronic Ignition system uses a coil-at-plug method of spark distribution. In this type of ignition system, the powertrain control module (PCM) triggers the correct ignition coil based on the 58X signal received from the crankshaft position sensor (CKP). The spark plug connected to the coil fires when the PCM opens the ground circuit for the coil's primary circuit.

During crank, the PCM monitors the CKP 58X signal. The CKP signal is used to determine which cylinder will fire first. After the CKP 58X signal has been processed by the PCM, it will command all six injectors to allow a priming shot of fuel for all the cylinders. After the priming, the injectors are left "OFF" during the next six 58X reference pulses from the CKP. This allows each cylinder a chance to use the fuel from the priming shot. During this waiting period, a camshaft position (CMP) signal pulse will have been received by the PCM. The CMP signal allows the PCM to operate the injectors sequentially based on camshaft position. If the camshaft position signal is not present at start-up, the PCM will begin sequential fuel delivery with a 1-in-6 chance that fuel delivery is correct. The engine will run without a CMP signal, but will set a DTC code.

## Diagnostic Aids

An intermittent problem may be caused by a poor connection, rubbed-through wire insulation or a wire broken inside the insulation. Check for the following items:

- Poor connection or damaged harness – Inspect the PCM harness and connectors for improper mating, broken locks, improperly formed or damaged terminals, poor terminal-to-wire connection, and damaged harness.
- Faulty engine coolant temperature sensor – Using a Tech 2, compare engine coolant temperature with intake air temperature on a completely cool engine. Engine coolant temperature should be within 10°C of intake air temperature. If not, replace the ECT sensor.

## Test Description

Number(s) below refer to the step number(s) on the Diagnostic Chart.

5. An obvious cause of low fuel pressure would be an empty fuel tank.
6. The engine will easily start and run if a few injectors are disabled. It is not necessary to test all injectors at this time since this step is only a test to verify that all of the injectors have not been disabled by fuel contamination.
7. A blinking test light verifies that the PCM is monitoring the 58X crankshaft reference signal and is capable of activating the injectors. If there is an open or shorted driver circuit, DTCs 201 to 206 and a misfire DTCs 301 to 306 should be set.
19. By using a spark tester, each ignition coil's ability to produce 25,000 volts is verified.

25. If there is an open or shorted driver circuit, DTCs 201 to 206 and a misfire DTCs 301 to 306 should be set. All six injector driver circuits can be checked at one time without removing the intake manifold if a J 39021-95 test light is available. This is the alternative procedure:

- With the ignition "OFF," disconnect the gray connector located at the rear of the air filter, attached to a bracket on the purge canister.
- Connect test light J 39021-95 to the connector. Do any of the light constantly illuminate or fail to blink when the engine is cranked? If so, repair the short or open circuit, or replace the PCM if indicated.

This procedure only tests the driver circuit as far as the test connection, so step 31 is added to test the circuit all the way to the injector.

### Engine Cranks But Will Not Run

Step	Action	Value(s)	Yes	No
1	Was the "On-Board Diagnostic (OBD) System Check" performed?	—	Go to Step 2	Go to <i>OBD System Check</i>
2	Check the 15 A ignition coil fuse, the 15 A engine fuse, and the 30 A PCM fuse. Was a fuse blown?	—	Go to Step 3	Go to Step 4
3	Check for a short to ground and replace the fuse. Is the action complete?	—	Verify repair	—
4	1. Ignition "OFF," install a fuel pressure gauge at the test fitting on the fuel supply line in the engine compartment. (Use a shop cloth to absorb any fuel leakage while making the connection.) 2. Ignition "ON," observe the fuel pressure. Is the fuel pressure within the specified values, and does it hold steady?	285-375 kpa (43-55 psi)	Go to Step 6	Go to Step 5
5	Is any fuel pressure indicated?	—	Go to <i>Fuel System Electrical Test</i>	Go to <i>Fuel System Diagnosis</i>
6	Install the switch box J 39021-2 at the injector test connector and activate an injector. Did the fuel pressure drop when the injector was activated?	—	Go to Step 7	Go to Step 14
7	Install an injector test light at the #2 cylinder injector harness connector. Does the light blink when the engine is cranked?	—	Go to Step 8	Go to Step 20
8	1. Remove the 5-pin connector at the ignition module. 2. Ignition "ON." 3. Use a test light at the harness connector to verify that the module is being supplied with B+ and ground. Was a problem found?	—	Go to Step 9	Go to Step 10
9	Repair the open ignition feed circuit or ground circuit to the ignition module. Is the action complete?	—	Verify repair	—
10	1. Ignition "ON." 2. While the coil connectors are disconnected, touch each coil connector's ignition feed terminal with a grounded test light (the ignition feed wire is black with orange tracer). Did the test light illuminate?	—	Go to Step 12	Go to Step 11
11	Repair the open ignition feed circuit. Is the action complete?	—	Verify repair	—
12	While the coil connectors are disconnected, touch each connector's secondary ground terminal with a test light to B+. (The ground wires are black.) Did the test light illuminate at each coil connector?	—	Go to Step 14	Go to Step 13
13	Repair the open secondary ground circuit. Is the action complete?	—	Verify repair	—

### Engine Cranks But Will Not Run (Cont'd)

Step	Action	Value(s)	Yes	No
14	<p>1. Test the fuel for contamination.</p> <p>2. If a problem is found, clean the fuel system and correct the contaminated fuel condition as necessary. Replace the fuel filter and replace any injectors that are not delivering fuel (see Injector Balance Test).</p> <p>Was a problem found?</p>	—	Verify repair	Go to <i>Step 15</i>
15	<p>1. Remove any ignition coil and install a spark tester at the spark plug end of the coil.</p> <p>2. Observe the tester while the engine is cranking.</p> <p>Was a crisp, blue spark observed? Only one or two sparks followed by no result is considered the same as "No Spark."</p>	—	Go to <i>Step 17</i>	Go to <i>Step 16</i>
16	<p>Replace the ignition coil, and return to Step 19 to test the remaining coils.</p> <p>Is the action complete?</p>	—	Verify repair	—
17	<p>Repeat Step 19 for each coil. Remove only one coil at a time, and reinstall each coil on its spark plug after testing, but do not refasten coils with screws at this time.</p> <p>After all coils have passed the spark test, does the engine start?</p>	—	Refasten all coils with their screws	Go to <i>Step 18</i>
18	<p>1. Remove the spark plugs from all cylinders.</p> <p>2. Visually inspect the spark plug electrodes.</p> <p>3. Replace any spark plugs with loose or missing electrodes or cracked insulators.</p> <p>Did your inspection reveal any spark plugs exhibiting excessive fouling?</p>	—	Correct the fouling condition	Go to <i>Step 19</i>
19	<p>Refer to <i>Engine Mechanical Diagnosis</i> to diagnose the following conditions:</p> <ul style="list-style-type: none"> <li><input type="radio"/> Faulty or incorrect camshaft drive belts</li> <li><input type="radio"/> Leaking or sticky valves or rings</li> <li><input type="radio"/> Excessive valve deposits</li> <li><input type="radio"/> Loose or worn rocker arms</li> <li><input type="radio"/> Weak valve springs</li> <li><input type="radio"/> Incorrect valve timing</li> <li><input type="radio"/> Leaking head gasket</li> </ul> <p>Is the action complete?</p>	—	Verify repair	Go to <i>Step 21</i>
20	<p>Observe the "Engine Speed" data display on the Tech 2 while cranking the engine.</p> <p>Is the engine RPM indicated?</p>	—	Go to <i>Step 21</i>	Go to <i>Step 30</i>
21	<p>1. Disconnect the 7-pin gray connector at the rear of the air filter beneath the point where the air duct attaches to the MAF sensor.</p> <p>2. Ignition "ON."</p> <p>3. Using a test light connected to ground, probe the ignition terminal at the PCM (female) side of the 7-pin connector.</p> <p>Is the test light "ON?"</p>	—	Go to <i>Step 22</i>	Go to <i>Step 28</i>



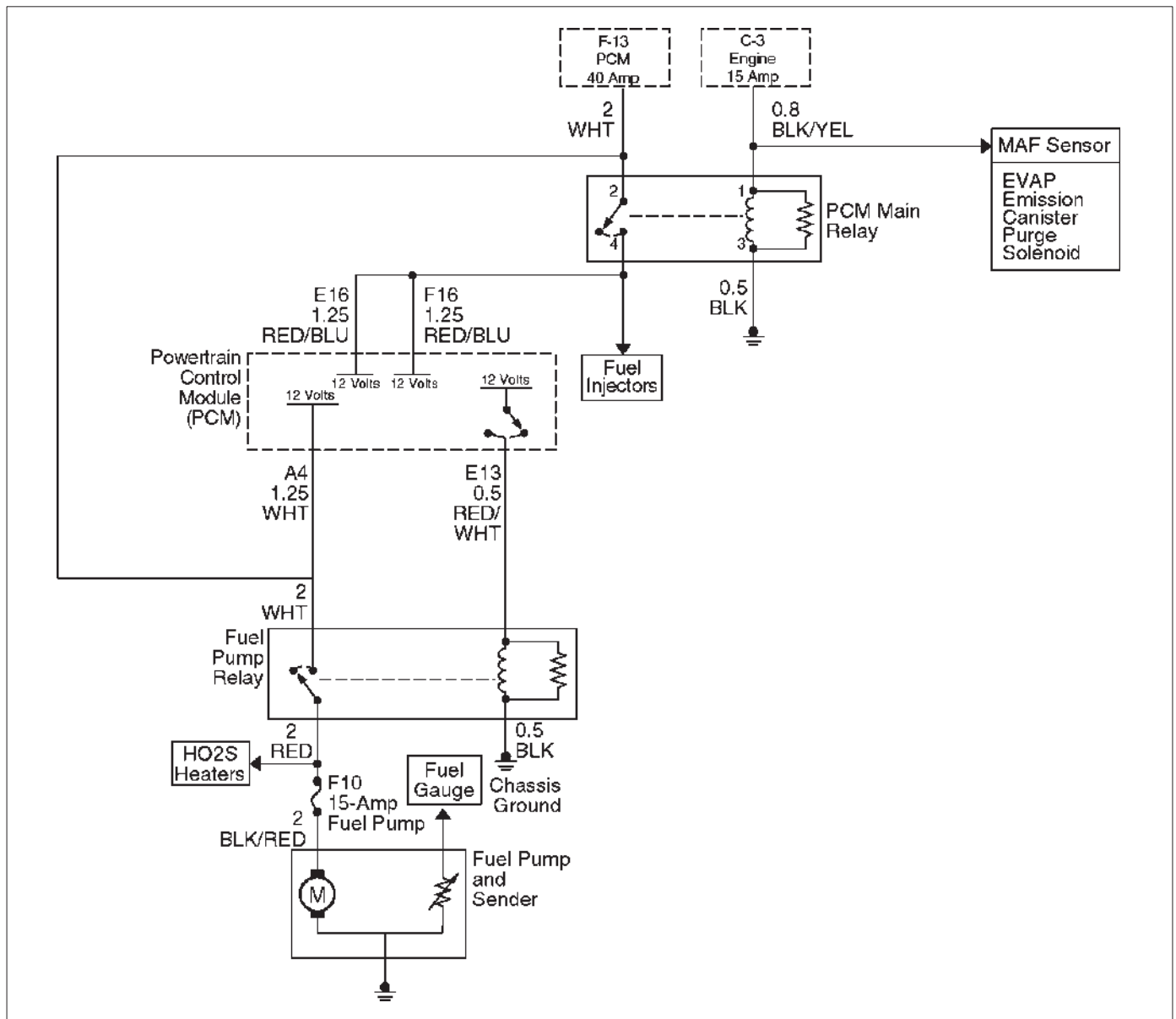
### Engine Cranks But Will Not Run (Cont'd)

Step	Action	Value(s)	Yes	No
22	1. At the PCM (female) side of the connector mentioned in step 25, connect a test light between the ignition + terminal and one of the injector driver circuits at the same connector. 2. Ignition "ON." 3. Observe the test light, and repeat the test for each injector driver circuit.  Did the test light stay on when checking any of the 6 injector driver circuits?	—	Go to <i>Step 23</i>	Go to <i>Step 25</i>
23	1. Ignition "OFF," disconnect the PCM. 2. Ignition "ON," observe the test light.  Is the test light "ON?"	—	Go to <i>Step 24</i>	Go to <i>Step 29</i>
24	Locate and repair the short to ground in the injector driver circuit.  Is the action complete?	—	Verify repair	—
25	1. Using the same test location as in step 26, connect a test light between the ignition terminal and one of the driver circuits. 2. Crank the engine and observe the test light. 3. Repeat for each injector driver circuit.  Did the light blink during the test for each circuit?	—	Go to <i>Step 27</i>	Go to <i>Step 26</i>
26	Check for an open injector driver circuit.  Was a problem found?	—	Verify repair	Go to <i>Step 29</i>
27	1. At the injector (male) side of the gray connector mentioned in step 25, connect an ohmmeter between the ignition pin and one of the driver circuit pins. 2. Check for continuity in the circuit. 3. Repeat for each injector circuit. The readings should be approximately equal to the specified value for injector resistance.  Was a problem found?	12.5 ohms	Verify repair	Go to <i>Step 8</i>
28	Repair the ignition feed circuit.  Is the action complete?	—	Verify repair	—
29	Replace the PCM.  <b>IMPORTANT:</b> The replacement PCM must be programmed. Refer to <i>On-Vehicle Service in Powertrain Control Module and Sensors for procedures</i> .  And also refer to latest Service Bulletin.  Check to see if the Latest software is released or not. And then Down Load the LATEST PROGRAMMED SOFTWARE to the replacement PCM.  Is the action complete?	—	Verify repair	—

### Engine Cranks But Will Not Run (Cont'd)

Step	Action	Value(s)	Yes	No
30	1. Raise the vehicle and disconnect the CKP sensor harness. 2. Ignition "ON." 3. With a test light to ground, probe the harness ignition feed terminal. Did the light illuminate?	—	Go to <i>Step 32</i>	Go to <i>Step 31</i>
31	Check the ignition feed wire between the sensor and the PCM for a short to ground or open circuit. Is the action complete?	—	Verify repair	—
32	1. Ignition "ON." 2. At the CKP harness connector, connect a test light between the ignition and ground terminals. Did the light illuminate?	—	Go to <i>Step 34</i>	Go to <i>Step 33</i>
33	Check the sensor ground circuit for an open or short to voltage. Is the action complete?	—	Verify repair	—
34	Check the signal circuit between the sensor and the PCM for a short to ground, short to voltage, or an open. Was a problem found?	—	Verify repair	Go to <i>Step 35</i>
35	Replace the CKP position sensor. Is the action complete?	—	Verify repair	Go to <i>Step 29</i>

## Fuel System Electrical Test



D06RX074

### Circuit Description

When the ignition switch is first turned "ON," the powertrain control module (PCM) energizes the fuel pump relay which applies power to the in-tank fuel pump. The fuel pump relay will remain "ON" as long as the engine is running or cranking and the PCM is receiving 58X crankshaft position pulses. If no 58X crankshaft position pulses are present, the PCM de-energizes the fuel pump relay within 2 seconds after the ignition is turned "ON" or the engine is stopped.

The fuel pump delivers fuel to the fuel rail and injectors, then to the fuel pressure regulator. The fuel pressure regulator controls fuel pressure by allowing excess fuel to be returned to the fuel tank. With the engine stopped and ignition "ON," the fuel pump can be turned "ON" by using a command by the Tech 2.

### Diagnostic Aids

An intermittent may be caused by a poor connection, rubbed-through wire insulation, or a wire broken inside the insulation. Check for the following items:

- Poor connection or damaged harness – Inspect the PCM harness and connectors for improper mating, broken locks, improperly formed or damaged terminals, poor terminal-to-wire connection, and damaged harness.

### Test Description

Number(s) below refer to the step number(s) on the Diagnostic Chart.

2. If the fuel pump is operating but incorrect pressure is noted, the fuel pump wiring is OK and the "Fuel System Pressure Test" chart should be used for diagnosis.

**CAUTION:** To reduce the risk of fire and personal injury:

- It is necessary to relieve fuel system pressure before connecting a fuel pressure gauge. Refer to Fuel Pressure Relief Procedure, below.
- A small amount of fuel may be released when disconnecting the fuel lines. Cover fuel line fittings with a shop towel before disconnecting, to catch any fuel that may leak out. Place the towel in an approved container when the procedure is completed.

2. Remove the fuel pump relay from the underhood relay center.
3. Start the engine and allow it to stall.
4. Crank the engine for an additional 3 seconds.

**Fuel Gauge Installation**

1. Remove the shoulder fitting cap.
2. Install fuel gauge J 34730-1 to the fuel feed line located in front of and above the right side valve train cover .
3. Reinstall the fuel pump relay.

**Fuel Pressure Relief Procedure**

1. Remove the fuel cap.

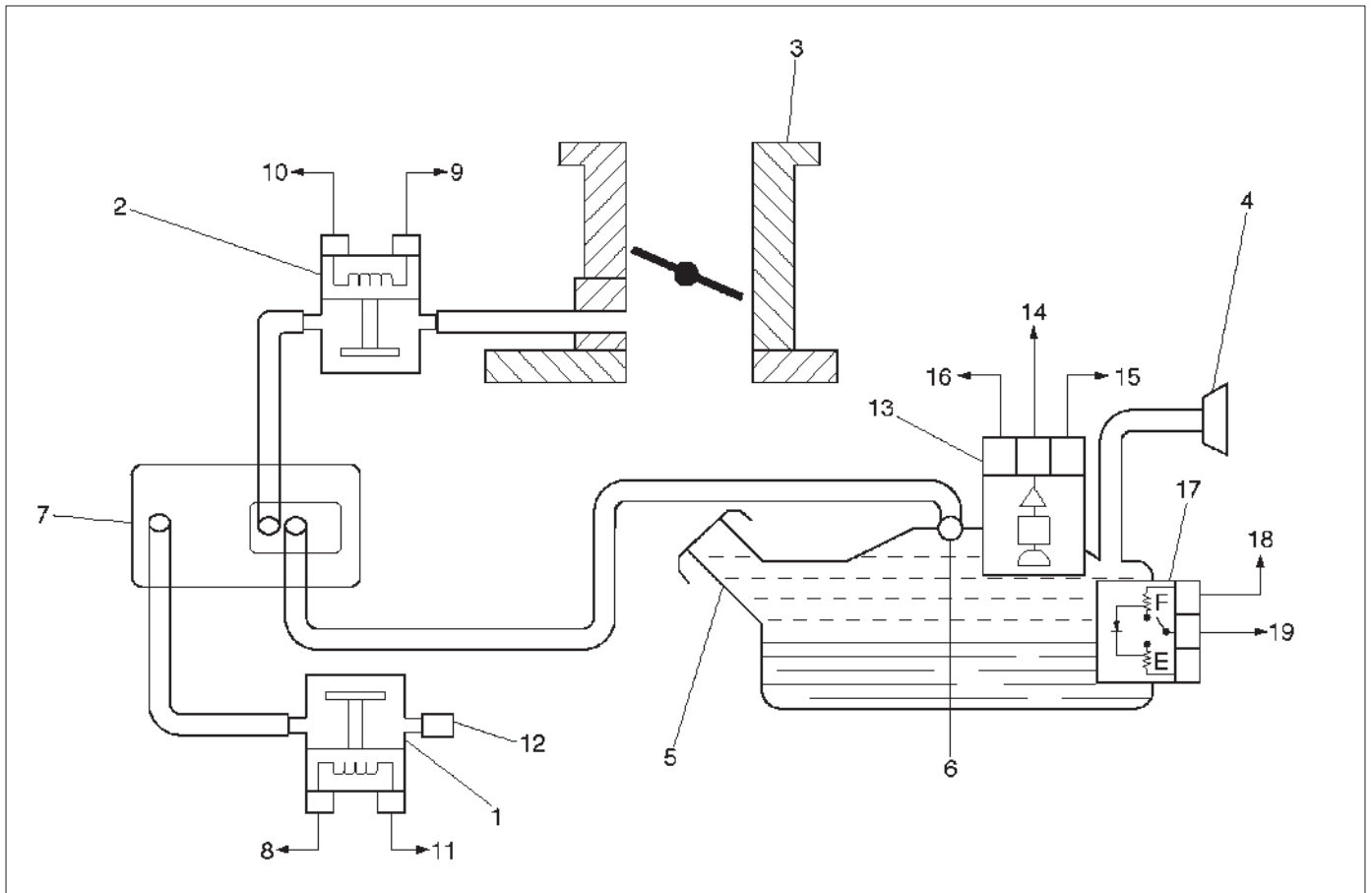
**Fuel System Electrical Test**

Step	Action	Value(s)	Yes	No
1	Was the "On-Board Diagnostic (OBD) System Check" performed?	—	Go to Step 2	Go to <i>OBD System Check</i>
2	1. Read the "Caution" above. 2. Relieve the fuel system pressure and install the fuel pump pressure gauge to the test fitting. 3. Ignition ON, Engine is Off. 4. Use a Tech 2 to command the fuel pump "ON." (Refer to the Miscellaneous Test.)  Is there an immediate pressure build-up which indicates the pump is running?	—	Go to Step 3	Go to Step 4
3	1. Verify that the pump is not running by removing the fuel filler cap and listening. 2. Command the pump "ON" with the Tech 2. Did the pump turn "OFF" after 2 seconds?	—	Test completed	Go to Step 12
4	1. Ignition "OFF." 2. Remove the fuel pump relay. 3. Using a test light connected to ground, probe the battery feed to the relay. Did the light illuminate?	—	Go to Step 6	Go to Step 5
5	Repair short or open battery feed to fuel pump relay. Is the action complete?	—	Verify repair	—
6	1. Connect a test light between the two wires that connect to the fuel pump relay pull-in coil. 2. Ignition "ON." Did the test light illuminate for 2 seconds and then turn off?	—	Go to Step 12	Go to Step 7
7	1. With a test light connected to battery (-), probe the fuel pump relay connector at the wire which runs from the relay pull-in coil to the PCM. 2. Ignition "ON." Did the test light illuminate for 2 seconds and then turn off?	—	Go to Step 8	Go to Step 9
8	Locate and repair open in the fuel pump relay ground circuit. Is the action complete?	—	Verify repair	—

### Fuel System Electrical Test (Cont'd)

Step	Action	Value(s)	Yes	No
9	Check for short or open between the PCM and the fuel pump relay. Was a problem found?	—	Verify repair	Go to <i>Step 10</i>
10	1. Check the fuel pump relay circuit for a poor terminal connection at the PCM. 2. If a problem is found, replace terminal as necessary. Was a problem found?	—	Verify repair	Go to <i>Step 11</i>
11	Replace the PCM. <b>IMPORTANT:</b> The replacement PCM must be programmed. Refer to <i>On-Vehicle Service in Powertrain Control Module and Sensors for procedures.</i> And also refer to latest Service Bulletin. Check to see if the Latest software is released or not. And then Down Load the LATEST PROGRAMMED SOFTWARE to the replacement PCM. Is the action complete?	—	Verify repair	—
12	1. Reconnect the fuel pump relay. 2. Disconnect the fuel pump electrical connector at the fuel tank. 3. Using a test light connected to ground, probe the fuel pump feed wire (harness side). 4. Command the fuel pump "ON" with a Tech 2. Did the light illuminate for 2 seconds?	—	Go to <i>Step 15</i>	Go to <i>Step 13</i>
13	1. Honk the horn to verify that the horn relay is functioning. 2. Substitute the horn relay for the fuel pump relay. 3. Leave the test light connected as in step 12. 4. Command the fuel pump "ON" with the Tech 2. Did the test light illuminate for 2 seconds when the fuel pump was commanded "ON?"	—	Go to <i>Step 17</i>	Go to <i>Step 14</i>
14	1. Re-connect the horn relay in its proper location. 2. Check for a short circuit, blown fuse or open circuit between the relay and the fuel tank. Is the action complete?	—	Verify repair	—
15	1. With the fuel pump electrical connector at the fuel tank disconnected, connect a test light between the feed wire and the ground wire (harness side). 2. Command the fuel pump "ON" with a Tech 2. Did the test light illuminate for 2 seconds?	—	Go to <i>Step 18</i>	Go to <i>Step 16</i>
16	Repair the open circuit in the fuel pump ground wire. Is the action complete?	—	Verify repair	—
17	1. Re-connect the horn relay in its proper location. 2. Replace the fuel pump relay. Is the action complete?	—	Verify repair	—
18	Replace the fuel pump. Is the action complete?	—	Verify repair	—

## Fuel System Diagnosis



TS30006

### Legend

- |                         |   |
|-------------------------|---|
| (1) Vent Solenoid       | (10) EVAP Purge Solenoid Driver Signal from PCM |
| (2) EVAP Purge Solenoid | (11) Vent Solenoid Driver Signal from PCM       |
| (3) Throttle Body       | (12) Vent Filter                                |
| (4) Fuel Filler Neck    | (13) Fuel Tank Pressure Sensor                  |
| (5) Fuel Tank           | (14) Fuel Tank Pressure Signal to PCM           |
| (6) Rollover Valve      | (15) 5 Volt Reference "A" Circuit from PCM      |
| (7) EVAP Canister       | (16) Sensor Ground Circuit from PCM             |
| (8) Ignition Feed       | (17) Fuel Level Sensor                          |
| (9) From Battery        | (18) Fuel Level Signal to PCM                   |
|                         | (19) 5 Volt Return                              |

### Circuit Description

When the ignition switch is turned "ON," the powertrain control module (PCM) will turn "ON" the in-tank fuel pump. The in-tank fuel pump will remain "ON" as long as the engine is cranking or running and the PCM is receiving 58X crankshaft position pulses. If there are no 58X crankshaft position pulses, the PCM will turn the in-tank fuel pump "OFF" 2 seconds after the ignition switch is turned "ON" or 2 seconds after the engine stops running. The in-tank fuel pump is an electric pump within an integral reservoir. The in-tank fuel pump supplies fuel through an in-line fuel filter to the fuel rail assembly. The fuel pump is designed to provide fuel at a pressure above the pressure needed by the fuel injectors. A fuel pressure regulator, attached to the fuel rail, keeps the fuel available

to the fuel injectors at a regulated pressure. Unused fuel is returned to the fuel tank by a separate fuel return line.

### Test Description

Number(s) below refer to the step number(s) on the Diagnostic Chart.

2. Connect the fuel pressure gauge to the fuel feed line as shown in the fuel system illustration. Wrap a shop towel around the fuel pressure connection in order to absorb any fuel leakage that may occur when installing the fuel pressure gauge. With the ignition switch "ON" and the fuel pump running, the fuel pressure indicated by the fuel pressure gauge should be 333-376 kpa (48-55 psi). This pressure is controlled by the amount of pressure the spring inside the fuel pressure regulator can provide.

3. A fuel system that cannot maintain a constant fuel pressure has a leak in one or more of the following areas:
- The fuel pump check valve.
  - The fuel pump flex line.
  - The valve or valve seat within the fuel pressure regulator.
  - The fuel injector(s).
4. Fuel pressure that drops off during acceleration, cruise, or hard cornering may cause a lean condition. A lean condition can cause a loss of power, surging, or misfire. A lean condition can be diagnosed using a Tech 2. If an extremely lean condition occurs, the oxygen sensor(s) will stop toggling. The oxygen sensor output voltage(s) will drop below 500 mV. Also, the fuel injector pulse width will increase.
- When the engine is at idle, the manifold pressure is low (high vacuum). This low pressure (high vacuum) is applied to the fuel pressure regulator diaphragm. The low pressure (high vacuum) will offset the pressure being applied to the fuel pressure regulator diaphragm by the spring inside the fuel pressure regulator. When this happens, the result is lower fuel pressure. The fuel pressure at idle will vary slightly as the barometric pressure changes, but the fuel pressure at idle should always be less than the fuel pressure noted in step 2 with the engine "OFF."
16. Check the spark plug associated with a particular fuel injector for fouling or saturation in order to determine if that particular fuel injector is leaking. If checking the spark plug associated with a particular fuel injector for fouling or saturation does not determine that a particular fuel injector is leaking, use the following procedure:
- Remove the fuel rail, but leave the fuel lines and injectors connected to the fuel rail. Refer to *Fuel Rail Assembly* in *On-Vehicle Service*.
  - Lift the fuel rail just enough to leave the fuel injector nozzles in the fuel injector ports.

**CAUTION:** In order to reduce the risk of fire and personal injury that may result from fuel spraying on the engine, verify that the fuel rail is positioned over the fuel injector ports and verify that the fuel injector retaining clips are intact.

- Pressurize the fuel system by connecting a 10 amp fused jumper between B+ and the fuel pump relay connector.
- Visually and physically inspect the fuel injector nozzles for leaks.

17. A rich condition may result from the fuel pressure being above 376 kpa (55 psi). A rich condition may cause a DTC P0132 or a DTC P0172 to set. Driveability conditions associated with rich conditions can include hard starting (followed by black smoke) and a strong sulfur smell in the exhaust.
20. This test determines if the high fuel pressure is due to a restricted fuel return line or if the high fuel pressure is due to a faulty fuel pressure regulator.
21. A lean condition may result from fuel pressure below 333 kpa (48 psi). A lean condition may cause a DTC P0131 or a DTC P0171 to set. Driveability conditions associated with lean conditions can include hard starting (when the engine is cold), hesitation, poor driveability, lack of power, surging, and misfiring.
22. Restricting the fuel return line causes the fuel pressure to rise above the regulated fuel pressure. Command the fuel pump "ON" with the Tech 2. The fuel pressure should rise above 376 kpa (55 psi) as the fuel return line becomes partially closed.

NOTE: Do not allow the fuel pressure to exceed 414 kpa (60 psi). Fuel pressure in excess of 414 kpa (60 psi) may damage the fuel pressure regulator.

**CAUTION:** To reduce the risk of fire and personal injury:

- It is necessary to relieve fuel system pressure before connecting a fuel pressure gauge. Refer to **Fuel Pressure Relief Procedure**, below.
- A small amount of fuel may be released when disconnecting the fuel lines. Cover fuel line fittings with a shop towel before disconnecting, to catch any fuel that may leak out. Place the towel in an approved container when the procedure is completed.

### Fuel Pressure Relief Procedure

1. Remove the fuel cap.
2. Remove the fuel pump relay from the underhood relay center.
3. Start the engine and allow it to stall.
4. Crank the engine for an additional 3 seconds.

### Fuel Gauge Installation

1. Remove the shoulder fitting cap.
2. Install fuel gauge J 34730-1 to the fuel feed line located in front of and above the right side valve train cover.
3. Reinstall the fuel pump relay.

## Fuel System Diagnosis

Step	Action	Value(s)	Yes	No
1	Was the "On-Board Diagnostic (OBD) System Check" performed?	—	Go to Step 2	Go to <i>OBD System Check</i>
2	1. Turn the ignition "OFF." 2. Turn the air conditioning system "OFF." 3. Relieve fuel system pressure and install the fuel pressure gauge. 4. Turn the ignition "ON." NOTE: The fuel pump will run for approximately 2 seconds. Use the Tech 2 to command the fuel pump "ON". (Refer to the Miscellaneous Test.) 5. Observe the fuel pressure indicated by the fuel pressure gauge with the fuel pump running. Is the fuel pressure within the specified limits?	290-376 kpa (42-55 psi)	Go to Step 3	Go to Step 17
3	NOTE: The fuel pressure will drop when the fuel pump stops running, then it should stabilize and remain constant. Does the fuel pressure indicated by the fuel pressure gauge remain constant?	—	Go to Step 4	Go to Step 12
4	1. When the vehicle is at normal operation temperature, turn the ignition "ON" to build fuel pressure and observe the measurement on the gauge. 2. Start the engine and observe the fuel pressure gauge. Did the reading drop by the amount specified after the engine was started?	21-105 kpa (3-15 psi)	Go to Step 5	Go to Step 9
5	Is fuel pressure dropping off during acceleration, cruise, or hard cornering?	—	Go to Step 6	Check for improper fuel
6	Visually and physically inspect the following items for a restriction: <input type="radio"/> The in-pipe fuel filter. <input type="radio"/> The fuel feed line. Was a restriction found?	—	Verify repair	Go to Step 7
7	Remove the fuel tank and visually and physically inspect the following items: <input type="radio"/> The fuel pump strainer for a restriction. <input type="radio"/> The fuel line for a leak. <input type="radio"/> Verify that the correct fuel pump is in the vehicle. Was a problem found in any of these areas?	—	Verify repair	Go to Step 8
8	Replace the fuel pump. Is the action complete?	—	Verify repair	—
9	1. Disconnect the vacuum hose from the fuel pressure regulator. 2. With the engine idling, apply 12-14 inches of vacuum to the fuel pressure regulator. Does the fuel pressure indicated by the fuel pressure gauge drop by the amount specified?	21-105 kpa (3-15 psi)	Go to Step 10	Go to Step 11



### Fuel System Diagnosis (Cont'd)

Step	Action	Value(s)	Yes	No
10	Locate and repair the loss of vacuum to the fuel pressure regulator. Is the action complete?	—	Verify repair	—
11	Replace the fuel pressure regulator. Is the action complete?	—	Verify repair	—
12	1. Run the fuel pump with the Tech 2. 2. After pressure has built up, turn off the pump and clamp the supply hose shut with suitable locking pliers which will not damage the hose. Does the fuel pressure indicated by the fuel pressure gauge remain constant?	—	Go to <i>Step 13</i>	Go to <i>Step 15</i>
13	Visually inspect the fuel supply line and repair any leaks. Was a problem found?	—	Verify repair	Go to <i>Step 14</i>
14	Remove the fuel tank and inspect for leaky hose or in-tank fuel line. Was a problem found?	—	Verify repair	Go to <i>Step 8</i>
15	1. If the pliers are still clamped to the fuel supply hose, remove the locking pliers. 2. With suitable locking pliers, which will not damage the hose, clamp the fuel return line to prevent fuel from returning to the fuel tank. 3. Run the fuel pump with the Tech 2. 4. After pressure has built up, remove power to the pump. Does the fuel pressure indicated by the fuel pressure gauge remain constant?	—	Go to <i>Step 11</i>	Go to <i>Step 16</i>
16	Locate and replace any leaking fuel injector(s). Is the action complete?	—	Verify repair	—
17	Is the fuel pressure indicated by the fuel pressure gauge above the specified limit?	376 kpa (55 psi)	Go to <i>Step 18</i>	Go to <i>Step 21</i>
18	1. Relieve the fuel pressure. Refer to the <i>Fuel Pressure Relief</i> . 2. Disconnect the fuel return line from the fuel rail. 3. Attach a length of flexible hose to the fuel rail return outlet passage. 4. Place the open end of the flexible hose into an approved gasoline container. 5. Run the fuel pump with the Tech 2. 6. Observe the fuel pressure indicated by the fuel pressure gauge with the fuel pump running. Is the fuel pressure within the specified limits?	290-376 kpa (42-55 psi)	Go to <i>Step 19</i>	Go to <i>Step 20</i>
19	Locate and correct the restriction in the fuel return line. Is the action complete?	—	Verify repair	—
20	Visually and physically inspect the fuel rail outlet passages for a restriction. Was a restriction found?	—	Verify repair	Go to <i>Step 11</i>

### Fuel System Diagnosis (Cont'd)

Step	Action	Value(s)	Yes	No
21	Is the fuel pressure indicated by the fuel pressure gauge above the specified value?	0 kpa (0 psi)	Go to <i>Step 22</i>	Go to <i>Step 23</i>
22	<p>1. Command the fuel pump "ON" with the Tech 2.</p> <p>2. Using suitable pliers which will not damage the fuel hose, gradually apply pressure with the pliers to pinch the flexible fuel return hose closed.</p> <p><b>CAUTION: Do not let the fuel pressure exceed the second specified value.</b></p> <p>Does the fuel pressure indicated by the fuel pressure gauge rise above the first specified value?</p>	<p>376 kpa (55 psi)</p> <p>414 kpa (60 psi)</p>	Go to <i>Step 11</i>	Go to <i>Step 7</i>
23	<p>1. Command the fuel pump "ON" with the Tech 2.</p> <p>2. Remove the fuel filler cap and listen for the sound of the fuel pump running.</p> <p>3. Turn the pump off.</p> <p>Was the fuel pump running?</p>	—	Go to <i>Step 7</i>	Go to <i>Fuel System Electrical Test Chart</i>

## Idle Air Control (IAC) System Check

### Circuit Description

The powertrain control module (PCM) controls engine idle speed with the idle air control (IAC) valve. To increase idle speed, the PCM retracts the IAC valve pintle away from its seat, allowing more air to bypass the throttle bore. To decrease idle speed, it extends the IAC valve pintle towards its seat, reducing bypass air flow. A Tech 2 will read the PCM commands to the IAC valve in counts. Higher counts indicate more air bypass (higher idle). Lower counts indicate less air is allowed to bypass (lower idle).

### Diagnostic Aids

A slow, unstable, or fast idle may be caused by a non-IAC system problem that cannot be overcome by the IAC valve. Out of control range IAC Tech 2 counts will be above 60 if idle is too low, and zero counts if idle is too high. The following checks should be made to repair a non-IAC system problem:

- Vacuum leak (high idle) – If idle is too high, stop the engine. Fully extend (low) IAC with the IAC motor analyzer J 37027-A. Start the engine. If idle speed is above 800 RPM, locate and correct the vacuum leak, including the PCV system. Check for binding of the throttle blade or linkage.
- Lean heated oxygen sensor signal (high air/fuel ratio) – The idle speed may be too high or too low. Engine speed may vary up and down, and disconnecting the IAC valve does not help. Diagnostic trouble codes P0131, P0151, P0171, or P0174 may be set. Tech 2 oxygen (O<sub>2</sub>) voltage will be less than 100 mV (0.1 V). Check for low regulated fuel pressure, water in fuel, or a restricted injector.
- Rich heated oxygen sensor signal (low air/fuel ratio) – The idle speed will be too low. Tech 2 IAC counts will usually be above 80. The system is obviously rich and may exhibit black smoke in the exhaust. Tech 2 O<sub>2</sub> voltage will be fixed at about 750 mV (0.75 V). Check for high fuel pressure, or a leaking or sticking injector. A silicon-contaminated heated oxygen sensor will show an O<sub>2</sub> voltage slow to respond on the Tech 2.

- Throttle body – Remove the IAC valve and inspect the bore for foreign material.
- IAC valve electrical connections – IAC valve connections should be carefully checked for proper contact.
- PCV valve – An incorrect or faulty PCV valve may result in an incorrect idle speed. Refer to *Diagnosis, Rough Idle, Stalling*. If intermittent poor driveability or idle symptoms are resolved by disconnecting the IAC, carefully recheck the connections and valve terminal resistance, or replace the IAC.

### Test Description

Number(s) below refer to the step number(s) on the Diagnostic Chart.

1. The IAC motor analyzer J 37027-A is used to extend and retract the IAC valve. Valve movement is verified by an engine speed change. If no change in engine speed occurs, the valve can be resettled when removed from the throttle body.
2. This step checks the quality of the IAC movement in step 1. Between 700 revolutions per minute (RPM) and about 1500 RPM, the engine speed should change smoothly with each flash of the tester light in both extend and retract. If the IAC valve is retracted beyond the control range (about 1500 RPM), it may take many flashes to extend the IAC valve before engine speed will begin to drop. This is normal on certain engines. Fully extending the IAC may cause engine stall. This may be normal.
6. Steps 1 and 2 verified the proper IAC valve operation. This step checks the IAC circuits. Each lamp on the noid light should flash red and green while the IAC valve is cycled. While the sequence of color is not important, if either light is "OFF" or does not flash red and green, check the circuits for faults, beginning with poor terminal contacts.

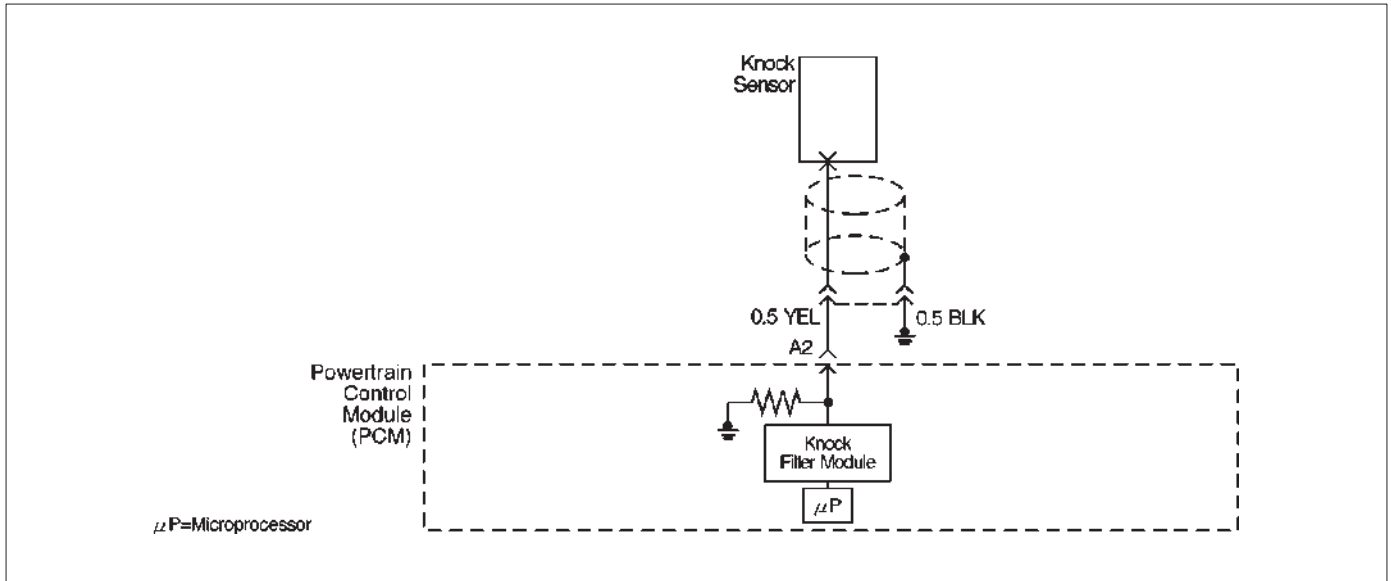
### Idle Air Control (IAC) System Check

Step	Action	Value(s)	Yes	No
1	1. Ignition "OFF." 2. Connect the IAC motor analyzer J37027-A to the IAC valve. 3. Set the parking brake. 4. Block the wheels. 5. Turn the air conditioning "OFF." 6. Idle the engine in Park. 7. Install the Tech 2. Display the RPM. 8. Use the IAC motor analyzer J37027-A to extend and retract the IAC valve. 9. The engine speed should decrease and increase as the IAC is cycled. Does the RPM change?	—	Go to <i>Step 2</i>	Go to <i>Step 3</i>
2	RPM should change smoothly with each flash of the IAC motor analyzer J 37027-A light. Does the RPM change within the range specified?	700-1500 RPM	Go to <i>Step 6</i>	Go to <i>Step 3</i>
3	Check the IAC passages. Are the IAC passages OK?	—	Go to <i>Step 4</i>	Go to <i>Step 5</i>
4	Clear any obstruction from the IAC passages. Is the action complete?	—	Verify repair	—
5	Replace the IAC. Refer to <i>On-Vehicle Service, Idle Air Control Valve</i> . Is the action complete?	—	Verify repair	—
6	1. Install the appropriate IAC node light from motor analyzer J 37027-A into the powertrain control module harness. 2. Cycle the IAC motor analyzer J 37027-A and observe the noid lights. 3. Both the lights should cycle red and green, but never "OFF," as the RPM is changed over its range. Do the lights cycle red and green?	—	Go to <i>Step 7</i>	Go to <i>Step 8</i>
7	1. Use the other connector on the IAC motor analyzer J 37027-A pigtail. 2. Check the resistance across the IAC coils. Measure the resistance between terminal A and terminal B. 3. Measure the resistance between terminal C and terminal D. Is the resistance within the specified range?	40-80 ohms	Go to <i>Step 9</i>	Go to <i>Step 10</i>
8	If the circuits did not test green and red, check the following: <ul style="list-style-type: none"> <li><input type="radio"/> Faulty connector terminal contacts</li> <li><input type="radio"/> Open circuits, including connections</li> <li><input type="radio"/> Circuits shorted to ground or voltage</li> <li><input type="radio"/> Faulty powertrain control module connection or powertrain control module.</li> </ul> Are repairs necessary?	—	Go to <i>Step 13</i>	—

### Idle Air Control (IAC) System Check (Cont'd)

Step	Action	Value(s)	Yes	No
9	1. Check the resistance between the IAC terminal B and terminal C. 2. Check the resistance between the IAC terminal A and terminal D. Is the resistance infinite?	—	Go to <i>Step 11</i>	Go to <i>Step 12</i>
10	Replace the IAC. Refer to <i>On-Vehicle Service, Idle Air Control Valve</i> . Is the action complete?	—	Go to <i>Step 7</i>	—
11	Check the IAC valve and circuit. Are the IAC valve and circuit OK?	—	Refer to <i>Diagnostic Aids</i>	Go to <i>Step 12</i>
12	Replace the IAC. Refer to <i>On-Vehicle Service, Idle Air Control Valve</i> . Is the action Complete?	—	Go to <i>Step 9</i>	—
13	Repair as necessary. Is the action complete?	—	Go to <i>Step 6</i>	—

## Knock Sensor (KS) System Check (Engine Knock, Poor Performance, or Poor Economy)



### Circuit Description

The knock sensor (KS) sends an AC voltage signal to the powertrain control module (PCM). As the KS detects engine knock, the signal to the PCM changes in amplitude and frequency. The PCM retards timing if the engine speed is over 900 RPM.

### Diagnostic Aids

If the KS system checks OK, but detonation is the complaint, refer to *Diagnosis, Detonation/Spark Knock*.

### Test Description

The numbers below refer to the step numbers on the Diagnostic Chart.

7. The change in signal speed depends on how hard the tapping is done. Normally there is about 1.5 to 10 mV at PCM pin A2 with the engine off. Loud tapping should be able to make the reading jump to 20-25 mV AC.

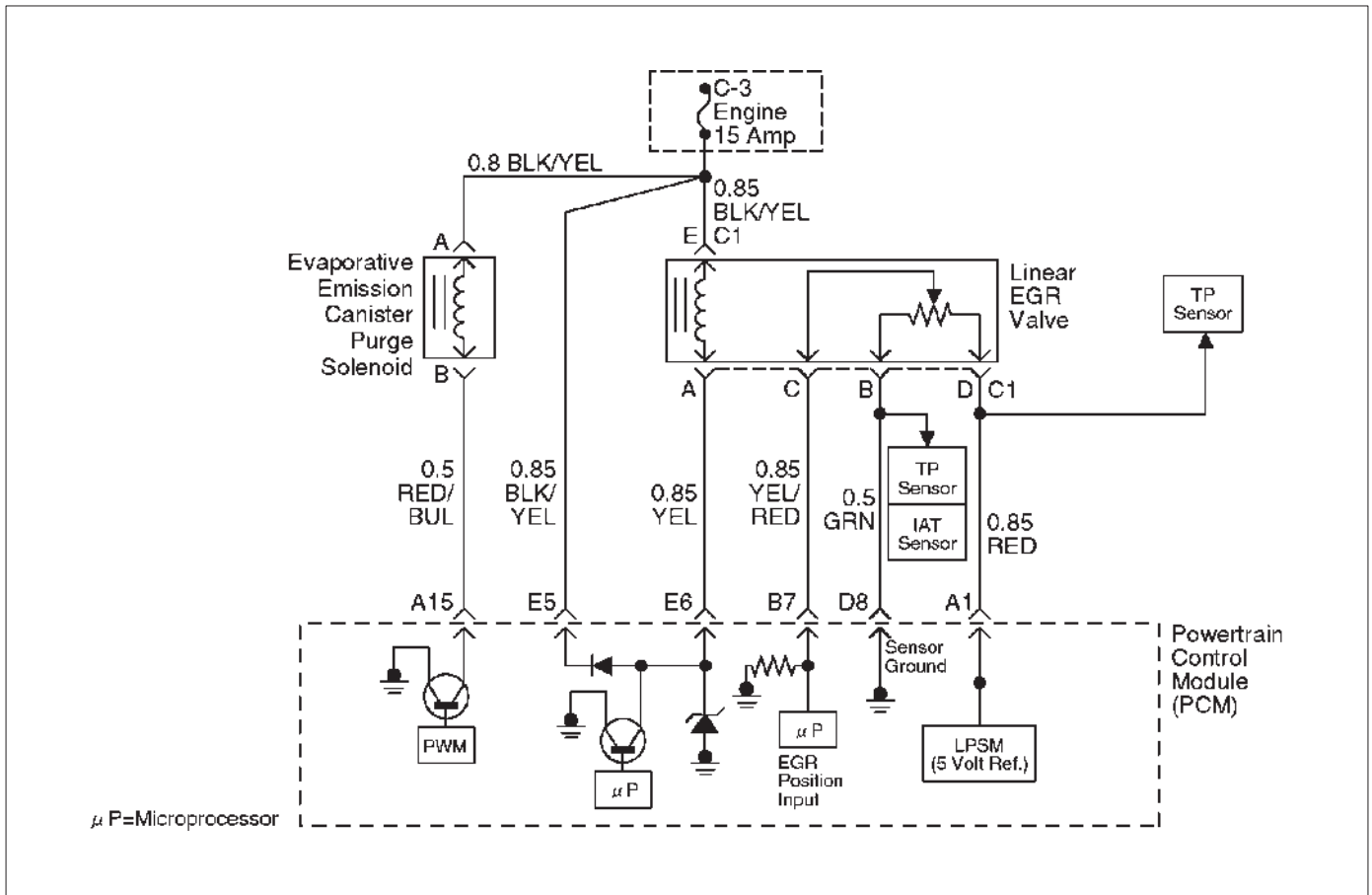
## Knock Sensor (KS) System Check (Engine Knock, Poor Performance, or Poor Economy)

Step	Action	Value(s)	Yes	No
1	Is DTC P0325 or P0327 set?	—	Go to <i>DTC P0325 or DTC P0327</i>	Go to <i>Step 2</i>
2	1. Install the Tech 2. 2. Turn the ignition "ON." 3. On the Tech 2 select F1: Data List, F2: Misfire. 4. Cycle through the list until "Knock Retard" is displayed.  Is knock retard at the specified value?	0°	Go to <i>Step 4</i>	Go to <i>Step 5</i>
3	Replace the PCM.  <b>IMPORTANT:</b> The replacement PCM must be programmed. Refer to <i>On-Vehicle Service in Powertrain Control Module and Sensors</i> for procedures.  And also refer to latest Service Bulletin.  Check to see if the Latest software is released or not. And then Down Load the LATEST PROGRAMMED SOFTWARE to the replacement PCM.  Is the action complete?	—	Verify repair	—

### Knock Sensor (KS) System Check (Engine Knock, Poor Performance, or Poor Economy) (Cont'd)

Step	Action	Value(s)	Yes	No
4	1. Start the engine. 2. Monitor the knock retard display on the Tech 2 while changing the throttle setting to place different loads on the engine.  Is knock retard at the specified value? (Turn the ignition "OFF.")	0°	Go to <i>Step 7</i>	Go to <i>Step 5</i>
5	1. At the rear of the engine, behind the rear fuel injector on the side, disconnect the 2-wire knock sensor harness connector.  NOTE: The connector for the knock sensor can not easily be removed unless common chamber is removed. (Knock Sensor is on Right side of block). Also, there are two(2) shield grounded wires.  The connector only has one wire (Yellow). Please use an other method.  2. Attach the positive lead of DVM to B+. 3. On the main harness side of the connector, use the negative lead of the DVM to probe the connector pin that is connected to the black wire.  Does the DVM indicate the specified value? (Reconnect the knock sensor harness.)	B+	Go to <i>Step 7</i>	Go to <i>Step 6</i>
6	Repair the open black wire ground for the shield which prevents stray electromagnetic pulses from affecting the knock signal.  Is the action complete?	—	Verify repair	—
7	1. Reconnect the wire harness. 2. Set a DVM to AC voltage. 3. With the DVM, backprobe the PCM connector at A2. 4. Tap the engine lift bracket with a socket extension.  Did the DVM show an increase in AC voltage while tapping on the lift bracket?	—	System OK	Go to <i>Step 8</i>
8	Replace the knock sensor.  Is the action complete?	—	Verify repair	—

## Exhaust Gas Recirculation (EGR) System Check



D06RX075

### Circuit Description

A properly operation exhaust gas recirculation (EGR) system will directly affect the air/fuel requirements of the engine. Since the exhaust gas introduced into the air/fuel mixture is an inert gas (contains very little or no oxygen), less fuel is required to maintain a correct air/fuel ratio. Introducing exhaust gas into the combustion chamber lowers combustion temperatures and reduces the formation of oxides of nitrogen (NO<sub>x</sub>) in the exhaust gas. Lower combustion temperatures also prevent detonation. If the EGR pintle were to stay closed, the inert exhaust gas would be replaced with air and the air/fuel mixture would be leaner. The powertrain control module (PCM) would compensate for the lean condition by adding fuel, resulting in higher long term fuel trim values.

### Diagnostic Aids

The EGR valve chart is a check of the EGR system. An EGR pintle constantly in the closed position could cause detonation and high emissions of NO<sub>x</sub>. It could also result in high long term fuel trim values in the open throttle cell, but not in the closed throttle cell. An EGR pintle constantly in the open position would cause a rough idle. Also, an EGR mounted incorrectly (rotated 180°) could cause rough idle. Check for the following items:

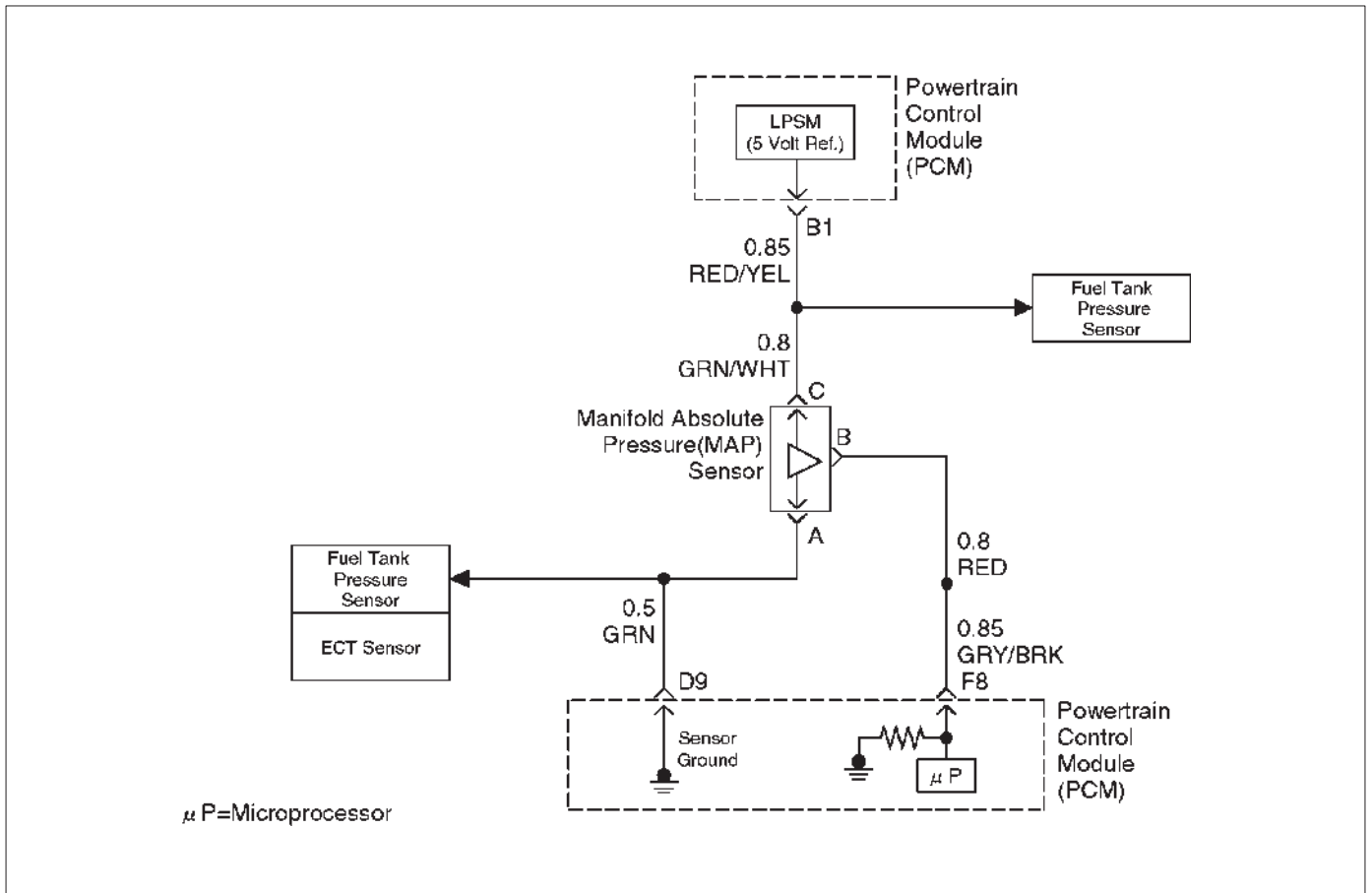
- EGR passages – Check for restricted or blocked EGR passages.
- Manifold absolute pressure sensor – A manifold absolute pressure sensor may shift in calibration enough to affect fuel delivery. Refer to *Manifold Absolute Pressure Output Check*.



### Exhaust Gas Recirculation (EGR) System Check

Step	Action	Value(s)	Yes	No
1	Check the EGR valve for looseness. Is the EGR valve Loose?	—	Go to <i>Step 2</i>	Go to <i>Step 3</i>
2	Tighten the EGR valve. Is the action complete?	—	Verify repair	—
3	1. Place the transmission selector in Park or Neutral. 2. Start the engine and idle until warm. 3. Using a Tech 2, command EGR "50% ON." (Refer to the Miscellaneous Test.) Does the engine idle rough and lose RPMs?	—	EGR system working properly. No problem found.	Go to <i>Step 4</i>
4	1. Engine "OFF." 2. Ignition "ON." 3. Using a test light to ground, check the EGR harness between the EGR valve and the ignition feed. Does the test light illuminate?	—	Go to <i>Step 6</i>	Go to <i>Step 5</i>
5	Repair the EGR harness ignition feed. Was the problem corrected?	—	Verify repair	Go to <i>Step 6</i>
6	1. Remove the EGR valve. 2. Visually and physically inspect the EGR valve pintle, valve passages and adapter for excessive deposits, obstructions or any restrictions. Does the EGR valve have excessive deposits, obstructions or any restrictions?	—	Go to <i>Step 7</i>	Go to <i>Step 8</i>
7	Clean or replace EGR system components as necessary. Was the problem corrected?	—	Verify repair	Go to <i>Step 8</i>
8	1. Ground the EGR valve metal case to battery (-). 2. Using a Tech 2, command EGR "ON" and observe the EGR valve pintle for movement. Does the EGR valve pintle move according to command?	—	Go to <i>Step 9</i>	Go to <i>DTC P1404 chart</i>
9	1. Remove the EGR inlet and outlet pipes from the intake and exhaust manifolds. 2. Visually and physically inspect manifold EGR ports and EGR inlet and outlet pipes for blockage or restriction caused by excessive deposits or other damage. Do the manifold EGR ports or inlet and outlet pipes have excessive deposits, obstructions, or any restrictions?	—	Go to <i>Step 10</i>	EGR system working properly. No problem found.
10	Clean or replace EGR system components as necessary. Is the action complete?	—	Verify repair	—

## Manifold Absolute Pressure (MAP) Output Check



D06RX076

### Circuit Description

The manifold absolute pressure (MAP) sensor measures the changes in the intake MAP which result from engine load (intake manifold vacuum) and engine speed changes; and converts these into a voltage output. The powertrain control module (PCM) sends a 5-volt reference voltage to the MAP sensor. As the MAP changes, the output voltage of the sensor also changes. By monitoring the the sensor output voltage, the PCM knows the MAP. A lower pressure (low voltage) output voltage will be about 1-2 volts at idle. Higher pressure (high voltage) output voltage will be about 4-4.8 volts at wide open throttle. The MAP sensor is also used, under certain conditions, to measure barometric pressure, allowing the PCM to make adjustments for different altitudes. The PCM uses the MAP sensor to diagnose proper operation of the EGR system, in addition to other functions.

### Test Description

**IMPORTANT:** Be sure to use the same diagnostic test equipment for all measurements.

The number(s) below refer to the step number(s) on the Diagnostic Chart.

2. Applying 34 kpa (10 Hg) vacuum to the MAP sensor should cause the voltage to be 1.5-2.1 volts less than the voltage at step 1. Upon applying vacuum to the sensor, the change in voltage should be instantaneous. A slow voltage change indicates a faulty sensor.
3. Check the vacuum hose to the sensor for leaking or restriction. Be sure that no other vacuum devices are connected to the MAP hose.

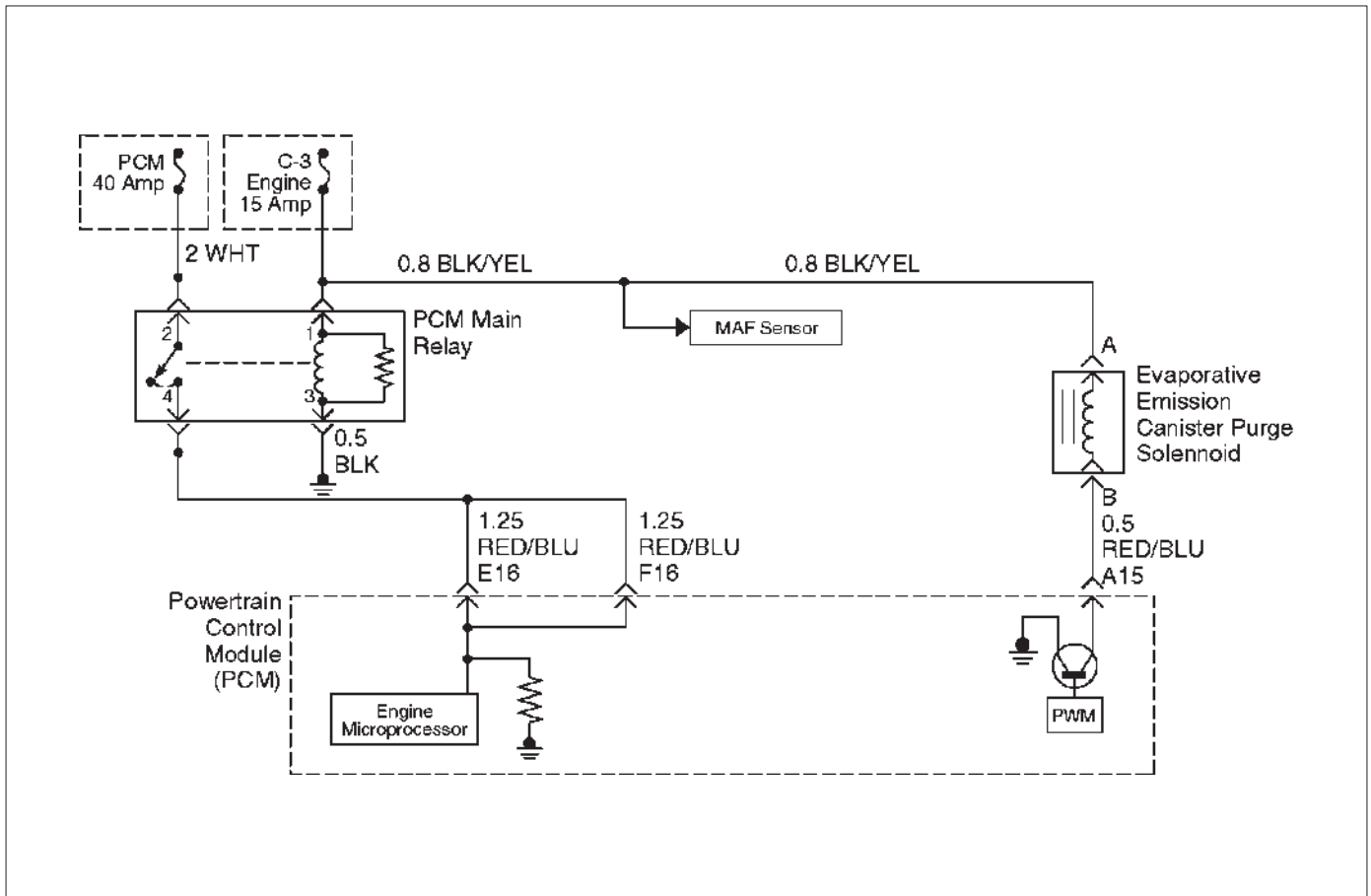
**IMPORTANT:** Make sure the electrical connector remains securely fastened.

4. Disconnect the sensor from the bracket. Twist the sensor with your hand to check for an intermittent connection. Output changes greater than 0.10 volt indicate a bad sensor.

## Manifold Absolute Pressure (MAP) Output Check

Step	Action	Value(s)	Yes	No
1	1. Turn the ignition "OFF" and leave it "OFF" for 15 seconds. 2. Ignition "ON." Don't crank engine. 3. The Tech 2 should indicate a manifold absolute pressure (MAP) sensor voltage. 4. Compare this scan reading to scan reading of a known good vehicle obtained using the exact same procedure as in Steps 1-4. Is the voltage reading the same +/-0.40 volt?	—	Go to <i>Step 2</i>	Go to <i>Step 5</i>
2	1. Disconnect the vacuum hose at the MAP sensor and plug the hose. 2. Connect a hand vacuum pump to the MAP sensor. 3. Start the engine. 4. Apply 34 kpa (10 Hg) of vacuum and note the voltage change. Is the voltage change 1.5-2.1 volts less than Step 1?	—	Go to <i>Step 3</i>	Go to <i>Step 4</i>
3	Check the sensor cover for leakage or restriction. Does the hose supply vacuum to the MAP sensor only?	—	Go to <i>Step 5</i>	Go to <i>Step 4</i>
4	Repair the material to block. Is the action complete?	—	Verify repair	—
5	Check the sensor connection. Is the sensor connection good?	—	Go to <i>Step 6</i>	Go to <i>Step 7</i>
6	Refer to <i>On-Vehicle Service, MAP Sensor</i> . Is the action complete?	—	Verify repair	—
7	Repair the poor connection. Is the action complete?	—	Verify repair	—

## Evaporative (EVAP) Emissions Canister Purge Valve Check



D06RX153

### Circuit Description

Canister purge is controlled by a solenoid valve that allows manifold vacuum to purge the canister. The powertrain control module (PCM) supplies a ground to energize the solenoid valve (purge "ON"). The EVAP purge solenoid control is turned "ON" and "OFF" several times a second. The duty cycle (pulse width or "ON" time) is determined by engine operating conditions including load, throttle position, coolant temperature and ambient temperature. The duty cycle is calculated by the PCM and the purge solenoid is enabled when the appropriate conditions have been met:

- The engine run time after start is more than 60 seconds.
- The engine coolant temperature is above 30°C (86°F).
- The fuel control system is operating in the closed-loop mode.

### Diagnostic Aids

- Make a visual check of vacuum hoses.
- Check the throttle body for possible cracked.
- Check the malfunction indicator lamp for a possible mechanical problem.

### Test Description

The number(s) below refer to the step number(s) on the Diagnostic Chart.

1. Check to see if the solenoid is open or closed. The solenoid is normally de-energized in this step, so it should be closed.
2. This step checks to determine if the solenoid was open due to an electrical circuit problem or a defective solenoid.
3. This should normally energize the solenoid, opening the valve and allowing the vacuum to drop (purge "ON").

## Evaporative (EVAP) Emissions Canister Purge Valve Check

Step	Action	Value(s)	Yes	No
1	1. Ignition "OFF." 2. Ignition "ON," engine "OFF." 3. At the throttle body, disconnect the hose that goes to the pump solenoid. 4. Using a hand vacuum pump with an attached vacuum gauge J 23738-A, apply vacuum (10" Hg or 34 kpa) to the solenoid. Does the solenoid hold the vacuum?	—	Go to <i>Step 3</i>	Go to <i>Step 2</i>
2	1. Disconnect the solenoid electrical connector. 2. As in Step 1, apply vacuum (10" Hg or 34 kpa) to the solenoid. Does the solenoid hold the vacuum?	—	Go to <i>Step 4</i>	Go to <i>Step 7</i>
3	1. At the throttle body, put a cap over the vacuum port where the hose was disconnected for testing. This is to prevent a vacuum leak when the engine is started. 2. Ignition "OFF." 3. Install the Tech 2. 4. Apply vacuum to the purge solenoid with the hand vacuum pump. 5. Start the engine, run at 2500 RPM. 6. Using the Tech 2, select Powertrain, 3.5-V6 6VE1, F3: Misc. Tests, F2: EVAP Purge, F0: EVAP Purge. (Refer to the Miscellaneous Test.) 7. Turn the purge solenoid "ON." Did the vacuum drop when the purge was turned on?	—	Go to <i>Step 8</i>	Go to <i>Step 9</i>
4	Check for a short to ground in the RED/BLU wire. Is there a short?	—	Go to <i>Step 5</i>	Go to <i>Step 6</i>
5	Repair the short to ground. Is the action complete?	—	Verify repair	—
6	Replace the PCM. <b>IMPORTANT:</b> The replacement PCM must be programmed. Refer to <i>On-Vehicle Service in Powertrain Control Module and Sensors for procedures</i> . And also refer to latest Service Bulletin. Check to see if the Latest software is released or not. And then Down Load the LATEST PROGRAMMED SOFTWARE to the replacement PCM. Is the action complete?	—	Verify repair	—
7	Replace the faulty purge solenoid. Refer to <i>On-Vehicle Service, EVAP Canister Purge Solenoid</i> . Is the action complete?	—	Verify repair	—

### Evaporative (EVAP) Emissions Canister Purge Valve Check (Cont'd)

Step	Action	Value(s)	Yes	No
8	1. Turn the ignition "OFF." 2. At the throttle body, install a vacuum gauge where the hose from the purge solenoid was disconnected for testing. 3. Start the engine. 4. Stabilize the engine speed at about 2500 RPM. 5. Momentarily snap the throttle open and let it return to idle.  Is there approximately 10" Hg (34 kpa) of vacuum available at the EVAP emission canister purge solenoid?	—	No problem found in the EVAP emission canister purge valve check	Refer to <i>Diagnostic Aids</i>
9	1. Disconnect the solenoid electrical connector. 2. Connect a test lamp between the harness terminals.  Does the test lamp light?	—	Go to <i>Step 7</i>	Go to <i>Step 10</i>
10	Probe terminal A and terminal B with a test lamp to ground.  Does the test lamp light on both terminals?	—	Go to <i>Step 11</i>	Go to <i>Step 12</i>
11	Repair the short to voltage in the RED/BLUE wire.  Is the action complete?	—	Verify repair	—
12	Does one of the terminals light the test lamp?	—	Go to <i>Step 13</i>	Go to <i>Step 14</i>
13	Check for an open in the RED/BLU wire between the purge solenoid and the PCM.  Was there an open circuit?	—	Go to <i>Step 15</i>	Go to <i>Step 6</i>
14	Repair the open in the BLK/YEL wire.  Is the action complete?	—	Verify repair	—
15	Repair the open in the RED/BLU wire.  Is the action complete?	—	Verify repair	—

## PCM Diagnostic Trouble Codes

The following table lists the diagnostic trouble codes supported by this vehicle application. If any DTCs not listed here are displayed by a Tech 2, the Tech 2 data may

be faulty; notify the Tech 2 manufacturer of any DTCs displayed that are not included in the following table.

### PCM Diagnostic Trouble Codes

DTC	Description	Type	Illuminate MIL
P0101	MAF System Performance	B	Yes
P0102	MAF Sensor Circuit Low Frequency	A	Yes
P0103	MAF Sensor Circuit High Frequency	A	Yes
P0106	MAP System Performance	B	Yes
P0107	MAP Sensor Circuit Low Voltage	A	Yes
P0108	MAP Sensor Circuit High Voltage	A	Yes
P0112	IAT Sensor Circuit Low Voltage	A	Yes
P0113	IAT Sensor Circuit High Voltage	A	Yes
P0117	ECT Sensor Circuit Low Voltage	A	Yes
P0118	ECT Sensor Circuit High Voltage	A	Yes
P0121	TP System Performance	A	Yes
P0122	TP Sensor Circuit Low Voltage	A	Yes
P0123	TP Sensor Circuit High Voltage	A	Yes
P0125	ECT Excessive Time to Closed Loop Fuel Control	B	Yes
P0131	HO2S Circuit Low Voltage Bank 1 Sensor 1	A	Yes
P0132	HO2S Circuit High Voltage Bank 1 Sensor 1	A	Yes
P0133	HO2S Slow Response Bank 1 Sensor 1	B	Yes
P0134	HO2S Circuit Insufficient Activity Bank 1 Sensor 1	A	Yes
P0135	HO2S Heater Circuit Bank 1 Sensor 1	B	Yes
P0137	HO2S Circuit Low Voltage Bank 1 Sensor 2	A	Yes
P0138	HO2S Circuit High Voltage Bank 1 Sensor 2	A	Yes
P0140	HO2S Circuit Insufficient Activity Bank 1 Sensor 2	A	Yes
P0141	HO2S Heater Circuit Bank 1 Sensor 2	B	Yes
P0151	HO2S Circuit Low Voltage Bank 2 Sensor 1	A	Yes
P0152	HO2S Circuit High Voltage Bank 2 Sensor 1	A	Yes
P0153	HO2S Circuit Slow Response Bank 2 Sensor 1	B	Yes
P0154	HO2S Circuit Insufficient Activity Bank 2 Sensor 1	A	Yes
P0155	HO2S Heater Circuit Bank 2 Sensor 1	B	Yes
P0157	HO2S Circuit Low Voltage Bank 2 Sensor 2	A	Yes
P0158	HO2S Circuit High Voltage Bank 2 Sensor 2	A	Yes
P0160	HO2S Circuit Insufficient Activity Bank 2 Sensor 2	A	Yes
P0161	HO2S Heater Circuit Bank 2 Sensor 2	B	Yes
P0171	Fuel Trim System Lean Bank 1	B	Yes
P0172	Fuel Trim System Rich Bank 1	B	Yes
P0174	Fuel Trim System Lean Bank 2	B	Yes
P0175	Fuel Trim System Rich Bank 2	B	Yes
P0201	Injector 1 Control Circuit	A	Yes
P0202	Injector 2 Control Circuit	A	Yes

**6VE1 3.5L ENGINE DRIVEABILITY AND EMISSIONS 6E-111**

<b>DTC</b>	<b>Description</b>	<b>Type</b>	<b>Illuminate MIL</b>
P0203	Injector 3 Control Circuit	A	Yes
P0204	Injector 4 Control Circuit	A	Yes
P0205	Injector 5 Control Circuit	A	Yes
P0206	Injector 6 Control Circuit	A	Yes
P0218	Transmission Fluid Overtemperature (Refer to 4L30-E Automatic Transmission)	D	No
P0300	Engine Misfire Detected	B	Yes
P0301	Cylinder 1 Misfire Detected	B	Yes
P0302	Cylinder 2 Misfire Detected	B	Yes
P0303	Cylinder 3 Misfire Detected	B	Yes
P0304	Cylinder 4 Misfire Detected	B	Yes
P0305	Cylinder 5 Misfire Detected	B	Yes
P0306	Cylinder 6 Misfire Detected	B	Yes
P0325	KS Module Circuit	B	No
P0327	KS Sensor Circuit	B	No
P0336	58X Reference Signal Circuit	B	Yes
P0337	CKP Sensor Circuit Low Frequency	B	Yes
P0341	CMP Sensor Circuit Performance	B	Yes
P0342	CMP Sensor Circuit Low	B	Yes
P0351	Ignition 1 Control Circuit	A	Yes
P0352	Ignition 2 Control Circuit	A	Yes
P0353	Ignition 3 Control Circuit	A	Yes
P0354	Ignition 4 Control Circuit	A	Yes
P0355	Ignition 5 Control Circuit	A	Yes
P0356	Ignition 6 Control Circuit	A	Yes
P0401	EGR Flow Insufficient	A	Yes
P0402	EGR Pintol Crank Open Error	B	Yes
P0404	EGR Open Stuck	B	Yes
P0405	EGR Low Voltage	A	Yes
P0406	EGR High Voltage	A	Yes
P0420	TWC System Low Efficiency Bank 1	A	Yes
P0430	TWC System Low Efficiency Bank 2	A	Yes
P0440	EVAP System No Flow During Purge	B	Yes
P0442	EVAP System Small Leak Detected	A	Yes
P0446	EVAP Canister Vent Blocked	A	Yes
P0452	Tank Pressure Sensor Low Voltage	D	Yes
P0453	Tank Pressure Sensor High Voltage	D	Yes
P0462	Fuel Level Sensor Circuit-Low Voltage	D	No
P0463	Fuel Level Sensor Circuit-High Voltage	D	No
P0502	VSS Circuit Low Input	B	Yes
P0506	Idle Air Control System Low RPM	B	Yes
P0507	Idle Air Control System High RPM	B	Yes
P0562	System Voltage Low	D	No



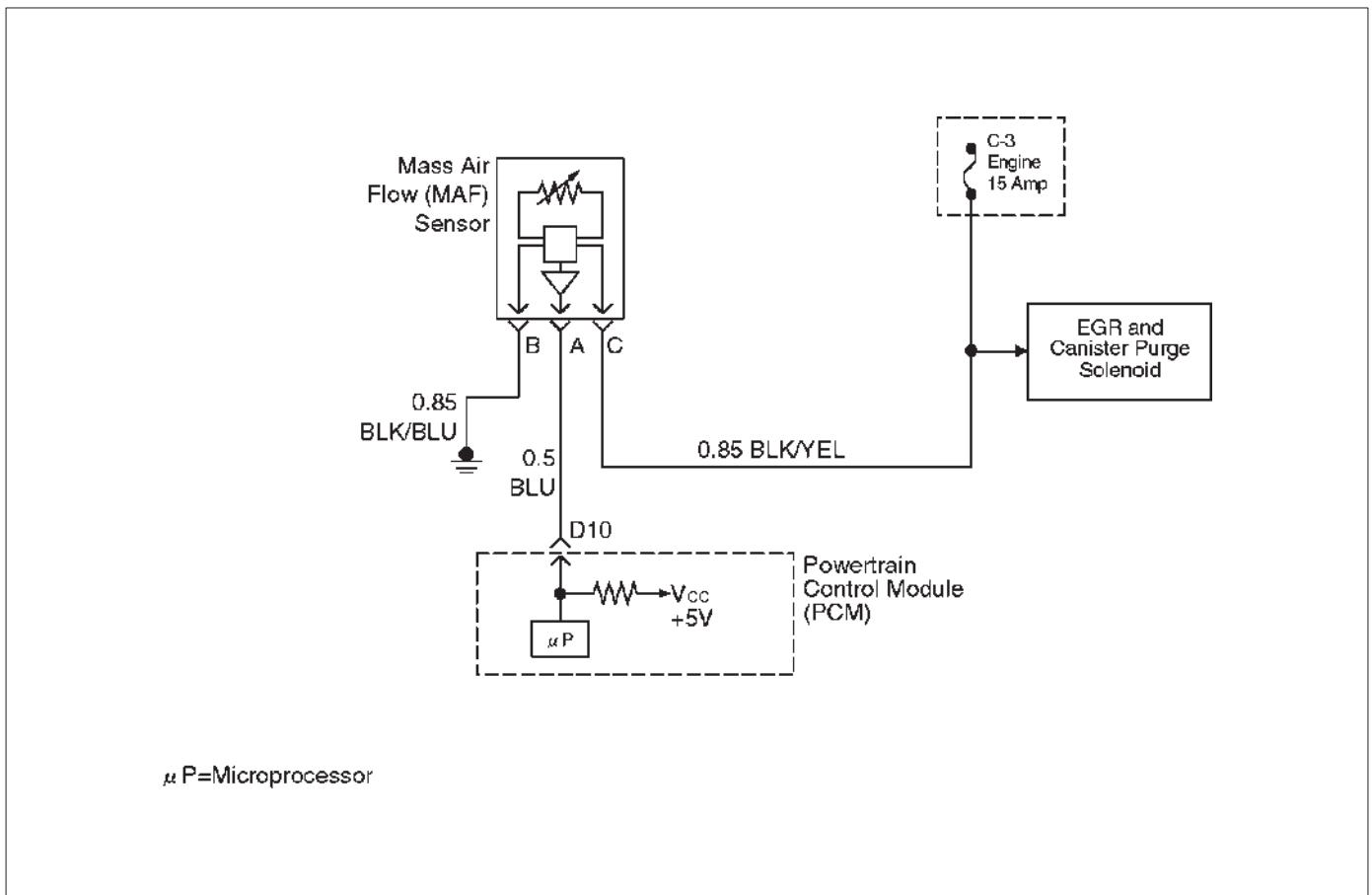
**6E-112 6VE1 3.5L ENGINE DRIVEABILITY AND EMISSIONS**

<b>DTC</b>	<b>Description</b>	<b>Type</b>	<b>Illuminate MIL</b>
P0563	System Voltage High	D	No
P0601	PCM Memory	A	Yes
P0705	Transmission Rang Switch Illegal Position (Refer to <i>4L30-E Automatic Transmission</i> )	D	No
P0706	Transmission Range Switch Performance (Refer to <i>4L30-E Automatic Transmission</i> )	D	No
P0712	Transmission Fluid Temperature (TFT) Sensor Low Voltage (Refer to <i>4L30-E Automatic Transmission Diagnosis</i> )	D	No
P0713	Transmission Fluid Temperature (TFT) Sensor High Voltage (Refer to <i>4L30-E Automatic Transmission Diagnosis</i> )	D	No
P0719	Brake Switch Circuit Low (Refer to <i>4L30-E Automatic Transmission Diagnosis</i> )	D	No
P0722	Output Shaft Sensor Circuit No Signal (Refer to <i>4L30-E Automatic Transmission</i> )	A	Yes
P0723	Output Shaft Sensor Circuit Intermittent Signal (Refer to <i>4L30-E Automatic Transmission</i> )	A	Yes
P0724	Brake Switch Circuit High (Refer to <i>4L30-E Automatic Transmission Diagnosis</i> )	D	Yes
P0730	Incorrect Gear Ratio (Refer to <i>4L30-E Automatic Transmission</i> )	C	No
P0742	Torque Converter Clutch (TCC) Circuit Stuck On (Refer to <i>4L30-E Automatic Transmission Diagnosis</i> )	A	Yes
P0748	Transmission Pressure Control Solenoid (PCS) – Electrical Circuit Fault (Refer to <i>4L30-E Automatic Transmission Diagnosis</i> )	C	No
P0751	Transmission Shift Solenoid “A” Performance	B	Yes
P0753	Transmission Shift Solenoid “A” – Electrical Circuit Fault (Refer to <i>4L30-E Automatic Transmission Diagnosis</i> )	A	Yes
P0756	Transmission Shift Solenoid “B” Performance	B	Yes
P0758	Transmission Shift Solenoid “B” – Electrical Circuit Fault (Refer to <i>4L30-E Automatic Transmission Diagnosis</i> )	A	Yes
P1106	MAP Sensor Circuit Intermittent High Voltage	D	No
P1107	MAP Sensor Circuit Intermittent Low Voltage	D	No
P1111	IAT Sensor Circuit Intermittent High Voltage	D	No
P1112	IAT Sensor Circuit Intermittent Low Voltage	D	No
P1114	ECT Sensor Circuit Intermittent Low Voltage	D	No
P1115	ECT Sensor Circuit Intermittent High Voltage	D	No
P1121	TP Sensor Circuit Intermittent High Voltage	D	No
P1122	TP Sensor Circuit Intermittent Low Voltage	D	No
P1133	HO2S Insufficient Switching Bank 1 Sensor 1	B	Yes
P1134	HO2S Transition Time Ratio Bank 1 Sensor 1	B	Yes
P1153	HO2S Insufficient Switching Bank 2 Sensor 1	B	Yes
P1154	HO2S Transition Time Ratio Bank 2 Sensor 1	B	Yes
P1171	Fuel System Lean During Acceleration	A	Yes
P1380	ABS Rough Road ABS System Fault	D	No
P1381	ABS Rough Class 2 Serial Link Error	D	Yes
P1404	EGR Close Stuck	A	Yes
P1441	EVAP System Flow During Non-Purge	B	Yes
P1508	IAC System Low RPM	B	Yes

**6VE1 3.5L ENGINE DRIVEABILITY AND EMISSIONS 6E-113**

<b>DTC</b>	<b>Description</b>	<b>Type</b>	<b>Illuminate MIL</b>
P1509	IAC System High RPM	B	Yes
P1618	Serial Peripheral Interface (SPI) PCM Interprocessor Communication Error	A	Yes
P1625	PCM Unexpected Reset	A	No
P1640	Driver-1-Input High Voltage	D	No
P1650	Quad Driver Module "A" Fault	D	No
P1790	TRANS ROM Checksum Error (Refer to <i>4L30-E Automatic Transmission Diagnosis</i> )	A	Yes
P1792	TRANS EEPROM Checksum Error (Refer to <i>4L30-E Automatic Transmission Diagnosis</i> )	A	Yes
P1835	TRANS Kick Down Switch Malfunction (Refer to <i>4L30-E Automatic Transmission Diagnosis</i> )	D	No
P1850	Brake Band Apply Solenoid Malfunction (Refer to <i>4L30-E Automatic Transmission Diagnosis</i> )	D	No
P1860	TCC PWM Solenoid Circuit Fault (Refer to <i>4L30-E Automatic Transmission Diagnosis</i> )	A	Yes
P1870	Transmission Component Slipping (Refer to <i>4L30-E Automatic Transmission Diagnosis</i> )	A	Yes

## Diagnostic Trouble Code (DTC) P0101 MAF System Performance



D06RX077

### Circuit Description

The mass air flow (MAF) sensor measures the amount of air which passes through it into the engine during a given time. The powertrain control module (PCM) uses the mass air flow information to monitor engine operating conditions for fuel delivery calculations. A large quantity of air entering the engine indicates an acceleration or high load situation, while a small quantity of air indicates deceleration or idle.

The MAF sensor produces a frequency signal which can be monitored using a Tech 2. The frequency will vary within a range of around 4 to 7g/s at idle to around 25 to 40g/s at maximum engine load. DTC P0101 will be set if the signal from the MAF sensor does not match a predicted value based on throttle position and engine RPM.

### Conditions for Setting the DTC

- The engine is running.
- No TP sensor or MAP sensor DTCs are set.
- The throttle is steady, TP angle doesn't change by more than 1%.
- System voltage is between 11.5 volts and 16 volts.
- Calculated air flow is between 25 g/second and 40 g/second.
- Above conditions present for at least 1 second.
- MAF signal frequency indicates an airflow significantly higher or lower than a predicted value based on throttle position and engine RPM for a total of 12.5 seconds over a 25-second period of time.

### Action Taken When the DTC Sets

- The PCM will illuminate the malfunction indicator lamp (MIL) after the second consecutive trip in which the fault is detected.
- The PCM calculates an airflow value based on idle air control valve position, throttle position, RPM and barometric pressure.
- The PCM will store conditions which were present when the DTC was set as Freeze Frame and in the Failure Records data.

### Conditions for Clearing the MIL/DTC

- The PCM will turn the MIL "OFF" on the third consecutive trip cycle during which the diagnostic has been run and the fault condition is no longer present.
- A history DTC P0101 will clear after 40 consecutive warm-up cycles have occurred without a fault.
- DTC P0101 can be cleared by using the Tech 2 "Clear Info" function or by disconnecting the PCM battery feed.

### Diagnostic Aids

An intermittent may be caused by the following:

- Poor connections.
- Mis-routed harness.
- Rubbed through wire insulation.
- Broken wire inside the insulation.

Refer to Intermittents under service category Symptoms. Any un-metered air may cause this DTC to set. Check for the following:

- The duct work at the MAF sensor for leaks.
- An engine vacuum leak.
- The PCV system for vacuum leaks.
- An incorrect PCV valve.
- The engine oil dip stick not fully seated.
- The engine oil fill cap loose or missing.

2. The MAF system performance or “rationality” diagnostic uses the MAP sensor signal along with other input to calculate an expected airflow rate that is then compared to the actual measured airflow from the MAF sensor. The first few steps of this table verify that the MAP sensor is working properly.

6. Verifies the signal circuit from the MAF sensor electrical connector to the PCM.

Verifies whether a ground and B+ circuit is available.

**Test Description**

Number(s) below refer to the step number(s) on the Diagnostic Chart.

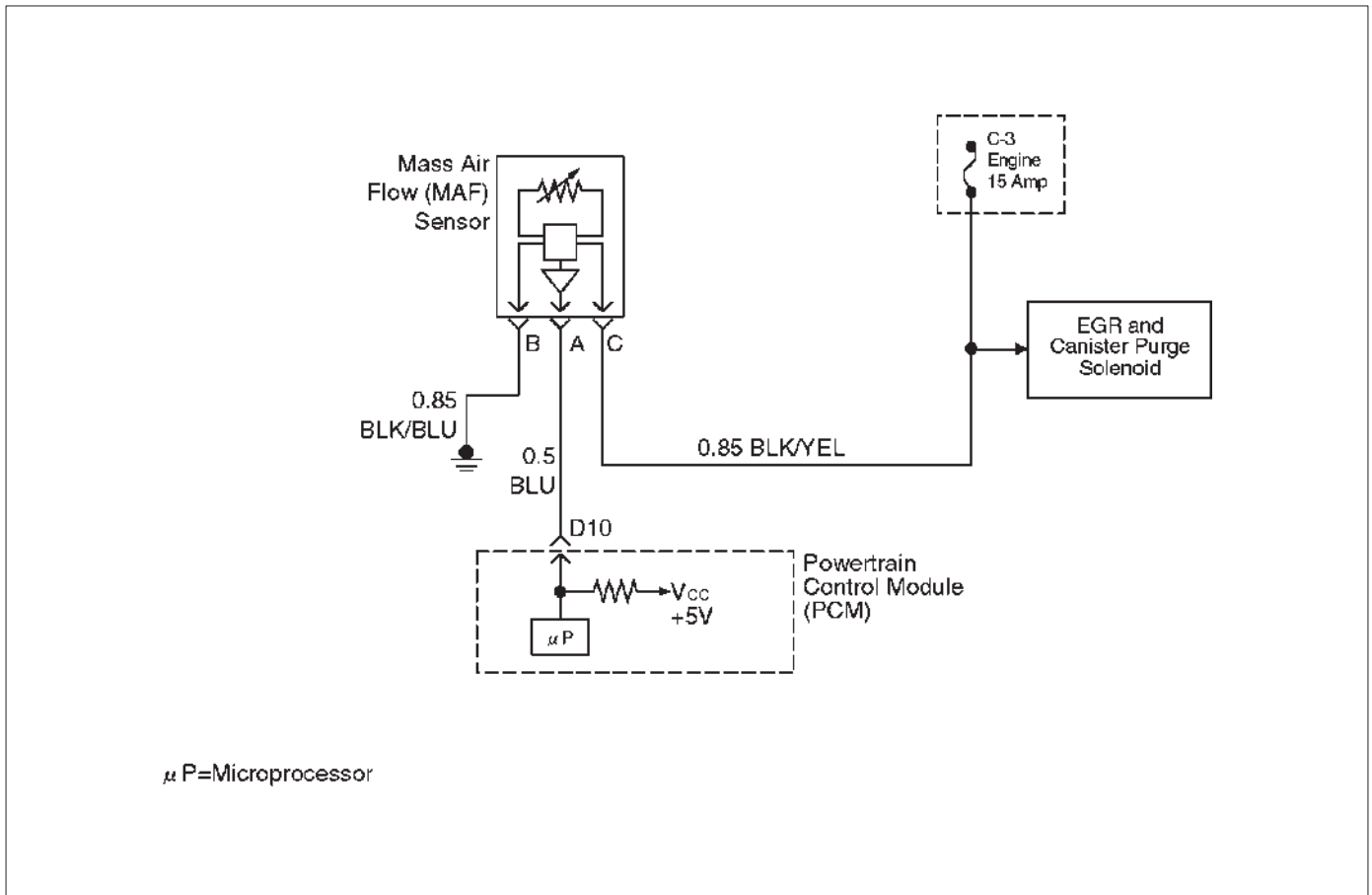
**DTC P0101 – MAF System Performance**

Step	Action	Value(s)	Yes	No
1	Was the “On-Board Diagnostic (OBD) System Check” performed?	—	Go to Step 2	Go to OBD System Check
2	1. Ignition “OFF.” 2. Disconnect the Mass Air Flow (MAF) Sensor harness connector from the MAF Sensor. 3. Place an unpowered test lamp between the 12 volt signal circuit and the ground circuit, both at the MAF Sensor connector. 4. Ignition “ON,” Engine “OFF.” Did the test lamp illuminate?	—	Go to Step 6	Go to Step 3
3	1. Ignition “ON,” Engine “OFF.” 2. Using a Digital Voltmeter (DVM), check the 12 volt signal circuit for the correct voltage. Did the DVM indicate a value within the following range?	11.5 to 12.5 Volt	Go to Step 5	Go to Step 4
4	1. Ignition “OFF.” 2. Check the 12 volt signal circuit for the following conditions: <input type="radio"/> An open circuit <input type="radio"/> A short to ground Was the problem found?	—	Verify repair	—
5	Check the MAF ground circuit for the following conditions: <input type="radio"/> An open circuit <input type="radio"/> A short to voltage Was a problem found?	—	Verify repair	—
6	1. Ignition “OFF.” 2. Check the MAF Sensor signal circuit between the PCM and the MAF Sensor for the following conditions: <input type="radio"/> An open circuit <input type="radio"/> A short to ground <input type="radio"/> A short to battery voltage Was a problem found?	—	Verify repair	Go to Step 7

## DTC P0101 – MAF System Performance (Cont'd)

Step	Action	Value(s)	Yes	No
7	1. Connect the MAF Sensor wiring harness connector to the MAF Sensor. 2. Connect the Tech 2 to the vehicle. 3. Place the Transmission in Park/Neutral, and fully apply the Parking Brake. 4. Start the engine. 5. Select the Mass Air Flow (MAF) parameter on the Tech 2. With the engine idling, does the Tech 2 display the following value(s)?	4 to 7 g/s	Go to Step 8	Go to Step 9
8	Observe the Tech 2 value while increasing the engine RPM to its upper limit. Does the Tech 2 display the following value(s)?	25 to 40 g/s	Go to Step 10	Go to Step 9
9	Replace the MAF Sensor. Is the action complete?	—	Verify repair	—
10	Replace the PCM. <b>IMPORTANT:</b> The PCM must be reprogrammed. Refer to PCM reprogramming. And also refer to latest Service Bulletin. Check to see if the Latest software is released or not. And then Down Load the LATEST PROGRAMMED SOFTWARE to the replacement PCM. Is the action complete?	—	Verify repair	—

## Diagnostic Trouble Code (DTC) P0102 MAF Sensor Circuit Low Frequency



### Circuit Description

The mass air flow (MAF) sensor measures the amount of air which passes through it into the engine during a given time. The powertrain control module (PCM) uses the mass air flow information to monitor engine operating conditions for fuel delivery calculations. A large quantity of air entering the engine indicates an acceleration or high load situation, while a small quantity of air indicates deceleration or idle.

The MAF sensor produces a frequency signal which can be monitored using a Tech 2. The frequency will vary within a range of around 4 to 7g/s at idle to around 1900 Hz at maximum engine load. DTC P0102 will be set if the signal from the MAF sensor is below the possible range of a normally operating MAF sensor.

### Conditions for Setting the DTC

- The engine is running above 500 RPM for greater than 10 seconds.
- System voltage is above 11.5 volts.
- MAF signal frequency is below 1.6g/s for a total of 50-percent of the last 1000 samples monitored. A sample is taken every cylinder event.

### Action Taken When the DTC Sets

- The PCM will illuminate the malfunction indicator lamp (MIL) the first time the fault is detected.
- The PCM calculates an air flow value based on idle air control valve position, throttle position, RPM and barometric pressure.

- The PCM will store conditions which were present when the DTC was set as Freeze Frame and in the Failure Records data.

### Conditions for Clearing the MIL/DTC

- The PCM will turn the MIL "OFF" on the third consecutive trip cycle during which the diagnostic has been run and the fault condition is no longer present.
- A history DTC P0102 will clear after 40 consecutive warm-up cycles have occurred without a fault.
- DTC P0102 can be cleared by using the Tech 2 "Clear Info" function or by disconnecting the PCM battery feed.

### Diagnostic Aids

Check for the following conditions:

- Poor connection at PCM – Inspect harness connectors for backed-out terminals, improper mating, broken locks, improperly formed or damaged terminals, and poor terminal-to-wire connection.
- Misrouted harness – Inspect the MAF sensor harness to ensure that it is not routed too close to high voltage wires.
- Damaged harness – Inspect the wiring harness for damage. If the harness appears to be OK, observe the Tech 2 while moving connectors and wiring harnesses related to the MAF sensor. A change in the display will indicate the location of the fault.
- Plugged intake air duct or filter element – A wide-open throttle acceleration from a stop should cause the mass air flow displayed on a Tech 2 to increase from

**6E-118 6VE1 3.5L ENGINE DRIVEABILITY AND EMISSIONS**

about 3-6 g/second at idle to 100 g/second or greater at the time of the 1-2 shift. If not, check for a restriction. If DTC P0102 cannot be duplicated, the information included in the Failure Records data can be useful in determining vehicle mileage since the DTC was last set.

**Test Description**

Number(s) below refer to the step number(s) on the Diagnostic Chart.

2. This step verifies that the problem is present at idle.
4. A voltage reading of less than 4 or over 5 volts at the MAF sensor signal circuit indicates a fault in the wiring or a poor connection.
5. This verifies that ignition feed voltage and a good ground are available at the MAF sensor.

**DTC P0102 – MAF Sensor Circuit Low Frequency**

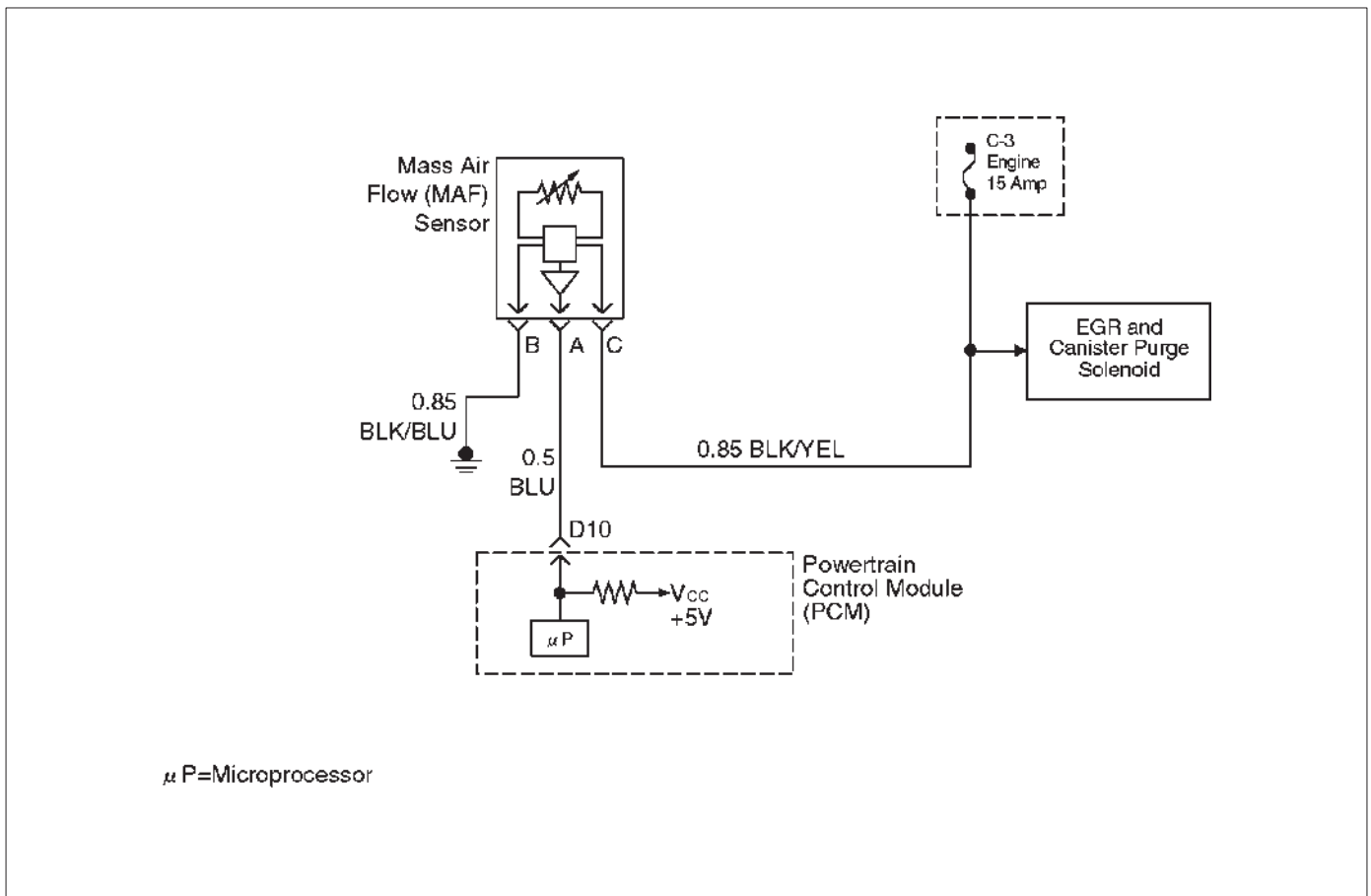
Step	Action	Value(s)	Yes	No
1	Was the "On-Board Diagnostic (OBD) System Check" performed?	—	Go to Step 2	Go to <i>OBD System Check</i>
2	1. Start the engine. 2. With the engine idling, monitor "MAF Frequency" display on the Tech 2. Is the "MAF Frequency" below the specified value?	1.6 g/s	Go to Step 4	Go to Step 5
3	1. Ignition "ON," engine "OFF." 2. Review and record Tech 2 Failure Records data. 3. Operate the vehicle within Failure Records conditions as noted. 4. Using a Tech 2, monitor "DTC" info for DTC P0102. Does the Tech 2 indicate DTC P0102 failed this ignition?	—	Go to Step 4	Refer to <i>Diagnostic Aids</i>
4	1. Ignition "OFF." 2. Disconnect the MAF sensor connector. 3. Ignition "ON," engine "OFF." 4. Using a DVM, measure voltage between the MAF sensor signal circuit and battery ground. Is the voltage near the specified value?	5 V	Go to Step 5	Go to Step 8
5	Connect a test light between the MAF sensor ignition feed and ground circuits at the MAF sensor harness connector. Is the test light "ON?"	—	Go to Step 13	Go to Step 6
6	Connect a test light between the MAF sensor ignition feed circuit and battery ground. Is the test light "ON?"	—	Go to Step 12	Go to Step 7
7	1. Check for a poor connection at the MAF sensor. 2. If a poor connection is found, replace the faulty terminal(s). Was a poor connection found?	—	Verify repair	Go to Step 11
8	1. Ignition "OFF." 2. Disconnect the MAF sensor. 3. Disconnect the PCM connector for the MAF signal circuit. 4. Ignition "ON," engine "OFF." 5. With the DVM, measure the voltage between the MAF signal terminal at the PCM and battery ground. Is the voltage under the specified value?	4 V	Go to Step 9	Go to Step 10

**DTC P0102 – MAF Sensor Circuit Low Frequency (Cont'd)**

Step	Action	Value(s)	Yes	No
9	1. Ignition "OFF." 2. Disconnect the PCM white connector. 3. Ignition "ON." 4. Check the MAF sensor signal circuit for a short to 5 volts. Is the action complete?	—	Verify repair	—
10	1. Ignition "OFF." 2. Disconnect the PCM white connector. 3. Ignition "ON." 4. Check the MAF sensor signal circuit between the PCM and the MAF sensor for an open, short to ground, or short to the MAF ground circuit. Is the action complete?	—	Verify repair	Go to Step 13
11	Locate and repair the open in the ground circuit to the MAF sensor. Is the action complete?	—	Verify repair	—
12	Locate and repair the open in the ignition feed circuit to the MAF sensor. Is the action complete?	—	Verify repair	—
13	Replace the MAF sensor. Is the action complete?	—	Verify repair	Go to Step 14
14	Replace the PCM. <b>IMPORTANT:</b> The replacement PCM must be programmed. Refer to <i>On-Vehicle Service in Powertrain Control Module and Sensors</i> for procedures. And also refer to latest Service Bulletin. Check to see if the Latest software is released or not. And then Down Load the LATEST PROGRAMMED SOFTWARE to the replacement PCM. Is the action complete?	—	Verify repair	—



## Diagnostic Trouble Code (DTC) P0103 MAF Sensor Circuit High Frequency



### Circuit Description

The mass air flow (MAF) sensor measures the amount of air which passes through it into the engine during a given time. The powertrain control module (PCM) uses the mass air flow information to monitor engine operating conditions for fuel delivery calculations. A large quantity of air entering the engine indicates an acceleration or high load situation, while a small quantity of air indicates deceleration or idle.

The MAF sensor produces a frequency signal which can be monitored using a Tech 2. The frequency will vary within a range of around 4 to 7g/s at idle to around 9000 Hz at maximum engine load. DTC P0103 will be set if the signal from the MAF sensor is above the possible range of a normally operating MAF sensor.

### Conditions for Setting the DTC

- The engine is running above 500 RPM for more than 10 seconds.
- System voltage is above 11.5 volts.
- MAF signal frequency is above 40g/s for a total of 50 percent of the last 200 samples monitored. A sample is taken every cylinder event.

### Action Taken When the DTC Sets

- The PCM will illuminate the malfunction indicator lamp (MIL) the first time the fault is detected.

- The PCM calculates an airflow value based on idle air control valve position, throttle position, RPM and barometric pressure.
- The PCM will store conditions which were present when the DTC was set as Freeze Frame and in the Failure Records data.

### Conditions for clearing the MIL/DTC

- The PCM will turn the MIL "OFF" on the third consecutive trip cycle during which the diagnostic has been run and the fault condition is no longer present.
- A history DTC P0103 will clear after 40 consecutive warm-up cycles have occurred without a fault.
- DTC P0103 can be cleared by using the Tech 2 "Clear Info" function or by disconnecting the PCM battery feed.

### Diagnostic Aids

If DTC P0103 cannot be duplicated, the information included in the Failure Records data can be useful in determining vehicle mileage since the DTC was last set.

### Test Description

Number(s) below refer to the step number(s) on the Diagnostic Chart.

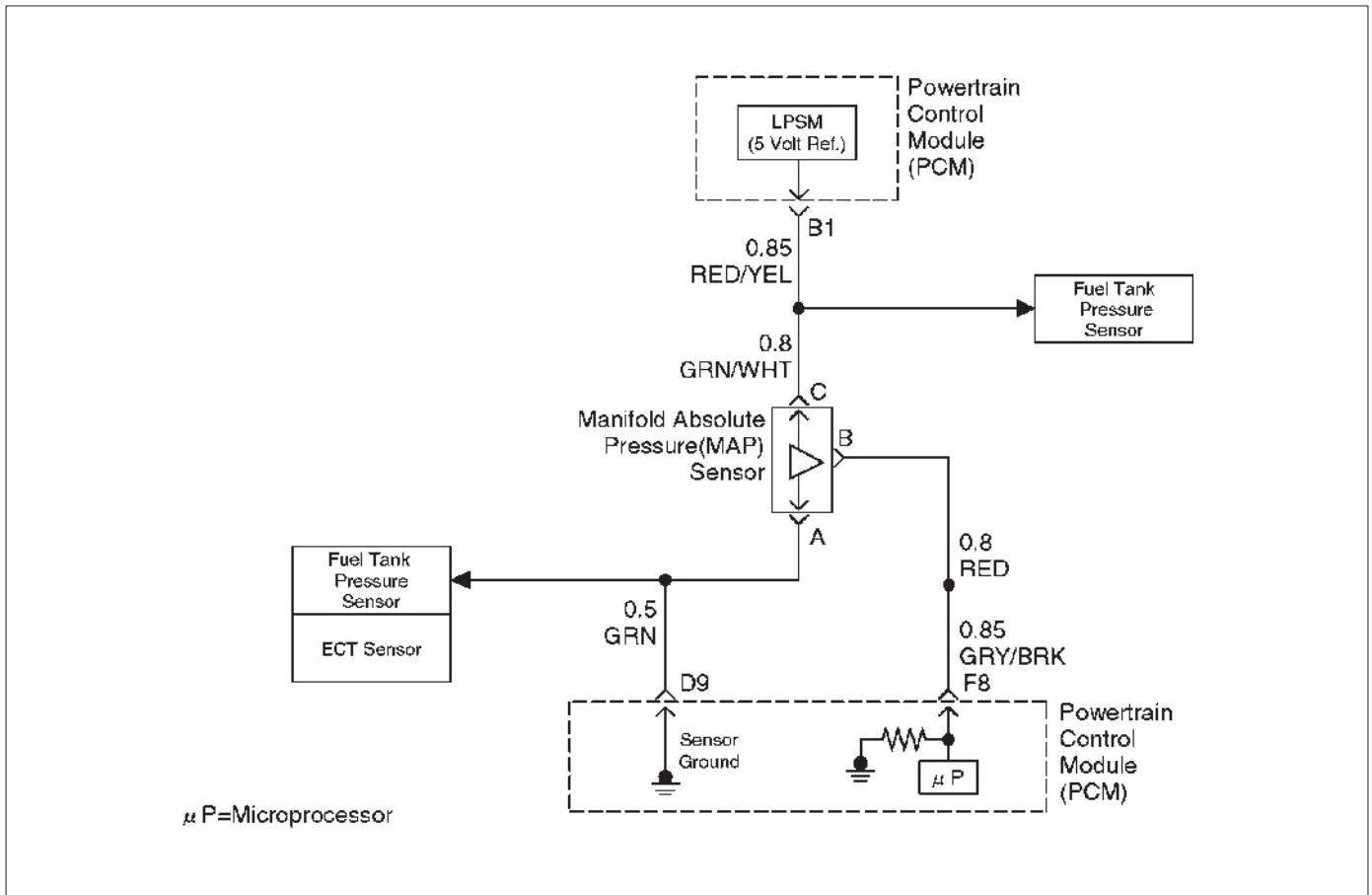
2. This step verifies that the problem is present at idle.

4. A frequency reading with the MAF sensor connector disconnected indicates an electromagnetic interference (EMI) related fault.
9. This vehicle is equipped with a PCM which utilizes an electrically erasable programmable read only memory (EEPROM). When the PCM is being replaced, the new PCM must be programmed. Refer to *PCM Replacement and Programming Procedures* in *Powertrain Control Module (PCM) and Sensor*.

### DTC P0103 – MAF Sensor Circuit High Frequency

Step	Action	Value(s)	Yes	No
1	Was the "On-Board Diagnostic (OBD) System Check" performed?	—	Go to Step 2	Go to <i>OBD System Check</i>
2	1. Ignition "ON," engine "OFF." 2. Review and record Tech 2 Failure Records data. 3. Operate the vehicle within Failure Records conditions as noted. 4. Using a Tech 2, monitor "DTC" info for DTC P0103. Does the Tech 2 indicate DTC P0103 failed this ignition?	—	Go to Step 3	Refer to <i>Diagnostic Aids</i>
3	1. Start the engine. 2. With the engine idling, monitor "MAF Frequency" display on the Tech 2. Is "MAF Frequency" above the specified value?	40g/s	Go to Step 4	Go to Step 7
4	1. Ignition "OFF." 2. Disconnect the MAF sensor connector. 3. Ignition "ON," engine idling. 4. Using a Tech 2, monitor "MAF Frequency." Does the Tech 2 indicate a "MAF Frequency" at the specified value?	0g/s	Go to Step 5	Go to Step 6
5	Replace the MAF sensor. Is the action complete?	—	Verify repair	Go to Step 8
6	1. Check the MAF harness for incorrect routing near high voltage components (solenoids, relays, motors). 2. If incorrect routing is found, correct the harness routing. Was a problem found?	—	Verify repair	Go to Step 6
7	1. With the engine idling, monitor "MAF Frequency" display on the Tech 2. 2. Quickly snap open throttle to wide open throttle while under a road load and record value. Does the Tech 2 indicate "MAF Frequency" above the specified value?	40g/s	Go to Step 5	Go to Step 8
8	Replace the PCM. <b>IMPORTANT:</b> The replacement PCM must be programmed. Refer to <i>On-Vehicle Service in Powertrain Control Module and Sensors</i> for procedures. And also refer to latest Service Bulletin. Check to see if the Latest software is released or not. And then Down Load the LATEST PROGRAMMED SOFTWARE to the replacement PCM. Is the action complete?	—	Verify repair	—

## Diagnostic Trouble Code (DTC) P0106 MAP System Performance



D06RX076

### Circuit Description

The manifold absolute pressure (MAP) sensor responds to changes in intake manifold pressure (vacuum). The MAP sensor signal voltage to the powertrain control module (PCM) varies from below 2 volts at idle (high vacuum) to above 4 volts at wide-open throttle (low vacuum) at sea level.

The MAP sensor is used to determine: manifold pressure changes while the linear exhaust gas recirculation (EGR) flow test diagnostic is being run (refer to DTC P0401), engine vacuum level for some other diagnostics, and barometric pressure (BARO). The PCM compares the MAP sensor signal to a calculated MAP based on throttle position and various engine load factor. If the PCM detects a MAP signal that varies excessively above or below the calculated value, DTC P0106 will set.

### Conditions for Setting the DTC

- No TP sensor DTCs are present.
- Engine speed is steady, changing less than 100 RPM.
- Throttle position is steady, throttle angle changes less than 1%.
- EGR flow rate is steady, changing less than 4%.
- IAC valve counts are steady, changing less than 10 counts.
- No change in brake switch, A/C clutch, TCC or power steering pressure switch status.
- Above conditions are met for longer than 1 second.
- Actual MAP value varies more than 10 kpa.

- The MAP value must vary for a total of 10 seconds over a 20-second period of time that the samples were monitored.
- The failure must occur for 2 consecutive trips.

### Action Taken When the DTC Sets

- The PCM will illuminate the malfunction indicator lamp (MIL) after the second consecutive trip in which the fault is detected.
- The PCM will default to a BARO value of 79.3 kpa.
- The PCM will store conditions which were present when the DTC was set as Freeze Frame and in the Failure Records data.

### Conditions for Clearing the MIL/DTC

- The PCM will turn the MIL "OFF" on the third consecutive trip cycle during which the diagnostic has been run and the fault condition is no longer present.
- A history DTC P0106 will clear after 40 consecutive warm-up cycles have occurred without a fault.
- DTC P0106 can be cleared by using the Tech 2 "Clear Info" function or by disconnecting the PCM battery feed.

### Diagnostic Aids

Check for the following conditions:

- Poor connection at PCM – Inspect harness connectors for backed-out terminals, improper mating, broken locks, improperly formed or damaged terminals, and poor terminal-to-wire connection.

**6E-124 6VE1 3.5L ENGINE DRIVEABILITY AND EMISSIONS**

○ Damaged harness – Inspect the wiring harness for damage. If the harness appears to be OK, observe the MAP display on the Tech 2 while moving connectors and wiring harnesses related to the sensor. A change in the display will indicate the location of the fault.

If DTC P0106 cannot be duplicated, the information included in the Failure Records data can be useful in

determining vehicle mileage since the DTC was last set. If it is determined that the DTC occurs intermittently, performing the DTC P1106 or P1107 Diagnostic Chart may isolate the cause of the fault.

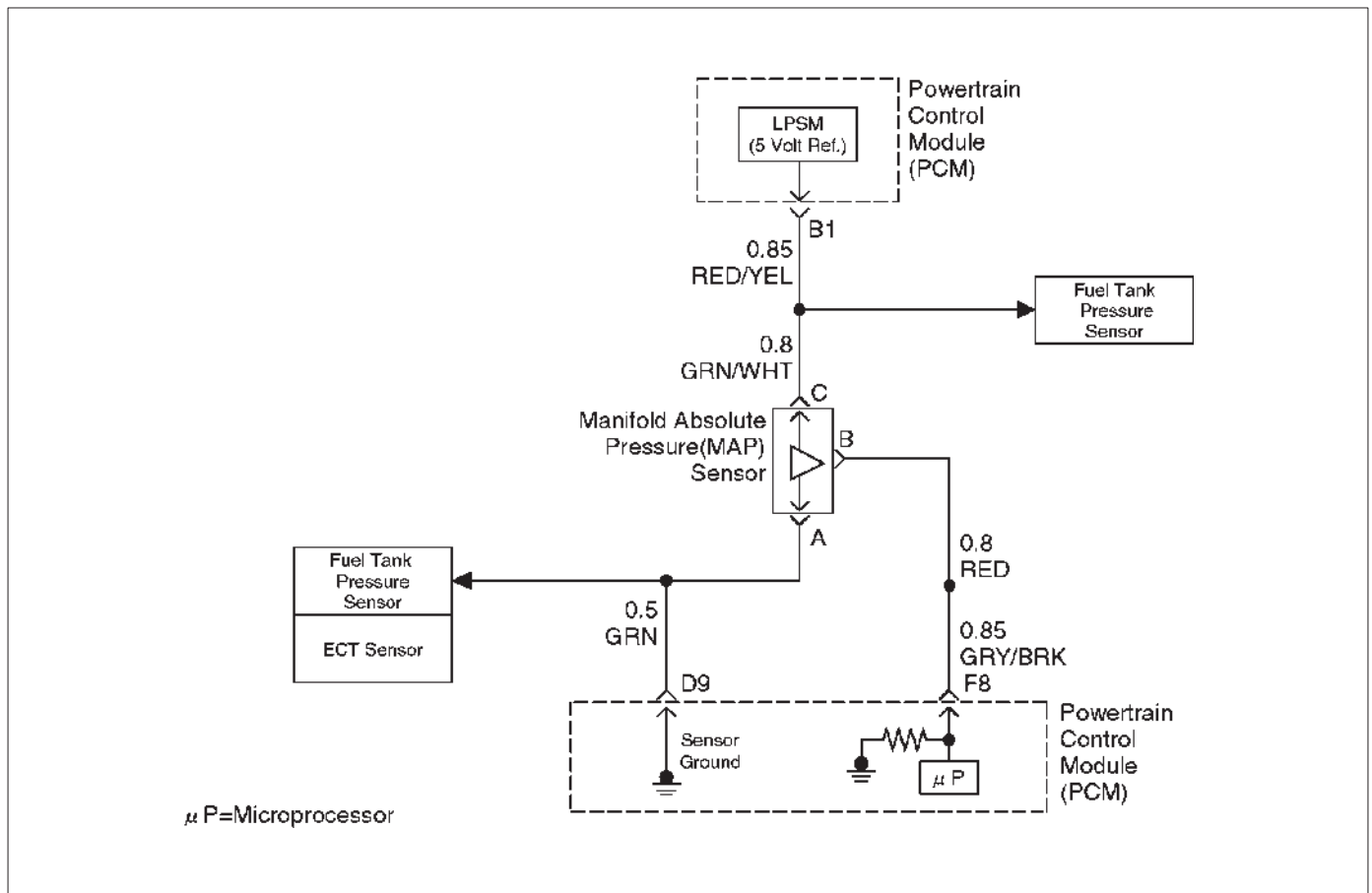
**DTC P0106 – MAP System Performance**

Step	Action	Value(s)	Yes	No
1	Was the “On-Board Diagnostic (OBD) System Check” performed?	—	Go to Step 2	Go to <i>OBD System Check</i>
2	1. Ignition “ON,” engine “OFF.” 2. Review and record Tech 2 Failure Records data. 3. Operate the vehicle within Failure Records conditions as noted. 4. Using a Tech 2, monitor “DTC” info for DTC P0106. Does the Tech 2 indicate DTC P0106 failed?	—	Go to Step 4	Go to Step 3
3	1. Check for the following conditions: ○ Vacuum hoses disconnected, damaged, or incorrectly routed; ○ Intake manifold vacuum leaks; ○ Vacuum leaks at throttle body; ○ Vacuum leaks at EGR valve flange and pipes; ○ Crankcase ventilation valve faulty, missing or incorrectly installed. 2. If a problem is found, repair as necessary. Was a problem found?	—	Verify repair	Refer to <i>Diagnostic Aids</i>
4	1. Disconnect the MAP sensor electrical connector. 2. Observe the MAP value displayed on the Tech 2. Is the MAP value near the specified value?	11 kpa	Go to Step 5	Go to Step 13
5	1. Connect a test light between B+ and the MAP sensor signal circuit at the MAP sensor harness connector. 2. Observe the MAP value displayed on the Tech 2. Is the MAP value near the specified value?	105 kpa	Go to Step 6	Go to Step 9
6	1. Jumper the 5 volt reference “A” circuit and the MAP signal circuit together at the MAP sensor harness connector. 2. Observe the MAP value displayed on the Tech 2. Is the MAP value near the specified value?	104 kpa	Go to Step 7	Go to Step 8
7	1. Ignition “OFF.” 2. Disconnect the PCM and check the sensor ground circuit for high resistance, an open between the PCM and the MAP sensor, or for a poor connection at the PCM. 3. If a problem is found, repair as necessary. Was a problem found?	—	Verify repair	Go to Step 11

**DTC P0106 – MAP System Performance (Cont'd)**

Step	Action	Value(s)	Yes	No
8	1. Check the 5 volt reference "A" circuit for high resistance, an open between the PCM and the MAP sensor, or a poor connection at the PCM. 2. If a problem is found, repair as necessary. Was a problem found?	—	Verify repair	Go to <i>Step 10</i>
9	1. Ignition "OFF." 2. Disconnect the PCM, and check the MAP sensor signal circuit for high resistance, an open, a short to ground, or a short to the sensor ground circuit. 3. If a problem is found, repair as necessary. Was a problem found?	—	Verify repair	Go to <i>Step 10</i>
10	1. Check the MAP sensor signal circuit for a poor connection at the PCM. 2. If a problem is found, repair as necessary. Did the terminal require replacement?	—	Verify repair	Go to <i>Step 14</i>
11	1. Check for a poor connection at the MAP sensor. 2. If a problem is found, repair as necessary. Was a problem found?	—	Verify repair	Go to <i>Step 12</i>
12	Replace the MAP sensor. Is the action complete?	—	Verify repair	—
13	1. Ignition "OFF," disconnected the PCM. 2. Ignition "ON," check the MAP signal circuit for a short to voltage or a short to the 5 volt reference "A" circuit. 3. If a problem is found, repair as necessary. Was a problem found?	—	Verify repair	Go to <i>Step 14</i>
14	Replace the PCM. <b>IMPORTANT:</b> The replacement PCM must be programmed. Refer to <i>On-Vehicle Service in Powertrain Control Module and Sensors</i> for procedures. And also refer to latest Service Bulletin. Check to see if the Latest software is released or not. And then Down Load the LATEST PROGRAMMED SOFTWARE to the replacement PCM. Is the action complete?	—	Verify repair	—

## Diagnostic Trouble Code (DTC) P0107 MAP Sensor Circuit Low Voltage



D06RX076

### Circuit Description

The manifold absolute pressure (MAP) sensor responds to changes in intake manifold pressure (vacuum). The MAP sensor signal voltage to the powertrain control module (PCM) varies from below 2 volts at idle (high vacuum) to above 4 volts with the ignition "ON," engine not running or at wide-open throttle (low vacuum).

The MAP sensor is used to determine manifold pressure changes while the exhaust gas recirculation (EGR) flow test diagnostic is being run (refer to *DTC P0401*), to determine engine vacuum level for some other diagnostics and to determine barometric pressure (BARO). The PCM monitors the MAP signals for voltages outside the normal range of the MAP sensor. If the PCM detects a MAP signal voltage that is excessively low, DTC P0107 will be set.

### Conditions for Setting the DTC

- No TP sensor DTCs present.
- Engine is running.
- Throttle angle is above 1% if engine speed is less than 1000 RPM.
- Throttle angle is above 2% if engine speed is above 1000 RPM.
- The MAP sensor indicates manifold absolute pressure at or below 11 kpa for a total of approximately 10 seconds over a 16-second period.
- Ignition voltage more than 11 volts.

### Action Taken When the DTC Sets

- The PCM will illuminate the malfunction indicator lamp (MIL) the first time the fault is detected.
- The PCM will default to a BARO value of 79.3 kpa.
- The PCM will store conditions which were present when the DTC was set as Freeze Frame and in the Failure Records data.

### Conditions for Clearing the MIL/DTC

- The PCM will turn the MIL "OFF" on the third consecutive trip cycle during which the diagnostic has been run and the fault condition is no longer present.
- A history DTC P0107 will clear after 40 consecutive warm-up cycles have occurred without a fault.
- DTC P0107 can be cleared by using the Tech 2 "Clear Info" function or by disconnecting the PCM battery feed.

### Diagnostic Aids

Check for the following conditions:

- Check for intermittent codes.
- The MAP sensor shares a 5 Volt reference with the Fuel Tank Pressure Sensor. If these codes are also set, it could indicate a problem with the 5 Volt reference circuit.
- The MAP sensor shares a ground with the Fuel Tank Pressure Sensor, the ECT sensor, and the Transmission Fluid Temperature sensor.
- Poor connection at PCM – Inspect harness connectors for backed-out terminals, improper mating, broken

locks, improperly formed or damaged terminals, and poor terminal-to-wire connection.

- Damaged harness – Inspect the wiring harness for damage. If the harness appears to be OK, observe the MAP display on the Tech 2 while moving connectors and wiring harnesses related to the sensor. A change in the display will indicate the location of the fault.

If DTC P0107 cannot be duplicated, the information included in the Failure Records data can be useful in determining vehicle mileage since the DTC was last set. If it is determined that the DTC occurs intermittently, performing the DTC P0107 Diagnostic Chart may isolate the cause of the fault.

### DTC P0107 – MAP Sensor Circuit Low Voltage

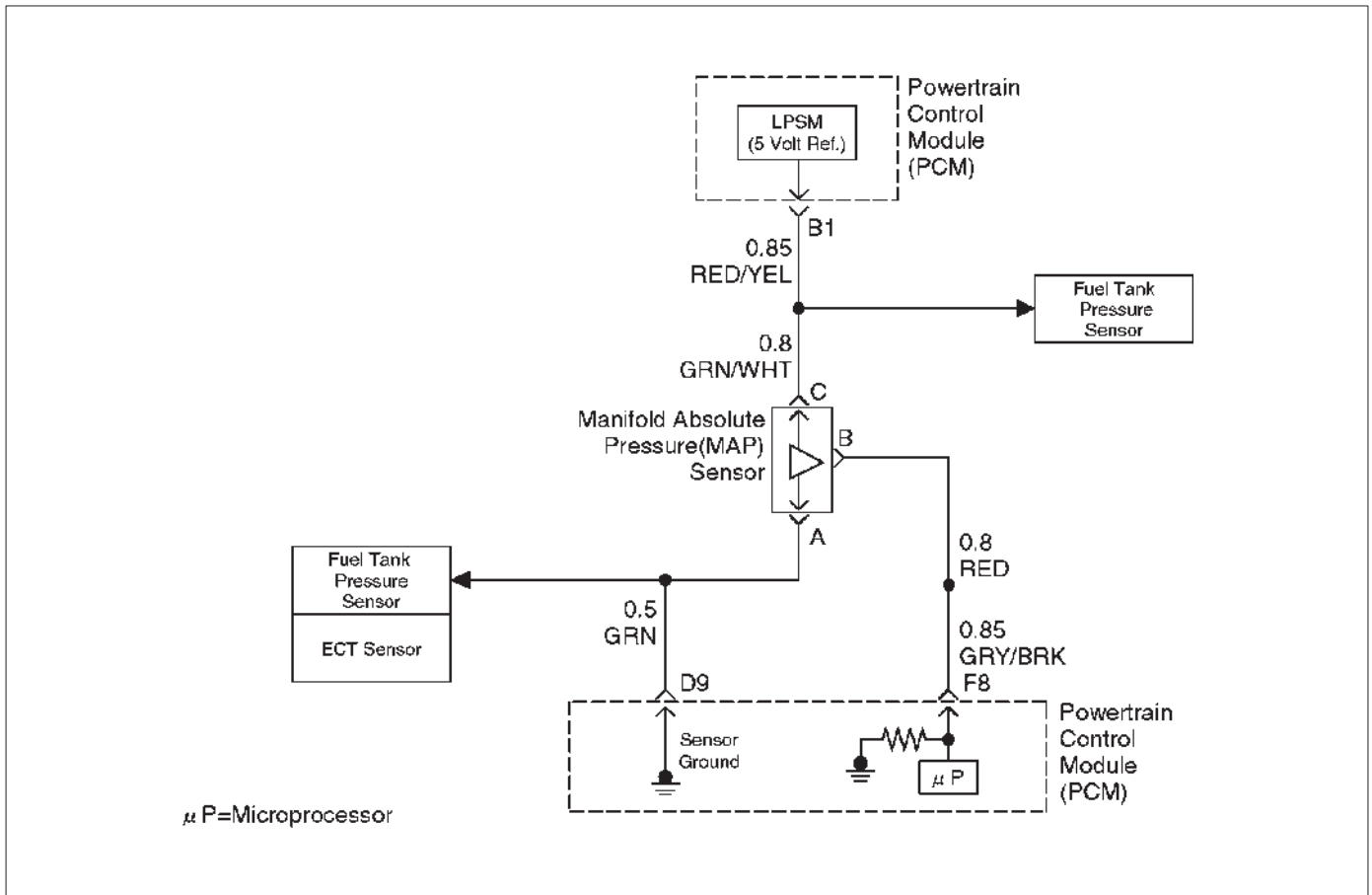
Step	Action	Value(s)	Yes	No
1	Was the "On-Board Diagnostic (OBD) System Check" performed?	—	Go to Step 2	Go to <i>OBD System Check</i>
2	1. Ignition "ON," engine "OFF." 2. With the throttle closed, observe the MAP value displayed on the Tech 2. Is the MAP value near the specified value?	11 kpa at sea level	Go to Step 4	Go to Step 3
3	1. Ignition "ON," engine "OFF." 2. Review and record Tech 2 Failure Records data. 3. Operate the vehicle within Failure Records conditions as noted. 4. Using a Tech 2, monitor "DTC" info for DTC P0107. Does the Tech 2 indicate DTC P0107 failed?	—	Go to Step 4	Refer to <i>Diagnostic Aids</i>
4	1. Ignition "OFF." 2. Disconnect the MAP sensor electrical connector. 3. Jumper the 5 volt reference "A" circuit and the MAP signal together at the MAP sensor harness connector. 4. Ignition "ON." 5. Observe the MAP value displayed on the Tech 2. Is the MAP value near the specified value? (If no, start with diagnosis chart for other sensors in the circuit and see if 5V returns.)	5 V 104 kpa	Go to Step 10	Go to Step 5
5	1. Disconnect the jumper. 2. Connect a test light between B+ and the MAP sensor signal circuit at the MAP sensor harness connector. 3. Observe the MAP value displayed on the Tech 2. Is the MAP value near the specified value.	5 V 104 kpa	Go to Step 6	Go to Step 8
6	1. Ignition "OFF." 2. Disconnect the PCM and check the 5 volt reference "A" circuit for an open or short to ground. 3. If the 5 volt reference "A" circuit is open or shorted to ground, repair it as necessary. Was the 5 volt reference "A" circuit open or shorted to ground?	—	Verify repair	Go to Step 7
7	Check the 5 volt reference "A" circuit for a poor connection at the PCM and replace the terminal if necessary. Did the terminal require replacement?	—	Verify repair	Go to Step 11



**DTC P0107 – MAP Sensor Circuit Low Voltage (Cont'd)**

Step	Action	Value(s)	Yes	No
8	1. Ignition "OFF." 2. Disconnect the PCM, and check the MAP signal circuit for an open, short to ground, or short to the sensor ground circuit. 3. If the MAP sensor signal circuit is open or shorted to ground, repair it as necessary. Was the MAP signal circuit open or shorted to ground?	—	Verify repair	Go to <i>Step 9</i>
9	Check the MAP sensor signal circuit for a poor connection at the PCM and the MAP sensor; replace the terminal if necessary. Did the terminal require replacement?	—	Verify repair	Go to <i>Step 11</i>
10	Replace the MAP sensor. Is the action complete?	—	Verify repair	—
11	Replace the PCM. <b>IMPORTANT:</b> The replacement PCM must be programmed. Refer to <i>On-Vehicle Service in Powertrain Control Module and Sensors</i> for procedures. And also refer to latest Service Bulletin. Check to see if the Latest software is released or not. And then Down Load the LATEST PROGRAMMED SOFTWARE to the replacement PCM. Is the action complete?	—	Verify repair	—

## Diagnostic Trouble Code (DTC) P0108 MAP Sensor Circuit High Voltage



D06RX076

### Circuit Description

The manifold absolute pressure (MAP) sensor responds to changes in intake manifold pressure (vacuum). The MAP sensor signal voltage to the powertrain control module (PCM) varies from below 2 volts at idle (high vacuum) to above 4 volts with the key "ON," engine not running or at wide-open throttle (low vacuum).

The MAP sensor is used to determine manifold pressure changes while the linear EGR flow test diagnostic is being run (refer to *DTC P0401*), to determine engine vacuum level for some other diagnostics and to determine barometric pressure (BARO). The PCM monitors the MAP signals for voltages outside the normal range of the MAP sensor. If the PCM detects a MAP signal voltage that is excessively high, DTC P0108 will be set.

### Conditions for Setting the DTC

- No TP sensor DTCs present.
- Engine is running for more than 10 seconds.
- Throttle position is below 3% if engine speed is below 1000 RPM.
- Throttle position is below 10% if engine speed is above 1000 RPM.
- The MAP sensor indicates an intermittent manifold absolute pressure above 80 kpa for a total of approximately 10 seconds over a 16-second period.

### Action Taken When the DTC Sets

- The PCM will illuminate the malfunction indicator lamp (MIL) the first time the fault is detected.
- The PCM will default to a BARO value of 79.3 kpa.
- The PCM will store conditions which were present when the DTC was set as Freeze Frame and in the Failure Records data.

### Conditions for Clearing the MIL/DTC

- The PCM will turn the MIL "OFF" on the third consecutive trip cycle during which the diagnostic has been run and the fault condition is no longer present.
- A history DTC P0108 will clear after 40 consecutive warm-up cycles have occurred without a fault.
- DTC P0108 can be cleared by using the Tech 2 "Clear Info" function or by disconnecting the PCM battery feed.

### Diagnostic Aids

Check for the following conditions:

- The MAP sensor shares a 5 Volt reference with the Fuel Tank Pressure Sensor. If these codes are also set, it could indicate a problem with the 5 Volt reference circuit.
- The MAP sensor shares a ground with the Fuel Tank Pressure Sensor, the ECT sensor, and the Transmission Fluid Temperature sensor.
- Poor connection at PCM – Inspect harness connectors for backed-out terminals, improper mating, broken

locks, improperly formed or damaged terminals, and poor terminal-to-wire connection.

- Damaged harness – Inspect the wiring harness for damage. If the harness appears to be OK, observe the MAP display on the Tech 2 while moving connectors and wiring harnesses related to the sensor. A change in the display will indicate the location of the fault.

If DTC P0108 cannot be duplicated, the information included in the Failure Records data can be useful in determining vehicle mileage since the DTC was last set. If it is determined that the DTC occurs intermittently, performing the DTC P1108 Diagnostic Chart may isolate the cause of the fault.

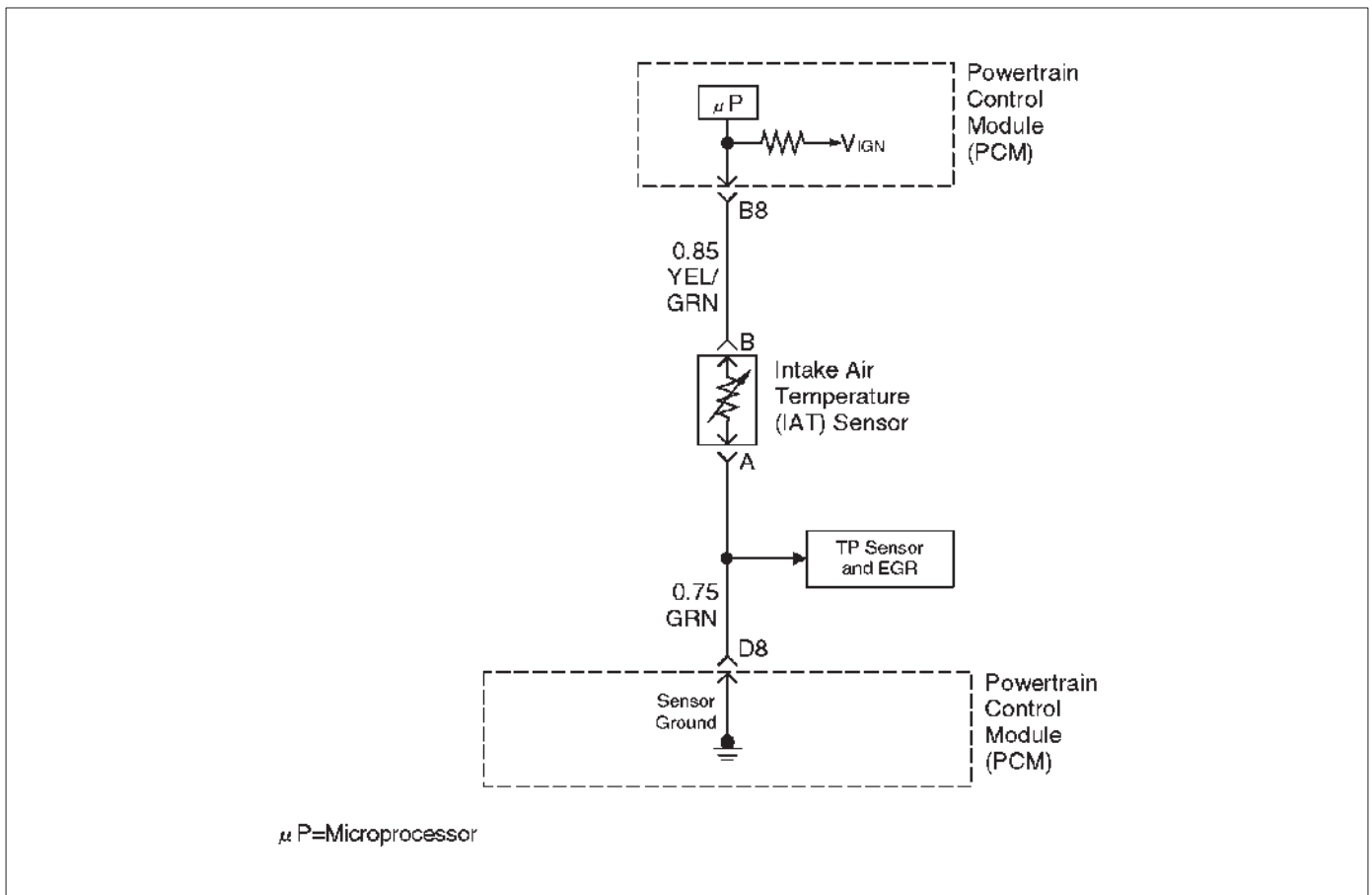
### DTC P0108 – MAP Sensor Circuit High Voltage

Step	Action	Value(s)	Yes	No
1	Was the "On-Board Diagnostic (OBD) System Check" performed?	—	Go to Step 2	Go to <i>OBD System Check</i>
2	1. If the engine idle is rough, unstable or incorrect, repair the idle problem before using this chart. Refer to <i>Symptoms</i> section. 2. With the engine idling, note the MAP value on the Tech 2. Is the MAP reading above the specified value?	90 kpa	Go to Step 4	Go to Step 3
3	1. Ignition "ON," engine "OFF." 2. Review and record Tech 2 Failure Records data. 3. Operate the vehicle within Failure Records conditions as noted. 4. Using a Tech 2, monitor "DTC" info for DTC P0108. Does the Tech 2 indicate DTC P0108 failed this ignition?	—	Go to Step 4	Refer to <i>Diagnostic Aids</i>
4	1. Ignition "OFF." 2. Disconnect the MAP sensor electrical connector. 3. Ignition "ON." 4. Note the MAP sensor voltage displayed on the Tech 2. (If no, start with diagnostic chart for other sensors in the circuit and see if 5V returns.) Is the MAP sensor voltage at the specified value?	0.0 V 11 kpa	Go to Step 5	Go to Step 6
5	Probe the sensor ground circuit with a test light to B+. Is the test light "ON?"	—	Go to Step 7	Go to Step 9
6	1. Check the MAP signal circuit for a short to voltage or a short to the 5 volt reference "A" circuit. 2. If the MAP sensor signal circuit is shorted, repair circuit as necessary. Was the MAP sensor signal circuit shorted?	—	Verify repair	Go to Step 11
7	1. Check for a poor sensor ground terminal connection at the MAP sensor electrical connector. 2. If a problem is found, replace the faulty terminal. Did the terminal require replacement?	—	Verify repair	Go to Step 8
8	Check for a plugged or leaking vacuum supply to the MAP sensor. Is the vacuum supply plugged or leaking?	—	Verify repair	Go to Step 12
9	1. Check for a poor sensor ground terminal connection at the PCM. 2. If a problem is found, replace the faulty terminal. Did the terminal require replacement?	—	Verify repair	Go to Step 10

**DTC P0108 – MAP Sensor Circuit High Voltage (Cont'd)**

Step	Action	Value(s)	Yes	No
10	<p>1. Check the continuity of the MAP sensor ground circuit.</p> <p>2. If the MAP sensor ground circuit measures over 5 ohms, repair open or poor connection.</p> <p>Was a condition found and corrected?</p>	—	Verify repair	Go to <i>Step 11</i>
11	<p>Replace the PCM.</p> <p><b>IMPORTANT:</b> The replacement PCM must be programmed. Refer to <i>On-Vehicle Service</i> in <i>Powertrain Control Module and Sensors</i> for procedures.</p> <p>And also refer to latest Service Bulletin.</p> <p>Check to see if the Latest software is released or not. And then Down Load the LATEST PROGRAMMED SOFTWARE to the replacement PCM.</p> <p>Is the action complete?</p>	—	Verify Repair	—
12	<p>Replace the MAP sensor.</p> <p>Is the action complete?</p>	—	Verify repair	—

## Diagnostic Trouble Code (DTC) P0112 IAT Sensor Circuit Low Voltage



D06RX078

### Circuit Description

The intake air temperature (IAT) sensor is a thermistor which measures the temperature of the air entering the engine. The powertrain control module (PCM) applies 5 volts through a pull-up resistor to the IAT sensor. When the intake air is cold, the sensor resistance is high and the PCM will monitor a high signal voltage on the IAT signal circuit. If the intake air is warm, the sensor resistance is lower, causing the PCM to monitor a lower voltage. DTC P0112 will set when the PCM detects an excessively low signal voltage on the intake air temperature sensor signal circuit.

### Conditions for Setting the DTC

- The engine has been running for over 2 minutes.
- Vehicle speed is greater than 30 mph (48 km/h) .
- IAT signal voltage indicates and intake air temperature greater than 148°C (298°F) (about 5 volts) for a total of 12.5 seconds over a 25-second period of time.

### Action Taken When the DTC Sets

- The PCM will illuminate the malfunction indicator lamp (MIL) the first time the fault is detected.
- The PCM will store conditions which were present when the DTC was set as Freeze Frame and in the Failure Records data.

### Conditions for Clearing the MIL/DTC

- The PCM will turn the MIL "OFF" on the third consecutive trip cycle during which the diagnostic has been run and the fault condition is no longer present.
- A history DTC P0112 will clear after 40 consecutive warm-up cycles have occurred without a fault.
- DTC P0112 can be cleared by using the Tech 2 "Clear Info" function or by disconnecting the PCM battery feed.

### Diagnostic Aids

Check for the following conditions:

- Poor connection at PCM – Inspect harness connectors for backed-bout terminals, improper mating, broken locks, improperly formed or damaged terminals, and poor terminal-to-wire connection.
  - Damaged harness – Inspect the wiring harness for damage. If the harness appears to be OK, observe the IAT display on the Tech 2 while moving connectors and wiring harnesses related to the IAT sensor. A change in the IAT display will indicate the location of the fault.
- If DTC P0112 cannot be duplicated, the information included in the Failure Records data can be useful in determining vehicle mileage since the DTC was last set.

## Test Description

Number(s) below refer to the step number(s) on the Diagnostic Chart:

2. Verifies that the fault is present.
3. If DTC P0112 can be repeated only by duplicating the Failure Records condition, refer to the *Temperature vs. Resistance Value* table. The table may be used to test the IAT sensor at various temperatures to evaluate the possibility of a "shifted" sensor that may be stored above or below a certain temperature. If this is the case, replace the IAT sensor. If the IAT sensor appears to be OK, the fault is intermittent; refer to *Diagnostic Aids*.

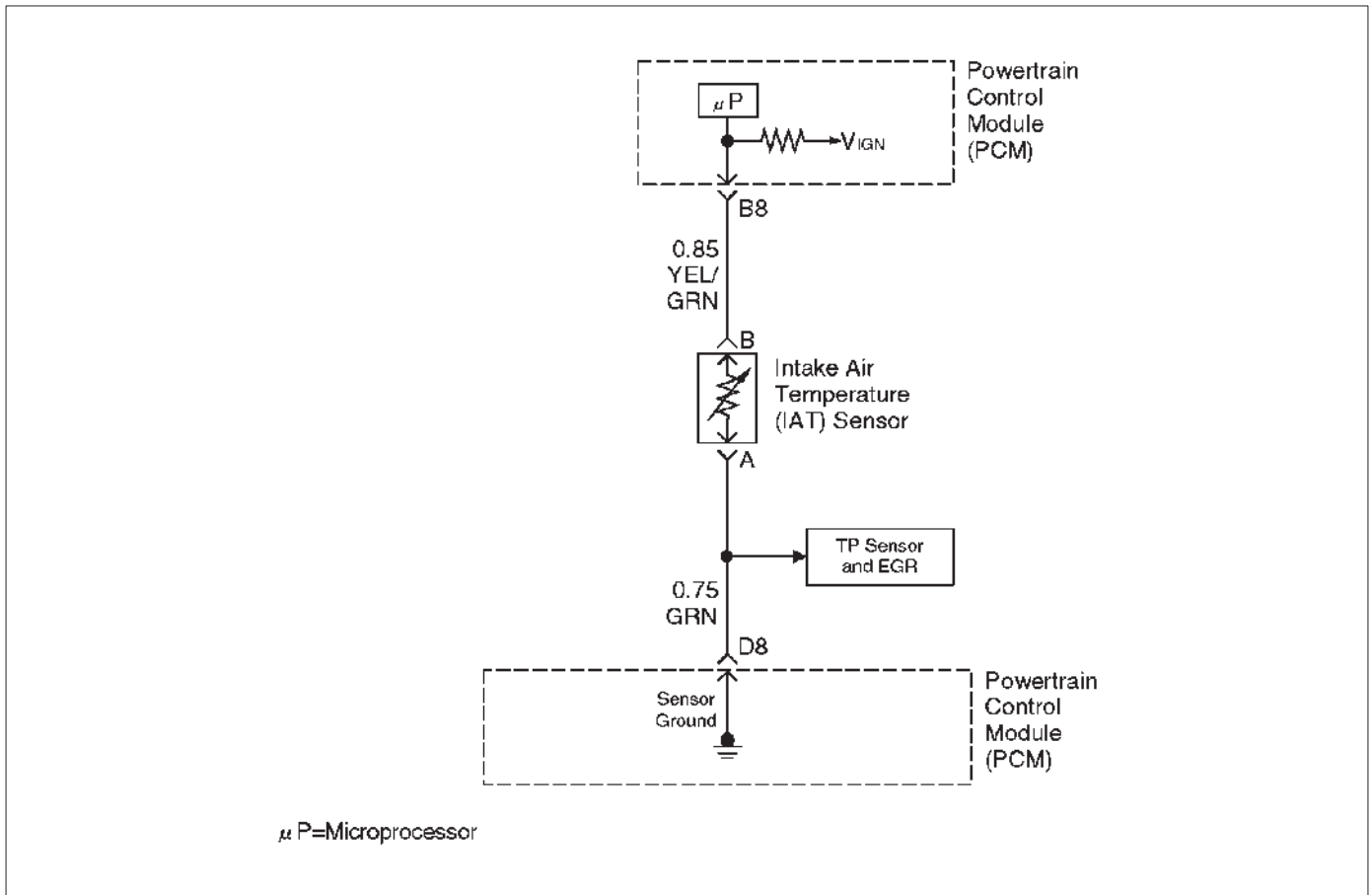
## Intake Air Temperature Sensor

°C	°F	OHMS
<b>Temperature vs. Resistance Values (approximate)</b>		
100	212	177
80	176	332
60	140	667
45	113	1188
35	95	1802
25	77	2796
15	59	4450
5	41	7280
-5	23	12300
-15	5	21450
-30	-22	52700
-40	-40	100700

## DTC P0112-IAT Sensor Circuit Low Voltage

Step	Action	Value(s)	Yes	No
1	Was the "On-Board Diagnostic (OBD) System Check" performed?	—	Go to Step 2	Go to <i>OBD System Check</i>
2	1. Ignition "ON," engine "OFF." 2. Using a Tech 2, monitor the intake air temperature (IAT). Is the intake air temperature greater than the specified value?	148°C (283°F)	Go to Step 4	Go to Step 3
3	1. Ignition "ON," engine "OFF." Review and record Tech 2 Failure Records data. 2. Operate the vehicle within Failure Records conditions as noted. 3. Using a Tech 2, monitor the "DTC" info for DTC P0112. Does the Tech 2 indicate DTC P0112 failed this ignition?	—	Refer to <i>Test Description</i>	Refer to <i>Diagnostic Aids</i>
4	1. Ignition "OFF." 2. Disconnect the IAT sensor electrical connector. 3. Ignition "ON." 4. Observe the intake air temperature on the Tech 2. Is the intake air temperature below the specified value?	-38°C (-36°F)	Go to Step 6	Go to Step 5
5	1. Ignition "OFF." 2. Disconnect the PCM electrical connectors. 3. Check the IAT sensor signal circuit for a short to ground. Is the IAT sensor signal circuit shorted to ground?	—	Verify repair	Go to Step 7
6	Replace the IAT sensor. Is the action complete?	—	Verify repair	—
7	Replace the PCM. <b>IMPORTANT:</b> The replacement PCM must be programmed. Refer to <i>On-Vehicle Service in Powertrain Control Module and Sensors</i> for procedures. And also refer to latest Service Bulletin. Check to see if the Latest software is released or not. And then Down Load the LATEST PROGRAMMED SOFTWARE to the replacement PCM. Is the action complete?	—	Verify repair	—

## Diagnostic Trouble Code (DTC) P0113 IAT Sensor Circuit High Voltage



D06RX078

### Circuit Description

The intake air temperature (IAT) sensor is a thermistor which measures the temperature of the air entering the engine. The powertrain control module (PCM) applies 5 volts through a pull-up resistor to the IAT sensor. When the intake air is cold, the sensor resistance is high and the PCM will monitor a high signal voltage on the IAT signal circuit. If the intake air is warm, the sensor resistance is lower causing the PCM to monitor a lower voltage. DTC P0113 will set when the PCM detects an excessively high signal voltage on the intake air temperature sensor signal circuit.

### Conditions for Setting the DTC

- The engine has been running for over 4 minutes.
- Vehicle speed is less than 20 mph (32 km/h).
- ECT signal temperature is above 60°C (140°F).
- Mass air flow is less than 20 g/second.
- IAT signal voltage indicates an intake air temperature less than -39°C (-38°F) for total of 12.5 seconds over a 25-second period.

### Action Taken When the DTC Sets

- The PCM will illuminate the malfunction indicator lamp (MIL) the first time the fault is detected.
- The PCM will store conditions which were present when the DTC was set as Freeze Frame and in the Failure Records data.

### Conditions for Clearing the MIL/DTC

- The PCM will turn the MIL "OFF" on the third consecutive trip cycle during which the diagnostic has been run and the fault condition is no longer present.
- A history DTC P0113 will clear after 40 consecutive warm-up cycles have occurred without a fault.
- DTC P0113 can be cleared by using the Tech 2 "Clear Info" function or by disconnecting the PCM battery feed.

### Diagnostic Aids

Check for the following conditions:

- The IAT sensor shares a ground with the EGR position sensor and the TP sensor. Check the ground if these DTC's are set.
- Poor connection at PCM – Inspect harness connectors for backed-out terminals, improper mating, broken locks, improperly formed or damaged terminals, and poor terminal-to-wire connection.
- Damaged harness – Inspect the wiring harness for damage. If the harness appears to be OK, observe the IAT display on the Tech 2 while moving connectors and wiring harnesses related to the IAT sensor. A change in the IAT display will indicate the location of the fault. If DTC P0113 cannot be duplicated, the information included in the Failure Records data can be useful in determining vehicle mileage since the DTC was last set.



**Test Description**

Number(s) below refer to the step number(s) on the Diagnostic Chart:

2. Verifies that the fault is present.
3. If DTC P0113 can be repeated only by duplicating the Failure Records conditions, refer to the "Temperature vs. Resistance Values" table. The table may be used to test the IAT sensor at various temperatures to evaluate the possibility of a "shifted" sensor that may be open above or below a certain temperature. If this is the case, replace the IAT sensor. If the IAT sensor appears to be OK, the fault is intermittent; refer to *Diagnostic Aids*.

**Intake Air Temperature Sensor**

°C	°F	OHMS
<b>Temperature vs. Resistance Values (approximate)</b>		
100	212	177
80	176	332
60	140	667
45	113	1188
35	95	1802
25	77	2796
15	59	4450
5	41	7280
-5	23	12300
-15	5	21450
-30	-22	52700
-40	-40	100700

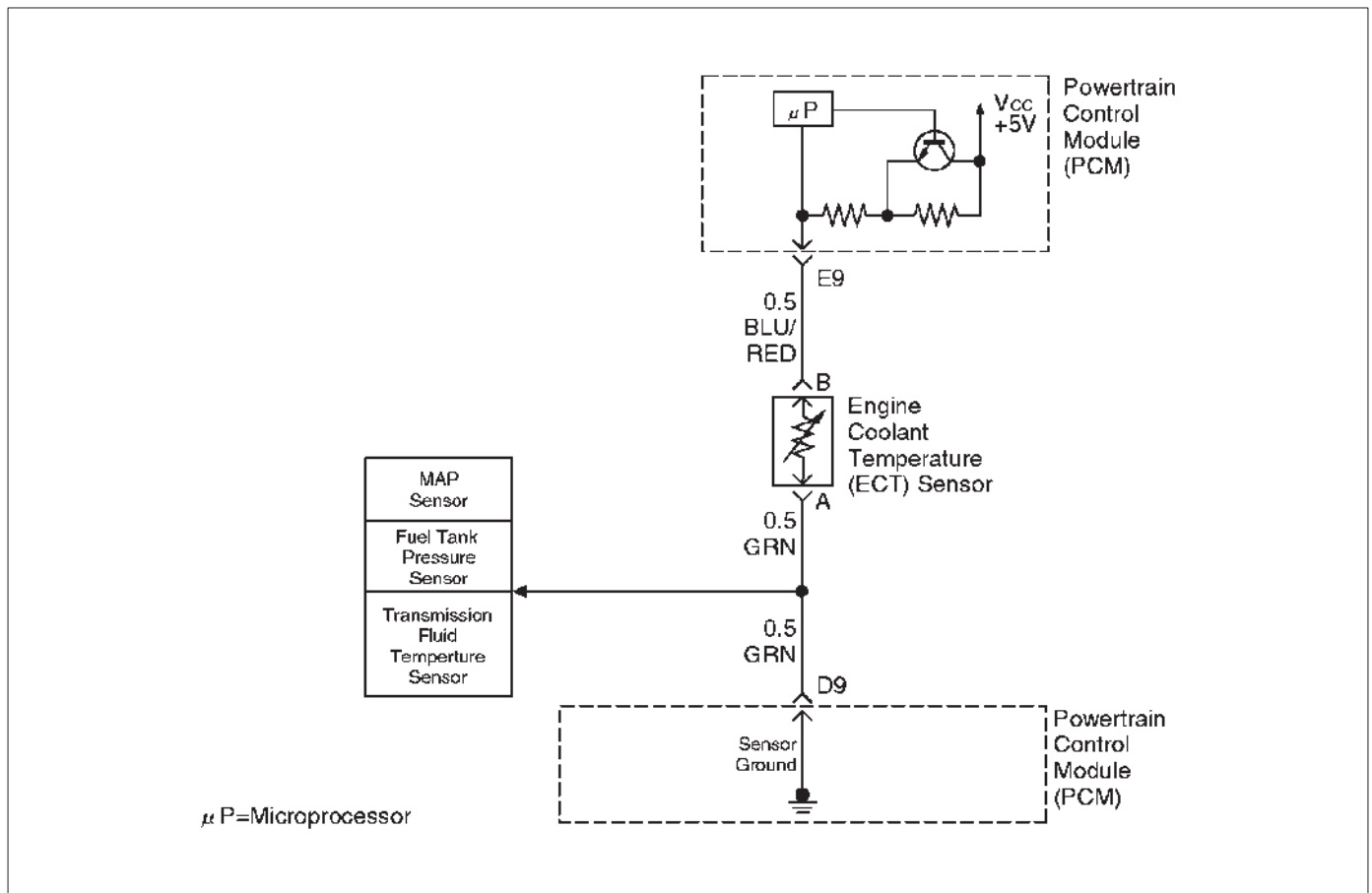
**DTC P0113 –IAT Sensor Circuit High Voltage**

Step	Action	Value(s)	Yes	No
1	Was the "On-Board Diagnostic (OBD) System Check" performed?	—	Go to Step 2	Go to OBD System Check
2	Ignition "ON," engine "OFF." Observe the "Intake Air Temp" display on the Tech 2. Is the "Intake Air Temp" below the specified value?	-38°C (-36°F)	Go to Step 4	Go to Step 3
3	1. Ignition "ON," engine "OFF." 2. Review and record Tech 2 Failure Records data parameters. 3. Operate the vehicle within Failure Records conditions as noted. 4. Using a Tech 2, monitor "DTC" info for DTC P0113. Does the Tech 2 indicate DTC P0113 failed?	—	Refer to Test Description	Refer to Diagnostic Aids
4	1. Ignition "OFF." 2. Disconnect the IAT sensor electrical connector. 3. Jumper the IAT signal circuit and the sensor ground circuit together at the IAT sensor harness connector. 4. Ignition "ON." 5. Observe the "Intake Air Temp" display on the Tech 2. Is the "Intake Air Temp" at the specified value?	140°C (284°F)	Go to Step 6	Go to Step 5
5	1. Jumper the IAT signal circuit at the IAT sensor harness connector to chassis ground. 2. Observe the "Intake Air Temp" display on the Tech 2. Is the "Intake Air Temp" at the specified value?	140°C (284°F)	Go to Step 7	Go to Step 8

**DTC P0113 –IAT Sensor Circuit High Voltage (Cont'd)**

Step	Action	Value(s)	Yes	No
6	Check for poor connections at the IAT sensor and replace terminals if necessary. Did any terminals require replacement?	—	Verify repair	Go to <i>Step 10</i>
7	1. Ignition "OFF." 2. Disconnect the PCM, and check the IAT sensor ground circuit for an open. 3. If the IAT sensor ground circuit is open, repair it as necessary. Was the IAT sensor ground circuit open?	—	Verify repair	Go to <i>Step 9</i>
8	1. Ignition "OFF." 2. Disconnect the PCM, and check the IAT signal circuit for an open. 3. If the IAT sensor signal circuit is open, repair it as necessary. Was the IAT signal circuit open?	—	Verify repair	Go to <i>Step 9</i>
9	Check for a poor sensor ground or IAT signal circuit terminal connection at the PCM and replace terminal(s) if necessary. Did any of the terminals need to be replaced?	—	Verify repair	Go to <i>Step 11</i>
10	Replace the IAT sensor. Is the action complete?	—	Verify repair	—
11	Replace the PCM. <b>IMPORTANT:</b> The replacement PCM must be programmed. Refer to <i>On-Vehicle Service in Powertrain Control Module and Sensors</i> for procedures. And also refer to latest Service Bulletin. Check to see if the Latest software is released or not. And then Down Load the LATEST PROGRAMMED SOFTWARE to the replacement PCM. Is the action complete?	—	Verify repair	—

## Diagnostic Trouble Code (DTC) P0117 ECT Sensor Circuit Low Voltage



D06RX079

### Circuit Description

The engine coolant temperature (ECT) sensor is a thermistor mounted on a coolant crossover pipe at the front of the engine. The powertrain control module (PCM) applies a voltage (about 5 volts) through a pull-up resistor to the ECT signal circuit. When the engine coolant is cold, the sensor (thermistor) resistance is high, therefore the PCM will measure a high signal voltage. As the engine coolant warms, the sensor resistance becomes lower, and the ECT signal voltage measured at the PCM drops. With a fully warmed-up engine, the ECT signal voltage should measure about 1.5 to 2.0 volts.

### Conditions for Setting the DTC

- Engine running time is longer than one minute.
- The ECT sensor signal indicates an engine coolant temperature greater than 150°C (302°F) (about 0.10 V) for a total of 50 seconds over a 100-second period.

### Action Taken When the DTC Sets

- The PCM will illuminate the malfunction indicator lamp (MIL) the first time the fault is detected.
- The PCM will substitute the ECT reading with a default engine coolant temperature value. The default value is based on start-up intake air temperature and running time.
- The PCM will store conditions which were present when the DTC was set as Freeze Frame and in the Failure Records data.

### Conditions for Clearing the MIL/DTC

- The PCM will turn the MIL "OFF" on the third consecutive trip cycle during which the diagnostic has been run and the fault condition is no longer present.
- A history DTC P0117 will clear after 40 consecutive warm-up cycles have occurred without a fault.
- DTC P0117 can be cleared by using the Tech 2 "Clear Info" function or by disconnecting the PCM battery feed.

### Diagnostic Aids

Check for the following conditions:

- Poor connection at PCM – Inspect harness connectors for backed-out terminals, improper mating, broken locks, improperly formed or damaged terminals, and poor terminal-to-wire connection.
- Damaged harness – Inspect the wiring harness for damage. If the harness appears to be OK, observe the ECT display on the Tech 2 while moving connectors and wiring harnesses related to the ECT sensor. A change in the ECT display will indicate the location of the fault.

If DTC P0117 cannot be duplicated, the information included in the Failure Records data can be useful in determining vehicle mileage since the DTC was last set. If it is determined that the DTC occurs intermittently, performing the DTC P1114 Diagnostic Chart may isolate the cause of the fault.

## Test Description

Number(s) below refer to the step number(s) on the Diagnostic Chart.

2. Verifies that the fault is present.
3. If DTC P0117 can be repeated only by duplicating the Failure Records conditions, refer to the "Temperature vs. Resistance Values" table. The table may be used to test the ECT sensor at various temperatures to evaluate the possibility of a "shifted" sensor that may be shorted above or below a certain temperature. If this is the case, replace the ECT sensor. If the ECT sensor appears to be OK, the fault is intermittent; refer to *Diagnostic Aids*.

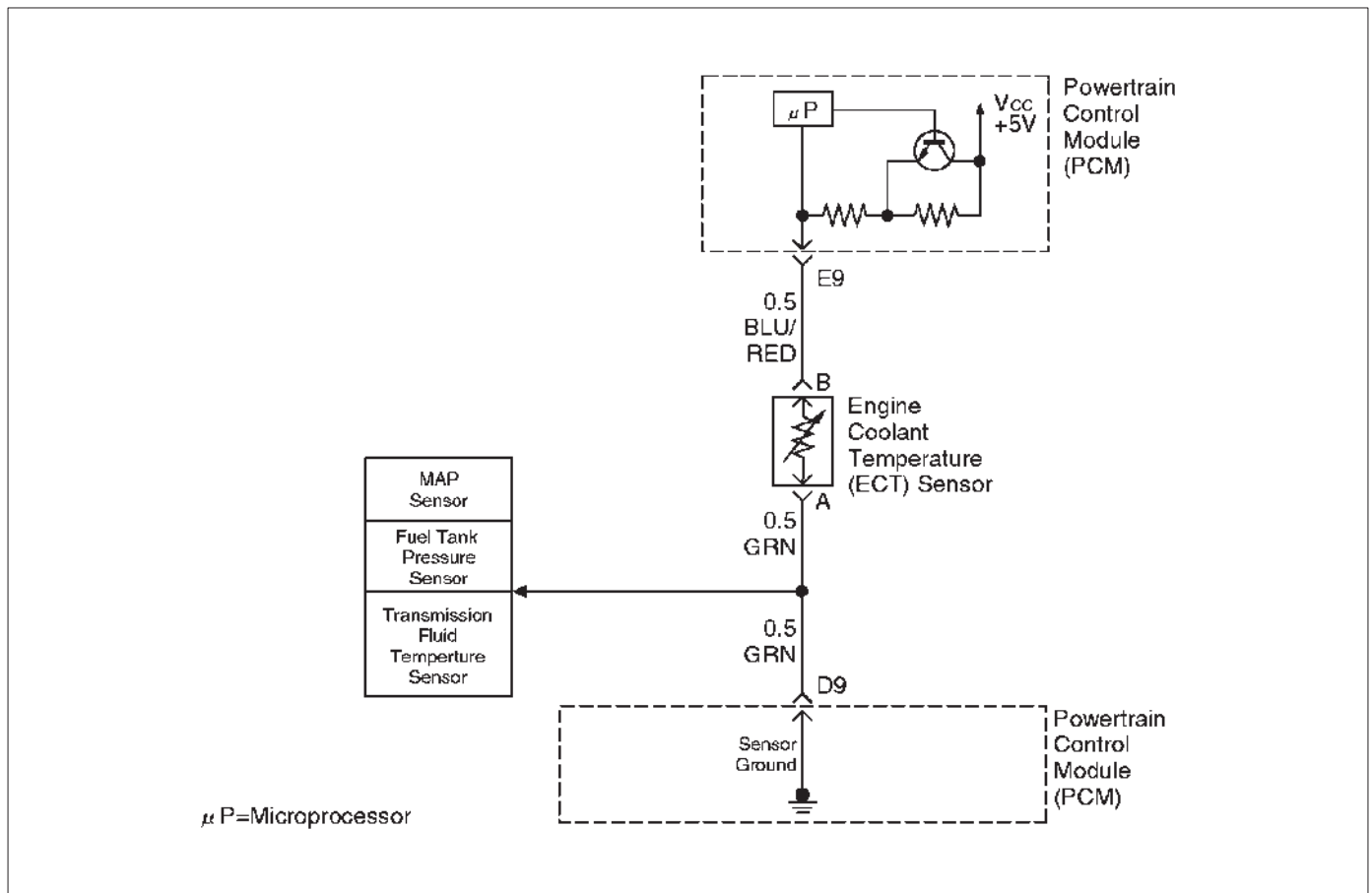
## Engine Coolant Temperature Sensor

°C	°F	OHMS
<b>Temperature vs. Resistance Values (approximate)</b>		
100	212	177
80	176	332
60	140	667
45	113	1188
35	95	1802
25	77	2796
15	59	4450
5	41	7280
-5	23	12300
-15	5	21450
-30	-22	52700
-40	-40	100700

### DTC P0117 – ECT Sensor Low Voltage

Step	Action	Value(s)	Yes	No
1	Was the "On-Board Diagnostic (OBD) System Check" performed?	—	Go to Step 2	Go to <i>OBD System Check</i>
2	1. Ignition "ON," engine "OFF." 2. Observe the "Eng Cool Temp" display on the Tech 2. Is the "Eng Cool Temp" below the specified value?	139°C (282°F)	Go to Step 4	Go to Step 3
3	1. Ignition "ON," engine "OFF." 2. Review and record Tech 2 Failure Records data. 3. Operate the vehicle within Failure Records conditions as noted. 4. Using a Tech 2, monitor "DTC" info for DTC P0117. Does the Tech 2 indicate DTC P0117 failed this ignition?	—	Go to Step 4	Refer to <i>Diagnostic Aids</i>
4	1. Disconnect the ECT sensor electrical connector. 2. Observe the "Eng Cool Temp" display on the Tech 2. Is the "Eng Cool Temp" at the specified value?	-39°C (-38°F)	Go to Step 6	Go to Step 5
5	1. Ignition "OFF." 2. Disconnect the PCM and check the ECT signal circuit for a short to ground or a short to the sensor ground circuit. 3. If the ECT signal circuit is shorted, repair it as necessary. Was the ECT signal circuit shorted to ground?	—	Verify repair	Go to Step 7
6	Replace the ECT sensor. Is the action complete?	—	Verify repair	—
7	Replace the PCM. <b>IMPORTANT:</b> The replacement PCM must be programmed. Refer to <i>On-Vehicle Service in Powertrain Control Module and Sensors</i> for procedures. And also refer to latest Service Bulletin. Check to see if the Latest software is released or not. And then Down Load the LATEST PROGRAMMED SOFTWARE to the replacement PCM. Is the action complete?	—	Verify repair	—

## Diagnostic Trouble Code (DTC) P0118 ECT Sensor Circuit High Voltage



D06RX079

### Circuit Description

The engine coolant temperature (ECT) sensor is a thermistor mounted in on a coolant crossover pipe at the front of the engine. The powertrain control module (PCM) applies a voltage (about 5 volts) through a pull-up resistor to the ECT signal circuit. When the engine coolant is cold, the sensor (thermistor) resistance is high, therefore the PCM will measure a high signal voltage. As the engine coolant warms, the sensor resistance becomes less, and the ECT signal voltage measured at the PCM drops. With a fully warmed-up engine, the ECT signal voltage should measure about 1.5 to 2.0 volts.

### Conditions for Setting the DTC

- Engine running time is longer than 1.5 minutes.
- The ECT sensor signal indicates an engine coolant temperature of  $-39^{\circ}\text{C}$  ( $-38^{\circ}\text{F}$ ) or less (about 5 volts) for a total of 50 seconds over a 100-second period.

### Action Taken When the DTC Sets

- The PCM will illuminate the malfunction indicator lamp (MIL) the first time the fault is detected.
- The PCM will substitute the ECT reading with a default engine coolant temperature value. The default value is based on start-up intake air temperature and running time.
- The PCM will store conditions which were present when the DTC was set as Freeze Frame and in the Failure Records data.

### Conditions for Clearing the MIL/DTC

- The PCM will turn the MIL "OFF" on the third consecutive trip cycle during which the diagnostic has been run and the fault condition is no longer present.
- A history DTC P0118 will clear after 40 consecutive warm-up cycles have occurred without a fault.
- DTC P0118 can be cleared by using the Tech 2 "Clear Info" function or by disconnecting the PCM battery feed.

### Diagnostic Aids

Check for the following conditions:

The ECT shares a ground with the Transmission Fluid Temperature sensor, the Fuel Tank Pressure sensor, and the MAP sensor.

Check the ground if these DTCs are also set.

- Poor connection at PCM – Inspect harness connectors for backed-out terminals, improper mating, broken locks, improperly formed or damaged terminals, and poor terminal-to-wire connection.
- Damaged harness – Inspect the wiring harness for damage. If the harness appears to be OK, observe the ECT display on the Tech 2 while moving connectors and wiring harnesses related to the ECT sensor. A change in the ECT display will indicate the location of the fault.

If DTC P0118 cannot be duplicated, the information included in the Failure Records data can be useful in determining vehicle mileage since the DTC was last set. If it is determined that the DTC occurs intermittently,

## 6E-142 6VE1 3.5L ENGINE DRIVEABILITY AND EMISSIONS

performing the DTC P1115 Diagnostic Chart may isolate the cause of the fault.

### Test Description

Number(s) below refer to the step number(s) on the Diagnostic Chart.

2. Verifies that the fault is present.
3. If DTC P0118 can be repeated only by duplicating the Failure Records conditions, refer to the "Temperature vs. Resistance Value" table. The table may be used to test the ECT sensor at various temperatures to evaluate the possibility of a "shifted" sensor that may be shorted above or below a certain temperature. If this is the case, replace the ECT sensor. If the ECT sensor appears to be OK, the fault is intermittent; refer to *Diagnostic Aids*.

### Engine Coolant Temperature Sensor

°C	°F	OHMS
<b>Temperature vs. Resistance Values (approximate)</b>		
100	212	177
80	176	332
60	140	667
45	113	1188
35	95	1802
25	77	2796
15	59	4450
5	41	7280
-5	23	12300
-15	5	21450
-30	-22	52700
-40	-40	100700

### DTC P0118 – ECT Sensor Circuit High Voltage

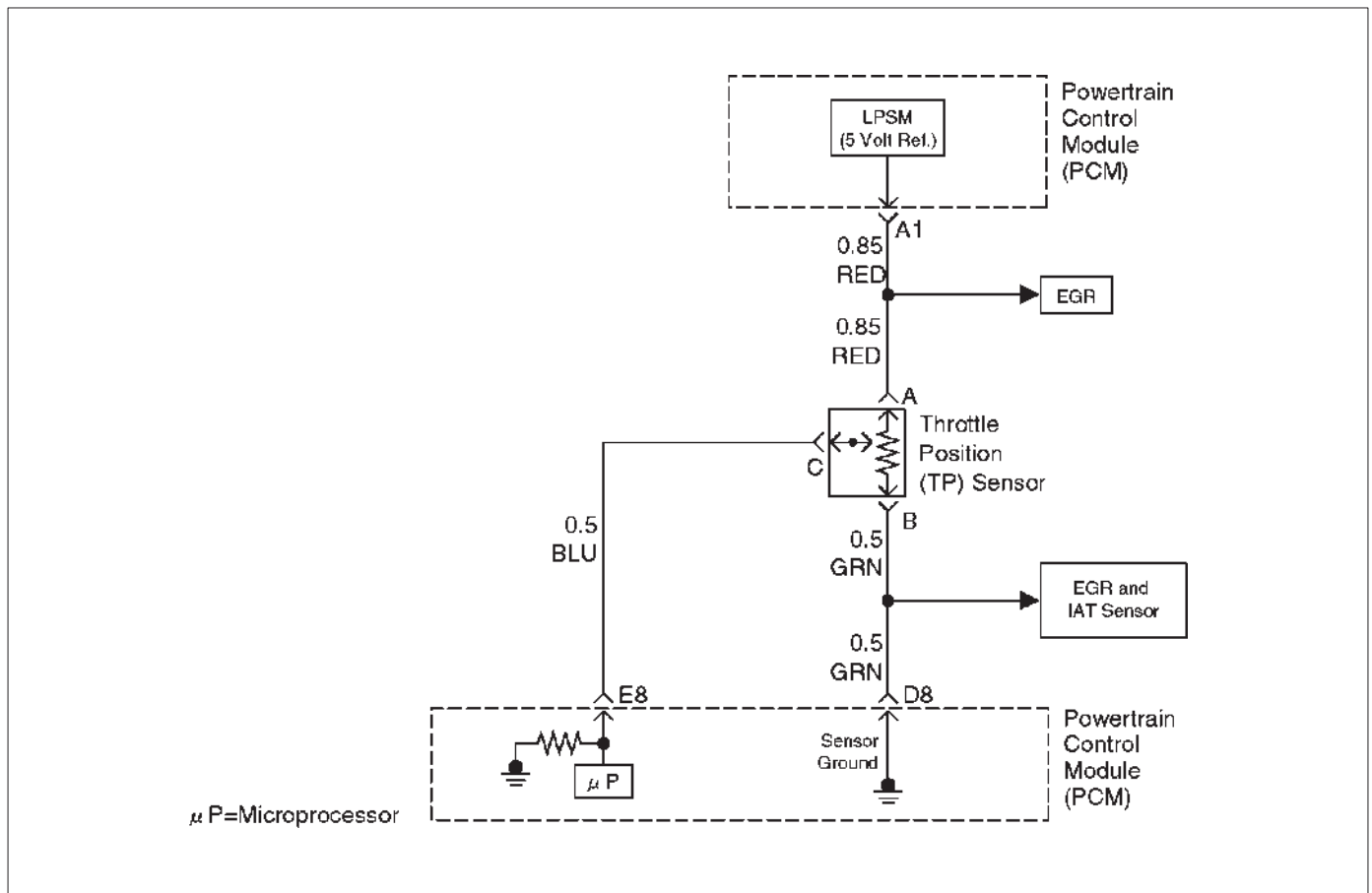
Step	Action	Value(s)	Yes	No
1	Was the "On-Board Diagnostic (OBD) System Check" performed?	—	Go to Step 2	Go to <i>OBD System Check</i>
2	1. Ignition "ON," engine "OFF." 2. Observe the "Eng Cool Temp" display on the Tech 2. Is the "Eng Cool Temp" below the specified value?	-39°C (-38°F)	Go to Step 4	Go to Step 3
3	1. Ignition "ON," engine "OFF." 2. Review and record Tech 2 Failure Records data. 3. Operate the vehicle within Failure Records conditions as noted. 4. Using a Tech 2, monitor the "DTC" info for DTC P0118. Does the Tech 2 indicate DTC P0118 failed?	—	Refer to <i>Test Description</i>	Refer to <i>Diagnostic Aids</i>
4	1. Disconnect the ECT sensor electrical connector. 2. Jumper the ECT signal circuit and the sensor ground circuit together at the ECT sensor harness connector. 3. Observe the "Eng Cool Temp" display on the Tech 2. Is the "Eng Cool Temp" at the specified value?	140°C (284°F)	Go to Step 6	Go to Step 5
5	1. Jumper the ECT signal circuit at the ECT sensor harness connector to chassis ground. 2. Observe the "Eng Cool Temp" display on the Tech 2. Is the "Eng Cool Temp" at the specified value?	140°C (284°F)	Go to Step 7	Go to Step 8
6	Check for poor connections at the ECT sensor and replace terminals if necessary. Did any terminals require replacement?	—	Verify repair	Go to Step 10

**DTC P0118 – ECT Sensor Circuit High Voltage (Cont'd)**

Step	Action	Value(s)	Yes	No
7	1. Ignition "OFF." 2. Disconnect the PCM, and check the ECT sensor ground circuit for an open. 3. If the ECT sensor ground circuit is open, repair it as necessary. Was the ECT sensor ground circuit open?	—	Verify repair	Go to <i>Step 9</i>
8	1. Ignition "OFF." 2. Disconnect the PCM, and check the ECT signal circuit for an open. 3. If the ECT sensor signal circuit is open, repair it as necessary. Was the ECT signal circuit open?	—	Verify repair	Go to <i>Step 9</i>
9	Check for a poor sensor ground or ECT signal circuit terminal connection at the PCM and replace terminal(s) if necessary. Did any of the terminals need to be replaced?	—	Verify repair	Go to <i>Step 11</i>
10	Replace the ECT sensor. Is the action complete?	—	Verify repair	—
11	Replace the PCM. <b>IMPORTANT:</b> The replacement PCM must be programmed. Refer to <i>On-Vehicle Service</i> in <i>Powertrain Control Module and Sensors</i> for procedures. And also refer to latest Service Bulletin. Check to see if the Latest software is released or not. And then Down Load the LATEST PROGRAMMED SOFTWARE to the replacement PCM. Is the action complete?	—	Verify repair	—



## Diagnostic Trouble Code (DTC) P0121 TP System Performance



### Circuit Description

The throttle position (TP) sensor circuit provides a voltage signal that changes relative to throttle blade angle. The signal voltage will vary from about 0.6 volts at closed throttle to about 4.5 volts at wide open throttle (WOT). The TP signal is used by the powertrain control module (PCM) for fuel control and many of the PCM-controlled outputs. The PCM monitors throttle position and compares actual throttle position from the TP sensor to a predicted TP value calculated from engine speed. If the PCM detects an out-of-range condition, DTC P0121 will set.

### Conditions for Setting the DTC

- The engine is running.
- No MAP DTCs, or P0121, P0122, P1122, P0123 are set.
- MAP reading is below 55 kpa.
- Throttle is steady, throttle angle is changing less than 1%.
- Predicted throttle angle is not close to actual throttle angle.
- Above conditions are present for a total of 12.5 seconds over a 25-second period of time.

### Action Taken When the DTC Sets

- The PCM will illuminate the malfunction indicator lamp (MIL) after the second consecutive trip in which the fault is detected.

- The PCM will store conditions which were present when the DTC was set as Freeze Frame and in the Failure Records data.
- The PCM will use a default throttle position based on mass air flow and RPM.

### Conditions for Clearing the MIL/DTC

- The PCM will turn the MIL "OFF" on the third consecutive trip cycle during which the diagnostic has been run and the fault condition is no longer present.
- A history DTC P0121 will clear after 40 consecutive warm-up cycles have occurred without a fault.
- DTC P0121 can be cleared by using the Tech 2 "Clear info" function or by disconnecting the PCM battery feed.

### Diagnostic Aids

Check for the following conditions:

- Skewed MAP signal or faulty Map sensor – An incorrect MAP signal may cause the PCM to incorrectly calculate the predicted TP sensor value during high engine load situations. Check for an unusually low MAP reading. This condition can cause DTC P0121 to be set.
- The TP Sensor shares a 5 Volt reference with the EGR Valve. If these codes are also set, it could indicate a problem with the 5 Volt reference circuit or components itself.
- The TP Sensor share a ground with the EGR Valve and the IAT Sensor.

- Poor connection at PCM – Inspect harness connectors for backed-out terminals, improper mating, broken locks improperly formed or damaged terminals, and poor terminal-to-wire connection.
- Damaged harness – Inspect the wiring harness for damage. If the harness appears to be OK, observe the ECT display on the Tech 2 while moving connectors and wiring harnesses related to the sensor. A change in the display will indicate the location of the fault.

If DTC P0121 cannot be duplicated, the information included in the Failure Records data can be useful in determining vehicle mileage since the DTC was last set. If it is determined that the DTC occurs intermittently, performing the DTC P1122 and DTC P1121 Diagnostic Charts may isolate the cause of the fault.

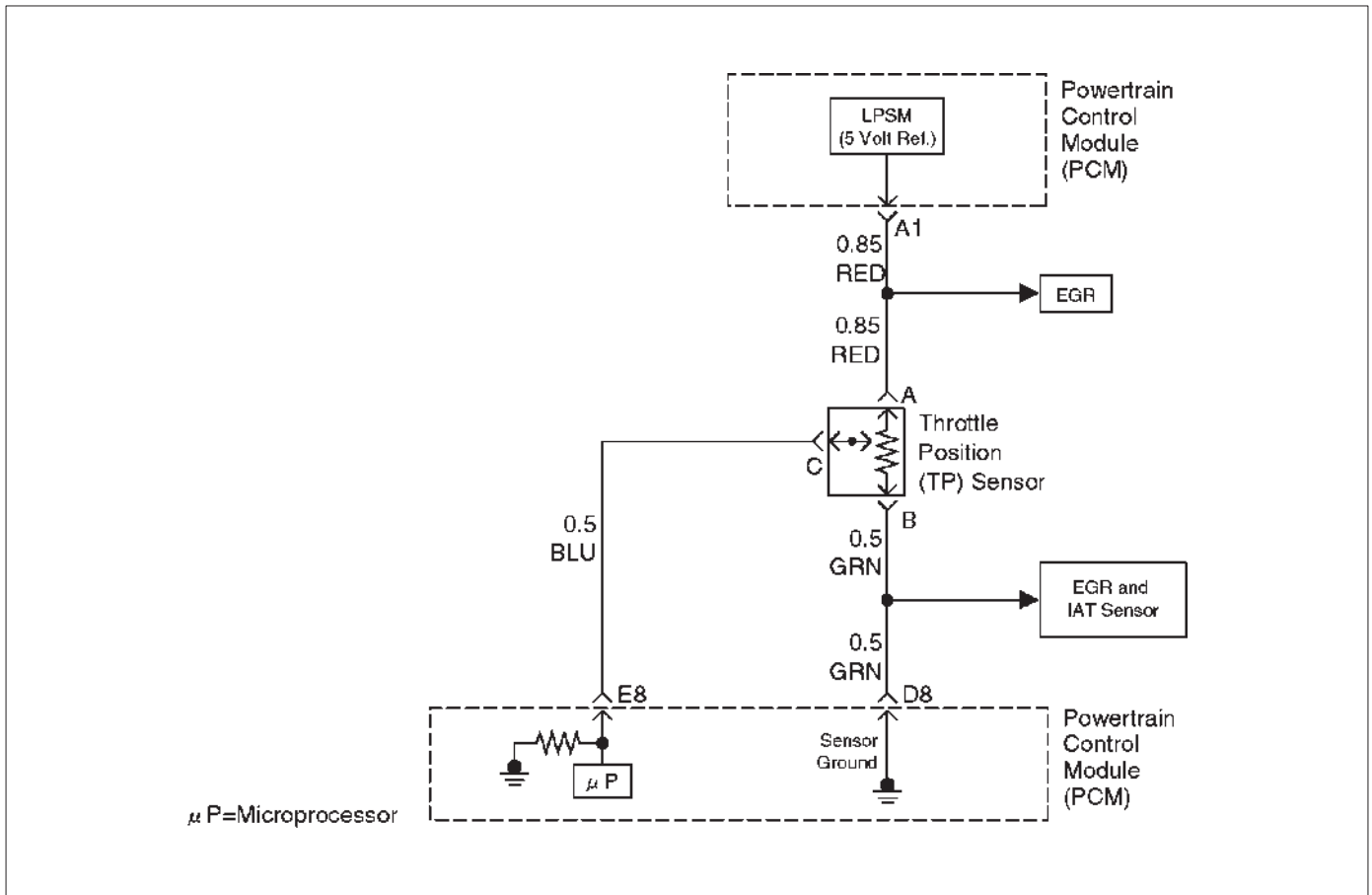
### DTC P0121 –TP System Performance

Step	Action	Value(s)	Yes	No
1	Was the "On-Board Diagnostic (OBD) System Check" performed?	—	Go to Step 2	Go to OBD System Check
2	1. Ignition "ON," engine not running. 2. Observe the MAP reading on the Tech 2. Is the MAP reading less than the specified value?	65 kpa	Go to Step 3	Go to Step 6
3	1. Disconnected the MAP sensor. 2. Connect a test light between the 5 volt reference "A" circuit and the MAP signal circuit at the MAP sensor harness connector. 3. Observe the MAP reading on the Tech 2. Is the MAP reading less than the specified value? (If no, start with diagnosis chart for other sensors in the circuit and see if 5V returns.)	65 kpa	Go to Step 5	Go to Step 4
4	1. Check the MAP signal circuit between the PCM and the MAP sensor for an open, short to ground, or short to the MAP ground circuit. 2. If the MAP signal circuit is open or shorted, repair it as necessary. Was the MAP signal circuit open or shorted?	—	Verify repair	Go to Step 12
5	Replace the MAP sensor. Is the action complete?	—	Verify repair	—
6	Observe the TP angle reading on the Tech 2 while slowly opening the throttle. Does the TP angle increase steadily and evenly from the closed throttle value to the wide open throttle value?	Closed throttle = 0% Wide open throttle = 100%	Refer to Diagnostic Aids	Go to Step 7
7	1. Disconnect the TP sensor. 2. Observe the TP sensor reading on the Tech 2. Is the TP sensor reading near the specified value?	0 V	Go to Step 8	Go to Step 9
8	1. Connect a test light between the 5 volt reference "A" circuit and the TP sensor signal circuit at the TP sensor harness connector. 2. Observe the TP sensor reading on the Tech 2. Is the TP sensor reading at the specified value?	5 V	Go to Step 11	Go to Step 10

## DTC P0121 –TP System Performance (Cont'd)

Step	Action	Value(s)	Yes	No
9	<p>Check the following items:</p> <ol style="list-style-type: none"> <li>1. TP signal circuit for a short to voltage.</li> <li>2. TP sensor ground circuit for high resistance between the PCM and the TP sensor.</li> <li>3. TP sensor ground circuit for a poor connection.</li> <li>4. If a problem is found, repair wiring harness as necessary.</li> </ol> <p>Was a problem found?</p>	—	Verify repair	Go to <i>Step 12</i>
10	<p>Check the following items:</p> <ol style="list-style-type: none"> <li>1. TP signal circuit or 5 volt reference "A" circuit for a poor connection.</li> <li>2. TP signal circuit or 5 volt reference "A" circuit for high resistance between the PCM and the TP sensor.</li> <li>3. If a problem is found, repair wiring harness as necessary.</li> </ol> <p>Was a problem found?</p>	—	Verify repair	Go to <i>Step 12</i>
11	<p>Replace the TP sensor.</p> <p>Is the action complete?</p>	—	Verify repair	—
12	<p>Replace the PCM.</p> <p><b>IMPORTANT:</b> The replacement PCM must be programmed. Refer to <i>On-Vehicle Service</i> in <i>Powertrain Control Module and Sensors</i> for procedures.</p> <p>And also refer to latest Service Bulletin.</p> <p>Check to see if the Latest software is released or not. And then Down Load the LATEST PROGRAMMED SOFTWARE to the replacement PCM.</p> <p>Is the action complete?</p>	—	Verify repair	—

## Diagnostic Trouble Code (DTC) P0122 TP Sensor Circuit Low Voltage



### Circuit Description

The throttle position (TP) sensor circuit provides a voltage signal that changes relative to throttle blade angle. The signal voltage will vary from below 0.6 volts at closed throttle to about 4.5 volts at wide open throttle (WOT). The TP signal is used by the powertrain control module (PCM) for fuel control and many of the PCM-controlled outputs.

### Conditions for Setting the DTC

- The ignition is "ON."
- TP sensor signal voltage is less than 0.22 volt for a total of 0.78 second over a 1.5-second period.

### Action Taken When the DTC Sets

- The PCM will illuminate the malfunction indicator lamp (MIL) the first time the fault is detected.
- The PCM will store conditions which were present when the DTC was set as Freeze Frame and in the Failure Records data.
- The PCM will use a default throttle position based on mass air flow and RPM.

### Conditions for Clearing the MIL/DTC

- The PCM will turn the MIL "OFF" on the third consecutive trip cycle during which the diagnostic has been run and the fault condition is no longer present.
- A history DTC P0122 will clear after 40 consecutive warm-up cycles have occurred without a fault.

- DTC P0122 can be cleared by using the Tech 2 "Clear Info" function or by disconnecting the PCM battery feed.

### Diagnostic Aids

Check for the following conditions:

- Check intermittent codes.
- The TP sensor shares a 5 Volt reference with the EGR position sensor. Check the 5 Volt reference if these DTCs are also set.
- The TP sensor shares a ground with the IAT sensor and the EGR position sensor.
- Poor connection at PCM – Inspect harness connectors for backed-out terminals, improper mating, broken locks, improperly formed or damaged terminals, and poor terminal-to-wire connection.
- Damaged harness – Inspect the wiring harness for damage. If the harness appears to be OK, observe the throttle position display on the Tech 2 while moving connectors and wiring harnesses related to the TP sensor. A change in the display will indicate the location of the fault.

If DTC P0122 cannot be duplicated, the information included in the Failure Records data can be useful in determining vehicle mileage since the DTC was last set. If it is determined that the DTC occurs intermittently, performing the DTC P1122 Diagnostic Chart may isolate the cause of the fault.

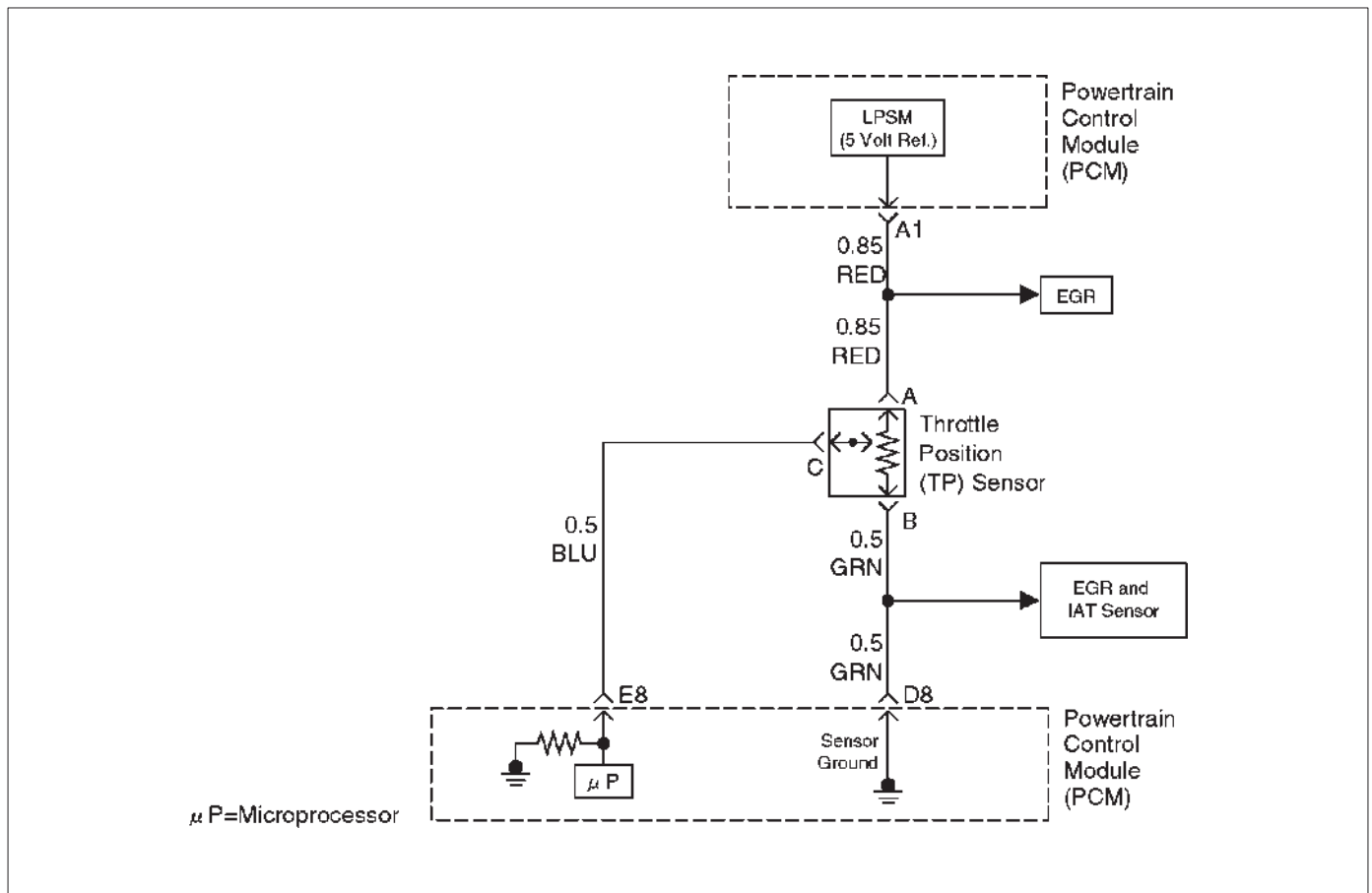
**DTC P0122 –TP Sensor Circuit Low Voltage**

Step	Action	Value(s)	Yes	No
1	Was the "On-Board Diagnostic (OBD) System Check" performed?	—	Go to Step 2	Go to <i>OBD System Check</i>
2	1. Ignition "ON," engine "OFF." 2. With the throttle closed, observe the "TP Sensor" display on the Tech 2. Is the "TP Sensor" below the specified value?	0.22 V	Go to Step 4	Go to Step 3
3	1. Ignition "ON," engine "OFF." 2. Review and record Tech 2 Failure Records data. 3. Operate the vehicle within Failure Records conditions as noted. 4. Using a Tech 2, monitor the "DTC" info for DTC P0122. Does the Tech 2 indicate DTC P0122 failed?	—	Go to Step 4	Refer to <i>Diagnostic Aids</i>
4	1. Ignition "OFF." 2. Disconnect the TP sensor electrical connector. 3. Jumper the 5 volt reference "A" circuit and the TP signal together at the TP sensor harness connector. 4. Ignition "ON." Observe the "TP Sensor" display on the Tech 2. (If no, start with diagnosis chart for other sensors in the circuit and see if 5V returns.) Is the "TP Sensor" at the specified value?	5 V	Go to Step 10	Go to Step 5
5	1. Disconnect jumper. 2. Connect a test light between B+ and the TP sensor signal circuit at the TP sensor harness connector. Observe the "TP Sensor" display on the Tech 2. Is the "TP Sensor" at the specified value? (If no, start with diagnosis chart for other sensors in the circuit and see if 5V returns.)	5 V	Go to Step 6	Go to Step 8
6	1. Ignition "OFF." 2. Disconnect the PCM and check the 5 volt reference "A" circuit for an open or short to ground. 3. If the 5 volt reference "A" circuit is open or shorted to ground, repair it as necessary. Was the 5 volt reference "A" circuit open or shorted to ground?	—	Verify repair	Go to Step 7
7	Check the 5 volt reference "A" circuit for a poor connection at the PCM and replace the terminal if necessary. Did the terminal require replacement?	—	Verify repair	Go to Step 12
8	1. Ignition "OFF." 2. Disconnect the PCM, and check the TP signal circuit for an open, short to ground, or short to the sensor ground circuit. 3. If the TP sensor signal circuit is open or shorted to ground, repair it as necessary. Was the TP signal circuit open or shorted to ground?	—	Verify repair	Go to Step 9

**DTC P0122 –TP Sensor Circuit Low Voltage (Cont'd)**

Step	Action	Value(s)	Yes	No
9	Check the TP sensor signal circuit for a poor connection at the PCM and replace the terminal if necessary. Did the terminal require replacement?	—	Verify repair	Go to <i>Step 12</i>
10	Check the TP sensor signal circuit for a poor connection at the TP sensor and replace the terminal if necessary. Did the terminal require replacement?	—	Verify repair	Go to <i>Step 11</i>
11	Replace the TP sensor. Is the action complete?	—	Verify repair	—
12	Replace the PCM. <b>IMPORTANT:</b> The replacement PCM must be programmed. Refer to <i>On-Vehicle Service</i> in <i>Powertrain Control Module and Sensors</i> for procedures. And also refer to latest Service Bulletin. Check to see if the Latest software is released or not. And then Down Load the LATEST PROGRAMMED SOFTWARE to the replacement PCM. Is the action complete?	—	Verify repair	—

## Diagnostic Trouble Code (DTC) P0123 TP Sensor Circuit High Voltage



### Circuit Description

The throttle position (TP) sensor circuit provides a voltage signal that changes relative to throttle blade angle. The signal voltage will vary from about 0.6 volts at closed throttle to about 4.5 volts at wide open throttle (WOT). The TP signal is one of the most important inputs used by the powertrain control module (PCM) for fuel control and many of the PCM-controlled outputs.

### Conditions for Setting the DTC

- The ignition is "ON."
- TP sensor signal voltage is greater than 4.88 volts for a total of 0.78 second over a 1.5-second period.

### Action Taken When the DTC Sets

- The PCM will illuminate the malfunction indicator lamp (MIL) the first time the fault is detected.
- The PCM will store conditions which were present when the DTC was set as Freeze Frame and in the Failure Records data.
- The PCM will use a default throttle position based on mass air flow and RPM.

### Conditions for Clearing the MIL/DTC

- The PCM will turn the MIL "OFF" on the third consecutive trip cycle during which the diagnostic has been run and the fault condition is no longer present.
- A history DTC P0123 will clear after 40 consecutive warm-up cycles have occurred without a fault.

- DTC P0123 can be cleared by using the Tech 2 "Clear Info" function or by disconnecting the PCM battery feed.

### Diagnostic Aids

Check for the following conditions:

- Check intermittent codes.
- The TP sensor shares a 5 Volt reference with the EGR position sensor. Check the 5 Volt reference if these DTCs are also set.
- The TP sensor shares a ground with the IAT sensor and the EGR position sensor. Check the ground if these other DTCs are also set.
- Poor connection at PCM – Inspect harness connectors for backed-out terminals, improper mating, broken locks, improperly formed or damaged terminals, and poor terminal-to-wire connection.
- Damaged harness – Inspect the wiring harness for damage. If the harness appears to be OK, observe the TP sensor display on the Tech 2 while moving connectors and wiring harnesses related to the TP sensor. A change in the display will indicate the location of the fault.
- Faulty TP sensor – With the ignition key "ON," engine "OFF," observe the TP sensor display on the Tech 2 while slowly depressing the accelerator to wide open throttle. If a voltage over 4.88 volts is seen at any point in normal accelerator travel, replace the TP sensor.

If DTC P0123 cannot be duplicated, the information included in the Failure Records data can be useful in determining vehicle mileage since the DTC was last set. If it is determined that the DTC occurs intermittently,

performing the DTC P1121 Diagnostic Chart may isolate the cause of the fault.

○ EGR valve

Disconnect the component while observing the TP sensor display on the Tech 2. If the reading changes drastically when this component is disconnected, replace the component that affected the reading.

**Test Description**

Number (s) below refer to the step number(s) on the Diagnostic Chart.

7. Components that share the TP sensor 5 volt reference "A" circuit include the following device:

**DTC P0123 – TP Sensor Circuit High Voltage**

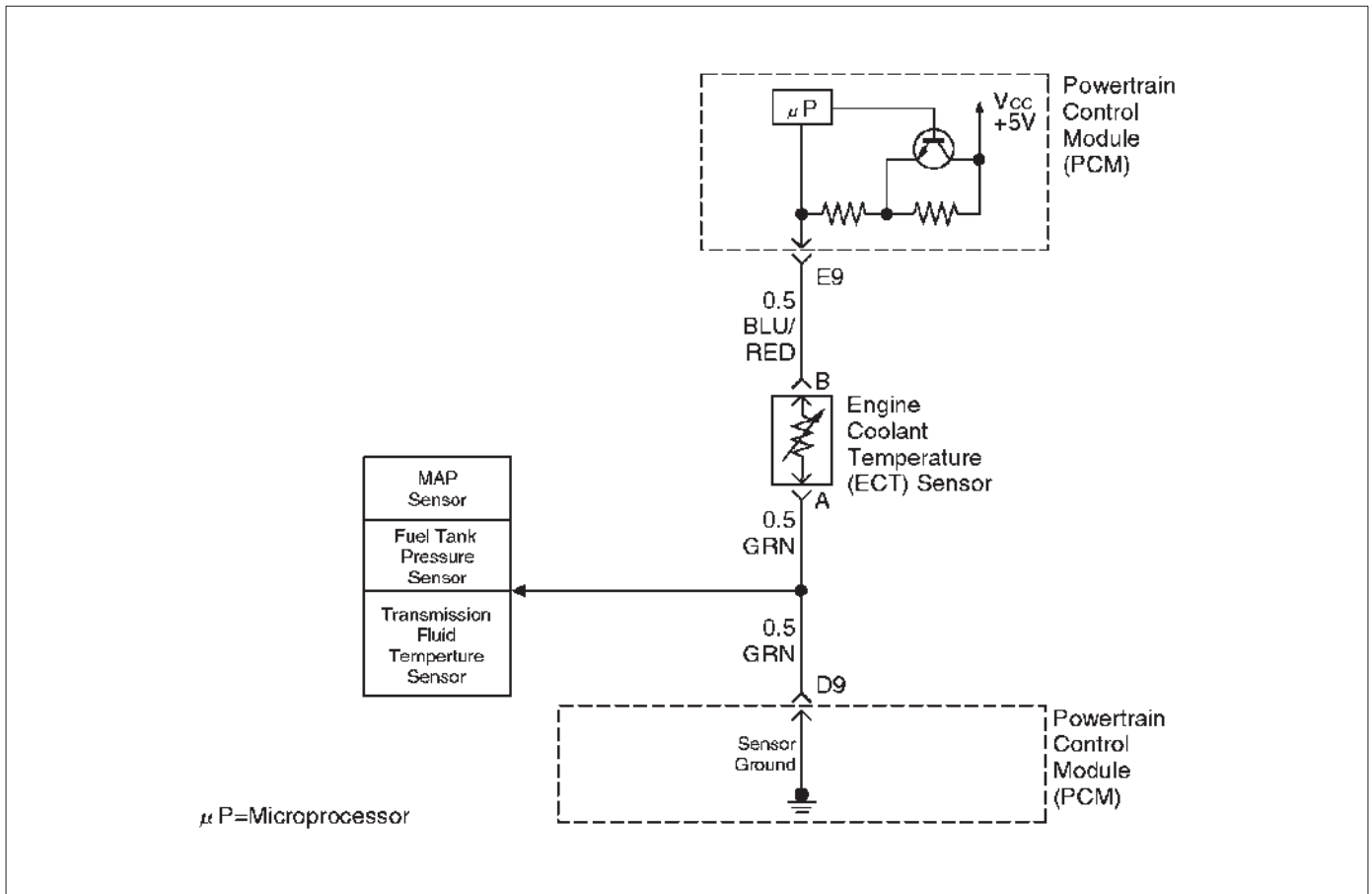
Step	Action	Value(s)	Yes	No
1	Was the "On-Board Diagnostic (OBD) System Check" performed?	—	Go to Step 2	Go to OBD System Check
2	1. Ignition "ON," engine "OFF." 2. With the throttle closed, observe the "TP Sensor" display on the Tech 2.(If no, start with diagnosis chart for other sensors in the circuit and see if 5V returns.) Is the "TP Sensor" above the specified value?	4.88 V	Go to Step 4	Go to Step 3
3	1. Ignition "ON," engine "OFF." 2. Review and record Tech 2 Failure Records data. 3. Operate the vehicle within Failure Records conditions as noted. 4. Using a Tech 2, monitor "DTC" info for DTC P0123. Does the Tech 2 indicate DTC P0123 failed.	—	Go to Step 4	Refer to Diagnostic Aids
4	1. Disconnect the TP sensor electrical connector. 2. Observe the "TP Sensor" display on the Tech 2. Is the "TP Sensor" near the specified value?	0 V	Go to Step 5	Go to Step 6
5	Probe the sensor ground circuit at the TP sensor harness connector with a test light connected to B+. Is the test light "ON?"	—	Go to Step 7	Go to Step 10
6	1. Ignition "OFF," disconnect the PCM. 2. Ignition "ON," engine "OFF." 3. Check for a short to voltage on the TP sensor signal circuit. 4. If the TP sensor signal circuit is shorted, repair it as necessary. Was the TP sensor signal circuit shorted?	—	Verify repair	Go to Step 12
7	1. Ignition "ON." 2. Monitor the "TP Sensor" Tech 2 display while disconnecting each of the components that share the 5 volt reference "A" circuit (one at a time). 3. If the "TP Sensor" Tech 2 display changes, replace the component that caused the display to change when disconnected. Does disconnecting any of these components cause the "TP Sensor" display to change?	—	Verify repair	Go to Step 8



## DTC P0123 – TP Sensor Circuit High Voltage (Cont'd)

Step	Action	Value(s)	Yes	No
8	1. Ignition "OFF," disconnect the PCM. 2. Ignition "ON," engine "OFF." 3. Check for a short to B+ on the 5 volt reference "A" circuit. 4. If the 5 volt reference "A" circuit is shorted, repair it as necessary. Was the 5 volt reference "A" circuit shorted?	—	Verify repair	Go to <i>Step 9</i>
9	Check for poor electrical connections at the TP sensor and replace terminals if necessary. Did any terminals require replacement?	—	Verify repair	Go to <i>Step 11</i>
10	1. Ignition "OFF." 2. Disconnect the PCM, and check for an open sensor ground circuit to the TP sensor. 3. If a problem is found, repair it as necessary. Was the sensor ground circuit to the TP sensor open?	—	Verify repair	Go to <i>Step 12</i>
11	Replace the TP sensor. Is the action complete?	—	Verify repair	—
12	Replace the PCM. <b>IMPORTANT:</b> The replacement PCM must be programmed. Refer to <i>On-Vehicle Service in Powertrain Control Module and Sensors</i> for procedures. And also refer to latest Service Bulletin. Check to see if the Latest software is released or not. And then Down Load the LATEST PROGRAMMED SOFTWARE to the replacement PCM. Is the action complete?	—	Verify repair	—

## Diagnostic Trouble Code (DTC) P0125 ECT Excessive Time to Closed Loop Fuel Control



### Circuit Description

To provide the best possible combination of driveability, fuel economy, and emission control, a "closed loop" air/fuel metering system is used. When the vehicle is first started, the powertrain control module (PCM) controls fuel delivery in "open loop," ignoring the heated oxygen sensor (HO2S) signals and calculating air/fuel ratio based on inputs from the engine coolant temperature, throttle position, and mass air flow sensors. The PCM will begin using the Bank 1 HO2S 1 and Bank 2 HO2S 1 signals for controlling fuel delivery under "closed loop" conditions when the following conditions have been met:

- The HO2S output signals are varying, indicating that the sensors are hot enough to operate properly.
- The engine coolant temperature sensor indicates coolant temperature above 50°C (122°F).
- Time since start-up is at least 16 seconds for a warm engine or 23 seconds for a cold engine.

### Conditions for Setting the DTC

- No active IAT or ECT DTC(s) are present.
- Engine is running.
- Vehicle speed is greater than 5 mph (8 km/h).
- Intake air temperature is greater than -10°C (14°F) 0°C (32°F).
- Start-up engine coolant temperature is between -10°C (-14°F) and 28°C (82°F).

- For a warm engine (intake air temperature is greater than 10°C/50°F), engine coolant temperature sufficient to allow "closed loop" operation (50°C/122°F) is not achieved within 2 minutes of start-up. For a cold engine (intake air temperature between -7°C and 10°C), engine coolant temperature sufficient to allow "closed loop" operation (50°C/122°F) is not achieved within 10 minutes of start-up.

- The above condition fails 20 consecutive times.

### Action Taken When the DTC Sets

- The PCM will illuminate the malfunction indicator lamp (MIL) after the second consecutive trip in which the fault is detected.
- The PCM will store conditions which were present when the DTC was set as Freeze Frame and in the Failure Records data.

### Conditions for Clearing the MIL/DTC

- The PCM will turn the MIL "OFF" on the third consecutive trip cycle during which the diagnostic has been run and the fault condition is no longer present.
- A history DTC P0125 will clear after 40 consecutive warm-up cycles have occurred without a fault.
- DTC P0125 can be cleared by using the Tech 2 "Clear Info" function or by disconnecting the PCM battery feed.

**Diagnostic Aids**

DTC P0125 set indicates a faulty ECT sensor. Comparing the engine coolant temperature displayed on a Tech 2 with actual coolant temperature measured with a thermometer may isolate this condition. If the displayed engine coolant temperature is not close to the actual coolant temperature, replace the ECT sensor.

Check for the following conditions:

- Poor connection at PCM – Inspect harness connectors for backed-out terminals, improper mating, broken locks, improperly formed or damaged terminals, and poor terminal-to-wire connection.
- Damaged harness – Inspect the wiring harness for damage. If the harness appears to be OK, observe the display on the Tech 2 while moving connectors and wiring harnesses related to the sensor. A change in the display will indicate the location of the fault.

If DTC P0125 cannot be duplicated, the information included in the Failure Records data can be useful in determining vehicle mileage since the DTC was last set.

**Test Description**

Number(s) below refer to the step number(s) on the Diagnostic Chart.

2. Comparing the engine coolant temperature displayed on a Tech 2 with actual coolant temperature measured with a thermometer may isolate this condition. If the displayed engine coolant temperature is not close to the actual coolant temperature, replace the ECT sensor. If the temperatures are close, the fault is intermittent; refer to *Diagnostic Aids*.

**Engine Coolant Temperature**

°C	°F	OHMS
<b>Temperature vs. Resistance Values (approximate)</b>		
100	212	177
80	176	332
60	140	667
45	113	1188
35	95	1802
25	77	2796
15	59	4450
5	41	7280
-5	23	12300
-15	5	21450
-30	-22	52700
-40	-40	100700

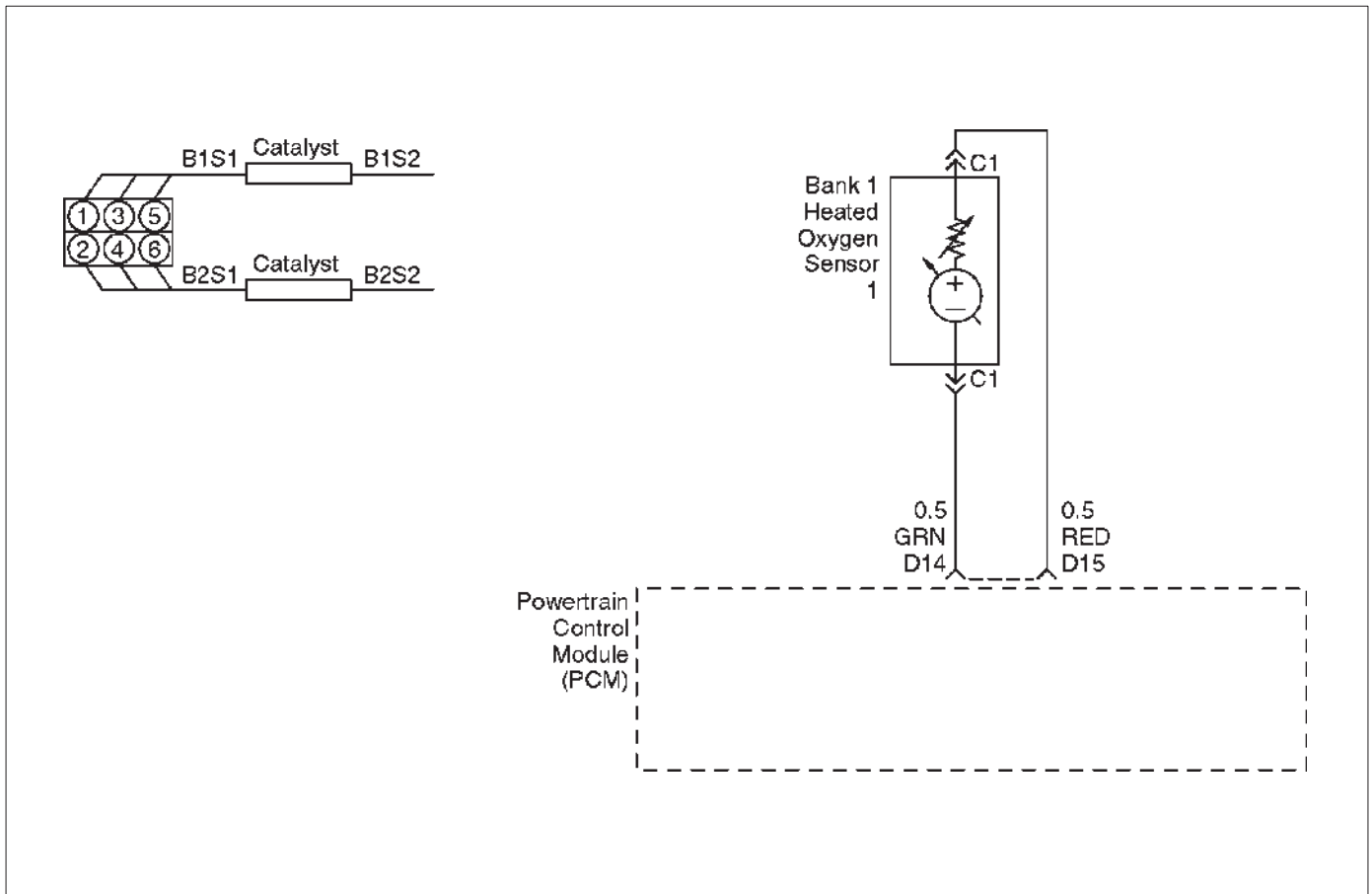
**DTC P0125 –ECT Excessive Time to Closed Loop Fuel Control**

Step	Action	Value(s)	Yes	No
1	Was the “On-Board Diagnostic (OBD) System Check” performed?	—	Go to Step 2	Go to <i>OBD System Check</i>
2	Are any ECT sensor DTCs set?	—	Go to applicable ECT sensor DTC chart	Go to Step 3
3	1. Allow the engine to cool completely. 2. Check the cooling system coolant level (refer to <i>Cooling and Radiator</i> ). Is the coolant level OK?	—	Go to Step 4	Go to Step 9
4	1. Start the engine. 2. With the engine idling, monitor “ENG COOL TEMP” display on the Tech 2. Does “ENG COOL TEMP” increase to above the specified value within 2 minutes?	21 °C (70 °F)	Refer to <i>Diagnostic Aids</i>	Go to Step 5
5	Check for proper operation of the thermostat (refer to <i>Cooling and Radiator</i> ). Is the thermostat operating correctly?	—	Go to Step 6	Go to Step 9

**DTC P0125 –ECT Excessive Time to Closed Loop Fuel Control (Cont'd)**

Step	Action	Value(s)	Yes	No
6	Compare engine coolant temperature displayed on the Tech 2 to the actual coolant temperature measured with a thermometer. (Observe normal precautions when opening the cooling system.)  Is the Tech 2 engine coolant temperature indication close to the measured temperature?	—	Go to Step 9	Go to Step 7
7	1. Ignition "OFF." 2. Disconnect the PCM. 3. Using a DVM, measure the resistance of the ECT at the PCM connector. 4. Compare the DVM reading with the chart in "Test Description."  Is the chart value approximately equal to the thermometer reading?	—	Go to Step 12	Go to Step 8
8	Check for high resistance in wiring related to the ECT sensor. Also, check for poor connections at the ECT sensor and the PCM.  Was a problem found?	—	Go to Step 10	Go to Step 11
9	Refer to <i>Cooling and Radiator</i> for cooling system diagnosis and repair condition as necessary.  Is the action complete?	—	Verify repair	—
10	Replace the faulty terminal(s) or repair faulty wiring as necessary.  Is the action complete?	—	Verify repair	—
11	Replace the ECT sensor.  Is the action complete?	—	Verify repair	—
12	Replace the PCM.  <b>IMPORTANT:</b> The replacement PCM must be programmed. Refer to <i>On-Vehicle Service in Powertrain Control Module and Sensors</i> for procedures.  And also refer to latest Service Bulletin.  Check to see if the Latest software is released or not. And then Down Load the LATEST PROGRAMMED SOFTWARE to the replacement PCM.  Is the action complete?	—	Verify repair	—

## Diagnostic Trouble Code (DTC) P0131 HO2S Circuit Low Voltage Bank 1 Sensor 1



### Circuit Description

The powertrain control module (PCM) supplies a bias voltage of about 450 mV between the heated oxygen sensor (HO2S) signal high and signal low circuits. When measured with a 10 megaohm digital voltmeter, this may display as low as 350 mV. The oxygen sensor varies the voltage within a range of about 1000 mV when the exhaust is rich, down through about 10 mV when exhaust is lean. The PCM constantly monitors the HO2S signal during "closed loop" operation and compensates for a rich or lean condition by decreasing or increasing injector pulse width as necessary. If the Bank 1 HO2S 1 voltage remains excessively low for an extended period of time, DTC P0131 will be set.

### Conditions for Setting the DTC

- No related DTCs.
- Vehicle is operating in "closed loop."
- Engine coolant temperature is above 60°C (140°F).
- "Closed loop" commanded air/fuel ratio is between 14.5 and 14.8.
- Throttle angle is between 3% and 19%.
- Bank 1 HO2S 1 signal voltage remains below 22 mV during normal "closed loop" operation for a total of 77 seconds over a 90-second period of time.

### Action Taken When the DTC Sets

- The PCM will illuminate the malfunction indicator lamp (MIL) the first time the fault is detected.
- The PCM will store conditions which were present when the DTC was set as Freeze Frame and in the Failure Records data.
- "Open loop" fuel control will be in effect.

### Conditions for Clearing the MIL/DTC

- The PCM will turn the MIL "OFF" on the third consecutive trip cycle during which the diagnostic has been run and the fault condition is no longer present.
- A history DTC P0131 will clear after 40 consecutive warm-up cycles have occurred without a fault.
- DTC P0131 can be cleared by using the Tech 2 "Clear Info" function or by disconnecting the PCM battery feed.

### Diagnostic Aids

Check for the following conditions:

- Heated oxygen sensor wiring – The sensor pigtail may be routed incorrectly and contacting the exhaust system.
- Poor PCM to engine block grounds.
- Fuel pressure – The system will go lean if pressure is too low. The PCM can compensate for some decrease. However, if fuel pressure is too low, a DTC P0131 may be set. Refer to *Fuel System Diagnosis*.
- Lean injector(s) – Perform "Injector Balance Test."

- Vacuum leaks – Check for disconnected or damaged vacuum hoses and for vacuum leaks at the intake manifold, throttle body, EGR system, and PCV system.
- Exhaust leaks – An exhaust leak may cause outside air to be pulled into the exhaust gas stream past the HO2S, causing the system to appear lean. Check for exhaust leaks that may cause a false lean condition to be indicated.
- MAF sensor – The system can go lean if the MAF sensor signal indicates an engine airflow measurement that is not correct. Disconnect the MAF sensor to see if the lean condition is corrected. If so, replace the MAF sensor.
- Fuel contamination – Water, even in small amounts, can be delivered to the fuel injectors. The water can cause a lean exhaust to be indicated. Excessive alcohol in the fuel can also cause this condition. Refer to *Fuel System Diagnosis* for the procedure to check for fuel contamination.

- If none of the above conditions are present, replace the affected HO2S.

**Test Description**

Number(s) below refer to step numbers on the diagnostic chart.

- 3. DTC P0131 failing during operation may indicate a condition described in the “Diagnostic Aids” above. If the DTC P0131 test passes while the Failure Records conditions are being duplicated, an intermittent condition is indicated.

Reviewing the Failure Records vehicle mileage since the diagnostic test last failed may help determine how often the condition that caused the DTC to be set occurs. This may assist in diagnosing the condition.

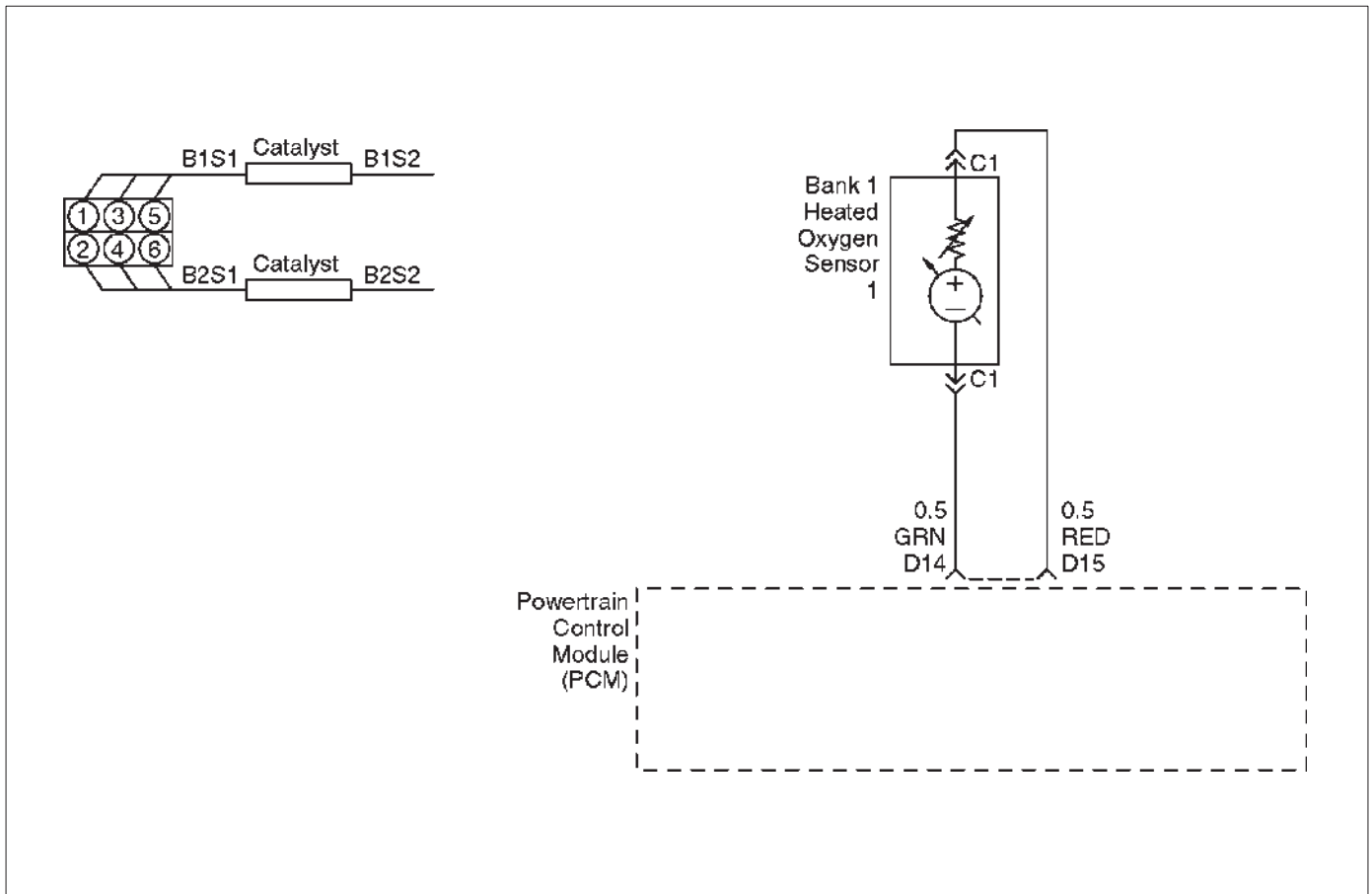
**DTC P0131 –HO2S Circuit Low Voltage Bank 1 Sensor 1**

Step	Action	Value(s)	Yes	No
1	Was the “On-Board Diagnostic (OBD) System Check” performed?	—	Go to Step 2	Go to <i>OBD System Check</i>
2	1. Install the Tech 2. 2. Run the engine at operating temperature. 3. Operate the vehicle within the parameters specified under “Conditions for Setting the DTC” criteria included in Diagnostic Support. 4. Using a Tech 2, monitor Bank 1 HO2S 1 voltage. Does the Bank 1 HO2S 1 voltage remain below the specified value?	22 mV	Go to Step 4	Go to Step 3
3	1. Ignition “ON,” engine “OFF,” review and record Tech 2 Failure Records data and note parameters. 2. Operate the vehicle within Failure Records conditions as noted. 3. Using a Tech 2, monitor “DTC” info for DTC P0131 until the DTC P0131 test runs. Note test result. Does Tech 2 indicate DTC P0131 failed this ignition?	—	Go to Step 4	Refer to <i>Diagnostic Aids</i>
4	1. Turn the ignition “OFF.” 2. Disconnect the PCM. 3. Check the Bank 1 HO2S 1 high and low circuits for a short to ground or a short to the heater ground circuit. Are the Bank 1 HO2S 1 signal circuits shorted to ground?	—	Go to Step 5	Go to Step 6
5	Repair the Bank 1 HO2S 1 signal circuit. Is the action complete?	—	Verify repair	—
6	1. Turn the ignition “OFF,” HO2S 1 and PCM disconnected. 2. Check for continuity between the high and low signal circuits. Was there continuity between the high and low circuits?	—	Go to Step 7	Go to Step 8

**DTC P0131 –HO2S Circuit Low Voltage Bank 1 Sensor 1 (Cont'd)**

Step	Action	Value(s)	Yes	No
7	Repair the short between the high and low circuits. Is the action complete?	—	Verify repair	—
8	1. Ignition "OFF." 2. Reconnect the PCM, leave the sensor disconnected. 3. Ignition "ON." Does the Tech 2 indicate Bank 1 HO2S 1 voltage between the specified values?	425-475 mV	Refer to <i>Diagnostic Aids</i>	Go to <i>Step 9</i>
9	Replace the PCM. <b>IMPORTANT:</b> The replacement PCM must be programmed. Refer to <i>On-Vehicle Service in Powertrain Control Module and Sensors</i> for procedures. And also refer to latest Service Bulletin. Check to see if the Latest software is released or not. And then Down Load the LATEST PROGRAMMED SOFTWARE to the replacement PCM. Is the action complete?	—	Verify repair	—

## Diagnostic Trouble Code (DTC) P0132 HO2S Circuit High Voltage Bank 1 Sensor 1



D06RX081

### Circuit Description

The powertrain control module (PCM) supplies a bias voltage of about 450 mV between the heated oxygen sensor (HO2S) signal and low circuits. When measured with a 10 megaohm digital voltmeter, this may display as low as 320 mV. The oxygen sensor varies the voltage within a range of about 1000 mV when exhaust is rich, down through about 10 mV when exhaust is lean. The PCM constantly monitors the HO2S signal during "closed loop" operation and compensates for a rich or lean condition by decreasing or increasing injector pulse width as necessary. If the Bank 1 HO2S 1 voltage remains excessively high for an extended period of time, DTC P0132 will be set.

### Conditions for Setting the DTC

- No related DTCs.
  - Engine coolant temperature is above 60°C (140°F)
  - "Closed loop" commanded air/fuel ratio is between 14.5 and 14.8.
  - Throttle angle is between 3% and 19%.
  - Bank 1 HO2S 1 signal voltage remains above 952 mV during normal "closed loop" operation for a total of 77 seconds over a 90-second period.
- OR
- Bank 1 HO2S 1 signal voltage remains above 500 mV during "deceleration fuel cutoff mode" operation for 3 seconds.

### Action Taken When the DTC Sets

- The PCM will illuminate the malfunction indicator lamp (MIL) the first time the fault is detected.
- The PCM will store conditions which were present when the DTC was set as Freeze Frame and in the Failure Records data.
- "Open loop" fuel control will be in effect.

### Conditions for Clearing the MIL/DTC

- The PCM will turn the MIL "OFF" on the third consecutive trip cycle during which the diagnostic has been run and the fault condition is no longer present.
- A history DTC P0132 will clear after 40 consecutive warm-up cycles have occurred without a fault.
- DTC P0132 can be cleared by using the Tech 2 "Clear Info" function or by disconnecting the PCM battery feed.

### Diagnostic Aids

Check the following items:

- Fuel pressure – The system will go rich if pressure is too high. The PCM can compensate for some increase. However, if fuel pressure is too high, a DTC P0132 may be set. Refer to *Fuel System Diagnosis*.
- Perform "Injector Balance Test" – Refer to *Fuel System Diagnosis*.
- Check the EVAP canister for fuel saturation – If full of fuel, check canister control and hoses. Refer to *Evaporative (EVAP) Emission Control System*.



## 6E-160 6VE1 3.5L ENGINE DRIVEABILITY AND EMISSIONS

- MAF sensor –The system can go rich if MAF sensor signal indicates an engine airflow measurement that is not correct. Disconnect the MAF sensor to see if the rich condition is corrected. If so, replace the MAF sensor.
- Check for a leak in the fuel pressure regulator diaphragm by checking the vacuum line to the regulator for the presence of fuel. There should be no fuel in the vacuum line.
- An intermittent TP sensor output will cause the system to go rich due to a false indication of the engine accelerating.
- Shorted Heated Oxygen Sensor (HO2S) –If the HO2S is internally shorted, the HO2S voltage displayed on the Tech 2 will be over 1 volt. Try disconnecting the affected HO2S with the key “ON,” engine “OFF.” If the displayed HO2S voltage changes from over 1000 mV to around 450 mV, replace the HO2S. Silicon contamination of the HO2S can also cause a high HO2S voltage to be indicated. This condition is indicated by a powdery white deposit on the portion of the HO2S exposed to the exhaust stream. If contamination is noticed, replace the affected HO2S.
- Open HO2S Signal Circuit or Faulty HO2S–A poor connection or open in the HO2S signal circuit can cause the DTC to set during deceleration fuel mode.

An HO2S which is faulty and not allowing a full voltage swing between the rich and lean thresholds can also cause this condition. Operate the vehicle by monitoring the HO2S voltage with a Tech 2. If the HO2S voltage is limited within a range between 300 mV to 600 mV, check the HO2S signal circuit wiring and associated terminal conditions.

- If none of the above conditions are present, replace the affected HO2S.

### Test Description

Number(s) below refer to the step number(s) on the Diagnostic Chart.

3. DTC P0132 failing during “deceleration fuel cutoff mode” operation may indicate a condition described in the “Diagnostic Aids” above. If the DTC P0132 test passes while the Failure Records conditions are being duplicated, an intermittent condition is indicated.

Reviewing the Failure Records vehicle mileage since the diagnostic test last failed may help determine how often the condition that caused the DTC to be set occurs. This may assist in diagnosing the condition.

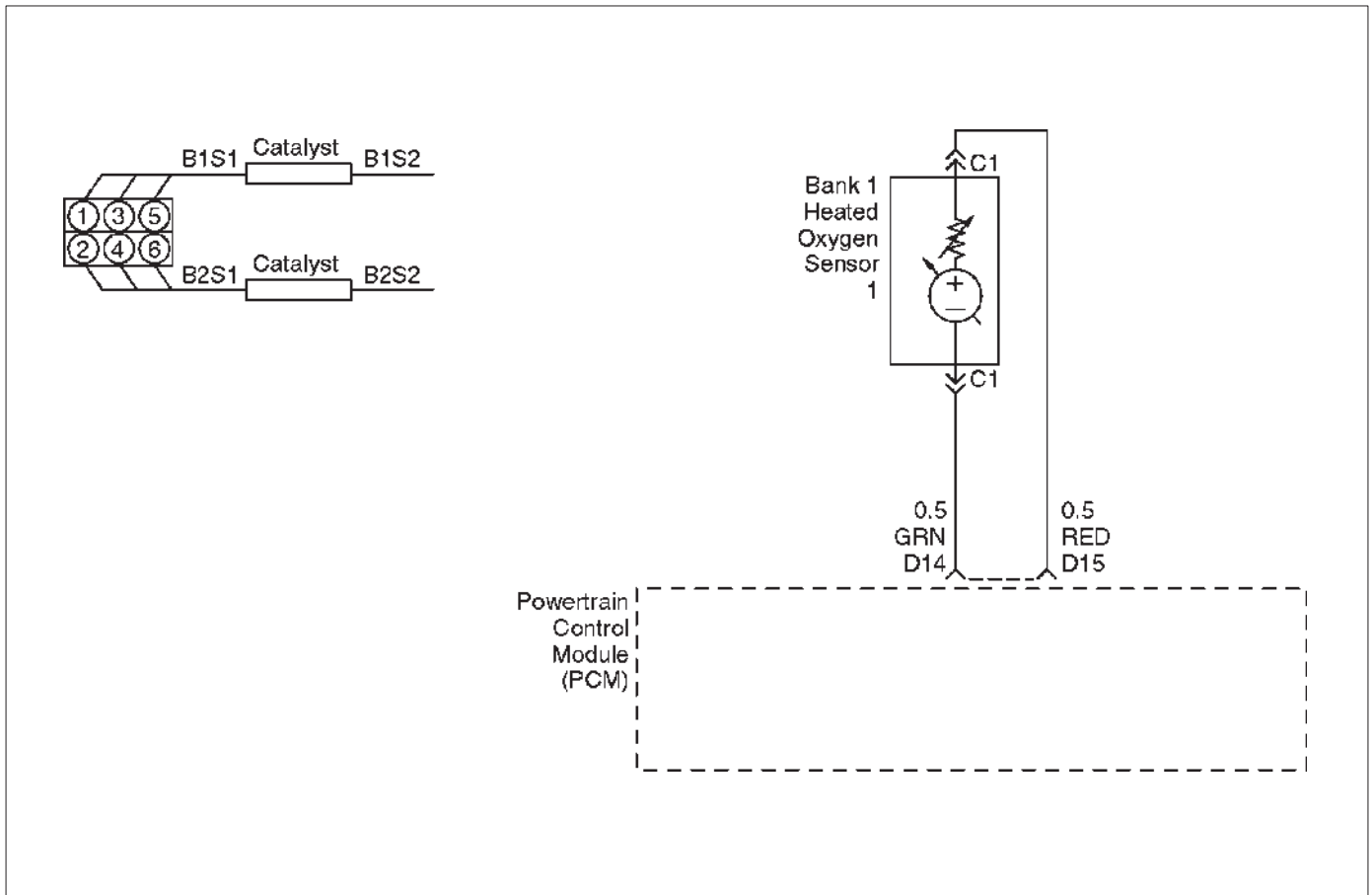
### DTC P0132 – HO2S Circuit High Voltage Bank 1 Sensor 1

Step	Action	Value(s)	Yes	No
1	Was the “On-Board Diagnostic (OBD) System Check” performed?	—	Go to Step 2	Go to <i>OBD System Check</i>
2	1. Install the Tech 2. 2. Run the engine at operating temperature. 3. Operate the vehicle within parameters specified under “Conditions for Setting the DTC” included in Diagnostic Support. 4. Using a Tech 2, monitor Bank 1 HO2S 1 voltage. Does the Bank 1 HO2S 1 voltage remain above the specified value?	952 mV (500 mV in deceleration fuel cutoff mode)	Go to Step 4	Go to Step 3
3	1. Ignition “ON,” review and record Tech 2 Failure Records data. 2. Operate the vehicle within Failure Records conditions as noted. 3. Using a Tech 2, monitor “DTC” info for DTC P0132 until the DTC P0132 test runs. 4. Note the test result. Does the Tech 2 indicate DTC P0132 failed this ignition?	—	Go to Step 4	Refer to <i>Diagnostic Aids</i>
4	1. Ignition “OFF.” 2. Disconnect Bank 1 HO2S 1. 3. Ignition “ON.” 4. At HO2S Bank 1 Sensor 1 connector (PCM side) use a DVM to measure voltages at the high and low signal terminals. Are the voltages in the specified range?	3-4 V	Go to Step 5	Go to Step 6
5	Repair short to voltage in signal circuit. Is the action complete?	—	Verify repair	—

**DTC P0132 – HO2S Circuit High Voltage Bank 1 Sensor 1 (Cont'd)**

Step	Action	Value(s)	Yes	No
6	1. Ignition "ON," engine "OFF." 2. At Bank 1 HO2S 1 connector (PCM side) jumper both the HO2S high and low signal circuits (PCM side) to ground. 3. Using a Tech 2, monitor Bank 1 HO2S 1 voltage. Is Bank 1 HO2S 1 voltage below the specified value?	10 mV	Go to <i>Step 7</i>	Go to <i>Step 8</i>
7	1. Disconnect the jumpers to ground from Bank 1 HO2S 1 PCM-side connector. 2. With the HO2S 1 connector disconnected, monitor Bank 1 HO2S 1 voltage. Is Bank 1 HO2S 1 voltage between the specified values?	425-475 mV	Refer to <i>Diagnostic Aids</i>	Go to <i>Step 8</i>
8	Replace the PCM. <b>IMPORTANT:</b> The replacement PCM must be programmed. Refer to <i>On-Vehicle Service</i> in <i>Powertrain Control Module and Sensors</i> for procedures. And also refer to latest Service Bulletin. Check to see if the Latest software is released or not. And then Down Load the LATEST PROGRAMMED SOFTWARE to the replacement PCM. Is the action complete?	—	Verify repair	—

## Diagnostic Trouble Code (DTC) P0133 HO2S Slow Response Bank 1 Sensor 1



D06RX081

### Circuit Description

The powertrain control module (PCM) continuously monitors the heated oxygen sensor (HO2S) activity for 90 seconds after "closed loop" has been enabled. During the monitoring period the PCM counts the number of times that a rich-to-lean and lean-to-rich response is indicated and adds the amount of time it took to complete all rich-to-lean transitions and lean-to-rich transitions. With this information, an average time for rich-to-lean and lean-to-rich transitions can be determined. If the average response time of either transition is too slow, a DTC P0133 will be set.

A lean-to-rich transition is indicated when the HO2S voltage changes from less than 300 mV to greater than 600 mV. A rich-to-lean transition is indicated when the HO2S voltage changes from more than 600 mV to less than 300 mV. An HO2S that responds too slowly is likely to be faulty and should be replaced.

### Conditions for Setting the DTC

- No related DTCs.
- Engine coolant temperature (ETC) is above 50°C (122°F) for automatic transmission; 75°C (167°F) for manual transmission.
- Engine is operating in "closed loop."
- Engine has been running for at least 1 minute.
- Engine speed is between 1500 RPM and 3000 RPM.
- Canister purge duty cycle is greater than 2%.
- Mass air flow is between 9 g/second and 42 g/second.

- All above conditions are met for 3 seconds.
- 90 seconds after "closed loop" has been enabled, Bank1 HO2S 1 average transition time between 300 mV and 600 mV is too slow. The lean-to-rich average transition response time was longer than 94 milliseconds or rich-to-lean average transition response time was longer than 105 milliseconds.

### Action Taken When the DTC Sets

- The PCM will illuminate the malfunction indicator Lamp (MIL) after the second consecutive trip in which the fault is detected.
- The PCM will store conditions which were present when the DTC was set as Freeze Frame and in the Failure Records data.
- "Open loop" fuel control will be in effect.

### Conditions for Clearing the MIL/DTC

- The PCM will turn the MIL "OFF" on the third consecutive trip cycle during which the diagnostic has been run and the fault condition is no longer present.
- A history DTC P0133 will clear after 40 consecutive warm-up cycles have occurred without a fault.
- DTC P0133 can be cleared by using the Tech 2 "Clear Info" function or by disconnecting the PCM battery feed.

### Diagnostic Aids

Check for the following conditions:

- Poor connection at PCM – Inspect harness connectors for backed-out terminals, improper mating, broken

locks, improperly formed or damaged terminals, and poor terminal-to-wire connection.

- Damaged harness – Inspect the wiring harness for damage. If the harness appears to be OK, observe the Bank 1 HO2S 1 display on the Tech 2 while moving connectors and wiring harnesses related to the sensor. A change in the display will indicate the location of the fault.

If DTC P0133 cannot be duplicated, reviewing the Failure Records vehicle mileage since the diagnostic test last failed may help determine how often the condition that caused the DTC to be set occurs. This may assist in diagnosing the condition.

### **Test Description**

Number(s) below refer to the step number(s) on the Diagnostic Chart.

2. Verifies that the fault is currently present.
3. HO2S transition time, ratio mean volts and switching DTCs set for multiple sensors indicate probable contamination. Before replacing the sensors, isolate and correct the source of the contamination to avoid damaging the replacement sensors.

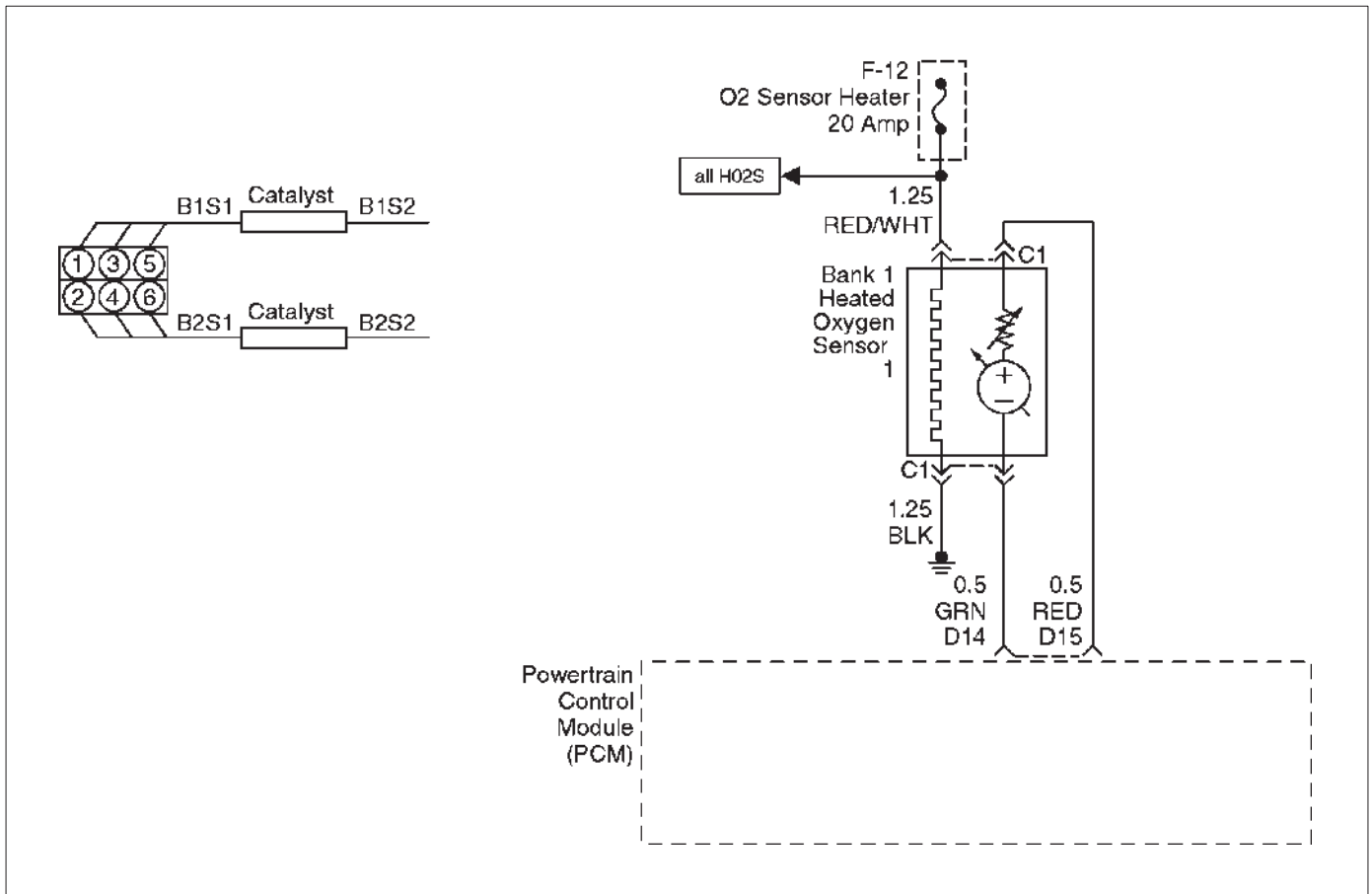
**DTC P0133 – HO2S Slow Response Bank 1 Sensor 1**

Step	Action	Value(s)	Yes	No
1	Was the "On-Board Diagnostic (OBD) System Check" performed?	—	Go to Step 2	Go to <i>OBD System Check</i>
2	NOTE: If any DTCs are set (expect P0153, P1133, P1134, P1153, and/or P1154), refer to those DTCs before proceeding with this diagnostic chart. 1. Install the Tech 2. 2. Idle the engine at operating temperature. 3. Operate the vehicle within parameters specified under "Conditions for Setting the DTC" included in Diagnostic Support. 4. Using a Tech 2, monitor "DTC" info for DTC P0133 until the DTC P0133 test runs. 5. Note the test result. Does the Tech 2 indicate DTC P0133 failed this ignition?	—	Go to Step 3	Refer to <i>Diagnostic Aids</i>
3	Did the Tech 2 also indicate DTC P0153, P1133, P1134, P1153, and/or P1154 failed this ignition?	—	Go to Step 17	Go to Step 4
4	Check for leaks at the pipe joints. Are the joints leaking?	—	Go to Step 5	Go to Step 6
5	Tighten the U-bolt nuts at the leaking joints. Is the action complete?	—	Go to Step 2	—
6	Check for gaskets that are damaged or improperly installed. Are there damaged or misaligned gaskets?	—	Go to Step 7	Go to Step 8
7	1. Replace damaged gaskets. 2. Align the connections. 3. Tighten the connections. Is the action complete?	—	Go to Step 2	—
8	Check for loose exhaust flange connections. Are the flange connections loose?	—	Go to Step 2	Go to Step 10
9	Tighten the stud nuts or bolts to specifications. Is the action complete?	—	Go to Step 2	—
10	Check for burned or corroded exhaust pipes. Are the exhaust pipes burned or corroded?	—	Go to Step 11	Go to Step 12
11	Replace the exhaust pipes, as required. Is the action complete?	—	Go to Step 2	—
12	Check for leaks at the exhaust manifold. Are there leaks at the exhaust manifold?	—	Go to Step 13	Go to Step 14
13	Tighten the bolts to specifications to replace the manifold if necessary. Is the action complete?	—	Go to Step 2	—

## DTC P0133 – HO2S Slow Response Bank 1 Sensor 1 (Cont'd)

Step	Action	Value(s)	Yes	No
14	Visually/physically inspect the following items: <ul style="list-style-type: none"> <li>○ Ensure that the Bank 1 HO2S 1 is securely installed.</li> <li>○ Check for corrosion on terminals.</li> <li>○ Check terminal tension (at Bank 1 HO2S 1 and at the PCM).</li> <li>○ Check for damaged wiring.</li> </ul> Was a problem found in any of the above areas?	—	Go to Step 18	Go to Step 15
15	1. Disconnect Bank 1 HO2S 1. 2. Ignition "ON." 3. Using a DVM at the PCM side of the HO2S 1 connector, measure the voltage between the high signal circuit and ground. Also measure the voltage between the low signal circuit and ground. Are both voltages in the specified range?	3-4 V	Go to Step 16	Go to Step 19
16	1. With Bank 1 HO2S 1 disconnected, jumper the high and low (PCM side) signal circuits to ground. 2. Ignition "ON." 3. Using a Tech 2, monitor the Bank 1 HO2S 1 voltage. Does the Tech 2 indicate less than 10 mV and immediately return to about 450 mV when the jumper is removed?	—	Go to Step 21	Go to Step 22
17	Replace the affected heated oxygen sensors. NOTE: Before replacing sensors, the cause of the contamination must be determined and corrected. <ul style="list-style-type: none"> <li>○ Fuel contamination.</li> <li>○ Use of improper RTV sealant.</li> <li>○ Engine oil/coolant consumption.</li> </ul> Is the action complete?	—	Verify repair	—
18	Repair condition as necessary. Is the action complete?	—	Verify repair	—
19	Check for faulty PCM connections or terminal damage. Is the action complete?	—	Verify repair	Go to Step 20
20	Repair open, short or grounded signal circuit. Is the action complete?	—	Verify repair	—
21	Replace Bank 1 HO2S 1. Is the action complete?	—	Verify repair	—
22	Replace the PCM. <b>IMPORTANT:</b> The replacement PCM must be programmed. Refer to <i>On-Vehicle Service in Powertrain Control Module and Sensors</i> for procedures. And also refer to latest Service Bulletin. Check to see if the Latest software is released or not. And then Down Load the LATEST PROGRAMMED SOFTWARE to the replacement PCM. Is the action complete?	—	Verify repair	—

## Diagnostic Trouble Code (DTC) P0134 HO2S Circuit Insufficient Activity Bank 1 Sensor 1



### Circuit Description

- The powertrain control module (PCM) supplies a bias voltage of about 450 mV between the heated oxygen sensor (HO2S) high and low circuits. When measured with a 10 megaohm digital voltmeter, this may display as low as 320 mV. The oxygen sensor varies the voltage within a range of about 1000 mV when the exhaust is rich, down through about 10 mV when exhaust is lean. The PCM constantly monitors the HO2S signal during “closed loop” operation and compensates for a rich or lean condition by decreasing or increasing injector pulse width as necessary. If the Bank 1 HO2S 1 voltage remains at or near the 450 mV bias for an extended period of time, DTC P0134 will be set, indicating an open sensor signal or sensor low circuit.
- Heated oxygen sensors are used to minimize the amount of time required for “closed loop” fuel control operation and to allow accurate catalyst monitoring. The oxygen sensor heater greatly decreases the amount of time required for fuel control sensors Bank 1 HO2S 1 and Bank 2 HO2S 1 to become active.
- Oxygen sensor heaters are required by post-catalyst monitor sensors to maintain a sufficiently high temperature for accurate exhaust oxygen content readings further from the engine.

### Conditions for Setting the DTC

- No related DTCs.
- Battery voltage is above 10 volts.
- Engine run time is longer than 40 seconds.

- Oxygen sensor heater has been determined to be functioning properly.
- Bank 1 HO2S 1 signal voltage remains between 400 mV and 500 mV for a total of 77 seconds over a 90-second period of time.

### Action Take When the DTC Sets

- The PCM will illuminate the malfunction indicator lamp (MIL) the first time the fault is detected.
- The PCM will store conditions which were present when the DTC was set as Freeze Frame and in the Failure Records data.
- “Open loop” fuel control will be in effect.

### Conditions for Clearing the MIL/DTC

- The PCM will turn the MIL “OFF” on the third consecutive trip cycle during which the diagnostic has been run and the fault condition is no longer present.
- A history DTC P0134 will clear after 40 consecutive warm-up cycles have occurred without a fault.
- DTC P0134 can be cleared by using the Tech 2 “Clear Info” function or by disconnecting the PCM battery feed.

### Diagnostic Aids

Check for the following conditions:

- Poor connection or damaged harness – Inspect the harness connectors for backed-out terminals, improper mating, broken locks, improperly formed or

damaged terminals, poor terminal-to-wire connection, and damaged harness.

- Faulty HO2S heater or heater circuit – With the ignition “ON,” engine “OFF,” after a cool down period, the HO2S 1 voltage displayed on the Tech 2 is normally 455-460 mV. A reading over 1000 mV indicates a signal line shorted to voltage. A reading under 5 mV indicates a signal line shorted to ground or signal lines shorted together. Disconnect the HO2S and connect a test light between the HO2S ignition feed and heater ground circuits. If the test light does not light for 2 seconds when the ignition is turned on, repair the open ignition feed or sensor ground circuit as necessary. If the test light lights and the HO2S signal and low circuits are OK, replace the HO2S.
- Intermittent test – With the Ignition “ON,” monitor the HO2S signal voltage while moving the wiring harness

and related connectors. If the fault is induced, the HO2S signal voltage will change. This may help isolate the location of the malfunction.

**Test Description**

Number(s) below refer to the step number(s) on the Diagnostic Chart.

- 3. If the DTC P0134 test passes while the Failure Records conditions are being duplicated, an intermittent conditions is indicated.

Reviewing the Failure Records vehicle mileage since the diagnostic test last failed may help determine how often the condition that caused the DTC to be set occurs. This may assist in diagnosing the condition.

**DTC P0134 –HO2S Circuit Insufficient Activity Bank 1 Sensor 1**

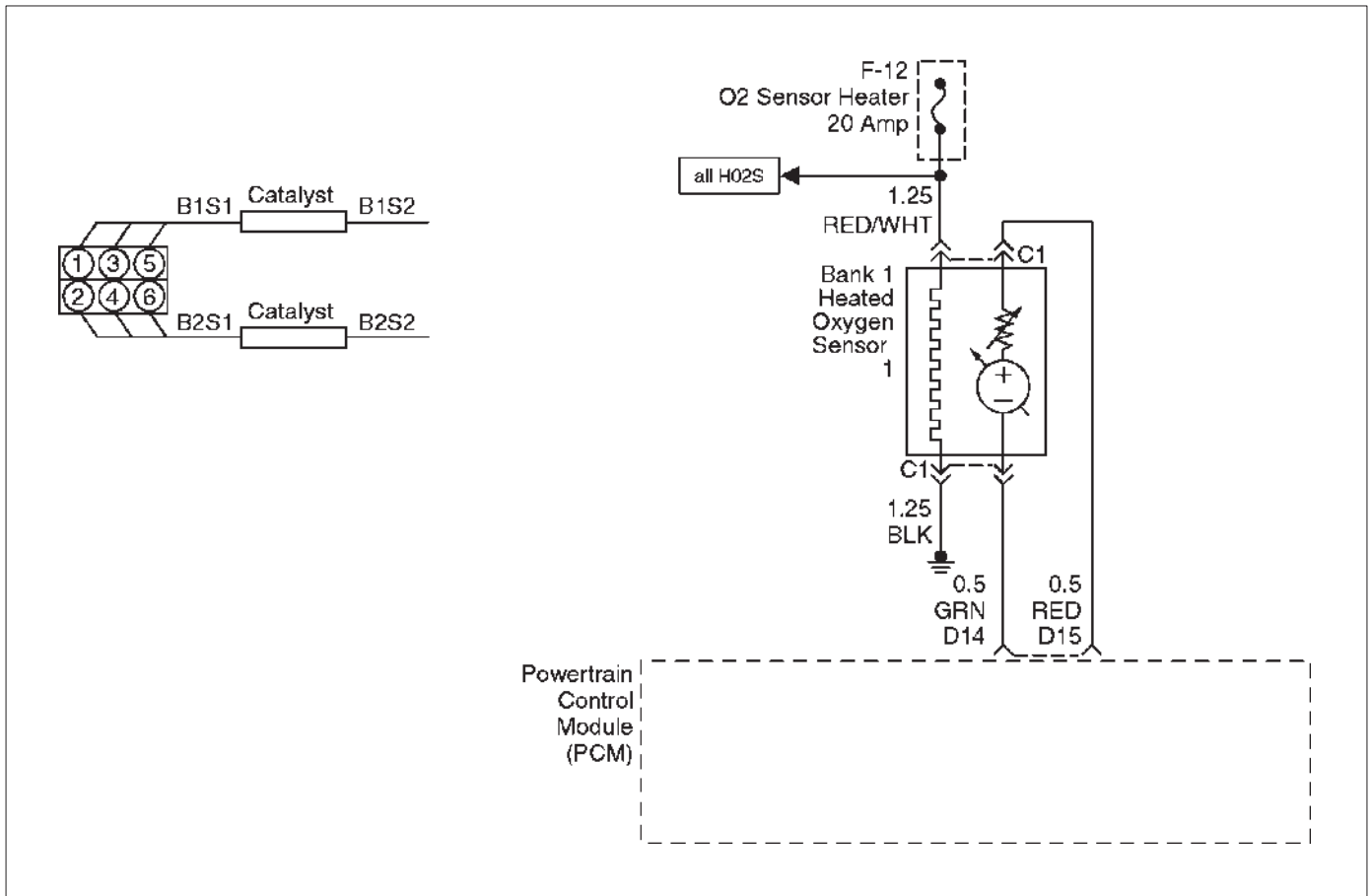
Step	Action	Value(s)	Yes	No
1	Was the “On-Board Diagnostic (OBD) System Check” performed?	—	Go to Step 2	Go to <i>OBD System Check</i>
2	1. Install the Tech 2. 2. Run the engine at operating temperature. 3. Operate the engine above 1200 RPM for two minutes.  Does the Tech 2 indicate Bank 1 HO2S 1 voltage varying outside the specified values?	400-500 mV	Go to Step 3	Go to Step 4
3	1. Ignition “ON,” engine “OFF,” review and record Tech 2 Failure Records data and note parameters. 2. Operate the vehicle within Failure Records conditions as noted. 3. Using a Tech 2, monitor “DTC” info for DTC P0134 until the DTC P0134 test runs. 4. Note the test result.  Does the Tech 2 indicate DTC P0134 failed this ignition?	—	Go to Step 4	Refer to <i>Diagnostic Aids</i>
4	Check for a damaged harness.  Was a problem found?	—	Verify repair	Go to Step 5
5	Check for poor Bank 1 HO2S 1 high and low circuit terminal connections at the Bank 1 HO2S 1 harness connector and replace terminal(s) if necessary.  Did any terminals require replacement?	—	Verify repair	Go to Step 6
6	Check for poor Bank 1 HO2S 1 high and low circuit terminal connections at the PCM and replace terminals if necessary.  Did any terminals require replacement?	—	Verify repair	Go to Step 7
7	1. Ignition “OFF.” 2. With the PCM disconnected, check continuity of the Bank 1 HO2S 1 high circuit. 3. If the Bank 1 HO2S 1 high circuit measures over 5.0 ohms, repair open or poor connection as necessary.  Was a Bank 1 HO2S 1 high circuit problem found and corrected?	—	Verify repair	Go to Step 8



**DTC P0134 –HO2S Circuit Insufficient Activity Bank 1 Sensor 1 (Cont'd)**

Step	Action	Value(s)	Yes	No
8	1. Ignition "OFF." 2. With the PCM disconnected, check continuity of the Bank 1 HO2S 1 low circuit. 3. If the Bank 1 HO2S 1 low circuit measures over 5 ohms, repair open or poor connection as necessary. Was a Bank 1 HO2S 1 low circuit problem found and corrected?	—	Verify repair	Go to <i>Step 9</i>
9	1. Ignition "ON," engine "OFF." 2. Disconnect Bank 1 HO2S 1 and jumper the HO2S high and low circuits (PCM side) to ground. 3. Using a Tech 2, monitor Bank 1 HO2S 1 voltage. Is Bank 1 HO2S 1 voltage in the specified range?	0-10 mV	Go to <i>Step 10</i>	Go to <i>Step 11</i>
10	Replace Bank 1 HO2S 1. Is the action complete?	—	Verify repair	—
11	Replace the PCM. <b>IMPORTANT:</b> The replacement PCM must be programmed. Refer to <i>On-Vehicle Service in Powertrain Control Module and Sensors</i> for procedures. And also refer to latest Service Bulletin. Check to see if the Latest software is released or not. And then Down Load the LATEST PROGRAMMED SOFTWARE to the replacement PCM. Is the action complete?	—	Verify repair	—

## Diagnostic Trouble Code (DTC) P0135 HO2S Heater Circuit Bank 1 Sensor 1



### Circuit Description

Heated oxygen sensors are used to minimize the amount of time required for “closed loop” fuel control operation and to allow accurate catalyst monitoring. The oxygen sensor heater greatly decreases the amount of time required for fuel control sensors Bank 1 HO2S 1 and Bank 2 HO2S 1 to become active. Oxygen sensor heaters are required by post-catalyst monitor sensors to maintain a sufficiently high temperature which allows accurate exhaust oxygen content readings further from the engine. The powertrain control module (PCM) will run the heater test only after a cold start (determined by engine coolant and intake air temperature at the time of start-up) and only once during an ignition cycle. When the engine is started the PCM will monitor the HO2S voltage. When the HO2S voltage indicates a sufficiently active sensor, the PCM looks at how much time has elapsed since start-up. If the PCM determines that too much time was required for the Bank 1 HO2S 1 to become active, a DTC P0135 will set. The time it should take the HO2S to reach operating temperature is based on the accumulated amount of air that has passed through the MAF sensor and into the engine (more accumulated air flow = shorter time to HO2S activity).

### Conditions for Setting the DTC

- No related DTCs.
- Intake air temperature (IAT) is less than 32°C (90°F) at start-up.

- Engine coolant temperature (ECT) is less than 32°C (90°F) at start-up.
- IAT and ECT are within 6°C (11°F) of each other at start-up.
- Ignition voltage is between 11 and 18 V.
- Average mass air flow is less than 21 g/second during sample period.
- Bank 1 HO2S 1 voltage does not change more than 150 mV from the bias voltage (between 400 mV and 500 mV) for a longer amount of time than it should. The maximum amount of time to come up to operating range is 150 seconds. This warm-up time depends on the engine coolant temperature at start-up and accumulate air flow since start-up.

### Action Taken When the DTC Sets

- The PCM will illuminate the malfunction indicator lamp (MIL) after the second consecutive trip in which the fault is detected.
- The PCM will store conditions which were present when the DTC was set as Freeze Frame and in the Failure Records data.

### Conditions for Clearing the MIL/DTC

- The PCM will turn the MIL “OFF” on the third consecutive trip cycle during which the diagnostic has been run and the fault condition is no longer present.
- A history DTC P0135 will clear after 40 consecutive warm-up cycles have occurred without a fault.

D06RX082

○ DTC P0135 can be cleared by using the Tech 2 “Clear Info” function or by disconnecting the PCM battery feed.

**Diagnostic Aids**

Check for the following conditions:

- Poor connection at PCM – Inspect harness connectors for backed-out terminals, improper mating, broken locks, improperly formed or damaged terminals, and poor terminal-to-wire connection.
- Damaged harness – Inspect the wiring harness for damage. If the harness appears to be OK, observe the ECT display on the Tech 2 while moving connectors and wiring harnesses related to the sensor. A change in the display will indicate the location of the fault.

Reviewing the Failure Records vehicle mileage since the diagnostic test last failed may help determine how often the condition that caused the DTC to be set occurs. This may assist in diagnosing the condition.

**Test Description**

Number(s) below refer to the step number(s) on the Diagnostic Chart.

2. The HO2S should be allowed to cool before performing this test. If the HO2S heater is functioning, the signal voltage will gradually increase or decrease as the sensor element warms. If the heater is not functioning, the HO2S signal will remain near the 450 mV bias voltage.
4. Ensures that the ignition feed circuit to the HO2S is not open or shorted. The test light should be connected to a good chassis ground, in case the HO2S low or HO2S heater ground circuit is faulty.
5. Checks the HO2S heater ground circuit.
6. Checks or an open or shorted HO2S heater element.
10. An open HO2S signal or low circuit can cause the HO2S heater to appear faulty. Check these circuits before replacing the sensor.

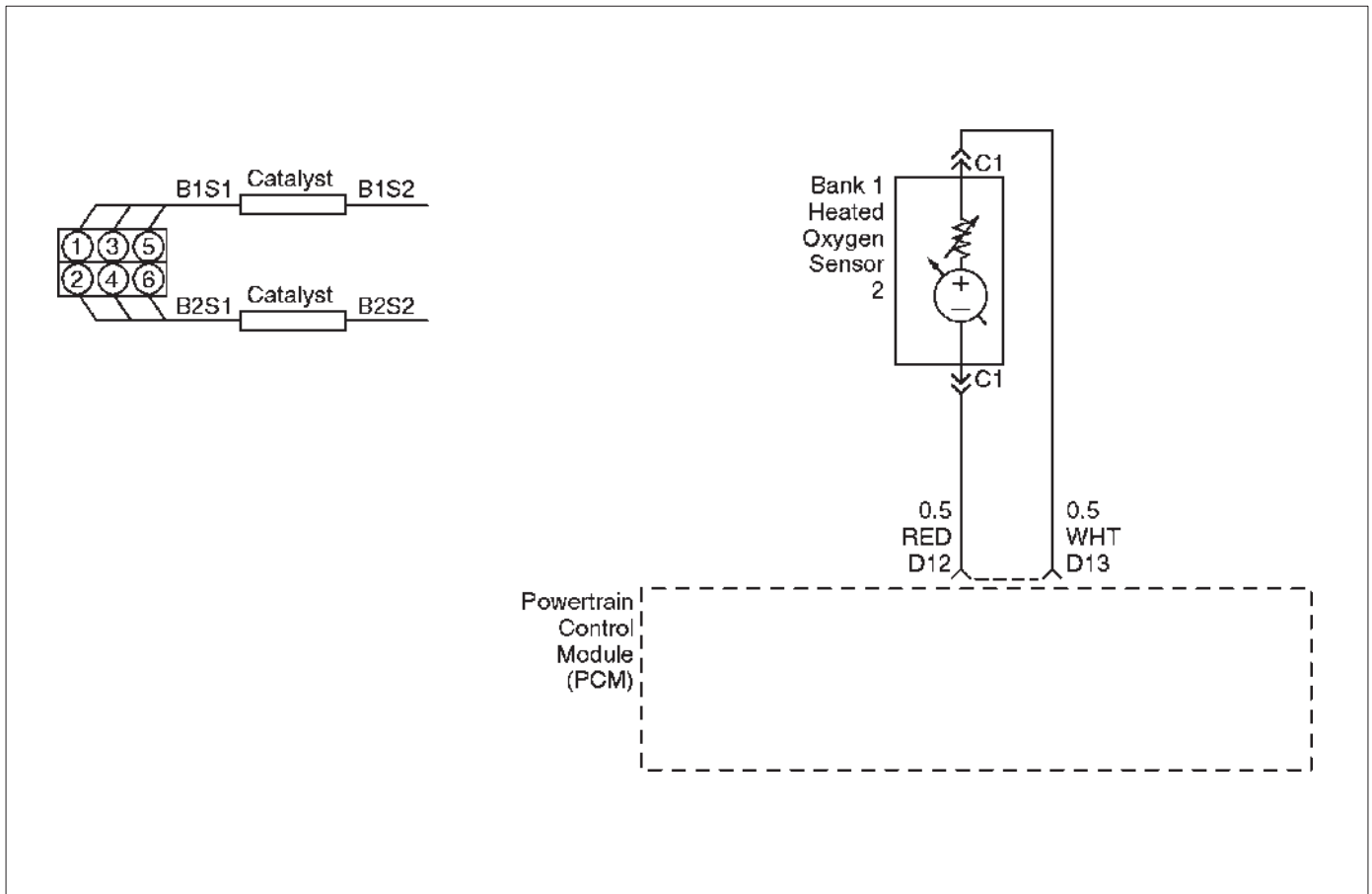
**DTC P0135 – HO2S Heater Circuit Bank 1 Sensor 1**

Step	Action	Value(s)	Yes	No
1	Was the “On-Board Diagnostic (OBD) System Check” performed?	—	Go to Step 2	Go to <i>OBD System Check</i>
2	NOTE: If the engine has just been operating, allow the engine to cool for at least 15 minutes before proceeding.  1. Remove the fuel pump relay. 2. Connect a fused jumper at the fuel pump relay socket, between the battery positive at the relay and the relay wire that leads to the fuel pump and HO2S fuses. 3. Ignition “OFF.” 4. Install a Tech 2. 5. Ignition “ON,” engine “OFF.” 6. Monitor the Bank 1 HO2S 1 voltage for several minutes.  Did the HO2S voltage go from bias voltage to above or below the specified values?	Above 650 mV or below 250 mV	Refer to <i>Diagnostic Aids</i>	Go to Step 3
3	Inspect the fuse for the Bank 1 HO2S 1 ignition feed.  Is the fuse open?	—	Go to Step 15	Go to Step 4
4	1. Ignition “OFF.” 2. Raise the vehicle. 3. Disconnect the Bank 1 HO2S 1 electrical connector. 4. Using a test light connected to a good ground (do not use Bank 1 HO2S 1 heater ground or Bank 1 HO2S 1 low), probe the ignition feed circuit at the Bank 1 HO2S 1 electrical connector (PCM harness side).  Does the test light illuminate?	—	Go to Step 5	Go to Step 7
5	Connect the test light between the Bank 1 HO2S 1 ignition feed and the Bank 1 HO2S 1 heater ground.  Does the test light illuminate?	—	Go to Step 6	Go to Step 8

**DTC P0135 – HO2S Heater Circuit Bank 1 Sensor 1 (Cont'd)**

Step	Action	Value(s)	Yes	No
6	1. Allow the HO2S to cool for at least 15 minutes. 2. Using a DVM, measure the resistance between the Bank 1 HO2S 1 ignition feed and the Bank 1 HO2S 1 heater ground at the Bank 1 HO2S 1 pigtail. Is the HO2S heater resistance within the specified values?	3-6 ohms	Go to <i>Step 9</i>	Go to <i>Step 10</i>
7	Repair the open Bank 1 HO2S 1 ignition feed circuit to Bank 1 HO2S 1. Is the action complete?	—	Verify repair	—
8	Repair the open Bank 1 HO2S 1 heater ground circuit to Bank 1 HO2S 1. Is the action complete?	—	Verify repair	—
9	1. Check for a poor connection at the Bank 1 HO2S 1 harness terminals. 2. If a poor connection is found, replace terminals. Was a poor connection found?	—	Verify repair	Go to <i>Step 10</i>
10	Check for a poor Bank 1 HO2S 1 high or low circuit terminal connection at the Bank 1 HO2S 1 harness connector and replace terminal(s) if necessary. Did any terminals require replacement?	—	Verify repair	Go to <i>Step 11</i>
11	1. Ignition "OFF." 2. Disconnect the PCM and check the continuity of the Bank 1 HO2S 1 signal circuit and the Bank 1 HO2S 1 low circuit. 3. If the Bank 1 HO2S 1 high circuit or HO2S low circuit measures over 5 ohms, repair open or poor connection as necessary. Was a problem found?	—	Verify repair	Go to <i>Step 12</i>
12	Check for a poor Bank 1 HO2S 1 low circuit terminal connection at the PCM and replace the terminal if necessary. Did the terminal require replacement?	—	Verify repair	Go to <i>Step 13</i>
13	Check for a poor Bank 1 HO2S 1 high circuit terminal connection at the PCM and replace the terminal if necessary. Did the terminal require replacement?	—	Verify repair	Go to <i>Step 14</i>
14	Replace the Bank 1 HO2S 1. Is the action complete?	—	Verify repair	—
15	Locate and repair the short to ground in Bank 1 HO2S 1 ignition feed circuit and replace the fault fuse. Is the action complete?	—	Verify repair	—

## Diagnostic Trouble Code (DTC) P0137 HO2S Circuit Low Voltage Bank 1 Sensor 2



### Circuit Description

The powertrain control module (PCM) supplies bias voltage of about 450 mV between the heated oxygen sensor (HO2S) signal high and signal low circuits. When measured with a 10 megaohm impedance digital voltmeter, this may display as low as 350 mV. The oxygen sensor varies the voltage within a range of about 1000 mV when exhaust is rich, down through about 10 mV when the exhaust is lean. The PCM constantly monitors the HO2S signal during "closed loop" operation and compensates for a rich or lean condition by decreasing or increasing injector pulse width as necessary. If the Bank 1 HO2S 2 signal voltage remains excessively low for an extended period of time, DTC P0137 will be set.

### Conditions for Setting the DTC

- No related DTCs.
- Engine is operating in "closed loop."
- Engine coolant temperature is above 60°C (140°F).
- "Closed loop" commanded air/fuel ratio is between 14.5 and 14.8.
- Throttle angle is between 3% and 19%.
- Bank 1 HO2S 2 signal voltage remains below 22 mV during normal "closed loop" operation for a total of 106 seconds over a 125-second period of time.

OR

- Bank 1 HO2S 2 signal voltage remains below 400 mV during power enrichment mode fuel control operation for up to 5 seconds.

### Action Taken When the DTC Sets

- The PCM will illuminate the malfunction indicator lamp (MIL) the first time the fault is detected.
- The PCM will store conditions which were present when the DTC set as Freeze Frame and in the Failure Records data.

### Conditions for Clearing the MIL/DTC

- The PCM will turn the MIL "OFF" on the third consecutive trip cycle during which the diagnostic has been run and the fault condition is no longer present.
- A history DTC P0137 will clear after 40 consecutive warm-up cycles have occurred without a fault.
- DTC P0137 can be cleared by using the Tech 2 "Clear Info" function or by disconnecting the PCM battery feed.

### Diagnostic Aids

Check for the following conditions:

- Heated oxygen sensor wiring – The sensor pigtail may be mispositioned and contacting the exhaust system.
- Poor PCM to engine grounds.
- Fuel pressure – A condition which causes a lean exhaust can cause DTC P0137 to set. The system will go lean if pressure is too low. The PCM can

compensate for some decrease. However, if fuel pressure is too low, a DTC P0137 may be set. Refer to *Fuel System Diagnosis*.

- Lean injector(s) – Perform “Injector Balance Test.”
- Vacuum leaks – Check for disconnected or damaged vacuum hoses and for vacuum leaks at the intake manifold, throttle body, EGR system, and PCV system.
- Exhaust leaks – An exhaust leak may cause outside air to be pulled into the exhaust gas stream past the HO2S, causing the DTC P0137 to set. Check for exhaust leaks near the Bank 1 HO2S 2 sensor.
- MAF sensor – The system can go lean if the MAF sensor signal indicates an engine airflow measurement that is not correct. Disconnect the MAF sensor to see if the lean condition is corrected. If so, replace the MAF sensor.
- Fuel contamination – Water, even in small amounts, can be delivered to the fuel injectors. The water can cause a lean exhaust to be indicated. Excessive

alcohol in the fuel can also cause this condition. Refer to *Fuel System Diagnosis* for procedure to check for fuel contamination.

- If none of the above conditions are present, replace the affected HO2S.

**Test Description**

Number(s) below refer to the step number(s) on the Diagnostic Chart.

- 3. DTC P0137 failing during operation may indicate a condition described in the “Diagnostic Aids” above. If the DTC0137 test passes while the Failure Records conditions are being duplicated, an intermittent condition is indicated.

Reviewing the Failure Records vehicle mileage since the diagnostic test last failed may help determine how often the condition that caused the DTC to be set occurs. This may assist in diagnosing the condition.

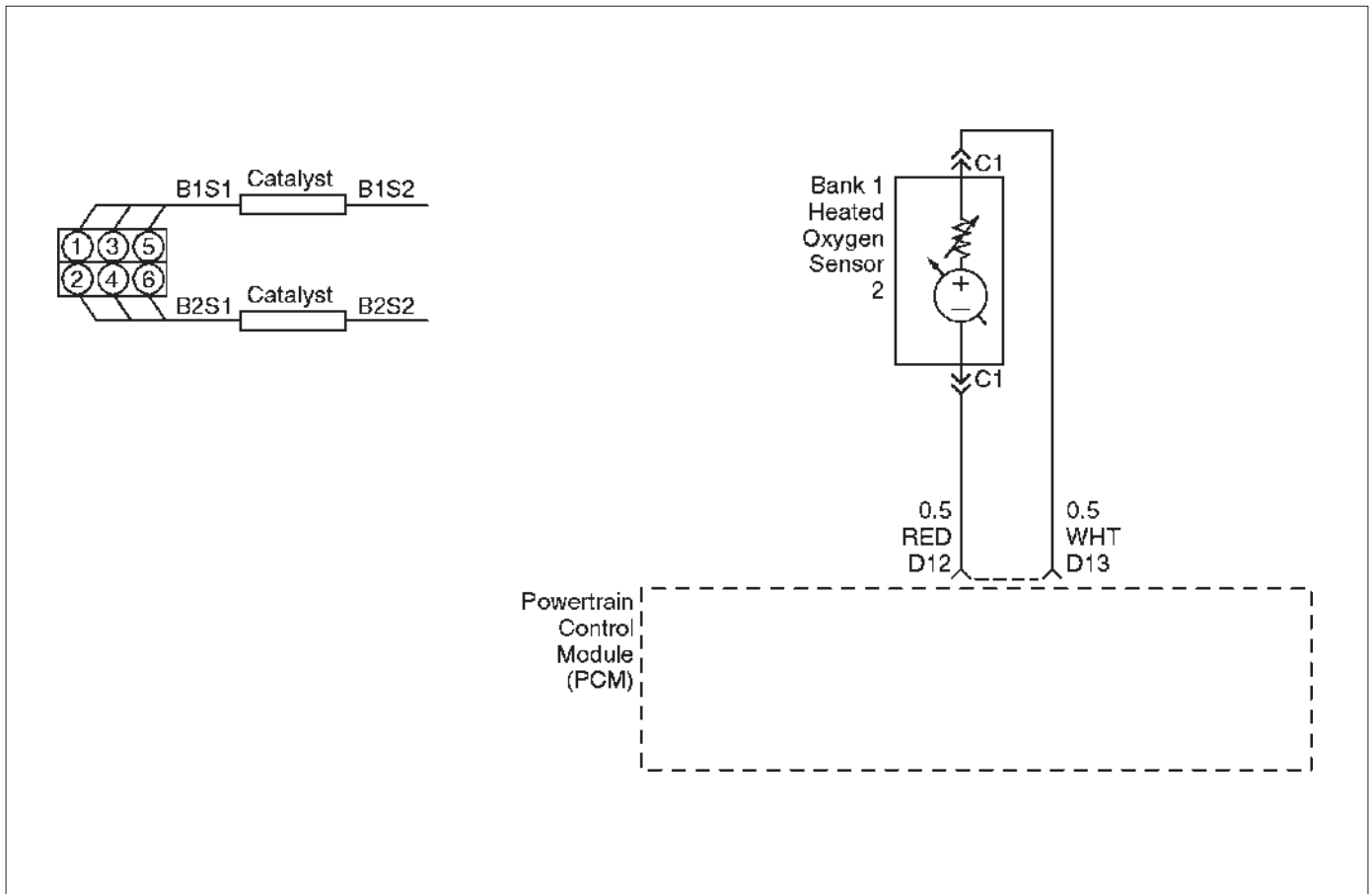
**DTC P0137 –HO2S Circuit Low Voltage Bank 1 Sensor 2**

Step	Action	Value(s)	Yes	No
1	Was the “On-Board Diagnostic (OBD) System Check” performed?	—	Go to Step 2	Go to <i>OBD System Check</i>
2	1. Install the Tech 2. 2. Run the engine at operating temperature. 3. Operate the vehicle within the parameters specified under “Conditions for Setting the DTC” criteria included in Diagnostic Support. 4. Using a Tech 2, monitor Bank 1 HO2S 2 voltage. Does the Bank 1 HO2S voltage remain below the specified value?	22 mV	Go to Step 4	Go to Step 3
3	1. Ignition “ON,” engine “OFF,” review and record Tech 2 Failure Records data and note parameters. 2. Operate the vehicle within Failure Records conditions as noted. 3. Using a Tech 2, monitor “DTC” info for DTC P0137 until the DTC P0137 test runs. 4. Note the test result. Does the Tech 2 indicate DTC P0137 failed this ignition?	—	Go to Step 4	Refer to <i>Diagnostic Aids</i>
4	1. Turn ignition “OFF.” 2. Disconnect the PCM. 3. Check the Bank 1 HO2S 2 high and low signal circuits for a short to ground or a short to the heater ground circuit. Were Bank 1 HO2S 2 signal circuits shorted?	—	Go to Step 5	Go to Step 6
5	Repair the Bank 1 HO2S 2 signal circuit. Is the action complete?	—	Verify repair	—
6	1. Ignition “OFF.” 2. Leave the PCM and HO2S 2 disconnected. 3. Check for continuity between the high and low signal circuits. Was there continuity between the high and low circuits?	—	Go to Step 7	Go to Step 8

**DTC P0137 –HO2S Circuit Low Voltage Bank 1 Sensor 2 (Cont'd)**

Step	Action	Value(s)	Yes	No
7	Repair the short between the high and low circuits. Is the action complete?	—	Verify repair	—
8	1. Ignition "OFF." 2. Reconnect the PCM, leave HO2S 2 disconnected. 3. Ignition "ON." Does the Tech 2 indicate Bank 1 HO2S 2 voltage near the specified value?	425-475 mV	Refer to <i>Diagnostic Aids</i>	Go to <i>Step 9</i>
9	Replace the PCM. <b>IMPORTANT:</b> The replacement PCM must be programmed. Refer to <i>On-Vehicle Service in Powertrain Control Module and Sensors</i> for procedures. And also refer to latest Service Bulletin. Check to see if the Latest software is released or not. And then Down Load the LATEST PROGRAMMED SOFTWARE to the replacement PCM. Is the action complete?	—	Verify repair	—

## Diagnostic Trouble Code (DTC) P0138 HO2S Circuit High Voltage Bank 1 Sensor 2



### Circuit Description

The powertrain control module (PCM) supplies bias voltage of about 450 mV between the heated oxygen sensor (HO2S) signal high and signal low circuits. When measured with a 10 megaohm digital voltmeter, this may display as low as 320 mV. The oxygen sensor varies the voltage within a range of about 1000 mV when exhaust is rich, down through about 10 mV when the exhaust is lean. The PCM constantly monitors the HO2S signal during "closed loop" operation and compensates for a rich or lean condition by decreasing or increasing injector pulse width as necessary. If the Bank 1 HO2S 2 voltage remains excessively high for an extended period of time, DTC P0138 will be set.

### Conditions for Setting the DTC

- No related DTCs.
- Engine is operating in "closed loop."
- "Closed loop" commanded air/fuel ratio is between 14.5 and 14.8.
- Engine coolant temperature is above 60°C (140°F).
- Throttle angle is between 3% and 19%.
- Bank 1 HO2S 2 signal voltage remains above 952 mV during normal "closed loop" operation for a total of 106 seconds over a 125-second period of time.

OR

- Bank 1 HO2S 2 signal voltage remains above 500 mV during deceleration fuel cut-off mode operation for up to 3 seconds.

### Action Taken When the DTC Sets

- The PCM will illuminate the malfunction indicator lamp (MIL) the first time the fault is detected.
- The PCM will store conditions which were present when the DTC was set as Freeze Frame and in the Failure Records data.

### Conditions for Clearing the MIL/DTC

- The PCM will turn the MIL "OFF" on the third consecutive trip cycle during which the diagnostic has been run and the fault condition is no longer present.
- A history DTC P0138 will clear after 40 consecutive warm-up cycles have occurred without a fault.
- DTC P0138 can be cleared by using the Tech 2 "Clear Info" function or by disconnecting the PCM battery feed.

### Diagnostic Aids

Check for the following conditions:

- Fuel pressure – An excessively rich fuel mixture can cause a DTC P0138 to be set. Refer to *Fuel System Diagnosis*.
- Rich injector(s) – Perform "Injector Balance Test."
- Leaking injector – Refer to *Fuel System Diagnosis*.

D06RX083



## 6E-176 6VE1 3.5L ENGINE DRIVEABILITY AND EMISSIONS

- Evaporative emissions (EVAP) canister purge – Check for fuel saturation. If full of fuel, check the canister control and hoses. Refer to *Evaporative Emission (EVAP) Control System*.
- MAF sensor –The system can go rich if the MAF sensor signal indicates an engine airflow measurement that is not correct. Disconnect the MAF sensor to see if the rich condition is corrected. If so, replace the MAF sensor.
- Check for a leak in fuel pressure regulator diaphragm by checking the vacuum line to the regulator for the presence of fuel. There should be no fuel in the vacuum line.
- TP sensor – An intermittent TP sensor output will cause the system to go rich, due to a false indication of the engine accelerating.
- Shorted Heated Oxygen Sensor (HO2S) – If the HO2S is internally shorted the HO2S voltage displayed on the Tech 2 will be over 1 volt. Try disconnecting the affected HO2S with the key “ON,” engine “OFF.” If the displayed HO2S voltage changes from over 1000 mV to around 450 mV, replace the HO2S. Silicon contamination of the HO2S can also cause a high HO2S voltage to be indicated. This condition is indicated by a powdery white deposit on the portion of the HO2S exposed to the exhaust stream. If contamination is noticed, replace the affected HO2S.
- Open HO2S Signal Circuit of Faulty HO2S – A poor connection or open in the HO2S signal circuit can cause the DTC to set during deceleration fuel mode. An HO2S which is faulty and not allowing a full voltage swing between the rich and lean thresholds can also cause this condition. Operate the vehicle while monitoring the HO2S voltage with a Tech 2. If the HO2S voltage is limited within a range between 300 mV to 600 mV, check the HO2S signal and wiring and associated terminal connections.
- If none of the above conditions are present, replace the affected HO2S.

### Test Description

Number(s) below refer to the step number(s) on the Diagnostic Chart.

3. DTC P0138 being set during deceleration fuel mode operation may indicate a condition described in the “Diagnostic Aids” above. If the DTC P0138 test passes while the Failure Records conditions are being duplicated, an intermittent condition is indicated.

Reviewing the Failure Records vehicle mileage since the diagnostic test last failed may help determine how often the condition that caused the DTC to be set occurs. This may assist in diagnosing the condition.

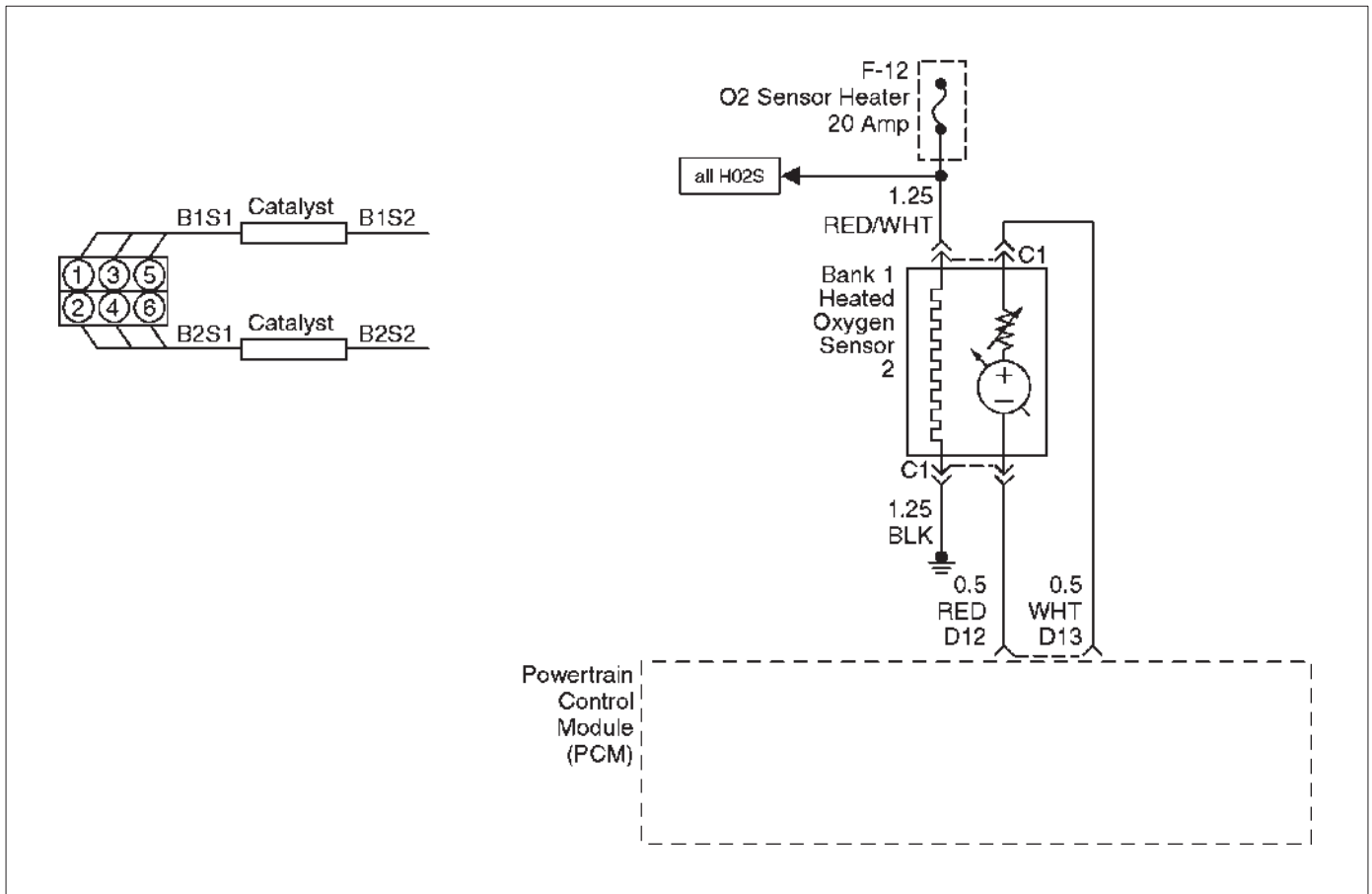
### DTC P0138 – HO2S Circuit High Voltage Bank 1 Sensor 2

Step	Action	Value(s)	Yes	No
1	Was the “On-Board Diagnostic (OBD) System Check” performed?	—	Go to Step 2	Go to <i>OBD System Check</i>
2	<ol style="list-style-type: none"> <li>1. Install the Tech 2.</li> <li>2. Run the engine at operating temperature.</li> <li>3. Operate the vehicle within the parameters specified under “Conditions for Setting the DTC” criteria included in Diagnostic Support.</li> <li>4. Using a Tech 2, monitor Bank 1 HO2S 2 voltage.</li> </ol> Does the Bank 1 HO2S voltage remain above the specified value?	952 mV (500 mV in deceleration fuel cutoff mode)	Go to Step 4	Go to Step 3
3	<ol style="list-style-type: none"> <li>1. Ignition “ON,” review and record Tech 2 Failure Records data.</li> <li>2. Operate the vehicle within Failure Records conditions as noted.</li> <li>3. Using a Tech 2, monitor “DTC” info for DTC P0138 until the DTC P0138 test runs.</li> <li>4. Note the test result.</li> </ol> Does the Tech 2 indicate DTC P0138 failed this ignition?	—	Go to Step 4	Refer to <i>Diagnostic Aids</i>
4	<ol style="list-style-type: none"> <li>1. Ignition “OFF.”</li> <li>2. Disconnect Bank 1 HO2S 1.</li> <li>3. Ignition “ON.”</li> <li>4. At the HO2S Bank 1 Sensor 2 connector (PCM side), use a DVM to measure voltages at the high and low signal terminals.</li> </ol> Are the voltages above the specified range?	3-4 V	Go to Step 5	Go to Step 6

**DTC P0138 – HO2S Circuit High Voltage Bank 1 Sensor 2 (Cont'd)**

Step	Action	Value(s)	Yes	No
5	Repair short to voltage in the signal circuit. Is the action complete?	—	Verify repair	—
6	1. Ignition "ON," engine"OFF." 2. At Bank 1 HO2S 2 connector (PCM side) jumper both the HO2S high and low signal circuits (PCM side) to ground. 3. Using a Tech 2, monitor Bank 1 HO2S 2 voltage. Is Bank 1 HO2S 2 voltage below the specified value?	10 mV	Go to <i>Step 7</i>	Go to <i>Step 8</i>
7	1. Disconnect the jumpers to ground from Bank 1 HO2S 2 PCM-side connector. 2. With the HO2S 2 connector disconnected, monitor BANK 1 HO2S 2 voltage. Is the Bank 1 HO2S 2 voltage between the specified values?	425-475 mV	Refer to <i>Diagnostic Aids</i>	Go to <i>Step 8</i>
8	Replace the PCM. <b>IMPORTANT:</b> The replacement PCM must be programmed. Refer to <i>On-Vehicle Service in Powertrain Control Module and Sensors</i> for procedures. And also refer to latest Service Bulletin. Check to see if the Latest software is released or not. And then Down Load the LATEST PROGRAMMED SOFTWARE to the replacement PCM. Is the action complete?	—	Verify repair	—

## Diagnostic Trouble Code(DTC) P0140 HO2S Circuit Insufficient Activity Bank 1 Sensor 2



### Circuit Description

To control emissions of hydrocarbons (HC), carbon monoxide (CO), and oxides of nitrogen (NO<sub>x</sub>), a three-way catalytic converter is used. The catalyst within the converter promotes a chemical reaction which oxidizes the HC and CO present in the exhaust gas, converting them into harmless water vapor and carbon dioxide. The catalyst also reduces NO<sub>x</sub>, converting it to nitrogen. The powertrain control module (PCM) has the ability to monitor this process using the Bank 1 HO2S 1 and the Bank 1 HO2S 2 heated oxygen sensors. The Bank 1 HO2S 2 sensor produces an output signal which indicates the amount of oxygen present in the exhaust gas entering the three-way catalytic converter. The Bank 1 HO2S 2 sensor produces an output signal which indicates the oxygen storage capacity of the catalyst; this in turn indicates the catalyst's ability to convert exhaust gases efficiently. If catalyst is operating efficiently, the Bank 1 HO2S 1 signal will be far more active than that produced by the Bank 1 HO2S 2 sensor. If the Bank 1 HO2S 2 signal voltage remains between 400 mV and 500 mV for an extended period of time, DTC P0140 will be set. Heated oxygen sensors are used to minimize the amount of time required for "closed loop" fuel control operation and to allow accurate catalyst monitoring. The oxygen sensor heater greatly decreases the amount of time required for fuel control sensors Bank 1 HO2S 1 and Bank 2 HO2S 1 to become active. Oxygen sensor heaters are required by post-catalyst monitor sensors to

maintain a sufficiently high temperature for accurate exhaust oxygen content readings further from the engine.

### Conditions for Setting the DTC

- No related DTCs.
- Battery voltage is above 10 volts.
- Engine run time is longer than 40 seconds.
- Oxygen sensor heater is functioning properly.
- Engine is operating in "closed loop"
- Bank 1 HO2S 2 signal voltage remains between 426 mV and 474 mV for a total of 106 seconds over a 125-second period of time.

### Action Taken When the DTC Sets

- The PCM will illuminate the malfunction indicator lamp (MIL) the first time the fault is detected.
- The PCM will store conditions which were present when the DTC was set as Freeze Frame and in the Failure Records data.

### Conditions for Cleaning the MIL/DTC

- The PCM will turn the MIL "OFF" on the third consecutive trip cycle during which the diagnostic has been run and the fault condition is no longer present.
- A history DTC P0140 will clear after 40 consecutive warm-up cycles have occurred without a fault.
- DTC P0140 can be cleared by using the Tech 2 "Clear Info" function or by disconnecting the PCM battery feed.

**Diagnostic Aids**

Check for the following conditions:

- Poor connection or damaged harness– Inspect the harness connectors for backed-out terminals, improper mating, broken locks, improperly formed or damaged terminals, poor terminal-to-wire connection, and damaged harness.
- Faulty HO2S heater or heater circuit–With the ignition “ON,” engine “OFF,” the HO2S voltage displayed on a Tech 2 should gradually drop to below 250 mV. If not, disconnect the HO2S and connect a test light between the HO2S ignition feed and heater ground circuits. If the test light does not light, repair the open ignition feed or sensor ground circuit as necessary. If the test light lights and the HO2S signal and low circuits are OK, replace the HO2S.

- Intermittent test–With the ignition “ON,” monitor the HO2S signal voltage while moving the wiring harness and related connectors. If the fault is induced, the HO2S signal voltage will change. This may help isolate the location of the malfunction.

**Test Description**

Number (s) below refer to the step number (s) on the Diagnostic Chart.

- 3. If the DTC P0140 test passes while the Failure Records conditions are being duplicated, an intermittent condition is indicated.

Reviewing the Failure Records vehicle mileage since the diagnostic test last failed may help determine how often the condition that caused the DTC to be set occurs. This may assist in diagnosing the condition.

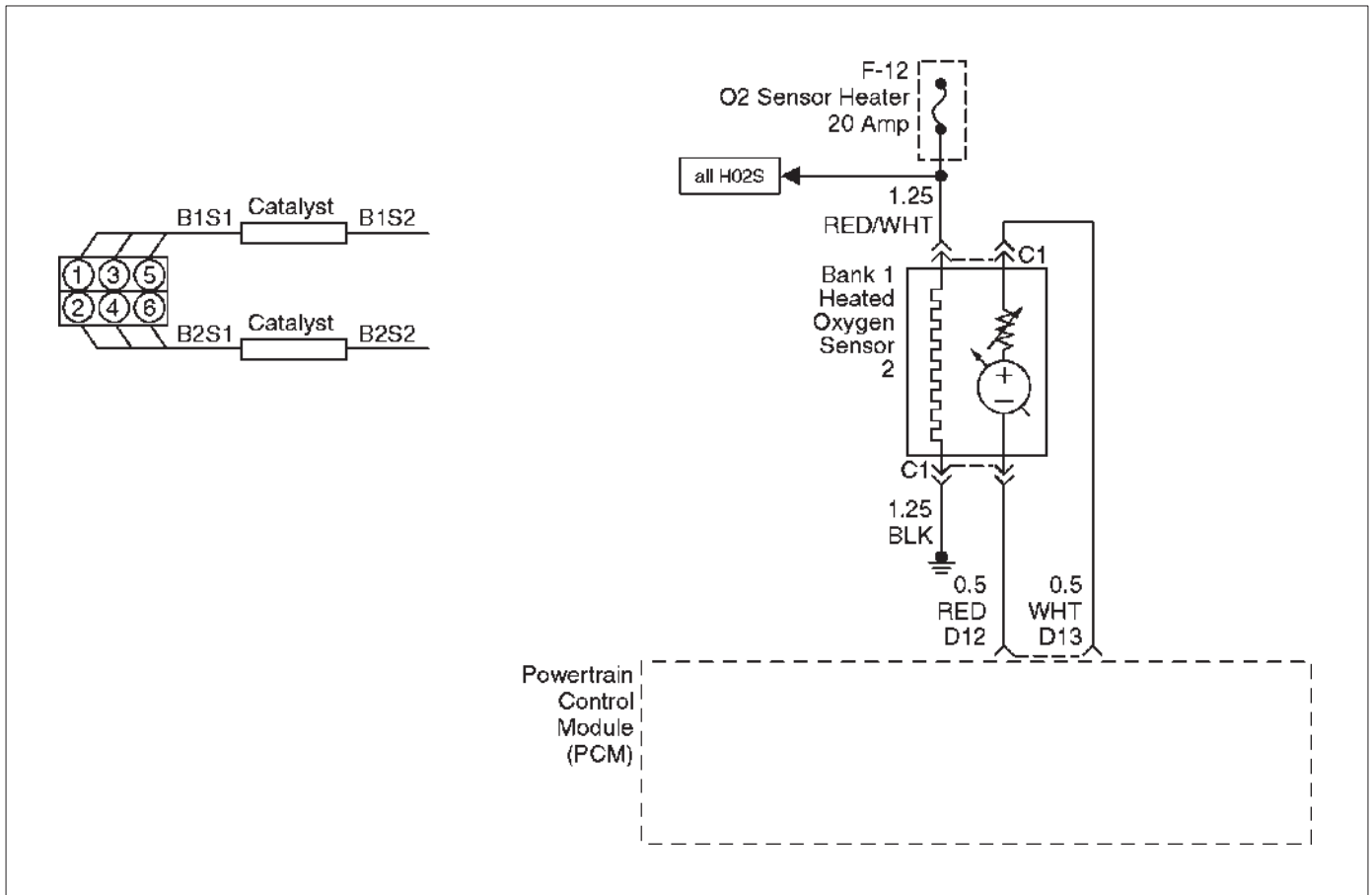
**DTC P0140 – HO2S Circuit Insufficient Activity BANK 1 SENSOR 2**

Step	Action	Value(s)	Yes	No
1	Was the “On-Board Diagnostic (OBD) System Check” performed?	—	Go to Step 2	Go to <i>OBD System Check</i>
2	1. Install the Tech 2. 2. Run the engine at operating temperature. 3. Operate the engine above 1200 RPM for two minutes.  Does the Tech 2 indicate Bank 1 HO2S 2 voltage varying outside the specified values?	425-475 mV	Go to Step 3	Go to Step 4
3	1. Ignition “ON,” engine “OFF,” review and record Tech 2 Failure Records data and note parameters. 2. Operate the vehicle within Failure Records conditions as noted. 3. Using a Tech 2, monitor “DTC” info for DTC P0140 until the DTC P0140 test runs. 4. Note the test result.  Does the Tech 2 indicate DTC P0140 failed this ignition?	—	Go to Step 4	Refer to <i>Diagnostic Aids</i>
4	Check for a damaged harness.  Was a problem found?	—	Verify repair	Go to Step 5
5	Check for poor Bank 1 HO2S 2 high and low circuit terminal connections at the Bank 1 HO2S 2 harness connector and replace terminal(s) if necessary.  Did any terminals require replacement?	—	Verify repair	Go to Step 6
6	Check for poor Bank 1 HO2S 2 high and low circuit terminal connections at the PCM and replace terminal(s) if necessary.  Did any terminals require replacement?	—	Verify repair	Go to Step 7
7	1. Ignition “OFF.” 2. With the PCM disconnected, check continuity of the Bank 1 HO2S 2 high circuit. 3. If the Bank 1 HO2S 2 high circuit measures over 5.0 ohms, repair open or poor connection as necessary.  Was a Bank 1 HO2S 2 high circuit problem found and corrected?	—	Verify repair	Go to Step 8

**DTC P0140 – HO2S Circuit Insufficient Activity BANK 1 SENSOR 2 (Cont'd)**

Step	Action	Value(s)	Yes	No
8	1. Ignition "OFF." 2. With the PCM disconnected, check continuity of the Bank 1 HO2S 2 high circuit. 3. If the Bank 1 HO2S 2 low circuit measures over 5.0 ohms, repair open or poor connection as necessary. Was a Bank 1 HO2S 2 low circuit problem found and corrected?	—	Verify repair	Go to <i>Step 9</i>
9	1. Ignition "ON," engine "OFF." 2. Disconnect Bank 1 HO2S 2 and jumper the HO2S high and low circuits (PCM side) to ground. 3. Using a Tech 2, monitor Bank 1 HO2S 2 voltage. Is Bank 1 HO2S 2 voltage in the specified range?	0-10 mV	Go to <i>Step 10</i>	Go to <i>Step 11</i>
10	Replace Bank 1 HO2S 2. Is the action complete?	—	Verify repair	—
11	Replace the PCM. <b>IMPORTANT:</b> The replacement PCM must be programmed. Refer to <i>On-Vehicle Service in Powertrain Control Module and Sensors</i> for procedures. And also refer to latest Service Bulletin. Check to see if the Latest software is released or not. And then Down Load the LATEST PROGRAMMED SOFTWARE to the replacement PCM. Is the action complete?	—	Verify repair	—

**Diagnostic Trouble Code (DTC) P0141 HO2S Heater Circuit Bank 1 Sensor 2**



**Circuit Description**

Heated oxygen sensors are used to minimize the amount of time required for closed loop fuel control operation and to allow accurate catalyst monitoring. The oxygen sensor heater greatly decreases the amount of time required for fuel control sensors Bank 1 HO2S 1 and Bank 2 HO2S 1 to become active. Oxygen sensor heaters are required by post-catalyst monitor sensors to maintain a sufficiently high temperature which allows accurate exhaust oxygen content readings further from the engine.

The powertrain control module (PCM) will run the heater test only after a cold start (determined by engine coolant and intake air temperature at the time of start-up) and only once during an ignition cycle. When the engine is started the PCM will monitor the HO2S voltage. When the Bank HO2S voltage indicates a sufficiently active sensor, the PCM looks at how much time has elapsed since start-up. If the PCM determines that too much time was required for the Bank 1 HO2S 2 to become active, a DTC P0141 will set. The time it should take the HO2S to reach operating temperature is based on the total amount of air that has passed through the MAF sensor and into the engine (more total airflow = shorter time to HO2S activity).

**Conditions for Setting the DTC**

- No related DTCs.
- Intake air temperature (IAT) is less than 32°C (90°F) at start-up.

- Engine coolant temperature (ECT) is less than 32°C (90°F) at start-up.
- IAT and ECT are within 6°C (11°F) of each other at start-up.
- Ignition voltage is between 11 volts and 18 volts.
- Average mass airflow is less than 23 g/second during the sample period.
- Bank 1 HO2S 2 voltage does not change more than 150 mV from the bias voltage (between 400 mV–500 mV) for a longer amount of time than it should. The maximum amount of time to come up to operating range is 300 seconds. This warm-up time depends on the engine coolant temperature at start-up and accumulated air flow since start-up.

**Action Taken When the DTC Sets**

- The PCM will illuminate the malfunction indicator lamp (MIL) after the second consecutive trip in which the fault is detected.
- The PCM will store conditions which were present when the DTC was set as Freeze Frame and in the Failure Records data.

**Conditions for Clearing the MIL/DTC**

- The PCM will turn the MIL “OFF” on the third consecutive trip cycle during which the diagnostic has been run and the fault condition is no longer present.
- A history DTC P0141 will clear after 40 consecutive warm-up cycles have occurred without a fault.

○ DTC P0141 can be cleared by using the Tech 2 “Clear Info” function or by disconnecting the PCM battery feed.

**Diagnostic Aids**

Check for the following conditions:

- Poor connection at PCM – Inspect harness connectors for backed-out terminals, improper mating, broken locks, improperly formed or damaged terminals, and poor terminal-to-wire connection.
- Damaged harness – Inspect the wiring harness for damage. If the harness appears to be OK, observe the display on the Tech 2 while moving connectors and wiring harnesses related to the sensor. A change in the display will indicate the location of the fault.

Reviewing the Failure Records vehicle mileage since the diagnostic test last failed may help determine how often the condition that caused the DTC to be set occurs. This may assist in diagnosing the condition.

2. The HO2S should be allowed to cool before performing this test. If the HO2S heater is functioning, the signal voltage will gradually increase or decrease as the sensor element warms. If the heater is not functioning, the HO2S signal will remain near the 450 mV bias voltage.
4. This ensures that the ignition feed circuit to the HO2S is not open or shorted. The test light should be connected to a good chassis ground, in case the HO2S low or HO2S heater ground circuit is faulty.
5. This checks the HO2S heater ground circuit.
6. This checks for an open or shorted HO2S heater element.
11. An open HO2S signal or low circuit can cause the HO2S heater to appear faulty. Check these circuits before replacing the sensor.

**Test Description**

Number(s) below refer to the step number(s) on the Diagnostic Chart.

**DTC P0141 – HO2S Heater Circuit Bank 1 Sensor 2**

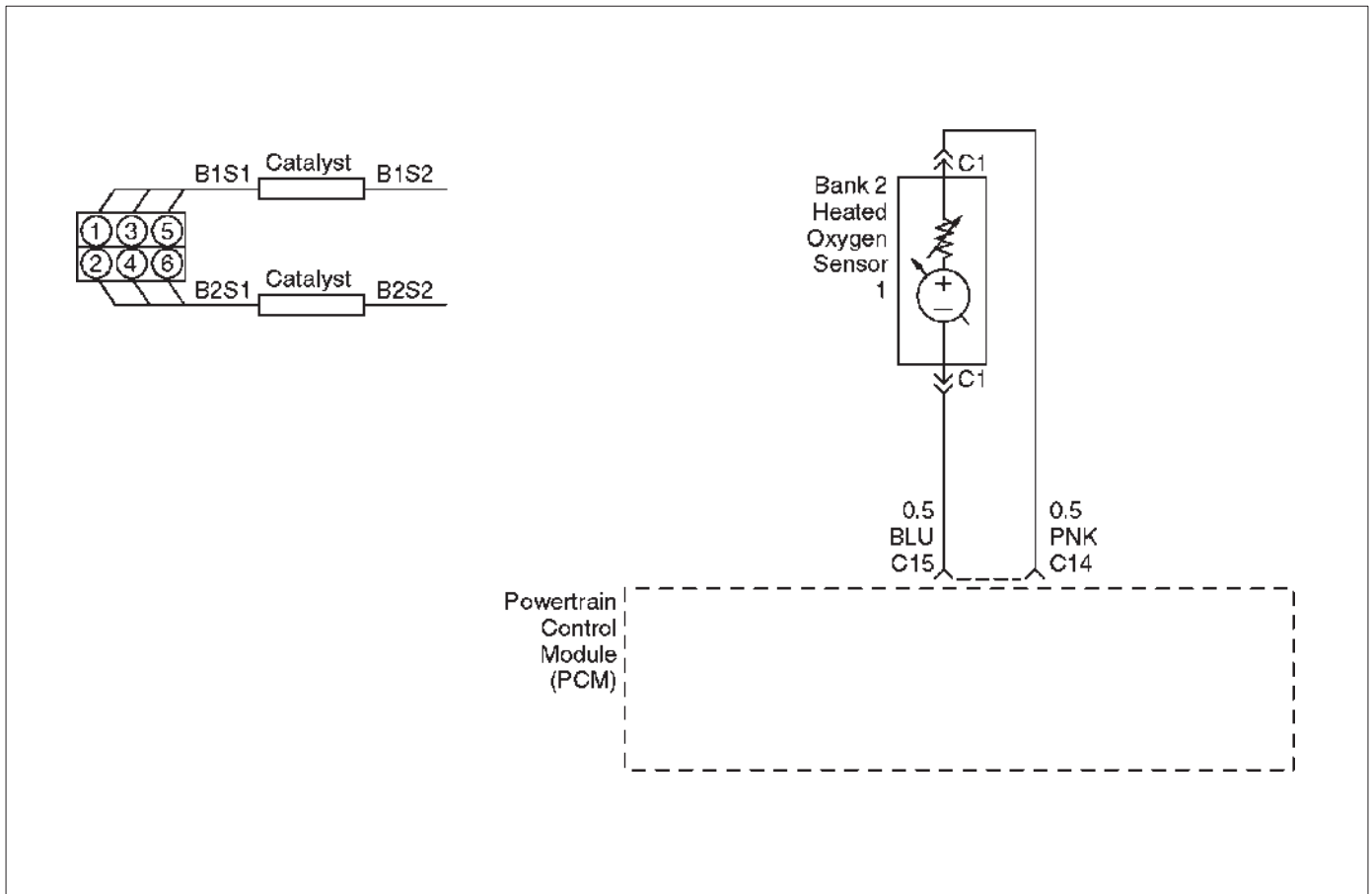
Step	Action	Value(s)	Yes	No
1	Was the “On-Board Diagnostic (OBD) System Check” performed?	—	Go to Step 2	Go to OBD System Check
2	NOTE: If the engine has just been operating, allow the engine to cool for at least 15 minutes before proceeding. 1. Remove the fuel pump relay. 2. Connect a fused jumper at the fuel pump relay socket, between the battery positive at the relay and the relay wire that leads to the fuel pump and HO2S fuses. 3. Ignition “OFF.” 4. Install a Tech 2. 5. Ignition “ON,” engine “OFF.” 6. Monitor the Bank 1 HO2S 1 voltage for several minutes. Did the HO2S voltage go from bias voltage to above or below the specified values?	Above 650 mV or below 250 mV	Refer to Diagnostic Aids	Go to Step 3
3	Inspect the fuse for Bank 1 HO2S 2 ignition feed. Is the fuse open?	—	Go to Step 15	Go to Step 4
4	1. Ignition “OFF.” 2. Raise the vehicle. 3. Disconnect the Bank 1 HO2S 2 electrical connector. 4. Using a test light connected to a good ground (do not use Bank 1 HO2S 2 heater ground or Bank 1 HO2S 2 low), probe the ignition feed circuit at the Bank 1 HO2S 2 electrical connector (PCM harness side). Does the test light illuminate?	—	Go to Step 5	Go to Step 7

**DTC P0141 – HO2S Heater Circuit Bank 1 Sensor 2 (Cont'd)**

Step	Action	Value(s)	Yes	No
5	Connect the test light between the Bank 1 HO2S 2 ignition feed and the Bank 1 HO2S 2 heater ground. Does the test light illuminate?	—	Go to <i>Step 6</i>	Go to <i>Step 8</i>
6	1. Allow the HO2S to cool for at least 15 minutes. 2. Using a DVM, measure the resistance between the Bank 1 HO2S 2 ignition feed and the Bank 1 HO2S 2 heater ground at the Bank 1 HO2S 2 pigtail. Is the HO2S resistance within the specified values?	3-6 ohms	Go to <i>Step 9</i>	Go to <i>Step 10</i>
7	Repair the open Bank 1 HO2S 2 ignition feed circuit to Bank 1 HO2S 2. Is the action complete?	—	Verify repair	—
8	Repair the open Bank 1 HO2S 2 heater ground circuit. Is the action complete?	—	Verify repair	—
9	1. Check for a poor connection at the Bank 1 HO2S 2 harness terminals. 2. If a poor connection is found, replace the terminals. Was a poor connection found?	—	Verify repair	Go to <i>Step 10</i>
10	1. Ignition "OFF." 2. Disconnect the PCM and check the continuity of the Bank 1 HO2S 2 signal circuit and the Bank 1 HO2S 2 low circuit. 3. If the Bank 1 HO2S 2 signal circuit or the HO2S low circuit measures over 5 ohms, repair the open or poor connection as necessary. Was a problem found?	—	Verify repair	Go to <i>Step 11</i>
11	1. Ignition "OFF." 2. Disconnect the PCM and check the continuity of the Bank 1 HO2S 1 signal circuit and the Bank 1 HO2S 1 low circuit. 3. If the Bank 1 HO2S 1 high circuit or the HO2S low circuit measures over 5 ohms, repair the open or poor connection as necessary. Was a problem found?	—	Verify repair	Go to <i>Step 12</i>
12	Check for a poor Bank 1 HO2S 2 low circuit terminal connection at the PCM and replace the terminal if necessary. Did the terminal require replacement?	—	Verify repair	Go to <i>Step 13</i>
13	Check for a poor Bank 1 HO2S 2 high circuit terminal connection at the PCM and replace the terminal if necessary. Did the terminal require replacement?	—	Verify repair	Go to <i>Step 14</i>
14	Replace Bank 1 HO2S 2. Is the action complete?	—	Verify repair	—
15	Locate and repair the short to ground in Bank 1 HO2S 2 ignition feed circuit and replace the faulty fuse. Is the action complete?	—	Verify repair	—



## Diagnostic Trouble Code (DTC) P0151 HO2S Circuit Low Voltage Bank 2 Sensor 1



D06RX087

### Circuit Description

The powertrain control module (PCM) supplies a bias voltage of about 450 mV between the heated oxygen sensor (HO2S) signal high and signal low circuits. When measured with a 10 megaohm digital voltmeter, this may display as low as 320 mV. The oxygen sensor varies the voltage within a range of about 1000 mV when the exhaust is rich, down through about 10 mV when exhaust is lean. The PCM constantly monitors the HO2S signal during "closed loop" operation and compensates for a rich or lean condition by decreasing or increasing injector pulse width as necessary. If the Bank 2 HO2S 1 voltage remains excessively low for an extended period of time, DTC P0151 will be set.

### Conditions for Setting the DTC

- No related DTCs.
- The engine is operating in "closed loop."
- Engine coolant temperature is above 60°C (140°F).
- "Closed loop" commanded air/fuel ratio is between 14.5 and 14.8.
- Throttle angle is between 3% and 19%.
- Bank 2 HO2S 1 signal voltage remains below 22 mV during normal "closed loop" operation for a total of 77 seconds over a 90-second period of time.

### Action Taken When the DTC Sets

- The PCM will illuminate the malfunction indicator lamp (MIL) the first time the fault is detected.
- The PCM will store conditions which were present when the DTC was set as Freeze Frame and in the Failure Records data.
- "Open loop" fuel control will be in effect.

### Conditions for Clearing the MIL/DTC

- The PCM will turn the MIL "OFF" on the third consecutive trip cycle during which the diagnostic has been run and the fault condition is no longer present.
- A history DTC P0151 will clear after 40 consecutive warm-up cycles have occurred without a fault.
- DTC P0151 can be cleared by using the Tech 2 "Clear Info" function or by disconnecting the PCM battery feed.

### Diagnostic Aids

Check for the following conditions:

- Heated oxygen sensor wiring – The sensor pigtail may be mispositioned and contacting the exhaust system.
- Poor PCM to engine block grounds.
- Fuel pressure – The system will go lean if pressure is too low. The PCM can compensate for some decrease. However, if fuel pressure is too low, a DTC P0151 may be set. Refer to *Fuel System Diagnosis*.
- Lean injector(s) – Perform "Injector Balance Test."

- Vacuum leaks – Check for disconnected or damaged vacuum hoses and for vacuum leaks at the intake manifold, throttle body, EGR system, and PCV system.
- Exhaust leaks – An exhaust leak may cause outside air to be pulled into the exhaust gas stream past the HO2S, causing the system to appear lean. Check for exhaust leaks that may cause a false lean condition to be indicated.
- MAF sensor –The system can go lean if the MAF sensor signal indicates an engine airflow measurement that is not correct. Disconnect the MAF sensor to see if the lean condition is corrected. If so, replace the MAF sensor.
- Fuel contamination – Water, even in small amounts, can be delivered to the fuel injectors. The water can cause a lean exhaust to be indicated. Excessive alcohol in the fuel can also cause this condition. Refer to *Fuel System Diagnosis* for the procedure to check for fuel contamination.

- If none of the above conditions are present, replace the affected HO2S.

**Test Description**

Number(s) below refer to the step number(s) on the Diagnostic Chart.

- 3. DTC P0151 failing during operation may indicate a condition described in the “Diagnostic Aids” above. If the DTC P0151 test passes while the Failure Records conditions are being duplicated, an intermittent condition is indicate.

Reviewing the Failure Records vehicle mileage since the diagnostic test last failed may help determine how often the condition that caused the DTC to be set occurs. This may assist in diagnosing the condition.

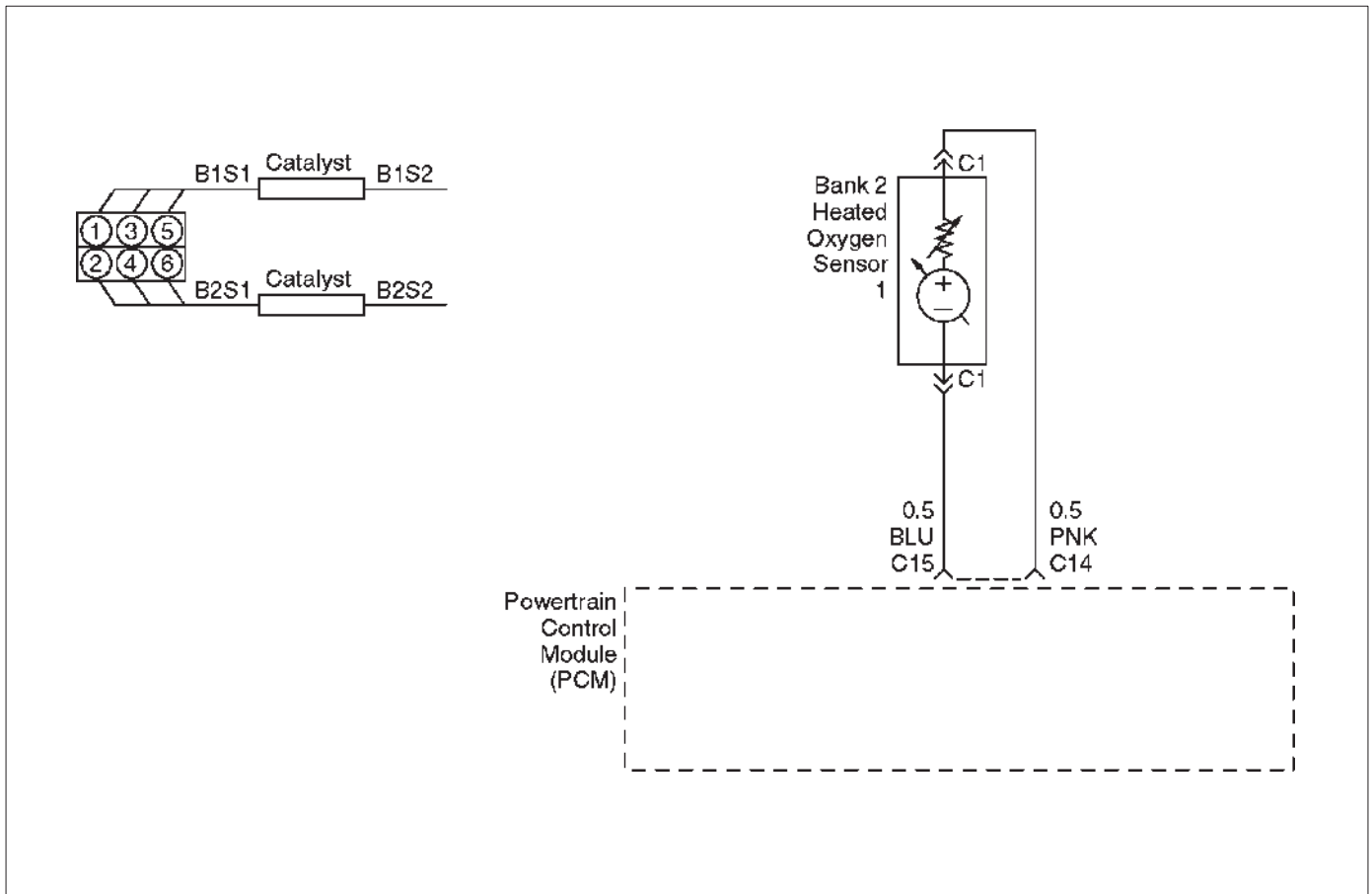
**DTC P0151 – HO2S Circuit Low Voltage Bank 2 Sensor 1**

Step	Action	Value(s)	Yes	No
1	Was the “On-Board Diagnostic (OBD) System Check” performed?	—	Go to Step 2	Go to <i>OBD System Check</i>
2	1. Install the Tech 2. 2. Run the engine at operating temperature. 3. Operate the vehicle within the parameters specified under “Conditions for Setting the DTC” criteria included in Diagnostic Support. 4. Using a Tech 2, monitor Bank 2 HO2S 1 voltage. Does the Bank 2 HO2S 1 voltage remain below the specified value?	22 mV	Go to Step 4	Go to Step 3
3	1. Ignition “ON,” engine “OFF,” review and record Tech 2 Failure Records data and note parameters. 2. Operate the vehicle within Failure Records conditions as noted. 3. Using a Tech 2, monitor “DTC” info for DTC P0151 until the DTC P0151 test runs. 4. Note test result. Does the Tech 2 indicate DTC P0151 failed this ignition?	—	Go to Step 4	Refer to <i>Diagnostic Aids</i>
4	1. Turn ignition “OFF.” 2. Disconnect the PCM. 3. Check the Bank 2 HO2S 1 high and low signal circuits for a short to ground or a short to the heater ground circuit. Were Bank 2 HO2S 1 signal circuits shorted?	—	Go to Step 5	Go to Step 6
5	Repair the Bank 2 HO2S 1 signal circuit. Is the action complete?	—	Verify repair	—
6	1. Ignition “OFF.” 2. Leave the PCM and HO2S 1 disconnected. 3. Check for continuity between the high and low signal circuits. Was there continuity between the high and low circuits?	—	Go to Step 7	Go to Step 8

**DTC P0151 – HO2S Circuit Low Voltage Bank 2 Sensor 1 (Cont'd)**

Step	Action	Value(s)	Yes	No
7	Repair the short between the high and low circuits. Is the action complete?	—	Verify repair	—
8	1. Ignition "OFF." 2. Reconnect the PCM, leave HO2S disconnected. 3. Ignition "ON." Does the Tech 2 indicate Bank 2 HO2S 1 voltage near the specified value?	425-475 mV	Refer to <i>Diagnostic Aids</i>	Go to <i>Step 9</i>
9	Replace the PCM. <b>IMPORTANT:</b> The replacement PCM must be programmed. Refer to <i>On-Vehicle Service in Powertrain Control Module and Sensors</i> for procedures. And also refer to latest Service Bulletin. Check to see if the Latest software is released or not. And then Down Load the LATEST PROGRAMMED SOFTWARE to the replacement PCM. Is the action complete?	—	Verify repair	—

## Diagnostic Trouble Code (DTC) P0152 HO2S Circuit HIGH Voltage Bank 2 Sensor 1



### Circuit Description

The powertrain control module (PCM) supplies a bias voltage of about 450 mV between the heated oxygen sensor (HO2S) signal high and signal low circuits. When measured with a 10 megaohm digital voltmeter, this may display as low as 320 mV. The oxygen sensor varies the voltage within a range of about 1000 mV when the exhaust is rich, down through about 10 mV when exhaust is lean. The PCM constantly monitors the HO2S signal during “closed loop” operation and compensates for a rich or lean condition by decreasing or increasing the injector pulse width as necessary. If the Bank 2 HO2S 1 voltage remains excessively high for an extended period of time, DTC P0152 will be set.

### Conditions for Setting the DTC

- No related DTCs.
- The engine is operating in “closed loop.”
- The engine coolant temperature is above 60°C (140°F).
- “Closed loop” commanded air/fuel ratio between 14.5 and 14.8.
- Throttle angle between 3% and 19%.
- Bank 2 HO2S 1 signal voltage remains above 952 mV during normal “closed loop” operation for a total of 77 seconds over a 90-second period.

OR

- Bank 2 HO2S 1 signal voltage remains above 500 mV during deceleration fuel cutoff mode operation for up to 3 seconds.

### Action Taken When the DTC Sets

- The PCM will illuminate the malfunction indicator lamp (MIL) the first time the fault is detected.
- The PCM will store conditions which were present when the DTC was set as Freeze Frame and in the Failure Records data.
- “Open loop” fuel control will be in effect.

### Conditions for Clearing the MIL/DTC

- The PCM will turn the MIL “OFF” on the third consecutive trip cycle during which the diagnostic has been run and the fault condition is no longer present.
- A history DTC P0152 will clear after 40 consecutive warm-up cycles have occurred without a fault.
- DTC P0152 can be cleared by using the Tech 2 “Clear Info” function or by disconnecting the PCM battery feed.

### Diagnostic Aids

Check for the following conditions:

- Fuel pressure – The system will go rich if pressure is too high. The PCM can compensate for some increase. However, if fuel pressure is too high, a DTC P0152 may be set. Refer to *Fuel System Diagnosis*.
- Rich injector(s) – Perform “Injector Balance Test.”

D06RX087

- Leaking injector – Refer to *Fuel System Diagnosis*.
- Evaporative emissions (EVAP) system – Check the canister for fuel saturation. If the canister is full of fuel, check EVAP control system components and hoses. Refer to *Evaporative Emission (EVAP) Control System*.
- MAF sensor – The system can go rich if the MAF sensor signal indicates an engine airflow measurement that is not correct. Disconnect the MAF sensor to see if rich condition is corrected. If so, replace MAF sensor.
- Check for leaking fuel pressure regulator diaphragm by checking vacuum line to regulator for the presence of fuel. There should be no fuel in the vacuum line.
- TP sensor – An intermittent TP sensor output will cause the system to go rich, due to a false indication of the engine accelerating.
- Shorted Heated Oxygen Sensor (HO2S)– If the HO2S is internally shorted, the HO2S voltage displayed on the Tech 2 will be over 1 volt. Try disconnecting the affected HO2S with the key “ON,” engine “OFF.” If the displayed HO2S voltage changes from over 1000 mV to around 450 mV, replace the HO2S. Silicon contamination of the HO2S can cause a high HO2S voltage to be indicated. This condition is indicated by powdery white deposit on the portion of the HO2S exposed to the exhaust stream. If contamination is noticed, replace the affected HO2S.
- Open HO2S Signal Circuit of Faulty HO2S– A poor connection or open in the HO2S signal circuit can cause the DTC to set during deceleration fuel mode. An HO2S which is faulty and not allowing a full voltage switch between the rich and lean thresholds can also cause the condition. Operate the vehicle while monitoring the HO2S voltage with a Tech 2. If the HO2S is limited within a range between 300 mV to 600 mV, check the HO2S signal circuit wiring and associated terminal connections.
- If none of the above conditions are present, replace the affected HO2S.

**Test Description**

Number(s) below refer to the step number(s) on the Diagnostic Chart.

- 3. DTC P0152 failing during deceleration fuel cutoff mode operation may indicate a condition described in the “Diagnostic Aids” above. If the DTC P0152 test passes while the Failure Records conditions are being duplicated, an intermittent condition is indicated.

Reviewing the Failure Records vehicle mileage since the diagnostic test last failed may help determine how often the condition that caused the DTC to be set occurs. This may assist in diagnosing the condition.

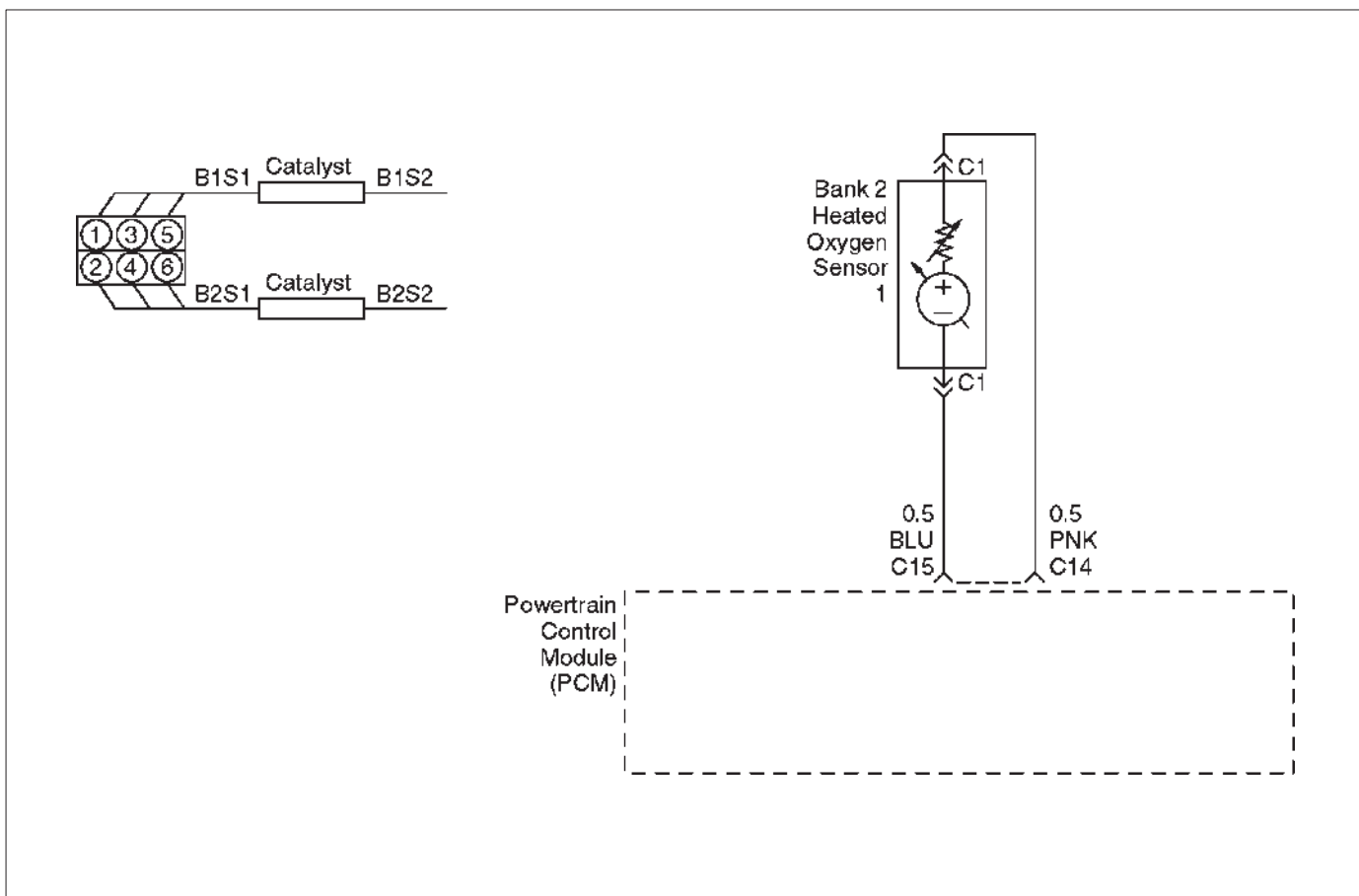
**DTC P0152 – HO2S Circuit High Voltage Bank 2 Sensor 1**

Step	Action	Value(s)	Yes	No
1	Was the “On-Board Diagnostic (OBD) System Check” performed?	—	Go to Step 2	Go to <i>OBD System Check</i>
2	1. Install the Tech 2. 2. Engine is at operating temperature. 3. Operate the vehicle within the parameters specified under “Conditions for Setting the DTC” criteria included in Diagnostic Support. 4. Using a Tech 2, monitor Bank 2 HO2S 1 voltage. Does the Bank 2 HO2S 1 voltage remain above the specified value?	952 mV (500 mV in deceleration fuel cut-off mode)	Go to Step 4	Go to Step 3
3	1. Ignition “ON.” 2. Review and record Tech 2 Failure Records data. 3. Operate the vehicle within Failure Records conditions as noted. 4. Using a Tech 2, monitor “DTC” info for DTC P0152 until the DTC P0152 test runs. 5. Note the test result. Does the Tech 2 indicate DTC P0152 failed this ignition?	—	Go to Step 4	Refer to <i>Diagnostic Aids</i>
4	1. Ignition “OFF.” 2. Disconnect Bank 2 HO2S 1. 3. Ignition “ON.” 4. At HO2S Bank 2 Sensor 1 connector (PCM side) use a DVM to measure voltages at the high and low signal terminals. Are the voltages in the specified range?	3-4 V	Go to Step 5	Go to Step 6

**DTC P0152 – HO2S Circuit High Voltage Bank 2 Sensor 1 (Cont'd)**

Step	Action	Value(s)	Yes	No
5	Repair short to voltage in signal circuit. Is the action complete?	—	Verify repair	—
6	1. Ignition "ON," engine"OFF." 2. At Bank 2 HO2S 1 connector (PCM side) jumper both the HO2S high and low signal circuits (PCM side) to ground. 3. Using a Tech 2, monitor Bank 2 HO2S 1 voltage. Is Bank 2 HO2S 1 voltage below the specified value?	10 mV	Go to <i>Step 7</i>	Go to <i>Step 8</i>
7	1. Disconnect the jumpers to ground from Bank 2 HO2S 1 PCM-side connector. 2. With the HO2S 1 connector disconnected, monitor Bank 2 HO2S 1 voltage. Is the Bank 2 HO2S 1 voltage between the specified values?	425-475 mV	Refer to <i>Diagnostic Aids</i>	Go to <i>Step 8</i>
8	Replace the PCM. <b>IMPORTANT:</b> The replacement PCM must be programmed. Refer to <i>On-Vehicle Service in Powertrain Control Module and Sensors</i> for procedures. And also refer to latest Service Bulletin. Check to see if the Latest software is released or not. And then Down Load the LATEST PROGRAMMED SOFTWARE to the replacement PCM. Is the action complete?	—	Verify repair	—

## Diagnostic Trouble Code (DTC) P0153 HO2S Slow Response Bank 2 Sensor 1



D06RX087

### Circuit Description

The powertrain control module (PCM) continuously monitors the heated oxygen sensor (HO2S) activity for 90 seconds after "closed loop" has been enabled. During the monitoring period the PCM counts the number of times that a rich-to-lean and lean-to-rich response is indicated and adds the amount of time it took to complete all rich-to-lean transitions and lean-to-rich transitions. With this information, an average time for rich-to-lean and lean-to-rich transitions can be determined. If the average response time of either transition is too slow, a DTC P0153 will be set.

A lean-to-rich transition is indicated when the HO2S voltage changes from less than 300 mV to greater than 600 mV. A rich-to-lean transition is indicated when the HO2S voltage changes from more than 600 mV to less than 300 mV. An HO2S that responds too slowly is likely to be faulty and should be replaced.

### Conditions for Setting the DTC

- No related DTCs.
- Engine coolant temperature (ECT) is above 50°C (122°F) for automatic transmission; 75° (167°F) for manual transmission.
- The engine is operating in "closed loop."
- Engine has been running for at least one minute.
- Canister purge duty cycle is above 2%.
- Engine speed is between 1500 RPM and 3000 RPM.
- Mass air flow is between 9 g/second and 42 g/second.

- All above conditions are met for 3 seconds.
- 90 seconds after "closed loop" has been enabled, Bank 2 HO2S 1 average transition time between 300 mV and 600 mV is too slow. The lean-to-rich average transition response time was longer than 94 milliseconds or the rich-to-lean average transition response time was longer than 105 milliseconds.

### Action Taken When the DTC Sets

- The PCM will illuminate the malfunction indicator lamp (MIL) after the second consecutive trip in which the fault is detected.
- The PCM will store conditions which were present when the DTC set as Freeze Frame and in the Failure Records data.
- "Open loop" fuel control will be in effect.

### Conditions for Clearing the MIL/DTC

- The PCM will turn the MIL "OFF" on the third consecutive trip cycle during which the diagnostic has been run and the fault condition is no longer present.
- A history DTC P0153 will clear after 40 consecutive warm-up cycles have occurred without a fault.
- DTC P0153 can be cleared by using the Tech 2 "Clear Info" function or by disconnecting the PCM battery feed.

### Diagnostic Aids

Check for the following conditions:

- Poor connection at PCM – Inspect harness connectors for backed-out terminals, improper mating, broken

locks, improperly formed or damaged terminals, and poor terminal-to-wire connection.

- Damaged harness – Inspect the wiring harness for damage. If the harness appears to be OK, observe the Bank 2 HO2S 1 display on the Tech 2 while moving connectors and wiring harnesses related to the sensor. A change in the display will indicate the location of the fault.

Reviewing the Failure Records vehicle mileage since the diagnostic test last failed may help determine how often the condition that caused the DTC to be set occurs. This may assist in diagnosing the condition.

### **Test Description**

Number(s) below refer to the step number(s) on the Diagnostic Chart.

2. Verifies that the fault is currently present.
3. HO2S transition time, ratio mean volts and switching DTCs set for multiple sensors indicate probable contamination. Before replacing the sensors, isolate and correct the source of the contamination to avoid damaging the replacement sensors.



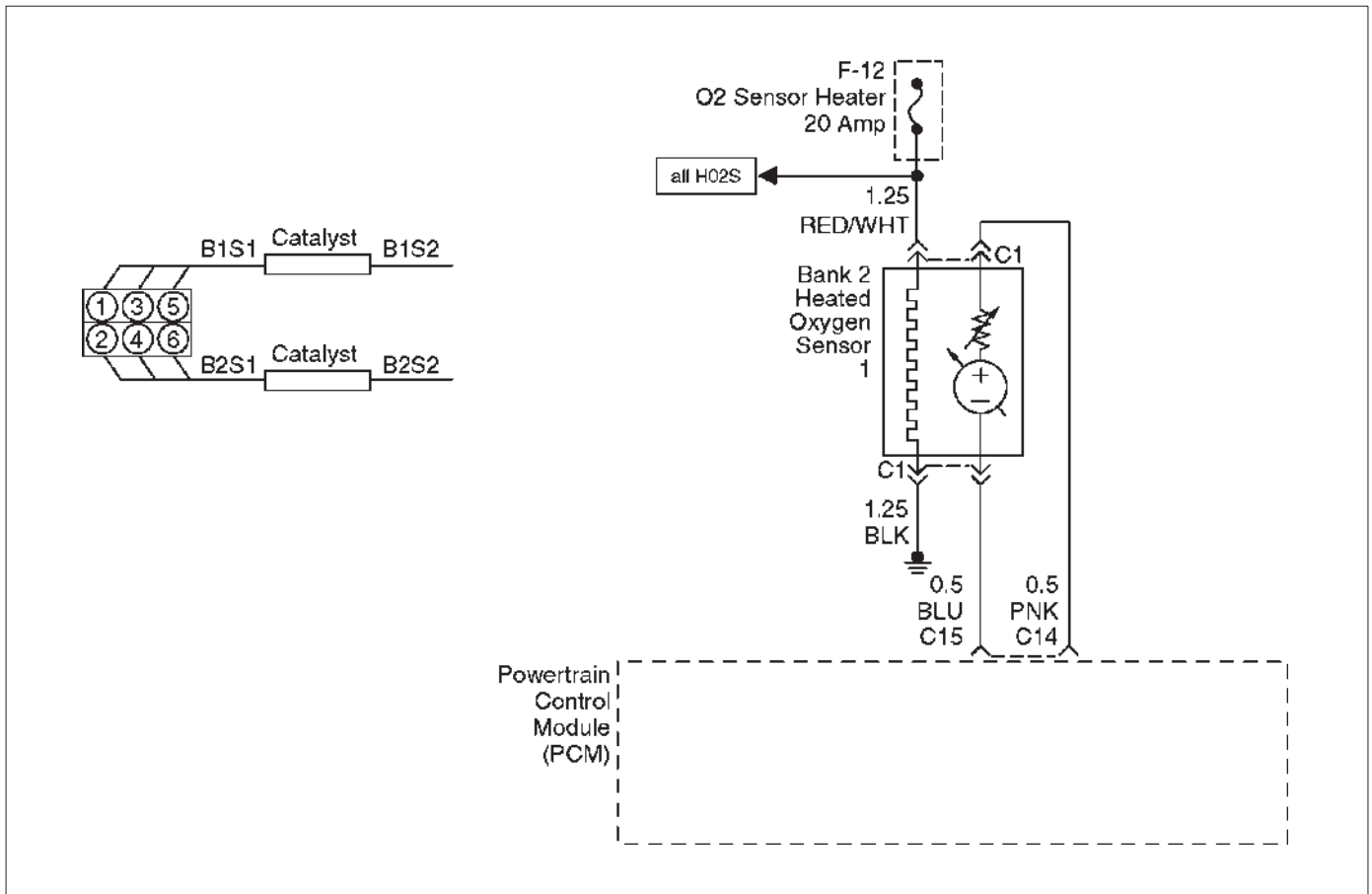
**DTC P0153 – HO2S Slow Response Bank 2 Sensor 1**

Step	Action	Value(s)	Yes	No
1	Was the "On-Board Diagnostic (OBD) System Check" performed?	—	Go to Step 2	Go to <i>OBD System Check</i>
2	NOTE: If any DTCs are set, (except P0133, P1133, P1134, P1153, and/or P1154), refer to those DTCs before proceeding with this diagnostic chart. 1. Install the Tech 2. 2. Idle the engine at operating temperature. 3. Operate the vehicle within parameters specified under "Conditions for Setting the DTC" criteria included in Diagnostic Support. 4. Using a Tech 2, monitor "DTC" info for DTC P0153 until the DTC P0153 test runs. 5. Note the test result. Does the Tech 2 indicate DTC P0153 failed this ignition?	—	Go to Step 3	Refer to <i>Diagnostic Aids</i>
3	Did the Tech 2 also indicate DTC P0153, P1133, P1134, P1153, and/or P1154 test failed this ignition?	—	Go to Step 17	Go to Step 4
4	Check for leaks at the pipe joints. Are the joints leaking?	—	Go to Step 5	Go to Step 6
5	Tighten the U-bolt nuts at the leaking joint. Is your action complete?	—	Go to Step 2	—
6	Check for gaskets that are damage or improperly installed. Are there damaged or misaligned gaskets?	—	Go to Step 7	Go to Step 8
7	1. Replace the damaged gaskets. 2. Align the connections. 3. Tighten the connections. Is your action complete?	—	Go to Step 2	—
8	Check for loose exhaust flange connections. Are the flange connections loose?	—	Go to Step 9	Go to Step 10
9	Tighten the stud nuts or bolts to specifications. Is your action complete?	—	Go to Step 2	—
10	Check for burned or corroded exhaust pipes. Are the exhaust pipes burned or corroded?	—	Go to Step 11	Go to Step 12
11	Replace the exhaust pipes, as required. Is your action complete?	—	Go to Step 2	—
12	Check for leaks at the exhaust manifold. Are there leaks at the exhaust manifold?	—	Go to Step 13	Go to Step 14
13	Tighten the bolts to specifications or replace the manifold if necessary. Is your action complete?	—	Go to Step 2	—

**DTC P0153 – HO2S Slow Response Bank 2 Sensor 1 (Cont'd)**

Step	Action	Value(s)	Yes	No
14	1. Visually/physically inspect the following items: <ul style="list-style-type: none"> <li>○ Ensure that the Bank 2 HO2S 1 is securely installed.</li> <li>○ Check for corrosion on terminals.</li> <li>○ Check terminal tension (at Bank 2 HO2S 1 and at the PCM).</li> <li>○ Check for damaged wiring.</li> </ul> Was a problem found in any of the above areas?	—	Go to Step 18	Go to Step 15
15	1. Disconnect Bank 2 HO2S 1. 2. Ignition "ON." 3. Using a DVM at the PCM side of the HO2S 1 connector, measure the voltage between the high signal circuit and ground. Are both voltages in the specified range?	3-4 V	Go to Step 16	Go to Step 19
16	1. With Bank 2 HO2S 1 disconnected, jumper the high and low (PCM side) signal circuits to ground. 2. Ignition "ON." 3. Using a Tech 2, monitor the Bank 2 HO2S 1 voltage. Does the Tech 2 indicate less than 10 mV and immediately return to about 450 mV when the jumper is removed?	—	Go to Step 21	Go to Step 22
17	Replace the affected heated oxygen sensors. NOTE: Before replacing the sensors, the cause of the contamination must be determined and corrected. <ul style="list-style-type: none"> <li>○ Fuel contamination.</li> <li>○ Use of improper RV sealant.</li> <li>○ Engine oil/coolant consumption.</li> </ul> Is the action complete?	—	Verify repair	—
18	Repair condition as necessary. Is the action complete?	—	Verify repair	—
19	Check for faulty PCM connections or terminal damage. Is the action complete?	—	Verify repair	Go to Step 20
20	Repair open, short or grounded signal circuit. Is the action complete?	—	Verify repair	—
21	Replace Bank 2 HO2S 1. Is the action complete?	—	Verify repair	—
22	Replace the PCM. <b>IMPORTANT:</b> The replacement PCM must be programmed. Refer to <i>On-Vehicle Service in Powertrain Control Module and Sensors</i> for procedures. And also refer to latest Service Bulletin. Check to see if the Latest software is released or not. And then Down Load the LATEST PROGRAMMED SOFTWARE to the replacement PCM. Is the action complete?	—	Verify repair	—

## Diagnostic Trouble Code (DTC) P0154 HO2S Circuit Insufficient Activity Bank 2 Sensor 1



D06RX088

### Circuit Description

The powertrain control module (PCM) supplies a bias voltage of about 450 mV between the heated oxygen sensor (HO2S) high and low circuits. When measured with a 10 megaohm digital voltmeter, this may display as low as 320 mV. The oxygen sensor varies the voltage within a range of about 1000 mV when the exhaust is rich, down through about 10 mV when exhaust is lean. The PCM constantly monitors the HO2S signal during "closed loop" operation and compensates for a rich or lean condition by decreasing or increasing injector pulse width as necessary. If the Bank 2 HO2S 1 voltage remains at or near the 450 mV bias for an extended period of time, DTC P0154 will be set, indicating an open sensor signal or sensor low circuit.

Heated oxygen sensors are used to minimize the amount of time required for "closed loop" fuel control operation and to allow accurate catalyst monitoring. The oxygen sensor heater greatly decreases the amount of time required for fuel control sensors Bank 1 HO2S 1 and Bank 2 HO2S 1 to become active. Oxygen sensor heaters are required by post-catalyst monitor sensors to maintain a sufficiently high temperature for accurate exhaust oxygen content readings further from the engine.

### Conditions for Setting the DTC

- No related DTCs.
- Battery voltage is above 10 volts.

- Engine running time is longer than 40 seconds.
- Oxygen sensor heater is functioning properly.
- Bank 2 HO2S 1 signal voltage remains between 400 mV and 500 mV for a total of 77 seconds over a 90-second period of time.

### Action Taken When the DTC Sets

- The PCM will illuminate the malfunction indicator lamp (MIL) the first time the fault is detected.
- The PCM will store conditions which were present when the DTC was set as Freeze Frame and in the Failure Records data.
- "Open loop" fuel control will be in effect.

### Conditions for Clearing the MIL/DTC

- The PCM will turn the MIL "OFF" on the third consecutive trip cycle during which the diagnostic has been run and the fault condition is no longer present.
- A history DTC P0154 will clear after 40 consecutive warm-up cycles have occurred without a fault.
- DTC P0154 can be cleared by using the Tech 2 "Clear Info" function or by disconnecting the PCM battery feed.

### Diagnostic Aids

Check for the following conditions:

- Poor connection or damaged harness – Inspect the harness connectors for backed-out terminals,

improper mating, broken locks, improperly formed or damaged terminals, poor terminal-to-wire-connection, and damaged harness.

- Faulty HO2S heater or heater circuit – With the ignition “ON,” engine “OFF,” the HO2S 1 voltage displayed on the Tech 2 is normally 455-460 mV. A reading over 1000 mV indicates a signal line shorted to voltage. A reading under 5 mV indicates a signal line shorted to ground or signal lines shorted together. If not, disconnect the HO2S and connect a test light between the HO2S ignition feed and heater ground circuits. If the test light does not light for 2 seconds when the ignition is turned on, repair the open ignition feed or sensor ground circuit as necessary. If the test light lights and the HO2S signal and low circuits are OK, replace the HO2S.
- Intermittent test – With the ignition “ON,” monitor the HO2S signal voltage while moving the wiring harness

and related connectors. If the fault is induced, the HO2S signal voltage will change. This may help isolate the location of the malfunction.

**Test Description**

Number(s) below refer to the step number(s) on the Diagnostic Chart.

- 3. If the DTC P0154 test passes while the Failure Records conditions are being duplicated, an intermittent condition is indicated.

Reviewing the Failure Records vehicle mileage since the diagnostic test last failed may help determine how often the condition that caused the DTC to be set occurs. This may assist in diagnosing the condition.

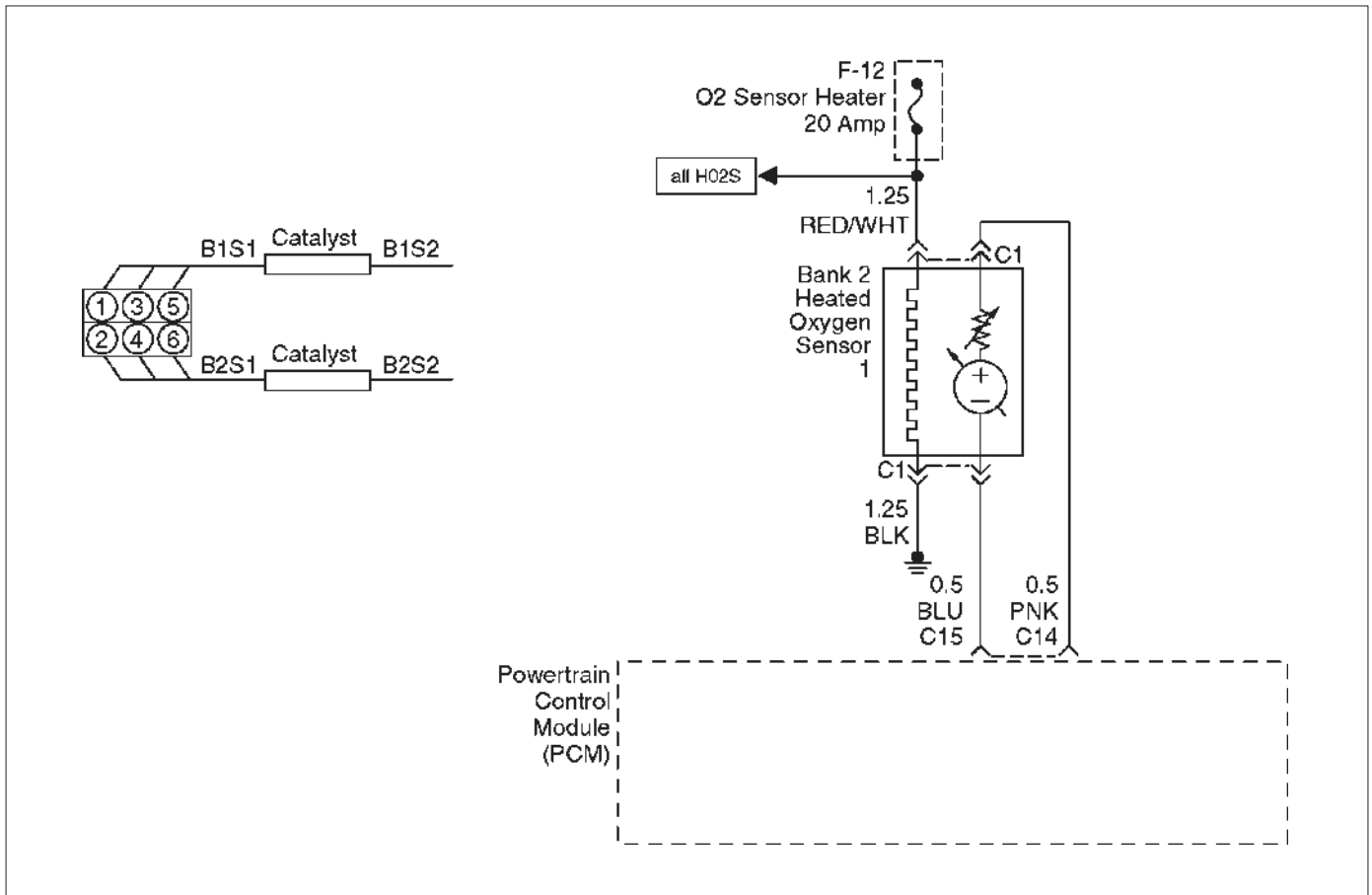
**DTC P0154 –HO2S Circuit Insufficient Activity Bank 2 Sensor 1**

Step	Action	Value(s)	Yes	No
1	Was the “On-Board Diagnostic (OBD) System Check” performed?	—	Go to Step 2	Go to <i>OBD System Check</i>
2	1. Install the Tech 2. 2. Run the engine at operating temperature. 3. Operate the engine above 1200 RPM for two minutes.  Does the Tech 2 indicate Bank 2 HO2S 1 voltage varying outside the specified values?	400-500 mV	Go to Step 3	Go to Step 4
3	1. Ignition “ON,” engine “OFF.” 2. Review and record Tech 2 Failure Records data and note parameters. 3. Operate the vehicle within Failure Records conditions as noted. 4. Using a Tech 2, monitor “DTC” info for DTC P0154 until the DTC P0154 test runs. 5. Note the test result.  Does the Tech 2 indicate DTC P0154 failed this ignition?	—	Go to Step 4	Refer to <i>Diagnostic Aids</i>
4	Check for a damaged harness.  Was a problem found?	—	Verify repair	Go to Step 5
5	Check for a poor Bank 2 HO2S 1 high and low circuit terminal connections at the Bank 2 HO2S 1 harness connector and replace terminal(s) if necessary.  Did any terminals require replacement?	—	Verify repair	Go to Step 6
6	Check for a poor Bank 2 HO2S 1 high and low circuit terminal connections at the PCM and replace terminal(s) if necessary.  Did the terminal require replacement?	—	Verify repair	Go to Step 7

**DTC P0154 –HO2S Circuit Insufficient Activity Bank 2 Sensor 1 (Cont'd)**

Step	Action	Value(s)	Yes	No
7	1. Ignition "OFF." 2. With the PCM disconnected, check continuity of the Bank 2 HO2S 1 high circuit. 3. If the Bank 2 HO2S 1 high circuit measures over 5.0 ohms, repair open or poor connection as necessary. Was a Bank 2 HO2S 1 high circuit problem found and corrected?	—	Verify repair	Go to <i>Step 8</i>
8	1. Ignition "OFF." 2. With the PCM disconnected, check continuity of the Bank 2 HO2S 1 low circuit. 3. If the Bank 2 HO2S 1 low circuit measures over 5.0 ohms, repair open or poor connection as necessary. Was a Bank 2 HO2S 1 low circuit problem found and corrected?	—	Verify repair	Go to <i>Step 9</i>
9	1. Ignition "ON," engine "OFF." 2. Disconnect Bank 2 HO2S 1 and jumper the HO2S high and low circuits (PCM side) to ground. 3. Using a Tech 2, monitor Bank 2 HO2S 1 voltage. Is the Bank 2 HO2S 1 voltage in the specified range?	0-10 mV	Go to <i>Step 10</i>	Go to <i>Step 11</i>
10	Replace Bank 2 HO2S 1. Is the action complete?	—	Verify repair	—
11	Replace the PCM. <b>IMPORTANT:</b> The replacement PCM must be programmed. Refer to <i>On-Vehicle Service in Powertrain Control Module and Sensors</i> for procedures. And also refer to latest Service Bulletin. Check to see if the Latest software is released or not. And then Down Load the LATEST PROGRAMMED SOFTWARE to the replacement PCM. Is the action complete?	—	Verify repair	—

## Diagnostic Trouble Code (DTC) P0155 HO2S Heater Circuit Bank 2 Sensor 1



### Circuit Description

Heated oxygen sensors are used to minimize the amount of time required for closed loop fuel control operation and to allow accurate catalyst monitoring. The oxygen sensor heater greatly decreases the amount of time required for fuel control sensors Bank 1 HO2S 1 and Bank 2 HO2S 1 to become active. Oxygen sensor heaters are required by post-catalyst monitor sensors to maintain a sufficiently high temperature which allows accurate exhaust oxygen content readings further from the engine.

The powertrain control module (PCM) will run the heater test only after a cold start (determined by engine coolant and intake air temperature at the time of start-up) and only once during an ignition cycle. When the engine is started the PCM will monitor the HO2S voltage. When the Bank HO2S voltage indicates a sufficiently active sensor, the PCM looks at how much time has elapsed since start-up. If the PCM determines that too much time was required for the Bank 2 HO2S 1 to become active, a DTC P0155 will set. The time it should take the HO2S to reach operating temperature is based on the total amount of air that has passed through the mass air flow (MAF) sensor and into the engine (more total air flow = shorter time to HO2S activity).

### Conditions for Setting the DTC

- No related DTCs.
- Intake air temperature (IAT) is less than 32°C (90°F) at start-up.

- Engine coolant temperature (ECT) is less than 32°C (90°F) at start-up.
- IAT and ECT are within 6°C (11°F) of each other at start-up.
- Ignition voltage is between 11 volts and 18 volts.
- Average mass air flow for the sample period is less than 21 g/second.
- Bank 1 HO2S 2 voltage does not change more than 150 mV from the bias voltage (between 400 mV-500 mV) for a longer amount of time than it should. The maximum amount of time to come up to operating range is 150 seconds. This warm-up time depends on the engine coolant temperature at start-up and accumulated air flow since start-up.

### Action Taken When the DTC Sets

- The PCM will illuminate the malfunction indicator lamp (MIL) after the second consecutive trip in which the fault is detected.
- The PCM will store conditions which were present when the DTC was set as Freeze Frame and in the Failure Records data.

### Conditions for Clearing the MIL/DTC

- The PCM will turn the MIL "OFF" on the third consecutive trip cycle during which the diagnostic has been run and the fault condition is no longer present.
- A history DTC P0155 will clear after 40 consecutive warm-up cycles have occurred without a fault.

D06RX088

○ DTC P0155 can be cleared by using the Tech 2 “Clear info” function or by disconnecting the PCM battery feed.

**Diagnostic Aids**

Check for the following conditions:

- Poor connection at PCM – Inspect harness connectors for backed-out terminals, improper mating, broken locks, improperly formed or damaged terminals, and poor terminal-to-wire connection.
- Damaged harness – Inspect the wiring harness for damage. If the harness appears to be OK, observe the display on the Tech 2 while moving connectors and wiring harnesses related to the sensor. A change in the display will indicate the location of the fault.

Reviewing the Failure Records vehicle mileage since the diagnostic test last failed may help determine how often the condition that caused the DTC to be set occurs. This may assist in diagnosing the condition.

2. The HO2S should be allowed to cool before performing this test. If the HO2S heater is functioning, the signal voltage will gradually increase or decrease as the sensor element warms. If the heater is not functioning, the HO2S signal will remain near the 450 mV bias voltage.
4. Ensures that the ignition feed circuit to the HO2S is not open or shorted. The test light should be connected to a good chassis ground, in case the HO2S low or HO2S heater ground circuit is faulty.
5. Checks the HO2S heater ground circuit.
6. Checks for an open or shorted HO2S heater element.
10. An open HO2S signal or low circuit can cause the HO2S heater to appear faulty. Check these circuits before replacing the sensor.

**Test Description**

Number(s) below refer to the step number(s) on the Diagnostic Chart.

**DTC P0155 – HO2S Heater Circuit Bank 2 Sensor 1**

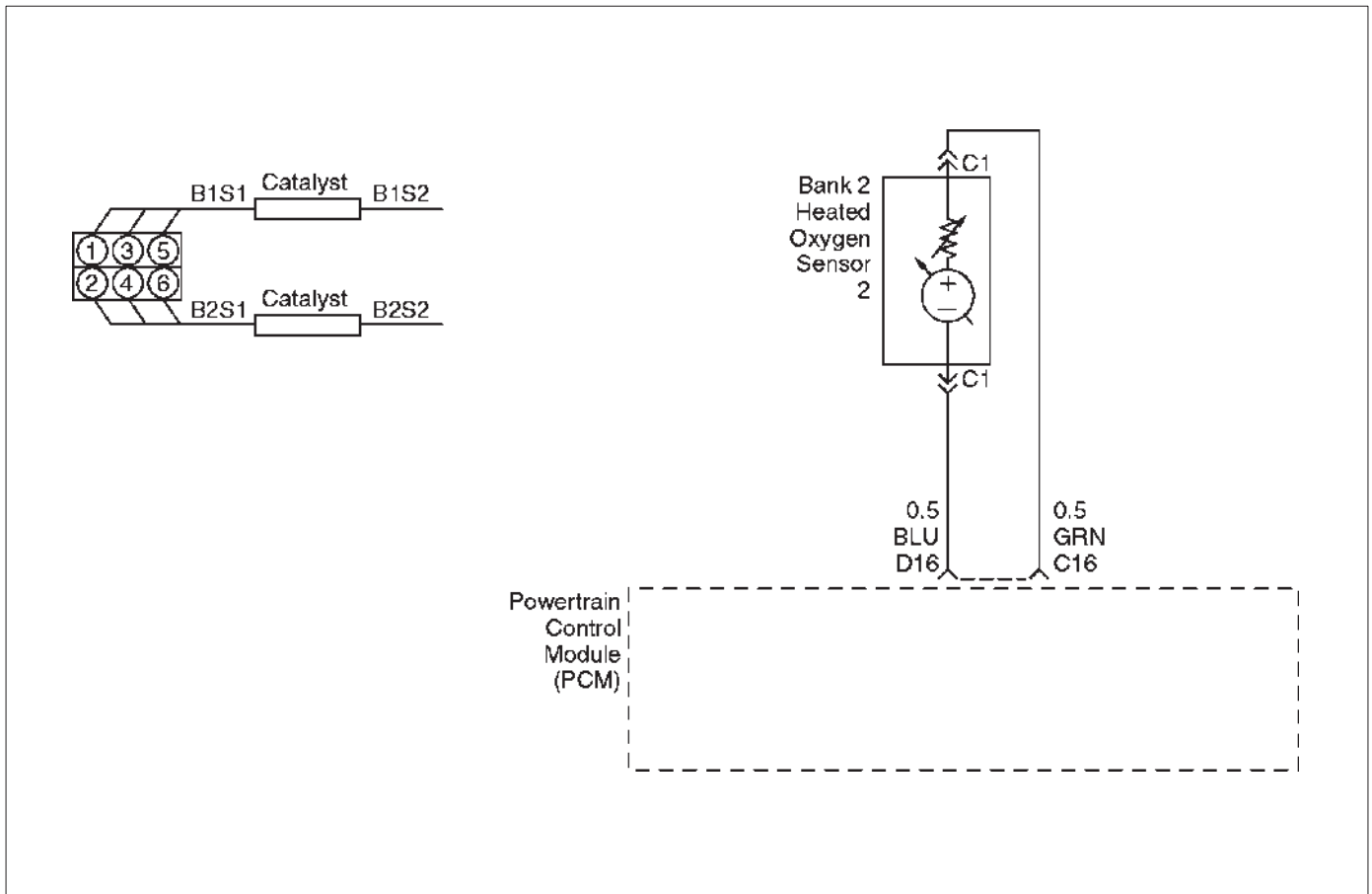
Step	Action	Value(s)	Yes	No
1	Was the “On-Board Diagnostic (OBD) System Check” performed?	—	Go to Step 2	Go to OBD System Check
2	NOTE: If the engine has just been operating, allow the engine to cool for at least 15 minutes before proceeding. 1. Remove the fuel pump relay. 2. Connect a fused jumper at the fuel pump relay socket, between the battery positive at the relay and the relay wire that leads to the fuel pump and HO2S fuses. 3. Ignition “OFF.” 4. Install a Tech 2. 5. Ignition “ON,” engine “OFF.” 6. Monitor the Bank 1 HO2S 1 voltage for several minutes. Did the HO2S voltage go from bias voltage to above or below the specified value?	Above 650 mV or below 250 mV	Refer to Diagnostic Aids	Go to Step 3
3	Inspect the fuse for the Bank 2 HO2S 1 ignition feed. Is the fuse open?	—	Go to Step 15	Go to Step 4
4	1. Ignition “OFF.” 2. Raise the vehicle. 3. Disconnect the Bank 2 HO2S 1 electrical connector. 4. Using a test light connected to a known good ground (do not use Bank 2 HO2S 1 heater ground or Bank 2 HO2S 1 low), probe the ignition feed circuit at the Bank 2 HO2S 1 electrical connector (PCM harness side). Does the test light illuminate?	—	Go to Step 5	Go to Step 7

**DTC P0155 – HO2S Heater Circuit Bank 2 Sensor 1 (Cont'd)**

Step	Action	Value(s)	Yes	No
5	Connect the test light between Bank 2 HO2S 1 ignition feed and Bank 2 HO2S 1 heater ground. Does the test light illuminate?	—	Go to <i>Step 6</i>	Go to <i>Step 8</i>
6	1. Allow the HO2S to cool for at least 15 minutes. 2. Using a DVM, measure resistance between the Bank 2 HO2S 1 ignition feed and the Bank 2 HO2S 1 heater ground at the Bank 2 HO2S 1 pigtail. Is the HO2S resistance within the specified values?	3-6 ohms	Go to <i>Step 9</i>	Go to <i>Step 10</i>
7	Repair the open Bank 2 HO2S 1 ignition feed circuit to Bank 2 HO2S 1. Is the action complete?	—	Verify repair	—
8	Repair the open Bank 2 HO2S 1 heater ground circuit. Is the action complete?	—	Verify repair	—
9	1. Check for a poor connection at the Bank 2 HO2S 1 harness terminals. 2. If a poor connection is found, replace terminals. Was a poor connection found?	—	Verify repair	Go to <i>Step 10</i>
10	Check for a poor Bank 2 HO2S 1 signal or low circuit terminal connection at the Bank 2 HO2S 1 harness connector and replace terminal(s) if necessary. Did any terminals require replacement?	—	Verify repair	Go to <i>Step 11</i>
11	1. Ignition "OFF." 2. Disconnect the PCM and check the continuity of the Bank 2 HO2S 1 signal circuit and the Bank 2 HO2S 1 low circuit. 3. If the Bank 2 HO2S 1 signal circuit or HO2S low circuit measures over 5 ohms, repair open or poor connection as necessary. Was a problem found?	—	Verify repair	Go to <i>Step 12</i>
12	Check for a poor Bank 2 HO2S 1 low circuit terminal connection at the PCM and replace the terminal if necessary. Did the terminal require replacement?	—	Verify repair	Go to <i>Step 13</i>
13	Check for a poor Bank 2 HO2S 1 signal circuit terminal connection at the PCM and replace the terminal if necessary. Did the terminal require replacement?	—	Verify repair	Go to <i>Step 14</i>
14	Replace Bank 2 HO2S 1. Is the action complete?	—	Verify repair	—
15	Locate and repair short to ground in Bank 2 HO2S 1 ignition feed circuit and replace the faulty fuse. Is the action complete?	—	Verify repair	—



## Diagnostic Trouble Code (DTC) P0157 HO2S Circuit Low Voltage Bank 2 Sensor 2



### Circuit Description

To control emissions of hydrocarbons (HC), carbon monoxide (CO), and oxides of nitrogen (NO<sub>x</sub>), a three-way catalytic converter is used. The catalyst within the converter promotes a chemical reaction which oxidizes the HC and CO present in the exhaust gas, converting them into harmless water vapor and carbon dioxide. The catalyst also reduces NO<sub>x</sub>, converting it to nitrogen. The powertrain control module (PCM) has the ability to monitor this process using the Bank 2 HO2S 1 and the Bank 2 HO2S 2 heated oxygen sensors. The Bank 2 HO2S 1 sensor produces an output signal which indicates the amount of oxygen present in the exhaust gas entering the three-way catalytic converter. The Bank 2 HO2S 2 sensor produces an output signal which indicates the oxygen storage capacity of the catalyst; this in turn indicates the catalyst's ability to convert exhaust gases efficiently. If the catalyst is operating efficiently, the Bank 2 HO2S 1 signal will be far more active than that produced by the Bank 2 HO2S 2 sensor. If the Bank 2 HO2S 2 signal voltage remains excessively low for an extended period of time, DTC P0157 will be set.

### Conditions for Setting the DTC

- No related DTCs.
- The engine is operating in "closed loop."
- Engine coolant temperature is above 60°C (140°F).

- "Closed loop" commanded air/fuel ratio is between 14.5 and 14.8
  - Throttle angle is between 3% and 19%.
  - Bank 2 HO2S 2 signal voltage remains below 22 mV during normal "closed loop" operation for a total of 106 seconds over a 125-second period of time.
- OR
- Bank 2 HO2S 2 signal voltage remains below 400 mV during "power enrichment" mode fuel control operation for up to 5 seconds.

### Action Taken When the DTC Sets

- The PCM will illuminate the malfunction indicator lamp (MIL) the first time the fault is detected.
- The PCM will store conditions which were present when the DTC was set as Freeze Frame and in the Failure Records data.

### Conditions for Clearing the MIL/DTC

- The PCM will turn the MIL "OFF" on the third consecutive trip cycle during which the diagnostic has been run and the fault condition is no longer present.
- A history DTC P0157 will clear after 40 consecutive warm-up cycles have occurred without a fault.
- DTC P0157 can be cleared by using the Tech 2 "Clear Info" function or by disconnecting the PCM battery feed.

**Diagnostic Aids**

Check for the following conditions:

- Heated oxygen sensor wiring – The sensor pigtail may be mispositioned and contacting the exhaust system.
- Poor PCM to engine grounds.
- Fuel pressure – A condition which causes a lean exhaust can cause DTC P0157 to set. The system will go lean if pressure is too low. The PCM can compensate for some decrease. However, if fuel pressure is too low, a DTC P0157 may be set. Refer to *Fuel System Diagnosis*.
- Lean injector(s) – Perform “Injector Balance Test.”
- Vacuum leaks – Check for disconnected or damaged vacuum hoses and for vacuum leaks at the intake manifold, throttle body, EGR system, and PCV system.
- Exhaust leaks – An exhaust leak may cause outside air to be pulled into the exhaust gas stream past the HO2S, causing the DTC P0157 to set. Check for exhaust leaks near the Bank 1 HO2S 2 sensor.
- MAF sensor – The system can go lean if the MAF sensor signal indicates an engine airflow

measurement that is not correct. Disconnect the MAF sensor to see if the condition is corrected. If so, replace the MAF sensor.

- Fuel contamination – Water, even in small amounts, can be delivered to the fuel injectors. The water can cause a lean exhaust to be indicated. Excessive alcohol in the fuel can also cause this condition. Refer to *Fuel System Diagnosis* for the procedure to check for fuel contamination.
- If none of above conditions are present, replace the affected HO2S 2.

**Test Description**

Number(s) below refer to the step number(s) on the Diagnostic Chart.

- 3. DTC P0157 failing during operation may indicate a condition described in the “Diagnostic Aids” above. If the DTC P0157 test passes while the Failure Records conditions are being duplicated, an intermittent condition is indicated.

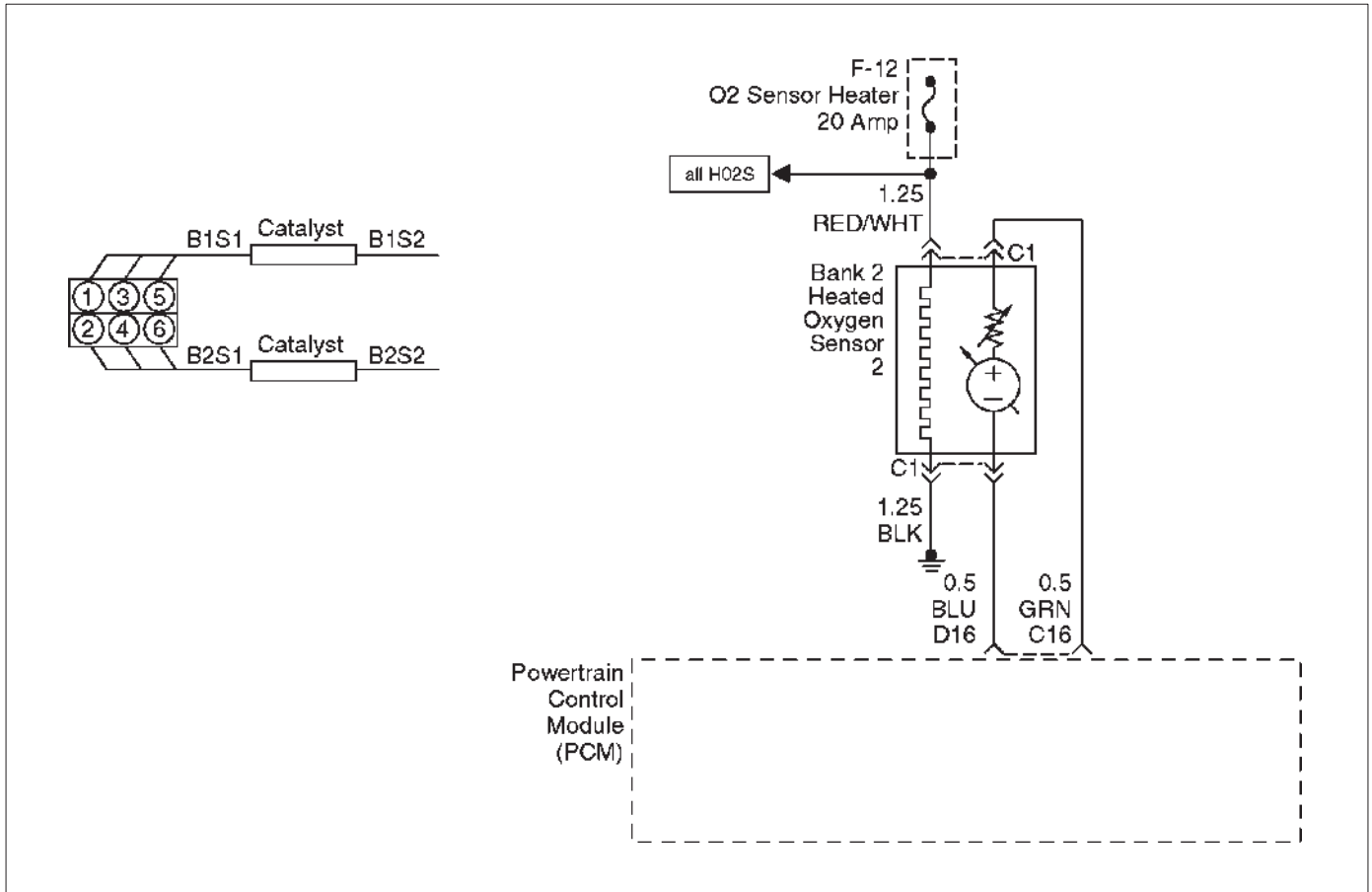
**DTC P0157 – HO2S Circuit Low Voltage Bank 2 Sensor 2**

Step	Action	Value(s)	Yes	No
1	Was the “On-Board Diagnostic (OBD) System Check” performed?	—	Go to Step 2	Go to <i>OBD System Check</i>
2	1. Install the Tech 2. 2. Run the engine at operating temperature. 3. Operate the vehicle within the parameters specified under “Conditions for Setting the DTC” criteria included in Diagnostic Support. 4. Using a Tech 2, monitor Bank 2 HO2S 2 voltage. Does the Bank 2 HO2S 2 voltage remain below the specified value?	22 mV	Go to Step 4	Go to Step 3
3	1. Ignition “ON,” engine “OFF.” 2. Review and record Tech 2 Failure Records data and note parameters. 3. Operate the vehicle within Failure Records conditions as noted. 4. Using a Tech 2, monitor “DTC” info for DTC P0157 until the DTC P0157 test runs. 5. Note the test result. Does the Tech 2 indicate DTC P0157 failed this ignition?	—	Go to Step 4	Refer to <i>Diagnostic Aids</i>
4	1. Turn the ignition “OFF.” 2. Disconnect the PCM. 3. Check the Bank 2 HO2S 2 high and low signal circuits for a short to ground or a short to the heater ground circuit. Were Bank 2 HO2S 2 signal circuits shorted?	—	Go to Step 5	Go to Step 6
5	Repair the Bank 1 HO2S 2 signal circuit. Is the action complete?	—	Verify repair	—

**DTC P0157 – HO2S Circuit Low Voltage Bank 2 Sensor 2 (Cont'd)**

Step	Action	Value(s)	Yes	No
6	1. Ignition "OFF." 2. Leave the PCM and HO2S 2 disconnected. 3. Check for continuity between the high and low signal circuits. Was there continuity between the high and low circuits?	—	Go to <i>Step 7</i>	Go to <i>Step 8</i>
7	Repair the short between the high and low circuits. Is the action complete?	—	Verify repair	—
8	1. Ignition "OFF." 2. Reconnect the PCM, leave HO2S 2 disconnected. 3. Ignition "ON." Does the Tech 2 indicate Bank 2 HO2S 2 voltage near the specified value?	425-475 mV	Refer to <i>Diagnostic Aids</i>	Go to <i>Step 9</i>
9	Replace the PCM. <b>IMPORTANT:</b> The replacement PCM must be programmed. Refer to <i>On-Vehicle Service in Powertrain Control Module and Sensors</i> for procedures. And also refer to the latest Service Bulletin. Check to see if the Latest software is released or not. And then Down Load the LATEST PROGRAMMED SOFTWARE to the replacement PCM. Is the action complete?	—	Verify repair	—

## Diagnostic Trouble Code (DTC) P0158 HO2S Circuit High Voltage Bank 2 Sensor 2



### Circuit Description

To control emissions of hydrocarbons (HC), carbon monoxide (CO), and oxides of nitrogen (NO<sub>x</sub>), a three-way catalytic converter is used. The catalyst within the converter promotes a chemical reaction which oxidizes the HC and CO present in the exhaust gas, converting them into harmless water vapor and carbon dioxide. The catalyst also reduces NO<sub>x</sub>, converting it to nitrogen. The powertrain control module (PCM) has the ability to monitor this process using the Bank 2 HO2S 1 and the Bank 2 HO2S 2 heated oxygen sensors. The Bank 2 HO2S 1 sensor produces an output signal which indicates the amount of oxygen present in the exhaust gas entering the three-way catalytic converter. The Bank 2 HO2S 2 sensor produces an output signal which indicates the oxygen storage capacity of the catalyst; this in turn indicates the catalyst's ability to convert exhaust gases efficiently. If the catalyst is operating efficiently, the Bank 2 HO2S 1 signal will be far more active than that produced by the Bank 2 HO2S 2 sensor. If the Bank 2 HO2S 2 signal voltage remains excessively high for an extended period of time, DTC P0158 will be set.

### Conditions for Setting the DTC

- No related DTCs.
- Engine is operating in "closed loop."
- "Closed loop" commanded air/fuel ratio is between 14.5 and 14.8.

- Engine coolant temperature is above 60°C (140°F).
  - Throttle angle is between 3% and 19%.
  - Bank 2 HO2S 2 signal voltage remains above 952 mV during normal "closed loop" operation for a total of 106 seconds over a 125-second period.
- OR
- Bank 2 HO2S 2 signal voltage remains above 500 mV during deceleration fuel cutoff mode operation for up to 3 seconds.

### Action Taken When the DTC Sets

- The PCM will illuminate the malfunction indicator lamp (MIL) the first time the fault is detected.
- The PCM will store conditions which were present when the DTC was set as Freeze Frame and in the Failure Records data.

### Conditions for Clearing the MIL/DTC

- The PCM will turn the MIL "OFF" on the third consecutive trip cycle during which the diagnostic has been run and the fault condition is no longer present.
- A history DTC P0158 will clear after 40 consecutive warm-up cycles have occurred without a fault.
- DTC P0158 can be cleared by using the Tech 2 "Clear Info" function or by disconnecting the PCM battery feed.

D06RX090

**Diagnostic Aids**

Check for the following conditions:

- Fuel pressure – An excessively rich fuel mixture can cause a DTC P0158 to be set. Refer to *Fuel System Diagnosis*.
- Rich injector(s) – Perform “Injector Balance Test.”
- Leaking injector – Refer to *Fuel System Diagnosis*.
- Evaporative emissions (EVAP) canister purge – Check for fuel saturation. If full of fuel, check canister control and hoses. Refer to *Evaporative Emission (EVAP) Control System*.
- MAF sensor –The system can go rich if the MAF sensor signal indicates an engine airflow measurement that is not correct. Disconnect the MAF sensor to see if a rich condition is corrected. If so, replace the MAF sensor.
- Check for a leaking fuel pressure regulator diaphragm by checking the vacuum line to the regulator for the presence of fuel. There should be no fuel in the vacuum line.
- TP sensor – An intermittent TP sensor output will cause the system to go rich, due to a false indication of the engine accelerating.
- Shorted Heated Oxygen Sensor (HO2S) – If the HO2S is internally shorted, the HO2S voltage displayed on the Tech 2 will be over 1 volt. Try disconnecting the affected HO2S with the key “ON,” engine “OFF.” If the displayed HO2S voltage changes from over 1000 mV to around 450 mV, replace the HO2S. Silicon contamination of the HO2S can also cause a high HO2S voltage to be indicated. This condition is

indicated by a powdery white deposit on the portion of the HO2S exposed to the exhaust stream. If contamination is noticed, replace the affected HO2S.

- Open HO2S signal or low circuit, or faulty HO2S – A poor connection or open in the HO2S signal or low circuit can cause the DTC to set during deceleration fuel cutoff mode operation. An HO2S which is faulty and does not allow full voltage swing between the rich and lean thresholds can also cause this condition. Operate the vehicle while monitoring the HO2S voltage with a Tech 2. If the HO2S voltage is limited within a range between 300 mV to 600 mV, check the HO2S signal and low circuit wiring and associated terminal connections. If the wiring and connections are OK, replace the HO2S.
- If none of above conditions are present, replace the affected HO2S.

**Test Description**

Number(s) below refer to the step number(s) on the Diagnostic Chart.

3. DTC P0158 being set during deceleration fuel cutoff mode operation may indicate a condition described in the “Diagnostic Aids” above. If the DTC P0158 test passes while the Failure Records conditions are being duplicated, an intermittent condition is indicated.

Reviewing the Failure Records vehicle mileage since the diagnostic test last failed may help determine how often the condition that caused the DTC to be set occurs. This may assist in diagnosing the condition.

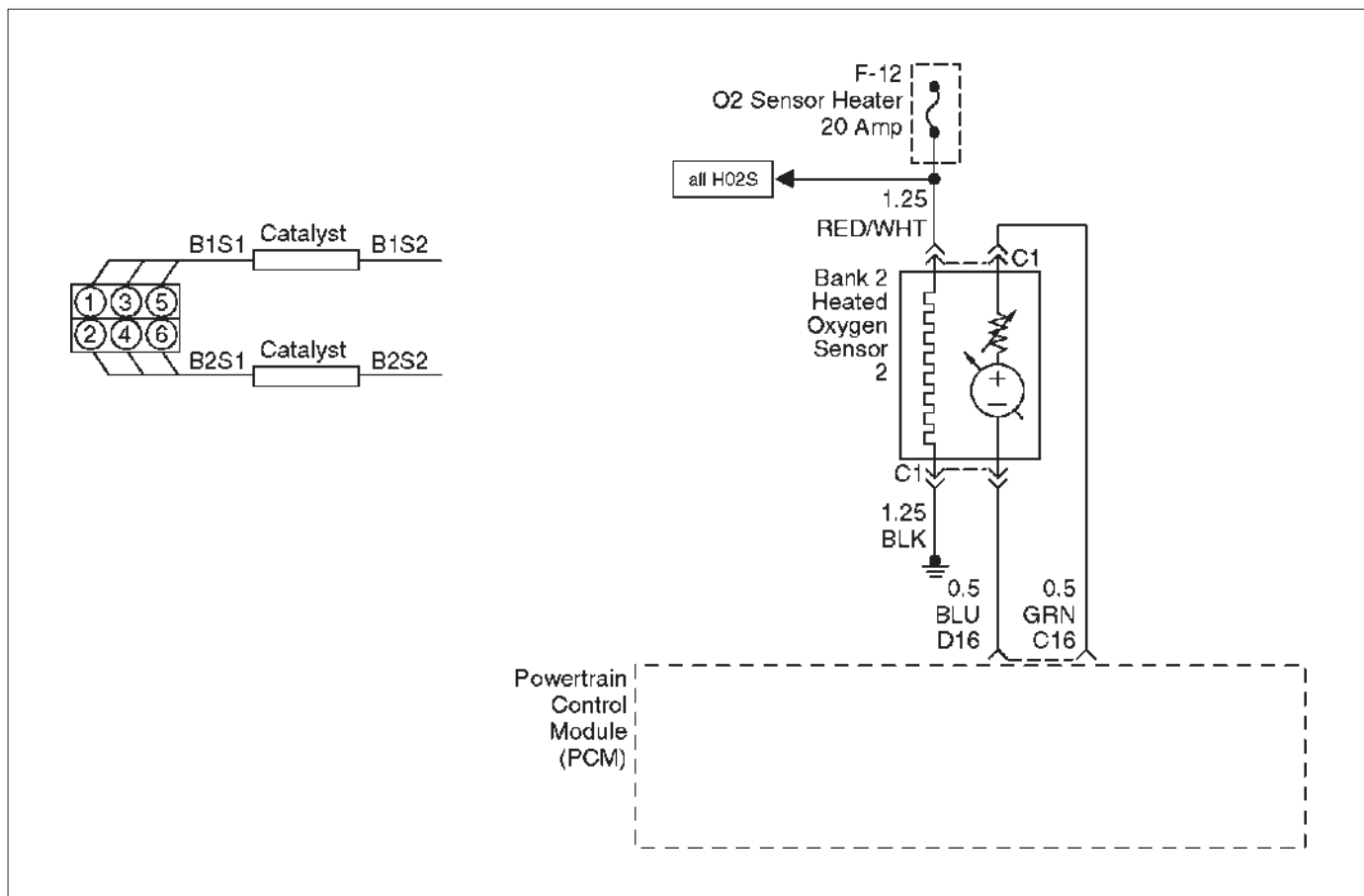
**DTC P0158 – HO2S Circuit High Voltage Bank 2 Sensor 2**

Step	Action	Value(s)	Yes	No
1	Was the “On-Board Diagnostic (OBD) System Check” performed?	—	Go to Step 2	Go to <i>OBD System Check</i>
2	1. Install the Tech 2. 2. Run the engine at operating temperature. 3. Operate the vehicle within parameters specified under “Conditions for Setting the DTC” criteria included in Diagnostic Support. 4. Using a Tech 2, monitor Bank 2 HO2S 2 voltage. Does the Bank 2 HO2S 2 voltage remain above the specified value?	952 mV (500 mV in deceleration fuel cut-out mode)	Go to Step 4	Go to Step 3
3	1. Ignition “ON.” 2. Review and record Tech 2 Failure Records data. 3. Operate the vehicle within Failure Records conditions as noted. 4. Using a Tech 2, monitor “DTC” info for DTC P0158 until the DTC P0158 test runs. 5. Note the test result. Does the Tech 2 indicate DTC P0158 failed this ignition?	—	Go to Step 4	Refer to <i>Diagnostic Aids</i>

**DTC P0158 – HO2S Circuit High Voltage Bank 2 Sensor 2 (Cont'd)**

Step	Action	Value(s)	Yes	No
4	1. Ignition "OFF." 2. Disconnect Bank 2 HO2S 2. 3. Ignition "ON." 4. At the HO2S Bank 2 Sensor 2 connector (PCM side), use a DVM to measure voltages at the high and low signal terminals. Are the voltages in the specified range?	3-4 V	Go to <i>Step 5</i>	Go to <i>Step 6</i>
5	Repair short to voltage in signal circuit. Is the action complete?	—	Verify repair	—
6	1. Ignition "ON," engine "OFF." 2. At Bank 2 HO2S 2 connector (PCM side) jumper both the HO2S high and low signal circuits (PCM side) to ground. 3. Using a Tech 2, monitor Bank 2 HO2S 2 voltage. Is Bank 2 HO2S 2 voltage below the specified value?	10 mV	Go to <i>Step 7</i>	Go to <i>Step 8</i>
7	1. Disconnect the jumpers to ground from Bank 2 HO2S 2 PCM-side connector. 2. With the HO2S 2 connector disconnected, monitor Bank 2 HO2S 2 voltage. Is Bank 2 HO2S 2 voltage between the specified values?	425-475 mV	Refer to <i>Diagnostic Aids</i>	Go to <i>Step 8</i>
8	Replace the PCM. <b>IMPORTANT:</b> The replacement PCM must be programmed. Refer to <i>On-Vehicle Service</i> in <i>Powertrain Control Module and Sensors</i> for procedures. And also refer to the latest Service Bulletin. Check to see if the Latest software is released or not. And then Down Load the LATEST PROGRAMMED SOFTWARE to the replacement PCM. Is the action complete?	—	Verify repair	—

## Diagnostic Trouble Code (DTC) P0160 HO2S Circuit Insufficient Activity Bank 2 Sensor 2



### Circuit Description

To control emissions of hydrocarbons (HC), carbon monoxide (CO), and oxides of nitrogen (NO<sub>x</sub>), a three-way catalytic converter is used. The catalyst within the converter promotes a chemical reaction which oxidizes the HC and CO present in the exhaust gas, converting them into harmless water vapor and carbon dioxide. The catalyst also reduces NO<sub>x</sub>, converting it to nitrogen. The powertrain control module (PCM) has the ability to monitor this process using the Bank 2 HO2S 1 and the Bank 2 HO2S 2 heated oxygen sensors. The Bank 2 HO2S 1 sensor produces an output signal which indicates the amount of oxygen present in the exhaust gas entering the three-way catalytic converter. The Bank 2 HO2S 2 sensor produces an output signal which indicates the oxygen storage capacity of the catalyst; this in turn indicates the catalyst's ability to convert exhaust gases efficiently. If the catalyst is operating efficiently, the Bank 2 HO2S 1 signal will be far more active than that produced by the Bank 2 HO2S 2 sensor. If the Bank 2 HO2S 2 signal voltage remains between 400 mV and 500 mV for an extended period of time, DTC P0160 will be set.

Heated Oxygen sensors are used to minimize the amount of time required for "closed loop" fuel control operation and allow accurate catalyst monitoring. The oxygen sensor heater greatly decreases the amount of time required for fuel control sensors Bank 1 HO2S 1 and Bank

2 HO2S 1 to become active. Oxygen sensor heaters are required by post-catalyst monitor sensors to maintain a sufficiently high temperature for accurate exhaust oxygen content readings further from the engine.

### Conditions for Setting the DTC

- No related DTCs.
- Battery voltage is above 10 volts.
- Engine run time is longer than 40 seconds.
- Oxygen sensor heater is functioning properly.
- Engine is in "closed loop" operation.
- Bank 2 HO2S 2 signal voltage remains between 426 mV and 474 mV for a total of 106 seconds over a 125-second period of time.

### Action Taken When the DTC Sets

- The PCM will illuminate the malfunction indicator lamp (MIL) the first time the fault is detected.
- The PCM will store conditions which were present when the DTC was set as Freeze Frame and in the Failure Records data.

### Conditions for Clearing the MIL/DTC

- The PCM will turn the MIL "OFF" on the third consecutive trip cycle during which the diagnostic has been run and the fault condition is no longer present.
- A history DTC P0160 will clear after 40 consecutive warm-up cycles have occurred without a fault.

- DTC P0160 can be cleared by using the Tech 2 “Clear Info” function or by disconnecting the PCM battery feed.

**Diagnostic Aids**

Check for the following conditions:

- Poor connection or damaged harness – Inspect the harness connectors for backed-out terminals, improper mating, broken locks, improperly formed or damaged terminals, poor terminal-to-wire connection, and damaged harness.
- Faulty HO2S heater or heater circuit – With the ignition “ON,” engine “OFF,” the HO2S voltage displayed on a Tech 2 should gradually drop to below 250 mV. If not, disconnect the HO2S and connect a test light between the HO2S ignition feed and heater ground circuits. If the test light does not light, repair the open ignition feed or sensor ground circuit as necessary. If the test light lights and the HO2S signal and low circuits are OK, replace the HO2S.

- Intermittent test – With the ignition “ON,” monitor the HO2S signal voltage while moving the wiring harness and related connectors. If the fault is induced, the HO2S signal voltage will change. This may help isolate the location of the malfunction.

**Test Description**

Number(s) below refer to the step number(s) on the Diagnostic Chart.

- 3. If the DTC P0160 test passes while the Failure Records conditions are being duplicated, an intermittent condition is indicated.

Reviewing the Failure Records vehicle mileage since the diagnostic test last failed may help determine how often the condition that caused the DTC to be set occurs. This may assist in diagnosing the condition.

**DTC P0160 – HO2S Circuit Insufficient Activity Bank 2 Sensor 2**

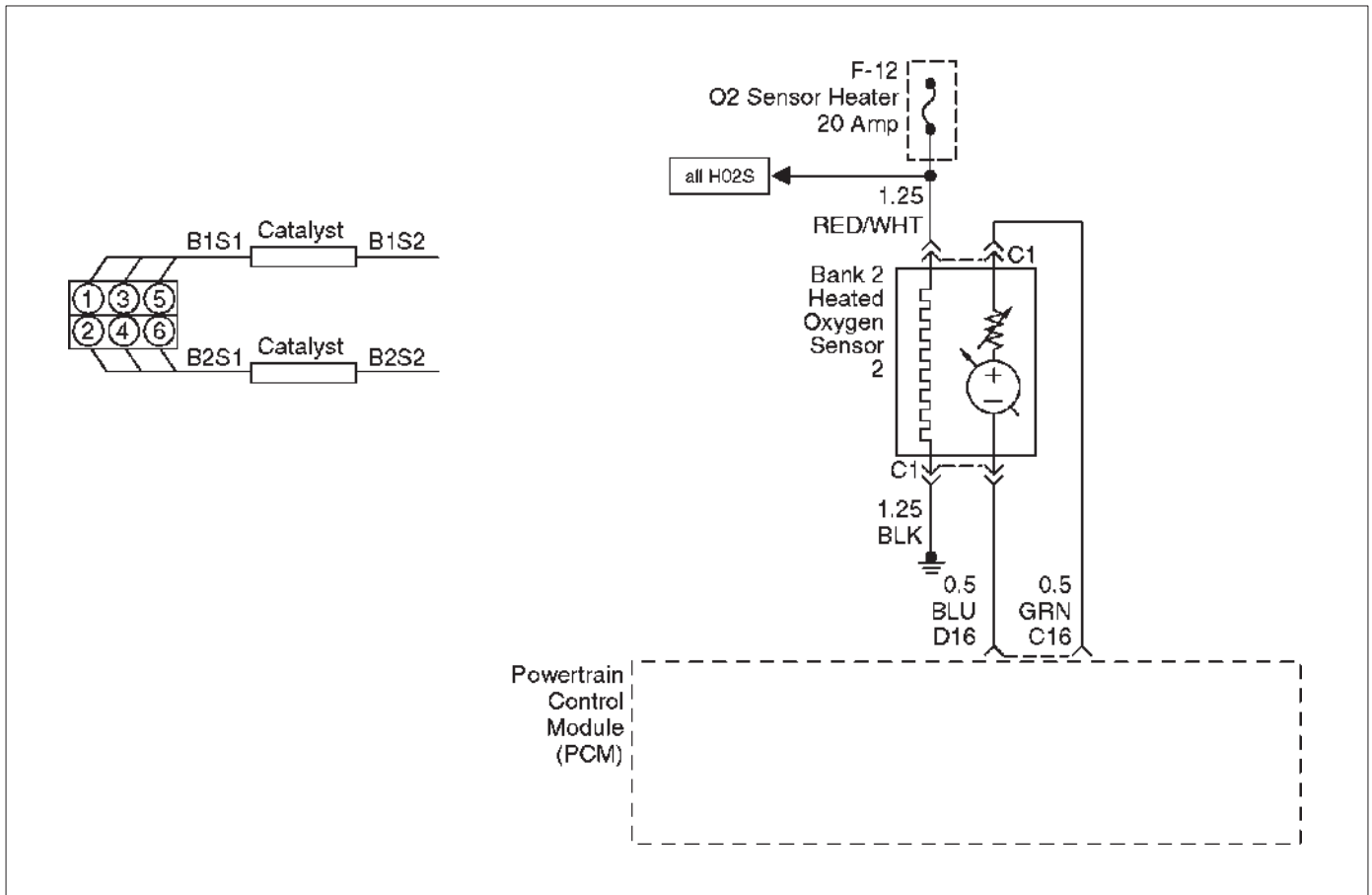
Step	Action	Value(s)	Yes	No
1	Was the “On-Board Diagnostic (OBD) System Check” performed?	—	Go to Step 2	Go to <i>OBD System Check</i>
2	1. Install the Tech 2. 2. Run the engine at operating temperature. 3. Operate the engine above 1200 RPM for two minutes.  Does the Tech 2 indicate Bank 2 HO2S 2 voltage varying outside the specified values?	425-475 mV	Go to Step 3	Go to Step 4
3	1. Ignition “ON,” engine “OFF,” review and record Tech 2 Failure Records data and note parameters. 2. Operate the vehicle within Failure Records conditions as noted. 3. Using a Tech 2, monitor “DTC” info for DTC P0160 until the DTC P0160 test runs. 4. Note the test result.  Does the Tech 2 indicate DTC P0160 failed this ignition?	—	Go to Step 4	Refer to <i>Diagnostic Aids</i>
4	Check for a damaged harness.  Was problem found?	—	Verify repair	Go to Step 5
5	Check for poor Bank 2 HO2S 2 high and low circuit terminal connections at the Bank 2 HO2S 2 harness connector and replace terminal(s) if necessary.  Did either terminal require replacement?	—	Verify repair	Go to Step 6
6	Check for poor Bank 2 HO2S 2 high and low circuit terminal connections at the PCM and replace terminals if necessary.  Did any terminals require replacement?	—	Verify repair	Go to Step 7



**DTC P0160 – HO2S Circuit Insufficient Activity Bank 2 Sensor 2 (Cont'd)**

Step	Action	Value(s)	Yes	No
7	1. Ignition "OFF." 2. With the PCM disconnected, check continuity of the Bank 2 HO2S 2 high circuit. 3. If the Bank 2 HO2S 2 high circuit measures over 5.0 ohms, repair open or poor connections as necessary. Was a Bank 2 HO2S 2 high circuit problem found and corrected?	—	Verify repair	Go to <i>Step 8</i>
8	1. Ignition "OFF." 2. With the PCM disconnected, check continuity of the Bank 2 HO2S 2 low circuit. 3. If the Bank 2 HO2S 2 low circuit measures over 5 ohms, repair open or poor connections as necessary. Was a Bank 2 HO2S 2 low circuit problem found and corrected?	—	Verify repair	Go to <i>Step 9</i>
9	1. Ignition "ON," engine "OFF." 2. Disconnect Bank 2 HO2S 2 and jumper the HO2S high and low circuits (PCM side) to ground. 3. Using a Tech 2, monitor Bank 2 HO2S 2 voltage. Is Bank 2 HO2S 2 voltage in the specified range?	0-10 mV	Go to <i>Step 10</i>	Go to <i>Step 11</i>
10	Replace Bank 2 HO2S 2. Is the action complete?	—	Verify repair	—
11	Replace the PCM. <b>IMPORTANT:</b> The replacement PCM must be programmed. Refer to <i>On-Vehicle Service</i> in <i>Powertrain Control Module and Sensors</i> for procedures. And also refer to the latest Service Bulletin. Check to see if the Latest software is released or not. And then Down Load the LATEST PROGRAMMED SOFTWARE to the replacement PCM. Is the action complete?	—	Verify repair	—

## Diagnostic Trouble Code (DTC) P0161 HO2S Heater Circuit Bank 2 Sensor 2



### Circuit Description

Heated oxygen sensors are used to minimize the amount of time required for "closed loop" fuel control operation and to allow accurate catalyst monitoring. The oxygen sensor heater greatly decreases the amount of time required for fuel control sensors Bank 1 HO2S 1 and Bank 2 HO2S 1 to become active. Oxygen sensor heaters are required by post-catalyst monitor sensors to maintain a sufficiently high temperature which allows accurate exhaust oxygen content readings further from the engine. The powertrain control module (PCM) will run the heater test only after a cold start (determined by engine coolant and intake air temperature at the time of start-up) and only once during an ignition cycle. When the engine is started, the PCM will monitor the HO2S voltage. When the Bank 2 HO2S 2 voltage indicates a sufficiently active sensor, the PCM looks at how much time has elapsed since start-up. If the PCM determines that too much time was required for the Bank 2 HO2S 2 to become active, a DTC P0161 will set. The time it should take the HO2S to reach operating temperature is based on the total amount of air that has passed through the MAF sensor and into the engine (more total air flow = shorter time to HO2S activity).

### Conditions for Setting the DTC

- No related DTCs.
- Intake air temperature (IAT) is less than 32°C (90°F) at start-up.

- Engine coolant temperature (ECT) is less than 32°C (90°F) at start-up.
- IAT and ECT are within 6°C (11°F) of each other at start-up.
- Ignition voltage is between 11 volts and 18 volts.
- Average mass air flow for the sample period is less than 23 g/second.
- Bank 2 HO2S 2 voltage does not change more than 150 mV from the bias voltage (between 400 mV-500 mV) for a longer amount of time than it should. The maximum amount of time to come up to operating range is 300 seconds. This warm-up time depends on the engine coolant temperature at start-up and accumulated air flow since start-up.

### Action Taken When the DTC Sets

- The PCM will illuminate the malfunction indicator lamp (MIL) after the second consecutive trip in which the fault is detected.
- The PCM will store conditions which were present when the DTC was set as Freeze Frame and in the Failure Records data.

### Conditions for Clearing the MIL/DTC

- The PCM will turn the MIL "OFF" on the third consecutive trip cycle during which the diagnostic has been run and the fault condition is no longer present.
- A history DTC P0161 will clear after 40 consecutive warm-up cycles have occurred without a fault.

D06RX090

## 6E-210 6VE1 3.5L ENGINE DRIVEABILITY AND EMISSIONS

- DTC P0161 can be cleared by using the Tech 2 “Clear Info” function or by disconnecting the PCM battery feed.

### Diagnostic Aids

Check for the following conditions:

- Poor connection at PCM – Inspect harness connectors for backed-out terminals, improper mating, broken locks, improperly formed or damaged terminals, and poor terminal-to-wire connection.
- Damaged harness – Inspect the wiring harness for damage. If the harness appears to be OK, observe the display on the Tech 2 while moving connectors and wiring harnesses related to the sensor. A change in the display will indicate the location of the fault.

Reviewing the Failure Records vehicle mileage since the diagnostic test last failed may help determine how often the condition that caused the DTC to be set occurs. This may assist in diagnosing the condition.

### Test Description

Number(s) below refer to the step number(s) on the Diagnostic Chart.

2. The HO2S should be allowed to cool before performing this test. If the HO2S heater is functioning, the signal voltage will gradually increase or decrease as the sensor element warms. If the heater is not functioning, the HO2S signal will remain near the 450 mV bias voltage.
4. This ensures that the ignition feed circuit to the HO2S is not open or shorted. The test light should be connected to a good chassis ground, in case the HO2S low or HO2S heater ground circuit is faulty.
5. This checks the HO2S heater ground circuit.
6. This checks for an open or shorted HO2S heater element.
11. An open HO2S signal or low circuit can cause the HO2S heater to appear faulty. Check these circuits before replacing the sensor.

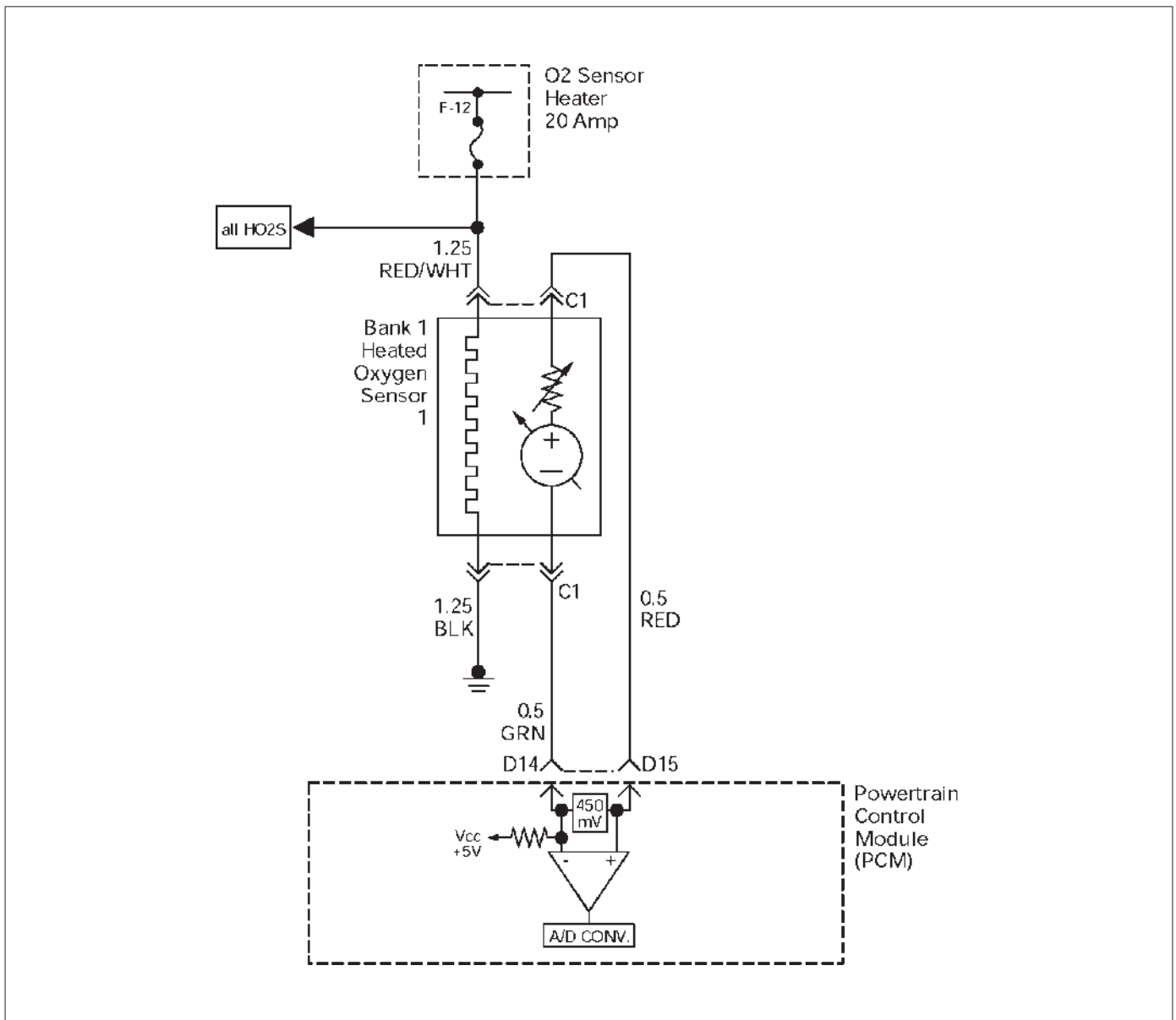
## DTC P0161 – HO2S Heater Circuit Bank 2 Sensor 2

Step	Action	Value(s)	Yes	No
1	Was the “On-Board Diagnostic (OBD) System Check” performed?	—	Go to Step 2	Go to <i>OBD System Check</i>
2	NOTE: If the engine has just been operating, allow the engine to cool for at least 15 minutes before proceeding. 1. Remove the fuel pump relay. 2. Connect a fused jumper at the fuel pump relay socket, between the battery positive at the relay and the relay wire that leads to the fuel pump and HO2S fuses. 3. Ignition “OFF.” 4. Install a Tech 2. 5. Ignition “ON,” engine “OFF.” 6. Monitor the Bank 2 HO2S 2 voltage for several minutes. Did the HO2S voltage go from bias voltage to above or below the specified values?	Above 650 mV or Below 250 mV	Refer to <i>Diagnostic Aids</i>	Go to Step 3
3	Inspect the fuse for the Bank 2 HO2S 2 ignition feed. Is the fuse open?	—	Go to Step 15	Go to Step 4
4	1. Ignition “OFF.” 2. Raise the vehicle. 3. Disconnect the Bank 2 HO2S 2 electrical connector. 4. Using a test light connected to a known good ground (do not use Bank 2 HO2S 2 heater ground or Bank 2 HO2S 2 low), probe the ignition feed circuit at the Bank 2 HO2S 2 electrical connector (PCM harness side). Does the test light illuminate?	—	Go to Step 5	Go to Step 7

**DTC P0161 – HO2S Heater Circuit Bank 2 Sensor 2 (Cont'd)**

Step	Action	Value(s)	Yes	No
5	Connect the test light between the Bank 2 HO2S 2 ignition feed and the Bank 2 HO2S 2 heater ground. Does the test light illuminate?	—	Go to <i>Step 6</i>	Go to <i>Step 8</i>
6	1. Allow the HO2S to cool for at least 15 minutes. 2. Using a DVM, measure resistance between the Bank 2 HO2S 2 ignition feed and the Bank 2 HO2S 2 heater ground at the Bank 2 HO2S 2 pigtail. Is the HO2S resistance within the specified values?	3-6 ohms	Go to <i>Step 9</i>	Go to <i>Step 10</i>
7	Repair the open Bank 2 HO2S 2 ignition feed circuit to Bank 2 HO2S 2. Is the action complete?	—	Verify repair	—
8	Repair the open Bank 2 HO2S 2 heater ground circuit. Is the action complete?	—	Verify repair	—
9	1. Check for a poor connection at the Bank 2 HO2S 2 harness terminals. 2. If a poor connection is found, replace the terminals. Was a poor connection found?	—	Verify repair	Go to <i>Step 10</i>
10	1. Ignition "OFF." 2. Disconnect the PCM and check the continuity of the Bank 2 HO2S 2 signal circuit and the Bank 2 HO2S 2 low circuit. 3. If the Bank 2 HO2S 2 signal circuit or HO2S low circuit measures over 5 ohms, repair the open or poor connection as necessary. Was a problem found?	—	Verify repair	Go to <i>Step 11</i>
11	1. Ignition "OFF." 2. Disconnect the PCM and check the continuity of the Bank 2 HO2S 2 signal circuit and the Bank 2 HO2S 2 low circuit. 3. If the Bank 2 HO2S 2 signal circuit or HO2S low circuit measures over 5 ohms, repair the open or poor connection as necessary. Was a problem found?	—	Verify repair	Go to <i>Step 12</i>
12	Check for a poor Bank 2 HO2S 2 low circuit terminal connection at the PCM and replace the terminal if necessary. Did the terminal require replacement?	—	Verify repair	Go to <i>Step 13</i>
13	Check for a poor Bank 2 HO2S 2 high circuit terminal connection at the PCM and replace the terminal if necessary. Did the terminal require replacement?	—	Verify repair	Go to <i>Step 14</i>
14	Replace Bank 2 HO2S 2. Is the action complete?	—	Verify repair	—
15	Locate and repair the short to ground in the Bank 2 HO2S 2 ignition feed circuit and replace the faulty fuse. Is the action complete?	—	Verify repair	—

## Diagnostic Trouble Code (DTC) P0171 Fuel Trim System Lean Bank 1



### Circuit Description

To provide the best possible combination of driveability, fuel economy, and emission control, a "closed loop" air/fuel metering system is used. While in "closed loop," the powertrain control module (PCM) monitors the Bank 1 HO2S 1 and Bank 2 HO2S 1 signals and adjusts fuel delivery based upon the HO2S signal voltages. A change made to fuel delivery will be indicated by the long and short term fuel trim values which can be monitored with a Tech 2. Ideal fuel trim values are around 0%; if the HO2S signals are indicating a lean condition the PCM will add fuel, resulting in fuel trim values above 0%. If a rich condition is detected, the fuel trim values will be below 0%, indicating that the PCM is reducing the amount of fuel delivered. If an excessively lean condition is detected on Bank 1, the PCM will set DTC P0171.

The PCM's maximum authority to control long term fuel trim allows a range between -15% (automatic transmission) or -12% (manual transmission) and +20%. The PCM monitors fuel trim under various engine

speed/load fuel trim cells before determining the status of the fuel trim diagnostic.

### Conditions for Setting the DTC

- No Tech 2 test is being run.
- None of the following: EGR DTCs, HO2S DTCs, (response, transition, open, low volts, no activity), MAF DTCs, TP sensor DTCs, MAP DTCs, IAT DTCs, canister purge DTCs, EVAP DTCs, injector circuit DTCs, or misfire DTCs.
- Engine coolant temperature is between 25°C (77°F) and 100°C (212°F).
- Intake air temperature is between -40°C (-40°F) and 120°C (248°F).
- Manifold absolute pressure is between 24 kpa and 99 kpa.
- Throttle angle is steady below 95%.
- Vehicle speed is below 136 km/h (85 mph).
- Engine speed is between 400 and 6,000 RPM.
- Barometric pressure is greater than 72.5 kpa.

- Mass air flow is between 2 g/second and 200 g/second.
- Ignition voltage is above 9.5 volts.
- Fuel system is in “closed loop.”
- Canister purge duty cycle is greater than 0% if on.

### Action Taken When the DTC Sets

- The PCM will illuminate the malfunction indicator lamp (MIL) after the second consecutive trip in which the fault is detected.
- The PCM will store conditions which were present when the DTC was set as Freeze Frame and in the Failure Records data.

### Conditions for Clearing the MIL/DTC

- The PCM will turn the MIL “OFF” on the third consecutive trip cycle during which the diagnostic has been run and the fault condition is no longer present.
- A history DTC P0171 will clear after 40 consecutive warm-up cycles have occurred without a fault.
- DTC P0171 can be cleared by using the Tech 2 “Clear Info” function or by disconnecting the PCM battery feed.

### Diagnostic Aids

Check for the following conditions:

- Poor connection at PCM – Inspect harness connectors for backed-out terminals, improper mating, broken locks, improperly formed or damaged terminals, and poor terminal-to-wire connection.
- Damaged harness – Inspect the wiring harness for damage. If the harness appears to be OK, observe the Bank 1 HO2S 1 display on the Tech 2 while moving connectors and wiring harnesses related to the engine harness. A change in the display will indicate the location of the fault.

Reviewing the Failure Records vehicle mileage since the diagnostic test last failed may help determine how often the condition that caused the DTC to be set occurs. This may assist in diagnosing the condition.

### Test Description

Number(s) below refer to the step number(s) on the Diagnostic Chart.

2. DTCs other than P0171 and P0174 may indicate a condition present which may cause a lean condition. If this is the case, repairing the condition which caused the other DTC will most likely correct the DTC P0171/P0174.
4. If the DTC P0171 test passes while the Failure Records conditions are being duplicated, the lean condition is intermittent. Refer to *Diagnostic Aids* or *Symptoms* for additional information on diagnosing intermittent problems.

## DTC P0171 – Fuel Trim System Lean Bank 1

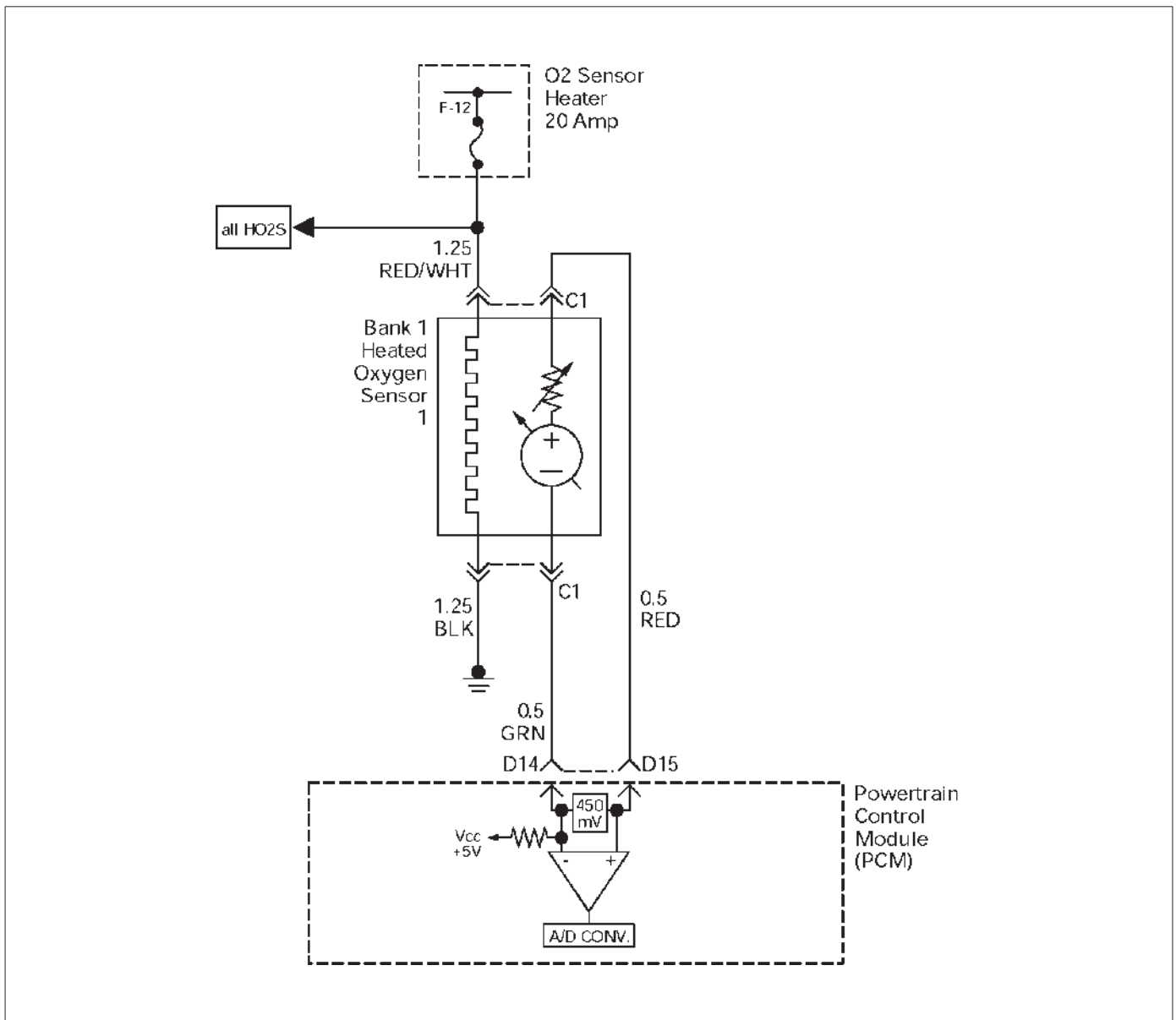
Step	Action	Value(s)	Yes	No
1	Was the “On-Board Diagnostic (OBD) System Check” performed?	—	Go to <i>Step 2</i>	Go to <i>OBD System Check</i>
2	Are any DTCs set other than P0171 and P0174?	—	Go to the applicable DTC charts and repair the other DTCs before proceeding with this chart	Go to <i>Step 3</i>
3	1. Start the engine and operate the vehicle in “closed loop.” 2. Observe the “BANK 1 L.T. FUEL TRIM” display on the Tech 2. Is the displayed value greater than the specified value?	L.T. Fuel Trim: +20%	Go to <i>Step 5</i>	Go to <i>Step 4</i>
4	1. Review and record the Tech 2 Failure Records data. 2. Clear the DTC P0171/P0174 and operate the vehicle to duplicate the Failure Records conditions. 3. Monitor the Tech 2 “DTC” info for DTC P0171 while operating the vehicle to duplicate the Failure Records conditions. 4. Continue operating the vehicle until the DTC P0171 test runs and note the test result. Does the Tech 2 indicate DTC P0171 failed this ignition?	—	Go to <i>Step 5</i>	The lean condition is not present. If a driveability symptom still exists, refer to <i>Symptoms</i> section.
5	Was DTC P0174 also set?	—	Go to <i>Step 6</i>	Go to <i>Step 15</i>
6	Visually and physically inspect the vacuum hoses for disconnections, splits, kinks, improper routing and improper connections and repair any problem found. Did your inspection reveal a problem requiring repair?	—	Verify repair	Go to <i>Step 7</i>
7	Visually and physically inspect the crankcase ventilation valve for proper installation and repair any problem found (refer to <i>Crankcase Ventilation System</i> ). Did your inspection reveal a problem requiring repair?	—	Verify repair	Go to <i>Step 8</i>
8	1. Inspect the MAF sensor inlet screen for damage or for the presence of foreign objects which may partially block the air flow sample through the MAF sensor. 2. Correct any problem that is found as necessary. Did your inspection of the MAF sensor reveal a condition requiring repair?	—	Verify repair	Go to <i>Step 9</i>
9	Start the engine and note the idle quality. Is a high or unsteady idle being experienced?	—	Go to <i>Step 10</i>	Go to <i>Step 11</i>
10	1. Visually and physically inspect the throttle body, intake manifold, EGR valve and the EGR feed pipe for vacuum leaks. 2. Repair any vacuum leaks as necessary. Did your inspection reveal a vacuum leak?	—	Verify repair	Go to <i>Step 11</i>

**DTC P0171 – Fuel Trim System Lean Bank 1 (Cont'd)**

Step	Action	Value(s)	Yes	No
11	Check the fuel for excessive water, alcohol, or other contaminants (see <i>Diagnosis in Engine Fuel</i> for the procedure) and correct the contaminated fuel condition if present (see <i>Engine Fuel</i> ). Was the fuel contaminated?	—	Verify repair	Go to Step 12
12	1. Visually and physically inspect the PCM injector grounds, power grounds and sensor grounds to ensure that they are clean, tight, and in their proper locations. 2. If a faulty ground condition is present, correct it as necessary. Did your inspection reveal a condition requiring repair?	—	Verify repair	Go to Step 13
13	1. Disconnect the MAF sensor electrical connector. 2. Operate the vehicle in “closed loop” while monitoring the “BANK 1 S.T. FUEL TRIM” displayed on the Tech 2. Does “BANK 1 S.T. FUEL TRIM” value decrease to near the specified value?	0%	Go to Step 19	Go to Step 14
14	Perform the procedure in the “Fuel System Pressure Test” and repair fuel system problem if necessary. Did Fuel System Pressure Test isolate a condition requiring repair?	—	Verify repair	Go to Step 15
15	1. Visually and physically inspect the intake manifold, injector O-rings, EGR adapter, EGR valve and the EGR feed pipes for vacuum leaks. 2. Repair any problem that is found. Did your inspection reveal a problem?	—	Verify repair	Go to Step 16
16	Visually and physically inspect the Bank 1 exhaust manifold for leaks and loose or missing hardware and correct any problem found. Did your inspection reveal a problem?	—	Verify repair	Go to Step 17
17	Perform the “Injector Balance Test,” and correct any problem found (refer to <i>Fuel Metering System</i> ). Did Injector Balance Test isolate a problem?	—	Verify repair	Go to Step 18
18	1. Visually and physically inspect the Bank 1 HO2S 1 to ensure that it is installed securely and that the Bank 1 HO2S 1 pigtail and wiring harness are not contacting the exhaust or otherwise damaged. 2. If a problem is found, correct it as necessary. Did your inspection reveal a problem?	—	Verify repair	Refer to <i>Diagnostic Aids</i>
19	Replace the MAF sensor. Is the action complete?	—	Verify repair	—



## Diagnostic Trouble Code (DTC) P0172 Fuel Trim System Rich Bank 1



### Circuit Description

To provide the best possible combination of driveability, fuel economy, and emission control, a "closed loop" air/fuel metering system is used. While in "closed loop," the powertrain control module (PCM) monitors the Bank 1 heated oxygen sensors (HO2S) 1 and Bank 2 HO2S 1 signals and adjusts fuel delivery based upon the HO2S signal voltages. A change made to fuel delivery will be indicated by the long and short term fuel trim values which can be monitored with a Tech 2. Ideal fuel trim values are around 0%; if the HO2S signals are indicating a lean condition the PCM will add fuel, resulting in fuel trim values above 0%. If a rich condition is detected, the fuel trim values will be below 0%, indicating that the PCM is reducing the amount of fuel delivered. If an excessively rich condition is detected on Bank 1, the PCM will set DTC P0172.

The PCM's maximum authority to control long term fuel trim allows a range between -15% and +20%. The PCM's maximum authority to control short term fuel trim allows a

range between -11% and +20%. The PCM monitors fuel trim under various engine speed/load fuel trim cells before determining the status of the fuel trim diagnostic.

### Conditions for Setting the DTC

- No Tech 2 test is being run.
- None of the following was set: EGR DTCs, HO2S DTCs, (response, transition, open, low volts, no activity), MAF DTCs, TPS DTCs, MAP DTCs, IAT DTCs, canister purge DTCs, EVAP DTCs, injector circuit DTCs, or misfire DTCs.
- Engine coolant temperature is between 25°C (77°F) and 100°C (212°F).
- Intake air temperature is between -40°C (-40°F) and 120°C (248°F).
- Manifold absolute pressure is between 24 kpa and 99 kpa.
- Throttle angle is steady below 95%.
- Vehicle speed is below 136 km/h (85 mph).
- Engine speed is between 400 and 6,000 RPM.

- Barometric pressure is greater than 72.5 kpa.
- Mass air flow is between 2 g/second and 200 g/second.
- Ignition voltage is above 9.5 volts.
- Fuel system is in “closed loop.”
- Canister purge duty cycle is greater than 0%, if “ON.”

**Action Taken When the DTC Sets**

- The PCM will illuminate the malfunction indicator lamp (MIL) after the second consecutive trip in which the fault is detected.
- The PCM will store conditions which were present when the DTC was set as Freeze Frame and in the Failure Records data.

**Conditions for Clearing the MIL/DTC**

- The PCM will turn the MIL “OFF” on the third consecutive trip cycle during which the diagnostic has been run and the fault condition is no longer present.
- A history DTC P0172 will clear after 40 consecutive warm-up cycles have occurred without a fault.
- DTC P0172 can be cleared by using the Tech 2 “Clear Info” function or by disconnecting the PCM battery feed.

**Diagnostic Aids**

Check for the following conditions:

- Poor connection at PCM – Inspect harness connectors for backed-out terminals, improper mating, broken

locks, improperly formed or damaged terminals, and poor terminal-to-wire connection.

- Damaged harness – Inspect the wiring harness for damage. If the harness appears to be OK, observe the Bank 1 HO2S 1 display on the Tech 2 while moving connectors and wiring harnesses related to the engine harness. A change in the display will indicate the location of the fault.

Reviewing the Failure Records vehicle mileage since the diagnostic test last failed may help determine how often the condition that caused the DTC to be set occurs. This may assist in diagnosing the condition.

**Test Description**

Number(s) below refer to the step number(s) on the Diagnostic Chart.

2. DTCs other than P0172 and P0175 may indicate a condition present which may cause a lean condition. If this is the case, repairing the condition which caused the other DTC will most likely correct the DTC P0172/P0175.
4. If the DTC P0172 test passes while the Failure Records conditions are being duplicated, the rich condition is intermittent. Refer to *Diagnostic Aids* or *Symptoms* for additional information on diagnosing intermittent problems.

**DTC P0172 – Fuel Trim System Rich Bank 1**

Step	Action	Value(s)	Yes	No
1	Was the “On-Board Diagnostic (OBD) System Check” performed?	—	Go to Step 2	Go to <i>OBD System Check</i>
2	Are any DTCs set other than P0172 and P0175?	—	Go to the applicable DTC charts and repair the other DTCs before proceeding with this chart	Go to Step 3
3	1. Start the engine and operate the vehicle in “closed loop.” 2. Observe “B1 Long Term Fuel Trim” display on the Tech 2. Is the displayed value more negative than the specified value?	L.T. Fuel Trim: -15%	Go to Step 5	Go to Step 4
4	1. Review and record the Tech 2 Failure Records data. 2. Clear the DTC P0172/P0175 and operate the vehicle to duplicate the Failure Records conditions. 3. Monitor the Tech 2 “DTC” info for DTC P0172 while operating the vehicle to duplicate the Failure Records conditions. 4. Continue operating the vehicle until the DTC P0172 test runs and note test result. Does the Tech 2 indicate DTC P0172 failed this ignition?	—	Go to Step 5	The rich condition is not present. If a driveability symptom still exists, refer to <i>Symptoms</i> .

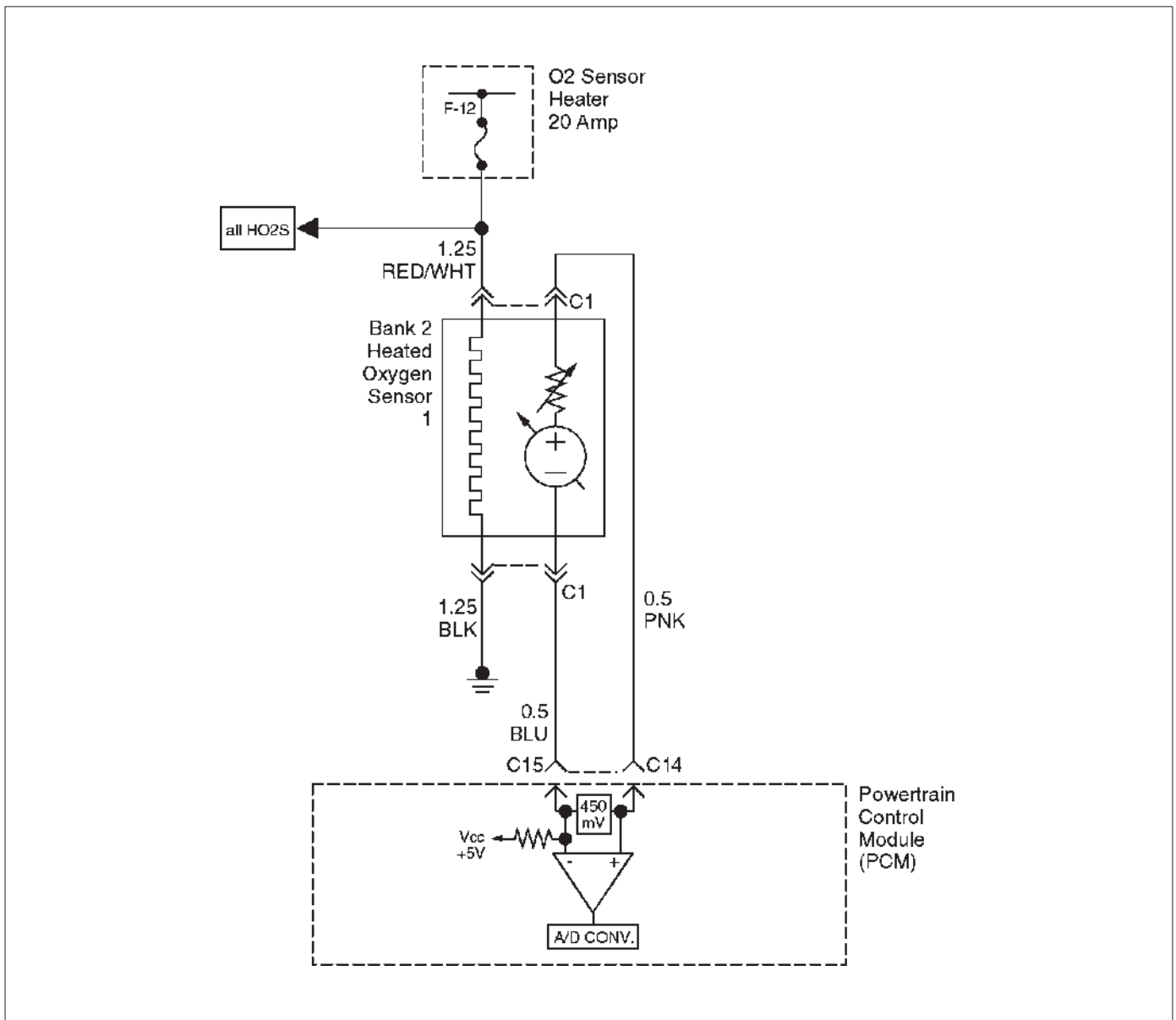
## DTC P0172 – Fuel Trim System Rich Bank 1 (Cont'd)

Step	Action	Value(s)	Yes	No
5	Is DTC P0175 also set?	—	Go to <i>Step 6</i>	Go to <i>Step 15</i>
6	Visually and physically inspect the air filter element and replace it if necessary. Did the air filter require replacement?	—	Verify repair	Go to <i>Step 7</i>
7	Visually and physically inspect the air intake duct for collapse or restriction and repair if necessary. Did your inspection reveal a condition requiring repair?	—	Verify repair	Go to <i>Step 8</i>
8	Inspect the MAF sensor inlet screen for damage or for the presence of foreign objects which may partially block air flow through the screen and correct any problem found. Did your inspection of the MAF sensor reveal a condition requiring repair or replacement?	—	Verify repair	Go to <i>Step 9</i>
9	Start the engine and note the idle quality. Is a low or unsteady idle being experienced?	—	Go to <i>Step 10</i>	Go to <i>Step 11</i>
10	1. Ignition "OFF." 2. Physically inspect the throttle body bore, throttle plate, and IAC passages for coking and foreign objects. 3. If a problem was found, repair as necessary. Did your inspection reveal a condition requiring repair?	—	Verify repair	Go to <i>Step 11</i>
11	1. Disconnect the vacuum hose from the fuel pressure regulator and inspect the hose for the presence of fuel. 2. If fuel is present in the vacuum hose, replace the fuel pressure regulator (refer to <i>Fuel Metering System</i> ). Did the fuel pressure regulator require replacement?	—	Verify repair	Go to <i>Step 12</i>
12	Ignition "ON," engine "OFF," monitor the TP Angle display on the Tech 2 while slowly depressing the accelerator pedal. Does the TP Angle display increase steadily and evenly from minimum value at closed throttle to maximum value at wide-open throttle?	Minimum 0% Maximum 100%	Go to <i>Step 13</i>	Go to <i>Step 21</i>
13	1. Disconnect the MAF sensor electrical connector. 2. Operate the vehicle in "closed loop" while monitoring the "BANK 1 L.T. FUEL TRIM" and "BANK 1 S. T. FUEL TRIM" display on the Tech 2. Did both values change to near the specified value?	0%	Go to <i>Step 22</i>	Go to <i>Step 14</i>
14	1. Perform "Fuel System Pressure Test." 2. If Fuel System Pressure Test isolates a problem, repair as necessary (refer to <i>Engine Fuel</i> or <i>Fuel Metering System</i> ). Did the Fuel System Pressure Test isolate a problem requiring repair?	—	Verify repair	Go to <i>Step 15</i>
15	1. Ignition "ON," engine "OFF." 2. Connect a test light between the harness connector terminals of canister purge solenoid. Is the test light on?	—	Go to <i>Step 16</i>	Go to <i>Step 19</i>

## DTC P0172 – Fuel Trim System Rich Bank 1 (Cont'd)

Step	Action	Value(s)	Yes	No
16	Check for short to ground in the wire (red/blue) between the canister purge solenoid and PCM terminal A-15. Was there a short to ground?	—	Go to <i>Step 17</i>	Go to <i>Step 18</i>
17	Repair the short to ground. Is the action complete?	—	Verify repair	—
18	Replace the PCM. <b>IMPORTANT:</b> The replacement PCM must be programmed. Refer to <i>On-Vehicle Service in Powertrain Control Module and Sensors</i> for procedures. And also refer to the latest Service Bulletin. Check to see if the Latest software is released or not. And then Down Load the LATEST PROGRAMMED SOFTWARE to the replacement PCM. Is the action complete?	—	Verify repair	—
19	1. Perform the "Injector Balance Test." 2. If Injector Balance Test isolates a problem, repair as necessary (refer to <i>Fuel Metering System</i> ). Did the Injector Balance Test isolate a problem requiring repair?	—	Verify repair	Go to <i>Step 20</i>
20	1. Remove and visually/physically inspect the Bank 1 HO2S 1 for silicon contamination. This will be indicated by a powdery white deposit on the portion of the HO2S that is exposed to the exhaust stream. 2. If contamination is evident on the Bank 1 HO2S 1, replace the contaminated sensors. Did the sensor require replacement?	—	Verify repair	Refer to <i>Diagnostic Aids</i>
21	1. Check the TP sensor mounting screws and tighten or replace them as necessary if they are loose or missing. 2. If the screws are OK, replace the TP sensor. Is the action complete?	—	Verify repair	—
22	Replace the MAF sensor. Is the action complete?	—	Verify repair	—

## Diagnostic Trouble Code (DTC) P0174 Fuel Trim System Lean Bank 2



### Circuit Description

To provide the best possible combination of driveability, fuel economy, and emission control, a “closed loop” air/fuel metering system is used. While in “closed loop,” the powertrain control module (PCM) monitors the Bank 1 HO2S 1 and Bank 2 HO2S 1 signals and adjusts fuel delivery based upon the HO2S signal voltages. A change made to fuel delivery will be indicated by the long and short term fuel trim values which can be monitored with a Tech 2. Ideal fuel trim values are around 0%; if the HO2S signals are indicating a lean condition the PCM will add fuel, resulting in fuel trim values above 0%. If a rich condition is detected, the fuel trim values will be below 0%, indicating that the PCM is reducing the amount of fuel delivered. If an excessively lean condition is detected on Bank 2, the PCM will set DTC P0174.

The PCM's maximum authority to control long term fuel trim allows a range between  $-15\%$  (automatic transmission) or  $-12\%$  (manual transmission) and  $+20\%$ . The PCM monitors fuel trim under various engine

speed/load fuel trim cells before determining the status of the fuel trim diagnostic.

### Conditions for Setting the DTC

- No Tech 2 test is being run.
- None of the following DTCs are set: idle system, EGR, HO2S, (response, transition, open, low volts, no activity), MAF, TP sensor, MAP, IAT, canister purge, EVAP, injector circuit, or misfire.
- Engine coolant temperature is between  $25^{\circ}\text{C}$  ( $77^{\circ}\text{F}$ ) and  $100^{\circ}\text{C}$  ( $212^{\circ}\text{F}$ ).
- Intake air temperature is between  $-40^{\circ}\text{C}$  ( $-40^{\circ}\text{F}$ ) and  $120^{\circ}\text{C}$  ( $248^{\circ}\text{F}$ ).
- Manifold absolute pressure is between 24 kpa and 99 kpa.
- Throttle angle is steady below 95%.
- Vehicle speed is below 136 km/h (85 mph).
- Engine speed is between 400 and 6,000 RPM.
- Barometric pressure is greater than 72.5 kpa.
- Mass air flow is between 2 g/second and 200 g/second.

- Ignition voltage is above 9.5 volts.
- Fuel system is in “closed loop.”
- Canister purge duty cycle is greater than 15%, if “ON.”

### Action Taken When the DTC Sets

- The PCM will illuminate the malfunction indicator lamp (MIL) after the second consecutive trip in which the failure is detected.
- The PCM will store conditions which were present when the DTC was set as Freeze Frame and in the Failure Records data.

### Conditions for Clearing the MIL/DTC

- The PCM will turn the MIL “OFF” on the third consecutive trip cycle during which the diagnostic has been run and the fault condition is no longer present.
- A history DTC P0174 will clear after 40 consecutive warm-up cycles have occurred without a fault.
- DTC P0174 can be cleared by using the Tech 2 “Clear Info” function or by disconnecting the PCM battery feed.

### Diagnostic Aids

Check for the following conditions:

- Poor connection at PCM – Inspect harness connectors for backed-out terminals, improper mating, broken locks, improperly formed or damaged terminals, and poor terminal-to-wire connection.
- Damaged harness – Inspect the wiring harness for damage. If the harness appears to be OK, observe the Bank 2 HO2S 1 display on the Tech 2 while moving connectors and wiring harnesses related to the engine harness. A change in the display will indicate the location of the fault.

Reviewing the Failure Records vehicle mileage since the diagnostic test last failed may help determine how often the condition that caused the DTC to be set occurs. This may assist in diagnosing the condition.

### Test Description

Number(s) below refer to the step number(s) on the Diagnostic Chart.

2. DTCs other than P0171 and P0174 may indicate a condition present which may cause a lean condition. If this is the case, repairing the condition which caused the other DTC will most likely correct the DTC P0171/P0174.
4. If the DTC P0174 test passes while the Failure Records conditions are being duplicated, the lean condition is intermittent. Refer to *Diagnostic Aids* or *Symptoms* for additional information on diagnosing intermittent problems.

### DTC P0174 – Fuel Trim System Lean Bank 2

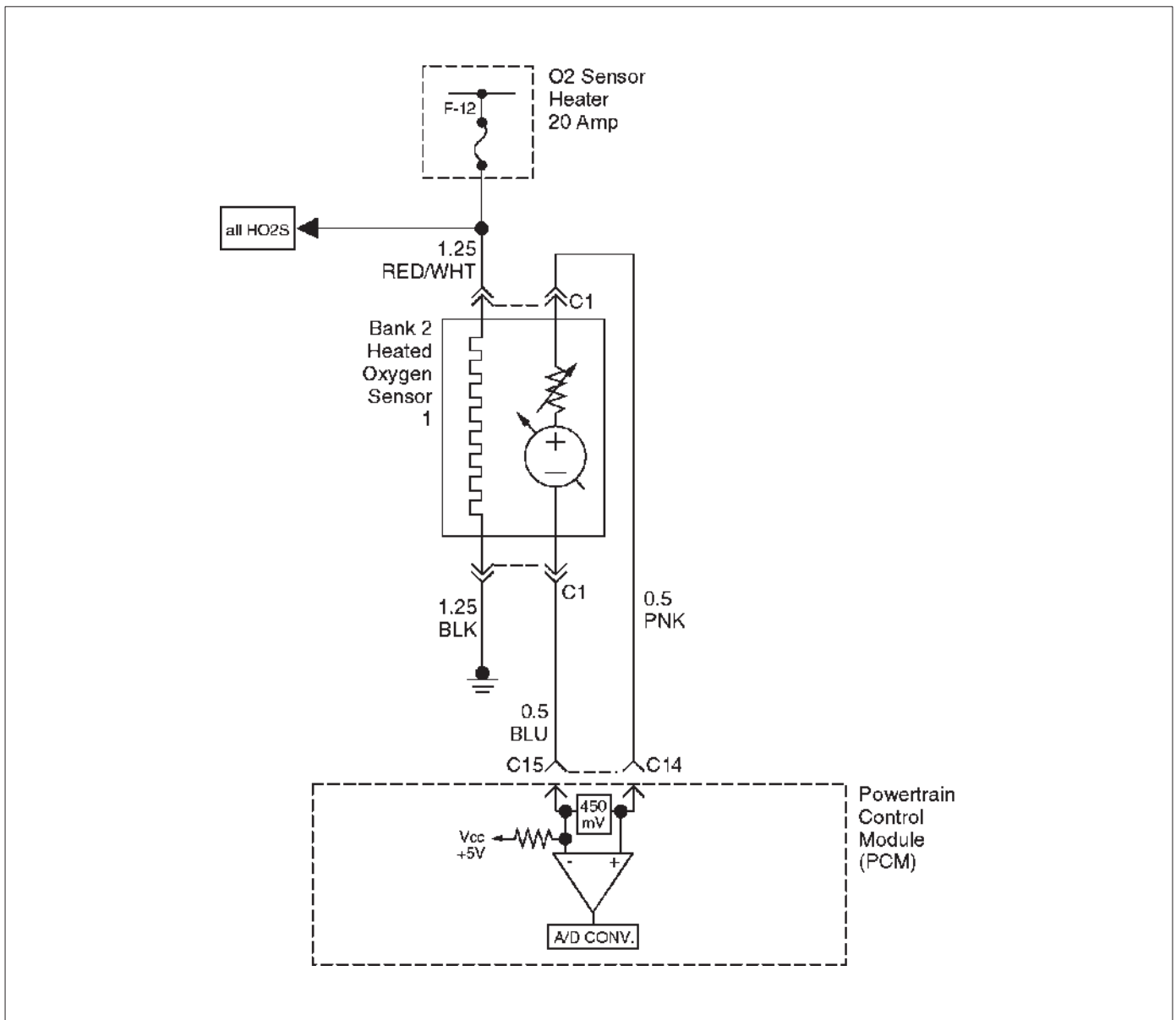
Step	Action	Value(s)	Yes	No
1	Was the “On-Board Diagnostic (OBD) System Check” performed?	—	Go to <i>Step 2</i>	Go to <i>OBD System Check</i>
2	Are any DTCs set other than P0174 and P0171?	—	Go to the applicable DTC charts and repair the other DTCs before proceeding with this chart.	Go to <i>Step 3</i>
3	1. Start the engine and operate the vehicle in “closed loop.” 2. Observe the “BANK 2 L.T. FUEL TRIM” display on the Tech 2. Is the displayed values greater than the specified values?	L.T. Fuel Trim: +20%	Go to <i>Step 5</i>	Go to <i>Step 4</i>
4	1. Review and record Tech 2 Failure Records data. 2. Clear the DTC P0171/P0174 and operate the vehicle to duplicate the Failure Records conditions. 3. Monitor the Tech 2 “DTC” info for DTC P0174 while operating the vehicle to duplicate the Failure Records conditions. 4. Continue operating the vehicle until the DTC P0174 test runs. 5. Note the test result. Does the Tech 2 indicate DTC P0174 failed this ignition?	—	Go to <i>Step 5</i>	The lean condition is not present. If a driveability symptom still exists, refer to <i>Symptoms</i> section.
5	Was DTC P0171 also set?	—	Go to <i>Step 6</i>	Go to <i>Step 15</i>
6	Visually and physically inspect the vacuum hoses for disconnections, splits, kinks, improper routing and improper connections and repair any problem found. Did your inspection reveal a problem requiring repair?	—	Verify repair	Go to <i>Step 7</i>
7	Visually and physically inspect the crankcase ventilation valve for proper installation and repair any problem found (refer to <i>Crankcase Ventilation System</i> ). Did your inspection reveal a problem requiring repair?	—	Verify repair	Go to <i>Step 8</i>
8	1. Inspect the MAF sensor inlet screen for damage or for the presence of foreign objects which may partially block the air flow sample through the MAF sensor. 2. Correct any problem that is found as necessary. Did your inspection of the MAF sensor reveal a condition requiring repair?	—	Verify repair	Go to <i>Step 9</i>
9	Start the engine and note the idle quality. Is a high or unsteady idle being experienced?	—	Go to <i>Step 10</i>	Go to <i>Step 11</i>

**DTC P0174 – Fuel Trim System Lean Bank 2 (Cont'd)**

Step	Action	Value(s)	Yes	No
10	1. Visually and physically inspect the throttle body, intake manifold, EGR valve and the EGR feed pipe for vacuum leaks. 2. Repair any vacuum leaks as necessary. Did your inspection reveal a vacuum leak?	—	Verify repair	Go to <i>Step 11</i>
11	Check the fuel for excessive water, alcohol, or other contaminants (see <i>Diagnosis in Engine Fuel</i> for procedure) and correct the contaminated fuel condition is present (see <i>Engine Fuel</i> ). Was the fuel contaminated?	—	Verify repair	Go to <i>Step 12</i>
12	1. Visually and physically inspect the PCM injector grounds, power grounds and sensor grounds to ensure that they are clean, tight, and in their proper locations. 2. If a faulty ground condition is present, correct it as necessary. Did your inspection reveal a condition requiring repair?	—	Verify repair	Go to <i>Step 13</i>
13	1. Disconnect the MAF sensor electrical connector. 2. Operate the vehicle in “closed loop” while monitoring the “BANK 2 S.T. FUEL TRIM” displayed on the Tech 2. Does the “BANK 2 S.T. FUEL TRIM” value decrease to near the specified value?	0%	Go to <i>Step 19</i>	Go to <i>Step 14</i>
14	Perform the procedure in the “Fuel System Pressure Test” and repair fuel system problem if necessary. Did the Fuel System Pressure Test isolate a condition requiring repair?	—	Verify repair	Go to <i>Step 15</i>
15	1. Visually and physically inspect the intake manifold, injector O-rings, EGR adapter, EGR valve and the EGR feed pipes for vacuum leaks. 2. Repair any problem that is found. Did your inspection reveal a problem?	—	Verify repair	Go to <i>Step 16</i>
16	Visually and physically inspect the Bank 2 exhaust manifold for leaks and loose or missing hardware and correct any problem found. Did your inspection reveal a problem?	—	Verify repair	Go to <i>Step 17</i>
17	Perform the “Injector Balance Test,” and correct any problem found (refer to <i>Fuel Metering System</i> ). Did the Injector Balance Test isolate a problem?	—	Verify repair	Go to <i>Step 18</i>
18	1. Visually and physically inspect the Bank 2 HO2S 1 to ensure that it is installed securely and that the Bank 2 HO2S 1 pigtail and wiring harness are not contacting the exhaust or otherwise damaged. 2. If a problem is found, correct it as necessary. Did your inspection reveal a problem?	—	Verify repair	Refer to <i>Diagnostic Aids</i>
19	Replace the MAF sensor. Is the action complete?	—	Verify repair	—



## Diagnostic Trouble Code (DTC) P0175 Fuel Trim System Rich Bank 2



### Circuit Description

To provide the best possible combination of driveability, fuel economy, and emission control, a “closed loop” air/fuel metering system is used. While in “closed loop,” the powertrain control module (PCM) monitors the Bank 1 HO2S 1 and Bank 2 HO2S 1 signals and adjusts fuel delivery based upon the HO2S signal voltages. A change made to fuel delivery will be indicated by the long and short term fuel trim values which can be monitored with a Tech 2. Ideal fuel trim values are around 0%; if the HO2S signals are indicating a lean condition the PCM will add fuel, resulting in fuel trim values above 0%. If a rich condition is detected, the fuel trim values will be below 0%, indicating that the PCM is reducing the amount of fuel delivered. If an excessively rich condition is detected on Bank 2, the PCM will set DTC P0175.

The PCM's maximum authority to control long term fuel trim allows a range between -15% (automatic transmission) or -12% (manual transmission) and +20%. The PCM's maximum authority to control short term fuel

trim allows a range between -11% and +20%. The PCM monitors fuel trim under various engine speed/load fuel trim cells before determining the status of the fuel trim diagnostic.

### Conditions for Setting the DTC

- No Tech 2 test is being run.
- None of the following DTCs are set: idle system, EGR, HO2S, (response, transition, open, low volts, no activity), MAF, TPS, MAP, IAT, canister purge, EVAP, injector circuit, or misfire.
- Engine coolant temperature is between 25°C (77°F) and 100°C (212°F).
- Intake air temperature is between -40°C (-40°F) and 120°C (248°F).
- Manifold absolute pressure is between 24 kpa and 99 kpa.
- Throttle angle is steady below 95%.
- Vehicle speed is below 136 km/h (85 mph).
- Engine speed is between 400 and 6,000 RPM.

- Barometric pressure is greater than 72.5 kpa.
- Mass air flow is between 2 g/second and 200 g/second.
- Ignition voltage is above 9.5 volts.
- Fuel system is in “closed loop.”
- Canister purge duty cycle is greater than 15%, if “ON.”

**Action Taken When the DTC Sets**

- The PCM will illuminate the malfunction indicator lamp (MIL) after the second consecutive trip in which the failure is detected.
- The PCM will store conditions which were present when the DTC was set as Freeze Frame and in the Failure Records data.

**Conditions for Clearing the MIL/DTC**

- The PCM will turn the MIL “OFF” on the third consecutive trip cycle during which the diagnostic has been run and the fault condition is no longer present.
- A history DTC P0175 will clear after 40 consecutive warm-up cycles have occurred without a fault.
- DTC P0175 can be cleared by using the Tech 2 “Clear Info” function or by disconnecting the PCM battery feed.

**Diagnostic Aids**

Check for the following conditions:

- Poor connection at PCM – Inspect harness connectors for backed -out terminals, improper mating, broken

locks, improperly formed or damaged terminals, and poor terminal-to-wire connection.

- Damaged harness – Inspect the wiring harness for damage. If the harness appears to be OK, observe the Bank 2 HO2S 1 display on the Tech 2 while moving connectors and wiring harnesses related to the engine harness. A change in the display will indicate the location of the fault.

Reviewing the Failure Records Vehicle mileage since the diagnostic test last failed may help determine how often the condition that caused the DTC to be set occurs. This may assist in diagnosing the condition.

**Test Description**

Number(s) below refer to the step number(s) on the Diagnostic Chart.

2. DTCs other than P0172 and P0175 may indicate a condition present which may cause a lean condition. If this is the case, repairing the condition which caused the other DTC will most likely correct the DTC P0172/P0175.
4. If the DTC P0175 test passes while the Failure Records conditions are being duplicated, the rich condition is intermittent. Refer to *Diagnostic Aids* or *Symptoms* for additional information on diagnosing intermittent problems.

**DTC P0175 – Fuel Trim System Rich Bank 2**

Step	Action	Value(s)	Yes	No
1	Was the "On-Board Diagnostic (OBD) System Check" performed?	—	Go to Step 2	Go to <i>OBD System Check</i>
2	Are any DTCs set other than P0172 and P0175?	—	Go to the applicable DTC charts and repair the other DTCs before proceeding with this chart.	Go to <i>Step 3</i>
3	1. Start the engine and operate the vehicle in "closed loop." 2. Observe the "BANK 2 L.T. FUEL TRIM" display on the Tech 2. Is the displayed value more negative than the specified value?	L.T. Fuel Trim: -15%	Go to <i>Step 5</i>	Go to <i>Step 4</i>

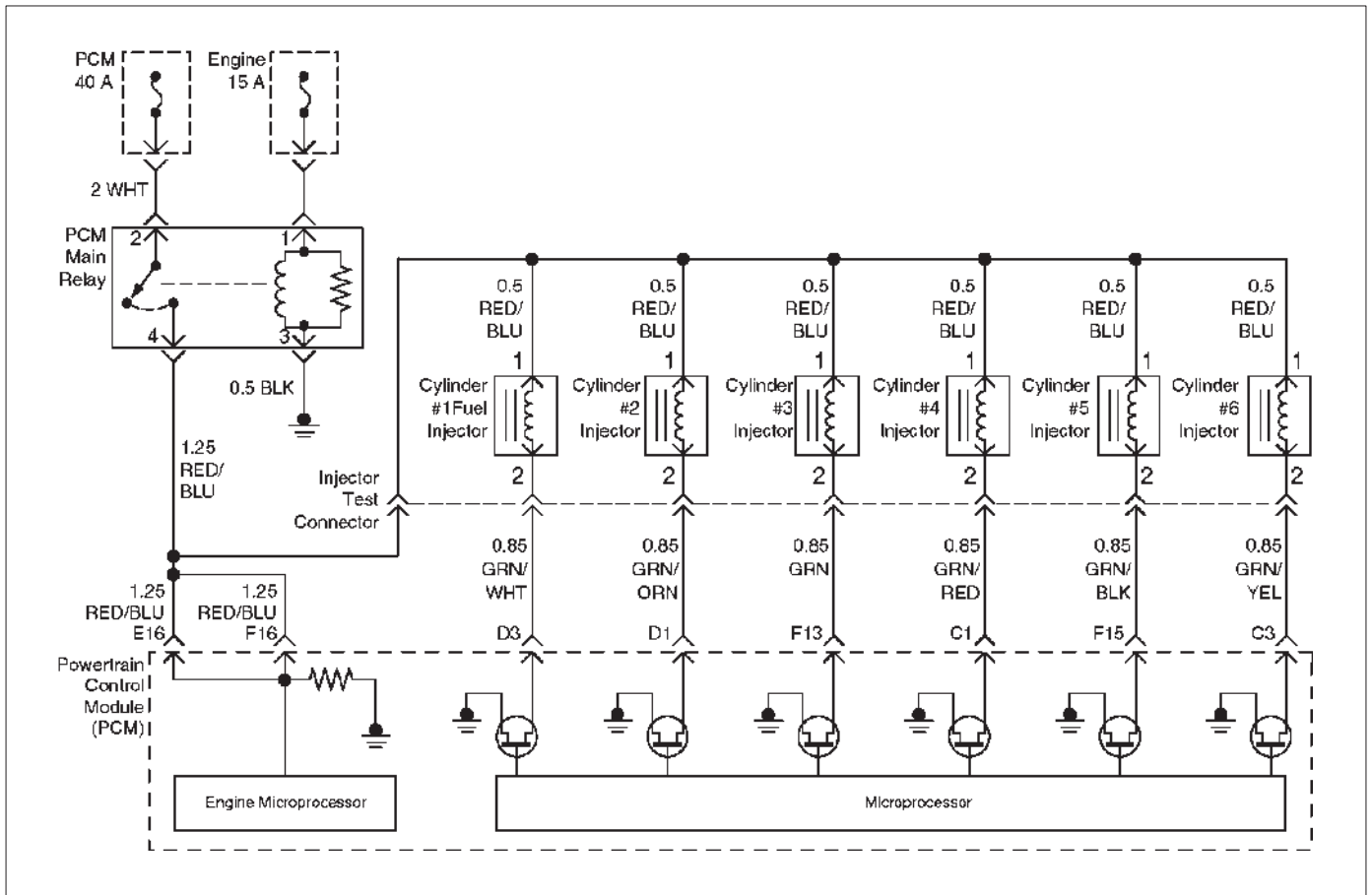
**DTC P0175 – Fuel Trim System Rich Bank 2 (Cont'd)**

Step	Action	Value(s)	Yes	No
4	<ol style="list-style-type: none"> <li>Review and record the Tech 2 Failure Records data.</li> <li>Clear the DTC P0172/P0175 and operate the vehicle to duplicate the Failure Records conditions.</li> <li>Monitor the Tech 2 "DTC" info for DTC P0175 while operating the vehicle to duplicate the Failure Records conditions.</li> <li>Continue operating the vehicle until the DTC P0175 test runs.</li> <li>Note the test result.</li> </ol> Does the Tech 2 indicate DTC P0175 failed this ignition?	—	Go to <i>Step 5</i>	The rich condition is not present. If a driveability symptom still exists, refer to <i>Symptoms</i> .
5	Was DTC P0172 also set?	—	Go to <i>Step 6</i>	Go to <i>Step 15</i>
6	Visually and physically inspect the air filter element and replace it if necessary. Did the air filter require replacement?	—	Verify repair	Go to <i>Step 7</i>
7	Visually and physically inspect the air intake duct for collapse or restriction and repair if necessary. Did your inspection reveal a problem requiring repair?	—	Verify repair	Go to <i>Step 8</i>
8	Inspect the MAF sensor inlet screen for damage or for the presence of foreign objects which may partially block air flow through the screen and correct any problem found. Did your inspection of the MAF sensor reveal a condition requiring repair or replacement?	—	Verify repair	Go to <i>Step 9</i>
9	Start the engine and note the idle quality. Is a low or unsteady idle being experienced?	—	Go to <i>Step 10</i>	Go to <i>Step 11</i>
10	<ol style="list-style-type: none"> <li>Turn the ignition off and physically inspect the throttle body bore, throttle plate, and IAC passages for coking and foreign objects.</li> <li>If a problem was found, repair as necessary.</li> </ol> Did your inspection reveal a condition requiring repair?	—	Verify repair	Go to <i>Step 11</i>
11	<ol style="list-style-type: none"> <li>Disconnect the vacuum hose from the fuel pressure regulator and inspect the hose for the presence of fuel.</li> <li>If fuel is present in the vacuum hose, replace the fuel pressure regulator (refer to <i>Fuel Metering System</i>).</li> </ol> Did the fuel pressure regulator require replacement?	—	Verify repair	Go to <i>Step 12</i>
12	<ol style="list-style-type: none"> <li>Ignition "ON," engine "OFF."</li> <li>Monitor the TP Angle display on the Tech 2 while slowly depressing the accelerator pedal.</li> </ol> Does the TP Angle display increase steadily and evenly from minimum value at closed throttle to maximum value at wide-open throttle?	Minimum 0% Maximum 100%	Go to <i>Step 13</i>	Go to <i>Step 21</i>
13	<ol style="list-style-type: none"> <li>Disconnect the MAF sensor electrical connector.</li> <li>Operate the vehicle in "closed loop" while monitoring the "BANK 2 L.T. FUEL TRIM" and "BANK 2 S.T. FUEL TRIM" display on the Tech 2.</li> </ol> Did both values change to near the specified value?	0%	Go to <i>Step 22</i>	Go to <i>Step 14</i>

## DTC P0175 – Fuel Trim System Rich Bank 2 (Cont'd)

Step	Action	Value(s)	Yes	No
14	1. Perform the "Fuel System Pressure Test." 2. If Fuel System Pressure Test isolates a problem, repair as necessary (refer to <i>Engine Fuel</i> or <i>Fuel Metering System</i> ). Did the Fuel System Pressure Test isolate a condition requiring repair?	—	Verify repair	Go to <i>Step 15</i>
15	1. Ignition "ON," engine "OFF." 2. Connect a test light between the harness connector terminals of canister purge solenoid. Is the test light on?	—	Go to <i>Step 16</i>	Go to <i>Step 19</i>
16	Check for short to ground in the wire (red/blue) between the canister purge solenoid and PCM terminal A-15. Was there a short to ground?	—	Go to <i>Step 17</i>	Go to <i>Step 18</i>
17	Repair the short to ground. Is the action complete?	—	Verify repair	—
18	Replace the PCM. <b>IMPORTANT:</b> The replacement PCM must be programmed. Refer to <i>On-Vehicle Service</i> in <i>Powertrain Control Module and Sensors</i> for procedures. And also refer to the latest Service Bulletin. Check to see if the Latest software is released or not. And then Down Load the LATEST PROGRAMMED SOFTWARE to the replacement PCM. Is the action complete?	—	Verify repair	—
19	1. Perform the "Injector Balance Test." 2. If the Injector Balance Test isolates a problem, repair as necessary (refer to <i>Fuel Metering System</i> ). Did the Injector Balance Test isolate a problem requiring repair?	—	Verify repair	Go to <i>Step 20</i>
20	1. Remove and visually/physically inspect the Bank 2 HO2S 1 for silicon contamination. This will be indicated by a powdery white deposit on the portion of the HO2S that is exposed to the exhaust stream. 2. If contamination is evident on the Bank 2 HO2S 1, replace the contaminated sensor. Did the sensor require replacement?	—	Verify repair	Refer to <i>Diagnostic Aids</i>
21	1. Check the TP sensor mounting screws and tighten or replace them as necessary if they are loose or missing. 2. If the screws are OK, replace the TP sensor. Is the action complete?	—	Verify repair	—
22	Replace the MAF sensor. Is the action complete?	—	Verify repair	—

## Diagnostic Trouble Code (DTC) P0201 Injector 1 Control Circuit



D06RX150

### Circuit Description

The powertrain control module (PCM) has six individual injector driver circuits. Each controls an injector. When a driver circuit is grounded by the PCM, the injector is activated. The PCM monitors the current in each driver circuit. The voltage on each driver is monitored to detect a fault. If the voltage is not what the PCM expects to monitor on the circuit, a DTC is set. This DTC is also set if an injector driver is shorted to voltage or if there is an open circuit.

### Conditions for Setting the DTC

- The battery voltage is more than 9 volts.
- The engine is turning, determined by 58X crankshaft position input signal.
- The injector voltage does not equal the ignition voltage when the injector is commanded "OFF" or the injector voltage does not equal 0 volts when the injector is commanded "ON."
- The above conditions are met for 15 seconds.

### Action Taken When the DTC Sets

- The PCM will illuminate the malfunction indicator lamp (MIL) the first time the fault is detected.
- The PCM will store conditions which were present when the DTC was set as Freeze Frame and in the Failure Records data.

### Conditions for Clearing the MIL/DTC

- The PCM will turn "OFF" the MIL on the third consecutive trip cycle in which the diagnostic has been run and the fault is no longer present.
- A history DTC P0201 will clear after 40 consecutive warm-up cycles occur without a fault.
- DTC P0201 can be cleared by using the Tech 2 "Clear Info" function or by disconnecting the PCM battery feed.

### Diagnostic Aids

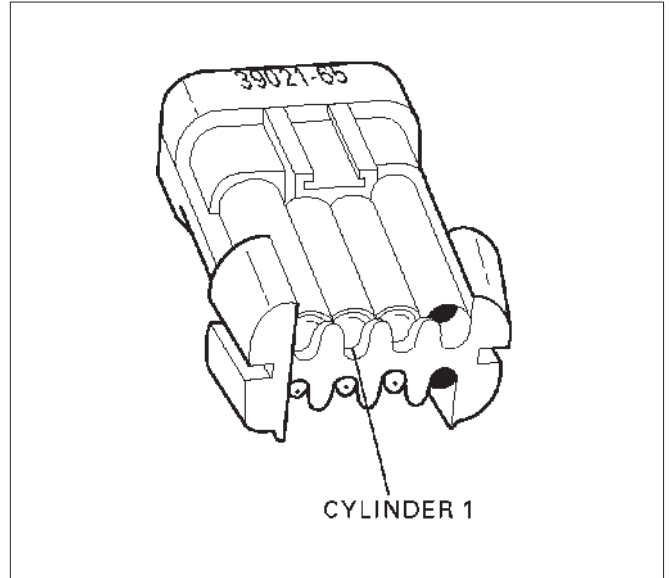
An injector driver circuit that is open or shorted to voltage will cause a DTC P0201 to set. It will also cause a misfire due to an inoperative injector. A misfire DTC will also be set indicating which cylinder is inoperative. Long term and short term fuel trims that are excessively high or low are a good indication that an injector is faulty. Use Fuel Injector Coil Test Procedure to check for faulty injectors.

**Test Description**

The number(s) below refer to the step number(s) on the Diagnostic Chart.

- 3. This step determines if DTC P0201 is the result of a hard failure or an intermittent condition.
- 5. A special injector test connector is provided so that the injectors can be electrically tested without removal of the manifold. The test connector can be identified by the blue connector lock which is tethered to the wiring harness. If the light for cylinder 1 is "ON" steady before cranking the engine as well as while cranking the engine, then the injector driver circuit is shorted to ground.

If the test light blinks while cranking, the PCM and the wiring to the injectors are OK. The Fuel Injector Coil Test Procedure will check if the injectors are faulty.



R321054

- 7. Because the test light was "ON" steady, voltage to the injector is OK, but the driver circuit is grounded at all times. This step determines if the circuit is shorted to ground or the PCM is faulty.
- 9. The reading should be about 12-14Φ.
- 10. Locating the open in the harness or in the injector will require removal of the manifold to provide access.

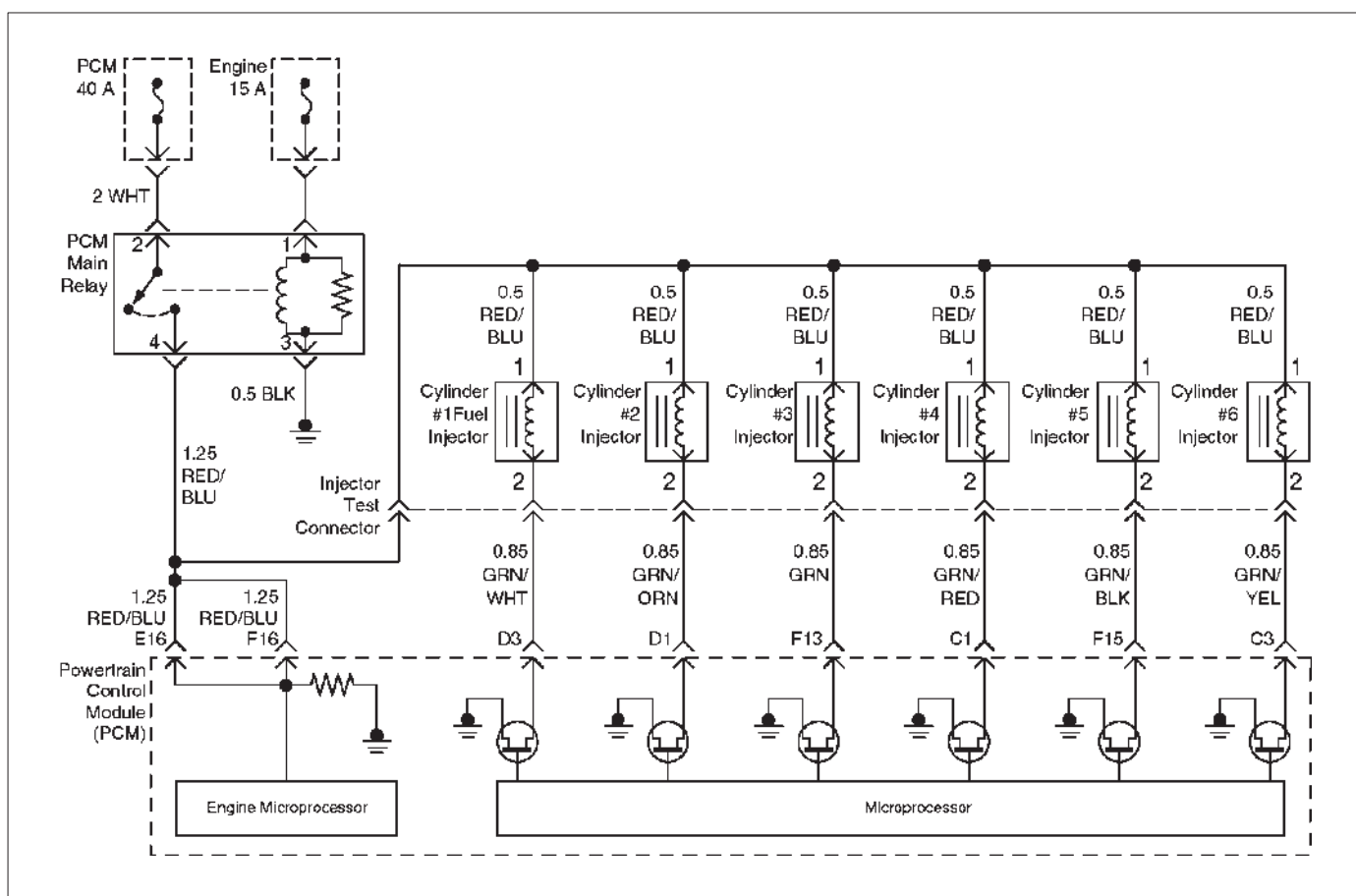
**DTC P0201 – Injector 1 Control Circuit**

Step	Action	Value(s)	Yes	No
1	Was the "On-Board Diagnostic (OBD) System Check" performed?	—	Go to Step 2	Go to <i>OBD System Check</i>
2	Will the engine start?	—	Go to Step 3	Go to <i>Engine Cranks But Will Not Run</i> chart
3	1. Install the Tech 2. Clear the DTC. 2. Idle the engine for one minute. Does DTC P0201 reset?	—	Go to Step 5	Go to Step 4
4	1. Review the Freeze Frame data with the ignition "ON" and the engine "OFF" and note the parameters. 2. Operate the vehicle within the Freeze Frame conditions as noted. Does P0201 reset?	—	Go to Step 5	Go to <i>Diagnostic Aids</i>
5	1. Engine "OFF." 2. Disconnect the injector connector. 3. Install an injector test light J-39021-65 on the injector test connector. 4. Crank the engine and note the light. Does the injector test light blink?	—	Go to <i>Fuel Injector Coil Test Procedure</i>	Go to Step 6

## DTC P0201 – Injector 1 Control Circuit (Cont'd)

Step	Action	Value(s)	Yes	No
6	Note whether the injector test light for cylinder 1 was "OFF" or "ON" steady in step 5. Was the test light "ON" steady while cranking the engine?	—	Go to Step 7	Go to Step 9
7	1. Disconnect the PCM connector for the affected injectors. 2. With a test light connected to B+, probe the affected injector driver circuit. Does the test light illuminate?	—	Go to Step 8	Go to Step 15
8	Repair short to ground in the injector driver circuit. Is the action complete?	—	Go to OBD System Check	—
9	1. Disconnect the injector test connector. 2. At the injector side of the harness, connect an ohmmeter between the positive wire (red with blue tracer) and the wire for cylinder 1 (green with white tracer). Does the ohmmeter indicate continuity?	—	Go to Step 11	Go to Step 10
10	Repair the open injector harness wire or open injector. Is the action complete?	—	Verify repair	—
11	At the PCM side of the injector test connector, check the green/white wire for a short to voltage. Was there a short to voltage?	—	Go to Step 12	Go to Step 13
12	Repair the short to voltage. Is the action complete?	—	Verify repair	—
13	Check for an open circuit between the injector test connector and the PCM. Was there an open circuit?	—	Go to Step 14	Go to Step 15
14	Repair the open circuit. Is the action complete?	—	Verify repair	—
15	Replace the PCM. <b>IMPORTANT:</b> The replacement PCM must be programmed. Refer to <i>On-Vehicle Service in Powertrain Control Module and Sensors</i> for procedures. And also refer to the latest Service Bulletin. Check to see if the Latest software is released or not. And then Down Load the LATEST PROGRAMMED SOFTWARE to the replacement PCM. Is the action complete?	—	Verify repair	—

## Diagnostic Trouble Code (DTC) P0202 Injector 2 Control Circuit



D06RX150

### Circuit Description

The powertrain control module (PCM) has six individual injector driver circuits. Each controls an injector. When a driver circuit is grounded by the PCM, the injector is activated. The PCM monitors the current in each driver circuit. The voltage on each driver is monitored to detect a fault. If the voltage is not what the PCM expects to monitor on the circuit, a DTC is set. This DTC is also set if an injector driver is shorted to voltage or if there is an open circuit.

### Conditions for Setting the DTC

- The battery voltage is more than 9 volts.
- The engine is turning, determined by 58X crankshaft position input signal.
- The injector voltage does not equal the ignition voltage when the injector is commanded "OFF" or the injector voltage does not equal 0 volts when the injector is commanded "ON."
- The above conditions are met for 15 seconds.

### Action Taken When the DTC Sets

- The PCM will illuminate the malfunction indicator lamp (MIL) the first time the fault is detected.
- The PCM will store conditions which were present when the DTC was set as Freeze Frame and in the Failure Records data.

### Conditions for Clearing the MIL/DTC

- The PCM will turn "OFF" the MIL on the third consecutive trip cycle in which the diagnostic has been run and the fault is no longer present.
- A history DTC P0202 will clear after 40 consecutive warm-up cycles occur without a fault.
- DTC P0202 can be cleared by using the Tech 2 "Clear Info" function or by disconnecting the PCM battery feed.

### Diagnostic Aids

An injector driver circuit that is open or shorted to voltage will cause a DTC P0202 to set. It will also cause a misfire due to an inoperative injector. A misfire DTC will also be set indicating which cylinder is inoperative. Long term and short term fuel trims that are excessively high or low are a good indication that an injector is faulty. Use Fuel Injector Coil Test Procedure to check for faulty injectors.

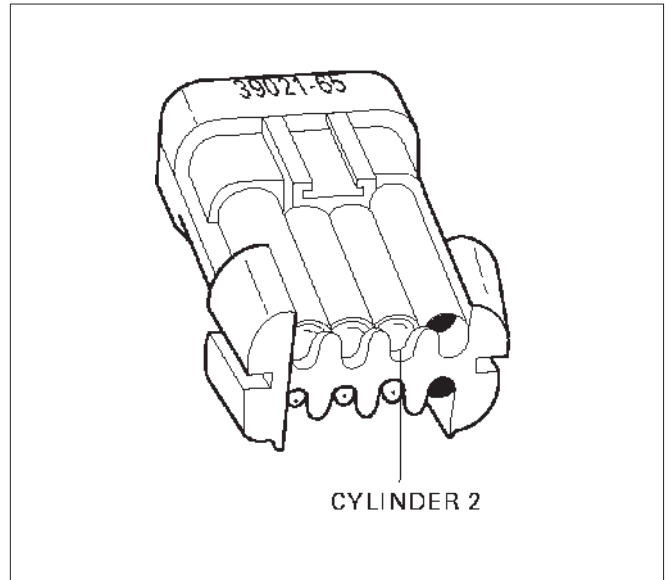


**Test Description**

The number(s) below refer to the step number(s) on the Diagnostic Chart.

- 3. This step determines if DTC P0202 is the result of a hard failure or an intermittent condition.
- 5. A special injector test connector is provided so that the injectors can be electrically tested without removal of the manifold. The test connector can be identified by the blue connector lock which is tethered to the wiring harness. If the light for cylinder 2 is "ON" steady before cranking the engine as well as while cranking the engine, then the injector driver circuit is shorted to ground.

If the test light blinks while cranking, the PCM and the wiring to the injectors are OK. The Fuel Injector Coil Test Procedure will check if the injectors are faulty.



R321055

- 7. Because the test light was "ON" steady, voltage to the injector is OK, but the driver circuit is grounded at all times. This step determines if the circuit is shorted to ground or the PCM is faulty.
- 9. The reading should be about 12-14Φ.
- 10. Locating the open in the harness or in the injector will require removal of the manifold to provide access.

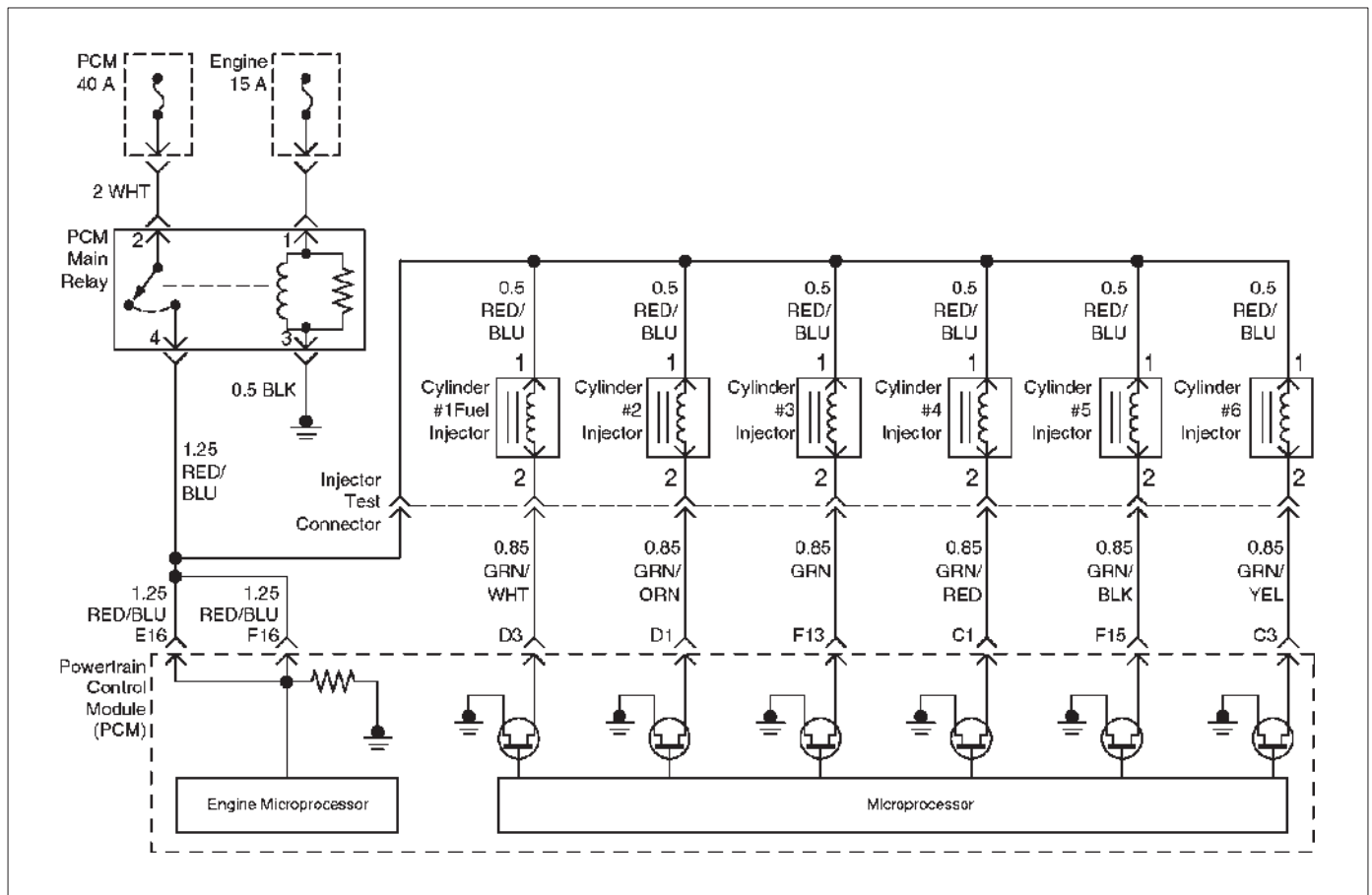
**DTC P0202 – Injector 2 Control Circuit**

Step	Action	Value(s)	Yes	No
1	Was the "On-Board Diagnostic (OBD) System Check" performed?	—	Go to Step 2	Go to <i>OBD System Check</i>
2	Will the engine start?	—	Go to Step 3	Go to <i>Engine Cranks But Will Not Run</i> chart
3	1. Install the Tech 2. Clear the DTC. 2. Idle the engine for one minute. Does DTC P0202 reset?	—	Go to Step 5	Go to Step 4
4	1. Review the Freeze Frame data with the ignition "ON" and the engine "OFF" and note the parameters. 2. Operate the vehicle within the Freeze Frame conditions as noted. Does P0202 reset?	—	Go to Step 5	Go to <i>Diagnostic Aids</i>
5	1. Engine "OFF." 2. Disconnect the injector test connector. 3. Install an injector test light J-39021-65 on injector connector. 4. Crank the engine and note the light. Does the cylinder 2 test light blink?	—	Go to <i>Fuel Injector Coil Test Procedure</i>	Go to Step 6

## DTC P0202 – Injector 2 Control Circuit (Cont'd)

Step	Action	Value(s)	Yes	No
6	Note whether the injector test light for cylinder 2 was "OFF" or "ON" steady in step 5. Was the test light "ON" steady while cranking the engine?	—	Go to Step 7	Go to Step 9
7	1. Disconnect the PCM connector for the affected injectors. 2. With a test light connected to B+, probe the affected injector driver circuit. Does the test light illuminate?	—	Go to Step 8	Go to Step 15
8	Repair short to ground in the injector driver circuit. Is the action complete?	—	Go to OBD System Check	—
9	1. Disconnect the injector test connector. 2. At the injector side of the harness, connect an ohmmeter between the positive wire (red with blue tracer) and the wire for cylinder 2 (green with orange tracer). Does the ohmmeter indicate continuity?	—	Go to Step 11	Go to Step 10
10	Repair the open injector harness wire or open injector. Is the action complete?	—	Verify repair	—
11	At the PCM side of the injector test connector, check the green/orange wire for a short to voltage. Was there a short to voltage?	—	Go to Step 12	Go to Step 13
12	Repair the short to voltage. Is the action complete?	—	Verify repair	—
13	Check for an open circuit between the injector test connector and the PCM. Was there an open circuit?	—	Go to Step 14	Go to Step 15
14	Repair the open circuit. Is the action complete?	—	Verify repair	—
15	Replace the PCM. <b>IMPORTANT:</b> The replacement PCM must be programmed. Refer to <i>On-Vehicle Service in Powertrain Control Module and Sensors</i> for procedures. And also refer to the latest Service Bulletin. Check to see if the Latest software is released or not. And then Down Load the LATEST PROGRAMMED SOFTWARE to the replacement PCM. Is the action complete?	—	Verify repair	—

## Diagnostic Trouble Code (DTC) P0203 Injector 3 Control Circuit



### Circuit Description

The powertrain control module (PCM) has six individual injector driver circuits. Each controls an injector. When the driver circuit is grounded by the PCM, the injector is activated. The PCM monitors the current in each driver circuit. The voltage on each driver is monitored to detect a fault. If the voltage is not what the PCM expects to monitor on the circuit, a DTC is set. This DTC is also set if an injector driver is shorted to voltage or if there is an open circuit.

### Conditions for Setting the DTC

- The battery voltage is more than 9 volts.
- The engine is turning, determined by the 58X crankshaft position input signal.
- The injector voltage does not equal the ignition voltage when the injector is commanded "OFF" or the injector voltage does not equal 0 volts when the injector is commanded "ON."
- The above conditions are met for 15 seconds.

### Action Taken When the DTC Sets

- The PCM will illuminate the malfunction indicator lamp (MIL) the first time the fault is detected.
- The PCM will store conditions which were present when the DTC was set as Freeze Frame and in the Failure Records data.

### Conditions for Clearing the MIL/DTC

- The PCM will turn "OFF" the MIL on the third consecutive trip cycle in which the diagnostic has been run and the fault is no longer present.
- A history DTC P0203 will clear after 40 consecutive warm-up cycles occur without a fault.
- DTC P0203 can be cleared by using the Tech 2 "Clear Info" function or by disconnecting the PCM battery feed.

### Diagnostic Aids

An injector driver circuit that is open or shorted to voltage will cause a DTC P0203 to set. It will also cause a misfire due to an inoperative injector. A misfire DTC will also be set indicating which cylinder is inoperative.

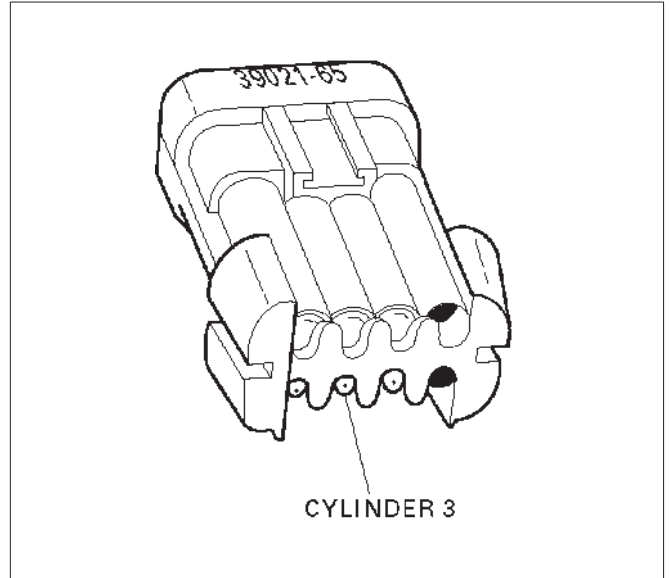
Long term and short term fuel trims that are excessively high or low are a good indication that an injector is faulty. Use Fuel Injector Coil Test Procedure to check for faulty injectors.

**Test Description**

The number(s) below refer to the step number(s) on the Diagnostic Chart.

- 3. This step determines if DTC P0203 is the result of a hard failure or an intermittent condition.
- 5. A special injector test connector is provided so that the injectors can be electrically tested without removal of the manifold. The test connector can be identified by the blue connector lock which is tethered to the wiring harness. If the light for cylinder 3 is "ON" steady before cranking the engine as well as while cranking the engine, then the injector driver circuit is shorted to ground.

If the test light blinks while cranking, the PCM and the wiring to the injectors are OK. The Fuel Injector Coil Test Procedure will check if the injectors are faulty.



R321056

- 7. Because the test light was "ON" steady, voltage to the injector is OK, but the driver circuit is grounded at all times. This step determines if the circuit is shorted to ground or the PCM is faulty.
- 9. The reading should be about 12-14Φ.
- 10. Locating the open in the harness or in the injector will require removal of the manifold to provide access.

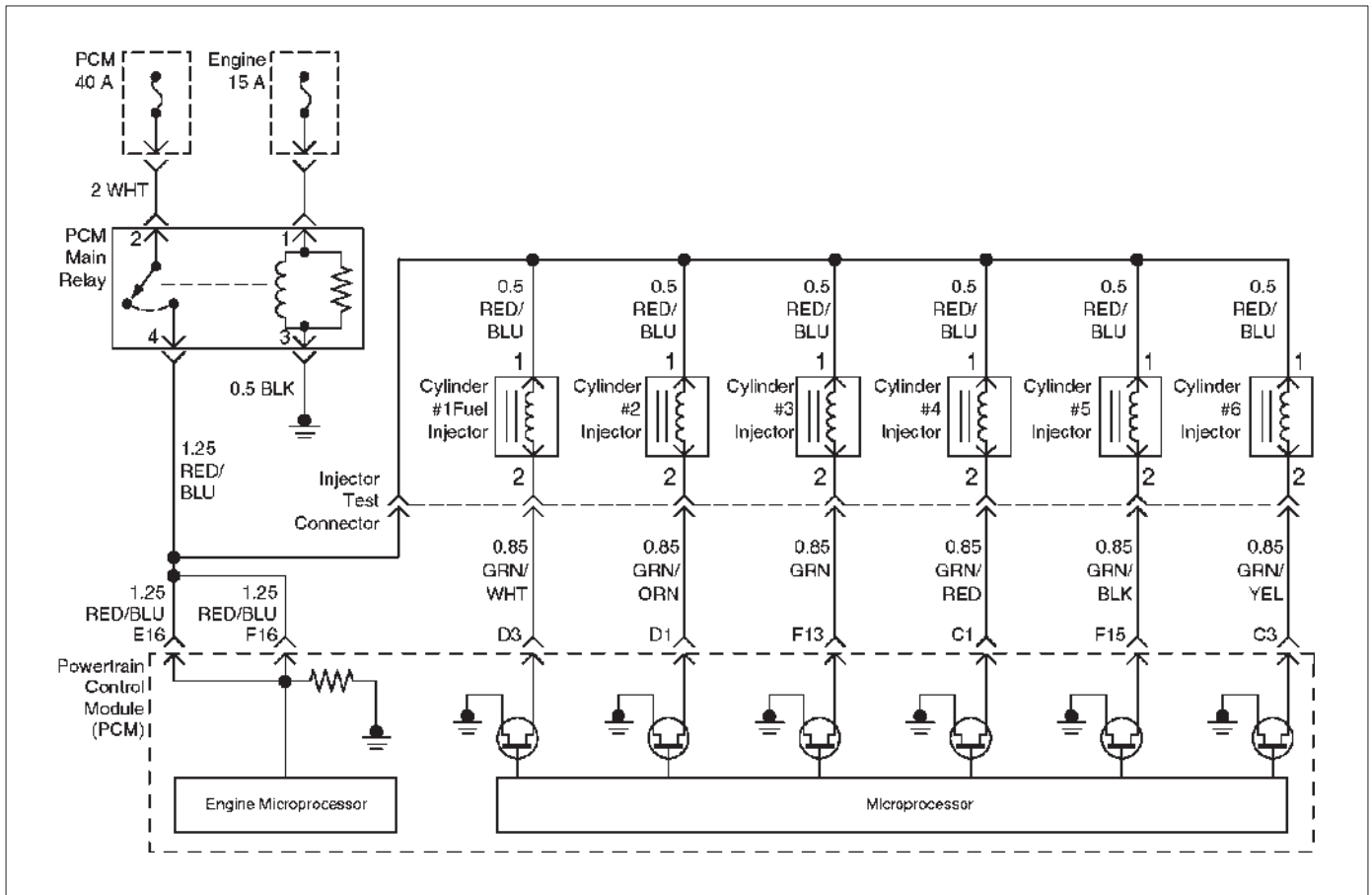
**DTC P0203 – Injector 3 Control Circuit**

Step	Action	Value(s)	Yes	No
1	Was the "On-Board Diagnostic (OBD) System Check" performed?	—	Go to Step 2	Go to <i>OBD System Check</i>
2	Will the engine start?	—	Go to Step 3	Go to <i>Engine Cranks But Will Not Run</i> chart
3	1. Install the Tech 2. Clear the DTC. 2. Idle the engine for one minute. Does DTC P0203 reset?	—	Go to Step 5	Go to Step 4
4	1. Review the Freeze Frame data with the ignition "ON" and the engine "OFF" and note the parameters. 2. Operate the vehicle within the Freeze Frame conditions as noted. Does P0203 reset?	—	Go to Step 5	Go to <i>Diagnostic Aids</i>
5	1. Engine "OFF." 2. Disconnect the injector test connector . 3. Install an injector test light J-39021-65 on injector connector. 4. Crank the engine and note the light. Does the cylinder 3 test light blink?	—	Go to <i>Fuel Injector Coil Test Procedure</i>	Go to Step 6

## DTC P0203 – Injector 3 Control Circuit (Cont'd)

Step	Action	Value(s)	Yes	No
6	Note whether the injector test light for cylinder 3 was "OFF" or "ON" steady in step 5. Was the test light "ON" steady while cranking the engine?	—	Go to Step 7	Go to Step 9
7	1. Disconnect the PCM connector for the affected injectors. 2. With a test light connected to B+, probe the affected injector driver circuit. Does the test light illuminate?	—	Go to Step 8	Go to Step 15
8	Repair short to ground in the injector driver circuit. Is the action complete?	—	Go to OBD System Check	—
9	1. Disconnect the injector test connector. 2. At the injector side of the harness, connect an ohmmeter between the positive wire (red with blue tracer) and the wire for cylinder 3 (green). Does the ohmmeter indicate continuity?	—	Go to Step 11	Go to Step 10
10	Repair the open injector harness wire or open injector. Is the action complete?	—	Verify repair	—
11	At the PCM side of the injector test connector, check the green wire for a short to voltage. Was there a short to voltage?	—	Go to Step 12	Go to Step 13
12	Repair the short to voltage. Is the action complete?	—	Verify repair	—
13	Check for an open circuit between the injector test connector and the PCM. Was there an open circuit?	—	Go to Step 14	Go to Step 15
14	Repair the open circuit. Is the action complete?	—	Verify repair	—
15	Replace the PCM. <b>IMPORTANT:</b> The replacement PCM must be programmed. Refer to <i>On-Vehicle Service in Powertrain Control Module and Sensors</i> for procedures. And also refer to the latest Service Bulletin. Check to see if the Latest software is released or not. And then Down Load the LATEST PROGRAMMED SOFTWARE to the replacement PCM. Is the action complete?	—	Verify repair	—

## Diagnostic Trouble Code (DTC) P0204 Injector 4 Control Circuit



D06RX150

### Circuit Description

The powertrain control module (PCM) has six individual injector driver circuits. Each controls an injector. When the driver circuit is grounded by the PCM, the injector is activated. The PCM monitors the current in each driver circuit. The voltage on each driver is monitored to detect a fault. If the voltage is not what the PCM expects to monitor on the circuit, a DTC is set. This DTC is also set if an injector driver is shorted to voltage or if there is an open circuit.

### Conditions for Setting the DTC

- The battery voltage is more than 9 volts.
- The engine is turning, determined by the 58X crankshaft position input signal.
- The injector voltage does not equal the ignition voltage when the injector is commanded "OFF" or the injector voltage does not equal 0 volts when the injector is commanded "ON."
- The above conditions are met for 15 seconds.

### Action Taken When the DTC Sets

- The PCM will illuminate the malfunction indicator lamp (MIL) the first time the fault is detected.
- The PCM will store conditions which were present when the DTC was set as Freeze Frame and in the Failure Records data.

### Conditions for Clearing the MIL/DTC

- The PCM will turn "OFF" the MIL on the third consecutive trip cycle in which the diagnostic has been run and the fault is no longer present.
- A history DTC P0204 will clear after 40 consecutive warm-up cycles occur without a fault.
- DTC P0204 can be cleared by using the Tech 2 "Clear Info" function or by disconnecting the PCM battery feed.

### Diagnostic Aids

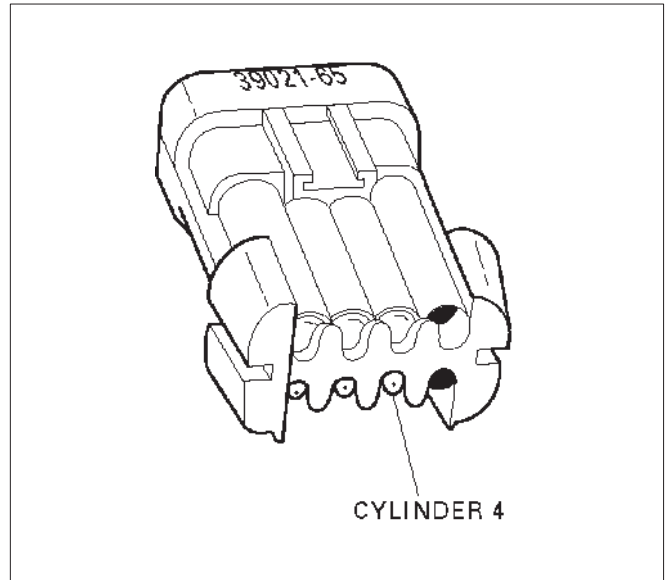
An injector driver circuit that is open or shorted to voltage will cause a DTC P0204 to set. It will also cause a misfire due to an inoperative injector. A misfire DTC will also be set indicating which cylinder is inoperative. Long term and short term fuel trims that are excessively high or low are a good indication that an injector is faulty. Use Fuel Injector Coil Test Procedure to check for faulty injectors.

**Test Description**

The number(s) below refer to the step number(s) on the Diagnostic Chart.

- 3. This step determines if DTC P0204 is the result of a hard failure or an intermittent condition.
- 5. A special injector test connector is provided so that the injectors can be electrically tested without removal of the manifold. The test connector can be identified by the blue connector lock which is tethered to the wiring harness. If the light for cylinder 4 is "ON" steady before cranking the engine as well as while cranking the engine, then the injector driver circuit is shorted to ground.

If the test light blinks while cranking, the PCM and the wiring to the injectors are OK. The Fuel Injector Coil Test Procedure will check if the injectors are faulty.



R321057

- 7. Because the test light was "ON" steady, voltage to the injector is OK, but the driver circuit is grounded at all times. This step determines if the circuit is shorted to ground or the PCM is faulty.
- 9. The reading should be about 12-14Φ.
- 10. Locating the open in the harness or in the injector will require removal of the manifold to provide access.

**DTC P0204 – Injector 4 Control Circuit**

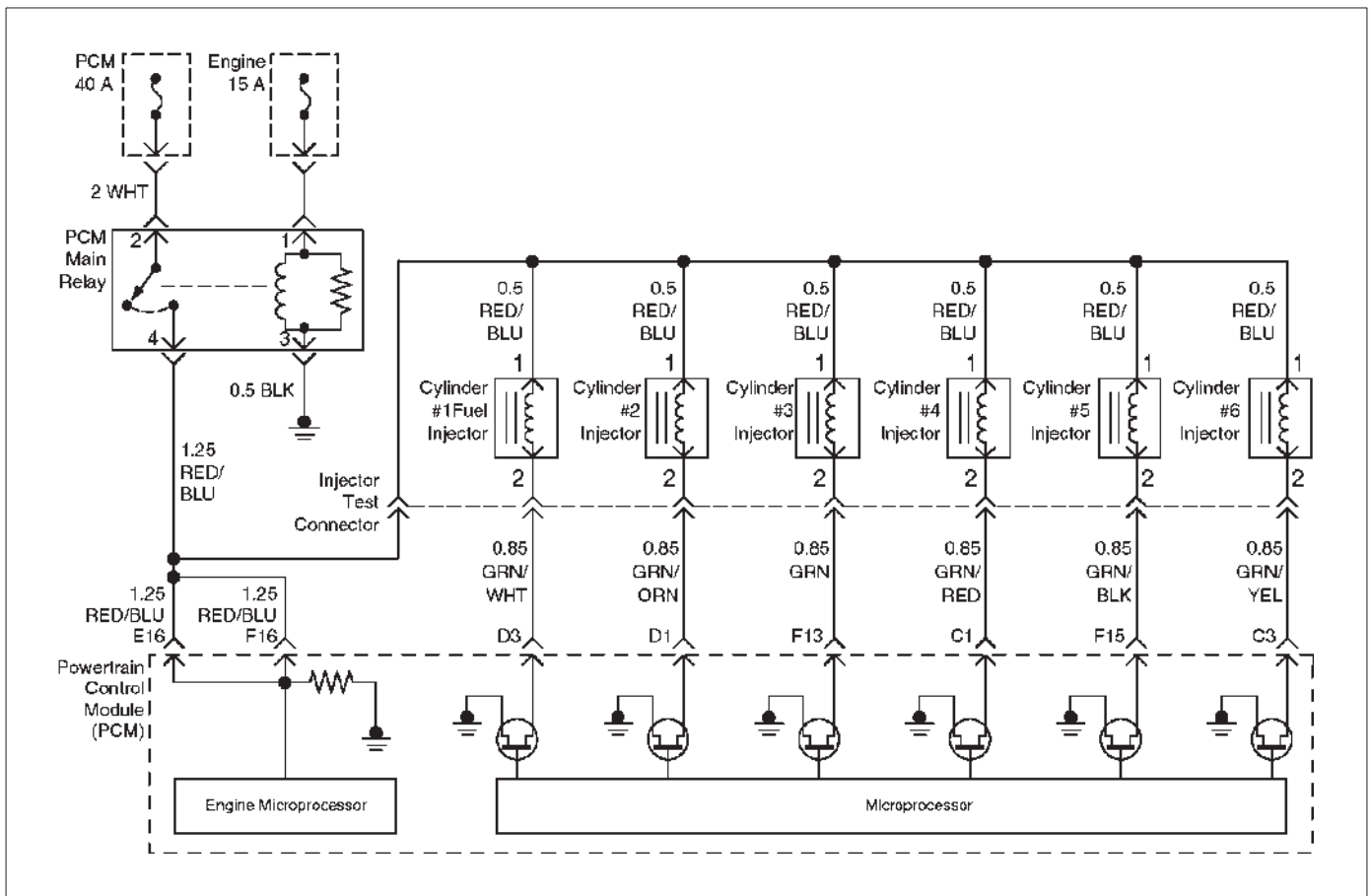
Step	Action	Value(s)	Yes	No
1	Was the "On-Board Diagnostic (OBD) System Check" performed?	—	Go to Step 2	Go to <i>OBD System Check</i>
2	Will the engine start?	—	Go to Step 3	Go to <i>Engine Cranks But Will Not Run</i> chart
3	1. Install the Tech 2. Clear the DTC. 2. Idle the engine for one minute. Does DTC P0204 reset?	—	Go to Step 5	Go to Step 4
4	1. Review the Freeze Frame data with the ignition "ON" and the engine "OFF" and note the parameters. 2. Operate the vehicle within the Freeze Frame conditions as noted. Does P0204 reset?	—	Go to Step 5	Go to <i>Diagnostic Aids</i>
5	1. Engine "OFF." 2. Disconnect the injector test connector. 3. Install an injector test light J-39021-65 on injector connector. 4. Crank the engine and note the light. Does the cylinder 4 test light blink?	—	Go to <i>Fuel Injector Coil Test Procedure</i>	Go to Step 6

**DTC P0204 – Injector 4 Control Circuit (Cont'd)**

Step	Action	Value(s)	Yes	No
6	Note whether the injector test light for cylinder 4 was "OFF" or "ON" steady in step 5. Was the test light "ON" steady while cranking the engine?	—	Go to <i>Step 7</i>	Go to <i>Step 9</i>
7	1. Disconnect the PCM connector for the affected injectors. 2. With a test light connected to B+, probe the affected injector driver circuit. Does the test light illuminate?	—	Go to <i>Step 8</i>	Go to <i>Step 15</i>
8	Repair short to ground in the injector driver circuit. Is the action complete?	—	Go to <i>OBD System Check</i>	—
9	1. Disconnect the injector test connector. 2. At the injector side of the harness, connect an ohmmeter between the positive wire (red with blue tracer) and the wire for cylinder 4 (green/red). Does the ohmmeter indicate continuity?	—	Go to <i>Step 11</i>	Go to <i>Step 10</i>
10	Repair the open injector harness wire or open injector. Is the action complete?	—	Verify repair	—
11	At the PCM side of the injector test connector, check the green/red wire for a short to voltage. Was there a short to voltage?	—	Go to <i>Step 12</i>	Go to <i>Step 13</i>
12	Repair the short to voltage. Is the action complete?	—	Verify repair	—
13	Check for an open circuit between the injector test connector and the PCM. Was there an open circuit?	—	Go to <i>Step 14</i>	Go to <i>Step 15</i>
14	Repair the open circuit. Is the action complete?	—	Verify repair	—
15	Replace the PCM. <b>IMPORTANT:</b> The replacement PCM must be programmed. Refer to <i>On-Vehicle Service in Powertrain Control Module and Sensors</i> for procedures. And also refer to the latest Service Bulletin. Check to see if the Latest software is released or not. And then Down Load the LATEST PROGRAMMED SOFTWARE to the replacement PCM. Is the action complete?	—	Verify repair	—



## Diagnostic Trouble Code (DTC) P0205 Injector 5 Control Circuit



D06RX150

### Circuit Description

The powertrain control module (PCM) has six individual injector driver circuits. Each controls an injector. When the driver circuit is grounded by the PCM, the injector is activated. The PCM monitors the current in each driver circuit. If the voltage is not what the PCM expects to monitor on the circuit, a DTC is set. This DTC is also set if an injector driver is shorted to voltage or if there is an open circuit.

### Conditions for Setting the DTC

- The battery voltage is more than 9 volts.
- The engine is turning, determined by the 58X crankshaft position input signal.
- The injector voltage does not equal the ignition voltage when the injector is commanded "OFF" or the injector voltage does not equal 0 volts when the injector is commanded "ON."
- The above conditions are met for 15 seconds.

### Action Taken When the DTC Sets

- The PCM will illuminate the malfunction indicator lamp (MIL) the first time the fault is detected.
- The PCM will store conditions which were present when the DTC was set as Freeze Frame and in the Failure Records data.

### Conditions for Clearing the MIL/DTC

- The PCM will turn "OFF" the MIL on the third consecutive trip cycle in which the diagnostic has been run and the fault is no longer present.
- A history DTC P0205 will clear after 40 consecutive warm-up cycles occur without a fault.
- DTC P0205 can be cleared by using the Tech 2 "Clear Info" function or by disconnecting the PCM battery feed.

### Diagnostic Aids

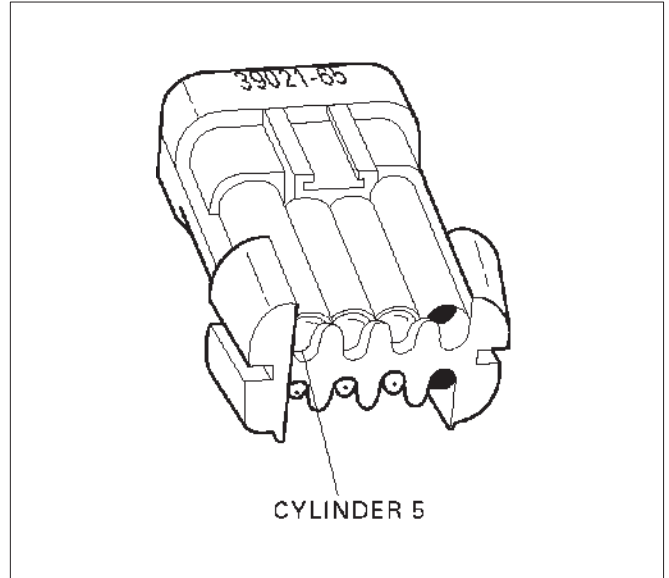
An injector driver circuit that is open or shorted to voltage will cause a DTC P0205 to set. It will also cause a misfire due to an inoperative injector. A misfire DTC will also be set indicating which cylinder is inoperative. Long term and short term fuel trims that are excessively high or low are a good indication that an injector is faulty. Use Fuel Injector Coil Test Procedure to check for faulty injectors.

**Test Description**

The number(s) below refer to the step number(s) on the Diagnostic Chart.

- 3. This step determines if DTC P0205 is the result of a hard failure or an intermittent condition.
- 5. A special injector test connector is provided so that the injectors can be electrically tested without removal of the manifold. The test connector can be identified by the blue connector lock which is tethered to the wiring harness. If the light for cylinder 5 is "ON" steady before cranking the engine as well as while cranking the engine, then the injector driver circuit is shorted to ground.

If the test light blinks while cranking, the PCM and the wiring to the injectors are OK. The Fuel Injector Coil Test Procedure will check if the injectors are faulty.



R321058

- 7. Because the test light was "ON" steady, voltage to the injector is OK, but the driver circuit is grounded at all times. This step determines if the circuit is shorted to ground or the PCM is faulty.
- 9. The reading should be about 12-14Φ.
- 10. Locating the open in the harness or in the injector will require removal of the manifold to provide access.

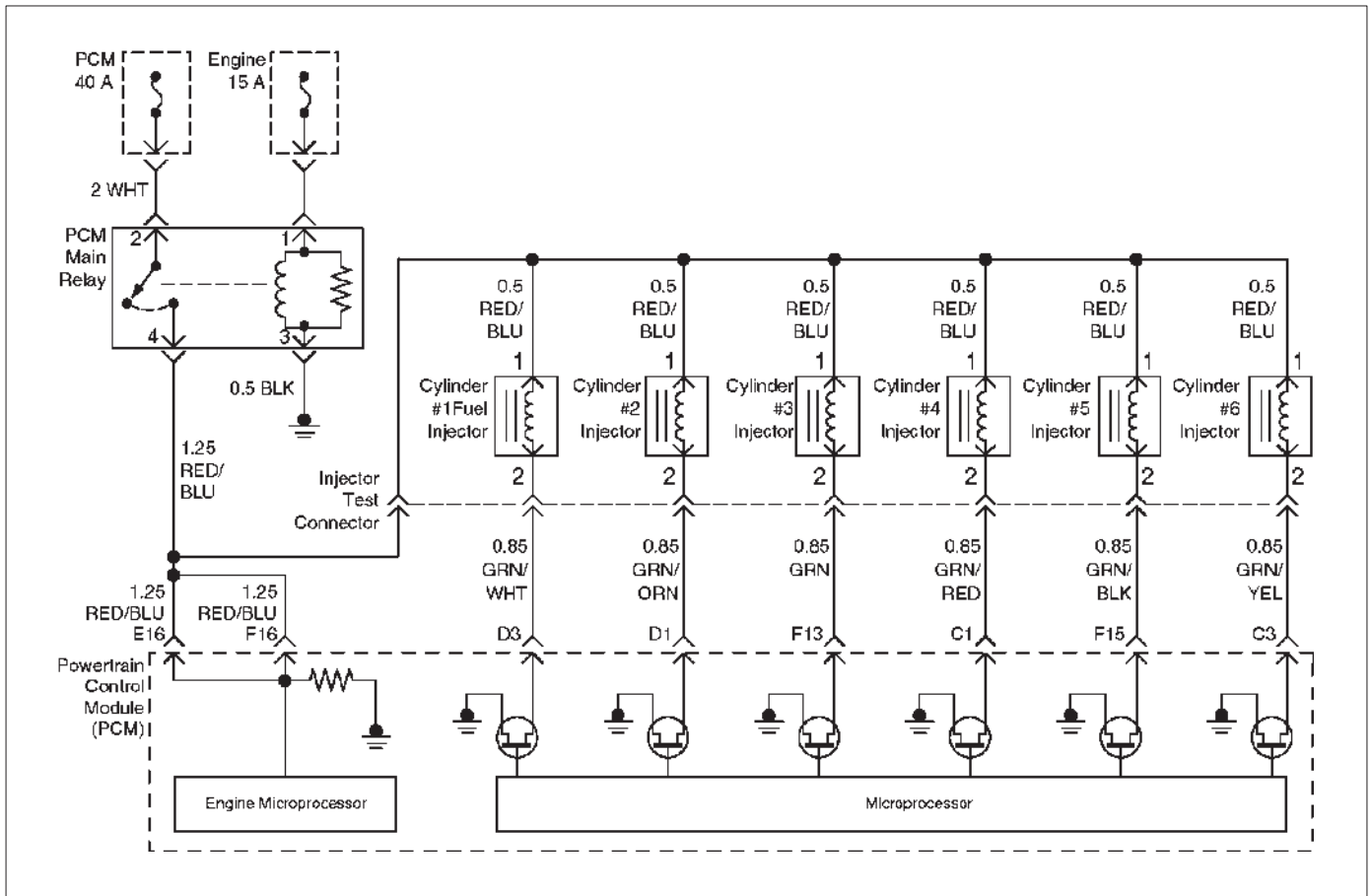
**DTC P0205 – Injector 5 Control Circuit**

Step	Action	Value(s)	Yes	No
1	Was the "On-Board Diagnostic (OBD) System Check" performed?	—	Go to Step 2	Go to <i>OBD System Check</i>
2	Will the engine start?	—	Go to Step 3	Go to <i>Engine Cranks But Will Not Run</i> chart
3	1. Install the Tech 2. Clear the DTC. 2. Idle the engine for one minute. Does DTC P0205 reset?	—	Go to Step 5	Go to Step 4
4	1. Review the Freeze Frame data with the ignition "ON" and the engine "OFF" and note the parameters. 2. Operate the vehicle within the Freeze Frame conditions as noted. Does P0205 reset?	—	Go to Step 5	Go to <i>Diagnostic Aids</i>
5	1. Engine "OFF." 2. Disconnect the injector test connector. 3. Install an injector test light J-39021-65 on injector connector. 4. Crank the engine and note the light. Does the cylinder 5 test light blink?	—	Go to <i>Fuel Injector Coil Test Procedure</i>	Go to Step 6

## DTC P0205 – Injector 5 Control Circuit (Cont'd)

Step	Action	Value(s)	Yes	No
6	Note whether the injector test light for cylinder 5 was "OFF" or "ON" steady in step 5. Was the test light "ON" steady while cranking the engine?	—	Go to Step 7	Go to Step 9
7	1. Disconnect the PCM connector for the affected injectors. 2. With a test light connected to B+, probe the affected injector driver circuit. Does the test light illuminate?	—	Go to Step 8	Go to Step 15
8	Repair short to ground in the injector driver circuit. Is the action complete?	—	Go to OBD System Check	—
9	1. Disconnect the injector test connector. 2. At the injector side of the harness, connect an ohmmeter between the positive wire (red with blue tracer) and the wire for cylinder 5 (green with black tracer). Does the ohmmeter indicate continuity?	—	Go to Step 11	Go to Step 10
10	Repair the open injector harness wire or open injector. Is the action complete?	—	Verify repair	—
11	At the PCM side of the injector test connector, check the green/black wire for a short to voltage. Was there a short to voltage?	—	Go to Step 12	Go to Step 13
12	Repair the short to voltage. Is the action complete?	—	Verify repair	—
13	Check for an open circuit between the injector test connector and the PCM. Was there an open circuit?	—	Go to Step 14	Go to Step 15
14	Repair the open circuit. Is the action complete?	—	Verify repair	—
15	Replace the PCM. <b>IMPORTANT:</b> The replacement PCM must be programmed. Refer to <i>On-Vehicle Service in Powertrain Control Module and Sensors</i> for procedures. And also refer to the latest Service Bulletin. Check to see if the Latest software is released or not. And then Down Load the LATEST PROGRAMMED SOFTWARE to the replacement PCM. Is the action complete?	—	Verify repair	—

## Diagnostic Trouble Code (DTC) P0206 Injector 6 Control Circuit



D06RX150

### Circuit Description

The powertrain control module (PCM) has six individual injector driver circuits. Each controls an injector. When the driver circuit is grounded by the PCM, the injector is activated. The PCM monitors the current in each driver circuit. The voltage on each driver is monitored to detect a fault. If the voltage is not what the PCM expects to monitor on the circuit, a DTC is set. This DTC is also set if an injector driver is shorted to voltage or if there is an open circuit.

### Conditions for Setting the DTC

- The battery voltage is more than 9 volts.
- The engine is turning, determined by 58X crankshaft position input signal.
- The injector voltage does not equal the ignition voltage when the injector is commanded "OFF" or the injector voltage does not equal 0 volts when the injector is commanded "ON."
- The above conditions are met for 15 seconds.

### Action Taken When the DTC Sets

- The PCM will illuminate the malfunction indicator lamp (MIL) the first time the fault is detected.
- The PCM will store conditions which were present when the DTC was set as Freeze Frame and in the Failure Records data.

### Conditions for Clearing the MIL/DTC

- The PCM will turn "OFF" the MIL on the third consecutive trip cycle in which the diagnostic has been run and the fault is no longer present.
- A history DTC P0206 will clear after 40 consecutive warm-up cycles occur without a fault.
- DTC P0206 can be cleared by using the Tech 2 "Clear Info" function or by disconnecting the PCM battery feed.

### Diagnostic Aids

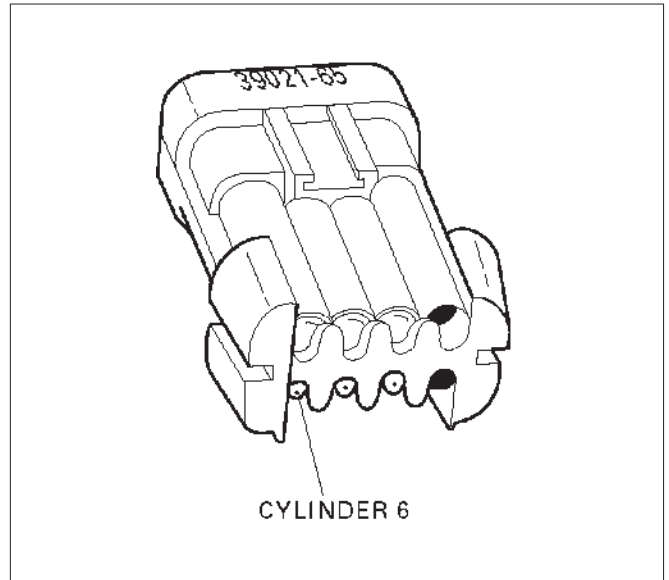
An injector driver circuit that is open or shorted to voltage will cause a DTC P0206 to set. It will also cause a misfire due to an inoperative injector. A misfire DTC will also be set indicating which cylinder is inoperative. Long term and short term fuel trims that are excessively high or low are a good indication that an injector is faulty. Use Fuel Injector Coil Test Procedure to check for faulty injectors.

**Test Description**

The number(s) below refer to the step number(s) on the Diagnostic Chart.

3. This step determines if DTC P0206 is the result of a hard failure or an intermittent condition.
5. A special injector test connector is provided so that the injectors can be electrically tested without removal of the manifold. The test connector can be identified by the blue connector lock which is tethered to the wiring harness. If the light for cylinder 6 is "ON" steady before cranking the engine as well as while cranking the engine, then the injector driver circuit is shorted to ground.

If the test light blinks while cranking, the PCM and the wiring to the injectors are OK. The Fuel Injector Coil Test Procedure will check if the injectors are faulty.



R321059

7. Because the test light was "ON" steady, voltage to the injector is OK, but the driver circuit is grounded at all times. This step determines if the circuit is shorted to ground or the PCM is faulty.
9. The reading should be about 12-14Φ.
10. Locating the open in the harness or in the injector will require removal of the manifold to provide access.

**DTC P0206 – Injector 6 Control Circuit**

Step	Action	Value(s)	Yes	No
1	Was the "On-Board Diagnostic (OBD) System Check" performed?	—	Go to Step 2	Go to <i>OBD System Check</i>
2	Will the engine start?	—	Go to Step 3	Go to <i>Engine Cranks But Will Not Run</i> chart
3	1. Install the Tech 2. Clear the DTC. 2. Idle the engine for one minute. Does DTC P0206 reset?	—	Go to Step 5	Go to Step 4
4	1. Review the Freeze Frame data with the ignition "ON" and the engine "OFF" and note the parameters. 2. Operate the vehicle within the Freeze Frame conditions as noted. Does P0206 reset?	—	Go to Step 5	Go to <i>Diagnostic Aids</i>
5	1. Engine "OFF." 2. Disconnect the injector test connector. 3. Install an injector test light J-39021-65 on injector connector. 4. Crank the engine and note the light. Does the cylinder 6 test light blink?	—	Go to <i>Fuel Injector Coil Test Procedure</i>	Go to Step 6

**DTC P0206 – Injector 6 Control Circuit (Cont'd)**

Step	Action	Value(s)	Yes	No
6	Note whether the injector test light for cylinder 6 was "OFF" or "ON" steady in step 5. Was the test light "ON" steady while cranking the engine?	—	Go to <i>Step 7</i>	Go to <i>Step 9</i>
7	1. Disconnect the PCM connector for the affected injectors. 2. With a test light connected to B+, probe the affected injector driver circuit. Does the test light illuminate?	—	Go to <i>Step 8</i>	Go to <i>Step 15</i>
8	Repair short to ground in the injector driver circuit. Is the action complete?	—	Go to <i>OBD System Check</i>	—
9	1. Disconnect the injector test connector. 2. At the injector side of the harness, connect an ohmmeter between the positive wire (red with blue tracer) and the wire for cylinder 6 (green with yellow tracer). Does the ohmmeter indicate continuity?	—	Go to <i>Step 11</i>	Go to <i>Step 10</i>
10	Repair the open injector harness wire or open injector Is the action complete?	—	Verify repair	—
11	At the PCM side of the injector test connector, check the green/yellow wire for a short to voltage. Was there a short to voltage?	—	Go to <i>Step 12</i>	Go to <i>Step 13</i>
12	Repair the short to voltage. Is the action complete?	—	Verify repair	—
13	Check for an open circuit between the injector test connector and the PCM. Was there an open circuit?	—	Go to <i>Step 14</i>	Go to <i>Step 15</i>
14	Repair the open circuit. Is the action complete?	—	Verify repair	—
15	Replace the PCM. <b>IMPORTANT:</b> The replacement PCM must be programmed. Refer to <i>On-Vehicle Service in Powertrain Control Module and Sensors</i> for procedures. And also refer to the latest Service Bulletin. Check to see if the Latest software is released or not. And then Down Load the LATEST PROGRAMMED SOFTWARE to the replacement PCM. Is the action complete?	—	Verify repair	—

## Diagnostic Trouble Code (DTC) P0300 Engine Misfire Detected

### Circuit Description

The powertrain control module (PCM) is able to detect a misfire by monitoring the 58X reference and the camshaft position input signals. If the PCM detects crankshaft speed variations that indicate 1% or more of cylinder firing events are misfires, the PCM will disable the torque converter clutch (TCC). If the RPM variation detected indicates a true misfire condition, DTC P0300 will be set. If the ABS rough road sensor input signal to the PCM determines that a rough road condition is present, the misfire diagnostic will be temporarily disabled.

### Conditions for Setting the DTC

- None of the following DTCs occur: TP sensor, MAF sensor, CMP sensor, VSS, ECT sensor, ABS rough road sensor, CKP sensor.
- The engine speed is between 600 and 6250 RPM.
- The system voltage is between 11 and 16 volts.
- The engine temperature sensor (ECT) indicates an engine temperature between  $-7^{\circ}\text{C}$  ( $20^{\circ}\text{F}$ ) and  $120^{\circ}\text{C}$  ( $248^{\circ}\text{F}$ ).
- Throttle angle is steady and throttle changes less than 3% per 125 milliseconds.
- The PCM detects a crankshaft RPM variation indicating a misfire that is sufficient to cause catalytic converter damage or emissions levels to exceed the mandated standard.

### Action Taken When the DTC Sets

- The PCM will illuminate the malfunction indicator lamp (MIL) the first time the fault is detected.
- If the misfire is severe enough to cause possible catalyst damage, the PCM will flash the MIL for as long as the misfire remains at catalyst damaging levels.
- The PCM will disable the TCC operation.
- The PCM will store conditions which were present when the DTC was set as Freeze Frame and in the Failure Records data.

### Conditions for Clearing the MIL/DTC

- The PCM will turn the MIL "OFF" on the third consecutive trip cycle in which the diagnostic has been run and the fault condition is no longer present.
- A history DTC P0300 will clear after 40 consecutive warm-up cycles occur without a fault.
- DTC P0300 can be cleared by using the Tech 2 "Clear Info" function or by disconnecting the PCM battery feed.

### Diagnostic Aids

The Tech 2 display "Misfire Cur. #1 through #6" can be useful to determine whether the misfire is isolated to a single cylinder.

- Damaged or faulty ignition coil – Check for cracks or other damage.
- Substitute a known good coil – Swap the ignition coils and retest. If the misfire follows the coil, replace the ignition coil.

If the misfire is random, check for the following conditions:

- System grounds – Ensure all connections are clean and properly tightened.
- MAF – A mass air flow (MAF) sensor output that causes the PCM to sense a lower than normal air flow will cause a lean condition.
- Air induction system – Air leaks into the induction system which bypass the MAF sensor will cause a lean condition. Check for disconnected or damaged vacuum hoses, incorrectly installed or faulty PCV valve, or for vacuum leaks at the throttle body, EGR valve, and intake manifold mounting surfaces.
- Fuel pressure – Perform a fuel system pressure test. A faulty fuel pump, plugged filter, or faulty fuel system pressure regulator will contribute to a lean condition.
- Injector(s) – Perform an injector coil/balance test to locate faulty injector(s) contributing to a lean or flooding condition. In addition to the above test, check the condition of the injector O-rings.
- EGR – Check for a leaking valve, adapter, or feed pipes which will contribute to a lean condition or excessive EGR flow.
- Fuel quality – Using fuel with the wrong octane rating for the vehicle may cause driveability problems. Although alcohol-enhanced fuels may raise the octane rating, the fuel's ability to turn into vapor in cold temperatures deteriorates. This may affect the cold driveability of the engine. The Reid Vapor Pressure of the fuel can also create problems in the fuel system, especially during the spring and fall when changes by the refineries may not coincide with changes in the weather.
- Vehicle marshalling – The transportation of new vehicles from the assembly plant to the dealership can involve as many as 60 key cycles within 2 to 3 miles of driving. This type of operation contributes to the fuel fouling of the spark plugs and will turn on the MIL with a P0300 Misfire DTC.

Reviewing the Failure Records vehicle mileage since the diagnostic test last failed may help determine how often the condition that caused the DTC to be set occurs. This may assist in diagnosing the condition.

**DTC P0300 – Engine Misfire Detected**

Step	Action	Value(s)	Yes	No
1	Was the “On-Board Diagnostic (OBD) System Check” performed?	—	Go to Step 2	Go to <i>OBD System Check</i>
2	<ol style="list-style-type: none"> <li>1. Start the engine. Run the engine at idle.</li> <li>2. Review and record the Tech 2 Freeze Frame data.</li> <li>3. Operate the vehicle to duplicate the conditions present when the DTC was set (as defined by the Freeze Frame data).</li> <li>4. Monitor the Tech 2 “Misfire Cur. #” display for each cylinder.</li> </ol> Is “Misfire Cur. #” display increasing for any cylinder (indicating a misfire currently occurring)?	—	Go to Step 3	Refer to <i>Diagnostic Aids</i>
3	<ol style="list-style-type: none"> <li>1. Visually and physically inspect the vacuum hoses for splits, kinks, and improper connections.</li> <li>2. If a problem is found, repair or replace the vacuum hoses as necessary.</li> </ol> Did your inspection reveal a problem?	—	Verify repair	Go to Step 4
4	<ol style="list-style-type: none"> <li>1. Visually and physically inspect the following areas for vacuum leaks:               <ul style="list-style-type: none"> <li>○ The intake manifold</li> <li>○ The injector O-rings</li> <li>○ The EGR adapter</li> <li>○ The EGR feed pipes</li> </ul> </li> <li>2. If a problem is found, repair the vacuum leak as necessary.</li> </ol> Did your inspection reveal a vacuum leak?	—	Verify repair	Go to Step 5
5	<ol style="list-style-type: none"> <li>1. Visually and physically inspect the crankcase ventilation valve for improper installation or damaged grommet.</li> <li>2. If a problem is found, repair as necessary (refer to <i>Crankcase Ventilation System</i>).</li> </ol> Did your inspection reveal a problem?	—	Verify repair	Go to Step 6
6	<ol style="list-style-type: none"> <li>1. Inspect the MAF sensor inlet screen for damage or for the presence of foreign objects that may partially block the air flow sample through the MAF sensor.</li> <li>2. If a problem is found, repair or replace the MAF sensor as necessary.</li> </ol> Did your inspection of the MAF sensor reveal a condition requiring repair or replacement?	—	Verify repair	Go to Step 7
7	<ol style="list-style-type: none"> <li>1. Remove the EGR valve and visually/physically inspect the valve to ensure that the pintle is not sticking partially open. Also, inspect the EGR valve pintle and seat for carbon deposits or burrs that may interfere with the pintle closing completely.</li> <li>2. If a problem is found, clean the EGR valve pintle and seat or replace the EGR valve as necessary.</li> </ol> Did your inspection reveal a problem?	—	Verify repair	Go to Step 8



## DTC P0300 – Engine Misfire Detected (Cont'd)

Step	Action	Value(s)	Yes	No
8	1. Install a spark tester at the spark plug end of the ignition coil for a cylinder that indicated a misfire. 2. Crank the engine while observing the spark tester. A crisp, blue spark should be observed. Is adequate spark present?	—	Go to <i>Step 14</i>	Go to <i>Step 9</i>
9	1. Remove and visually/physically inspect the ignition coil(s) associated with the cylinders that were indicated as misfiring. Ensure that the coil(s) are free of cracks. 2. If a problem is found, replace the damaged ignition coil(s) as necessary. Did any ignition coils require replacement?	—	Verify repair	Go to <i>Step 10</i>
10	1. Remove the spark plugs from the cylinders that were indicated as misfiring. 2. Visually inspect the spark plug electrodes. Does your inspection reveal any spark plugs exhibiting excessive fouling?	—	Go to <i>Engine Mechanical Diagnosis</i>	Go to <i>Step 11</i>
11	1. Visually inspect the spark plug insulators for cracks, carbon tracking, or other damage. 2. If a problem is found, replace the faulty spark plug(s) as necessary. Did your inspection reveal a problem?	—	Verify repair	Go to <i>Step 12</i>
12	1. Disconnect the MAF sensor electrical connector. 2. Operate the vehicle in "closed loop" while monitoring the "BANK 1 L.T. FUEL TRIM" and "BANK 1 S.T. FUEL TRIM" display on the Tech 2. Do both values decrease below the specified values?	"BANK 1 L.T. FUEL TRIM" below +20%; "BANK 1 S.T. FUEL TRIM" below +50%	Go to <i>Step 13</i>	Replace the ignition coil of the affected cylinder
13	Replace the ignition coil control module. Is the action complete?	—	Verify repair	—
14	1. Visually and physically inspect the PCM injector grounds, power grounds and sensor grounds to ensure that they are clean, tight and in their proper locations. 2. If a problem is found, correct the faulty ground condition as necessary. Did your inspection reveal a poor ground?	—	Verify repair	Go to <i>Step 15</i>
15	1. Perform the "Fuel System Pressure Test" procedure. 2. If a problem is found, repair as necessary (refer to <i>Engine Fuel or Fuel Metering System</i> ). Was a fuel system problem found?	—	Verify repair	Go to <i>Step 16</i>
16	1. Check the fuel for excessive water, alcohol, or other contaminants (refer to <i>Diagnosis in Engine Fuel</i> for procedure). 2. If a problem is found, correct the contaminated fuel condition as necessary. Was the fuel contaminated?	—	Verify repair	Go to <i>Step 17</i>

**DTC P0300 – Engine Misfire Detected (Cont'd)**

Step	Action	Value(s)	Yes	No
17	1. Perform the "Injector Coil/Balance Test." 2. If a problem is found, replace faulty injector(s) as necessary. Did any of the injectors require replacement?	—	Verify repair	Go to <i>Step 18</i>
18	1. Check for an engine mechanical problem. Refer to <i>Engine Mechanical Diagnosis</i> to diagnose the following conditions: <ul style="list-style-type: none"> <li><input type="radio"/> A faulty or incorrect camshaft</li> <li><input type="radio"/> Leaking or sticky valves or rings</li> <li><input type="radio"/> Excessive valve deposits</li> <li><input type="radio"/> Loose or worn rocker arms</li> <li><input type="radio"/> Weak valve springs</li> <li><input type="radio"/> Incorrect valve timing</li> <li><input type="radio"/> A leaking head gasket</li> <li><input type="radio"/> A loose or broken motor mount</li> </ul> 2. If a problem is found, repair as necessary. Was a basic engine mechanical problem found and repaired?	—	Verify repair	Go to <i>Step 19</i>
19	1. Check for a transmission TCC problem. Refer to <i>4L30-E Automatic Transmission Diagnosis</i> . 2. If a problem is found, repair the transmission as necessary. Refer to <i>4L30-E Automatic Transmission Unit Repair</i> . Was a transmission problem found and repaired?	—	Verify repair	Go to <i>Step 20</i>
20	Replace the MAF sensor. Is the action complete?	—	Verify repair	—

## Diagnostic Trouble Code (DTC) P0301 Cylinder Misfire Detected

### Circuit Description

The powertrain control module (PCM) has the ability to detect a misfire by monitoring the 58X reference and the camshaft position sensor input signals. If the PCM detects a crankshaft speed variation that indicates 1% or more of cylinder firing events are misfires, the PCM will disable the torque converter clutch (TCC). If the RPM variation detected indicates a misfire, the PCM attempts to calculate which cylinder is misfiring by associating crankshaft angle (using the camshaft position sensor signal) with the RPM variation (using the 58X reference). If cylinder #1 is isolated as the misfiring cylinder, DTC P0301 will set. If the ABS rough road sensor input signal to the PCM determines that a rough road condition is present, the misfire diagnostic will be temporarily disabled.

### Conditions for Setting the DTC

- None of the following DTCs occur: TP sensor, MAF sensor, camshaft position sensor, vehicle speed sensor, ECT sensor, crankshaft position sensor.
- The engine speed is between 600 and 6250 RPM.
- The system voltage is between 11 and 16 volts.
- The ECT indicates an engine temperature between  $-7^{\circ}\text{C}$  ( $28^{\circ}\text{F}$ ) and  $120^{\circ}\text{C}$  ( $248^{\circ}\text{F}$ ).
- The throttle angle is steady.
- The PCM is detecting a crankshaft RPM variation that indicates a misfire on cylinder #1 sufficient to cause three-way catalytic converter damage or emissions levels to exceed mandated standard.

### Action Taken When the DTC Sets

- The PCM will illuminate the malfunction indicator lamp (MIL) the first time the fault is detected.

- If the misfire is severe enough to cause possible catalyst damage, the PCM will flash the MIL for as long as the misfire remains at catalyst damaging levels.
- The PCM will store conditions which were present when the DTC was set as Freeze Frame and in the Failure Records data.

### Conditions for Clearing the MIL/DTC

- The PCM will turn the MIL "OFF" on the third consecutive ignition cycle in which the diagnostic has been run and the fault condition is no longer present.
- A history DTC P0301 will clear after 40 consecutive ignition cycles occur without a fault.
- DTC P0301 can be cleared by using the Tech 2 "Clear Info" function or by disconnecting the PCM battery feed.

### Diagnostic Aids

Check for the following conditions:

- System grounds – Ensure all connections are clean and properly tightened.
- Injector – Perform the injector coil/balance test to locate a faulty injector that contributes to a lean condition on the affected cylinder. In addition to the above test, check the condition of the injector O-ring.
- Faulty spark plug – Check for a cracked insulator, carbon tracking, incorrect gap, and worn electrodes.
- Damaged or faulty ignition coil – Check for cracks or other damage.
- Substitute a known good coil – Swap the ignition coils and retest. If the misfire follows the coil, replace the ignition coil.

## DTC P0301 – Cylinder Misfire Detected

Step	Action	Value(s)	Yes	No
1	Was the "On-Board Diagnostic (OBD) System Check" performed?	—	Go to Step 2	Go to <i>OBD System Check</i>
2	1. Start the engine. Run the engine at idle. 2. Review and record Tech 2 Freeze Frame data. 3. Monitor "Misfire Cur. #1" on the Tech 2. Is "Misfire Cur. #1" increasing (indicating a misfire currently occurring)?	—	Go to Step 4	Go to Step 3
3	Monitor "Misfire Hist. #1" while operating the vehicle to duplicate the conditions present when the DTC was set (as defined by the Freeze Frame data recorded in Step 2). Is "Misfire Hist. #1" increasing (indicating a misfire currently occurring)?	—	Go to Step 4	Refer to <i>Diagnostic Aids</i>
4	1. Visually and physically inspect the vacuum hoses for splits, kinks, and improper connections. Also, inspect the intake manifold for a vacuum leak. 2. If a problem is found, repair it as necessary. Did the inspection reveal a problem?	—	Verify repair	Go to Step 5

**DTC P0301 – Cylinder Misfire Detected (Cont'd)**

Step	Action	Value(s)	Yes	No
5	1. Install a spark tester at the spark plug end of the cylinder #1 ignition coil. 2. Crank the engine while observing the spark tester. A crisp, blue spark should be observed. Is adequate spark present?	—	Go to <i>Step 8</i>	Go to <i>Step 6</i>
6	1. Remove and visually/physically inspect the ignition coil associated with cylinder #1. Ensure that the coil is free of cracks and carbon tracking. 2. If a problem is found, replace the damaged ignition coil as necessary. Did the visual inspection reveal a problem?	—	Verify repair	Go to <i>Step 7</i>
7	1. Measure the ignition coil primary resistance. 2. If resistance is not within the specified value, replace the faulty ignition coil. Did the ignition coil require replacement?	2.6-2.7 K $\Phi$	Verify repair	Go to <i>Step 12</i>
8	Remove the cylinder #1 spark plug and visually inspect the spark plug electrode. Does the inspection reveal excessive fouling?	—	Go to <i>Contamination Diagnosis</i> chart in <i>Engine Mechanical Diagnosis</i>	Go to <i>Step 9</i>
9	1. Visually inspect the spark plug insulator for cracks, carbon tracking, or other damage. 2. If the spark plug is damaged, replace the spark plug. Did the inspection reveal a problem?	—	Verify repair	Go to <i>Step 10</i>
10	1. Perform the "Injector Coil/Balance Test." 2. If any faulty injectors are found, replace them as necessary. Did any of the injectors require replacement?	—	Verify repair	Go to <i>Step 11</i>
11	1. Inspect the injector O-rings for a vacuum leak. 2. If a problem is found, repair it as necessary. Did the inspection reveal a problem?	—	Verify repair	Go to <i>Step 12</i>
12	Check for an engine mechanical problem. Refer to <i>Engine Mechanical Diagnosis</i> to diagnose and repair the following conditions: <ul style="list-style-type: none"> <li><input type="radio"/> A faulty or incorrect camshaft</li> <li><input type="radio"/> Leaking or sticky valves or rings</li> <li><input type="radio"/> Excessive valve deposits</li> <li><input type="radio"/> Loose or worn rocker arms</li> <li><input type="radio"/> Weak valve springs</li> <li><input type="radio"/> A leaking head gasket</li> </ul> Was a basic engine mechanical problem found?	—	Verify repair	Refer to <i>Diagnostic Aids</i>

## Diagnostic Trouble Code (DTC) P0302 Cylinder Misfire Detected

### Circuit Description

The powertrain control module (PCM) has the ability to detect a misfire by monitoring the 58X reference and the camshaft position sensor input signals. If the PCM detects crankshaft speed variations that indicate 1% or more of cylinder firing events are misfires, the PCM will disable the torque converter clutch (TCC). If the RPM variation detected indicates a misfire, the PCM attempts to calculate which cylinder is misfiring by associating crankshaft angle (using the camshaft position sensor signal) with the RPM variation (using the 58X reference). If cylinder #2 is isolated as the misfiring cylinder, DTC P0302 will set. If the ABS rough road sensor input signal to the PCM determines that a rough road condition is present, the misfire diagnostic will be temporarily disabled.

### Conditions for Setting the DTC

- None of the following DTCs occur: TP sensor, MAF sensor, camshaft position sensor, vehicle speed sensor, ECT sensor, crankshaft position sensor.
- The engine speed is between 600 and 6250 RPM.
- The system voltage is between 11 and 16 volts.
- The ECT indicates an engine temperature between  $-7^{\circ}\text{C}$  ( $28^{\circ}\text{F}$ ) and  $120^{\circ}\text{C}$  ( $248^{\circ}\text{F}$ ).
- The throttle angle is steady.
- The PCM is detecting a crankshaft RPM variation that indicates a misfire on cylinder #2 sufficient to cause three-way catalytic converter damage or emissions levels to exceed mandated standard.

### Action Taken When the DTC Sets

- The PCM will illuminate the malfunction indicator lamp (MIL) the first time the fault is detected.

- If the misfire is severe enough to cause possible catalyst damage, the PCM will flash the MIL for as long as the misfire remains at catalyst damaging levels.
- The PCM will store conditions which were present when the DTC was set as Freeze Frame and in the Failure Records data.

### Conditions for Clearing the MIL/DTC

- The PCM will turn the MIL "OFF" on the third consecutive ignition cycle in which the diagnostic has been run and the fault condition is no longer present.
- A history DTC P0302 will clear after 40 consecutive ignition cycles occur without a fault.
- DTC P0302 can be cleared by using the Tech 2 "Clear Info" function or by disconnecting the PCM battery feed.

### Diagnostic Aids

Check for the following conditions:

- System grounds – Ensure all connections are clean and properly tightened.
- Injector – Perform the injector coil/balance test to locate a faulty injector that contributes to a lean condition on the affected cylinder. In addition to the above test, check the condition of the injector O-ring.
- Faulty spark plug – Check for a cracked insulator, carbon tracking, incorrect gap, and worn electrodes.
- Damaged or faulty ignition coil – Check for cracks, carbon tracking or other damage.
- Substitute a known good coil – Swap the ignition coils and retest. If the misfire follows the coil, replace the ignition coil.

## DTC P0302 – Cylinder Misfire Detected

Step	Action	Value(s)	Yes	No
1	Was the "On-Board Diagnostic (OBD) System Check" performed?	—	Go to Step 2	Go to <i>OBD System Check</i>
2	1. Start the engine. Run the engine at idle. 2. Review and record Tech 2 Freeze Frame data. 3. Monitor "Misfire Cur. #2" on the Tech 2. Is "Misfire Cur. #2" increasing (indicating a misfire currently occurring)?	—	Go to Step 4	Go to Step 3
3	Monitor "Misfire Hist. #2" while operating the vehicle to duplicate the conditions present when the DTC was set (as defined by the Freeze Frame data recorded in Step 2). Is "Misfire Hist. #2" increasing (indicating a misfire currently occurring)?	—	Go to Step 4	Refer to <i>Diagnostic Aids</i>

**DTC P0302 – Cylinder Misfire Detected (Cont'd)**

Step	Action	Value(s)	Yes	No
4	1. Visually and physically inspect the vacuum hoses for splits, kinks, and improper connections. Also, inspect the intake manifold for a vacuum leak. 2. If a problem is found, repair it as necessary. Did the inspection reveal a problem?	—	Verify repair	Go to <i>Step 5</i>
5	1. Install a spark tester at the spark plug end of the cylinder #2 ignition coil. 2. Crank the engine while observing the spark tester. A crisp, blue spark should be observed. Is adequate spark present?	—	Go to <i>Step 8</i>	Go to <i>Step 6</i>
6	1. Remove and visually/physically inspect the ignition coil associated with cylinder #2. Ensure that the coil is free of cracks and carbon tracking. 2. If a problem is found, replace the damaged ignition coil as necessary. Did the visual inspection reveal a problem?	—	Verify repair	Go to <i>Step 7</i>
7	1. Measure the ignition coil primary resistance. 2. If resistance is not within the specified value, replace the faulty ignition coil. Did the ignition coil require replacement?	2.6-2.7 K $\Omega$	Verify repair	Go to <i>Step 12</i>
8	Remove the cylinder #2 spark plug and visually inspect the spark plug electrode. Does the inspection reveal excessive fouling?	—	Go to <i>Contamination Diagnosis</i> chart in <i>Engine Mechanical Diagnosis</i>	Go to <i>Step 9</i>
9	1. Visually inspect the spark plug insulator for cracks, carbon tracking, or other damage. 2. If the spark plug is damaged, replace the spark plug. Did the inspection reveal a problem?	—	Verify repair	Go to <i>Step 10</i>
10	1. Perform the "Injector Coil/Balance Test." 2. If any faulty injectors are found, replace them as necessary. Did any of the injectors require replacement?	—	Verify repair	Go to <i>Step 11</i>
11	1. Inspect the injector O-rings for a vacuum leak. 2. If a problem is found, repair it as necessary. Did the inspection reveal a problem?	—	Verify repair	Go to <i>Step 12</i>
12	Check for an engine mechanical problem. Refer to <i>Engine Mechanical Diagnosis</i> to diagnose and repair the following conditions: <ul style="list-style-type: none"> <li>○ A faulty or incorrect camshaft</li> <li>○ Leaking or sticky valves or rings</li> <li>○ Excessive valve deposits</li> <li>○ Loose or worn rocker arms</li> <li>○ Weak valve springs</li> <li>○ A leaking head gasket</li> </ul> Was a basic engine mechanical problem found?	—	Verify repair	Refer to <i>Diagnostic Aids</i>

## Diagnostic Trouble Code (DTC) P0303 Cylinder Misfire Detected

### Circuit Description

The powertrain control module (PCM) has the ability to detect a misfire by monitoring the 58X reference and the camshaft position sensor input signals. If the PCM detects a crankshaft speed variation that indicates 1% or more of cylinder firing events are misfires, the PCM will disable the torque converter clutch (TCC). If the RPM variation detected indicates a misfire, the PCM attempts to calculate which cylinder is misfiring by associating crankshaft angle (using the camshaft position sensor signal) with the RPM variation (using the 58X reference). If cylinder #3 is isolated as the misfiring cylinder, DTC P0303 will set. If the ABS rough road sensor input signal to the PCM determines that a rough road condition is present, the misfire diagnostic will be temporarily disabled.

### Conditions for Setting the DTC

- None of the following DTCs occur: TP sensor, MAF sensor, camshaft position sensor, vehicle speed sensor, ECT sensor, crankshaft position sensor.
- The engine speed is between 600 and 6250 RPM.
- The system voltage is between 11 and 16 volts.
- The ECT indicates an engine temperature between -7°C (28°F) and 120°C (248°F).
- The throttle angle is steady.
- The PCM is detecting a crankshaft RPM variation that indicates a misfire on cylinder #3 sufficient to cause three-way catalytic converter damage or emissions levels to exceed mandated standard.

### Action Taken When the DTC Sets

- The PCM will illuminate the malfunction indicator lamp (MIL) the first time the fault is detected.

- If the misfire is severe enough to cause possible catalyst damage, the PCM will flash the MIL for as long as the misfire remains at catalyst damaging levels.
- The PCM will store conditions which were present when the DTC was set as Freeze Frame and in the Failure Records data.

### Conditions for Clearing the MIL/DTC

- The PCM will turn the MIL "OFF" on the third consecutive ignition cycle in which the diagnostic has been run and the fault condition is no longer present.
- A history DTC P0303 will clear after 40 consecutive ignition cycles occur without a fault.
- DTC P0303 can be cleared by using the Tech 2 "Clear Info" function or by disconnecting the PCM battery feed.

### Diagnostic Aids

Check for the following conditions:

- System grounds – Ensure all connections are clean and properly tightened.
- Injector — Perform the injector coil/balance test to locate a faulty injector that contributes to a lean condition on the affected cylinder. In addition to the above test, check the condition of the injector O-ring.
- Faulty spark plug – Check for a cracked insulator, carbon tracking, incorrect gap, and worn electrodes.
- Damaged or faulty ignition coil – Check for cracks, carbon tracking or other damage.
- Substitute a known good coil – Swap the ignition coils and retest. If the misfire follows the coil, replace the ignition coil.

## DTC P0303 – Cylinder Misfire Detected

Step	Action	Value(s)	Yes	No
1	Was the "On-Board Diagnostic (OBD) System Check" performed?	—	Go to Step 2	Go to <i>OBD System Check</i>
2	1. Start the engine. Run the engine at idle. 2. Review and record Tech 2 Freeze Frame data. 3. Monitor "Misfire Cur. #3" on the Tech 2. Is "Misfire Cur. #3" increasing (indicating a misfire currently occurring)?	—	Go to Step 4	Go to Step 3
3	Monitor "Misfire Hist. #3" while operating the vehicle to duplicate the conditions present when the DTC was set (as defined by the Freeze Frame data recorded in Step 2). Is "Misfire Hist. #3" increasing (indicating a misfire currently occurring)?	—	Go to Step 4	Refer to <i>Diagnostic Aids</i>

**DTC P0303 – Cylinder Misfire Detected (Cont'd)**

Step	Action	Value(s)	Yes	No
4	1. Visually and physically inspect the vacuum hoses for splits, kinks, and improper connections. Also, inspect the intake manifold for a vacuum leak. 2. If a problem is found, repair it as necessary. Did the inspection reveal a problem?	—	Verify repair	Go to <i>Step 5</i>
5	1. Install a spark tester at the spark plug end of the cylinder #3 ignition coil. 2. Crank the engine while observing the spark tester. A crisp, blue spark should be observed. Is adequate spark present?	—	Go to <i>Step 8</i>	Go to <i>Step 6</i>
6	1. Remove and visually/physically inspect the ignition coil associated with cylinder #3. Ensure that the coil is free of cracks and carbon tracking. 2. If a problem is found, replace the damaged ignition coil as necessary. Did the visual inspection reveal a problem?	—	Verify repair	Go to <i>Step 7</i>
7	1. Measure the ignition coil primary resistance. 2. If resistance is not within the specified value, replace the faulty ignition coil. Did the ignition coil require replacement?	2.6-2.7 K $\Phi$	Verify repair	Go to <i>Step 12</i>
8	Remove the cylinder #3 spark plug and visually inspect the spark plug electrode. Does the inspection reveal excessive fouling?	—	Go to <i>Contamination Diagnosis</i> chart in <i>Engine Mechanical Diagnosis</i>	Go to <i>Step 9</i>
9	1. Visually inspect the spark plug insulator for cracks, carbon tracking, or other damage. 2. If the spark plug is damaged, replace the spark plug. Did the inspection reveal a problem?	—	Verify repair	Go to <i>Step 10</i>
10	1. Perform the "Injector Coil/Balance Test." 2. If any faulty injectors are found, replace them as necessary. Did any of the injectors require replacement?	—	Verify repair	Go to <i>Step 11</i>
11	1. Inspect the injector O-rings for a vacuum leak. 2. If a problem is found, repair it as necessary. Did the inspection reveal a problem?	—	Verify repair	Go to <i>Step 12</i>
12	Check for an engine mechanical problem. Refer to <i>Engine Mechanical Diagnosis</i> to diagnose and repair the following conditions: <ul style="list-style-type: none"> <li>○ A faulty or incorrect camshaft</li> <li>○ Leaking or sticky valves or rings</li> <li>○ Excessive valve deposits</li> <li>○ Loose or worn rocker arms</li> <li>○ Weak valve springs</li> <li>○ A leaking head gasket</li> </ul> Was a basic engine mechanical problem found?	—	Verify repair	Refer to <i>Diagnostic Aids</i>



## Diagnostic Trouble Code (DTC) P0304 Cylinder Misfire Detected

### Circuit Description

The powertrain control module (PCM) has the ability to detect a misfire by monitoring the 58X reference and the camshaft position sensor input signals. If the PCM detects a crankshaft speed variation that indicates 1% or more of cylinder firing events are misfires, the PCM will disable the torque converter clutch (TCC). If the RPM variation detected indicates a misfire, the PCM attempts to calculate which cylinder is misfiring by associating crankshaft angle (using the camshaft position sensor signal) with the RPM variation (using the 58X reference). If cylinder #4 is isolated as the misfiring cylinder, DTC P0304 will set. If the ABS rough road sensor input signal to the PCM determines that a rough road condition is present, the misfire diagnostic will be temporarily disabled.

### Conditions for Setting the DTC

- None of the following DTCs occur: TP sensor, MAF sensor, camshaft position sensor, vehicle speed sensor, ECT sensor, crankshaft position sensor.
- The engine speed is between 600 and 6250 RPM.
- The system voltage is between 11 and 16 volts.
- The ECT indicates an engine temperature between  $-7^{\circ}\text{C}$  ( $28^{\circ}\text{F}$ ) and  $120^{\circ}\text{C}$  ( $248^{\circ}\text{F}$ ).
- The throttle angle is steady.
- The PCM is detecting a crankshaft RPM variation that indicates a misfire on cylinder #4 sufficient to cause three-way catalytic converter damage or emissions levels to exceed mandated standard.

### Action Taken When the DTC Sets

- The PCM will illuminate the malfunction indicator lamp (MIL) the first time the fault is detected.

- If the misfire is severe enough to cause possible catalyst damage, the PCM will flash the MIL for as long as the misfire remains at catalyst damaging levels.
- The PCM will store conditions which were present when the DTC was set as Freeze Frame and in the Failure Records data.

### Conditions for Clearing the MIL/DTC

- The PCM will turn the MIL "OFF" on the third consecutive ignition cycle in which the diagnostic has been run and the fault condition is no longer present.
- A history DTC P0304 will clear after 40 consecutive ignition cycles occur without a fault.
- DTC P0304 can be cleared by using the Tech 2 "Clear Info" function or by disconnecting the PCM battery feed.

### Diagnostic Aids

Check for the following conditions:

- System grounds – Ensure all connections are clean and properly tightened.
- Injector – Perform the injector coil/balance test to locate a faulty injector that contributes to a lean condition on the affected cylinder. In addition to the above test, check the condition of the injector O-ring.
- Faulty spark plug – Check for a cracked insulator, carbon tracking, incorrect gap, and worn electrodes.
- Damaged or faulty ignition coil – Check for cracks, carbon tracking or other damage.
- Substitute a known good coil – Swap the ignition coils and retest. If the misfire follows the coil, replace the ignition coil.

## DTC P0304 – Cylinder Misfire Detected

Step	Action	Value(s)	Yes	No
1	Was the "On-Board Diagnostic (OBD) System Check" performed?	—	Go to Step 2	Go to <i>OBD System Check</i>
2	1. Start the engine. Run the engine at idle. 2. Review and record Tech 2 Freeze Frame data. 3. Monitor "Misfire Cur. #4" on the Tech 2. Is "Misfire Cur. #4" increasing (indicating a misfire currently occurring)?	—	Go to Step 4	Go to Step 3
3	Monitor "Misfire Hist. #4" while operating the vehicle to duplicate the conditions present when the DTC was set (as defined by the Freeze Frame data recorded in Step 2). Is "Misfire Hist. #4" increasing (indicating a misfire currently occurring)?	—	Go to Step 4	Refer to <i>Diagnostic Aids</i>

**DTC P0304 – Cylinder Misfire Detected (Cont'd)**

Step	Action	Value(s)	Yes	No
4	1. Visually and physically inspect the vacuum hoses for splits, kinks, and improper connections. Also, inspect the intake manifold for a vacuum leak. 2. If a problem is found, repair it as necessary. Did the inspection reveal a problem?	—	Verify repair	Go to <i>Step 5</i>
5	1. Install a spark tester at the spark plug end of the cylinder #4 ignition wire. 2. Crank the engine while observing the spark tester. A crisp, blue spark should be observed. Is adequate spark present?	—	Go to <i>Step 8</i>	Go to <i>Step 6</i>
6	1. Remove and visually/physically inspect the ignition coil associated with cylinder #4. Ensure that the coil is free of cracks and carbon tracking. 2. If a problem is found, replace the damaged ignition coil as necessary. Did the visual inspection reveal a problem?	—	Verify repair	Go to <i>Step 7</i>
7	1. Measure the ignition coil primary resistance. 2. If resistance is not within the specified value, replace the faulty ignition coil. Did the ignition coil require replacement?	2.6-2.7 K $\Phi$	Verify repair	Go to <i>Step 12</i>
8	Remove the cylinder #4 spark plug and visually inspect the spark plug electrode. Does the inspection reveal excessive fouling?	—	Go to <i>Contamination Diagnosis</i> chart in <i>Engine Mechanical Diagnosis</i>	Go to <i>Step 9</i>
9	1. Visually inspect the spark plug insulator for cracks, carbon tracking, or other damage. 2. If the spark plug is damaged, replace the spark plug. Did the inspection reveal a problem?	—	Verify repair	Go to <i>Step 10</i>
10	1. Perform the "Injector Coil/Balance Test." 2. If any faulty injectors are found, replace them as necessary. Did any of the injectors require replacement?	—	Verify repair	Go to <i>Step 11</i>
11	1. Inspect the injector O-rings for a vacuum leak. 2. If a problem is found, repair it as necessary. Did the inspection reveal a problem?	—	Verify repair	Go to <i>Step 12</i>
12	Check for an engine mechanical problem. Refer to <i>Engine Mechanical Diagnosis</i> to diagnose and repair the following conditions: <ul style="list-style-type: none"> <li>○ A faulty or incorrect camshaft</li> <li>○ Leaking or sticky valves or rings</li> <li>○ Excessive valve deposits</li> <li>○ Loose or worn rocker arms</li> <li>○ Weak valve springs</li> <li>○ A leaking head gasket</li> </ul> Was a basic engine mechanical problem found?	—	Verify repair	Refer to <i>Diagnostic Aids</i>

## Diagnostic Trouble Code (DTC) P0305 Cylinder Misfire Detected

### Circuit Description

The powertrain control module (PCM) has the ability to detect a misfire by monitoring the 58X reference and the camshaft position sensor input signals. If the PCM detects a crankshaft speed variation that indicates 1% or more of cylinder firing events are misfires, the PCM will disable the torque converter clutch (TCC). If the RPM variation detected indicates a misfire, the PCM attempts to calculate which cylinder is misfiring by associating crankshaft angle (using the camshaft position sensor signal) with the RPM variation (using the 58X reference). If cylinder #5 is isolated as the misfiring cylinder, DTC P0305 will set. If the ABS rough road sensor input signal to the PCM determines that a rough road condition is present, the misfire diagnostic will be temporarily disabled.

### Conditions for Setting the DTC

- None of the following DTCs occur: TP sensor, MAF sensor, camshaft position sensor, vehicle speed sensor, ECT sensor, crankshaft position sensor.
- The engine speed is between 600 and 6250 RPM.
- The system voltage is between 11 and 16 volts.
- The ECT indicates an engine temperature between -7°C (28°F) and 120°C (248°F).
- The throttle angle is steady.
- The PCM is detecting a crankshaft RPM variation that indicates a misfire on cylinder #5 sufficient to cause three-way catalytic converter damage or emissions levels to exceed mandated standard.

### Action Taken When the DTC Sets

- The PCM will illuminate the malfunction indicator lamp (MIL) the first time the fault is detected.

- If the misfire is severe enough to cause possible catalyst damage, the PCM will flash the MIL for as long as the misfire remains at catalyst damaging levels.
- The PCM will store conditions which were present when the DTC was set as Freeze Frame and in the Failure Records data.

### Conditions for Clearing the MIL/DTC

- The PCM will turn the MIL "OFF" on the third consecutive ignition cycle in which the diagnostic has been run and the fault condition is no longer present.
- A history DTC P0305 will clear after 40 consecutive ignition cycles occur without a fault.
- DTC P0305 can be cleared by using the Tech 2 "Clear Info" function or by disconnecting the PCM battery feed.

### Diagnostic Aids

Check for the following conditions:

- System grounds – Ensure all connections are clean and properly tightened.
- Injector – Perform the injector coil/balance test to locate a faulty injector that contributes to a lean condition on the affected cylinder. In addition to the above test, check the condition of the injector O-ring.
- Faulty spark plug – Check for a cracked insulator, carbon tracking, incorrect gap, and worn electrodes.
- Damaged or faulty ignition coil – Check for cracks, carbon tracking or other damage.
- Substitute a known good coil – Swap the ignition coils and retest. If the misfire follows the coil, replace the ignition coil.

## DTC P0305 – Cylinder Misfire Detected

Step	Action	Value(s)	Yes	No
1	Was the "On-Board Diagnostic (OBD) System Check" performed?	—	Go to Step 2	Go to <i>OBD System Check</i>
2	1. Start the engine. Run the engine at idle. 2. Review and record Tech 2 Freeze Frame data. 3. Monitor "Misfire Cur. #5" on the Tech 2. Is "Misfire Cur. #5" increasing (indicating a misfire currently occurring)?	—	Go to Step 4	Go to Step 3
3	Monitor "Misfire Hist. #5" while operating the vehicle to duplicate the conditions present when the DTC was set (as defined by the Freeze Frame data recorded in Step 2). Is "Misfire Hist. #5" increasing (indicating a misfire currently occurring)?	—	Go to Step 4	Refer to <i>Diagnostic Aids</i>

**DTC P0305 – Cylinder Misfire Detected (Cont'd)**

Step	Action	Value(s)	Yes	No
4	1. Visually and physically inspect the vacuum hoses for splits, kinks, and improper connections. Also, inspect the intake manifold for a vacuum leak. 2. If a problem is found, repair it as necessary. Did the inspection reveal a problem?	—	Verify repair	Go to <i>Step 5</i>
5	1. Install a spark tester at the spark plug end of the cylinder #5 ignition wire. 2. Crank the engine while observing the spark tester. A crisp, blue spark should be observed. Is adequate spark present?	—	Go to <i>Step 8</i>	Go to <i>Step 6</i>
6	1. Remove and visually/physically inspect the ignition coil associated with cylinder #5. Ensure that the coil is free of cracks and carbon tracking. 2. If a problem is found, replace the damaged ignition coil as necessary. Did the visual inspection reveal a problem?	—	Verify repair	Go to <i>Step 7</i>
7	1. Measure the ignition coil primary resistance. 2. If resistance is not within the specified value, replace the faulty ignition coil. Did the ignition coil require replacement?	2.6-2.7 K $\Phi$	Verify repair	Go to <i>Step 12</i>
8	Remove the cylinder #5 spark plug and visually inspect the spark plug electrode. Does the inspection reveal excessive fouling?	—	Go to <i>Contamination Diagnosis</i> chart in <i>Engine Mechanical Diagnosis</i>	Go to <i>Step 9</i>
9	1. Visually inspect the spark plug insulator for cracks, carbon tracking, or other damage. 2. If the spark plug is damaged, replace the spark plug. Did the inspection reveal a problem?	—	Verify repair	Go to <i>Step 10</i>
10	1. Perform the "Injector Coil/Balance Test." 2. If any faulty injectors are found, replace them as necessary. Did any of the injectors require replacement?	—	Verify repair	Go to <i>Step 11</i>
11	1. Inspect the injector O-rings for a vacuum leak. 2. If a problem is found, repair it as necessary. Did the inspection reveal a problem?	—	Verify repair	Go to <i>Step 12</i>
12	Check for an engine mechanical problem. Refer to <i>Engine Mechanical Diagnosis</i> to diagnose and repair the following conditions: <ul style="list-style-type: none"> <li>○ A faulty or incorrect camshaft</li> <li>○ Leaking or sticky valves or rings</li> <li>○ Excessive valve deposits</li> <li>○ Loose or worn rocker arms</li> <li>○ Weak valve springs</li> <li>○ A leaking head gasket</li> </ul> Was a basic engine mechanical problem found?	—	Verify repair	Refer to <i>Diagnostic Aids</i>

## Diagnostic Trouble Code (DTC) P0306 Cylinder Misfire Detected

### Circuit Description

The powertrain control module (PCM) has the ability to detect a misfire by monitoring the 58X reference and the camshaft position sensor input signals. If the PCM detects a crankshaft speed variation that indicates 1% or more of cylinder firing events are misfires, the PCM will disable the torque converter clutch (TCC). If the RPM variation detected indicates a misfire, the PCM attempts to calculate which cylinder is misfiring by associating crankshaft angle (using the camshaft position sensor signal) with the RPM variation (using the 58X reference). If cylinder #6 is isolated as the misfiring cylinder, DTC P0306 will set. If the ABS rough road sensor input signal to the PCM determines that a rough road condition is present, the misfire diagnostic will be temporarily disabled.

### Conditions for Setting the DTC

- None of the following occur: TP sensor, MAF sensor, camshaft position sensor, vehicle speed sensor, ECT sensor, crankshaft position sensor.
- The engine speed is between 600 and 6250 RPM.
- The system voltage is between 11 and 16 volts.
- The ECT indicates an engine temperature between  $-7^{\circ}\text{C}$  ( $28^{\circ}\text{F}$ ) and  $120^{\circ}\text{C}$  ( $248^{\circ}\text{F}$ ).
- The throttle angle is steady.
- The PCM is detecting a crankshaft RPM variation that indicates a misfire on cylinder #6 sufficient to cause three-way catalytic converter damage or emissions levels to exceed mandated standard.

### Action Taken When the DTC Sets

- The PCM will illuminate the malfunction indicator lamp (MIL) the first time the fault is detected.

- If the misfire is severe enough to cause possible catalyst damage, the PCM will flash the MIL for as long as the misfire remains at catalyst damaging levels.
- The PCM will store conditions which were present when the DTC was set as Freeze Frame and in the Failure Records data.

### Conditions for Clearing the MIL/DTC

- The PCM will turn the MIL "OFF" on the third consecutive ignition cycle in which the diagnostic has been run and the fault condition is no longer present.
- A history DTC P0306 will clear after 40 consecutive ignition cycles occur without a fault.
- DTC P0306 can be cleared by using the Tech 2 "Clear Info" function or by disconnecting the PCM battery feed.

### Diagnostic Aids

Check for the following conditions:

- System grounds – Ensure all connections are clean and properly tightened.
- Injector – Perform the injector coil/balance test to locate a faulty injector that contributes to a lean condition on the affected cylinder. In addition to the above test, check the condition of the injector O-ring.
- Faulty spark plug – Check for a cracked insulator, carbon tracking, incorrect gap, and worn electrodes.
- Damaged or faulty ignition coil – Check for cracks or other damage.
- Substitute a known good coil – Swap the ignition coils and retest. If the misfire follows the coil, replace the ignition coil.

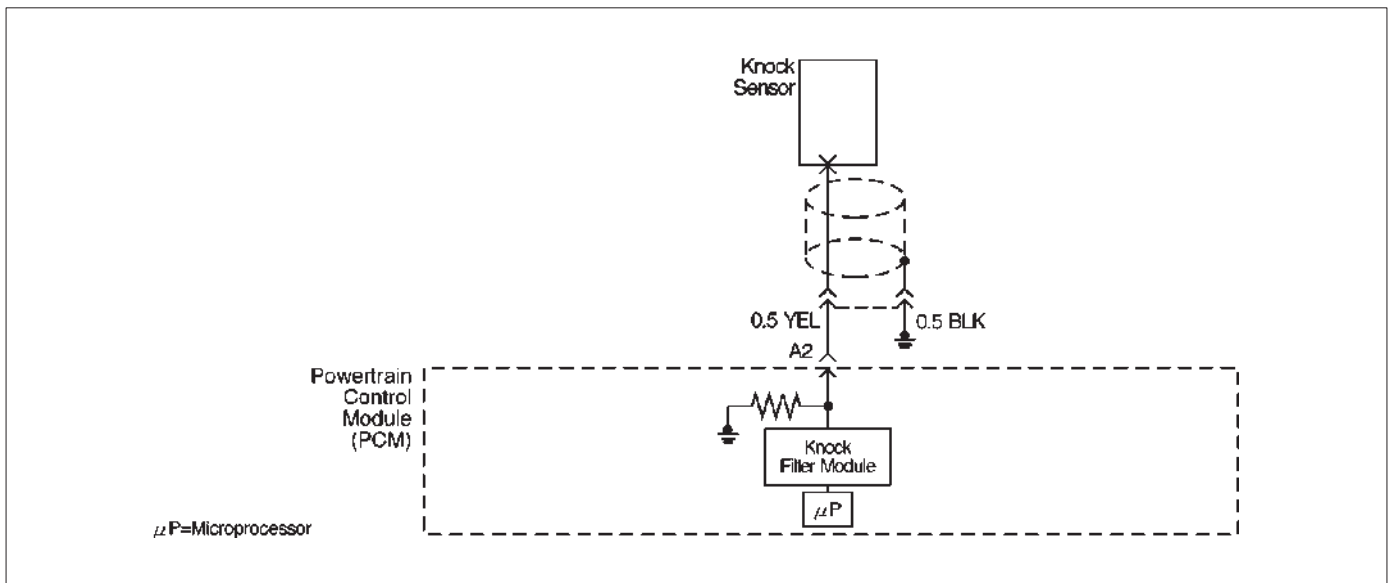
## DTC P0306 – Cylinder Misfire Detected

Step	Action	Value(s)	Yes	No
1	Was the "On-Board Diagnostic (OBD) System Check" performed?	—	Go to Step 2	Go to <i>OBD System Check</i>
2	1. Start the engine. Run the engine at idle. 2. Review and record Tech 2 Freeze Frame data. 3. Monitor "Misfire Cur. #6" on the Tech 2. Is "Misfire Cur. #6" increasing (indicating a misfire currently occurring)?	—	Go to Step 4	Go to Step 3
3	Monitor "Misfire Hist. #6" while operating the vehicle to duplicate the conditions present when the DTC was set (as defined by the Freeze Frame data recorded in Step 2). Is "Misfire Hist. #6" increasing (indicating a misfire currently occurring)?	—	Go to Step 4	Refer to <i>Diagnostic Aids</i>

**DTC P0306 – Cylinder Misfire Detected (Cont'd)**

Step	Action	Value(s)	Yes	No
4	1. Visually and physically inspect the vacuum hoses for splits, kinks, and improper connections. Also, inspect the intake manifold for a vacuum leak. 2. If a problem is found, repair it as necessary. Did the inspection reveal a problem?	—	Verify repair	Go to <i>Step 5</i>
5	1. Install a spark tester at the spark plug end of the cylinder #6 ignition wire. 2. Crank the engine while observing the spark tester. A crisp, blue spark should be observed. Is adequate spark present?	—	Go to <i>Step 8</i>	Go to <i>Step 6</i>
6	1. Remove and visually/physically inspect the ignition coil associated with cylinder #6. Ensure that the coil is free of cracks and carbon tracking. 2. If a problem is found, replace the damaged ignition coil as necessary. Did the visual inspection reveal a problem?	—	Verify repair	Go to <i>Step 7</i>
7	1. Measure the ignition coil primary resistance. 2. If resistance is not within the specified value, replace the faulty ignition coil. Did the ignition coil require replacement?	2.6-2.7 K $\Omega$	Verify repair	Go to <i>Step 12</i>
8	Remove the cylinder #6 spark plug and visually inspect the spark plug electrode. Does the inspection reveal excessive fouling?	—	Go to <i>Contamination Diagnosis</i> chart in <i>Engine Mechanical Diagnosis</i>	Go to <i>Step 9</i>
9	1. Visually inspect the spark plug insulator for cracks, carbon tracking, or other damage. 2. If the spark plug is damaged, replace the spark plug. Did the inspection reveal a problem?	—	Verify repair	Go to <i>Step 10</i>
10	1. Perform the "Injector Coil/Balance Test." 2. If any faulty injectors are found, replace them as necessary. Did any of the injectors require replacement?	—	Verify repair	Go to <i>Step 11</i>
11	1. Inspect the intake manifold and the injector O-rings for a vacuum leak. 2. If a problem is found, repair it as necessary. Did the inspection reveal a problem?	—	Verify repair	Go to <i>Step 12</i>
12	Check for an engine mechanical problem. Refer to <i>Engine Mechanical Diagnosis</i> to diagnose and repair the following conditions: <ul style="list-style-type: none"> <li>○ A faulty or incorrect camshaft</li> <li>○ Leaking or sticky valves or rings</li> <li>○ Excessive valve deposits</li> <li>○ Loose or worn rocker arms</li> <li>○ Weak valve springs</li> <li>○ A leaking head gasket</li> </ul> Was a basic engine mechanical problem found?	—	Verify repair	Refer to <i>Diagnostic Aids</i>

## Diagnostic Trouble Code (DTC) P0325 KS Module Circuit



### Circuit Description

The knock sensor is used to detect engine detonation, allowing the powertrain control module (PCM) to retard ignition control (IC) spark timing based on the knock sensor (KS) signal being received. The knock sensor produces an AC signal so that under a no knock condition the signal on the KS circuit measures about 0.007 V AC. The KS signal's amplitude and frequency depend upon the amount of knock being experienced. The PCM contains a non-replaceable knock filter module called a signal-to-noise enhancement filter (SNEF) module. This filter module in the PCM determines whether knock is occurring by comparing the signal level on the KS circuit with the voltage level on the noise channel. The noise channel allows the PCM to reject any false knock signal by knowing the amount of normal engine mechanical noise present. Normal engine noise varies depending on engine speed and load. When the PCM determines that an abnormally low noise channel voltage level is being experienced, a DTC P0325 will set.

### Conditions for Setting the DTC

- Engine has been running for at least 30 seconds.
- The PCM determines that its internal signal from its knock filter module indicates a continuous knocking condition for more than 10 seconds.

### Action Taken When the DTC Sets

- The PCM will store conditions which were present when the DTC was set as Freeze Frame and in the Failure Records data.

- The PCM will use a "substitute" default spark retard value of 6 degrees to minimize knock during conditions when knock is likely to occur.

### Conditions for Clearing the MIL/DTC

- The PCM will turn the MIL "OFF" on the third consecutive trip cycle during which the diagnostic has been run and the fault condition is no longer present.
- A history DTC P0325 will clear after 40 consecutive warm-up cycles have occurred without a fault.
- DTC P0325 can be cleared by using the Tech 2 "Clear Info" function or by disconnecting the PCM battery feed.

### Diagnostic Aids

Check for the following conditions:

- Poor connection at PCM – Inspect the knock sensor and PCM connectors for backed-out terminals, broken locks, and improperly formed or damaged terminals.
- Misrouted harness – Inspect the knock sensor harness to ensure that it is not routed too close to high voltage circuits such as spark plug coils.

Reviewing the Failure Records vehicle mileage since the diagnostic test last failed may help determine how often the condition that caused the DTC to be set occurs. This may assist in diagnosing the condition.

### Test Description

Number(s) below refer to the step number(s) on the Diagnostic Chart.

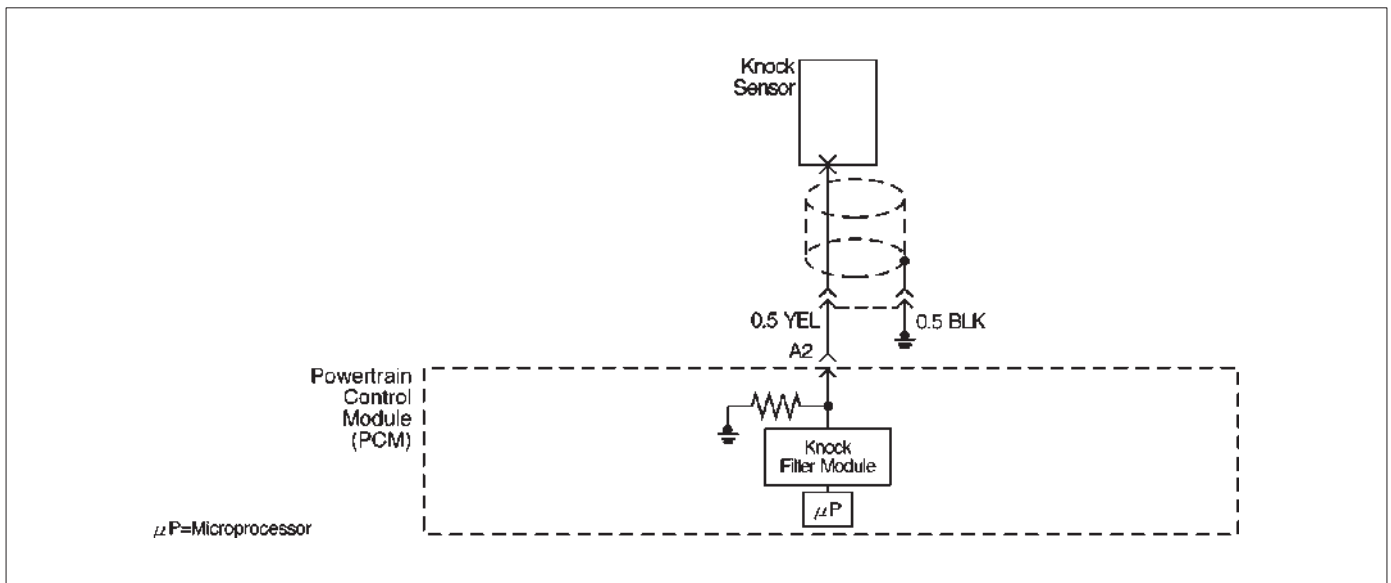
2. Ensures that the fault is present.

**DTC P0325 – KS Module Circuit**

Step	Action	Value(s)	Yes	No
1	Was the "On-Board Diagnostic (OBD) System Check" performed?	—	Go to Step 2	Go to <i>OBD System Check</i>
2	<p><b>IMPORTANT:</b> If an engine knock can be heard, repair the engine mechanical problem before proceeding with this diagnostic.</p> <p>1. Operate the vehicle within parameters specified under criteria included in "Conditions for Setting the DTC."</p> <p>2. Using a Tech 2, monitor "DTC" info for DTC P0325 until the DTC P0325 test runs.</p> <p>3. Note the test result.</p> <p>Does the Tech 2 indicate DTC P0325 failed this ignition?</p>	—	Go to Step 4	Go to Step 3
3	<p>1. Ignition "ON," engine "OFF."</p> <p>2. Review and record Tech 2 Failure Records data for DTC P0325.</p> <p>3. Operate the vehicle within Failure Records conditions.</p> <p>4. Using a Tech 2, monitor "DTC" info for DTC P0325 until the DTC P0325 test runs.</p> <p>Does the Tech 2 indicate DTC P0325 test failed this ignition?</p>	—	Go to Step 4	Refer to <i>Diagnostic Aids</i>
4	<p>Replace the PCM.</p> <p><b>IMPORTANT:</b> The replacement PCM must be programmed. Refer to <i>On-Vehicle Service in Powertrain Control Module and Sensors</i> for procedures.</p> <p>And also refer to latest Service Bulletin.</p> <p>Check to see if the Latest software is released or not. And then Down Load the LATEST PROGRAMMED SOFTWARE to the replacement PCM.</p> <p>Is the action complete?</p>	—	Verify repair	—



## Diagnostic Trouble Code (DTC) P0327 KS Sensor Circuit



D06RW035-1

### Circuit Description

The powertrain control module (PCM) uses the knock sensor to detect engine detonation, allowing the PCM to retard ignition control (IC) spark timing based on the knock sensor (KS) signal being received. The knock sensor produces an AC signal so that under a no knock condition the signal on the KS circuit measures about 0.007 V AC. The signal amplitude and frequency are dependent upon the amount of knock being experienced. The PCM monitors the KS signal and can diagnose the KS sensor and circuitry.

### Conditions for Setting the DTC

- Engine running for at least 10 seconds.
- The TP sensor is greater than 5%.
- The ECT sensor is greater than 60°C (140°F).
- Engine speed is between 2000 and 4000 RPM.
- The knock sensor signal voltage is less than 0.20 volts, or greater than 4.8 volts.
- All conditions are present for more than 15 seconds.

### Action Taken When the DTC Sets

- The PCM will illuminate the malfunction indicator lamp (MIL) after the second consecutive trip in which the fault is detected.
- The PCM will store conditions which were present when the DTC was set as Freeze Frame and in the Failure Records data.

- The PCM will use a calculated spark retard value to minimize knock during conditions when knock is likely to occur. The calculated value will vary based on engine speed and load.

### Conditions for Clearing the MIL/DTC

- The PCM will turn the MIL "OFF" on the third consecutive trip cycle during which the diagnostic has been run and the fault condition is no longer present.
- A history DTC P0327 will clear after 40 consecutive warm-up cycles have occurred without a fault.
- DTC P0327 can be cleared by using the Tech 2 "Clear Info" function or by disconnecting the PCM battery feed.

### Diagnostic Aids

Reviewing the Failure Records vehicle mileage since the diagnostic test last failed may help determine how often the condition that caused the DTC to be set occurs. This may assist in diagnosing the condition.

### Test Description

Number(s) below refer to the step number(s) on the Diagnostic Chart.

2. Ensures that the fault is present.

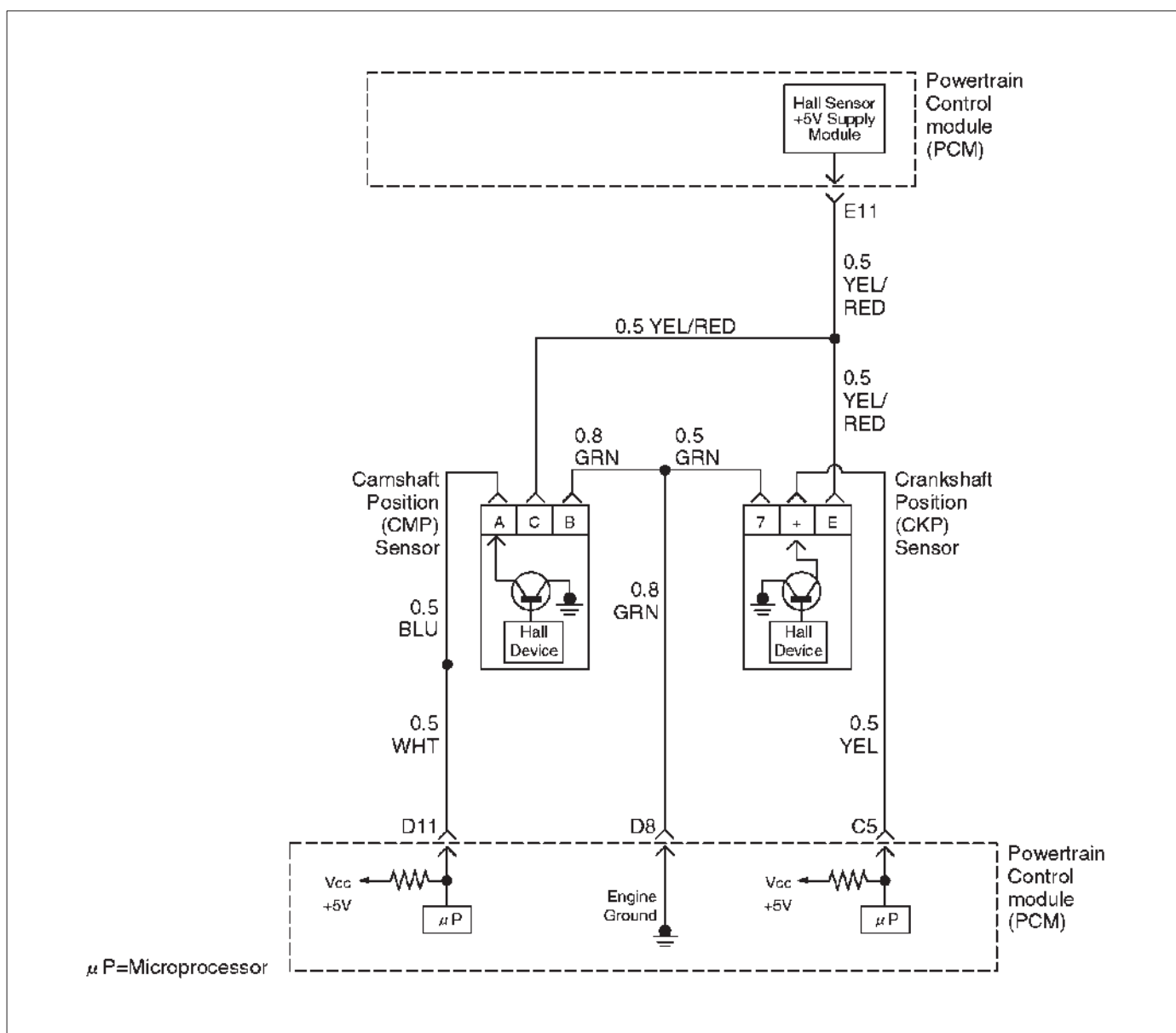
## DTC P0327 – KS Sensor Circuit

Step	Action	Value(s)	Yes	No
1	Was the "On-Board Diagnostic (OBD) System Check" performed?	—	Go to Step 2	Go to <i>OBD System Check</i>
2	<b>IMPORTANT:</b> If an engine knock can be heard, repair the engine mechanical problem before proceeding with this diagnostic. 1. Operate the engine within the conditions specified in diagnostic support "Conditions for Setting the DTC." 2. Using a Tech 2, monitor "DTC" info for DTC P0327 until the DTC P0327 test runs. 3. Note the test result. Does the Tech 2 indicate DTC P0327 failed this ignition?	—	Go to Step 4	Go to Step 3
3	1. Ignition "ON," engine "OFF." 2. Review and record Tech 2 Failure Records data. 3. Operate the vehicle within Failure Records conditions. 4. Using a Tech 2, monitor "DTC" info for DTC P0327 until the DTC P0327 test runs. 5. Note the test result. Does the Tech 2 indicate DTC P0327 failed this ignition?	—	Go to Step 4	Refer to <i>Diagnostic Aids</i>
4	Using a test light to battery +, check the black/blue wire (PCM side) to verify that the shield connection is good. Did the test light illuminate?	—	Go to Step 6	Go to Step 5
5	Repair the open shield ground. Is the action complete?	—	Verify repair	—
6	1. Ignition "OFF," disconnect the PCM. 2. Check the KS signal circuit for a poor terminal connection at the PCM. 3. If a problem is found, replace the faulty terminal. Was a problem found?	—	Verify repair	Go to Step 7
7	1. Ignition "OFF," PCM disconnected. 2. Check the KS signal circuit between the PCM and the knock sensor connector for an open, a short to voltage, or a short to ground. 3. If a problem is found, repair as necessary. Was a problem found?	—	Verify repair	Go to Step 8
8	1. Ignition "OFF," PCM disconnected. 2. Knock sensor connected. 3. Measure the resistance of the knock sensor by connecting the DVM between the PCM connector and the engine block. Is the resistance of the knock sensor near the specified value?	100K ohms	Go to Step 9	Go to Step 10

## DTC P0327 – KS Sensor Circuit (Cont'd)

Step	Action	Value(s)	Yes	No
9	1. Ignition "OFF," PCM disconnected. 2. Connect the DVM to monitor AC voltage between the PCM connector and engine ground. 3. Tap on the engine lift bracket with a socket extension while observing the signal indicated on the DVM.  Is any signal indicated on the DVM while tapping on the engine lift bracket?	—	Go to <i>Step 11</i>	Go to <i>Step 10</i>
10	Replace the knock sensor.  Is the action complete?	—	Verify repair	—
11	Replace the PCM.  <b>IMPORTANT:</b> The replacement PCM must be programmed. Refer to <i>On-Vehicle Service</i> in <i>Powertrain Control Module and Sensors</i> for procedures.  And also refer to latest Service Bulletin.  Check to see if the Latest software is released or not. And then Down Load the LATEST PROGRAMMED SOFTWARE to the replacement PCM.  Is the action complete?	—	Verify repair	—

## Diagnostic Trouble Code (DTC) P0336 58X Reference Signal Circuit



D06RX091

**Circuit Description**

The 58X reference signal is produced by the crankshaft position (CKP) sensor. During one crankshaft revolution, 58 crankshaft pulses will be produced. The powertrain control module (PCM) uses the 58X reference signal to calculate engine RPM and crankshaft position. The PCM constantly monitors the number of pulses on the 58X reference circuit and compares them to the number of camshaft position (CMP) signal pulses being received. If the PCM receives an incorrect number of pulses on the 58X reference circuit, DTC P0336 will set.

**Conditions for Setting the DTC**

- Engine is running.
- Extra or missing pulse is detected between consecutive 58X reference pulses.
- Above condition is detected in 10 of 100 crankshaft rotations.

**Action Taken When the DTC Sets**

- The PCM will illuminate the malfunction indicator lamp (MIL) after the second consecutive trip in which the fault is detected.
- The PCM will store conditions which were present when the DTC was set as Freeze Frame and in the Failure Records data.

**Conditions for Clearing the MIL/DTC**

- The PCM will turn the MIL "OFF" on the third consecutive trip cycle during which the diagnostic has been run and the fault condition is no longer present.
- A history DTC P0336 will clear after 40 consecutive warm-up cycles have occurred without a fault.
- DTC P0336 can be cleared by using the Tech 2 "Clear Info" function or by disconnecting the PCM battery feed.

### Diagnostic Aids

An intermittent may be caused by a poor connection, rubbed-through wire insulation or a wire broken inside the insulation. Check for:

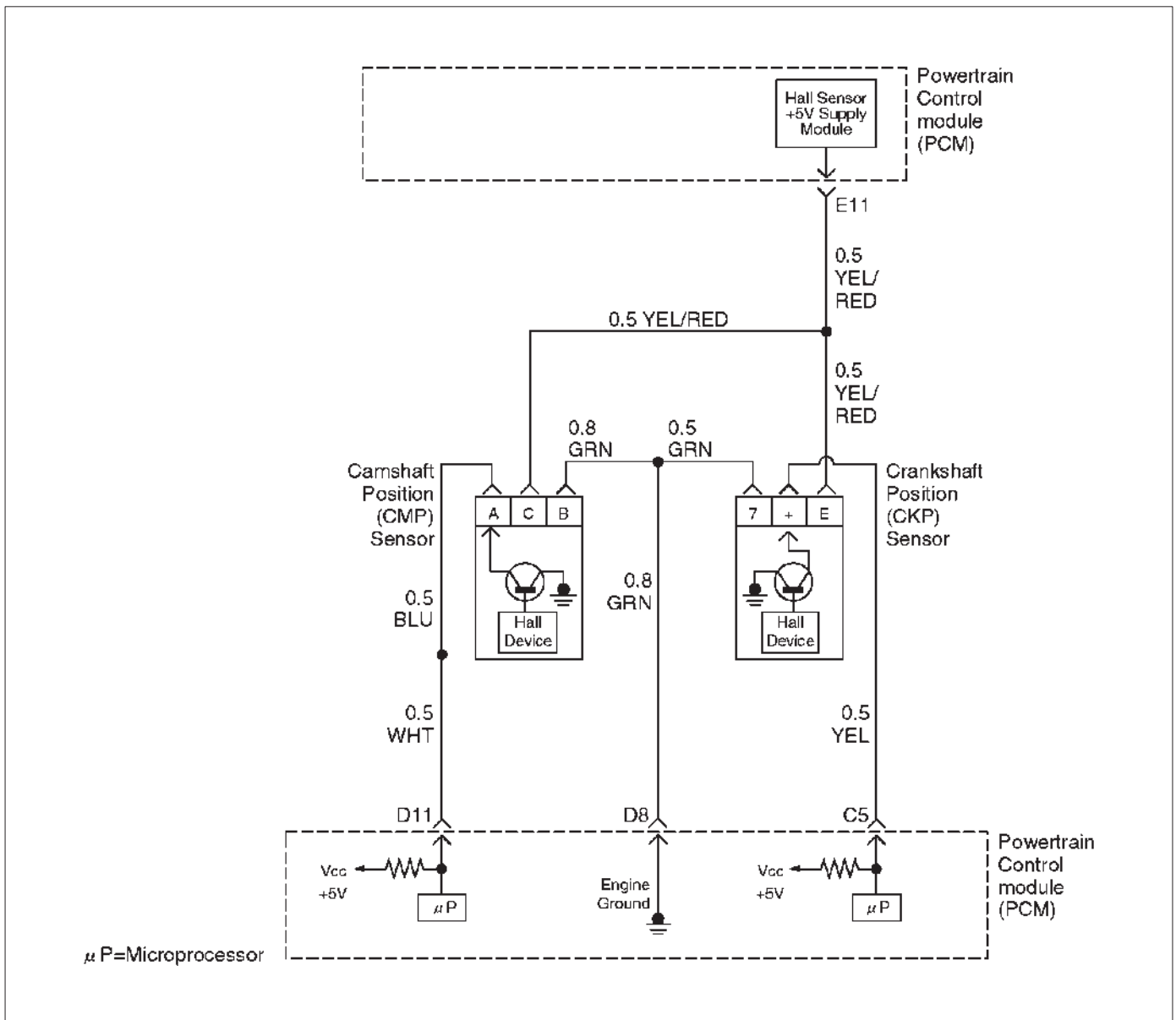
- Poor connection - Inspect the PCM harness and connectors for improper mating, broken locks, improperly formed or damaged terminals, and poor terminal-to-wire connection.
- Damaged harness – Inspect the wiring harness for damage. If the harness appears to be OK, disconnect the PCM, turn the ignition on and observe a voltmeter connected to the 58X reference circuit at the PCM harness connector while moving connectors and wiring harnesses related to the ICM. A change in voltage will indicate the location of the fault.

Reviewing the Failure Records vehicle mileage since the diagnostic test last failed may help determine how often the condition that caused the DTC to be set occurs. This may assist in diagnosing the condition.

### DTC P0336 – 58X Reference Signal Circuit

Step	Action	Value(s)	Yes	No
1	Was the "On-Board Diagnostic (OBD) System Check" performed?	—	Go to Step 2	Go to <i>OBD System Check</i>
2	Attempt to start the engine. Does the engine start?	—	Go to Step 3	Go to " <i>Engine Cranks But Will Not Run</i> " chart
3	1. Review and record Failure Records information. 2. Clear DTC P0336. 3. Start the engine and idle for 1 minute. 4. Observe DTCs. Is DTC P0336 set?	—	Go to Step 4	Refer to Diagnostic Aids
4	1. Disconnect the PCM and CKP sensor. 2. Check for an open or a short to ground in the 58X reference circuit between the CKP sensor connector and the PCM harness connector. 3. If a problem is found, repair as necessary. Was a problem found?	—	Verify repair	Go to Step 5
5	1. Reconnect the PCM and CKP sensor. 2. Connect a DVM to measure voltage on the 58X reference circuit at the PCM connector. 3. Observe the voltage while cranking the engine. Is the voltage near the specified value?	2.5 V	Go to Step 8	Go to Step 6
6	Check the connections at the CKP sensor and replace the terminals if necessary. Did any terminals require replacement?	—	Verify repair	Go to Step 7
7	Replace the CKP sensor. Use caution to avoid any hot oil that may drip out. Is the action complete?	—	Verify repair	—
8	Check connections at the PCM and replace the terminals if necessary. Did any terminals require replacement?	—	Verify repair	Go to Step 10
9	Replace the PCM. <b>IMPORTANT:</b> The replacement PCM must be programmed. Refer to <i>On-Vehicle Service in Powertrain Control Module and Sensors</i> for procedures. And also refer to latest Service Bulletin. Check to see if the Latest software is released or not. And then Down Load the LATEST PROGRAMMED SOFTWARE to the replacement PCM. Is the action complete?	—	Verify repair	—

## Diagnostic Trouble Code (DTC) P0337 CKP Sensor Circuit Low Frequency



### Circuit Description

The 58X reference signal is produced by the crankshaft position (CKP) sensor. During one crankshaft revolution, 58 crankshaft reference pulses will be produced. The powertrain control module (PCM) uses the 58X reference signal to calculate engine RPM and crankshaft position. The PCM constantly monitors the number of pulses on the 58X reference circuit and compares them to the number of camshaft position (CMP) signal pulses being received. If the PCM does not receive pulses on the 58X reference circuit, DTC P0337 will set.

### Conditions for Setting the DTC

- No camshaft position (CMP) sensor DTCs are set.
- Engine cranking.
- Crankshaft position (CKP) sensor signal is not present between two cam pulses.

- CKP reference pulse is not detected within 8 CMP pulses.

### Action Taken When the DTC Sets

- The PCM will illuminate the malfunction indicator lamp (MIL) after the second consecutive trip in which the fault is detected.
- The PCM will store conditions which were present when the DTC was set as Freeze Frame and in the Failure Records data.

### Conditions for Clearing the MIL/DTC

- The PCM will turn the MIL "OFF" on the third consecutive trip cycle during which the diagnostic has been run and the fault condition is no longer present.
- A history DTC P0337 will clear after 40 consecutive warm-up cycles have occurred without a fault.

○ DTC P0337 can be cleared by using the Tech 2 “Clear Info” function or by disconnecting the PCM battery feed.

**Diagnostic Aids**

An intermittent may be caused by a poor connection, rubbed-through wire insulation or a wire broken inside the insulation. Check for:

○ Poor connection – Inspect the PCM harness and connectors for improper mating, broken locks, improperly formed or damaged terminals, and poor terminal-to-wire connection.

○ Damaged harness – Inspect the wiring harness for damage. If the harness appears to be OK, disconnect the PCM, turn the ignition on and observe a voltmeter connected to the 58X reference circuit at the PCM harness connector while moving connectors and wiring harnesses related to the ICM. A change in voltage will indicate the location of the fault.

Reviewing the Failure Records vehicle mileage since the diagnostic test last failed may help determine how often the condition that caused the DTC to be set occurs. This may assist in diagnosing the condition.

**DTC P0337 – CKP Sensor Circuit Low Frequency**

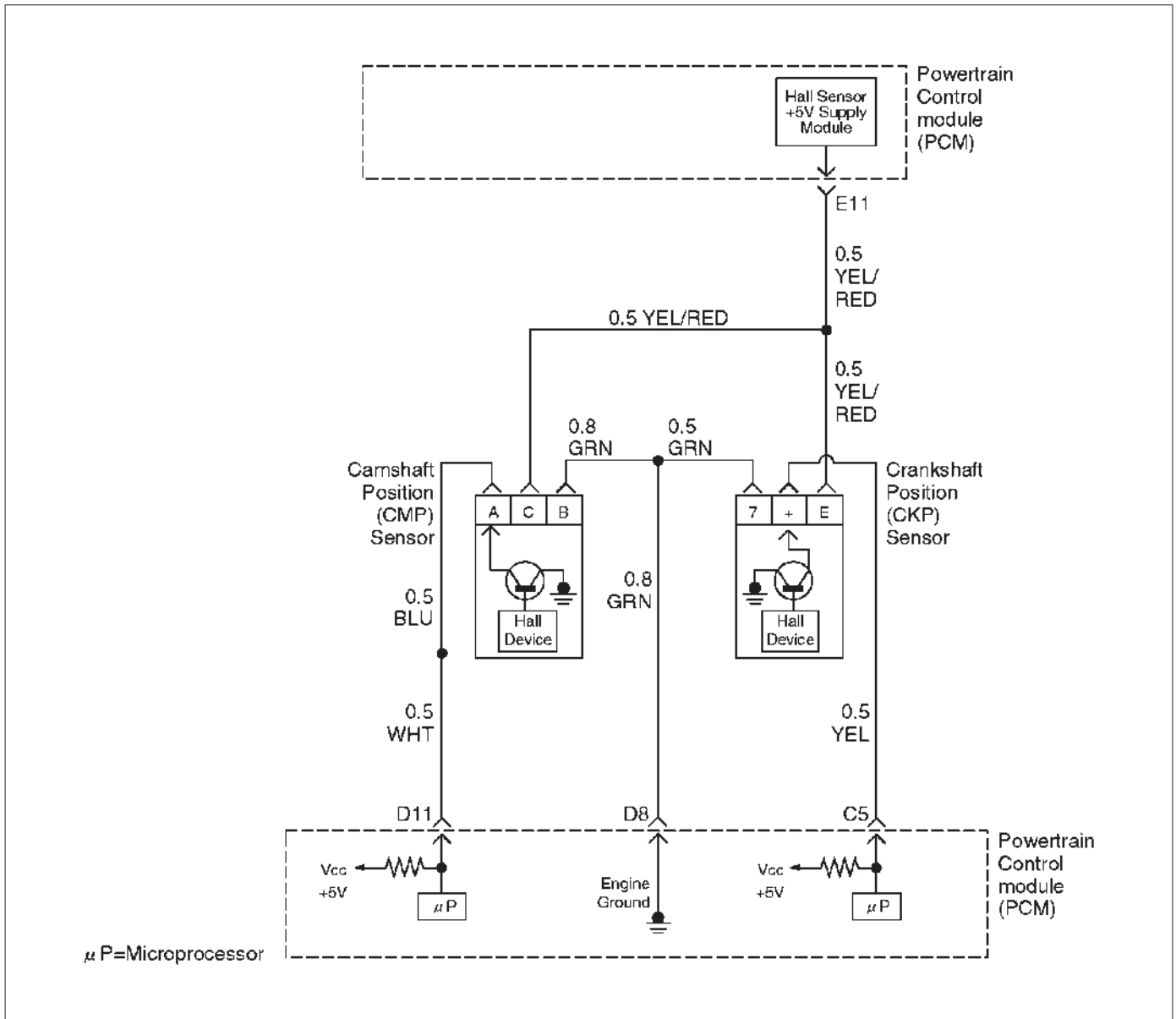
Step	Action	Value(s)	Yes	No
1	Was the “On-Board Diagnostic (OBD) System Check” performed?	—	Go to Step 2	Go to <i>OBD System Check</i>
2	Attempt to start the engine. Does the engine start?	—	Go to Step 3	Go to <i>Chart 3</i>
3	1. Review and record Failure Records information. 2. Clear DTC P0337. 3. Start the engine and idle for 1 minute. 4. Observe DTCs. Is DTC P0337 set?	—	Go to Step 4	Refer to <i>Diagnostic Aid</i>
4	1. Disconnect the CKP sensor. 2. Ignition “ON.” 3. Using a DVM, verify that 5 V reference and ground are being supplied at the sensor connector (PCM side). Are 4-6 volts and ground available at the sensor?	—	Go to Step 7	Go to Step 5
5	1. Ignition “ON.” 2. With a DVM, backprobe the PCM connector 5 V reference and ground connections. Are 5 V reference and ground available at the PCM?	—	Go to Step 6	Go to Step 11
6	Check 5 V reference or ground between the CKP sensor and PCM and repair the open circuit, short to ground or short to voltage. Is the action complete?	—	Verify repair	—
7	1. Ignition “OFF.” 2. Disconnect the PCM and CKP sensor. 3. Check for an open or a short to ground in the 58X reference circuit between the CKP sensor connector and the PCM harness connector. 4. If a problem is found, repair as necessary. Was a problem found?	—	Verify repair	Go to Step 8
8	1. Reconnect the PCM and CKP sensor. 2. Connect a DVM to measure voltage on the 58X reference circuit at the PCM connector. 3. Observe the voltage while cranking the engine. Is the voltage near the specified value?	2.5 V	Go to Step 11	Go to Step 9



## DTC P0337 – CKP Sensor Circuit Low Frequency (Cont'd)

Step	Action	Value(s)	Yes	No
9	Check the connections at the CKP sensor and replace the terminals if necessary. Did any terminals require replacement?	—	Verify repair	Go to <i>Step 10</i>
10	Replace the CKP sensor. Use caution and avoid hot oil that may drip out. Is the action complete?	—	Verify repair	—
11	Check the connections at the PCM and replace the terminals if necessary. Did any terminals require replacement?	—	Verify repair	Go to <i>Step 12</i>
12	Replace the PCM. <b>IMPORTANT:</b> The replacement PCM must be programmed. Refer to <i>On-Vehicle Service</i> in <i>Powertrain Control Module and Sensors</i> for procedures. And also refer to latest Service Bulletin. Check to see if the Latest software is released or not. And then Down Load the LATEST PROGRAMMED SOFTWARE to the replacement PCM. Is the action complete?	—	Verify repair	—

## Diagnostic Trouble Code (DTC) P0341 CMP Sensor Circuit Performance



D06RX091

### Circuit Description

The CMP signal is produced by the camshaft position (CMP) sensor pulses when the engine is running and crankshaft position (CKP) sync pulses are also being received. The powertrain control module (PCM) uses the CMP signal pulses to initiate sequential fuel injection. The PCM constantly monitors the number of pulses on the CMP signal circuit and compares the number of CMP pulses to the number of 58X reference pulses received. If the PCM receives an incorrect number of pulses on the CMP reference circuit, DTC P0341 will set and the PCM will initiate injector sequence without the CMP signal with a one in six chance that injector sequence is correct. The engine will continue to start and run normally, although the misfire diagnostic will be affected if a misfiring condition occurs.

### Conditions for Setting the DTC

- The engine is running (1X CMP reference pulses are being received).
- The CMP sensor signal is not detected at the correct interval every 6 cylinders.
- Above condition fails for 100 occurrences within 200 test samples.

### Action Taken When the DTC Sets

- The PCM will illuminate the malfunction indicator lamp (MIL) after the second consecutive trip in which the fault is detected.
- The PCM will initiate the injector sequence without the CMP signal with a one in six chance that the injector sequence is correct.
- The PCM will store conditions which were present when the DTC was set as Freeze Frame and in the Failure Records data.

### Conditions for Clearing the MIL/DTC

- The PCM will turn the MIL "OFF" on the third consecutive trip cycle during which the diagnostic has been run and the fault condition is no longer present.
- A history DTC P0341 will clear after 40 consecutive warm-up cycles have occurred without a fault.
- DTC P0341 can be cleared by using the Tech 2 "Clear Info" function or by disconnecting the PCM battery feed.

### Diagnostic Aids

An intermittent may be caused by a poor connection, rubbed-through wire insulation or a wire broken inside the insulation. Check for:

- Poor connection – Inspect the PCM harness and connectors for improper mating, broken locks, improperly formed or damaged terminals, and poor terminal-to-wire connection.
- Damaged harness – Inspect the wiring harness for damage. If the harness appears to be OK, disconnect the PCM, turn the ignition on and observe a voltmeter connected to the CMP signal circuit at the PCM harness connector while moving connectors and wiring harnesses related to the ICM and the CMP sensor. A change in voltage will indicate the location of the fault.

Reviewing the Failure Records vehicle mileage since the diagnostic test last failed may help determine how often the condition that caused the DTC to be set occurs. This may assist in diagnosing the condition.

### Test Description

Number(s) below refer to the step number(s) on the Diagnostic Chart.

2. Ensures that the fault is present.
12. Determines whether the fault is being caused by a missing camshaft magnet or a faulty sensor. The voltage measured in this step should read around 4 volts, toggling to near 0 volts when the CMP sensor interfaces with the camshaft magnet.

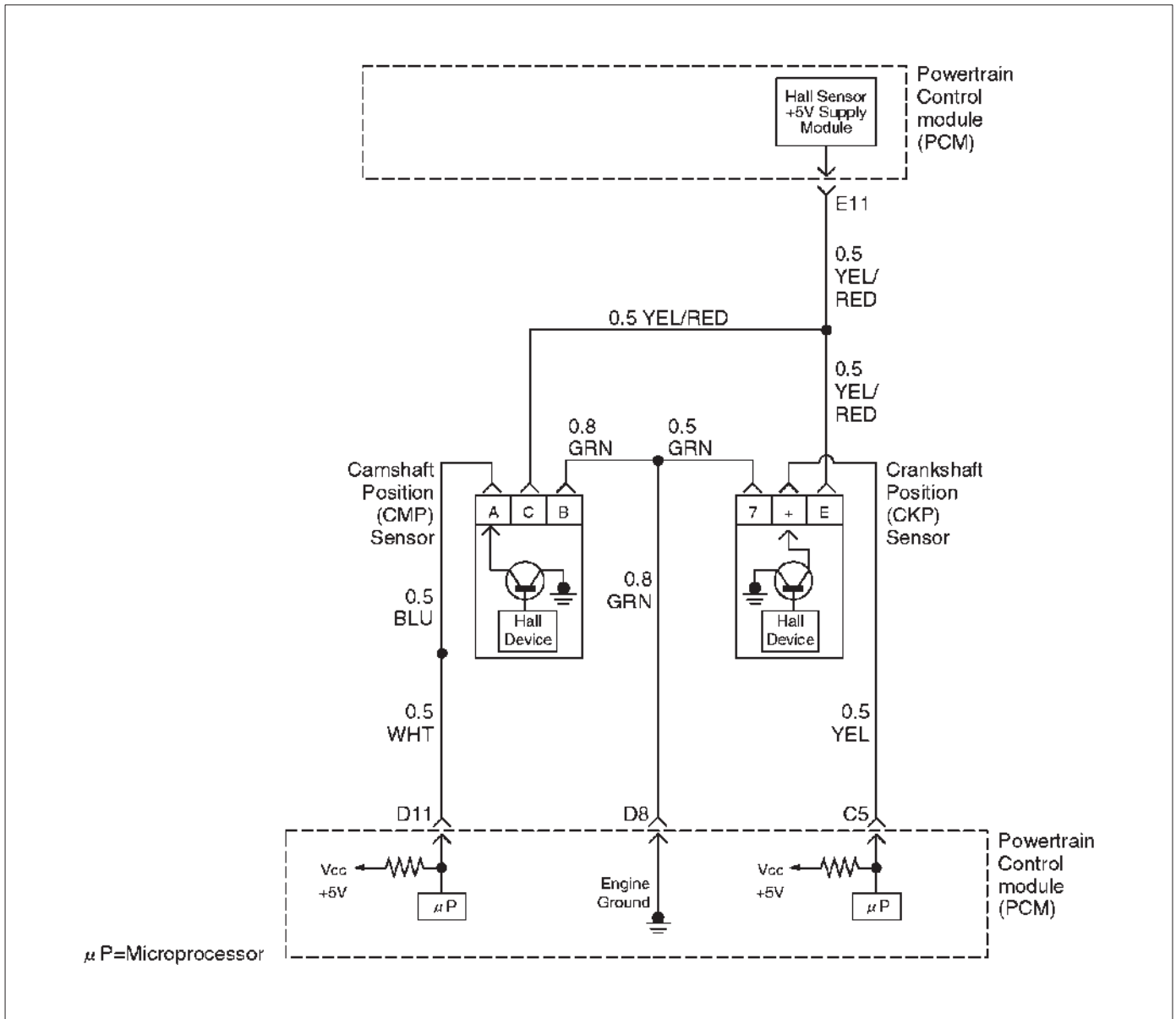
**DTC P0341 – CMP Sensor Circuit Performance**

Step	Action	Value(s)	Yes	No
1	Was the "On-Board Diagnostic (OBD) System Check" performed?	—	Go to Step 2	Go to <i>OBD System Check</i>
2	1. Ignition "ON." 2. Review and record Tech 2 Failure Records data. 3. Operate the vehicle within Failure Records conditions as noted. 4. Using a Tech 2, monitor "DTC" info for DTC P0341 until the DTC P0341 test runs. 5. Note the test result. Does the Tech 2 indicate DTC P0341 failed this ignition?	—	Go to Step 3	Refer to <i>Diagnostic Aids</i>
3	1. Disconnect the CMP sensor. 2. Measure the voltage between the sensor feed circuit and the sensor ground circuit at the CMP sensor harness connector. Does the voltage measure near the specified value?	4-6 V	Go to Step 4	Go to Step 5
4	Measure the voltage between the CMP sensor signal circuit and the sensor ground circuit at the CMP sensor harness connector. Does the voltage measure near the specified value?	4-6 V	Go to Step 11	Go to Step 8
5	If the voltage measured in step 3 was <b>less</b> than 4-6 volts, proceed directly to step 6 without completing this step. If the voltage in step 3 was <b>greater</b> than 4-6 V, repair the short to voltage in the CMP feed circuit. Is the action complete?	—	Verify repair	—
6	1. Check for poor connections at the camshaft position sensor. 2. If a problem is found, repair it as necessary. Was a problem found?	—	Verify repair	Go to Step 7
7	1. Ignition "OFF," disconnect the PCM and the CMP sensor. 2. Check the following circuits for an open between the ignition control module and the CMP sensor: ○ The sensor feed circuit. 3. If a problem is found, repair as necessary. Was a problem found?	—	Verify repair	Go to Step 9
8	1. Ignition "OFF," disconnect the PCM (leave the CMP sensor disconnected). 2. Ignition "ON," check the following circuits: ○ The CMP sensor signal circuit for an open or a short to voltage. ○ The CMP sensor input signal circuit for a short to ground. 3. If a problem is found, repair it as necessary. Was a problem found?	—	Verify repair	Go to Step 9
9	Check for a short or open in the sensor ground circuit. Was a problem found?	—	Verify repair	Go to Step 10

## DTC P0341 – CMP Sensor Circuit Performance (Cont'd)

Step	Action	Value(s)	Yes	No
10	1. Check for poor connections at the PCM. 2. If a problem is found, repair it as necessary. Was a problem found?	—	Verify repair	Go to <i>Step 11</i>
11	Backprobe the PCM connector with a DVM to monitor voltage on the camshaft position input signal circuit while cranking the engine with the sensor connected. (Use rubber band, tape, or an assistant to keep the DVM lead in contact with the sensor terminal during this test.) Does the voltage toggle between the specified values?	4-0 V	Go to <i>Step 15</i>	Go to <i>Step 12</i>
12	1. Remove the CMP sensor. 2. Place a magnet on the CMP sensor. (If you use a magnet that is too small to cover the face of the sensor, test on every part of the sensor face because only a small area will respond to this test.) Does the DVM display a voltage near the specified value?	0 V	Go to <i>Step 13</i>	Go to <i>Step 14</i>
13	Replace the faulty or missing camshaft position sensor magnet. Is the action complete?	—	Verify repair	—
14	Replace the camshaft position sensor. Is the action complete?	—	Verify repair	—
15	Replace the PCM. <b>IMPORTANT:</b> The replacement PCM must be programmed. Refer to <i>On-Vehicle Service in Powertrain Control Module and Sensors</i> for procedures. And also refer to latest Service Bulletin. Check to see if the Latest software is released or not. And then Down Load the LATEST PROGRAMMED SOFTWARE to the replacement PCM. Is the action complete?	—	Verify repair	—

## Diagnostic Trouble Code (DTC) P0342 CMP Sensor Circuit Low



### Circuit Description

The CMP signal produced by the camshaft position (CMP) sensor pulses when the engine is running and crankshaft position (CKP) sync pulses are also being received. The hall type CMP sensor and the CKP sensor share 5 V and ground connections at the powertrain control module (PCM). The third wire at the sensor is a signal circuit to the PCM. The PCM uses the CMP signal pulses to initiate sequential fuel injection. The PCM constantly monitors the number of pulses on the CMP signal circuit and compares the number of CMP pulses to the number of 58X reference pulses received. If the PCM does not receive pulses on the CMP reference circuit, DTC P0342 will set and the PCM will initiate injector sequence without the CMP signal with a one in six chance that injector sequence is correct. The engine will continue to start and run normally, although the misfire diagnostic will be affected if a misfiring condition occurs.

### Conditions for Setting the DTC

- The engine is running.
- The CMP sensor signal is not received by the PCM once every 6 cylinders.
- The above condition occurs for 10 seconds.

### Action Taken When the DTC Sets

- The PCM will illuminate the malfunction indicator lamp (MIL) after the second consecutive trip in which the fault is detected.
- The PCM will initiate injector sequence without the CMP signal with a one in six chance that the injector sequence is correct.
- The PCM will store conditions which were present when the DTC was set as Freeze Frame and in the Failure Records data.

**Conditions for Clearing the MIL/DTC**

- The PCM will turn the MIL “OFF” on the third consecutive trip cycle during which the diagnostic has been run and the fault condition is no longer present.
- A history DTC P0342 will clear after 40 consecutive warm-up cycles have occurred without a fault.
- DTC P0342 can be cleared by using the Tech 2 “Clear Info” function or by disconnecting the PCM battery feed.

**Diagnostic Aids**

An intermittent may be caused by a poor connection, rubbed-through wire insulation or a wire broken inside the insulation. Check for:

- Poor connection – Inspect the PCM harness and connectors for improper mating, broken locks, improperly formed or damaged terminals, and poor terminal to wire connection.

- Damaged harness – Inspect the wiring harness for damage. If the harness appears to be OK, disconnect the PCM, turn the ignition on and observe a voltmeter connected to the CMP signal circuit at the PCM harness connector while moving connectors and wiring harnesses related to the ICM and the CMP sensor. A change in voltage will indicate the location of the fault.

**Test Description**

Number(s) below refer to the step number(s) on the Diagnostic Chart.

- 2. Ensures that the fault is present.
- 14. Determines whether the fault is being caused by a damaged camshaft or a faulty PCM. The voltage measured in this step should read around 4 volts, toggling to near 0 volts when the CMP sensor interfaces with the camshaft magnet.

**DTC P0342 – CMP Sensor Circuit Low**

Step	Action	Value(s)	Yes	No
1	Was the “On-Board Diagnostic (OBD) System Check” performed?	—	Go to Step 2	Go to <i>OBD System Check</i>
2	1. Ignition “ON.” 2. Review and record Tech 2 Failure Records data. 3. Operate the vehicle within Failure Records conditions as noted. 4. Using a Tech 2, monitor “DTC” information for DTC P0342 until the DTC P0342 test runs. 5. Note test result. Does the Tech 2 indicate DTC P0342 failed this ignition?	—	Go to Step 3	Refer to <i>Diagnostic Aids</i>
3	1. Ignition “ON.” 2. Disconnect the CMP sensor. 3. Measure the voltage between the sensor feed circuit and the sensor ground circuit at the CMP sensor harness connector. Does the voltage measure near the specified value?	4-6 V	Go to Step 7	Go to Step 4
4	1. Ignition “OFF,” disconnect the PCM and the CMP sensor. 2. Check for poor connections at the camshaft position sensor. 3. If a problem is found, repair it as necessary. Was a problem found?	—	Verify repair	Go to Step 5
5	1. Check for poor connections at the PCM. 2. If a problem is found, repair it as necessary. Was a problem found?	—	Verify repair	Go to Step 6

**DTC P0342 – CMP Sensor Circuit Low (Cont'd)**

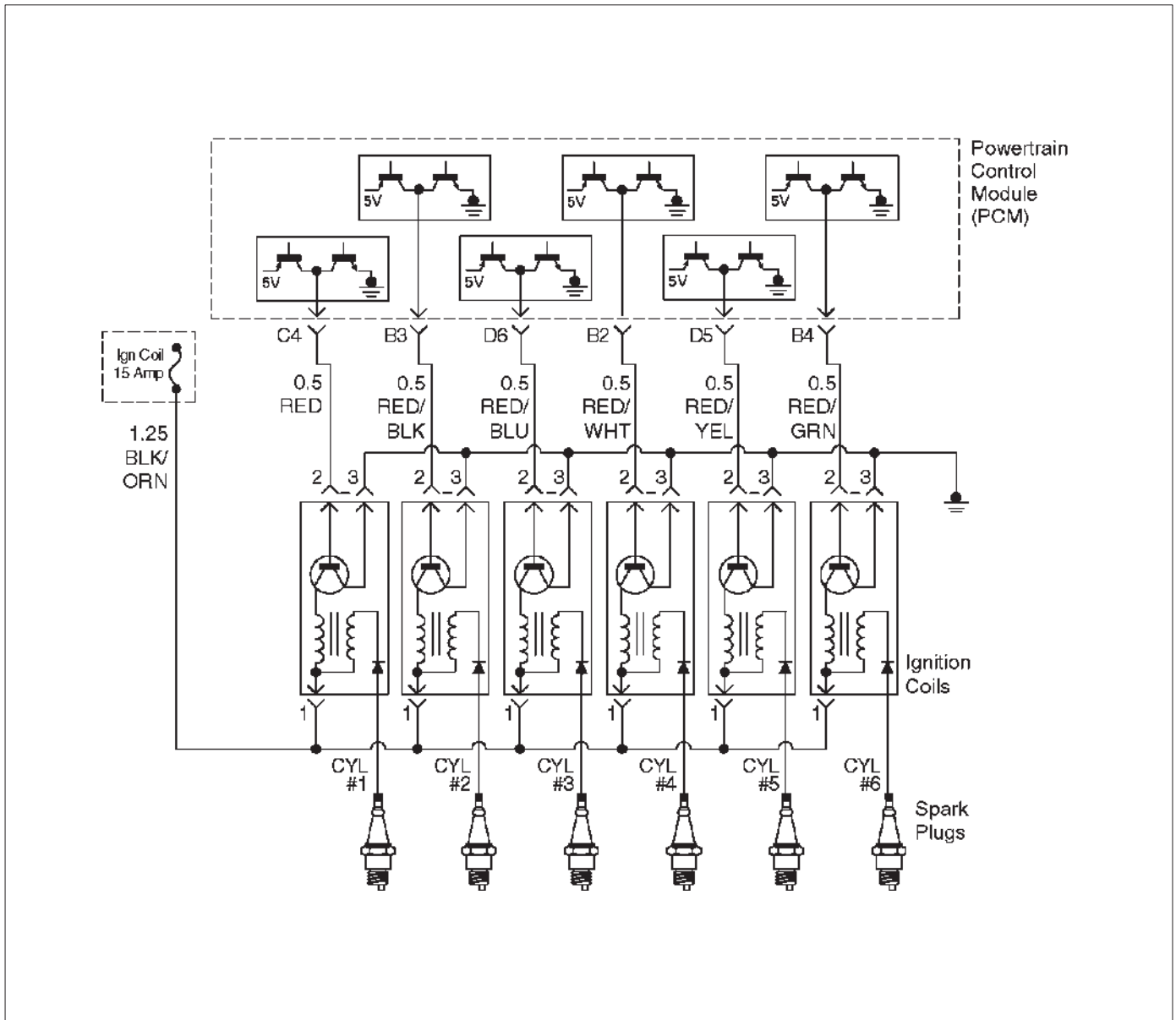
Step	Action	Value(s)	Yes	No
6	1. Check the following circuits between the PCM and the CMP sensor: <ul style="list-style-type: none"> <li>○ The sensor feed circuit. Open or short to ground?</li> <li>○ The sensor ground circuit. Open or short to voltage?</li> </ul> 2. If a problem is found, repair as necessary. Was a problem found?	—	Verify repair	—
7	1. Ignition "ON," engine "OFF." 2. Measure the voltage between the CMP sensor signal circuit and the sensor ground circuit at the CMP sensor harness connector. Does the voltage measure near the specified value?	4-6 V	Go to <i>Step 8</i>	Go to <i>Step 9</i>
8	1. Turn the ignition "OFF." 2. Disconnect the PCM and connect a DVM to monitor voltage on the camshaft position signal circuit at the PCM connector. 3. Ignition "ON." 4. Monitor the voltage display on the DVM while repeatedly touching the CMP sensor signal circuit at the CMP sensor connector with a test light to ground. Does the DVM voltage display switch between 0 and approximately 5 volts when the test light is touched to the CMP sensor signal circuit?	—	Go to <i>Step 12</i>	Go to <i>Step 9</i>
9	1. Ignition "OFF." 2. Leave the PCM disconnected. 3. Ignition "ON." 4. Probe the camshaft position signal circuit at the PCM connector with a test light to B+. 5. If the test light is "ON," locate and repair the short to ground in the camshaft position input signal circuit. Was either circuit shorted to ground?	—	Verify repair	Go to <i>Step 10</i>
10	1. Ignition "OFF." 2. Leave the PCM disconnected. 3. Ignition "ON." 4. Probe the camshaft position signal circuit with a test light to ground. 5. If the test light is "ON," locate and repair the short to voltage in the camshaft position input signal circuit. Was the test light "ON"?	—	Verify repair	Go to <i>Step 11</i>
11	1. Ignition "OFF," disconnect the PCM (leave the CMP sensor disconnected). 2. Ignition "ON," check the following circuit: <ul style="list-style-type: none"> <li>○ The CMP sensor signal circuit for an open.</li> </ul> 3. If a problem is found, repair it as necessary. Was a problem found?	—	Verify repair	—



**DTC P0342 – CMP Sensor Circuit Low (Cont'd)**

Step	Action	Value(s)	Yes	No
12	1. Ignition "ON." 2. Remove the CMP sensor. 3. Place a magnet on the CMP sensor. If you use a magnet that is too small to cover the face of the sensor, test on every part of the sensor face because only a small area will respond to this test. Does the DVM display a voltage near the specified value?	0 V	Go to <i>Step 14</i>	Go to <i>Step 13</i>
13	Replace the camshaft position sensor. Is the action complete?	—	Verify repair	—
14	Replace the PCM. NOTE: The replacement PCM must be programmed. Refer to <i>On-Vehicle Service in Powertrain Control Module and Sensors</i> for procedures. And also refer to latest Service Bulletin. Check to see if the Latest software is released or not. And then Down Load the LATEST PROGRAMMED SOFTWARE to the replacement PCM. Is the action complete?	—	Verify repair	—

## Diagnostic Trouble Code (DTC) P0351 Ignition 1 Control Circuit



### Circuit Description

The powertrain control module's (PCM) control circuit 1 provides a zero-volt or a 5-volt output signal to the ignition coil. The normal voltage on the circuit is zero volts. When the ignition coil receives the 5-volt signal from the PCM, it provides a ground path for the B+ supply to the primary side of the number 1 ignition coil. When the PCM shuts off the 5 volts to the ignition coil, the ignition coil turns "OFF." This causes the ignition coil primary magnetic field to collapse, producing a voltage in the secondary coil which fires the spark plug.

The circuit between the PCM and ignition coil is monitored for an open circuit, short to voltage, and short to ground. When the PCM detects a problem on ignition control circuit 1, it will set a DTC P0351.

### Conditions for Setting the DTC

- The ignition is "ON."
- The engine is turning, determined by the 58X crankshaft position input signal.

- The output voltage is not equal to 5 volts when output is "ON."
- The output voltage is not equal to 0 volts when output is "OFF."
- Twenty test failures occur within 40 samples of continuous spark events.

### Action Taken When the DTC Sets

- The PCM will illuminate the malfunction indicator lamp (MIL) the first time the fault is detected.
- The PCM will store conditions which were present when the DTC was set as Freeze Frame and in the Failure Records data.

### Conditions for Clearing the MIL/DTC

- The PCM will turn the MIL "OFF" on the third consecutive trip cycle in which the diagnostic has been run and the fault condition is no longer present.
- A history DTC P0351 will clear after 40 consecutive warm-up cycles occur without a fault.

## 6E-282 6VE1 3.5L ENGINE DRIVEABILITY AND EMISSIONS

○ DTC P0351 can be cleared by using the Tech 2 “Clear Info” function or by disconnecting the PCM battery feed.

### Diagnostic Aids

Check for the following conditions:

○ Poor connection at PCM – Inspect the harness connectors for backed-out terminals, improper mating, broken locks, improperly formed or damaged terminals, and poor terminal-to-wire connections.

○ Damaged harness – Inspect the wiring harness for damage. If the harness appears to be OK, observe the Tech 2 display related to DTC P0351 while moving the connector and wiring related to the ignition system. A change in the display will indicate the location of the fault.

Reviewing the Failure Records vehicle mileage since the diagnostic test last failed may help determine how often the condition that caused the DTC to be set occurs. This may assist in diagnosing the condition.

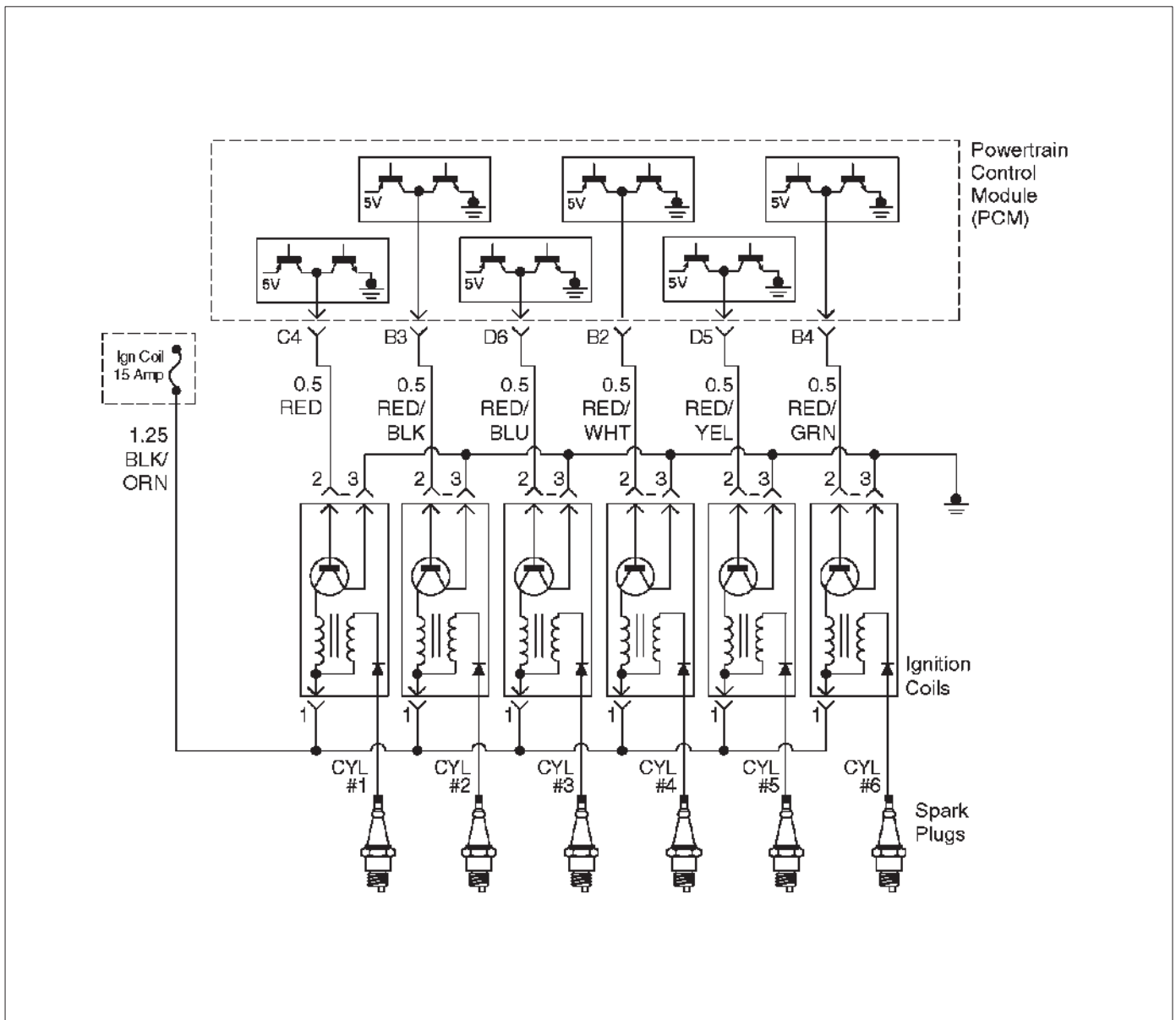
## DTC P0351 – Ignition 1 Control Circuit

Step	Action	Value(s)	Yes	No
1	Was the “On-Board Diagnostic (OBD) System Check” performed?	—	Go to Step 2	Go to <i>OBD System Check</i>
2	1. Ignition “ON,” engine “OFF.” 2. Review and record Tech 2 Failure Records data. 3. Operate the vehicle within Failure Record conditions as noted. 4. Use a Tech 2 to monitor the “DTC” information for DTC P0351 until the DTC P0351 test runs. 5. Note the test result. Does the Tech 2 indicate DTC P0351 failed this ignition cycle?	—	Go to Step 3	Go to <i>Diagnostic Aids</i>
3	Check for faulty connection at ignition coil. Was a problem found?	—	Verify repair	Go to Step 4
4	Check for faulty connection at PCM connector. Was a problem found?	—	Verify repair	Go to Step 5
5	1. Ignition “ON,” engine “OFF.” 2. Back probe the ignition control circuit 1 at the PCM with a DVM. Is the voltage near the specified value?	25-55 mV	Go to Step 6	Go to Step 9
6	1. Ignition “ON,” engine running. 2. Back probe the ignition control circuit at the PCM for the cylinder being tested. Is the voltage in the specified range, rapidly toggling back and forth to a reading 20-50 mV higher?	100-180 mV	Go to Step 7	Go to Step 13
7	1. Ignition “OFF.” 2. Disconnect the 3-pin and connector at the ignition coil. 3. Check ignition control circuit 1 voltage at the ignition coil connector while cranking the engine. Does the voltage measure between the specified values?	200-1200 mV	Go to Step 8	Go to Step 11
8	Replace the ignition coil. Is the action complete?	—	Verify repair	—
9	1. Ignition “OFF.” 2. Disconnect the PCM and the ignition coil. 3. Check ignition control circuit 1 for short to ground. Was a problem found?	—	Verify repair	Go to Step 10

### DTC P0351 – Ignition 1 Control Circuit (Cont'd)

Step	Action	Value(s)	Yes	No
10	Check ignition control circuit 1 for short to voltage. Was a problem found?	—	Verify repair	Go to <i>Step 13</i>
11	Check for an open ignition control circuit 1. Was the ignition control circuit open?	—	Go to <i>Step 12</i>	Go to <i>Step 13</i>
12	Repair the open ignition control circuit. Is the action complete?	—	Verify repair	—
13	Replace the PCM. <b>IMPORTANT:</b> The replacement PCM must be programmed. Refer to <i>On-Vehicle Service</i> in <i>Powertrain Control Module and Sensors</i> for procedures. And also refer to latest Service Bulletin. Check to see if the Latest software is released or not. And then Down Load the LATEST PROGRAMMED SOFTWARE to the replacement PCM. Is the action complete?	—	Verify repair	—

## Diagnostic Trouble Code (DTC) P0352 Ignition 2 Control Circuit



### Circuit Description

The powertrain control module's (PCM) control circuit 2 provides a zero-volt or a 5-volt output signal to the ignition coil. The normal voltage on the circuit is zero volts. When the ignition coil receives the 5-volt signal from the PCM, it provides a ground path for the B+ supply to the primary side of the number 2 ignition coil. When the PCM shuts off the 5 volts to the ignition coil, the ignition coil turns "OFF." This causes the ignition coil primary magnetic field to collapse, producing a voltage in the secondary coil which fires the spark plug.

The circuit between the PCM and ignition coil is monitored for an open circuit, short to voltage, and short to ground. When the PCM detects a problem on ignition control circuit 2, it will set a DTC P0352.

### Conditions for Setting the DTC

- The ignition is "ON."
- The engine is turning, determined by the 58 X crankshaft position input signal.

- The output voltage is not equal to 5 volts when output is "ON."
- The output voltage is not equal to 0 volts when output is "OFF."
- Twenty test failures occur within 40 samples of continuous spark events.

### Action Taken When the DTC Sets

- The PCM will illuminate the malfunction indicator lamp (MIL) the first time the fault is detected.
- The PCM will store conditions which were present when the DTC was set as Freeze Frame and in the Failure Records data.

### Conditions for Clearing the MIL/DTC

- The PCM will turn the MIL "OFF" on the third consecutive trip cycle in which the diagnostic has been run and the fault condition is no longer present.
- A history DTC P0352 will clear after 40 consecutive warm-up cycles occur without a fault.

○ DTC P0352 can be cleared by using the Tech 2 “Clear Info” function or by disconnecting the PCM battery feed.

**Diagnostic Aids**

Check for the following conditions:

○ Poor connection at PCM – Inspect the harness connectors for backed-out terminals, improper mating, broken locks, improperly formed or damaged terminals, and poor terminal-to-wire connections.

○ Damaged harness – Inspect the wiring harness for damage. If the harness appears to be OK, observe the Tech 2 display related to DTC P0352 while moving the connector and wiring related to the ignition system. A change in the display will indicate the location of the fault.

Reviewing the Failure Records vehicle mileage since the diagnostic test last failed may help determine how often the condition that caused the DTC to be set occurs. This may assist in diagnosing the condition.

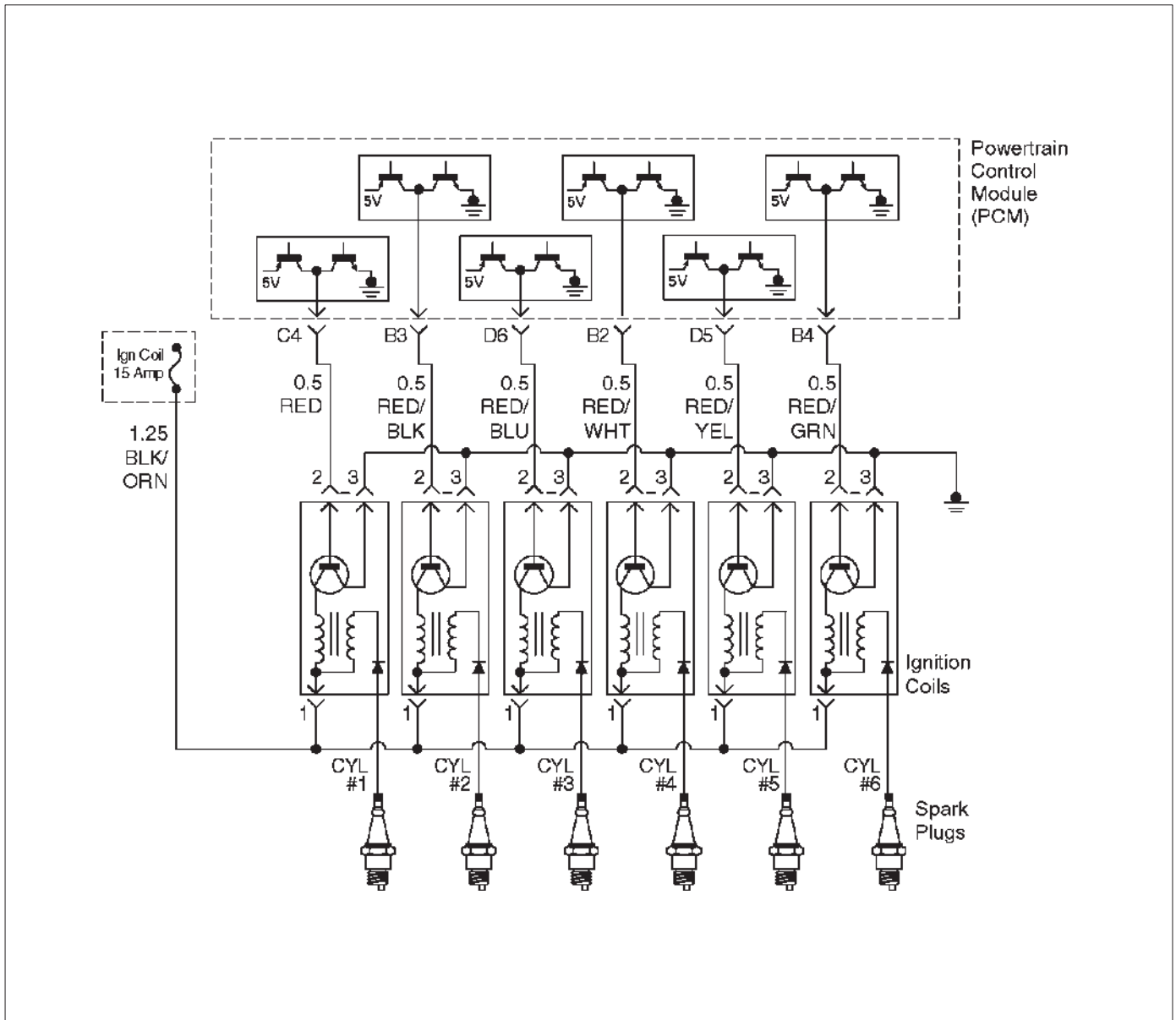
**DTC P0352 – Ignition 2 Control Circuit**

Step	Action	Value(s)	Yes	No
1	Was the “On-Board Diagnostic (OBD) System Check” performed?	—	Go to Step 2	Go to <i>OBD System Check</i>
2	1. Ignition “ON,” engine “OFF.” 2. Review and record Tech 2 Failure Records data. 3. Operate the vehicle within Failure Record conditions as noted. 4. Use a Tech 2 to monitor the “DTC” information for DTC P0352 until the DTC P0352 test runs. 5. Note the test result. Does the Tech 2 indicate DTC P0352 failed this ignition cycle?	—	Go to Step 3	Go to <i>Diagnostic Aids</i>
3	Check for faulty connection at ignition coil. Was a problem found?	—	Verify repair	Go to Step 4
4	Check for faulty connection at PCM connector. Was a problem found?	—	Verify repair	Go to Step 5
5	1. Ignition “ON,” engine “OFF.” 2. Back probe the ignition control circuit 2 at the PCM with a DVM . Is the voltage near the specified value?	25-55 mV	Go to Step 6	Go to Step 9
6	1. Ignition “ON,” engine running. 2. Back probe the ignition control circuit at the PCM for the cylinder being tested. Is the voltage in the specified range, rapidly toggling back and forth to a reading 20-50 mV higher?	100-180 mV	Go to Step 7	Go to Step 13
7	1. Ignition “OFF.” 2. Disconnect the 3-pin connector at the ignition coil. 3. Check ignition control circuit 2 voltage at the ignition coil connector while cranking the engine connector. Does the voltage measure between the specified values?	200-1200 mV	Go to Step 8	Go to Step 11
8	Replace the ignition coil. Is the action complete?	—	Verify repair	—
9	1. Ignition “OFF.” 2. Disconnect the PCM and the ignition coil. 3. Check ignition control circuit 2 for short to ground. Was a problem found?	—	Verify repair	Go to Step 10
10	Check ignition control circuit 2 for short to voltage. Was a problem found?	—	Verify repair	Go to Step 13

## DTC P0352 – Ignition 2 Control Circuit (Cont'd)

Step	Action	Value(s)	Yes	No
11	Check for an open ignition control circuit 2. Was the ignition control circuit open?	—	Go to <i>Step 12</i>	Go to <i>Step 13</i>
12	Repair the open ignition control circuit. Is the action complete?	—	Verify repair	—
13	Replace the PCM. <b>IMPORTANT:</b> The replacement PCM must be programmed. Refer to <i>On-Vehicle Service</i> in <i>Powertrain Control Module and Sensors</i> for procedures. And also refer to latest Service Bulletin. Check to see if the Latest software is released or not. And then Down Load the LATEST PROGRAMMED SOFTWARE to the replacement PCM. Is the action complete?	—	Verify repair	—

## Diagnostic Trouble Code (DTC) P0353 Ignition 3 Control Circuit



### Circuit Description

The powertrain control module's (PCM) control circuit 3 provides a zero-volt or a 5-volt output signal to the ignition coil. The normal voltage on the circuit is zero volts. When the ignition coil receives the 5-volt signal from the PCM, it provides a ground path for the B+ supply to the primary side of the number 3 ignition coil. When the PCM shuts off the 5 volts to the ignition coil, the ignition coil turns "OFF." This causes the ignition coil primary magnetic field to collapse, producing a voltage in the secondary coil which fires the spark plug.

The circuit between the PCM and ignition coil is monitored for an open circuit, short to voltage, and short to ground. When the PCM detects a problem on ignition control circuit 3, it will set a DTC P0353.

### Conditions for Setting the DTC

- The ignition is "ON."
- The engine is turning, determined by the 58X crankshaft position input signal.

- The output voltage is not equal to 5 volts when output is "ON."
- The output voltage is not equal to 0 volts when output is "OFF."
- Twenty test failures occur within 40 samples of continuous spark events.

### Action Taken When the DTC Sets

- The PCM will illuminate the malfunction indicator lamp (MIL) the first time the fault is detected.
- The PCM will store conditions which were present when the DTC was set as Freeze Frame and in the Failure Records data.

### Conditions for Clearing the MIL/DTC

- The PCM will turn the MIL "OFF" on the third consecutive trip cycle in which the diagnostic has been run and the fault condition is no longer present.
- A history DTC P0353 will clear after 40 consecutive warm-up cycles occur without a fault.



○ DTC P0353 can be cleared by using the Tech 2 “Clear Info” function or by disconnecting the PCM battery feed.

**Diagnostic Aids**

Check for the following conditions:

○ Poor connection at PCM – Inspect the harness connectors for backed-out terminals, improper mating, broken locks, improperly formed or damaged terminals, and poor terminal-to-wire connections.

○ Damaged harness – Inspect the wiring harness for damage. If the harness appears to be OK, observe the Tech 2 display related to DTC P0353 while moving the connector and wiring related to the ignition system. A change in the display will indicate the location of the fault.

Reviewing the Failure Records vehicle mileage since the diagnostic test last failed may help determine how often the condition that caused the DTC to be set occurs. This may assist in diagnosing the condition.

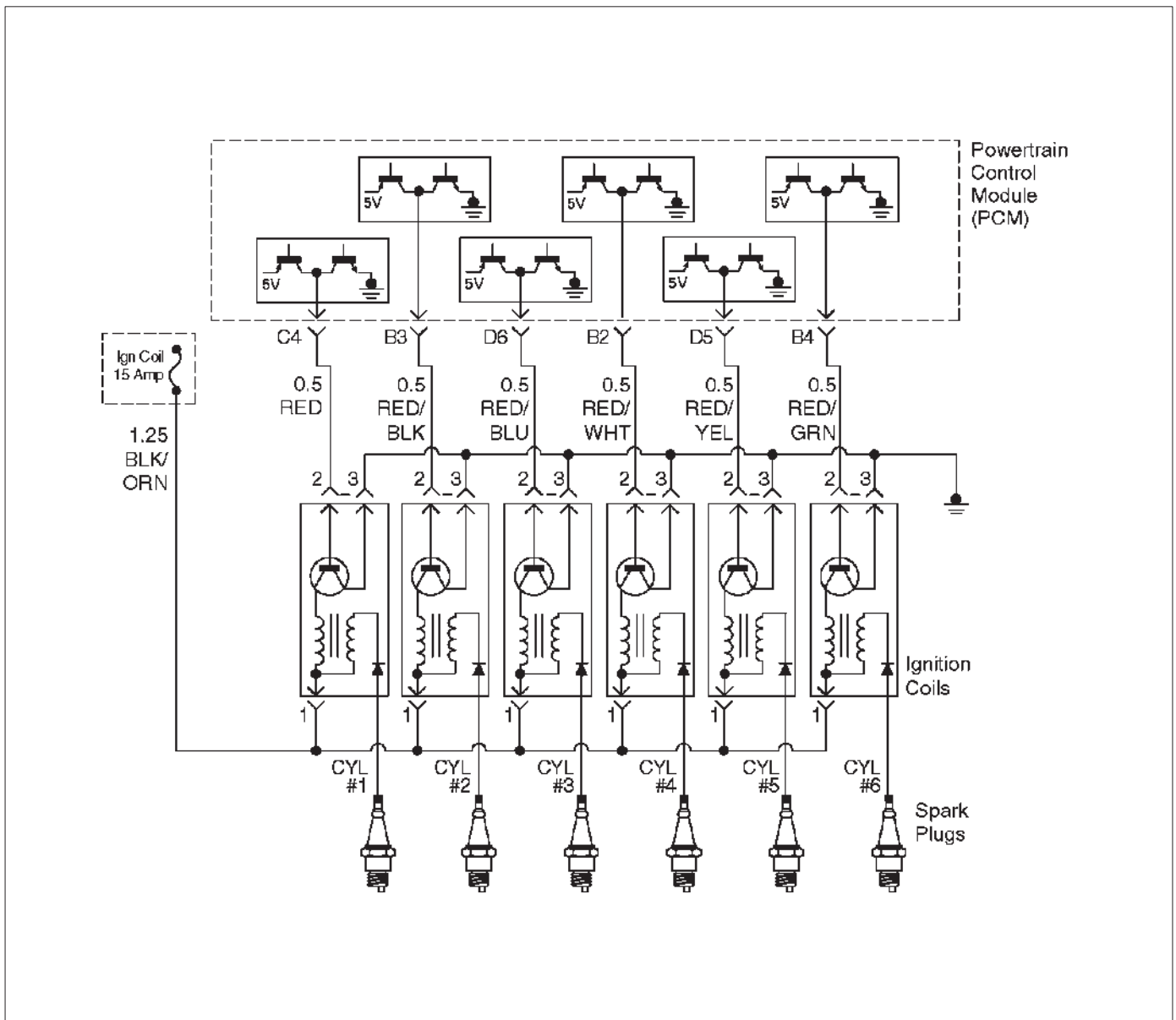
**DTC P0353 – Ignition 3 Control Circuit**

Step	Action	Value(s)	Yes	No
1	Was the “On-Board Diagnostic (OBD) System Check” performed?	—	Go to Step 2	Go to <i>OBD System Check</i>
2	1. Ignition “ON,” engine “OFF.” 2. Review and record Tech 2 Failure Records data. 3. Operate the vehicle within Failure Record conditions as noted. 4. Use a Tech 2 to monitor the “DTC” information for DTC P0353 until the DTC P0353 test runs. 5. Note the test result. Does the Tech 2 indicate DTC P0353 failed this ignition cycle?	—	Go to Step 3	Go to <i>Diagnostic Aids</i>
3	Check for faulty connection at ignition coil. Was a problem found?	—	Verify repair	Go to Step 4
4	Check for faulty connection at PCM connector. Was a problem found?	—	Verify repair	Go to Step 5
5	1. Ignition “ON,” engine “OFF.” 2. Back probe the ignition control circuit 3 at the PCM with a DVM positive lead with the negative lead to ground. Is the voltage near the specified value?	25-55 mV	Go to Step 6	Go to Step 9
6	1. Ignition “ON,” engine running. 2. Back probe the ignition control circuit at the PCM for the cylinder being tested. Is the voltage in the specified range, rapidly toggling back and forth to a reading 20-50 mV higher?	100-180 mV	Go to Step 7	Go to Step 13
7	1. Ignition “OFF.” 2. Disconnect the 3-pin connector at the ignition coil. 3. Check ignition control circuit 3 voltage at the ignition coil connector while cranking the engine. Does the voltage measure between the specified values?	200-1200 mV	Go to Step 8	Go to Step 11
8	Replace the ignition coil. Is the action complete?	—	Verify repair	—
9	1. Ignition “OFF.” 2. Disconnect the PCM and the ignition coil. 3. Check ignition control circuit 3 for short to ground. Was a problem found?	—	Verify repair	Go to Step 10

## DTC P0353 – Ignition 3 Control Circuit (Cont'd)

Step	Action	Value(s)	Yes	No
10	Check ignition control circuit 3 for short to voltage. Was a problem found?	—	Verify repair	Go to <i>Step 13</i>
11	Check for an open ignition control circuit 3. Was the ignition control circuit open?	—	Go to <i>Step 12</i>	Go to <i>Step 13</i>
12	Repair the open ignition control circuit. Is the action complete?	—	Verify repair	—
13	Replace the PCM. <b>IMPORTANT:</b> The replacement PCM must be programmed. Refer to <i>On-Vehicle Service</i> in <i>Powertrain Control Module and Sensors</i> for procedures. And also refer to latest Service Bulletin. Check to see if the Latest software is released or not. And then Down Load the LATEST PROGRAMMED SOFTWARE to the replacement PCM. Is the action complete?	—	Verify repair	—

## Diagnostic Trouble Code (DTC) P0354 Ignition 4 Control Circuit



### Circuit Description

The powertrain control module's (PCM) control circuit 4 provides a zero-volt or a 5-volt output signal to the ignition coil. The normal voltage on the circuit is zero volts. When the ignition coil receives the 5-volt signal from the PCM, it provides a ground path for the B+ supply to the primary side of the number 4 ignition coil. When the PCM shuts off the 5 volts to the ignition coil, the ignition coil turns "OFF." This causes the ignition coil primary magnetic field to collapse, producing a voltage in the secondary coil which fires the spark plug.

The circuit between the PCM and ignition coil is monitored for an open circuit, short to voltage, and short to ground. When the PCM detects a problem on ignition control circuit 4, it will set a DTC P0354.

### Conditions for Setting the DTC

- The ignition is "ON."
- The engine is turning, determined by the 58X crankshaft position input signal.

- The output voltage is not equal to 5 volts when output is "ON."
- The output voltage is not equal to 0 volts when output is "OFF."
- Twenty test failures occur within 40 samples of continuous spark events.

### Action Taken When the DTC Sets

- The PCM will illuminate the malfunction indicator lamp (MIL) the first time the fault is detected.
- The PCM will store conditions which were present when the DTC was set as Freeze Frame and in the Failure Records data.

### Conditions for Clearing the MIL/DTC

- The PCM will turn the MIL "OFF" on the third consecutive trip cycle in which the diagnostic has been run and the fault condition is no longer present.
- A history DTC P0354 will clear after 40 consecutive warm-up cycles occur without a fault.

○ DTC P0354 can be cleared by using the Tech 2 “Clear Info” function or by disconnecting the PCM battery feed.

**Diagnostic Aids**

Check for the following conditions:

○ Poor connection at PCM – Inspect the harness connectors for backed-out terminals, improper mating, broken locks, improperly formed or damaged terminals, and poor terminal-to-wire connections.

○ Damaged harness – Inspect the wiring harness for damage. If the harness appears to be OK, observe the Tech 2 display related to DTC P0354 while moving the connector and wiring related to the ignition system. A change in the display will indicate the location of the fault.

Reviewing the Failure Records vehicle mileage since the diagnostic test last failed may help determine how often the condition that caused the DTC to be set occurs. This may assist in diagnosing the condition.

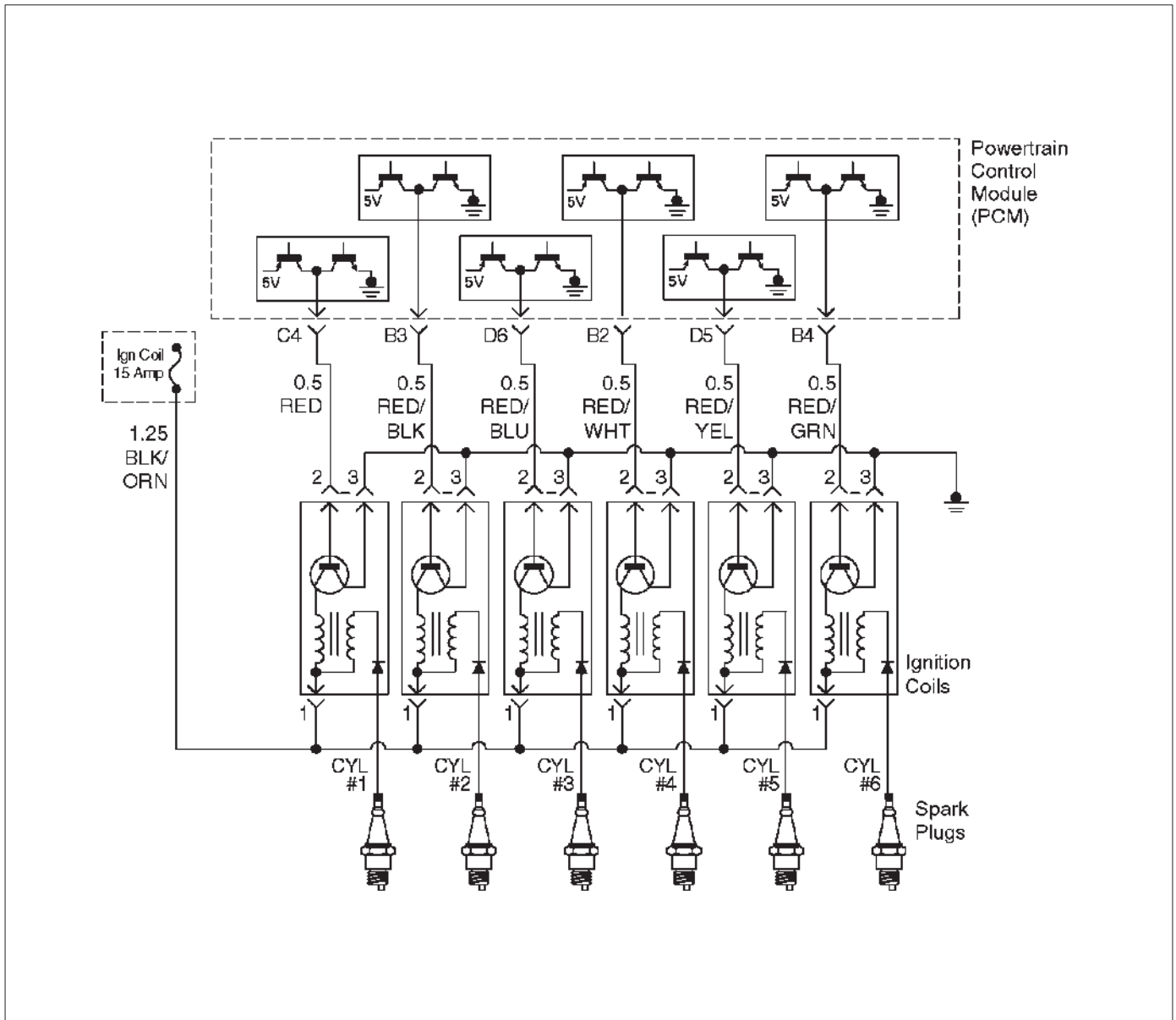
**DTC P0354 – Ignition 4 Control Circuit**

Step	Action	Value(s)	Yes	No
1	Was the “On-Board Diagnostic (OBD) System Check” performed?	—	Go to Step 2	Go to <i>OBD System Check</i>
2	1. Ignition “ON,” engine “OFF.” 2. Review and record Tech 2 Failure Records data. 3. Operate the vehicle within Failure Record conditions as noted. 4. Use a Tech 2 to monitor the “DTC” information for DTC P0354 until the DTC P0354 test runs. 5. Note the test result. Does the Tech 2 indicate DTC P0354 failed this ignition cycle?	—	Go to Step 3	Go to <i>Diagnostic Aids</i>
3	Check for faulty connection at ignition coil. Was a problem found?	—	Verify repair	Go to Step 4
4	Check for faulty connection at PCM connector. Was a problem found?	—	Verify repair	Go to Step 5
5	1. Ignition “ON,” engine “OFF.” 2. Back probe the ignition control circuit 4 at the PCM with a DVM positive lead with the negative lead to ground. Is the voltage near the specified value?	25-55 mV	Go to Step 6	Go to Step 9
6	1. Ignition “ON,” engine running. 2. Back probe the ignition control circuit at the PCM for the cylinder being tested. Is the voltage in the specified range, rapidly toggling back and forth to a reading 20-50 mV higher?	100-180 mV	Go to Step 7	Go to Step 13
7	1. Ignition “OFF.” 2. Disconnect the 3-pin connector at the ignition coil. 3. Check ignition control circuit 4 voltage at the ignition coil connector while cranking the engine. Does the voltage measure between the specified values?	200-1200 mV	Go to Step 8	Go to Step 11
8	Replace the ignition coil. Is the action complete?	—	Verify repair	—
9	1. Ignition “OFF.” 2. Disconnect the PCM and the ignition coil. 3. Check ignition control circuit 4 for short to ground. Was a problem found?	—	Verify repair	Go to Step 10

## DTC P0354 – Ignition 4 Control Circuit (Cont'd)

Step	Action	Value(s)	Yes	No
10	Check ignition control circuit 4 for short to voltage. Was a problem found?	—	Verify repair	Go to <i>Step 13</i>
11	Check for an open ignition control circuit 4. Was the ignition control circuit open?	—	Go to <i>Step 12</i>	Go to <i>Step 13</i>
12	Repair the open in ignition control circuit. Is the action complete?	—	Verify repair	—
13	Replace the PCM. <b>IMPORTANT:</b> The replacement PCM must be programmed. Refer to <i>On-Vehicle Service</i> in <i>Powertrain Control Module and Sensors</i> for procedures. And also refer to latest Service Bulletin. Check to see if the Latest software is released or not. And then Down Load the LATEST PROGRAMMED SOFTWARE to the replacement PCM. Is the action complete?	—	Verify repair	—

## Diagnostic Trouble Code (DTC) P0355 Ignition 5 Control Circuit



### Circuit Description

The powertrain control module's (PCM) control circuit 5 provides a zero-volt or a 5-volt output signal to the ignition coil. The normal voltage on the circuit is zero volts. When the ignition coil receives the 5-volt signal from the PCM, it provides a ground path for the B+ supply to the primary side of the number 5 ignition coil. When the PCM shuts off the 5 volts to the ignition coil, the ignition coil turns "OFF." This causes the ignition coil primary magnetic field to collapse, producing a voltage in the secondary coil which fires the spark plug.

The circuit between the PCM and ignition coil is monitored for an open circuit, short to voltage, and short to ground. When the PCM detects a problem on ignition control circuit 5, it will set a DTC P0355.

### Conditions for Setting the DTC

- The ignition is "ON."
- The engine is turning, determined by the 58X crankshaft position input signal.

- The output voltage is not equal to 5 volts when output is "ON."
- The output voltage is not equal to 0 volts when output is "OFF."
- Twenty test failures occur within 40 samples of continuous spark events.

### Action Taken When the DTC Sets

- The PCM will illuminate the malfunction indicator lamp (MIL) the first time the fault is detected.
- The PCM will store conditions which were present when the DTC was set as Freeze Frame and in the Failure Records data.

### Conditions for Clearing the MIL/DTC

- The PCM will turn the MIL "OFF" on the third consecutive trip cycle in which the diagnostic has been run and the fault condition is no longer present.
- A history DTC P0355 will clear after 40 consecutive warm-up cycles occur without a fault.

○ DTC P0355 can be cleared by using the Tech 2 “Clear Info” function or by disconnecting the PCM battery feed.

**Diagnostic Aids**

Check for the following conditions:

○ Poor connection at PCM – Inspect the harness connectors for backed-out terminals, improper mating, broken locks, improperly formed or damaged terminals, and poor terminal-to-wire connections.

○ Damaged harness – Inspect the wiring harness for damage. If the harness appears to be OK, observe the Tech 2 display related to DTC P0355 while moving the connector and wiring related to the ignition system. A change in the display will indicate the location of the fault.

Reviewing the Failure Records vehicle mileage since the diagnostic test last failed may help determine how often the condition that caused the DTC to be set occurs. This may assist in diagnosing the condition.

**DTC P0355 – Ignition 5 Control Circuit**

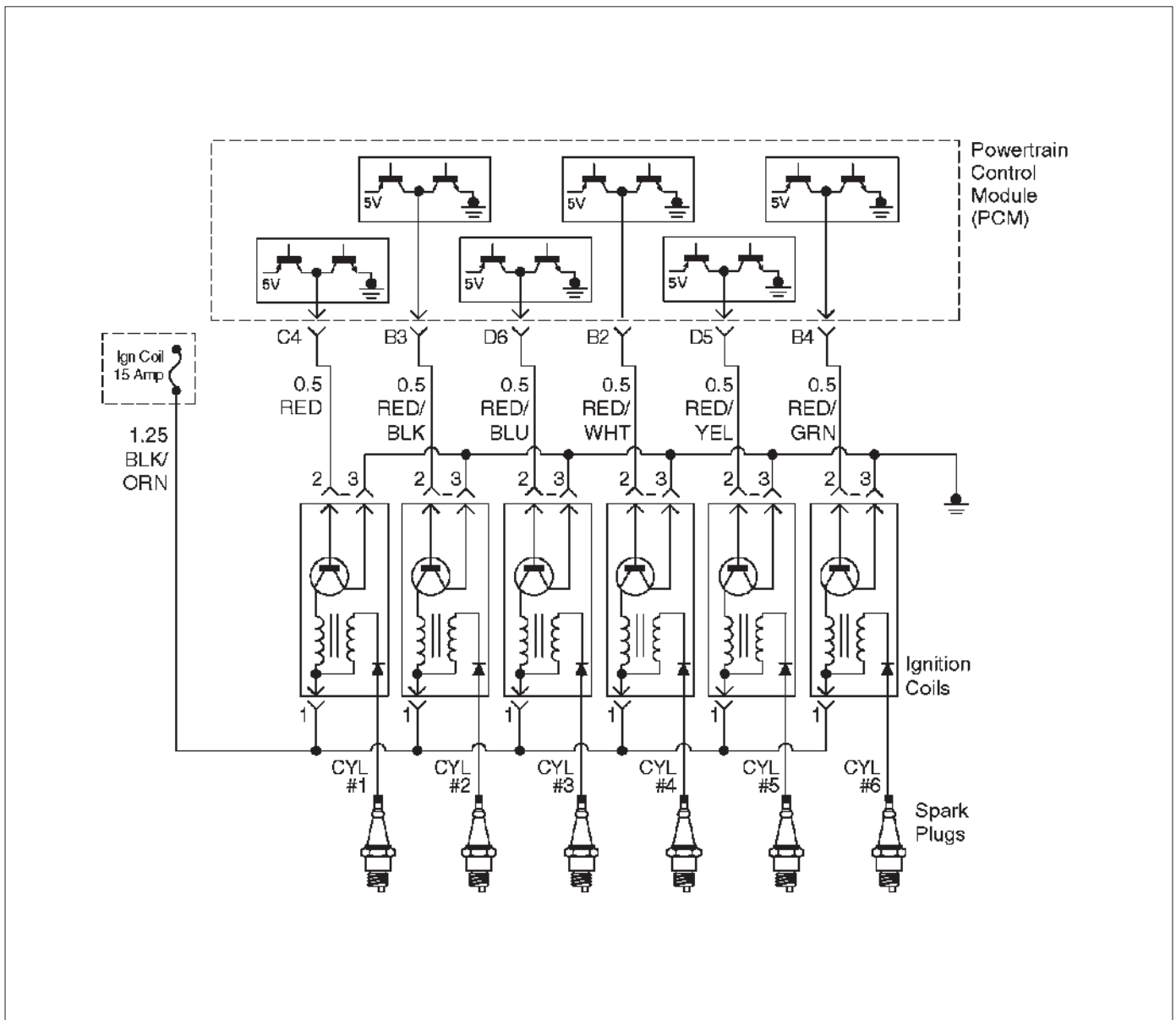
Step	Action	Value(s)	Yes	No
1	Was the “On-Board Diagnostic (OBD) System Check” performed?	—	Go to Step 2	Go to <i>OBD System Check</i>
2	1. Ignition “ON,” engine “OFF.” 2. Review and record Tech 2 Failure Records data. 3. Operate the vehicle within Failure Record conditions as noted. 4. Use a Tech 2 to monitor the “DTC” information for DTC P0355 until the DTC P0355 test runs. 5. Note the test result. Does the Tech 2 indicate DTC P0355 failed this ignition cycle?	—	Go to Step 3	Go to <i>Diagnostic Aids</i>
3	Check for faulty connection at ignition coil. Was a problem found?	—	Verify repair	Go to Step 4
4	Check for faulty connection at PCM connector. Was a problem found?	—	Verify repair	Go to Step 5
5	1. Ignition “ON,” engine “OFF.” 2. Back probe the ignition control circuit 5 at the PCM with a DVM positive lead with the negative lead to ground. Is the voltage near the specified value?	25-55 mV	Go to Step 6	Go to Step 9
6	1. Ignition “ON,” engine running. 2. Back probe the ignition control circuit at the PCM for the cylinder being tested. Is the voltage in the specified range, rapidly toggling back and forth to a reading 20-50 mV higher?	100-180 mV	Go to Step 7	Go to Step 13
7	1. Ignition “OFF.” 2. Disconnect the 3-pin connector at the ignition coil. 3. Check ignition control circuit 5 voltage at the ignition coil connector while cranking the engine. Does the voltage measure between the specified values?	200-1200 mV	Go to Step 8	Go to Step 11
8	Replace the ignition coil. Is the action complete?	—	Verify repair	—
9	1. Ignition “OFF.” 2. Disconnect the PCM and the ignition coil. 3. Check ignition control circuit 5 for short to ground. Was a problem found?	—	Verify repair	Go to Step 10

### DTC P0355 – Ignition 5 Control Circuit (Cont'd)

Step	Action	Value(s)	Yes	No
10	Check ignition control circuit 5 for short to voltage. Was a problem found?	—	Verify repair	Go to <i>Step 13</i>
11	Check for an open ignition control circuit 5. Was the ignition control circuit open?	—	Go to <i>Step 12</i>	Go to <i>Step 13</i>
12	Repair the open ignition control circuit. Is the action complete?	—	Verify repair	—
13	Replace the PCM. <b>IMPORTANT:</b> The replacement PCM must be programmed. Refer to <i>On-Vehicle Service</i> in <i>Powertrain Control Module and Sensors</i> for procedures. And also refer to latest Service Bulletin. Check to see if the Latest software is released or not. And then Down Load the LATEST PROGRAMMED SOFTWARE to the replacement PCM. Is the action complete?	—	Verify repair	—



## Diagnostic Trouble Code (DTC) P0356 Ignition 6 Control Circuit



### Circuit Description

The powertrain control module's (PCM) control circuit 6 provides a zero-volt or a 5-volt output signal to the ignition coil. The normal voltage on the circuit is zero volts. When the ignition coil receives the 5-volt signal from the PCM, it provides a ground path for the B+ supply to the primary side of the number 6 ignition coil. When the PCM shuts off the 5 volts to the ignition coil, the ignition coil turns "OFF." This causes the ignition coil primary magnetic field to collapse, producing a voltage in the secondary coil which fires the spark plug.

The circuit between the PCM and ignition coil is monitored for an open circuit, short to voltage, and short to ground. When the PCM detects a problem on ignition control circuit 6, it will set a DTC P0356.

### Conditions for Setting the DTC

- The ignition is "ON."
- The engine is turning, determined by the 58X crankshaft position input signal.

- The output voltage is not equal to 5 volts when output is "ON."
- The output voltage is not equal to 0 volts when output is "OFF."
- Twenty test failures occur within 40 samples of continuous circuit monitoring.

### Action Taken When the DTC Sets

- The PCM will illuminate the malfunction indicator lamp (MIL) the first time the fault is detected.
- The PCM will store conditions which were present when the DTC was set as Freeze Frame and in the Failure Records data.

### Conditions for Clearing the MIL/DTC

- The PCM will turn the MIL "OFF" on the third consecutive trip cycle in which the diagnostic has been run and the fault condition is no longer present.
- A history DTC P0356 will clear after 40 consecutive warm-up cycles occur without a fault.

○ DTC P0356 can be cleared by using the Tech 2 “Clear Info” function or by disconnecting the PCM battery feed.

**Diagnostic Aids**

Check for the following conditions:

○ Poor connection at PCM – Inspect the harness connectors for backed-out terminals, improper mating, broken locks, improperly formed or damaged terminals, and poor terminal-to-wire connections.

○ Damaged harness – Inspect the wiring harness for damage. If the harness appears to be OK, observe the Tech 2 display related to DTC P0356 while moving the connector and wiring related to the ignition system. A change in the display will indicate the location of the fault.

Reviewing the Failure Records vehicle mileage since the diagnostic test last failed may help determine how often the condition that caused the DTC to be set occurs. This may assist in diagnosing the condition.

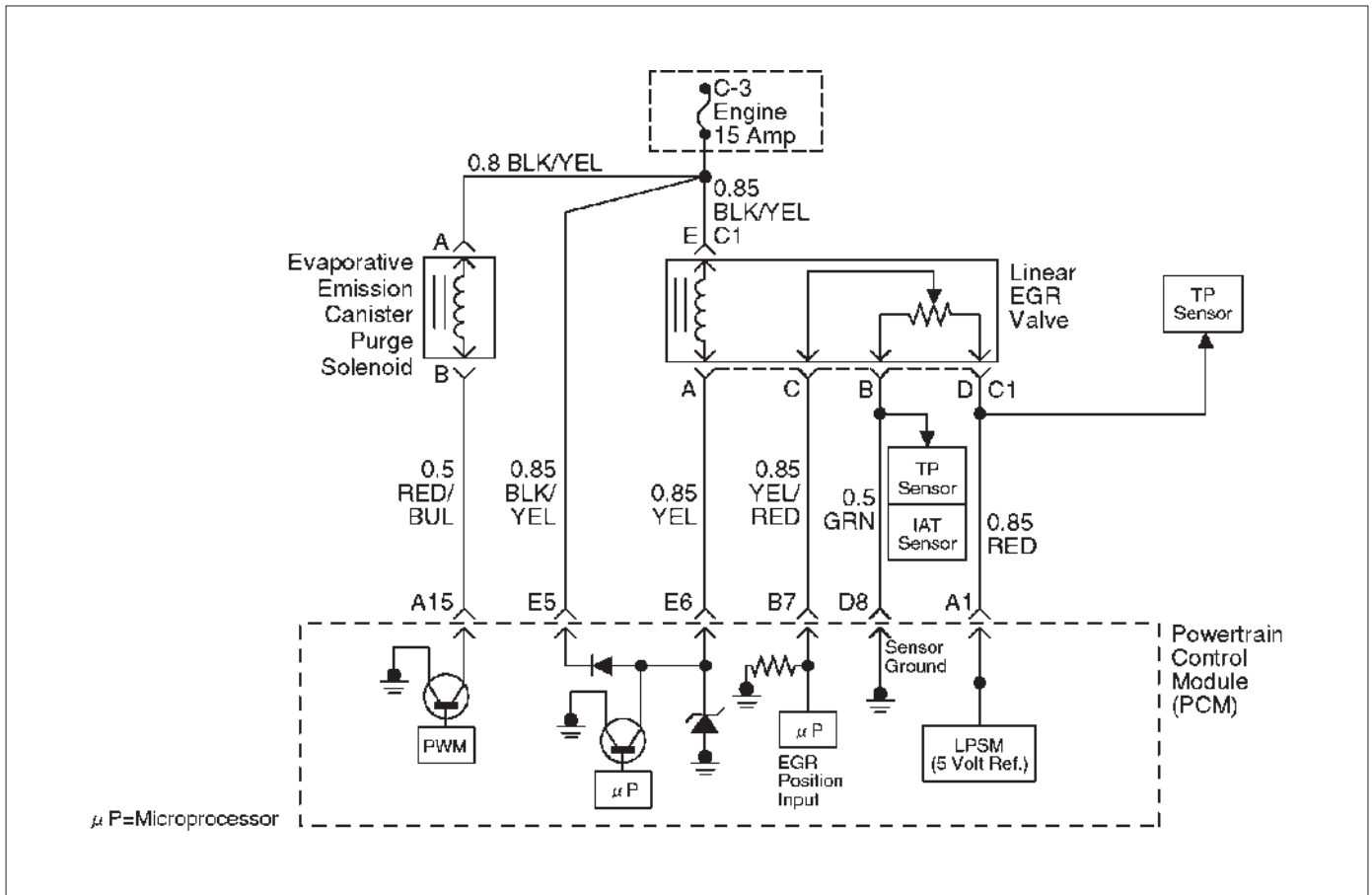
**DTC P0356 – Ignition 6 Control Circuit**

Step	Action	Value(s)	Yes	No
1	Was the “On-Board Diagnostic (OBD) System Check” performed?	—	Go to Step 2	Go to <i>OBD System Check</i>
2	1. Ignition “ON,” engine “OFF.” 2. Review and record Tech 2 Failure Records data. 3. Operate the vehicle within Failure Record conditions as noted. 4. Use a Tech 2 to monitor the “DTC” information for DTC P0356 until the DTC P0356 test runs. 5. Note the test result. Does the Tech 2 indicate DTC P0356 failed this ignition cycle?	—	Go to Step 3	Go to <i>Diagnostic Aids</i>
3	Check for faulty connection at ignition coil. Was a problem found?	—	Verify repair	Go to Step 4
4	Check for faulty connection at PCM connector. Was a problem found?	—	Verify repair	Go to Step 5
5	1. Ignition “ON,” engine “OFF.” 2. Back probe the ignition control circuit 6 at the PCM with a DVM positive lead with the negative lead to ground. Is the voltage near the specified value?	25-55 mV	Go to Step 6	Go to Step 9
6	1. Ignition “ON,” engine running. 2. Back probe the ignition control circuit at the PCM for the cylinder being tested. Is the voltage in the specified range, rapidly toggling back and forth to a reading 20-50 mV higher?	100-180 mV	Go to Step 7	Go to Step 13
7	1. Ignition “OFF.” 2. Disconnect the 3-pin connector at the ignition coil. 3. Check ignition control circuit 6 voltage at the ignition coil connector while cranking the engine. Does the voltage measure between the specified values?	200-1200 mV	Go to Step 8	Go to Step 11
8	Replace the ignition coil. Is the action complete?	—	Verify repair	—
9	1. Ignition “OFF.” 2. Disconnect the PCM and the ignition coil. 3. Check ignition control circuit 6 for short to ground. Was a problem found?	—	Verify repair	Go to Step 10

## DTC P0356 – Ignition 6 Control Circuit (Cont'd)

Step	Action	Value(s)	Yes	No
10	Check ignition control circuit 6 for short to voltage. Was a problem found?	—	Verify repair	Go to <i>Step 13</i>
11	Check for an open ignition control circuit 6. Was the ignition control circuit open?	—	Go to <i>Step 12</i>	Go to <i>Step 13</i>
12	Repair the open ignition control circuit. Is the action complete?	—	Verify repair	—
13	Replace the PCM. <b>IMPORTANT:</b> The replacement PCM must be programmed. Refer to <i>On-Vehicle Service</i> in <i>Powertrain Control Module and Sensors</i> for procedures. And also refer to latest Service Bulletin. Check to see if the Latest software is released or not. And then Down Load the LATEST PROGRAMMED SOFTWARE to the replacement PCM. Is the action complete?	—	Verify repair	—

## Diagnostic Trouble Code (DTC) P0401 EGR Flow Insufficient



### Circuit Description

The powertrain control module (PCM) tests the exhaust gas recirculation (EGR) system during deceleration by momentarily commanding the EGR valve to open while monitoring the manifold absolute pressure (MAP) sensor signal. When the EGR valve is opened, the PCM monitors the change in MAP input signal. The PCM compares the MAP change to a RPM vs. BARO table. When the PCM interprets the change in MAP to be out of limits, the PCM will set DTC P0401. The number of test samples required to accomplish this may vary according to the severity of the detected flow error. Normally, the PCM will only allow one EGR flow test sample to be taken during an ignition cycle. To aid in verifying a repair, the PCM allows twelve test samples during the first ignition cycle following a Tech 2 "Clear Info" or a battery disconnect. Between nine and twelve samples should be sufficient for the PCM to determine adequate EGR flow and pass the EGR test.

### Conditions for Setting the DTC

- No TP sensor, vehicle speed sensor (VSS), misfire, IAC, IAT sensor, MAP sensor, EGR Pintle Position sensor, ECT sensor, misfire, or automatic transmission DTCs set.
- Barometric pressure is above 75 kpa.
- Engine coolant temperature is greater than 60°C (140°F).
- Ignition voltage between 11.5 and 16 volts.

- Vehicle speed is greater than 24 km/h (15 mph).
- IAC position is steady, changing less than 10 counts.
- A/C clutch status is unchanged.
- TCC status is unchanged.

### Start Test

- TP angle is less than 1%.
  - EGR duty cycle is less than 1%.
  - MAP is steady, changing less than 2 kpa.
  - Engine speed is between 1100 RPM and 2000 RPM.
  - MAP between 10 kpa and 40 kpa.
- The test will be aborted if the vehicle speed changes by more than 16 km/h (10 mph), engine speed changes by more than 100 RPM or the EGR is opened less than 95% of commanded position.
- The PCM will only run the EGR test during a closed throttle condition.
  - The PCM will only run the EGR test at vehicle speeds above 24 km/h (15 mph).
  - Several deceleration cycles will be necessary to run a sufficient number of EGR flow tests.

### Diagnostic Aids

Check for the following conditions:

- Poor connection or damaged harness – Inspect the wiring harness for damage. If the harness appears to be OK, observe the Actual EGR Position display on the Tech 2 while moving connectors and wiring harnesses

related to the EGR valve. A change in the display will indicate the location of the fault.

- Ensure EGR valve is correctly mounted. See *On-Vehicle Service*.

Reviewing the Failure Records vehicle mileage since the diagnostic test last failed may help determine how often the condition that caused the DTC to be set occurs. This may assist in diagnosing the condition.

NOTE: If the EGR valve shows signs of excessive heat, check the exhaust system for blockage (possibly a plugged catalytic converter) using the "Restricted Exhaust System Check."

### **Test Description**

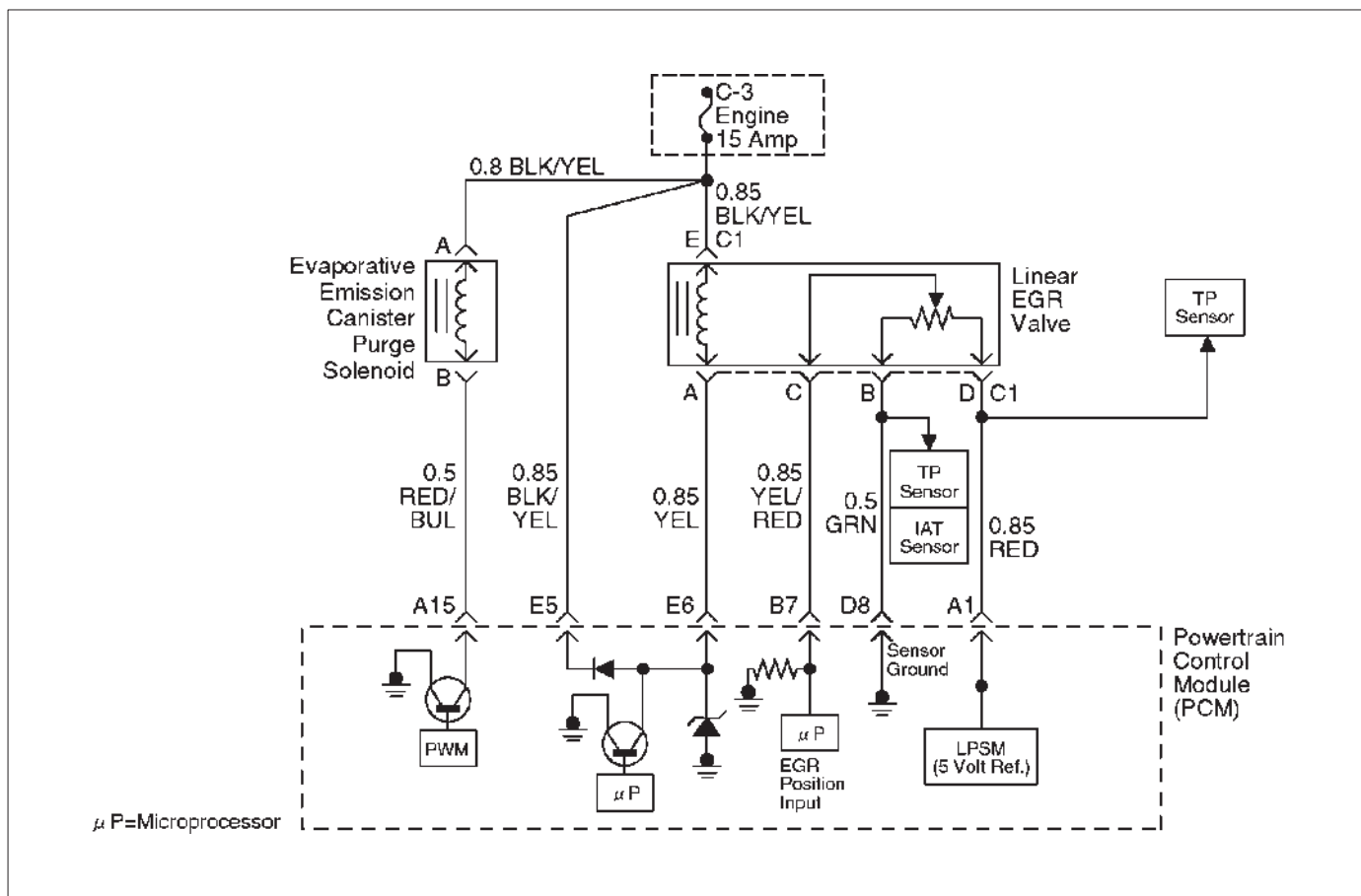
Number(s) below refer to the step number(s) on the Diagnostic Chart

3. A malfunctioning MAP sensor can set an EGR DTC. The MAP sensor could send a constant signal which is not low enough to set a low MAP DTC. The constant signal from the MAP sensor also may not be high enough to set a high MAP DTC. This step verifies that the MAP sensor is responding.

**DTC P0401 – EGR Flow Insufficient**

Step	Action	Value(s)	Yes	No
1	Was the "On-Board Diagnostic (OBD) System Check" performed?	—	Go to <i>Step 2</i>	Go to <i>OBD System Check</i>
2	Is DTC P1406 also set?	—	Go to <i>DTC 1406</i>	Go to <i>Step 3</i>
3	1. Start the engine. 2. Monitor the MAP signal with a Tech 2 while idling. 3. While idling, jab the accelerator pedal about halfway down and immediately let the engine return to idle. Did the MAP value on the Tech 2 show an immediate large change?	—	Go to <i>Step 5</i>	Go to <i>Step 4</i>
4	Replace the MAP sensor. Is the action complete?	—	Verify repair	—
5	1. Inspect the exhaust system for modification of original installed parts or leaks. 2. If a problem was found, repair exhaust system as necessary. Was a condition present that required repair?	—	Go to <i>Step 8</i>	Go to <i>Step 6</i>
6	1. Remove the EGR valve. 2. Visually and physically inspect the pintle, valve passages and the adapter for excessive deposits or any kind of a restriction. 3. If a problem is found, clean or replace EGR system components as necessary. Was a condition present that required repair?	—	Go to <i>Step 8</i>	Go to <i>Step 7</i>
7	1. Remove the EGR inlet and outlet pipes from the exhaust manifold and the intake manifold. 2. Inspect the manifold EGR ports and the EGR inlet and outlet pipes for a blockage caused by excessive deposits or other damage. 3. If a problem is found, correct the condition as necessary. Was a condition present that required repair?	—	Go to <i>Step 8</i>	Refer to <i>Diagnostic Aids</i>
8	1. Review and record the Tech 2 Failure Records data. 2. Clear DTC and monitor the Tech 2 System Info Screen while operating the vehicle as specified in "Diagnostic Aids." 3. Using a Tech 2, monitor "DTC" info for DTC P0401 until the DTC P0401 test runs. 4. Note the test result. Does the Tech 2 indicate DTC P0401 failed this ignition?	—	—	Repair complete

## Diagnostic Trouble Code (DTC) P0402 EGR Pintle Position Error



D06RX075

### Circuit Description

The powertrain control module (PCM) monitors the EGR valve pintle position input to ensure that the valve responds properly to commands from the PCM, and to detect a fault if pintle position is stuck open. If the PCM detects a pintle position signal indicates more than 21.5% and more than for 625 msec during cranking, the PCM will set DTC P0402.

### Conditions for Setting the DTC

- Ignition voltage is between 11 and 16 volts.
- Intake Air temp is more than 3°C
- At Engine revolution less than 600 RPM, EGR pintle position indicates more than 21.5% and more than for 625 msec.

### Action Taken When the DTC Sets

- The PCM will illuminate the malfunction indicator lamp (MIL) after the second consecutive trip in which the fault is detected.
- The PCM will store conditions which were present when the DTC was set as Freeze Frame and in Failure Records data.

### Conditions for Clearing the MIL/DTC

- The PCM will turn the MIL "OFF" on the third consecutive trip cycle during which the diagnostic has been run and the fault condition is no longer present.

- A history DTC P0402 will clear after 40 consecutive warm-up cycles have occurred without a fault.
- DTC P0402 can be cleared by using the Tech 2 "Clear Info" function or by disconnecting the PCM battery feed.

### Diagnostic Aids

Check for the following conditions:

- Foreign material on EGR valve between pintle and seat may cause EGR stuck open. Inspect foreign material in EGR valve.
- Excessive carbon deposit may cause unsmooth operation of EGR valve shaft. Inspect carbon deposit and clean up inside of carbon deposit.
- Poor connection or damaged harness—inspect the wiring harness for damage. If the harness appears to be OK, observe the EGR actual position display on the Tech 2 while moving connectors and wiring harnesses related to EGR valve. A change in the display will indicate the location of the fault.

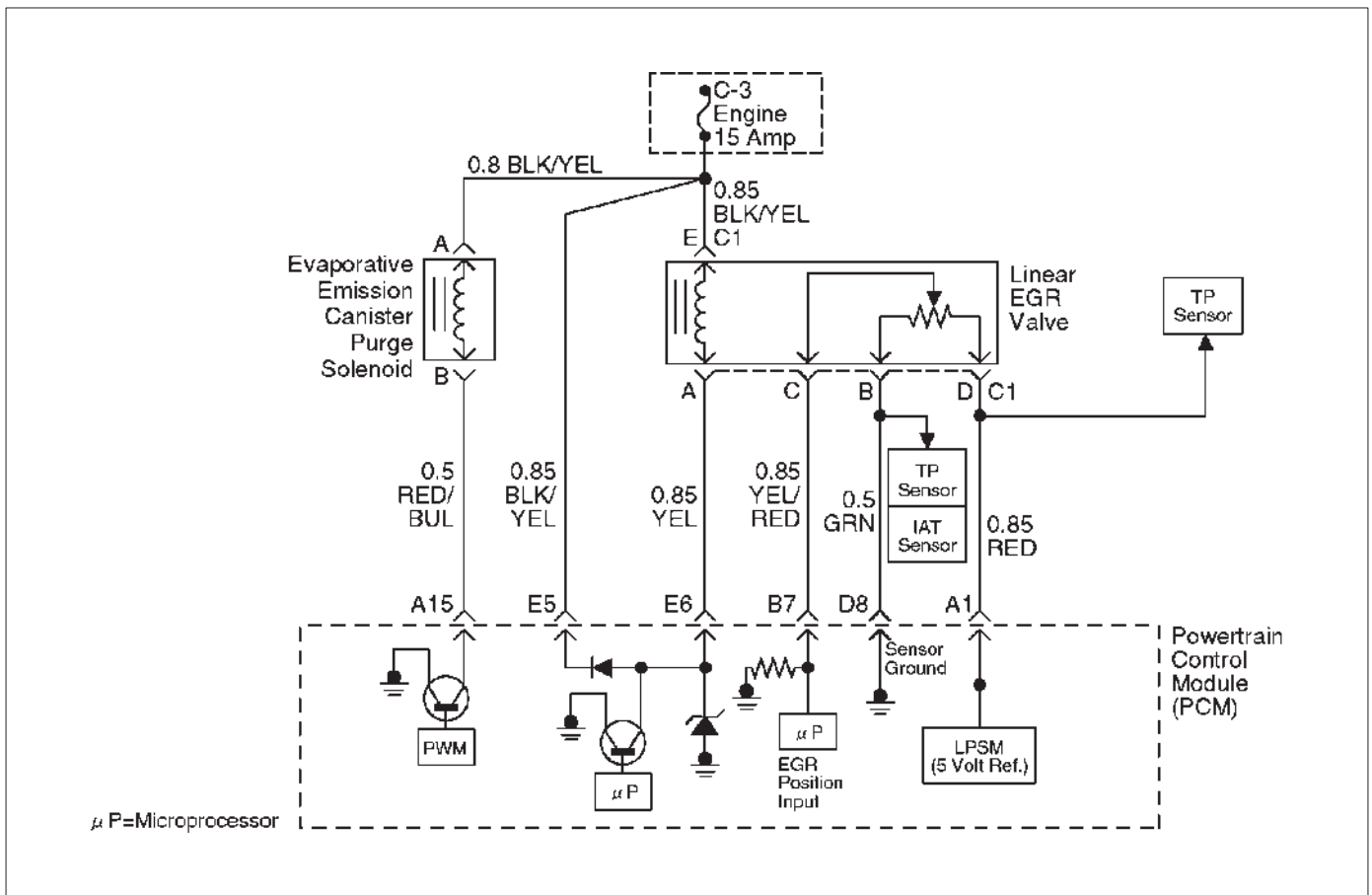
NOTE: If the EGR valve shows signs of excessive heat, check the exhaust system for blockage (possibly a plugged catalytic converter) using the "Restricted Exhaust System Check".

**DTC P0402 – EGR Pintle Position Error**

Step	Action	Value(s)	Yes	No
1	Was the “On-Board Diagnostic (OBD) System Check” performed?	—	Go to Step 2	Go to <i>OBD System Check</i>
2	1. Ignition “ON”, engine “OFF”, review and record Tech 2 Failure Records data. 2. Operate the vehicle within Failure Records conditions as noted. 3. Using a Tech 2, monitor “DTC” info for DTC P0402 until the DTC P0402 test runs. Note the result. Does the Tech 2 indicates DTC P0402 failed this ignition?	—	Go to Step 3	Refer to <i>Diagnostic Aids</i>
3	1. Disconnect the EGR valve harness connector. 2. Inspect the EGR valve and connectors for damaged pin or terminals. Were there any damaged pins or terminals?	—	Go to Step 4	Go to Step 5
4	Repair the damaged pin or terminal. Is the action complete?	—	Verify repair	—
5	1. Remove EGR valve from Engine. 2. Inspect EGR valve whether there is any foreign material between seat and pintle. Was any foreign material in EGR valve?	—	Go to Step 6	Go to Step 7
6	1. Remove EGR valve foreign material from EGR valve and clean up inside. 2. Visually inspect damage of pintle and seat, which leakage may occur. Was there any severe damage which affects function?	—	Go to Step 7	Verify repair Go to Step 8
7	1. Reconnect. 2. Ignition “OFF”. 3. Install the Tech 2. 4. Run the engine at idle. 5. On Tech-II, select special function for EGR. 6. Use the “UP” arrow to increase the EGR from 0% to 40%. Did EGR work properly?	—	—	Go to Step 8
8	Replace the EGR valve. Does DTC P0402 still fail “DTC” test on the Tech 2?	—	Go to Step 9	Verify repair
9	Replace the EGR valve. Is the action complete?	—	Verify repair	—



## Diagnostic Trouble Code (DTC) P0404 EGR Pintle Open/Stuck



D06RX075

### Circuit Description

The powertrain control module (PCM) monitors the EGR valve pintle position input to ensure that the valve responds properly to commands from the PCM, and to detect a fault if pintle position is different from commanded position. If the PCM detects a pintle position signal indicates more than 15 points different between current and commanded and more than 15 seconds, the PCM will set DTC P0404.

### Conditions for Setting the DTC

- Ignition voltage is between 11 and 16 volts.
- Intake Air temp is more than 3°C.
- Desire EGR position is more than 0.
- The difference between desired EGR and current EGR is less than 3%.
- Difference EGR pintle position between current and commanded position becomes more than 15% and last more than 15 seconds, and this condition meets three times in a trip. Then it trigger, the PCM lights on.

### Action Taken When the DTC Sets

- The PCM will illuminate the malfunction indicator lamp (MIL) as soon as failure detected after consecutive 2nd trip in which the fault is detected.

- The PCM will store conditions which were present when the DTC was set as Freeze Frame and in Failure Records data.

### Conditions for Clearing the MIL/DTC

- The PCM will turn the MIL "OFF" on the third consecutive trip cycle during which the diagnostic has been run and the fault condition is no longer present.
- A history DTC P0404 will clear after 40 consecutive warm-up cycles have occurred without a fault.
- DTC P0404 can be cleared by using the Tech 2 "Clear Info" function or by disconnecting the PCM battery feed.

### Diagnostic Aids

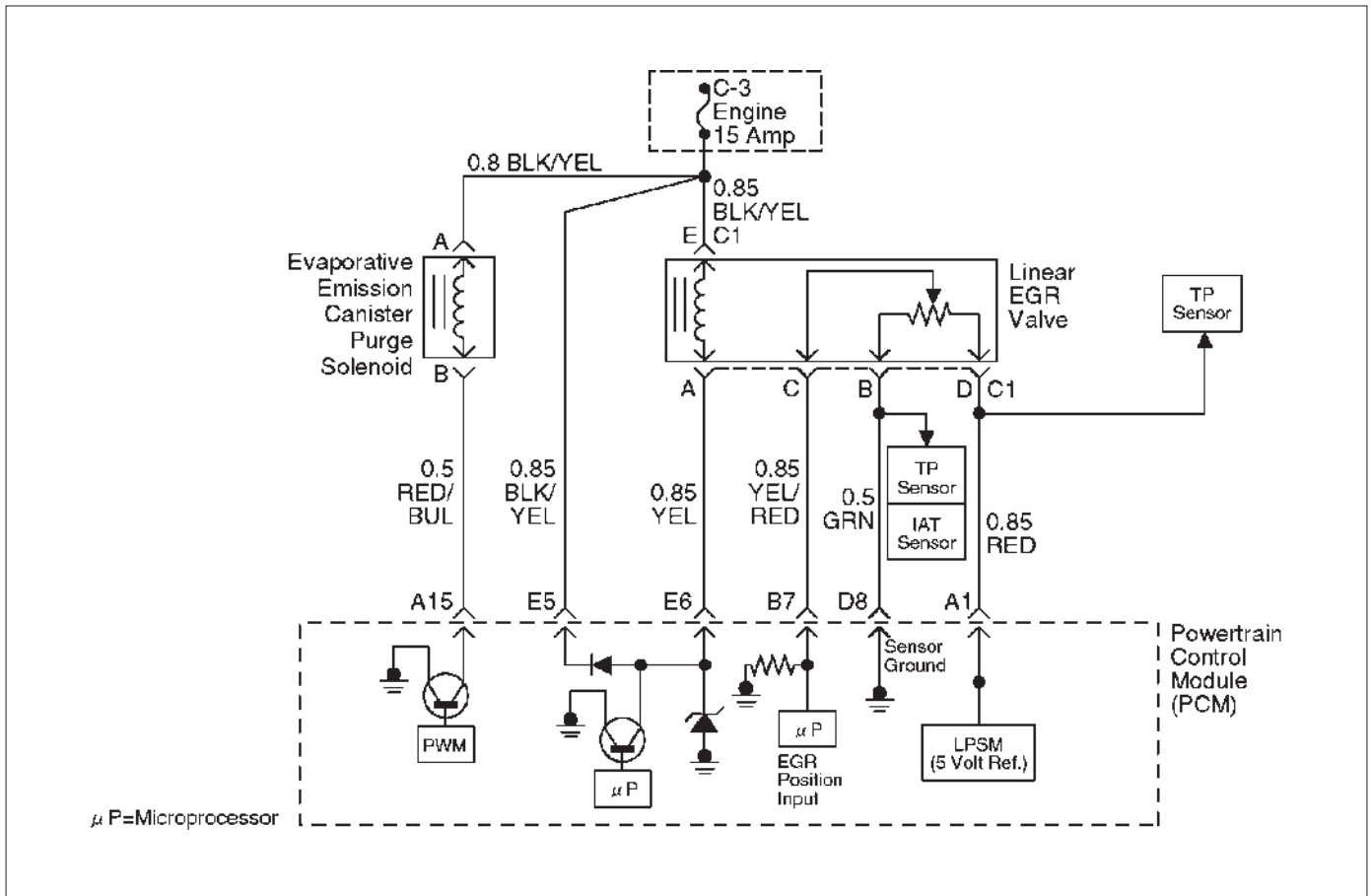
Check for the following conditions:

- Excessive carbon deposit on EGR valve shaft may cause EGR stuck open or unsmooth operation. Those carbon deposit may occur by unusual port operation. Clean up carbon may make smooth function of EGR valve.
- Poor connection or damaged harness – Inspect the wiring harness for damage. If the harness appears to be OK, observe the EGR actual position display on the Tech 2 while moving connectors and wiring harnesses related to EGR valve. A change in the display will indicate the location of the fault.

## DTC P0404 – EGR Pintle Open/Stuck

Step	Action	Value(s)	Yes	No
1	Was the “On-Board Diagnostic (OBD) System Check” performed?	—	Go to Step 2	Go to <i>OBD System Check</i>
2	1. Ignition “ON,” engine “OFF”, review and record Tech 2 Failure Records Data. 2. Operate the vehicle within Failure Records conditions as noted. 3. Using a Tech 2, monitor “DTC” info for DTC P0404 until the DTC P0404 test runs. Note the result. Does the Tech 2 indicates DTC P0404 failed this ignition?	—	Go to Step 3	Refer to <i>Diagnostic Aids</i>
3	1. Disconnect the EGR valve harness connector. 2. Inspect the EGR valve and connectors for damaged pin or terminals. Were there any damaged pins or terminals?	—	Go to Step 4	Go to Step 5
4	Repair the damaged pin or terminal.	—	Verify repair	Is the action complete?
5	1. Remove EGR valve from Engine. 2. Inspect EGR valve whether there is any excessive carbon deposit on EGR shaft. Was excessive carbon deposit on EGR valve shaft?	—	Go to Step 6	Go to Step 7
6	1. Clean up EGR valve shaft and inside of EGR valve. 2. Visually inspect damage of pintle and seat if is bent, leakage may occur. Was there any severe damage which affects function?	—	Go to Step 8	Verify repair Go to Step 7
7	1. Reconnect. 2. Ignition “OFF”. 3. Install the Tech 2. 4. Run the engine at idle. 5. On the Tech 2, select EGR Control Test. 6. Use the “UP” arrow to increase the EGR from 0% to 40%. Did EGR work properly?	—	—	Go to Step 8
8	Replace the EGR valve. Does DTC P0404 still fail “DTC” test on the Tech 2?	—	Go to Step 9	Verify repair
9	Replace the PCM. <b>IMPORTANT:</b> The replacement PCM must be programmed. Refer to <i>On-Vehicle Service in Powertrain Control Module and Sensors</i> for procedures. And also refer to latest Service Bulletin. Check to see if the Latest software is released or not. And then Down Load the LATEST PROGRAMMED SOFTWARE to the replacement PCM. Is the action complete?	—	Verify repair	—

## Diagnostic Trouble Code (DTC) P0405 EGR Low Voltage



### Circuit Description

The powertrain control module (PCM) monitors the EGR valve pintle position input to ensure that the valve responds properly to command from the PCM. If current pintle position voltage indicates less than 0.1 V and last more than 10 seconds, then the PCM will set DTC P0405.

### Conditions for Setting the DTC

- Ignition voltage is between 11 and 16 volts.
- EGR pintle position output voltage is less than 0.1 volt and last more than 10 sec. Action taken when the DTC sets.

### Action Taken When the DTC Sets

- The PCM will illuminate the malfunction indicator lamp (MIL) as soon as failure detected.
- The PCM will store conditions which were present when the DTC was set as Freeze Frame and in Failure Records data.

### Conditions for Clearing the MIL/DTC

- The PCM will turn the MIL "OFF" on the third consecutive trip cycle during which the diagnostic has been run and the fault condition is no longer present.
- A history DTC P0402 will clear after 40 consecutive warm-up cycles have occurred without a fault.
- DTC P0405 can be cleared by using the Tech 2 "Clear Info" function or by disconnecting the PCM battery feed.

### Diagnostic Aids

Check for the following conditions:

- Poor connection or damaged harness – Inspect the wiring harness for damage. If the harness appears to be OK, observe the EGR actual position display on the Tech 2 while moving connectors and wiring harnesses related to EGR valve. A change in the display will indicate the location of the fault.

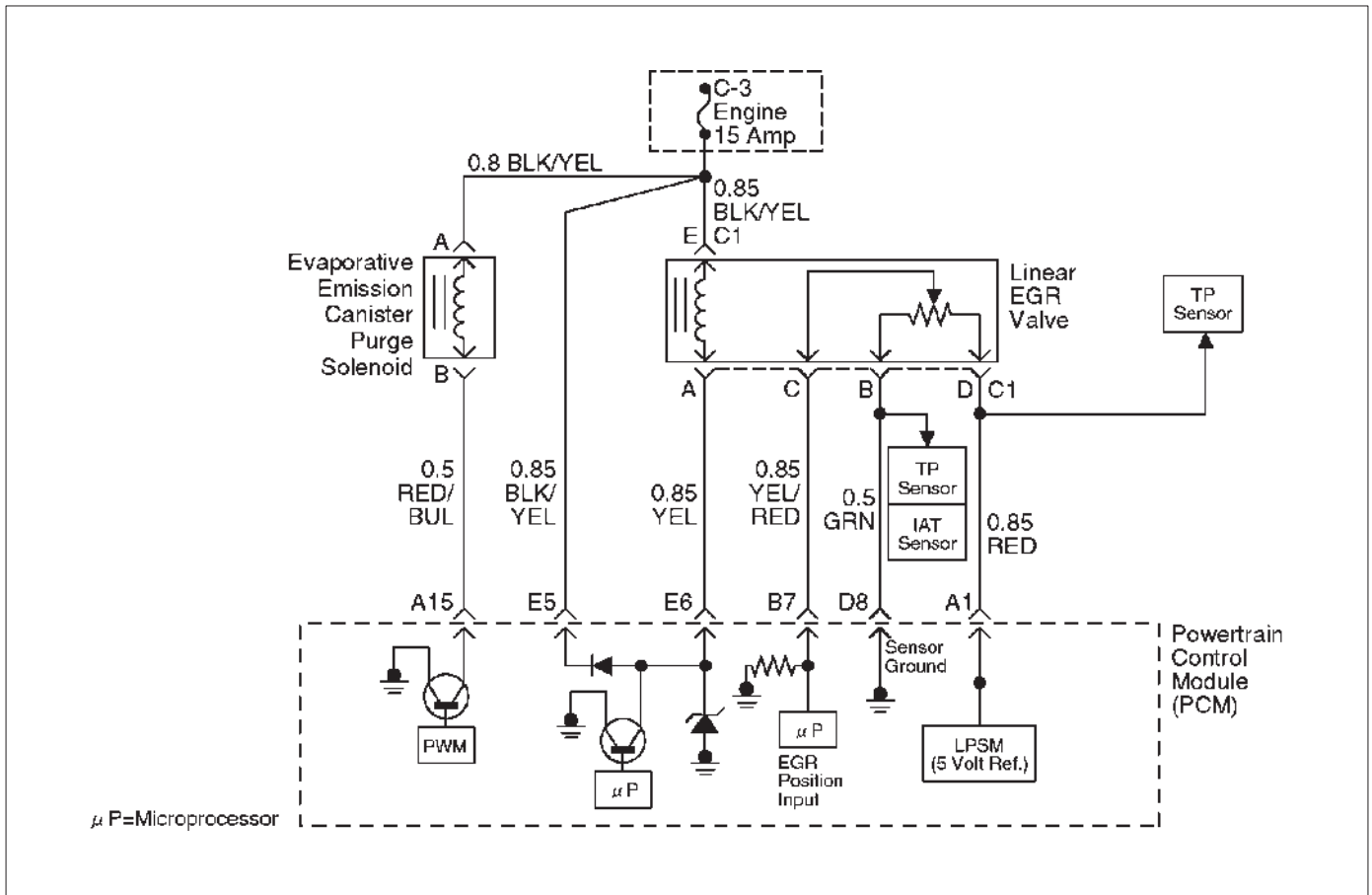
**DTC P0405 – EGR Low Volt**

Step	Action	Value(s)	Yes	No
1	Was the "On-Board Diagnostic (OBD) System Check" performed?	—	Go to Step 2	Go to <i>OBD System Check</i>
2	1. Ignition "ON," engine "OFF", review and record Tech 2 Failure Records Data. 2. Operate the vehicle within Failure Records conditions as noted. 3. Using a Tech 2, monitor "DTC" info for DTC P0405 until the DTC P0405 test runs. Note the result. Does the Tech 2 indicates DTC P0405 failed this ignition?	—	Go to Step 3	Refer to <i>Diagnostic Aids</i>
3	1. Disconnect the EGR valve harness connector. 2. Inspect the EGR valve and connectors for damaged pin or terminals. Were there any damaged pins or terminals?	—	Go to Step 4	Go to Step 5
4	Repair the damaged pin or terminal. Is the action complete?	—	Verify repair	—
5	1. Disconnect the EGR harness connector. 2. Ignition "ON". 3. At the EGR valve, use a DVM to check the voltage at the 5 volt reference wire (RED) and ground (B). Did the DVM indicate the specified value?	4–6 V	Go to Step 6	Go to Step 7
6	1. Disconnect the EGR harness connector. 2. Measure resistance between terminal B and D. Was resistance in range?	5–5.5 K $\Omega$	Go to Step 10	Go to Step 17
7	1. Ignition "ON". 2. At the PCM connector, backprobe with a DVM at the 5 volt reference for the EGR valve. Did the DVM indicate the specified value?	4–6 V	Go to Step 8	Go to Step 18
8	Repair the open 5 volt reference circuit. Is the action complete?	—	Verify repair	—
9	Repair the damaged sensor ground wire. Is the action complete?	—	Verify repair	—
10	1. Disconnect the EGR harness 2. Use an ohmmeter to measure between the pintle position pin and the sensor ground pin on the EGR valve.  NOTE: J-35616 Connector Test Adapter Kit may be useful for gaining access to the recessed pins on the valve.  Was the ohmmeter reading approximately equal to the specified value?	1 to 1.25 K $\Omega$	Go to Step 13	Go to Step 17
11	1. Ignition "ON". 2. Backprobe with a DVM to measure voltage at EGR valve pintle position pin and sensor ground pin. Was voltage in range?	Less than 0.1 V	Go to Step 17	Go to Step 12

## DTC P0405 – EGR Low Volt (Cont'd)

Step	Action	Value(s)	Yes	No
12	1. Ignition "ON". 2. Backprobe with a DVM to measure voltage at PCM sensor ground pin and pintle position pin. Was voltage in range?	Less than 0.1 V	Go to <i>Step 13</i>	Go to <i>Step 18</i>
13	1. Ignition "OFF". 2. Disconnect the EGR harness. 3. Check short circuit between EGR pintle position circuit and EGR ground circuit. Was any short circuit?	—	Go to <i>Step 14</i>	Go to <i>Step 18</i>
14	Locate and repair the short to ground in the pintle position circuit Is the action complete?	—	Verify repair	—
15	1. Ignition "OFF". 2. Disconnect the PCM. 3. Ignition "ON". 4. Measure the voltage between the EGR pintle position circuit and ground. Is the measured voltage near the specified value?	Less than 0.1 V	Go to <i>Step 17</i>	Go to <i>Step 16</i>
16	Check for a short circuit between other wires and the pintle position circuit Is there any short circuit?	—	Repair short circuit Verify repair	Go to <i>Step 17</i>
17	Replace the EGR valve. Does DTC P1404 still fail "DTC test on the Tech 2"?	—	Go to <i>Step 18</i>	Verify repair
18	Examine the PCM pin and terminal connection. Was there a damaged terminal?	—	Go to <i>Step 4</i>	Go to <i>Step 19</i>
19	Replace the PCM. <b>IMPORTANT:</b> The replacement PCM must be programmed. Refer to <i>On-Vehicle Service in Powertrain Control Module and Sensors</i> for procedures. And also refer to latest Service Bulletin. Check to see if the Latest software is released or not. And then Down Load the LATEST PROGRAMMED SOFTWARE to the replacement PCM. Is the action complete?	—	Verify repair	—

## Diagnostic Trouble Code (DTC) P0406 EGR High Voltage



D06RX075

### Circuit Description

The powertrain control module (PCM) monitors the EGR valve pintle position input to ensure that the valve responds properly to command from the PCM. If current pintle position voltage indicates more than 4.8 V and last more than 10 seconds, then the PCM will set DTC P0406.

### Conditions for Setting the DTC

- Ignition voltage is between 11 and 16 volts.
- EGR pintle position output voltage is more than 4.8 volt and last more than 10 sec.

### Action Taken When the DTC Sets

- The PCM will illuminate the malfunction indicator lamp (MIL) as soon as failure detected.
- The PCM will store conditions which were present when the DTC was set as Freeze Frame and in Failure Records data.

### Conditions for Clearing the MIL/DTC

- The PCM will turn the MIL "OFF" on the third consecutive trip cycle during which the diagnostic has been run and the fault condition is no longer present.
- A history DTC P0402 will clear after 40 consecutive warm-up cycles have occurred without a fault.
- DTC P0404 can be cleared by using the Tech 2 "Clear Info" function or by disconnecting the PCM battery feed.

### Diagnostic Aids

Check for the following conditions:

- Poor connection or damaged harness – Inspect the wiring harness for damage. If the harness appears to be OK, observe the EGR actual position display on the Tech 2 while moving connectors and wiring harnesses related to EGR valve. A change in the display will indicate the location of the fault.

**DTC P0406 – EGR High Voltage**

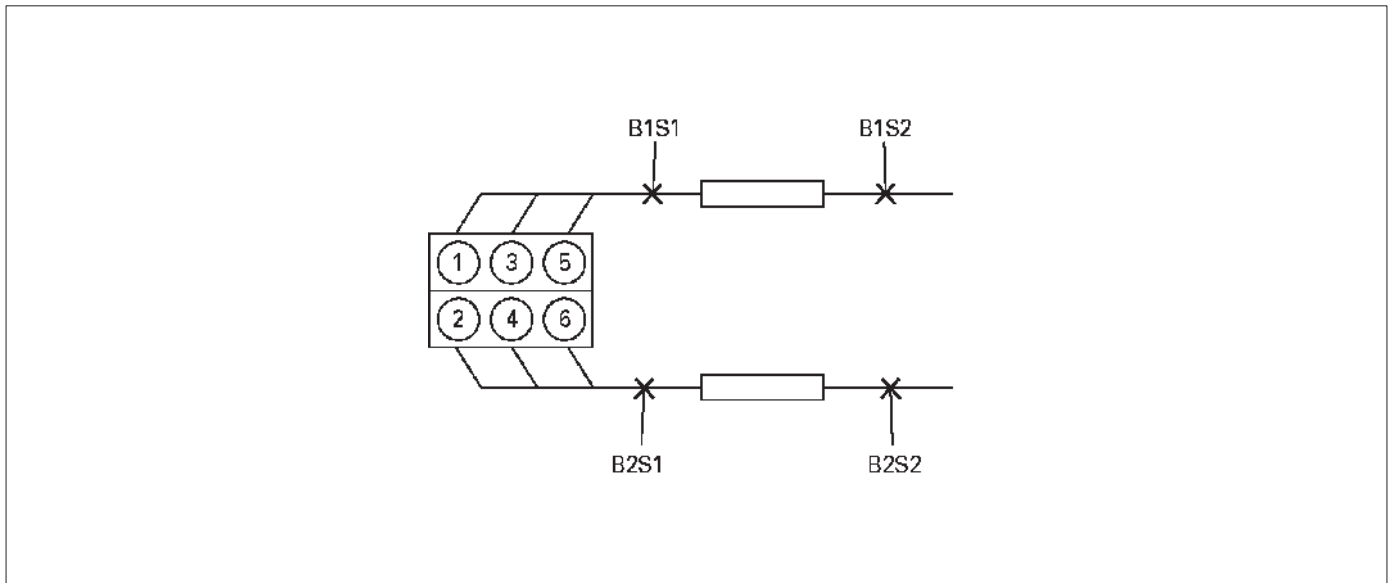
Step	Action	Value(s)	Yes	No
1	Was the "On-Board Diagnostic (OBD) System Check" performed?	—	Go to Step 2	Go to <i>OBD System Check</i>
2	1. Ignition "ON," engine "OFF", review and record Tech 2 Failure Records Data. 2. Operate the vehicle within Failure Records conditions as noted. 3. Using a Tech 2, monitor "DTC" info for DTC P0406 until the DTC P0406 test runs. Note the result. Does the Tech 2 indicates DTC P0406 failed this ignition?	—	Go to Step 3	Refer to <i>Diagnostic Aids</i>
3	1. Disconnect the EGR valve harness connector. 2. Inspect the EGR valve and connectors for damaged pin or terminals. Were there any damaged pins or terminals?	—	Go to Step 4	Go to Step 5
4	Repair the damaged pin or terminal. Is the action complete?	—	Verify repair	Is the action complete?
5	1. Disconnect the EGR harness connector. 2. Ignition "ON". 3. At the EGR valve, use a DVM to check the voltage at the 5 volt reference wire (RED). Did the DVM indicate the specified value?	4–6 V	Go to Step 8	Go to Step 6
6	1. Ignition "ON". 2. At the PCM connector, backprobe with a DVM at the 5 volt reference for the EGR valve. Did the DVM indicate the specified value?	4–6 V	Go to Step 7	Go to Step 16
7	Repair the open 5 volt reference circuit Is the action complete?	—	Verify repair	—
8	1. Ignition "OFF" 2. Disconnect the EGR harness. 3. Use a DVM to check for an resistance between D (5 V reference) and B (Sensor Ground) at EGR sensor terminals.  NOTE: J-35616 Connector Test Adapter Kit may be useful for gaining access to the recessed pins on the valve. Was the measured resistance in range?	5 to 5 K $\Omega$	Go to Step 9	Go to Step 15
9	1. Ignition "OFF". 2. Disconnect the EGR harness. 3. Use a DVM to check for an resistance between B and C at EGR sensor terminal. Is there an open circuit?	—	Go to Step 15	Go to Step 10
10	1. Ignition "OFF". 2. Disconnect the EGR harness at PCM connector. 3. Use a DVM to check for shorted wire between A1 and B7. Is there a shorted wire?	—	Go to Step 14	Go to Step 11

**DTC P0406 – EGR High Voltage (Cont'd)**

Step	Action	Value(s)	Yes	No
11	1. Ignition "ON". 2. Use a DVM to backprobe at terminal C of EGR valve for voltage. Was measured voltage more than 4.8 V?	more than 4.8 V	Go to <i>Step 12</i>	Go to <i>Step 12</i>
12	1. Ignition "ON". 2. Stay the EGR harness connected. 3. Check voltage by backproving at PCM B7 terminal. Was voltage more than 4.8 V?	4.8 V	Go to <i>Step 16</i>	Go to <i>Step 13</i>
13	1. Locate short circuit at EGR harness between RED to RED or GREEN, RED to YEL. 2. Replace EGR harness. Is the action complete?	—	Verify repair	—
14	Replace EGR harness. Is the action complete?	—	Verify repair	—
15	Replace the EGR valve. Does DTC P1404 still fail "DTC test on the Tech 2?"	—	Go to <i>Step 16</i>	Verify repair
16	Replace the PCM. <b>IMPORTANT:</b> The replacement PCM must be programmed. Refer to <i>On-Vehicle Service</i> in <i>Powertrain Control Module and Sensors</i> for procedures. And also refer to latest Service Bulletin. Check to see if the Latest software is released or not. And then Down Load the LATEST PROGRAMMED SOFTWARE to the replacement PCM. Is the action complete?	—	Verify repair	—



## Diagnostic Trouble Code (DTC) P0420 TWC System Low Efficiency Bank 1



### Circuit Description

To control emissions of hydrocarbons (HC), carbon monoxide (CO), and oxides of nitrogen (NO<sub>x</sub>), a three-way catalyst (TWC) is used. The catalyst promotes a chemical reaction which oxidizes the HC and CO present in the exhaust gas, converting them into harmless water vapor and carbon dioxide. The catalyst also reduces NO<sub>x</sub>, converting it to nitrogen. The powertrain control module (PCM) has the ability to monitor this process using the Bank 1 HO<sub>2</sub>S 1 and the Bank 1 HO<sub>2</sub>S 2 heated oxygen sensors. The Bank 1 HO<sub>2</sub>S 1 sensor produces an output signal which indicates the amount of oxygen present in the exhaust gas entering the three-way catalytic converter. The Bank 1 HO<sub>2</sub>S 2 sensor produces an output signal which indicates the oxygen storage capacity of the catalyst; this in turn indicates the catalyst's ability to convert exhaust gases efficiently. If the catalyst is operating efficiently, the Bank 1 HO<sub>2</sub>S 1 signal will be far more active than that produced by the Bank 1 HO<sub>2</sub>S 2 sensor. If the PCM detects a level of Bank 1 HO<sub>2</sub>S 2 activity that indicates the catalyst is no longer operating efficiently, DTC P0420 will be set.

### Conditions for Setting the DTC

- No related DTCs.
- The engine is operating in "closed loop."
- Engine air load is below 99%.
- Engine coolant temperature is above 60°C (140°F).
- Mass air flow is between 8 g/second and 50 g/second.
- Change in engine load is below 8%.
- Engine speed is below 3500 RPM.
- Vehicle speed is between 26 km/h and 123 km/h (16 mph and 75 mph).
- Catalyst temperature is above 399°C (750°F).
- The PCM determines that the catalyst's oxygen storage capacity is below the acceptable threshold.

### Action Taken When the DTC Sets

- The PCM will illuminate the malfunction indicator lamp (MIL) the first time the fault is detected.

- The PCM will store conditions which were present when the DTC was set as Freeze Frame and in the Failure Records data.

### Conditions for Clearing the MIL/DTC

- The PCM will turn the MIL "OFF" on the third consecutive trip cycle during which the diagnostic has been run and the fault condition is no longer present.
- A history DTC P0420 will clear after 40 consecutive warm-up cycles have occurred without a fault.
- DTC P0420 can be cleared by using the Tech 2 "Clear Info" function or by disconnecting the PCM battery feed.

### Diagnostic Aids

Check for the following conditions:

- Poor connection at PCM – Inspect harness connectors for backed-out terminals, improper mating, broken locks, improperly formed or damaged terminals, and poor terminal-to-wire connection.
- Damaged harness – Inspect the wiring harness for damage. If the harness appears to be OK, observe the display on the Tech 2 while moving connectors and wiring harnesses related to the sensor. A change in the display will indicate the location of the fault.

Reviewing the Failure Records vehicle mileage since the diagnostic test last failed may help determine how often the condition that caused the DTC to be set occurs. This may assist in diagnosing the condition.

- Bank 1 HO<sub>2</sub>S 1/Bank 1 HO<sub>2</sub>S 2 Activity Test:
  - Ensure that the engine is fully warmed up.
  - Using a Tech 2, monitor Bank 1 HO<sub>2</sub>S 1 and Bank 1 HO<sub>2</sub>S 2 displays in "Park" while using the Tech 2 IAC RPM control function to maintain a mass air flow of 10 g/second. Compare the amount of activity (frequency and amplitude) on Bank 1 HO<sub>2</sub>S 1 to the activity on Bank 1 HO<sub>2</sub>S 2 over a 30 second period.

If the amount of activity on Bank 1 HO<sub>2</sub>S 2 is nearly as great as the activity on Bank 1 HO<sub>2</sub>S 1, a problem exists. Use the DTC P0420 diagnostic chart. If much less activity is noted on Bank 1 HO<sub>2</sub>S 2, the system is functioning properly.

The "TWC Monitor Test Counter" displayed on the Tech 2 may be used to monitor the progress of the TWC diagnostic. To complete the TWC diagnostic with a good catalyst, the counter must be allowed to increment to 49 samples and roll over to 0 at least twice. A failed catalyst will require three or more 50-sample tests to report a failure.

### Test Description

Number(s) below refer to the step number(s) on the Diagnostic Chart.

7. Difficulty completing the DTC P0420 "Status This Ign." test may be encountered in areas where test conditions cannot be maintained easily, especially in urban areas. To minimize the amount of driving required to complete the DTC P0420 "Status This Ign." test, use the following procedure:
- Allow the engine to warm completely.
  - With the vehicle in "Park," monitor mass air flow on the Tech 2 and hold part throttle to maintain a reading of over 12 g/second for at least 2 minutes. This will achieve the "warm catalyst" required for running the test.
  - Operate the vehicle in second or third gear to remain in the DTC P0420 test conditions described in "Conditions for Setting the DTC" as much as possible. If you must stop the vehicle, maintain the "warm catalyst" criteria as follows:
    - Place the vehicle in "Park" or "Neutral."
    - Hold part throttle to maintain a mass air flow reading of over 15 g/second for the duration of the stop.

## DTC P0420 – TWC System Low Efficiency Bank 1

Step	Action	Value(s)	Yes	No
1	Was the “On-Board Diagnostic (OBD) System Check” performed?	—	Go to Step 2	Go to <i>OBD System Check</i>
2	Are any other DTCs set (such as P0140, P0146)?	—	Diagnose other DTC(s) first	Go to Step 3
3	<p>1. Visually and physically inspect the three-way catalytic converter for damage. Check for the following:</p> <ul style="list-style-type: none"> <li><input type="radio"/> dents</li> <li><input type="radio"/> severe discoloration caused by excessive temperatures</li> <li><input type="radio"/> holes</li> <li><input type="radio"/> internal rattle caused by damaged catalyst</li> </ul> <p>2. Also, ensure that the three-way catalytic converter is a proper original equipment manufacturer part.</p> <p>Did your inspection reveal a problem?</p>	—	Go to Step 6	Go to Step 4
4	<p>1. Visually and physically inspect the exhaust system between the three-way catalytic converter and the rear converter flange for leaks, damage, and loose or missing hardware.</p> <p>2. If a problem is found, repair as necessary.</p> <p>Did your inspection reveal a problem?</p>	—	Go to Step 7 to verify repair	Go to Step 5
5	<p>1. Visually and physically inspect the Bank 1 HO2S 2.</p> <p>2. Ensure that the Bank 1 HO2S 2 is secure and that the pigtail and wiring harness is not contacting the exhaust pipe or is not otherwise damaged.</p> <p>3. If a problem is found, repair as necessary.</p> <p>Did your inspection reveal a problem?</p>	—	Go to Step 7 to verify repair	Go to Step 6
6	<p>Replace the three-way catalytic converter.</p> <p>NOTE: Check for conditions which may cause catalyst damage (refer to <i>Diagnostic Aids</i>).</p> <p>Is the action complete?</p>	—	Go to Step 7 to verify repair	—
7	<p>1. Review and record the Tech 2 Failure Records data.</p> <p>2. Clear DTC P0420.</p> <p>3. Start the engine and allow it to warm up until the engine coolant temperature monitored on the Tech 2 is above the specified value.</p> <p>4. Run the engine to maintain the specified mass air flow range for at least 2 minutes.</p> <p>5. Operate the vehicle to maintain DTC P0420 test conditions (refer to <i>DTC Test Description</i> in <i>Diagnostic Support</i> for detailed instructions).</p> <p>6. Using a Tech 2, monitor “DTC” info for DTC P0420 until the DTC P0420 test runs.</p> <p>7. Note the test result.</p> <p>Does the Tech 2 indicate DTC P0420 passed this ignition?</p>	<p>Engine coolant temp: greater than 60°C (140°F).</p> <p>Mass air flow: between 8 g/second and 50 g/second</p>	Repair complete. If a driveability symptom still exists, refer to <i>Symptoms</i> .	Go to the <i>Diagnostic Aids</i>

## Diagnostic Trouble Code (DTC) P0430 TWC System Low Efficiency Bank 2

### Circuit Description

To control emissions of hydrocarbons (HC), carbon monoxide (CO), and oxides of nitrogen (NOx), a three-way catalyst (TWC) is used. The catalyst promotes a chemical reaction which oxidizes the HC and CO present in the exhaust gas, converting them into harmless water vapor and carbon dioxide. The catalyst also reduces NOx, converting it to nitrogen. The powertrain control module (PCM) has the ability to monitor this process using the Bank 2 HO2S 1 and the Bank 2 HO2S 2 heated oxygen sensors. The Bank 2 HO2S 1 sensor produces an output signal which indicates the amount of oxygen present in the exhaust gas entering the three-way catalytic converter. The Bank 2 HO2S 2 sensor produces an output signal which indicates the oxygen storage capacity of the catalyst; this in turn indicates the catalyst's ability to convert exhaust gases efficiently. If the catalyst is operating efficiently, the Bank 2 HO2S 1 signal will be far more active than that produced by the Bank 2 HO2S 2 sensor. If the PCM detects a level of Bank 2 HO2S 2 activity that indicates the catalyst is no longer operating efficiently, DTC P0430 will be set.

### Conditions for Setting the DTC

- No related DTCs.
- The engine is operating in "closed loop."
- Engine air load is below 99%.
- Engine coolant temperature is above 60°C (140°F).
- Mass air flow is between 8 g/second and 50 g/second.
- Change in engine load is below 8%.
- Engine speed is below 3500 RPM.
- Vehicle speed is between 26 km/h and 123 km/h (16 mph and 75 mph).
- Catalyst temperature is above 399°C (750°F).
- The PCM determines that the catalyst's oxygen storage capacity is below the acceptable threshold.

### Action Taken When the DTC Sets

- The PCM will illuminate the malfunction indicator lamp (MIL) the first time the fault is detected.
- The PCM will store conditions which were present when the DTC was set as Freeze Frame and in the Failure Records data.

### Conditions for Clearing the MIL/DTC

- The PCM will turn the MIL "OFF" on the third consecutive trip cycle during which the diagnostic has been run and the fault condition is no longer present.
- A history DTC P0430 will clear after 40 consecutive warm-up cycles have occurred without a fault.
- DTC P0430 can be cleared by using the Tech 2 "Clear Info" function or by disconnecting the PCM battery feed.

### Diagnostic Aids

Check for the following conditions:

- Poor connection at PCM – Inspect harness connectors for backed-out terminals, improper mating, broken locks, improperly formed or damaged terminals, and poor terminal-to-wire connection.
- Damaged harness – Inspect the wiring harness for damage. If the harness appears to be OK, observe the display on the Tech 2 while moving connectors and wiring harnesses related to the sensor. A change in the display will indicate the location of the fault.

Reviewing the Failure Records vehicle mileage since the diagnostic test last failed may help determine how often the condition that caused the DTC to be set occurs. This may assist in diagnosing the condition.

- Bank 2 HO2S 1/Bank 2 HO2S 2 Activity Test:
  - Ensure that the engine is fully warmed up.
  - Using a Tech 2, monitor Bank 2 HO2S 1 and Bank 2 HO2S 2 displays in "Park" while using the Tech 2 IAC RPM control function to maintain a mass air flow of 10 g/second. Compare the amount of activity (frequency and amplitude) on Bank 2 HO2S 1 to the activity on Bank 2 HO2S 2 over a 30 second period.

If the amount of activity on Bank 2 HO2S 2 is nearly as great as the activity on Bank 2 HO2S 1, a problem exists. Use the DTC P0430 diagnostic chart. If much less activity is noted on Bank 2 HO2S 2, the system is functioning properly.

### Test Description

Number(s) below refer to the step number(s) on the Diagnostic Chart.

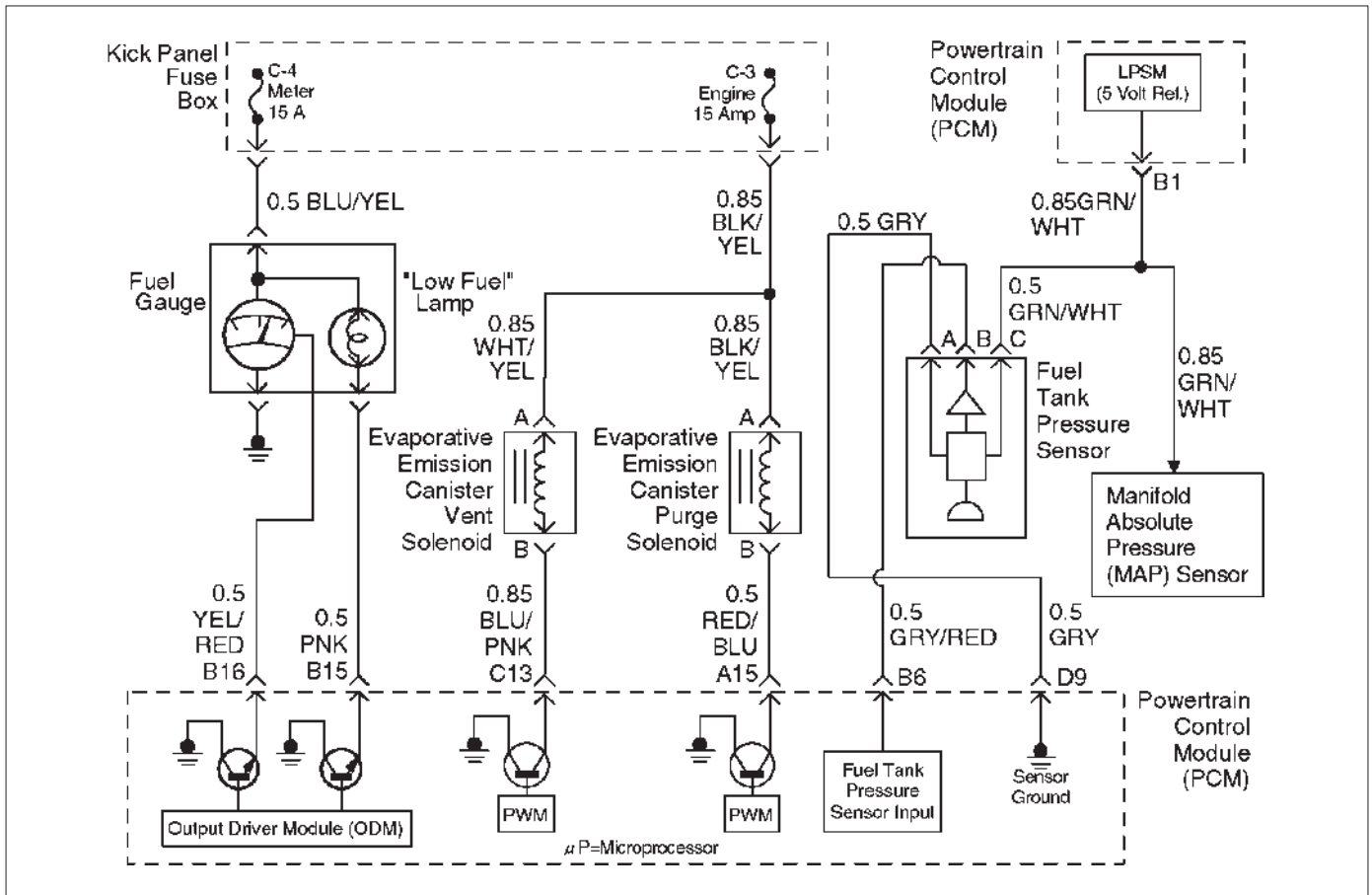
7. Difficulty completing the DTC P0430 "Status This Ign." test may be encountered in areas where test conditions cannot be maintained easily, especially in urban areas. To minimize the amount of driving required to complete the DTC P0430 "Status This Ign." test, use the following procedure:
  - Allow the engine to warm completely.
  - With the vehicle in "Park," monitor mass air flow on the Tech 2 and hold part throttle to maintain a reading of over 12 g/second for at least 2 minutes. This will achieve the "warm catalyst" required for running the test.
  - Operate the vehicle in second or third gear to remain in the DTC P0430 test conditions described in "Conditions for Setting the DTC" as much as possible. If you must stop the vehicle, maintain the "warm catalyst" criteria as follows:
    - Place the vehicle in "Park" or "Neutral."
    - Hold part throttle to maintain a mass air flow reading of over 15 g/second for the duration of the stop.

The "TWC Monitor Test Counter" displayed on the Tech 2 may be used to monitor the progress of the TWC diagnostic. To complete the TWC diagnostic with a good catalyst, the counter must be allowed to increment to 49 samples and roll over to 0 at least twice.

## DTC P0430 – TWC System Low Efficiency Bank 2

Step	Action	Value(s)	Yes	No
1	Was the “On-Board Diagnostic (OBD) System Check” performed?	—	Go to Step 2	Go to <i>OBD System Check</i>
2	Are any other DTCs set (such as P0160)?	—	Diagnose other DTC(s) first	Go to Step 3
3	<p>1. Visually and physically inspect the three-way catalytic converter for damage. Check for the following:</p> <ul style="list-style-type: none"> <li><input type="radio"/> dents</li> <li><input type="radio"/> severe discoloration caused by excessive temperatures</li> <li><input type="radio"/> holes</li> <li><input type="radio"/> internal rattle caused by damaged catalyst</li> </ul> <p>2. Also, ensure that the three-way catalytic converter is a proper original equipment manufacturer part.</p> <p>Did your inspection reveal a problem?</p>	—	Go to Step 6	Go to Step 4
4	<p>1. Visually and physically inspect the exhaust system between the three-way catalytic converter and the rear converter flange for leaks, damage, and loose or missing hardware.</p> <p>2. If a problem is found, repair as necessary.</p> <p>Did your inspection reveal a problem?</p>	—	Go to Step 7 to verify repair	Go to Step 5
5	<p>1. Visually and physically inspect the Bank 2 HO2S 2.</p> <p>2. Ensure that the Bank 2 HO2S 2 is secure and that the pigtail and wiring harness is not contacting the exhaust pipe or is not otherwise damaged.</p> <p>3. If a problem is found, repair as necessary.</p> <p>Did your inspection reveal a problem?</p>	—	Go to Step 7 to verify repair	Go to Step 6
6	<p>Replace the three-way catalytic converter.</p> <p>NOTE: Check for conditions which may cause catalyst damage (refer to <i>Diagnostic Aids</i>).</p> <p>Is the action complete?</p>	—	Go to Step 7 to verify repair	—
7	<p>1. Review and record the Tech 2 Failure Records data.</p> <p>2. Clear DTC P0430.</p> <p>3. Start the engine and allow it to warm up until the engine coolant temperature monitored on the Tech 2 is above the specified value.</p> <p>4. Run the engine to maintain the specified mass air flow range for at least 2 minutes.</p> <p>5. Operate the vehicle to maintain DTC P0430 test conditions (refer to <i>DTC Test Description</i> in <i>Diagnostic Support</i> for detailed instructions).</p> <p>6. Using a Tech 2, monitor “DTC” info for DTC P0430 until the DTC P0430 test runs.</p> <p>7. Note the test result.</p> <p>Does the Tech 2 indicate DTC P0430 passed this ignition?</p>	<p>Engine coolant temp: greater than 60°C (140°F).</p> <p>Mass air flow: between 8 g/second and 50 g/second</p>	<p>Repair complete. If a driveability symptom still exists, refer to <i>Symptoms</i>.</p>	Go to the <i>Diagnostic Aids</i>

## Diagnostic Trouble Code (DTC) P0440 EVAP System



### Circuit Description

The evaporative system includes the following components:

- Fuel tank
- EVAP canister vent solenoid
- Fuel tank pressure sensor
- Fuel pipes and hoses
- Vapor lines
- Fuel cap
- Evaporative emissions canister
- Purge lines
- EVAP canister purge solenoid

The evaporative leak detection diagnostic strategy is based on applying vacuum to the EVAP system and monitoring vacuum decay. The powertrain control module (PCM) monitors vacuum level via the fuel tank pressure sensor input. At an appropriate time, the EVAP canister purge solenoid and the EVAP canister vent solenoid are turned "ON," allowing engine vacuum to draw a small vacuum on the entire evaporative emissions system. If a sufficient vacuum level cannot be achieved, a large leak or a faulty EVAP canister purge solenoid is indicated. This can be caused by the following conditions:

- Disconnected or faulty fuel tank pressure sensor
- Missing or faulty fuel cap
- Disconnected, damaged, pinched, or blocked EVAP purge line
- Disconnected or damaged EVAP vent hose

- Disconnected, damaged, pinched, or blocked fuel tank vapor line
  - Disconnected or faulty EVAP canister purge solenoid
  - Disconnected or faulty EVAP canister vent solenoid
  - Open ignition feed circuit to the EVAP canister vent solenoid or the EVAP canister purge solenoid
  - Damaged EVAP canister
  - Leaking fuel sender assembly O-ring
  - Leaking fuel tank or fuel filler neck
- Any of the above conditions can set DTC P0440.

### Conditions for Setting the DTC

- No TP sensor, ODM, IAT sensor, or MAP sensor DTCs set.
- Start-up engine coolant temperature is less than 32°C (90°F).
- Start-up engine coolant temperature is not more than 7°C (13°F) greater than start-up intake air temperature.
- Start-up intake air temperature is greater than 4°C (39°F).
- Start-up intake air temperature is not more than 2°C (4°F) greater than start-up engine coolant temperature.
- Vehicle speed is less than 75 mph (120 km/h).
- Throttle position is greater than 7% but less than 30%.
- Minimal fuel slosh.
- Fuel tank level is between 15% and 85%.
- BARO is greater than 75 kpa.

## 6E-318 6VE1 3.5L ENGINE DRIVEABILITY AND EMISSIONS

- The EVAP system is unable to achieve or maintain vacuum during the diagnostic test.
- Above conditions are present for 60 to 180 seconds.

### Action Taken When the DTC Sets

- The PCM will illuminate the MIL during the second key cycle in which the DTC sets.
- The PCM will store conditions which were present when the DTC set as Freeze Frame and in the Failure Records data.

### Conditions for Clearing the MIL/DTC

- The PCM will turn the MIL "OFF" when the diagnostic has been run and the fault condition is no longer present.
- A history DTC P0440 will clear after 40 consecutive warm-up cycles have occurred without a fault.
- DTC P0440 can be cleared by using the Tech 2 "Clear Info" function or by disconnecting the PCM battery feed.

### Diagnostic Aids

Check for the following conditions:

- Cracked or punctured EVAP canister.
- Damaged or disconnected source vacuum line, EVAP purge line, vent hose or fuel tank vapor line.
- Poor connection at PCM – Inspect harness connectors for backed-out terminals, improper mating, broken locks, improperly formed or damaged terminals, and poor terminal to wire connection.
- Damaged harness–Inspect the wiring harness to the EVAP canister vent solenoid, EVAP canister purge solenoid and the fuel tank pressure sensor for an intermittent open or short circuit.

- Kinked, pinched, or plugged vacuum source, EVAP purge, or fuel tank vapor line–Verify that the lines are not restricted.

Reviewing the Failure Records vehicle mileage since the diagnostic test last failed may help determine how often the condition that caused the DTC to be set occurs. This may assist in diagnosing the condition.

### Test Description

Number(s) below refer to the step number(s) on the Diagnostic Chart.

2. If an EVAP canister vent solenoid or an EVAP canister purge solenoid electrical fault is present, the purge system will not operate correctly. Repairing the electrical fault will very likely correct the condition that set DTC P0440.
3. Checks the fuel tank pressure sensor at ambient pressure.
4. Determines whether or not the EVAP system can be sealed sufficiently to be pressurized. If not, the large leak must be located and corrected before continuing with diagnosis.
5. Verifies that the fuel tank pressure sensor accurately reacts to EVAP system pressure changes.
8. Checks for a blocked EVAP canister purge solenoid. The PCM commands the EVAP canister purge solenoid "OFF" (open) and the vent solenoid "ON" (closed) with the Tech 2 "System Perf." EVAP output control function activated. Any pressure in the system should be released through the EVAP canister purge solenoid within a few seconds when "System Perf." is activated.
9. Ensures that sufficient source vacuum is present at the EVAP canister purge solenoid.

## DTC P0440 – EVAP System

Step	Action	Value(s)	Yes	No
1	Was the "On-Board Diagnostic (OBD) System Check" performed?	—	Go to Step 2	Go to <i>OBD System Check</i>
2	Is DTC P0452 or P0453 also set?	—	Go to <i>other DTC first</i>	Go to Step 3
3	1. Ignition "OFF." 2. Remove the fuel cap. 3. Ignition "ON." 4. Observe "Fuel Tank Pressure" on the Tech 2. Does the Tech 2 indicate "Fuel Tank Pressure" at the specified value?	1.51 V	Go to Step 4	Go to <i>DTC P0452 or DTC P0453</i>

## DTC P0440 – EVAP System (Cont'd)

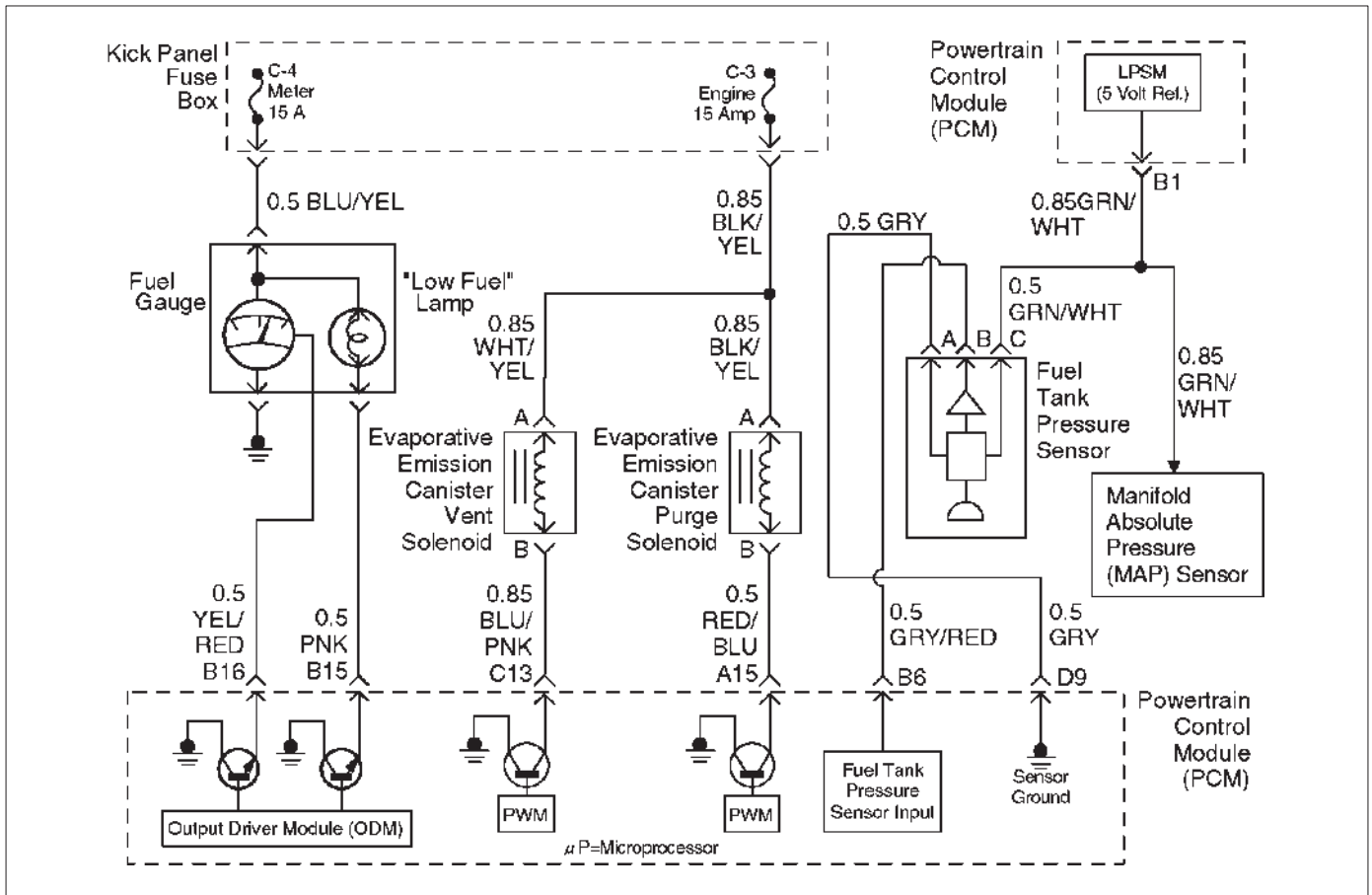
Step	Action	Value(s)	Yes	No
4	<p><b>IMPORTANT:</b> Before continuing with diagnosis, zero the EVAP pressure and vacuum gauges on the EVAP pressure/purge cart J 41413 (refer to tool operating instructions).</p> <ol style="list-style-type: none"> <li>1. Replace the fuel cap.</li> <li>2. Capture Failure Records data for DTC P0440 and clear DTCs.</li> <li>3. Using the Tech 2, command the EVAP canister vent solenoid "ON" (closed).</li> <li>4. Connect the EVAP pressure/purge cart J 41413 to the EVAP service port.</li> <li>5. Attempt to pressurize the EVAP system using the EVAP pressure/purge cart J 41413 (monitor pressure using gauge on cart).</li> </ol> <p>Can EVAP system be pressurized to specified value?</p>	5 in. H2O	Go to Step 5	Go to Step 6
5	<ol style="list-style-type: none"> <li>1. Maintain fuel tank pressure at 5 inches at H2O.</li> <li>2. Observe "Fuel Tank Vacuum" on the Tech 2.</li> </ol> <p>Does Tech 2 indicate "Fuel Tank Vacuum" at the specified value?</p>	1.47–1.51 V	Go to Step 8	Go to Step 7
6	<ol style="list-style-type: none"> <li>1. Disconnect the fuel tank vapor line and the EVAP purge line from the EVAP canister.</li> <li>2. Block the canister fitting for the fuel tank vapor line.</li> <li>3. Connect a hand vacuum pump to the canister fitting for the EVAP purge line.</li> <li>4. Ensure that the EVAP canister vent solenoid is still commanded "ON" (closed).</li> <li>5. Attempt to apply vacuum to the EVAP canister.</li> </ol> <p>Can the vacuum be maintained at the specified value?</p>	5 in. Hg	Go to Step 11	Go to Step 10
7	<ol style="list-style-type: none"> <li>1. Visually/physically check for the following conditions: <ul style="list-style-type: none"> <li>○ Restricted fuel tank vapor line.</li> <li>○ Restricted EVAP purge line.</li> </ul> </li> <li>2. If a problem is found, repair as necessary.</li> </ol> <p>Was a problem found?</p>	—	Go to Step 16	Go to DTC P0452 or DTC P0453
8	<ol style="list-style-type: none"> <li>1. Disconnect the vacuum source line at the EVAP canister purge solenoid and plug the vacuum source fitting on the solenoid.</li> <li>2. Using the Tech 2 output tests function, select "System Perf." and activate.</li> <li>3. Pressurize the EVAP system to the specified value 5 in. H2O (monitor pressure using gauge on cart).</li> <li>4. Observe the EVAP pressure gauge on the EVAP pressure/purge cart J 41413 while removing the plug from the EVAP canister purge solenoid.</li> </ol> <p>Does "Fuel Tank Pressure" decrease to the specified value within 15 seconds while "System Perf." is activated?</p>	1.51 V	Go to Step 9	Go to Step 13



## DTC P0440 – EVAP System (Cont'd)

Step	Action	Value(s)	Yes	No
9	<p>1. Connect the in. Hg vacuum gauge on the EVAP pressure/purge cart J 41413 to the vacuum source line.</p> <p>2. Ignition "ON," engine idling.</p> <p>3. Run the engine above 2000 RPM and observe source vacuum level (monitor vacuum using gauge on cart).</p> <p>Does source vacuum level exceed the specified value?</p>	15 in. Hg	Refer to <i>Diagnostic Aids</i>	Go to <i>Step 14</i>
10	<p>1. Visually/physically check for the following conditions:</p> <ul style="list-style-type: none"> <li><input type="radio"/> Vent hose disconnected or the damaged.</li> <li><input type="radio"/> EVAP canister damaged.</li> </ul> <p>2. If a problem is found, repair as necessary.</p> <p>Was a problem found?</p>	—	Go to <i>Step 16</i>	Go to <i>Step 15</i>
11	<p>1. Visually/physically check for the following conditions:</p> <ul style="list-style-type: none"> <li><input type="radio"/> Missing or faulty fuel cap.</li> <li><input type="radio"/> Disconnected or leaking fuel tank vapor line.</li> <li><input type="radio"/> Disconnected or damaged EVAP purge line.</li> </ul> <p>2. If a problem is found, repair as necessary.</p> <p>Was a problem found?</p>	—	Go to <i>Step 16</i>	Go to <i>Step 12</i>
12	<p>1. Using Tech 2, command the EVAP canister vent solenoid "ON" (closed).</p> <p>2. With the cart connected to the EVAP service port, continuously attempt to pressurize the EVAP system by leaving the cart control knob in the pressurize position.</p> <p>3. Using ultrasonic leak detector J 41416, locate and repair leak in EVAP system. (It may be necessary to partially lower the fuel tank to examine the connections on top of the tank.)</p> <p>Is the action complete?</p>	—	Go to <i>Step 16</i>	—
13	<p>Replace the EVAP canister purge solenoid.</p> <p>Is the action complete?</p>	—	Go to <i>Step 16</i>	—
14	<p>Locate and repair cause of no source vacuum to the EVAP canister purge solenoid.</p> <p>Is the action complete?</p>	—	Go to <i>Step 16</i>	—
15	<p>Replace the EVAP canister vent solenoid.</p> <p>Is the action complete?</p>	—	Go to <i>Step 16</i>	—
16	<p>1. Ignition "ON," engine not running.</p> <p>2. Using the Tech 2, command the EVAP canister vent solenoid "ON" (closed).</p> <p>3. Using the EVAP pressure/purge cart J 41413, pressurize and monitor the EVAP system to 15 in. H<sub>2</sub>O.</p> <p>4. Switch the rotary switch on the cart to "HOLD" and observe the EVAP pressure gauge.</p> <p>Does the pressure decrease to less than the specified value within 2 minutes?</p>	2.14 V	Go to <i>Step 4</i>	Verify repair

## Diagnostic Trouble Code (DTC) P0442 EVAP System Small Leak Detected



D06RX143

### Circuit Description

The evaporative system includes the following components:

- Fuel tank
- EVAP canister vent solenoid
- Fuel tank pressure sensor
- Fuel pipes and hoses
- Vapor lines
- Fuel cap
- Evaporative emissions canister
- Purge lines
- EVAP canister purge solenoid

The evaporative leak detection diagnostic strategy is based on applying vacuum to the EVAP system and monitoring vacuum decay. The powertrain control module (PCM) monitors vacuum level via the fuel tank pressure sensor input. At an appropriate time, the EVAP canister purge solenoid and the EVAP canister vent solenoid are turned "ON," allowing engine vacuum to draw a small vacuum on the entire evaporative emissions system. After the desired vacuum level has been achieved, the EVAP canister purge solenoid is turned "OFF," sealing the system. A leak is detected by monitoring for a decrease in vacuum level over a given time period, all other variables remaining constant. A small leak in the system will cause DTC P0442 to be set.

### Conditions for Setting the DTC

- No TP sensor, ODM, IAT sensor, or MAP sensor DTCs set.
- The DTC P0440 diagnostic test has passed.
- A vacuum decay condition, indicating a small leak, is detected during the diagnostic test.

### Action Taken When the DTC Sets

- The PCM will illuminate the malfunction indicator lamp (MIL) during the second key cycle in which the DTC sets.
- The PCM will store conditions which were present when the DTC was set as Freeze Frame and in the Failure Records data.

### Conditions for Clearing the MIL/DTC

- The PCM will turn the MIL "OFF" on the third consecutive trip cycle during which the diagnostic has been run and the fault condition is no longer present.
- A history DTC P0442 will clear after 40 consecutive warm-up cycles have occurred without a fault.
- DTC P0442 can be cleared by using the Tech 2 "Clear Info" function or by disconnecting the PCM battery feed.

**Diagnostic Aids**

Check for the following conditions:

- Cracked or punctured EVAP canister.
- Damaged source vacuum line, EVAP purge line, EVAP vent hose or fuel tank vapor line.
- Poor connection at PCM – Inspect harness connectors for backed-out terminals, improper mating, broken locks, improperly formed or damaged terminals, and poor terminal to wire connection.
- Damaged harness—Inspect the wiring harness to the EVAP canister vent solenoid, EVAP canister purge solenoid and the fuel tank pressure sensor for an intermittent open or short circuit.

Reviewing the Failure Records vehicle mileage since the diagnostic test last failed may help determine how often

the condition that caused the DTC to be set occurs. This may assist in diagnosing the condition.

**Test Description**

Number(s) below refer to the step number(s) on the Diagnostic Chart.

2. If an EVAP canister vent solenoid or an EVAP canister purge solenoid electrical fault is present, the purge system will not operate correctly. Repairing the electrical fault will very likely correct the condition that set DTC P0442.
3. Checks the fuel tank pressure sensor at ambient pressure.
4. Verifies that the fuel tank pressure sensor accurately reacts to EVAP system pressure changes.

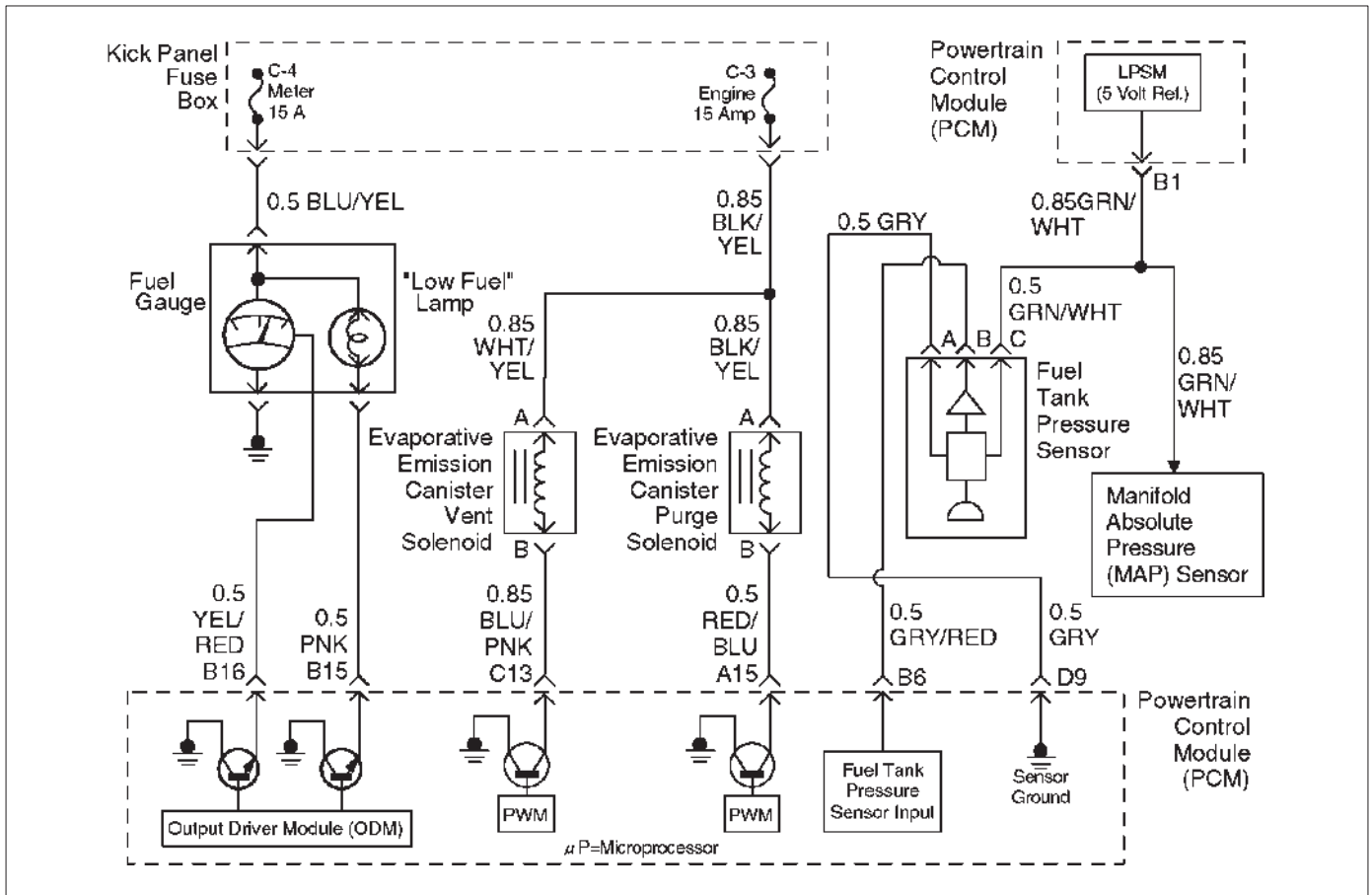
**DTC P0442 – EVAP System Leak Detected**

Step	Action	Value(s)	Yes	No
1	Was the “On-Board Diagnostic (OBD) System Check” performed?	—	Go to Step 2	Go to <i>OBD System Check</i>
2	1. Ignition “OFF.” 2. Remove the fuel cap. 3. Ignition “ON.” 4. Observe “Fuel Tank Pressure” on the Tech 2. Does the Tech 2 indicate “Fuel Tank Pressure” at the specified value?	1.51V	Go to Step 3	Go to <i>Fuel Tank Pressure System</i>
3	<b>IMPORTANT:</b> Before continuing with diagnosis, zero the EVAP pressure and vacuum gauges on EVAP pressure/purge cart J 41413 (refer to tool operating instructions). 1. Replace the fuel cap. 2. Capture Failure Records data for DTC P0442 and clear DTCs. 3. Connect the EVAP pressure/purge cart J 41413 to the EVAP service port. 4. Using the Tech 2, command the EVAP canister vent solenoid “ON” (closed). 5. Using the EVAP pressure/purge cart J 41413, pressurize the EVAP system to the specified value. 6. Observe “Fuel Tank Pressure” on the Tech 2. Does the Tech 2 indicate “Fuel Tank Pressure” at the specified value?	1.52V – 1.69V	Go to Step 4	Go to <i>Fuel Tank Pressure System</i>
4	1. Ignition “ON,” engine idling. 2. Using the Tech 2, command the EVAP canister vent solenoid “ON” (closed). 3. Using the EVAP pressure/purge cart J 41413, pressurize the EVAP system to 15 in. H2O. 4. Switch the rotary switch on the cart to “HOLD” and observe the EVAP pressure gauge. Does the pressure decrease to less than the specified value within 2 minutes?	1.47 – 1.51V	Go to Step 5	Refer to <i>Diagnostic Aids</i>

**DTC P0442 – EVAP System Leak Detected (Cont'd)**

Step	Action	Value(s)	Yes	No
5	1. Disconnect the fuel tank vapor line and the EVAP purge line from the EVAP canister. 2. Block the canister fitting for the fuel tank vapor line. 3. Connect a hand vacuum pump to the canister fitting for the EVAP purge line. 4. Ensure that the EVAP canister vent solenoid is still commanded "ON" (closed). 5. Attempt to apply vacuum to the EVAP canister. Can the vacuum be maintained at the specific value?	5 in. Hg	Go to <i>Step 8</i>	Go to <i>Step 6</i>
6	1. Visually/physically check for the following conditions: <ul style="list-style-type: none"> <li><input type="radio"/> Vent hose disconnected or damaged.</li> <li><input type="radio"/> EVAP canister damaged.</li> </ul> 2. If a problem is found, repair as necessary. Was a problem found?	—	Go to <i>Step 10</i>	Go to <i>Step 7</i>
7	Replace the EVAP canister vent solenoid. Is the action complete?	—	Go to <i>Step 10</i>	—
8	1. Visually/physically check for the following conditions: <ul style="list-style-type: none"> <li><input type="radio"/> Missing or faulty fuel cap.</li> <li><input type="radio"/> Disconnected or leaking fuel tank vapor line.</li> <li><input type="radio"/> Disconnected or damaged EVAP purge line.</li> </ul> 2. If a problem is found, repair as necessary. Was a problem found?	—	Go to <i>Step 10</i>	Go to <i>Step 9</i>
9	1. Using Tech 2, command the EVAP canister vent solenoid "ON" (closed). 2. With the cart connected to the EVAP service port, continuously attempt to pressurize the EVAP system by leaving the cart control knob in the pressurize position. 3. Using ultrasonic leak detector J 41416, locate and repair leak in EVAP system. (It may be necessary to partially lower the fuel tank to examine the connections on top of the tank.) Is the action complete?	—	Go to <i>Step 10</i>	—
10	1. Ignition "ON," engine not running. 2. Using the Tech 2, command the EVAP canister vent solenoid "ON" (closed). 3. Using the EVAP pressure/purge cart J 41413, pressurize and monitor the EVAP system to 15 in. H <sub>2</sub> O. 4. Switch the rotary switch on the cart to "HOLD" and observe the EVAP pressure gauge. Does the pressure decrease to less than the specified value within 2 minutes?	2.14V	Go to <i>Step 2</i>	Verify repair

## Diagnostic Trouble Code (DTC) P0446 EVAP Canister Vent Blocked



D06RX143

### Circuit Description

The evaporative system includes the following components:

- Fuel tank
- EVAP canister vent solenoid
- Fuel tank pressure sensor
- Fuel pipes and hoses
- Vapor lines
- Fuel cap
- Evaporative emissions canister
- Purge lines
- EVAP canister purge solenoid

An incorrect fuel tank pressure sensor signal is detected by monitoring fuel tank pressure when the key is first turned "ON" during a cold start. If the fuel tank pressure signal is out of range, DTC P0446 will set. A restricted or blocked EVAP vent path is detected by monitoring fuel tank pressure during normal operation (EVAP canister vent solenoid open, EVAP canister purge solenoid normal). With the EVAP canister vent solenoid open, vacuum level in the system should be very low unless the vent path is blocked. A blockage can be caused by the following condition:

- Faulty EVAP canister vent solenoid (stuck closed).
  - Plugged, kinked or pinched vent hose.
  - Shorted EVAP canister vent solenoid driver circuit.
  - Plugged evaporative canister.
- If any of these conditions are present, DTC P0446 will set.

### Conditions for Setting the DTC

- No TP sensor, ODM, IAT sensor, or MAP sensor DTCs set.
  - Start-up engine coolant temperature is less than 32°C (90°F).
  - Start-up engine coolant temperature is not more than 7°C (13°F) greater than start-up intake air temperature.
  - Start-up intake air temperature is greater than 4°C (39°F).
  - Start-up intake air temperature is not more than 2°C (4°F) greater than start-up engine coolant temperature.
  - Vehicle speed is less than 75 mph (120 km/h).
  - Throttle position is greater than 7% but less than 30%.
  - Minimal fuel slosh.
  - Fuel tank level is between 15% and 85%.
  - BARO is greater than 75 kpa.
  - Fuel tank pressure is not between -1.5 and 1.5 in. H<sub>2</sub>O when ignition is turned "ON."
- OR
- No TP sensor, ODM, IAT sensor, or MAP sensor DTCs set.
  - DTC P0442 diagnostic test has passed.
  - Normal system operation is commanded (EVAP canister vent solenoid open, EVAP canister purge solenoid normal).
  - Fuel tank pressure is less than -10 in. H<sub>2</sub>O.
  - Above conditions are present for 60 to 180 seconds.

**Action Taken When the DTC Sets**

- The PCM will illuminate the MIL during the second key cycle in which the DTC sets.
- The PCM will store conditions which were present when the DTC set as Freeze Frame and Failure Records data.

**Conditions for Clearing the MIL/DTC**

- The PCM will turn the MIL “OFF” on the third consecutive trip cycle during which the diagnostic has been run and the fault condition is no longer present.
- A history DTC P0446 will clear after 40 consecutive warm-up cycles have occurred without a fault.
- DTC P0446 can be cleared by using the Tech 2 “Clear Info” function or by disconnecting the PCM battery feed.

**Diagnostic Aids**

Check for the following conditions:

- Poor connection at PCM – Inspect harness connectors for backed-out terminals, improper mating, broken locks, improperly formed or damaged terminals, and poor terminal to wire connection.
- Damaged harness–Inspect the wiring harness to the EVAP canister vent solenoid, EVAP canister purge

solenoid and the fuel tank pressure sensor for an intermittent open or short circuit.

- Kinked, pinched, or plugged vent hose–Verify that the vent hose between the EVAP canister and EVAP canister vent solenoid is not restricted.

Reviewing the Failure Records vehicle mileage since the diagnostic test last failed may help determine how often the condition that caused the DTC to be set occurs. This may assist in diagnosing the condition.

**Test Description**

Number(s) below refer to the step number(s) on the Diagnostic Chart.

2. If a vent solenoid electrical fault is present, the purge system will not operate correctly. Repairing the electrical fault will very likely correct the condition that set DTC P0446.
3. Checks the fuel tank pressure sensor at ambient pressure.
4. Verifies that the fuel tank pressure sensor accurately reacts to EVAP system pressure changes.
6. Checks for a blocked EVAP canister.

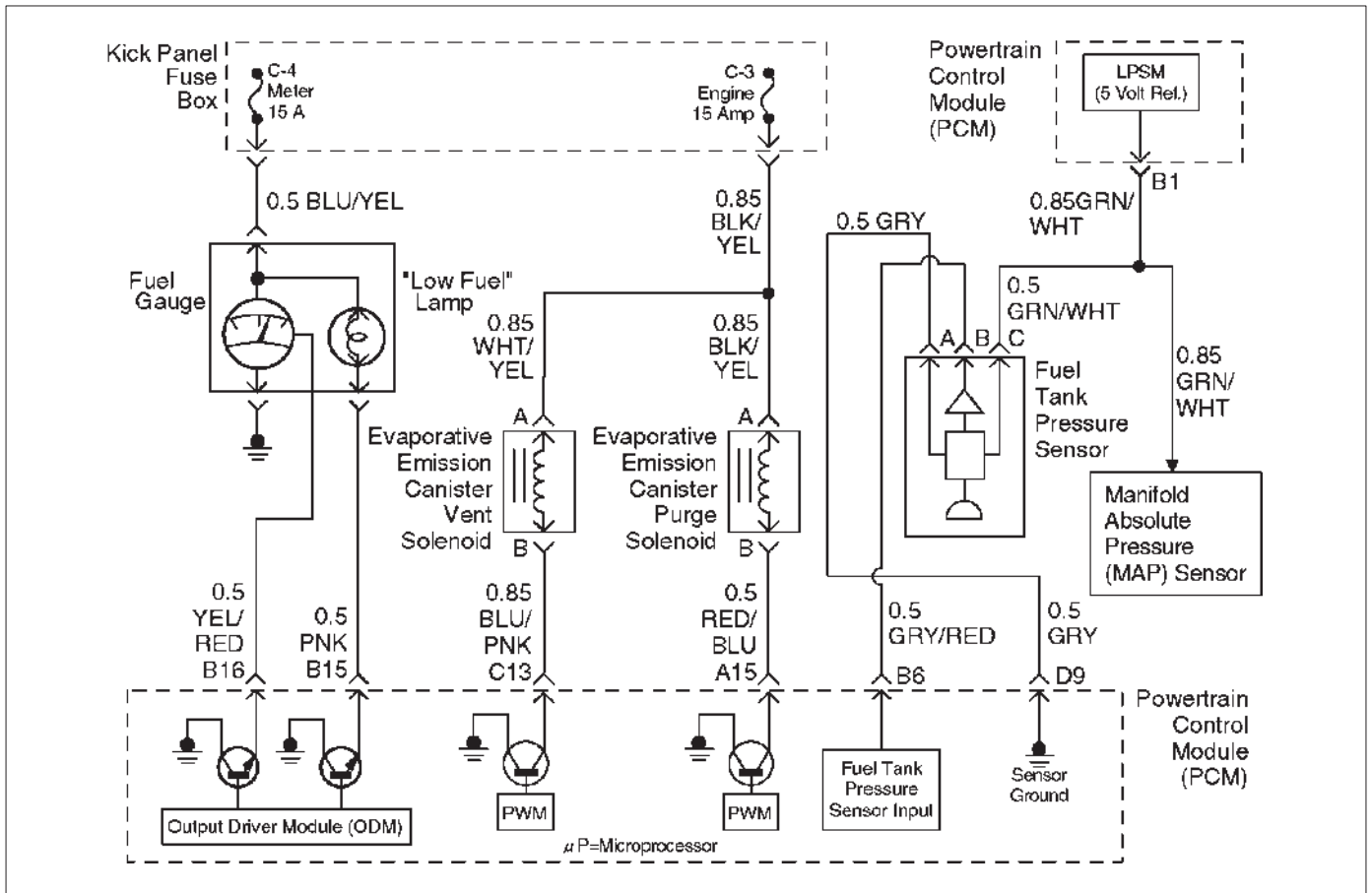
**DTC P0446– EVAP Canister Vent Blocked**

Step	Action	Value(s)	Yes	No
1	Was the “On-Board Diagnostic (OBD) System Check” performed?	—	Go to Step 2	Go to <i>OBD System Check</i>
2	1. Ignition “ON.” 2. Capture Failure Records data for DTC P0446 and clear DTCs. 3. Ignition “OFF.” 4. Remove the fuel cap. 5. Ignition “ON.” 6. Observe “Fuel Tank Pressure” on the Tech 2. Does Tech 2 indicate “Fuel Tank Pressure” at the specified value?	1.51V	Go to Step 3	Go to <i>Fuel Tank Pressure System</i>
3	<b>IMPORTANT:</b> Before continuing with diagnosis, zero the EVAP pressure and vacuum gauges on the EVAP pressure/purge cart J 41413 (refer to tool operating instructions). 1. Replace the fuel cap. 2. Using the Tech 2, command the EVAP vent solenoid “ON” (closed). 3. Connect the EVAP pressure/purge cart J 41413 to the EVAP service port. 4. Using the EVAP pressure/purge cart J 41413, pressurize the EVAP system to the specified value. 5. Observe “Fuel Tank Pressure” on the Tech 2. Does Tech 2 indicate “Fuel Tank Pressure” at the specified value?	1.52 – 1.69V	Go to Step 4	Go to <i>Fuel Tank Pressure System</i>

**DTC P0446– EVAP Canister Vent Blocked (Cont'd)**

Step	Action	Value(s)	Yes	No
4	1. Maintain the EVAP pressure at 5 in. at H <sub>2</sub> O. 2. Using Tech 2, command the EVAP vent solenoid "OFF" (open) while observing the EVAP pressure gauge on the cart J 41413. Does the EVAP pressure return to the specified value within 5 seconds?	0 in. H <sub>2</sub> O	Refer to <i>Diagnostic Aids</i>	Go to <i>Step 5</i>
5	1. Disconnect the large vent hose (marked "AIR") from the EVAP canister. 2. Switch the rotary switch on the cart J 41413 to "PURGE." 3. Ignition "ON," engine idling at normal operating temperature. 4. Observe vacuum gauge for 5 seconds while holding the engine speed at 2500 RPM. Does the vacuum remain less than the specified value?	30 in. H <sub>2</sub> O	Go to <i>Step 6</i>	Go to <i>Step 8</i>
6	1. Inspect the vent hose between the EVAP canister and the EVAP canister vent solenoid for kinks, pinched areas, or any other form of blockage. 2. If a problem is found, repair as necessary. Was a problem found?	—	Go to <i>Step 9</i>	Go to <i>Step 7</i>
7	Replace the EVAP canister vent solenoid. Is the action complete?	—	Go to <i>Step 9</i>	—
8	Replace the EVAP canister. Is the action complete?	—	Go to <i>Step 9</i>	—
9	1. Using Tech 2, command the EVAP canister vent solenoid "ON" (closed). 2. Using the EVAP pressure/purge cart J 41413, pressurize and monitor the EVAP system to 15 in. H <sub>2</sub> O. 3. Switch the rotary switch on cart J 41413 to "HOLD." 4. Using the Tech 2, command the EVAP canister vent solenoid "OFF" (open) while observing the EVAP pressure gauge on cart J 41413. Does the EVAP pressure return to the specified value within 5 seconds?	1.51V	Verify repair	Go to <i>Step 2</i>

**Diagnostic Trouble Code (DTC) P0452 Fuel Tank Pressure Sensor Low Voltage**



**Circuit Description**

The powertrain control module (PCM) monitors fuel tank pressure sensor of the Enhanced Evapo system. When the tank pressure output indicates low voltage, PCM will set DTC P0452.

**Conditions for Setting the DTC**

- Ignition voltage is between 0.3 and 4.7 volts.
- Tank sensor output is less than 0.2 volts for 12.5 sec.
- 100 test failures within a 200 tests.

**Action Taken When the DTC Sets**

- The PCM will illuminate the malfunction indicator lamp (MIL) as soon as failure detected.
- The PCM will store conditions which were present when the DTC was set as Freeze Frame and in Failure Records data.

**Conditions for Clearing the MIL/DTC**

- The PCM will turn the MIL "OFF" on the third consecutive trip cycle during which the diagnostic has been run and the fault condition is no longer present.

- A history DTC P0402 will clear after 40 consecutive warm-up cycles have occurred without a fault.
- DTC P0404 can be cleared by using the Tech 2 "Clear Info" function or by disconnecting the PCM battery feed.

**Diagnostic Aids**

Check for the following conditions:

- Open circuit of 5 volt reference line – Inspect wiring harness from PCM to the sensor. The PCM turns P0452, and P0107 at the same time.
- Open circuit or short circuit to ground line – Inspect wiring harness from PCM to the sensor. The PCM turns P0452 and P0107 at the same time.
- Tank fuel pressure sensor malfunction may cause P0452.

Reviewing the Failure Records vehicle mileage since the diagnostic test last failed may help determine how often the condition that caused the DTC to be set occurs. This may assist in diagnosing the condition.



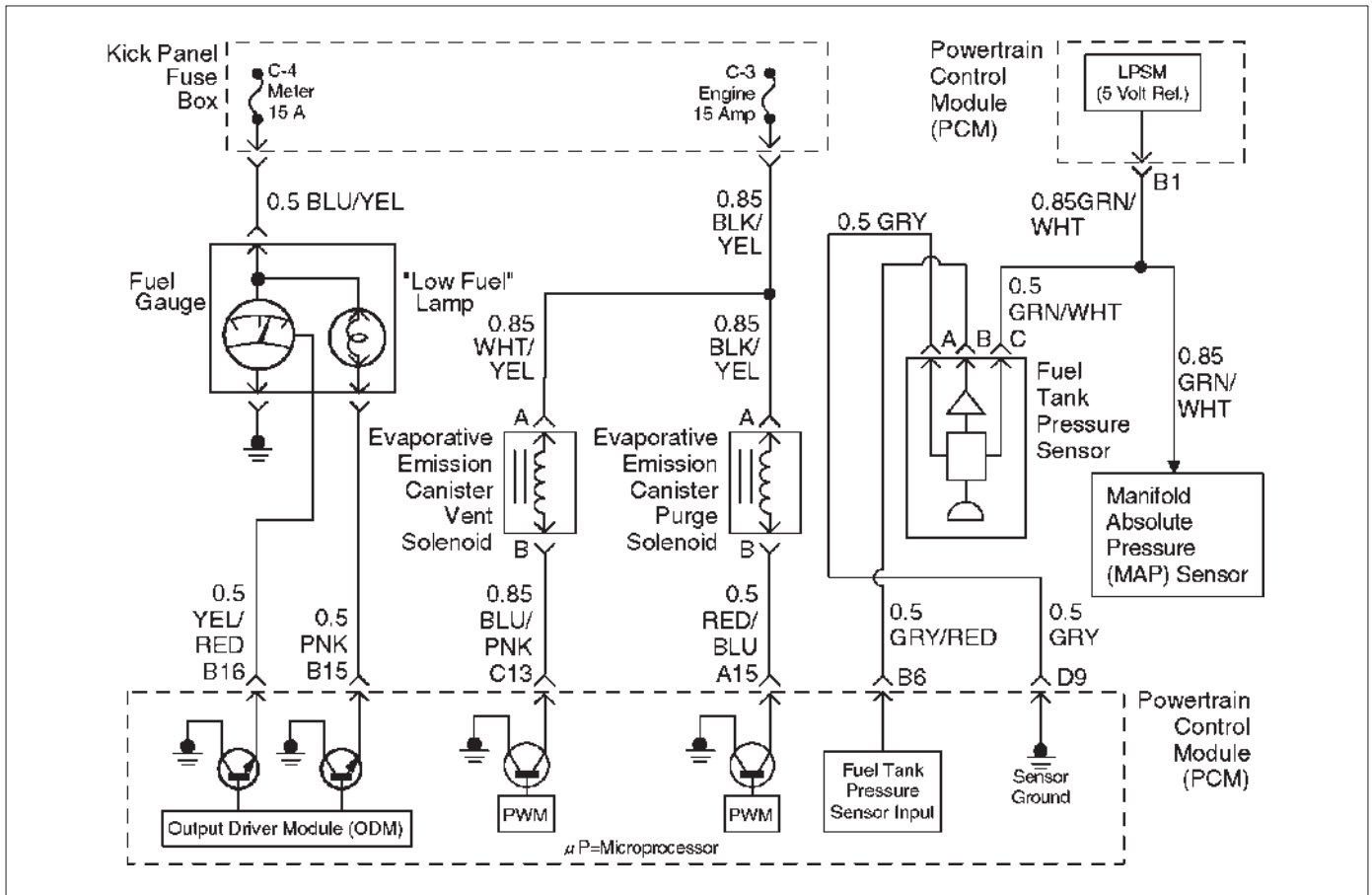
**DTC P0452 – Tank Pressure Sensor Low Voltage**

Step	Action	Value(s)	Yes	No
1	Was the "On-Board Diagnostic (OBD) System Check" performed?	—	Go to Step 2	Go to <i>OBD System Check</i>
2	1. Ignition "ON," engine "OFF", review and record Tech 2 Failure Records Data. 2. Operate the vehicle within Failure Records conditions as noted. 3. Using a Tech 2, monitor "DTC" info for DTC P0452 until the DTC P0452 test runs. Note the result. Does the Tech 2 indicates DTC P0452 or P0452/P0107 failed this ignition?	—	P0452/P0107 turn on Go to Step 3 P0452 turns on Go to Step 6	Refer to <i>Diagnostic Aids</i>
3	1. Ignition "OFF". 2. Disconnect connector at the PCM. 3. Ignition "ON". 4. At the PCM connector, measure voltage with a DVM at B1 and B6 terminals. Was the voltage in range of voltage?	4–6 V	Go to Step 4	Go to Step 10
4	1. Ignition "OFF". 2. Connect the PCM connector to the PCM. 3. Backprobe with a DVM at fuel tank pressure sensor between 5 V reference terminal and sensor ground terminal. Was the voltage within range?	4–6 V	For P0452 go to Step 5 and for P0107, go to diagnosis section.	Go to Step 5
5	1. Locate open wiring of 5 volt reference circuit from the PCM to fuel tank pressure sensor. 2. Repair wiring harness. Is the action complete?	—	Verify repair	—
6	1. Ignition "ON" 2. At the PCM connector, backprobe with a DVM at the sensor output for the voltage. Was voltage within the range?	Less than 0.2 V	Go to Step 7	Go to Step 10
7	At the sensor output terminal, backprobe with a DVM at the sensor output Was voltage within the range?	Less than 0.2 V	Go to Step 9	Go to Step 8
8	1. Locate open circuit or short circuit to ground line. 2. Repair the harness. Is the action complete?	—	Verify repair	—

**DTC P0452 – Tank Pressure Sensor Low Voltage (Cont'd)**

Step	Action	Value(s)	Yes	No
9	1. Locate open circuit or short circuit to ground line. 2. Repair the harness. Is the action complete?	—	Verify repair	—
10	Replace the PCM. <b>IMPORTANT:</b> The replacement PCM must be programmed. Refer to <i>On-Vehicle Service</i> in <i>Powertrain Control Module and Sensors</i> for procedures. And also refer to latest Service Bulletin. Check to see if the Latest software is released or not. And then Down Load the LATEST PROGRAMMED SOFTWARE to the replacement PCM. Is the action complete?	—	Verify repair	—

## Diagnostic Trouble Code (DTC) P0453 Fuel Tank Pressure Sensor High Voltage



### Circuit Description

The powertrain control module (PCM) monitors fuel tank pressure sensor of the Enhanced Evapo system. When the tank pressure output indicates high voltage, PCM will set DTC P0453.

### Conditions for Setting the DTC

- Tank sensor output is more than 4.9 volts for 12.5 sec.
- 100 test failures within a 200 tests.

### Action Taken When the DTC Sets

- The PCM will illuminate the malfunction indicator lamp (MIL) as soon as failure detected.
- The PCM will store conditions which were present when the DTC was set as Freeze Frame and in Failure Records data.

### Conditions for Clearing the MIL/DTC

- The PCM will turn the MIL "OFF" on the third consecutive trip cycle during which the diagnostic has been run and the fault condition is no longer present.

- A history DTC P0453 will clear after 40 consecutive warm-up cycles have occurred without a fault.
- Info function or by disconnecting the PCM battery feed.

### Diagnostic Aids

Check for the following conditions:

- Open circuit of sensor ground line – Inspect wiring harness from PCM to the sensor. The PCM turns P0453, and P0108 at the same time.
- Open circuit or short circuit to 5 volt reference line – Inspect wiring harness from PCM to the sensor. The PCM turns P0453 and P0108 at the same time.
- Tank fuel pressure sensor malfunction may cause P0453.

Reviewing the Failure Records vehicle mileage since the diagnostic test last failed may help determine how often the condition that caused the DTC to be set occurs. This may assist in diagnosing the condition.

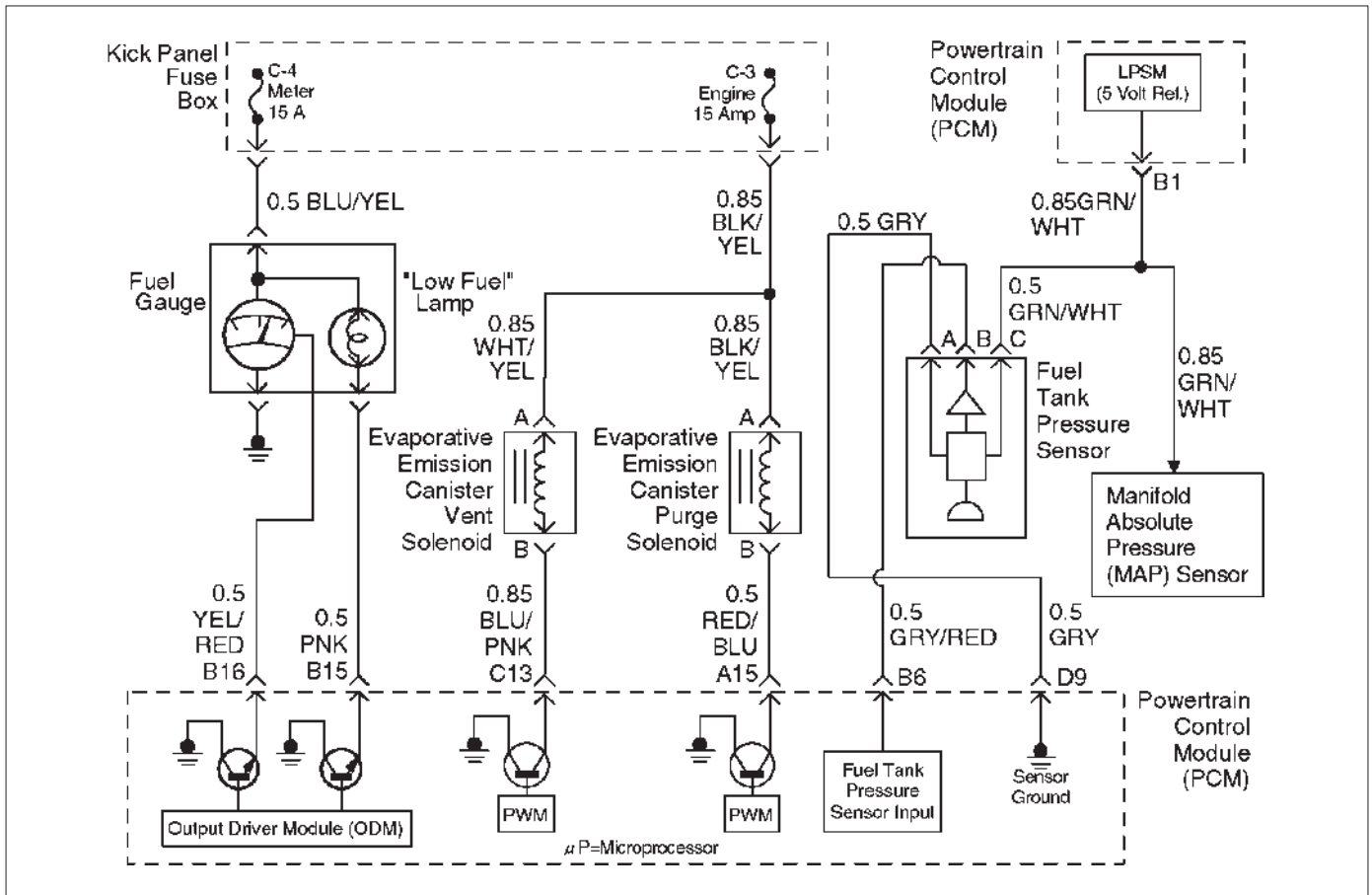
### DTC P0453 – Fuel Tank Pressure Sensor High Voltage

Step	Action	Value(s)	Yes	No
1	Was the "On-Board Diagnostic (OBD) System Check" performed?	—	Go to Step 2	Go to <i>OBD System Check</i>
2	1. Ignition "ON," engine "OFF", review and record Tech 2 Failure Records Data. 2. Operate the vehicle within Failure Records conditions as noted. 3. Using a Tech 2, monitor "DTC" info for DTC P0452 until the DTC P0452 test runs. Note the result. Does the Tech 2 indicates DTC P0452 or P0452/P0107 failed this ignition?	—	P0453/P0108 turn on Go to Step 3 P0452 turns on Go to Step 6	Refer to <i>Diagnostic Aids</i>
3	1. Ignition "OFF". 2. Disconnect connector at the PCM. 3. Ignition "ON". 4. At the PCM connector, measure voltage with a DVM at B1 and B6 terminals. Was the voltage in range of voltage?	4–6 V	Go to Step 4	Go to Step 10
4	1. Ignition "OFF". 2. Connect the PCM connector to the PCM. 3. Disconnect sensor harness at fuel pressure sensor. Measure voltage with a DVM at the end of the tank pressure wiring between 5 V reference terminal and sensor ground terminal. Was the voltage within range?	4–6 V	For P0453 go to Step 6 and for P0108, go to diagnosis section.	Go to Step 5
5	1. Locate open wiring of ground line from the PCM to fuel tank pressure sensor. 2. Repair wiring harness. Is the action complete?	—	Verify repair	—
6	1. Ignition "ON". 2. At the PCM connector, backprobe with a DVM at the sensor output for the voltage. Was voltage within the range?	More than 4.9 V	Go to Step 7	Go to Step 10
7	At the sensor output terminal, backprobe with a DVM at the sensor output. Was the voltage within range?	More than 4.9 V	Go to Step 9	Go to Step 8
8	1. Locate open circuit or short circuit to ground line. 2. Repair the harness. Is the action complete?	—	Verify repair	—

**DTC P0453 – Fuel Tank Pressure Sensor High Voltage (Cont'd)**

Step	Action	Value(s)	Yes	No
9	Replace the tank pressure sensor. Is the action complete?	—	Verify repair	—
10	Replace the PCM. <b>IMPORTANT:</b> The replacement PCM must be programmed. Refer to <i>On-Vehicle Service</i> in <i>Powertrain Control Module and Sensors</i> for procedures. And also refer to latest Service Bulletin. Check to see if the Latest software is released or not. And then Down Load the LATEST PROGRAMMED SOFTWARE to the replacement PCM. Is the action complete?	—	Verify repair	—

## Diagnostic Trouble Code (DTC) P0462 Fuel Level Sensor Circuit—Low Voltage



### Circuit Description

The fuel level sensor is an important input to powertrain control module (PCM) for the enhanced evaporative system diagnostic. Fuel level information is needed for the PCM to know the volume of fuel in the tank. The fuel level affects the rate of change in air pressure in the evaporative system. Several of the enhanced evaporative system diagnostic sub-tests are dependent upon correct fuel level information. The diagnostic will not run when the tank is greater than 85%, or less than 15% full. Fuel level DTCs should be diagnosed before other evaporative system DTCs because they can cause other DTCs to be set.

The sending unit is a float in the fuel tank which moves a wiper arm across a variable resistor. Low fuel level causes high resistance in the sending unit, and this is recognized by the PCM because the circuit operates at a corresponding low voltage. When the circuit is continuously open or has a high resistance connection, DTC P0462 is set.

### Conditions for Setting the DTC

- Fuel tank level "slosh test" is completed.
- Fuel tank level "main test" is completed.
- Fuel tank level data is valid.
- Fuel tank level signal is less than a specified value.
- There are 100 test failures within a 200-test sample.

### Action Taken When the DTC Sets

- The PCM will not turn the malfunction indicator lamp (MIL) "ON."
- The PCM will store conditions which were present when the DTC was set as Failure Records only. This information will not be stored as Freeze Frame data.

### Conditions for Clearing the DTC

- The PCM will turn the MIL "OFF" after three consecutive trips without a fault condition present. A history DTC will be cleared if no fault conditions have been detected for 40 warm-up cycles (engine coolant temperature has risen 4°C (40°F) from the start-up ECT, and ECT exceeds 71°C (160°F) during that same ignition cycle).
- DTC P0462 can be cleared by using the scan tool "Clear Info" function or by disconnecting the PCM battery feed.

### Diagnostic Aids

- Damaged harness—Inspect the wiring harness for damage. If the harness appears to be OK, observe the fuel level display on the scan tool while moving connectors and wiring harnesses related to the sensor. A change in the display will indicate the location of the fault.

### Test Description

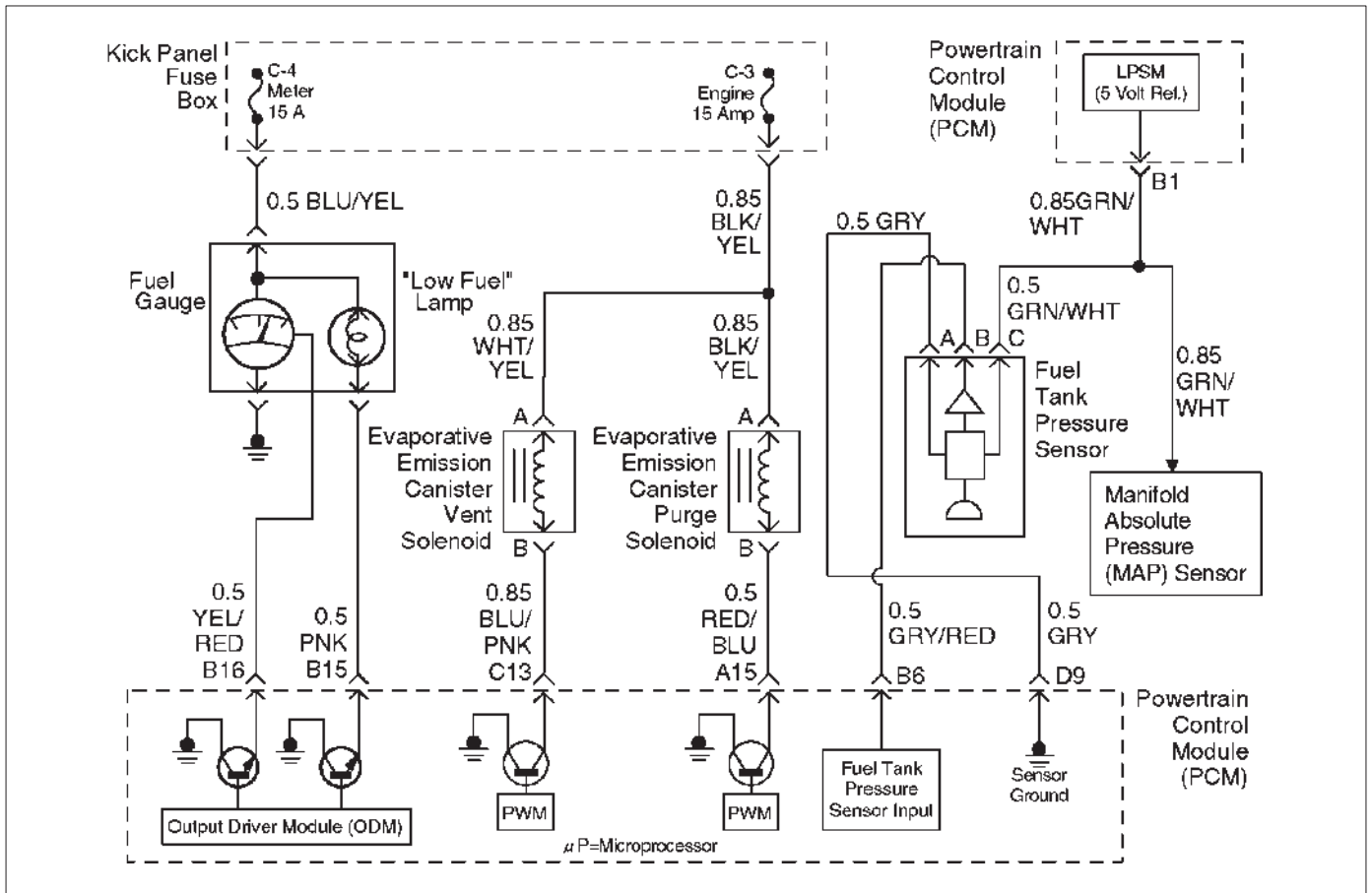
Number(s) below refer to the step number(s) on the Diagnostic Chart.

7. The following chart can be used to check the sending unit:

### DTC P0462– Fuel Level Sensor Circuit –Low Voltage

Step	Action	Value(s)	Yes	No
1	Was the “On-Board Diagnostic (OBD) System Check” performed?	—	Go to <i>Step 2</i>	Go to <i>OBD System Check</i>
2	Were any ECT or MAP DTCs set? (ECT and MAP sharing Ground with PCM term D9)	—	Go to other DTC chart	Go to <i>Step 3</i>
3	1. Disconnected the fuel level sensor harness from its connector at the fuel tank. 2. Ignition “ON,” engine “OFF.” 3. Using a DVM, measure the voltage between the sensor harness positive and ground wires. Is the voltage approximately equal to the specified value?	5 V	Go to <i>Step 7</i>	Go to <i>Step 4</i>
4	1. Ignition “ON,” engine “OFF.” 2. With a DVM, backprobe the PCM connector at the terminal which supplies 5 volts to the fuel level sensor. Is the voltage approximately equal to the specified value?	5 V	Go to <i>Step 5</i>	Go to <i>Step 10</i>
5	1. Ignition “ON,” engine “OFF.” 2. Fuel level sensor disconnected from wiring harness. 3. With a DVM, probe the 5-volt supply wire at the sensor harness. Is the voltage approximately equal to the value measured in Step 4?	—	Go to <i>Step 6</i>	Go to <i>Step 10</i>
6	Check for open or high resistance connection in the ground wire between the PCM and the fuel level sensor. Is the action complete?	—	Verify repair	—
7	Remove the fuel level sensor and check the following: <input type="radio"/> Does the arm move freely? <input type="radio"/> Are the wires open or intermittently open when wiggled? Was a problem found?	—	Go to <i>Step 8</i>	Go to <i>Step 10</i>
8	Replace the fuel level sensor. Is the action complete?	—	Verify repair	—
9	Replace the PCM. <b>IMPORTANT:</b> The replacement PCM must be programmed. Refer to <i>On-Vehicle Service in Powertrain Control Module and Sensors</i> for procedures. And also refer to latest Service Bulletin. Check to see if the Latest software is released or not. And then Down Load the LATEST PROGRAMMED SOFTWARE to the replacement PCM. Is the action complete?	—	Verify repair	—
10	Short to ground between the PCM connector and the fuel level sensor. Is the action complete?	—	Verify repair	—

**Diagnostic Trouble Code (DTC) P0463 Fuel Level Sensor Circuit–High Voltage**



D06RX143

**Circuit Description**

The fuel level sensor is an important input to powertrain control module (PCM) for the enhanced evaporative system diagnostic. Fuel level information is needed for the PCM to know the volume of fuel in the tank. The fuel level affects the rate of change in air pressure in the evaporative system. Several of the enhanced evaporative system diagnostic sub-tests are dependent upon correct fuel level information. The diagnostic will not run when the tank is greater than 85% or less than 15%, full. Fuel level DTCs should be diagnosed before other evaporative system DTCs because they can cause other DTCs to be set.

The sending unit is a float in the fuel tank which moves a wiper arm across a variable resistor. High fuel level causes low resistance in the sending unit. This is recognized by the PCM because the circuit operates at a corresponding high voltage. When the circuit is continuously shorted to a voltage source greater than a specified value, or when the 5 volt signal is shorted to ground, DTC P0463 is set.

**Conditions for Setting the DTC**

- Fuel tank level “slosh test” is completed.
- Fuel tank level “main test” is completed.
- Fuel tank level data is valid.
- Fuel tank level signal is greater than a specified value.
- There are 100 test failures within a 200-test sample.

**Action Taken When the DTC Sets**

- The PCM will not turn the malfunction indicator lamp (MIL) “ON.”
- The PCM will store conditions which were present when the DTC set as Failure Records only. This information will not be stored as Freeze Frame data.

**Conditions for Clearing the DTC**

- The PCM will turn the MIL “OFF” after three consecutive trips without a fault condition present. A history DTC will be cleared if no fault conditions have been detected for 40 warm-up cycles (engine coolant temperature has risen 4°C (40°F) from the start-up ECT, and ECT exceeds 71°C (160°F) during that same ignition cycle) or the scan tool clearing function has been used.
- DTC P0463 can be cleared by using the scan tool “Clear Info” function or by disconnecting the PCM battery feed.

**Diagnostic Aids**

- Damaged harness–Inspect the wiring harness for damage. If the harness appears to be OK, observe the fuel level display on the scan tool while moving connectors and wiring harnesses related to the sensor. A change in the display will indicate the location of the fault.

**Test Description**

Number(s) below refer to the step number(s) on the Diagnostic Chart.



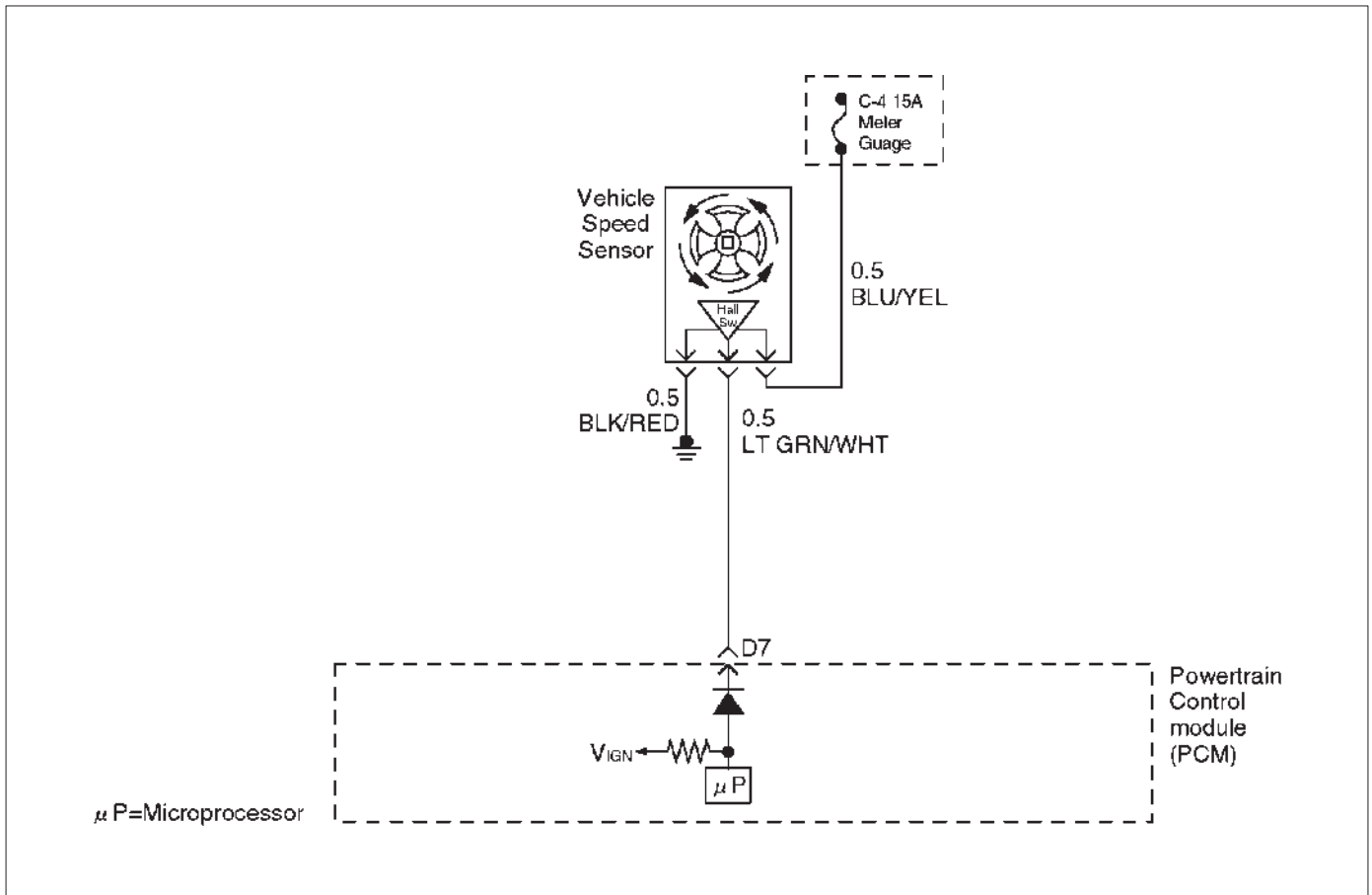
2. The ETC and MAP sensors share a ground at PCM terminal D9.

9. Equates the resistance values at various float positions to the following fuel gauge readings:

### DTC P0463– Fuel Level Sensor Circuit –High Voltage

Step	Action	Value(s)	Yes	No
1	Was the “On-Board Diagnostic (OBD) System Check” performed?	—	Go to <i>Step 2</i>	Go to <i>OBD System Check</i>
2	Were any ECT or MAP DTCs set? (ECT and MAP sharing Ground with PCM term D9)	—	Go to other DTC chart	Go to <i>Step 3</i>
3	1. Disconnected the fuel level sensor harness from its connector at the fuel tank. 2. Ignition “ON,” engine “OFF.” 3. Using a DVM, measure the voltage between the sensor harness positive and ground wires. Is the voltage approximately equal to the specified value?	5 V	Go to <i>Step 9</i>	Go to <i>Step 4</i>
4	With the negative DVM lead connected to ground, use the positive DVM lead to probe the sensor ground wire with the harness still disconnected. Does the DVM indicate a short to a voltage source?	—	Go to <i>Step 5</i>	Go to <i>Step 6</i>
5	Repair short to voltage between the sensor and the PCM. Is the repair complete?	—	Verify repair	—
6	With the negative DVM lead connected to ground, use the positive DVM lead to probe the sensor positive wire with the harness still disconnected. Does the DVM indicate a voltage greater than the specified value?	5 V	Go to <i>Step 5</i>	Go to <i>Step 7</i>
7	Open circuit between the PCM connector and the fuel level sensor?	—	Verify repair	Go to <i>Step 8</i>
8	Replace the PCM. <b>IMPORTANT:</b> The replacement PCM must be programmed. Refer to <i>On-Vehicle Service in Powertrain Control Module and Sensors</i> for procedures. And also refer to latest Service Bulletin. Check to see if the Latest software is released or not. And then Down Load the LATEST PROGRAMMED SOFTWARE to the replacement PCM. Is the action complete?	—	Verify repair	—
9	Remove the fuel level sensor and check the following: <input type="radio"/> Does the arm move freely? <input type="radio"/> Are the wire leads shorted together? Was a problem found?	—	Go to <i>Step 10</i>	Go to <i>Step 8</i>
10	Replace the fuel level sensor. Is the repair complete?	—	Verify repair	—

## Diagnostic Trouble Code (DTC) P0502 VSS Circuit Low Input



D06RX149

### Circuit Description

The vehicle speed sensor has a magnet rotated by the transmission output shaft. Attached to the sensor is a hall effect circuit that interacts with the magnetic field created by the rotating magnet. A 12-volt operating supply for the speed sensor hall circuit is supplied from the meter fuse. The VSS pulses to ground the 9-volt signal sent from the powertrain control module (PCM) on the reference circuit. The PCM interprets vehicle speed by the number of pulses to ground per second on the reference circuit.

### Conditions for Setting the DTC

- Engine is running.
- Engine coolant temperature is above 60°C (140°F).
- Engine speed is between 1800 RPM and 2500 RPM.
- Throttle angle is between 10% and 40%.
- Engine load is greater than 50 kpa.
- MAP sensor indicates greater than 50 kpa manifold pressure.
- PCM detects no VSS signal for 12.5 seconds over a period of 25 seconds.

### Action Taken When the DTC Sets

- The PCM will illuminate the malfunction indicator lamp (MIL) the first time the fault is detected.
- The PCM will store conditions which were present when the DTC was set as Freeze Frame and in the Failure Records data.

### Conditions for Clearing the MIL/DTC

- The PCM will turn the MIL "OFF" on the third consecutive trip cycle during which the diagnostic has been run and the fault condition is no longer present.
- A history DTC P0502 will clear after 40 consecutive warm-up cycles have occurred without a fault.
- DTC P0502 can be cleared by using the Tech 2 "Clear Info" function or by disconnecting the PCM battery feed.

### Test Description

Number(s) below refer to the step number(s) on the Diagnostic Chart.

10. To avoid backprobing the VSS and possibly damaging a seal or terminal, the VSS output can be tested at the point where the transmission harness connects to the engine harness. Power and ground are applied by jumpers to the VSS through the connectors which are located to the rear of the air cleaner assembly. The VSS signal is monitored with a DVM as the rear driveshaft turns. The wheels can be turned to rotate the driveshaft, or in 2-wheels-drive vehicles the driveshaft can be turned directly.
12. The speedometer-to-PCM VSS signal wire is spliced to a wire leading to the cruise control module. If a short to ground or voltage is indicated between the PCM and speedometer, it could be on the cruise control circuit if the vehicle is equipped with cruise control.

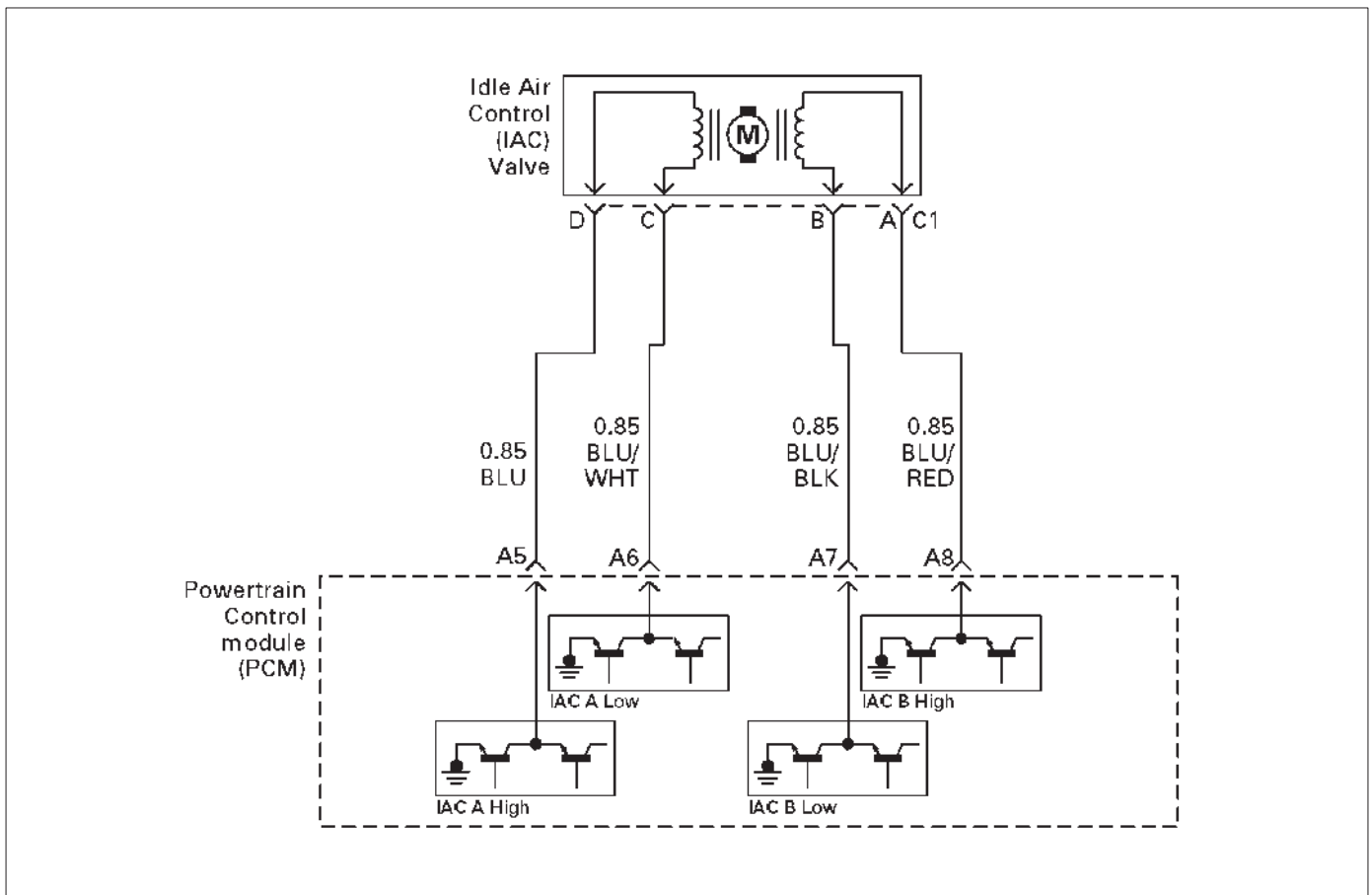
**DTC P0502 – VSS Circuit Low Input**

Step	Action	Value(s)	Yes	No
1	Was the "On-Board Diagnostic (OBD) System Check" performed?	—	Go to <i>Step 2</i>	Go to <i>OBD System Check</i>
2	Does the speedometer work?	—	Go to <i>Step 10</i>	Go to <i>Step 3</i>
3	1. Disconnect the VSS connector. 2. Ignition "ON." 3. Using a test light to battery +, probe the connector ground wire. Did the light illuminate?	—	Go to <i>Step 5</i>	Go to <i>Step 4</i>
4	Repair the sensor ground. Is the action complete?	—	Verify repair	—
5	1. Ignition "ON," sensor disconnected. 2. Using a DVM, measure at the VSS connector between ground and voltage supply. Was the measurement near the specified value?	Battery voltage	Go to <i>Step 7</i>	Go to <i>Step 6</i>
6	Repair the open or short to ground which may have blown the meter fuse. Is the action complete?	—	Verify repair	—
7	1. Ignition "ON," VSS disconnected. 2. Using a DVM, measure at the VSS connector between ground and the wire from the speedometer. Was the measurement near the specified value?	7.5-8 V	Go to <i>Step 9</i>	Go to <i>Step 8</i>
8	Check for an open or short circuit between the speedometer and the VSS. Was an open or short circuit located?	—	Verify repair	Go to <i>Step 9</i>
9	Replace the speedometer. Is the action complete?	—	Verify repair	—

**DTC P0502 – VSS Circuit Low Input (Cont'd)**

Step	Action	Value(s)	Yes	No
10	<p>1. Ignition "OFF."</p> <p>2. Disconnect the MAF sensor. The connector attaches the VSS wires from the transmission harness to the left-side engine harness.</p> <p>3. Disconnect the black 16-way connector.</p> <p>4. Select a terminal adapter from kit J 35616 that can be used with a jumper to supply B+ to the blue wire with a yellow tracer (transmission side of the connector).</p> <p>5. Use another terminal adapter to attach a voltmeter to the light-green wire with a white tracer (next to the wire in the previous step.)</p> <p>6. Disconnect the blue connector next to the black 16-way connector, and locate the black/red tracer wire at one corner of the blue connector. The black/red wire is the VSS ground. Use a terminal adapter to attach a jumper to ground to the black/red VSS ground wire at the transmission side of the blue connector.</p> <p>7. Raise the rear wheels off the ground with transmission in neutral.</p> <p>Does the DVM toggle back and forth between 0.6 V and 10 V as the wheels (and driveshaft) are rotated?</p>	—	Go to Step 11	Go to Step 12
11	<p>Replace the VSS.</p> <p>Is the action complete?</p>	—	Verify repair	—
12	<p>Check for an open or short between the PCM and the speedometer.</p> <p>Was a problem found?</p>	—	Verify repair	Go to Step 13
13	<p>Replace the PCM.</p> <p><b>IMPORTANT:</b> The replacement PCM must be programmed. Refer to <i>On-Vehicle Service in Powertrain Control Module and Sensors</i> for procedures.</p> <p>AND also refer to latest Service Bulletin.</p> <p>Check to see if the Latest software is released or not. And then Down Load the LATEST PROGRAMMED SOFTWARE to the replacement PCM.</p> <p>Is the action complete?</p>	—	Verify repair	—

## Diagnostic Trouble Code (DTC) P0506 Idle Air Control System Low RPM



T321115

### Circuit Description

The powertrain control module (PCM) controls engine idle speed by adjusting the position of the idle air control (IAC) motor pintle. The IAC is a bi-directional stepper motor driven by two coils. The PCM applies current to the IAC coils in steps (counts) to extend the IAC pintle into a passage in the throttle body to decrease air flow. The PCM reverses the current to retract the pintle, increasing air flow. This method allows highly accurate control of idle speed and quick response to changes in engine load. If the PCM detects a condition where too low of an idle speed is present and the PCM is unable to adjust idle speed by increasing the IAC counts, DTC P0506 will set, indicating a problem with the idle control system.

### Conditions for Setting the DTC

- No Tech 2 test is being run.
- No TPS, VSS, ECT, EGR, MAF, MAP, IAT, misfire, low voltage, fuel system, canister purge, injector control, or ignition control DTCs are set.
- Barometric pressure is above 75 kpa.
- Canister purge duty cycle is above 10%.
- Engine running time is more than 125 seconds.
- Vehicle speed is less than 1 mph.
- Engine coolant temperature (ECT) is above 50°C.
- Ignition voltage is between 9.5 volts and 16.7 volts.
- The throttle is closed.
- EVAP purge duty cycle more than 10%.
- All conditions are met for 10 seconds.

- Engine speed is more than 100-200 RPM lower than desired idle based upon coolant temperature.

### Action Taken When the DTC Sets

- The PCM will illuminate the malfunction indicator lamp (MIL) after the second consecutive trip in which the fault is detected.
- The PCM will store conditions which were present when the DTC was set as Freeze Frame and in the Failure Records data.

### Conditions for Clearing the MIL/DTC

- DTC P0506 can be cleared by using the Tech 2 "Clear Info" function or by disconnecting the PCM battery feed.

### Diagnostic Aids

Check for the following conditions:

- Poor connection at PCM or IAC motor – Inspect harness connectors for backed-out terminals, improper mating, broken locks, improperly formed or damaged terminals, and poor terminal-to-wire connection.
- Damaged harness – Inspect the wiring harness for damage.
- Restricted air intake system – Check for a possible collapsed air intake duct, restricted air filter element, or foreign objects blocking the air intake system.
- Throttle body – Check for objects blocking the IAC passage or throttle bore, excessive deposits in the IAC

passage and on the IAC pintle, and excessive deposits in the throttle bore and on the throttle plate.

- Large vacuum leak – Check for a condition that causes a large vacuum leak, such as an incorrectly installed or faulty PCV valve or brake booster hose disconnected.

Reviewing the Failure Records vehicle mileage since the diagnostic test last failed may help determine how often the condition that caused the DTC to be set occurs. This may assist in diagnosing the condition.

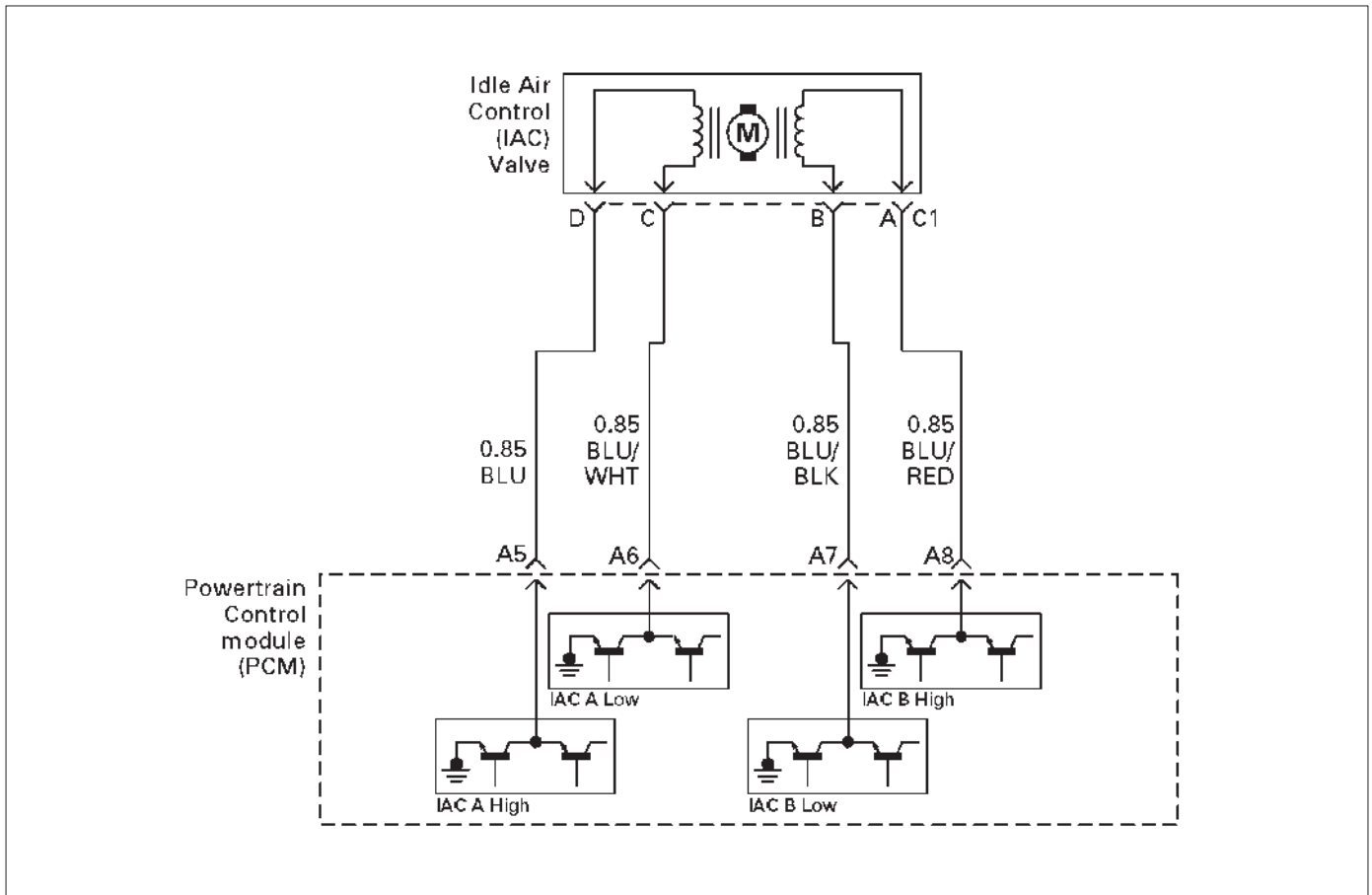
### DTC P0506 – Idle Air Control System Low RPM

Step	Action	Value(s)	Yes	No
1	Was the “On-Board Diagnostic (OBD) System Check” performed?	—	Go to Step 2	Go to <i>OBD System Check</i>
2	Are any other DTCs set?	—	Go to other DTC first	Go to Step 3
3	<p>1. Start the engine.</p> <p>2. Turn all accessories “OFF” (A/C, rear defroster, etc.)</p> <p>3. Using a Tech 2, command RPM up to 1500, down to 500, and then up to 1500 while monitoring “Engine Speed” on the Tech 2.</p> <p>NOTE: This Tech 2 command may cause the engine to “cut out” when RPM goes above 1500. If this occurs, the “cutting out” will stop when the Tech 2 command for the test is discontinued, or if the Tech 2 command is changed to less than 1500RPM.</p> <p>Does the “Engine Speed” remain within the specified value of “Desired Idle” for each RPM command?</p>	±50 RPM	No trouble found. Go to <i>Diagnostic Aids</i>	Go to Step 4
4	<p>1. Disconnect the IAC.</p> <p>2. Install IAC Node Light J 37027A or equivalent.</p> <p>3. With the engine running, command RPM up to 1500, down to 500, and then up to 1500 while observing the node light.</p> <p>NOTE: This Tech 2 command may cause the engine to “cut out” when RPM goes above 1500. If this occurs, the “cutting out” will stop when the Tech 2 command for the test is discontinued, or if the Tech 2 command is changed to less than 1500RPM.</p> <p>Does each node light cycle red and green (never “OFF”)?</p>	—	Go to Step 6	Go to Step 5
5	<p>1. Check the following circuits for an open, short to voltage, short to ground, or poor connection at the PCM:</p> <ul style="list-style-type: none"> <li>○ IAC “A” low</li> <li>○ IAC “A” high</li> <li>○ IAC “B” low</li> <li>○ IAC “B” high</li> </ul> <p>2. If a problem is found, repair as necessary.</p> <p>Was a problem found?</p>	—	Verify repair	Go to Step 9

## DTC P0506 – Idle Air Control System Low RPM (Cont'd)

Step	Action	Value(s)	Yes	No
6	<p>Visually/physically inspect for the following conditions:</p> <ul style="list-style-type: none"> <li>○ Throttle body tampering (adjustment screw plug removed).</li> <li>○ Restricted air intake system. Check for a possible collapsed air intake duct, restricted air filter element, or foreign objects blocking the air intake system.</li> <li>○ Throttle body. Check for objects blocking the IAC passage or throttle bore, excessive deposits in the IAC passage and on the IAC pintle, and excessive deposits in the throttle bore and on the throttle plate.</li> </ul> <p>Do any of the above require a repair?</p>	—	Refer to appropriate section for on-vehicle service	Go to <i>Step 7</i>
7	<p>1. Check for a poor connection at the IAC harness connector.</p> <p>2. If a problem is found, replace faulty terminals as necessary.</p> <p>Was a problem found?</p>	—	Verify repair	Go to <i>Step 8</i>
8	<p>Replace the IAC valve.</p> <p>Is the action complete?</p>	—	Verify repair	—
9	<p>Replace the PCM.</p> <p><b>IMPORTANT:</b> The replacement PCM must be programmed. Refer to <i>On-Vehicle Service in Powertrain Control Module and Sensors</i> for procedures.</p> <p>ANd also refer to latest Service Bulletin.</p> <p>Check to see if the Latest software is released or not. And then Down Load the LATEST PROGRAMMED SOFTWARE to the replacement PCM.</p> <p>Is the action complete?</p>	—	Verify repair	—

## Diagnostic Trouble Code (DTC) P0507 Idle Air Control System High RPM



T321115

### Circuit Description

The powertrain control module (PCM) controls engine idle speed by adjusting the position of the idle air control (IAC) motor pintle. The IAC is a bi-directional stepper motor driven by two coils. The PCM applies current to the IAC coils in steps (counts) to extend the IAC pintle into a passage in the throttle body to decrease air flow. The PCM reverses the current to retract the pintle, increasing air flow. This method allows highly accurate control of idle speed and quick response to changes in engine load. If the PCM detects a condition where too high of an idle speed is present and the PCM is unable to adjust idle speed by increasing the IAC counts, DTC P0507 will set, indicating a problem with the idle control system.

### Conditions for Setting the DTC

- No Tech 2 test is being run.
- No TPS, VSS, ECT, EGR, MAF, MAP, IAT, misfire, low voltage, fuel system, canister purge, injector control or ignition control DTCs are set.
- Barometric pressure is above 75 kpa.
- Canister purge duty cycle is above 10%.
- Engine running time is more than 125 seconds.
- Vehicle speed is less than 1 mph.
- Engine coolant temperature (ECT) is above 50°C.
- Ignition voltage is between 9.5 volts and 16.7 volts.
- The throttle is closed.
- EVAP purge duty cycle is more than 10%.
- All conditions are met for 10 seconds.

- Engine speed is more than 100-200 RPM higher than desired idle based upon coolant temperature.

### Action Taken When the DTC Sets

- The PCM will illuminate the malfunction indicator lamp (MIL) after the second consecutive trip in which the fault is detected.
- The PCM will store conditions which were present when the DTC was set as Freeze Frame and in the Failure Records data.

### Conditions for Clearing the MIL/DTC

- The PCM will turn the MIL "OFF" on the third consecutive trip cycle during which the diagnostic has been run and the fault condition is no longer present.
- A history DTC P0507 will clear after 40 consecutive warm-up cycles have occurred without a fault.
- DTC P0507 can be cleared by using the Tech 2 "Clear Info" function or by disconnecting the PCM battery feed.

### Diagnostic Aids

Check for the following conditions:

- Poor connection at PCM or IAC motor – Inspect harness connectors for backed-out terminals, improper mating, broken locks, improperly formed or damaged terminals, and poor terminal-to-wire connection.
- Damaged harness – Inspect the wiring harness for damage.



**6E-344 6VE1 3.5L ENGINE DRIVEABILITY AND EMISSIONS**

- Vacuum leak – Check for a condition that causes a vacuum leak, such as disconnected or damaged hoses, leaks at EGR valve and EGR pipe to intake manifold, leak at the throttle body, a faulty or incorrectly installed PCV valve, leaks at the intake manifold, etc.
- Throttle body – Check for sticking throttle plate. Also inspect the IAC passage for deposits or objects which

will not allow the IAC pintle to fully extend or properly seat.

If DTC P0507 cannot be duplicated, reviewing the Failure Records vehicle mileage since the diagnostic test last failed may help determine how often the condition that caused the DTC to be set occurs. This may assist in diagnosing the condition.

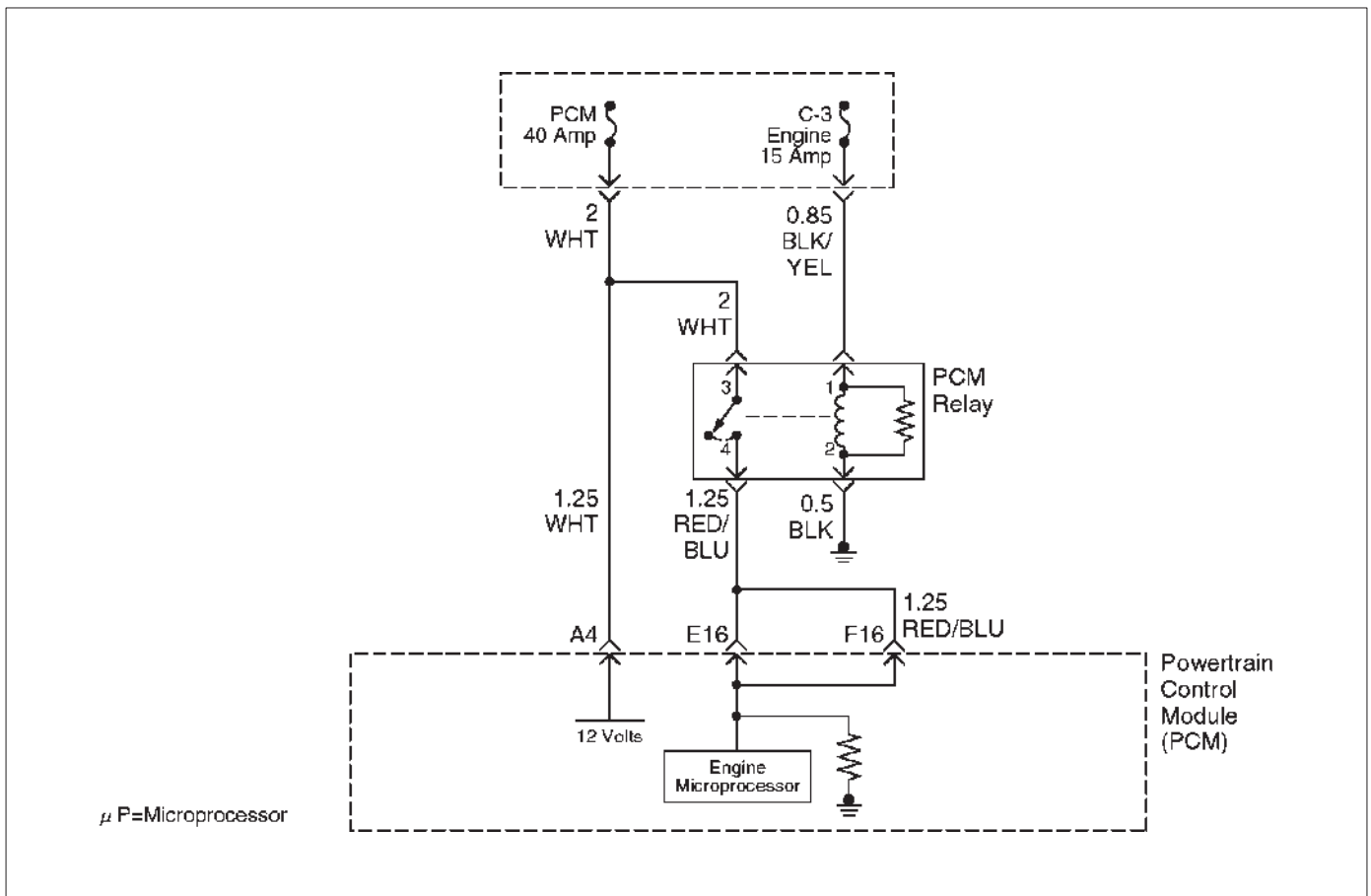
**DTC P0507 – Idle Air Control System High RPM**

Step	Action	Value(s)	Yes	No
1	Was the "On-Board Diagnostic (OBD) System Check" performed?	—	Go to Step 2	Go to <i>OBD System Check</i>
2	Are any other DTCs set?	—	Go to other DTC first	Go to Step 3
3	<p>1. Start the engine.</p> <p>2. Turn all accessories "OFF" (A/C, rear defroster, etc.)</p> <p>3. Using a Tech 2, command RPM up to 1500, down to 500, and then up to 1500 while monitoring "Engine Speed" on the Tech 2.</p> <p>NOTE: This Tech 2 command may cause the engine to "cut out" when RPM goes above 1500. If this occurs, the "cutting out" will stop when the Tech 2 command for the test is discontinued, or if the Tech 2 command is changed to less than 1500RPM.</p> <p>Does "Engine Speed" remain within the specified value of "Desired Idle" for each RPM command?</p>	± 50 RPM	No trouble found. Go to <i>Diagnostic Aids</i>	Go to Step 4
4	<p>1. Disconnect the IAC.</p> <p>2. Install IAC Node Light J 37027A or equivalent.</p> <p>3. With the engine running, command RPM up to 1500, down to 500, and then up to 1500 while observing the node light.</p> <p>NOTE: This Tech 2 command may cause the engine to "cut out" when RPM goes above 1500. If this occurs, the "cutting out" will stop when the Tech 2 command for the test is discontinued, or if the Tech 2 command is changed to less than 1500RPM.</p> <p>Does each node light cycle red and green (never "OFF")?</p>	—	Go to Step 6	Go to Step 5
5	<p>1. Check the following circuits for an open, short to voltage, short to ground, or poor connection at the PCM:</p> <ul style="list-style-type: none"> <li>○ IAC "A" low</li> <li>○ IAC "A" high</li> <li>○ IAC "B" low</li> <li>○ IAC "B" high</li> </ul> <p>2. If a problem is found, repair as necessary.</p> <p>Was a problem found?</p>	—	Verify repair	Go to Step 9

**DTC P0507 – Idle Air Control System High RPM (Cont'd)**

Step	Action	Value(s)	Yes	No
6	<p>Visually/physically inspect for the following conditions:</p> <ul style="list-style-type: none"> <li>○ Vacuum leaks</li> <li>○ Throttle body tampering (adjustment screw plug removed).</li> <li>○ Throttle plate or throttle shaft for binding.</li> <li>○ Accelerator and cruise control cables for being mis-adjusted or for binding.</li> <li>○ Faulty, missing, or incorrectly installed PCV valve.</li> </ul> <p>Do any of the above require a repair?</p>	—	Refer to appropriate section for on-vehicle service	Go to <i>Step 7</i>
7	<p>1. Check for a poor connection at the IAC harness connector.</p> <p>2. If a problem is found, replace faulty terminals as necessary.</p> <p>Was a problem found?</p>	—	Verify repair	Go to <i>Step 8</i>
8	<p>Replace the IAC valve.</p> <p>Is the action complete?</p>	—	Verify repair	—
9	<p>Replace the PCM.</p> <p><b>IMPORTANT:</b> The replacement PCM must be programmed. Refer to <i>On-Vehicle Service in Powertrain Control Module and Sensors</i> for procedures.</p> <p>ANd also refer to latest Service Bulletin.</p> <p>Check to see if the Latest software is released or not. And then Down Load the LATEST PROGRAMMED SOFTWARE to the replacement PCM.</p> <p>Is the action complete?</p>	—	Verify repair	—

## Diagnostic Trouble Code (DTC) P0562 System Voltage Low



D06RX148

### Circuit Description

The powertrain control module (PCM) monitors the system voltage on the ignition feed terminal to the PCM. A system voltage DTC will set whenever the voltage is below a calibrated value.

### Conditions for Setting the DTC

- Ignition "ON."
- System voltage is below 11.5 volts for 15 minutes.

### Action Taken When the DTC Sets

- The PCM will not illuminate the malfunction indicator lamp (MIL).
- The PCM will store as Failure Records conditions which were present when the DTC was set. This information will not be stored as Freeze Frame data.

### Conditions for Clearing the MIL/DTC

- A history DTC P0562 will clear after 40 consecutive warm-up cycles have occurred without a fault.
- DTC P0562 can be cleared by using the Tech 2 "Clear Info" function or by disconnecting the PCM battery feed.

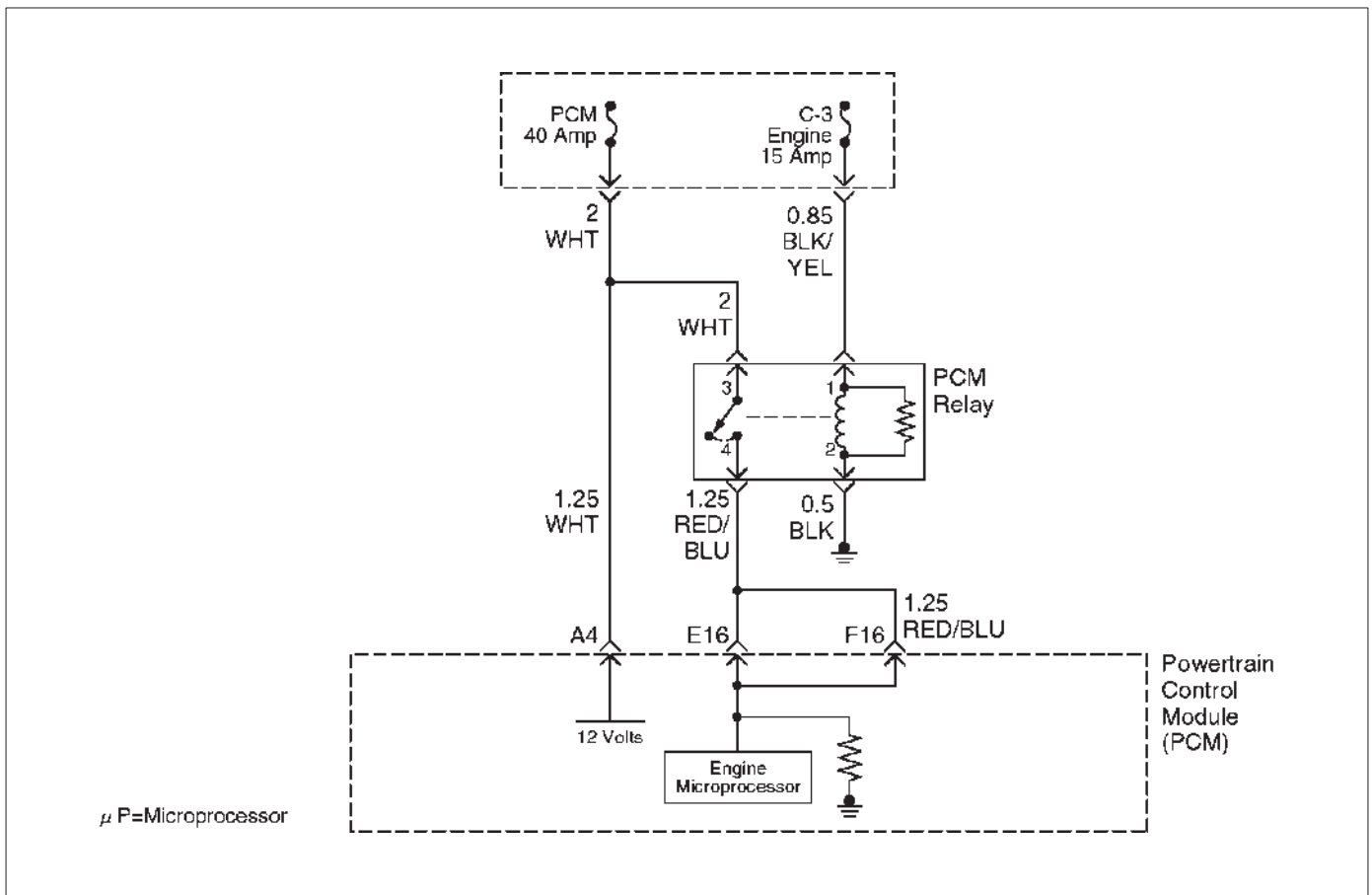
### Diagnostic Aids

If the DTC sets when an accessory is operated, check for a poor connection or excessive current draw.

## DTC P0562 – System Voltage Low

Step	Action	Value(s)	Yes	No
1	Was the "On-Board Diagnostic (OBD) System Check" performed?	—	Go to Step 2	Go to <i>OBD System Check</i>
2	Using a DVM, measure the battery voltage at the battery. Is the battery voltage greater than the specified value?	11.5 V	Go to Step 3	Charge battery, then go to Step 3
3	1. Install a Tech 2. 2. Select "Ignition Volts" on the Tech 2. 3. Start the engine and raise the engine speed to the specified value. 4. Load the electrical system by turning on the headlights, high blower, etc. Is the ignition voltage approximately equal to the specified value?	2000 RPM 12.8-14.1 V	Go to Step 4	Go to <i>Starting/Charging</i>
4	1. Ignition "OFF." 2. Disconnect the PCM connector at the PCM. 3. Using a DVM, measure the battery voltage at the PCM connector A-4. Is it approximately equal to battery voltage?	—	Check for excessive current draw with ignition "OFF," engine "OFF."	Go to Step 5
5	1. Check for faulty connections at the PCM harness terminals. 2. Repair as necessary. Was a repair necessary?	—	Verify repair	Go to Step 6
6	Check for an open battery feed circuit to the PCM. Is the action complete?	—	Verify repair	Go to Step 7
7	Replace the PCM. <b>IMPORTANT:</b> The replacement PCM must be programmed. Refer to <i>On-Vehicle Service in Powertrain Control Module and Sensors</i> for procedures. AND also refer to latest Service Bulletin. Check to see if the Latest software is released or not. And then Down Load the LATEST PROGRAMMED SOFTWARE to the replacement PCM. Is the action complete?	—	Verify repair	—

## Diagnostic Trouble Code (DTC) P0563 System Voltage High



D06RX148

### Circuit Description

The powertrain control module (PCM) monitors the system voltage on the ignition feed terminals to the PCM. A system voltage DTC will set whenever the voltage is above a calibrated value.

### Conditions for Setting the DTC

- Ignition "ON."
- System voltage is above 16 volts for 15 minutes.

### Action Taken When the DTC Sets

- The PCM will not illuminate the malfunction indicator lamp (MIL).
- The PCM will store as Failure Records only conditions which were present when the DTC was set. This information will not be stored as Freeze Frame data.

### Conditions for Clearing the MIL/DTC

- A history DTC P0563 will clear after 40 consecutive warm-up cycles have occurred without a fault.
- DTC P0563 can be cleared by using the Tech 2 "Clear Info" function or by disconnecting the PCM battery feed.

### Diagnostic Aids

If the DTC sets when an accessory is operated, check for a poor connection or excessive current draw.

**DTC P0563 – System Voltage High**

Step	Action	Value(s)	Yes	No
1	Was the "ON-Board Diagnostic (OBD) System Check" performed?	—	Go to Step 2	Go to <i>OBD System Check</i>
2	Using a DVM, measure the battery voltage at the battery. Is the battery voltage less than the specified value?	11.5 V	Go to Step 3	Go to Step 4
3	1. Charge the battery and clean the battery terminals. 2. Clean the battery ground cable connection if corrosion is indicated. Is the battery voltage less than the specified value?	11.5 V	Replace battery	Go to Step 4
4	1. Turn "OFF" all the accessories. 2. Install a Tech 2. 3. Select the ignition voltage parameter on the Tech 2. 4. Start the engine and raise the engine RPM to the specified value. Is the voltage more than 2.5 volts greater than the measurement taken in step 2 or 3?	2000 RPM	Go to <i>Starting/Charging</i>	Go to Step 5
5	Replace the PCM. <b>IMPORTANT:</b> The replacement PCM must be programmed. Refer to <i>On-Vehicle Service in Powertrain Control Module and Sensors</i> for procedures. AND also refer to latest Service Bulletin. Check to see if the Latest software is released or not. And then Down Load the LATEST PROGRAMMED SOFTWARE to the replacement PCM. Is the action complete?	—	Verify repair	—

## Diagnostic Trouble Code (DTC) P0601 PCM Memory

### Circuit Description

The powertrain control module (PCM) used in this vehicle utilizes an electrically erasable programmable read-only memory (EEPROM). The EEPROM contains program information and the calibrations required for engine, transmission, and powertrain diagnostics operation. Unlike the PROM used in past applications, the EEPROM is not replaceable. When the PCM is replaced or a calibration update is required, the PCM must be programmed using a Tech 2. Refer to *On-Vehicle Service in Powertrain Control Module and Sensors* for the EEPROM programming procedure.

### Conditions for Setting the DTC

- The PCM detects an internal program fault (check sum error).

### Action Taken When the DTC Sets

- The PCM will not illuminate the malfunction indicator lamp (MIL).

- The PCM will store conditions which were present when the DTC was set in the Failure Records data only.

### Conditions for Clearing the MIL/DTC

- The PCM will turn the MIL "OFF" on the third consecutive trip cycle during which the diagnostic has been run and the fault condition is no longer present.
- A history DTC P0601 will clear after 40 consecutive warm-up cycles have occurred without a fault.
- DTC P0601 can be cleared by using the Tech 2 "Clear Info" function or by disconnecting the PCM battery feed.

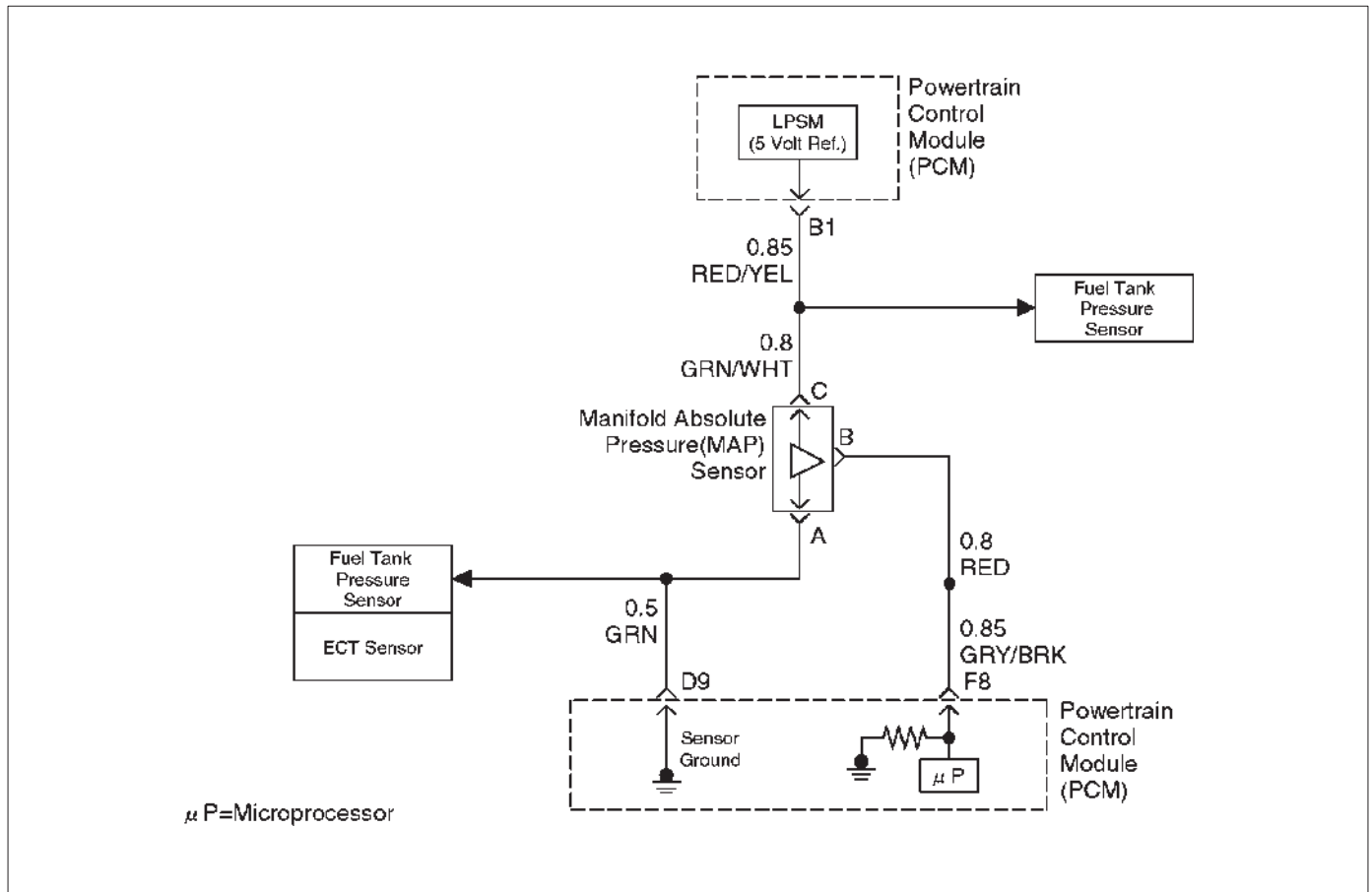
### Diagnostic Aids

- DTC P0601 indicates that the contents of the EEPROM have changed since the PCM was programmed. The only possible repair is PCM replacement. Remember to program the replacement PCM with the correct software and calibration for the vehicle.

## DTC P0601 – PCM Memory

Step	Action	Value(s)	Yes	No
1	Was the "On-Board Diagnostic (OBD) System Check" performed?	—	Go to Step 2	Go to <i>OBD System Check</i>
2	Replace the PCM. <b>IMPORTANT:</b> The replacement PCM must be programmed. Refer to <i>On-Vehicle Service in Powertrain Control Module and Sensors</i> for procedures. ANd also refer to latest Service Bulletin. Check to see if the Latest software is released or not. And then Down Load the LATEST PROGRAMMED SOFTWARE to the replacement PCM. Is the action complete?	—	Verify repair	—

## Diagnostic Trouble Code (DTC) P1106 MAP Sensor Circuit Intermittent High Voltage



D06RX076

### Circuit Description

The manifold absolute pressure (MAP) sensor responds to changes in intake manifold pressure (vacuum). The MAP sensor signal voltage to the PCM varies from below 2 volts at idle (high vacuum) to above 4 volts with the ignition "ON," engine not running or at wide-open throttle (low vacuum).

The MAP sensor is used to determine manifold pressure changes while the liner EGR flow test diagnostic is being run (refer to *DTC P0401*), to determine engine vacuum level for some other diagnostics and to determine barometric pressure (BARO). The PCM compares the MAP sensor signal to a calculated MAP based on throttle position and various engine load factors. If the PCM detects a MAP signal that is intermittently above the calculated value, DTC P1106 will set.

### Conditions for Setting the DTC

- No TP sensor DTCs are present.
- Engine is running for at least 10 seconds.
- Throttle angle is below 3% if engine speed is below 1000 RPM.
- Throttle angle is below 10% if engine speed is above 1000 RPM.
- The MAP sensor indicates an intermittent manifold absolute pressure above 80 kpa for a total of approximately 5 seconds over a 16-second period of time.

### Action Taken When the DTC Sets

- The PCM will not illuminate the malfunction indicator lamp (MIL).
- The PCM will store conditions which were present when the DTC was set as Failure Records data only. This information will not be stored as Freeze Frame data.

### Conditions for Clearing the MIL/DTC

- A history DTC P1106 will clear after 40 consecutive warm-up cycles have occurred without a fault.
- DTC P1106 can be cleared by using the Tech 2 "Clear Info" function or by disconnecting the PCM battery feed.

### Diagnostic Aids

Check for the following conditions:

- Leaking or plugged vacuum supply line to the MAP sensor.
- Inspect PCM harness connectors for backed-out terminals, improper mating, broken locks, improperly formed or damaged terminals, and poor terminal-to-wire connection.
- Inspect the wiring harness for damage. If the harness appears to be OK, observe the MAP display on the Tech 2 while moving connectors and wiring harnesses related to the sensor. A change in the display will indicate the location of the fault.

Reviewing the Failure Records vehicle mileage since the diagnostic test last failed may help determine how often



**6E-352 6VE1 3.5L ENGINE DRIVEABILITY AND EMISSIONS**

the condition that caused the DTC to be set occurs. This may assist in diagnosing the condition.

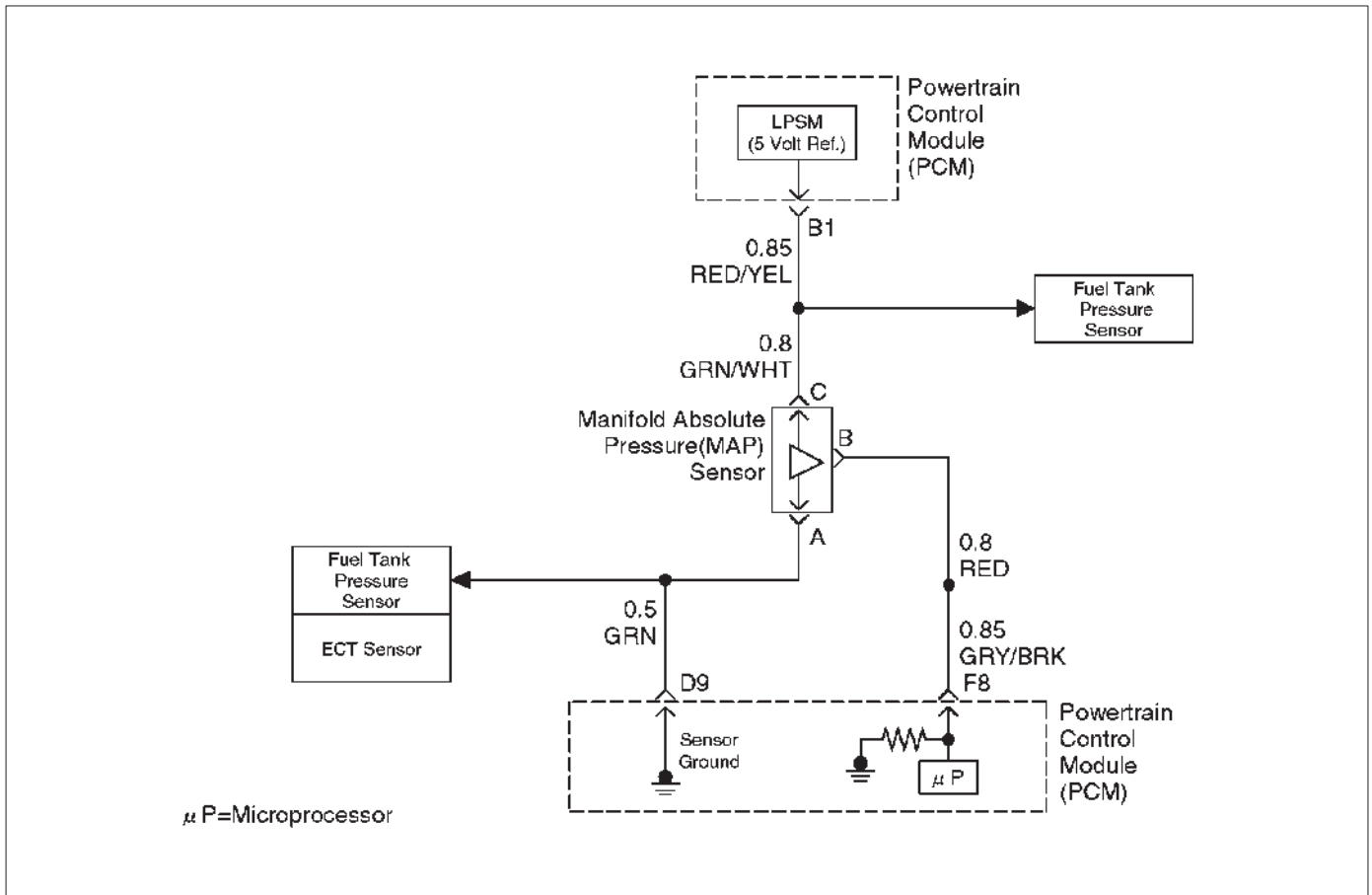
- The MAP sensor shares a 5 Volt Reference with the Fuel Tank Pressure sensor. Check the 5 Volt reference if this DTC is also set.

- The MAP sensor shares a ground with the Fuel Tank Pressure sensor and the ECT Sensor. Check the ground if these other DTCs are also set.

**DTC P1106 – MAP Sensor Circuit Intermittent High Voltage**

Step	Action	Value(s)	Yes	No
1	Was the "On-Board Diagnostic (OBD) System Check" performed?	—	Go to Step 2	Go to <i>OBD System Check</i>
2	Is DTC P0108 also set?	—	Go to <i>DTC P0108</i> chart first	Go to Step 3
3	Are DTC P1111, P1115, and/or P1121 also set?	—	Go to Step 6	Go to Step 4
4	Check for a poor sensor ground circuit terminal connection at the MAP sensor. Was a problem found?	—	Go to Step 9	Go to Step 5
5	Check the MAP signal circuit between the MAP sensor connector and the PCM for an intermittent short to voltage. Was a problem found?	—	Go to Step 10	Go to Step 8
6	Check for an intermittent short to voltage on the 5 volt reference "A" circuit between the PCM and the following components: ○ MAP sensor ○ EGR valve ○ TP sensor Was a problem found?	—	Go to Step 10	Go to Step 7
7	Check for a poor sensor ground circuit terminal connection at the PCM. Was a problem found?	—	Go to Step 9	Go to Step 8
8	Check for an intermittent open or a faulty splice in the sensor ground circuit. Was a problem found?	—	Go to Step 10	Refer to <i>Diagnostic Aids</i>
9	Replace the faulty harness connector terminal for the sensor ground circuit. Is the action complete?	—	Verify repair	—
10	Locate and repair the intermittent open/short circuit in the wiring harness as necessary. Is the action complete?	—	Verify repair	—

## Diagnostic Trouble Code (DTC) P1107 MAP Circuit Intermittent Low Voltage



D06RX076

### Circuit Description

The manifold absolute pressure (MAP) sensor responds to changes in intake manifold pressure (vacuum). The MAP sensor signal voltage to the powertrain control module (PCM) varies from below 2 volts at idle (high vacuum) to above 4 volts with the ignition "ON," engine not running or at wide-open throttle (low vacuum).

The MAP sensor is used to determine manifold pressure changes while the linear EGR flow test diagnostic is being run (refer to *DTC P0401*), to determine engine vacuum level for some other diagnostics and to determine barometric pressure (BARO). The PCM compares the MAP sensor signal to a calculated MAP based on throttle position and various engine load factors. If the PCM detects a MAP signal that is intermittently below the calculated value, DTC P1107 will be set.

### Conditions for Setting the DTC

- No TP sensor DTCs are present.
- Engine is running.
- Ignition voltage is more than 11 volts.
- Throttle angle is above 1% if engine speed is less than 1000 RPM.
- Throttle angle is above 2% if engine speed is above 1000 RPM.
- The MAP sensor indicates an intermittent manifold absolute pressure below 11 kpa for a total of approximately 5 seconds over a 16-second period of time.

### Action Taken When the DTC Sets

- The PCM will not illuminate the malfunction indicator lamp (MIL).
- The PCM will store conditions which were present when the DTC was set as Failure Records data only. This information will not be stored as Freeze Frame data.

### Conditions for Clearing the MIL/DTC

- A history DTC P1107 will Clear after 40 consecutive warm-up cycles have occurred without a fault.
- DTC P1107 can be cleared by using the Tech 2 "Clear Info" function or by disconnecting the PCM battery feed.

### Diagnostic Aids

Check for the following conditions:

- Poor connection at PCM – Inspect harness connectors for backed-out terminals, improper mating, broken locks, improperly formed or damaged terminals, and poor terminal-to-wire connection.
- The MAP Sensor shares a 5 Volt reference with the EGR Valve. If these codes are also set, it could indicate a problem with the 5 Volt reference circuit or components itself.
- The MAP Sensor share a ground with the EGR Valve and the IAT Sensor.
- Damaged harness – Inspect the wiring harness for damage. If the harness appears to be OK, observe the MAP display on the Tech 2 while moving connectors

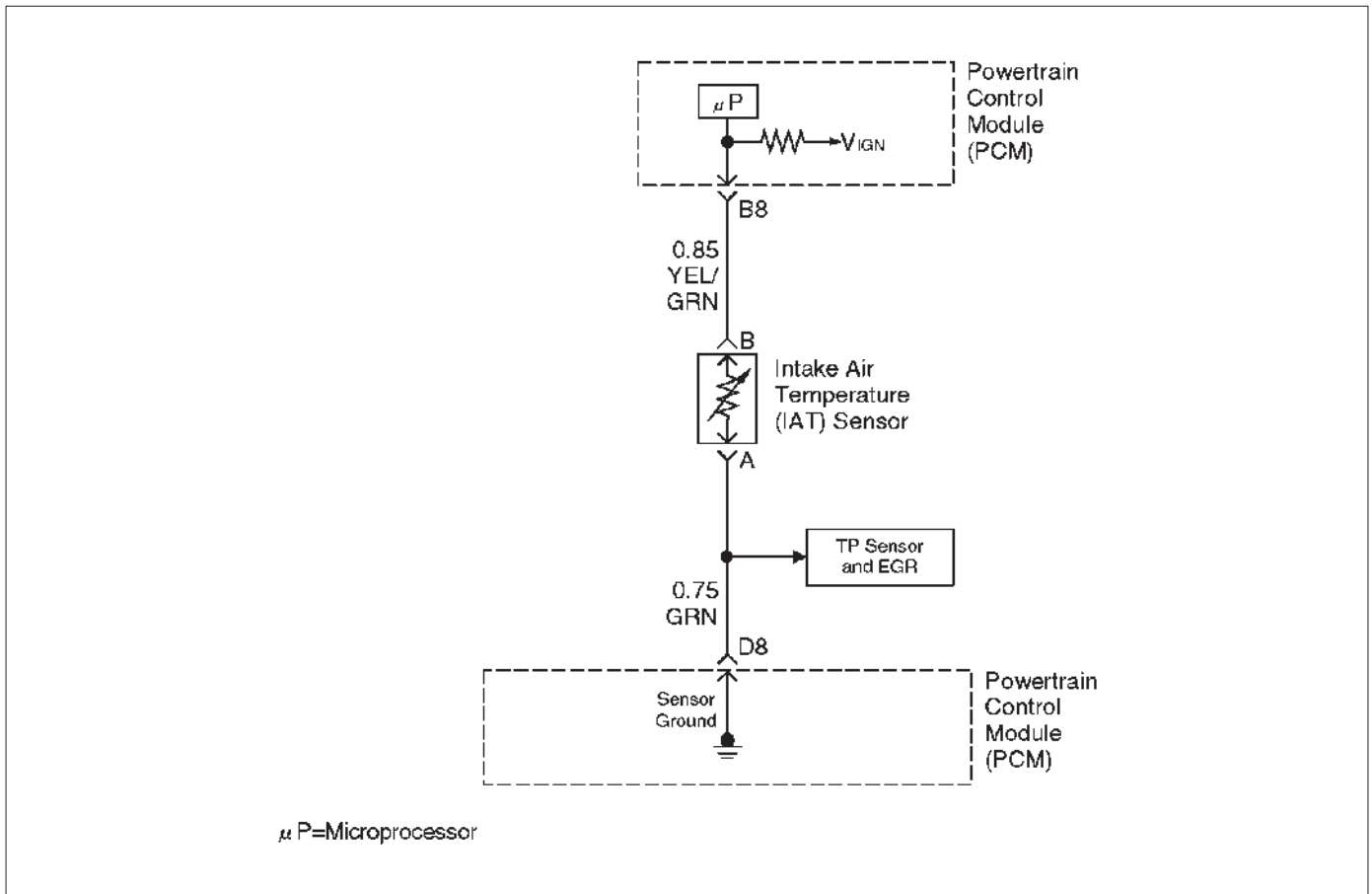
and wiring harnesses related to the sensor. A change in the display will indicate the location of the fault. Reviewing the Failure Records vehicle mileage since the diagnostic test last failed may help determine how often

the condition that caused the DTC to be set occurs. This may assist in diagnosing the condition.

### DTC P1107 – MAP Sensor Circuit Intermittent Low Voltage

Step	Action	Value(s)	Yes	No
1	Was the "On-Board Diagnostic (OBD) System Check" performed?	—	Go to Step 2	Go to OBD System Check
2	Is DTC P0107 also set?	—	Go to DTC P0107 chart first	Go to Step 3
3	Is DTC P1122 also set?	—	Go to Step 6	Go to Step 4
4	Check for a poor 5 volt reference "A" circuit or MAP signal circuit terminal connection at the MAP sensor. Was a problem found?	—	Go to Step 9	Go to Step 5
5	Check the MAP signal circuit between the MAP sensor connector and the PCM for an intermittent open or short to ground. Was a problem found?	—	Go to Step 10	Go to Step 8
6	Check for an intermittent short to ground on the 5 volt reference "A" circuit between the PCM and the following components: <ul style="list-style-type: none"> <li><input type="radio"/> MAP sensor</li> <li><input type="radio"/> EGR valve</li> <li><input type="radio"/> TP sensor</li> </ul> Was a problem found?	—	Go to Step 10	Go to Step 7
7	Check for a poor 5 volt reference "A" terminal connection at the PCM. Was a problem found?	—	Go to Step 9	Go to Step 8
8	Check for an intermittent open or a faulty splice in the 5 volt reference "A" circuit. Was a problem found? (If no, start with the diagnosis chart for other sensors in the circuit and see if 5V returns.)	—	Go to Step 10	Refer to Diagnostic Aids
9	Replace the faulty harness connector terminal(s) for the 5 volt reference "A" circuit and/or the MAP signal circuit as necessary. Is the action complete?	—	Verify repair	—
10	Repair intermittent open/short circuit in the wiring harness as necessary. Is the action complete?	—	Verify repair	—

## Diagnostic Trouble Code (DTC) P1111 IAT Sensor Circuit Intermittent High Voltage



### Circuit Description

The intake air temperature (IAT) sensor is a thermistor which measures the temperature of the air entering the engine. The powertrain control module (PCM) applies 5 volts through a pull-up resistor to the IAT sensor. When the intake air is cold, the sensor resistance is high and the PCM will monitor a high signal voltage on the IAT signal circuit. If the intake air is warm, the sensor resistance is lower causing the PCM to monitor a lower voltage. DTC P1111 will set when the PCM intermittently detects an excessively high signal voltage on the intake air temperature sensor signal circuit.

### Conditions for Setting the DTC

- The engine has been running for over 4 minutes.
- Vehicle speed is less than 32 km/h (20 mph).
- Engine coolant temperature is above 60°C (140°F).
- Mass air flow is less than 20g/second.
- IAT signal voltage indicates and intake air temperature intermittently less than -39°C (-38°F) (about 5 volts) for approximately 2.5 seconds over a 25-second period of time.

### Action Taken When the DTC Sets

- The PCM will substitute a default value for intake air temperature.

- The PCM will store conditions which were present when the DTC set as Failure Records data only. This information will not be stored as Freeze Frame data.
- DTC P1111 does not illuminate the MIL.

### Conditions for Clearing the MIL/DTC

- A history DTC P1111 will clear after 40 consecutive warm-up cycles have occurred without a fault.
- DTC P1111 can be cleared by using the Tech 2 "Clear Info" function or by disconnecting the PCM battery feed.

### Diagnostic Aids

Check for the following conditions:

- Poor connection at PCM – Inspect harness connectors for backed-out terminals, improper mating, broken locks, improperly formed or damaged terminals, and poor terminal-to-wire connection.
  - Damaged harness – Inspect the wiring harness for damage. If the harness appears to be OK, observe the IAT display on the Tech 2 while moving connectors and wiring harnesses related to the IAT sensor. A change in the IAT display will indicate the location of the fault.
- Reviewing the Failure Records vehicle mileage since the diagnostic test last failed may help determine how often the condition that caused the DTC to be set occurs. This may assist in diagnosing the condition.

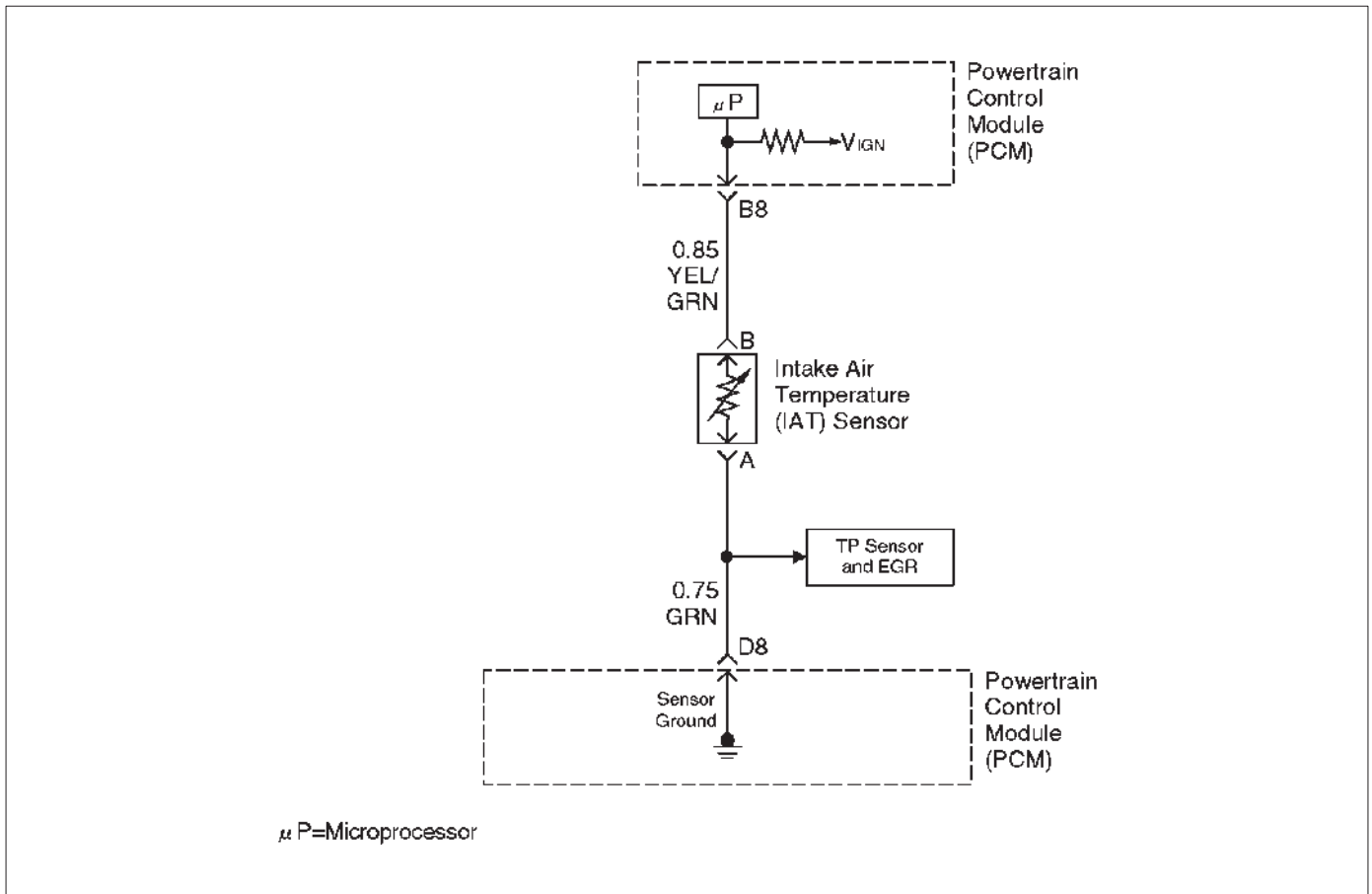
**Intake Air Temperature Sensor**

°C	°F	OHMS
<b>Temperature vs. Resistance Values (approximate)</b>		
100	212	177
80	176	332
60	140	667
45	113	1188
35	95	1802
25	77	2796
15	59	4450
5	41	7280
-5	23	12300
-15	5	21450
-30	-22	52700
-40	-40	100700

**DTC P1111 –IAT Sensor Circuit Intermittent High Voltage**

Step	Action	Value(s)	Yes	No
1	Was the “On-Board Diagnostic (OBD) System Check” performed?	—	Go to <i>Step 2</i>	Go to <i>OBD System Check</i>
2	Is DTC P0113 also set?	—	Go to <i>DTC P0113</i> chart first	Go to <i>Step 3</i>
3	Is DTC P1106, P1115, and/or P1121 also set?	—	Go to <i>Step 6</i>	Go to <i>Step 4</i>
4	1. Check for a poor sensor ground circuit terminal connection at the IAT sensor. 2. If a problem is found, repair as necessary. Was a problem found?	—	Verify repair	Go to <i>Step 5</i>
5	1. Check for a poor IAT signal circuit terminal connection at the IAT sensor. 2. If a problem is found, repair as necessary. Was a problem found?	—	Verify repair	Go to <i>Step 6</i>
6	1. Check the IAT signal circuit between the IAT sensor connector and the PCM for an intermittent open. 2. If a problem is found, repair as necessary. Was a problem found?	—	Verify repair	Go to <i>Step 7</i>
7	1. Check the IAT signal circuit between the IAT sensor connector and the PCM for an intermittent short to voltage. 2. If a problem is found, repair as necessary. Was a problem found?	—	Verify repair	Go to <i>Step 8</i>
8	1. Check for a poor sensor ground circuit terminal connection at the PCM. 2. If a problem is found, repair as necessary. Was a problem found?	—	Verify repair	Go to <i>Step 9</i>
9	1. Check for an intermittent open or a faulty splice in the sensor ground circuit. 2. If a problem is found, repair as necessary. Was a problem found?	—	Verify repair	Refer to <i>Diagnostic Aids</i>

## Diagnostic Trouble Code (DTC) P1112 IAT Sensor Circuit Intermittent Low Voltage



D06RX078

### Circuit Description

The intake air temperature (IAT) sensor is a thermistor which measures the temperature of the air entering the engine. The powertrain control module (PCM) applies 5 volts through a pull-up resistor to the IAT sensor. When the intake air is cold, the sensor resistance is high and the PCM will monitor a high signal voltage on the IAT signal circuit. If the intake air is warm, the sensor resistance becomes lower, causing the PCM to monitor a lower voltage. DTC P1112 will set when the PCM intermittently detects an excessively low signal voltage on the intake air temperature sensor signal circuit.

### Conditions for Setting the DTC

- The engine has been running for over 2 minutes.
- Vehicle speed is greater than 48 km/h (30 mph).
- IAT signal voltage is greater than 148°C (298°F) (about 0.10 volt) for a total of 2.5 seconds over a 25-second period of time.

### Action Taken When the DTC Sets

- The PCM will not illuminate the malfunction indicator lamp (MIL).
- The PCM will store conditions which were present when the DTC was set as Failure Records data only. This information will not be stored as Freeze Frame data.
- The PCM will substitute a default value for intake air temperature.

### Conditions for Clearing the MIL/DTC

- A history DTC P1112 will clear after 40 consecutive warm-up cycles have occurred without a fault.
- DTC P1112 can be cleared by using the Tech 2 "Clear Info" function or by disconnecting the PCM battery feed.

### Diagnostic Aids

Check for the following conditions:

- Poor connection at PCM – Inspect harness connectors for backed-out terminals, improper mating, broken locks, improperly formed or damaged terminals, and poor terminal-to-wire connection.
- Damaged harness – Inspect the wiring harness for damage. If the harness appears to be OK, observe the IAT display on the Tech 2 while moving connectors and wiring harnesses related to the IAT sensor. A change in the IAT display will indicate the location of the fault. Reviewing the Failure Records vehicle mileage since the diagnostic test last failed may help determine how often the condition that caused the DTC to be set occurs. This may assist in diagnosing the condition.

**Test Description**

Number(s) below refer to the step number(s) on the Diagnostic Chart.

2. Verifies that the fault is present.
3. If DTC P1112 can be repeated only by duplicating the Failure Records conditions, refer to the "Temperature vs. Resistance Value Chart." The chart may be used to test the IAT sensor at various temperatures to evaluate the possibility of a "shifted" sensor that may be shorted above or below a certain temperature. If this is the case, replace the IAT sensor.

**Intake Air Temperature Sensor**

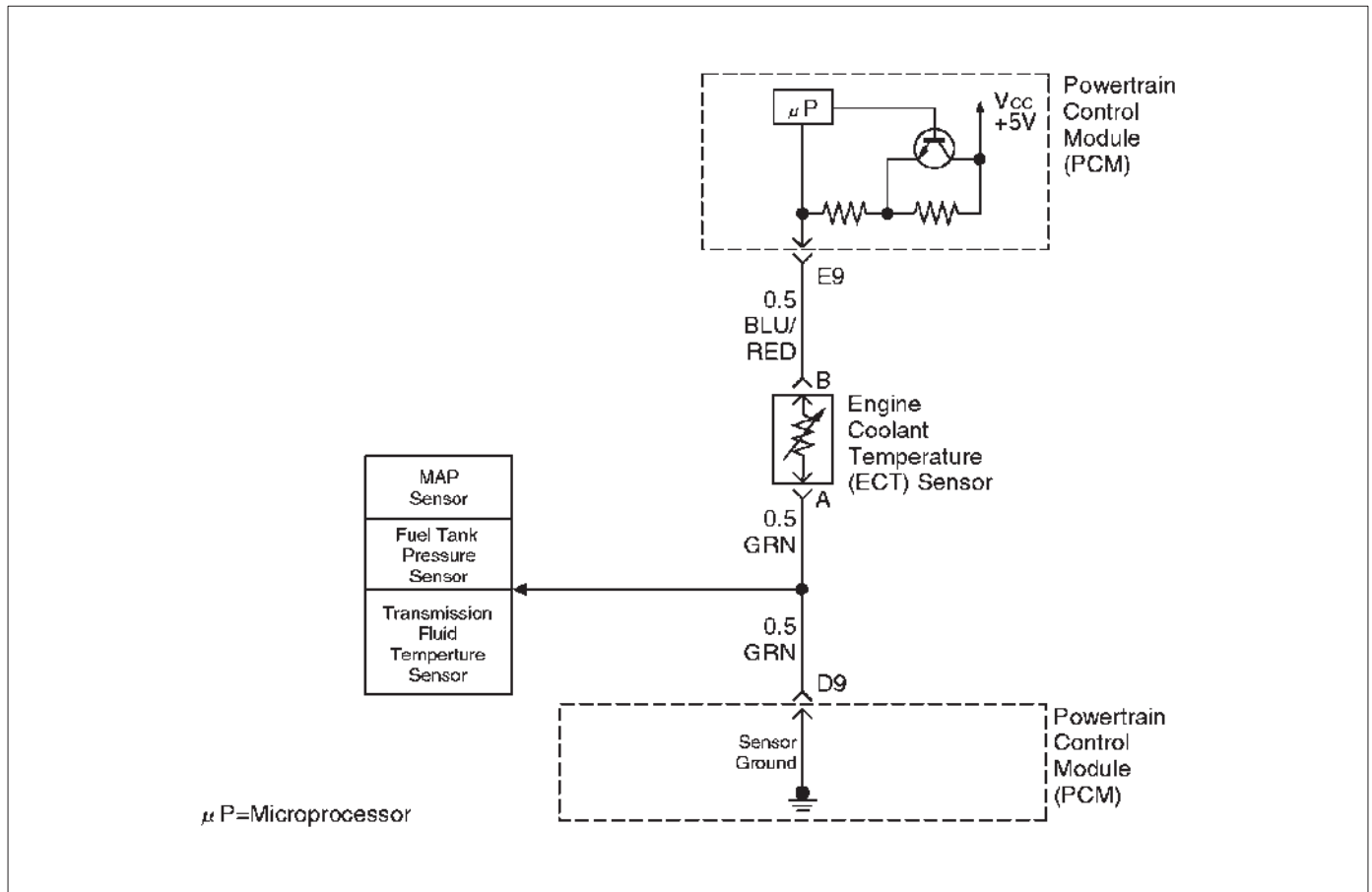
°C	°F	OHMS
<b>Temperature vs. Resistance Values (approximate)</b>		
100	212	177
80	176	332
60	140	667
45	113	1188
35	95	1802
25	77	2796
15	59	4450
5	41	7280
-5	23	12300
-15	5	21450
-30	-22	52700
-40	-40	100700

**DTC P1112 – IAT Sensor Circuit Intermittent Low Voltage**

Step	Action	Value(s)	Yes	No
1	Was the "On-Board Diagnostic (OBD) System Check" performed?	—	Go to Step 2	Go to <i>OBD System Check</i>
2	Is DTC P0112 also set?	—	Go to <i>DTC P0112</i> first	Go to Step 3
3	1. Check the IAT signal circuit between the IAT sensor connector and the PCM for an intermittent short to ground. 2. If a problem is found, repair as necessary. Was a problem found?	—	Verify repair	Refer to <i>Diagnostic Aids</i>



## Diagnostic Trouble Code (DTC) P1114 ECT Sensor Circuit Intermittent Low Voltage



### Circuit Description

The engine coolant temperature (ECT) sensor is a thermistor mounted in the engine coolant stream. The powertrain control module (PCM) applies a voltage (about 5.0 volts) through a pull-up resistor to the ECT signal circuit. When the engine coolant is cold, the sensor (thermistor) resistance is high, therefore the PCM will measure a high signal voltage. As the engine coolant warms, the sensor resistance becomes less, and the ECT signal voltage measured at the PCM drops. With a fully warmed up engine, the ECT signal voltage should measure about 1.5 to 2.0 volts. If the PCM detects an ECT signal that is intermittently below the range of the ECT sensor, DTC P1114 will set.

### Conditions for Setting the DTC

- Engine run time longer than 60 seconds.
- The ECT sensor signal is intermittently greater than 150°C (302°F) (about 0.10 volt) for a total of 10 seconds over a 100-second period.

### Action Taken When the DTC Sets

- The PCM will not illuminate the malfunction indicator lamp (MIL).

- The PCM will store conditions which were present when the DTC set as Failure Records data only. This information will not be stored as Freeze Frame data.

### Conditions for Clearing the MIL/DTC

- A history DTC P1114 will clear after 40 consecutive warm-up cycles have occurred without a fault.
- DTC P1114 can be cleared by using the Tech 2 "Clear Info" function or by disconnecting the PCM battery feed.

### Diagnostic Aids

Check for the following conditions:

- Poor connection at PCM – Inspect harness connectors for backed-out terminals, improper mating, broken locks, improperly formed or damaged terminals, and poor terminal-to-wire connection.
- Damaged harness – Inspect the wiring harness for damage. If the harness appears to be OK, observe the ECT display on the Tech 2 while moving connectors and wiring harnesses related to the ECT sensor. A change in the ECT display will indicate the location of the fault.

Reviewing the Failure Records vehicle mileage since the diagnostic test last failed may help determine how often

the condition that caused the DTC to be set occurs. This may assist in diagnosing the condition.

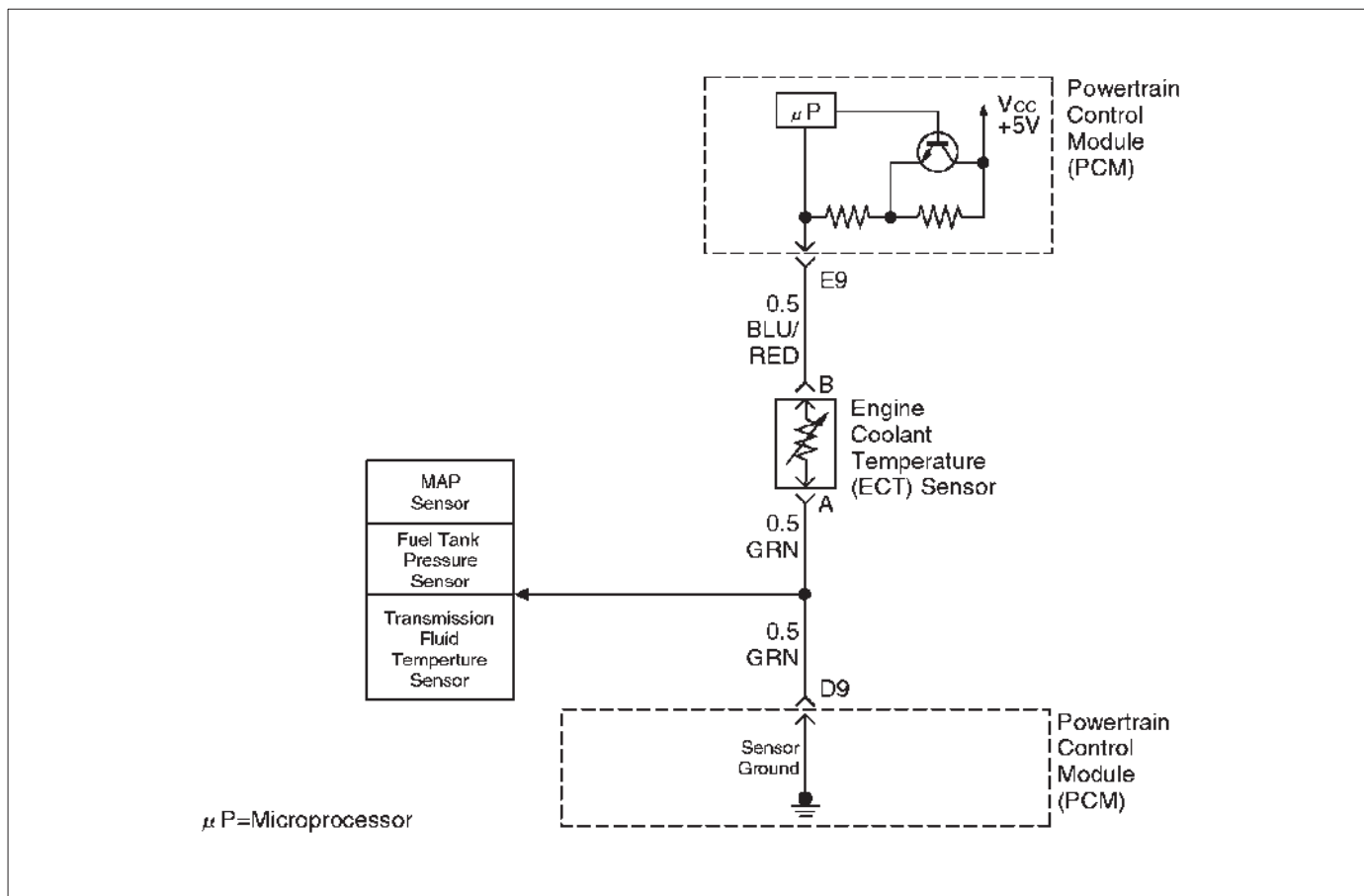
**Engine Coolant Temperature Sensor**

°C	°F	OHMS
<b>Temperature vs. Resistance Values (approximate)</b>		
100	212	177
80	176	332
60	140	667
45	113	1188
35	95	1802
25	77	2796
15	59	4450
5	41	7280
-5	23	12300
-15	5	21450
-30	-22	52700
-40	-40	100700

**DTC P1114 – ECT Circuit Intermittent Low Voltage**

Step	Action	Value(s)	Yes	No
1	Was the “On-Board Diagnostic (OBD) System Check” performed?	—	Go to <i>Step 2</i>	Go to <i>OBD System Check</i>
2	Is DTC P0117 also set?	—	Go to <i>DTC P0117</i> first	Go to <i>Step 3</i>
3	1. Check the ECT signal circuit between the ECT sensor connector and the PCM for an intermittent short to ground. 2. If a problem is found, repair as necessary. Was a problem found?	—	Verify repair	Refer to <i>Diagnostic Aids</i>

## Diagnostic Trouble Code (DTC) P1115 ECT Sensor Circuit Intermittent High Voltage



### Circuit Description

The engine coolant temperature (ECT) sensor is a thermistor mounted in the engine coolant stream. The powertrain control module (PCM) applies a voltage (about 5.0 volts) through a pull-up resistor to the ECT signal circuit. When the engine coolant is cold, the sensor (thermistor) resistance is high, therefore the PCM will measure a high signal voltage. As the engine coolant warms, the sensor resistance becomes less, and the ECT signal voltage measured at the PCM drops. With a fully warmed up engine, the ECT signal voltage should measure about 1.5 to 2.0 volts. If the PCM detects an ECT signal that is intermittently above the range of the ECT sensor, DTC P1115 will set.

### Conditions for Setting the DTC

- Engine running time longer than 90 seconds.
- The ECT sensor signal is intermittently greater than  $-39^{\circ}\text{C}$  ( $-38^{\circ}\text{F}$ ) (about 5 volts) for a total of 10 seconds over a 100-second period.

### Action Taken When the DTC Sets

- The PCM will not illuminate the malfunction indicator lamp (MIL).

- The PCM will store conditions which were present when the DTC was set as Failure Records data only. This information will not be stored as Freeze Frame data.

### Conditions for Clearing the MIL/DTC

- A history DTC P1115 will clear after 40 consecutive warm-up cycles have occurred without a fault.
- DTC P1115 can be cleared by using the Tech 2 "Clear Info" function or by disconnecting the PCM battery feed.

### Diagnostic Aids

Check for the following conditions:

- Poor connection at PCM – Inspect harness connectors for backed-out terminals, improper mating, broken locks, improperly formed or damaged terminals, and poor terminal-to-wire connection.
- Damaged harness – Inspect the wiring harness for damage. If the harness appears to be OK, observe the ECT display on the Tech 2 while moving connectors and wiring harnesses related to the ECT sensor. A change in the ECT display will indicate the location of the fault.

Reviewing the Failure Records vehicle mileage since the diagnostic test last failed may help determine how often

the condition that caused the DTC to be set occurs. This may assist in diagnosing the condition.

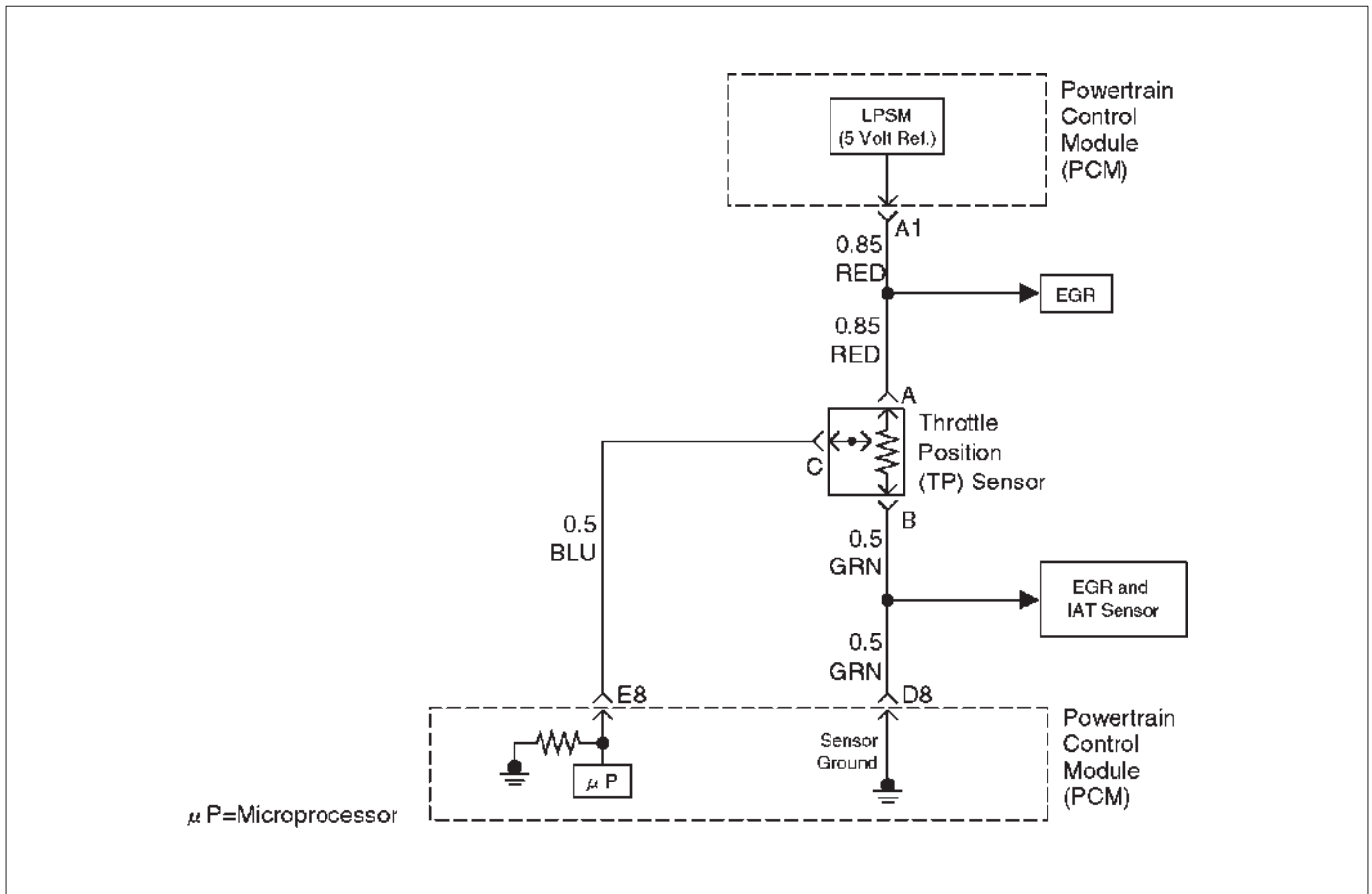
### Engine Coolant Temperature Sensor

°C	°F	OHMS
<b>Temperature vs. Resistance Values (approximate)</b>		
100	212	177
80	176	332
60	140	667
45	113	1188
35	95	1802
25	77	2796
15	59	4450
5	41	7280
-5	23	12300
-15	5	21450
-30	-22	52700
-40	-40	100700

**DTC P1115 – ECT Sensor Circuit Intermittent High Voltage**

Step	Action	Value(s)	Yes	No
1	Was the "On-Board Diagnostic (OBD) System Check" performed?	—	Go to <i>Step 2</i>	Go to <i>OBD System Check</i>
2	Is DTC P0118 also set?	—	Go to <i>DTC P0118</i> chart first	Go to <i>Step 3</i>
3	Is DTC P1106, P1111, and/or P1121 also set?	—	Go to <i>Step 8</i>	Go to <i>Step 4</i>
4	1. Check for a poor sensor ground circuit terminal connection at the ECT sensor. 2. If a problem is found, repair as necessary. Was a problem found?	—	Verify repair	Go to <i>Step 5</i>
5	1. Check for a poor ECT signal circuit terminal connection at the ECT sensor. 2. If a problem is found, repair as necessary. Was a problem found?	—	Verify repair	Go to <i>Step 6</i>
6	1. Check the ECT signal circuit between the ECT sensor connector and the PCM for an intermittent open. 2. If a problem is found, repair as necessary. Was a problem found?	—	Verify repair	Go to <i>Step 7</i>
7	1. Check the ECT signal circuit between the ECT sensor connector and the PCM for an intermittent short to voltage. 2. If a problem is found, repair as necessary. Was a problem found?	—	Verify repair	Go to <i>Step 8</i>
8	1. Check for a poor sensor ground circuit terminal connection at the PCM. 2. If a problem is found, repair as necessary. Was a problem found?	—	Verify repair	Go to <i>Step 9</i>
9	1. Check for an intermittent open or a faulty splice in the sensor ground circuit. 2. If a problem is found, repair as necessary. Was a problem found?	—	Verify repair	Refer to <i>Diagnostic Aids</i>

## Diagnostic Trouble Code (DTC) P1121 TP Sensor Circuit Intermittent High Voltage



### Circuit Description

The throttle position (TP) sensor circuit provides voltage signal that changes relative to the throttle blade angle. The signal voltage will vary from about 0.6 volts at closed throttle to about 4.5 volts at wide open throttle (WOT). The TP signal is one of the most important inputs used by the powertrain control module (PCM) for fuel control and for most of the PCM controlled outputs. If the PCM detects a TP signal that is intermittently above the range of the TP sensor, DTC P1121 will be set.

### Conditions for Setting the DTC

- The ignition is "ON."
- TP sensor indicates a throttle position voltage intermittently greater than 4.9 volts for a total of 0.15 seconds over a 1.5-second period.

### Action Taken When the DTC Sets

- The PCM will not illuminate the malfunction indicator lamp (MIL).
- The PCM will store conditions which were present when the DTC was set as Failure Records data only. This information will not be stored as Freeze Frame data.

### Conditions for Clearing the MIL/DTC

- A history DTC P1121 will clear after 40 consecutive warm-up cycles have occurred without a fault.

- DTC P1121 can be cleared by using the Tech 2 "Clear Info" function or by disconnecting the PCM battery feed.

### Diagnostic Aids

Check for the following conditions:

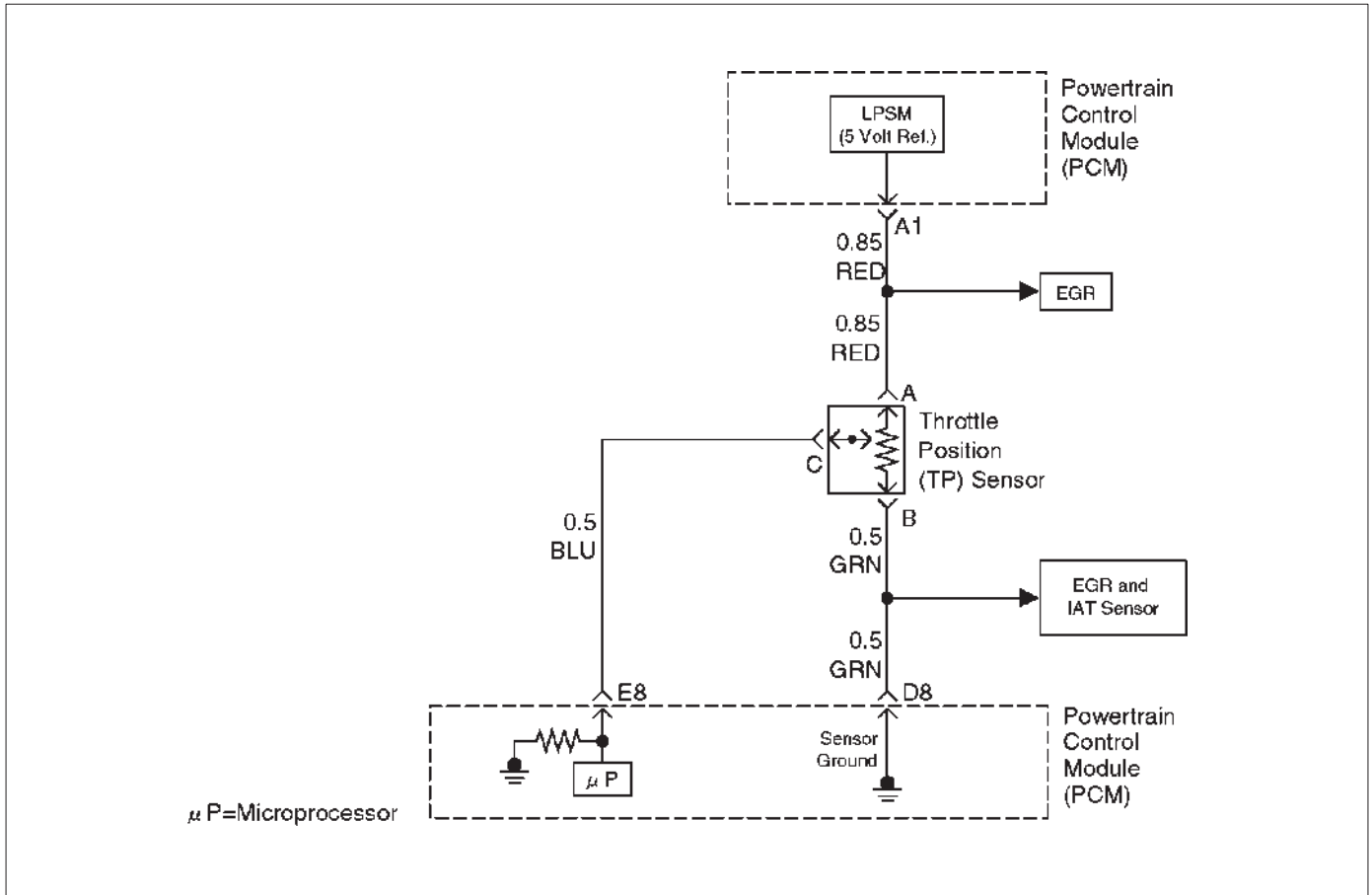
- Poor connection at PCM— Inspect the harness connectors for backed-out terminals, improper mating, broken locks, improperly formed or damaged terminals, and poor terminal-to-wire connection.
- The TP Sensor shares a 5 Volt reference with the EGR Valve. If these codes are also set, it could indicate a problem with the 5 Volt reference circuit or components itself.
- The TP Sensor share a ground with the EGR Valve and the IAT Sensor.
- Damaged harness – Inspect the wiring harness for damage. If the harness appears to be OK, observe the throttle position display on the Tech 2 while moving connectors and wiring harnesses related to the TP sensor. A change in the display will indicate the location of the fault.

If DTC P1121 cannot be duplicated, reviewing the Failure Records vehicle mileage since the diagnostic test last failed may help to determine how often the condition that caused the DTC to be set occurs. This may assist in diagnosing the condition.

**DTC P1121 – TP Sensor Circuit Intermittent High Voltage**

Step	Action	Value(s)	Yes	No
1	Was the "On-Board Diagnostic (OBD) System Check" performed?	—	Go to <i>Step 2</i>	Go to <i>OBD System Check</i>
2	Is DTC P0123 also set?	—	Go to <i>DTC P0123</i> first	Go to <i>Step 3</i>
3	Is DTC P1111, P1115, and/or P1106 also set?	—	Go to <i>Step 6</i>	Go to <i>Step 4</i>
4	Check for a poor sensor ground circuit terminal connection at the TP sensor. Was a problem found?	—	Go to <i>Step 9</i>	Go to <i>Step 5</i>
5	Check the TP signal circuit between the TP sensor connector and the PCM for an intermittent short to voltage. Was a problem found?	—	Go to <i>Step 10</i>	Go to <i>Step 8</i>
6	Check for an intermittent short to voltage on the 5 volt reference "A" circuit between the PCM and the following components: ○ MAP sensor ○ EGR valve ○ TP sensor Was a problem found?	—	Go to <i>Step 10</i>	Go to <i>Step 7</i>
7	Check for a poor sensor ground terminal connection at the PCM. Was a problem found?	—	Go to <i>Step 9</i>	Go to <i>Step 8</i>
8	Check for an intermittent open or a faulty splice in the sensor ground circuit. Was a problem found? (If no, start with the diagnosis chart for other sensors in the circuit and see if 5V returns.)	—	Go to <i>Step 10</i>	Refer to <i>Diagnostic Aids</i>
9	Replace the faulty harness connector terminal for the sensor ground circuit. Is the action complete?	—	Verify repair	—
10	Repair intermittent open/short circuit in wiring harness as necessary. Is the action complete?	—	Verify repair	—

## Diagnostic Trouble Code (DTC) P1122 TP Sensor Circuit Intermittent Low Voltage



### Circuit Description

The throttle position (TP) sensor circuit provides voltage signal that changes relative to the throttle blade angle. The signal voltage will vary from about 0.6 volts at closed throttle to about 4.5 volts at wide open throttle (WOT). The TP signal is one of the most important inputs used by the powertrain control module (PCM) for fuel control and for most of the PCM controlled outputs. If the PCM detects a TP signal that is intermittently below the range of the TP sensor, DTC P1121 will be set.

### Conditions for Setting the DTC

- The ignition is "ON."
- TP sensor indicates a throttle position signal intermittently less than 0.22 volt for a total of 0.15 seconds over a 1.5-second period.

### Action Taken When the DTC Sets

- The PCM will not illuminate the malfunction indicator lamp (MIL).
- The PCM will store conditions which were present when the DTC was set as Failure Records data only. This information will not be stored as Freeze Frame data.

### Conditions for Clearing the MIL/DTC

- A history DTC P1122 will clear after 40 consecutive warm-up cycles have occurred without a fault.

- DTC P1122 can be cleared by using the Tech 2 "Clear Info" function or by disconnecting the PCM battery feed.

### Diagnostic Aids

Check for the following conditions:

- Poor connection at PCM – Inspect harness connectors for backed-out terminals, improper mating, broken locks, improperly formed or damaged terminals, and poor terminal-to-wire connection.
- The TP Sensor shares a 5 Volt reference with the EGR Valve. If these codes are also set, it could indicate a problem with the 5 Volt reference circuit or components itself.
- The TP Sensor share a ground with the EGR Valve and the IAT Sensor.
- Damaged harness – Inspect the wiring harness for damage. If the harness appears to be OK, observe the throttle position display on the Tech 2 while moving connectors and wiring harnesses related to the TP sensor. A change in the display will indicate the location of the fault.

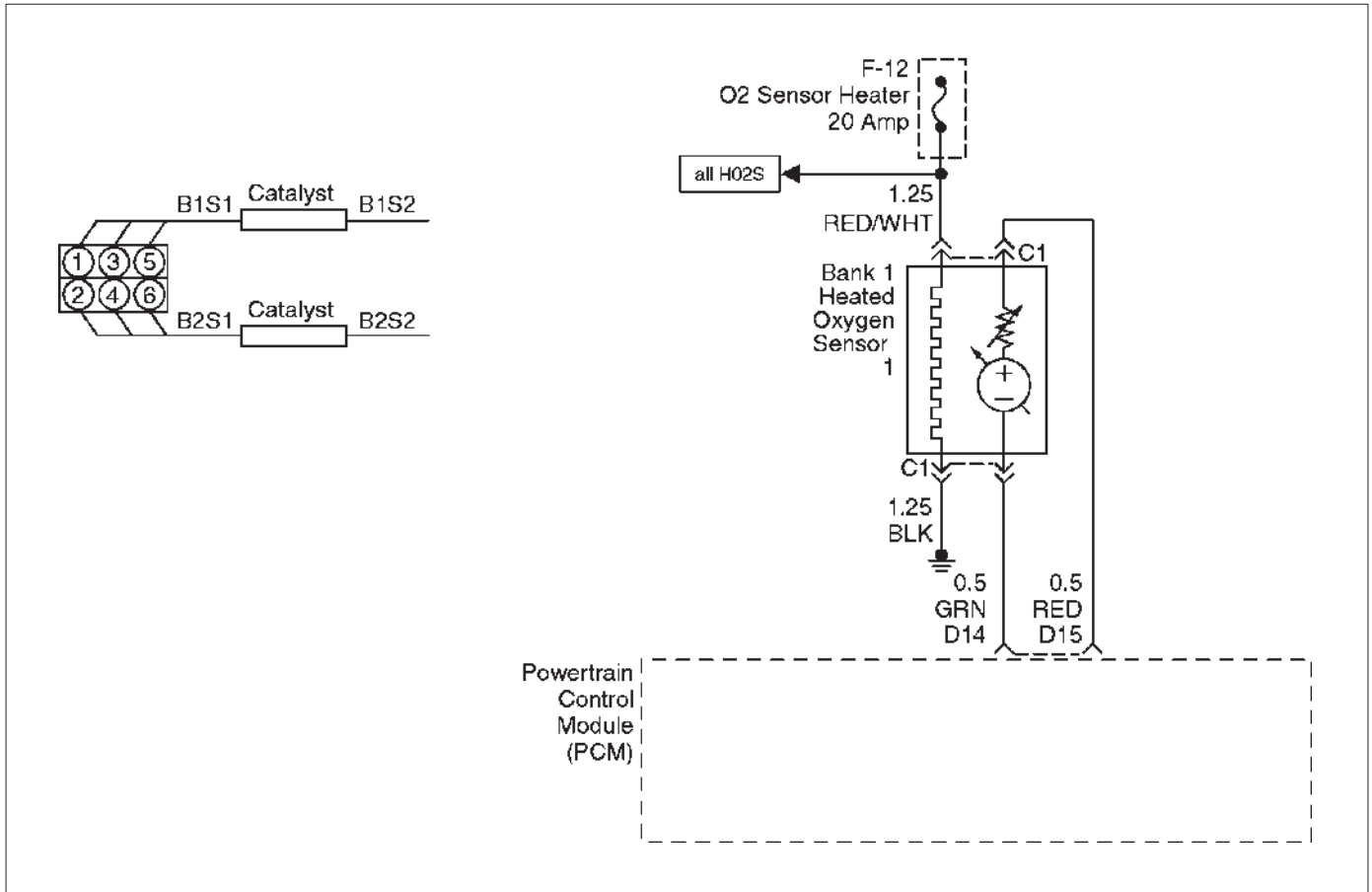
Reviewing the Failure Records vehicle mileage since the diagnostic test last failed may help to determine how often the condition that caused the DTC to be set occurs. This may assist in diagnosing the condition.



**DTC P1122 – TP Circuit Intermittent Low Voltage**

Step	Action	Value(s)	Yes	No
1	Was the "On-Board Diagnostic (OBD) System Check" performed?	—	Go to <i>Step 2</i>	Go to <i>OBD System Check</i>
2	Is DTC P0122 also set?	—	Go to <i>DTC P0122</i> first	Go to <i>Step 3</i>
3	Is DTC P1107 also set?	—	Go to <i>Step 6</i>	Go to <i>Step 4</i>
4	Check for a poor 5 volt reference "A" circuit or TP signal circuit terminal connection at the TP sensor. Was a problem found?	—	Go to <i>Step 9</i>	Go to <i>Step 5</i>
5	Check the TP signal circuit between the TP sensor connector and the PCM for an intermittent open or short to ground. Was a problem found?	—	Go to <i>Step 10</i>	Go to <i>Step 8</i>
6	Check for an intermittent short to ground on the 5 volt reference "A" circuit between the PCM and the following components: <input type="radio"/> MAP sensor <input type="radio"/> EGR valve <input type="radio"/> TP sensor Was a problem found?	—	Go to <i>Step 10</i>	Go to <i>Step 7</i>
7	Check for a poor 5 volt reference "A" circuit terminal connection at the PCM. Was a problem found?	—	Go to <i>Step 9</i>	Go to <i>Step 8</i>
8	Check for an intermittent open or a faulty splice in the 5 volt reference "A" circuit. Was a problem found? (If no, start with the diagnosis chart for other sensors in the circuit and see if 5V returns.)	—	Go to <i>Step 10</i>	Refer to <i>Diagnostic Aids</i>
9	Replace the faulty harness connector terminal(s) for the 5 volt reference "A" circuit and/or the TP signal circuit as necessary. Is the action complete?	—	Repair complete. If a driveability symptom still exists, refer to <i>Symptoms</i> .	—
10	Repair the intermittent open/short circuit in wiring harness as necessary. Is the action complete?	—	Repair complete. If a driveability symptom still exists, refer to <i>Symptoms</i> .	—

## Diagnostic Trouble Code (DTC) P1133 HO2S Insufficient Switching Bank 1 Sensor 1



### Circuit Description

The powertrain control module (PCM) monitors the heated oxygen sensor (HO2S) activity for 90 seconds after “closed loop” and stoichiometric operation have been enabled. During this test period the PCM counts the number of times that the HO2S signal voltage crosses the rich-to-lean and lean-to-rich threshold. If the PCM determines that the HO2S did not switch enough times, DTC P1133 will be set.

A lean-to-rich switch is determined when the HO2S voltage changes above and below 450 mV.

Heated oxygen sensors are used to minimize the amount of time required for “closed loop” fuel control operation and to allow accurate catalyst monitoring. The oxygen sensor heater greatly decreases the amount of time required for fuel control sensors Bank 1 HO2S 1 and Bank 2 HO2S 1 to become active. Oxygen sensor heaters are required by post-catalyst monitor sensors to maintain a sufficiently high temperature for accurate exhaust oxygen content readings further from the engine.

### Conditions for Setting the DTC

- Engine coolant temperature (ECT) is above 50°C (122°F).
- Engine is operating in “closed loop”.
- The engine has been running at least one minute.
- Canister purge duty cycle is greater than 2%.
- Engine speed is between 1500 RPM and 3000 RPM.

- Mass air flow (MAF) is between 9 g/second and 42 g/second.
- Above conditions are present for 3 seconds.
- 90 seconds after “closed loop” and stoichiometric operation have been achieved, the PCM monitors the oxygen sensor as it switches above and below 450 mV. If fewer than 23 rich-to-lean and lean-to-rich switches are detected, DTC P1133 will be set.

### Action Taken When the DTC Sets

- The PCM will illuminate the malfunction indicator lamp (MIL) after the second consecutive trip in which the fault is detected.
- “Open loop” fuel control will be in effect.
- The PCM will store conditions which were present when the DTC was set as Freeze Frame and in the Failure Records data.

### Conditions for Clearing the MIL/DTC

- The PCM will turn the MIL “OFF” on the third consecutive trip cycle during which the diagnostic has been run and the fault condition is no longer present.
- A history DTC P1133 will clear after 40 consecutive warm-up cycles have occurred without a fault.
- DTC P1133 can be cleared by using Tech 2 “Clear Info” function or by disconnecting the PCM battery feed.

D06RX082

**Diagnostic Aids**

A malfunction in the HO2S heater ignition feed or ground circuit may cause a DTC P1133 to set. Check HO2S heater circuitry for intermittent faults or poor connections. If connections and wiring are OK and DTC P1133 continues to set, replace the Bank 1 HO2S 1. Reviewing the Failure Records vehicle mileage since the diagnostic test last failed may help to determine how often the condition that caused the DTC to be set occurs. This may assist in diagnosing the condition.

**Test Description**

Number(s) below refer to the step number(s) on the Diagnostic Chart.

- 3. A condition that affects other heated oxygen sensors indicates probable contamination. To avoid damaging the replacement sensors, correct the condition which caused the contamination before replacing the affected sensors.
- 5. This step checks for conditions which may cause the heated oxygen sensor to appear faulty. Correct any of the described conditions if present.
- 11. To avoid damaging replacement sensors, correct the condition which caused the contamination before replacing the affected sensors.

**DTC P1133 – HO2S Insufficient Switching Bank 1 Sensor 1**

Step	Action	Value(s)	Yes	No
1	Was the "On-Board Diagnostic (OBD) System Check" performed?	—	Go to Step 2	Go to <i>OBD System Check</i>
2	<b>IMPORTANT:</b> If any DTCs are set (except P1153 or P1154) refer to those DTCs before proceeding with this diagnostic chart. 1. Engine idling at operating temperature. 2. Operating the vehicle within parameters specified under "Conditions for Setting the DTC" criteria included in Diagnostic Support. 3. Using a Tech 2, monitor "DTC" info for DTC P1133 until the DTC P1133 test runs. 4. Note the test result. Does the Tech 2 indicate DTC P1133 failed this ignition?	—	Go to Step 3	Refer to <i>Diagnostic Aids</i>
3	Did the Tech 2 also indicate that the P1153 or P1154 tests failed?	—	Go to Step 20	Go to Step 4
4	Check for leaks at the exhaust pipe joints. Are the joints leaking?	—	Go to Step 5	Go to Step 6
5	Tighten the bolt/nuts at the leaking joints. Is your action complete?	—	Go to Step 2	—
6	Check for gaskets that are damaged or improperly installed. Are there damaged or misaligned gaskets?	—	Go to Step 7	Go to Step 8
7	1. Replace the damaged gaskets. 2. Align the connections. 3. Tighten the connections. Is your action complete?	—	Go to Step 2	—
8	Check for loose exhaust flange connections. Are the flange connections loose?	—	Go to Step 9	Go to Step 10
9	Tighten the stud nuts or bolts to specifications. Is your action complete?	—	Go to Step 2	—
10	Check for burned or corroded exhaust pipes. Are the exhaust pipes burned or corroded?	—	Go to Step 11	Go to Step 12

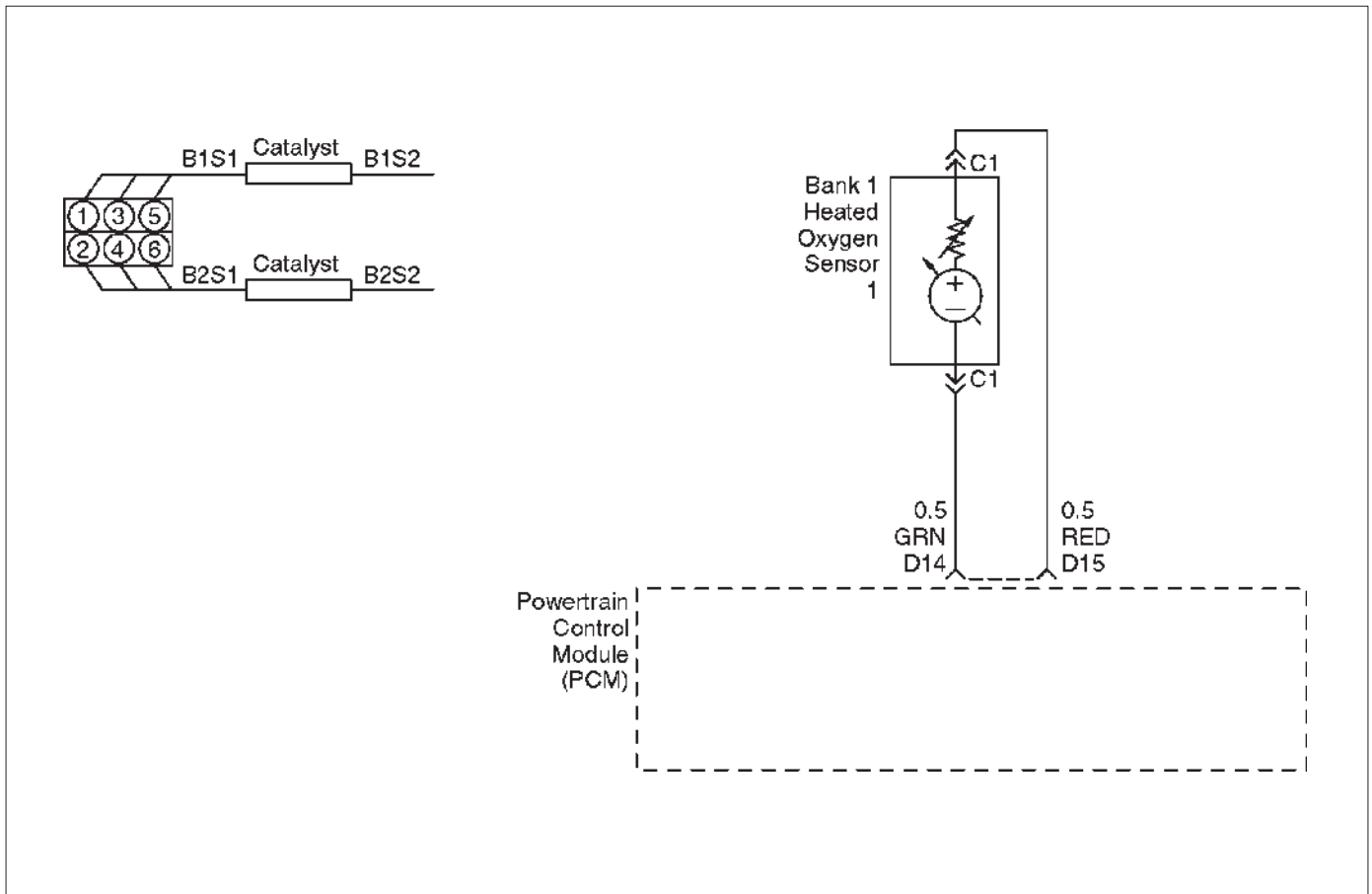
**DTC P1133 – HO2S Insufficient Switching Bank 1 Sensor 1 (Cont'd)**

Step	Action	Value(s)	Yes	No
11	Replace the exhaust pipes, as required. Is your action complete?	—	Go to <i>Step 2</i>	—
12	Check for leaks at the exhaust manifold. Are there leaks at the exhaust manifold?	—	Go to <i>Step 13</i>	Go to <i>Step 14</i>
13	Tighten the bolts to specifications or replace the manifold if necessary. Is your action complete?	—	Go to <i>Step 2</i>	—
14	Visually/physically inspect the following items: <input type="radio"/> Ensure that the Bank 1 HO2S 1 is securely installed. <input type="radio"/> Check for corrosion on the terminals. <input type="radio"/> Check the terminals at Bank 1 HO2S 1 and at the PCM. <input type="radio"/> Check for damaged wiring. Was a problem found in any of the above areas?	—	Verify repair	Go to <i>Step 15</i>
15	1. Disconnect Bank 1 HO2S 1. 2. Ignition "ON." 3. Using a DVM at the PCM side of the connector, check the voltage between the high signal circuit and ground. Also measure between the low signal circuit and ground. Are both voltages in the specified range?	3-4 mV	Go to <i>Step 18</i>	Go to <i>Step 16</i>
16	1. Ignition "OFF." 2. Check for damage to PCM pins or terminals. Was a problem found.	—	Verify repair	Go to <i>Step 17</i>
17	Check for a short to voltage or ground or an open in the signal circuit. Was a problem found?	—	Verify repair	Go to <i>Step 18</i>
18	1. Ignition "OFF." 2. Disconnect the PCM connector. 3. With the HO2S disconnected, check for high and low signal circuits shorted together between the PCM and HO2S. Was a problem found?	—	Verify repair	Go to <i>Step 19</i>
19	With the PCM connected and Bank 1 HO2S 1 disconnected from the harness, check Bank 1 HO2S 1 with a Tech 2. Is the voltage in the specified range?	425-475 mV	Go to <i>Step 21</i>	Go to <i>Step 22</i>
20	Replace the affected heated oxygen sensors. NOTE: Before replacing the sensors, the cause of the contamination must be determined and corrected. <input type="radio"/> Fuel contamination <input type="radio"/> Use of improper RTV sealant. <input type="radio"/> Engine oil/coolant consumption. Is the action complete?	—	Verify repair	—

**DTC P1133 – HO2S Insufficient Switching Bank 1 Sensor 1 (Cont'd)**

Step	Action	Value(s)	Yes	No
21	Replace Bank 1 HO2S 1. Is the action complete?	—	Verify repair	—
22	Replace the PCM. <b>IMPORTANT:</b> The replacement PCM must be programmed. Refer to <i>On-Vehicle Service</i> in <i>Powertrain Control Module and Sensors</i> for procedures. And also refer to latest Service Bulletin. Check to see if the Latest software is released or not. And then Down Load the LATEST PROGRAMMED SOFTWARE to the replacement PCM. Is the action complete?	—	Verify repair	—

## Diagnostic Trouble Code (DTC) P1134 HO<sub>2</sub>S Transition Time Ratio Bank 1 Sensor 1



### Circuit Description

The powertrain control module (PCM) monitors the heated oxygen sensor (HO<sub>2</sub>S) activity for 90 seconds after “closed loop” and stoichiometric operation have been established. During the monitoring period the PCM counts the number of times that the HO<sub>2</sub>S responds from rich-to-lean and from lean-to-rich and adds the amount of time it took to complete all transitions. With this information, an average time for all transitions can be determined. The PCM then divides the rich-to-lean average by the lean-to-rich average to obtain a ratio. If the HO<sub>2</sub>S transition time ratio is not within this range, DTC P1134 will be set, indicating that the oxygen sensor is not responding as expected to changes in exhaust oxygen content.

### Conditions for Setting the DTC

- No related DTCs.
- Engine coolant temperature (ECT) is above 50°C (122°F).
- Engine is operating in “closed loop.”
- The engine has been running at least one minute.
- Canister purge duty cycle is greater than 2%.
- Engine speed is between 1500 RPM and 3000 RPM.
- Mass air flow (MAF) is between 9 g/second and 42 g/second.
- Above conditions are present for a 3-second monitoring period.

- 90 seconds after “closed loop” and stoichiometric operation have been enabled, Bank 1 HO<sub>2</sub>S 1 transition ratio between lean-to-rich and rich-to-lean is less than 0.44 or greater than 3.8.

### Action Taken When the DTC Sets

- The PCM will illuminate the malfunction indicator lamp (MIL) after second consecutive trip in which the fault is detected.
- “Open loop” fuel control will be in effect.
- The PCM will store conditions which were present when the DTC was set as Freeze Frame and in the Failure Records data.

### Conditions for Clearing the MIL/DTC

- The PCM will turn the MIL “OFF” on the third consecutive trip cycle during which the diagnostic has been run and the fault condition is no longer present.
- A history DTC P1134 will clear after 40 consecutive warm-up cycles have occurred without a fault.
- DTC P1134 can be cleared by using the Tech 2 “Clear Info” function or by disconnecting the PCM battery feed.

### Diagnostic Aids

A malfunction in the HO<sub>2</sub>S heater ignition feed or ground circuit may cause a DTC P1134 to set. Check HO<sub>2</sub>S heater circuitry for intermittent faults or poor connections. If connections and wiring are OK and DTC P1134 continues to set, replace the Bank 1 HO<sub>2</sub>S 1.

**6E-374 6VE1 3.5L ENGINE DRIVEABILITY AND EMISSIONS**

Reviewing the Failure Records vehicle mileage since the diagnostic test last failed may help determine how often the condition that caused the DTC to be set occurs. This may assist in diagnosing the condition.

**Test Description**

Number(s) below refer to the step number(s) on the Diagnostic Chart.

3. A condition that affects other heated oxygen sensors indicates probable contamination. To avoid damaging replacement sensors, correct the condition which caused the contamination before replacing the affected sensors.

5. This step checks for conditions which may cause the heated oxygen sensor to appear faulty. Correct any of the described conditions if present.

8. To avoid damaging replacement sensors, correct the condition which caused the contamination before replacing the affected sensors.

**DTC P1134 – HO2S Transition Time Ratio Bank 1 Sensor 1**

Step	Action	Value(s)	Yes	No
1	Was the "On-Board Diagnostic (OBD) System Check" performed?	—	Go to Step 2	Go to <i>OBD System Check</i>
2	<b>IMPORTANT:</b> If any DTCs are set (except P1153 and/or P1154), refer to those DTCs before proceeding with this diagnostic chart. 1. Idle the engine at operating temperature. 2. Operate the vehicle within parameters specified under "Conditions for Setting the DTC" criteria included in Diagnostic Support. 3. Using a Tech 2, monitor "DTC" info for DTC P1134 until the DTC P1134 test runs. 4. Note the test result. Does Tech 2 indicate DTC 1134 failed this ignition?	—	Go to Step 3	Refer to <i>Diagnostic Aids</i>
3	Did the Tech 2 also indicate P1153, and/or P1154 test failed?	—	Go to Step 17	Go to Step 4
4	Check for leaks at the exhaust pipe joints. Are the joints leaking?	—	Go to Step 5	Go to Step 6
5	Tighten the U-bolt nuts at the leaking joints. Is your action complete?	—	Go to Step 2	—
6	Check for gaskets that are damaged or improperly installed. Are there damaged or misaligned gaskets?	—	Go to Step 7	Go to Step 8
7	1. Replace the damaged gaskets. 2. Align the connections. 3. Tighten the connections. Is your action complete?	—	Go to Step 2	—
8	Check for loose exhaust flange connections. Are the flange connections loose?	—	Go to Step 9	Go to Step 10
9	Tighten the stud nuts or bolts to specifications. Is your action complete?	—	Go to Step 2	—
10	Check for burned or corroded exhaust pipes. Are the exhaust pipes burned or corroded?	—	Go to Step 11	Go to Step 12
11	Replace the exhaust pipes, as required. Is your action complete?	—	Go to Step 2	—

**DTC P1134 – HO2S Transition Time Ratio Bank 1 Sensor 1 (Cont'd)**

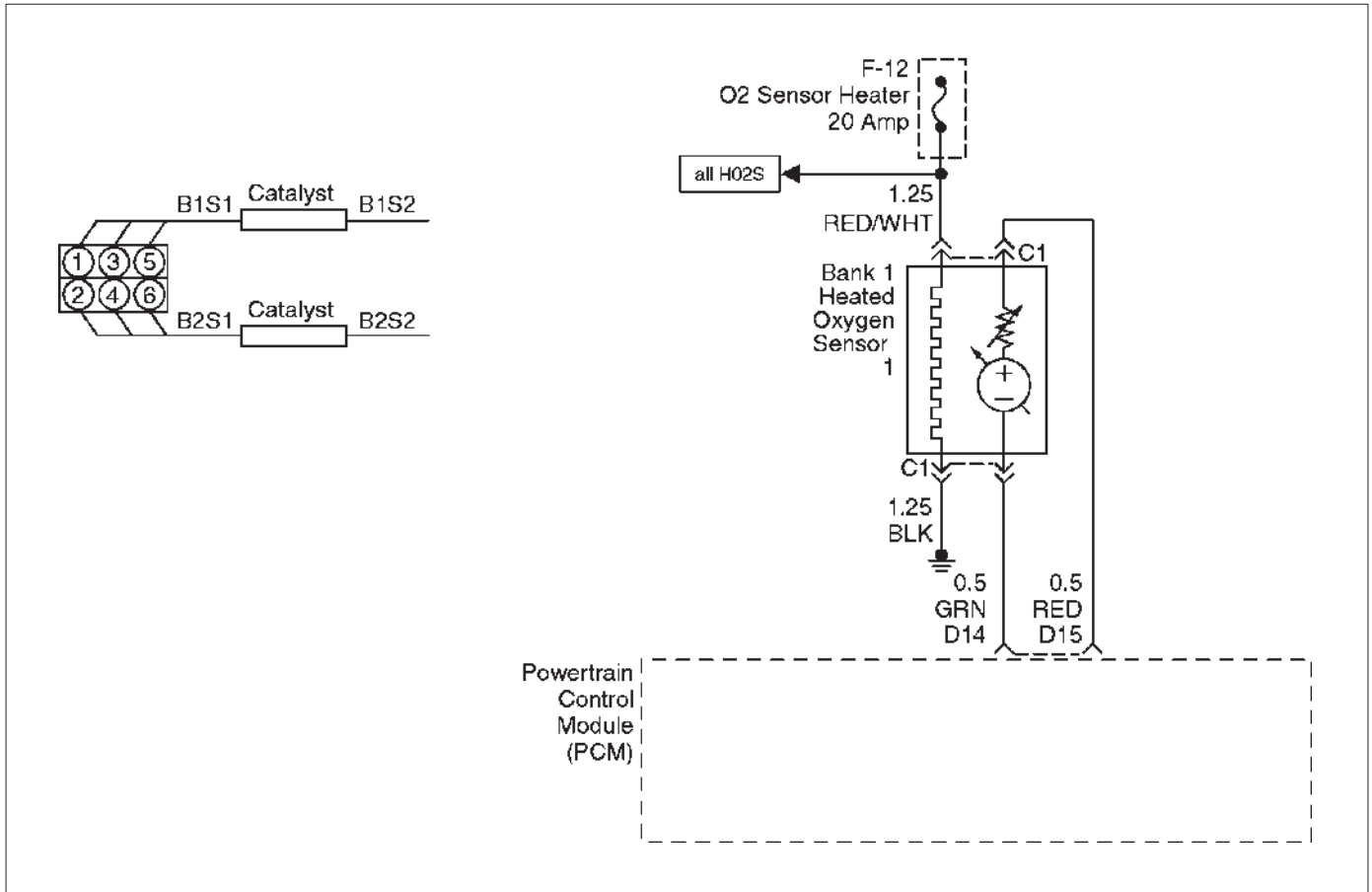
Step	Action	Value(s)	Yes	No
12	Check for leaks at the exhaust manifold. Are there leaks at the exhaust manifold?	—	Go to <i>Step 13</i>	Go to <i>Step 14</i>
13	Tighten the bolts to specifications or replace the manifold if necessary. Is your action complete?	—	Go to <i>Step 2</i>	—
14	Visually/physically inspect the following items: <ul style="list-style-type: none"> <li>○ Ensure that the Bank 1 HO2S 1 is securely installed.</li> <li>○ Check for corrosion on terminals.</li> <li>○ Check the terminal tension (at Bank 1 HO2S 1 and at the PCM).</li> <li>○ Check for damaged wiring.</li> </ul> Was a problem found in any of the above areas?	—	Go to <i>Step 18</i>	Go to <i>Step 15</i>
15	1. Disconnect Bank 1 HO2S 1. 2. Ignition "ON." 3. Using a DVM at the PCM side of the HO2S 1 connector, measure the voltage between the high signal circuit and ground. 4. Also measure the voltage between the low signal circuit and ground. Are both voltages in the specified range?	3-4V	Go to <i>Step 16</i>	Go to <i>Step 19</i>
16	1. With Bank 1 HO2S 1 disconnected, jumper the high and low (PCM side) signal circuits to ground. 2. Ignition "ON." 3. Using a Tech 2, monitor the Bank 1 HO2S 1 voltage. Does the Tech 2 indicate less than 10 mV and immediately return to about 450 mV when the jumper is removed?	—	Go to <i>Step 21</i>	Go to <i>Step 22</i>
17	Replace affected heated oxygen sensors. NOTE: Before replacing sensors, the cause of the contamination must be determined and corrected. <ul style="list-style-type: none"> <li>○ Fuel contamination.</li> <li>○ Use of improper RTV sealant.</li> <li>○ Engine oil/coolant consumption.</li> </ul> Is the action complete?	—	Verify repair	—
18	Repair condition as necessary. Is the action complete?	—	Verify repair	—
19	Check for faulty PCM connections or terminal damage. Is the action complete?	—	Verify repair	Go to <i>Step 20</i>
20	Repair open, short or grounded signal circuit. Is the action complete?	—	Verify repair	Go to <i>Step 7</i>



## DTC P1134 – HO2S Transition Time Ratio Bank 1 Sensor 1 (Cont'd)

Step	Action	Value(s)	Yes	No
21	Replace Bank 1 HO2S 1. Is the action complete?	—	Verify repair	—
22	Replace the PCM. <b>IMPORTANT:</b> The replacement PCM must be programmed. Refer to <i>On-Vehicle Service</i> in <i>Powertrain Control Module and Sensors</i> for procedures. And also refer to latest Service Bulletin. Check to see if the Latest software is released or not. And then Down Load the LATEST PROGRAMMED SOFTWARE to the replacement PCM. Is the action complete?	—	Verify repair	—

## Diagnostic Trouble Code (DTC) P1153 HO2S Insufficient Switching Bank 2 Sensor 1



### Circuit Description

The powertrain control module (PCM) monitors the heated oxygen sensor (HO2S) activity for 90 seconds after "closed loop" and stoichiometric operation have been enabled. During this test period the PCM counts the number of times that the HO2S signal voltage crosses the rich-to-lean and lean-to-rich thresholds. If the PCM determines that the HO2S did not switch enough times, DTC P1153 will be set.

A lean-to-rich switch is determined when the HO2S voltage changes above and below 450 mV.

Heated oxygen sensors are used to minimize the amount of time required for "closed loop" fuel control operation and to allow accurate catalyst monitoring. The oxygen sensor heater greatly decreases the amount of time required for fuel control sensors Bank 1 HO2S 1 and Bank 2 HO2S 1 to become active. Oxygen sensor heaters are required by post-catalyst monitor sensors to maintain a sufficiently high temperature for accurate exhaust oxygen content readings further from the engine.

### Conditions for Setting the DTC

- The engine is operating in "closed loop."
- Engine coolant temperature (ECT) is above 50°C (122°F).
- The engine has been running at least one minute.
- Canister purge duty cycle is greater than 2%.
- Engine speed is between 1500 RPM and 3000 RPM.

- Mass air flow is between 9 g/second and 42 g/second.
- Above conditions are present for a 3 seconds.
- 90 seconds after "closed loop" and stoichiometric operation have been enabled, the PCM monitors the oxygen sensor switching above and below 450 mV. If fewer than 27 rich-to-lean and lean-to-rich switches for Bank 2 HO2S 1 are detected, DTC P1153 will set.

### Action Taken When the DTC Sets

- The PCM will illuminate the malfunction indicator lamp (MIL) after the second consecutive trip in which the fault is detected.
- "Open loop" fuel control will be in effect.
- The PCM will store conditions which were present when the DTC was set as Freeze Frame and in the Failure Records data.

### Conditions for Clearing the MIL/DTC

- The PCM will turn the MIL "OFF" on the third consecutive trip cycle during which the diagnostic has been run and the fault condition is no longer present.
- A history DTC P1153 will clear after 40 consecutive warm-up cycles have occurred without a fault.
- DTC P1153 can be cleared by using the Tech 2 "Clear Info" function or by disconnecting the PCM battery feed.

D06RX082

**Diagnostic Aids**

A malfunction in the HO2S heater ignition feed or ground circuit may cause a DTC P1153 to set. Check HO2S heater circuitry for intermittent faults or poor connections. If connections and wiring are OK and DTC P1153 continues to set, replace the Bank 2 HO2S 1. Reviewing the Failure Records vehicle mileage since the diagnostic test last failed may help determine how often the condition that caused the DTC to be set occurs. This may assist in diagnosing the condition.

**Test Description**

Number(s) below refer to the step number(s) on the Diagnostic Chart.

3. A condition that affects other heated oxygen sensors indicates probable contamination. To avoid damaging replacement sensors, correct the condition which caused the contamination before replacing the affected sensors.
5. This step checks for conditions which may cause the heated oxygen sensor to appear faulty. Correct any of the described conditions if present.
8. To avoid damaging replacement sensors, correct the condition which caused the contamination before replacing the affected sensors.

**DTC P1153 – HO2S Insufficient Switching Bank 2 Sensor 1**

Step	Action	Value(s)	Yes	No
1	Was the "On-Board Diagnostic (OBD) System Check" performed?	—	Go to Step 2	Go to <i>OBD System Check</i>
2	<b>IMPORTANT:</b> If any DTCs are set, (except P1133 and/or P1134), refer to those DTCs before proceeding with this diagnostic chart. 1. Idle the engine at operating temperature. 2. Operate the vehicle within parameters specified under "Conditions for Setting the DTC" criteria included in Diagnostic Support. 3. Using a Tech 2, monitor "DTC" info for DTC P1153 until the DTC P1153 test runs. Note the test result. Does Tech 2 indicate DTC failed this ignition?	—	Go to Step 3	Refer to <i>Diagnostic Aids</i>
3	Did the Tech 2 also indicate P1133 and/or P1134 test failed?	—	Go to Step 20	Go to Step 4
4	Check for leaks at the exhaust pipe joints. Are the joints leaking?	—	Go to Step 5	Go to Step 6
5	Tighten the U-bolt nuts at the leaking joints. Is your action complete?	—	Go to Step 2	—
6	Check for gaskets that are damaged or improperly installed. Are there damaged or misaligned gaskets?	—	Go to Step 7	Go to Step 8
7	1. Replace the damaged gaskets. 2. Align the connections. 3. Tighten the connections. Is your action complete?	—	Go to Step 2	—
8	Check for loose exhaust flange connections. Are the flange connections loose?	—	Go to Step 9	Go to Step 10
9	Tighten the stud nuts or bolts to specifications. Is your action complete?	—	Go to Step 2	—
10	Check for burned or corroded exhaust pipes. Are the exhaust pipes burned or corroded?	—	Go to Step 11	Go to Step 12

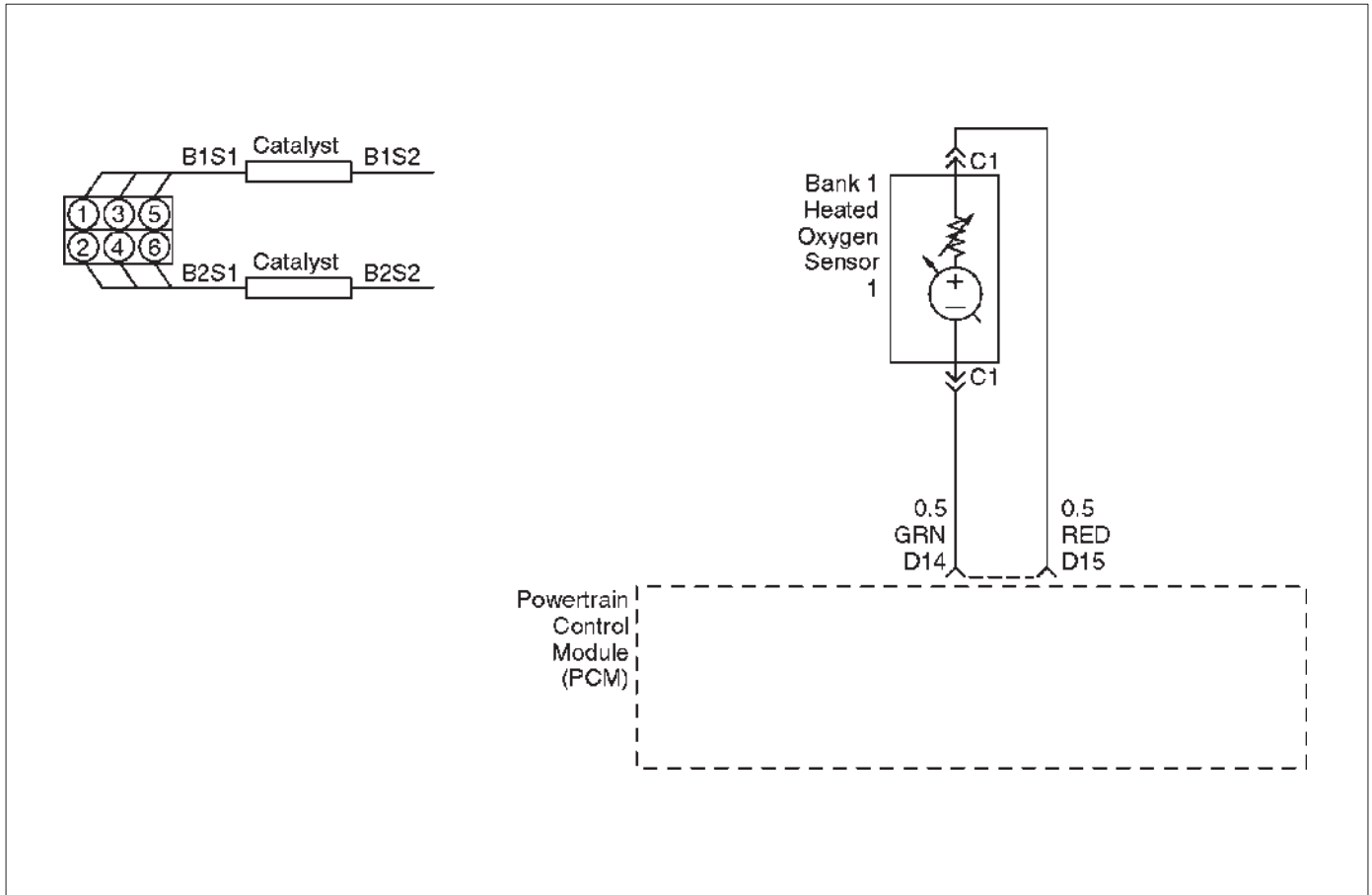
**DTC P1153 – HO2S Insufficient Switching Bank 2 Sensor 1 (Cont'd)**

Step	Action	Value(s)	Yes	No
11	Replace the exhaust pipes, as required. Is your action complete?	—	Go to <i>Step 2</i>	—
12	Check for leaks at the exhaust manifold. Are there leaks at the exhaust manifold?	—	Go to <i>Step 13</i>	Go to <i>Step 14</i>
13	Tighten the bolts to specifications or replace the manifold if necessary. Is your action complete?	—	Go to <i>Step 2</i>	—
14	Visually/physically inspect the following items: <input type="radio"/> Ensure that the Bank 2 HO2S 1 is securely installed. <input type="radio"/> Check for corrosion on terminals. <input type="radio"/> Check the terminal tension at Bank 2 HO2S 1 and at the PCM. <input type="radio"/> Check for damaged wiring. Was a problem found in any of the above areas?	—	Verify repair	Go to <i>Step 15</i>
15	1. Disconnect Bank 2 HO2S 1. 2. Ignition "ON." 3. Using a DVM at the PCM side of the connector, check the voltage between the high signal circuit and ground. Also measure between the low signal circuit and ground. Are both voltages in the specified range?	3-4V	Go to <i>Step 18</i>	Go to <i>Step 16</i>
16	1. Ignition "ON." 2. Check for damage to PCM pins or terminals. Was a problem found?	—	Verify repair	Go to <i>Step 17</i>
17	Check for short to voltage or ground or an open in the signal circuit. Was a problem found?	—	Verify repair	Go to <i>Step 18</i>
18	1. Ignition "OFF." 2. Disconnect the PCM connector. 3. With HO2S disconnected, check for high and low signal circuits shorted together between the PCM and HO2S. Was a problem found?	—	Verify repair	Go to <i>Step 19</i>
19	With the PCM connected and Bank 2 HO2S 1 disconnected from the harness, check Bank 2 HO2S 1 with a Tech 2. Is the voltage in the specified range?	425-475 mV	Go to <i>Step 21</i>	Go to <i>Step 22</i>
20	Replace affected heated oxygen sensors. NOTE: Before replacing sensors, the cause of the contamination must be determined and corrected. <input type="radio"/> Fuel contamination. <input type="radio"/> Use of improper RTV sealant. <input type="radio"/> Engine oil/coolant consumption. Is the action complete?	—	Verify repair	—

**DTC P1153 – HO2S Insufficient Switching Bank 2 Sensor 1 (Cont'd)**

Step	Action	Value(s)	Yes	No
21	Replace Bank 2 HO2S 1. Is the action complete?	—	Verify repair	—
22	Replace the PCM. <b>IMPORTANT:</b> The replacement PCM must be programmed. Refer to <i>On-Vehicle Service</i> in <i>Powertrain Control Module and Sensors</i> for procedures. And also refer to latest Service Bulletin. Check to see if the Latest software is released or not. And then Down Load the LATEST PROGRAMMED SOFTWARE to the replacement PCM. Is the action complete?	—	Verify repair	—

## Diagnostic Trouble Code (DTC) P1154 HO2S Circuit Transition Time Ratio Bank 2 Sensor 1



### Circuit Description

The powertrain control module (PCM) monitors the heated oxygen sensor (HO2S) activity for 90 seconds after “closed loop” and stoichiometric operation have been enabled. During the monitor period the PCM counts the number of times that the HO2S responds from rich-to-lean and from lean-to-rich and adds the amount of time it took to complete all transitions. With this information, an average time for all transitions can be determined. The PCM then divides the rich-to-lean average by the lean-to-rich average to obtain a ratio. If the HO2S transition time ratio is not within this range, DTC P1154 will be set, indicating that the oxygen sensor is not responding as expected to changes in exhaust oxygen content.

### Conditions for Setting the DTC

- No related DTCs.
- Engine coolant temperature (ETC) is above 50°C (122°F).
- The engine is operating in “closed loop.”
- The engine has been running at least one minute.
- Canister purge duty cycle is greater than 2%.
- Engine speed is between 1500 RPM and 3000 RPM.
- Mass air flow is between 9 g/second and 42 g/second.
- Above conditions are present for a 3-second monitoring period.

- 90 seconds after “closed loop” and stoichiometric operation have been enabled, Bank 2 HO2S 1 transition ratio between lean to rich and rich to lean is less than 0.44 or greater than 3.8.

### Action Taken When the DTC Sets

- The PCM will illuminate the malfunction indicator lamp (MIL) after the second consecutive trip in which the fault is detected.
- “Open loop” fuel control will be in effect.
- The PCM will store conditions which were present when the DTC was set as Freeze Frame and in the Failure Records data.

### Conditions for Clearing the MIL/DTC

- The PCM will turn the MIL “OFF” on the third consecutive trip cycle during which the diagnostic has been run and the fault condition is no longer present.
- A history DTC P1154 will clear after 40 consecutive warm-up cycles have occurred without a fault.
- DTC P1154 can be cleared by using the Tech 2 “Clear Info” function or by disconnecting the PCM battery feed.

### Diagnostic Aids

A multifunction in the HO2S heater ignition feed or ground circuit may cause a DTC P1154 to set. Check HO2S heater circuitry for intermittent faults or poor connections.

## 6E-382 6VE1 3.5L ENGINE DRIVEABILITY AND EMISSIONS

If connections and wiring are OK and DTC P1154 continues to set, replace the Bank 2 HO2S 1. Reviewing the Failure Records vehicle mileage since the diagnostic test last failed may help determine how often the condition that caused the DTC to be set occurs. This may assist in diagnosing the condition.

### Test Description

Number(s) below refer to the step number(s) on the Diagnostic Chart.

3. A condition that affects other heated oxygen sensors indicates probable contamination. To avoid damaging replacement sensors, correct the condition which caused the contamination before replacing the affected sensors.
5. This step checks for conditions which may cause the heated oxygen sensor to appear faulty. Correct any of the described conditions if present.
8. To avoid damaging replacement sensors, correct the condition which caused the contamination before replacing the affected sensors.

### DTC P1154 – HO2S Transition Time Ratio Bank 2 Sensor 1

Step	Action	Value(s)	Yes	No
1	Was the "On-Board Diagnostic (OBD) System Check" performed?	—	Go to Step 2	Go to <i>OBD System Check</i>
2	<b>IMPORTANT:</b> If any other DTCs are set (except P1133 and/or P1134), refer to those DTCs before proceeding with this diagnostic chart. 1. Idle the engine at operating temperature. 2. Operate the vehicle within parameters specified under "Conditions for Setting the DTC" criteria included in Diagnostic Support. 3. Using a Tech 2, monitor "DTC" info for DTC P1154 until the DTC P1154 test runs. Note the test result. Does Tech 2 indicate DTC failed this ignition?	—	Go to Step 3	Refer to <i>Diagnostic Aids</i>
3	Did the Tech 2 also indicate P1133, and/or P1134 test failed?	—	Go to Step 17	Go to Step 4
4	Check for leaks at the exhaust pipe joints. Are the joints leaking?	—	Go to Step 5	Go to Step 6
5	Tighten the U-bolt nuts at the leaking joints. Is your action complete?	—	Go to Step 2	—
6	Check for gaskets that are damaged or improperly installed. Are there damaged or misaligned gaskets?	—	Go to Step 7	Go to Step 8
7	1. Replace the damaged gaskets. 2. Align the connections. 3. Tighten the connections. Is your action complete?	—	Go to Step 2	—
8	Check for loose exhaust flange connections. Are the flange connections loose?	—	Go to Step 9	Go to Step 10
9	Tighten the stud nuts or bolts to specifications. Is your action complete?	—	Go to Step 2	—
10	Check for burned or corroded exhaust pipes. Are the exhaust pipes burned or corroded?	—	Go to Step 11	Go to Step 12
11	Replace the exhaust pipes, as required. Is your action complete?	—	Go to Step 2	—

**DTC P1154 – HO2S Transition Time Ratio Bank 2 Sensor 1 (Cont'd)**

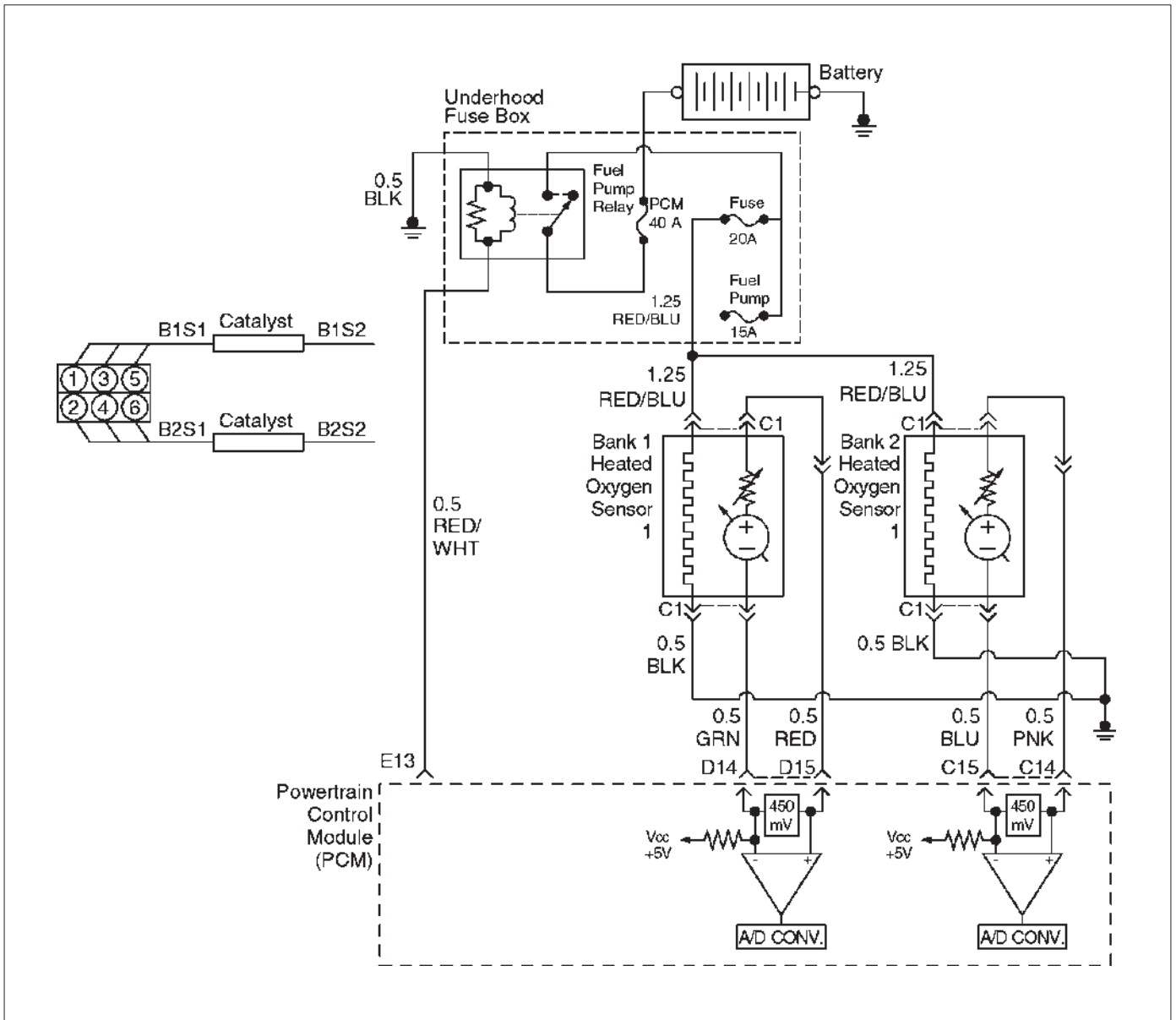
Step	Action	Value(s)	Yes	No
12	Check for leaks at the exhaust manifold. Are there leaks at the exhaust manifold?	—	Go to <i>Step 13</i>	Go to <i>Step 14</i>
13	Tighten the bolts to specifications or replace the manifold if necessary. Is your action complete?	—	Go to <i>Step 2</i>	—
14	Visually/physically inspect the following items: <ul style="list-style-type: none"> <li><input type="radio"/> Ensure that the Bank 2 HO2S 1 is securely installed.</li> <li><input type="radio"/> Check for corrosion on terminals.</li> <li><input type="radio"/> Check terminal tension (at Bank 2 HO2S 1 and at the PCM).</li> <li><input type="radio"/> Check for damaged wiring.</li> </ul> Was a problem found in any of the above areas?	—	Go to <i>Step 18</i>	Go to <i>Step 15</i>
15	1. Disconnect Bank 2 HO2S 1. 2. Ignition "ON." 3. Using a DVM at the PCM side of the HO2S 1 connector, measure the voltage between the high signal circuit and ground. Also measure the voltage between the low signal circuit and ground. Are both voltages in the specified range?	3-4 V	Go to <i>Step 16</i>	Go to <i>Step 19</i>
16	1. With Bank 2 HO2S 1 disconnected, jumper the high and low (PCM side) signal circuits to ground. 2. Ignition "ON." 3. Using a Tech 2, monitor the Bank 2 HO2S 1 voltage. Does the Tech 2 indicate less than 10 mV and immediately return to about 450 mV when the jumper is removed?	—	Go to <i>Step 21</i>	Go to <i>Step 22</i>
17	Replace affected heated oxygen sensors. NOTE: Before replacing sensors, the cause of the contamination must be determined and corrected. <ul style="list-style-type: none"> <li><input type="radio"/> Fuel contamination.</li> <li><input type="radio"/> Use of improper RTV sealant.</li> <li><input type="radio"/> Engine oil/coolant consumption.</li> </ul> Is the action complete?	—	Verify repair	—
18	Repair condition as necessary. Is the action complete?	—	Verify repair	—
19	Check for faulty PCM connections or terminal damage. Is the action complete?	—	Verify repair	Go to <i>Step 20</i>
20	Repair open, short or grounded signal circuit. Is the action complete?	—	Verify repair	—



## DTC P1154 – HO2S Transition Time Ratio Bank 2 Sensor 1 (Cont'd)

Step	Action	Value(s)	Yes	No
21	Replace Bank 2 HO2S 1. Is the action complete?	—	Verify repair	—
22	Replace the PCM. <b>IMPORTANT:</b> The replacement PCM must be programmed. Refer to <i>On-Vehicle Service</i> in <i>Powertrain Control Module and Sensors</i> for procedures. And also refer to latest Service Bulletin. Check to see if the Latest software is released or not. And then Down Load the LATEST PROGRAMMED SOFTWARE to the replacement PCM. Is the action complete?	—	Verify repair	—

**Diagnostic Trouble Code (DTC) P1171 Fuel System Lean During Acceleration**



**Circuit Description**

The powertrain control module (PCM) internal circuitry can identify if the vehicle fuel system is capable of supplying adequate amounts of fuel during heavy acceleration (power enrichment). The PCM monitors the voltage of the oxygen sensor during power enrichment. When a power enrichment mode of operation is requested during “closed loop” operation (by heavy acceleration), the PCM will provide more fuel to the engine. Under these conditions the PCM should detect a “rich” condition (high oxygen sensor voltage). If this “rich” exhaust is not detected at this time, a DTC P1171 will set. A plugged fuel filter, restricted fuel line, restricted in-tank filter or defective fuel pump can prevent adequate amounts of fuel from being supplied during power enrichment mode.

**Conditions for Setting the DTC**

- No related DTCs.

- Engine is operating in “closed loop power enrichment” mode for 3 seconds.
- Engine coolant temperature is above 60°C (140°F).
- While in “power enrichment” mode the oxygen sensor voltage remains below 400 mV for 3 seconds.

**Action Taken When the DTC Sets**

- The PCM will illuminate the malfunction indicator lamp (MIL) the first the fault is detected.
- The PCM will store conditions which were present when the DTC was set as Freeze Frame and in the Failure Records data.

**Conditions for Clearing the MIL/DTC**

- The PCM will turn the MIL “OFF” on the third consecutive trip cycle during which the diagnostic has been run and the fault condition is no longer present.
- A history DTC P1171 will clear after 40 consecutive warm-up cycles have occurred without a fault.

- DTC P1171 can be cleared by using the Tech 2 “Clear Info” function or by disconnecting the PCM battery feed.

### **Diagnostic Aids**

- A restricted fuel filter or fuel line, restricted in-tank filter, or a defective fuel pump may supply adequate amounts of fuel at idle, but may not be able to supply enough fuel during heavy acceleration.
- Water or alcohol in the fuel may cause low HO2S voltage during acceleration.
- Check for faulty or plugged fuel injector(s).
- Check for low fuel.

### **Test Description**

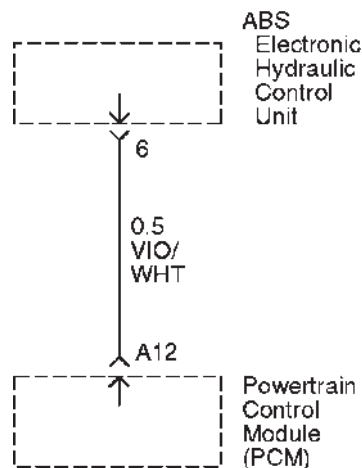
Number(s) below refer to the step number(s) on the Diagnostic Chart.

4. When the engine is idling or at steady cruise, the HO2S voltage should vary from between approximately 100 mV to 900 mV. It is possible to measure a satisfactory fuel pressure at idle even though the pressure may drop at high flow requirements. It may be necessary to watch fuel pressure at high engine load.
5. Wrap a shop towel around the fuel pressure connector to absorb any small amount of fuel leakage that may occur when installing gauge. Ignition “ON,” pump pressure should be 280-320 kpa.
7. Add Caution, Use correct pliers so damage to fuel lines will not occur.

**DTC P1171 – Fuel System Lean During Acceleration**

Step	Action	Value(s)	Yes	No
1	Was the "On-Board Diagnostic (OBD) System Check" performed?	—	Go to <i>Step 2</i>	Go to <i>OBD System Check</i>
2	Are any component-related DTCs set?	—	Go to component DTC charts	Go to <i>Step 3</i>
3	1. Check the vehicle's fuel tank for an adequate amount of fuel. 2. Add fuel to the vehicle's fuel tank if the tank is almost empty. Was fuel added to the vehicle's fuel tank?	—	Go to <i>Step 4</i>	Go to <i>Step 5</i>
4	1. Place the transmission in park. 2. Using a Tech 2, observe HO2S 1 voltage while running warm engine 75°C-95°C (167°F-203°F) at 1200 RPM. 3. HO2S 1 voltage should vary within the specified range. 4. Quickly open the throttle halfway for a few seconds. Did the voltage suddenly rise toward the high end of the specified range?	100-900 mV	Go to <i>Fuel System Electrical Test</i>	Go to <i>Step 5</i>
5	1. Disconnect the fuel pump relay and crank the engine to relieve the fuel pressure. 2. Install the fuel pressure gauge. 3. Start the engine and idle at normal operating temperature. 4. Disconnect the vacuum line going to the fuel pressure regulator. With the engine running, is the fuel pressure within the specified range?	280-325 kpa (41-46 psi)	Go to <i>OBD System Check</i>	Go to <i>Step 6</i>
6	Check for restricted fuel lines or restricted in-line filter. Was a problem found?	—	Verify repair	Go to <i>Step 7</i>
7	1. Ignition "OFF." 2. Remove the fuel pump relay and replace it with a fused jumper which will connect the relay's battery terminal to the terminal leading to the fuel pump fuse. 3. While the fuel pump is operating, use pliers to slowly close the return line (do not exceed the first specified value). Using the pliers to restrict the return line, can the fuel pressure be manipulated to exceed the second specified value?	414 kpa (60 psi) 325 kpa (46 psi)	Go to <i>Diagnostic Aids</i>	Go to <i>Step 8</i>
8	Check for: <input type="radio"/> Faulty fuel pump <input type="radio"/> Restricted fuel pump strainer (sock) <input type="radio"/> Incorrect fuel pump <input type="radio"/> Incorrect fuel being used <input type="radio"/> Hot fuel Is the action complete?	—	Verify repair	—

## Diagnostic Trouble Code (DTC) P1380 ABS Rough Road ABS System Fault



D06RX144

### Circuit Description

The powertrain control module (PCM) monitors ABS fault signal. When PCM receives fault signal, PCM will set DTC P1380.

### Conditions for Setting the DTC

- Vehicle speed is more than 5 mph.
- Load is less than 99%.
- Engine revolution is less than 6250 rpm.
- PCM receives ABS fault signals from ABS unit.
- Ignition on.
- Misfire DTCs exist.
- 100 test failures within 120 test samples.

### Action Taken When the DTC Sets

- The PCM will store DTC 1380 only, no MIL turn on.

### Conditions for Clearing the MIL/DTC

- A history DTC P1380 will clear after 40 consecutive warm-up cycles have occurred without a fault.
- DTC 1380 can be cleared by using Tech-2 or disconnecting the PCM battery feed.

### Diagnostic Aids

Check for the following conditions:

- PCM and ABS communication line short circuit to other line may cause faulty signal. Inspect communication line.
- Follow ABS ECU diagnosis procedure, refer to ABS procedure page.

### DTC P1380 – ABS Rough Road ABS System Fault

Step	Action	Value(s)	Yes	No
1	Was the "On-Board Diagnostic (OBD) System Check" performed?	—	Go to <i>Step 2</i>	Go to <i>OBD System Check</i>
2	<p>1. Ignition "ON," engine "OFF", review and record Tech 2 Failure Records Data.</p> <p>2. Operate the vehicle within Failure Records conditions as noted.</p> <p>3. Using a Tech 2, monitor "DTC" info for DTC P1380 and Misfire DTCs until the DTC P1380 and Misfire DTCs test runs. Note the result.</p> <p>Does the Tech 2 indicates DTC P1380 and Misfire DTCs failed this ignition?</p>	—	Refer to ABS diagnosis After inspecting ABS unit repeat <i>Step 2</i> If problem still exists, go to <i>Step 3</i>	Clear DTC by Tech 2
3	<p>Check short circuit among communication line of PCM/ABS and others.</p> <p>Does short circuit exist?</p>	—	Repair wiring Verify repair	Go to <i>Step 4</i>
4	<p>Replace the PCM.</p> <p><b>IMPORTANT:</b> The replacement PCM must be programmed. Refer to <i>On-Vehicle Service in Powertrain Control Module and Sensors</i> for procedures.</p> <p>And also refer to latest Service Bulletin.</p> <p>Check to see if the Latest software is released or not. And then Down Load the LATEST PROGRAMMED SOFTWARE to the replacement PCM.</p> <p>Is the action complete?</p>	—	Verify repair	—

## Diagnostic Trouble Code (DTC) P1381 ABS Rough Road Class 2 Serial Link Error

### Circuit Description

The powertrain control module (PCM) monitors no ABS signal. When PCM does not receive ABS signal, PCM will set DTC P1381.

### Conditions for Setting the DTC

- PCM does not receive ABS signals from ABS ECU.
- Vehicle speed is more than 0 mph.
- Load is less than 99%.
- Engine revolution is less than 6250rpm.
- 2.5 second after key on.
- Misfire DTCs exist.
- 100 test failures within 120 test samples.

### Action Taken When the DTC Sets

- The PCM will store DTC 1381 only, no MIL turn on.

### Conditions for Clearing the MIL/DTC

- A history code DTC P1381 will clear after 40 consecutive warm-up cycles have occurred without a fault.
- DTC P1381 can be cleared by Tech-2 or by disconnecting the PCM battery feed.

### Diagnostic Aids

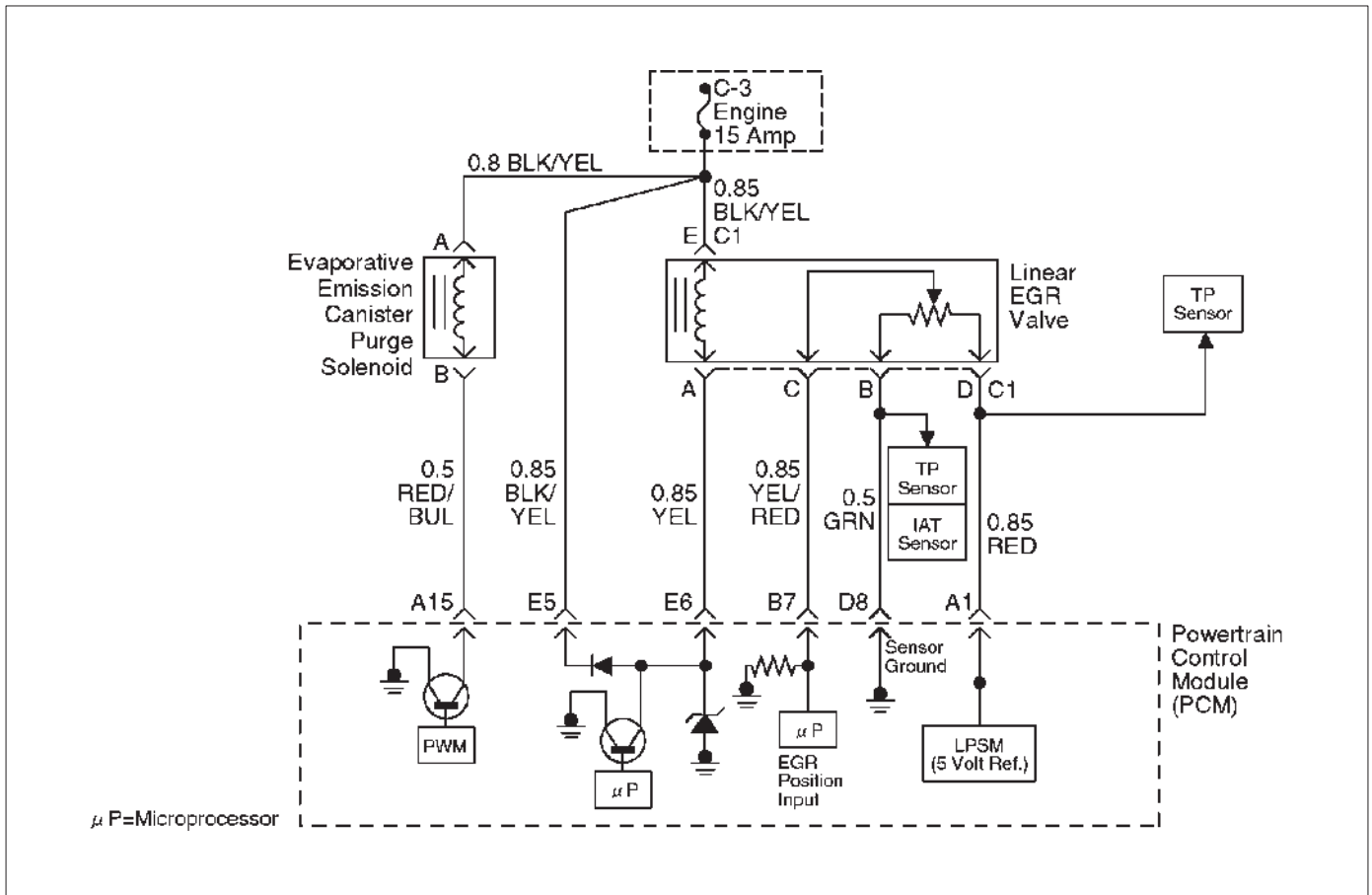
Check for the following conditions:

- Inspect open circuit of communication wire between ABS ECU and PCM.
  - Follow ABS ECU diagnosis procedure.
- Reviewing the Failure Records vehicle mileage since the diagnostic test last failed may help determine how often the condition that caused the DTC to be set occurs. This may assist in diagnosing the condition.

## DTC P1381 – ABS Rough Road Class 2 Serial Link Error

Step	Action	Value(s)	Yes	No
1	Was the "On-Board Diagnostic (OBD) System Check" performed?	—	Go to <i>Step 2</i>	Go to <i>OBD System Check</i>
2	1. Ignition "ON," engine "OFF", review and record Tech 2 Failure Records Data. 2. Operate the vehicle within Failure Records conditions as noted. 3. Using a Tech 2, monitor "DTC inf. for DTC P1381 and Misfire DTCs until the DTC P1381 and Misfire DTCs test runs. Note the result. Does the Tech 2 indicates DTC P1381 and Misfire DTCs failed this ignition?	—	Refer to ABS diagnosis After inspecting ABS, repeat <i>Step 2</i> If problem still exists, go to <i>Step 3</i>	Clear DTC by Tech 2
3	Check open circuit among communication line of PCM/ABS and others. Does short circuit exists?	—	Repair wiring Verify repair	Go to <i>Step 4</i>
4	Replace the PCM. <b>IMPORTANT:</b> The replacement PCM must be programmed. Refer to <i>On-Vehicle Service in Powertrain Control Module and Sensors</i> for procedures. And also refer to latest Service Bulletin. Check to see if the Latest software is released or not. And then Down Load the LATEST PROGRAMMED SOFTWARE to the replacement PCM. Is the action complete?	—	Verify repair	—

## Diagnostic Trouble Code (DTC) P1404 EGR Stuck Closed



D06RX075

### Circuit Description

The powertrain control module (PCM) monitors the EGR valve pintle position input to ensure that the valve responds properly to commands from the PCM, and to detect a fault if current pintle zero position is different from the learned zero position. If the PCM detects a pintle position signal indicates more than 30 % different between current zero position and the learned zero position for more than 5 seconds, and this condition exists 3 times during trip, then the PCM will set DTC P1404.

### Conditions for Setting the DTC

- Ignition voltage is between 11 and 16 volts.
- Intake Air temp is more than 3°C.
- Desired EGR position is 0.
- Difference of EGR pintle position between current and the learned zero is more than 30 % for more than 5 seconds, and exists three time to the above condition during a trip the PCM will set DTC 1404. Then it trigger the PCM lights on.

### Action Taken When the DTC Sets

- The PCM will illuminate the malfunction indicator lamp (MIL) after consecutive 2nd trip in which the fault is detected.
- The PCM will store conditions which were present when the DTC was set as Freeze Frame and in Failure Records data.

### Conditions for Clearing the MIL/DTC

- The PCM will turn the MIL “OFF” on the third consecutive trip cycle during which the diagnostic has been run and the fault condition is no longer present.
- A history DTC P1404 will clear after 40 consecutive warm-up cycles have occurred without a fault.
- DTC P1404 can be cleared by using the Tech 2 “Clear Info” function or by disconnecting the PCM battery feed.

### Diagnostic Aids

Check for the following conditions:

- Excessive carbon deposit on EGR valve shaft and/or foreign material may cause the EGR valve not to fully seated. The carbon deposit may occur by unusual port operation. Remove foreign material and/or excessive carbon deposit on EGR valve shaft and may allow the EGR valve to be fully seated.
- Poor connection or damaged harness – Inspect the wiring harness for damage.

Reviewing the Failure Records vehicle mileage since the diagnostic test last failed may help determine how often the condition that caused the DTC to be set occurs. This may assist in diagnosing the condition.



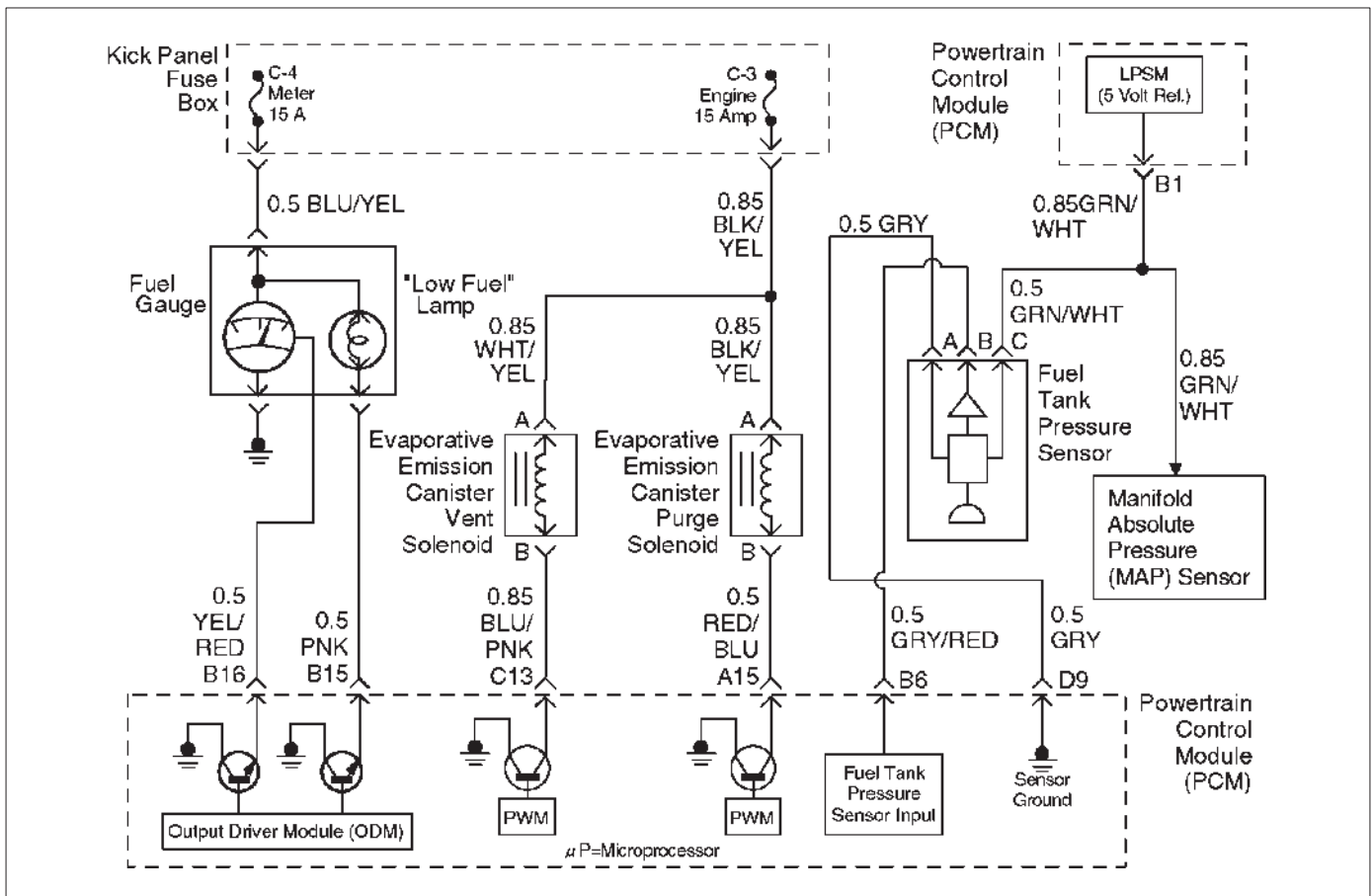
**DTC P1404 – EGR Stuck Closed**

Step	Action	Value(s)	Yes	No
1	Was the "On-Board Diagnostic (OBD) System Check" performed?	—	Go to Step 2	Go to <i>OBD System Check</i>
2	1. Ignition "ON," engine "OFF", review and record Tech 2 Failure Records Data. 2. Operate the vehicle within Failure Records conditions as noted. 3. Using a Tech 2, monitor "DTC inf. for DTC P1404 until the DTC P1404 test runs. Note the result. Does the Tech 2 indicates DTC P1404 failed this ignition?	—	Go to Step 3	Refer to <i>Diagnostic Aids</i>
3	1. Disconnect the EGR valve harness connector. 2. Inspect the EGR valve and connectors for damaged pin or terminals. Were there any damaged pins or terminals?	—	Go to Step 4	Go to Step 5
4	Repair the damaged pin or terminal. Is the action complete?	—	Verify repair	—
5	1. Remove EGR valve from Engine. 2. Inspect EGR valve for any excessive carbon deposit on EGR shaft. 3. Inspect for any foreign material inside of EGR valve. Was excessive carbon deposit on EGR valve shaft and/or foreign material in EGR valve ?	—	Go to Step 6	Go to Step 7
6	1. Clean up EGR valve shaft and inside of EGR valve. 2. Remove foreign material from EGR valve. 3. Visually inspect damage of pintle and seat to see if it is bent. If damaged leakage may occur. Was there any severe damage which affects function?	—	Go to Step 8	Verify repair Go to Step 7
7	1. Install the EGR valve. 2. Ignition "OFF". 3. Install the Tech 2. 4. Run the engine at idle. 5. On the Tech 2, select EGR Control Test. 6. Use the "UP" arrow to increase the EGR from 0% to 40%. Did EGR work properly?	—	—	Go to Step 8
8	1. Reset the learned zero EGR valve position. 2. Repeat step 7. Did EGR work properly?	—	Verify repair	Go to Step 9

**DTC P1404 – EGR Stuck Closed (Cont'd)**

Step	Action	Value(s)	Yes	No
9	Replace the EGR valve. Does DTC P1404 still fail "DTC" test on the Tech 2?	—	Go to <i>Step 10</i>	Verify repair
10	Replace the PCM. <b>IMPORTANT:</b> The replacement PCM must be programmed. Refer to <i>On-Vehicle Service</i> in <i>Powertrain Control Module and Sensors</i> for procedures. And also refer to latest Service Bulletin. Check to see if the Latest software is released or not. And then Down Load the LATEST PROGRAMMED SOFTWARE to the replacement PCM. Is the action complete?	—	Verify repair	—

## Diagnostic Trouble Code (DTC) P1441 EVAP System Flow During Non-Purge



D06RX143

## Circuit Description

Canister purge is controlled by a solenoid valve that allows manifold vacuum to purge the canister. The powertrain control module (PCM) supplies a ground to energize the solenoid valve (purge "ON"). The EVAP purge solenoid control is pulse-width modulated (PWM) or turned "ON" and "OFF" several times a second. The duty cycle (pulse width) is determined by engine operating conditions including load, throttle position, coolant temperature and ambient temperature. The duty cycle is calculated by the PCM and the output is commanded when the appropriate conditions have been met.

## Conditions for Setting the DTC

- No active ECT sensor, IAT sensor, MAP sensor, or TP sensor DTCs set.
- BARO reading is above 85 kpa.
- Engine coolant temperature is below 70°C (158°F).
- Start-up intake air temperature (IAT) and start-up engine coolant temperature (ECT) are both above 5°C (41°F).
- The difference between start-up ECT and start-up IAT is less than 25°C (45°F).
- TP sensor indicates a throttle position above 12%.
- Battery voltage is between 11.5 volts and 16 volts.
- Engine speed is between 800 and 6,000 RPM.
- Canister purge duty cycle is below 3%.
- All conditions are present for at least 3 seconds.

## Action Taken When the DTC Sets

- The PCM will illuminate the malfunction indicator lamp (MIL) after the second consecutive trip in which the fault is detected.
- The PCM will store conditions which were present when the DTC was set as Freeze Frame and in the Failure Records data.

## Conditions for Clearing the MIL/DTC

- The PCM will turn the MIL "OFF" on the third consecutive trip cycle during which the diagnostic has been run and the fault condition is no longer present.
- A history DTC P1441 will clear after 40 consecutive warm-up cycles have occurred without a fault.
- DTC P1441 can be cleared by using the Tech 2 "Clear Info" function or by disconnecting the PCM battery feed.

## Diagnostic Aids

Check for the following conditions:

- Poor connection at PCM – Inspect harness connectors for backed-out terminals, improper mating, broken locks, improperly formed or damaged terminals, and poor terminal-to-wire connection.
- Damaged harness – Inspect the wiring harness for damage. If the harness appears to be OK, observe the EVAP vacuum switch display on the Tech 2 while moving connectors and wiring harnesses related to the sensor. A change in the display will indicate the location of the fault.

Reviewing the Failure Records vehicle mileage since the diagnostic test last failed may help determine how often the condition that caused the DTC to be set occurs. This may assist in diagnosing the condition.

**Test Description**

Number(s) below refer to the step number(s) on the Diagnostic Chart.

2. The canister purge vacuum switch is normally closed when no vacuum (purge) is present. With the ignition "ON" and the engine "OFF," there shouldn't be any vacuum (purge) present in the EVAP system.

- 3. Determines if the PCM is able to control the EVAP purge solenoid valve.
- 4. Determines if the DTC will set under the conditions present when the DTC was originally stored. If not, the fault is intermittent.
- 5. Checks for a grounded EVAP purge solenoid driver circuit, a faulty EVAP vacuum switch, or a leaking EVAP purge solenoid valve.

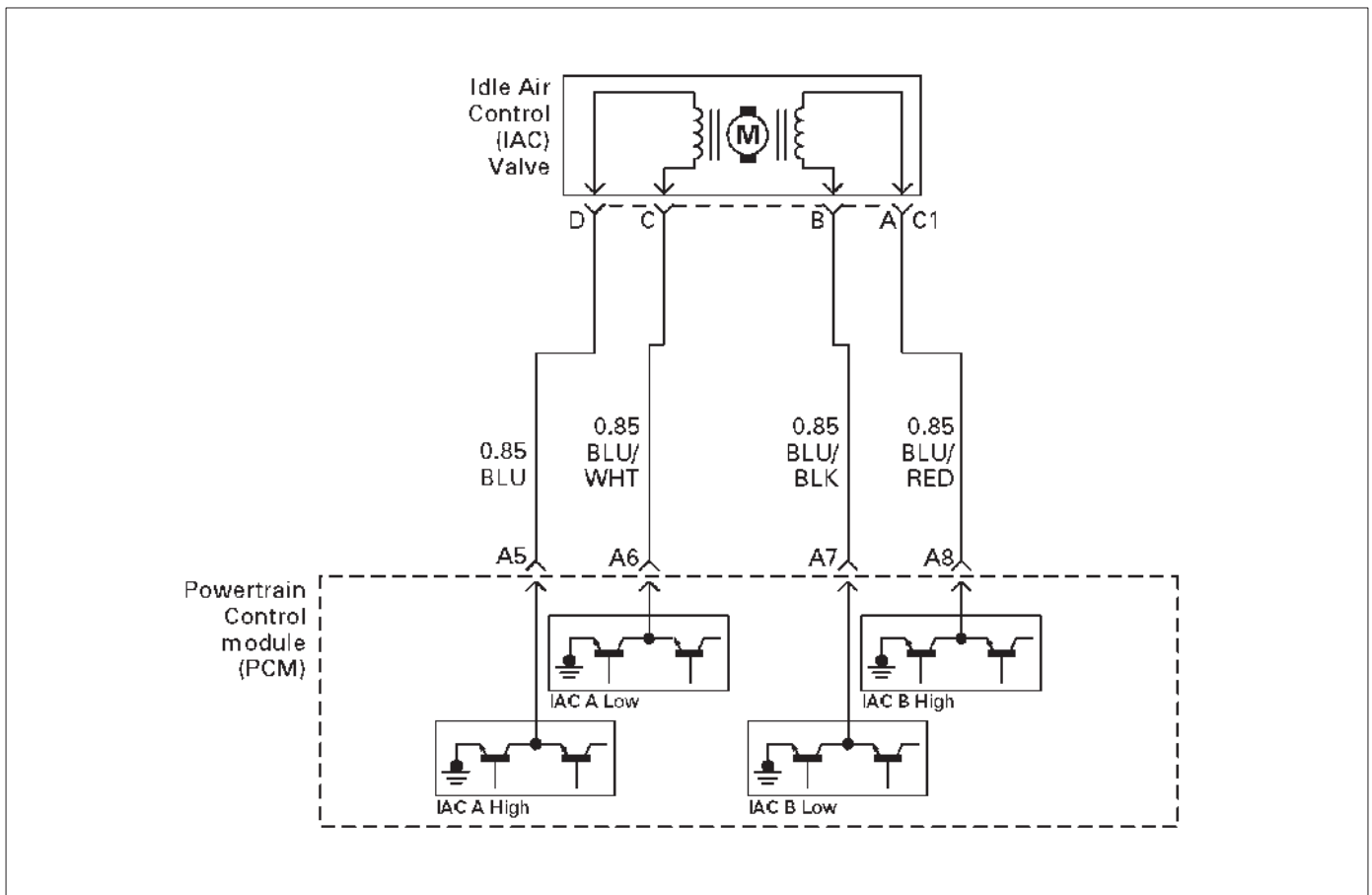
**DTC P1441 – EVAP System Flow During Non-Purge**

Step	Action	Value(s)	Yes	No
1	Was the "On-Board Diagnostic (OBD) System Check" performed?	—	Go to Step 2	Go to <i>OBD System Check</i>
2	1. Ignition "OFF." 2. Remove the fuel filler cap. 3. Ignition "ON." 4. Observe "Fuel Tank Pressure" on the Tech 2. Is "Fuel Tank Pressure" at the specified value?	1.51V	Go to Step 3	Go to <i>DTC P0452 or P0453</i>
3	1. Re-install the fuel filler cap. 2. Using the Tech 2, command the EVAP Vent Solenoid Valve "ON" (Closed). 3. Disconnect the canister side rubber hose end that hose is connected between the Purge Solenoid Valve and Canister. <b>IMPORTANT:</b> Before continuing with the diagnosis, zero the EVAP pressure/purge cart J41413 (refer to the tool operating instructions). And then monitor the fuel tank inner pressure using the Tech 2. Does the fuel tank pressure remain the specified value?	1.52 - 1.60V	Go to Step 4	Go to Step 6
4	1. Disconnect the EVAP pressure/purge cart J41413, and then plug the hose end. 2. Disconnect the rubber hose end of engine vacuum source side, (the hose connected between Purge Solenoid Valve and engine). 3. Connect the vacuum hand pump to this rubber hose end. 4. Then apply the -15 in H2O vacuum by the vacuum pump. 5. Monitor the fuel tank inner pressure using the Tech 2. Does the fuel tank inner pressure hold the specified value?	1.47 - 1.51V	Go to Step 6	Go to Step 5
5	Replace the Purge Solenoid Valve.	—	Verify Repair	—

**DTC P1441 – EVAP System Flow During Non-Purge (Cont'd)**

Step	Action	Value(s)	Yes	No
6	1. Check leaks, kinks or pinched hoses at the EVAP system rubber hose line, and also check if the rubber hoses are correctly connected or not. 2. Check for a leak from Vent Solenoid Valve and EVAP system rubber hoses, and also check for clogged Filter of air separator which is located near the vent solenoid valve.  Was a problem found? Using the Vacuum Hose Routing Diagram, repair or re-connect the rubber hoses correctly.	—	Verify Repair	Go to <i>Step 7</i>
7	1. Start engine. 2. Remove the Fuel Filler cap. 3. Using the Tech 2, command the EVAP Vent Solenoid Valve "ON" (closed) and Purge Solenoid Valve "OFF" (0%). 4. Replace the Fuel Filler Cap. 5. Run the engine at 2500RPM constant while monitoring "Fuel Tank Vacuum" on the Tech 2.  Does the fuel tank vacuum remain at the specified value while the EVAP Vent Solenoid Valve "ON" (closed) and Purge Solenoid Valve "OFF" (0%)?	30 - 40 %	Verify Repair	Go to <i>Diagnostic Aids</i>

## Diagnostic Trouble Code (DTC) P1508 IAC System Low RPM



T321115

### Circuit Description

The powertrain control module (PCM) controls engine idle speed by adjusting the position of the idle air control (IAC) motor pintle. The IAC is a bi-directional stepper motor driven by two coils. The PCM applies current to the IAC coils in steps (counts) to extend the IAC pintle into a passage in the throttle body to decrease air flow. The PCM reverses the current to retract the pintle, increasing air flow. This method allows highly accurate control of idle speed and quick response to changes in engine load. If the PCM detects a condition where too low of an idle speed is present and the PCM is unable to adjust idle speed by increasing the IAC counts, DTC P1508 will set, indicating a problem with the idle control system.

### Conditions for Setting the DTC

- No Tech 2 test is being run.
- None of these DTCs are set: TP sensor, VSS, ECT, EGR, fuel system, MAF, MAP, IAT, canister purge, injector control or ignition control.
- Barometric pressure is above 75 kpa.
- Engine coolant temperature (ECT) is above 50°C (120°F).
- Engine speed is more than 100-200 RPM lower than desired idle, based upon coolant temperature.
- The engine has been running for at least 125 seconds.
- Vehicle speed is less than 1 mph.
- Canister purge duty cycle is above 10%.
- Ignition voltage is between 9.5 volts and 16.7 volts.

- The throttle is closed.
- Engine speed is lower than desired idle.
- All of the above conditions are met for 10 seconds.

### Action Taken When the DTC Sets

- The PCM will illuminate the malfunction indicator lamp (MIL) after the second consecutive trip in which the fault is detected.
- The PCM will store conditions which were present when the DTC was set as Freeze Frame and in the Failure Records data.

### Conditions for Clearing the MIL/DTC

- The PCM will turn the MIL "OFF" on the third consecutive trip cycle during which the diagnostic has been run and the fault condition is no longer present.
- A history DTC P1508 will clear after 40 consecutive warm-up cycles have occurred without a fault.
- DTC P1508 can be cleared by using the Tech 2 "Clear Info" function or by disconnecting the PCM battery feed.

### Diagnostic Aids

Check for the following conditions:

- Poor connection at PCM or IAC motor – Inspect harness connectors for backed-out terminals, improper mating, broken locks, improperly formed or damaged terminals, and poor terminal-to-wire connection.
- Damaged harness – Inspect the wiring for damage.

## 6E-398 6VE1 3.5L ENGINE DRIVEABILITY AND EMISSIONS

- Restricted air intake system – Check for a possible collapsed air intake duct, restricted air filter element, or foreign objects blocking the air intake system.
- Throttle body – Check for objects blocking the IAC passage or throttle bore, excessive deposits in the IAC passage and on the IAC pintle, and excessive deposits in the throttle bore and on the throttle plate.
- Large vacuum leak – Check for a condition that causes a large vacuum leak, such as an incorrectly installed or

faulty PCV valve or a disconnected brake booster hose.

Reviewing the Failure Records vehicle mileage since the diagnostic test last failed may help determine how often the condition that caused the DTC to be set occurs. This may assist in diagnosing the condition.

### DTC P1508 – IAC System Low RPM

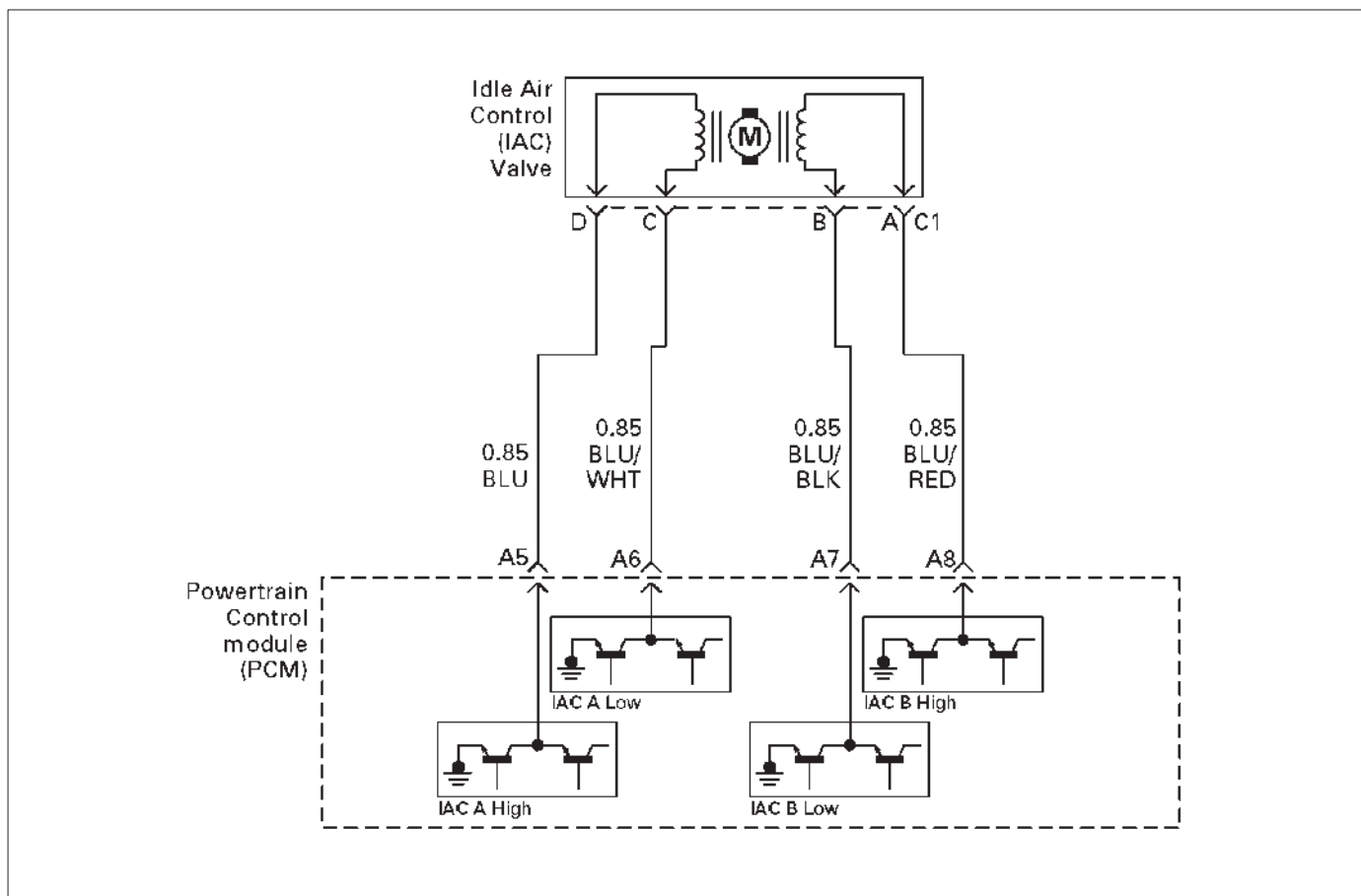
Step	Action	Value(s)	Yes	No
1	Was the "On-Board Diagnostic (OBD) System Check" performed?	—	Go to Step 2	Go to <i>OBD System Check</i>
2	<p>1. Start the engine.</p> <p>2. Turn all accessories "OFF"(A/C, rear defroster, etc).</p> <p>3. Using a Tech 2, command RPM up to 1500, down to 500, and then up to 1500 while monitoring the "Engine Speed" on the Tech 2.</p> <p>NOTE: This Tech 2 command may cause the engine to "cut out" when RPM goes above 1500. If this occurs, the "cutting out" will stop when the Tech 2 command for the test is discontinued, or if the Tech 2 command is changed to less than 1500 RPM.</p> <p>Does the "Engine Speed" remain within the specified value of the "Desired Idle" for each RPM command?</p>	± 50 RPM	No trouble found. Go to <i>Diagnostic Aids</i>	Go to Step 3
3	<p>1. Disconnect the IAC.</p> <p>2. Install IAC Noid Light J 37027 or equivalent.</p> <p>3. With the engine running, command RPM up to 1500, down to 500, and then up to 1500 while observing the Noid light.</p> <p>NOTE: This Tech 2 command may cause the engine to "cut out" when RPM goes above 1500. If this occurs, the "cutting out" will stop when the Tech 2 command for the test is discontinued, or if the Tech 2 command is changed to less than 1500 RPM.</p> <p>Does each Noid light cycle red and green (never "OFF")?</p>	—	Go to Step 5	Go to Step 4
4	<p>1. Check the following circuits for an open, short to voltage, short ground, or poor connections at the PCM:</p> <ul style="list-style-type: none"> <li>○ IAC "A" Low.</li> <li>○ IAC "A" High.</li> <li>○ IAC "B" Low.</li> <li>○ IAC "B" High.</li> </ul> <p>2. If a problem is found, repair as necessary,</p> <p>Was a problem found?</p>	—	Verify repair	Go to Step 8

**DTC P1508 – IAC System Low RPM (Cont'd)**

Step	Action	Value(s)	Yes	No
5	Visually/physically inspect for following conditions: <input type="radio"/> Restricted air intake system. Check for a possible collapsed air intake duct, restricted air filter element, or foreign objects blocking the air intake system. <input type="radio"/> Throttle body. Check for objects blocking the IAC passage or throttle bore, excessive deposits in the IAC passage and on the IAC pintle, and excessive deposits in the throttle bore and on the throttle plate. Do any of the above require a repair?	—	Refer to appropriate section for on-vehicle service	Go to Step 6
6	1. Check for a poor connection at the IAC harness connector. 2. If a problem is found, replace faulty terminals as necessary. Was a problem found?	—	Verify repair	Go to Step 7
7	Replace the IAC valve. Is the action complete?	—	Verify repair	—
8	Replace the PCM. <b>IMPORTANT:</b> The replacement PCM must be programmed. Refer to <i>On-Vehicle Service in Powertrain Control Module and Sensors</i> for procedures. And also refer to latest Service Bulletin. Check to see if the Latest software is released or not. And then Down Load the LATEST PROGRAMMED SOFTWARE to the replacement PCM. Is the action complete?	—	Verify repair	—



## Diagnostic Trouble Code (DTC) P1509 IAC System High RPM



T321115

### Circuit Description

The powertrain control module (PCM) controls engine idle speed by adjusting the position of the idle air control (IAC) motor pintle. The IAC is a bi-directional stepper motor driven by two coils. The PCM applies current to the IAC coils in steps (counts) to extend the IAC pintle into a passage in the throttle body to decrease air flow. The PCM reverses the current to retract the pintle, increasing air flow. This method allows highly accurate control of idle speed and quick response to changes in engine load. If the PCM detect a condition where too high of an idle speed is present and the PCM is unable to adjust idle speed by increasing the IAC counts, DTC P1509 will set, indicating a problem with the idle control system.

### Conditions for Setting the DTC

- No Tech 2 test is being run.
- None of these DTCs are set: TP sensor, VSS, ECT, EGR, fuel system, MAF, MAP, IAT, canister purge, injector control or ignition control.
- Barometric pressure is above 75 kpa.
- Engine coolant temperature is above 50°C (120°F).
- Engine speed is more than 100-200 RPM lower than desired idle, based upon coolant temperature.
- The engine has been running for at least 125 seconds.
- Vehicle speed is less than 1 mph.
- Canister purge duty cycle is above 10%.
- Ignition voltage is between 9.5 volts and 16.7 volts.
- Engine speed is lower than desired idle.

- All of the above conditions are met for 5 seconds.

### Action Taken When the DTC Sets

- The PCM will illuminate the malfunction indicator lamp (MIL) after the second consecutive trip in which the fault is detected.
- The PCM will store conditions which were present when the DTC was set as Freeze Frame and in the Failure Records data.

### Conditions for Clearing the MIL/DTC

- The PCM will turn the MIL "OFF" on the third consecutive trip cycle during which the diagnostic has been run and the fault condition is no longer present.
- A history DTC P1509 will clear after 40 consecutive warm-up cycles have occurred without a fault.
- DTC P1509 can be cleared by using the Tech 2 "Clear Info" function or by disconnecting the PCM battery feed.

### Diagnostic Aids

Check for the following conditions:

- Poor connection at PCM or IAC motor – Inspect harness connectors for backed-out terminals, improper mating, broken locks, improperly formed or damaged terminals, and poor terminal-to-wire connection.
- Damaged harness – Inspect the wiring for damage.
- Vacuum leak – Check for a condition that causes a vacuum leak, such as disconnected or damaged hoses, leaks at the EGR valve and the EGR pipe to the

intake manifold, leaks at the throttle body, faulty or incorrectly installed PCV valve, leaks at the intake manifold, etc.

- Throttle body – Check for sticking throttle plate. Also inspect the IAC passage for deposits or objects which keep the IAC pintle from fully extending.

Reviewing the Failure Records vehicle mileage since the diagnostic test last failed may help determine how often the condition that caused the DTC to be set occurs. This may assist in diagnosing the condition.

### DTC P1509 – IAC System High RPM

Step	Action	Value(s)	Yes	No
1	Was the “On-Board Diagnostic (OBD) System Check” performed?	—	Go to Step 2	Go to <i>OBD System Check</i>
2	<p>1. Start the engine.</p> <p>2. Turn all accessories “OFF” (A/C, rear defroster, etc.).</p> <p>3. Using a Tech 2, command RPM up to 1500, down to 500, and then up to 1500 while monitoring “Engine Speed” on the Tech 2.</p> <p>NOTE: This Tech 2 command may cause the engine to “cut out” when RPM goes above 1500. If this occurs, the “cutting out” will stop when the Tech 2 command for the test is discontinued, or if the Tech 2 command is changed to less than 1500 RPM.</p> <p>Does the “Engine Speed” remain within the specified value of “Desired Idle” for each RPM command?</p>	± 50 RPM	No trouble found. Go to <i>Diagnostic Aids</i>	Go to Step 3
3	<p>1. Disconnect the IAC.</p> <p>2. Install IAC Noid Light J 37027 or equivalent.</p> <p>3. With the engine running, command RPM up to 1500, down to 500, and then up to 1500 while observing the Noid light.</p> <p>NOTE: This Tech 2 command may cause the engine to “cut out” when RPM goes above 1500. If this occurs, the “cutting out” will stop when the Tech 2 command for the test is discontinued, or if the Tech 2 command is changed to less than 1500 RPM.</p> <p>Does each Noid light cycle red and green (never “OFF”)?</p>	—	Go to Step 5	Go to Step 4
4	<p>1. Check the following circuits for an open, short to voltage, short ground, or poor connections at the PCM:</p> <ul style="list-style-type: none"> <li>○ IAC “A” Low</li> <li>○ IAC “A” High</li> <li>○ IAC “B” Low</li> <li>○ IAC “B” High</li> </ul> <p>2. If a problem its found, repair as necessary.</p> <p>Was a problem found?</p>	—	Verify repair	Go to Step 8
5	<p>Visually/physically inspect for following conditions:</p> <ul style="list-style-type: none"> <li>○ Vacuum leaks.</li> <li>○ Throttle plate or throttle shaft for binding.</li> <li>○ Accelerator and cruise control cables for being misadjusted or for binding.</li> <li>○ Faulty, missing, or incorrectly installed PCV valve.</li> </ul> <p>Do any of the above require a repair?</p>	—	Refer to appropriate section for on-vehicle service	Go to Step 6

## DTC P1509 – IAC System High RPM (Cont'd)

Step	Action	Value(s)	Yes	No
6	<p>1. Check for a poor connection at the IAC harness connector.</p> <p>2. If a problem is found, replace faulty terminals as necessary.</p> <p>Was a problem found?</p>	—	Verify repair	Go to <i>Step 7</i>
7	<p>Replace the IAC valve.</p> <p>Is the action complete?</p>	—	Verify repair	—
8	<p>Replace the PCM.</p> <p><b>IMPORTANT:</b> The replacement PCM must be programmed, Refer to <i>On-Vehicle Service</i> in <i>Powertrain Control Module and Sensors</i> for procedures.</p> <p>And also refer to latest Service Bulletin.</p> <p>Check to see if the Latest software is released or not. And then Down Load the LATEST PROGRAMMED SOFTWARE to the replacement PCM.</p> <p>Is the action complete?</p>	—	Verify repair	—

## Diagnostic Trouble Code (DTC) P1618 Serial Peripheral Interface (SPI) PCM Interprocessor Communication Error

### Circuit Description

The serial peripheral interface (SPI) communication is used internally by the PCM to send messages between the engine processor and the automatic transmission processor. Included in each message sent between the two-processors is a checksum of the message. Both the engine processor and automatic transmission processor will compare this check sum value with the calculated value. If the checksums don't match, the processor will view the new data as being corrupted and ignore the values. The processor will then use the previous message. The receiving processor will then send a message to the sending processor informing it that it's last message was corrupted.

### Conditions for Setting the DTC

- Battery voltage is above 9.0 V for 2 seconds.
- The PCM detects an internal program fault (check sum of data communications error).
- Check sum fault present for 3 out 6 seconds.
- No TCM resets for 2 seconds.

### Action Taken When the DTC Sets

- The PCM will flash the "Check Trans" lamp the first time the fault is detected.
- The PCM will store conditions which were present when the DTC was set as Freeze Frame and in the Failure Records data.
- The automatic transmission will operate in the "safety mode" to protect the mechanical parts of the transmission. Shift quality and/or gear changes may not be normal.

### Conditions for Clearing the MIL/DTC

- The PCM will turn the "Check Trans" lamp "OFF" on the third consecutive trip cycle during which the diagnostic has been run and the fault is no longer present.
- A history DTC P1618 will clear after 40 consecutive warm-up cycles have occurred without a fault.
- DTC P1618 can be cleared by using the Tech 2 "Clear Info" function or by disconnecting the PCM battery feed.

## DTC P1618 – Serial Peripheral Interface (SPI) PCM Interprocessor Communication Error

Step	Action	Value(s)	Yes	No
1	Was the "On-Board Diagnostic (OBD) System Check" performed?	—	Go to Step 2	Go to <i>OBD System Check</i>
2	Is the EEPROM calibration the latest version available?	—	Go to Step 4	Go to Step 3
3	Reprogram the PCM with the latest available calibrations.  Does DTC P1618 re-appear when the <i>OBD System Check</i> is repeated?	—	Go to Step 4	Repair completed
4	Replace the PCM.  <b>IMPORTANT:</b> The replacement PCM must be programmed. Refer to <i>On-Vehicle Service in Powertrain Control Module and Sensors</i> for procedures.  And also refer to latest Service Bulletin.  Check to see if the Latest software is released or not. And then Down Load the LATEST PROGRAMMED SOFTWARE to the replacement PCM.  Is the action complete?	—	Verify repair	—

## Diagnostic Trouble Code (DTC) P1625 PCM Unexpected Reset

### Circuit Description

The powertrain control module (PCM) monitors unexpected PCM reset. This will not turn on MIL light on, only records code DTC P1625.

### Conditions for Setting the DTC

- Clock or COP (Computer Operating Properly) reset.

### Action Taken When the DTC Sets

- The PCM will not illuminate the malfunction indicator lamp (MIL).
- The PCM will store conditions which were present when the DTC was set as Failure Records only. This information will not be stored as Freeze Frame data.

### Conditions for Clearing the MIL/DTC

- The PCM will turn the MIL "OFF" on the third consecutive trip cycle during which the diagnostic has been run and the fault condition is no longer present.
- A history DTC P1625 will clear after 40 consecutive warm-up cycles have occurred without a fault.
- DTC P1625 can be cleared by disconnecting the PCM battery feed.

### Diagnostic Aids

Check for the following conditions:

- P1625 alone stored does not need diagnosis. Clear DTC code.

## DTC P1625 – PCM Unexpected Reset

Step	Action	Value(s)	Yes	No
1	Was the "On-Board Diagnostic (OBD) System Check" performed?	—	Go to Step 2	Go to <i>OBD System Check</i>
2	1. Ignition is "ON". 2. Install the Tech 2. 3. Start the engine at let it Idle. 4. On the Tech 2, select "DTC info". Does the Tech 2 indicate DTC P1625 failed?	—	Go to Step 3	Go to <i>Diagnostic Aids</i>
3	1. Ignition is "ON". 2. Clear DTC P1625 by using the Tech 2 "Clear Info". 3. Start the engine at let it Idle. 4. On the Tech 2, select "DTC info". Does the Tech 2 indicate DTC P1625 failed?	—	Go to Step 4	Go to <i>Diagnostic Aids</i>
4	1. Check for aftermarket electronics, such as transceiver, stereos, and anti theft devices. They may radiate EMI into the control system if they are improperly installed. (This may cause a false sensor reading and turn on the MIL.) 2. If a problem is found, repair as necessary. Was a problem found?	—	Verify repair	—

## Diagnostic Trouble Code (DTC) P1640 Driver-1-Output Circuit Fault (ODM)

### Circuit Description

Output driver modules (ODMs) are used by the powertrain control module (PCM) to turn "ON" many of the current-driven devices that are needed to control various engine and transmission functions. Each ODM is capable of controlling up to 7 separate outputs by applying ground to the device which the PCM is commanding "ON."

Unlike the Quad Driver Modules (QDMs) used in prior model years, ODMs have the capability of diagnosing each output circuit individually. DTC P1640 set indicates an improper voltage level has been detected on an ODM output.

Since A/C is an option, No A/C will cause the air conditioning clutch relay output to always fail. If a fault is seen on the air conditioning clutch relay output, it will not be logged as a fault until the A/C request input interrupts a high voltage, indicating that A/C has been installed.

### Conditions for Setting the DTC

- Ignition "ON."
- Engine running.
- No DTC 1618.
- Ignition voltage is above 13.2 volts for 4 seconds.
- Output voltage does not equal ignition voltage when output is "OFF" or output voltage is not less than 1 volt when output is "ON."
- Above conditions occur for at least 1 second.

### Action Taken When the DTC Sets

- The PCM will not illuminate the malfunction indicator lamp (MIL).
- The PCM will store conditions which were present when the DTC was set as Failure Records only. This information will not be stored as Freeze Frame data.

### Conditions for Clearing the MIL/DTC

- A history DTC P1640 will clear after 40 consecutive warm-up cycles occur without a fault.
- DTC P1640 can be cleared by using the Tech 2 "Clear Info" function or by disconnecting the PCM battery feed.

### Diagnostic Aids

Check for the following conditions:

- Poor connection at PCM – Inspect harness connectors for backed-out terminals, improper mating, broken locks, improperly formed or damaged terminals, and poor terminal-to-wire connection.
- Damaged harness – Inspect the wiring harness for damage. If the harness appears to be OK, disconnect the PCM, turn the ignition "ON" and observe a voltmeter connected to the suspect driver circuit at the PCM harness connector while moving connectors and wiring harnesses relates to the MIL. A change in voltage will indicate the location of the fault.
- Poor connection at component – Examine for damaged connectors, unplugged connector, or damaged terminals at the following locations: Instrument cluster harness, canister purge solenoid, A/C clutch relay. An open ignition feed circuit at any of these components will cause DTC P1640 to be set.

Reviewing the Failure Records vehicle mileage since the diagnostic test last failed may help determine how often the condition that caused the DTC to be set occurs. This may assist in diagnosing the condition.

The following PCM pins are controlled by output driver modules (ODMs):

- A13 – "Check Engine Lamp"
- A14 – SVS ("Check Trans")
- A15 – EVAP Canister Purge
- A16 – Band Apply
- B14 – A/C Clutch
- B15 – Low Fuel Lamp
- C13 – EVAP VENT Solenoid
- B16 – Fuel Gauge Control

### Test Description

Number(s) below refer to the step number(s) on the Diagnostic Chart.

- 11.A short to ground on the ignition side of the component will blow the fuse. Since the fuse was checked in Step 2, a short to ground would be between the affected component and the PCM.

**DTC P1640 – Driver-1-Output Circuit Fault (ODM)**

Step	Action	Value(s)	Yes	No
1	Was the “On-Board Diagnostic (OBD) System Check” performed?	—	Go to Step 2	Go to <i>OBD System Check</i>
2	Check the fuse for the driver circuit that was shown as faulty. Was the fuse blown?	—	Go to Step 5	Go to Step 6
3	1. Check for a short to ground between the fuse and the affected component. 2. Replace the fuse after making any necessary repairs. Is the action complete?	—	Verify repair	—
4	Disconnect the PCM connector for the affected driver circuit. Is there any damage to the PCM pin or connector?	—	Go to Step 5	Go to Step 6
5	Repair the damaged pin or terminal. Is the action complete?	—	Verify repair	—
6	1. Leave the PCM connector for the lamp driver circuit disconnected. 2. Ignition “ON.” 3. Using a DVM, check the voltage at the PCM connector for the affected lamp driver circuit. Was the voltage equal to the specified value?	B+	Go to Step 14	Go to Step 7
7	1. Ignition “ON.” 2. Check for battery voltage at the fuse for the affected lamp circuit. Was battery voltage available at the fuse?	—	Go to Step 9	Go to Step 8
8	Repair the open circuit between the ignition switch and the fuse. Is the action complete?	—	Verify repair	—
9	1. Ignition “OFF.” 2. Disconnect the PCM connector for the affected driver terminal. 3. Connect an ohmmeter between a good ground and the PCM connector for the affected driver. Did the ohmmeter indicate continuity?	—	Go to Step 10	Go to Step 11
10	Repair the short to ground between the affected component and its PCM driver terminal. Is the action complete?	—	Verify repair	—
11	Repair the open circuit between the fuse and the PCM driver terminal for the affected circuit. Is the action complete?	—	Verify repair	—
12	1. Connect the PCM. 2. Start the engine and let it idle. 3. Backprobe the affected terminal at the PCM with a DVM. Was the voltage equal to the specified value?	+B	Go to Step 14	Go to Step 13

## DTC P1640 – Driver-1-Output Circuit Fault (ODM) (Cont'd)

Step	Action	Value(s)	Yes	No
13	1. Run the engine at idle. 2. Check for battery voltage at the fuse for the affected circuit.  Was battery voltage available at the fuse?	—	Go to <i>Step 9</i>	Go to <i>Step 8</i>
14	Replace the PCM.  <b>IMPORTANT:</b> The replacement PCM must be programmed. Refer to <i>On-Vehicle Service</i> in <i>Powertrain Control Module and Sensors</i> for procedures.  And also refer to latest Service Bulletin.  Check to see if the Latest software is released or not. And then Down Load the LATEST PROGRAMMED SOFTWARE to the replacement PCM.  Is the action complete?	—	Verify repair	—



## Diagnostic Trouble Code (DTC) P1650 Quad Driver Module “A” Fault

### Circuit Description

The Quad Driver Module (QDMs) are used by the powertrain control module (PCM) to turn “ON” current-driven devices that are needed to control two engine functions. The PCM monitors open or short circuit of either of Canister Control Purge (CCP) Vent solenoid or Variable Intake Manifold (VIM).

### Conditions for Setting the DTC

- Ignition “ON”.
- Engine running.
- No DTC P1618.
- Ignition voltage.
- Output voltage does not equal voltage is not less than 1 volt when out put is “ON”.
- Above conditions occur for at least 0.5 second.

### Action Taken When the DTC Sets

- The PCM will not illuminate the malfunction indicator lamp (MIL).
- The PCM will store conditions which were present when the DTC was set as Failure Records only. This information will not be stored as Freeze Frame data.

### Conditions for Clearing the MIL/DTC

- The PCM will turn the MIL “OFF” on the third consecutive trip cycle during which the diagnostic has been run and the fault condition is no longer present.
- A history DTC P1650 will clear after 40 consecutive warm-up cycles have occurred without a fault.
- DTC P1650 can be cleared by using the Tech 2 “Clear Info” function or by disconnecting the PCM battery feed.

### Diagnostic Aids

Check for the following conditions:

- Poor connection at PCM – Inspect harness connectors for backed-out terminals, improper mating, broken locks, improperly formed or damaged terminals, and poor terminal-to-wire connection.
- Damaged harness – Inspect the wiring harness for damage. If the harness appears to be OK, disconnect the PCM, turn the ignition “ON” and observe a voltmeter connected to the suspect driver circuit at the PCM harness connector while moving connectors and wiring harnesses relates to the MIL. A change in voltage will indicate the location of the fault.
- Poor connection at component – Examine for damaged connectors, unplugged connector, or damaged terminals at the following locations: canister purge solenoid, fuel level sensor. An open ignition feed circuit at any of these components will cause DTC P1650 to be set.

Reviewing the Failure Records vehicle mileage since the diagnostic test last failed may help determine how often the condition that caused the DTC to be set occurs. This may assist in diagnosing the condition.

### The following PCM pins are controlled by Quad driver modules (QDMs):

- C11 – VIM
- C13 – Canister control VENT Solenoid

### Test Description

11. A short to ground on the ignition side of the component will blow the fuse. Since the fuse was checked in Step 2, a short to ground would be between the affected component and the PCM.

**DTC P1650 – Quad Driver Module (QDM) “A” Fault**

Step	Action	Value(s)	Yes	No
1	Was the “On-Board Diagnostic (OBD) System Check” performed?	—	Go to Step 2	Go to <i>OBD System Check</i>
2	Check the fuse for the driver circuit that was shown as faulty. Was the fuse blown?	—	Go to Step 5	Go to Step 6
3	1. Check for a short to ground between the fuse and the affected component. 2. Replace the fuse after making any necessary repairs. Is the action complete?	—	Verify repair	—
4	Disconnect the PCM connector for the affected driver circuit. Is there any damage to the PCM pin or connector?	—	Go to Step 5	Go to Step 6
5	Repair the damaged pin or terminal. Is the action complete?	—	Verify repair	—
6	Were either of the lamp circuits for “Check Engine” or “Check Trans.” indicated as faulty by the Tech 2?	—	Go to Step 7	Go to Step 13
7	1. Leave the PCM connector for the lamp driver circuit disconnected. 2. Ignition “ON.” 3. Using a DVM, check the voltage at the PCM connector for the affected lamp driver circuit. Was the voltage equal to the specified value?	B+	Go to Step 15	Go to Step 8
8	1. Ignition “ON.” 2. Check for battery voltage at the fuse for the affected lamp circuit. Was battery voltage available at the fuse?	—	Go to Step 10	Go to Step 9
9	Repair the open circuit between the ignition switch and the fuse. Is the action complete?	—	Verify repair	—
10	1. Ignition “OFF.” 2. Disconnect the PCM connector for the affected driver terminal. 3. Connect an ohmmeter between a good ground and the PCM connector for the affected driver. Did the ohmmeter indicate continuity?	—	Go to Step 11	Go to Step 12
11	Repair the short to ground between the affected component and its PCM driver terminal. Is the action complete?	—	Verify repair	—
12	Repair the open circuit between the fuse and the PCM driver terminal for the affected circuit. Is the action complete?	—	Verify repair	—

## DTC P1650 – Quad Driver Module (QDM) “A” Fault (Cont’d)

Step	Action	Value(s)	Yes	No
13	1. Connect the PCM. 2. Start the engine and let it idle. 3. Backprobe the affected terminal at the PCM with a DVM.  Was the voltage equal to the specified value?	+B	Go to <i>Step 15</i>	Go to <i>Step 14</i>
14	1. Run the engine at idle. 2. Check for battery voltage at the fuse for the affected circuit.  Was battery voltage available at the fuse?	—	Go to <i>Step 10</i>	Go to <i>Step 9</i>
15	Replace the PCM.  <b>IMPORTANT:</b> The replacement PCM must be programmed. Refer to <i>On-Vehicle Service in Powertrain Control Module and Sensors</i> for procedures.  And also refer to latest Service Bulletin.  Check to see if the Latest software is released or not. And then Down Load the LATEST PROGRAMMED SOFTWARE to the replacement PCM.  Is the action complete?	—	Verify repair	—

## Symptom Diagnosis

### Preliminary Checks

Before using this section, perform the “On-Board Diagnostic (OBD) System Check” and verify all of the following items:

- The powertrain control module (PCM) and malfunction indicator lamp (MIL) (Check Engine lamp) are operating correctly.
- There are no DTC(s) stored.
- Tech 2 data is within normal operating range. Refer to *Typical Scan Data Values*.
- Verify the customer complaint and locate the correct symptom in the table of contents. Perform the procedure included in the symptom chart.

### Visual/Physical Check

Several of the symptom procedures call for a careful visual/physical check. This can lead to correcting a problem without further checks and can save valuable time.

This check should include the following items:

- PCM grounds for cleanliness, tightness and proper location.
- Vacuum hoses for splits, kinks, and proper connections, as shown on the “Vehicle Emission Control Information” label. Check thoroughly for any type of leak or restriction.
- Air intake ducts for collapsed or damaged areas.
- Air leaks at throttle body mounting area, mass air flow (MAF) sensor and intake manifold sealing surfaces.
- Ignition components for cracking, hardness, and carbon tracking.
- Wiring for proper connections, pinches and cuts.

### Intermittents

**IMPORTANT:** An intermittent problem may or may not turn on the malfunction indicator lamp (MIL) or store a DTC. DO NOT use the Diagnostic Trouble Code (DTC) charts for intermittent problems. The fault must be present to locate the problem.

Most intermittent problems are caused by faulty electrical connections or wiring. Perform a careful visual/physical check for the following conditions:

- Poor mating of the connector halves or a terminal not fully seated in the connector (backed out).
- Improperly formed or damaged terminal.
- All connector terminals in the problem circuit should be carefully checked for proper contact tension.
- Poor terminal-to-wire connection. This requires removing the terminal from the connector body to check.

Road test the vehicle with a J 39200 Digital Multimeter connected to a suspected circuit. An abnormal voltage when the malfunction occurs is a good indication that there is a fault in the circuit being monitored.

Use a Tech 2 to help detect intermittent conditions. The scan tool has several features that can be used to locate

an intermittent condition. Use the following feature to find intermittent faults:

- Using a Tech 2’s “Freeze Frame” buffer or “Failure Records” buffer can aid in locating an intermittent condition. Review and record the information in the freeze frame or failure record associated with the intermittent DTC being diagnosed. The vehicle can be driven within the conditions that were present when the DTC originally set.

To check for loss of diagnostic code memory, disconnect the MAP sensor and idle the engine until the MIL (Check Engine lamp) comes on. DTC P0107 should be stored and kept in memory when the ignition is turned “OFF.” If not, the PCM is faulty. When this test is completed, make sure that you clear the DTC P0107 from memory.

An intermittent MIL (Check Engine lamp) with no stored DTC may be caused by the following:

- Ignition coil shorted to ground and arcing.
- MIL (Check Engine lamp) wire to PCM shorted to ground.
- Poor PCM grounds. Refer to the PCM wiring diagrams.

Check for improper installation of electrical options such as lights, cellular phones, etc. Check all wires from the PCM to the ignition coils for poor connections.

Check for an open diode across the A/C compressor clutch and check for other open diodes (refer to wiring diagrams in *Electrical Diagnosis*).

If problem has not been found, refer to *PCM Connector Symptom* tables.

- Check the “Broadcast Code” of the PCM, and compare it with the latest Isuzu service bulletins and/or Isuzu EEPROM reprogramming equipment to determine if an update to the PCM’s reprogrammable memory has been released. To check the “Broadcast Code,” connect the Tech 2, then look for “ID info,” then select “Broadcast Code.” This should display a 4 character code, such as “XBYA” (example only). This identifies the contents of the reprogrammable software and calibration contained in the PCM. If the Broadcast code is not the most current available, it is advisable to reprogram the PCM’s EEPROM memory, which may either help identify a hard-to-find problem or may fix the problem.

## Hard Start Symptom

Step	Action	Value(s)	Yes	No
1	<p><b>DEFINITION:</b> Engine cranks, but does not start for a long time. Does eventually run, or may start but immediately stalls.</p> <p>Was the "On-Board Diagnostic (OBD) System Check" performed?</p>	—	Go to <i>Step 2</i>	Go to <i>OBD System Check</i>
2	<p>1. Perform a bulletin search.</p> <p>2. If a bulletin that addresses the symptom is found, correct the condition as instructed in the bulletin.</p> <p>Was a bulletin found that addresses the symptom?</p>	—	Verify repair	Go to <i>Step 3</i>
3	<p>Was a visual/physical check performed?</p>	—	Go to <i>Step 4</i>	Go to <i>Visual/Physical Check</i>
4	<p>Check engine coolant temperature (ECT) sensor for shift in value. After 8 hours with the hood up and the engine not running, connect the Tech 2. With the ignition "ON" and the engine not running, compare engine coolant temperature to intake air temperature.</p> <p>Are ECT and IAT within the specified value of each other?</p>	$\pm 5^{\circ}\text{C}$ ( $\pm 9^{\circ}\text{F}$ )	Go to <i>Step 9</i>	Go to <i>Step 5</i>
5	<p>1. Using a Tech 2, display the engine coolant temperature and note the value.</p> <p>2. Check the resistance of the engine coolant temperature sensor.</p> <p>3. Refer to <i>Engine Coolant Temperature Sensor Temperature vs. Resistance</i> chart on <i>DTC P0118 Diagnostic Support</i> for resistance specifications.</p> <p>Is the resistance value near the resistance for the temperature noted?</p>	—	Go to <i>Step 7</i>	Go to <i>Step 6</i>
6	<p>Replace the ECT sensor.</p> <p>Is the action complete?</p>	—	Verify repair	—
7	<p>Locate and repair high resistance or poor connection in the ECT signal circuit or the ECT sensor ground.</p> <p>Is the action complete?</p>	—	Verify repair	—
8	<p>1. Check for a faulty, plugged, or incorrectly installed PCV valve.</p> <p>2. If a problem is found, repair as necessary.</p> <p>Was a problem found?</p>	—	Verify repair	Go to <i>Step 9</i>
9	<p>1. Check for water- or alcohol-contaminated fuel.</p> <p>2. If a problem is found, repair as necessary.</p> <p>Was a problem found?</p>	—	Verify repair	Go to <i>Step 10</i>
10	<p>1. Perform the procedure in <i>Fuel System Pressure Test</i>.</p> <p>2. If a problem is found, repair as necessary.</p> <p>Was a problem found?</p>	—	Verify repair	Go to <i>Step 11</i>
11	<p>1. Check for proper ignition voltage output with spark tester J 26792 (ST-125). Refer to <i>Electric Ignition System</i> for procedure.</p> <p>2. If a problem is found, repair as necessary.</p> <p>Was a problem found?</p>	—	Verify repair	Go to <i>Step 12</i>

### Hard Start Symptom (Cont'd)

Step	Action	Value(s)	Yes	No
12	<p>1. Remove spark plugs. Check for wet plugs, cracks, wear, improper gap, burned electrodes, or heavy deposits. Refer to <i>Electronic Ignition System</i>.</p> <p>NOTE: If spark plugs are gas or oil fouled, the cause of the fouling must be determined before replacing the spark plugs.</p> <p>2. If a problem is found, repair as necessary.</p> <p>Was a problem found?</p>	—	Verify repair	Go to <i>Step 13</i>
13	<p>1. Remove the ignition coils and check the ignition coils for cracks or carbon tracking.</p> <p>2. If a problem is found, replace affected coil(s) as necessary.</p> <p>Was a problem found?</p>	—	Verify repair	Go to <i>Step 14</i>
14	<p>1. Check IAC operation. Perform the procedure in the <i>DTC P0506, Step 6</i> diagnostic table.</p> <p>2. If a problem is found, repair as necessary.</p> <p>Was a problem found?</p>	—	Verify repair	Go to <i>Step 15</i>
15	<p>1. Check for the following engine mechanical problems (refer to <i>Engine Mechanical</i>):</p> <ul style="list-style-type: none"> <li><input type="radio"/> Low compression</li> <li><input type="radio"/> Leaking cylinder head gaskets</li> <li><input type="radio"/> Worn or incorrect camshaft</li> <li><input type="radio"/> Camshaft drive belt slipped or stripped</li> </ul> <p>2. If a problem is found, repair as necessary.</p> <p>Was a problem found?</p>	—	Verify repair	Go to <i>Step 16</i>
16	<p>1. Review all diagnostic procedures within this table.</p> <p>2. If all procedures have been completed and no malfunctions have been found, review/inspect the following:</p> <ul style="list-style-type: none"> <li><input type="radio"/> Visual/physical inspection</li> <li><input type="radio"/> Tech 2 data</li> <li><input type="radio"/> Freeze Frame data/Failure Records buffer</li> <li><input type="radio"/> All electrical connections within a suspected circuit and/or system.</li> </ul> <p>3. If a problem is found, repair as necessary.</p> <p>Was a problem found?</p>	—	Verify repair	Contact Technical Assistance

## Surges and/or Chuggles Symptom

Step	Action	Value(s)	Yes	No
1	<p><b>DEFINITION:</b> Engine power variation under steady throttle or cruise. Feels like the vehicle speeds up and slows down with no change in the accelerator pedal.</p> <p>Was the "On-Board Diagnostic (OBD) System Check" performed?</p>	—	Go to Step 2	Go to OBD System Check
2	<p>1. Perform a bulletin search. 2. If a bulletin that addresses the symptom is found, correct the condition as instructed in the bulletin.</p> <p>Was a bulletin found that addresses the symptom?</p>	—	Verify repair	Go to Step 3
3	<p>Was a visual/physical check performed?</p>	—	Go to Step 4	Go to Visual/Physical Check
4	<p>Be sure that the driver understands transmission torque converter clutch and A/C compressor operation as explained in the owner's manual. Inform the customer how the TCC and the A/C clutch operate.</p> <p>Is the customer experiencing a normal condition?</p>	—	System OK	Go to Step 5
5	<p>1. Check the the fuel control heated oxygen sensors (HO2S, B1S1 and B2S1). The fuel control heated oxygen sensors (HO2S) should respond quickly to different throttle positions. If they don't, check them for silicone or other contaminants from fuel or use of improper RTV sealant. The sensors may have a white powdery coating. Silicon contamination causes a high but false HO2S signal voltage (rich exhaust indication). The PCM will then reduce the amount of fuel delivered to the engine, causing a severe driveability problem. For more information, refer to <i>Powertrain Control Module (PCM) and Sensors</i>.</p> <p>2. If a problem is found, repair as necessary.</p> <p>Was a problem found?</p>	—	Verify repair	Go to Step 6
6	<p>1. Check the fuel pressure. Refer to <i>Fuel System Pressure Test</i>. 2. If a problem is found, repair as necessary.</p> <p>Was a problem found?</p>	—	Verify repair	Go to Step 7
7	<p>Monitor the long term fuel trim on the Tech 2. Is the long term fuel trim significantly in the negative range (rich condition)?</p>	—	Go to Step 8	Go to Step 9
8	<p>1. Check items that can cause the engine to run rich. Refer to <i>Diagnostic Aids in DTC P0172 Diagnostic Support</i>. 2. If a problem is found, repair as necessary.</p> <p>Was a problem found?</p>	—	Go to Step 10	Verify repair
9	<p>1. Check items that can cause the engine to run lean. Refer to <i>Diagnostic Aids in DTC P0171</i>. 2. If a problem is found, repair as necessary.</p> <p>Was a problem found?</p>	—	Go to Step 10	Verify repair

**Surges and/or Chuggles Symptom (Cont'd)**

Step	Action	Value(s)	Yes	No
10	<p>1. Check for proper ignition voltage output with spark tester J 26792 (ST-125). Refer to <i>Electric Ignition System</i> for procedure.</p> <p>2. If a problem is found, repair as necessary.</p> <p>Was a problem found?</p>	—	Verify repair	Go to <i>Step 11</i>
11	<p>1. Check the ignition coils for cracks or carbon tracking.</p> <p>2. If a problem is found, repair as necessary.</p> <p>Was a problem found?</p>	—	Verify repair	Go to <i>Step 12</i>
12	<p>1. Remove the spark plugs and check for wet plugs, cracks, wear, improper gap, burned electrodes, or heavy deposits. Refer to <i>Electronic Ignition System</i>.</p> <p>NOTE: If spark plugs are gas or oil fouled, the cause of the fouling must be determined before replacing the spark plugs.</p> <p>2. If a problem is found, repair as necessary.</p> <p>Was a problem found?</p>	—	Verify repair	Go to <i>Step 13</i>
13	<p>1. Check the injector connections.</p> <p>2. If any of the injector connectors are connected to an incorrect cylinder, correct as necessary.</p> <p>Was a problem found?</p>	—	Verify repair	Go to <i>Step 14</i>
14	<p>1. Check PCM grounds for the cleanliness, tightness and proper locations. Refer to the PCM wiring diagrams in <i>Electrical Diagnosis</i>.</p> <p>2. If a problem is found, repair as necessary.</p> <p>Was a problem found?</p>	—	Verify repair	Go to <i>Step 15</i>
15	<p>1. Check MAF sensor connections.</p> <p>2. If a problem is found, replace the faulty terminals as necessary. Refer to <i>Electrical Diagnosis</i> for wiring repair procedures.</p> <p>Was a problem found?</p>	—	Verify repair	Go to <i>Step 16</i>
16	<p>1. Visually/physically check vacuum hoses for splits, kinks, and proper connections and routing as shown on the "Vehicle Emission Control Information" label.</p> <p>2. If a problem is found, repair as necessary.</p> <p>Was a problem found?</p>	—	Verify repair	Go to <i>Step 17</i>



### Surges and/or Chuggles Symptom (Cont'd)

Step	Action	Value(s)	Yes	No
17	1. Check the exhaust system for possible restriction: <ul style="list-style-type: none"> <li><input type="radio"/> Inspect the exhaust system for damaged or collapsed pipes.</li> <li><input type="radio"/> Inspect the muffler for heat distress or possible internal failure.</li> <li><input type="radio"/> Check for a possible plugged three-way catalytic converter by checking the exhaust system back pressure. Refer to <i>Restricted Exhaust System Check</i>.</li> </ul> 2. If a problem is found, repair as necessary. Was a problem found?	—	Verify repair	Go to <i>Step 18</i>
18	1. Review all diagnostic procedures within this table. 2. If all procedures have been completed and no malfunctions have been found, review/inspect the following: <ul style="list-style-type: none"> <li><input type="radio"/> Visual/physical inspection</li> <li><input type="radio"/> Tech 2 data</li> <li><input type="radio"/> Freeze Frame data/Failure Records buffer</li> <li><input type="radio"/> All electrical connections within a suspected circuit and/or system.</li> </ul> 3. If a problem is found, repair as necessary. Was a problem found?	—	Verify repair	Contact Technical Assistance

## Lack of Power, Sluggish or Spongy Symptom

Step	Action	Value(s)	Yes	No
1	<p><b>DEFINITION:</b> Engine delivers less than expected power. Little or no increase in speed when accelerator pedal is pushed down part-way.</p> <p>Was the "On-Board Diagnostic (OBD) System Check" performed?</p>	—	Go to <i>Step 2</i>	Go to <i>OBD System Check</i>
2	<p>1. Perform a bulletin search. 2. If a bulletin that addresses the symptom is found, correct the condition as instructed in the bulletin.</p> <p>Was a bulletin found that addresses the symptom?</p>	—	Verify repair	Go to <i>Step 3</i>
3	<p>Was a visual/physical check performed?</p>	—	Go to <i>Step 4</i>	Go to <i>Visual/Physical Check</i>
4	<p>1. Remove and check the air filter element for dirt or restrictions. Refer to <i>Air Intake System</i> in <i>ON-Vehicle Service</i>. 2. Replace the air filter element if necessary.</p> <p>Was a repair required?</p>	—	Verify repair	Go to <i>Step 5</i>
5	<p>1. Check for low fuel pressure. Refer to <i>Fuel System Pressure Test</i>. 2. If a problem is found, repair as necessary.</p> <p>Was a problem found?</p>	—	Verify repair	Go to <i>Step 6</i>
6	<p>1. Check for water- or alcohol-contaminated fuel. 2. If a problem is found, repair as necessary.</p> <p>Was a problem found?</p>	—	Verify repair	Go to <i>Step 7</i>
7	<p>1. Using a Tech 2, monitor the knock sensor (KS) system for excessive spark retard activity. Refer to <i>Knock Sensor (KS) System</i>. 2. If a problem is found, repair as necessary.</p> <p>Was a problem found?</p>	—	Verify repair	Go to <i>Step 8</i>
8	<p>1. Install the Tech 2. 2. Run the engine at idle. 3. On the Tech 2, select F3: Miscellaneous Test, F6: Variable Intake Manifold. 4. Repeat Switch ON or OFF of VIM solenoid valve by using the Tech 2. 5. Check to see if the actuator works normally. 6. If a problem is found, repair as necessary.</p> <p>Was a problem found?</p>	—	Verify repair	Go to <i>Step 9</i>
9	<p>1. Check for proper ignition voltage output with spark tester J 26792 (ST-125). Refer to <i>Electronic Ignition System</i> for procedure. 2. If a problem is found, repair as necessary.</p> <p>Was a problem found?</p>	—	Verify repair	Go to <i>Step 10</i>

### Lack of Power, Sluggish or Spongy Symptom (Cont'd)

Step	Action	Value(s)	Yes	No
10	<p>1. Remove the spark plugs and check for wet plugs, cracks, wear, improper gap, burned electrodes, or heavy deposits. Refer to <i>Electronic Ignition System</i>.</p> <p>NOTE: If spark plugs are gas or oil fouled, the cause of the fouling must be determined before replacing the spark plugs.</p> <p>2. If a problem is found, repair as necessary.</p> <p>Was a problem found?</p>	—	Verify repair	Go to <i>Step 11</i>
11	<p>1. Check the ignition coils for cracks or carbon tracking.</p> <p>2. If a problem is found, repair as necessary.</p> <p>Was a problem found?</p>	—	Verify repair	Go to <i>Step 12</i>
12	<p>1. Check the PCM grounds for the cleanliness, tightness and proper locations. Refer to the PCM wiring diagrams in <i>Electrical Diagnosis</i>.</p> <p>2. If a problem is found, repair as necessary.</p> <p>Was a problem found?</p>	—	Verify repair	Go to <i>Step 13</i>
13	<p>1. Check the exhaust system for possible restriction:</p> <ul style="list-style-type: none"> <li>○ Inspect the exhaust system for damaged or collapsed pipes.</li> <li>○ Inspect the muffler for heat distress or possible internal failure.</li> <li>○ Check for a possible plugged three-way catalytic converter by checking the exhaust system back pressure. Refer to <i>Restricted Exhaust System Check</i>.</li> </ul> <p>2. If a problem is found, repair as necessary.</p> <p>Was a problem found?</p>	—	Verify repair	Go to <i>Step 14</i>
14	<p>1. Check the torque converter clutch (TCC) for proper operation. Refer to <i>4L30-E Transmission Diagnosis</i>.</p> <p>2. If a problem is found, repair as necessary.</p> <p>Was a problem found?</p>	—	Verify repair	Go to <i>Step 15</i>
15	<p>1. Check for an engine mechanical problem. Check for low compression, incorrect or worn camshaft, loose timing belt, etc. Refer to <i>Engine Mechanical</i>.</p> <p>2. If a problem is found, repair as necessary.</p> <p>Was a problem found?</p>	—	Verify repair	Go to <i>Step 16</i>
16	<p>1. Review all diagnostic procedures within this table.</p> <p>2. If all procedures have been completed and no malfunctions have been found, review/inspect the following:</p> <ul style="list-style-type: none"> <li>○ Visual/physical inspection</li> <li>○ Tech 2 data</li> <li>○ Freeze Frame data/Failure Records buffer</li> <li>○ All electrical connections within a suspected circuit and/or system.</li> </ul> <p>3. If a problem is found, repair as necessary.</p> <p>Was a problem found?</p>	—	Verify repair	Contact Technical Assistance

## Detonation/Spark Knock Symptom

Step	Action	Value(s)	Yes	No
1	<p><b>DEFINITION:</b> A mild to severe ping, usually worse under acceleration. The engine makes sharp metallic knocks that change with throttle opening.</p> <p>Was the "On-Board Diagnostic (OBD) System Check" performed?</p>	—	Go to <i>Step 2</i>	Go to <i>OBD System Check</i>
2	<p>1. Perform a bulletin search. 2. If a bulletin that addresses the symptom is found, correct the condition as instructed in the bulletin.</p> <p>Was a bulletin found that addresses the symptom?</p>	—	Verify repair	Go to <i>Step 3</i>
3	<p>Was a visual/physical check performed?</p>	—	Go to <i>Step 4</i>	Go to <i>Visual/Physical Check</i>
4	<p>If Tech 2 readings are normal (refer to <i>Typical Scan Values</i>) and there are no engine mechanical faults, fill the fuel tank with a known quality gasoline that has a minimum octane rating of 87 and re-evaluate the vehicle performance.</p> <p>Is detonation present?</p>	—	Go to <i>Step 5</i>	Verify repair
5	<p>1. Check the transmission range switch circuit. Use a Tech 2 and be sure the Tech 2 indicates that the vehicle is in drive with the gear selector in drive or overdrive.</p> <p>2. If a problem is found, diagnose and repair the transmission range switch as necessary (refer to <i>4L30-E Automatic Transmission Diagnosis</i>).</p> <p>Was a problem found?</p>	—	Verify repair	Go to <i>Step 6</i>
6	<p>1. Check TCC operation. Refer to <i>4L30-E Transmission Diagnosis</i>.</p> <p>2. If a problem is found, repair as necessary.</p> <p>Was a problem found?</p>	—	Verify repair	Go to <i>Step 7</i>
7	<p>1. Check for obvious overheating problems:</p> <ul style="list-style-type: none"> <li>○ Low engine coolant.</li> <li>○ Restricted air flow to radiator, or restricted water flow through radiator.</li> <li>○ Correct coolant solution should be a 50/50 mix of approved antifreeze/coolant and water. Refer to <i>Engine Cooling</i>.</li> <li>○ EGR operation. Refer to <i>DTC P0401</i>.</li> </ul> <p>2. If a problem is found, repair as necessary.</p> <p>Was a problem found?</p>	—	Verify repair	Go to <i>Step 8</i>
8	<p>1. Check fuel pressure. Refer to Chart Fuel System Pressure Test.</p> <p>2. If a problem is found, repair as necessary.</p> <p>Was a problem found?</p>	—	Verify repair	Go to <i>Step 9</i>

### Detonation/Spark Knock Symptom (Cont'd)

Step	Action	Value(s)	Yes	No
9	<p>1. Check items that can cause an engine to run lean (long term fuel trim significantly in the positive range). For a lean condition, refer to <i>Diagnostic Aids</i> in <i>DTC P0171 Diagnostic Support</i>.</p> <p>2. If a problem is found, repair as necessary.</p> <p>Was a problem found?</p>	—	Verify repair	Go to <i>Step 10</i>
10	<p>1. Spark plugs for proper heat range. Refer to <i>General Information</i>.</p> <p>2. If incorrect spark plugs are installed, replace spark plugs as necessary.</p> <p>Did any spark plugs require replacement?</p>	—	Verify repair	Go to <i>Step 11</i>
11	<p>1. Remove excessive carbon buildup with a top engine cleaner. Refer to instructions on the top engine cleaner can.</p> <p>2. Re-evaluate vehicle performance.</p> <p>Is detonation still present?</p>	—	Go to <i>Step 12</i>	Verify repair
12	<p>1. Check for an engine mechanical problem. Perform a cylinder compression check. Refer to <i>Engine Mechanical</i>.</p> <p>2. If a problem is found, repair as necessary.</p> <p>Was a problem found?</p>	—	Verify repair	Go to <i>Step 13</i>
13	<p>1. Review all diagnostic procedures within this table.</p> <p>2. If all procedures have been completed and no malfunctions have been found, review/inspect the following:</p> <ul style="list-style-type: none"> <li><input type="radio"/> Visual/physical inspection</li> <li><input type="radio"/> Tech 2 data</li> <li><input type="radio"/> Freeze Frame data/Failure Records buffer</li> <li><input type="radio"/> All electrical connections within a suspected circuit and/or system.</li> </ul> <p>3. If a problem is found, repair as necessary.</p> <p>Was a problem found?</p>	—	Verify repair	Contact Technical Assistance

## Rough, Unstable, or Incorrect Idle, Stalling Symptom

Step	Action	Value(s)	Yes	No
1	<p><b>DEFINITION:</b> Engine runs unevenly at idle. If severe, the engine or vehicle may shake. Engine idle speed may vary in RPM. Either condition may be severe enough to stall the engine.</p> <p>Was the "On-Board Diagnostic (OBD) System Check" performed?</p>	—	Go to <i>Step 2</i>	Go to <i>OBD System Check</i>
2	<p>1. Perform a bulletin search. 2. If a bulletin that addresses the symptom is found, correct the condition as instructed in the bulletin.</p> <p>Was a bulletin found that addresses the symptom?</p>	—	Go to <i>Step 13</i>	Go to <i>Step 3</i>
3	<p>Was a visual/physical check performed?</p>	—	Go to <i>Step 4</i>	Go to <i>Visual/Physical Check</i>
4	<p>1. Check the PCM grounds for cleanliness, tightness and proper routing. Refer to the PCM wiring diagrams in <i>Electrical Diagnosis</i>. 2. If a problem is found, repair as necessary.</p> <p>Was a problem found?</p>	—	Verify repair	Go to <i>Step 5</i>
5	<p>Observe the long term fuel trim on the Tech 2. Is the long term fuel trim significantly in the negative range (rich condition)?</p>	—	Go to <i>Step 6</i>	Go to <i>Step 7</i>
6	<p>1. Check items that can cause the engine to run rich. Refer to <i>Diagnostic Aids in DTC P0172 Diagnostic Support</i>. 2. If a problem is found, repair as necessary.</p> <p>Was a problem found?</p>	—	Verify repair	Go to <i>Step 9</i>
7	<p>Is the long term fuel trim significantly in the positive range (lean condition)?</p>	—	Go to <i>Step 8</i>	Go to <i>Step 9</i>
8	<p>1. Check items that can cause the engine to run lean. Refer to <i>Diagnostic Aids in DTC P0171 Diagnostic Support</i>. 2. If a problem is found, repair as necessary.</p> <p>Was a problem found?</p>	—	Verify repair	Go to <i>Step 9</i>
9	<p>1. Check for incorrect idle speed. Ensure that the following conditions are present:  <input type="radio"/> The engine is fully warm.  <input type="radio"/> The accessories are "OFF."  2. Using a Tech 2, monitor the IAC position.  Is the IAC position within the specified values?</p>	Between 10 and 50 counts	Go to <i>Step 11</i>	Go to <i>Step 10</i>

### Rough, Unstable, or Incorrect Idle, Stalling Symptom (Cont'd)

Step	Action	Value(s)	Yes	No
10	<p>1. Visually/physically inspect for the following conditions:</p> <ul style="list-style-type: none"> <li>○ Restricted air intake system. Check for a possible collapsed air intake duct, restricted air filter element, or foreign objects blocking the air intake system.</li> <li>○ Throttle body. Check for objects blocking the IAC passage or throttle bore, excessive deposits in the IAC passage and on the IAC pintle, and excessive deposits in the throttle bore and on the throttle plate.</li> <li>○ Large vacuum leak. Check for a condition that causes a large vacuum leak, such as an incorrectly installed or faulty crankcase ventilation valve or a disconnected brake booster hose.</li> </ul> <p>2. If a problem is found, repair as necessary.</p> <p>Was a problem found?</p>	—	Verify repair	Go to <i>Step 8</i>
11	<p>Check the injector connections. If any of the injectors are connected to an incorrect cylinder, correct as necessary.</p> <p>Was a problem found?</p>	—	Verify repair	Go to <i>Step 12</i>
12	<p>1. Perform the "Injector Coil/Balance Test" in <i>Fuel Metering System</i>.</p> <p>2. If a problem is found, repair as necessary.</p> <p>Was a problem found?</p>	—	Verify repair	Go to <i>Step 13</i>
13	<p>1. Check for fuel in the pressure regulator vacuum hose.</p> <p>2. If fuel is present, replace the fuel pressure regulator assembly. Refer to <i>Fuel Metering System</i>.</p> <p>3. If a problem is found, repair as necessary.</p> <p>Was a problem found?</p>	—	Verify repair	Go to <i>Step 14</i>
14	<p>1. Check for proper ignition voltage output with spark tester J 26792 (ST-125). Refer to <i>Electronic Ignition System</i> for the procedure.</p> <p>2. If a problem is found, repair as necessary.</p> <p>Was a problem found?</p>	—	Verify repair	Go to <i>Step 15</i>
15	<p>1. Remove spark plugs. Check for wet plugs, cracks, wear, improper gap, burned electrodes, or heavy deposits. Refer to <i>Electronic Ignition System</i>.</p> <p>NOTE: If spark plugs are gas or oil fouled, the cause of the fouling must be determined before replacing the spark plugs.</p> <p>2. If a problem is found, repair as necessary.</p> <p>Was a problem found?</p>	—	Verify repair	Go to <i>Step 16</i>
16	<p>1. Check ignition coils for cracks or carbon tracking.</p> <p>2. If a problem is found, repair as necessary.</p> <p>Was a problem found?</p>	—	Verify repair	Go to <i>Step 17</i>

### Rough, Unstable, or Incorrect Idle, Stalling Symptom (Cont'd)

Step	Action	Value(s)	Yes	No
17	Using a Tech 2, monitor the throttle position (TP) angle with the engine idling. Is the TP angle at the specified value and steady?	0%	Go to <i>Step 18</i>	Refer to <i>DTC P0123</i> for further diagnosis
18	1. Check the positive crankcase ventilation (PCV) valve for proper operation. Refer to <i>Crankcase Ventilation System</i> . 2. If a problem is found, repair as necessary. Was a problem found?	—	Verify repair	Go to <i>Step 19</i>
19	1. Check the transmission range switch circuit. Use a Tech 2 and be sure the Tech 2 indicates that the vehicle is in drive with the gear selector in drive or overdrive. 2. If a problem is found, diagnose and repair the transmission range switch as necessary (refer to <i>4L30-E Automatic Transmission Diagnosis</i> ). Was a problem found?	—	Verify repair	Go to <i>Step 20</i>
20	1. Check for the following engine mechanical items. Refer to <i>Engine Mechanical</i> for diagnosis procedures: <ul style="list-style-type: none"> <li><input type="radio"/> Low compression</li> <li><input type="radio"/> Sticking or leaking valves</li> <li><input type="radio"/> Worn camshaft lobe(s)</li> <li><input type="radio"/> Camshaft drive belt slipped or stripped</li> <li><input type="radio"/> Incorrect valve timing</li> <li><input type="radio"/> Worn rocker arms</li> <li><input type="radio"/> Broken valve springs</li> </ul> 2. If a problem is found, repair as necessary. Was a problem found?	—	Verify repair	Go to <i>Step 21</i>
21	1. Check for faulty motor mounts. Refer to <i>Engine Mechanical</i> for inspection of mounts. 2. If a problem is found, repair as necessary. Was a problem found?	—	Verify repair	Go to <i>Step 22</i>
22	1. Review all diagnostic procedures within this table. 2. If all procedures have been completed and no malfunctions have been found, review/inspect the following: <ul style="list-style-type: none"> <li><input type="radio"/> Visual/physical inspection</li> <li><input type="radio"/> Tech 2 data</li> <li><input type="radio"/> Freeze Frame data/Failure Records buffer</li> <li><input type="radio"/> All electrical connections within a suspected circuit and/or system.</li> </ul> 3. If a problem is found, repair as necessary. Was a problem found?	—	Verify repair	Contact Technical Assistance



### Poor Fuel Economy Symptom

Step	Action	Value(s)	Yes	No
1	<p><b>DEFINITION:</b> Fuel economy, as measured by an actual road test, is noticeably lower than expected. Also, economy is noticeably lower than it was on this vehicle at one time, as previously shown by an actual road test. (Non-standard tires will cause odometer readings to be incorrect, and that may cause fuel economy to appear poor when it is actually normal.)</p> <p>Was the "On-Board Diagnostic (OBD) System Check" performed?</p>	—	Go to Step 2	Go to <i>OBD System Check</i>
2	<p>1. Perform a bulletin search. 2. If a bulletin that addresses the symptom is found, correct the condition as instructed in the bulletin.</p> <p>Was a bulletin found that addresses the symptom?</p>	—	Verify repair	Go to Step 3
3	<p>Was a visual/physical check performed?</p>	—	Go to Step 4	Go to <i>Visual/Physical Check</i>
4	<p>Check owner's driving habits.</p> <ul style="list-style-type: none"> <li><input type="radio"/> Is the A/C "ON" full time (defroster mode "ON")?</li> <li><input type="radio"/> Are tires at the correct pressure?</li> <li><input type="radio"/> Are excessively heavy loads being carried?</li> <li><input type="radio"/> Is acceleration too much, too often?</li> </ul> <p>Was a problem found?</p>	—	Go to Step 5	Go to Step 6
5	<p>Review the items in Step 4 with the customer and advise as necessary.</p> <p>Is the action complete?</p>	—	System OK	—
6	<p>1. Visually/physically check: Vacuum hoses for splits, kinks, and improper connections and routing as shown on the "Vehicle Emission Control Information" label. 2. If a problem is found, repair as necessary.</p> <p>Was a problem found?</p>	—	Verify repair	Go to Step 7
7	<p>1. Remove and check the air filter element for dirt or for restrictions. Refer to <i>Air Intake System</i>. 2. Replace the air filter element if necessary.</p> <p>Was a repair required?</p>	—	Verify repair	Go to Step 8
8	<p>1. Remove spark plugs and check for wet plugs, cracks, wear, improper gap, burned electrodes, or heavy deposits. Refer to <i>Spark Plug Replacement</i>.</p> <p>NOTE: If spark plugs are gas or oil fouled, the cause of the fouling must be determined before replacing the spark plugs.</p> <p>2. If a problem is found, repair as necessary.</p> <p>Was a problem found?</p>	—	Verify repair	Go to Step 9
9	<p>1. Check for low engine coolant level. Refer to <i>Engine Cooling</i>. 2. If a problem is found, repair as necessary.</p> <p>Was a problem found?</p>	—	Verify repair	Go to Step 10

### Poor Fuel Economy Symptom (Cont'd)

Step	Action	Value(s)	Yes	No
10	<p>1. Check for an incorrect or faulty engine thermostat. Refer to <i>Engine Cooling</i>.</p> <p>2. If a problem is found, repair as necessary.</p> <p>Was a problem found?</p>	—	Verify repair	Go to Step 11
11	<p>1. Check for low engine compression. Refer to <i>Engine Mechanical</i>.</p> <p>2. If a problem is found, repair as necessary.</p> <p>Was a problem found?</p>	—	Verify repair	Go to Step 12
12	<p>1. Check the TCC operation. Refer to <i>4L30-E Transmission Diagnosis</i>.</p> <p>2. If a problem is found, repair as necessary.</p> <p>Was a problem found?</p>	—	Verify repair	Go to Step 13
13	<p>1. Check the exhaust system for possible restriction:</p> <ul style="list-style-type: none"> <li>○ Inspect the exhaust system for damaged or collapsed pipes.</li> <li>○ Inspect the muffler for heat distress or possible internal failure.</li> <li>○ Check for a possible plugged three-way catalytic converter by checking the exhaust system back pressure. Refer to <i>Restricted Exhaust System Check</i>.</li> </ul> <p>2. If a problem is found, repair as necessary.</p> <p>Was a problem found?</p>	—	Verify repair	Go to Step 14
14	<p>Check for proper calibration of the speedometer.</p> <p>Does the speed indicated on the speedometer closely match the vehicle speed displayed on the Tech 2?</p>	—	Go to Step 16	Go to Step 15
15	<p>Diagnose and repair an inaccurate speedometer condition as necessary. Refer to <i>Vehicle Speed Sensor</i> in <i>Electrical Diagnosis</i>.</p> <p>Was a problem found?</p>	—	Verify repair	—
16	<p>1. Check the air intake system and the crankcase for air leaks. Refer to <i>Air Intake System</i> and <i>Crankcase Ventilation System</i>.</p> <p>2. If a problem is found, repair as necessary.</p> <p>Was a problem found?</p>	—	Verify repair	Go to Step 17
17	<p>1. Review all diagnostic procedures within this table.</p> <p>2. When all procedures have been completed and no malfunctions have been found, review/inspect the following:</p> <ul style="list-style-type: none"> <li>○ Visual/physical inspection</li> <li>○ Tech 2 data</li> <li>○ Freeze Frame data/Failure Records buffer</li> <li>○ All connections within a suspected circuit and/or system.</li> </ul> <p>3. If a problem is found, repair as necessary.</p> <p>Was a problem found?</p>	—	Verify repair	Go to Step 18
18	<p>Perform the procedure in <i>Fuel System Pressure Test</i>.</p> <p>Was the fuel pressure normal?</p>	—	Contact Technical Assistance	Verify repair

## Excessive Exhaust Emissions or Odors Symptom

Step	Action	Value(s)	Yes	No
1	<p><b>DEFINITION:</b> Vehicle fails an emission test. Vehicle has excessive "rotten egg" smell. (Excessive odors do not necessarily indicate excessive emissions.)</p> <p>Was the "On-Board Diagnostic (OBD) System Check" performed?</p>	—	Go to Step 2	Go to <i>OBD System Check</i>
2	<p>1. Perform a bulletin search. 2. If a bulletin that addresses the symptom is found, correct the condition as instructed in the bulletin.</p> <p>Was a bulletin found that addresses the symptom?</p>	—	Go to Step 13	Go to Step 3
3	<p>Was a thorough visual/physical check performed?</p>	—	Go to Step 4	Go to <i>Visual/Physical Check</i>
4	<p>1. Check for vacuum leaks. Check vacuum lines, intake manifold, throttle body, etc. 2. If a problem is found, repair as necessary.</p> <p>Were any vacuum leaks located?</p>	—	Go to Step 13	Go to Step 5
5	<p>1. Check the fuel cap for proper installation. 2. Secure the fuel cap if necessary.</p> <p>Was the fuel cap installed properly?</p>	—	Go to Step 6	Go to Step 13
6	<p>1. Check the fuel pressure. Perform the procedure in <i>Fuel System Pressure Test</i>. 2. If a problem is found, repair as necessary.</p> <p>Was a problem found?</p>	—	Go to Step 13	Go to Step 7
7	<p>1. Check for a faulty, plugged, or incorrectly installed crankcase ventilation valve; also check the crankcase ventilation system for plugging. 2. If a problem is found, repair as necessary.</p> <p>Was a problem found?</p>	—	Go to Step 13	Go to Step 8
8	<p>1. Check the injector connections. 2. If any of the injectors are connected to an incorrect cylinder, correct as necessary.</p> <p>Was a problem found?</p>	—	Go to Step 13	Go to Step 9
9	<p>1. Perform the "Injector Coil/Balance Test" in <i>Fuel Metering System</i>. 2. If a problem is found, repair as necessary.</p> <p>Was a problem found?</p>	—	Go to Step 13	Go to Step 10
10	<p>1. Refer to <i>Engine Cooling</i> for cooling system diagnosis. 2. If a problem is found, repair as necessary.</p> <p>Was a problem found?</p>	—	Go to Step 13	Go to Step 11
11	<p>1. Check EVAP canister for fuel loading. Refer to <i>Evaporative Emission Control System</i>. 2. If a problem is found, repair as necessary.</p> <p>Was a problem found?</p>	—	Go to Step 13	Go to Step 12

**Excessive Exhaust Emissions or Odors Symptom (Cont'd)**

Step	Action	Value(s)	Yes	No
12	1. Remove excessive carbon buildup with a top engine cleaner. Refer to the instructions on the top engine cleaner can. 2. Perform the exhaust emission test. Does the vehicle pass the test?	—	System OK	Go to <i>Step 14</i>
13	Perform the exhaust emission test. Does the vehicle pass the test?	—	System OK	Go to <i>Step 14</i>
14	Does the exhaust emission test indicate excessive CO and HC levels or is long term fuel trim significantly in the negative range (rich condition)?	—	Go to <i>Step 15</i>	Go to <i>Step 16</i>
15	1. Check items that can cause the engine to run rich. Refer to <i>Diagnostic Aids in DTC P0172 Diagnostic Support</i> . Make any necessary repairs. 2. Perform the exhaust emission test. Does the vehicle pass the test?	—	System OK	Go to <i>Step 17</i>
16	1. Check items that can cause the engine to run lean. Refer to <i>Diagnostic Aids in DTC P0171 Diagnostic Support</i> . Make any necessary repairs. 2. Perform the exhaust emission test. Does the vehicle pass the test?	—	System OK	Go to <i>Step 17</i>
17	1. Check the EGR system (refer to <i>DTC P0401</i> ). 2. If a problem is found, repair as necessary. Was a problem found?	—	Go to <i>Step 13</i>	Go to <i>Step 18</i>
18	1. Check for an engine mechanical problem. Perform a cylinder compression check (refer to <i>Engine Mechanical</i> ). 2. If a problem is found, repair as necessary. Was a problem found?	—	Go to <i>Step 13</i>	Go to <i>Step 19</i>
19	1. Review all diagnostic procedures within this table. 2. If all procedures have been completed and no malfunctions have been found, review/inspect the following: <ul style="list-style-type: none"> <li>○ Visual/physical inspection</li> <li>○ Tech 2 data</li> <li>○ Freeze Frame data/Failure Records butter</li> <li>○ All electrical connections within a suspected circuit and/or system.</li> </ul> 3. If a problem is found, repair as necessary. Was a problem found?	—	Verify repair	Contact Technical Assistance

### Dieseling, Run-On Symptom

Step	Action	Value(s)	Yes	No
1	<p><b>DEFINITION:</b> Engine continues to run after key is turned "OFF," but runs very rough. If engine runs smooth, check ignition switch and adjustment.</p> <p>Was the "On-Board Diagnostic (OBD) System Check" performed?</p>	—	Go to <i>Step 2</i>	Go to <i>OBD System Check</i>
2	<p>1. Perform a bulletin search. 2. If a bulletin that addresses the symptom is found, correct the condition as instructed in the bulletin.</p> <p>Was a bulletin found that addresses the symptom?</p>	—	Verify repair	Go to <i>Step 3</i>
3	<p>Was a visual/physical check performed?</p>	—	Go to <i>Step 4</i>	Go to <i>Visual/Physical Check</i>
4	<p>1. Check for a short between B+ and any of the ignition feed circuits. 2. If a problem is found, repair as necessary.</p> <p>Was a problem found?</p>	—	Verify repair	Go to <i>Step 5</i>
5	<p>1. Review all diagnostic procedures within this table. 2. If all procedures have been completed and no malfunctions have been found, review/inspect the following:</p> <ul style="list-style-type: none"> <li>○ Visual/physical inspection</li> <li>○ Tech 2 data</li> <li>○ Freeze Frame data/Failure Records buffer</li> <li>○ All electrical connections within a suspected circuit and/or system</li> </ul> <p>3. If a problem is found, repair as necessary.</p> <p>Was a problem found?</p>	—	Verify repair	Contact Technical Assistance

## Backfire Symptom

Step	Action	Value(s)	Yes	No
1	<p><b>DEFINITION:</b> Fuel ignites in the intake manifold, or in the exhaust system, making a loud popping noise.</p> <p>Was the "On-Board Diagnostic (OBD) System Check" performed?</p>	—	Go to <i>Step 2</i>	Go to <i>OBD System Check</i>
2	<p>1. Perform a bulletin search. 2. If a bulletin that addresses the symptom is found, correct the condition as instructed in the bulletin.</p> <p>Was a bulletin found that addresses the symptom?</p>	—	Verify repair	Go to <i>Step 3</i>
3	<p>Was a visual/physical check performed?</p>	—	Go to <i>Step 4</i>	Go to <i>Visual/Physical Check</i>
4	<p>1. Check for proper ignition voltage coil output with spark tester J 26792 (ST-125). Refer to <i>Electric Ignition System</i> for procedure. 2. If a problem is found, repair as necessary.</p> <p>Was a problem found?</p>	—	Verify repair	Go to <i>Step 5</i>
5	<p>1. Remove spark plugs and check for wet plugs, cracks, wear, improper gap, burned electrodes, or heavy deposits. Refer to <i>Electronic Ignition System</i>.</p> <p>NOTE: If spark plugs are gas or oil fouled, the cause of the fouling must be determined before replacing the spark plugs. Refer to <i>DTC P0172</i> to determine the cause of a rich condition or <i>Engine Mechanical</i> for an oil fouling condition.</p> <p>2. If a problem is found, repair as necessary.</p> <p>Was a problem found?</p>	—	Verify repair	Go to <i>Step 6</i>
6	<p>1. Visually/physically inspect the ignition coils for cracks. 2. If a problem is found, repair as necessary.</p> <p>Was a problem found?</p>	—	Verify repair	Go to <i>Step 7</i>
7	<p>1. Check for an intermittent ignition system malfunction:</p> <ul style="list-style-type: none"> <li>○ Intermittent CKP 58X signal.</li> <li>○ Intermittent ignition feed circuit or sensor ground circuit to the crankshaft position sensor.</li> </ul> <p>2. If a problem is found, repair as necessary.</p> <p>Was a problem found?</p>	—	Verify repair	Go to <i>Step 8</i>
8	<p>1. Check the fuel pressure. Refer to <i>Fuel System Pressure Test</i>. 2. If a problem is found, repair as necessary.</p> <p>Was a problem found?</p>	—	Verify repair	Go to <i>Step 9</i>

### Backfire Symptom (Cont'd)

Step	Action	Value(s)	Yes	No
9	<p>1. Check for the following engine mechanical conditions. Refer to <i>Engine Mechanical</i> for diagnosis procedures:</p> <ul style="list-style-type: none"> <li><input type="radio"/> Low compression</li> <li><input type="radio"/> Sticking or leaking valves</li> <li><input type="radio"/> Worn camshaft lobe(s)</li> <li><input type="radio"/> Camshaft drive belt slipped or stripped</li> <li><input type="radio"/> Incorrect valve timing</li> </ul> <p>2. If a problem is found, repair as necessary. Was a problem found?</p>	—	Verify repair	Go to <i>Step 10</i>
10	<p>1. Check the intake and exhaust manifold(s) for casting flash. Refer to <i>Engine Mechanical</i>.</p> <p>2. If a problem is found, repair as necessary. Was a problem found?</p>	—	Verify repair	Go to <i>Step 11</i>
11	<p>1. Review all diagnostic procedures within this table.</p> <p>2. If all procedures have been completed and no malfunctions have been found, review/inspect the following:</p> <ul style="list-style-type: none"> <li><input type="radio"/> Visual/physical inspection</li> <li><input type="radio"/> Tech 2 data</li> <li><input type="radio"/> Freeze Frame data/Failure Records buffer</li> <li><input type="radio"/> All electrical connections within a suspected circuit and/or system.</li> </ul> <p>3. If a problem is found, repair as necessary. Was a problem found?</p>	—	Verify repair	Contact Technical Assistance

## Cuts Out, Misses Symptom

Step	Action	Value(s)	Yes	No
1	<p><b>DEFINITION:</b> Steady pulsation or jerking that follows engine speed; usually more pronounced as engine load increases.</p> <p>Was the "On-Board Diagnostic (OBD) System Check" performed?</p>	—	Go to <i>Step 2</i>	Go to <i>OBD System Check</i>
2	<p>1. Perform a bulletin search.</p> <p>2. If a bulletin that addresses the symptom is found, correct the condition as instructed in the bulletin.</p> <p>Was a bulletin found that addresses the symptom?</p>	—	Go to <i>Step 13</i>	Go to <i>Step 3</i>
3	<p>Was a visual/physical check performed?</p>	—	Go to <i>Step 4</i>	Go to <i>Visual/Physical Check</i>
4	<p>1. Check the PCM grounds for clearness, tightness and proper routing. Refer to the PCM wiring diagrams in <i>Electrical Diagnosis</i>.</p> <p>2. If a problem is found, repair as necessary.</p> <p>Was a problem found?</p>	—	Verify repair	Go to <i>Step 5</i>
5	<p>Observe the long term fuel trim on the Tech 2.</p> <p>Is the long term fuel trim significantly in the negative range (rich condition)?</p>	—	Go to <i>Step 6</i>	Go to <i>Step 7</i>
6	<p>1. Check items that can cause the engine to run rich. Refer to <i>Diagnostic Aids in DTC P0172 Diagnostic Support</i>.</p> <p>2. If a problem is found, repair as necessary.</p> <p>Was a problem found?</p>	—	Verify repair	Go to <i>Step 9</i>
7	<p>Is the long term fuel trim significantly in the positive range (lean condition)?</p>	—	Go to <i>Step 8</i>	Go to <i>Step 9</i>
8	<p>1. Check items that can cause the engine to run lean. Refer to <i>Diagnostic Aids in DTC P0171 Diagnostic Support</i>.</p> <p>2. If a problem is found, repair as necessary.</p> <p>Was a problem found?</p>	—	Verify repair	Go to <i>Step 9</i>
9	<p>1. Check for incorrect idle speed. Ensure that the following conditions are present:</p> <ul style="list-style-type: none"> <li>○ The engine is fully warm.</li> <li>○ The accessories are "off."</li> </ul> <p>2. Using a Tech 2, monitor the IAC position.</p> <p>Is the IAC position within the specified values?</p>	Between 5 and 50 counts	Go to <i>Step 11</i>	Go to <i>Step 10</i>



## Cuts Out, Misses Symptom (Cont'd)

Step	Action	Value(s)	Yes	No
10	<p>1. Visually/physically inspect for the following conditions:</p> <ul style="list-style-type: none"> <li>○ Restricted air intake system. Check for a possible collapsed air intake duct, restricted air filter element, or foreign objects blocking the air intake system.</li> <li>○ Throttle body. Check for objects blocking the IAC passage or throttle bore, excessive deposits in the IAC passage and on the IAC pintle, and excessive deposits in the throttle bore and on the throttle plate.</li> <li>○ Large vacuum leak. Check for a condition that causes a large vacuum leak, such as an incorrectly installed or faulty PCV valve or brake booster hose disconnected.</li> </ul> <p>2. If a problem is found, repair as necessary.</p> <p>Was a problem found?</p>	—	Verify repair	Go to <i>Step 8</i>
11	<p>Check the injector connections. If any of the injectors are connected to an incorrect cylinder, correct as necessary.</p> <p>Was a problem found?</p>	—	Verify repair	Go to <i>Step 12</i>
12	<p>1. Perform the "Injector Coil/Balance Test" in <i>Fuel Metering System</i>.</p> <p>2. If a problem is found, repair as necessary.</p> <p>Was a problem found?</p>	—	Verify repair	Go to <i>Step 13</i>
13	<p>1. Check for fuel in the pressure regulator vacuum hose.</p> <p>2. If fuel is present, replace the fuel pressure regulator assembly. Refer to <i>Fuel Metering System</i>.</p> <p>3. If a problem is found, repair as necessary.</p> <p>Was a problem found?</p>	—	Verify repair	Go to <i>Step 14</i>
14	<p>1. Check for proper ignition voltage output with spark tester J 26792 (ST-125). Refer to <i>Electronic Ignition System</i> for the procedure.</p> <p>2. If a problem is found, repair as necessary.</p> <p>Was a problem found?</p>	—	Verify repair	Go to <i>Step 15</i>
15	<p>1. Remove spark plugs. Check for wet plugs, cracks, wear, improper gap, burned electrodes, or heavy deposits. Refer to <i>Electronic Ignition System</i>.</p> <p>NOTE: If spark plugs are gas or oil fouled, the cause of the fouling must be determined before replacing the spark plugs.</p> <p>2. If a problem is found, repair as necessary.</p> <p>Was a problem found?</p>	—	Verify repair	Go to <i>Step 16</i>
16	<p>1. Check ignition coils for cracks or carbon tracking.</p> <p>2. If a problem is found, repair as necessary.</p> <p>Was a problem found?</p>	—	Verify repair	Go to <i>Step 17</i>
17	<p>Using a Tech 2, monitor the TP angle with the engine idling.</p> <p>Is the TP angle at the specified value and steady?</p>	0%	Go to <i>Step 18</i>	Refer to <i>DTC P0123</i> for further diagnosis

## Cuts Out, Misses Symptom (Cont'd)

Step	Action	Value(s)	Yes	No
18	<p>1. Check the PCV valve for proper operation. Refer to <i>Crankcase Ventilation System</i>.</p> <p>2. If a problem is found, repair as necessary.</p> <p>Was a problem found?</p>	—	Verify repair	Go to <i>Step 19</i>
19	<p>1. Check the transmission range switch circuit. Use a Tech 2 and be sure the Tech 2 indicates that the vehicle is in drive with the gear selector in drive or overdrive.</p> <p>2. If a problem is found, diagnose and repair the transmission range switch as necessary (refer to <i>4L30-E Automatic Transmission Diagnosis</i>).</p> <p>Was a problem found?</p>	—	Verify repair	Go to <i>Step 20</i>
20	<p>1. Check the following engine mechanical items. Refer to <i>Engine Mechanical</i> for diagnosis procedures:</p> <ul style="list-style-type: none"> <li><input type="radio"/> Low compression</li> <li><input type="radio"/> Sticking or leaking valves</li> <li><input type="radio"/> Worn camshaft lobe(s)</li> <li><input type="radio"/> Camshaft drive belt slipped or stripped</li> <li><input type="radio"/> Incorrect valve timing</li> <li><input type="radio"/> Worn rocker arms</li> <li><input type="radio"/> Broken valve springs</li> </ul> <p>2. If a problem is found, repair as necessary.</p> <p>Was a problem found?</p>	—	Verify repair	Go to <i>Step 21</i>
21	<p>1. Check for faulty motor mounts. Refer to <i>Engine Mechanical</i> for inspection of mounts.</p> <p>2. If a problem is found, repair as necessary.</p> <p>Was a problem found?</p>	—	Verify repair	Go to <i>Step 22</i>
22	<p>1. Review all diagnostic procedures within this table.</p> <p>2. If all procedures have been completed and no malfunctions have been found, review/inspect the following:</p> <ul style="list-style-type: none"> <li><input type="radio"/> Visual/physical inspection</li> <li><input type="radio"/> Tech 2 data</li> <li><input type="radio"/> Freeze Frame data/Failure Records buffer</li> <li><input type="radio"/> All electrical connections within a suspected circuit and/or system</li> </ul> <p>3. If a problem is found, repair as necessary.</p> <p>Was a problem found?</p>	—	Verify repair	Contact Technical Assistance

## Hesitation, Sag, Stumble Symptom

Step	Action	Value(s)	Yes	No
1	<p><b>DEFINITION:</b> Momentary lack of response as the accelerator is pushed down. Can occur at any vehicle speed. Usually most pronounced when first trying to make the vehicle move, as from a stop sign. May cause the engine to stall if severe enough.</p> <p>Was the "On-Board Diagnostic (OBD) System Check" performed?</p>	—	Go to Step 2	Go to <i>OBD System Check</i>
2	<p>1. Perform a bulletin search. 2. If a bulletin that addresses the symptom is found, correct the condition as instructed in the bulletin.</p> <p>Was a bulletin found that addresses the symptom?</p>	—	Verify repair	Go to Step 3
3	<p>Was a visual/physical check performed?</p>	—	Go to Step 4	Go to <i>Visual/Physical Check</i>
4	<p>1. Check the fuel control heated oxygen sensors (HO2S, B1S1 and B2S1). The fuel control heated oxygen sensors (HO2S) should respond quickly to different throttle positions. If they don't, check them for silicon or other contaminants from fuel or use of improper RTV sealant. The sensors may have a white powdery coating. Silicon contamination causes a high but false HO2S signal voltage (rich exhaust indication). The PCM will then reduce the amount of fuel delivered to the engine, causing a severe driveability problem. For more information, refer to <i>Powertrain Control Module (PCM) and Sensors</i>.</p> <p>2. If a problem is found, repair as necessary.</p> <p>Was a problem found?</p>	—	Verify repair	Go to Step 5
5	<p>1. Check the fuel pressure. Refer to <i>Fuel System Pressure Test</i>. 2. If a problem is found, repair as necessary.</p> <p>Was a problem found?</p>	—	Verify repair	Go to Step 6
6	<p>Observe the TP angle display on the Tech 2 while slowly increasing throttle pedal.</p> <p>Does the TP angle display steadily increase from 0% at closed throttle to 100% at WOT?</p>	—	Go to Step 7	Go to Step 18
7	<p>Monitor the long term fuel trim on the Tech 2.</p> <p>Is the long term fuel trim significantly in the negative range (rich condition)?</p>	—	Go to Step 8	Go to Step 9
8	<p>1. Check items that can cause the engine to run rich. Refer to <i>Diagnostic Aids in DTC P0172 Diagnostic Support</i>. 2. If a problem is found, repair as necessary.</p> <p>Was a problem found?</p>	—	Verify repair	Go to Step 10
9	<p>1. Check items that can cause the engine to run lean. Refer to <i>Diagnostic Aids in DTC P0171 Diagnostic Support</i>. 2. If a problem is found, repair as necessary.</p> <p>Was a problem found?</p>	—	Verify repair	Go to Step 10

### Hesitation, Sag, Stumble Symptom (Cont'd)

Step	Action	Value(s)	Yes	No
10	<p>1. Check for proper ignition voltage output with spark tester J 26792 (ST-125). Refer to <i>Electronic Ignition System</i> for the procedure.</p> <p>2. If a problem is found, repair as necessary.</p> <p>Was a problem found?</p>	—	Verify repair	Go to <i>Step 11</i>
11	<p>1. Check the ignition coils for cracks or carbon tracking.</p> <p>2. If a problem is found, repair as necessary.</p> <p>Was a problem found?</p>	—	Verify repair	Go to <i>Step 12</i>
12	<p>1. Remove spark plugs and check for wet plugs, cracks, wear, improper gap, burned electrodes, or heavy deposits. Refer to <i>Electronic Ignition System</i>.</p> <p>NOTE: If spark plugs are gas or oil fouled, the cause of the fouling must be determined before replacing the spark plugs.</p> <p>2. If a problem is found, repair as necessary.</p> <p>Was a problem found?</p>	—	Verify repair	Go to <i>Step 13</i>
13	<p>1. Check the PCM grounds for clearness, tightness and proper routing. Refer to the PCM wiring diagrams in <i>Electrical Diagnosis</i>.</p> <p>2. If a problem is found, repair as necessary.</p> <p>Was a problem found?</p>	—	Verify repair	Go to <i>Step 14</i>
14	<p>1. Check the MAF sensor connections.</p> <p>2. If a problem is found, replace the faulty terminals as necessary. Refer to <i>Electrical Diagnosis</i> for wiring repair procedures.</p> <p>Was a problem found?</p>	—	Verify repair	Go to <i>Step 15</i>
15	<p>1. Visually/physically check vacuum hoses for splits, kinks, and proper connections and routing as shown on the "Vehicle Emission Control Information" label.</p> <p>2. If a problem is found, repair as necessary.</p> <p>Was a problem found?</p>	—	Verify repair	Go to <i>Step 16</i>
16	<p>1. Review all diagnostic procedures within this table.</p> <p>2. If all procedures have been completed and no malfunctions have been found, review/inspect the following:</p> <ul style="list-style-type: none"> <li><input type="radio"/> Visual/physical inspection</li> <li><input type="radio"/> Tech 2 data</li> <li><input type="radio"/> Freeze Frame data/Failure Records buffer</li> <li><input type="radio"/> All electrical connections within a suspected circuit and/or system</li> </ul> <p>3. If a problem is found, repair as necessary.</p> <p>Was a problem found?</p>	—	Verify repair	Contact Technical Assistance

### Bank 1 Restricted Exhaust System Check

Step	Action	Value(s)	Yes	No
1	Was the "On-Board Diagnostic (OBD) System Check" performed?	—	Go to <i>Step 2</i>	Go to <i>OBD System Check</i>
2	1. Remove the Bank 1 HO2S 2. 2. Install the Exhaust Backpressure Tester (BT-8515-V or equivalent) in place of the Bank 1 HO2S 2. 3. Run the engine at normal operating temperature. 4. Increase the engine speed to 2000 RPM and allow 10 seconds for pressure to build. 5. Observe the exhaust system backpressure reading on the gauge.  Does the reading exceed the amount in the value column?	8.62 kpa (1.25 psi)	Go to <i>Step 3</i>	Go to <i>Step 4</i>
3	Repair the restriction in the exhaust system after the catalytic converter. Possible faults include: <input type="radio"/> Collapsed pipe <input type="radio"/> Heat distress <input type="radio"/> Internal muffler failure  Is the action complete?	—	Verify repair	—
4	1. Install the Bank 1 HO2S 2. 2. Install the Exhaust Backpressure Tester in place of Bank 1 HO2S 1. 3. Run the engine at normal operating temperature. 4. Increase the engine speed to 2000 RPM and allow 10 seconds for pressure to build. 5. Observe the exhaust system backpressure reading on the gauge.  Does the reading exceed the amount in the value column?	8.62 kpa (1.25 psi)	Go to <i>Step 5</i>	No trouble found. If a driveability symptom exists, refer to symptom charts
5	Repair the restriction in the catalytic converter.  Is the action complete?	—	Verify repair	—

NOTE: DTCs will be set by running the vehicle to normal operating temperature after a cold start with the O2 sensor disconnected. After performing these tests, use the Tech 2 to erase the DTCs that were set by the lack of O2 sensor activity.

### Bank 2 Restricted Exhaust System Check

Step	Action	Value(s)	Yes	No
1	Was the "On-Board Diagnostic (OBD) System Check" performed?	—	Go to Step 2	Go to <i>OBD System Check</i>
2	1. Remove the Bank 2 HO2S 2. 2. Install the Exhaust Backpressure Tester (BT-8515-V or equivalent) in place of the Bank 2 HO2S 2. 3. Run the engine at normal operating temperature. 4. Increase the engine speed to 2000 RPM and allow 10 seconds for pressure to build. 5. Observe the exhaust system backpressure reading on the gauge.  Does the reading exceed the amount in the value column?	8.62 kpa (1.25 psi)	Go to Step 3	Go to Step 4
3	Repair the restriction in the exhaust system after the catalytic converter. Possible faults include: <input type="radio"/> Collapsed pipe <input type="radio"/> Heat distress <input type="radio"/> Internal muffler failure  Is the action complete?	—	Verify repair	—
4	1. Install the Bank 2 HO2S 2. 2. Install the Exhaust Back pressure Tester in place of Bank 1 HO2S 1. 3. Run the engine at normal operating temperature. 4. Increase the engine speed to 2000 RPM and allow 10 seconds for pressure to build. 5. Observe the exhaust system backpressure reading on the gauge.  Does the reading exceed the amount in the value column?	8.62 kpa (1.25 psi)	Go to Step 5	No trouble found. If a driveability symptom exists, refer to symptom charts
5	Repair the restriction in the catalytic converter.  Is the action complete?	—	Verify repair	—

NOTE: DTCs will be set by running the vehicle to normal operating temperature after a cold start with the O2 sensor disconnected. After performing these tests, use the Tech 2 to erase the DTCs that were set by the lack of O2 sensor activity.

## Default Matrix Table

### Service Procedure Default Strategy

A referral strategy has been established to assist the technician with additional information when the cause of the failure cannot be determined. If no problem is found after performing diagnostics, then refer to the default matrix table for further diagnostic information.

### Default Matrix Table

Strategy Based Diagnostic Charts	Initial Diagnosis	Default Section(s)
On-Board Diagnostic (OBD) System Check	Vehicle does not enter diagnostics.	Chassis Electrical
On-Board Diagnostic (OBD) System Check	Vehicle enters diagnostics and communicates with the Tech 2. MIL is "ON" in diagnostics. Engine does not start and run.	Ignition System Check
On-Board Diagnostic (OBD) System Check	Engine starts and runs, no PCM codes set. Customer complains of vibration.	—
On-Board Diagnostic (OBD) System Check	Engine starts and runs, no PCM codes set. Customer complains of harsh or soft shift, poor performance, delayed or no engagement into drive or reverse, transmission fluid leak, transmission noise or vibration, or improper TCC operation.	Automatic Transmission
PCM Power and Ground Check	On-Board Diagnostic (OBD) System Check.	Chassis Electrical
PCM Power and Ground Check	On-Board Diagnostic (OBD) System Check. PCM power and ground circuits OK. Data link voltage incorrect.	Chassis Electrical
On-Board Diagnostic (OBD) System Check	Engine starts and runs, no PCM codes set. Customer complains of harsh or soft shift, poor performance, delayed or no engagement into drive or reverse, transmission fluid leak, transmission noise or vibration, or improper TCC operation.	Automatic Transmission

Symptoms	Initial Diagnosis	Default Section(s)
Intermittents	<ol style="list-style-type: none"> <li>1. On-board Diagnostic (OBD) system check.</li> <li>2. Careful visual/physical inspections.</li> </ol>	Chassis Electrical
Hard Starts	<ol style="list-style-type: none"> <li>1. OBD system check.</li> <li>2. Sensors (ECT, MAP, MAF, TP) ; MAP output chart.</li> <li>3. Fuel system electrical test, fuel system diagnosis.</li> <li>4. Ignition system.</li> <li>5. IAC system check.</li> </ol>	Engine Mechanical, Ignition System Check, Exhaust System Diagnosis
Surges and/or Chuggles	<ol style="list-style-type: none"> <li>1. OBD system check.</li> <li>2. Heated oxygen sensors.</li> <li>3. Fuel system diagnosis.</li> <li>4. Ignition system.</li> </ol>	Calibration ID "Broadcast Code"/Service Bulletins, Ignition System Check, Generator Output, Exhaust System Diagnosis, 4L30-E System Test

**6VE1 3.5L ENGINE DRIVEABILITY AND EMISSIONS 6E-439**

Symptoms	Initial Diagnosis	Default Section(s)
Lack of Power, Sluggish or Spongy	<ol style="list-style-type: none"> <li>1. OBD system check.</li> <li>2. Fuel system diagnosis.</li> <li>3. Ignition system.</li> <li>4. Knock sensor.</li> <li>5. EGR operation.</li> <li>6. EGR system check.</li> </ol>	Refer to <i>Exhaust System</i> in <i>Engine Exhaust</i> , TCC Operation, Calibration ID/Service Bulletins
Detonation/Spark Knock	<ol style="list-style-type: none"> <li>1. OBD system check.</li> <li>2. Transmission range switch.</li> <li>3. EGR operation.</li> <li>4. EGR system check.</li> <li>5. TCC operation.</li> <li>6. Fuel system diagnosis.</li> <li>7. Ignition system.</li> <li>8. Knock sensor.</li> </ol>	TCC operation, Cooling System, Ignition System Check, Calibration ID/Service Bulletins
Hesitation, Sag, Stumble	<ol style="list-style-type: none"> <li>1. OBD system check.</li> <li>2. TP.</li> <li>3. MAP output check.</li> <li>4. Fuel system diagnosis.</li> <li>5. Fuel injector and fuel injector balance test.</li> <li>6. EVAP emission canister purge valve.</li> <li>7. Ignition system.</li> </ol>	EGR Operation, EGR System Check, Generator Output Voltage (refer to <i>Chassis Electrical</i> ), Calibration ID/Service Bulletins, Ignition System Check
Cuts Out, Misses	<ol style="list-style-type: none"> <li>1. OBD system check.</li> <li>2. Cylinder balance test.</li> </ol>	Ignition System Check
Rough, Unstable, or Incorrect Idle, Stalling	<ol style="list-style-type: none"> <li>1. OBD system check.</li> <li>2. Fuel injector and fuel injector balance test.</li> <li>3. EVAP emission canister purge valve check.</li> <li>4. Ignition system.</li> <li>5. IAC operation.</li> <li>6. EGR operation.</li> </ol>	MAP Output Check, Throttle Linkage, IAC System Check, EGR System Check, A/C Clutch Control Circuit Diagnosis, Crankcase Ventilation System, Calibration ID/Service Bulletins, Generator Output Voltage (refer to <i>Chassis Electrical</i> ), Exhaust Diagnosis
Poor Fuel Economy	<ol style="list-style-type: none"> <li>1. OBD system check.</li> <li>2. Careful visual/physical inspection.</li> <li>3. Ignition system.</li> <li>4. Cooling system.</li> </ol>	TCC Operation, Exhaust System (refer to <i>Engine Exhaust</i> )
Engine Cranks But Will Not Run	<ol style="list-style-type: none"> <li>1. OBD system check.</li> </ol>	Fuel System Electrical Diagnosis, Fuel System Diagnosis, Fuel Injector and Fuel Injector Balance Test.



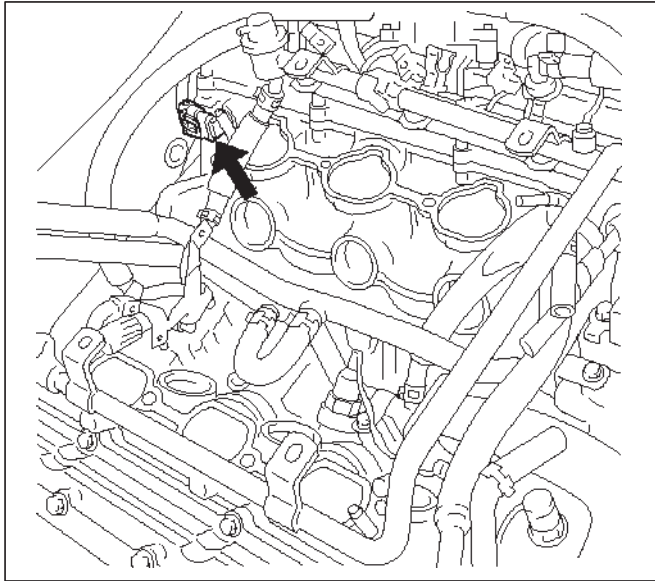
**6E-440 6VE1 3.5L ENGINE DRIVEABILITY AND EMISSIONS**

Symptoms	Initial Diagnosis	Default Section(s)
Excessive Exhaust Emissions or Odors	<ol style="list-style-type: none"> <li>1. OBD system check.</li> <li>2. Emission test.</li> <li>3. Cooling system.</li> <li>4. Fuel system diagnosis.</li> <li>5. Fuel injector and fuel injector balance test.</li> <li>6. EVAP emission canister purge valve.</li> <li>7. Crankcase ventilation system.</li> <li>8. Ignition system.</li> <li>9. MAP output check.</li> </ol>	EGR System Check, Exhaust Diagnosis, Calibration ID/Service Bulletins
Dieseling, Run-On	<ol style="list-style-type: none"> <li>1. OBD system check.</li> <li>2. Careful visual/physical inspection.</li> <li>3. Fuel system diagnosis.</li> </ol>	—
Backfire	<ol style="list-style-type: none"> <li>1. OBD system check.</li> <li>2. Ignition system.</li> <li>3. Fuel system diagnosis.</li> <li>4. Fuel injector and fuel injector balance test.</li> <li>5. EGR operation, EGR system check.</li> </ol>	Exhaust System Diagnosis, Intake Casting Flash, Ignition System Check
Misfire	<ol style="list-style-type: none"> <li>1. OBD system check.</li> <li>2. Ignition system.</li> <li>3. Fuel system diagnosis.</li> <li>4. Fuel injector and fuel injector balance test.</li> </ol>	Vibrations, Transmission, Driveshaft and Axle
Catalyst Monitor	<ol style="list-style-type: none"> <li>1. OBD system check.</li> <li>2. Careful visual/physical inspection.</li> <li>3. Heated oxygen sensors.</li> </ol>	Exhaust System
Fuel Trim	<ol style="list-style-type: none"> <li>1. OBD system check.</li> <li>2. Careful visual/physical inspection.</li> <li>3. Fuel system diagnosis.</li> <li>4. Heated oxygen sensors, MAF sensors.</li> </ol>	Exhaust System Intake Air System
Evaporative Emissions	<ol style="list-style-type: none"> <li>1. OBD system check.</li> <li>2. Careful visual/physical inspection.</li> <li>3. Fuel system diagnosis.</li> </ol>	—
Heated Oxygen Sensors	<ol style="list-style-type: none"> <li>1. OBD system check.</li> <li>2. Careful visual/physical inspection.</li> </ol>	Exhaust System

## On-Vehicle Service Camshaft Position (CMP) Sensor

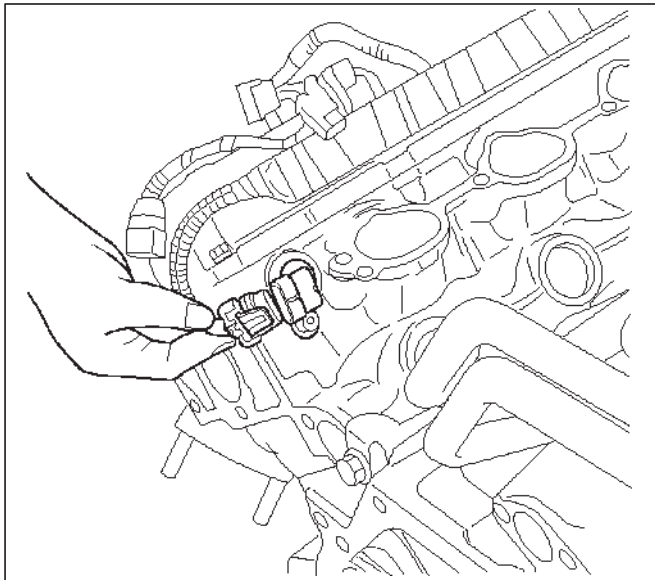
### Removal Procedure

1. Disconnect the negative battery cable.
2. Remove the engine cover.
3. Remove the common chamber assembly.  
Refer to Common Chamber in Engine Mechanical.



014RW120

4. Disconnect the electrical connector to the CMP sensor.



014RV053

5. Remove the CMP retaining bolt from the side of left cylinder head.
6. Remove the CMP sensor from the cylinder head.

### Inspection Procedure

1. Inspect the sensor O-ring for cracks or leaks.
2. Replace the O-ring if it is worn or damaged.
3. Lubricate the new O-ring with engine oil.

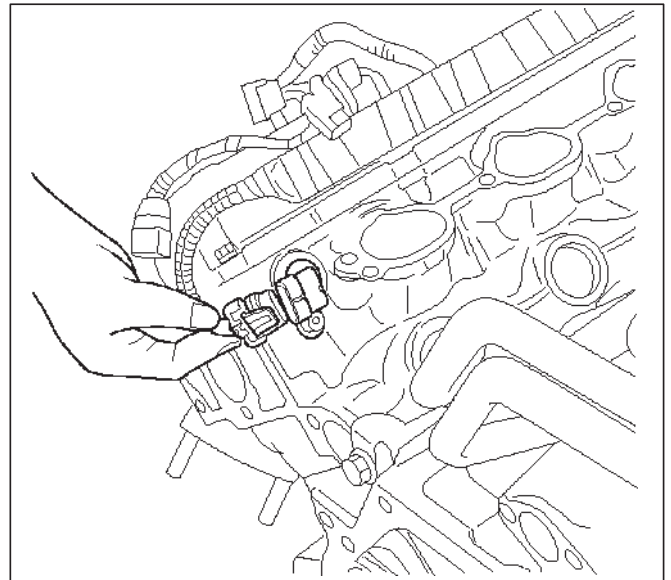
4. Install the lubricated O-ring.

### Installation Procedure

1. Install the CMP sensor in the cylinder head.
2. Install the CMP sensor retaining bolt.

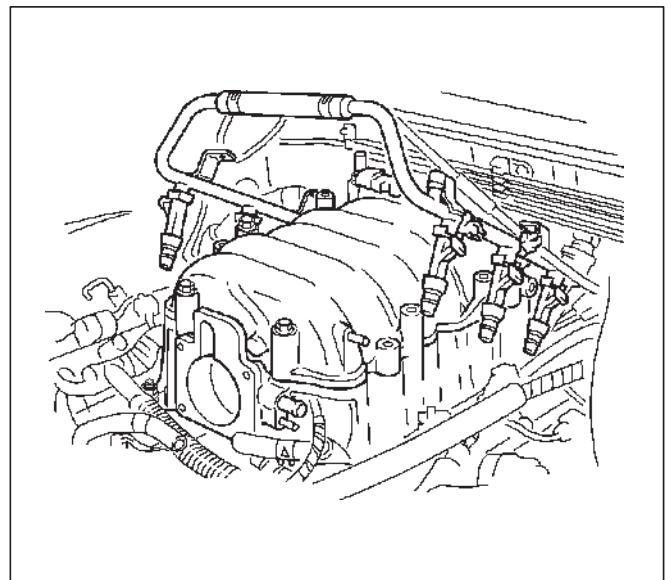
#### Tighten

- Tighten the retaining screw to 9 N·m (78 lb in.).
3. Connect the electrical connector to the CMP sensor.



014RV053

4. Install the common chamber assembly.  
Refer to Common Chamber in Engine Mechanical.



014RW106

5. Install the engine cover.
6. Connect the negative battery cable.

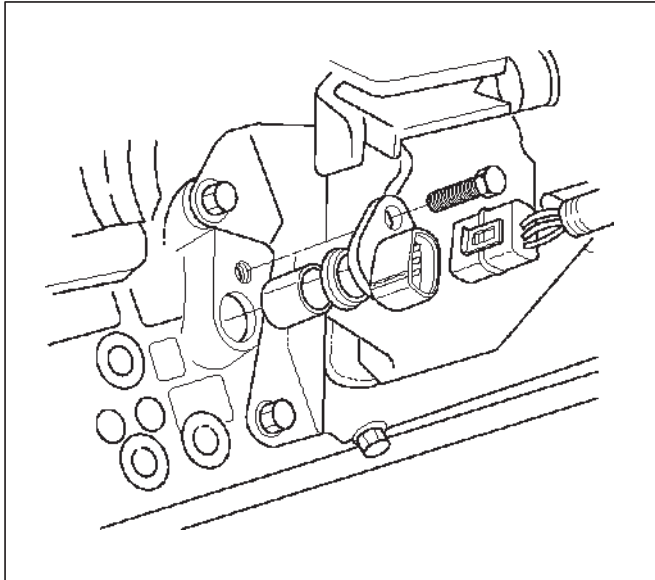
## Crankshaft Position (CKP) Sensor

### Removal Procedure

1. Disconnect the negative battery cable.

2. Disconnect the electrical connector to the CKP sensor.
3. Remove one bolt and the CKP sensor from the right side of the engine block, just behind the mount.

NOTE: Use caution to avoid any hot oil that might drip out.



### Inspection Procedure

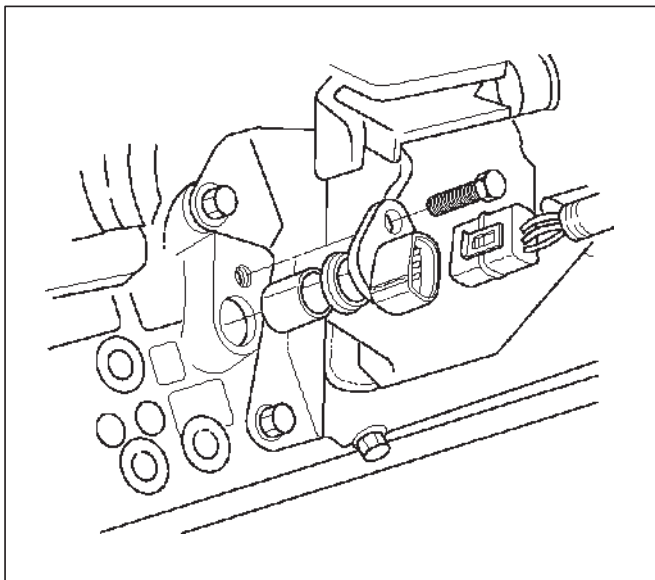
1. Inspect the sensor O-ring for cracks or leaks.
2. Replace the O-ring if it is worn or damaged.
3. Lubricate the new O-ring with engine oil.
4. Install the lubricated O-ring.

### Installation Procedure

1. Install the CKP sensor in the engine block.
2. Install the CKP sensor mounting bolt.

**Tighten**

- Tighten the mounting bolt to 9 N·m (78 lb in.).



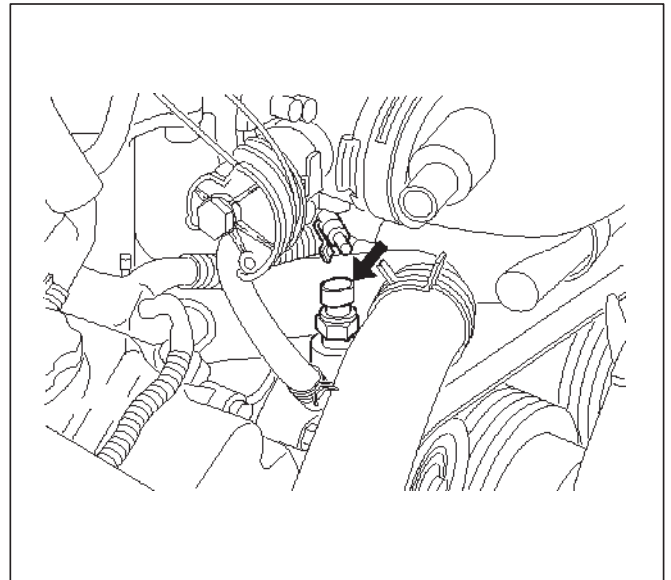
3. Connect the electrical connector to the CKP sensor.
4. Connect the negative battery cable.

## Engine Coolant Temperature (ECT) Sensor

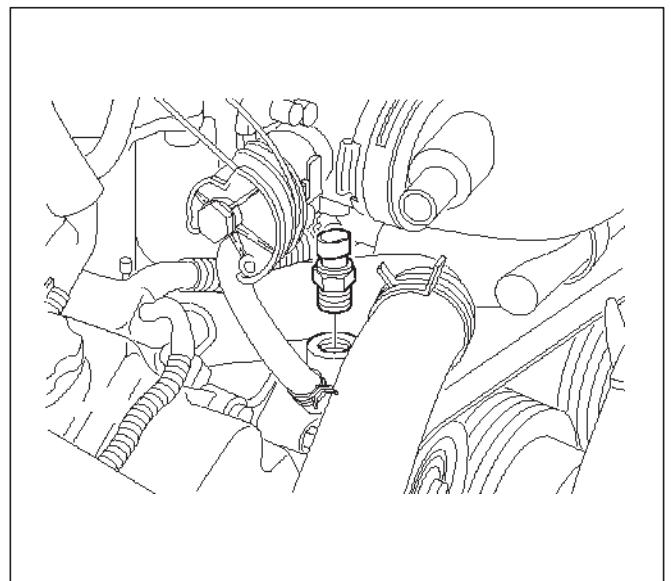
### Removal Procedure

NOTE: Care must be taken when handling the engine coolant temperature (ECT) sensor. Damage to the ECT sensor will affect proper operation of the fuel injection system.

1. Disconnect the negative battery cable.
2. Drain the radiator coolant. Refer to *Draining and Refilling Cooling System in Engine Cooling*.
3. Disconnect the electrical connector.



4. Remove the ECT sensor from the coolant crossover.

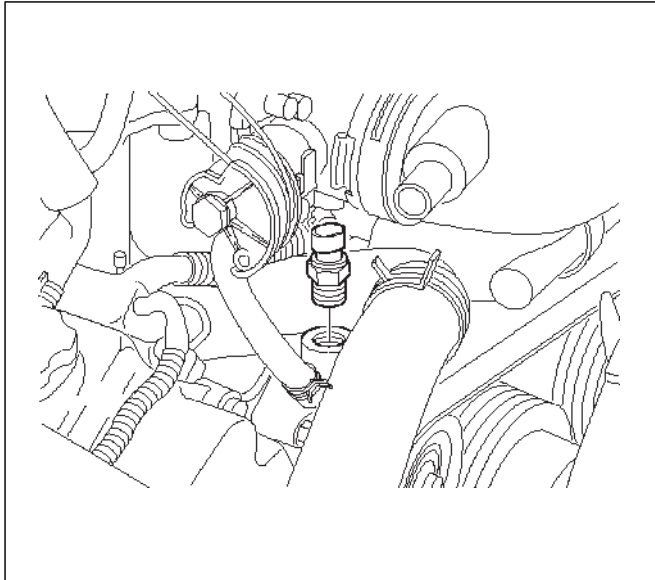


## Installation Procedure

1. Apply sealer or the equivalent to the threads of the ECT sensor.
2. Install the ECT sensor in the coolant crossover.

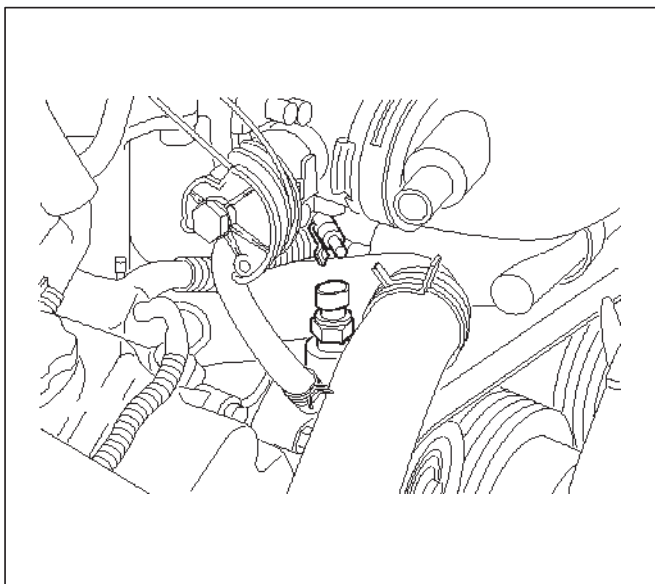
**Tighten**

- Tighten the ECT sensor to 30 N-m (22 lb ft.).



014RW086

3. Connect the electrical connector.



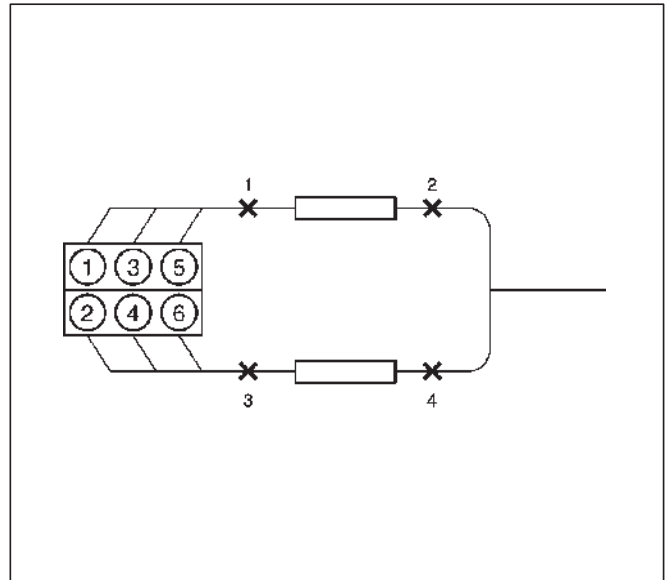
014RW085

4. Fill the radiator with coolant. Refer to *Draining and Refilling Cooling System* in *Engine Cooling*.
5. Connect the negative battery cable.

## Heated Oxygen Sensor (HO2S)

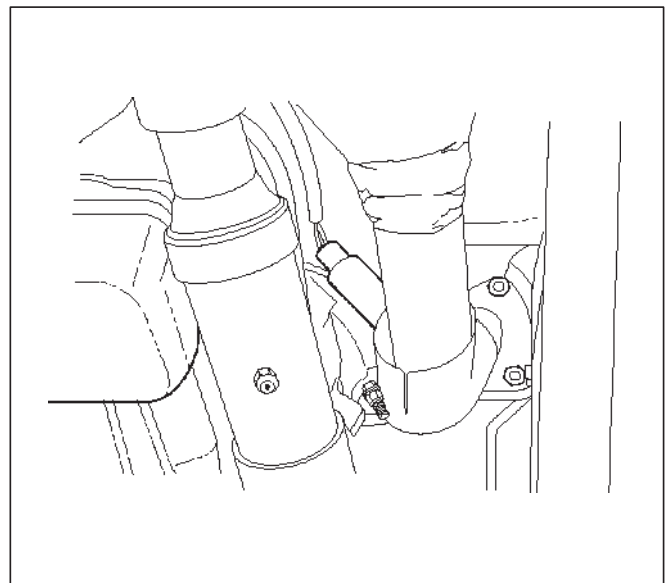
### Removal Procedure

1. Disconnect the negative battery cable.
2. Locate the four oxygen sensors.



060RW008

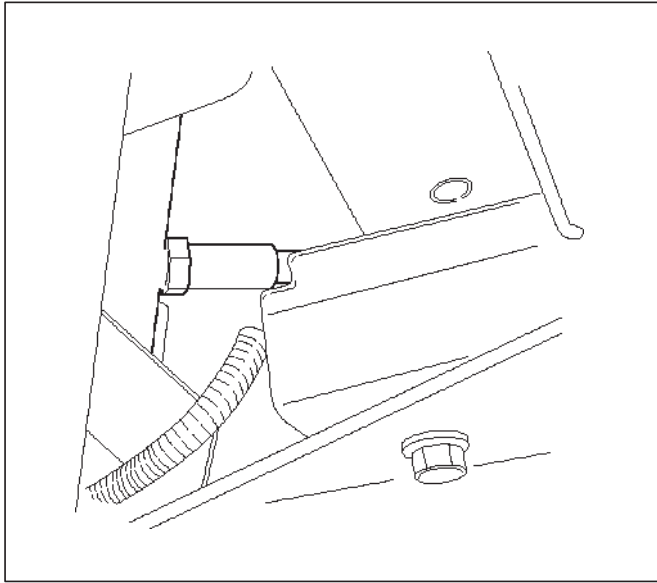
- Bank 1 sensor 1 is mounted on the exhaust pipe ahead of the right-hand catalytic converter.



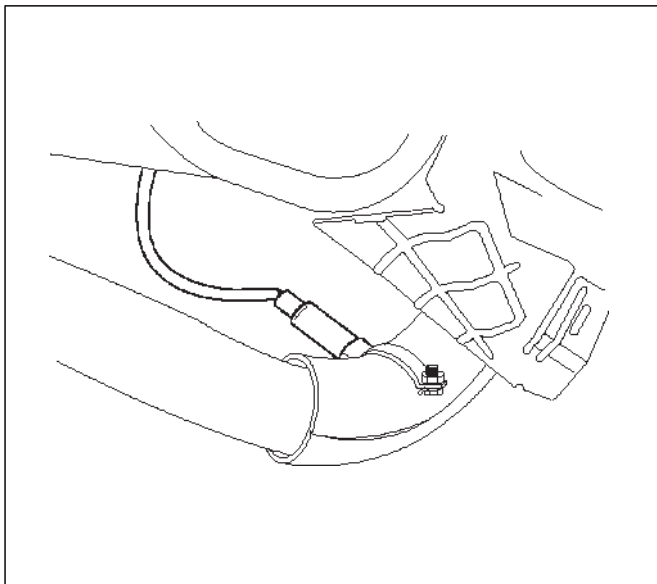
TS22912

## 6E-444 6VE1 3.5L ENGINE DRIVEABILITY AND EMISSIONS

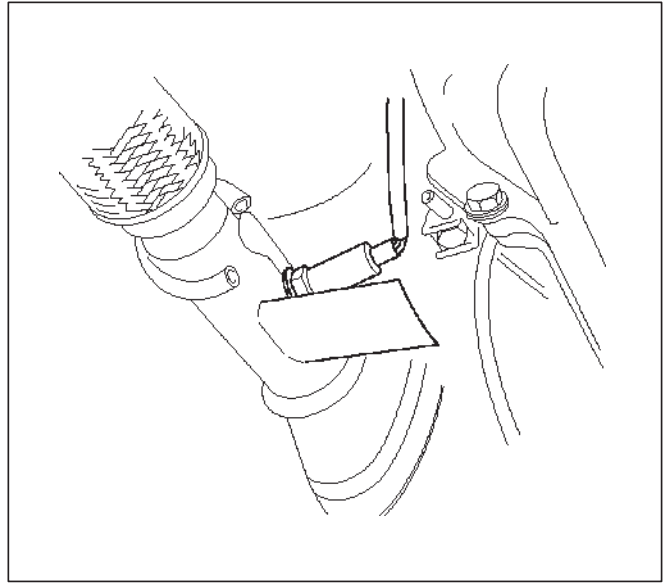
○Bank 1 sensor 2 (automatic transmission only) is mounted behind the right-hand catalytic converter.



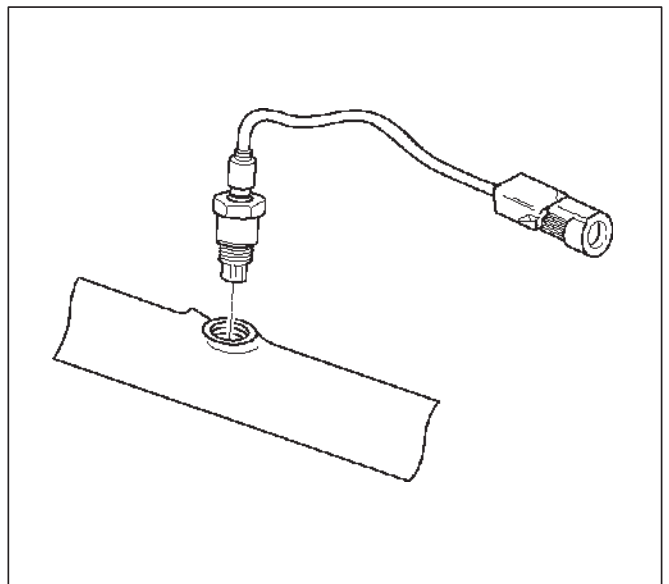
○Bank 2 sensor 1 is mounted on the exhaust pipe ahead of the left-hand catalytic converter.



○Bank 2 sensor 2 (automatic transmission) is mounted behind the left-hand catalytic converter.



3. Disconnect the pigtail from the wiring harness.

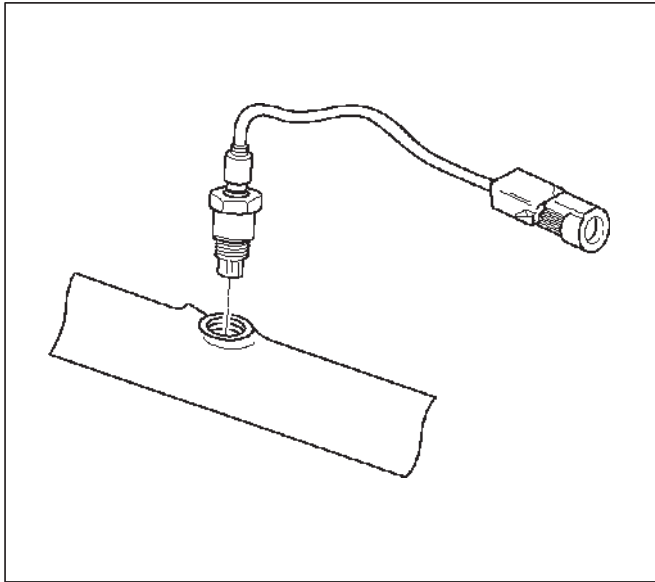


**IMPORTANT:** The pigtail is permanently attached to the sensor. Be careful not to pull the wires out.

**NOTE:** Do not use a torch to remove an HO2S unless the sensor is being replaced. Using a torch could damage the sensor.

4. Remove the sensor from the exhaust pipe.

- Because of the expansion and contraction of the metal in the exhaust system over time, this may be difficult if the engine temperature is below 48°C (120°F).

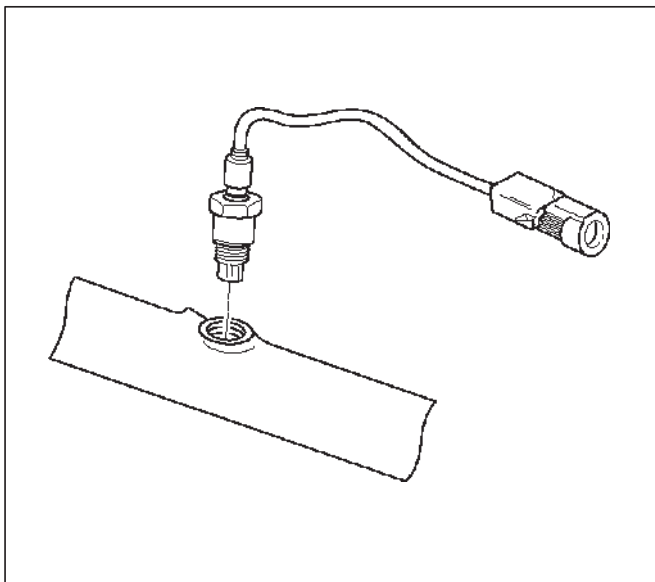


TS23739

### Inspection Procedure

All four sensors are identical. Inspect each in the same way.

1. Inspect the pigtail and the electrical connector for grease, dirt, corrosion, and bare wires or worn insulation.
2. Inspect the louvered end of the sensor for grease, dirt, or other contaminations.



TS23739

### Installation Procedure

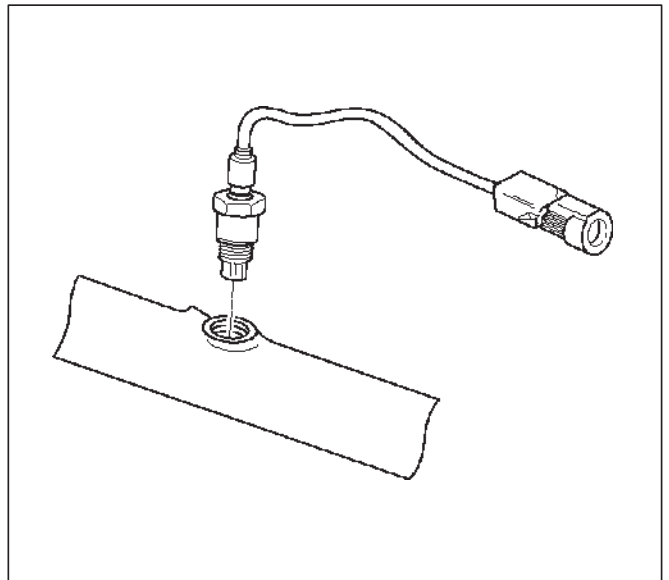
#### IMPORTANT:

- A special anti-seize compound, P/N 5613695, is used on the HO2S threads. This compound consists of glass beads suspended in a liquid graphite solution. The graphite burns away with engine heat, but the glass beads will remain, making the sensor easier to remove.
- New or service sensors will already have the compound applied to the threads. If a sensor is removed and is to be reinstalled for any reason, the threads must have anti-seize compound applied.

1. Apply anti-seize compound or the equivalent to the threads of the oxygen sensor, if necessary.
2. Install the oxygen sensor on the exhaust pipe in its original position.

#### Tighten

- Tighten the oxygen sensor to 55 N·m (40 lb in.).



TS23739

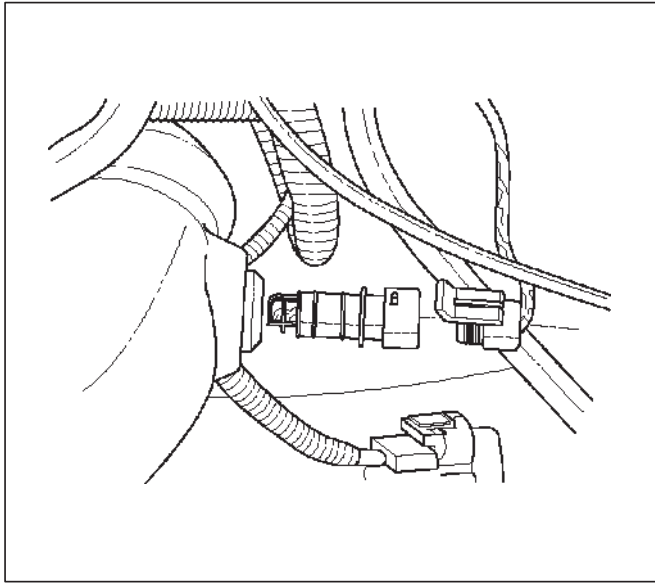
3. Connect the pigtail to the wiring harness.
4. Connect the negative battery cable.

### Intake Air Temperature (IAT) Sensor

#### Removal Procedure

1. Disconnect the negative battery cable.
2. Remove the engine cover
3. The IAT sensor is located in the intake air duct, behind the throttle body.

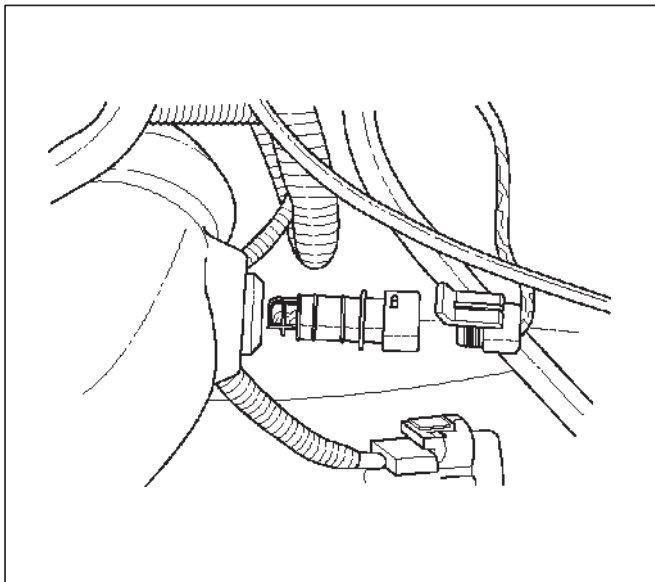
4. Disconnect the electrical connector from the IAT sensor.



5. Remove the IAT sensor from the intake air duct by using a rocking motion while pulling the sensor.

### Installation Procedure

1. Install the IAT sensor into the grommet in the intake air duct.
2. Correct the IAT electrical connector.

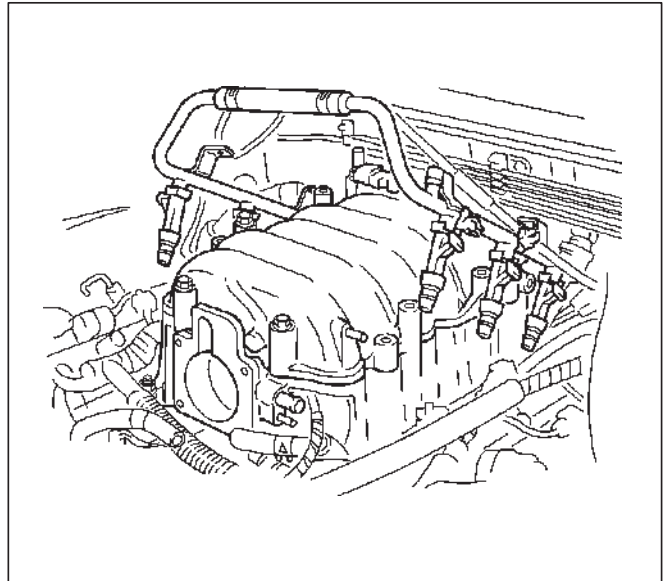


3. Install the engine cover.
4. Connect the negative battery cable.

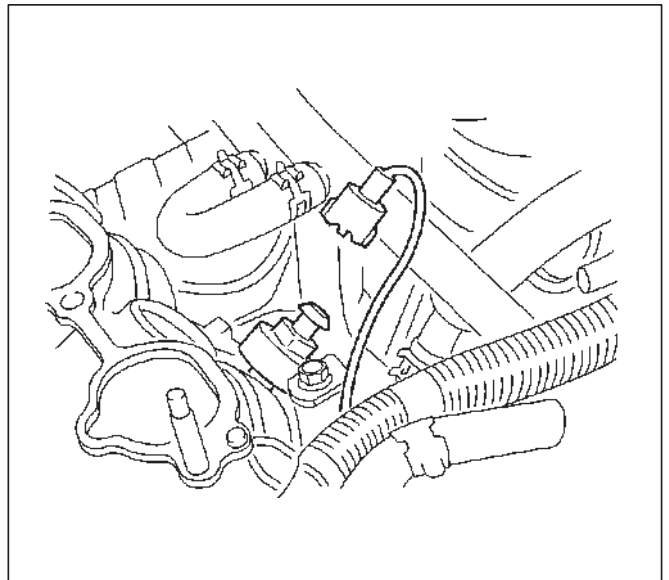
## Knock Sensor (KS)

### Removal Procedure

1. Disconnect the negative battery cable.
2. Drain the cooling system. Refer to *Draining and Filling the Cooling System* in *Engine Cooling*.
3. Remove the engine cover.
4. Remove the common chamber assembly. Refer to *Common Chamber* in *Engine Mechanical*.



5. Disconnect the electrical connector from the knock sensor.



6. Unscrew the knock sensor from the engine block.

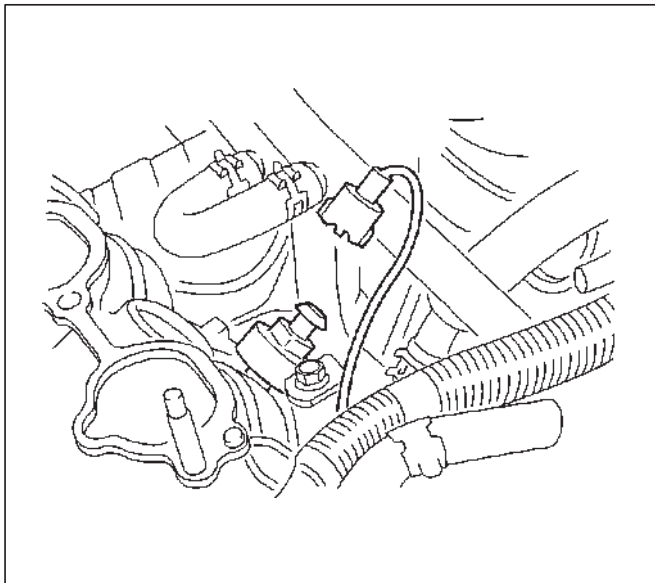
## Installation Procedure

NOTE: Do not apply thread sealant to the sensor threads. The sensor is coated at the factory and applying additional sealant will affect the sensor's ability to detect detonation.

1. Screw the knock sensor into the engine block.

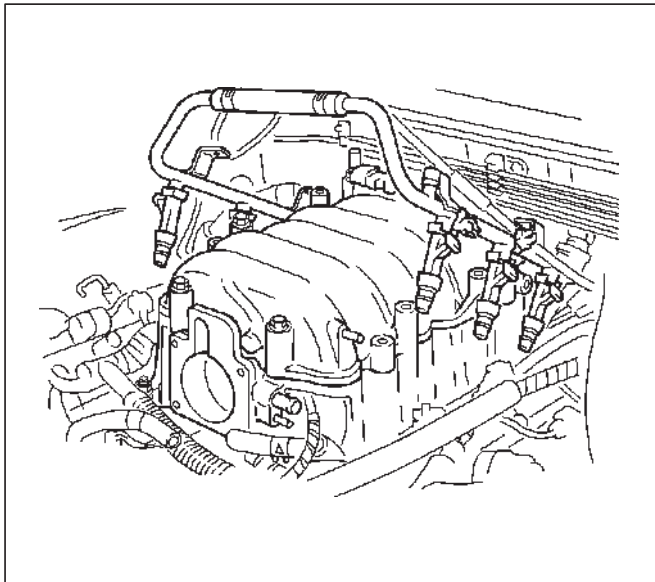
### Tighten

- Tighten the knock sensor to 20 N·m (177 lb in.).



014RW103

2. Connect the electrical connector to the knock sensor.
3. Install the common chamber assembly.  
Refer to Common Chamber in Engine Mechanical.



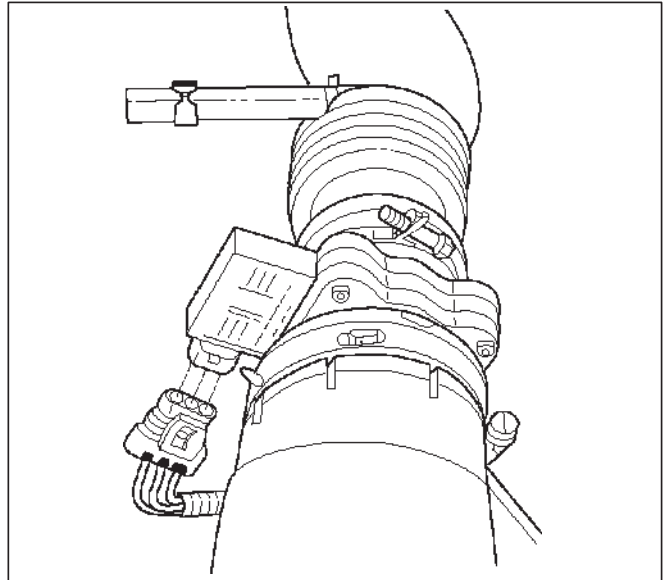
014RW106

4. Install the engine cover.
5. Fill the cooling system.  
Refer to Draining and Filling the Cooling System in Engine Cooling.
6. Connect the negative battery cable.

## Mass Air Flow (MAF) Sensor

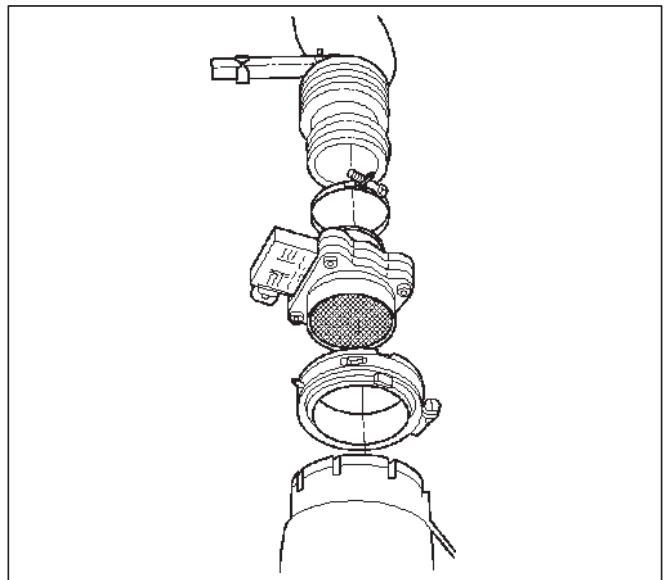
### Removal Procedure

1. Disconnect the negative battery cable.
2. Disconnect the electrical connector from the MAF sensor.



TS23740

3. Loosen the clamps which secure the intake air duct and the air cleaner to the MAF sensor.
4. Remove the intake air duct from the MAF sensor.
5. Remove the MAF sensor from the air cleaner.



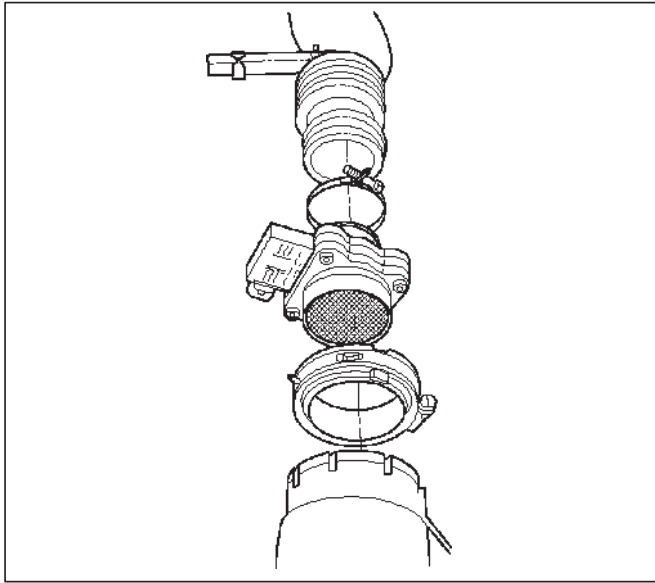
TS23781

### Installation Procedure

1. Install the MAF sensor on the air cleaner with the clamp.



2. Install the intake air duct and the clamp on the MAF sensor.

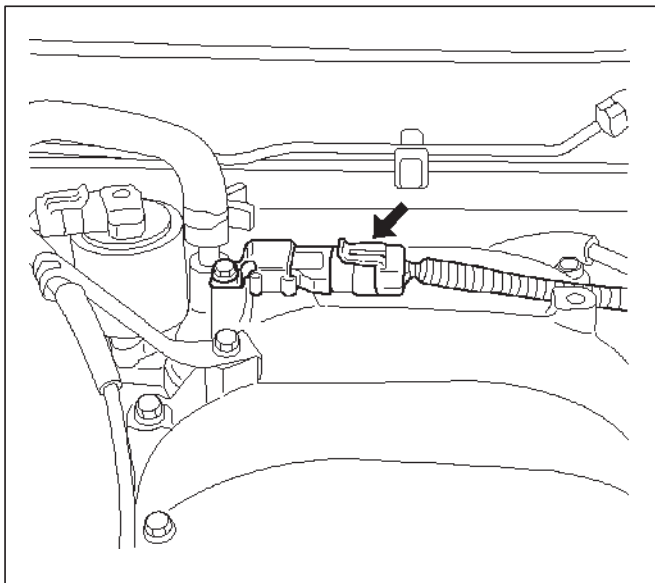


3. Tighten the clamps to secure the MAF sensor to the intake air duct and the air cleaner.
4. Connect the MAF electrical connector.
5. Connect the negative battery cable.

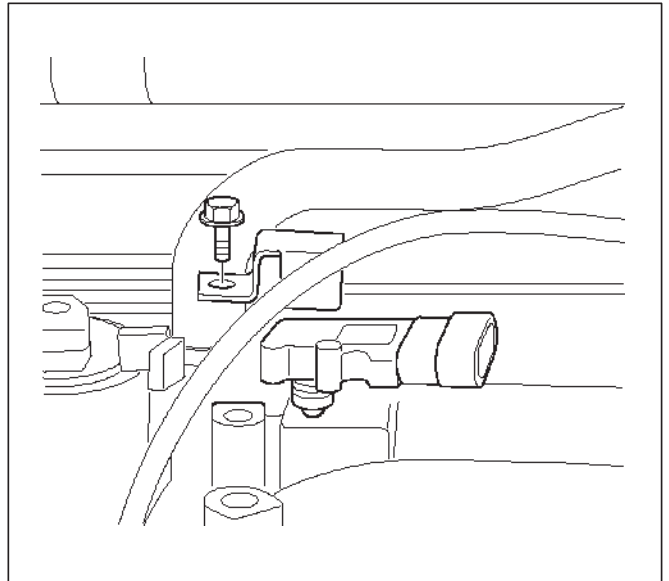
## Manifold Absolute Pressure (MAP) Sensor

### Removal Procedure

1. Disconnect the negative battery cable.
2. Disconnect the electrical connector from the MAP sensor.

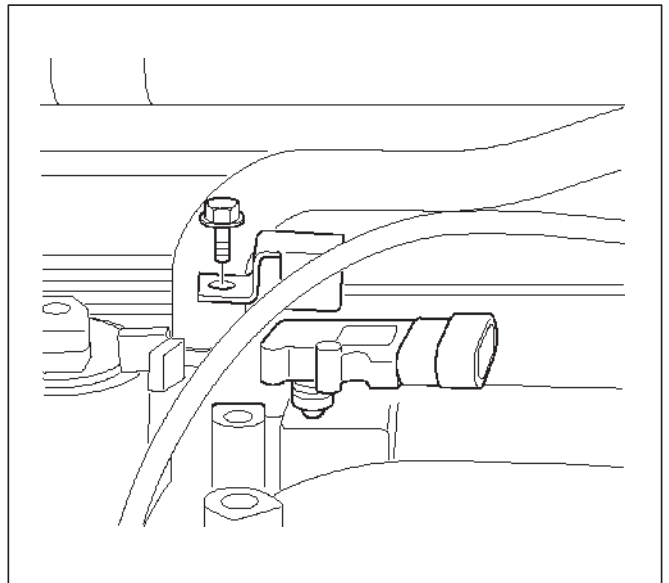


3. Remove the bolt securing the MAP sensor to the mounting bracket on the common chamber.
4. Remove the MAP sensor from the mounting bracket.



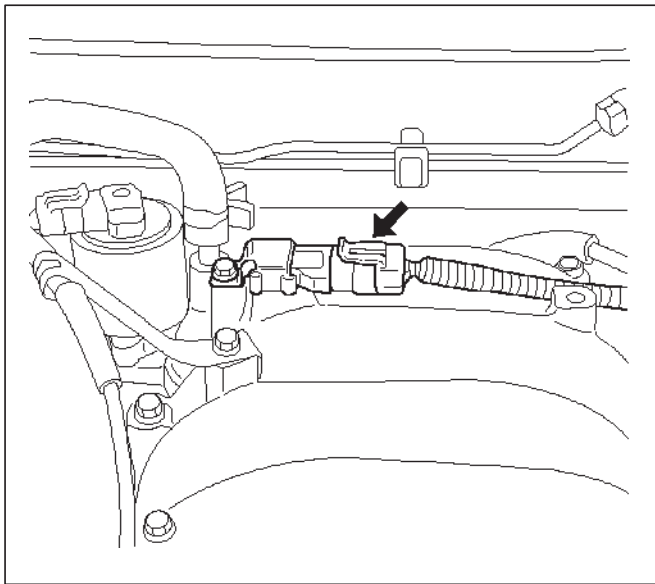
### Installation Procedure

1. Install the MAP sensor in the mounting bracket.



2. Install the mounting bracket retaining bolt on the common chamber.

3. Connect the MAP electrical connector.



4. Connect the negative battery cable.

## Malfunction Indicator Lamp (MIL)

### Removal and Installation Procedure

Refer to Warning light bulb, indicator light valve, illumination light bulb, A/T indicator light bulb in Meter and Gauge.

## Powertrain Control Module (PCM)

### Service Precaution

NOTE: To prevent possible electrostatic discharge damage to the PCM, do not touch the connector pins or soldered components on the circuit board.

### Electrostatic Discharge (ESD) Damage

Electronic components used in the control systems are often designed to carry very low voltage. Electronic components are susceptible to damage caused by electrostatic discharge. Less than 100 volts of static electricity can cause damage to some electronic components. By comparison, it takes as much as 4,000 volts for a person to even feel the zap of a static discharge.

There are several ways for a person to become statically charged. The most common methods of charging are by friction and by induction. An example of charging by friction is a person sliding across a car seat.

Charging by induction occurs when a person with well insulated shoes stands near a highly charged object and momentarily touches ground. Charges of the same polarity are drained off leaving the person highly charged with the opposite polarity. Static charges can cause

damage, therefore, it is important to use care when handling and testing electronic components.

NOTE: To prevent possible Electrostatic Discharge damage, follow these guidelines:

- Do not touch the control module connector pins or soldered components on the control module circuit board.
- Do not open the replacement part package until the part is ready to be installed.
- Before removing the part from the package, ground the package to a known good ground on the vehicle.
- If the part has been handled while sliding across the seat, or while sitting down from a standing position, or while walking a distance, touch a known good ground before installing the part.

NOTE: To prevent internal PCM damage, the ignition must be in the "OFF" position in order to disconnect or reconnect power to the PCM (for example: battery cable, PCM pigtail, PCM fuse, jumper cables, etc.).

**IMPORTANT:** When replacing the production PCM with a service PCM, it is important to transfer the broadcast code and production PCM number to the service PCM label. This will allow positive identification of PCM parts throughout the service life of the vehicle. Do not record this information on the metal PCM cover.

**IMPORTANT:** The ignition should always be in the "OFF" position in order to install or remove the PCM connectors.

Service of the PCM should normally consist of either replacement of the PCM or EEPROM programming. If the diagnostic procedures call for the PCM to be replaced, the PCM should be checked first to ensure it is the correct part. If it is, remove the faulty PCM and install the new service PCM.

The service PCM EEPROM will not be programmed. DTC P0601 indicates the check sum error.

### Removal Procedure

1. Disconnect the negative battery cable.
2. Block the wheels.
3. Remove the front console assembly.
  1. Remove the four screws.
  2. Remove the transfer shift lever knob by unscrewing the knob.
  3. Move the transmission gear selector out of the park position.
  4. Lift up sharply on the back edge of the assembly.
  5. Disconnect the seat heater switch connectors (if equipped).
  6. Disconnect the POWER and WINTER switch connectors.
  7. Lift out the front console assembly.
4. Disconnect the red, white, and blue electrical connectors at the PCM.
5. Remove the two screws in the front of the PCM.
6. Remove the one screw at the left rear of the PCM.

7. Pull the PCM straight out from the dashboard.

### Installation Procedure

1. Insert the PCM into the dashboard.
  - Line up the holes in front for the mounting screws.
2. Install the PCM with two screws in the front and one screw at the left rear.
3. Plug the red, white, and blue connectors into the appropriate sockets.

## EEPROM

### General Description

The Electronically Erasable Programmable Read Only Memory (EEPROM) is a permanent memory that is physically soldered within the PCM. The EEPROM contains program and calibration information that the PCM needs to control powertrain operation.

### EEPROM Programming

1. Step-up – Ensure that the following conditions have been met:
  - The battery is fully charged.
  - The ignition is “ON.”
  - The Vehicle Interface Module cable connection at the DLC is secure.
2. Program the PCM using the latest software matching the vehicle. Refer to up-to-date ITCS equipment user’s instructions.
3. If the PCM fails to program, proceed as follows:
  - Ensure that all PCM connections are OK.
  - Check the ITCS equipment for the latest software version.
  - Attempt to program the PCM. If the PCM still cannot be programmed properly, replace the PCM. The replacement PCM must be programmed.

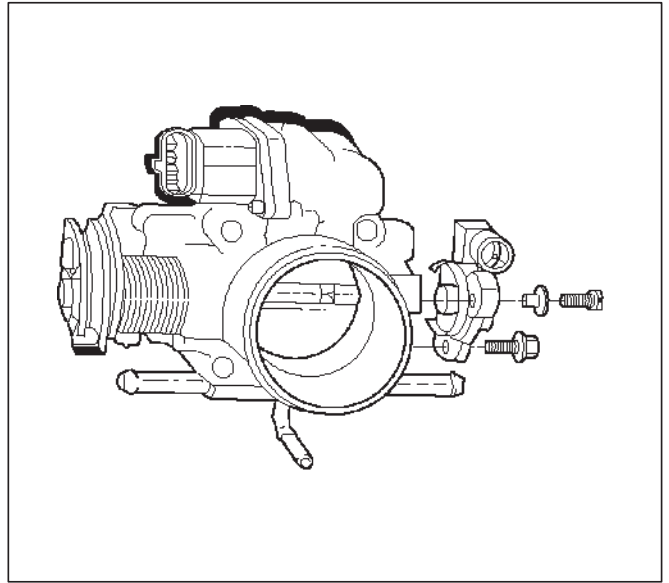
### Functional Check

1. Perform the On-Board Diagnostic System Check.
2. Start the engine and run for one minute.
3. Scan for DTCs using the Tech 2.

## Throttle Position (TP) Sensor

### Removal Procedure

1. Disconnect the negative battery cable.
2. Disconnect the TPS electrical connector.
3. Remove the bolts and the TP sensor from the throttle body.



TS23747

NOTE: Do not clean the TP sensor by soaking it in solvent. The sensor will be damaged as a result.

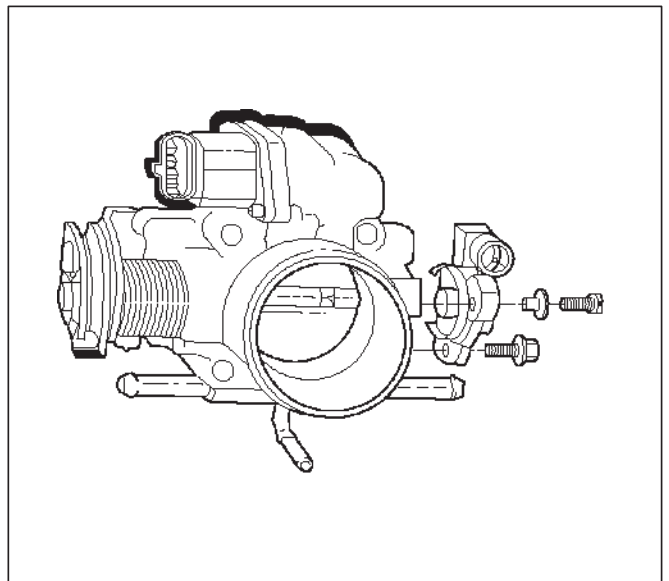
### Function Check

Use a Tech 2 to check the TP sensor output voltage at closed throttle.

- The voltage should be under 0.85 volt.
- If the reading is greater than 0.85 volt, check the throttle shaft to see if it is binding. Check that the throttle cable is properly adjusted, also. Refer to *Throttle Cable Adjustment*.
- If the throttle shaft is not binding and the throttle cable is properly adjusted, install a new TP sensor.

### Installation Procedure

1. Install the TP sensor on the throttle body with the bolts.



TS23747

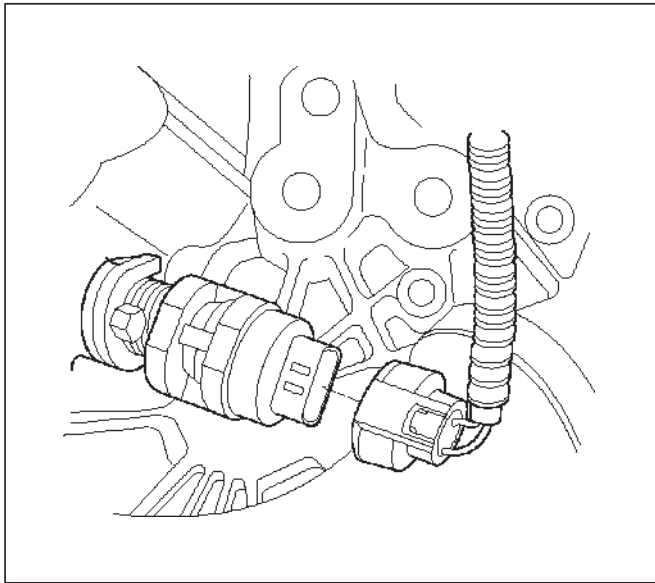
2. Connect the TP electrical connector.
3. Install the negative battery cable.

## Vehicle Speed Sensor (VSS)

### Removal Procedure

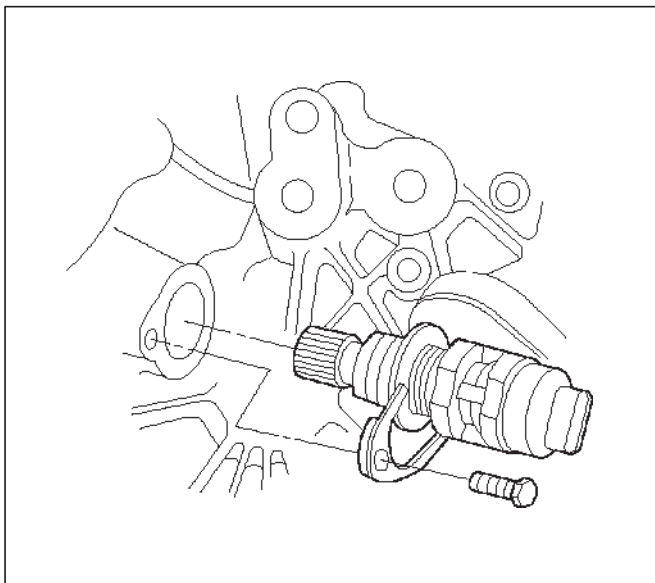
**CAUTION:** The VSS is located on the right side of the transfer case just ahead of the rear propeller shaft and very close to the exhaust pipes. Be sure that the exhaust pipes are cool enough to touch before trying to remove the VSS. If the pipes are hot, you could be burned.

1. Disconnect the negative battery cable.
2. Disconnect the VSS electrical connector.



3. Remove the bolt and the clamp securing the VSS in place.

**IMPORTANT:** Have a container ready to catch any fluid that leaks out when the VSS is removed from the transfer case.



4. Remove the VSS from the transfer case by wiggling it slightly and pulling it straight out.

### Inspection Procedure

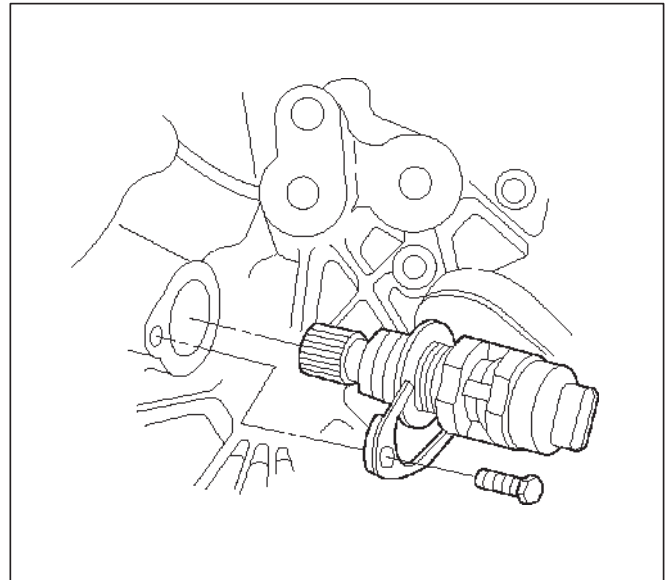
1. Inspect the electrical connector for signs of corrosion or warping. Replace the VSS if the electrical connector is corroded or warped.
2. Inspect the VSS driven gear for chips, breaks, or worn condition. Replace the VSS if the driven gear is chipped, broken or worn.
3. Inspect the O-ring for wear, nicks, tears, or looseness. Replace the O-ring if necessary.

### Installation Procedure

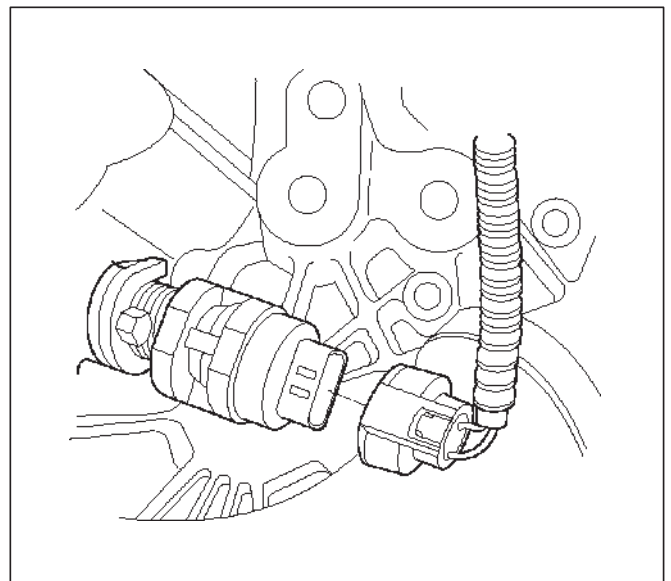
1. Install the VSS in the transfer case with the notch for the connector facing the rear.
2. Secure the VSS in place with the clamp and the bolt.

#### Tighten

- Tighten the bolt to 16 N·m (12 lb ft.).



3. Connect the VSS electrical connector.

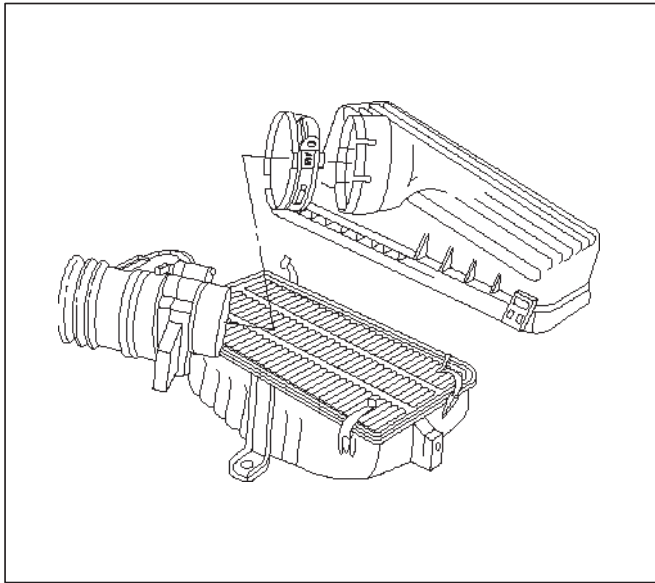


4. Check the transfer case oil level. Add fluid if necessary.
5. Connect the negative battery cable.

## Air Cleaner/Air Filter

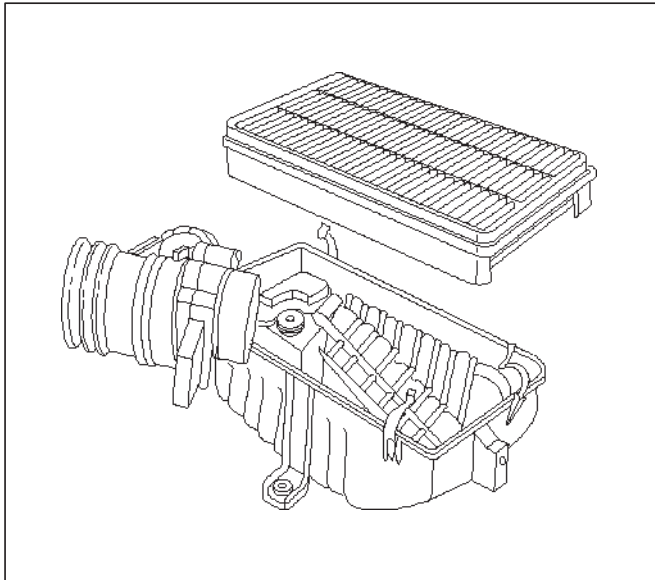
### Removal Procedure

1. Loosen the clamp between the air cleaner lid and the mass air flow sensor.
2. Release the four latches securing the lid to the air cleaner housing.
3. Remove the air cleaner lid.



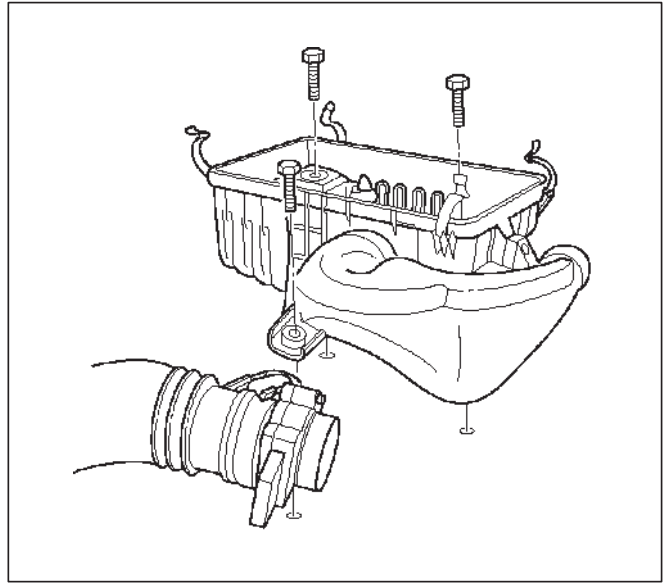
TS23973

4. Remove the air filter element.



TS23794

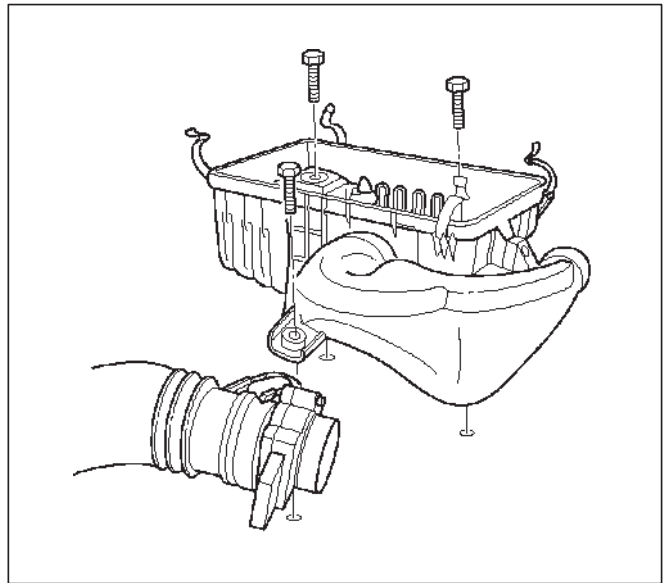
5. Remove the retaining bolts and the air cleaner housing from the vehicle.



130RT002

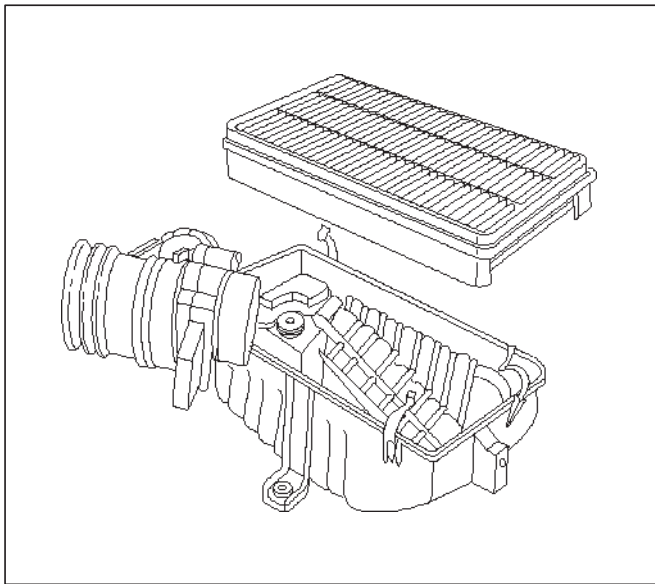
### Installation Procedure

1. Install the air cleaner housing in the vehicle with the retaining bolts.



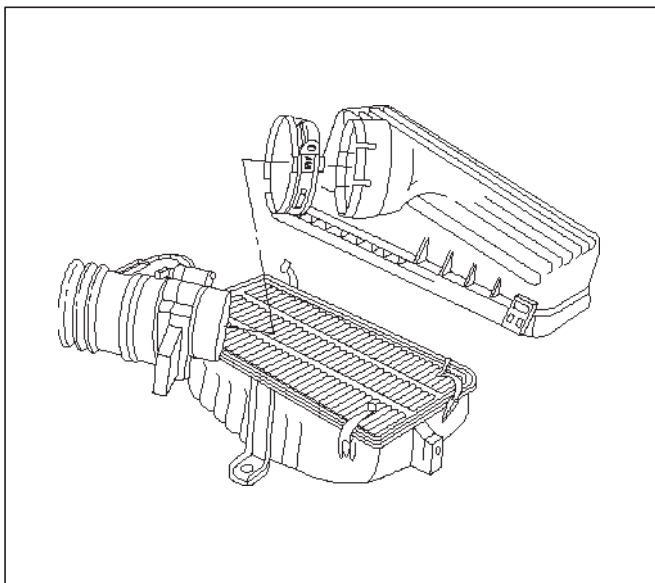
130RT002

2. Install the air filter element in the air cleaner housing.



TS23794

3. Install the air cleaner lid on the MAF sensor and the air cleaner housing.



TS23973

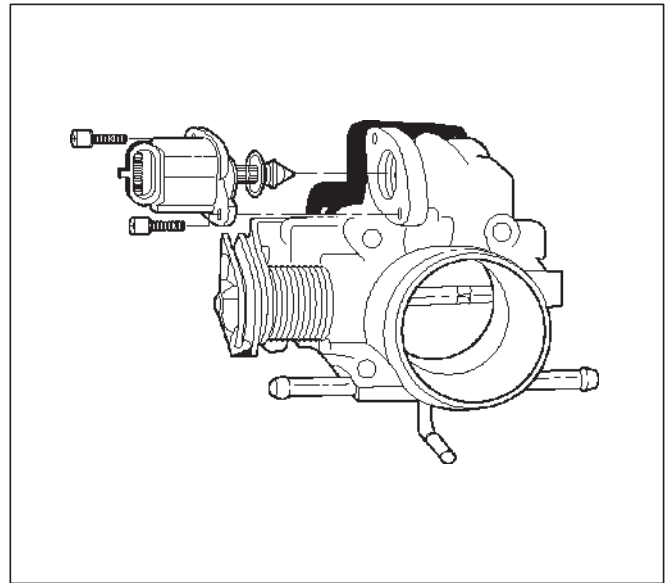
4. Tighten the clamp and secure the four latches between the lid and the air cleaner housing.

## Idle Air Control (IAC) Valve

### Removal Procedure

1. Disconnect the negative battery cable.
2. Disconnect the IAC electrical connector.
3. Remove the bolts and the IAC valve from the throttle body.

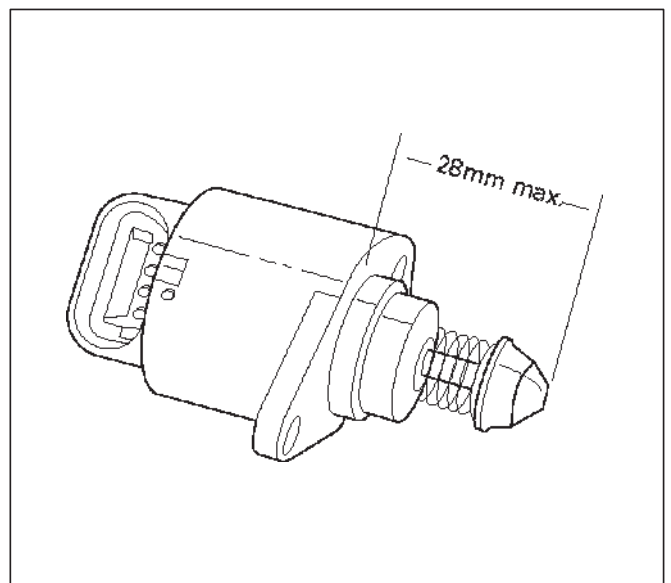
NOTE: Do not clean the IAC valve by soaking it in solvent. The valve will be damaged as a result.



TS23745

### Cleaning, Inspection, and Measurement Procedure

- Clean the IAC valve O-ring sealing surface, pintle valve seat and air passage.
  - Use carburetor cleaner and a parts cleaning brush to remove carbon deposits. Do not use a cleaner that contains methyl ethyl ketone. This is an extremely strong solvent and not necessary for this type of deposit.
  - Shiny spots on the pintle are normal and do not indicate misalignment or a bent pintle shaft.
  - If the air passage has heavy deposits, remove the throttle body for complete cleaning.



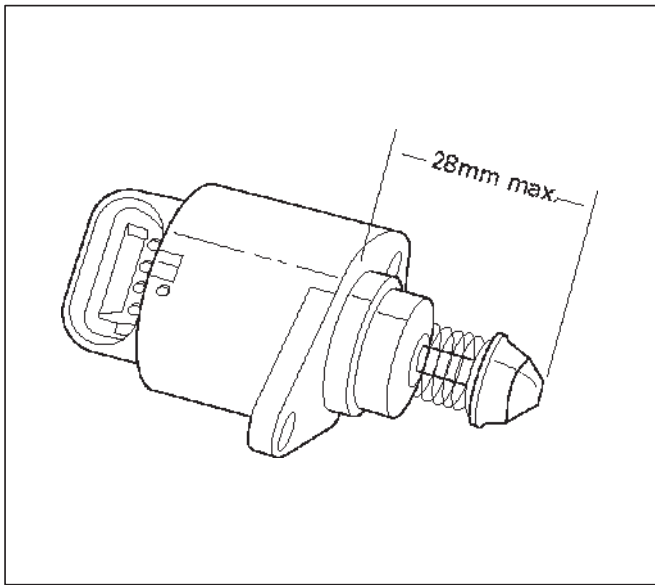
TS23746

- Inspect the IAC valve O-ring for cuts, cracks, or distortion. Replace the O-ring if damaged.

- In order to install a new IAC valve, measure the distance between the tip of the pintle and the mounting flange. If that measurement is 28 mm (1.1 in.) or less, the valve needs no adjustment. If the measurement is greater than 28 mm (1.1 in.), apply finger pressure and retract the valve. The force required to retract the pintle on a new valve will not damage the valve, shaft, or pintle.

**NOTE:** Do not push or pull on the IAC valve pintle on IAC valves that have been in service. The force required to move the pintle may damage it.

**IMPORTANT:** Use an identical replacement part in order to replace a valve. IAC valve pintle shape and diameter are designed for the specific application.

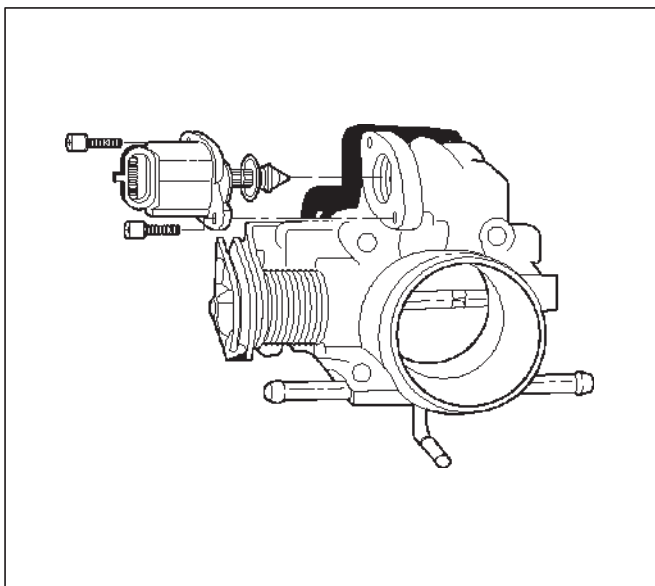


### Installation Procedure

1. Install the IAC valve on the throttle body with the bolts.

**Tighten**

- Tighten the bolts to 1 N·m (9 lb in.).



2. Connect the IAC valve electrical connector.
3. Install the negative battery cable.

## Common Chamber

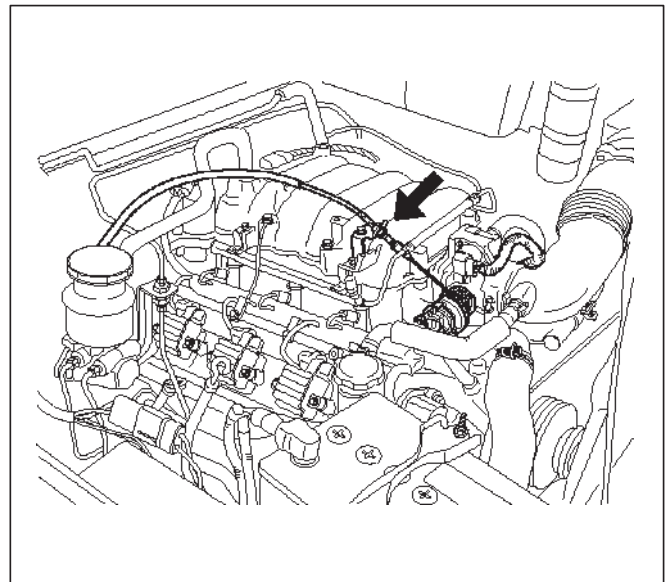
### Removal and Installation Procedure

Refer to Common Chamber in Engine Mechanical.

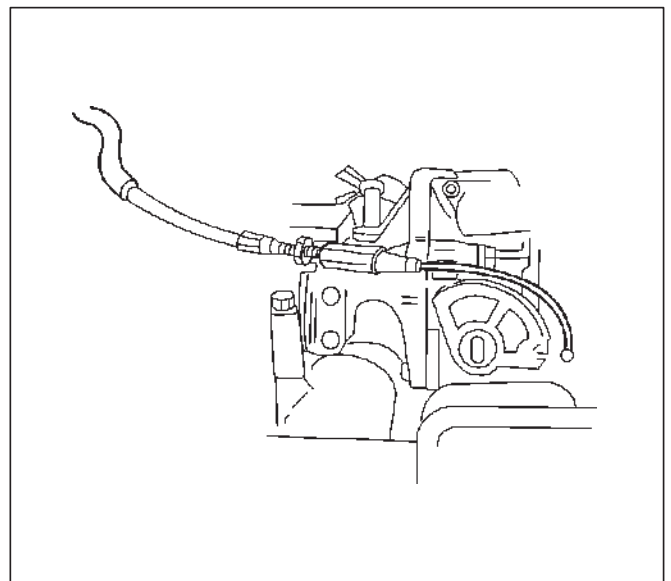
## Accelerator Cable Assembly

### Removal Procedure

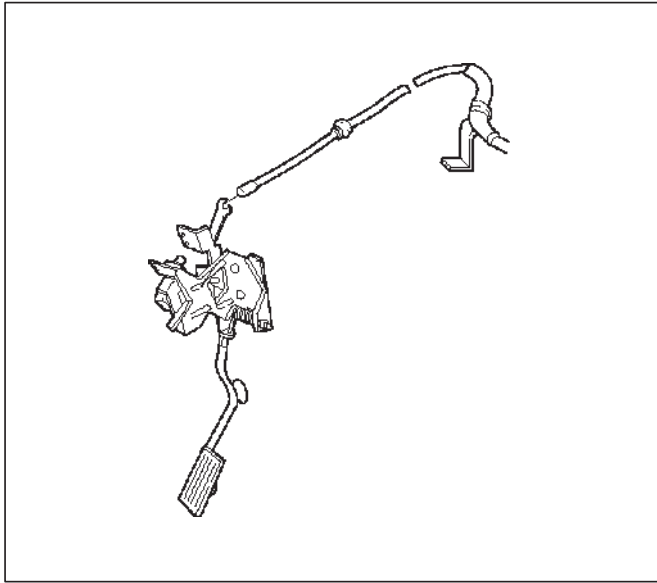
1. Remove the engine cover.
2. Loosen the adjusting nut on the cable bracket mounting on the common chamber.



3. Remove the accelerator control cable (on the throttle valve end).



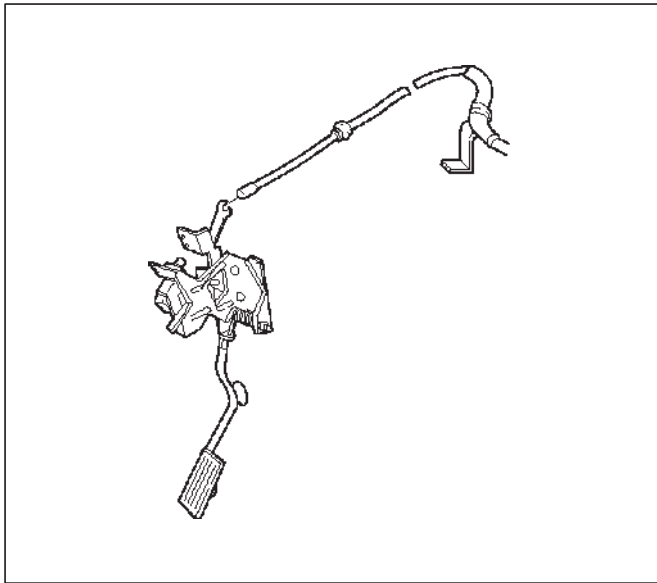
4. Remove the accelerator control cable (on the accelerator pedal end).



TS23982

5. Remove the grommet.

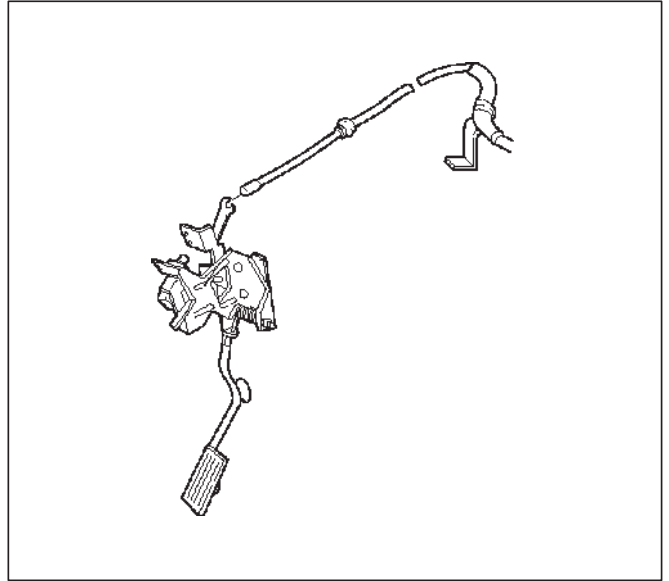
6. Remove the accelerator control cable.



TS23983

## Installation Procedure

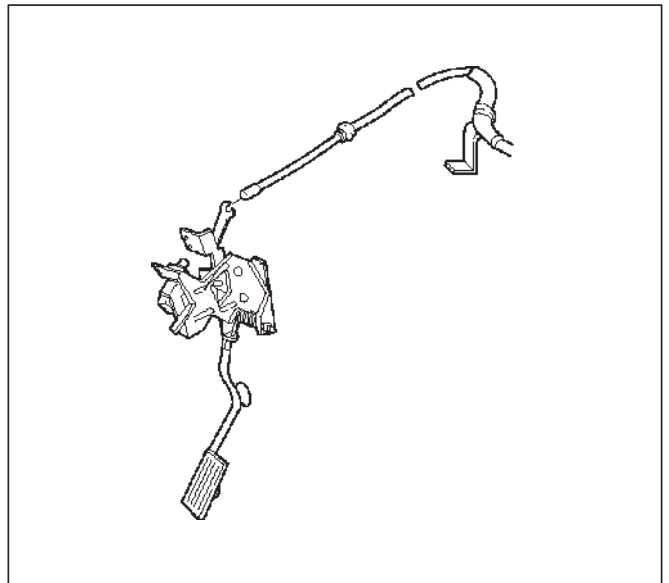
1. Install the accelerator control cable.



TS23983

2. Install the grommet.

3. Install the accelerator control cable (on the accelerator pedal end).



TS23982

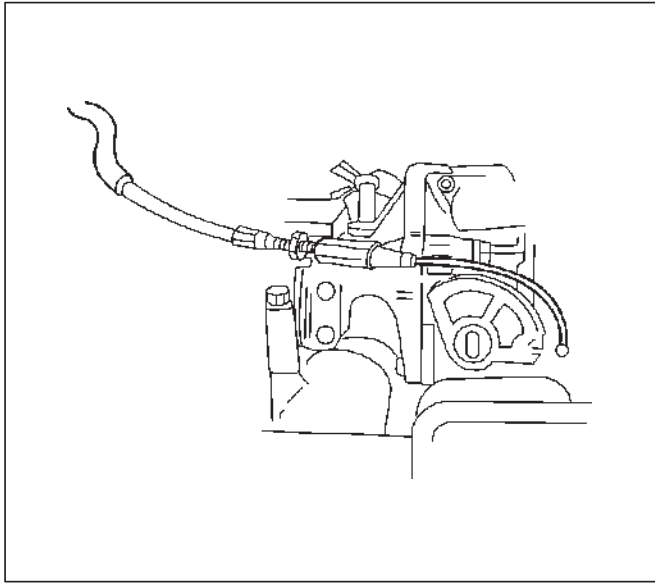
## Inspection Procedure

Check the following items, and replace the control cable if any abnormality is found:

- The control cable should move smoothly.
- The control cable should not be bent or kinked.
- The control cable should be free of damage and corrosion.

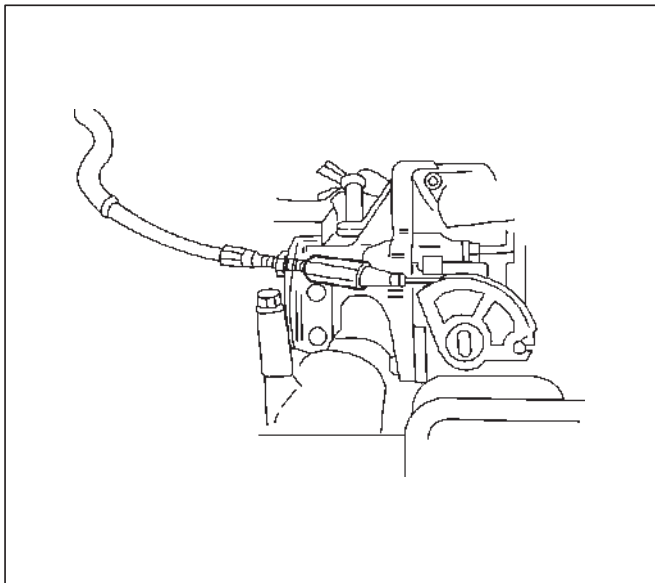


4. Install the accelerator control cable (on the throttle valve end).



101RW006

5. Install the adjusting nut.



101RW007

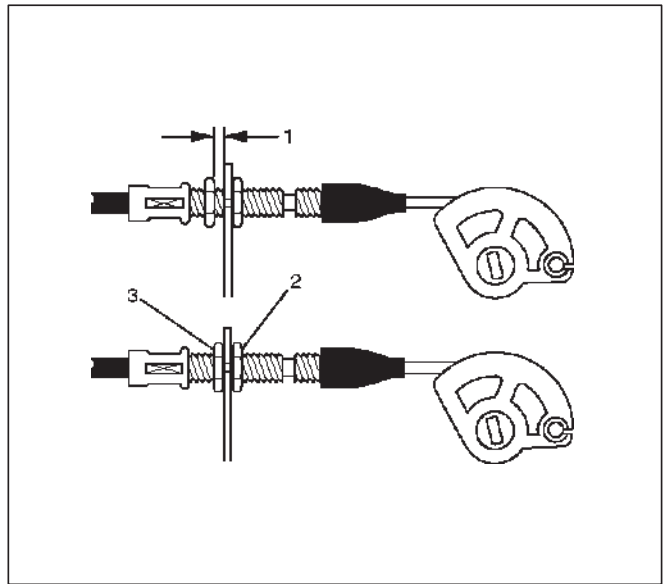
6. Adjust the accelerator cable at the throttle body. Refer to *Accelerator Cable Adjustment*.

7. Install the engine cover.

## Adjustment Procedure

1. Loosen the adjusting nut and lock nut.
2. Pull outer cable closing fully the throttle valve.

3. Tighten adjusting nut and lock nut temporarily.

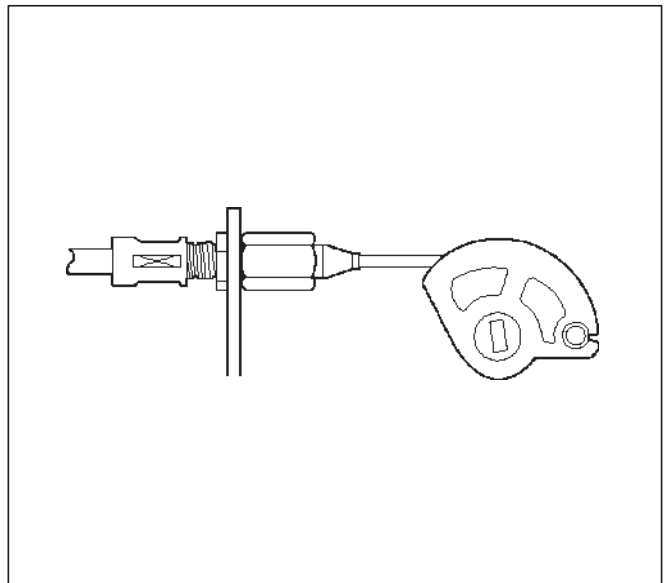


035RW004

4. Loosen adjusting nut by three turns and tighten lock nut. Then, manually operating the throttle valve, make sure that the valve lever returns up to the stopper screw.

**IMPORTANT:** The valve lever must return up to the stopper screw. If the valve lever does not reach the stopper screw, repeat the procedure again from step 1.

5. It does not reach the stopper screw, repeat from step 1.

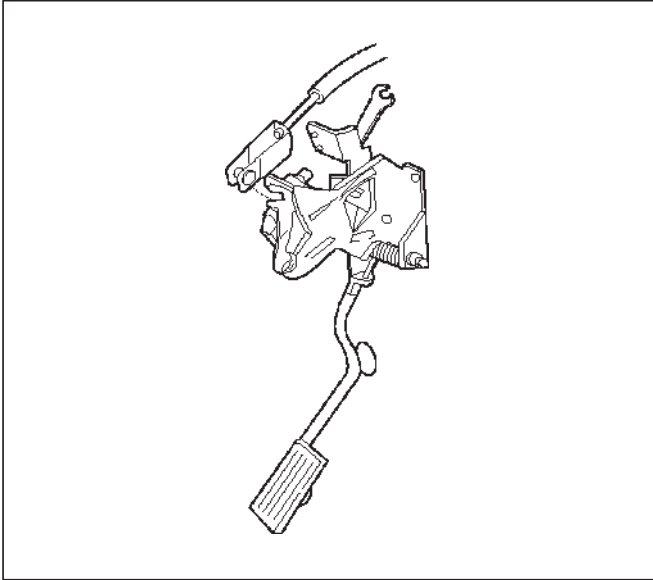


TS23782

## Accelerator Pedal Replacement

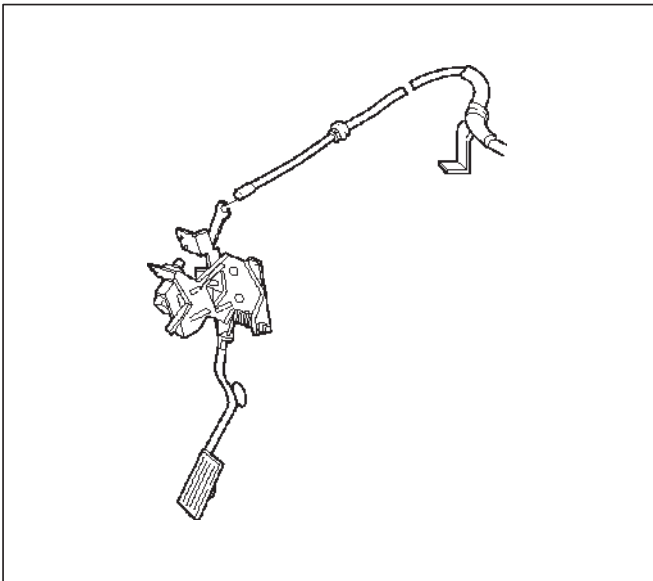
### Removal Procedure

1. Disconnect the cruise control cable from the accelerator pedal assembly.



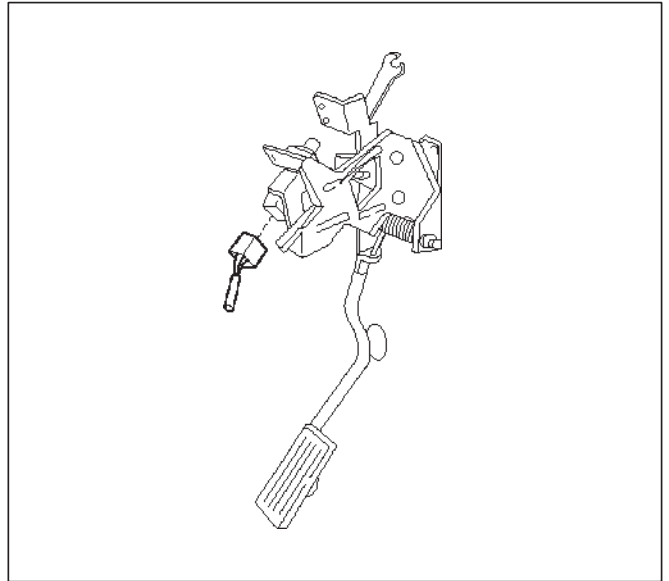
TS24053

2. Disconnect the accelerator pedal control cable from the accelerator pedal assembly.



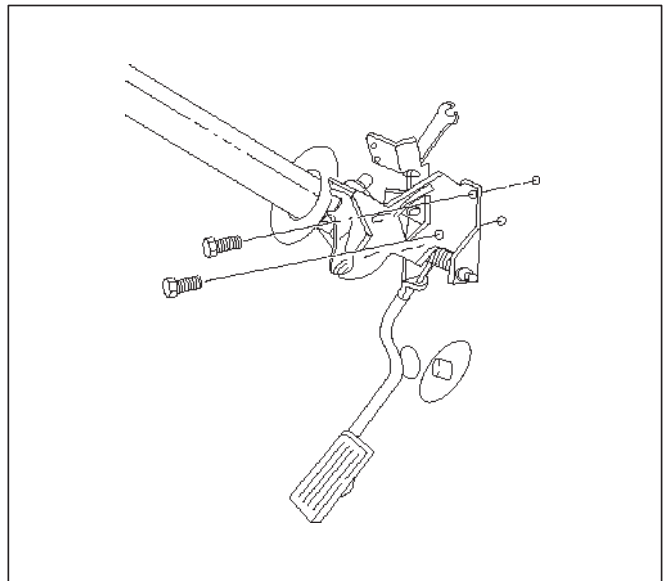
TS24054

3. Disconnect the wiring harness from the kick-down switch.



TS24038

4. Remove the two screws from the accelerator pedal assembly.



TS24055

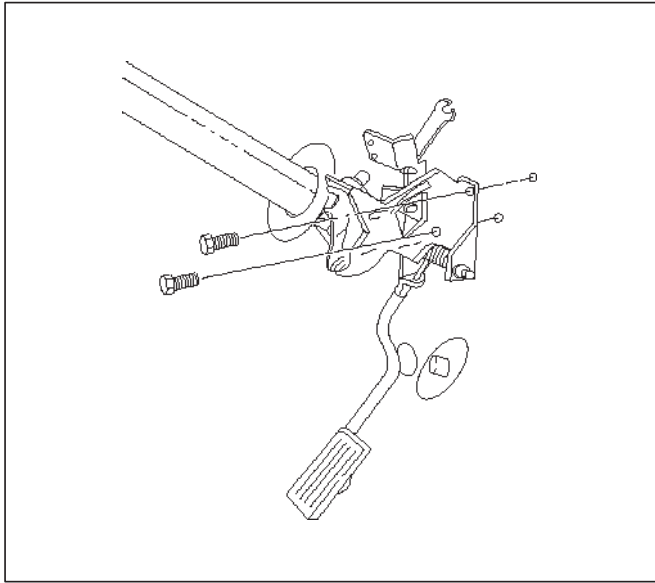
5. Remove the accelerator pedal assembly from the bulkhead.

### Installation Procedure

1. Install the accelerator pedal assembly on the bulkhead.

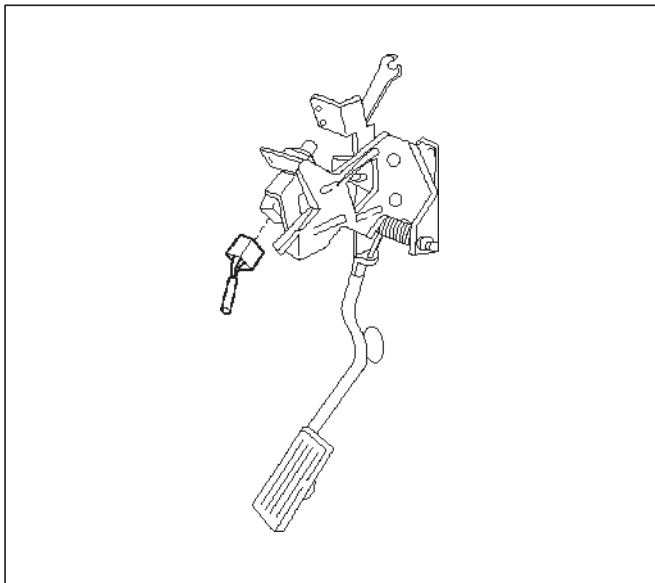
**6E-458 6VE1 3.5L ENGINE DRIVEABILITY AND EMISSIONS**

2. Install the two screws to the accelerator pedal assembly.



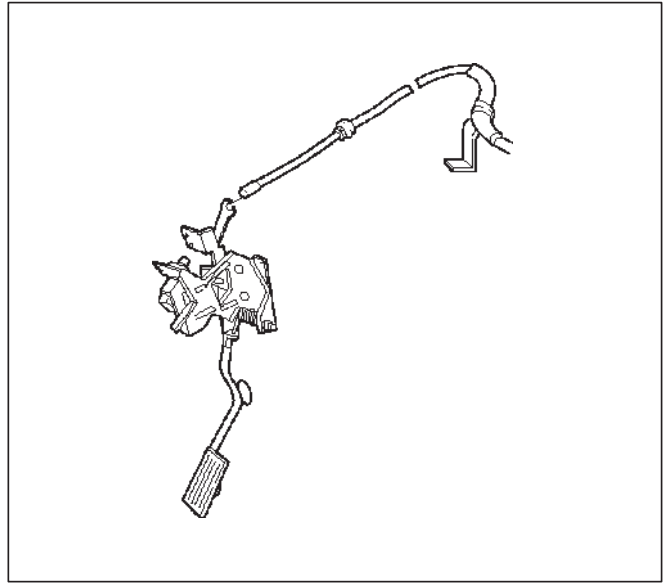
TS24055

3. Connect the wiring harness to the kick-down switch.



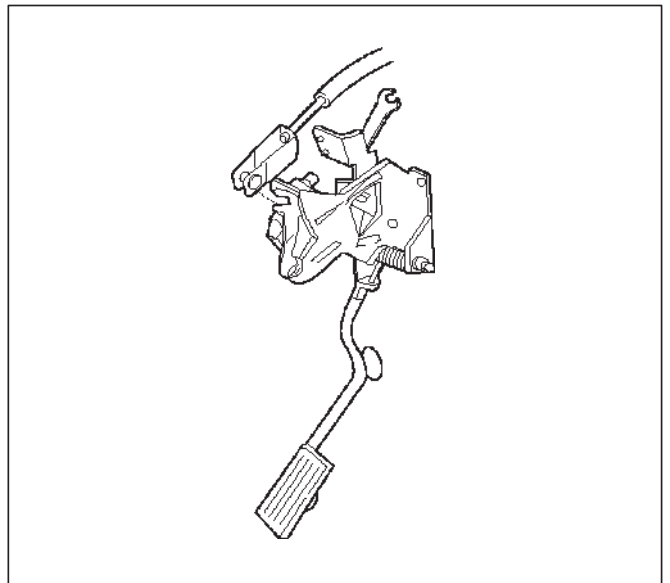
TS24038

4. Connect the accelerator pedal control cable to the accelerator pedal assembly.



TS24054

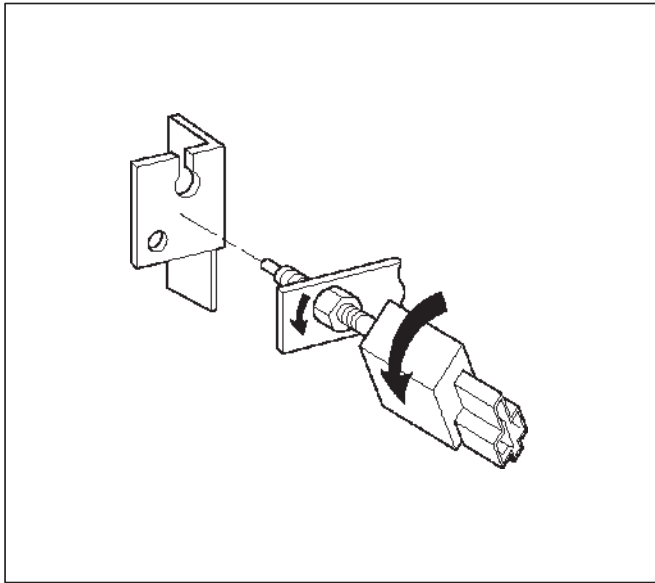
5. Connect the cruise control cable to the accelerator pedal assembly.



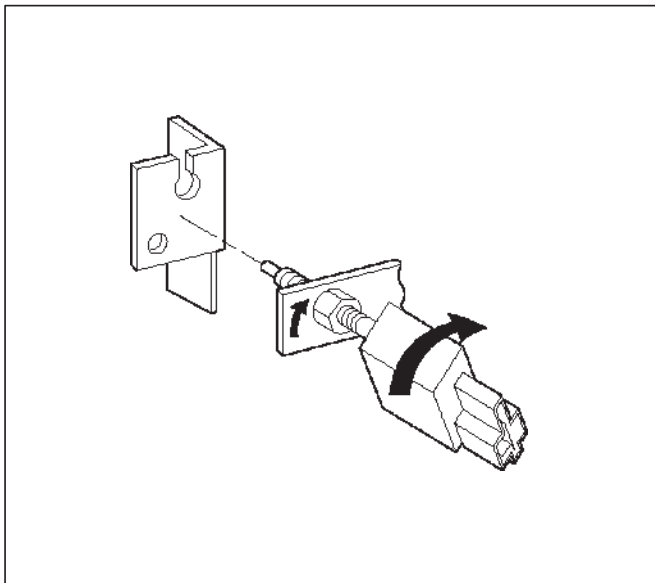
TS24053

## Pedal Stroke Adjustment Procedure

1. Loosen the jam nut and rotate the kick-down switch counterclockwise.



2. Fully depress the pedal and hold it by hand. Rotate the switch clockwise until the switch clicks.
3. Rotate the switch 1/2 turn further and lock it in this position by tightening the jam nut.



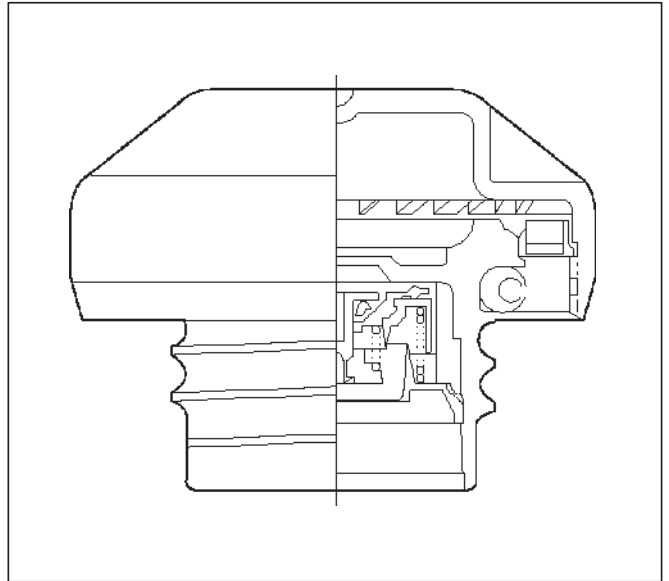
4. Step on the accelerator pedal and make sure there is a clicking sound at the full-stroke position.

## Fuel Filter Cap

### General Description

The fuel filter cap includes a vacuum valve and a pressure valve.

If high vacuum or high pressure occurs in the fuel tank, each valve works to adjust the pressure in order to prevent damage to the tank at the EGR valve.



### Inspection Procedure

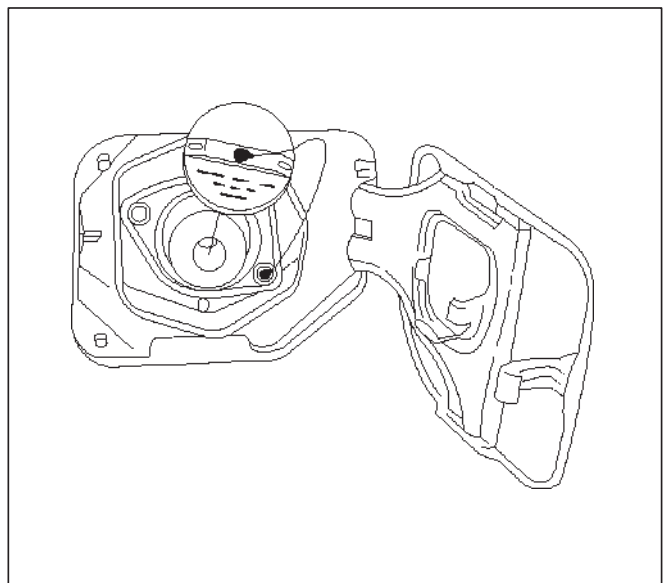
NOTE: Replace the fuel filler cap with the same type of filler cap that was originally installed on the vehicle.

- Check the seal ring in the filler cap for any abnormality and for seal condition.
- Replace the filler cap if any abnormality is found.

## Fuel Filter

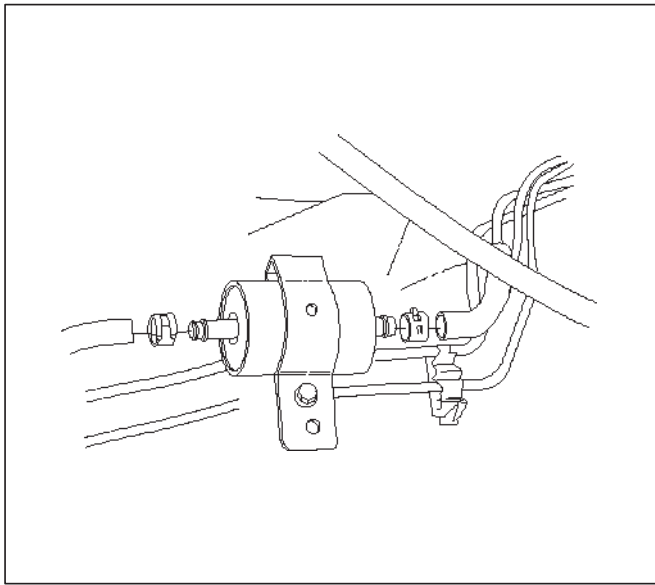
### Removal Procedure

1. Disconnect the negative battery cable.
2. Remove the fuel filler cap.

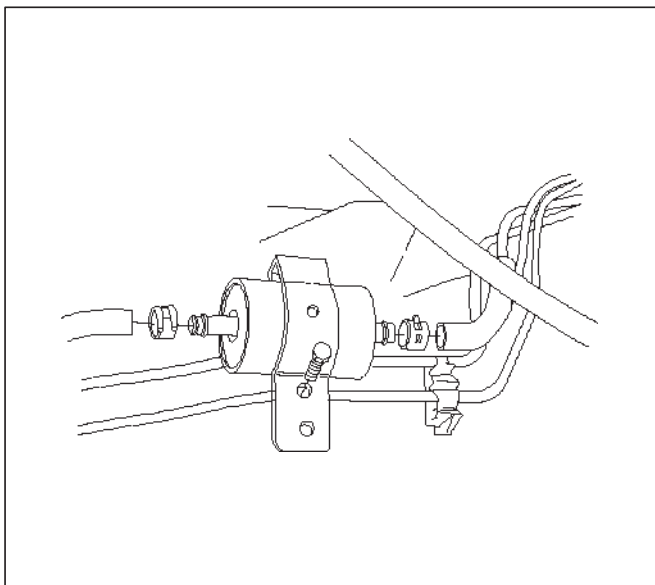


3. Disconnect the fuel line from the fuel filter on the engine side.

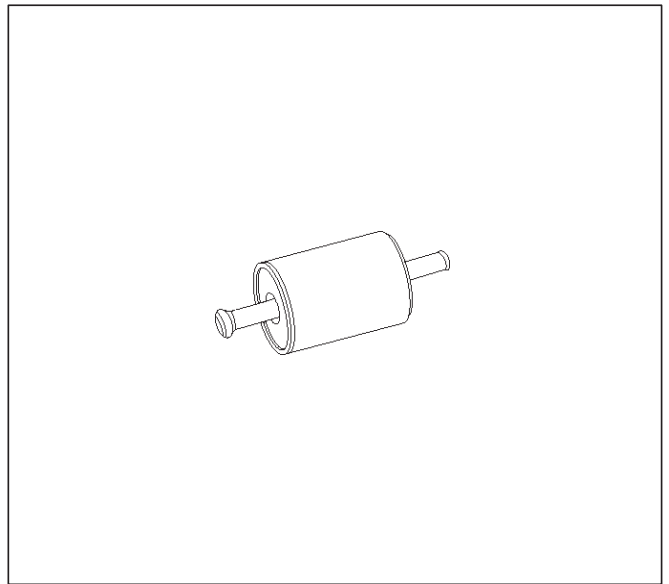
4. Disconnect the fuel line from the fuel filter on the fuel tank side.



5. Remove the bolt on the fuel filter holder.



6. Remove the fuel filter.

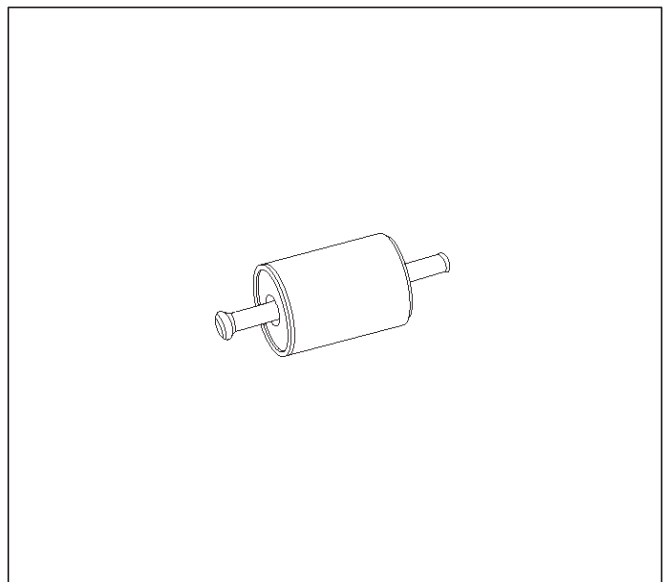


### Inspection Procedure

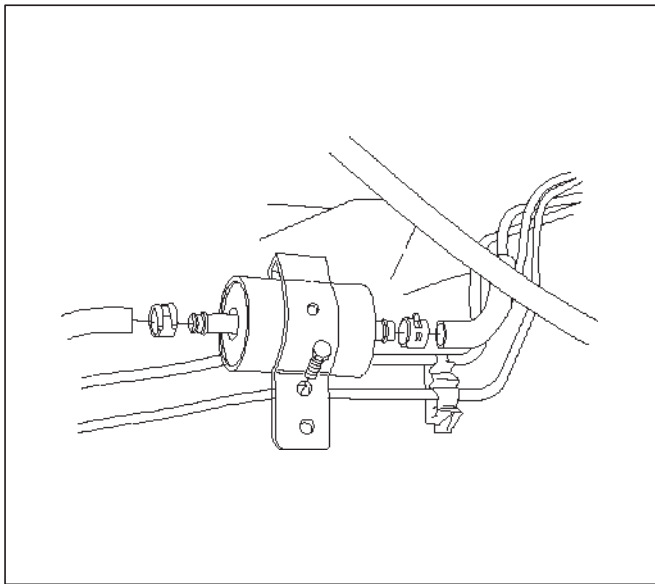
1. Replace the fuel filter when the following occur:
  - Fuel leaks from the fuel filter body.
  - The fuel filter body is damaged.
  - The fuel filter is clogged with dirt or sediment.
2. If the drain hole is clogged, clean the drain.

### Installation Procedure

1. Install the fuel filter in the correct direction.

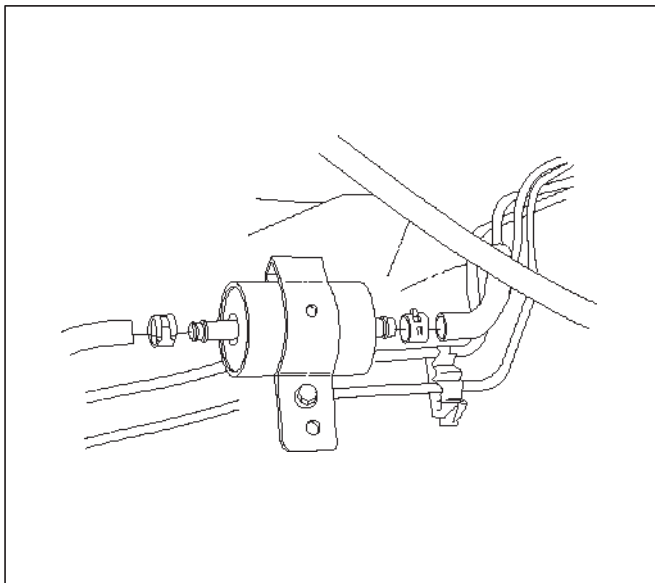


2. Install the bolt on the fuel filter holder.



041RW007

3. Connect the fuel line on the engine side.  
4. Connect the fuel line on the fuel tank side.



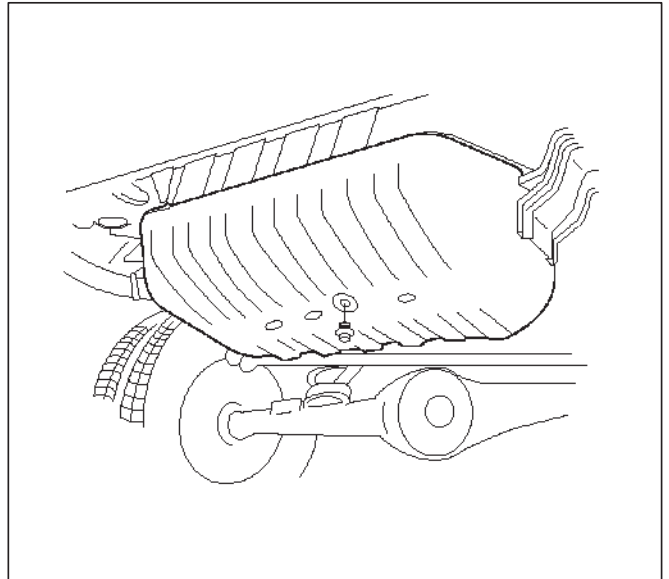
041RW006

5. Install the fuel filler cap.  
6. Connect the negative battery cable.

3. Drain the fuel from the tank.

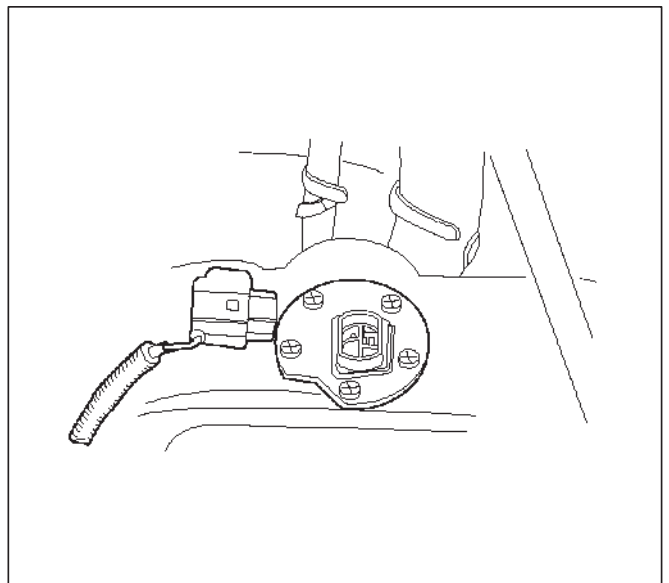
**Tighten**

○ Tighten the drain plug to 20 N-m (14 lb ft.).



TS22907

4. Disconnect the wiring connector from the fuel gauge unit.



TS23771

5. Remove the fuel gauge unit retaining screws.

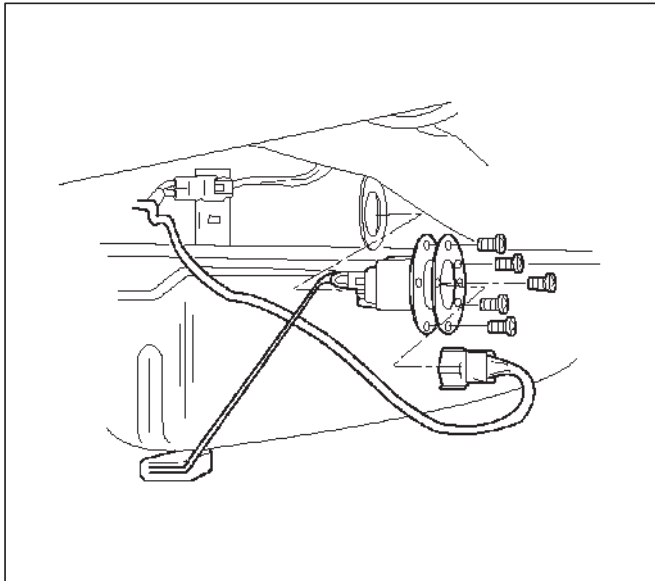
## Fuel Gauge Unit

### Removal Procedure

1. Disconnect the negative battery cable.  
2. Loosen the fuel filler cap.

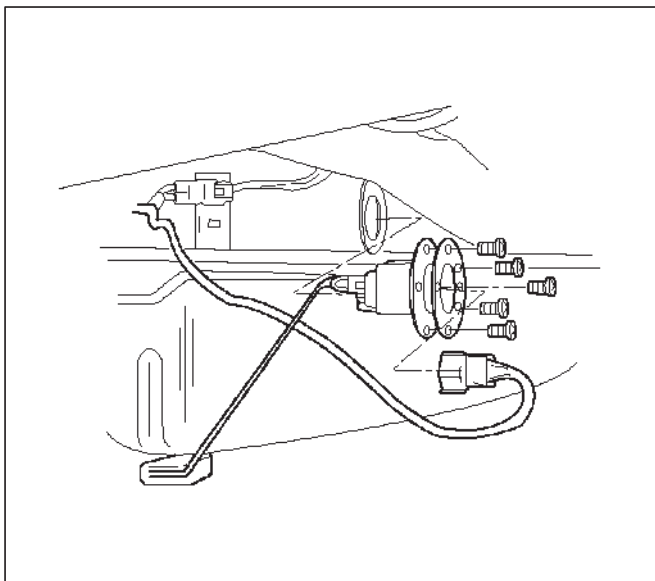
6. Remove the fuel gauge unit.

- Cover or plug the fuel tank to prevent dust, dirt, or debris from entering the tank.

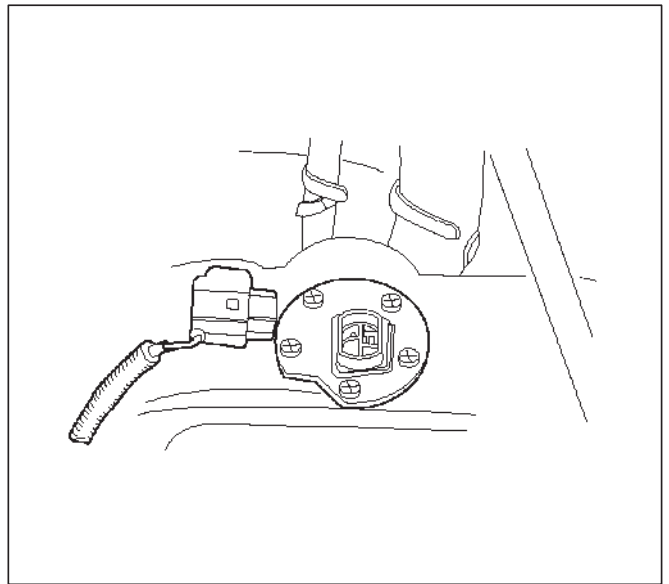


## Installation Procedure

1. Install the fuel gauge unit.
2. Install the fuel gauge unit retaining screws.



3. Connect the wiring connector to the fuel gauge unit.



4. Fill the fuel tank with fuel.

- Tighten the fuel filler cap.
- Check for leaks at the fuel gauge unit gasket.

5. Connect the negative battery cable.

## Fuel Injectors

### Removal Procedure

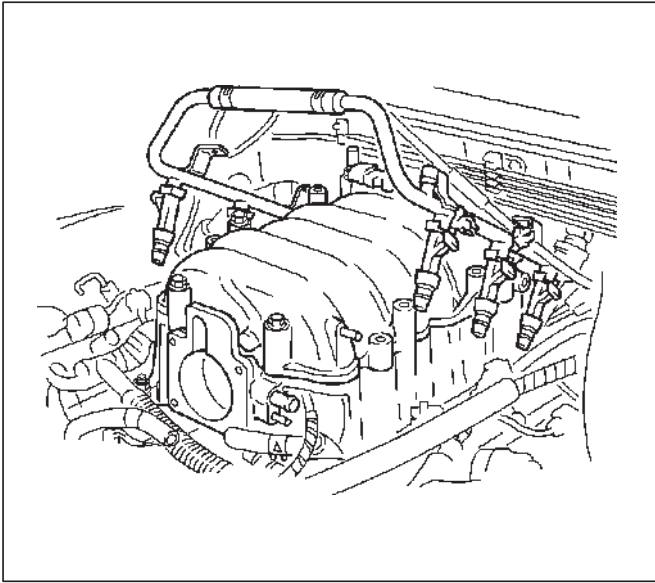
NOTE: If the fuel injectors are leaking, the engine oil may be contaminated with fuel. Check the oil for signs of contamination and change the oil and the filter if necessary.

NOTE: Use care in removing the fuel injectors in order to prevent damage to the fuel injector electrical connector pins or the fuel injector nozzles. The fuel injector is an electrical component and should not be immersed in any type of cleaner as this may damage the fuel injector.

**IMPORTANT:** Fuel injectors are serviced as a complete assembly only.

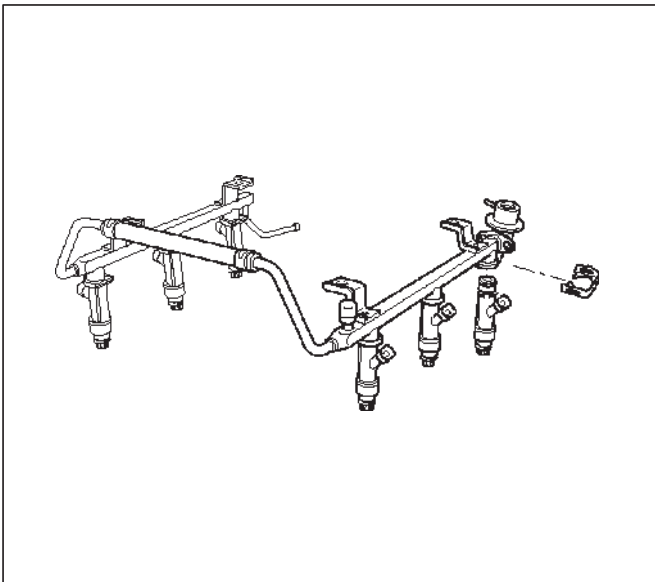
1. Disconnect the negative battery cable.

2. Remove the fuel rail. Refer to *Fuel Rail*.



014RW106

3. Remove the injector retainer clip.



F06RW017

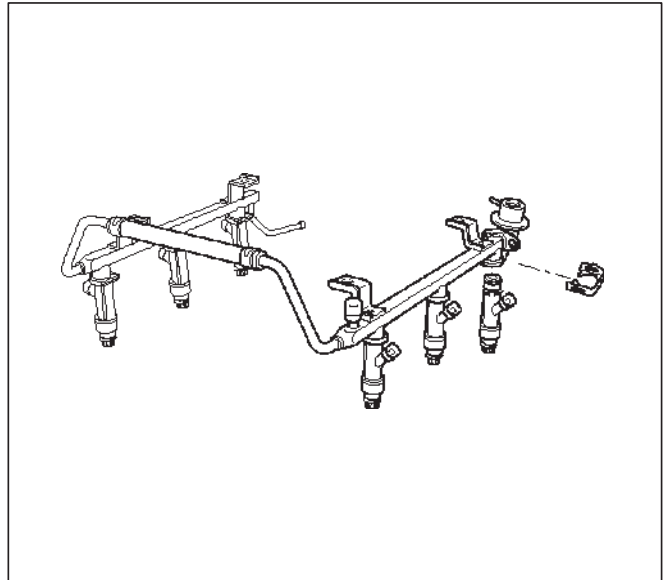
4. Remove the fuel injector assembly.
5. Remove the O-ring from the fuel injector.
6. Remove the O-ring backup from the fuel injector .

### Inspection Procedure

1. Inspect the O-rings for cracks or leaks.
2. Replace worn or damaged O-rings.
3. Lubricate the new O-rings with engine oil before installation.

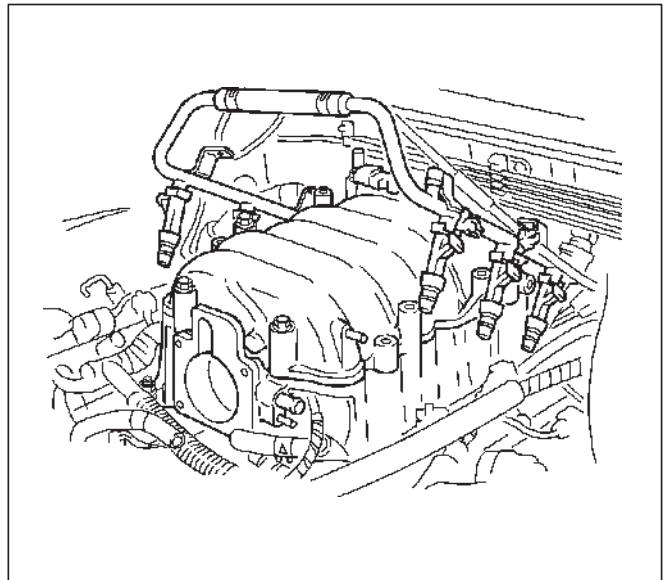
### Installation Procedure

1. Install the O-ring backup on the fuel injector.
2. Install the new O-ring on the fuel injector.
3. Install the fuel injector on the fuel rail.



F06RW017

4. Use new fuel injector retainer clips to retain the fuel injector to the fuel rail.
5. Coat the end of the fuel injector with engine oil.
6. Install the fuel rail. Refer to *Fuel Rail*.



014RW106

7. Install the engine cover.
8. Connect the negative battery cable.



## Fuel Pressure Regulator

### Removal Procedure

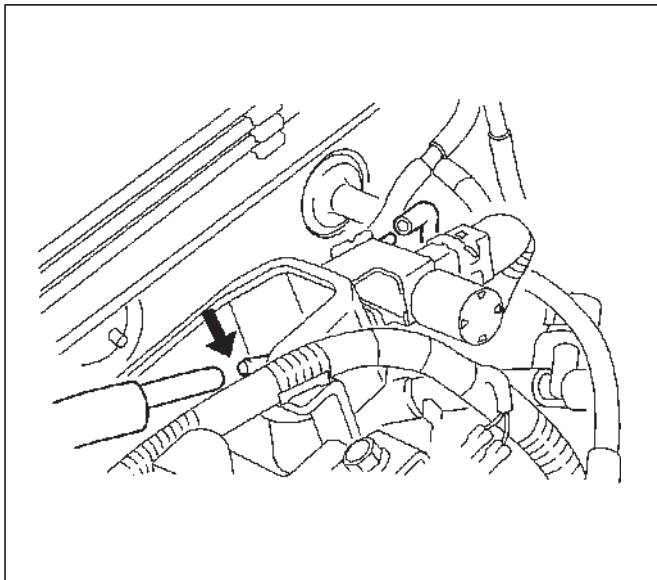
**CAUTION:** To reduce the risk of fire and personal injury, it is necessary to relieve the fuel system pressure before servicing the fuel system components.

**CAUTION:** After relieving the system pressure, a small amount of fuel may be released when servicing fuel lines or connections. Reduce the chance of personal injury by covering the fuel line fittings with a shop towel before disconnecting the fittings. The towels will absorb any fuel that may leak out. When the disconnect is completed, place the towel in an approved container.

**NOTE:** Compressed air must never be used to test or clean a fuel pressure regulator, as damage to the fuel pressure regulator may result.

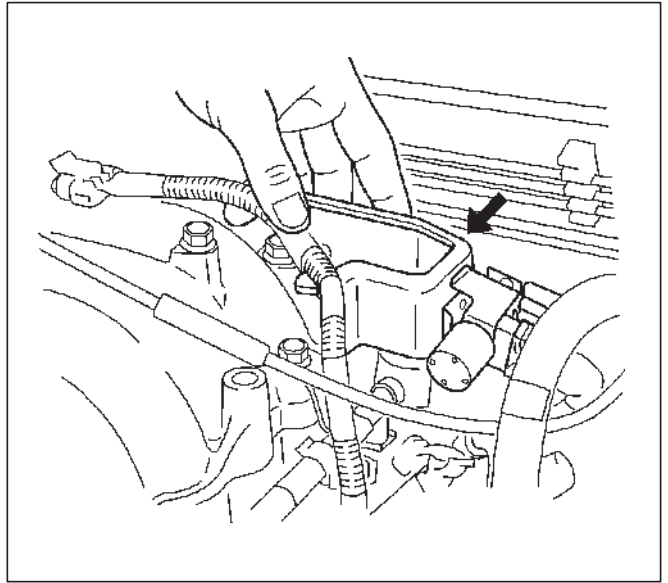
**NOTE:** To prevent damage to the fuel pressure regulator, do not immerse the pressure regulator in solvent.

1. Depressurize the fuel system. Refer to *Fuel Pressure Relief Procedure*.
2. Disconnect the negative battery cable.
3. Remove the fuel pump relay. Refer to *Fuel Pump Relay*.
4. Remove the pressure regulator hose from the fuel pressure regulator.



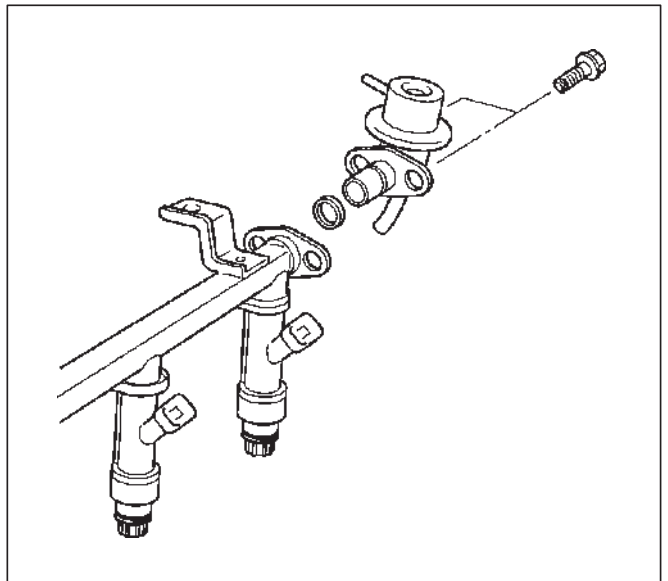
014RW110

5. Remove the two bolts from the protector that secures the common chamber.



014RW109

6. Remove the fuel pressure regulator attaching screw.



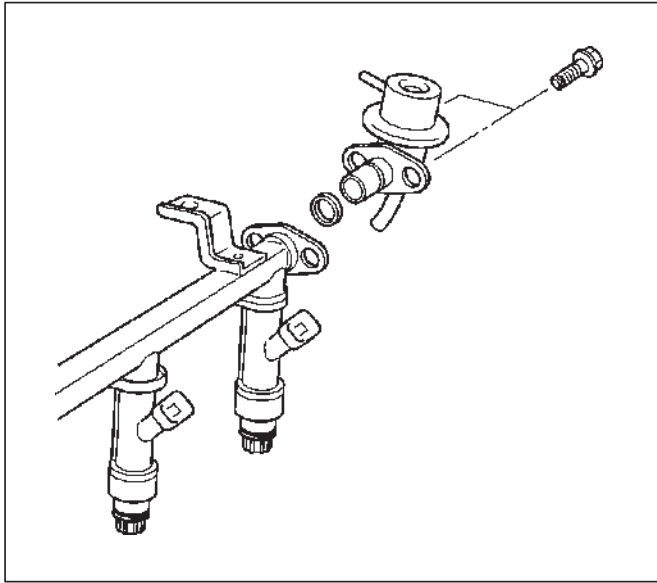
F06RW016

7. Remove the fuel pressure regulator from the fuel rail.

### Disassembly Procedure

1. Remove the O-ring from the fuel pressure regulator.
2. Loosen the swivel nut.
3. Remove the fuel return line from the fuel pressure regulator.
4. Remove the O-ring from the fuel return line.

- The O-ring may be left inside the fuel pressure regulator instead of on the fuel return line.



F06RW016

### Assembly Procedure

1. Install a new O-ring on the fuel return line.
2. Install the fuel return line on the fuel pressure regulator.

NOTE: Do not over-tighten the swivel nut on the fuel pressure regulator. The fuel pressure regulator can be damaged and fuel may leak if the swivel nut is over-tightened.

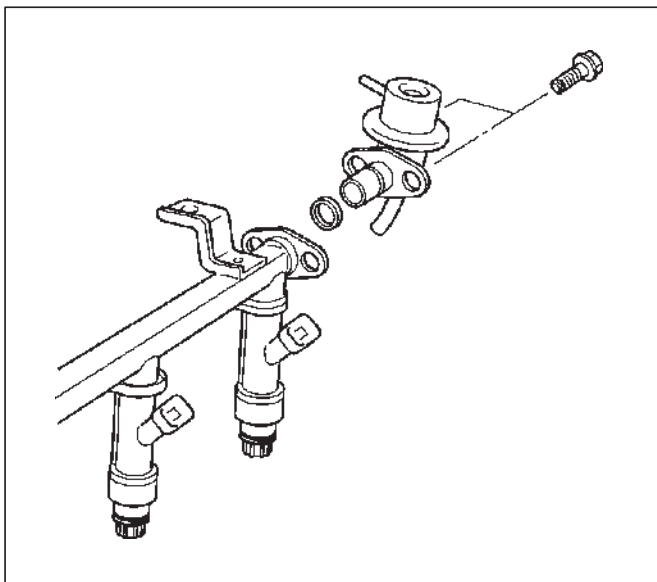
3. Tighten the swivel nut.
4. Install a new O-ring on the fuel pressure regulator.

### Installation Procedure

1. Install the fuel pressure regulator attaching screw.

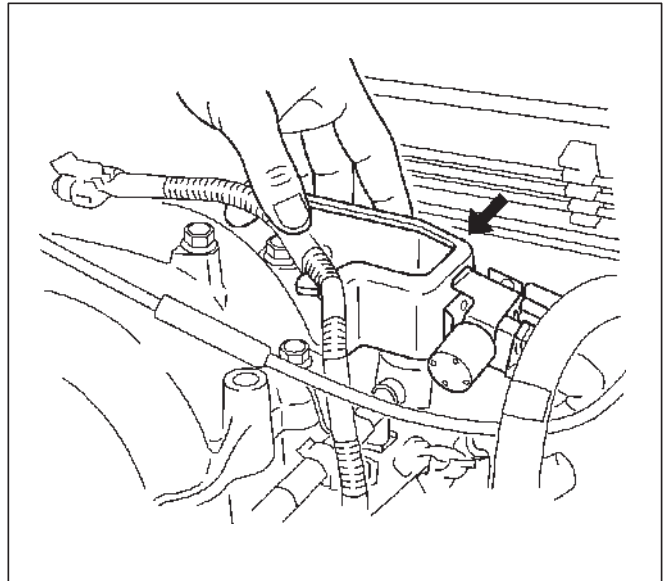
**Tighten**

- Tighten the fuel pressure regulator attaching screw to 3 N-m (26 lb in.).



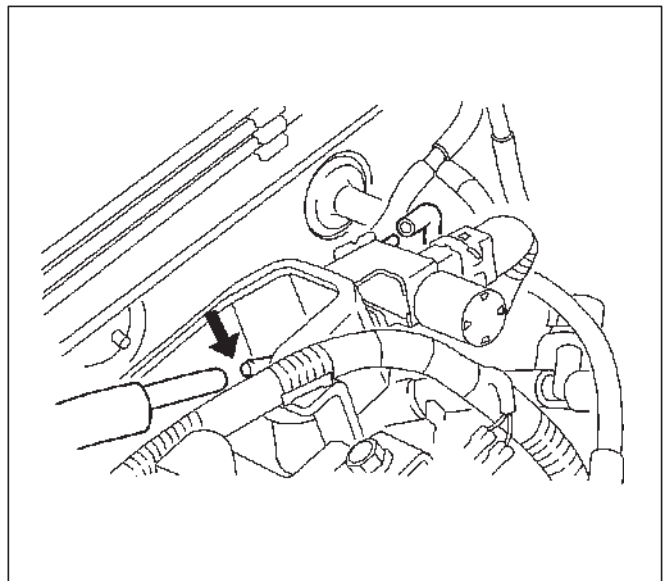
F06RW016

2. Install the fuel pressure regulator on the fuel rail.
3. Install the two bolts to the protector that secures the common chamber.



014RW109

4. Install the pressure regulator hose to the fuel pressure regulator.



014RW110

5. Install the fuel pump relay. Refer to *Fuel Pump Relay*.
6. Connect the negative battery cable.
7. Crank the engine until it starts. Cranking the engine may take longer than usual due to trapped air in the fuel lines.

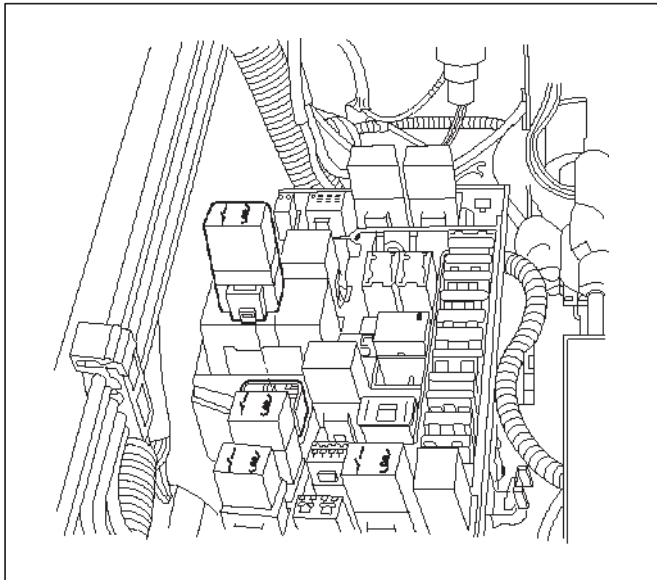
## Fuel Metering System

### Fuel Pressure Relief Procedure

**CAUTION:** To reduce the risk of fire and personal injury, it is necessary to relieve the fuel system pressure before servicing the fuel system components.

**CAUTION:** After relieving the system pressure, a small amount of fuel may be released when servicing fuel lines or connections. Reduce the chance of personal injury by covering the fuel line fittings with a shop towel before you disconnect the fittings. The towels will absorb any fuel that may leak out. When the disconnect is completed, place the towel in an approved container.

1. Remove the fuel cap.
2. Remove the fuel pump relay from the underhood relay box. Refer to *Fuel Pump Relay*.



TS23976R

3. Start the engine and allow it to stall.
4. Crank the engine for 30 seconds.
5. Disconnect the negative battery cable.

## Fuel Pump Assembly

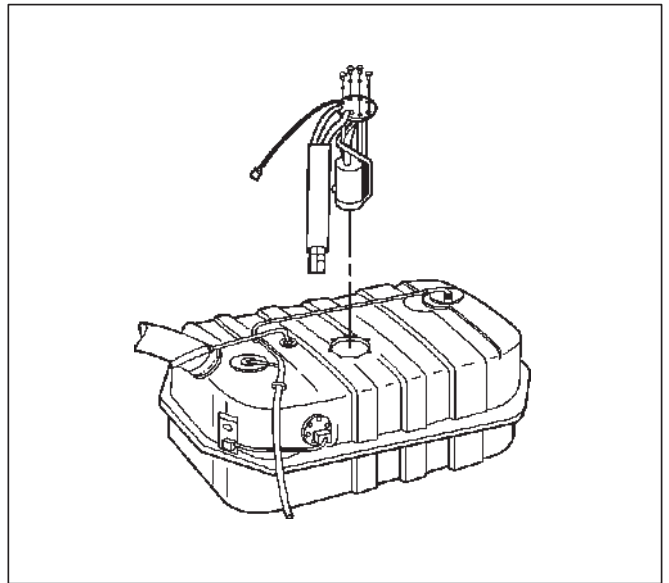
### Removal Procedure

1. Disconnect the negative battery cable.
2. Drain all the fuel from the tank.
3. Install and tighten the drain plug.

#### Tighten

- Tighten the drain plug to 20 N·m (14 lb ft.).
4. Remove the fuel tank. Refer to *Fuel Tank*.
  5. Remove the retaining screws from the fuel tank.
  6. Remove the fuel pump assembly from the fuel tank.

- Cover the fuel pump opening in order to prevent dust, dirt, or debris from entering the fuel tank.



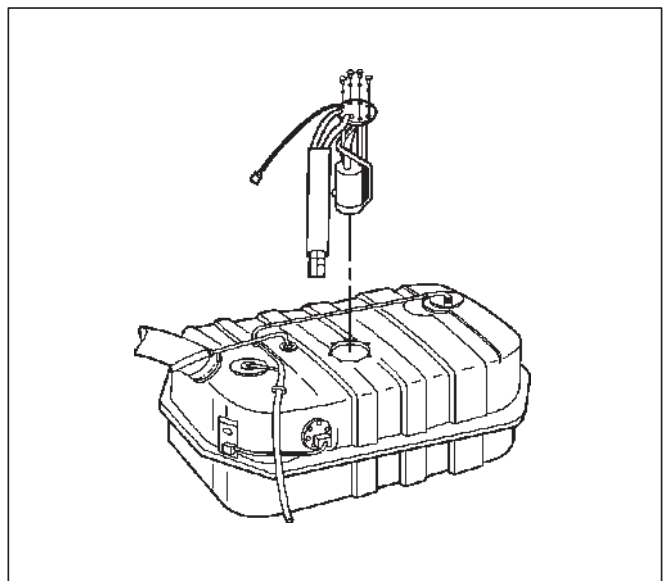
TS23795

### Inspection Procedure

1. Inspect the fuel pump gasket for tears, cracks, stretching, or rotting. If any of these conditions are found, replace the fuel pump gasket.
2. Inspect the in-tank fuel filter for tears or evidence of dirt, debris, or water in the fuel. If any of these conditions are found, replace the in-tank fuel filter.

### Installation Procedure

1. Install the fuel pump assembly.
2. Install the fuel pump assembly retaining screws.
3. Install the fuel tank assembly. Refer to *Fuel Tank*.
4. Fill the tank with fuel.
5. Tighten the fuel filler cap.
6. Connect the negative battery cable.

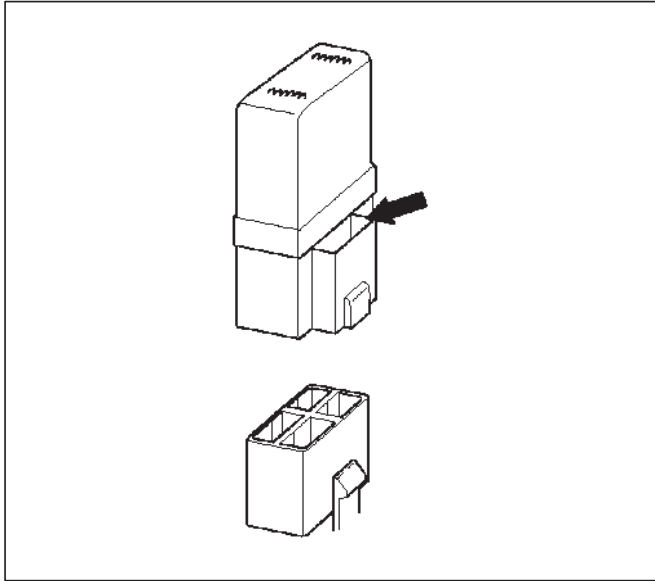


TS23795

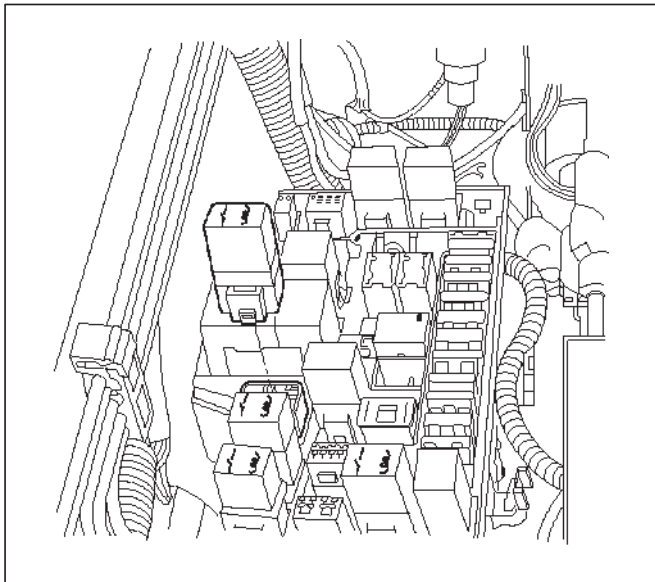
## Fuel Pump Relay

### Removal Procedure

1. Remove the fuse and relay box cover from under the hood.
2. Consult the diagram on the cover to determine which is the correct relay.
3. Insert a small screwdriver into the catch slot on the forward side of the fuel pump relay.
  - The screwdriver blade will release the catch inside.

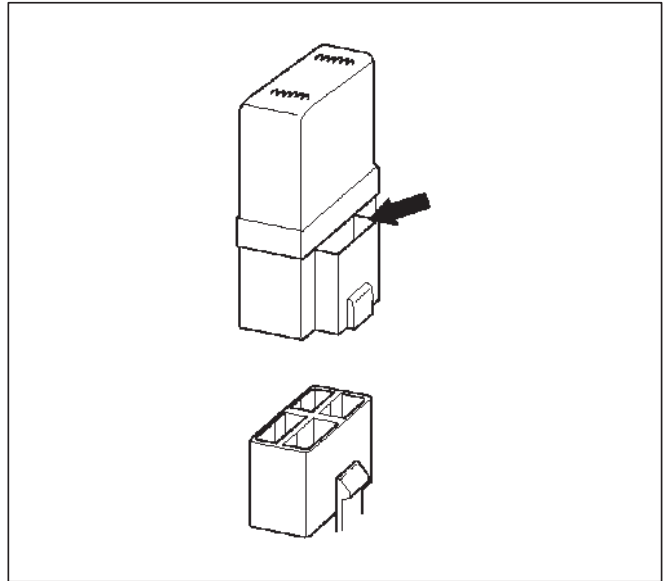


4. Pull the relay straight up and out of the fuse and relay box.



### Installation Procedure

1. Insert the relay into the correct place in the fuse and relay box with the catch slot facing forward.
2. Press down until the catch engages.
  - An audible "click" will be heard.



3. Install the fuse and relay box cover.

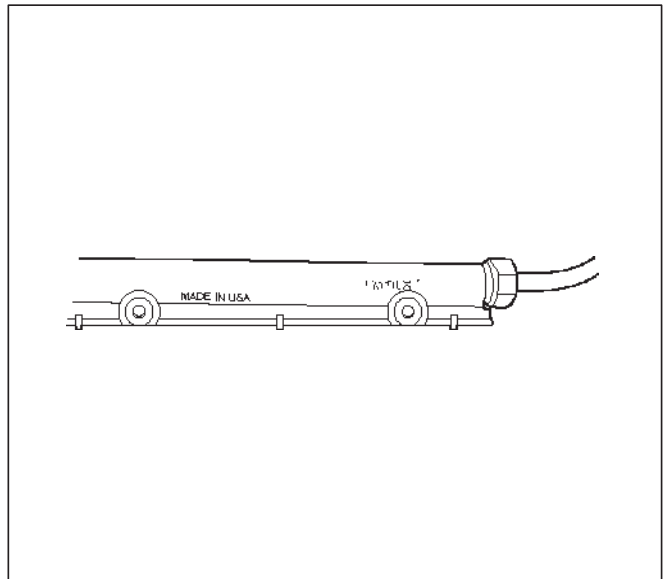
## Fuel Rail Assembly

### Removal Procedure

#### NOTE:

- Do not attempt to remove the fuel inlet fitting on the fuel rail. It is staked in place. Removing the fuel inlet fitting will result in damage to the fuel rail or the internal O-ring seal.
- Use care when removing the fuel rail assembly in order to prevent damage to the injector electrical connector terminals and the injector spray tips.
- Fittings should be capped and holes plugged during servicing to prevent dirt and other contaminants from entering open lines and passages.

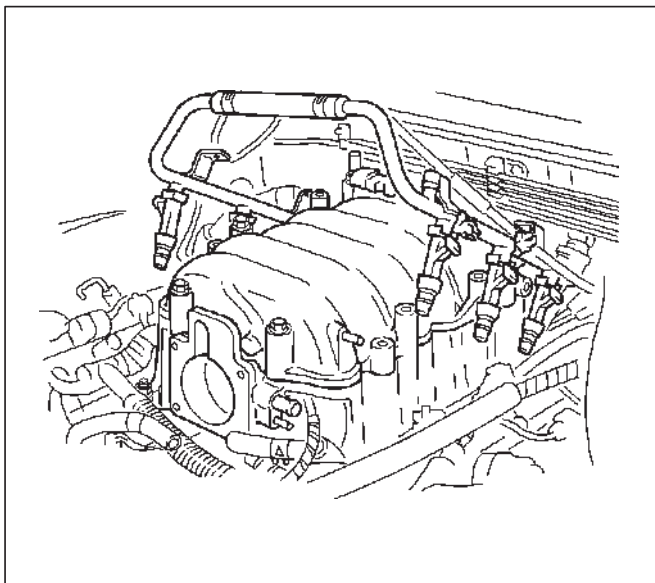
**IMPORTANT:** An eight-digit identification number is stamped on the side of the fuel rail. Refer to this number when you service the fuel rail or when a replacement part is required.



## 6E-468 6VE1 3.5L ENGINE DRIVEABILITY AND EMISSIONS

Before removal, the fuel rail assembly may be cleaned with a spray type engine cleaner. Follow the spray package instructions. Do not immerse the fuel rails in liquid cleaning solvent.

1. Depressurize the fuel system. Refer to Fuel Pressure Relief Procedure in this Section.
2. Disconnect the negative battery cable.
3. Remove the engine cover.
4. Disconnect the accelerator pedal cable from throttle body and cable bracket.
5. Disconnect the connectors from manifold absolute pressure sensor, solenoid valve, electric vacuum sensing valve.
6. Disconnect the vacuum hose on canister VSV and positive crankcase ventilation hose.
7. Remove the common chamber. Refer to the common chamber in Engine Mechanical.
  1. Lift up carefully on the fuel injectors. Do not separate the fuel injectors from the fuel rail.
  2. If an injector becomes separated from the fuel rail, the injector O-ring seals and the retainer clip must be replaced.
  3. Drain residual fuel into an approved container.



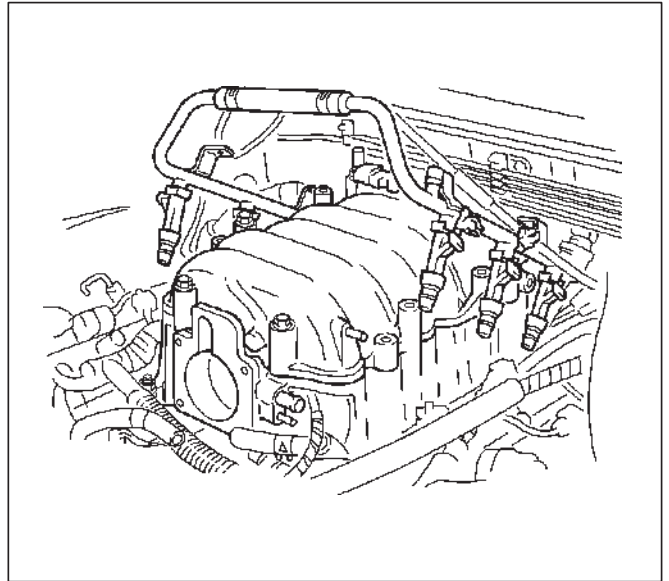
014RW106

8. If removal of the fuel pressure regulator is necessary, refer to *Fuel Pressure Regulator*.
9. If removal of the fuel injectors is necessary, refer to *Fuel Injectors*.

### Installation Procedure

1. If the fuel injectors were removed, install them. Refer to *Fuel Injectors*.
2. If the fuel pressure regulator was removed, install it. Refer to *Fuel Pressure Regulator*.

3. Install the common chamber. Refer to common chamber in engine Mechanical.



014RW106

4. Connect the vacuum hose on Canister VSV and positive crankcase ventilation hose.
5. Connect the connectors to manifold absolute pressure sensor, solenoid valve, electric vacuum sensing valve.
6. Connect the accelerator pedal cable to throttle body and cable bracket.
7. Install the engine cover.
8. Connect the negative battery cable.
9. Crank the engine until it starts. Cranking the engine may take longer than usual due to trapped air in the fuel rail and in the injectors.

## Fuel Tank

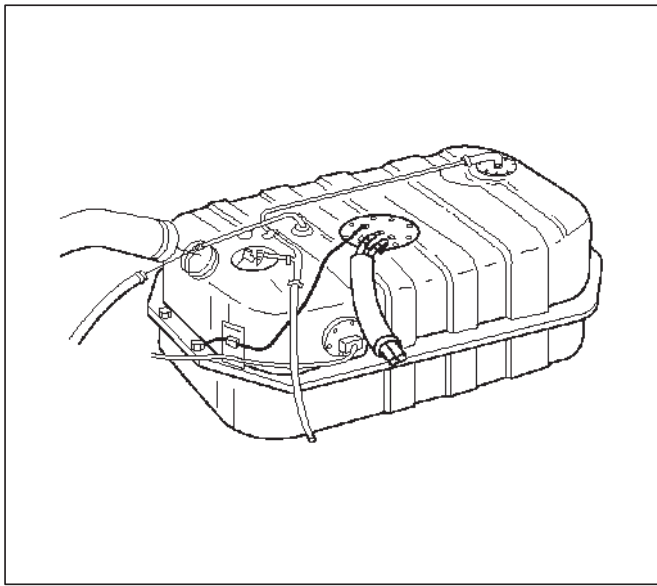
### Removal Procedure

1. Disconnect the negative battery cable.
2. Loosen the fuel filler cap.
3. Drain the fuel from the tank into an approved container.
4. Install and tighten the drain plug.

#### Tighten

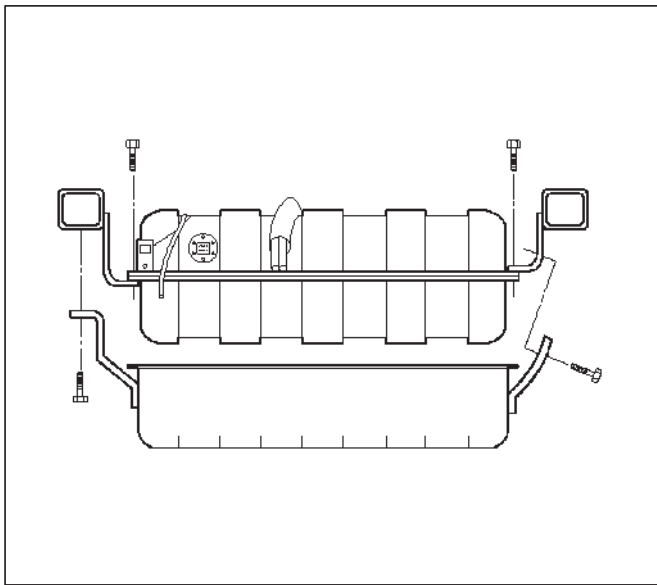
- Tighten the drain plug to 20 N-m (14 lb ft.).
5. Disconnect the fuel filler hose at the fuel tank.

6. Disconnect the air breather hose at the fuel tank.



TS23796

7. Remove the undercover retaining bolts.  
8. Remove the undercover.

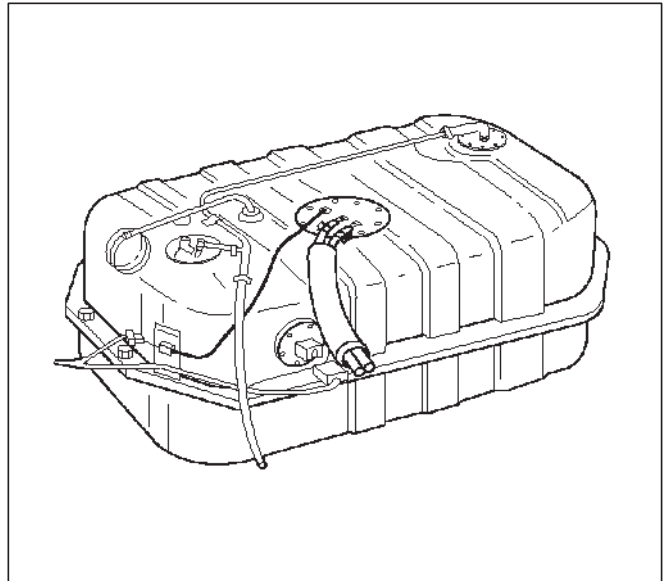


TS23797

9. Disconnect the wiring connector to the fuel pump.  
10. Disconnect the wiring connector to the fuel gauge unit.  
11. Remove the fuel gauge unit connector from the bracket.  
12. Disconnect the EVAP vapor hose.  
13. Disconnect the fuel supply hose.

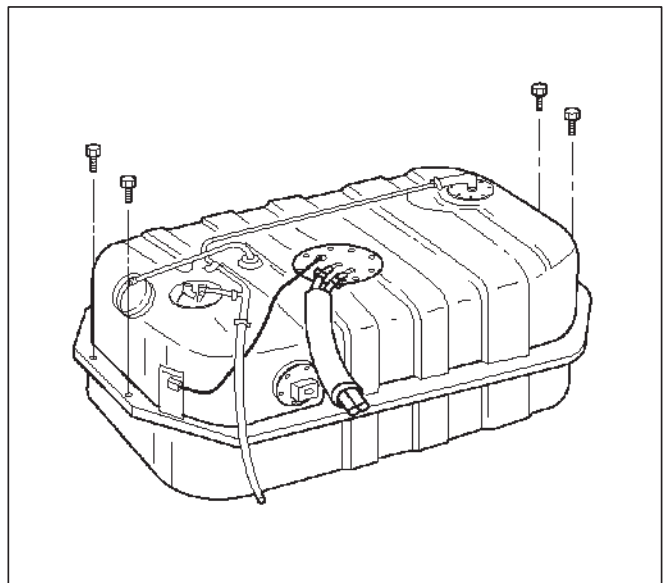
14. Disconnect the fuel return hose.

○ Plug the hoses to prevent dust from entering the hoses.



TS23769

15. Remove the fuel tank retaining bolts on both sides.  
16. Remove the fuel tank.



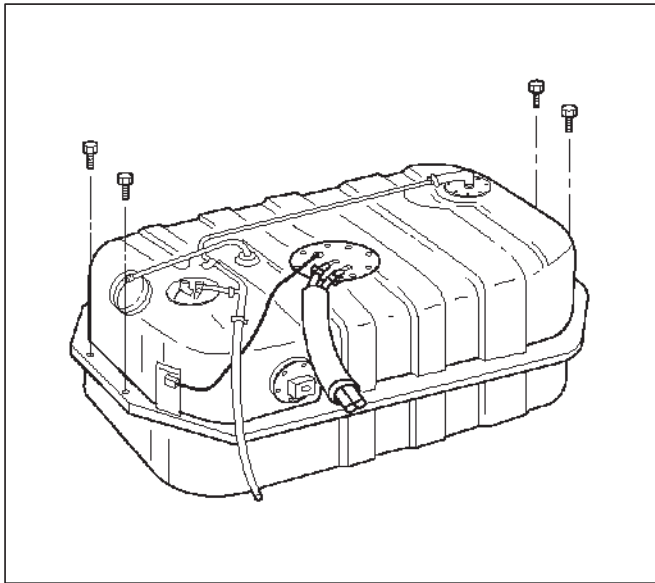
TS23770

## Installation Procedure

1. Install the fuel tank.
  - Place the flanges on the left and right side of the tank on the bracket.
2. Install the fuel tank retaining bolts.

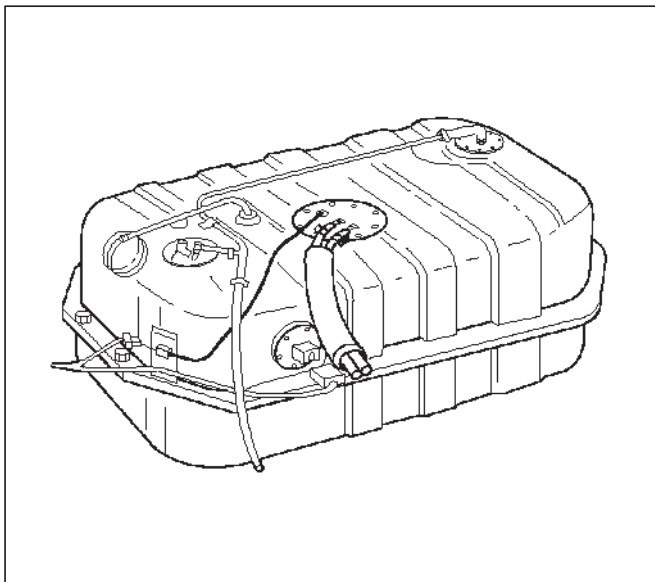
**Tighten**

- Tighten the fuel tank retaining bolts to 36 N·m (27 lb ft.).



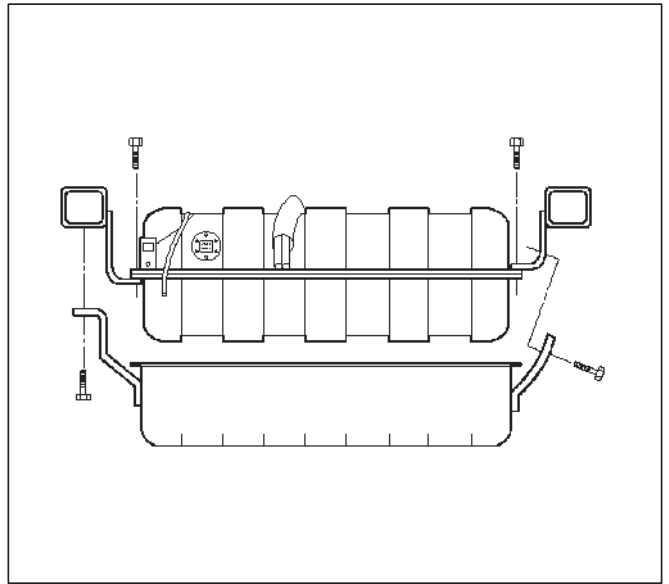
TS23770

3. Connect the fuel return hose.
4. Connect the fuel supply hose.
5. Connect the EVAP vapor hose.
6. Connect the wiring connector for the fuel gauge unit.
7. Connect the fuel gauge wiring connector to the bracket.
8. Connect the wiring connector for the fuel pump.



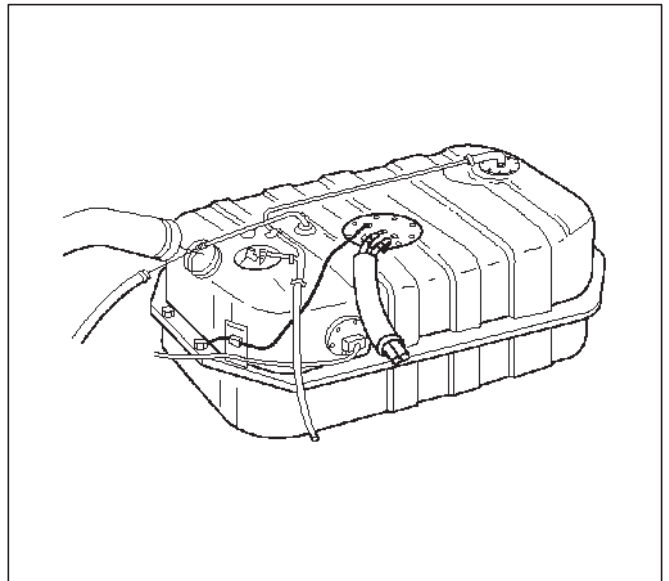
TS23769

9. Install the undercover.
10. Secure the undercover with the retaining bolts.



TS23757

11. Connect the fuel filler fuse at the tank.
12. Connect the air breather hose at the tank.



TS23796

13. Fill the fuel tank with fuel.
14. Tighten the fuel filler cap.
15. Connect the negative battery cable.

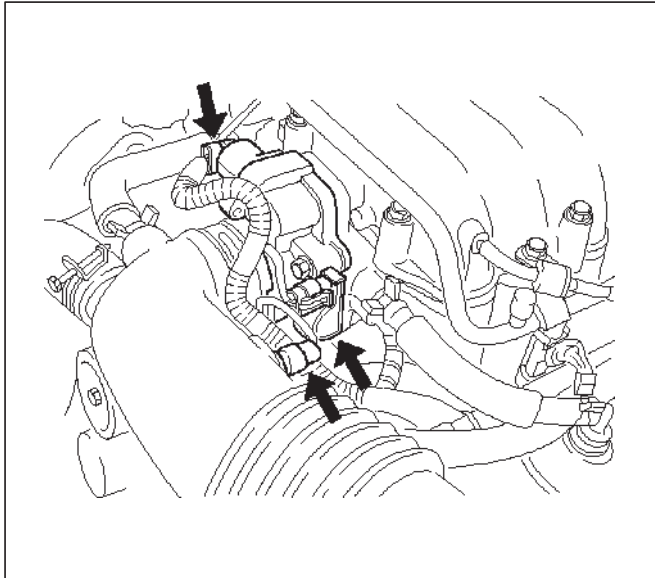
## Throttle Body (TB)

### Removal Procedure

1. Disconnect the negative battery cable.
2. Drain the cooling system. Refer to *Cooling System*.
3. Remove the accelerator cable assembly. Refer to *Accelerator Cable in Engine Speed Control System*.

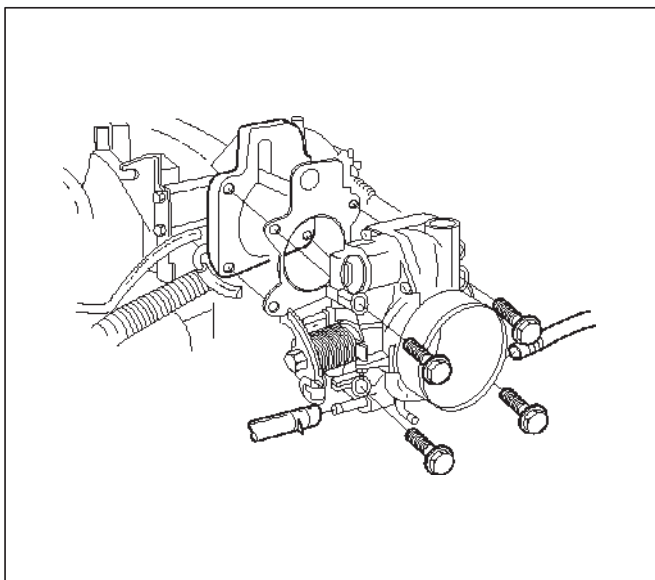
4. Disconnect the electrical connectors:

- Throttle position (TP) sensor.
- Idle air control (IAC) solenoid.
- Intake air temperature (IAT) sensor. Refer to *Intake Air Temperature Sensor*.



035RW023

5. Disconnect the vacuum hose below the air horn.
6. Remove the intake air duct clamp.
7. Disconnect the intake air duct.
8. Disconnect the coolant lines from the throttle body.
9. Remove the bolts from the common chamber.
10. Remove the throttle body from the common chamber.
11. Remove the gasket from the upper intake manifold.



035RW024

12. Remove the IAC. Refer to *Idle Air Control (IAC) Solenoid*.
13. Remove the TP sensor. Refer to *Throttle Position (TP) Sensor*.

## Inspection Procedure

NOTE: Do not use solvent of any type when you clean the gasket surfaces on the intake manifold and the throttle body assembly. The gasket surfaces and the throttle body assembly may be damaged as a result.

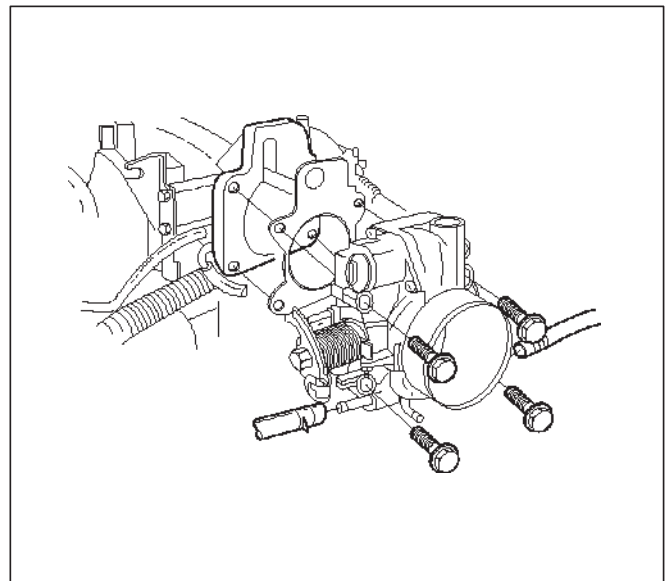
- If the throttle body gasket needs to be replaced, remove any gasket material that may be stuck to the mating surfaces of the manifold.
- Do not leave any scratches in the aluminum casting.

## Installation Procedure

1. Install the TP sensor. Refer to *Throttle Position (TP) Sensor*.
2. Install the IAC. Refer to *Idle Air Control (IAC) Solenoid*.
3. Install the gasket on the common chamber.
4. Install the throttle body on the common chamber.
5. Secure the gasket and the throttle body with the four bolts.
  - The vacuum lines must be properly routed under the throttle body before tightening the mounting bolts.

### Tighten

- Tighten the throttle body mounting bolts to 24 N·m (17 lb ft.).

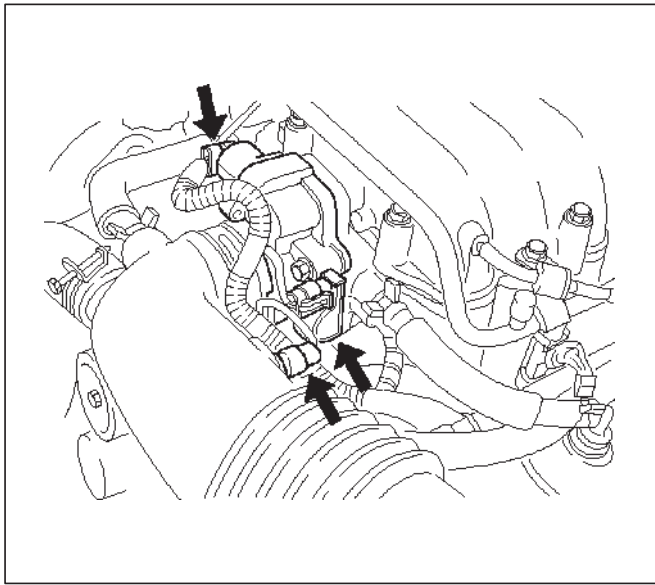


035RW024

6. Install the coolant lines.
7. Connect all the vacuum lines.
8. Install the intake air duct.
9. Tighten the intake air duct clamp.
10. Connect all the electrical connectors:
  - Throttle position (TP) sensor.
  - Idle air control (IAC) solenoid.



- Intake air temperature (IAT) sensor. Refer to *Intake Air Temperature Sensor*.



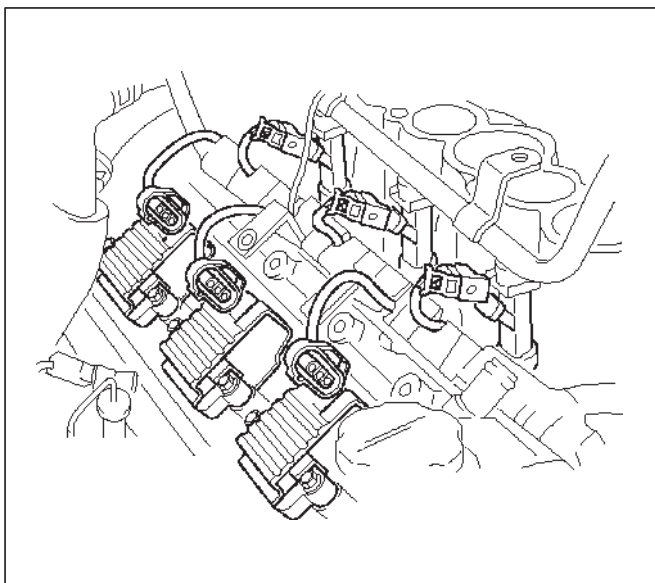
035RW023

11. Install the accelerator cable assembly. Refer to *Accelerator Cable in Engine Speed Control System*.
12. Fill the cooling system. Refer to *Cooling System*.
13. Install the negative battery cable.

## Electronic Ignition System

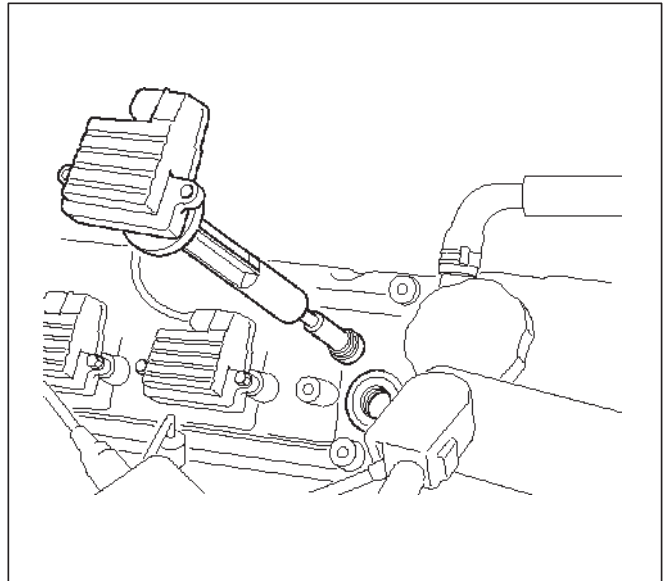
### Removal Procedure

1. Disconnect the negative battery cable.
2. Disconnect the electrical connector at the coil module.
3. Remove the two screws that secure the coil module to the rocker cover.



014RW108

4. Remove the coil module and the spark plug boot from the spark plug.
- Twist the coil module while pulling it straight up.



014RW091

5. Use the spark plug socket in order to remove the spark plug from the engine.

### Spark Plug Gap Check

- Check the gap of all spark plugs before installation.
- Use a round wire feeler gauge to ensure an accurate check.
- Plugs installed with the wrong gap can cause poor engine performance and excessive emissions.

### Installation Procedure

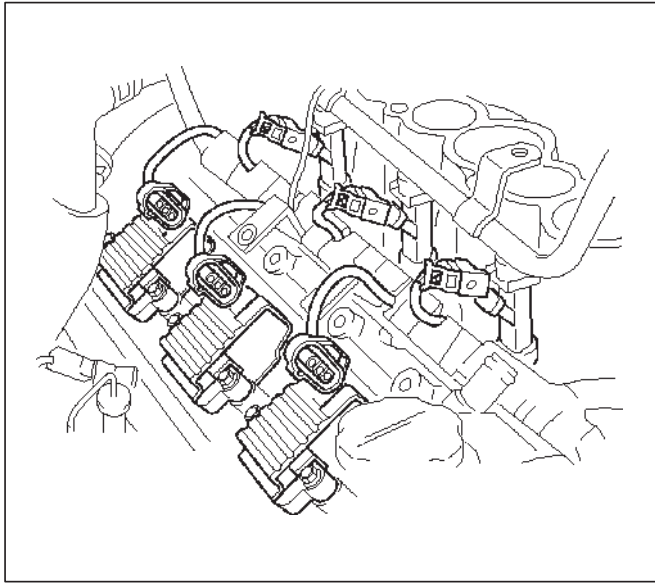
NOTE: The plug must thread smoothly into the cylinder head and be fully seated. Use a thread chaser if necessary to clean the threads in the cylinder head. Cross-threading or failure to fully seat the spark plug can cause plug overheating, exhaust blow-by gases, or thread damage. Do not overtighten the spark plugs. Over tightening can cause aluminum threads to strip.

1. Install the spark plug in the engine. Use the appropriate spark plug socket.

#### Tighten

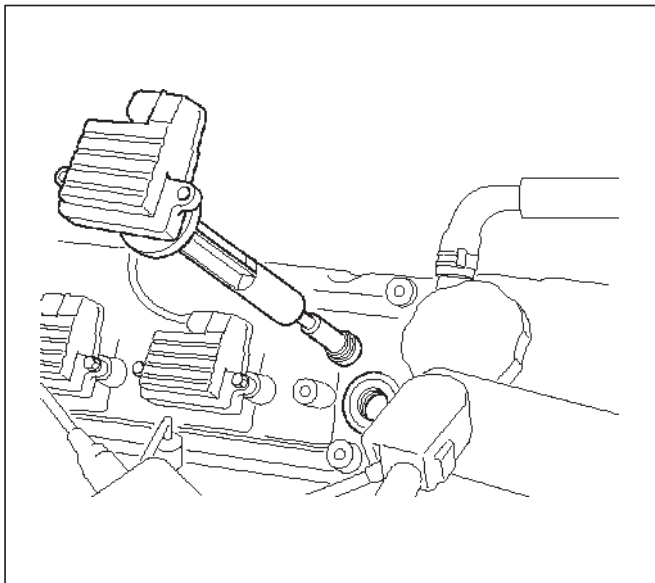
- Tighten the spark plug to 18 N·m (13 lb ft.).

2. Install the coil module and spark plug boot over the spark plug.



014RW108

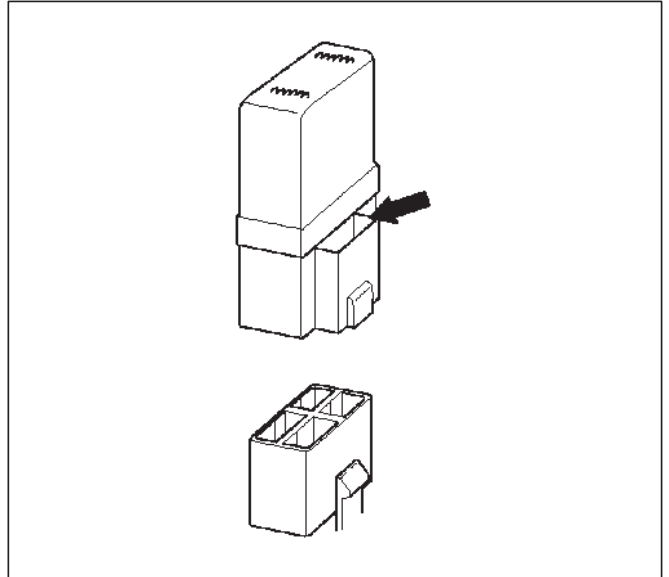
3. Secure the coil module to the rocker cover with two screws.



014RW091

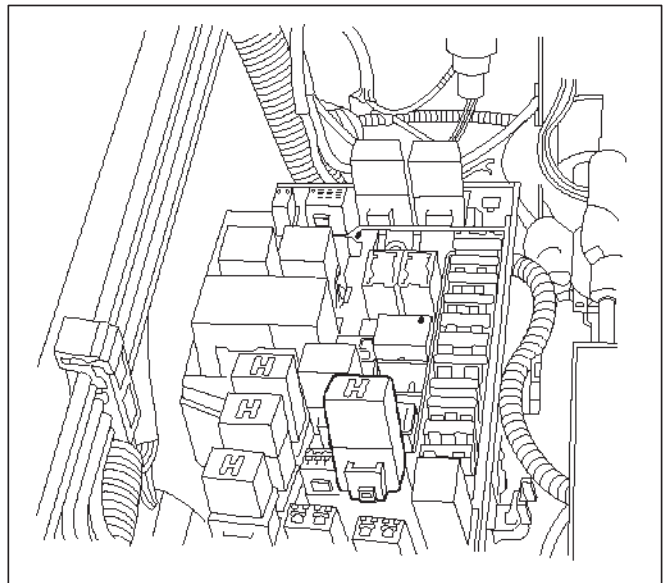
4. Connect the electrical connector at the coil module.
5. Connect the negative battery cable.

2. Consult the diagram on the cover to determine which is the correct relay.
3. Insert a small screwdriver into the catch slot on the forward side of the fuel pump relay.
  - The screwdriver blade will release the catch inside.



T321092

4. Pull the relay straight up and out of the fuse and relay box.



TS23986

## Catalytic Converter

### Removal and Installation Procedure

Refer to *Engine Exhaust in Engine*.

## Air Conditioning Relay

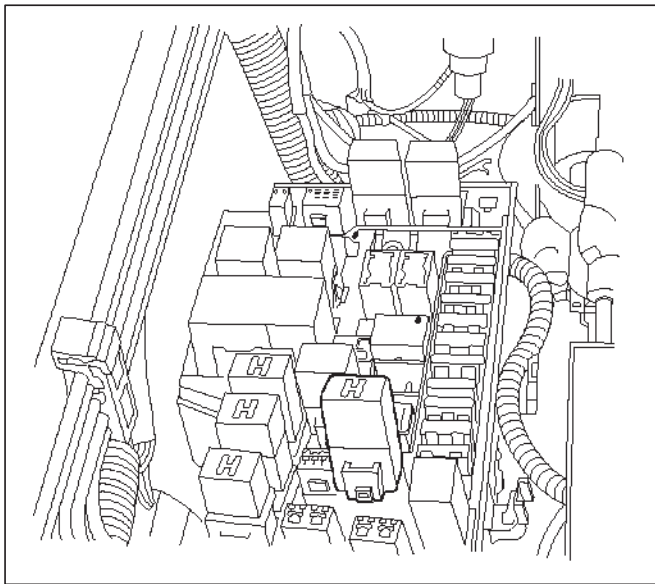
### Removal Procedure

1. Remove the fuse and relay box cover from under the hood.

### Installation Procedure

1. Insert the relay into the correct place in the fuse and relay box with the catch slot facing forward.
2. Press down until the catch engages.
  - An audible "click" will be heard.

3. Install the fuse and relay box cover.



TS23986

## EVAP Canister Hoses

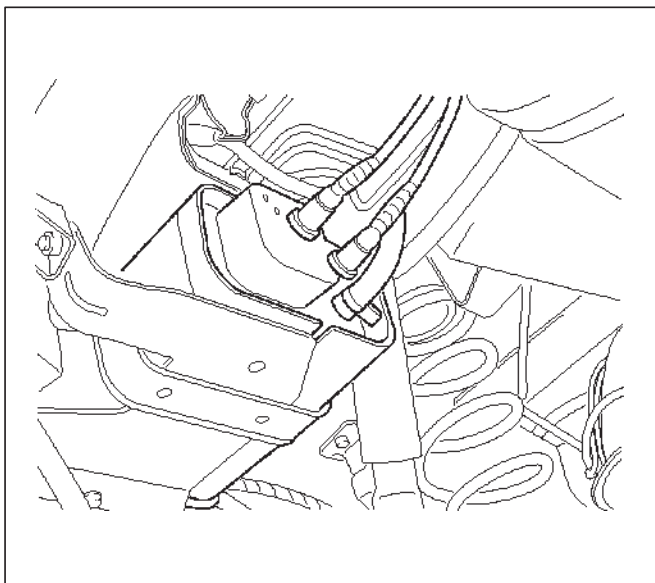
### Service Information

To view the routing of the EVAP canister hoses, refer to *Vehicle Emission Control Information in Diagnosis*. Use 6148M or equivalent when you replace the EVAP canister hoses.

## EVAP Canister

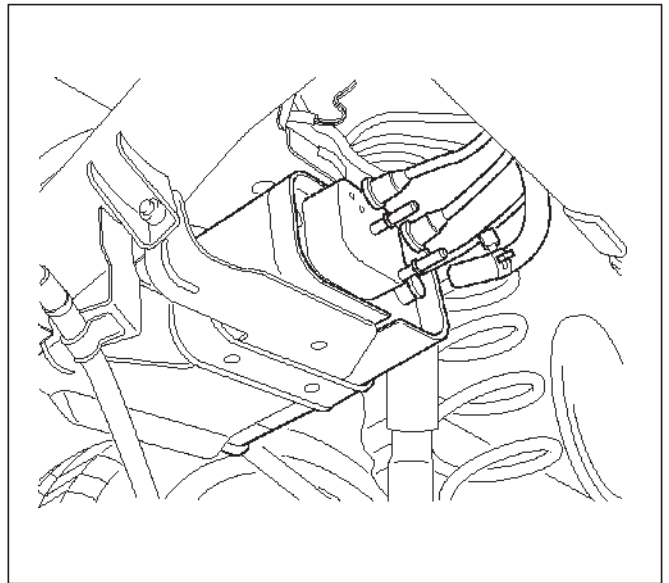
### Removal Procedure

1. Disconnect the negative battery cable.
2. Disconnect the three hoses from the EVAP canister.



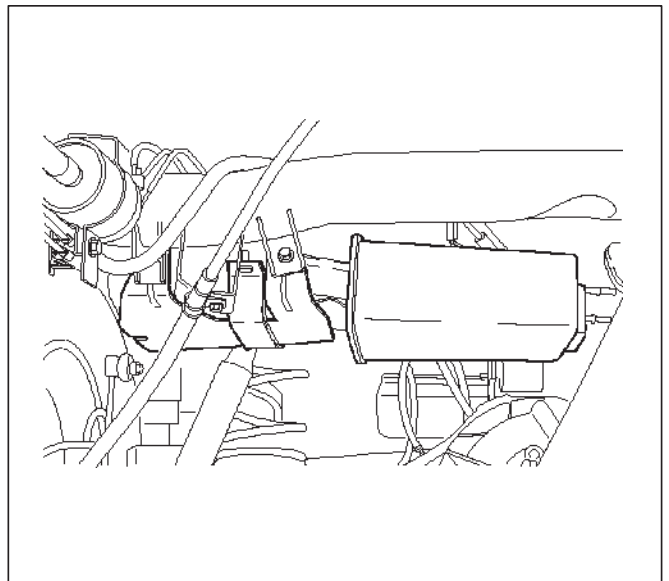
014RW145

3. Disconnect the fuel vapor connector and the purge hose from the EVAP canister vent solenoid.



014RW147

4. Remove the retaining two bolts on the mounting bracket and slide the canister out of mounting bracket.



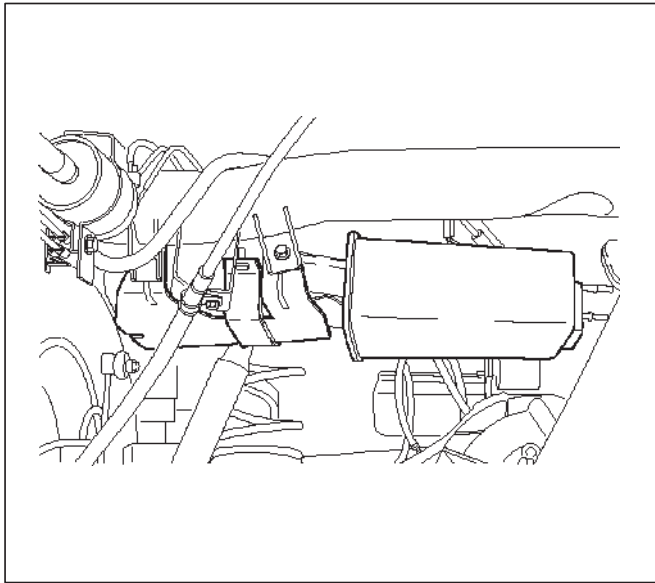
014RW146

### Inspection Procedure

1. Inspect the hoses for cracks and leaks.
2. Inspect the canister for a damaged case.

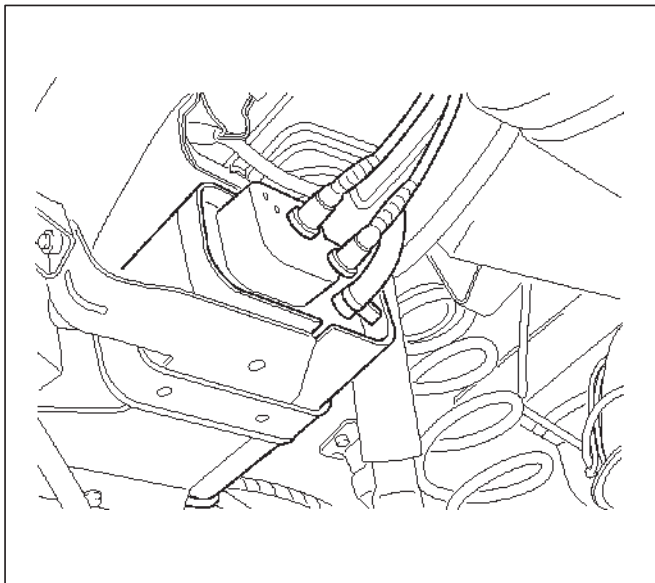
## Installation Procedure

1. Slide the canister into mounting bracket and install the mounting bracket two bolts.



014RW146

2. Connect the fuel vapor connector to the EVAP canister vent solenoid.
3. Connect the three hoses to the EVAP canister.



014RW145

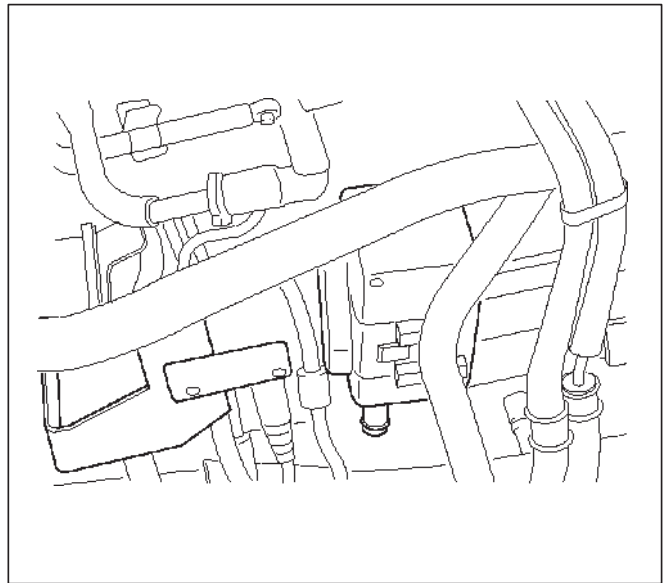
4. Disconnect the negative battery cable.

## EVAP Canister Vent Solenoid

### Removal Procedure

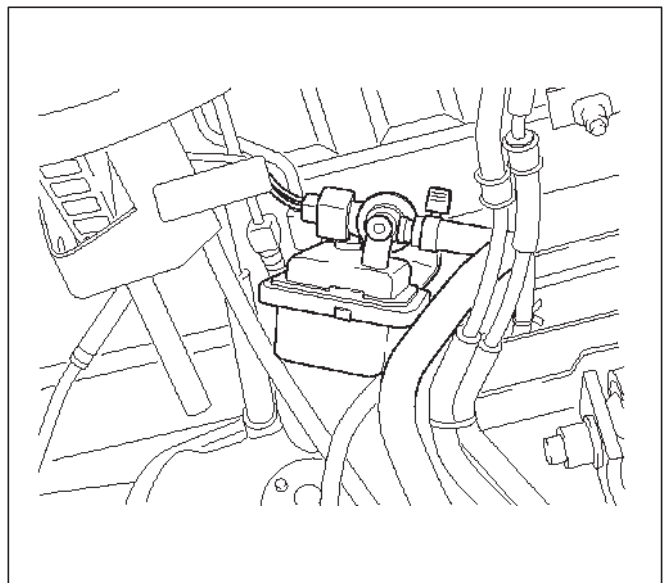
1. Disconnect the negative battery cable.

2. Slide out the EVAP canister vent solenoid from mounting bracket.



014RW149

3. Disconnect the connector and hose.



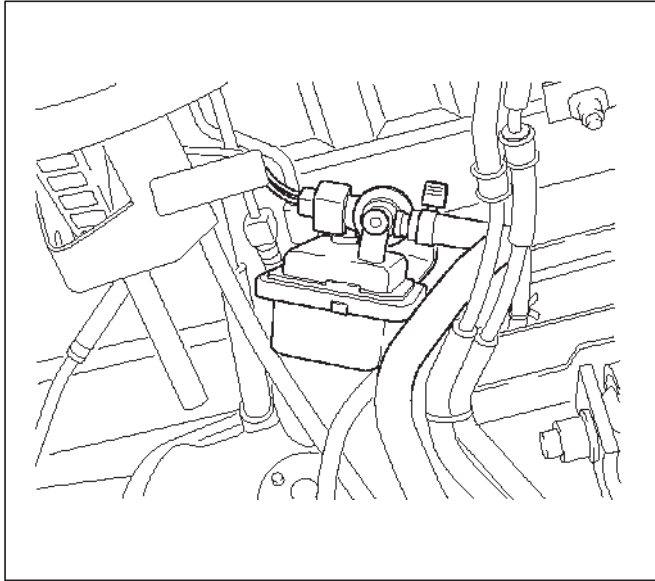
014RW148

### Inspection Procedure

1. Check for cracks or leaks.
2. Energize the solenoid and try to blow through it. The solenoid should not allow passage of air when energized. (J 35616 Connector Test Kit can be used to easily attach jumper wires from the battery to the solenoid).

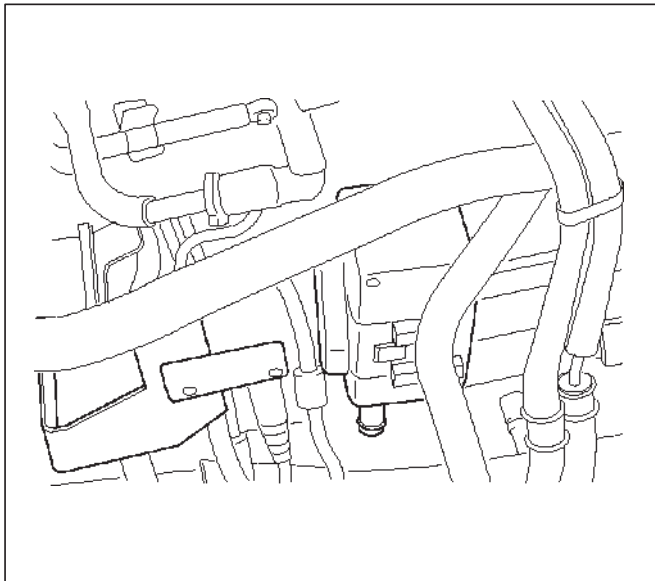
## Installation Procedure

1. Connect the connector and hose.



014RW148

2. Slide the EVAP canister vent solenoid into mounting bracket.



014RW149

3. Connect the negative battery cable.

## Fuel Tank Pressure Sensor

### Removal Procedure

1. Remove the fuel pump assembly. Refer to *Fuel Tank In Fuel Pump*.

2. Carefully pry the fuel tank pressure sensor out of the top of the fuel pump assembly.

### Inspection Procedure

1. Inspect the vapor pressure sensor for cracks in the housing and corrosion on the electrical terminals.
2. Inspect the rubber grommet for tears and signs of rot.

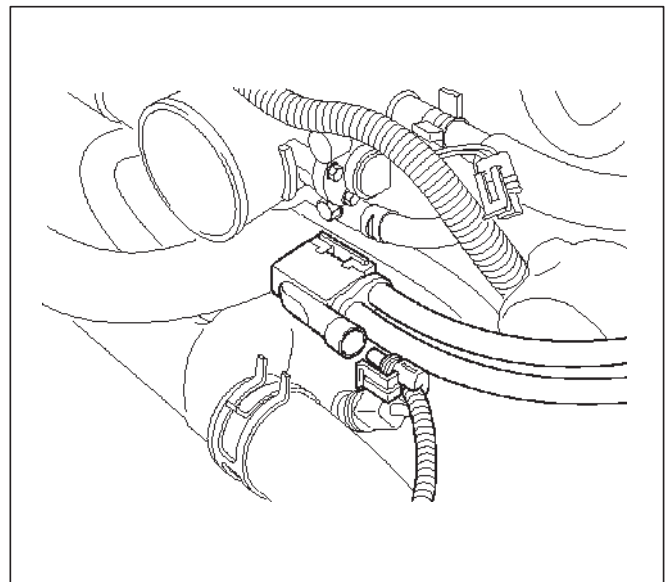
### Installation Procedure

1. Install the rubber grommet on the fuel pump assembly.
2. Install the fuel tank vapor pressure sensor on the fuel pump assembly.
  - Insert the sensor nipple firmly into the grommet.
  - Keep twisting and pushing the sensor until the wide portion of the nipple shows on the other side of the grommet.
3. Install the fuel pump assembly on the fuel tank. Refer to *Fuel Tank In Fuel Pump*.

## EVAP Canister Purge Solenoid

### Removal Procedure

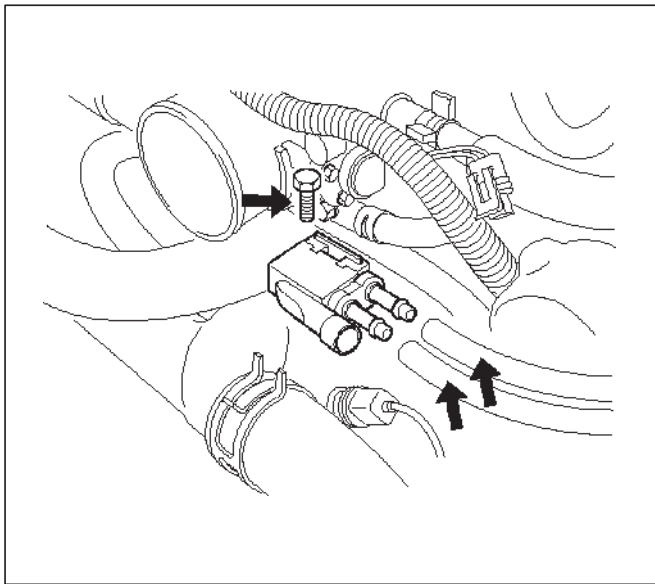
1. Disconnect the electrical connector from the EVAP canister purge solenoid.
2. Disconnect the vacuum hoses from the EVAP canister purge solenoid.



014RW136

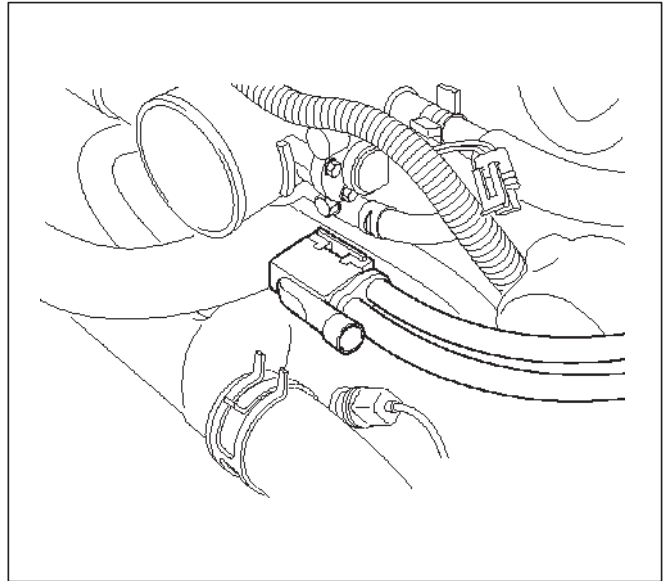
3. Remove the EVAP canister purge solenoid retaining bolt from the upper intake manifold.

4. Remove the EVAP canister purge solenoid.



014RW137

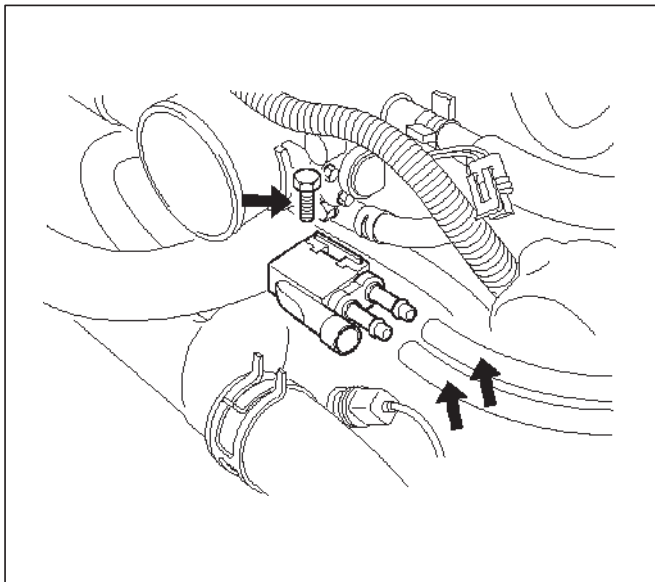
4. Connect the electrical connector to the EVAP canister purge solenoid.



014RW138

## Installation Procedure

1. Install the EVAP canister purge solenoid on the upper intake manifold.
2. Install the EVAP canister purge solenoid retaining bolt.
3. Connect the vacuum hoses to the EVAP canister purge solenoid.



014RW137

## Fuel Tank Vent Valve

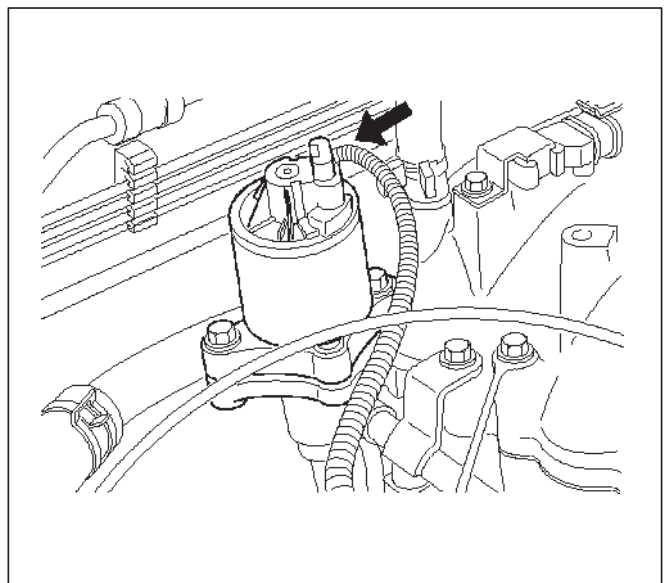
### Removal and Installation Procedure

Refer to *Fuel Pump*

## Linear Exhaust Gas Recirculation (EGR) Valve

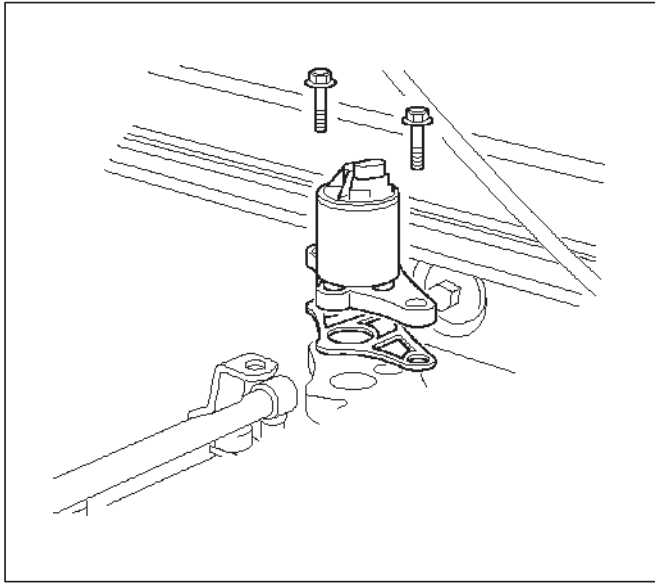
### Removal Procedure

1. Disconnect the negative battery cable.
2. Disconnect the electrical connector at the EGR valve.



014RW139

3. Remove the bolt and the nut from the upper intake manifold.



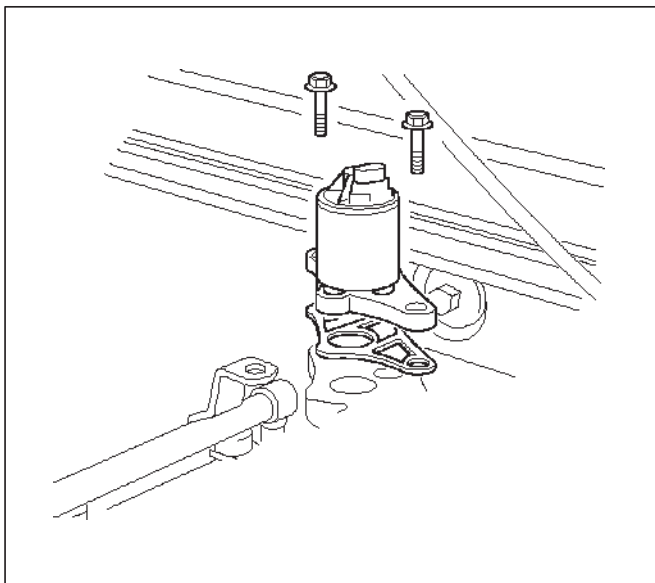
014RW098

4. Remove the EGR valve from the upper intake manifold.
5. Remove the gasket from the upper intake manifold.

## Installation Procedure

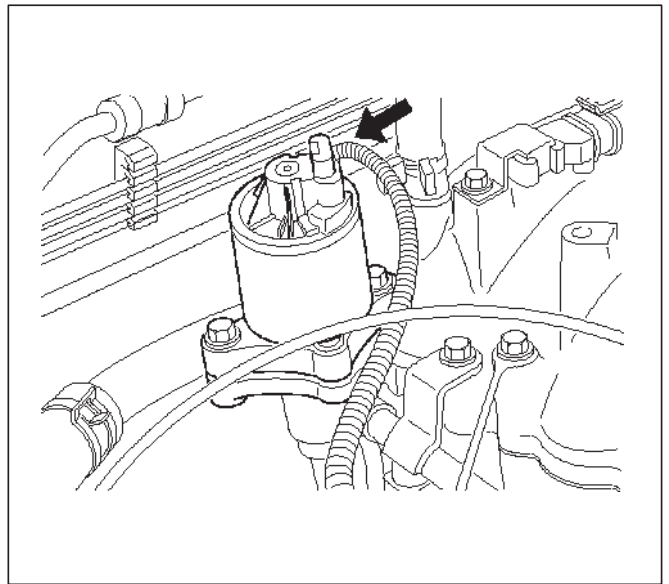
1. Install the gasket on the upper intake manifold.
2. Install the EGR valve on the upper intake manifold.
3. Secure the EGR valve and the gasket with the bolt and the nut.

**NOTE:** It is possible to install the EGR valve rotated 180° from the correct position. Make sure that the base of the valve is placed so that it aligns with the mounting flange.



014RW098

4. Connect the electrical connector at the EGR valve.



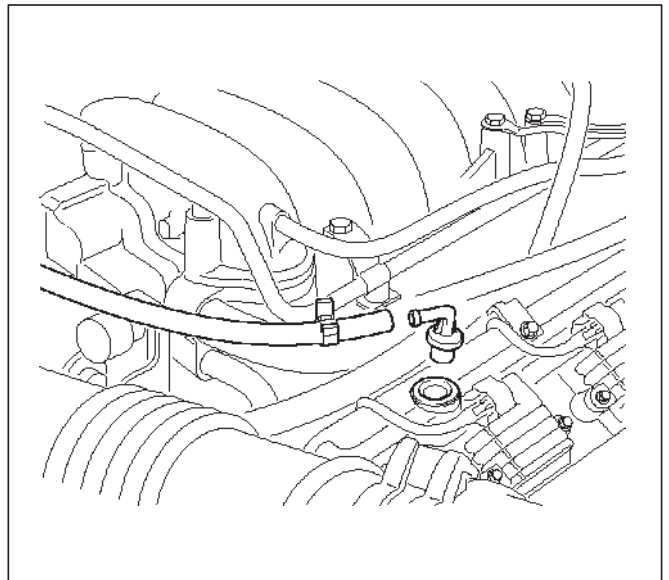
014RW139

5. Connect the negative battery cable.

## Positive Crankcase Ventilation (PCV) Valve

### Removal Procedure

1. Remove the vacuum hose at the PCV valve.
  - Slide the clamp back to release the hose.
2. Pull the PCV valve from the rubber grommet in the right valve cover.



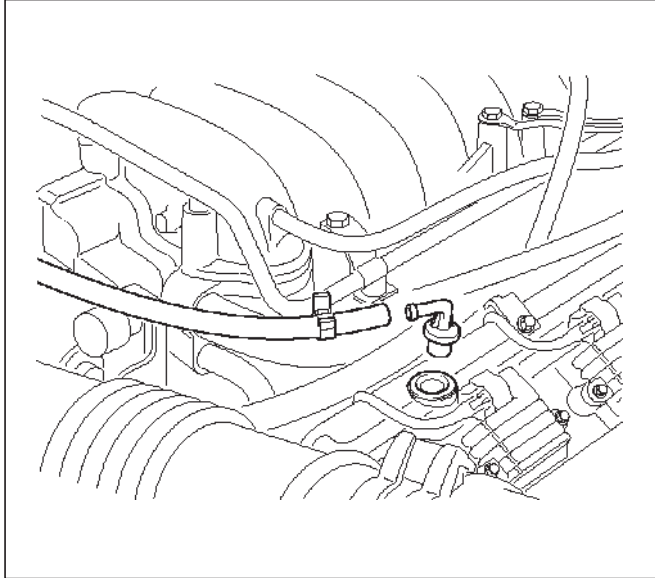
014RW097

### Inspection Procedure

1. Shake the valve and listen for the rattle of the needle inside the valve.
2. If the valve does not rattle, replace the valve.

## Installation Procedure

1. Push the PCV valve into the rubber grommet in the left valve cover.
2. Install the vacuum hose on the PCV valve and secure the vacuum hose with the clamp.



## Wiring and Connectors

### Wiring Harness Service

The control module harness electrically connects the control module to the various solenoids, switches and sensors in the vehicle engine compartment and passenger compartment.

Replace wire harnesses with the proper part number replacement.

Because of the low amperage and voltage levels utilized in powertrain control systems, it is essential that all wiring in environmentally exposed areas be repaired with crimp and seal splice sleeves.

The following wire harness repair information is intended as a general guideline only. Refer to *Chassis Electrical* for all wire harness repair procedures.

### Connectors and Terminals

Use care when probing a connector and when replacing terminals. It is possible to short between opposite terminals. Damage to components could result. Always use jumper wires between connectors for circuit checking. NEVER probe through Weather-Pack seals. Use an appropriate connector test adapter kit which contains an assortment of flexible connectors used to probe terminals during diagnosis. Use an appropriate fuse remover and test tool for removing a fuse and to adapt the fuse holder to a meter for diagnosis.

Open circuits are often difficult to locate by sight because oxidation or terminal misalignment are hidden by the

connectors. Merely wiggling a connector on a sensor, or in the wiring harness, may temporarily correct the open circuit. Intermittent problems may also be caused by oxidized or loose connections.

Be certain of the type of connector/terminal before making any connector or terminal repair. Weather-Pack and Com-Pack III terminals look similar, but are serviced differently.

## PCM Connectors and Terminals

### Removal Procedure

1. Remove the connector terminal retainer.
2. Push the wire connected to the affected terminal through the connector face so that the terminal is exposed.
3. Service the terminal as necessary.

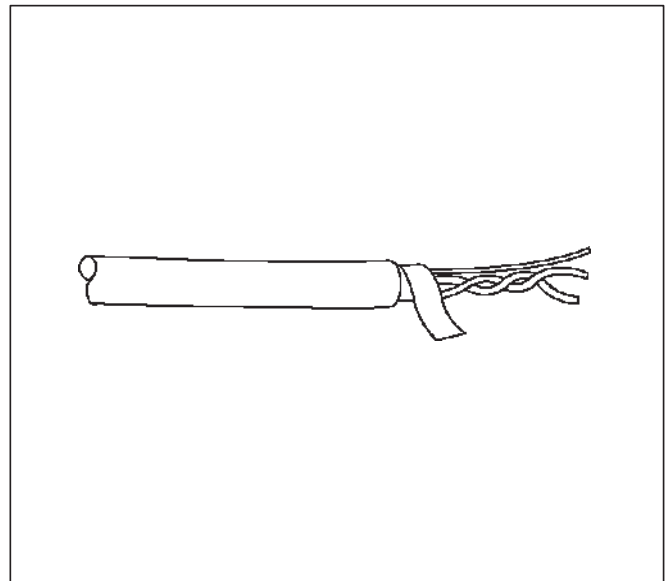
### Installation Procedure

1. Bend the tab on the connector to allow the terminal to be pulled into position within the connector.
2. Pull carefully on the wire to install the connector terminal retainer.

## Wire Harness Repair: Twisted Shielded Cable

### Removal Procedure

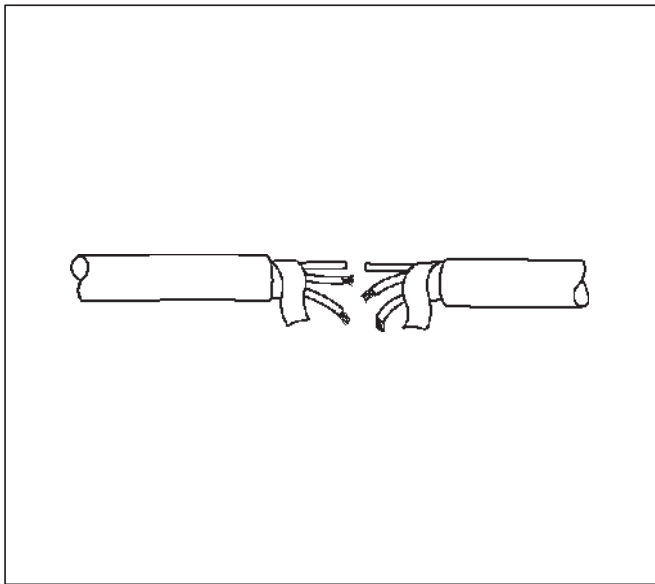
1. Remove the outer jacket.
2. Unwrap the aluminum/mylar tape. Do not remove the mylar.



3. Untwist the conductors.

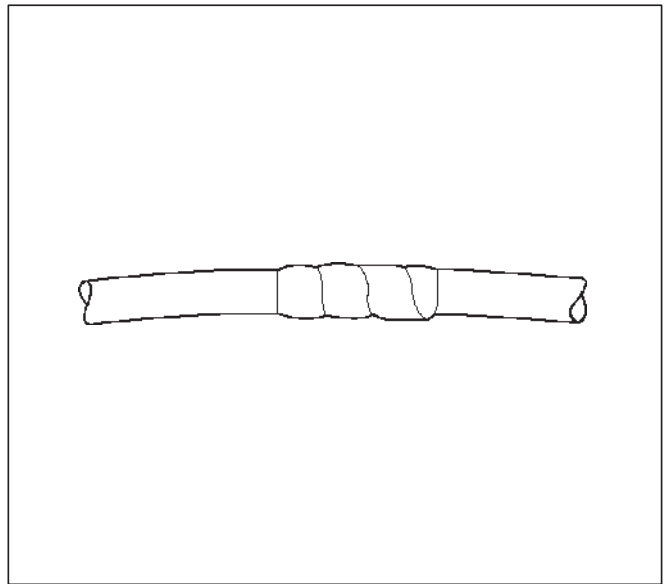


4. Strip the insulation as necessary.



048

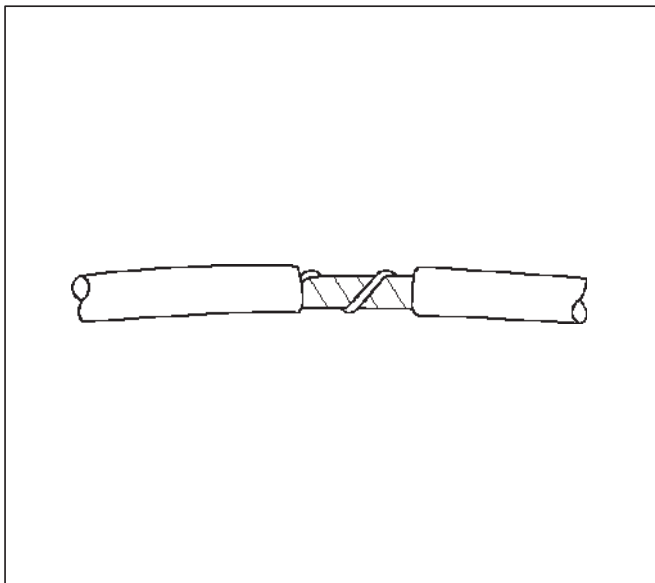
4. Tape over the whole bundle to secure.



050

### Installation Procedure

1. Splice the wires using splice clips and rosin core solder.
2. Wrap each splice to insulate.
3. Wrap the splice with mylar and with the drain (uninsulated) wire.

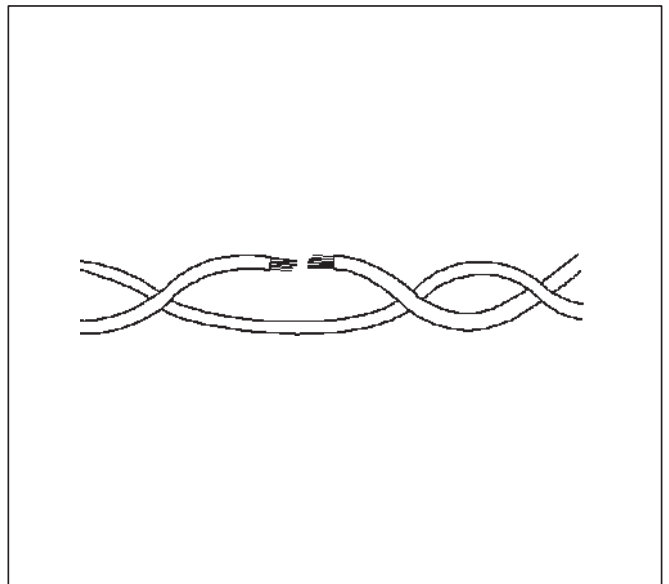


049

### Twisted Leads

#### Removal Procedure

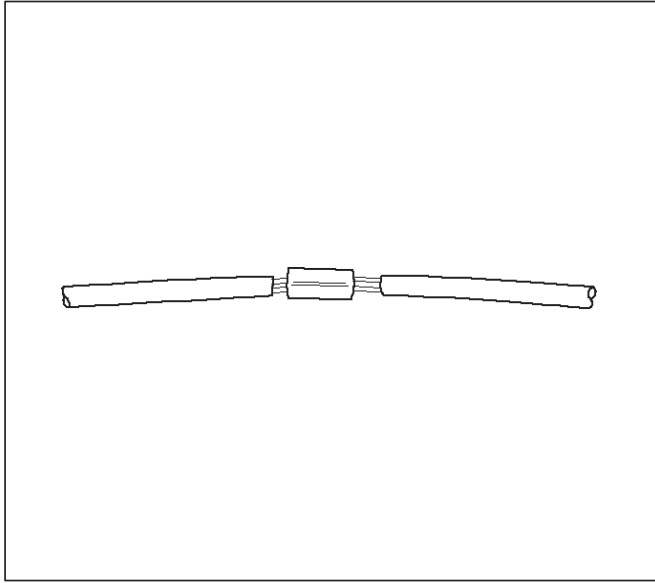
1. Locate the damaged wire.
2. Remove the insulation as required.



051

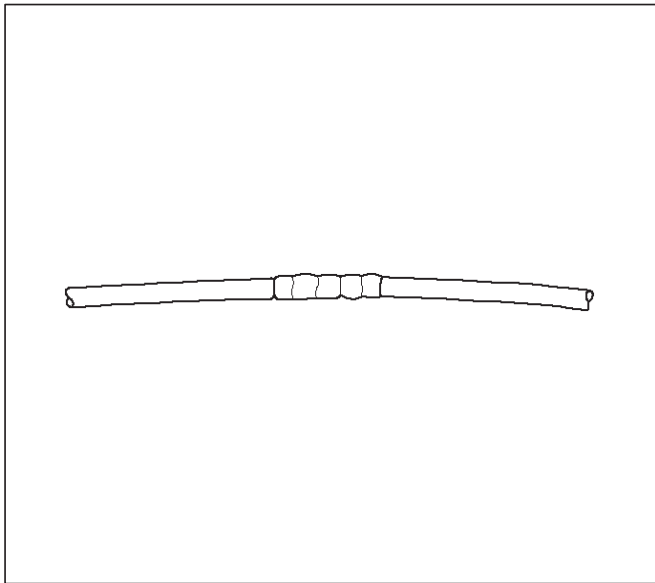
## Installation Procedure

1. Use splice clips and rosin core solder in order to splice the two wires together.



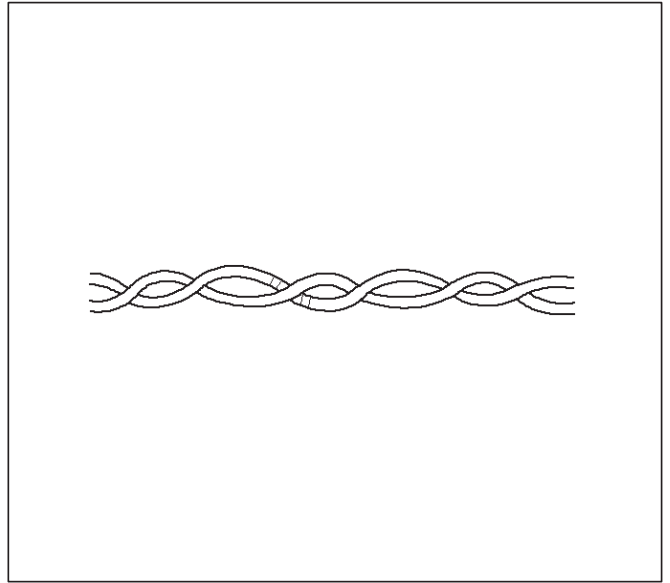
052

2. Cover the splice with tape in order to insulate it from the other wires.



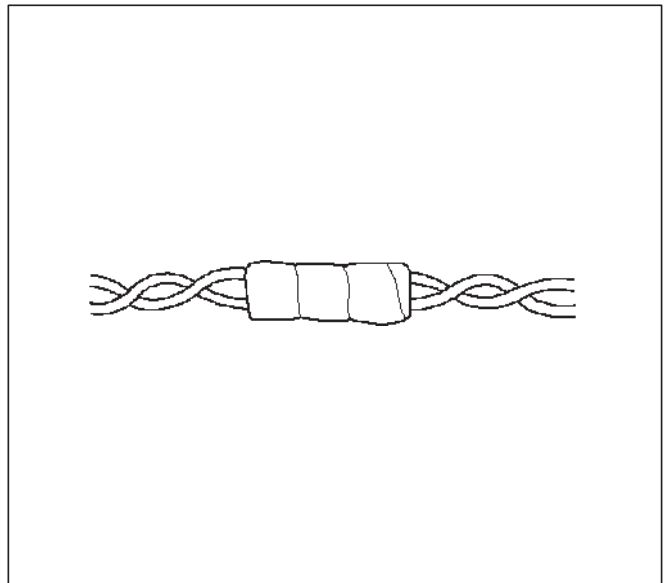
053

3. Twist the wires as they were before starting this procedure.



054

4. Tape the wires with electrical tape. Hold in place.



055

## Weather-Pack Connector

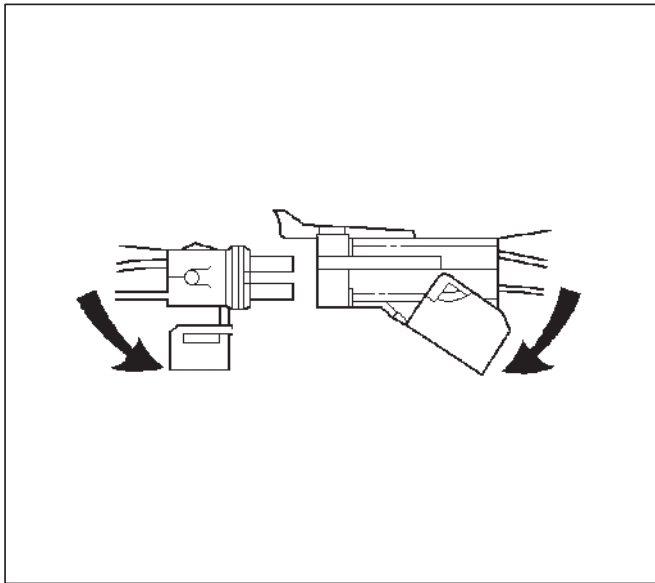
### Tools Required

J 28742-A Weather-Pack II Terminal Remover

### Removal Procedure

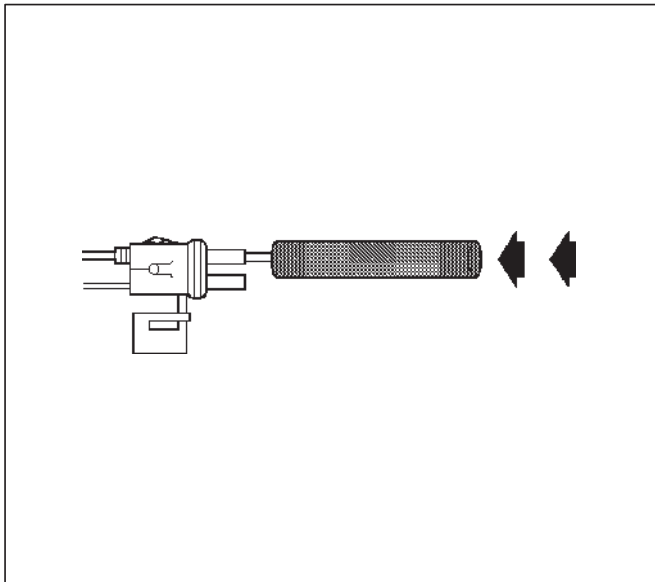
A Weather-Pack connector can be identified by a rubber seal at the rear of the connector. This engine room connector protects against moisture and dirt, which could lead to oxidation and deposits on the terminals. This protection is important, because of the low voltage and the low amperage found in the electronic systems.

1. Open the secondary lock hinge on the connector.

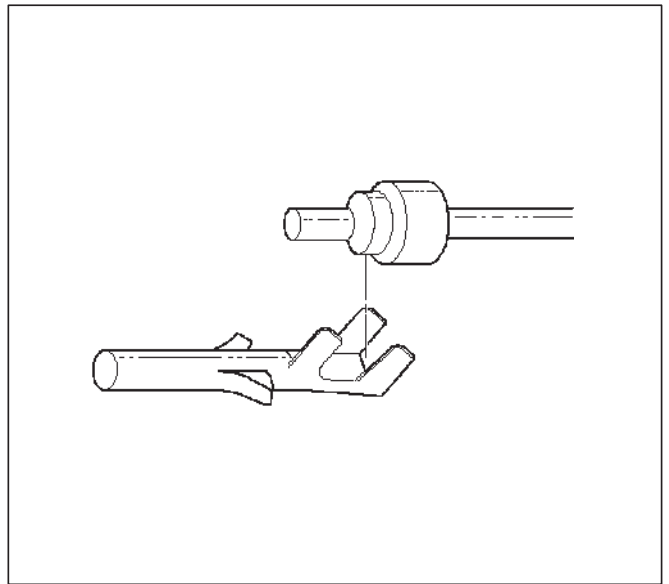


2. Use tool J 28742-A or the equivalent to remove the pin and the sleeve terminals. Push on J 28742-A to release.

**NOTE:** Do not use an ordinary pick or the terminal may be bent or deformed. Unlike standard blade terminals, these terminals cannot be straightened after they have been improperly bent.



3. Cut the wire immediately behind the cable seal.

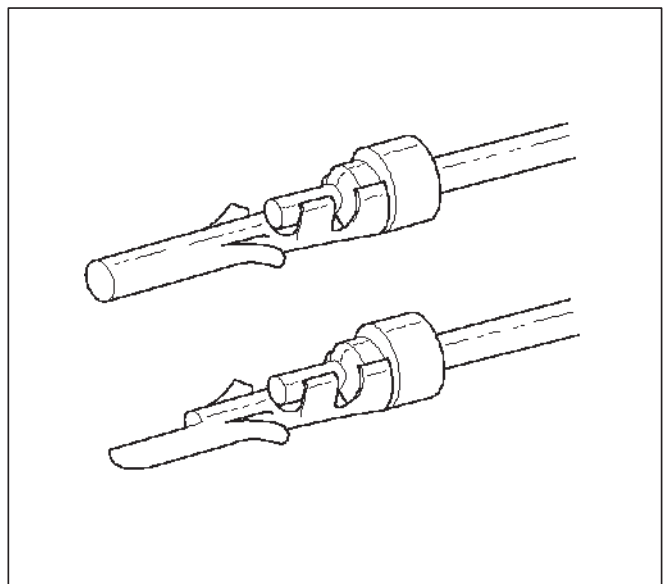


### Installation Procedure

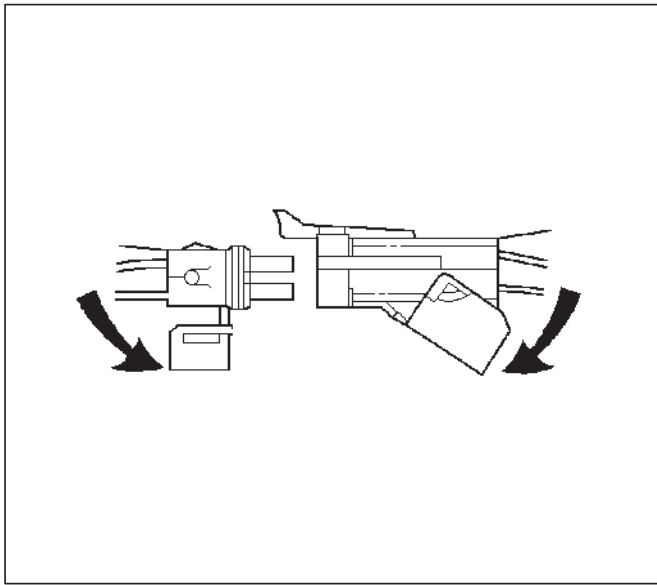
Make certain the connectors are properly seated and all of the sealing rings are in place when you reconnect the leads. The secondary lock hinge provides a backup locking feature for the connector. The secondary lock hinge is used for added reliability. This flap should retain the terminals even if the small terminal lock tangs are not positioned properly.

Do not replace the Weather-Pack connections with standard connections. Read the instructions provided with the Weather-Pack connector and terminal packages.

1. Replace the terminal.
2. Slip the new seal onto the wire.
3. Strip 5 mm (0.2") of insulation from the wire.
4. Crimp the terminal over the wire and the seal.



5. Push the terminal and the connector to engage the locking tangs.



6. Close the secondary locking hinge.

### Com-Pack III

#### General Information

The Com-Pack III terminal looks similar to some Weather-Pack terminals. This terminal is not sealed and is used where resistance to the environment is not required. Use the standard method when repairing a terminal. Do not use the Weather-Pack terminal tool J 28742-A or equivalent. These will damage the terminals.

### Metri-Pack

#### Tools Required

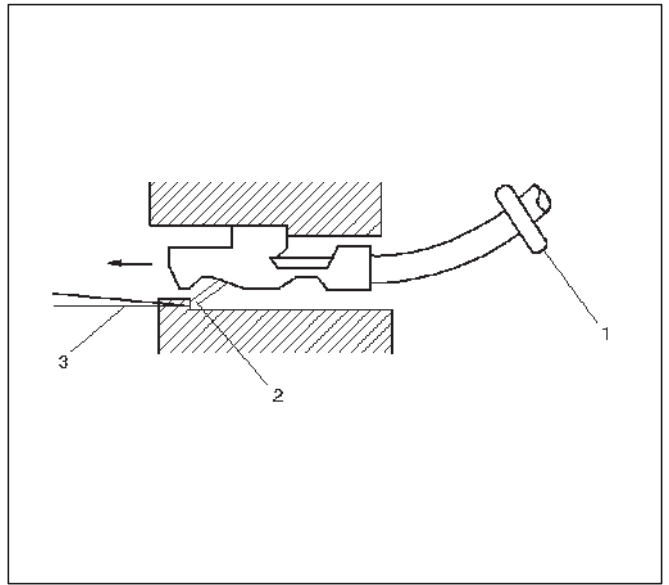
J 35689 Terminal Remover

#### Removal Procedure

Some connectors use terminals called Metri-Pack Series 150. These may be used at the engine coolant temperature (ECT) sensor.

1. Slide the seal (1) back on the wire.

2. Insert the J 35689 tool or equivalent (3) in order to release the terminal locking tang (2).

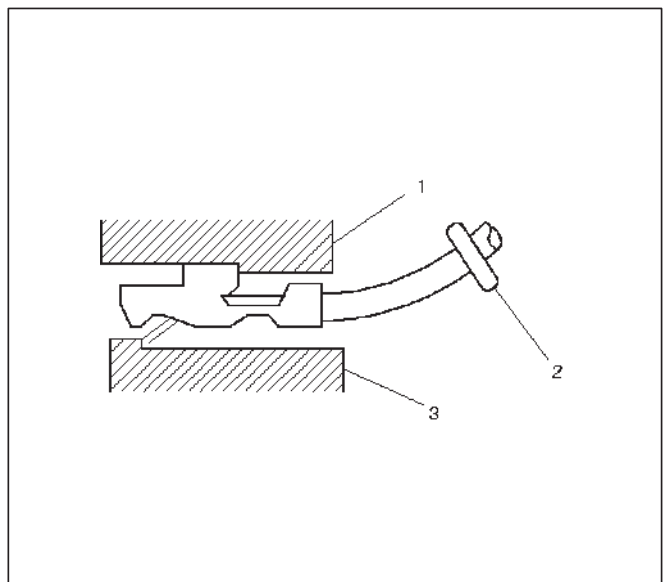


3. Push the wire and the terminal out through the connector. If you reuse the terminal, reshape the locking tang.

#### Installation Procedure

Metri-Pack terminals are also referred to as "pull-to-seat" terminals.

1. In order to install a terminal on a wire, the wire must be inserted through the seal (2) and through the connector (3).
2. The terminal (1) is then crimped onto the wire.



3. Then the terminal is pulled back into the connector to seat it in place.

## General Description (PCM and Sensors)

### 58X Reference PCM Input

The powertrain control module (PCM) uses this signal from the crankshaft position (CKP) sensor to calculate engine RPM and crankshaft position at all engine speeds. The PCM also uses the pulses on this circuit to initiate injector pulses. If the PCM receives no pulses on this circuit, DTC P0337 will set. The engine will not start and run without using the 58X reference signal.

### A/C Request Signal

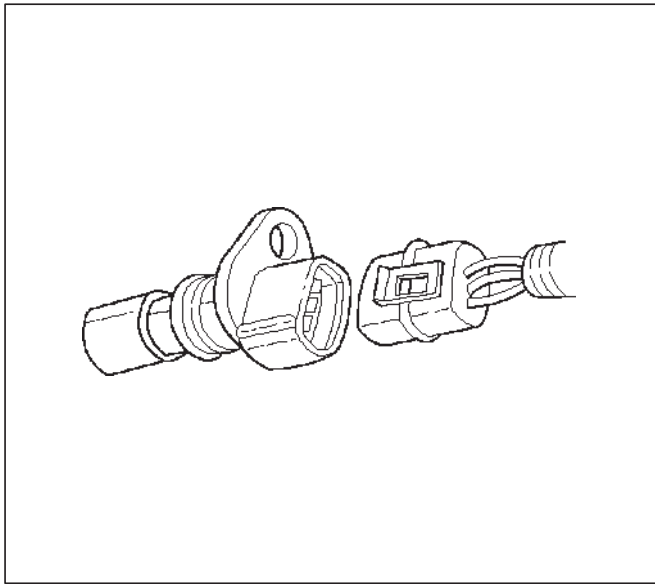
This signal tells the PCM when the A/C mode is selected at the A/C control head. The PCM uses this to adjust the idle speed before turning "ON" the A/C clutch. The A/C compressor will be inoperative if this signal is not available to the PCM.

Refer to *A/C Clutch Circuit Diagnosis* for A/C wiring diagrams and diagnosis for the A/C electrical system.

### Crankshaft Position (CKP) Sensor

The crankshaft position (CKP) sensor provides a signal used by the powertrain control module (PCM) to calculate the ignition sequence. The CKP sensor initiates the 58X reference pulses which the PCM uses to calculate RPM and crankshaft position.

Refer to *Electronic Ignition System* for additional information.

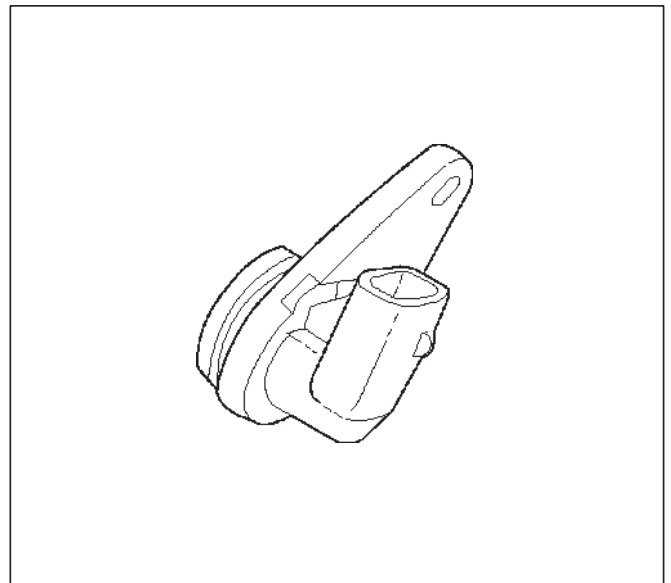


### Camshaft Position (CMP) Sensor and Signal

The camshaft position (CMP) sensor sends a CMP signal to the PCM. The PCM uses this signal as a "sync pulse" to trigger the injectors in the proper sequence. The PCM

uses the CMP signal to indicate the position of the #1 piston during its power stroke. This allows the PCM to calculate true sequential fuel injection (SFI) mode of operation. If the PCM detects an incorrect CMP signal while the engine is running, DTC P0341 will set. If the CMP signal is lost while the engine is running, the fuel injection system will shift to a calculated sequential fuel injection mode based on the last fuel injection pulse, and the engine will continue to run. As long as the fault is present, the engine can be restarted. It will run in the calculated sequential mode with a 1-in-6 chance of the injector sequence being correct.

Refer to *DTC P0341* for further information.

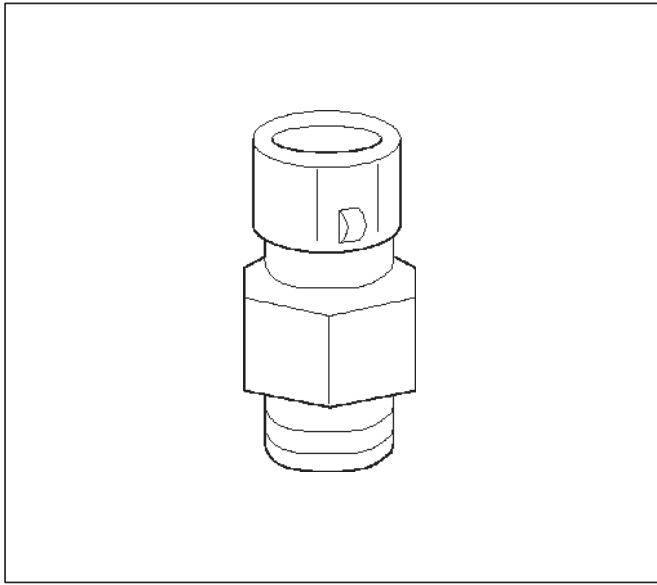


### Engine Coolant Temperature (ECT) Sensor

The engine coolant temperature (ECT) sensor is a thermistor (a resistor which changes value based on temperature) mounted in the engine coolant stream. Low coolant temperature produces a high resistance of 100,000 ohms at  $-40^{\circ}\text{C}$  ( $-40^{\circ}\text{F}$ ). High temperature causes a low resistance of 70 ohms at  $130^{\circ}\text{C}$  ( $266^{\circ}\text{F}$ ). The PCM supplies a 5-volt signal to the ECT sensor through resistors in the PCM and measures the voltage. The signal voltage will be high when the engine is cold and low when the engine is hot. By measuring the voltage, the PCM calculates the engine coolant temperature. Engine coolant temperature affects most of the systems that the PCM controls.

The Tech 2 displays engine coolant temperature in degrees. After engine start-up, the temperature should rise steadily to about  $85^{\circ}\text{C}$  ( $185^{\circ}\text{F}$ ). It then stabilizes when the thermostat opens. If the engine has not been run for several hours (overnight), the engine coolant temperature and intake air temperature displays should be close to each other. A hard fault in the engine coolant

sensor circuit will set DTC P0177 or DTC P0118. An intermittent fault will set a DTC P1114 or P1115.



0016

### Electrically Erasable Programmable Read Only Memory (EEPROM)

The electrically erasable programmable read only memory (EEPROM) is a permanent memory chip that is physically soldered within the PCM. The EEPROM contains the program and the calibration information that the PCM needs to control powertrain operation.

Unlike the PROM used in past applications, the EEPROM is not replaceable. If the PCM is replaced, the new PCM will need to be programmed. Equipment containing the correct program and calibration for the vehicle is required to program the PCM.

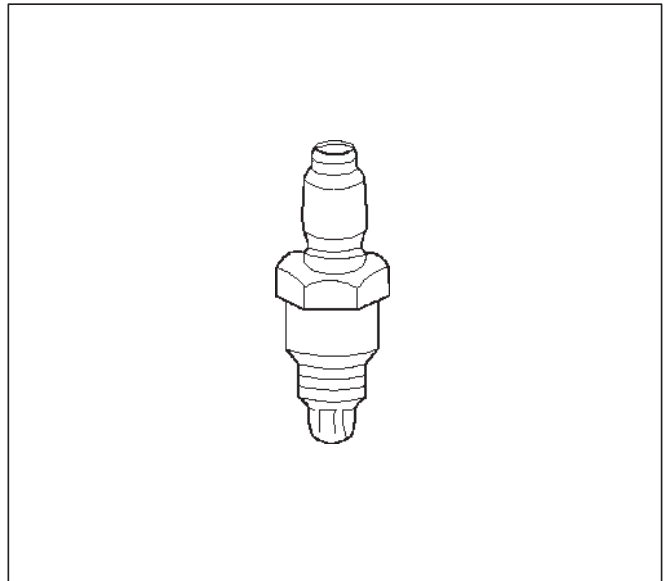
### Fuel Control Heated Oxygen Sensors

The fuel control heated oxygen sensors (Bank 1 HO2S 1 and Bank 2 HO2S 1) are mounted in the exhaust stream where they can monitor the oxygen content of the exhaust gas. The oxygen present in the exhaust gas reacts with the sensor to produce a voltage output. This voltage should constantly fluctuate from approximately 100 mV to 900 mV. The heated oxygen sensor voltage can be monitored with a Tech 2. By monitoring the voltage output of the oxygen sensor, the PCM calculates the pulse width command for the injectors to produce the proper combustion chamber mixture.

- Low HO2S voltage is a lean mixture which will result in a rich command to compensate.
- High HO2S voltage is a rich mixture which will result in a lean command to compensate.

An open Bank 1 HO2S 1 signal circuit will set a DTC P0134 and the Tech 2 will display a constant voltage between 400-500 mV. A constant voltage below 300 mV in the sensor circuit (circuit grounded) will set DTC P0131. A constant voltage above 800 mV in the circuit will set DTC P0132. Faults in the Bank 2 HO2S 1 signal circuit will cause DTC 0154 (open circuit), DTC P0151 (grounded circuit), or DTC P0152 (signal voltage high) to set. A fault in the Bank 1 HO2S 1 heater circuit will cause

DTC P0135 to set. A fault in the Bank 2 HO2S 1 heater circuit will cause DTC P0155 to set. The PCM can also detect HO2S response problems. If the response time of an HO2S is determined to be too slow, the PCM will store a DTC that indicates degraded HO2S performance.



0012

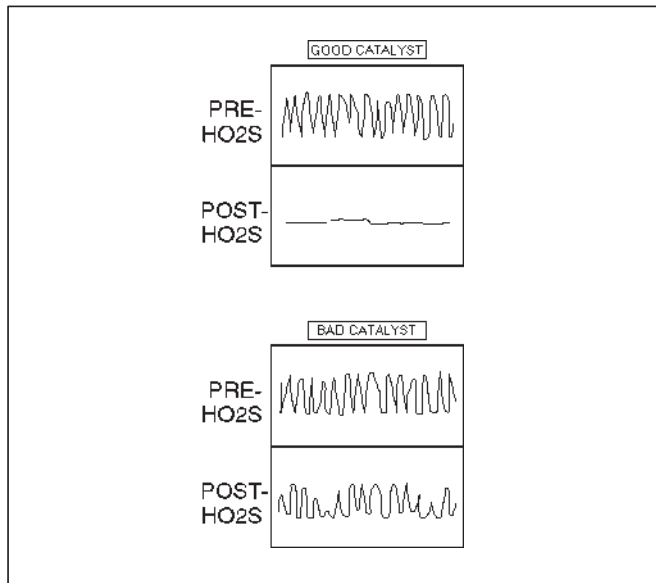
### Catalyst Monitor Heated Oxygen Sensors

Three-way catalytic converters are used to control emissions of hydrocarbons (HC), carbon monoxide (CO), and oxides of nitrogen (NOx). The catalyst within the converters promotes a chemical reaction. This reaction oxidizes the HC and CO present in the exhaust gas and converts them into harmless water vapor and carbon dioxide. The catalyst also reduces NOx by converting it to nitrogen. The PCM can monitor this process using the Bank 1 HO2S 2 and the Bank 2 HO2S 2 heated oxygen sensors. The Bank 1 HO2S 1 and the Bank 2 HO2S 1 sensors produce an output signal which indicates the amount of oxygen present in the exhaust gas entering the three-way catalytic converter. The Bank 1 HO2S 2 and the Bank 2 HO2S 2 sensors produce an output signal which indicates the oxygen storage capacity of the catalyst. This indicates the catalyst's ability to efficiently convert exhaust gases. If the catalyst is operating efficiently, the Bank 1 HO2S 1 and the Bank 2 HO2S 1 signals will be more active than the signals produced by the Bank 1 HO2S 2 and the Bank 2 HO2S 2 sensors.

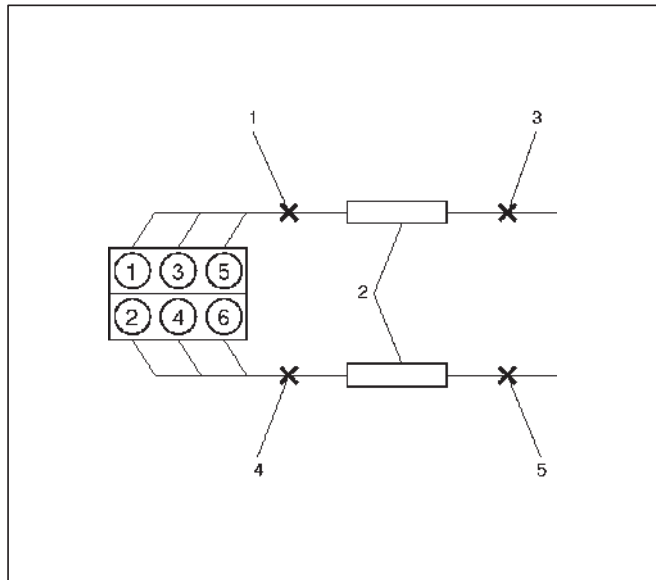
The catalyst monitor sensors operate the same as the fuel control sensors. The Bank 1 HO2S 2 and the Bank 2 HO2S 2 sensors' main function is catalyst monitoring, but they also have a limited role in fuel control. If a sensor output indicates a voltage either above or below the 450 mV bias voltage for an extended period of time, the PCM will make a slight adjustment to fuel trim to ensure that fuel delivery is correct for catalyst monitoring.

A problem with the Bank 1 HO2S 2 signal circuit will set DTC P0137, P0138, or P0140, depending on the specific condition. A problem with the Bank 2 HO2S 2 signal circuit will set DTC P0157, P0158, or P0160, depending on the specific condition. A fault in the heated oxygen sensor heater element or its ignition feed or ground will

result in lower sensor response. This may cause incorrect catalyst monitor diagnostic results.



TS24067



TS23965A

**Legend**

- (1) Bank 1 Sensor 1 (Fuel Control)
- (2) Catalytic Converter
- (3) Bank 1 Sensor 2 (Catalyst Monitor)
- (4) Bank 2 Sensor 1 (Fuel Control)
- (5) Bank 2 Sensor 2 (Catalyst Monitor)

**Intake Air Temperature (IAT) Sensor**

The intake air temperature (IAT) sensor is a thermistor which changes its resistance based on the temperature of air entering the engine. Low temperature produces a high resistance of 100,000 ohms at -40°C (-40°F). High temperature causes low resistance of 70 ohms at 130°C (266°F). The PCM supplies a 5-volt signal to the sensor through a resistor in the PCM and monitors the signal voltage. The voltage will be high when the incoming air is

cold. The voltage will be low when the incoming air is hot. By measuring the voltage, the PCM calculates the incoming air temperature. The IAT sensor signal is used to adjust spark timing according to the incoming air density.

The Tech 2 displays the temperature of the air entering the engine. The temperature should read close to the ambient air temperature when the engine is cold and rise as underhood temperature increases. If the engine has not been run for several hours (overnight), the IAT sensor temperature and engine coolant temperature should read close to each other. A fault in the IAT sensor circuit will set DTC P0112 or DTC P0113.

**Knock Sensor**

Insufficient gasoline octane levels may cause detonation in some engines. Detonation is an uncontrolled explosion (burn) in the combustion chamber. This uncontrolled explosion results from a flame front opposite that of the normal flame front produced by the spark plug. The rattling sound normally associated with detonation is the result of two or more opposing pressures (flame fronts) colliding within the combustion chamber. Light detonation is sometimes considered normal, but heavy detonation could result in engine damage.

A knock sensor system is used to control detonation. This system is designed to retard spark timing up to 20 degrees to reduce detonation in the engine. This allows the engine to use maximum spark advance to improve driveability and fuel economy.

The knock sensor system has two major components:

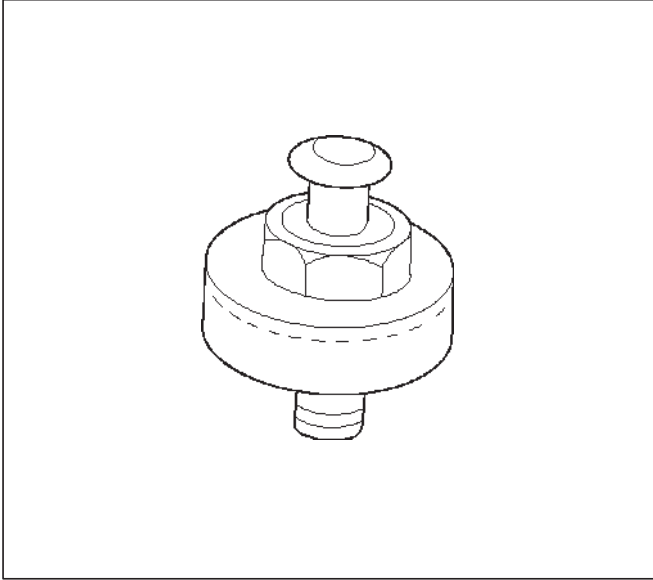
- The knock sensor.

The knock sensor, mounted in the engine block near the cylinders, detects abnormal vibration in the engine. The sensor produces an AC output signal of about 10 millivolts. The signal amplitude and frequency are dependent on the amount of knock being experienced. The signal voltage increases with the severity of the knock. This signal voltage is input to the PCM. The PCM then retards the ignition control (IC) spark timing based on the KS signal being received.

The PCM determines whether knock is occurring by comparing the signal level on the KS circuit with the voltage level on the noise channel. The noise channel allows the PCM to reject any false knock signal by indicating the amount of normal engine mechanical noise present. Normal engine noise varies depending on the engine speed and load. If the voltage level on the KS noise channel circuit is below the range considered normal, DTC P0327 will set, indicating a fault in the KS circuit or the knock sensor. If the PCM determines that an abnormal minimum or maximum noise level is being experienced, DTC P0325 will set.

The PCM contains the circuitry which allows the PCM to utilize the KS signal and diagnose the KS sensor and the KS circuitry. A continuous knock condition will be indicated, and the PCM will set DTC P0325.

If the KS module is faulty, the entire PCM must be replaced.



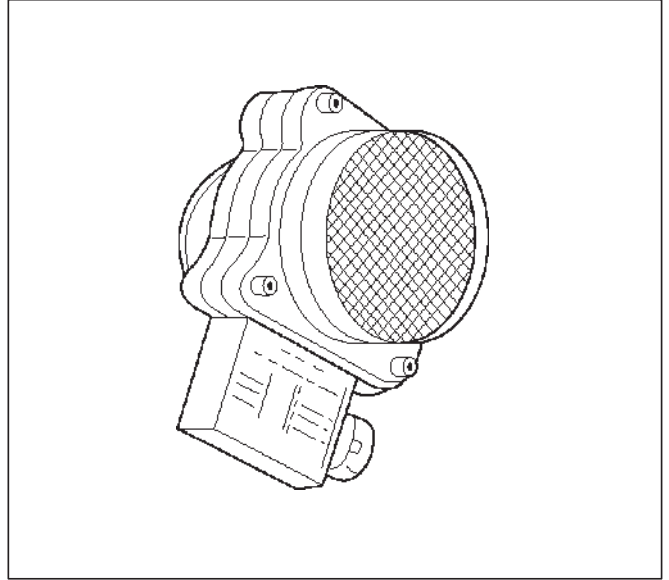
### Linear Exhaust Gas Recirculation (EGR) Control

The PCM monitors the exhaust gas recirculation (EGR) actual position and adjusts the pintle position accordingly. The PCM uses information from the following sensors to control the pintle position:

- Engine coolant temperature (ECT) sensor.
- Throttle position (TP) sensor.
- Mass air flow (MAF) sensor.

### Mass Air Flow (MAF) Sensor

The mass air flow (MAF) sensor measures the difference between the volume and the quantity of air that enters the engine. "Volume" means the size of the space to be filled. "Quantity" means the number of air molecules that will fit into the space. This information is important to the PCM because heavier, denser air will hold more fuel than lighter, thinner air. The PCM adjusts the air/fuel ratio as needed depending on the MAF value. The Tech 2 reads the MAF value and displays it in terms of grams per second (gm/s). At idle, the Tech 2 should read between 4-7 gm/s on a fully warmed up engine. Values should change quickly on acceleration. Values should remain stable at any given RPM. A failure in the MAF sensor or circuit will set DTC P0101, DTC P0102, or DTC P0103.



### Manifold Absolute Pressure (MAP) Sensor

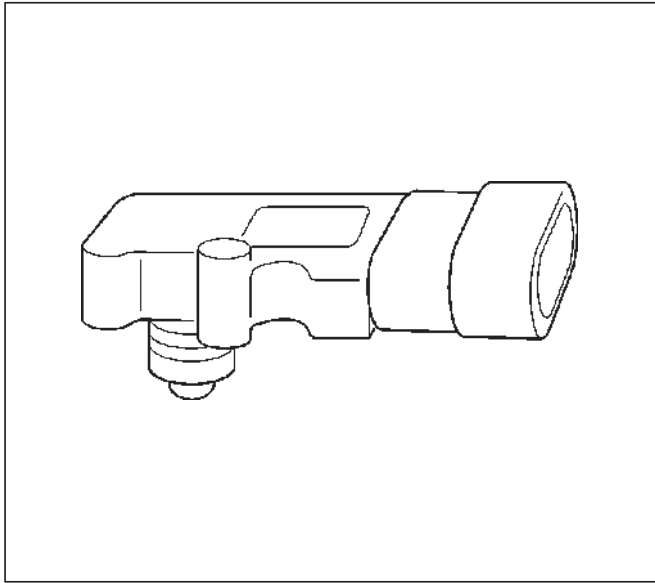
The manifold absolute pressure (MAP) sensor responds to changes in intake manifold pressure (vacuum). The MAP sensor signal voltage to the PCM varies from below 2 volts at idle (high vacuum) to above 4 volts with the ignition ON, engine not running or at wide-open throttle (low vacuum).

The MAP sensor is used to determine the following:

- Manifold pressure changes while the linear EGR flow test diagnostic is being run. Refer to *DTC P0401*.
- Engine vacuum level for other diagnostics.
- Barometric pressure (BARO).

If the PCM detects a voltage that is lower than the possible range of the MAP sensor, DTC P0107 will be set. A signal voltage higher than the possible range of the sensor will set DTC P0108. An intermittent low or high voltage will set DTC P1107 or DTC P1106, respectively. The PCM can detect a shifted MAP sensor. The PCM compares the MAP sensor signal to a calculated MAP based on throttle position and various engine load factors. If the PCM detects a MAP signal that varies excessively above or below the calculated value, DTC P0106 will set.





055RW004

### Powertrain Control Module (PCM)

The powertrain control module (PCM) is located in the passenger compartment below the center console. The PCM controls the following:

- Fuel metering system.
- Transmission shifting.
- Ignition timing.
- On-board diagnostics for powertrain functions.

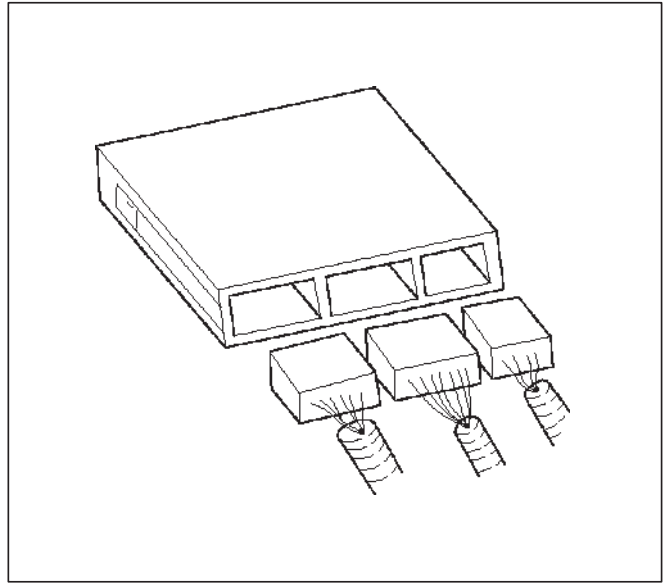
The PCM constantly observes the information from various sensors. The PCM controls the systems that affect vehicle performance. The PCM performs the diagnostic function of the system. It can recognize operational problems, alert the driver through the MIL (Service Engine Soon lamp), and store diagnostic trouble codes (DTCs). DTCs identify the problem areas to aid the technician in making repairs.

- IPCM-6KT for automatic transmission-equipped vehicles.

### PCM Function

The PCM supplies either 5 or 12 volts to power various sensors or switches. The power is supplied through resistances in the PCM which are so high in value that a test light will not light when connected to the circuit. In some cases, even an ordinary shop voltmeter will not give an accurate reading because its resistance is too low. Therefore, a digital voltmeter with at least 10 megohms input impedance is required to ensure accurate voltage readings. Tool J 39200 meets this requirement. The PCM controls output circuits such as the injectors, IAC, cooling fan relays, etc., by controlling the ground or the power feed circuit through transistors or through either of the following two devices:

- Output Driver Module (ODM)
- Quad Driver Module (QDM)



0005

### PCM Components

The PCM is designed to maintain exhaust emission levels to government mandated standards while providing excellent driveability and fuel efficiency. The PCM monitors numerous engine and vehicle functions via electronic sensors such as the throttle position (TP) sensor, heated oxygen sensor (HO2S), and vehicle speed sensor (VSS). The PCM also controls certain engine operations through the following:

- Fuel injector control
- Ignition control module
- Knock sensor
- Automatic transmission shift functions
- Cruise control
- Evaporative emission (EVAP) purge
- A/C clutch control

### PCM Voltage Description

The PCM supplies a buffered voltage to various switches and sensors. It can do this because resistance in the PCM is so high in value that a test light may not illuminate when connected to the circuit. An ordinary shop voltmeter may not give an accurate reading because the voltmeter input impedance is too low. Use a 10-megohm input impedance digital voltmeter (such as J 39200) to assure accurate voltage readings.

The input/output devices in the PCM include analog-to-digital converters, signal buffers, counters, and special drivers. The PCM controls most components with electronic switches which complete a ground circuit when turned "ON." These switches are arranged in groups of 4 and 7, called either a surface-mounted quad driver module (QDM), which can independently control up to 4 output terminals, or QDMs which can independently control up to 7 outputs. Not all outputs are always used.

### PCM Input/Outputs

#### Inputs – Operating Conditions Read

- Air Conditioning "ON" or "OFF"

- Engine Coolant Temperature
- Crankshaft Position
- Exhaust Oxygen Content
- Electronic Ignition
- Manifold Absolute Pressure
- Battery Voltage
- Throttle Position
- Vehicle Speed
- Fuel Pump Voltage
- Power Steering Pressure
- Intake Air Temperature
- Mass Air Flow
- Engine Knock
- Camshaft Position

#### Outputs – Systems Controlled

- EVAP Canister Purge
- EVAP Canister VENT
- Exhaust Gas Recirculation (EGR)
- Ignition Control
- Fuel Control
- Idle Air Control
- Electric Fuel Pump
- Air Conditioning
- Diagnostics
  - Malfunction Indicator Lamp
  - Data Link Connector (DLC)
  - Data Output
- Check Trans Lamp
- Alternator Gain Control

#### PCM Service Precautions

The PCM is designed to withstand normal current draws associated with vehicle operation. Avoid overloading any circuit. When testing for opens and shorts, do not ground or apply voltage to any of the PCM's circuits unless instructed to do so. These circuits should only be tested using digital voltmeter J 39200. The PCM should remain connected to the PCM or to a recommended breakout box.

#### Reprogramming The PCM

Reprogramming of the PCM is done without removing it from the vehicle. This provides a flexible and cost-effective method of making changes in software calibrations.

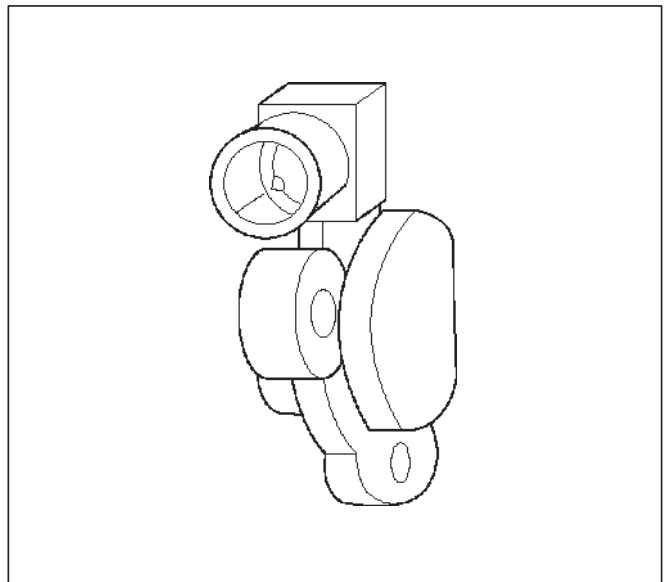
Refer to the latest Techline information on reprogramming or flashing procedures.

#### Throttle Position (TP) Sensor

The throttle position (TP) sensor is a potentiometer connected to the throttle shaft on the throttle body. The PCM monitors the voltage on the signal line and calculates throttle position. As the throttle valve angle is changed (accelerator pedal moved), the TP sensor signal also changes. At a closed throttle position, the output of the TP sensor is low. As the throttle valve opens, the

output increases so that at wide open throttle (WOT), the output voltage should be above 4 volts.

The PCM calculates fuel delivery based on throttle valve angle (driver demand). A broken or loose TP sensor may cause intermittent bursts of fuel from an injector and unstable idle because the PCM thinks the throttle is moving. A hard failure in the TP sensor 5-volt reference or signal circuits will set either a DTC P0122 or DTC P0123. A hard failure with the TP sensor ground circuit may set DTC P0123 and DTC P0112. Once a DTC is set, the PCM will use an artificial default value based on engine RPM and mass air flow for the throttle position, and some vehicle performance will return. A high idle may result when either DTC P0122 or DTC P0123 is set. The PCM can detect intermittent TP sensor faults. DTC P1121 or DTC P1122 will set if an intermittent high or low circuit failure is being detected. The PCM can also detect a shifted TP sensor. The PCM monitors throttle position and compares the actual TP sensor reading to a predicted TP value calculated from engine speed. If the PCM detects an out-of-range condition, DTC P0121 will be set.



0021

#### Transmission Fluid Temperature (TFT) Sensor

The transmission fluid temperature sensor is a thermistor which changes its resistance based on the temperature of the transmission fluid. For a complete description of the TFT sensor, refer to *4L30-E Automatic Transmission Diagnosis*.

A failure in the TFT sensor or associated wiring will cause DTC P0712 or DTC P0713 to set. In this case, engine coolant temperature will be substituted for the TFT sensor value and the transmission will operate normally.

#### Transmission Range Switch

**IMPORTANT:** The vehicle should not be driven with the transmission range switch disconnected; idle quality will be affected.

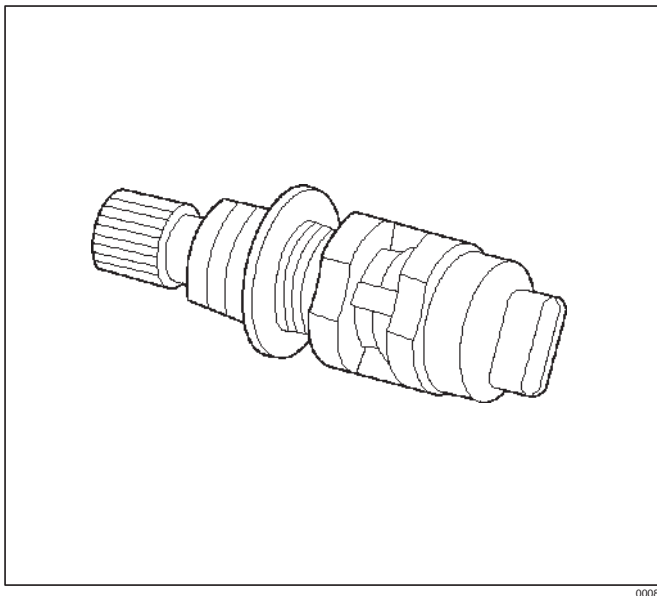
The four inputs from the transmission range switch indicate to the PCM which position is selected by the transmission selector lever. This information is used for

ignition timing, EVAP canister purge, EGR and IAC valve operation.

For more information on the transmission on the transmission range switch, refer to *4L30-E Automatic Transmission*.

### Vehicle Speed Sensor (VSS)

The PCM determines the speed of the vehicle by converting a pulsing voltage signal from the vehicle speed sensor (VSS) into miles per hour. The PCM uses this signal to operate the cruise control, speedometer, and the TCC and shift solenoids in the transmission. For more information on the TCC and shift solenoids, refer to *4L30-E Automatic Transmission*.



### Use of Circuit Testing Tools

Do not use a test light to diagnose the powertrain electrical systems unless specifically instructed by the diagnostic procedures. Use Connector Test Adapter Kit J 35616 whenever diagnostic procedures call for probing connectors.

### Aftermarket Electrical and Vacuum Equipment

Aftermarket (add-on) electrical and vacuum equipment is defined as any equipment which connects to the vehicle's electrical or vacuum systems that is installed on a vehicle after it leaves the factory. No allowances have been made in the vehicle design for this type of equipment.

**NOTE:** No add-on vacuum equipment should be added to this vehicle.

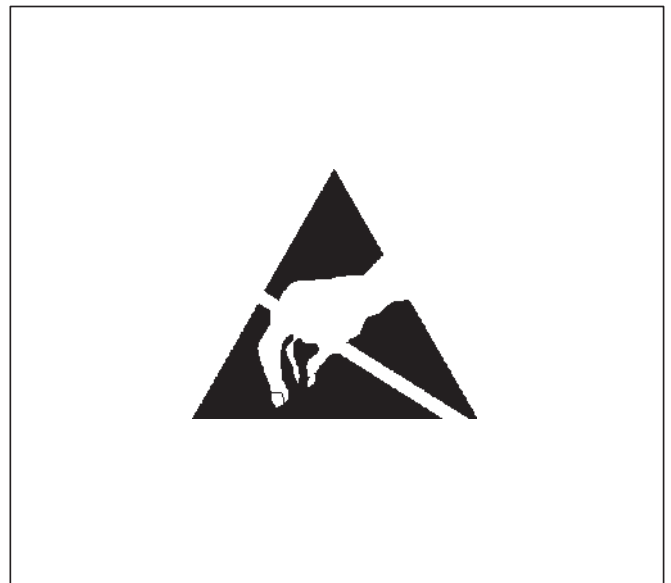
**NOTE:** Add-on electrical equipment must only be connected to the vehicle's electrical system at the battery (power and ground).

Add-on electrical equipment, even when installed to these guidelines, may still cause the powertrain system to malfunction. This may also include equipment not connected to the vehicle electrical system such as portable telephones and radios. Therefore, the first step in diagnosing any powertrain problem is to eliminate all

aftermarket electrical equipment from the vehicle. After this is done, if the problem still exists, it may be diagnosed in the normal manner.

### Electrostatic Discharge Damage

Electronic components used in the PCM are often designed to carry very low voltage. Electronic components are susceptible to damage caused by electrostatic discharge. Less than 100 volts of static electricity can cause damage to some electronic components. By comparison, it takes as much as 4000 volts for a person to feel even the zap of a static discharge.



There are several ways for a person to become statically charged. The most common methods of charging are by friction and induction.

- An example of charging by friction is a person sliding across a vehicle seat.
- Charge by induction occurs when a person with well insulated shoes stands near a highly charged object and momentarily touches ground. Charges of the same polarity are drained off leaving the person highly charged with the opposite polarity. Static charges can cause damage, therefore it is important to use care when handling and testing electronic components.

**NOTE:** To prevent possible electrostatic discharge damage, follow these guidelines:

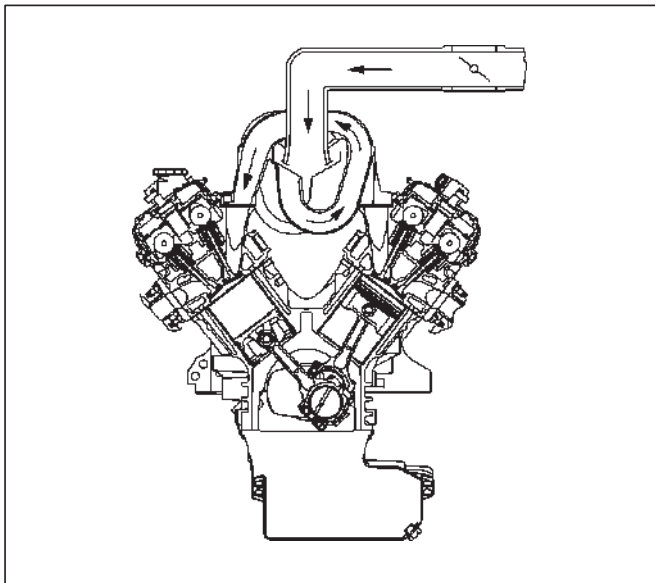
- Do not touch the PCM connector pins or soldered components on the PCM circuit board.
- Do not touch the knock sensor module component leads.
- Do not open the replacement part package until the part is ready to be installed.
- Before removing the part from the package, ground the package to a known good ground on the vehicle.
- If the part has been handled while sliding across the seat, while sitting down from a standing position, or while walking a distance, touch a known good ground before installing the part.

## General Description (Air Induction)

### Air Induction System

The air induction system filters contaminants from the outside air, and directs the progress of the air as it is drawn into the engine. A remote-mounted air cleaner prevents dirt and debris in the air from entering the engine. The air duct assembly routes filtered air to the throttle body. Air enters the engine by the following steps:

1. Through the throttle body.
2. Into the common chamber.
3. Through the cylinder head intake ports.
4. Into the cylinders.



## General Description (Fuel Metering)

### Acceleration Mode

The PCM provides extra fuel when it detects a rapid increase in the throttle position and the air flow.

### Accelerator Controls

The accelerator control system is a cable-type system with specific linkage adjustments. Refer to *Cable Adjustment*.

### Battery Voltage Correction Mode

When battery voltage is low, the PCM will compensate for the weak spark by increasing the following:

- The amount of fuel delivered.
- The idle RPM.

- Ignition dwell time.

### CMP Signal

The PCM uses this signal to determine the position of the number 1 piston during its power stroke, allowing the PCM to calculate true sequential multiport fuel injection (SFI). Loss of this signal will set a DTC P0341. If the CMP signal is lost while the engine is running, the fuel injection system will shift to a calculated sequential fuel injection based on the last fuel injection pulse, and the engine will continue to run. The engine can be restarted and will run in the calculated sequential mode as long as the fault is present, with a 1-in-6 chance of being correct.

### Clear Flood Mode

Clear a flooded engine by pushing the accelerator pedal down all the way. The PCM then de-energizes the fuel injectors. The PCM holds the fuel injectors de-energized as long as the throttle remains above 80% and the engine speed is below 800 RPM. If the throttle position becomes less than 80%, the PCM again begins to pulse the injectors "ON" and "OFF," allowing fuel into the cylinders.

### Deceleration Mode

The PCM reduces the amount of fuel injected when it detects a decrease in the throttle position and the air flow. When deceleration is very fast, the PCM may cut off fuel completely for short periods.

### Engine Speed/Fuel Disable Mode

The PCM monitors engine speed. It turns off the fuel injectors when the engine speed increases above 6400 RPM. The fuel injectors are turned back on when engine speed decreases below 6150 RPM.

### Fuel Cutoff Mode

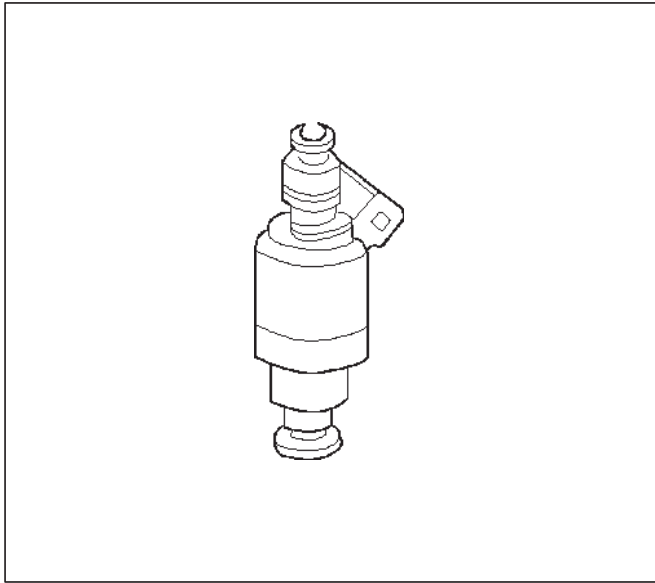
No fuel is delivered by the fuel injectors when the ignition is "OFF." This prevents engine run-on. In addition, the PCM suspends fuel delivery if no reference pulses are detected (engine not running) to prevent engine flooding.

### Fuel Injector

The sequential multiport fuel injection (SFI) fuel injector is a solenoid-operated device controlled by the PCM. The PCM energizes the solenoid, which opens a valve to allow fuel delivery.

The fuel is injected under pressure in a conical spray pattern at the opening of the intake valve. Excess fuel not used by the injectors passes through the fuel pressure regulator before being returned to the fuel tank.

A fuel injector which is stuck partly open will cause a loss of fuel pressure after engine shut down, causing long crank times.



### Fuel Metering System Components

The fuel metering system is made up of the following parts:

- The fuel injectors.
- The throttle body.
- The fuel rail.
- The fuel pressure regulator.
- The PCM.
- The crankshaft position (CKP) sensor.
- The camshaft position (CMP) sensor.
- The idle air control (IAC) valve.
- The fuel pump.
- The fuel pump relay.

### Basic System Operation

The fuel metering system starts with the fuel in the fuel tank. An electric fuel pump, located in the fuel tank, pumps fuel to the fuel rail through an in-line fuel filter. The pump is designed to provide fuel at a pressure above the pressure needed by the injectors. A fuel pressure regulator in the fuel rail keeps fuel available to the fuel injectors at a constant pressure. A return line delivers unused fuel back to the fuel tank. Refer to *Section 6C* for further information on the fuel tank, line filter, and fuel pipes.

### Fuel Metering System Purpose

The basic function of the air/fuel metering system is to control the air/fuel delivery to the engine. Fuel is delivered to the engine by individual fuel injectors mounted in the intake manifold near each intake valve.

The main control sensor is the heated oxygen sensor (HO2S) located in the exhaust system. The HO2S tells the PCM how much oxygen is in the exhaust gas. The PCM changes the air/fuel ratio to the engine by controlling the amount of time that fuel injector is "ON." The best mixture to minimize exhaust emissions is 14.7 parts of air

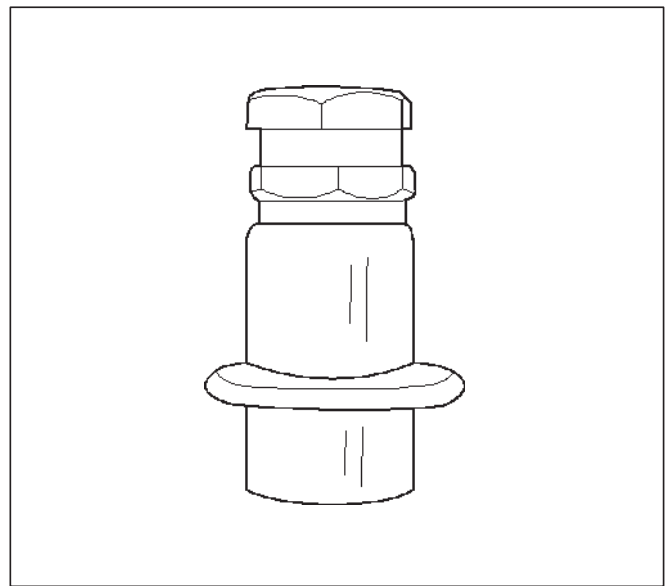
to 1 part of gasoline by weight, which allows the catalytic converter to operate most efficiently. Because of the constant measuring and adjusting of the air/fuel ratio, the fuel injection system is called a "closed loop" system.

The PCM monitors signals from several sensors in order to determine the fuel needs of the engine. Fuel is delivered under one of several conditions called "modes." All modes are controlled by the PCM.

### Fuel Pressure Regulator

The fuel pressure regulator is a diaphragm-operated relief valve mounted on the fuel rail with fuel pump pressure on one side and manifold pressure on the other side. The fuel pressure regulator maintains the fuel pressure available to the injector at three times barometric pressure adjusted for engine load. It may be serviced separate.

If the pressure is too low, poor performance and a DTC P0131, DTC P0151, DTC P0171 or DTC P1171 will be the result. If the pressure is too high, excessive odor and/or a DTC P0132, DTC P0152, DTC P0172 or DTC P0175 will be the result. Refer to *Fuel System Diagnosis* for information on diagnosing fuel pressure conditions.



### Fuel Pump Electrical Circuit

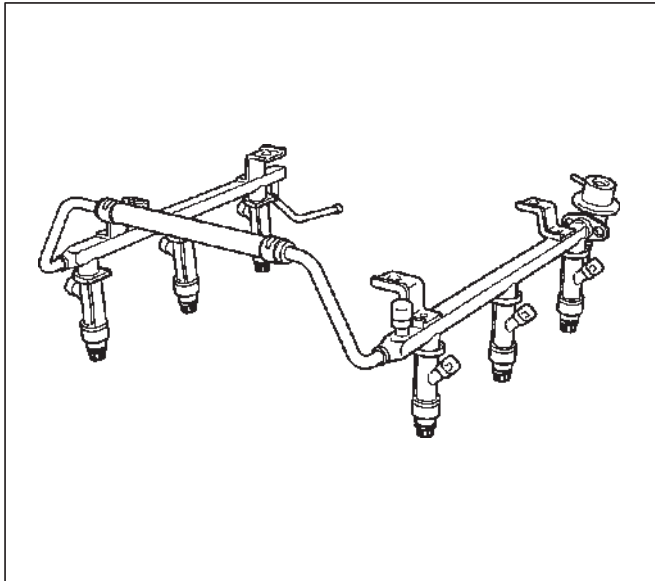
When the key is first turned "ON," the PCM energizes the fuel pump relay for two seconds to build up the fuel pressure quickly. If the engine is not started within two seconds, the PCM shuts the fuel pump off and waits until the engine is cranked. When the engine is cranked and the 58 X crankshaft position signal has been detected by the PCM, the PCM supplies 12 volts to the fuel pump relay to energize the electric in-tank fuel pump.

An inoperative fuel pump will cause a "no-start" condition. A fuel pump which does not provide enough pressure will result in poor performance.

### Fuel Rail

The fuel rail is mounted to the top of the engine and distributes fuel to the individual injectors. Fuel is delivered to the fuel inlet tube of the fuel rail by the fuel lines. The fuel goes through the fuel rail to the fuel

pressure regulator. The fuel pressure regulator maintains a constant fuel pressure at the injectors. Remaining fuel is then returned to the fuel tank.



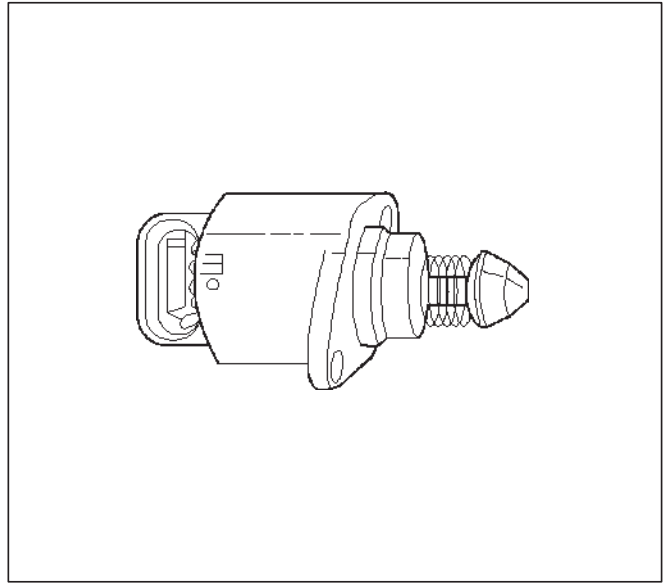
### Idle Air Control (IAC) Valve

The purpose of the idle air control (IAC) valve is to control engine idle speed, while preventing stalls due to changes in engine load. The IAC valve, mounted in the throttle body, controls bypass air around the throttle plate. By moving the conical valve (pintle) in (to decrease air flow) or out (to increase air flow), a controlled amount of air can move around the throttle plate. If the RPM is too low, the PCM will retract the IAC pintle, resulting in more air moving past the throttle plate to increase the RPM. If the RPM is too high, the PCM will extend the IAC pintle, allowing less air to move past the throttle plate, decreasing the RPM.

The IAC pintle valve moves in small steps called counts. During idle, the proper position of the IAC pintle is calculated by the PCM based on battery voltage, coolant temperature, engine load, and engine RPM. If the RPM drops below a specified value, and the throttle plate is closed, the PCM senses a near-stall condition. The PCM will then calculate a new IAC pintle valve position to prevent stalls.

If the IAC valve is disconnected and reconnected with the engine running, the idle RPM will be wrong. In this case, the IAC must be reset. The IAC resets when the key is cycled "ON" then "OFF." When servicing the IAC, it should only be disconnected or connected with the ignition "OFF."

The position of the IAC pintle valve affects engine start-up and the idle characteristics of the vehicle. If the IAC pintle is fully open, too much air will be allowed into the manifold. This results in high idle speed, along with possible hard starting and a lean air/fuel ratio. DTC P0507 or DTC P1509 may set. If the IAC pintle is stuck closed, too little air will be allowed in the manifold. This results in a low idle speed, along with possible hard starting and a rich air/fuel ratio. DTC P0506 or DTC P1508 may set. If the IAC pintle is stuck part-way open, the idle may be high or low and will not respond to changes in the engine load.



### Run Mode

The run mode has the following two conditions:

- Open loop
- Closed loop

When the engine is first started the system is in "open loop" operation. In "open loop," the PCM ignores the signal from the heated oxygen sensor (HO2S). It calculates the air/fuel ratio based on inputs from the TP, ECT, and MAF sensors.

The system remains in "open loop" until the following conditions are met:

- The HO2S has a varying voltage output showing that it is hot enough to operate properly (this depends on temperature).
- The ECT has reached a specified temperature.
- A specific amount of time has elapsed since starting the engine.
- Engine speed has been greater than a specified RPM since start-up.

The specific values for the above conditions vary with different engines and are stored in the programmable read only memory (PROM). When these conditions are met, the system enters "closed loop" operation. In "closed loop," the PCM calculates the air/fuel ratio (injector on-time) based on the signal from the HO2S. This allows the air/fuel ratio to stay very close to 14.7:1.

### Starting Mode

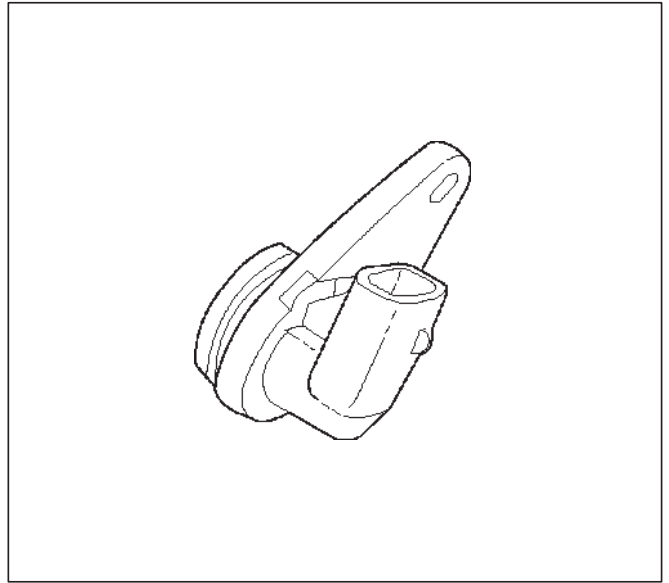
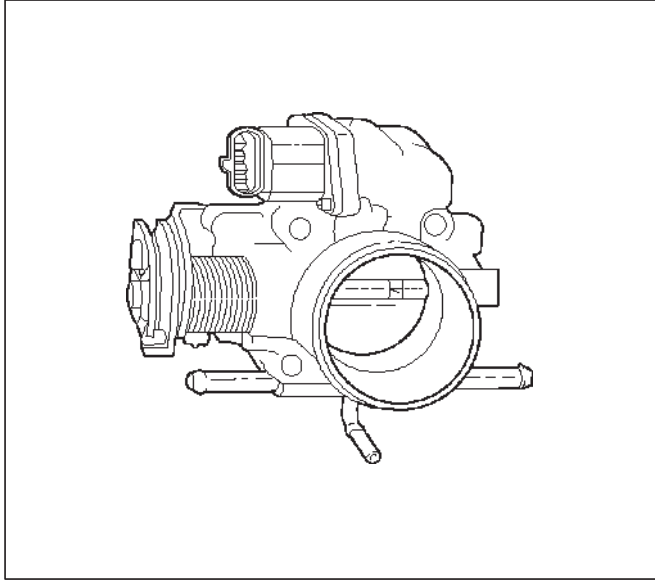
When the ignition is first turned "ON," the PCM energizes the fuel pump relay for two seconds to allow the fuel pump to build up pressure. The PCM then checks the engine coolant temperature (ECT) sensor and the throttle position (TP) sensor to determine the proper air/fuel ratio for starting.

The PCM controls the amount of fuel delivered in the starting mode by adjusting how long the fuel injectors are energized by pulsing the injectors for very short times.

## Throttle Body Unit

The throttle body has a throttle plate to control the amount of air delivered to the engine. The TP sensor and IAC valve are also mounted on the throttle body. Vacuum ports located behind the throttle plate provide the vacuum signals needed by various components.

Engine coolant is directed through a coolant cavity in the throttle body to warm the throttle valve and to prevent icing.



## Crankshaft Position (CKP) Sensor

The crankshaft position (CKP) sensor provides a signal used by the powertrain control module (PCM) to calculate the ignition sequence. The sensor initiates the 58X reference pulses which the PCM uses to calculate RPM and crankshaft position. Refer to *Electronic Ignition System* for additional information.

## General Description (Electronic Ignition System)

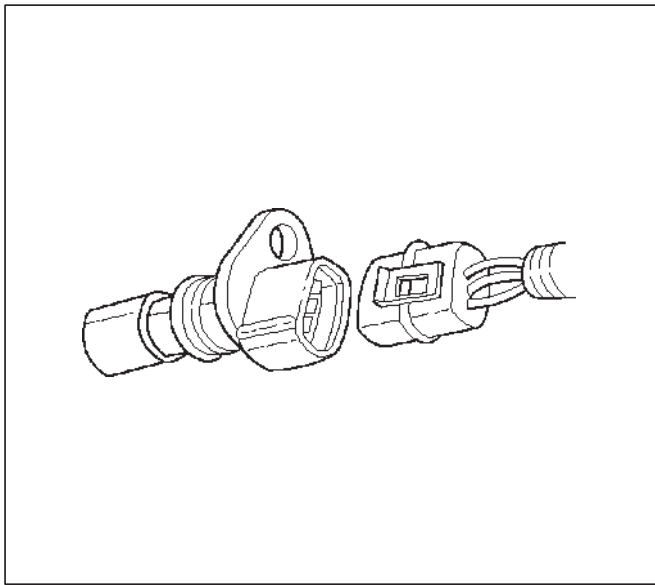
### Camshaft Position (CMP) Sensor

CMP is located Left Hard Rear cylinder head. When the Hall-effect switch is activated, it grounds the signal line to the PCM, pulling the camshaft position sensor signal circuit's applied voltage low. This is a CMP signal. The CMP signal is created as piston #1 is approximately 25° after top dead center on the power stroke. If the correct CMP signal is not received by the PCM, DTC P0341 will be set.

## Electronic Ignition

The electronic ignition system controls fuel combustion by providing a spark to ignite the compressed air/fuel mixture at the correct time. To provide optimum engine performance, fuel economy, and control of exhaust emissions, the PCM controls the spark advance of the ignition system. Electronic ignition has the following advantages over a mechanical distributor system:

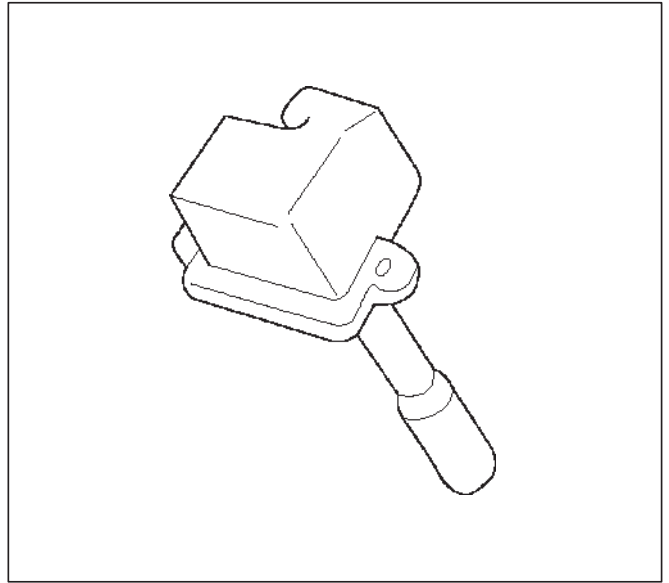
- No moving parts.
- Less maintenance.
- Remote mounting capability.
- No mechanical load on the engine.
- More coil cooldown time between firing events.
- Elimination of mechanical timing adjustments.
- Increased available ignition coil saturation time.



0013

## Ignition Coils

A separate coil-at-plug module is located at each spark plug. The coil-at-plug module is attached to the engine with two screws. It is installed directly to the spark plug by an electrical contact inside a rubber boot. A three-way connector provides 12-volt primary supply from the 15-amp ignition fuse, a ground-switching trigger line from the PCM, and a ground.

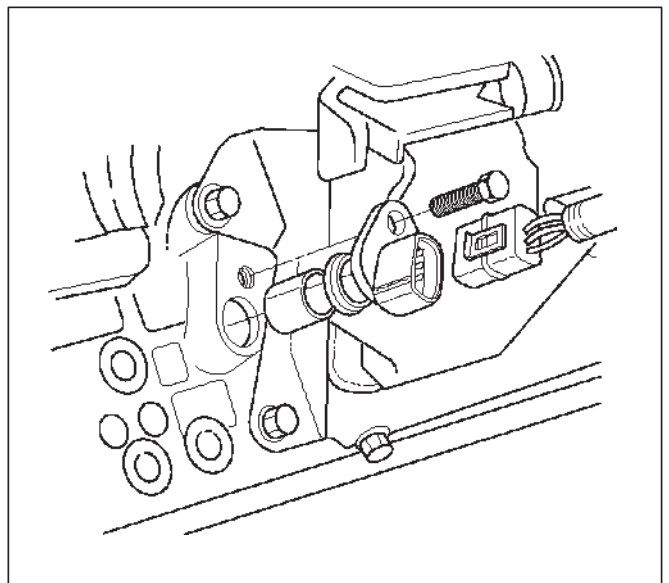


0001

## Ignition Control

The ignition control (IC) spark timing is the PCM's method of controlling the spark advance and the ignition dwell. The IC spark advance and the ignition dwell are calculated by the PCM using the following inputs:

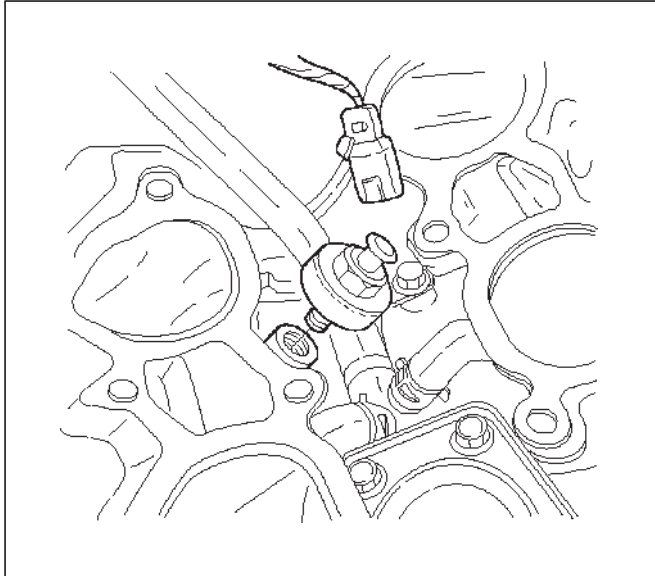
- Engine speed.
- Crankshaft position (58X reference).
- Camshaft position (CMP) sensor.
- Engine coolant temperature (ECT) sensor.
- Throttle position (TP) sensor.
- Knock signal (knock sensor).
- Park/Neutral position (PRNDL input).
- Vehicle speed (vehicle speed sensor).
- PCM and ignition system supply voltage.
- The crankshaft position (CKP) sensor sends the PCM a 58X signal related to the exact position of the crankshaft.



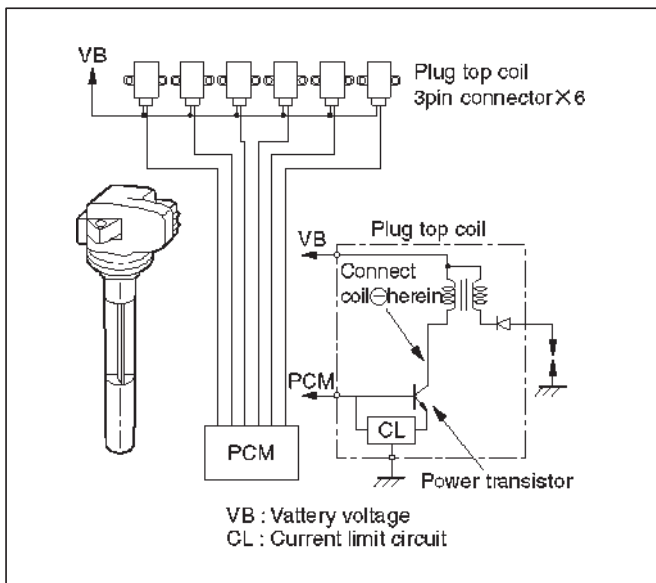
TS22909



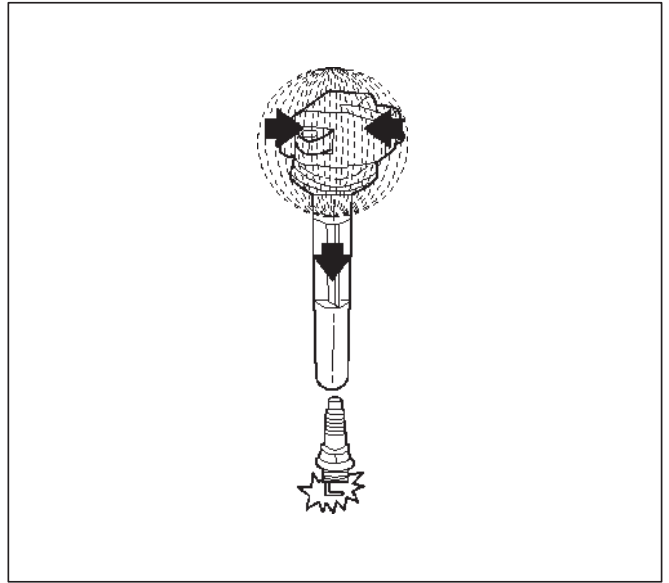
- The camshaft position (CMP) sensor sends a signal related to the position of the camshaft.
- The knock sensor tells the PCM if there is any problem with pre-ignition or detonation. This information allows the PCM to retard timing, if necessary.



Based on these sensor signals and engine load information, the PCM sends 5V to each ignition coil.



The PCM applies 5V signal voltage to the ignition coil requiring ignition. This signal sets on the power transistor of the ignition coil to establish a grounding circuit for the primary coil, applying battery voltage to the primary coil. At the ignition timing, the PCM stops sending the 5V signal voltage. Under this condition the power transistor of the ignition coil is set off to cut the battery voltage to the primary coil, thereby causing a magnetic field generated in the primary coil to collapse. On this moment a line of magnetic force flows to the secondary coil, and when this magnetic line crosses the coil, high voltage induced by the secondary ignition circuit to flow through the spark plug to the ground.



### Knock Sensor (KS) PCM Input

The knock sensor (KS) system is comprised of a knock sensor and the PCM. The PCM monitors the KS signals to determine when engine detonation occurs. When a knock sensor detects detonation, the PCM retards the spark timing to reduce detonation. Timing may also be retarded because of excessive mechanical engine or transmission noise.

### Powertrain Control Module (PCM)

The PCM is responsible for maintaining proper spark and fuel injection timing for all driving conditions. To provide optimum driveability and emissions, the PCM monitors the input signals from the following components in order to calculate spark timing:

- Engine coolant temperature (ECT) sensor.
- Intake air temperature (IAT) sensor.
- Mass air flow (MAF) sensor.
- PRNDL input from transmission range switch.
- Throttle position (TP) sensor.
- Vehicle speed sensor (VSS) .
- Crankshaft position (CKP) sensor.

### Spark Plug

Although worn or dirty spark plugs may give satisfactory operation at idling speed, they frequently fail at higher engine speeds. Faulty spark plugs may cause poor fuel economy, power loss, loss of speed, hard starting and generally poor engine performance. Follow the scheduled maintenance service recommendations to ensure satisfactory spark plug performance. Refer to *Maintenance and Lubrication*.

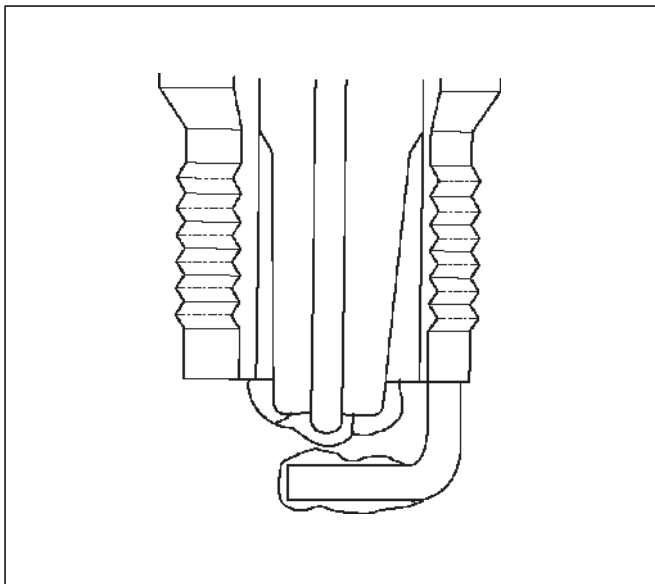
Normal spark plug operation will result in brown to grayish-tan deposits appearing on the insulator portion of the spark plug. A small amount of red-brown, yellow, and white powdery material may also be present on the insulator tip around the center electrode. These deposits are normal combustion by-products of fuels and lubricating oils with additives. Some electrode wear will also occur. Engines which are not running properly are

often referred to as “misfiring.” This means the ignition spark is not igniting the air/fuel mixture at the proper time. While other ignition and fuel system causes must also be considered, possible causes include ignition system conditions which allow the spark voltage to reach ground in some other manner than by jumping across the air gap at the tip of the spark plug, leaving the air/fuel mixture unburned. Refer to *DTC P0300*. Misfiring may also occur when the tip of the spark plug becomes overheated and ignites the mixture before the spark jumps. This is referred to as “pre-ignition.”

Spark plugs may also misfire due to fouling, excessive gap, or a cracked or broken insulator. If misfiring occurs before the recommended replacement interval, locate and correct the cause.

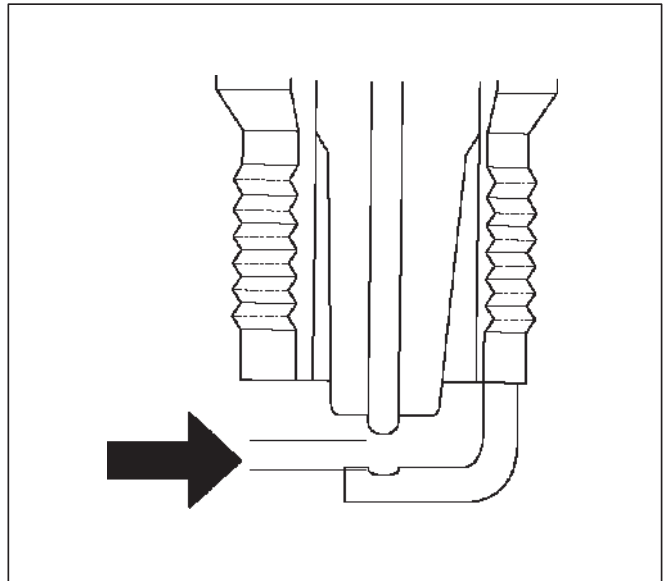
Carbon fouling of the spark plug is indicated by dry, black carbon (soot) deposits on the portion of the spark plug in the cylinder. Excessive idling and slow speeds under light engine loads can keep the spark plug temperatures so low that these deposits are not burned off. Very rich fuel mixtures or poor ignition system output may also be the cause. Refer to *DTC P0172*.

Oil fouling of the spark plug is indicated by wet oily deposits on the portion of the spark plug in the cylinder, usually with little electrode wear. This may be caused by oil during break-in of new or newly overhauled engines. Deposit fouling of the spark plug occurs when the normal red-brown, yellow or white deposits of combustion by products become sufficient to cause misfiring. In some cases, these deposits may melt and form a shiny glaze on the insulator around the center electrode. If the fouling is found in only one or two cylinders, valve stem clearances or intake valve seals may be allowing excess lubricating oil to enter the cylinder, particularly if the deposits are heavier on the side of the spark plug facing the intake valve.



TS23995

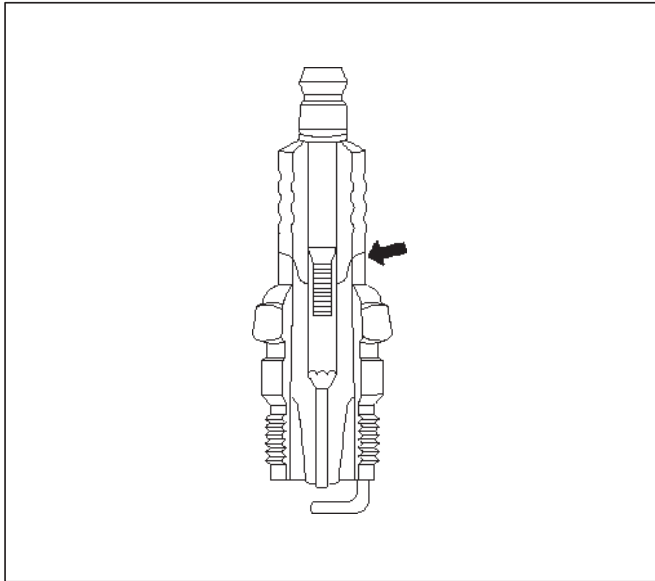
Excessive gap means that the air space between the center and the side electrodes at the bottom of the spark plug is too wide for consistent firing. This may be due to improper gap adjustment or to excessive wear of the electrode during use. A check of the gap size and comparison to the gap specified for the vehicle in *Maintenance and Lubrication* will tell if the gap is too wide. A spark plug gap that is too small may cause an unstable idle condition. Excessive gap wear can be an indication of continuous operation at high speeds or with engine loads, causing the spark to run too hot. Another possible cause is an excessively lean fuel mixture.



TS23992

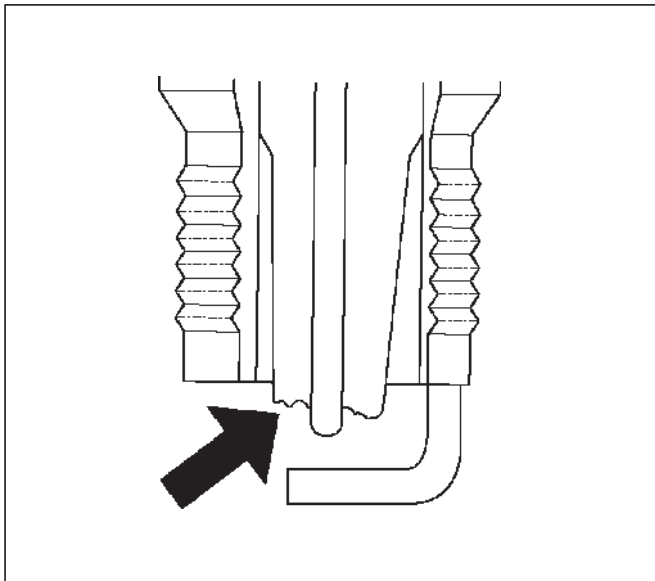
Low or high spark plug installation torque or improper seating can result in the spark plug running too hot and can cause excessive center electrode wear. The plug and the cylinder head seats must be in good contact for proper heat transfer and spark plug cooling. Dirty or damaged threads in the head or on the spark plug can keep it from seating even though the proper torque is applied. Once spark plugs are properly seated, tighten them to the torque shown in the Specifications Table. Low torque may result in poor contact of the seats due to a loose spark plug. Overtightening may cause the spark plug shell to be stretched and will result in poor contact between the seats. In extreme cases, exhaust blow-by and damage beyond simple gap wear may occur.

Cracked or broken insulators may be the result of improper installation, damage during spark plug re-gapping, or heat shock to the insulator material. Upper insulators can be broken when a poorly fitting tool is used during installation or removal, when the spark plug is hit from the outside, or is dropped on a hard surface. Cracks in the upper insulator may be inside the shell and not visible. Also, the breakage may not cause problems until oil or moisture penetrates the crack later.



TS23994

A broken or cracked lower insulator tip (around the center electrode) may result from damage during re-gapping or from "heat shock" (spark plug suddenly operating too hot).



TS23993

- Damage during re-gapping can happen if the gapping tool is pushed against the center electrode or the insulator around it, causing the insulator to crack. When re-gapping a spark plug, make the adjustment by bending only the ground side terminal, keeping the tool clear of other parts.
- "Heat shock" breakage in the lower insulator tip generally occurs during several engine operating conditions (high speeds or heavy loading) and may be caused by over-advanced timing or low grade fuels. Heat shock refers to a rapid increase in the tip temperature that causes the insulator material to crack.

Spark plugs with less than the recommended amount of service can sometimes be cleaned and re-gapped, then returned to service. However, if there is any doubt about the serviceability of a spark plug, replace it. Spark plugs with cracked or broken insulators should always be replaced.

## A/C Clutch Diagnosis

### A/C Clutch Circuit Operation

A 12-volt signal is supplied to the A/C request input of the PCM when the A/C is selected through the A/C control switch.

The A/C compressor clutch relay is controlled through the PCM. This allows the PCM to modify the idle air control position prior to the A/C clutch engagement for better idle quality. If the engine operating conditions are within their specified calibrated acceptable ranges, the PCM will enable the A/C compressor relay. This is done by providing a ground path for the A/C relay coil within the PCM. When the A/C compressor relay is enabled, battery voltage is supplied to the compressor clutch coil. The PCM will enable the A/C compressor clutch whenever the engine is running and the A/C has been requested. The PCM will not enable the A/C compressor clutch if any of the following conditions are met:

- The throttle is greater than 90%.
- The engine speed is greater than 6315 RPM.
- The ECT is greater than 119°C (246°F).
- The IAT is less than 5°C (41°F).
- The throttle is more than 80% open.

### A/C Clutch Circuit Purpose

The A/C compressor operation is controlled by the powertrain control module (PCM) for the following reasons:

- It improves idle quality during compressor clutch engagement.
- It improves wide open throttle (WOT) performance.
- It provides A/C compressor protection from operation with incorrect refrigerant pressures.

The A/C electrical system consists of the following components:

- The A/C control head.
- The A/C refrigerant pressure switches.
- The A/C compressor clutch.
- The A/C compressor clutch relay.
- The PCM.

### A/C Request Signal

This signal tells the PCM when the A/C mode is selected at the A/C control head. The PCM uses this to adjust the idle speed before turning on the A/C clutch. The A/C compressor will be inoperative if this signal is not available to the PCM.

Refer to *A/C Clutch Circuit Diagnosis* for A/C wiring diagrams and diagnosis for A/C electrical system.

## General Description (Evaporative (EVAP) Emission System)

### EVAP Emission Control System Purpose

The basic evaporative emission (EVAP) control system used on all vehicles is the charcoal canister storage method. Gasoline vapors from the fuel tank flow into the canister through the inlet labeled "TANK." These vapors are absorbed into the activated carbon (charcoal) storage device (canister) in order to hold the vapors when the vehicle is not operating. The canister is purged by PCM control when the engine coolant temperature is over 60°C (140°F), the IAT reading is over 10°C (50°F), and the engine has been running. Air is drawn into the canister through the air inlet grid. The air mixes with the vapor and the mixture is drawn into the intake manifold.

### EVAP Emission Control System Operation

The EVAP canister purge is controlled by a solenoid valve that allows the manifold vacuum to purge the canister. The powertrain control module (PCM) supplies a ground to energize the solenoid valve (purge on). The EVAP purge solenoid control is pulse-width modulated (PWM) (turned on and off several times a second). The duty cycle (pulse width) is determined by engine operating conditions including load, throttle position, coolant temperature and ambient temperature. The duty cycle is calculated by the PCM. The output is commanded when the appropriate conditions have been met. These conditions are:

- The engine is fully warmed up.
- The engine has been running for a specified time.
- The IAT reading is above 10°C (50°F).

A continuous purge condition with no purge commanded by the PCM will set a DTC P1441.

Poor idle, stalling and poor driveability can be caused by:

- A malfunctioning purge solenoid.
- A damaged canister.
- Hoses that are split, cracked, or not connected properly.

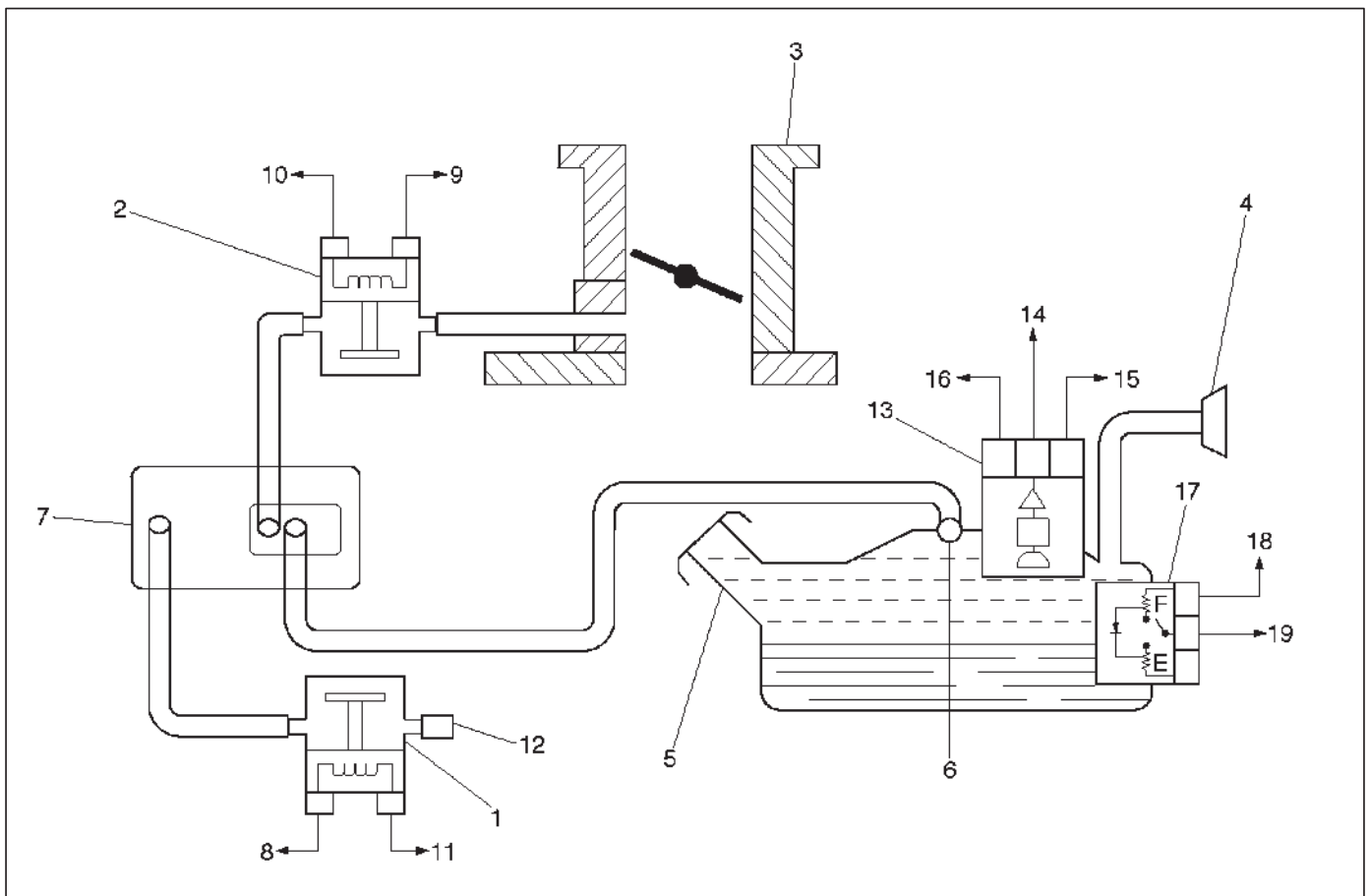
### Enhanced Evaporative Emission Control System

The basic purpose of the Enhanced Evaporative Emissions control system is the same as other EVAP systems. A charcoal-filled canister captures and stores gasoline fumes. When the PCM determines that the time is right, it opens a purge valve which allows engine vacuum to draw the fumes into the intake manifold.

The difference between this and other systems is that the PCM monitors the vacuum and/or pressure in the system to determine if there is any leakage. If the PCM determines that the EVAP system is leaking or not functioning properly, it sets a Diagnostic Trouble Code (DTC) in the PCM memory.

The enhanced EVAP system is required to detect evaporative fuel system leaks as small as 0.040 in. (1.0 mm) between the fuel filler cap and purge solenoid. The

system can test the evaporative system integrity by applying a vacuum signal (ported or manifold) to the fuel tank to create a small vacuum. The PCM then monitors the ability of the system to maintain the vacuum. If the vacuum remains for a specified period of time, there are no evaporative leaks and a PASS report is sent to the diagnostic executive. If there is a leak, the system either will not achieve a vacuum, or a vacuum cannot be maintained. Usually, a failure can only be detected after a cold start with a trip of sufficient length and driving conditions to run the needed tests. The enhanced EVAP system diagnostic will conduct up to eight specific sub-tests to detect fault conditions. If the diagnostic fails a sub-test, the PCM will store a Diagnostic Trouble Code (DTC) to indicate the type of detected.



**Legend**

- (1) Vent Solenoid
- (2) EVAP Purge Solenoid
- (3) Throttle Body
- (4) Fuel Filler Neck
- (5) Fuel Tank
- (6) Rollover Valve
- (7) EVAP Canister
- (8) Ignition Feed
- (9) From Battery
- (10) EVAP Purge Solenoid Driver Signal from PCM
- (11) Vent Solenoid Driver Signal from PCM
- (12) Vent Filter
- (13) Fuel Tank Pressure Sensor
- (14) Fuel Tank Pressure Signal to PCM
- (15) 5 Volt Reference "A" Circuit from PCM
- (16) Sensor Ground Circuit from PCM
- (17) Fuel Level Sensor
- (18) Fuel Level Signal to PCM
- (19) 5 Volt Return

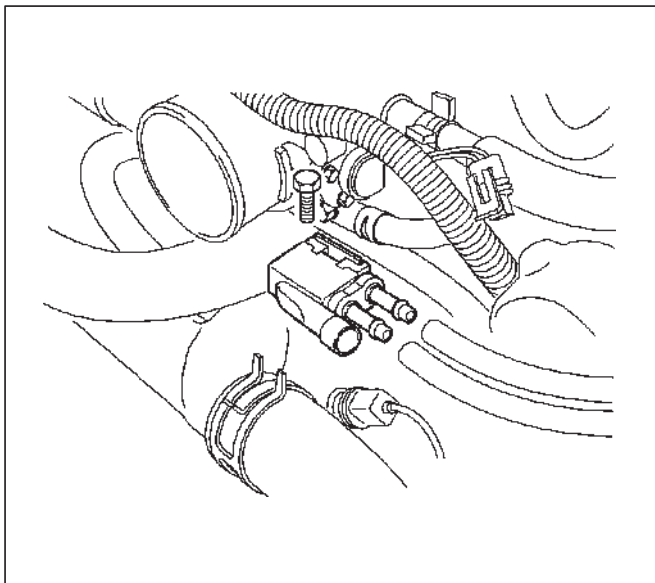
**Electrical Components**

The electrical components that make up the enhanced EVAP system are:

- Fuel Tank Pressure Sensor. The fuel tank pressure sensor is a three-wire strain gauge sensor similar to a common MAP sensor. However, the fuel tank pressure sensor has very different electrical characteristics due to its pressure differential design. The sensor measures the difference between the air pressure (or vacuum) in the fuel tank and the outside air pressure.

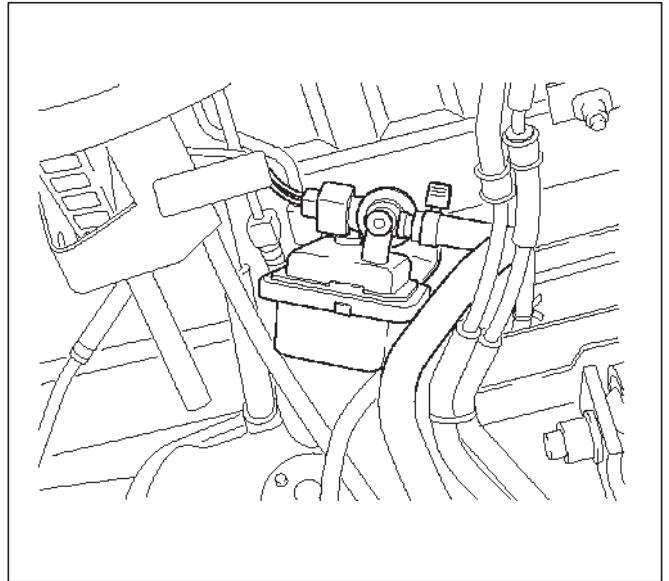
The sensor mounts at the top of the fuel pump assembly. A three-wire electrical harness connects it to the PCM. The PCM supplies a five-volt reference voltage and a ground to the sensor. The sensor will return a voltage between 0.1 and 4.9 volts. When the air pressure in the fuel tank is equal to the outside air pressure, such as when the fuel cap is removed, the output voltage of the sensor will be 1.3 to 1.7 volts.

- EVAP Canister Purge Solenoid. Normally closed, the purge solenoid opens upon the PCM's signal to allow engine vacuum to purge gasoline fumes from the canister. Mounted on the water pipe to front of the engine assembly.



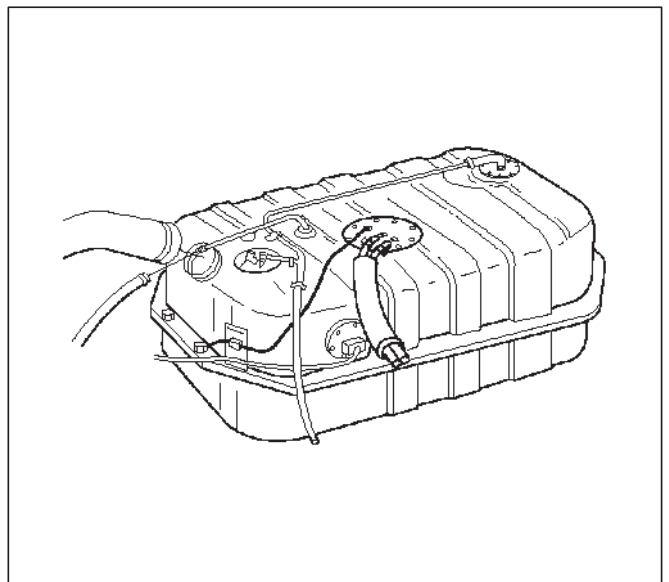
014RW093

- EVAP Canister Vent Solenoid. Located next to the canister, the vent solenoid opens to allow air into the EVAP system. Fresh air is necessary to completely remove gasoline fumes from the canister during purge. The EVAP vent solenoid closes to seal off the evaporative emissions system for leak testing.



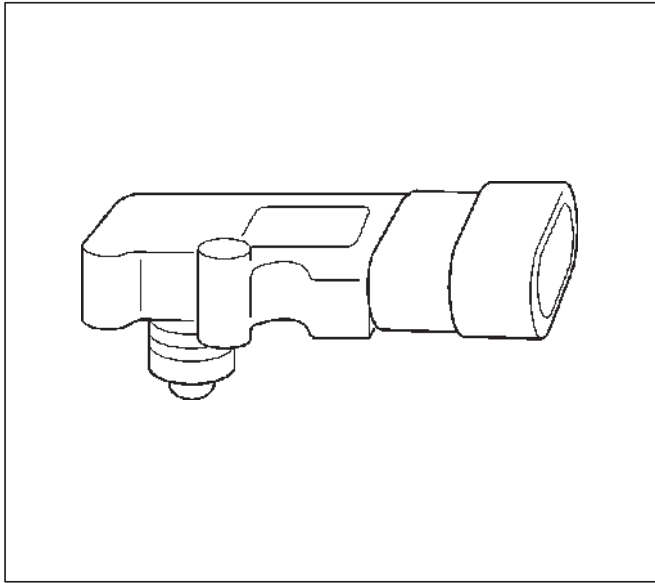
014RW146

- Fuel Level Sensor. The fuel level sensor is an important input to the PCM for the enhanced EVAP system diagnostic. The PCM needs fuel level information to know the volume of fuel in the tank. The fuel level affects the rate of change of air pressure in the EVAP system. Several of the enhanced EVAP system diagnostic sub-tests are dependent upon correct fuel level information. The diagnostic will not run when the tank is less than 15% or more than 85% full. Be sure to diagnose any Fuel Level Sensor DTCs first, as they can cause other DTCs to set.



TS23796

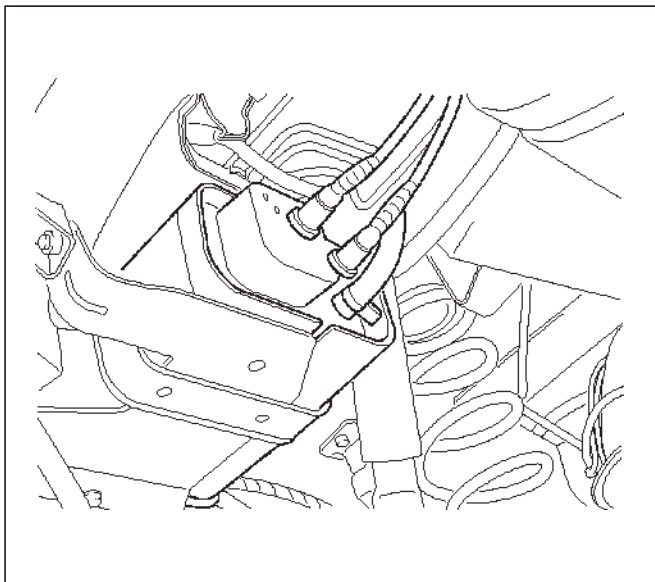
- Manifold Absolute Pressure (MAP) Sensor. The PCM compares the signals from the fuel tank pressure sensor and the MAP sensor to ensure that a relative vacuum is maintained the EVAP system.



055RW004

### Non-Electrical Components

- Purge/Vacuum Hoses. Made of rubber compounds, these hoses route the gasoline fumes from their sources to the canister and from the canister to the intake air flow.
- EVAP Canister. Mounted on a bracket ahead of the fuel tank, the canister stores fuel vapors until the PCM determines that engine conditions are right for them to be remove and burned.
- Fuel Tank. The tank has a built-in air space designed for the collection of gasoline fumes.



014RW145

- Vacuum Source. The vacuum source is split between two ports, one on either side of the throttle body.
- Fuel Cap. The fuel cap is designed to be an integral part of the EVAP system.

### System Fault Detection

The EVAP leak detection strategy is based on applying vacuum to the EVAP system and monitoring vacuum decay. The PCM monitors vacuum level via the fuel tank pressure sensor. At an appropriate time, the EVAP purge solenoid and the EVAP vent solenoid are turned "ON," allowing the engine vacuum to draw a small vacuum on the entire evaporative emission system.

After the desired vacuum level has been achieved, the EVAP purge solenoid is turned "OFF," sealing the system. A leak is detected by monitoring for a decrease in vacuum level over a given time period, all other variables remaining constant. A small leak in the system will cause DTC P0442 to be set.

If the desired vacuum level cannot be achieved in the test described above, a large leak or a faulty EVAP purge solenoid is indicated.

Leaks can be caused by the following conditions:

- Disconnected or faulty fuel tank pressure sensor
- Missing or faulty fuel cap
- Disconnected, damaged, pinched, or blocked EVAP purge line
- Disconnected or damaged EVAP vent hose
- Disconnected, damaged, pinched, or blocked fuel tank vapor line
- Disconnected or faulty EVAP purge solenoid
- Disconnected or faulty EVAP vent solenoid
- Open ignition feed circuit to the EVAP vent or purge solenoid
- Damaged EVAP canister
- Leaking fuel sender assembly O-ring
- Leaking fuel tank or fuel filler neck

A restricted or blocked EVAP vent path is detected by drawing vacuum into the EVAP system, turning "OFF" the EVAP vent solenoid and the EVAP purge solenoid (EVAP vent solenoid "OPEN," EVAP purge Pulse Width Modulate (PWM) "0%") and monitoring the fuel tank vacuum sensor input. With the EVAP vent solenoid open, any vacuum in the system should decrease quickly unless the vent path is blocked. A blockage like this will set DTC P0446 and can be caused by the following conditions:

- Faulty EVAP vent solenoid (stuck closed)
- Plugged, kinked or pinched vent hose
- Shorted EVAP vent solenoid driver circuit
- Plugged EVAP canister

The PCM supplies a ground to energize the purge solenoid (purge "ON"). The EVAP purge control is PWM, or turned "ON" and "OFF," several times a second. The duty cycle (pulse width) is determined by engine operating conditions including load, throttle position, coolant temperature and ambient temperature. The duty cycle is calculated by the PCM and the output is commanded when the appropriate conditions have been met.

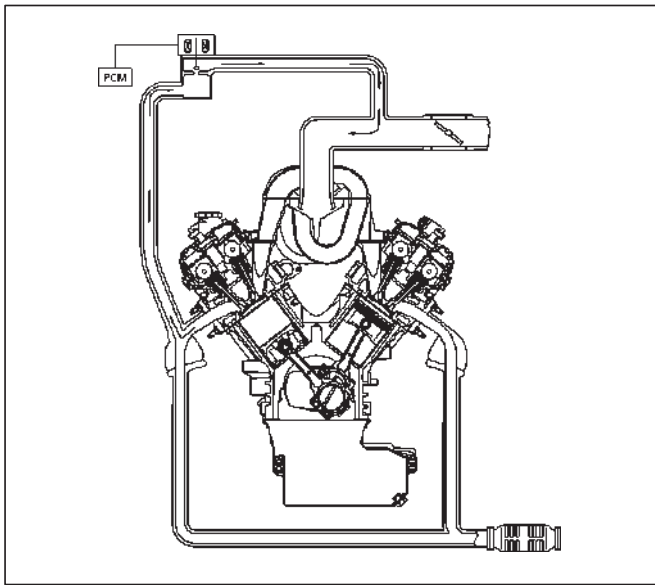
The system checks for conditions that cause the EVAP system to purge continuously by commanding the EVAP vent solenoid "ON" and the EVAP purge solenoid "OFF" (EVAP vent solenoid "CLOSED," EVAP purge PWM "0%"). If fuel tank vacuum level increases during the test, a continuous purge flow condition is indicated, which will set a DTC P1441. This can be caused by the following conditions:

- EVAP purge solenoid leaking
- EVAP purge and engine vacuum lines switched at the EVAP purge solenoid
- EVAP purge solenoid driver circuit grounded

## General Description (Exhaust Gas Recirculation (EGR) System)

### EGR Purpose

The exhaust gas recirculation (EGR) system is used to reduce emission levels of oxides of nitrogen (NOx). NOx emission levels are caused by a high combustion temperature. The EGR system lowers the NOx emission levels by decreasing the combustion temperature.



057RW002

### Linear EGR Valve

The main element of the system is the linear EGR valve. The EGR valve feeds small amounts of exhaust gas back into the combustion chamber. The fuel/air mixture will be diluted and combustion temperatures reduced.

### Linear EGR Control

The PCM monitors the EGR actual position and adjusts the pintle position accordingly. It uses information from the following sensors to control the pintle position:

- Engine coolant temperature (ECT) sensor.
- Throttle position (TP) sensor.
- Mass air flow (MAF) sensor.

## Linear EGR Valve Operation and Results of Incorrect Operation

The linear EGR valve is designed to accurately supply EGR to the engine independent of intake manifold vacuum. The valve controls EGR flow from the exhaust to the intake manifold through an orifice with a PCM controlled pintle. During operation, the PCM controls pintle position by monitoring the pintle position feedback signal. The feedback signal can be monitored with a Tech 2 as "Actual EGR Pos." "Actual EGR Pos." should always be near the commanded EGR position ("Desired EGR Pos."). If a problem with the EGR system will not allow the PCM to control the pintle position properly, DTC P1406 will set. The PCM also tests for EGR flow. If incorrect flow is detected, DTC P0401 will set. If DTCs P0401 and/or P1406 are set, refer to the DTC charts.

The linear EGR valve is usually activated under the following conditions:

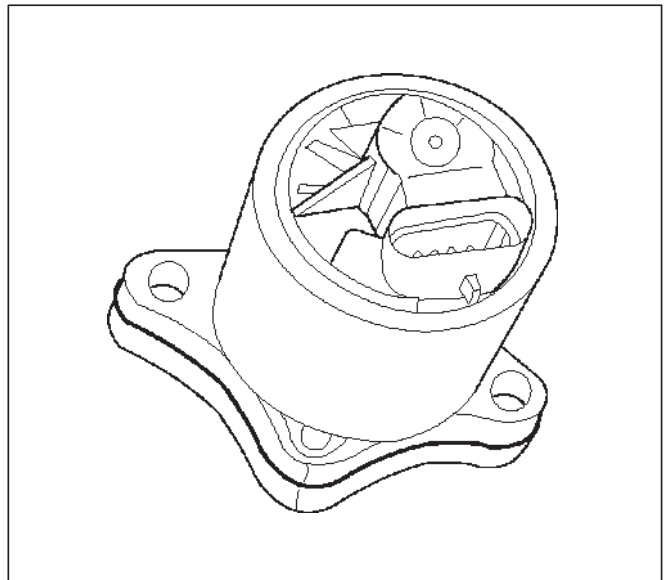
- Warm engine operation.
- Above-idle speed.

Too much EGR flow at idle, cruise or cold operation may cause any of the following conditions to occur:

- Engine stalls after a cold start.
- Engine stalls at idle after deceleration.
- Vehicle surges during cruise.
- Rough idle.
- DTC P0300 (misfire detected).

Too little or no EGR flow may allow combustion temperatures to get too high. This could cause:

- Spark knock (detonation).
- Engine overheating.
- Emission test failure.
- DTC P0401 (EGR flow test).
- Poor fuel economy.



0017

### EGR Pintle Position Sensor

The PCM monitors the EGR valve pintle position input to ensure that the valve responds properly to commands from the PCM and to detect a fault if the pintle position



sensor and control circuits are open or shorted. If the PCM detects a pintle position signal voltage outside the normal range of the pintle position sensor, or a signal voltage that is not within a tolerance considered acceptable for proper EGR system operation, the PCM will set DTC P1406.

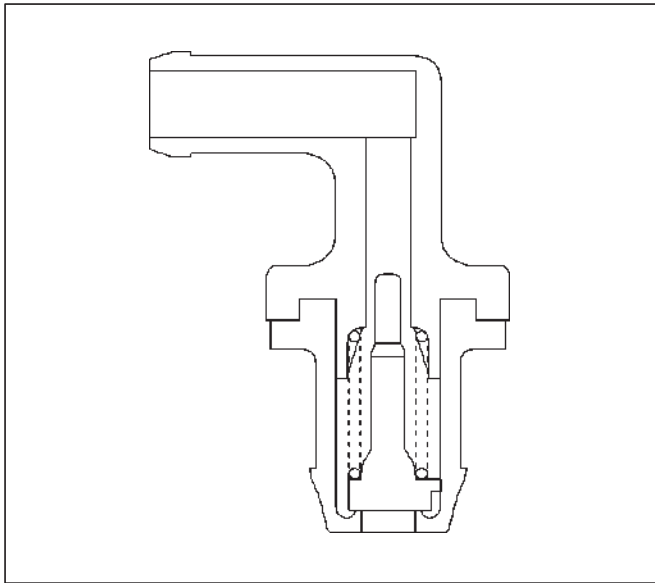
## General Description (Positive Crankcase Ventilation (PCV) System)

### Crankcase Ventilation System Purpose

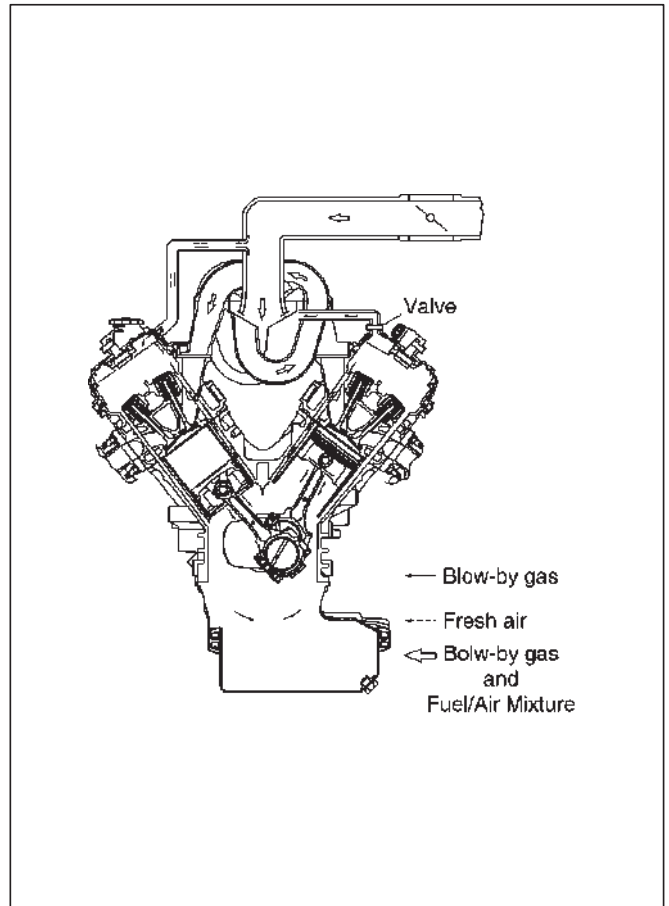
The crankcase ventilation system is used to consume crankcase vapors in the combustion process instead of venting them to the atmosphere. Fresh air from the throttle body is supplied to the crankcase and mixed with blow-by gases. This mixture is then passed through the positive crankcase ventilation (PCV) valve into the common chamber.

### Crankcase Ventilation System Operation

The primary control is through the positive crankcase ventilation (PCV) valve. The PCV valve meters the flow at a rate that depends on the intake vacuum. The PCV valve restricts the flow when the inlet vacuum is highest. The PCV valve can seal the common chamber off in case of sudden high pressure in the crankcase.



While the engine is running, exhaust gas and small amounts of the fuel/air mixture escape past the piston rings and enter the crankcase. These gases are mixed with clean air entering through a tube from the air intake duct.



During normal, part-throttle operation, the system is designed to allow crankcase gases to flow through the PCV valve into the throttle body to be consumed by normal combustion.

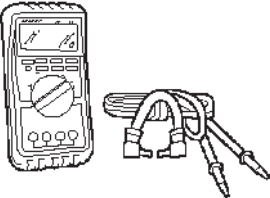
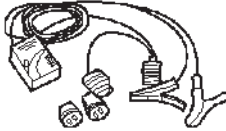
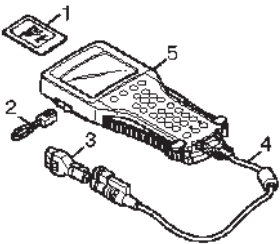
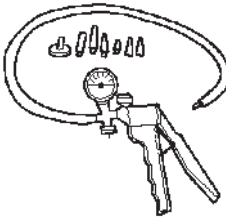
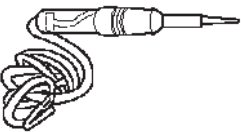
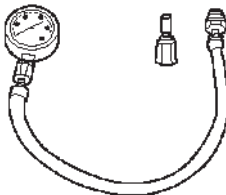

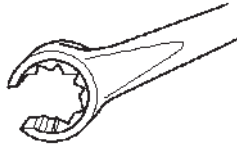
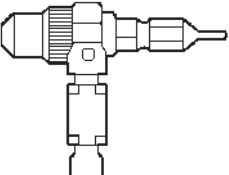



A plugged valve or PCV hose may cause the following conditions:

- Rough idle.
- Stalling of slow idle speed.
- Oil leaks.
- Sludge in the engine.

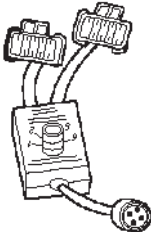
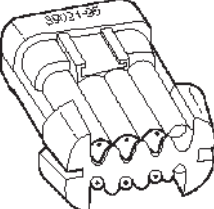
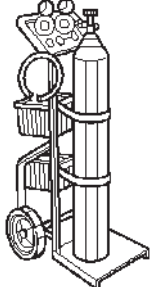
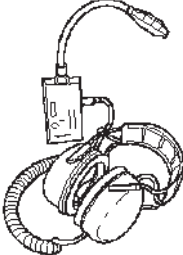
A leaking PCV hose would cause:

- Rough idle.
- Stalling.
- High idle speed.

**Special Tools**

ILLUSTRATION	TOOL NO. TOOL NAME	ILLUSTRATION	TOOL NO. TOOL NAME
	<p><b>J 39200</b> High Impedance Multimeter (Digital Voltmeter – DVM)</p>		<p><b>J 37027-A</b> IAC Motor Analyzer</p>
	<p>(1) PCMCIA Card (2) RS232 Loop Back Connector (3) SAE 16/19 Adapter (4) DLC Cable (5) TECH-2</p>		<p><b>J 23738-A</b> Vacuum Pump with Gauge</p>
	<p><b>J 34142-B</b> Unpowered Test Light</p>		<p><b>BT-8515/8515V</b> Exhaust Back Pressure Tester</p>
	<p>Connector Test Adapter Kit J 35616-A/BT-8637</p>		<p><b>J 39194-B</b> Heated Oxygen Sensor Wrench</p>
	<p><b>J 26792/BT-7220-1</b> Spark Tester</p>		<p><b>J 35689-A</b> Terminal Remover</p>
	<p><b>J 34730-E</b> Port Fuel Injection Diagnostic Kit</p>		<p><b>J 28742-A</b> Weather Pack II Terminal Remover</p>

6E-506 6VE1 3.5L ENGINE DRIVEABILITY AND EMISSIONS

ILLUSTRATION	TOOL NO. TOOL NAME
	<p><b>J 39021-90</b> Injector Switch Box</p>
	<p><b>J 39021-65</b> Injector Test Light</p>
	<p><b>J 41413<sup>1</sup></b> EVAP Pressure/Purge Diagnostic Station</p>
	<p><b>J 41416<sup>2</sup></b> Ultrasonic Leak Detector</p>

1. J 41413 EVAP Pressure/Purge Diagnostic Station is a multipurpose tool which is used to perform several diagnostic procedures for enhanced emission testing. The station will accommodate a nitrogen gas filled cylinder which is used to pressurize the vehicle EVAP system for a leakdown test and leak location test when a vehicle is repaired for leakage in the enhanced evaporative emission control system. It also has two additional gauges (inches of mercury and inches of water) which are used to measure both source vacuum and EVAP canister purge vacuum to verify correct operation and vapor flow within the canister purge circuit.
2. J 41416 Ultrasonic Leak Detector is a microprocessor-based device used to detect leaks in the enhanced evaporative emission control system. The evaporative system is pressurized to 30 inches of water using the J 41413 EVAP Pressure/Purge Diagnostic System. Small leaks in the EVAP system will emit sound at a high frequency undetectable by a human ear but detectable with the J 41416. The technician traces along the evaporative system and can pinpoint leaks due to corroded lines, cracked hoses, or a damaged EVAP component. The detector includes a high quality set of headphones to block out surrounding shop noise and the LED sensitivity meter allows a visual reference for locating leaks in conjunction with the audio output heard through the headphones. Powered by (1) nine volt battery.

VEHICROSS

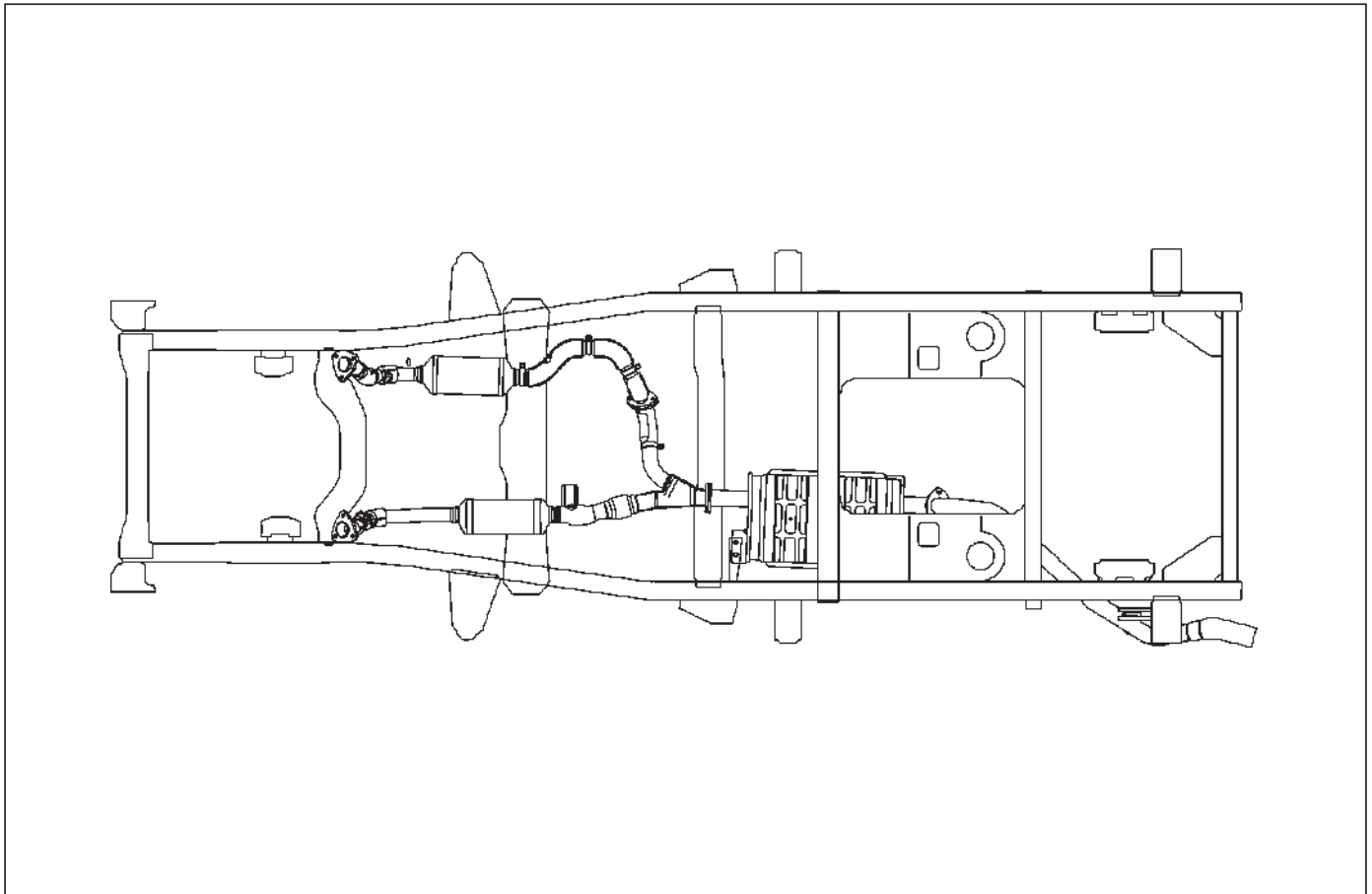
# ENGINE

## ENGINE EXHAUST

### CONTENTS

General Description .....	6F-2	Exhaust Silencer and Associated Parts ...	6F-5
Three Way Catalytic Converter LH .....	6F-3	Removal .....	6F-5
Removal .....	6F-3	Installation .....	6F-5
Installation .....	6F-3	Rear Exhaust pipe .....	6F-6
Three Way Catalytic Converter RH .....	6F-4	Rear Exhaust pipe and Associated Parts .	6F-6
Removal .....	6F-4	Removal .....	6F-6
Installation .....	6F-4	Installation .....	6F-6
Exhaust Silencer .....	6F-5	Main Data and Specifications .....	6F-7

## General Description



150RX005

When inspecting or replacing exhaust system components, make sure there is adequate clearance from all points on the underbody to prevent overheating the floor pan and possible damage to the passenger compartment insulation and trim materials.

Check complete exhaust system and nearby body areas and rear compartment lid for broken, damaged, missing or mispositioned parts, open seams, holes, loose connections or other deterioration which could permit exhaust fumes to seep into the rear compartment or passenger compartment. Dust or water in the rear compartment may be an indication of a problem in one of these areas. Any faulty areas should be corrected immediately.

### Hangers

Various types of hangers are used to support exhaust system(s). These include conventional rubber straps, rubber rings, and rubber blocks.

The installation of exhaust system supports is very important, as improperly installed supports can cause annoying vibrations which can be difficult to diagnose.

### Three Way Catalytic Converter

The three way catalytic converter is an emission control device added to the exhaust system to reduce pollutants from the exhaust gas stream.

**CAUTION: The catalytic converter requires the use of unleaded fuel only.**

Periodic maintenance of the exhaust system is not required. If the vehicle is raised for other service, it is advisable to check the condition of the complete exhaust system.

A dual bed monolith catalytic converter is used in combination with three way catalytic converter.

Catalytic Types:

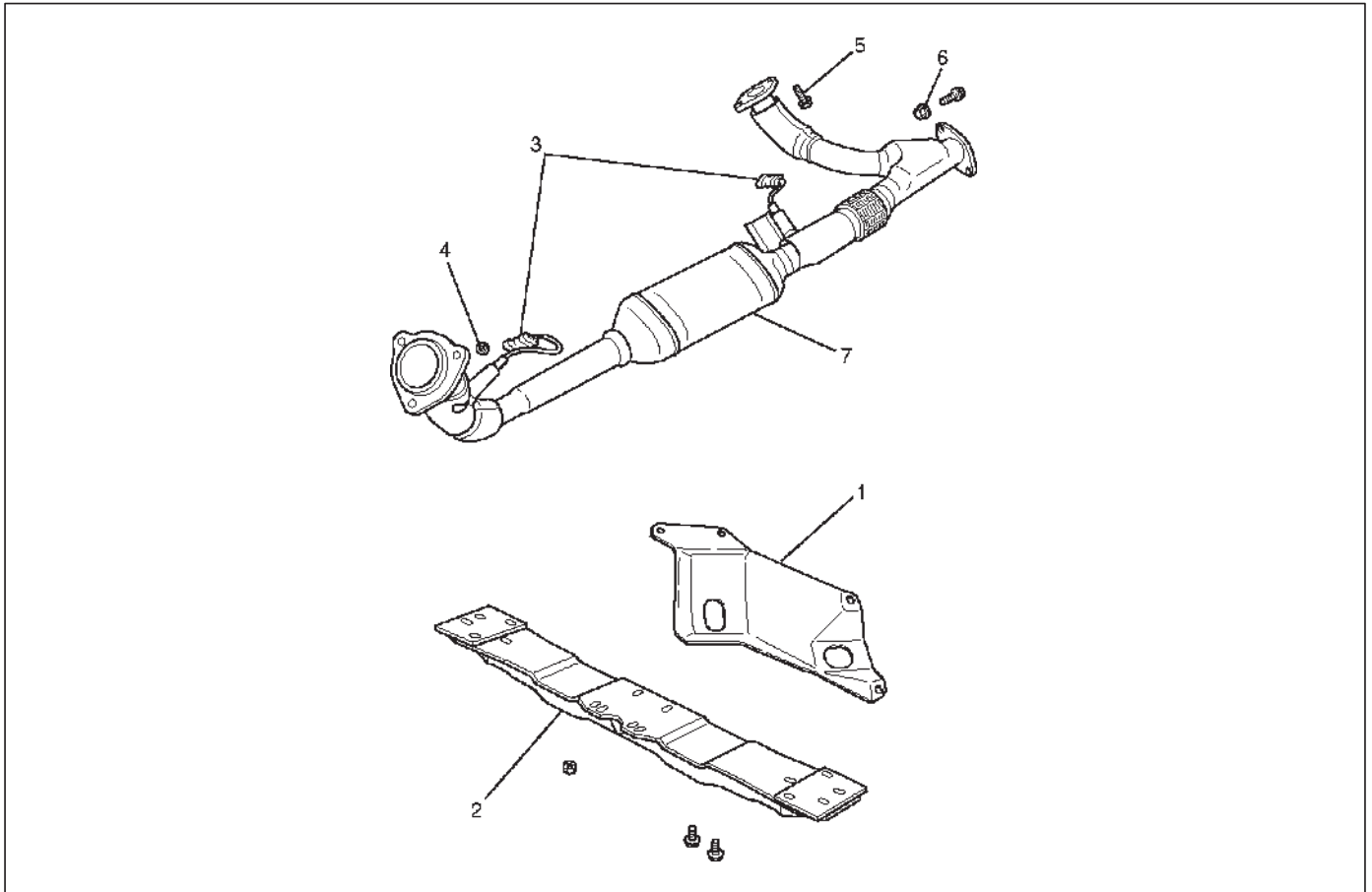
Three way (Reduction/Oxidation) catalyst

The catalyst coating on the three way (reduction) converter contains platinum and rhodium which lowers the levels of nitrous oxide (NO<sub>x</sub>) as well as hydrocarbons (HC) and carbon monoxide (Co).

### Gasket

The gasket must be replaced whenever a new exhaust pipe, muffler or catalytic converter is installed.

## Three Way Catalytic Converter LH



035RX010

### Legend

- |                                  |   |
|----------------------------------|---|
| (1) Transfer Under Cover         | (4) Front Exhaust Pipe Fixing Three Stud Nuts   |
| (2) 3rd Crossmember              | (5) Front Exhaust Pipe RH Fixing Bolts and Nuts |
| (3) O2 Sensor Harness Connectors | (6) Front Exhaust Pipe Fixing Bolts and Nuts    |
|                                  | (7) Front Exhaust Pipe LH                       |

### Removal

1. Disconnect battery ground cable.
2. Raise the vehicle and support with suitable safety stands.
3. Remove transfer under cover (1).
4. Remove 3rd Crossmember (2).
5. Disconnect front Heated Oxygen (O<sub>2</sub>) sensor harness connector and rear O<sub>2</sub> sensor harness connector (3).
6. Remove front exhaust pipe flange three fixing stud nuts (4) from exhaust manifold side and two nuts (5)(6) from rear end of exhaust front pipe (7).

### Installation

1. Install front exhaust pipe flange (7) and tighten three studs nuts (4) and two nuts (5)(6) to the specified torque.

#### Torque

**Stud nuts : 67 N·m (49 lb ft)**

**Nuts : 43 N·m (32 lb ft)**

2. Reconnect O<sub>2</sub> sensor harness connector (3).
3. Install 3rd crossmember (2) and tighten Bolts to the specified torque.

#### Torque

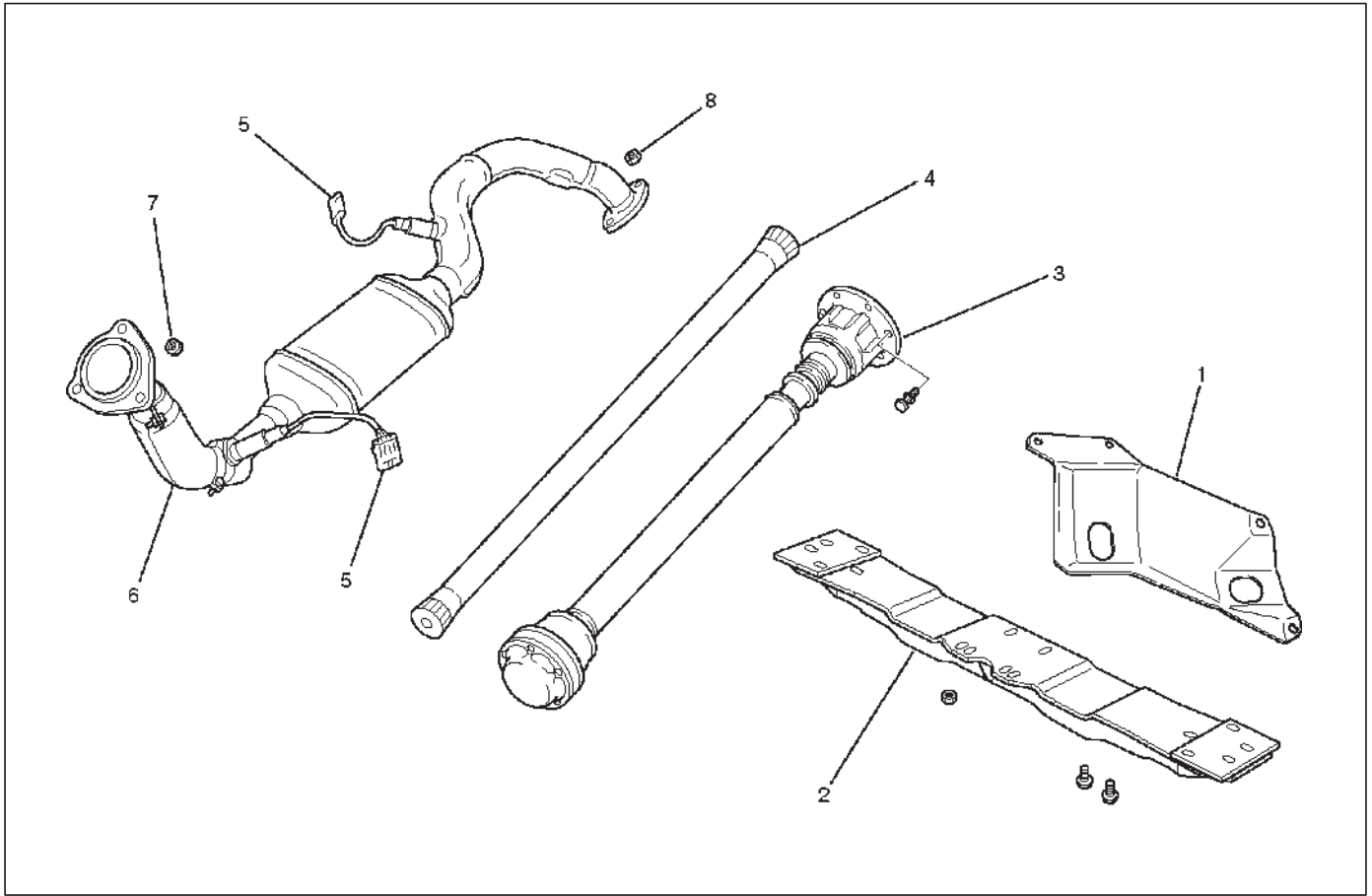
**Bolts : 50 N·m (37 lb ft)**

4. Install transfer Under Cover (1) and tighten Bolts to the specified torque.

#### Torque

**Bolts : 46 N·m (34 lb ft)**

## Three Way Catalytic Converter RH



035RX012

### Legend

- |                           |   |
|---------------------------|---|
| (1) Transfer Under Cover  | (5) O2 Sensor Harness Connectors              |
| (2) 3rd Crossmember       | (6) Front Exhaust Pipe                        |
| (3) Front Propeller Shaft | (7) Front Exhaust Pipe Fixing Three Stud Nuts |
| (4) Torsion Bar           | (8) Front Exhaust Pipe Fixing Bolts and Nuts  |

### Removal

1. Disconnect battery ground cable.
2. Raise the vehicle and support with suitable safety stands.
3. Remove torsion bar (4). Refer to removal procedure in Front Suspension section.
4. Remove transfer under cover (1).
5. Remove 3rd crossmember (2).
6. Remove front propeller shaft (3).
7. Disconnect front Heated Oxygen (O<sub>2</sub>) sensor harness connectors (5).
8. Remove front exhaust pipe fixing nuts (8).
9. Remove three stud nuts (7) from exhaust manifold then remove the exhaust front pipe (6).

### Installation

1. Install front exhaust pipe (6) and tighten three stud nuts (7) and two nuts (8) to the specified torque.

#### Torque

**Stud nuts : 67 N·m (49 lb ft)**

**Nuts : 43 N·m (32 lb ft)**

2. Reconnect O<sub>2</sub> sensor harness connector (5).

3. Install front propeller shaft (3) and tighten Bolts to the specified torque.

#### Torque

**Bolts : 63 N·m (46 lb ft)**

4. Install 3rd crossmember (2) and tighten Bolts to the specified torque.

#### Torque

**Bolts : 50 N·m (37 lb ft)**

5. Install transfer under cover (1) and tighten Bolts to the specified torque.

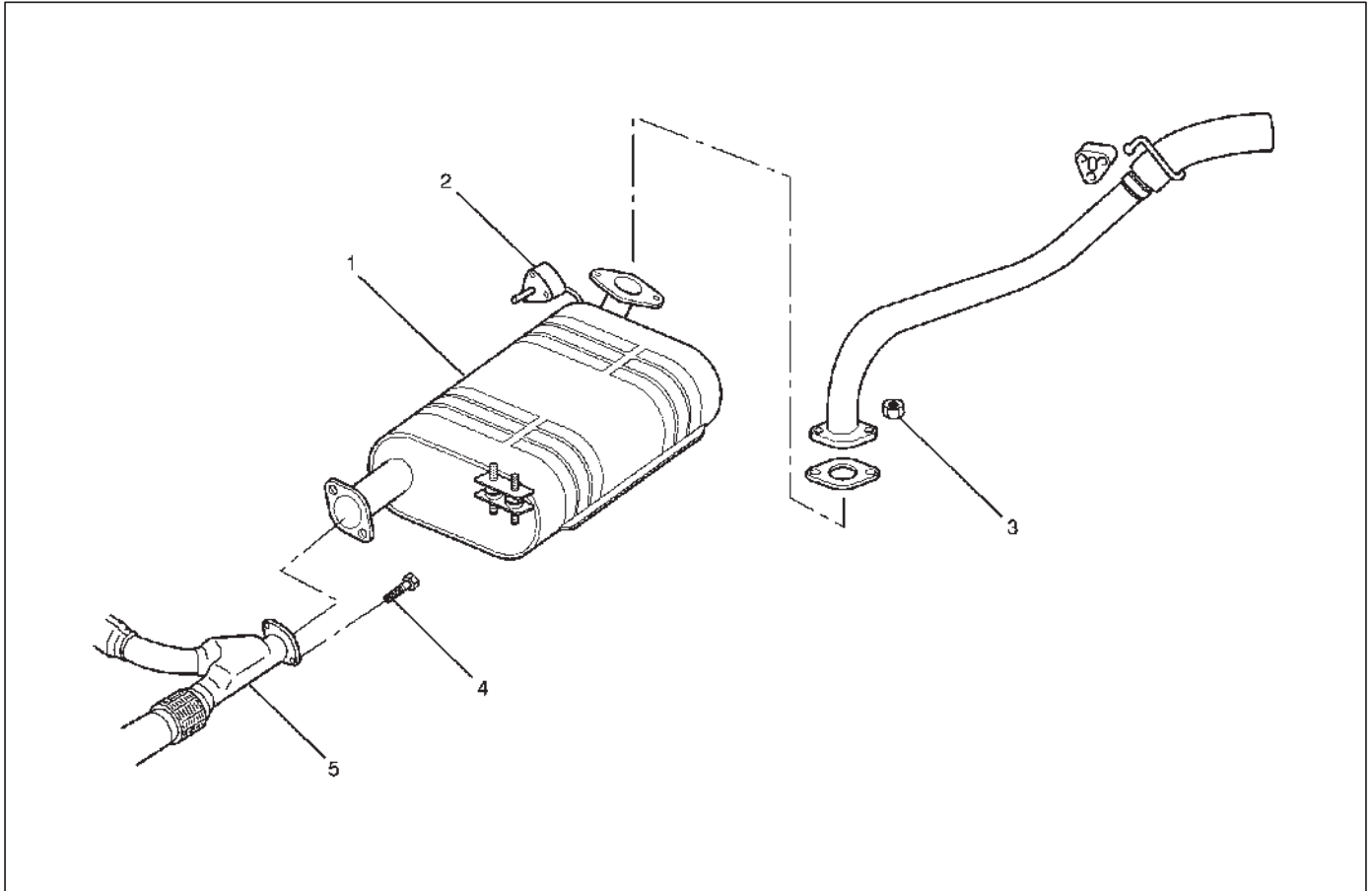
**Torque**

**Bolts : 46 N·m (34 lb ft)**

6. Install the torsion bar (4) and readjust the vehicle height. Refer to the installation and vehicle height adjustment instructions in the Front Suspension Section.

## Exhaust Silencer

### Exhaust Silencer and Associated Parts



E06RX003

**Legend**

- (1) Exhaust Silencer
- (2) Mounting Rubber

- (3) Exhaust Silencer Fixing Nuts
- (4) Exhaust Silencer Fixing Bolts
- (5) Exhaust Front Pipe

### Removal

1. Disconnect battery ground cable.
2. Raise the vehicle and support with suitable safety stands.
3. Remove exhaust silencer fixing nuts (3) then disconnect rear exhaust pipe from exhaust silencer.
4. Remove exhaust silencer fixing bolts (4) then disconnect exhaust silencer from front exhaust pipe (5).
5. Remove exhaust silencer mounting nuts from chassis side then remove exhaust silencer (1).

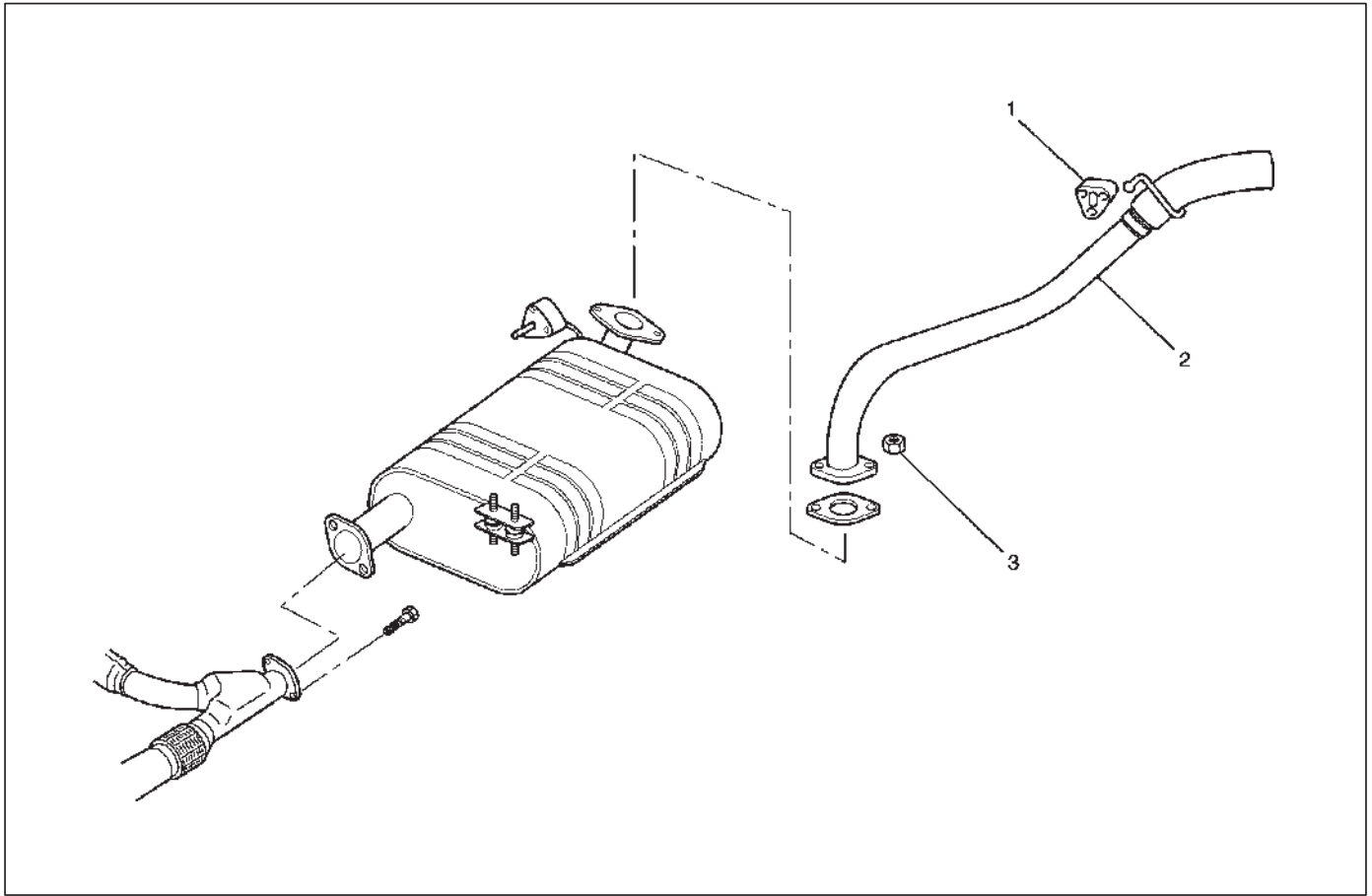
### Installation

1. Install the exhaust silencer (1) chassis side and tighten four nuts to the specified torque.  
**Nuts: 16 N·m (12 lb ft)**
2. Install the exhaust silencer and tighten two bolts (4) on front exhaust pipe to specified torque.  
**Bolts: 43 N·m (32 lb ft)**
3. Install the rear exhaust pipe and tighten on exhaust silencer to specified torque.  
**Nuts: 43 N·m (32 lb ft)**



## Rear Exhaust pipe

### Rear Exhaust pipe and Associated Parts



E06RX004

#### Legend

(1) Mounting Rubber

(2) Rear Exhaust Pipe

(3) Rear Exhaust Pipe Fixing Nuts

### Removal

1. Disconnect battery ground cable.
2. Raise the vehicle and support with suitable safety stands.
3. Remove rear exhaust pipe fixing nuts (3), then disconnect rear exhaust pipe from exhaust silencer.
4. Remove mounting rubber (1).
5. Remove rear exhaust pipe (2).

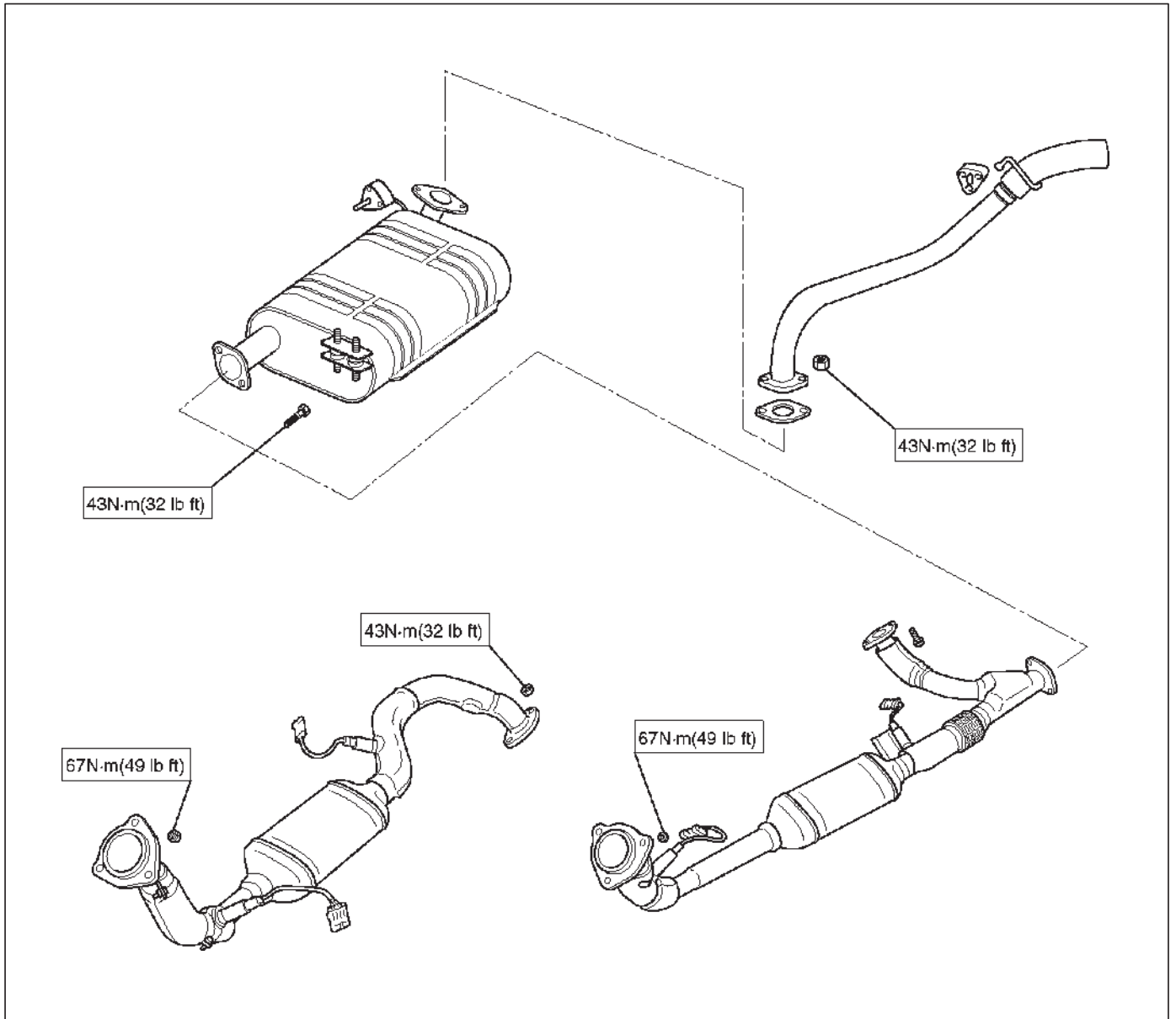
### Installation

1. Install the mounting rubber (1).
2. Install the exhaust pipe (2) and tighten two nuts (3) on exhaust silencer to specified torque.

**Nuts: 43 N·m (32 lb ft)**

# Main Data and Specifications

## Torque Specifications



VEHICROSS

# ENGINE

## ENGINE LUBRICATION

### CONTENTS

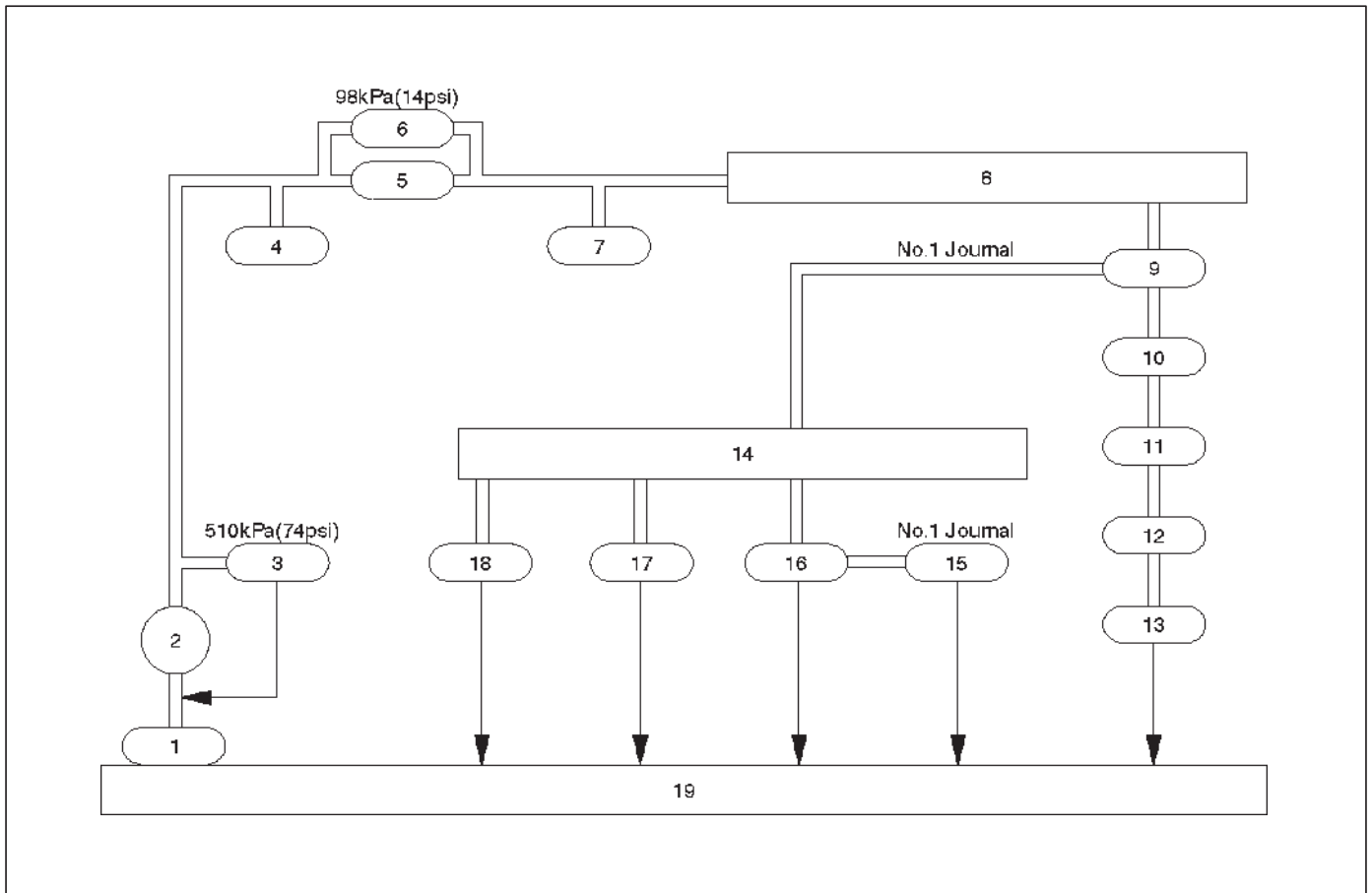
Service Precaution .....	6G-1	Removal .....	6G-9
General Description .....	6G-2	Installation .....	6G-9
Oil Pump .....	6G-3	Oil Pump Oil Seal .....	6G-11
Oil Pump and Associated Parts .....	6G-3	Removal .....	6G-11
Oil Pump and Associated Parts .....	6G-3	Installation .....	6G-11
Inspection and Repair .....	6G-4	Oil Filter .....	6G-12
Reassembly .....	6G-5	Removal .....	6G-12
Oil Pan and Crankcase .....	6G-7	Installation .....	6G-12
Removal .....	6G-7	Main Data and Specification .....	6G-13
Installation .....	6G-7	Special Tool .....	6G-14
Oil Pump .....	6G-9		

### Service Precaution

**WARNING: THIS VEHICLE HAS A SUPPLEMENTAL RESTRAINT SYSTEM (SRS). REFER TO THE SRS COMPONENT AND WIRING LOCATION VIEW IN ORDER TO DETERMINE WHETHER YOU ARE PERFORMING SERVICE ON OR NEAR THE SRS COMPONENTS OR THE SRS WIRING. WHEN YOU ARE PERFORMING SERVICE ON OR NEAR THE SRS COMPONENTS OR THE SRS WIRING, REFER TO THE SRS SERVICE INFORMATION. FAILURE TO FOLLOW WARNINGS COULD RESULT IN POSSIBLE AIR BAG DEPLOYMENT, PERSONAL INJURY, OR OTHERWISE UNNEEDED SRS SYSTEM REPAIRS.**

**CAUTION:** Always use the correct fastener in the proper location. When you replace a fastener, use **ONLY** the exact part number for that application. ISUZU will call out those fasteners that require a replacement after removal. ISUZU will also call out the fasteners that require thread lockers or thread sealant. **UNLESS OTHERWISE SPECIFIED**, do not use supplemental coatings (Paints, greases, or other corrosion inhibitors) on threaded fasteners or fastener joint interfaces. Generally, such coatings adversely affect the fastener torque and the joint clamping force, and may damage the fastener. When you install fasteners, use the correct tightening sequence and specifications. Following these instructions can help you avoid damage to parts and systems.

General Description



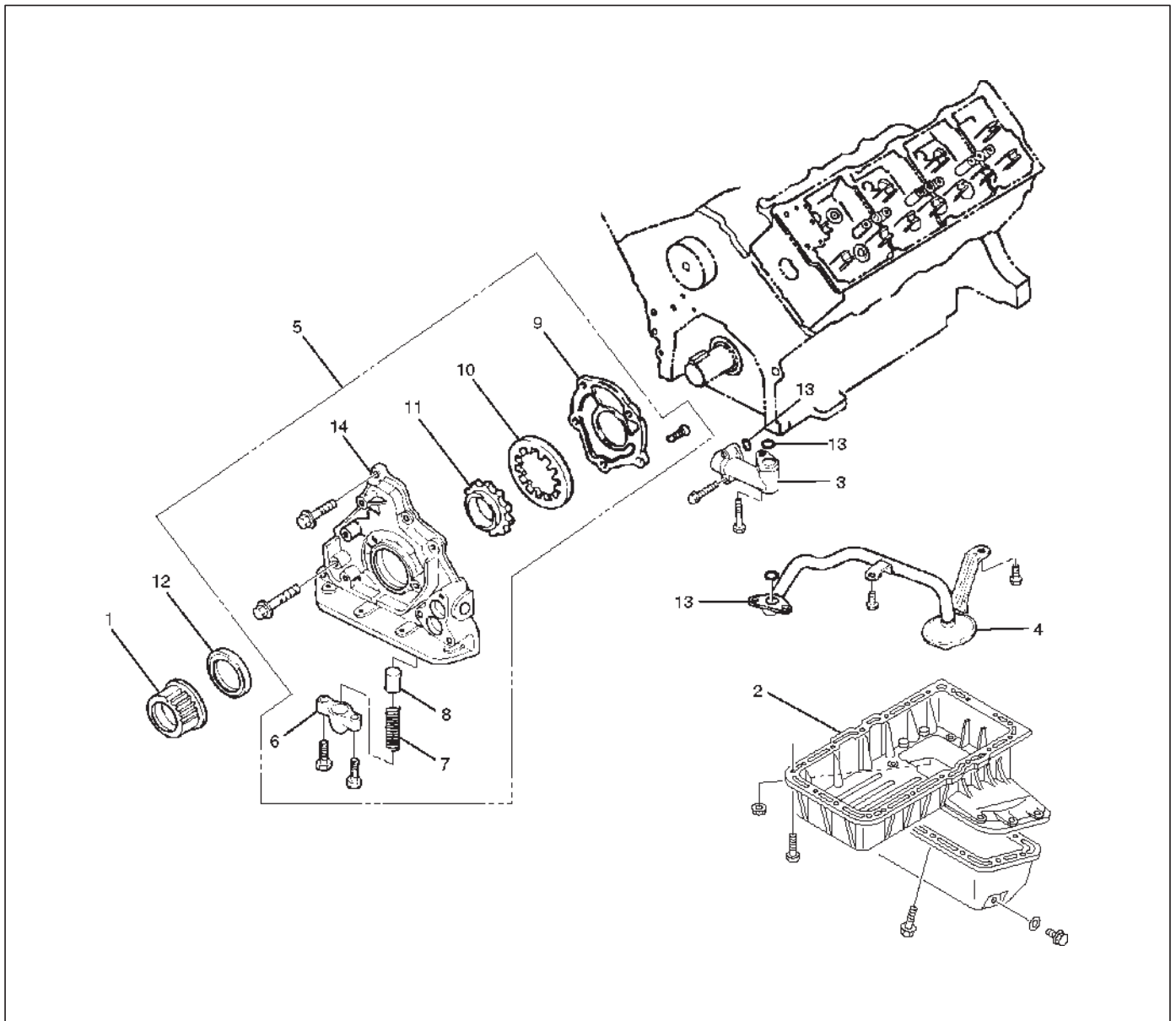
C06RW002

Legend

- |                         |   |
|-------------------------|---|
| (1) Oil Strainer        | (10) Crankshaft                         |
| (2) Oil Pump            | (11) Connecting Rod Bearing             |
| (3) Relief Valve        | (12) Connecting Rod                     |
| (4) Oil Pressure Switch | (13) Piston                             |
| (5) Oil Filter          | (14) Oil Gallery; Cylinder Head         |
| (6) Safety Valve        | (15) Camshaft                           |
| (7) Oil Pressure Unit   | (16) Camshaft Journal                   |
| (8) Oil Gallery         | (17) Front Journal; Camshaft Drive Gear |
| (9) Crankshaft Bearing  | (18) Rear Journal; Camshaft Drive Gear  |
|                         | (19) Oil Pan                            |

# Oil Pump

## Oil Pump and Associated Parts



051RW005

### Legend

- |                              |                    |
|------------------------------|--------------------|
| (1) Crankshaft Timing Pulley | (8) Relief Valve   |
| (2) Crankcase with Oil Pan   | (9) Oil Pump Cover |
| (3) Oil Pipe                 | (10) Driven Gear   |
| (4) Oil Strainer             | (11) Drive Gear    |
| (5) Oil Pump Assembly        | (12) Oil Seal      |
| (6) Plug                     | (13) O-ring        |
| (7) Spring                   | (14) Oil Pump Body |

## Oil Pump and Associated Parts

1. Remove crankshaft timing pulley.
2. Remove crankcase with oil pan.
3. Remove oil pipe.
4. Remove oil strainer.
5. Remove oil pump assembly.
6. Remove plug.
7. Remove spring.
8. Remove relief valve.
9. Remove oil pump cover.
10. Remove driven gear.

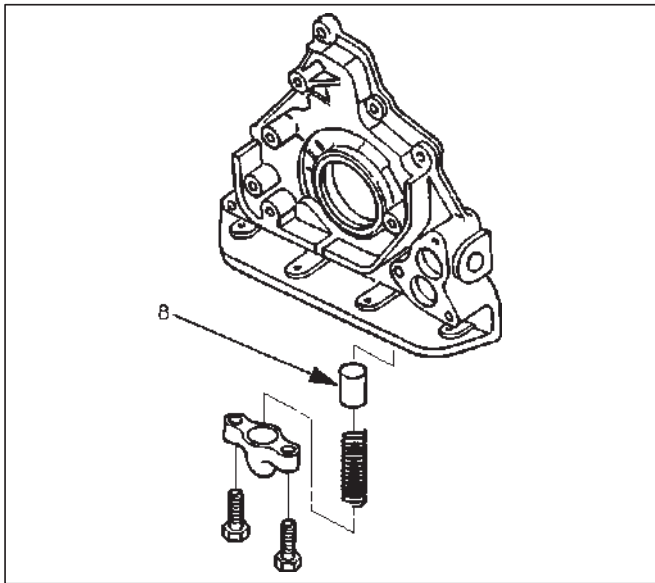
11. Remove drive gear.
12. Remove oil seal.
13. Remove O-ring.

## Inspection and Repair

**CAUTION:** Make necessary correction or parts replacement if wear, damage or any other abnormal conditions are found during inspection.

### Relief Valve (8)

- Check to see that the relief valve slides freely.
- The oil pump must be replaced if the relief valve does not slide freely.
- Replace the spring and/or the oil pump assembly (5) if the spring is damaged or badly worn.



### Body (14) and Gears (10, 11)

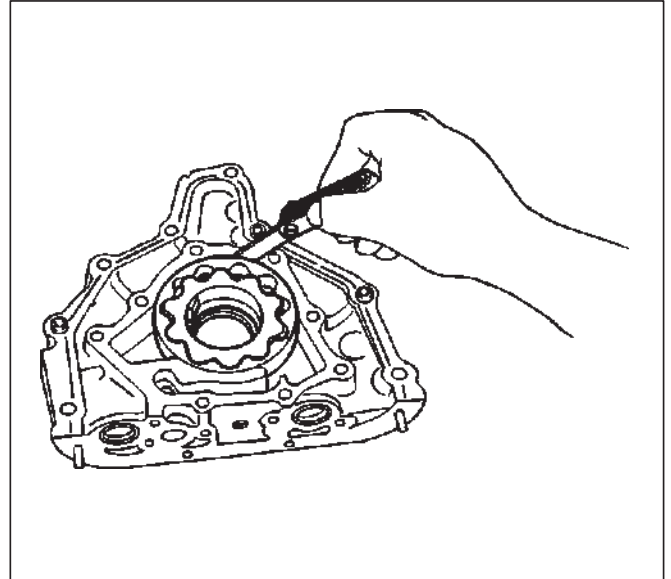
The pump assembly must be replaced if one or more of the conditions below is discovered during inspection.

- Badly worn or damaged driven gear (10).
- Badly worn drive gear (11) driving face.
- Badly scratched or scored body sliding face (14) or driven gear (10).
- Badly worn or damaged gear teeth.

Measure the clearance between the body and the driven gear with a feeler gauge.

**Standard : 0.10 mm–0.18 mm  
(0.0039 in.–0.0070 in)**

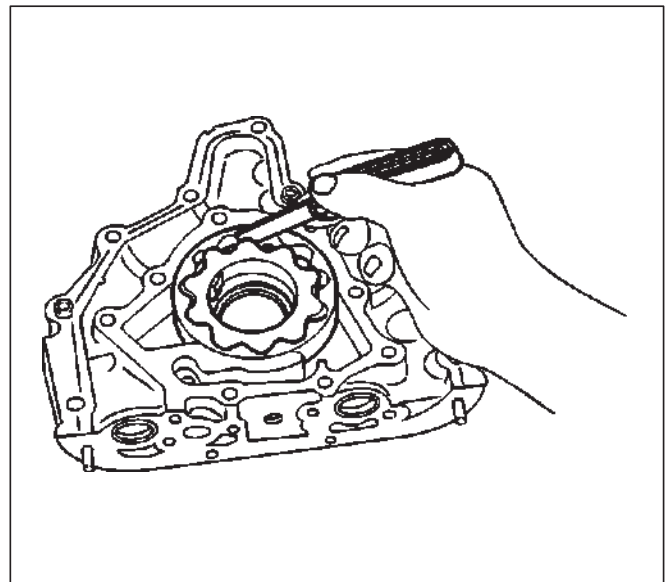
**Limit : 0.20mm (0.0079 in)**



- Measure the clearance between the drive gear and driven gear with a feeler gauge.

**Standard : 0.11 mm–0.24 mm  
(0.0043 in–0.0094 in)**

**Limit : 0.35mm (0.0138 in)**

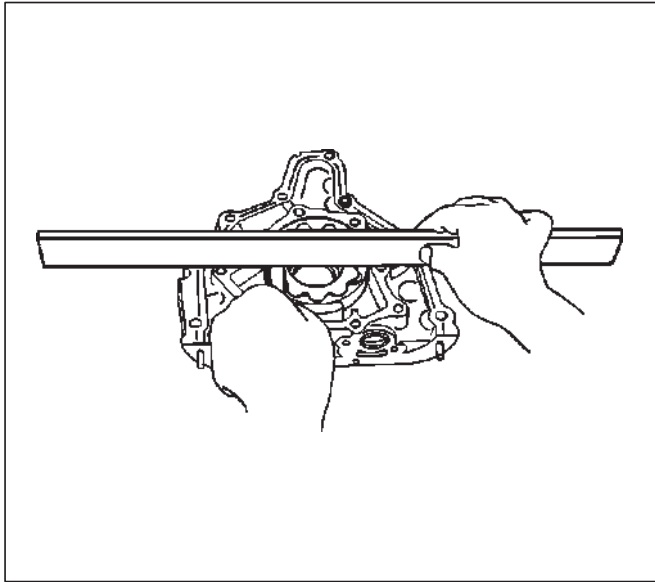


- Measure the side clearance with a precision straight edge and a feeler gauge.

**Clearance**

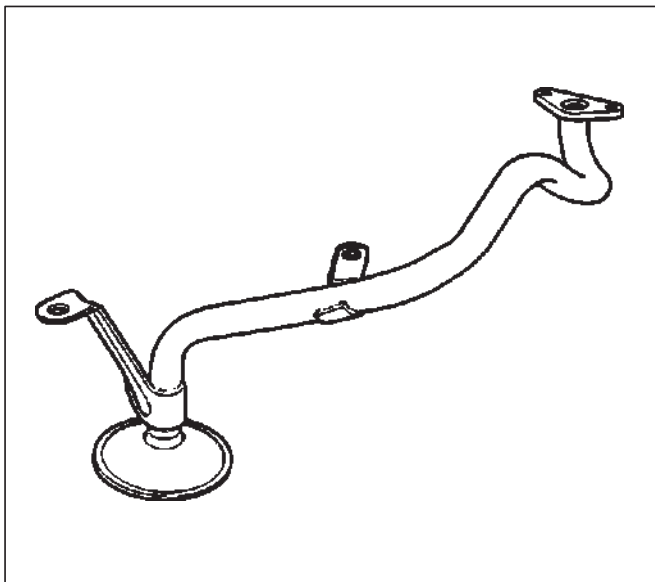
**Standard : 0.03 mm–0.09 mm  
(0.0011 in–0.0035 in)**

**Limit : 0.15mm (0.0059 in)**



**Oil Strainer**

Check the oil strainer for cracking and scoring. If cracking and scoring are found, the oil strainer must be replaced.



**Reassembly**

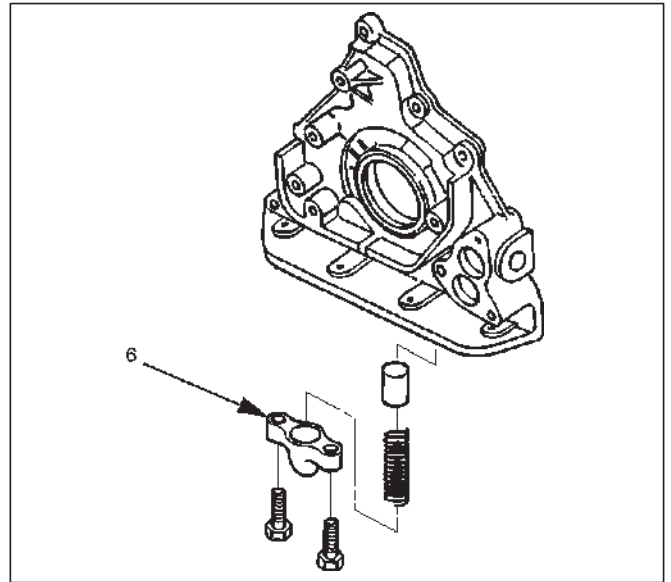
1. Install drive gear (11).
2. Install driven gear (10).
3. Install oil pump cover (9) and first, loosely tighten all of the attaching screws. Next, tighten the attaching screws to the specified torque.

**Torque : 10 N-m (89 lb in)**

After installation, check that the gear rotates smoothly.

4. Install relief valve (8) and apply engine oil to the relief valve and spring (7).
5. Install spring (7).
6. Install the plug (6).

**Torque : 8 N-m (69 lb in)**



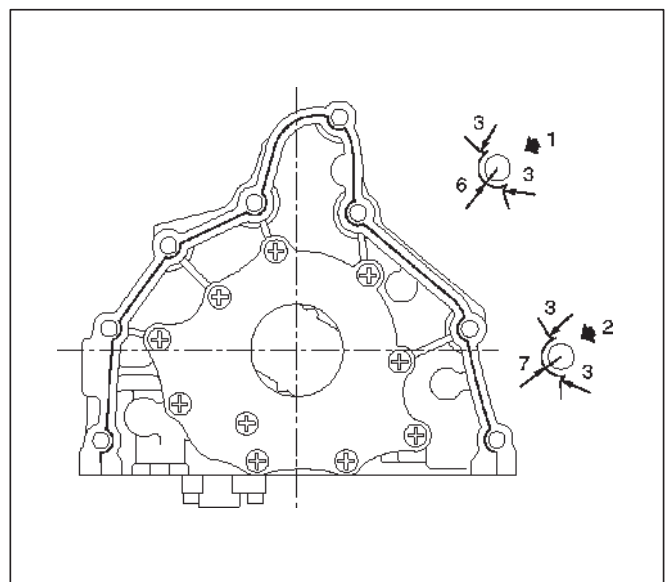
7. Install oil pump assembly (5).

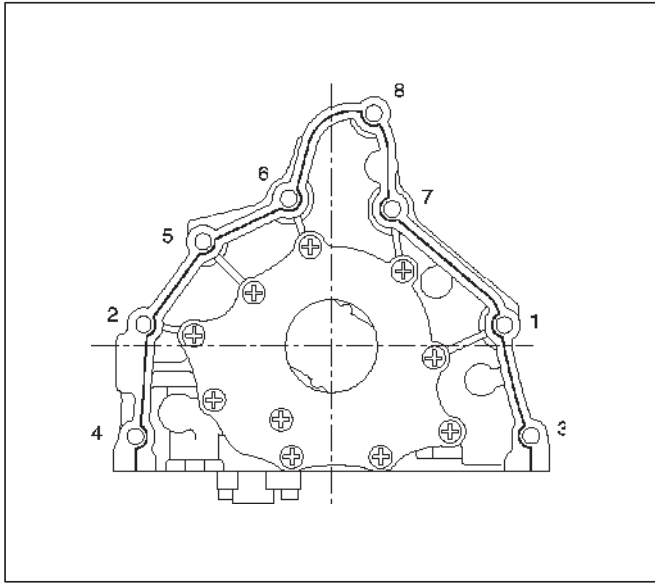
- Carefully remove any oil from the cylinder body and the pump. Apply sealant (TB-1207B or equivalent) to the pump fitting face as shown in illustration. Take care that sealant is not applied to oil port surfaces. The oil pump assembly must be installed within 5 minutes after sealant application before the sealant hardens.

**CAUTION: Do not apply an excessive amount of sealant to the contact surface. Applying too much sealant will overflow the contact surfaces. This could cause serious damage to the engine.**

- Attach oil pump assembly to cylinder body.
- Tighten the oil pump fixing bolts.

**Torque : 25 N-m (18 lb-ft)**



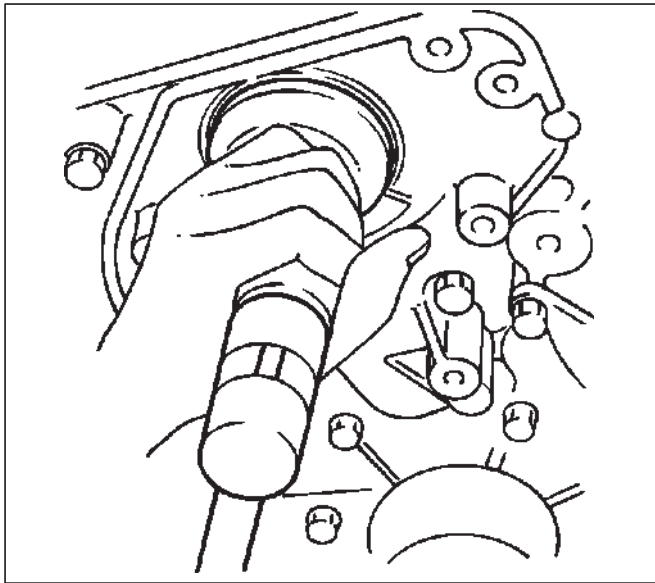


051RW001

**Legend**

- (1) Around Bolt Holes
- (2) Around Dowel Pin

8. Install the new oil seal (12). Apply engine oil to the oil seal lip before installation then use J-39202 oil seal Installer, install oil seal.



015RS001

9. Install oil strainer (4) with O-ring (13).

**Torque: 25 N-m (18 lb ft)**

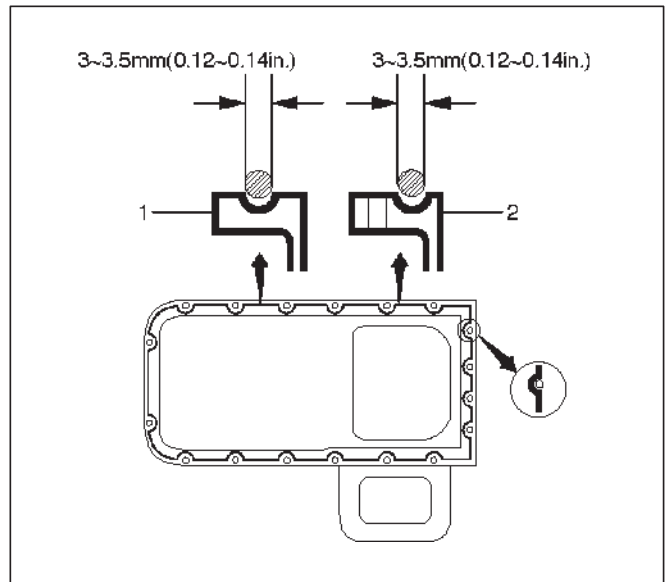
10. Install oil pipe (3) with O-ring (13).

**Torque: 25 N-m (18 lb ft)**

11. Install crankcase with oil pan (2).

- Remove oil on crankcase mounting surface and dry the surface.
- Apply a proper 4.5 mm (0.7 in) wide bead of sealant (TB1207C or equivalent) to the crankcase mounting surface. The bead must be continuous.
- The crankcase must be installed within 5 minutes after sealant application before the sealant hardens.
- Tighten fixing bolts to the specified torque.

**Torque : 10 N-m (89 lb in)**



013RW010

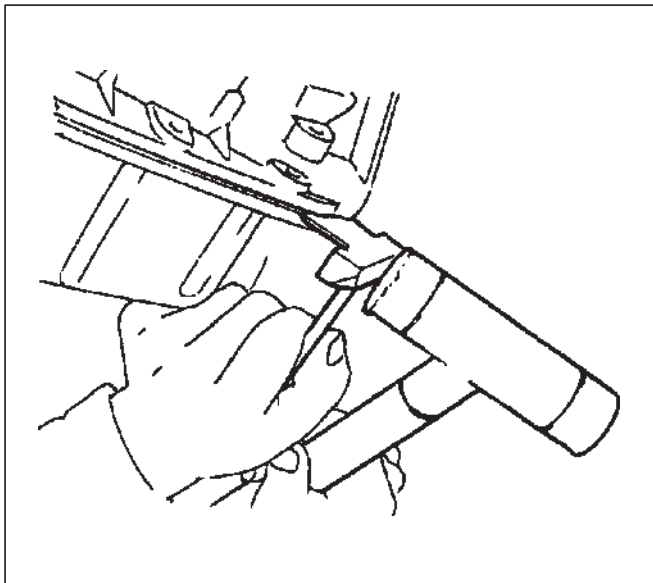
12. Install crankshaft timing pulley.



## Oil Pan and Crankcase

### Removal

1. Disconnect battery ground cable.
2. Drain engine oil.
3. Lift vehicle by supporting the frame.
4. Remove front wheels.
5. Remove oil level dipstick from level gauge tube.
6. Remove stone guard.
7. Remove radiator under fan shroud.
8. Remove suspension cross member fixing bolts, 2 pcs each per side and remove suspension cross member.
9. Remove pitman arm and relay lever assembly, using the J-29107 remover, remove pitman arm from the steering unit and remove four fixing bolts for relay lever assembly.
10. Remove axle housing assembly four fixing bolts from housing isolator side and mounting bolts from wheel side. At this time support the axle with a garage jack and remove axle housing assembly.
11. Remove oil pan fixing bolts.
12. Remove oil pan, using J-37228 sealer cutter, remove oil pan.



13. Remove crankcase fixing bolts.
14. Remove crankcase, using J-37228 sealer cutter, remove crankcase.

**NOTE:** Do not deform or damage the flange of oil pan and crankcase.

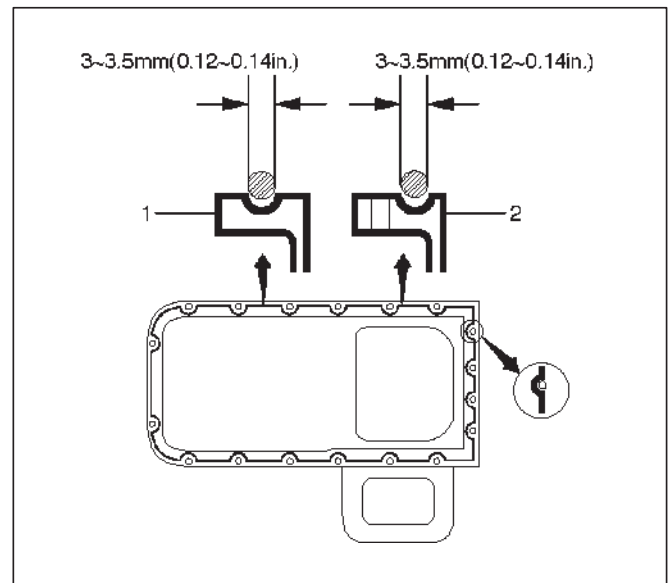
Replace the oil pan and/or crankcase if deformed or damaged.

### Installation

1. Install crankcase.
  1. Remove residual sealant, lubricant and moisture from mounting surface, then dry thoroughly.
  2. Properly apply a 4.5 mm (0.7 in) wide bead of sealant (TB-1207C or equivalent) to mounting surface of crankcase.

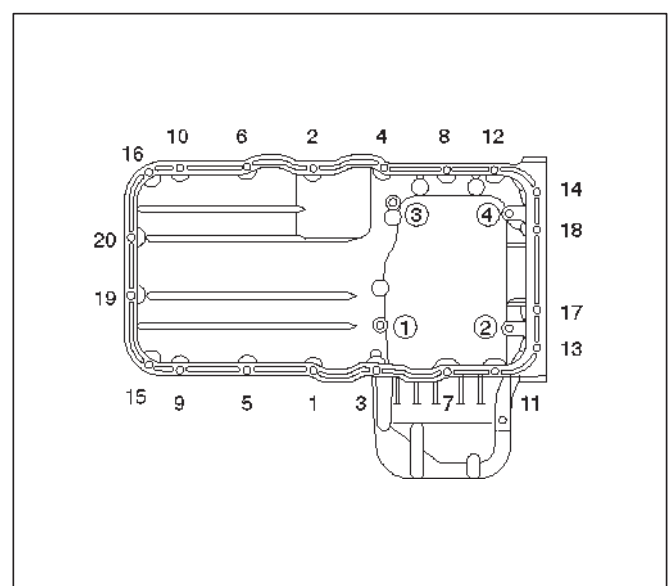
Sealant bead must be continuous.

○The crankcase must be installed within 5 minutes after sealant application before the sealant hardens.



3. Install crankcase, tighten crankcase fixing bolts to the specified torque.

**Torque : 10 N-m (89 lb in)**



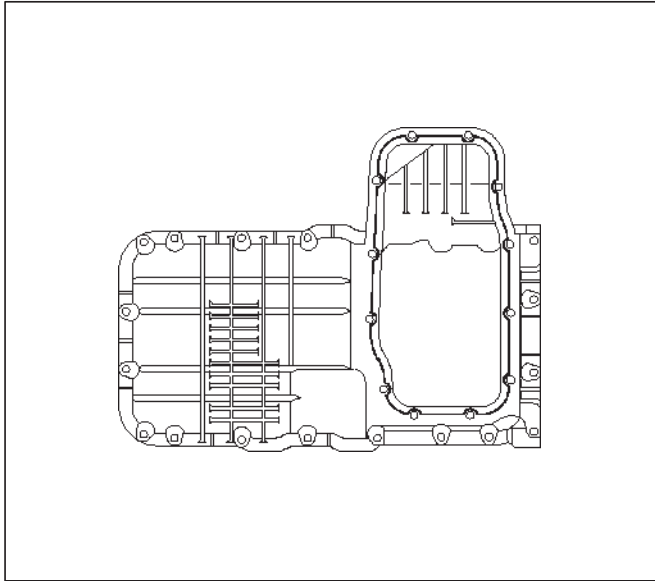
## 6G-8 ENGINE LUBRICATION

### 2. Install oil pan

1. Remove residual sealant, lubricant and moisture from mounting surface, then dry thoroughly.
2. Properly apply a 4.5 mm (0.7 in) wide bead of sealant (TB-1207C or equivalent) to mounting surface of oil pan.

Sealant bead must be continuous.

- The crankcase must be installed within 5 minutes after sealant application before the sealant hardens.



3. Install oil pan, tighten oil pan fixing bolts to the specified torque.

**Torque : 25 N-m (18 lb ft)**

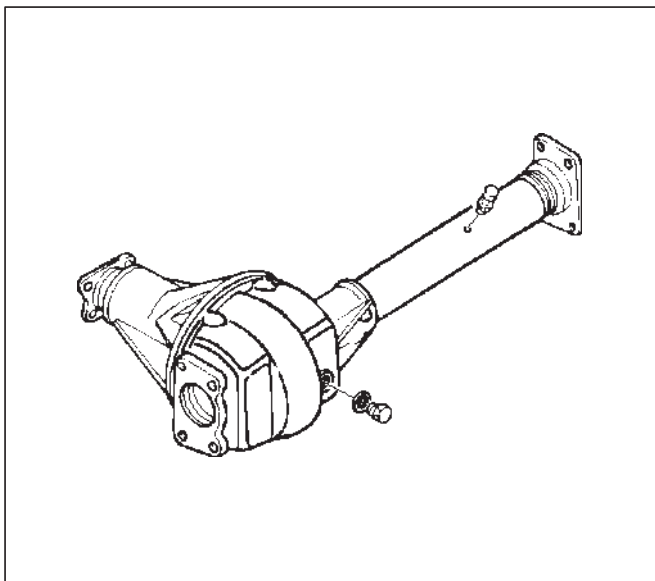
3. Install axle housing assembly and tighten fixing bolts to the specified torque.

**Axle case bolts**

**Torque : 82 N-m (60 lb ft)**

**Mounting bolts**

**Torque : 152 N-m (112 lb ft)**

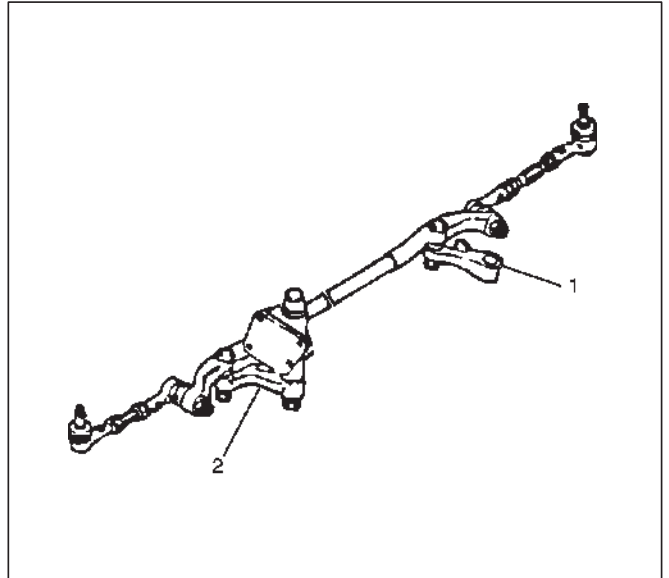


4. Install relay lever assembly and tighten fixing bolts.

**Torque: 44 N-m (32 lb ft)**

5. Engage teeth of pitman arm and steering unit, and tighten nut to the specified torque.

**Torque : 216 N-m (159 lb ft)**

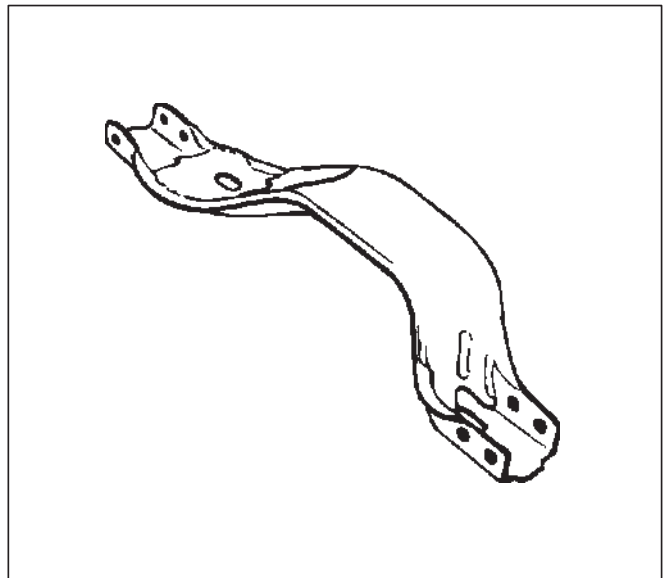


### Legend

- (1) Pitman Arm
- (2) Relay Lever

6. Install suspension cross member and tighten fixing bolts to the specified torque.

**Torque : 78 N-m (58 lb ft)**



7. Install radiator under fan shroud.

8. Install stone guard.

9. Install engine oil level dipstick.

10. Fill engine oil until full level on engine oil gauge dipstick.

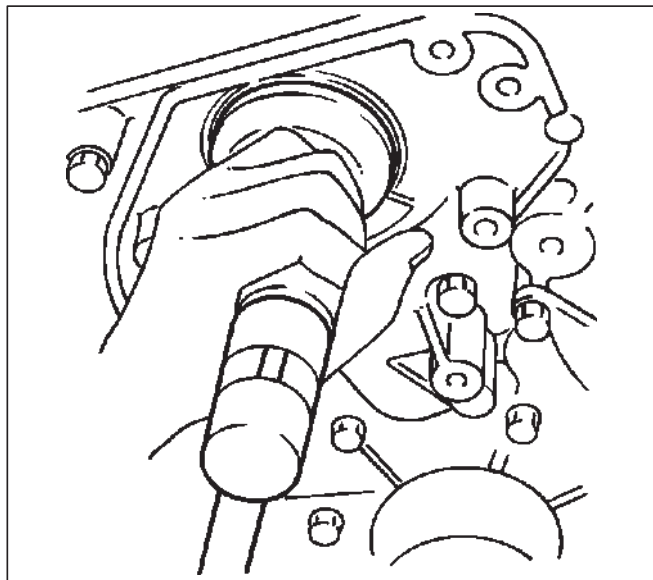
## Oil Pump

### Removal

1. Disconnect battery ground cable.
2. Drain engine oil.
3. Remove crankcase assembly.
  - Refer to removal procedure for Oil Pan and Crankcase in this manual.
4. Remove crankshaft pulley.
  - Refer to removal procedure for Crankshaft Pulley in this manual.
5. Remove timing belt.
  - Refer to removal procedure for Timing Belt in this manual.
6. Remove timing pulley from crankshaft.
7. Remove four fixing bolts from oil filter assembly.
8. Remove oil strainer fixing bolts, remove oil strainer assembly with O-ring.
9. Remove three bolts from oil pipe and O-ring.
10. Remove eight oil pump fixing bolts, then oil pump assembly.
11. Remove sealant from mounting surface of oil pump assembly, cylinder block and take care not to damage mounting surfaces of oil pump and cylinder block.

- Use J-39202 installer when installing new oil seal.
- Apply engine oil to oil seal lip.
- Install oil pump assembly to the cylinder block.

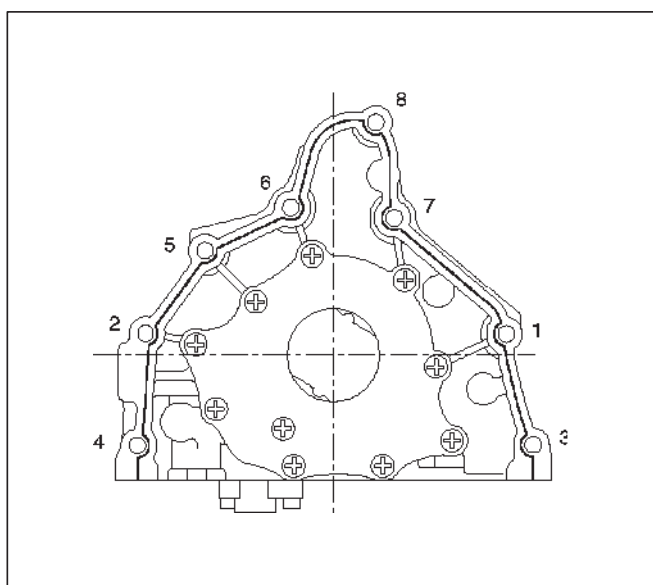
NOTE: Do not damage oil seal during installation of oil pump assembly.



015RS001

- Tighten fixing bolts to the specified torque.

**Torque : 25 N-m (18 lb ft)**



051RW001

2. Install oil pipe with O-ring, tighten fixing bolt to the specified torque.

**Torque : 10 N-m (89 lb in)**

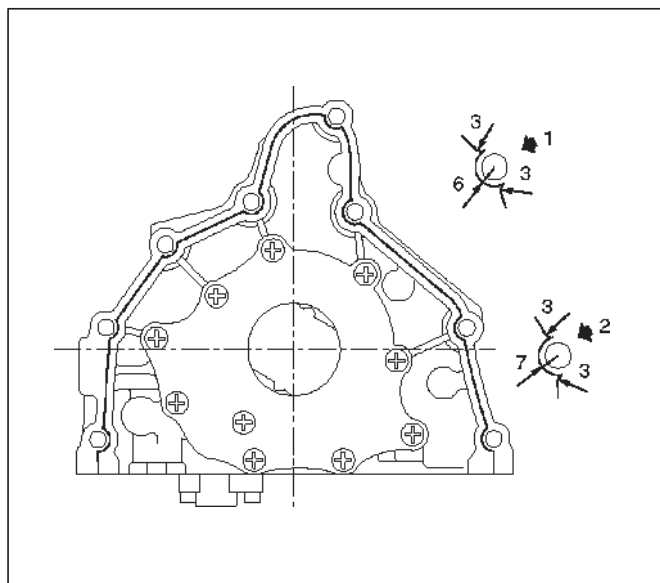
3. Install oil strainer with O-ring, tighten fixing bolt to the specified torque.

**Torque : 25 N-m (18 lb ft)**

### Installation

1. Install oil pump assembly
  - Apply sealant (TB-1207B or equivalent) to the oil pump mounting surfaces as shown in the illustration.
  - The oil pump assembly must be installed within 5 minutes after sealant application before the sealant hardens.

NOTE: Do not apply sealant to the oil ports.



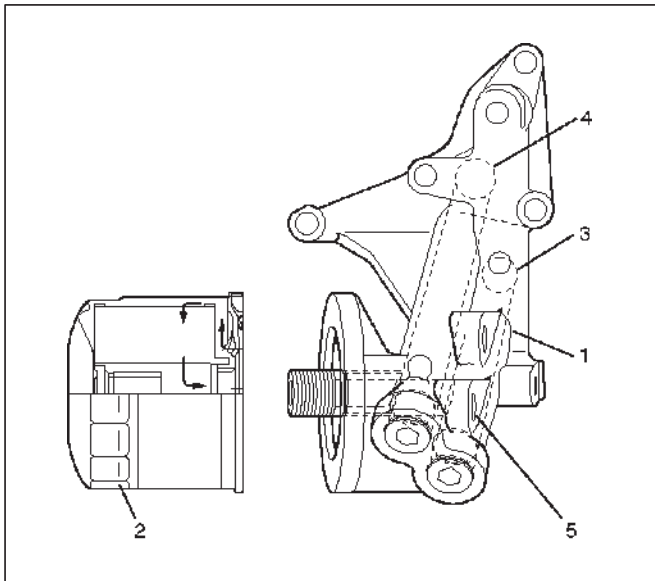
051RW002

## 6G-10 ENGINE LUBRICATION

---

4. Install oil filter assembly and tighten bolts to the specified torque.

**Torque : 25 N·m (18 lb ft)**



050RW001

### Legend

- (1) Oil Pump
- (2) Oil Filter
- (3) Oil Gallery
- (4) From Oil Filter
- (5) To Oil Filter

---

5. Install timing pulley on crankshaft.

Install timing belt.

○Refer to installation procedure for Timing Belt in this manual.

6. Install crankshaft pulley.

○Refer to install procedure for Crankshaft Pulley in this manual.

7. Install crankcase assembly.

○Refer to installation procedure for Oil Pan and Crankcase in this manual.

8. Refill engine oil until full level on engine oil dipstick.

## Oil Pump Oil Seal

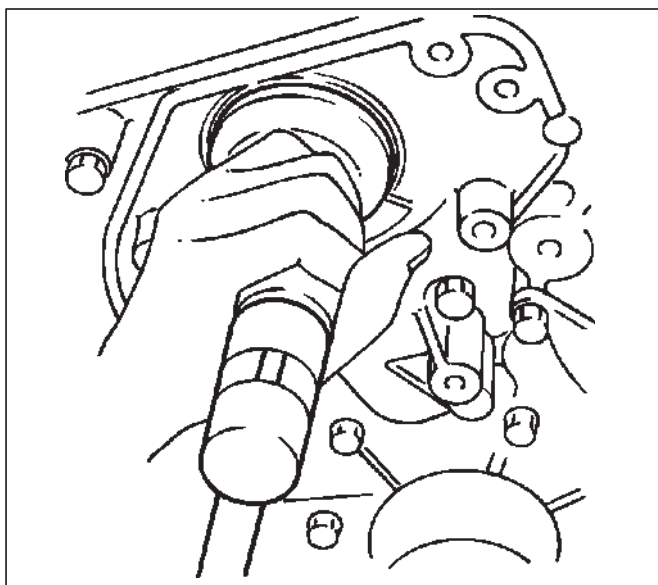
### Removal

1. Disconnect battery ground cable.
2. Drain engine oil.
3. Remove crankshaft pulley.  
○Refer to removal procedure for Crankshaft Pulley in this manual.
4. Remove timing belt.  
○Refer to removal procedure for Timing Belt in this manual.
5. Remove timing pulley from crankshaft.
6. Remove oil pump oil seal using a sealer puller.

NOTE: Take care not to damage sealing surfaces of oil pump and crankshaft when removing oil seal.

### Installation

1. Install oil pump oil seal, apply engine oil to oil seal lip, then install oil seal using J-39202 installer.



015RS001

2. Install timing pulley to crankshaft.
3. Install timing belt.  
○Refer to installation procedure for Timing Belt in this manual.
4. Install crankshaft pulley.  
○Refer to installation procedure for Crankshaft Pulley in this manual.
5. Refill engine oil until full level.

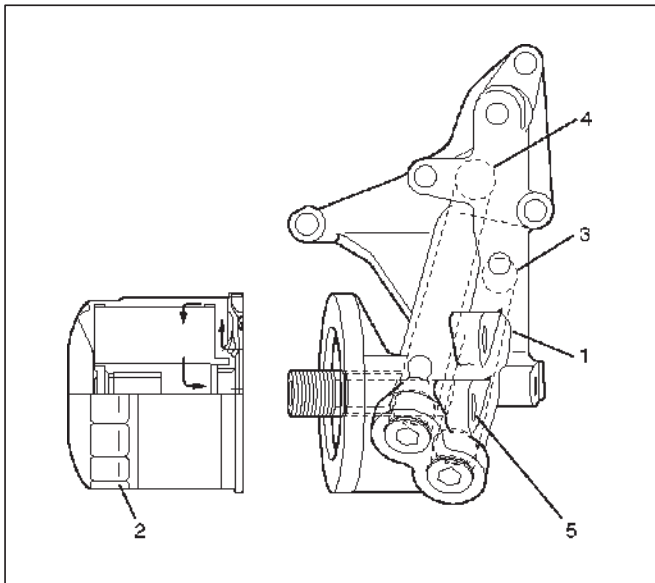
## Oil Filter

### Removal

1. Disconnect battery ground cable.
2. Drain engine oil.
3. Remove oil filter using J-36390 filter wrench.

### Installation

1. Clean filter fitting surface and apply small amount of engine oil to sealing surface.
2. Install oil filter cartridge by hand until it comes in contact with sealing surface then rotate additional 2/3 turn to tighten using J-36390 filter wrench.



### Legend

- (1) Oil Pump
- (2) Oil Filter
- (3) Oil Gallery
- (4) From Filter
- (5) To Filter

3. Fill engine oil until full level on dipstick.
4. Reconnect battery ground cable.

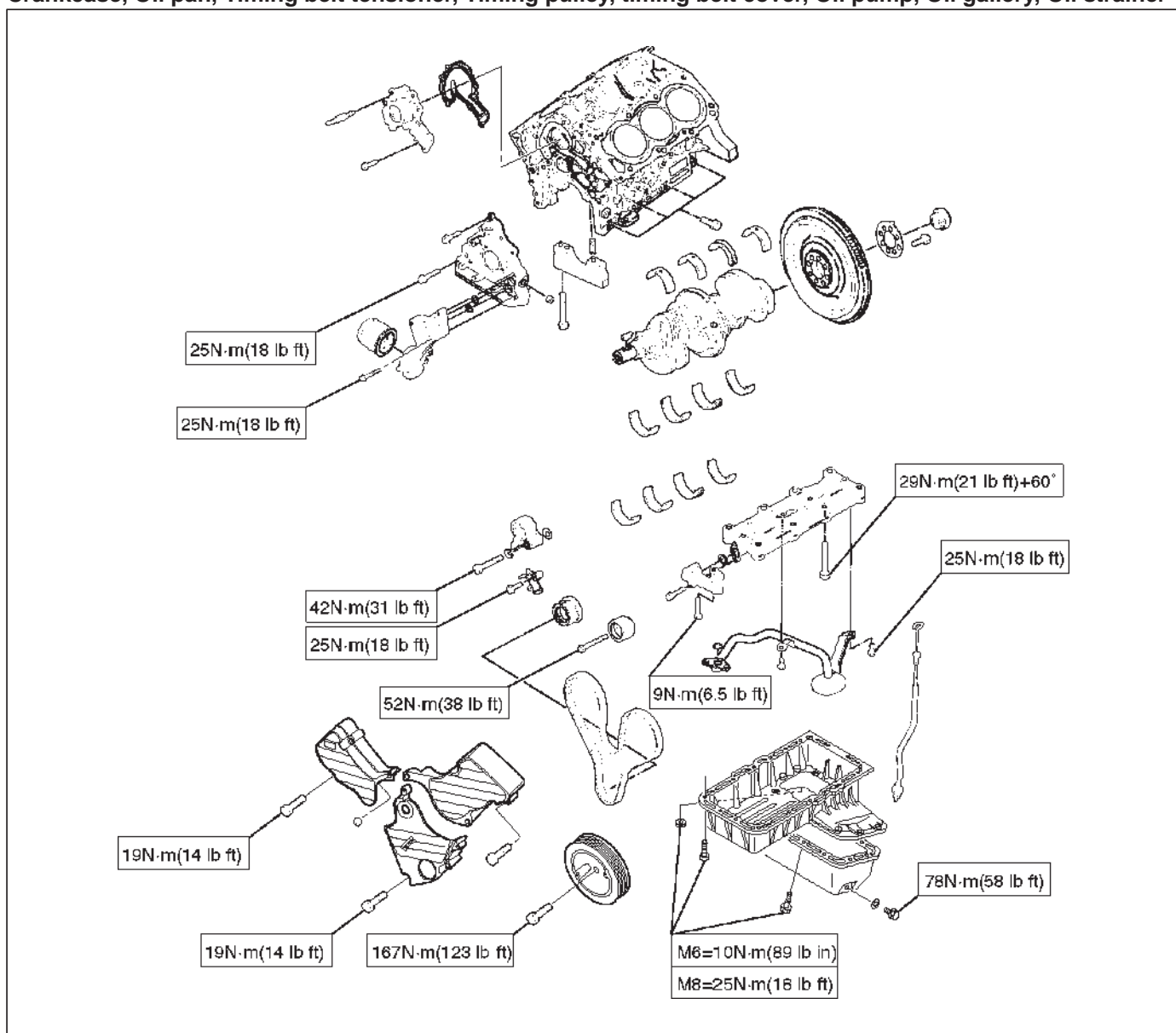
## Main Data and Specification

### General Specification

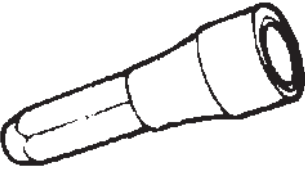
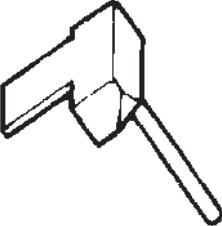

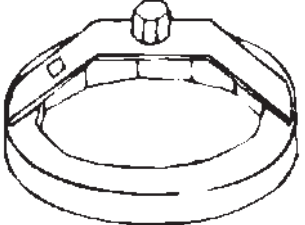
Item	Specifications
	6VE1
Oil capacity	5.3 liters

### Torque Specifications

Crankcase, Oil pan, Timing belt tensioner, Timing pulley, timing belt cover, Oil pump, Oil gallery, Oil strainer



Special Tool

ILLUSTRATION	TOOL NO. TOOL NAME
 <p>901RT044</p>	<p><b>J-39202</b> Installer; Oil pump oil seal</p>
 <p>901RT042</p>	<p><b>J-37228</b> Seal cutter</p>
 <p>901RT038</p>	<p><b>J-29107</b> Universal pitman arm puller</p>
 <p>901RT034</p>	<p><b>J-36390</b> Wrench; Oil filter</p>



VEHICROSS

# ENGINE

## ENGINE SPEED CONTROL SYSTEM

### CONTENTS

Service Precaution .....	6H-1	Accelerator Pedal .....	6H-3
Accelerator Pedal Control Cable .....	6H-2	Accelerator Pedal and Associated Parts ..	6H-3
Removal .....	6H-2	Removal .....	6H-3
Inspection .....	6H-2	Installation .....	6H-3
Installation .....	6H-2		

### Service Precaution

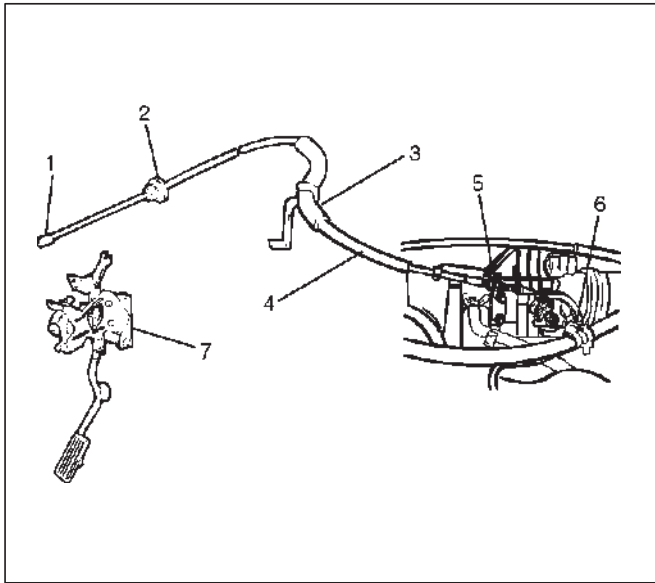
**WARNING: THIS VEHICLE HAS A SUPPLEMENTAL RESTRAINT SYSTEM (SRS). REFER TO THE SRS COMPONENT AND WIRING LOCATION VIEW IN ORDER TO DETERMINE WHETHER YOU ARE PERFORMING SERVICE ON OR NEAR THE SRS COMPONENTS OR THE SRS WIRING. WHEN YOU ARE PERFORMING SERVICE ON OR NEAR THE SRS COMPONENTS OR THE SRS WIRING, REFER TO THE SRS SERVICE INFORMATION. FAILURE TO FOLLOW WARNINGS COULD RESULT IN POSSIBLE AIR BAG DEPLOYMENT, PERSONAL INJURY, OR OTHERWISE UNNEEDED SRS SYSTEM REPAIRS.**

**CAUTION:** Always use the correct fastener in the proper location. When you replace a fastener, use **ONLY** the exact part number for that application. ISUZU will call out those fasteners that require a replacement after removal. ISUZU will also call out the fasteners that require thread lockers or thread sealant. **UNLESS OTHERWISE SPECIFIED**, do not use supplemental coatings (Paints, greases, or other corrosion inhibitors) on threaded fasteners or fastener joint interfaces. Generally, such coatings adversely affect the fastener torque and the joint clamping force, and may damage the fastener. When you install fasteners, use the correct tightening sequence and specifications. Following these instructions can help you avoid damage to parts and systems.

## Accelerator Pedal Control Cable

### Removal

1. Loosen the nut(5) on the cable bracket mounted on the common chamber.
2. Remove cable clip(3).
3. Disconnect accelerator pedal (AP) control cable(6). (on throttle valve side)
4. Disconnect AP control cable(1) on AP pedal(7) side.
5. Remove molding cap(2).
6. Remove AP control cable(4).



101RW001

### Inspection

Check the following items, and replace the control cable if any abnormality is found:

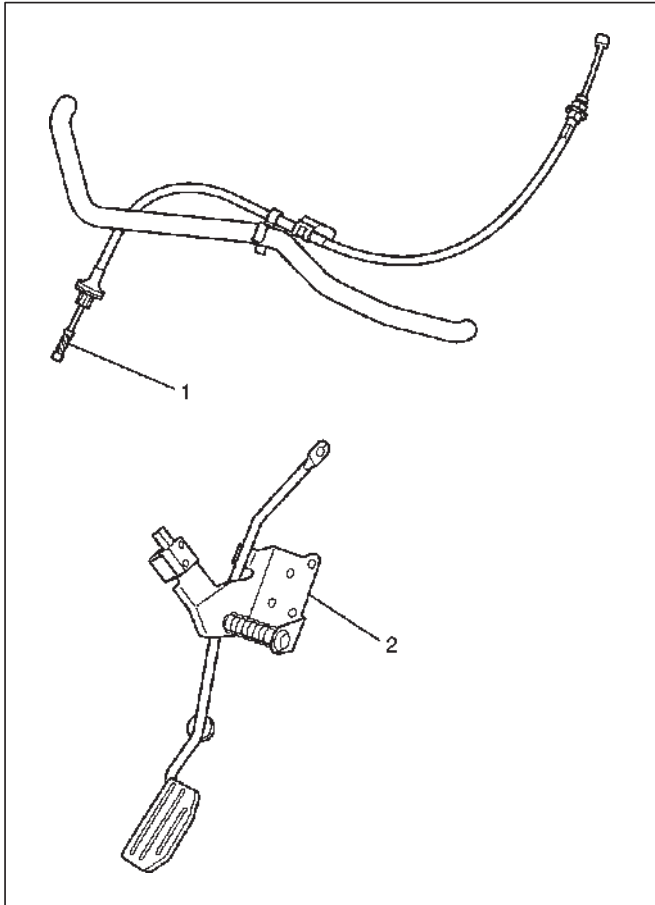
- The control cable should move smoothly.
- The control cable should not be bent or kinked.
- The control cable should be free of damage and corrosion.

### Installation

1. Install AP control cable(4).
2. Install molding cap(2).
3. Connect AP control cable(1). (on AP side)
4. Connect AP control cable(6). (on throttle valve side)
5. Install cable clip(3).
6. Install nut(5).

## Accelerator Pedal

### Accelerator Pedal and Associated Parts



035RX006

### Legend

- (1) Accelerator Pedal Control Cable
- (2) Accelerator Pedal Assembly

### Removal

1. Accelerator Pedal control cable(1).
2. Disconnect wire harness.
3. Accelerator Pedal assembly(2).

### Installation

1. Accelerator pedal assembly(2).
2. Connect wire harness.
3. Accelerator pedal control cable(1).

VEHICROSS

# ENGINE

## INDUCTION

### CONTENTS

Service Precaution .....	6J-1
Air Cleaner Element .....	6J-2
Removal .....	6J-2
Inspection .....	6J-2
Installation .....	6J-2

### Service Precaution

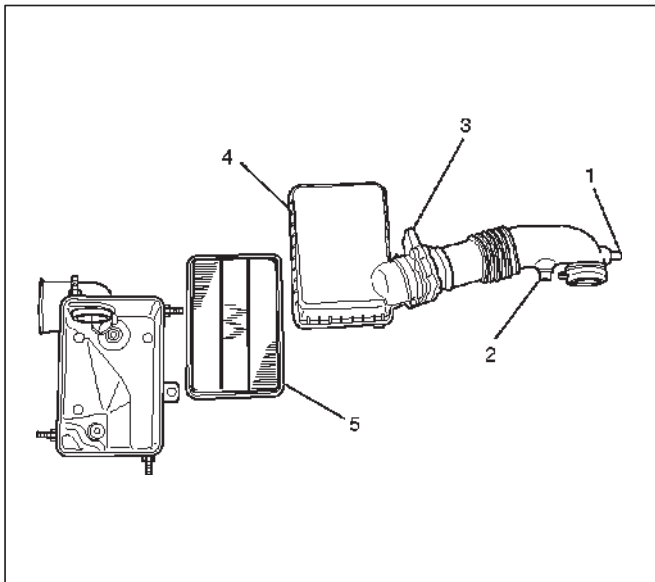
**WARNING: THIS VEHICLE HAS A SUPPLEMENTAL RESTRAINT SYSTEM (SRS). REFER TO THE SRS COMPONENT AND WIRING LOCATION VIEW IN ORDER TO DETERMINE WHETHER YOU ARE PERFORMING SERVICE ON OR NEAR THE SRS COMPONENTS OR THE SRS WIRING. WHEN YOU ARE PERFORMING SERVICE ON OR NEAR THE SRS COMPONENTS OR THE SRS WIRING, REFER TO THE SRS SERVICE INFORMATION. FAILURE TO FOLLOW WARNINGS COULD RESULT IN POSSIBLE AIR BAG DEPLOYMENT, PERSONAL INJURY, OR OTHERWISE UNNEEDED SRS SYSTEM REPAIRS.**

**CAUTION: Always use the correct fastener in the proper location. When you replace a fastener, use ONLY the exact part number for that application. ISUZU will call out those fasteners that require a replacement after removal. ISUZU will also call out the fasteners that require thread lockers or thread sealant. UNLESS OTHERWISE SPECIFIED, do not use supplemental coatings (Paints, greases, or other corrosion inhibitors) on threaded fasteners or fastener joint interfaces. Generally, such coatings adversely affect the fastener torque and the joint clamping force, and may damage the fastener. When you install fasteners, use the correct tightening sequence and specifications. Following these instructions can help you avoid damage to parts and systems.**

## Air Cleaner Element

### Removal

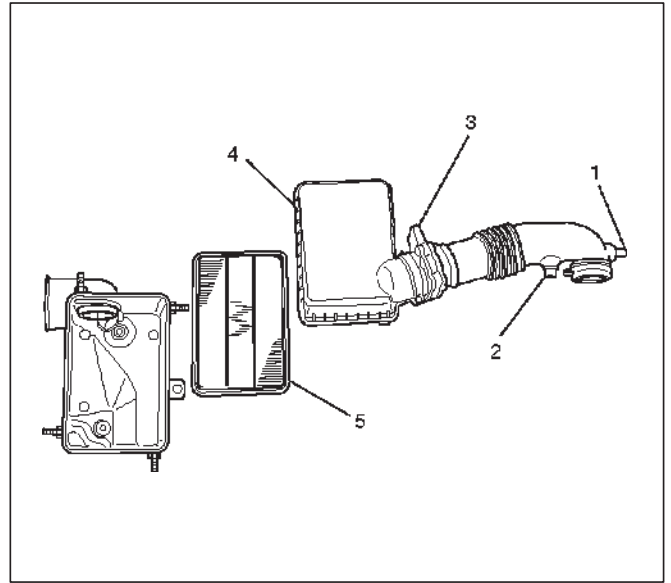
1. Remove positive ventilation hose connector(1).
2. Remove intake air temperature sensor(2).
3. Remove air flow sensor(3).
4. Remove air cleaner duct assembly(4).
5. Remove air cleaner element(5).



130RW003

### Installation

1. Install air cleaner element(5).
2. Attach the air cleaner duct cover to the body completely, then clamp it with the clip(4).
3. Install mass air flow sensor(3).
4. Install air temperature sensor(2).
5. Install positive crankcase ventilation hose connector(1).



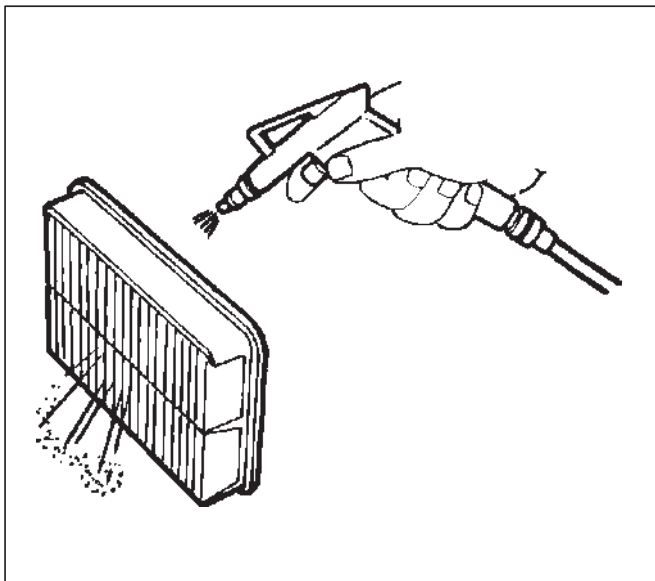
130RW003

### Inspection

Check the air cleaner filter for damage or dust clogging. Replace if it is damaged, or clean if it is clogged.

### Cleaning Method

Tap the air cleaner filter gently so as not to damage the paper filter, or clean the element by blowing with compressed air of about 490 kpa (71 psi) from the clean side if it is extremely dirty.



130RW002

# TRANSMISSION

## AUTOMATIC TRANSMISSION (4L30-E)

### CONTENTS

Service Precaution .....	7A-3	Removal .....	7A-43
Construction .....	7A-3	Installation .....	7A-43
Range Reference Chart .....	7A-4	Speed Sensor (Extension Housing) .....	7A-44
Normal Operation Of 1999 4L30-E Transmission .....	7A-5	Removal .....	7A-44
Diagnosis .....	7A-5	Installation .....	7A-44
Driver Information .....	7A-5	Transmission Oil Temperature Sensor (Adapter Case) .....	7A-44
General Diagnosis Procedure .....	7A-8	Removal .....	7A-44
Preliminary Inspection Chart .....	7A-9	Installation .....	7A-44
Checking Transmission Fluid Level and Condition .....	7A-10	Front Oil Seal (Converter Housing) .....	7A-45
Test Driving .....	7A-11	Removal .....	7A-45
Mechanical / Hydraulic Diagnosis Check Trans Indicator Chart .....	7A-12	Installation .....	7A-45
Mechanical / Hydraulic Diagnosis Symptoms Index .....	7A-13	Rear Oil Seal (Extension Housing) .....	7A-45
Stall Test .....	7A-23	Removal .....	7A-45
Line Pressure Test .....	7A-23	Installation .....	7A-46
Shift Speed Chart .....	7A-24	Transmission (4L30-E) .....	7A-46
Lockup Speed Chart .....	7A-26	Disassembly .....	7A-46
Changing Transmission Fluid .....	7A-27	Reassembly .....	7A-50
Selector Lever .....	7A-27	Converter Housing And Oil Pump Assembly Disassembled View .....	7A-61
Inspection .....	7A-27	Disassembly .....	7A-61
Removal .....	7A-28	Inspection And Repair .....	7A-61
Installation .....	7A-28	Reassembly .....	7A-61
Mode Switch .....	7A-29	Oil Pump .....	7A-62
Removal .....	7A-29	Disassembled View .....	7A-62
Installation .....	7A-29	Disassembly .....	7A-62
Transmission (With Transfer Case) .....	7A-31	Inspection And Repair .....	7A-62
Transmission And Associated Parts .....	7A-31	Reassembly .....	7A-62
Removal .....	7A-31	Main Case Valve Body .....	7A-63
Installation .....	7A-35	Disassembled View .....	7A-63
Solenoid (Main Case Valve Body) .....	7A-39	Disassembly .....	7A-63
Removal .....	7A-39	Inspection And Repair .....	7A-64
Installation .....	7A-39	Reassembly .....	7A-64
Solenoid (Adapter Case Valve Body) .....	7A-40	Adapter Case Valve Body .....	7A-65
Removal .....	7A-40	Disassembled View .....	7A-65
Installation .....	7A-40	Disassembly .....	7A-65
Valve Body Assembly (Main Case) .....	7A-41	Inspection And Repair .....	7A-65
Removal .....	7A-41	Reassembly .....	7A-65
Installation .....	7A-41	Third Clutch And Sprag Unit .....	7A-67
Valve Body Assembly (Adapter Case) .....	7A-43	Disassembled View .....	7A-67
Removal .....	7A-43	Disassembly .....	7A-67
Installation .....	7A-43	Inspection And Repair .....	7A-68
Powertrain Control Module (PCM) .....	7A-43	Reassembly .....	7A-68
		Third Clutch .....	7A-69

## 7A-2 AUTOMATIC TRANSMISSION (4L30-E)

---

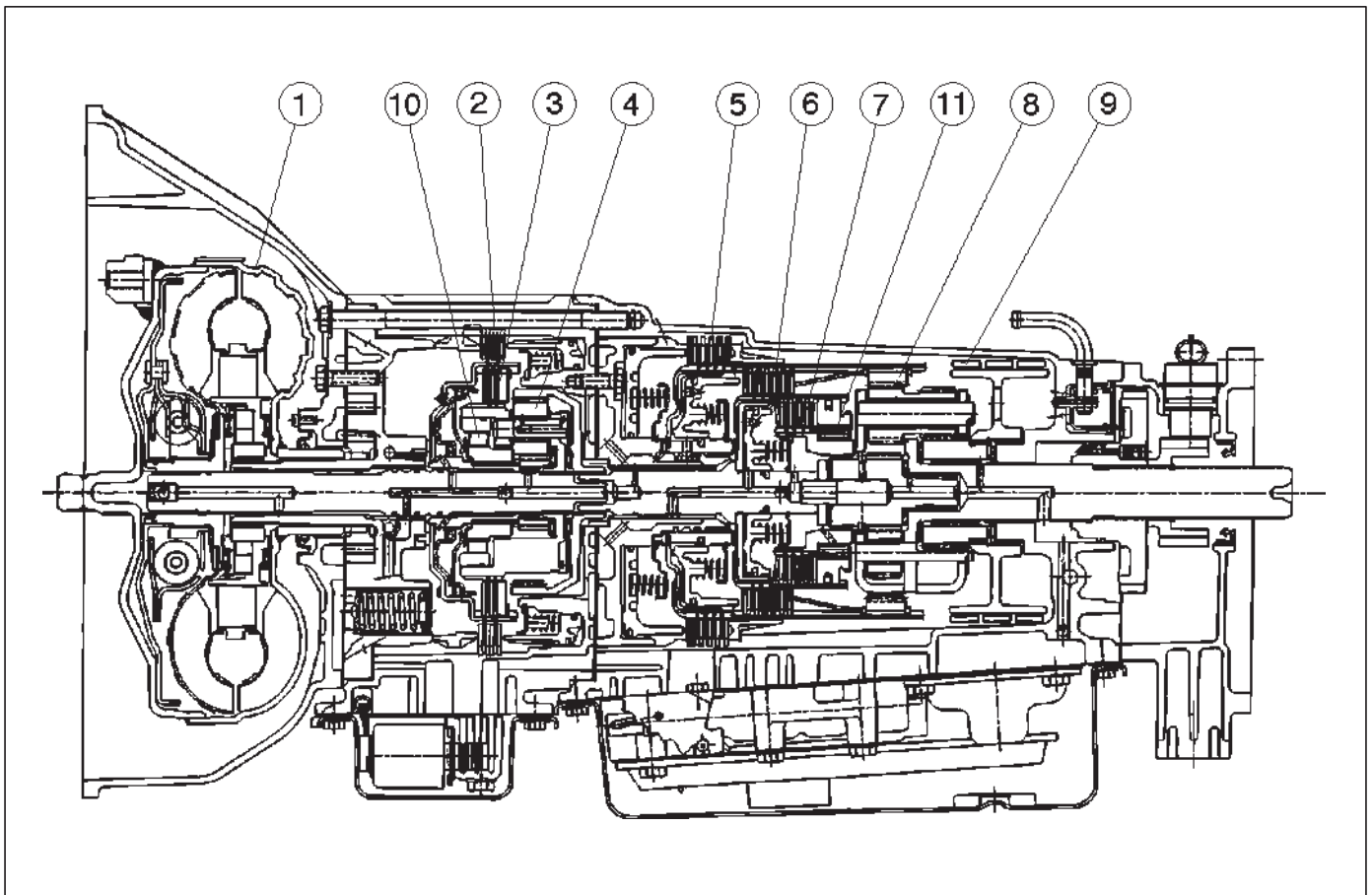
Disassembled View .....	7A-69
Disassemble .....	7A-69
Inspection And Repair .....	7A-69
Reassembly .....	7A-69
Sprag Unit .....	7A-71
Disassembled View .....	7A-71
Disassembly .....	7A-71
Inspection And Repair .....	7A-71
Reassembly .....	7A-71
Second Clutch .....	7A-72
Disassembled View .....	7A-72
Disassembly .....	7A-72
Inspection And Repair .....	7A-73
Reassembly .....	7A-73
3-4 Accumulator Piston .....	7A-74
Disassembled View .....	7A-74
Disassembly .....	7A-74
Inspection And Repair .....	7A-74
Reassembly .....	7A-75
Reverse Clutch Piston And Center Support .	7A-76
Disassembled View .....	7A-76
Disassembly .....	7A-76
Inspection And Repair .....	7A-77
Reassembly .....	7A-77
Overrun Clutch And Turbine Shaft .....	7A-78
Disassembled View .....	7A-78
Disassembly .....	7A-78
Inspection And Repair .....	7A-79
Reassembly .....	7A-79
Main Data And Specification .....	7A-81
Special Tools .....	7A-85
4L30-E Parts List .....	7A-88

## Service Precaution

**WARNING:** THIS VEHICLE HAS A SUPPLEMENTAL RESTRAINT SYSTEM (SRS). REFER TO THE SRS COMPONENT AND WIRING LOCATION VIEW IN ORDER TO DETERMINE WHETHER YOU ARE PERFORMING SERVICE ON OR NEAR THE SRS COMPONENTS OR THE SRS WIRING. WHEN YOU ARE PERFORMING SERVICE ON OR NEAR THE SRS COMPONENTS OR THE SRS WIRING, REFER TO THE SRS SERVICE INFORMATION. FAILURE TO FOLLOW WARNINGS COULD RESULT IN POSSIBLE AIR BAG DEPLOYMENT, PERSONAL INJURY, OR OTHERWISE UNNEEDED SRS SYSTEM REPAIRS.

**CAUTION:** Always use the correct fastener in the proper location. When you replace a fastener, use **ONLY** the exact part number for that application. ISUZU will call out those fasteners that require a replacement after removal. ISUZU will also call out the fasteners that require thread lockers or thread sealant. **UNLESS OTHERWISE SPECIFIED**, do not use supplemental coatings (Paints, greases, or other corrosion inhibitors) on threaded fasteners or fastener joint interfaces. Generally, such coatings adversely affect the fastener torque and the joint clamping force, and may damage the fastener. When you install fasteners, use the correct tightening sequence and specifications. Following these instructions can help you avoid damage to parts and systems.

## Construction



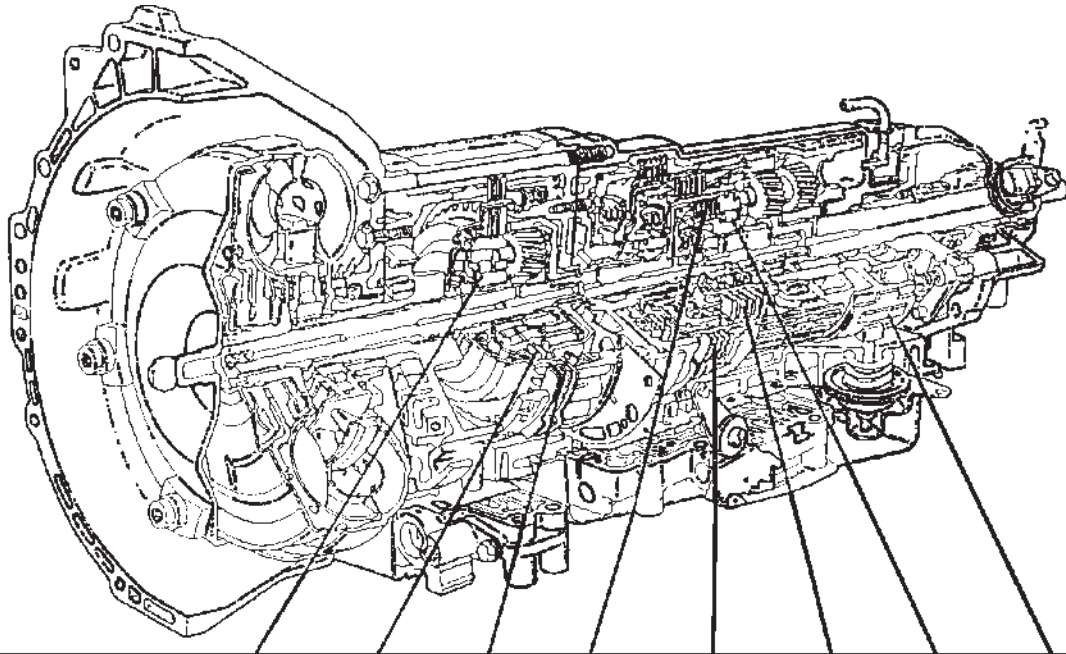
A07RS001

### Legend

- |                                   |  |
|-----------------------------------|--|
| (1) Torque Converter Clutch (TCC) | (7) Third Clutch (C3)                            |
| (2) Fourth Clutch (C4)            | (8) Ravigneaux Planetary Gear Set                |
| (3) Overrun Clutch (OC)           | (9) Brake Band (B)                               |
| (4) Overdrive Unit                | (10) Overdrive Free Wheel (One Way Clutch) (OFW) |
| (5) Reverse Clutch (RC)           | (11) Sprag Free Wheel (One Way Clutch) (PFW)     |
| (6) Second Clutch (C2)            |  |



Range Reference Chart

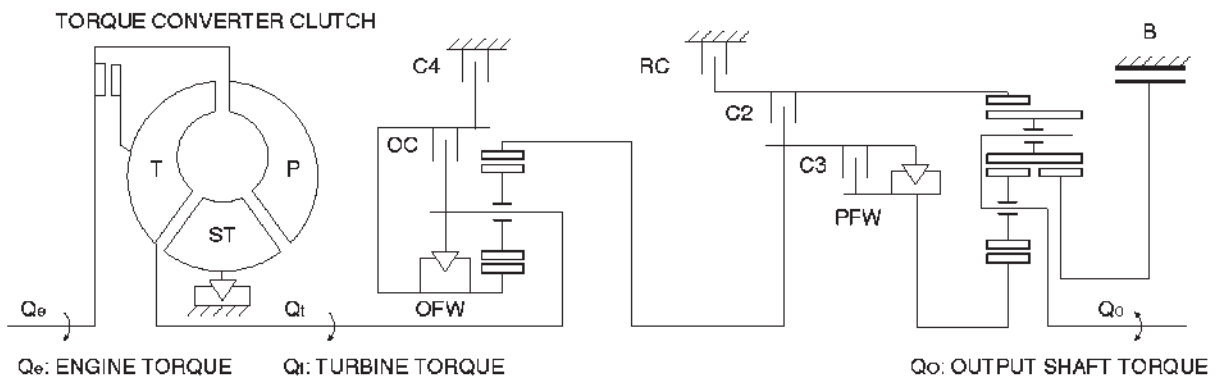


RANGE	GEAR	SOL A N.C.	SOL B N.O.	O/DRIVE ROLLER CLUTCH (OFW)	OVERRUN CLUTCH (OC)	FOURTH CLUTCH (C4)	THIRD CLUTCH (C3)	REVERSE CLUTCH (RC)	SECOND CLUTCH (C2)	PRINCIPLE SPRAG ASSEMBLY (PFW)	BAND ASSEMBLY (B)	ENGINE BRAKING
P-N		OFF	ON		APPLIED							NO
R	REVERSE	OFF	ON	LD	APPLIED			APPLIED		LD		NO
D	1ST	OFF	ON	LD	APPLIED					LD	APPLIED	NO
	2ND	ON	ON	LD	APPLIED				APPLIED	FW	APPLIED	YES
	3RD	ON	OFF	LD	APPLIED		APPLIED		APPLIED	NE		YES
	4TH	OFF	OFF	FW		APPLIED	APPLIED		APPLIED	NE		YES
3	1ST	OFF	ON	LD	APPLIED					LD	APPLIED	NO
	2ND	ON	ON	LD	APPLIED				APPLIED	FW	APPLIED	YES
	3RD	ON	OFF	LD	APPLIED		APPLIED		APPLIED	NE		YES
2	1ST	OFF	ON	LD	APPLIED		APPLIED			LD	APPLIED	YES
	2ND	ON	ON	LD	APPLIED				APPLIED	FW	APPLIED	YES
L	1ST	OFF	ON	LD	APPLIED		APPLIED			LD	APPLIED	YES

LD : LOCKED IN DRIVE

FW : FREEWHEELING

NE : NOT EFFECTIVE



## Normal Operation Of 1999 4L30-E Transmission

### Torque Converter Clutch (TCC)

#### Application Conditions:

The TCC is normally applied in 2nd, 3rd and 4th gears only when all of the following conditions exist:

- The engine coolant temperature is above 70°C (158°F).
- The brake pedal is released.
- The shift pattern requests TCC apply.

Moreover, TCC is always applied in 2nd, 3rd and 4th gears when the transmission oil temperature is above 135°C (275°F).

This mode should be canceled at 125°C (257°F).

### ATF Warning Lamp

The ATF warning lamp will be constantly on (not flashing) if the transmission oil temperature is above 145°C (293°F).

The ATF warning lamp goes off again when the transmission oil temperature is below 125°C (257°F).

### Special Shift Pattern When The Engine Is Cold:

A special shift pattern is activated when the engine coolant temperature is below 70°C (158°F). (3-4 shifts, for example, are delayed for small throttle openings and will occur a few MPH higher.)

## Diagnosis

### Introduction

The systematic troubleshooting information covered by this Section offers a practical and systematic approach to diagnosing 4L30-E transmission, using information that can be obtained from road tests, electrical diagnosis, oil pressure checks or noise evaluation.

The key to correcting a complaint is to make use of all of the available symptoms and logically letting them direct you to the cause.

When dealing with automatic transmission complaints, it is best to gather as many symptoms as possible before making the decision to remove the transmission from the vehicle.

Frequently, the correction of the complaint does not require removal of the transmission from the vehicle.

### Driver Information

To analyze the problem fill out a complete description of the owner's complaint.

Please draw a circle around the right information and complete the following form. (The next page is an example of a completed form). You can draw a circle around many numbers if you are not sure.

7A-6 AUTOMATIC TRANSMISSION (4L30-E)

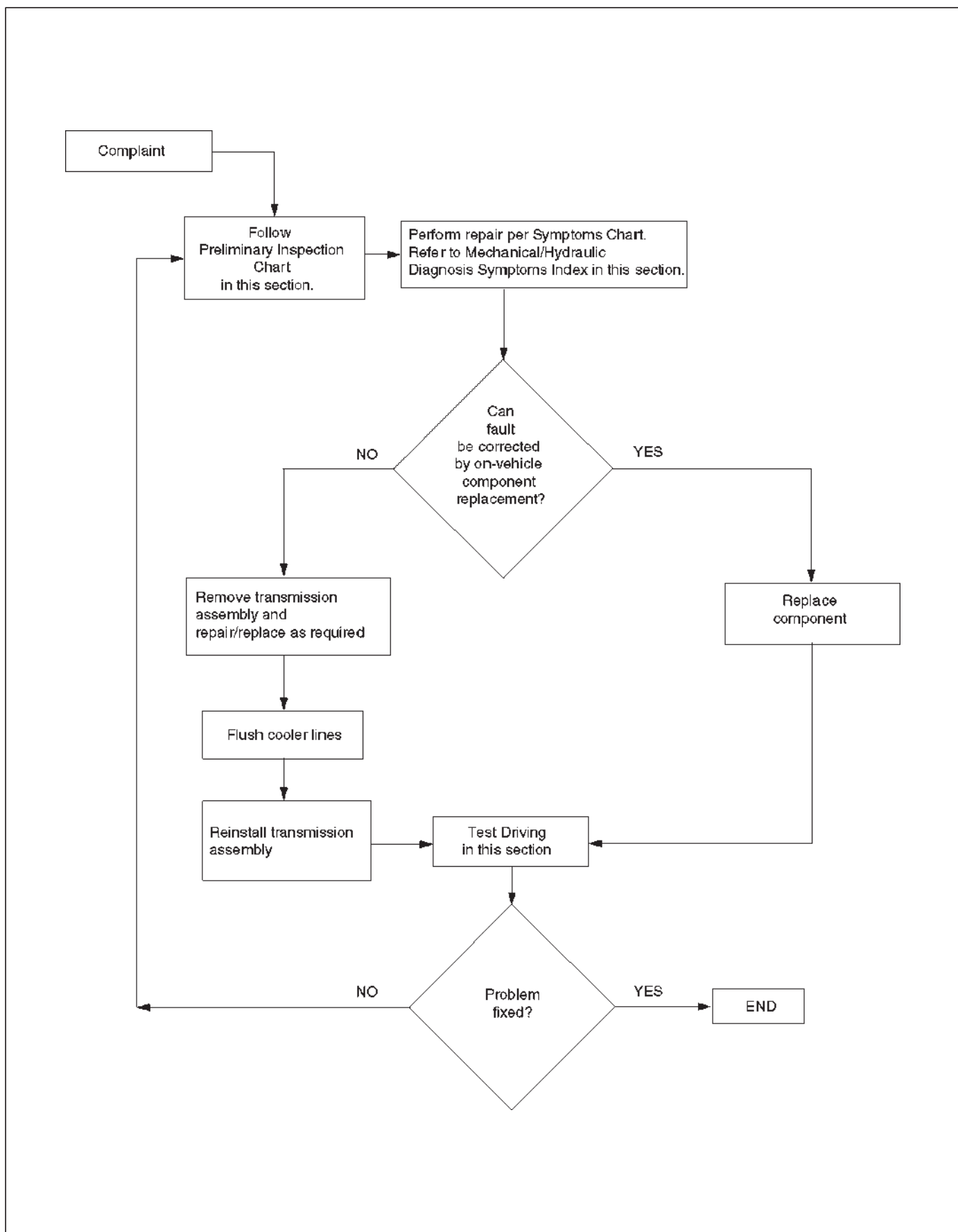
A - Today's date :		Month : .....	Day : .....	Year : .....																																												
B - End User Name, Address :																																																
C - Date of Problem :		Month : .....	Day : .....	Year : .....																																												
D - Mileage : ..... Miles / Km		E - With Ignition ON is CHECK TRANS Indicator : 1- Flashing      2- Not Flashing		F - Car load when problem occurred : 1 - Towing a trailer      2- ..... people OR ..... Kg																																												
G - Weather conditions when problem : 1- Clear      2- Cloudy 3- Rain      4- Snow 5- Unstable      6- Any		H - Weather Temperature when problem: 1- Hot      2- Warm 3- Cool      4- Cold 5- Unstable      6- Any		I - Road Conditions when problem : 1- Any      2- Inter City 3- Outside City      4- Highway 5- Uphill      6- Downhill 7- Unpaved      8- Snow 9 - Others :																																												
J - Frequency of the Problem : 1- Always      2- Occasional : ..... times/day, ..... times/month 3- Only Once      4- Others :		K - Engine Condition : 1- Always      2- At Cold 3- During Warming up 4- After Warming or Hot 5- Others																																														
L - Engine Speed when the problem occured : 1- Idling      2- Starting 3- Stalling      4- High RPM 5- Low RPM		M - Transmission Condition when it occurred : 1- Any      2- Idling 3- Starting      4- Driving 5- Accelerating      6- Coasting 7- In corner      8- Shifting																																														
<p><b>N - If there is a Transmission driveability problem BEFORE THE CHECK TRANS INDICATOR WAS FLASHING :</b></p> <table border="0"> <tr> <td>1- No Power</td> <td>in Range : All - P - R - N - D - 3 - 2 - L</td> <td>during a :</td> <td>upshift : 1-2 / 2-3 / 3-4 or downshift : 4-3 / 3-2 / 2-1</td> </tr> <tr> <td>2- No shift</td> <td>in Range : All - P - R - N - D - 3 - 2 - L</td> <td>during a :</td> <td>upshift : 1-2 / 2-3 / 3-4 or downshift : 4-3 / 3-2 / 2-1</td> </tr> <tr> <td>3- Shift Shock</td> <td>in Range : All - P - R - N - D - 3 - 2 - L</td> <td>during a :</td> <td>upshift : 1-2 / 2-3 / 3-4 or downshift : 4-3 / 3-2 / 2-1</td> </tr> <tr> <td>4- Shift Slip</td> <td>in Range : All - P - R - N - D - 3 - 2 - L</td> <td>during a :</td> <td>upshift : 1-2 / 2-3 / 3-4 or downshift : 4-3 / 3-2 / 2-1</td> </tr> <tr> <td>5- Shift Delayed</td> <td>in Range : All - P - R - N - D - 3 - 2 - L</td> <td>during a :</td> <td>upshift : 1-2 / 2-3 / 3-4 or downshift : 4-3 / 3-2 / 2-1</td> </tr> <tr> <td>6- Shift Point too high</td> <td>in Range : All - P - R - N - D - 3 - 2 - L</td> <td>during a :</td> <td>upshift : 1-2 / 2-3 / 3-4 or downshift : 4-3 / 3-2 / 2-1</td> </tr> <tr> <td>7- Shift Point too low</td> <td>in Range : All - P - R - N - D - 3 - 2 - L</td> <td>during a :</td> <td>upshift : 1-2 / 2-3 / 3-4 or downshift : 4-3 / 3-2 / 2-1</td> </tr> <tr> <td>8- TCC Shudder</td> <td>in Range : All - P - R - N - D - 3 - 2 - L</td> <td>during a :</td> <td>upshift : 1-2 / 2-3 / 3-4 or downshift : 4-3 / 3-2 / 2-1</td> </tr> <tr> <td>9- Noise</td> <td>in Range : All - P - R - N - D - 3 - 2 - L</td> <td>during a :</td> <td>upshift : 1-2 / 2-3 / 3-4 or downshift : 4-3 / 3-2 / 2-1</td> </tr> <tr> <td>Noise type :</td> <td>1- Buzz      2- Whine      3- Clunk      4- Rattle      5- Whistle //      6- light      7- medium      8- heavy</td> <td>during a :</td> <td>upshift : 1-2 / 2-3 / 3-4 or downshift : 4-3 / 3-2 / 2-1</td> </tr> <tr> <td>10- Other : .....</td> <td>in Range : All - P - R - N - D - 3 - 2 - L</td> <td>during a :</td> <td>upshift : 1-2 / 2-3 / 3-4 or downshift : 4-3 / 3-2 / 2-1</td> </tr> </table>					1- No Power	in Range : All - P - R - N - D - 3 - 2 - L	during a :	upshift : 1-2 / 2-3 / 3-4 or downshift : 4-3 / 3-2 / 2-1	2- No shift	in Range : All - P - R - N - D - 3 - 2 - L	during a :	upshift : 1-2 / 2-3 / 3-4 or downshift : 4-3 / 3-2 / 2-1	3- Shift Shock	in Range : All - P - R - N - D - 3 - 2 - L	during a :	upshift : 1-2 / 2-3 / 3-4 or downshift : 4-3 / 3-2 / 2-1	4- Shift Slip	in Range : All - P - R - N - D - 3 - 2 - L	during a :	upshift : 1-2 / 2-3 / 3-4 or downshift : 4-3 / 3-2 / 2-1	5- Shift Delayed	in Range : All - P - R - N - D - 3 - 2 - L	during a :	upshift : 1-2 / 2-3 / 3-4 or downshift : 4-3 / 3-2 / 2-1	6- Shift Point too high	in Range : All - P - R - N - D - 3 - 2 - L	during a :	upshift : 1-2 / 2-3 / 3-4 or downshift : 4-3 / 3-2 / 2-1	7- Shift Point too low	in Range : All - P - R - N - D - 3 - 2 - L	during a :	upshift : 1-2 / 2-3 / 3-4 or downshift : 4-3 / 3-2 / 2-1	8- TCC Shudder	in Range : All - P - R - N - D - 3 - 2 - L	during a :	upshift : 1-2 / 2-3 / 3-4 or downshift : 4-3 / 3-2 / 2-1	9- Noise	in Range : All - P - R - N - D - 3 - 2 - L	during a :	upshift : 1-2 / 2-3 / 3-4 or downshift : 4-3 / 3-2 / 2-1	Noise type :	1- Buzz      2- Whine      3- Clunk      4- Rattle      5- Whistle //      6- light      7- medium      8- heavy	during a :	upshift : 1-2 / 2-3 / 3-4 or downshift : 4-3 / 3-2 / 2-1	10- Other : .....	in Range : All - P - R - N - D - 3 - 2 - L	during a :	upshift : 1-2 / 2-3 / 3-4 or downshift : 4-3 / 3-2 / 2-1
1- No Power	in Range : All - P - R - N - D - 3 - 2 - L	during a :	upshift : 1-2 / 2-3 / 3-4 or downshift : 4-3 / 3-2 / 2-1																																													
2- No shift	in Range : All - P - R - N - D - 3 - 2 - L	during a :	upshift : 1-2 / 2-3 / 3-4 or downshift : 4-3 / 3-2 / 2-1																																													
3- Shift Shock	in Range : All - P - R - N - D - 3 - 2 - L	during a :	upshift : 1-2 / 2-3 / 3-4 or downshift : 4-3 / 3-2 / 2-1																																													
4- Shift Slip	in Range : All - P - R - N - D - 3 - 2 - L	during a :	upshift : 1-2 / 2-3 / 3-4 or downshift : 4-3 / 3-2 / 2-1																																													
5- Shift Delayed	in Range : All - P - R - N - D - 3 - 2 - L	during a :	upshift : 1-2 / 2-3 / 3-4 or downshift : 4-3 / 3-2 / 2-1																																													
6- Shift Point too high	in Range : All - P - R - N - D - 3 - 2 - L	during a :	upshift : 1-2 / 2-3 / 3-4 or downshift : 4-3 / 3-2 / 2-1																																													
7- Shift Point too low	in Range : All - P - R - N - D - 3 - 2 - L	during a :	upshift : 1-2 / 2-3 / 3-4 or downshift : 4-3 / 3-2 / 2-1																																													
8- TCC Shudder	in Range : All - P - R - N - D - 3 - 2 - L	during a :	upshift : 1-2 / 2-3 / 3-4 or downshift : 4-3 / 3-2 / 2-1																																													
9- Noise	in Range : All - P - R - N - D - 3 - 2 - L	during a :	upshift : 1-2 / 2-3 / 3-4 or downshift : 4-3 / 3-2 / 2-1																																													
Noise type :	1- Buzz      2- Whine      3- Clunk      4- Rattle      5- Whistle //      6- light      7- medium      8- heavy	during a :	upshift : 1-2 / 2-3 / 3-4 or downshift : 4-3 / 3-2 / 2-1																																													
10- Other : .....	in Range : All - P - R - N - D - 3 - 2 - L	during a :	upshift : 1-2 / 2-3 / 3-4 or downshift : 4-3 / 3-2 / 2-1																																													
O - Other customer concern and comments																																																
P - Isuzu Vehicle Code :		.....	Q - VIN Number	.....																																												
R - Date of Vehicle Registration		Month : .....	Day : .....	Year : .....																																												
S - Trans. model :		.....	T - A/T Serial Number :	.....																																												
U - Your name :		.....																																														
V - Dealer Name, Address, Phone																																																

F07R036

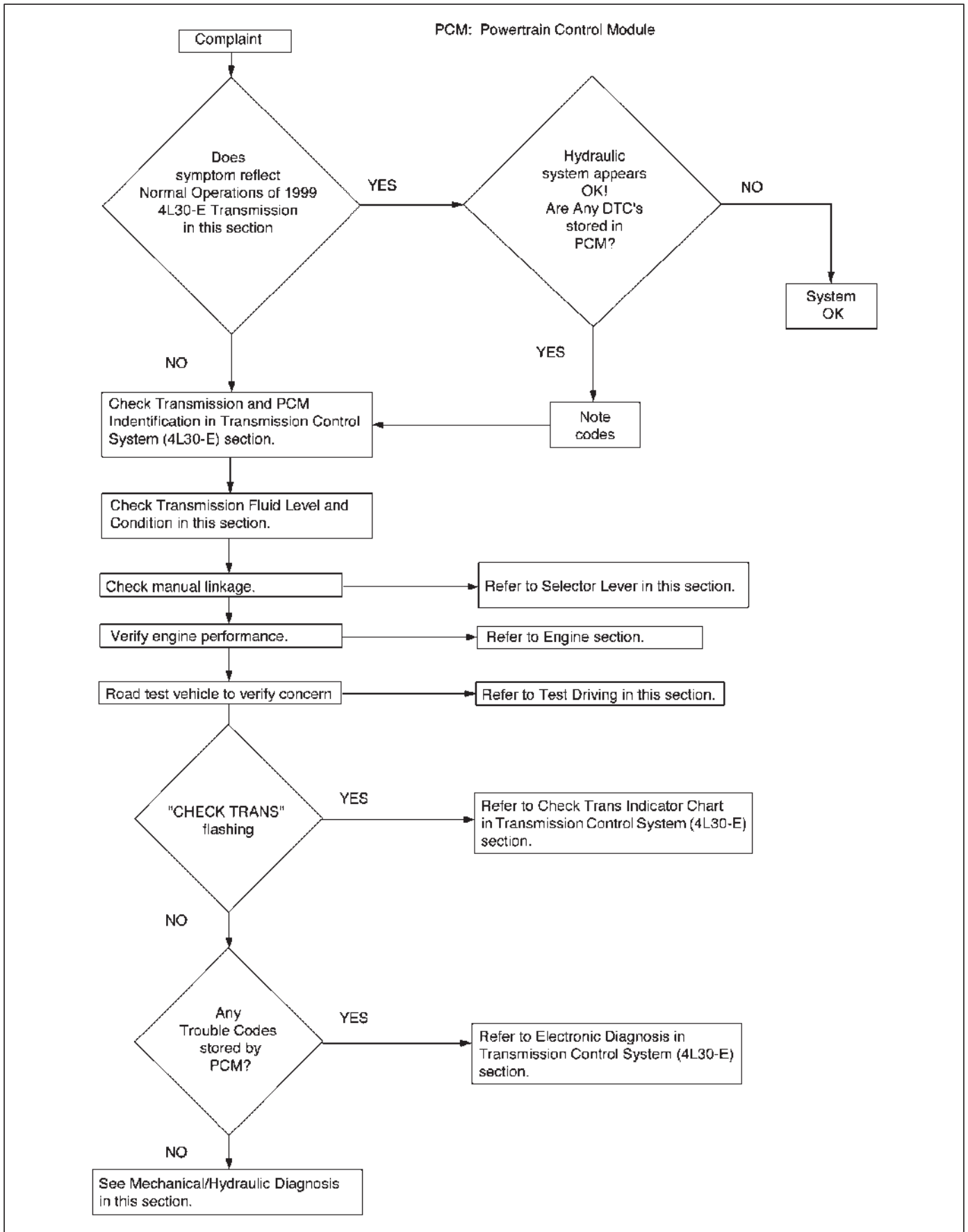
Example of form completed.

A - Today's date :		Month : April.....	Day : 13.....	Year : 1994.....	
B - End User Name, Address :		Dave Smith 6584, Arlington road Plymouth MI 48170 USA			
C - Date of Problem :		Month : April.....	Day : 8.....	Year : 1994.....	
D - Mileage : 12230 <u>1</u> (Mile) / Km		E - With Ignition ON is CHECK TRANS Indicator : <u>1</u> - Flashing      2 - Not Flashing		F - Car load when problem occurred : 1 - Towing a trailer      2 - <u>2</u> ..... people OR ..... Kg	
G - Weather conditions when problem : 1- Clear      2- Cloudy 3- Rain      4- Snow 5- Unstable <u>6</u> - Any		H - Weather Temperature when problem: 1- Hot      2- Warm 3- Cool      4- Cold 5- Unstable <u>6</u> - Any		I - Road Conditions when problem : 1- Any      2- Inter City 3- Outside City <u>4</u> - Highway 5 - Uphill      6- Downhill 7- Unpaved <del>8- Snow</del> 9 - Others	J - Frequency of the Problem : 1- Always <u>2</u> - Occasional : ..... times/day, .....3..... times/month 3- Only Once      4- Others :
K - Engine Condition : 1- Always      2- At Cold 3- During Warming up <u>4</u> - After Warming or Hot 5- Others		L - Engine Speed when the problem occurred : 1- Idling      2- Starting 3- Stalling <u>4</u> - High RPM 5- Low RPM		M - Transmission Condition when it occurred : 1- Any      2- Idling 3- Starting      4- Driving <u>5</u> - Accelerating <u>6</u> - Coasting 7- In corner <u>8</u> - Shifting	<i>this means do not take this into account</i>
N - If there is a Transmission driveability problem BEFORE THE CHECK TRANS INDICATOR WAS FLASHING : 1- No Power      in Range : All - P - R - N - D - 3 - 2 - L      during a : upshift : 1-2 / 2-3 / 3-4 or downshift : 4-3 / 3-2 / 2-1 2- No shift      in Range : All - P - R - N - D - 3 - 2 - L      during a : upshift : 1-2 / 2-3 / 3-4 or downshift : 4-3 / 3-2 / 2-1 <u>3</u> - Shift Shock      in Range : All - P - R - N - <u>3</u> - 2 - L      during a : <u>upshift</u> : 2 / 2-3 / <u>3-4</u> or <u>downshift</u> : <u>1-3</u> / 3-2 / 2-1 4- Shift Slip      in Range : All - P - R - N - D - 3 - 2 - L      during a : upshift : 1-2 / 2-3 / 3-4 or downshift : 4-3 / 3-2 / 2-1 5- Shift Delayed      in Range : All - P - R - N - D - 3 - 2 - L      during a : upshift : 1-2 / 2-3 / 3-4 or downshift : 4-3 / 3-2 / 2-1 6- Shift Point too high      in Range : All - P - R - N - D - 3 - 2 - L      during a : upshift : 1-2 / 2-3 / 3-4 or downshift : 4-3 / 3-2 / 2-1 7- Shift Point too low      in Range : All - P - R - N - D - 3 - 2 - L      during a : upshift : 1-2 / 2-3 / 3-4 or downshift : 4-3 / 3-2 / 2-1 8- TCC Shudder      in Range : All - P - R - N - D - 3 - 2 - L      during a : upshift : 1-2 / 2-3 / 3-4 or downshift : 4-3 / 3-2 / 2-1 9- Noise      in Range : All - P - R - N - D - 3 - 2 - L      during a : upshift : 1-2 / 2-3 / 3-4 or downshift : 4-3 / 3-2 / 2-1 Noise type :    1- Buzz    2- Whine    3- Clunk    4- Rattle    5- Whistle //    6- light    7- medium    8- heavy 10- Other : ..... in Range : All - P - R - N - D - 3 - 2 - L      during a : upshift : 1-2 / 2-3 / 3-4 or downshift : 4-3 / 3-2 / 2-1					
O - Other customer concern and comments :  (This is just an example). Shift shock very harsh overall during a downshift. Not sure if it's the 4-3 or 3-2.					
P - Isuzu Vehicle Code :		94 UCR	Q - VIN Number	4S2CV58ZXM4324047	
R - Date of Vehicle Registration		Month : November.	Day : .....18.....	Year : 1993.....	
S - Trans. model :		4L30-E	T - A/T Serial Number :	96 358 654	
U - Your name :		Joe Spring			
V - Dealer Name, Address, Phone  Kent Helfrich Home town ISUZU 900 - 999 - 9999					

## General Diagnosis Procedure



### Preliminary Inspection Chart



## Checking Transmission Fluid Level and Condition

Checking fluid level and condition (color and odor) at regular intervals will provide early diagnosis information about the transmission. This information may be used to correct a condition that, if not detected early, could result in major transmission repairs.

**IMPORTANT:** When new, automatic transmission fluid is red in color. As the vehicle is driven, the transmission fluid will begin to look darker in color. The color may eventually appear light brown.

A dark brown color with burnt odor may indicate excessive fluid deterioration and signal a need for fluid change.

### Fluid Level

When adding or changing fluid, use only DEXRON®-III. Refer to Maintenance and Lubrication in General Information section for maintenance information and servicing interval.

**CAUTION: DO NOT OVERFILL.**

**Overfilling will cause foaming, loss of fluid, abnormal shifting and possible damage to the transmission.**

1. Park the vehicle on level ground and apply the parking brake firmly.
2. Check fluid level with engine running at idle.

**NOTE:** Be sure that transmission fluid temperature is below 30°C (86°F).

3. Move the selector lever through all gear ranges.
4. Move the selector lever to "Park".
5. Let engine idle for 3 minutes and open the overfill screw (1).
6. Add released transmission fluid until it flows out over the overfill screw opening.
7. Let engine idle until a fluid temperature between 32°C (90°F) and 57°C (135°F) is reached, then close the overfill screw (1).

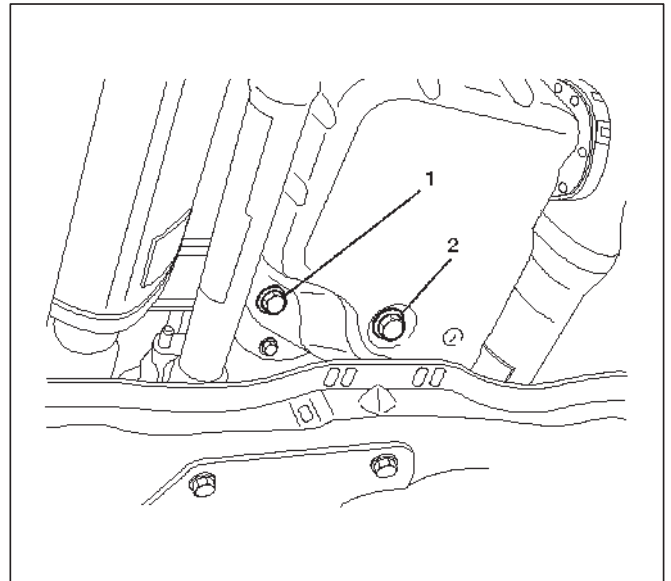
**Torque: 38 N•m (28 lb ft)**

**NOTE:** To prevent fluid leaks, the overfill screw and oil drain screws gasket must be replaced each time these screws are removed.

**NOTE:** Check transmission fluid temperature with scan tool.

Minimum fluid level → 57°C (135°F)

Maximum fluid level → 32°C (90°F)



242RW003

**CAUTION: Do not open overfill screw with engine stopped.**

**CAUTION: DO NOT CHECK FLUID LEVEL UNDER THESE CONDITIONS:**

- Immediately after driving at sustained highway speeds.
- In heavy city traffic during hot weather.
- If vehicle is towing a trailer.

If the vehicle has been operated under these conditions, shut the engine off and allow the vehicle to "cool" for thirty (30) minutes. After the cool down period, restart the vehicle and continue from step 2 above.

**Fluid Condition**

FLUID CONDITION				
	NORMAL*		CONTAMINATED	
COLOR	RED OR LIGHT BROWN	BROWN	NON-TRANSPARENT / PINK	BROWN
DRAIN REQUIRED?	NO	YES	YES	YES
CONTAMINATION	NONE	Very small amount of foreign material in bottom of pan	Contamination by coolant or other source	Large pieces of metal or other foreign material in bottom of pan
CORRECT LEVEL AND CONDITION	1. LOW LEVEL: A. Add fluid to obtain proper level & check for external leaks. B. Correct cause of leak. 2. HIGH LEVEL: - Remove excess fluid	- Remove both pans - Change filter - Flush cooler - Add new fluid - Check level	- Repair/replace radiator cooler - Transmission overhaul required - Check for: ○ Damaged plates and seals ○ Contaminated solenoids - Flush cooler - Add new fluid - Check level	- Transmission overhaul required - Flush cooler and cooler lines - Add new fluid - Check level

\*Fluid should be changed according to maintenance schedule.

**Test Driving**

Some 4L30-E automatic transmission complaint will require a test drive as a part of the diagnostic procedure. Some codes will not set unless the vehicle is moving. The purpose of the test drive is to duplicate the customer's complaint condition and set a current Powertrain Control Module (PCM) trouble code. Perform this procedure before each 4L30-E automatic transmission repair, and again after repairs are made.

**IMPORTANT:**

- Duplicate the condition under which the customer's complaint was observed.
- Depending on the complaint, the line pressure gauge and the scan tool may be required during the test drive.
- During the test drive, it is important to record all necessary data from the areas being monitored, for use in diagnosis. Also listen for and note any unusual noises.

The following procedure should be used to test drive 4L30-E automatic transmission complaint vehicles:

1. Turn the ignition ON without starting the engine. Check that the "CHECK TRANS" lamp comes on for approximately 2 seconds and then goes out and remains out.
  - If the lamp is flashing, GOTO Check Trans Indicator in Transmission Control System (4L30-E) section.
  - If no serial data is present, GOTO OBD System Check. Refer to Driveability and Emissions in Engine section.

○ If the lamp stays ON or stays OFF, GOTO "Check Trans" Check in Transmission Control System (4L30-E) section.

2. Drive the vehicle. During the test drive, be sure that the transmission achieves normal operating temperature (approx. 20 minutes). Allow the transmission to go through all of its gear ranges, checking shift timing and firmness. Duplicate the owner's complaint condition as closely as possible during the test drive.
3. If, during the test drive, the "CHECK TRANS" lamp comes on, use the scan tool to check for trouble codes.
4. If, during the test drive, a problem is felt, but the "CHECK TRANS" lamp does not come on and no trouble codes are present, drive the vehicle with the PCM disconnected (manually shifting the vehicle).
  - In Manual L, the vehicle operates in first gear.
  - In Manual 2, the vehicle operates in third gear.
  - In Manual 3 or "D", the vehicle operates in fourth gear.
 If the problem still exists with the PCM disconnected, refer to Mechanical/Hydraulic Diagnosis in this section.
5. If no problem has been found at this point, check all underhood connections that supply power to the PCM and ignition fuses. Physically and visually inspect all the PCM harness connectors for loose or corroded terminals. Inspect the PCM ground points.

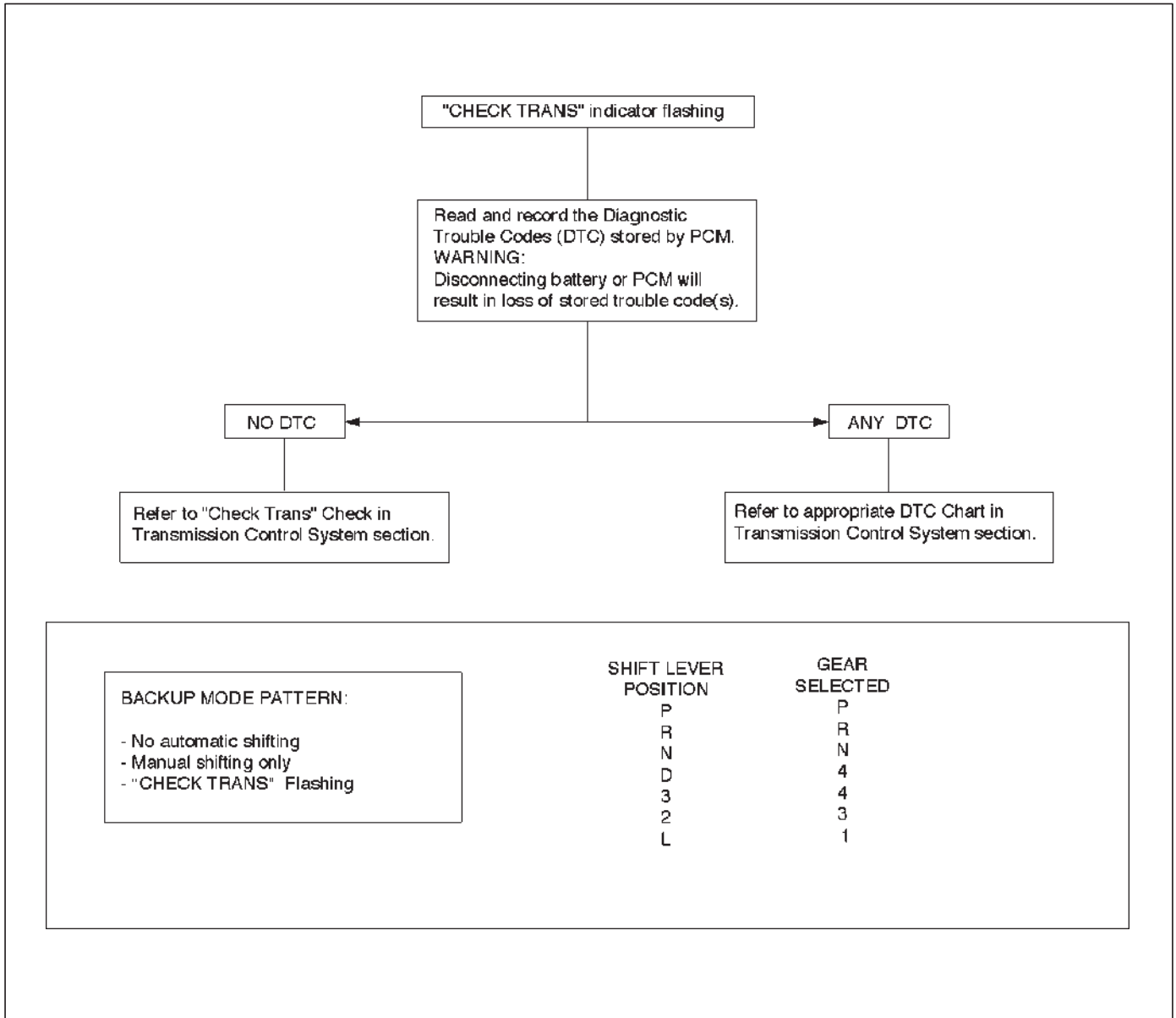


## Mechanical / Hydraulic Diagnosis Check Trans Indicator Chart

### Preform Preliminary Inspection First!

When the "CHECK TRANS" indicator is flashing, it indicates that a problem related to the transmission, the Powertrain Control Module (PCM), or the vehicle harness has occurred.

The system is now operating in a "BACKUP MODE" where the risk of further damaging the transmission has been reduced. The vehicle may be shifted manually. If the initial problem is intermittent or seldom, switching the engine OFF/ON might allow normal operation again until the problem reoccurs.



## Mechanical / Hydraulic Diagnosis Symptoms Index

Perform Preliminary Inspection First!

CHART	SYMPTOMS
1	NO ENGINE START IN NEUTRAL OR PARK
2	NO FORWARD GEARS IN ANY RANGE/NO REVERSE
3	NO ENGINE BRAKE IN ANY RANGE
4	POOR SHIFTING IN ALL GEARS (ALL HARSH OR ALL SOFT)
5a	DELAYS IN DRIVE AND REVERSE
5b	DELAYS IN REVERSE ONLY
6	DIAGNOSTIC TROUBLE CODE (DTC) P0730
7	HARSH 1-2 SHIFT
8	HARSH 3-4 SHIFT
9a	3-2 DOWNSHIFT COMPLAINT
9b	HARSH SHIFT WHEN SHIFTING INTO "D" OR ACCELERATING FROM STOP
9c	COASTDOWN HARSH SHIFT OR CLUNK AT 3-2 DOWNSHIFT
10	INTERMITTENT 4TH TO 2ND GEAR DOWNSHIFT AT STEADY SPEED
11	ENGINE FLARE AT SHIFTING DURING TURNING ONLY (USUALLY WITH WARM ENGINE)
12	ENGINE FLARE DURING 1-2 OR 2-3 SHIFT
13	SHUDDER ONLY DURING TORQUE CONVERTER CLUTCH (TCC) APPLYING
14	POSSIBLE CAUSES OF TRANSMISSION NOISE
15a	POSSIBLE CAUSES OF LOW LINE PRESSURE
15b	POSSIBLE CAUSES OF HIGH LINE PRESSURE
16	POSSIBLE CAUSES OF TRANSMISSION FLUID LEAKS

NOTE: Numbers with parenthesis on the following charts refer to Parts List at end of this section.

### Chart 1: No Engine Start In Neutral Or Park

Step	Action	Yes	No
1	Does engine start when shift lever moved from drive to neutral mostly in hot condition?	Go to Step 2	Go to Step 3
2	Does engine start in park at any condition?	Re-test vehicle	Go to Step 4
3	Does engine also not start in neutral when shift lever moved from park to neutral?	Go to Step 4	Go to Step 5
4	Check mode switch (63) setting. Readjust if necessary. Problems fixed?	Re-test vehicle	Go to Step 5
5	Check start circuit of mode switch (63) open in neutral. Was open found?	Locate and repair open(s)	Replace mode switch (63)

## 7A-14 AUTOMATIC TRANSMISSION (4L30-E)

### Chart 2: No Forward Gears In Any Range/No Reverse

Step	Action	Yes	No
1	Check line pressure. Refer to Line Pressure Test in this section. Was line pressure normal?	Go to Step 2	Use Chart 15a: Possible Causes of Low Line Pressure in this section
2	1. Check internal linkage: – Manual linkage (58) not moving manual valve (326). 2. Check for internal mechanical damage: – Turbine shaft (506) broken loose. – Overrun roller clutch (516) broken loose.  Was the problem found?	Repair or replace	—

### Chart 3: No Engine Brake In Any Range

Step	Action	Yes	No
1	Check line pressure. Refer to Line Pressure Test in this section. Was line pressure normal?	Go to Step 2	Use Chart 15a: Possible Causes of Low Line Pressure in this section
2	1. Check for overrun clutch leaks caused by: – Damaged piston lip (513) – Check ball defective (504) 2. Check for overrun lockout valve (705) stuck by foreign material. 3. Check for leaks at turbine shaft (506) caused by: – Teflon seal rings damaged (508) – Excessive wear of turbine shaft bearing surfaces.  Was the problem found?	Repair or replace	—

**Chart 4: Poor Shifting In All Gears (All Harsh Or All Soft)**

Step	Action	Yes	No
1	Check line pressure. Refer to Line Pressure Test in this section. Was line pressure normal?	Go to Step 2	Go to Step 3
2	1. Check for these conditions which could affect clutch apply time: <ul style="list-style-type: none"> <li>- Defective band apply solenoid (323).</li> <li>- Defective servo or/and accumulator piston.</li> <li>- Excessive clutch piston travel.</li> </ul> 2. Check of possible causes of internal leaks: <ul style="list-style-type: none"> <li>- Cut or damaged sealing ring(s)</li> <li>- Damaged sealing gasket(s)</li> <li>- Check ball missing or out of location in 2nd and 3rd clutch pistons.</li> </ul> 3. Check for causes of burned clutch plates or band. Was the problem found?	Repair or replace	—
3	Was the line pressure high?	Go to Step 4	Use Chart 15a: Possible Causes of Low Line Pressure in this section
4	Were DTCs P0560 and P0705 set?	Diagnose those DTC(s) first	Use Chart 15b: Possible Causes of High Line Pressure in this section

**Chart 5a: Delays In Drive And Reverse**

NOTE: A short delay (less than 3 seconds) when first engaging drive or reverse after allowing vehicle to sit overnight is normal.

Step	Action	Yes	No
1	Check line pressure. Refer to Line Pressure Test in this section. Was line pressure normal?	More than 3 second delay in drive and reverse with engine off 1 hour or less. Teflon seals (508) on turbine shaft damaged. Repair	Use Chart 15a: Possible Causes of Low Line Pressure in this section.

**Chart 5b: Delays In Reverse Only**

Step	Action	Yes	No
1	Check line pressure. Refer to Line Pressure Test in this section. Was line pressure normal?	Go to Step 2	Use Chart 15a: Possible Causes of Low Line Pressure in this section.
2	Main case valve body gasket (88) damaged. <ul style="list-style-type: none"> <li>- Reverse check ball (85) in valve body (84) missing or out of location.</li> <li>- Check for restrictions at valve body transfer plate orifice.</li> </ul> Was the problem found?	Repair	—

**7A-16 AUTOMATIC TRANSMISSION (4L30-E)**

**Chart 6: Diagnostic Trouble Code (DTC) P0730**

Step	Action	Yes	No
1	Check line pressure. Refer to Line Pressure Test in this section. Was line pressure normal?	Go to Step 2	Use Chart 15b: Possible Causes of High Line Pressure in this section
2	1. 1st and 2nd gear missing or 3rd and 4th gear missing. Check appropriate shift valve. If OK replace solenoid. 2. No engine brake in any range (All ranges in Drive and Reverse are OK). Check for suspected conditions modifying delays to clutch apply: – Overrun clutch seal damaged. – Excessive overrun clutch piston travel. – Defective 3-4 accumulator piston. – Causes of internal leaks. – Causes of burned clutch plates. 3. 1st and 4th gear missing or 2nd and 3rd gear missing. Shift solenoid A stuck. Replace shift solenoid A. 4. DTC P0730 is set in D range 1st gear above 3500 rpm. Go to Step 3. 5. DTC P0730 is set in D range 3rd gear between 55-80 mph. NOTE: Perform this test within safe and legal limits. Check for suspected conditions modifying delays to clutch apply: – 4th clutch seal damaged. – Excessive 4th clutch piston travel. – Defective 3-4 accumulator piston. – Causes of internal leaks. – Causes of burned clutch plates. Was the problem found?	Repair or replace	—
3	Check 3rd gear in “D” in winter mode. Does vehicle move?	Shift solenoid A stuck. Replace shift solenoid A.	Go to Step 4
4	Check for suspected conditions modifying delays to clutch apply: – 2nd clutch seal damaged. – Excessive 2nd clutch piston travel. – Defective accumulator piston. – Causes of internal leaks. – Check ball missing or out of location in 2nd clutch. – Seals cut, damaged or missing. – Gaskets defective. – Causes of burned clutch plates. Was the problem found?	Repair or replace	—

**Chart 7: Harsh 1–2 Shift**

Step	Action	Yes	No
1	Check line pressure. Refer to Line Pressure Test in this section. Was line pressure normal?	Check for 1–2 accumulator valve (320) stuck by foreign material in main case valve body.	Use Chart 15b: Possible Causes of High Line Pressure in this section.

**Chart 8: Harsh 3–4 Shift**

Step	Action	Yes	No
1	Check line pressure. Refer to Line Pressure Test in this section. Was line pressure normal?	Go to Step 2	Use Chart 15b: Possible Causes of High Line Pressure in this section
2	1. Check for 3–4 accumulator valve (407) stuck in adapter case valve body (401). 2. Check for 3–4 accumulator piston (18) stuck in adapter case (20). Was the problem found?	Repair or replace	—

**Chart 9a: 3–2 Downshift Complaint**

Step	Action	Yes	No
1	Check line pressure. Refer to Line Pressure Test in this section. Was line pressure normal?	Go to Step 2	Use Chart 15a: Possible Causes of Low Line Pressure in this section
2	Does DTC P1850 set?	Diagnose P1850 first	Replace band apply solenoid (PWM) (323)

**Chart 9b: Harsh Shift When Shifting Into “D” Or Accelerating From Stop**

Step	Action	Yes	No
1	Check line pressure. Refer to Line Pressure Test in this section. Was line pressure normal?	Go to Step 2	Use Chart 15b: Possible Causes of High Line Pressure in this section
2	Does DTC P1850 set?	Diagnose P1850 first	Replace band apply solenoid (PWM) (323)

## 7A-18 AUTOMATIC TRANSMISSION (4L30-E)

### Chart 9c: Coastdown Harsh Shift Or Clunk At 3-2 Downshift

Step	Action	Yes	No
1	Check line pressure. Refer to Line Pressure Test in this section. Was line pressure normal?	Go to Step 2	Use Chart 15b: Possible Causes of High Line Pressure in this section
2	Does DTC P1850 set?	Diagnose P1850 first	Replace band apply solenoid (PWM) (323)

### Chart 10: Intermittent 4TH TO 2ND Gear Downshift At Steady Speed

Step	Action	Yes	No
1	Check for consistent speed sensor reading with scan tool. Was the reading correct?	Replace mode switch for intermittent contact.	Go to Step 2
2	1. Check for wiring harness damage or short to ground. If OK, go to (2). 2. Check transmission speed sensor connections. If OK, go to (3). 3. Replace transmission speed sensor. Was the replacement complete?	—	Replace speed sensor.

### Chart 11: Engine Flare At Shifting During Turning Only (Usually With Warm Engine)

Step	Action	Yes	No
1	Check for oil leaks at transmission. Was the problem found?	Replace transmission oil filter and gasket	—

### Chart 12: Engine Flare During 1-2 Or 2-3 Shift

Step	Action	Yes	No
1	Check line pressure. Refer to Line Pressure Test in this section. Was line pressure normal?	Go to Step 2	Use Chart 15a: Possible Causes of Low Line Pressure in this section
2	1. Check for a stuck 1-2 accumulator valve (320). 2. Check for servo piston (106) leaks. 3. Check for a stuck band apply solenoid (323). Was line pressure normal?	Repair or replace	—

**Chart 13: Shudder Only During Torque Converter Clutch (TCC) Applying**

Step	Action	Yes	No
1	<p>1. TCC shudder is one of the most commonly misdiagnosed conditions in an automatic transmission. The key to diagnosing TCC shudder is to note when it happens and under what conditions. Once the TCC has been fully applied, it is nearly impossible to make it shudder. TCC shudder (short burst of noise normally less than 1 second) will only occur during clutch applying. It is not a steady state condition.</p> <p>2. Drive until whole drivetrain is at normal operating temperature.</p> <ul style="list-style-type: none"> <li>– On 4WD vehicles, the test must be performed with transfer case selector lever in “2H” position.</li> <li>– Shudder is a short burst of noise normally less than 1 second in duration, and can be induced by the following maneuver:</li> </ul> <p>3. From coast condition at 50 mph in “D” range (Normal mode), depress the throttle to 1/4-1/3 throttle. If present, shudder will occur within 5 seconds together with TCC application. (The scan tool may be used to determine the exact time of TCC applying)</p> <p>Was the problem found?</p>	<p>Replace transmission fluid and filter (remove both pans) and flush cooler lines.</p> <p>Replace converter assembly and O-ring on turbine shaft</p>	<p>Perform mechanical inspection of other drivetrain components.</p>

**Chart 14: Possible Causes Of Transmission Noise**

**CAUTION:** Before checking transmission for what is believed to be transmission noise, ensure presence and positioning of insulating plugs, pads etc. Also make sure that noise does not come from other drivetrain components.

Condition	Possible cause	Correction
Whine or Buzz	Oil level low	Fill with ATF, check for external leaks.
	Plugged or restricted oil filter	Inspect oil filter. Replace oil filter or ATF as necessary.
	Damaged oil filter gasket	Replace oil filter gasket.
Knocking noise from front of transmission.	Loose bolts (Converter to flex plate)	Tighten to specifications.
	Cracked or broken flex plate	Replace flex plate.
	Converter damaged	Replace converter.
Knocking noise while driving, mostly on acceleration.	Transmission mount loose or broken	Tighten mount bolts or replace transmission mount.
	Cooler line mounts loose or broken	Tighten or replace cooler line mounts.
	Cooler lines touching body or frame	Repair or replace as necessary.
Knocking noise when vehicle is stationary.	Loose flex plate mounting bolts	Tighten to specifications.
	Cracked or broken flex plate	Replace flex plate.
	Damaged converter	Replace converter.



**7A-20 AUTOMATIC TRANSMISSION (4L30-E)**

**Chart 15a: Possible Causes of Low Line Pressure**

<b>Step</b>	<b>Action</b>	<b>Yes</b>	<b>No</b>
1	Check oil level. Was the problem found?	Fill with ATF	Go to Step 2
2	Check for defective throttle position sensor. Was the problem found?	Replace throttle position sensor	Go to Step 3
3	Check for plugged, loose, or damaged oil filter (79). Was the problem found?	Inspect oil filter, tighten bolts or replace oil filter (79)	Go to Step 4
4	Check for a stuck force motor plunger (404). (Adapter case valve body) Was the problem found?	Replace force motor plunger (404)	Go to Step 5
5	Check for a stuck feed limit valve (412). (Adapter case valve body) Was the problem found?	Replace feed limit valve (412)	Go to Step 6
6	Check for loose converter bolts (4 & 5). Was the problem found?	Tighten converter bolts (4 & 5)	Go to Step 7
7	Check for a stuck pressure regulator valve (208). (Oil pump) Was the problem found?	Replace pressure regulator valve (208)	Go to Step 8
8	Check for a stuck boost valve (205).(Oil pump) Was the problem found?	Replace boost valve (205)	Go to Step 9
9	Check for blocked intermediate oil passages to pressure regulator valve. (Oil pump) Was the problem found?	Replace oil pump	Go to Step 10
10	Check for defective oil pump (9, 201, 202 & 209). Was the problem found?	Replace oil pump	Go to Step 11
11	Check for internal leaks. – Check balls missing or out of location in valve bodies – Seals cut or damaged – Gaskets defective, etc. Was the problem found?	Install balls, or correct ball location Replace seals Replace gaskets	—

**Chart 15b: Possible Causes Of High Line Pressure**

NOTE: If transmission is operating in backup mode, high line pressure will be present.

Step	Action	Yes	No
1	Check for defective throttle position sensor. Was the problem found?	Replace throttle position sensor.	Go to Step 2.
2	Check for a stuck force motor plunger (404). (Open circuit/intermittent) (Adapter case valve body) Was the problem found?	Replace force motor plunger (404)	Go to Step 3
3	Check for a stuck feed limit valve (412). (Adapter case valve body) Was the problem found?	Replace force motor plunger (412)	Go to Step 4
4	Check converter bolts (4 & 5). Was the problem found?	Tighten converter bolts (4 & 5)	Go to Step 5
5	Check for a stuck pressure regulator valve (208). (Oil pump) Was the problem found?	Replace pressure regulator valve (208)	Go to Step 6
6	Check for a stuck boost valve (205). (Oil pump) Was the problem found?	Replace boost valve (205)	Go to Step 7
7	Check for internal leaks. <ul style="list-style-type: none"> <li>- Check balls missing or out of location in valve bodies</li> <li>- Seals cut or missing</li> <li>- Gaskets defective, etc.</li> </ul> Was the problem found?	Install balls, or correct ball location  Replace seals Replace gaskets	—

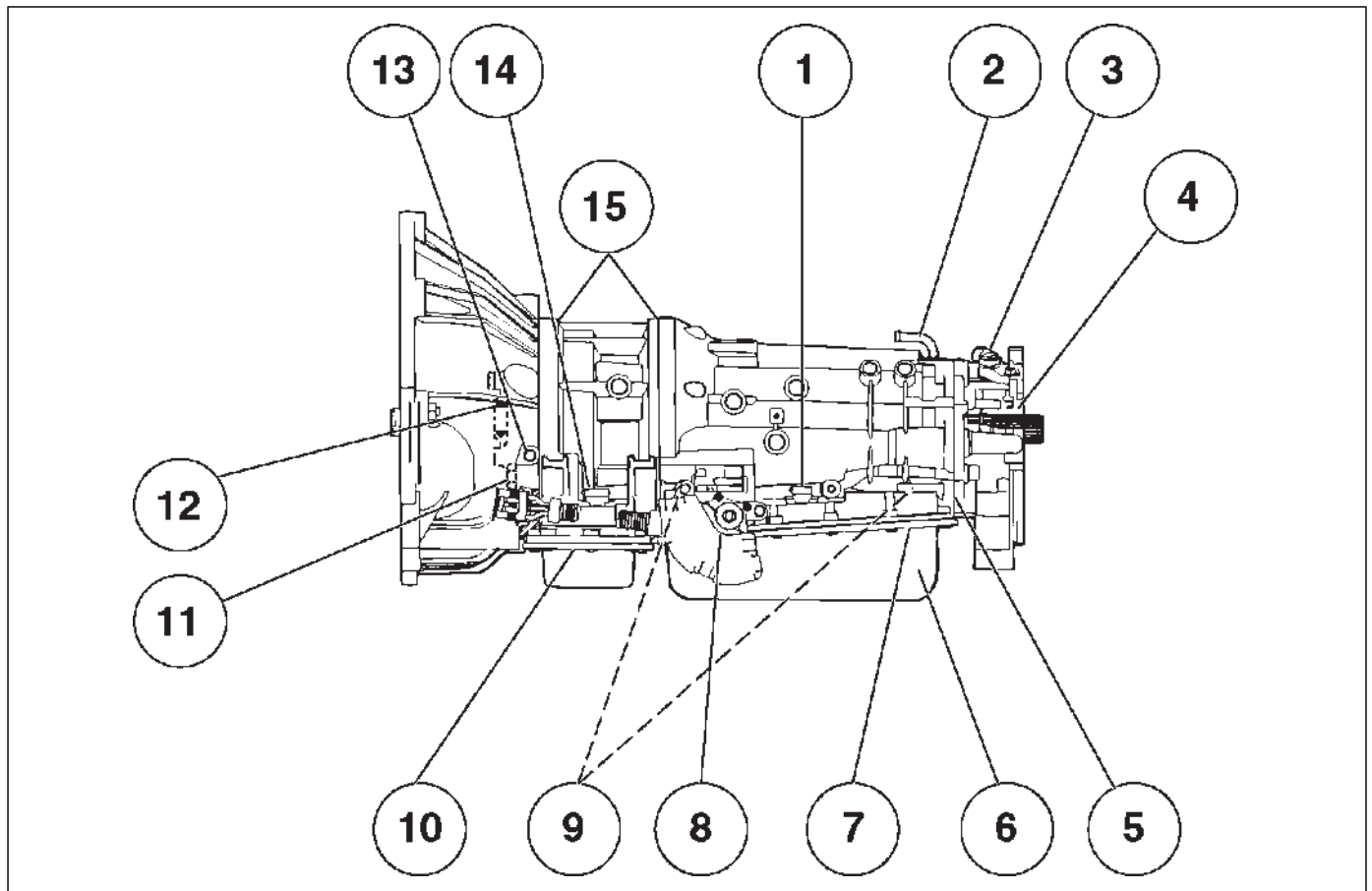
**Chart 16: Possible Causes Of Transmission Fluid Leaks**

Before attempting to correct an oil leak, the actual source of the leak must be determined. In many cases, the source of the leak may be difficult to determine due to "wind flow" around the engine and transmission. The suspected area should be wiped clean before inspecting for the source of the leak.

Oil leaks around the engine and transmission are generally carried toward the rear of the vehicle by the air stream. In determining the source of an oil leak, the following two checks should be made:

1. With the engine running, check for external line pressure leaks.
2. With the engine off, check for oil leaks due to the raised oil level caused by drainback of converter oil into the transmission.

**Possible Causes Of Fluid Leaks Due To Sealing Malfunction**



240RX008

**Legend**

- |   |  |
|---|--|
| (1) Electrical Connector (Main Case) Seal   | (9) Oil Cooler Connectors (2)                                |
| (2) Transmission Vent (Breather)            | (10) Oil Pan Gasket (Adapter Case)                           |
| (3) Speed Sensor O-Ring                     | (11) Converter housing attaching bolts not correctly torqued |
| (4) Extension (Adapter) Lip Seal            | (12) Converter Housing Lip Seal                              |
| (5) Extension (Adapter) to Main Case Gasket | (13) Line Pressure Tap Plug                                  |
| (6) Overfill and Oil Drain Screws Gasket    | (14) Electrical Connector (Adapter Case) Seal                |
| (7) Oil Pan Gasket (Main Case)              | (15) Adapter Case Seal Rings (2)                             |
| (8) Selector Shaft Seal                     |  |

## Stall Test

The stall test allows you to check the transmission for internal abrasion and the one way clutch for slippage. Torque converter performance can also be evaluated. The stall test results together with the road test results will identify transmission components requiring servicing or adjustment.

### Stall Test Procedure:

1. Check the level of the engine coolant, the engine oil, and the automatic transmission fluid. Replenish if necessary.
2. Block the wheels and set the parking brake.
3. Connect a tachometer to the engine.
4. Start the engine and allow it to idle until the engine coolant temperature reaches 70 – 80°C (158 – 176°F).
5. Hold the brake pedal down as far as it will go.
6. Place the selector in the “D” range.
7. Gradually push the accelerator pedal to the floor. The throttle valve will be fully open.

Note the engine speed at which the tachometer needle stabilizes.

**Stall Speed : 2,100 ±150 rpm**

NOTE: Do not continuously run this test longer than 5 seconds.

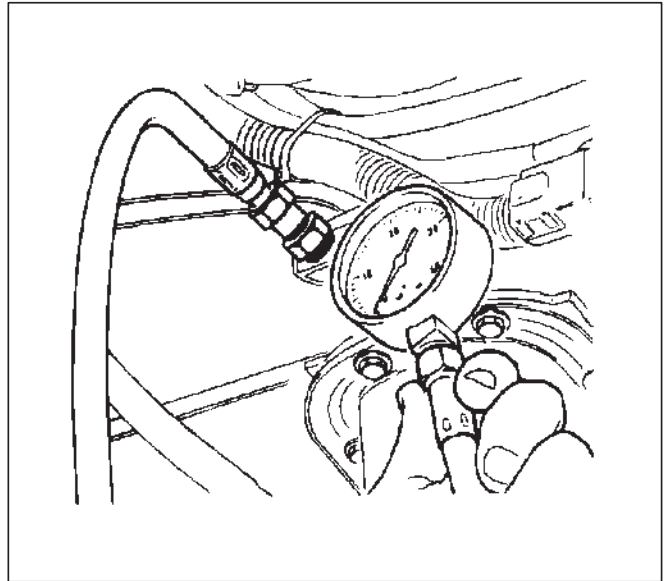
8. Release the accelerator pedal.
9. Place the selector in the “N” range.
10. Run the engine at 1,200 rpm for one minute. This will cool the transmission fluid.
11. Repeat Steps 7 – 10 for the “3”, “2”, “L” and “R” ranges.

## Line Pressure Test

The line pressure test checks oil pump and control valve pressure regulator valve function. It will also detect oil leakage.

### Line Pressure Test Procedure:

1. Check the level of the engine coolant, the engine oil, and the automatic transmission fluid. Replenish if required.
2. Block the wheels and set the parking brake.
3. Remove the pressure detection plug at the left side of the transmission case. Set J-29770-A pressure gauge and adapter to the pressure detection plug hole.



4. Start the engine and allow it to idle until the engine coolant temperature reaches 70 – 80°C (158 – 176°F).
5. Hold the brake pedal down as far as it will go.
6. Place the selector in the “D” range.
7. Note the pressure gauge reading with the engine idling.
8. Gradually push the accelerator pedal to the floor. The throttle valve will be fully open. Note the pressure gauge reading with the accelerator pedal fully depressed.

NOTE: Do not continuously run this test longer than 5 seconds.

9. Release the accelerator pedal.
10. Place the selector in the “N” range.
11. Run the engine at 1,200 rpm for one minute. This will cool the transmission fluid.
12. Repeat Steps 7 – 11 for the “3”, “2”, “L”, and “R” ranges.
13. Install a pressure detection plug to the transmission case, applying recommended thread locking agent (LOCTITE 242) or its equivalent to thread of plug. Make sure that thread is cleaned before applying locking agents.
14. Tighten the pressure detection plug to the specified torque.

**Torque: 9 – 14N·m (7 – 10lb ft)**

## 7A-24 AUTOMATIC TRANSMISSION (4L30-E)

MODE	LEVER POSITION	ENGINE SPEED	LINE PRESSURE		FORCE MOTOR CURRENT
			kpa	PSI	
NORMAL/POWER	D,3,2,L	IDLE	312-363	45.2-52.6	VARIABLE
WINTER	D	IDLE	312 - 363	45.2 - 52.6	0.9 - 1.0A
NORMAL/POWER WINTER	REVERSE	IDLE	419 - 486	60.7 - 70.5	0.9 - 1.0A
NORMAL/POWER	D, 3, 2, L	STALL SPEED	1,236 - 1,320	179.3 - 191.4	0.1 - 0.2A
WINTER	D	STALL SPEED	1,236 - 1,320	179.3 - 191.4	0.1 - 0.2A
NORMAL/POWER WINTER	REVERSE	STALL SPEED	1,634 - 1,743	236.9 - 252.8	0.1 - 0.2A

### Shift Speed Chart

Transfer gear ratio	High: 1.000
Rear axle ratio	4.300

#### “Normal mode”

##### Upshift

Range	Throttle opening	1 → 2 (First Gear) (Second Gear) km/h (mph)		2 → 3 (Second Gear) (Third Gear) km/h (mph)		3 → 4 (Third Gear) (Fourth Gear) km/h (mph)	
		D (Drive)	Fully opened	42 ~ 48 (26 ~ 30)	86 ~ 92 (54 ~ 58)	139 ~ 145 (87 ~ 91)	
	Half throttle	29 ~ 35 (18 ~ 22)	58 ~ 64 (36 ~ 40)	113 ~ 118 (70 ~ 74)			
3 (Third)	Fully opened	52 ~ 58 (33 ~ 36)	105 ~ 111 (66 ~ 69)	—			
	Half throttle	32 ~ 38 (20 ~ 24)	58 ~ 64 (36 ~ 40)	—			
2 (Second)	Fully opened	52 ~ 58 (33 ~ 36)	—	—			
	Half throttle	32 ~ 38 (20 ~ 24)	—	—			

##### Downshift

Range	Throttle opening	1 ← 2 (First Gear) (Second Gear) km/h (mph)		2 ← 3 (Second Gear) (Third Gear) km/h (mph)		3 ← 4 (Third Gear) (Fourth Gear) km/h (mph)	
		D (Drive)	Fully opened	17 ~ 23 (11 ~ 14)	75 ~ 81 (47 ~ 51)	118 ~ 124 (74 ~ 78)	
	Half throttle	23 ~ 29 (14 ~ 18)	32 ~ 38 (20 ~ 24)	65 ~ 71 (40 ~ 44)			
	Fully closed	13 ~ 19 (8 ~ 12)	20 ~ 26 (12 ~ 16)	28 ~ 34 (17 ~ 21)			
3 (Third)	Fully opened	42 ~ 48 (26 ~ 30)	92 ~ 98 (58 ~ 61)	—			
	Half throttle	15 ~ 21 (9 ~ 13)	34 ~ 40 (21 ~ 25)	—			
	Fully closed	13 ~ 19 (8 ~ 12)	15 ~ 21 (9 ~ 13)	—			
2 (Second)	Fully opened	43 ~ 49 (27 ~ 31)	100 ~ 106 (63 ~ 66)	—			
	Half throttle	15 ~ 21 (9 ~ 13)	94 ~ 100 (59 ~ 63)	—			
	Fully closed	13 ~ 19 (8 ~ 12)	82 ~ 88 (51 ~ 55)	—			
L (First)	—	50 ~ 56 (31 ~ 35)	—	—			

**“Power mode”**

**Upshift**

Range	Throttle opening	1 → 2 (First Gear) (Second Gear) km/h (mph)	2 → 3 (Second Gear) (Third Gear) km/h (mph)	3 → 4 (Third Gear) (Fourth Gear) km/h (mph)
D (Drive)	Fully opened	47 ~ 53 (29 ~ 33)	89 ~ 95 (56 ~ 59)	140 ~ 146 (88 ~ 91)
	Half throttle	37 ~ 43 (23 ~ 27)	73 ~ 79 (45 ~ 49)	126 ~ 132 (78 ~ 82)
3 (Third)	Fully opened	52 ~ 58 (33 ~ 36)	105 ~ 111 (66 ~ 69)	—
	Half throttle	37 ~ 43 (23 ~ 27)	74 ~ 80 (46 ~ 50)	—
2 (Second)	Fully opened	52 ~ 58 (33 ~ 36)	—	—
	Half throttle	37 ~ 43 (23 ~ 27)	—	—

**Downshift**

Range	Throttle opening	1 ← 2 (First Gear) (Second Gear) km/h (mph)	2 ← 3 (Second Gear) (Third Gear) km/h (mph)	3 ← 4 (Third Gear) (Fourth Gear) km/h (mph)
D (Drive)	Fully opened	33 ~ 39 (21 ~ 24)	79 ~ 85 (49 ~ 52)	126 ~ 132 (79 ~ 82)
	Half throttle	21 ~ 27 (13 ~ 17)	50 ~ 56 (31 ~ 35)	94 ~ 100 (58 ~ 62)
	Fully closed	13 ~ 19 (8 ~ 12)	23 ~ 29 (14 ~ 18)	45 ~ 51 (28 ~ 32)
3 (Third)	Fully opened	43 ~ 49 (27 ~ 30)	96 ~ 102 (60 ~ 63)	—
	Half throttle	21 ~ 27 (13 ~ 17)	53 ~ 59 (33 ~ 37)	—
	Fully closed	13 ~ 19 (8 ~ 12)	24 ~ 30 (15 ~ 19)	—
2 (Second)	Fully opened	43 ~ 49 (27 ~ 30)	100 ~ 106 (63 ~ 66)	—
	Half throttle	21 ~ 27 (13 ~ 17)	94 ~ 100 (59 ~ 63)	—
	Fully closed	13 ~ 19 (8 ~ 12)	82 ~ 88 (51 ~ 55)	—
L (First)	—	53 ~ 59 (33 ~ 36)	—	—

**“Winter mode”**

D range, winter mode ON → OFF	31 ~ 37 km/h (19 ~ 23 mph)
-------------------------------	----------------------------

**7A-26 AUTOMATIC TRANSMISSION (4L30-E)****Lockup Speed Chart**

Transfer gear ratio	High: 1.000
Rear axle ratio	4.300

D range, Throttle opening 9%	Mode	Lockup ON			Lockup OFF		
		2nd km/h (mph)	3rd km/h (mph)	4th km/h (mph)	2nd km/h (mph)	3rd km/h (mph)	4th km/h (mph)
	Normal	72 ~ 78 (45 ~ 48)	53 ~ 59 (33 ~ 37)	78 ~ 84 (48 ~ 52)	67 ~ 73 (42 ~ 45)	45 ~ 51 (28 ~ 32)	73 ~ 79 (45 ~ 49)
	Power	72 ~ 78 (45 ~ 48)	77 ~ 83 (48 ~ 52)	77 ~ 83 (48 ~ 52)	67 ~ 73 (42 ~ 45)	68 ~ 74 (42 ~ 46)	72 ~ 78 (45 ~ 48)

## Changing Transmission Fluid

There is no need to change the transmission fluid unless the transmission is used under one or more of the following heavy duty conditions.

- A. Repeated short trips
- B. Driving on rough roads
- C. Driving on dusty roads
- D. Towing a trailer

If the vehicle is used under these conditions, change the fluid every 20,000 miles (32,000 km.)

More over, the remaining life percentage of ATF can be estimated by using Tech 2 as an auxiliary tool to judge the right time for ATF replacement.

The remaining life percentage is calculated from ATF'S heat history. When it is close to 0%, ATF replacement is recommended.

1. Place a large drain pan under the oil pan.
2. Remove the transmission oil drain screw (2) and drain fluid.
3. Tighten drain screw (2).

**Torque: 38 N•m (28 lb ft)**

4. Remove the transmission overfill screw (1) and fill transmission through overfill screw opening, using DEXRON®-III ATF.

NOTE: Add transmission fluid until it flows out over the overfill screw opening.

5. Let engine idle until a fluid temperature between 32° C (90° F) and 57° C (135° F) is reached.
6. Add transmission fluid until it flows out over the overfill screw opening, then close the overfill screw (1).

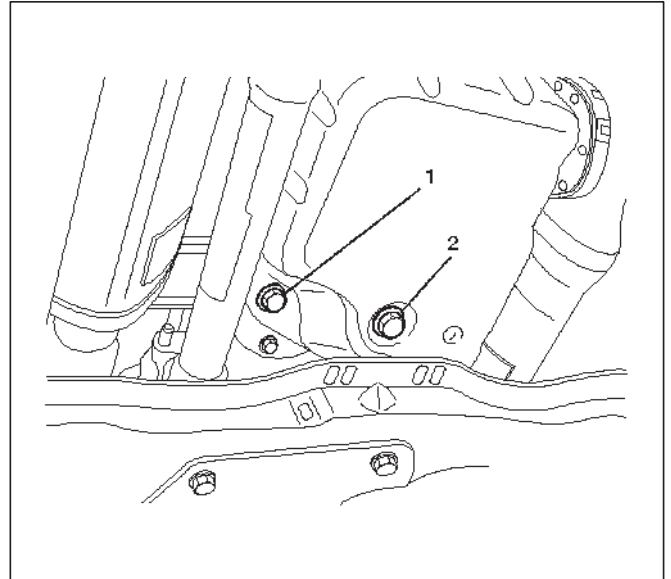
**Torque: 38 N•m (28 lb ft)**

NOTE: To prevent fluid leaks, the overfill screw and oil drain screws gasket must be replaced each time these screws are removed.

NOTE: Check transmission fluid temperature with service scan tool.

7. Reset "Oil Life Monitor" data by using Tech 2.

Refer to Tech 2 OBD II Connection in Transmission Control System (4L30-E) section.

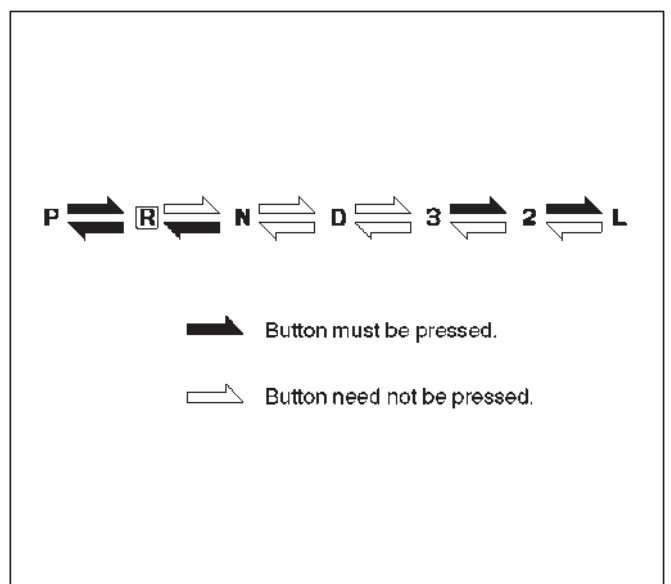


242RW003

## Selector Lever

### Inspection

1. Make sure that when the selector lever is shifted from "P" to "L", a "clicking" can be felt at each shift position. Make sure that the gear corresponds to that of the position plate indicator.
2. Check to see if the selector lever can be shifted as shown in illustration.

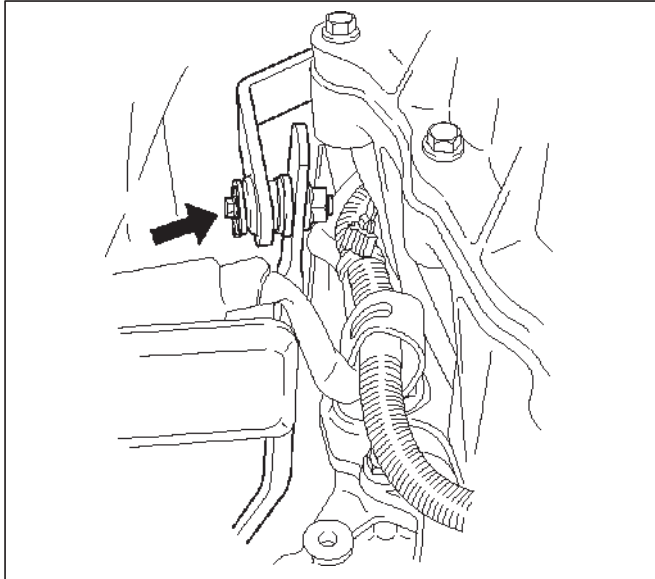


C07RW006



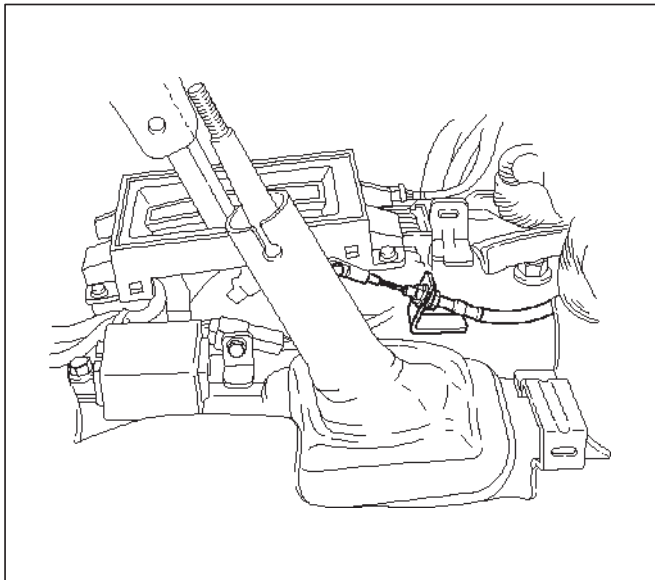
## Removal

1. Place selector lever in neutral.
2. Disconnect battery ground cable.
3. Raise the vehicle and support it on jack stands.  
Disconnect shift control rod from the selector lever assembly side.



256RX004

4. Remove transfer control lever knob.
5. Remove center console and rear console.  
○ Disconnect wiring harness connectors from the console.
6. Remove PCM covers.



256RX003

7. Disconnect shift lock cable from the selector lever assembly side.
8. Disconnect wiring harness connectors from the selector lever assembly.
9. Remove selector lever assembly.

## Installation

To install, follow the removal steps in the reverse order, noting the following points:

### Adjustment of select lever and control rod

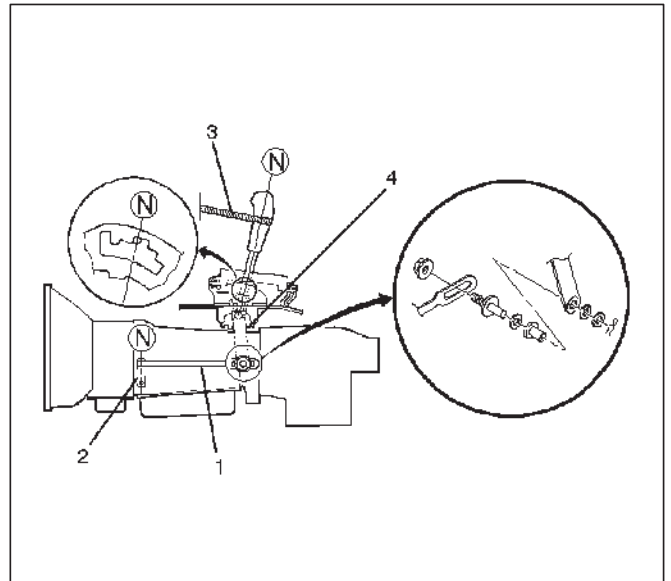
1. Place the vehicle on a level surface.

NOTE: If the vehicle is not on level surface, the shift control rod set positions will vary with the movement of engine. To prevent possible misadjustment of the control rod, the vehicle must be placed on a level surface.

2. Install the shift control rod (1) to the transmission select lever (2), and then place the lever in the "N" position.
3. Set select lever in the "N" position.
4. Push select lever forward ("R" position side) and secure it (using a rubber band (3), etc.) so that the pin comes into contact with the wall of the detent plate.
5. Install the shift control rod (1) to the selector lever arm (4).

**Torque: 32 N•m (24 lb ft)**

NOTE: Do not apply oil to the threaded portions.



256RW014

6. After adjustment, make sure that the selector lever operates normally, and that each selector position is properly indicated. (The red mark shows through the window.)

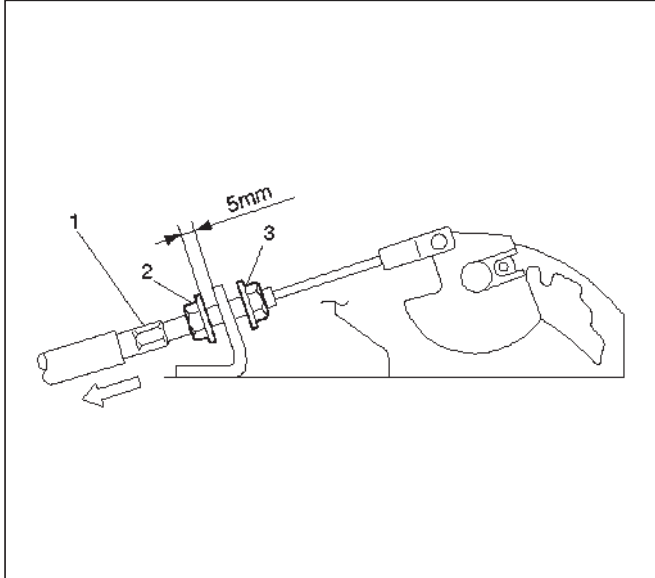
### Adjustment of shift lock cable

1. Set ignition key in "LOCK" position and selector lever in "P" position.
2. Adjust cable screw cap on selector lever side to provide a gap (slack for cable) of 1 – 2 mm between rod on steering lock side and stopper.  
Adjust cap as follows:
  - a. Pull screw cap (1) in arrow direction to remove inner cable slack.
  - b. With cable kept as (a), adjust gap between nut (2) and bracket to 5 mm (0.2 in).

- c. Lock inner cable by turning nut (3) while holding nut (2) in place.

**Torque : 3.7 N•m (33 lb in)**

NOTE: Clean the cable threads, and do not apply oil to them.



256RW015

3. Check the shift lock operation:

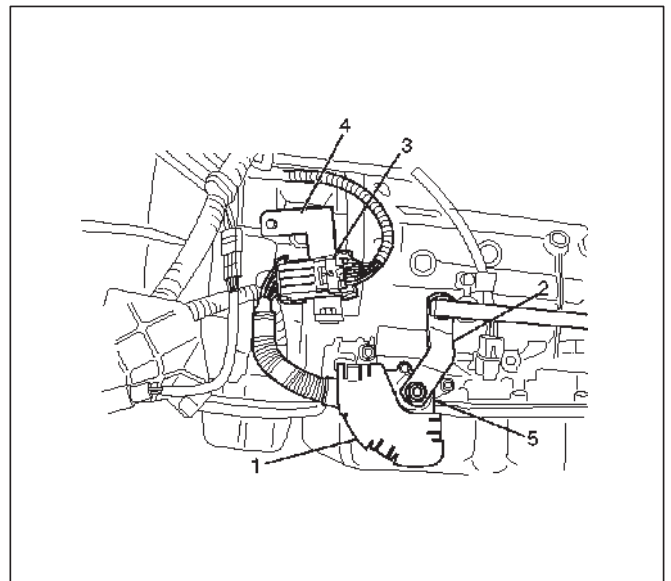
- a. Selector lever should not move out of "P" position with ignition key in "Lock" position.
- b. Selector lever can be moved out of "P" position with ignition key in "ON" position only when brake pedal is depressed.
- c. Ignition key can be turned to "LOCK" position only when selector lever is in "P" position (key can be pulled out).

If (a) and (c) fail, readjust cable. If (b) fails, readjust connector wiring and brake pedal switch.

## Mode Switch

### Removal

1. Place selector lever in neutral.
2. Disconnect battery ground cable.
3. Remove mode switch cover (1).
4. Disconnect selector lever (2) from the mode switch.
5. Disconnect transmission harness from the mode switch connector (3).
6. Remove bracket with mode switch connector from the transmission case.
7. Remove mode switch connector (3) from the bracket (4).
8. Remove two mode switch bolts and nut then remove mode switch (5).



210RW008

### Installation

To install, follow the removal steps in the reverse order, noting the following points;

1. Torque

**Mode switch bolt: 13 N•m (113 lb in)**

**Selector lever nut: 23 N•m (17 lb ft)**

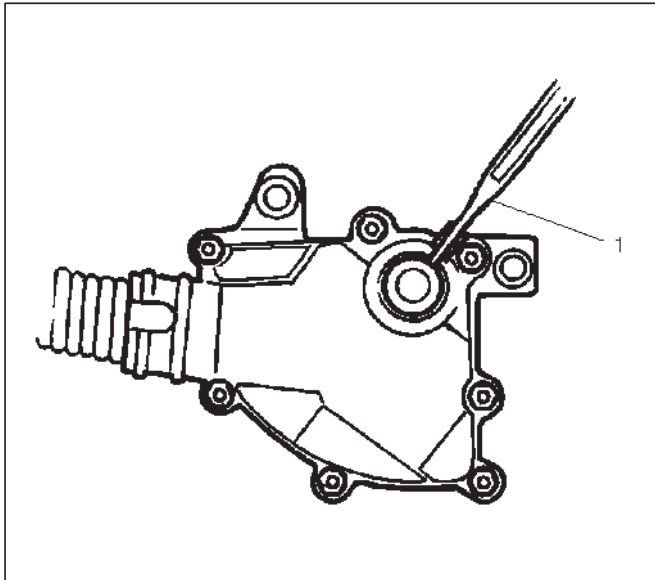
## 7A-30 AUTOMATIC TRANSMISSION (4L30-E)

### 2. Mode switch setting procedure

Perform either of the following adjustment procedures:

#### Procedure 1

- Place selector lever in neutral.
- Remove selector lever from the mode switch.
- Remove the mode switch cover.
- Loosen the two 10 mm screws.
- Rotate the mode switch until the slot in the mode switch housing aligns with the selector shaft bushing, and insert a 3/32 in. (2.4 mm) drill bit or punch (1) into the slot.
- Tighten the screws to 13 N·m (113 lb in).
- After completing adjustment, snap the mode switch cover into place.
- Reinstall the selector lever.

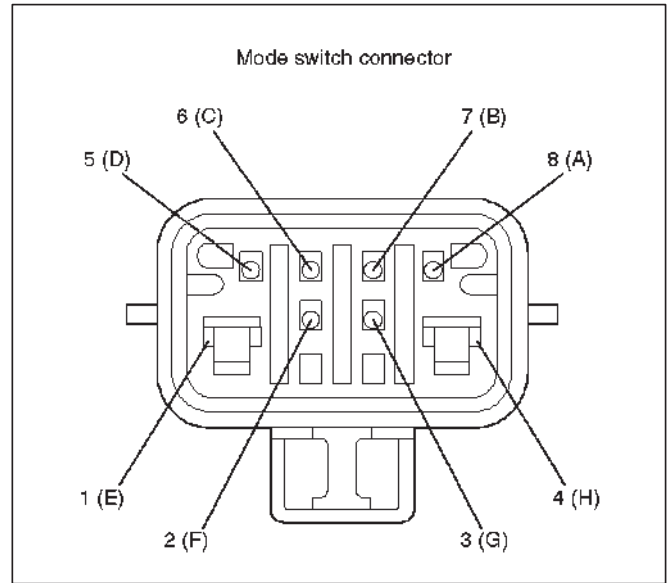


249RW001

#### Procedure 2

- Place selector lever in neutral.
- Disconnect transmission harness connector from mode switch connector.
- Remove mode switch connector with bracket from the transmission case.
- Connect multimeter (resistance mode) to terminals 1(E) and 4(H) on mode switch connector.
- Loosen two mounting screws.
- Rotate mode switch slightly in both directions to determine the range (approx. 5 degrees) of electrical contact.
- Position mode switch in middle of contact range.
- Tighten two mounting screws.
- Remove multimeter and install mode switch harness connector with bracket to the transmission case.

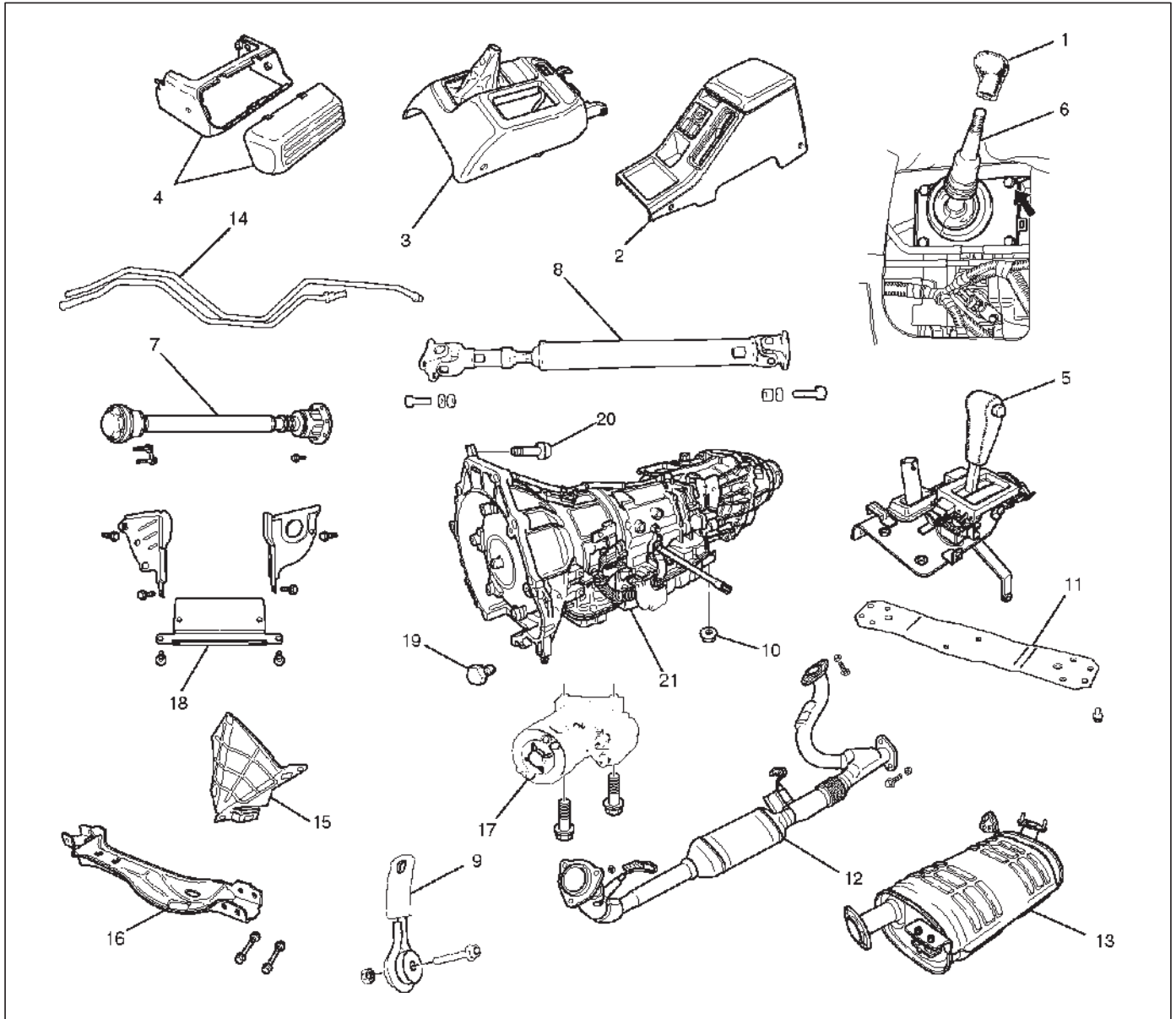
- Connect transmission harness connector to mode switch connector.



F07RW003

## Transmission (With Transfer Case)

### Transmission And Associated Parts



150RX007

#### Legend

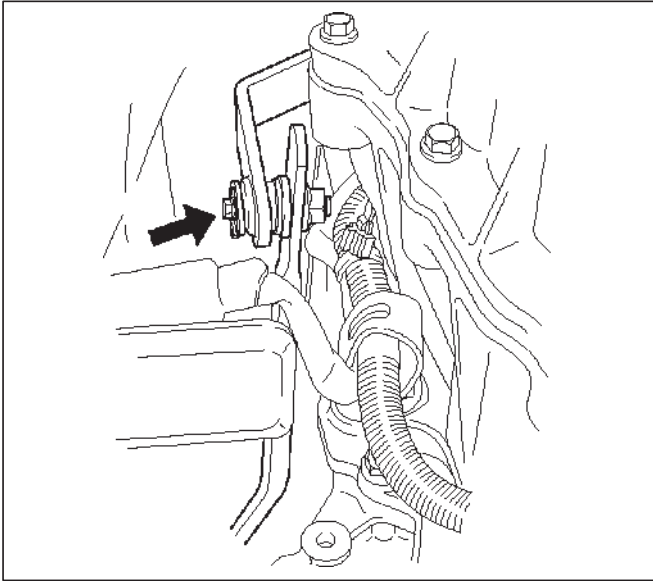
- |                                 |   |
|---------------------------------|---|
| (1) Transfer Control Lever Knob | (12) Left Catalytic Converter Assembly                |
| (2) Rear Console                | (13) Exhaust Silencer Assembly                        |
| (3) Center Console              | (14) Transmission Oil Cooler Pipe                     |
| (4) PCM Cover                   | (15) Harness Protector                                |
| (5) Selector Lever Assembly     | (16) Front Crossmember                                |
| (6) Transfer Control Lever      | (17) Starter  |
| (7) Front Propeller Shaft       | (18) Under Cover                                      |
| (8) Rear Propeller Shaft        | (19) Flex Plate Torque Cover Bolt (Non-reusable part) |
| (9) Seat Belt Tension Rod       | (20) Engine Transmission Bolt                         |
| (10) Rear Mount Nut             | (21) Transmission Assembly                            |
| (11) Third Crossmember          |   |

#### Removal

1. Remove engine hood.
2. Place selector lever in neutral.
3. Disconnect battery ground cable.

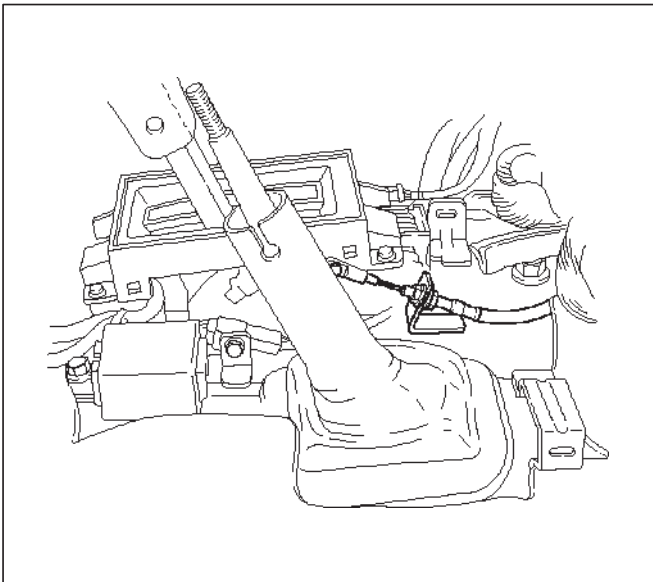
## 7A-32 AUTOMATIC TRANSMISSION (4L30-E)

4. Raise the vehicle and support it on jack stands.  
Disconnect shift control rod from the selector lever assembly side.



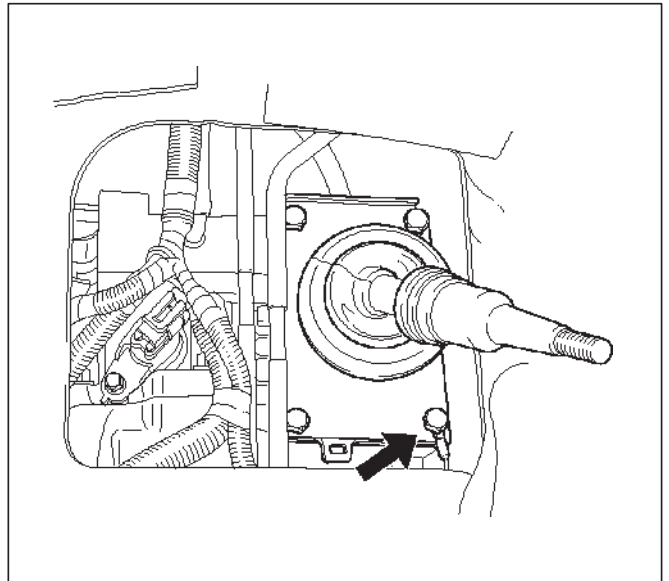
256RX004

5. Remove transfer control lever knob (1).
6. Remove rear console (2).
7. Remove center console (3).
8. Remove two PCM covers (4).
9. Disconnect shift lock cable from the selector lever assembly side.



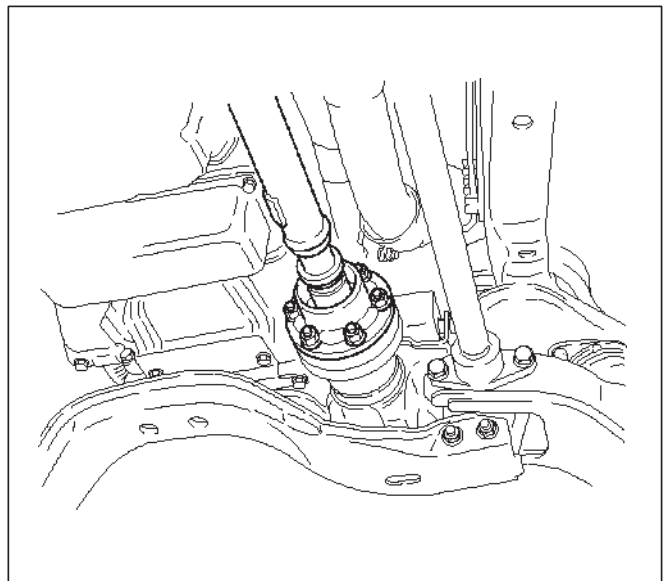
256RX003

10. Disconnect wiring harness connectors and remove selector lever assembly (5).
11. Disconnect ground cable and remove transfer control lever (6).



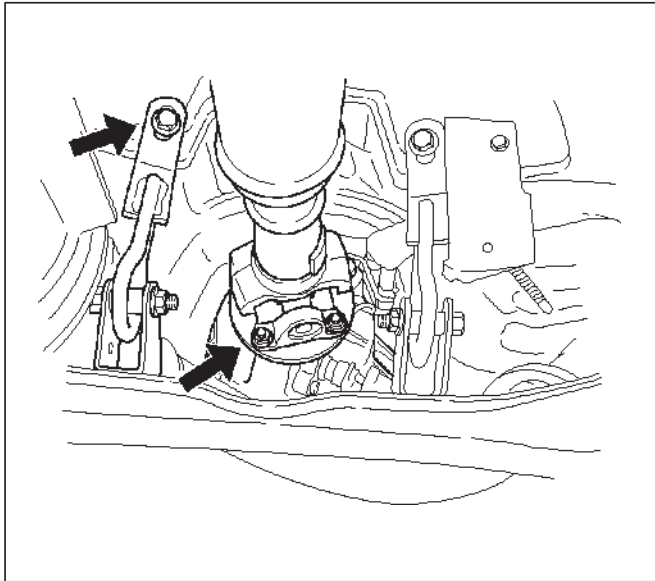
241RX002

12. Remove front propeller shaft assembly (7).



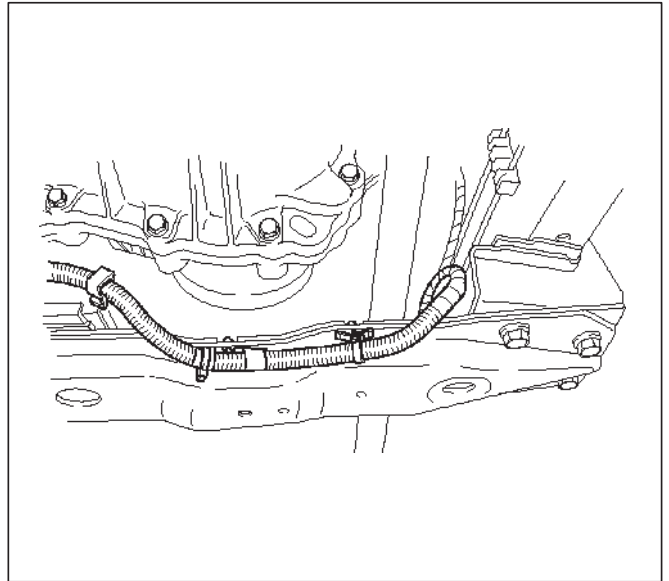
401RX014

13. Disconnect rear propeller shaft (8) from the transfer case flange.
14. Disconnect seat belt tension rod (9) from the floor.



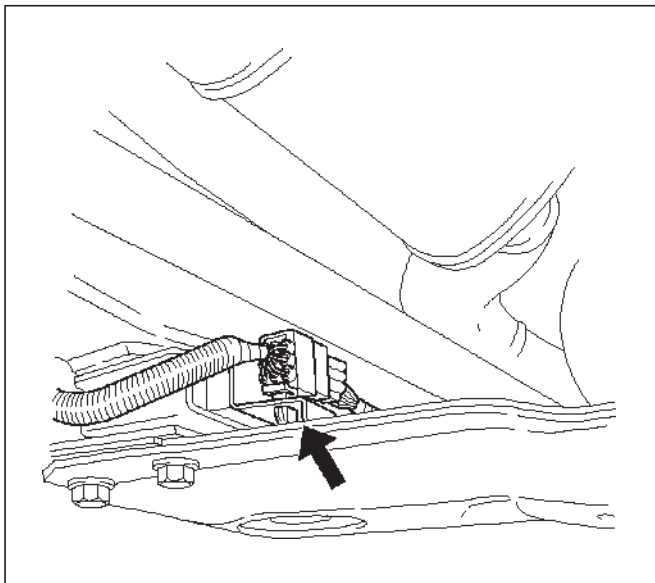
401RX013

15. Support transfer case with a jack and remove two rear mount nuts (10) from the third crossmember.
16. Disconnect harness clip and bracket from the third crossmember side.

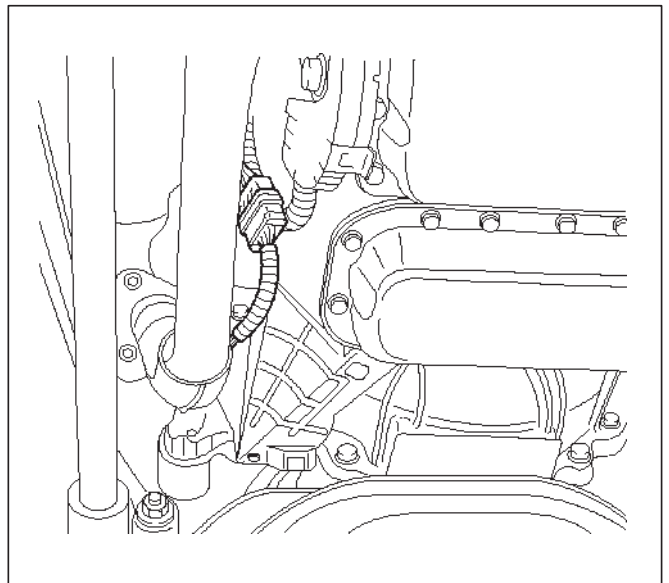


F07RX006

17. Remove eight third crossmember bolts and third crossmember (11).
18. Disconnect two oxygen sensor connectors of the left catalytic converter from the transmission harness.



F07RX005

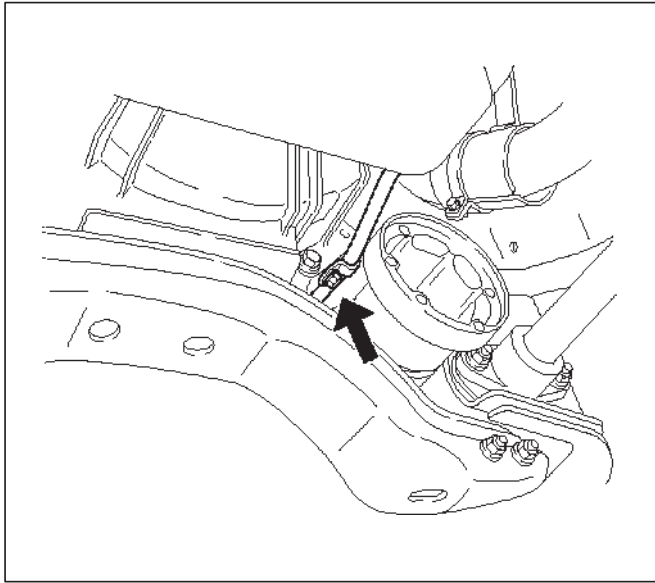


150RW002

19. Remove left catalytic converter assembly (12).
  20. Remove exhaust silencer assembly (13).
  21. Loosen right catalytic converter nuts to exhaust manifold.
- NOTE:** This will make the next steps easier.
22. Disconnect two oxygen sensor connectors of the right catalytic converter from the transmission harness.
  23. Disconnect transmission oil cooler pipe (14) from the transmission case.

## 7A-34 AUTOMATIC TRANSMISSION (4L30-E)

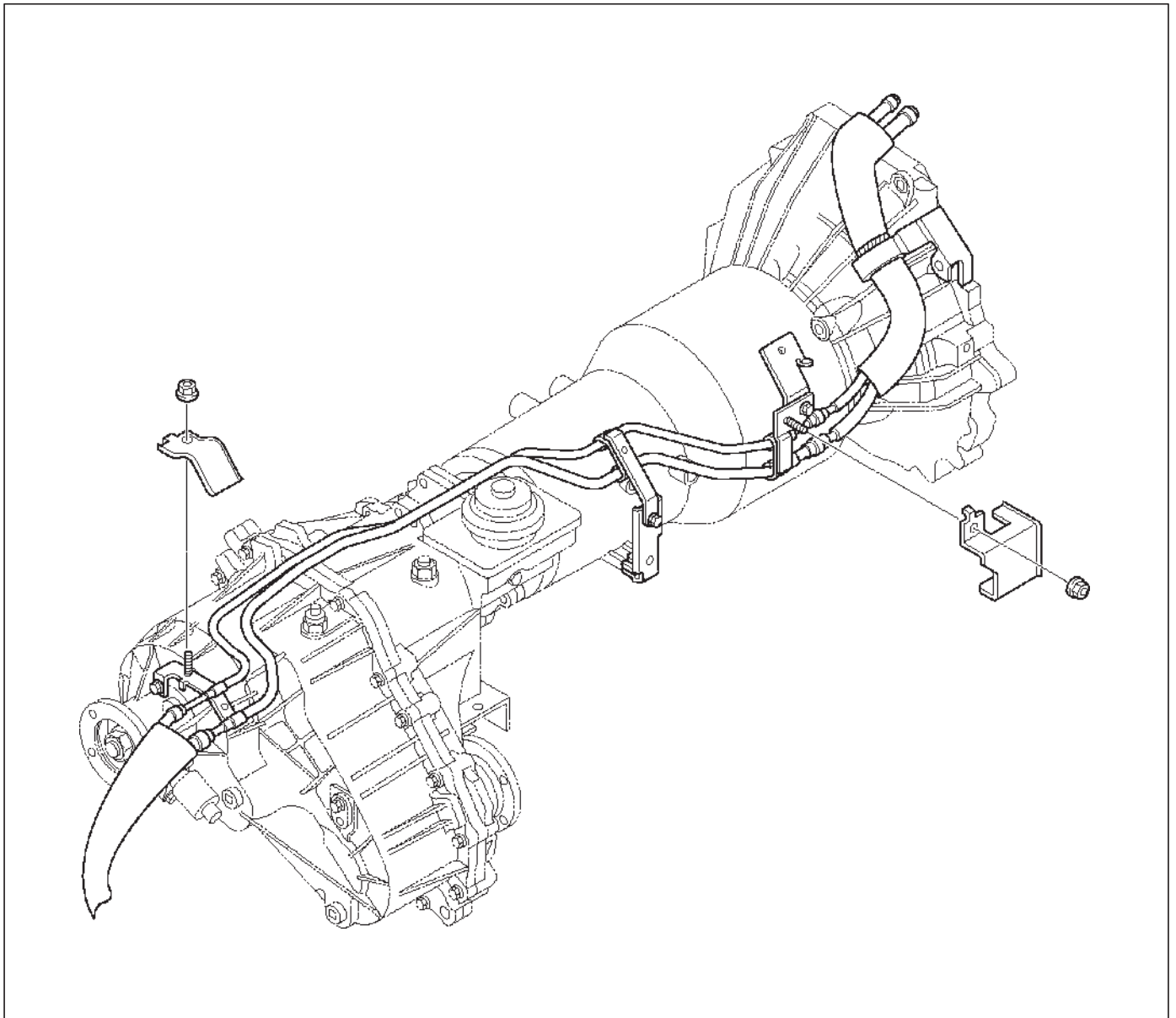
24. Remove oil pipe clamp bracket from the torque converter housing.



253RX001

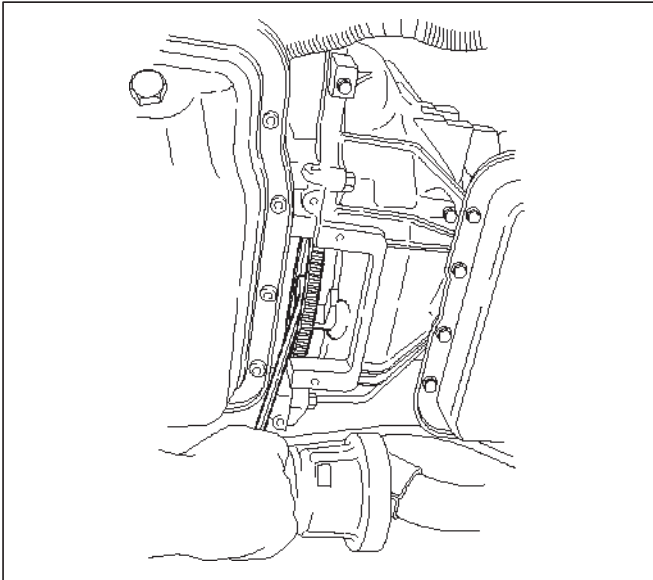
25. Loosen oil pipe clamp bolt at right engine mount side.

26. Disconnect fuel pipe clamp bracket from the transmission side.



141RX003

27. Remove harness protector (15).
28. Disconnect transmission harness connectors from the transmission and transfer case.
29. Remove front crossmember (16).
30. Remove starter (17).
31. Remove under covers (3 pieces) (18) from the transmission case.
32. Remove flex plate torque converter fixing bolts (6 pieces) (19) by turning crankshaft.

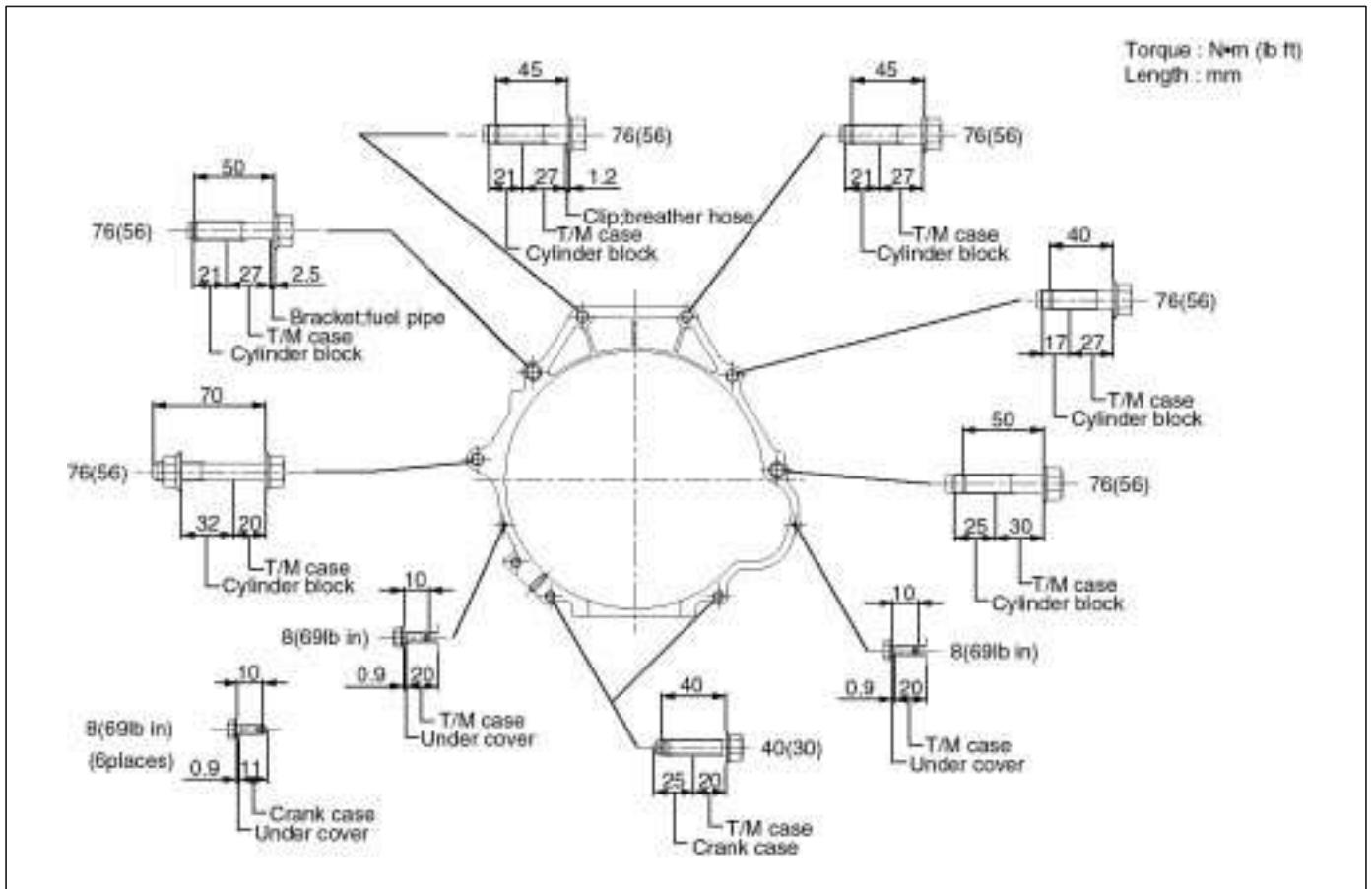


240RX007

33. Support the transmission with a transmission jack and remove the jack from the transfer case.
34. Remove engine transmission fixing bolts (20).
35. Remove transmission assembly with transfer case (21).

**Installation**

1. Slowly raise transmission jack until front of the transmission is aligned rear of the engine, then install transmission assembly with transfer case.
2. Tighten engine transmission fixing bolts to the specified torque.





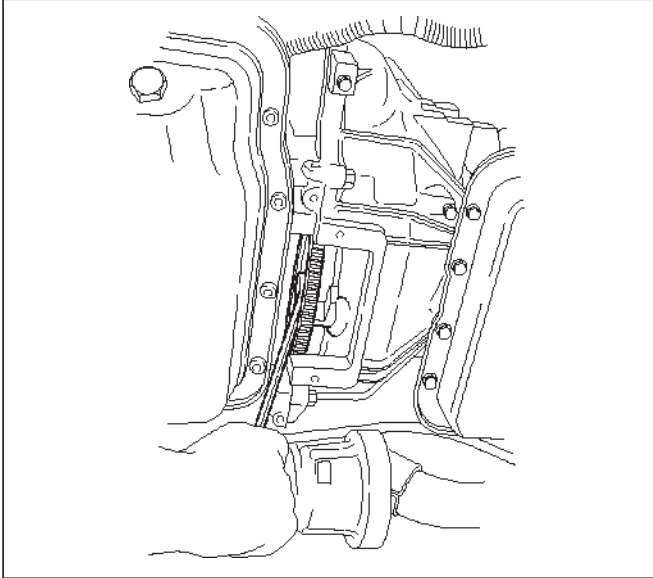
## 7A-36 AUTOMATIC TRANSMISSION (4L30-E)

---

- Support transfer case with a jack, and remove the transmission jack.
- Install flex plate torque converter bolts (6 pieces) by turning crankshaft.

**Torque: 54 N•m (40 lb ft)**

NOTE: Do not reuse the flex plate torque converter bolt.



240RX007

- Install under cover (3 pieces), and tighten the bolts to the specified torque.

**Torque: 8 N•m (69 lb in)**

- Install starter, and tighten the bolts to the specified torque.

**Torque: 40 N•m (30 lb ft)**

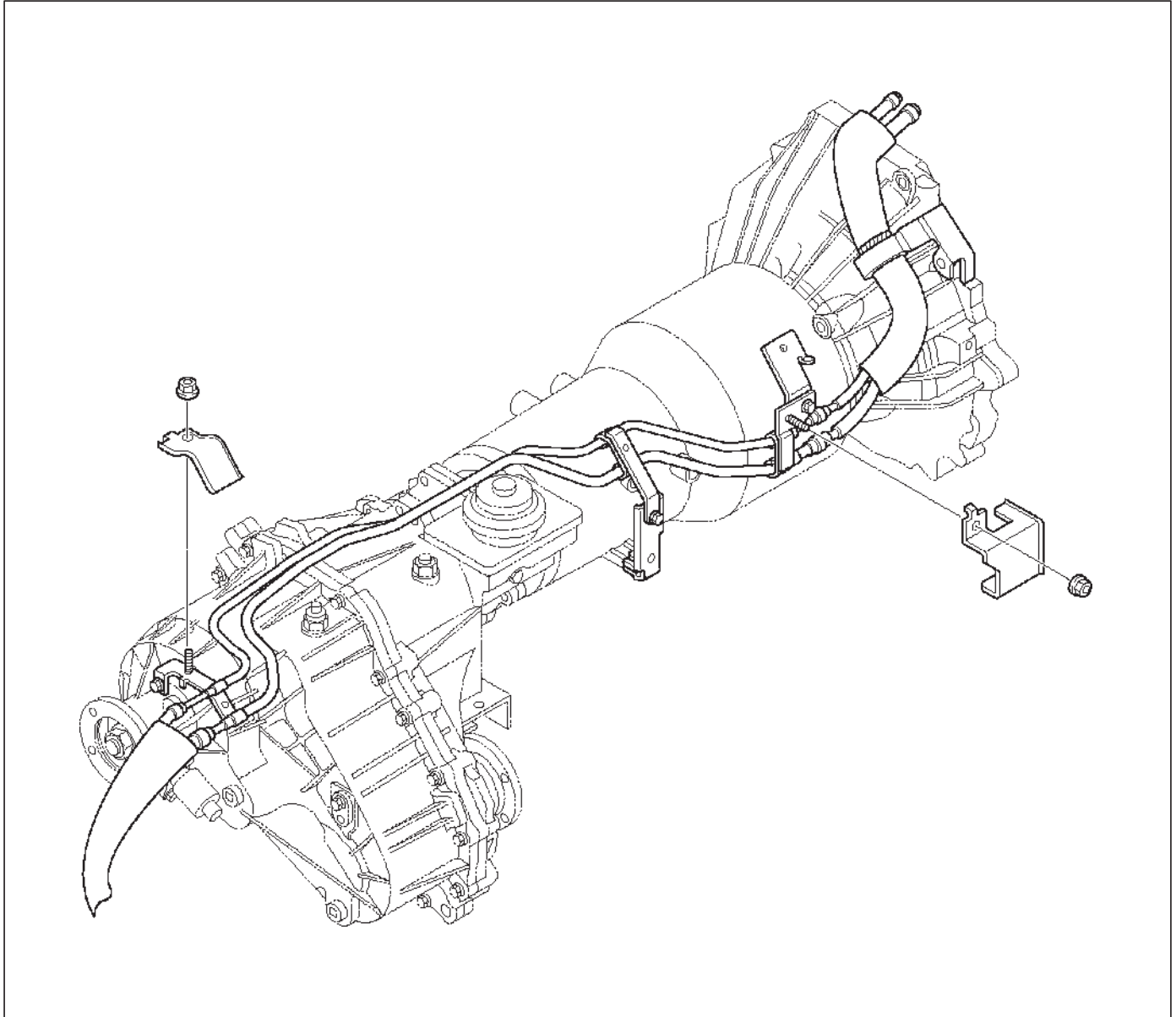
- Install front crossmember, and tighten the bolts to the specified torque.

**Torque: 78 N•m (58 lb ft)**

- Connect transmission harness connectors to the transmission and transfer case.

- Install harness connector.

10. Connect fuel pipe clamp bracket to the transmission side.



141RX003

11. Install transmission oil cooler pipe to the transmission, and tighten the nuts to the specified torque.

**Torque: 44 N•m (33 lb ft)**

12. Install oil pipe clamp bracket to the torque converter housing.

13. Tighten oil pipe clamp bolt at right engine mount side.

14. Tighten right catalytic converter bolts to the specified torque.

**Torque: 67 N•m (49 lb ft)**

15. Connect two oxygen sensor connectors of the right catalytic converter to the transmission harness.

16. Install left catalytic converter assembly, and tighten the bolts to the specified torque.

**Exhaust pipe to exhaust manifold: 67 N•m (49 lb ft)**

**Exhaust pipe flange bolt: 43 N•m (32 lb ft)**

17. Connect two oxygen sensor connectors of the left catalytic converter to the transmission harness.

18. Install exhaust silencer assembly.

19. Install third crossmember, and tighten the bolts to the specified torque.

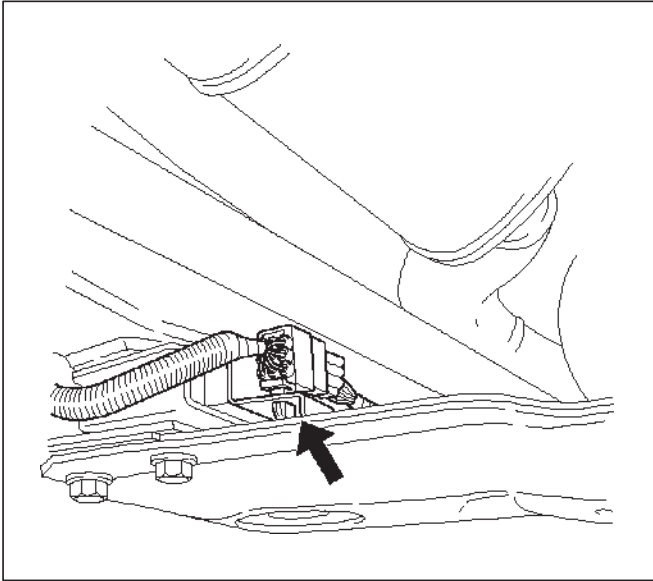
**Torque: 50 N•m (37 lb ft)**

20. Install rear mount nuts, and tighten the nuts to the specified torque.

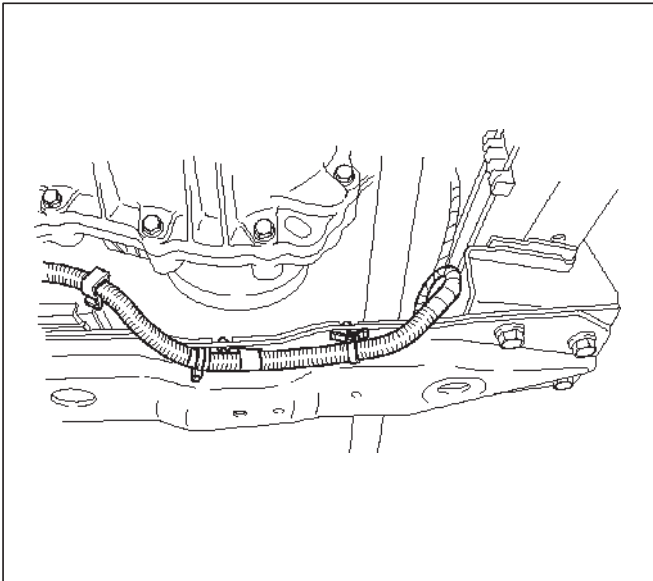
**Torque: 50 N•m (37 lb ft)**

## 7A-38 AUTOMATIC TRANSMISSION (4L30-E)

21. Remove the jack from the transfer case.
22. Connect harness clip and bracket to the third crossmember.



F07RX005



F07RX006

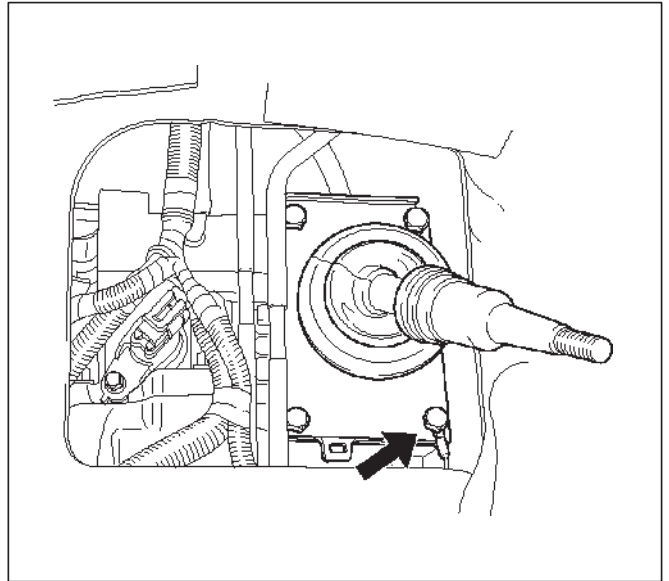
23. Install rear propeller shaft, and tighten the bolts to the specified torque.

**Torque: 63 N•m (46 lb ft)**

24. Install seat belt tension rod to the floor.
25. Install front propeller shaft, and tighten the bolts to the specified torque.

**Torque: 63 N•m (46 lb ft)**

26. Install transfer control lever and connect ground cable.



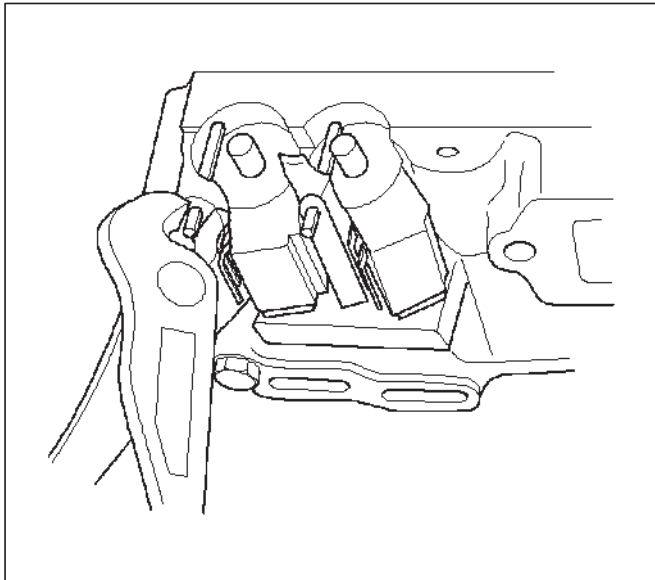
241RX002

27. Connect wiring harness and install selector lever assembly.
28. Connect shift control rod to the selector lever assembly.
29. Connect shift lock cable to the selector lever assembly.  
Refer to Selector Lever in this section.
30. Install two PCM covers.
31. Install center console assembly.
32. Install rear console assembly.
33. Install transfer control lever knob.
34. Connect battery ground cable.
35. Install engine hood.

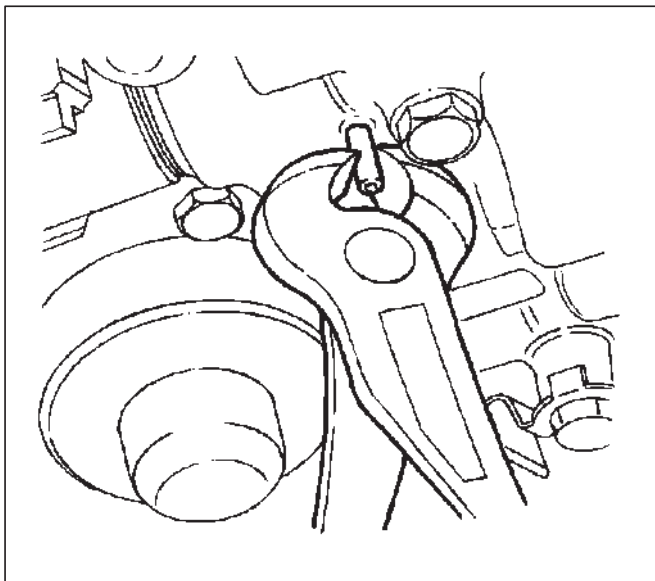
## Solenoid (Main Case Valve Body)

### Removal

1. Raise the vehicle and support it on jack stands.
2. Disconnect battery ground cable.
3. Drain fluid.
4. Support transfer case with a jack and remove third crossmember.
5. Remove sixteen 10 mm screws, main case oil pan, magnet, and gasket.
6. Remove three 13 mm screws, oil filter.
7. Disconnect wiring harness from band control solenoid and shift solenoids. Pull only on connectors, not on wiring harness.
8. Remove spring pin for shift solenoid A, shift solenoid B, and band control solenoid respectively, using suitable pliers taking care not to damage solenoids.



210RW010

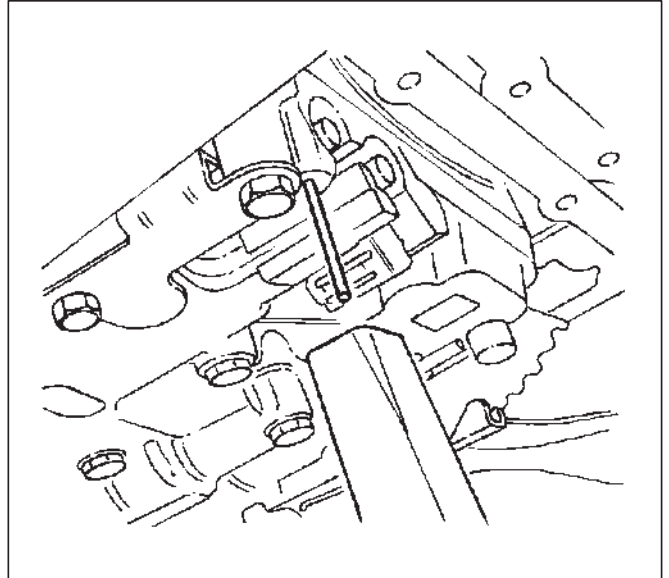


244RW003

9. Remove shift solenoid A, shift solenoid B, band control solenoid, and gaskets from main case valve body. Do not pull on wiring harness. Remove solenoids by grasping the metal tip.

### Installation

1. Install shift solenoid A, shift solenoid B, band control solenoid with new gaskets to main case valve body respectively.
2. Carefully install spring pin with hammer to avoid damage to valve body, etc.



243RW004

3. Connect wiring harness to solenoids.
4. Install oil filter with a new gasket and the three 13 mm screws. Tighten the screws to the specified torque.  
**Torque: 20 N•m (15 lb ft)**
5. Install magnet, main case oil pan with new gasket, sixteen 10 mm screws. Tighten the screws to the specified torque.  
**Torque: 11 N•m (96 lb in)**
6. Install third crossmember and rear mount nuts. Tighten the nuts and bolts to the specified torque.  
**Third crossmember bolt: 50 N•m (37 lb ft)**  
**Rear mount nut: 50 N•m (37 lb ft)**
7. Fill transmission through the overfill screw hole of oil pan, using ATF DEXRON®-III. Refer to Changing Transmission Fluid in this section.
8. Connect the battery ground cable.

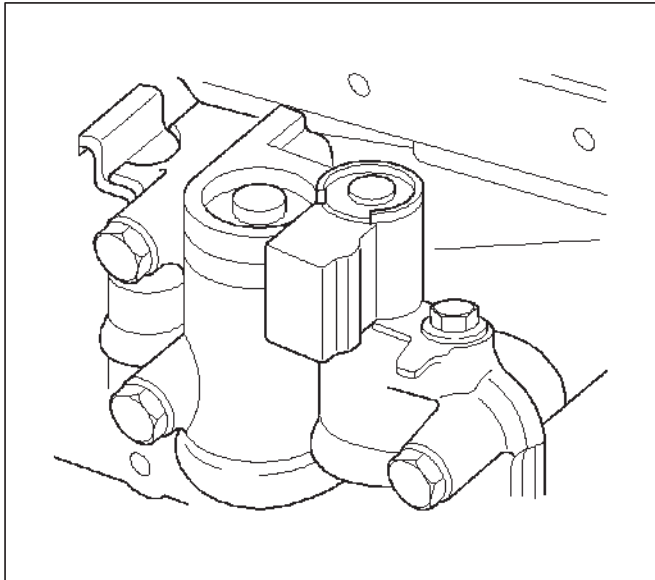
## Solenoid (Adapter Case Valve Body)

### Removal

1. Raise the vehicle and support it on jack stands.
2. Disconnect battery ground cable.
3. Drain fluid.
4. Remove adapter case oil pan twelve fixing 10 mm screws, adapter case oil pan, and gasket.

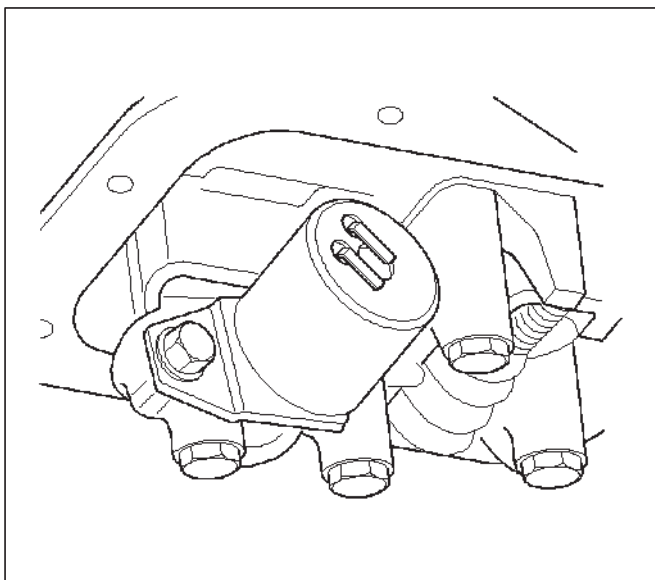
NOTE: Oil pan still contains transmission fluid. Place a large drain container under the oil pan and drain the fluid carefully.

5. Disconnect wiring harness from force motor solenoid and converter clutch solenoid. Pull only on connectors, not on wiring harness.
6. Remove 11 mm bolt and converter clutch solenoid with two O-rings.



210RW011

7. Remove 11 mm bolt, retainer, and force motor solenoid.



210RW009

### Installation

1. Install force motor solenoid, retainer, and 11 mm bolt to adapter case valve body. Tighten the bolt to the specified torque.

**Torque: 10 N•m (87 lb in)**

2. Install converter clutch solenoid with two O-rings, and 11 mm bolt to adapter case valve body. Tighten the bolt to the specified torque.

**Torque : 10 N•m (87 lb in)**

3. Connect wiring harness assembly to solenoids.
4. Install adapter case oil pan, new gasket, and twelve 10 mm screws. Tighten the screws to the specified torque.

**Torque : 11 N•m (96 lb in)**

5. Fill transmission through overfill screw hole oil pan, using ATF DEXRON®-III. Refer to Changing Transmission Fluid in this section.
6. Connect battery ground cable.

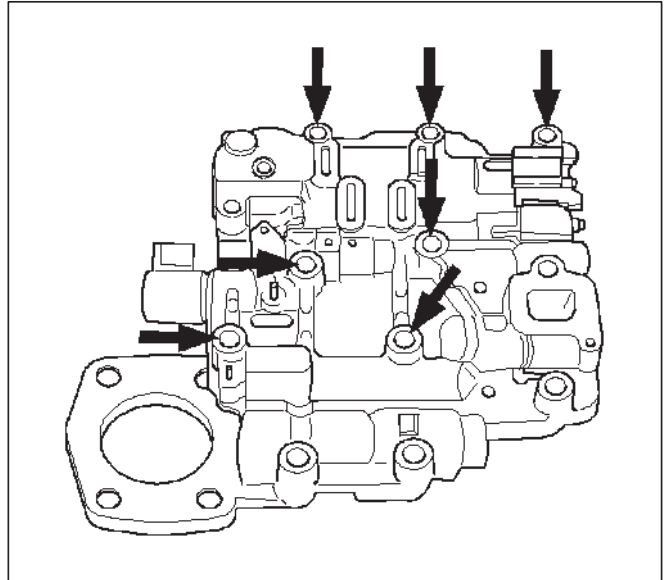
## Valve Body Assembly (Main Case)

### Removal

1. Raise the vehicle and support it on jack stands.
2. Disconnect battery ground cable.
3. Drain fluid.
4. Support transfer case with a jack and remove third crossmember.
5. Remove sixteen 10 mm screws, main case oil pan, magnet and gasket.
6. Remove three 13 mm oil filter fixing screws, then remove oil filter.
7. Remove two 13 mm manual detent fixing screws, then remove roller and spring assembly.
8. Disconnect wiring harness from band control solenoid and shift solenoids. Pull only on connectors, not on wiring harness.
9. Remove four 13 mm servo cover fixing screws, then remove servo cover and gasket.
10. Remove seven 13 mm valve body fixing screws.
  - Disconnect the ground wire from the main case valve body.
11. Remove main case valve body with manual valve link and transfer plate. Note the position of the link (long end into valve, short end into range selector lever).
12. Remove transfer plate gasket from main case.
13. Remove two check balls from main case.

4. Install seven 13 mm screws, and tighten them to the specified torque.

**Torque: 20 N•m (15 lb ft)**



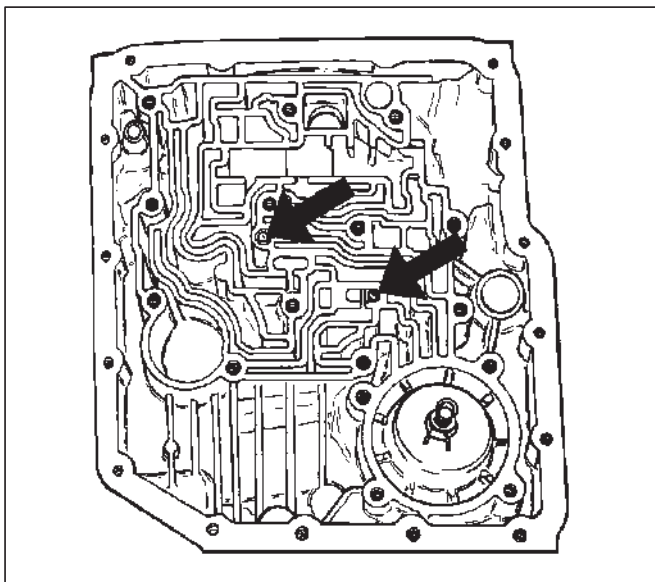
243RS008

5. Install 8.5 mm connector of ground wire the head of this valve body bolt and reinstall it. Tighten the bolt to the specified torque.

**Torque: 20 N•m (15 lb ft)**

### Installation

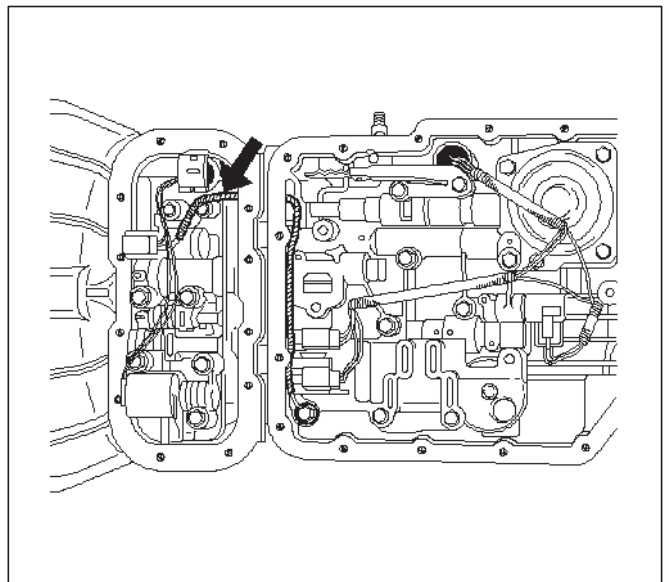
1. Install two check balls to main case.



244RW002

2. Inspect electrical 4 pin connector and seal of main case. Replace if necessary.
3. Use two J-25025-B guide pin to install main case.
  - Install valve body assembly and manual valve link.

**NOTE:** Valve must be extended as the short end of manual valve link is connected to the range selector lever. Long end of link goes into valve.



244RW001

6. Remove two guide pins from main case.
7. Install servo cover gasket, cover, and four 13 mm screws. Tighten the screws to the specified torque.

**Torque: 25 N•m (18 lb ft)**

8. Connect wiring harness to band control and shift solenoids.
9. Install roller and spring assembly to manual detent.
  - Install two 13 mm screws, and tighten them to the specified torque.

**Torque: 20 N•m (15 lb ft)**

## 7A-42 AUTOMATIC TRANSMISSION (4L30-E)

---

10. Install oil filter and three 13 mm screws. Tighten the screws to the specified torque.

**Torque : 20 N•m (15 lb ft)**

11. Install oil pan gasket, magnet, oil pan and sixteen 10 mm screws. Tighten the screws to the specified torque.

**Torque: 11 N•m (96 lb in)**

12. Install third crossmember and rear mount. Tighten the bolts and nuts to the specified torque.

Torque

**Third crossmember bolt: 50 N•m (37 lb ft)**

**Rear mount nut: 50 N•m (37 lb ft)**

13. Fill transmission through overfill screw hole of oil pan, using ATF DEXRON®-III. Refer to Changing Transmission Fluid in this section.

14. Connect battery ground cable.

## Valve Body Assembly (Adapter Case)

### Removal

1. Raise the vehicle and support it on jack stands.
2. Disconnect battery ground cable.
3. Drain fluid.
4. Remove twelve 10 mm adapter case oil pan fixing screws, adapter case oil pan, and gasket.

NOTE: Oil pan still contains transmission fluid. Place a large drain container under the oil pan.

Drain the fluid carefully.

5. Disconnect wiring harness from force motor solenoid and converter clutch solenoid. Pull only on connectors, not on wiring harness.
6. Remove seven 13 mm screws from adapter case valve body assembly, then remove transfer plate, two gaskets, and adapter case valve body.

### Installation

1. Inspect electrical 5 pin connector and seal of adapter case. Replace if necessary.
2. Install gasket, transfer plate, and gasket.
3. Install adapter case valve body and seven 13 mm screws. Tighten the screws to the specified torque.

**Torque: 20 N•m (15 lb ft)**

4. Connect wiring harness assembly to converter clutch solenoid and force motor.
5. Install oil pan gasket, oil pan, and twelve 10 mm screws. Tighten the screws to the specified torque.

**Torque: 11 N•m (96 lb in)**

6. Fill transmission through the overfill screw hole of oil pan, using ATF DEXRON®-III. Refer to Changing Transmission Fluid in this section.
7. Connect battery ground cable.

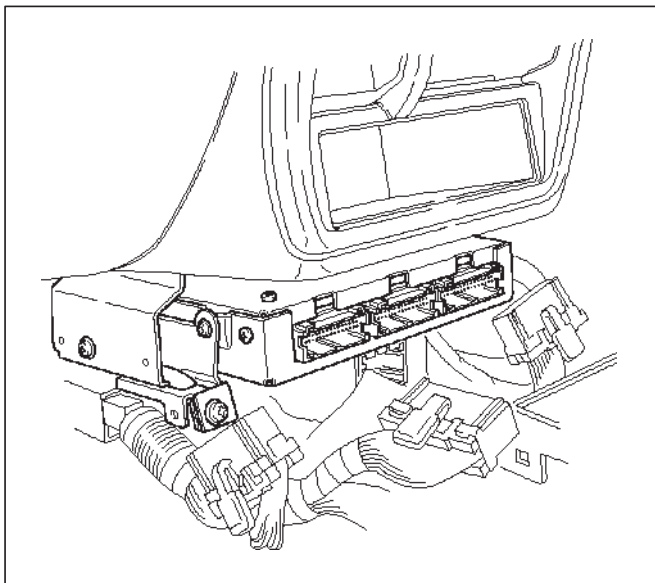
## Powertrain Control Module (PCM)

### Removal

1. Place selector lever in neutral.
2. Disconnect battery ground cable.
3. Remove rear console and center console.
4. Remove PCM covers.
5. Disconnect PCM wiring harness connectors from PCM.
6. Remove three PCM retaining screws.
7. Remove two brackets from PCM.

### Installation

1. Install two brackets to PCM.
2. Install three PCM retaining screws.
3. Connect PCM wiring harness connectors to PCM.
4. Install PCM covers.
5. Install rear console and center console.
6. Connect battery ground cable.



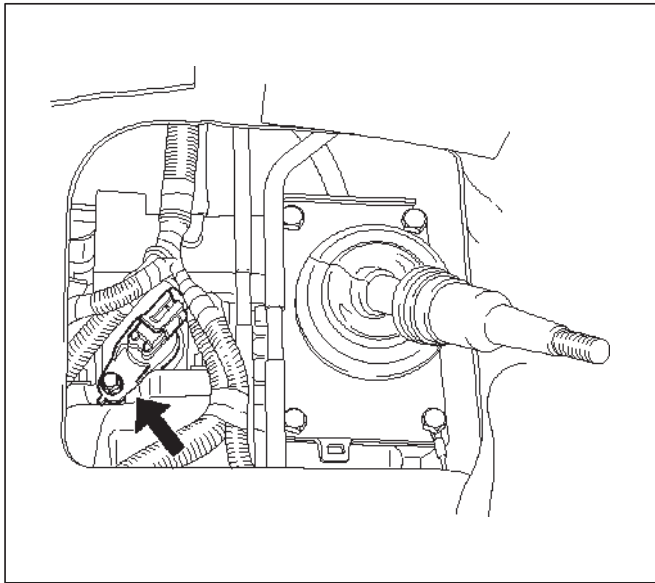
826RX013



## Speed Sensor (Extension Housing)

### Removal

1. Place selector lever in neutral.
2. Disconnect battery ground cable.
3. Remove rear console and center console.
4. Remove selector lever assembly.
5. Disconnect speed sensor harness connector from speed sensor.
6. Remove one 10 mm screw and speed sensor with O-ring.



241RX001

### Installation

1. Inspect the speed sensor O-ring, and replace it if necessary.
2. Install speed sensor assembly and 10 mm screw.  
**Torque: 9 N•m (78 lb in)**
3. Connect speed sensor harness connector to speed sensor.
4. Install selector lever assembly.  
○Adjust shift lock cable. Refer to Selector Lever in this section.
5. Install rear console and center console.
6. Connect battery ground cable.

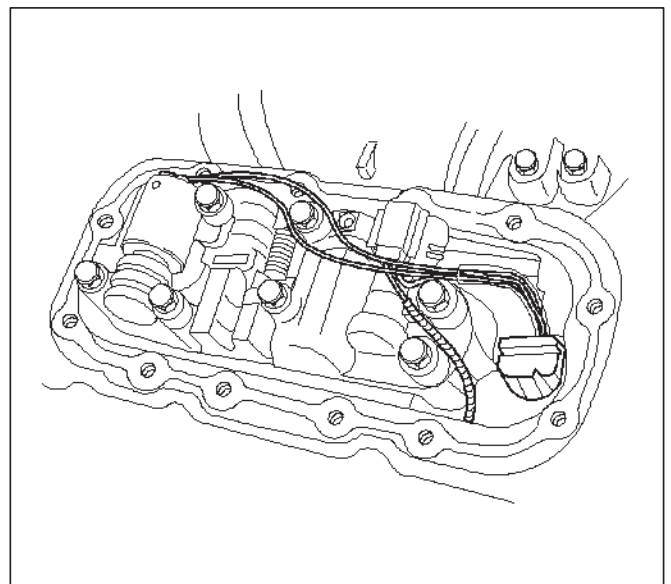
## Transmission Oil Temperature Sensor (Adapter Case)

### Removal

1. Raise the vehicle and support it on jack stands.
2. Disconnect battery ground cable.
3. Drain fluid.
4. Remove twelve 10 mm adapter case oil pan fixing screws, adapter case oil pan, and gasket.

NOTE: Oil pan still contains transmission fluid. Place a large drain container under the oil pan, and drain the fluid carefully.

5. Disconnect wiring harness from force motor solenoid, converter clutch solenoid, and 5 pin connector of adapter case. Pull only on connectors, not on wiring harness.
6. Disconnect ground wire from converter clutch solenoid wiring harness connector.
7. Remove wiring harness assembly (transmission oil temperature sensor).



243RW002

### Installation

1. Connect ground wire to converter clutch solenoid wiring harness connector of the wiring harness assembly.

2. Install wiring harness assembly to converter clutch solenoid, force motor, and 5 pin connector of adapter case.
3. Install oil pan gasket, oil pan, and twelve 10 mm fixing screws. Tighten the screws to the specified torque.

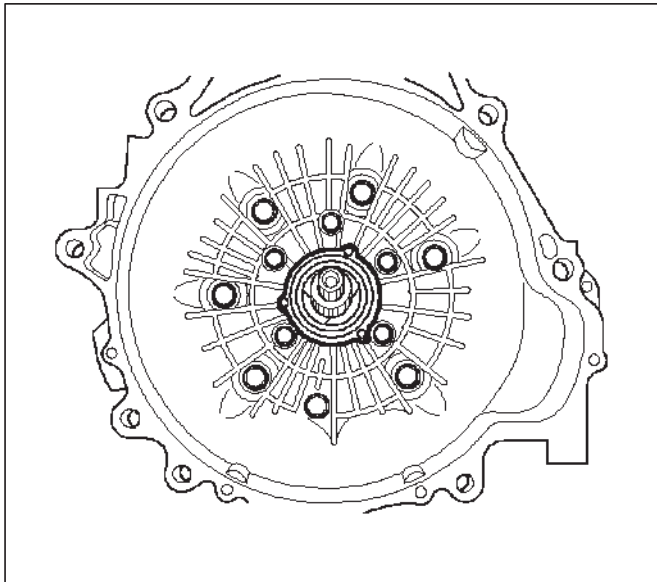
**Torque: 11 N•m (96 lb in)**

4. Fill transmission through the overfill screw hole of oil pan, using ATF DEXRON®-III. Refer to Changing Transmission Fluid in this section.
5. Connect battery ground cable.

## Front Oil Seal (Converter Housing)

### Removal

1. Remove transmission assembly with transfer case from the vehicle. Refer to Transmission (with Transfer Case) in this section.
2. Remove torque converter from converter housing.
3. Remove three screws and oil seal ring from converter housing.



241RW008

### Installation

1. Apply clean ATF to the new oil seal ring lip.
  - Install oil seal ring to converter housing. Tighten the screws to the specified torque.

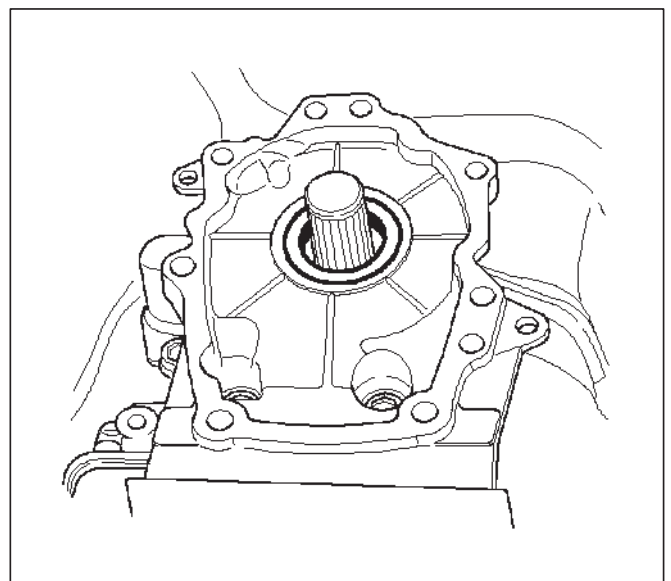
**Torque: 3 N•m (26 lb in)**

2. Install torque converter to converter housing.
3. Install transmission assembly with transfer case to the vehicle. Refer to Transmission (with Transfer Case) in this section.

## Rear Oil Seal (Extension Housing)

### Removal

1. Remove transfer case assembly from the vehicle. Refer to Transfer Case in Drive Line/Axle section.
2. Remove rear oil seal from transmission extension housing.



241RW005

## Installation

1. Use J-36797 extension housing oil seal installer, and install the rear oil seal to the transmission extension housing.

2. Install the transfer case assembly to the vehicle. Refer to Transfer Case in Drive Line/Axle section.

## Transmission (4L30-E)

### Disassembly

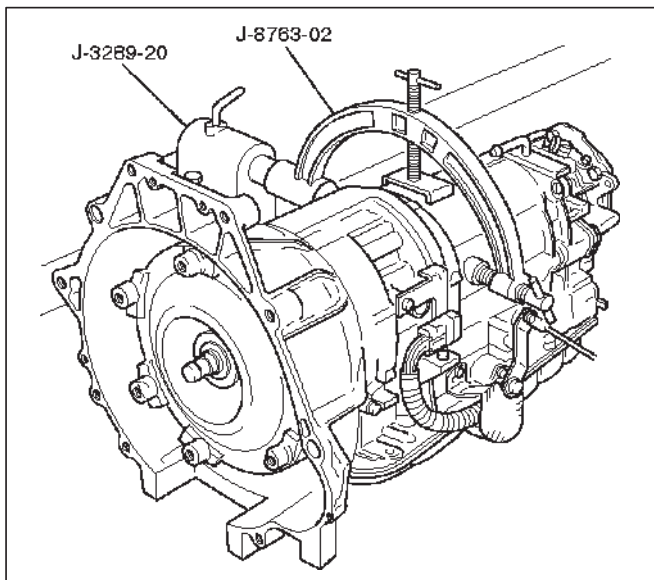
NOTE: During the disassembly and reassembly, perform the following:

- Wash each part thoroughly, and blow air through each oil passage and groove to eliminate blockage.
- Seal rings, roll pins, and gaskets should be replaced.
- When assembling the components, apply DEXRON®-III Automatic Transmission Fluid (ATF) to each seal, rotating part, and sliding part.
- Do not dip part facings, such as clutch or brake drive plates, in cleaner when washing it. Also, always coat parts with new ATF two or three times after cleaning with solvent.

1. Remove torque converter (1).

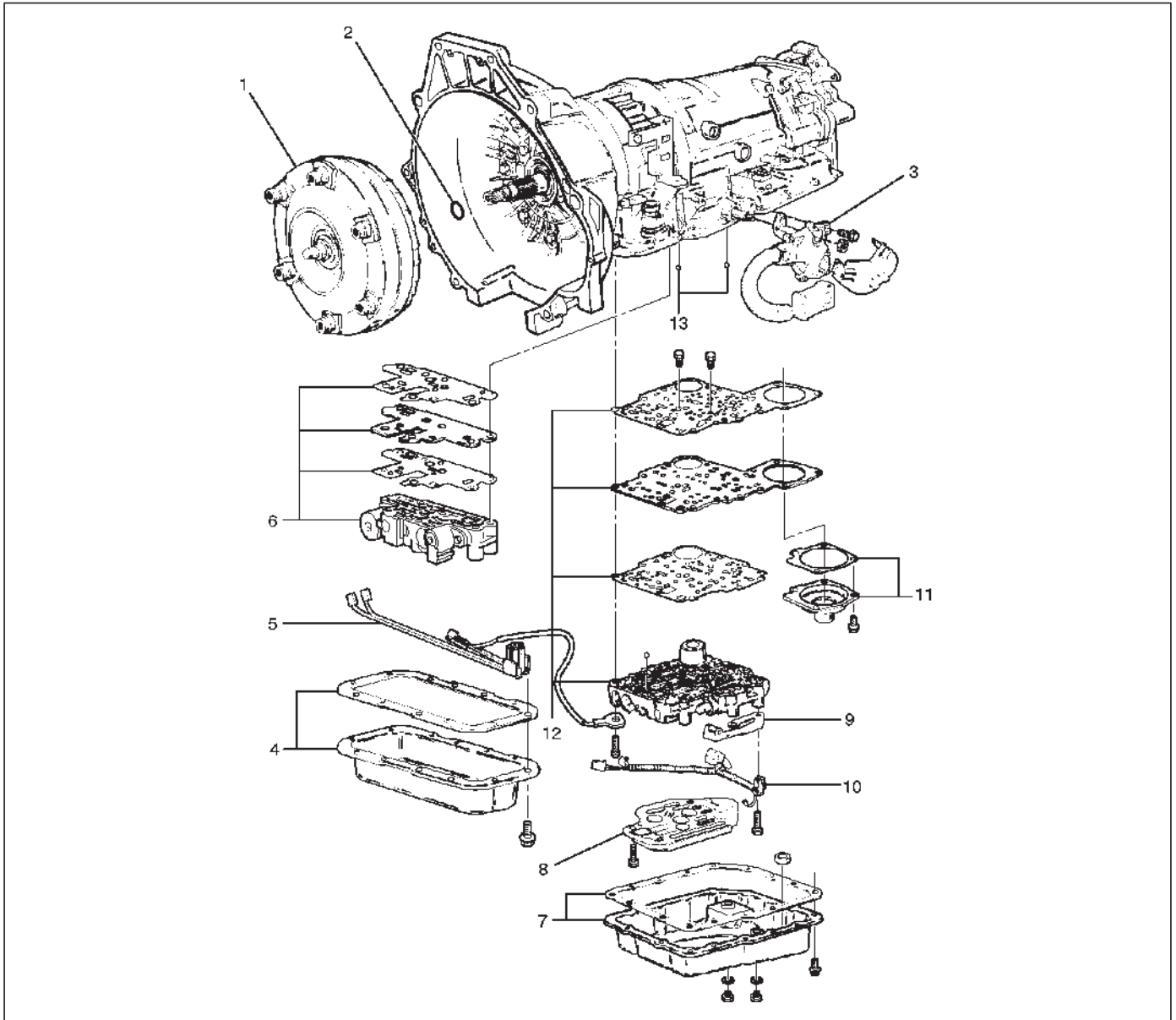
- Drain fluid from torque converter.
- Attach J-8763-02 holding fixture to the transmission and set it on J-3289-20 holding fixture base.

NOTE: Do not overtighten the tool, as case damage may result.



420RW021

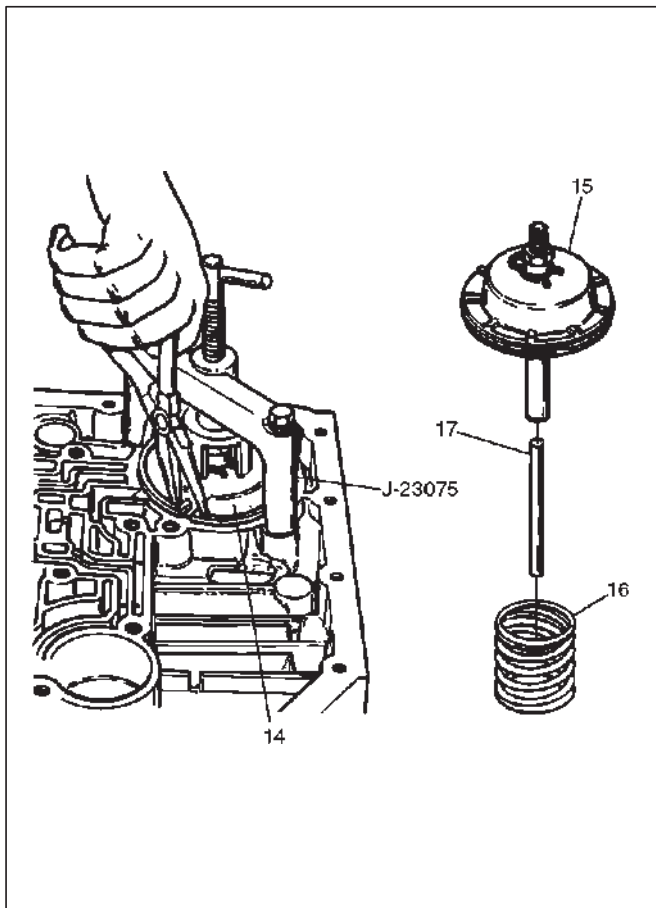
2. Remove O-ring (2) from turbine shaft.
3. Remove two 10mm mode switch screws, selector lever nut, cover, and mode switch (3).
4. Remove twelve 10mm adapter case oil pan (4) fixing screws, adapter oil pan, and gasket.
5. Disconnect electrical wiring connections (5) from solenoids and 5 pin connector of adapter case. Pull on connectors only, not on wiring harness.
6. Remove seven 13mm adapter case valve body (6) fixing screws, adapter case valve body assembly, transfer plate, and two gaskets.
  - Remove wiring harness and 5 pin connector.
7. Remove sixteen 10mm main case oil pan (7) fixing screws, main oil pan, magnet, and gasket.
8. Remove three 13mm oil filter (8) fixing screws and oil filter.
9. Remove two 13mm manual detent (9) fixing screws, roller and spring, and manual detent.
10. Disconnect wiring harness assembly (10) from band apply solenoid, shift solenoids, and main case 4 pin connector. Pull on connectors only, not on wiring harness.
11. Remove four 13mm servo cover (11) fixing screws, servo cover, and gasket.
12. Remove seven 13mm valve body screws and ground wire from main case.
  - Remove wiring harness assembly (5) from the adapter case side.
  - Remove main valve body assembly (12) with manual valve link and transfer plate. Note the position of the link (long end into valve, short end into range selector lever).
  - Remove 4 pin connector.
  - Remove gasket transfer plate from main case.
13. Remove two check balls (13) from main case.



240RW022

14. Turn transmission to vertical position to drain fluid. Return back to horizontal position when drained.
  - Install J-23075 servo piston spring compressor with offset to the rear of case.
  - Compress servo piston assembly.
  - Remove servo piston retaining ring (14).
  - Slowly release servo piston assembly (15).
  - Remove tool.
15. Remove servo piston assembly (15), return spring (16), and servo apply rod (17).

## 7A-48 AUTOMATIC TRANSMISSION (4L30-E)



16. Rotate transmission to horizontal position, pan side down.

- Remove one 10mm screw, and speed sensor (18) with "O" ring.

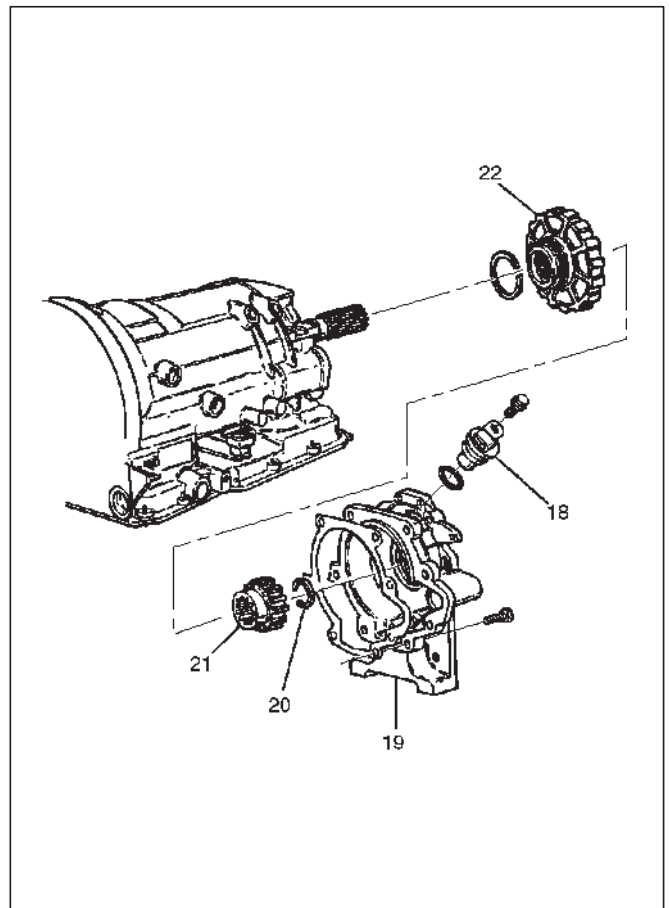
17. Remove seven 8mm extension housing hexagon socket head screws, extension housing assembly (19), and gasket.

18. Remove retaining ring (20).

NOTE: Use extra long, needle-nose pliers.

19. Remove speed wheel (21).

20. Remove wheel parking lock (with seal ring) (22).



21. Rotate transmission to vertical position, converter housing up.

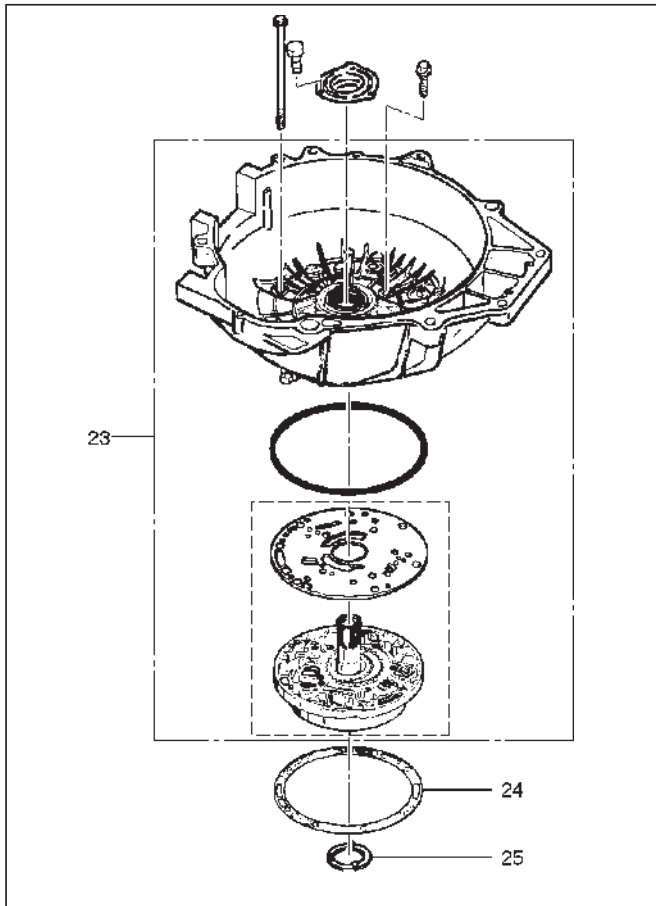
- Loosen the converter housing and oil pump assembly fixing screws, but do not remove the five 13 mm inner screws if oil pump disassembly is required.

- Remove seven outer screws.

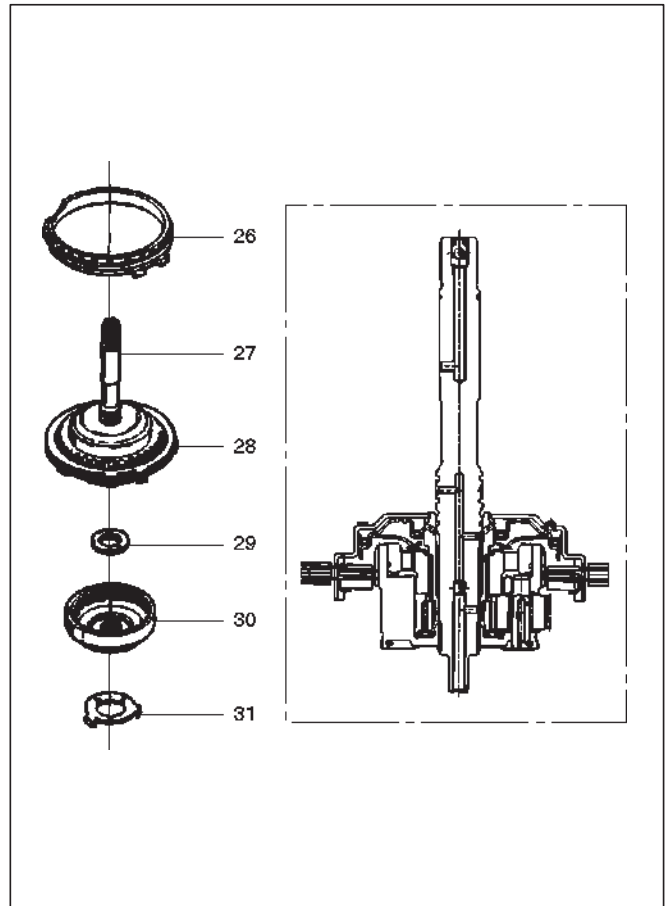
- Remove converter housing and oil pump assembly (23).

22. Remove gasket (24).

23. Remove selective thrust washer (25).



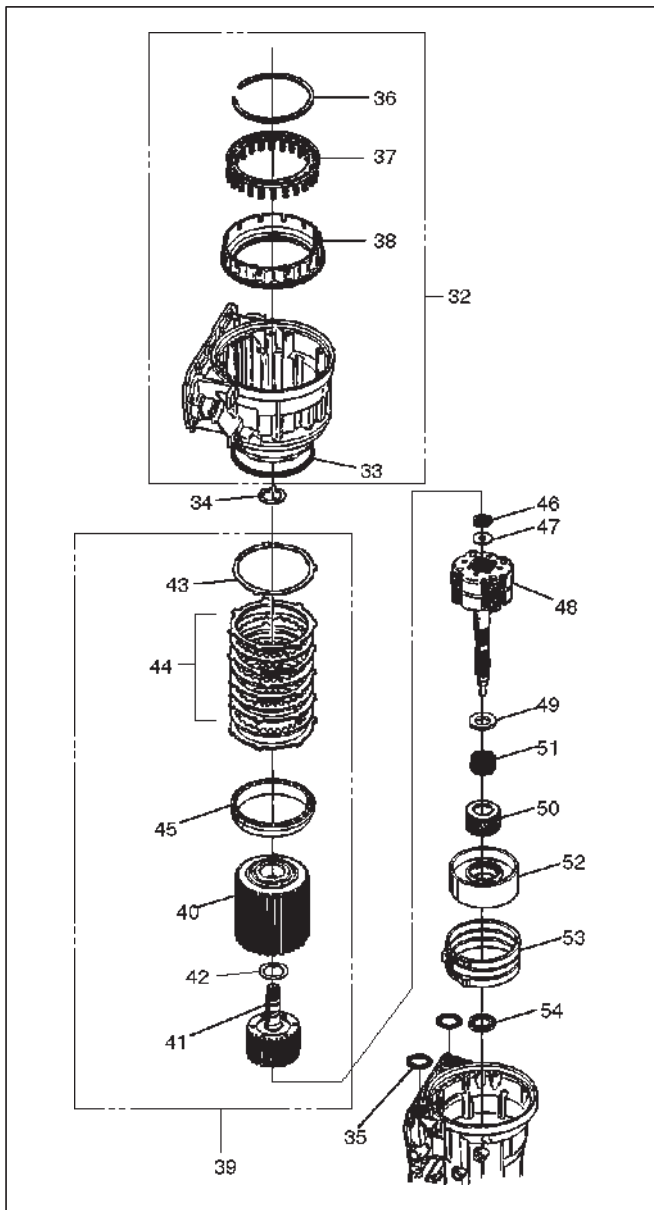
24. Remove fourth clutch retainer (26).
25. Grasp turbine shaft and lift out the overrun clutch housing assembly (27) and fourth clutch plates (28).
26. Remove thrust bearing assembly (29).
27. Remove overdrive internal gear (30).
28. Remove thrust washer (31).



29. Remove adapter case and center support assembly (with fourth clutch piston) (32).
30. Remove seal ring (33).
31. Remove selective thrust washer (34) and two O-ring seals (35) from main case.
32. Use J-23327 and J-23327-90 compressor to compress the fourth clutch spring retainer and springs (37).
  - Release snap ring (36) from groove.
  - Remove clutch compressor and snap ring (36).
33. Remove retainer and spring assembly (37).
34. Insert two converter housing/main case screws to hold adapter case while pulling out fourth clutch piston (38).
  - Remove fourth clutch piston assembly (38) from the adapter case.
  - Remove converter housing/main case screws.
35. Grasp intermediate shaft, twist and pull out the second and third clutch drum assemblies with reverse clutch plates while holding onto output shaft (39).

## 7A-50 AUTOMATIC TRANSMISSION (4L30-E)

36. Separate second (40) and third clutch (41) assemblies.
37. Remove thrust washer (42).
38. Remove reverse clutch plates (43 and 44) and reverse clutch pressure plate (45).
39. Remove bearing (46) and washer (47).
40. Remove planetary carrier assembly (48).
41. Remove thrust bearing (49).
42. Remove reaction sun gear (50)
43. Remove needle bearing (51).
44. Remove brake drum (52).
45. Remove brake band (53).
46. Remove thrust bearing (54).



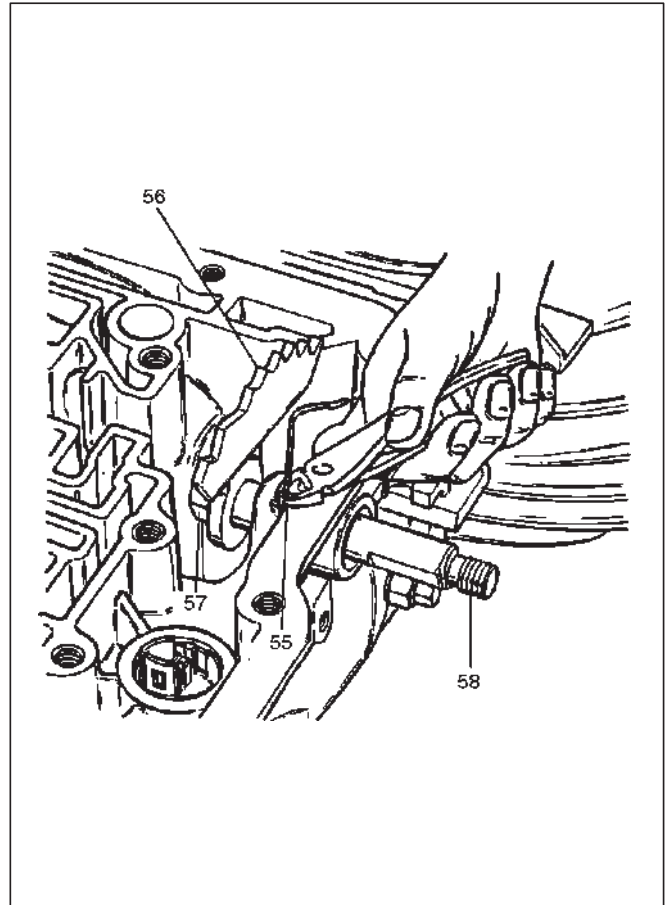
47. Rotate case to horizontal position, valve body side facing up.

- Remove spring pin (55), using cutting pliers, then remove parking lock and selector lever assembly (56).

NOTE: Insert wire in the center of the spring pin to prevent it from collapsing during removal. Be aware of pin height. Protect machined face of main case.

48. Remove parking lock and range selector lever 17 mm nut (57).
49. Remove parking lock and range selector lever (56), and actuator assembly.
50. Remove selector shaft (58).

NOTE: Inspect the shaft for burrs before removing to prevent damaging seal. If necessary, remove burrs by lightly sanding with an oilstone.



## Reassembly

1. Inspect selector shaft seal, and replace it if necessary.

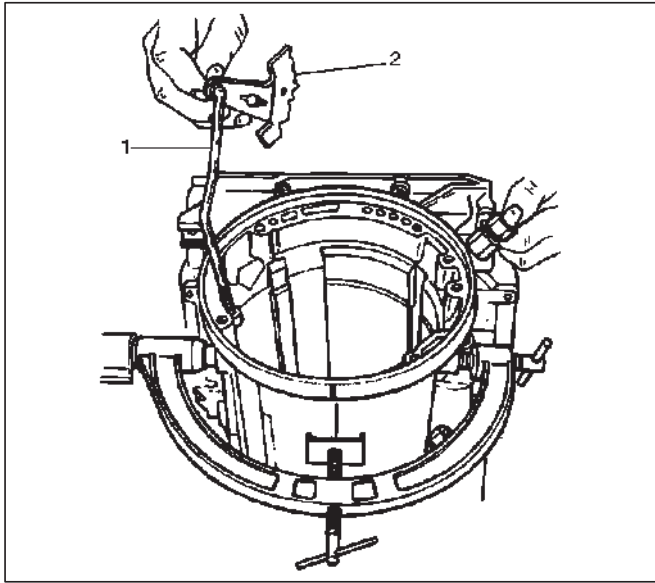
NOTE: Use a seal installer when replacing the seal.

- Install selector shaft.

NOTE: Spring pin groove must be positioned inside the case.

2. Install spring pin. Be sure the selector shaft can move freely. Do not push the pin flush with the case surface. Leave enough height for removal.
3. Install actuator assembly (1).
4. Install parking lock and range selector lever (2) and new 17 mm nut. Tighten the nut to the specified torque.

**Torque: 22 N•m (16 lb ft)**



249RS005

5. Rotate main case to vertical position, extension end facing down.

○Install brake band assembly (3).

NOTE: Be sure to align servo pin area with the servo hole.

6. Install thrust bearing (4).

NOTE: The case bushing acts as a guide for the thrust bearing.

7. Install brake drum (5).

8. Install reaction sun gear (6).

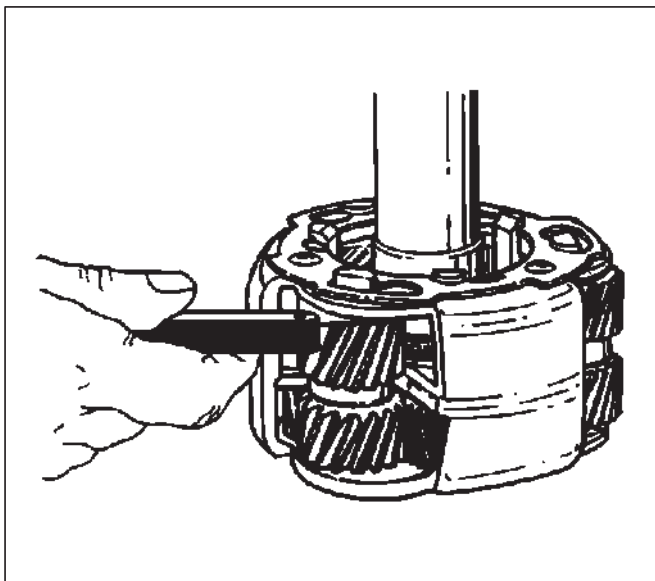
9. Install needle bearing (7).

10. Inspect planetary carrier assembly (8) for wear and damage. If necessary replace it.

○Measure pinion end play clearance with a feeler gauge.

**Clearance: 0.13mm–0.89mm (0.005 in–0.035 in)**

If clearance is outside specified value, replace the planetary carrier assembly.



248RS001

11. Install the thrust bearing (9) on the output shaft.

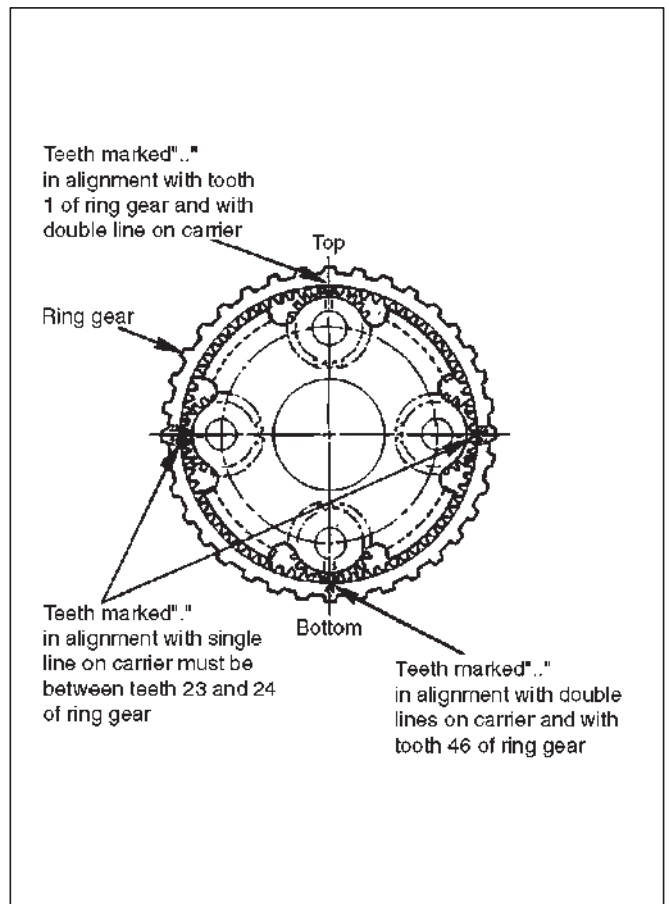
NOTE: Use petroleum jelly to hold the thrust bearing in place.

12. Align planetary pinions. Each pinion is marked with double points to indicate the master tooth space and exactly opposite with a single point to indicate the master tooth. The markings on the planetary carrier consist of double lines which are to be lined up with the double points on two opposite pinions; the single lines are to be lined up with the single points on the other two pinions.

○After all four pinions are lined up, slide on the third clutch assembly. Rotate third clutch and check mark alignment. Considering that the ring gear tooth between the double points of one planetary pinion is tooth number 1, count the teeth to check that the single points on the two adjacent pinions are between teeth 23 and 24 of the ring gear, and that the ring gear tooth between the double points of the opposite pinion is tooth number 46. If the ring gear and pinions are not lined up, remove, and realign them.

13. Install planetary carrier (8) with third clutch (12).

NOTE: Do not force. When properly aligned, the parts will fit together easily.



248RS002

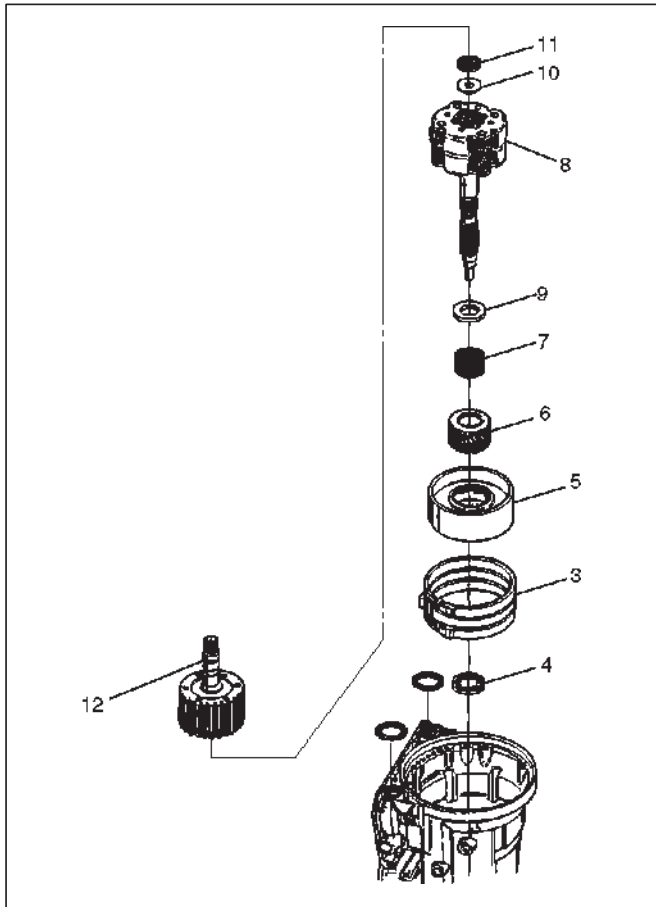
14. Remove the third clutch (12).

15. Install bearing (11) and washer (10).



## 7A-52 AUTOMATIC TRANSMISSION (4L30-E)

NOTE: Use petroleum jelly to hold the washer and bearing in place.



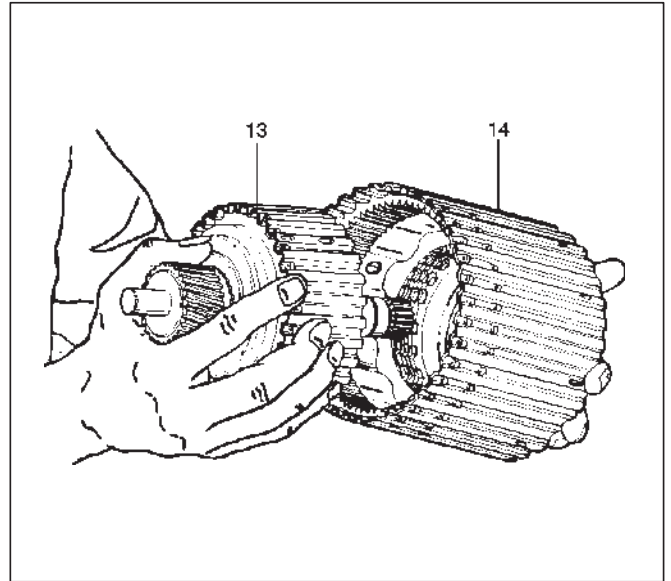
16. Carefully align the second clutch plate inner tangs.

- Install thrust washer, tangs pointing downward, and locating tang positioned in slot on second clutch hub.

NOTE: Use petroleum jelly to hold thrust washer in place.

17. Install third clutch and intermediate shaft assembly (13) into the second clutch drum (14).

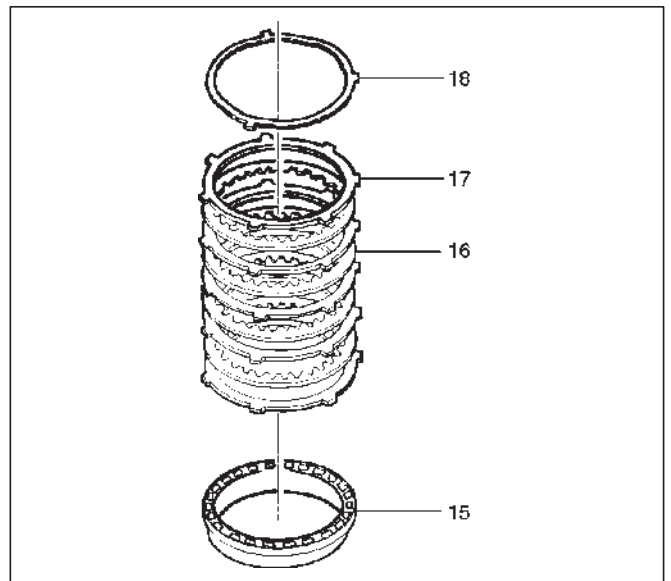
18. Install second and third clutch assemblies into the main case. Twist output shaft and clutch assemblies to ensure proper fit.



19. Install pressure plate (15) with lip side up, tang facing valve body face.

20. Install reverse clutch plates. Start with a steel plate (17) and alternate with a lined plate (16).

21. Install waved clutch plate (18) with center tang facing valve body side.

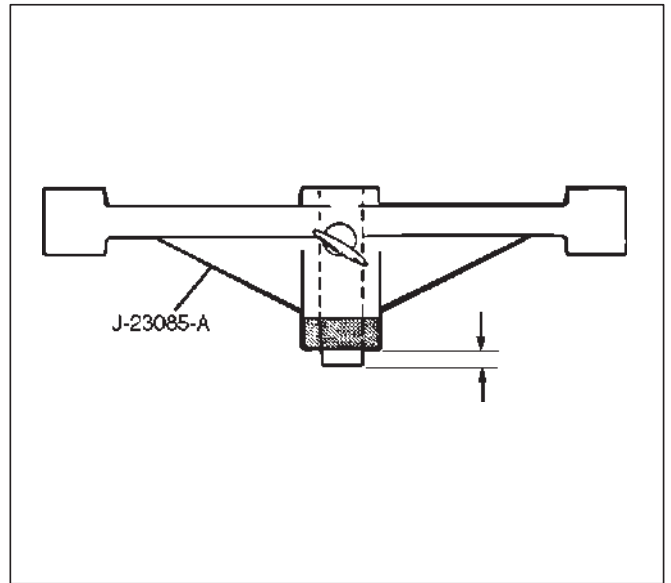
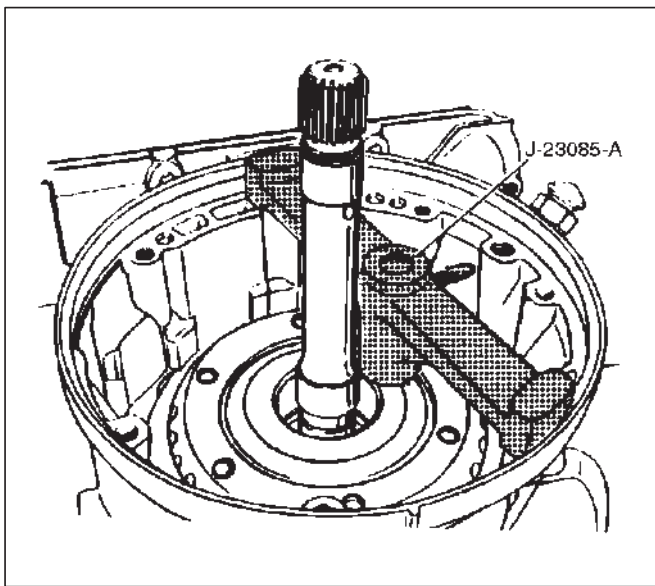


22. Second clutch end play measurement

1. Install the J-23085-A Selective washer gauging tool (with spacer ring) on the case flange and against the intermediate shaft.
2. Position the inner shaft of the gauging tool against the thrust surface of the second clutch hub.
3. Tighten thumb screw. Remove the tool.
4. Fit the spacer ring on the inner shaft of the tool.
5. Measure the gap, and select the appropriate washer as shown in the chart.

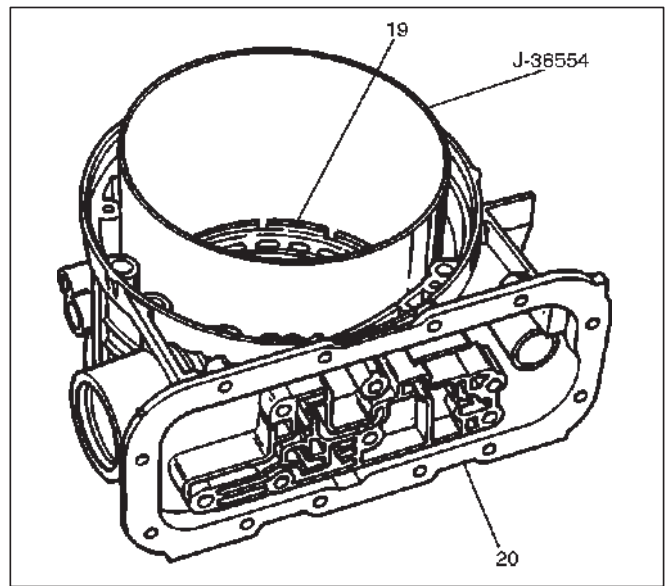
Selective Thrust Washer	
Gap: mm(in)	Color
1.53 – 1.63 (0.060 – 0.064)	Yellow
1.72 – 1.82 (0.068 – 0.072)	Red
1.91 – 2.01 (0.075 – 0.079)	Black
2.10 – 2.20 (0.083 – 0.087)	Natural
2.29 – 2.39 (0.090 – 0.094)	Green
2.48 – 2.58 (0.098 – 0.102)	Blue

FOLLOWING THE PROCEDURE SHOULD RESULT IN FINAL END-PLAY FROM 0.36 mm TO 0.79 mm (0.014 in TO 0.031 in)



23. Inspect fourth clutch piston seals and replace if necessary.

- Lubricate J-38554 fourth clutch piston fitter and install it on fourth clutch piston (19).
- Install fourth clutch piston (19) in adapter case (20).
- Remove fitter.

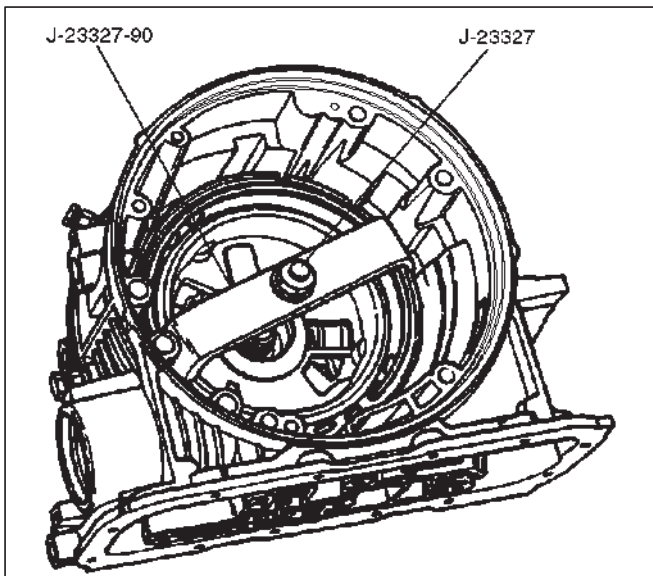
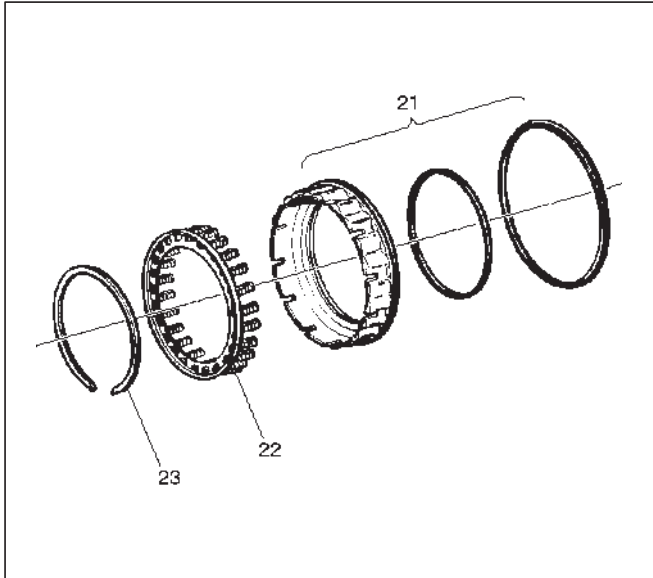


24. Install retainer and spring assembly (22) into fourth clutch piston (21).

## 7A-54 AUTOMATIC TRANSMISSION (4L30-E)

25. Install snap ring (23) in adapter case.

- Install J-23327 and J-23327-90 fourth clutch spring compressor.
- Seat snap ring in groove.
- Remove compressor.

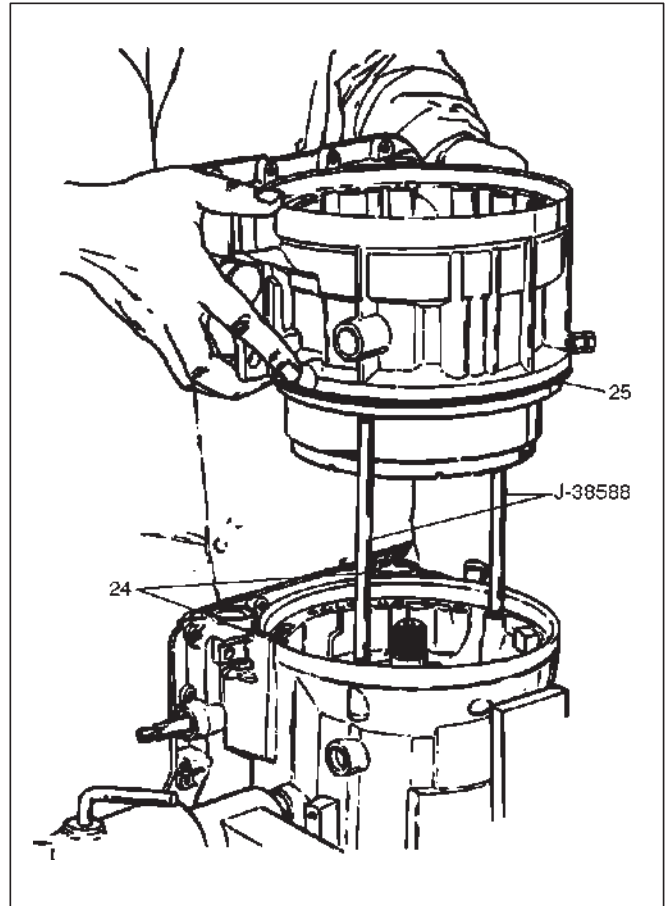


26. Install selective washer using petroleum jelly.

27. Install two O-ring seals (24) in main case and adapter case/main case seal ring (25).

28. Install J-38588 guide pins.

- Install adapter case and center support assembly to main case.



29. Install thrust washer (26) into adapter case, with tangs pointing downwards.

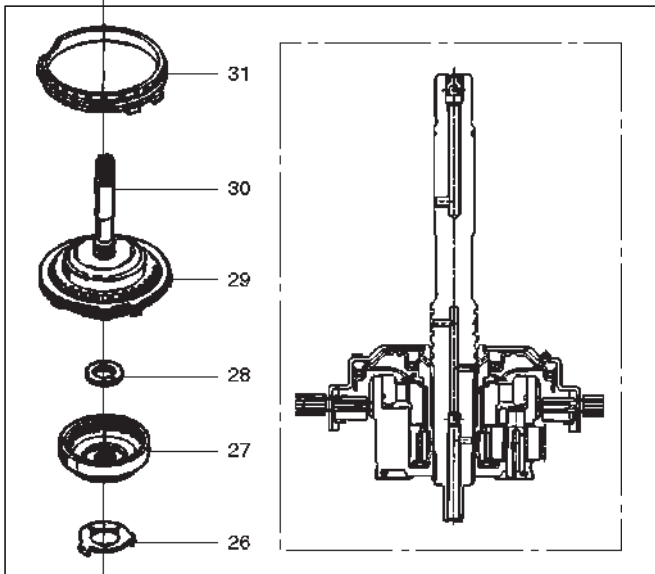
30. Preassemble overdrive internal gear (27) and thrust bearing assembly (28) onto the turbine shaft and overrun clutch assembly.

NOTE: Install bearing assembly, black side up. Use petroleum jelly to keep assembly in place.

31. Install overdrive carrier (30) and internal gear assembly into adapter case.

32. Install fourth clutch plates (29) in the following order: Steel, Lined, Steel, Steel, Lined, Steel. Steel plates go in with short tang facing towards valve body surface.

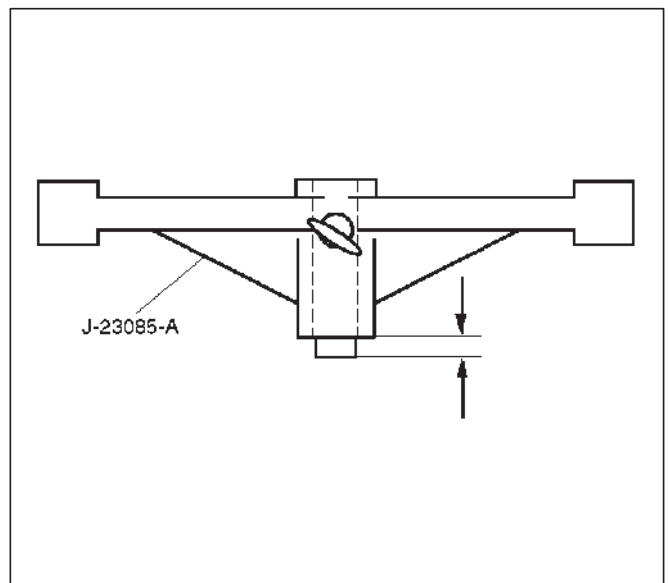
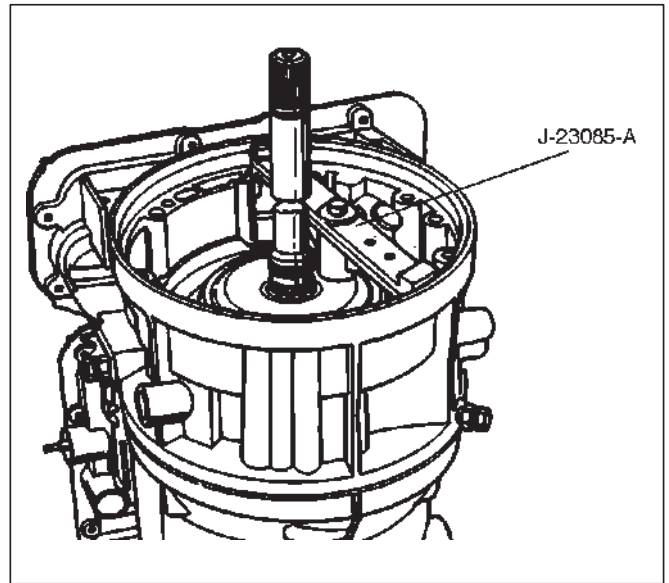
33. Install fourth clutch retainer (31) with the notch facing up and positioned towards valve body surface.



34. Overdrive clutch end play measurement

1. Install the J-23085-A selective washer gauging tool on the adapter case flange and against the input shaft.
2. Position the inner shaft of the tool against the thrust surface of the overrun clutch housing.
3. Tighten thumb screw. Remove the tool.
4. Measure gap. Select appropriate size washer as shown in the chart.
5. Set selective thrust washer aside.

Selective Thrust Washer	
Gap: mm(in)	Color
1.53 – 1.63 (0.060 – 0.064)	Yellow
1.72 – 1.82 (0.068 – 0.072)	Red
1.91 – 2.01 (0.075 – 0.079)	Black
2.10 – 2.20 (0.083 – 0.087)	Natural
2.29 – 2.39 (0.090 – 0.094)	Green
2.48 – 2.58 (0.098 – 0.102)	Blue
FOLLOWING THE PROCEDURE SHOULD RESULT IN FINAL END-PLAY FROM 0.1 mm TO 0.8 mm (0.004 in TO 0.03 in)	



35. Install selective washer (32).

NOTE: Use petroleum jelly to hold selective washer in place.

36. Install gasket (33).

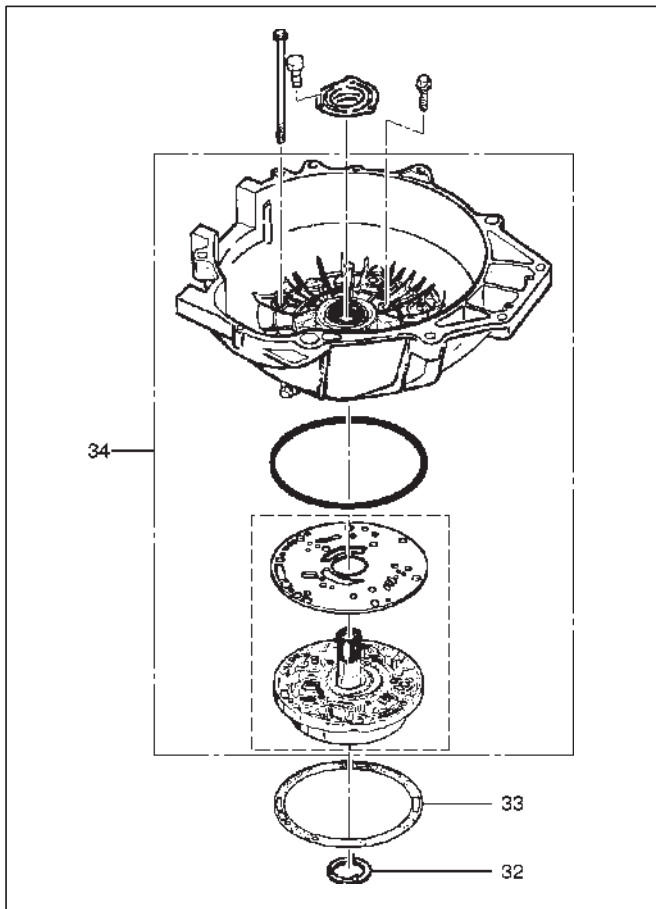
37. Install converter housing and oil pump assembly (34) to adapter case.

○Fit and tighten seven outer 13 mm screws.

**Torque: 39 N•m (29 lb ft)**

## 7A-56 AUTOMATIC TRANSMISSION (4L30-E)

- Ensure free rotation of pump using J-23082-01 oil pump rotation tool.



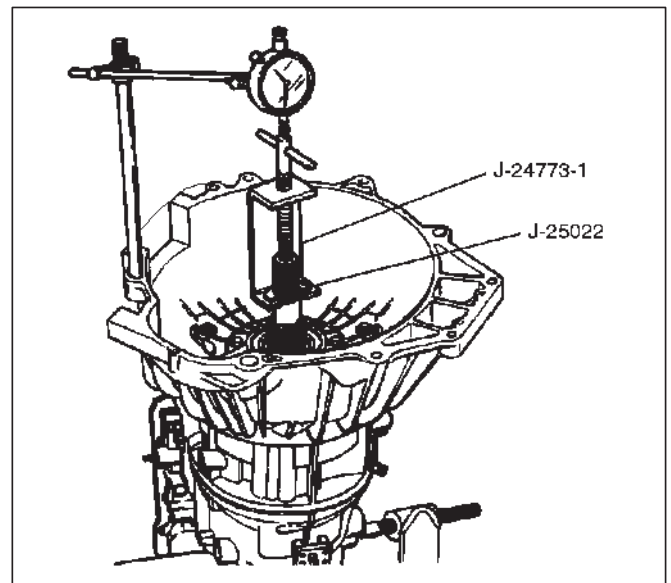
### 38. Overdrive clutch end play measurement

1. Fit J-25022 and J-24773-1 turbine shaft puller on turbine shaft.
2. Position axial play checking tool on converter housing mating face.
3. Pull turbine shaft upwards with puller until first resistance is met. (due to weight of overdrive assembly).
4. Maintain shaft in this position and set indicator to zero.
5. Pull turbine shaft further upwards with puller. Read end play shown on indicator.

**End play: 0.1mm – 0.8mm (0.004 in – 0.031in)**

6. Remove axial play checking tool and puller.

NOTE: If end play is not correct, repeat selective washer selection.



39. Inspect extension housing oil seal and replace if necessary, using J-36797 extension housing oil seal installer.

- Rotate transmission to horizontal position, with valve body side down.
- Inspect parking wheel seal ring. Replace if necessary.
- Install wheel parking lock assembly (35).

40. Install speed wheel (36) and snap ring (37).

NOTE: Use extra long, needle-nose pliers.

41. Install gasket onto extension assembly with a thin coating of oil.

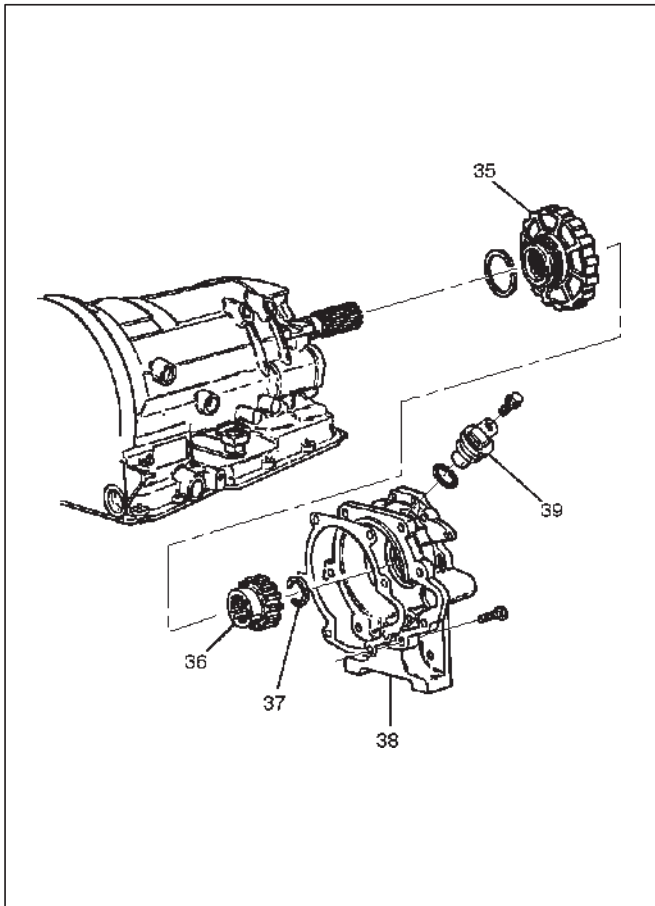
- Install extension housing assembly (38), and align parking pawl shaft.
- Install actuator assembly into extension assembly.
- Install seven 8 mm hexagon socket head screws.

**Torque: 32 N•m (24 lb ft)**

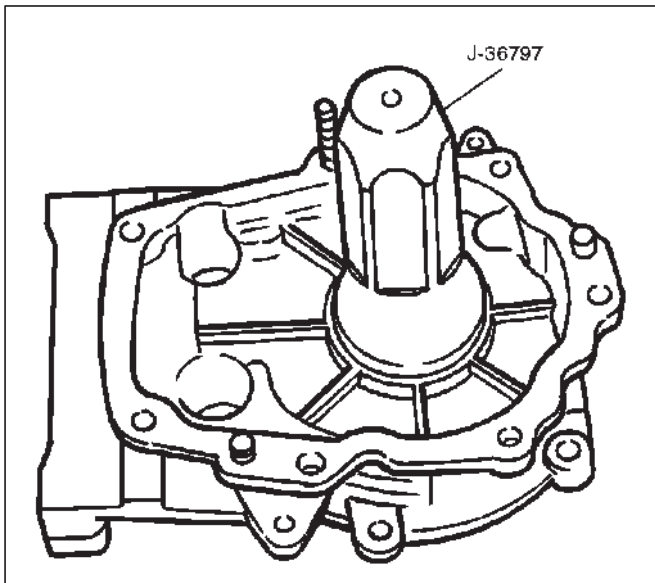
42. Inspect speed sensor O-ring. Replace if necessary.

- Install speed sensor assembly (39) and 10 mm screw.

**Torque: 9 N•m (78 lb in)**



241RW009



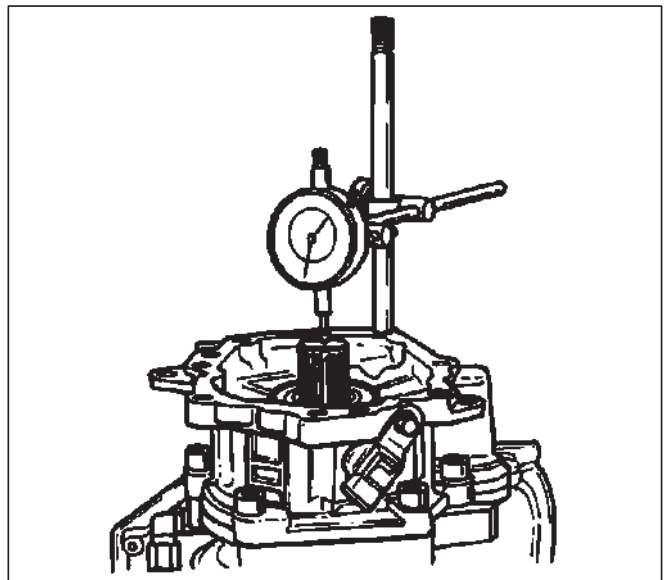
241RS004

**43. Main case end play measurement**

1. Attach axial play checking tool on the extension housing and set indicator to zero on output shaft.
2. Manually push output shaft upwards.

**End play: 0.36mm – 0.80mm (0.014 in – 0.031in)**

3. Remove axial play checking tool.
4. If end play is not correct, repeat selective washer selection.



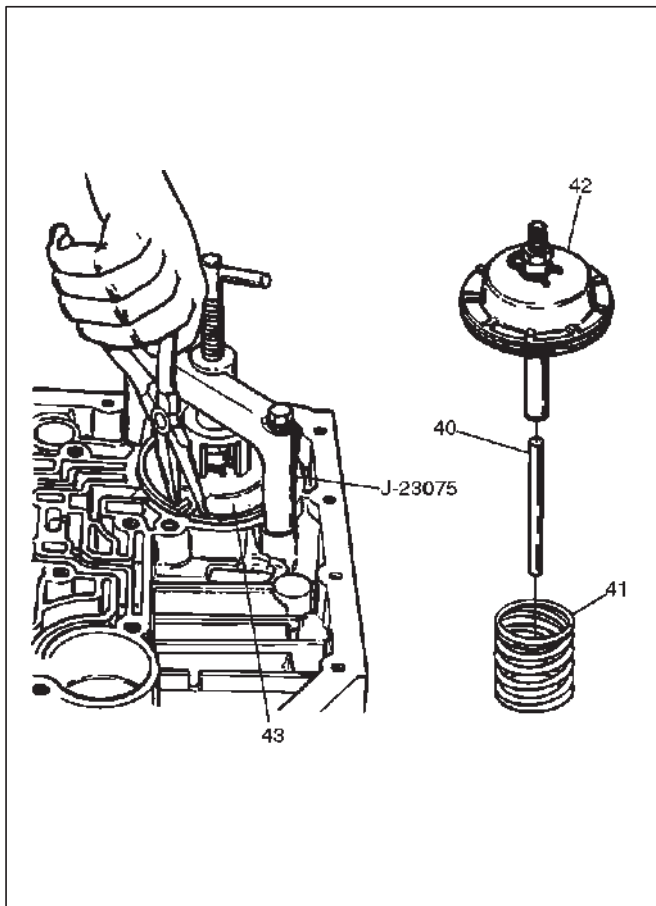
241RS005

**44. Inspect servo piston seal ring. Replace if necessary.**

- Ensure brake band is correctly positioned. Rotate output shaft if necessary.
- Install J-38428 servo piston fitter in servo bore.
- Install apply rod (40), round end toward band, return spring (41) and piston assembly (42).

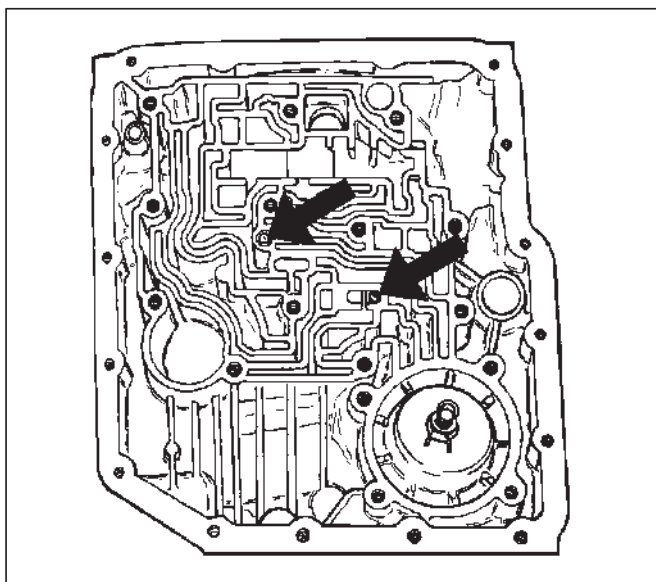
**45. Install the J-23075 servo spring compressor with offset to rear of case.**

- Compress servo piston seal ring, using fitter while tightening the tool screw.
- Install servo piston retaining ring (43).
- Remove tool.
- Adjust the brake band by tightening the servo adjusting screw to 4.5 N·m torque. Be certain the lock nut is loose, then back-off the screw five turns exactly. Hold piston sleeve with wrench and tighten lock nut to 18.5 N·m torque. Be certain the adjusting screw does not turn.



46. Install two check balls (44).

242RW004



47. Inspect main case electrical connector and seal, replace if necessary.

244RW002

○ Install electrical 4 pin connector/main case and wiring harness.

48. Install two J-25025-B guide pins into main case.

○ Install main case valve body complete assembly (45) and manual valve link.

NOTE: Valve must be extended as the short end of manual valve link is connected to the range selector lever. Long end of link goes into valve.

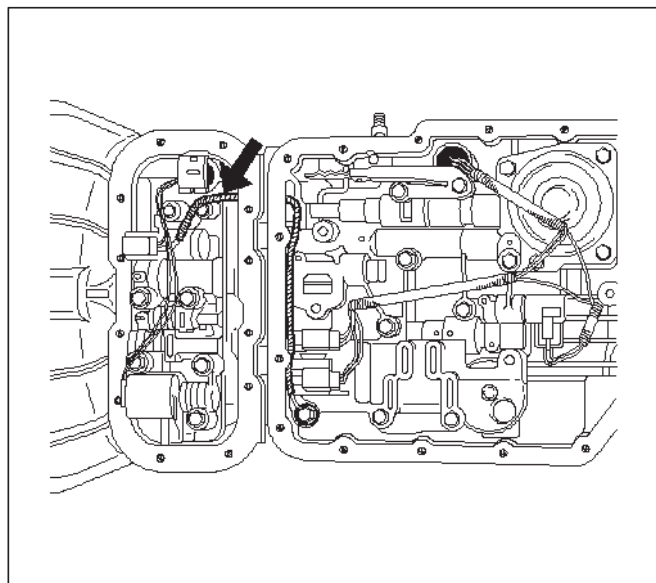
○ Install seven 13 mm screws.

**Torque: 20 N•m (15 lb ft)**

○ Pass ground wire of adapter case wiring harness assembly through the hole joining adapter fluid area and main case fluid area.

○ Assemble 8.5 mm connector of ground wire under the head of this valve body bolt and reinstall it.

○ Remove two guide pins.



49. Install servo cover gasket, cover (46) and four 13 mm screws.

244RW001

**Torque: 25 N•m (18 lb ft)**

50. Connect wiring harness (47) to band control, shift solenoids, and main case 4 pin connector.

51. Install manual detent roller and spring assembly (48) with clip.

○ Install two 13 mm screws.

**Torque: 20 N•m (15 lb ft)**

52. Install oil filter (49), and three 13 mm screws.

**Torque: 20 N•m (15 lb ft)**

53. Install oil pan gasket, magnet, main oil pan (50), and sixteen 10 mm screws.

**Torque: 11 N•m (96 lb in)**

54. Inspect adapter case electrical connector and seal. Replace if necessary.

○ Install electrical five pin connector and harness assembly (52) in bottom of adapter case.

55. Install gasket, transfer plate, and gasket.

○ Install adapter case valve body (51) and seven 13 mm screws.

**Torque: 20 N•m (15 lb ft)**

56. Connect wiring harness assembly (52) to converter clutch solenoid, force motor, and 5 pin connector.

57. Install oil pan gasket, adapter case oil pan (53), and twelve 10 mm screws.

**Torque: 11 N•m (96 lb in)**

○Rotate transmission, with bottom pan facing down.

58. Install mode switch (54), two 10 mm screws, selector lever nut, and cover.

**10 mm screw**

**Torque: 13 N•m (113 lb in)**

**Nut**

**Torque: 23 N•m (17 lb ft)**

○Adjust using setting tool, refer to Mode Switch in this section.

59. Install O-ring (55) on turbine shaft.

60. Install torque converter (56).

The converter assembly must be replaced under any of the following conditions:

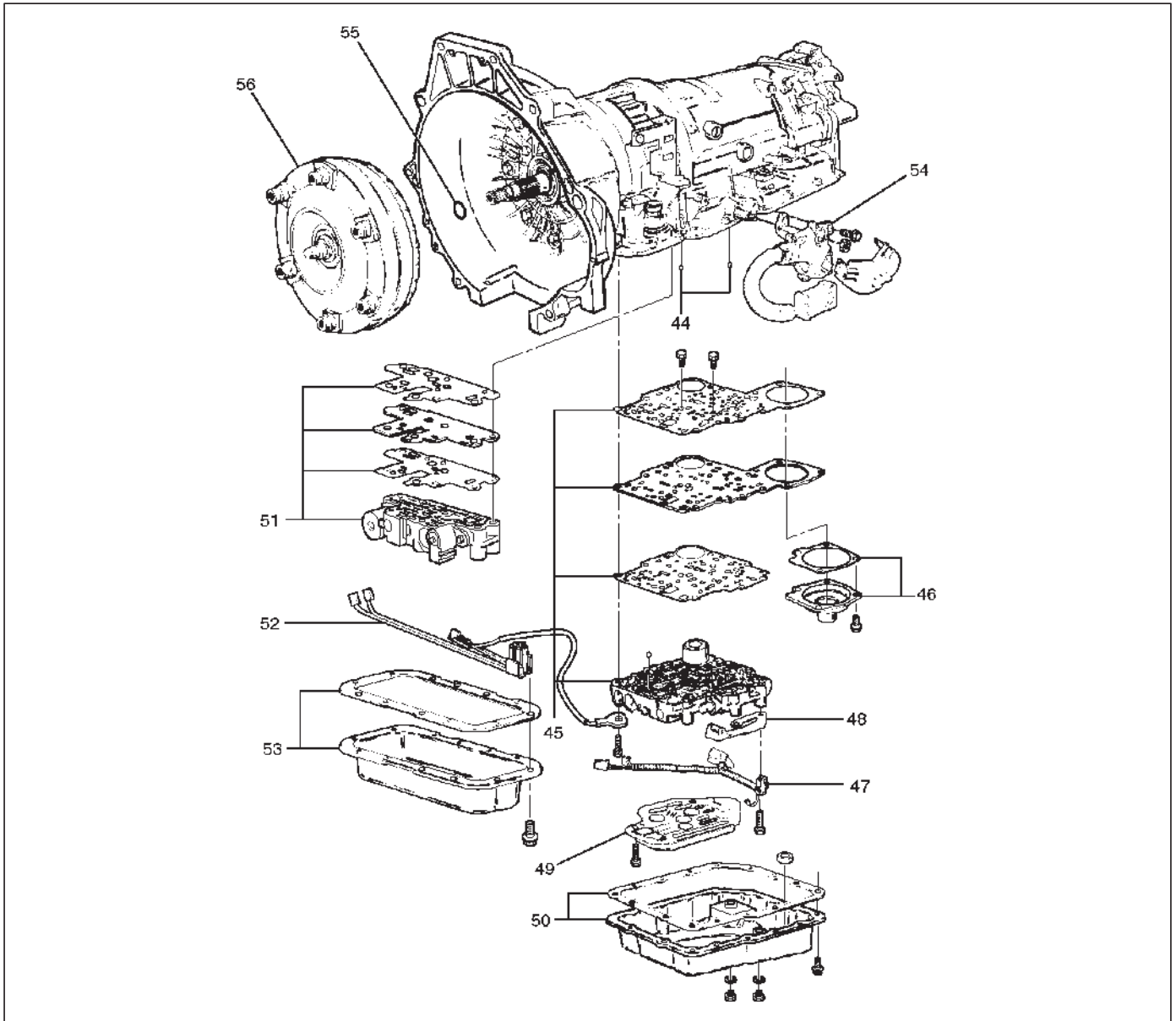
- a. Evidence of damage to the pump assembly.
- b. Metal particles are found after flushing the cooler lines.
- c. External leaks in hub weld area.
- d. Converter pilot broken, damaged, or poor fit into crankshaft.
- e. Converter hub scored or damaged.
- f. Internal failure in stator.
- g. Contamination from engine coolant.
- h. Excess end play.

○Rotate transmission, bell housing up. Spin converter to insure proper fit.

61. Fill transmission through the overfill screw hole of oil pan, using ATF DEXRON®-III. Refer to Changing Transmission Fluid in this section.

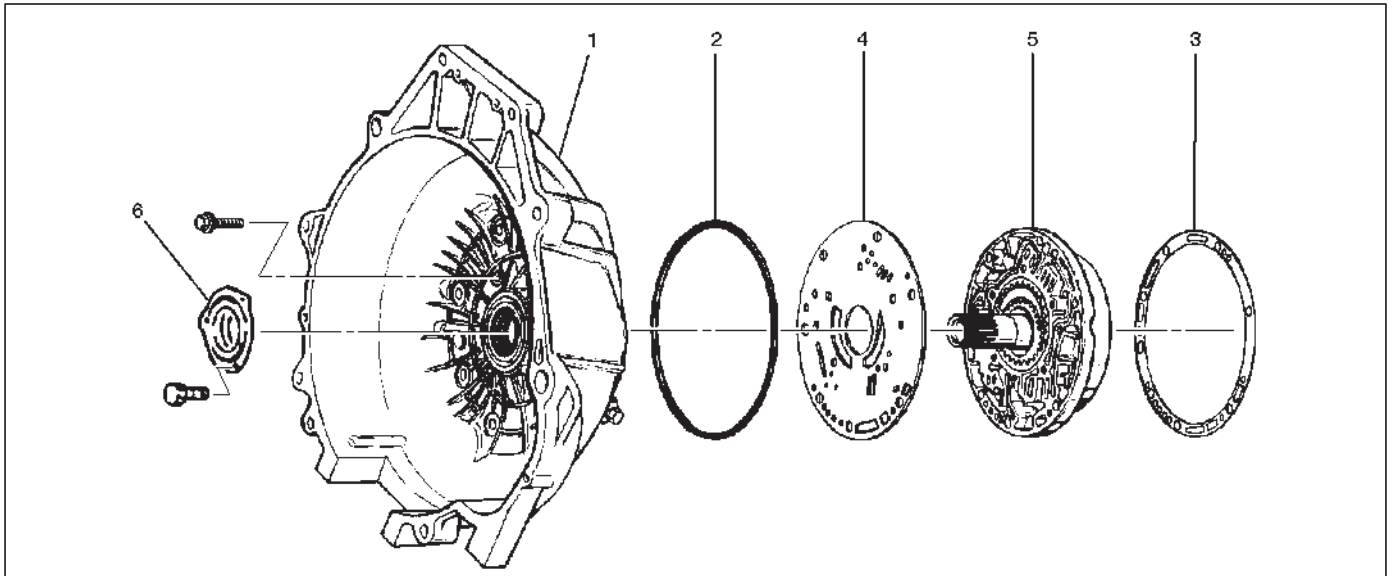


7A-60 AUTOMATIC TRANSMISSION (4L30-E)



## Converter Housing And Oil Pump Assembly

### Disassembled View



241RW003

#### Legend

- |                       |                       |
|-----------------------|-----------------------|
| (1) Converter Housing | (4) Wear Plate        |
| (2) Outer Seal Ring   | (5) Oil Pump Assembly |
| (3) Gasket            | (6) Oil Seal Ring     |

### Disassembly

1. Remove oil pump assembly from converter housing.
2. Remove outer seal ring.
3. Remove gasket.
4. Remove wear plate.
5. Remove oil seal ring.

### Inspection And Repair

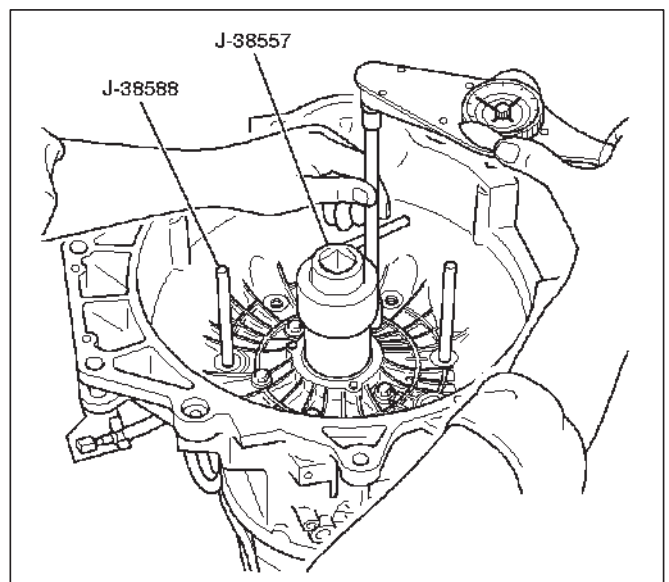
#### Visual Check:

If any damage, deformation, or local wear is found in a converter housing, outer seal ring, wear plate, or oil seal ring, replace it.

### Reassembly

1. Install wear plate onto oil pump assembly.
2. Install converter housing onto complete oil pump assembly. Align with two short J-38588 guide pins on outer bolt holes.
  - Loosely install five 13mm bolts.
  - Center converter housing using J-38557 centering tool.
  - Tighten five inner 13mm bolts in an alternating pattern.

**Torque: 20 N•m (15 lb ft)**



241RW002

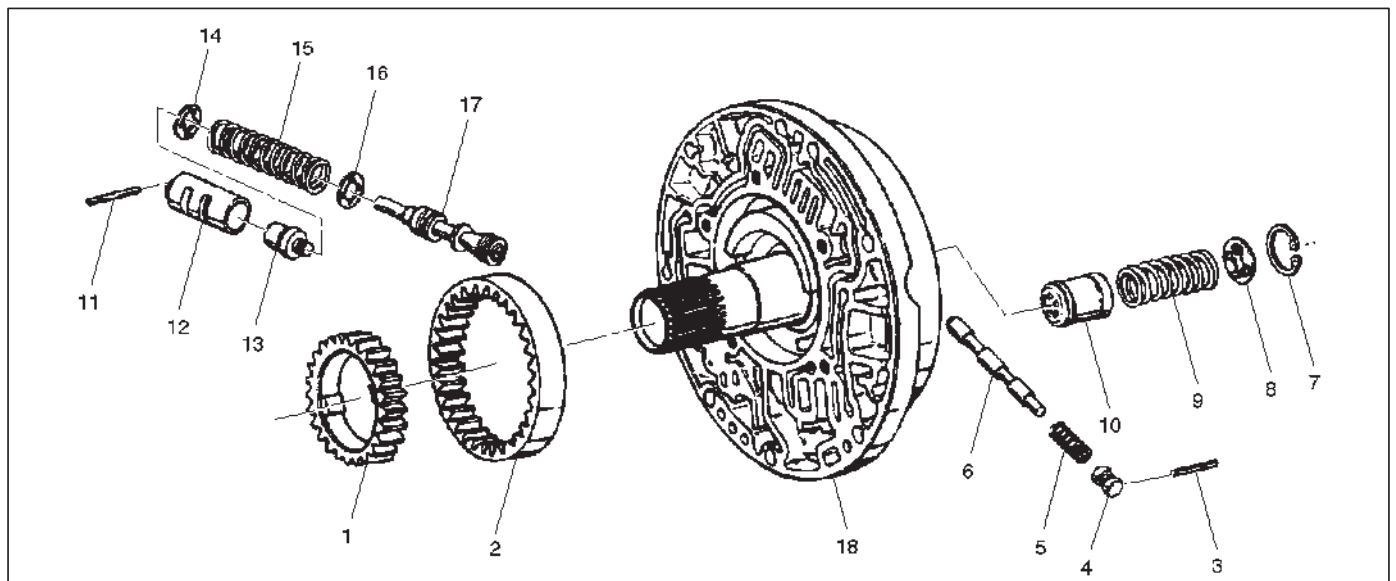
3. Install oil seal ring (3 screws).

**Torque: 3 N•m (26 lb in)**

4. Install gasket.
5. Install outer seal ring.

## Oil Pump

### Disassembled View



241RS014

#### Legend

- |                                    |   |
|------------------------------------|---|
| (1) Oil Pump Drive Gear            | (10) Throttle Signal Accumulator Piston |
| (2) Oil Pump Driven Gear           | (11) Sleeve Pin                         |
| (3) Pin                            | (12) Sleeve                             |
| (4) Plug                           | (13) Boost Valve                        |
| (5) Spring                         | (14) Spring Seat                        |
| (6) Converter Clutch Control Valve | (15) Valve Spring                       |
| (7) Snap Ring                      | (16) Spring Seat                        |
| (8) Spring Seat                    | (17) Pressure Regulator Valve           |
| (9) Spring                         | (18) Oil Pump Assembly                  |

### Disassembly

1. Remove oil pump drive gear (1) and driven gear (2).
2. Remove pin (3) from oil pump assembly (18).
3. Remove plug (4), spring (5), and converter clutch control valve (6).
4. Remove snap ring (7) from oil pump assembly (18).
5. Remove spring seat (8), spring (9), and throttle signal accumulator piston (10).
6. Remove sleeve pin (11) from oil pump assembly (18).
7. Remove sleeve (12), boost valve (13), spring seat (14), valve spring (15), spring seat (16), and pressure regulator valve (17).

### Inspection And Repair

#### Visual Check:

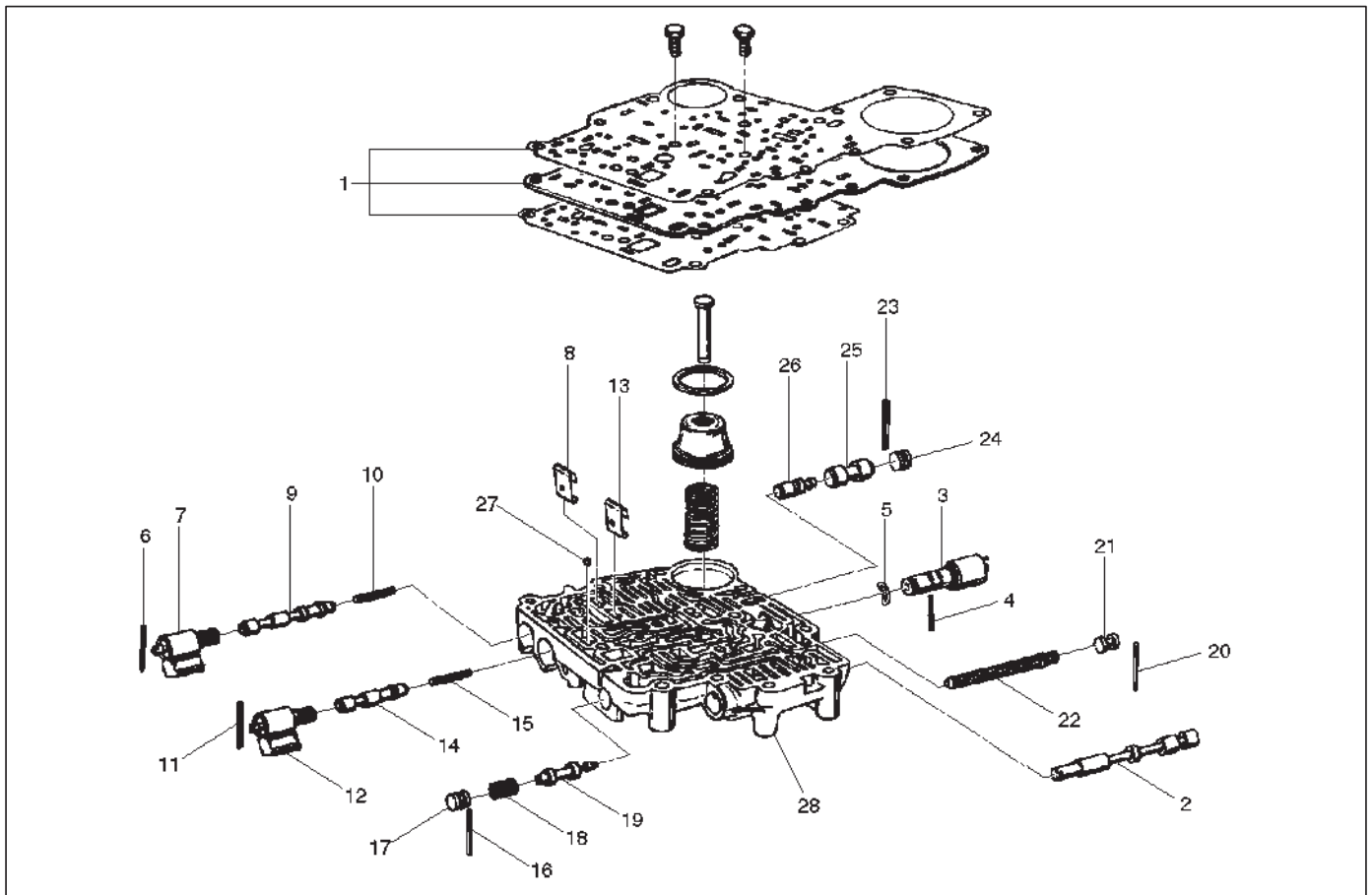
If any damage, deformation or wear is found, replace the damaged part.

### Reassembly

1. Lubricate and preinstall pressure regulator spring seat (16) on valve (17), with the flat side against shoulder.
2. Install pressure regulator valve (17) and spring seat (16) assembly, valve spring (15), and spring seat (14) with the flat side away from spring to oil pump assembly (18).
3. Assemble boost valve (13) into sleeve (12).
4. Install boost valve and sleeve assembly, and sleeve pin (11) to oil pump assembly (18).
5. Install throttle signal accumulator piston (10), spring (9), and spring seat (8), with the flat side away from the spring, and snap ring (7) to oil pump assembly (18).
6. Install converter clutch control valve (6), spring (5), plug (4), and pin (3) to oil pump assembly (18).
7. Install oil pump driven gear (2) and drive gear (1).

## Main Case Valve Body

### Disassembled View



244RS010

#### Legend

- |                                |                                    |
|--------------------------------|------------------------------------|
| (1) Gaskets and Transfer Plate | (15) Spring                        |
| (2) Manual Valve               | (16) Spring Pin                    |
| (3) Band Control Solenoid      | (17) Plug                          |
| (4) Pin                        | (18) Spring                        |
| (5) Waved Washer               | (19) Low Pressure Control Valve    |
| (6) Spring Pin                 | (20) Spring Pin                    |
| (7) Solenoid A                 | (21) Plug                          |
| (8) Retainer                   | (22) Band Control Screen Assembly  |
| (9) 1-2/3-4 Shift Valve        | (23) Spring Pin                    |
| (10) Spring                    | (24) Plug                          |
| (11) Spring Pin                | (25) 1-2 Accumulator Valve         |
| (12) Solenoid B                | (26) 1-2 Accumulator Control Valve |
| (13) Retainer                  | (27) Check Ball                    |
| (14) 2-3 Shift Valve           | (28) Main Case Valve Body          |

### Disassembly

1. Remove two 11mm bolts from valve body (28), then remove gaskets and transfer plate (1).
2. Remove manual valve (2).
3. Push in band control solenoid (3) to compress waved washer (5), and remove pin (4).
4. Remove band control solenoid (3) and waved washer (5).
5. Remove spring pin (6) with a 3 mm dia punch.
6. Remove solenoid A (7) by grasping the metal tip. Do not grasp the connector housing.
7. Remove retainer (8), 1-2/3-4 shift valve (9), and spring (10).
8. Remove spring pin (11) with a 3 mm dia punch.
9. Remove solenoid B (12) by grasping the metal tip. Do not grasp the connector housing.

## 7A-64 AUTOMATIC TRANSMISSION (4L30-E)

10. Remove retainer (13), 2-3 shift valve (14), and spring (15).
11. Remove spring pin (16), plug (17), spring (18), and low pressure control valve (19).
12. Remove spring pin (20), plug (21), and band control screen assembly (22).
13. Remove spring pin (23), plug (24), 1-2 accumulator valve (25), and 1-2 accumulator control valve (26).
14. Remove check ball (27) from valve body (28).

### Inspection And Repair

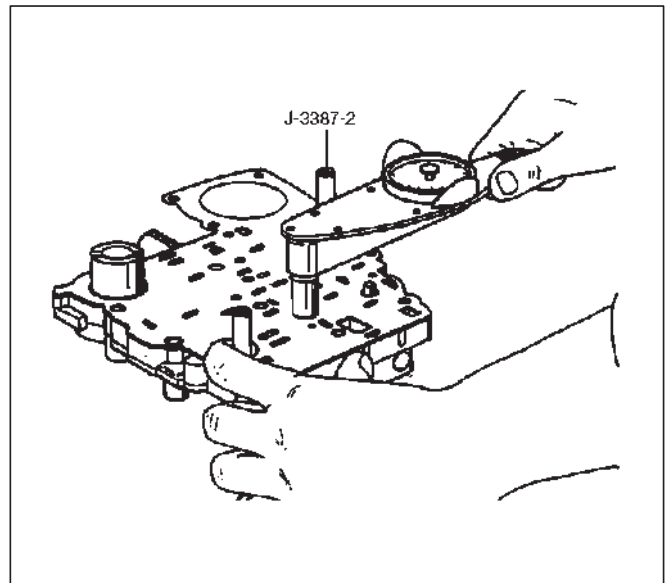
Inspect for the following, and replace any damaged or worn parts:

1. Damage or wear to each valve.
2. Damage in oil passages.
3. Cracks or damage to valve body.
4. Valve operations.
5. Spring fatigue.

### Reassembly

1. Install 1-2 accumulator control valve (26), 1-2 accumulator valve (25), plug (24), and spring pin (23).
2. Install band control screen assembly (22), plug (21), and spring pin (20).
3. Install low pressure control valve (19), spring (18), plug (17), and spring pin (16).
4. Install spring (15), 2-3 shift valve (14), retainer (13), solenoid B (12), and spring pin (11).
5. Install spring (10), 1-2/3-4 shift valve (9), retainer (8), solenoid A (7), and spring pin (6).
6. Install waved washer (5), band control solenoid (3), and pin (4).
7. Install manual valve (2).
8. Install check ball (27) to valve body (28).
9. Install gasket (valve body/transfer plate) and transfer plate using two J-3387-2 guide pins.
  - Install two 11mm bolts.

**Torque: 13 N•m (113 lb in)**

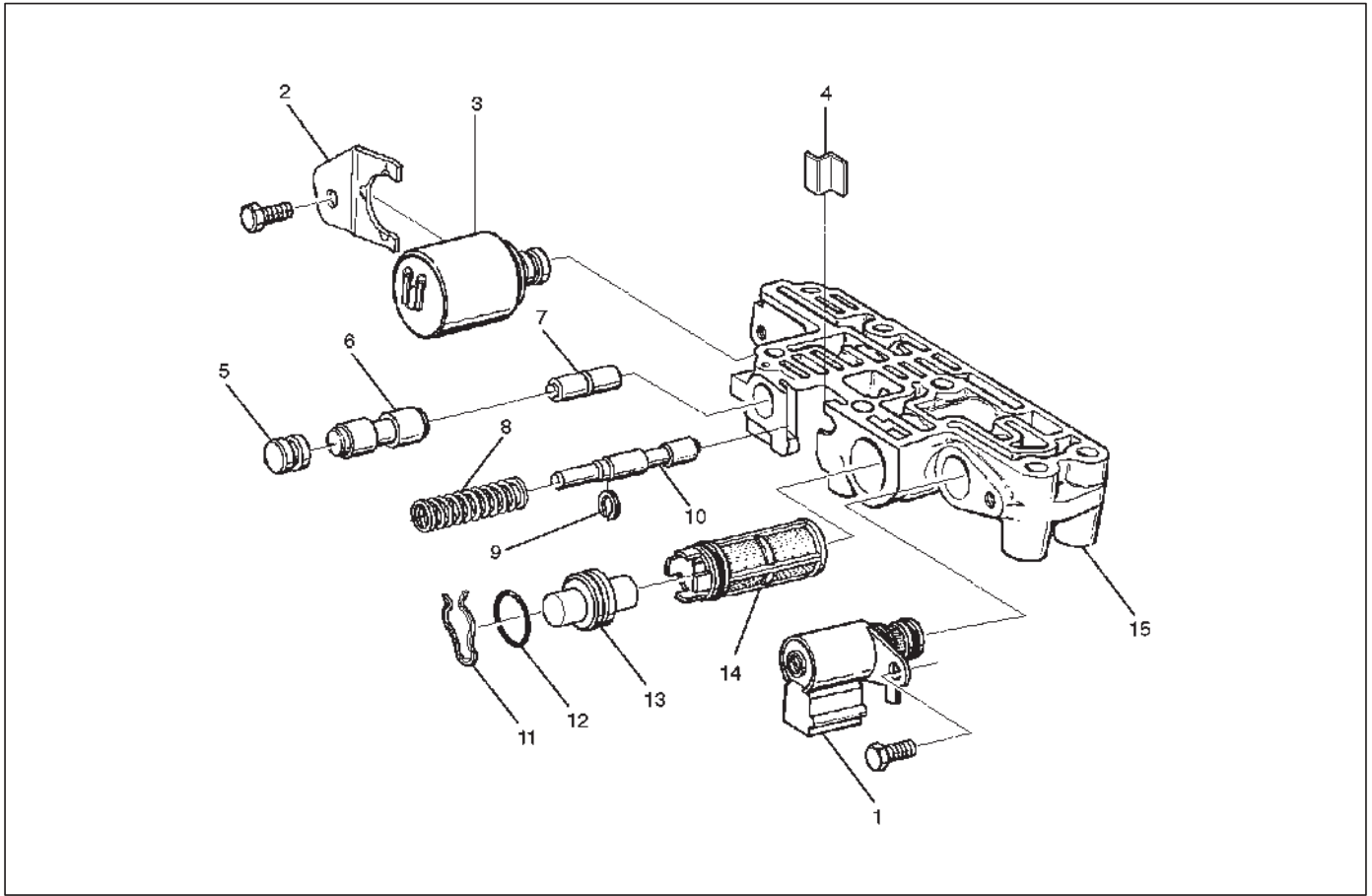


○Install gasket (transfer plate/main case).

244RS004

## Adapter Case Valve Body

### Disassembled View



243RW001

#### Legend

- |  |                                  |
|--|----------------------------------|
| (1) Converter Clutch Solenoid Assembly | (8) Spring                       |
| (2) Retainer                           | (9) Retaining Ring               |
| (3) Force Motor Solenoid               | (10) Feed Limit Valve            |
| (4) Retainer                           | (11) Plug Retainer               |
| (5) Plug                               | (12) O-Ring                      |
| (6) 3/4 Accumulator Valve              | (13) Plug                        |
| (7) 3/4 Accumulator Control Valve      | (14) Force Motor Screen Assembly |
|  | (15) Adapter Case Valve Body     |

### Disassembly

1. Remove 11mm bolt from valve body.
  - Remove converter control solenoid assembly (1).
2. Remove 11mm bolt and retainer (2) from valve body.
  - Remove force motor solenoid (3).
3. Remove retainer (4), plug (5), 3/4 accumulator valve (6), and 3/4 accumulator control valve (7).
4. Remove spring (8), retaining ring (9), and feed limit valve (10).
5. Remove plug retainer (11), O-ring (12), plug (13), and force motor screen assembly (14).
  - Use 5 mm bolt to pull plug.

### Inspection And Repair

Inspect for the following, and replace any damaged or worn parts:

1. Damage or wear to each valve.
2. Damage in oil passages.
3. Cracks or damage to valve body.
4. Valve operations.
5. Spring fatigue.

### Reassembly

1. Install force motor screen assembly (14), plug (13), O-ring (12), and plug retainer (11).
2. Install feed limit valve (10), retaining ring (9), and spring (8).

## 7A-66 AUTOMATIC TRANSMISSION (4L30-E)

---

3. Install 3/4 accumulator control valve (7), 3/4 accumulator valve (6), plug (5), and retainer (4).

4. Install force motor solenoid (3).

○ Place solenoid terminals pointing towards mating face.

○ Install retainer (2) and bolt.

**Torque: 10 N•m (87 lb in)**

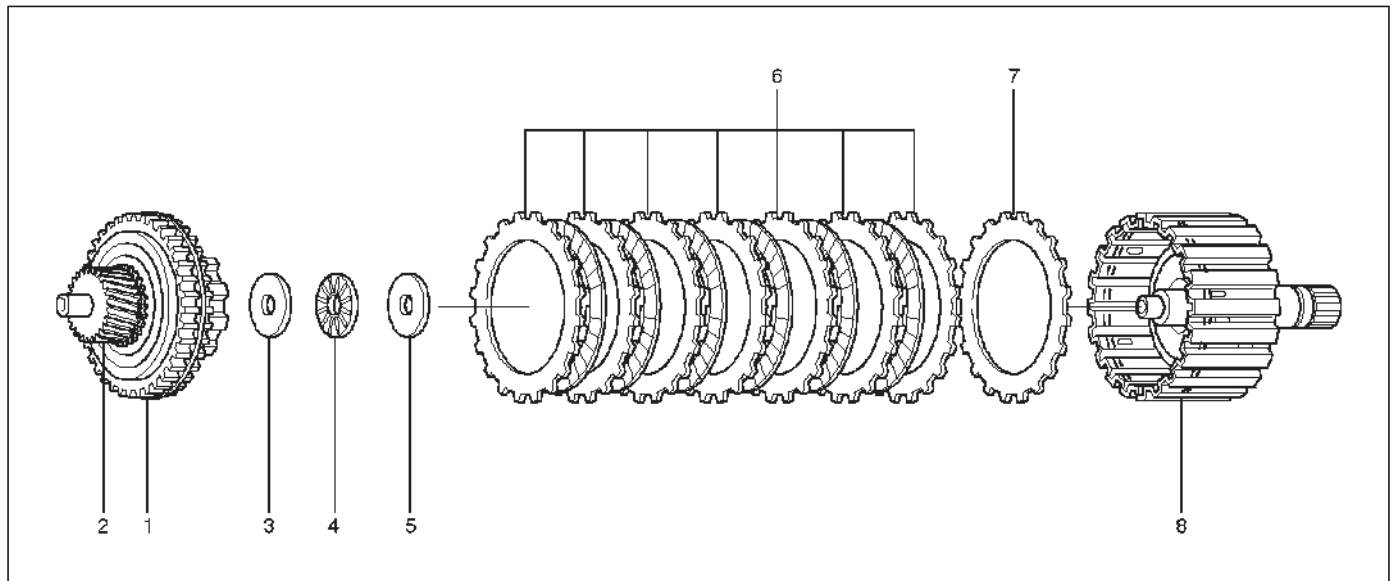
5. Install converter clutch solenoid assembly with two O-rings (1) to valve body.

○ Install bolt.

**Torque: 10 N•m (87 lb in)**

## Third Clutch And Sprag Unit

### Disassembled View



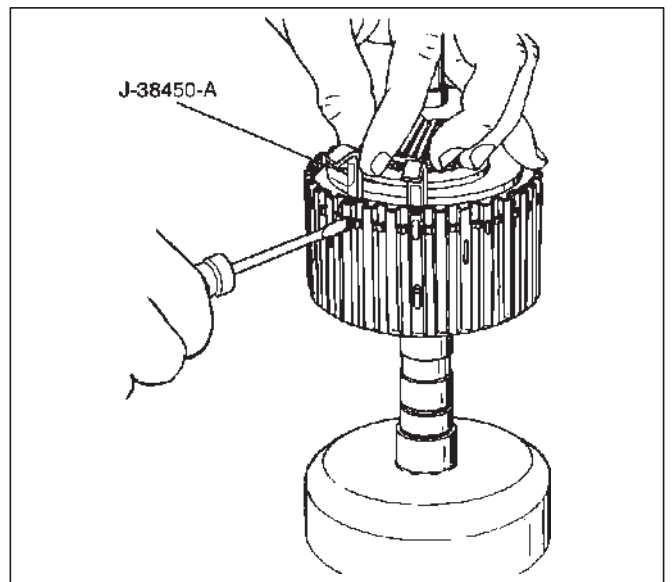
248RW001

#### Legend

- |  |                                       |
|--|---------------------------------------|
| (1) Retaining Ring                         | (5) Thrust Washer                     |
| (2) Input Sun Gear and Sprag Unit Assembly | (6) Clutch Plates                     |
| (3) Retaining Washer                       | (7) Third Clutch Spring Cushion Plate |
| (4) Bearing                                | (8) Third Clutch Drum Assembly        |

### Disassembly

1. Place the third clutch drum and intermediate shaft assembly upright, using the overdrive internal gear as a support.
2. Locate the ends of the retaining ring. Depress one end of the ring using a small screwdriver instead of the depressor handle provided with the tool J-38450-A. Slide one blade down between the third clutch drum and the retaining ring.
3. Remove a screwdriver and repeat this step for the other end of retaining ring.
4. Install the remaining four blades approximately (five) notches apart using a screwdriver to depress the retaining ring.
5. Pull up on input sun gear and sprag unit assembly (1 and 2) to release the retaining ring from third clutch drum assembly (8).
6. Remove the tool blades.



248RX001

7. Remove retaining washer (3), bearing (4), thrust washer (5), and clutch plates (6 and 7) from the third clutch drum assembly (8).



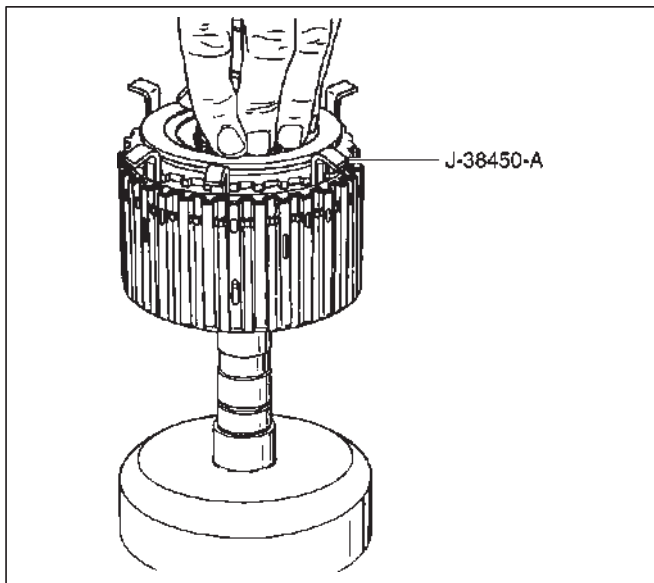
## Inspection And Repair

### Visual Check:

If any damage, deformation or wear is found, replace the damaged part.

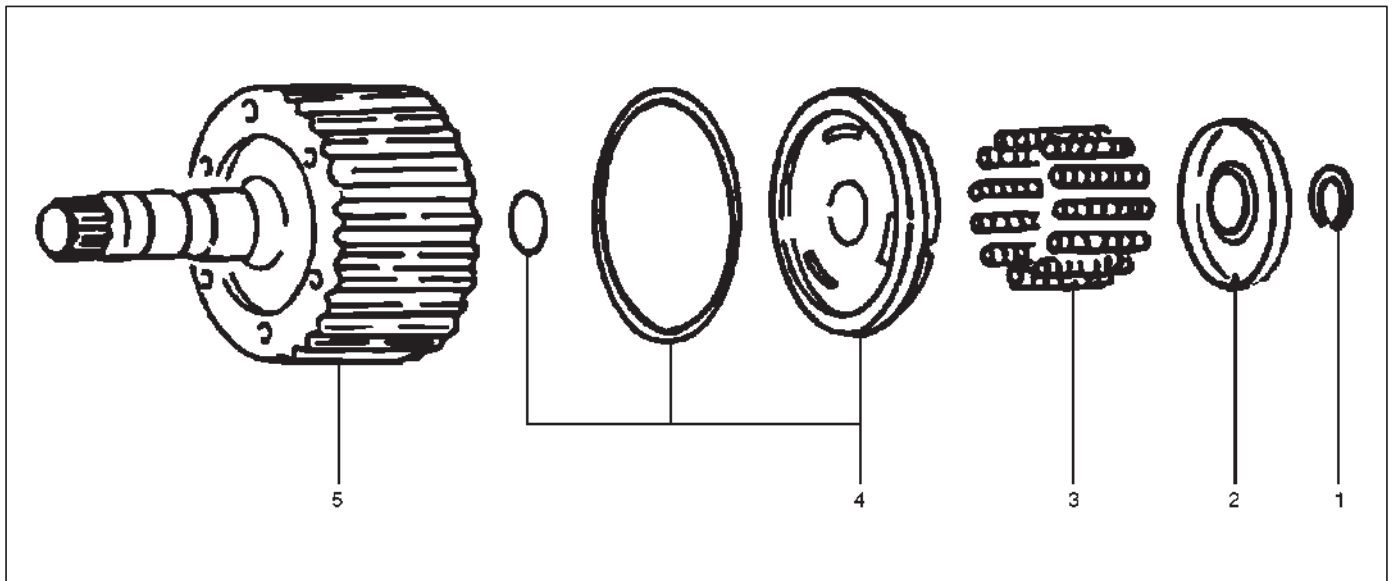
### Reassembly

1. Place third clutch drum and intermediate shaft assembly upright, using the overdrive internal gear as a support.
2. Install third clutch spring cushion plate (7), bevel face down.
3. Install third clutch plates (6) into third clutch drum assembly (8). Start with the steel clutch plate and alternate with lined plates.
4. Install thrust washer (5), bearing (4), and retaining washer (3).
5. Fully engage the hub splines of the input sun gear and sprag unit assembly (2) into the third clutch inner tangs.
  - Simultaneously rotate the outer sprag race to engage into the third clutch drum assembly (8).
6. Place J-38450-A blades between the retaining ring and the third clutch drum approximately (five) notches apart, and one blade at each end of the retaining ring (1). Push down on sprag assembly until the assembly is seated into the third clutch drum assembly (8).
7. Remove the tool blades and engage retaining ring into groove of third clutch drum.



## Third Clutch

### Disassembled View



248RS006

#### Legend

- (1) Retaining Ring
- (2) Spring Seat

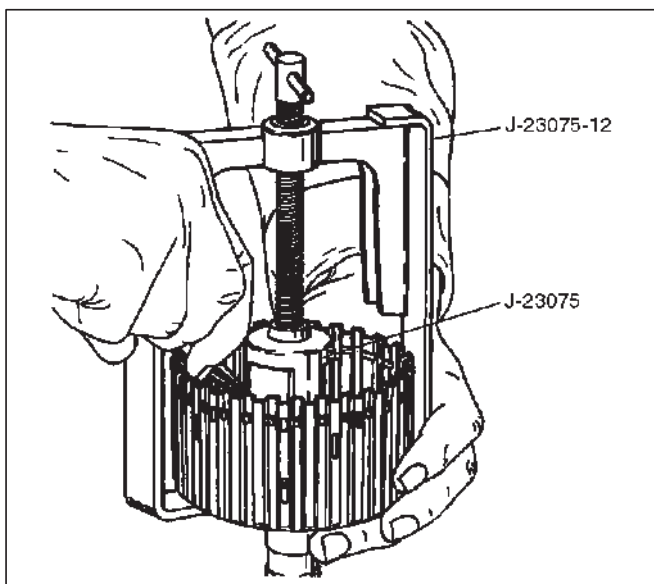
- (3) Springs
- (4) Piston Assembly
- (5) Third Clutch Drum

### Disassemble

1. Compress spring seat using the J-23075 spring compressor and J-23075-12 adapter tool.

NOTE: Do not over-stress the springs and seat. This will cause damage to the spring seat.

- Remove the tool.
- Remove retaining ring (1).



248RS007

2. Release the spring seat (2).

NOTE: Do not let the spring seat catch in the ring groove.

- Remove spring seat (2) and springs (3).

3. Remove piston assembly (4) from third clutch drum (5).

### Inspection And Repair

#### Visual check:

If any damage, deformation or wear is found, replace the damaged part.

#### Operation check:

Shake the piston and listen for check ball movement indicates proper check ball operation. Replace the piston if the check ball is missing or falls out.

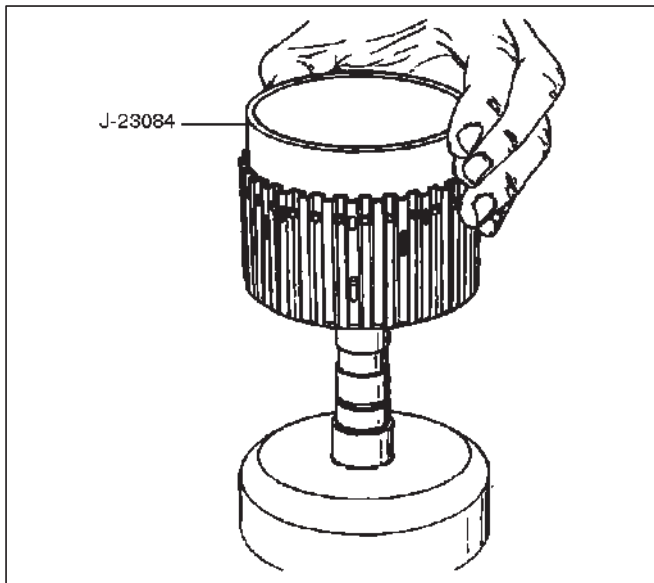
### Reassembly

1. The lip of the piston seal must point toward the front of the transmission. Lubricate the seal lip with transmission fluid.
  - Install piston assembly (4) into the third clutch drum (5). Use the J-23084 third clutch piston installer to protect the outer seal during installation.

## 7A-70 AUTOMATIC TRANSMISSION (4L30-E)

---

- Remove the seal installer.



2. Install twelve springs (3) and spring seat (2).

3. Place retaining ring (1) onto spring seat.

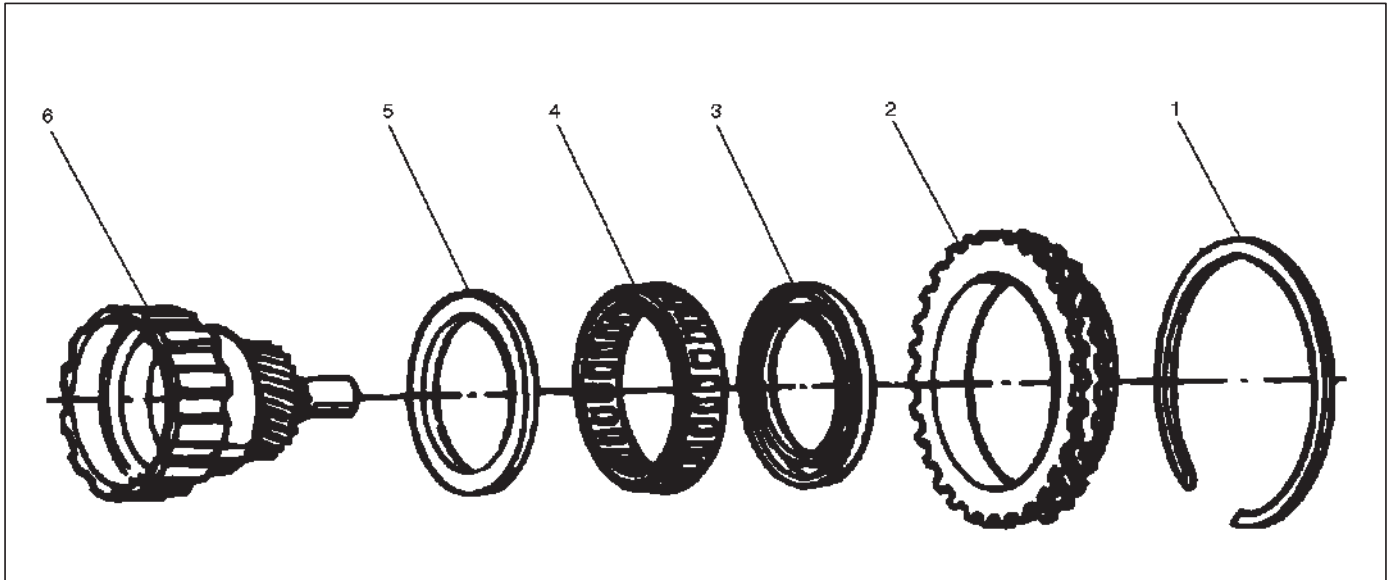
- Compress the piston springs, using the J-23075 piston spring compressor and J-23075-12 adapter.

**CAUTION: Do not over stress the springs and seat. Do not let the spring seat catch in the ring groove. This may cause damage to the spring seat.**

- Install spring seat retaining ring (1).
- Remove the piston spring compressor and adapter.

## Sprag Unit

### Disassembled View



248RS009

#### Legend

- |                      |  |
|----------------------|--|
| (1) Retaining Ring   | (4) Sprag Assembly                         |
| (2) Sprag Outer Race | (5) Ring                                   |
| (3) Ring             | (6) Third Clutch Hub and Sun Gear Assembly |

### Disassembly

1. Remove the sprag outer race, retaining ring, and sprag assembly from the third clutch hub and sun gear assembly.
2. Remove the rings and sprag assembly from the sprag outer race.

### Inspection And Repair

#### Visual Check:

If any damage, deformation or wear is found, replace the damaged part.

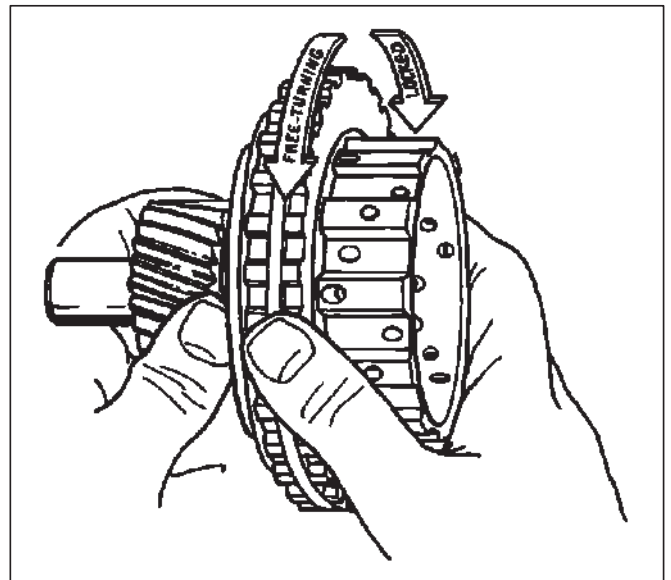
#### Reassembly

NOTE: Flared shoulder of the sprag cage faces the sun gear. This procedure must be followed exactly to be sure that the sprag assembly is installed properly.

1. Install rings and sprag assembly onto the third clutch hub and sun gear.
2. Install sprag outer race and retaining ring assembly over the sprag cage assembly.

- Place third clutch hub and sun gear assembly on a flat surface, sun gear facing up. Place sprag outer race and sprag assembly over the sun gear assembly, push down and turn the input sun counterclockwise at the same time.

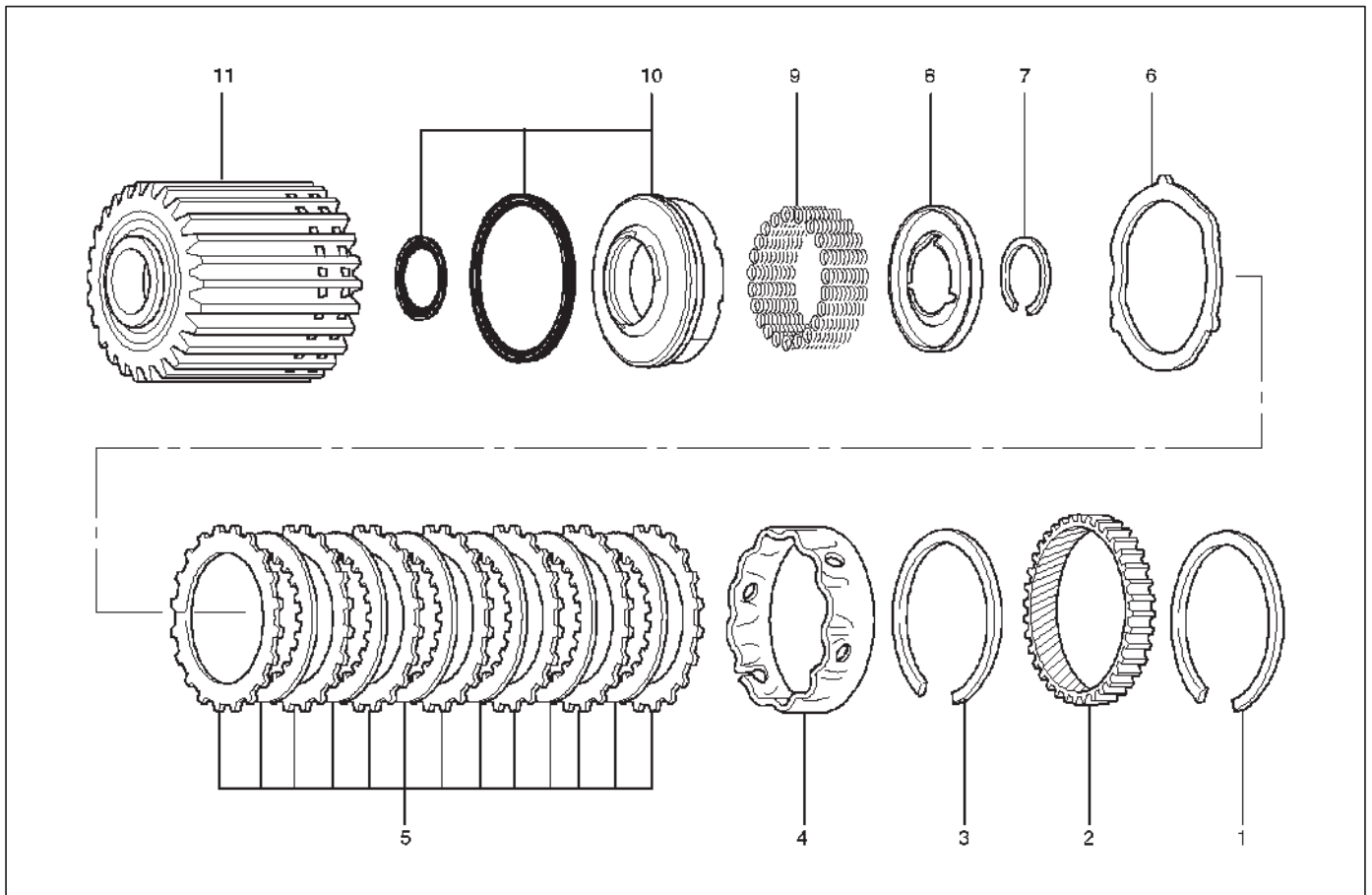
NOTE: Check correct rotation by holding the sun gear in your left hand and turning the outer race. The outer sprag race should turn freely towards you and should lock turning away from you.



248RS010

## Second Clutch

### Disassembled View



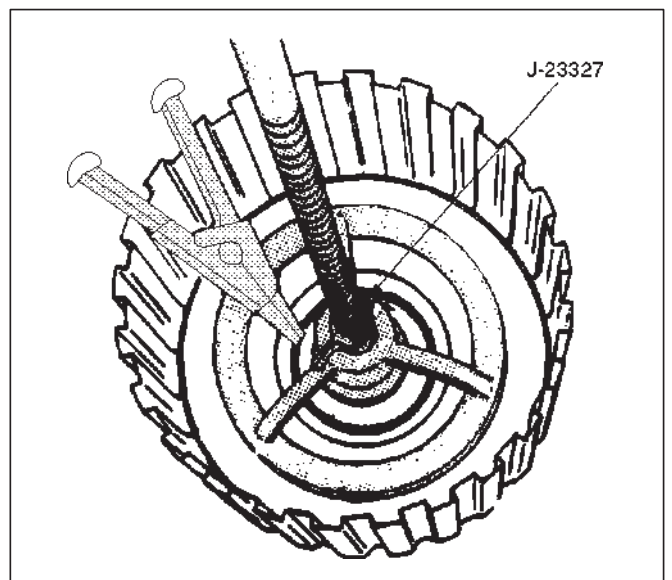
247RW001

#### Legend

- |                    |                         |
|--------------------|-------------------------|
| (1) Retaining Ring | (6) Waved Washer        |
| (2) Ring Gear      | (7) Retaining Ring      |
| (3) Retaining Ring | (8) Spring Seat         |
| (4) Spacer         | (9) Springs             |
| (5) Clutch Plates  | (10) Piston Assembly    |
|                    | (11) Second Clutch Drum |

### Disassembly

1. Remove retaining ring (1) from second clutch drum (11).
2. Remove ring gear (2), retaining ring (3), and spacer (4).
3. Remove clutch plates (5) and waved washer (6).
4. Remove retaining ring (7) using J-23327 compressor to compress the spring seat (8).
5. Remove spring seat (8), springs (9) and piston assembly (10) from second clutch drum (11).



247RS006

## Inspection And Repair

### Visual Check:

If any damage, deformation or wear is found, replace the damaged part.

### Operation Check:

Shake the piston and listen for check ball movement. Movement indicates proper check ball operation. Replace the piston if the check ball is missing or falls out.

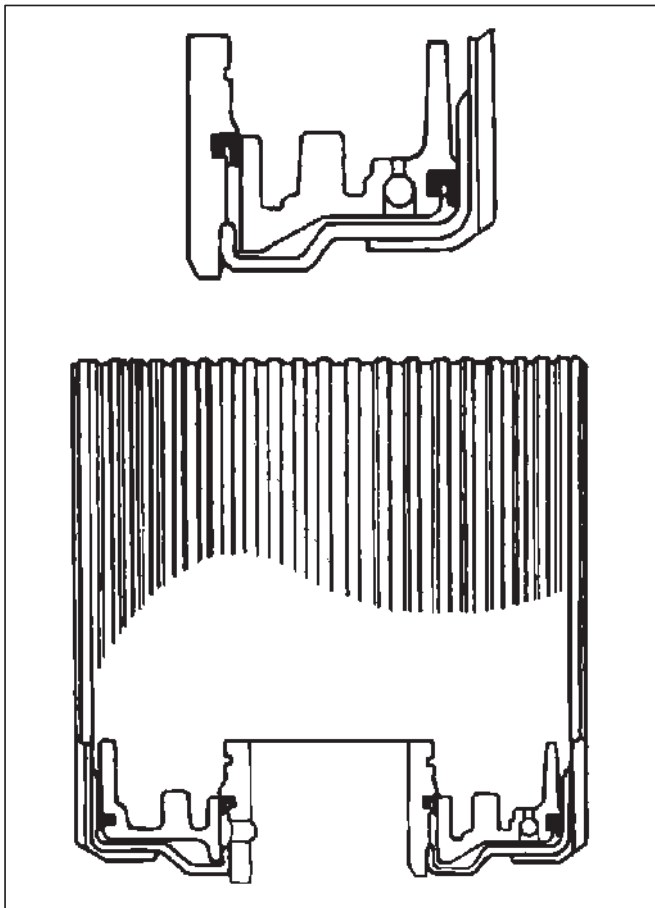
## Reassembly

1. Install piston assembly (10) into the second clutch drum (11).

○Lubricate the lip seal with transmission fluid. Use the J-23080-A second clutch piston installer to protect the outer piston lip seal.

NOTE: Lip of the seal should point toward front of transmission.

○Remove the installer.



247RS007

2. Install twenty-two piston springs (9) and spring seat (8) on the second clutch piston (10). Place retaining ring (7) onto spring seat.

○Use the J-23327 compressor to compress the piston springs.

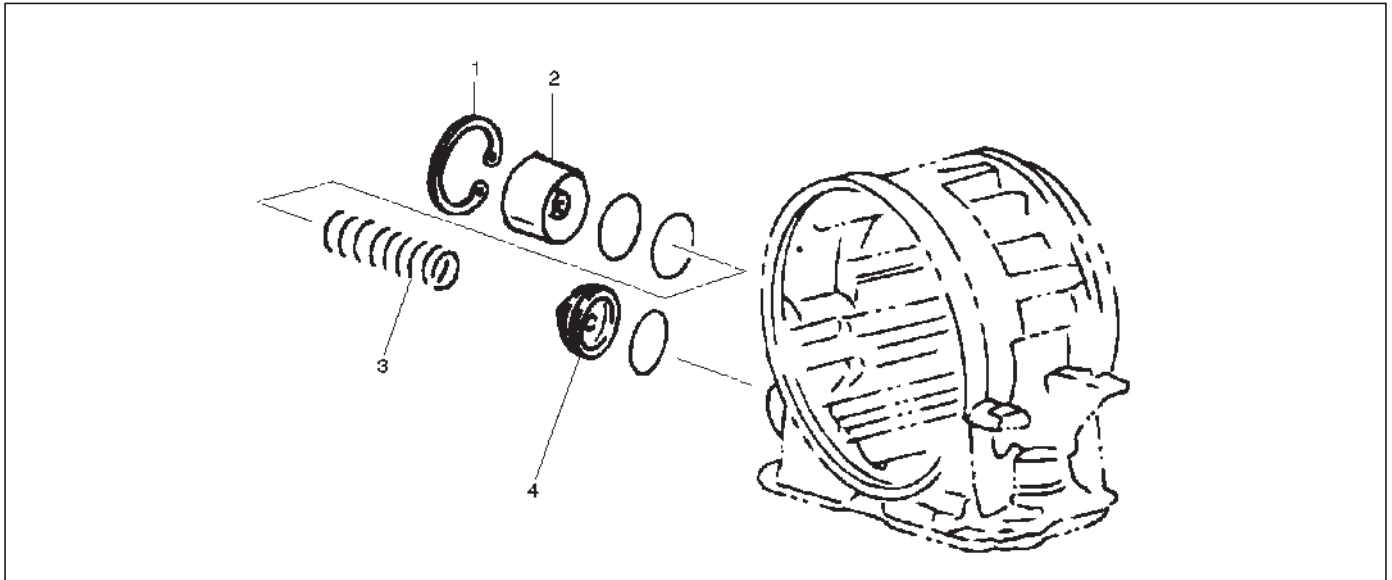
NOTE: Do not let spring seat catch in ring groove.

○Remove the compressor.

3. Install waved plate (6) and clutch plates (5). Start with a steel plate and alternate with lined plates.
  - Align second clutch inner tangs.
4. Install spacer (4), with the fluted end toward clutch plates.
5. Install retaining ring (3), ring gear (2) and retaining ring (1).

## 3-4 Accumulator Piston

### Disassembled View



244RS005

#### Legend

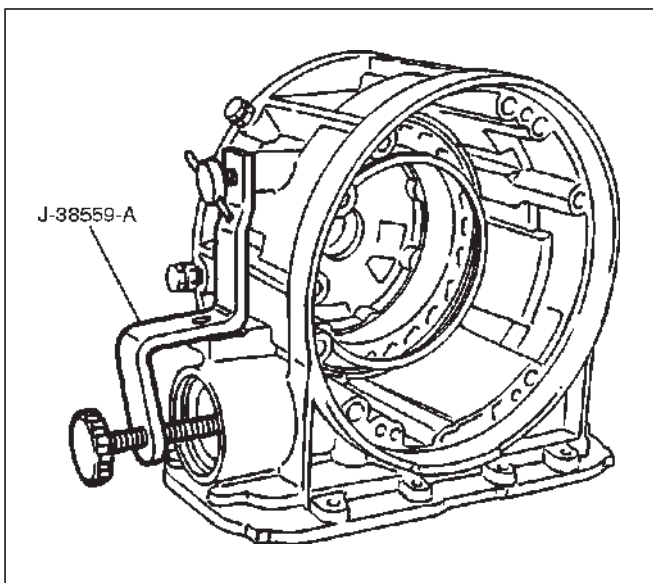
- (1) Snap Ring
- (2) Cover

- (3) Spring
- (4) Piston Assembly

### Disassembly

1. Install the J-38559-A cover compressor on adapter case.

- Compress piston cover then remove snap ring.

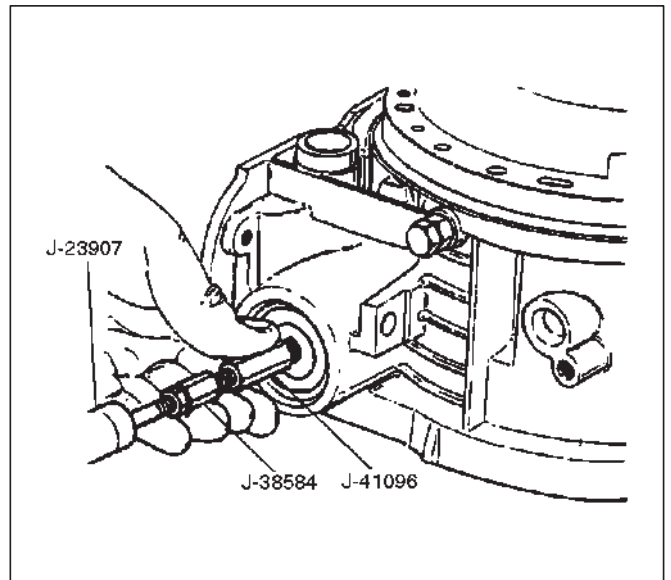


242RS007

2. Install the J-41096 cover remover and J-38584 adapter to center hole of cover.

- Use the J-23907 slide hammer to remove cover.

3. Remove spring and piston assembly.



242RW001

### Inspection And Repair

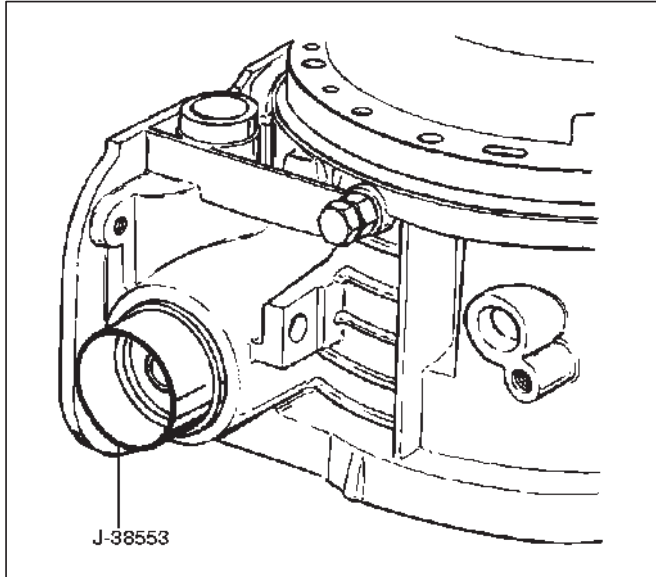
#### Visual Check:

If any damage, deformation or wear is found, replace the damaged part.

## Reassembly

1. Place the J-38553 piston fitter into adaptor case and push the piston into position, using suitable diameter tube.

○Remove the piston fitter.

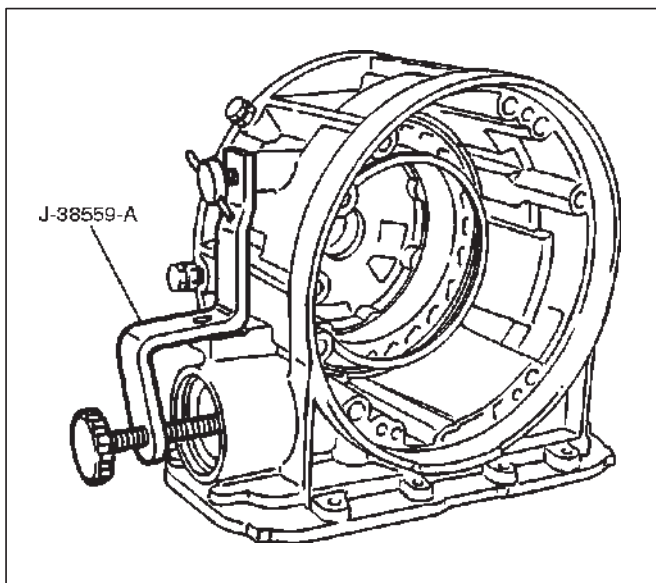


244RS006

2. Install spring and cover.
3. Install snap ring, using the J-38559-A compressor tool.

○Install snap ring in groove.

○Remove the compressor tool.

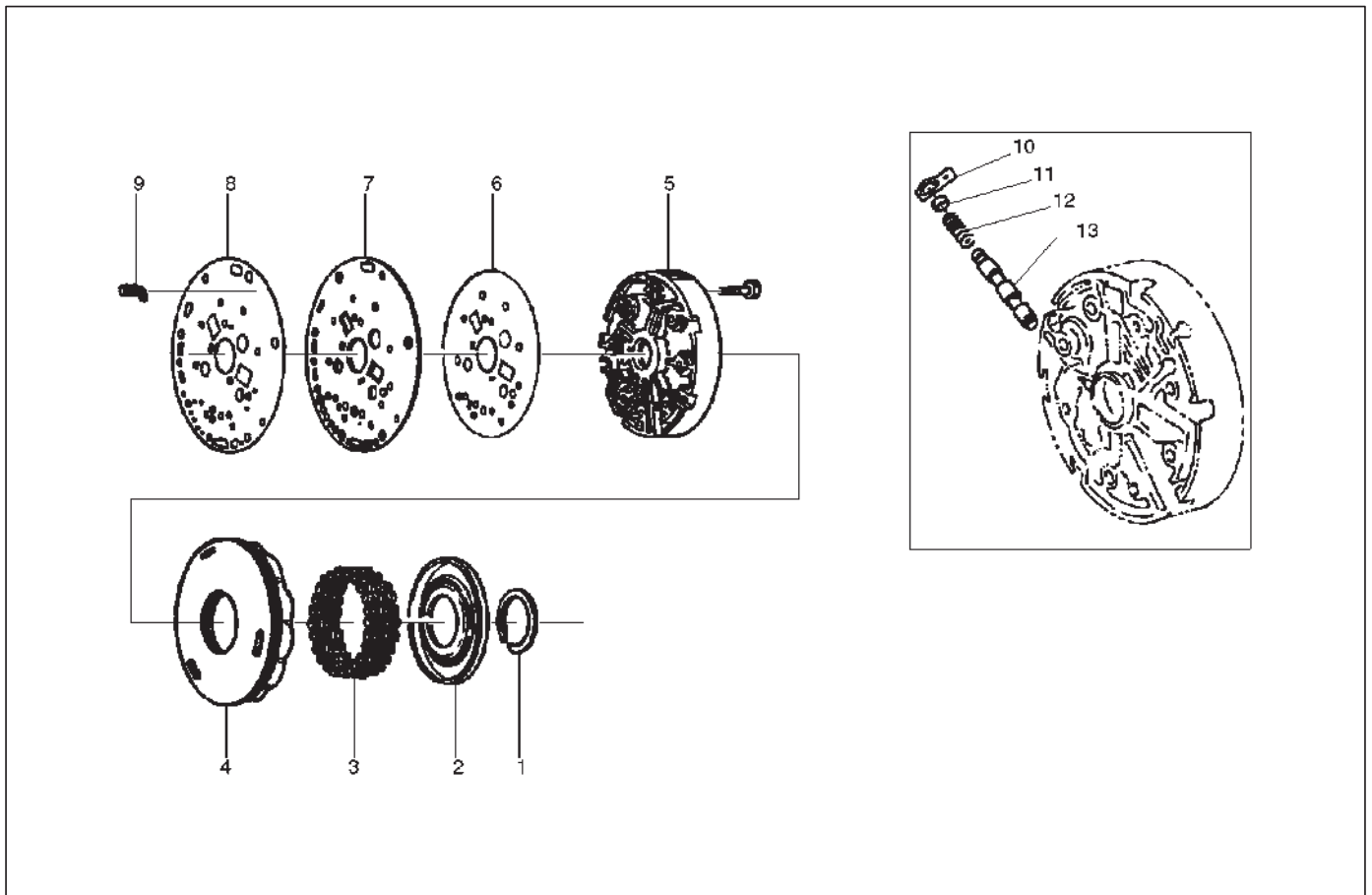


242RS007



## Reverse Clutch Piston And Center Support

### Disassembled View



242RS006

#### Legend

- |                     |                             |
|---------------------|-----------------------------|
| (1) Retaining Ring  | (7) Transfer Plate          |
| (2) Spring Seat     | (8) Gasket                  |
| (3) Springs         | (9) Restrictor              |
| (4) Piston Assembly | (10) Retainer Plate         |
| (5) Center Support  | (11) Plug                   |
| (6) Gasket          | (12) Spring                 |
|                     | (13) Overrun Lock Out Valve |

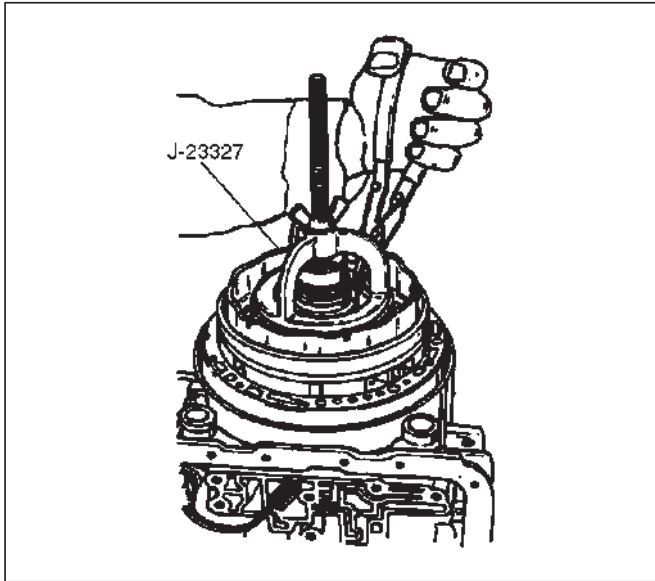
### Disassembly

1. Install the J-23327 compressor tool on spring seat, then compress the spring seat.

○Remove retaining ring (1).

**NOTE:** Do not over-stress the springs and seat, as this will cause damage to the spring seat.

○Remove the compressor tool.



2. Remove spring seat (2) and springs (3).
3. Remove piston assembly (4).
4. Remove 8 bolts from center support (5), then remove center support (5) from adapter case.
5. Remove gasket transfer plate/outer support (6), center support transfer plate (7), and gasket transfer plate/adapter case (8).
6. Remove restrictor (9) from adapter case housing.
7. Remove retainer plate (10), plug (11), spring (12), and overrun lock out valve (13) from center support (5).

## Inspection And Repair

### Visual Check:

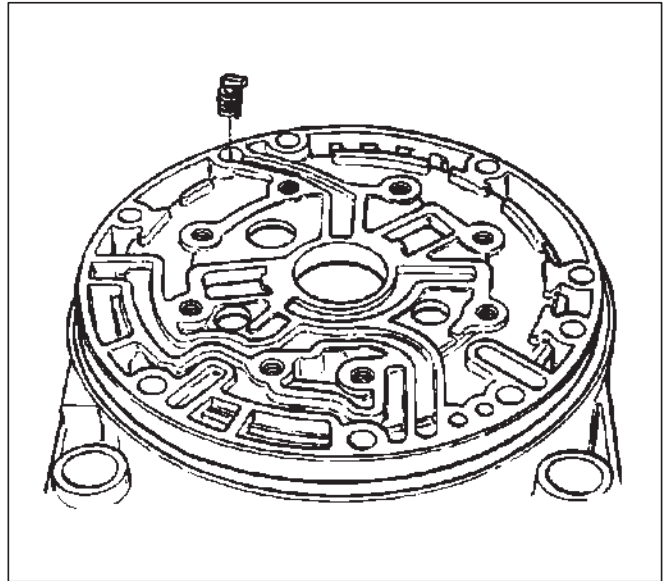
If any damage, deformation or wear is found, replace the damaged part.

## Reassembly

1. Install overrun lock out valve (13) and spring (12) to center support.

NOTE: Ensure correct assembly of valve. The spring should be located over the long small diameter end.

2. Install plug (11) and retainer plate (10).
3. Place restrictor (9) in the lube overdrive channel in the adapter case housing.



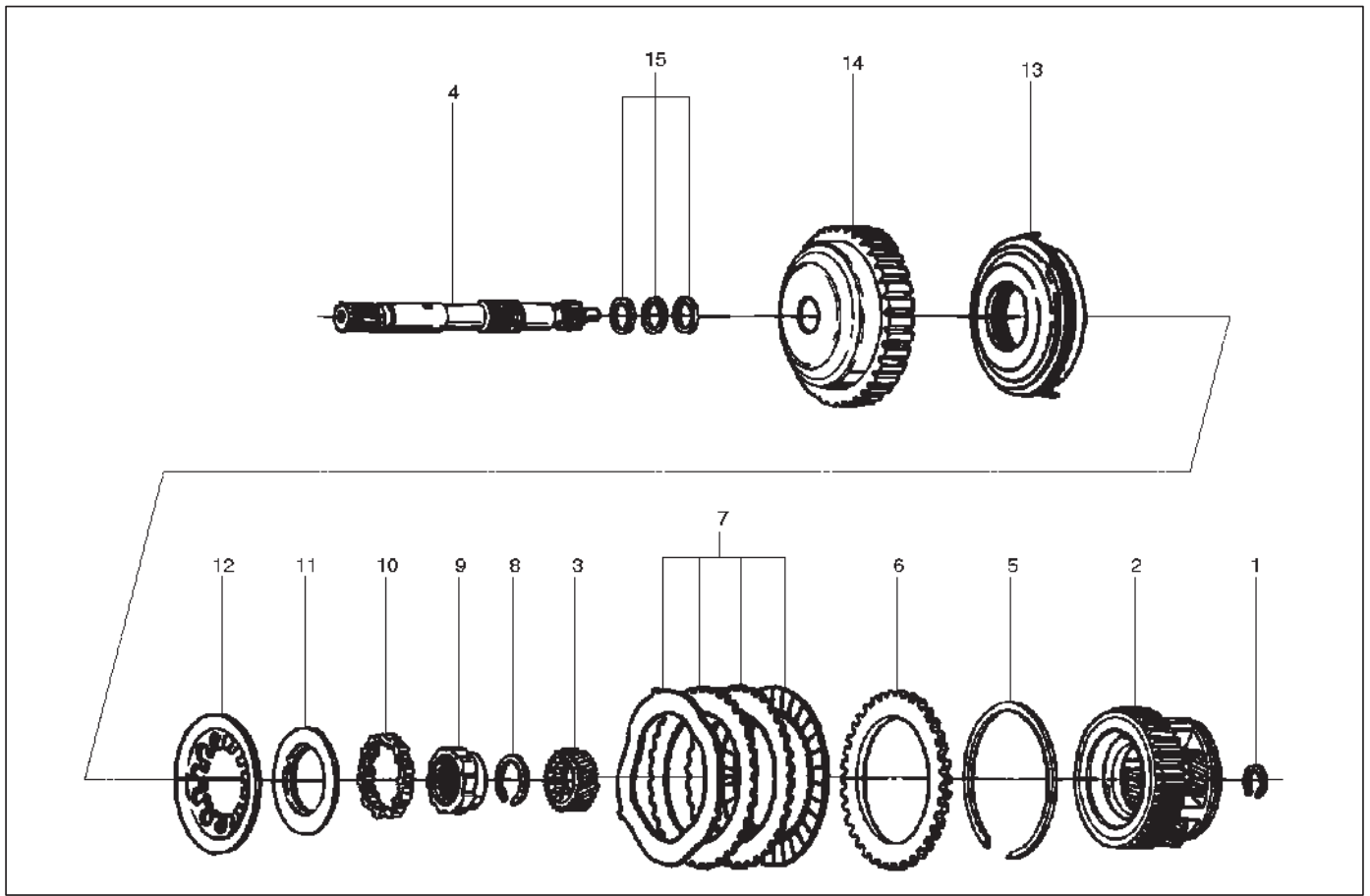
4. Install gasket transfer plate/adapter case (8), center support transfer plate (7), and gasket transfer plate/center support (6).
5. Install center support (5) with 8 bolts.

**Torque : 25 N•m (18 lb ft)**

6. Install piston assembly (4) into center support (5).
7. Install twenty four springs (3), spring seat (2), and retaining ring (1).
  - Install the J-23327 compressor and compress spring seat (2) and springs (3), then seat snap ring (1) in groove.
  - Remove the tool.

## Overrun Clutch And Turbine Shaft

### Disassembled View



252RW005

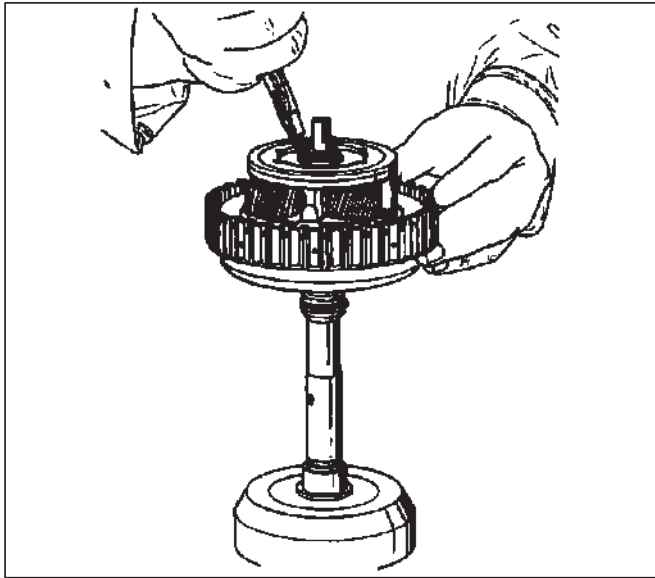
#### Legend

- |                                |   |
|--------------------------------|---|
| (1) Snap Ring                  | (8) Snap Ring                               |
| (2) Overdrive Carrier Assembly | (9) Overrun Roller Clutch Cam               |
| (3) Sun Gear                   | (10) Roller Clutch Assembly                 |
| (4) Turbine Shaft              | (11) Overrun Clutch Release Spring Retainer |
| (5) Snap Ring                  | (12) Diaphragm Spring                       |
| (6) Backing Plate              | (13) Piston Assembly                        |
| (7) Clutch Plates              | (14) Overrun Clutch Drum                    |
|                                | (15) Turbine Shaft Seal Rings               |

### Disassembly

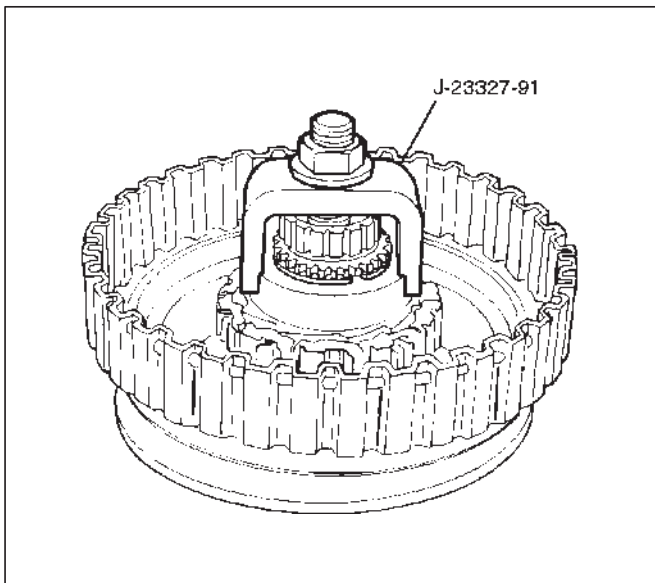
1. Position overrun clutch assembly upright, using the overdrive internal gear as a support.

○ Remove snap ring (1).



252RS009

2. Remove overdrive carrier assembly (2), sun gear (3) and turbine shaft (4).
3. Remove snap ring (5), backing plate (6), and clutch plates (7).
4. Compress diaphragm spring with the J-23327-91 compressor, then remove snap ring (8).



252RS010

5. Remove overrun roller clutch cam (9) and roller clutch assembly (10).
6. Remove overrun clutch release spring retainer (11) and diaphragm spring (12).
7. Remove piston assembly (13) from overrun clutch drum (14).
8. Remove turbine shaft seal rings (15).

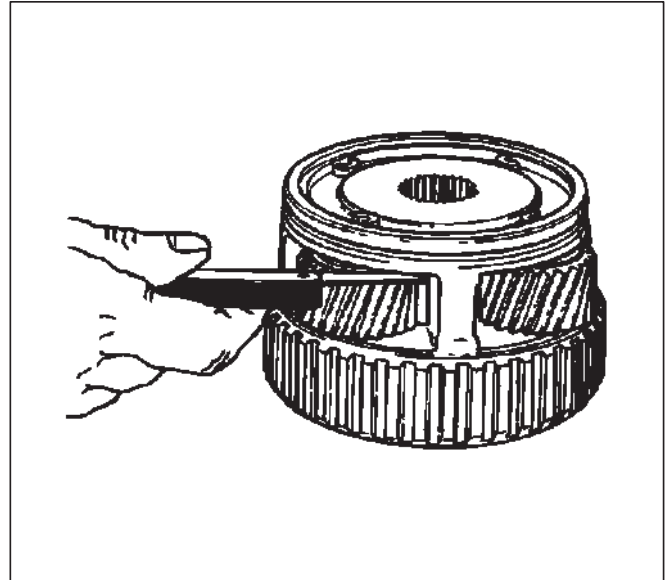
## Inspection And Repair

### Overdrive Carrier Check

- Check pinion end play with a feeler gauge.

**Clearance: 0.24mm–0.64mm (0.0094in–0.025in)**

If clearance is outside specified value, replace overdrive carrier assembly.



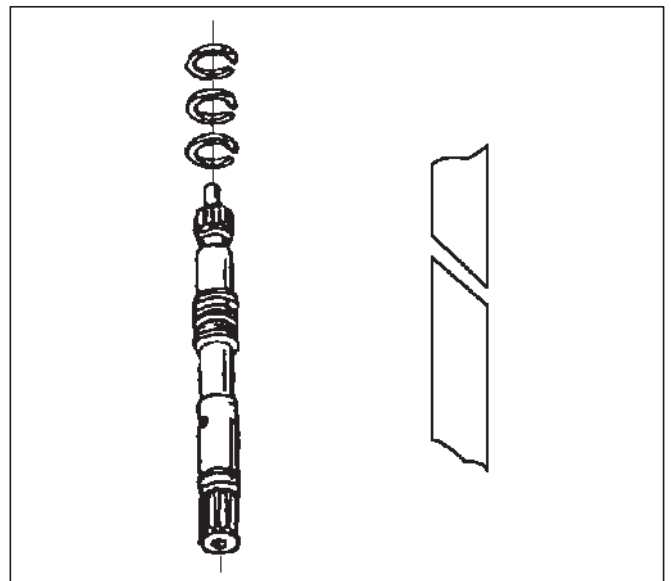
252RS011

### Visual Check:

If any damage, deformation or local wear is found, replace the damaged part.

### Reassembly

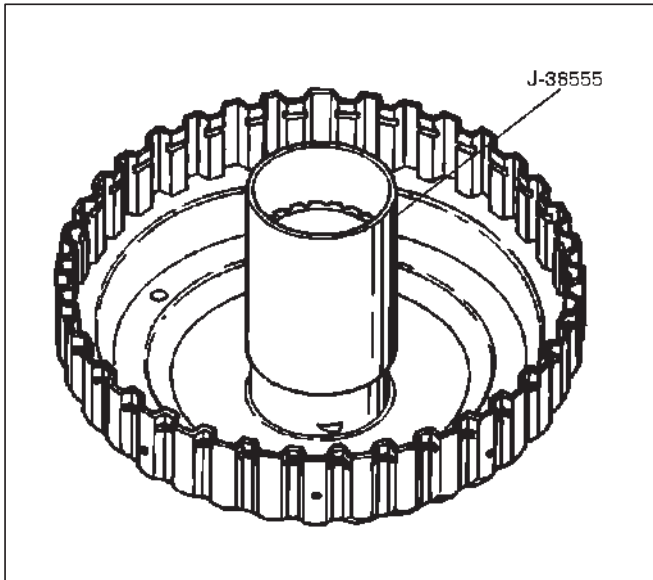
1. Install turbine shaft seal rings (15) with grease (petroleum jelly).



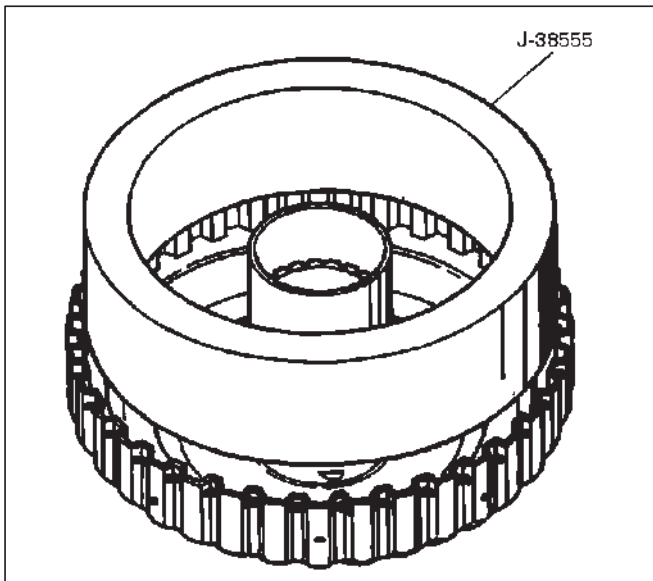
241RS008

## 7A-80 AUTOMATIC TRANSMISSION (4L30-E)

2. Install the J-38555 inner installer on the drum (14).
  - Pre-install piston assembly into J-38555 outer installer.
  - Install overrun clutch piston assembly (13). Use the outer installer while pushing piston into drum (14).
  - Remove the installer.



252RS012



252RS013

3. Install diaphragm spring (12).
4. Install overrun clutch release spring retainer (11) (lip faces upwards), overrun roller clutch assembly (10), and cam (9).
5. Place snap ring loosely on spring retainer.
  - Hold the J-23327-91 compressor in a vise and compress piston return spring with compressor.
  - Set snap ring (8) in ring groove.
  - Remove the compressor.
6. Install clutch plates (7), start with steel plate and alternate with lined plates.
7. Install backing plate (6).
8. Install snap ring (5).
9. Install overdrive sun gear with countersink pointing downwards.
10. Install the overdrive carrier assembly (2).

NOTE: Turn the assembly in a counter-clockwise direction only until roller clutch enters the outer race. After installation, rotate the assembly and listen for loose rollers.

11. Install turbine shaft (4) and snap ring (1).

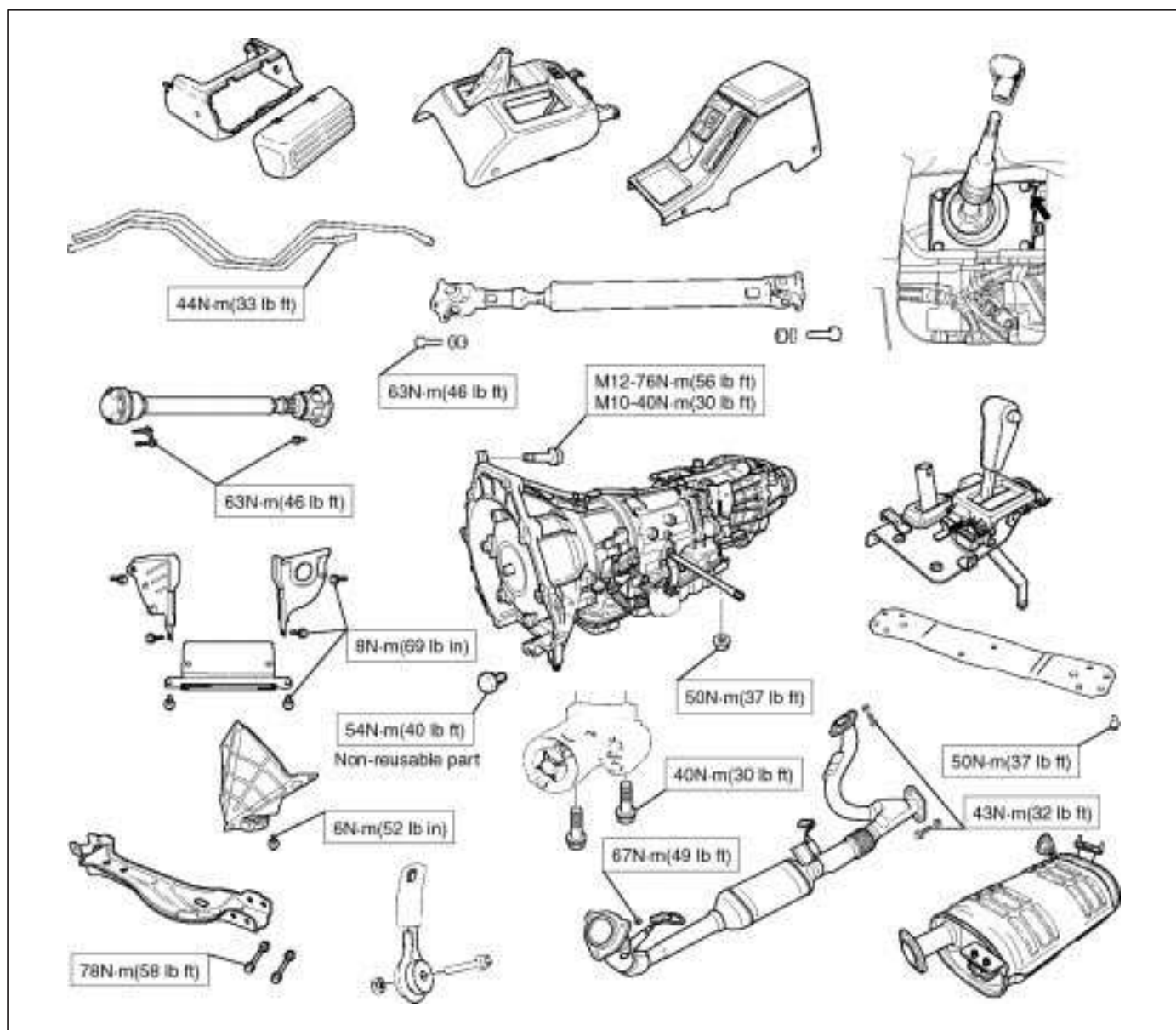
## Main Data And Specification

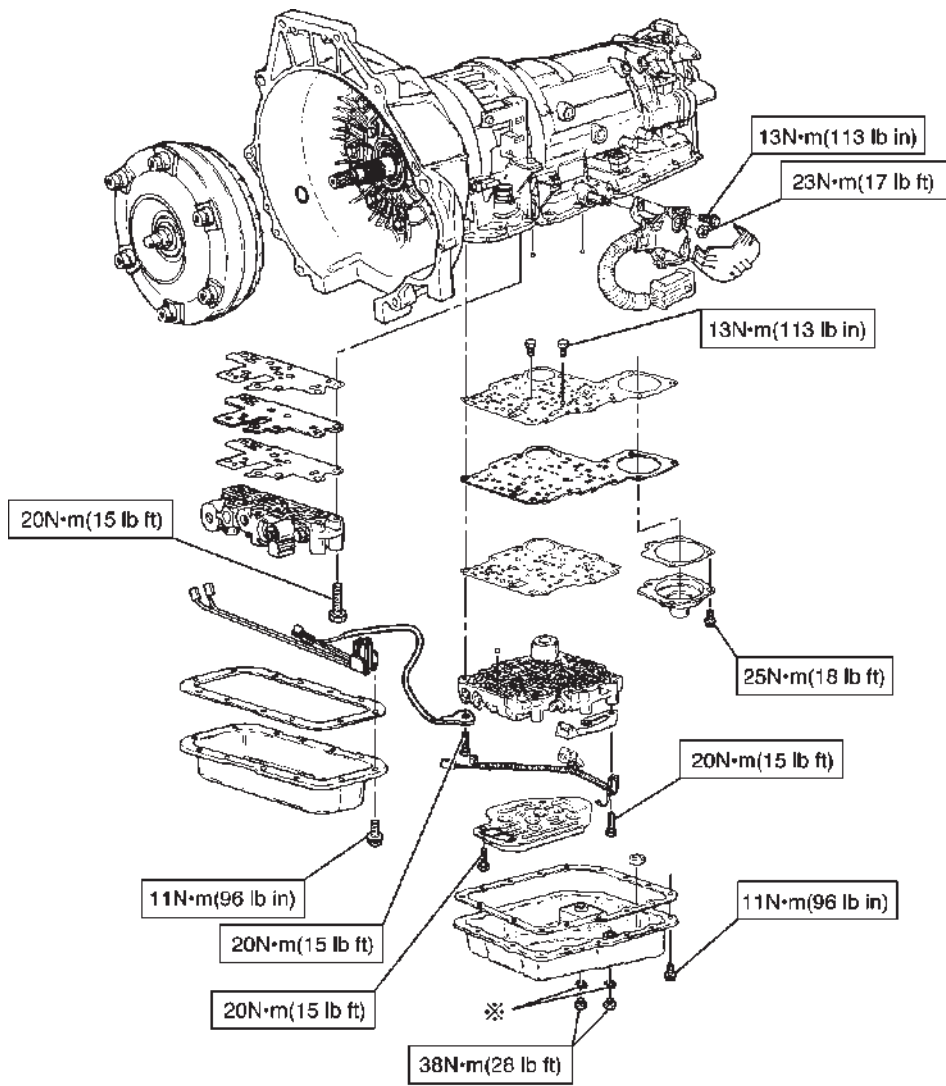
### General Specifications

		Remarks		
Model		THM 4L30-E		
Engine		V6 3.5L 6VE1		
Type		Automatic four speed overdrive in 4th gear lock-up clutch torque converter		
Control systems	Shift control	Hydraulic		
	Shift pattern	Electronic		
	Shift quality	Electronic		
	Lock-up clutch	Electronic		
Gear ratio	1st	2.856		
	2nd	1.618		
	3rd	1.000		
	4th (O/D)	0.723		
	Reverse	2.000		
Gear set		Noiseless, high torque capability		
Oil used	Name	ATF DEXRON®-III		
	Q'ty liter (qt)	8.6 (9.1)		
Torque converter		2,100 ± 150		
		Stall speed (rpm)		
	Reverse clutch	RC	4	Number of discs
	Second clutch	C2	6	
	Third clutch	C3	6	
	Brake band		Double wrap	
	Fourth clutch	C4	2	Number of discs
	Overrun clutch	OC	1	
	Overdrive	OFW	10	Number of rollers
	Principal	PFW	26	Number of sprags
Ravigneaux planetary gear set	Input sun gear		30	Number of teeth
	Pinion gear		19	
	Long pinion		23	
	Ring gear		90	
	Long pinion		19	
	Output sun gear		46	
Overdrive planetary gear set	Sun gear		31	Number of teeth
	Pinion gear		24	
	Ring gear		81	

# 7A-82 AUTOMATIC TRANSMISSION (4L30-E)

## Torque Specifications

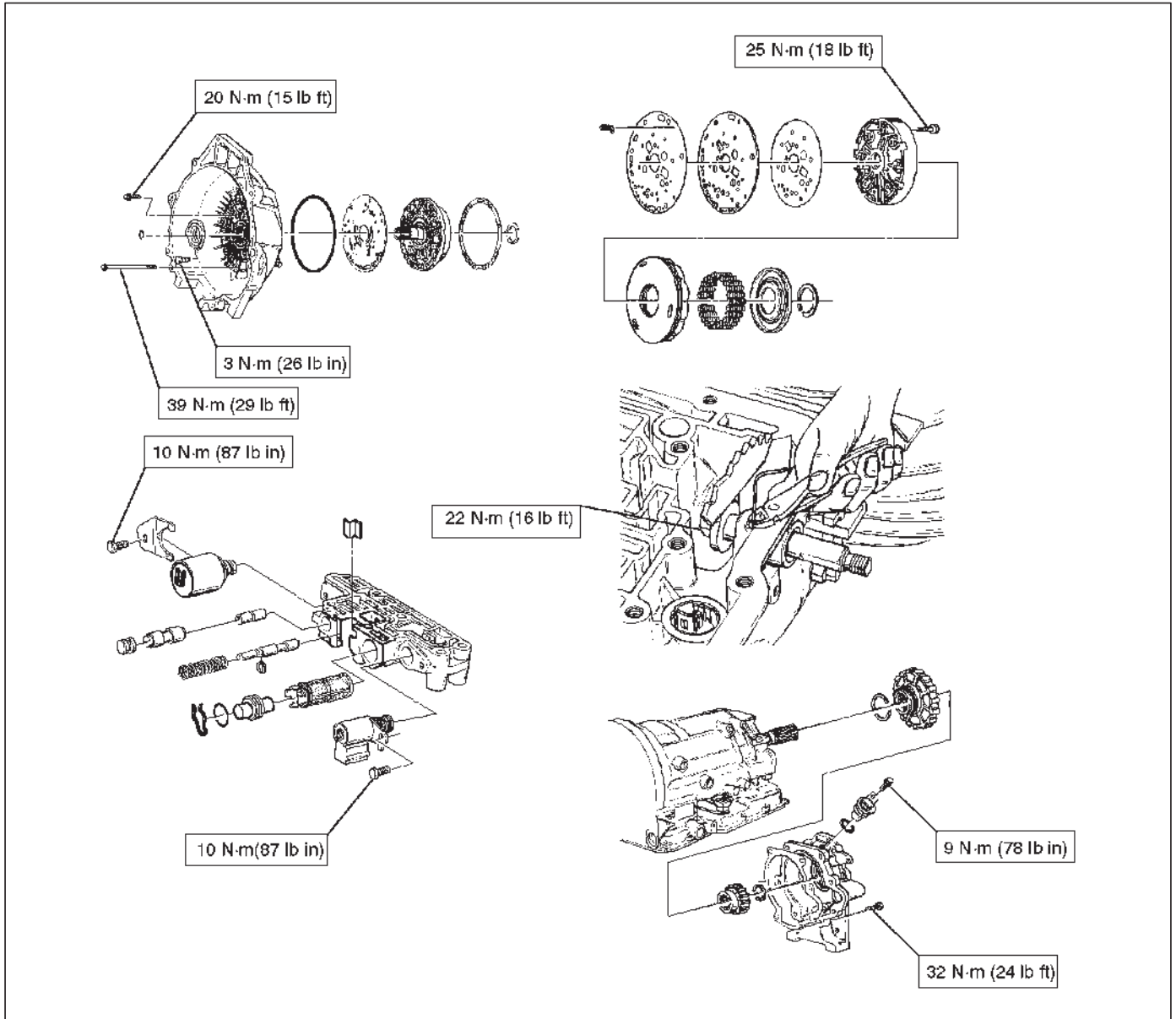




※ : Non-reusable part



7A-84 AUTOMATIC TRANSMISSION (4L30-E)



**Special Tools**

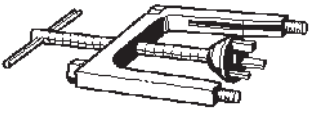
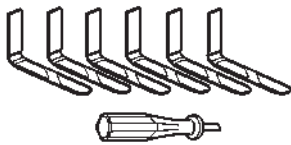
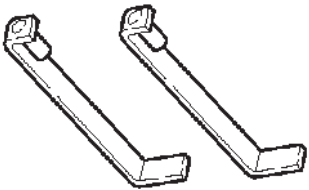
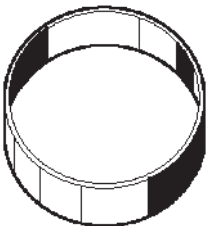
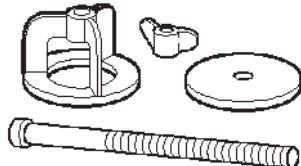


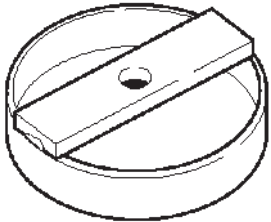
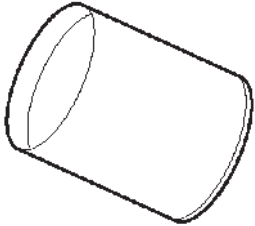

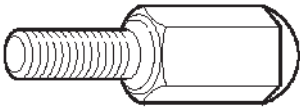
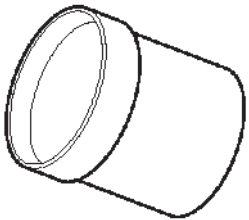
ILLUSTRATION	TOOL NO. TOOL NAME
 <p>901RT071</p>	<p><b>J-23075</b> Spring compressor (For servo piston)</p>
 <p>901RX007</p>	<p><b>J-38450-A</b> Third clutch snap ring compressor</p>
 <p>901RT072</p>	<p><b>J-23075-12</b> Third clutch spring compressor adapter (Use with J-23075)</p>
 <p>901RT074</p>	<p><b>J-23084</b> Third clutch piston installer</p>
 <p>901RT073</p>	<p><b>J-23327</b> Third clutch spring compressor</p>
 <p>901RT076</p>	<p><b>J-23080-A</b> Second clutch piston installer</p>

ILLUSTRATION	TOOL NO. TOOL NAME
 <p>901RT077</p>	<p><b>J-23085-A</b> Selective washer gauging tool</p>
 <p>901RT078</p>	<p><b>J-23327-90</b> Fourth clutch spring compressor (Use with J-23327)</p>
 <p>901RT079</p>	<p><b>J-38553</b> 3/4 Accumulator piston fitter</p>
 <p>901RT080</p>	<p><b>J-41096</b> Cover remover (Use with J-38584)</p>
 <p>901RT081</p>	<p><b>J-38584</b> Slide hammer adapter (Use with J-23907)</p>
 <p>901RT082</p>	<p><b>J-38554</b> Fourth clutch piston fitter</p>

7A-86 AUTOMATIC TRANSMISSION (4L30-E)

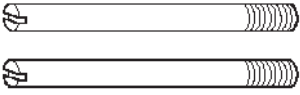
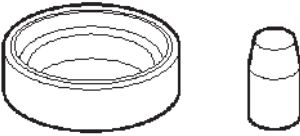
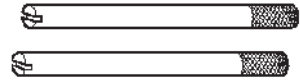
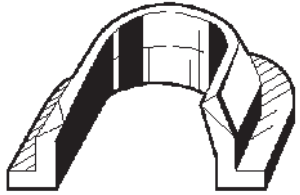
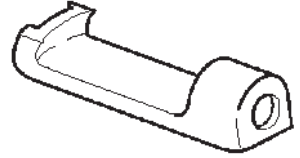
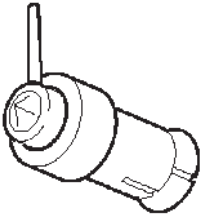
ILLUSTRATION	TOOL NO. TOOL NAME
 <p style="text-align: right; font-size: small;">901AT023</p>	<p style="text-align: center;"><b>J-38588</b> Guide pins; adapter case to main case</p>
 <p style="text-align: right; font-size: small;">901AT024</p>	<p style="text-align: center;"><b>J-38555</b> Overrun clutch piston seal installer set</p>
 <p style="text-align: right; font-size: small;">901AT025</p>	<p style="text-align: center;"><b>J-3387-2</b> Guide pins; gasket and transfer plate to valve body</p>
 <p style="text-align: right; font-size: small;">901AT026</p>	<p style="text-align: center;"><b>J-25022</b> Turbine shaft puller (Use with J-24773-1)</p>
 <p style="text-align: right; font-size: small;">901AT027</p>	<p style="text-align: center;"><b>J-23129</b> Oil seal remover (Use with J-23907 and J-38584)</p>
 <p style="text-align: right; font-size: small;">901AT028</p>	<p style="text-align: center;"><b>J-38557</b> Oil pump centering tool</p>

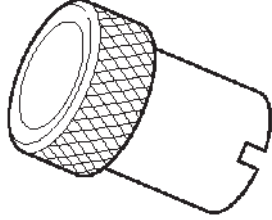
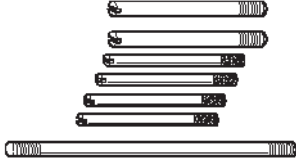

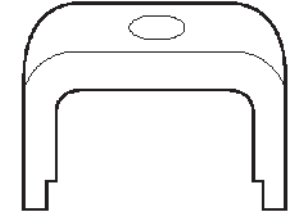
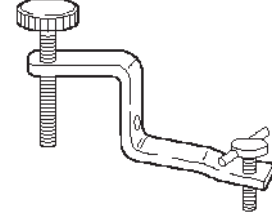
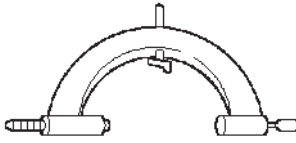
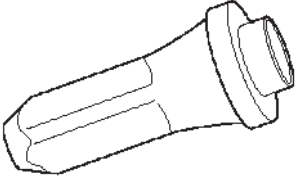
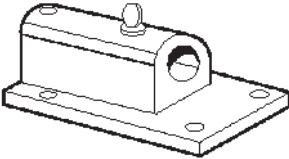

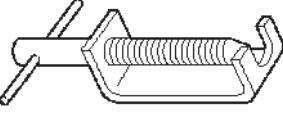
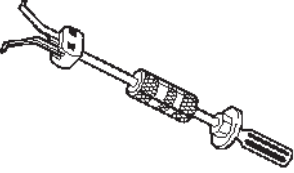
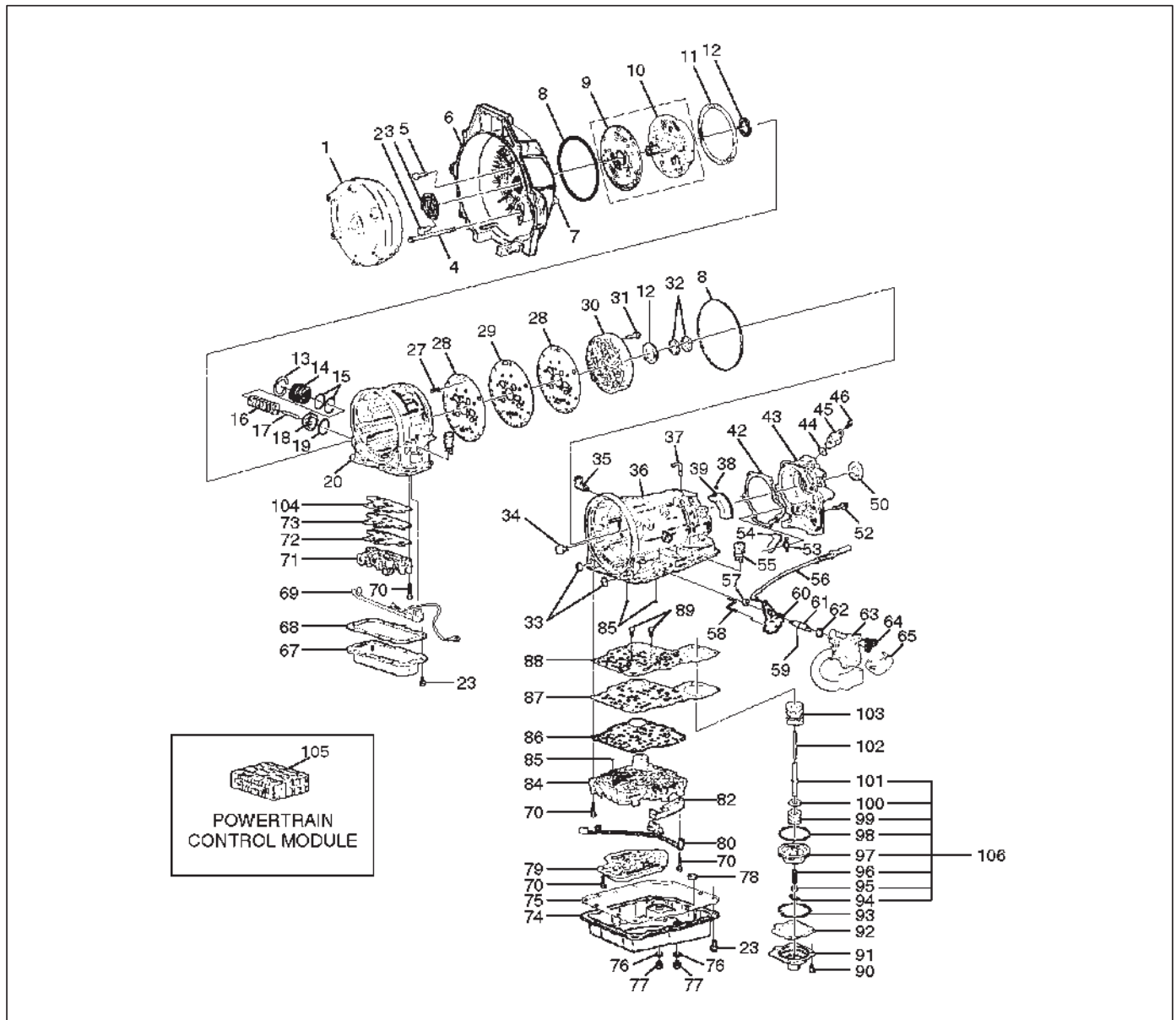
ILLUSTRATION	TOOL NO. TOOL NAME
 <p style="text-align: right; font-size: small;">901AT029</p>	<p style="text-align: center;"><b>J-23082-01</b> Oil pump rotation tool</p>
 <p style="text-align: right; font-size: small;">901AT030</p>	<p style="text-align: center;"><b>J-25025-B</b> Guide pins; valve body to main case</p>
 <p style="text-align: right; font-size: small;">901AT031</p>	<p style="text-align: center;"><b>J-38428</b> Servo piston fitter</p>
 <p style="text-align: right; font-size: small;">901AT032</p>	<p style="text-align: center;"><b>J-23327-91</b> Overrun clutch spring compressor</p>
 <p style="text-align: right; font-size: small;">901AT033</p>	<p style="text-align: center;"><b>J-38559-A</b> 3/4 Accumulator piston cover compressor</p>
 <p style="text-align: right; font-size: small;">901AT034</p>	<p style="text-align: center;"><b>J-8763-02</b> Holding fixture</p>

ILLUSTRATION	TOOL NO. TOOL NAME
 <p style="text-align: right; font-size: small;">901RT096</p>	<p style="text-align: center;"><b>J-36797</b> A/T extension housing oil seal installer (Inside)</p>
 <p style="text-align: right; font-size: small;">901RT096</p>	<p style="text-align: center;"><b>J-3289-20</b> Holding fixture base</p>
 <p style="text-align: right; font-size: small;">901RT097</p>	<p style="text-align: center;"><b>J-29770-A</b> Pressure gauge</p>
 <p style="text-align: right; font-size: small;">901RT098</p>	<p style="text-align: center;"><b>J-24773-1</b> End play fixture (Use with J-25022)</p>
 <p style="text-align: right; font-size: small;">901RT099</p>	<p style="text-align: center;"><b>J-23907</b> Slide hammer</p>

## 4L30-E Parts List

### Case And Associated Parts



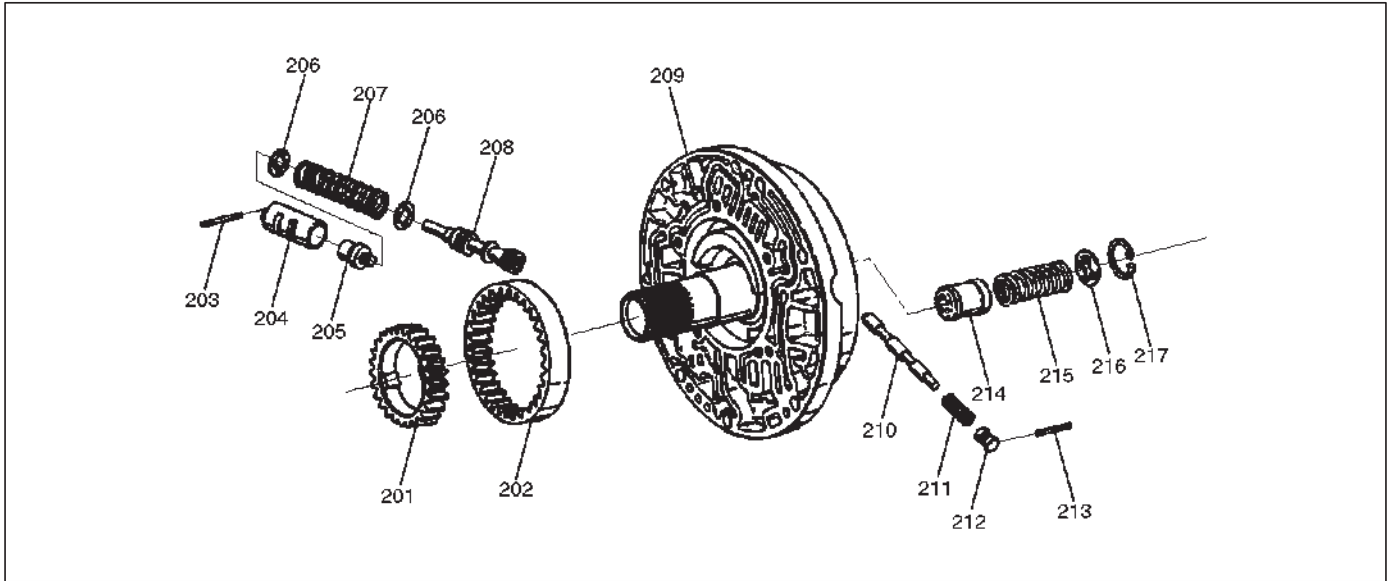
241RW014

#### Legend

- |   |   |
|---|---|
| (1) Torque Converter                      | (17) Pin, 3-4 Accumulator Piston            |
| (2) Screw, Seal Ring Assembly             | (18) Piston, 3-4 Accumulator                |
| (3) Seal Ring Assembly, Converter Housing | (19) Ring, 3-4, Accumulator Piston          |
| (4) Screw, Converter Housing/Main Case    | (20) Case, Adapter                          |
| (5) Screw, Converter Housing/Oil Pump     | (22) Connector, Electrical/Adapter Case     |
| (6) Housing, Converter                    | (23) Screw, Pan                             |
| (7) Plug, Converter Housing               | (27) Restrictor, Oil                        |
| (8) Seal, O-Ring                          | (28) Gasket, Transfer Plate/Adapter         |
| (9) Wear Plate, Oil Pump Body             | (29) Plate, Transfer Adapter/Center Support |
| (10) Pump Assembly, Oil                   | (30) Support Assembly, Center               |
| (11) Gasket                               | (31) Screw, Center Support                  |
| (12) Washer, Thrust Selective             | (32) Ring, Oil Seal                         |
| (13) Ring, Snap                           | (33) Seal, O-Ring Main Case                 |
| (14) Cover, 3-4 Accumulator Piston        | (34) Fitting, Cooler                        |
| (15) Seal, O-Ring, 3-4 Accumulator        | (35) Fitting Assembly, Cooler               |
| (16) Spring, 3-4 Accumulator Piston       | (36) Case, Main                             |
|   | (37) Breather, Pipe                         |

- |   |  |
|---|--|
| (38) Seal, O-Ring                           | (75) Gasket, Bottom Pan/Main Case              |
| (39) Reservoir                              | (76) Gasket, Oil Drain or Overfill Screw       |
| (42) Gasket, Extension Case                 | (77) Screw, Oil Drain or Overfill              |
| (43) Extension Assembly                     | (78) Magnet, Chip Collector                    |
| (44) Seal, O-Ring/Speed Sensor              | (79) Filter Oil                                |
| (45) Sensor Assembly, Speed                 | (80) Harness Assembly, Main Case               |
| (46) Screw, Speed Sensor                    | (82) Roller and Spring Assembly, Manual Detent |
| (50) Seal, Extension Assembly               | (84) Valve Body Assembly, Main Case            |
| (52) Screw, Extension/Main Case             | (85) Ball, Check                               |
| (53) Spring, Parking Pawl Lock              | (86) Gasket, Main V.B./Transfer Plate          |
| (54) Pawl, Parking Lock                     | (87) Plate, Main V.B./Transfer                 |
| (55) Connector, Electrical/Main Case        | (88) Gasket, Transfer/Main Case                |
| (56) Actuator Assembly, Parking Lock        | (89) Screw, Transfer Plate on V.B.             |
| (57) Nut, Parking Lock Lever                | (90) Screw, Servo Cover                        |
| (58) Link, Manual Valve                     | (91) Cover, Servo Piston                       |
| (59) Pin, Spring                            | (92) Gasket, Cover/Servo Piston                |
| (60) Lever, Parking Lock and Range Selector | (93) Ring, Retaining Servo Piston              |
| (61) Shaft, Selector                        | (94) Clip, Servo Piston                        |
| (62) Seal, Selector Shaft                   | (95) Nut, Servo Screw                          |
| (63) Mode Switch Assembly                   | (96) Screw, Servo Piston                       |
| (64) Screw and Conical Washer Assembly      | (97) Piston, Servo                             |
| (65) Shield, Mode Switch                    | (98) Seal, Ring/Servo Piston                   |
| (67) Pan, Bottom/Adapter Case               | (99) Spring, Cushion/Servo Piston              |
| (68) Gasket, Bottom Pan/Adapter Case        | (100) Seat, Cushion Spring                     |
| (69) Harness Assembly, Adapter Case         | (101) Sleeve, Servo Piston Adjust              |
| (70) Screw, Valve Body                      | (102) Rod, Apply/Servo Piston                  |
| (71) Valve Body Assembly, Adapter Case      | (103) Spring, Return/Servo Piston              |
| (72) Gasket, Adapter Valve Body             | (104) Gasket, Adapter Case/Transfer Plate      |
| (73) Plate, Adapter Valve Body/Transfer     | (105) Powertrain Control Module                |
| (74) Pan, Bottom/Main Case                  | (106) Servo Piston Assembly                    |
-

Pump Assembly

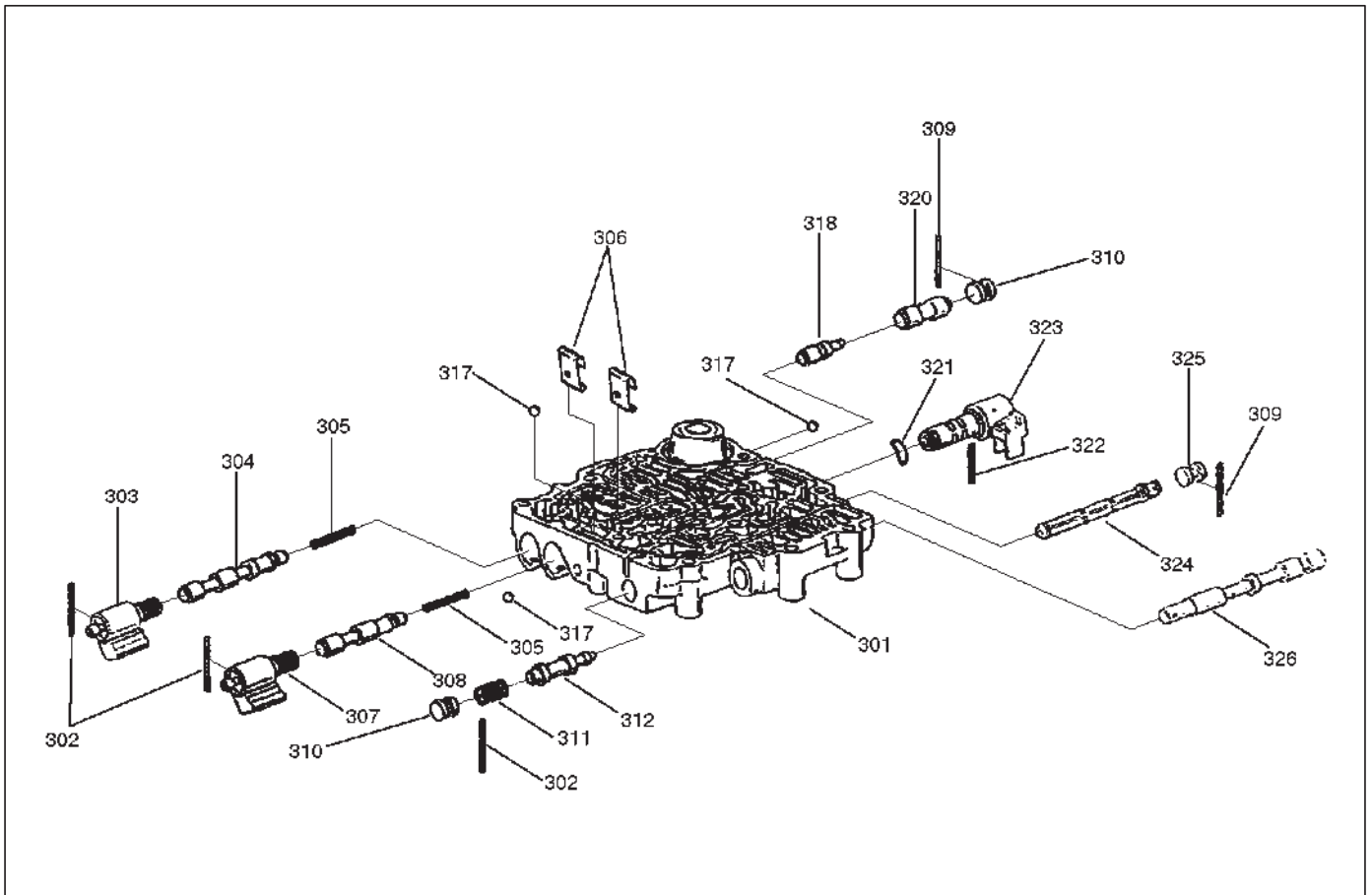


241RS019

Legend

- |   |  |
|---|--|
| (201) Gear, Oil Pump Drive                  | (209) Pump Assembly, Oil                       |
| (202) Gear, Oil Pump Driven                 | (210) Valve, Converter Clutch Control          |
| (203) Pin, Boost Valve Sleeve               | (211) Spring, Converter Clutch Control Valve   |
| (204) Sleeve, Boost Valve                   | (212) Plug, Converter Clutch Control Valve     |
| (205) Valve, Boost                          | (213) Pin, Spring                              |
| (206) Seat, Spring/Pressure Regulator Valve | (214) Piston, Throttle Signal Accumulator      |
| (207) Spring, Pressure Regulator Valve      | (215) Spring, Throttle Signal Accumulator      |
| (208) Valve, Pressure Regulator             | (216) Seat, Spring/Throttle Signal Accumulator |
|   | (217) Ring, Snap/Throttle Signal Accumulator   |

Valve Body Assemblies



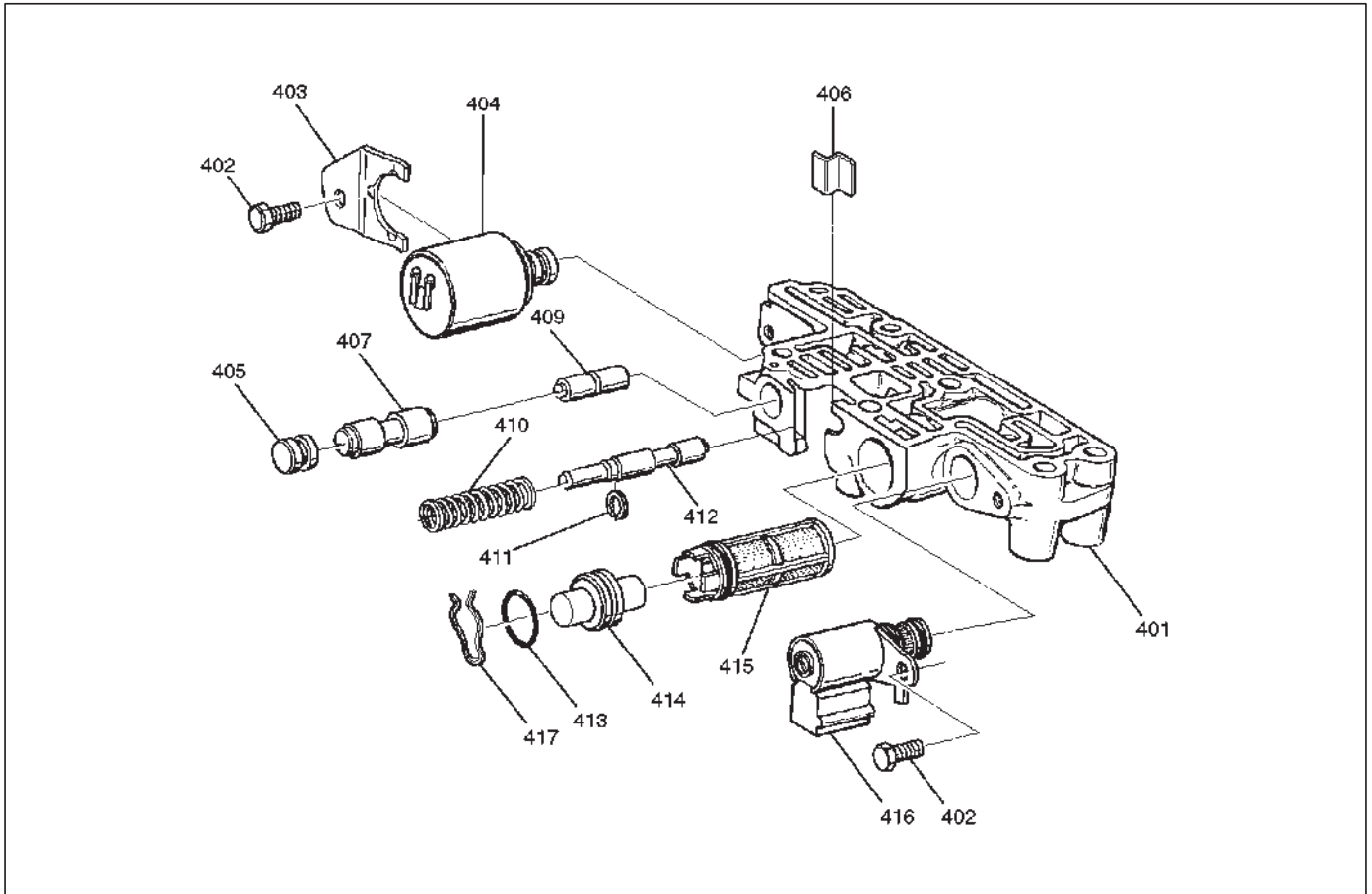
244RS009

**Legend**

- |                                       |   |
|---------------------------------------|---|
| (301) Body, Valve Main Case           | (311) Spring, Valve Low Pressure Control  |
| (302) Pin, Spring                     | (312) Valve, Low Pressure Control         |
| (303) Solenoid Assembly, ON/OFF N.C.  | (317) Ball, Check                         |
| (304) Valve, 1-2 and 3-4 Shift        | (318) Valve, 1-2 Accumulator Control      |
| (305) Spring, 1-2 and 3-4 (2-3) Shift | (320) Valve, 1-2 Accumulator              |
| (306) Retainer, Valve                 | (321) Washer, Waved PWM Solenoid          |
| (307) Solenoid Assembly, ON/OFF N.O.  | (322) Pin, Solenoid PWM                   |
| (308) Valve, 2-3 Shift                | (323) Solenoid Assembly, Band Control PWM |
| (309) Pin, Spring                     | (324) Screen Assembly, PWM Solenoid       |
| (310) Plug, Valve Bore                | (325) Plug, Screen                        |
|                                       | (326) Valve, Manual                       |



7A-92 AUTOMATIC TRANSMISSION (4L30-E)

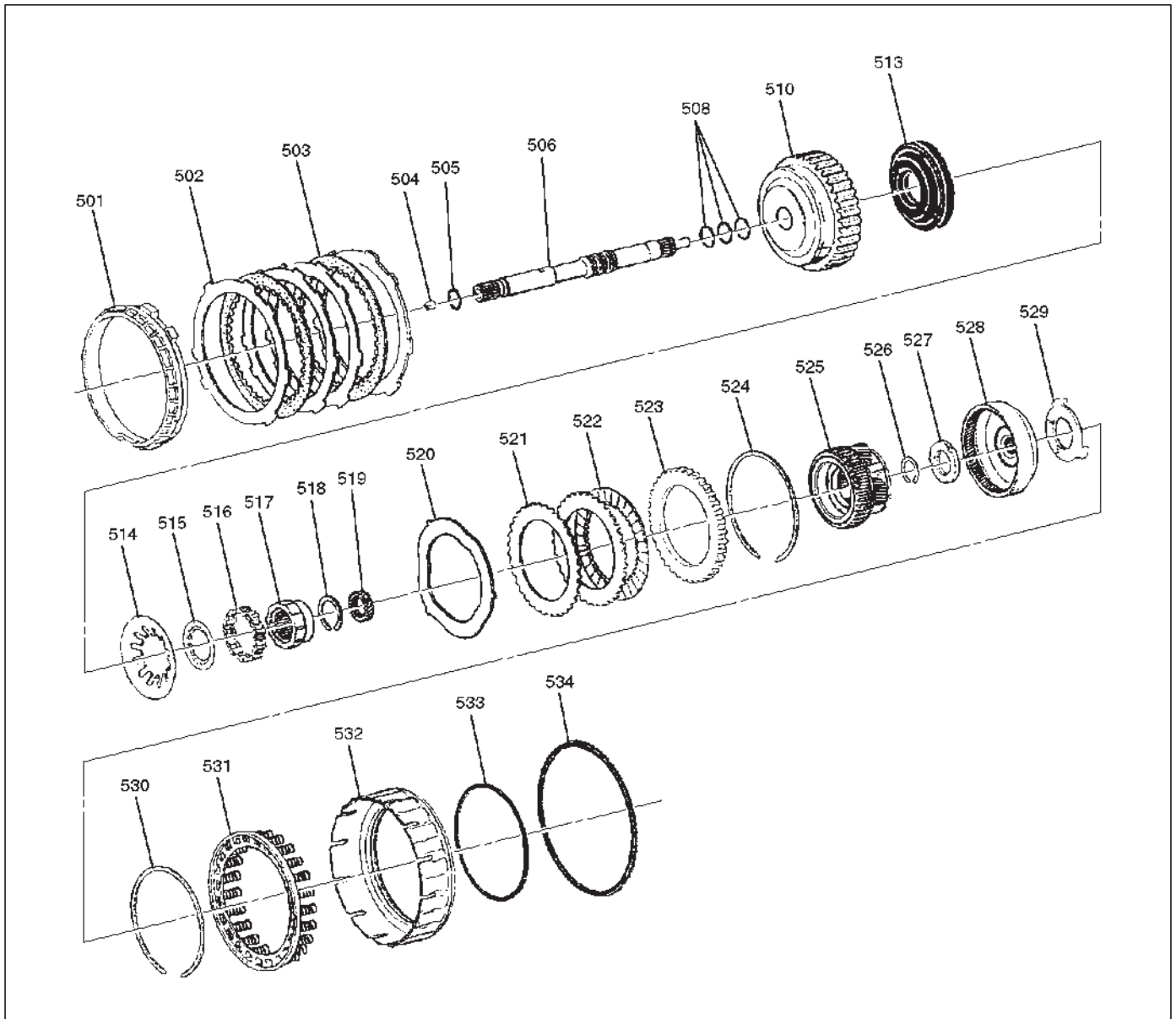


243RW003

**Legend**

- |                                      |   |
|--------------------------------------|---|
| (401) Body, Valve/Adapter Case       | (410) Spring, Feed Limit Valve                  |
| (402) Screw, Solenoid Force Motor    | (411) Ring, Retainer                            |
| (403) Retainer, Force Motor          | (412) Valve, Feed Limit                         |
| (404) Solenoid, Force Motor          | (413) Seal, O-Ring Plug Filter                  |
| (405) Plug, 3-4 Accumulator          | (414) Plug, Screen                              |
| (406) Plug and Spring Retainer       | (415) Screen Assembly, Force Motor              |
| (407) Valve, 3-4 Accumulator         | (416) Solenoid, Torque Conv. Clutch ON/OFF N.C. |
| (409) Valve, 3-4 Accumulator Control | (417) Plug Retainer                             |

Overdrive Internal Components



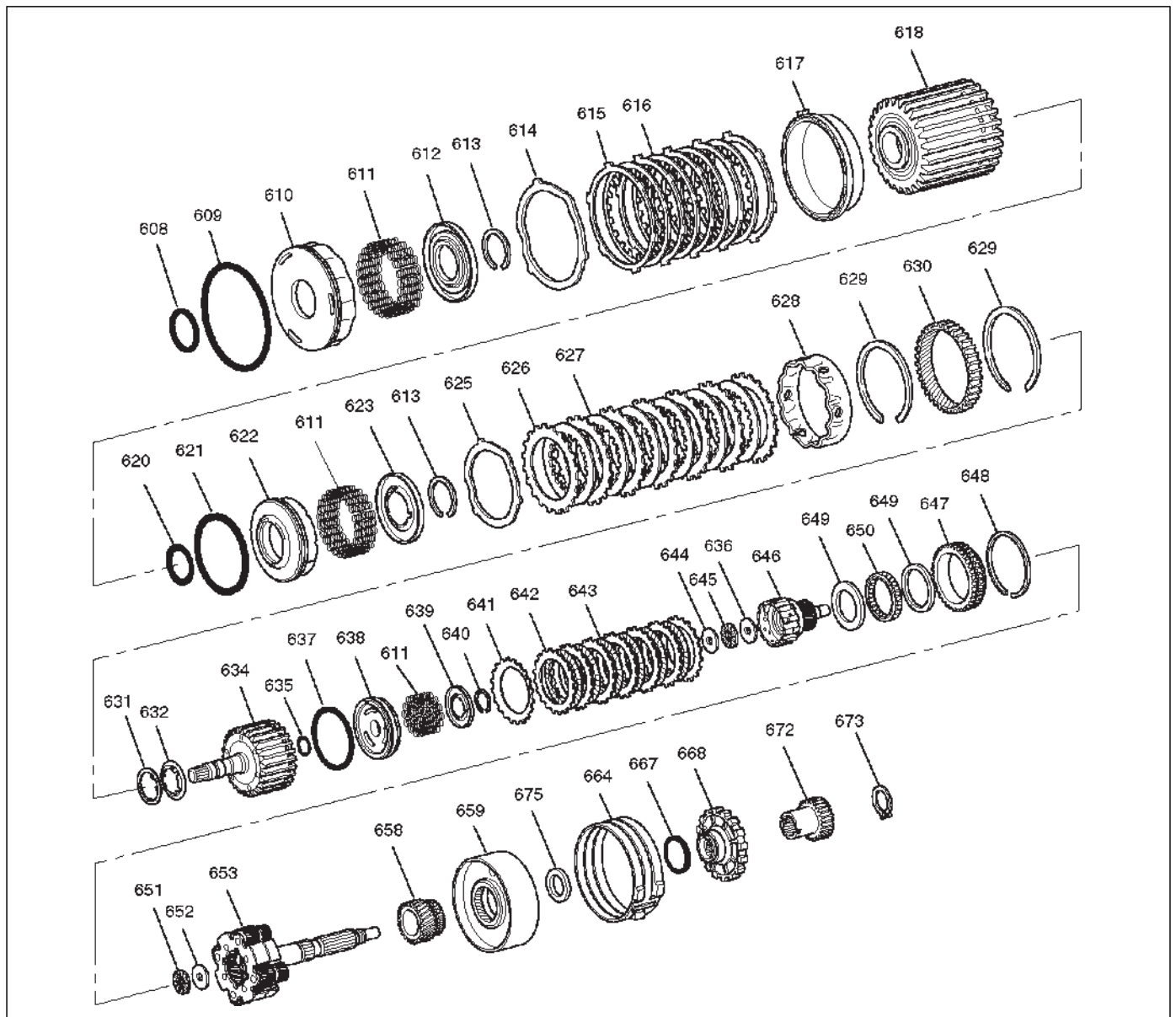
252RW003

**Legend**

- |   |  |
|---|--|
| (501) Retainer, 4th Clutch                    | (520) Plate, Waved/Overrun Clutch              |
| (502) Plate, 4th Clutch (Steel)               | (521) Plate, Overrun Clutch (Steel)            |
| (503) Plate Assembly, 4th Clutch (Lined)      | (522) Plate Assembly, Overrun Clutch (Lined)   |
| (504) Retainer And Ball Assembly, Check Valve | (523) Plate, Backing/Overrun Clutch            |
| (505) Seal, O-Ring/Turbine Shaft              | (524) Ring, Snap/Overrun Clutch Housing        |
| (506) Shaft, Turbine                          | (525) Carrier Assembly, Overdrive Complete     |
| (508) Ring, Oil Seal/Turbine Shaft            | (526) Ring, Snap/Turbine Shaft/Carrier         |
| (510) Housing, Overrun Clutch                 | (527) Bearing Assembly, Thrust                 |
| (513) Piston, Overrun Clutch                  | (528) Gear, Overdrive Internal                 |
| (514) Spring, Overrun Clutch Release          | (529) Washer, Thrust/Internal Gear/Support     |
| (515) Retainer, Release Spring/Overrun Clutch | (530) Ring, Snap/Adapter/4th Clutch Spring     |
| (516) Roller Assembly, Overdrive Clutch       | (531) Retainer and spring assembly, 4th clutch |
| (517) Cam, Overdrive Roller Clutch            | (532) Piston, 4th Clutch                       |
| (518) Ring, Snap/Overrun Clutch Hub           | (533) Seal, 4th Clutch Piston (Inner)          |
| (519) Gear, Overdrive Sun                     | (534) Seal, 4th Clutch Piston (outer)          |

## 7A-94 AUTOMATIC TRANSMISSION (4L30-E)

### Internal Components



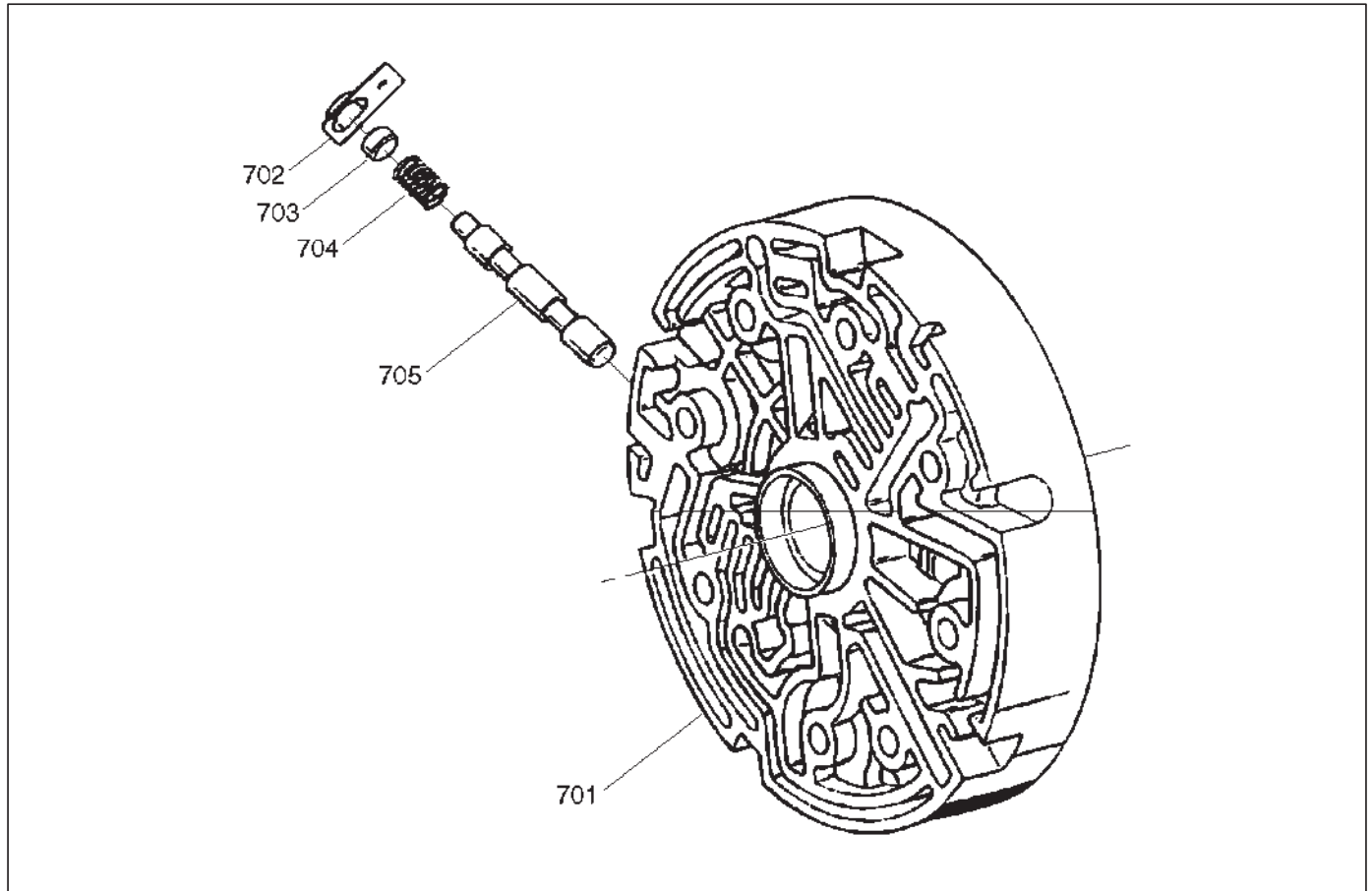
247RW002

#### Legend

- |  |  |
|--|--|
| (608) Seal, Reverse Clutch Piston (Inner)      | (627) Plate Assembly, 2nd Clutch (Lined)   |
| (609) Seal, Reverse Clutch Piston (Outer)      | (628) Spacer, 2nd Clutch                   |
| (610) Piston, Reverse Clutch                   | (629) Ring, Retaining                      |
| (611) Spring, Piston Clutch                    | (630) Gear, Ring                           |
| (612) Seat, Spring/Reverse Clutch              | (631) Washer, Thrust/2nd Clutch/3rd Clutch |
| (613) Ring, Retaining                          | (632) Thrust Washer, Clutch Hub            |
| (614) Plate, Waved/Reverse Clutch              | (634) Drum Assembly, 3rd Clutch            |
| (615) Plate, Reverse Clutch (Steel)            | (635) Seal, 3rd clutch piston (Inner)      |
| (616) Plate Assembly, Reverse Clutch (Lined)   | (636) Washer, Retaining                    |
| (617) Plate, Reverse Clutch Pressure/Selective | (637) Seal, 3rd Clutch Piston (Outer)      |
| (618) Drum Assembly, 2nd Clutch                | (638) Piston 3rd Clutch                    |
| (620) Seal, 2nd Clutch Piston (Inner)          | (639) Seat, Spring/3rd Clutch              |
| (621) Seal, 2nd Clutch Piston (Outer)          | (640) Ring, Retaining                      |
| (622) Piston, 2nd Clutch                       | (641) Plate, Spring Cushion/3rd Clutch     |
| (623) Seat, Spring/2nd Clutch                  | (642) Plate, 3rd Clutch (Steel)            |
| (625) Plate, Waved/2nd Clutch                  | (643) Plate Assembly, 3rd Clutch (Lined)   |
| (626) Plate, 2nd Clutch (Steel)                | (644) Washer, Thrust/Input Sun             |
|  | (645) Bearing, Input Shaft/Gear Assembly   |
|  | (646) Washer, Retaining                    |
|  | (647) Ring, Retaining                      |
|  | (648) Ring, Retaining                      |
|  | (649) Washer, Retaining                    |
|  | (650) Washer, Retaining                    |
|  | (651) Washer, Retaining                    |
|  | (652) Washer, Retaining                    |
|  | (653) Washer, Retaining                    |
|  | (658) Washer, Retaining                    |
|  | (659) Washer, Retaining                    |
|  | (664) Washer, Retaining                    |
|  | (667) Washer, Retaining                    |
|  | (668) Washer, Retaining                    |
|  | (672) Washer, Retaining                    |
|  | (673) Washer, Retaining                    |

- |                                       |                                     |
|---------------------------------------|-------------------------------------|
| (646) Gear Assembly, Input Sun        | (658) Gear, Reaction Sun            |
| (647) Race Assembly, Sprag            | (659) Drum, Reaction Sun            |
| (648) Ring, Retaining/Sprag           | (664) Band Assembly, Brake          |
| (649) Ring, Retaining                 | (667) Seal, Ring/Wheel Parking Lock |
| (650) Cage Assembly, Sprag            | (668) Wheel, Parking Lock           |
| (651) Bearing, Output Shaft/Input Sun | (672) Wheel, Speed                  |
| (652) Washer, Output Shaft/Input Sun  | (673) Ring, Retaining               |
| (653) Carrier Assembly, Planetary     | (675) Bearing, Thrust Assembly      |

**Center Support Assembly**



241RS010

**Legend**

- |                      |                               |
|----------------------|-------------------------------|
| (701) Center Support | (703) Plug, Lockout           |
| (702) Retainer Plate | (704) Spring, Overrun Lockout |
|                      | (705) Valve, Overrun Lockout  |

VEHICROSS

# TRANSMISSION

## TRANSMISSION CONTROL SYSTEM (4L30-E)

### CONTENTS

Service Precaution .....	7A1-2	DTC P0705 Transmission Range Switch (Mode Switch) Illegal Position .....	7A1-30
General Description .....	7A1-2	DTC P0706 Transmission Range Switch (Mode Switch) Performance .....	7A1-33
Electronic Control Diagram .....	7A1-3	DTC P0711 Transmission Fluid Temperature (TFT) Sensor Circuit Range/Performance ..	7A1-36
Powertrain Control Module (PCM) .....	7A1-4	DTC P0712 Transmission Fluid Temperature (TFT) Sensor Circuit Low Input .....	7A1-39
Control System Diagram .....	7A1-5	DTC P0713 Transmission Fluid Temperature (TFT) Sensor Circuit High Input .....	7A1-42
Shift Control .....	7A1-6	DTC P0719 TCC Brake Switch Circuit High (Stuck On) .....	7A1-45
Band Apply Control .....	7A1-6	DTC P0722 Transmission Output Speed Sensor (OSS) Low Input .....	7A1-48
Torque Converter Clutch Control .....	7A1-6	DTC P0723 Transmission Output Speed Sensor (OSS) Intermittent .....	7A1-51
Line Pressure Control .....	7A1-6	DTC P0724 TCC Brake Switch Circuit Low (Stuck Off) .....	7A1-54
On-Board Diagnostic System .....	7A1-6	DTC P0730 Transmission Incorrect Gear Ratio .....	7A1-56
Fail Safe Mechanism .....	7A1-6	DTC P0742 Torque Converter Clutch (TCC) Circuit Stuck On .....	7A1-59
Torque Management Control .....	7A1-6	DTC P0748 Pressure Control Solenoid (PCS) (Force Motor) Circuit Electrical .....	7A1-61
ATF Warning Control .....	7A1-6	DTC P0751 Shift Solenoid A Performance Without Input Speed .....	7A1-63
ABS Control .....	7A1-6	DTC P0753 Shift Solenoid A Electrical .....	7A1-65
Shift Mode Control .....	7A1-7	DTC P0756 Shift Solenoid B Performance Without Input Speed .....	7A1-68
Gear Shift Control .....	7A1-8	DTC P0758 Shift Solenoid B Electrical .....	7A1-70
Winter Drive Mode .....	7A1-9	DTC P1790 ROM Transmission Side Bad Check Sum .....	7A1-74
Backup Mode .....	7A1-9	DTC P1792 EEPROM Transmission Side Bad Check Sum .....	7A1-75
Functions of Input / Output Components ..	7A1-10	DTC P1835 Kickdown Switch Always On ...	7A1-76
Diagnosis .....	7A1-11	DTC P1850 Brake Band Apply Solenoid Malfunction .....	7A1-78
Electronic Diagnosis .....	7A1-11	DTC P1860 TCC Solenoid Electrical .....	7A1-82
Check Trans Indicator .....	7A1-11	DTC P1870 Transmission Component Slipping .....	7A1-85
Diagnostic Check .....	7A1-11	Circuit Diagram .....	7A1-87
“Check Trans” Check .....	7A1-12	Parts Location .....	7A1-89
Tech 2 OBD II Connection .....	7A1-13	Harness Connector Faces .....	7A1-90
F0: Transmission Data .....	7A1-17		
F1: PC Solenoid Data .....	7A1-18		
OBD II Diagnostic Management System ..	7A1-19		
16 – Terminal Data Link Connector (DLC) .	7A1-20		
Malfunction Indicator Lamp (MIL) .....	7A1-21		
Types Of Diagnostic Trouble Codes (DTCs)	7A1-21		
Clear DTC .....	7A1-21		
DTC Check .....	7A1-22		
PCM Precaution .....	7A1-22		
Information On PCM .....	7A1-22		
Intermittent Conditions .....	7A1-22		
Transmission And PCM Identification .....	7A1-23		
Isuzu Vehicross .....	7A1-23		
Diagnostic Trouble Code (DTC) Identification .....	7A1-24		
DTC P0218 Transmission Fluid Over Temperature .....	7A1-25		
DTC P0560 System Voltage Malfunction ...	7A1-27		

## Service Precaution

**WARNING: THIS VEHICLE HAS A SUPPLEMENTAL RESTRAINT SYSTEM (SRS). REFER TO THE SRS COMPONENT AND WIRING LOCATION VIEW IN ORDER TO DETERMINE WHETHER YOU ARE PERFORMING SERVICE ON OR NEAR THE SRS COMPONENTS OR THE SRS WIRING. WHEN YOU ARE PERFORMING SERVICE ON OR NEAR THE SRS COMPONENTS OR THE SRS WIRING, REFER TO THE SRS SERVICE INFORMATION. FAILURE TO FOLLOW WARNINGS COULD RESULT IN POSSIBLE AIR BAG DEPLOYMENT, PERSONAL INJURY, OR OTHERWISE UNNEEDED SRS SYSTEM REPAIRS.**

**CAUTION: Always use the correct fastener in the proper location. When you replace a fastener, use ONLY the exact part number for that application. ISUZU will call out those fasteners that require a replacement after removal. ISUZU will also call out the fasteners that require thread lockers or thread sealant. UNLESS OTHERWISE SPECIFIED, do not use supplemental coatings (Paints, greases, or other corrosion inhibitors) on threaded fasteners or fastener joint interfaces. Generally, such coatings adversely affect the fastener torque and the joint clamping force, and may damage the fastener. When you install fasteners, use the correct tightening sequence and specifications. Following these instructions can help you avoid damage to parts and systems.**

## General Description

The 4L30-E is a 4-speed fully automatic transmission. It uses a microcomputer as a control unit to judge running conditions including throttle opening rate and vehicle speed, then it sets the shifting point in the optimum timing so that best driving performance can be achieved.

In addition, the built-in shift mode select function can select three shift modes according to the driver's preference:

- Normal mode –Normal shift pattern.
- Winter mode –Starts in 3rd gear to reduce slippage on ice or snow.
- Power mode has a delayed upshift for when more powerful acceleration is required.

Also, the built-in fail safe function ("backup mode") assures driving performance even if the vehicle speed sensor, throttle signal or any solenoid fails.

Further, the self-diagnostic function conducts diagnosis in a short time when the control system fails, thus improving serviceability.

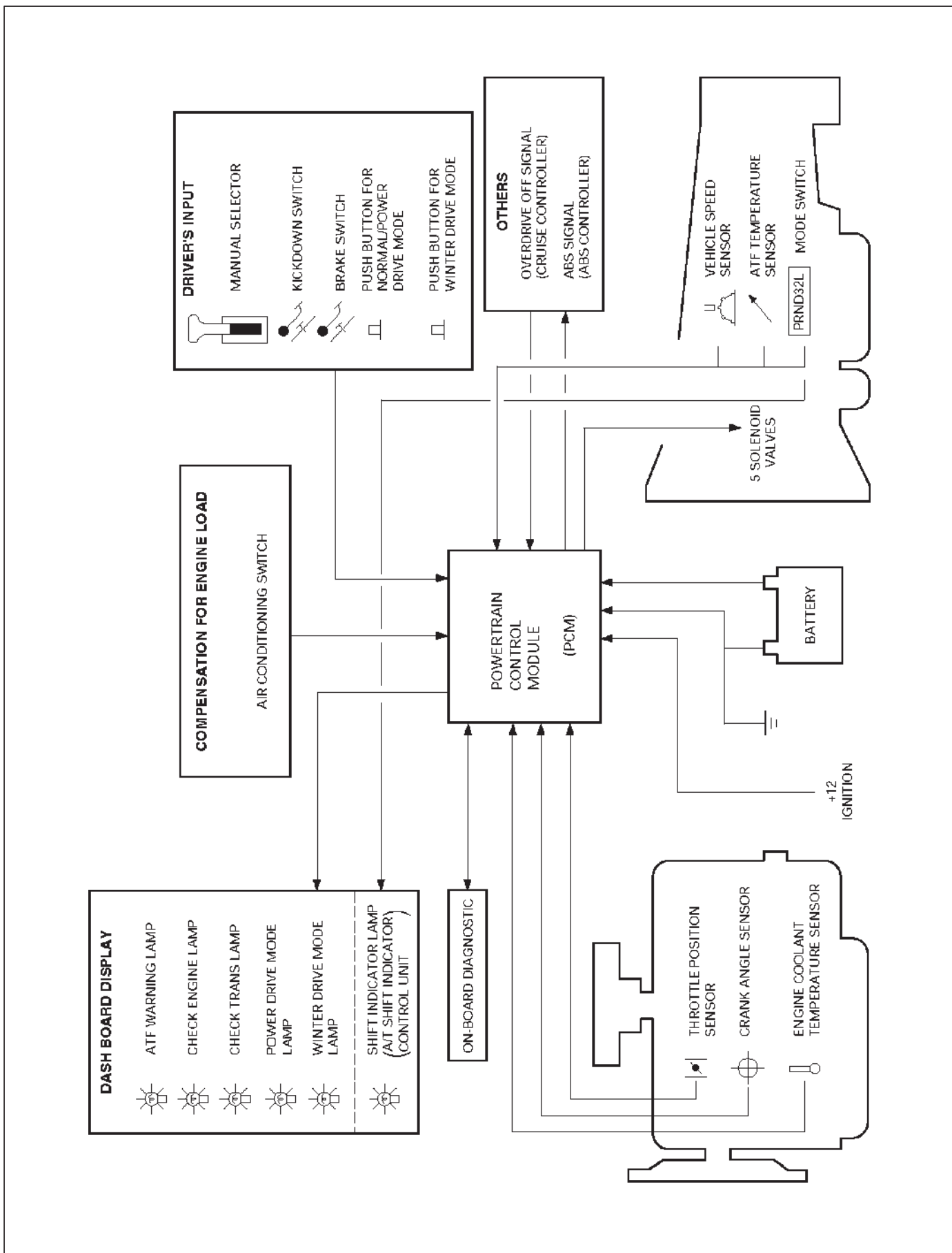
The major features of 4L30-E are as follows:

- A compact structure consisting of 2 sets of planetary gears and flat torque converter.
- Electronic control selects the optimum shift mode according to the driving conditions.
- Electronic control maintains the optimum hydraulic pressure for clutch, band brake as well as transmission so that shift feeling is improved.
- Two sets of planetary gears reduce friction of power train.

Also, a lockup mechanism in the torque converter reduces fuel consumption.

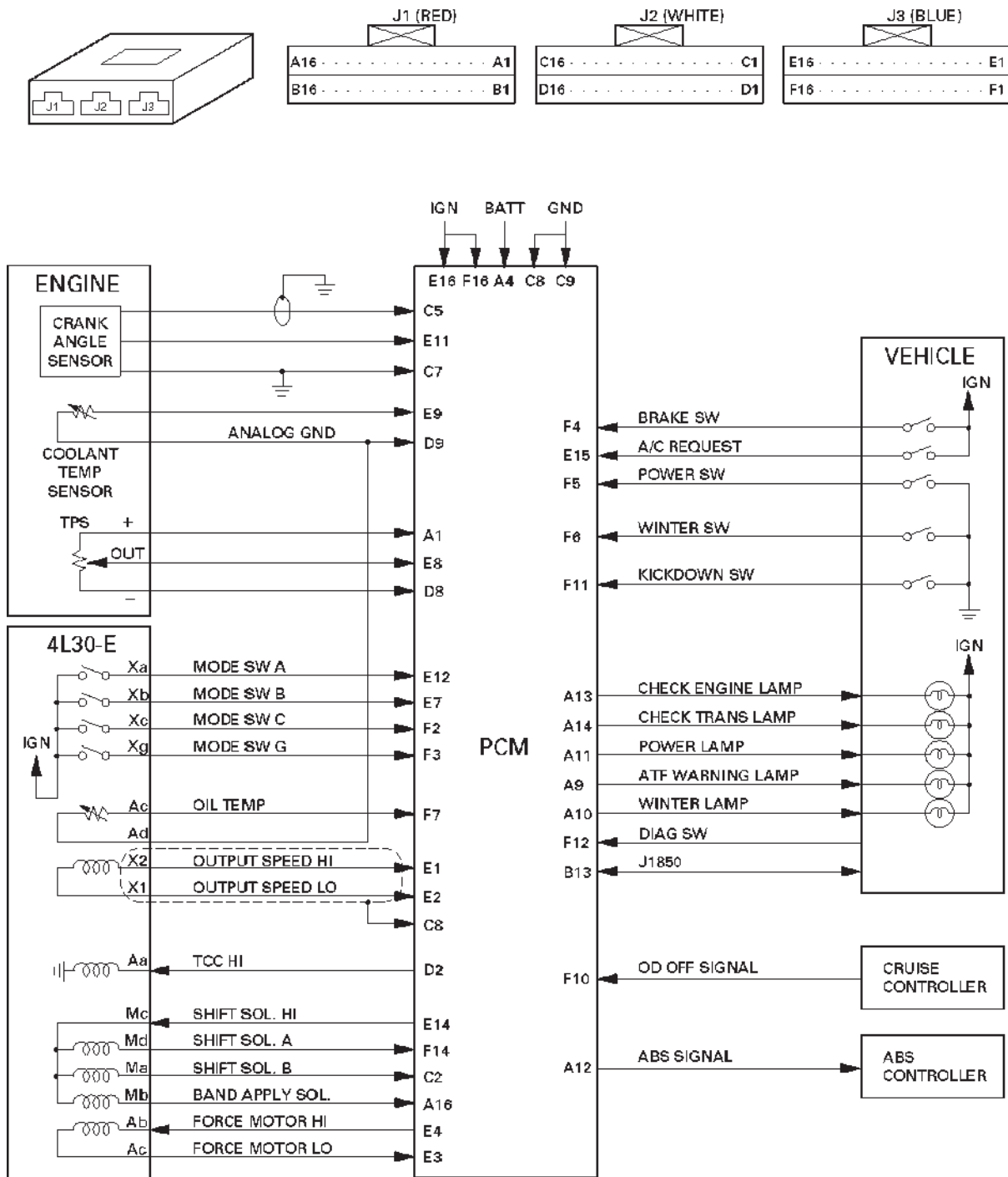
- Wide gear ratio and high torque rate of torque converter provide excellent starting performance.

Electronic Control Diagram



# 7A1-4 TRANSMISSION CONTROL SYSTEM (4L30-E)

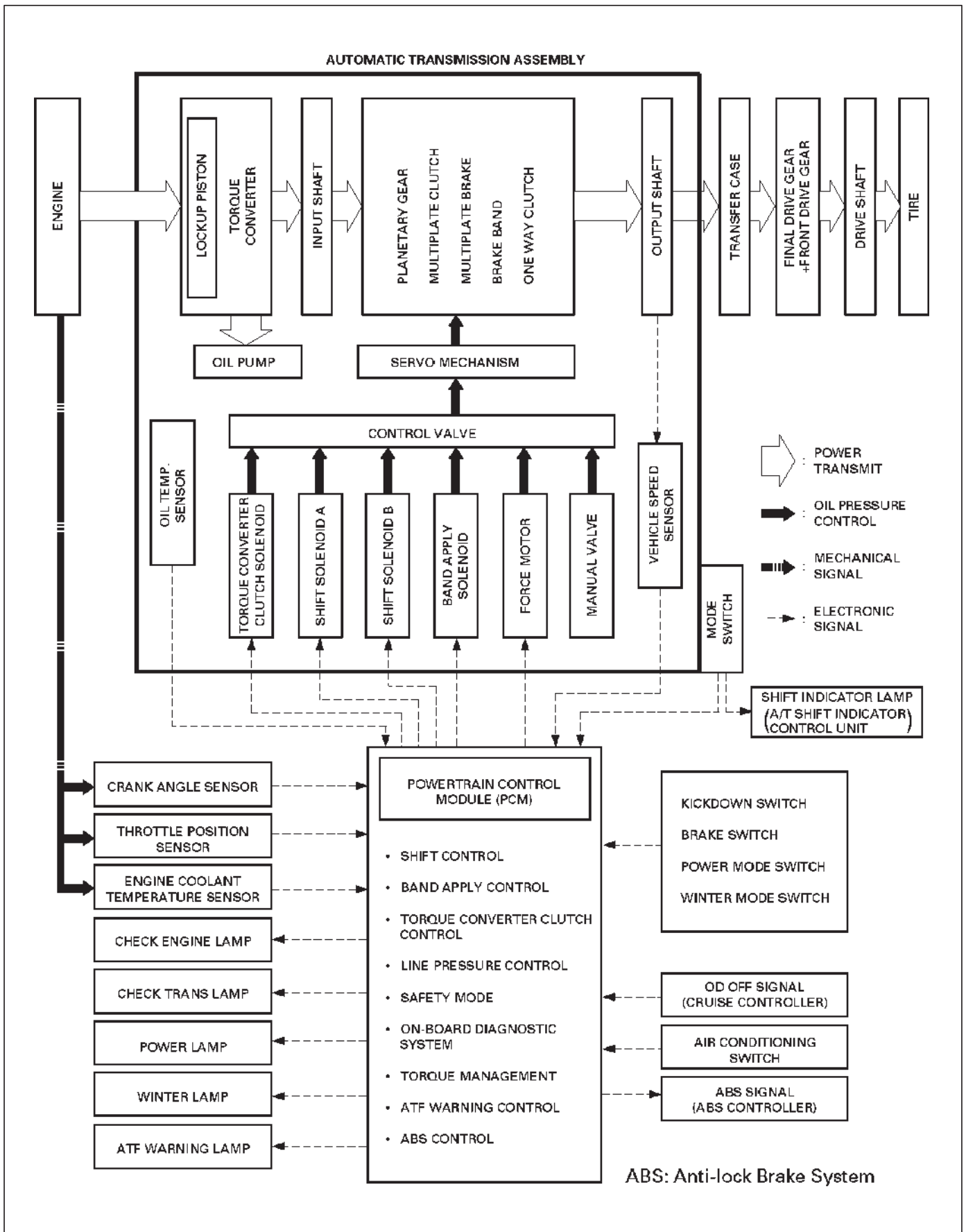
## Powertrain Control Module (PCM)



TPS: Throttle Position Sensor  
 TCC: Torque Converter Clutch  
 ABS: Anti-Lock Brake System



Control System Diagram



## 7A1-6 TRANSMISSION CONTROL SYSTEM (4L30-E)

---

### **Shift Control**

The transmission gear is shifted according to the shift pattern selected by the driver. In shifting gears, the gear ratio is controlled by the ON/ OFF signal using the shift solenoid A and the shift solenoid B.

### **Band Apply Control**

The band apply is controlled when in the 3-2 downshift (engine overrun prevention) and the garage shift (shock control).

The band apply solenoid is controlled by the signal from the Pulse Width Modulation (PWM) to regulate the flow of the oil.

### **Torque Converter Clutch Control**

The clutch ON/OFF is controlled by moving the converter clutch valve through shifting Torque Converter Clutch (TCC) solenoid using the ON/OFF signal.

### **Line Pressure Control**

The throttle signal allows the current signal to be sent to the force motor. After receiving the current signal, the force motor activates the pressure regulator valve to regulate the line pressure.

### **On-Board Diagnostic System**

Several malfunction displays can be stored in the Powertrain Control Module (PCM) memory, and read out of it afterward.

The serial data lines, which are required for the testing of the final assembly and the coupling to other electronic modules, can be regulated by this function.

### **Fail Safe Mechanism**

If there is a problem in the transmission system, the PCM will go into a "backup" mode.

The vehicle can still be driven, but the driver must use the select lever to shift gears.

### **Torque Management Control**

The transmission control side sends the absolute spark advance signal to the engine control side while the transmission is being shifted. This controls the engine spark timing in compliance with the vehicle running condition to reduce the shocks caused by the change of speed.

### **ATF Warning Control**

The oil temperature sensor detects the ATF oil temperature to control the oil temperature warning, TCC, and the winter mode.

### **ABS Control**

When the select lever is at "L" or "R" range, a signal is sent to the ABS controller as one of the ABS control conditions.

Shift Mode Control

① Mode Type

Mode Type	Select lever position
Normal drive mode (NOR)	Entire range (excluding "R")
Power drive mode (PWR)	Entire range (excluding "R")
Winter drive mode	"D", "N", "R" and "P" range

② Mode selection

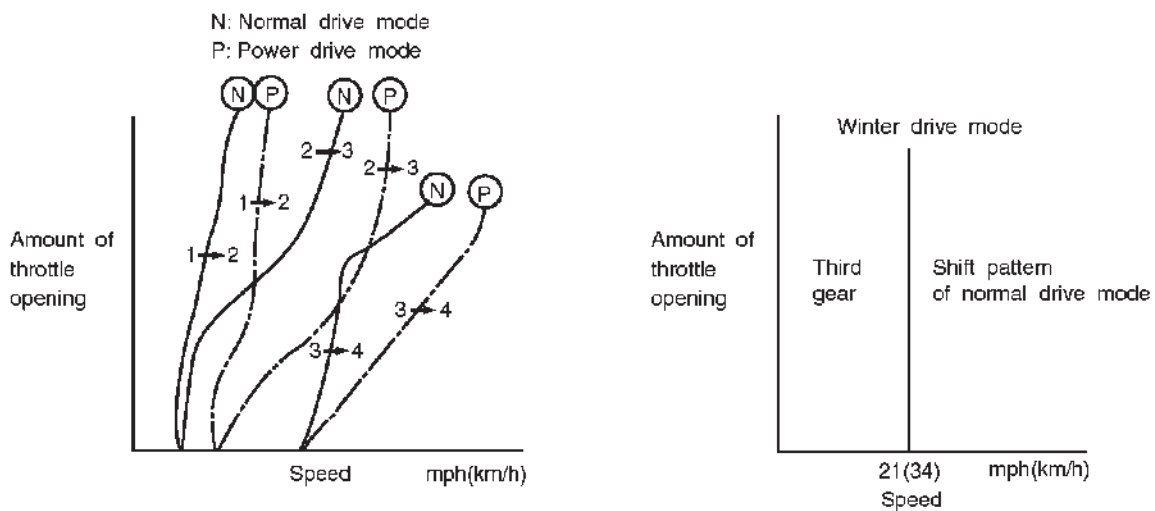
Mode Type	SWITCH (SW)		LAMP	
	POW/NOR. SW	WINTER SW	POWER DRIVE LAMP	WINTER DRIVE LAMP
Normal drive mode (NOR)	OFF	OFF	OFF	OFF
Power drive mode (PWR)	ON	OFF	ON	OFF
Winter drive mode	ON/OFF	ON	OFF	ON

However, the winter switch prevails over the PWR/NOR switch.  
 The mode becomes normal drive mode when the winter switch is operated from ON to OFF.

③ Comparison of mode

- (1) The normal drive mode is set at the normal shift points.
- (2) The shift points of the power drive mode are shifted to the higher speed side, compared to the normal drive mode.
- (3) The winter drive mode is a special mode used exclusively for starting in third gear.

Shift diagram



## 7A1-8 TRANSMISSION CONTROL SYSTEM (4L30-E)

### Gear Shift Control

#### ① Shift pattern

SELECT LEVER RANGE	SHIFT PATTERN
D (Drive)	1 ⇄ 2TCC ⇄ 3TCC ⇄ 4TCC
3 (Third)	1 ⇄ 2TCC ⇄ 3TCC ← 4TCC
2 (Second)	1 ⇄ 2TCC ← 3TCC
L (First)	1 ← 2

TCC = Torque Converter Clutch

#### ② Gear position

The gear is selected by ON/OFF of two solenoids.

Gear \ SOL	A	B
4 (Fourth)	×	×
3 (Third)	○	×
2 (Second)	○	○
1 (First)	×	○
P (park)		
R (Reverse)	×	○
N (Neutral)		

○ = ON

× = OFF

Shift solenoid A  
(Normally closed)

ON → PRESSURE TO  
SHIFT VALVE

Shift solenoid B  
(Normally open)

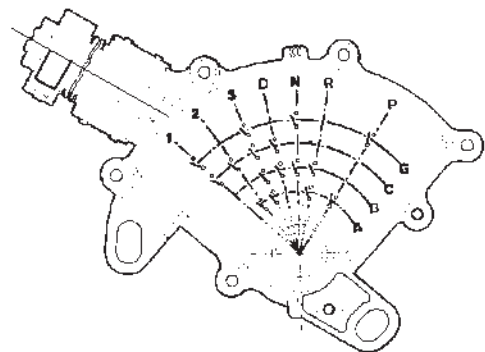
OFF → PRESSURE TO  
SHIFT VALVE

#### ③ Selecting gear position

Seven types of positions can be selected according to 5 signals from the mode switch as below.

SELECT LEVER RANGE	MODE SW TERMINALS				
	5(D)	8(A)	7(B)	6(C)	3(G)
P (park)	•	•			•
R (Reverse)	•	•	•		
N (Neutral)	•		•		•
D (Drive)	•		•	•	
3 (Third)	•	•	•	•	•
2 (Second)	•	•		•	
L (First)	•			•	•

• = Continuity



## Winter Drive Mode

### 1. Operation

The winter switch will operate when switched on after all of the following conditions are present:

#### Conditions:

- a. The select lever position is "D", "N", "R" and "P" range.
- b. Vehicle speed is 7 mph (11 km/h) or less.
- c. Transmission oil temperature is 120°C (248°F) or less.
- d. Kickdown switch is off.
- e. Accelerator opening is at 8% or less.

### 2. Cancel Release

1. Cancellation by driver
  - a. Turning off the winter drive mode switch
  - b. Shifting select position to "3", "2", or "L" (Winter drive mode is not canceled by selecting "N", "R", or "P" from "D")
  - c. Ignition key is turned off.
2. Automatic cancellation
  - a. When vehicle runs at 21mph (34 km/h) or more for 1 second or more
  - b. When transmission oil temperature reaches 140°C (284°F) or above

NOTE: The mode returns to normal drive mode or power drive mode after the winter drive mode is canceled.

## Backup Mode

If a major system failure occurs which could affect safety or damage the transmission under normal vehicle operation, the diagnostic system detects the fault and overrides the Powertrain Control Module (PCM).

The "CHECK TRANS" light flashes to alert the driver, and the transmission must be manually shifted as follows:

Select lever position	Gear Ratio Selected
D	4 (Fourth)
Manual 3	4 (Fourth)
Manual 2	3 (Third)
Manual L	1 (First)
R	Reverse

Shifts are firmer to prevent clutch slip and consequent wear. The fault should be corrected as soon as possible.

## 7A1-10 TRANSMISSION CONTROL SYSTEM (4L30-E)

### Functions of Input / Output Components

Components		Function	
I N P U T  S I G N A L	Speed sensor (fixed to transmission (T/M))	Senses rotation of output shaft and feeds the data to Powertrain Control Module (PCM).	
	Throttle position sensor (TPS) (fixed to engine)	Senses the extent of throttle valve opening and the speed of the throttle valve lever motion to open the valve. Feeds the data to PCM.	
	Brake Switch (SW) (fixed to brake pedal)	Senses whether the driver has pressed the brake pedal or not and feeds the information to PCM.	
	Kickdown SW (fixed to accelerator pedal)	Senses whether the driver has pushed the accelerator pedal fully or not, and feeds the information to PCM.	
	Mode SW (fixed to T/M)	Senses the select lever position, and feeds the information to PCM.	
	Power drive SW (fixed to front console)	Senses whether the driver has selected the power mode, and feeds the information to PCM.	
	T/M oil temp. sensor	Senses the T/M oil temperature and feeds the data to PCM	
	Engine coolant temperature sensor	Senses the engine coolant temperature, and feeds the data to PCM.	
	Engine speed signal	Feeds the signals monitoring engine speed to PCM from crank angle sensor.	
	Air conditioning information	Senses whether the air conditioner has been switched on or not, and feeds the information to PCM.	
	Winter switch (fixed to front console)	Senses whether the driver has selected the winter mode, and feeds the information to PCM.	
	Cruise controller (Overdrive OFF signal)	Downshift takes place when Overdrive OFF signal is received from auto cruise control unit.	
O U T P U T  S I G N A L	S O L E N O I D	Shift solenoid A, B	Selects shift point and gear position suited to the vehicle running condition on the basis of PCM output.
		Band apply solenoid	Controls oil flow suited to the vehicle running condition on the basis of PCM output.
		Torque Converter Clutch solenoid	Controls clutch engagement/disengagement suited to the vehicle running condition on the basis of PCM output.
		Force motor (Pressure regulator valve)	Adjusts the oil pump delivery pressure to line pressure suited to the vehicle running condition on the basis of PCM output.
	S I G N A L	Power drive mode lamp	Informs the driver whether the vehicle is in power mode or not.
		Winter drive mode lamp	Informs the driver whether the vehicle is in winter mode or not.
		T/M monitor lamp ("CHECK TRANS")	Informs the driver of failure in the system.
		ATF warning lamp	Lights when ATF oil temperature rises.
		ABS signal	When the select lever is at "Reverse" or "L" range, sends a signal to the ABS controller as one of the ABS control conditions.

## Diagnosis

### Electronic Diagnosis

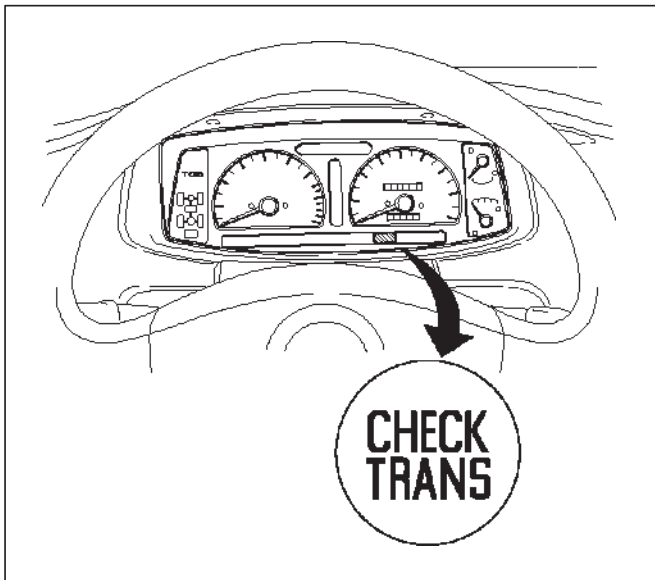
#### How To Diagnose The Problem

1. To avoid incorrect diagnostics, this book needs to be followed accurately. Unless stated, do not jump directly to a section that could contain the solution. Some important information may be missed.
2. The sections in CAPITALS and bold are the main sections that can be found in the contents.
3. The GOTO "**SECTION**" means to continue to check going to the "section".
4. The GOTHROUGH "**SECTION**" means to go through the "section" and then to go back to the place the GOTHROUGH was written.
5. BASIC ELECTRIC CIRCUITS:  
You should understand the basic theory of electricity. This includes the meaning of voltage, amps, ohms, and what happens in a circuit with an open or shorted wire. You should also be able to read and understand wiring diagrams.

#### Check Trans Indicator

Find CHECK TRANS indicator and verify if it is

- A. Flashing: GOTO **DIAGNOSTIC CHECK**.
- B. Staying on: GOTHROUGH **CHECK TRANS CHECK**.
- C. Is never ON when the ignition key is turned on: GOTHROUGH **CHECK TRANS CHECK**.
- D. Is ON during 2 seconds at ignition but OFF after: Normal operation. No DTC or malfunction.



#### Diagnostic Check

This test determines if the transmission or its inputs, outputs, connections, or sensors are failing.

1. Connect the Tech 2: GOTHROUGH **Tech 2 OBD II CONNECTION**.
2. Turn on the ignition but not the engine.

3. Push "F0" on Tech 2 to see the Diagnostic Trouble Code (DTC):

4. Do you have a DTC?

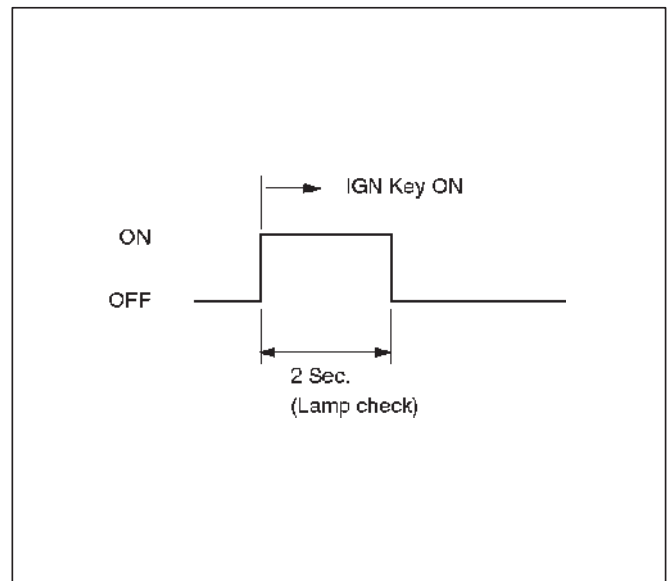
YES: write down all code numbers and do the **DTC CHECK**

NO: the DTC can not help you finding the problem.

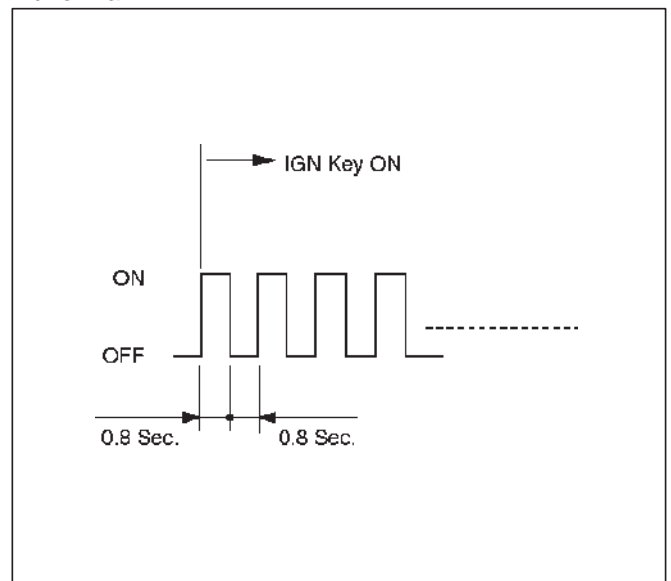
1. GOTHROUGH "**CHECK TRANS**" **CHECK**

2. IF it is flashing and the flash is 0.8 seconds ON and 0.8 seconds OFF, this means that you should have a DTC stored. Please recheck GOTO **DIAGNOSTIC CHECK** and if you find the same problem, replace the Powertrain Control Module (PCM).

Normal



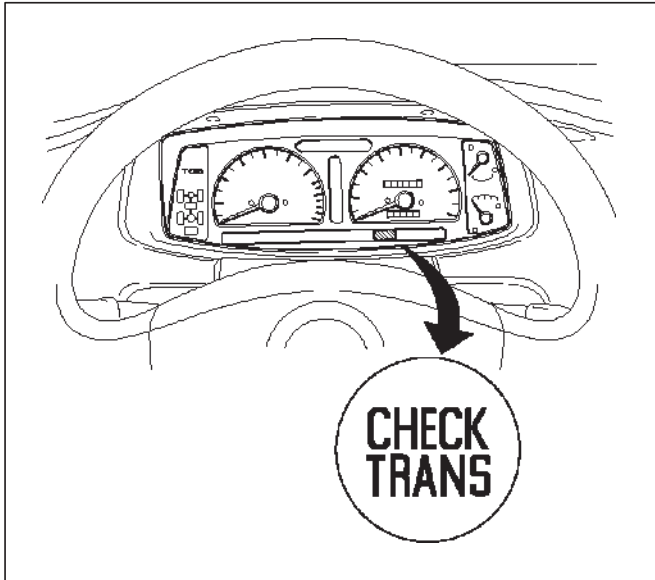
Abnormal



## 7A1-12 TRANSMISSION CONTROL SYSTEM (4L30-E)

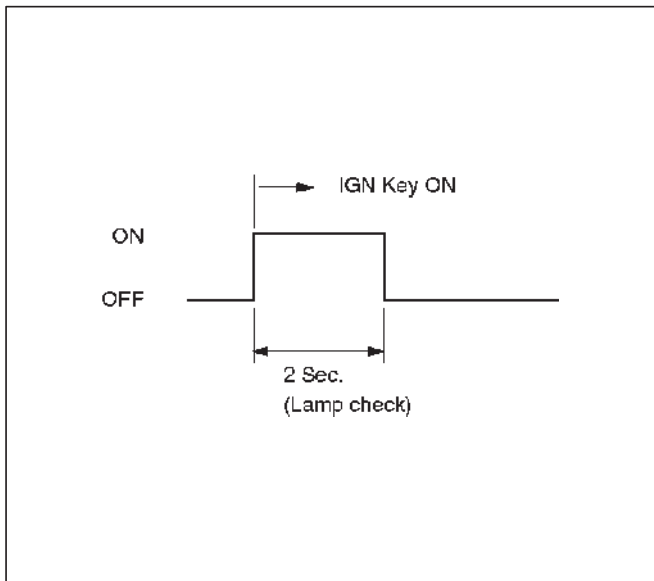
### “Check Trans” Check

1. Indicator it is ON during 2 seconds at ignition (or when the engine is cranked) but it is OFF after the engine starts. The indicator is working normally GOTO **DIAGNOSTIC CHECK**.



821RX030

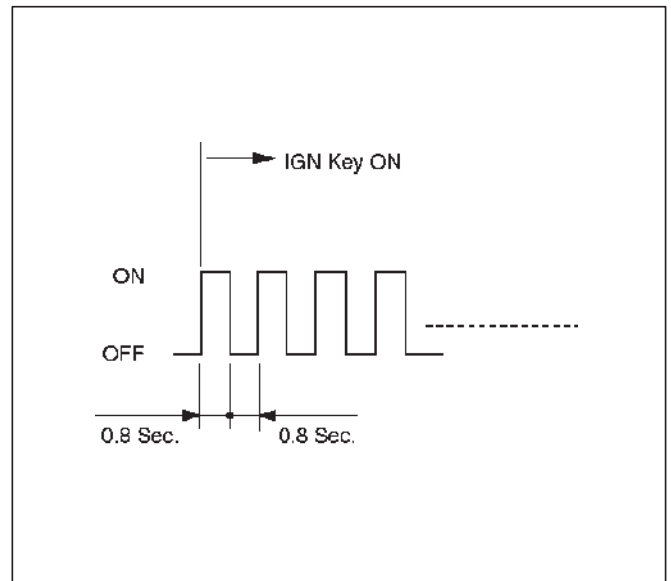
### Normal



C07RW047

2. Indicator it is flashing and the flash is 0.8 seconds ON and 0.8 seconds OFF always when ignition is on (engine cranked or not). This means that there is a malfunction. GOTO **DIAGNOSTIC CHECK**.

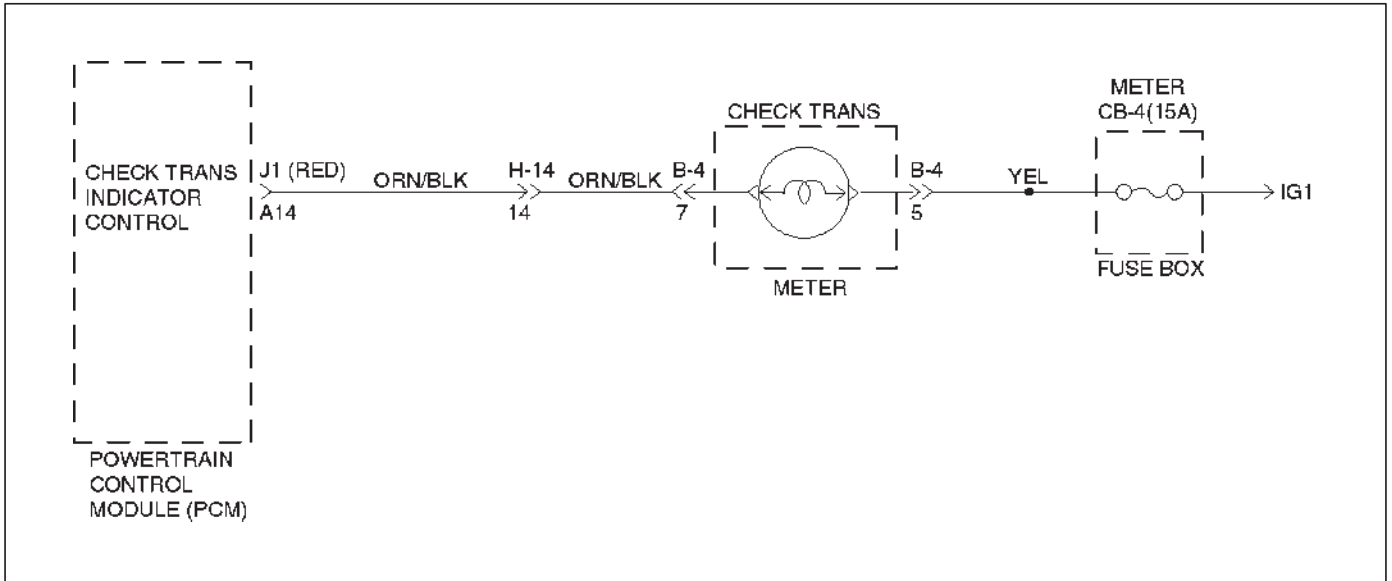
### Abnormal



C07RX009

3. Indicator it is staying ON always when Ignition is ON.
  1. This means that connection between the lamp and the PCM is shorted to ground.
  2. Verify if instrument panel terminal 7 of connector B-4 is shorted to ground.
  3. Verify if the PCM connector J1 (RED) terminal A14 is shorted to ground.
  4. Verify that the instrument panel terminal 5 of connector B-4 is connected to battery.
  5. IF problem solved: GOTO **CHECK TRANS INDICATOR**.  
NO: Replace Powertrain Control Module (PCM).
4. Indicator it is staying OFF with the ignition ON (engine OFF).
  1. This means that connection between the lamp and the PCM is shorted to battery or opened.
  2. Verify if instrument panel terminal 7 of connector B-4 is shorted to battery or open.
  3. Verify if the PCM connector J1 (RED) terminal A14 is shorted to battery or open.
  4. Verify that the instrument panel terminal 5 of connector B-4 is connected to battery. If not, check the fuses.
  5. IF problem solved: GOTO **CHECK TRANS INDICATOR**.  
NO: Replace Powertrain Control Module (PCM).



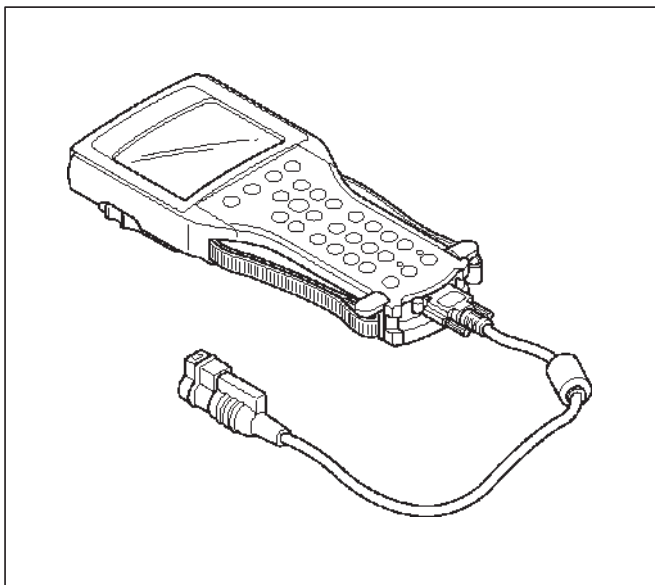


D07RX001

### Tech 2 OBD II Connection

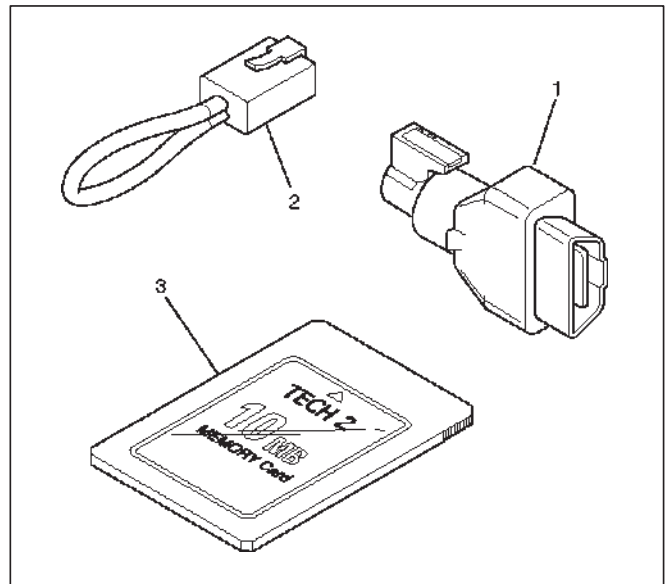
In order to access OBD II Powertrain Control Module (PCM) data, use of the Tech 2 scan tool kit (7000086) is required.

1. The electronic diagnosis equipment is composed of:
  1. Tech 2 hand-held scan tool unit (7000057) and DLC cable (3000095).



901RW176

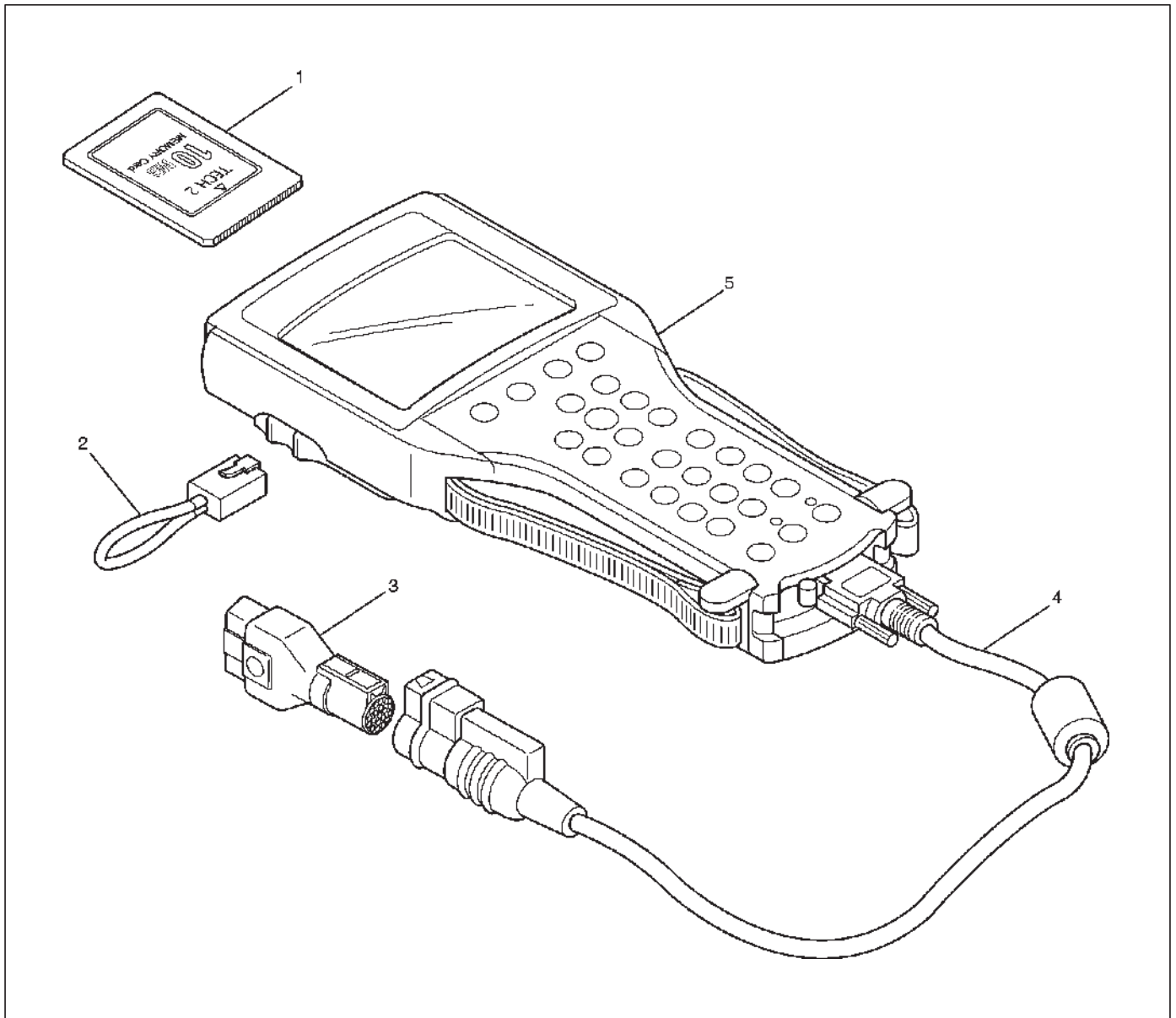
2. SAE 16/19 adaptor (3000098) (1), RS 232 loop back connector (3000112) (2), and PCMCIA card (3000117) (3).



F07RW033

## 7A1-14 TRANSMISSION CONTROL SYSTEM (4L30-E)

### 2. Connecting the TECH2



901RW180

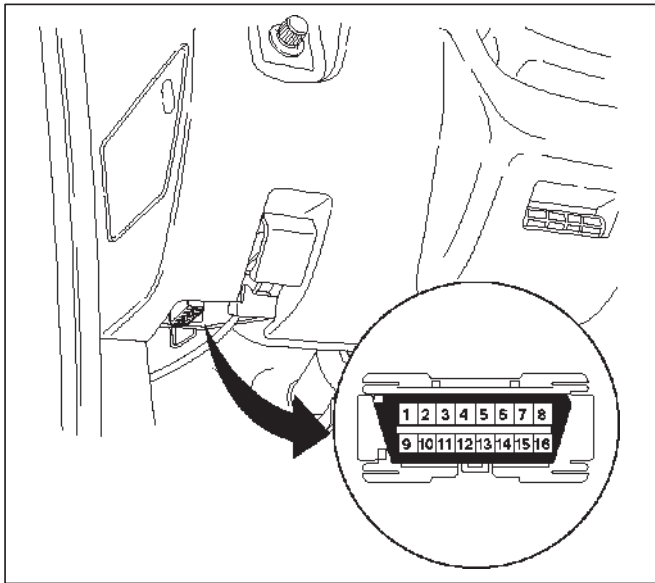
#### Legend

- |                                |                       |
|--------------------------------|-----------------------|
| (1) PCMCIA Card                | (3) SAE 16/19 Adaptor |
| (2) RS 232 Loop Back Connector | (4) DLC Cable         |
|                                | (5) Tech 2            |

○ Before operating the Isuzu PCMCIA card with the Tech 2, the following steps must be performed:

1. The Isuzu 99 System PCMCIA card (1) inserts into the Tech 2 (5).
2. Connect the SAE 16/19 adaptor (3) to the DLC cable (4).
3. Connect the DLC cable to the Tech 2 (5)
4. Make sure the vehicle ignition is off.

5. Connect the Tech 2 SAE 16/19 adaptor to the vehicle DLC.



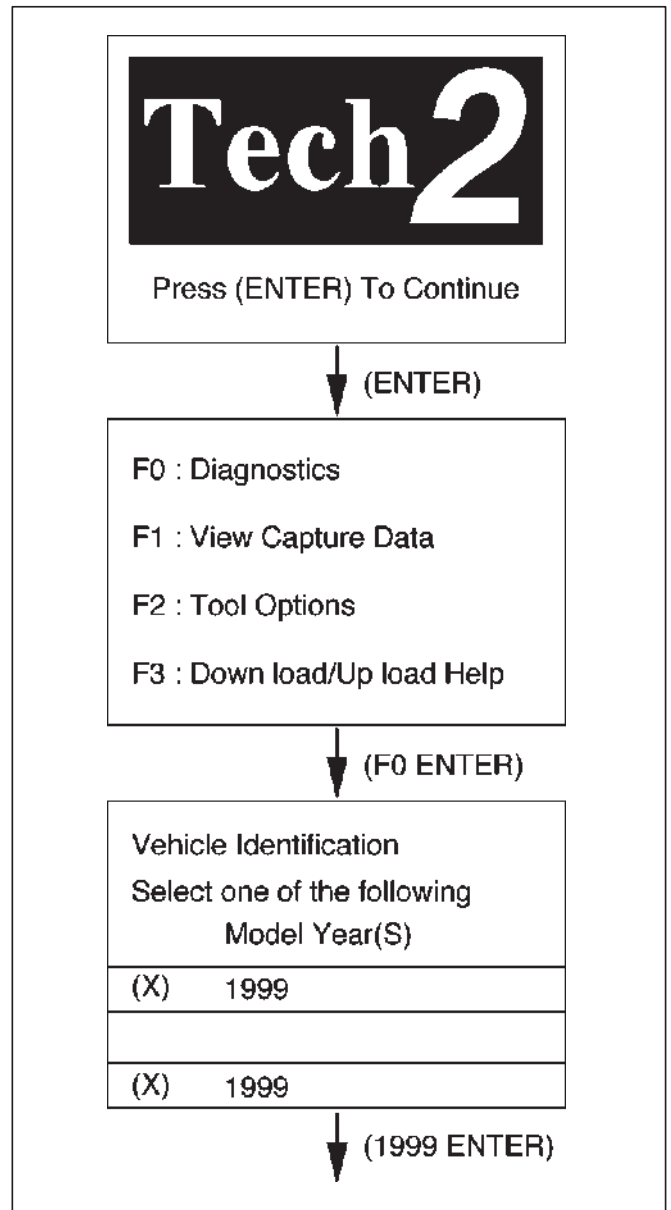
821RX029

6. The vehicle ignition turns on.
7. Verify the Tech 2 power up display.



060RW009

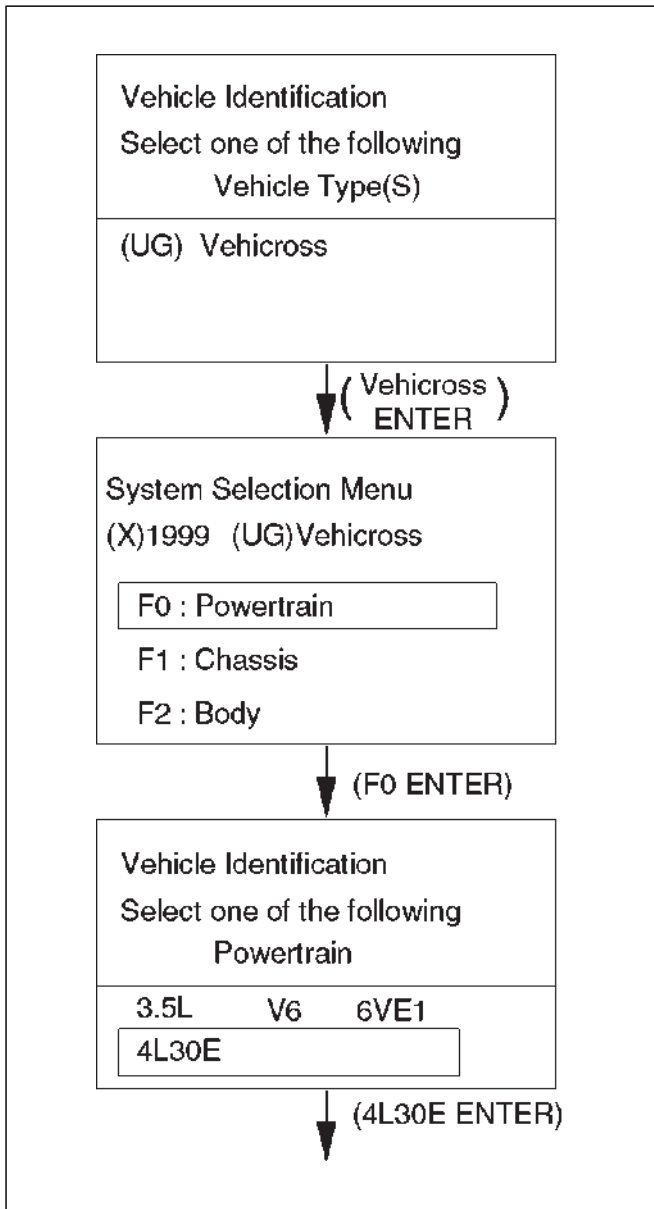
8. The power up screen is displayed when you power up the tester with the Isuzu systems PCMCIA card. Follow the operating procedure below.



060RX004

NOTE: The RS232 Loop back connector is only to use for diagnosis of Tech 2 and refer to user guide of the Tech 2.

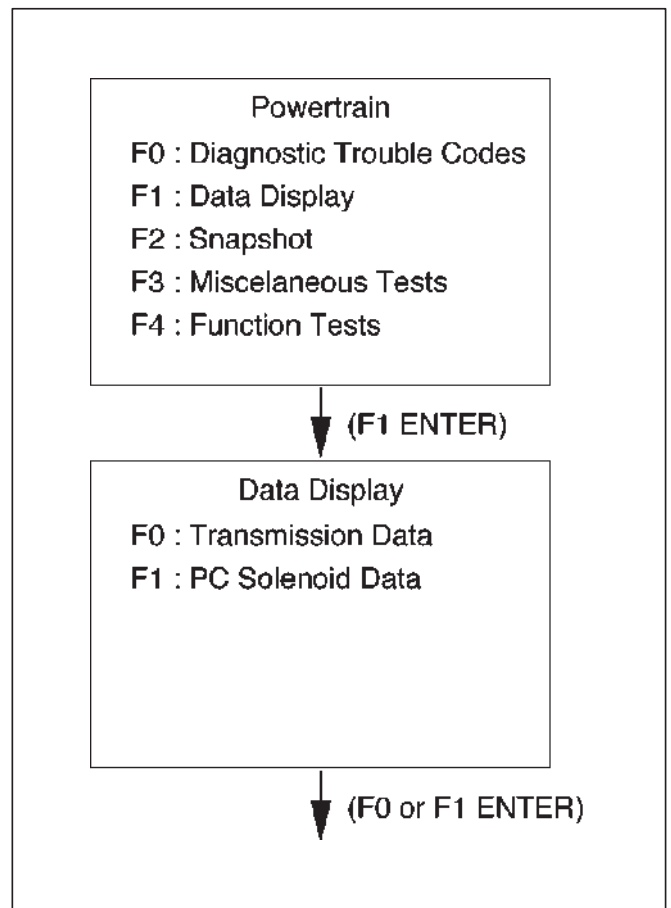
## 7A1-16 TRANSMISSION CONTROL SYSTEM (4L30-E)



Once the test vehicle has been identified an "Application (Powertrain) Menu" screen appears. Please select the appropriate application.

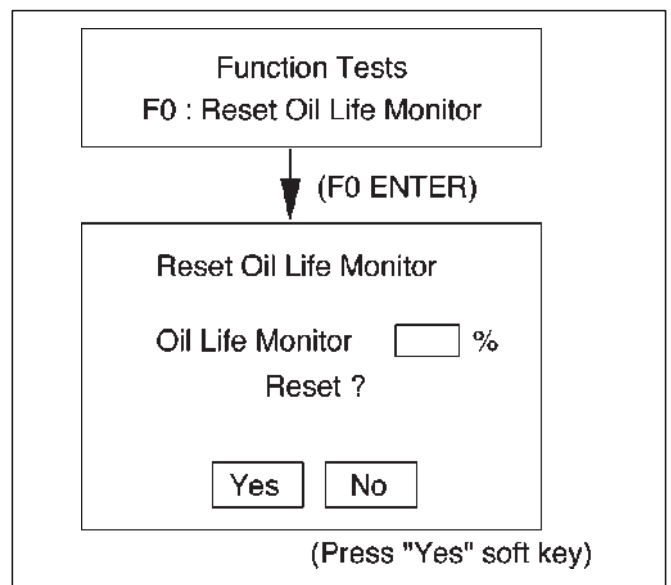
### Data Display

When F1: Data Display is selected, a "Data Display Menu" screen appears. Please select either "Transmission Data" or "PC Solenoid Data".



### Function Tests (Reset Oil Life Monitor)

When F4: Function Tests is selected from the "Powertrain Menu", a "Reset Oil Life Monitor Menu" screen appears. When the ATF has been replaced, select "F0" and reset "Oil Life Monitor" data.



**F0: Transmission Data**

Item	Unit	Engine running at idle
Engine Speed	RPM	750 ~ 900 RPM
Vehicle Speed	km/h, MPH	0 MPH
Throttle Position	%	0 %
Throttle Position Sensor	V	0.5 ~ 1.0 V
Manifold Absolute Pressure	kpa	approx. 40 kpa
Barometric Pressure	kpa	approx. 102 kpa
AT Output Speed (Automatic Transmission)	RPM	0 RPM
AT Input Speed Ratio (Automatic Transmission)		0.0
Ignition Voltage	V	12.8 ~ 14.1 V
AT Oil Temperature (Automatic Transmission)	°C, °F	70 ~ 80°C (158 ~ 176°F)
AT Oil Life Monitor (Automatic Transmission)	%	100 %
Commanded Gear		1
Current Gear		1
Mode Switch C	Inactive, Active	Inactive
Mode Switch B	Inactive, Active	Inactive
Mode Switch A	Inactive, Active	Active
Mode Switch G	Inactive, Active	Active
Actual Gear		Park
1-2 Shift Solenoid A	Off, On	Off
2-3 Shift Solenoid B	Off, On	On
Brake Switch	Off, On	Off
Solenoid Brake Band	Off, On	Off
TCC Slip Speed	RPM	750 ~ 900 RPM
TCC Status	Disabled, Enabled	Enabled
TCC Solenoid	Off, On	Off
TCC Duty Cycle	%	0 %
TCC Apply Mode	No Apply, In Apply	No Apply
TCC Release Mode	No, Yes	No
TCC On Mode	No, Yes	No
TCC Off Mode	No, Yes	Yes
Default Gear	No, Yes	No
Engine Warm	No, Yes	Yes
A/C Request	Yes, No	Yes
A/C Clutch Relay	Off, On	On
Winter Switch	Off, On	Off
Winter Drive Lamp	Off, On	Off
Kickdown Switch	Off, On	Off
ATF Lamp (Automatic Transmission)	Off, On	Off
Power Switch	Normal, Power	Normal
Power Drive Lamp	Off, On	Off
ABS Status	On, Off	Off

## 7A1-18 TRANSMISSION CONTROL SYSTEM (4L30-E)

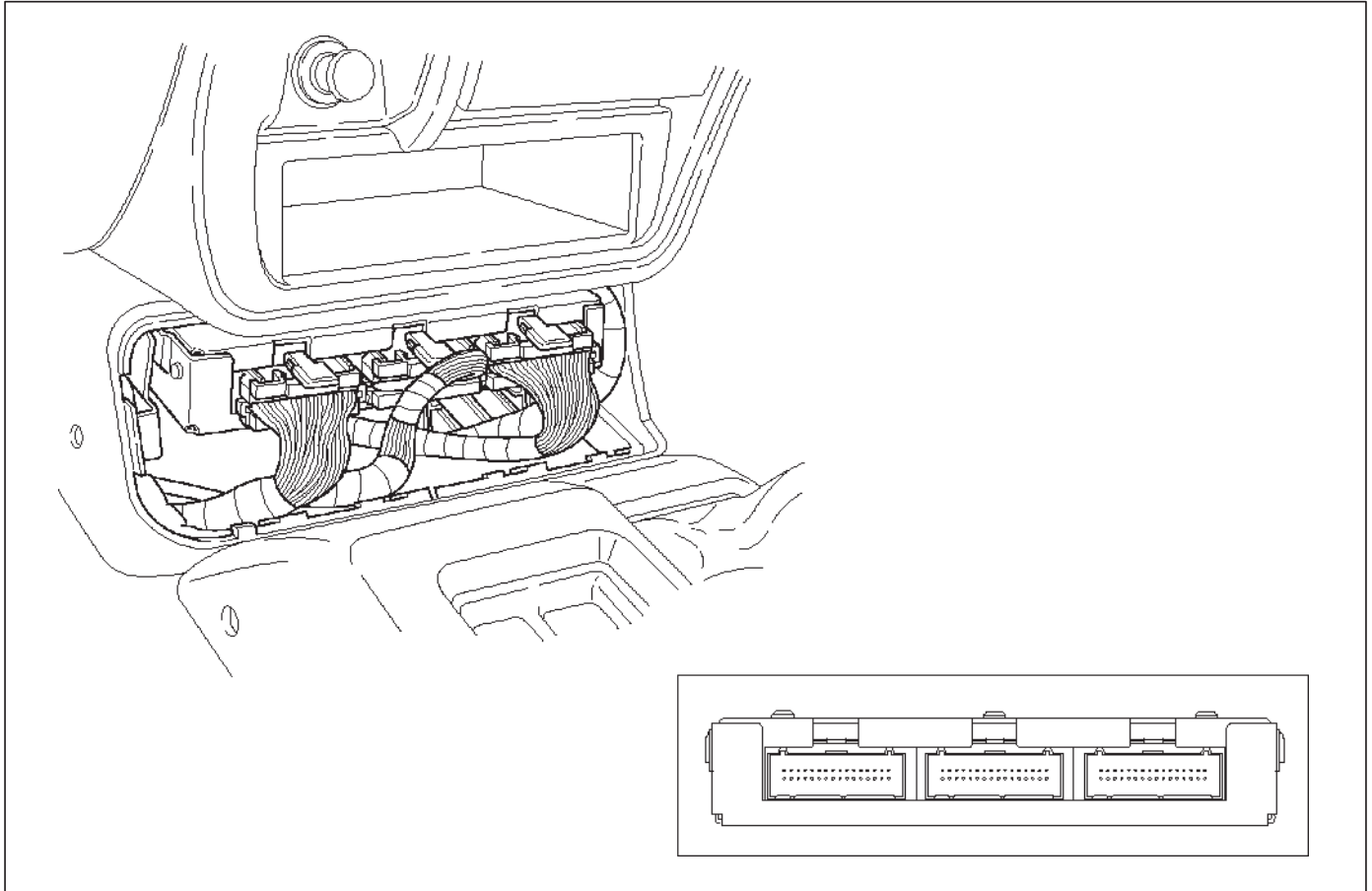
---

### F1: PC Solenoid Data

Item	Unit	Engine running at idle
Engine Speed	RPM	750 ~ 900 RPM
Vehicle Speed	km/h, MPH	0 MPH
Throttle Position	%	0 %
Throttle Position Sensor	V	0.5 ~ 1.0 V
Manifold Absolute Pressure	kpa	approx. 40 kpa
Barometric Pressure	kpa	approx. 102 kpa
PCS Current (Pressure Control Solenoid)	A	approx. 1.0 A
PCS Actual Current (Pressure Control Solenoid)	A	approx. 1.0 A
PCS Duty Cycle (Pressure Control Solenoid)	%	approx. 45 %
Desired PCS Pressure (Pressure Control Solenoid)	kpa	43 ~ 52 kpa
Shift Pressure (Line Pressure)	kpa	43 ~ 52 kpa
Transmission Temperature	°C, °F	75 ~ 110 °C (167 ~ 230 °F)

## OBD II Diagnostic Management System

### Powertrain Control Module (PCM) Location



C07RX004

### Class 2 Serial Data Bus

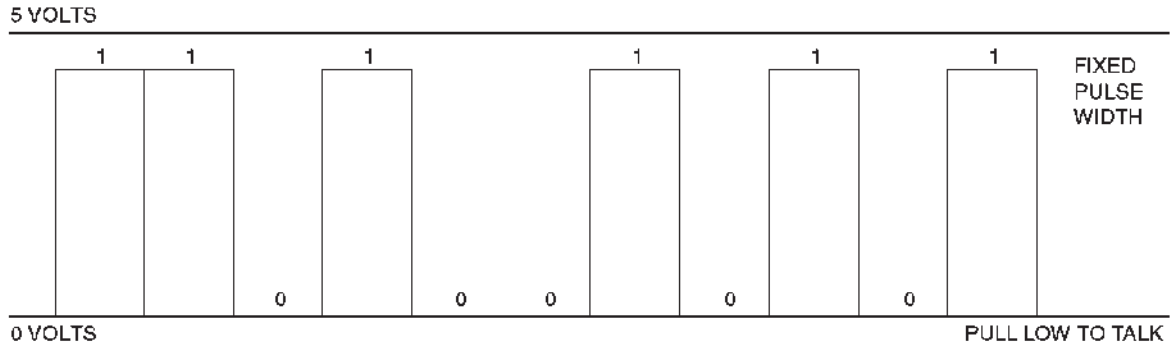
OBD II technology requires a much more sophisticated PCM than does OBD I technology. The OBD II PCM diagnostic management system not only monitors systems and components that can impact emissions, but they also run active tests on these systems and components. The decision making functions of OBD II PCMs have also greatly increased. To accommodate this expansion in diagnostic complexity, Isuzu engineers have designed the Class 2 serial data bus, which meets SAE J1850 recommended practice for serial data.

“Serial Data” refers to information which is transferred in a linear fashion – over a single line, one bit at a time. A “Data Bus” is an electronic pathway through which serial data travels.

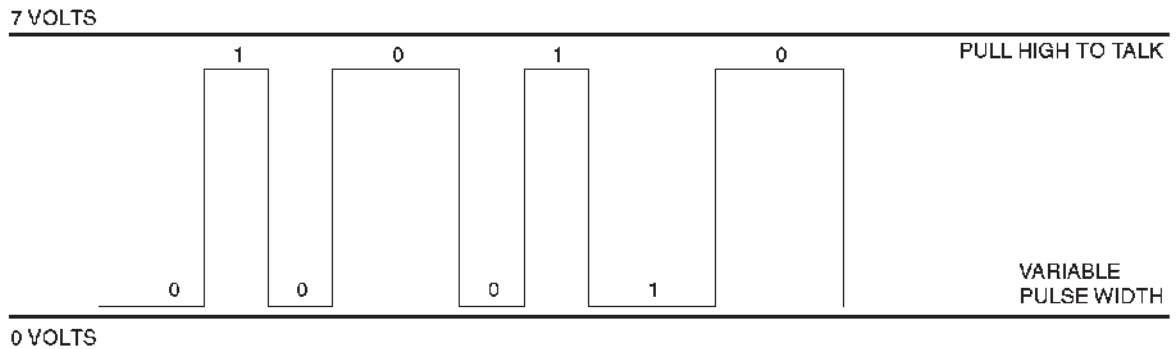
VEHICROSS previously used a 5 volt data bus called UART, which is an acronym for “Universal Asynchronous Receive and Transmit”. When neither the vehicle’s control module nor the diagnostic tool, such as a Tech 2, are “talking,” the voltage level of the bus at rest is 5 volts. The two computers talk to each other at a rate of 8,192 bits per second, by toggling or switching the voltage on the data bus from 5 volts to ground.

Class 2 data, which is used on OBD II vehicles, is quite different. Data is transferred at a rate of 10.4 kilobits per second, and the voltage is toggled between zero and 7 volts.

**UART**



**CLASS 2**



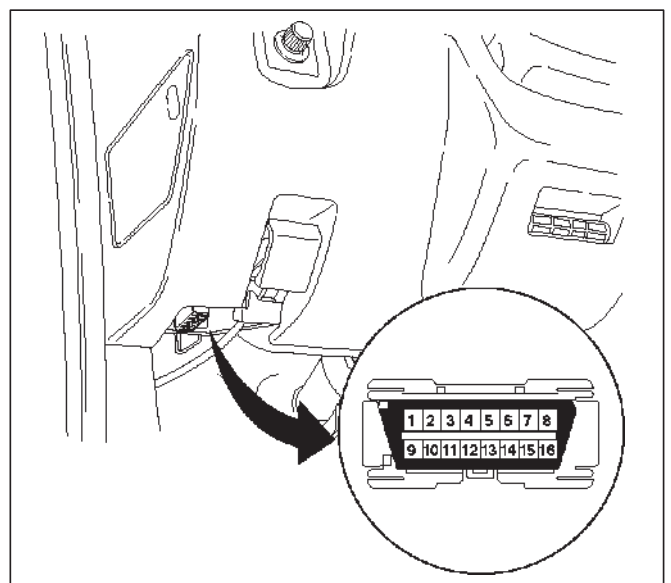
Class 2 data is also pulse width modulated. Each bit of information can have one of two lengths: long or short. On the other hand, UART data bits come in only one length (short). The pulse width modulation of Class 2 data allows better utilization of the data line.

The message carried on Class 2 data streams are also prioritized. This means that if two devices try to communication on the data line at the same time, only the higher priority message will continue. The device with the lower priority message must wait.

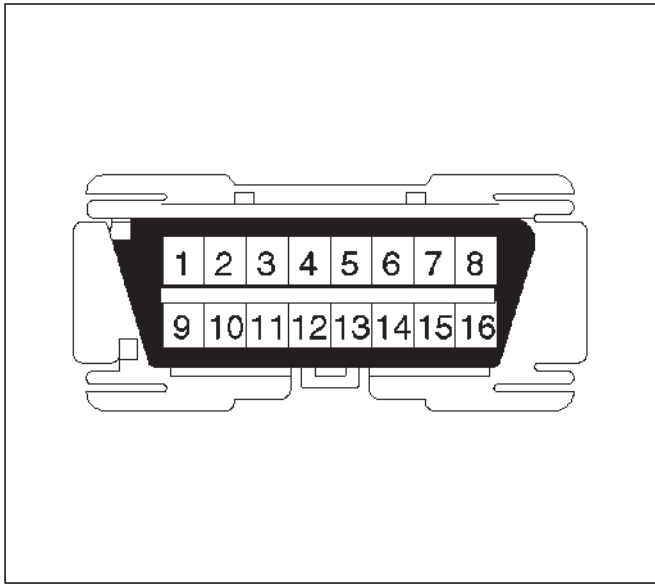
NOTE: The Class 2 data wire is always terminal 2 of the new 16-terminal Data Link Connector (DLC).

**16 – Terminal Data Link Connector (DLC)**

OB2 II standardizes Data Link Connector (DLC) configurations. The DLC, formerly referred to as the ALDL, will be a 16-terminal connector found on the lower left side of the driver's side instrument panel. All manufacturers must conform to this 16-terminal standard.







810RT022

- PIN 1 – (Not used)
- PIN 2 – J1850 Bus + L line on 2-wire systems, or single wire (Class 2)
- PIN 3 – (Not used)
- PIN 4 – Chassis ground pin
- PIN 5 – Signal ground pin
- PIN 6 – PCM diagnostic enable
- PIN 7 – ABS diagnostic enable
- PIN 8 – TOD diagnostic enable
- PIN 9 – Primary UART
- PIN 10 – (Not used)
- PIN 11 – (Not used)
- PIN 12 – ABS diagnostic or CCM diagnostic enable
- PIN 13 – SIR diagnostic enable
- PIN 14 – (Not used)
- PIN 15 – (Not used)
- PIN 16 – Battery power from vehicle unswitched (4 AMP MAX.)

### Malfunction Indicator Lamp (MIL)

The Malfunction Indicator Lamp (MIL) looks the same as the MIL you are already familiar with (“CHECK ENGINE” lamp). However, OBD II requires that it illuminate under a strict set of guidelines. Basically, the MIL is turned on when the PCM detects a DTC that will impact the vehicle’s emissions.

The MIL is under the control of the Diagnostic Executive. The MIL will be turned on if a component or system which has an impact on vehicle emissions indicates a malfunction or fails to pass an emissions-related diagnostic test. It will stay on until the system or component passes the same test, for three consecutive trips, with no emissions-related faults.

### Types Of Diagnostic Trouble Codes (DTCs)

The Diagnostic Executive classifies Diagnostic Trouble Codes (DTCs) into certain categories. Each type has different requirements to set the code, and the Diagnostic Executive will only illuminate the Malfunction Indicator

Lamp (MIL) for emissions-related DTCs. DTCs fall into four categories: A, B, C, and D; only types A and B are emission-related. The following descriptions define these categories:

#### TYPE A

Will store the DTC and turn on the MIL (“Check Engine” lamp) on the first trip in which an emission-related diagnostic test has run and reported a “test failed” to the Diagnostic Executive.

#### TYPE B

Will store the DTC and turn on the MIL on the second consecutive trip in which an emission-related diagnostic test has run and reported a “test failed” to the Diagnostic Executive. After one failure, the type B DTC is “armed,” or prepared to store a history code and turn on the MIL if a second failure occurs. One passed test will disarm a type B DTC. Some special conditions apply to misfire and fuel trim DTCs. For a type B DTC to store and turn on the MIL, two ignition cycles are required.

#### TYPE C

Will store the DTC and turn on a “SERVICE” lamp (“Check Trans” lamp) on the first trip that a non-emission-related diagnostic test has run and reported a “test failed” to the Diagnostic Executive. This type of DTC will be used in future applications.

#### TYPE D

Will store a DTC but will not turn on the MIL on the first trip that a non-emission-related diagnostic test has run and reported a “test failed” to the Diagnostic Executive. These codes can be very helpful for vehicle service when the driver may comment about a condition, but the MIL did not turn on.

### Clear DTC

NOTE: If you clear the DTC (Diagnostic Trouble Codes) you will not be able to read any codes recorded during the last occurrence.

NOTE: To use the DTC again to identify a problem, you will need to reproduce the fault or the problem. This may require a new test drive or just turning the ignition on (this depends on the nature of the fault).

1. IF you have a Tech 2:

1. Connect the Tech 2 if it is still not connected **GOTROUGH Tech 2 OBD II CONNECTION.**
2. Push “F1: Clear DTC Info” in the Application Menu and answer “Yes” to the question “Do you want to clear DTC’S?”
  - a. When a malfunction remains as it is the Tech 2 displays “4L30E CODES NOT CLEARED”. This means that the problem is still there or that the recovery was not done. Please **GOTO DTC CHECK.**
  - b. When a malfunction has been repaired and the recovery is done. The Tech 2 displays “4L30E CODES CLEARED”.

2. IF you have no Tech 2:

To clear the DTC, remove Fuse “PCM” (FL-4, 40A) for at least 10 seconds.

## 7A1–22 TRANSMISSION CONTROL SYSTEM (4L30–E)

### DTC Check

1. Diagnostic Trouble Codes (DTC) have been identified by Tech 2.
2. You have written the list of the DTCs. The order of the malfunctions has no meanings for this PCM. Usually only one or two malfunctions should be set for a given problem.
3. Check directly the DTCs you identified. The DTCs are sorted by number. Refer to Diagnostic Trouble Code (DTC) Identification in this section.

### PCM Precaution

#### The PCM can be damaged by:

1. Electrostatic discharge
2. The short circuit of some terminals to voltage or to ground.

#### Electrostatic Discharge Damage Description:

1. Electronic components used to control systems are often designed to carry very low voltage, and are very susceptible to damage caused by electrostatic discharge. It is possible for less than 100 volts of static electricity to cause damage to some electronic components. By comparison, it takes as much as 4,000 volts for a person to even feel the zap of a static discharge.
2. There are several ways for a person to become statically charged. The most common methods of charging are by friction and induction. An example of charging by friction is a person sliding across a car seat, in which a charge of as much as 25,000 volts can build up. Charging by induction occurs when a person with well insulated shoes stands near a highly charged object and momentarily touches ground. Charges for the same polarity are drained off, leaving the person highly charged with the opposite polarity. Static charges of either type can cause damage, therefore, it is important to use care when handling and testing electronic components.

#### NOTICE: To prevent possible electrostatic discharge damage:

1. Do not touch the PCM connector pins or soldered components on the PCM circuit board.
2. Be sure to follow the guidelines listed below if servicing any of these electronic components:
3. Do not open the replacement part package until it is time to install the part.
4. Avoid touching electrical terminals of the part.
5. Before removing the part from its package, ground the package to a known good ground on the vehicle.
6. Always touch a known good ground before handling the part. This step should be repeated before installing the part if the part has been handled while sliding across the seat, while sitting down from a standing position or while walking some distance.

### Information On PCM

1. The Powertrain Control Module (PCM) is located in the center console and is the control center of the electronic transmission control system.
2. The PCM must be maintained at a temperature below 85°C (185°F) at all times. This is most essential if the vehicle is put through a paint baking process. The PCM will become inoperative if its temperature exceeds 85°C (185°F). Therefore, it is recommended that the PCM be removed or that temporary insulation be placed around the PCM during the time the vehicle is in a paint oven or other high temperature process.
3. The PCM is designed to process the various inputs and then respond by sending the appropriate electrical signals to control transmission upshift, downshift, shift feel and torque converter clutch engagement.
4. The PCM constantly interprets information from the various sensors, and controls the systems that affect transmission and vehicle performance. By analyzing operational problems, the PCM is able to perform a diagnostic function by displaying DTC(s) and aid the technician in making repairs.

### Intermittent Conditions

If the Tech 2 displays a diagnostic trouble code as intermittent, or if after a test drive a DTC does not reappear though the detection conditions for this DTC are present, the problem is most likely a faulty electrical connection or loose wiring. Terminals and grounds should always be the prime suspect. Intermittents rarely occur inside sophisticated electronic components such as the PCM.

Use the DTC information to understand which wires and sensors are involved.

When an intermittent problem is encountered, check suspect circuits for:

1. Poor terminal to wire connection.
2. Terminals not fully seated in the connector body (backed out).
3. Improperly formed or damaged terminals.
4. Loose, dirty, or corroded ground connections:  
HINT: Any time you have an intermittent in more than one circuit, check whether the circuits share a common ground connection.
5. Pinched or damaged wires.
6. Electro–Magnetic Interference (EMI):  
HINT: Check that all wires are properly routed away from spark plug wires, distributor wires, coil, and generator. Also check for improperly installed electrical options, such as lights, 2–way radios, etc.

Use the F2 SNAPSHOT mode of the Tech 2 to help isolate the cause of an intermittent fault. The snapshot mode will record information before and after the problem occurs. Set the snapshot to “trigger” on the suspect DTC. If you notice the reported symptom during the test drive, trigger the snapshot manually.

After the snapshot has been triggered, command the Tech 2 to play back the flow of data recorded from each of

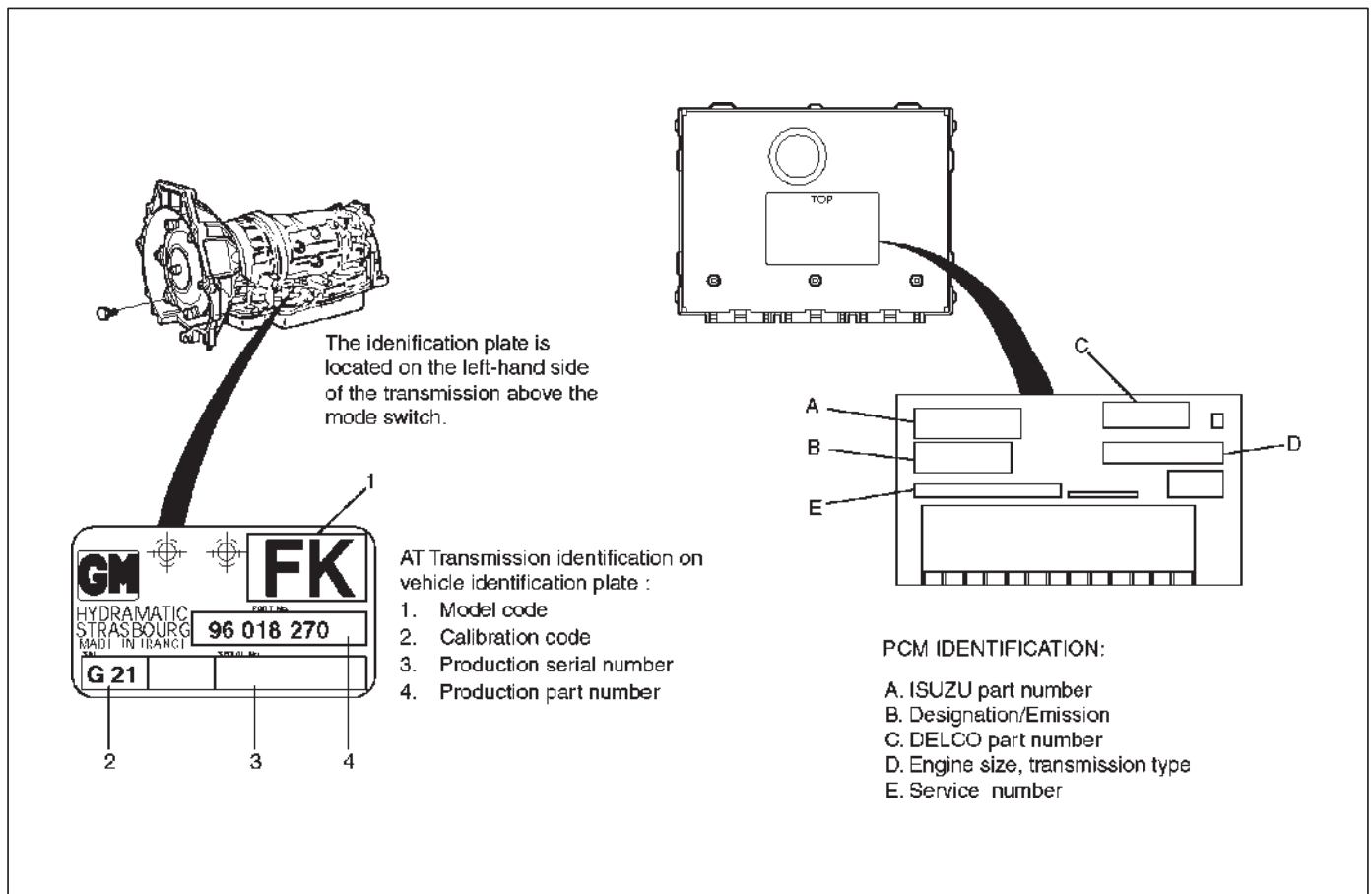
the various sensors. Signs of an intermittent fault in a sensor circuit are sudden unexplainable jump in data values out of the normal range.

### Transmission And PCM Identification

The chart below contains a list of all important information concerning rear axle ratio, Powertrain Control Module (PCM), and transmission identification.

VEHICLE		Rr axle Ratio	PCM	TRANSMISSION		
Type	Engine		ISUZU Parts No.	Calibration Code	Isuzu Part No.	Model Code
Isuzu / Vehi-cross	3.5L V6	4.300	8-09375-599-1	G21	8-96018-270-4	FK (4X4)

### Isuzu Vehicross



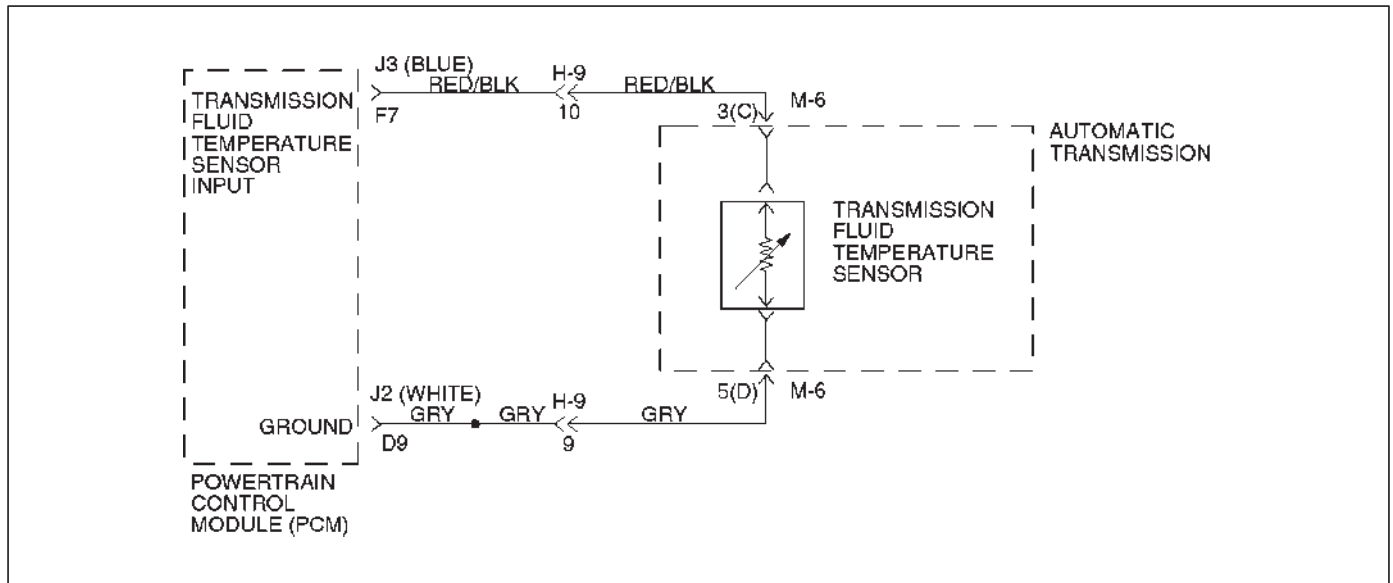
## 7A1-24 TRANSMISSION CONTROL SYSTEM (4L30-E)

### Diagnostic Trouble Code (DTC) Identification

DTC NUMBER	DTC NAME	DTC TYPE	MIL "CHECK ENGINE"	"CHECK TRANS"
P0218	Transmission Fluid Over Temperature	D		
P0560	System Voltage Malfunction	D		
P0705	Transmission Range Switch (Mode Switch) Illegal Position	D		
P0706	Transmission Range Switch (Mode Switch) Performance	D		
P0711	Transmission Fluid Temperature (TFT) Sensor Circuit Range/Performance	D		
P0712	Transmission Fluid Temperature (TFT) Sensor Circuit Low Input	D		
P0713	Transmission Fluid Temperature (TFT) Sensor Circuit High Input	D		
P0719	TCC Brake Switch Circuit High (Stuck ON)	D		
P0722	Transmission Output Speed Sensor (OSS) Low Input	B	ON	Flash
P0723	Transmission Output Speed Sensor (OSS) Intermittent	B	ON	Flash
P0724	TCC Brake Switch Circuit Low (Stuck OFF)	D		
P0730	Transmission Incorrect Gear Ratio	C		Flash
P0742	Torque Converter Clutch (TCC) Circuit Stuck ON	B	ON	Flash
P0748	Pressure Control Solenoid (PCS) (Force Motor) Circuit Electrical	C		Flash
P0751	Shift Solenoid A Performance Without Input Speed	B	ON	Flash
P0753	Shift Solenoid A Electrical	B	ON	Flash
P0756	Shift Solenoid B Performance Without Input Speed	B	ON	Flash
P0758	Shift Solenoid B Electrical	B	ON	Flash
P1790	ROM Transmission Side Bad Check Sum	B	ON	Flash
P1792	EEPROM Transmission Side Bad Check Sum	B	ON	Flash
P1835	Kickdown Switch Always ON	D		
P1850	Brake Band Apply Solenoid Malfunction	D		
P1860	TCC Solenoid Electrical	B	ON	Flash
P1870	Transmission Component Slipping	B	ON	Flash

DTC TYPE	DEFINITION
B	Emission related, turn on MIL (Check Engine) and flashing Check Trans after 2 consecutive trips with failure
C	Non-emission related, flashing Check Trans on 1st failure
D	Non-emission related, no lamps

## DTC P0218 Transmission Fluid Over Temperature



D07RX002

### Circuit Description

The Transmission Fluid Temperature (TFT) sensor is a thermister that controls the signal voltage to the PCM. The PCM supplies a 5-volt reference to the sensor on circuit RED/BLK. When the transmission fluid is cold, the sensor resistance is high and the PCM will sense high signal voltage. As the fluid temperature warms to a normal transmission operating temperature of 100°C (212°F), the sensor resistance becomes less and the voltage decreases to 1.5 to 2.0 volts.

This DTC detects a high transmission temperature for a long period of time. This is a type "D" DTC.

### Conditions For Setting The DTC

- No TFT DTCs P0712 or P0713.
- TFT is greater than 135°C (275°F).
- All conditions met for 21 seconds.

### Action Taken When The DTC Sets

- Hot mode TCC Shift Pattern.
- The PCM will not illuminate the Malfunction Indicator Lamp (MIL) and CHECK TRANS Lamp.
- ATF Lamp ON. (TFT is greater than 145°C (293°F).)
- Disable E-side TCC OFF request.

### Conditions For Clearing The DTC

- The DTC can be cleared from the PCM history by using a scan tool.
- The DTC will be cleared from history when the vehicle has achieved 40 warm-up cycles without a failure reported.
- The PCM will cancel the DTC default actions when the fault no longer exists and the ignition is cycled "off" long enough to power down the PCM.

### Diagnostic Aids

- Inspect the wiring for poor electrical connections at the PCM and at the transmission 16-way connector. Look for possible bent, backed out, deformed, or damaged terminals. Check for weak terminal tension as well.

Also check for a chafed wire that could short to bare metal or other wiring. Inspect for a broken wire inside the insulation.

- When diagnosing for a possible intermittent short or open condition, move the wiring harness while observing test equipment for a change.
- Check harness routing for a potential short to ground in circuit RED/BLK.
- Scan tool TFT sensor temperature should rise steadily to about 100°C (212°F), then stabilize.
- Check for a "skewed" (mis-scaled) sensor by comparing the TFT sensor temperature to the ambient temperature after a vehicle cold soak. A "skewed" sensor can cause delayed garage shifts or TCC complaints.
- Check for a possible torque converter stator problem.
- Verify customer driving habits, trailer towing, etc.

### Test Description

The numbers below refer to the step numbers on the diagnostic chart.

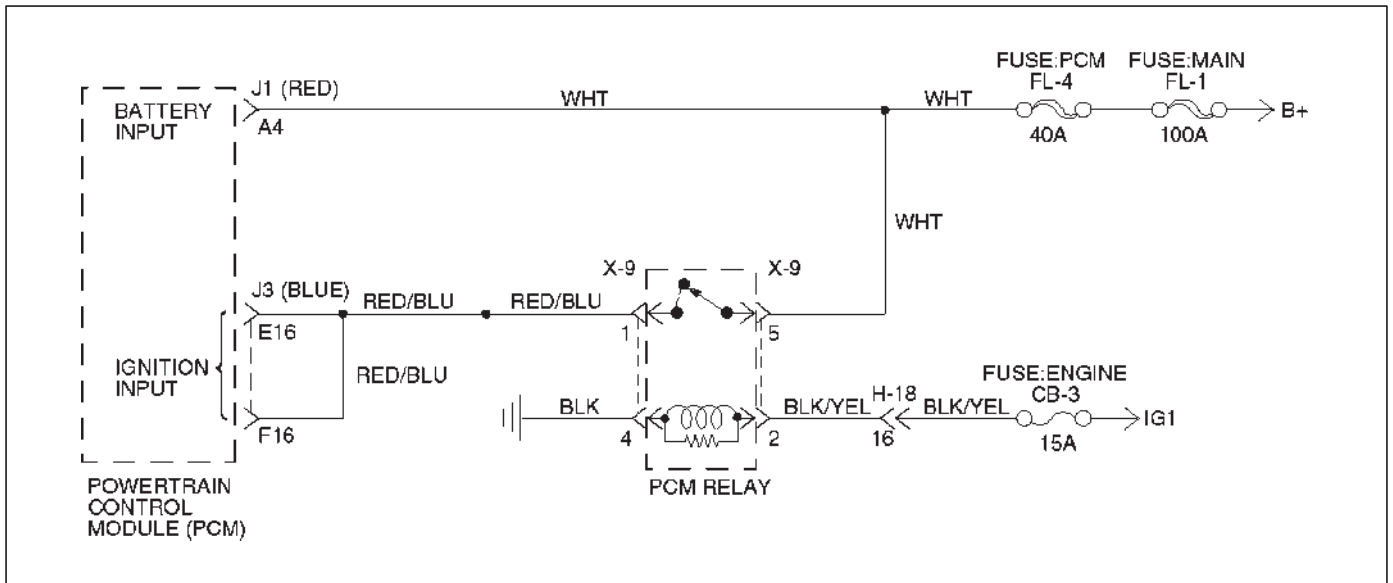
3. This test checks for a "skewed" sensor or shorted circuit.
4. This test simulates a TFT DTC P0713.

**7A1–26 TRANSMISSION CONTROL SYSTEM (4L30–E)**

**DTC P0218 Transmission Fluid Over Temperature**

<b>Step</b>	<b>Action</b>	<b>Yes</b>	<b>No</b>
1	Were you sent here from the “Powertrain On–Board Diagnostic (OBD) System Check”?	Go to Step 2	Go to OBD System Check Refer to Driveability and Emissions in Engine section
2	Perform the following checks: ○ Check for possible engine system problems. ○ Transmission fluid checking procedure. Refer to Checking Transmission Fluid Level and Condition in Automatic Transmission (4L30–E) Section.  Were the checks performed?	Go to Step 3	—
3	1. Install the scan tool. 2. With the engine “off”, turn the ignition switch “on”. <b>NOTE:</b> Before clearing DTC(s), use the scan tool to record “Failure Records” for reference, as data will be lost when “Clear Info” function is used. 3. Record the DTC “Failure Records”.  Is the TFT sensor signal voltage less than 0.33 volts?	Go to Step 4	Go to Diagnostic Aids
4	1. Turn the ignition “off”. 2. Disconnect the transmission 16–way connector H–9 (additional DTCs may set).  Is the TFT sensor signal voltage greater than 4.92 volts?	Go to Internal Wiring Harness Check.	Go to Step 5
5	Inspect/repair circuit RED/BLK for a short to ground.  Was a problem found?	Go to Step 7	Go to Step 6
6	1. Inspect the PCM for poor connections. 2. Replace the PCM if no poor connections were found.  Is the replacement complete?	Go to Step 7	—
7	1. After the repair is complete, use the scan tool to select “DTC”, then “Clear Info” function and ensure the following conditions are met: TFT is less than 125°C (257°F) for at least 10 seconds. 2. Review the scan tool “DTC Info”.  Has the last test failed or is the current DTC displayed?	Begin diagnosis again Go to Step 1	Repair verified Exit DTC table

## DTC P0560 System Voltage Malfunction



D07RX003

### Circuit Description

Circuit WHT is the battery voltage feed for the PCM. Circuit RED/BLU is the ignition voltage feed for the PCM. This DTC detects a low voltage or a high voltage. This is a type "D" DTC.

### Conditions For Clearing The DTC

System Voltage Low:

- Engine speed is greater than 1,000 rpm.
- System voltage is less than 10 volts at a maximum transmission temperature of 150°C (302°F).
- System voltage is less than 7.3 volts at a minimum transmission temperature of -40°C (-40°F).
- All conditions met for 4 seconds.

System Voltage High:

- System voltage is greater than 16 volts for 2 seconds.

### Action Taken When The DTC Sets

- Fixed to 4th gear.
- Maximum line pressure.
- Inhibit TCC engagement.
- The PCM will not illuminate the Malfunction Indicator Lamp (MIL) and CHECK TRANS Lamp.

### Conditions For Clearing The DTC

- The DTC can be cleared from the PCM history by using a scan tool.

- The DTC will be cleared from history when the vehicle has achieved 40 warmup cycles without a failure reported.
- The PCM will cancel the DTC default actions when the fault no longer exists and the ignition is cycled "off" long enough to power down the PCM.

### Diagnostic Aids

- Charging the battery with a battery charger and jump starting an engine may set DTC(s). If DTC(s) set when an accessory is operated, check for faulty connections or excessive current draw.
- Check for faulty connections at the starter solenoid or fusible link.
- Check for loose/damaged terminals at generator.
- Check belt wear/tension.

### Test Description

The numbers below refer to the step numbers on the diagnostic chart.

4. This test checks charging system voltage.
5. This test checks battery voltage input at the PCM.
7. This test checks ignition voltage input at the PCM.

## 7A1-28 TRANSMISSION CONTROL SYSTEM (4L30-E)

### DTC P0560 System Voltage Malfunction

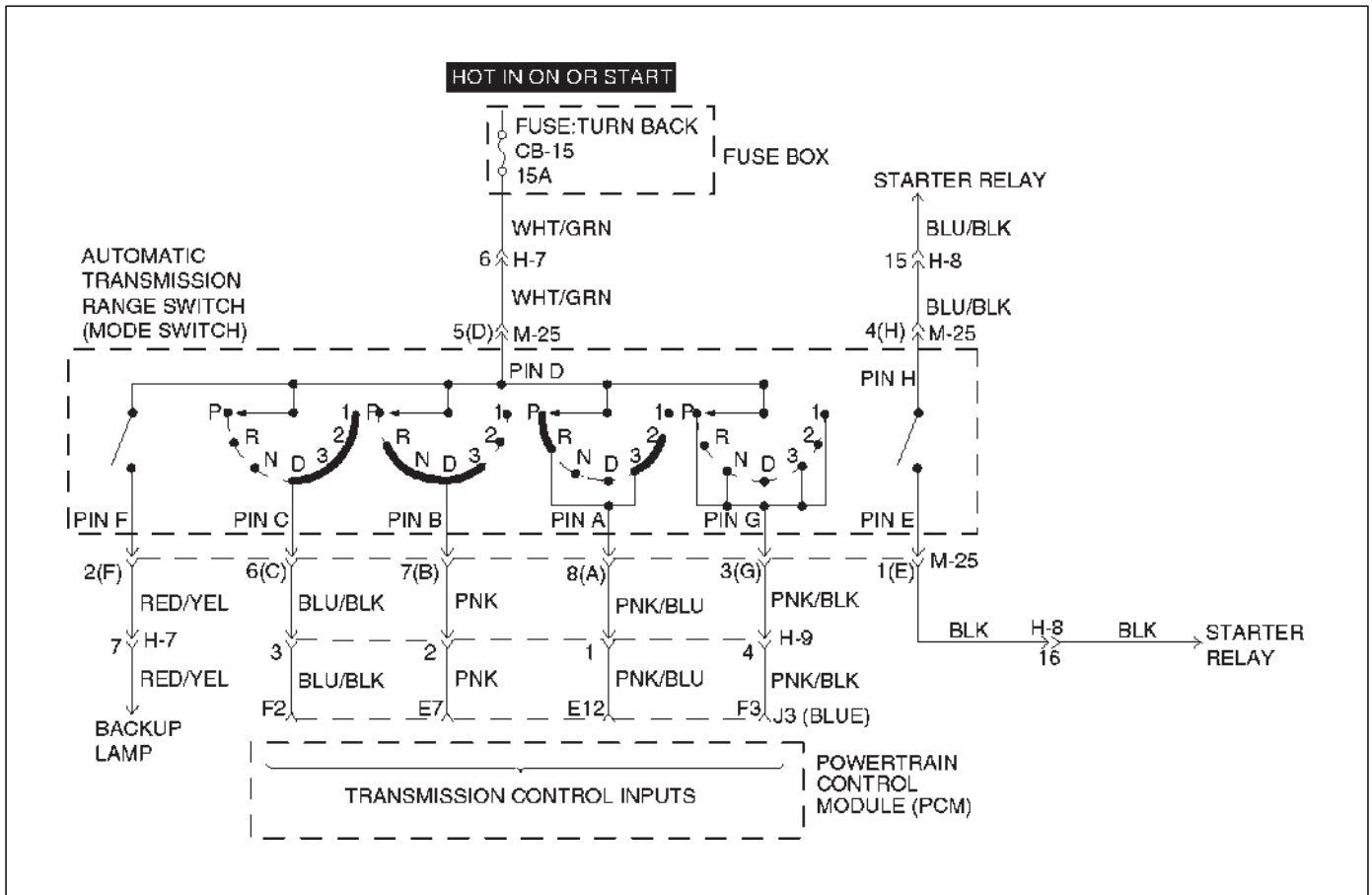
Step	Action	Yes	No
1	Were you sent here from the "Powertrain On-Board Diagnostic (OBD) System Check"?	Go to Step 2	Go to OBD System Check Refer to Driveability and Emissions in Engine section
2	1. Install the scan tool. 2. With the engine "off", turn the ignition switch "on". NOTE: Before clearing DTC(s), use the scan tool to record "Failure Records" for reference, as data will be lost when the "Clear Info" function is used. 3. Record the DTC "Failure Records". Note: If any other DTCs are present, refer to their applicable diagnostic charts before continuing. 4. Using the J-39200 DVOM, measure the battery voltage across the battery terminals. Record the measurement for future reference. Is the voltage higher than 10.5 volts?	Go to Step 3	Go to Engine Electrical in Engine section
3	Start the engine and warm to normal operating temperature. Is the generator/check engine light "on"?	Go to Starting and Charging System in Engine section	Go to Step 4
4	1. Increase the engine speed to 1,000-1,500 rpm. 2. Observe scan tool system voltage. Is the system voltage within 13-15 volts.	Go to Step 5	Go to Starting and Charging System in Engine section
5	1. Turn the ignition switch "off". 2. Disconnect the J1 (RED) and J3 (BLUE) PCM connector (additional DTCs will set). 3. With the engine "off", turn the ignition switch "on". 4. Using the J39200 DVOM, measure the battery voltage input at PCM connector terminals J1-A4 and J3-E16. Is there a voltage variance between the voltage measured at the battery (taken in Step 2) and at terminals J1-A4 and J3-E16 that is greater than 0.5 volts?	Go to Step 6	Go to Step 7
6	Repair the high resistance condition in circuit WHT. Was the circuit repaired?	Go to Step 11	—
7	1. Disconnect the J3 (BLUE) PCM connector. 2. Measure the ignition voltage input at PCM connector terminals J3-E16 and J3-F16. Is there a voltage variance between the voltage measured at the battery (taken in Step 2) and at terminals J3-E16 and J3-F16 that is greater than 0.5 volts?	Go to Step 8	Go to Step 9
8	Repair the high resistance condition in circuit RED/BLU. Was the circuit repaired?	Go to Step 11	—
9	Check PCM connector terminals J1-A4, J3-E16 and J3-F16 for bent, damaged, or backed out connector pins. Also check for weak terminal tension. Was a problem found?	Go to Step 11	Go to Step 10



**DTC P0560 System Voltage Malfunction (Cont'd)**

Step	Action	Yes	No
10	Replace the PCM. Is the replacement complete?	Go to Step 11	—
11	1. After the repair is complete, use the scan tool to select "DTC", then "Clear Info" function and operate the vehicle under the following conditions: Start the vehicle and warm to normal operating temperature. The PCM must see a system voltage between 10 and 16 volts. 2. Review the scan tool "DTC Info". Has the last test failed or is the current DTC displayed?	Begin diagnosis again Go to Step 1	Repair verified Exit DTC table

## DTC P0705 Transmission Range Switch (Mode Switch) Illegal Position



D07RX004

## Circuit Description

- The range switch supplies the Powertrain Control Module (PCM) with information regarding the selector lever position: P, R, N, D 3, 2 or L. The selector lever position is indicated by the state of four ON/OFF contracts. The range switch is located on one side of the transmission. It is on the transmission manual shaft and is fixed to the main case.
- The range switch is also used to provide the information P or N to the engine crank wiring. The engine can be cranked only if connector M-25 terminal 4(H) is connected to terminal 1(E) which is connected to ground.
- The range switch is also used to provide the backup lamp power in reverse. This is why the range switch is supplied through a 15A fuse (CB-15). This fuse can burn due to a short circuit in the backup lamp.

This DTC detects when a fuse is open or the range switch circuit does not work. This is a type "D" DTC.

## Conditions For Setting The DTC

- Range switch illegal positions met for 5 seconds.

## Action Taken When The DTC Sets

- Default to D position.
- Inhibit torque management.
- Maximum line pressure.

- The PCM will not illuminate the Malfunction Indicator Lamp (MIL) and CHECK TRANS Lamp.

## Conditions For Clearing The DTC

- The DTC can be cleared from the PCM history by using a scan tool.
- The DTC will be cleared from history when the vehicle has achieved 40 warmup cycles without a failure reported.
- The PCM will cancel the DTC default actions when the fault no longer exists and the ignition is cycled "off" long enough to power down the PCM.

## Diagnostic Aids

- Refer to accompanying chart for the normal range signals and the illegal combinations.
- Inspect the wiring for poor electrical connections at the PCM and at the transmission 8-way connector. Look for possible bent, backed out, deformed or damaged terminals. Check for weak terminal tension as well. Also check for a chafed wire that could short to bare metal or other wiring. Inspect for a broken wire inside the insulation.
- When diagnosing for a possible intermittent short or open condition, move the wiring harness while observing test equipment for a change.

- Refer to the “Range Switch Logic Table” or “Functional Test Procedure” for further information.

**Test Description**

The numbers below refer to the step numbers on the diagnostic chart:

- 3. This test checks the indicated range signal to the manual valve actually selected.
- 6. This test checks for continuity between each selected range switch connector terminals.

**Range Switch Logic Table**

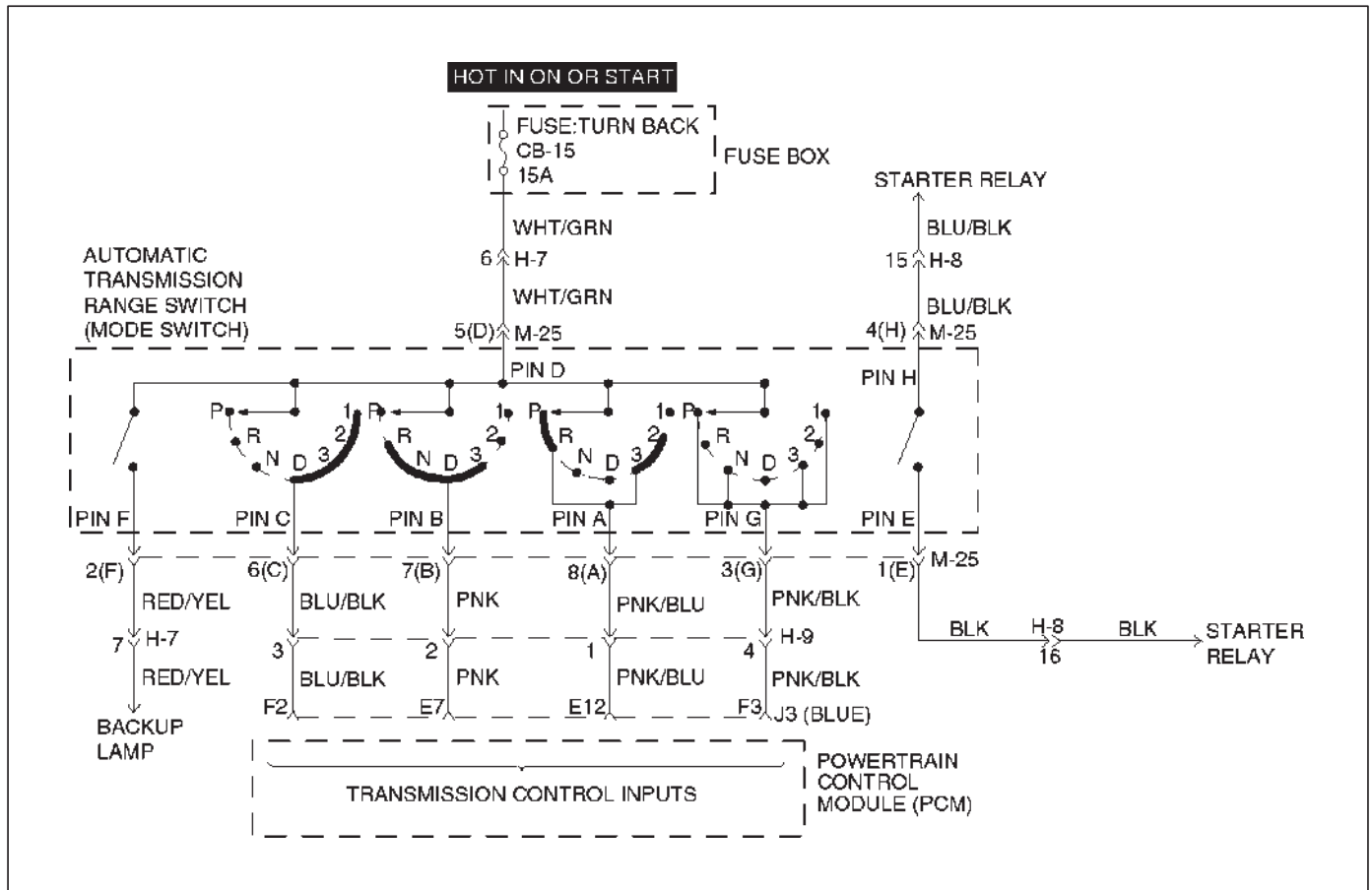
Range Position	Range Switch Pin			
	A	B	C	P(G)
Park	ON	OFF	OFF	ON
Reverse	ON	ON	OFF	OFF
Neutral	OFF	ON	OFF	ON
D4	OFF	ON	ON	OFF
D3	ON	ON	ON	ON
2	ON	OFF	ON	OFF
L	OFF	OFF	ON	ON
Illegal	OFF	OFF	OFF	OFF
Illegal	OFF	OFF	OFF	ON

## 7A1-32 TRANSMISSION CONTROL SYSTEM (4L30-E)

### DTC P0705 Transmission Range Switch (Mode Switch) Illegal Position

Step	Action	Yes	No
1	Were you sent here from the "Powertrain On-Board Diagnostic (OBD) System Check"?	Go to Step 2	Go to OBD System Check Refer to Driveability and Emissions in Engine section
2	Perform the following checks: <input type="radio"/> The transmission linkage from the select lever to the manual valve is adjusted properly. <input type="radio"/> Diagnostic circuit check. Were the checks performed?	Go to Step 3	—
3	1. Install the scan tool. 2. With the engine "off", turn the ignition switch "on". NOTE: Before clearing DTC(s), use the scan tool to record "Freeze Frame" and "Failure Records" for reference, as data will be lost when the "Clear Info" function is used. 3. Record the DTC "Freeze Frame" and "Failure Records". 4. Select each transmission range: D1, D2, D3, D4, N, R, and P. Does each selected transmission range match the scan tool "Range Switch" display?	Go to Diagnostic Aids	Go to Step 4
4	Are all range switch pin displays incorrect?	Go to Step 5	Go to Step 6
5	Check fuse and wiring to the 8-way connector terminal 5(D) for opens. Refer to Mode Switch in Automatic Transmission (4L30-E) section. If no problem was found, replace the range switch. Is the replacement complete?	Go to Step 9	—
6	1. Disconnect the 8-way range switch connector. 2. Using ohmmeter, check continuity between terminal 5(D) and respectively terminals 3(G), 6(C), 7(B) and 8(A) of the 8-way range switch connector. 3. Move shift selector lever through all positions and compare results with "Range Switch Logic Table". Is one range switch pin display incorrect?	Go to Step 7	Go to Step 8
7	Check the affected wiring and connector, and repair. Is the repair complete?	Go to Step 9	—
8	Check the Powertrain Control Module (PCM) connectors for poor connection. If no problem was found, replace the PCM. Is the replacement complete?	Go to Step 9	—
9	1. After the repair is complete, use the scan tool to select "DTC", then "Clear Info" function and road test the vehicle. 2. Review the scan tool "DTC Info". Has the last test failed or is the current DTC displayed?	Begin diagnosis again Go to Step 1	Repair verified Exit DTC table

## DTC P0706 Transmission Range Switch (Mode Switch) Performance



D07RX004

### Circuit Description

- The range switch supplies the Powertrain Control Module (PCM) with information regarding the selector lever position: P, R, N, D, 3, 2 or L. The selector lever position is indicated by the state of four ON/OFF contracts. The range switch is located on one side of the transmission. It is on the transmission manual shaft and is fixed to the main case.
- The range switch is also used to provide the information P or N to the engine crank wiring. The engine can be cranked only if connector M-25 terminal 4(H) is connected to terminal 1(E) which is connected to ground.
- The range switch is also used to provide the backup lamp power in reverse. This is why the mode switch is supplied through a 15A fuse (CB-15). This fuse can burn due to a shot circuit in the backup lamp.
- This DTC detects an invalid state of the range switch or the range switch circuit by deciphering the range switch inputs. This is a type "D" DTC.

### Conditions For Setting The DTC

This DTC will set if any of the following conditions occurs:

#### Condition 1 ("R" bad position):

- Engine is running.
- No output speed DTCP0722, P0723.

- Output speed greater than 3,200 RPM.
- Range switch indicates "R".
- All conditions met for 4 seconds.

#### Condition 2 ("P" or "N" bad position):

- Engine is running.
- No TPS codes.
- Engine speed is less than 3,000 RPM.
- TP angle is greater than 20%.
- Range switch indicates "P" or "N".
- All conditions met for 4 seconds.

### Action Taken When The DTC Sets

- Default to "D" position.
- The PCM will not illuminate the Malfunction Indicator Lamp (MIL) and CHECK TRANS Lamp.

### Conditions For Clearing The DTC

- The DTC can be cleared from the PCM history by using a scan tool.
- The DTC will be cleared from history when the vehicle has achieved 40 warmup cycles without a failure reported.
- The PCM will cancel the DTC default actions when the fault no longer exists and the ignition is cycled "off" long enough to power down the PCM.

## 7A1-34 TRANSMISSION CONTROL SYSTEM (4L30-E)

---

### Diagnostic Aids

- Refer to the accompanying chart for the normal range signals and the illegal combinations.
- Inspect the wiring for poor electrical connections at the PCM and at the transmission 8-way connector. Look for possible bent, backed out, deformed or damaged terminals. Check for weak terminal tension as well. Also check for a chafed wire that could short to bare metal or other wiring. Inspect for a broken wire inside the insulation.
- When diagnosing for a possible intermittent short or open condition, move the wiring harness while observing test equipment for a change.
- Refer to the “Range Switch Logic Table” or “Functional Test Procedure” for further information.

### Test Description

The numbers below refer to the step numbers on the diagnostic chart:

3. This test checks the indicated range signal to the manual valve actually selected.
6. This test checks for continuity between each selected range switch connector terminals.

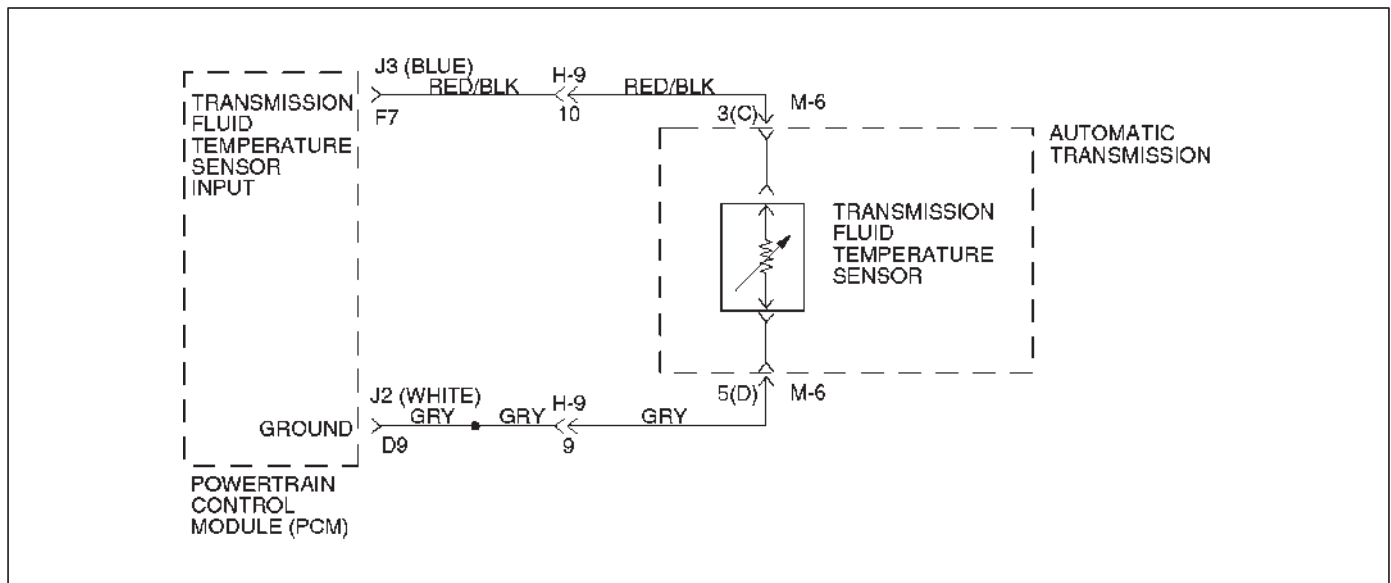
### Range Switch Logic Table

Range Position	Range Switch Pin			
	A	B	C	P(G)
Park	ON	OFF	OFF	ON
Reverse	ON	ON	OFF	OFF
Neutral	OFF	ON	OFF	ON
D4	OFF	ON	ON	OFF
D3	ON	ON	ON	ON
2	ON	OFF	ON	OFF
L	OFF	OFF	ON	ON
Illegal	OFF	OFF	OFF	OFF
Illegal	OFF	OFF	OFF	ON

**DTC P0706 Transmission Range Switch (Mode Switch) Performance**

Step	Action	Yes	No
1	Were you sent here from the "Powertrain On-Board Diagnostic (OBD) System Check"?	Go to Step 2	Go to OBD System Check Refer to Driveability and Emissions in Engine section
2	Perform the following checks: ○ The transmission linkage from the select lever to the manual valve is adjusted properly. ○ Diagnostic circuit check.  Were the checks performed?	Go to Step 3	—
3	1. Install the scan tool. 2. With the engine "off", turn the ignition switch "on".  NOTE: Before clearing DTC(s), use the scan tool to record "Freeze Frame" and "Failure Records" for reference, as data will be lost when the "Clear Info" function is used. 3. Record the DTC "Freeze Frame" and "Failure Records". 4. Select each transmission range: D1, D2, D3, D4, N, R, and P.  Does each selected transmission range match the scan tool "Range Switch" display?	Go to Diagnostic Aids	Go to Step 4
4	Are all range switch pin displays incorrect?	Go to Step 5	Go to Step 6
5	Check fuse and wiring to the 8-way connector terminal 5(D) for opens. Refer to Mode Switch in Automatic Transmission (4L30-E) section. If no problem was found, replace the range switch.  Is the replacement complete?	Go to Step 9	—
6	1. Disconnect the 8-way range switch connector. 2. Using ohmmeter, check continuity between terminal 5(D) and respectively terminals 3(G), 6(C), 7(B) and 8(A) of the 8-way range switch connector. 3. Move shift selector lever through all positions and compare results with "Range Switch Logic Table".  Is one range switch pin display incorrect?	Go to Step 7	Go to Step 8
7	Check the affected wiring and connector, and repair.  Is the repair complete?	Go to Step 9	—
8	Check the Powertrain Control Module (PCM) connectors for poor connection. If no problem was found, replace the PCM.  Is the replacement complete?	Go to Step 9	—
9	1. After the repair is complete, use the scan tool to select "DTC", then "Clear Info" function and road test the vehicle. 2. Review the scan tool "DTC Info".  Has the last test failed or is the current DTC displayed?	Begin diagnosis again Go to Step 1	Repair verified Exit DTC table

## DTC P0711 Transmission Fluid Temperature (TFT) Sensor Circuit Range/Performance



D07RX002

### Circuit Description

The TFT sensor is a thermister that controls the signal voltage to the PCM. The PCM supplies a 5-volt reference signal to the sensor on circuit RED/BLK. When the transmission fluid is cold, the sensor resistance is high and the PCM detects high signal voltage. As the transmission fluid temperature increases to normal operating temperature of 100°C (212°F), the sensor resistance becomes less and the voltage decreases to 1.5 to 2 volts.

When the PCM detects a TFT sensor that remains at the startup value, or a sensor that has a change delta of greater than 20°C (36°F) less than 1 second, DTC P0711 sets. DTC P0711 is a type D.

### Conditions For Setting The DTC

- No VSS DTCs P0722 or P0723.
- No Transmission Component Slipping DTC P1870.
- Engine is running.
- TFT is between 20 A/D (Analog/Digital) counts and 248 A/D counts.
- TFT is between -40°C (-40°F) and +21°C (69.8°F) at engine startup.
- Engine coolant temperature is greater than 70°C (150°F).
- Engine coolant temperature has changed by greater than 50°C (90°F) since engine startup.
- Vehicle speed has been greater than 5 mph for greater than 410 seconds since engine startup (cumulative timer).
- TCC slip speed has been greater than 120 rpm for greater than 410 seconds since engine startup (cumulative timer).
- Battery voltage is between 10 and 16 volts.

All of the above is true and either of the following occurs:

- If the sensor is stuck, the TFT has not changed for greater than 2 counts (from startup temperature) for greater than 410 seconds.
- If the sensor shows an unrealistic change, the TFT exhibits a change delta of greater than 20°C (36°F), greater than 14 times in 7 seconds.

### Action Taken When The DTC Sets

- Transmission default temperature will be:
  - 80°C (176°F) if engine temperature code is set.
  - 100°C (212°F) if engine temperature is warm.
  - 80°C (176°F) if engine run time is greater than 5 minutes.
  - 21°C (69.8°F) if engine run time is less than 5 minutes.
- The PCM will not illuminate the Malfunction Indicator Lamp (MIL) and CHECK TRANS Lamp.

### Conditions For Clearing The DTC

- The DTC can be cleared from the PCM history by using a scan tool.
- The DTC will be cleared from history when the vehicle has achieved 40 warmup cycles without a failure reported.
- The PCM will cancel the DTC default actions when the fault no longer exists and the ignition is cycled "off" long enough to power down the PCM.

### Diagnostic Aids

- Inspect the wiring for poor electrical connection at the PCM. Inspect the wiring for poor electrical connections at the transmission 16-way connector H-9. Look for the following conditions:
  - a. A bent terminal
  - b. A backed out terminal



- c. A damaged terminal
  - d. Poor terminal tension
  - e. A chafed wire
  - f. A broken wire inside the insulation
- When diagnosing for an intermittent short or open connection, move the wiring harness while watching the test equipment for a change.
- First diagnose and clear any engine DTCs or TP Sensor codes. Then inspect for any transmission DTCs that may have reset.

3. This test checks PCM and associated wiring up to the 16-way connector H-9. If the voltage increases to match chart the problem is isolated to the transmission wiring.

**Resistance Chart**

°C	°F	Resistance (kΩ)
-40	-40	672
0	32	65
20	68	25
80	176	2.5
120	248	0.78
150	304	0.37

**Test Description**

The number below refers to the step number on the diagnostic chart:

**DTC P0711 Transmission Fluid Temperature (TFT) Sensor Circuit Range/Performance**

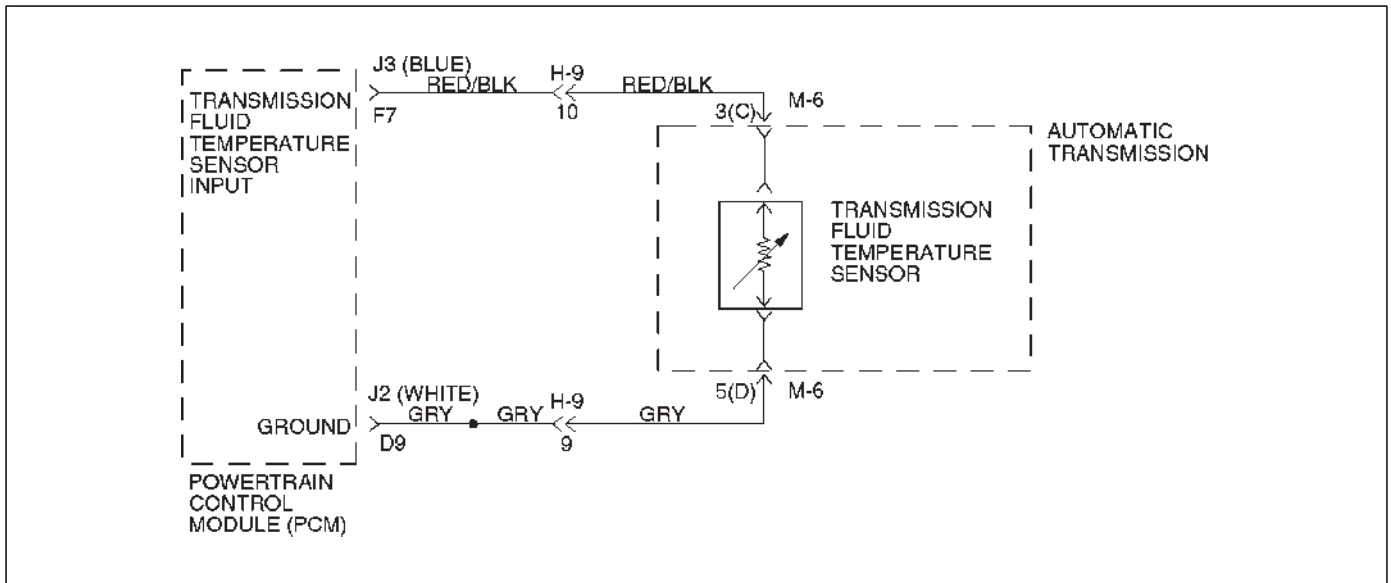
Step	Action	Yes	No
1	Was the Powertrain On-Board Diagnostic (OBD) System Check performed?	Go to Step 2	Go to OBD System Check Refer to Driveability and Emissions in Engine section
2	Perform the transmission fluid checking procedure. Refer to Checking Transmission Fluid Level and Condition in Automatic Transmission (4L30-E) section.  Did you perform the fluid checking procedure?	Go to Step 3	Go to Checking Transmission Fluid Level and Condition in Automatic Transmission (4L30-E) section
3	1. Install the scan tool. 2. With the engine "off", turn the ignition switch to the "on" position.  NOTE: Before clearing DTCs, use the scan tool in order to record the Freeze Frame and Failure Records for reference. The Clear Info function will erase the data. 3. Record the DTC Freeze Frame and Failure Records. 4. Select TFT on the scan tool. 5. While observing the scan tool display, move or massage the engine wiring harness from PCM connectors F7 and D9 to the transmission 16-way connector H-9.  Does the TFT change by more than ±20°C (36°F)?	Go to Step 6	Go to Step 4

## 7A1-38 TRANSMISSION CONTROL SYSTEM (4L30-E)

### DTC P0711 Transmission Fluid Temperature (TFT) Sensor Circuit Range/Performance (Cont'd)

Step	Action	Yes	No
4	<ol style="list-style-type: none"> <li>1. Turn the ignition "off".</li> <li>2. Disconnect the transmission 16-way connector H-9.</li> <li>3. Install Jumper Harness on the transmission side of the 16-way connector H-9.</li> <li>4. Using the J39200 DVOM and J35616 Connector Test Adapter Kit, connect the DVOM leads from terminal M6-3(C) to terminal M6-5(D).</li> <li>5. Set the DVOM on MIN/MAX to measure resistance.</li> <li>6. Record the TFT sensor resistance.</li> <li>7. Move or massage the automatic transmission wiring harness assembly from the 16-way connector H-9 to the TFT sensor connector.</li> </ol> <p>Does the DVOM MAX display a resistance greater than the value recorded in Action item 6 of this step?</p>	Go to Step 7	Go to Step 5
5	<p>Does the DVOM MIN display a resistance less than the value recorded in Action item 6 of step 4?</p>	Go to Step 8	—
6	<p>Inspect circuit RED/BLK and GRY of the engine wiring harness for an intermittent open or short condition. Repair the circuits if necessary.</p> <p>Did you find a problem?</p>	Go to Step 12	Go to Step 11
7	<p>Inspect the automatic transmission wiring harness assembly for an intermittent open in circuits RED/BLK and GRY.</p> <p>Did you find a problem?</p>	Go to Step 9	Go to Step 10
8	<p>Inspect the automatic transmission wiring harness assembly for an intermittent shorted condition in circuits RED/BLK and GRY.</p> <p>Did you find a problem?</p>	Go to Step 9	Go to Step 10
9	<p>Replace the automatic transmission wiring harness assembly.</p> <p>Is the replacement complete?</p>	Go to Step 12	—
10	<p>Replace TFT Sensor. Refer to Transmission Oil Temperature Sensor (Adapter Case) in Automatic Transmission (4L30-E) section.</p> <p>Is the replacement complete?</p>	Go to Step 12	—
11	<p>Replace the PCM. Refer to Powertrain Control Module (PCM) in Automatic Transmission (4L30-E) section.</p> <p>Is the replacement complete?</p>	Go to Step 12	—
12	<p>In order to verify your repair, perform the following procedure.</p> <ol style="list-style-type: none"> <li>1. Select DTC.</li> <li>2. Select Clear Info.</li> <li>3. Drive the vehicle and ensure the following conditions are met: <ul style="list-style-type: none"> <li>○The TFT changes by more than 2.25°C (4.05°F) for 11 seconds since startup.</li> <li>○The TFT does not change by more than 20°C (36°F) within 0.200 second for a period of at least 11 seconds.</li> </ul> </li> <li>4. Select Specific DTC.</li> <li>5. Enter DTC P0711.</li> </ol> <p>Has the test run and passed?</p>	System OK	<p>Begin the diagnosis again</p> <p>Go to Step 1</p>

## DTC P0712 Transmission Fluid Temperature (TFT) Sensor Circuit Low Input



D07RX002

### Circuit Description

The TFT sensor is a thermister that controls the signal voltage to the PCM. The PCM supplies a 5-volt reference signal to the sensor on circuit RED/BLK. When the transmission fluid is cold, the sensor resistance is high. The PCM detects high signal voltage. As the transmission fluid temperature increases to the normal operating temperature of 100°C (212°F), the sensor resistance becomes less and the voltage decreases to 1.5 to 2 volts. With transmission fluid over temperature and DTC P0218 also set, check the transmission cooling system.

This DTC detects a continuous short to ground in the TFT signal circuit or the TFT sensor. This is a type "D" DTC.

### Conditions For Setting The DTC

- Battery voltage is between 10 and 16 volts.
- Ignition is "on".
- TFT sensor indicating a voltage less than 0.4 volts.
- All conditions met for 20 seconds.

### Action Taken When The DTC Sets

- Transmission default temperature will be:
  - 80°C (176°F) if engine temperature code is set.
  - 100°C (212°F) if engine temperature is warm.
  - 80°C (176°F) if engine run time is greater than 5 minutes.
  - 21°C (69.8°F) if engine run time is less than 5 minutes.
- The PCM will not illuminate the Malfunction Indicator Lamp (MIL) and CHECK TRANS Lamp.

### Conditions For Clearing The DTC

- The DTC can be cleared from the PCM history by using a scan tool.

- The DTC will be cleared from history when the vehicle has achieved 40 warmup cycles without a failure reported.
- The PCM will cancel the DTC default actions when the fault no longer exists and the ignition is cycled "off" long enough to power down the PCM.

### Diagnostic Aids

- Check harness routing for a potential short to ground in circuit RED/BLK. Scan tool TFT display should rise steadily to about 100°C (212°F), then stabilize.
- Inspect the wiring for poor electrical connection at the PCM and at the transmission 16-way connector. Look for possible bent, backed out, deformed or damaged terminals. Check for weak terminal tension as well. Also check for a chafed wire that could short to bare metal or other wiring. Inspect for a broken wire inside the insulation.
- When diagnosing for a possible intermittent short or open condition, move the wiring harness while observing test equipment for a change.
- The temperature to resistance value scale may be used to test the TFT sensor at the various temperature levels to evaluate the possibility of a "skewed" (mis-scaled) sensor.
  - A "skewed" sensor could result in delayed garage shifts or TCC complaints.
- Verify customer driving habits, trailer towing, etc.

### Test Description

The numbers below refer to the step numbers on the diagnostic chart:

3. This test checks for a short to ground or a "skewed" sensor.
4. This test checks for an internal fault within the transmission by creating an open.

## 7A1-40 TRANSMISSION CONTROL SYSTEM (4L30-E)

### Resistance Chart

°C	°F	Resistance (k $\Phi$ )
-40	-40	672
0	32	65
20	68	25
80	176	2.5
120	248	0.78
150	304	0.37

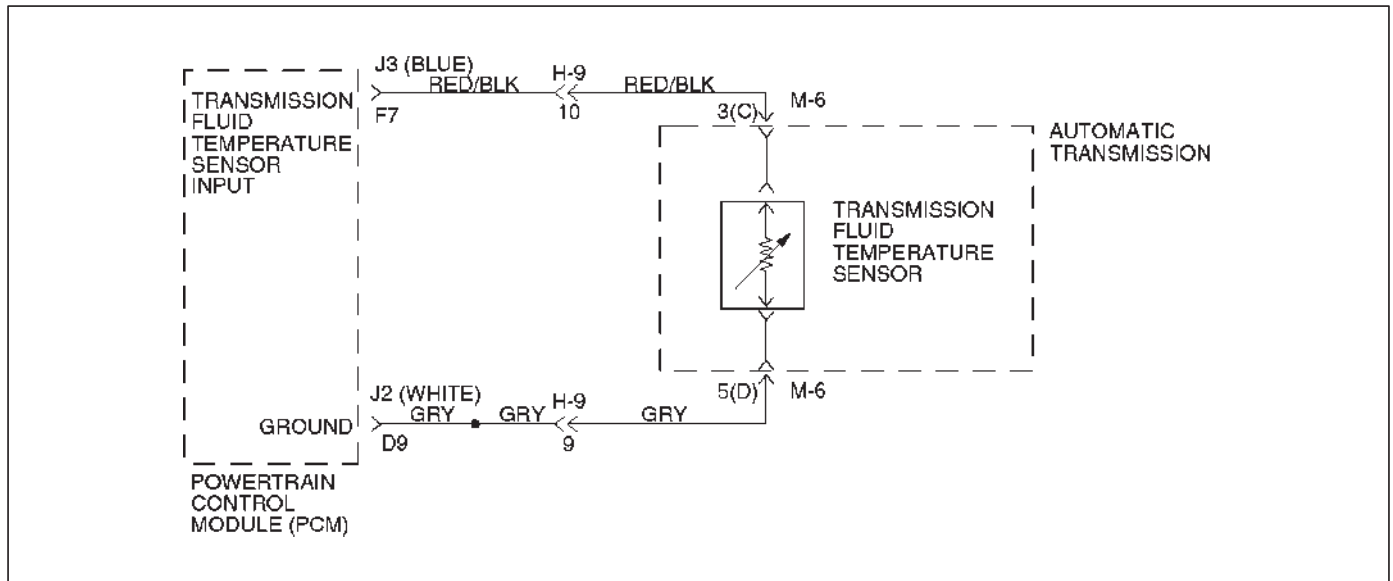
### DTC P0712 Transmission Fluid Temperature (TFT) Sensor Circuit Low Input

Step	Action	Yes	No
1	Were you sent here from the "Powertrain On-Board Diagnostic (OBD) System Check"?	Go to Step 2	Go to OBD System Check Refer to Driveability and Emissions in Engine section
2	Perform the transmission fluid checking procedure. Refer to Checking Transmission Fluid Level and Condition in Automatic Transmission (4L30-E) section.  Was the fluid checking procedure performed?	Go to Step 3	Refer to Checking Transmission Fluid Level and Condition in Automatic Transmission (4L30-E) section
3	1. Install the scan tool. 2. With the engine "off", turn the ignition switch "on". NOTE: Before clearing DTC(s), use the scan tool to record "Freeze Frame" and "Failure Records" for reference, as data will be lost when the "Clear Info" function is used. 3. Record the DTC "Freeze Frame" and "Failure Records".  Does the scan tool display a TFT sensor signal voltage less than 0.4 volts?	Go to Step 4	Go to Diagnostic Aids
4	1. Turn the ignition "off". 2. Disconnect the transmission 16-way connector H-9. 3. Turn the ignition "on".  Does the TFT signal voltage change to match the voltage 4.92 volts?	Go to Step 5	Go to Step 10
5	Using the J39200 DVOM, measure the resistance between terminals 3(C) and 5 (D).  Is the resistance within specifications? (See Resistance Chart.)	Go to Diagnostic Aids	Go to Step 6
6	1. Disconnect the transmission 5-way connector M-6. 2. Using the J39200 DVOM, measure the resistance between terminals 3(C) and 5(D).  Is the resistance within specifications? (See Resistance Chart.)	Go to Diagnostic Aids	Go to Step 7
7	1. Remove the transmission oil pan. Refer to Transmission Oil Temperature Sensor (Adapter Case) in Automatic Transmission (4L30-E) section. 2. Check the internal wiring harness for a short to ground.  Was a problem found?	Go to Step 9	Go to Step 8

**DTC P0712 Transmission Fluid Temperature (TFT) Sensor Circuit Low Input (Cont'd)**

<b>Step</b>	<b>Action</b>	<b>Yes</b>	<b>No</b>
8	1. Disconnect the internal wiring harness at the TFT sensor. 2. Measure the resistance of the TFT sensor. Is the resistance within specifications? (See Resistance Chart.)	Go to Diagnostic Aids	Go to Step 9
9	Replace the TFT Sensor. Is the replacement complete?	Go to Step 13	—
10	Check circuit RED/BLK for a short to ground. Was a problem found?	Go to Step 13	Go to Step 11
11	Check the PCM for faulty connections. Was a problem found?	Go to Step 13	Go to Step 12
12	Replace the PCM. Refer to Powertrain Control Module (PCM) in Automatic Transmission (4L30-E) section. Is the replacement complete?	Go to Step 13	—
13	1. After the repair is complete, use the scan tool to select "DTC", then "Clear Info" function and ensure the following conditions are met: TFT sensor indicates a voltage greater than 0.33 volts for 2 seconds. 2. Review the scan tool "DTC info". Has the last test failed or is the current DTC displayed?	Begin diagnosis again Go to Step 1	Repair verified Exit DTC table

## DTC P0713 Transmission Fluid Temperature (TFT) Sensor Circuit High Input



D07RX002

### Circuit Description

The TFT sensor is a thermistor that controls the signal voltage to the PCM. The PCM supplies a 5-volt reference signal to the sensor on circuit RED/BLK. When the transmission fluid is cold, the sensor resistance is high and the PCM will sense high signal voltage. As the transmission fluid temperature warms to the normal operating temperature of 100°C (212°F), the sensor resistance becomes less and the voltage decreases to about 1.5 to 2 volts.

This DTC detects a continuous open or short to power in the TFT signal circuit or the TFT sensor. This is a type "D" DTC.

### Conditions For Setting The DTC

- Battery voltage is between 10 and 16 volts.
- Ignition is "on".
- TFT sensor indicating a voltage greater than 4.86 volts.
- All conditions met for 20 seconds.

### Action Taken When The DTC Sets

- Transmission default temperature will be:
  - 80°C (176°F) if engine temperature code is set.
  - 100°C (212°F) if engine temperature is warm.
  - 80°C (176°F) if engine run time is greater than 5 minutes.
  - 21°C (69.8°F) if engine run time is less than 5 minutes.
- The PCM will not illuminate the Malfunction Indicator Lamp (MIL) and CHECK TRANS Lamp.

### Conditions For Clearing The DTC

- The DTC can be cleared from the PCM history by using a scan tool.

- The DTC will be cleared from history when the vehicle has achieved 40 warmup cycles without a failure reported.
- The PCM will cancel the DTC default actions when the fault no longer exists and the ignition is cycled "off" long enough to power down the PCM.

### Diagnostic Aids

- Inspect the wiring for poor electrical connection at the PCM and at the transmission 16-way connector. Look for possible bent, backed out, deformed or damaged terminals. Check for weak terminal tension as well. Also check for a chafed wire that could short to bare metal or other wiring. Inspect for a broken wire inside the insulation.
- When diagnosing for a possible intermittent short or open condition, move the wiring harness while observing test equipment for a change.
- Scan tool displays transmission fluid temperature in degrees. After transmission is operating, the temperature should rise steadily to about 100°C (212°F), then stabilize.
- The temperature to resistance value scale may be used to check the TFT sensor at the various temperature levels to evaluate the possibility of a "skewed" (mis-scaled) sensor.
 

A "skewed" sensor could result in hard shifts or TCC complaints.

### Test Description

The numbers below refer to the step numbers on the diagnostic chart:

3. This check verifies problem in the TFT sensor circuit.
4. This test simulates a TFT sensor DTC P0712. If the PCM recognizes the low signal voltage (high temperature), and the scan tool displays 146°C (295°F) or greater, the PCM and wiring are OK.

5. This test checks the TFT sensor and internal wiring harness.

**Resistance Chart**

°C	°F	Resistance (k $\Phi$ )
-40	-40	672
0	32	65
20	68	25
80	176	2.5
120	248	0.78
150	304	0.37

**DTC P0713 Transmission Fluid Temperature (TFT) Sensor Circuit High Input**

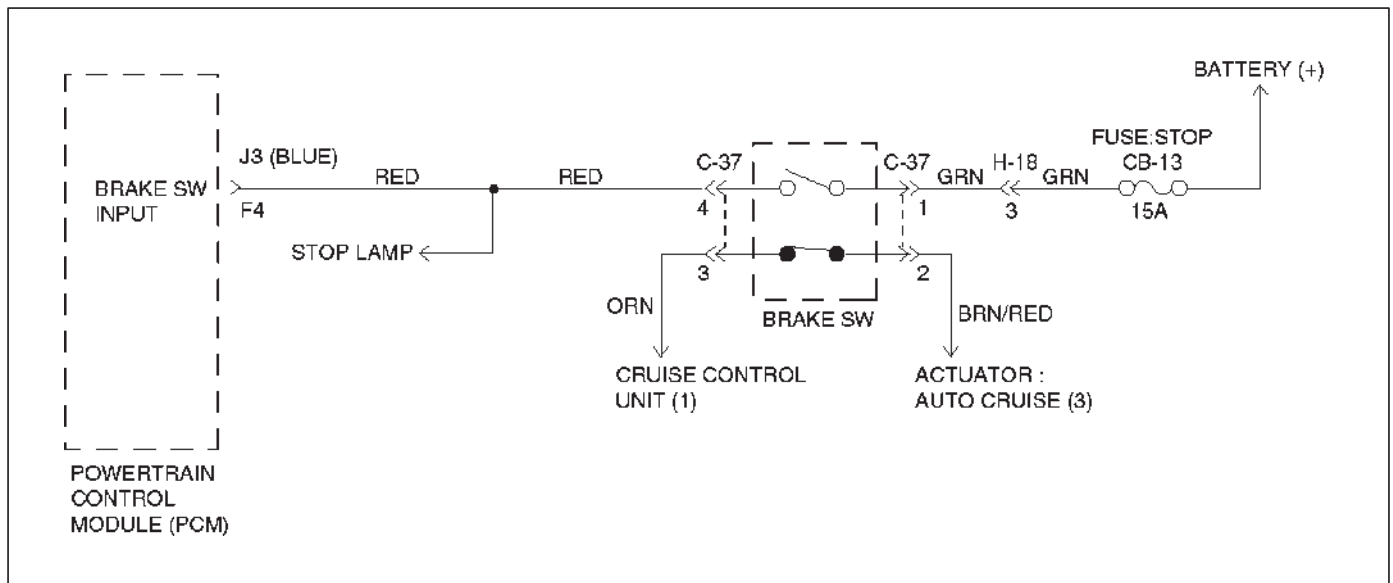
Step	Action	Yes	No
1	Were you sent here from the "Powertrain On-Board Diagnostic (OBD) System Check"?	Go to Step 2	Go to OBD System Check Refer to Driveability and Emission in Engine section
2	Perform the transmission fluid checking procedure. Refer to Checking Transmission Fluid Level and Condition in Automatic Transmission (4L30-E) section. Was the fluid checking procedure performed?	Go to Step 3	Refer to Checking Transmission Fluid Level and Condition in Automatic Transmission (4L30-E) section
3	1. Install the scan tool. 2. With the engine "off", turn the ignition switch "on". NOTE: Before clearing DTC(s), use the scan tool to record "Freeze Frame" and "Failure Records" for reference, as data will be lost when the "Clear Info" function is used. 3. Record the DTC "Freeze Frame" and "Failure Records". Does the scan tool display a TFT sensor signal voltage greater than 4.86 volts?	Go to Step 4	Go to Diagnostic Aids
4	1. Turn the ignition "off". 2. Disconnect the transmission 16-way connector H-9. 3. Install a fused jumper wire from terminal 3(C) to 5(D) on the engine harness. 4. Turn the ignition "on". Does the TFT signal voltage drop to less than 0.4 volts?	Go to Step 5	Go to Step 10
5	1. Turn the ignition "off". 2. Using the J39200 DVOM, measure the resistance between terminals 3(C) and 5(D). Is the resistance within specifications? (See Resistance Chart.)	Go to Diagnostic Aids	Go to Step 6
6	1. Disconnect the transmission 5-way connector M-6. 2. Using the J39200 DVOM, measure the resistance between terminals 3(C) and 5(D). Is the resistance within specifications? (See Resistance Chart.)	Go to Diagnostic Aids	Go to Step 7

## 7A1-44 TRANSMISSION CONTROL SYSTEM (4L30-E)

### DTC P0713 Transmission Fluid Temperature (TFT) Sensor Circuit High Input (Cont'd)

Step	Action	Yes	No
7	<p>1. Remove the transmission oil pan. 2. Check the internal wiring harness for an open. Refer to Transmission Oil Temperature Sensor (Adapter Case) in Automatic Transmission (4L30-E) section.</p> <p>Was a problem found and corrected?</p>	Go to Step 14	Go to Step 8
8	<p>1. Disconnect the internal wiring harness at the TFT sensor. 2. Measure the resistance of the TFT sensor.</p> <p>Is the resistance within specifications? (See Resistance Chart.)</p>	Go to Diagnostic Aids	Go to Step 9
9	<p>Replace TFT sensor. Refer to Transmission Oil Temperature Sensor (Adapter Case) in Automatic Transmission (4L30-E) section.</p> <p>Is the replacement complete?</p>	Go to Step 14	—
10	<p>Check circuit RED/BLK for an open or short to B+.</p> <p>Was a problem found?</p>	Go to Step 14	Go to Step 11
11	<p>Check circuit GRY for an open.</p> <p>Was a problem found?</p>	Go to Step 14	Go to Step 12
12	<p>Check the PCM for faulty or intermittent connections.</p> <p>Was a problem found?</p>	Go to Step 14	Go to Step 13
13	<p>Replace the PCM. Refer to Powertrain Control Module (PCM) in Automatic Transmission (4L30-E) section.</p> <p>Is the replacement complete?</p>	Go to Step 14	—
14	<p>1. After the repair is complete, use the scan tool to select "DTC", then "Clear Info" function and ensure the following conditions are met: TFT sensor indicates a voltage less than 4.92 volts for 2 seconds.</p> <p>2. Review the scan tool "DTC Info".</p> <p>Has the last test failed or is the current DTC displayed?</p>	<p>Begin diagnosis again Go to Step 1</p>	<p>Repair verified Exit DTC table</p>



**DTC P0719 TCC Brake Switch Circuit High (Stuck On)**

D07RX005

**Circuit Description**

The TCC brake switch is used to indicate brake pedal status. The normally opened brake switch signal voltage circuit is opened.

Brake switch supplies a B+ signal on circuit RED to the PCM when the brakes are applied. The PCM uses this signal to deenergize the TCC solenoid when the brakes are applied.

This DTC detects a closed brake switch during accelerations. This is a type "D" DTC.

**Conditions For Setting The DTC**

- No OSS DTCs P0722 or P0723.
- The PCM detects a closed brake switch/circuit (12 volts) for 2 seconds, and the following events occur seven consecutive times: vehicle speed is less than 8 km/h (5 mph); then vehicle speed is between 8 and 32 km/h (5 and 20 mph) for 4 seconds; then vehicle speed is greater than 32 km/h (20 mph) for 4 seconds.

**Action Taken When The DTC Sets**

- If throttle opening is greater than 10% and vehicle speed is greater than 45 km/h (28 mph), then disregard brake switch contingency for TCC off mode.
- The PCM will not illuminate Malfunction Indicator Lamp (MIL) and CHECK TRANS Lamp.

**Conditions For Clearing The DTC**

- The DTC can be cleared from the PCM history by using a scan tool.

- The DTC will be cleared from history when the vehicle has achieved 40 warmup cycles without a failure reported.
- The PCM will cancel the DTC default actions when the fault no longer exists and the ignition is cycled "off" long enough to power down the PCM.

**Diagnostic Aids**

- Inspect the wiring for poor electrical connections at the PCM and TCC brake switch. Look for possible bent, backed out, deformed or damaged terminals. Check for weak terminal tension as well. Also check for a chafed wire that could short to bare metal or other wiring. Inspect for a broken wire inside the insulation.
- When diagnosing for a possible intermittent short or open condition, move the wiring harness while observing test equipment for a change.
- Check customer driving habits and/or unusual driving conditions (i.e. stop and go, highway).
- Check brake switch for proper mounting and adjustment.

**Test Description**

The numbers below refer to the step numbers on the diagnostic chart:

3. This test checks for voltage at the brake switch.
6. This test checks the brake switch.
9. This test checks circuit RED at the PCM.

**7A1-46 TRANSMISSION CONTROL SYSTEM (4L30-E)**

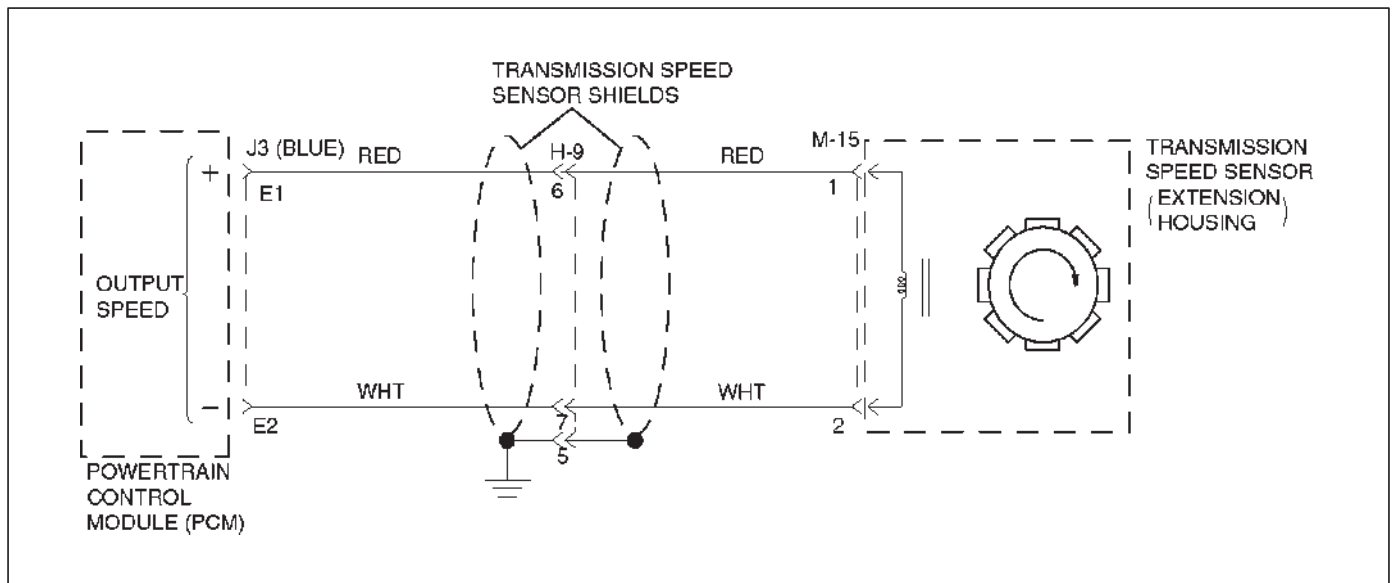
**DTC P0719 TCC Brake Switch Circuit High (Stuck On)**

Step	Action	Yes	No
1	Were you sent here from the "Powertrain On-Board Diagnostic (OBD) System Check"?	Go to Step 2	Go to OBD System Check Refer to Driveability and Emissions in Engine section
2	<p>1. Install the scan tool.</p> <p>2. With the engine "off", turn the ignition switch "on". If ABS code is set, check applicable fuse.</p> <p>NOTE: Before clearing DTC(s), use the scan tool to record "Freeze Frame" and "Failure Records" for reference, as data will be lost when the "Clear Info" function is used.</p> <p>3. Record the DTC "Freeze Frame" and "Failure Records".</p> <p>4. Apply then release the brake pedal.</p> <p>Does the scan tool display "TCC Brake Switch" as "closed" with the brake pedal applied, and then display "open" when the brake pedal is released?</p>	Go to Diagnostic Aids	Go to Step 3
3	<p>1. Connect the test light to ground.</p> <p>2. Back probe ignition feed circuit terminal C37-1 at the brake switch.</p> <p>Is the test light "on"?</p>	Go to Step 4	Go to Step 5
4	<p>1. Connect the test light to ground.</p> <p>2. Back probe circuit terminal C37-4 at the brake switch.</p> <p>Is the test light "off"?</p>	Go to Step 8	Go to Step 6
5	<p>Repair the open in battery feed circuit terminal C37-1 to the brake switch.</p> <p>If fuse is open, check circuit terminal C37-4 for a short to ground.</p> <p>Is the repair complete?</p>	Go to Step 14	—
6	<p>Disconnect brake switch connector C-37 and ignition switch "on".</p> <p>Is the test light "on"?</p>	Go to Step 9	Go to Step 7
7	<p>Check the brake switch short (C37-1 and C37-4).</p> <p>Was a problem found?</p>	Go to Step 10	Go to Step 11
8	<p>Check circuit terminal C37-4 for a short to voltage.</p> <p>Ignition switch "on".</p> <p>Is the test light "on"?</p>	Go to Step 9	Go to Step 11
9	<p>1. Disconnect the J3 (BLUE) PCM connector.</p> <p>2. Check circuit terminal C37-4 for a short to voltage.</p> <p>Was a problem found?</p>	Go to Step 14	Go to Step 11
10	<p>Replace the brake switch.</p> <p>Is the replacement complete?</p>	Go to Step 14	—
11	<p>1. Turn the ignition "off".</p> <p>2. Reconnect the J3 (BLUE) PCM connector.</p> <p>3. Turn the ignition "on".</p> <p>Does the scan tool display "TCC Brake Switch" as "open" with the brake applied, then display "closed" with the brake pedal released?</p>	Go to Diagnostic Aids	Go to Step 12
12	<p>Check the PCM for faulty or intermittent connections.</p> <p>Was a problem found and corrected?</p>	Go to Step 14	Go to Step 13

**DTC P0719 TCC Brake Switch Circuit High (Stuck On) (Cont'd)**

Step	Action	Yes	No
13	Replace the PCM. Refer to Powertrain Control Module (PCM) in Automatic Transmission (4L30-E) section. Is the replacement complete?	Go to Step 14	—
14	1. After the repair is complete, use the scan tool to select "DTC", then "Clear Info" function and ensure the following conditions are met: The PCM brake switch signal must indicate 0 volts for 1 seconds with the brake pedal applied. 2. Review the scan tool "DTC Info". Has the last test failed or is the current DTC displayed?	Begin diagnosis again Go to Step 1	Repair verified Exit DTC table

## DTC P0722 Transmission Output Speed Sensor (OSS) Low Input



D07RX006

### Circuit Description

Output speed information is provided to the PCM by the OSS, which is a permanent magnet (PM) generator. The PM generator produces a pulsing AC voltage. The AC voltage level and number of pulses increases as the speed of the vehicle increases. The PCM then converts the pulsing voltage to output speed, which is used for calculations. The vehicle speed can be displayed with a scan tool.

This DTC detects a low output speed when there is a high engine speed in a drive gear range. This is a type "B" DTC.

### Conditions For Setting The DTC

- No MAP DTCs P0107 or P0108, P0106, P1106, P1107.
- No TPS DTCs P0122 or P0123.
- Not in Park or Neutral.
- TP angle is greater than 10%.
- Engine vacuum is between 0 and 70kpa.
- Engine speed is between 3,000 and 7,000 rpm.
- Transmission output speed is less than 0 rpm.
- All conditions met for 5 seconds.

### Action Taken When The DTC Sets

- Fixed to 4th gear.
- Maximum line pressure.
- Inhibit TCC engagement.
- The PCM will illuminate the Malfunction Indicator Lamp (MIL) and CHECK TRANS Lamp.

### Conditions For Clearing The MIL/DTC

- The PCM will turn off the MIL and CHECK TRANS Lamp after three consecutive ignition cycles without a failure reported.
- The DTC can be cleared from the PCM history by using a scan tool. The DTC will be cleared from history when the vehicle has achieved 40 warmup cycles without a failure reported.
- The PCM will cancel the DTC default actions when the fault no longer exists and the ignition is cycled "off" long enough to power down the PCM.

### Diagnostic Aids

- An OSS DTC P0722 will set when no output speed is at detected at start off.
- Inspect the wiring for poor electrical connection at the PCM. Look for possible bent, backed out, deformed or damaged terminals. Check for weak terminal tension as well. Also check for a chafed wire that could short to bare metal or other wiring. Inspect for a broken wire inside the insulation.
- When diagnosing for a possible intermittent short or open condition, move the wiring harness while observing test equipment for a change.

### Test Description

The numbers below refer to the step numbers on the diagnostic chart:

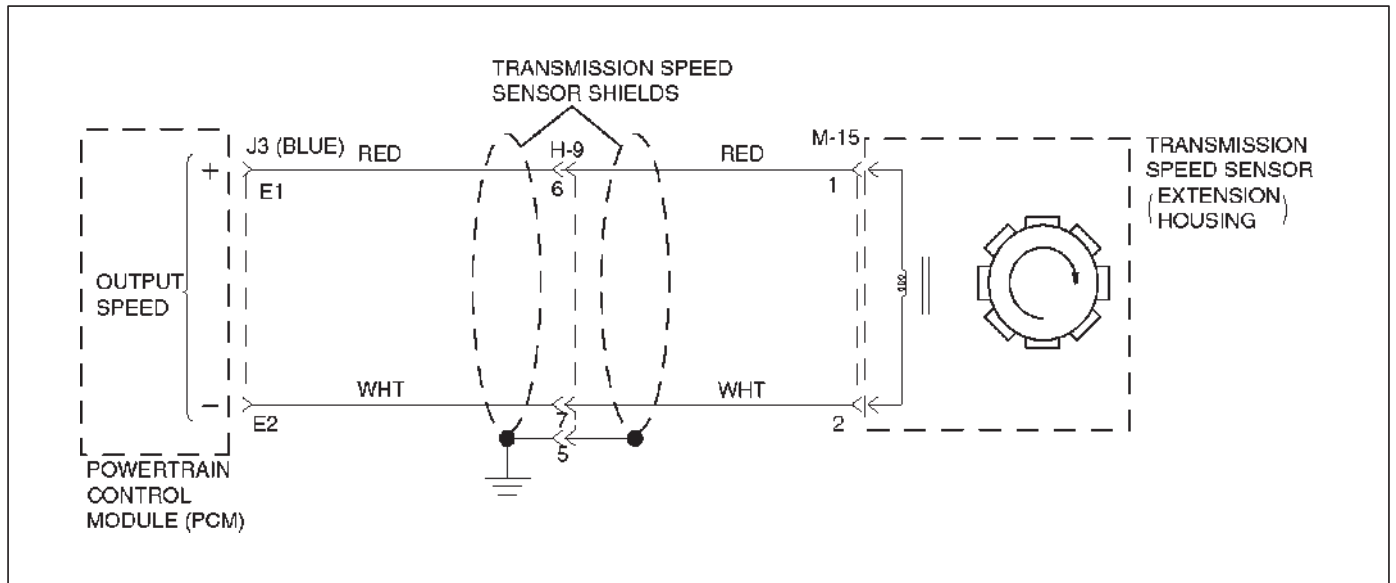
5. This test checks the OSS circuit.
6. This test checks the integrity of the OSS.
8. This test checks the 5-volt and ground circuit of the PCM.

**DTC P0722 Transmission Output Speed Sensor (OSS) Low Input**

Step	Action	Yes	No
1	Were you sent here from the "Powertrain On-Board Diagnostic (OBD) System Check"?	Go to Step 2	Go to OBD System Check Refer to Driveability and Emissions in Engine section
2	<ol style="list-style-type: none"> <li>1. Install the scan tool.</li> <li>2. With the engine "off", turn the ignition switch "on".</li> </ol> <p>NOTE: Before clearing DTC(s), use the scan tool to record "Freeze Frame" and "Failure Records" for reference, as data will be lost when the "Clear Info" function is used.</p> <ol style="list-style-type: none"> <li>3. Record the DTC "Freeze Frame" and "Failure Records".</li> <li>4. Raise the drive wheels.</li> <li>5. Start the engine.</li> <li>6. Place the transmission in any drive range.</li> </ol> <p>With the drive wheels rotating, does the "Trans Output Speed" increase with the drive wheel speed?</p>	Go to Diagnostic Aids	Go to Step 3
3	Does the speedometer work?	Go to Step 4	Go to Step 5
4	Check for the most current and/or incorrect calibration. Is the calibration current?	Go to Step 17	Go to Step 5
5	<ol style="list-style-type: none"> <li>1. Turn the ignition "off".</li> <li>2. Disconnect the J3 (BLUE) PCM connector.</li> <li>3. Using the J39200 DVOM, measure the resistance between harness connector terminals J3-E1 and J3-E2.</li> </ol> <p>Is the reading 3,000 ohms?</p>	Go to Step 6	Go to Step 7
6	<ol style="list-style-type: none"> <li>1. Select AC volts.</li> <li>2. Rotate the rear wheels, ensuring the driveshaft is turning.</li> </ol> <p>Is the voltage greater than 0.5 volts?</p>	Go to Step 8	Go to Step 9
7	Inspect circuits RED and WHT for a poor connection or an open circuit. Was a problem found?	Go to Step 18	Go to Step 9
8	<ol style="list-style-type: none"> <li>1. Reconnect the J3 (BLUE) PCM connector.</li> <li>2. Disconnect the OSS harness from the OSS.</li> <li>3. With the engine "off", turn the ignition "on".</li> <li>4. Using the J 39200 DVOM, measure the voltage at the OSS harness connector terminals M15-1 and M15-2.</li> </ol> <p>Is the reading between 4.0 to 5.1 volts?</p>	Go to Step 17	Go to Step 11
9	<ol style="list-style-type: none"> <li>1. Remove the OSS.</li> <li>2. Check the output shaft speed sensor rotor for damage or misalignment. Refer to Speed Sensor (Extension Housing) in Automatic Transmission (4L30-E) section.</li> </ol> <p>Was a problem found?</p>	Go to Step 18	Go to Step 10
10	Replace the OSS. Is the replacement complete?	Go to Step 18	—
11	Was the reading in step 8 less than 4.0 volts?	Go to Step 13	Go to Step 12
12	Was the reading in Step 8 greater than 5.1 volts?	Go to Step 16	—
13	Using the J 39200 DVOM to chassis ground, measure the voltage on circuit RED. Is the reading between 4.0 to 5.1 volts?	Go to Step 14	Go to Step 15

**7A1-50 TRANSMISSION CONTROL SYSTEM (4L30-E)****DTC P0722 Transmission Output Speed Sensor (OSS) Low Input (Cont'd)**

<b>Step</b>	<b>Action</b>	<b>Yes</b>	<b>No</b>
14	Repair the open in circuit WHT. Is the repair complete?	Go to Step 18	—
15	Check circuit RED for a short to ground or open. Was a problem found and corrected?	Go to Step 18	Go to Step 17
16	Repair the short to B+ in circuit RED. Is the repair complete?	Go to Step 18	—
17	Replace the PCM. Refer to Powertrain Control Module (PCM) in automatic Transmission (4L30-E) section. Is the replacement complete?	Go to Step 18	—
18	1. After the repair is complete, use the scan tool to select "DTC", then "Clear Info" function and operate the vehicle under the following conditions: Transmission output speed is greater than 101 rpm for 3 seconds. 2. Review the scan tool "DTC Info". Has the last test failed or is the current DTC displayed?	Begin diagnosis again Go to Step 1	Repair verified Exit DTC table

**DTC P0723 Transmission Output Speed Sensor (OSS) Intermittent****Circuit Description**

Output speed information is provided to the PCM by the OSS, which is a permanent magnet (PM) generator. The PM generator produces a pulsing AC voltage. The AC voltage level and number of pulses increases as the speed of the vehicle increases. The PCM then converts the pulsing voltage to output speed, which is used for calculations. The vehicle speed can be displayed with a scan tool.

This DTC detects a low output speed when there is a high engine speed in a drive gear range. This is a type "B" DTC.

**Conditions For Setting The DTC**

In Park or Neutral:

- Transmission output speed change is greater than 10,000 rpm.
- Conditions met for 6 seconds.
- Engine running time is greater than 2 seconds.

Not in Park or Neutral:

- Transmission output speed change is greater than 512 rpm.
- Conditions met for 0.075 seconds
- Engine running time is greater than 2 seconds.
- Engine vacuum is less than 70 kpa.
- Output speed is greater than 1,380 rpm for 1 second.
- NORAW-NOLAST < 60 rpm for 6 seconds.

NORAW: Latest raw data of output shaft speed.

NOLAST: Filtered pervious data of output speed.

**Action Taken When The DTC Sets**

- Fixed to 4th gear.
- Maximum line pressure.
- Inhibit TCC engagement.

- The PCM will illuminate the Malfunction Indicator Lamp (MIL) and CHECK TRANS Lamp.

**Conditions For Clearing The MIL/DTC**

- The PCM will turn off the MIL and CHECK TRANS Lamp after three consecutive ignition cycles without a failure reported.
- The DTC can be cleared from the PCM history by using a scan tool.
- The DTC will be cleared from history when the vehicle has achieved 40 warmup cycles without a failure reported.
- The PCM will cancel the DTC default actions when the fault no longer exists and the ignition is cycled "off" long enough to power down the PCM.

**Diagnostic Aids**

- A OSS DTC P0723 will set when output speed has been detected and is lost.
- Inspect the wiring for poor electrical connection at the PCM. Look for possible bent, backed out, deformed or damaged terminals. Check for weak terminal tension as well. Also check for a chafed wire that could short to bare metal or other wiring. Inspect for a broken wire inside the insulation.
- When diagnosing for a possible intermittent short or open condition, move the wiring harness while observing test equipment for a change.

**Test Description**

The numbers below refer to the step numbers on the diagnostic chart:

5. This test checks the OSS circuit.
6. This test checks the integrity of the OSS.
8. This test checks the 5-volt and ground circuit of the PCM.

## 7A1-52 TRANSMISSION CONTROL SYSTEM (4L30-E)

### DTC P0723 Transmission Output Speed Sensor (OSS) Intermittent

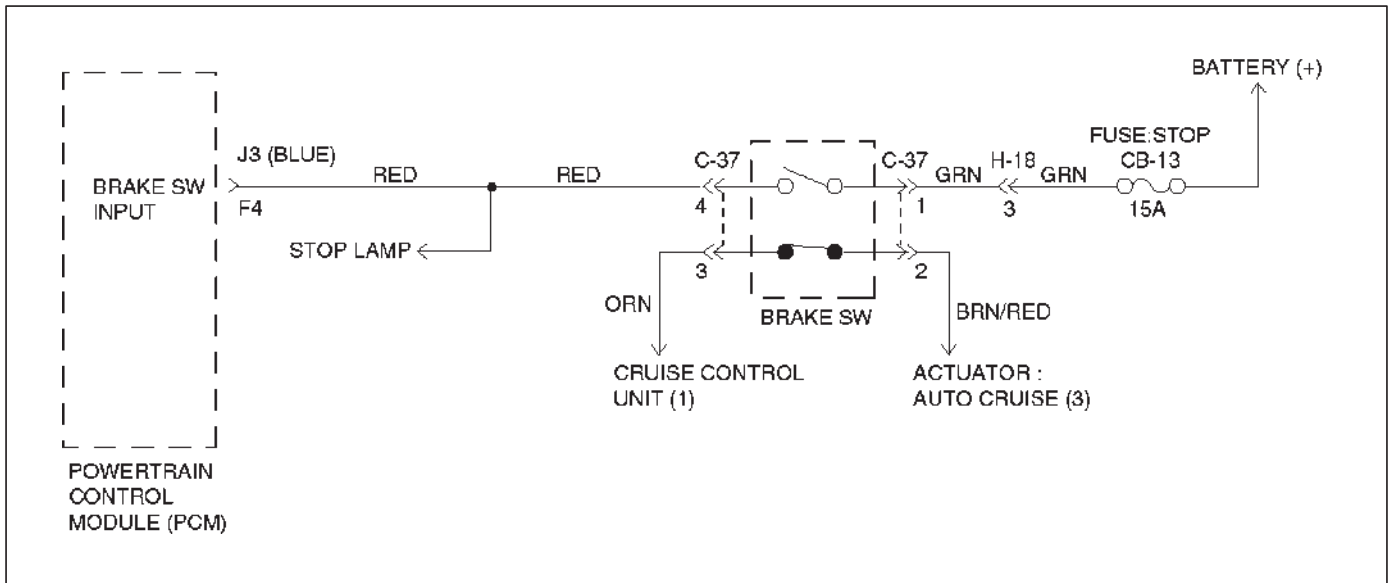
Step	Action	Yes	No
1	Were you sent here from the "Powertrain On-Board Diagnostic (OBD) System Check"?	Go to Step 2	Go to OBD System Check Refer to Driveability and Emissions in Engine section
2	<ol style="list-style-type: none"> <li>1. Install the scan tool.</li> <li>2. With the engine "off", turn the ignition switch "on".</li> </ol> <p>NOTE: Before clearing DTC(s), use the scan tool to record "Freeze Frame" and "Failure Records" for reference, as data will be lost when the "Clear Info" function is used.</p> <ol style="list-style-type: none"> <li>3. Record the DTC "Freeze Frame" and "Failure Records".</li> <li>4. Raise the drive wheels.</li> <li>5. Start the engine.</li> <li>6. Place the transmission in any drive range.</li> </ol> <p>With the drive wheels rotating, does the "Trans Output Speed" increase with the drive wheel speed?</p>	Go to Diagnostic Aids	Go to Step 3
3	Does the speedometer work?	Go to Step 4	Go to Step 5
4	Check for the most current and/or incorrect calibration. Is the calibration current?	Go to Step 17	Go to Step 5
5	<ol style="list-style-type: none"> <li>1. Turn the ignition "off".</li> <li>2. Disconnect the J3 (BLUE) PCM connector.</li> <li>3. Using the J39200 DVOM, measure the resistance between harness connector terminals J3-E1 and J3-E2.</li> </ol> <p>Is the reading 3,000 ohms?</p>	Go to Step 6	Go to Step 7
6	<ol style="list-style-type: none"> <li>1. Select AC volts.</li> <li>2. Rotate the rear wheels, ensuring the driveshaft is turning.</li> </ol> <p>Is the voltage greater than 0.5 volts?</p>	Go to Step 8	Go to Step 9
7	Inspect circuits RED and WHT for a poor connection or an open circuit. Was a problem found?	Go to Step 18	Go to Step 9
8	<ol style="list-style-type: none"> <li>1. Reconnect the J3 (BLUE) PCM connector.</li> <li>2. Disconnect the OSS harness from the OSS.</li> <li>3. With the engine "off", turn the ignition "on".</li> <li>4. Using the J 39200 DVOM, measure the voltage at the OSS harness connector terminals M15-1 and M15-2.</li> </ol> <p>Is the reading between 4.0 to 5.1 volts?</p>	Go to Step 17	Go to Step 11
9	<ol style="list-style-type: none"> <li>1. Remove the OSS.</li> <li>2. Check the output shaft speed sensor rotor for damage or misalignment. Refer to Speed Sensor (Extension Housing) in Automatic Transmission (4L30-E) section.</li> </ol> <p>Was a problem found?</p>	Go to Step 18	Go to Step 10
10	Replace the OSS. Is the replacement complete?	Go to Step 18	—
11	Was the reading in step 8 less than 4.0 volts?	Go to Step 13	Go to Step 12
12	Was the reading in Step 8 greater than 5.1 volts?	Go to Step 16	—
13	Using the J 39200 DVOM to chassis ground, measure the voltage on circuit RED. Is the reading between 4.0 to 5.1 volts?	Go to Step 14	Go to Step 15



**DTC P0723 Transmission Output Speed Sensor (OSS) Intermittent (Cont'd)**

<b>Step</b>	<b>Action</b>	<b>Yes</b>	<b>No</b>
14	Repair the open in circuit WHT. Is the repair complete?	Go to Step 18	—
15	Check circuit RED for a short to ground or open. Was a problem found and corrected?	Go to Step 18	Go to Step 17
16	Repair the short to B+ in circuit RED. Is the repair complete?	Go to Step 18	—
17	Replace the PCM. Refer to Powertrain Control Module (PCM) in Automatic Transmission (4L30-E) section. Is the replacement complete?	Go to Step 18	—
18	1. After the repair is complete, use the scan tool to select "DTC", then "Clear Info" function and operate the vehicle under the following conditions: Transmission output speed is greater than 101 rpm for 3 seconds. 2. Review the scan tool "DTC Info". Has the last test failed or is the current DTC displayed?	Begin diagnosis again Go to Step 1	Repair verified Exit DTC table

## DTC P0724 TCC Brake Switch Circuit Low (Stuck Off)



D07RX005

### Circuit Description

The TCC brake switch is used to indicate brake pedal status. The normally opened brake switch signal voltage supplies a B+ signal on circuit RED to the PCM when the brakes are applied. The PCM uses this signal to deenergize the TCC solenoid when the brakes are applied. This DTC detects an open brake switch during decelerations. This is a type "D" DTC.

### Conditions For Setting The DTC

- No OSS DTCs P0722 or P0723.
- The PCM detects an open brake switch/circuit (0 volts) during decelerations and the following events occur seven consecutive times: vehicle speed is greater than 32 km/h (20 mph) for 4 seconds; then vehicle speed is between 8 and 32 km/h (5 and 20 mph) for 4 seconds; then vehicle speed is less than 8 km/h (5 mph).

### Action Taken When The DTC Sets

- The PCM will not illuminate the Malfunction Indicator Lamp (MIL) and CHECK TRANS Lamp.

### Conditions For Clearing The DTC

- The DTC can be cleared from the PCM history by using a scan tool.

- The DTC will also be cleared from history when the vehicle has achieved 40 warmup cycles without a failure reported.
- The PCM will cancel the DTC default actions when the fault no longer exists and the ignition is cycled "off" long enough to power down the PCM.

### Diagnostic Aids

- Inspect the wiring for poor electrical connection at the PCM. Look for possible bent, backed out, deformed or damaged terminals. Check for weak terminal tension as well. Also check for a chafed wire that could short to bare metal or other wiring. Inspect for a broken wire inside the insulation.
- When diagnosing for a possible intermittent short or open condition, move the wiring harness while observing test equipment for a change.
- Check customer driving habits and/or unusual traffic conditions (i.e. stop and go, expressway).
- Check brake switch for proper mounting and adjustment.

### Test Description

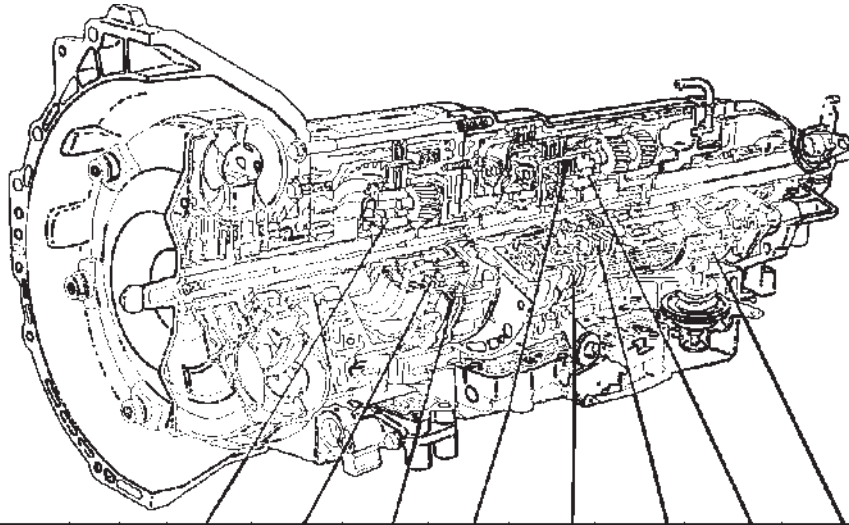
The numbers below refer to the step numbers on the diagnostic chart:

3. This test checks for voltage at the brake switch.
6. This test checks the brake switch.

**DTC P0724 TCC Brake Switch Circuit Low (Stuck Off)**

Step	Action	Yes	No
1	Were you sent here from the "Powertrain On-Board Diagnostic (OBD) System Check"?	Go to Step 2	Go to OBD System Check Refer to Driveability and Emissions in Engine section
2	1. Install the scan tool. 2. With the engine "off", turn the ignition switch "on". NOTE: Before clearing DTC(s), use the scan tool to record "Failure Records" for reference, as data will be lost when the "Clear Info" function is used. 3. Record the DTC "Failure Records". 4. Apply then release the brake pedal.  Does the scan tool display "TCC Brake Switch" as "closed" with the brake pedal applied, and then display "open" when the brake pedal is released?	Go to Diagnostic Aids	Go to Step 3
3	1. Connect the test light to ground. 2. Back probe ignition feed circuit terminal C37-1 at the brake switch.  Is the test light "on"?	Go to Step 4	Go to Step 5
4	1. Connect the test light to ground. 2. Back probe circuit terminal C37-4 at the brake switch. 3. Apply the brake pedal.  Is the test light "on" when the brake pedal is applied?	Go to Step 7	Go to Step 6
5	Repair the open in ignition feed circuit terminal C37-1 to the brake switch. If fuse is open, check circuit terminal C37-4.  Is the repair complete?	Go to Step 11	—
6	1. Disconnect C37 connector. 2. Check the resistance between terminal C37-1 and C37-4.  Is the resistance 0 ohm with the brake pedal applied?	Go to Step 7	Go to Step 8
7	Check circuit terminal C37-4 for a open.  Was a problem found?	Go to Step 11	Go to Step 9
8	Replace the brake switch.  Is the replacement complete?	Go to Step 11	—
9	Check PCM for faulty connections.  Was a problem found?	Go to Step 11	Go to Step 10
10	Replace the PCM. Refer to Powertrain Control Module (PCM) in Automatic Transmission (4L30-E) section.  Is the replacement complete?	Go to Step 11	—
11	1. After the repair is complete, use the scan tool to select "DTC", then "Clear Info" function and ensure the following conditions are met: The PCM brake switch signal must indicate 12 volts for 1 seconds with the brake pedal released. 2. Review the scan tool "DTC Info".  Has the last test failed or is the current DTC displayed?	Begin diagnosis again Go to Step 1	Repair verified Exit DTC table

DTC P0730 Transmission Incorrect Gear Ratio



RANGE	GEAR	SOL A N.C.	SOL B N.O.	O/D ROLLER CLUTCH (OFW)	OVERRUN CLUTCH (OC)	FOURTH CLUTCH (C4)	THIRD CLUTCH (C3)	REVERSE CLUTCH (RC)	SECOND CLUTCH (C2)	PRINCIPLE SPRAG ASSEMBLY (PFW)	BAND ASSEMBLY (B)	ENGINE BRAKING
P-N		OFF	ON		APPLIED							NO
R	REVERSE	OFF	ON	LD	APPLIED			APPLIED		LD		NO
D	1ST	OFF	ON	LD	APPLIED					LD	APPLIED	NO
	2ND	ON	ON	LD	APPLIED				APPLIED	FW	APPLIED	YES
	3RD	ON	OFF	LD	APPLIED		APPLIED		APPLIED	NE		YES
	4TH	OFF	OFF	FW		APPLIED	APPLIED		APPLIED	NE		YES
3	1ST	OFF	ON	LD	APPLIED					LD	APPLIED	NO
	2ND	ON	ON	LD	APPLIED				APPLIED	FW	APPLIED	YES
	3RD	ON	OFF	LD	APPLIED		APPLIED		APPLIED	NE		YES
2	1ST	OFF	ON	LD	APPLIED		APPLIED			LD	APPLIED	YES
	2ND	ON	ON	LD	APPLIED				APPLIED	FW	APPLIED	YES
L	1ST	OFF	ON	LD	APPLIED		APPLIED			LD	APPLIED	YES

LD : LOCKED IN DRIVE

FW : FREEWHEELING

NE : NOT EFFECTIVE

D07RT015

**Circuit Description**

- The Powertrain Control Module (PCM) calculates the slippage of the converter and transmission based upon the engine speed, the output speed, and the current gear ratio.
- The slippage of the converter at a high enough engine speed is low. The transmission should not slip more than a given value when there is no shift.
- This DTC detects a slip at each gear. This is a type "C" DTC.

- 3 seconds since downshift.
- 3 seconds since garage shift (N→D).
- And one of the following conditions occur:
  - Slip is greater than 508 rpm in 1st gear.
  - Slip is greater than 468 rpm in 2nd gear.
  - Slip is greater than 449 rpm on 3rd gear.
  - Slip is greater than 440 rpm on 4th gear.
- All conditions met for 5.5 seconds.

**Conditions For Setting The DTC**

- No Output Speed Sensor DTC(s) P0722, P0723.
- Not in Park, Neutral, or Reverse.
- Engine speed is greater than 3,500 rpm.
- 3 seconds since upshift.

**Action Taken When The DTC Sets**

- Maximum line pressure.
- The PCM will not illuminate the Malfunction Indicator Lamp (MIL).
- The PCM will illuminate the CHECK TRANS Lamp.

**Conditions For Clearing The DTC/CHECK TRANS Lamp**

- The PCM will turn “off” the CHECK TRANS Lamp after three consecutive ignition cycles without a failure reported.
- The DTC can be cleared from PCM memory by using a scan tool.
- The DTC can also be cleared from memory when the vehicle has made 40 warmup cycles without a failure reported.
- The PCM will cancel the DTC Actions Taken items when the fault conditions no longer exist and the ignition is cycles “off” long enough to power down the PCM.

**Diagnostic Aids**

- Check for intermittent output speed sensor circuit problems.
- Check for possible incorrect calibration. (PCM part No., tire specification, and rear axle ratio)

**Test Description**

The numbers below refer to the step numbers on the diagnostic chart:

3. This step checks for possible low fluid level causing slipping resulting in an undefined gear ratio.
4. This step checks for correct gear ratios for commanded gears.
5. This step checks for low line pressure.

**DTC P0730 Transmission Incorrect Gear Ratio**

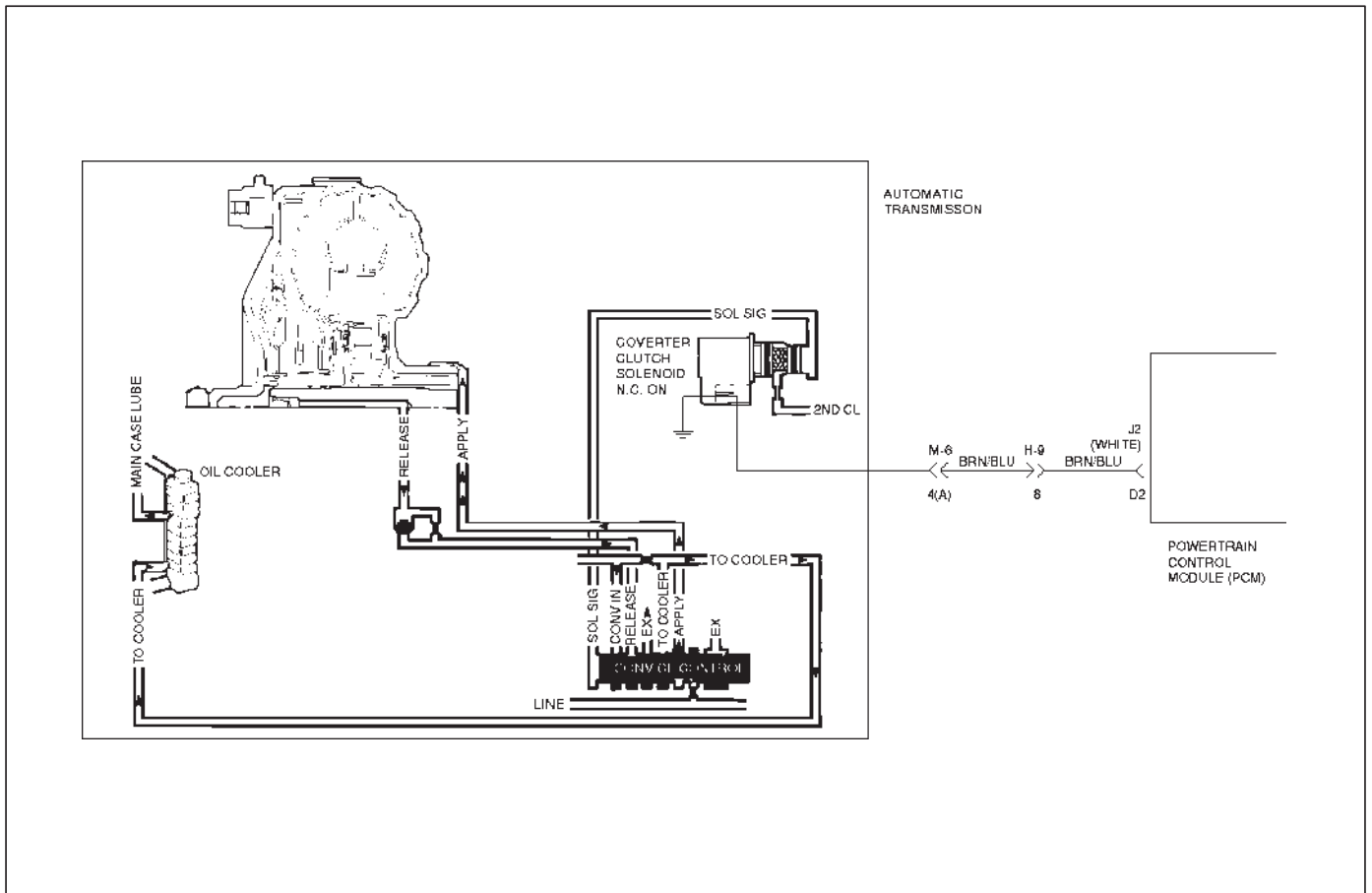
Step	Action	Yes	No
1	Were you sent here from the “On-Board Diagnostic (OBD) System Check”?	Go to Step 2	Go to OBD System Check Refer to Driveability and Emission in Engine section
2	Visually inspect the transmission cooling system for fluid leaks. ○ Refer to Chart 16: Possible Causes of Transmission Fluid Leaks of Mechanical/Hydraulic Diagnosis Symptoms Index in Automatic Transmission (4L30-E) section.  Was condition found and corrected?	Go to Step 7	Go to Step 3
3	Refer to Checking Transmission Fluid Level and Condition in Automatic Transmission (4L30-E) section.  Has transmission fluid checking procedure been performed?	Go to Step 4	Go to Checking Transmission Fluid Level and Condition in Automatic Transmission (4L30-E) section
4	1. Install the scan tool. 2. Turn the ignition switch to the “on” position. 3. Engine not running.  NOTE: Before clearing DTC(s) use the scan tool to record the “Failure Records” for reference, as data will be lost when the “Clear Info” function is used.  4. Record the Failure Record data. 5. Use the scan tool snapshot mode to record transmission gear ratios. 6. Drive vehicle in transmission gear ranges 1, 2, 3, and D with the engine speed is greater than 3,500 rpm for 5.5 seconds. 7. Record each transmission gear. 1st:2.73 – 2.99 2nd:1.54 – 1.71 3rd:0.93 – 1.05 4th:0.66 – 0.78  Does commanded gear ratio match ranges as shown?	Refer to Diagnostic Aids	Go to Step 5

**7A1-58 TRANSMISSION CONTROL SYSTEM (4L30-E)**

**DTC P0730 Transmission Incorrect Gear Ratio (Cont'd)**

Step	Action	Yes	No
5	Perform line pressure check. <input type="radio"/> Refer to Line Pressure Test in Automatic Transmission (4L30-E) section.  Was condition found and corrected?	Go to Step 7	Go to Step 6
6	Check for possible clutch slippage. <input type="radio"/> Refer to Chart 6: Diagnostic Trouble Code (DTC) P0730 of Mechanical/Hydraulic Diagnosis Symptoms Index in Automatic Transmission (4L30-E) section.  Was condition found and corrected?	Go to Step 7	—
7	1. After the repair is complete, use the scan tool to select "DTC", then "Clear info" function. 2. Operate the vehicle under the following conditions: <input type="radio"/> Drive the vehicle in D4 with the engine speed greater than 3,500 rpm to obtain anyone of the following gear ratios for seven seconds.  1st 1:2.73 – 1:2.99 2nd 1:1.54 – 1:1.71 3rd 1:0.93 – 1:1.05 4th 1:0.66 – 1:0.78  Has the last test failed?	Begin diagnosis again Go to Step 1	Repair verified Exit DTC table

## DTC P0742 Torque Converter Clutch (TCC) Circuit Stuck On



### Circuit Description

The PCM energizes the TCC solenoid by creating an ignition voltage on circuit BRN/BLU. When ignition voltage is energized by the PCM, the TCC solenoid stops converter signal oil from exhausting. This causes converter signal oil pressure to increase and move the TCC valve. The TCC solenoid will deenergize when the PCM no longer provides ignition voltage. When the TCC solenoid is deenergized, it will exhaust fluid and release the TCC.

This DTC detects low torque converter slip when the TCC is commanded "off". This is a type "B" DTC.

### Conditions For Setting The DTC

The following conditions occur once per TCC cycle, three consecutive times:

- No TPS DTCs P0122 or P0123.
- No OSS DTCs P0722 or P0723.
- No TCC solenoid DTC P1860.
- TP angle is greater than 20%.
- Engine speed is greater than 500 rpm and less than 3,000 rpm.
- Engine vacuum is between 0 and 70 kpa.
- Commanded gear is not 1st.
- Gear range is D4.
- TCC is commanded "off".
- No TCC Stuck off DTC P1870.

- TCC slip speed is between -20 and 40 rpm for 4 seconds.
- Vehicle speed is greater than 25 km/h (15 mph) and less than 120 km/h (75 mph).
- Speed ratio is greater than 0.9 and less than 1.8.

### Action Taken When The DTC Sets

- The PCM will illuminate the Malfunction Indicator Lamp (MIL) and CHECK TRANS Lamp.
- Inhibit TCC engagement.

### Conditions For Clearing The MIL/DTC

- The PCM will turn off the MIL and CHECK TRANS Lamp after three consecutive ignition cycles without a failure reported.
- The DTC can be cleared from the PCM history by using a scan tool.
- The DTC will be cleared from history when the vehicle has achieved 40 warmup cycles without a failure reported.
- The PCM will cancel the DTC default actions when the fault no longer exists and the ignition is cycled "off" long enough to power down the PCM.

## 7A1-60 TRANSMISSION CONTROL SYSTEM (4L30-E)

### Diagnostic Aids

- If the TCC is mechanically stuck “on” with the parking brake applied and any gear range selected, the TCC fluid will mechanically apply the TCC, possibly causing an engine stall.

### Test Description

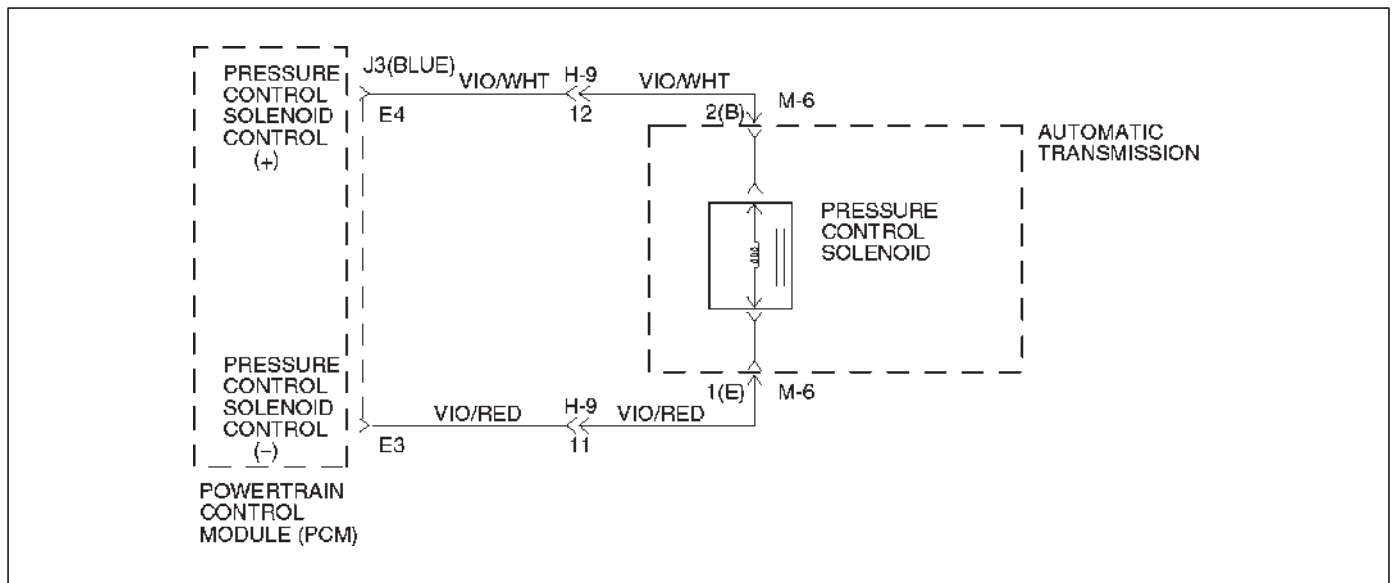
The number below refers to the step number on the diagnostic chart:

3. This test checks the mechanical state of the TCC. (When the PCM commands the TCC solenoid “off”, the slip speed should increase).

### DTC P0742 Torque Converter Clutch (TCC) Circuit Stuck On

Step	Action	Yes	No
1	Were you sent here from the “Powertrain On–Board Diagnostic (OBD) System Check”?	Go to Step 2	Go to OBD System Check Refer to Driveability and Emissions in Engine section
2	1. Install the scan tool. 2. With the engine “off”, turn the ignition switch “on”. NOTE: Before clearing DTC(s), use the scan tool to record “Freeze Frame” and “Failure Records” for reference, as data will be lost when the “Clear Info” function is used. 3. Record the DTC “Freeze Frame” and “Failure Records”. 4. Using the scan tool, verify the “TP Sensor” operation. Are the “TP Sensor” values within 0.6 – 5.0 volts?	Go to Step 3	Go to Diagnostic Aids
3	Drive the vehicle in the D4 drive range in fourth gear under steady acceleration, with a TP angle greater than 20%. Does the scan tool display “TCC Slip Speed” between –30 and +30 rpm, while the displayed TCC solenoid state is “off”?	Go to Step 4	Go to Diagnostic Aids
4	The TCC is mechanically stuck “on”. Check the following items: ○ Clogged exhaust orifice in the TCC solenoid. ○ Converter clutch apply valve stuck in the apply position. ○ Misaligned or damaged valve body gasket. ○ Restricted release passage. Was a problem found and corrected?	Go to Step 5	—
5	1. After the repair is complete, use the scan tool to select “DTC”, then “Clear Info” function and ensure the following conditions are met: TCC slip speed must be between 200 and 2,500 rpm for 4 seconds. 2. Review the scan tool “DTC Info”. Has the last test failed or is the current DTC displayed?	Begin diagnosis again Go to Step 1	Repair verified Exit DTC table



**DTC P0748 Pressure Control Solenoid (PCS) (Force Motor) Circuit Electrical**

D07RX008

**Circuit Description**

The PCS is a PCM-controlled device used to regulate transmission line pressure. The PCM compares TPS voltage, engine rpm, and other inputs to determine the line pressure appropriate for a given load. The PCM will regulate the pressure by applying a varying amperage to the PCS. The applied amperage can vary from 0.1 to 1 amp, and is monitored by the PCM.

This DTC detects a continuous open or short to ground in the PCS circuit or the PCS. This is a type "C" DTC.

**Conditions For Setting The DTC**

- Battery voltage is between 10 and 16 volts.
- The PCM detects that the different between commanded and actual current is 200 milliamperes (mA) for over 1 second.

**Action Taken When the DTC Sets**

- The PCM will not illuminate the Malfunction Indicator Lamp (MIL).
- Maximum line pressure.
- The PCM will illuminate the CHECK TRANS Lamp.

**Conditions For Clearing The DTC/CHECK TRANS Lamp**

- The PCM will turn "off" the CHECK TRANS Lamp after three consecutive ignition cycles without a failure reported.

- The DTC can be cleared from PCM history by using a scan tool.
- The DTC will be cleared from memory when the vehicle has achieved 40 warmup cycles without a failure reported.
- The PCM will cancel the DTC default actions when the fault no longer exists and the ignition is cycled "off" long enough to power down the PCM.

**Diagnostic Aids**

- Inspect the wiring for poor electrical connection at the PCM and at the transmission 5-way connector. Look for possible bent, backed out, deformed or damaged terminals. Check for weak terminal tension as well. Also check for a chafed wire that could short to bare metal or other wiring. Inspect for a broken wire inside the insulation.
- When diagnosing for a possible intermittent short or open condition, move the wiring harness while observing test equipment for a change.

**Test Description**

The numbers below refer to the step numbers on the diagnostic chart:

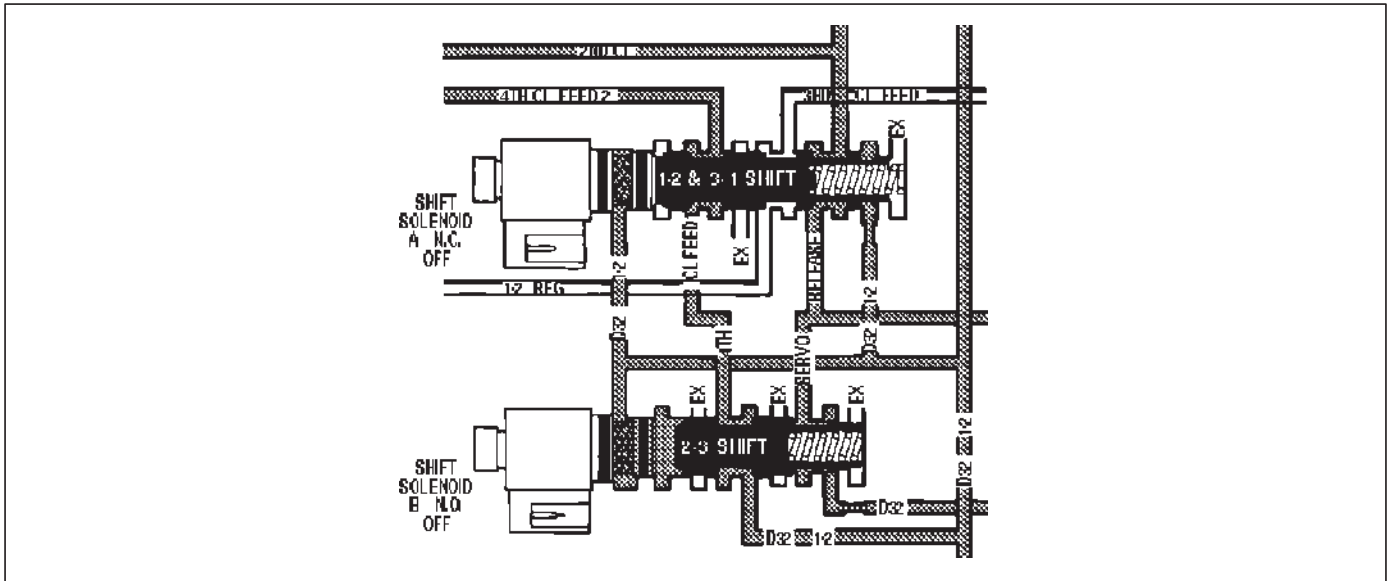
2. This test checks the ability of the PCM to command the PCS.
3. This test checks the PCS and internal wiring harness for incorrect resistance.

## 7A1-62 TRANSMISSION CONTROL SYSTEM (4L30-E)

### DTC P0748 Pressure Control Solenoid (PCS) (Force Motor) Circuit Electrical

Step	Action	Yes	No
1	Were you sent here from the "Powertrain On-Board Diagnostic (OBD) System Check"?	Go to Step 2	Go to OBD System Check Refer to Driveability and Emission in Engine section
2	<p>1. Install the scan tool.</p> <p>2. With the engine "off", turn the ignition switch "on".</p> <p>NOTE: Before clearing DTC(s), use the scan tool to record "Failure Records" for reference, as data will be lost when the "Clear Info" function is used.</p> <p>3. Record the DTC "Failure Records".</p> <p>4. While the engine is operating, put the transmission in Park.</p> <p>5. Using the scan tool, apply 0.1 amp through 1.0 amp while observing "PC Ref. Current" and "PC Act. Current".</p> <p>Is the "PC Act. Current" reading always within 0.16 amp?</p>	Go to Diagnostic Aids	Go to Step 3
3	<p>1. Turn the ignition "off".</p> <p>2. Disconnect the transmission 5-way connector M-6.</p> <p>3. Using the J39200 DVOM, measure the resistance between terminals M6-2(B) and M6-1(E).</p> <p>Is the resistance within 3-7 ohms?</p>	Go to Step 7	Go to Step 4
4	<p>1. Remove the transmission oil pan. Refer to Solenoid (Adapter Case Valve Body) in Automatic Transmission (4L30-E) section.</p> <p>2. Disconnect the internal wiring harness at the PCS.</p> <p>3. Measure the resistance of the PCS.</p> <p>Is the resistance within 3-7 ohms?</p>	Go to Step 6	Go to Step 5
5	<p>Replace the PCS.</p> <p>Is the replacement complete?</p>	Go to Step 10	—
6	<p>Repair the internal wiring harness for an open.</p> <p>Is the repair complete?</p>	Go to Step 10	—
7	<p>Inspect/repair circuits J3-E4, M6-2(B), J3-E3, and M6-1(E).</p> <p>Was a problem found?</p>	Go to Step 10	Go to Step 8
8	<p>Inspect/repair circuits J3-E4, M6-2(B), J3-E3, and M6-1(E) for a short to ground or poor connections.</p> <p>Was a problem found?</p>	Go to Step 10	Go to Step 9
9	<p>Replace the PCM. Refer to Powertrain Control Module (PCM) in Automatic Transmission (4L30-E) section.</p> <p>Is the replacement complete?</p>	Go to Step 10	—
10	<p>1. After the repair is complete, use the scan tool to select "DTC", then "Clear Info" function and ensure the following conditions are met: The PCS duty cycle is not at its electrical high or low limit.</p> <p>2. Review the scan tool "DTC Info".</p> <p>Has the last test failed or is the current DTC displayed?</p>	<p>Begin diagnosis again</p> <p>Go to Step 1</p>	<p>Repair verified</p> <p>Exit DTC table</p>

## DTC P0751 Shift Solenoid A Performance Without Input Speed



D07RT01

### Circuit Description

The shift solenoid A is used to control fluid flow acting on the 1–2 and 3–4 shift valves. The solenoid is a normally close exhaust valve that is used with the shift solenoid B to allow four different shifting combinations.

The DTC detects a 2–3 only or a 1–4 only shift pattern depending on the state of the mechanical failure. This is a type “B” DTC.

### Conditions For Setting The DTC

- No TPS DTCs P0122 or P0123.
- No OSS DTCs P0722 or P0723.
- No TCC solenoid DTC P0742, P1860.
- No shift solenoid A DTC P0753.
- No shift solenoid B DTC P0758.
- Gear range is D4.
- Vehicle speed is greater than 10 km/h (6.25 mph).
- Transmission temperature is between 20° and 125°C (68° and 257°F).

All the above conditions have been met and the combination of conditions 1, 2, 3, and 4 or 1, 2, 3, and 5 occur two consecutive times.

#### Condition 1:

- Commanded 1–2 shift.
- TP angle is between 10 and 60%.
- TP angle is constant within +/-3%.
- Vehicle speed is between 18 and 50 km/h (11 and 31 mph).
- Within 2.2 seconds, the engine speed in 2nd gear must be 100 rpm greater than the last speed in 1st gear.

#### Condition 2:

- Commanded 2–3 shift.
- TP angle is between 13 and 60%.

- TP angle is constant within +/-5%.
- Vehicle speed is between 30 and 88 km/h (20 and 45 mph).
- Within 2 seconds, the engine speed in 3rd gear must be 64 rpm less than the last speed in 2nd gear.

#### Condition 3:

- Commanded 3–4 shift.
- TP angle is between 7 and 60%.
- TP angle is constant within +/-5%.
- Vehicle speed is between 40 and 140 km/h (25 and 87 mph).
- Within 0.7 seconds, the engine speed in 4th gear must be –60 rpm greater than the last speed in 3rd gear.

#### Condition 4:

- Commanded 4th gear.
- TCC is “on”.
- TP angle is between 15 and 60%.
- Speed ratio is between 0.85 and 1.2 (speed ratio is engine speed ÷ output speed).
- TCC slip speed is between 100 and 2,000 rpm for 3 seconds.

#### Condition 5:

- Commanded 4th gear.
- TCC is “on”.
- TP angle is between 13 and 60%.
- Speed ratio is between 0.5 and 0.85.
- TCC slip speed is between –50 and 500 rpm for 3 seconds.

### Action Taken When the DTC Sets

- Maximum line pressure.

## 7A1-64 TRANSMISSION CONTROL SYSTEM (4L30-E)

- The PCM will illuminate the Malfunction Indicator Lamp (MIL) and CHECK TRANS Lamp.

### Conditions For Clearing The The MIL/DTC

- The PCM will turn off the MIL and CHECK TRANS Lamp after three consecutive ignition cycles without a failure reported.
- The DTC can be cleared from the PCM history by using a scan tool.
- The DTC will be cleared from history when the vehicle has achieved 40 warmup cycles without a failure reported.
- The PCM will cancel the DTC default actions when the fault no longer exists and the ignition is cycled "off" long enough to power down the PCM.

### Diagnostic Aids

- Verify that the transmission meets the specifications in the 4L30-E shift speed chart.

- Other internal transmission failures may cause more than one shift to occur.
- A shift solenoid A performance problem could set a shift solenoid B DTC P0756 or a transmission component slipping DTC P1870.

### Test Description

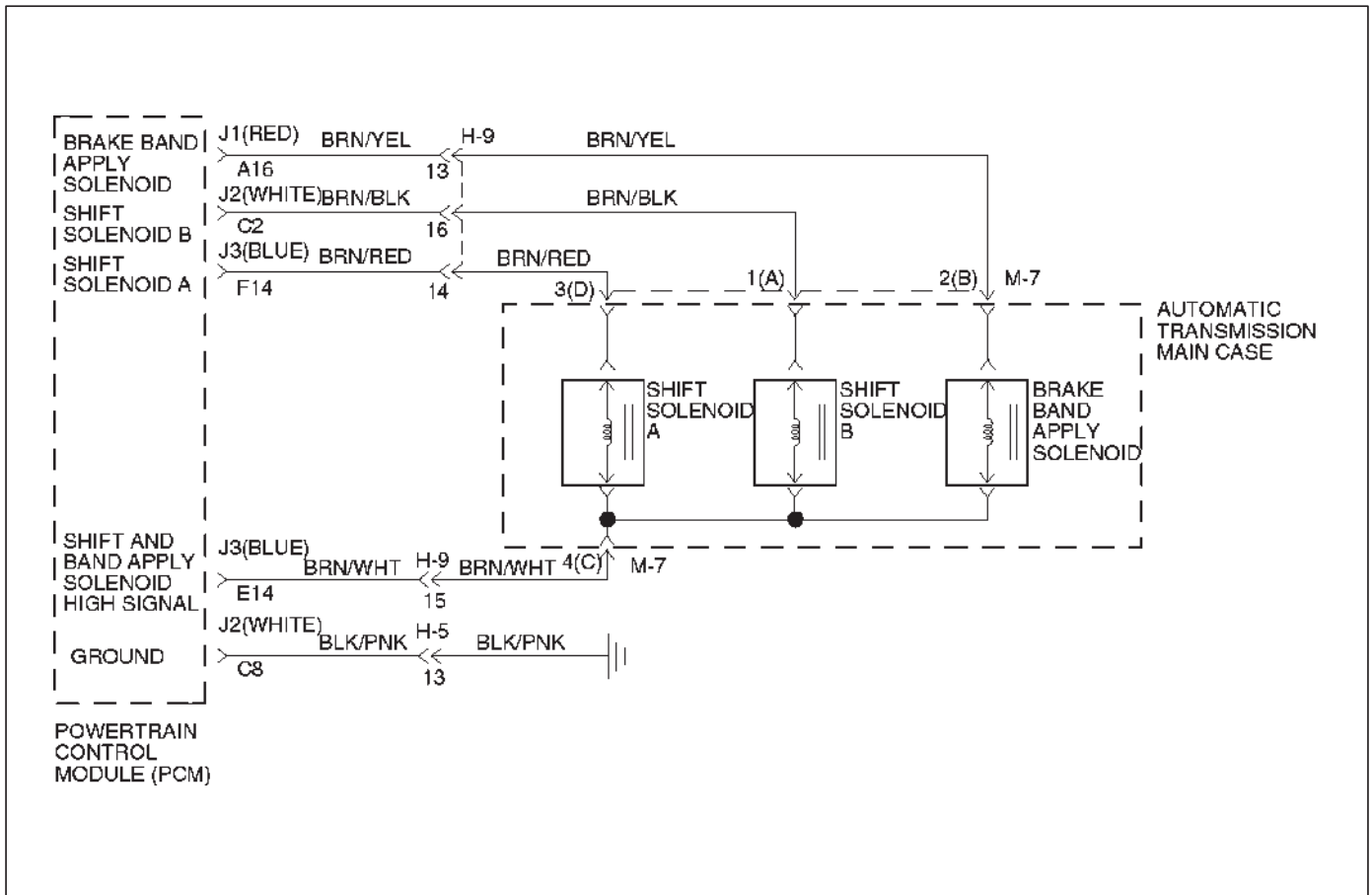
The numbers below refer to the step numbers on the diagnostic chart:

- This test checks the function of the range switch (mode switch).
- This test checks that the scan tool commanded all shifts, all shifts solenoids responded correctly, but all the shifts did not occur.

### DTC P0751 Shift Solenoid A Performance Without Input Speed

Step	Action	Yes	No
1	Were you sent here from the "Powertrain On-Board Diagnostic (OBD) System Check"?	Go to Step 2	Go to OBD System Check Refer to Driveability and Emissions in Engine section
2	1. Install the scan tool. 2. With the engine "off", turn the ignition switch "on". NOTE: Before clearing DTC(s), use the scan tool to record "Freeze Frame" and "Failure Records" for reference, as data will be lost when the "Clear Info" function is used. 3. Record the DTC "Freeze Frame" and "Failure Records". 4. With the engine operating, apply the brake pedal and select each transmission range D1, D2, D3, D4, N, R, and P. Does each selected transmission range match the "TR Switch" on the scan tool?	Go to Step 3	Go to "Range Switch Logic Table"
3	1. While the engine is operating, raise the drive wheels. 2. With the transmission in D4 range, use the scan tool to command 1st, 2nd and 3rd, and 4th gears while accelerating the vehicle. Was a 2-3 or 1-4 only shift pattern detected? (Road testing the vehicle may be necessary).	Go to Step 4	Go to Diagnostic Aids
4	Check the shift solenoid/hydraulic circuit for: ○ One or both of the shift solenoids for an internal malfunction. ○ Contamination or sediment in one or both of the shift solenoids. ○ Damaged seals on one or both of the shift solenoids. Refer to Solenoid (Main Case Valve Body) in Automatic Transmission (4L30-E) section. Was a problem found and corrected?	Go to Step 5	Go to Diagnostic Aids
5	1. After the repair is complete, use the scan tool to select "DTC", then "Clear Info" function and road test the vehicle. 2. Review the scan tool "DTC Info". Has the last test failed or is the current DTC displayed?	Begin diagnosis again Go to Step 1	Repair verified Exit DTC table

## DTC P0753 Shift Solenoid A Electrical



### Circuit Description

- The shift solenoid A is a simple on/off solenoid located in the main case valve body. The solenoid is the normally closed type. In second or third gear, the Powertrain Control Module (PCM) energizes the solenoid to open a fluid inlet port. When the port is open, fluid pressure actuates the shift valve.
- The solenoid is activated by current. This current is produced by applying a voltage to one side (the High side) and a ground to the other side (Low side).
- The High Side Driver (HSD) is a circuit of the PCM that acts as a switch between the solenoids and the supply voltage. The High side of the solenoid is permanently supplied with voltage, except in BACKUP MODE or when ignition is off the HSD is turned off.

This DTC detects a continuous open or short to ground in the shift solenoid A circuit or the shift solenoid A. This is a type "B" DTC.

### Conditions For Setting The DTC

- Ignition is "on", Engine "run".
- Battery voltage is between 10 and 16 volts.
- The PCM commands the solenoid "on" and the voltage remains high (B+) or the PCM commands the solenoid "off" and the voltage remains low (zero volts).
- All conditions met for 0.33 seconds.

### Action Taken When The DTC Sets

- Maximum line pressure.
- Immediate landing to 4th gear.
- Inhibit TCC engagement.
- The PCM will illuminate the Malfunction Indicator Lamp (MIL) and CHECK TRANS Lamp.

### Conditions For Clearing The MIL/DTC

- The PCM will turn off the MIL and CHECK TRANS Lamp after three consecutive ignition cycles without a failure reported.
- The DTC can be cleared from the PCM history by using a scan tool.
- The DTC will be cleared from history when the vehicle has achieved 40 warmup cycles without a failure reported.
- The PCM will cancel the DTC default actions when the fault no longer exists and the ignition is cycled "off" long enough to power down the PCM.

### Diagnostic Aids

- Inspect the wiring for poor electrical connection at the PCM and at the transmission 16-way connector. Look for possible bent, backed out, deformed or damaged terminals. Check for weak terminal tension as well. Also check for a chafed wire that could short to bare metal or other wiring. Inspect for a broken wire inside the insulation.

## 7A1–66 TRANSMISSION CONTROL SYSTEM (4L30–E)

- When diagnosing for a possible intermittent short or open condition, move the wiring harness while observing test equipment for a change.
- An open ignition feed circuit can cause multiple DTCs to set.
- A shift solenoid B DTC P0756 could also set with a shift solenoid A electrical failure.

### Test Description

The numbers below refer to the step numbers on the diagnostic chart:

3. This test checks for power to the shift solenoid A from the ignition through the PCM.

5. This test measures the resistance of the component.
9. This test checks the function of the shift solenoid A and the transmission internal wiring harness.

### Shift Solenoid Status Chart

Gear	Shift solenoid A	Shift solenoid B
1st	OFF	ON
2nd	ON	ON
3rd	ON	OFF
4th	OFF	OFF

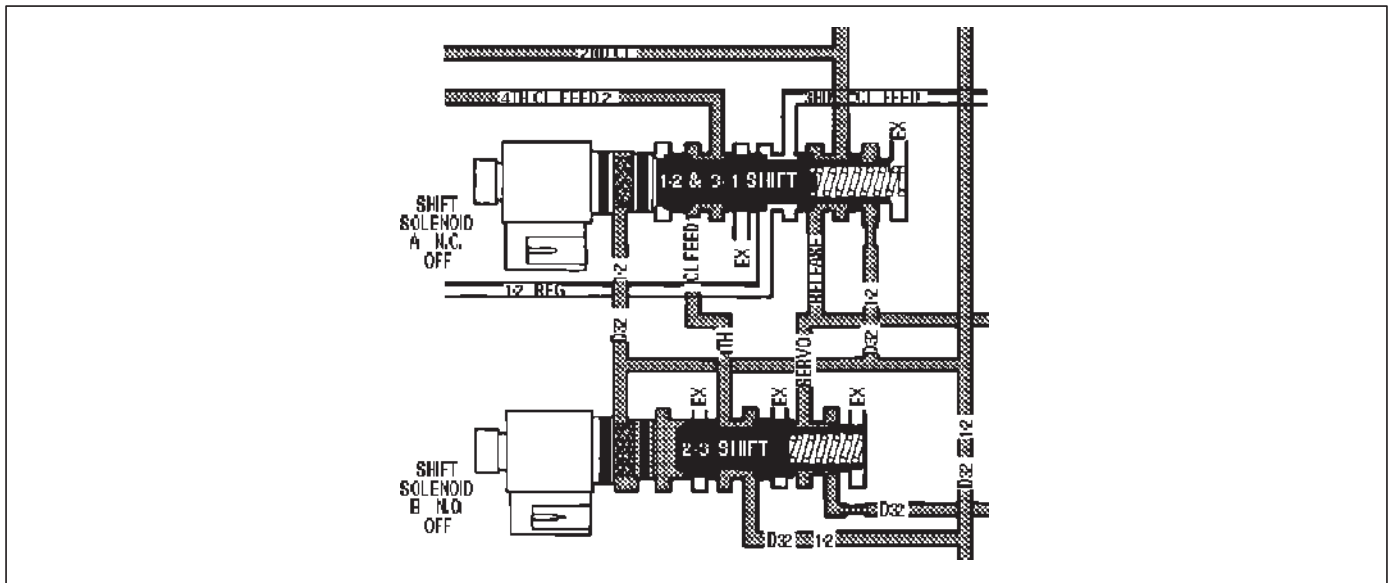
### DTC P0753 Shift Solenoid A Electrical

Step	Action	Yes	No
1	Were you sent here from the "Powertrain On–Board Diagnostic (OBD) System Check"?	Go to Step 2	Go to OBD System Check Refer to Driveability and Emissions in Engine section
2	1. Install the scan tool. 2. With the engine "on", turn the ignition switch "on". NOTE: Before clearing DTC(s), use the scan tool to record "Freeze Frame" and "Failure Records" for reference, as data will be lost when the "Clear Info" function is used. 3. Record the DTC "Freeze Frame" and "Failure Records". Were DTCs P0753, P0758, P1860 set?	Go to Step 3	Go to Diagnostic Aids
3	1. Turn the ignition "on". 2. Using the J39200 DVOM, measure the voltage between PCM connector terminals J3–E14 and J2–C8 (GND). Is the voltage within 10–12 volts?	Go to Step 4	Go to Step 5
4	1. Turn the ignition "off". 2. Disconnect the J3 (BLUE) PCM connector. 3. Turn the ignition "on". 4. Using the J39200 DVOM, measure the voltage between PCM connector terminals J3–F14 and ground. Is the voltage within 10 – 12 volts?	Go to Step 11	Go to Step 5
5	1. Turn the ignition "off". 2. Disconnect the J3 (BLUE) PCM connector. 3. Using the J39200 DVOM, measure the resistance between PCM connector terminals J3–E14 and J3–F14. Is the resistance within 18 – 20 ohms?	Go to Step 6	Go to Step 7
6	1. Disconnect the J1 (RED) and J2 (WHITE) PCM connectors. 2. Using the J39200 DVOM, check a continuity between PCM terminals J3–F14 and ground. Is there a continuity?	Go to Step 12	Go to Step 8
7	1. Disconnect the 16–way harness connector H–9. 2. Using the J39200 DVOM, measure the resistance between terminals H9–14 and H9–15. Is the resistance within 18–20 ohms?	Go to Step 14	Go to Step 9

**DTC P0753 Shift Solenoid A Electrical (Cont'd)**

Step	Action	Yes	No
8	Using the J39200 DVOM, check a continuity between J3 (BLUE) PCM terminal E14 and ground. Is there a continuity?	Go to Step 13	Go to Step 10
9	1. Disconnect the transmission main case 4 pin connector M-7. 2. Using the J39200 DVOM, measure the resistance between terminals M7-3(D) and M7-4(C). Is the resistance within 18-20 ohms?	Go to Step 15	Go to Step 16
10	Check every connection at the PCM connector. Was a problem found?	Go to Step 18	Go to Step 17
11	The wiring harness between PCM connector terminals J3-F14 and transmission harness terminal M7-3(D) is shorted to voltage. Was a problem found and corrected?	Go to Step 19	—
12	The wiring harness between PCM connector terminal J3-F14 and transmission harness terminal M7-3(D) is shorted to ground. Was a problem found and corrected?	Go to Step 19	—
13	The wiring harness between PCM connector terminals J3-E14 and transmission harness terminal M7-4(C) is shorted to ground. Was a problem found and corrected?	Go to Step 19	—
14	The wiring harness between PCM connector J3 and transmission 16-way connector H-9 is open or poor connection. Was a problem found and corrected?	Go to Step 19	—
15	The wiring harness between transmission 16-way connector H-9 and transmission main case connector M-7 is open or has a poor connection. Was a problem found and corrected?	Go to Step 19	—
16	The shift solenoid A is faulty. Replace the shift solenoid A. Refer to Solenoid (Main Case Valve Body) in Automatic Transmission (4L30-E) section. Is the replacement complete?	Go to Step 19	—
17	The PCM may be faulty. Replace the PCM. Refer to Powertrain Control Module (PCM) in Automatic Transmission (4L30-E) section. Is the replacement complete?	Go to Step 19	—
18	Repair the PCM connector connection. Was a problem found and corrected?	Go to Step 19	—
19	1. After the repair is complete, use the scan tool to select "DTC", then "Clear Info" function and operate the vehicle under the following conditions: ○The shift solenoid A is commanded "on" and voltage drops to zero. ○The shift solenoid A is commanded "off" and voltage increases to B+. 2. Review the scan tool "DTC Info". Has the last test failed or is the current DTC displayed?	Begin diagnosis again Go to Step 1	Repair verified Exit DTC table

## DTC P0756 Shift Solenoid B Performance Without Input Speed



D07RT01

### Circuit Description

The shift solenoid B is used to control fluid flow acting on the 2–3 shift valves. The solenoid is a normally open exhaust valve that is used with the shift solenoid (A) to allow four different shift combinations.

This DTC detects a non 2–3 upshift and a non 1st gear when 1st gear is commanded, or 1st gear when 4th gear is commanded. This is a type “B” DTC.

### Conditions For Setting The DTC

- No TPS DTCs P0122 or P0123.
- No OSS DTCs P0722 or P0723.
- No TCC solenoid DTC P0742, P1860.
- No shift solenoid DTCs P0753, P0758.
- Vehicle speed is greater than 10 km/h (6.25 mph).
- Gear range is D4.
- Engine vacuum is between 0 and 70 kpa.
- Engine speed is less than 6,000 rpm.
- Transmission fluid temperature is between 20° and 125°C (68° and 257°F).
- TCC is “off”.

All of the above conditions have been met and either one of the following fail conditions occurs:

- The solenoid is stuck “on” and conditions 3 and 4 are present two consecutive times.
- The solenoid is stuck “off” and conditions 1 and 3 are present two consecutive times.

### Condition 1:

- TP angle is greater than 45%.
- 1st gear is commanded for 3 seconds.
- Speed ratio is between 0.5 and 2.65 (speed ratio is engine speed ÷ output speed).
- Transmission output speed is between 320 and 2,000 rpm.
- TCC slip speed is between –200 and –4,000 rpm for 1.8 seconds.

### Condition 2:

- Not used.

### Condition 3:

- Commanded 2–3 shift.
- TP angle is between 10 and 60%.
- TP angle is within +/-5%.
- 3rd gear is commanded for 2 seconds.
- 3rd gear speed ratio is greater than the last 2nd gear speed ratio minus 0.05.
- 3rd gear TCC slip speed is greater than or equal to the last 2nd gear TCC slip speed plus 520 rpm for 1.8 seconds.
- Discontinue test if time since shift commanded is 5.57 seconds.

### Condition 4:

- TP angle is greater than 10%.
- 4th gear is commanded for 1 second.
- Speed ratio is between 2.0 and 4.0.
- Transmission output speed is between 0 and 8,192 rpm.
- TCC slip speed is between 2,000 and 5,000 rpm for 3 seconds.

### Action Taken When the DTC Sets

- Maximum line pressure.
- The PCM will illuminate the Malfunction Indicator Lamp (MIL) and CHECK TRANS Lamp.

### Conditions For Clearing The MIL/DTC

- The PCM will turn off the MIL and CHECK TRANS Lamp after three consecutive ignition cycles without a failure reported.
- The DTC can be cleared from the PCM history by using a scan tool.



- The DTC will be cleared from history when the vehicle has achieved 40 warmup cycles without a failure reported.
- The PCM will cancel the DTC default actions when the fault no longer exists and the ignition is cycled "off" long enough to power down the PCM.

**Diagnostic Aids**

- A shift solenoid A electrical failure could also set a shift solenoid B performance DTC P0756.

- A shift solenoid B electrical failure could also set a shift solenoid B performance DTC P0756.

**Test Description**

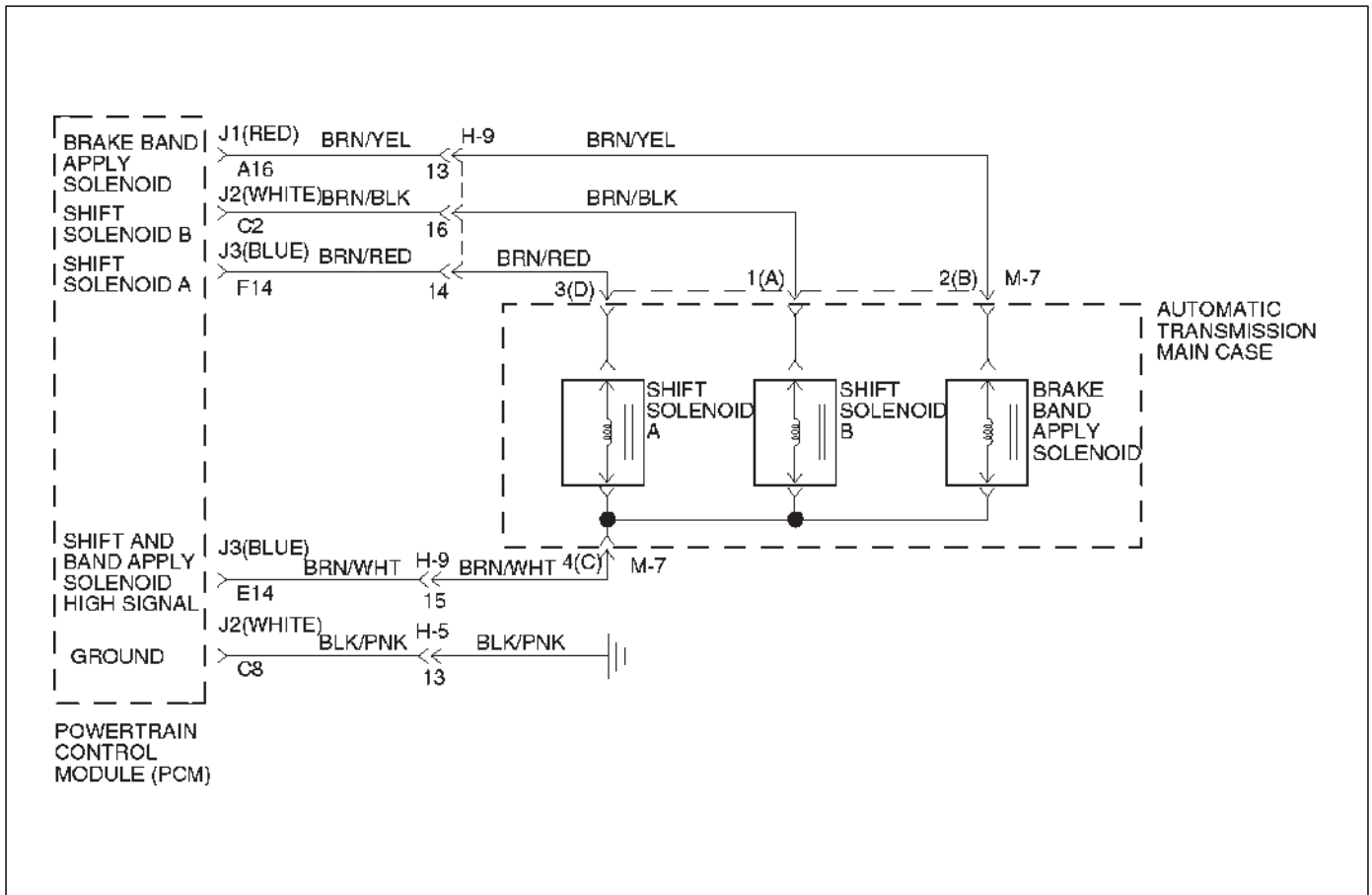
The numbers below refer to the step numbers on the diagnostic chart:

2. This test checks the function of the range switch (mode switch).
3. This test checks for selected gear ratio vs. a ratio not obtainable under normal driving conditions.

**DTC P0756 Shift Solenoid B Performance Without Input Speed**

Step	Action	Yes	No
1	Were you sent here from the "Powertrain On-Board Diagnostic (OBD) System Check"?	Go to Step 2	Go to OBD System Check Refer to Driveability and Emissions in Engine section
2	1. Install the scan tool. 2. With the engine "off", turn the ignition switch "on". NOTE: Before clearing DTC(s), use the scan tool to record "Freeze Frame" and "Failure Records" for reference, as data will be lost when the "Clear Info" function is used. 3. Record the DTC "Freeze Frame" and "Failure Records". 4. With the engine operating, apply the brake pedal and select each transmission range D1, D2, D3, D4, N, R, and P. Does each selected transmission range match the "TR Switch" on the scan tool?	Go to Step 3	Go to "Range Switch Logic Table"
3	1. While the engine is operating, raise the drive wheels. 2. With the transmission in D4 range, use the scan tool to command 1st, 2nd, and 3rd, and 4th gears while accelerating the vehicle. Was 1st gear commanded and not achieved, or 4th gear commanded and other than 4th gear occurred? (Road testing the vehicle may be necessary.)	Go to Step 4	Go to Diagnostic Aids
4	Check the shift solenoid/hydraulic circuit for: ○ One or both of the shift solenoids for an internal malfunction. ○ Contamination or sediment in one or both of the shift solenoids. ○ Damaged seals on the one or both of the shift solenoids. Refer to Solenoid (Main Case Valve Body) in Automatic Transmission (4L30-E) section. Was a problem found and corrected?	Go to Step 5	Go to Diagnostic Aids
5	1. After the repair is complete, use the scan tool to select "DTC", then "Clear Info" function and road test the vehicle. 2. Review the scan tool "DTC Info". Has the last test failed or is the current DTC displayed?	Begin diagnosis again Go to Step 1	Repair verified Exit DTC table

DTC P0758 Shift Solenoid B Electrical



Circuit Description

- The shift solenoid B is a simple on/off solenoid located in the main case valve body. It is normally open. When the port is open, fluid pressure actuates the shift valve. In first or second gear, the Powertrain Control Module (PCM) energizes the solenoid to close a fluid inlet port.
- The solenoid is activated by current. This current is provided by applying a voltage to one side (the High side) and a ground to the other side (Low side).
- The High Side Driver (HSD) is a circuit of the PCM that acts as a switch between the solenoids and the supply voltage. The High side of the solenoid is permanently supplied with voltage. In BACKUP MODE or when the ignition is off, the HSD is turned off.

This DTC detects a continuous open or short to ground in the shift solenoid B circuit or shift solenoid B. This is a type "B" DTC.

Conditions For Setting The DTC

- Ignition is "on", Engine "run".
- Battery voltage is between 10 and 16 volts.
- The PCM commands the solenoid "on" and the voltage remains high (B+) or the PCM commands the solenoid "off" and the voltage remains low (zero volts).
- All conditions met for 0.33 seconds.

Action Taken When The DTC Sets

- Fixed to 4th gear.
- Maximum line pressure.
- Inhibit TCC engagement.
- The PCM will illuminate the Malfunction Indicator Lamp (MIL) and CHECK TRANS Lamp.

Conditions For Clearing The MIL/DTC

- The PCM will turn off the MIL and CHECK TRANS Lamp after three consecutive ignition cycles without a failure reported.
- The DTC can be cleared from the PCM history by using a scan tool.
- The DTC will be cleared from history when the vehicle has achieved 40 warmup cycles without a failure reported.
- The PCM will cancel the DTC default actions when the fault no longer exists and the ignition is cycled "off" long enough to power down the PCM.

Diagnostic Aids

- Inspect the wiring for poor electrical connections at the PCM and at the transmission 16-way connector. Look for possible bent, backed out, deformed or damaged terminals. Check for weak terminal tension as well. Also check for a chafed wire that could short to bare metal or other wiring. Inspect for a broken wire inside the insulation.

- When diagnosing for a possible intermittent short or open condition, move the wiring harness while observing test equipment for a change.

**Shift Solenoid Status Chart**

Gear	Shift solenoid A	Shift solenoid B
1st	OFF	ON
2nd	ON	ON
3rd	ON	OFF
4th	OFF	OFF

**Test Description**

The numbers below refer to the step numbers on the diagnostic char:

- 5. This test measures the resistance of the component.
- 7. This test checks the function of the shift solenoid B and the transmission internal wiring harness.
- 11. This test checks for power to the shift solenoid B from the ignition through the PCM.

**DTC P0758 Shift Solenoid B Electrical**

Step	Action	Yes	No
1	Were you sent here from the "Powertrain On-Board Diagnostic (OBD) System Check"?	Go to Step 2	Go to OBD System Check Refer to Driveability and Emissions in Engine section
2	1. Install the scan tool. 2. With the engine "on", turn the ignition switch "on". NOTE: Before clearing DTC(s), use the scan tool to record "Freeze Frame" and "Failure Records" for reference, as data will be lost when the "Clear Info" function is used. 3. Record the DTC "Freeze Frame" and "Failure Records". Were DTCs P0753, P0758, P1860 set?	Go to Step 4	Go to Step 3
3	1. The engine "on". 2. Apply brake pedal and select transmission range "D". 3. Press and hold down the winter switch and select transmission mode "winter". Does the scan tool display DTC P0758 at 3rd gear?	Go to Step 8	Go to Diagnostic Aids
4	1. Turn the ignition "off". 2. Disconnect the J2 (WHITE) and J3 (BLUE) PCM connectors. 3. Turn the ignition "on". 4. Using the J39200 DVOM, measure the voltage between PCM connector terminals J2-C2 and J2-C8. Is the voltage within 10 – 12 volts?	Go to Step 15	Go to Step 5
5	1. Turn the ignition "off". 2. Using the J39200 DVOM, measure the resistance between PCM connector terminals J2-C2 and J3-E14. Is the resistance within 18 – 20 ohms?	Go to Step 16	Go to Step 6
6	1. Disconnect the transmission 16-way connector H-9. 2. Using the J39200 DVOM, measure the resistance between terminals H9-16 and H9-15. Is the resistance within 18 – 20 ohms?	Go to Step 17	Go to Step 7
7	1. Disconnect the transmission main case connector M-7. 2. Using the J39200 DVOM, measure the resistance between terminals M7-1(A) and M7-4(C). Is the resistance within 18 – 20 ohms?	Go to Step 18	Go to Step 19

## 7A1-72 TRANSMISSION CONTROL SYSTEM (4L30-E)

### DTC P0758 Shift Solenoid B Electrical (Cont'd)

Step	Action	Yes	No
8	<ol style="list-style-type: none"> <li>1. Turn the ignition "off".</li> <li>2. Disconnect the J2 (WHITE) and J3 (BLUE) PCM connectors.</li> <li>3. Using the J39200 DVOM, measure the resistance between PCM connector terminals J2-C2 and J3-E14.</li> </ol> <p>Is the resistance within 18 – 20 ohms?</p>	Go to Step 9	Go to Step 10
9	<p>Using the J39200 DVOM, check a continuity between PCM connector terminal J2-C2 and ground.</p> <p>Is there a continuity?</p>	Go to Step 20	Go to Step 11
10	<ol style="list-style-type: none"> <li>1. Disconnect the transmission 16-way connector H-9.</li> <li>2. Using the J39200 DVOM, measure the resistance between terminals H9-16 and H9-15.</li> </ol> <p>Is the resistance within 18-20 ohms?</p>	Go to Step 21	Go to Step 12
11	<p>Using the J39200 DVOM, check a continuity between PCM connector terminal J3-E14 and ground.</p> <p>Is there a continuity?</p>	Go to Step 22	Go to Step 13
12	<ol style="list-style-type: none"> <li>1. Disconnect the transmission main case connector M-7.</li> <li>2. Using the J39200 DVOM, measure the resistance between terminals M7-1(A) and M7-4(C).</li> </ol> <p>Is the resistance within 18 – 20 ohms?</p>	Go to Step 23	Go to Step 24
13	<p>Check every connection of the PCM and transmission 16-way connector H-9.</p> <p>Was a problem found and corrected?</p>	Go to Step 26	Go to Step 14
14	<ol style="list-style-type: none"> <li>1. Connect the J2 (WHITE) and J3 (BLUE) PCM connectors to the PCM.</li> <li>2. Turn the ignition "on", the engine "on".</li> <li>3. Repeat Step 3.</li> </ol> <p>Does the scan tool display DTC P0758 at 3rd gear?</p>	Go to Step 25	Go to Diagnostic Aids
15	<p>The wiring harness between PCM connector terminal J2-C2 and transmission main case terminal M7-1(A) is shorted to voltage.</p> <p>Was a problem found and corrected?</p>	Go to Step 26	—
16	<p>The PCM internal terminal J2-C2 is shorted to voltage. Replace the PCM. Refer to Powertrain Control Module (PCM) in Automatic Transmission (4L30-E) section.</p> <p>Is the replacement complete?</p>	Go to Step 26	—
17	<p>The wiring harness between PCM connector and transmission 16-way connector is shorted.</p> <p>Was a problem found and corrected?</p>	Go to Step 26	—
18	<p>The wiring harness between transmission 16-way connector and transmission main case connector is shorted.</p> <p>Was a problem found and corrected?</p>	Go to Step 26	—
19	<p>The shift solenoid B is faulty, or the internal wiring harness from the shift solenoid B is shorted.</p> <p>Was a problem found and corrected?</p>	Go to Step 26	—
20	<p>The wiring harness between PCM connector terminal J2-C2 and transmission main case connector terminal M7-1(A) is shorted to ground.</p> <p>Was a problem found and corrected?</p>	Go to Step 26	—

**DTC P0758 Shift Solenoid B Electrical (Cont'd)**

Step	Action	Yes	No
21	The wiring harness between PCM connector terminal J2-C2 and transmission 16-way connector terminal H9-16, or between PCM connector terminal J3-E14 and 16-way connector terminal H9-15 is open. Was a problem found and corrected?	Go to Step 26	—
22	The wiring harness between PCM connector terminal J3-E14 and transmission main case connector terminal M7-4(C) is shorted to ground. Was a problem found and corrected?	Go to Step 26	—
23	The wiring harness between transmission 16-way connector terminal H9-16 and transmission main case connector terminal M7-1(A), or between H9-15 and M7-4(C) is open. Was a problem found and corrected?	Go to Step 26	—
24	The internal wiring harness from the shift solenoid B is open, or the shift solenoid B is faulty. Was a problem found and corrected?	Go to Step 26	—
25	Replace the PCM. Is the replacement complete?	Go to Step 26	—
26	1. After the repair is complete, use the scan tool to select "DTC", then "Clear Info" function and operate the vehicle under the following conditions: ○The shift solenoid B is commanded "on" and voltage drop to zero. ○The shift solenoid B is commanded "off" and voltage increases to B+. 2. Review the scan tool "DTC Info". Has the last test failed or is the current DTC displayed?	Begin diagnosis again Go to Step 1	Repair verified Exit DTC table

## 7A1-74 TRANSMISSION CONTROL SYSTEM (4L30-E)

### DTC P1790 ROM Transmission Side Bad Check Sum

#### Circuit Description

Transmission Side Read Only Memory (ROM) and Electronically Erasable Programmable Read Only Memory (EEPROM) is an electronic circuit that controls the transmission control in the Powertrain Control Module (PCM).

This DTC detects a check sum error. This is a type "B" DTC.

#### Conditions For Setting The DTC

- Detects check sum error for 1 second.

#### Action Taken When The DTC Sets

- Maximum line pressure.

- Immediate landing to 4th gear.
- Inhibit TCC engagement.
- The PCM will illuminate the Malfunction Indicate Lamp (MIL) and CHECK TRANS Lamp.

#### Conditions For Clearing The MIL/DTC

- The PCM will turn off the MIL and CHECK TRANS Lamp after three consecutive ignition cycles without a failure reported.
- The DTC can be cleared from the PCM history by using a scan tool.
- The DTC will be cleared from history when the vehicle has achieved 40 warmup cycles without a failure reported.
- The PCM will cancel the DTC default actions when the fault no longer exists and the ignition is cycled "off" long enough to power down the PCM.

### DTC P1790 ROM Transmission Side Bad Check Sum

Step	Action	Yes	No
1	Were you sent here from the "Powertrain On-Board Diagnostic (OBD) System Check"?	Go to Step 2	Go to OBD System Check Refer to Driveability and Emissions in Engine section
2	1. Install the scan tool. 2. With the engine "off", turn the ignition switch "on". NOTE: Before clearing DTC(s), use the scan tool to record "Failure Records" for reference, as data will be lost when the "Clear Info" function is used. 3. Record the DTC "Failure Records". Was DTC P1790 set?	Go to Step 5	Go to Step 3
3	Was DTC P1792 set?	Go to Step 4	—
4	1. Remove the PCM. Refer to Powertrain Control Module (PCM) in Automatic Transmission (4L30-E) section. 2. Using the ITCS, make a reprogramming the transmission EEPROM. Was the reprogramming complete?	Go to Step 6	—
5	Replace the PCM. Is the replacement complete?	Go to Step 6	—
6	1. After the repair is complete, use the scan tool to select "DTC", then "Clear Info" function and operate the vehicle. 2. Review the scan tool "DTC Info". Has the last test failed or is the current DTC displayed?	Begin diagnosis again Go to Step 1	Repair verified Exit DTC table

## DTC P1792 EEPROM Transmission Side Bad Check Sum

### Circuit Description

Transmission Side Read Only Memory (ROM) and Electronically Erasable Programmable Read Only Memory (EEPROM) is an electronic circuit that controls the transmission control in the Powertrain Control Module (PCM).

This DTC detects a check sum error. This is a type "B" DTC.

### Conditions For Setting The DTC

- Detects check sum error for 1 second.

### Action Taken When The DTC Sets

- Maximum line pressure.

- Immediate landing to 4th gear.
- Inhibit TCC engagement.
- The PCM will illuminate the Malfunction Indicate Lamp (MIL) and CHECK TRANS Lamp.

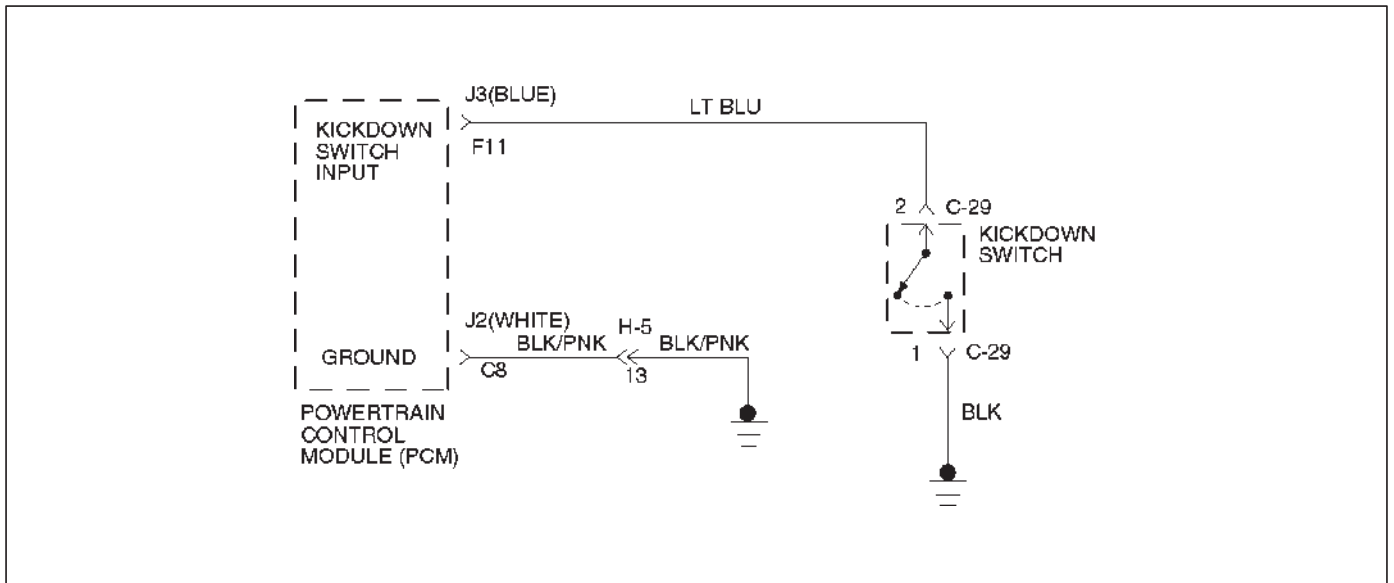
### Conditions For Clearing The MIL/DTC

- The PCM will turn off the MIL and CHECK TRANS Lamp after three consecutive ignition cycles without a failure reported.
- The DTC can be cleared from the PCM history by using a scan tool.
- The DTC will be cleared from history when the vehicle has achieved 40 warmup cycles without a failure reported.
- The PCM will cancel the DTC default actions when the fault no longer exists and the ignition is cycled "off" long enough to power down the PCM.

## DTC P1792 EEPROM Transmission Side Check Bad Check Sum

Step	Action	Yes	No
1	Were you sent here from the "Powertrain On-Board Diagnostic (OBD) System Check"?	Go to Step 2	Go to OBD System Check Refer to Driveability and Emissions in Engine section
2	1. Install the scan tool. 2. With the engine "off", turn the ignition switch "on". NOTE: Before clearing DTC(s), use the scan tool to record "Failure Records" for reference, as data will be lost when the "Clear Info" function is used. 3. Record the DTC "Failure Records". Was DTC P1790 set?	Go to Step 5	Go to Step 3
3	Was DTC P1792 set?	Go to Step 4	—
4	1. Remove the PCM. Refer to Powertrain Control Module (PCM) in Automatic Transmission (4L30-E) section. 2. Using the ITCS, make a reprogramming the transmission EEPROM. Was the reprogramming complete?	Go to Step 6	—
5	Replace the PCM. Is the replacement complete?	Go to Step 6	—
6	1. After the repair is complete, use the scan tool to select "DTC", then "Clear Info" function and operate the vehicle. 2. Review the scan tool "DTC Info". Has the last test failed or is the current DTC displayed?	Begin diagnosis again Go to Step 1	Repair verified Exit DTC table

## DTC P1835 Kickdown Switch Always On



D07RX010

### Circuit Description

- When the driver presses the accelerator pedal down fully, the kickdown switch closes, sending a ground signal to the Powertrain Control Module (PCM).
- This information is used to perform shifts at high engine speed.
- When the kickdown switch is closed, the Throttle Position Sensor (TPS) is already at 100%.
- This DTC detects a closed kickdown switch when TP angle is less than 70%.
- This is a type "D" DTC.

### Conditions For Setting The DTC

- No TPS DTCs P0122 or P0123.
- TP angle is less than 70%.
- Kickdown switch is "on".
- All conditions met for 1 second.

### Action Taken When The DTC Sets.

- Kickdown mode control is off.
- The PCM will not illuminate the Malfunction Indicator Lamp (MIL) and CHECK TRANS Lamp.

### Conditions For Clearing The DTC

- The DTC can be cleared from the PCM history by using a scan tool.
- The DTC will be cleared from history when the vehicle has achieved 40 warmup cycles without a failure reported.
- The PCM will cancel the DTC default actions when the fault no longer exists and the ignition is cycled "off" long enough to power down the PCM.

### Diagnostic Aids

- Check the wiring harness for a short to ground between the PCM and kickdown switch.
- Check the kickdown switch for failure.
- Check kickdown adjustment.

### Test Description

The numbers below refer to the step numbers on the diagnostic chart:

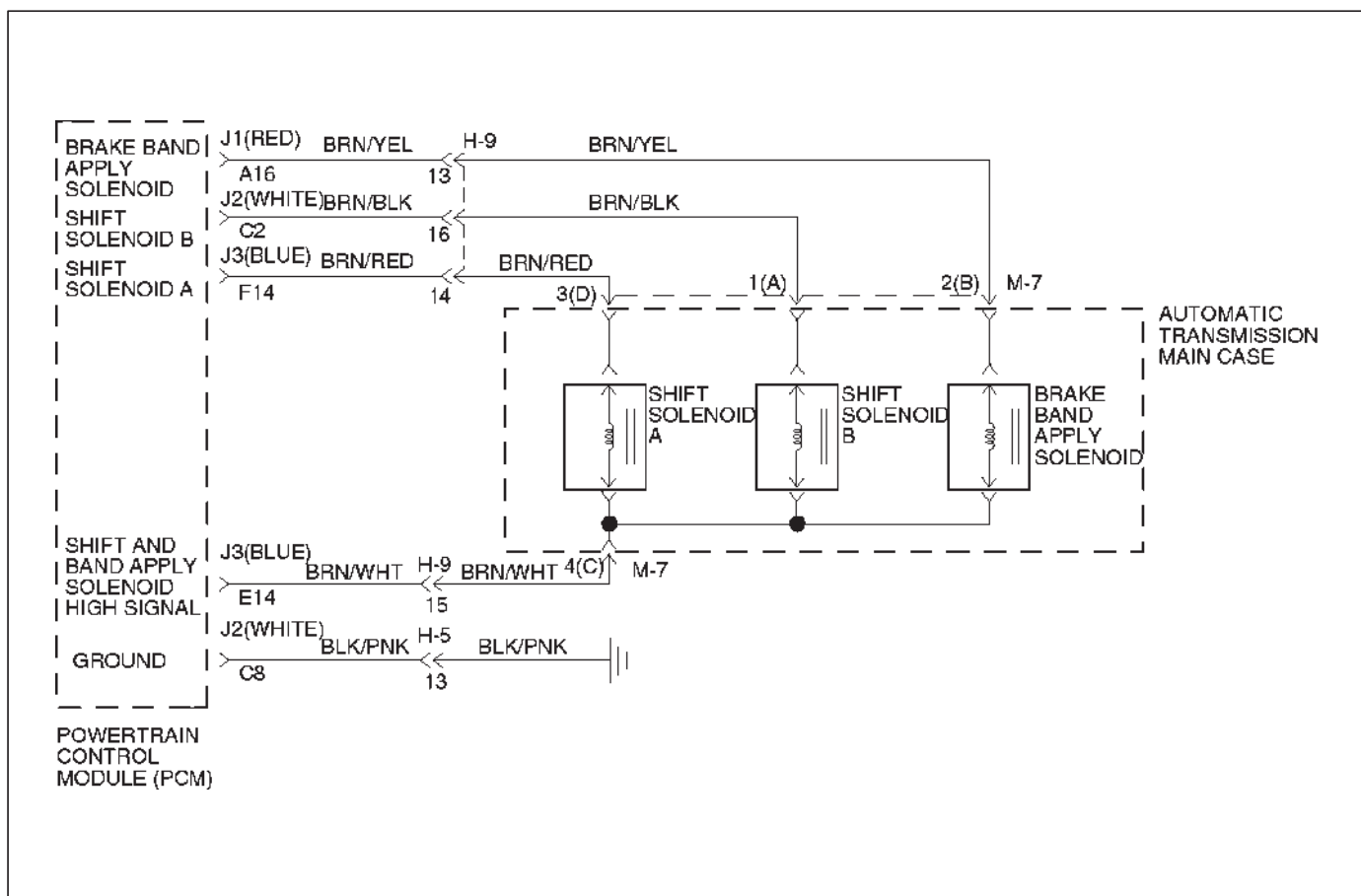
2. This test checks for short to ground or kickdown switch failure.
4. This test checks for regulation kickdown switch.



**DTC P1835 Kickdown Switch Always On**

Step	Action	Yes	No
1	Were you sent here from the "Powertrain On-Board Diagnostic (OBD) System Check"?	Go to Step 2	Go to OBD System Check Refer to Driveability and Emissions in Engine section
2	1. Install the scan tool. 2. With the engine "on", turn the ignition switch "on". NOTE: Before clearing DTC(s), use the scan tool to record "Failure Records" for reference, as data will be lost when the "Clear Info" function is used. 3. Record the DTC "Failure Records". Does the scan tool display "Kickdown switch" "low" (closed switch)?	Go to Step 3	Go to Step 4
3	1. Turn the ignition "off". 2. Disconnect the J3 (BLUE) PCM connector. 3. Using the J39200 DVOM, check a continuity between PCM connector terminal J3-F11 and ground. Is there a continuity?	Go to Step 5	Go to Step 8
4	The TP angle goes from 0% to 100% with the accelerator pedal depressed. Is the kickdown switch "on" when TP angle is below 70%?	Go to Step 6	Go to Diagnostic Aids
5	1. Disconnect the kickdown switch connector C-29. 2. Using the J39200 DVOM, check a continuity between terminals C29-1 and C29-2. Is there a continuity?	Go to Step 7	Go to Step 9
6	Adjust the kickdown switch. Is the kickdown switch "on" when TP angle is above 95%?	Go to Step 10	—
7	Replace the kickdown switch. Is the replacement complete?	Go to Step 10	—
8	Replace the PCM. Refer to Powertrain Control Module (PCM) in Automatic Transmission (4L30-E) section. Is the replacement complete?	Go to Step 10	—
9	Repair the short to ground in circuit LT BLUE. Is the repair complete?	Go to Step 10	—
10	1. After the repair is complete, use the scan tool to select "DTC", then "Clear Info" function and ensure the following condition is met: The torque converter stator temperature switch circuit does not indicate a hot mode when the transmission fluid temperature is less than 60°C (140°F) for at least 5 seconds. 2. Review the scan tool "DTC Info". Has the last test failed or is the current DTC displayed?	Begin diagnosis again Go to Step 1	Repair verified Exit DTC table

## DTC P1850 Brake Band Apply Solenoid Malfunction



D07RX009

## Circuit Description

- The brake band apply solenoid is a normally open solenoid which controls the flow of fluid for brake band application. The Powertrain Control Module (PCM) uses Pulse Width Modulation (PWM) and changes the duty cycle to control the solenoid. The PCM turns the solenoid on (energized) and off (deenergized) at a constant frequency. The length of time the solenoid is energized during each on/off cycle is called the pulse width. By varying or "modulating" the pulse width, the solenoid output pressure is changed. Since the solenoid is normally open, increasing the pulse width increases the duty cycle and decreases the output pressure. PWM control provides smooth band application without an accumulator. The band is only applied in first and second gears.
- In the event of an electrical failure (open), the solenoid regulates at the maximum oil flow (0% duty cycle).
- The solenoid is activated by current. This current is produced by applying a voltage to one side (the High side) and a ground to the other side (Low side).
- The High Side Driver (HSD) is a circuit of the PCM that acts as a switch between the solenoids and the supply voltage. The High side of the solenoid is permanently supplied with voltage. When the ignition is off, the HSD is turned off.

This DTC detects a continuous open or short to ground in the brake band apply solenoid circuit or the brake band apply solenoid. This is a type "D" DTC.

## Conditions For Setting The DTC

- Battery voltage is between 10 and 16 volts.
- Ignition is "on", Engine "run".
- The PCM commands the solenoid "on" and the voltage remains high (B+) or the PCM commands the solenoid "off" and the voltage remains low (zero volts).
- All conditions met in 1.3 seconds.

## Action Taken When The DTC Sets

- Inhibit brake band apply solenoid.
- The PCM will not illuminate the Malfunction Indicator Lamp (MIL) and CHECK TRANS Lamp.

## Conditions For Clearing The DTC

- The DTC can be cleared from the PCM history by using a scan tool.
- The DTC will be cleared from history when the vehicle has achieved 40 warmup cycles without a failure reported.
- The PCM will cancel the DTC default actions when the fault no longer exists and the ignition is cycled "off" long enough to power down the PCM.

**Diagnostic Aids**

- Inspect the wiring for poor electrical connection at the PCM and at the transmission 16-way connector. Look for possible bent, backed out, deformed or damaged terminals. Check for weak terminal tension as well. Also check for a chafed wire that could short to bare metal or other wiring. Inspect for a broken wire inside the insulation.
- When diagnosing for a possible intermittent short or open condition, move the wiring harness while observing test equipment for a change.

**Test Description**

The numbers below refer to the step numbers on the diagnostic chart:

3. This test checks for power to the brake band apply solenoid from the ignition through the PCM.
4. This test checks the resistance of the transmission internal wiring harness and brake band apply solenoid.
5. This test checks the ability of the PCM and wiring to control the ground circuit.

**DTC P1850 Brake Band Apply Solenoid Malfunction**

Step	Action	Yes	No
1	Were you sent here from the "Powertrain On-Board Diagnostic (OBD) System Check"?	Go to Step 2	Go to OBD System Check Refer to Driveability and Emissions in Engine section
2	1. Install the scan tool. 2. With the engine "on", turn the ignition switch "on". NOTE: Before clearing DTC(s), use the scan tool to record "Freeze Frame" and "Failure Records" for reference, as data will be lost when the "Clear Info" function is used. 3. Record the DTC "Freeze Frame" and "Failure Records". Were DTCs P0753, P0758 set?	Go to Step 3	Go to Step 4
3	Using the J39200 DVOM, back probe between PCM connector terminals J3-E14 and J2-C8. Is the voltage between 10 to 12 volts?	Go to Step 5	Go to Step 6
4	1. Turn the ignition "off". 2. Disconnect the J1 (RED) and J3 (BLUE) PCM connectors. 3. Using the J39200 DVOM, measure the resistance between PCM connector terminals J1-A16 and J3-E14. Is the resistance within 10-12 ohms?	Go to Step 12	Go to Step 13
5	Using the J39200 DVOM, back probe between PCM connector terminals J1-A16 and J2-C8. Is the voltage between 10 to 12 volts?	Go to Step 26	Go to Step 4
6	1. Turn the ignition "off". 2. Disconnect the J1 (RED) and J3 (BLUE) PCM connectors. 3. Using the J39200 DVOM, check continuity between PCM terminal J3-E14 and ground. Is there a continuity?	Go to Step 7	Go to Step 9
7	1. Disconnect the transmission 16-way connector H-9. 2. Using the J39200 DVOM, check continuity between connector H9-13 and ground. Is there a continuity?	Go to Step 8	Go to Step 17
8	1. Disconnect the transmission main case connector M-7. 2. Using the J39200 DVOM, check continuity between the terminal M7-2(B) and ground. Is there a continuity?	Go to Step 18	Go to Step 19

## 7A1-80 TRANSMISSION CONTROL SYSTEM (4L30-E)

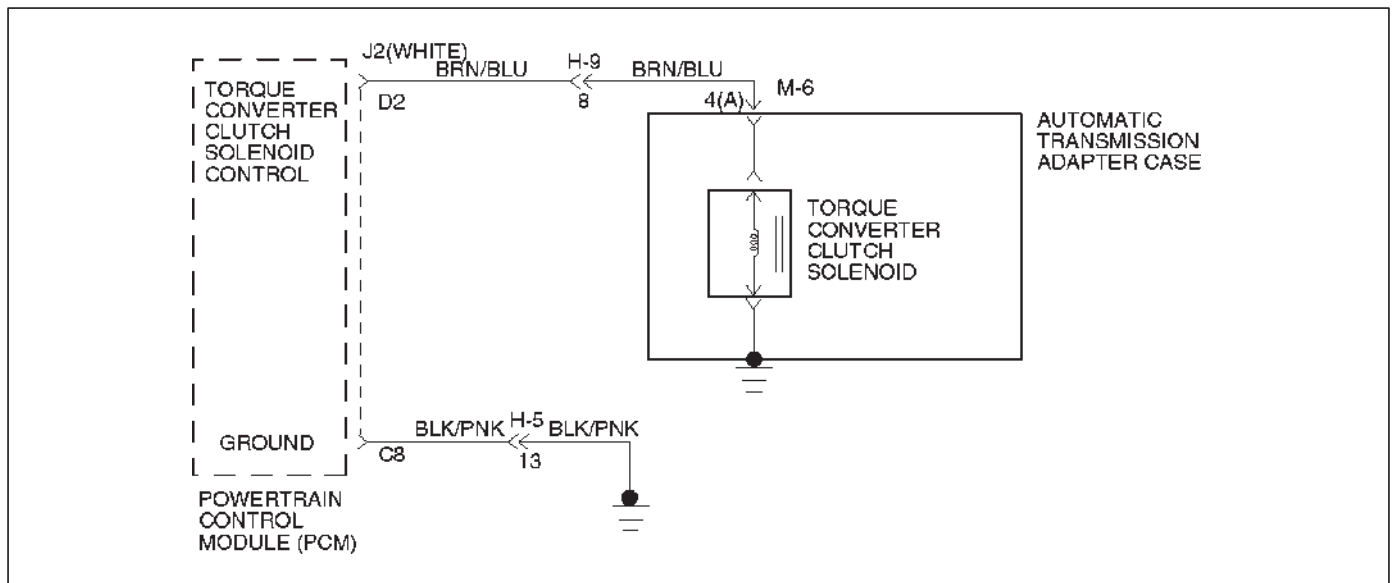
### DTC P1850 Brake Band Apply Solenoid Malfunction (Cont'd)

Step	Action	Yes	No
9	1. Disconnect the J1 (RED) PCM Connector. 2. Using the J39200 DVOM, measure the resistance between PCM connector terminals J1-A16 and J3-E14.  Is the resistance within 10-12 ohms?	Go to Step 26	Go to Step 10
10	1. Disconnect the transmission 16-way connector H-9. 2. Using the J39200 DVOM, measure the resistance between terminal H9-13 and H9-15.  Is the resistance within 10-12 ohms?	Go to Step 17	Go to Step 11
11	1. Disconnect the transmission main case connector M-7. 2. Using the J39200 DVOM, measure the resistance between terminals M7-2(B) and M7-4(C).  Is the resistance within 10-12 ohms?	Go to Step 20	Go to Step 21
12	Using the J39200 DVOM, check continuity between PCM terminal J1-A16 and ground.  Is there a continuity?	Go to Step 14	Go to Step 26
13	1. Disconnect the transmission 16-way connector H-9. 2. Using the J39200 DVOM, measure the resistance between terminal H9-13 and H9-15.  Is the resistance within 10-12 ohms?	Go to Step 24	Go to Step 15
14	1. Disconnect the transmission 16-way connector H-9. 2. Using the J39200 DVOM, check continuity between terminal H9-13 and ground.  Is there a continuity?	Go to Step 16	Go to Step 22
15	1. Disconnect the transmission main case connector M-7. 2. Using the J39200 DVOM, measure the resistance between terminals M7-2(B) and M7-4(C).  Is the resistance within 10-12 ohms?	Go to Step 25	Go to Step 21
16	1. Disconnect the transmission main case connector M-7. 2. Using the J39200 DVOM, check continuity between the terminal M7-2(B) and ground.  Is there a continuity?	Go to Step 18	Go to Step 23
17	The wiring harness between PCM terminal J3-E14 and transmission 16-way connector terminal H9-15 is open.  Was a problem found and corrected?	Go to Step 27	—
18	The brake band apply solenoid is faulty, or the internal wiring harness from the brake band apply solenoid is shorted to ground.  Was a problem found and corrected?	Go to Step 27	—
19	The wiring harness between the transmission 16-way connector terminal H9-15 and the transmission main case connector terminal M7-4(C) is shorted to ground.  Was a problem found and corrected?	Go to Step 27	—
20	The wiring harness between the transmission 16-way connector terminal H9-15 and the transmission main case connector terminal M7-4(C) is open.  Was a problem found and corrected?	Go to Step 27	—
21	The brake band apply solenoid is faulty, or the internal wiring harness from the brake band apply solenoid is open.  Was a problem found and corrected?	Go to Step 27	—

**DTC P1850 Brake Band Apply Solenoid Malfunction (Cont'd)**

Step	Action	Yes	No
22	The wiring harness between the PCM connector terminal J1-A16 and transmission 16-way connector terminal H9-13 is shorted to ground. Was a problem found and corrected?	Go to Step 27	—
23	The wiring harness between the transmission 16-way connector terminal H9-13 and the transmission main case connector terminal M7-2(B) is shorted to ground. Was a problem found and corrected?	Go to Step 27	—
24	The wiring harness between the PCM connector terminal J1-A16 and the 16-way connector terminal H9-13 is open. Was a problem found and corrected?	Go to Step 27	—
25	The wiring harness between the transmission 16-way connector terminal H9-13 and the transmission main case connector terminal M7-2(B) is open. Was a problem found and corrected?	Go to Step 27	—
26	Check every connection at the PCM. If OK, replace the PCM. Refer to Powertrain Control Module (PCM) in Automatic Transmission (4L30-E) section. Is the replacement complete?	Go to Step 27	—
27	1. After the repair is complete, use the scan tool to select "DTC", then "Clear Info" function and ensure the following conditions are met: <ul style="list-style-type: none"> <li>○The brake band apply solenoid is commanded "on" and the volts drop to zero.</li> <li>○The brake band apply solenoid is commanded "off" and the volts increase to B+.</li> </ul> 2. Review the scan tool "DTC Info". Has the last test failed or is the current DTC displayed?	Begin diagnosis again Go to Step 1	Repair verified Exit DTC table

## DTC P1860 TCC Solenoid Electrical



D07RX011

## Circuit Description

The PCM allows current to flow through the solenoid coil according to the duty cycle (percentage of “on” and “off” time). This current flow through the solenoid coil creates a magnetic field that magnetizes the solid core. The magnetized core attracts the check ball to seat against spring pressure. This blocks the exhaust for the TCC signal fluid and allows 2–3 drive fluid to feed to TCC signal circuit. The TCC signal fluid pressure acts on the TCC regulator valve to regulate line pressure and to apply fluid pressure to the torque converter clutch shift valve. When the TCC shift valve is in the apply position, regulated apply fluid pressure is directed through the TCC valve to apply the torque converter clutch. The TCC solenoid is used in conjunction with the TCC solenoid to regulate fluid to the torque converter. The TCC solenoid is attached to the valve body within the transmission. This DTC detects a continuous open or short to ground or ignition in the TCC circuit or the TCC solenoid. This is a type “B” DTC.

## Conditions For Setting The DTC

- Battery voltage is between 10 and 16 volts.
- No shift solenoid A DTCs P0751 or P0753.
- No shift solenoid B DTCs P0756 or P0758.
- Ignition is “on”, Engine “run”.
- The PCM commands the solenoid “on” and the voltage remains low (zero volts).
- The PCM commands the solenoid “off” and the voltage remains high (B+).
- All conditions met for 0.25 seconds.

## Action Taken When The DTC Sets

- Inhibit TCC engagement.
- The PCM will illuminate the Malfunction Indicator Lamp (MIL) and CHECK TRANS Lamp.

## Conditions For Clearing The MIL/DTC

- The PCM will turn off the MIL and CHECK TRANS Lamp after three consecutive ignition cycles without a failure reported.
- The DTC can be cleared from the PCM history by using a scan tool.
- The DTC will be cleared from history when the vehicle has achieved 40 warmup cycles without a failure reported.
- The PCM will cancel the DTC default actions when the fault no longer exists and the ignition is cycled “off” long enough to power down the PCM.

## Diagnostic Aids

- Inspect the wiring for poor electrical connections at the PCM and at the transmission 16-way connector. Look for possible bent, backed out, deformed or damaged terminals. Check for weak terminal tension as well. Also check for a chafed wire that could short to bare metal or other wiring. Inspect for a broken wire inside the insulation.
- When diagnosing for a possible intermittent short or open condition, move the wiring harness while observing test equipment for a change.

## Test Description

The numbers below refer to the step numbers on the diagnostic chart:

3. This test checks for voltage to the solenoid.
4. This test checks the ability of the PCM and wiring to control the ignition circuit.
9. This test checks the resistance of the TCC solenoid and the internal wiring harness.

**DTC P1860 TCC Solenoid Electrical**

Step	Action	Yes	No
1	Were you sent here from the "Powertrain On-Board Diagnostic (OBD) System Check"?	Go to Step 2	Go to OBD System Check Refer to Driveability and Emissions in Engine section
2	1. Install the scan tool. 2. With the engine "on", turn the ignition switch "on". NOTE: Before clearing DTC(s), use the scan tool to record "Freeze Frame" and "Failure Records" for reference, as data will be lost when the "Clear Info" function is used. 3. Record the DTC "Freeze Frame" and "Failure Records".	Go to Step 3	Go to Step 4
3	Using the J39200 DVOM, back probe between PCM connector terminals J2-D2 and J2-C8. Is the voltage 0 ?	Go to Step 5	Go to Step 6
4	1. Apply brake pedal and select transmission range "D". 2. Do a test drive, and increase the vehicle speed to TCC "on" at 4th. Does the scan tool display DTC P1860 at TCC "ON"?	Go to Step 10	Go to Diagnostic Aids
5	1. Turn the ignition "off". 2. Disconnect the J2 (WHITE) PCM connector. 3. Using the J39200 DVOM, measure the resistance between PCM connector terminals J2-D2 and J2-C8. Is the resistance within 18 – 20 ohms?	Go to Step 7	Go to Step 8
6	The wiring harness between PCM connector terminal J2-D2 and transmission adapter case connector terminal M6-4(A) is shorted to voltage. Was a problem found and corrected?	Go to Step 19	Go to Step 20
7	Intermittent condition. Check the wiring harness and terminals between PCM connector J2 and transmission adapter case connector M-6. Was a problem found and corrected?	Go to Step 19	Go to Step 20
8	1. Disconnect the transmission 16-way connector H-9. 2. Using the J39200 DVOM, measure the resistance between terminal H9-8 and ground. Is the resistance within 18 – 20 ohms?	Go to Step 16	Go to Step 9
9	1. Disconnect the transmission adapter case connector M-6. 2. Using the J39200 DVOM, measure the resistance between terminal M6-4(A) and ground. Is the resistance within 18 – 20 ohms?	Go to Step 17	Go to Step 18
10	1. Turn the ignition "off". 2. Disconnect the J2 (WHITE) PCM connector. 3. Using the J39200 DVOM, measure the resistance between terminals J2-D2 and J2-C8. Is the resistance within 18 – 20 ohms?	Go to Step 19	Go to Step 11
11	1. Disconnect the transmission 16-way connector H-9. 2. Using the J39200 DVOM, measure the resistance between terminal H9-8 and ground. Is the resistance within 18-20 ohms?	Go to Step 13	Go to Step 12

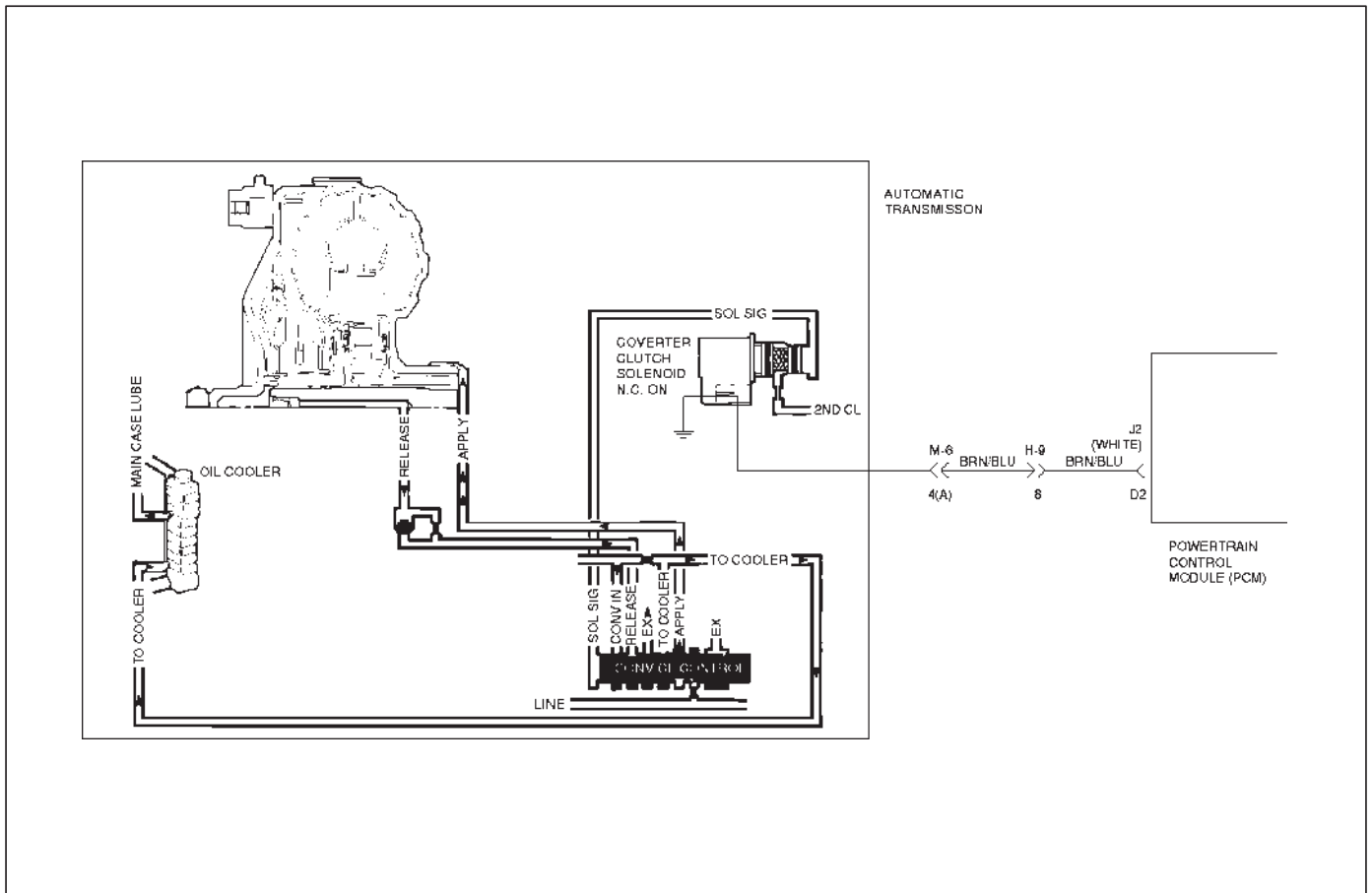
## 7A1-84 TRANSMISSION CONTROL SYSTEM (4L30-E)

### DTC P1860 TCC Solenoid Electrical (Cont'd)

Step	Action	Yes	No
12	1. Disconnect the transmission adapter case connector M-6. 2. Using the J39200 DVOM, measure the resistance between terminal M6-4(A) and ground.  Is the resistance within 18-20 ohms?	Go to Step 14	Go to Step 15
13	The wiring harness between PCM connector terminal J2-D2 and transmission 16-way connector terminal H9-8 is shorted to ground.  Was a problem found and corrected?	Go to Step 21	—
14	The wiring harness between transmission 16-way connector H-9 and adapter case connector M-6 is shorted to ground.  Was a problem found and corrected?	Go to Step 21	—
15	The TCC solenoid is faulty, or the internal wiring harness from the TCC solenoid is shorted to ground.  Was a problem found and corrected?	Go to Step 21	—
16	The wiring harness between PCM connector terminal J2-D2 and transmission 16-way connector terminal H9-8 is open.  Was a problem found and corrected?	Go to Step 21	—
17	The wiring harness between transmission 16-way connector terminal H9-8 and adapter case terminal M6-4(A) is open.  Was a problem found and corrected?	Go to Step 21	—
18	The TCC solenoid is faulty, or the internal wiring harness from the TCC solenoid is open.  Was a problem found and corrected?	Go to Step 21	—
19	Check every connection at the PCM. If OK, replace the PCM. Refer to Powertrain Control Module (PCM) in Automatic Transmission (4L30-E) section.  Is the replacement complete?	Go to Step 21	—
20	Check the PCM connector terminal J2-D2, transmission 16-way connector terminal H9-8 and transmission adapter case connector terminal M6-4(A).  Was a problem found and corrected?	Go to Step 21	—
21	1. After the repair is complete, use the scan tool to select "DTC", then "Clear Info" function and ensure the following conditions are met: <ul style="list-style-type: none"> <li>○The TCC solenoid is commanded "on" and the volts increase to B+.</li> <li>○The TCC solenoid is commanded "off" and the volts drop to zero.</li> </ul> 2. Review the scan tool "DTC Info".  Has the last test failed or is the current DTC displayed?	Begin diagnosis again Go to Step 1	Repair verified Exit DTC table



## DTC P1870 Transmission Component Slipping



### Circuit Description

The PCM monitors the difference in engine speed and transmission output speed. In D3 drive range with the TCC engaged, the engine speed should closely match transmission output speed.

This DTC detects excessive TCC slip when the TCC is engaged. This is a type "B" DTC.

### Conditions For Setting The DTC

The following conditions are met for three TCC cycles with reported excessive TCC slip conditions.

- No TPS DTCs P0122 or P0123.
- No OSS DTCs P0722 or P0723.
- No shift solenoid A DTCs P0751 or P0753.
- No shift solenoid B DTCs P0756 or P0758.
- No TCC solenoid DTC P1860.
- No TCC solenoid DTC P0742.
- Engine speed is between 800 and 3,360 rpm.
- Engine vacuum is between 0 and 70 kpa.
- Gear range is D4.
- TP angle is between 12 and 70%.
- TFT is between 20° and 141°C (68° and 286°F).
- TCC is "on" for 3 seconds.
- TCC slip speed is between 200 rpm and 800 rpm for 10 seconds.
- Vehicle speed is between 38 km/h (24 mph) and 110 km/h (69 mph).

- Speed ratio is between 0.6 and 0.95.
- No MAP DTCs P0106 or P1106 or P0107 or P1107 or P0108.

### Action Taken When The DTC Sets

- Only stored in memory.
- The PCM will illuminate the Malfunction Indicator Lamp (MIL) and CHECK TRANS Lamp.

### Conditions For Clearing The MIL/DTC

- The PCM will turn off the MIL and CHECK TRANS Lamp after three consecutive ignition cycles without a failure reported.
- The DTC can be cleared from the PCM history by using a scan tool.
- The DTC will be cleared from history when the vehicle has achieved 40 warmup cycles without a failure reported.
- The PCM will cancel the DTC default actions when the fault no longer exists and the ignition is cycled "off" long enough to power down the PCM.

### Diagnostic Aids

- Range switch malfunction could set a DTC P1870.
- A mechanical failure of the shift solenoids, TCC solenoid, or TCC PWM solenoid could set a DTC P1870.
- Internal transmission failures may set a DTC P1870.

## 7A1-86 TRANSMISSION CONTROL SYSTEM (4L30-E)

- An intermittent or incorrect engine speed signal may set a DTC P1870.

### Test Description

The numbers below refer to the step numbers on the diagnostic chart:

2. This test checks the indicated range signal to the actual selected range. A faulty switch could set a DTC P1870.
3. This test checks the torque converter for slippage while in a commanded lockup state.

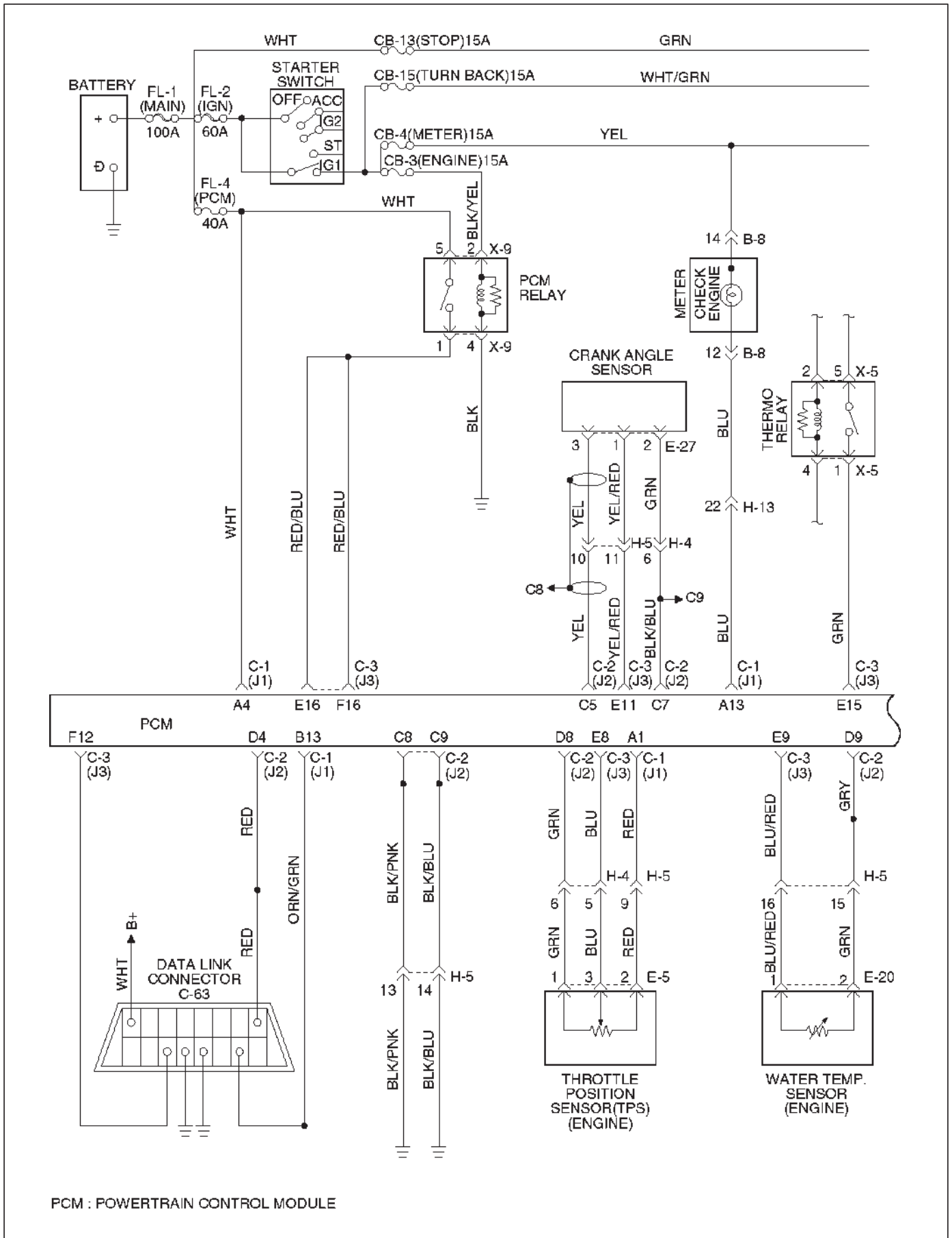
**Range Switch Logic Table**

Range Position	Range Switch Pin			
	A	B	C	P(G)
Park	ON	OFF	OFF	ON
Reverse	ON	ON	OFF	OFF
Neutral	OFF	ON	OFF	ON
D4	OFF	ON	ON	OFF
D3	ON	ON	ON	ON
2	ON	OFF	ON	OFF
L	OFF	OFF	ON	ON
Illegal	OFF	OFF	OFF	OFF
Illegal	OFF	OFF	OFF	ON

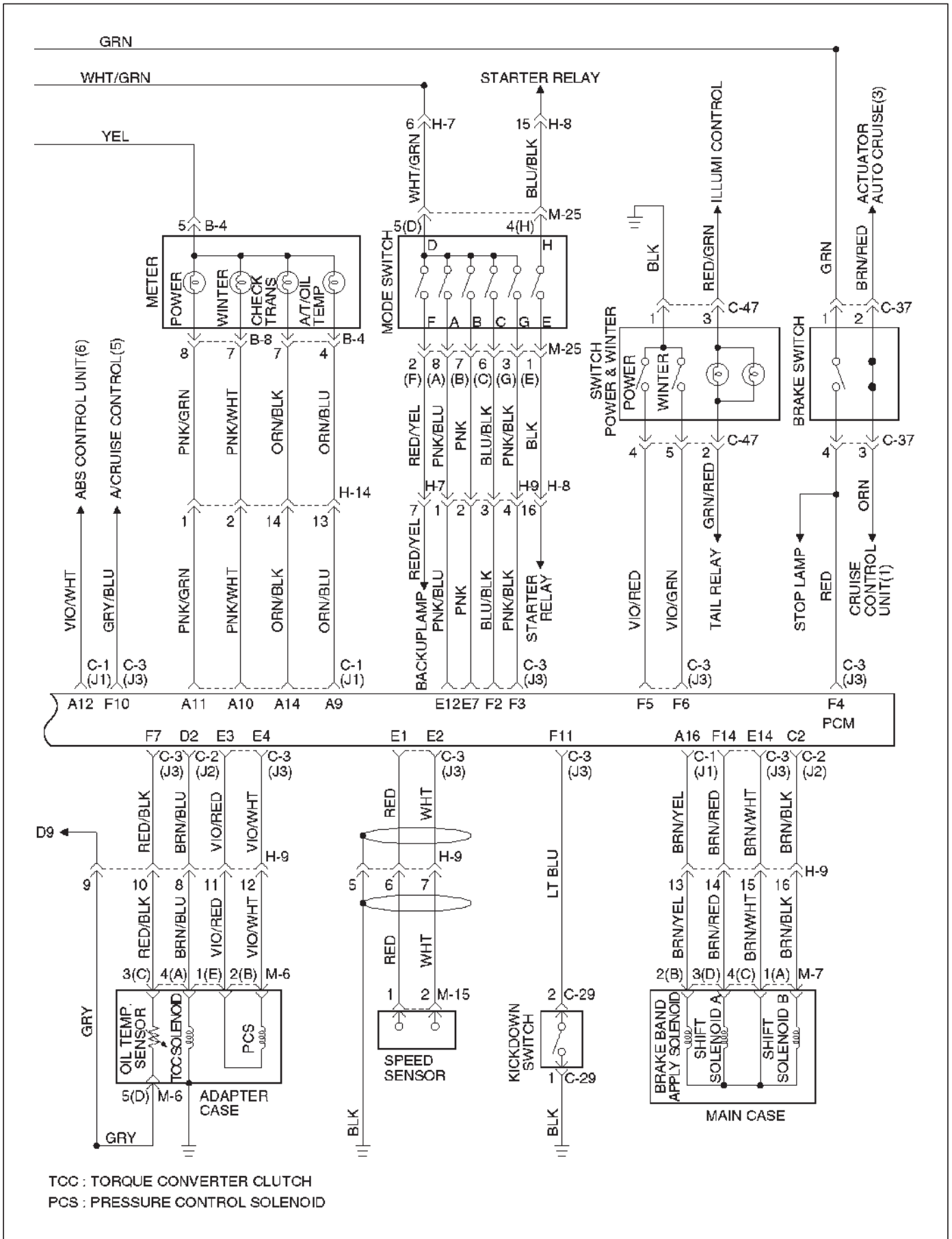
### DTC P1870 Transmission Component Slipping

Step	Action	Yes	No
1	Were you sent here from the "Powertrain On-Board Diagnostic (OBD) System Check"?	Go to Step 2	Go to OBD System Check Refer to Driveability and Emissions in Engine section
2	<ol style="list-style-type: none"> <li>1. Install the scan tool.</li> <li>2. With the engine "off", turn the ignition switch "on".</li> </ol> <p>NOTE: Before clearing DTC(s), use the scan tool to record "Freeze Frame" and "Failure Records" for reference, as data will be lost when the "Clear Info" function is used.</p> <ol style="list-style-type: none"> <li>3. Record the DTC "Freeze Frame" and "Failure Records".</li> <li>4. Apply the brake pedal.</li> <li>5. Select each transmission range: D1, D2, D3, D4, N, R, and P.</li> </ol> <p>Does each selected transmission range match the scan tool "TR Switch" display?</p>	Go to Step 3	Go to "Range Switch Logic Table"
3	<p>Drive the vehicle in 4th gear while the TCC is engaged.</p> <p>At any time is the "TCC Slip Speed" greater than 130 rpm for 8 seconds while the TCC is engaged?</p>	Go to System Diagnosis Charts	Go to Diagnostic Aids

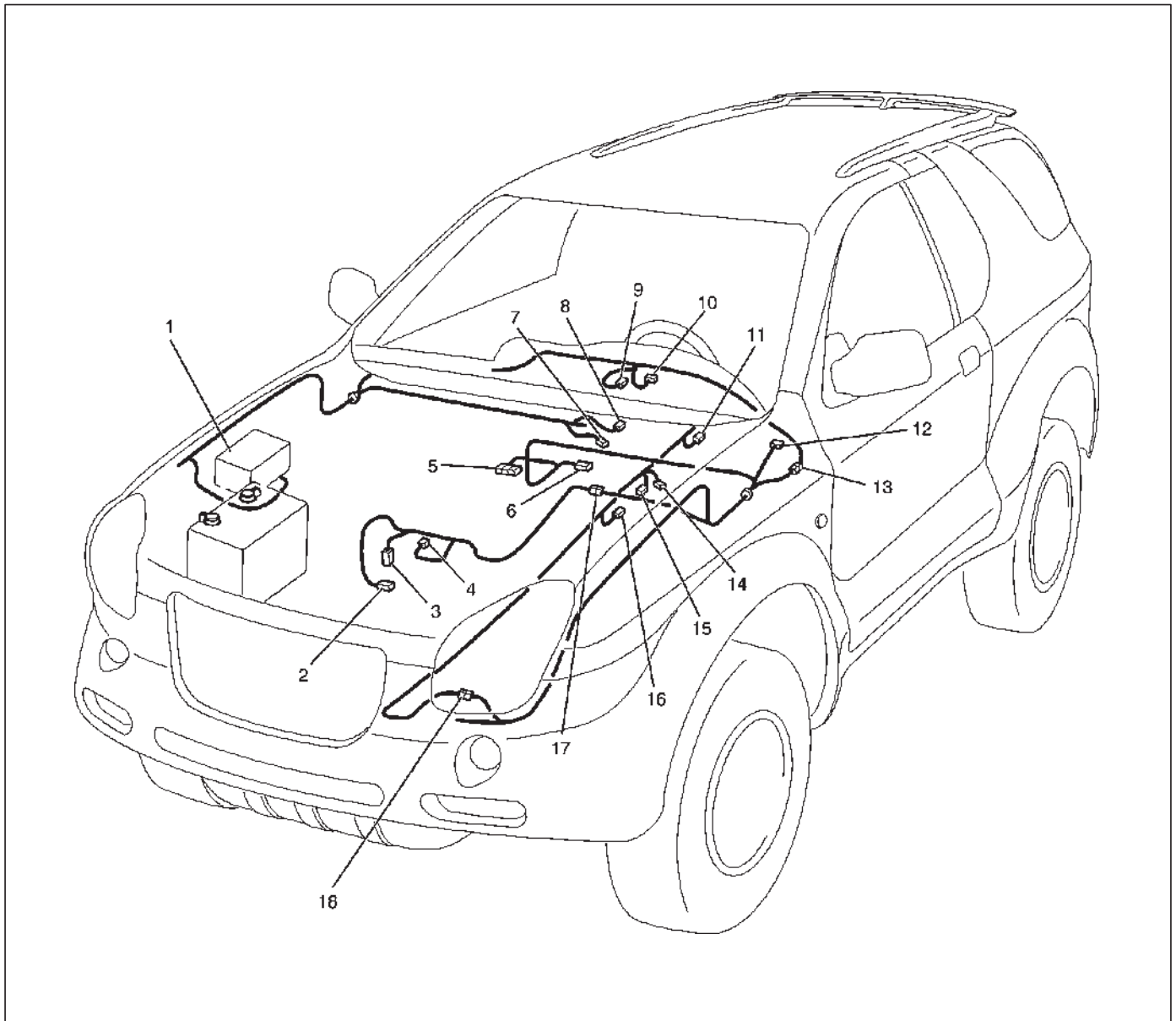
Circuit Diagram



# 7A1-88 TRANSMISSION CONTROL SYSTEM (4L30-E)



Parts Location



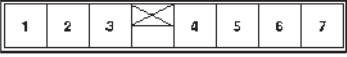


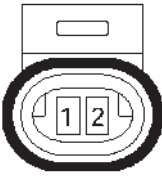
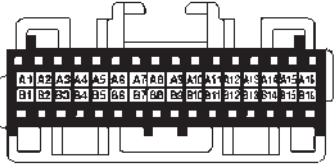

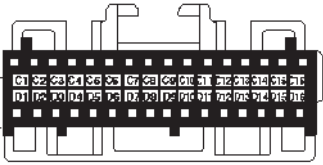

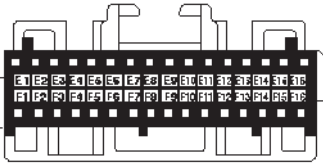

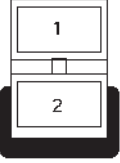





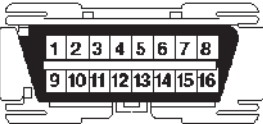
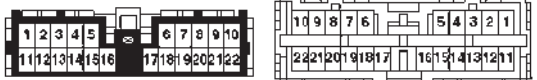
D07RX012

**Legend**

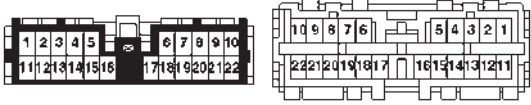
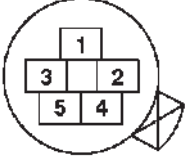
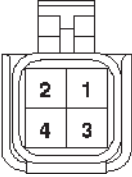

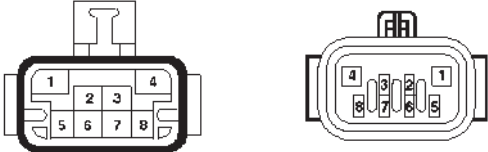

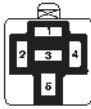
- |  |                              |
|--|------------------------------|
| (1) Relay and Fuse Box (X-5, X-9)        | (10) Connector B-8           |
| (2) Connector E-27                       | (11) Connector M-15          |
| (3) Connector E-20                       | (12) Connector C-63          |
| (4) Connector E-5                        | (13) Connector H-13, H-14    |
| (5) Connector C-1(J1), C-2(J2), C-3(J3), | (14) Connector M-7           |
| (6) Connector C-47                       | (15) Connector M-25          |
| (7) Connector C-29                       | (16) Connector M-6           |
| (8) Connector C-37                       | (17) Connector H-4, H-5      |
| (9) Connector B-4                        | (18) Connector H-7, H-8, H-9 |

7A1-90 TRANSMISSION CONTROL SYSTEM (4L30-E)

Harness Connector Faces

No.	Connector face	No.	Connector face
B-4		E-5	
B-8		E-20	
C-1 (J1)		E-27	
C-2 (J2)		H-4	 (BLUE)
C-3 (J3)		H-5	 (GREEN)
C-29		H-7	 (BLACK)
C-37		H-8	 (BLUE)
C-47		H-9	 (GREEN)
C-63		H-13	 (WHITE)

TRANSMISSION CONTROL SYSTEM (4L30-E) 7A1-91

No.	Connector face	No.	Connector face
H-14	 <p>(BLUE)</p>		
M-6			
M-7			
M-15			
M-25			
X-5			
X-9			

VEHICROSS

# BODY AND ACCESSORIES

## LIGHTING SYSTEM

### CONTENTS

Service Precaution .....	8A-2	Installation .....	8A-10
Headlight Bulb .....	8A-2	Map Light Switch/Bulb .....	8A-11
Removal .....	8A-2	Removal .....	8A-11
Installation .....	8A-2	Installation .....	8A-11
Headlight .....	8A-3	Cigarette Lighter Illumination Bulb .....	8A-11
Removal .....	8A-3	Removal .....	8A-11
Installation .....	8A-3	Installation .....	8A-11
Headlight Adjustment .....	8A-3	Ashtray Illumination Bulb .....	8A-12
Fender Marker Light Bulb .....	8A-5	Removal .....	8A-12
Removal .....	8A-5	Installation .....	8A-12
Installation .....	8A-5	HVAC Bezel Illumination Light Bulb .....	8A-12
Front Side Marker Light Bulb .....	8A-5	Removal and Installation .....	8A-12
Removal .....	8A-5	Shift Lever Illumination Light Bulb (A/T) ....	8A-13
Installation .....	8A-5	Removal .....	8A-13
Rear Side Marker Light Bulb .....	8A-6	Installation .....	8A-13
Removal .....	8A-6	Starter Switch .....	8A-13
Installation .....	8A-6	Removal .....	8A-13
Parking Light Bulb .....	8A-6	Installation .....	8A-13
Removal .....	8A-6	Lighting Switch (Combination Switch) .....	8A-14
Installation .....	8A-6	Removal .....	8A-14
Taillight Bulb .....	8A-7	Installation .....	8A-14
Removal .....	8A-7	Stoplight Switch .....	8A-15
Installation .....	8A-7	Removal .....	8A-15
License Plate Light Bulb .....	8A-7	Installation .....	8A-15
Removal .....	8A-7	Turn Signal Switch(Combination Switch) ...	8A-16
Installation .....	8A-7	Removal and Installation .....	8A-16
Stoplight Bulb .....	8A-8	Hazard Warning Switch .....	8A-16
Removal and Installation .....	8A-8	Removal .....	8A-16
High Mounted Stop Light .....	8A-8	Installation .....	8A-16
Removal .....	8A-8	Key Remind Switch(Starter Switch) .....	8A-16
Installation .....	8A-8	Removal and Installation .....	8A-16
Front Turn Signal Light Bulb .....	8A-9	Door Switch .....	8A-17
Removal .....	8A-9	Removal .....	8A-17
Installation .....	8A-9	Installation .....	8A-17
Rear Turn Signal Light Bulb .....	8A-9	Rear Defogger Switch .....	8A-17
Removal .....	8A-9	Removal .....	8A-17
Installation .....	8A-9	Installation .....	8A-17
Backup Light Bulb .....	8A-10	Illumination Controller .....	8A-18
Removal .....	8A-10	Removal .....	8A-18
Installation .....	8A-10	Installation .....	8A-18
Dome Light Bulb .....	8A-10	Main Data and Specifications .....	8A-19
Removal .....	8A-10		



## Service Precaution

**WARNING:** THIS VEHICLE HAS A SUPPLEMENTAL RESTRAINT SYSTEM (SRS). REFER TO THE SRS COMPONENT AND WIRING LOCATION VIEW IN ORDER TO DETERMINE WHETHER YOU ARE PERFORMING SERVICE ON OR NEAR THE SRS COMPONENTS OR THE SRS WIRING. WHEN YOU ARE PERFORMING SERVICE ON OR NEAR THE SRS COMPONENTS OR THE SRS WIRING, REFER TO THE SRS SERVICE INFORMATION. FAILURE TO FOLLOW WARNINGS COULD RESULT IN POSSIBLE AIR BAG DEPLOYMENT, PERSONAL INJURY, OR OTHERWISE UNNEEDED SRS SYSTEM REPAIRS.

**CAUTION:** Always use the correct fastener in the proper location. When you replace a fastener, use **ONLY** the exact part number for that application. ISUZU will call out those fasteners that require a replacement after removal. ISUZU will also call out the fasteners that require thread lockers or thread sealant. **UNLESS OTHERWISE SPECIFIED**, do not use supplemental coatings (Paints, greases, or other corrosion inhibitors) on threaded fasteners or fastener joint interfaces. Generally, such coatings adversely affect the fastener torque and the joint clamping force, and may damage the fastener. When you install fasteners, use the correct tightening sequence and specifications. Following these instructions can help you avoid damage to parts and systems.

## Headlight Bulb

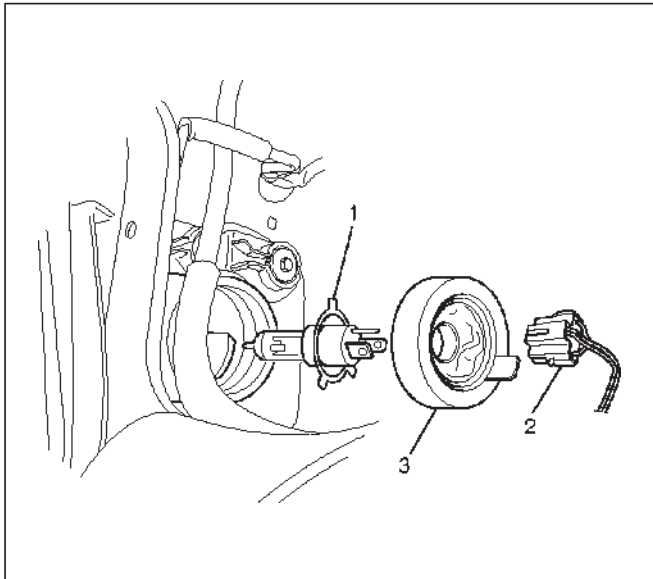
### Removal

1. Disconnect the battery ground cable.
2. Disconnect the connector(2).
3. Remove the cover(3).
4. Pull the bulb(1) out from the headlight body.

**CAUTION:** The halogen bulb develops a very high temperature. Do not touch the glass portion. If any stain is on the glass surface, it will scorch and the glass will be damaged.

### Installation

To install, follow the removal steps in the reverse order.

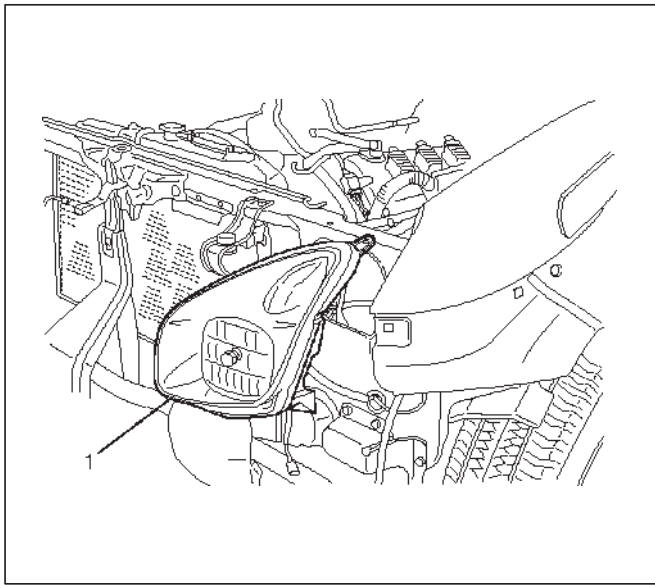


801RX007

## Headlight

### Removal

1. Disconnect the battery ground cable.
2. Remove the radiator grille.  
Refer to Radiator Grille and Front End Lower Panel in Body Structure section.
3. Remove the front bumper.  
Refer to Front bumper in Body Structure section.
4. Remove the headlight unit assembly(1)
  - Disconnect the connector.
  - Remove the 3 screws.



801RX006

### Installation

To install, follow the removal steps in the reverse order.

**CAUTION:** After installing the headlight, be sure to adjust the headlight aim.

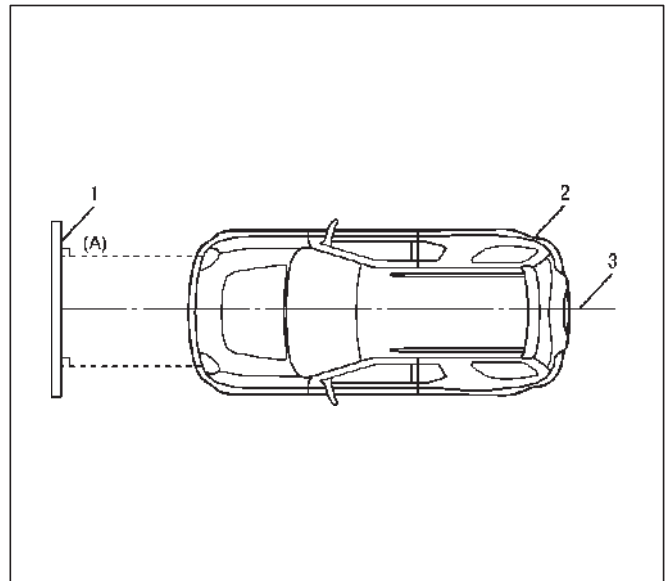
### Headlight Adjustment

#### Preparation

Place the vehicle with 1 – person in driver seat, on a level surface and check to see if the inflation pressure of the tires is correct, the linses are clean, the battery is sufficiently charged, and adjust to place vehicle by using the screen.

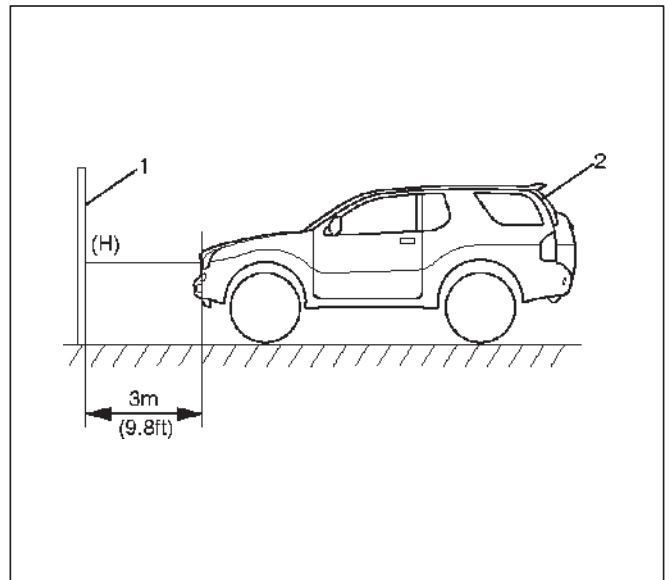
1. Set up the screen (1) on a level surface.
2. Put on the screen at right angles to the center line (3).

3. Adjust the center of the vehicle (2) to the center line on floor.



801RX015

4. Keep the vehicle (2) 3m (9.8 ft) apart from the screen (1).
5. Toward the screen from the bulb center mark of headlight, extend a parallel line (A) to the floor and draw a vertical line (V) at an intersection point of screen and a parallel line (A).

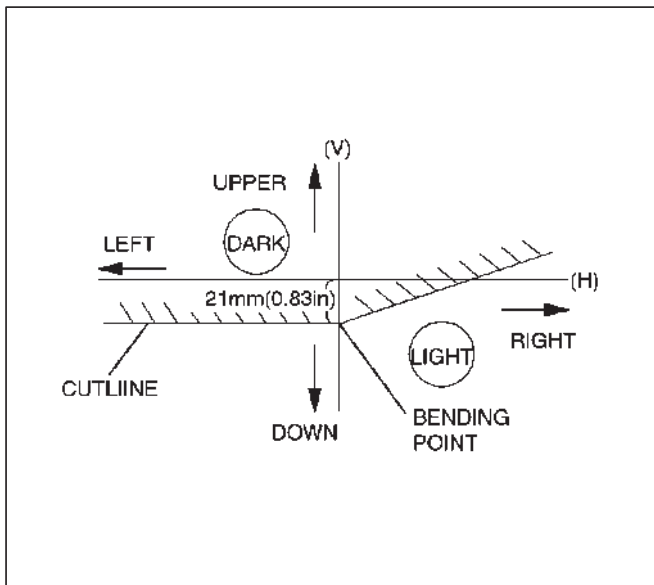


801RX012

6. Measure a height (H) from the bulb mark of headlight to the floor and draw a horizontal line on the screen.
7. Turn on the low beam of headlight.

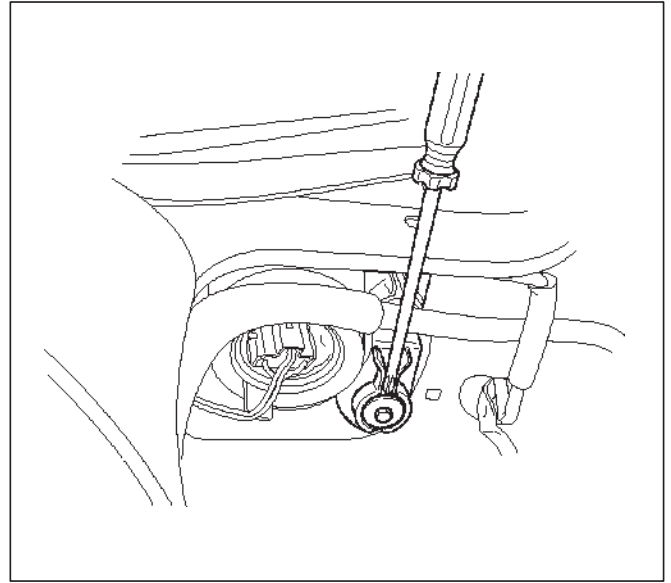
## 8A-4 LIGHTING SYSTEM

8. Adjust the bending point to the vertical line (V) by horizontal adjustment and adjust cut line 21mm (0.83in) below horizontal line (H) by vertical adjustment.



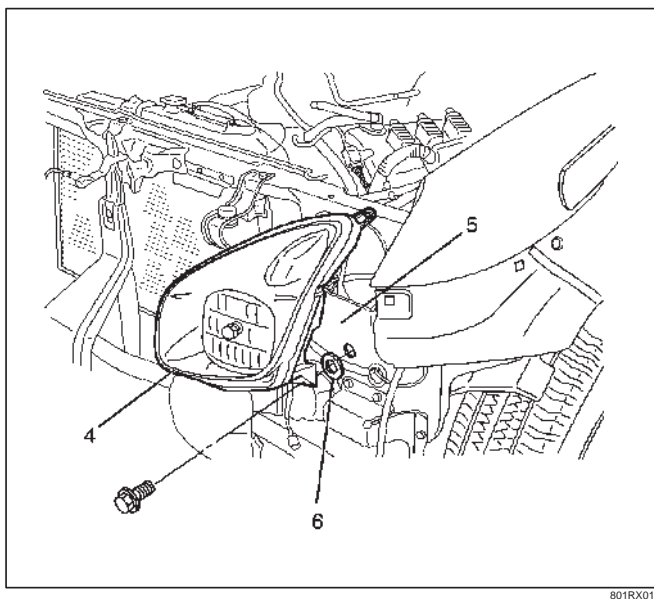
### Vertical Adjustment

Use a screwdriver for vertical and horizontal adjustment.



### Horizontal Adjustment

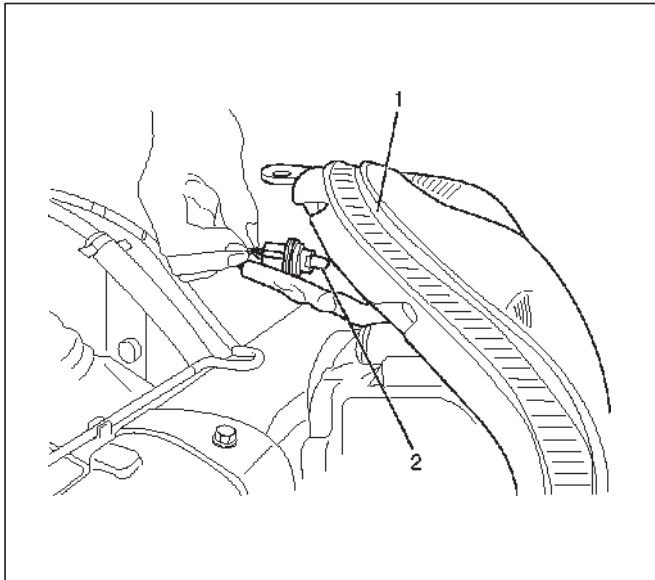
Inserting the spacer (6) between headlight assembly (4) and deflector panel (5), adjust the horizontal aiming of headlight.



## Fender Marker Light Bulb

### Removal

1. Disconnect the battery ground cable.
2. Remove the bulb.
  - Turn the socket counterclockwise to remove it from the headlight unit(1).
  - Pull out the bulb(2) from the socket.



801RX005

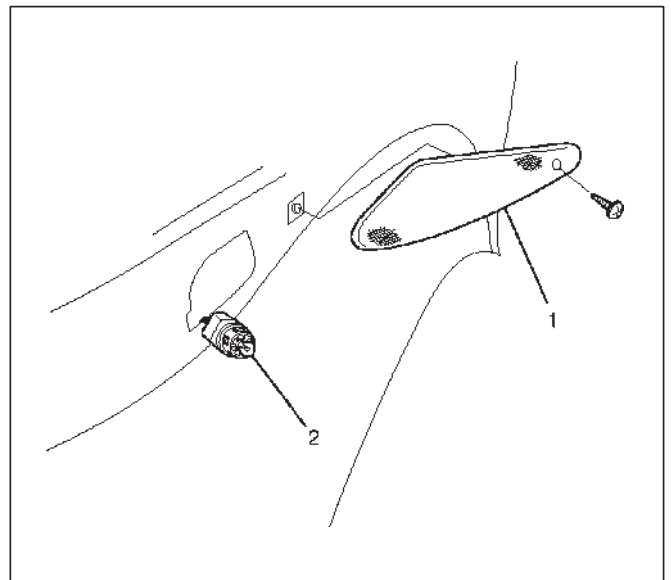
### Installation

To install, follow the removal steps in the reverse order.

## Front Side Marker Light Bulb

### Removal

1. Disconnect the battery ground cable.
2. Remove the front side maker light assembly(1).
  - Remove the one screws.
3. Remove the bulb(2).
  - Remove the side marker light socket by turning it counterclockwise.
  - Remove the bulb by turning it counterclockwise while pushing it at the same time.



801RX008

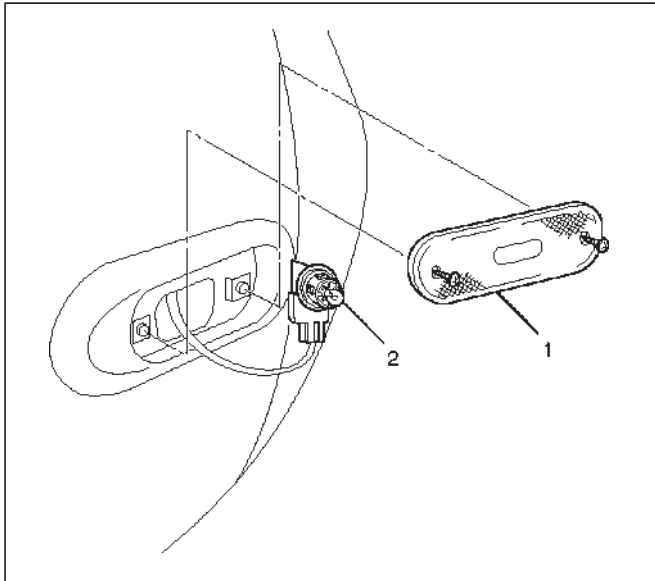
### Installation

To install, follow the removal steps in the reverse order.

## Rear Side Marker Light Bulb

### Removal

1. Disconnect the battery ground cable.
2. Remove the rear side maker light assembly(1).
  - Remove the two screws.
3. Remove the bulb(2).
  - Remove the side marker light socket by turning it counterclockwise.
  - Pullout the bulb(2) from the socket.



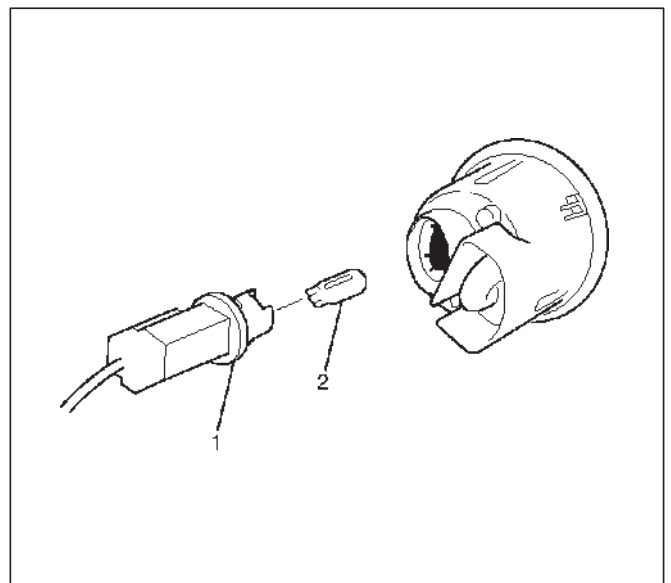
### Installation

To install, follow the removal steps in the reverse order.

## Parking Light Bulb

### Removal

1. Disconnect the battery ground cable.
2. Remove the bulb(2).
  - Turn the socket(1) counterclockwise to remove it from back of the front bumper.
  - Pull out the bulb(2) from the socket.



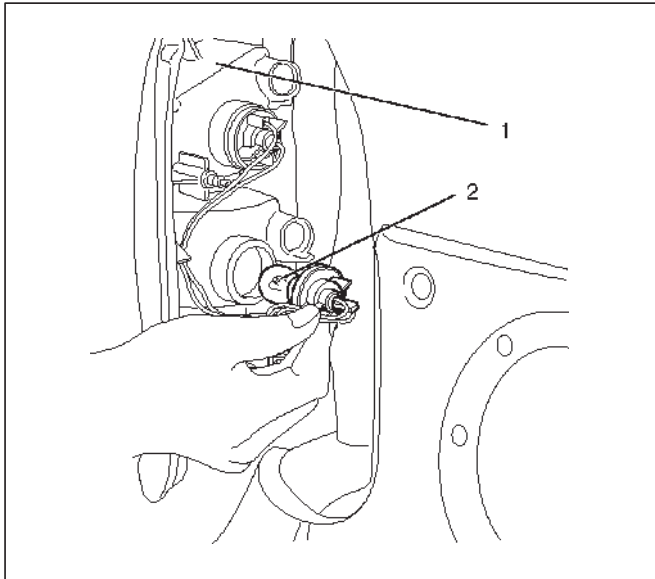
### Installation

To install, follow the removal steps in the reverse order.

## Taillight Bulb

### Removal

1. Disconnect the battery ground cable.
2. Remove the rear combination light assembly(1).
  - Remove the 2 screws.
3. Remove the taillight bulb.
  - Remove the socket by turning it counterclockwise.
  - Turn the bulb(2) counterclockwise while pushing it to remove it from the socket.



803RX006

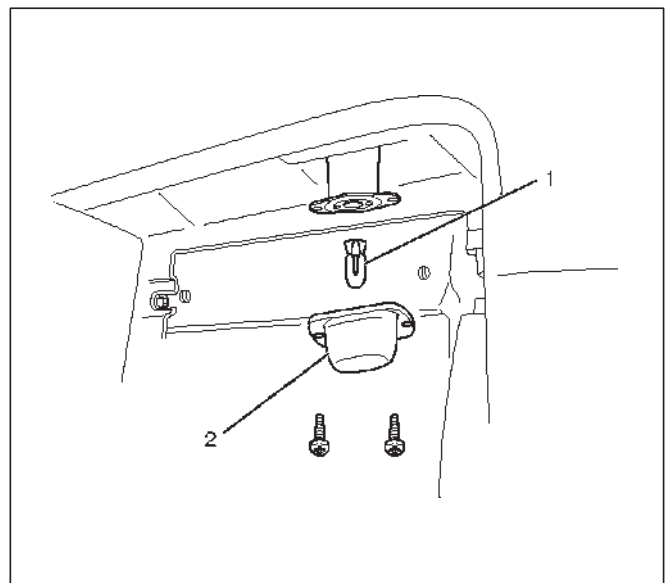
### Installation

To install, follow the removal steps in the reverse order.

## License Plate Light Bulb

### Removal

1. Disconnect the battery ground cable.
2. Remove the lens(2).
  - Remove the 2 screws.
3. Remove the bulb(1).
  - Pull out the bulb(1).



803RX007

### Installation

To install, follow the removal steps in the reverse order.

## Stoplight Bulb

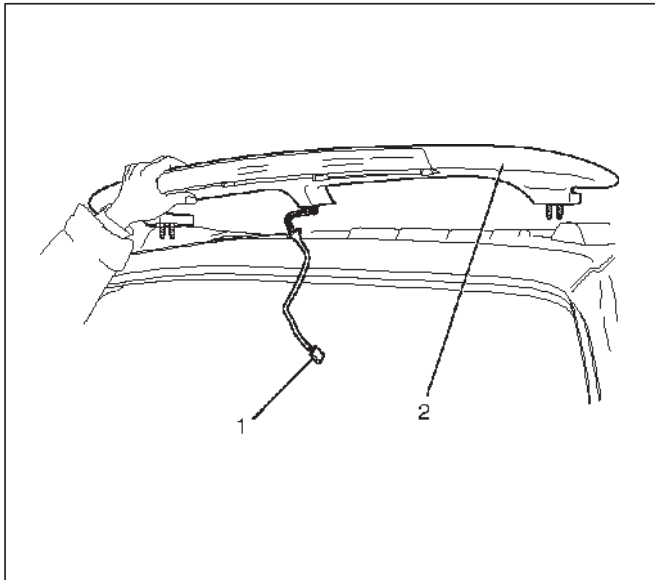
### Removal and Installation

Refer to Taillight Bulb in this section.

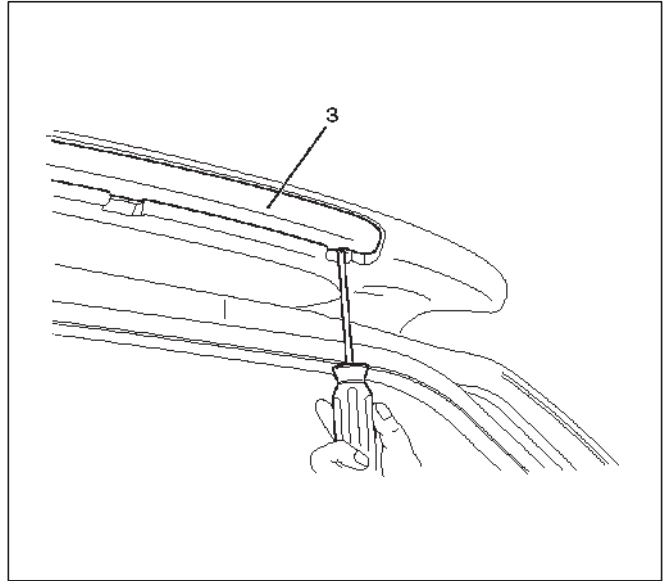
### High Mounted Stop Light

#### Removal

1. Disconnect the battery ground cable.
2. Remove the roof end spoiler/high mounted stop light assembly(2).
  - Remove the tail gate upper cover.  
Refer to the Interior Trim Assembly in Body section.
  - Disconnect the high mounted stop light connector(1).
  - Remove the 5 fixing nuts.
  - Pull out the connector(1).



3. Remove the high mounted stop light assembly(3).
  - Remove the 4 fixing screws.
  - Pull out the connector from the roof end spoiler.



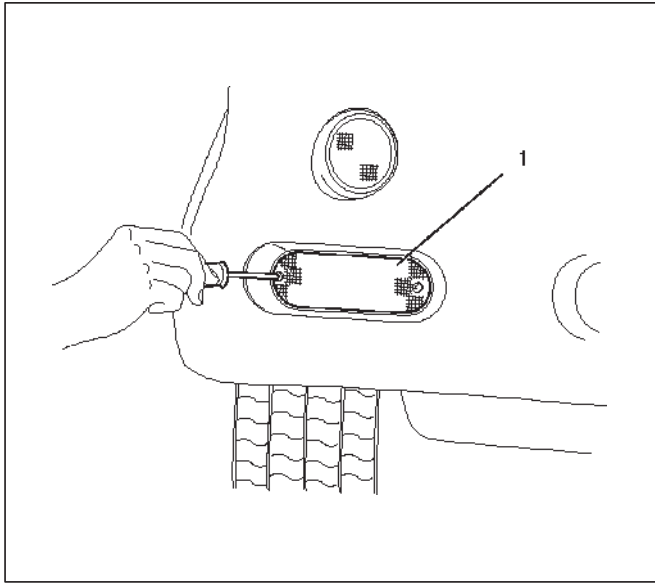
#### Installation

To install, follow the removal steps in the reverse order.

## Front Turn Signal Light Bulb

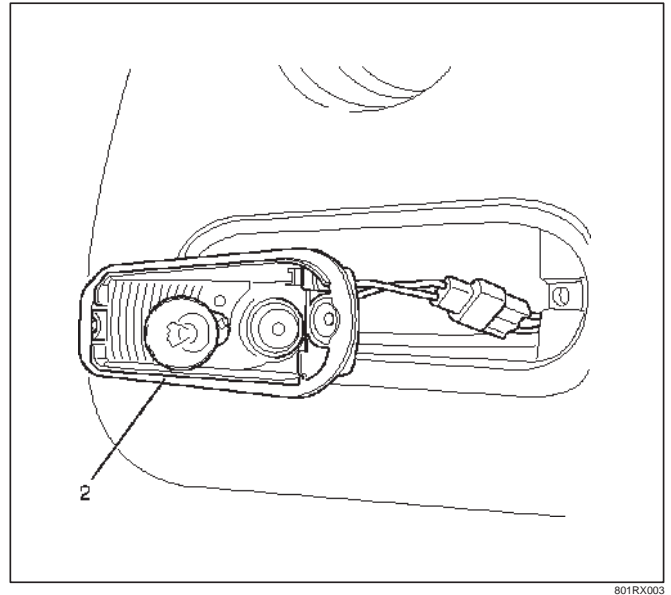
### Removal

1. Disconnect the battery ground cable.
2. Remove the lens(1).
  - Remove the 2 screws.



3. Remove the bulb(2).

- Turn the bulb(2) counterclockwise while pushing it to remove it from the socket.



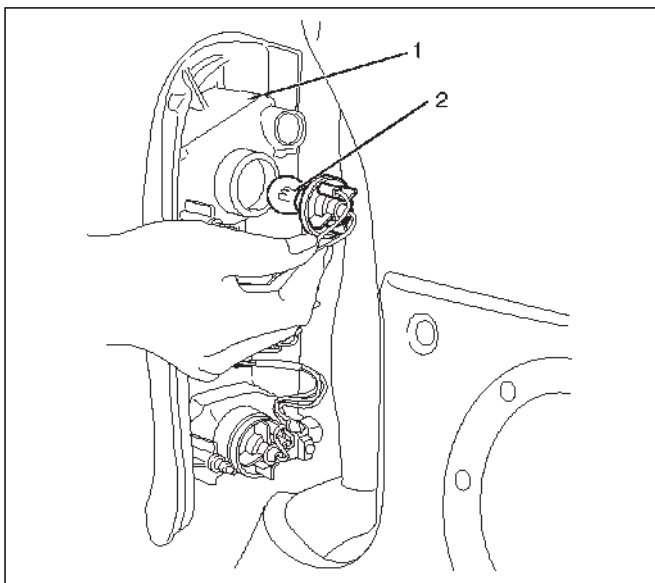
### Installation

To install, follow the removal steps in the reverse order.

## Rear Turn Signal Light Bulb

### Removal

1. Disconnect the battery ground cable.
2. Remove the rear combination light assembly(1).
  - Remove the 2 screws.
3. Remove the bulb(2).
  - Turn the bulb(2) counterclockwise while pushing it to remove it from the socket.



### Installation

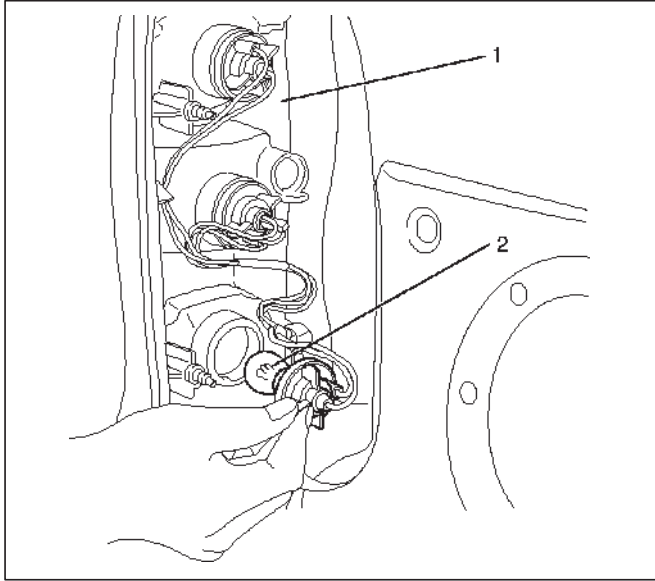
To install, follow the removal steps in the reverse order.



## Backup Light Bulb

### Removal

1. Disconnect the battery ground cable.
2. Remove the rear combination light assembly(1).
  - Remove the 2 screws.
3. Remove the bulb(3).
  - Turn the bulb(3) counterclockwise while pushing it to remove it from the socket.



803RX004

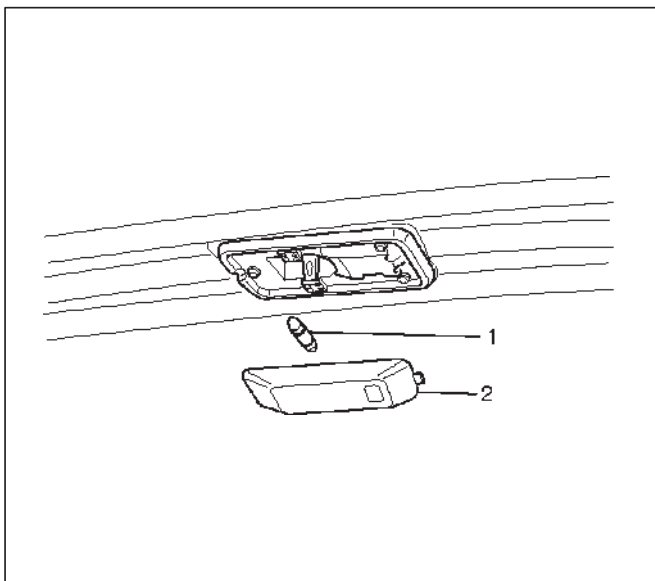
### Installation

To install, follow the removal steps in the reverse order.

## Dome Light Bulb

### Removal

1. Disconnect the battery ground cable.
2. Remove the lens(2).
  - Release the locks at 3 locations.
3. Remove the bulb(1).
  - Pull out the bulb.



805RX003

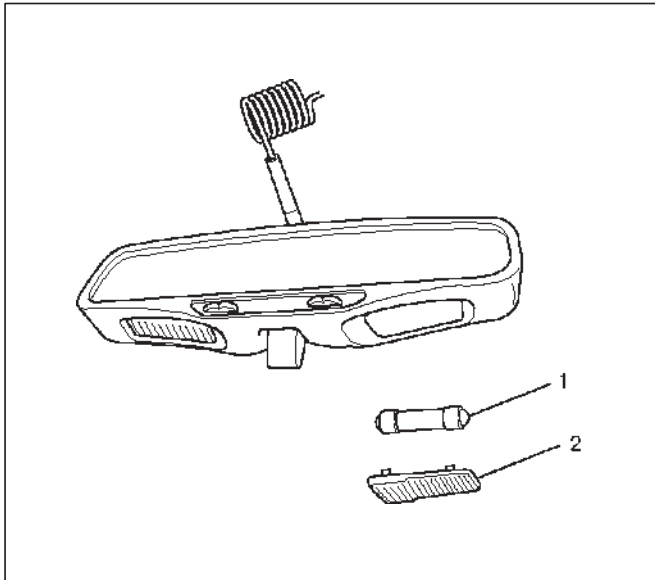
### Installation

To install, follow the removal steps in the reverse order.

## Map Light Switch/Bulb

### Removal

1. Disconnect the battery ground cable.
2. Remove the lens(2).
  - Release the locks.
3. Remove the bulb(1).
  - Pull out the bulb.



720RX006

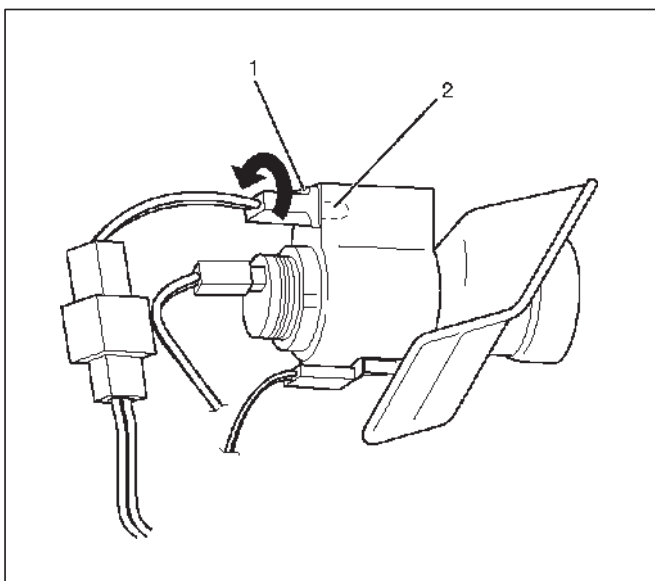
### Installation

To install, follow the removal steps in the reverse order.

## Cigarette Lighter Illumination Bulb

### Removal

1. Disconnect the battery ground cable.
2. Remove the bulb(2).
  - Remove the socket(1) by turning it counterclockwise.
  - Pull out the bulb.



826RX005

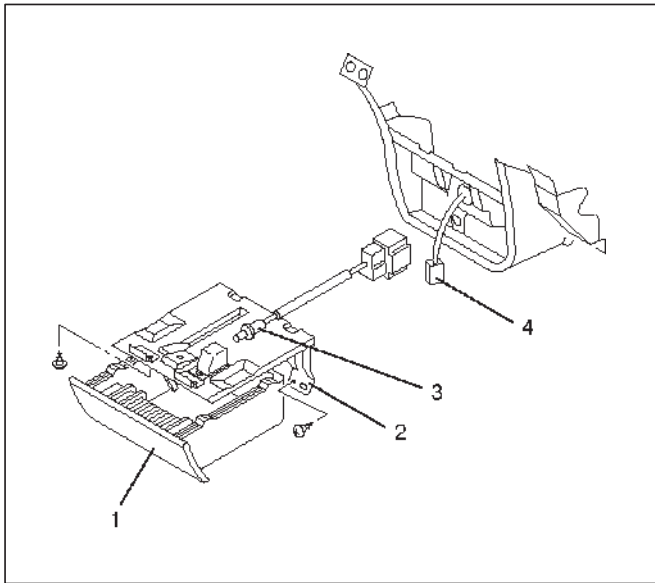
### Installation

To install, follow the removal steps in the reverse order.

## Ashtray Illumination Bulb

### Removal

1. Disconnect the battery ground cable.
2. Remove the ashtray(1).
3. Remove the ashtray guide(2).
  - Remove the 3 screws.
4. Remove the connector(4).
5. Remove the bulb(3).
  - Remove the socket by turning it counterclockwise.
  - Pull out the bulb.



### Installation

To install, follow the removal steps in the reverse order.

## HVAC Bezel Illumination Light Bulb

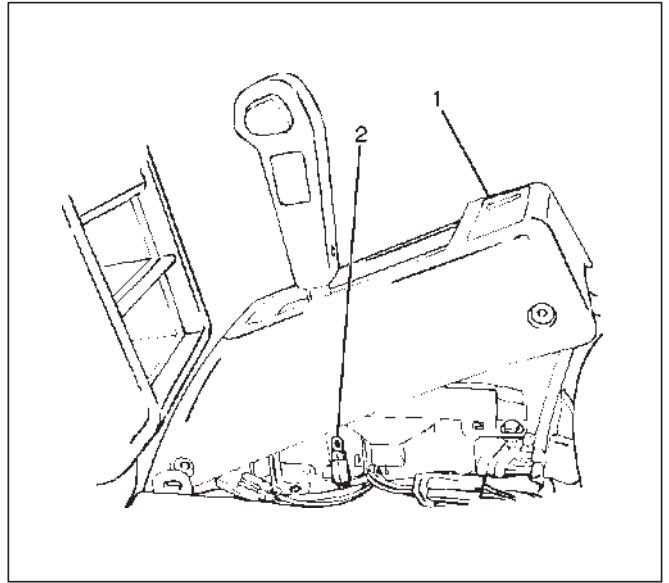
### Removal and Installation

Refer to Control Panel Illumination bulb in Heating, Ventilation and Air Conditioning (HVAC) section.

## Shift Lever Illumination Light Bulb (A/T)

### Removal

1. Disconnect the battery ground cable.
2. Remove the rear console box assembly.
  - Remove the 4 screws.
3. Remove the center console box assembly.
  - Remove the 4 screws.
4. Remove the indicator cover.
  - Remove the 4 screws.
5. Remove the bulb (1).
  - Turn the bulb socket counterclockwise.
  - Pull out the bulb from the socket.



255RX001

### Installation

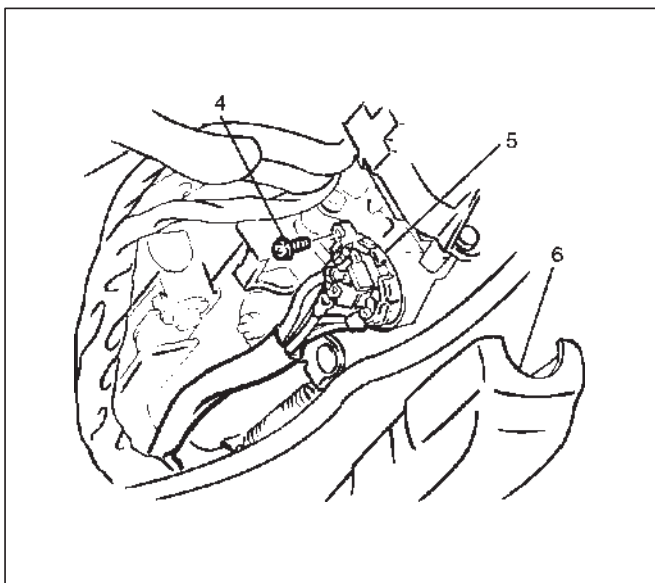
To install, follow the removal steps in the reverse order.

## Starter Switch

### Removal

1. Disconnect the battery ground cable.
2. Remove the instrument Panel driver lower cover.
 

Refer to Instrument Panel Assembly in Body Structure section.
3. Remove the steering cowl(3).
  - Remove the 7 screws.
4. Remove starter switch(2).
  - Disconnect the starter switch connector.
  - Remove the screw(1).



431RW005

### Installation

To install, follow the removal steps in the reverse order.

## Lighting Switch (Combination Switch)

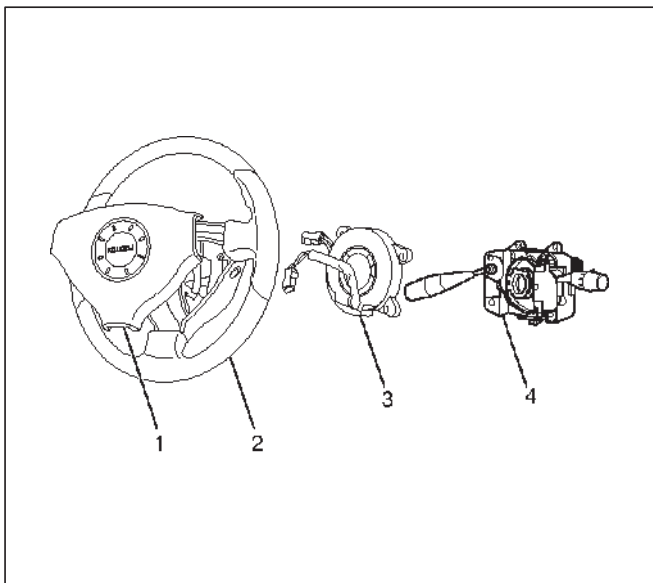
### Removal

1. Disconnect the battery ground cable.
2. Remove the instrument panel driver lower cover.  
Refer to the Instrument Panel Assembly in Body Structure section.
3. Remove the steering cowl.
  - Remove the 7 screws.
4. Disconnect the SDM (air bag controller) connector located at lower of the instrument panel driver lower cover.
5. Remove the driver inflator module(1).
  - Remove the 4 fixing screws and disconnect the drive inflator module connector.

**CAUTION:** When carrying a live inflator module, make sure the bag opening is pointed away from you. In case of an accidental deployment, the bag will then deploy with minimal chance of injury. Never carry the inflator module by the wires or connector on the underside of the module.

When placing a live inflator module on a bench or other surface, always face the bag and trim cover up, away from the surface. This is necessary so that a free space is provided to allow the air bag to expand in the unlikely event of accidental deployment.

6. Remove the steering wheel(2).  
Refer to the Steering Wheel in Steering section.
7. Remove SRS coil assembly(3).
  - Disconnect the SRS coil connector.
  - Remove the 4 fixing screws.
8. Remove lighting switch(4).
  - Disconnect the lighting switch connector.
  - Remove the 4 fixing screws.

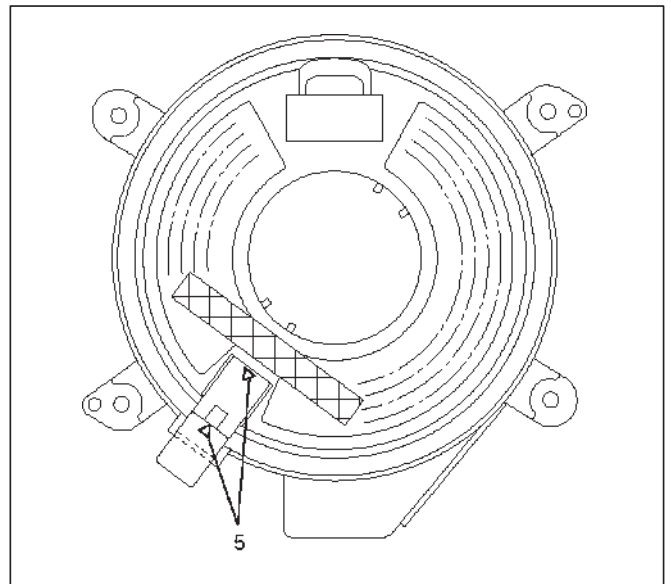


### Installation

To install, follow the removal steps in the reverse order, noting the following points.

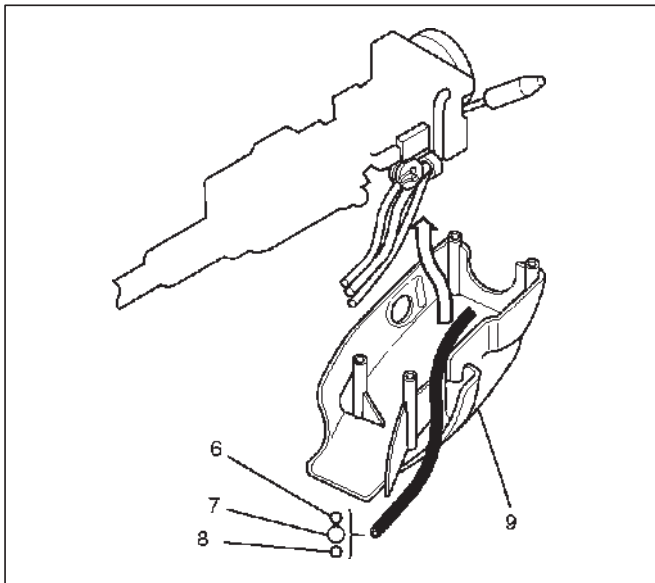
1. Check to see if the vehicle is in the straight driving condition and turn the rotary section of the SRS coil assembly provided to the upper surface of the lighting switch (combination switch) counterclockwise fully until it stops.

Then from where it stops, turn it back about 3 rotations to set the alignment marks(5) together before installing the steering wheel.



2. Tighten the steering shaft nut to the specified torque.  
**Torque: 34 N·m (25 lb ft)**
3. When connect the double lock type of inflator module connector, insert the connector completely and lock at outside.  
Imperfect locking may cause malfunction of SRS system circuit.

4. When installing the steering cowl(6), be sure to pass the harnesses through the route as shown in the figure so that the starter switch harness(9), the combination switch harness(8) and inflator module harness(7) will not get caught.

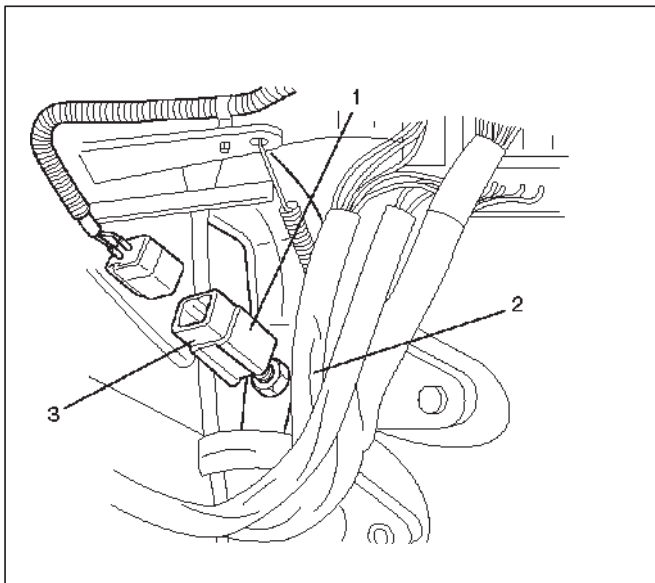


431RW023

## Stoplight Switch

### Removal

1. Disconnect the battery ground cable.
2. Remove the stoplight switch(10).
  - Disconnect the connector(12).
  - Loosen the lock nut(11) and turning the stoplight switch.

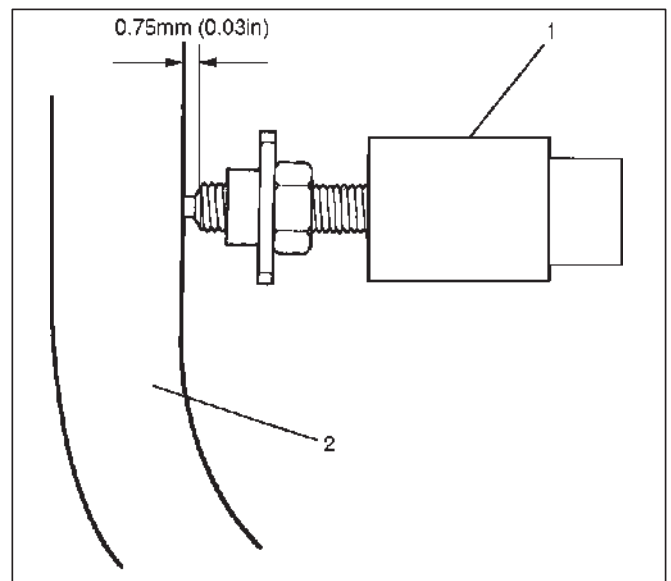


310RX003

### Installation

To install, follow the removal steps in the reverse order, noting the following points.

1. Check to see if the brake pedal has been returned by the return spring to the specified position.
2. Turn the switch(1) clockwise until the tip of the threaded portion of the stoplight switch contacts the pedal arm.
3. Turn the stoplight switch counterclockwise until the space (A) between the tip of the threaded portion and the pedal arm(2) is 0.75 mm (0.03 in.).



310RX004

## Turn Signal Switch(Combination Switch)

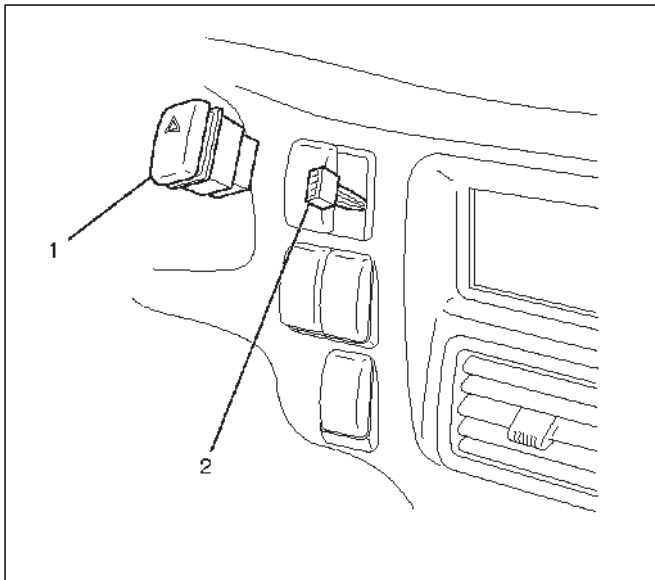
### Removal and Installation

Refer to the removal and installation steps of the Lighting Switch (Combination Switch) in this section.

## Hazard Warning Switch

### Removal

1. Disconnect the battery ground cable.
2. Remove the instrument Panel cluster Assembly.  
Refer to the Instrument Panel Assembly in Body Structure section.
3. Remove the hazard warning switch(1).
  - Disconnect the connector(2).
  - Push the lock from the back side of the instrument panel cluster assembly.



825RX030

### Installation

To install, follow the removal steps in the reverse order, noting the following point.

1. Push in the switch with your fingers until it locks securely.

## Key Remind Switch(Starter Switch)

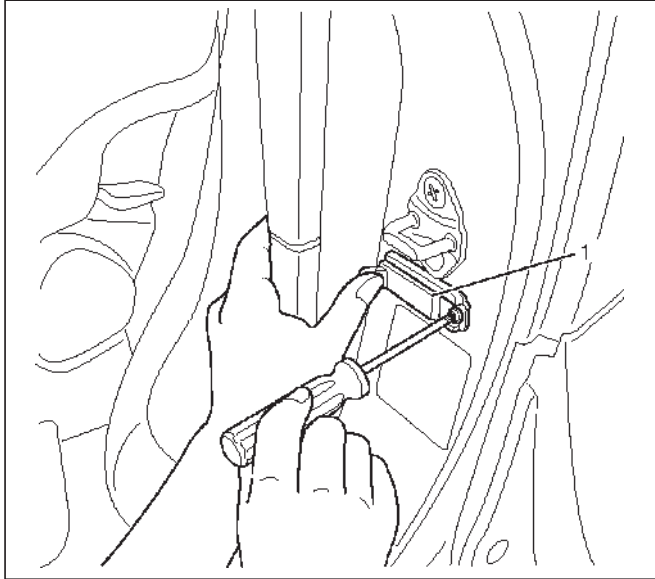
### Removal and Installation

Refer to the removal and installation on steps of the Stator Switch in this section.

## Door Switch

### Removal

1. Disconnect the battery ground cable.
2. Remove the switch(1).
  - Remove the screw.
  - Disconnect the connector.



825RX034

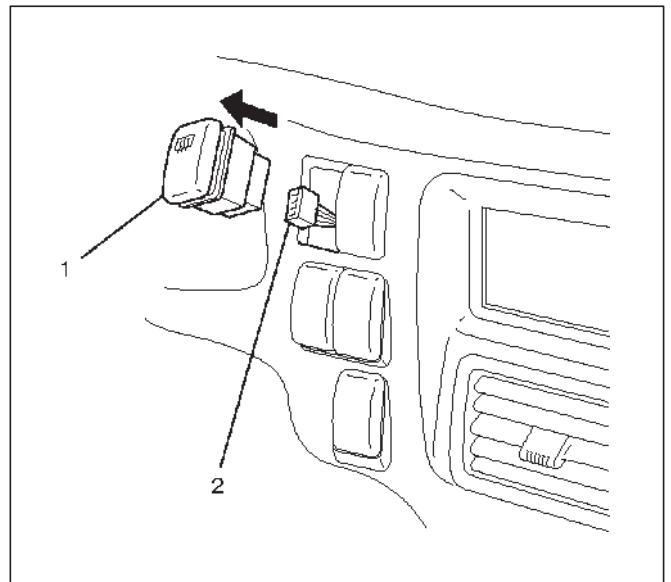
### Installation

To install, follow the removal steps in the reverse order.

## Rear Defogger Switch

### Removal

1. Disconnect the battery ground cable.
2. Remove the instrument panel cluster assembly.  
Refer to Instrument Panel Assembly in Body Structure section.
3. Remove the rear defogger switch(1).
  - Disconnect the connector(2).
  - Push the lock from the back side of the instrument panel cluster assembly.



826RX007

### Installation

To install, follow the removal steps in the reverse order, noting the following point.

1. Push in the switch with your fingers until it locks securely.



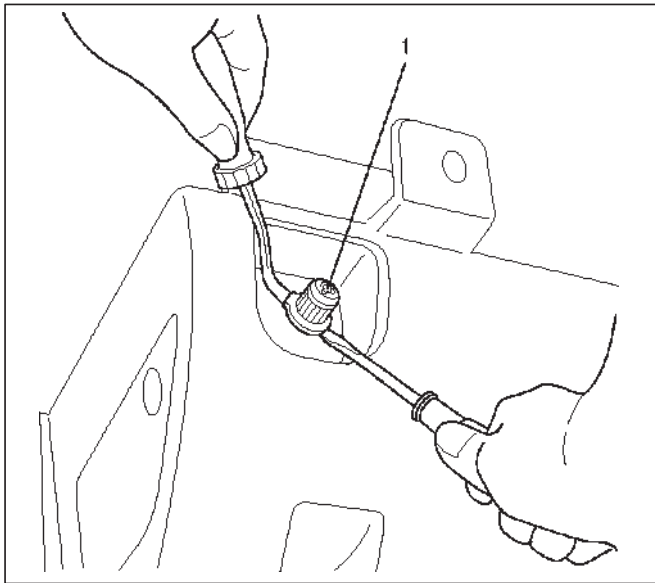
## Illumination Controller

### Removal

1. Disconnect the battery ground cable.
2. Remove the instrument panel driver lower cover assembly.
  - Refer to the Instrument Panel Assembly in Body Structure section.
3. Remove the illumination controller.
  - Disconnect the controller connector.
  - Remove the controller knob(1).
  - Remove the nut.
  - Remove the controller from the back side of the instrument panel drive lower cover assembly.

### Installation

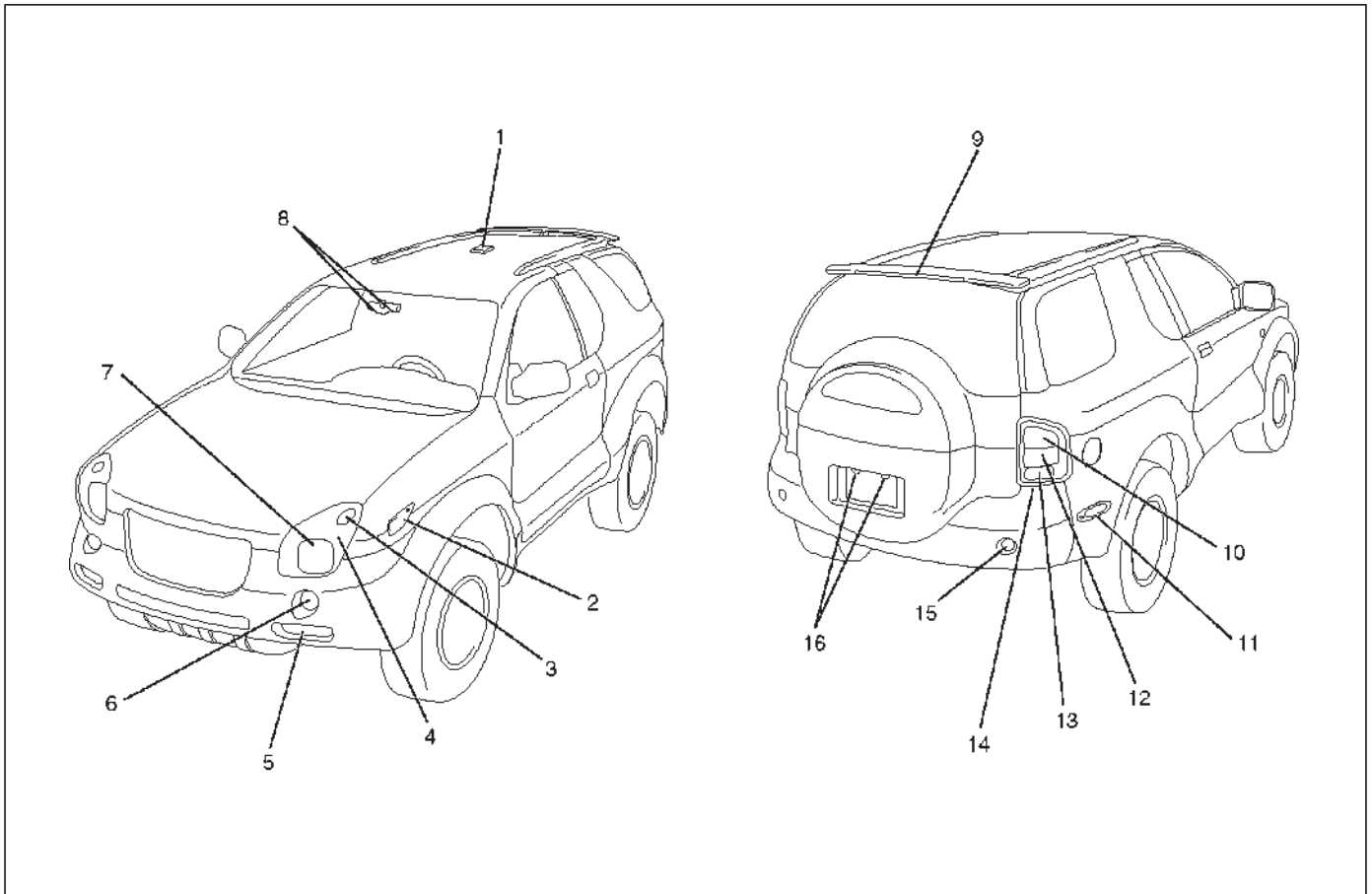
To install, follow the removal steps in the reverse order.



826RX011

## Main Data and Specifications

### Light and Bulb Specifications



810RX011

#### Legend

- |                             |                             |
|-----------------------------|-----------------------------|
| (1) Dome Light              | (9) High Mounted Stop Light |
| (2) Front Side Marker Light | (10) Rear Turn Signal Light |
| (3) Fender Marker Light     | (11) Rear Side Marker Light |
| (4) Combination Headlight   | (12) Tail Light/Stop Light  |
| (5) Front Turn Signal Light | (13) Backup Light           |
| (6) Parking Light           | (14) Rear Combination Light |
| (7) Headlight               | (15) Reflector              |
| (8) Map Light               | (16) License Plate Light    |

**8A-20 LIGHTING SYSTEM**

Light Name		Bulb No.	Rated Power	Number of Bulbs	Lens Color	Remarks
Combination Headlight	Headlight	9003	60W/55W	2	White	Halogen
	Fender Marker Light	158	3.4W	2	White	Yellow Bulb
Perking Light		194	3.8W	2	White	
Front Turn Signal Light		1156	27W	2	White	
Front Side Marker Light		194	3.8W	2	Amber	
Rear Combination Light	Tail/Stop Light	1157 NA	27W/8W	2	Red	
	Turn Signal Light	1156	27W	2	Amber	
	Backup Light	1156	27W	2	White	
High Mount Stop Light		—	—	1	Red	LED
License Plate Light		168	5W	2	White	
Rear Side Marker Light		194	3.8W	2	Red	
Map Light		168	5W	2	White	
Dome Light		—	10W	1	White	

**LIGHTING SYSTEM 8A-21**

Light Name		Bulb No.	Rated Power	Number of Bulbs	Lens Color	Remarks
Indicator / Warning Light	Air Conditioning SW	—	60mA	1		
	RR Defogger SW	—	60mA	1		W/O Timer
		—	80mA	1		W/Timer
	Check Trans	74	0.84W	1	Red	Meter
	A/T Oil Temp	74	0.84W	1	Red	Meter
	Mirror Defogger SW	—	0.84W	1		
	Cruise Set	74	1.4W	1	Green	Meter
	Cruise Main	74	1.4W	1	Green	Meter
	Power Drive	74	1.4W	1	Amber	Meter
	Winter Driver	74	1.4W	1	Green	Meter
	Turn Signal	74	1.4W	2	Green	Meter
	High Beam	74	1.4W	1	Blue	Meter
	ABS	74	1.4W	1	Amber	Meter
	Seat Belt	80	2W	1	Red	Meter
	Malfunction Indicator (Check Engine)	74	1.4W	1	Red	Meter
	Low Fuel	74	1.4W	1	Amber	Meter
	Oil Pressure	74	1.4W	1	Red	Meter
	Brake System	74	1.4W	1	Red	Meter
	Charge	74	1.4W	1	Red	Meter
	A/T Shift Position	74	0.91W	7	P,N,D,3,2, L : Green R : Amber	Meter
	Air Bag	80	2W	1	Red	Meter
TOD	Front-1	74	Led	1	Green	
	Front-2	74	Led	1	Green	
	Front-3	74	Led	1	Green	
	Rear	74	Led	1	Green	
	Auto	74	Led	1	Green	
	Check	74	Led	1	Red	

**Torque Specifications**

Application	N·m	Lb Ft	Lb In
Steering Shaft Nut	34	25	—

VEHICROSS

# BODY AND ACCESSORIES

## WIPER / WASHER SYSTEM

### CONTENTS

Service Precaution .....	8B-1	Removal .....	8B-4
Windshield Wiper/Washer System .....	8B-2	Installation .....	8B-4
General Description .....	8B-2	Windshield Wiper Arm/Blade .....	8B-5
Windshield Wiper And Washer Switch .....	8B-2	Removal .....	8B-5
Removal and Installation .....	8B-2	Installation .....	8B-5
Windshield Wiper Motor .....	8B-2	Windshield Wiper Blade Rubber .....	8B-6
Removal .....	8B-2	Removal .....	8B-6
Installation .....	8B-2	Installation .....	8B-6
Windshield Washer Motor .....	8B-3	Alarm & Relay Control Unit .....	8B-7
Removal .....	8B-3	Removal .....	8B-7
Installation .....	8B-3	Installation .....	8B-7
Washer Nozzle Angle Adjustment .....	8B-3	Intermittent Relay .....	8B-7
Windshield Wiper Linkage .....	8B-4	Removal .....	8B-7
Windshield Wiper Linkage and Associated		Installation .....	8B-7
Parts .....	8B-4	Main Data and Specifications .....	8B-8

### Service Precaution

**WARNING: THIS VEHICLE HAS A SUPPLEMENTAL RESTRAINT SYSTEM (SRS). REFER TO THE SRS COMPONENT AND WIRING LOCATION VIEW IN ORDER TO DETERMINE WHETHER YOU ARE PERFORMING SERVICE ON OR NEAR THE SRS COMPONENTS OR THE SRS WIRING. WHEN YOU ARE PERFORMING SERVICE ON OR NEAR THE SRS COMPONENTS OR THE SRS WIRING, REFER TO THE SRS SERVICE INFORMATION. FAILURE TO FOLLOW WARNINGS COULD RESULT IN POSSIBLE AIR BAG DEPLOYMENT, PERSONAL INJURY, OR OTHERWISE UNNEEDED SRS SYSTEM REPAIRS.**

**CAUTION: Always use the correct fastener in the proper location. When you replace a fastener, use ONLY the exact part number for that application. ISUZU will call out those fasteners that require a replacement after removal. ISUZU will also call out the fasteners that require thread lockers or thread sealant. UNLESS OTHERWISE SPECIFIED, do not use supplemental coatings (Paints, greases, or other corrosion inhibitors) on threaded fasteners or fastener joint interfaces. Generally, such coatings adversely affect the fastener torque and the joint clamping force, and may damage the fastener. When you install fasteners, use the correct tightening sequence and specifications. Following these instructions can help you avoid damage to parts and systems.**

## Windshield Wiper/Washer System

### General Description

The circuit consists of the starter switch, windshield wiper & washer switch, windshield wiper motor, windshield washer motor and windshield intermittent relay alarm & relay control unit.

When the wiper & washer switch is turned on with the starter switch on, the battery voltage is applied to the wiper motor to activate the wiper.

The washer motor squirts glass cleaning fluid while the washer switch is being pushed. The intermittent relay is used to control motion of the wiper.

## Windshield Wiper And Washer Switch

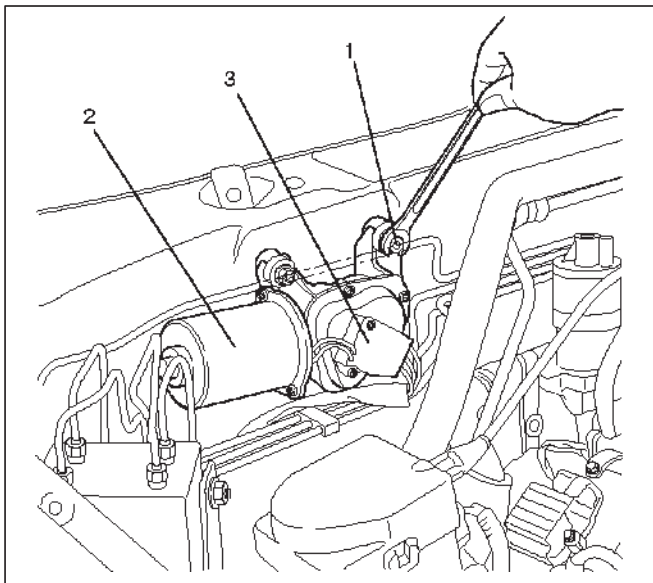
### Removal and Installation

Refer to the Lighting Switch (Combination Switch) in Lighting System section.

## Windshield Wiper Motor

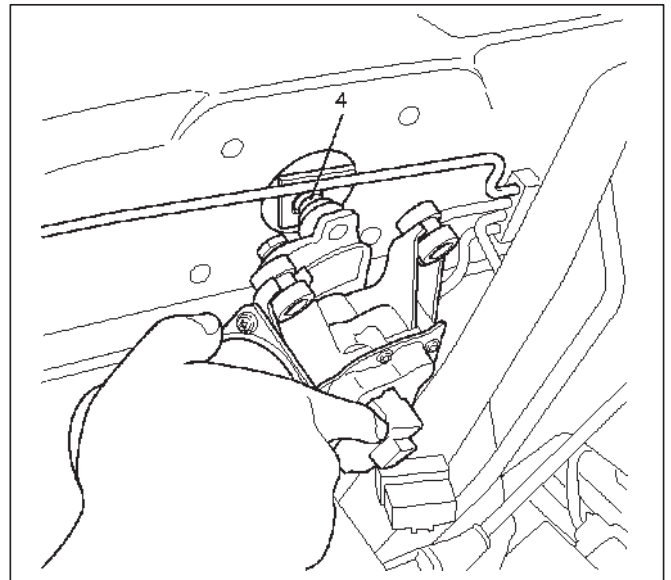
### Removal

1. Disconnect the battery ground cable.
2. Remove the wiper motor (2).
  - Disconnect the motor connector (3).
  - Remove the 4 mounting bolts (1).



880RX010

- Remove the crank arm fixing ball (4).



880RX011

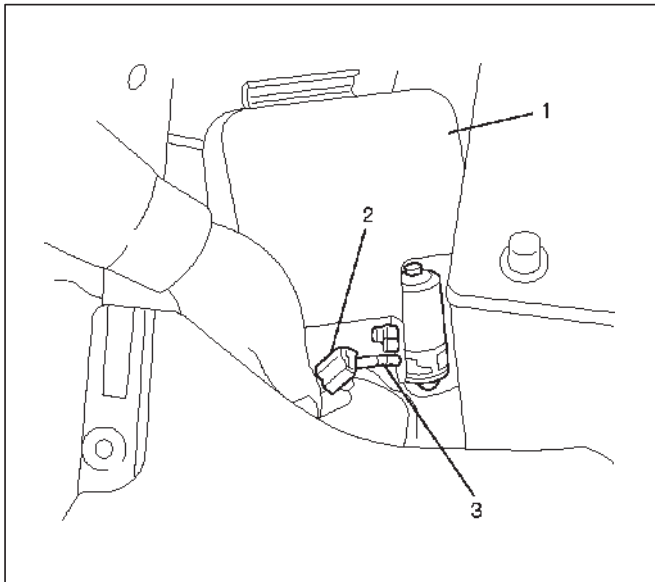
### Installation

To install, follow the removal steps in the reverse order.

## Windshield Washer Motor

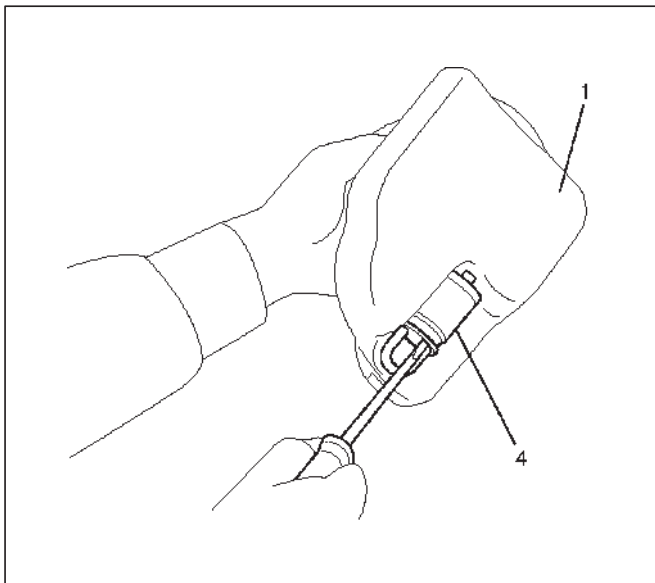
### Removal

1. Disconnect the battery ground cable.
2. Remove the washer tank (1).
  - Disconnect the washer motor connector (2).
  - Disconnect the washer hose (3).
  - Pull out the washer tank assembly (1).



880RX006

3. Remove the washer motor (4).
  - Pull the washer motor from the washer tank (1).



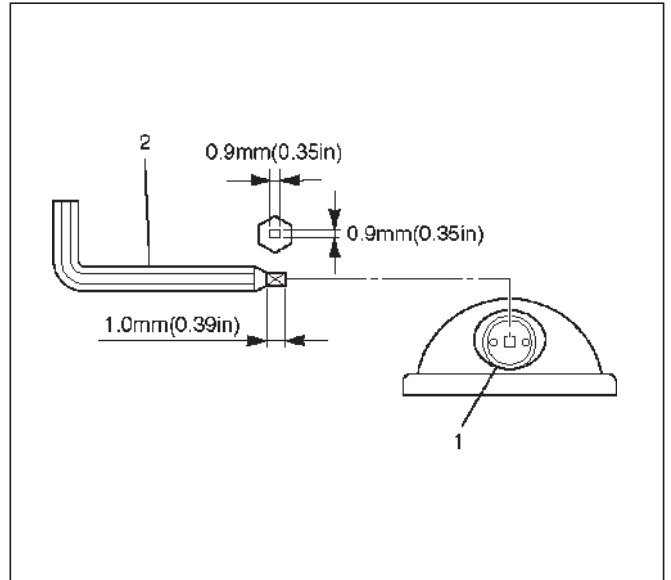
880RX005

### Installation

To install, follow the removal steps in the reverse order.

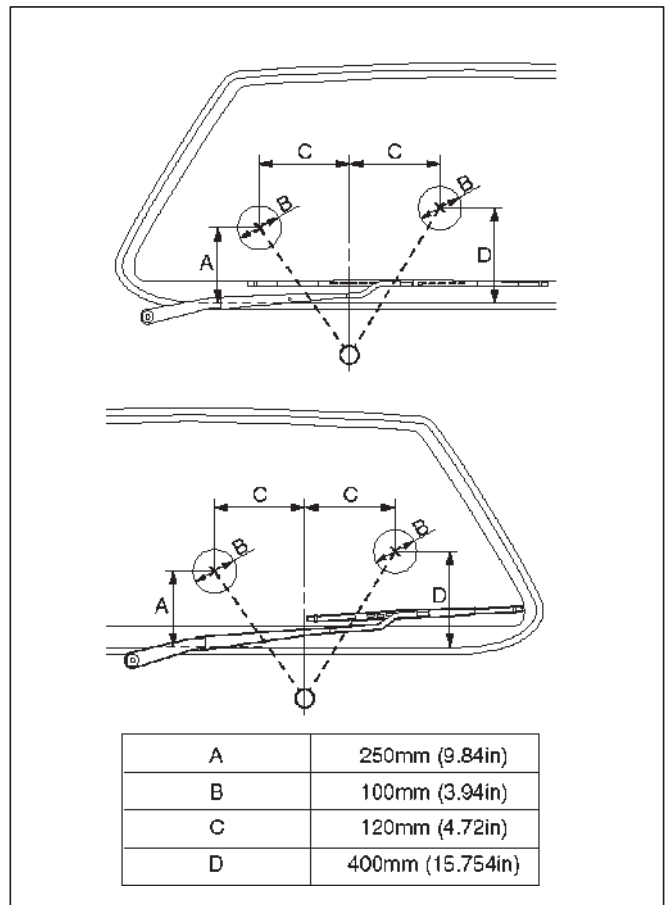
### Washer Nozzle Angle Adjustment

1. Adjust the washer nozzle (1) with pin (2).



880RX007

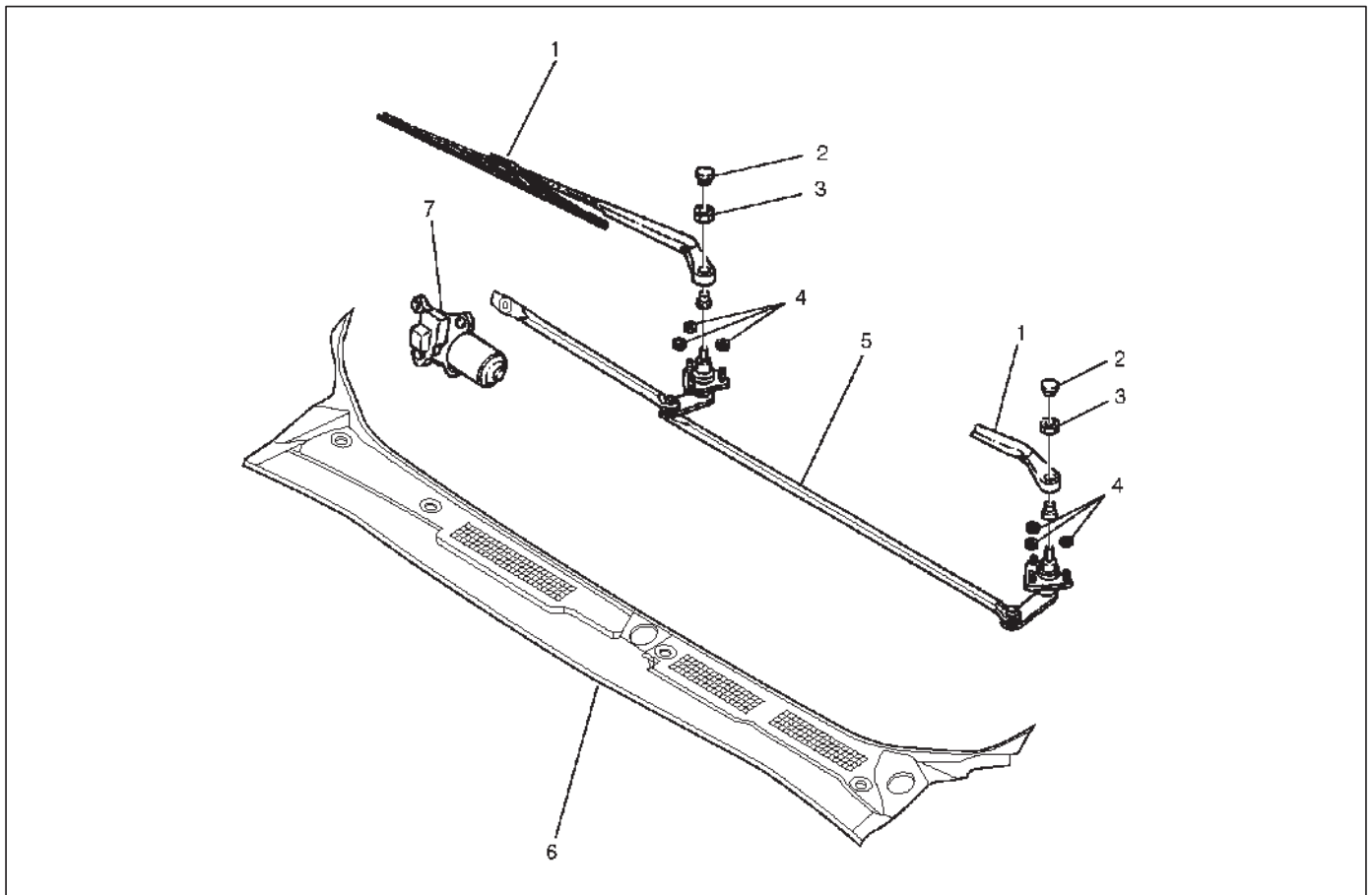
### Washer Spray Pattern



880RX009

## Windshield Wiper Linkage

### Windshield Wiper Linkage and Associated Parts



880RX003

#### Legend

- |                       |                            |
|-----------------------|----------------------------|
| (1) Wiper Arm/Blade   | (4) Pivot Mounting Nut     |
| (2) Wiper Arm Nut Cap | (5) Wiper Linkage Assembly |
| (3) Wiper Arm Nut     | (6) Vent Cowl Cover        |
|                       | (7) Wiper Motor Assembly   |

#### Removal

1. Disconnect the battery ground cable.
2. Remove the wiper motor assembly (7).  
Refer to the Windshield Wiper Motor in this section.
3. Remove the wiper arm/blade (1).
  - Remove the wiper arm nut cap (2) and nut (3).
4. Remove the vent cowl cover (6).
  - Remove the 5 screws and 3 clips.
5. Remove the wiper linkage assembly (5).
  - Remove the pivot mounting nuts (4), and then take out the wiper linkage assembly (5) from the opening of the cowl.

#### Installation

To install, follow the removal steps in the reverse order noting the following points.

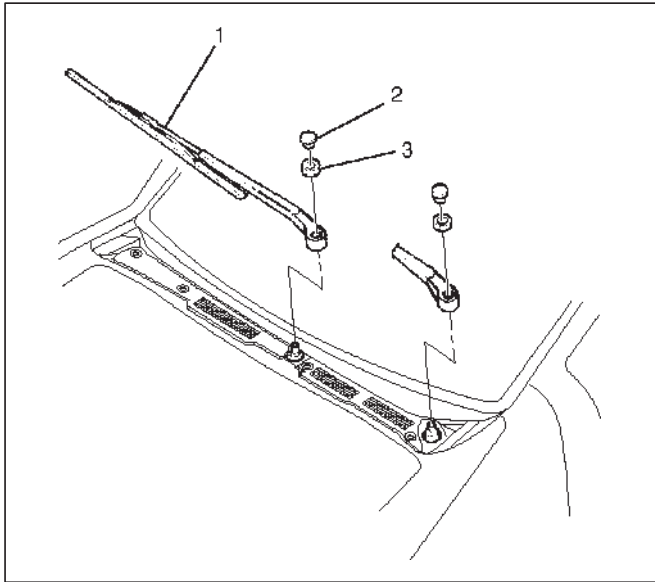
1. Install wiper arm/blade.
  - Before installing the wiper arm/blade to the shaft, confirm that the motor stop at the auto-stop position.
  - Set the wiper arm/blade to the specified position.  
Refer to the Windshield Wiper Arm/Blade in this section.



## Windshield Wiper Arm/Blade

### Removal

1. Disconnect the battery ground cable.
2. Remove the wiper arm/blade (1).
  - Pry the cap (2) off with the tip of a screwdriver.
  - Remove the nut (3).



880RX012

### Installation

To install, follow the removal steps in the reverse order noting the following points.

1. Install wiper arm/blade.
  - Before installing the wiper arm/blade (1) to the shaft, confirm that the motor stop at the auto-stop position.
  - Set the wiper arm/blade so that the tips of both blades are positioned as below.

#### Driver side:A

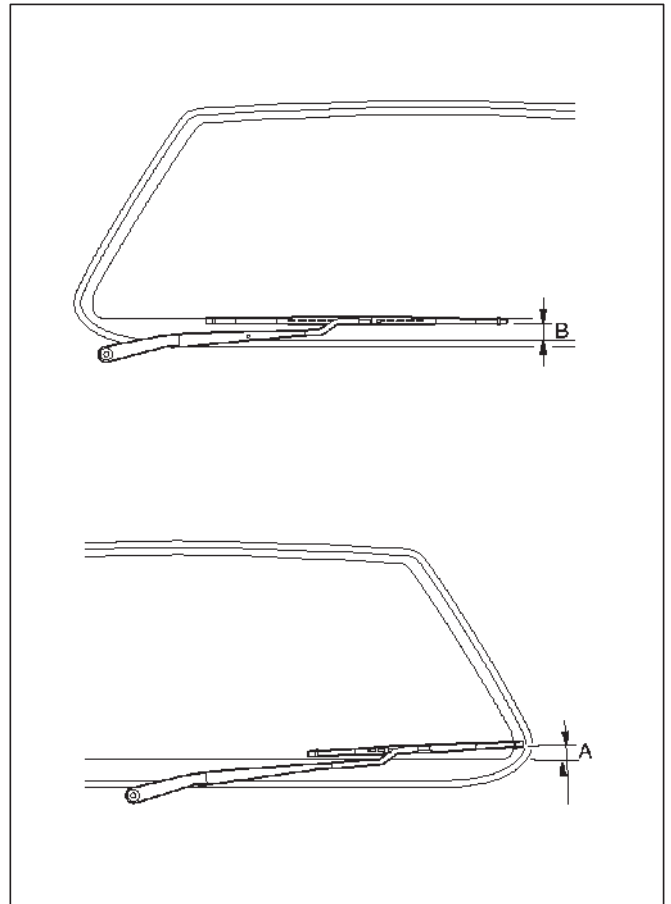
About 40 mm (1.57 in) from the upper edge of the cowl cover rubber seal as shown in the figure.

#### Assistant side:B

About 50 mm (1.97 in) from the upper edge of the black ceramic coating as shown in the figure.

- Tighten the nuts to the specified torque.

**Torque: 31 N·m (23 lb ft)**



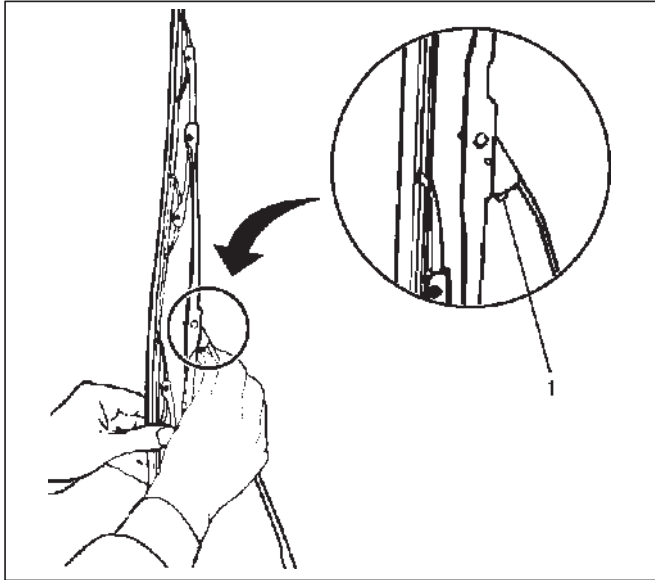
880RX006

## Windshield Wiper Blade Rubber

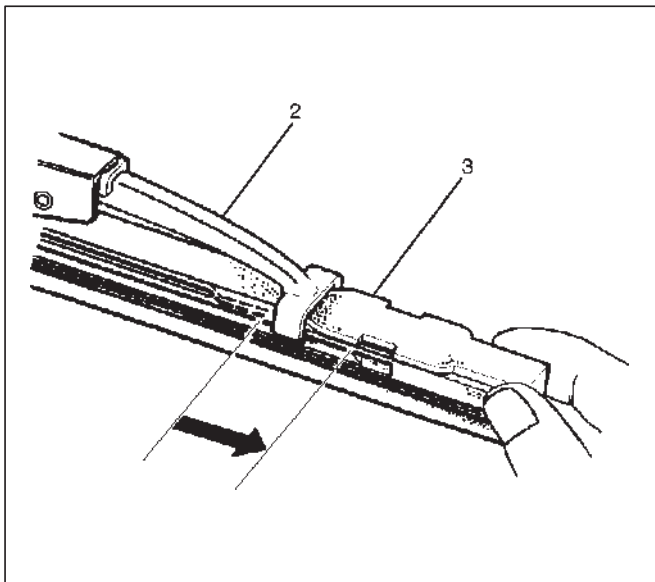
### Removal

1. Push the wiper blade lock(1) while pulling the wiper blade in the arrow direction as shown in the figure.

**CAUTION:** When the wiper blade has been removed, wrap the tip of the wiper arm with cloth, to avoid damaging the glass.



2. Pull the end of rubber and remove the projection(3) from the click of the blade stay (2).

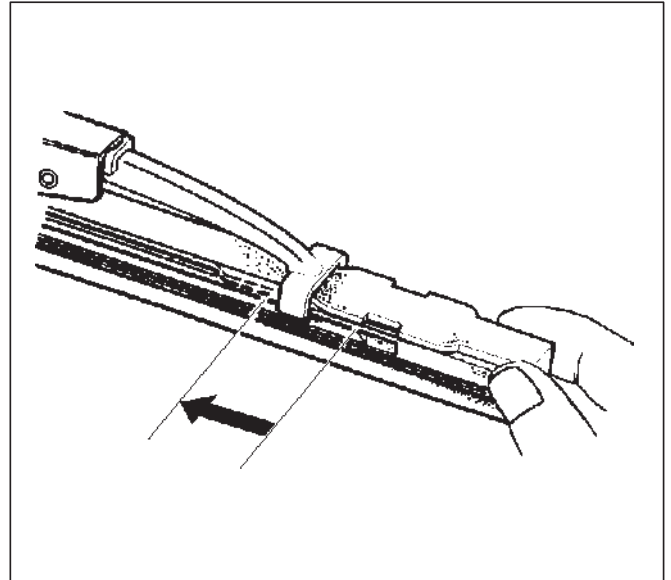


3. Pull the rubber out in the same direction.

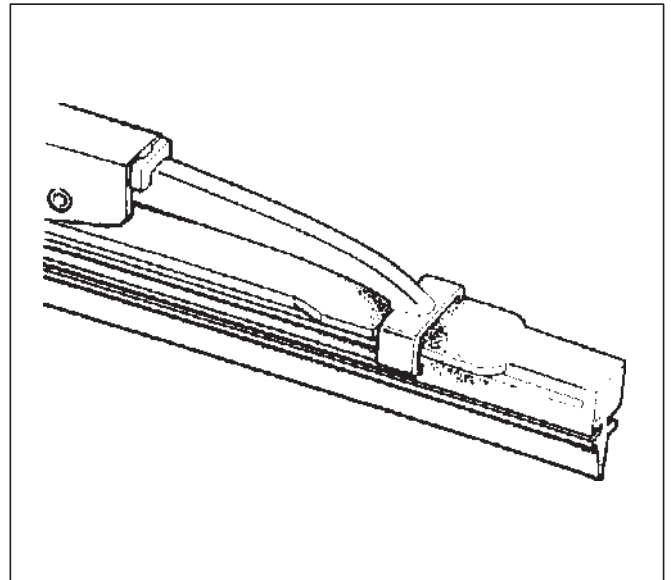
### Installation

To install, follow the removal steps in the reverse order, noting the following points.

1. Install the click of the blade stay in the groove of the new rubber and slide it in. Complete wiper blade installation by pushing the click.



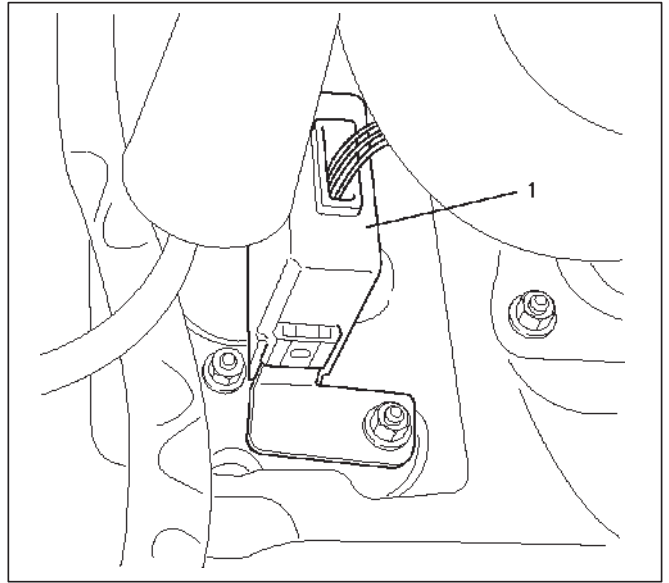
2. Finally, check that the click of the stay has caught in the hole of the rubber.



## Alarm & Relay Control Unit

### Removal

1. Disconnect the battery ground cable.
2. Remove the glove box.
3. Remove the instrument panel driver lower cover assembly.
  - Refer to the Instrument Panel Assembly in Body Structure section.
4. Remove the driver Knee bolster reinforcement assembly.
5. Remove the fixing two bolts, disconnect the connectors and then remove the alarm & relay control unit (1).



826RX010

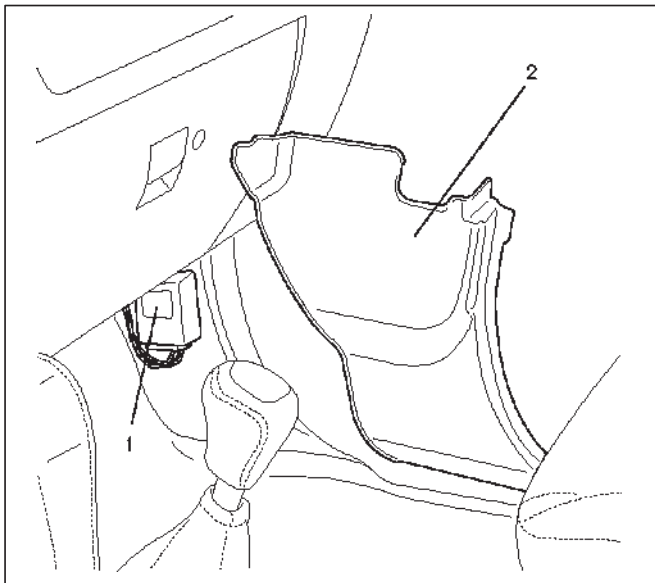
### Installation

To install, follow the removal steps in the reverse order.

## Intermittent Relay

### Removal

1. Disconnect the battery ground cable.
2. Remove the dash side trim panel (RH) (2).
3. Disconnect the connector.
4. Remove a fixing nut to remove the intermittent relay (1).



826RX012

### Installation

To install, follow the removal steps in the reverse order.

## 8B-8 WIPER/WASHER SYSTEM

---

### Main Data and Specifications

#### Torque Specifications

Application	N·m	lb·ft	lb·in
Windshield Wiper Arm Fixing Nuts	31	23	—

# BODY AND ACCESSORIES

## ENTERTAINMENT

### CONTENTS

Service Precaution .....	8C-1	Installation .....	8C-4
Cigarette Lighter .....	8C-2	Tweeter Assembly .....	8C-5
General Description .....	8C-2	Removal .....	8C-5
Removal .....	8C-2	Installation .....	8C-5
Installation .....	8C-2	Rear Speaker .....	8C-5
Antenna .....	8C-3	Removal .....	8C-5
Removal .....	8C-3	Installation .....	8C-5
Installation .....	8C-3	Horn (Low note) .....	8C-6
Radio .....	8C-4	Removal .....	8C-6
Removal .....	8C-4	Installation .....	8C-6
Installation .....	8C-4	Horn (High note) .....	8C-6
Front Speaker .....	8C-4	Removal .....	8C-6
Removal .....	8C-4	Installation .....	8C-6

### Service Precaution

**WARNING: THIS VEHICLE HAS A SUPPLEMENTAL RESTRAINT SYSTEM (SRS). REFER TO THE SRS COMPONENT AND WIRING LOCATION VIEW IN ORDER TO DETERMINE WHETHER YOU ARE PERFORMING SERVICE ON OR NEAR THE SRS COMPONENTS OR THE SRS WIRING. WHEN YOU ARE PERFORMING SERVICE ON OR NEAR THE SRS COMPONENTS OR THE SRS WIRING, REFER TO THE SRS SERVICE INFORMATION. FAILURE TO FOLLOW WARNINGS COULD RESULT IN POSSIBLE AIR BAG DEPLOYMENT, PERSONAL INJURY, OR OTHERWISE UNNEEDED SRS SYSTEM REPAIRS.**

**CAUTION: Always use the correct fastener in the proper location. When you replace a fastener, use ONLY the exact part number for that application. ISUZU will call out those fasteners that require a replacement after removal. ISUZU will also call out the fasteners that require thread lockers or thread sealant. UNLESS OTHERWISE SPECIFIED, do not use supplemental coatings (Paints, greases, or other corrosion inhibitors) on threaded fasteners or fastener joint interfaces. Generally, such coatings adversely affect the fastener torque and the joint clamping force, and may damage the fastener. When you install fasteners, use the correct tightening sequence and specifications. Following these instructions can help you avoid damage to parts and systems.**

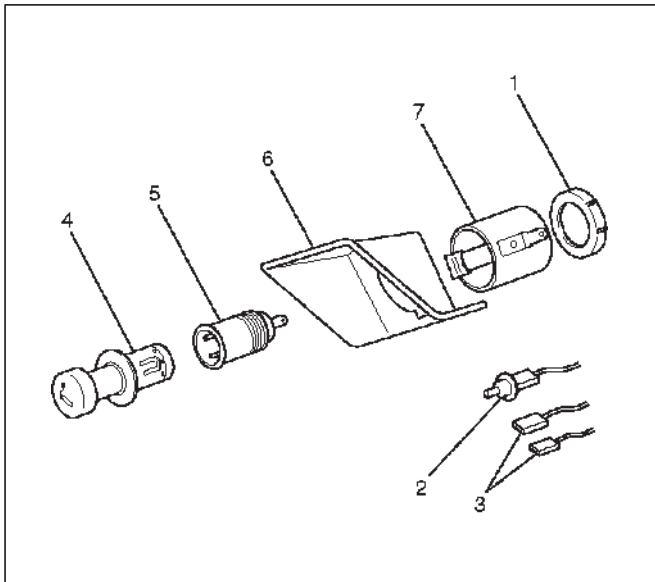
## Cigarette Lighter

### General Description

When the cigarette lighter is pushed in with the starter switch at either "ACC" or "ON" position, a circuit is formed in the cigarette lighter case to heat the lighter coil. The cigarette lighter is sprung back to its original position after the lighter coil is heated.

### Removal

1. Disconnect the battery ground cable.
2. Remove the illumination light socket(2).
3. Disconnect the connectors(3).
4. Remove the cigarette lighter.
  - Remove the retaining ring(1) by turning it counterclockwise.
  - Remove the outer case(7), cigarette lighter(4) socket(5), and bezel(6).



826RX004

### Installation

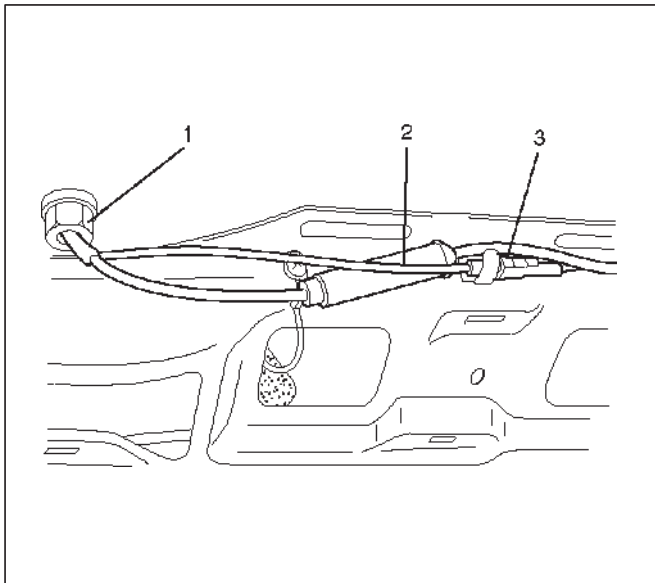
To install, follow the removal steps in the reverse order, noting the following point.

1. When installing the bezel, align the projected portion of the socket with the notch of the bezel.

## Antenna

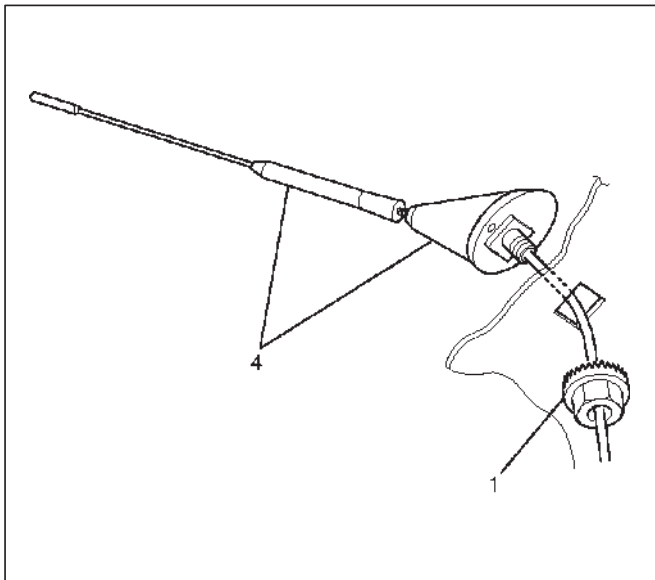
### Removal

1. Disconnect the battery ground cable.
2. Remove the tail gate upper cover.  
Refer to the Interior Trim Assembly in Body section.
3. Disconnect the antenna feeder plug(2) and connector(3).



890RX020

4. Remove the antenna assembly(4).  
○Remove the mounting nut(1).



890RX019

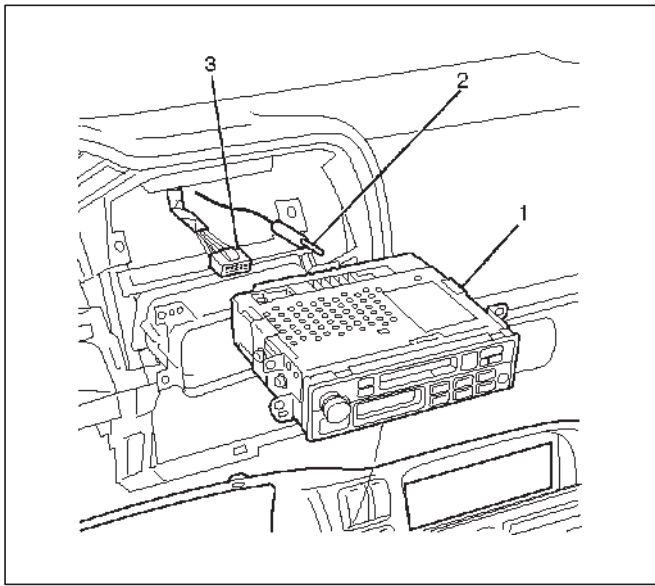
### Installation

To install, follow the removal steps in the reverse order.

## Radio

### Removal

1. Disconnect the battery ground cable.
2. Remove the instrument panel cluster assembly.  
Refer to the Instrument Panel Assembly in Body Structure section.
3. Remove the radio(1).
  - Remove the 2 fixing screws.
  - Disconnect the radio connector(3) and antenna feeder plug(2).



890RX015

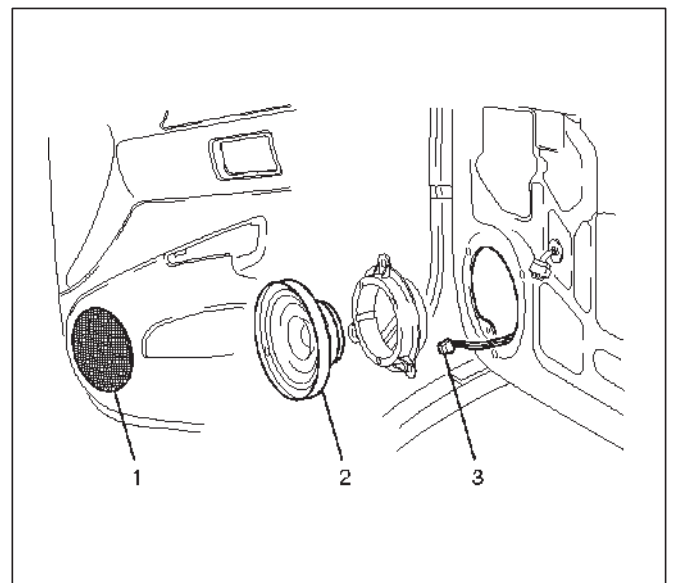
### Installation

To install, follow the removal steps in the reverse order.

## Front Speaker

### Removal

1. Disconnect the battery ground cable.
2. Remove the door trim panel with speaker grille(1).  
Refer to the Door Assembly in Body section.
3. Remove the speaker(2).
  - Remove the 3 fixing screws.
  - Disconnect the connector(3).



890RX016

### Installation

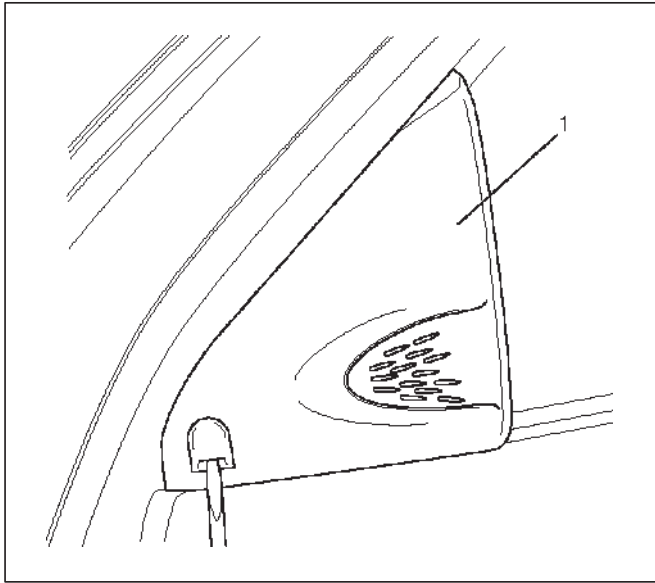
To install, follow the removal steps in the reverse order.



## Tweeter Assembly

### Removal

1. Disconnect the battery ground cable.
2. Remove the tweeter assembly(1).
  - Pry the tweeter assembly(1) off with the tip of a screwdriver.
  - Disconnect the connector.
  - Remove the screws.



890RX017

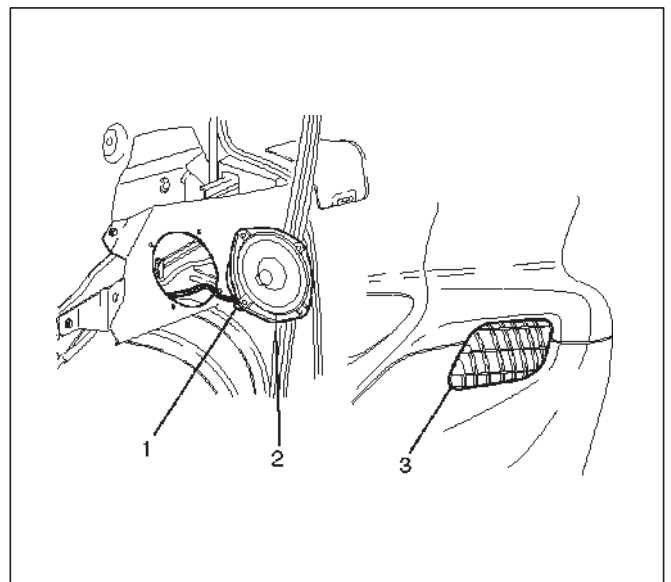
### Installation

To install, follow the removal steps in the reverse order.

## Rear Speaker

### Removal

1. Disconnect the battery ground cable.
2. Remove the center pillar inner trim cover with speaker grille(3).  
Refer to the Door Assembly in Body section.
3. Remove the rear speaker(2).
  - Remove the 4 screws.
  - Disconnect the connector(1).



890RX018

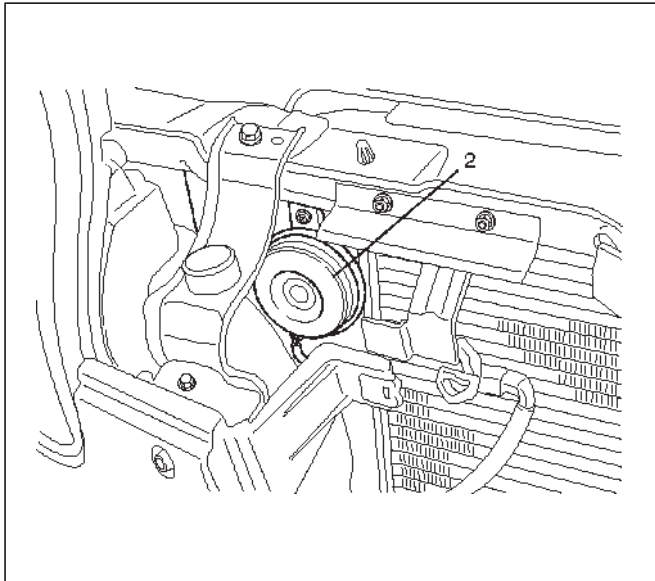
### Installation

To install, follow the removal steps in the reverse order.

## Horn (Low note)

### Removal

1. Disconnect the battery ground cable.
2. Remove the radiator grille.
  - Refer to Engine Hood and Fender in Body Structure section.
3. Remove the horn(1).
  - Disconnect the connector.
  - Remove the horn mounting bolt.



828RX002

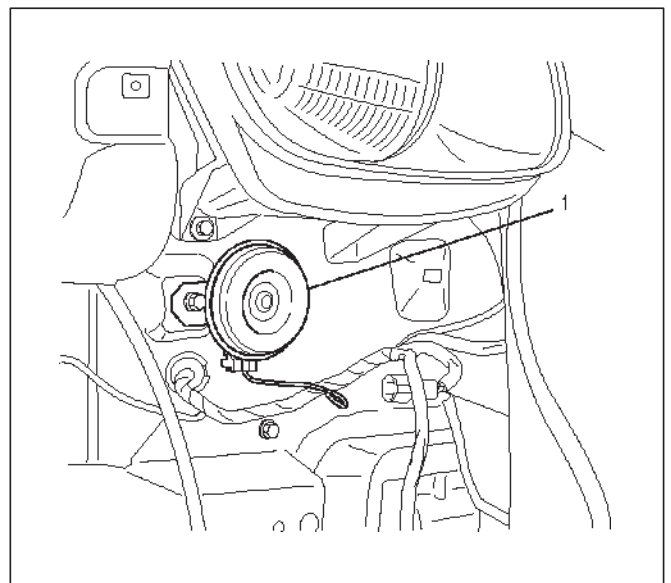
### Installation

To install, follow the removal steps in the reverse order.

## Horn (High note)

### Removal

1. Disconnect the battery ground cable.
2. Remove the radiator grille.
  - Refer to Engine Hood and Fender in Body Structure section.
3. Remove the front bumper.
  - Refer to Front bumper in Body Structure section.
4. Remove the horn(1).
  - Disconnect the connector.
  - Remove the horn mounting bolt.



828RX003

### Installation

To install, follow the removal steps in the reverse order.

VEHICROSS

# BODY AND ACCESSORIES

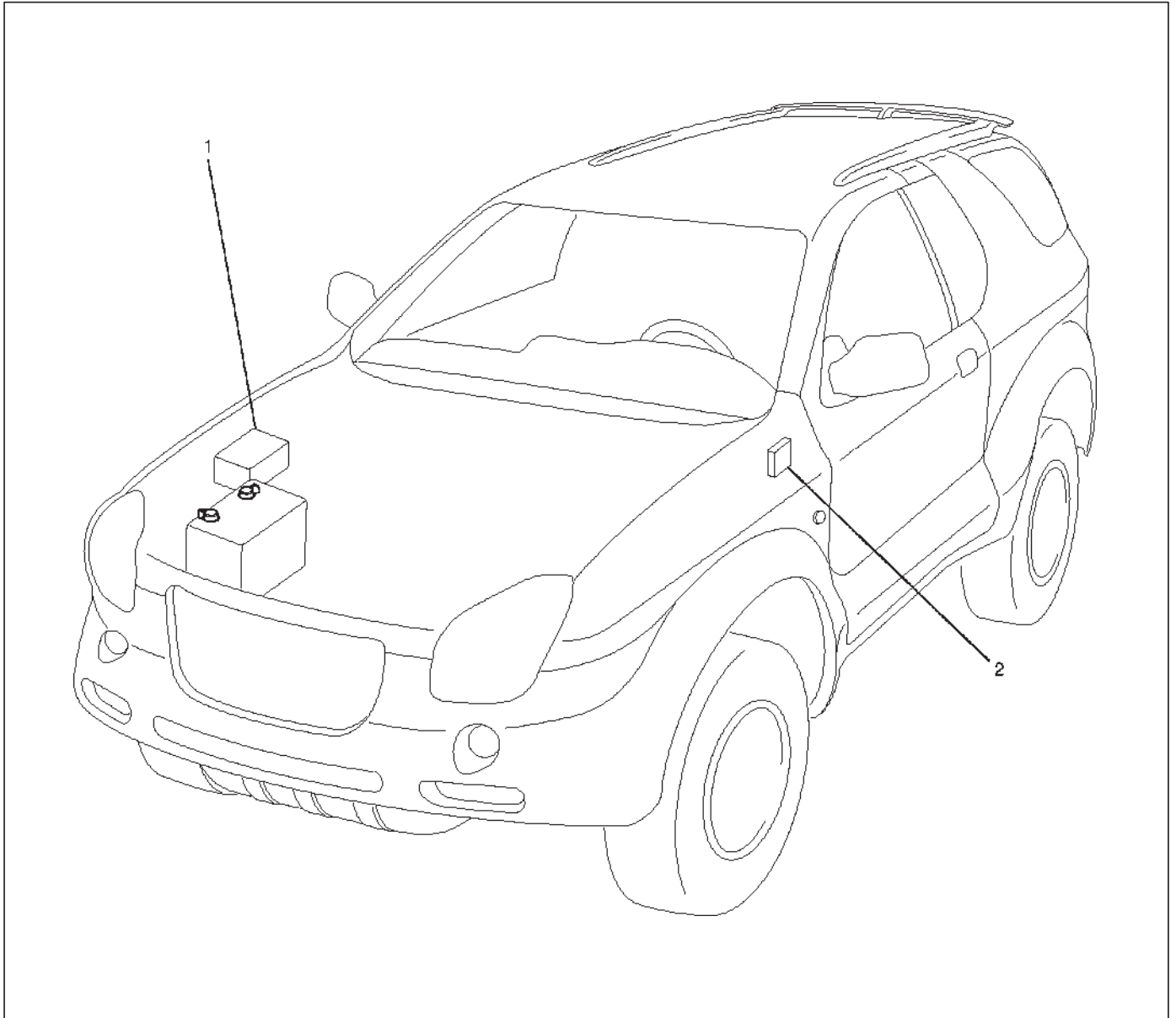
## WIRING SYSTEM

### CONTENTS

Fuse, Relay and Diode .....	8D-2
Relay and Fuse Box / Relay Box Location	8D-2
Fuse Layout .....	8D-3
Relay Layout .....	8D-4
Diode Layout .....	8D-5
Circuit Diagram .....	8D-6
Harness and Connector Location .....	8D-30

## Fuse, Relay and Diode

### Relay and Fuse Box / Relay Box Location



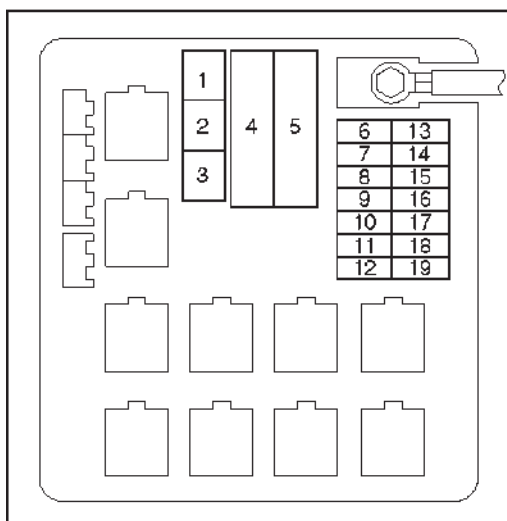
D08RX336

#### Legend

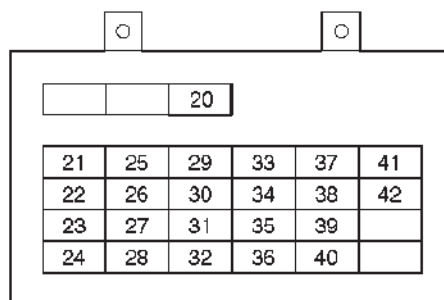
- (1) Relay and Fuse Box
- (2) Relay Box

# Fuse Layout

RELAY AND FUSE BOX



FUSE BOX

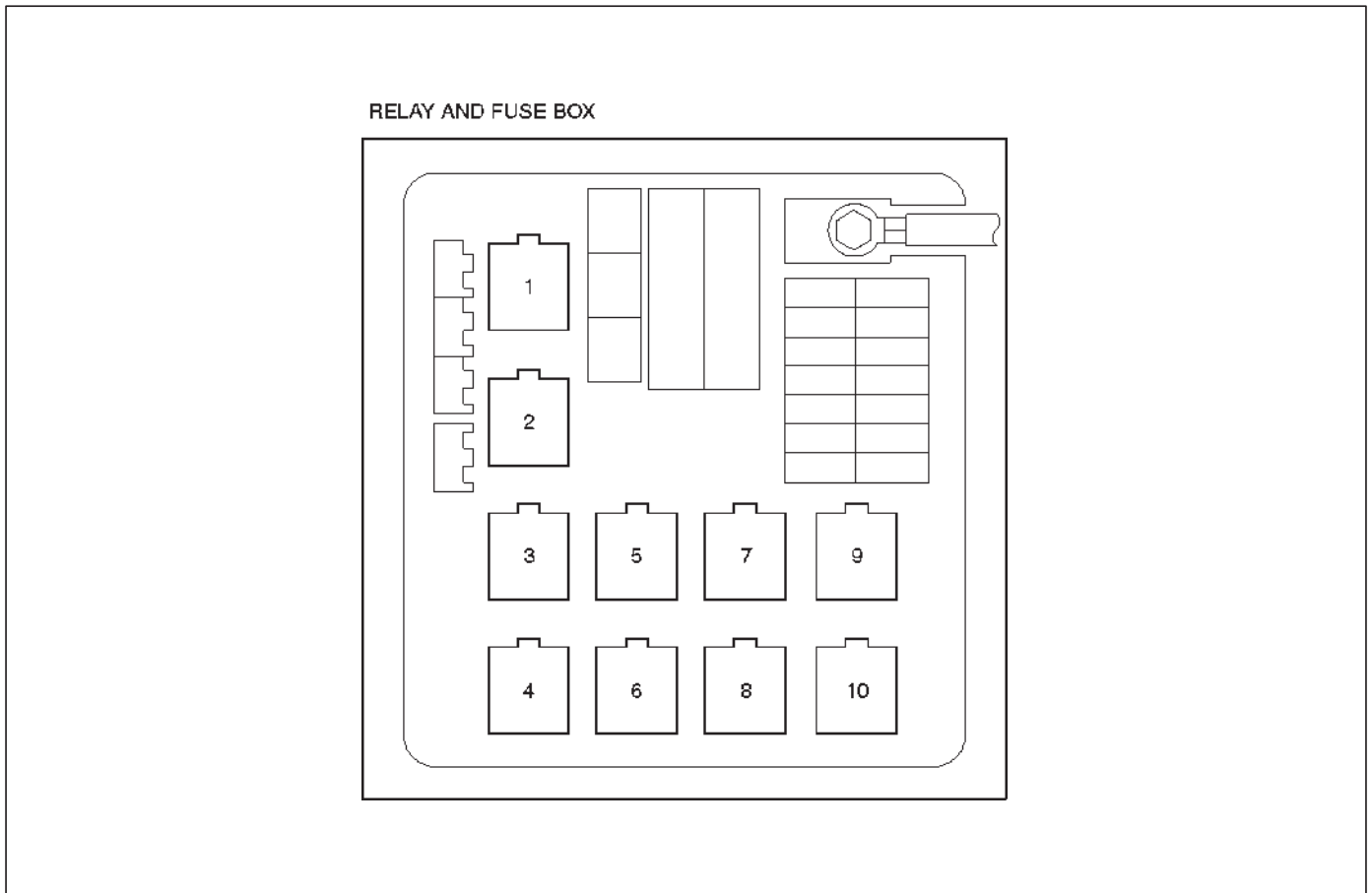


**Legend**

- (1) ABS (40A)
- (2) PCM (40A)
- (3) Condenser Fan (30A)
- (4) Main (100A)
- (5) Key SW (60A)
- (6) EB-1
- (7) EB-2
- (8) EB-3
- (9) EB-4
- (10) EB-5
- (11) EB-6
- (12) EB-7
- (13) EB-8
- (14) EB-9
- (15) EB-10
- (16) EB-11
- (17) EB-12
- (18) EB-13
- (19) EB-14
- (20) Circuit Breaker (20A)
- (21) CB-1

- (22) CB-2
- (23) CB-3
- (24) CB-4
- (25) CB-5
- (26) CB-6
- (27) CB-7
- (28) CB-8
- (29) CB-9
- (30) CB-10
- (31) CB-11
- (32) CB-12
- (33) CB-13
- (34) CB-14
- (35) CB-15
- (36) CB-16
- (37) CB-17
- (38) CB-18
- (39) CB-19
- (40) CB-20
- (41) CB-21
- (42) CB-22

## Relay Layout

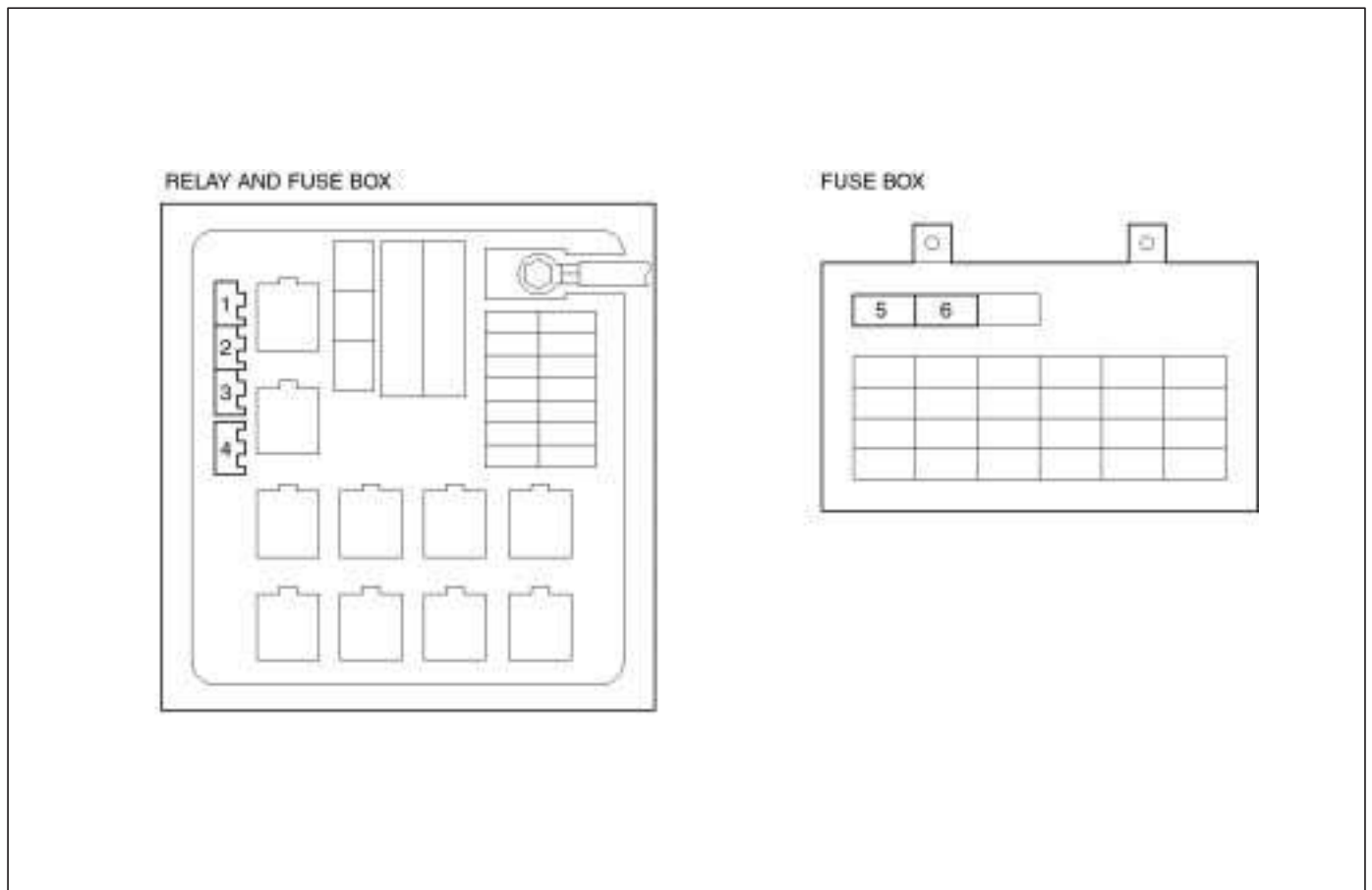


D08RX338

### Legend

- |                     |                           |
|---------------------|---------------------------|
| (1) Headlight Relay | (6) Heater Relay          |
| (2) Not Used        | (7) Starter Relay         |
| (3) Fuel Pump Relay | (8) Starter Cut Relay     |
| (4) Horn Relay      | (9) PCM Main Relay        |
| (5) Thermo Relay    | (10) A/C Compressor Relay |

## Diode Layout



D08RX339

### Legend

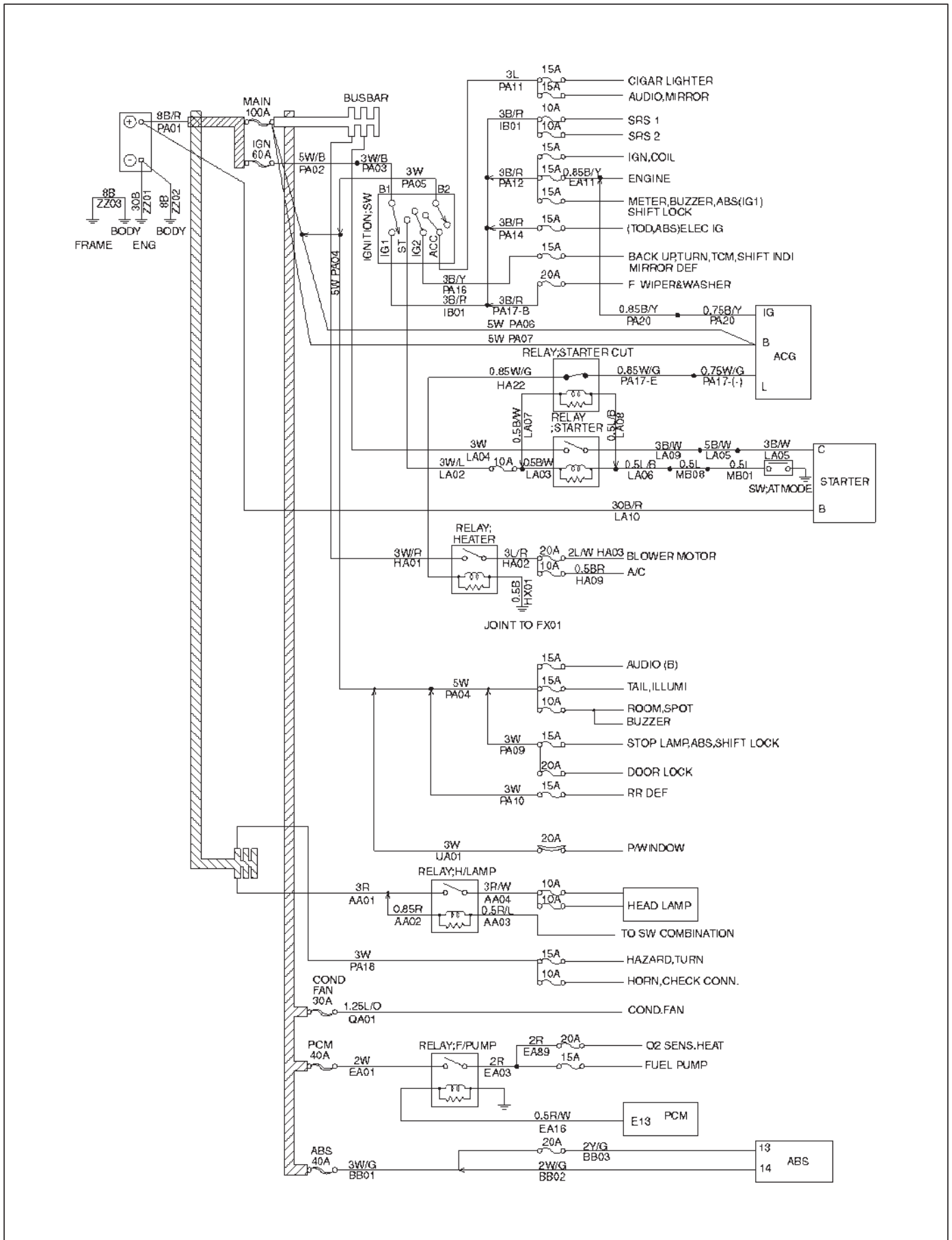
- (1) Not Used
- (2) Not Used
- (3) Not Used

- (4) Not Used
- (5) Not Used
- (6) Diode B-29

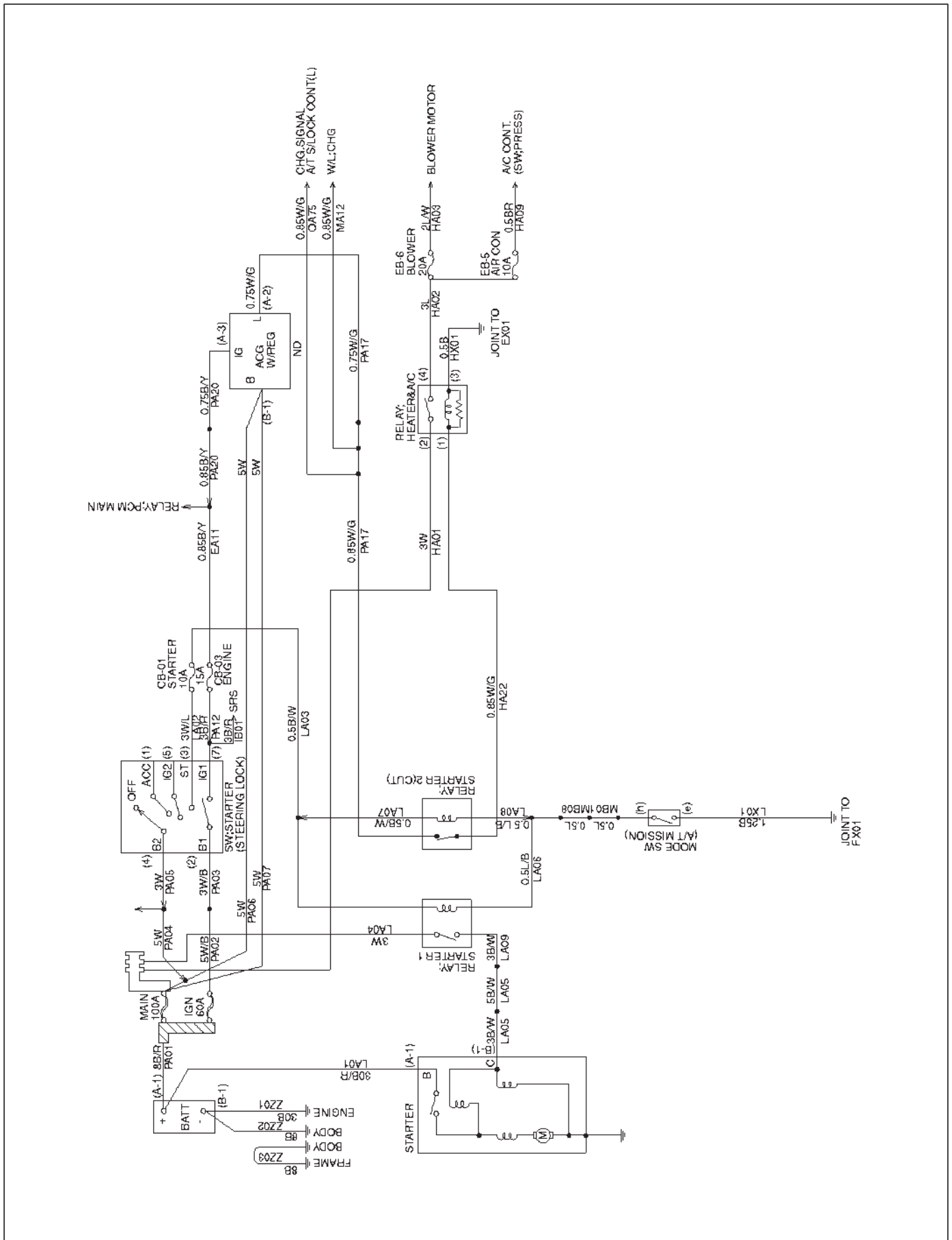
## Circuit Diagram



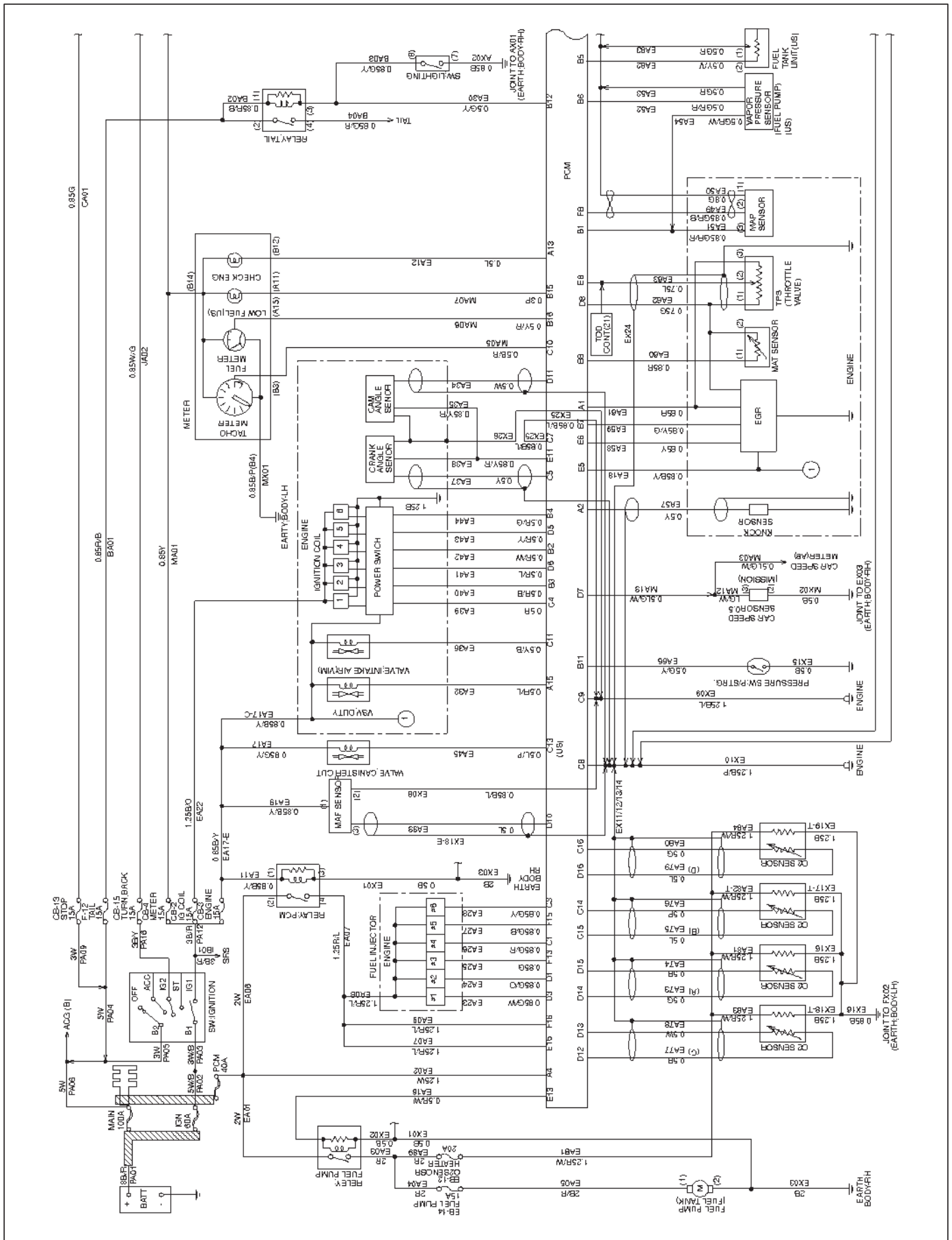
Circuit Diagram-1



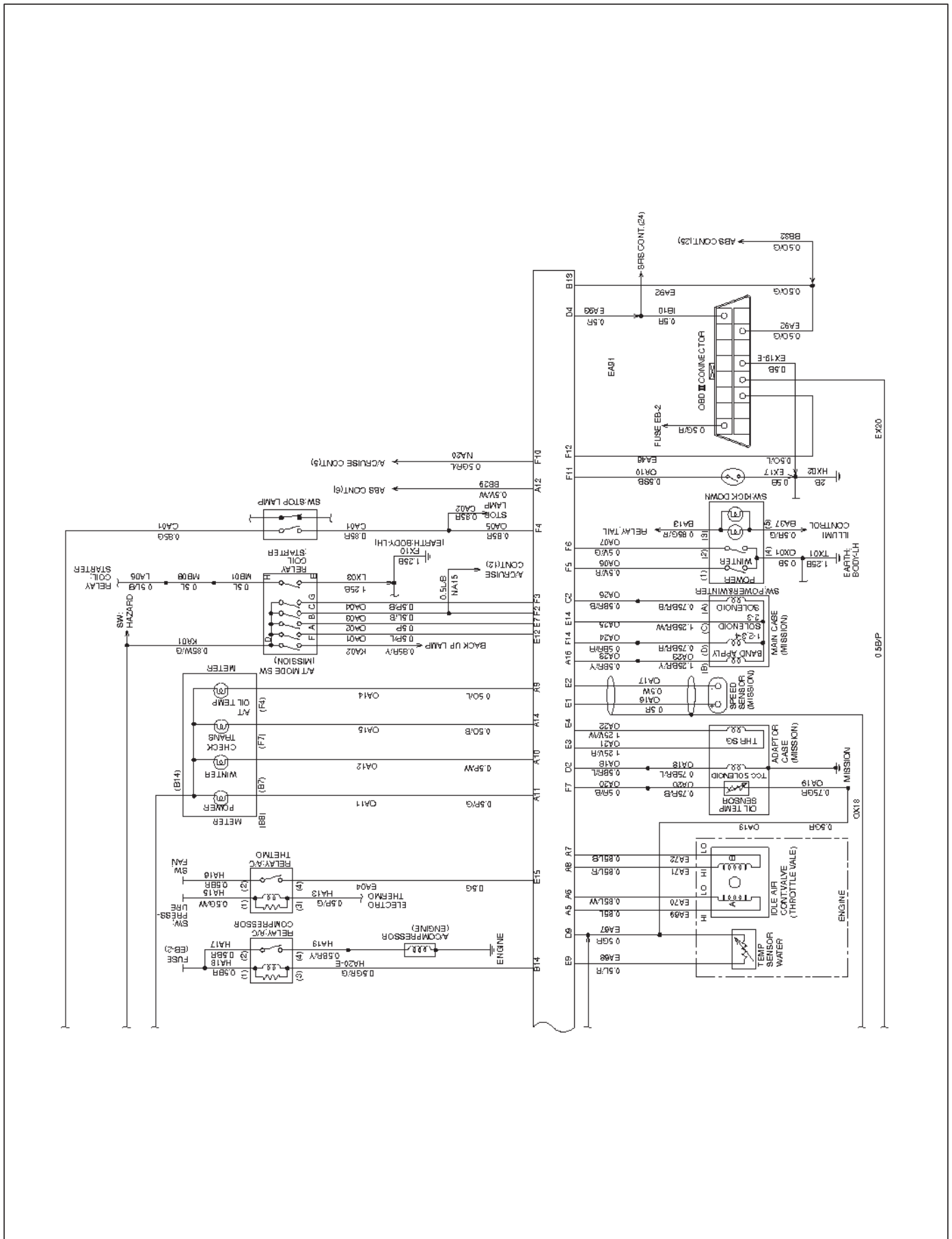
Circuit Diagram-2



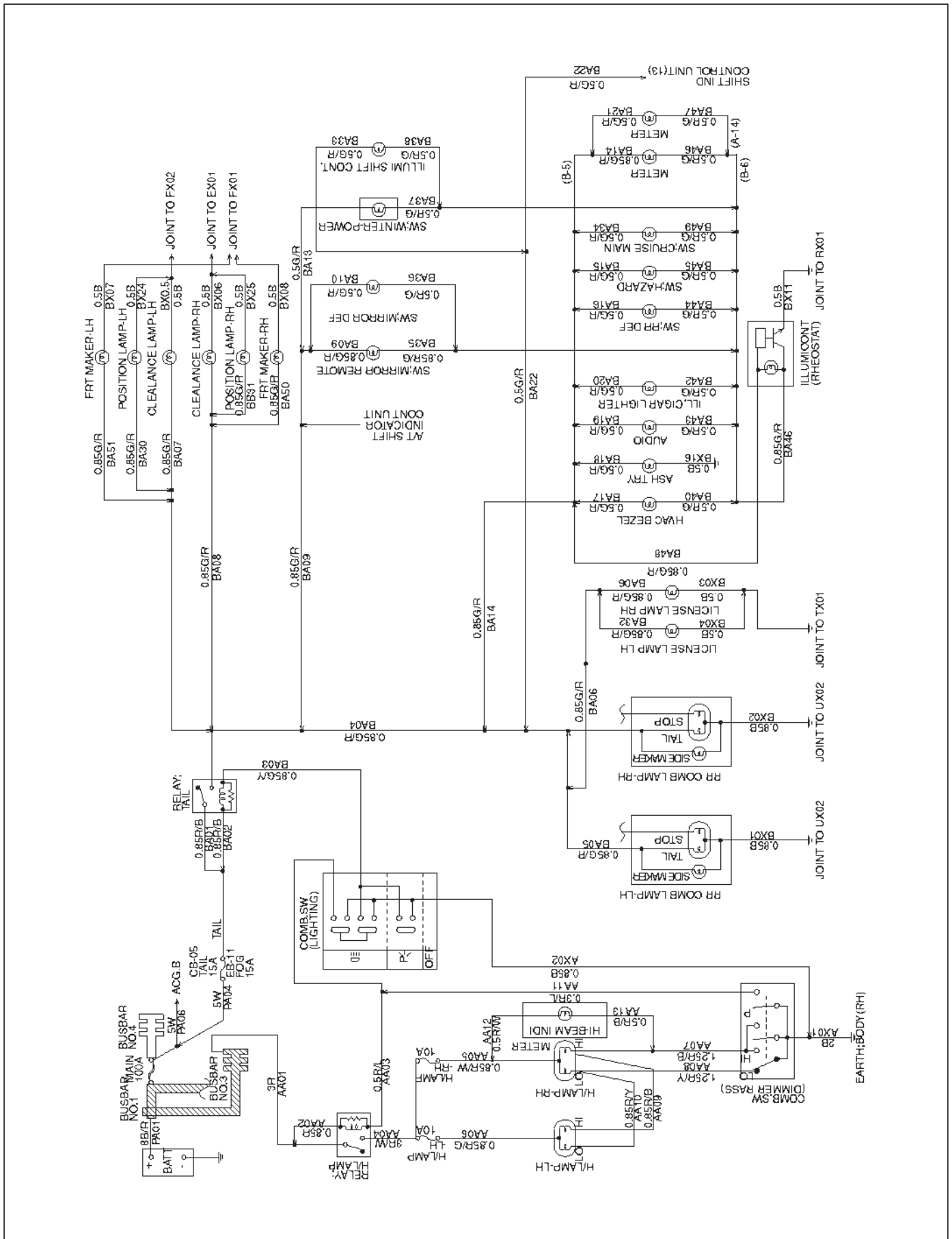
Circuit Diagram-3



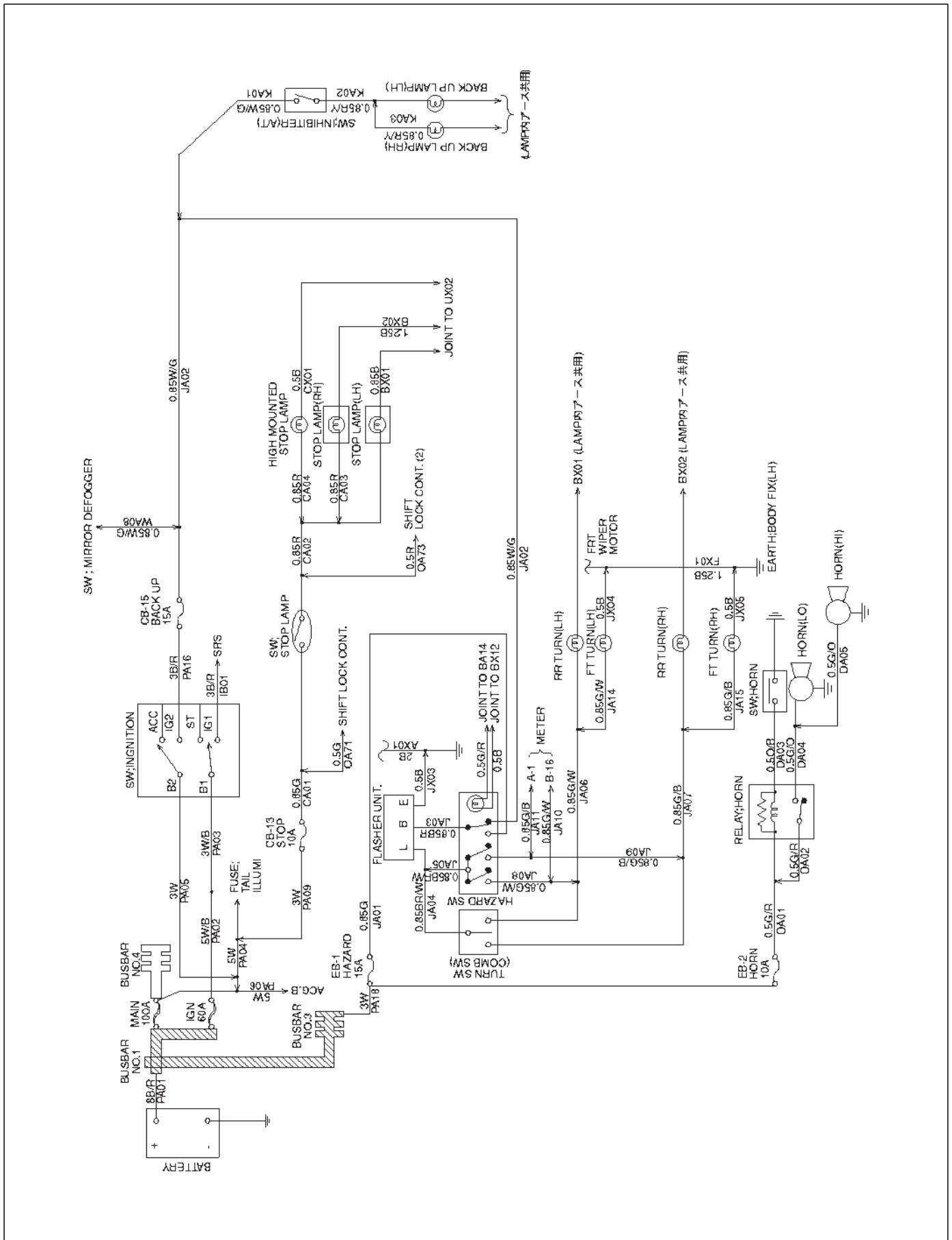
Circuit Diagram-4



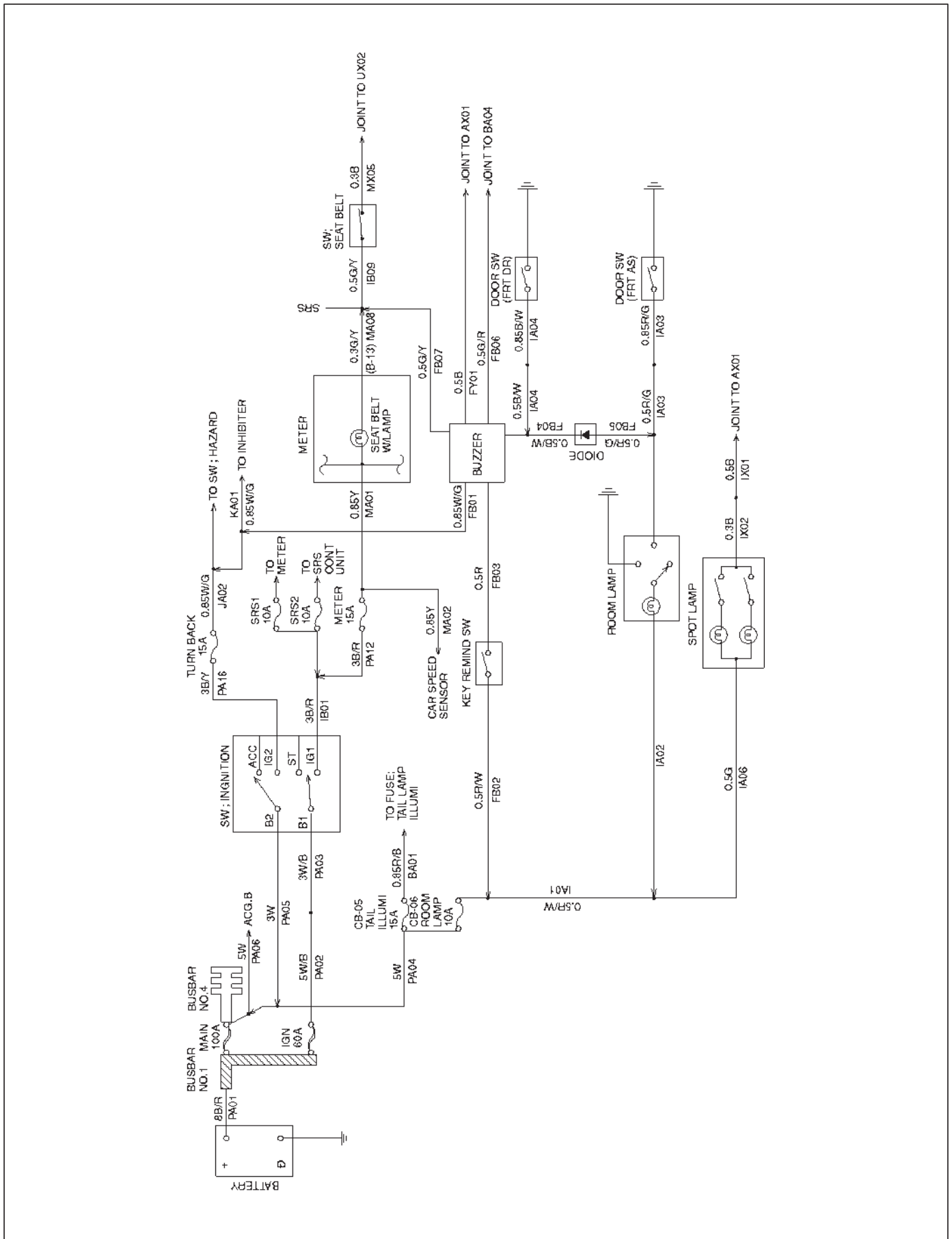
Circuit Diagram-5



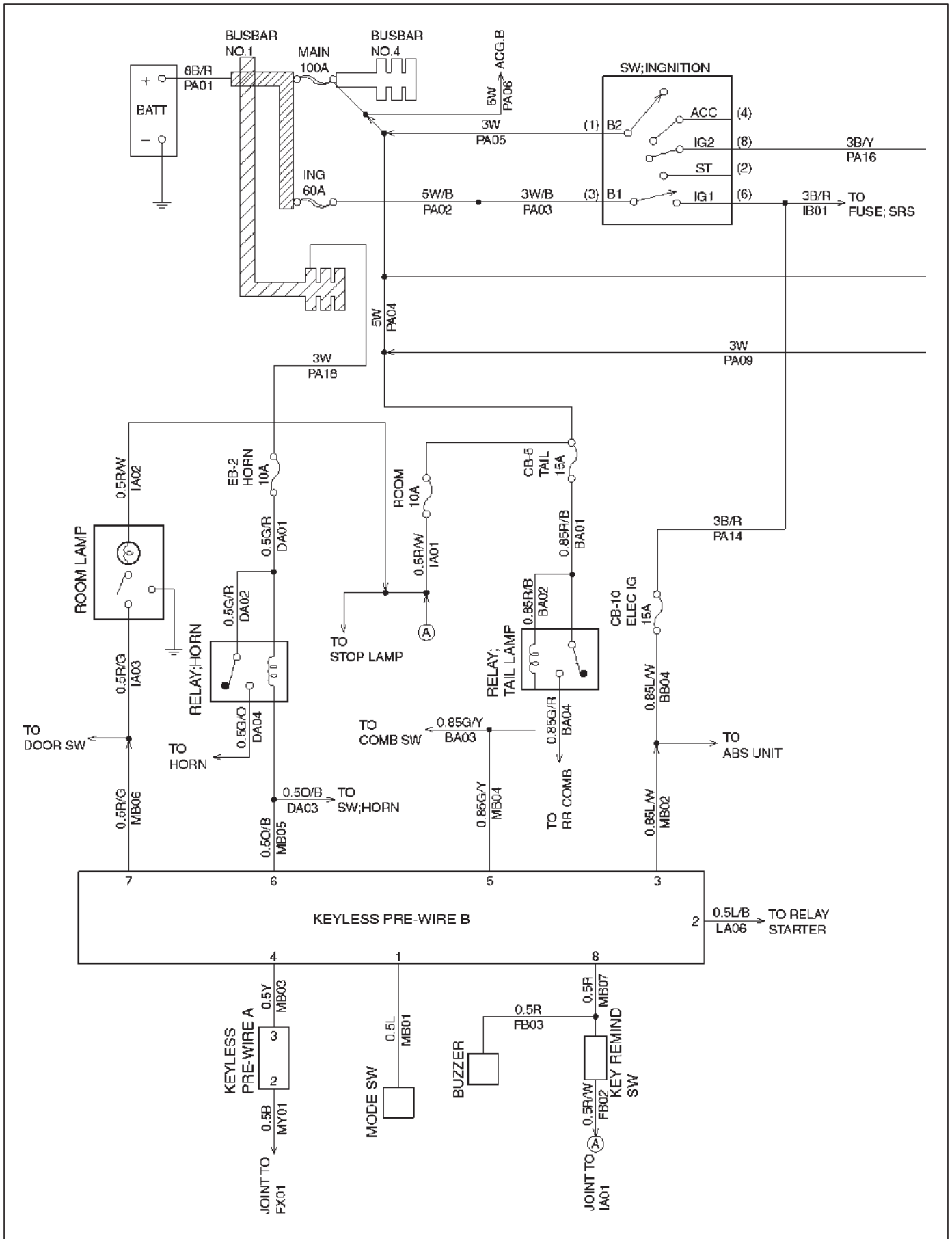
Circuit Diagram-6



Circuit Diagram-7

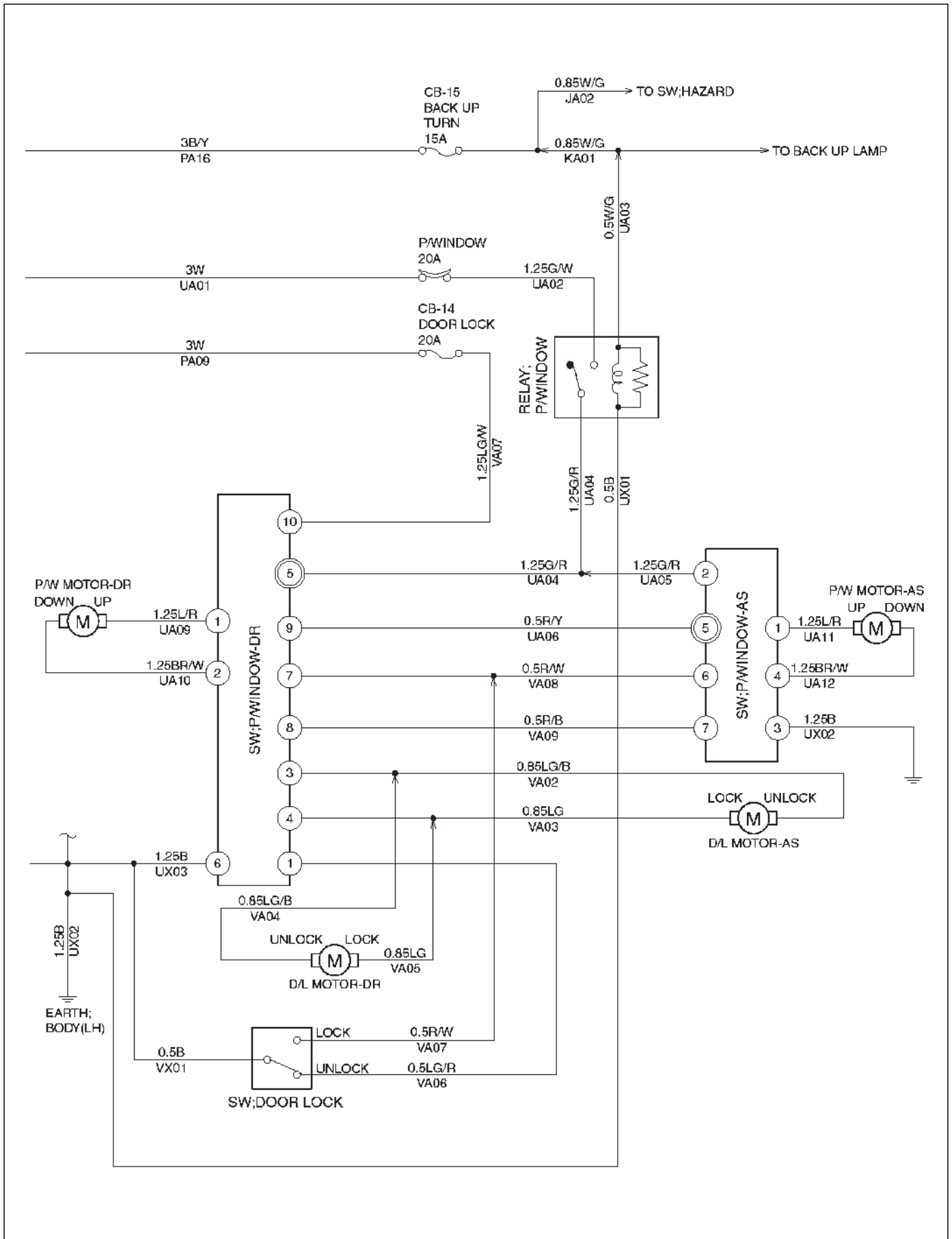


Circuit Diagram-8

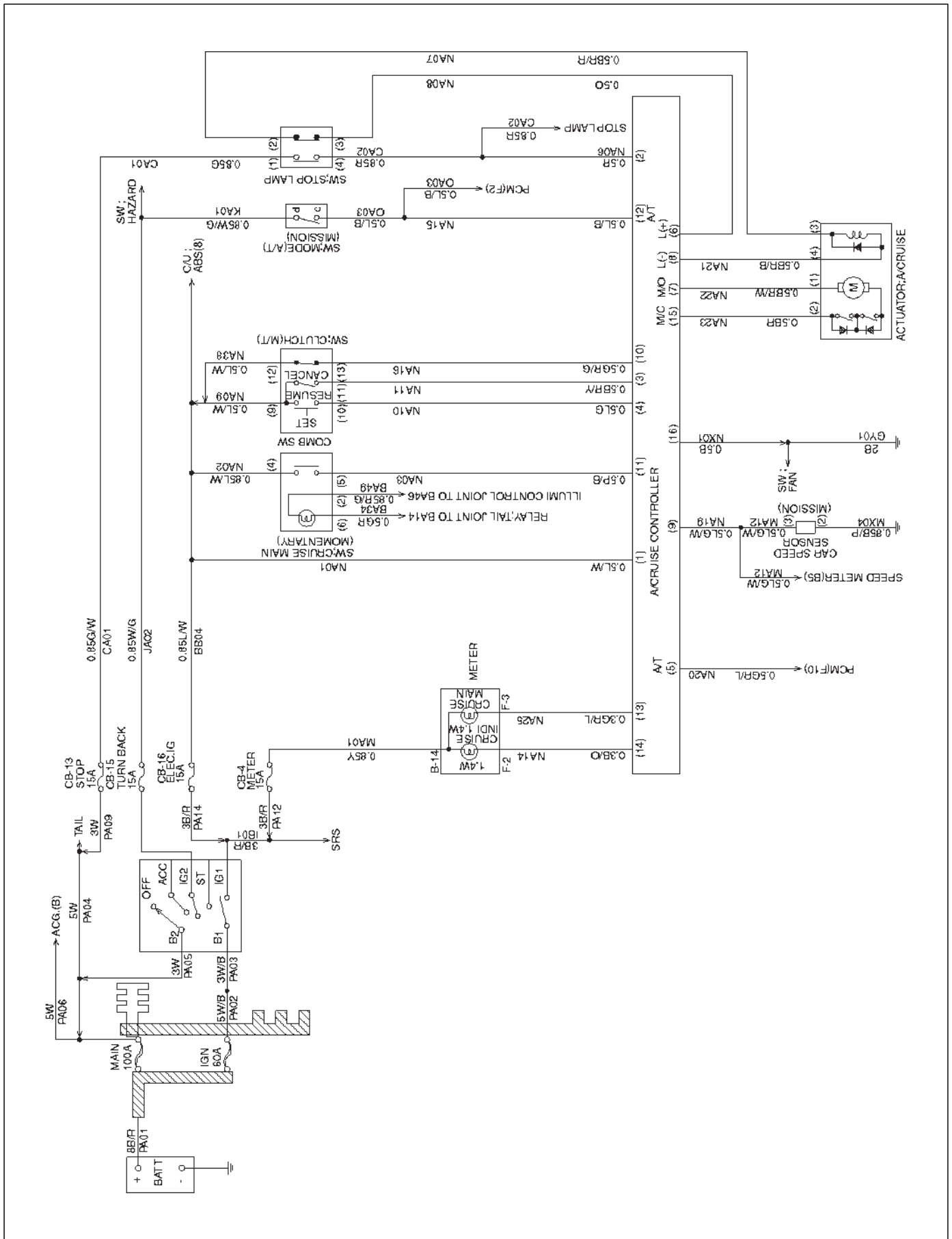




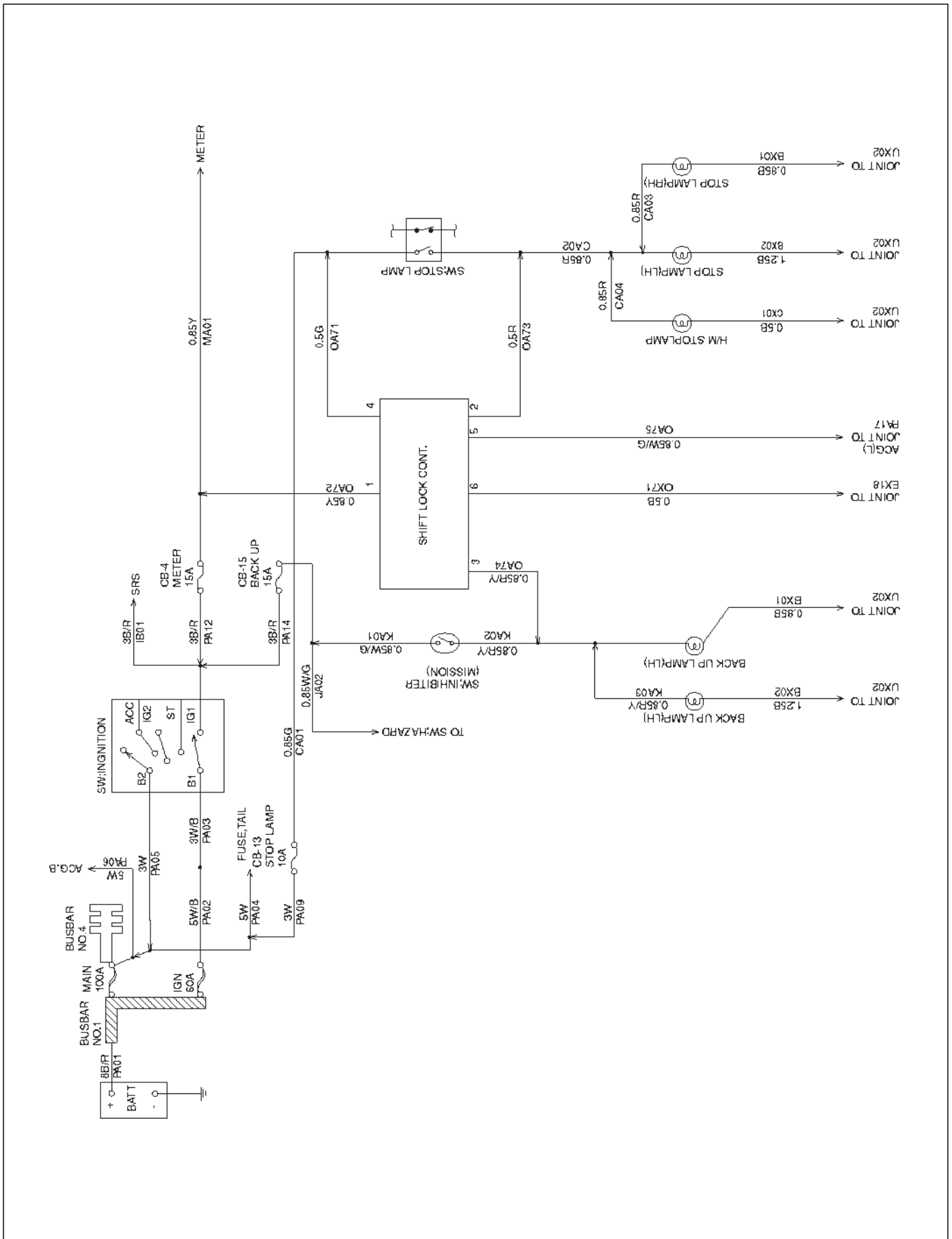
Circuit Diagram-9



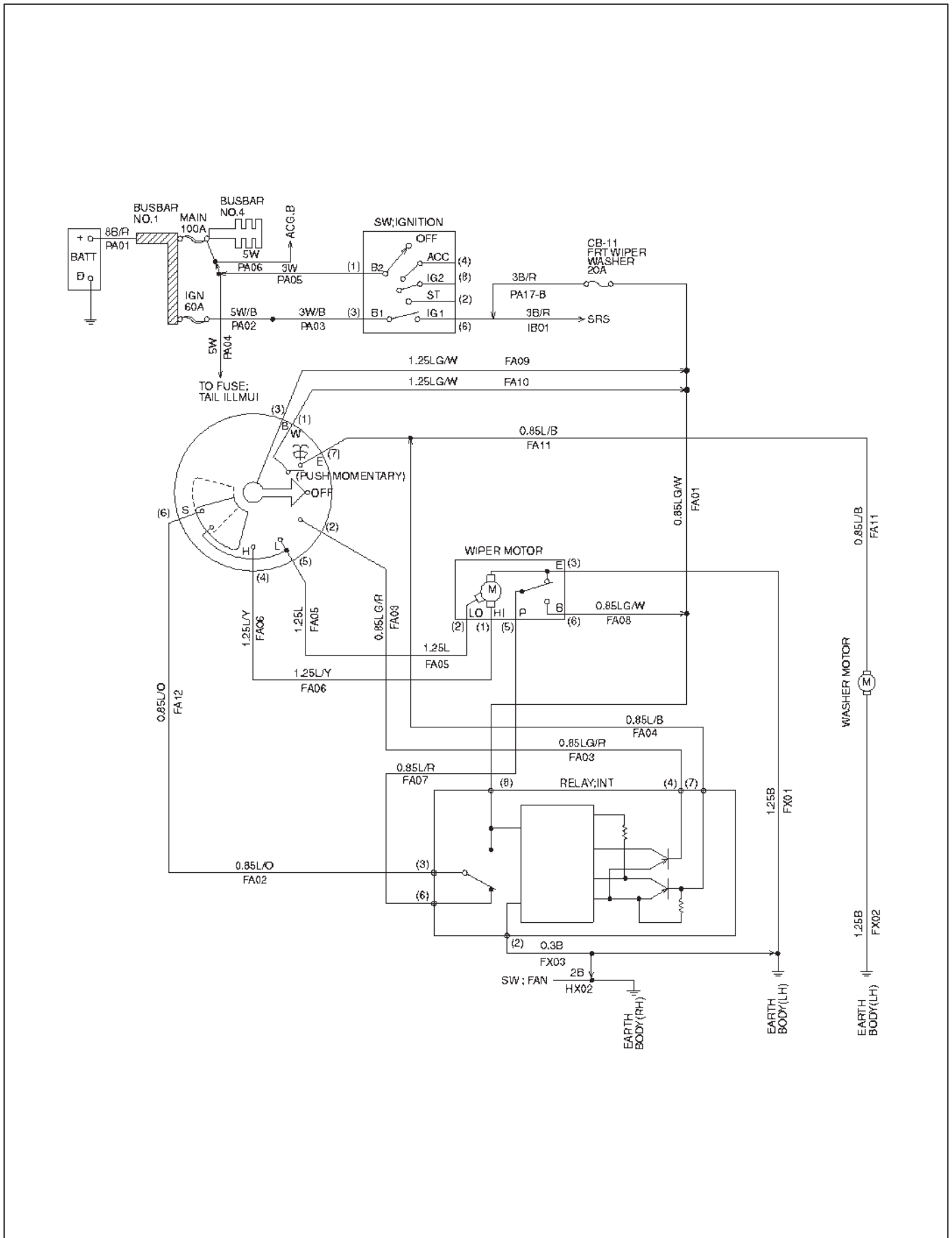
Circuit Diagram-10



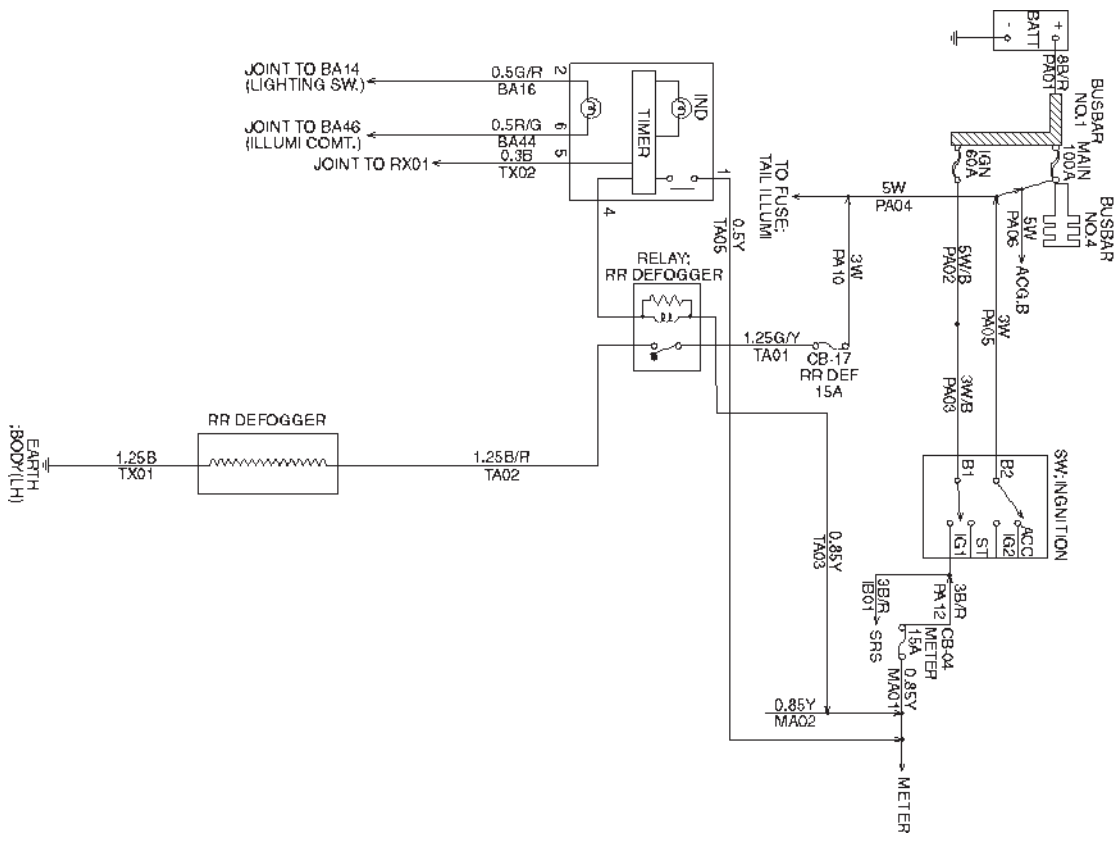
Circuit Diagram-11



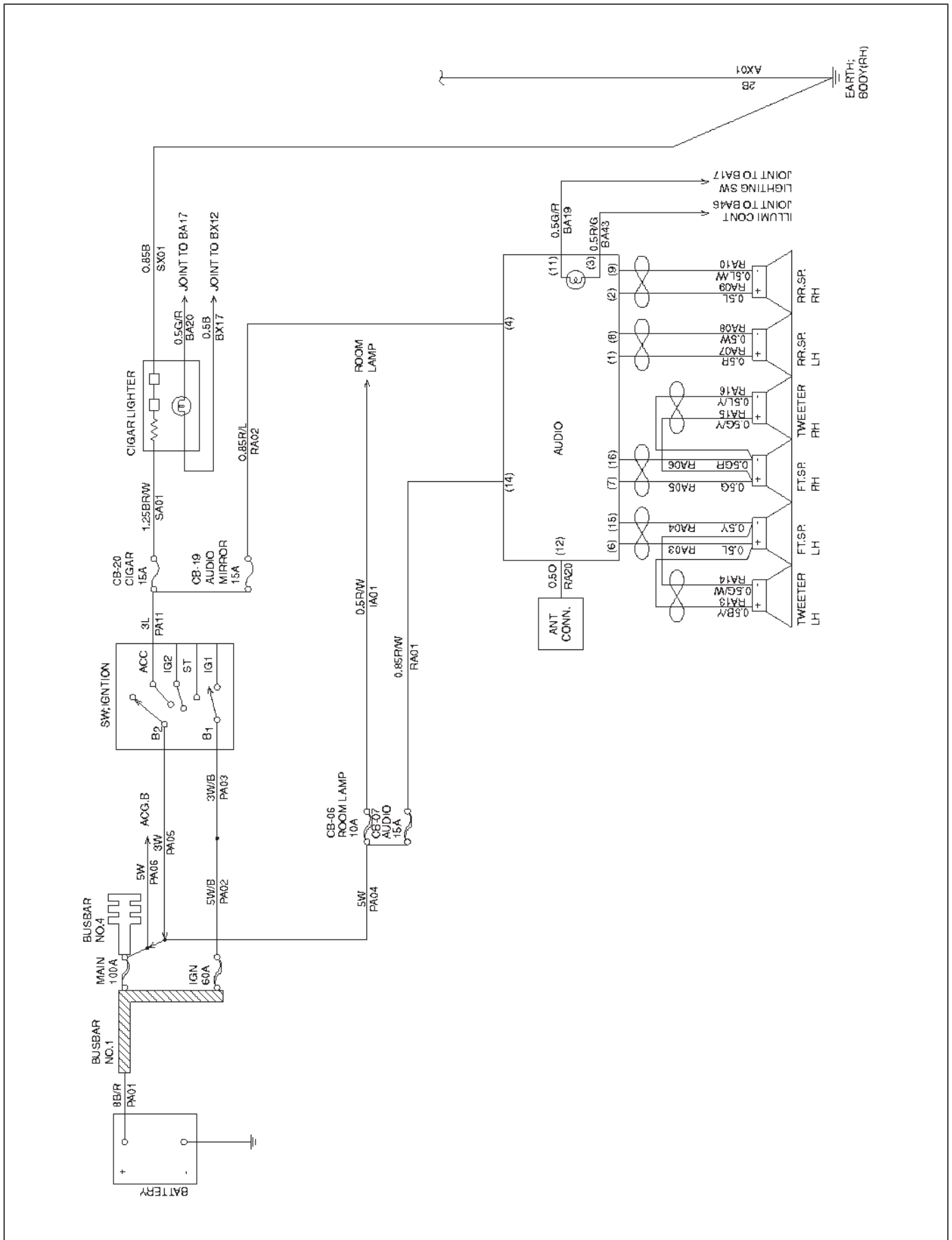
Circuit Diagram-12



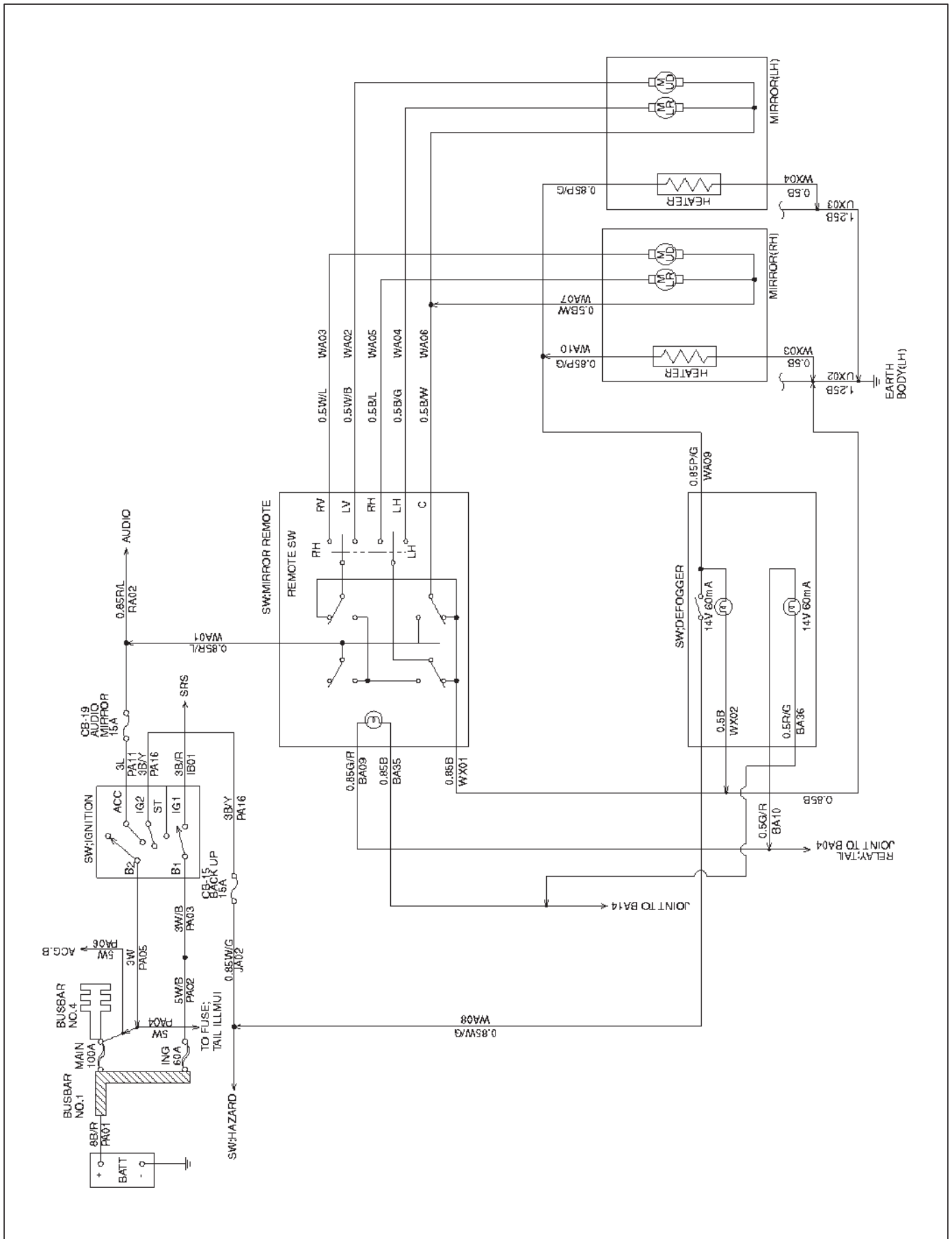
Circuit Diagram-13



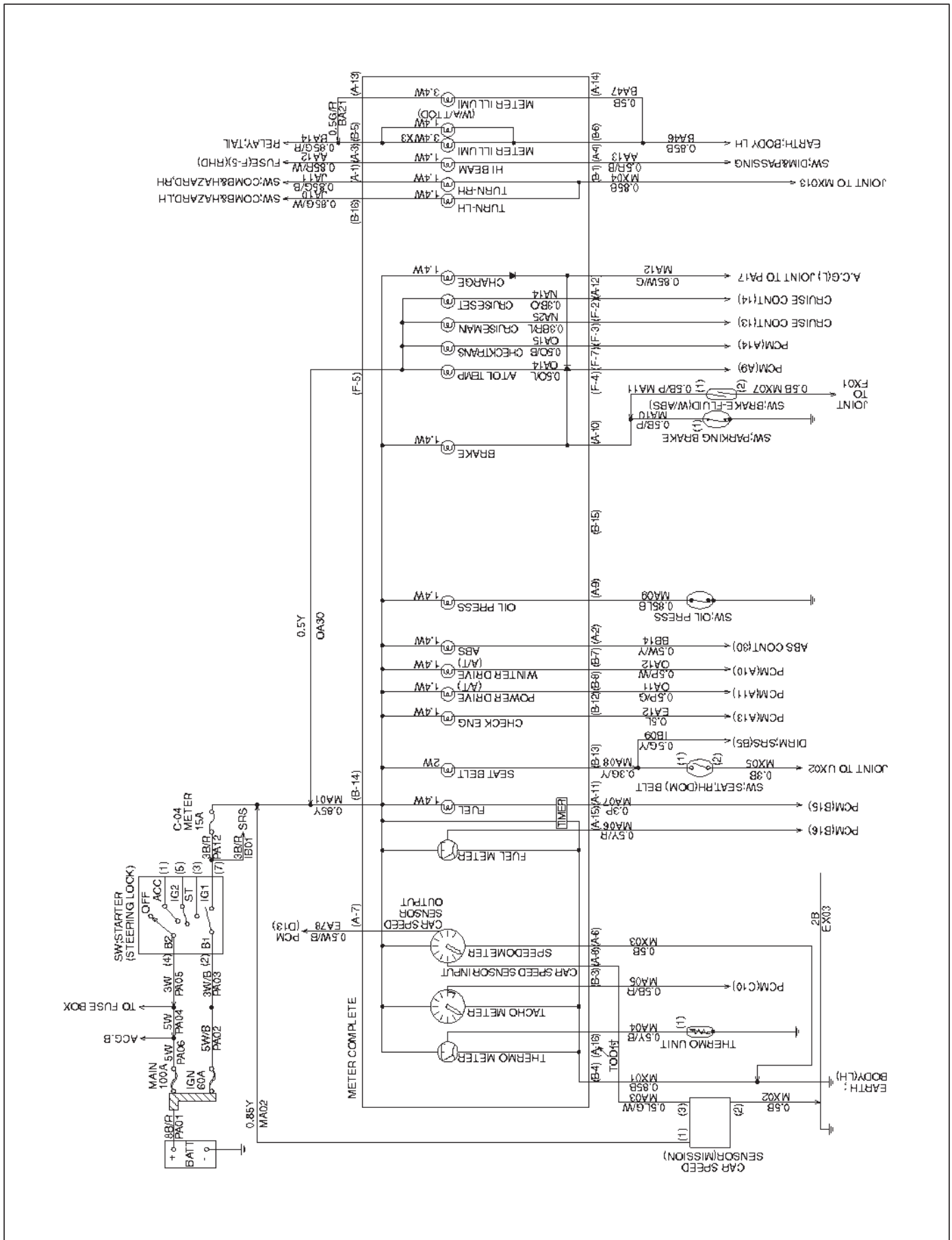
Circuit Diagram-14



Circuit Diagram-15

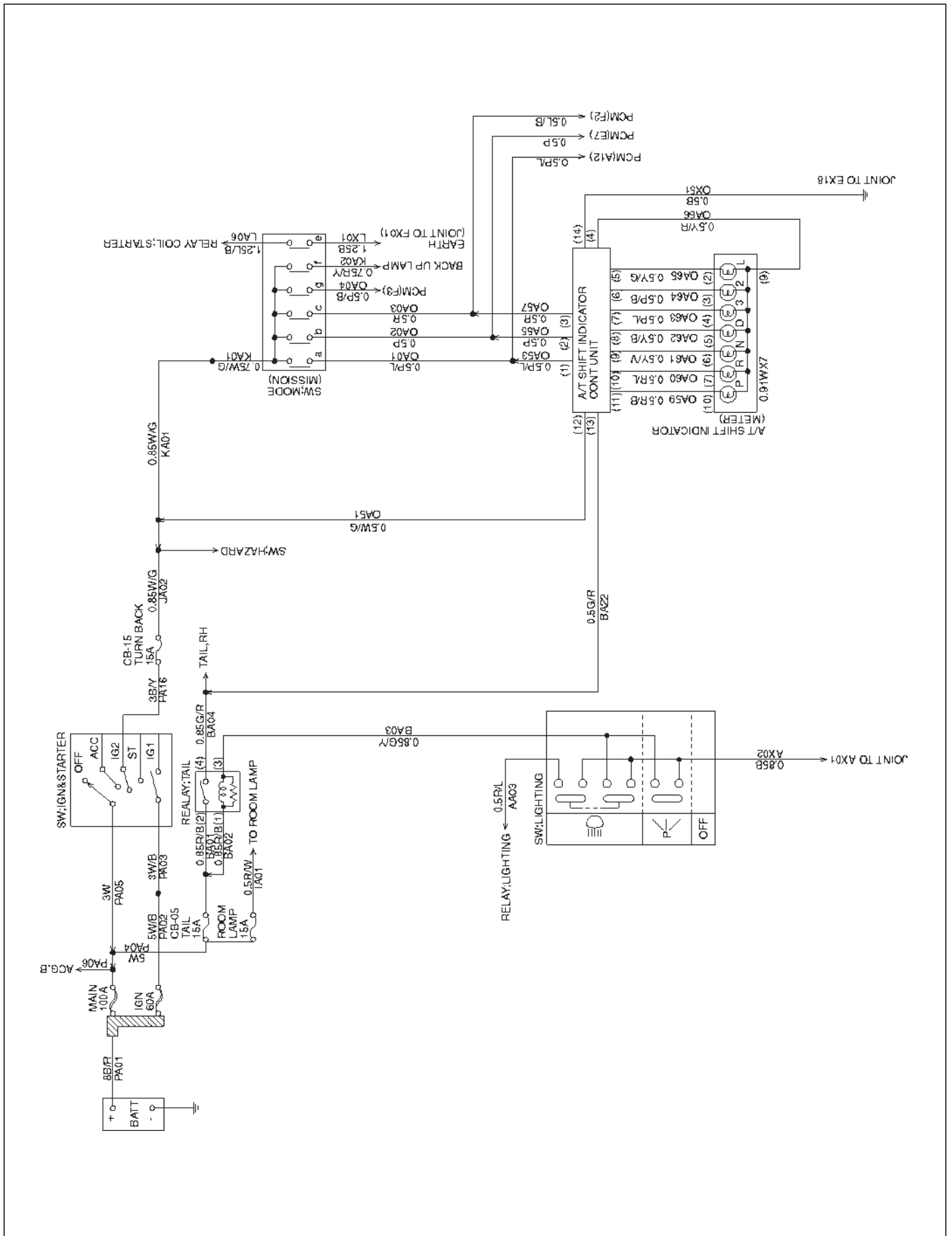


Circuit Diagram-16

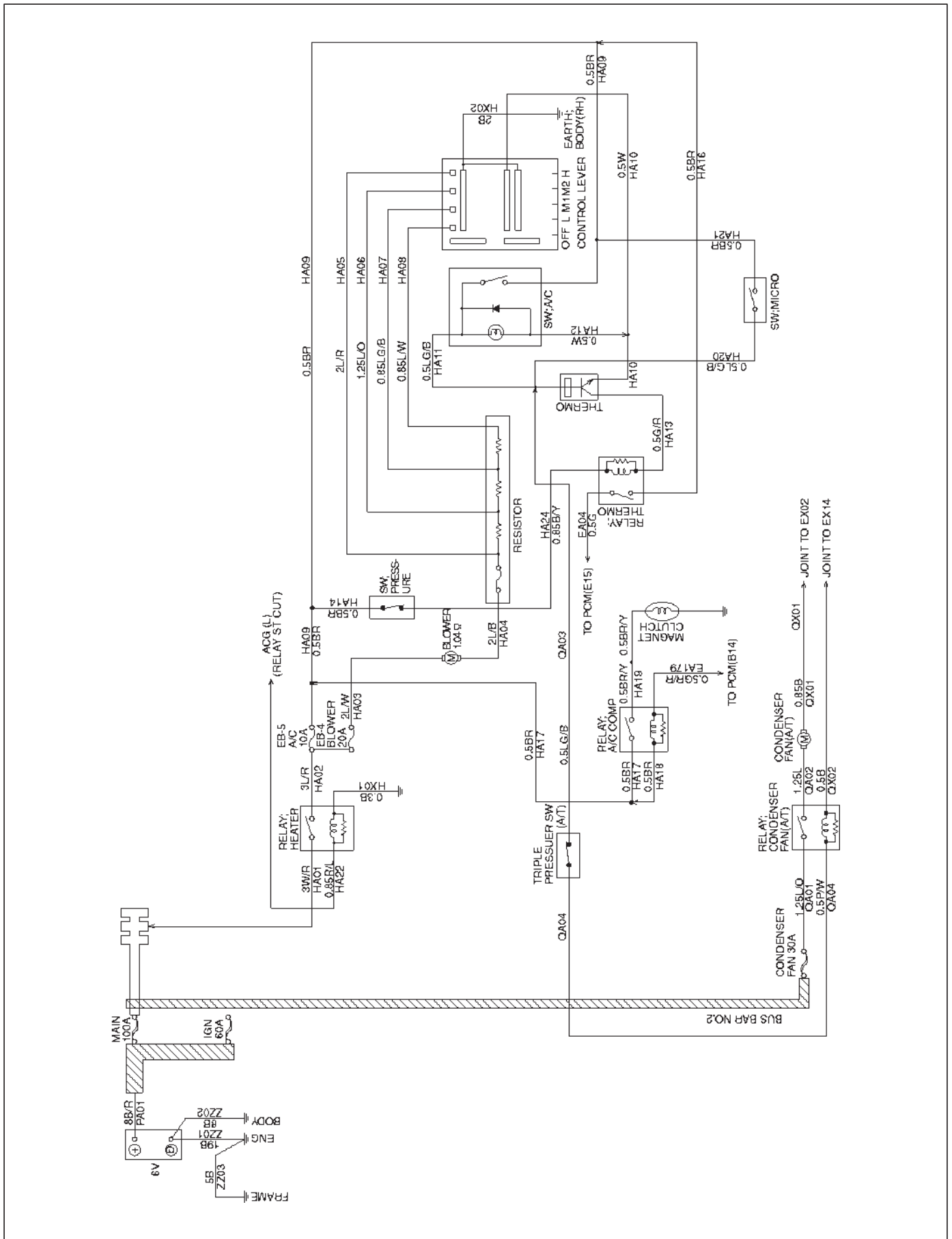




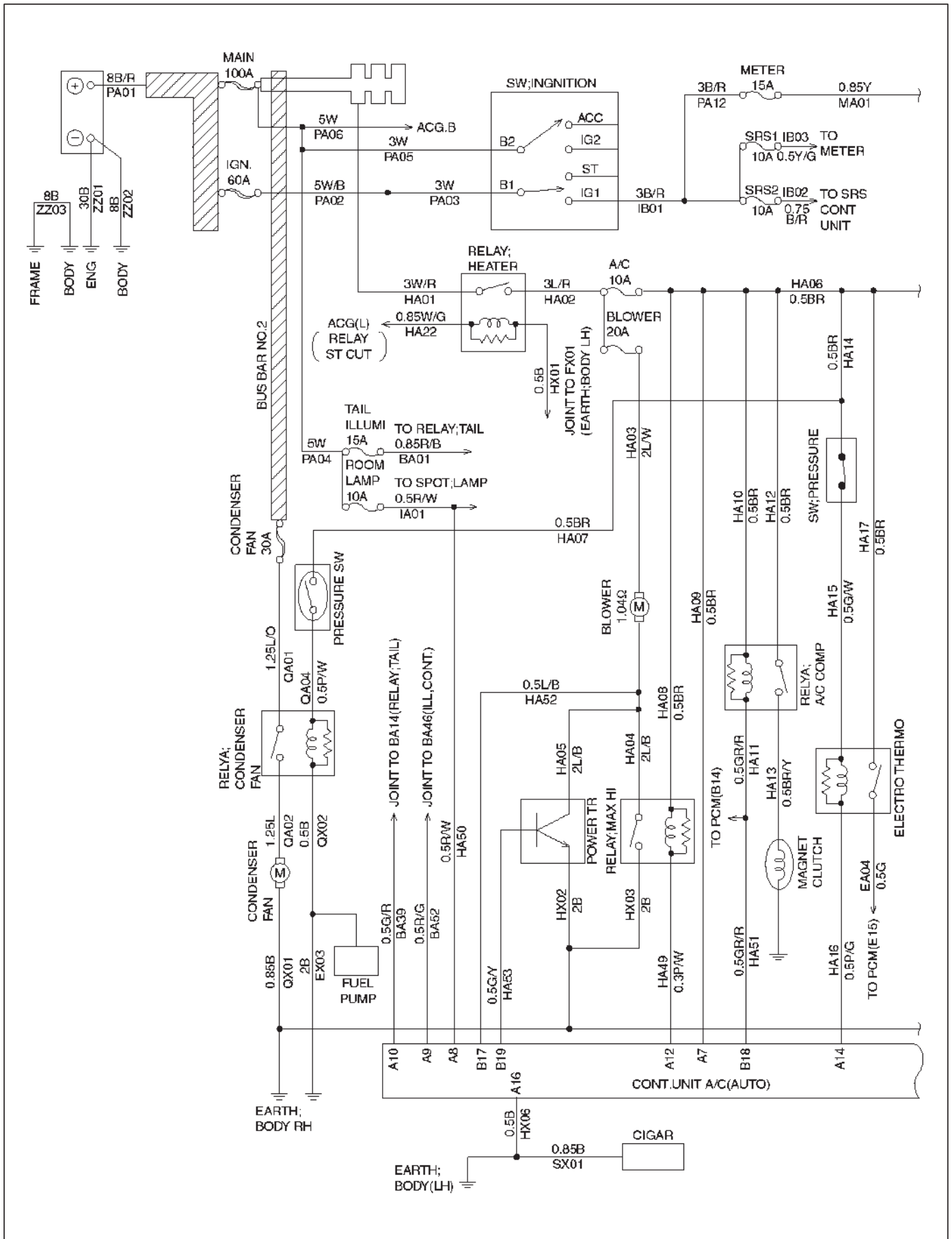
Circuit Diagram-17



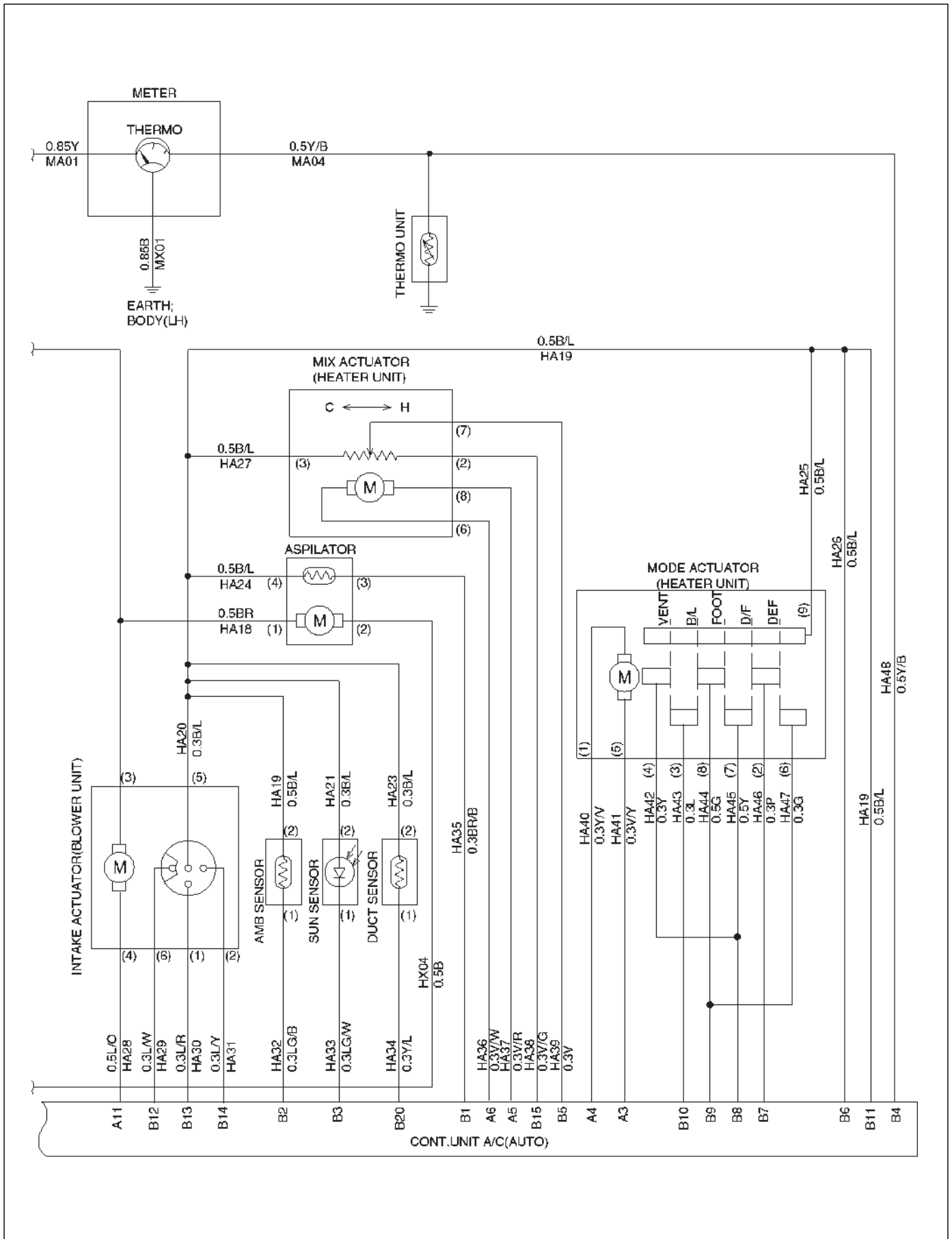
Circuit Diagram-18



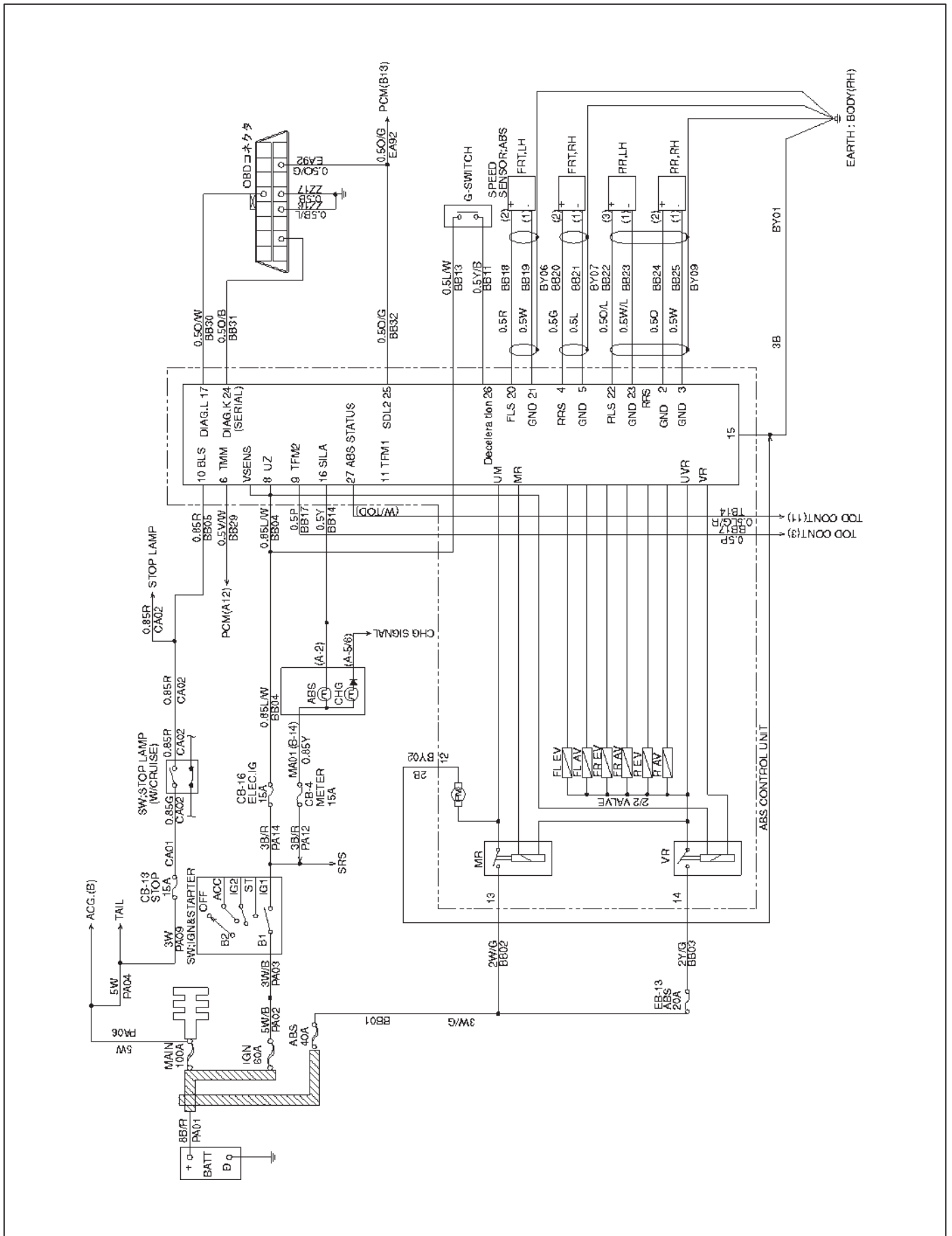
Circuit Diagram-19



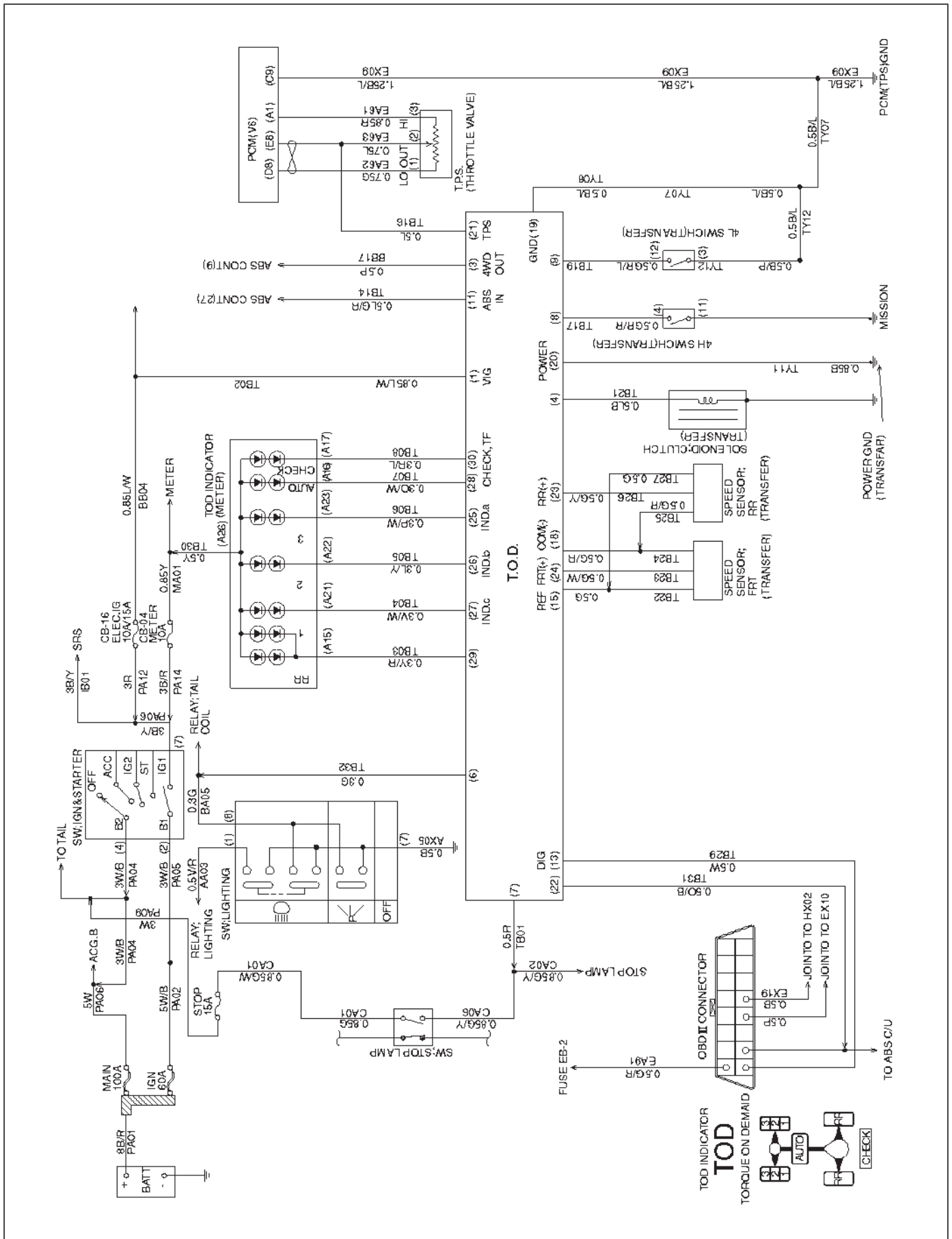
Circuit Diagram-20



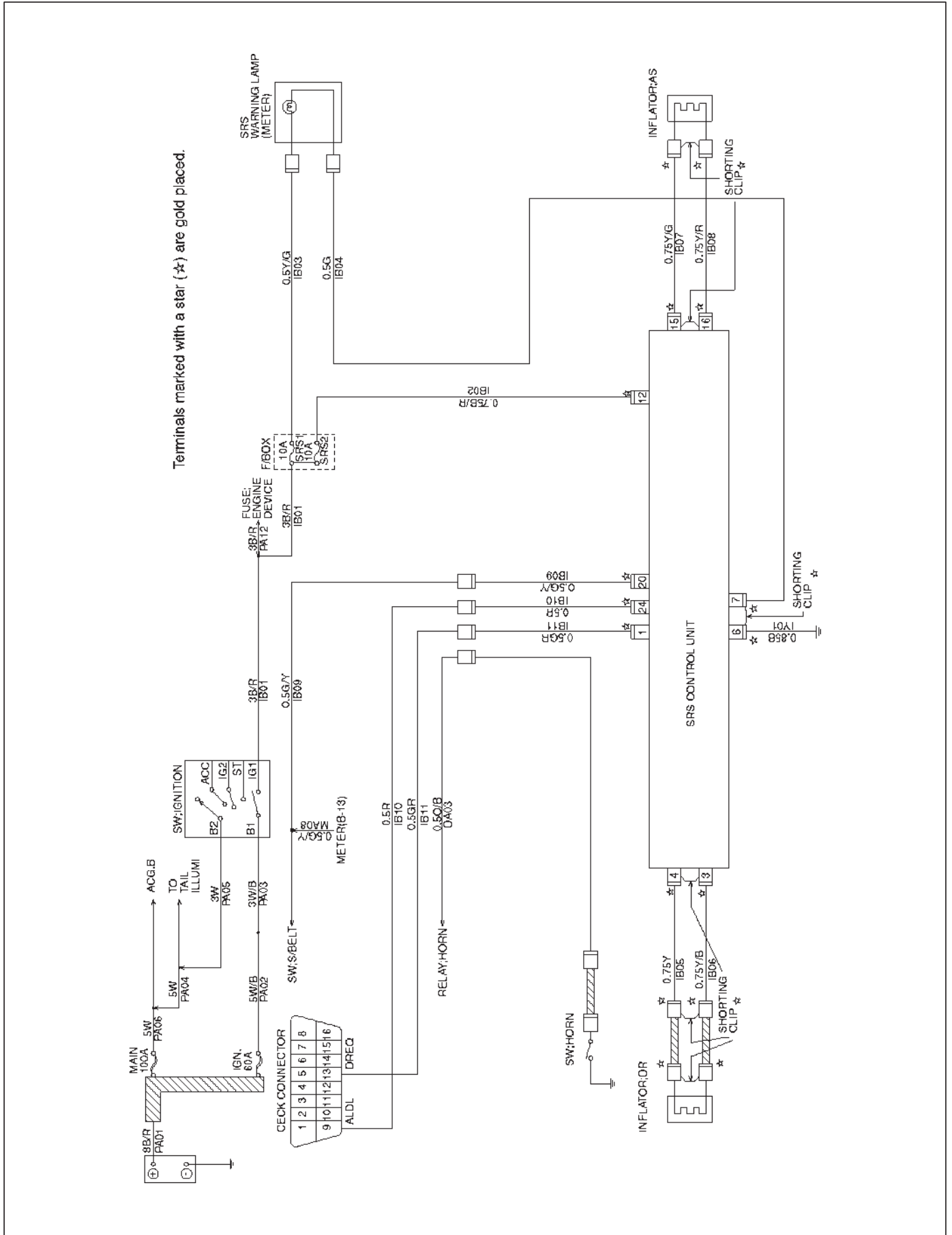
Circuit Diagram-21



Circuit Diagram-22



Circuit Diagram-23

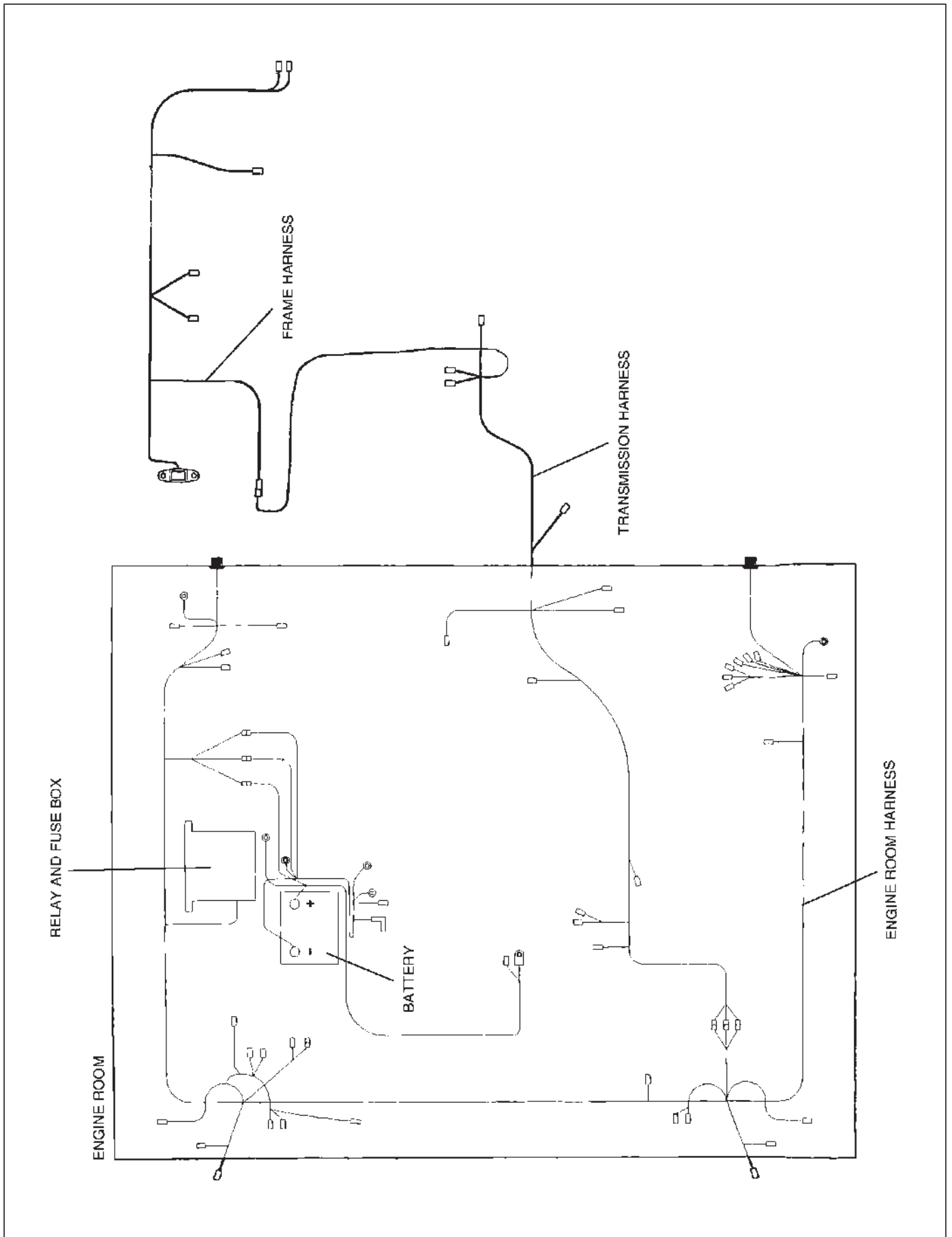


Terminals marked with a star (☆) are gold plated.

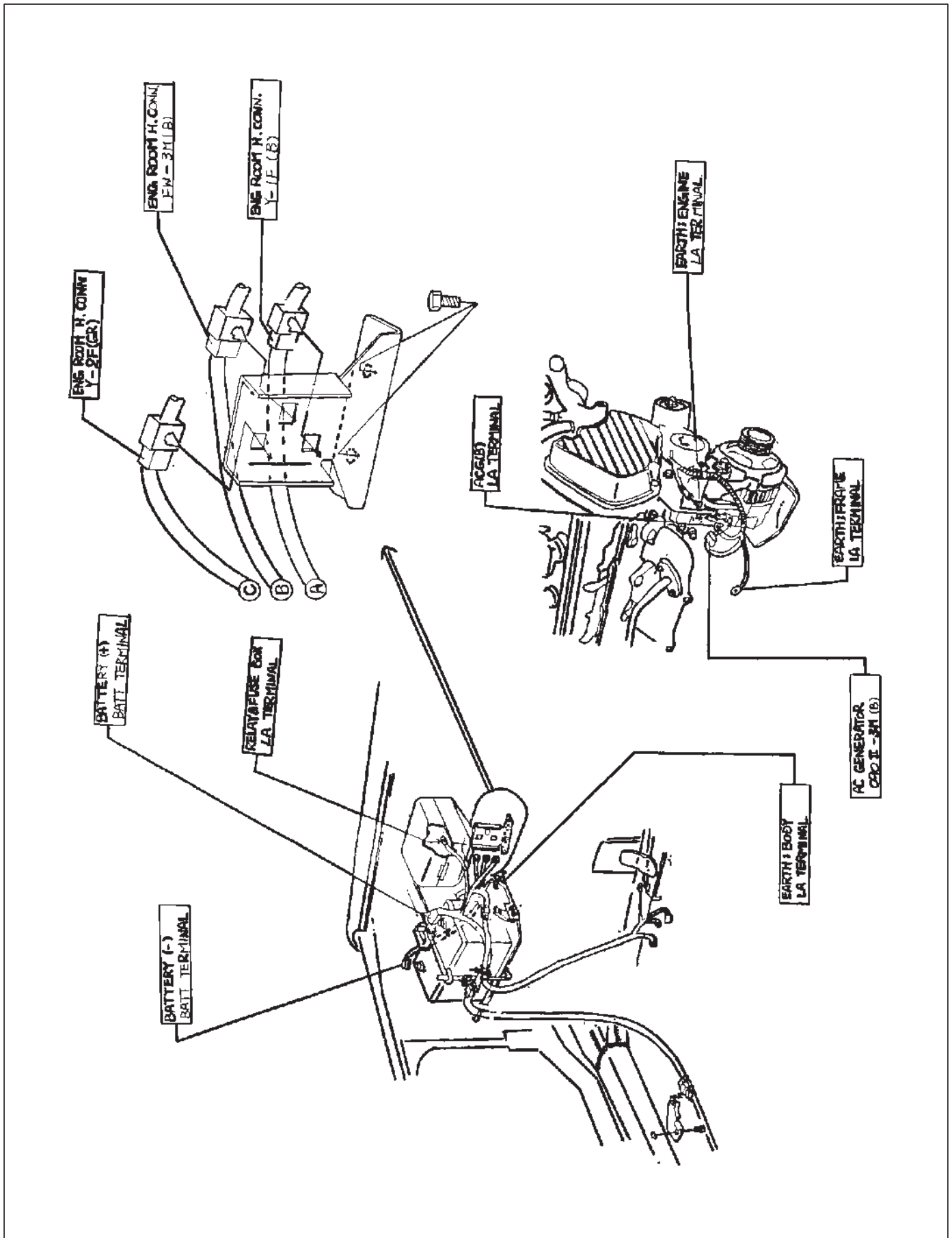
## Harness and Connector Location



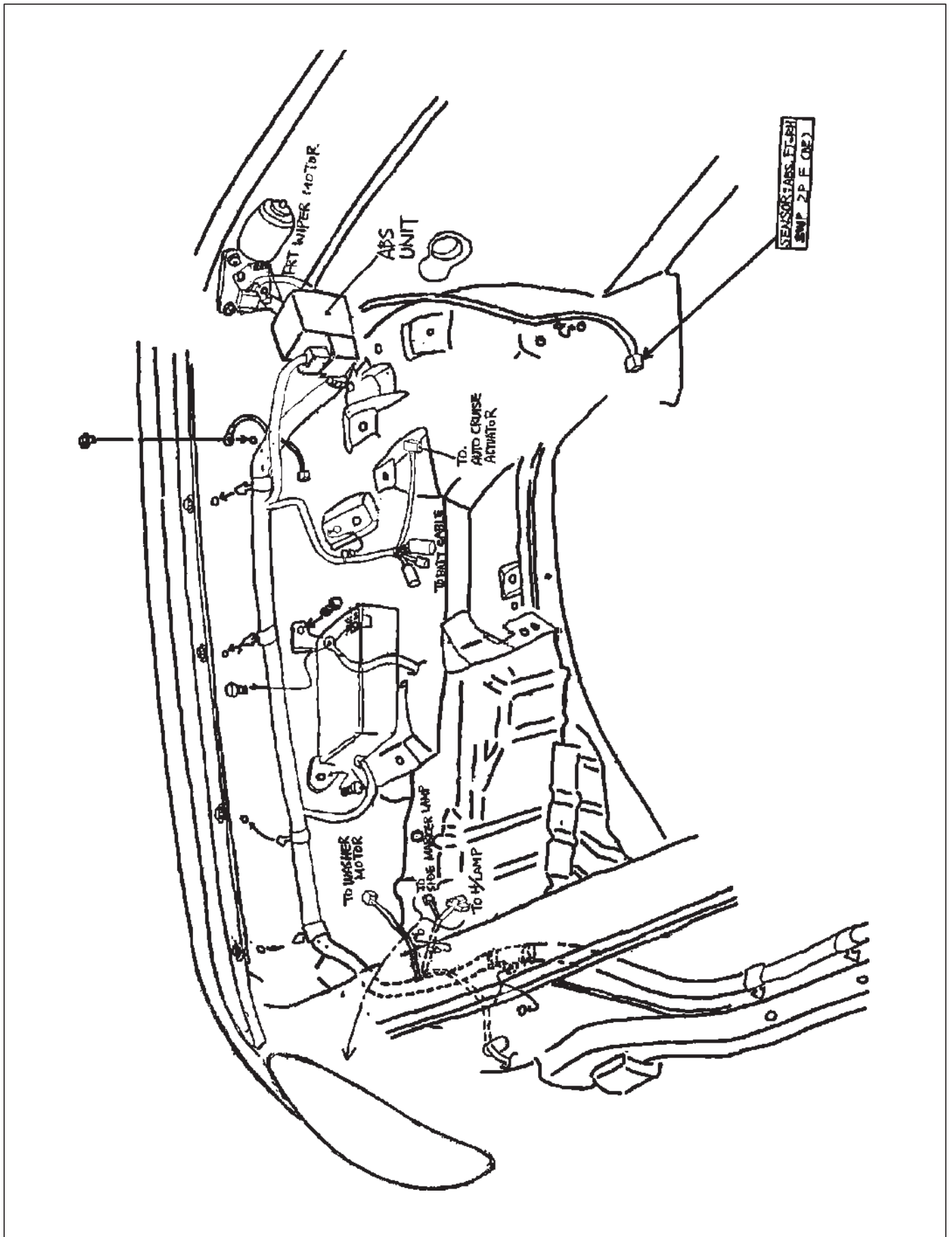
Location-1



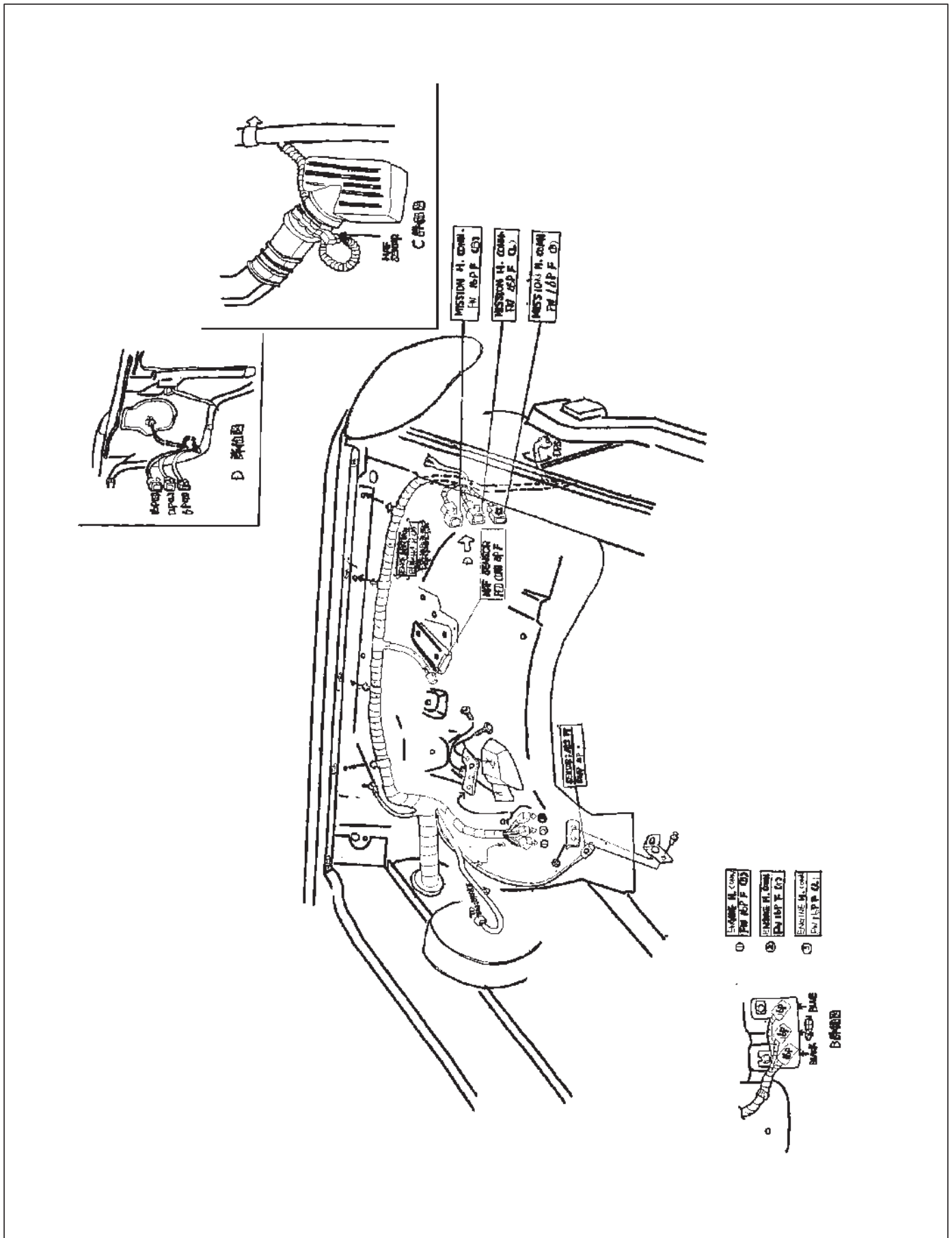
Location-2



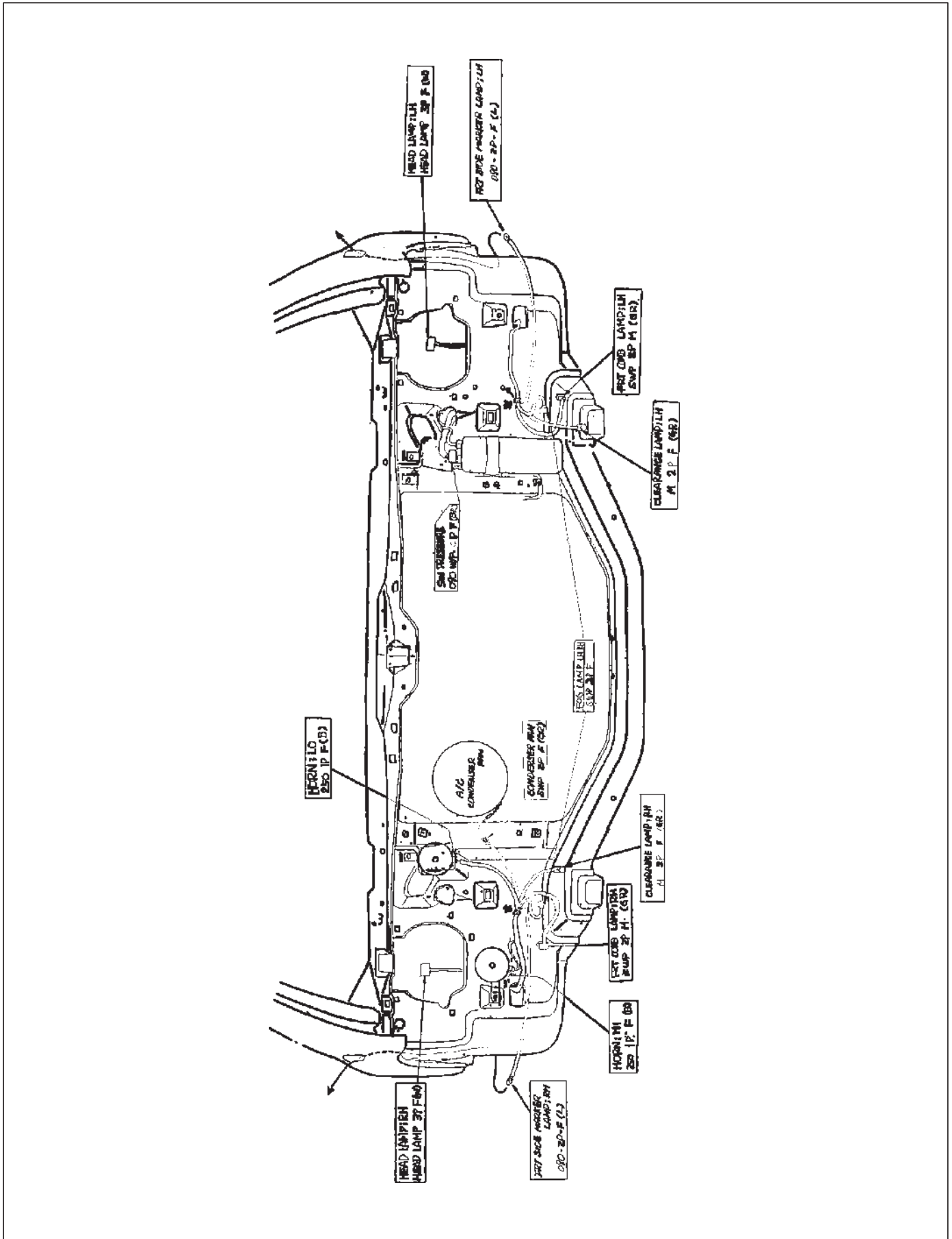
Location-3



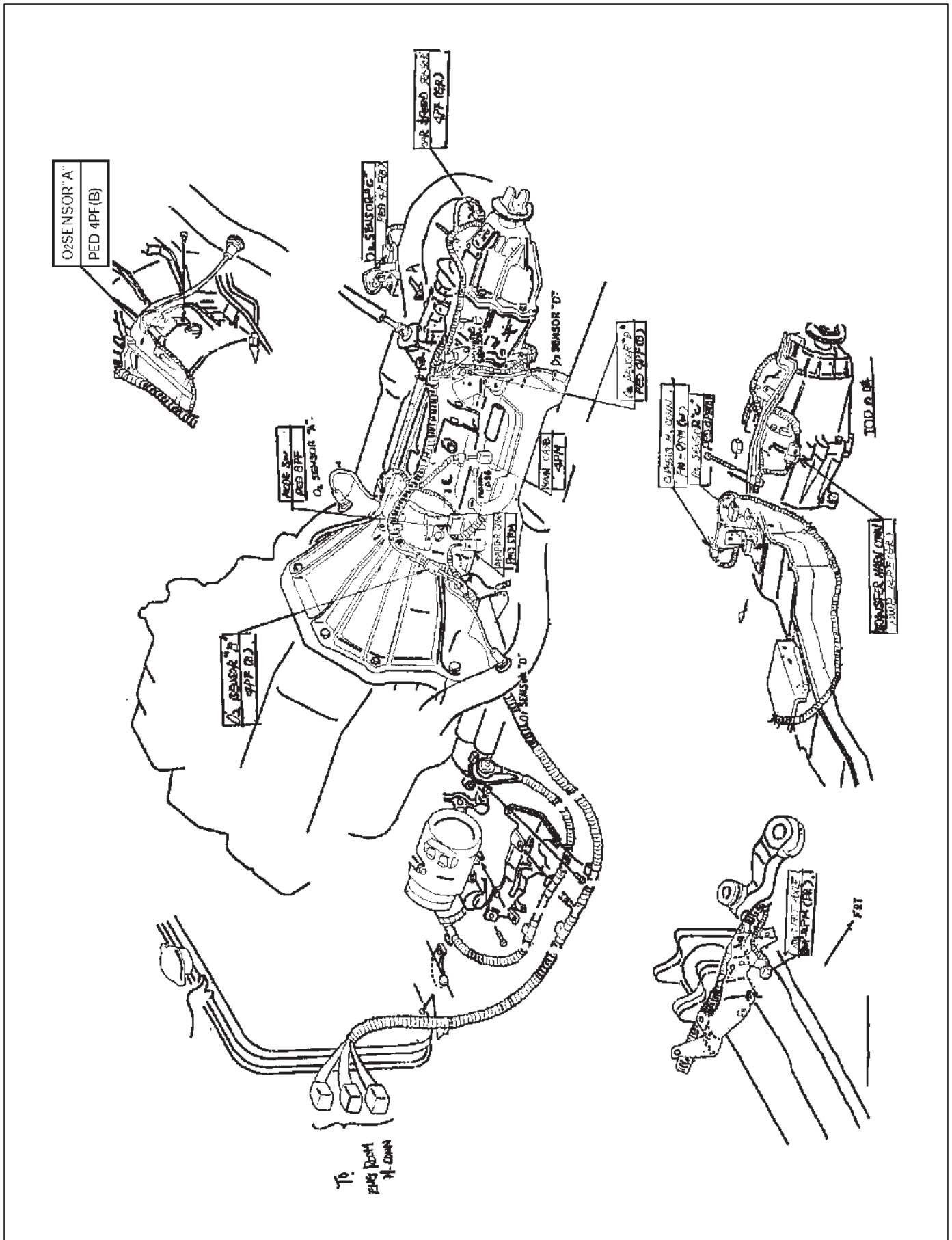
Location-4



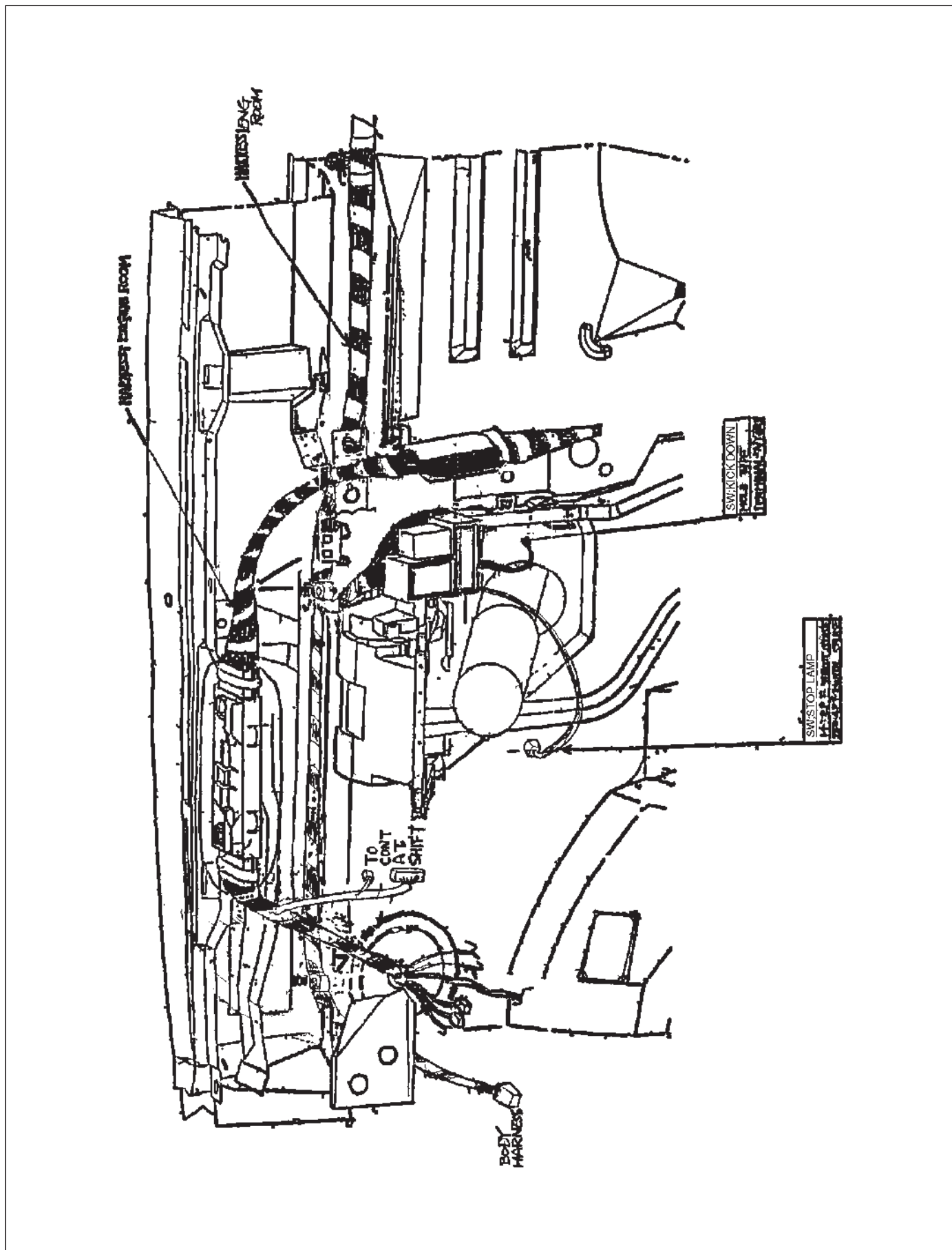
Location-5



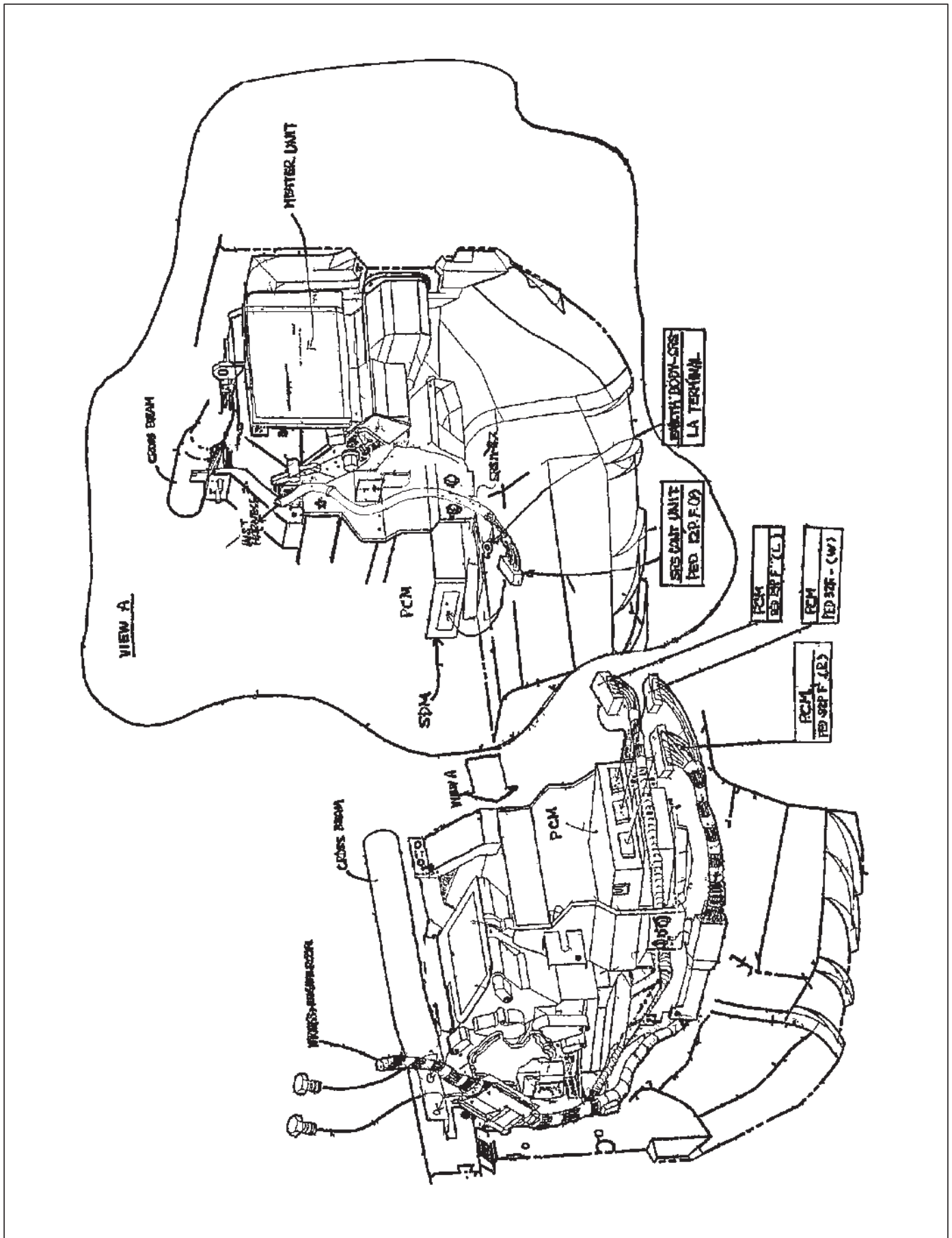
Location-6



Location-7

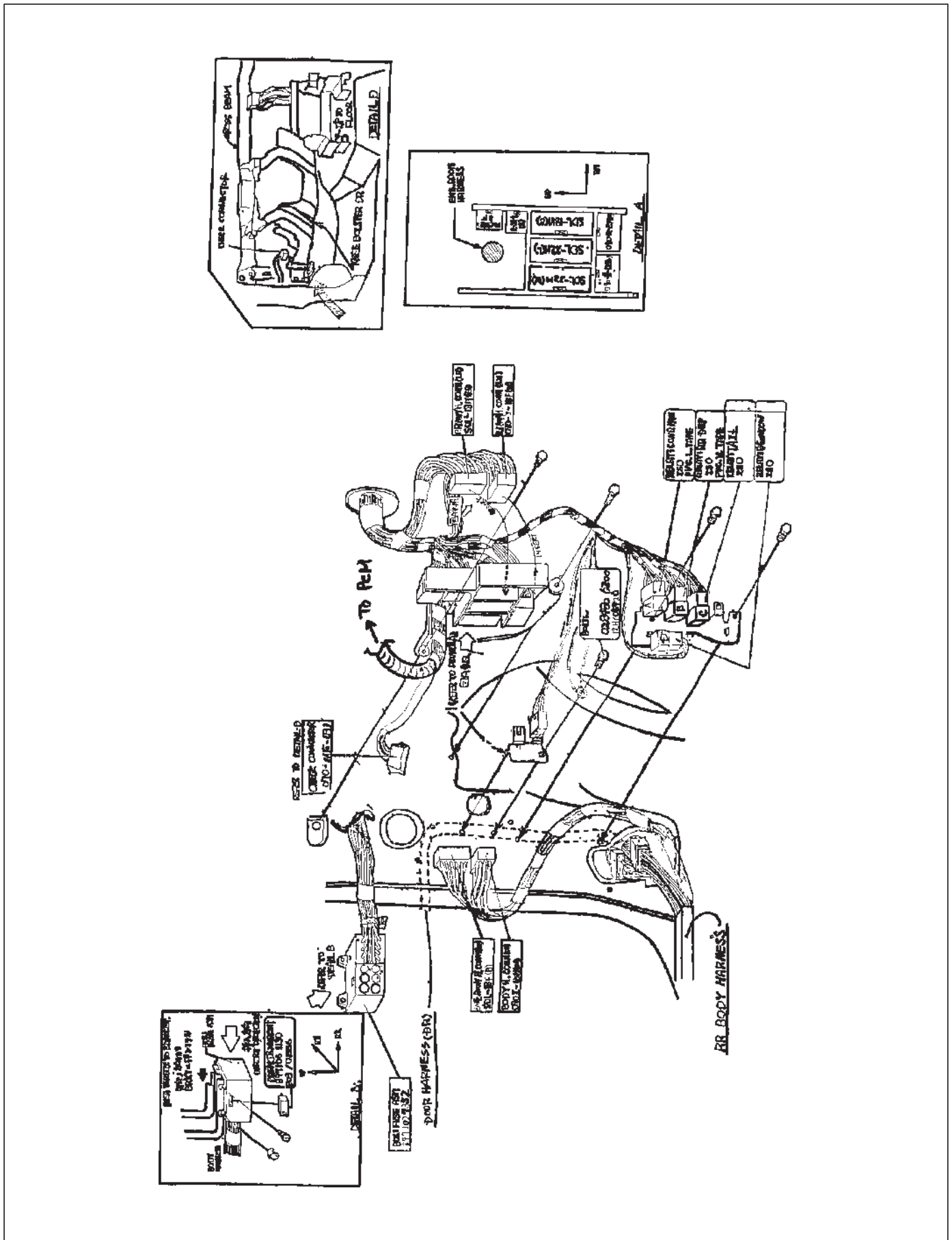


Location-8

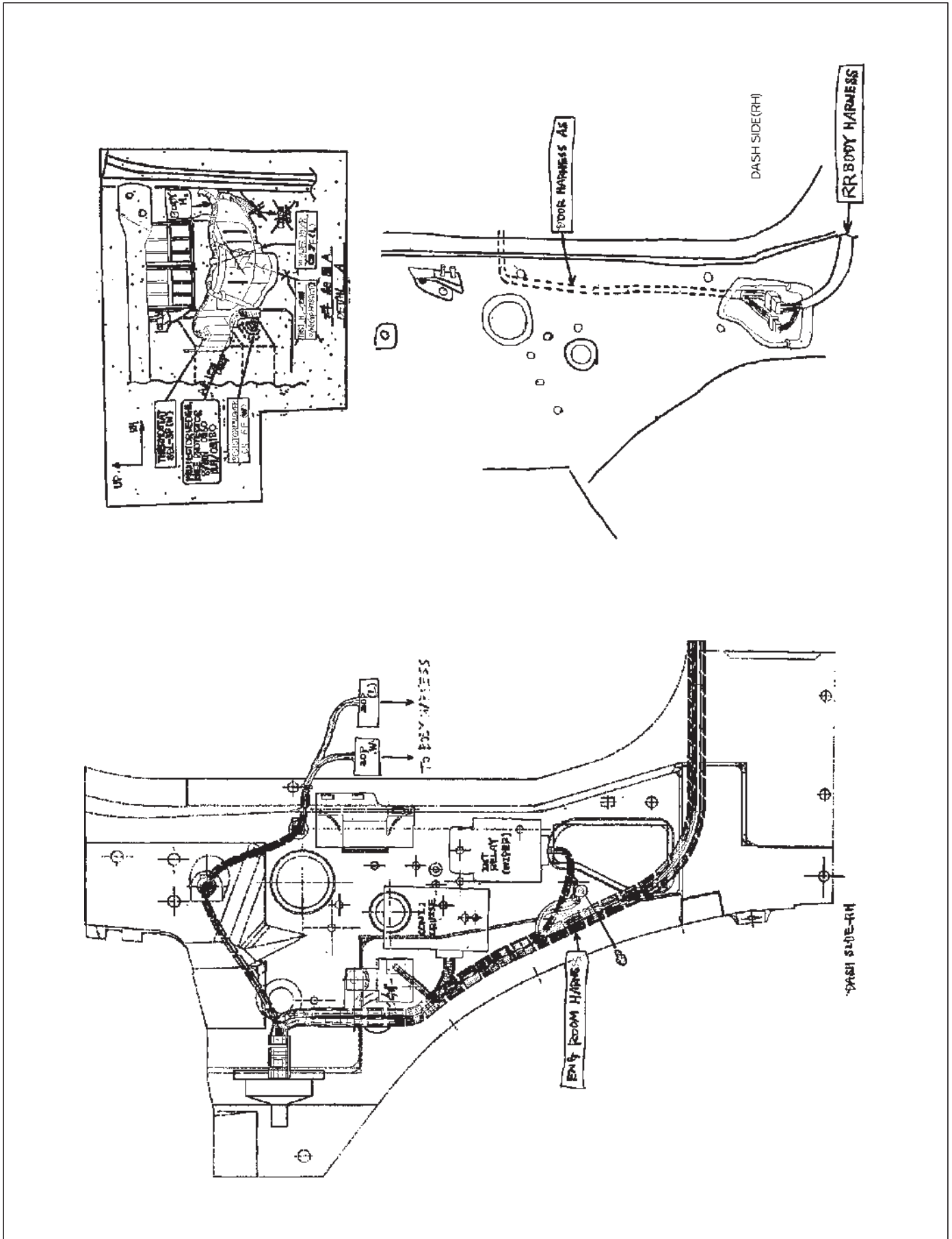




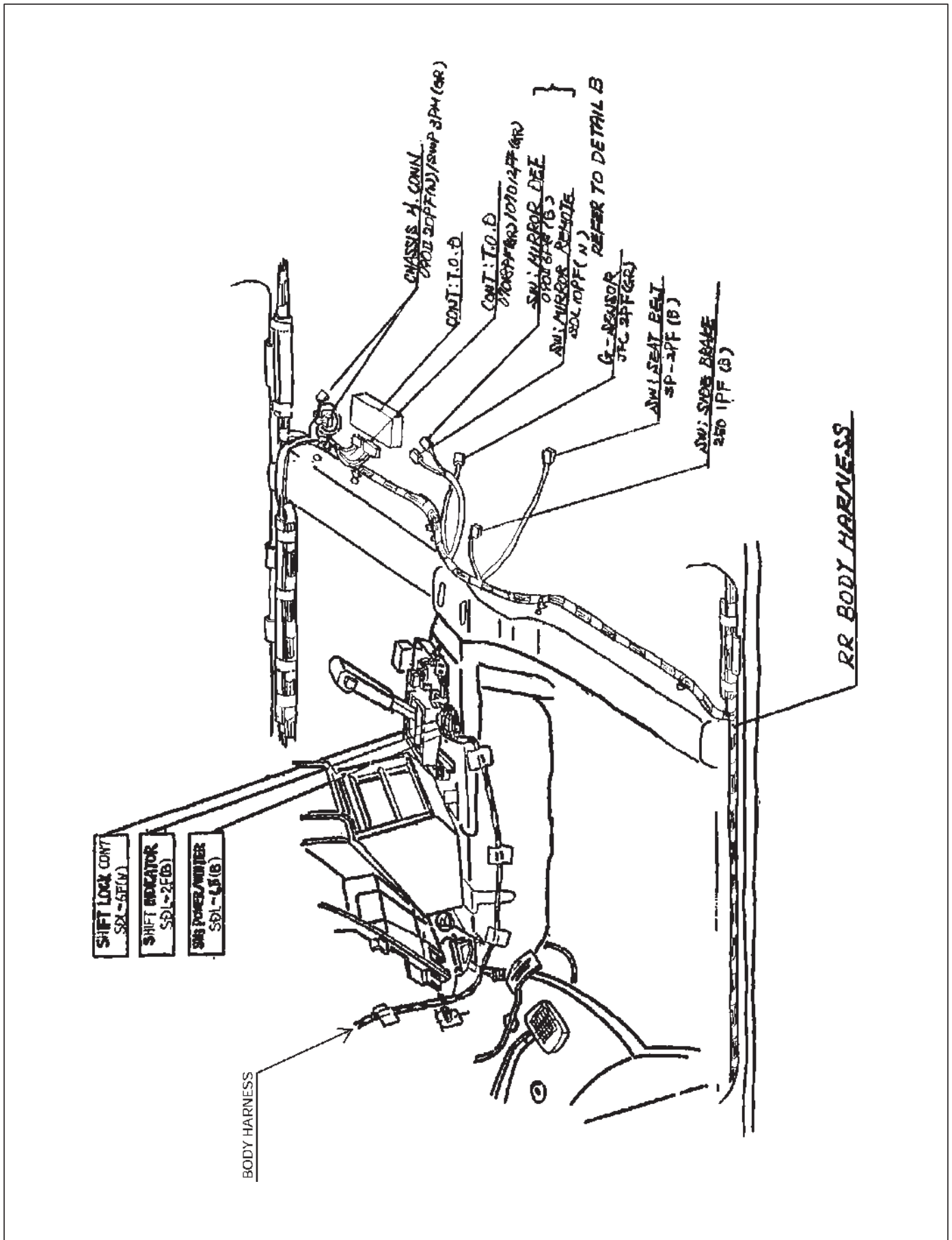
Location-9



Location-10

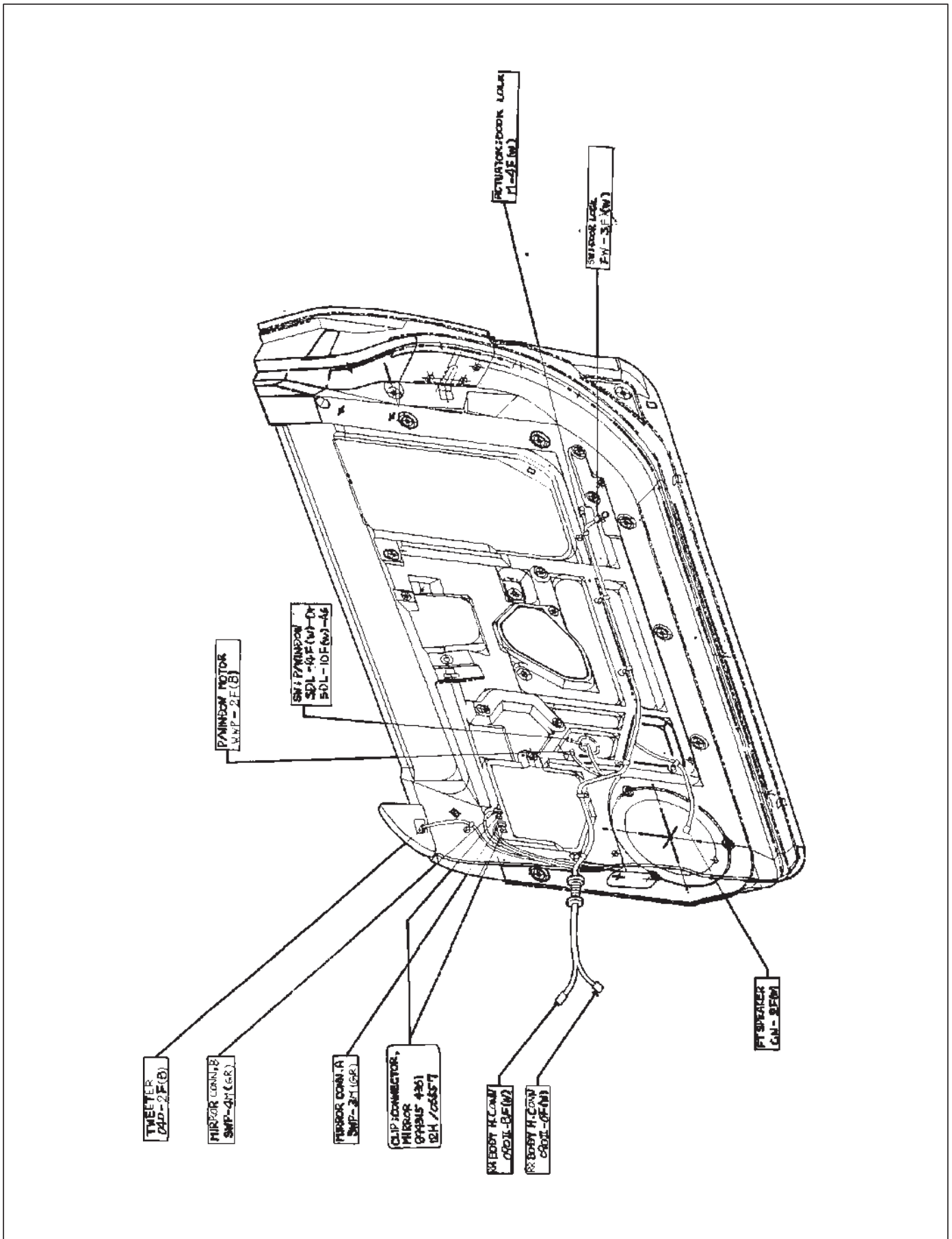


Location-11

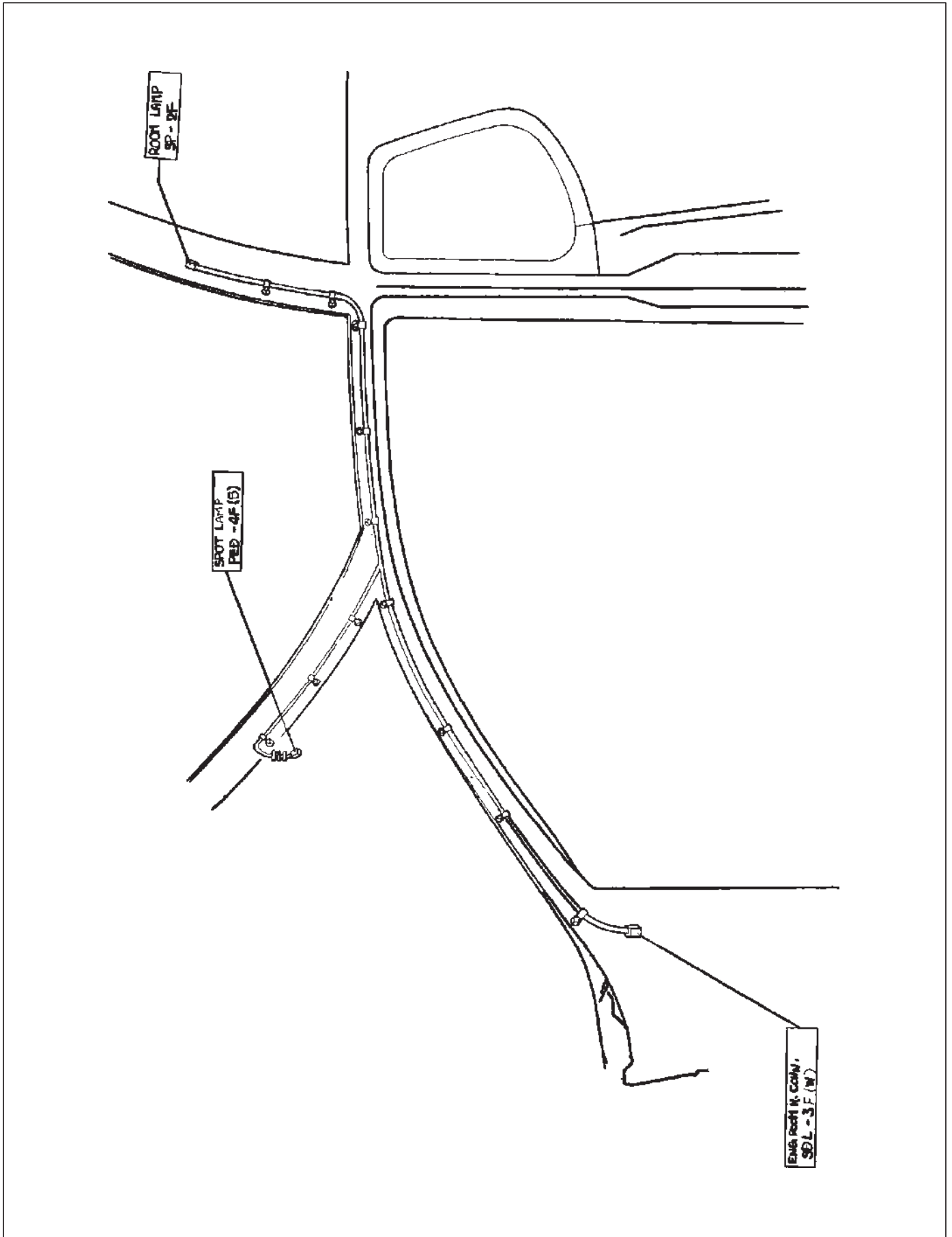




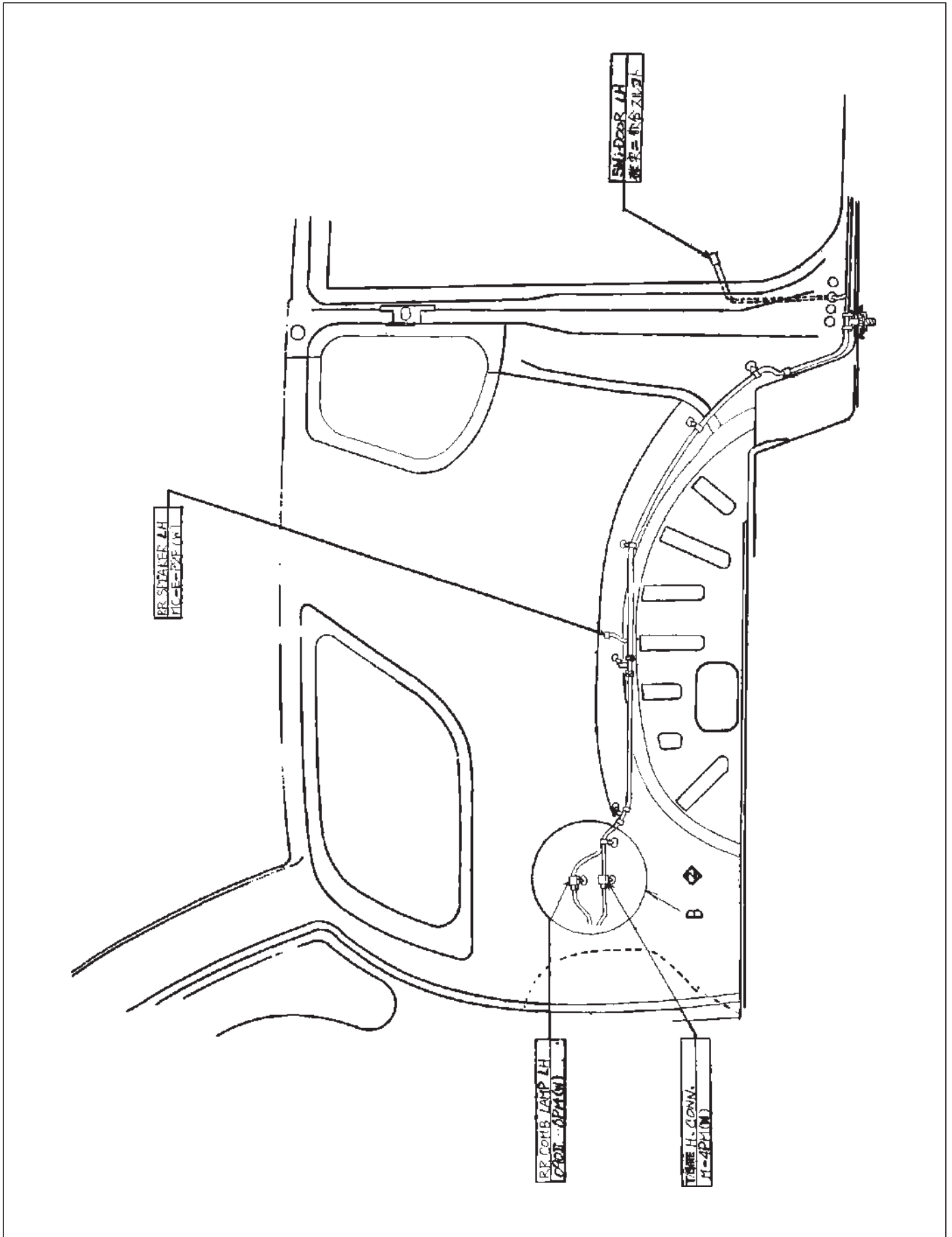
Location-13



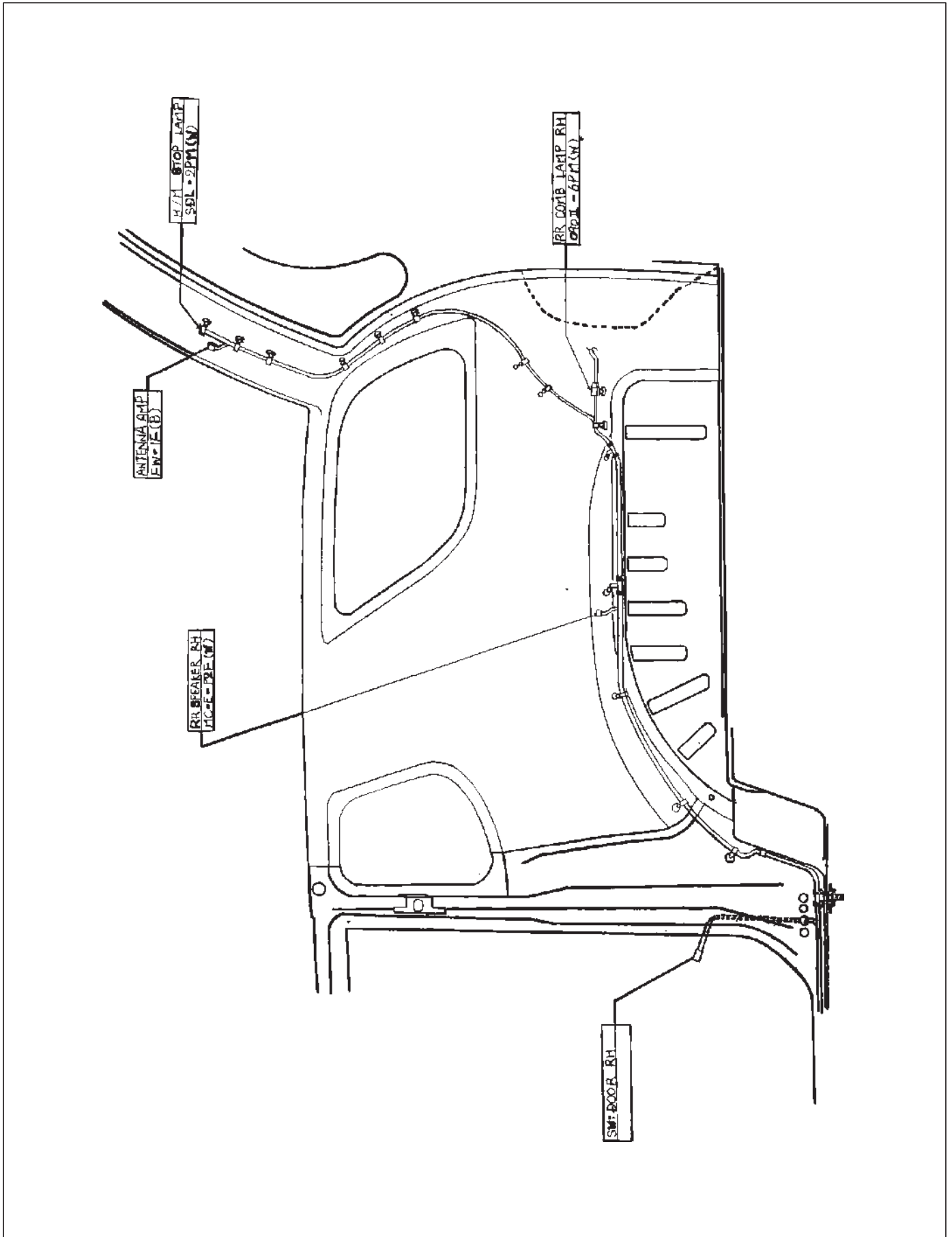
Location-14



Location-15

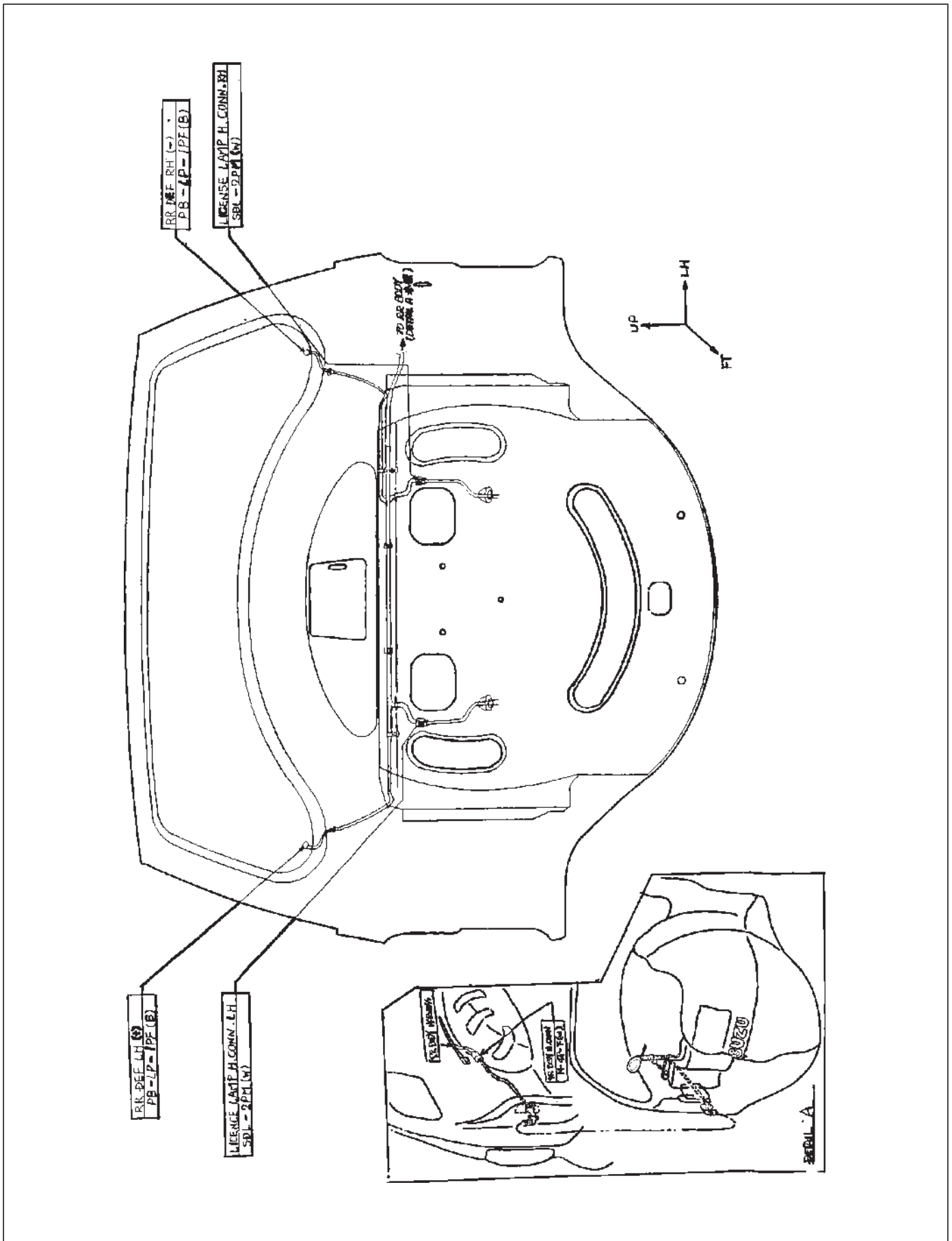


Location-16

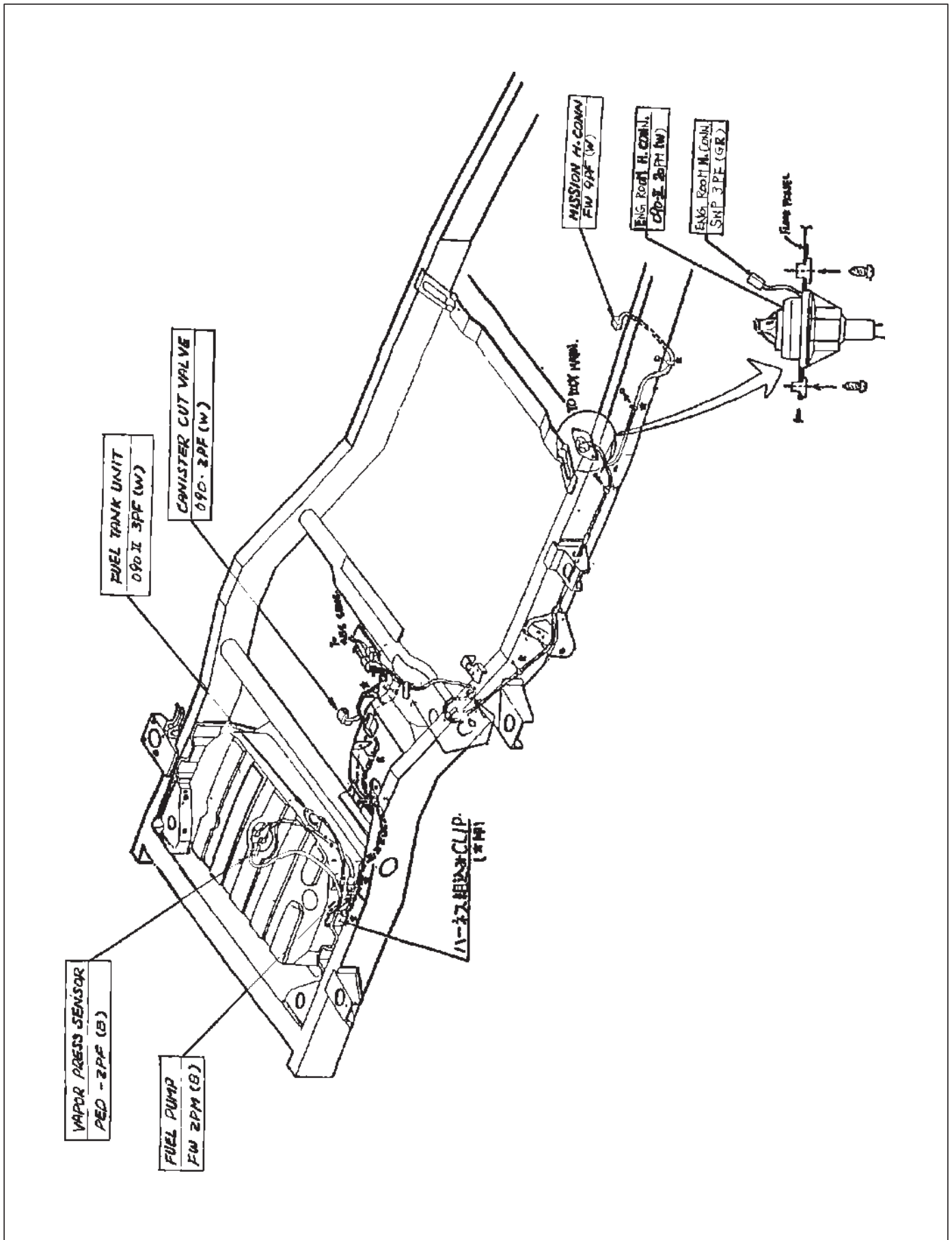




Location-17



Location-18



# BODY AND ACCESSORIES

## METER AND GAUGE

### CONTENTS

Service Precaution .....	8E-1	Removal .....	8E-10
Meter Assembly .....	8E-2	Installation .....	8E-10
General Description .....	8E-2	Warning Light Bulb, Indicator Light Bulb, Illumination Light Bulb .....	8E-11
Layout for Meters/Gauges, Warning Lights, Indicator Lights and Illumination Lights ...	8E-2	Removal .....	8E-11
Table for Meter/Gauge Connector Terminal Connections .....	8E-4	Installation .....	8E-11
Removal .....	8E-6	A/T Indicator Light Bulb .....	8E-11
Installation .....	8E-6	Removal .....	8E-11
Speedometer .....	8E-7	Installation .....	8E-11
Removal .....	8E-7	Vehicle Speed Sensor .....	8E-12
Installation .....	8E-7	Removal .....	8E-12
Tachometer .....	8E-8	Installation .....	8E-12
Removal .....	8E-8	Thermo Unit .....	8E-12
Installation .....	8E-8	Removal .....	8E-12
Coolant Temperature gauge and Fuel Gauge	8E-9	Installation .....	8E-12
Removal .....	8E-9	Fuel Tank Unit .....	8E-13
Installation .....	8E-9	Removal .....	8E-13
TOD Indicator Assembly .....	8E-10	Installation .....	8E-13
		Main Data and Specifications .....	8E-14

### Service Precaution

**WARNING: THIS VEHICLE HAS A SUPPLEMENTAL RESTRAINT SYSTEM (SRS). REFER TO THE SRS COMPONENT AND WIRING LOCATION VIEW IN ORDER TO DETERMINE WHETHER YOU ARE PERFORMING SERVICE ON OR NEAR THE SRS COMPONENTS OR THE SRS WIRING. WHEN YOU ARE PERFORMING SERVICE ON OR NEAR THE SRS COMPONENTS OR THE SRS WIRING, REFER TO THE SRS SERVICE INFORMATION. FAILURE TO FOLLOW WARNINGS COULD RESULT IN POSSIBLE AIR BAG DEPLOYMENT, PERSONAL INJURY, OR OTHERWISE UNNEEDED SRS SYSTEM REPAIRS.**

**CAUTION: Always use the correct fastener in the proper location. When you replace a fastener, use ONLY the exact part number for that application. ISUZU will call out those fasteners that require a replacement after removal. ISUZU will also call out the fasteners that require thread lockers or thread sealant. UNLESS OTHERWISE SPECIFIED, do not use supplemental coatings (Paints, greases, or other corrosion inhibitors) on threaded fasteners or fastener joint interfaces. Generally, such coatings adversely affect the fastener torque and the joint clamping force, and may damage the fastener. When you install fasteners, use the correct tightening sequence and specifications. Following these instructions can help you avoid damage to parts and systems.**

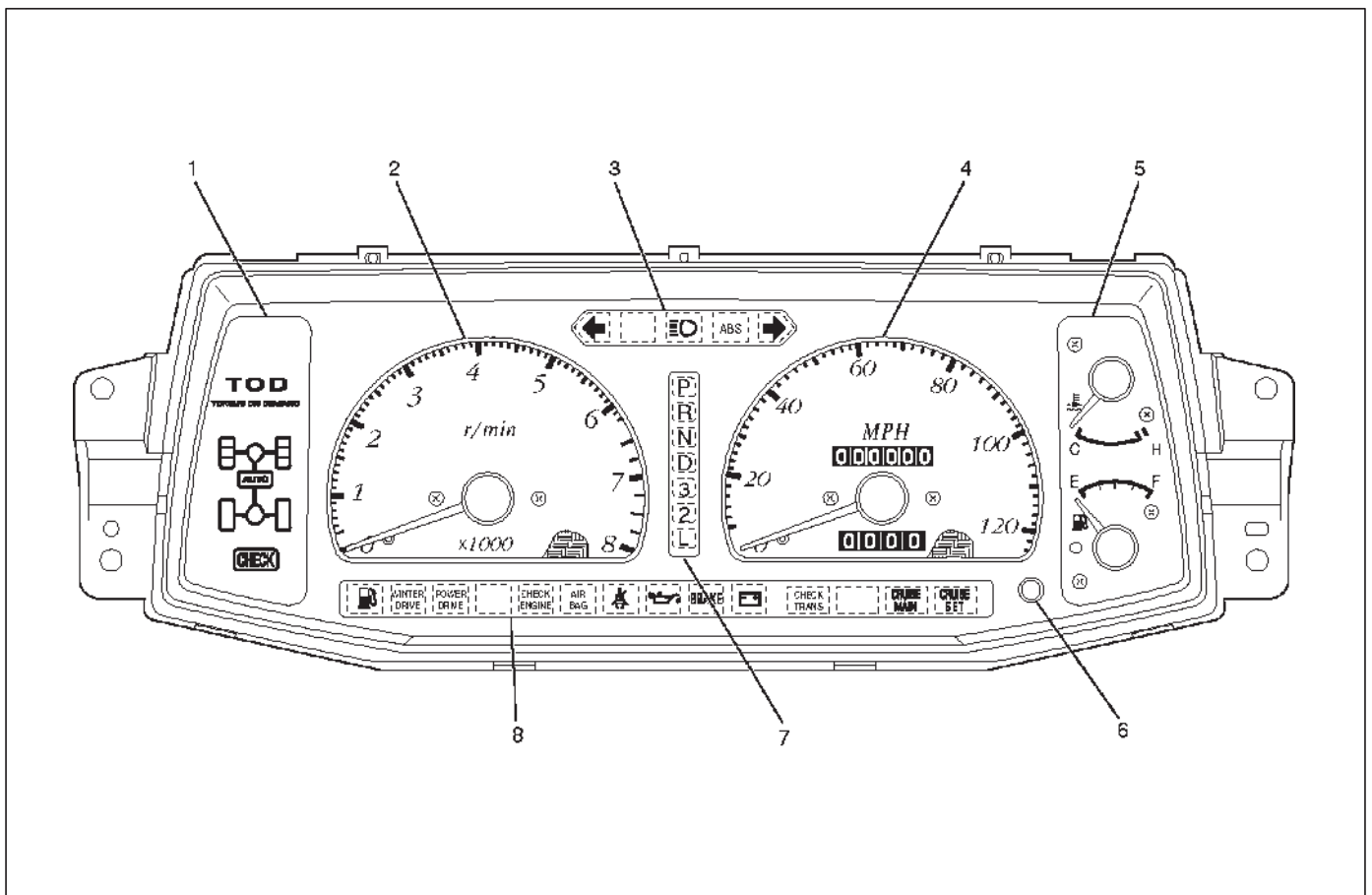
## Meter Assembly

### General Description

The meter assembly has the speedometer, tachometer, engine coolant temperature gauge, fuel gauge and warning/indicator lights. In addition, the meter assembly containing TOD (Torque on Demand) has the TOD indicator light, or the meter assembly not containing TOD has the voltmeter and oil pressure gauge instead of the TOD indicator.

### Layout for Meters/Gauges, Warning Lights, Indicator Lights and Illumination Lights

#### Meter Assembly (Front View)

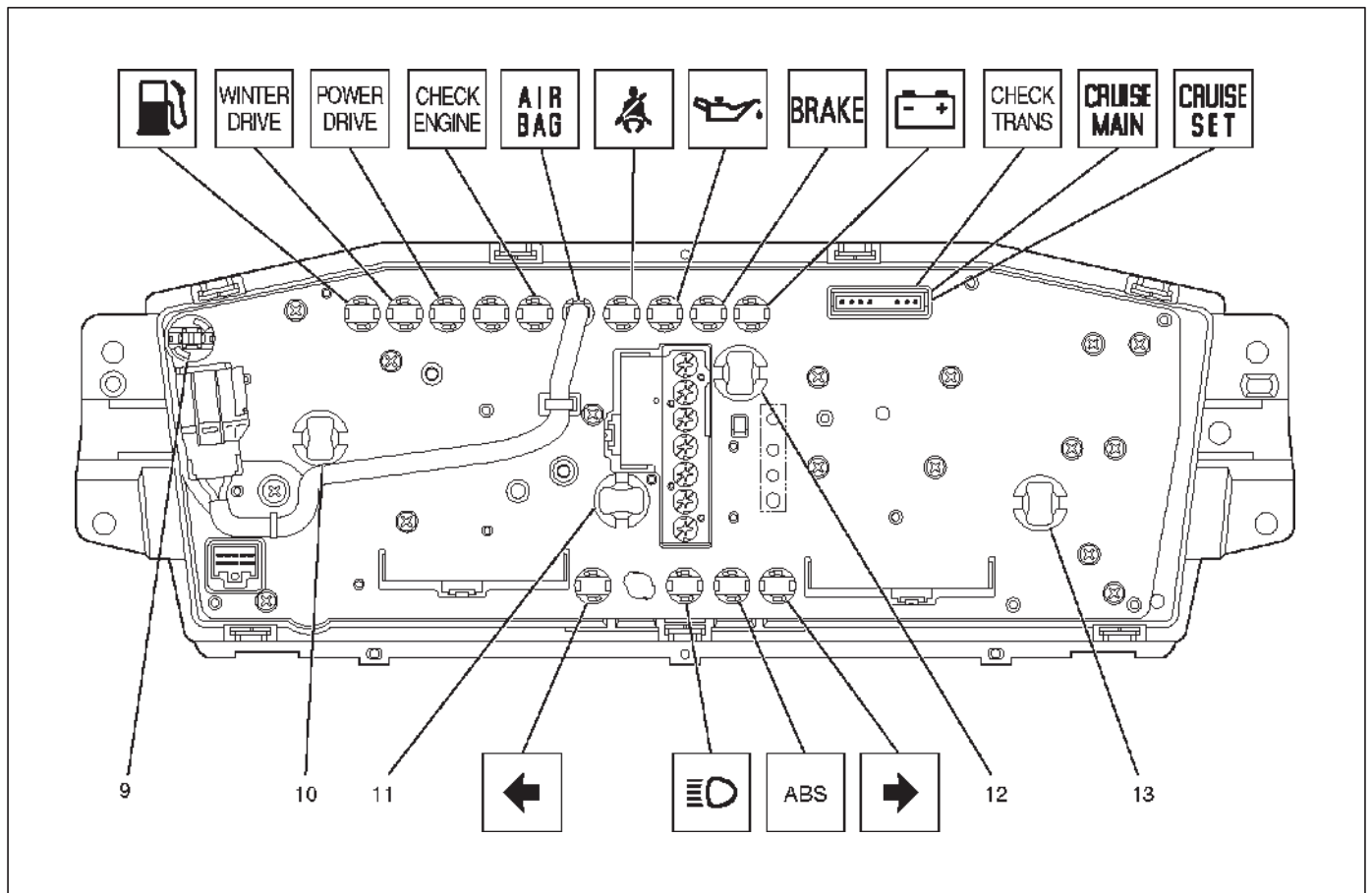


826RX001

#### Legend

- |                        |  |
|------------------------|--|
| (1) TOD indicator      | (5) Coolant Temperature Gauge & Fuel Gauge |
| (2) Tachometer         | (6) Reset Knob                             |
| (3) Warning Light Lens | (7) A/T Shift Indicator                    |
| (4) Speedometer        | (8) Warning Light Lens                     |

Meter Assembly (Rear View)



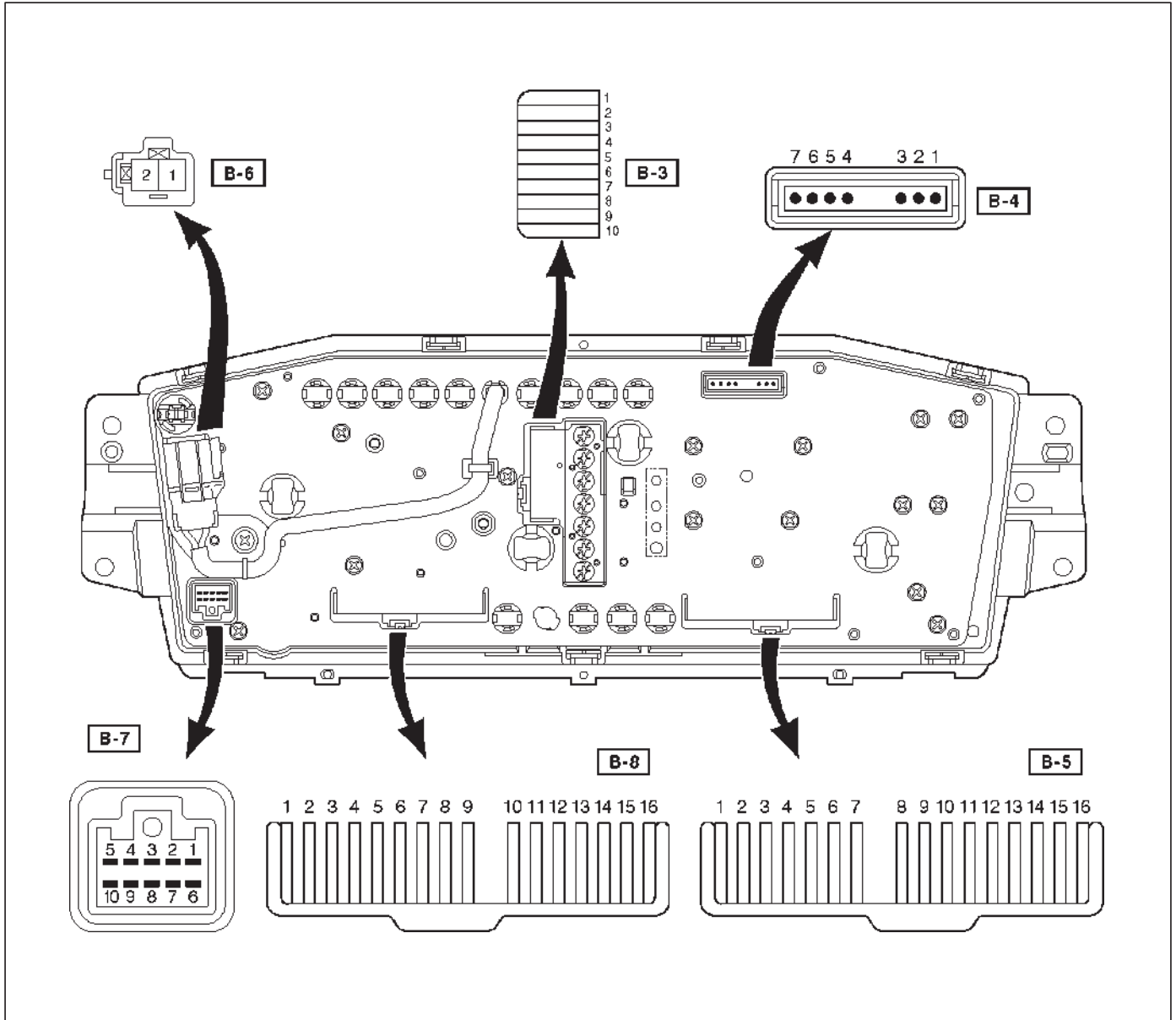
826RX002

**Legend**

- (9) TOD Light
- (10) Illumination Light

- (11) Illumination Light
- (12) Illumination Light
- (13) Illumination Light

### Table for Meter/Gauge Connector Terminal Connections Meter Assembly



Connector B-3	
Terminal	Function
1	—
2	L position
3	2 position
4	3 position
5	D position
6	N position
7	R position
8	—
9	A/T shift indicator control unit
10	P position

Connector B-4	
Terminal	Function
1	—
2	
3	CRUSIE MAIN
4	A/T Oil Temp
5	Battery +
6	—
7	CHECKTRANS warning light

Connector B-5	
Terminal	Function
1	Turn signal indicator light (RH)
2	ABS warning light
3	High beam indicator light (+)
4	High beam indicator light (-)
5	—
6	Ground
7	Speedometer (out)
8	Speedometer (in)
9	Oil pressure warning light
10	Brake warning light
11	Low fuel warning light
12	Charge warning light
13	Illumination light (+)
14	Illumination light (-)
15	Fuel gauge
16	Coolant temperature gauge

Connector B-6	
Terminal	Function
1	Battery +
2	SDM (air bag controller)

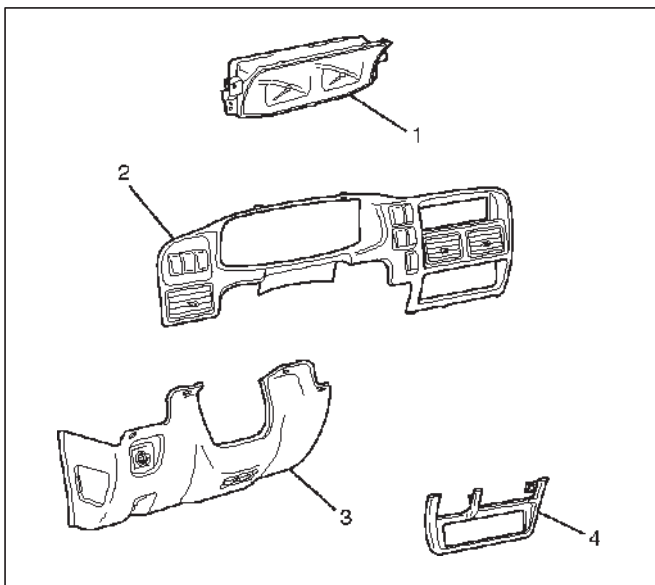
Connector B-7	
Terminal	Function
1	—
2	FRONT 1
3	—
4	REAR
5	CHECK
6	—
7	Battery +
8	AUTO
9	FRONT 3
10	FRONT 2

Connector B-8	
Terminal	Function
1	Ground
2	—
3	Tachometer
4	Ground
5	Illumination light (+)
6	Illumination light (-)
7	WINTER DRIVE indicator light
8	POWER DRIVE indicator light
9	—
10	—
11	—
12	CHECK ENGINE warning light
13	Seat belt warning light
14	Battery +
15	—
16	Turn signal indicator light (LH)

## 8E-6 METER AND GAUGE

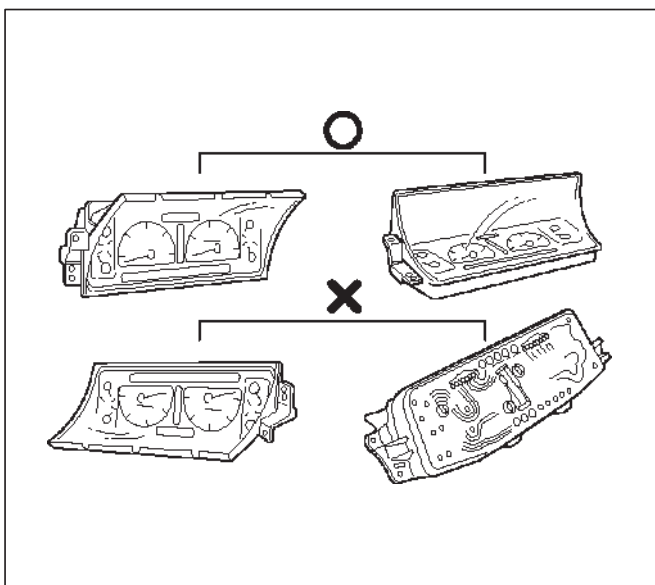
### Removal

1. Disconnect the battery ground cable.
2. Remove the instrument panel driver lower cover(3).  
Refer to the Instrument Panel Assembly in Body Structure section.
3. Remove the lower cluster assembly(4).  
Refer to the Instrument Panel Assembly in Body Structure section.
4. Remove the instrument panel cluster assembly(2).  
Refer to the Instrument Panel Assembly in Body Structure section.
5. Remove the meter assembly(1).
  - Remove the 4 fixing screws.
  - Disconnect the meter connectors.



821RX028

**CAUTION:** The removed meter assembly should be placed upright or with its face side up.



821RX027

### Installation

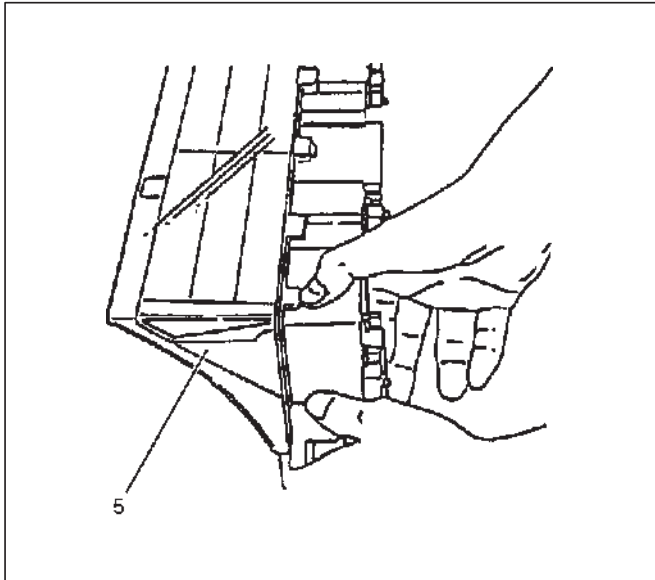
To install, follow the removal steps in the reverse order.



## Speedometer

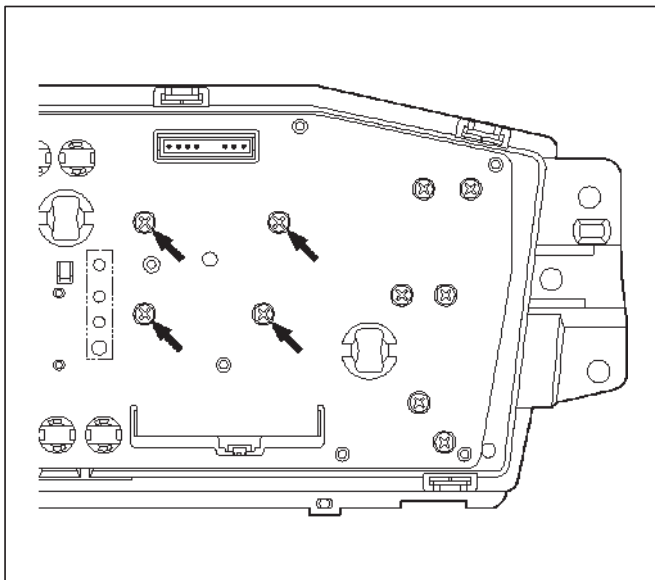
### Removal

1. Disconnect the battery ground cable.
2. Remove the meter assembly.  
Refer to the Meter Assembly in this section.
3. Remove meter cluster glass(5).  
○Push the seven catches on the peripheral with your finger.



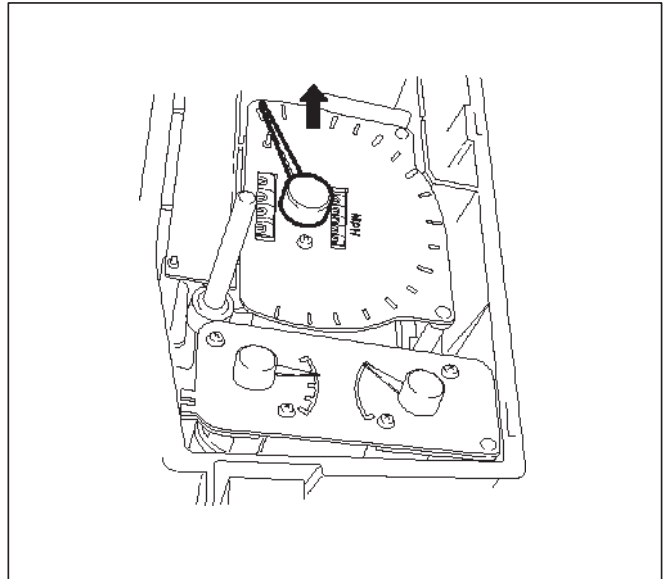
821RX031

4. Remove the speedometer assembly.  
○Remove the 4 fixing screws securing the meter at the back side of the meter assembly.



826RV049

- Lift the meter carefully.



821RX032

### Installation

To install, follow the removal steps in the reverse order.

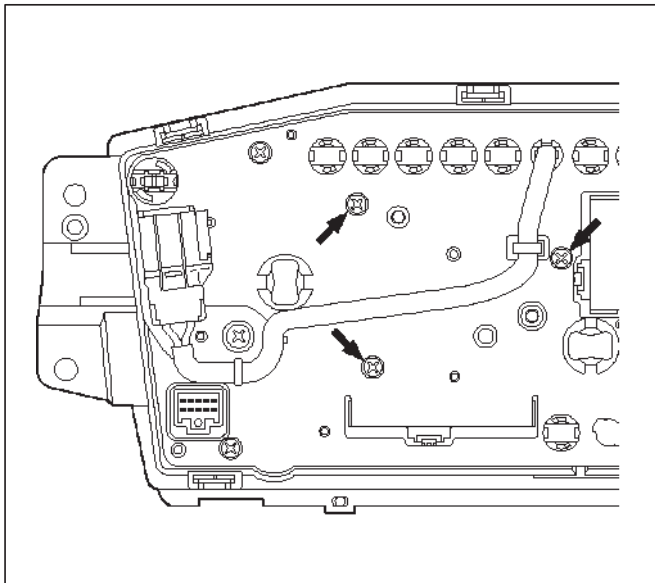
## Tachometer

### Removal

1. Disconnect the battery ground cable.
2. Remove the meter assembly.  
Refer to the Meter Assembly in this section.
3. Remove meter cluster glass.  
Refer to the Speedometer in this section.
4. Remove the tachometer.
  - Remove the 3 fixing screws securing the meter at the back side of the meter assembly.
  - Lift the meter carefully to remove it.

### Installation

To install, follow the removal steps in the reverse order.

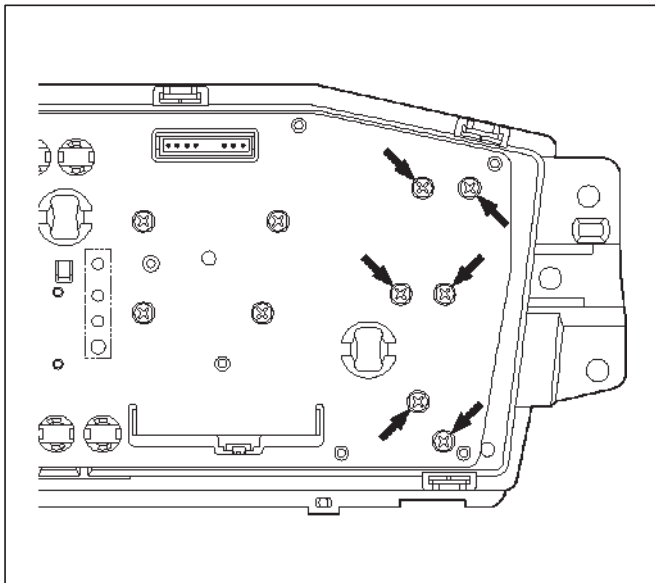


826RV048

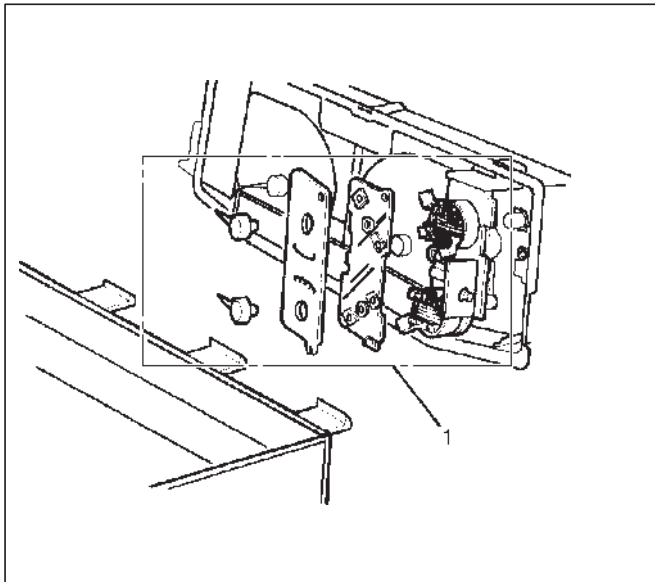
## Coolant Temperature gauge and Fuel Gauge

### Removal

1. Disconnect the battery ground cable.
2. Remove the meter assembly.  
Refer to the Meter Assembly in this section.
3. Remove meter cluster glass.  
Refer to the Speedometer in this section.
4. Remove the gauges.  
○Remove the 6 fixing screws securing the gauges body from the back side of the meter assembly(1).



826RV046



821RX026

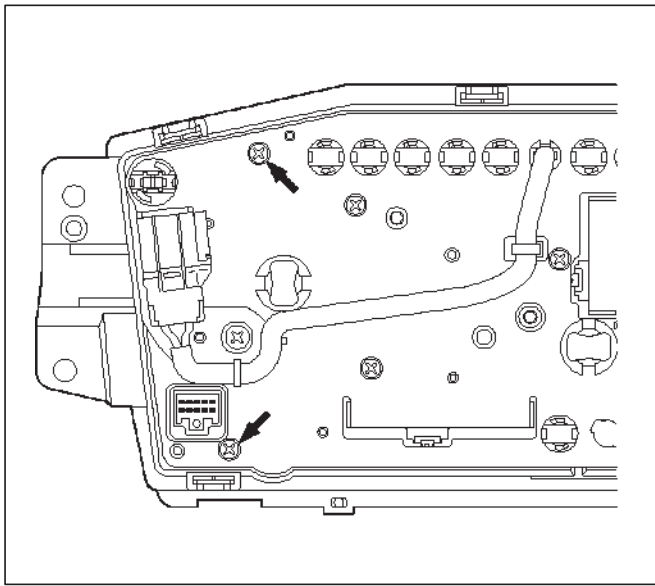
### Installation

To install, follow the removal steps in the reverse order.

## TOD Indicator Assembly

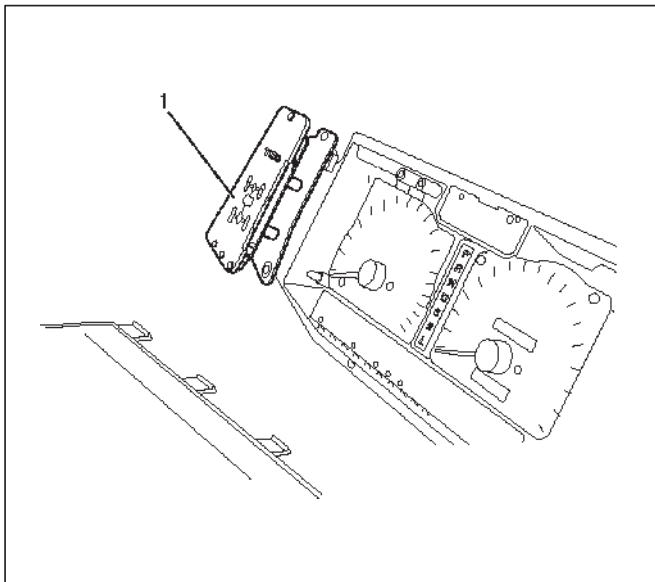
### Removal

1. Disconnect the battery ground cable.
2. Remove the meter assembly.  
Refer to the Meter Assembly in this section.
3. Remove the meter cluster glass.  
Refer to the Speedometer in this section.
4. Remove the TOD indicator assembly(1).  
○Remove the 2 fixing screws securing the indicator from the back side of the meter assembly.



826RV047

- Lift the TOD indicator assembly carefully.



826RX008

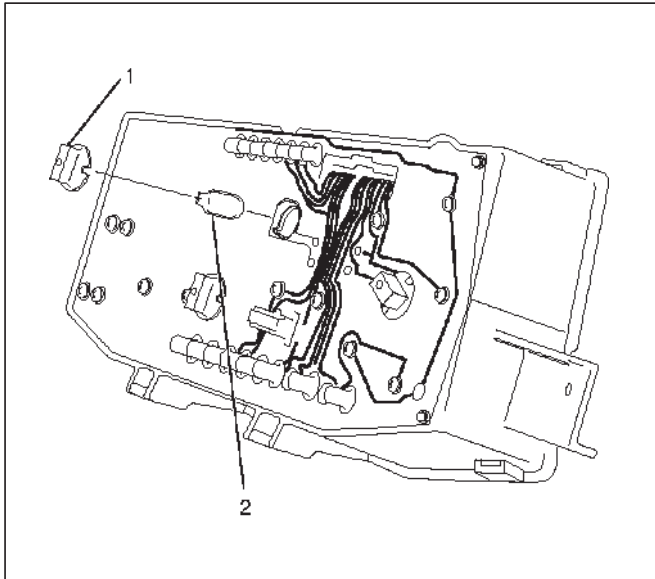
### Installation

To install, follow the removal steps in the reverse order.

## Warning Light Bulb, Indicator Light Bulb, Illumination Light Bulb

### Removal

1. Disconnect the battery ground cable.
2. Remove the meter assembly.  
Refer to the Meter Assembly in this section.
3. Remove the illumination light bulb.
  - Hold the bulb socket(1) by hand and turning it counterclockwise.
  - Pull out the bulb(2) from the socket(2).



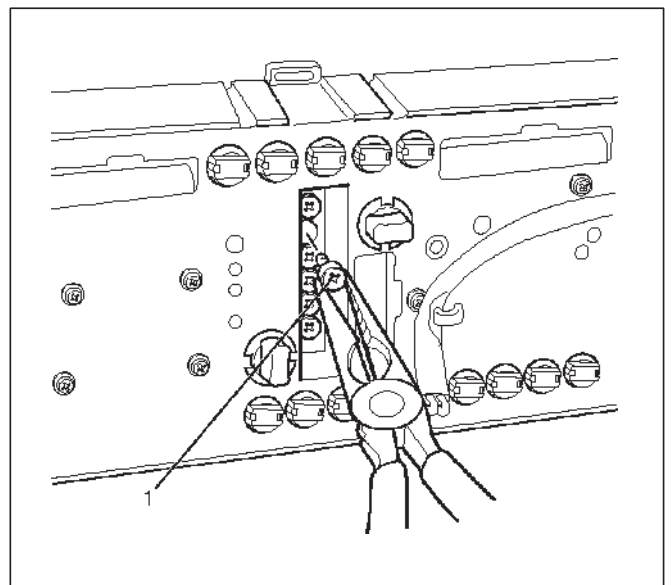
### Installation

To install, follow the removal steps in the reverse order.

## A/T Indicator Light Bulb

### Removal

1. Disconnect the battery ground cable.
2. Remove the meter assembly.  
Refer to the Meter Assembly in this section.
3. Remove the A/T indicator light bulb.
  - Hold the bulb socket(1) with small tip pliers and turning it counterclockwise to remove the socket(1) from the back side of the meter body.
  - Pull out the bulb from the socket.



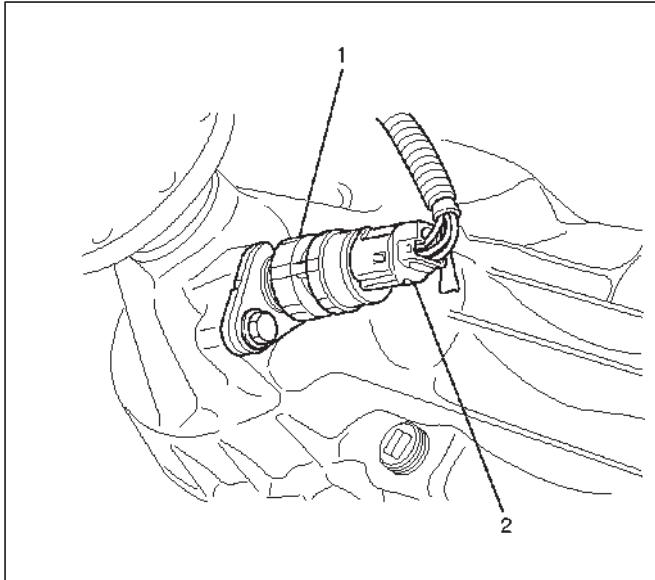
### Installation

To install, follow the removal steps in the reverse order.

## Vehicle Speed Sensor

### Removal

1. Disconnect the battery ground cable.
2. Disconnect the connector(2).
3. Remove the vehicle speed sensor(1).
  - Remove the one bolt.
  - Rotate the sensor counterclockwise.



826RX003

### Installation

To install, follow the removal steps in the reverse order, noting the following point.

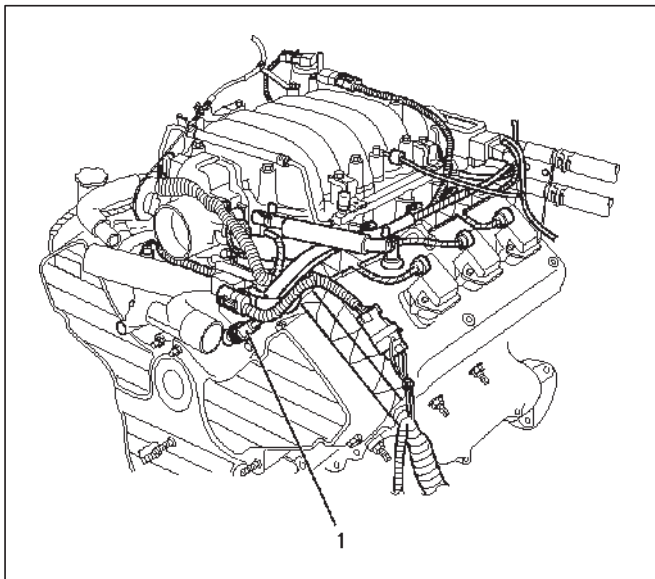
1. Tighten the vehicle speed sensor to the specified torque.

**Torque: 27 N-m (20 lb-ft)**

## Thermo Unit

### Removal

1. Disconnect the battery ground cable.
2. Remove the thermo unit(1).
  - Disconnect the connector.
  - Rotate the thermo unit counterclockwise.



060RX079

### Installation

To install, follow the removal steps in the reverse order, noting the following point.

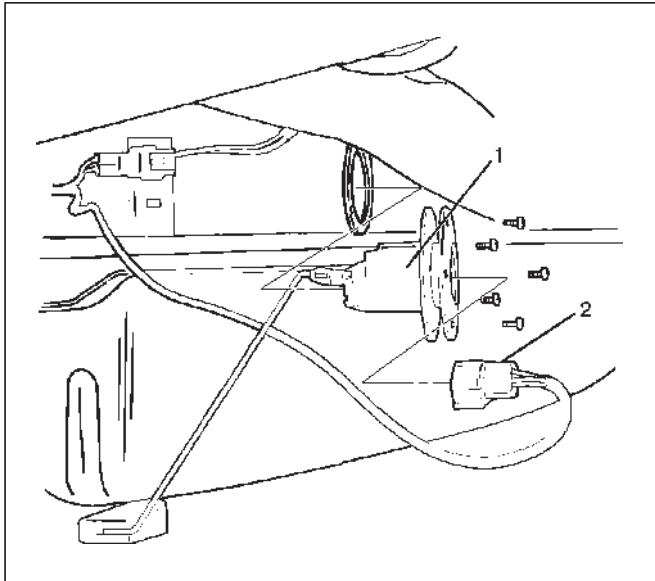
1. Tighten the thermo unit to the specified torque.

**Torque: 30 N-m (22 lb-ft)**

## Fuel Tank Unit

### Removal

1. Disconnect the battery ground cable.
2. Remove the fuel tank assembly.  
Refer to the Fuel Tank in the Engine Fuel section.
3. Remove the fuel tank unit(1).
  - Disconnect the connector(2).
  - Remove the 5 fixing screws.



140RX012

### Installation

To install, follow the removal steps in the reverse order.

## Main Data and Specifications

### Torque Specifications

Application	N·m	lb·ft	lb·in
Vehicle Speed Sensor Fixing	27	20	—
Thermo Sensor Fixing	30	22	—



VEHICROSS

# BODY AND ACCESSORIES

## BODY STRUCTURE

### CONTENTS

Service Precaution .....	8F-2	Front Door Assembly .....	8F-31
Frame .....	8F-2	Parts Location .....	8F-31
General Description .....	8F-2	Removal .....	8F-31
Frame Dimensions .....	8F-3	Installation .....	8F-32
Front Bumper .....	8F-4	Door Strikers .....	8F-33
Parts Location .....	8F-4	Adjustment .....	8F-33
Removal .....	8F-5	Front Window Regulator, Glass and Glass	
Installation .....	8F-5	Run .....	8F-34
Rear Bumper .....	8F-6	Parts Location .....	8F-34
Parts Location .....	8F-6	Removal .....	8F-35
Removal .....	8F-6	Installation .....	8F-37
Installation .....	8F-6	Tailgate Assembly .....	8F-38
Engine Hood .....	8F-7	Parts Location .....	8F-38
Parts Location .....	8F-7	Removal .....	8F-38
Removal .....	8F-7	Installation .....	8F-39
Installation .....	8F-8	Tailgate Dove – Tail .....	8F-40
Engine Hood Cover .....	8F-9	Parts Location .....	8F-40
Parts Location .....	8F-9	Removal .....	8F-40
Removal .....	8F-9	Installation .....	8F-40
Installation .....	8F-9	Spare Tire Carrier .....	8F-41
Engine Hood Lock .....	8F-10	Parts Location .....	8F-41
Parts Location .....	8F-10	Removal .....	8F-41
Removal .....	8F-10	Installation .....	8F-41
Installation .....	8F-11	Windshield .....	8F-42
Radiator Grille .....	8F-11	Parts Location .....	8F-42
Parts Location .....	8F-11	Removal .....	8F-42
Removal .....	8F-11	Installation .....	8F-43
Installation .....	8F-11	Rear Quarter Glass .....	8F-47
Front Fender Panel .....	8F-12	Parts Location .....	8F-47
Parts Location .....	8F-12	Removal .....	8F-47
Removal .....	8F-12	Installation .....	8F-48
Installation .....	8F-13	Center Glass .....	8F-49
Body Mounting .....	8F-14	Parts Location .....	8F-49
Parts Location .....	8F-14	Removal .....	8F-49
Tightening Torque .....	8F-14	Installation .....	8F-50
Body Dimension .....	8F-15	Tailgate Glass .....	8F-51
Instrument Panel Assembly and Cross		Parts Location .....	8F-51
Beam Assembly .....	8F-25	Removal .....	8F-51
Parts Location .....	8F-25	Installation .....	8F-51
Removal .....	8F-26	Main Data and Specifications .....	8F-53
Installation .....	8F-29		

## Service Precaution

**WARNING: THIS VEHICLE HAS A SUPPLEMENTAL RESTRAINT SYSTEM (SRS). REFER TO THE SRS COMPONENT AND WIRING LOCATION VIEW IN ORDER TO DETERMINE WHETHER YOU ARE PERFORMING SERVICE ON OR NEAR THE SRS COMPONENTS OR THE SRS WIRING. WHEN YOU ARE PERFORMING SERVICE ON OR NEAR THE SRS COMPONENTS OR THE SRS WIRING, REFER TO THE SRS SERVICE INFORMATION. FAILURE TO FOLLOW WARNINGS COULD RESULT IN POSSIBLE AIR BAG DEPLOYMENT, PERSONAL INJURY, OR OTHERWISE UNNEEDED SRS SYSTEM REPAIRS.**

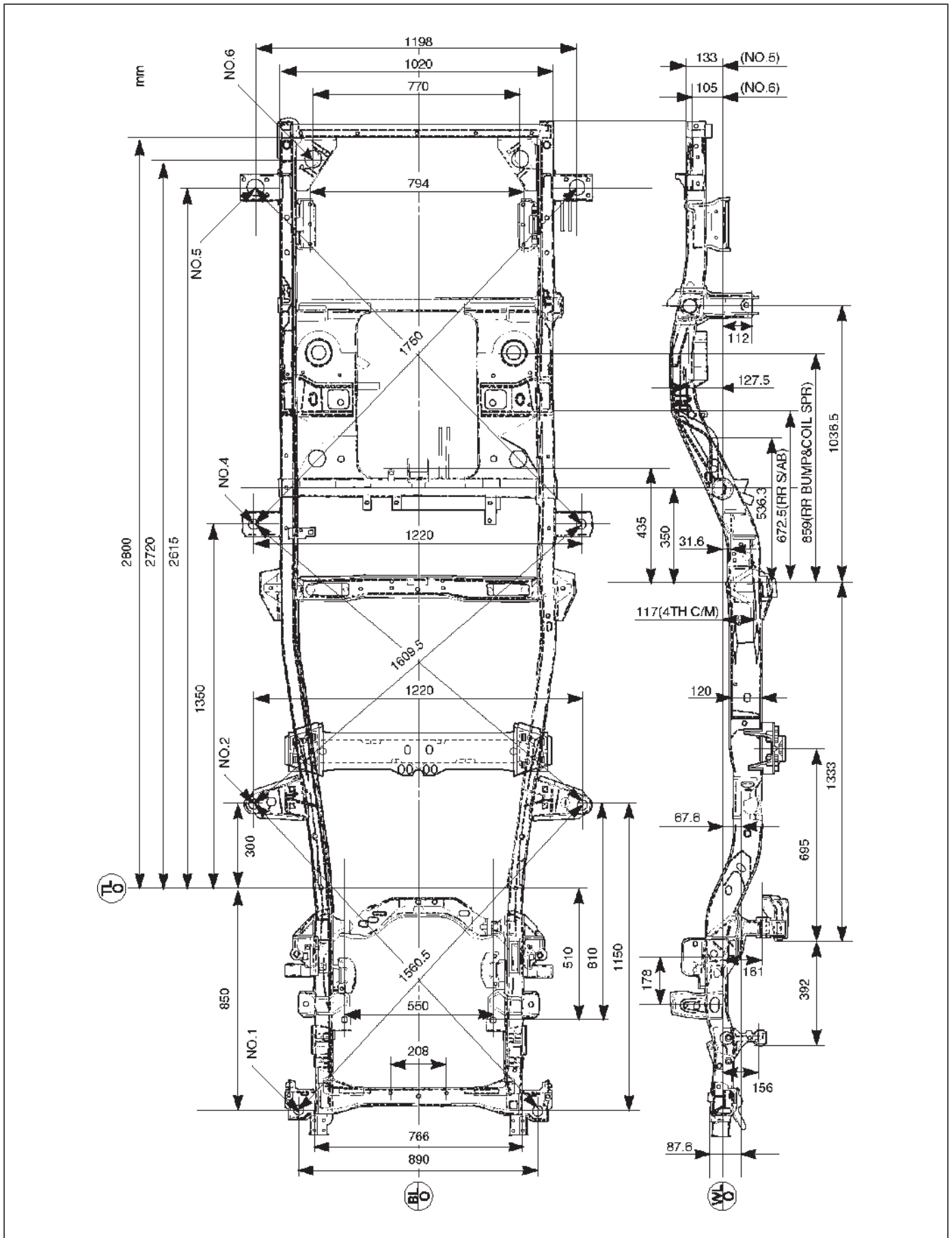
**CAUTION: Always use the correct fastener in the proper location. When you replace a fastener, use ONLY the exact part number for that application. ISUZU will call out those fasteners that require a replacement after removal. ISUZU will also call out the fasteners that require thread lockers or thread sealant. UNLESS OTHERWISE SPECIFIED, do not use supplemental coatings (Paints, greases, or other corrosion inhibitors) on threaded fasteners or fastener joint interfaces. Generally, such coatings adversely affect the fastener torque and the joint clamping force, and may damage the fastener. When you install fasteners, use the correct tightening sequence and specifications. Following these instructions can help you avoid damage to parts and systems.**

## Frame

### General Description

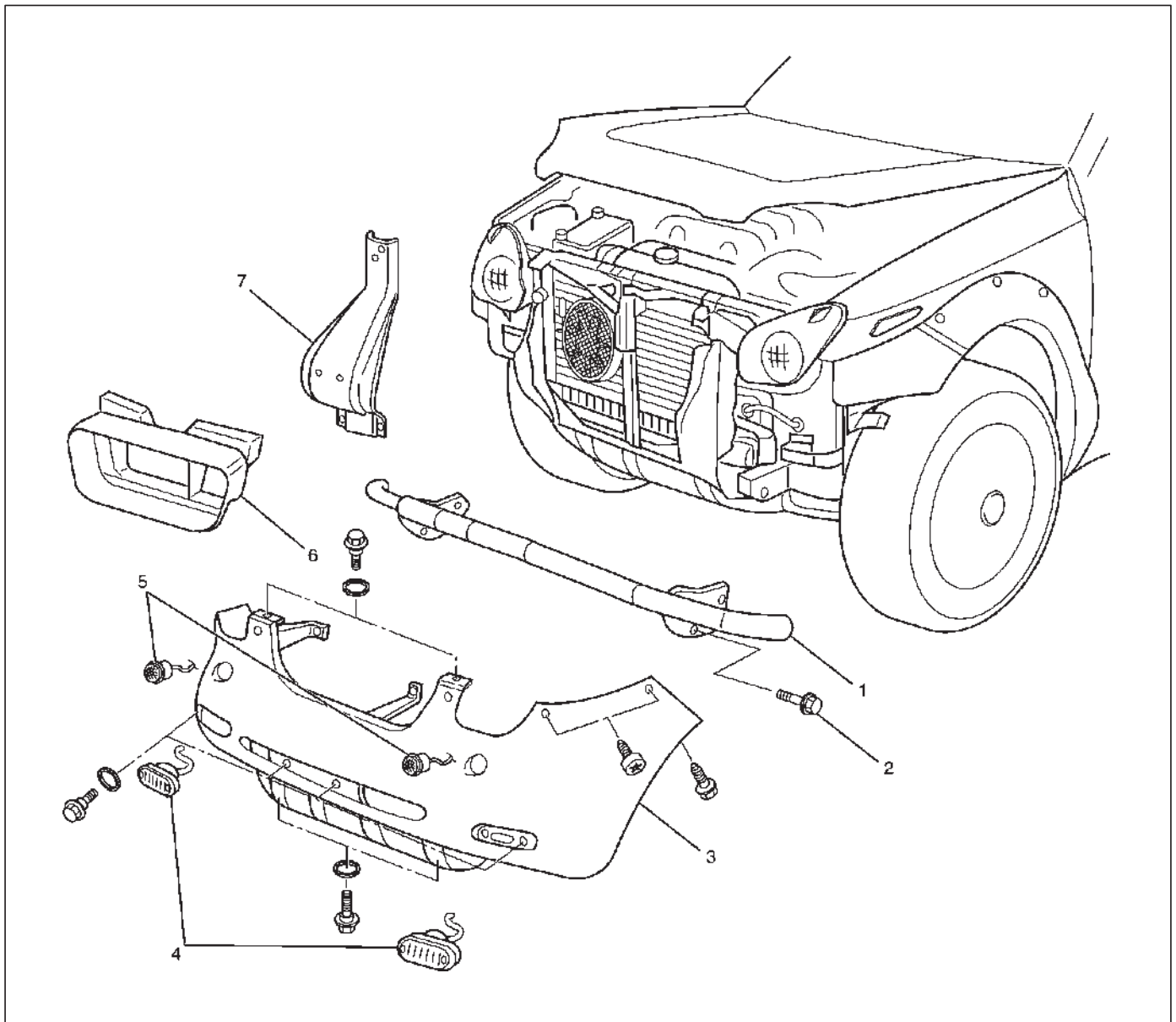
Proper frame alignment is important to assure normal vehicle life and performance of many other parts of the vehicle. If the vehicle has been involved in a fire, collision or has been overloaded, it is necessary to check the frame alignment.

Frame Dimensions



## Front Bumper

### Parts Location



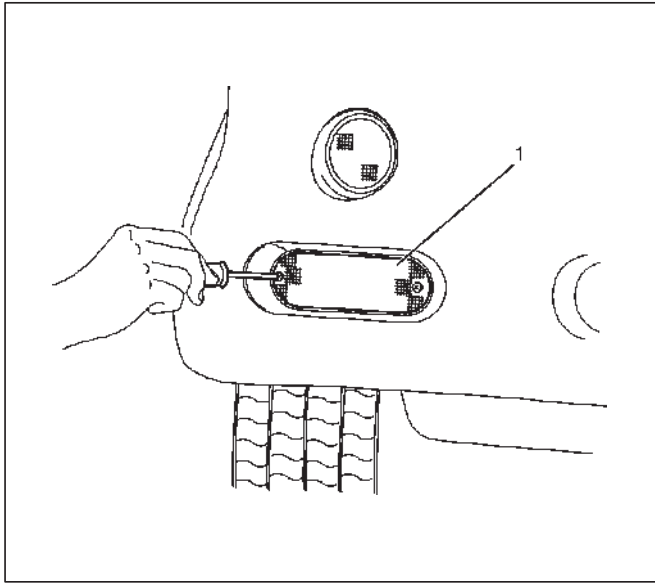
601RX002

#### Legend

- |                                   |                                       |
|-----------------------------------|---------------------------------------|
| (1) Front Bumper Beam             | (4) Front Turn Signal Light           |
| (2) Front Bumper Beam Fixing Bolt | (5) Parking Light                     |
| (3) Front Bumper Assembly         | (6) Radiator Grille                   |
|                                   | (7) Front Bumper Lower Center Support |

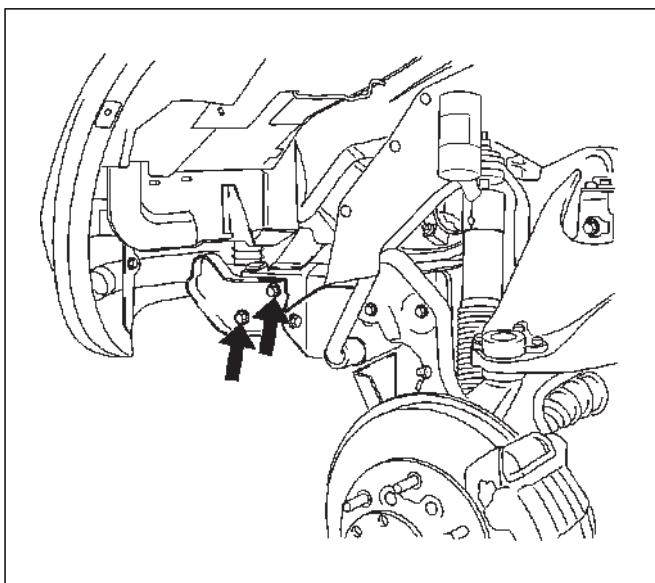
## Removal

1. Disconnect the battery ground cable.
2. Remove the radiator grille.
  - Refer to Radiator Grille in this section.
3. Remove the front turn signal light (1).
  - Remove the two screws and disconnect the front turn signal light connector (RH & LH).



825RX019

4. Remove the front bumper assembly.
  - Remove the eight bolts and six screws.
5. Remove the parking light.
  - Disconnect the parking light connector.
  - Turn the parking light assembly clockwise from the back side of front bumper and push it out.
6. Remove the bumper lower center support.
  - Remove the four bolts.
7. Remove the front bumper beam.
  - Remove the two bolts from each side.



601RX003

## Installation

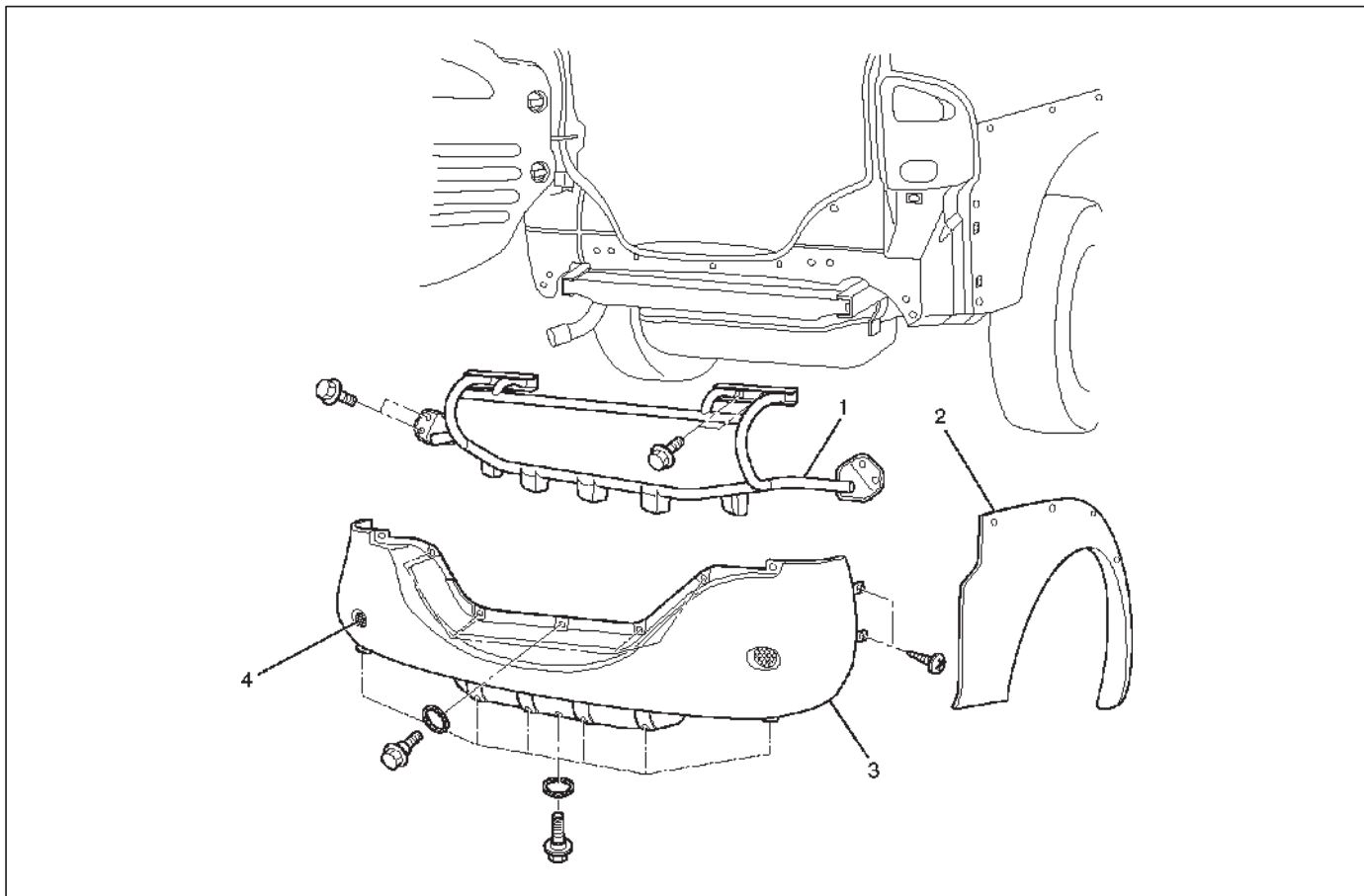
To install, follow the removal steps in the reverse order noting the following points:

1. Tighten the bumper beam bolts to the specified torque.

**Torque: 118 N·m (87 lb ft)**

## Rear Bumper

### Parts Location



690RX001

#### Legend

- |                            |                          |
|----------------------------|--------------------------|
| (1) Rear Bumper Support    | (3) Rear Bumper Assembly |
| (2) Rear Quarter Protector | (4) Rear Reflector       |

### Removal

1. Disconnect the battery ground cable.
2. Remove the rear quarter protector.
  - Refer to body side Protectors in Exterior/Interior Trim section.
3. Remove the rear bumper assembly.
  - Remove the twelve fixing bolts and four screws.
4. Remove the rear reflector.
5. Remove the rear bumper support.
  - Remove the eight fixing bolts.

### Installation

To install, follow the removal steps in the reverse order, noting the following points.

1. Use a new double-sided adhesive tape whenever installing the rear fender protector. Using a white gasoline, clean the places in advance where a double-sided adhesive tape is affixed.
2. To tear the remaining old double-sided adhesive tape off, use 3M (\*) or equivalent.

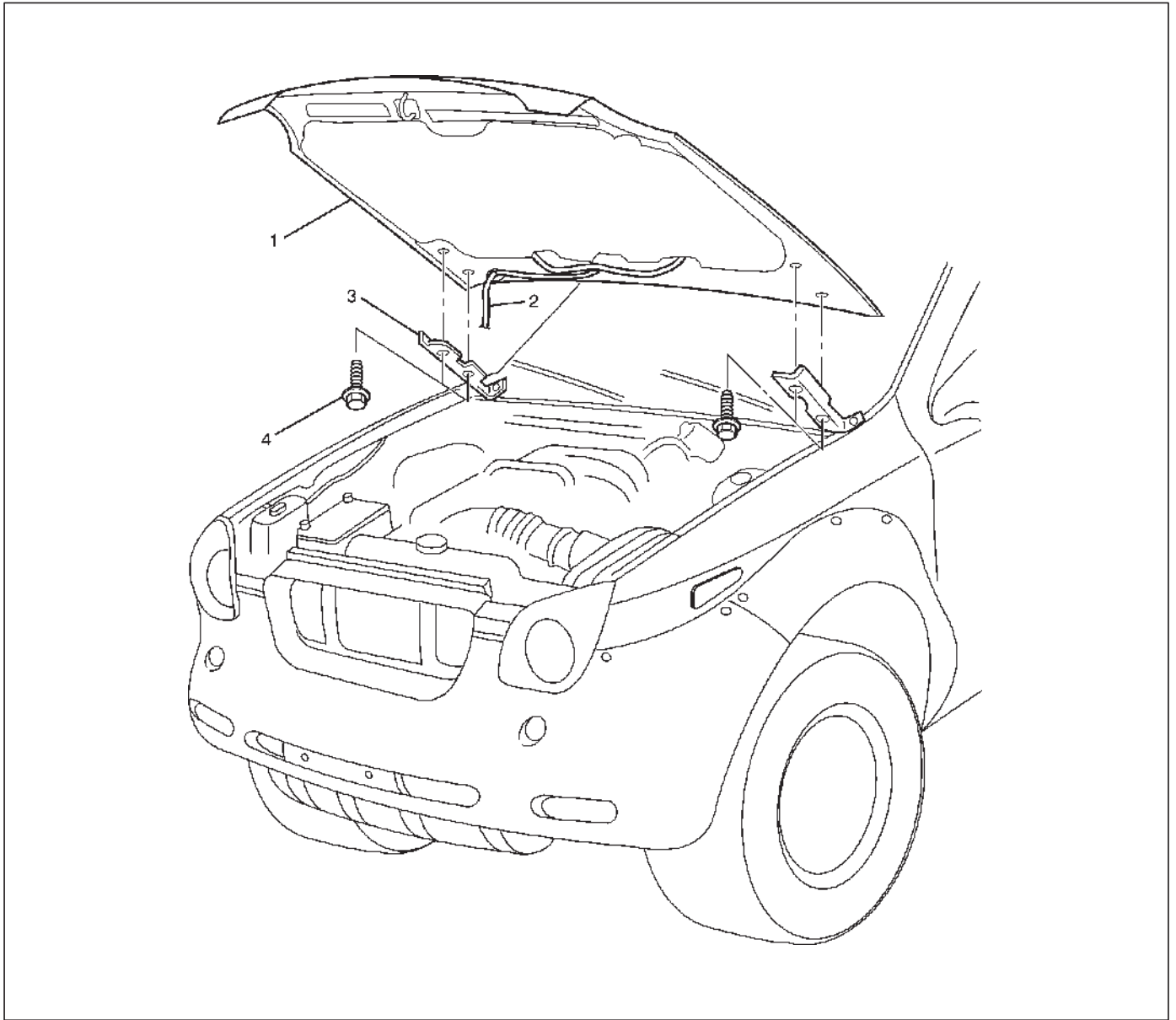
\* SCOTCH-BRITE MOLDING ADHESIVE AND STRIPE REMOVAL DISK.

#07501 (4inch)

#07502 (6inch)

## Engine Hood

### Parts Location



610RX002

### Legend

- |                                   |                |
|-----------------------------------|----------------|
| (1) Engine Hood                   | (3) Hood Hinge |
| (2) Windshield Washer Nozzle Tube | (4) Hinge Bolt |

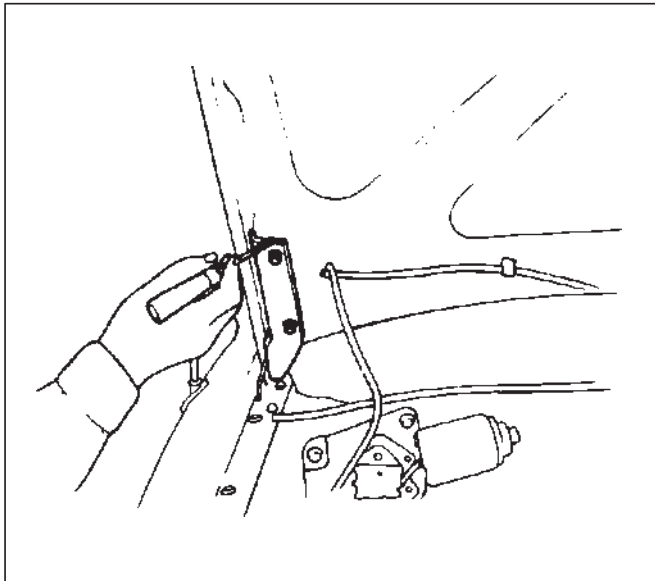
### Removal

1. Open and support the engine hood.
2. Disconnect the battery ground cable.
3. Disconnect the washer nozzle tube.

## 8F-8 BODY STRUCTURE

4. Remove the four hood hinge fixing bolts.

- Before removing the hinges from the engine hood, scribe a mark of a hinges to facilitate installation in the original position.



610RS006

5. Remove the engine hood.

### Installation

To install, follow the removal steps in the reverse order, noting the following points.

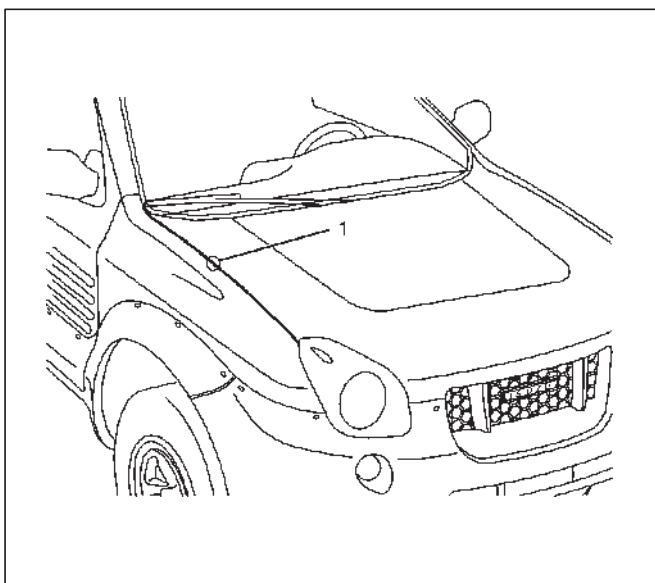
1. Tighten the engine hood fixing bolts to the specified torque.

**Torque: 15 N·m (11 lb ft)**

2. Check the engine hood and fender (1).

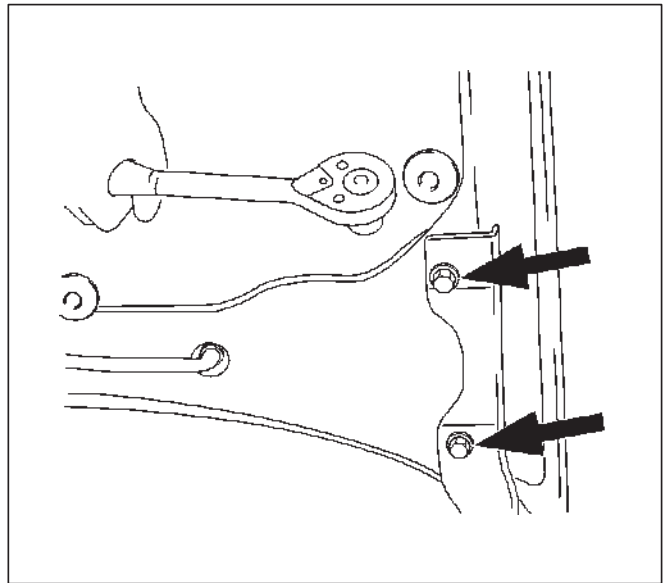
**Clearance: 4.2mm (0.165 in)**

**Height: Flush**



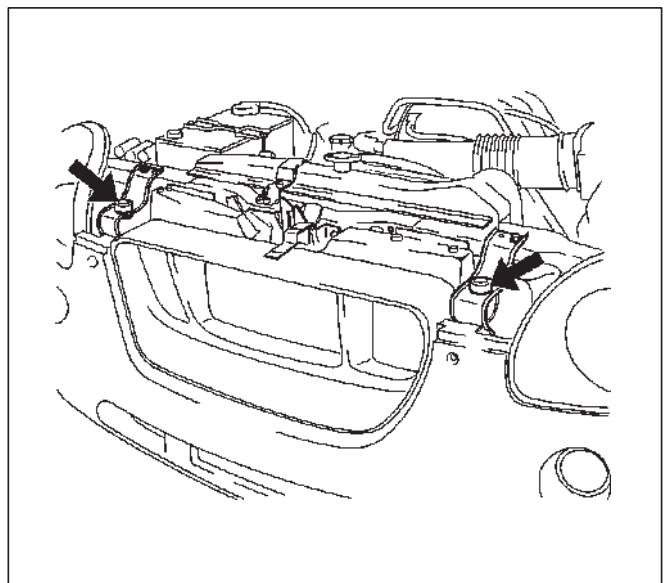
610RX003

- Adjust clearance with the hinges on the engine hood.



610RX004

- Adjust the height (step) with the hood rests.

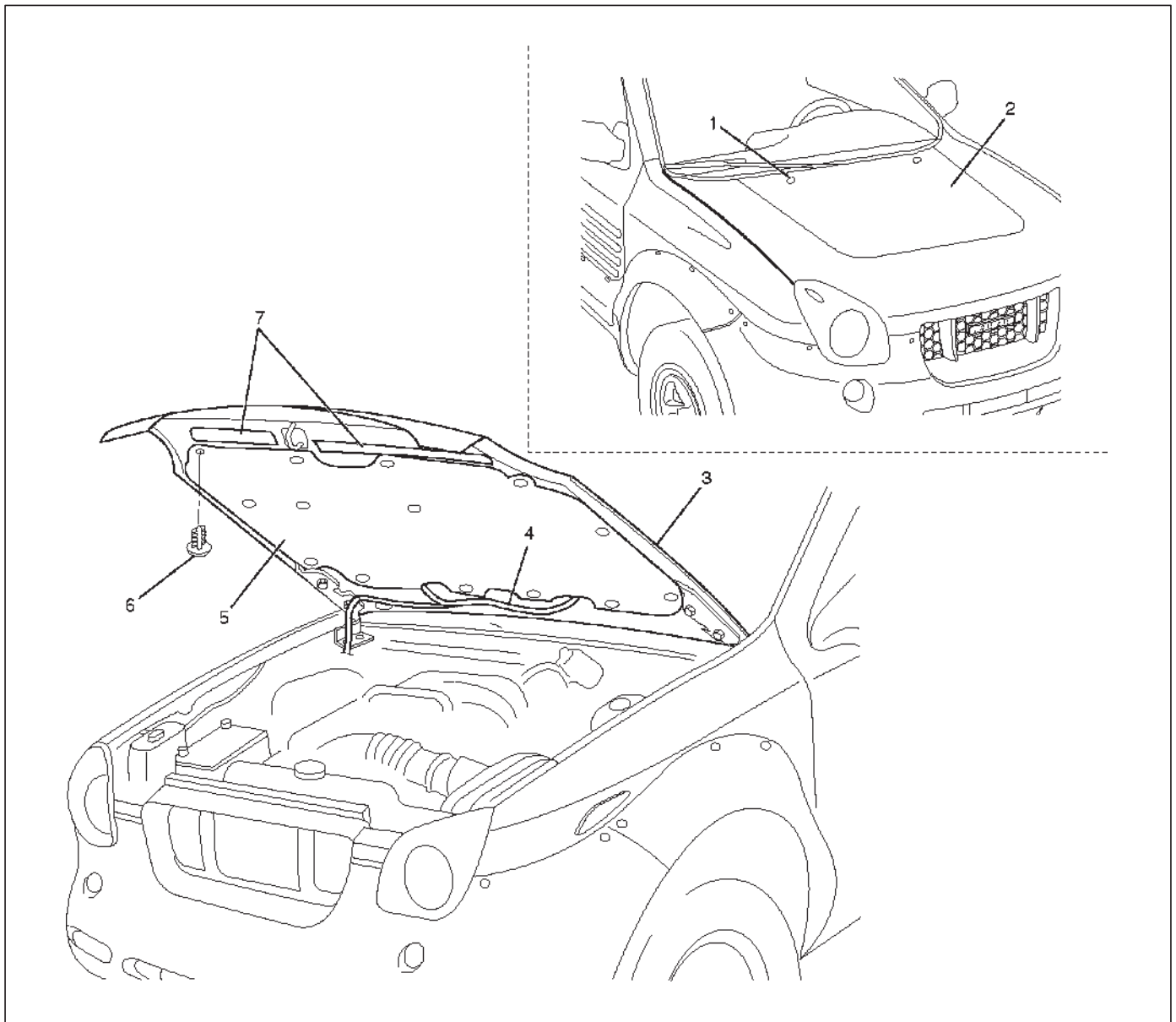


610RX005



## Engine Hood Cover

### Parts Location



610RX011

#### Legend

- |                                |                            |
|--------------------------------|----------------------------|
| (1) Washer Nozzle              | (4) Washer Nozzle Tube     |
| (2) Engine Hood Cover Assembly | (5) Engine Hood Insulation |
| (3) Engine Hood                | (6) Clip                   |
|                                | (7) Platform Seal          |

### Removal

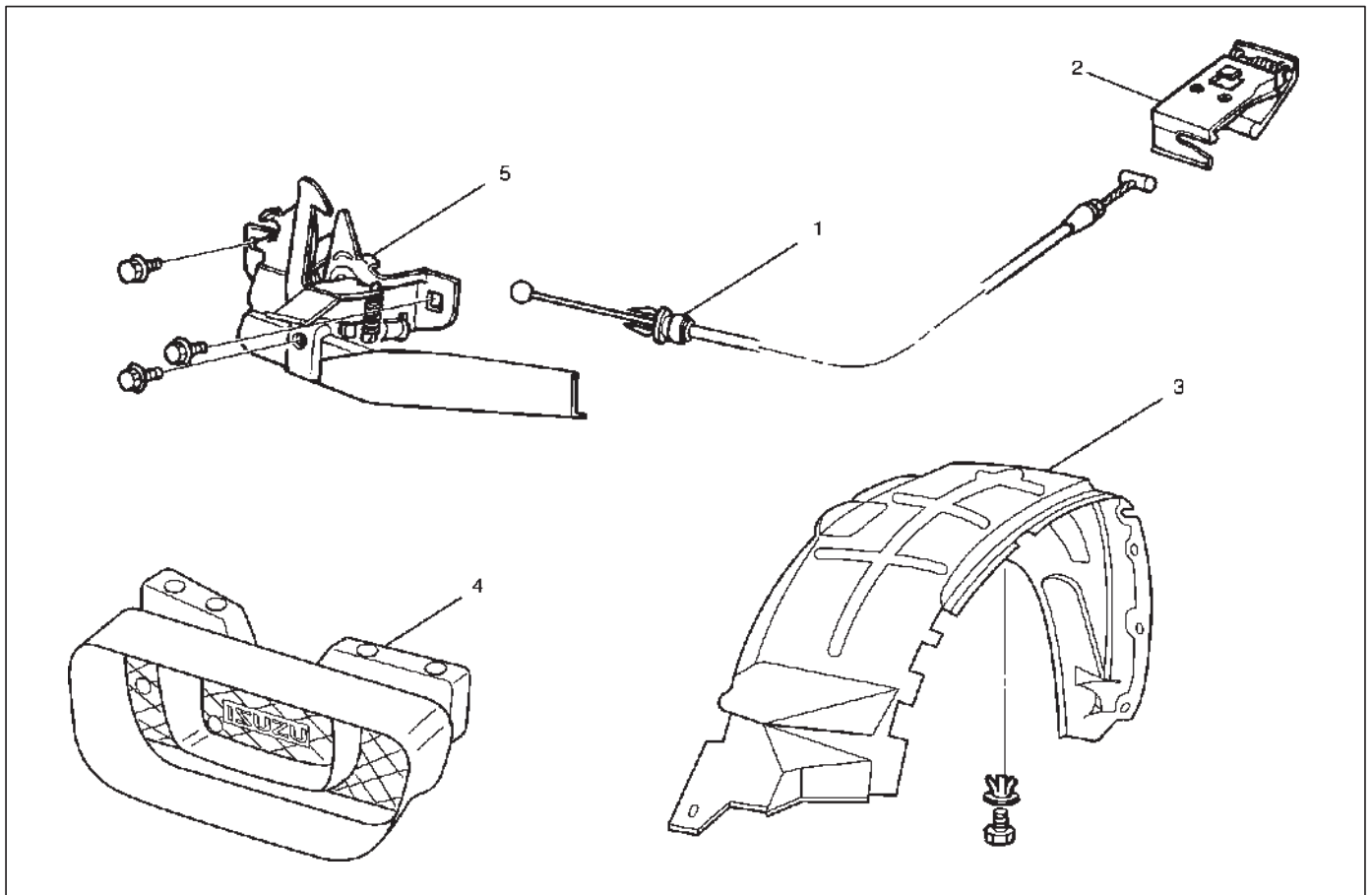
1. Open the hood.
2. Support the hood.
3. Disconnect the battery ground cable.
4. Remove the engine hood insulation.
  - Pull out the fourteen clips.
5. Disconnect the washer nozzle tubes and pull out the clips.
6. Remove the two washer nozzles.
  - Remove the two nuts.
7. Remove the engine hood cover assembly.
  - Remove the twelve nuts.

### Installation

To install, follow the removal steps in reverse order.

## Engine Hood Lock

### Parts Location



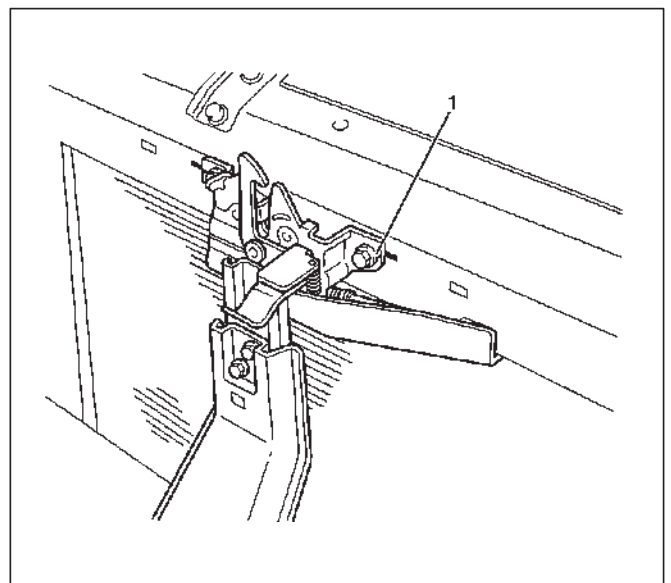
610RX006

### Legend

- |                             |                               |
|-----------------------------|-------------------------------|
| (1) Control Cable           | (3) Inner Liner               |
| (2) Hood Lock Control Lever | (4) Radiator Grille           |
|                             | (5) Engine Hood Lock Assembly |

### Removal

1. Remove hood lock control lever.
2. Remove inner liner.
3. Remove control cable.
  - Remove the cable fixing clips from the body panel.
4. Remove radiator grille.
  - Refer to Radiator Grille in this section.
5. Remove engine hood lock assembly.
  - Apply setting marks (1) to the hood lock assembly and the body prior to removal.



610RX007

## Installation

To install, follow the removal steps in reverse order noting the following points:

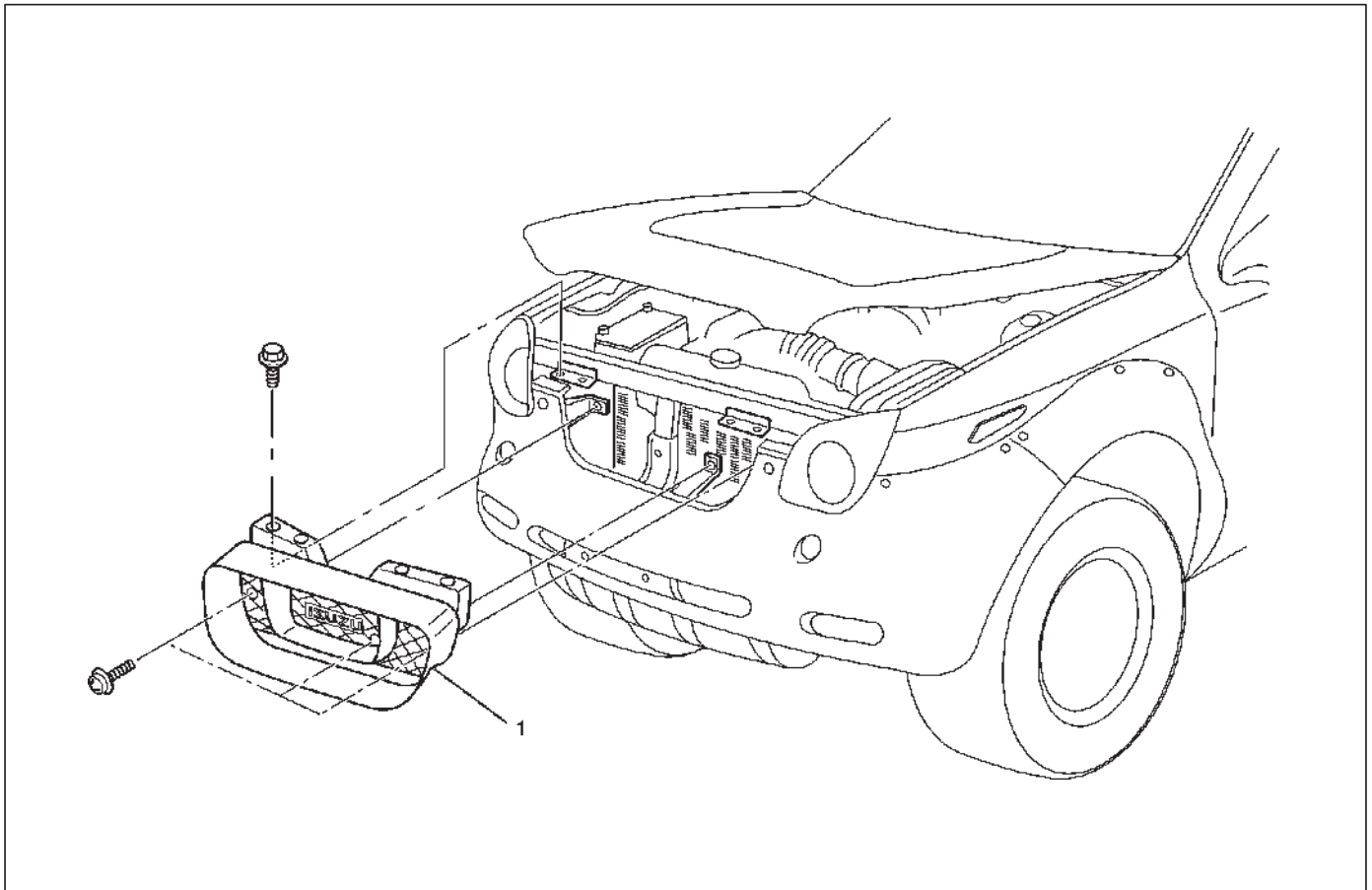
1. Reroute the control cable to its original position, and check and see if the lock assembly and control lever work normally.

2. Tighten the hood lock assembly fixing bolts to the specified torque.

**Torque 10 N·m (87 lb in)**

## Radiator Grille

### Parts Location



603RX002

### Legend

- (1) Radiator Grille

## Removal

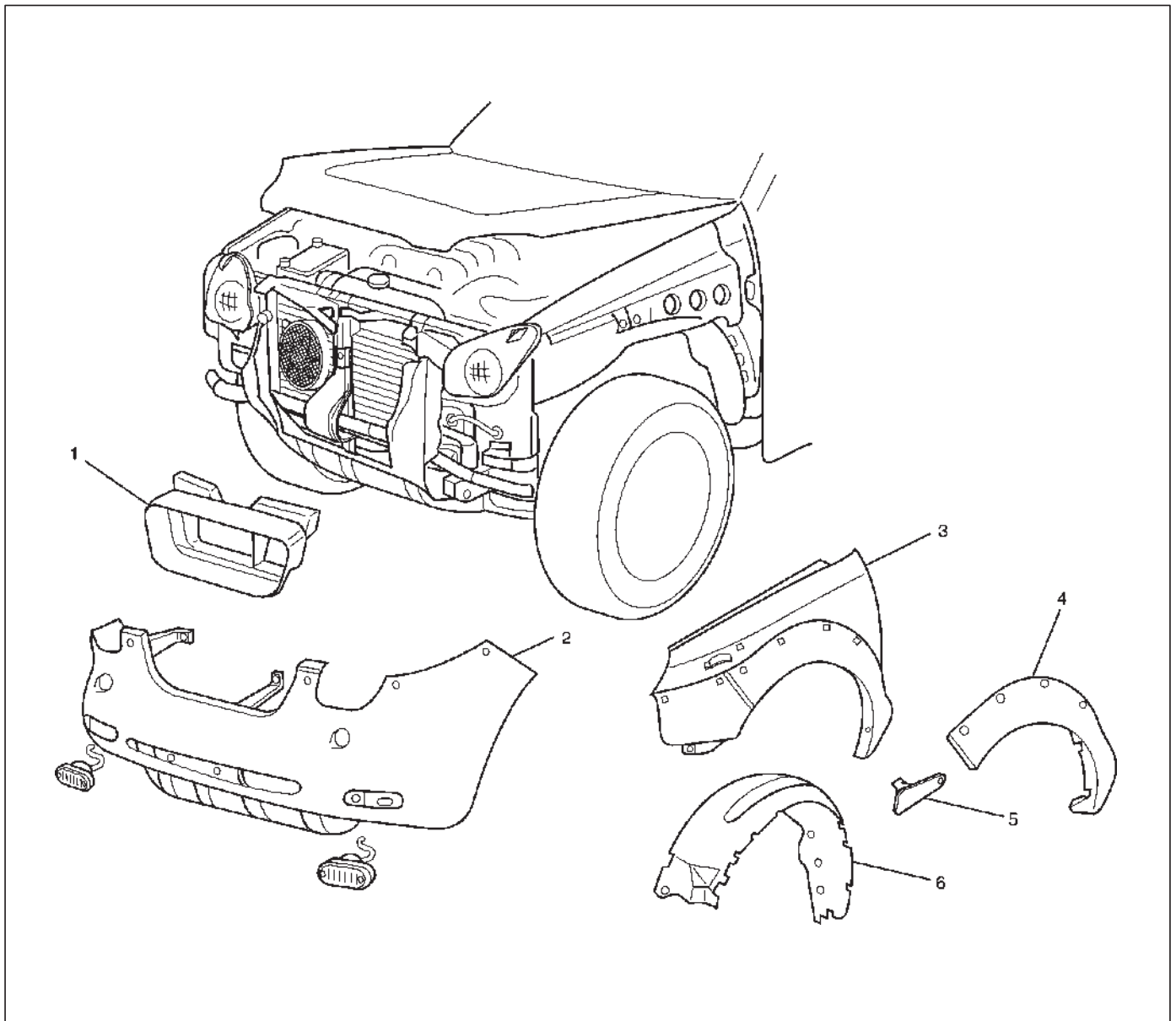
1. Open and support the engine hood.
2. Disconnect the battery ground cable.
3. Remove the radiator grille.
  - Remove the four fixing bolts and three fixing screws.

## Installation

To install, follow the removal steps in reverse order.

## Front Fender Panel

### Parts Location



614RX003

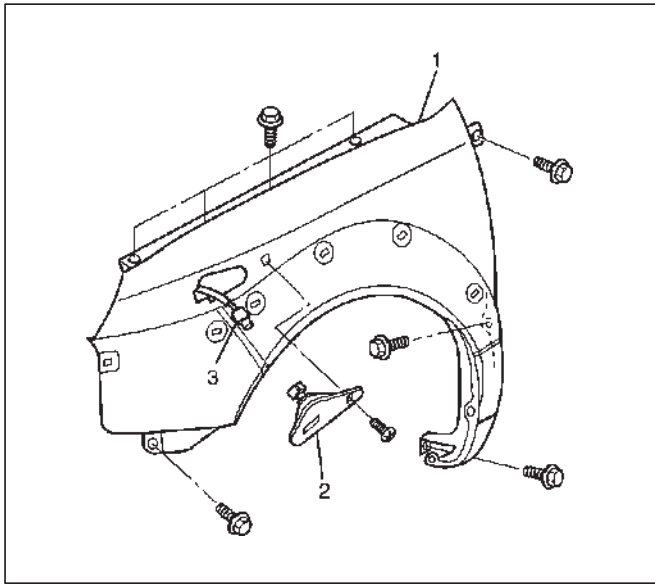
#### Legend

- |                           |                             |
|---------------------------|-----------------------------|
| (1) Radiator Grille       | (4) Front Fender Protector  |
| (2) Front Bumper Assembly | (5) Front Side Marker Light |
| (3) Front Fender Panel    | (6) Inner Liner             |

### Removal

1. Open and support the engine hood.
2. Disconnect the battery ground cable.
3. Remove the radiator grille.
  - Refer to Radiator Grille in this section.
4. Remove the front bumper assembly.
  - Refer to Front Bumper in this section.
5. Remove the inner liner.
6. Remove front fender protector.
  - Refer to Body Side Protectors in Exterior/Interior Trim section.
7. Remove the front side marker light (2).
  - Remove the screw and disconnect the connector (3).

8. Remove the front fender panel (1).
  - Remove the eight fixing bolts.



614RX004

2. Use a new double-sided adhesive tape whenever installing the front fender protector. Using a white gasoline, clean the places in advance where a double-sided adhesive tape is affixed.
3. To tear the remaining old double-sided adhesive tape off, use 3M (\*) or equivalent.

\* SCOTCH-BRITE MOLDING ADHESIVE AND STRIPE REMOVAL DISK.

#07501 (4inch)

#07502 (6inch)

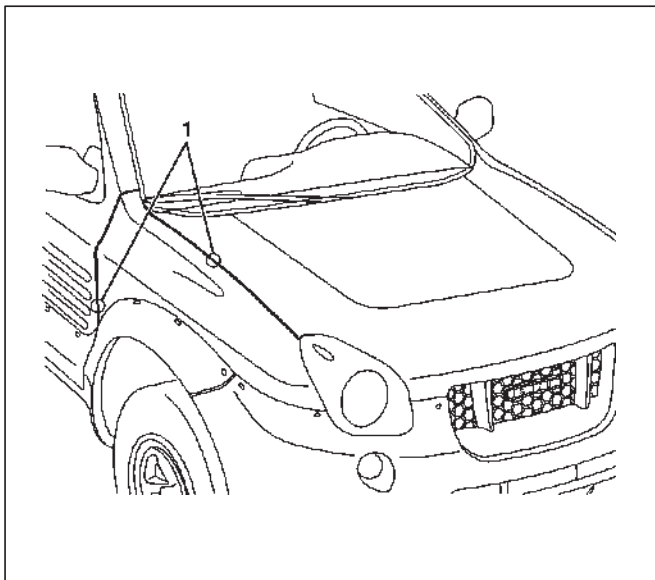
## Installation

To install, follow the removal steps in the reverse order noting the following points.

1. Check the engine hood and fender.

**Clearance: 4.2mm (0.165 in)**

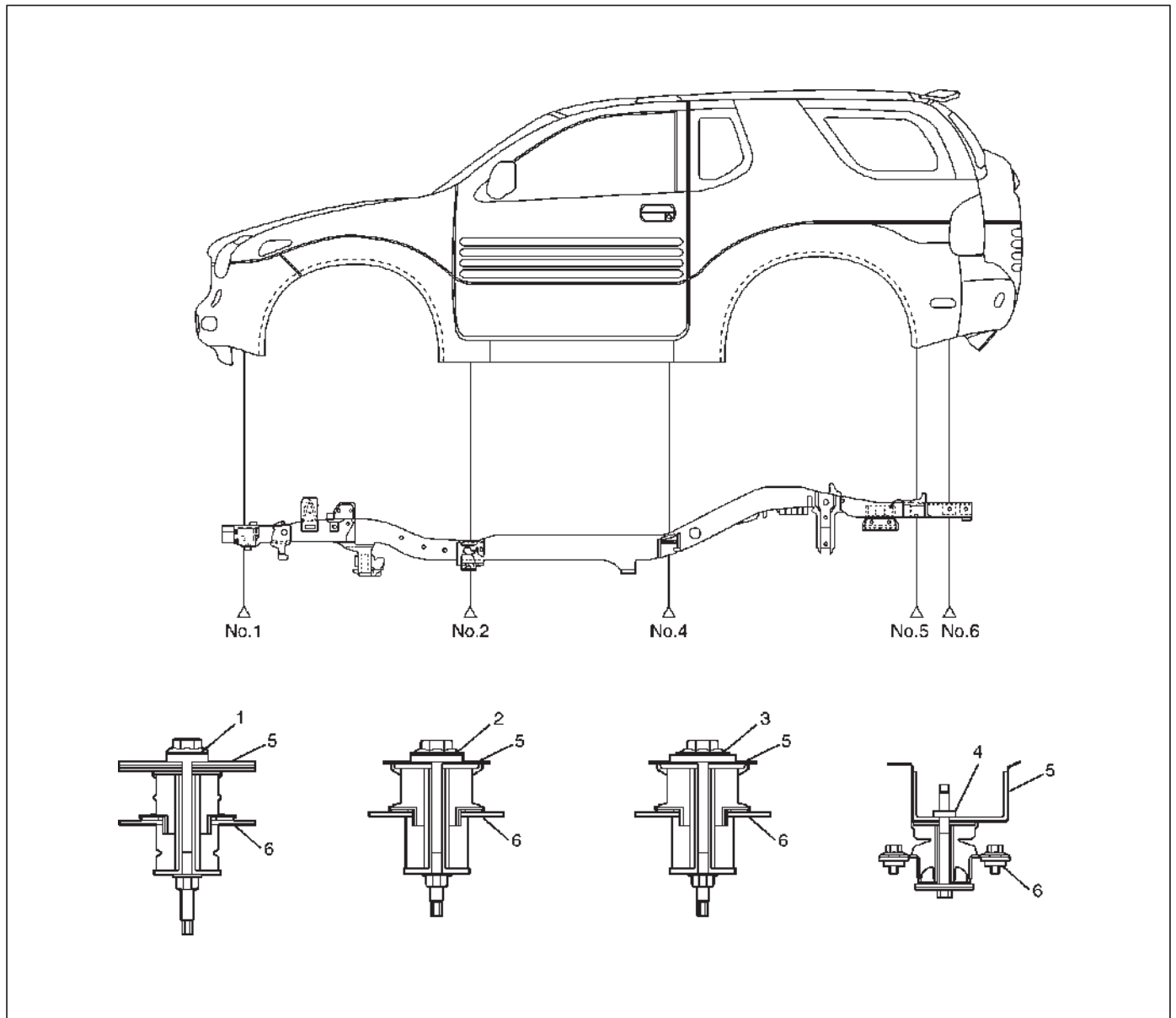
**Height: Flush**



614RX005

## Body Mounting

### Parts Location



510RX003

### Legend

- (1) No.1 Body Mounting
- (2) No.2 Body Mounting
- (3) No.4 Body Mounting

- (4) No.5 & 6 Body Mounting
- (5) Body Side Mounting Bracket
- (6) Frame Side Mounting Bracket

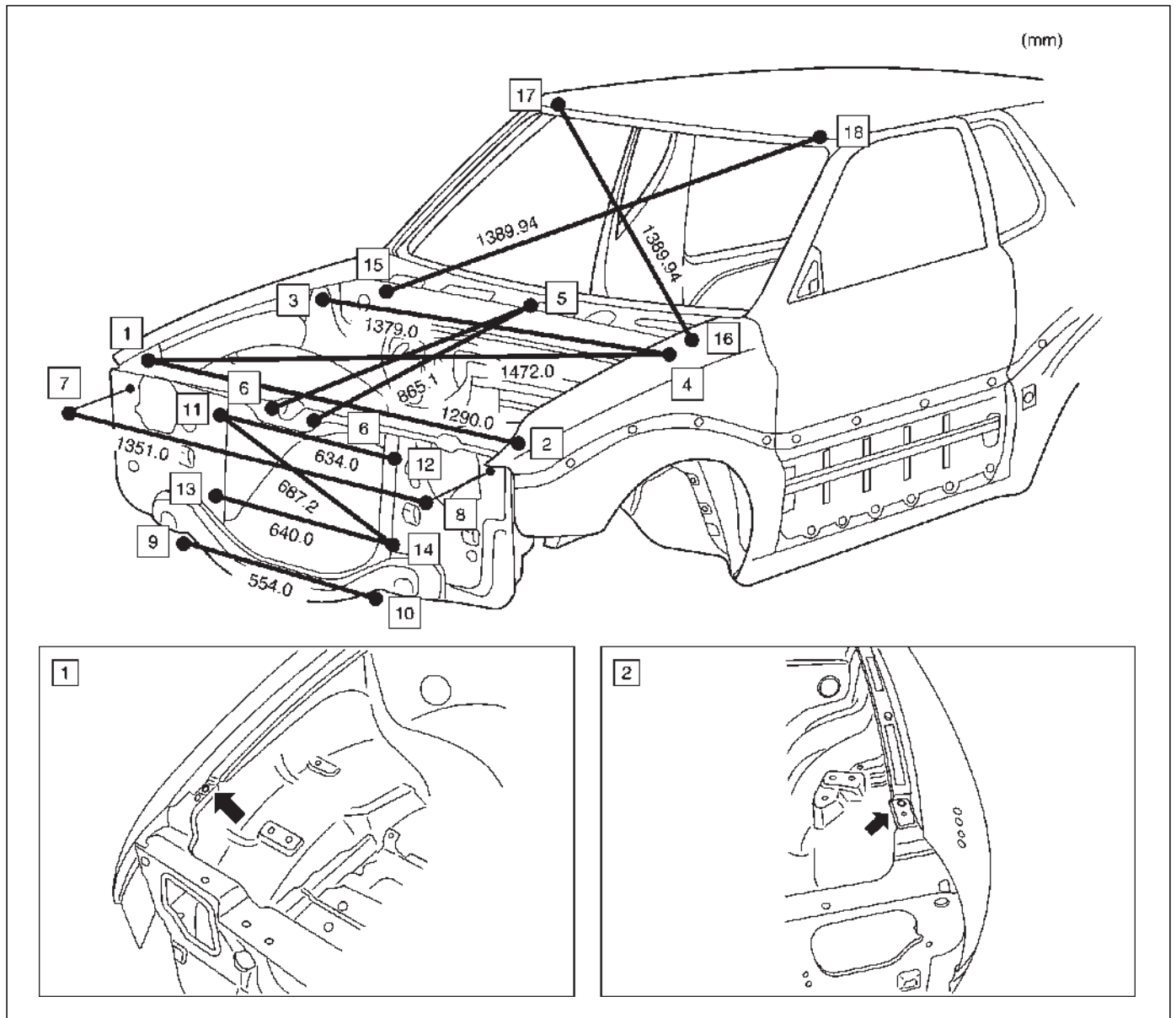
### Tightening Torque

1. Tighten the body mounting bolts to specified torque.

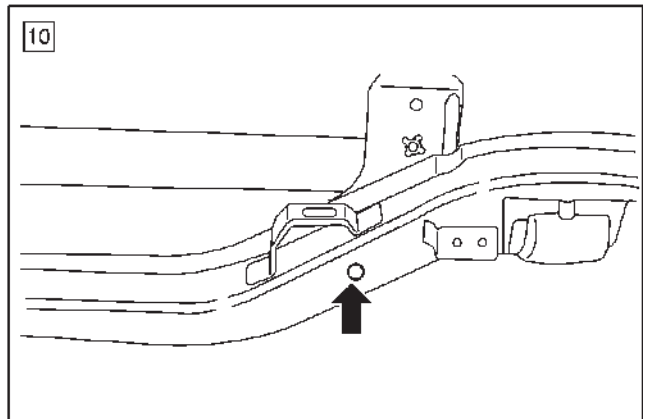
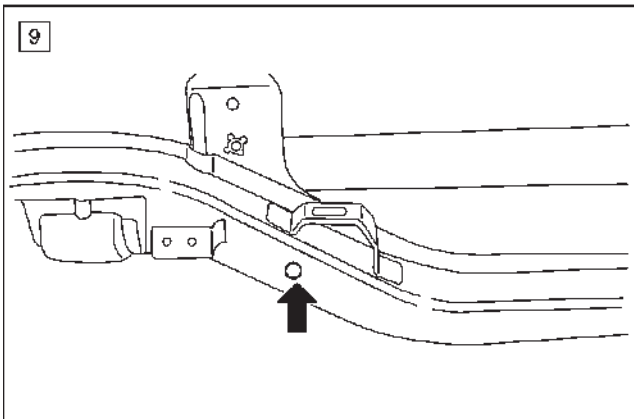
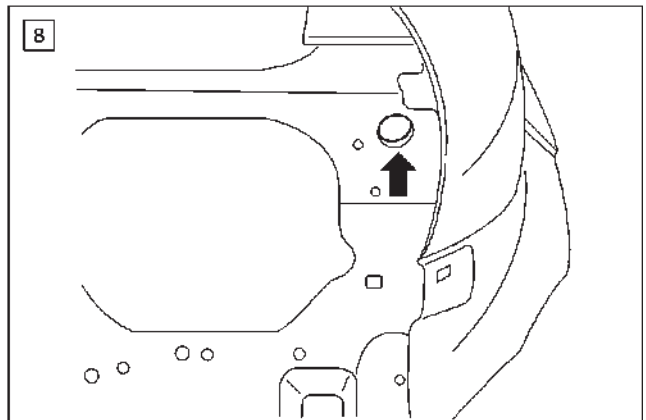
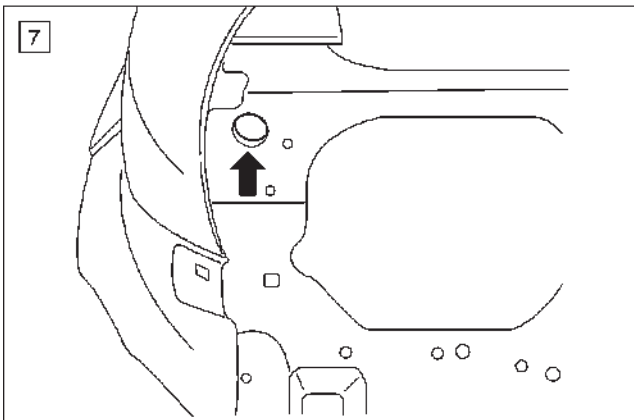
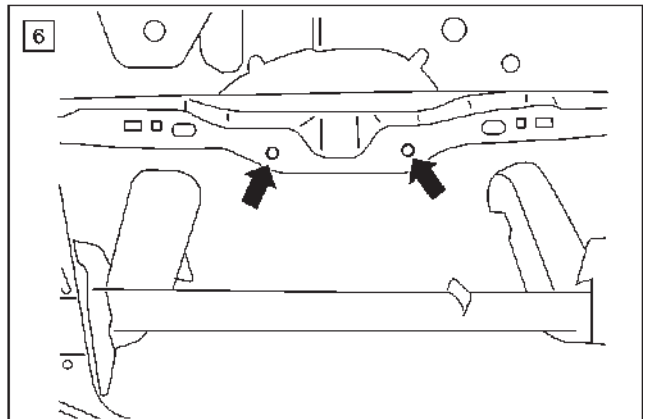
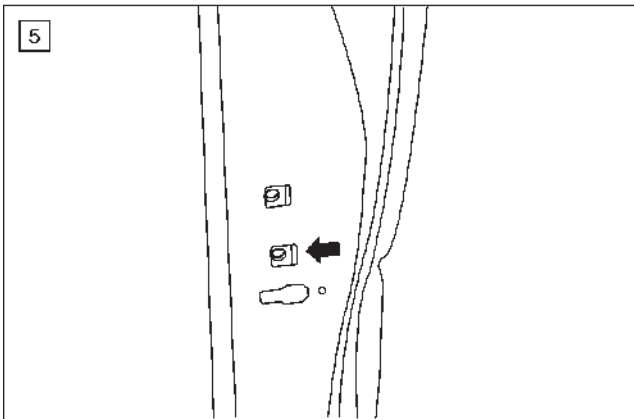
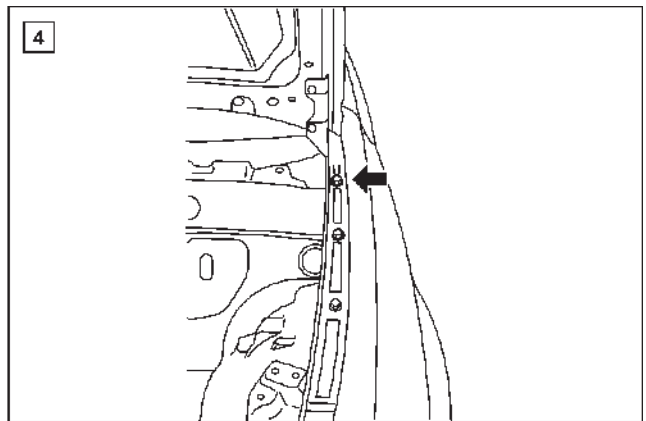
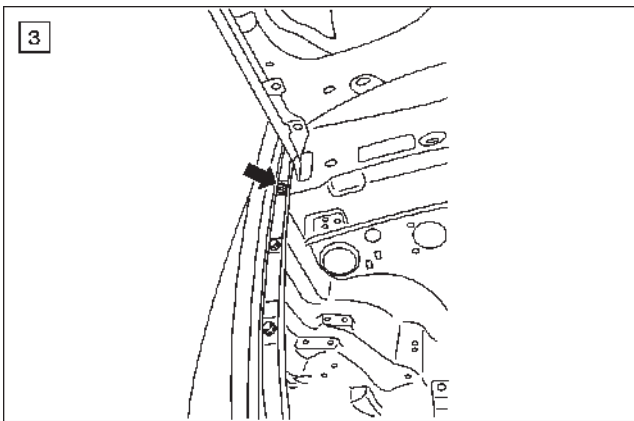
**Torque: 50 N·m (41 lb ft)**

# Body Dimension

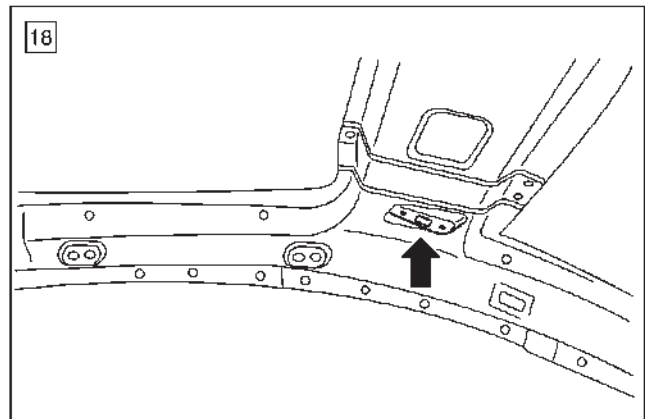
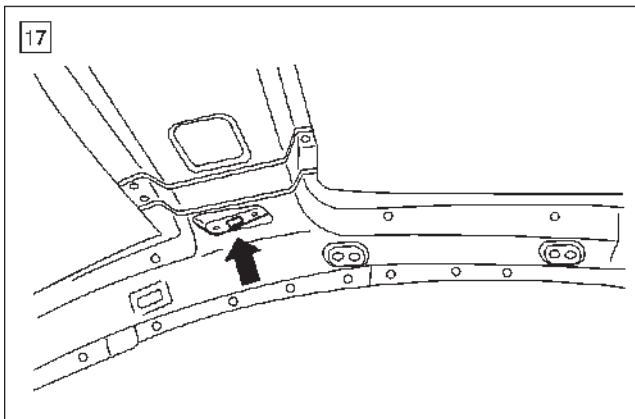
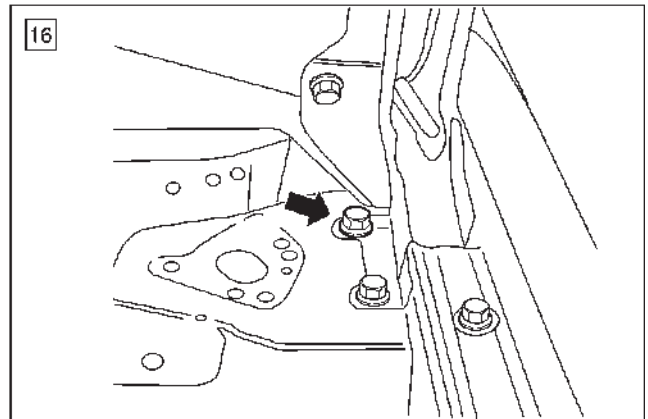
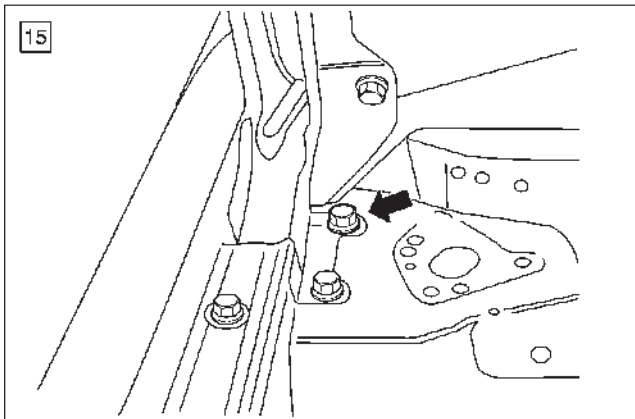
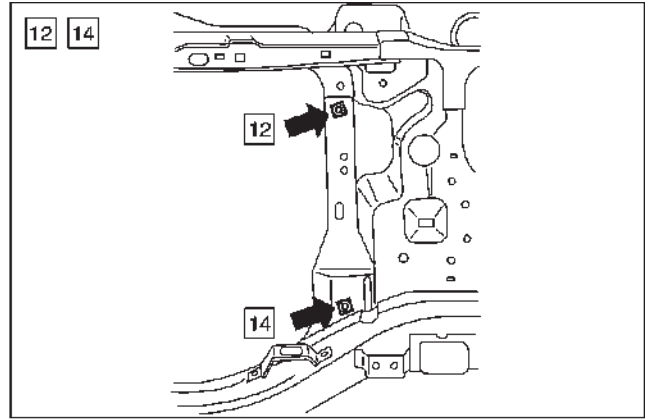
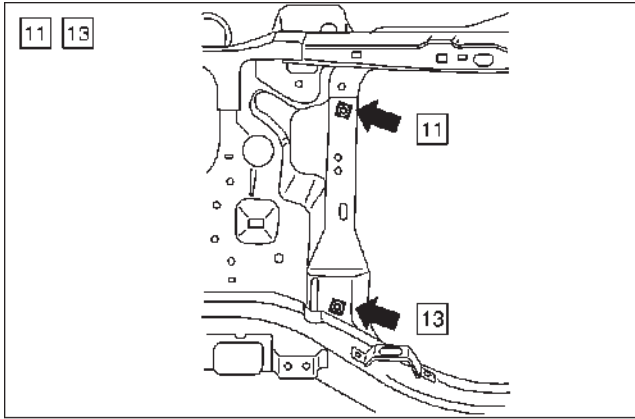
## Front Section



8F-16 BODY STRUCTURE

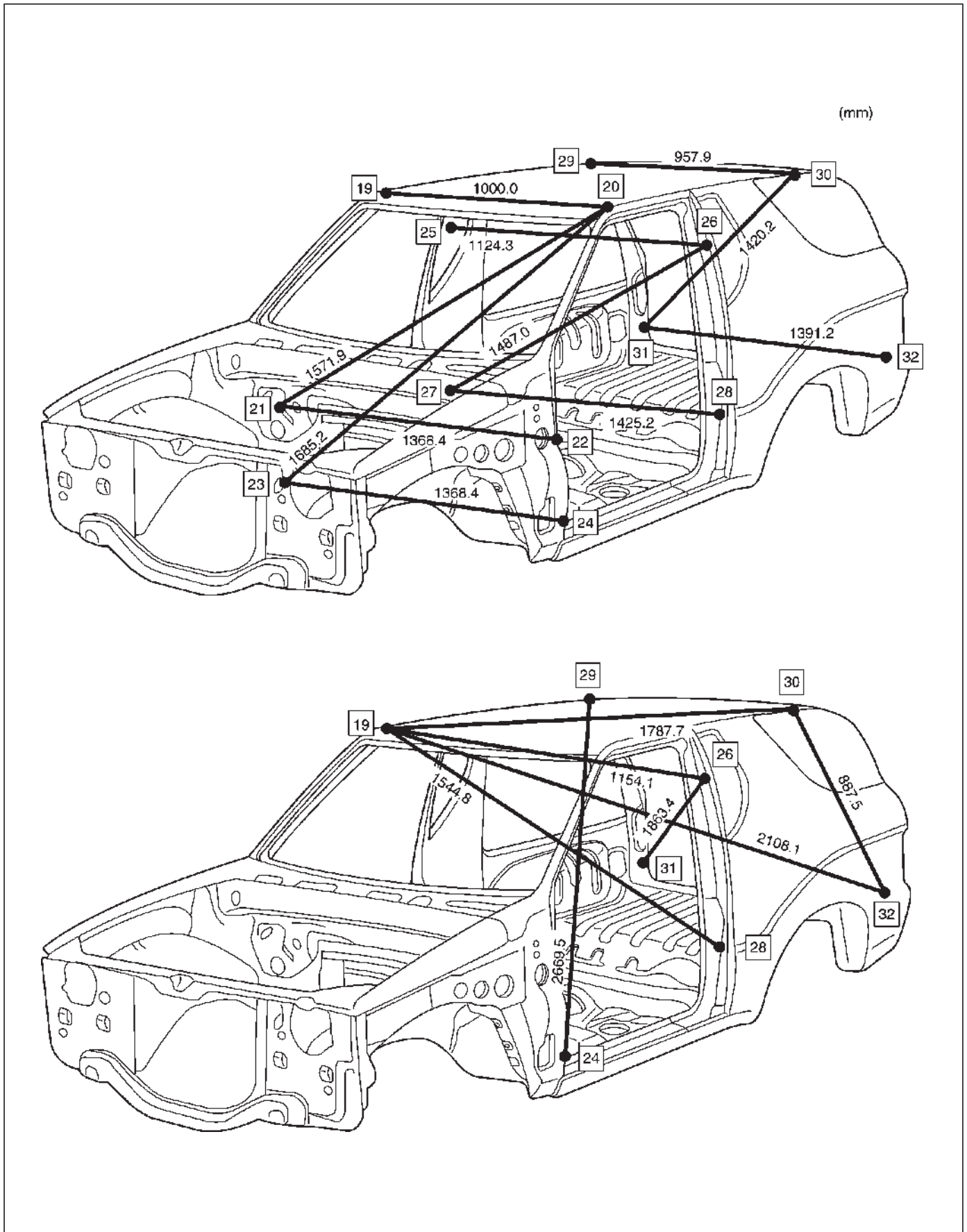


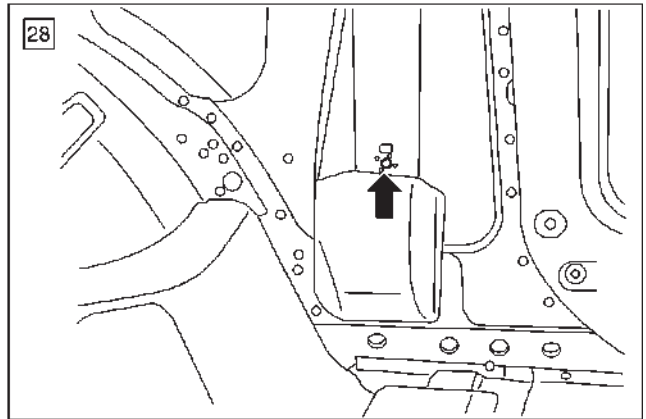
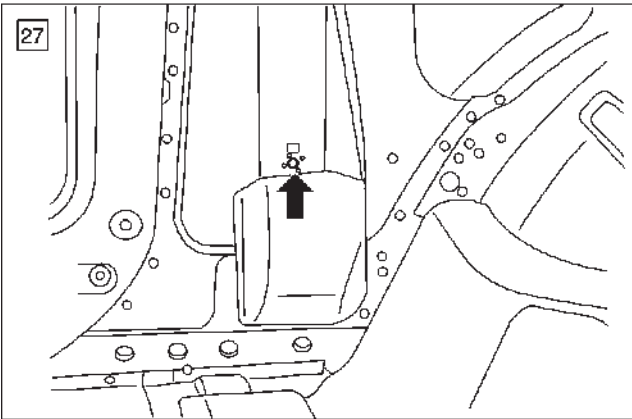
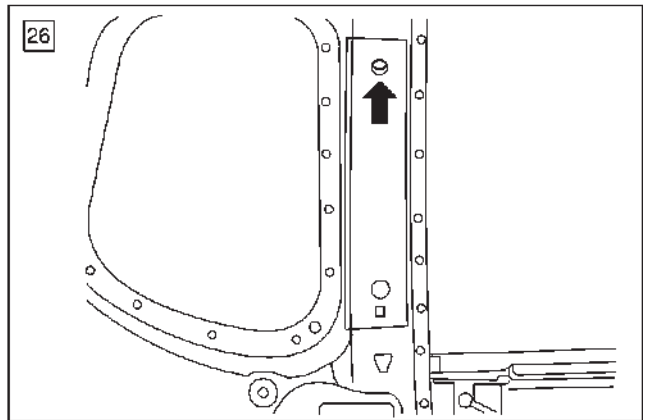
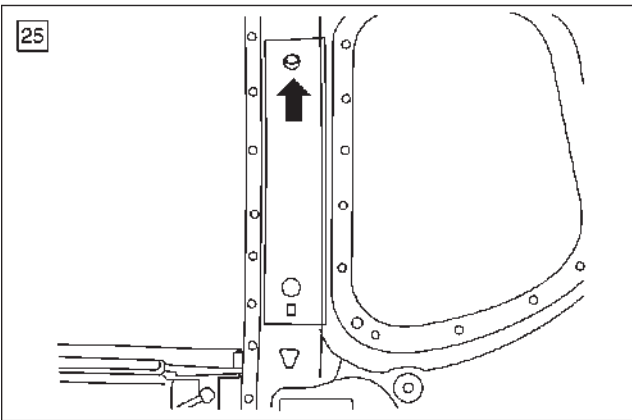
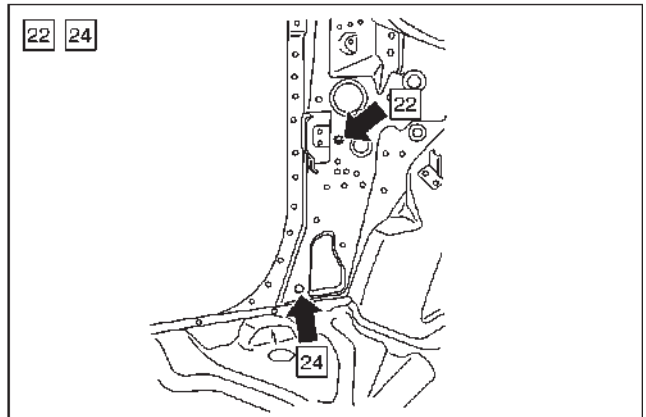
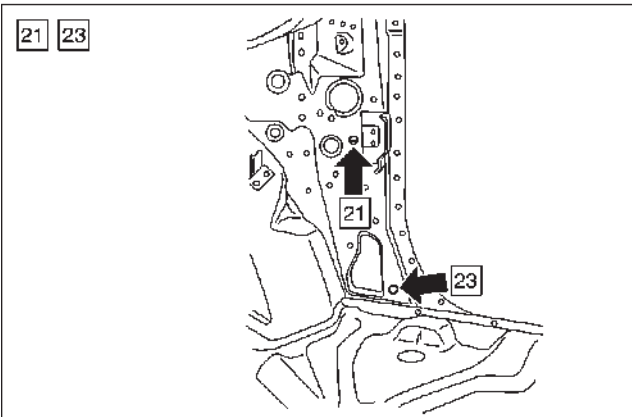
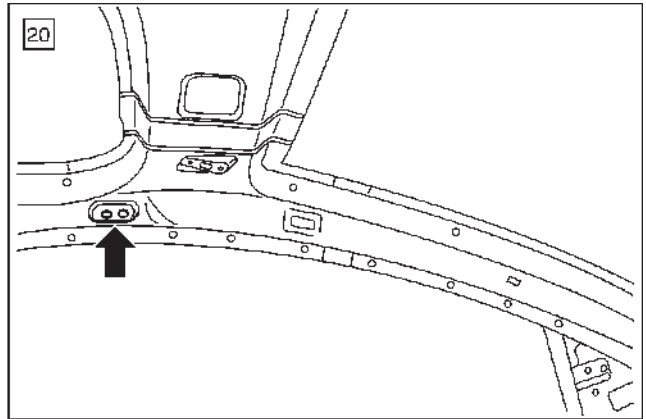
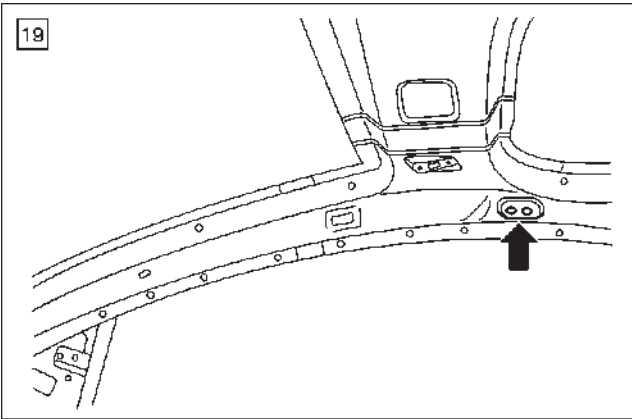




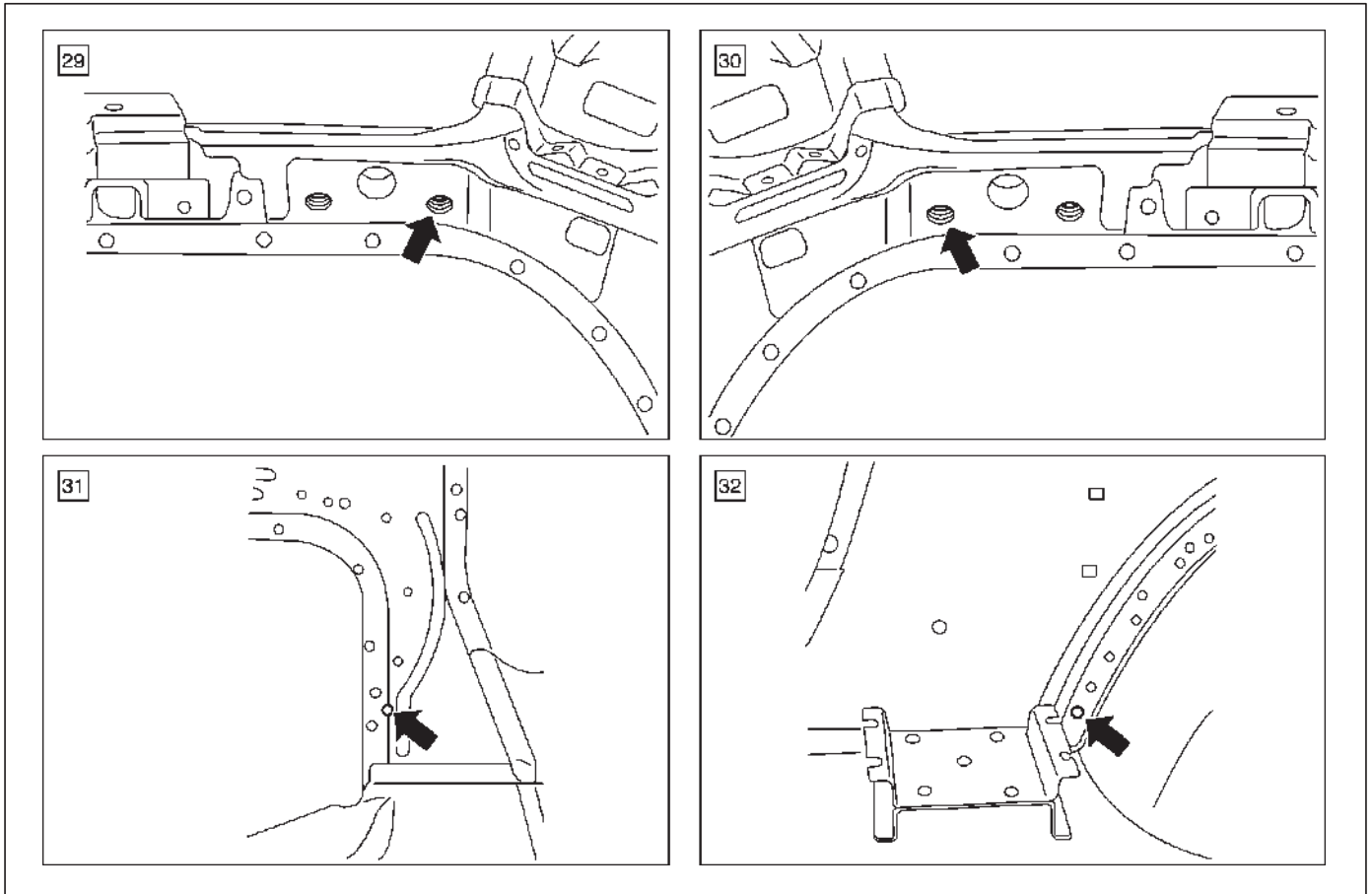
# 8F-18 BODY STRUCTURE

## Room Section

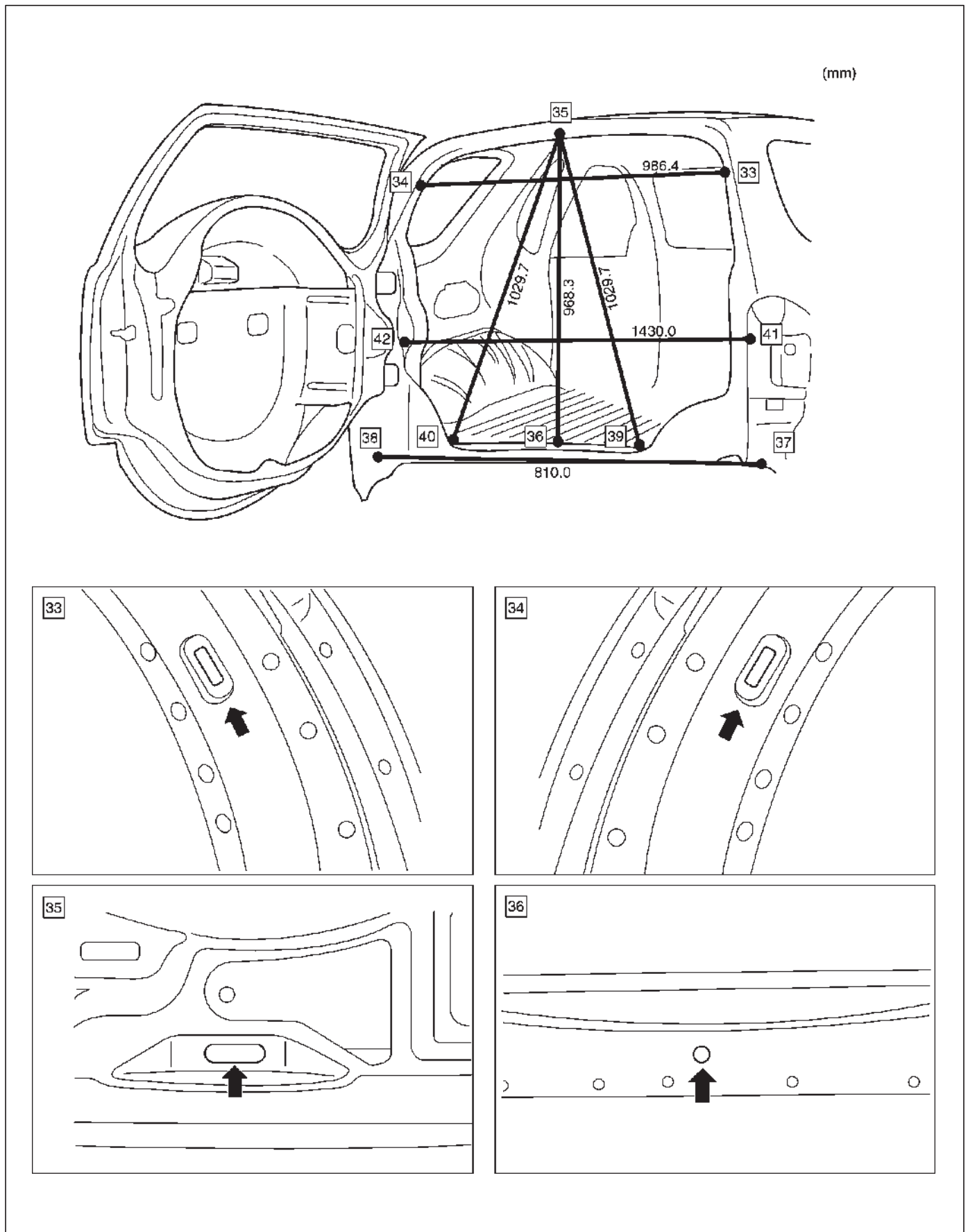




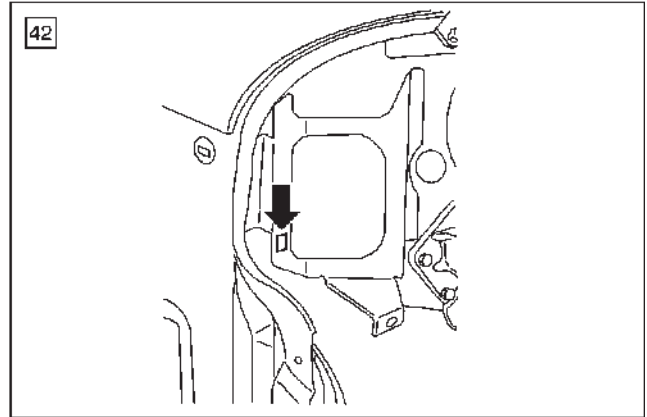
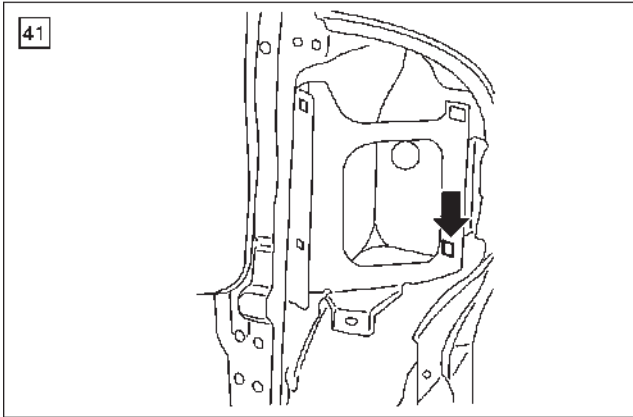
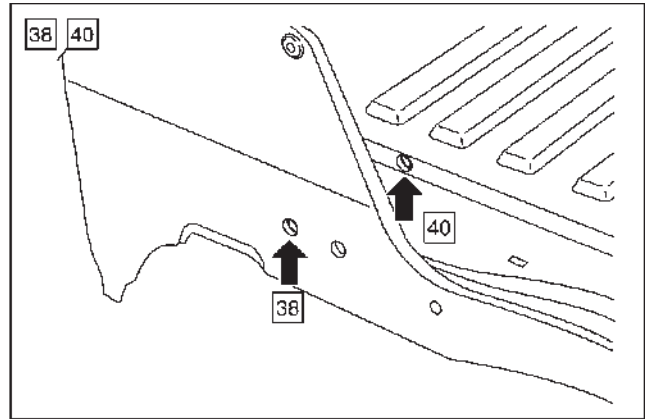
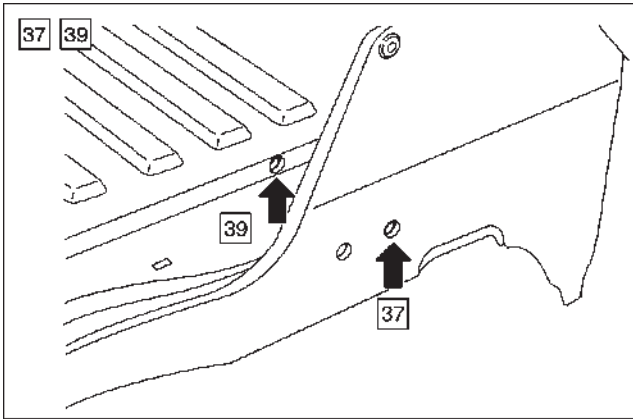
8F-20 BODY STRUCTURE



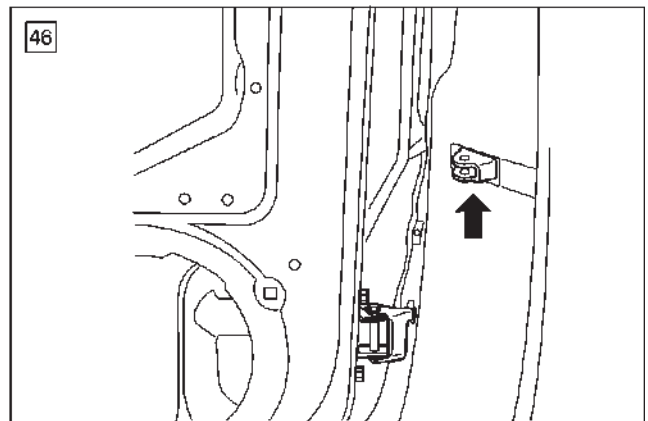
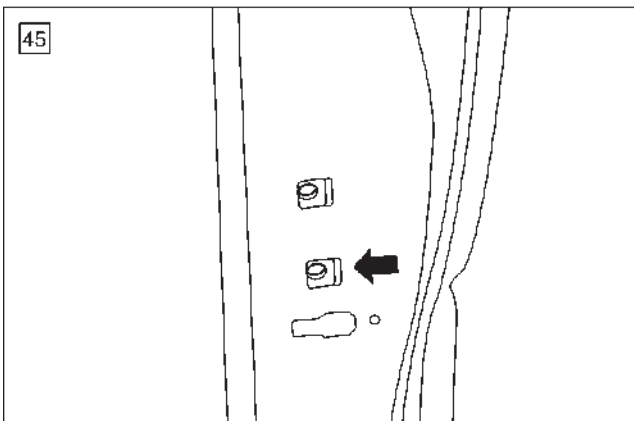
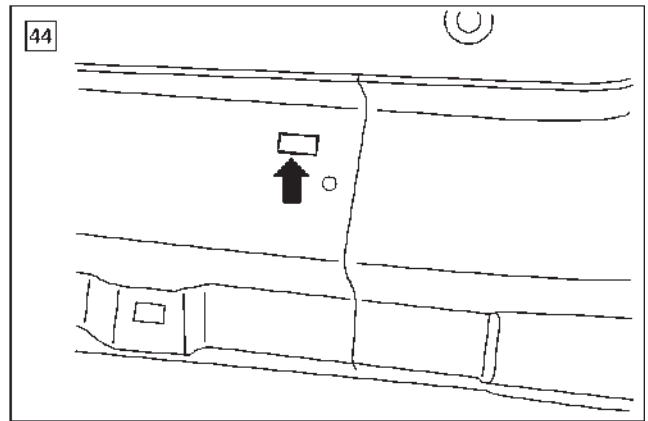
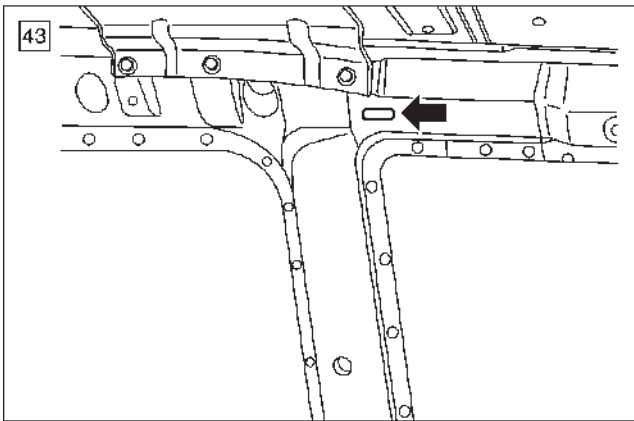
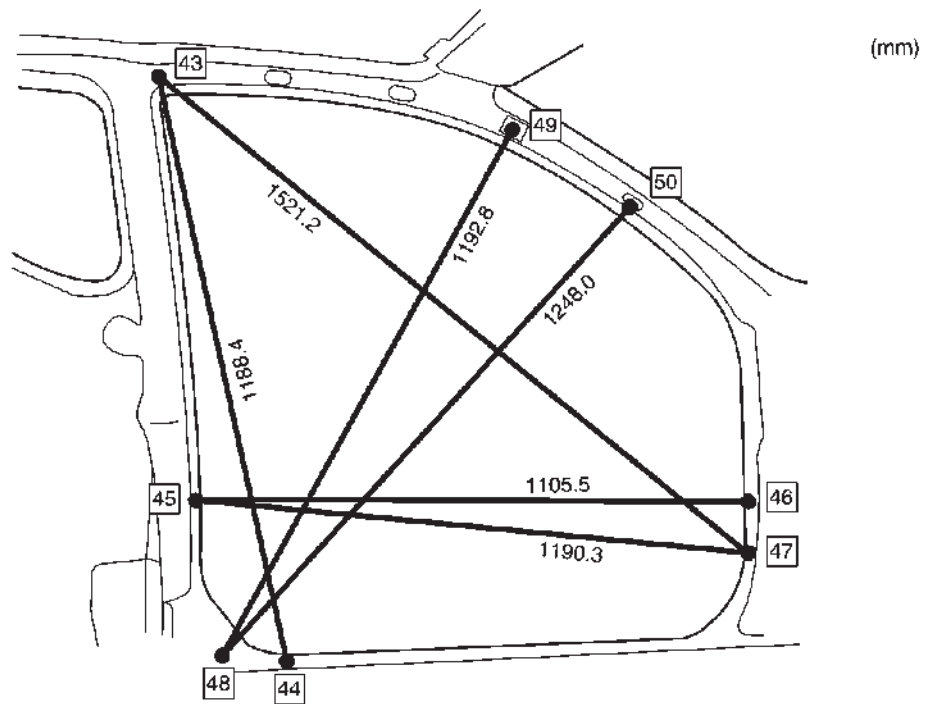
Rear Section



8F-22 BODY STRUCTURE

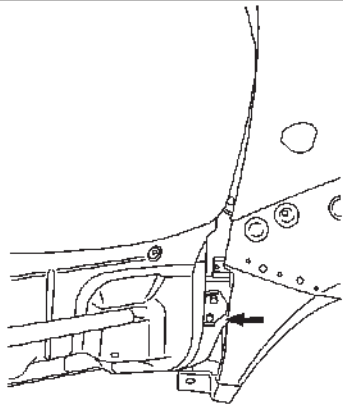


Side Section

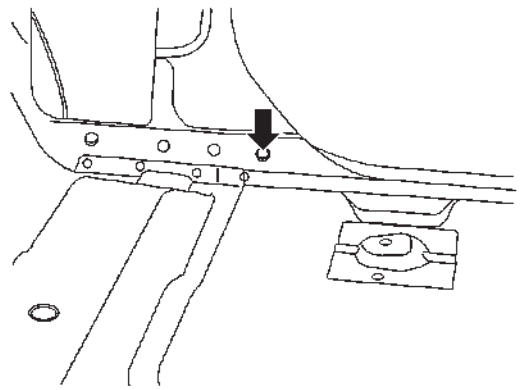


8F-24 BODY STRUCTURE

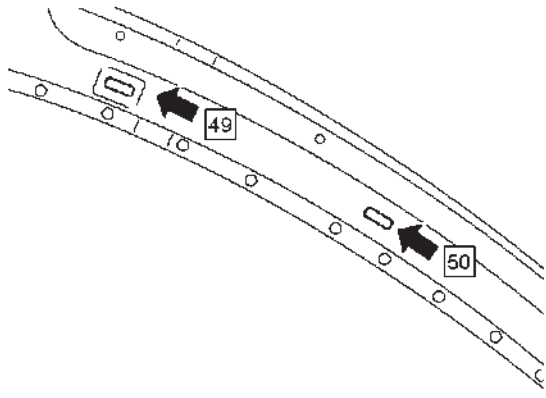
47



48



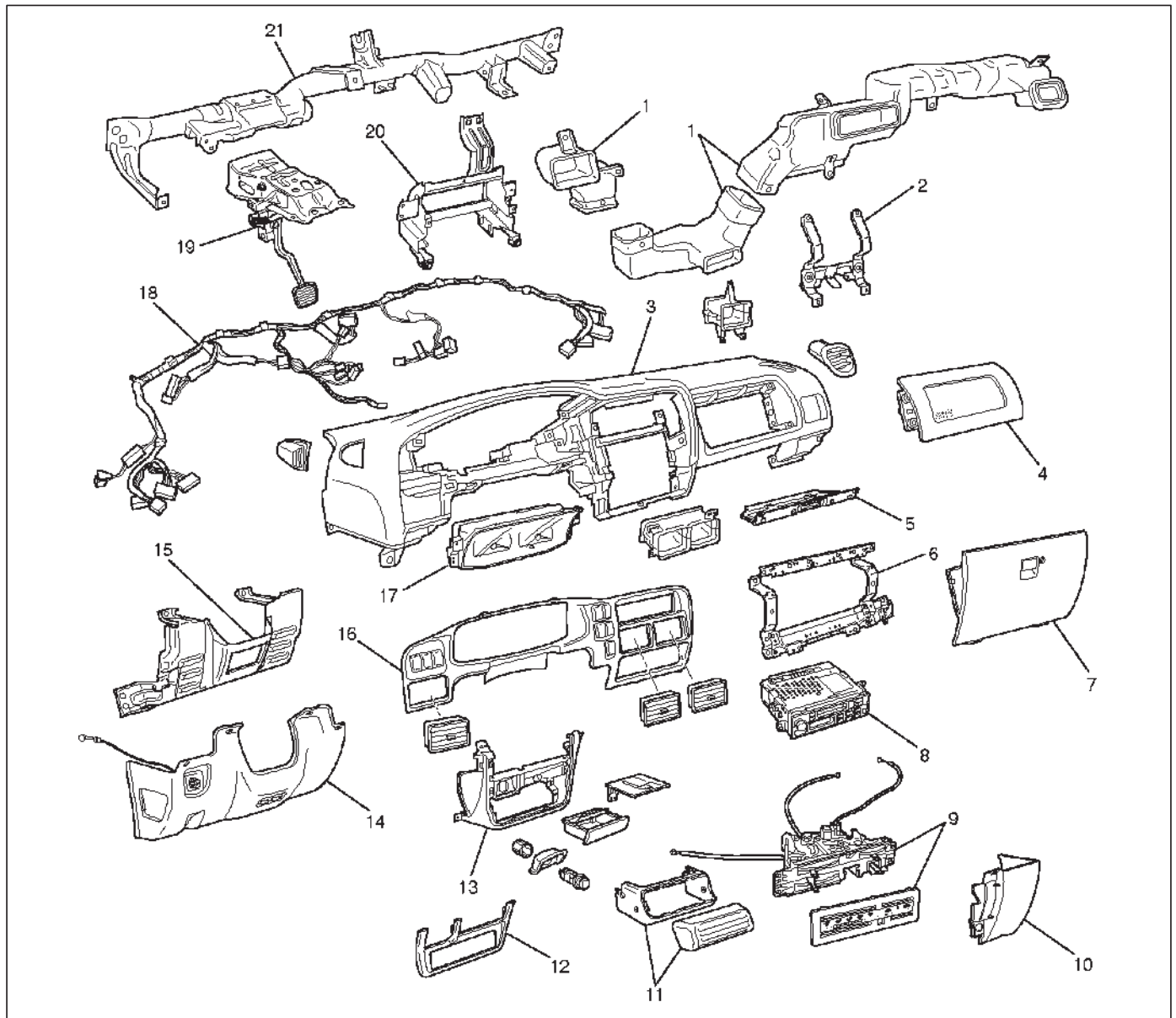
49





# Instrument Panel Assembly and Cross Beam Assembly

## Parts Location



740RX050

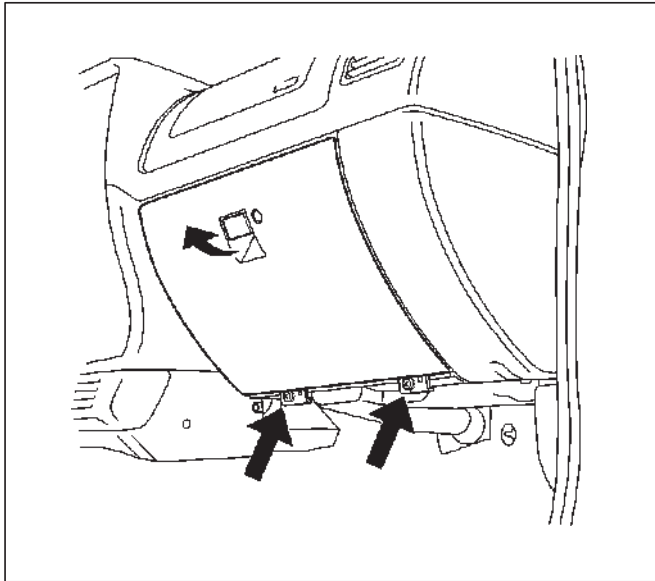
### Legend

- |   |  |
|---|--|
| (1) Vent Duct Assembly                      | (11) Front Lower Console Cover           |
| (2) Passenger Air Bag Reinforcement         | (12) Lower Cluster                       |
| (3) Instrument Panel Assembly               | (13) Instrument Panel Lower Center Cover |
| (4) Passenger Air Bag Assembly              | (14) Instrument Panel Driver Lower Cover |
| (5) Glove Box Cover                         | (15) Driver Knee Bolster                 |
| (6) Passenger Knee Bolster                  | (16) Meter Cluster Assembly              |
| (7) Glove Box Assembly                      | (17) Meter Assembly                      |
| (8) Radio Assembly                          | (18) Instrument Harness Assembly         |
| (9) Air Conditioner Control Lever Assembly  | (19) Brake Pedal & Bracket Assembly      |
| (10) Instrument Panel Passenger Lower Cover | (20) Instrument Panel Center Bracket     |
|   | (21) Cross Beam Assembly                 |

## Removal

**CAUTION:** For precautions on installation or removal of SRS—air bag system, refer to Supplemental Restraint System (SRS) — AIR BAG in Restraint section.

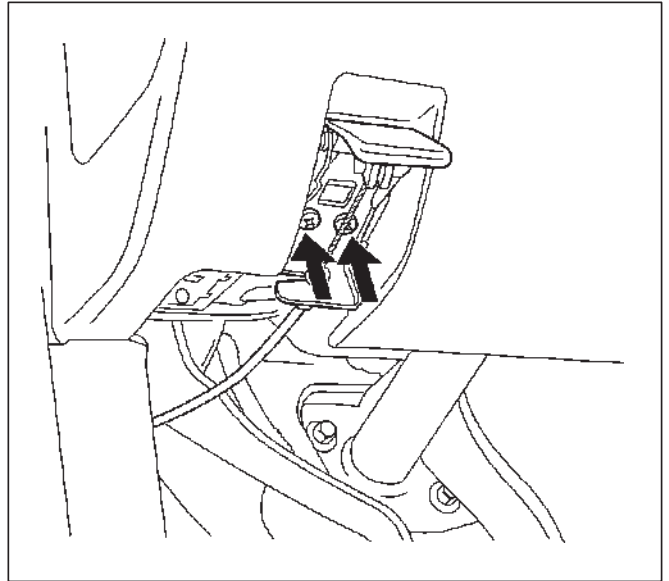
1. Disconnect the battery ground cable.
2. Remove the front lower console cover.
  - Remove the four fixing screws.
3. Remove the glove box assembly.
  - Remove the two fixing screws and pull the lever.



740RX051

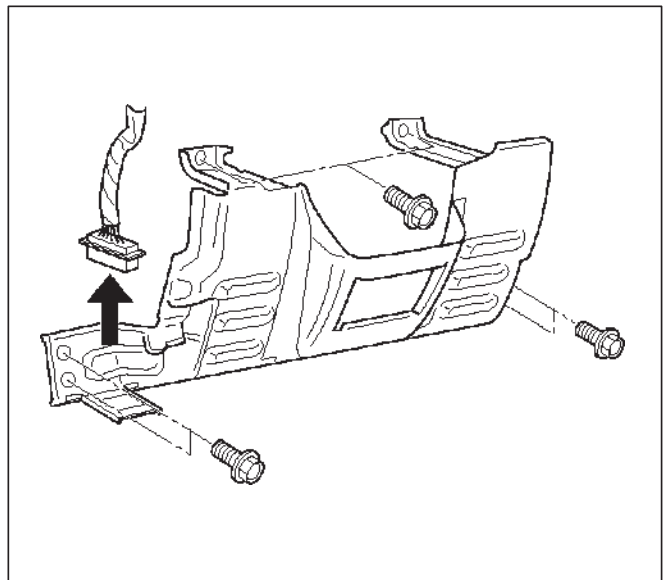
4. Remove the glove box cover.
  - Remove the four fixing screws, then pull out the glove box cover.
5. Remove the instrument panel passenger lower cover.
  - Remove the three fixing screws and the clip.
6. Remove the instrument panel driver lower cover.
  - Remove the two fixing screws to remove the engine hood opener.

- Disconnect the engine control cable at the accelerator pedal side.



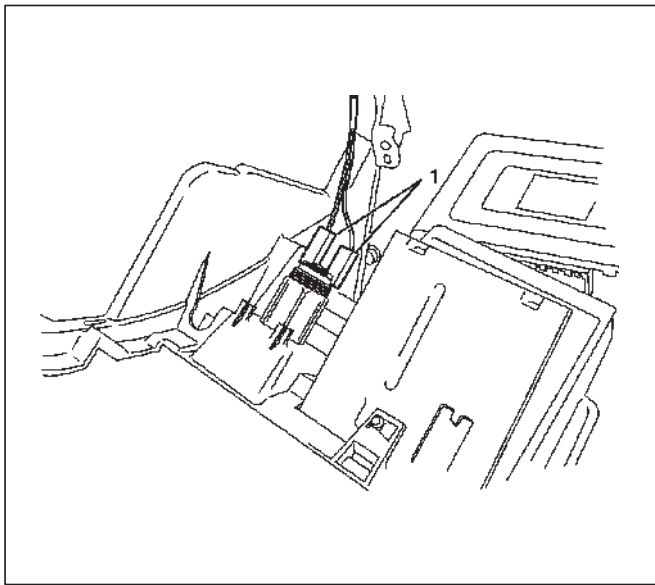
740RX052

7. Remove the lower cluster.
8. Remove the meter cluster assembly.
  - Remove the three fixing screws and the seven clips.
  - Disconnect the switch connectors.
9. Remove the driver knee bolster.
  - Remove the six fixing bolts.
  - Remove the data link connector.



740RX057

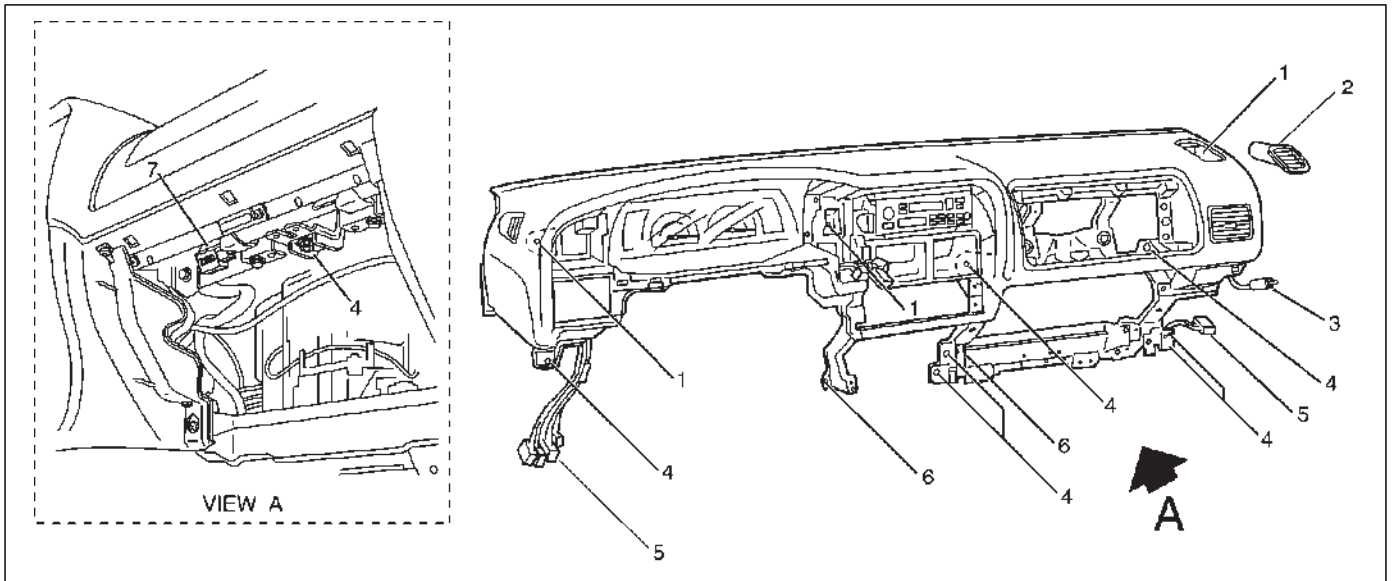
10. Remove the instrument panel lower center cover.
- Remove the seven fixing screws.
  - Disconnect the cigarette lighter connectors (1).



740RX056

11. Air conditioner control lever assembly.
- Refer to Control Lever Assembly and/or Control Cable in Heating, Ventilation and Air Conditioning (HVAC) section.
12. Remove the instrument panel assembly.
- Disconnect the instrument harness connectors (5) and the antenna feeder cable connector (3).
  - Remove the side defroster grille (2).
  - Remove the eight fixing bolts (4), the three fixing nuts (1) and the two fixing screws (6).
  - Disconnect the passenger air bag assembly harness connector (7) (view A).

**CAUTION:** For precautions on installation or removal of SRS - air bag system, refer to Supplemental Restraint System (SRS) - AIR BAG in Restraint section.



740RX053

## 8F-28 BODY STRUCTURE

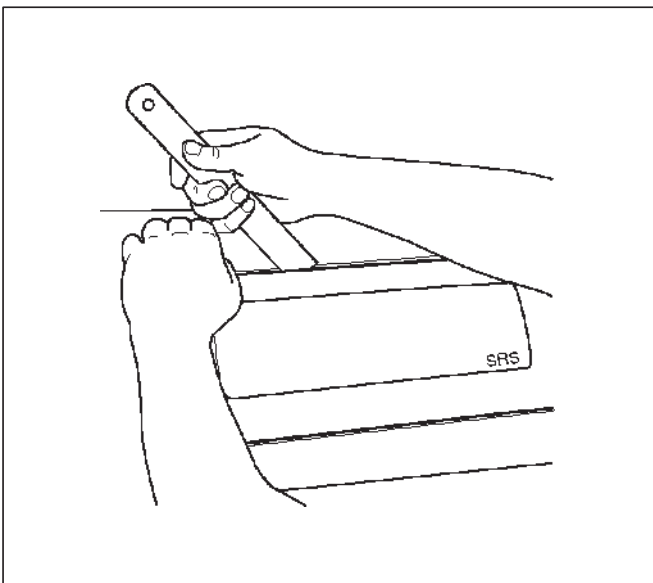
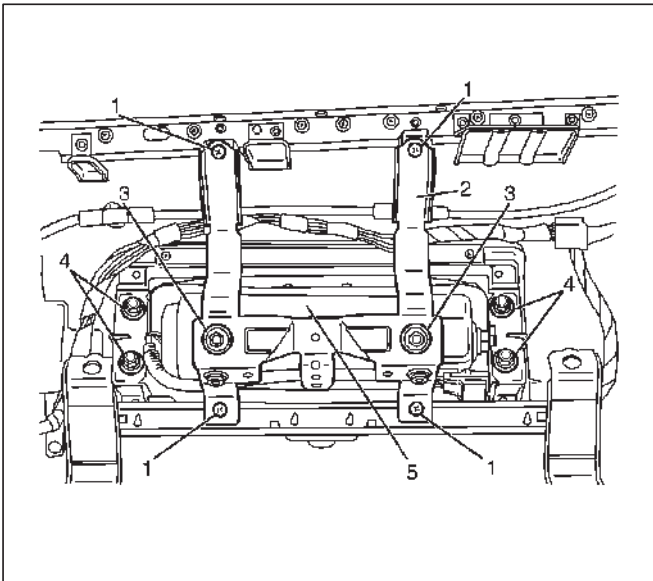
### 13. Remove the passenger air bag assembly (5).

- From the back of the instrument panel, remove the four fixing bolts (4) on the passenger air bag assembly and the two fixing nuts (3) and the washers on the reinforcement (2).
- As the instrument panel side and passenger air bag assembly side are fixed with double-sided adhesive tapes, tear away the tapes carefully not deform and scratch the air bag.

NOTE: When tearing away the tapes, protect the instrument panel side and passenger air bag side with masking tapes.

### 14. Remove passenger air bag reinforcement (2).

- Remove the four fixing screws (1).



### 15. Remove the meter assembly.

- Remove the four fixing screws and disconnect the meter harness connectors.

### 16. Remove the radio assembly.

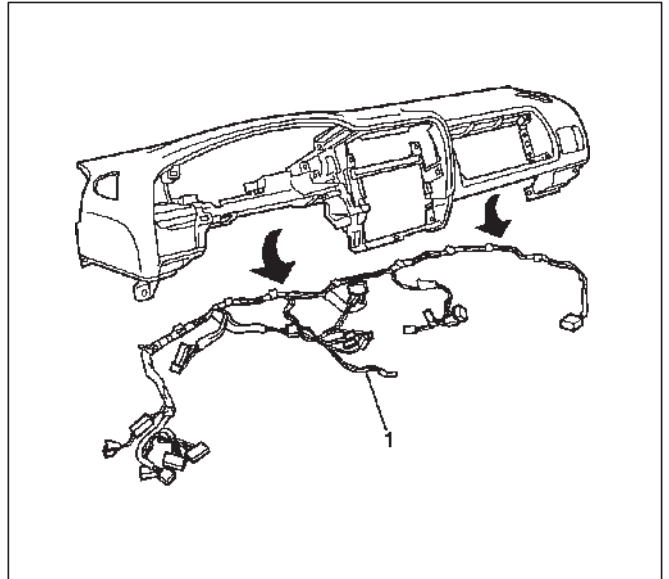
- Remove the two fixing screws.

### 17. Remove vent duct assembly.

- Refer to Ventilation Duct in Heating, Ventilation and Air Conditioning (HVAC) section.

### 18. Remove the instrument harness assembly(1).

- Remove the four fixing screws and the clips.



### 19. Remove the passenger knee bolster.

- Remove the six fixing screws.

### 20. Remove the instrument panel center bracket (5).

- Remove the four fixing bolts (4) and the two fixing nuts (3).

### 21. Remove brake pedal and bracket assembly.

- Refer to Brake Pedal in Brakes section.

### 22. Remove the cross beam assembly (13).

- Remove the two fixing bolts (6) of the steering column (7).

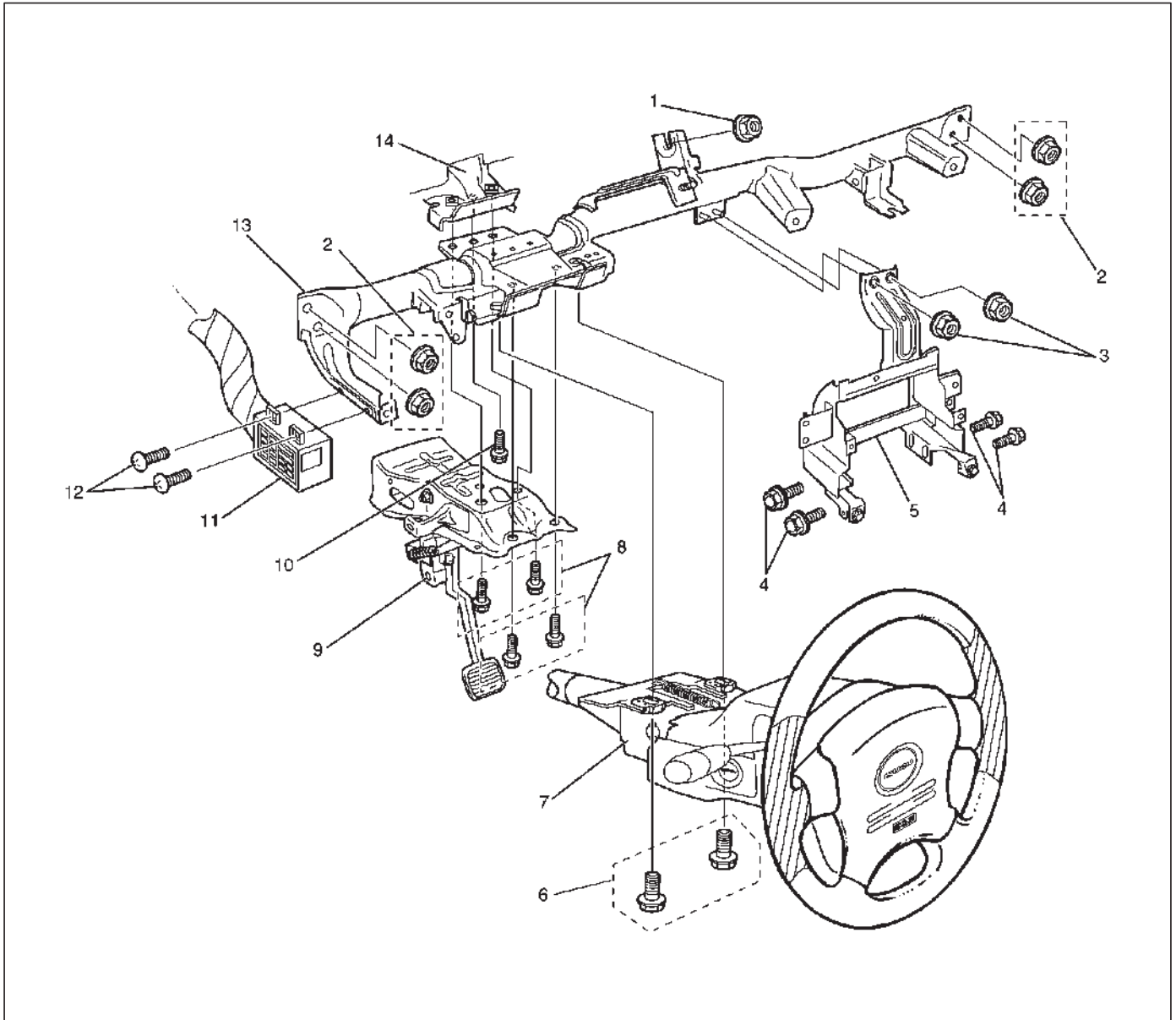
NOTE: Refer to Steering Column in Supplemental Restraint System section.

- Remove the four fixing bolts (8) of the brake pedal bracket (9).

- Remove the fixing bolt (10) of the steering column fixing bracket (14).

- Remove the two fixing screws (12) to remove the fuse box (11).

- Remove the five fixing nuts (1)(2) of the cross beam assembly (13).

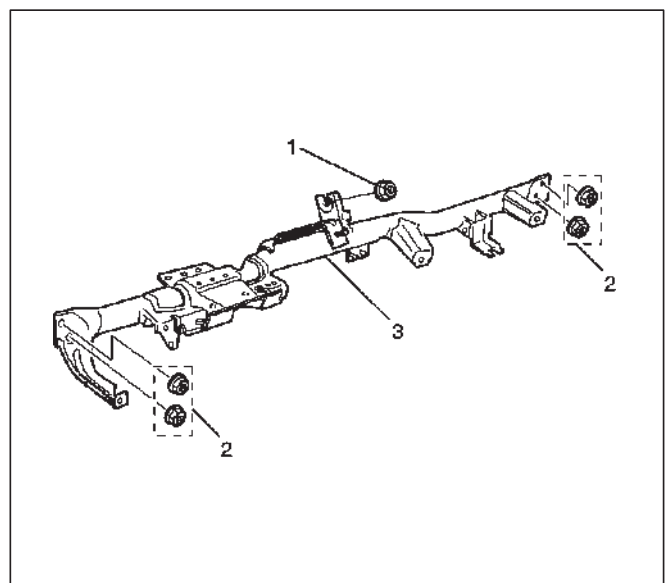


740RX054

## Installation

To install, follow the removal steps in the reverse order, noting the following points.

1. Installation the cross beam assembly (3).
  - Tighten the center nut (1) then tighten the both sides nuts (2) in order to tighten the cross beam.

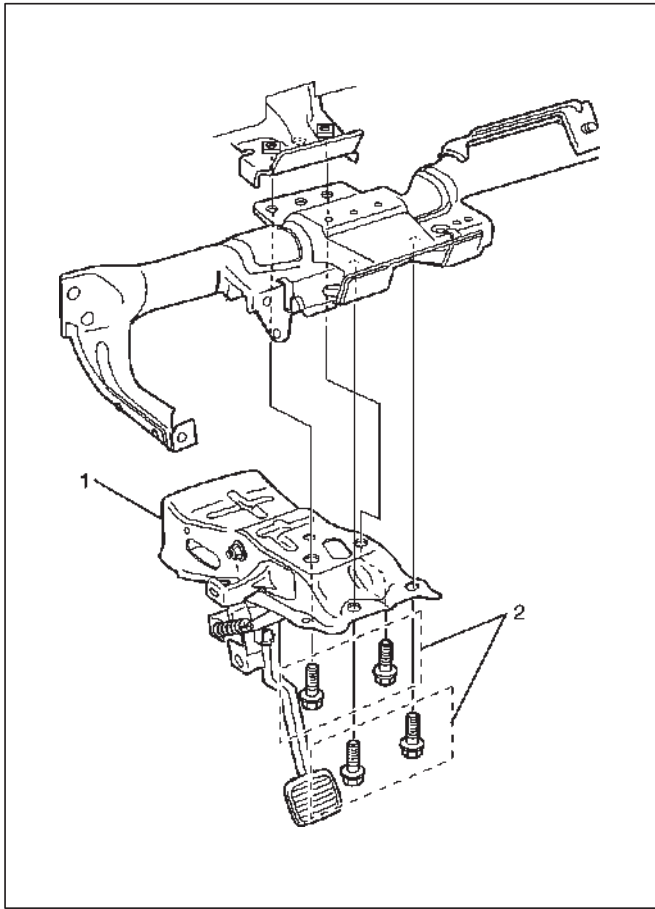


740RX059

## 8F-30 BODY STRUCTURE

○Tighten the brake pedal bracket (1) fixing bolts (2) to the specified torque.

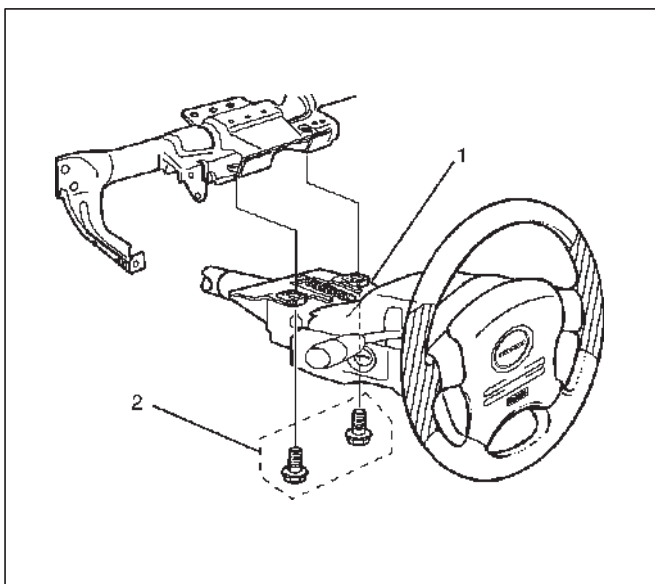
**Torque 13 N·m (113 lb in)**



310RX002

○Tighten the steering column (1) fixing bolts (2) to the specified torque.

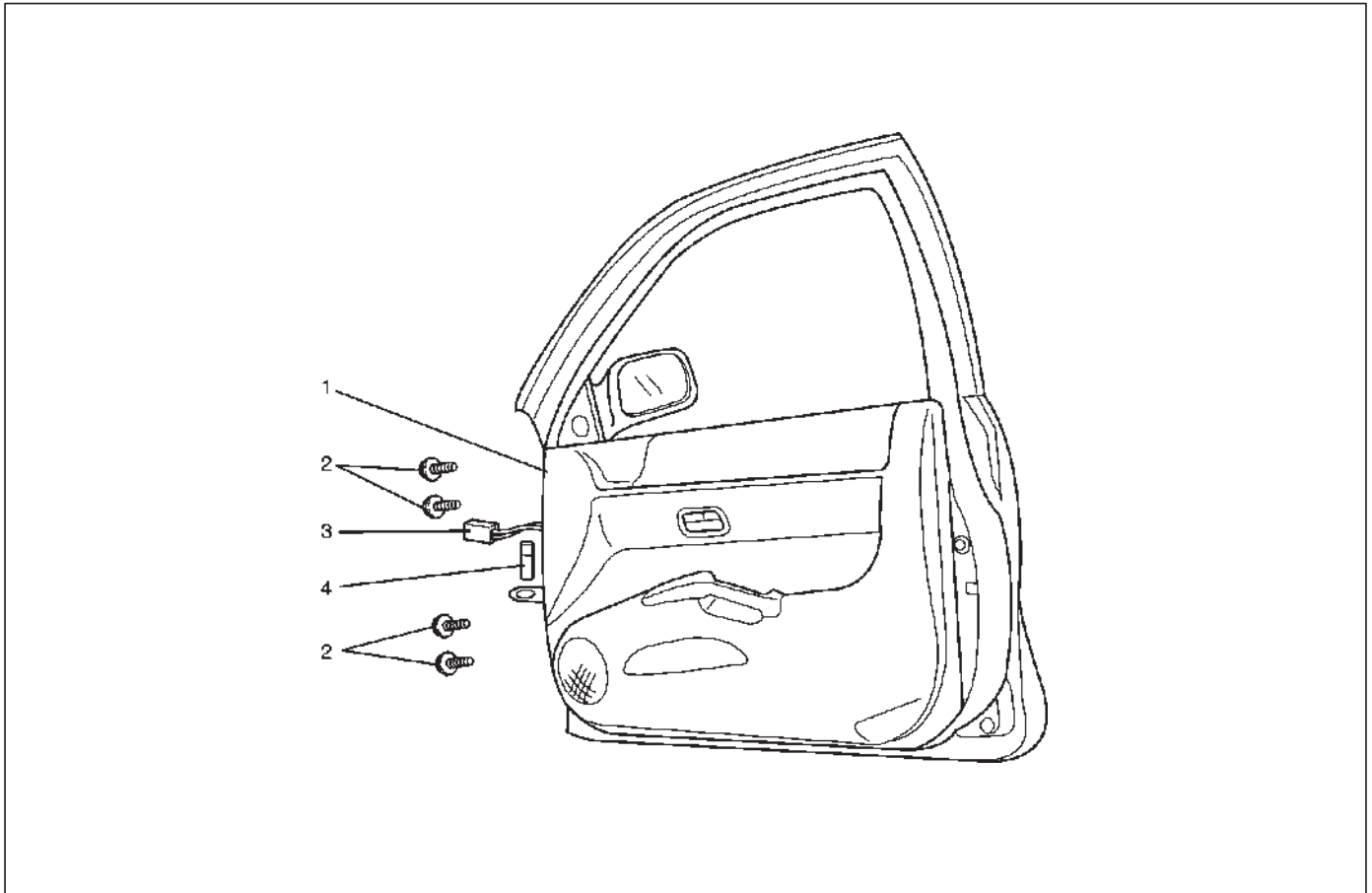
**Torque 17 N·m (12 lb ft)**



430RX004

## Front Door Assembly

### Parts Location



630RX017

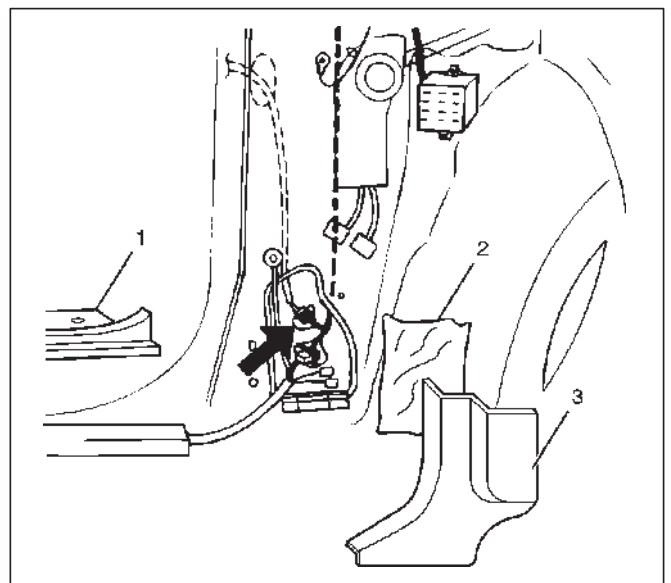
### Legend

- (1) Front Door Assembly
- (2) Hinge Bolt

- (3) Door Harness Connector
- (4) Door Check Arm Pin

### Removal

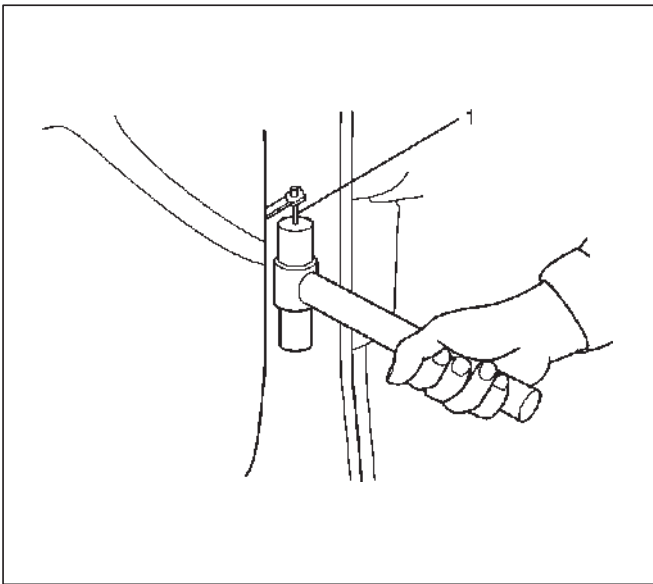
1. Disconnect battery ground cable.
2. Remove the door sill plate (1).
  - Remove the clip and four screws.
3. Remove the dash side trim cover (3).
4. Peel the insulator (2) off from the dash side panel and then disconnect the door harness connectors.



630RX019

## 8F-32 BODY STRUCTURE

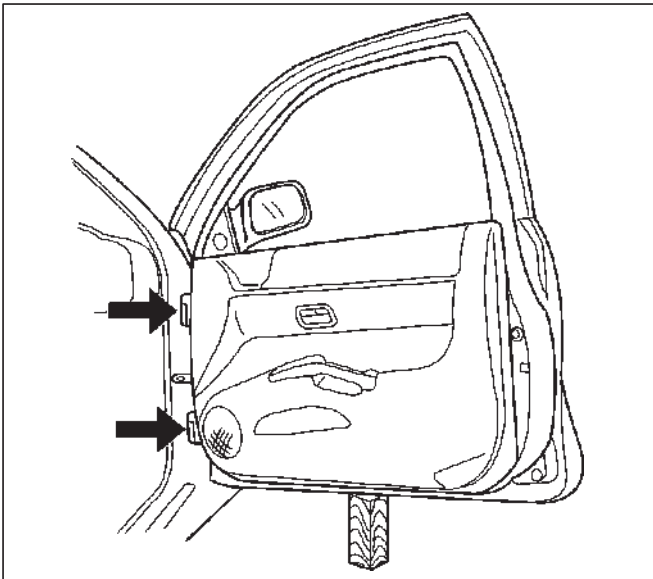
5. Remove the door check arm pin (1).



630RX018

6. Remove upper and lower hinge bolts.

- Before removing, apply setting marks on the body side hinge.
- Position a wood block under the door for protection and support the door assembly with hands during removal or installation.



630RX020

7. Pull out the door harness grommet.

8. Remove front door assembly.

### Installation

To install, follow the removal steps in the reverse order, noting the following points.

1. Align the door fitting to the body by referring to Front Fender Panel this section.
2. Tighten the door hinge bolts to the specified torque.

**Torque 34 N·m (25 lb ft)**

3. Apply chassis grease to the door check arm pin and the door hinge moving surface.

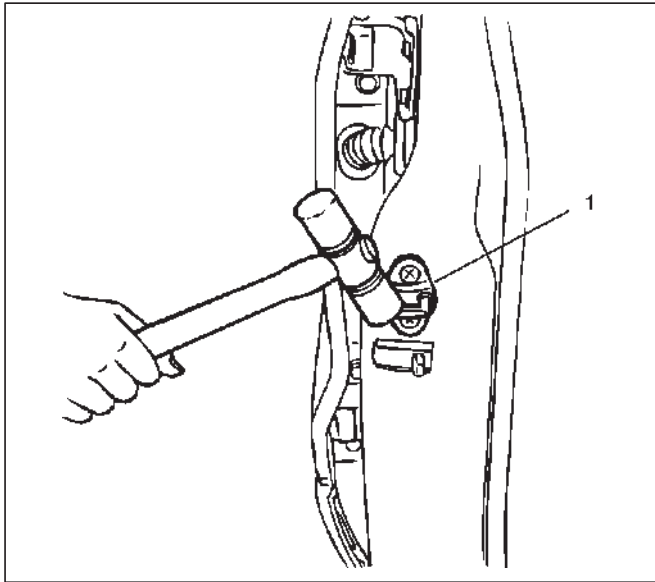


## Door Strikers

### Adjustment

1. Loosen the striker (1).
2. Tap with a plastic hammer to align.
3. Tighten the striker screws to the specified torque.

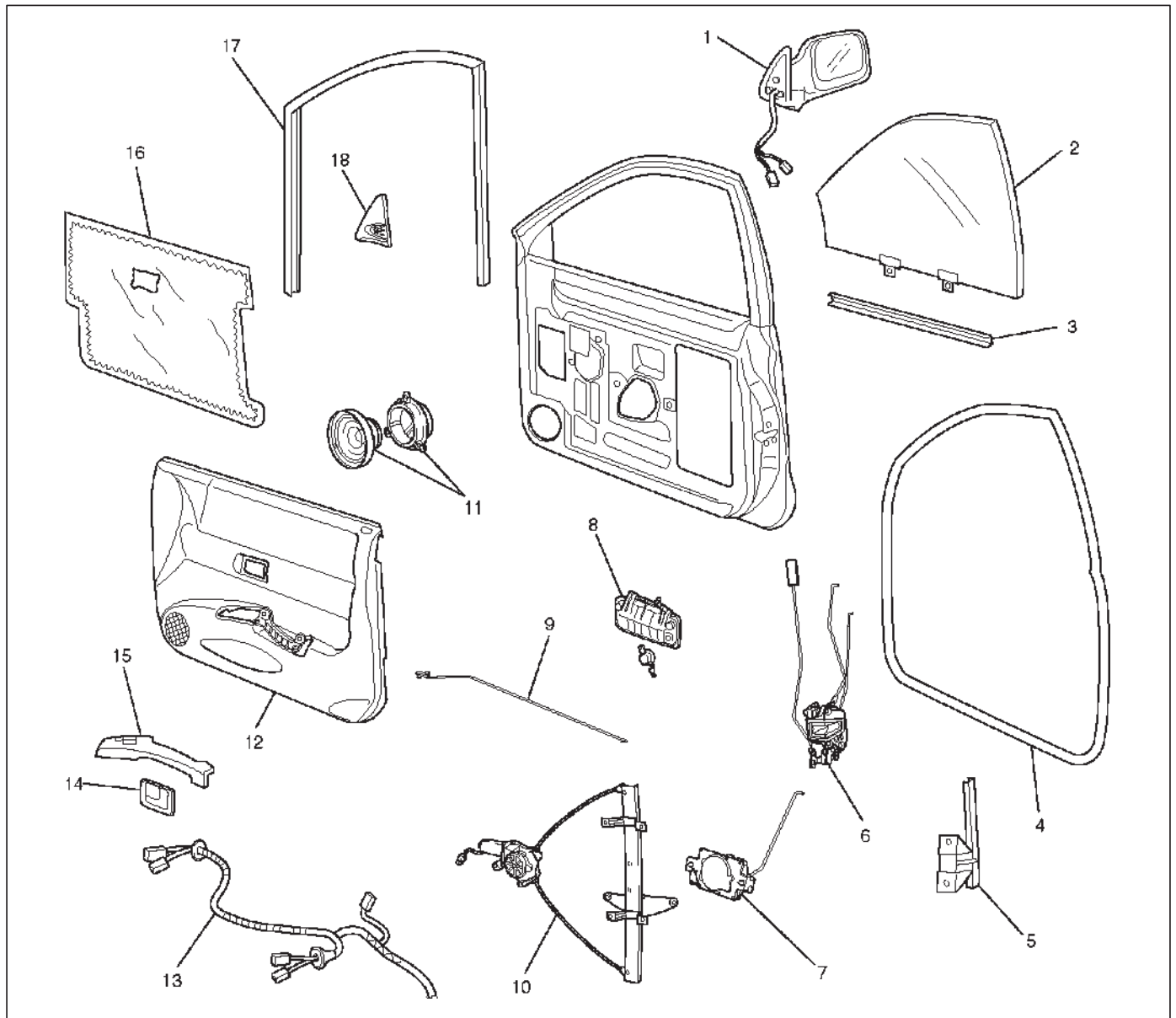
**Torque 15 N·m (11 lb ft)**



632RS001

## Front Window Regulator, Glass and Glass Run

### Parts Location



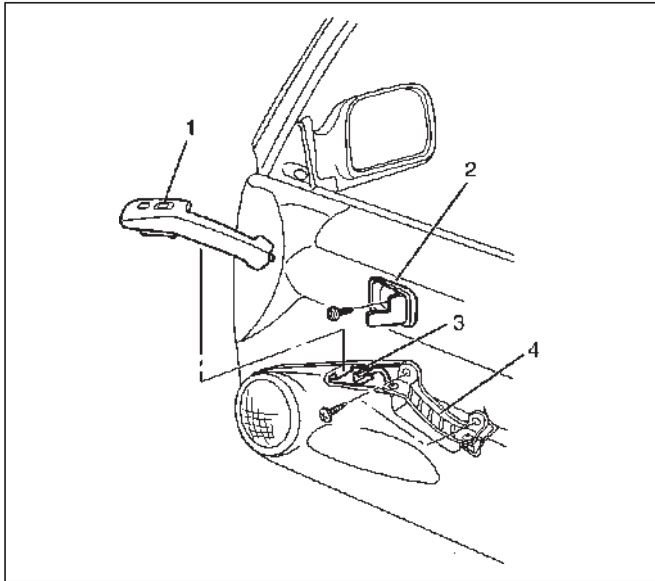
631RX004

#### Legend

- |                                       |   |
|---------------------------------------|---|
| (1) Door Mirror Assembly              | (10) Window Regulator Assembly          |
| (2) Glass                             | (11) Front Speaker Assembly/Speaker Box |
| (3) Outer Waist Seal                  | (12) Door Trim Assembly                 |
| (4) Door Seal                         | (13) Door Harness                       |
| (5) Glass Run Rear Channel            | (14) Inside Handle                      |
| (6) Door Lock Assembly                | (15) Power Window Switch/Grip Cover     |
| (7) Door Lock Actuator Assembly       | (16) Waterproof Sheet                   |
| (8) Outside Handle/Door Lock Cylinder | (17) Glass Run                          |
| (9) Inside Handle Link                | (18) Tweeter Assembly                   |

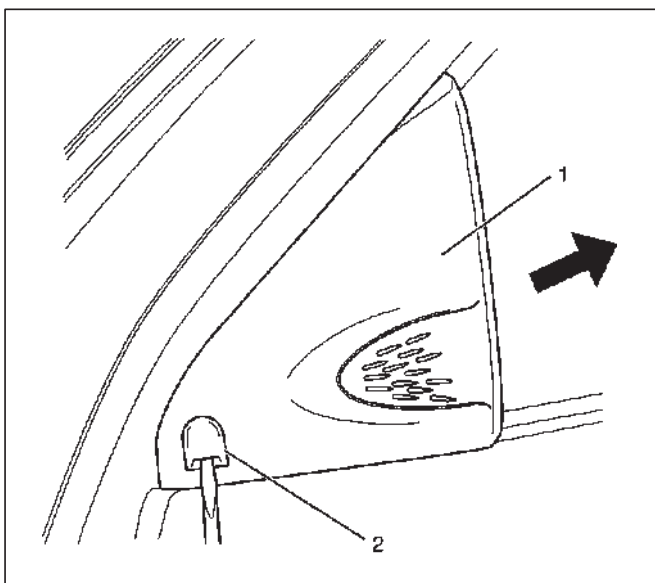
## Removal

1. Disconnect the battery ground cable.
2. Remove the grip cover (1).
  - Pry out the grip cover and disconnect the power window switch connector (3).
  - Remove the two screws fixing the grip (4) to the door inner panel.
3. Remove the inside handle (2).
  - Remove the screw and then disconnect the inside handle link.



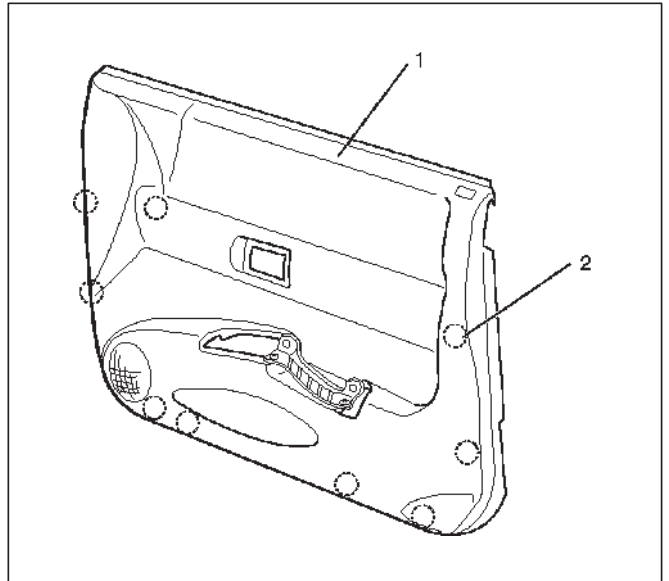
635RX001

4. Remove the tweeter assembly (1).
  - Pry the screw cover (2) off with the screwdriver and remove the screw.
  - Pull the tweeter assembly backward.
  - Disconnect the connector.



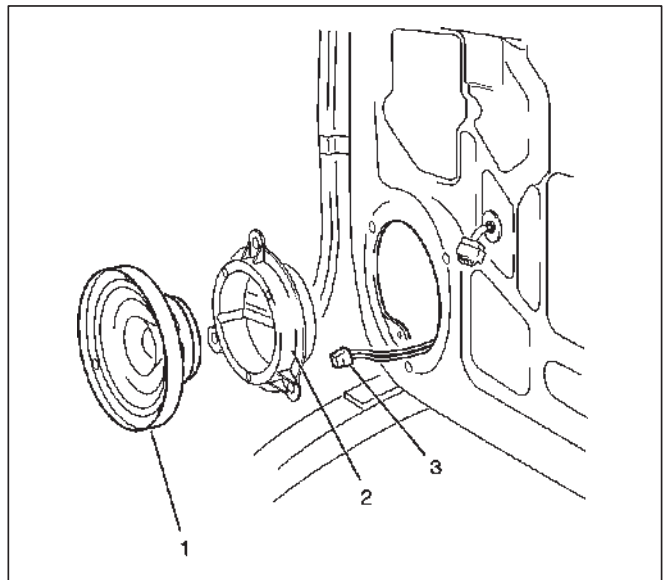
890RX014

5. Remove the door trim assembly (1).
  - Pull out the door trim assembly at the nine clip positions (2).



635RX002

6. Remove the waterproof sheet.
  - Take notice of the door harness and the grommet, peel the waterproof sheet off the door panel carefully.
7. Remove the front speaker assembly (1).
  - Remove the three screws and disconnect the connector (3).
8. Remove the speaker box (2).
  - Remove the three screws.

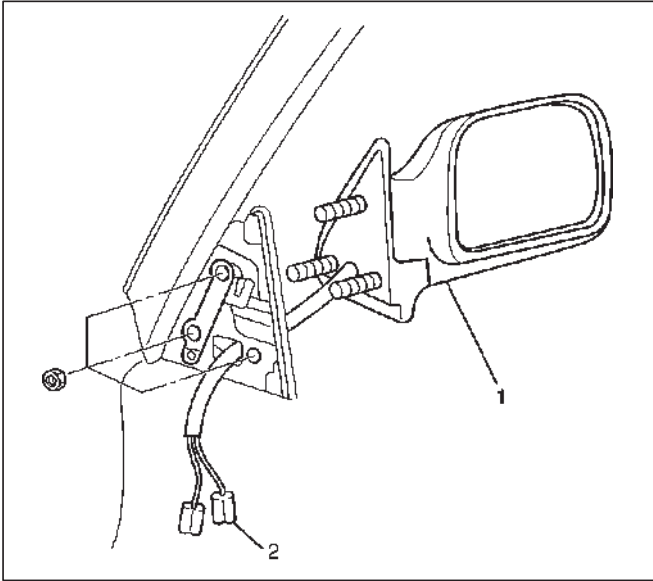


825RX026

## 8F-36 BODY STRUCTURE

9. Remove the door mirror assembly (1).

- Remove the three fixing nuts and disconnect the harness connectors (2).



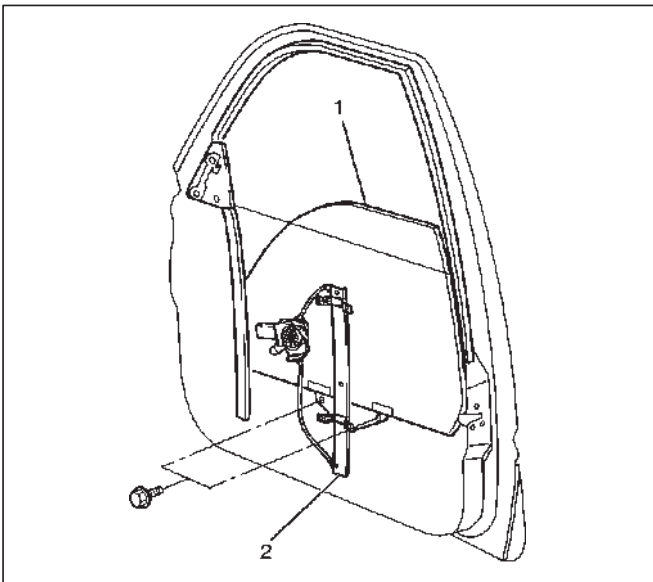
720RX005

10. Remove the glass run rear channel.

11. Remove the outer waist seal.

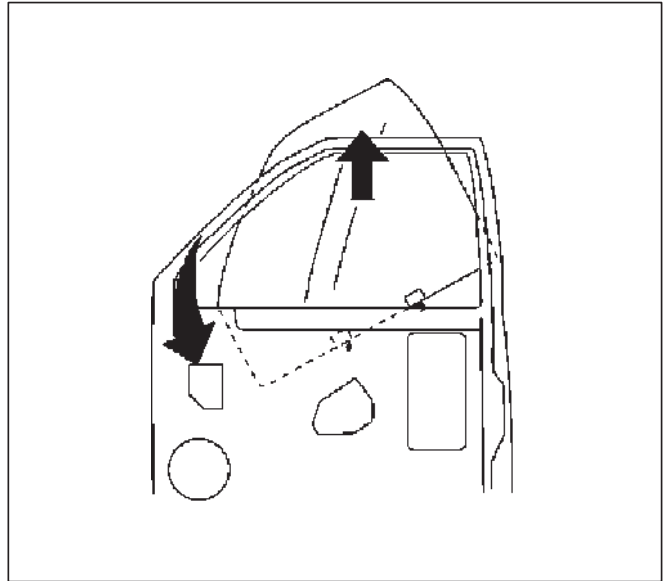
12. Remove the door glass.

- Bring the glass (1) down to the position where the fixing bolts can be seen.
- Remove the two glass fixing bolts from the window regulator (2).



631RX005

- When the front side of the glass comes off the glass run, turn the glass inside out and pull it up from its rear side.



631RV001

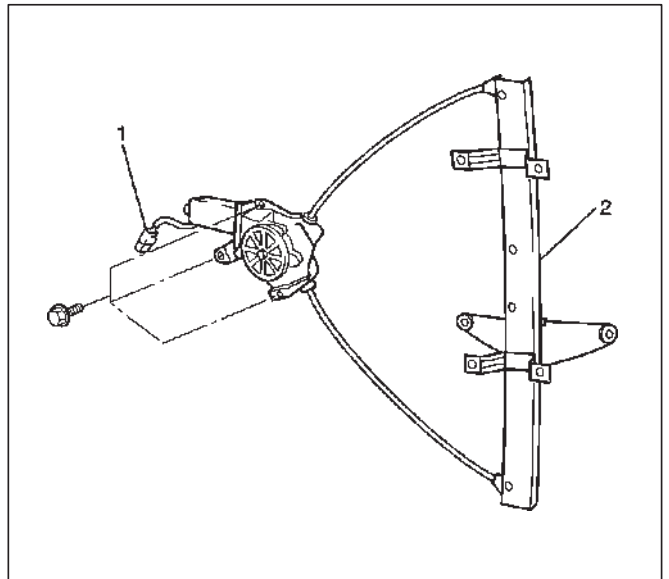
13. Remove the glass run.

14. Remove the inside handle link.

- Remove the clip and disconnect the linkage from the door lock assembly.

15. Remove the window regulator assembly (2).

- Disconnect the window regulator motor harness connector (1) and remove the clip from the panel.
- Remove the four window regulator fixing screws and the three motor fixing bolts.



631RX006

16. Remove the door lock actuator assembly.
  - Remove the two fixing bolts and disconnect the actuator connector.
  - Disconnect the link from the door lock assembly.
17. Remove the door lock assembly.
  - Remove the three fixing screws.
  - Disconnect the link from outside handle and door lock cylinder.
18. Remove the outside handle/door lock cylinder.
19. Remove the door seal.
20. Remove the door harness.

## Installation

To install, follow the removal steps in the reverse order, noting the following points.

1. Tighten the outside handle fixing bolts to the specified torque.

**Torque 8 N·m (69 lb in)**

2. Tighten the door lock assembly fixing screws to the specified torque.

**Torque 7 N·m (61 lb in)**

3. Tighten the window regulator and motor fixing bolts to the specified torque.

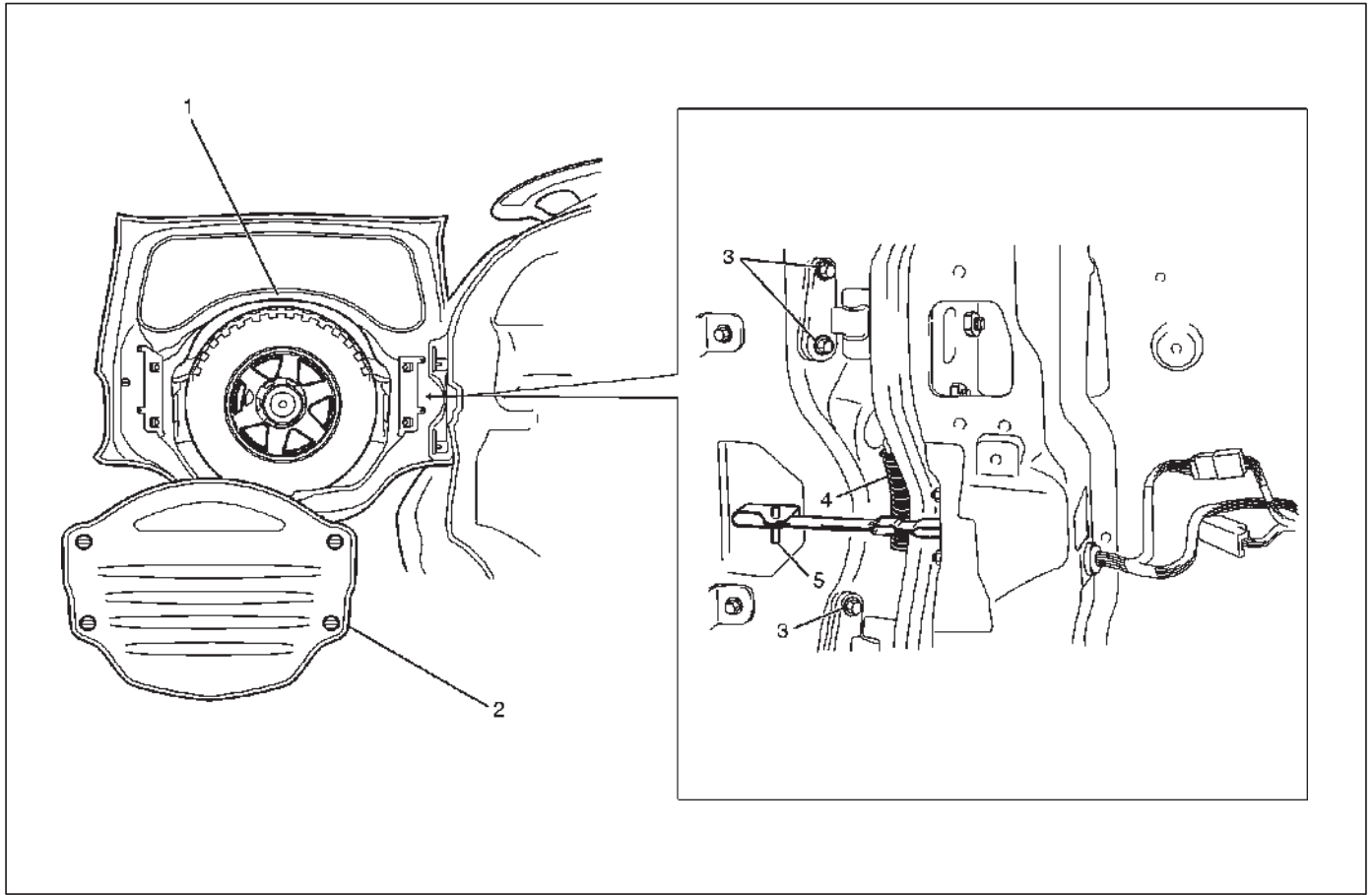
**Torque 8 N·m (69 lb in)**

4. Tighten the door glass fixing bolts to the specified torque.

**Torque 8 N·m (69 lb in)**

## Tailgate Assembly

### Parts Location



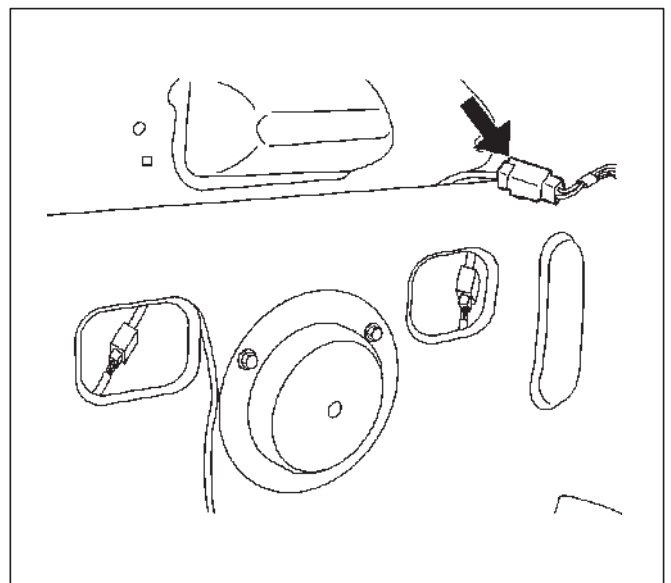
530RX002

### Legend

- |                         |                            |
|-------------------------|----------------------------|
| (1) Spare Tire          | (3) Hinge Bolt             |
| (2) Tailgate Trim Cover | (4) Tailgate Harness       |
|                         | (5) Tailgate Check Arm Pin |

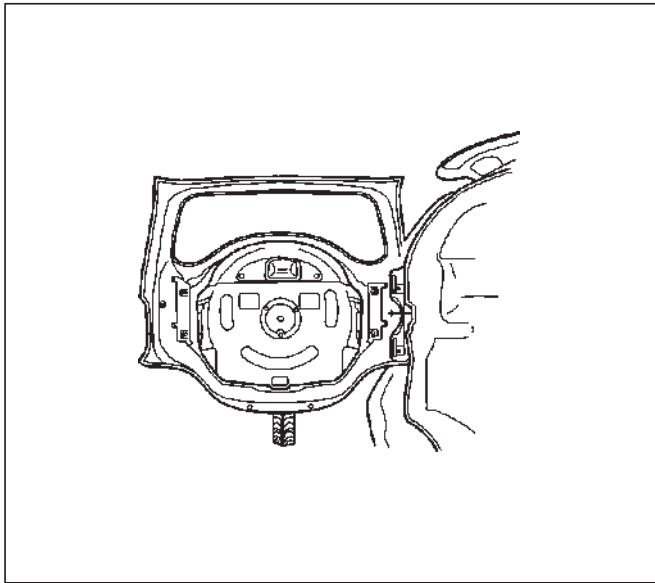
### Removal

1. Disconnect the battery ground cable.
2. Remove the tailgate trim cover.
  - Loosen the four fixing knob.
3. Remove the spare tire.
  - Remove the center fixing bolt.
4. Disconnect the tailgate harness at the connector.



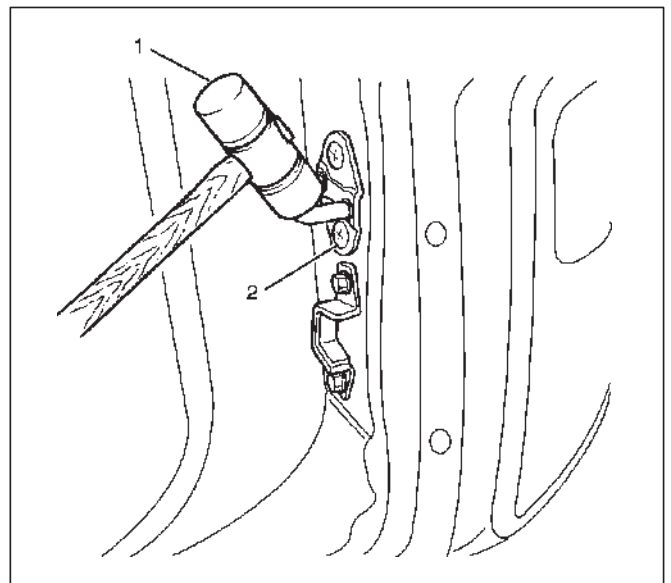
530RX004

5. Remove the tailgate check arm pin.
6. Remove the hinge bolts (3).
  - Apply a setting mark on the tailgate side hinge.
  - Position a wood block under the tailgate for protection and support the tailgate assembly with hands during removal or installation.



7. Remove the tailgate assembly.

4. Adjust the tailgate striker.
  - Loosen the striker screws (2).
  - Tap the striker with a plastic hammer (1) to align.



5. Tighten the striker screws to the specified torque.
 

**Torque : 13 N·m (113 lb in)**

## Installation

To install, follow the removal steps in the reverse order, noting the following points.

1. Apply chassis grease to the tailgate hinge and the tailgate check arm moving surface.
2. Align the tailgate fitting to the body with the hinges.

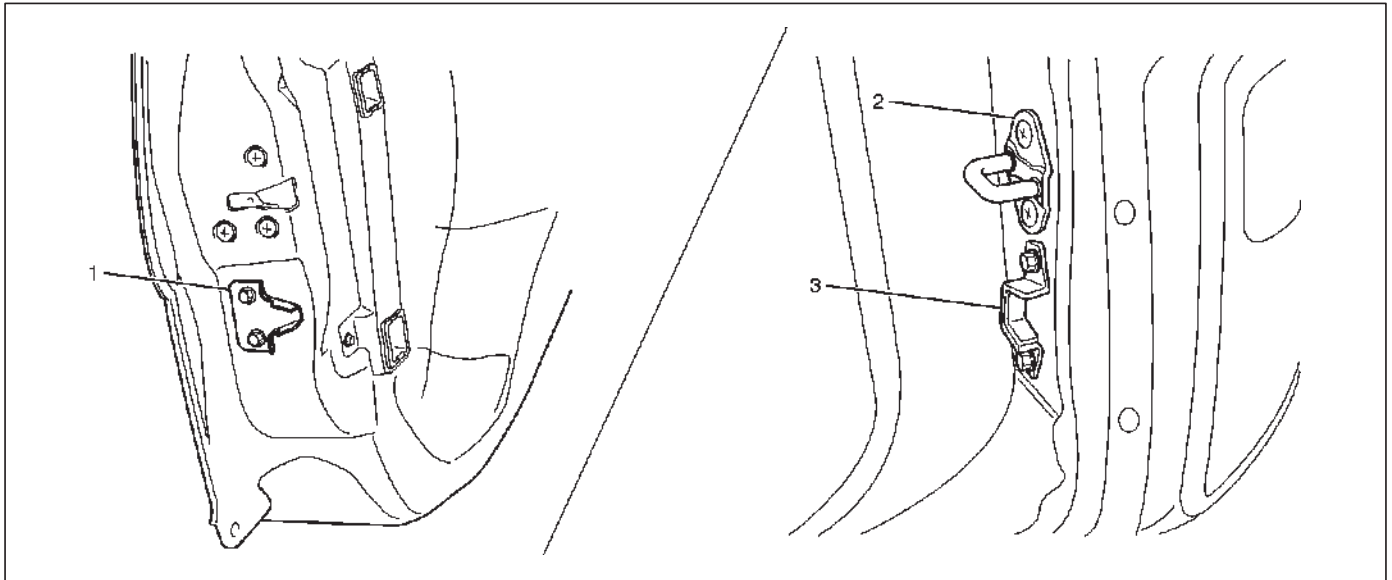
**NOTE:** Be sure to align the tailgate after installing the spare tire.

3. Tighten the hinge bolts to the specified torque.

**Torque : 34 N·m (25 lb ft)**

## Tailgate Dove – Tail

### Parts Location



683RX001

### Legend

(1) Tailgate Side Dove – Tail

(2) Tailgate Striker

(3) Body Side Dove – Tail

### Removal

1. Remove the tailgate side dove-tail.
  - Remove the two fixing bolts.
2. Remove the bolt side dove-tail.
  - Remove the two fixing bolts.

### Installation

To install, follow the removal steps in the reverse order, noting the following points.

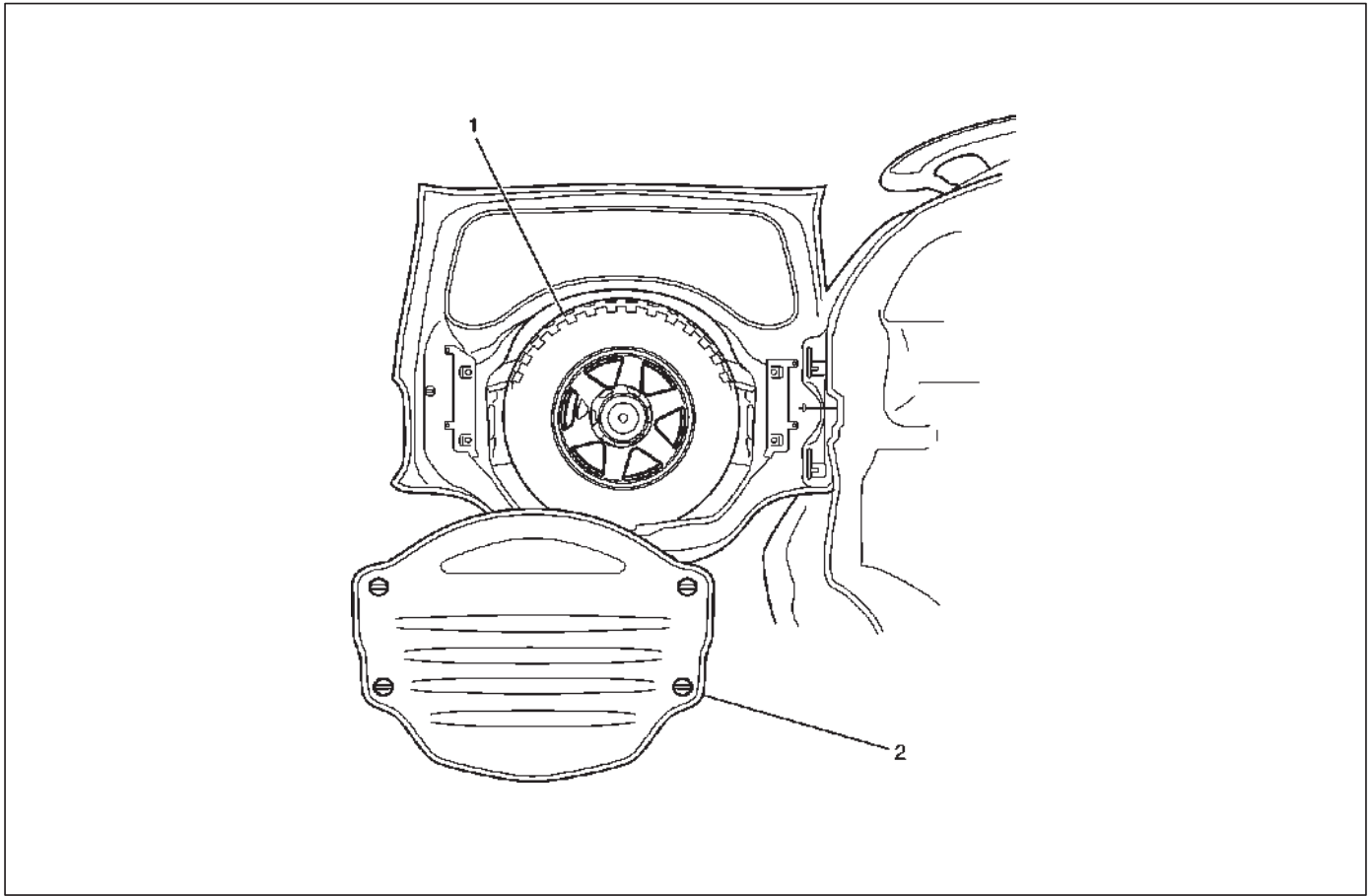
1. Tighten the fixing bolts to the specified torque.

**Torque 13 N·m (113 lb in)**



## Spare Tire Carrier

### Parts Location



530RX003

### Legend

- (1) Spare Tire
- (2) Tailgate Trim Cover

### Removal

1. Remove the tailgate trim cover (2).
  - Loosen the four fixing knobs.
2. Remove the spare tire (1).
  - Remove the center fixing bolt.

### Installation

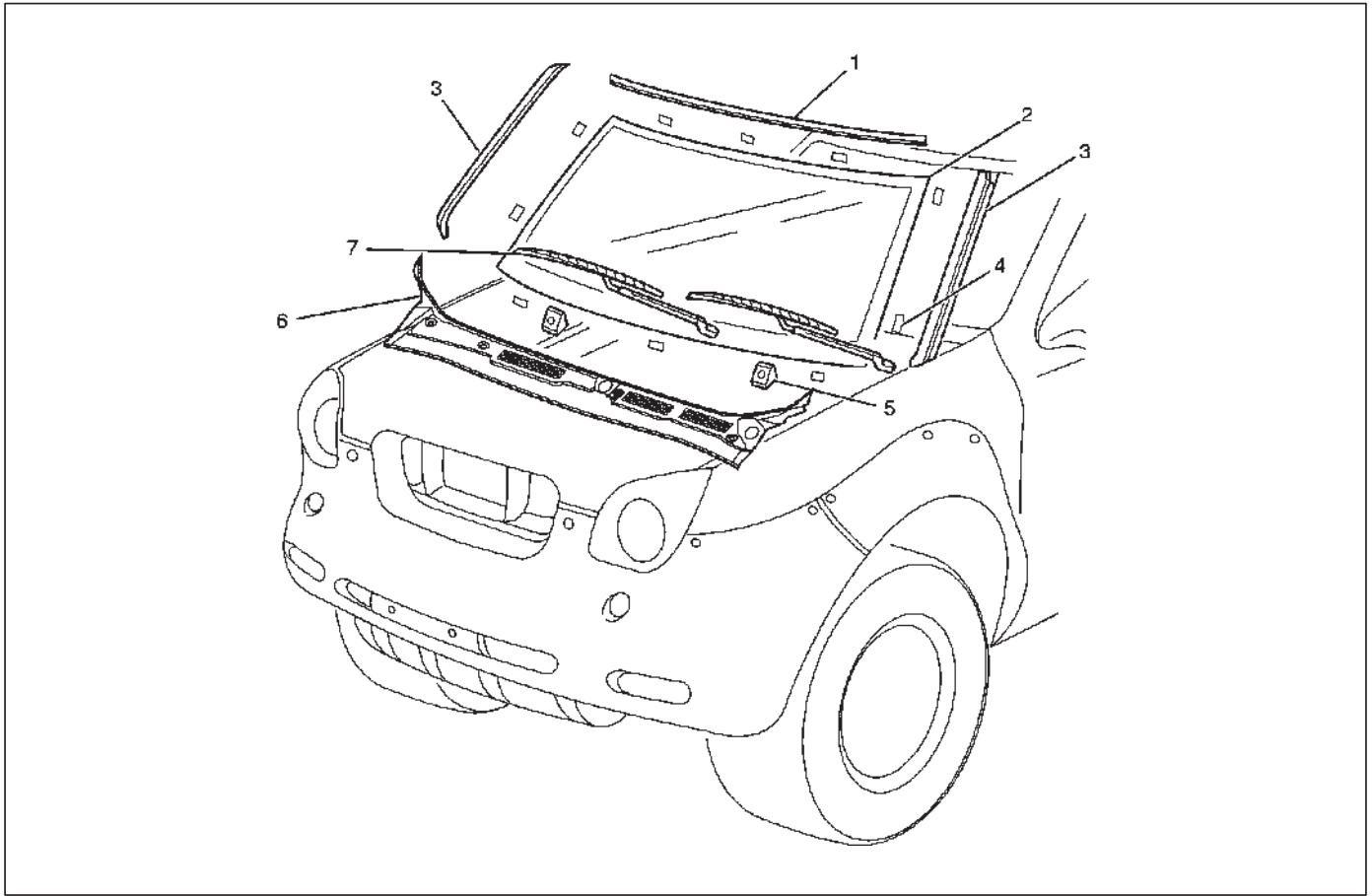
To install, follow the removal steps in the reverse order, noting the following points.

1. Tighten the spare tire fixing bolt to the specified torque.

**Torque 50 N·m (37 lb ft)**

## Windshield

### Parts Location



607RX003

#### Legend

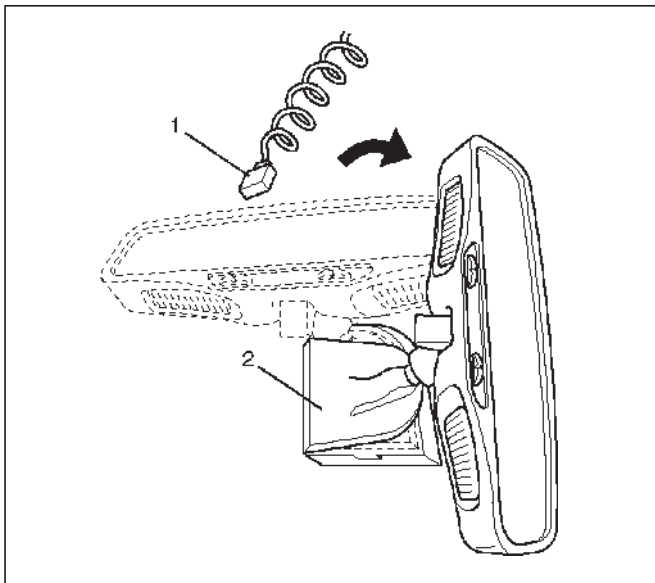
- |                              |                        |
|------------------------------|------------------------|
| (1) Windshield Upper Molding | (4) Spacer             |
| (2) Windshield               | (5) Windshield Support |
| (3) Windshield Side Molding  | (6) Cowl Cover         |
|                              | (7) Wiper Arm Assembly |

### Removal

1. Disconnect the battery ground cable.
2. Remove the windshield wiper arm assembly.
  - Refer to Windshield Wiper Arm/Blade in Wiper/Washer System section.
3. Remove the cowl cover.
  - Remove the three clips and five fixing screws.
4. Remove the windshield side molding.
  - Pull the molding out from the windshield side molding clip.
5. Remove the windshield support.
6. Remove the windshield upper molding.
7. Remove the front pillar trim cover.
8. Remove the sun visors and sun visor holders.
  - Refer to Headlining in Exterior/ Interior Trim section.

9. Remove the rear view mirror.

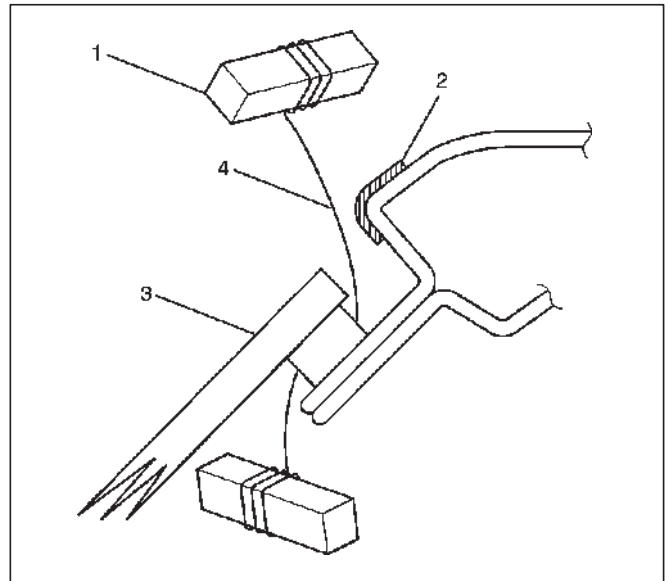
- Disconnect the connector (1).
- Turn the channel mount (2) 90 degrees clockwise and pull down.



10. Remove the windshield (3).

- Use a knife or a pick to make a hole in part of the adhesive caulking material.
- Secure one end of a piece of steel piano wire (4) (0.6mm/0.02 inches diameter) to a piece of wood (1) that can serve as a handle.
- Use a pair of needle nose pliers to insert the other end of the piano wire through adhesive caulking material at the edge of the windshield glass.
- Secure the other end of the piano wire to another piece of wood.
- With the aid of an assistant, carefully move the piano wire with a sawing motion to cut through the adhesive caulking material around the entire circumference of the windshield glass.

**CAUTION:** Apply an adhesive cloth tape (2) to the edge of the vehicle body to protect the coated surface. Pay attention to the spacers given at 10 positions of the glued part.

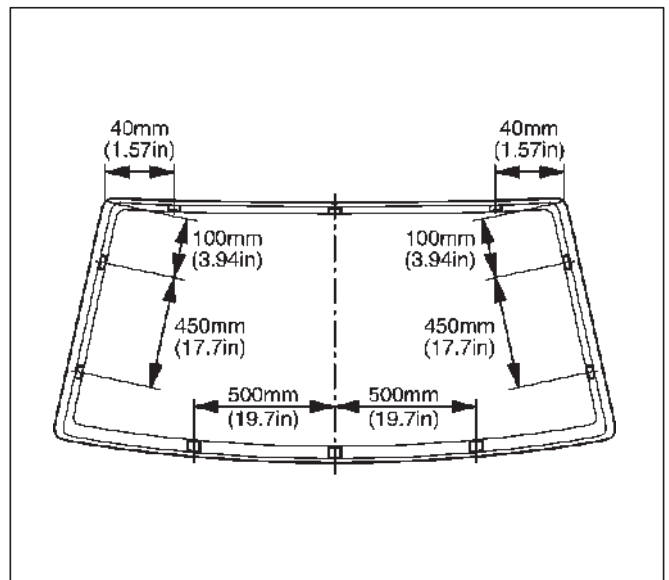


- Clean the remaining adhesive caulking material from the area of the body which holds the windshield.

11. Remove the spacer.

## Installation

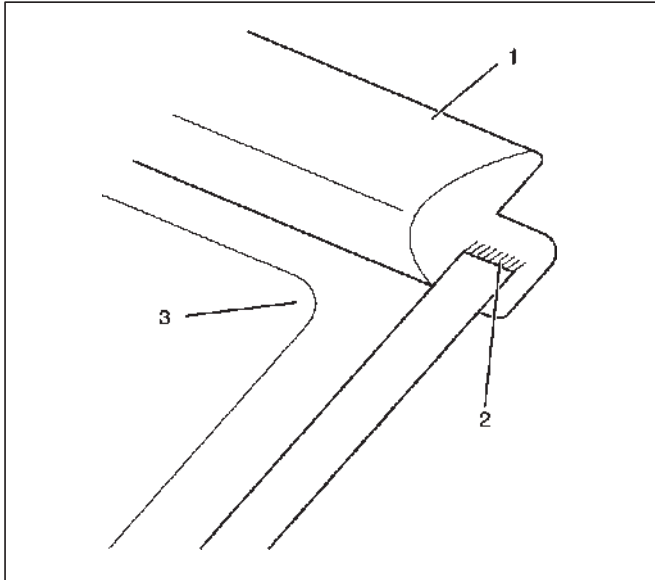
1. Clean the bonding surfaces of both the windshield and body panel with a soft rag and white gasoline.
2. Install the spacer.
  - Attach spacers in ten locations as shown in the figure.
  - Always use new spacer.



## 8F-44 BODY STRUCTURE

---

3. Install the windshield upper molding (1).
  - Peel off the adhesive tape (2) from the windshield upper molding, and start applying it with one end of the glass (3) and cut away the surplus at the other end of the glass for length adjustment.
  - Always use new upper molding.



607RX006

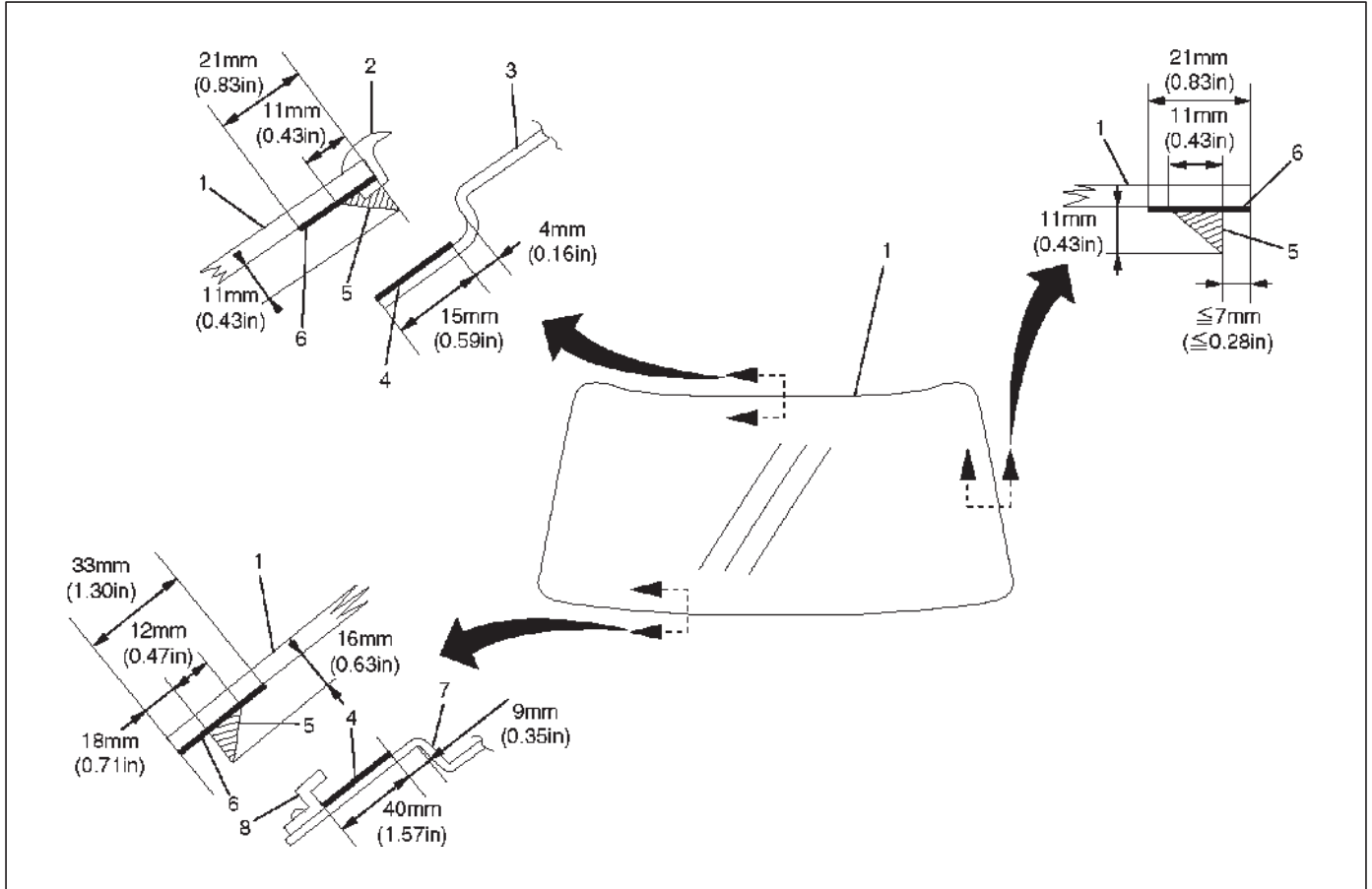
4. Temporary install the windshield support.
5. Install the windshield (1).
  - Apply primer (6) (Sun star #435-40 or equivalent) to the windshield side bonding surface as shown in the figure.
  - Apply primer (4) (Sun star #435-95 or equivalent) to the body side bonding surface as shown in the figure.
  - Allow curing time of at least 3 minutes after application of the primer before applying adhesive.

NOTE: Apply an adhesive 3 minutes or more but within 24 hours after the application of primer. If more than 24 hours have passed, reapply primer.

Adhesive should be handled as follows:

- Use the adhesive manufactured 3 months or less ago.

- Wipe off adhesive stains on positions other than requires application.
- Stir the adhesive for a minute or more before use.



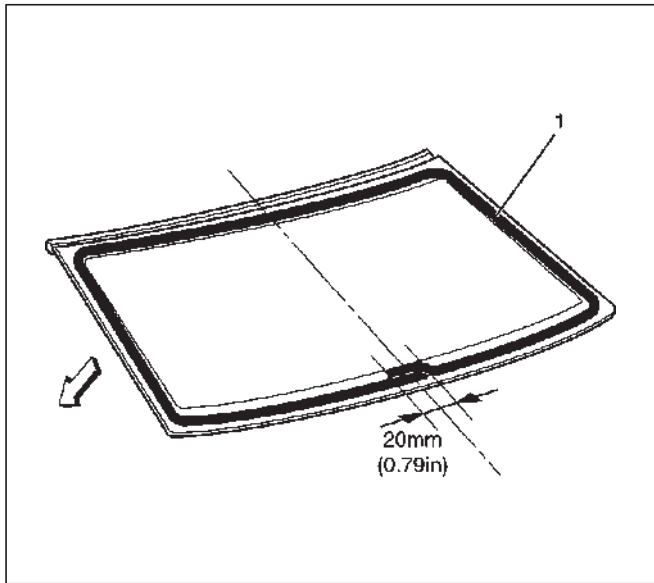
607RX008

**Legend**

- (1) Windshield
- (2) Windshield Upper Molding
- (3) Roof Panel
- (4) Primer Coating Area (Body Side)

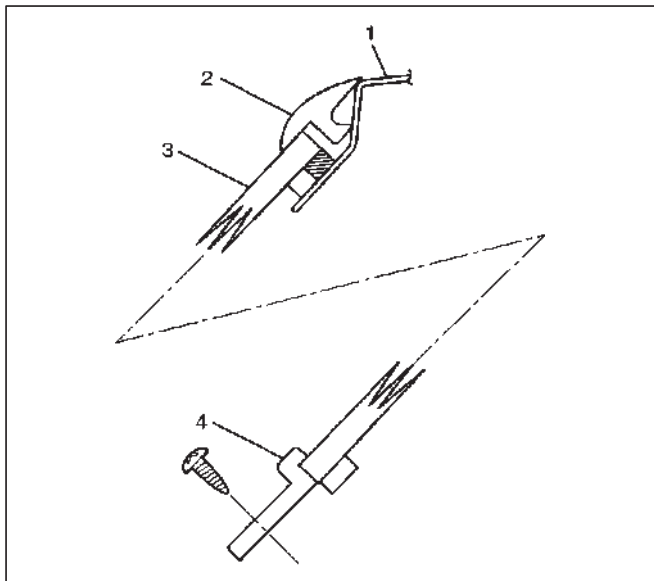
- (5) Sealing Adhesive
- (6) Primer Coating Area (Windshield Side)
- (7) Cowl Upper Panel
- (8) Windshield Support

- After drying primer completely, apply a sealing adhesive (1) (Sun star #555 or equivalent) along the edge of the glass so that the sealing adhesive has a 20 mm (0.79 in) junction at middle of the base of the glass.



607RX007

- Set the windshield(3) with sealing adhesive applied along its edge in the body panel. Specifically, adjust windshield support (4) with the upper molding (2) making contact with the body panel (1), press the glass, and tighten the windshield support.

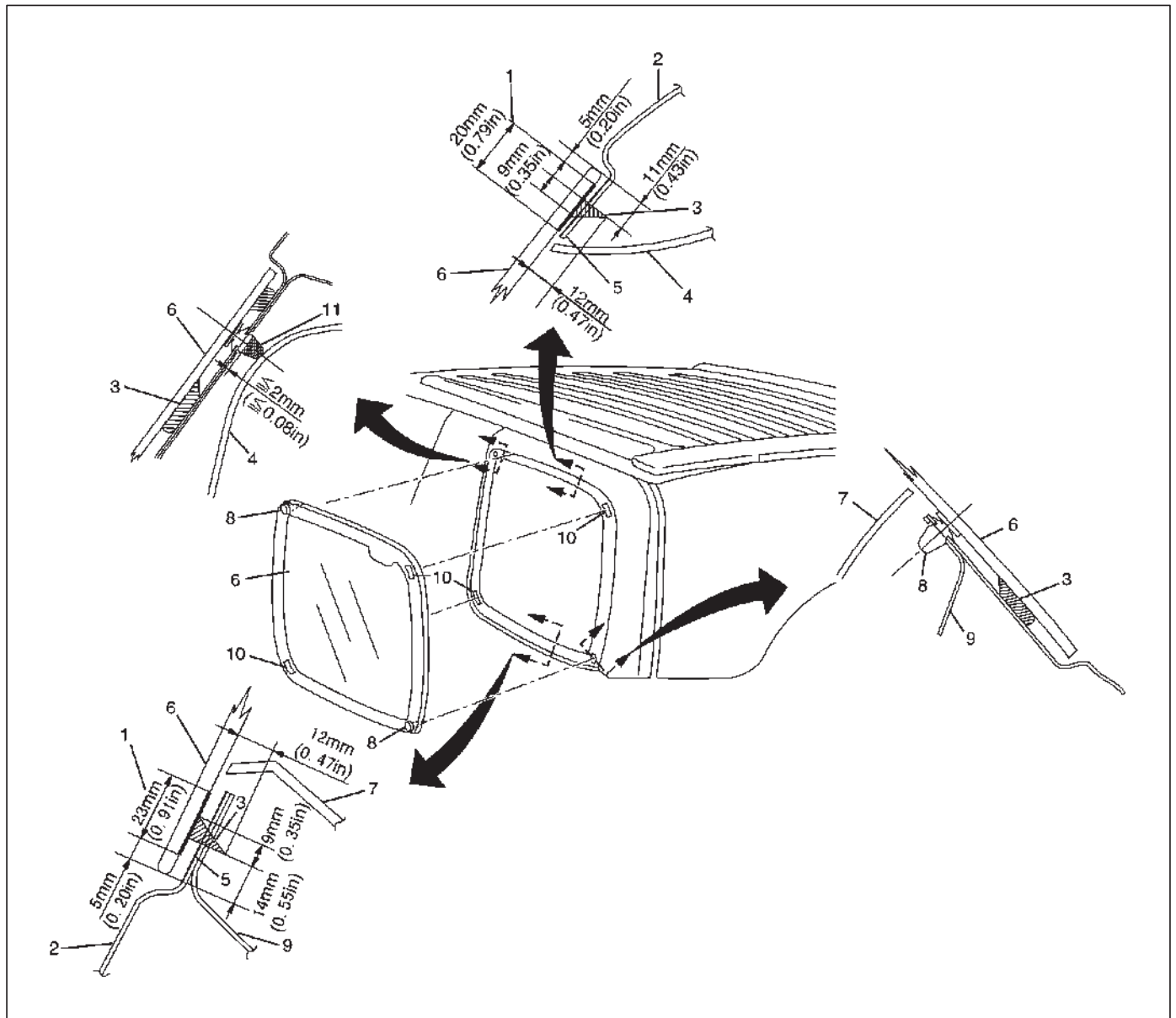


607RX008

6. Install the rear view mirror and connect the connector.
7. Install the sun visor and sun visor holders.
8. Install the front pillar trim cover.
9. Install the windshield side molding.
  - Let the upper side of the side molding make contact with the upper molding so that the side molding is put upon the upper molding. The lower side is inserted in the fender panel.
10. Install the cowl cover.
11. Install the wiper arm assembly.
  - Refer to Windshield Wiper Arm/Blade in Wiper/Washer System section.
12. Cure the adhesive at the temperature of 20 - 30°C (68 - 86°F) for 24 hours.
13. Check that the windshield does not leak water.

## Rear Quarter Glass

### Parts Location



641RX006

#### Legend

- |                                      |                             |
|--------------------------------------|-----------------------------|
| (1) Primer Coating Area (Glass Side) | (6) Rear Quarter Glass      |
| (2) Outer Panel                      | (7) Luggage Side Trim Cover |
| (3) Sealing Adhesive                 | (8) Clip                    |
| (4) Rear Quarter Trim Cover          | (9) Inner Panel             |
| (5) Primer Coating Area (Body Side)  | (10) Velcro Fastener        |
|                                      | (11) Portion to be cut      |

### Removal

1. Disconnect the battery ground cable.
2. Remove the interior trim cover and seat belt assembly.
  - Refer to Interior Trim Cover and Assist Grip in Exterior/Interior Trim section.
3. Remove the rear quarter glass.
  - Refer to windshield in this section.
  - Apply an adhesive cloth tape to the edge of the vehicle body to protect the coated surface.

## 8F-48 BODY STRUCTURE

- Cut away the adhesive around the rear quarter glass positioning clip with a cutter knife, etc., since it cannot be cut with a piano wire.

6. Cure the adhesive at the temperature of 20 - 30°C (68 - 86°F) for 24 hours.
7. Check that the rear quarter glass does not leak water.

### Installation

To install, follow the removal steps in the reverse order, noting the following points.

1. Clean the bonding surfaces of both the quarter glass and body panel with a soft rag and white gasoline.
2. Apply primer (sun star #435 - 40 or equivalent) to the rear quarter glass side bonding surface as shown in the figure.

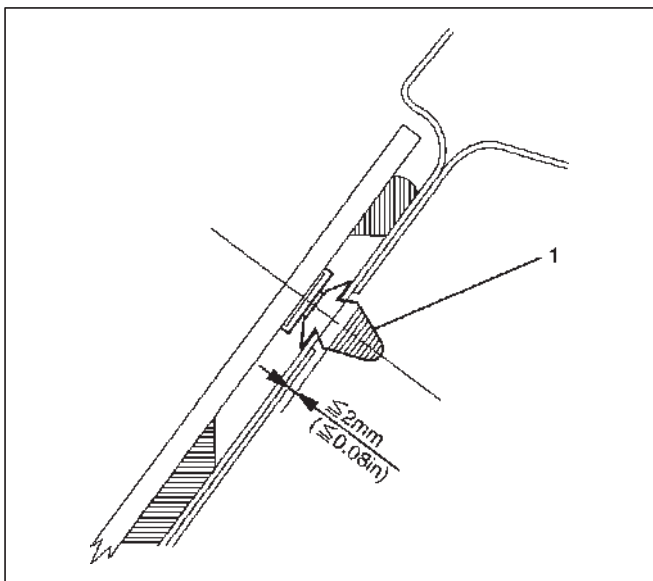
NOTE: Apply an adhesive 3 minutes or more but within 24 hours after the application of primer. If more than 24 hours have passed, reapply primer.

Primer should be handled as follows:

- Use the primer manufactured 3 months or less ago and having been kept in a refrigerator.
  - Wipe off primer stains on positions other than requires application.
  - Stir the primer for a minute or more before use.
3. After drying primer completely, apply a sealing adhesive (Penguin seal #557 or equivalent) along the edge of the glass so that the sealing adhesive has a 20 mm (0.79 in) junction at rear lower side of the glass.
  4. After applying adhesive, insert the rear quarter glass positioning clip into the body panel hole. Then press the glass.
    - Knock the velcro fastener lightly with a rubber hammer to bring the glass into contact completely.
    - Pay attention to the clearance between the glass and body.

NOTE: Affix the glass within 5 minutes of application.

5. After the rear quarter glass is fixed securely, cut the projecting portion of the front upper side clip (1).

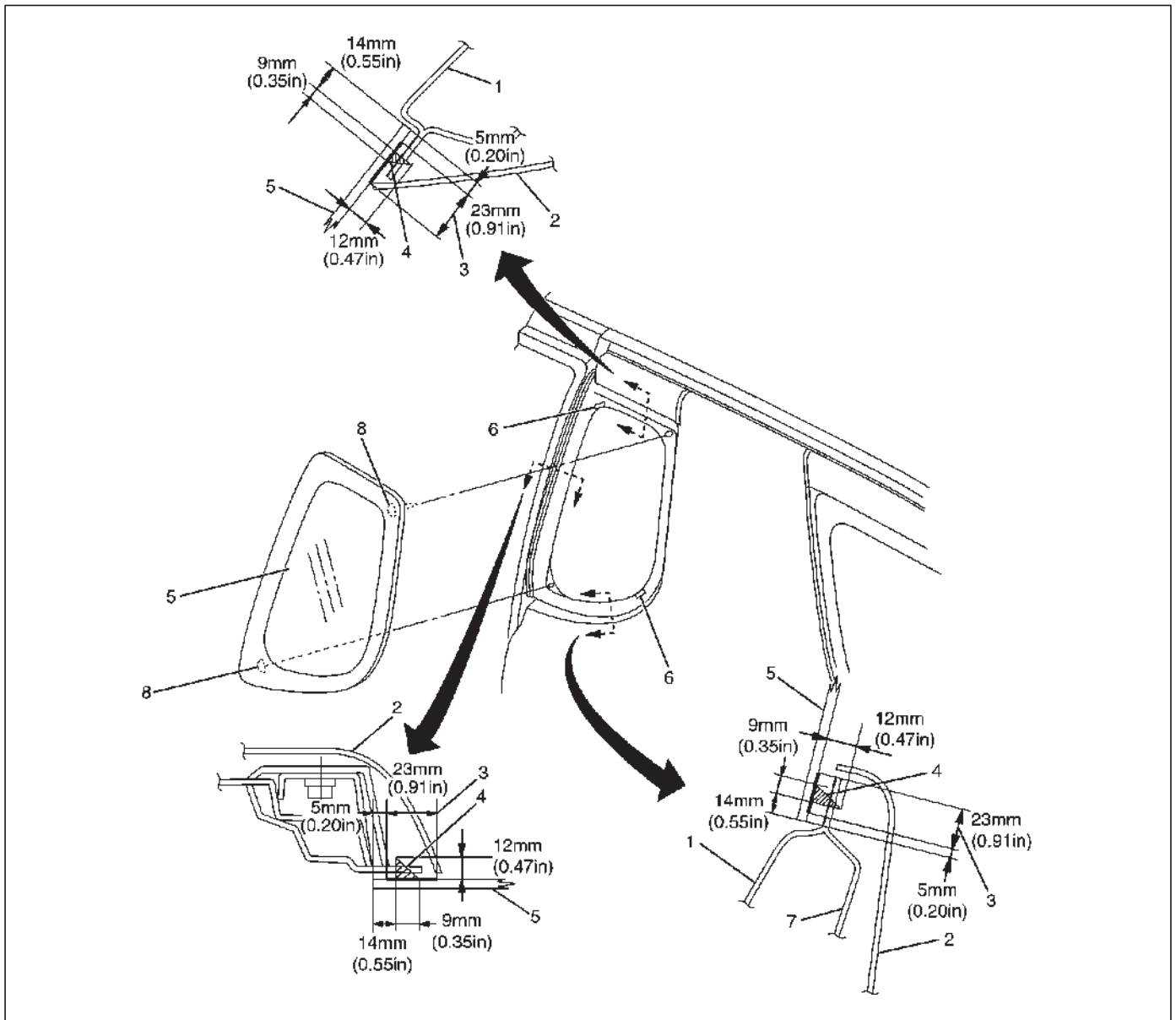


641RX007



## Center Glass

### Parts Location



641RX005

#### Legend

- |                         |                               |
|-------------------------|-------------------------------|
| (1) Quarter Outer Panel | (5) Center Glass              |
| (2) Quarter Trim Cover  | (6) Spacer                    |
| (3) Primer Coating Area | (7) Quarter Inner Upper Panel |
| (4) Sealing Adhesive    | (8) Clip                      |

### Removal

1. Disconnect the battery ground cable.
2. Remove the interior trim covers and seat belts assembly.
  - Refer to Interior Trim Cover and Assist Grip in Exterior/Interior Trim section.
3. Remove the center glass.
  - Refer to Windshield in the section.

**CAUTION:** Apply an adhesive cloth tape to the edge of the vehicle body to protect the coated surface. Cut away the adhesive around the center glass positioning clip with a cutter knife, etc., since it cannot be cut with a piano wire.

## **Installation**

To install, follow the removal steps in the reverse order, noting the following points.

1. Clean the bonding surfaces of both the quarter glass and body panel with a soft rag and white gasoline.
2. Apply primer (sun star #435 - 40 or equivalent) to the center glass side bonding surface as shown in the figure.

**NOTE:** Apply an adhesive 3 minutes or but within 24 hours after the application of primer. If more than 24 hours have passed, reapply primer.

Primer should be handled as follows:

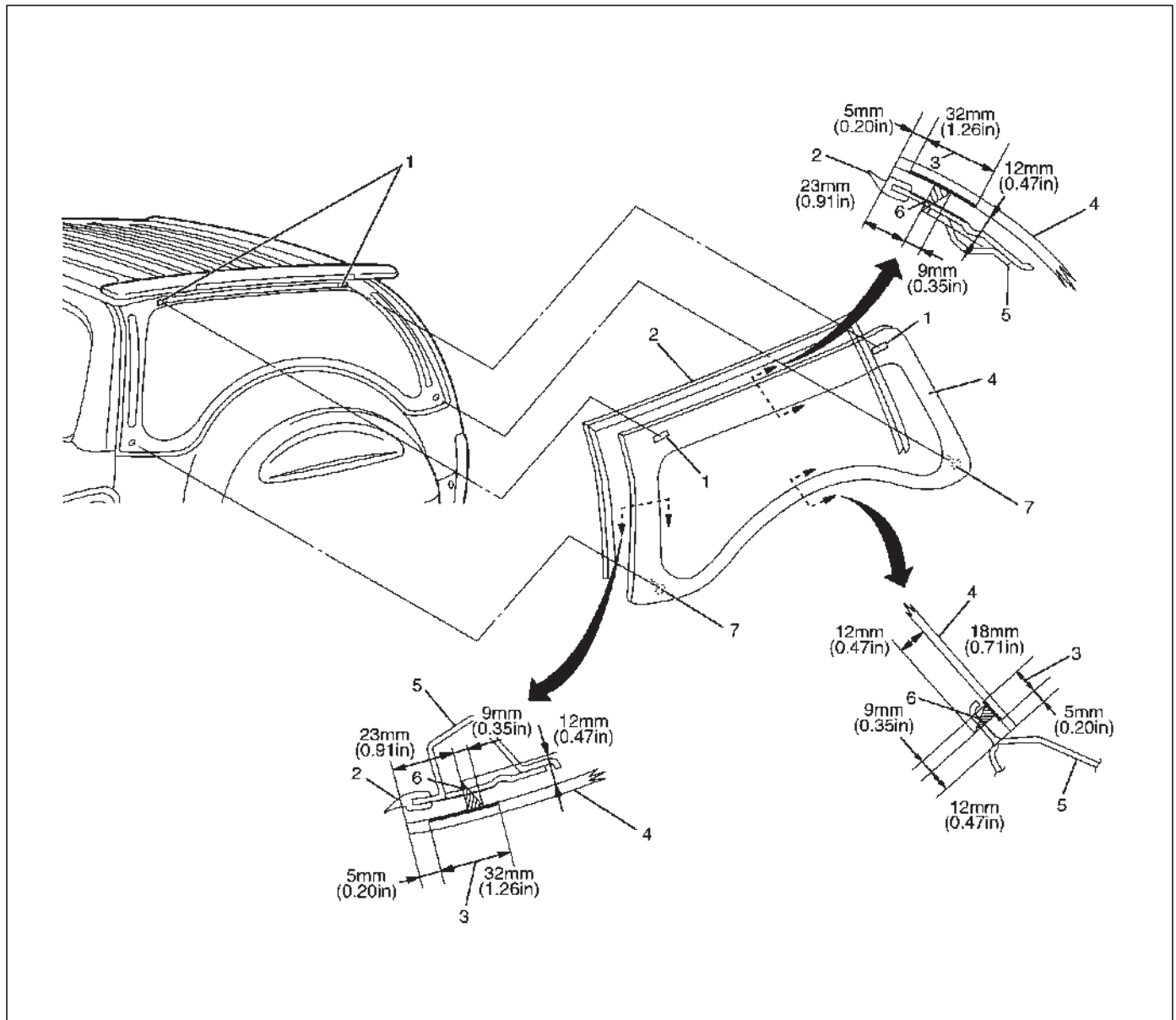
- Use the primer manufactured 3 months or less ago and having been kept in an refrigerator.
  - Wipe off primer stains on positions other than requires application.
  - Stir the primer for a minute or more before use.
3. After applying adhesive, insert the center glass positioning clip into the body panel hole. Then press the glass.

**NOTE:** Affix the glass within 5 minutes of application.

4. Cure the adhesive at the temperature of 20 - 30 °C (68 - 86 °F) for 24 hours.
5. Check that the center glass does not leak water.

## Tailgate Glass

### Parts Location



#### Legend

- |                         |                      |
|-------------------------|----------------------|
| (1) Velcro Fastener     | (4) Tailgate Glass   |
| (2) Tailgate Seal       | (5) Tailgate Panel   |
| (3) Primer Coating Area | (6) Sealing Adhesive |
|                         | (7) Clip             |

### Removal

1. Disconnect the battery ground cable.
2. Disconnect the rear defogger connector.
3. Remove the tailgate seal.
  - Pull out the tailgate seal from the tailgate panel.
4. Remove the tailgate trim cover.
  - Loosen the four fixing knobs.
5. Remove the tailgate glass.
  - Refer to Windshield in this section.

**CAUTION:** Apply an adhesive cloth tape to the edge of the vehicle body to protect the coated surface. Cut away the adhesive around the tailgate glass positioning clip with a cutter knife, etc., since it cannot be cut with a piano wire.

### Installation

To install, follow the removal steps in the reverse order, noting the following points.

1. Clean the bonding surfaces of both the quarter glass and body panel with a soft rag and white gasoline.

## 8F-52 BODY STRUCTURE

---

2. Apply primer (sun star #435 - 40 or equivalent) to the tailgate glass side bonding surface as shown in the figure.

NOTE: Apply an adhesive 3 minutes or but within 24 hours after the application of primer. If more than 24 hours have passed, reapply primer.

Primer should be handled as follows:

- Use the primer manufactured 3 months or less ago and having been kept in an refrigerator.
  - Wipe off primer stains on positions other than requires application.
  - Stir the primer for a minute or more before use.
3. After applying adhesive, insert the tailgate glass positioning clip into the body panel hole Then press the glass.

NOTE: Affix the glass within 5 minutes of application.

4. Cure the adhesive at the temperature of 20 - 30 °C (68 - 86 °F) for 24 hours.
5. Check that the tailgate glass does not leak water.

## Main Data and Specifications

### Torque Specifications

Application	N-m	lb ft	lb in
Front Bumper Beam Fixing Bolts	118	87	—
Engine Hood Hinge Bolts	15	11	—
Engine Hood Lock Assembly Fixing Bolts	10	—	87
Body Mounting Bolts	50	41	—
Brake Pedal Bracket Fixing Bolts	13	—	113
Steering Column Fixing Bolts	17	12	—
Front Door Hinge Bolts	34	25	—
Front Door Striker Screws	15	11	—
Front Door Outside Handle Fixing Bolts	8	—	69
Front Door Lock Assembly Fixing Screw	7	—	61
Front Door Window Regulator and Motor Fixing Bolts	8	—	69
Front Door Glass Fixing Bolts	8	—	69
Tailgate Hinge Bolts	34	25	—
Tailgate Striker Screws	13	—	113
Tailgate Dove-tail Fixing Bolts	13	—	113
Spare Tire Fixing Bolt	50	37	—

# BODY AND ACCESSORIES

## SEATS

### CONTENTS

Service Precaution .....	8G-1	Rear Seat Assembly .....	8G-4
Front Seat Assembly .....	8G-2	Disassembled View .....	8G-4
Disassembled View .....	8G-2	Removal .....	8G-4
Removal .....	8G-2	Installation .....	8G-4
Installation .....	8G-3	Disassembly .....	8G-5
Disassembly .....	8G-3	Reassembly .....	8G-5
Reassembly .....	8G-3	Main Data and Specifications .....	8G-6

### Service Precaution

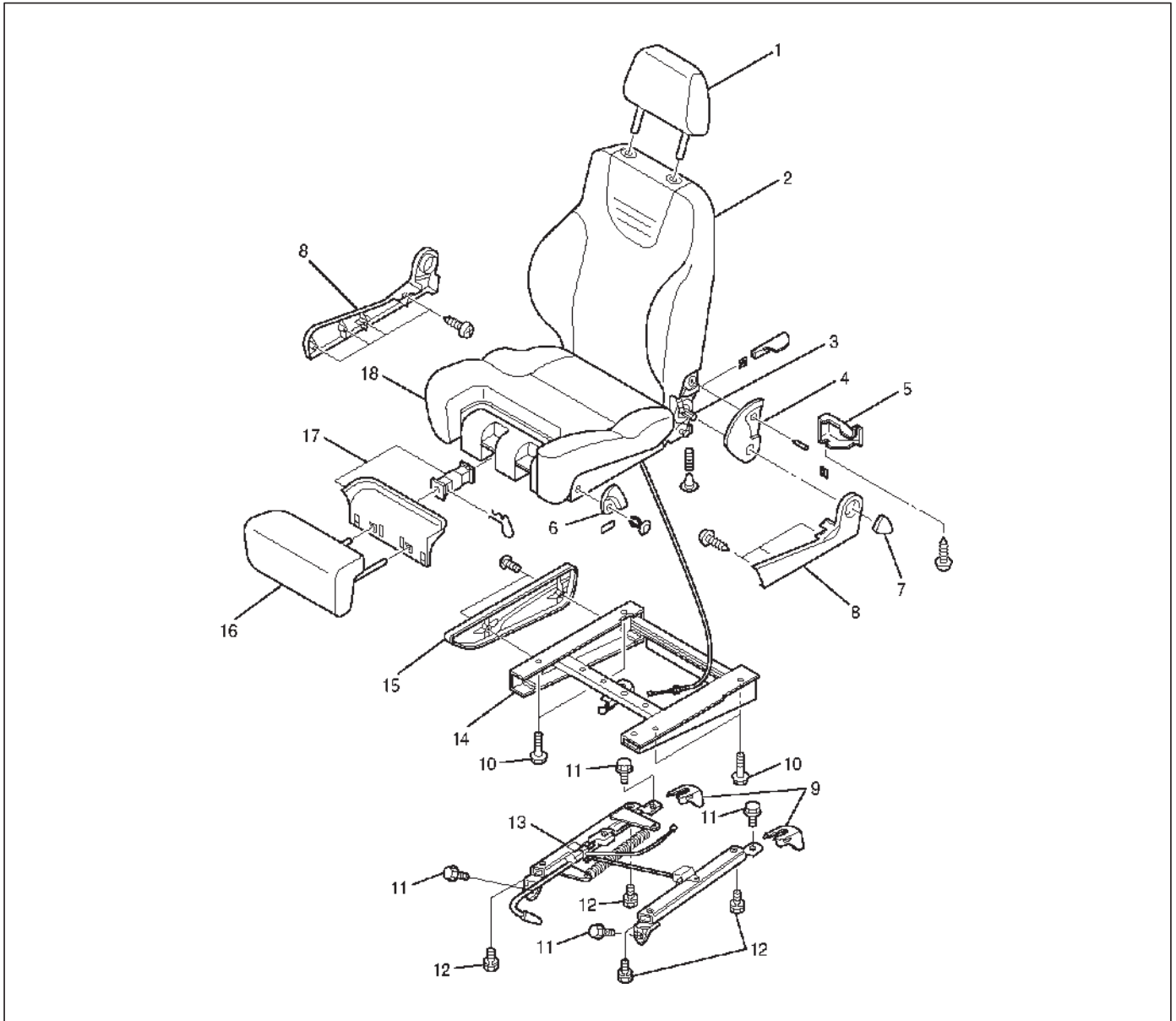
**WARNING: THIS VEHICLE HAS A SUPPLEMENTAL RESTRAINT SYSTEM (SRS). REFER TO THE SRS COMPONENT AND WIRING LOCATION VIEW IN ORDER TO DETERMINE WHETHER YOU ARE PERFORMING SERVICE ON OR NEAR THE SRS COMPONENTS OR THE SRS WIRING. WHEN YOU ARE PERFORMING SERVICE ON OR NEAR THE SRS COMPONENTS OR THE SRS WIRING, REFER TO THE SRS SERVICE INFORMATION. FAILURE TO FOLLOW WARNINGS COULD RESULT IN POSSIBLE AIR BAG DEPLOYMENT, PERSONAL INJURY, OR OTHERWISE UNNEEDED SRS SYSTEM REPAIRS.**

**CAUTION: Always use the correct fastener in the proper location. When you replace a fastener, use ONLY the exact part number for that application. ISUZU will call out those fasteners that require a replacement after removal. ISUZU will also call out the fasteners that require thread lockers or thread sealant. UNLESS OTHERWISE SPECIFIED, do not use supplemental coatings (Paints, greases, or other corrosion inhibitors) on threaded fasteners or fastener joint interfaces. Generally, such coatings adversely affect the fastener torque and the joint clamping force, and may damage the fastener. When you install fasteners, use the correct tightening sequence and specifications. Following these instructions can help you avoid damage to parts and systems.**

## Front Seat Assembly

### Disassembled View

This illustration is based on the passenger's side seat.



750RX010

#### Legend

- |                              |   |
|------------------------------|---|
| (1) Headrest                 | (10) Fixing Bolt (Seat Spacer to Seat Frame)    |
| (2) Seat Back Assembly       | (11) Fixing Bolt (Seat Adjuster to Floor Panel) |
| (3) Reclining Device         | (12) Fixing Bolt (Seat Adjuster to Seat Spacer) |
| (4) Reclining Cover          | (13) Seat Adjuster                              |
| (5) Rear Cover               | (14) Seat Spacer                                |
| (6) Cover                    | (15) Front Seat Cover                           |
| (7) Reclining Knob           | (16) Seat Side Support                          |
| (8) Side Cover               | (17) Guide Box                                  |
| (9) Seat Adjuster Rear Cover | (18) Seat Cushion Assembly                      |

### Removal

1. Disconnect the battery ground cable.
2. Remove the seat adjuster rear cover.
3. Remove the front seat assembly.
  - Remove the four seat adjuster fixing bolts.

## Installation

To install, follow the removal steps in the reverse order, noting the following points.

1. Tighten the front seat assembly fixing bolts to the specified torque.

**Torque: 40 N·m (30 lb ft)**

## Disassembly

1. Remove the headrest.
2. Remove the front seat cover.
  - Remove the two fixing screws.
3. Remove the reclining knob.
4. Remove the reclining cover.
5. Remove the cover.
6. Remove the side covers.
  - Remove the four fixing screws.
7. Remove the rear cover.
8. Remove the reclining device.
  - Remove the four bolts.
  - Remove the walk-in cable from reclining device (Passenger seat side).
9. Remove the seat back assembly.
10. Remove the seat adjuster.
  - Remove the four fixing bolts.
  - Remove the walk-in cable from seat adjuster (Passenger seat side).
11. Remove the seat spacer.
  - Remove the four fixing bolts.
12. Remove the seat cushion assembly.
13. Remove the seat side support.
14. Remove the guide box.

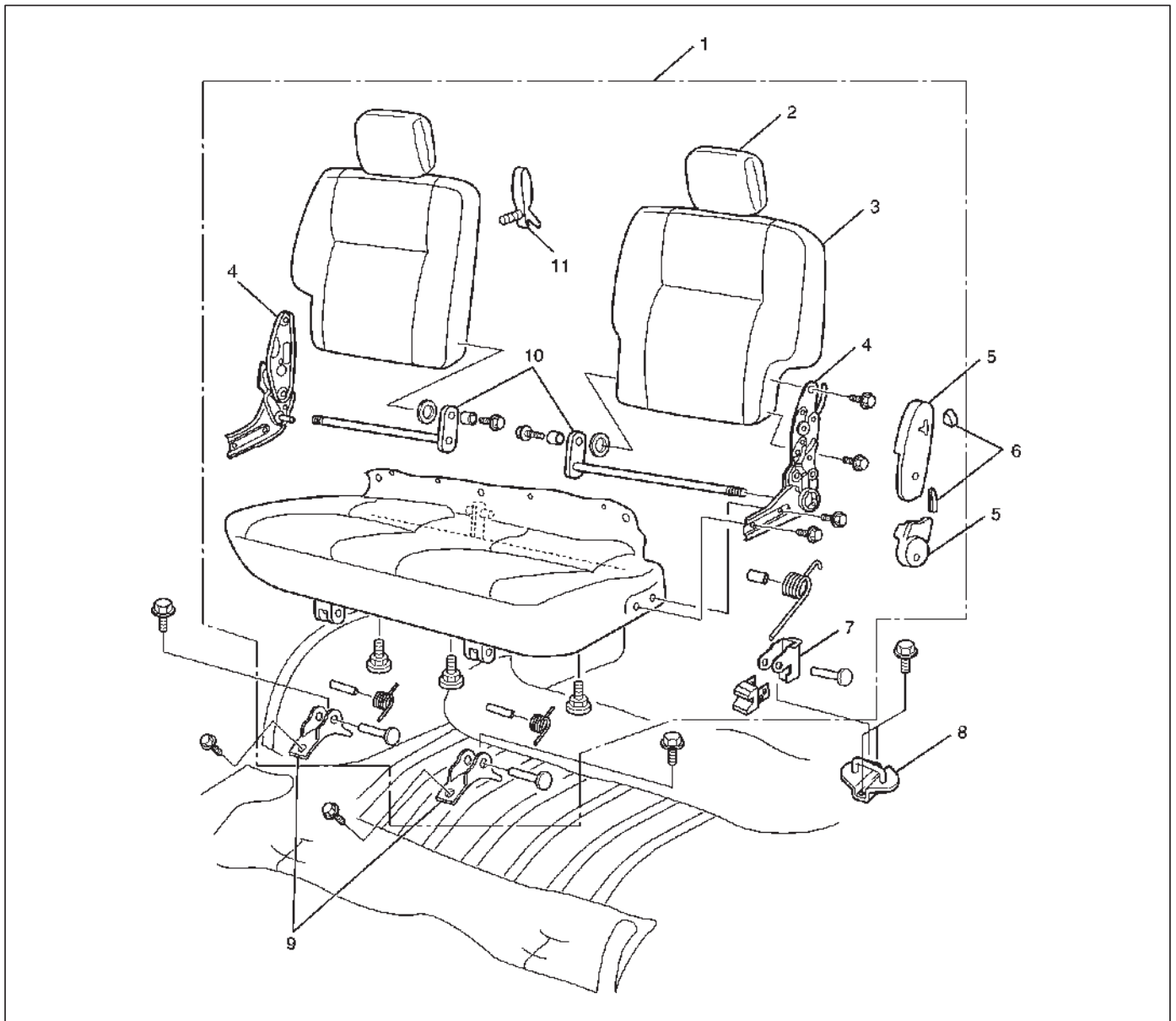
## Reassembly

To reassembly, follow the removal steps in the reverse order.



## Rear Seat Assembly

### Disassembled View



755RX014

#### Legend

- |                               |                                |
|-------------------------------|--------------------------------|
| (1) Rear Seat Assembly        | (6) Reclining Knob             |
| (2) Headrest                  | (7) Hook Sub-Assembly          |
| (3) Seat Back Assembly        | (8) Seat Lock Striker          |
| (4) Reclining Device Assembly | (9) Hinge                      |
| (5) Reclining Cover           | (10) Center Hinge Sub-Assembly |
|                               | (11) Stopper Band              |

### Removal

1. Disconnect the battery ground cable.
2. Lift the hook to release the rear seat lock and tilt the rear seat assembly forward.
3. Remove the rear seat assembly.
  - Remove the four rear seat hinge fixing bolts.

### Installation

To install, follow the removal steps in the reverse order, nothing the following points.

1. Tighten the rear seat hinge fixing bolts to the specified torque.

**Torque: 39 N·m (29 lb ft)**

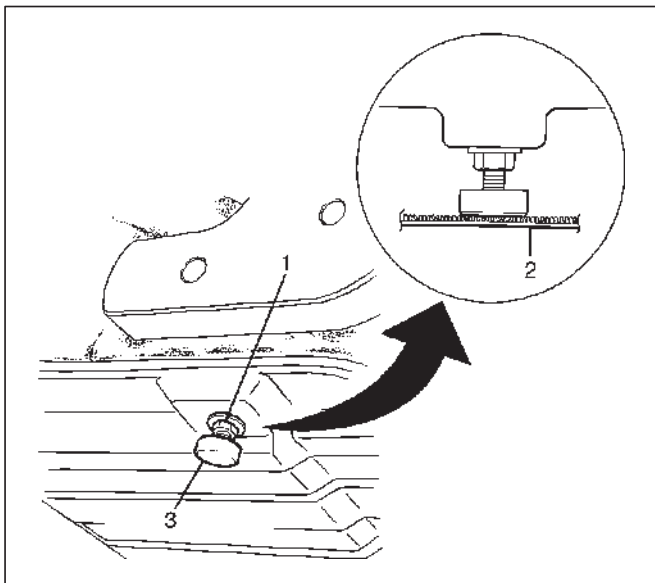
## Disassembly

1. Remove the headrest.
2. Remove the reclining knob.
3. Remove the reclining cover.
4. Remove the reclining device assembly.
  - Remove the two seat cushion side fixing bolts.
  - Fold the seat back and then remove the two seat back side fixing bolts.
5. Remove the seat back assembly.
  - Remove the center hinge side fixing bolt.
6. Remove the center hinge sub-assembly.
  - Put off the seat cushion stopper and the rear end the hog rings retaining trim cover, and then draw out the sub-assembly.
7. Remove the stopper band.
8. Remove the seat lock striker.

## Reassembly

To reassemble, follow the disassembly steps in the reverse order, nothing the following point.

1. Loosen the rubber stopper lock nut(1). Adjust the stopper(3) so there is no clearance between the bottom of the stopper and the carpet(2) while you make sure the rear seat is firmly locked. Then tighten the lock nut securely.



775RS005

## Main Data and Specifications

### Torque Specifications

Application	N·m	lb ft	lb in
Front Seat Assembly Fixing Bolts	40	30	—
Rear Seat Hinge Fixing bolts	39	29	—

VEHICROSS

# BODY AND ACCESSORIES

## SECURITY AND LOCKS

### CONTENTS

Service Precaution .....	8H-1	Tailgate Lock, Lock Cylinder and Associated Parts .....	8H-6
Front Door Lock Assembly .....	8H-2	Removal .....	8H-6
Front Door Lock Assembly and Associated Parts .....	8H-2	Installation .....	8H-7
Removal .....	8H-2	Key .....	8H-8
Installation .....	8H-3	Key Coding .....	8H-8
Front Outside Handle and Door Lock Cylinder	8H-4	Key Styles .....	8H-8
Front Outside Handle, Door Lock Cylinder and Associated Parts .....	8H-4	Power Door Lock System .....	8H-9
Removal .....	8H-4	General Description .....	8H-9
Installation .....	8H-5	Front Door Lock Actuator Removal .....	8H-9
Tailgate Lock and Lock Cylinder .....	8H-6	Front Door Lock Actuator Installation .....	8H-9
		Main Data and Specifications .....	8H-10

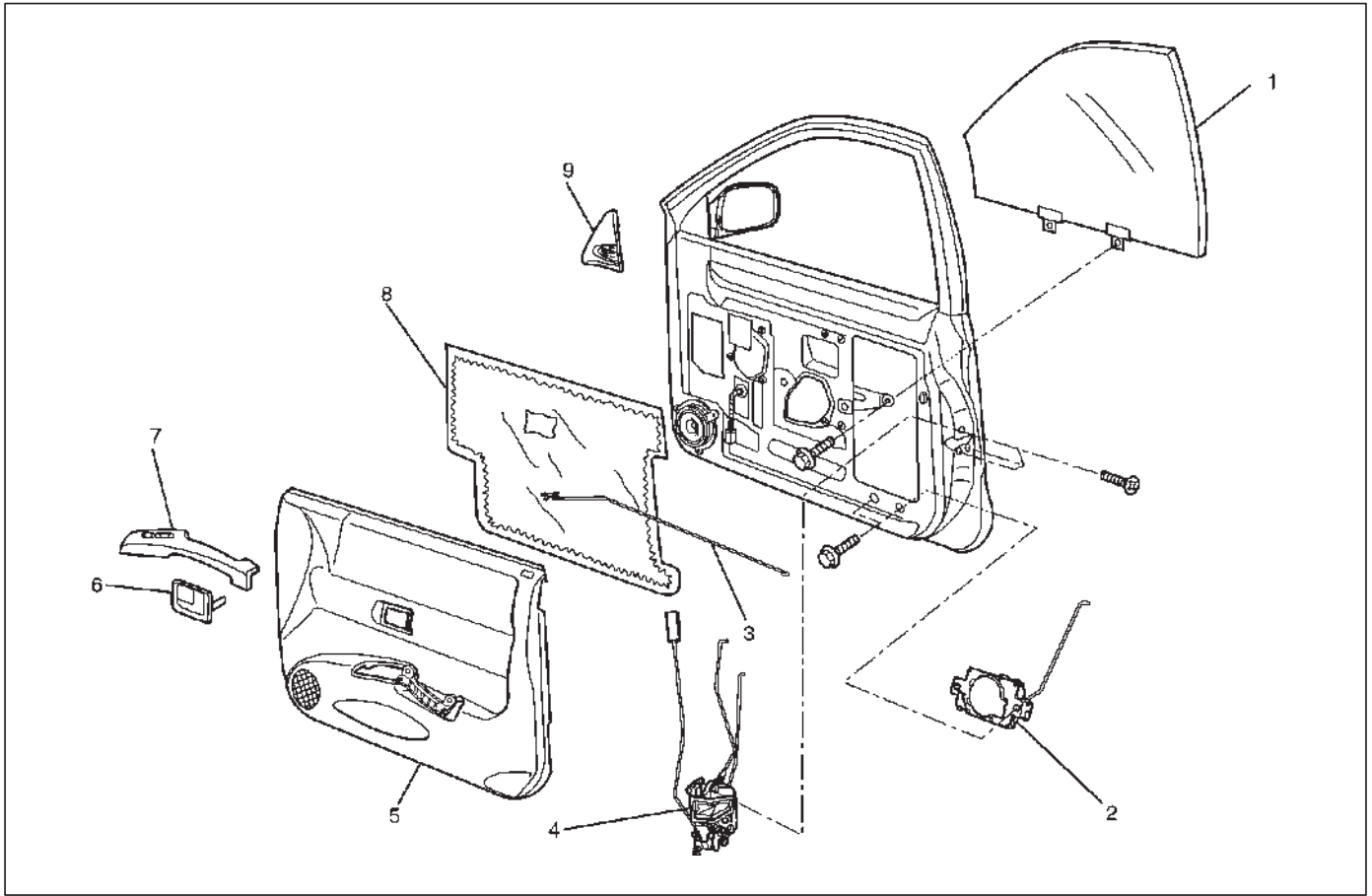
### Service Precaution

**WARNING: THIS VEHICLE HAS A SUPPLEMENTAL RESTRAINT SYSTEM (SRS). REFER TO THE SRS COMPONENT AND WIRING LOCATION VIEW IN ORDER TO DETERMINE WHETHER YOU ARE PERFORMING SERVICE ON OR NEAR THE SRS COMPONENTS OR THE SRS WIRING. WHEN YOU ARE PERFORMING SERVICE ON OR NEAR THE SRS COMPONENTS OR THE SRS WIRING, REFER TO THE SRS SERVICE INFORMATION. FAILURE TO FOLLOW WARNINGS COULD RESULT IN POSSIBLE AIR BAG DEPLOYMENT, PERSONAL INJURY, OR OTHERWISE UNNEEDED SRS SYSTEM REPAIRS.**

**CAUTION: Always use the correct fastener in the proper location. When you replace a fastener, use ONLY the exact part number for that application. ISUZU will call out those fasteners that require a replacement after removal. ISUZU will also call out the fasteners that require thread lockers or thread sealant. UNLESS OTHERWISE SPECIFIED, do not use supplemental coatings (Paints, greases, or other corrosion inhibitors) on threaded fasteners or fastener joint interfaces. Generally, such coatings adversely affect the fastener torque and the joint clamping force, and may damage the fastener. When you install fasteners, use the correct tightening sequence and specifications. Following these instructions can help you avoid damage to parts and systems.**

## Front Door Lock Assembly

### Front Door Lock Assembly and Associated Parts



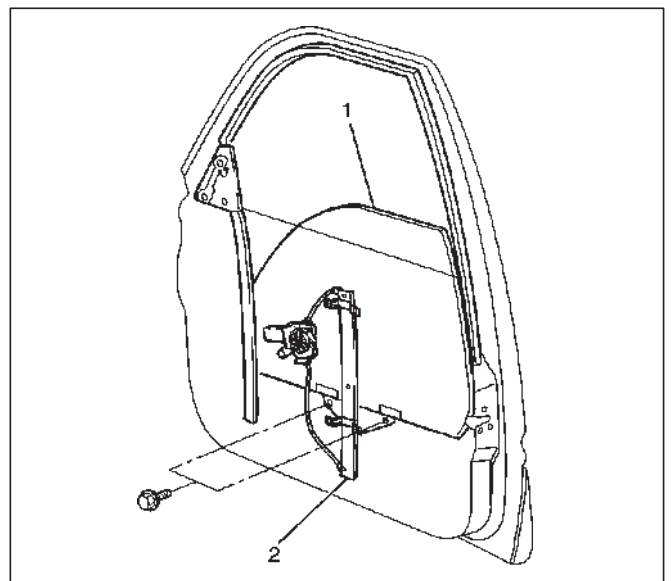
632RX004

#### Legend

- |                        |                                      |
|------------------------|--------------------------------------|
| (1) Door Glass         | (5) Door Trim Assembly               |
| (2) Door Lock Actuator | (6) Inside Handle                    |
| (3) Inside Handle Link | (7) Power Window Switch / Grip Cover |
| (4) Door Lock Assembly | (8) Waterproof Sheet                 |
|                        | (9) Tweeter Assembly                 |

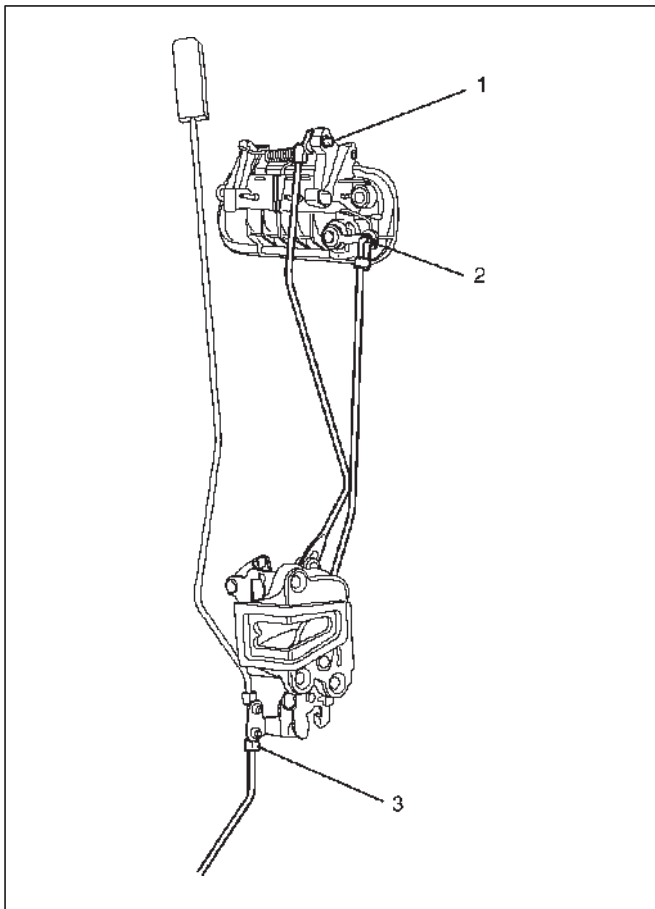
#### Removal

1. Disconnect the battery ground cable.
2. Remove the door trim assembly.
  - Refer to Front Window Regulator, Glass and Glass Run in Body Structure section.
3. Remove the waterproof sheet.
4. Remove the door glass (1).
  - Remove the two fixing bolts from the window regulator (2).



631RX005

5. Remove the inside handle link.
  - Remove the clip and disconnect the link from the door lock assembly.
6. Remove the door lock actuator.
  - Remove the two fixing bolts and disconnect the actuator connector.
  - Disconnect the link (3) from the door lock assembly.
7. Remove the door lock assembly.
  - Remove the three fixing screws.
  - Disconnect the links from outside handle (1) and door lock cylinder (2).



## Installation

To install, follow the removal steps in the reverse order, noting the following points.

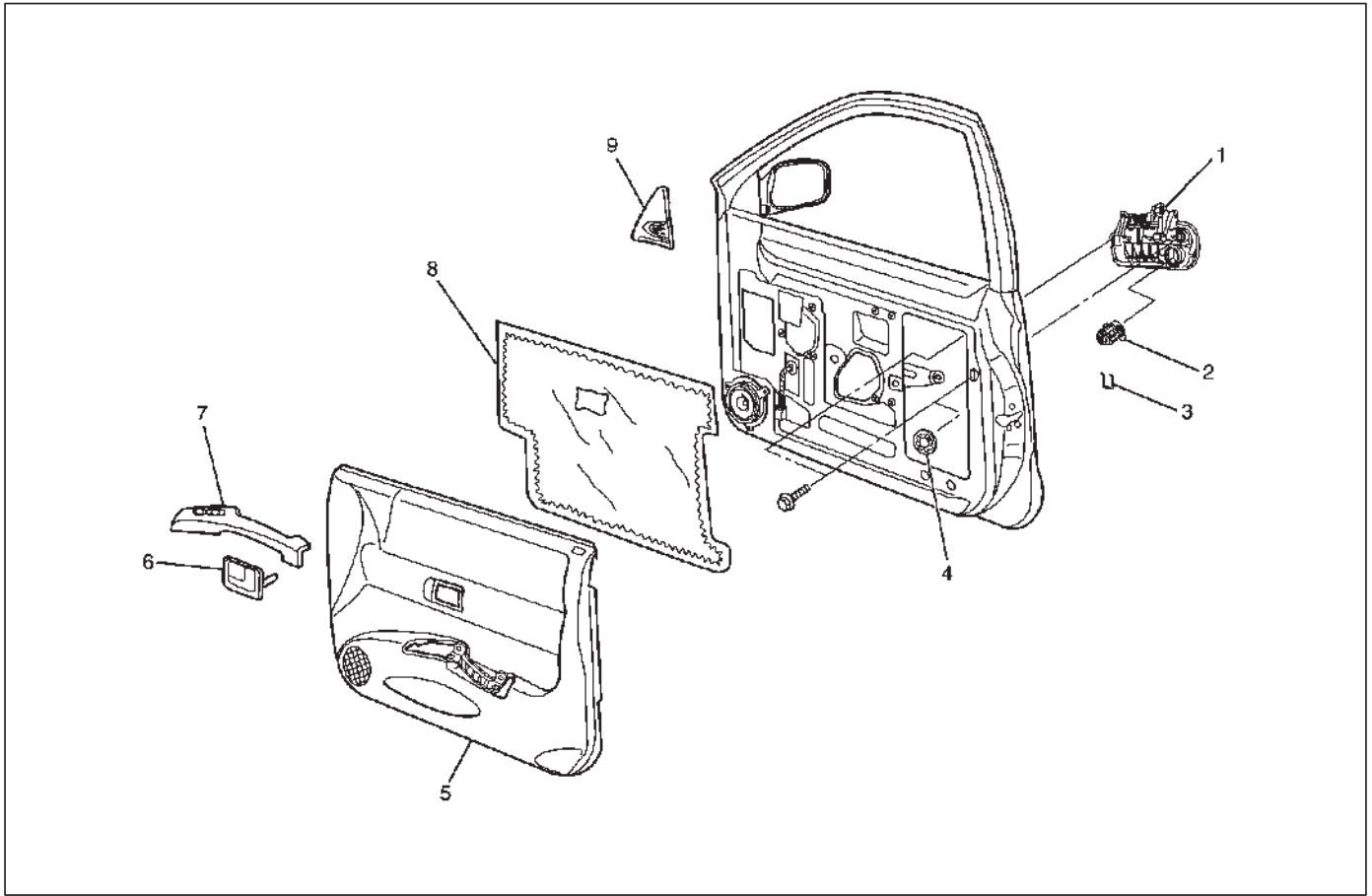
1. Apply chassis grease to the lock assembly and striker moving surface.
2. Tighten the door lock assembly fixing screws to the specified torque.

**Torque: 7 N·m (61 lb in)**

3. Check that the door lock operates smoothly.

## Front Outside Handle and Door Lock Cylinder

### Front Outside Handle, Door Lock Cylinder and Associated Parts



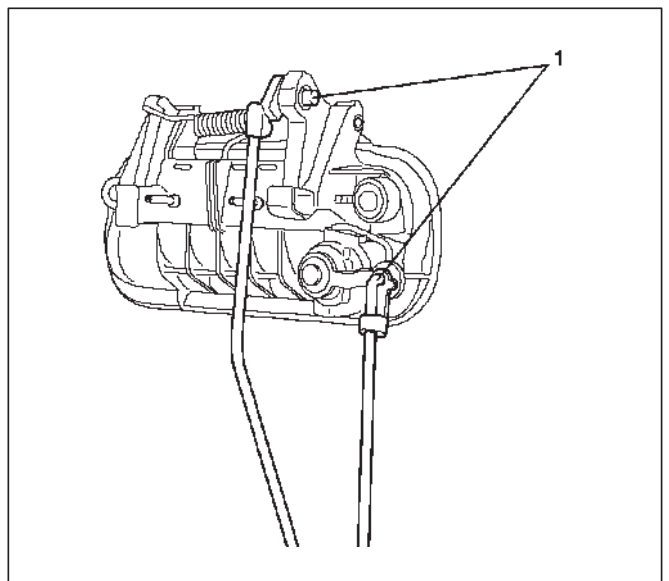
632RX006

#### Legend

- |                        |                                      |
|------------------------|--------------------------------------|
| (1) Outside Handle     | (5) Door Trim Assembly               |
| (2) Door Lock Cylinder | (6) Inside Handle                    |
| (3) Clip               | (7) Power Window Switch / Grip Cover |
| (4) Grommet            | (8) Waterproof Sheet                 |
|                        | (9) Tweeter Assembly                 |

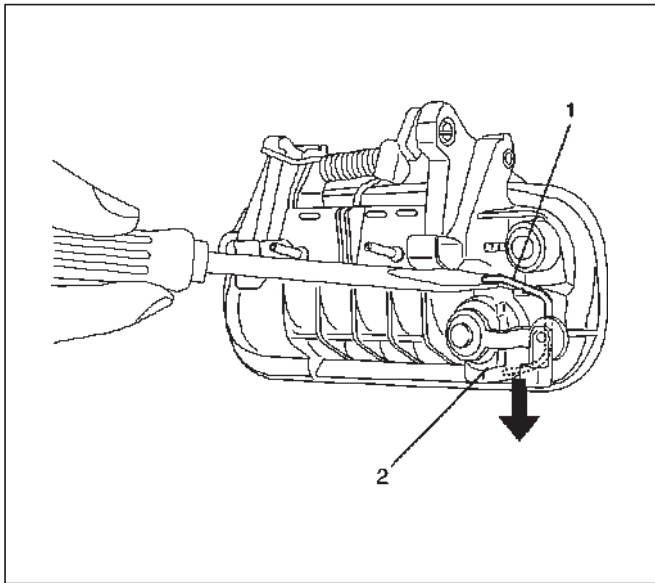
#### Removal

1. Disconnect the battery ground cable.
2. Remove the door trim assembly.
  - Refer to Front Window Regulator, Glass and Glass Run in Body Structure section.
3. Remove the waterproof sheet.
  - Take notice of the door harness and the grommet, peel the waterproof sheet off the door panel carefully.
4. Remove the Grommet.
5. Remove the outside handle.
  - Remove the two fixing bolts.
  - Disconnect the locking links (1).



632RX003

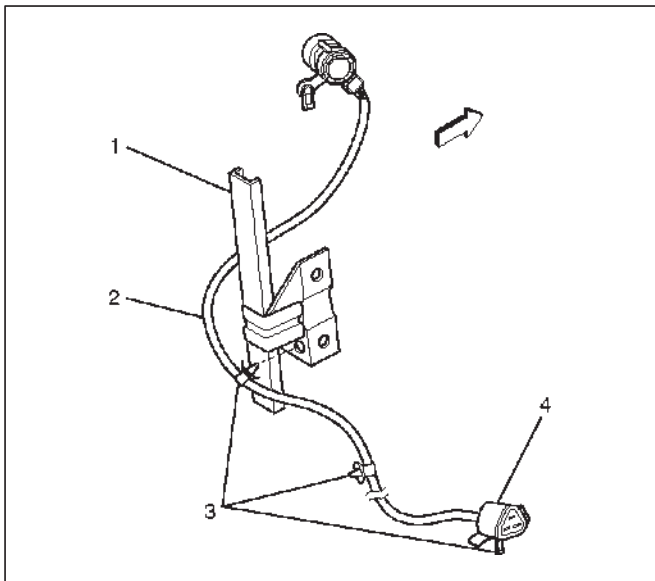
6. Remove the fixing clip(1) to remove the door lock cylinder(2).



632RX001

7. Remove the door lock cylinder switch harness (2) (driver's side only).

- Disconnect the connector (4).
- Remove the three clips (3) from door panel and rear guide rail (1).



632RX007

## Installation

To install, follow the removal steps in the reverse order, noting the following points.

1. When installing the door lock cylinder switch harness, pass through the back of rear guide rail.
2. Tighten the outside handle fixing bolts to the specified torque.

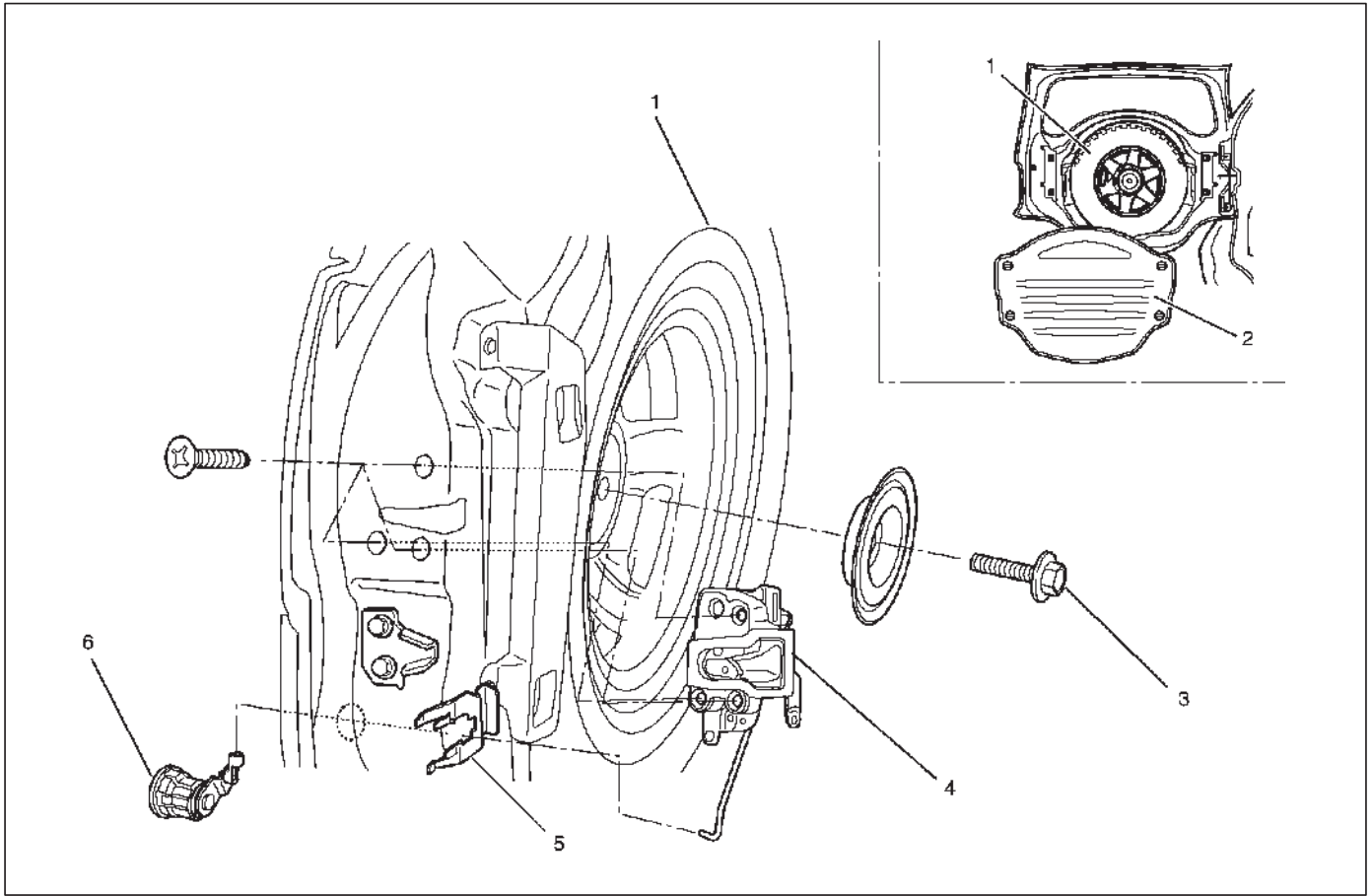
**Torque: 9 N·m (78 lb in)**

3. Check for smooth outside handle and lock cylinder operation.



## Tailgate Lock and Lock Cylinder

### Tailgate Lock, Lock Cylinder and Associated Parts



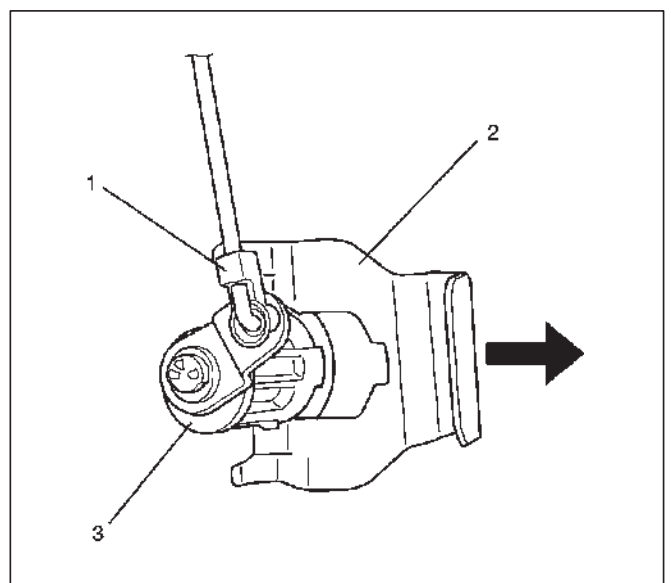
683RX004

#### Legend

- |                            |                                     |
|----------------------------|-------------------------------------|
| (1) Spare Tire             | (4) Tailgate Lock Assembly          |
| (2) Tailgate Trim Cover    | (5) Lock Cylinder Retaining Clip    |
| (3) Spare Tire Fixing Bolt | (6) Tailgate Lock Cylinder Assembly |

### Removal

1. Disconnect the battery ground cable.
2. Remove the tailgate trim cover.
  - Loosen the four fixing knob.
3. Remove the spare tire.
  - Refer to Spare Tire Carrier in Body Structure section.
4. Remove the tailgate lock cylinder assembly (3).
  - Disconnect the tailgate lock link (1).
  - Remove the lock cylinder retaining clip (2) with screwdriver to remove lock cylinder.



683RX005

5. Remove the tailgate lock assembly.
  - Remove the three fixing screws.

## Installation

To install, follow the removal steps in the reverse order, noting the following points.

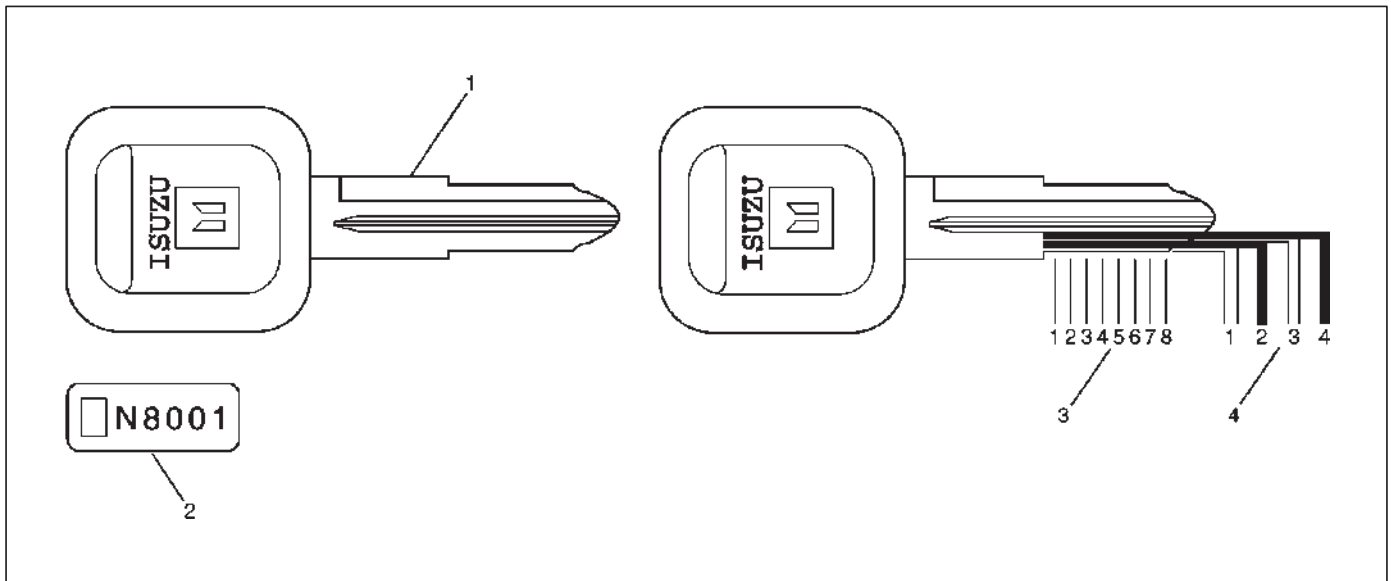
1. Apply chassis grease to the lock assembly and striker moving surface.
2. Tighten the tailgate lock assembly fixing screws to the specified torque.

**Torque: 7 N·m (61 lb in)**

3. Check that the tailgate lock operates correctly after installing it.

## Key

### Key Coding



730RW001

#### Legend

- (1) Key (Actual Size)
- (2) Key Code Tag

- (3) Position
- (4) Level

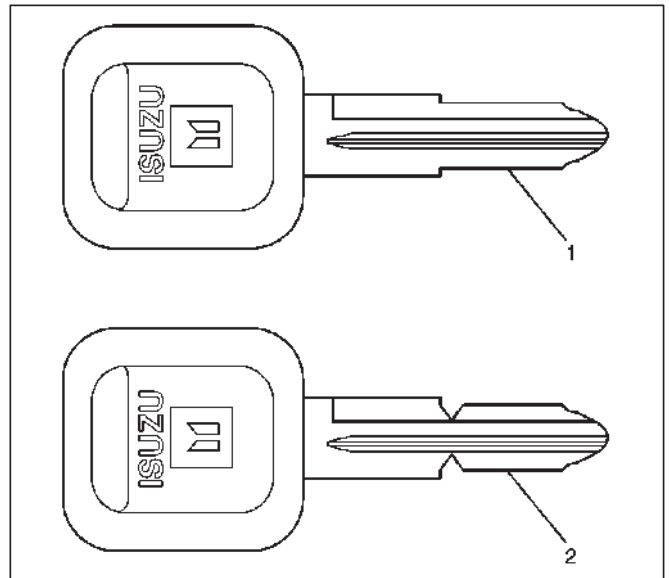
One key is used for the ignition, door, fuel filler door, glove box, and tailgate lock cylinders. The keys are cut on both edges to make them reversible.

Key identification is obtained from the five character key code stamped on the key code tag. From this key code, the key code cutting combination can be determined from a code list (available to owners of key cutting equipment from suppliers).

If key codes are not available from records or tags, the key code can be obtained from the right hand door lock cylinder (if lock has not been replaced). Lock cylinders supplied by the factory as service parts are unmarked.

If the original key is available, the key code cutting combination can be determined by laying the key on the diagram shown in the figure.

### Key Styles



730RS010

#### Legend

- (1) Blank Key Style "A"
- (2) Blank Key Style "B"

The keys come in styles A or B depending on the key code cutting combination. When the first position in the combination is a 1, 2 or 3, Style A is used. When the first position is a 4, Style B (factory pre-cut key) is used.

## Power Door Lock System

### General Description

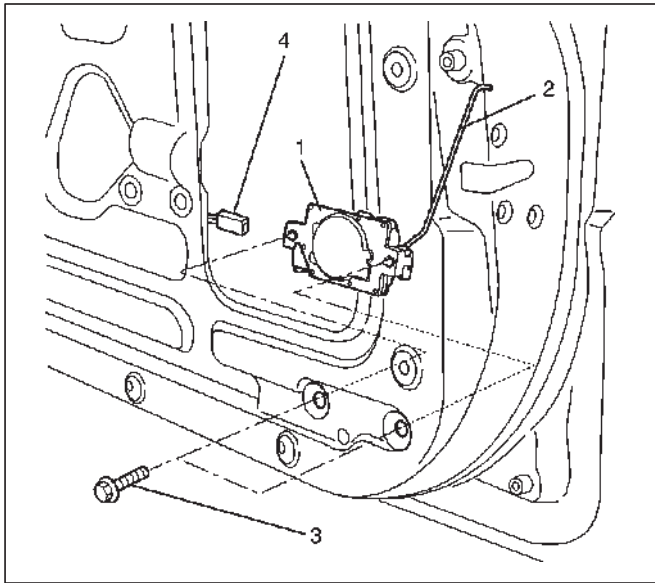
The circuit consists of the door lock & power window switch, door lock actuator and door lock switch – LH is always provided with battery voltage.

The key or the inside lock button on the driver's door can activate the lock mechanism of all the doors.

When the door lock switch is turned to lock or unlock position, current flows for about one second to the door lock actuator of each door connected with the door lock & power window switch – LH to activate the actuator to lock or unlock the door.

### Front Door Lock Actuator Removal

1. Disconnect the battery ground cable.
2. Remove the front door trim assembly.
  - Refer to Front Door Trim Assembly in Exterior/Interior Trim section.
3. Remove the waterproof sheet.
4. Remove the door lock actuator (1).
  - Remove the two fixing bolts (3) and disconnect the actuator connector (4).
  - Disconnect the link (2) from the door lock assembly.



632RX005

### Front Door Lock Actuator Installation

To install, follow the removal steps in the reverse order.

## Main Data and Specifications

### Torque Specifications

Application	N·m	lb ft	lb in
Front Door Lock Assembly Fixing Screws	7	—	61
Front Outside Handle Fixing Bolts	9	—	78
Tailgate Lock Assembly Fixing Screws	7	—	61

VEHICROSS

# BODY AND ACCESSORIES

## EXTERIOR / INTERIOR TRIM

### CONTENTS

Service Precaution .....	8J-1	Tailgate Protector .....	8J-11
Consoles .....	8J-2	Parts Location .....	8J-11
Consoles and Associated Parts .....	8J-2	Removal .....	8J-11
Removal .....	8J-2	Installation .....	8J-11
Installation .....	8J-2	Fuel Filler Lid .....	8J-12
Front Door Trim Assembly .....	8J-3	Parts Location .....	8J-12
Front Door Trim Assembly and		Removal .....	8J-12
Associated Parts .....	8J-3	Installation .....	8J-12
Removal .....	8J-3	Roof Rail Assembly .....	8J-13
Installation .....	8J-4	Parts Location .....	8J-13
Door Mirror .....	8J-4	Removal .....	8J-13
Door Mirror and Associated Parts .....	8J-4	Installation .....	8J-13
Removal .....	8J-4	Rear Roof Spoiler .....	8J-14
Installation .....	8J-4	Parts Location .....	8J-14
Interior Trim Cover and Assist Grip .....	8J-5	Removal .....	8J-14
Interior Trim Cover, Assist Grip and		Installation .....	8J-14
Associated Parts .....	8J-5	Power Door Mirror System .....	8J-15
Removal .....	8J-5	General Description .....	8J-15
Installation .....	8J-6	Door Mirror Control Switch and Door	
Headlining .....	8J-7	Mirror Defogger Switch Removal .....	8J-15
Parts Location .....	8J-7	Installation .....	8J-15
Removal .....	8J-7	Power Door Mirror .....	8J-15
Installation .....	8J-8	General Description .....	8J-15
Tailgate Trim Cover .....	8J-8	Removal and Installation .....	8J-15
Tailgate Trim Cover and Associated Parts ..	8J-8	Power Window System .....	8J-16
Removal .....	8J-8	General Description .....	8J-16
Installation .....	8J-8	Power Window Switch Removal and	
Body Side Protectors .....	8J-9	Installation .....	8J-16
Body Side Protectors and Associated Parts	8J-9	Power Window Motor Removal and	
Removal .....	8J-10	Installation .....	8J-17
Installation .....	8J-10	Main Data and Specifications .....	8J-18

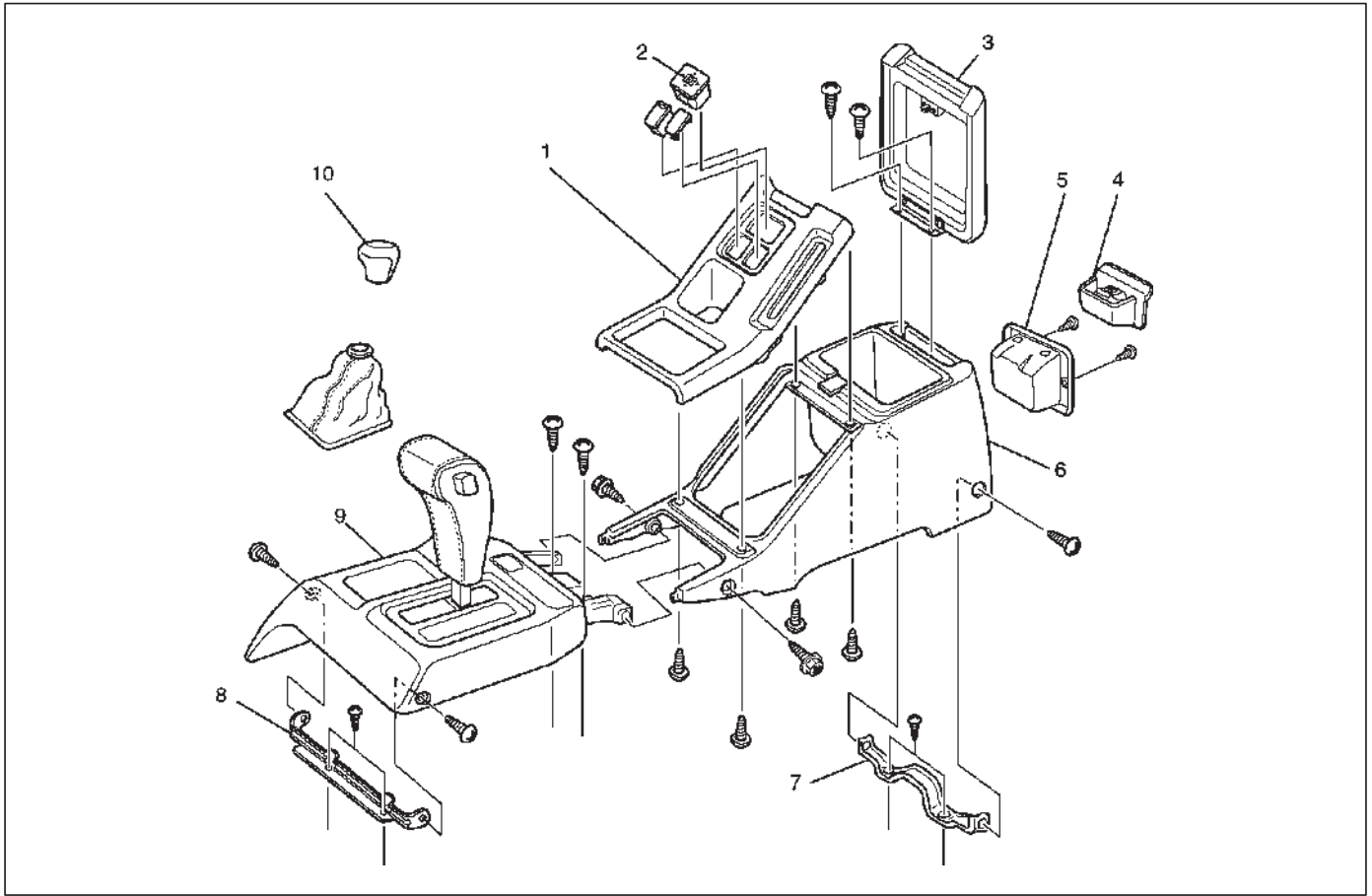
### Service Precaution

**WARNING: THIS VEHICLE HAS A SUPPLEMENTAL RESTRAINT SYSTEM (SRS). REFER TO THE SRS COMPONENT AND WIRING LOCATION VIEW IN ORDER TO DETERMINE WHETHER YOU ARE PERFORMING SERVICE ON OR NEAR THE SRS COMPONENTS OR THE SRS WIRING. WHEN YOU ARE PERFORMING SERVICE ON OR NEAR THE SRS COMPONENTS OR THE SRS WIRING, REFER TO THE SRS SERVICE INFORMATION. FAILURE TO FOLLOW WARNINGS COULD RESULT IN POSSIBLE AIR BAG DEPLOYMENT, PERSONAL INJURY, OR OTHERWISE UNNEEDED SRS SYSTEM REPAIRS.**

**CAUTION: Always use the correct fastener in the proper location. When you replace a fastener, use ONLY the exact part number for that application. ISUZU will call out those fasteners that require a replacement after removal. ISUZU will also call out the fasteners that require thread lockers or thread sealant. UNLESS OTHERWISE SPECIFIED, do not use supplemental coatings (Paints, greases, or other corrosion inhibitors) on threaded fasteners or fastener joint interfaces. Generally, such coatings adversely affect the fastener torque and the joint clamping force, and may damage the fastener. When you install fasteners, use the correct tightening sequence and specifications. Following these instructions can help you avoid damage to parts and systems.**

## Consoles

### Consoles and Associated Parts



745RX003

#### Legend

- |                                  |                             |
|----------------------------------|-----------------------------|
| (1) Rear Console Garnish         | (6) Rear Console Assembly   |
| (2) Remote Control Mirror Switch | (7) Rear Console Bracket    |
| (3) Rear Console Lid             | (8) Center Console Bracket  |
| (4) Ashtray                      | (9) Center Console Assembly |
| (5) Ashtray Case                 | (10) Transfer Knob          |

### Removal

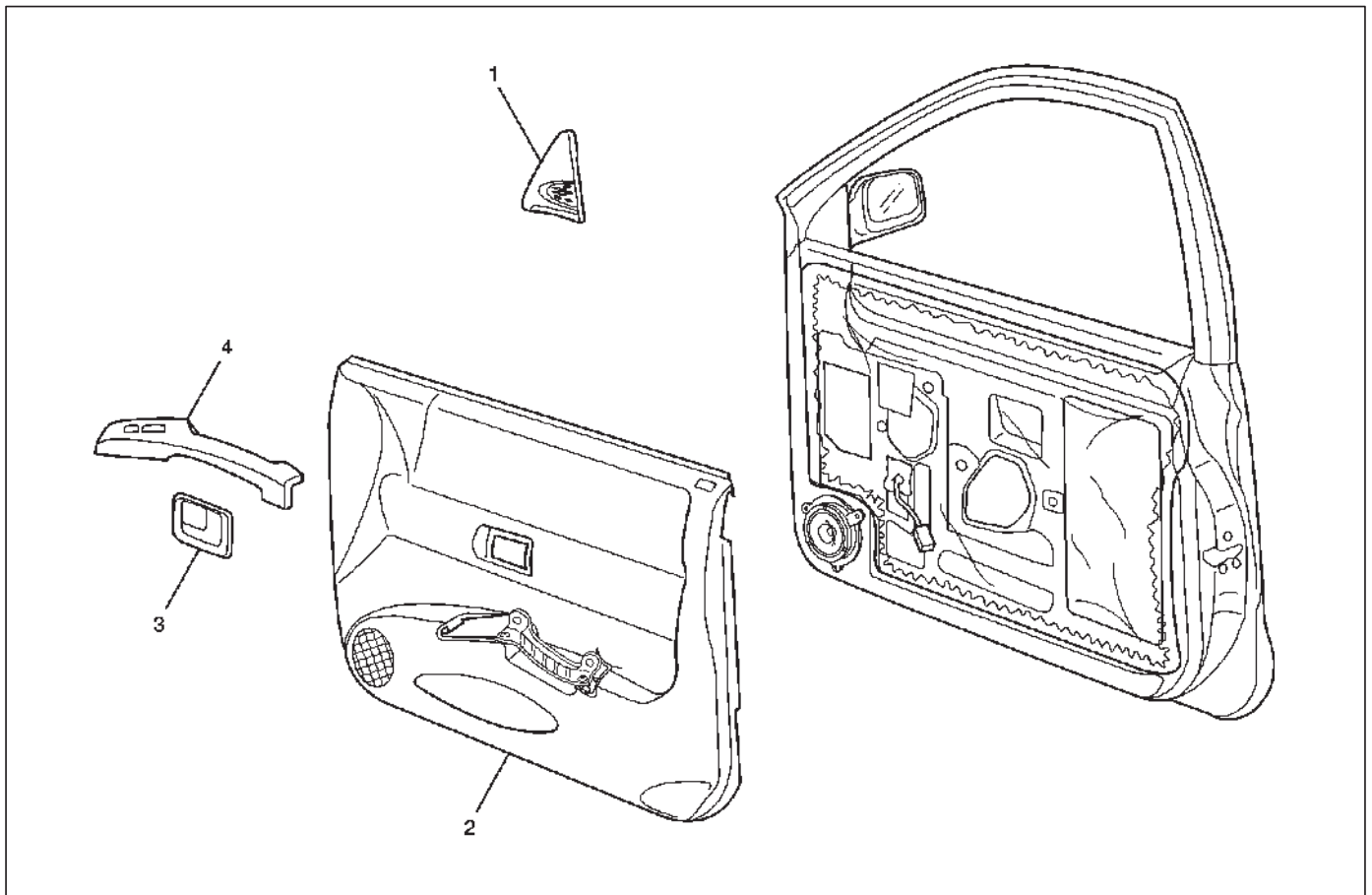
1. Disconnect the battery ground cable.
2. Remove rear console assembly.
  - Disconnect the switch connectors and remove the four fixing screws.
  - Remove the two screws to remove the rear console lid from the rear console assembly.
  - Remove the ashtray from the rear console assembly.
  - Remove the two screws to remove the ashtray case from the rear console assembly.
  - Remove the four screws to remove the rear console garnish from the rear console assembly.
3. Remove the center console assembly.
  - Remove the transfer control lever knob by turning it counterclockwise.
  - Disconnect the mode selector switch connector and remove the four fixing screws.
4. Remove the center console bracket.
  - Remove the two fixing screws.
5. Remove the rear console bracket.
  - Remove the two fixing screws.

### Installation

To install, follow the removal steps in the reverse order.

## Front Door Trim Assembly

### Front Door Trim Assembly and Associated Parts



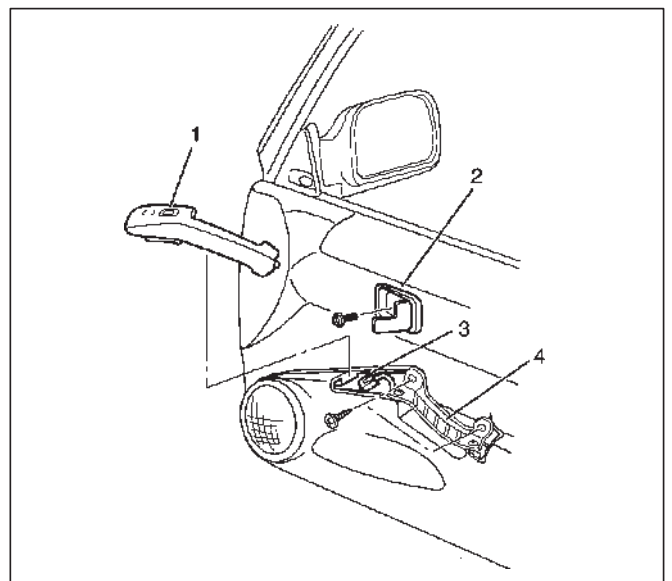
635RX003

#### Legend

- |                              |                                      |
|------------------------------|--------------------------------------|
| (1) Tweeter Assembly         | (3) Inside Handle                    |
| (2) Front Door Trim Assembly | (4) Power Window Switch / Grip Cover |

### Removal

1. Disconnect the battery ground cable.
2. Remove the power window switch / grip cover(1).
  - Pry out the grip cover and disconnect the power window switch connector(3).
  - Remove the two screws fixing the grip(4) to the door inner panel.
3. Remove the inside handle(2).
  - Remove the screw and then disconnect the inside handle link.



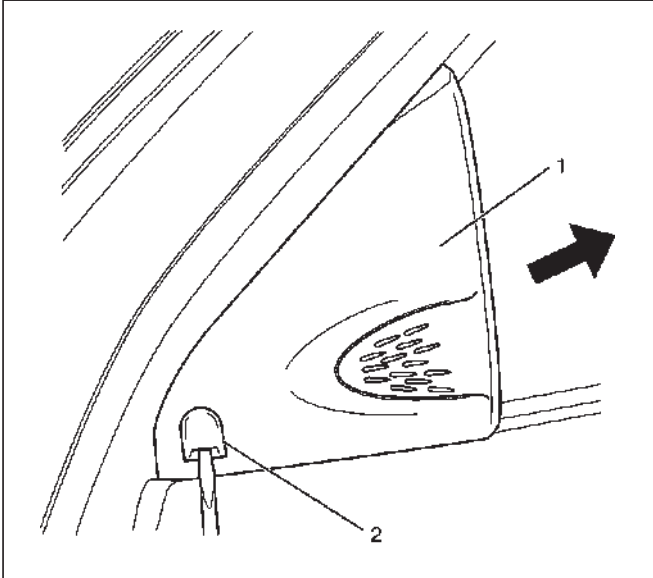
635RX001



## 8J-4 EXTERIOR/INTERIOR TRIM

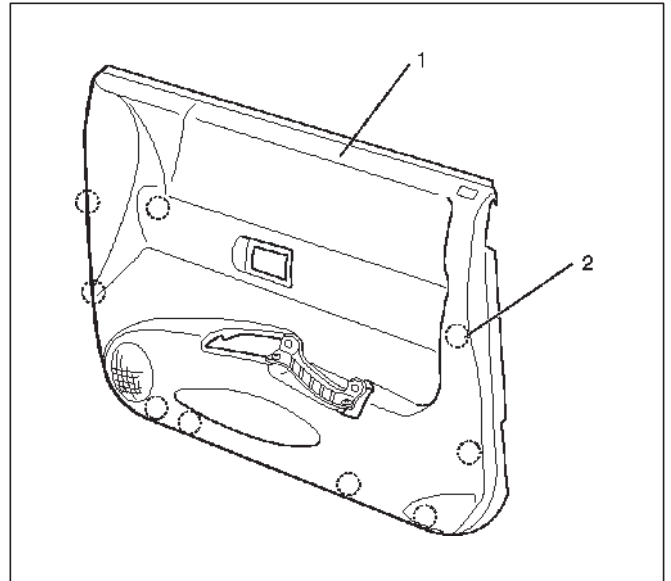
4. Remove the tweeter assembly(1).

- Pry the screw cover(2) off with the screwdriver and remove the screw.
- Pull the tweeter assembly backward.
- Disconnect the connector.



5. Remove the door trim assembly(1).

- Pull out the door trim assembly at the nine clip positions(2).

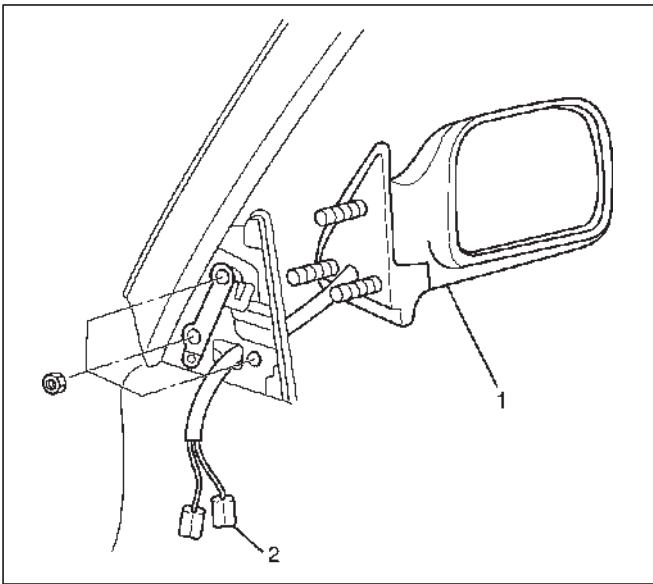


### Installation

To install, follow the removal steps in the reverse order.

## Door Mirror

### Door Mirror and Associated Parts



#### Legend

- (1) Door Mirror
- (2) Door Mirror Connector

### Removal

1. Disconnect the battery ground cable.
2. Remove the tweeter assembly.
  - Refer to Front Door Trim Assembly in this section.
3. Remove door mirror.
  - Remove the three fixing nuts and disconnect the connectors.

### Installation

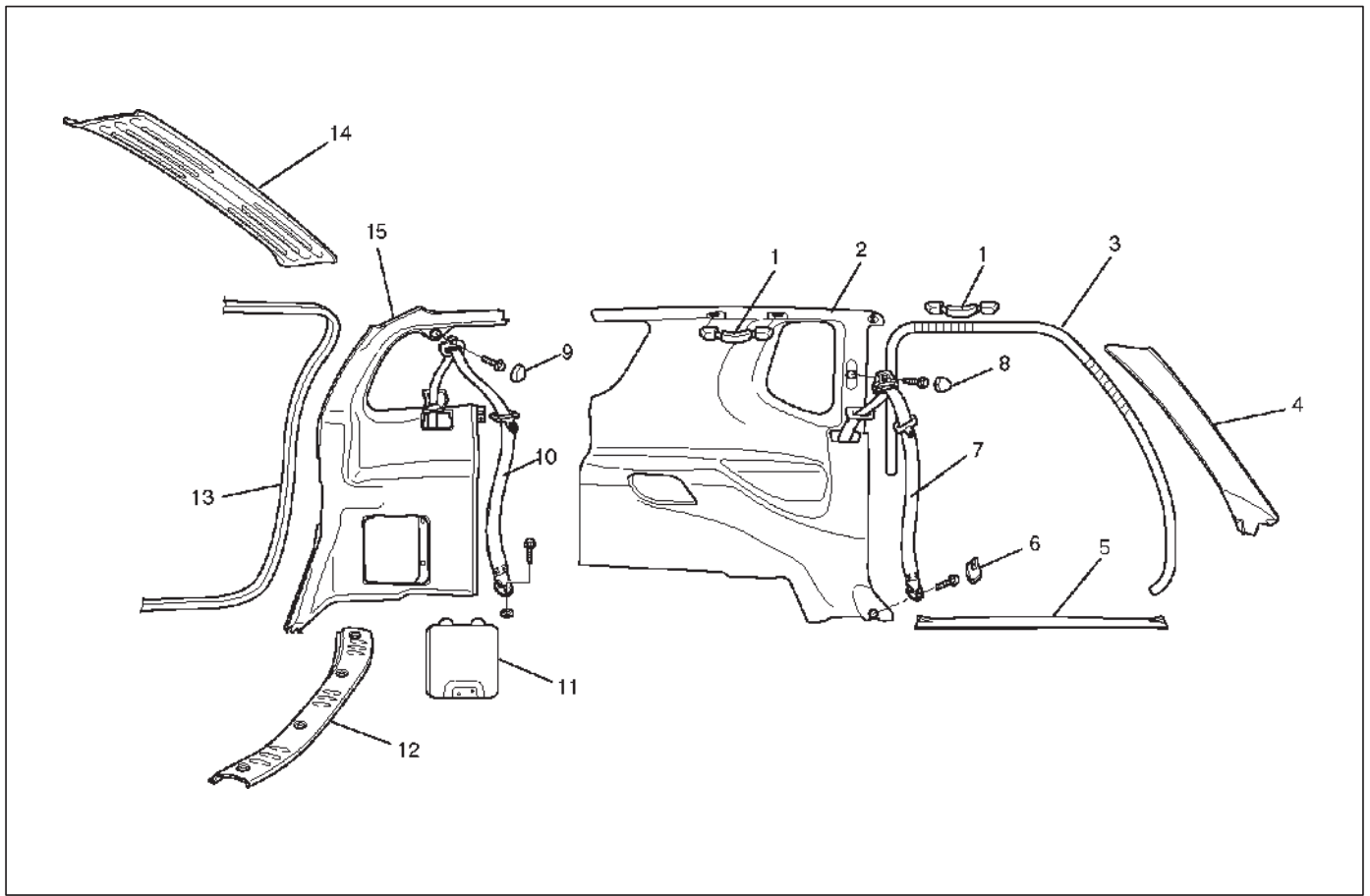
To install, follow the removal steps in the reverse order, nothing the following points.

1. Tighten the door mirror fixing nuts to the specified torque.

**Torque: 8 N·m (69 lb in)**

## Interior Trim Cover and Assist Grip

### Interior Trim Cover, Assist Grip and Associated Parts



643RX003

#### Legend

- |                              |                                      |
|------------------------------|--------------------------------------|
| (1) Assist Grip              | (8) Adjustable Shoulder Anchor Cover |
| (2) Quarter Trim Cover       | (9) Shoulder Anchor Cover            |
| (3) Front Door Finisher      | (10) Rear Seat Belt Assembly         |
| (4) Front Pillar Trim Cover  | (11) Jack Lid                        |
| (5) Sill Plate               | (12) Luggage Rear Trim Cover         |
| (6) Lower Anchor Cover       | (13) Tailgate Weather Strip          |
| (7) Front Seat Belt Assembly | (14) Rear Roof Trim Cover            |
|                              | (15) Luggage Side Trim Cover         |

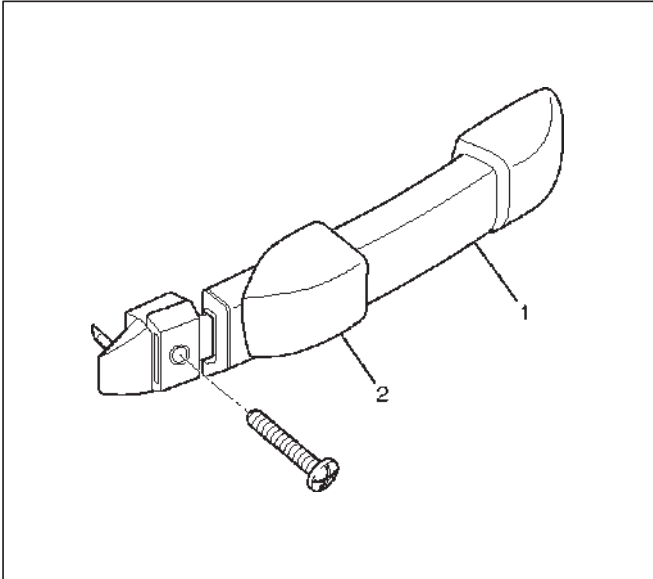
#### Removal

1. Disconnect the battery ground cable.
2. Remove the sill plate.
  - Remove the clip and four fixing screws.
3. Pull out the front door finisher.
4. Remove the front pillar trim cover.
  - Pry the two retainers free from the body panel and then pull front pillar trim cover upward.

## 8J-6 EXTERIOR/INTERIOR TRIM

5. Remove the assist grip(1).

- Move the covers(2) and remove the two fixing screws.



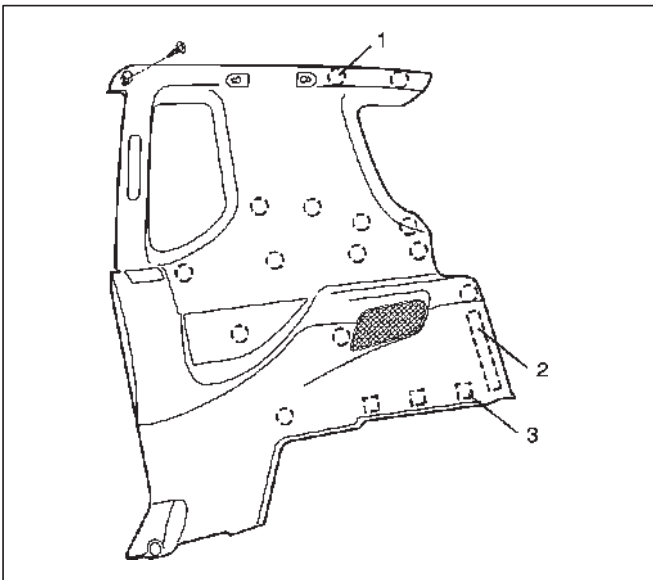
743RX001

6. Remove the front seat belt anchor bolts.

- Remove the upper anchor bolt and the lower anchor bolt.

7. Remove the quarter trim cover.

- Remove the fixing screw and pry the trim cover clips(1) free from the body panel.
- Peel off the trim cover at the adhesive tape(2) and velcro fasteners(3).



643RX001

8. Remove the rear seat belt anchor bolts.

- Remove the upper anchor bolt and the lower anchor bolt.

9. Remove the tailgate weather strip.

10. Remove the rear roof trim cover.

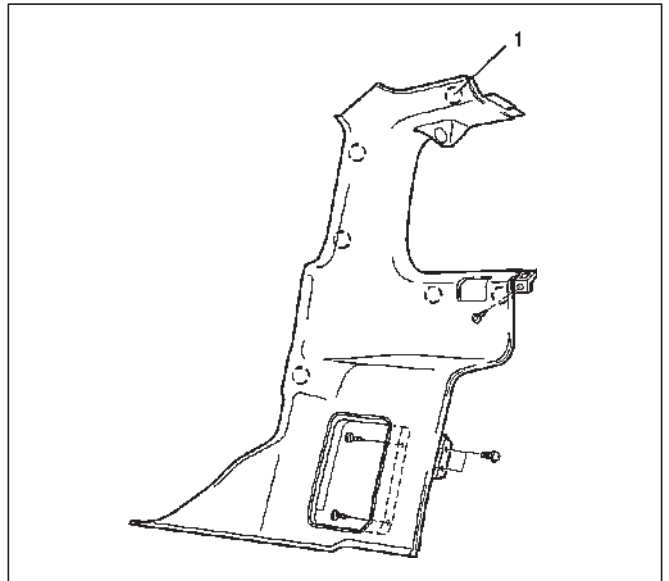
- Pry the trim cover retainers free from the body panel.

11. Remove the luggage rear trim cover.

- Remove the four screws.

12. Remove the luggage side trim cover.

- Remove the five fixing screws.
- Pry the trim cover clips(1) free from the body panel.
- Remove the two clips (RH side).



643RX002

## Installation

To install, follow the removal steps in the reverse order, noting the following point.

1. Tighten the front seat belt upper anchor bolt to the specified torque.

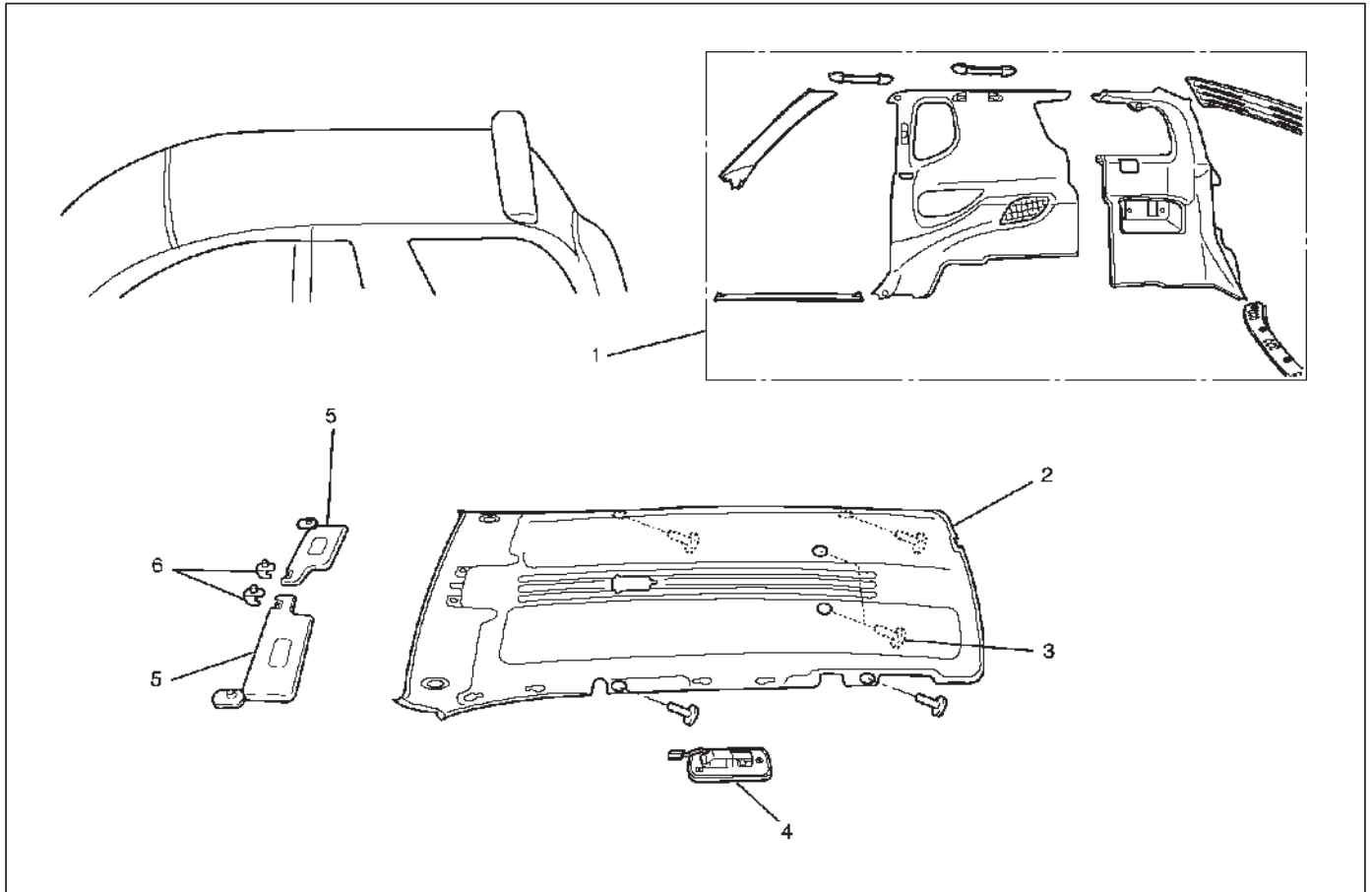
**Torque: 49 N·m (36 lb ft)**

2. Tighten the front seat belt lower anchor bolt and rear seat belt anchor bolts to the specified torque.

**Torque: 39 N·m (29 lb ft)**

## Headlining

### Parts Location



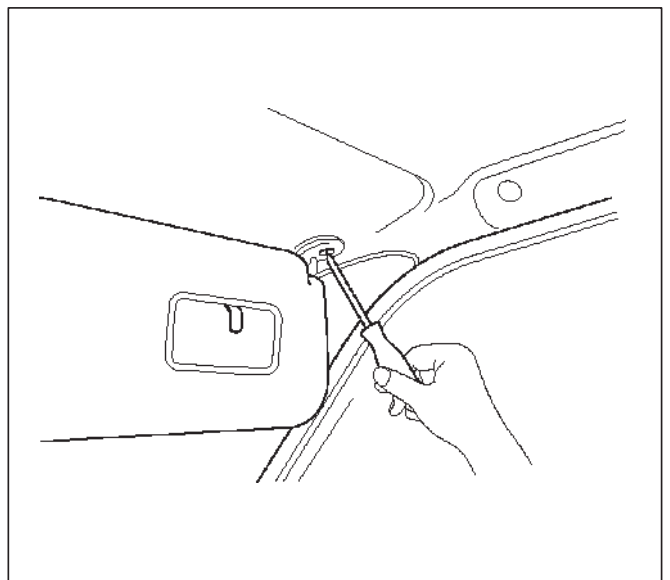
666RX001

#### Legend

- |   |                      |
|---|----------------------|
| (1) Interior Trim Covers & Assist Grips | (4) Dome Light       |
| (2) Headlining                          | (5) Sun Visor        |
| (3) Clip                                | (6) Sun Visor Holder |

### Removal

1. Disconnect the battery ground cable.
2. Remove the interior trim covers and assist grips.
  - Refer to Interior Trim Cover and Assist Grip in this section.
3. Remove the dome light.
  - Release the locks at three positions to remove the lens.
  - Remove the three screws and disconnect the connector.
4. Remove the sun visor.
  - Remove the two screws at the each sun visor.



743RX002

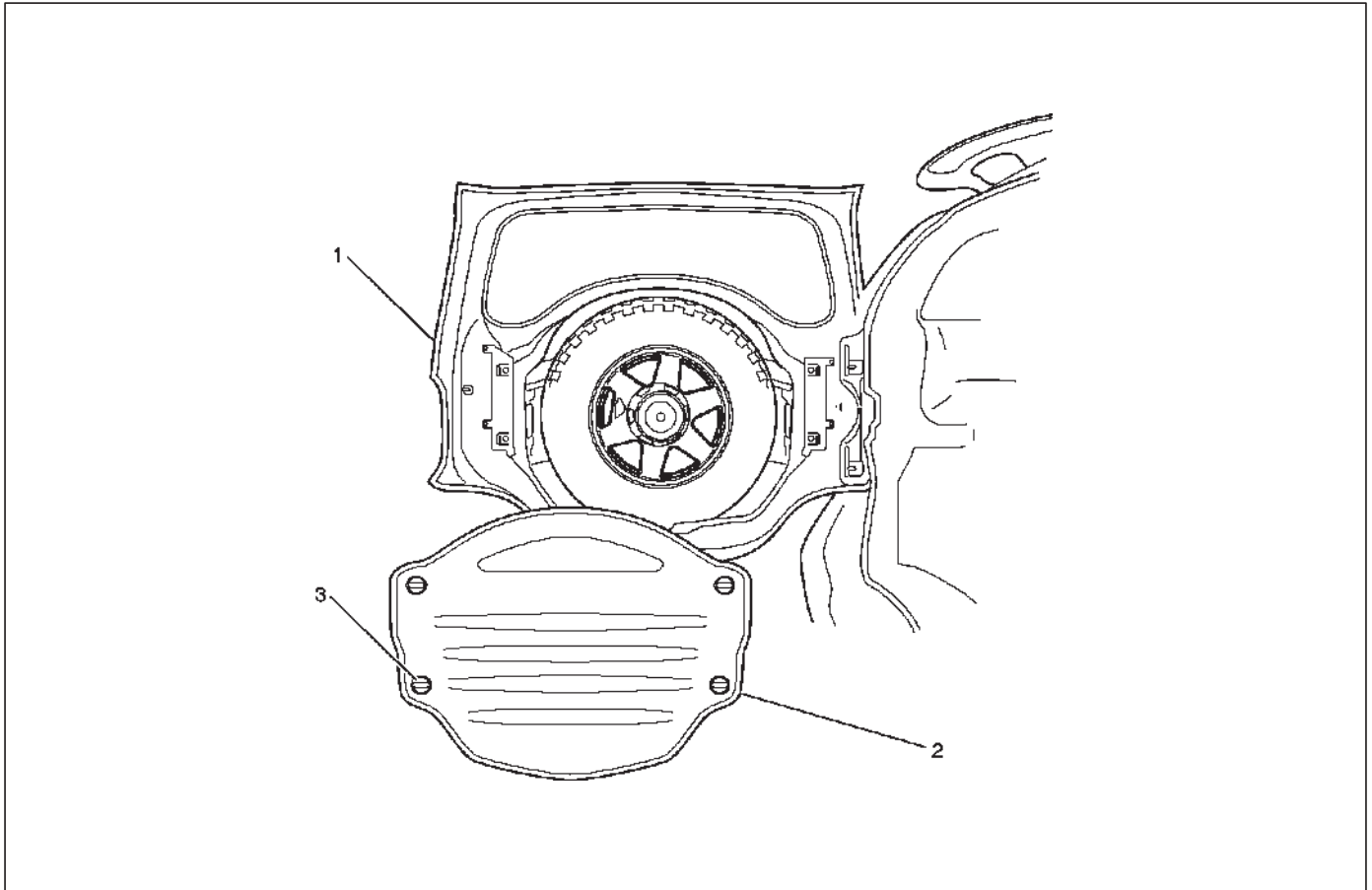
5. Remove the sun visor holder.
  - Remove the screw at each holder.
6. Remove the headlining.
  - Remove the six clips.

## Installation

To install, follow the removal steps in the reverse order.

## Tailgate Trim Cover

### Tailgate Trim Cover and Associated Parts



684RX001

#### Legend

(1) Tailgate

(2) Tailgate Trim Cover

(3) Knob

## Removal

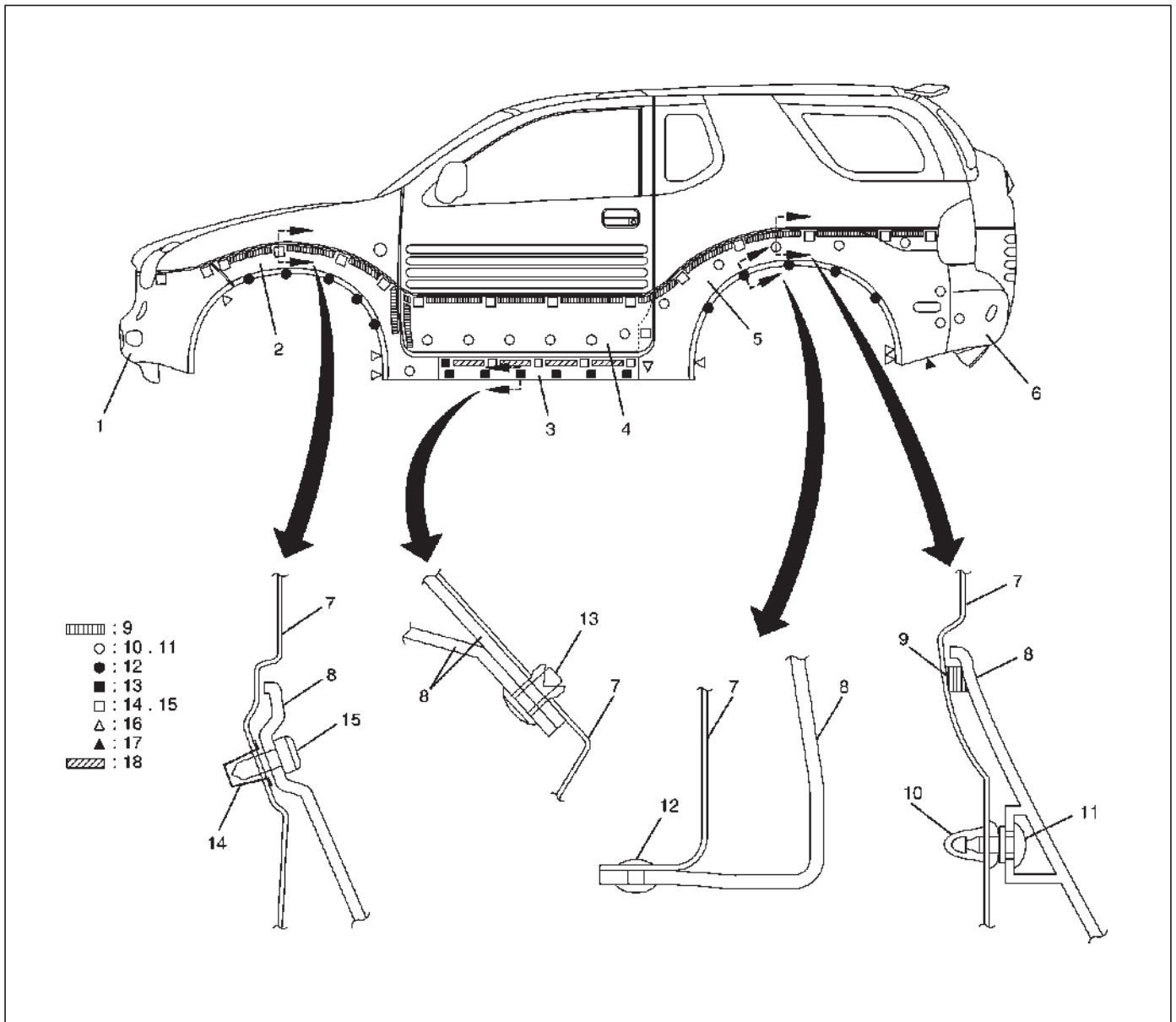
1. Disconnect the battery ground cable.
2. Remove the tailgate trim cover.
  - Loosen the four fixing knobs.

## Installation

To install, follow the removal steps in the reverse order.

## Body Side Protectors

### Body Side Protectors and Associated Parts



620RX002

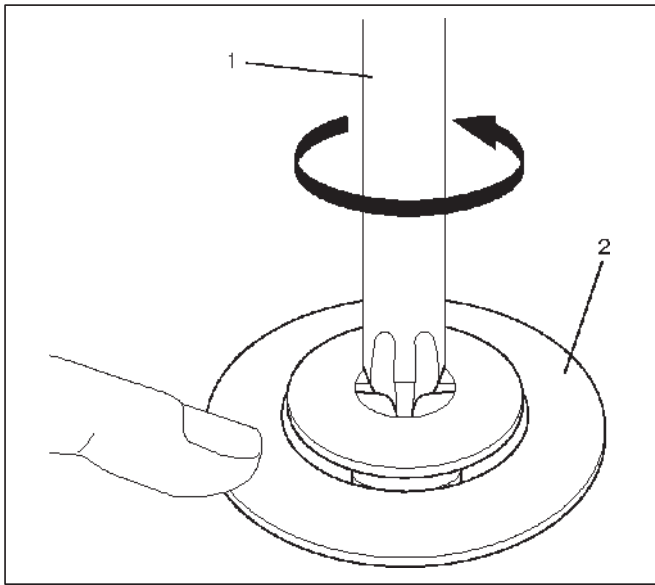
#### Legend

- |                                |   |
|--------------------------------|---|
| (1) Front Bumper               | (10) Body or Door Panel Side :Plastic Grommet |
| (2) Front Fender Protector     | (11) Protector Side :Plastic Clip             |
| (3) Rocker Protector           | (12) Blind Rivet                              |
| (4) Front Door Protector       | (13) Fastener                                 |
| (5) Rear Quarter Protector     | (14) Body or Door Panel Side :Plastic Grommet |
| (6) Rear Bumper                | (15) Protector Side :Inside Hex Screw         |
| (7) Body or Door Panel         | (16) Tap Screw                                |
| (8) Protector                  | (17) Bolt                                     |
| (9) Double-Sided Adhesive Tape | (18) Sponge Tape                              |

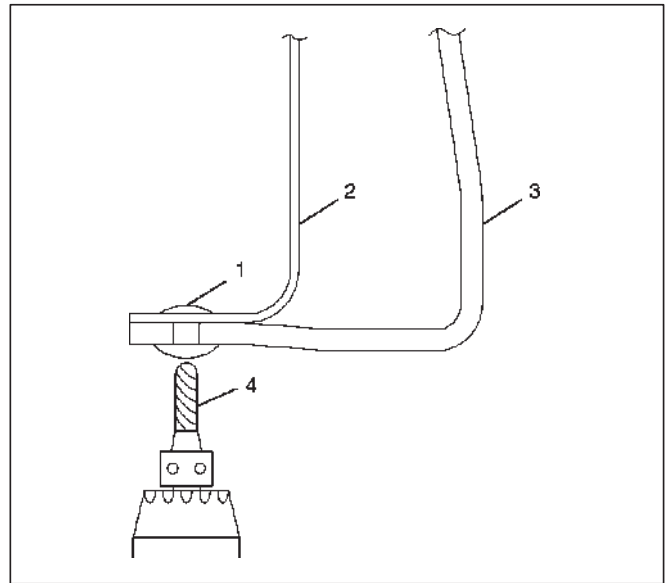
## Removal

1. Disconnect the battery ground cable.
2. Remove the rocker protector.
  - Remove the four inside hex screws and the seven fastener.

**CAUTION:** When removing the fastener by screw driver (1), hold the grommet (2) for not turning together with.



3. Remove the front fender protector.
  - Let a 5 mm (0.2 in) drill (4) go through the five blind rivets (1) to disengage riveted portions.
  - Remove the four inside hex screws, the two fixing screws and disengage the clips.
  - Pull out the portion of the double-sided adhesive tape of protector from body panel carefully.
4. Remove the rear quarter protector.
  - Let a 5 mm (0.2 in) drill (4) go through the five blind rivets (1) to disengage riveted portions.
  - Remove the six inside hex screws, the three fixing screws, the fixing bolt and disengage the seven clips (LH) or six clips (RH).
  - Pull out the portion of the double-sided adhesive tape of protector from body panel carefully.



5. Remove the rear side marker light.
  - Disconnect the connector.
  - Remove the two fixing nuts.
6. Remove the fuel filler lid assembly (RH only).
  - Remove the four fixing nuts and seven fixing bolts.
7. Remove the front door protector.
  - Remove the four inside hex screws and disengage the six clips.
  - Pull out the portion of the double-sided adhesive tape of protector from body panel carefully.

## Installation

To install, follow the removal steps in the reverse order, noting following points.

1. Use a new double-sided adhesive tape whenever installing the front fender protector, front door protector and rear quarter protector. Using a white gasoline, clean the places in advance where a double-sided adhesive tape is affixed.
2. To tear the remaining old double-sided adhesive tape off, use 3M (\*) or equivalent.

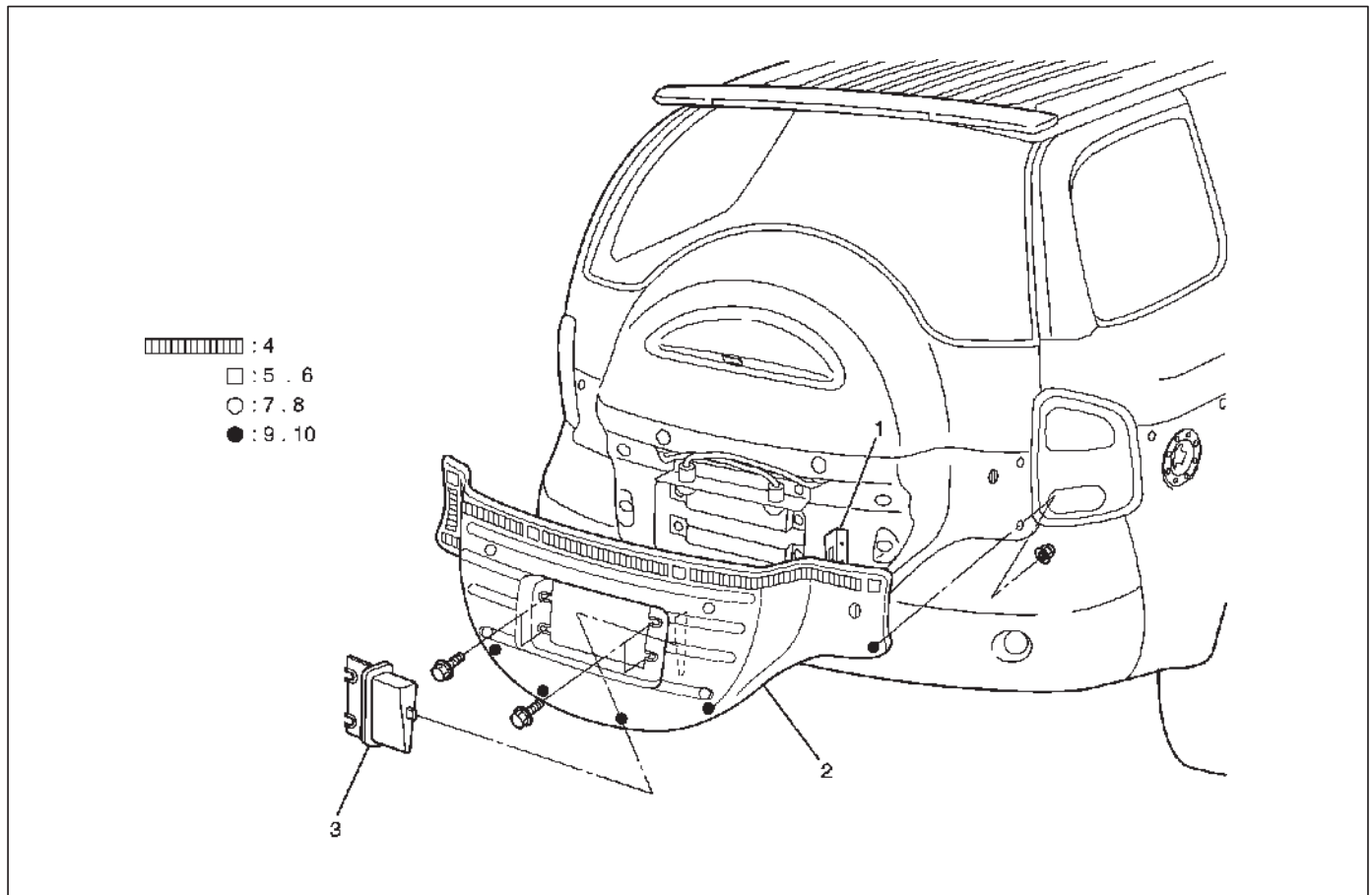
\* SCOTCH-BRITE MOLDING ADHESIVE AND STRIPE REMOVAL DISK.

#07501 (4 inch)

#07502 (6 inch)

## Tailgate Protector

### Parts Location



684RX002

#### Legend

- |  |  |
|--|--|
| (1) Tailgate Handle Bracket              | (6) Protector Side :Inside Hex Screw     |
| (2) Tailgate Protector                   | (7) Tailgate Panel Side :Plastic Grommet |
| (3) Tailgate Handle                      | (8) Protector Side :Plastic Clip         |
| (4) Double-Sided Adhesive Tape           | (9) Protector Side :Stud Bolt            |
| (5) Tailgate Panel Side :Plastic Grommet | (10) Fixing :Cap Nut                     |

### Removal

1. Disconnect the battery ground cable.
2. Remove the tailgate protector.
  - Remove the four bolts and pull out the tailgate handle.
  - Remove the four inside hex screws, the five fixing cap nuts and disengage the four clips.
  - Pull out the portion of the double-sided adhesive tape of protector from body panel carefully.

1. Use a new double-sided adhesive tape whenever installing the tailgate protector. Using a white gasoline, clean the places in advance where a double-sided adhesive tape is affixed.
2. To tear the remaining old double-sided adhesive tape off, use 3M (\*) or equivalent.

\* SCOTCH-BRITE MOLDING ADHESIVE AND STRIPE REMOVAL DISK.

#07501 (4 inch)

#07502 (6 inch)

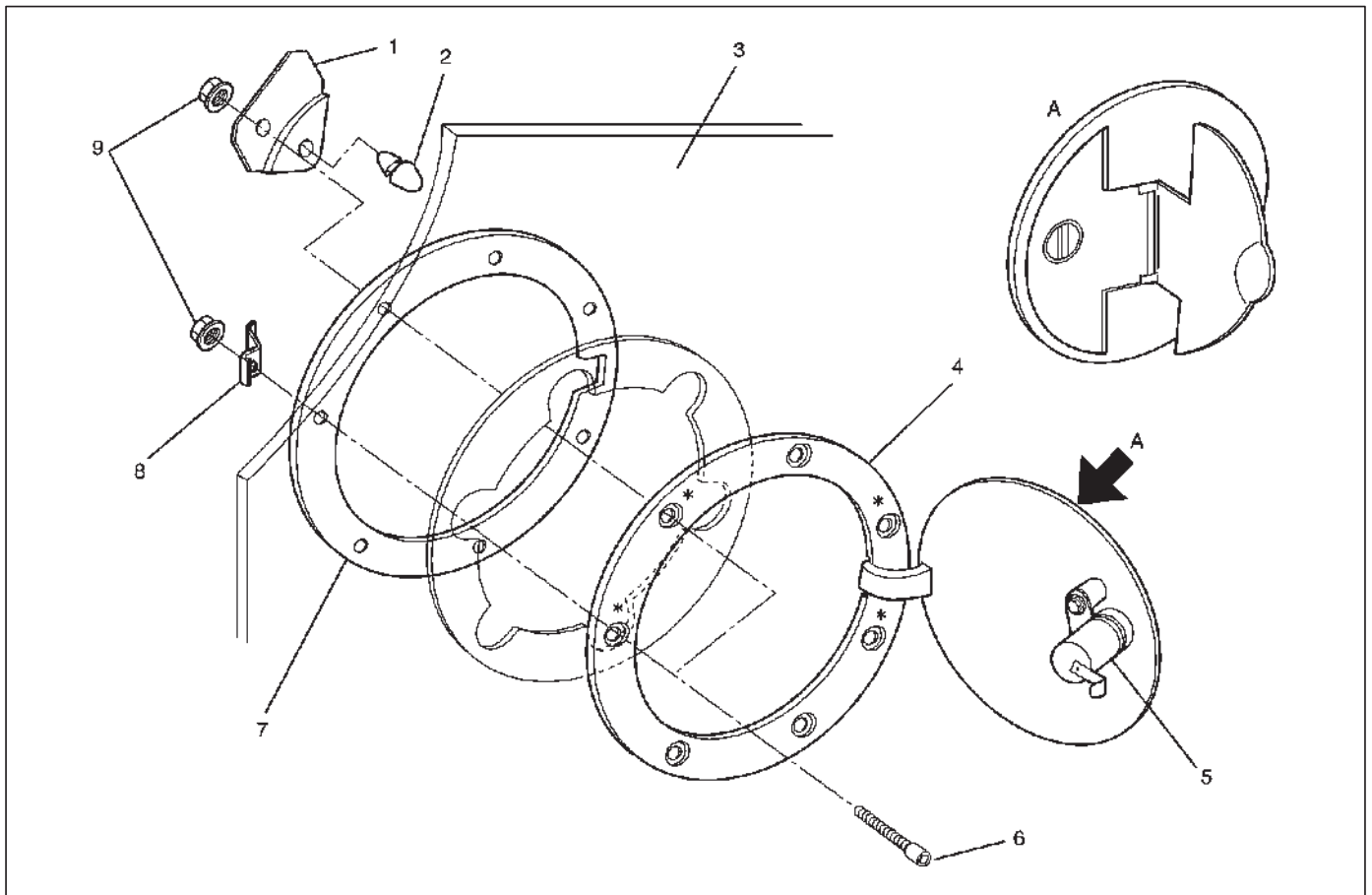
### Installation

To install, follow the removal steps in the reverse order, noting following points.



## Fuel Filler Lid

### Parts Location



686RX002

### Legend

- |                              |  |
|------------------------------|--|
| (1) Stopper Bracket          | (6) Fuel Filler Bolt   |
| (2) Buffer Rubber            | (7) Fuel Filler Plate  |
| (3) Rear Quarter Protector   | (8) Lock Hook  |
| (4) Fuel Filler Lid Assembly | (9) Fixing Nut :Used at the four positions marked with an asterisk (*) |
| (5) Key Cylinder             |  |

### Removal

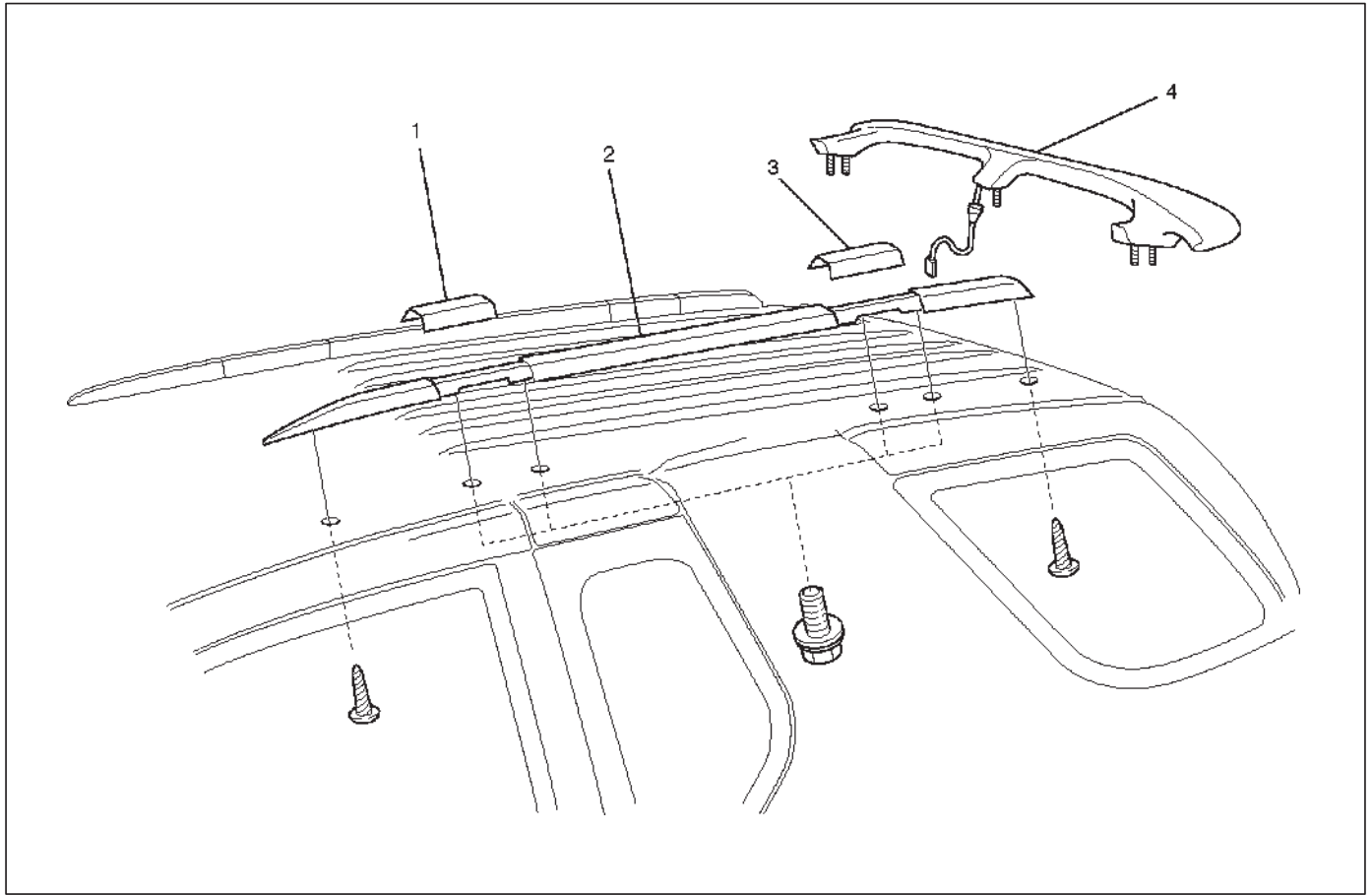
1. Disconnect the battery ground cable.
2. Remove the rear quarter protector.
  - Refer to Body Side Protector in this section.
3. Remove the fuel filler lid assembly.
  - Remove the four fixing nuts and seven fixing bolts.
4. Remove the key cylinder.
  - Remove the fixing bolt.

### Installation

To install, follow the removal steps in the reverse order.

## Roof Rail Assembly

### Parts Location



#### Legend

- |                           |                          |
|---------------------------|--------------------------|
| (1) Front Roof Rail Cover | (3) Rear Roof Rail Cover |
| (2) Roof Rail Assembly    | (4) Rear Roof Spoiler    |

### Removal

1. Disconnect the battery ground cable.
2. Remove the rear roof spoiler.
  - Refer to Rear Roof Spoiler in this section.
3. Remove the headlining.
  - Refer to Headlining in this section.
4. Remove the roof rail assembly.
  - Remove the four fixing bolts and two fixing screws.
  - Peel off the bonded portions with double-sided adhesive tape.

2. Tighten the roof rail assembly fixing bolts to the specified torque.

**Torque: 10 N·m (87 lb in)**

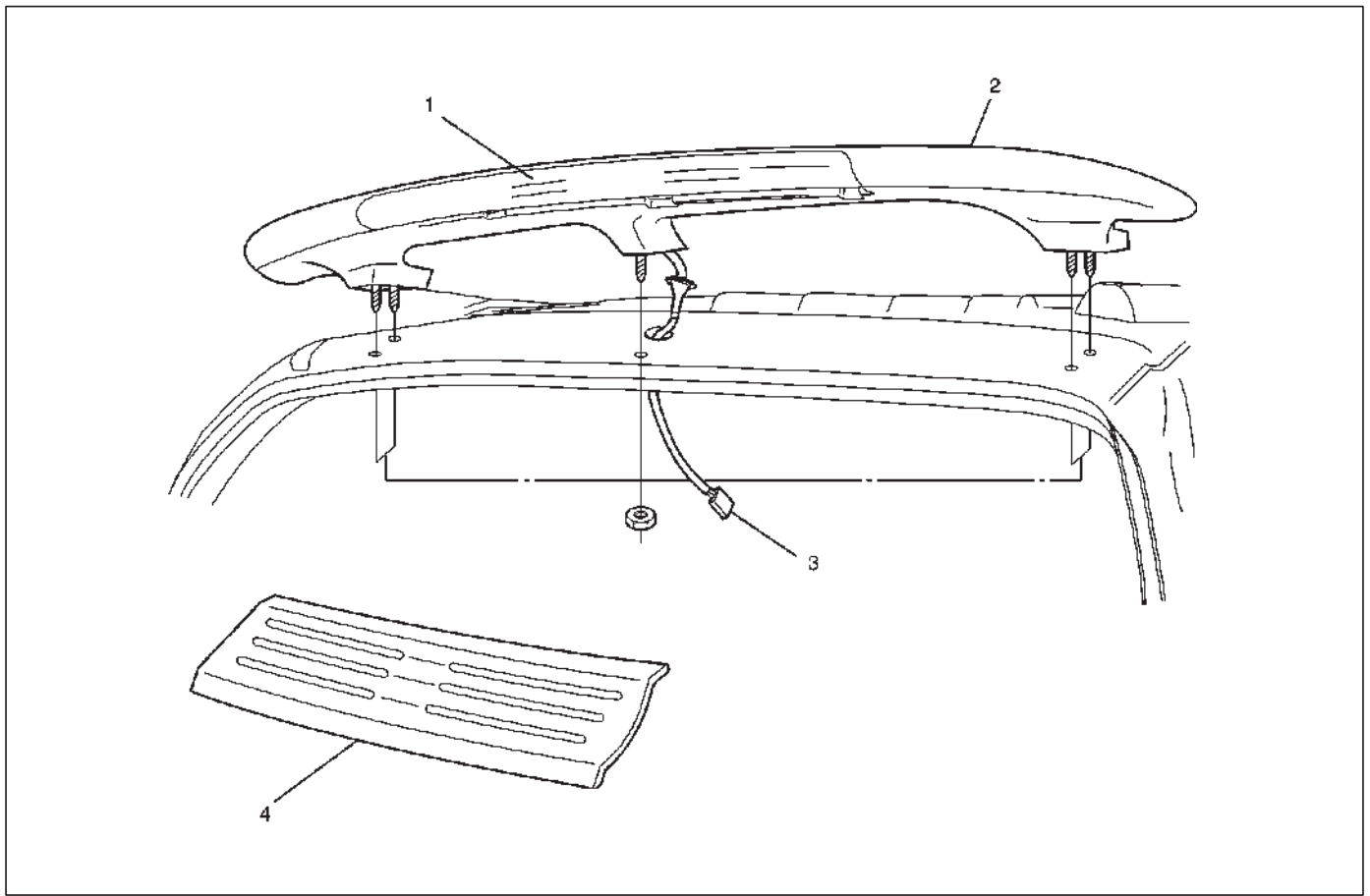
### Installation

To install, follow the removal steps in the reverse order, noting the following points.

1. Use a new double-sided adhesive tape whenever installing the tailgate protector. Using a white gasoline, clean the places in advance where a double-sided adhesive tape is affixed.

## Rear Roof Spoiler

### Parts Location



660RX023

### Legend

- |                                |                                      |
|--------------------------------|--------------------------------------|
| (1) High Mounted Stoplight     | (3) High Mounted Stoplight Connector |
| (2) Rear Roof Spoiler Assembly | (4) Rear Roof Trim Cover             |

### Removal

1. Disconnect the battery ground cable.
2. Remove the rear roof trim cover.
  - Pry the trim cover retainers free from the body panel.
3. Disconnect the high mounted stoplight connector.
4. Remove the rear roof spoiler assembly.
  - Remove the five fixing nuts and pull out the harness grommet.

### Installation

To install, follow the removal steps in the reverse order.

## Power Door Mirror System

### General Description

The circuit consists of the starter switch, door mirror control switch, defogger switch and door mirrors on both sides.

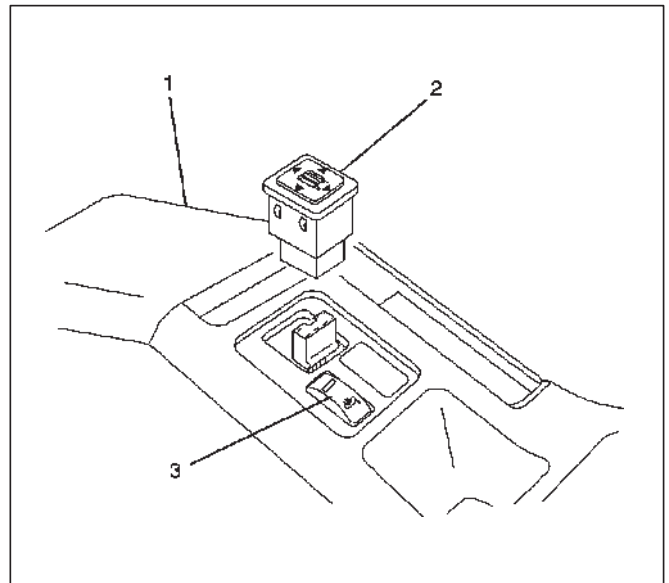
The door mirror switch consists of the control switch and defogger switch.

When the control switch is operated with the starter switch at either "ACC" or "ON" position, the motors incorporated in the door mirrors on both sides rotate to allow the horizontal and vertical adjustment of mirror angles.

When turning on the door mirror defogger switch with the starter switch at "ON" position, built-in heater in the mirror is activated to perform the defogger function.

### Door Mirror Control Switch and Door Mirror Defogger Switch Removal

1. Disconnect the battery ground cable.
2. Remove rear console assembly(1).
  - Remove the 4 screws.
3. Remove door mirror control switch(2).
  - Push the lock from the back side of the rear console.
4. Remove door mirror defogger switch(3).
  - Push the lock from the back side of the rear console.



825RX028

### Installation

To install, follow the removal steps in the reverse order, noting following points.

1. Depress the each switch with your fingers until it lock securely.

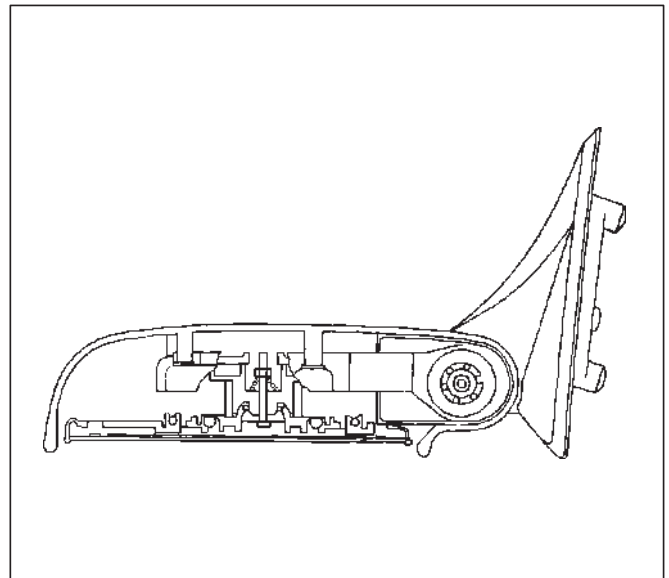
## Power Door Mirror

### General Description

Mirrors contain two driving motors for the horizontal and vertical movement of the mirror.

When control switch is operated with starter switch at either "ACC" or "ON" position, motors incorporated in door mirrors on both sides rotate to allow the horizontal and vertical adjustment of mirror angle.

The movement of the mirror is controlled by the direction of current running through these motors.



720RS004

### Removal and Installation

Refer to Door Mirror in this section.

## Power Window System

### General Description

The circuit consists of the starter switch, (door lock &) power window switch for each of the front windows and power window motors.

When the starter switch is turned on, the battery voltage is applied to each of the power window switches through the circuit breaker and the power window relay on the circuit. The "Down" switch of the driver's power window switch has a built-in function which can be operated by just touching it.

Accordingly, the window will roll down automatically by just setting the switch to the "AUTO" position.

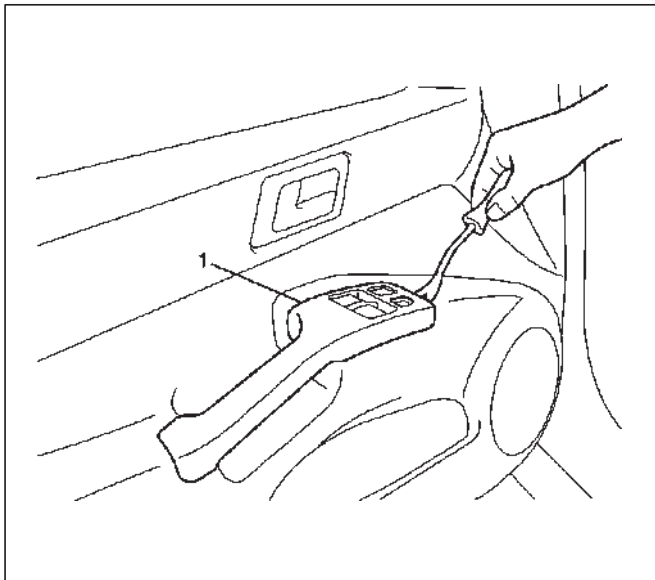
When the driver's power lock switch at the driver side is depressed, the power source to the passenger's power window switch is shut off. So, even if passenger's switch is operated, the power window motor will not operate.

### Power Window Switch Removal and Installation

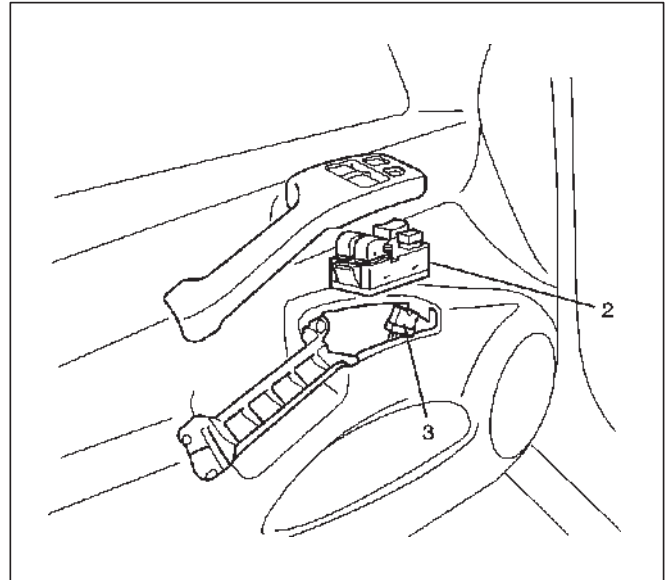
#### Driver Seat Side

##### Removal

1. Disconnect the battery ground cable.
2. Remove power window switch(2).
  - Pull out the grip cover(1) by pushing the spring clip with the tip of a screwdriver.
  - Disconnect the switch connector(3).
  - Remove the four fixing screws.



635RX004



635RX005

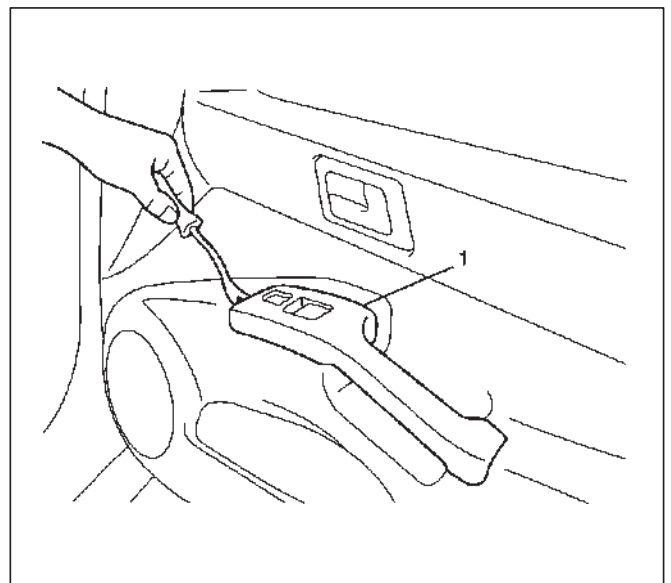
##### Installation

To install, follow the removal steps in the reverse order.

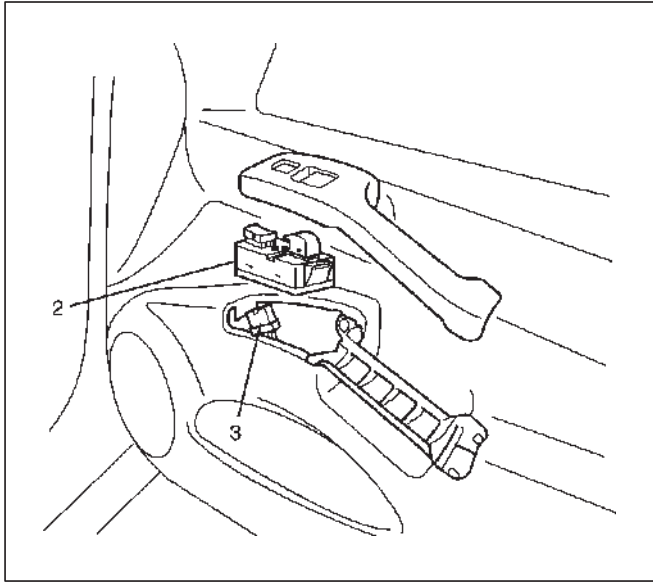
#### Passenger Seat Side

##### Removal

1. Disconnect the battery ground cable.
2. Remove power window switch(2).
  - Pull out the grip cover(1) by pushing the spring clip with the tip of a screwdriver.
  - Disconnect the switch connector(3).
  - Remove the four fixing screws.



635RX006



635RX007

**Installation**

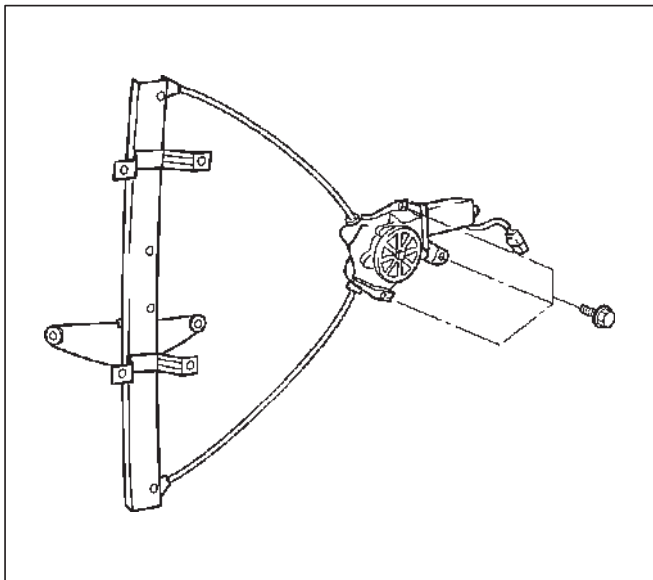
To install, follow the removal steps in the reverse order.

**Power Window Motor Removal and Installation**

**Driver Seat Side**

**Removal**

1. Disconnect the battery ground cable.
2. Remove window regulator assembly.
  - Refer to Front Window Regulator, Glass and Glass Run in Body Structure section.



631RX006

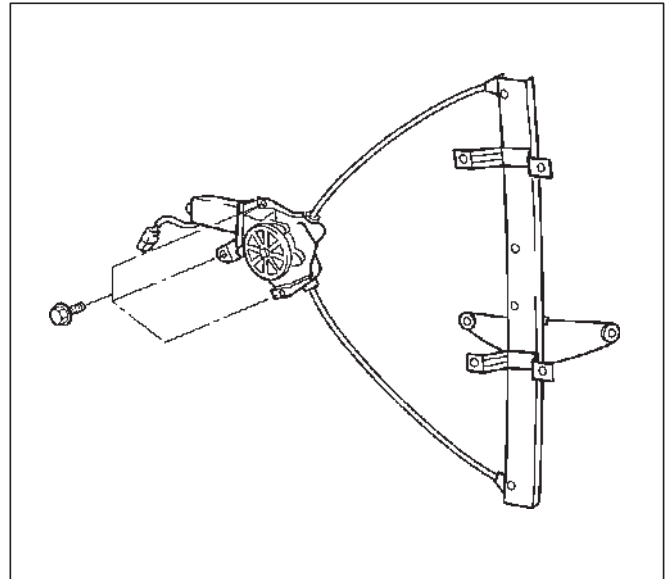
**Installation**

To install, follow the removal steps in the reverse order.

**Passenger Seat Side**

**Removal**

1. Disconnect the battery ground cable.
2. Remove window regulator assembly.
  - Refer to Front Window Regulator, Glass and Glass Run in Body Structure section.



631RX007

**Installation**

To install, follow the removal steps in the reverse order.

**Main Data and Specifications****Torque Specifications**

<b>Application</b>	<b>N·m</b>	<b>lb ft</b>	<b>lb in</b>
Door Mirror Fixing Nuts	8	—	69
Front Seat Belt Upper Anchor Bolt	49	36	—
Front Seat Belt Lower Anchor Bolt	39	29	—
Rear Seat Belt Anchor Bolts	39	29	—
Roof Rail Fixing Bolts	10	—	87

VEHICROSS

# RESTRAINTS

## CONTENTS

Seat Belt System .....	9A
Supplemental Restraint System (SRS) .....	9J
Restraint Control System .....	9J1

# SEAT BELT SYSTEM

## CONTENTS

Service Precaution .....	9A-1	Removal .....	9A-6
Front Seat Belt .....	9A-2	Installation .....	9A-6
Front Seat Belt and Associated Parts .....	9A-2	Rear Seat Belt Buckle Assembly .....	9A-7
Removal .....	9A-2	Removal .....	9A-7
Inspection .....	9A-2	Installation .....	9A-7
Installation .....	9A-3	Child Seat Tether Anchor Bracket (Child Restraint) .....	9A-8
Rear Seat Belt .....	9A-4	General Description .....	9A-8
Rear Seat Belt and Associated Parts .....	9A-4	Child Seat Tether Anchor Bracket and Associated Parts .....	9A-8
Removal .....	9A-4	Installation .....	9A-8
Inspection .....	9A-5	Main Data and Specifications .....	9A-9
Installation .....	9A-5		
Front Seat Belt Buckle Assembly .....	9A-6		
Front Seat Belt Buckle Assembly and Associated Parts .....	9A-6		

### Service Precaution

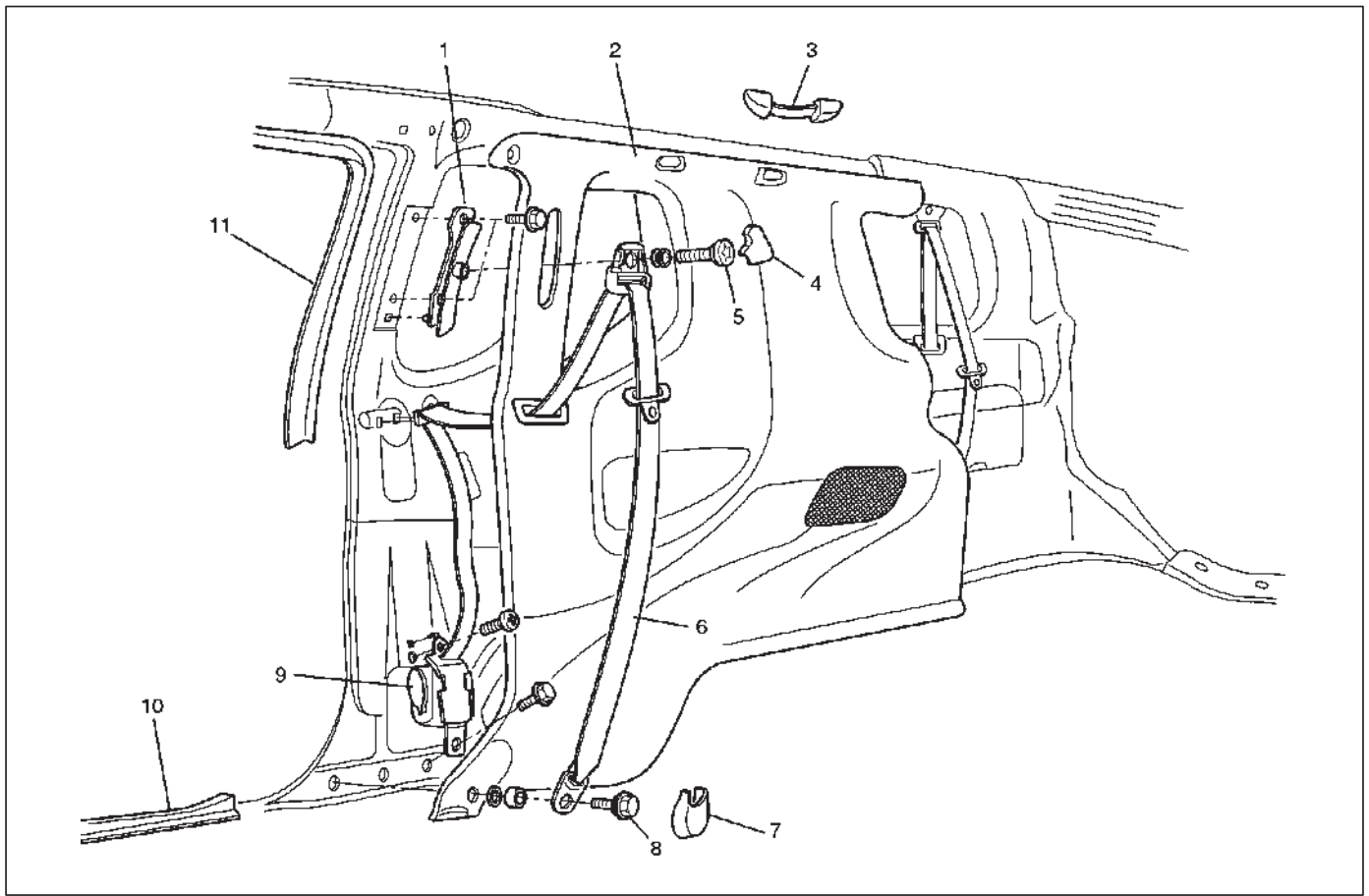
**WARNING: THIS VEHICLE HAS A SUPPLEMENTAL RESTRAINT SYSTEM (SRS). REFER TO THE SRS COMPONENT AND WIRING LOCATION VIEW IN ORDER TO DETERMINE WHETHER YOU ARE PERFORMING SERVICE ON OR NEAR THE SRS COMPONENTS OR THE SRS WIRING. WHEN YOU ARE PERFORMING SERVICE ON OR NEAR THE SRS COMPONENTS OR THE SRS WIRING, REFER TO THE SRS SERVICE INFORMATION. FAILURE TO FOLLOW WARNINGS COULD RESULT IN POSSIBLE AIR BAG DEPLOYMENT, PERSONAL INJURY, OR OTHERWISE UNNEEDED SRS SYSTEM REPAIRS.**

**CAUTION: Always use the correct fastener in the proper location. When you replace a fastener, use ONLY the exact part number for that application. ISUZU will call out those fasteners that require a replacement after removal. ISUZU will also call out the fasteners that require thread lockers or thread sealant. UNLESS OTHERWISE SPECIFIED, do not use supplemental coatings (Paints, greases, or other corrosion inhibitors) on threaded fasteners or fastener joint interfaces. Generally, such coatings adversely affect the fastener torque and the joint clamping force, and may damage the fastener. When you install fasteners, use the correct tightening sequence and specifications. Following these instructions can help you avoid damage to parts and systems.**



## Front Seat Belt

### Front Seat Belt and Associated Parts



760RX007

#### Legend

- |   |                              |
|---|------------------------------|
| (1) Adjustable Shoulder Anchor Assembly | (6) Front Seat Belt Assembly |
| (2) Quarter Trim Cover                  | (7) Lower Anchor Cover       |
| (3) Assist Grip & Cover                 | (8) Lower Anchor Bolt        |
| (4) Shoulder Anchor Cover               | (9) Retractor                |
| (5) Upper Anchor Bolt (Torx Bolt)       | (10) Sill Plate              |
|   | (11) Front Door Finisher     |

#### Removal

1. Disconnect the battery ground cable.
2. Remove the shoulder anchor cover and upper anchor bolt.
3. Remove the lower anchor bolt.
4. Remove the quarter trim cover.
  - Refer to Interior Trim Cover and Assist Grip in Exterior/Interior Trim section.
5. Remove the retractor.
  - Remove the fixing bolt and screw.
6. Remove the front seat belt assembly.
7. Remove the adjustable shoulder anchor assembly.
  - Remove the two fixing bolts.

#### Inspection

If any of the following abnormalities is found, replace on an assembly basis:

- Deform and malfunction of adjustable shoulder anchor.
- No smooth move of upper/lower anchors in the circumferential direction.
- Damaged and/or deformed through ring.
- Damaged and/or deformed tongue.
- Damaged and/or frayed of webbing.
- Deformed retractor bracket.
- Seat belt not rewound up.
- Resistance or abnormal sound when seat belt is wound out and rewound.
- Retractor abnormality.

## Inspection of retractor

1. ELR (Emergency Locking Retractor) lock inclining angle check.
  - When the retractor is moved gently from its installing position, make sure it is not locked within 15° in any directions, and it remains locked at 45° or larger.
2. ELR lock check.
  - When the seat belt is drawn slowly with the retractor installed, make sure it is not locked. And when it is drawn quickly, make sure it is locked.

**CAUTION: Do not disassemble the retractor.**

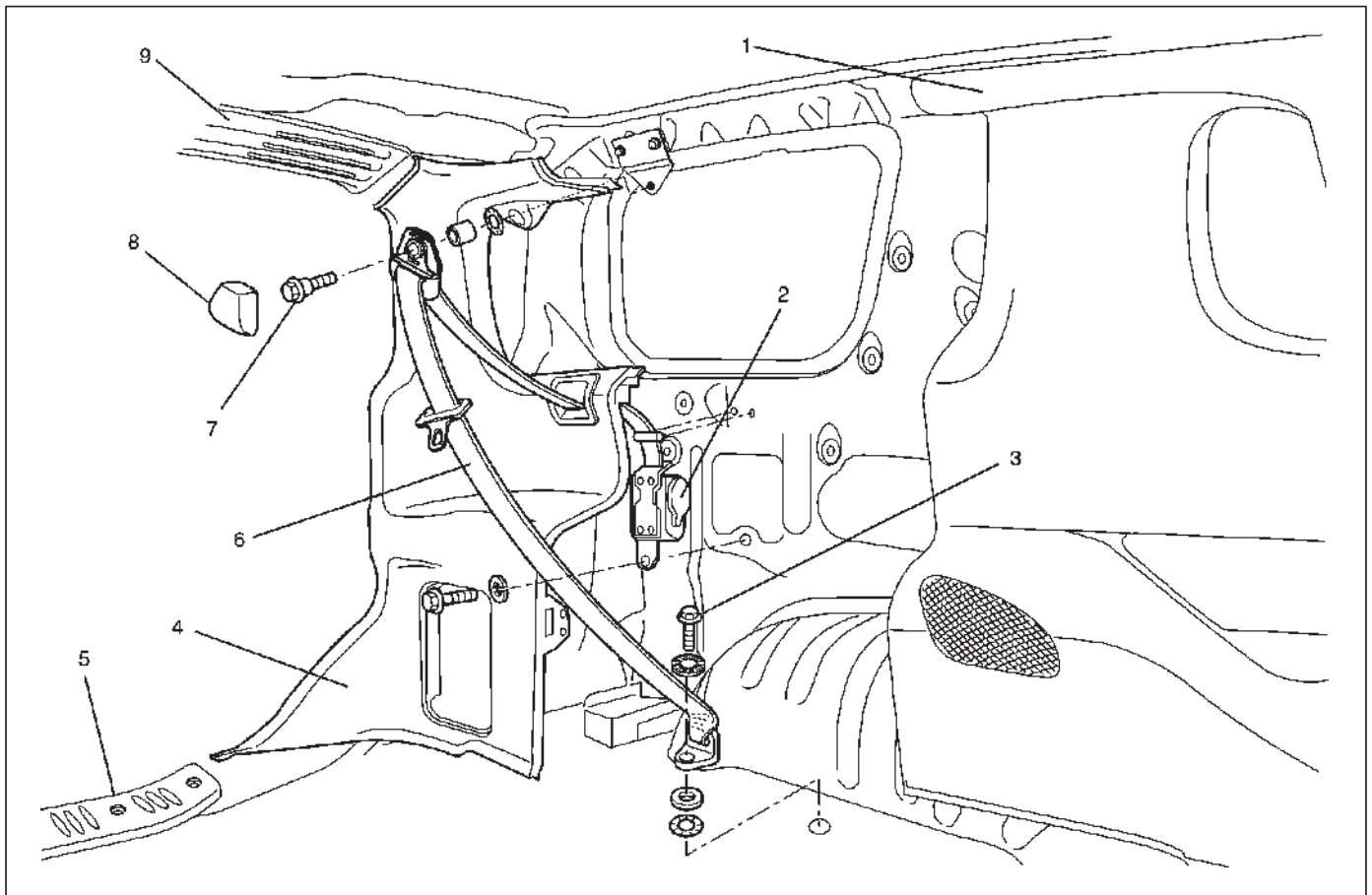
## Installation

To install, follow the removal steps in the reverse order, noting the following points.

1. Tighten the front seat belt upper anchor bolt to the specified torque.  
**Torque: 49 N·m (36 lb ft)**
2. Tighten the front seat belt lower anchor bolt to the specified torque.  
**Torque: 39 N·m (29 lb ft)**
3. Tighten the retractor fixing bolts to the specified torque.  
**Torque: 39 N·m (29 lb ft)**
4. Tighten the adjustable shoulder anchor assembly fixing bolts to the specified torque.  
**Torque: 39 N·m (29 lb ft)**

## Rear Seat Belt

### Rear Seat Belt and Associated Parts



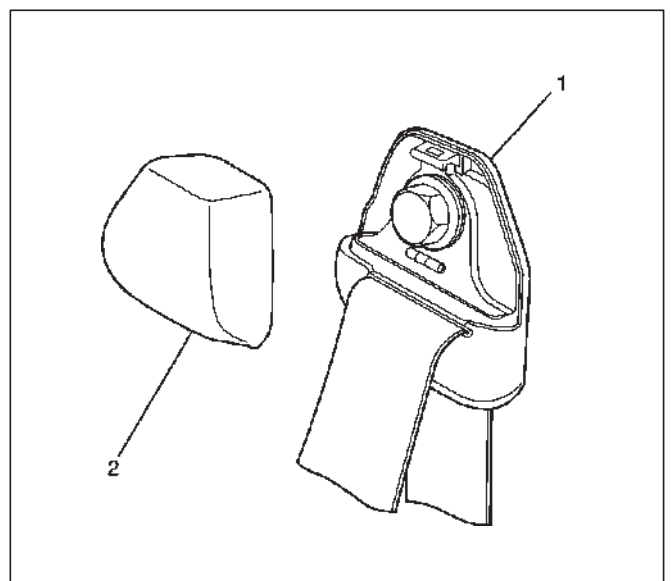
760RX008

#### Legend

- |                             |                             |
|-----------------------------|-----------------------------|
| (1) Quarter Trim Cover      | (5) Luggage Rear Trim Cover |
| (2) Retractor               | (6) Rear Seat Belt Assembly |
| (3) Lower Anchor Bolt       | (7) Upper Anchor Bolt       |
| (4) Luggage Side Trim Cover | (8) Shoulder Anchor Cover   |
|                             | (9) Rear Roof Trim Cover    |

### Removal

1. Disconnect the battery ground cable.
2. Remove the quarter trim cover.
  - Refer to Interior Trim Cover and Assist Grip in Exterior/Interior Trim section.
3. Remove the shoulder anchor cover(2) from the shoulder anchor(1).



755RX031

4. Remove the upper anchor bolt.
5. Remove the lower anchor bolt.
6. Remove the rear roof trim cover.
7. Remove the luggage rear trim cover.
8. Remove the luggage side trim cover.
  - Refer to Interior Trim Cover and Assist Grip in Exterior/Interior Trim section.
9. Remove the retractor.
  - Remove the fixing bolt.
10. Remove the rear seat belt assembly.

## Inspection

If any of the following abnormalities is found, replace on an assembly basis:

- No smooth move of upper/lower anchors in the circumferential direction.
- Damaged and/or deformed through ring.
- Damaged and/or deformed tongue.
- Damaged and/or frayed of webbing.
- Deformed retractor bracket.
- Seat belt not rewound up.
- Resistance or abnormal sound when seat belt is wound out and rewound.
- Retractor abnormality.

## Inspection of retractor

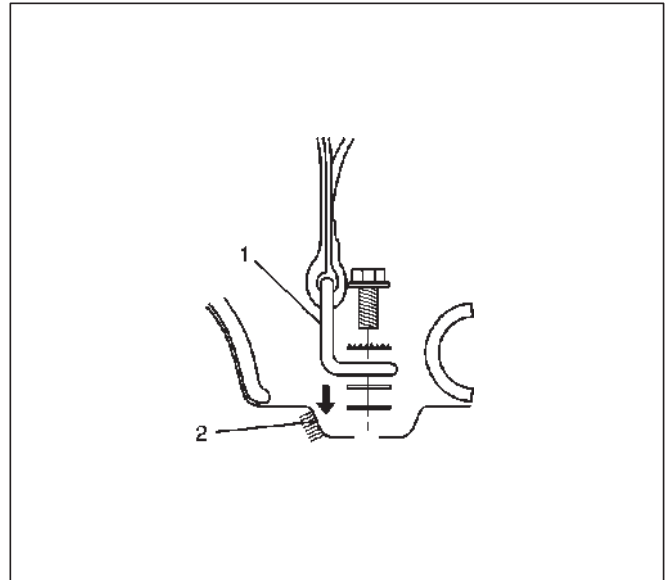
1. ELR (Emergency Locking Retractor) lock inclining angle check.
  - When the retractor is moved gently from its installing position, make sure it is not locked within  $15^\circ$  in any directions, and it remains locked at  $45^\circ$  or larger.
2. ELR lock check.
  - When the seat belt is drawn slowly with the retractor installed, make sure it is not locked. And when it is drawn quickly, make sure it is locked.

**CAUTION: Do not disassemble the retractor.**

## Installation

To install, follow the removal steps in the reverse order, noting the following points.

1. Fix the lower anchor(1) to the rotation-stop position(2) securely to install the rear seat belt assembly.



2. Tighten the seat belt anchor bolts to the specified torque.

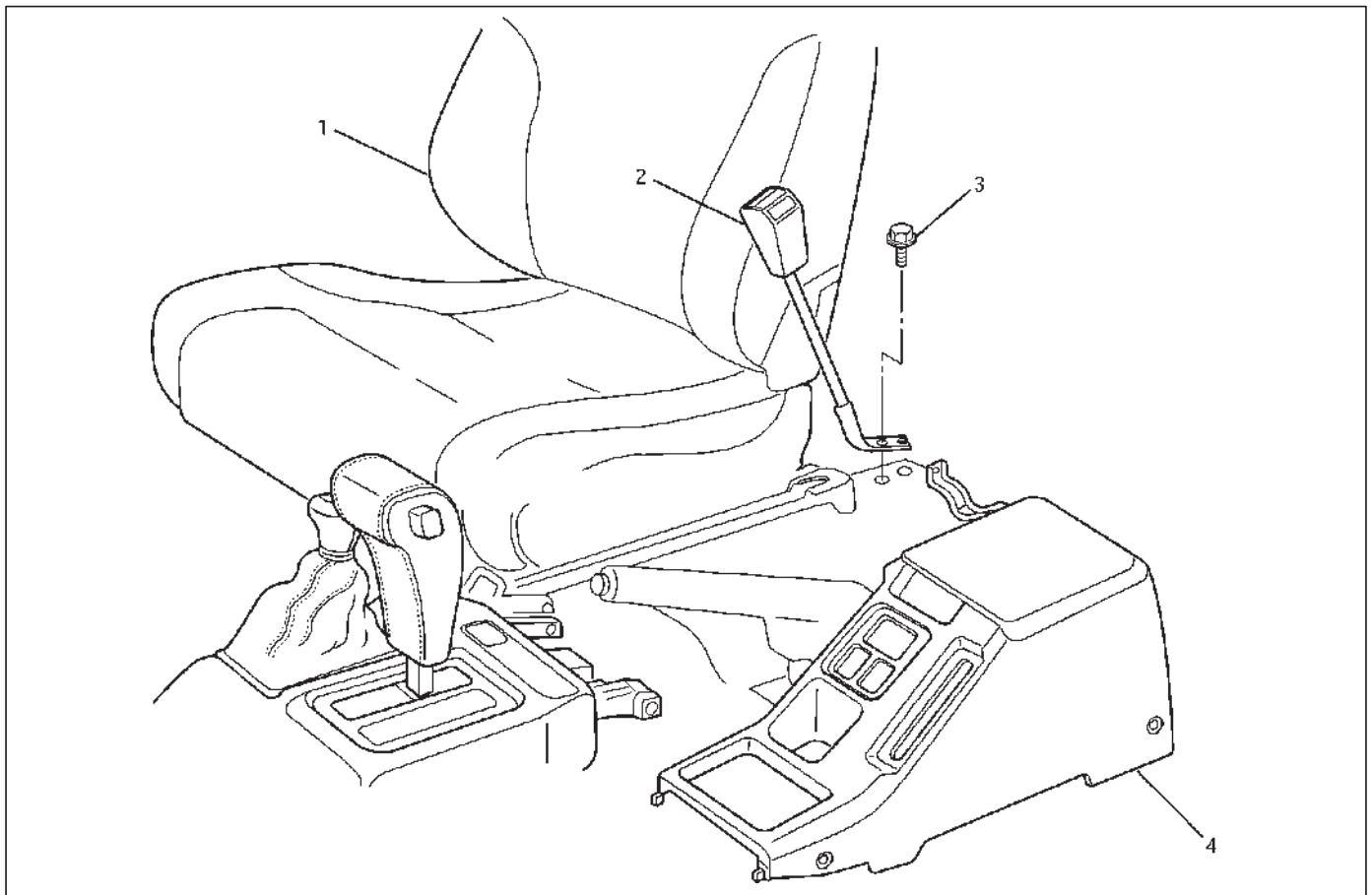
**Torque: 39 N·m (29 lb ft)**

3. Tighten the retractor fixing bolts to the specified torque.

**Torque: 39 N·m (29 lb ft)**

## Front Seat Belt Buckle Assembly

### Front Seat Belt Buckle Assembly and Associated Parts



760RX013

#### Legend

- |                                     |                           |
|-------------------------------------|---------------------------|
| (1) Front Seat Assembly             | (3) Buckle Anchor Bolt    |
| (2) Front Seat Belt Buckle Assembly | (4) Rear Console Assembly |

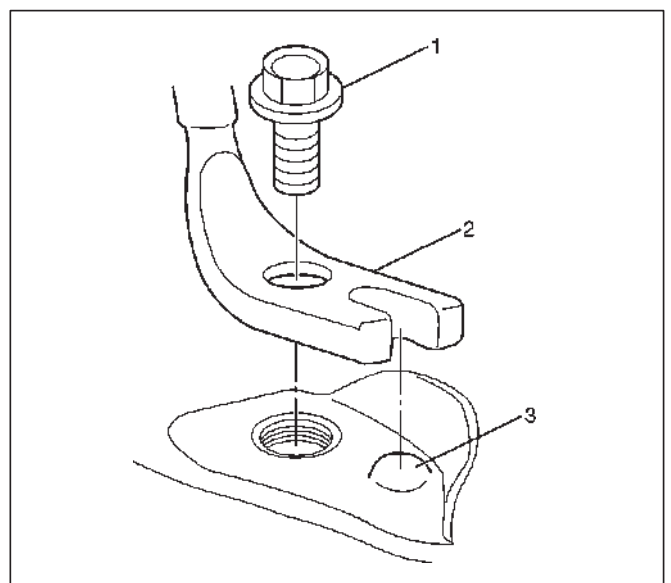
### Removal

1. Disconnect the battery ground cable.
2. Remove rear console assembly.
  - Refer to Console in Exterior/Interior Trim section.
3. Remove front seat assembly.
  - Refer to Front Seat Assembly in Seats section.
4. Remove front seat belt buckle assembly.
  - Disconnect the seat belt warning connector (driver's side) and remove the buckle anchor bolt.

### Installation

To install, follow the removal steps in the reverse order, noting the following points.

1. Tighten the buckle anchor bolt(1) to fix the buckle anchor(2) to the rotation-stop position(3) securely.



760RX011

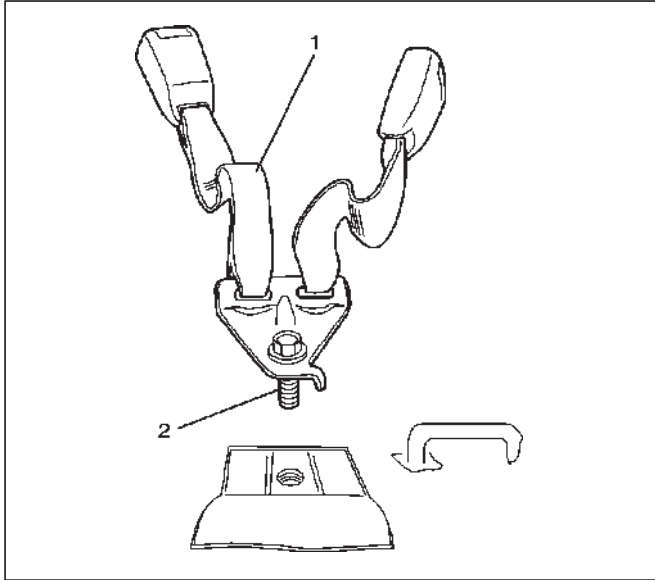
2. Tighten the buckle anchor bolts to the specified torque.

**Torque: 39 N·m (29 lb ft)**

## Rear Seat Belt Buckle Assembly

### Removal

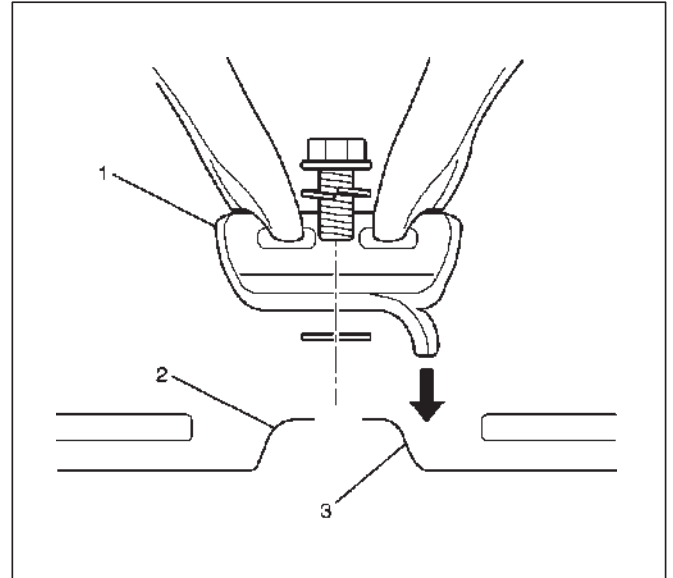
1. Disconnect the battery ground cable.
2. Remove rear seat belt buckle assembly(1).
  - Turn up the carpet slit portion in order to remove the buckle anchor bolt(2).



### Installation

To install, follow the removal steps in the reverse order, noting the following points.

1. Fix the buckle anchor(1) to the rotation-stop position(3) of the floor panel(2) securely to install the rear seat belt buckle assembly.



2. Tighten the buckle anchor fixing bolt to the specified torque.

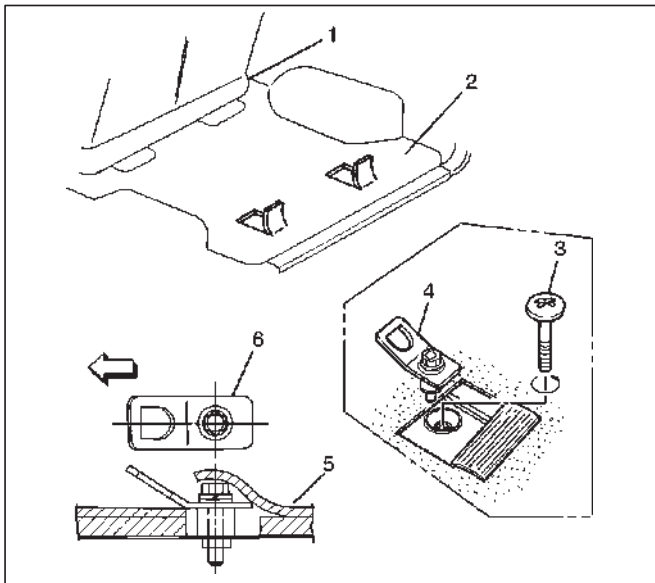
**Torque:39 N·m (29 lb ft )**

## Child Seat Tether Anchor Bracket (Child Restraint)

### General Description

Plastic plug is provided at three places on the luggage floor panel. Remove the center plug from the floor panel. Install the bracket to the hole where the plug is removed. Alternatively, the bracket may be installed in the right-hand or left-hand plug hole.

### Child Seat Tether Anchor Bracket and Associated Parts



760RX014

### Legend

- (1) Rear Seat
- (2) Luggage Floor
- (3) Plug
- (4) Child Seat Tether Anchor Bracket
- (5) Floor Carpet
- (6) Child Seat Tether Anchor Bracket

### Installation

1. Turn the plug counterclockwise to remove it.
2. Install the bracket such that its tether belt hook hole is facing toward the front of the vehicle.
3. Tighten the fixing bolt to the specified torque.

**Torque: 20 N·m (14 lb ft)**

**Main Data and Specifications****Torque Specifications**

<b>Application</b>	<b>N·m</b>	<b>lb ft</b>	<b>lb in</b>
Front Seat Belt Upper Anchor Bolts	49	36	—
Front Seat Belt Lower Anchor Bolts	39	29	—
Front Seat Belt Retractor Fixing Bolts	39	29	—
Adjustable Shoulder Anchor Assembly Fixing Bolts	39	29	—
Rear Seat Belt Anchor Bolts	39	29	—
Rear Seat Belt Retractor Fixing Bolts	39	29	—
Front Seat Belt Buckle Anchor Bolts	39	29	—
Rear Seat Belt Buckle Anchor Bolts	39	29	—
Child Seat Tether Anchor Bracket Fixing Bolts	20	14	—



VEHICROSS

# RESTRAINTS

## SUPPLEMENTAL RESTRAINT SYSTEM

### CONTENTS

Service Precaution .....	9J-1	Installation .....	9J-36
General Description .....	9J-2	Steering Wheel .....	9J-37
SRS Component and Wiring Location View .....	9J-4	Service Precautions .....	9J-37
Component Description .....	9J-4	Removal .....	9J-37
Definition .....	9J-7	Installation .....	9J-38
Diagnosis .....	9J-8	SRS Coil Assembly .....	9J-39
SRS Connector Body Face Views .....	9J-9	Service Precaution .....	9J-39
Repairs and Inspections Required After an Accident .....	9J-9	Removal .....	9J-39
On-Vehicle Service .....	9J-10	Installation .....	9J-40
Air Bag Assembly Handling / Shipping / Scraping .....	9J-11	Steering Column .....	9J-42
Special Tools .....	9J-27	Service Precaution .....	9J-42
Service Precaution .....	9J-32	Removal .....	9J-42
Sensing and Diagnostic Module (SDM) ....	9J-34	Installation .....	9J-44
Service Precautions .....	9J-34	Passenger Air Bag Assembly .....	9J-46
Removal .....	9J-34	Service Precaution .....	9J-46
Installation .....	9J-34	Removal .....	9J-46
Driver Air Bag Assembly .....	9J-36	Installation .....	9J-46
Service Precautions .....	9J-36	Main Data and Specifications .....	9J-47
Removal .....	9J-36	SRS Air Bag System Inspection Standards For Repair .....	9J-48

### Service Precaution

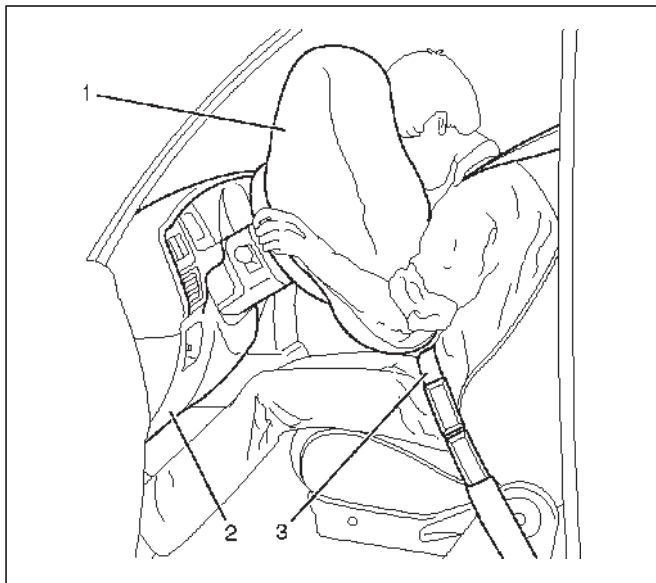
**WARNING: THIS VEHICLE HAS A SUPPLEMENTAL RESTRAINT SYSTEM (SRS). REFER TO THE SRS COMPONENT AND WIRING LOCATION VIEW IN ORDER TO DETERMINE WHETHER YOU ARE PERFORMING SERVICE ON OR NEAR THE SRS COMPONENTS OR THE SRS WIRING. WHEN YOU ARE PERFORMING SERVICE ON OR NEAR THE SRS COMPONENTS OR THE SRS WIRING, REFER TO THE SRS SERVICE INFORMATION. FAILURE TO FOLLOW WARNINGS COULD RESULT IN POSSIBLE AIR BAG DEPLOYMENT, PERSONAL INJURY, OR OTHERWISE UNNEEDED SRS SYSTEM REPAIRS.**

**CAUTION: Always use the correct fastener in the proper location. When you replace a fastener, use ONLY the exact part number for that application. ISUZU will call out those fasteners that require a replacement after removal. ISUZU will also call out the fasteners that require thread lockers or thread sealant. UNLESS OTHERWISE SPECIFIED, do not use supplemental coatings (Paints, greases, or other corrosion inhibitors) on threaded fasteners or fastener joint interfaces. Generally, such coatings adversely affect the fastener torque and the joint clamping force, and may damage the fastener. When you install fasteners, use the correct tightening sequence and specifications. Following these instructions can help you avoid damage to parts and systems.**

## General Description

**CAUTION:** When fasteners are removed, always reinstall them at the same location from which they were removed. If a fastener needs to be replaced, use the correct part number fastener for that application. If the correct part number fastener is not available, a fastener of equal size and strength (or stronger) may be used. Fasteners that are not reused, and those requiring thread locking compound will be called out. The correct torque value must be used when installing fasteners that require it. If the above conditions are not followed, parts or system damage could result.

## Restraint Devices



827RX033

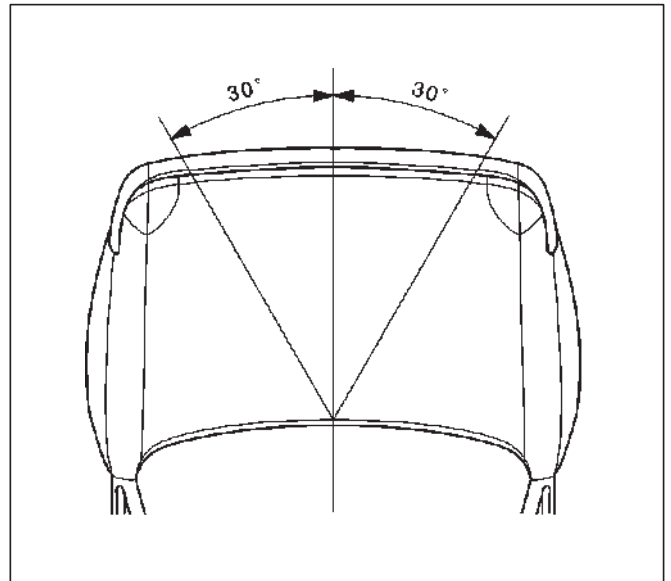
### Legend

- (1) Deployed Air Bag
- (2) Knee Bolster
- (3) Seat Belt

The Supplemental Restraint System (SRS) helps supplement the protection offered by the driver and front passenger seat belts by deploying an air bag from the center of the steering wheel and from the top of the right side of the instrument panel.

The air bag deploys when the vehicle is involved in a frontal crash of sufficient force up to 30 degrees off the

centerline of the vehicle. To further absorb the crash energy there is a knee bolster located beneath the instrument panel for both the driver and passenger, and the steering column is collapsible.

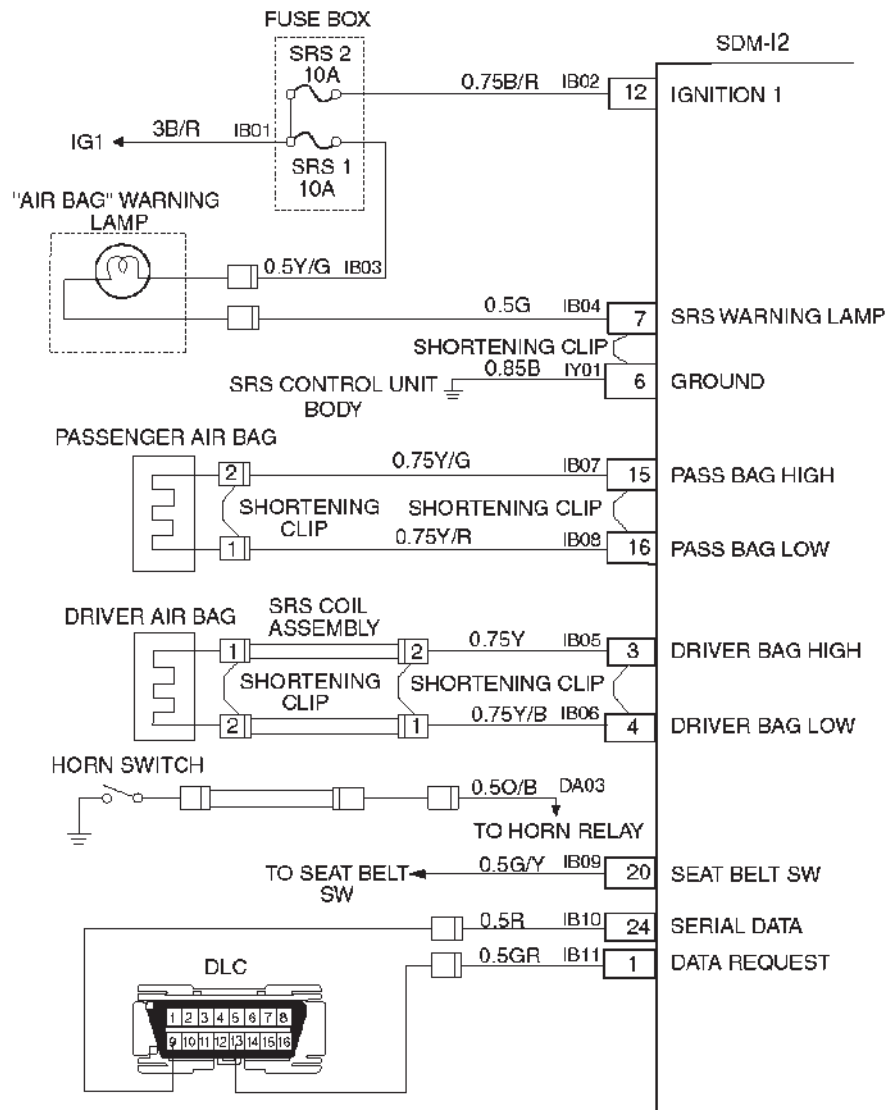


827RX009

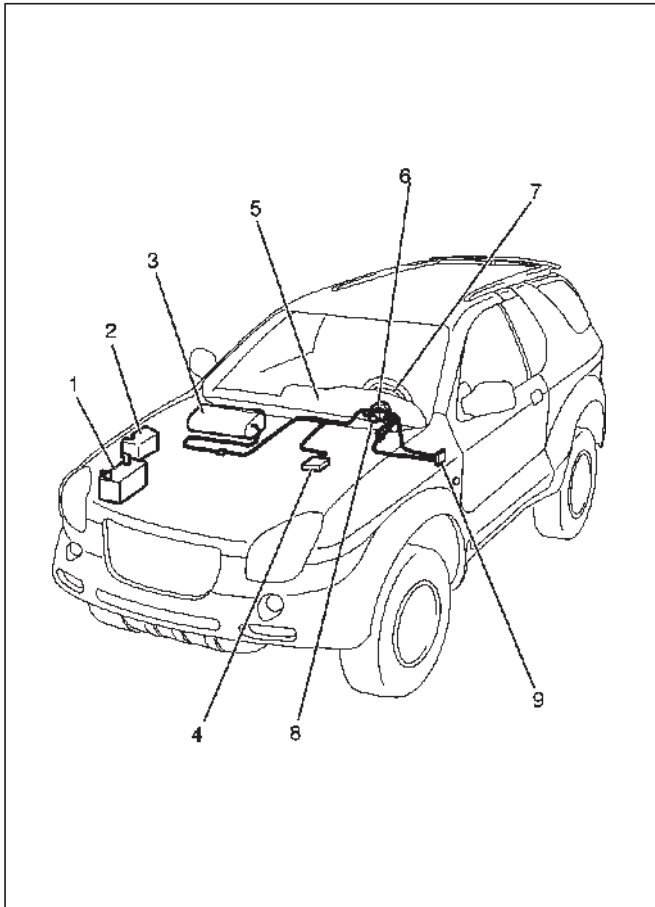
## System Description

The SRS consists of the Sensing and Diagnostic Module (SDM), the driver air bag assembly, the SRS coil assembly, the passenger air bag assembly, and the "AIR BAG" warning lamp in the instrument cluster. The SDM, SRS coil assembly (driver side only), driver air bag assembly, passenger air bag assembly and connector wire make up the deployment loops. The function of the deployment loops is to supply current through air bag assembly, which will cause deployment of the air bags in the event of a frontal crash of sufficient force, up to 30 degrees off the centerline of the vehicle. The air bag assemblies are only supplied enough current to deploy when the SDM detects vehicle velocity changes severe enough to warrant deployment.

The SDM contains a sensing device which converts vehicle velocity change to an electrical signal. The electrical signal generated is processed by the SDM and then compared to a value stored in memory. When the generated signal exceeds the stored value, the SDM will cause current to flow through the air bag assembly deploying the air bags.



## SRS Component and Wiring Location View



810RX010

### Legend

- (1) Battery
- (2) Relay & Fuse Box
- (3) Passenger Air Bag Assembly
- (4) SDM
- (5) Meter Assembly
- (6) SRS Coil Assembly
- (7) Driver Air Bag Assembly
- (8) Starter Switch
- (9) Fuse Box, SRS-1, SRS-2

## Component Description

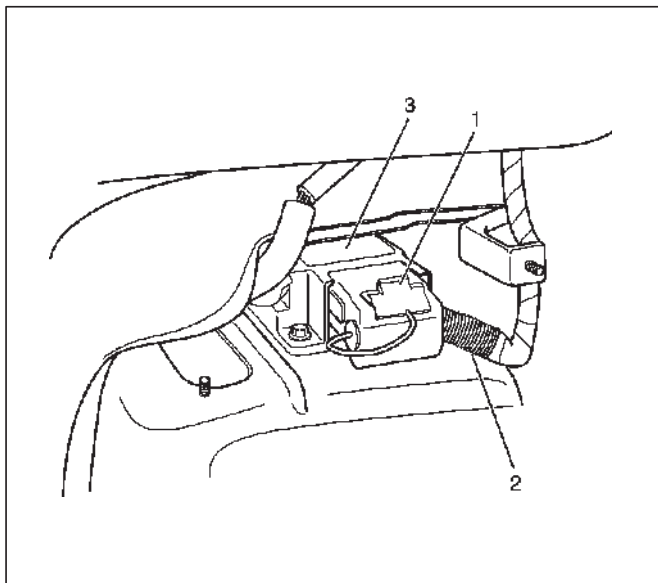
### SDM (Sensing and Diagnostic Module)

**WARNING: DURING SERVICE PROCEDURES, BE VERY CAREFUL WHEN HANDLING A SDM. NEVER STRIKE OR JAR THE SDM. NEVER POWER UP THE SRS WHEN THE SDM IS NOT RIGIDLY ATTACHED TO THE VEHICLE. ALL SDM AND MOUNTING BRACKET FASTENERS MUST BE CAREFULLY TORQUED AND THE ARROW MUST BE POINTED TOWARD THE FRONT OF THE VEHICLE TO ENSURE PROPER OPERATION OF THE SRS. THE SDM COULD BE ACTIVATED WHEN POWERED WHILE NOT RIGIDLY ATTACHED TO THE VEHICLE WHICH COULD CAUSE DEPLOYMENT AND RESULT IN PERSONAL INJURY.**

The SDM is designed to perform the following functions in the Supplemental Restraint System (SRS):

1. Energy Reserve — The SDM maintains 24-Volt Loop Reserve (24VLR) energy supply to provide deployment energy when ignition voltage is lost in a frontal crash.
2. Frontal Crash Detection — The SDM monitors vehicle velocity changes to detect frontal crashes which are severe enough to warrant deployment.
3. Air Bag Deployment — When a frontal crash of sufficient force is detected, the SDM will cause enough current to flow through the air bag assembly to deploy the air bag.
4. Malfunction Detection — The SDM performs diagnostic monitoring of SRS electrical components and sets a diagnostic trouble code when a malfunction is detected.
5. Frontal Crash Recording — The SDM records information regarding SRS status during frontal crash.
6. Malfunction Diagnosis — The SDM displays SRS diagnostic trouble codes and system status information through the use of a scan tool.
7. Driver Notification — The SDM warns the vehicle driver of SRS malfunctions by controlling the “Air Bag” warning lamp.

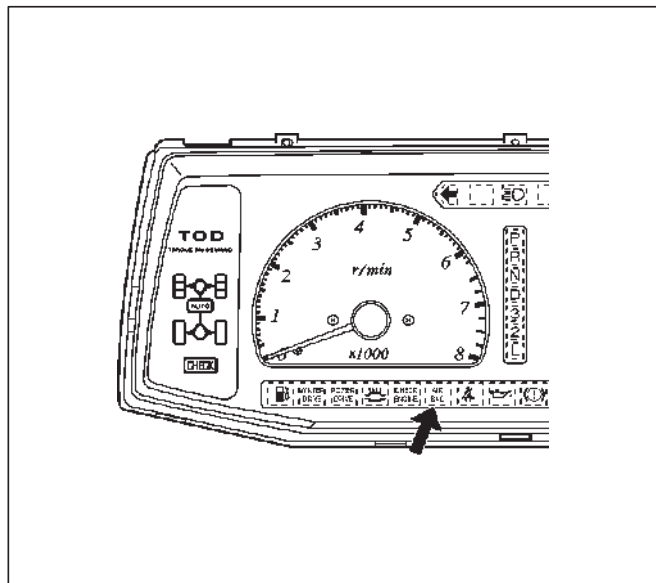
The SDM is connected to the SRS wiring harness by a 24-pin connector. This harness connector uses a shorting clip across certain terminals in the contact area. This shorting clip connects the “AIR BAG” warning lamp to ground when the SDM harness connector is disconnected or Connector Position Assurance (CPA) is not inserted even if completely connected. This will cause the “AIR BAG” warning lamp to come “ON” steady whenever the ignition switch is at the ON or START positions with the SDM disconnected.



827RW067

**Legend**

- (1) Connector Position Assurance (CPA)
- (2) Supplemental Restraint System (SRS) Harness
- (3) Sensing and Diagnostic Module (SDM)



821RX022

**SRS Coil Assembly**

The SRS coil assembly consists of two current carrying coils. This is attached to the steering column and allow rotation of the steering wheel while maintaining continuous contact of the driver deployment loop to the driver air bag assembly.

There is a shorting clip on the yellow 2-pin connector near the base of steering column which connects the SRS coil to the SRS wiring harness.

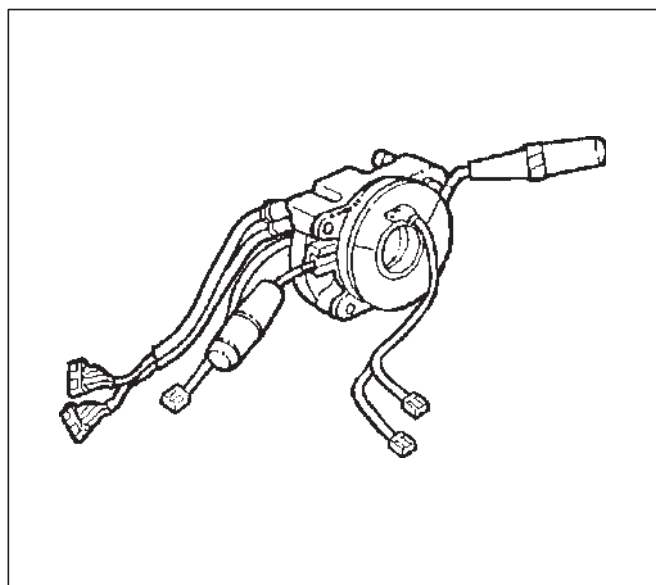
The shorting clip shorts to the SRS coil and driver air bag assembly when the yellow 2-pin connector is disconnected. The circuit to the driver air bag assembly is shorted in this way to help prevent unwanted deployment of the air bag when servicing the steering column or other SRS components.

**“Air Bag” Warning Lamp**

Ignition voltage is applied to the “AIR BAG” warning lamp when the ignition switch is at the ON or START positions. The SDM controls the lamp by providing ground with a lamp driver. The “AIR BAG” warning lamp is used in the SRS to do the following:

1. Verify lamp and SDM operation by flashing SEVEN (7) times when the ignition switch is first turned “ON”.
2. Warn the vehicle driver of SRS electrical system malfunctions which could potentially affect the operation of the SRS. These malfunctions could result in nondeployment in case of a frontal crash or deployment for conditions less severe than intended.

The “AIR BAG” warning lamp is the key to driver notification of SRS malfunctions. For proper lamp operation, refer to the “SRS Diagnostic System Check” in this section.



825RS071

## 9J-6 SUPPLEMENTAL RESTRAINT SYSTEM

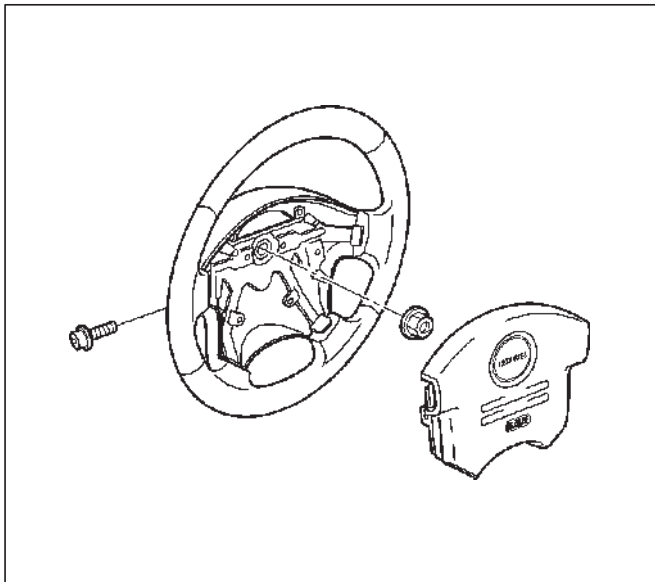
### Air Bag Assemblies

The air bag assembly consist of an inflatable air bag assembly and an inflator (a canister of gas-generating material and an initiating device). When the vehicle is in a frontal crash of sufficient force.

The SDM causes current flow through the deployment loops. Current passing through the inflator ignites the material in the air bag assembly. The gas produced from this reaction rapidly inflates the air bag assembly.

There is a shorting clip on the driver air bag assembly connector which connects the SRS coil assembly. The shorting clip shorts across the driver air bag assembly circuits when driver air bag assembly connector is disconnected.

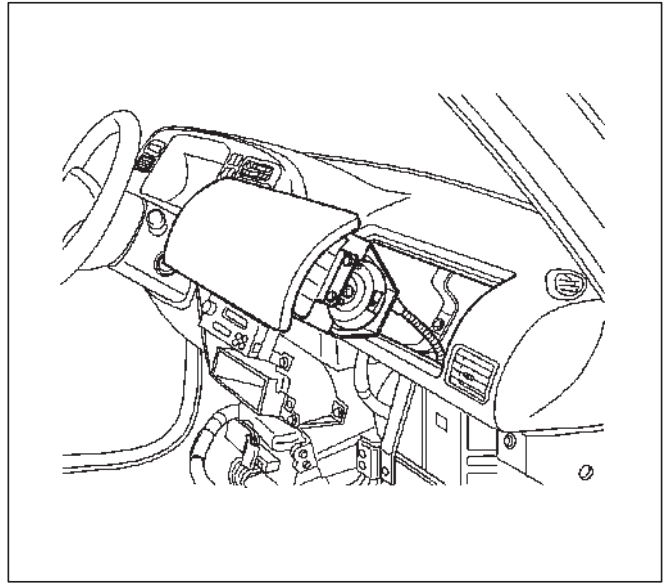
The circuit to the driver air bag assembly is shorted in this way to help prevent unwanted deployment of the air bag when servicing the driver air bag assembly, the steering column or other Supplemental Restraint System (SRS) components.



827RX001

There is a shorting clip on the passenger air bag assembly connector which connects to the SRS harness.

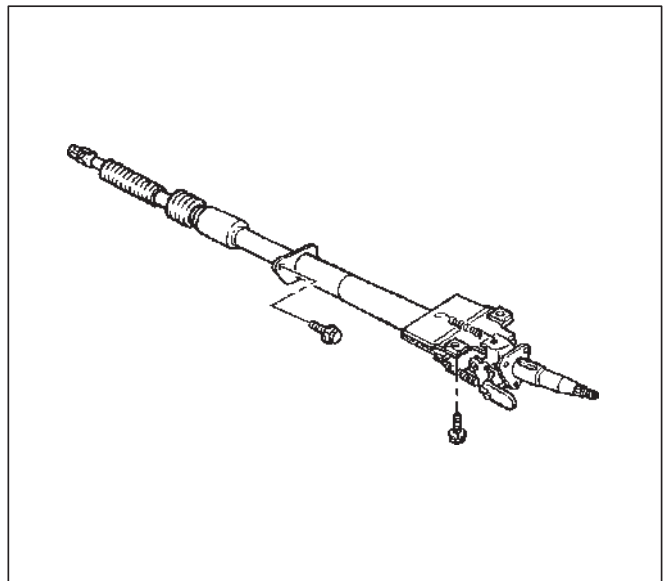
The shorting clip shorts across the passenger air bag assembly circuit when the passenger air bag assembly connector is disconnected. The circuit to the passenger air bag assembly is shorted in this way to help prevent unwanted deployment of the air bag when servicing the passenger air bag assembly, the instrument panel or other SRS components.



827RX052

### Steering Column

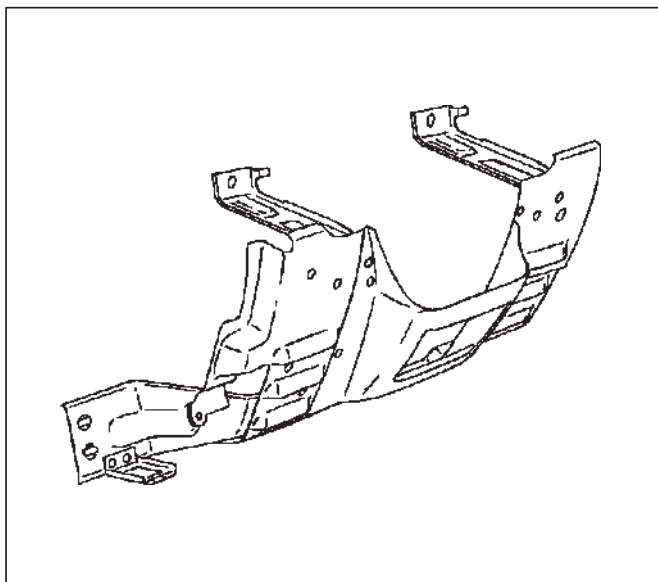
The steering column absorbs energy and is designed to compress in a frontal crash to decrease the chance of injury to the driver.



431RW019

## Knee Bolster

The knee bolsters are used to absorb energy to protect knees and control the forward movement of the vehicle's front seat occupants during a frontal crash, by limiting leg movement.



740RS021

## Definition

### Air Bag

An inflatable cloth cushion designed to deploy in certain frontal crashes. It supplements the protection offered by the seat belts by distributing the impact load more evenly over the vehicle occupant's head and torso.

### (B+)

Battery voltage, (B+) The voltage available at the battery at the time of the indicated measurement. With the key "ON" and the engine not running, the system voltage will likely be between 12 and 12.5 volts. At idle the voltage may be 14 to 16 volts. The voltage could be as low as 10 volts during engine cranking.

### Bulb Check

The Sensing and Diagnostic Module (SDM) will cause the "AIR BAG" warning lamp to flash seven times and then go "OFF" whenever the ignition switch transitions to the ON position from any other ignition switch position and no malfunctions are detected.

### "CONTINUOUS MONITORING"

Tests performed by the SDM on the SRS every 100 milliseconds while "Ignition 1" voltage is in the normal operating voltage range at the SDM.

### Data Link Connector (DLC)

Formerly "DLC" a connector which allows communication with an external computer, such as a scan tool.

### Deploy

To inflate the air bag.

### Deployment Loops

The circuits which supply current to the air bag assemblies to deploy the air bag.

### Diagnostic Trouble Code (DTC)

Formerly "Code", a numerical designator used by the SDM to indicate specific SRS malfunctions.

### Driver Current Source

An output of the SDM which applies current into the driver air bag assembly circuit during the "Initiator Assembly Resistance Test".

### Driver Air Bag Assembly

An assembly located in the steering wheel hub consisting of an inflatable bag, an inflator and an initiator.

### EEPROM

Electrically Erasable Programmable Read Only Memory. Memory which retains its contents when power is removed from the SDM.

### Ignition Cycle

The voltage at the SDM "Ignition 1" inputs, with ignition switch "ON", is within the normal operating voltage range for at least ten seconds before turning ignition switch "OFF".

### Ignition 1

A battery voltage (B+) circuit which is only powered with the ignition switch in the ON, or START positions.

### Initiator

The electrical component inside the air bag assembly which, when sufficient current flows, sets off the chemical reaction that inflates the air bag.

### "Initiator Assembly Resistance Test"

Tests performed once each ignition cycle when no malfunctions are detected during "Turn-ON" or "Continuous Monitoring." This test checks for the correct SDM configuration for the vehicle, shorts to "Ignition 1" in the deployment loops, high resistance or opens in the "Driver Side High", "Driver Side Low", "Passenger Side High" and "Passenger Side Low" circuits and measures the resistance of the inflator assembly consisting of: 1) Initiators, 2) SRS coil assembly (driver side only), 3) Connectors and associated wiring.

### Normal Operating Voltage Range

The voltage measured between the SDM "Ignition 1" terminals and "Ground" terminals is between 9 and 16 volts.

### Passenger Current Source

An output of the SDM which applies current into the passenger air bag assembly circuit during the "Initiator Assembly Resistance Test".

**Passenger Air Bag Assembly**

An assembly located in the right side of the instrument panel consisting of an inflatable bag, an inflator and an initiator.

**Scan Tool**

An external computer used to read diagnostic information from onboard computers via the data link connector.

**SDM**

Sensing and Diagnostic Module which provides reserve energy to the deployment loops, deploys the air bags when required and performs diagnostic monitoring of all SRS components.

**Serial Data**

Information representing the status of the SRS.

**SRS**

Supplemental Restraint System.

**SRS Coil Assembly**

An assembly of two current-carrying coils in the driver deployment loop that allows the rotation of the steering wheel while maintaining the continuous contact of the driver deployment loop to the driver air bag assembly.

**SRS Wiring Harness**

The wires and connectors that electrically connect the components in the Supplemental Restraint System (SRS).

**“Turn-ON”**

Test which the Sensing and Diagnostic Module (SDM) performs on the SRS once during each ignition cycle immediately after “Ignition 1” voltage is applied to the SDM and before “Continuous Monitoring”.

**Diagnosis**

**WARNING: TO AVOID DEPLOYMENT WHEN TROUBLESHOOTING THE SRS, DO NOT USE ELECTRICAL TEST EQUIPMENT SUCH AS A BATTERY-POWERED OR AC-POWERED VOLTMETER, OHMMETER, ETC., OR ANY TYPE OF ELECTRICAL EQUIPMENT OTHER THAN THAT SPECIFIED IN THIS MANUAL. DO NOT USE A NON-POWERED PROBE-TYPE TESTER. INSTRUCTIONS IN THIS MANUAL MUST BE FOLLOWED CAREFULLY, OTHERWISE PERSONAL INJURY MAY RESULT.**

**Diagnostic Trouble Codes**

The “SRS Diagnostic System Check” must always be the starting point of any SRS diagnosis. The “SRS Diagnostic System Check” checks for proper “AIR BAG” warning lamp operation and checks for SRS diagnostic trouble codes using the scan tool.

1. Current diagnostic trouble codes – Malfunctions that are presently being detected. Current diagnostic trouble codes are stored in Random Access Memory (RAM).
2. History diagnostic trouble codes – All malfunctions detected since the last time the history memory was cleared. History diagnostic trouble codes are stored in Electronically Erasable Programmable Read Only Memory (EEPROM).

**Scan Tool Diagnostics**

A scan tool is used to read current and history diagnostic trouble codes and to clear all diagnostic trouble codes after a repair is completed. The scan tool must be updated to communicate with the SRS through a replaceable cartridge before it can be used for SRS diagnostics. To use the scan tool, connect it to the data link connector and turn the ignition switch “ON”. The scan tool reads serial data from the SDM “Serial Data” line terminal “24” to the data link connector terminal “9”.

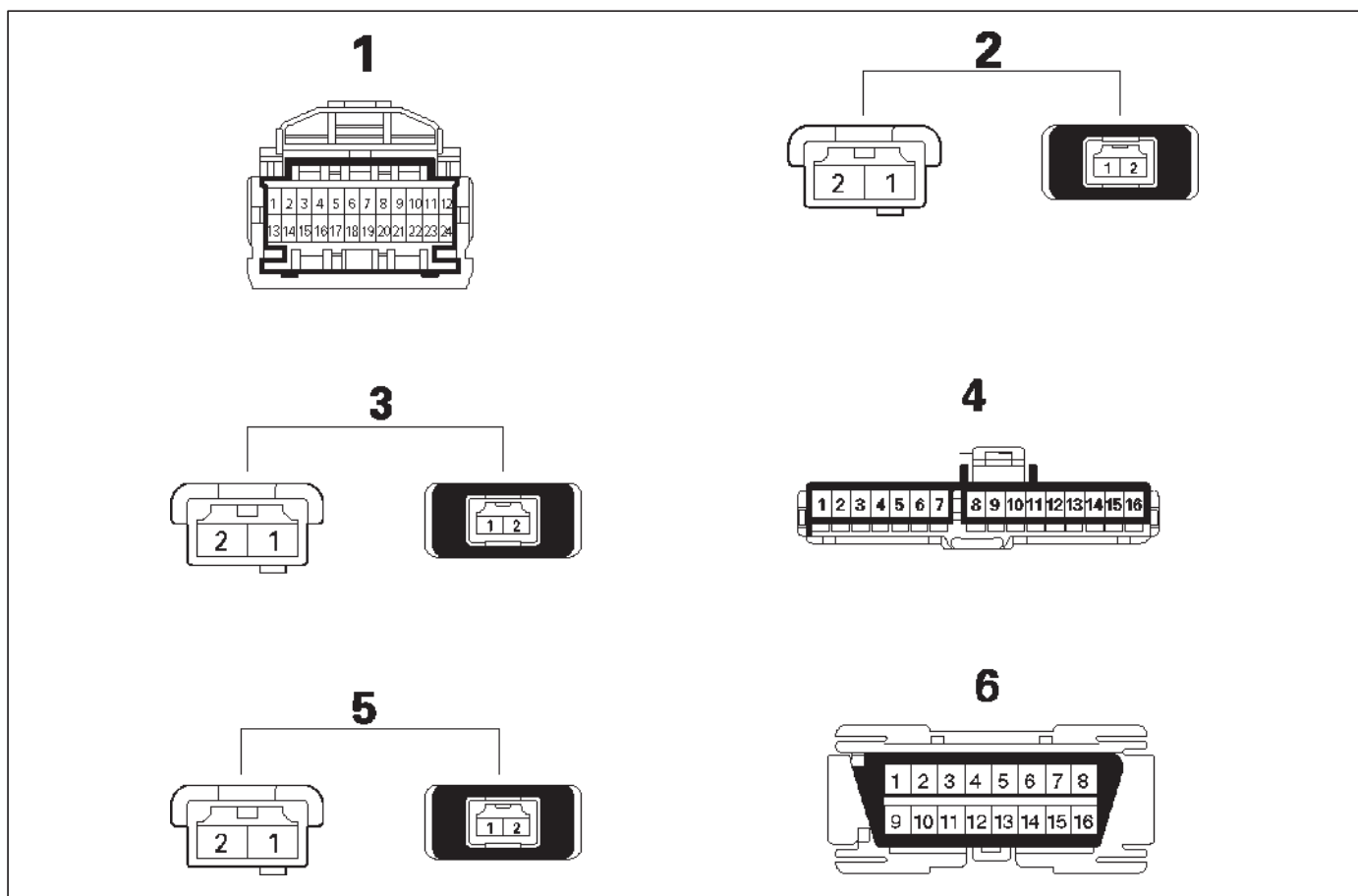
**Use of Special Tools**

**WARNING: TO AVOID DEPLOYMENT WHEN TROUBLESHOOTING THE SRS, DO NOT USE ELECTRICAL TEST EQUIPMENT SUCH AS A BATTERY-POWERED OR AC-POWERED VOLTMETER, OHMMETER, ETC, OR ANY TYPE OF ELECTRICAL EQUIPMENT OTHER THAN THAT SPECIFIED IN THIS MANUAL. DO NOT USE A NON POWERED PROBE-TYPE TESTER. INSTRUCTIONS IN THIS MANUAL MUST BE FOLLOWED CAREFULLY, OTHERWISE PERSONAL INJURY MAY RESULT. YOU SHOULD BE FAMILIAR WITH THE TOOLS LISTED IN THIS SECTION UNDER THE HANDLING SRS SPECIAL TOOLS.**

You should be able to measure voltage and resistance. You should be familiar with proper use of a scan tool such as the Tech 2 Diagnostic Computer, SRS Driver/Passenger Load Tool J-41433, Connector Test Adapter Kit J-35616-A, and the DVM (Digital Multimeter) J-39200.



## SRS Connector Body Face Views



D09RW003

### Legend

- (1) Sensing and Diagnostic Module (SDM)
- (2) Driver Air Bag Assembly
- (3) Passenger Air Bag Assembly
- (4) "Air Bag" Warning Lamp
- (5) Supplemental Restraint System (SRS) Coil Assembly
- (6) Data Link Connector (DLC)

## Repairs and Inspections Required After an Accident

NOTE: If any SRS components are damaged, they must be replaced. If SRS component mounting points are damaged, they must be replaced.

- Never use SRS parts from another vehicle. This does not include remanufactured parts purchased from an authorized dealer; they may be used for SRS repairs.
- Do not attempt to service the SDM, the SRS coil assembly, or the air bag assembly. Service of these items is by replacement only.
- Verify the part number of replacement air bag assembly.

**CAUTION: Never use the air bag assembly from another vehicle.**

**Use only the air bag assembly for Vehi CROSS (VX) models.**

**CAUTION: Proper operation of the sensors and Supplemental Restraint System (SRS) requires that any repairs to the vehicle structure return it to the original production configuration. Deployment requires, at a minimum, replacement of the SDM, air bag assembly and dimensional inspection of the steering column. Any visible damage to the SDM mounting bracket (s) requires replacement, and the steering column must be dimensionally inspected, whether deployment occurred or not.**

### Accident With Deployment – Component Replacement and Inspections

Certain SRS components must be replaced or inspected for damage after a frontal crash involving air bag deployment. Those components are:

- Air bag assembly
- SDM

## 9J-10 SUPPLEMENTAL RESTRAINT SYSTEM

**CAUTION:** Refer to “SDM Replacement Guidelines” below for important information on Sensing and Diagnostic Module (SDM) replacement in both deployment and non deployment crashes.

- Supplemental Restraint System (SRS) coil assembly—Inspect wiring and connector for any signs of scorching, melting, or damage due to excessive heat. Replace if damaged. Refer to SRS coil assembly in this section.

### Accident With or Without Deployment—Component Inspection

Certain SRS and restraint system components must be inspected after any crash, whether the air bag deployed or not. Those components are:

- Steering column—Dimensionally inspect per “Checking Steering Column for Accident Damage” in 3 of this workshop manual.
- Knee bolsters and mounting points—Inspect for any distortion, bending, cracking, or other damage.
- Instrument panel steering column reinforcement plate—Inspect for any distortion, bending, cracking, or other damage.
- Instrument panel braces—Inspect for any distortion, bending, cracking, or other damage.
- Seat belts and mounting points—Refer to “Seat Belts” in 10 of this workshop manual.

### SDM Replacement Guidelines

SDM replacement policy requires replacement of SDM, after crash involving air bag deployment when “SRS Warning Lamp” turn “ON”, “SRS Diagnosis” should be done according to “Section”.

### Wiring Damage

If any SRS wire harness is damaged, it should be replaced. Don't repair SRS harness. It is replace only.

### SRS Connector (Plastic Body And Terminal Metal Pin) Damage

If any connector or terminal in the SRS wire harness (except pigtails) is damaged, it should be replaced.

### SRS Wire Pigtail Damage

If the wiring pigtail (a wire or wires attached directly to the device, not by a connector) is damaged, the entire component (with pigtail) must be replaced. Examples of “pigtail” components are the driver air bag assembly, the passenger air bag assembly, and the SRS coil assembly.

## On-Vehicle Service

### Service Precautions

**WARNING: WHEN PERFORMING SERVICE ON OR AROUND SRS COMPONENTS OR SRS WIRING, FOLLOW THE PROCEDURES LISTED BELOW TO TEMPORARILY DISABLE THE SRS. FAILURE TO FOLLOW PROCEDURES COULD RESULT IN POSSIBLE AIR BAG DEPLOYMENT, PERSONAL INJURY OR OTHERWISE UNNEEDED SRS REPAIRS.**

The SDM in Driver—Passenger SRS can maintain sufficient voltage to cause a deployment for up to 15 seconds after the ignition switch is turned “OFF”, the battery is disconnected, or the fuse powering the SDM is removed.

Many of the service procedures require removal of the “SRS-2” fuse, and disconnection of the air bag assembly from the deployment loop to avoid an accidental deployment. If the air bag assembly is disconnected from the deployment loop as noted in the “Disabling the SRS” procedure that follows, service can begin immediately without waiting for the 15 second time period to expire.

### Disabling The SRS

#### Removal

Turn the ignition switch to “lock” and remove key.

1. Remove SRS fuse “SRS-1” and “SRS-2”, from left dash side lower fuse block or disconnect battery.
2. Disconnect yellow 2-pin connector at the base of steering column.
3. Remove glove box assembly, Refer to “Passenger Air Bag Assembly Replacement” in section.
4. Disconnect yellow 2-pin connector behind the glove box assembly.

**CAUTION: With the “SRS-2” fuse removed and ignition switch “ON”, “AIR BAG” warning lamp will be “ON”. This is normal operation and does not indicate an SRS malfunction.**

### Enabling The SRS

#### Installation

**CAUTION: Never use the air bag assembly from another vehicle. Use only the air bag assembly for Vehi CROSS (VX) models.**

Turn ignition switch to “LOCK” and remove key.

1. Connect yellow 2-pin connector passenger air bag assembly.
2. Install glove box assembly, refer to “Passenger Air Bag Assembly Replacement” in section.
3. Connect yellow 2-pin connector at the base of steering column.
4. Install “AIR BAG” fuse “SRS-1” and “SRS-2” to left dash side lower fuse block or connect battery.

Turn ignition switch to "ON" and verify that the "AIR BAG" warning lamp flashes seven times and then turns "OFF" If it does not operate as described, perform the "Supplemental Restraint System (SRS) Diagnostic System Check" in section.

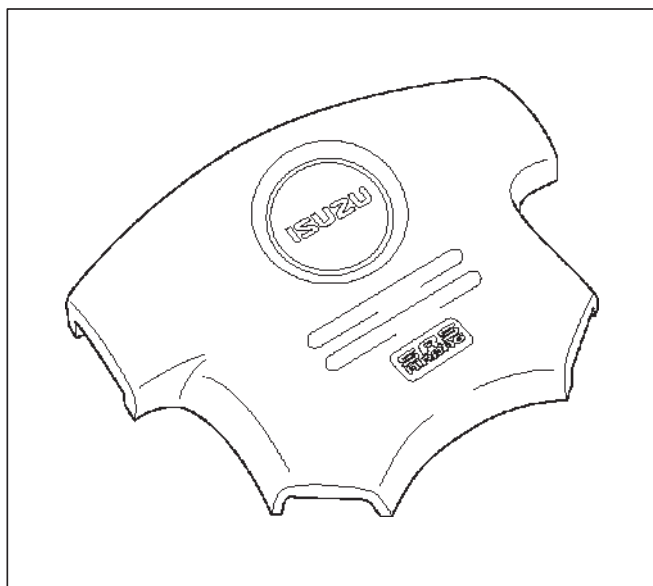
### Handling / Installation / Diagnosis

1. Air bag assembly should not be subjected to temperatures above 93°C (200°F).
2. Air bag assembly, and Sensing and Diagnostic Module (SDM) should not be used if they have been dropped from a height of 100 cm (3.28 feet).
3. When a SDM is replaced, it must be oriented with the arrow on the sensor pointing toward the front of the vehicle. It is very important for the SDM to be located flat on the mounting surface, parallel to the vehicle datum line. It is important that the SDM mounting surface is free of any dirt or other foreign material.
4. Do not apply power to the SRS unless all components are connected or a diagnostic chart requests it, as this will set a diagnostic trouble code.
5. The "SRS Diagnostic System Check" must be the starting point of any SRS diagnostics. The "SRS Diagnostic System Check" will verify proper "AIR BAG" warning lamp operation and will lead you to the correct chart to diagnose any SRS malfunctions. Bypassing these procedures may result in extended diagnostic time, incorrect diagnosis, and incorrect parts replacement.

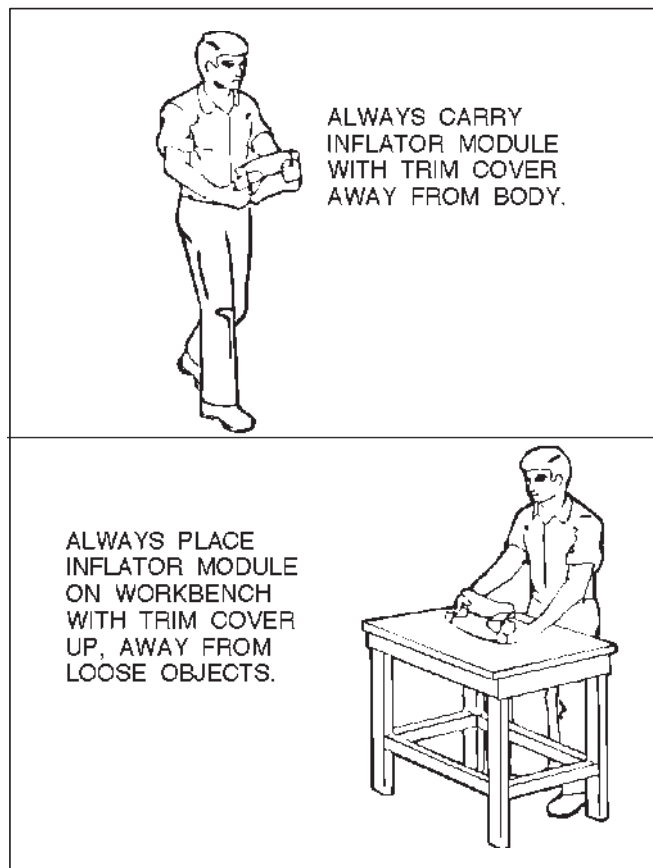
### Air Bag Assembly Handling / Shipping / Scrapping

#### Live (Undeployed) Air Bag Assembly

Special care is necessary when handling and storing a live (undeployed) air bag assembly. The rapid gas generation produced during deployment of the air bag could cause the air bag assembly, or an object in front of the air bag assembly, to be thrown through the air in the unlikely event of an accidental deployment.



**WARNING: WHEN CARRYING A LIVE AIR BAG ASSEMBLY, MAKE SURE THE BAG OPENING IS POINTED AWAY FROM YOU. IN CASE OF AN ACCIDENTAL DEPLOYMENT, THE BAG WILL THEN DEPLOY WITH MINIMAL CHANCE OF INJURY. NEVER CARRY THE AIR BAG ASSEMBLY BY THE WIRES OR CONNECTOR ON THE UNDERSIDE OF THE MODULE.**



### Air Bag Assembly Shipping Procedure For Live (Undeployed) Air Bag Assemblies

Service personnel should refer to the latest Service Bulletins for proper Supplemental Restraint System (SRS) air bag assembly shipping procedures.

### Deployed Air Bag Assembly

"You should wear gloves and glasses. After the air bag assembly has been deployed, the surface of the air bag may contain solid particulate. This solid particulate consists primarily of by products of the chemical reaction, Potassium Chloride and copper metal dust. Compounds of Potassium Borate, Strontium Chloride, Copper Chloride, and Ammonium Chloride may be found in amounts of about 1% (each) of the total particulate."

### Air Bag Assembly Scrapping Procedure

During the course of a vehicle's useful life, certain situations may arise which will necessitate the disposal of a live (undeployed) air bag assembly. This information covers proper procedures for disposing of a live air bag assembly.

Before a live air bag assembly can be disposed of, it must be deployed. A live air bag assembly must not be disposed of through normal refuse channels.

**WARNING: FAILURE TO FOLLOW PROPER SRS AIR BAG ASSEMBLY DISPOSAL PROCEDURES CAN RESULT IN AIR BAG DEPLOYMENT WHICH MAY CAUSE PERSONAL INJURY. AN UNDEPLOYED AIR BAG ASSEMBLY MUST NOT BE DISPOSED OF THROUGH NORMAL REFUSE CHANNELS. THE UNDEPLOYED AIR BAG ASSEMBLY CONTAINS SUBSTANCES THAT CAN CAUSE SEVERE ILLNESS OR PERSONAL INJURY IF THE SEALED CONTAINER IS DAMAGED DURING DISPOSAL. DISPOSAL IN ANY MANNER INCONSISTENT WITH PROPER PROCEDURES MAY BE A VIOLATION OF FEDERAL, STATE, AND / OR LOCAL LAW.**

In situations which require deployment of a live air bag assembly module, deployment may be accomplished inside or outside the vehicle. The method employed depends upon the final disposition of the particular vehicle, as noted in "Deployment Outside Vehicle" and "Deployment Inside Vehicle" in this section.

### Cautions About Air Bag Deployment And Disposal

Failure to follow proper procedures could result in erroneous air bag deployment which may cause personal injury. Be sure to follow proper procedures.

1. Turn off (Lock) the ignition switch and disconnect the minus terminal of the battery, then start the work 15 or more sec later. (Air bag is designed to work by the back-up power source even if the battery power source is cut off at vehicle collision).
2. Be sure not to disassemble the air bag.

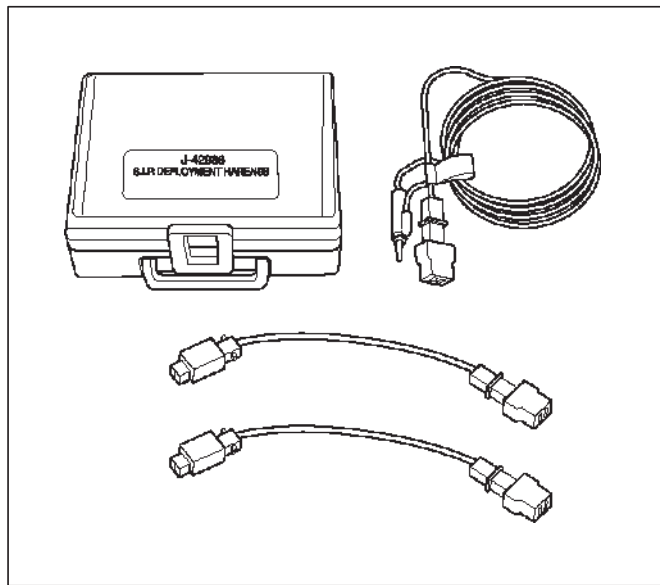
3. Do not give an impact to the air bag or bring the air bag close to magnet. (The air bag could deploy unexpectedly).
4. Place the air bag with its trim cover up.
5. Do not let the air bag deploy directly on the floor. (The air bag may be blown off 2 ~ 3 m (6.5 or 10 feet)).
6. Be sure to install the air bag firmly to a deployment tool (fixing tool).
7. Set a battery 10 m (33 feet) or more away from the air bag.
8. Before disconnecting air bag harness, ground the worker by touching the vehicle outer panel with bare hand.
9. When connecting or disconnecting the harness, do not work just in front of the air bag.
10. As deployment gives rise to big sound, warn the people around against it. Further, try to reduce the sound by covering the steering wheel or tires, and shut the vehicle windows in case of deployment inside the vehicle.
11. As deployment generates smoke, select a well ventilated place. (In case of deployment indoors, avoid deployment just under a fire alarm, smoke sensor, and fluorescent lamps).
12. Be careful not to inhale the smoke after deployment.
13. If part of the vehicle glass is damaged, cover the vehicle with a car cover to prevent the glass from braking at the time of deployment.
14. Do not touch the air bag immediately after deployment, since it remains hot for 30 minutes.
15. Do not water the air bag immediately after deployment.
16. Wear safety glasses and gloves throughout the work and wash the glasses and gloves after the work.
17. Do not reuse the removed air bag for another vehicle. (Deployment characteristic is different with vehicle types).

### Deployment Outside Vehicle (Driver Air Bag Assembly)

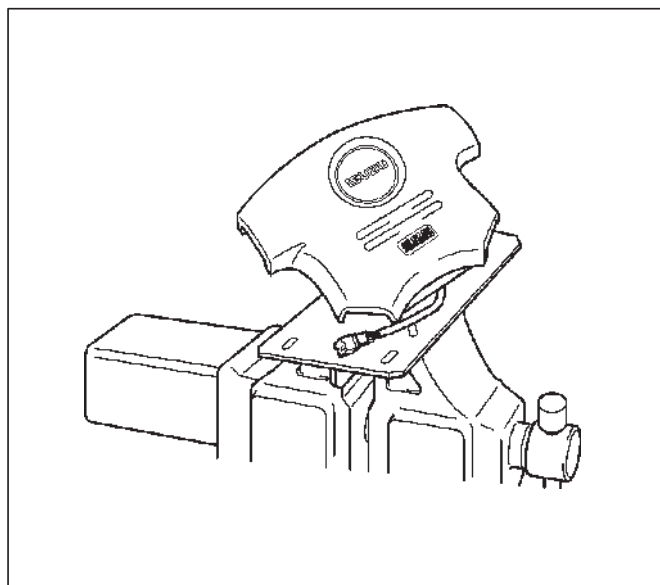
Deployment outside the vehicle is proper when the vehicle is to be returned to service. This includes, for example, situations in which the vehicle will be returned to useful service after a functionally or cosmetically deficient air bag assembly is replaced. Deployment and disposal of a malfunctioning air bag assembly is, of course, subject to any required retention period.

For deployment of a live (undeployed) air bag assembly outside the vehicle, the deployment procedure must be followed exactly. Always wear safety glasses during this deployment procedure until a deployed air bag assembly is scrapped or until an undeployed air bag assembly is shipped. Before performing the procedures you should be familiar with servicing the SRS and with proper handling of the air bag assembly. Procedures should be read fully before they are performed.

The following procedure requires use of J-42986 Supplemental Restraint System (SRS) Deployment Harness with the appropriate pigtail adapter. The procedure also requires the use of J-41497 Driver Side SRS Deployment Fixture. Do not attempt this procedure without J-42986 and fixture J-41497.



901RX046

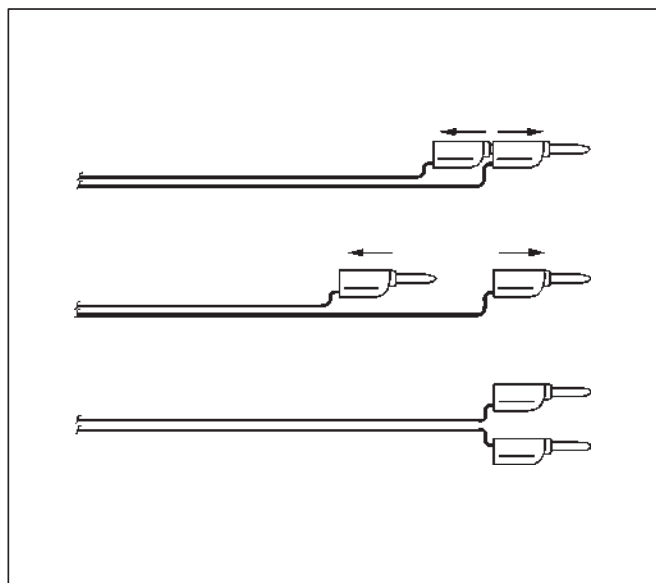


901RW296

**WARNING: FAILURE TO FOLLOW PROCEDURES IN THE ORDER LISTED MAY RESULT IN PERSONAL INJURY. NEVER CONNECT DEPLOYMENT HARNESS TO ANY POWER SOURCE BEFORE CONNECTING DEPLOYMENT HARNESS TO THE DRIVER AIR BAG ASSEMBLY. DEPLOYMENT HARNESS SHALL REMAIN SHORTED AND NOT BE CONNECTED TO A POWER SOURCE UNTIL THE AIR BAG IS TO BE DEPLOYED. THE AIR BAG ASSEMBLY WILL IMMEDIATELY DEPLOY THE AIR BAG WHEN A POWER SOURCE IS CONNECTED TO IT. WEAR SAFETY GLASSES THROUGHOUT THIS ENTIRE DEPLOYMENT AND DISPOSAL PROCEDURE.**

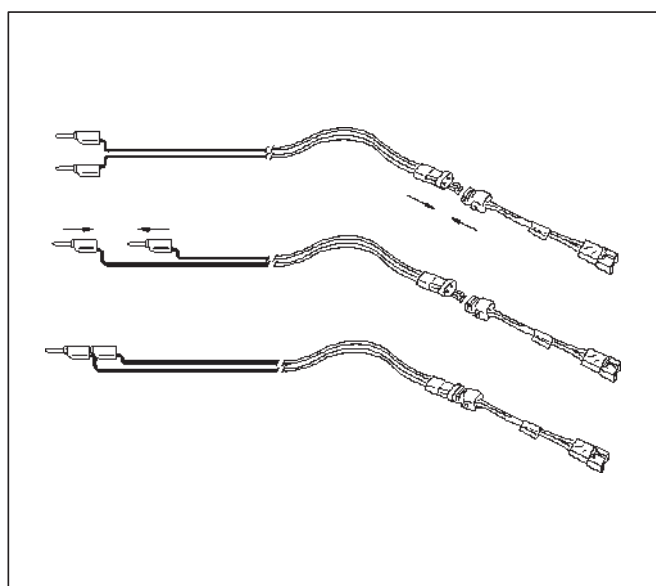
NOTE: This information applies only to driver air bag assembly . Refer to "Deployment Outside Vehicle (Passenger Air Bag Assembly)" in this section for information on passenger air bag assembly scrapping.

1. Turn ignition switch to "LOCK", remove key and put on safety glasses.
2. Inspect J-41434 SRS Deployment Harness and appropriate pigtail adapter for damage. If harness or pigtail adapter is damaged, discard and obtain a replacement.
3. Short the two SRS deployment harness leads together by fully seating one banana plug into the other. SRS deployment harness shall remain shorted and not be connected to a power source until the air bag is to be deployed.



827RS003

4. Connect the appropriate pigtail adapter to the SRS deployment harness.



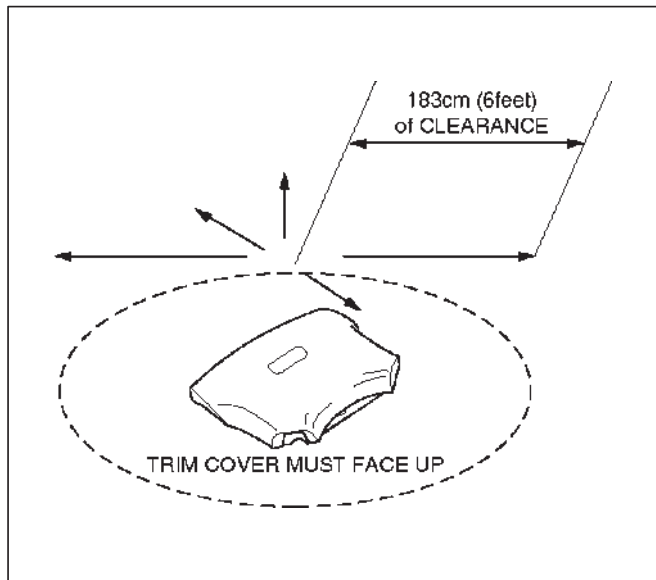
827RS004

## 9J-14 SUPPLEMENTAL RESTRAINT SYSTEM

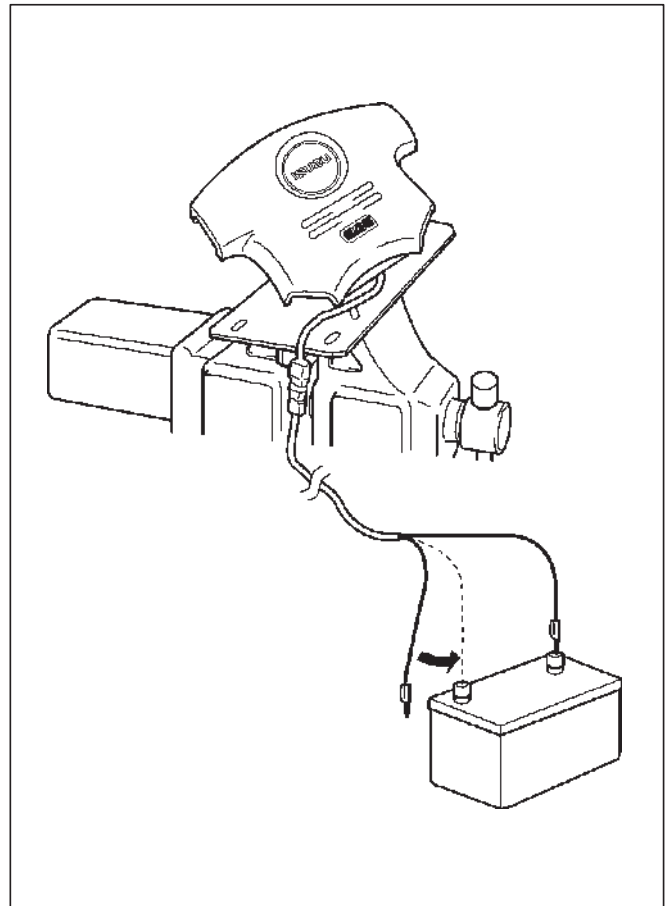
5. Remove the driver air bag assembly from vehicle. Refer to driver air bag assembly Removal in this Section.

**WARNING: WHEN STORING A LIVE AIR BAG ASSEMBLY OR WHEN LEAVING A LIVE AIR BAG ASSEMBLY UNATTENDED ON A BENCH OR OTHER SURFACE, ALWAYS FACE THE AIR BAG AND TRIM COVER UP AND AWAY FROM THE SURFACE. THIS IS NECESSARY SO THAT A FREE SPACE IS PROVIDED TO ALLOW THE AIR BAG TO EXPAND IN THE UNLIKELY EVENT OF ACCIDENTAL DEPLOYMENT. FAILURE TO FOLLOW PROCEDURES MAY RESULT IN PERSONAL INJURY.**

6. Clear a space on the ground about 183 cm (6 feet) in clearance where the driver air bag assembly is to be deployed. A paved, outdoor location where there is no activity is preferred. If an outdoor location is not available, a space on the shop floor where there is no activity and sufficient ventilation is recommended. Ensure no loose or flammable objects are within the deployment area.



7. Place the J-41497 on the bench vice. This is necessary to provide sufficient stabilization of the fixture during deployment.
8. Attach the Driver air bag assembly in the J-41497. Air bag assembly must be mounted such that the bag will deploy upward. **SECURELY HAND-TIGHTEN ALL FASTENERS PRIOR TO DEPLOYMENT.**
9. Extend double pole extension cord to a position for away 10 m (33 feet) from the air bag assembly.
10. Place a power source near the shorted end of the SRS deployment harness. Recommended application: 12 volts minimum, 2 amps minimum. A vehicle battery is suggested.



11. Connect the driver air bag assembly to the pigtail adapter on the Supplemental Restraint System (SRS) deployment harness. Deployment harness shall remain shorted and not be connected to a power source until the air bag is to be deployed. The driver air bag assembly will immediately deploy the air bag when a power source is connected to it.

**NOTE:** Ensure that the pigtail adapter is firmly seated into the driver air bag assembly connector. Failure to fully seat the connectors may leave the shorting bar located in the driver air bag assembly connector functioning (shorted) and may result in non deployment of the driver air bag assembly.

12. Verify that the area around the driver air bag assembly is clear of all people and loose or flammable objects.
13. Verify that the driver air bag assembly is firmly and properly in J-41497.
14. Notify all people in the immediate area that you intend to deploy the driver air bag. The deployment will be accompanied by a substantial noise which may startle the uninformed.
15. Separate the two banana plugs on the SRS deployment harness.

**NOTE:** When the air bag deploys, the rapid gas expansion will create a substantial noise. Notify all people in the immediate area that you intend to deploy the driver air bag.

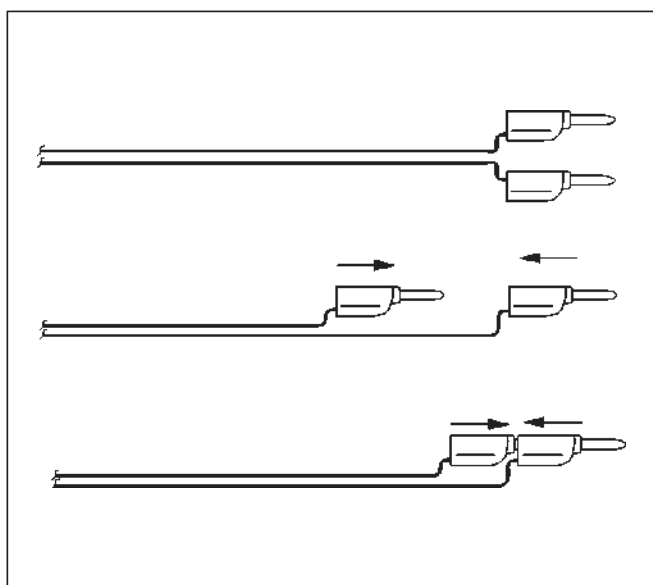
**WARNING: DEPLOYMENT HARNESS SHALL REMAIN SHORTED AND NOT BE CONNECTED TO A POWER SOURCE UNTIL THE AIR BAG IS TO BE DEPLOYED. THE AIR BAG ASSEMBLY WILL IMMEDIATELY DEPLOY THE AIR BAG WHEN A POWER SOURCE IS CONNECTED TO IT. CONNECTING THE DEPLOYMENT HARNESS TO THE POWER SOURCE SHOULD ALWAYS BE THE LAST STEP IN THE AIR BAG ASSEMBLY DEPLOYMENT PROCEDURE. FAILURE TO FOLLOW PROCEDURES IN THE ORDER LISTED MAY RESULT IN PERSONAL INJURY.**

16. Connect the Supplemental Restraint System (SRS) deployment harness wires to the power source to immediately deploy the driver air bag. Recommended application: 12 volts minimum, 2 amps minimum. A vehicle battery is suggested.
17. Disconnect the SRS deployment harness from the power source.
18. Short the two SRS deployment harness leads together by fully seating one banana plug into the other.
19. In the unlikely event that the driver air bag assembly did not deploy after following these procedures, proceed immediately with Steps 24 through 26. If the driver air bag assembly did deploy, proceed with Steps 20 through 23.
20. Put on a pair of shop gloves and safety glasses to protect your hands and eyes from possible irritation and heat when handling the deployed driver air bag assembly. After the air bag assembly has been deployed, the surface of the air bag may contain solid particulate. This solid particulate consists primarily of by products of the chemical reaction, Potassium Chloride and copper metal dust. Compounds of Potassium Borate, Strontium Chloride, Copper Chloride, and Ammonium Chloride may be found in amounts of about 1% (each) of the total particulate.

**WARNING: SAFETY PRECAUTIONS MUST BE OBSERVED WHEN HANDING A DEPLOYED AIR BAG ASSEMBLY. AFTER DEPLOYMENT, THE METAL SURFACES OF THE AIR BAG ASSEMBLY WILL BE VERY HOT. ALLOW THE INFLATOR MODULE TO COOL BEFORE HANDLING ANY METAL PORTION OF IT. DO NOT PLACE THE DEPLOYED AIR BAG ASSEMBLY NEAR ANY FLAMMABLE OBJECTS. FAILURE TO FOLLOW PROCEDURES MAY RESULT IN FIRE OR PERSONAL INJURY.**

**AFTER A DRIVER AIR BAG ASSEMBLY HAS BEEN DEPLOYED, THE METAL CANISTER AND SURROUNDING AREAS OF THE DRIVER AIR BAG ASSEMBLY WILL BE VERY HOT. DO NOT TOUCH THE METAL AREAS OF THE DRIVER AIR BAG ASSEMBLY FOR ABOUT TEN MINUTES AFTER DEPLOYMENT. IF THE DEPLOYED DRIVER AIR BAG ASSEMBLY MUST BE MOVED BEFORE IT IS COOL, WEAR GLOVES AND HANDLE BY THE AIR BAG OR TRIM COVER.**

21. Disconnect the pigtail adapter from the driver air bag assembly as soon after deployment as possible. This will prevent damage to the pigtail adapter or SRS deployment harness due to possible contact with the hot driver air bag assembly canister. The pigtail adapter can be reused. They should, however, be inspected for damage after each deployment and replaced if necessary.
  22. Dispose of the deployed driver air bag assembly through normal refuse channels after it has cooled for at least 30 minutes.
  23. Wash your hands with mild soap and water afterward.
- NOTE:** The remaining steps are to be followed in the unlikely event that the driver air bag assembly did not deploy after following these procedures.
24. Ensure that the SRS deployment harness has been disconnected from the power source and that its two banana plugs have been shorted together by fully seating one banana plug into the other.



25. Disconnect the pigtail adapter from the driver air bag assembly.

**WARNING: WHEN STORING A LIVE AIR BAG ASSEMBLY OR WHEN LEAVING A LIVE INFLATOR MODULE UNATTENDED ON A BENCH OR OTHER SURFACE, ALWAYS FACE THE BAG AND TRIM COVER UP AND AWAY FROM THE SURFACE. THIS IS NECESSARY SO THAT A FREE SPACE IS PROVIDED TO ALLOW THE AIR BAG TO EXPAND IN THE UNLIKELY EVENT OF ACCIDENTAL DEPLOYMENT. FAILURE TO FOLLOW PROCEDURES MAY RESULT IN PERSONAL INJURY.**

26. Temporarily store the driver air bag assembly with its trim cover facing up, away from the surface upon which it rests.

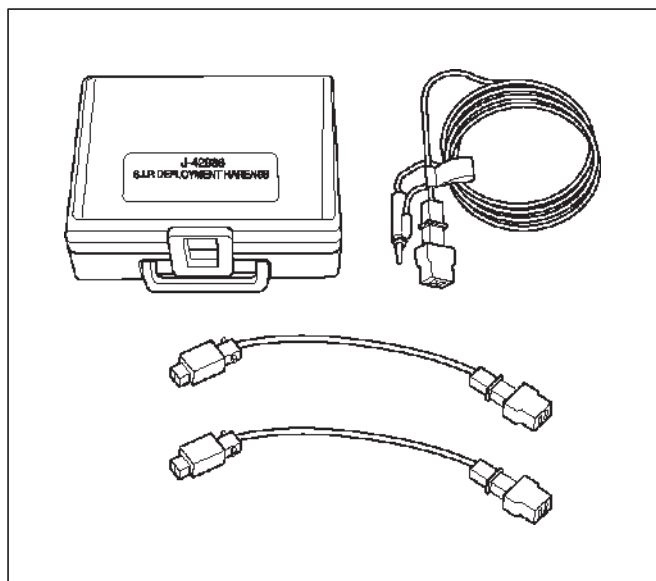
### Deployment Outside Vehicle (Passenger Air Bag Assembly)

**WARNING: FAILURE TO FOLLOW PROPER SRS AIR BAG ASSEMBLY DISPOSAL PROCEDURES CAN RESULT IN AIR BAG DEPLOYMENT WHICH MAY CAUSE PERSONAL INJURY. UNDEPLOYED AIR BAG ASSEMBLIES MUST NOT BE DISPOSED OF THROUGH NORMAL REFUSE CHANNELS. THE UNDEPLOYED AIR BAG ASSEMBLY CONTAINS SUBSTANCES THAT CAN CAUSE SEVERE ILLNESS OR PERSONAL INJURY IF THE SEALED CONTAINER IS DAMAGED DURING DISPOSAL. DISPOSAL IN ANY MANNER INCONSISTENT WITH PROPER PROCEDURES MAY BE A VIOLATION OF FEDERAL, STATE AND/OR LOCAL LAWS.**

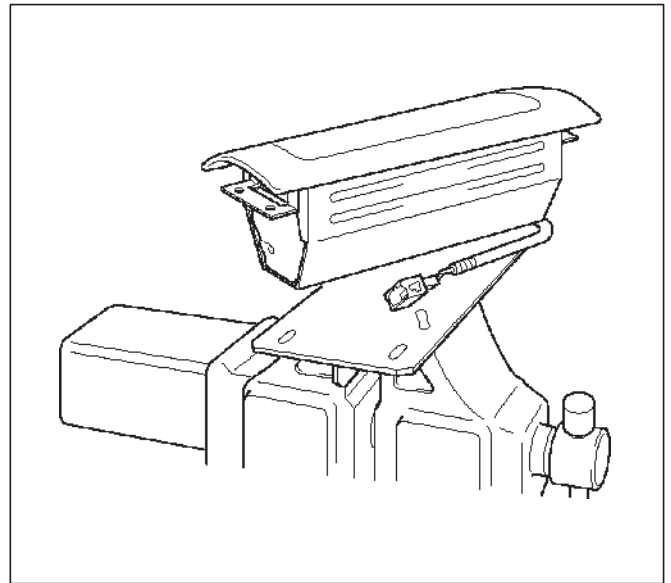
Deployment out of the vehicle is proper when the vehicle is to be returned to service. This includes, for example, situations in which a functionally or cosmetically deficient air bag assembly is replaced. Deployment and disposal of an air bag assembly is, of course, subject to any required retention period.

For deployment of a live air bag assembly out of the vehicle, the deployment procedure must be followed exactly. Always wear safety glasses during this deployment procedure until the deployed air bag assembly is scrapped. Before performing the procedures, you should be familiar with servicing the SRS system and with proper handling of the air bag assembly. Procedures should be read fully before they are performed.

The following procedure requires use of J-42986 SRS Deployment Harness with the appropriate pigtail adapter. The procedure also requires the use of J-41497 Passenger Side Supplemental Restraint System (SRS) Deployment Fixture. Do not attempt this procedure without J-42986 and fixture J-41497.



901RX046



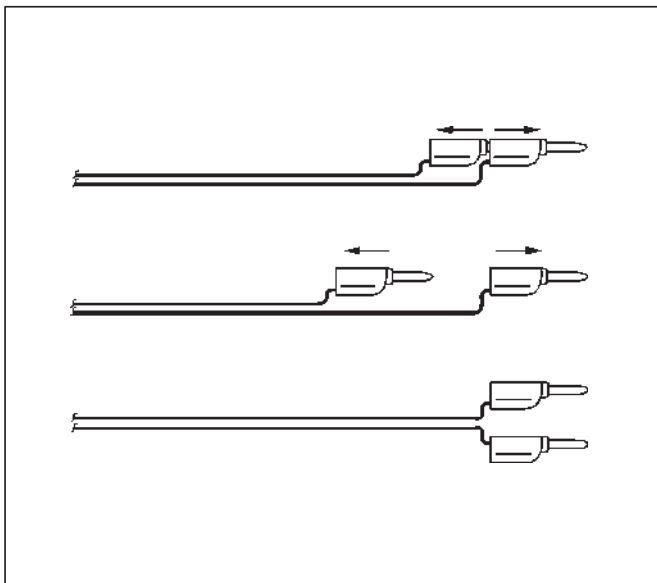
901RW199

**WARNING: FAILURE TO FOLLOW PROCEDURES IN THE ORDER LISTED MAY RESULT IN PERSONAL INJURY. NEVER CONNECT DEPLOYMENT HARNESS TO ANY POWER SOURCE BEFORE CONNECTING DEPLOYMENT HARNESS TO THE AIR BAG ASSEMBLY. DEPLOYMENT HARNESS SHALL REMAIN SHORTED AND NOT BE CONNECTED TO A POWER SOURCE UNTIL THE AIR BAG IS TO BE DEPLOYED. THE AIR BAG ASSEMBLY WILL IMMEDIATELY DEPLOY THE AIR BAG WHEN A POWER SOURCE IS CONNECTED TO IT. WEAR SAFETY GLASSES THROUGHOUT THIS ENTIRE DEPLOYMENT AND DISPOSAL PROCEDURE.**

NOTE: This information applies only to passenger air bag assembly. Information for disposing of a live driver air bag assembly can be found in "Deployment Outside Vehicle" (Driver Air Bag Assembly) in this section.

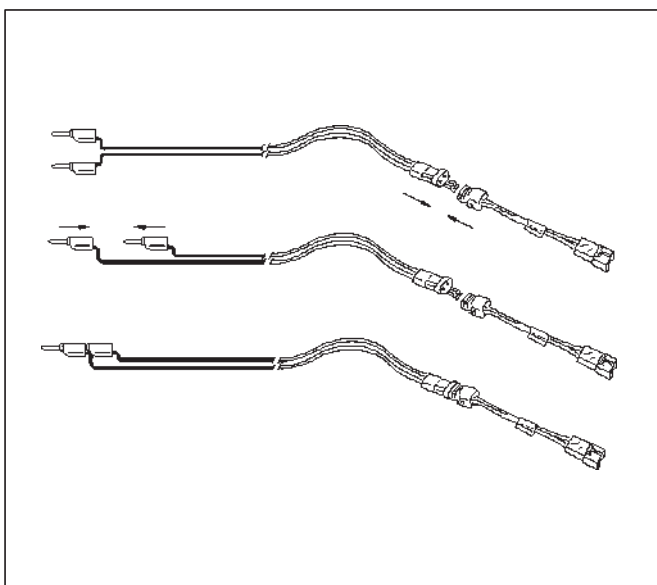
1. Turn ignition switch to "LOCK" remove key, and put on safety glasses.
2. Inspect J-41434 SRS Deployment Harness and appropriate pigtail adapter for damage. If harness or pigtail is damaged, discard and obtain a replacement.
3. Short the two SRS Deployment Harness leads together by fully seating one banana plug into the other. The SRS Deployment Harness shall remain shorted and not be connected to a power source until the air bag is to be deployed.





827RS003

4. Connect the appropriate pigtail adapter to the Supplemental Restraint System (SRS) Deployment Harness



827RS004

5. Remove passenger air bag assembly from vehicle. Refer to "Passenger Air Bag Assembly Removal" in this Section.

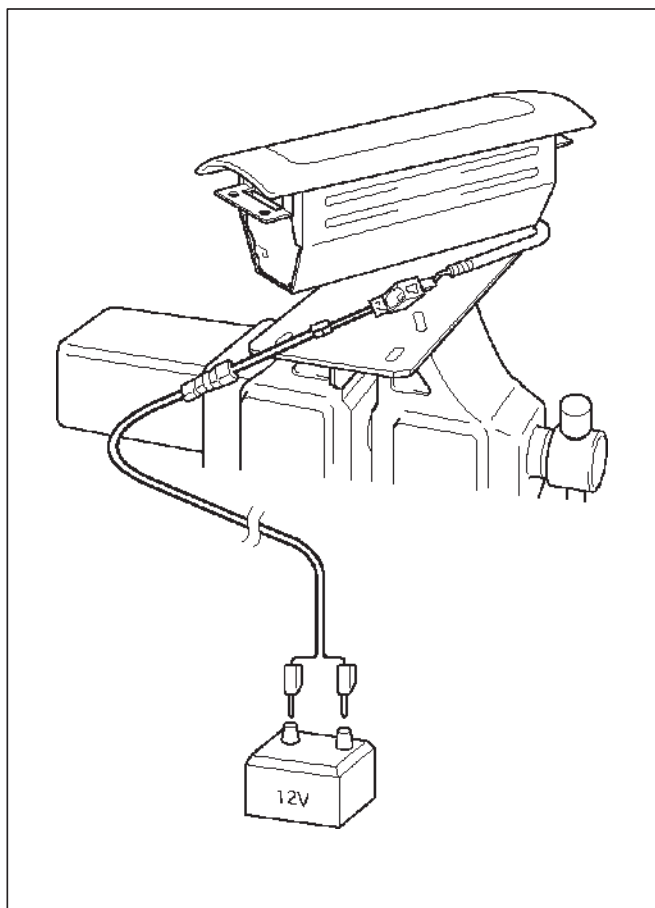
6. Clear a space on the ground approximately 183 cm (6 feet) in clearance where the fixture with attached air bag assembly is to be placed for deployment. A paved outdoor location where there is no activity is preferred. If an outdoor location is not available, a space on the shop floor where there is no activity and sufficient ventilation is recommended. Ensure that no loose or flammable objects are within the deployment area.

7. Place the J-41497 on the bench vice. This is necessary to provide sufficient stabilization of the fixture during deployment.

8. Attach the passenger air bag assembly in the J-41497. Air bag assembly must be mounted such that the bag will deploy upward. **SECURELY HAND-TIGHTEN ALL FASTENERS PRIOR TO DEPLOYMENT.**

9. Extend double pole extension cord to a position for away 10 m (33 feet) from the air bag assembly.

10. Place a power source near the shorted end of the SRS deployment harness. (Recommended application: 12 volts minimum, 2 amps minimum. A vehicle battery is suggested.)



901RX047

11. Connect the air bag assembly to the pigtail adapter on the SRS deployment harness. The SRS Deployment Harness shall remain shorted and not be connected to a power source until the air bag is to be deployed. The air bag assembly will immediately deploy the air bag when a power source is connected to it.

**NOTE:** Ensure that the pigtail adapter is firmly seated into the air bag assembly connector. Failure to fully seat the connectors may leave the shorting bar located in the air bag assembly connector functioning (shorting the deployment circuit) and may result in non deployment of the air bag assembly.

12. Verify that the area around the passenger air bag assembly is clear of all people and loose or flammable objects.

13. Verify that the passenger air bag assembly is firmly and properly in J-41497.

## 9J-18 SUPPLEMENTAL RESTRAINT SYSTEM

14. Notify all people in the immediate area of your intention to deploy the passenger air bag assembly. The deployment will be accompanied by a substantial noise which may startle the uninformed.
15. Separate the two banana plugs on the Supplemental Restraint System (SRS) deployment harness.

NOTE: When air bag deploys, the rapid gas expansion will create a substantial noise. Notify all people in the immediate area that you intend to deploy the air bag assembly.

**WARNING: DEPLOYMENT HARNESS SHALL REMAIN SHORTED AND NOT BE CONNECTED TO A POWER SOURCE UNTIL THE AIR BAG IS TO BE DEPLOYED. THE AIR BAG ASSEMBLY WILL IMMEDIATELY DEPLOY THE AIR BAG WHEN A POWER SOURCE IS CONNECTED TO IT. CONNECTING THE DEPLOYMENT HARNESS TO THE POWER SOURCE SHOULD ALWAYS BE THE LAST STEP IN THE AIR BAG ASSEMBLY DEPLOYMENT PROCEDURE. FAILURE TO FOLLOW PROCEDURES IN THE ORDER LISTED MAY RESULT IN PERSONAL INJURY.**

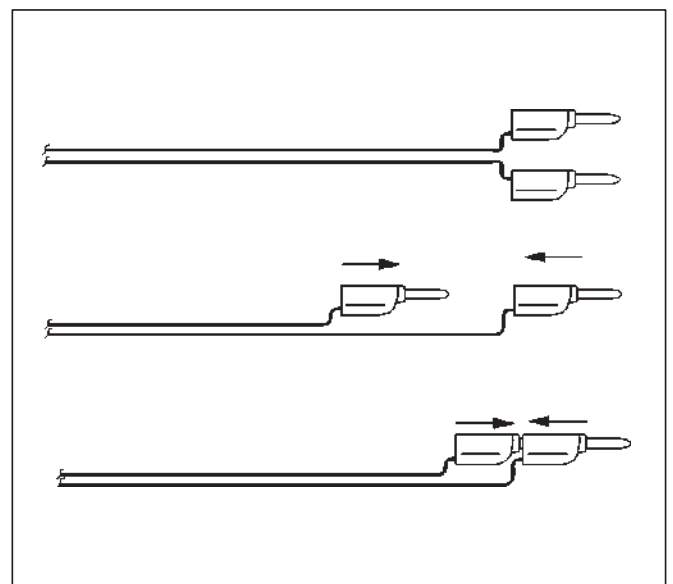
16. Connect the SRS deployment harness wires to the power source to immediately deploy the air bag assembly. Recommended application : 12 volts minimum, 2 amps minimum. A vehicle battery is suggested.
17. Disconnect the SRS deployment harness from the power source.
18. Short the two SRS deployment harness leads together by fully seating one banana plug into the other.
19. In the unlikely event that the passenger air bag assembly did not deploy after following these procedures, proceed immediately with Steps 24 through 26. If the passenger air bag assembly deployed as intended, proceed with Steps 20 through 23.
20. Put on a pair of shop gloves and safety glasses to protect your hands and eyes from possible irritation and heat when handling the deployed air bag assembly. After the air bag assembly has been deployed, the surface of the air bag may contain a powdery residue. This powder consists primarily of cornstarch (used to lubricate the bag as it inflates) and by products of the chemical reaction. Sodium hydroxide dust (similar to lye soap) is produced as a by product of the deployment reaction. The sodium hydroxide quickly reacts with the atmospheric moisture and is converted to sodium carbonate and sodium bicarbonate (baking soda). Therefore, it is unlikely that sodium hydroxide will be present for very long after deployment.

**WARNING: SAFETY PRECAUTIONS MUST BE OBSERVED WHEN HANDLING A DEPLOYED AIR BAG ASSEMBLY. AFTER DEPLOYMENT, THE METAL SURFACES OF THE AIR BAG ASSEMBLY WILL BE HOT. ALLOW THE AIR BAG ASSEMBLY TO COOL BEFORE HANDLING ANY METAL PORTION OF IT. DO NOT PLACE THE DEPLOYED INFLATOR MODULE NEAR ANY FLAMMABLE OBJECTS. FAILURE TO FOLLOW PROCEDURES MAY RESULT IN FIRE OR PERSONAL INJURY. AFTER AN AIR BAG ASSEMBLY HAS BEEN DEPLOYED, THE METAL CANISTER AND SURROUNDING AREAS OF THE AIR BAG ASSEMBLY WILL BE HOT. DO NOT TOUCH THE METAL AREAS OF THE AIR BAG ASSEMBLY FOR ABOUT THIRTY MINUTES AFTER DEPLOYMENT. IF THE DEPLOYED AIR BAG ASSEMBLY MUST BE MOVED BEFORE IT IS COOL, WEAR GLOVES AND HANDLE BY THE AIR BAG ITSELF.**

21. Disconnect the pigtail adapter from the air bag assembly as soon after deployment as possible to avoid damage to the pigtail adapter or SRS deployment harness from contacting the hot air bag assembly canister. The pigtail adapter and SRS deployment harness are designed to be reused. They should, however, be inspected for damage after each deployment and replaced if necessary.
22. Dispose of the deployed air bag assembly through normal refuse channels after it has cooled for at least 30 minutes.
23. Wash your hands with mild soap and water afterward.

NOTE: The remaining steps are to be followed in the unlikely event that the air bag assembly did not deploy after following the above procedures.

24. Ensure that the SRS deployment harness has been disconnected from the power source and that its two banana plugs have been shorted together by fully seating one banana plug into the other.



25. Disconnect the pigtail adapter from the air bag assembly.

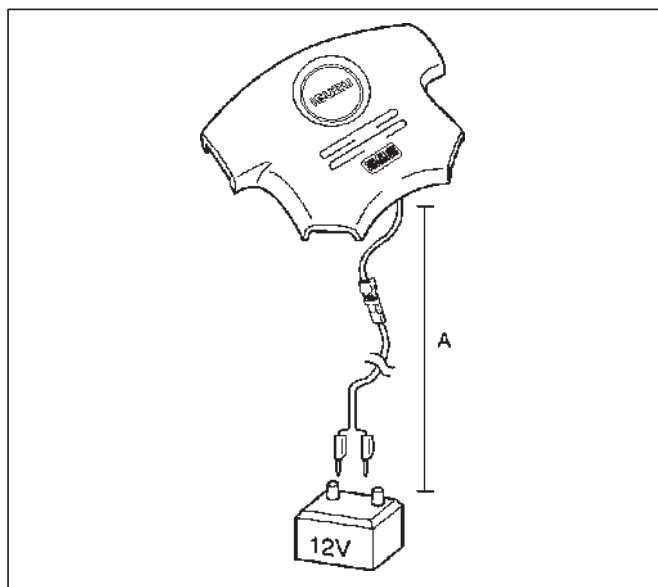
**WARNING: WHEN STORING A LIVE AIR BAG ASSEMBLY OR WHEN LEAVING A LIVE AIR BAG ASSEMBLY UNATTENDED ON A BENCH OR OTHER SURFACE, ALWAYS FACE THE BAG UP AND AWAY FROM THE SURFACE. THIS IS NECESSARY SO THAT A FREE SPACE IS PROVIDED TO ALLOW THE AIR BAG TO EXPAND IN THE UNLIKELY EVENT OF ACCIDENTAL DEPLOYMENT. FAILURE TO FOLLOW PROCEDURES MAY RESULT IN PERSONAL INJURY.**

26. Temporarily store the air bag assembly with the bag facing up, away from the surface upon which it rests.

**Deployment Outside Vehicle (Fixing Air Bag on Tire)**

Read and understand the items of “CAUTIONS ABOUT AIR BAG DEPLOYMENT AND DISPOSAL PROCEDURES” and “Usage of Deployment Tool” for safe deployment of air bag.

1. Remove air bag assembly from vehicle. Refer to air bag assembly Removal “in this section”.
2. Inspect J-41434 Supplemental Restraint System (SRS) Deployment Harness and appropriate pigtail adapter for damage. If harness or pigtail is damaged, discard and obtain a replacement.
3. Extend double pole extension cord to a position far away 10 m (33 feet) from the air bag assembly.
4. Place a power source near the extended end of SRS air bag deployment harness. (Use of 12V battery is recommended).

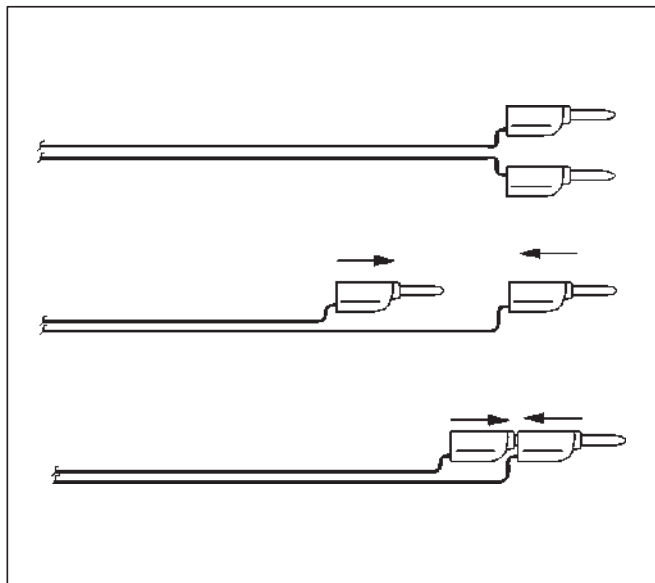


827RW057

**Legend**

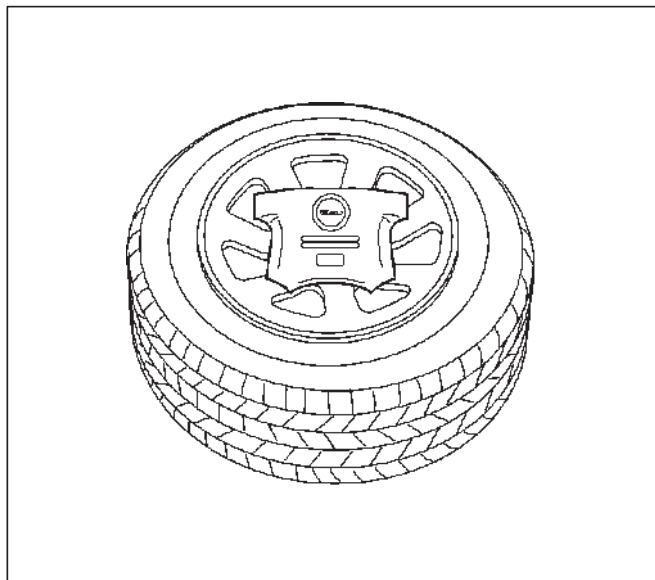
(A) 10 m (33 feet) or more

5. Insert one of the banana plugs into the other banana plug to short the two SRS air bag deployment harness. Do not the harness to a power source until deployment.



827RW055

6. Prepare four 15 inch or larger tires without wheel and two same size tires with wheels.



827RW056

7. How to fix Driver air bag.

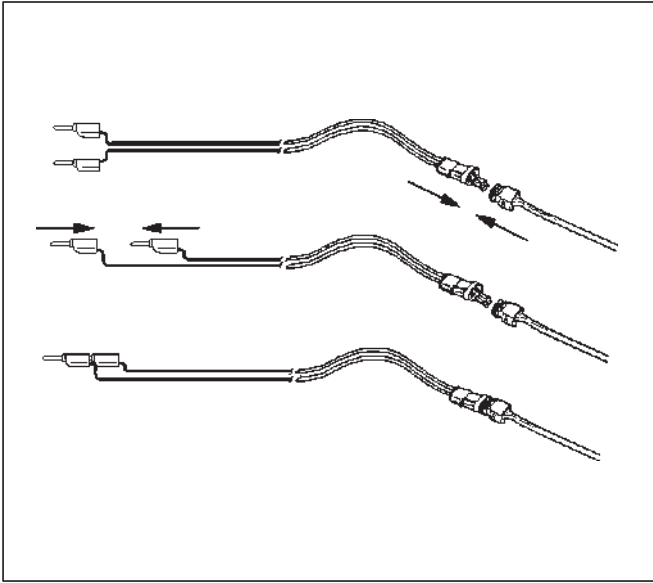
1. Fix the air bag with its trim cover up on a tire with a wheel using an automobile use wire harness, (core size: 0.05 inch) or a wire trebly at two or more points.
2. Connect SRS air bag assembly to the double pole extension cord of the air bag deployment harness.

Do not connect the deployment harness to a power source until air bag deployment.

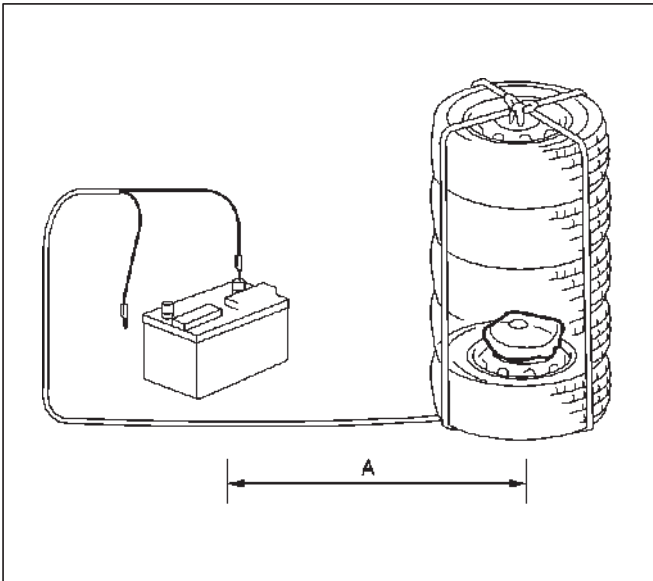
(If connected the SRS air bag assembly deploys immediately)

**NOTE:** Ensure that the pigtail adapter is firmly seated into the air bag assembly connector. Failure to fully seat the connectors may leave the shorting bar located in the air bag assembly connector functioning (shorting the deployment circuit) and may result in non deployment of the air bag assembly.

## 9J-20 SUPPLEMENTAL RESTRAINT SYSTEM



- Place three tires without wheel on the tire on which air bag is fixed and a tire with a wheel on top.  
Bind the five tires with a rope so that the tires may not collapse.

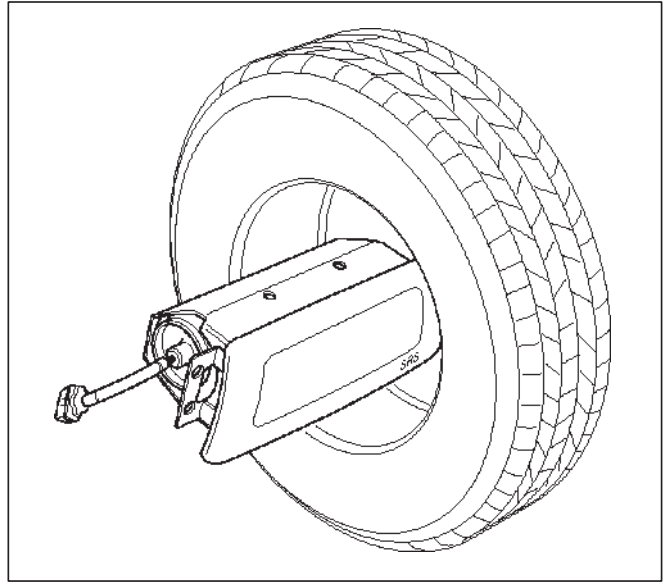


### Legend

(A) 10 m (33 feet) or more

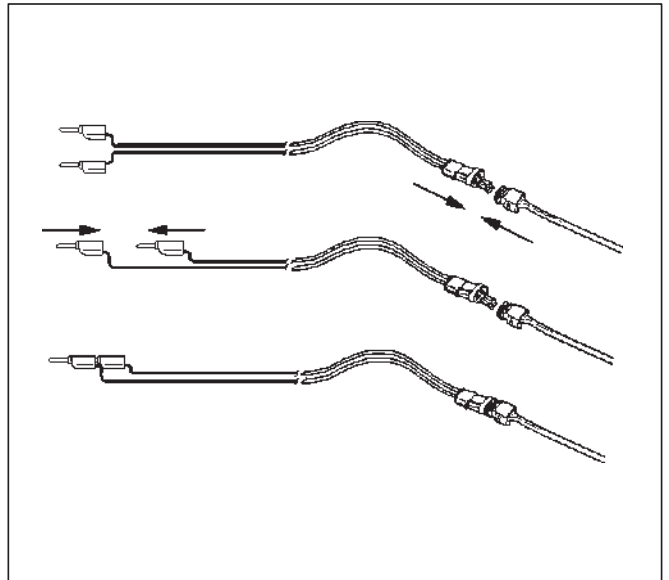
### 8. How to fix Passenger air bag.

- Fix the air bag with its trim cover side fixing the center of a tire without a wheel using an automobile use wire harness, (core size: 0.05 inch) or a wire trebly at two or more points.

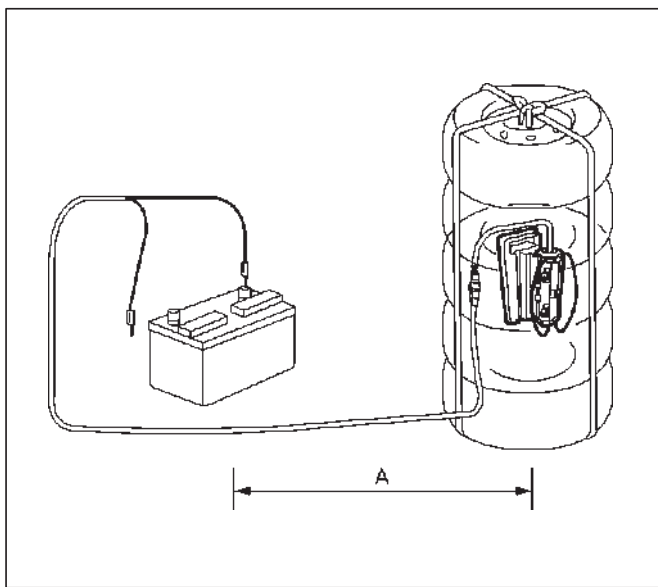


- Connect Supplemental Restraint System (SRS) air bag assembly to the deployment harness double pole extension cord end. Be sure not to connect the deployment harness to a power source. (If connected the SRS air bag assembly deploys immediately).

NOTE: Ensure that the pigtail adapter is firmly seated into the air bag assembly connector. Failure to fully seat the connectors may leave the shorting bar located in the air bag assembly connector functioning (shorting the deployment circuit) and may result in non deployment of the air bag assembly.



- Put a tire without wheel on another, put the tire on which the air bag is fixing, put a tire without a wheel, and finally put a tire with a wheel on top.  
Bind the tires with a rope so that the tires pile may not collapse.



827RW050

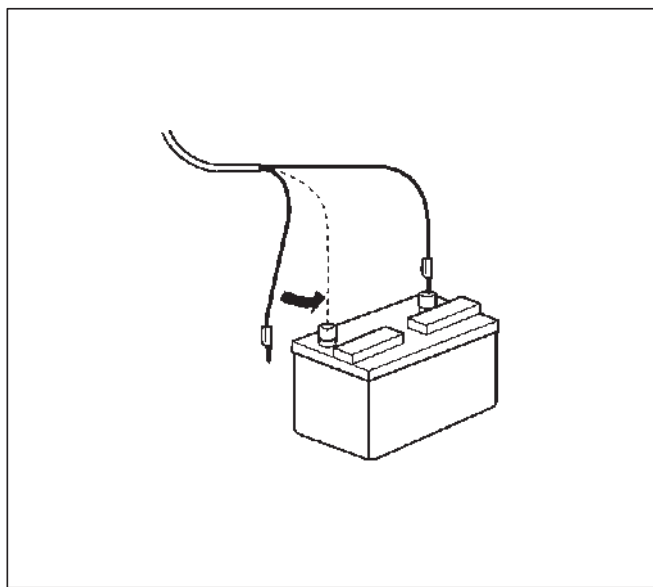
**Legend**

(A) 33 feet or more

9. Notify all people in the immediate area of your intention to deploy the passenger air bag assembly. The deployment will be accompanied by a substantial noise which may startle the uninformed.

**WARNING: DEPLOYED HARNESS SHALL REMAIN SHORTED AND NOT BE CONNECTED TO A POWER SOURCE UNTIL THE AIR BAG IS TO BE DEPLOYED. THE AIR BAG ASSEMBLY WILL IMMEDIATELY DEPLOY THE AIR BAG WHEN A CONNECTING THE DEPLOYMENT HARNESS TO THE POWER SOURCE SHOULD ALWAYS BE THE LAST STEP IN THE AIR BAG ASSEMBLY DEPLOYMENT PROCEDURE. FAILURE TO FOLLOW PROCEDURES IN THE ORDER LISTED MAY RESULT IN PERSONAL INJURY.**

10. Connect the Supplemental Restraint System (SRS) deployment harness wires to the power source to immediately deploy the air bag assembly. Recommended application : 12 volts minimum, 2 amps minimum. A vehicle battery is suggested.



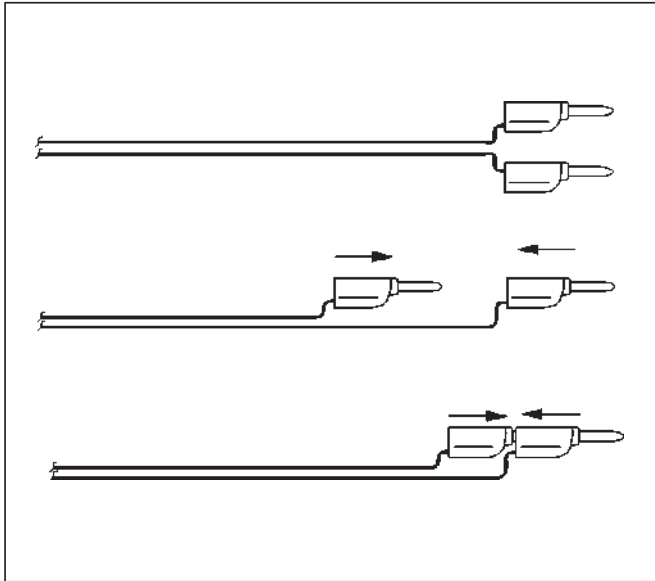
827LW011

**WARNING: SAFETY PRECAUTIONS MUST BE OBSERVED WHEN HANDLING A DEPLOYED AIR BAG ASSEMBLY. AFTER DEPLOYMENT, THE METAL SURFACES OF THE AIR BAG ASSEMBLY WILL BE VERY HOT. ALLOW THE AIR BAG ASSEMBLY TO COOL BEFORE HANDLING ANY METAL PORTION OF IT. DO NOT PLACE THE DEPLOYED INFLATOR MODULE NEAR ANY FLAMMABLE OBJECTS. FAILURE TO FOLLOW PROCEDURES MAY RESULT IN FIRE OR PERSONAL INJURY. AFTER AN AIR BAG ASSEMBLY HAS BEEN DEPLOYED, THE METAL CANISTER AND SURROUNDING AREAS OF THE AIR BAG ASSEMBLY WILL BE HOT. DO NOT TOUCH THE METAL AREAS OF THE AIR BAG ASSEMBLY FOR ABOUT THIRTY MINUTES AFTER DEPLOYMENT. IF THE DEPLOYED AIR BAG ASSEMBLY MUST BE MOVED BEFORE IT IS COOL, WEAR GLOVES AND HANDLE BY THE AIR BAG IT SELF.**

11. Disconnect the pigtail adapter from the air bag assembly as soon after deployment as possible to avoid damage to the pigtail adapter or SRS deployment harness from contacting the hot air bag assembly canister. The pigtail adapter and SRS deployment harness are designed to be reused. They should, however, be inspected for damage after each deployment and replaced if necessary.
12. Dispose of the deployed air bag assembly through normal refuse channels after it has cooled for at least 30 minutes.
13. Wash your hands with mild soap and water afterward.

**NOTE:** The remaining steps are to be followed in the unlikely event that the air bag assembly did not deploy after following the above procedures.

14. Ensure that the SRS deployment harness has been disconnected from the power source and that its two banana plugs have been shorted together by fully seating one banana plug into the other.

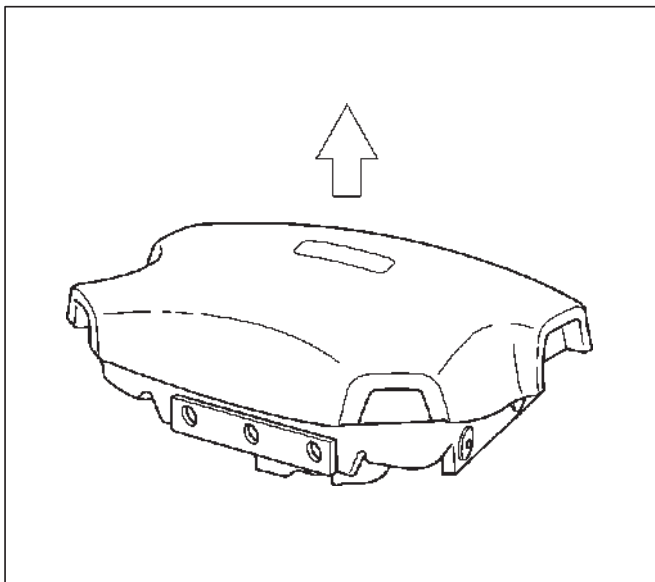


827RW055

15. Disconnect the pigtail adapter from the air bag assembly.

**WARNING: WHEN STORING A LIVE AIR BAG ASSEMBLY OR WHEN LEAVING A LIVE AIR BAG ASSEMBLY UNATTENDED ON A BENCH OR OTHER SURFACE, ALWAYS FACE THE BAG UP AND AWAY FROM THE SURFACE. THIS IS NECESSARY SO THAT A FREE SPACE IS PROVIDED TO ALLOW THE AIR BAG TO EXPAND IN THE UNLIKELY EVENT OF ACCIDENTAL DEPLOYMENT. FAILURE TO FOLLOW PROCEDURES MAY RESULT IN PERSONAL INJURY.**

16. Temporarily store the air bag assembly with the bag facing up, away from the surface upon which it rests.



066RW030

### Deployment Inside Vehicle (Vehicle Scrapping Procedure)

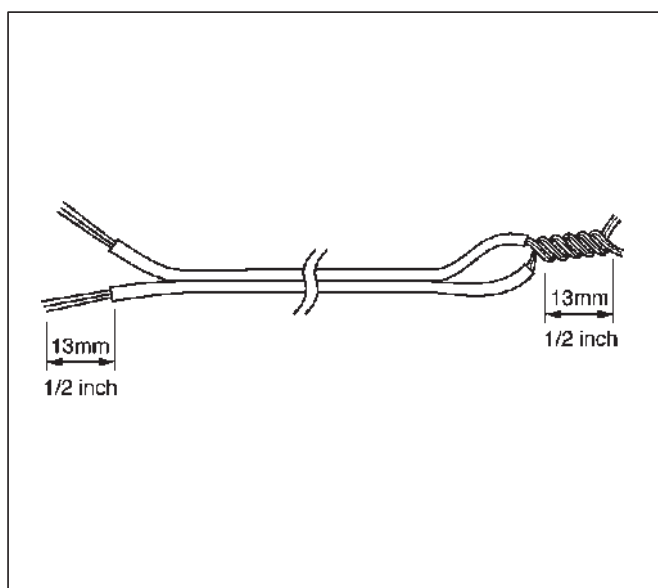
Deployment inside vehicle is proper when the vehicle is to be destroyed or salvaged for component parts. This includes, but is not limited to, the following situations:

1. The vehicle has completed its useful life.
2. The vehicle has been damaged beyond repair in a non deployment type accident.
3. The vehicle has been stripped or damaged beyond repair in a theft.
4. The vehicle will be salvaged for component parts to be used on a vehicle with a different Vehicle Identification Number (VIN) as opposed to being rebuilt as same VIN. Never use SRS components from another vehicle.

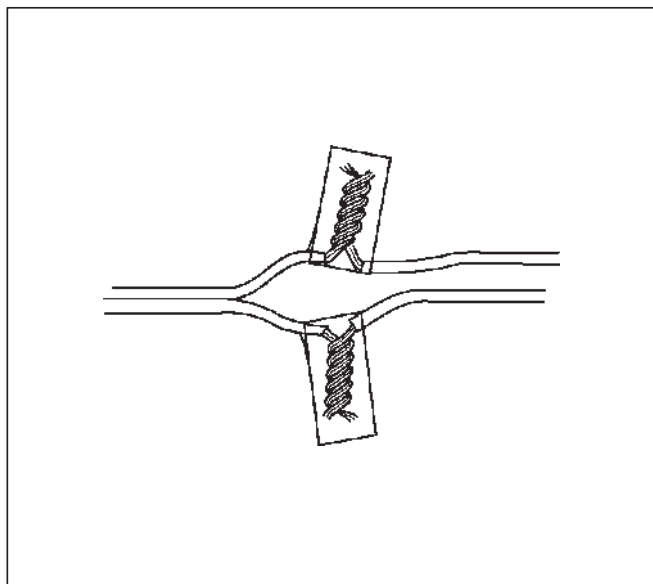
**WARNING: FAILURE TO FOLLOW PROPER SRS AIR BAG ASSEMBLY DISPOSAL PROCEDURES CAN RESULT IN AIR BAG DEPLOYMENT WHICH MAY CAUSE PERSONAL INJURY. UNDEPLOYED AIR BAG ASSEMBLIES MUST NOT BE DISPOSED OF THROUGH NORMAL REFUSE CHANNELS. THE UNDEPLOYED AIR BAG ASSEMBLY CONTAINS SUBSTANCES THAT CAN CAUSE SEVERE ILLNESS OR PERSONAL INJURY IF THE SEALED CONTAINER IS DAMAGED DURING DISPOSAL. DISPOSAL IN ANY MANNER INCONSISTENT WITH PROPER PROCEDURES MAY BE A VIOLATION OF FEDERAL, STATE AND/OR LOCAL LAWS.**

1. Turn ignition switch to "LOCK", remove key and put on safety glasses.
2. Remove all loose objects from front seats.
3. Disconnect Supplemental Restraint System (SRS) coil assembly, yellow 2-pin connector located at the base of the steering column.
4. Cut the SRS coil assembly yellow 2-pin harness connector from the vehicle leaving at least 16 cm (six inches) of wire at the connector.
5. Strip 13 mm (1/2 inch) of insulation from yellow-green and yellow-black wire lead of the connector.
6. Cut two 900 cm (30 feet) deployment wires from 0.8 mm<sup>2</sup> (18 gauge) or thicker multi-strand wire. These wires will be used to fabricate the driver deployment harness.
7. Strip 13 mm (1/2 inch) of insulation from both ends of the wires cut in the previous step.

- Short the wires by twisting together one end from each. Deployment wires shall remain shorted and not be connected to a power source until the air bag is to be deployed.



- Bend twisted connection made in the previous step flat and wrap tightly with electrical tape to insulate and secure.



**WARNING: FAILURE TO FOLLOW PROCEDURES IN THE ORDER LISTED COULD RESULT IN PERSONAL INJURY. NEVER CONNECT DEPLOYMENT WIRES TO ANY POWER SOURCE BEFORE CONNECTING DEPLOYMENT WIRES TO THE AIR BAG ASSEMBLY LEADS. DEPLOYMENT WIRES SHALL REMAIN SHORTED AND NOT BE CONNECTED TO A POWER SOURCE UNTIL THE AIR BAG IS TO BE DEPLOYED. THE AIR BAG ASSEMBLY WILL IMMEDIATELY DEPLOY THE AIR BAG WHEN A POWER SOURCE IS CONNECTED TO IT. WEAR SAFETY GLASSES THROUGHOUT THIS ENTIRE DEPLOYMENT AND DISPOSAL PROCEDURE.**

- Twist together one connector wire lead to one deployment wire. The connection should be mechanically secure.

- Twist together, bend and tape the remaining connector wire lead to the remaining deployment wire.
- Connect the deployment harness to the driver air bag assembly, yellow 2-pin connector at the base of the steering column. Route deployment harness out the driver side of the vehicle.

**WARNING: DEPLOYMENT WIRES SHALL REMAIN SHORTED AND NOT BE CONNECTED TO A POWER SOURCE UNTIL THE AIR BAG IS TO BE DEPLOYED.**

**THE AIR BAG ASSEMBLY WILL IMMEDIATELY DEPLOY THE AIR BAG WHEN A POWER SOURCE IS CONNECTED TO IT.**

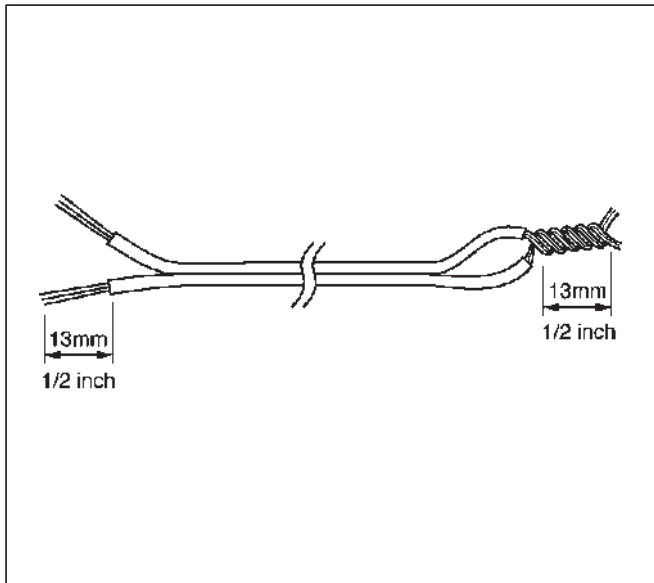
**CONNECTING THE DEPLOYMENT WIRES TO THE POWER SOURCE SHOULD ALWAYS BE THE FINAL STEP IN THE AIR BAG ASSEMBLY DEPLOYMENT PROCEDURE.**

**FAILURE TO FOLLOW PROCEDURES IN THE ORDER LISTED COULD RESULT IN PERSONAL INJURY.**

- Disconnect passenger air bag assembly, yellow 2-pin connector located behind glove box assembly.
- Cut the passenger air bag assembly harness connector from the vehicle leaving at least 16 cm (six inches) of wire at the connector.
- Strip 13 mm (1/2 inch) of insulation from yellow-green and yellow-red wire lead of the connector.
- Cut two 900 cm (30 feet) deployment wires from 0.8 mm<sup>2</sup> (18 gauge) or thicker multi-strand wire. These wires will be used to fabricate the passenger deployment harness.
- Strip 13 mm (1/2 inch) of insulation from both ends of the wires cut in the previous step.

## 9J-24 SUPPLEMENTAL RESTRAINT SYSTEM

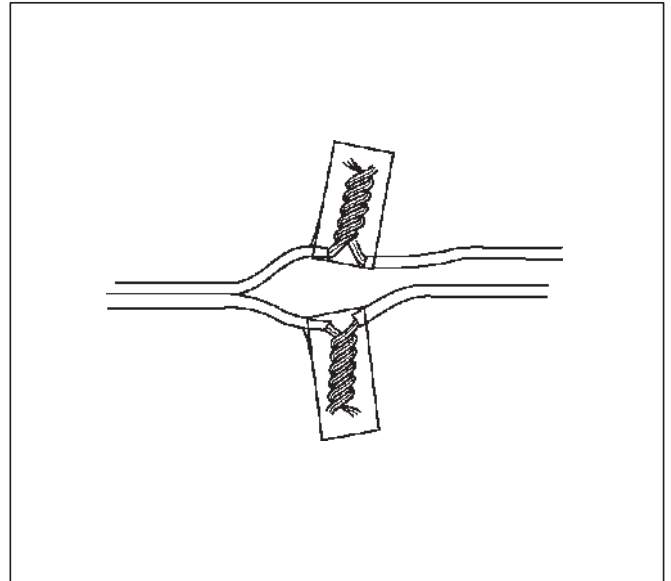
18. Short the wires by twisting together one end from each. Deployment wires shall remain shorted and not be connected to a power source until the air bag is to be deployed.



**WARNING: FAILURE TO FOLLOW PROCEDURES IN THE ORDER LISTED COULD RESULT IN PERSONAL INJURY. NEVER CONNECT DEPLOYMENT WIRES TO ANY POWER SOURCE BEFORE CONNECTING DEPLOYMENT WIRES TO THE AIR BAG ASSEMBLY LEADS. DEPLOYMENT WIRES SHALL REMAIN SHORTED AND NOT BE CONNECTED TO A POWER SOURCE UNTIL THE AIR BAG IS TO BE DEPLOYED. THE AIR BAG ASSEMBLY WILL IMMEDIATELY DEPLOY THE AIR BAG WHEN SAFETY GLASSES THROUGHOUT THIS ENTIRE DEPLOYMENT AND DISPOSAL PROCEDURE.**

19. Twist together one connector wire lead to one deployment wire. The connection should be mechanically secure.

20. Bend twisted connection made in the previous step flat and wrap tightly with electrical tape to insulate and secure.



21. Twist together, bend and tape the remaining connector wire lead to the remaining deployment wire.
22. Connect the deployment harness to the passenger air bag assembly, yellow 2-pin connector located behind the glove box assembly. Route deployment harness out the passenger side of the vehicle.

**WARNING: DEPLOYMENT WIRES SHALL REMAIN SHORTED AND NOT BE CONNECTED TO A POWER SOURCE UNTIL THE AIR BAG IS TO BE DEPLOYED. THE AIR BAG ASSEMBLY WILL IMMEDIATELY DEPLOY THE AIR BAG WHEN A POWER SOURCE IS CONNECTED TO IT. CONNECTING THE DEPLOYMENT WIRES SHOULD ALWAYS BE THE FINAL STEP IN THE AIR BAG ASSEMBLY DEPLOYMENT PROCEDURE. FAILURE TO FOLLOW PROCEDURES IN THE ORDER LISTED COULD RESULT IN PERSONAL INJURY.**

23. Verify that the inside of the vehicle and the area surrounding the vehicle are clear of all people and loose or flammable objects.
24. Stretch the driver and passenger deployment harness to their full length.
25. Completely cover windshield area and front door window openings with a drop cloth, blanket or similar item. This reduces the possibility of injury due to possible fragmentation of the vehicle's glass or interior.
26. Notify all people in the immediate area that you intend to deploy the air bags. The deployment will be accompanied by a substantial noise which may startle the uninformed.
27. Separate the two ends of the driver deployment harness wires.



**WARNING: DEPLOYMENT WIRES SHALL REMAIN SHORTED AND NOT BE CONNECTED TO A POWER SOURCE UNTIL THE AIR BAG IS TO A POWER SOURCE UNTIL THE AIR BAG IS TO BE DEPLOYED. THE AIR BAG ASSEMBLY WILL IMMEDIATELY DEPLOY THE AIR BAG WHEN A POWER SOURCE IS CONNECTED TO IT. CONNECTING THE DEPLOYMENT WIRES TO THE POWER SOURCE SHOULD ALWAYS BE THE FINAL STEP IN THE AIR BAG ASSEMBLY DEPLOYMENT PROCEDURE. FAILURE TO FOLLOW PROCEDURES IN THE ORDER LISTED COULD RESULT IN PERSONAL INJURY.**

NOTE: When the air bag deploys, the rapid gas expansion will create a substantial noise. Notify all people in the immediate area that you intend to deploy the air bags.

28. Connect the driver deployment harness wires to a power source to immediately deploy the driver air bag assembly. Recommended application: 12 volts minimum, 2 amps minimum. A vehicle battery is suggested.
29. Separate the two ends of the passenger deployment harness wires.

**WARNING: DEPLOYMENT WIRES SHALL REMAIN SHORTED AND NOT BE CONNECTED TO A POWER SOURCE UNTIL THE AIR BAG IS TO A POWER SOURCE UNTIL THE AIR BAG IS TO BE DEPLOYED. THE AIR BAG ASSEMBLY WILL IMMEDIATELY DEPLOY THE AIR BAG WHEN A POWER SOURCE IS CONNECTED TO IT. CONNECTING THE DEPLOYMENT WIRES TO THE POWER SOURCE SHOULD ALWAYS BE THE FINAL STEP IN THE AIR BAG ASSEMBLY DEPLOYMENT PROCEDURE. FAILURE TO FOLLOW PROCEDURES IN THE ORDER LISTED COULD RESULT IN PERSONAL INJURY.**

30. Connect the passenger deployment harness wires to a power source to immediately deploy the passenger air bag assembly. Recommended application: 12 volts minimum, 2 amps minimum. A vehicle battery is suggested. (Driver air bag assembly) Put on a pair of shop gloves and safety gasses to protect your hands and eyes from possible irritation and heat when handling the deployed air bag assembly. After the air bag assembly has been deployed, the surface of the air bag may contain solid particulate. This solid particulate consists primarily of by products of the chemical reaction, Potassium Chloride and copper metal dust. Compounds of Potassium Borate, Strontium Chloride, Copper Chloride, and Ammonium Chloride may be found in amounts of about 1% (each) of the total particulate.

(Passenger air bag assembly)

Put on a pair of shop gloves and safety glasses to protect your hands and eyes from possible irritation and heat when handling the deployed air bag assembly.

After the air bag assembly has been deployed, the surface of the air bag may contain a powdery residue. This powder consists primarily of cornstarch (used to lubricate the bag as it inflates) and by products of the chemical reaction. Sodium hydroxide dust (similar to lye soap) is produced as a by product of the deployment reaction. The sodium hydroxide then quickly reacts with atmospheric moisture and is converted to sodium carbonate and sodium bicarbonate (baking soda). Therefore, it is unlikely that sodium hydroxide will be present after deployment.

**WARNING: SAFETY PRECAUTIONS MUST BE OBSERVED WHEN HANDLING A DEPLOYED AIR BAG ASSEMBLY. AFTER DEPLOYMENT, THE METAL SURFACES OF THE AIR BAG ASSEMBLY WILL BE VERY HOT. ALLOW THE AIR BAG ASSEMBLY TO COOL BEFORE HANDLING ANY METAL PORTION OF IT. DO NOT PLACE THE HOT DEPLOYED AIR BAG ASSEMBLY NEAR ANY FLAMMABLE OBJECTS. FAILURE TO FOLLOW PROCEDURES COULD RESULT IN FIRE OR PERSONAL INJURY.**

After an air bag assembly has been deployed, the metal canister and surrounding areas of the air bag assembly will be very hot. Do not touch the metal areas of the air bag assembly for about 30 minutes after deployment. If the deployed air bag assembly must be moved before it is cool, wear gloves and handle by the air bag or trim cover.

31. Short the driver deployment harness wires by twisting together one end from each. Repeat this procedure for the passenger deployment harness.
32. Carefully remove drop cloth from vehicle and clean off any fragments or discard drop cloth entirely.
33. Disconnect driver deployment harness and passenger deployment harness from vehicle and discard.
34. In the unlikely event that either or both of the air bag assemblies did not deploy after following these procedures, proceed immediately with Steps 36 through 37. If the air bag assembly deployed, proceed to step 35.
35. With both air bags deployed, the vehicle may be scrapped in the same manner as a non-SRS equipped vehicle.

NOTE: The remaining steps are to be followed in the unlikely event that the air bag assembly did not deploy after following these procedures.

36. Remove the undeployed air bag assembly (s) from the vehicle. For driver air bag assembly refer to in the "Passenger Air Bag Assembly Removal" in this section.

**WARNING: WHEN STORING A LIVE AIR BAG ASSEMBLY OR WHEN LEAVING A LIVE AIR BAG ASSEMBLY UNATTENDED ON A BENCH OR OTHER SURFACE, ALWAYS FACE THE BAG AND TRIM COVER UP, AWAY FROM THE SURFACE. THIS IS NECESSARY SO THAT A FREE SPACE IS PROVIDED TO ALLOW THE AIR BAG TO EXPAND IN THE UNLIKELY EVENT OF ACCIDENTAL DEPLOYMENT. FAILURE TO FOLLOW PROCEDURES COULD RESULT IN PERSONAL INJURY.**

37. Temporarily store the air bag assembly with the air bag opening facing up, away from the surface upon which it rests.

### **Deployed Air Bag Assembly Handling**

Put on a pair of shop gloves and safety glasses to protect your hands and eyes from possible irritation and heat when handling the deployed air bag assembly.

After the air bag assembly has been deployed, the surface of the air bag may contain solid particulate. This solid particulate consists primarily of by products of the chemical reaction, Potassium Chloride and copper metal dust. Compounds of Potassium Borate, Strontium Chloride, Copper Chloride, and Ammonium Chloride may be found in amounts of about 1% (each) of the total particulate.

(Passenger air bag assembly)

Put on a pair of shop gloves and safety glasses to protect your hands and eyes from possible irritation and heat when handling the deployed air bag assembly.

After the air bag assembly has been deployed, the surface of the air bag may contain a powdery residue. This powder consists primarily of cornstarch (used to lubricate the bag as it inflates) and by products of the chemical reaction. Sodium hydroxide dust (similar to lye soap) is produced as a by product of the deployment reaction. The sodium hydroxide then quickly reacts with atmospheric moisture and is converted to sodium carbonate and sodium bicarbonate (baking soda). Therefore, it is unlikely that sodium hydroxide will be present after deployment.

## Special Tools

**WARNING: TO AVOID DEPLOYMENT WHEN TROUBLESHOOTING THE SRS, DO NOT USE ELECTRICAL TEST EQUIPMENT SUCH AS A BATTERY-POWERED OR AC-POWERED VOLTMETER, OHMMETER, ETC., OR ANY TYPE OF ELECTRICAL EQUIPMENT OTHER THAN THAT SPECIFIED IN THIS MANUAL. DO NOT USE A NON POWERED PROBE-TYPE TESTER. INSTRUCTIONS IN THIS MANUAL MUST BE FOLLOWED CAREFULLY, OTHERWISE PERSONAL INJURY MAY RESULT.**

### J-41433 SRS Driver/Passenger Load Tool

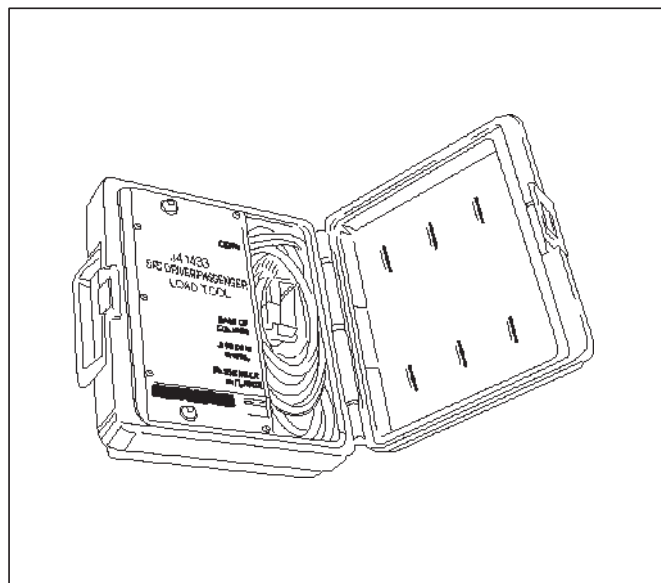
The Supplemental Restraint System (SRS) Driver/Passenger Load Tool J-41433 is used only when called for in this section. It is used as a diagnostic aid and safety device to prevent inadvertent air bag assembly deployment.

The load tool has four yellow connectors attached to its case.

The three small connectors are electrically functional and serve as resistive load substitutions.

No more than two connectors are used at any time. One of the small connectors is used to substitute for the load of the driver air bag assembly when it is connected at the top of the column to the SRS coil assembly. Another small connector is used to substitute for the load of the driver air bag assembly and the SRS coil assembly when it is connected at the base of the column to the SRS wiring harness. The third small connector is used to substitute for the load of the passenger air bag assembly when connected to the passenger air bag assembly harness connector.

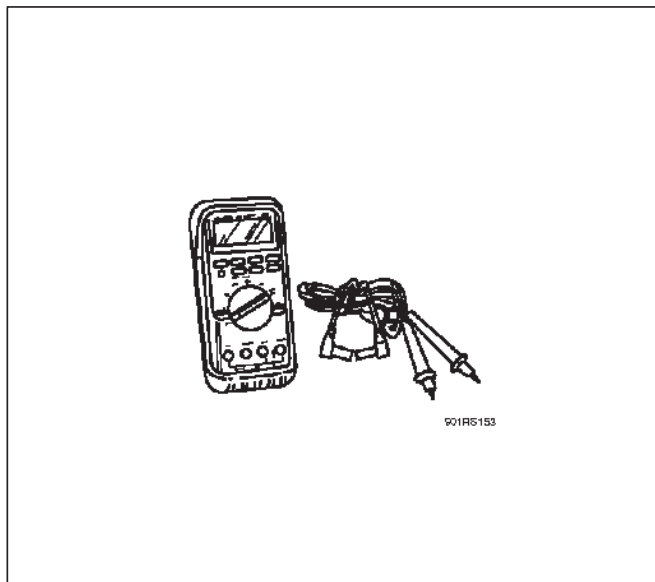
By substituting the resistance of the load tool when called for, a determination can be made as to whether an inflator circuit component is causing system malfunction and which component is causing the malfunction. The load tool should be used only when specifically called for in the diagnostic procedures.



901RS146

### J-39200 DVM

The J-39200 Digital Multimeter (DVM) is the preferred DVM for use in SRS diagnosis and repair. However, J-34029-A may be used if J-39200 is not available. No other DVMs are approved for SRS diagnosis and repair.

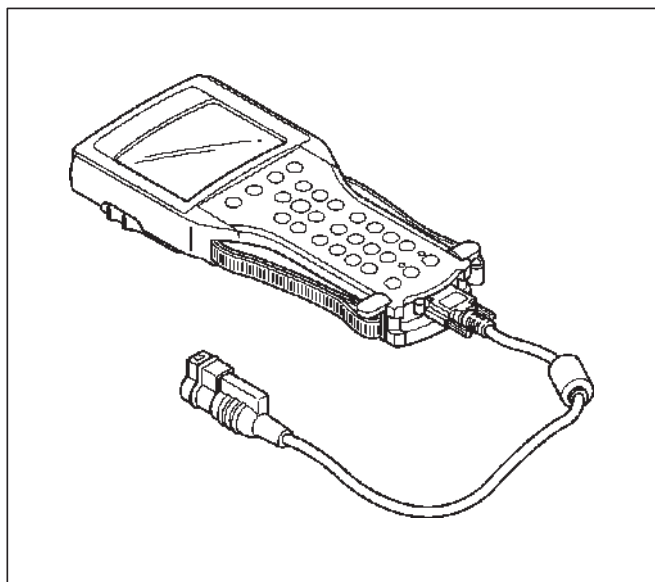


901RS153

901RS153

### Scan Tool

The Tech 2 is used to read and clear SRS Diagnostic Trouble Codes (DTCs). Refer to the Tech 2 Operator's Manual for specific information on how to use the Tech 2.



901RW176

## 9J-28 SUPPLEMENTAL RESTRAINT SYSTEM

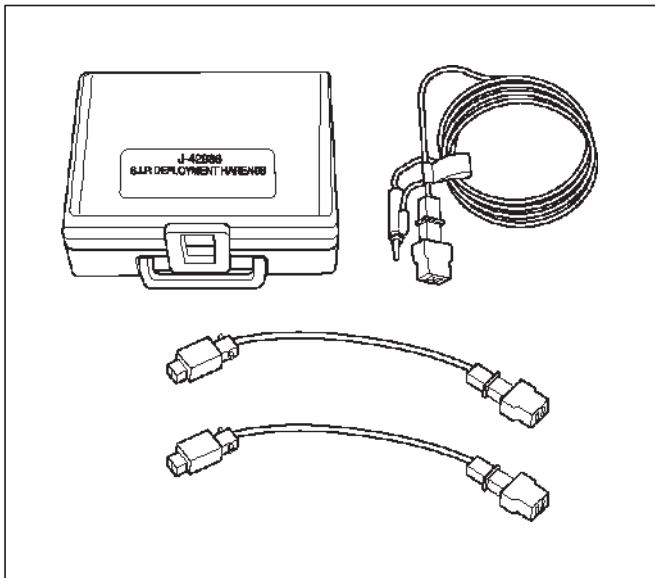
### J-35616-A Connector Test Adapter Kit

The J-35616-A Connector Test Adapter Kit must be used whenever a diagnostic procedure requests checking or probing a terminal. Using the appropriate adapter will ensure that no damage to the terminal will occur from the Digital Multimeter (DVM) probe, such as spreading or bending. The adapter will also give an idea of whether contact tension is sufficient, helping to find an open or intermittent open due to poor terminal contact.



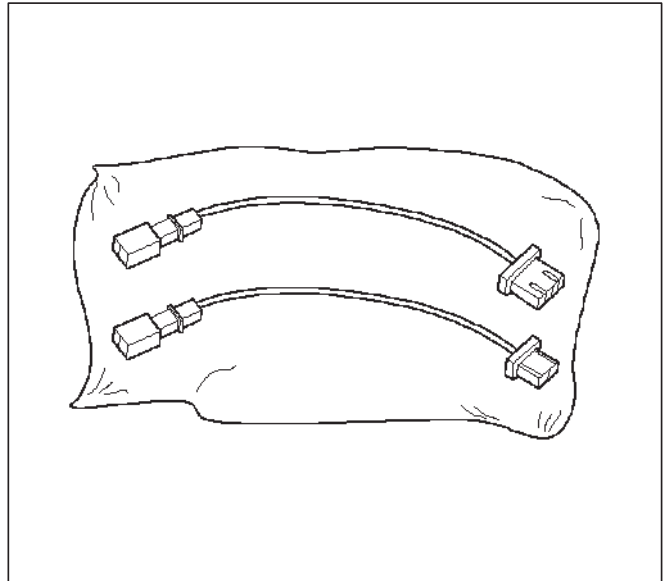
### J-42986 SRS Deployment Tool

The J-42986 Supplemental Restraint System (SRS) Deployment Tool must be used for deployment of the undeployed air bag.



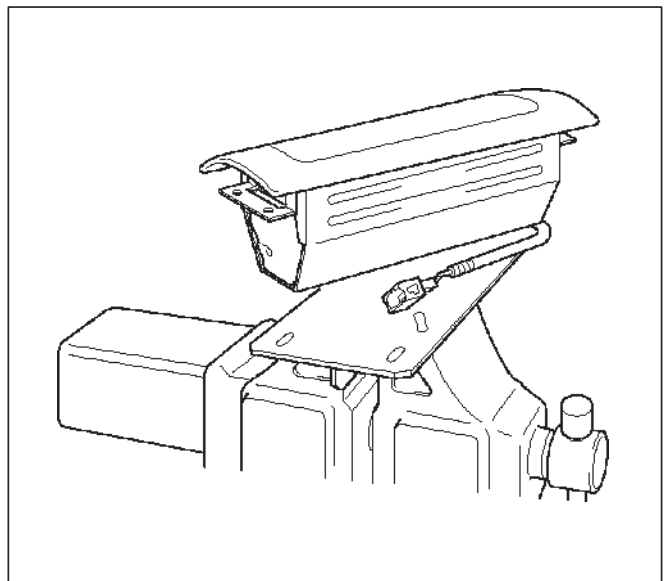
### J-42987 SRS Adapter For Load Tool

The J-42987 SRS Adapter be used for connect previous load tool to new SRS system when inspect SRS system harness.



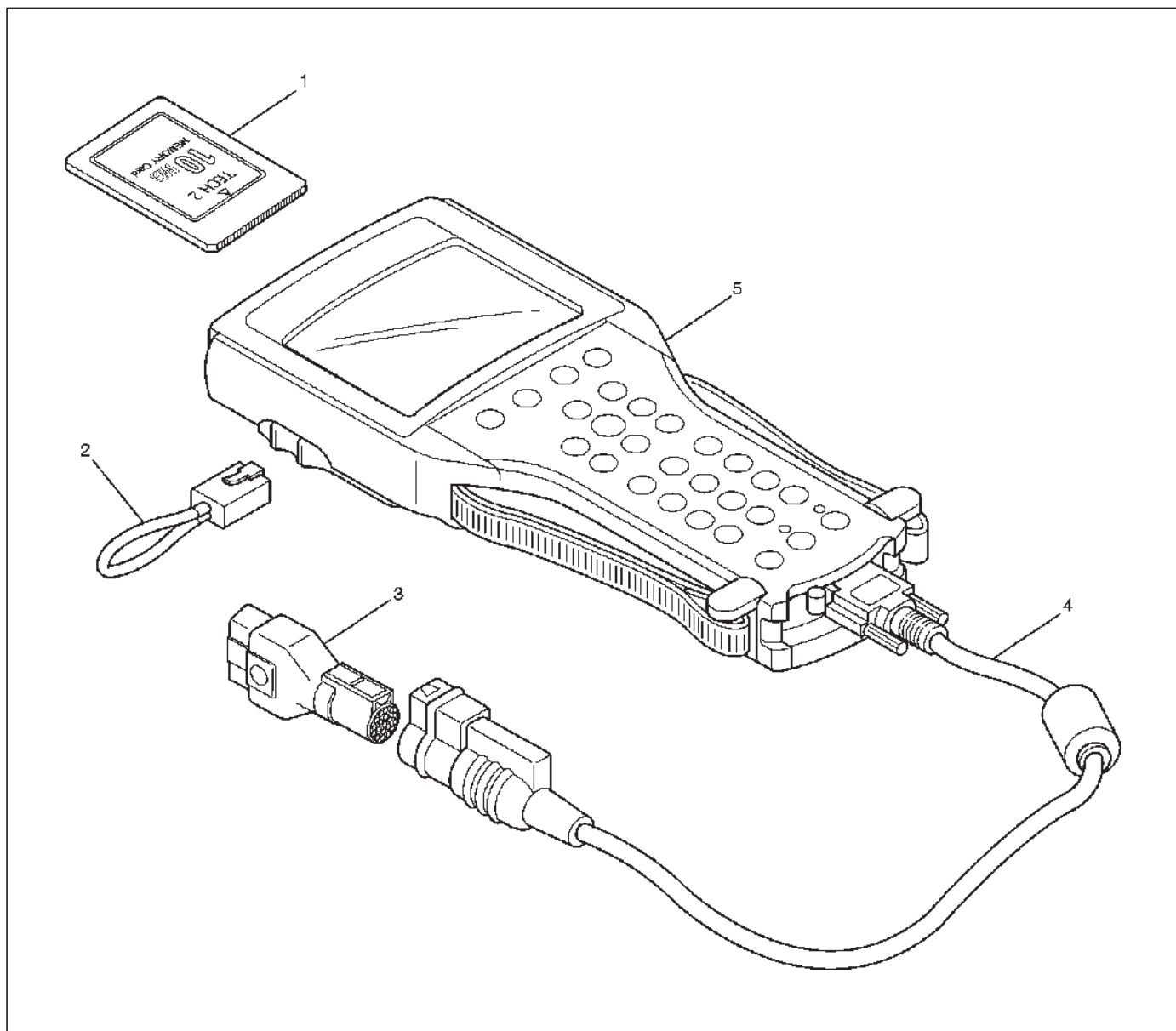
### J-41497 SRS Deployment Fixture

The J-41497 SRS Deployment Fixture must be used for deployment of the undeployed passenger side air bag.



### Tech 2 Scan Tool

From 1999 Vehi CROSS (VX), dealer service departments are recommended to use Tech 2. Please refer to Tech 2 scan tool user guide.



901RW180

#### Legend

- |                                |                                     |
|--------------------------------|-------------------------------------|
| (1) PCMCIA Card                | (3) SAE 16/19 Adaptor               |
| (2) RS 232 Loop Back Connector | (4) Data Link Connector (DLC) Cable |
|                                | (5) Tech-2                          |

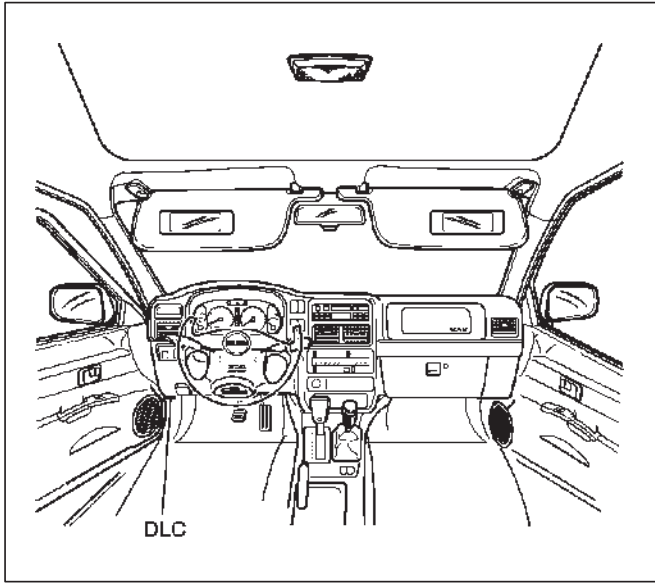
#### Getting Started

○ Before operating the Isuzu PCMCIA card with the Tech 2, the following steps must be performed:

1. The Isuzu 98 System PCMCIA card (1) inserts into the Tech 2 (5).
2. Connect the SAE 16/19 adaptor (3) to the DLC cable (4).
3. Connect the DLC cable to the Tech 2 (5)
4. Mark sure the vehicle ignition is off.

## 9J-30 SUPPLEMENTAL RESTRAINT SYSTEM

5. Connect the Tech 2 SAE 16/19 adapter to the vehicle Data Link Connector (DLC).



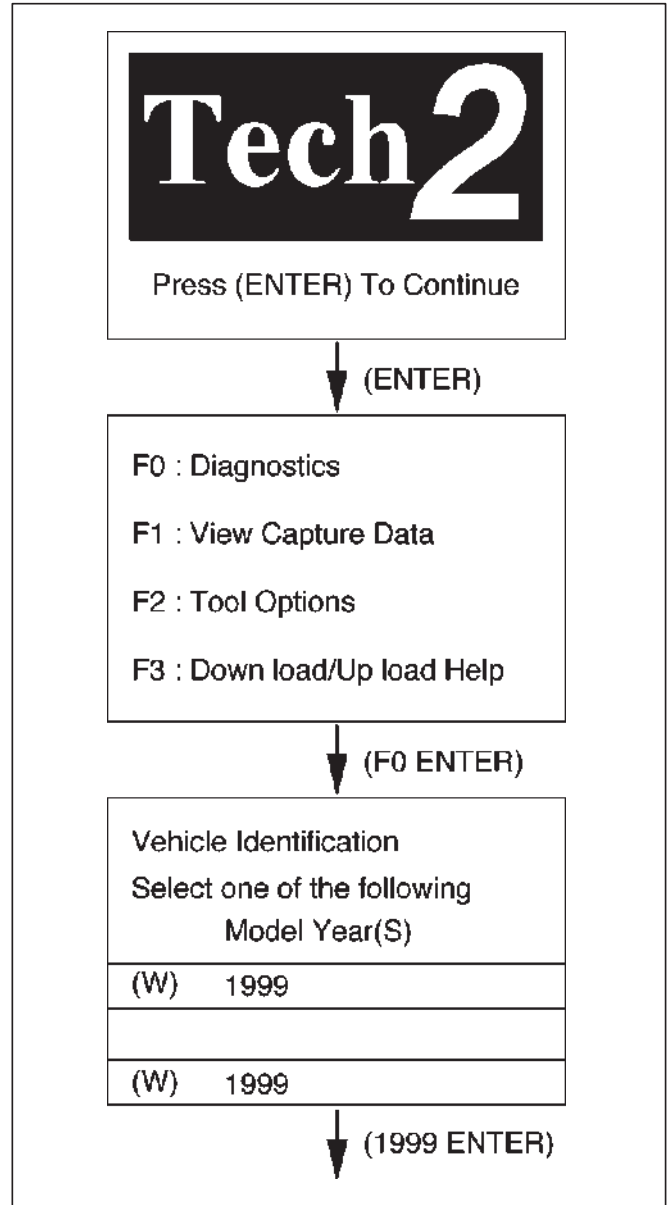
6. The vehicle ignition turns on.
7. Verify the Tech 2 power up display.



NOTE: The RS232 loop back connector is only to use for diagnosis of Tech 2 and refer to user guide of the Tech 2.

### Operating Procedure

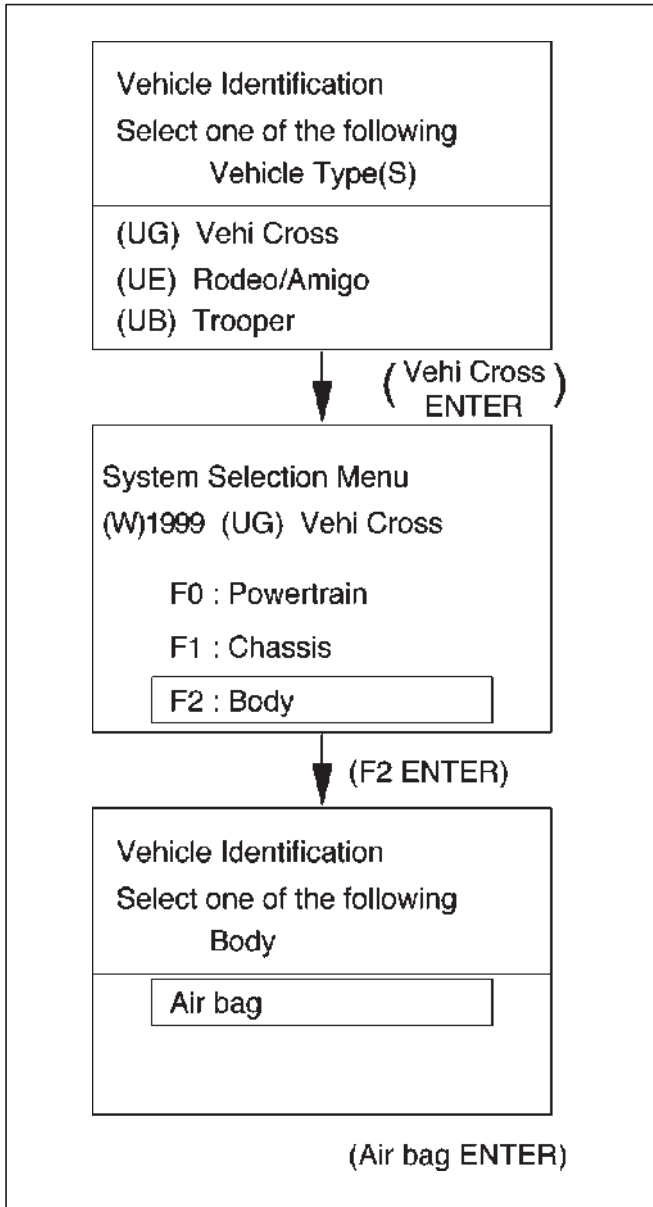
The power up screen is displayed when you power up the tester with the Isuzu systems PCMCIA card. Follow the operating procedure below.



740RX060

060RW009

060RX038



060RX039

## Service Precaution

**CAUTION:** When fasteners are removed, always reinstall them at the same location from which they were removed. If a fastener needs to be replaced, use the correct part number fastener for that application. If the correct part number fastener is not available, a fastener of equal size and strength (or stronger) may be used. Fasteners that are not reused, and those requiring thread locking compound will be called out. The correct torque value must be used when installing fasteners that require it. If the above conditions are not followed, parts or system damage could result.

**WARNING: WHEN PERFORMING SERVICE ON OR AROUND SUPPLEMENTAL RESTRAINT SYSTEM (SRS) COMPONENTS OR SRS WIRING, FOLLOW THE PROCEDURES LISTED BELOW TO TEMPORARILY DISABLE THE SRS. FAILURE TO FOLLOW PROCEDURES COULD RESULT IN POSSIBLE AIR BAG DEPLOYMENT, PERSONAL INJURY OR OTHERWISE UNNEEDED SRS REPAIRS.**

The Sensing and Diagnostic Module (SDM) in Driver–Passenger SRS can maintain sufficient voltage to cause a deployment for up to 15 seconds after the ignition switch is turned “OFF,” the battery is disconnected, or the fuse powering the SDM is removed.

Many of the service procedures require removal of the “SRS–1” fuse, and disconnection of the air bag assembly from the deployment loop to avoid an accidental deployment. If the air bag assembly is disconnected from the deployment loop as noted in the “Disabling the SRS” procedure that follows, service can begin immediately without waiting for the 15 second time period to expire.

### Disabling The SRS

#### Removal

Turn the ignition switch to “OFF” and turn the steering wheel so that the vehicle’s wheels are pointing straight ahead.

1. Remove SRS fuse SRS–1 and SRS–2, from left dash side lower fuse block or disconnect battery.
2. Disconnect yellow 2–pin connector at the base of steering column.
3. Remove glove box assembly; Refer to “Passenger Air Bag Assembly Replacement” in this section.
4. Disconnect passenger air bag assembly yellow 2–pin connector behind the glove box assembly.

**CAUTION:** With the “SRS–2” fuse removed and ignition switch “ON,” the “AIR BAG” warning lamp will be “ON.” This is normal operation and does not indicate an SRS malfunction.

### Enabling The SRS

#### Installation

Turn ignition switch to “LOCK” and remove key.

1. Connect yellow 2–pin connector passenger air bag assembly.
2. Install glove box assembly, Refer to “Passenger Air Bag Assembly Replacement” in this section.
3. Connect yellow 2–pin connector at the base of the steering column.
4. Install “AIR BAG” fuse SRS–1 and SRS–2 to left dash side lower fuse block or connect battery.

Turn ignition switch to “ON” and verify that the “AIR BAG” warning lamp flashes seven times and then turns “OFF” If it does not operate as described, perform the “SRS Diagnostic System Check”.

### Handling / Installation / Diagnosis

1. Air bag assembly should not be subjected to temperatures above 93°C (200°F).
2. Air bag assembly, and SDM should not be used if they have been dropped from a height of 100 cm (3.28 feet) or more.
3. When a SDM is replaced, it must be oriented with the arrow on the SDM pointing toward the front of the vehicle. It is very important for the SDM to be located flat on the mounting surface, parallel to the vehicle datum line. It is important that the SDM mounting surface is free of any dirt or other foreign material.
4. Do not apply power to the SRS unless all components are connected or a diagnostic chart requests it, as this will set a diagnostic trouble code.
5. The “SRS Diagnostic System Check” must be the starting point of any SRS diagnostics. The “SRS Diagnostic System Check” will verify proper “AIR BAG” warning lamp operation and will lead you to the correct chart to diagnose any SRS malfunctions. Bypassing these procedures may result in extended diagnostic time, incorrect diagnosis, and incorrect parts replacements.

### Inspections Required After An Accident

**CAUTION:** Certain SRS components must be replaced after a frontal crash involving air bag deployment.

In all types of accidents regardless of “Air Bag” deployment, visually inspect all of the following components and replace as required:

- Driver air bag assembly
- Passenger air bag assembly
- Steering wheel
- SRS coil assembly
- Steering column
- Knee bolster and instrument panel mounting attachments
- Driver seat and belt
- Passenger seat and belt
- SDM



Be sure to replace Sensing and Diagnostic Module (SDM) in accordance with "SDM Replacement Guidelines". In cases of collision without causing air bag deployment, SDM could be used unless this manual instructs to replace.

**CAUTION: Refer to SDM replacement Guidelines below for important information on SDM replacement in both deployment and non-deployment crashes.**

#### **SDM Replacement Guidelines**

1. In case that the air bag has been deployed, replace the SDM.
2. When DTC 51, 53 and 71 are set.
3. When SDM fell down from a 100 cm (3.3 feet) height.  
All above is SDM replacement Guideline.

Inspection is needed also on the following.

Inspect Supplemental Restraint System (SRS) coil assembly wiring and steering wheel for any signs of scorching melting or damage due to excessive heat. If coil assembly wire or steering wheel is damaged replace them. The steering column and wheel must be dimensionally checked to determine if they are damaged. Refer to in this Section of this manual.

Never use SRS parts from another vehicle. This does not include remanufactured parts purchased from an authorized Retailer they may be used for SRS repairs. Do not attempt to repair the SDM, the SRS harness, the SRS coil assembly, the air bag assembly, the steering wheel, or the steering column. Service of these items is replacement only.

Verify replacement part numbers.

**CAUTION: Proper operation of the SDM and Supplemental Restraint System (SRS) requires that any repairs to the vehicle structure return it to its original production configuration.**

## Sensing and Diagnostic Module (SDM)

### Service Precautions

**WARNING: DURING SERVICE PROCEDURES, BE VERY CAREFUL WHEN HANDLING SDM. NEVER STRIKE OR JAR SDM. UNDER SOME CIRCUMSTANCES, IT COULD CAUSE DEPLOYMENT AND RESULT IN PERSONAL INJURY OR IMPROPER OPERATION OF THE SUPPLEMENTAL RESTRAINT SYSTEM (SRS). SDM MOUNTING BRACKET BOLTS MUST BE CAREFULLY TORQUED TO ASSURE PROPER OPERATION. NEVER POWER UP THE SRS WHEN SDM IS NOT RIGIDLY ATTACHED TO THE VEHICLE. THE SDM COULD BE ACTIVATED WHEN POWERED WHILE NOT RIGIDLY ATTACHED TO THE VEHICLE WHICH COULD CAUSE DEPLOYMENT AND RESULT IN PERSONAL INJURY.**

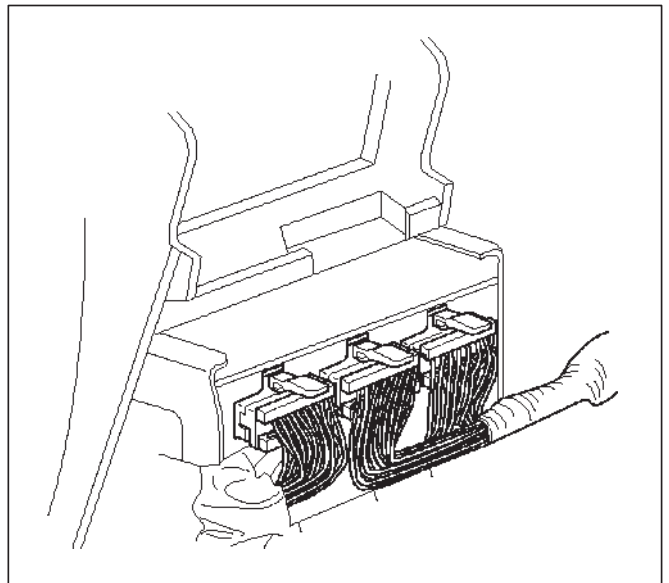
**WARNING: PROPER OPERATION OF THE SENSING AND DIAGNOSTIC MODULE (SDM) REQUIRES THE SDM TO BE RIGIDLY ATTACHED TO THE VEHICLE STRUCTURE AND THAT THE ARROW ON THE SENSOR BE POINTING TOWARD THE FRONT OF THE VEHICLE.**

SDM is specifically calibrated and is keyed to the SDM location SRS wiring harness. Caution should be used to ensure proper location of the SDM. The keying of the SDM to its location and wiring harness connectors should never be modified in the field.

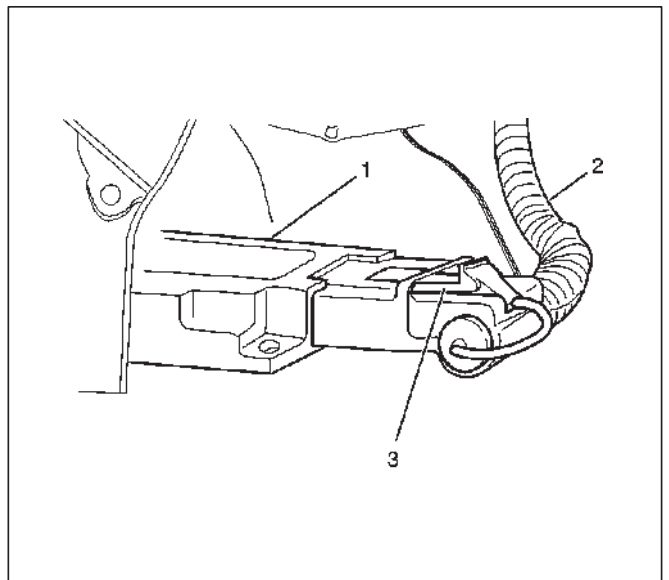
### Removal

1. Disable the SRS. (Refer to "Disable the SRS" in this manual)
2. Remove dressing panel around the radio and disconnect cigar lighter harness.
3. Remove the transfer shift lever knob.
4. Remove the center console.
5. Remove three connector from Powertrain Control Module (PCM).
6. Remove PCM with bracket. (Fixed four bolts)
7. Remove right side stay between instrument panel and floor.
8. Remove driver and passenger seat.
9. Turn over carpet to rear side.

10. Remove air conditioning duct for rear seat. (Transform the duct during removing it)



11. Pull CPA (3) (Connector Position Assurance—red color) out and push connector lock down to disconnect the SDM harness connector (2).
12. Remove the three SDM fixing bolts and remove SDM (1).



### Installation

1. Install the SDM (1) on bracket and fixing bolts and tighten the fixing bolts to the specified torque.  
**Torque: 10 N·m ± 3 N·m (87 ± 26 lb in)**
2. Connect the SDM harness connector (2) and after that, put CPA into connector (3).
3. Install air conditioning duct for rear seat to normal position.

4. Return carpet normal position.
5. Install right side stay between instrument panel and floor, tighten to the specified torque.  
**Torque: 10 N·m ± 3 N·m (87 ± 26 lb in)**
6. Install PCM with bracket and tighten to the specified torque.  
**Torque: 10 N·m ± 3 N·m (87 ± 26 lb in)**
7. Reconnect three connector to Powertrain Control Module (PCM).
8. Install the center console.
9. Install the transfer shift lever knob.
10. Install the dressing panel around the radio and reconnect cigar lighter harness.
11. Enable the SRS. (Refer to "Enabling the SRS" in this manual)

## Driver Air Bag Assembly

### Service Precautions

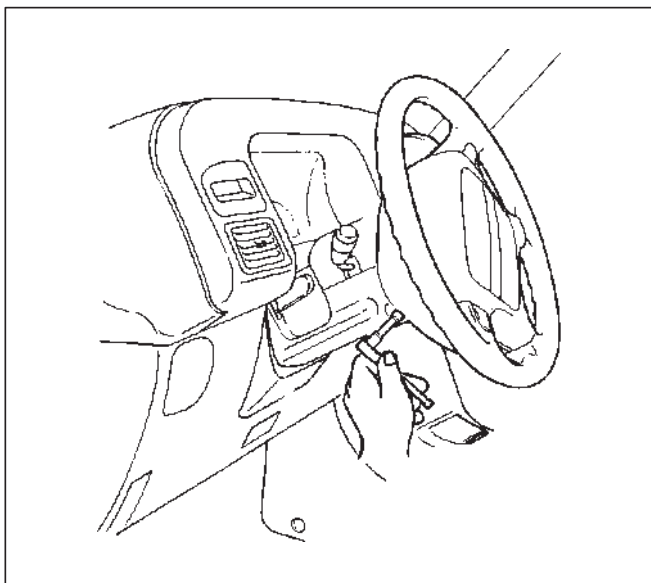
**WARNING: SAFETY PRECAUTIONS MUST BE FOLLOWED WHEN HANDLING A DEPLOYED AIR BAG ASSEMBLY. AFTER DEPLOYMENT, THE AIR BAG ASSEMBLY SURFACE MAY CONTAIN A SMALL AMOUNT OF SODIUM HYDROXIDE, A BY-PRODUCT OF THE DEPLOYMENT REACTION, THAT IS IRRITATING TO THE SKIN AND EYES. MOST OF THE POWDER ON THE AIR BAG ASSEMBLY IS HARMLESS. AS A PRECAUTION, WEAR GLOVES AND SAFETY GLASSES WHEN HANDLING A DEPLOYED AIR BAG ASSEMBLY, AND WASH YOUR HANDS WITH MILD SOAP AND WATER AFTERWARDS.**

**WARNING: WHEN CARRYING A LIVE AIR BAG ASSEMBLY, MAKE SURE THE BAG AND TRIM COVER ARE POINTED AWAY FROM YOU. NEVER CARRY AIR BAG ASSEMBLY BY THE WIRES OR CONNECTOR ON THE UNDERSIDE OF MODULE. IN THE CASE OF AN ACCIDENTAL DEPLOYMENT, THE BAG WILL THEN DEPLOY WITH MINIMAL CHANCE OF INJURY. WHEN PLACING A LIVE AIR BAG ASSEMBLY ON A BENCH OR OTHER SURFACE, ALWAYS FACE BAG AND TRIM COVER UP, AWAY FROM THE SURFACE. NEVER REST A STEERING COLUMN ASSEMBLY ON THE STEERING WHEEL WITH THE AIR BAG ASSEMBLY FACE DOWN AND COLUMN VERTICAL. THIS IS NECESSARY SO THAT A FREE SPACE IS PROVIDED TO ALLOW THE AIR BAG ASSEMBLY TO EXPAND IN THE UNLIKELY EVENT OF ACCIDENTAL DEPLOYMENT. OTHERWISE, PERSONAL INJURY COULD RESULT.**

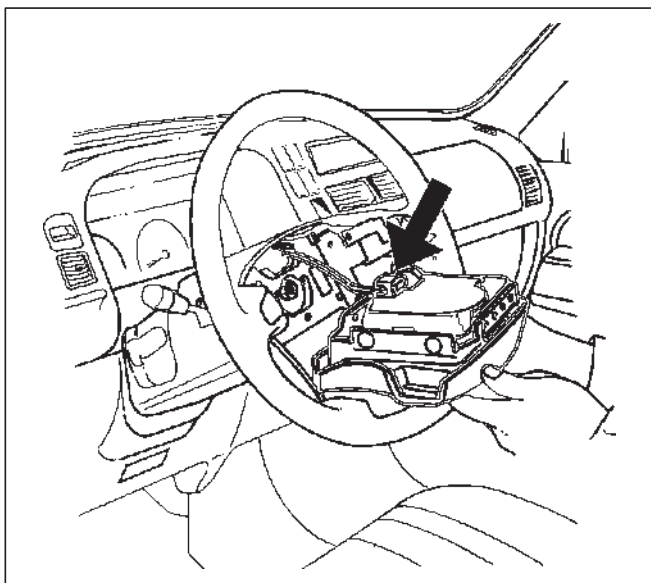
**NOTE:** In the event deployment has occurred, inspect coil assembly wire for any signs of scorching, melting or any other damage due to excessive heat. If the coil has been damaged, replace it.

### Removal

1. Disable the Supplemental Restraint System (SRS). (Refer to "Disabling the SRS" in this section.)
2. Remove air bag assembly from steering wheel by removing two bolts. Lift air bag assembly out of steering wheel.



3. Disconnect connector and remove air bag assembly.
4. Disconnect horn lead.



### Installation

1. Connect air bag to wiring harness connector.

**NOTE:** Pass the lead wire through the tabs on the plastic cover (wire protector) of air bag to prevent lead wire from being pinched.

2. Connect horn lead.
3. Install air bag into steering wheel and tighten bolts to specified sequence as shown in figure.

**Torque: 8.8 N·m (78 lb in)**

**CAUTION:** Never use the air bag assembly from another vehicle.

Use only the air bag assembly for Vehi CROSS (VX).

4. Enable the Supplemental Restraint System (SRS). (Refer to "Enabling the SRS" in this section.)

## Steering Wheel

### Service Precautions

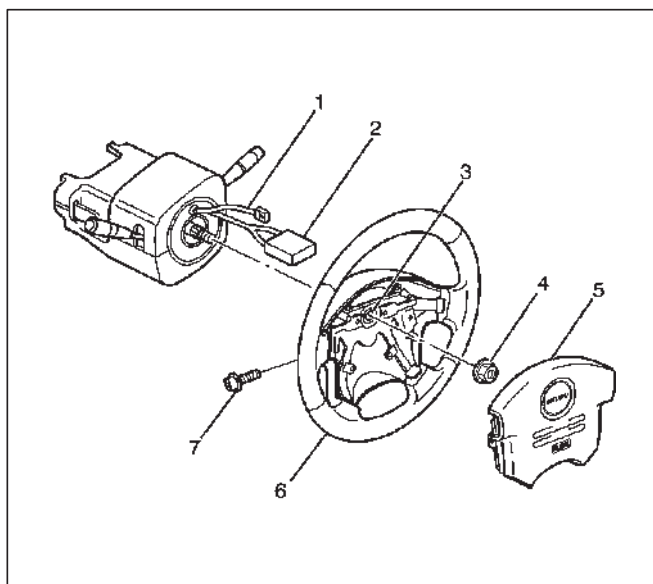
**WARNING: SAFETY PRECAUTIONS MUST BE FOLLOWED WHEN HANDLING A DEPLOYED AIR BAG ASSEMBLY. AFTER DEPLOYMENT, THE AIR BAG ASSEMBLY SURFACE MAY CONTAIN A SMALL AMOUNT OF SODIUM HYDROXIDE, A BY-PRODUCT OF THE DEPLOYMENT REACTION, THAT IS IRRITATING TO THE SKIN AND EYES. MOST OF THE POWDER ON THE AIR BAG ASSEMBLY IS HARMLESS. AS A PRECAUTION, WEAR GLOVES AND SAFETY GLASSES WHEN HANDLING A DEPLOYED AIR BAG ASSEMBLY, AND WASH YOUR HANDS WITH MILD SOAP AND WATER AFTERWARDS.**

**WARNING: WHEN CARRYING A LIVE AIR BAG ASSEMBLY, MAKE SURE THE BAG AND TRIM COVER ARE POINTED AWAY FROM YOU. NEVER CARRY AIR BAG ASSEMBLY BY THE WIRES OR CONNECTOR ON THE UNDERSIDE OF MODULE. IN THE CASE OF AN ACCIDENTAL DEPLOYMENT, THE BAG WILL THEN DEPLOY WITH MINIMAL CHANCE OF INJURY. WHEN PLACING A LIVE AIR BAG ASSEMBLY ON A BENCH OR OTHER SURFACE, ALWAYS FACE BAG AND TRIM COVER UP, AWAY FROM THE SURFACE. NEVER REST A STEERING COLUMN ASSEMBLY ON THE STEERING WHEEL WITH THE AIR BAG ASSEMBLY FACE DOWN AND COLUMN VERTICAL. THIS IS NECESSARY SO THAT A FREE SPACE IS PROVIDED TO ALLOW THE AIR BAG ASSEMBLY TO EXPAND IN THE UNLIKELY EVENT OF ACCIDENTAL DEPLOYMENT. OTHERWISE, PERSONAL INJURY COULD RESULT.**

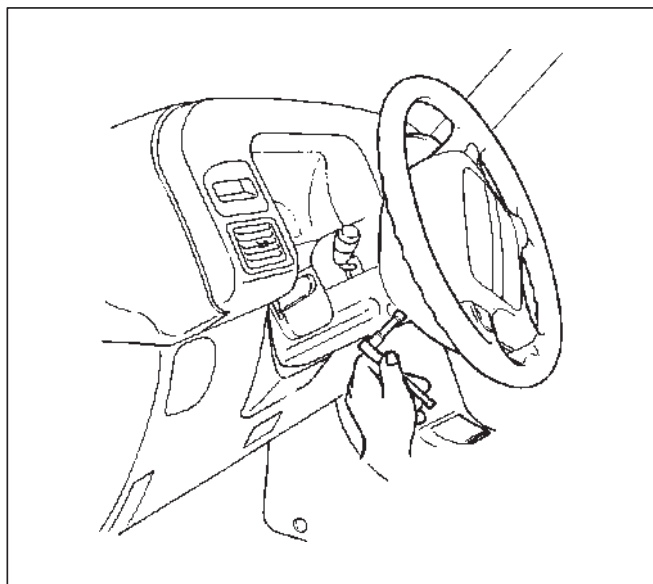
**NOTE:** In the event deployment has occurred, inspect coil assembly wire for any signs of scorching, melting or any other damage due to excessive heat. If the coil has been damaged, replace it.

### Removal

1. Disable the SRS. (Refer to "Disabling the SRS" in this section.)



2. Remove the air bag assembly (5) from steering wheel (6) by removing two bolts (7). Lift air bag assembly out of steering wheel.

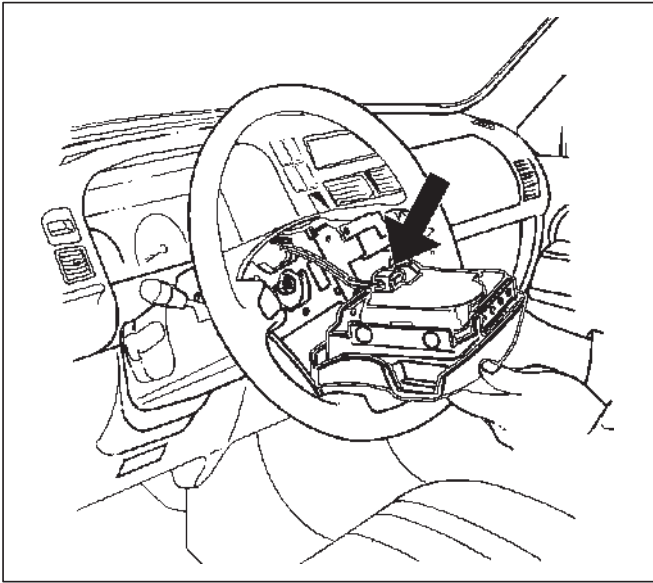


827RX002

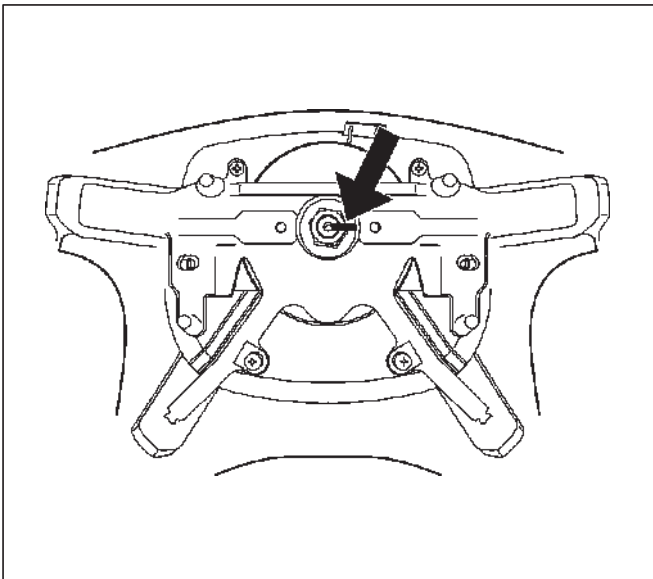
827RX006

## 9J-38 SUPPLEMENTAL RESTRAINT SYSTEM

3. Disconnect connector (2) and remove air bag assembly.



4. Disconnect horn lead (1)
5. Remove steering wheel attachment nut (4).
6. Move the tires to the straight ahead position before removing the steering wheel. Install steering wheel puller onto steering wheel and remove steering wheel with J-29752.
7. Apply a setting mark (3) across the steering wheel and shaft so parts can be reassembled in their original position.



8. Feed wiring through the wheel and remove wheel.

**CAUTION:** Never apply force to the steering wheel in direction of the shaft by using a hammer or other impact tools in an attempt to remove the steering wheel. The steering shaft is designed as an energy absorbing unit.

## Installation

1. Install the steering wheel and align the setting marks (3).
2. Tighten the steering wheel fixing nut (4) to the specified torque.

**Torque: 34 N·m (25 lb ft)**

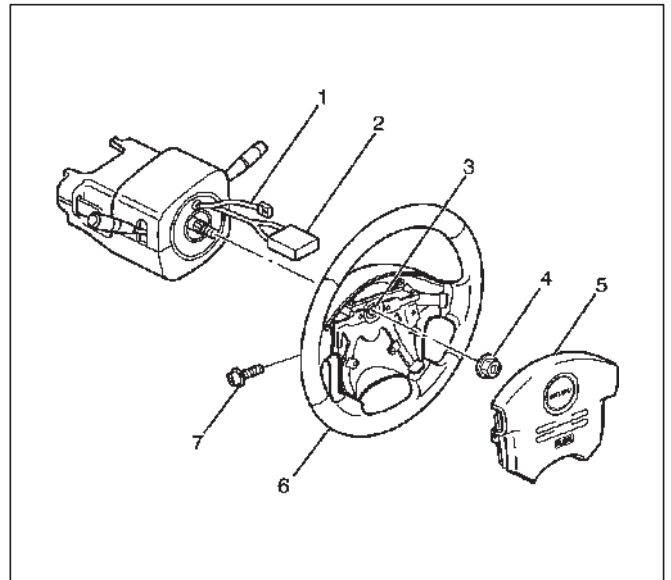
3. Connect horn lead (1).
4. Connect air bag to wiring harness connector (2).

**NOTE:** Pass the lead wire through the tabs on the plastic cover (wire protector) of air bag to prevent lead wire from being pinched.

5. Install air bag into steering wheel and tighten bolts (7) to specified sequence as show in figure.

**Torque: 8.8 N·m (78 lb in)**

**CAUTION:** Never use the air bag assembly from another vehicle. Use only the air bag assembly for Vehi CROSS (VX).



6. Enable the Supplemental Restraint System (SRS). (Refer to "Enabling The SRS" in this section.)

## SRS Coil Assembly

### Service Precaution

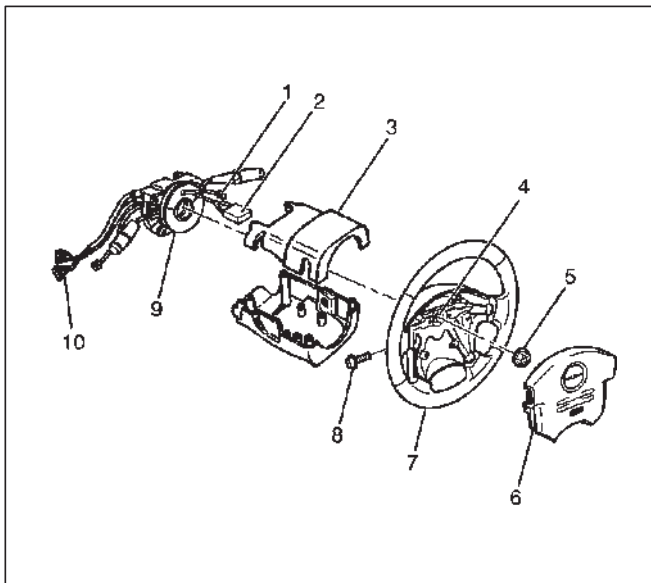
**WARNING: SAFETY PRECAUTIONS MUST BE FOLLOWED WHEN HANDLING A DEPLOYED AIR BAG ASSEMBLY. AFTER DEPLOYMENT, THE AIR BAG ASSEMBLY SURFACE MAY CONTAIN A SMALL AMOUNT OF SODIUM HYDROXIDE, A BY-PRODUCT OF THE DEPLOYMENT REACTION, THAT IS IRRITATING TO THE SKIN AND EYES. MOST OF THE POWDER ON THE AIR BAG ASSEMBLY IS HARMLESS. AS A PRECAUTION, WEAR GLOVES AND SAFETY GLASSES WHEN HANDLING A DEPLOYED AIR BAG ASSEMBLY, AND WASH YOUR HANDS WITH MILD SOAP AND WATER AFTERWARDS.**

**WARNING: WHEN CARRYING A LIVE AIR BAG ASSEMBLY, MAKE SURE THE BAG AND TRIM COVER ARE POINTED AWAY FROM YOU. NEVER CARRY AIR BAG ASSEMBLY BY THE WIRES OR CONNECTOR ON THE UNDERSIDE OF MODULE. IN THE CASE OF AN ACCIDENTAL DEPLOYMENT, THE BAG WILL THEN DEPLOY WITH MINIMAL CHANCE OF INJURY. WHEN PLACING A LIVE AIR BAG ASSEMBLY ON A BENCH OR OTHER SURFACE, ALWAYS FACE BAG AND TRIM COVER UP, AWAY FROM THE SURFACE. NEVER REST A STEERING COLUMN ASSEMBLY ON THE STEERING WHEEL WITH THE AIR BAG ASSEMBLY FACE DOWN AND COLUMN VERTICAL. THIS IS NECESSARY SO THAT A FREE SPACE IS PROVIDED TO ALLOW THE AIR BAG ASSEMBLY TO EXPAND IN THE UNLIKELY EVENT OF ACCIDENTAL DEPLOYMENT. OTHERWISE, PERSONAL INJURY COULD RESULT.**

**NOTE:** In the event deployment has occurred, inspect coil assembly wire for any signs of scorching, melting or any other damage due to excessive heat. If the coil has been damaged, replace it.

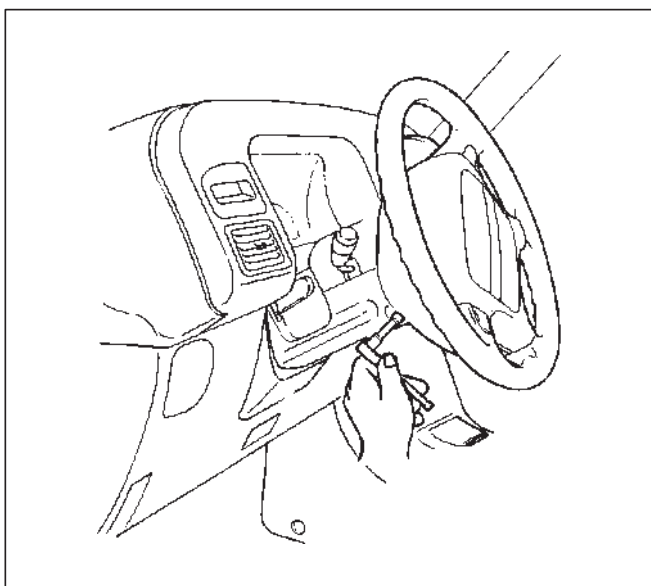
### Removal

1. Disable the Supplemental Restraint System (SRS). (Refer to "Disabling the SRS" in this section.)



825RW047-1

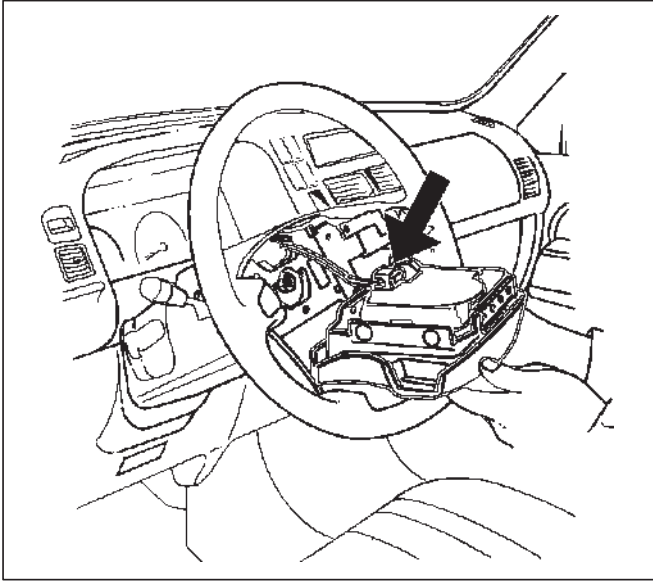
2. Remove the air bag assembly (6) from steering wheel (7) by removing two bolts (8). Lift air bag assembly out of steering wheel.



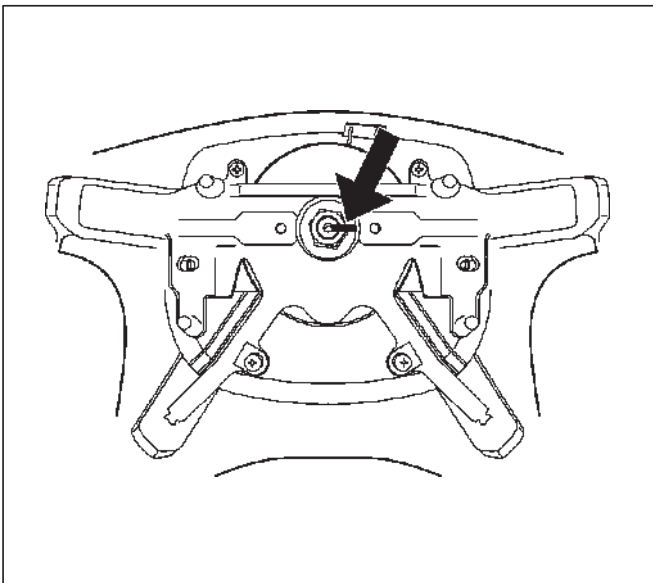
827RX008

## 9J-40 SUPPLEMENTAL RESTRAINT SYSTEM

3. Disconnect the 2-pin yellow connector (2) and remove air bag assembly.



4. Disconnect horn lead connector (1).
5. Remove the steering wheel attachment nut (5).
6. Move the tires to the straight ahead position before removing the steering wheel and remove wheel with J-29752.
7. Apply a setting mark (4) across the steering wheel and shaft so parts can be reassembled in their original position.



8. Feed wiring through the wheel and remove wheel.
9. Remove the steering lower cover.
10. Remove the driver knee bolster assembly.
11. Remove the steering column cover (3).
12. Disconnect the wiring harness connectors (10) located at the base of steering column.

**CAUTION:** Never apply force to the steering wheel in the direction of the shaft by using a hammer or other impact tools in an attempt to remove the

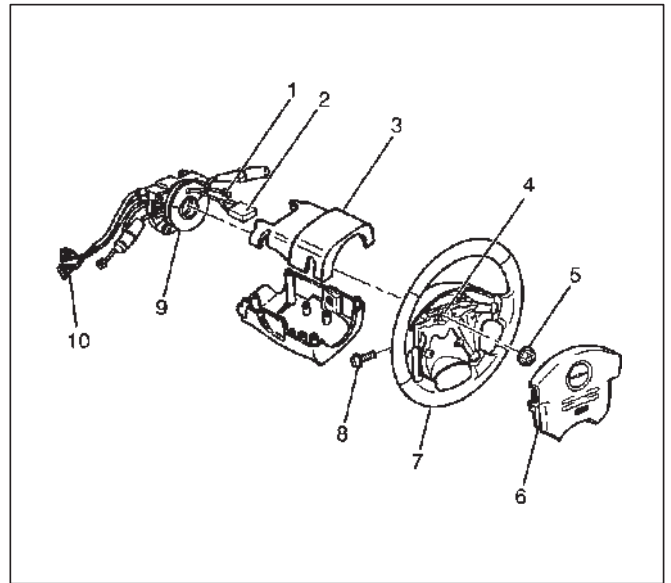
steering wheel. The steering shaft is designed as an energy absorbing unit.

13. Remove the combination switch assembly with Supplemental Restraint System (SRS) coil (9).

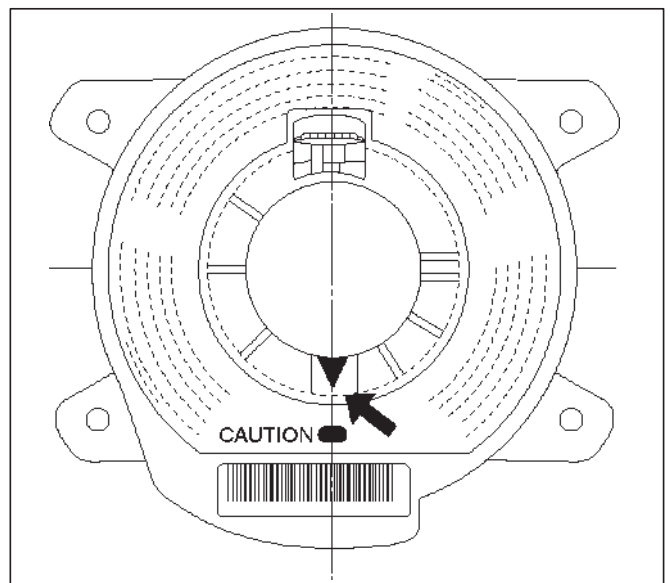
**NOTE:** SRS coil is a part of combination switch assembly, which cannot be replaced separately. Therefore, be sure not to remove the SRS coil from the combination switch assembly.

## Installation

1. Install the combination switch assembly with SRS coil (9).



2. Connect the wiring harness connectors (10) located at the base of steering column.
3. Turn the SRS coil clockwise to full, return about 3 turns and align the neutral mark.



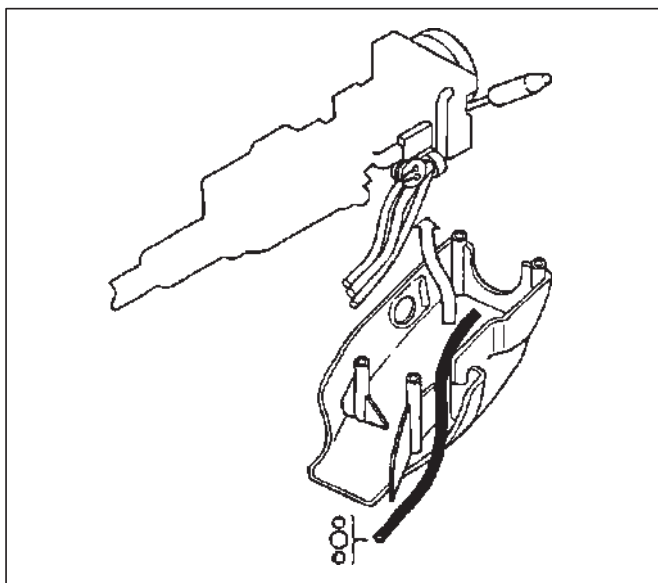


NOTE: Whenever installing the new combination switch with Supplemental Restraint System (SRS) coil, be sure to tear off the lock pin for aligning the neutral position before it is installed to the base of steering column.

**CAUTION: When turning the SRS coil clockwise to full, stop turning if resistance is felt. Forced further turning may damage the cable in the SRS coil.**

4. Install the steering column cover (3).

**CAUTION: When installing the steering column cover, be sure to thread each harness as illustrated so that the harnesses starter switch, combination switch and SRS coil may not catch wiring.**



5. Install the driver knee bolster assembly.

6. Install the steering lower cover.

7. Install the steering wheel and align the setting marks (4).

8. Tighten the steering wheel fixing nut (5) to the specified torque.

**Torque: 34 N·m (25 lb ft)**

9. Connect horn lead (1).

10. Connect air bag to wiring harness connector (2).

NOTE: Pass the lead wire through the tabs on the plastic cover (wire protector) of air bag to prevent lead wire from being pinched.

11. Install Air Bag (6) into steering wheel and tighten bolts (8) to specified sequence as figure.

**Torque: 8.8 N·m (78 lb in)**

**CAUTION: Never use the air bag assembly from another vehicle.**

**Use only the air bag assembly for Vehi CROSS (VX).**

12. Enable the SRS. (Refer to "Enabling The SRS" in this section.)

## Steering Column

### Service Precaution

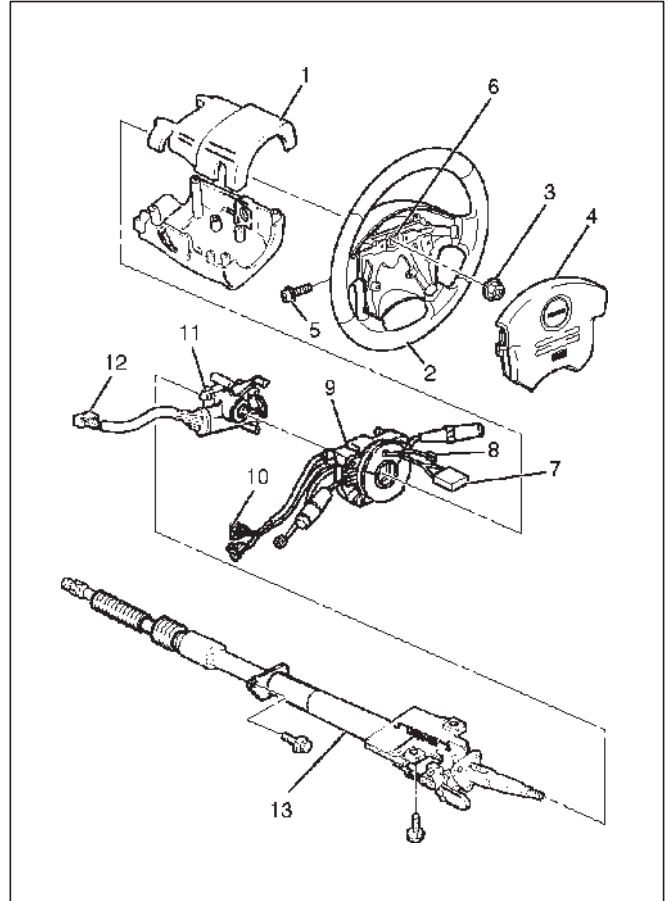
**WARNING: SAFETY PRECAUTIONS MUST BE FOLLOWED WHEN HANDLING A DEPLOYED AIR BAG ASSEMBLY. AFTER DEPLOYMENT, THE AIR BAG ASSEMBLY SURFACE MAY CONTAIN A SMALL AMOUNT OF SODIUM HYDROXIDE, A BY-PRODUCT OF THE DEPLOYMENT REACTION, THAT IS IRRITATING TO THE SKIN AND EYES. MOST OF THE POWDER ON THE AIR BAG ASSEMBLY IS HARMLESS. AS A PRECAUTION, WEAR GLOVES AND SAFETY GLASSES WHEN HANDLING A DEPLOYED AIR BAG ASSEMBLY, AND WASH YOUR HANDS WITH MILD SOAP AND WATER AFTERWARDS.**

**WARNING: WHEN CARRYING A LIVE AIR BAG ASSEMBLY, MAKE SURE THE BAG AND TRIM COVER ARE POINTED AWAY FROM YOU. NEVER CARRY AIR BAG ASSEMBLY BY THE WIRES OR CONNECTOR ON THE UNDERSIDE OF MODULE. IN THE CASE OF AN ACCIDENTAL DEPLOYMENT, THE BAG WILL THEN DEPLOY WITH MINIMAL CHANCE OF INJURY. WHEN PLACING A LIVE AIR BAG ASSEMBLY ON A BENCH OR OTHER SURFACE, ALWAYS FACE BAG AND TRIM COVER UP, AWAY FROM THE SURFACE. NEVER REST A STEERING COLUMN ASSEMBLY ON THE STEERING WHEEL WITH THE AIR BAG ASSEMBLY FACE DOWN AND COLUMN VERTICAL. THIS IS NECESSARY SO THAT A FREE SPACE IS PROVIDED TO ALLOW THE AIR BAG ASSEMBLY TO EXPAND IN THE UNLIKELY EVENT OF ACCIDENTAL DEPLOYMENT. OTHERWISE, PERSONAL INJURY COULD RESULT.**

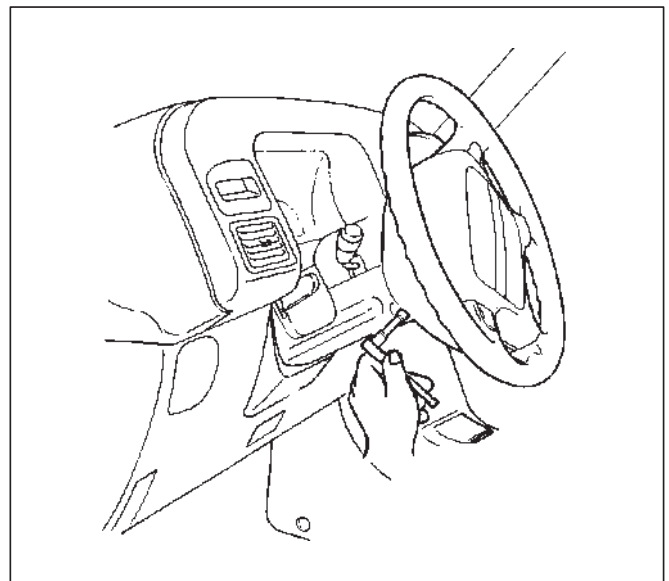
**NOTE:** In the event deployment has occurred, inspect coil assembly wire for any signs of scorching, melting or any other damage due to excessive heat. If the coil has been damaged, replace it.

### Removal

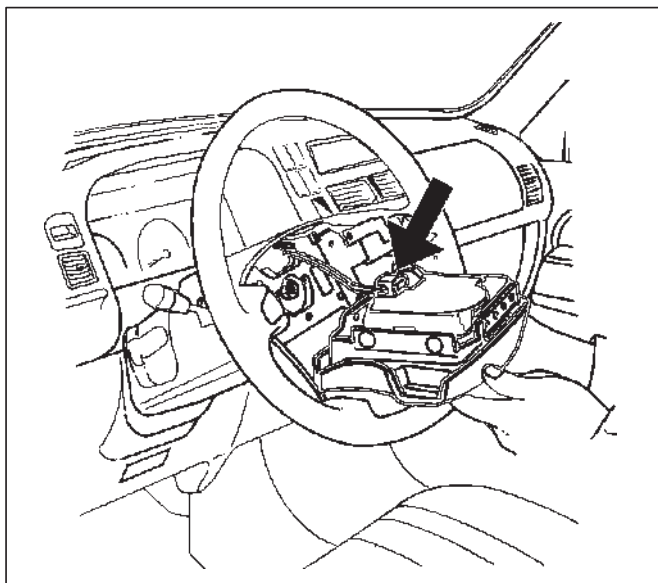
1. Disable the Supplemental Restraint System (SRS). (Refer to "Disabling The SRS" in this section.)



2. Remove the air bag assembly (4) from steering wheel (2) by removing two bolts (5). Lift air bag assembly out of steering wheel.

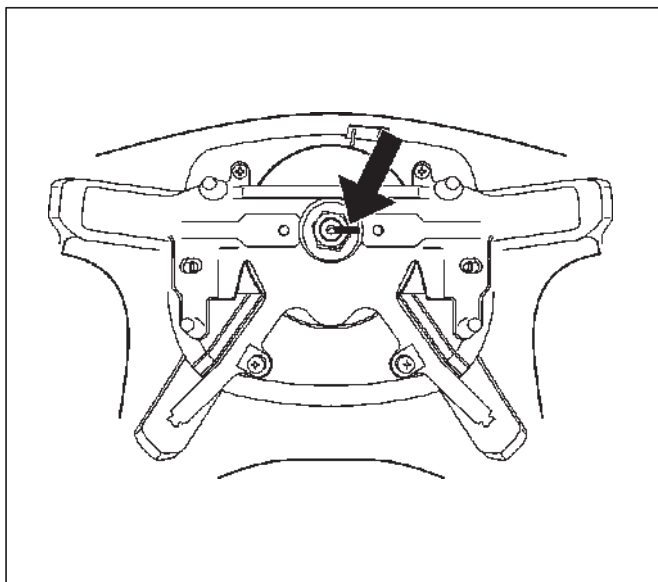


3. Disconnect the 2-pin yellow connector (7) and remove air bag assembly.



827RX007

4. Disconnect horn lead connector (8).
5. Remove the steering wheel attachment nut (3).
6. Move the tires to the straight ahead position before removing the steering wheel and removing wheel with J-29752.
7. Apply a setting mark (6) across the steering wheel and shaft so parts can be reassembled in their original position.



827RW063

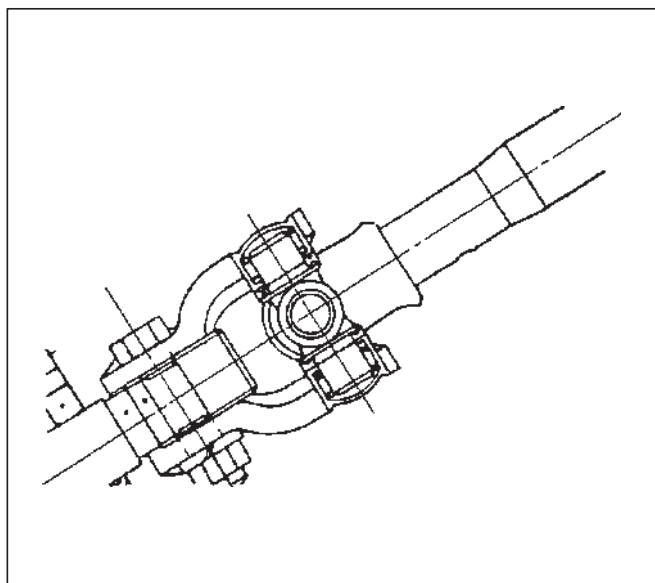
8. Feed wiring through the wheel and remove wheel.
9. Remove the steering lower cover.
10. Remove the driver knee bolster assembly.
11. Remove the steering column cover (1).
12. Disconnect the wiring harness connectors (10) located at the base of steering column.

**CAUTION:** Never apply force to the steering wheel in direction of the shaft by using a hammer or other impact tools in an attempt to remove the steering wheel. The steering shaft is designed as an energy absorbing unit.

13. Remove the combination switch assembly with Supplemental Restraint System (SRS) coil (9).

**NOTE:** SRS coil is a part of combination switch assembly, which cannot be replaced separately. Therefore, be sure not to remove the SRS coil from the combination switch assembly.

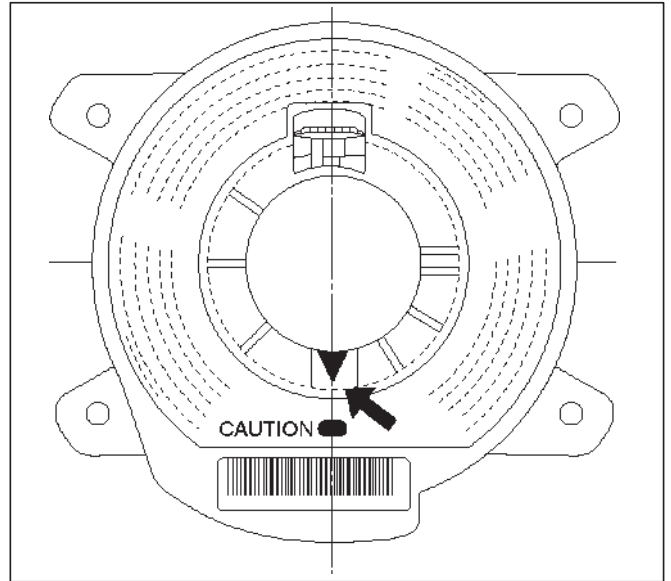
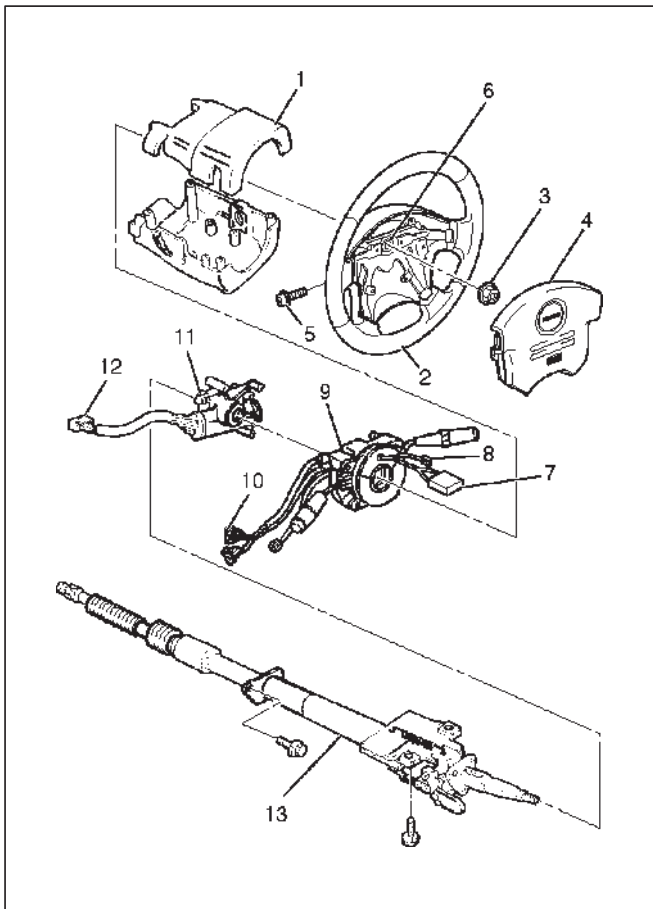
14. Remove the snap ring.
15. Remove the cushion rubber.
16. Disconnect shift lock cable.
17. Disconnect the starter switch harness connector (12) located base of steering column.
18. Remove steering lock cylinder assembly (11).
19. Apply a setting mark across the universal joint and steering shaft to reassemble the parts in their original position.



431RS013

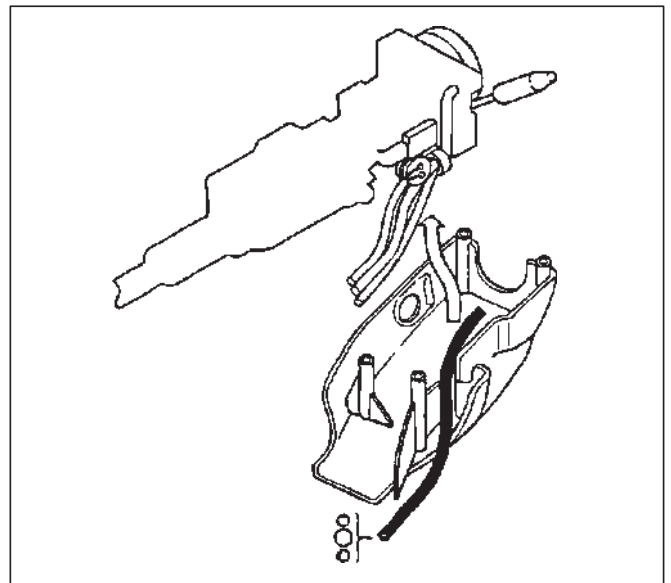
## 9J-44 SUPPLEMENTAL RESTRAINT SYSTEM

20. Remove steering column assembly (13).



**CAUTION:** When turning the SRS coil clockwise to full, stop turning if resistance is felt. Further forced turning may damage the cable in the SRS coil.

12. Install steering column cover (1).



**CAUTION:** When installing the steering column cover, be sure to wire (through each harness) as illustrated so that the harnesses starter switch, combination switch and SRS coil may not catch wiring.

13. Install the steering wheel (2) and align the setting marks (6).

14. Tighten the steering wheel fixing nut (3) to the specified torque.

**Torque: 34 N-m (25 lb ft)**

15. Connect horn lead (8).

16. Connect air Bag wiring harness connector (7).

**NOTE:** Pass the lead wire through the tabs on the plastic cover (wire protector) of air bag to prevent lead wire from being pinched.

## Installation

1. Install the steering column assembly (13) and align the setting marks on the universal joint and steering shaft made during removal.

2. Tighten the steering column fixing bolts (dash panel side) to the specified torque.

**Torque: 19 N-m (14 lb ft)**

3. Tighten the steering column fixing bolts (Cross beam) to the specified torque.

**Torque: 17 N-m (13 lb ft)**

4. Tighten the universal joint to the specified torque.

**Torque: 25 N-m (18 lb ft)**

5. Install steering lock cylinder assembly (11).

6. Connect shift lock cable.

7. Install cushion rubber.

8. Install snap ring.

9. Install the combination switch assembly with Supplemental Restraint System (SRS) coil (9).

10. Connect the wiring harness connector (10) located on the base of steering column.

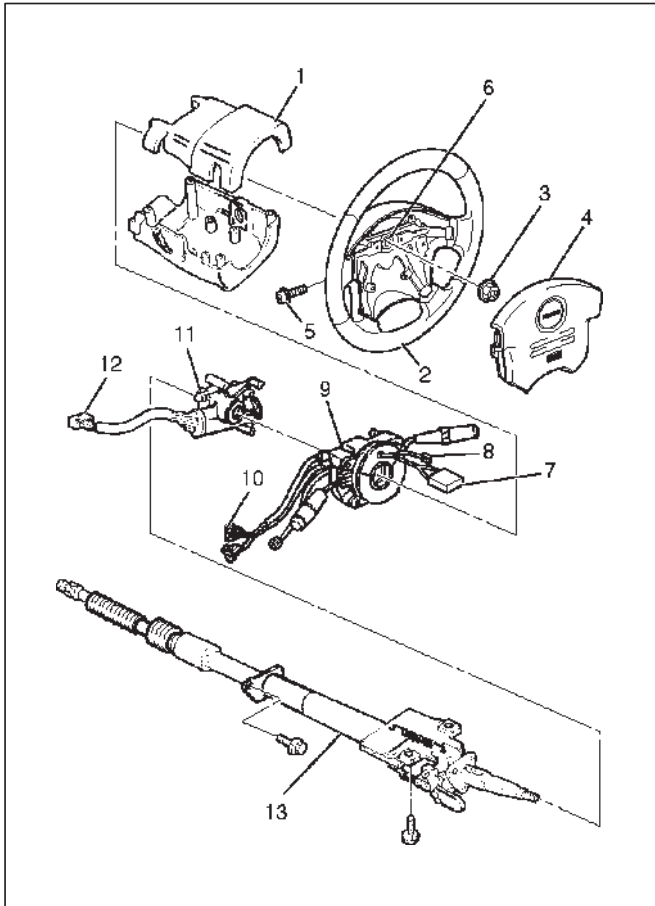
11. Turn the SRS coil clockwise to full, return about 3 turns and align the neutral mark.

17. Install air bag into steering wheel and tighten bolts (5) to specified sequence as shown in figure.

**Torque: 8.8 N·m (78 lb in)**

**CAUTION: Never use the air bag assembly from another vehicle.**

**Use only the air bag assembly for Vehi CROSS (VX).**



431RX015

18. Enable the Supplemental Restraint System (SRS) (Refer to "Enabling The SRS" in this section.)

## Passenger Air Bag Assembly

### Service Precaution

**WARNING: SAFETY PRECAUTIONS MUST BE FOLLOWED WHEN HANDLING A DEPLOYED AIR BAG ASSEMBLY. AFTER DEPLOYMENT, THE AIR BAG ASSEMBLY SURFACE MAY CONTAIN A SMALL AMOUNT OF SODIUM HYDROXIDE, A BY-PRODUCT OF THE DEPLOYMENT REACTION, THAT IS IRRITATING TO THE SKIN AND EYES. MOST OF THE POWDER ON THE AIR BAG ASSEMBLY IS HARMLESS. AS A PRECAUTION, WEAR GLOVES AND SAFETY GLASSES WHEN HANDLING A DEPLOYED AIR BAG ASSEMBLY, AND WASH YOUR HANDS WITH MILD SOAP AND WATER AFTERWARDS.**

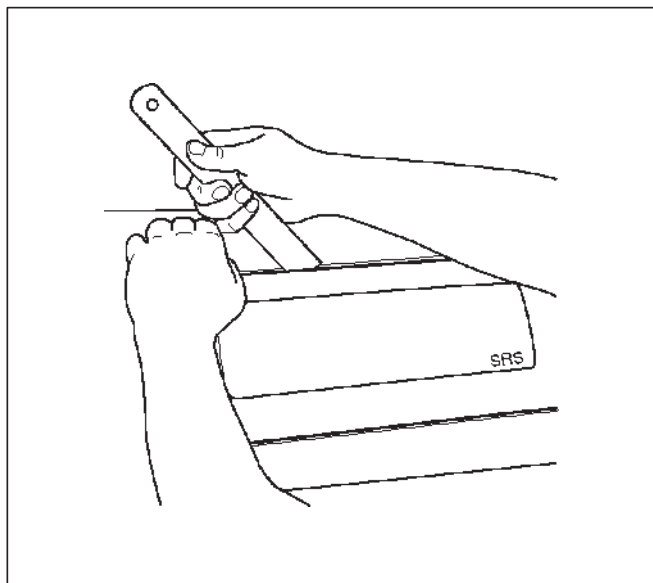
**WARNING: WHEN CARRYING A LIVE AIR BAG ASSEMBLY, MAKE SURE THE BAG AND TRIM COVER ARE POINTED AWAY FROM YOU. NEVER CARRY AIR BAG ASSEMBLY BY THE WIRES OR CONNECTOR ON THE UNDERSIDE OF MODULE. IN THE CASE OF AN ACCIDENTAL DEPLOYMENT, THE BAG WILL THEN DEPLOY WITH MINIMAL CHANCE OF INJURY. WHEN PLACING A LIVE AIR BAG ASSEMBLY ON A BENCH OR OTHER SURFACE, ALWAYS FACE BAG AND TRIM COVER UP, AWAY FROM THE SURFACE. NEVER REST A STEERING COLUMN ASSEMBLY ON THE STEERING WHEEL WITH THE AIR BAG ASSEMBLY FACE DOWN AND COLUMN VERTICAL. THIS IS NECESSARY SO THAT A FREE SPACE IS PROVIDED TO ALLOW THE AIR BAG ASSEMBLY TO EXPAND IN THE UNLIKELY EVENT OF ACCIDENTAL DEPLOYMENT. OTHERWISE, PERSONAL INJURY COULD RESULT.**

**NOTE:** In the event deployment has occurred, inspect coil assembly wire for any signs of scorching, melting or any other damage due to excessive heat. If the coil has been damaged, replace it.

### Removal

1. Disable the Supplemental Restraint System (SRS). (Refer to "Disabling the SRS" in this section.)
2. Remove glove box assembly.
3. Remove glove box cover.
4. Disconnect passenger air bag assembly harness connector.
5. Remove air bag assembly fixing bolts and nuts.
6. As the instrument panel side and Passenger air bag assembly side are fixed with both side adhesive tapes, tear away the tapes carefully not deform and scratch the air bag.

**NOTE:** When tearing away the tapes, protect the instrument panel side and passenger air bag side with masking tapes.

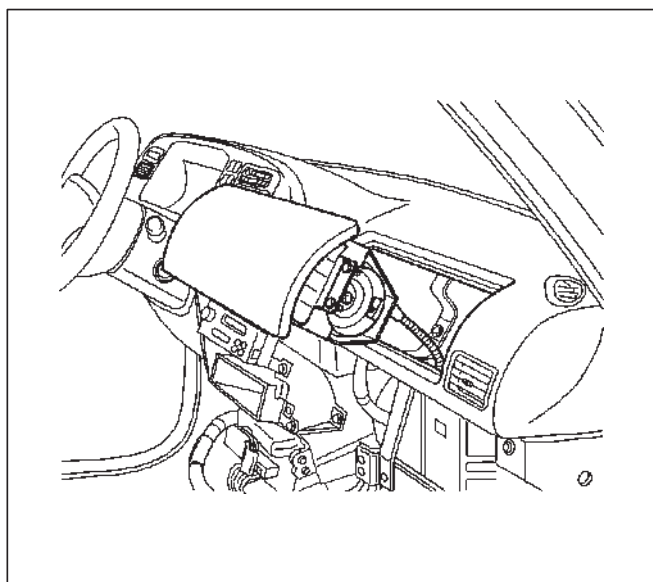


825RX031

### Installation

**NOTE:** Be sure to completely remove the remaining pieces of the duplicated adhesive tapes from both side of the removed passenger air bag and instrument panel.

1. Stick new both side adhesive tapes to the Passenger air bag assembly so that the assembly will not be shifted toward the instrument panel side.



827RX052

2. Install air bag assembly fixing nuts and bolts, and tighten to specified torque.

**Torque: 7.8 N-m (69 lb in)**

3. Connect air bag assembly harness connector.
4. Install glove box assembly and glove box cover.
5. Enable the SRS (Refer to "Enabling the SRS" in this section).

**Main Data and Specifications**  
**Fastener Tightening Specification**

Application	N·m	lb Ft	lb In
SDM	10	—	87
Driver air bag fixing bolt	8.8	—	78
Steering wheel fixing bolt	34	25	—
Steering column (dash panel side fixing bolts)	19	14	—
Steering column (Pedal bracket fixing bolts)	17	13	—
Steering column (Universal joint fixing bolt)	25	18	—
Passenger Air Bag fixing bolts and nuts	6	—	52

**SRS Air Bag System Inspection Standards For Repair**

Parts Name	Inspection Standard		Part Replacement Standard
	Collision	Trouble	
Driver Air bag Assembly	○	○	1. Air bag has deployed due to collision. 2. Pad surface has crack or scratch. 3. Connector has cracks. 4. Harness is disconnected or scratched.
Passenger Air bag Assembly	○	○	5. Air bag is soaked in water, oil etc. 6. Air bag has fallen from a height of about 100 cm (3.3) feet. 7. Trouble diagnosis in Workshop Manual resulted in part replacement.
Sensing and Diagnostic Module (SDM)	○	○	1. Air bag has deployed due to collision. 2. SDM is crack or deformed. 3. Connector has cracks. 4. SDM has fallen from a height of about 100 cm (3.3) feet. 5. Trouble diagnosis in Workshop Manual resulted in part replacement.
SRS Coil Assembly	○	○	1. Burn or melt due to overheat. 2. Case is cracked or deformed. 3. Trouble diagnosis in Workshop Manual resulted in part replacement.
SRS Harness	○	○	1. Air bag circuit wire harness is disconnected or damaged. 2. Connector has cracks. 3. Trouble diagnosis in Workshop Manual resulted in part replacement.
Steering Wheel	○		1. Bracket is deformed. 2. A new air bag cannot be installed with ease. 3. When a new air bag is installed, pad interferes with the steering wheel, and clearance is uneven.
Steering Column	○		1. Capsule is broken. 2. The fitting of column collapses. 3. Bellows pipe is deformed.
Instrument Panel & Knee bolster & Cover Glove box. Seat Seat Belt Wood shield Glass	○		1. Dent, bend, cracks, and deform.
Mounts	○		1. Repair or replace if dent, bend, cracks, and deform are found. 2. Retighten to specified torque if loose.

**Inspection Standards**

In cases of collision: When any type of collision has occurred regardless of air bag deployment.

In cases of trouble code: When trouble code has been detected by TECH 2 in case of the AIR BAG WARNING LIGHT failing to work or remaining lighted.



VEHICROSS

# RESTRAINTS

## SRS CONTROL SYSTEM

### CONTENTS

Service Precaution .....	9J1-1	DTC 19 Passenger Deployment Loop Short To Voltage .....	9J1-25
Diagnostic Information .....	9J1-2	DTC 21 Driver Deployment Loop Resistance High .....	9J1-27
Parts For Electrical Circuit .....	9J1-4	DTC 22 Driver Deployment Loop Resistance Low .....	9J1-30
System Schematic .....	9J1-5	DTC 24 Driver Deployment Loop Short To Ground .....	9J1-33
SRS Diagnostic System Check .....	9J1-5	DTC 25 Driver Deployment Loop Short To Voltage .....	9J1-35
Chart A SDM Integrity Check .....	9J1-8	DTC 26 Driver Deployment Loop Open ....	9J1-38
Chart B "AIR BAG" Warning Lamp Comes "ON" Steady .....	9J1-10	DTC 51 Deployment Event Commanded ...	9J1-41
Chart C "AIR BAG" Warning Lamp Does Not Come "ON" Steady .....	9J1-12	DTC 53 Deployment Commanded With Deployment Loop Fault Or Energy Reserves Out Of Range .....	9J1-43
DTC 15 Passenger Deployment Loop Resistance High .....	9J1-15	DTC 61 Warning Lamp Circuit Failure ....	9J1-45
DTC 16 Passenger Deployment Loop Resistance Low .....	9J1-18	DTC 71 Internal SDM Fault .....	9J1-47
DTC 17 Passenger Deployment Loop Open	9J1-21		
DTC 18 Passenger Deployment Loop Short To Ground .....	9J1-23		

### Service Precaution

**WARNING: THIS VEHICLE HAS A SUPPLEMENTAL RESTRAINT SYSTEM (SRS). REFER TO THE SRS COMPONENT AND WIRING LOCATION VIEW IN ORDER TO DETERMINE WHETHER YOU ARE PERFORMING SERVICE ON OR NEAR THE SRS COMPONENTS OR THE SRS WIRING. WHEN YOU ARE PERFORMING SERVICE ON OR NEAR THE SRS COMPONENTS OR THE SRS WIRING, REFER TO THE SRS SERVICE INFORMATION. FAILURE TO FOLLOW WARNINGS COULD RESULT IN POSSIBLE AIR BAG DEPLOYMENT, PERSONAL INJURY, OR OTHERWISE UNNEEDED SRS SYSTEM REPAIRS.**

**CAUTION: Always use the correct fastener in the proper location. When you replace a fastener, use ONLY the exact part number for that application. ISUZU will call out those fasteners that require a replacement after removal. ISUZU will also call out the fasteners that require thread lockers or thread sealant. UNLESS OTHERWISE SPECIFIED, do not use supplemental coatings (Paints, greases, or other corrosion inhibitors) on threaded fasteners or fastener joint interfaces. Generally, such coatings adversely affect the fastener torque and the joint clamping force, and may damage the fastener. When you install fasteners, use the correct tightening sequence and specifications. Following these instructions can help you avoid damage to parts and systems.**

## Diagnostic Information

### Diagnostic Procedures

**WARNING: WHEN FASTENERS ARE REMOVED, ALWAYS REINSTALL THEM AT THE SAME LOCATION FROM WHICH THEY WERE REMOVED. IF A FASTENER NEEDS TO BE REPLACED, USE THE CORRECT PART NUMBER FASTENER FOR THAT APPLICATION. IF THE CORRECT PART NUMBER FASTENER IS NOT AVAILABLE, A FASTENER OF EQUAL SIZE AND STRENGTH (OR STRONGER) MAY BE USED. FASTENERS THAT ARE NOT REUSED, AND THOSE REQUIRING THREAD LOCKING COMPOUND WILL BE CALLED OUT. THE CORRECT TORQUE VALUE MUST BE USED WHEN INSTALLING FASTENERS THAT REQUIRE IT. IF THE ABOVE CONDITIONS ARE NOT FOLLOWED, PARTS OR SYSTEM DAMAGE COULD RESULT.**

**WARNING: TO AVOID DEPLOYMENT WHEN TROUBLESHOOTING THE SRS, DO NOT USE ELECTRICAL TEST EQUIPMENT SUCH AS A BATTERY-POWERED OR AC-POWERED VOLTMETER, OHMMETER, ETC., OR ANY TYPE OF ELECTRICAL EQUIPMENT OTHER THAN THAT SPECIFIED IN THIS MANUAL. DO NOT USE A NONPOWERED, PROBE-TYPE TESTER. INSTRUCTIONS IN THIS MANUAL MUST BE FOLLOWED CAREFULLY, OTHERWISE PERSONAL INJURY MAY RESULT.**

The diagnostic procedures used in this section are designed to aid in finding and repairing SRS problems. Outlined below are the steps to find and repair SRS problems quickly and effectively. Failure to carefully follow these procedures may result in extended diagnostic time, incorrect diagnosis and incorrect parts Replacement.

#### 1. Perform The “SRS Diagnostic System Check.”

The “Supplemental Restraint System (SRS) Diagnostic System Check” should always be the starting point of any SRS diagnostics. The “SRS Diagnostic System Check” checks for proper “AIR BAG” warning lamp operation and checks for SRS trouble codes using both “Flash Code” and “Scan Tool” Methods.

#### 2. Refer To The Proper Diagnostic Chart As Directed By The “SRS Diagnostic System Check.”

The “SRS Diagnostic System Check” will lead you to the correct chart to diagnose any SRS problems. Bypassing these procedures may result in extended diagnostic time, incorrect diagnosis and incorrect parts Replacement.

#### 3. Repeat the “SRS Diagnostic System Check” After Any Repair Or Diagnostic Procedures Have Been Performed.

Performing the “SRS Diagnostic System Check” after all repair or diagnostic procedures will assure that the repair has been made correctly and that no other conditions exist.

### Diagnostic Codes

The Sensing and Diagnostic Module (SDM) maintains a history record of all diagnostic codes that have been detected since the SRS codes were last cleared during service.

1. Active Codes—Faults that are presently detected this ignition cycle. Active codes are stored in Random Access Memory (RAM).
2. History Codes—All faults detected since the last time the history fault memory was cleared. History codes are stored in Electronically Erasable Programmable Read only Memory (EEPROM).

### How To Read Trouble Codes

All codes (Active and history) can be read (or cleared) by using a scan tool or equivalent.

If a Diagnostic Trouble Code (DTC) is not available, have the vehicle serviced by dealer.

### How To Clear Trouble Codes

Trouble codes can only be cleared by using a scan tool. If a scan tool is not available then inform the owner of the stored codes and suggest that the codes are cleared upon the next visit to a dealership.

### Scan Tool Diagnostics

A scan tool can be used to read current and history codes and to clear all history codes after a repair is complete. The scan tool must be updated to communicate with the SRS through a replaceable cartridge for SRS diagnostics. To use the scan tool, connect it to the Data Link Connector (DLC) and turn the ignition switch “ON”. Then follow the manufacturer’s directions for communication with the SRS. The scan tool reads serial data from the Sensing and Diagnostic Module (SDM) “Serial Data” output (terminal 24) to the DLC.

### Basic Knowledge Required

Before using this section of the Service Manual, there is some basic knowledge which will be required. Without this knowledge, you will have trouble using the diagnostic procedures in this section. Use care to prevent harm or unwanted deployment. Read all cautions in the service manual and on warning labels attached to SRS components.

### Basic Electrical Circuits

You should understand the basic theory of electricity including series and parallel circuits, and understand the voltage drops across series resistors. You should know the meaning of voltage (volts), current (amps), and resistance (ohms). You should understand what happens in a circuit with an open or a shorted wire. You should be able to read and understand a wiring diagram.

## “Flash Code” Diagnostics

Flash code diagnostics can be used to read current codes and to determine if history codes are present but cannot be used to clear codes or read history codes. Flash code diagnostics is enabled by grounding terminal 13 shorting to terminal 4 of the DLC with the ignition switch “ON”. Grounding terminal 13 of the DLC pulls the “Diagnostics Request” input (Terminal 1) of the SDM low and signals the SDM to enter the flash code diagnostic display mode.

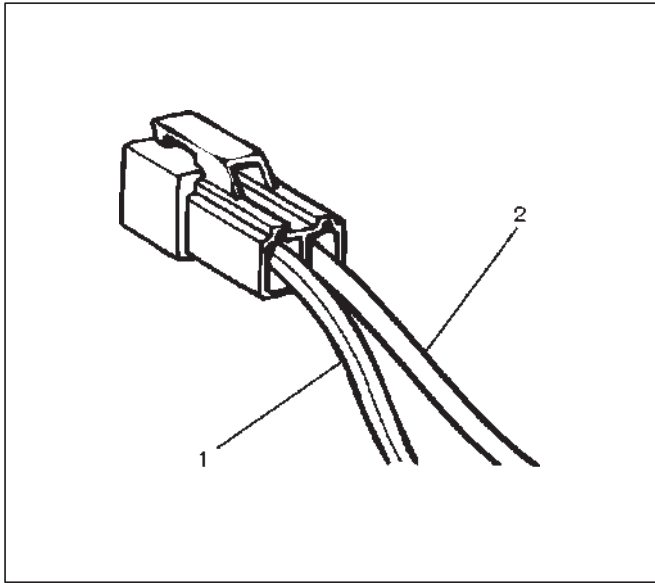
The SDM displays the trouble codes by flashing the warning lamp. Each code that is displayed will consist of a number of flashes which represents the tens digit, a 1.2 second pause, following by a number of flashes which represents the ones digit of the code. Each code is displayed one time before moving on to the next code. After all of the codes have been displayed, the entire code sequence will continually be repeated until ground is removed from terminal 13 of the DLC.

Two special codes exist when reading in the flash code mode (Flash Code 12 and Flash Code 13). “Flash Code 12” will always be the first code displayed when the flash code mode is enabled. Code 12 is not an indication of a SRS problem but an indication that the flash code mode has been enabled. If there are no current or history codes present, the SDM will display code 12 until ground is removed from the DLC at terminal 13. “Flash Code 13” will be displayed if there are history codes. To read the history codes, a scan tool must be used.

## Parts For Electrical Circuit

### Wiring

#### Wire Color

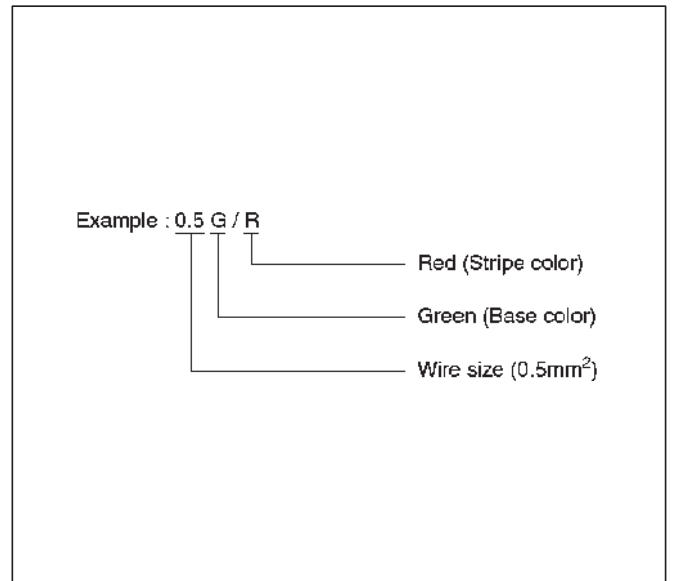


D08RX174

#### Legend

- (1) Colored Stripe
- (2) Single Color

All wires have color-coded insulation. Wires belonging to a system's main harness will have a single color. Wires belonging to a system's sub-circuits will have a colored stripe. Striped wires use the following code to show wire size and colors.



D08RX175

Abbreviations are used to indicate wire color within a circuit diagram. Refer to the following table.

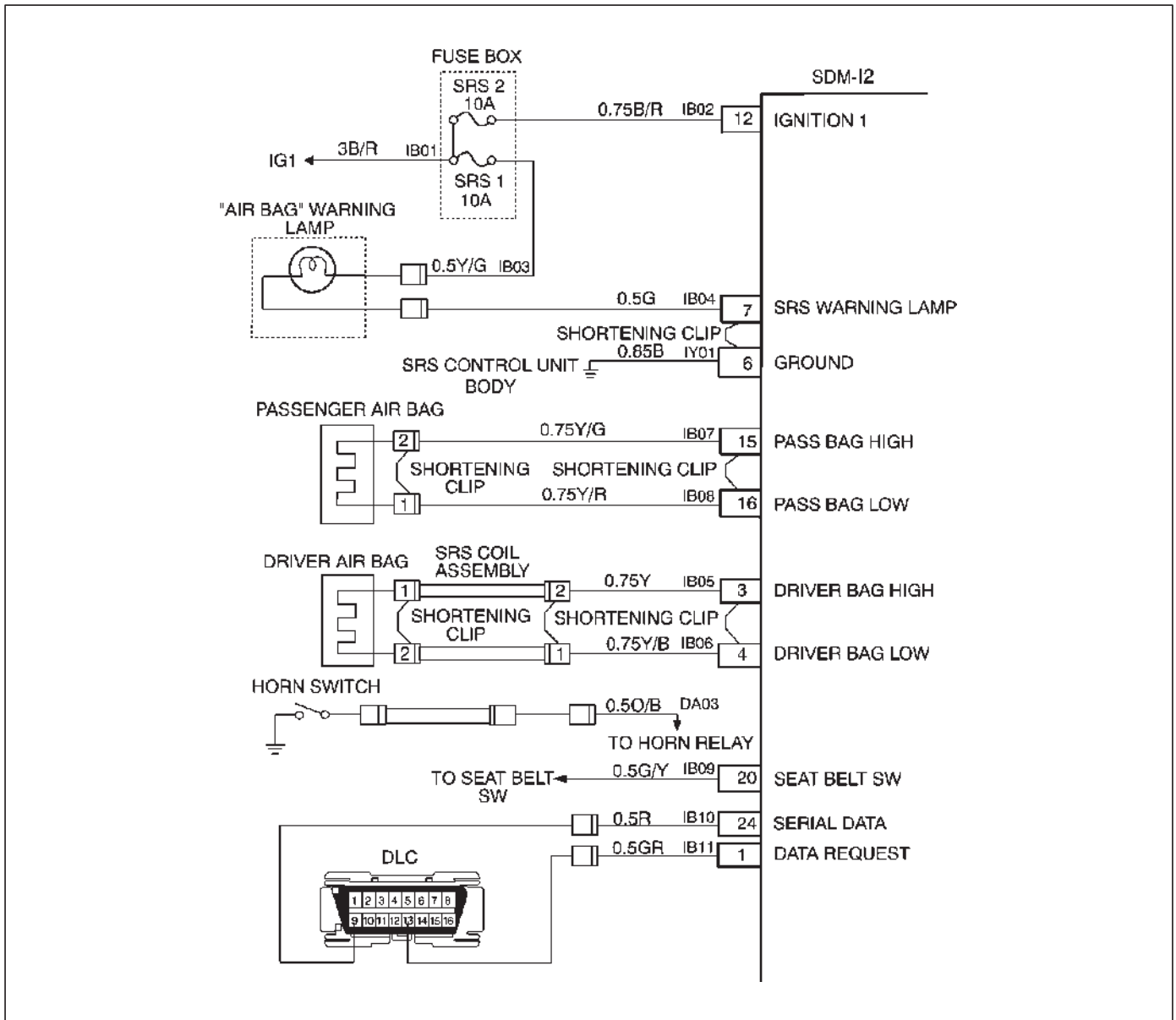
#### Wire Color Coding

Color-coding	Meaning	Color-coding	Meaning
B	Black	BR	Brown
W	White	LG	Light green
R	Red	GR	Grey
G	Green	P	Pink
Y	Yellow	LB	Light blue
L	Blue	V	Violet
O	Orange		

#### Distinction of Circuit by Wire Base Color

Base color	Circuits	Base color	Circuits
B	Starter circuit and grounding circuit	Y	Instrument circuit
W	Charging circuit	L, O, BR, LG, GR, P, SB, V	Other circuit
R	Lighting circuit		
G	Signal circuits		

## System Schematic



D09RX001

## SRS Diagnostic System Check

The diagnostic procedures used in this section are designed to find and repair Supplemental Restraint System (SRS) malfunctions. To get the best results, it is important to use the diagnostic charts and follow the sequence listed below:

- A. Perform the "SRS Diagnostic System Check."
 

The "SRS Diagnostic System Check" must be the starting point of any SRS diagnostics. The "SRS Diagnostic System Check" checks for proper "AIR BAG" warning lamp operation, the ability of the Sensing and Diagnostic Module (SDM) to communicate through the "Serial Data" line and whether SRS diagnostic trouble codes exist.
- B. Refer to the proper diagnostic chart as directed by the "SRS Diagnostic System Check."
 

The "SRS Diagnostic System Check" will lead you to the correct chart to diagnose any SRS malfunctions. Bypassing these procedures may result in extended

diagnostic time, incorrect diagnosis and incorrect parts replacement.

- C. Repeat the "SRS Diagnostic System Check" after any repair or diagnostic procedures have been performed.

Performing the "SRS Diagnostic System Check" after all repair or diagnostic procedures will ensure that the repair has been made correctly and that no other malfunctions exist

## Circuit Description

When the ignition switch is first turned "ON", "ignition 1" voltage is applied from the "SRS-2" fuse to the SDM at the "ignition 1" input terminals "12". The SDM responds by flashing the "AIR BAG" warning lamp seven times while performing tests on the SRS.

### Notes On System Check Chart:

Number(s) below refer to step number(s) on the "Supplemental Restraint System Diagnostic System Check" chart.

1. The "AIR BAG" warning lamp should flash seven times after ignition is first turned "ON."
2. After the "AIR BAG" warning lamp flashes seven times, it should turn "OFF."
3. Improper operation of the "AIR BAG" warning lamp is indicated. This test differentiates a warning lamp stays "ON" condition from a warning lamp does not come "ON" condition.
4. This test checks for the proper operation of the "Serial Data" line. This test will also determine whether history diagnostic trouble codes are stored and, if so, identify them.
5. This test checks for proper operation of the "Serial Data" line. This test will also identify the stored diagnostic trouble codes and whether they are current or history.

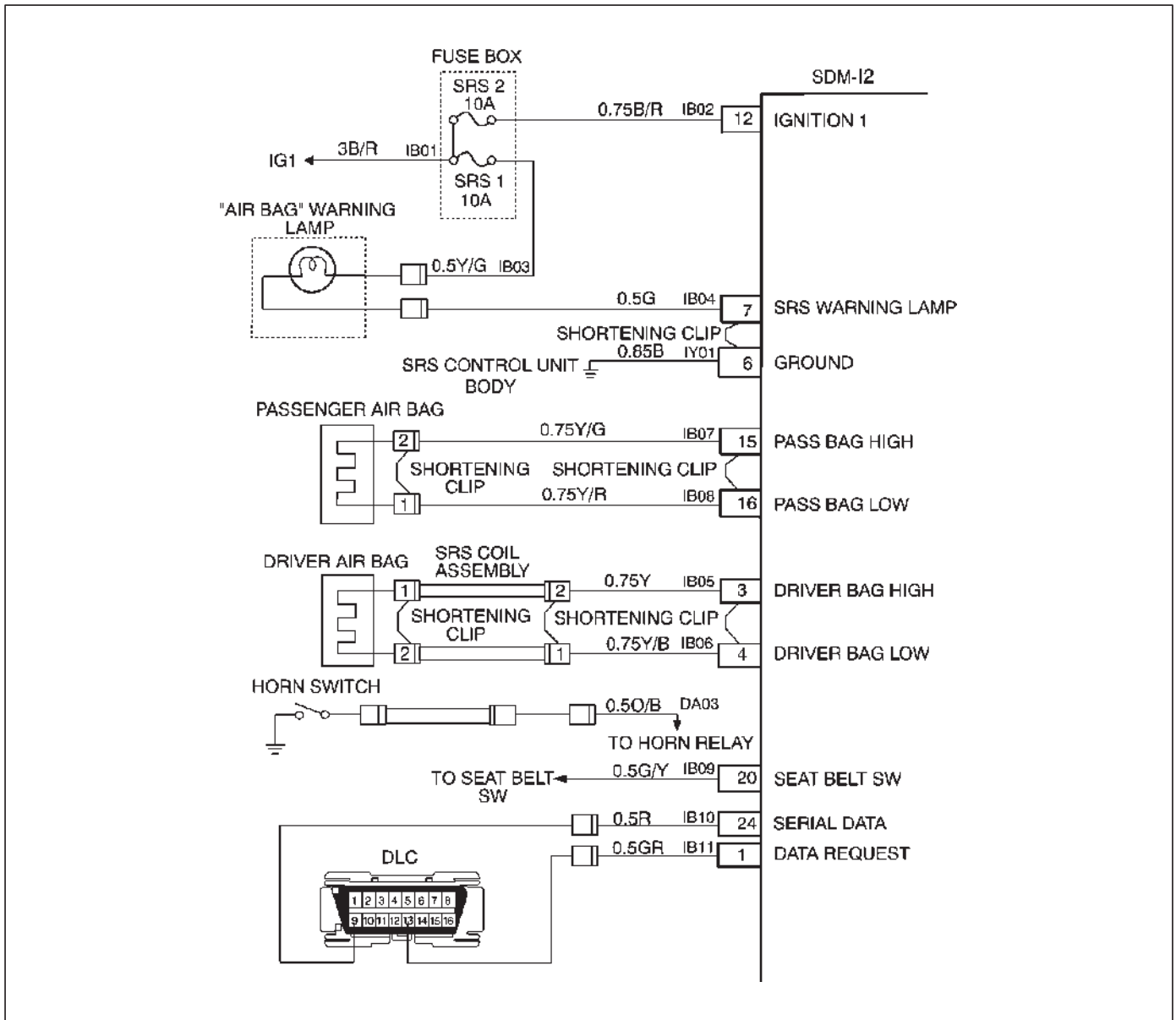
### Diagnostic Aids:

The order in which diagnostic trouble codes are diagnosed is very important. Failure to diagnose the diagnostic trouble codes in the order specified may result in extended diagnostic time, incorrect diagnosis and incorrect parts Replacement.

**SRS Diagnostic System Check**

Step	Action	Yes	No
1	Note the "AIR BAG" warning lamp when ignition switch is turned "ON." Does the "AIR BAG" warning lamp flash seven (7) times?	Go to Step 2	Go to Step 3
2	Note the "AIR BAG" warning lamp after it flashed 7 times. Does the "AIR BAG" warning lamp go "OFF"?	Go to Step 4	Go to Step 5
3	Note the "AIR BAG" warning lamp when ignition switch is turned "ON." Does the "AIR BAG" warning lamp come "ON" steady?	Go to Chart B.	Go to Chart C.
4	1. Ignition switch "OFF." 2. Connect a scan tool to data link connector. 3. Follow direction given in the scan tool instruction manual. 4. Ignition switch "ON." 5. Request the SRS diagnostic trouble code display recode all history diagnostic trouble code(s) specify as such, on repair order.  Is diagnostic trouble code(s) displayed?	Ignition switch "OFF."  When DTC 71 is set, go to DTC 71 chart.  For all other history codes refer to "Diagnostics Aids" for that specific DTC.  A history DTC indicates the malfunction has been repaired or is intermittent.	SRS is functional and free of malfunctions, no further diagnosis is required.  If scan tool indicates "No Data Received," refer to chassis electrical section.
5	1. Ignition switch "OFF." 2. Connect a scan tool to data link connector. 3. Follow directions as given in the scan tool instruction manual. 4. Ignition switch "ON." 5. Request the SRS diagnostic trouble code display, recode all diagnostic trouble code(s), specifying as current or history on repair order.  Is diagnostic trouble code(s) displayed?	Ignition switch "OFF."  When DTC 53 is set, go to DTC 53 chart.  When DTC 51 is set, go to DTC 51 chart.  When DTC 19 is set, go to DTC 19 chart.  When DTC 25 is set, go to DTC 25 chart.  Diagnose remaining current DTCs from lowest to highest. When only history DTCs exist, Refer to "Diagnostics Aids" for that specific DTC.  A history DTC indicates the malfunction has been repaired or is intermittent.	If scan tool indicates "No Data Received," refer to chassis electrical section.

Chart A SDM Integrity Check



D09RX001

**Circuit Description:**

When the Sensing and Diagnostic Module (SDM) recognizes "ignition 1" voltage, applied to terminals "12", is greater than 9 volts, the "AIR BAG" warning lamp is flashed 7 times to verify operation. At this time the SDM performs "Turn-ON" tests followed by "Continuous Monitoring" tests. When a malfunction is detected, the SDM sets a current diagnostic trouble code and illuminates the "AIR BAG" warning lamp. The SDM will clear current diagnostic trouble codes and move them to a history file when the malfunction is no longer detected and/or the ignition switch is cycled, except for Diagnostic Trouble Codes (DTCs) 51, 53 and 71. DTC 71 can only be cleared using a scan tool "Clear Codes" command in case that the malfunction on DTC 71 has been solved and no DTCs 51 and 53 were remained. DTCs 51, 53 and 71 can not be cleared after a "Clear Codes" command is issued.

**Chart Test Description:**

Number(s) below refer to step number(s) on the diagnostic chart:

1. This test confirms a current malfunction. If no current malfunction is occurring (history DTC set) the "Diagnostic Aids" for the appropriate diagnostic trouble code should be referenced. The SDM should not be replaced for a history diagnostic trouble code.
2. This test checks for a malfunction introduced into the SRS during the diagnostic process. It is extremely unlikely that a malfunctioning SDM would cause a new malfunction to occur during the diagnostic process.
3. When all circuitry outside the SDM has been found to operate properly, as indicated by the appropriate diagnostic chart, then and only then should the SDM be replaced.

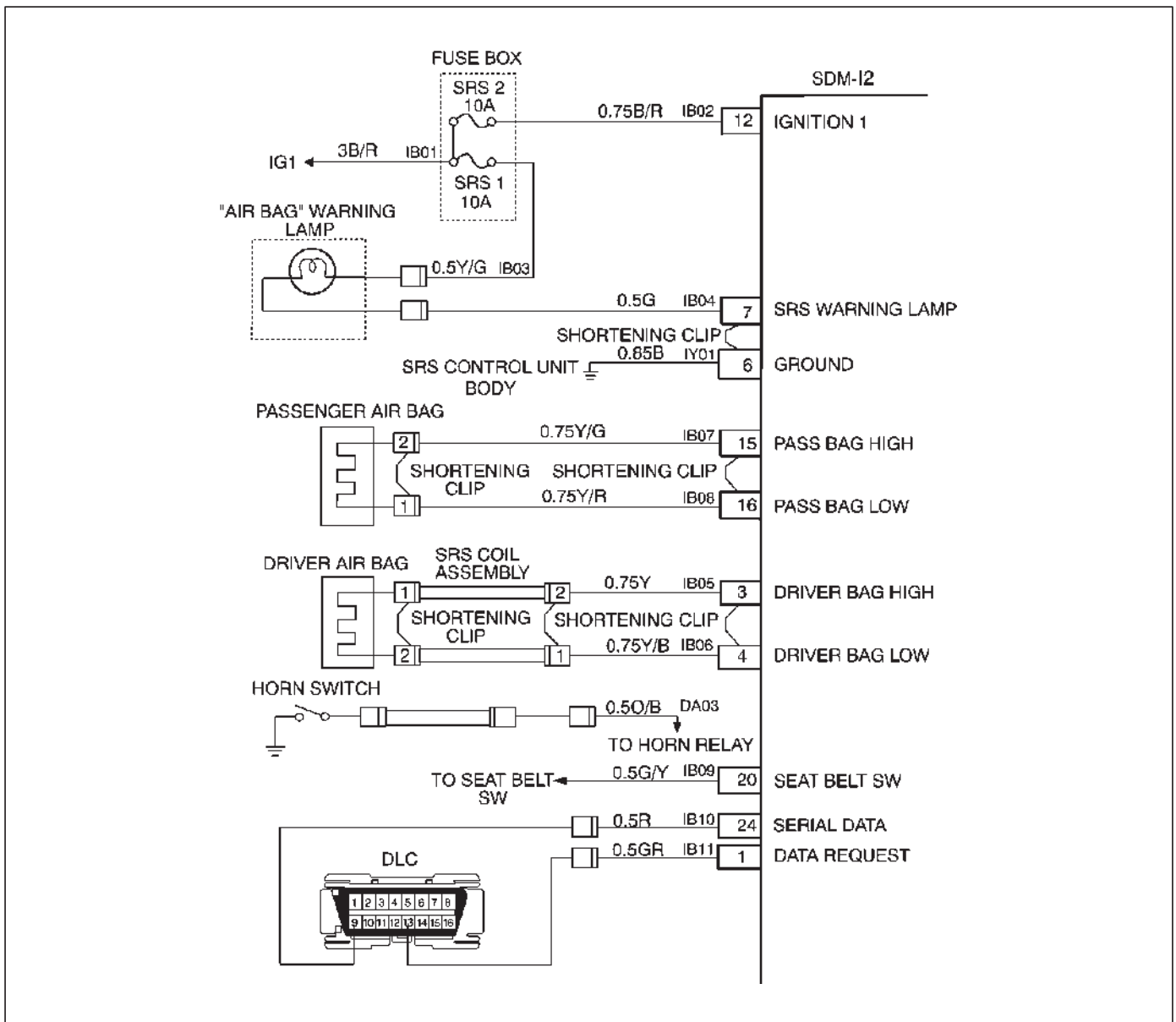


**Chart A SDM Integrity Check**

**WARNING: DURING SERVICE PROCEDURES. BE VERY CAREFUL WHEN HANDLING A SENSING AND DIAGNOSTIC MODULE (SDM). NEVER STRIKE OR JAR THE SDM. NEVER POWER UP THE SRS WHEN THE SDM IS NOT RIGIDLY ATTACHED TO THE VEHICLE. ALL SDM AND MOUNTING BRACKET FASTENERS MUST BE CAREFULLY TORQUED AND THE ARROW MUST BE POINTING TOWARD THE FRONT OF THE VEHICLE TO ENSURE PROPER OPERATION OF THE SRS. THE SDM COULD BE ACTIVATED WHEN POWERED WHILE NOT RIGIDLY ATTACHED TO THE VEHICLE WHICH COULD CAUSE DEPLOYMENT AND RESULT IN PERSONAL INJURY.**

Step	Action	Yes	No
1	1. This chart assumes that the "SRS Diagnostic System Check" and either a symptom chart or a diagnostic trouble code chart diagnosis have been performed. When all circuitry outside the SDM has been found to operate properly, as indicated by the appropriate diagnostic chart, and the symptom or DTC remains current, the following diagnostic procedures must be performed to verify the need for SDM Replacement. 2. Ignition switch "OFF." 3. Reconnect all SRS components, ensure all components are properly mounted. 4. Ensure the ignition switch has been "OFF" for at least 15 seconds. 5. Note "AIR BAG" warning lamp as ignition switch is turned "ON."  Does warning lamp flash 7 times then go "OFF"?	The symptom or DTC is no longer occurring. Clear SRS diagnostic trouble codes. Repeat the "SRS Diagnostic System Check."	Go to Step 2
2	Using a scan tool, request diagnostic trouble code display.  Is the same symptom or DTC occurring as was when the "SRS Diagnostic System Check" was first performed?	Ignition switch "OFF."  Go to the appropriate chart for the indicated malfunction.	Go to Step 3
3	1. Clear "SRS Diagnostic Trouble Codes." 2. Ignition switch "OFF" for at least two minutes. 3. Note "AIR BAG" warning lamp as ignition switch is turned "ON."  Does warning lamp flash 7 times then go "OFF"?	SRS is functional and free of malfunctions.  No further diagnosis is required. Go to Step 4	Ignition switch "OFF." Replace SDM. Go to Step 4
4	Reconnect all SRS components, ensure all components are properly mounted.  Was this step finished?	Repeat the "SRS Diagnostic System Check."	Go to Step 4

Chart B "AIR BAG" Warning Lamp Comes "ON" Steady



D09RX001

**Circuit Description:**

When the ignition switch is first turned "ON", "ignition 1" voltage is applied from the "SRS-1" fuse to "AIR BAG", warning lamp which is connected to "Supplemental Restraint System (SRS) warning lamp", terminal "7". The "SRS-2" fuses apply system voltage to the "ignition 1" inputs, terminals "12". The Sensing and Diagnostic Module (SDM) responds by flashing the "AIR BAG" warning lamp 7 times. If "ignition 1" voltage is less than 9 volts, the "AIR BAG" warning lamp will come "ON" solid with no DTCs set.

**Chart Test Description:**

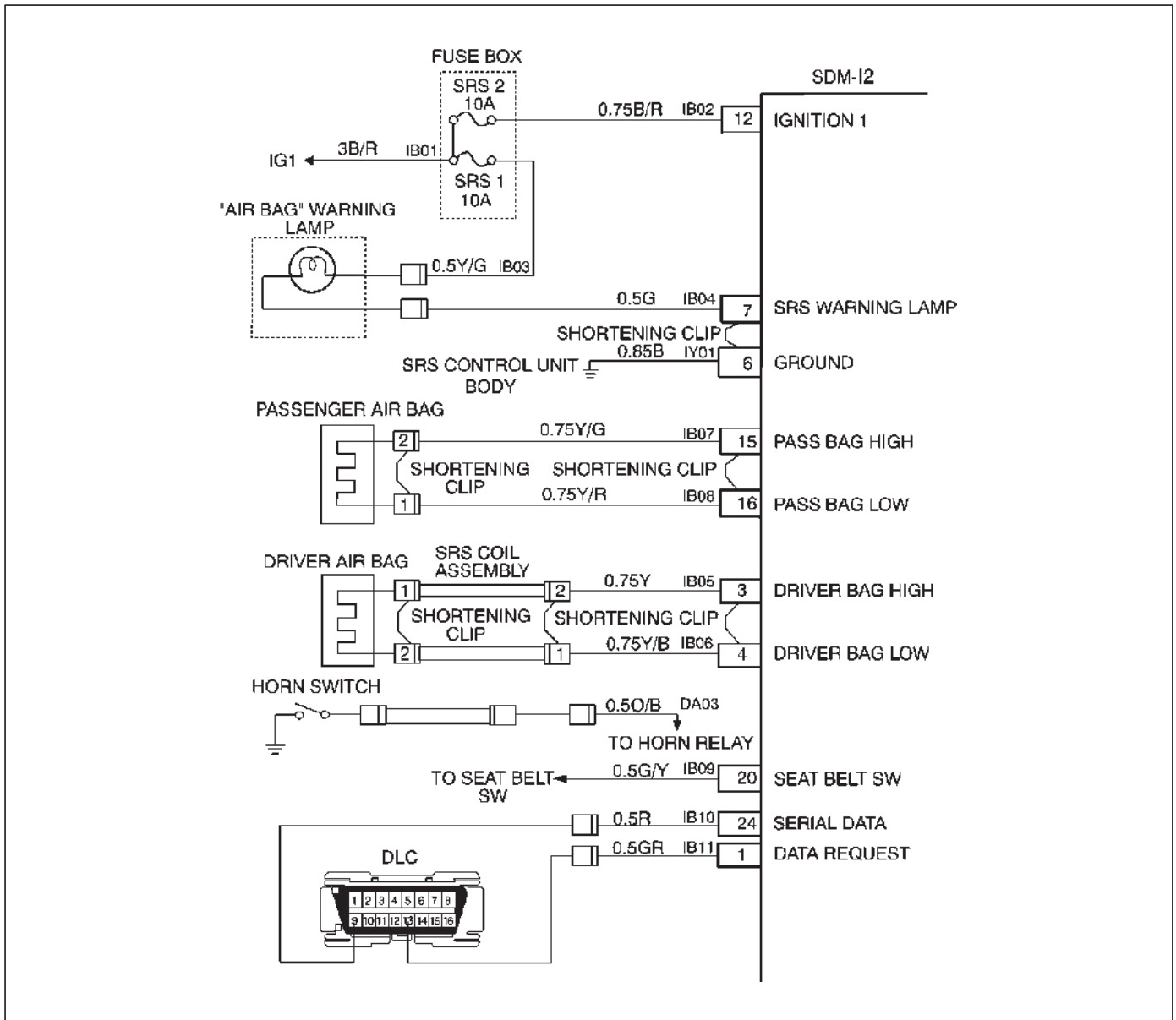
Number (s) below refer to step number (s) on the diagnostic chart.

2. This test checks for an open in the "ignition 1" circuit to the SDM.
3. This test checks for the voltage of "ignition 1."
4. This test determines whether the malfunction is a short to ground in Circuit IB04 – GREEN.

**Chart B “AIR BAG” Warning Lamp Comes “ON” Steady**

Step	Action	Yes	No
1	<p>1. When measurements are requested in this chart use J-39200 DVM with correct terminal adapter from J-35616-A.</p> <p>2. Ignition switch “OFF.”</p> <p>3. Connect scan tool to data link connector, Follow directions as given in the scan tool instruction manual.</p> <p>4. Ignition switch “ON.”</p> <p>5. Request SRS diagnostic trouble code display.</p> <p>Does scan tool indicate “No Data Received”?</p>	Go to Step 2	Go to Step 3
2	<p>1. Ignition switch “OFF.”</p> <p>2. Inspect SDM harness connector connection to SDM.</p> <p>Is it securely connected to the SDM?</p>	<p>Ignition switch “OFF.”</p> <p>Replace SDM.</p> <p>Go to Step 5</p>	<p>Connect SDM securely to de-activate shorting clip in SDM harness connector.</p> <p>Go to Step 5</p>
3	<p>Using scan tool, request SRS data list.</p> <p>Is “ignition” more than 9 volts?</p>	Go to Step 4	<p>Ignition switch “OFF.”</p> <p>Replace SDM.</p> <p>Go to Step 5</p>
4	<p>1. Ignition switch “OFF.”</p> <p>2. Disconnect SRS coil and passenger air bag assemblies. Yellow 2-pin connectors located at base of steering column and behind the glove box assembly.</p> <p>3. Disconnect SDM.</p> <p>4. Measure resistance from SDM harness connector terminal “6” to ground.</p> <p>Does J-39200 display “OL” (infinite)?</p>	Go to Chart A.	<p>Replace SRS harness.</p> <p>Go to Step 5</p>
5	<p>Reconnect all SRS components, ensure all components are properly mounted.</p> <p>Was this step finished?</p>	Repeat the “SRS Diagnostic System Check.”	Go to Step 5

Chart C "AIR BAG" Warning Lamp Does Not Comes "ON" Steady



D09RX001

**Circuit Description:**

When the ignition switch is first turned "ON", "ignition 1" voltage is applied from the "SRS-1" fuse to the "AIR BAG" warning lamp which is connected to "Supplemental Restraint System (SRS) warning lamp", terminal "7". The "SRS-2" fuse apply system voltage to the "ignition 1" inputs, terminals "12". The Sensing and Diagnostic Module (SDM) responds by flashing the "AIR BAG" warning lamp seven times. If "ignition 1" voltage is more than 16 volts, the "AIR BAG" warning lamp will be still "OFF" solid with no DTCs set.

**Chart Test Description:**

Number(s) below refer to step number(s) on the diagnostic chart:

1. This test decides whether power is available to SDM warning lamp power feed circuit.
2. This test determines whether the voltage is present in the warning lamp circuit.
3. This test determines if the malfunction is in the instrument cluster.
4. This test checks for open in the warning lamp circuitry.
5. This test isolates the IB04-GREEN circuit and checks for a short in the IB04-GREEN circuit to B+.
8. This test checks for a short from the SDM warning lamp power feed circuit to ground.
9. This test determines whether the short to ground is due to a short in the wiring.

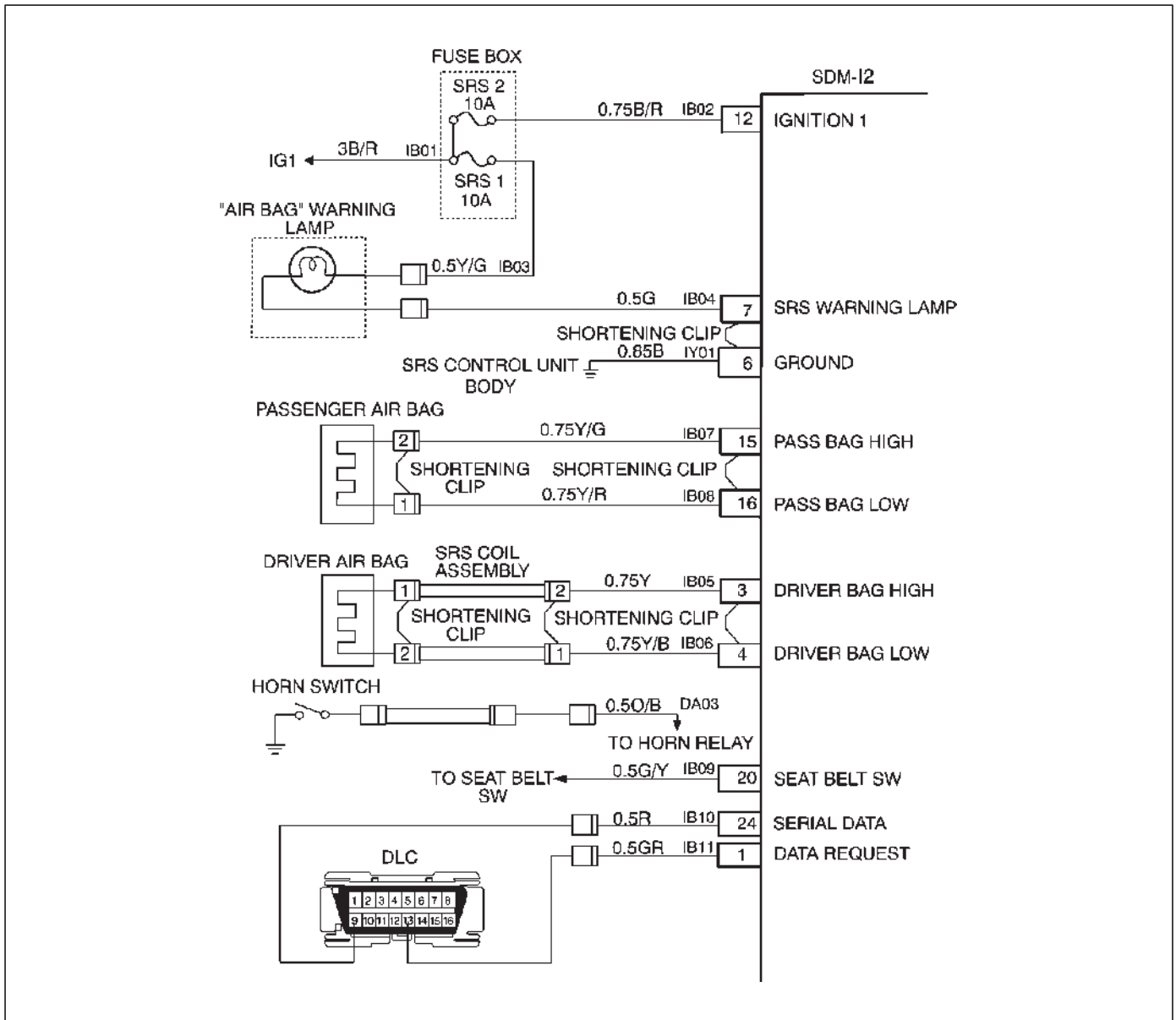
Chart C "AIR BAG" Warning Lamp Does Not Comes "ON" Steady

Step	Action	Yes	No
1	1. When measurements are requested in this chart use J-39200 DVM with correct terminal adapter from J-35616-A. 2. Ignition switch "OFF." 3. Remove and inspect "SRS-1" fuse to the "AIR BAG" warning lamp.  Is fuse good?	Go to Step 2	Go to Step 7
2	1. Ignition switch "OFF." 2. Disconnect SRS coil and passenger air bag assemblies. Yellow 2-pin connectors located at base of steering column and behind the glove box assembly. 3. Disconnect SDM. 4. Ignition switch "ON." 5. Measure voltage on SDM harness connector from terminal "7" to terminal "6" (ground).  Is system voltage present on terminal "7"?	Go to Step 4	Go to Step 3
3	1. Ignition switch "OFF." 2. Remove instrument meter cluster. 3. Check for proper connection to instrument cluster at IB04-GRN terminal. 4. If OK, then remove and inspect "AIR BAG" bulb.  Is bulb good?	Go to Step 5	Replace bulb. Go to Step 6
4	1. Ignition switch "OFF." 2. Disconnect instrument meter cluster harness connector. 3. Ignition switch "ON." 4. Measure voltage on SDM harness connector from terminal "7" to terminal "6" (ground).  Is voltage 1 volt or less?	Go to Chart A.	Replace SRS harness. Go to Step 6
5	1. Install bulb. 2. Measure resistance from instrument meter cluster harness connector IB04-GRN terminal to SDM harness connector terminal "7".  Is resistance 5.0 ohms or less?	Service instrument meter cluster. Go to Step 6	Replace SRS harness. Go to Step 6
6	Reconnect all SRS components, ensure all components are properly mounted.  Was this step finished?	Repeat the "SRS Diagnostic System Check."	Go to Step 6
7	Perform chart C.  Were you sent here from chart C?	Go to Step 8	Go to Step 1
8	1. Replace "SRS-1" meter fuse. 2. Ignition switch "ON" wait 10 seconds then ignition switch "OFF." 3. Remove and inspect "SRS-1" fuse.  Is fuse good?	Install "SRS-1" fuse. Go to Step 10	Go to Step 9

**9J1-14 RESTRAINT CONTROL SYSTEM****Chart C "AIR BAG" Warning Lamp Does Not Comes "ON" Steady (Cont'd)**

<b>Step</b>	<b>Action</b>	<b>Yes</b>	<b>No</b>
9	<ol style="list-style-type: none"><li>1. Disconnect SRS coil and passenger air bag assemblies. Yellow 2-pin connectors located at base of steering column and behind the glove box assembly.</li><li>2. Disconnect SDM.</li><li>3. Replace "SRS-1" fuse.</li><li>4. Ignition switch "ON" wait to 10 seconds.</li><li>5. Ignition switch "OFF".</li><li>6. Remove and inspection "SRS-1" fuse.</li></ol> Is fuse good?	Install "SRS-1" fuse. Go to Chart A.	Replace SRS harness. Replace "SRS-1" fuse. Go to Step 10
10	Reconnect all SRS components, ensure all components are properly mounted. Was this step finished?	Repeat the "SRS Diagnostic System Check."	Go to Step 10

## DTC 15 Passenger Deployment Loop Resistance High



D09RX001

### Circuit Description:

When the ignition switch is turned "ON", the Sensing and Diagnostic Module (SDM) will perform tests to diagnose critical malfunctions within itself. Upon passing these tests "ignition 1", and deployment loop voltages are measured to ensure they are within their respective normal voltage ranges. The SDM then proceeds with the "Resistance Measurement Test". "Passenger Bag Low" terminal "16" is grounded through a resistor and the passenger current source connected to "Passenger Bag High" terminal "15" allows a known amount of current to flow. By monitoring the voltage difference between "Passenger Bag High" and "Passenger Bag Low" the SDM calculates the combined resistance of the passenger air bag assembly, harness wiring Circuits(CKTs) IB07-YELLOW/GREEN and IB08-YELLOW/RED connector terminal contact.

### DTC Will Set When:

The combined resistance of the passenger air bag assembly, harness wiring CKTs IB07-YELLOW/GREEN and IB08-YELLOW/RED, and connector terminal contact is above a specified value. This test is run once each ignition cycle during the "Resistance Measurement Test" when:

- 1.No "higher priority faults" are detected during "Turn-ON."
2. "Ignition 1" voltage is in the specified value.

### Action Taken:

SDM turns "ON" the "AIR BAG" warning lamp and sets a diagnostic trouble code.

### DTC Will Clear When:

The ignition switch is turned "OFF."

## 9J1-16 RESTRAINT CONTROL SYSTEM

---

### DTC Chart Test Description:

Number(s) below refer to step number(s) on the diagnostic chart:

2. This test determines whether the malfunction is in the Sensing and Diagnostic Module (SDM).
3. This test verifies proper connection of the yellow 2-pin connector.
4. This test checks for proper contact and/or corrosion of the yellow 2-pin connector terminals.
5. The test checks for a malfunctioning passenger air bag assembly.
6. This test determines whether the malfunction is due to high resistance in the wiring.

### Diagnostic Aids:

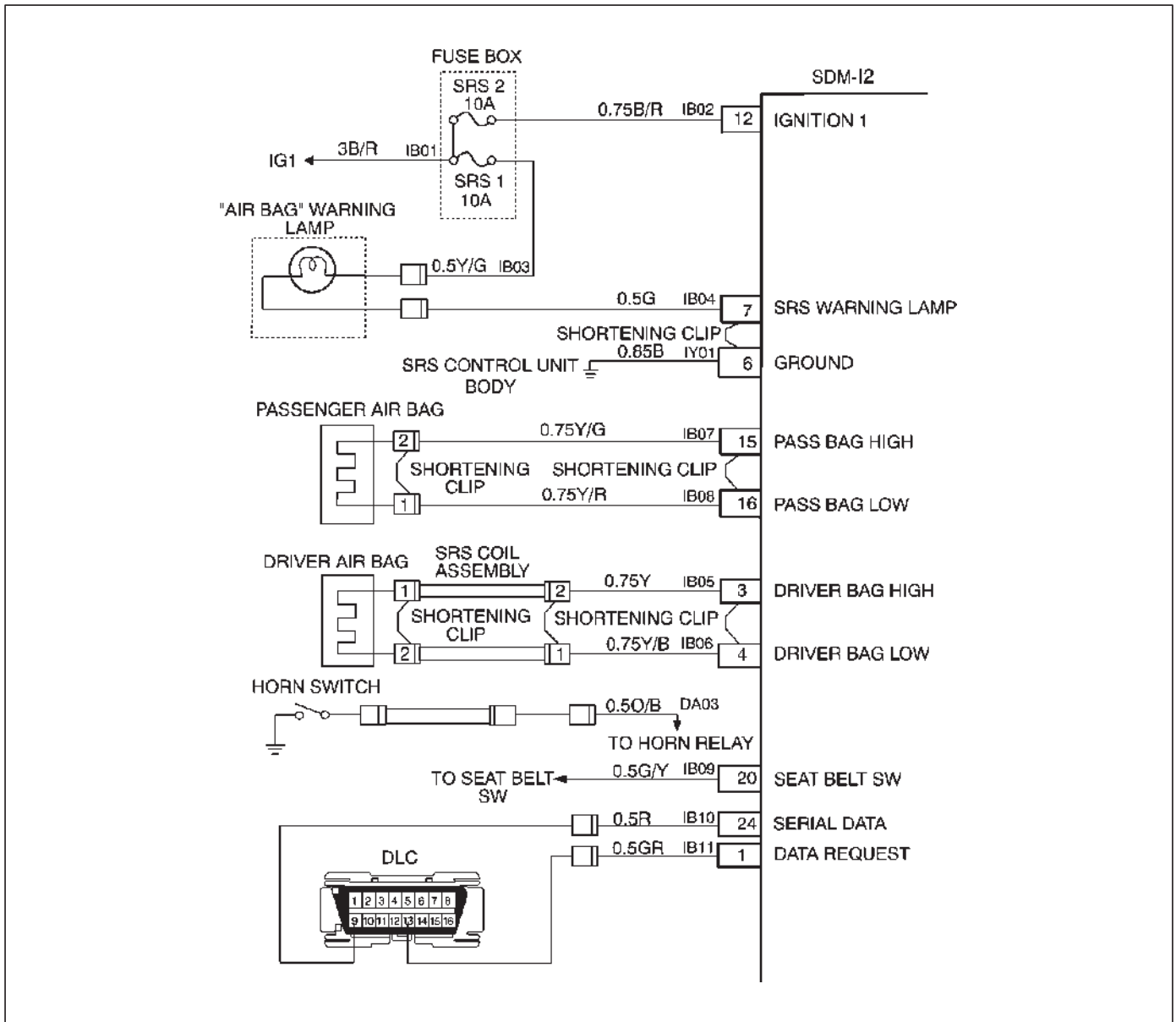
An intermittent condition is likely to be caused by a poor connection at the passenger air bag assembly harness connector terminals "1" and "2", SDM terminal "15" and "16", or a poor wire to terminal connection in Circuits(CKTs) IB07-YELLOW/GREEN and IB08-YELLOW/RED. This test for this diagnostic trouble code is only run while the "AIR BAG" warning lamp is performing the bulb check, unless Diagnostic Trouble Code (DTC) 17 or DTC 26 is detected. When a scan tool "Clear Codes" command is issued and the malfunction is still present, the DTC will not reappear until the next ignition cycle.



**DTC 15 Passenger Deployment Loop Resistance High**

Step	Action	Yes	No
1	Was the "SRS Diagnostic System Check" performed?	Go to Step 2	Go to the "SRS Diagnostic System Check."
2	1. When measurements are requested in this chart use J-39200 DVM with correct terminal adapter from J-35616-A. 2. Use scan tool data list function, read and record the passenger deployment loop resistance.  Is passenger resist more than 2.9 ohms?	Go to Step 3	Go to Chart A.
3	1. Ignition switch "OFF." 2. Make sure the passenger air bag assembly yellow 2-pin connector located behind the glove box assembly is seated properly.  Is the yellow 2-pin connector connected properly?	Go to Step 4	Seat passenger air bag assembly yellow 2-pin connector properly. Go to Step 7
4	1. Disconnect and inspect the passenger air bag assembly yellow 2-pin connector located behind the glove box assembly. 2. If OK, reconnect the passenger air bag assembly 2-pin connector. 3. Ignition switch "ON."  Is DTC 15 current?	Go to Step 5	Ignition switch "OFF." Go to Step 7
5	1. Ignition switch "OFF." 2. Disconnect SRS coil and passenger air bag 2-pin connectors located at the base of the steering column and behind the glove box assembly. 3. Connect J-41433 SRS driver / passenger load tool and appropriate adapters to SRS coil and passenger air bag assembly harness connectors. 4. Ignition switch "ON."  Is DTC 15 current?	Go to Step 6	Ignition switch "OFF." Replace the passenger air bag assembly. Go to Step 7
6	1. Ignition switch "OFF." 2. There has been an increase in the total circuit resistance of the passenger inflator deployment loop. 3. Use the high resolution ohmmeter mode of the DVM while checking CKTs IB07-YEL/GRN and IB08-YEL/RED, and SDM connector terminal "15" and "16" to locate the root cause.  Was a fault found?	Replace SRS harness. Go to Step 7	Go to Chart A.
7	1. Reconnect all components ensure all component are properly mounted. 2. Clear diagnostic trouble codes.  Was this step finished?	Repeat the "SRS Diagnostic System Check."	Go to Step 7

DTC 16 Passenger Deployment Loop Resistance Low



D09RX001

**Circuit Description:**

When the ignition switch is turned "ON", the Sensing and Diagnostic Module (SDM) will perform tests to diagnose critical malfunctions within itself. Upon passing these tests "ignition 1", and deployment loop voltages are measured to ensure they are within their respective normal voltage ranges. The SDM then proceeds with the "Resistance Measurement Test". "Passenger Bag Low" terminal "16" is grounded through a resistor and the passenger current source connected to "Passenger Bag High" terminal "15" allows a known amount of current to flow. By monitoring the voltage difference between "Passenger Bag High" and "Passenger Bag Low", the SDM calculates the combined resistance of the passenger air bag assembly, harness wiring Circuits(CKTs) IB07-YELLOW/GREEN and IB08-YELLOW/RED connector terminal contact.

**DTC Will Set When:**

The combined resistance of the passenger air bag assembly, harness wiring CKTs IB07-YELLOW/GREEN and IB08-YELLOW/RED, and connector terminal contact is above a specified value. This test is run once each ignition cycle during the "Resistance Measurement Test" when:

- 1.No "higher priority faults" are detected during "Turn-ON",
2. "Ignition 1" voltage is in the specified value.

**Action Taken:**

SDM turns "ON" the "AIR BAG" warning lamp and sets a diagnostic trouble code.

**DTC Will Clear When:**

The ignition switch is turned "OFF."

**DTC Chart Test Description:**

Number(s) below refer to step number(s) on the diagnostic chart:

2. This test determines whether the malfunction is in the Sensing and Diagnostic Module (SDM).
3. This test verifies connection of the yellow 2-pin connector.
4. This test checks for proper operation of the shorting clip in the yellow 2-pin connector.
5. The test checks for a malfunction passenger air bag assembly.
6. This test determines whether the malfunctioning is due to shorting in the wiring.

**Diagnostic Aids:**

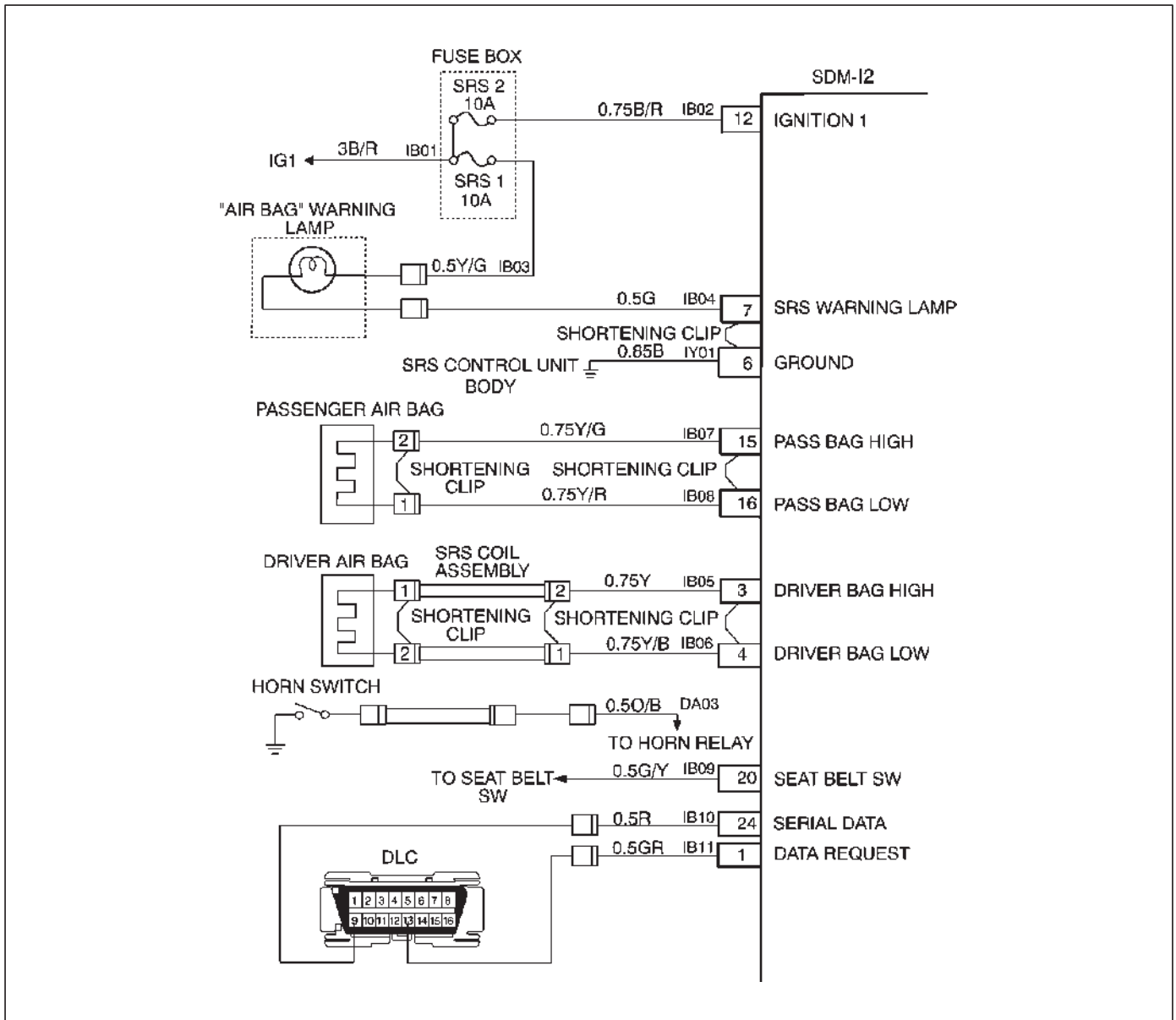
An intermittent condition is likely to be caused by a short between Circuits(CKTs) IB07-YELLOW/GREEN and IB08-YELLOW/RED, or a malfunctioning shorting clip on the passenger air bag assembly which would require replacement of the air bag assembly. The test for this diagnostic trouble code is only run while "AIR BAG" warning lamp is performing the bulb check, unless Diagnostic Trouble Code (DTC) 17 or DTC 26 is detected. When a scan tool "Clear Codes" command is issued and the malfunction is still present, the DTC will not reappear until the next ignition cycle.

**9J1-20 RESTRAINT CONTROL SYSTEM**

**DTC 16 Passenger Deployment Loop Resistance Low**

<b>Step</b>	<b>Action</b>	<b>Yes</b>	<b>No</b>
1	Was the "SRS Diagnostic System Check" performed?	Go to Step 2	Go to the "SRS Diagnostic System Check."
2	1. When measurements are requested in this chart use J-39200 DVM with correct terminal adapter from J-35616-A. 2. Using scan tool data list function, read and record the passenger deployment loop resistance.  Is passenger resist. less than 1.4 ohms?	Go to Step 3	Go to Chart A.
3	1. Ignition switch "OFF." 2. Make sure the passenger air bag assembly yellow 2-pin connector located behind the glove box assembly is seated properly.  Is the yellow 2-pin connector connected properly?	Go to Step 4	Seat passenger air bag assembly yellow 2-pin connector properly. Go to Step 7
4	1. Disconnect and inspect the passenger air bag assembly yellow 2-pin connector located behind the glove box assembly. 2. If OK, reconnect the passenger air bag assembly 2-pin connector. 3. Ignition switch "ON."  Is DTC 16 current?	Go to Step 5	Ignition switch "OFF."Go to Step 7
5	1. Ignition switch "OFF." 2. Disconnect SRS coil and passenger air bag 2-pin connectors located at the base of the steering column and behind the glove box assembly. 3. Connect J-41433 SRS driver / passenger load tool and appropriate adapters to SRS coil and passenger air bag assembly harness connectors. 4. Ignition switch "ON."  Is DTC 16 current?	Go to Step 6.	Ignition switch "OFF." Replace the passenger air bag assembly. Go to Step 7
6	1. Ignition switch "OFF." 2. There has been a decrease in the total circuit resistance of the passenger inflator deployment loop. 3. Use the high resolution ohmmeter mode of the DVM while checking CKTs IB07-YEL/GRN and IB08-YEL/RED, and SDM connector terminal "15" and "16" to locate the root cause.  Was a fault found?	Replace SRS harness. Go to Step 7	Go to Chart A.
7	1. Reconnect all components, ensure all component are properly mounted. 2. Clear diagnostic trouble codes.  Was this step finished?	Repeat the "SRS Diagnostic System Check."	Go to Step 7

## DTC 17 Passenger Deployment Loop Open



D09RX001

### Circuit Description:

When the ignition switch is turned "ON", the Sensing and Diagnostic Module (SDM) will perform tests to diagnose critical malfunctions within itself. Upon passing these tests, "ignition 1", and deployment loop voltages are measured to ensure they are within their respective normal voltage ranges. During "Continuous Monitoring" diagnostics, a fixed amount of current is flowing in the deployment loop. This produces proportional voltage drops in the loop. By monitoring the voltage difference between "Passenger Bag High" and "Passenger Bag Low", the SDM calculates the combined resistance of the passenger air bag assembly, harness wiring Circuits(CKTs) IB07-YELLOW/GREEN and IB08-YELLOW/RED, and connector terminal contact.

### DTC Will Set When:

The voltage difference between "Passenger Bag High" terminal "15" and "Passenger Bag Low" terminal "16" is

above or equal to a specified value for 500 milliseconds during "Continuous Monitoring".

### Action Taken:

SDM turns "ON" the "AIR BAG" warning lamp and sets a diagnostic trouble code.

### DTC Will Clear When:

The voltage difference between "Passenger Bag High" terminal "15" and "Passenger Bag Low" terminal "16" is below a specified value for 500 milliseconds during "Continuous Monitoring".

### DTC Chart Test Description:

Number(s) below refer to step number(s) on the diagnostic chart:

2. This test determines whether the malfunction is in the Sensing and Diagnostic Module (SDM).

## 9J1-22 RESTRAINT CONTROL SYSTEM

3. This test verifies proper connection of the yellow 2-pin connector.
4. This test checks for proper contact and/or corrosion of the shorting clip in the yellow 2-pin connector terminals.
5. The test checks for a malfunctioning passenger air bag assembly.
6. This test determines whether there is an open in the wiring.

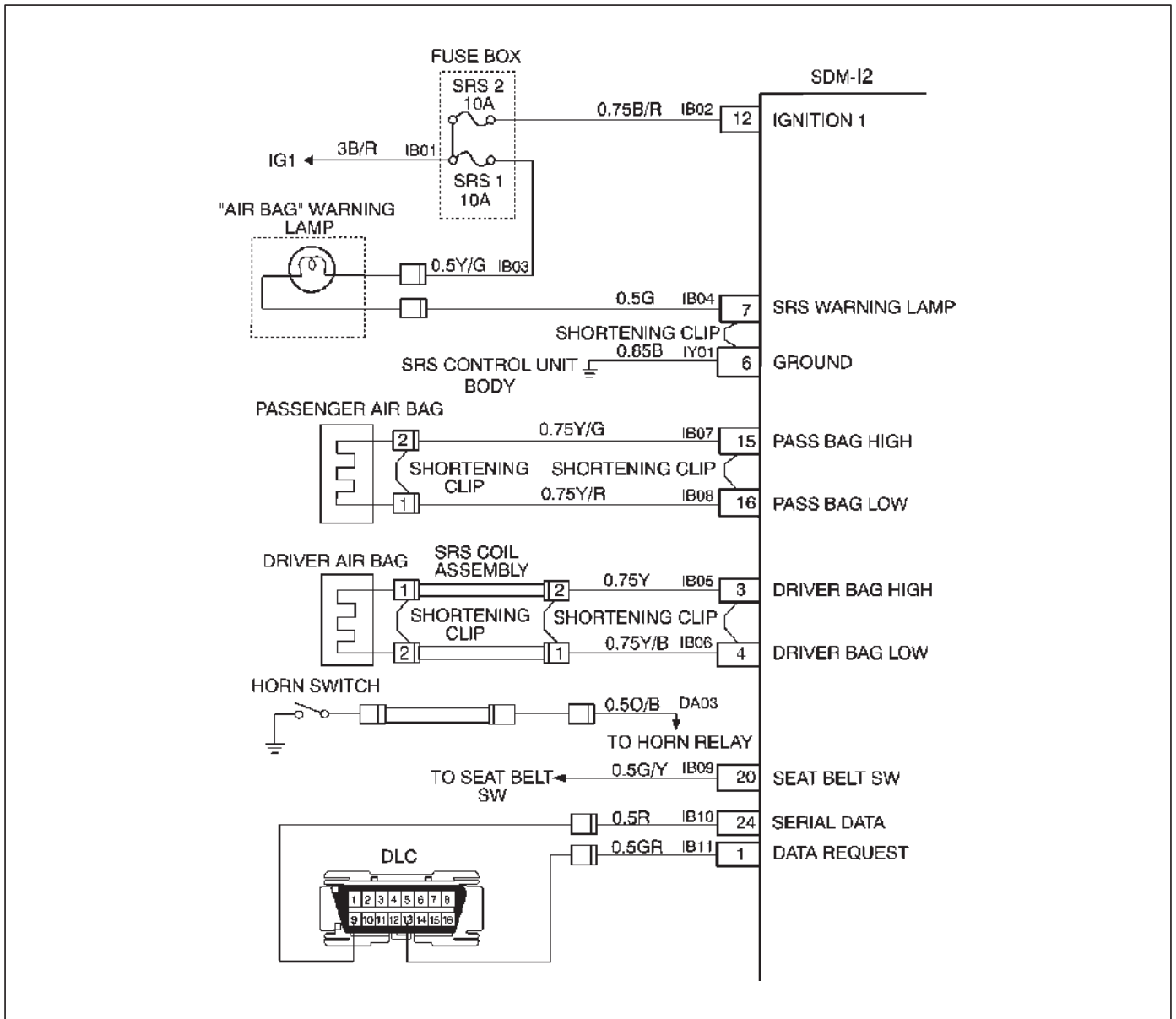
### Diagnostic Aids:

An intermittent condition is likely to be caused by a poor connection at the passenger air bag assembly harness connector terminals "1" and "2," SDM terminals "15" and "16," or an open in Circuits IB07-YELLOW/GREEN and IB08-YELLOW/RED.

### DTC 17 Passenger Deployment Loop Open

Step	Action	Yes	No
1	Was the "SRS Diagnostic System Check" performed?	Go to Step 2	Go to the "SRS Diagnostic System Check."
2	1. When measurements are requested in this chart use J-39200 DVM with correct terminal adapter from J-35616-A. 2. Using scan tool data list function, read and record the passenger differential voltage.  Is passenger differential voltage. more than 4.25 volts?	Go to Step 3	Go to Chart A.
3	1. Ignition switch "OFF." 2. Make sure the passenger air bag assembly yellow 2-pin connector located behind the glove box assembly is seated properly.  Is the yellow 2-pin connector connected properly?	Go to Step 4	Seat passenger air bag assembly yellow 2-pin connector properly. Go to Step 7
4	1. Disconnect and inspect the passenger air bag assembly yellow 2-pin connector located behind the glove box assembly. 2. If OK, reconnected the passenger air bag assembly yellow 2-pin connector. 3. Ignition switch "ON."  Is DTC 17 current?	Go to Step 5	Ignition switch "OFF." Go to Step 7
5	1. Ignition switch "OFF." 2. Disconnect SRS coil and passenger air bag assembly yellow 2-pin connectors located at the base of the steering column and behind the glove box assembly. 3. Connect J-41433 SRS driver / passenger load tool and appropriate adapters to SRS coil and passenger air bag assembly harness connectors. 4. Ignition switch "ON."  Is DTC 17 current?	Go to Step 6	Ignition switch "OFF." Replace the passenger air bag assembly. Go to Step 7
6	1. Ignition switch "OFF." 2. There has been an open circuit in the passenger inflator deployment loop. 3. Use the high resolution ohmmeter mode of the DVM while checking CKTs IB07-YEL/GRN and IB08-YEL/RED, and SDM connector terminal "15" and "16" to locate the root cause.  Was a fault found?	Replace SRS harness. Go to Step 7	Go to Chart A.
7	1. Reconnect all components ensure all component are properly mounted. 2. Clear diagnostic trouble codes.  Was this step finished?	Repeat the "SRS Diagnostic System Check."	Go to Step 7

## DTC 18 Passenger Deployment Loop Short To Ground



D09RX001

### Circuit Description:

When the ignition switch is turned "ON", the Sensing and Diagnostic Module (SDM) will perform tests to diagnose critical malfunctions within itself. Upon passing these tests, "ignition 1", and deployment loop voltages are measured to ensure they are within their respective normal voltage ranges.

The SDM monitors the voltages at "Driver Bag Low" terminal "4" and "Passenger Bag Low" terminal "16" to detect short to ground in the air bag assembly circuits.

### DTC Will Set When:

Neither of the two air bag assemblies is open. "Ignition 1" is within the normal operating voltage range. Once these conditions are met and the voltage at "Passenger Bag Low" is below a specified value, Diagnostic Trouble Code (DTC) 18 will set. This test is run once each ignition cycle and "Continuous Monitoring".

### Action Taken:

SDM turns "ON" the "AIR BAG" warning lamp and sets a diagnostic trouble code.

### DTC Will Clear When:

This malfunction is no longer occurring and the ignition switch is turned "OFF".

### DTC Chart Test Description:

Number(s) below refer to circled number(s) on the diagnostic chart:

2. This test determines whether the SDM is malfunctioning.
3. This test isolates the malfunction to one side of the passenger air bag assembly yellow 2-pin connector behind glove box compartment.
4. This test determines whether the malfunction is in Circuit(CKT) IB07-YELLOW/GREEN.

## 9J1-24 RESTRAINT CONTROL SYSTEM

5. This test determines whether the malfunction is in CKT IB08-YELLOW/RED.

Inspect CKTs IB07-YELLOW/GREEN and IB08-YELLOW/RED carefully for cutting or chafing. If the wiring pigtail of the passenger air bag assembly is damaged, the component must be replaced.

### Diagnostic Aids:

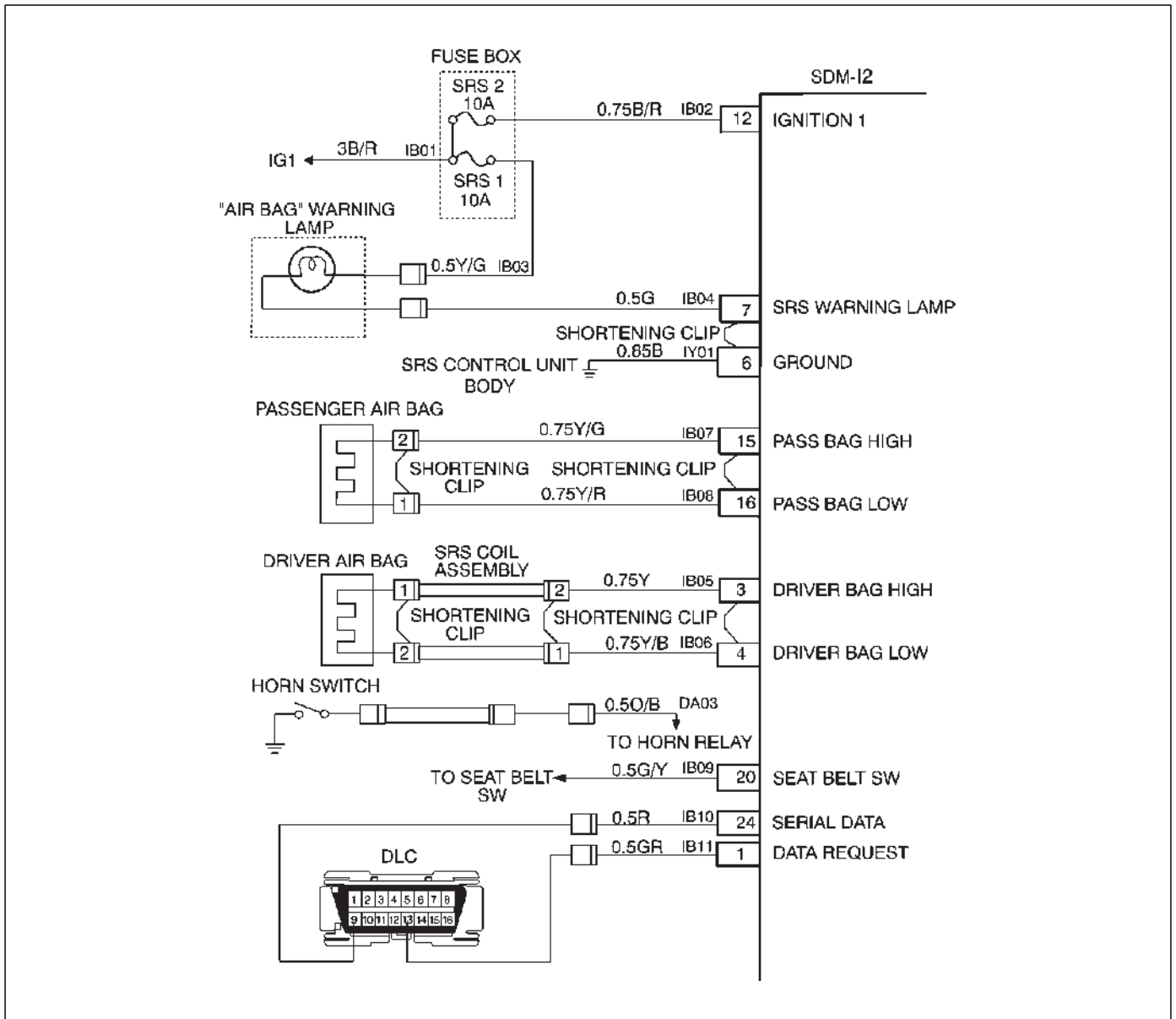
An intermittent condition is likely to be caused by a short to ground in the passenger air bag assembly circuit.

### DTC 18 Passenger Deployment Loop Short To Ground

Step	Action	Yes	No
1	Was the "SRS Diagnostic System Check" performed?	Go to Step 2	Go to the "SRS Diagnostic System Check."
2	<ol style="list-style-type: none"> <li>When measurements are requested in this chart use J-39200 DVM with correct terminal adapter from J-35616-A.</li> <li>Ignition switch "OFF."</li> <li>Connect scan tool data link connector. Follow directions as given in the scan tool operator's manual.</li> <li>Ignition switch "ON."</li> <li>Read passenger sense LO.</li> </ol> Is passenger sense LO less than 1.5 volts?	Go to Step 3	Go to Chart A.
3	<ol style="list-style-type: none"> <li>Ignition switch "OFF."</li> <li>Disconnect passenger air bag assembly yellow 2-pin connector behind the glove box assembly.</li> <li>Leave driver air bag assembly connected. Connect SRS driver / passenger load tool J-41433 and appropriate adapter to passenger air bag assembly harness connector.</li> <li>Ignition switch "ON."</li> </ol> Is DTC 18 current?	Go to Step 4	Ignition switch "OFF." Replace passenger air bag assembly. Go to Step 6
4	<ol style="list-style-type: none"> <li>Ignition switch "OFF."</li> <li>Disconnect SRS driver / passenger load tool.</li> <li>Measure resistance on SDM harness connector from terminal "15" to terminal "6" (ground).</li> </ol> Does J-39200 display "OL" (infinite)?	Go to Step 5	Replace SRS harness. Go to Step 6
5	Measure resistance on SDM harness connector from terminal "6" "16" to terminal (ground). Does J-39200 display "OL" (infinite)?	Go to Chart A.	Replace SRS harness. Go to Step 6
6	<ol style="list-style-type: none"> <li>Reconnect all components, ensure all component are properly mounted.</li> <li>Clear diagnostic trouble codes.</li> </ol> Was this step finished?	Repeat the "SRS Diagnostic System Check."	Go to Step 6



## DTC 19 Passenger Deployment Loop Short To Voltage



### Circuit Description:

When the ignition switch is turned "ON", the Sensing and Diagnostic Module (SDM) will perform tests to diagnose critical malfunctions within itself. Upon passing these tests, "ignition 1", and deployment loop voltages are measured to ensure they are within their respective normal voltage ranges.

The SDM monitors the voltages at "Driver Bag Low" terminal "4" and "Passenger Bag Low" terminal "16" to detect short to B+ in the air bag assembly circuits.

### DTC Will Set When:

"Ignition 1" is within the normal operating voltage range. Once these conditions are met and the voltage at "Passenger Bag Low" is above a specified value, Diagnostic Trouble Code (DTC) 19 will set. This test is run once each ignition cycle and "Continuous Monitoring".

### Action Taken:

SDM turns "ON" the "AIR BAG" warning lamp and sets DTC 19 and also DTC 71.

### DTC Will Clear When:

The SDM is replaced.

### DTC Chart Test Description:

Number(s) below refer to step number(s) on the diagnostic chart:

2. This test determines whether the malfunction is in the SDM.
3. This test isolates the malfunction to one side of the passenger air bag assembly yellow 2-pin connector behind glove box compartment.
4. This test determines whether the malfunction is in Circuit(CKT) IB07-YELLOW/GREEN.

## 9J1-26 RESTRAINT CONTROL SYSTEM

5. This test determines whether the malfunction is in CKT IB08-YELLOW/RED.

### Diagnostic Aids:

An intermittent condition is likely to be caused by a short to B+ in the passenger air bag assembly circuit. Inspect CKTs IB07-YELLOW/GREEN and IB08-YELLOW/RED

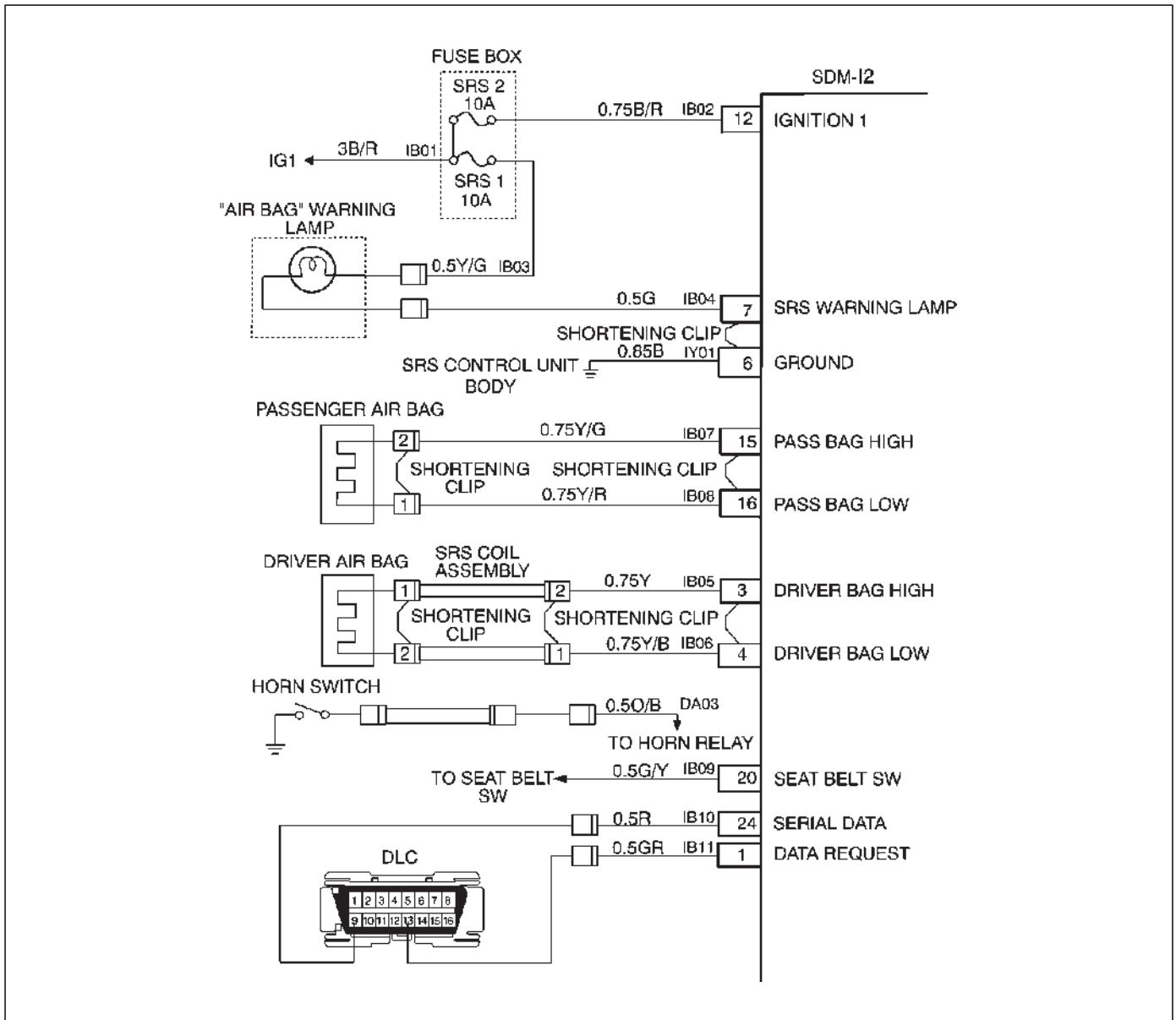
carefully for cutting or chafing. If the wiring pigtail of the passenger air bag assembly is damaged, the component must be replaced. A careful inspection of CKT IB07-YELLOW/GREEN and IB08-YELLOW/RED, including the passenger air bag assembly pigtail is essential to ensure that the replacement Sensing and Diagnostic Module (SDM) will not be damaged.

### DTC 19 Passenger Deployment Loop Short To Voltage

**CAUTION:** When DTC 19 has been set, it is necessary to replace the Sensing and Diagnostic Module (SDM). Setting Diagnostic Trouble Code (DTC) 19 and 25 or 51 or 53 will also cause DTC 71 to set. When a scan tool "CLEAR CODES" command is issued and the malfunction is no longer present, DTC 71 will remain current. Ensure that the short to voltage condition is repaired prior to installing a replacement SDM to avoid damaging the SDM.

Step	Action	Yes	No
1	Was the "SRS Diagnostic System Check" performed?	Go to Step 2	Go to the "SRS Diagnostic System Check."
2	<ol style="list-style-type: none"> <li>When measurements are requested in this chart use J-39200 DVM with correct terminal adapter from J-35616-A.</li> <li>Ignition switch "OFF."</li> <li>Connect scan tool data link connector. Follow directions as given in the scan tool operator's manual.</li> <li>Ignition switch "ON."</li> <li>Read passenger sense LO.</li> </ol> Is passenger sense LO more than 3.5 volts?	Go to Step 3	Go to Chart A.
3	<ol style="list-style-type: none"> <li>Ignition switch "OFF."</li> <li>Disconnect passenger air bag assembly yellow 2-pin connector behind the glove box assembly.</li> <li>Leave driver air bag assembly connected.</li> <li>Connect SRS driver / passenger load tool J-41433 and appropriate adapter to passenger air bag assembly harness connector.</li> <li>Ignition switch "ON."</li> </ol> Is passenger sense LO more than 3.5 volts?	Go to Step 4	Ignition switch "OFF." Replace passenger air bag assembly. Go to Step 6
4	<ol style="list-style-type: none"> <li>Ignition switch "OFF."</li> <li>Disconnect SDM.</li> <li>Disconnect SRS driver / passenger load tool.</li> <li>Measure resistance on SDM harness connector from terminal "15" to terminal "12" (IGNITION 1).</li> </ol> Does J-39200 display "0L" (infinite)?	Go to Step 5	Replace SRS harness. Go to Step 6
5	Measure resistance on SDM harness connector from terminal "16" to terminal "12" (IGNITION 1). Does J-39200 display "0L" (infinite)?	Go to Chart A.	Replace SRS harness. Go to Step 6
6	<ol style="list-style-type: none"> <li>Reconnect all components, ensure all component are properly mounted.</li> <li>Ignition switch "ON."</li> </ol> Is passenger sense LO less than 3.5 volts?	Ignition switch "OFF." Replace SDM. Go to Step 7	Go to Chart A.
7	<ol style="list-style-type: none"> <li>Reconnect all components, ensure all component are properly mounted.</li> <li>Clear diagnostic trouble codes.</li> </ol> Was this step finished?	Repeat the "SRS Diagnostic System Check."	Go to Step 7

## DTC 21 Driver Deployment Loop Resistance High



D09RX001

### Circuit Description:

When the ignition switch is turned "ON", the Sensing and Diagnostic Module (SDM) will perform tests to diagnose critical malfunctions within itself. Upon passing these tests, "ignition 1", and deployment loop voltages are measured to ensure they are within their respective normal voltage ranges.

The SDM then proceeds with the "Resistance Measurement Test" "Driver Bag Low" terminal "4" is grounded through a current sink and the driver current source connected to "Driver Bag High" terminal "3" allows a known amount of current to flow. By monitoring the voltage difference between "Driver Bag High" and "Driver Bag Low", the SDM calculates the combined resistance of the driver air bag assembly, SRS coil assembly, harness wiring Circuits(CKTs) IB05-YELLOW and IB06-YELLOW/BLACK, and connector terminal contact.

### DTC Will Set When:

The combined resistance of the driver air bag assembly, SRS Coil assembly, harness wiring CKTs IB05-YELLOW and IB06-YELLOW/BLACK, and connector terminal contact is above a specified value. This test run once each ignition cycle during the "Resistance Measurement Test" when:

No "higher priority faults" are detected during "Turn-ON"

"Ignition 1" voltage is in the specified value.

### Action Taken:

SDM turns "ON" the "AIR BAG" warning lamp and sets DTC 21.

### DTC Will Clear When:

The ignition switch is turned "OFF".

## 9J1-28 RESTRAINT CONTROL SYSTEM

---

### DTC Chart Test Description:

Number(s) below refer to step number(s) on the diagnostic chart:

2. This test determines whether the malfunction is in the Sensing and Diagnostic Module (SDM).
3. This test verifies proper connection of the yellow 2-pin connector at the base of the steering column.
4. This test checks for proper contact and/or corrosion of the 2-pin connector terminals at the base of steering column.
5. This test isolate the malfunction to one side of the Supplemental Restraint System (SRS) coil assembly yellow 2-pin connector located at the base of the steering column.
6. This test determines whether the malfunction is due to high resistance in the wiring.
7. This test determines whether the malfunction is in the SRS coil assembly or the driver air bag assembly.

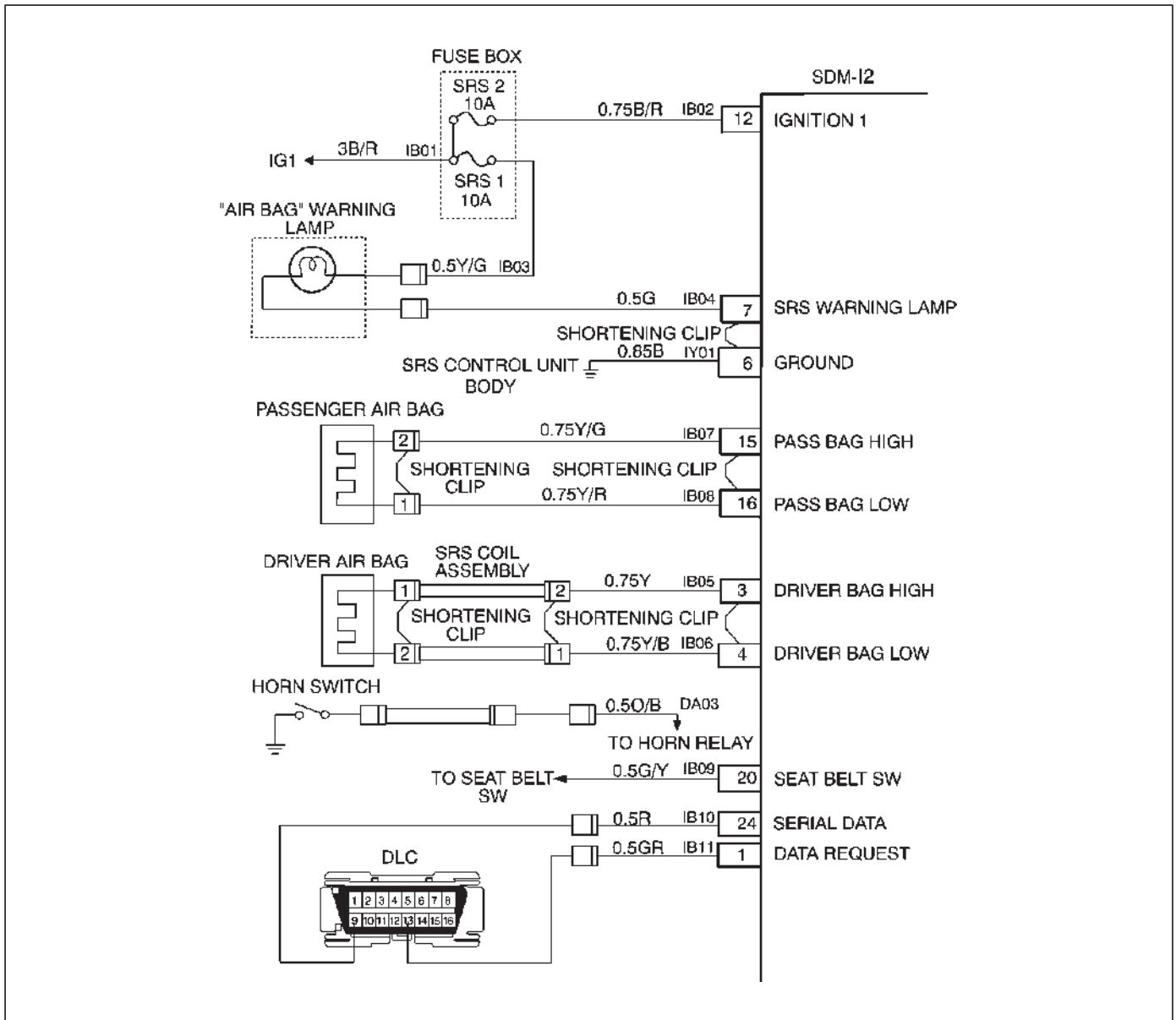
### Diagnostic Aids:

An intermittent condition is likely to be caused by a poor connection at terminals "1" and "2" of the SRS coil 2-pin connector at the base of the steering column, terminal "1" and "2" of the driver air bag assembly 2-pin connector at the top of the steering column, SDM terminals "3" and "4" or a poor wire to terminal connection in Circuit IB05-YELLOW or IB06-YELLOW/BLACK. The test for this diagnostic trouble code is only run while the "AIR BAG" warning lamp is performing the bulb check, unless Diagnostic Trouble Code (DTC) 17 or DTC 26 is detected. When a scan tool "Clear Codes" command is issued and the malfunction is still present, the DTC will not reappear until the next ignition cycle.

**DTC 21 Driver Deployment Loop Resistance High**

Step	Action	Yes	No
1	Was the "SRS Diagnostic System Check" performed?	Go to Step 2	Go to the "SRS Diagnostic System Check."
2	1. When measurements are requested in this chart use J-39200 DVM with correct terminal adapter from J-35616-A. 2. Use scan tool data list function, read and record the driver deployment loop resistance.  Is driver deployment loop resistance more than 4.4 ohms?	Go to Step 3	Go to Chart A.
3	1. Ignition switch "OFF." 2. Disconnect driver air bag assembly yellow 2-pin connector located at base of steering column is seated properly.  Is the 2-pin connector connected properly?	Go to Step 4	Seat SRS coil assembly 2-pin connector properly. Go to Step 8
4	1. Disconnect and inspect the SRS coil assembly yellow 2-pin connector located base of steering column. 2. If OK, reconnect the SRS coil assembly yellow 2-pin connector. 3. Ignition switch "ON."  Is DTC 21 current?	Go to Step 5	Ignition switch "OFF." Go to Step 8
5	1. Ignition switch "OFF." 2. Disconnect SRS coil and passenger air bag assembly yellow 2-pin connectors located at the base of steering column and behind the glove box assembly. 3. Connect SRS driver / passenger load tool J-41433 and appropriate adapter to SRS coil and passenger air bag assembly harness connectors. 4. Ignition switch "ON."  Is DTC 21 current?	Go to Step 6	Go to Step 7
6	1. Ignition switch "OFF." 2. There has been a increase in the total circuit resistance of the driver deployment loop. 3. Use the high resolution ohmmeter mode of the DVM while checking CKTs IB05-YEL/IB06-YEL/BLK, and SDM connector terminal "3" and "4" to locate the root cause.  Was a fault found?	Replace SRS harness. Go to Step 8	Go to Chart A.
7	1. Ignition switch "OFF." Disconnect SRS driver / passenger load tool from SRS coil assembly harness connector. Connect SRS driver / passenger load tool J-41433 on the top of steering column. Reconnect SRS coil assembly harness connector as the base of steering column. Ignition switch "ON."  Is DTC 21 current?	Ignition switch "OFF." Replace SRS COIL ASSEMBLY. Refer to in this section. Go to Step 8	Ignition switch "OFF." Replace driver air bag assembly. Go to Step 8
8	Reconnect all components, ensure all component are properly mounted. Clear diagnostic trouble codes.  Was this step finished?	Repeat the "SRS Diagnostic System Check."	Go to Step 8.

DTC 22 Driver Deployment Loop Resistance Low



D09RX001

**Circuit Description:**

When the ignition switch is turned “ON”, the Sensing and Diagnostic Module (SDM) will perform tests to diagnose critical malfunctions within itself. Upon passing these tests “ignition 1”, and deployment loop voltages are measured to ensure they are within their respective normal voltage ranges. The SDM then proceeds with the “Resistance Measurement Test” “Driver Bag Low” terminal “4” is grounded through a current sink and the driver current source connected to “Driver Bag High” terminal “3” allows a known amount of current to flow. By monitoring the voltage difference between “Driver Bag High” and “Driver Bag Low” the SDM calculates the combined resistance of the driver air bag assembly, Supplemental Restraint System (SRS) coil assembly, harness wiring Circuits(CKTs) IB05–YELLOW and IB06–YELLOW/BLACK and connector terminal contact.

**DTC Will Set When:**

The combined resistance of the driver air bag assembly, SRS coil assembly, harness wiring CKTs IB05–YELLOW and IB06–YELLOW/BLACK and connector terminal contact is above a specified value. This test is run once each ignition cycle during the “Resistance Measurement Test” when:

- 1.No “higher priority faults” are detected during “Turn-ON”
2. “Ignition 1” voltage is in the specified value.

**Action Taken:**

SDM turns “ON” the “AIR BAG” warning lamp and sets DTC 22.

**DTC Will Clear When:**

The ignition switch is turned “OFF.”

**DTC Chart Test Description:**

Number(s) below refer to step number(s) on the diagnostic chart:

2. This test determines whether the malfunction is in the Sensing and Diagnostic Module (SDM).
3. This test verifies proper connection of the yellow 2-pin connector at the base of the steering column.
4. This test checks for proper operation of the shorting clip in the yellow 2-pin connector.
5. This test isolate the malfunction to one side of the Supplemental Restraint System (SRS) coil assembly yellow 2-pin connector located at the base of steering column.
6. This test determines whether the malfunction is due to shorting in the wiring.
7. This test determines whether the malfunction is in the SRS coil assembly or the driver air bag assembly.

**Diagnostic Aids:**

An intermittent condition is likely to be caused by a short between Circuits IB05-YELLOW or IB06-YELLOW/BLACK or a malfunctioning shorting clip on the driver air bag assembly or SRS coil assembly which would require replacement of the component. The test for this diagnostic trouble code is only run while the "AIR BAG" warning lamp is performing the bulb check, unless Diagnostic Trouble Code (DTC) 17 or DTC 26 is detected. When a scan tool "Clear Codes" command is issued and the malfunction is still present, the DTC will not reappear until the next ignition cycle.

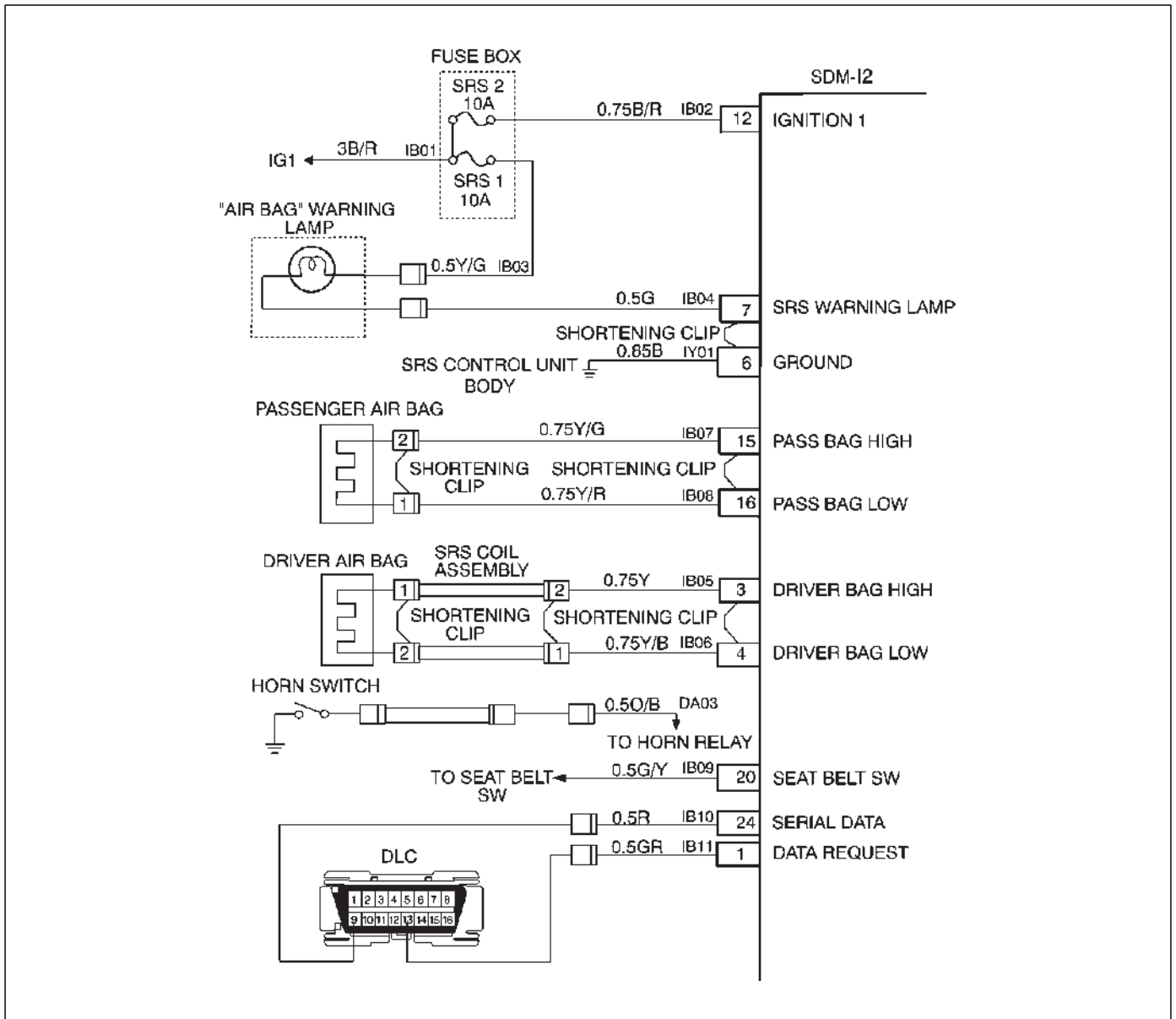
## 9J1-32 RESTRAINT CONTROL SYSTEM

### DTC 22 Driver Deployment Loop Resistance Low

Step	Action	Yes	No
1	Was the "SRS Diagnostic System Check" performed?	Go to Step 2	Go to the "SRS Diagnostic System Check."
2	1. When measurements are requested in this chart use J-39200 DVM with correct terminal adapter from J-35616-A. 2. Use scan tool data list function, read and record the driver deployment loop resistance.  Is driver resist. less than 1.9 ohms?	Go to Step 3	Go to Chart A.
3	1. Ignition switch "OFF." 2. Make sure the SRS coil assembly yellow 2-pin connector located at the base of steering column is seated properly.  Is the 2-pin connector connected properly?	Go to Step 4	Seat driver air bag assembly 2-pin connector properly. Go to Step 8
4	1. Disconnect and inspect the SRS coil assembly yellow 2-pin connector located base of steering column. 2. If OK, reconnect the driver air bag assembly yellow 2-pin connector. 3. Ignition switch "ON."  Is DTC 22 current?	Go to Step 5	Ignition switch "OFF." Go to Step 8
5	1. Ignition switch "OFF." 2. Disconnect SRS coil and passenger air bag 2-pin connectors located at the base of steering column and behind the glove box assembly. 3. Connect SRS driver / passenger load tool J-41433 and appropriate adapter to SRS coil and passenger air bag assembly harness connectors. 4. Ignition switch "ON."  Is DTC 22 current?	Go to Step 6	Go to Step 7
6	1. Ignition switch "OFF." 2. There has been a decrease in the total circuit resistance of the driver deployment loop. 3. Use the high resolution ohmmeter mode of the DVM while checking CKTs IB05-YEL and IB06-YEL/BLK, and SDM connector terminal "3" and "4" to locate the root cause.  Was a fault found?	Replace SRS harness. Go to Step 8	Go to Chart A.
7	1. Ignition switch "OFF." 2. Disconnect SRS driver / passenger load tool from SRS coil assembly harness connector. 3. Connect SRS driver / passenger load tool J-41433 to the top of steering column. 4. Reconnect SRS coil assembly harness connector as the base of steering column. 5. Ignition switch "ON."  Is DTC 22 current?	Ignition switch "OFF." Replace SRS coil assembly. Refer to in this section. Go to Step 8	Ignition switch "OFF." Replace driver air bag assembly. Go to Step 8
8	1. Reconnect all components, ensure all component are properly mounted. 2. Clear diagnostic trouble codes.  Was this step finished?	Repeat the "SRS Diagnostic System Check."	Go to Step 8



## DTC 24 Driver Deployment Loop Short To Ground



D09RX001

### Circuit Description:

When the ignition switch is turned "ON", the Sensing and Diagnostic Module (SDM) will perform tests to diagnose critical malfunctions within itself. Upon passing these tests, "ignition 1", and deployment loop voltages are measured to ensure they are within their respective normal voltage ranges.

The SDM monitors the voltage at "Driver Bag Low" terminal "4" and "Passenger Bag Low" terminal "16" to detect shorts to ground in the air bag assembly circuits.

### DTC Will Set When:

Neither of the two air bag assemblies is open. "Ignition 1" is within the normal operating voltage range. This test is run once each ignition cycle and "Continuous Monitoring". Once these conditions are met and the voltage at "Driver Bag Low" is below a specified value, DTC 24 will set.

### Action Taken:

SDM turns "ON" the "AIR BAG" warning lamp and sets a diagnostic trouble code.

### DTC Will Clear When:

The malfunction is no longer occurring and the ignition is turned "OFF."

### DTC Chart Test Description:

Number(s) below refer to step number(s) on the diagnostic chart:

2. This test determines whether the SDM is malfunctioning
3. This test isolates the malfunction to one side of the Supplemental Restraint System (SRS) coil assembly yellow 2-pin connector at the base of the steering column.
4. This test determines whether the malfunction is in Circuit(CKT) IB05-YELLOW.

## 9J1-34 RESTRAINT CONTROL SYSTEM

5. This test determines whether the malfunction is in CKT IB06-YELLOW/BLACK.
6. This test determines whether the malfunction is in the SRS coil assembly or the driver air bag assembly.

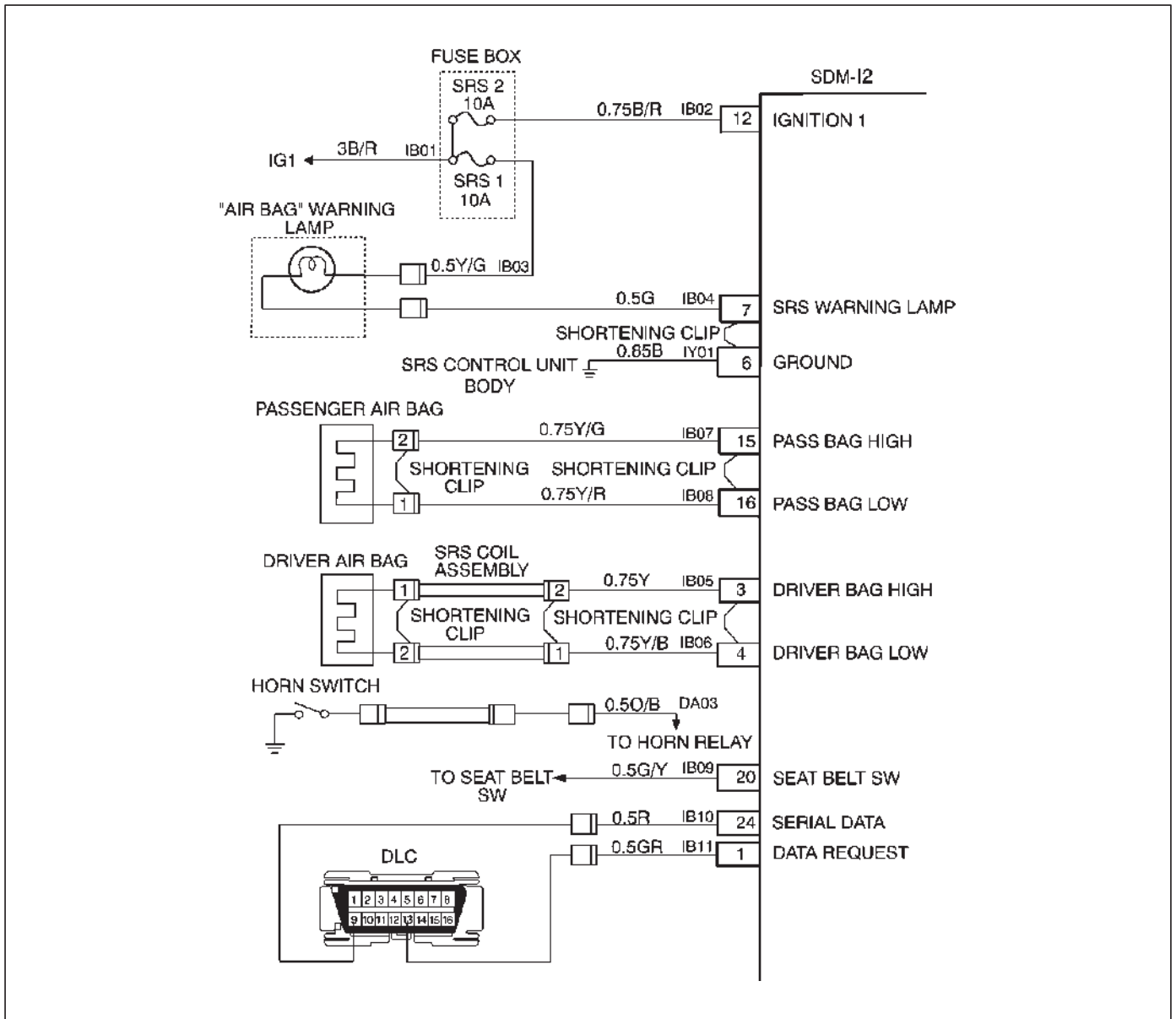
### Diagnostic Aids:

An intermittent condition is likely to be caused by a short to ground in the driver air bag assembly circuit. Inspect CKTs IB05-YELLOW and IB06-YELLOW/BLACK carefully for cutting or chafing.

### DTC 24 Driver Deployment Loop Short To Ground

Step	Action	Yes	No
1	Was the "SRS Diagnostic System Check" performed?	Go to Step 2	Go to the "SRS Diagnostic System Check."
2	<ol style="list-style-type: none"> <li>When measurements are requested in this chart use J-39200 DVM with correct terminal adapter from J-35616-A.</li> <li>Ignition switch "OFF."</li> <li>Connect scan tool data link connector. Follow directions as given in the scan tool operator's manual. Ignition switch "ON."</li> <li>Read driver sense LO.</li> </ol> Is driver sense LO less than 1.5 volts?	Go to Step 3	Go to Chart A.
3	<ol style="list-style-type: none"> <li>Ignition switch "OFF."</li> <li>Disconnect SRS coil assembly yellow 2-pin connector located at base of the steering column. Leave passenger air bag assembly connected.</li> <li>Connect SRS driver / passenger load tool J-41433 and appropriate adapter to SRS coil assembly harness connector.</li> <li>Ignition switch "ON."</li> </ol> Is DTC 24 current?	Go to Step 4	Go to Step 6
4	<ol style="list-style-type: none"> <li>Ignition switch "OFF."</li> <li>Disconnect SDM.</li> <li>Disconnect SRS driver / passenger load tool.</li> <li>Measure resistance on SDM harness connector "3" to terminal "6" (ground).</li> </ol> Does J-39200 display "0L" (infinite)?	Go to Step 5	Replace SRS harness. Go to Step 7
5	Measure resistance on SDM harness connector from terminal "4" to terminal "6" (ground). Does J-39200 display "0L" (infinite)?	Go to Chart A.	Replace SRS harness. Go to Step 7
6	<ol style="list-style-type: none"> <li>Ignition switch "OFF."</li> <li>Disconnect SRS driver / passenger load tool J-41433 from SRS coil assembly harness connector.</li> <li>Connect SRS driver / passenger load tool J-41433 and appropriate adapter J-35616-A to driver air bag assembly harness connector. Located top of the steering column.</li> <li>Reconnect SRS coil assembly harness connector as the base of steering column.</li> <li>Ignition switch "ON."</li> </ol> Is DTC 24 current?	Ignition switch "OFF." Replace SRS coil assembly. Refer to in this section. Go to Step 7	Ignition switch "OFF." Replace driver air bag assembly. Go to Step 7
7	<ol style="list-style-type: none"> <li>Reconnect all components, ensure all component are properly mounted.</li> <li>Clear diagnostic trouble codes.</li> </ol> Was this step finished?	Repeat the "SRS Diagnostic System Check."	Go to Step 7

## DTC 25 Driver Deployment Loop Short To Voltage



D09RX001

### Circuit Description:

When the ignition switch is turned "ON", the Sensing and Diagnostic Module (SDM) will perform tests to diagnose critical malfunctions within itself. Upon passing these tests, "ignition 1", and deployment loop voltages are measured to ensure they are within their respective normal voltage ranges.

The SDM monitors the voltage at "Driver Bag Low" terminal "4" and "Passenger Bag Low" terminal "16" to detect shorts to B+ in the air bag assembly circuits.

### DTC Will Set When:

"Ignition 1" is in the normal operating voltage range. This test is run once each ignition cycle and "Continuous Monitoring". Once these conditions are met and the voltage at "Driver Bag Low" is above a specified value, Diagnostic Trouble Code (DTC) 25 will set.

### Action Taken:

SDM turns "ON" the "AIR BAG" warning lamp and sets DTC 25 and also DTC 71

### DTC Will Clear When:

The SDM is replaced.

### DTC Chart Test Description:

Number(s) below refer to step number(s) on the diagnostic chart:

2. This test determines whether the SDM is malfunctioning.
3. This test isolates the malfunction to one side of the Supplemental Restraint System coil assembly yellow 2-pin connector at the base of steering column.
4. This test determines whether the malfunction is in Circuit(CKT) IB05-YELLOW.

## 9J1-36 RESTRAINT CONTROL SYSTEM

---

5. This test determines whether the malfunction is in CKT IB06-YELLOW/BLACK.
6. This test determines whether the malfunction is in the Supplemental Restraint System (SRS) coil assembly or the driver air bag assembly.

### **Diagnostic Aids:**

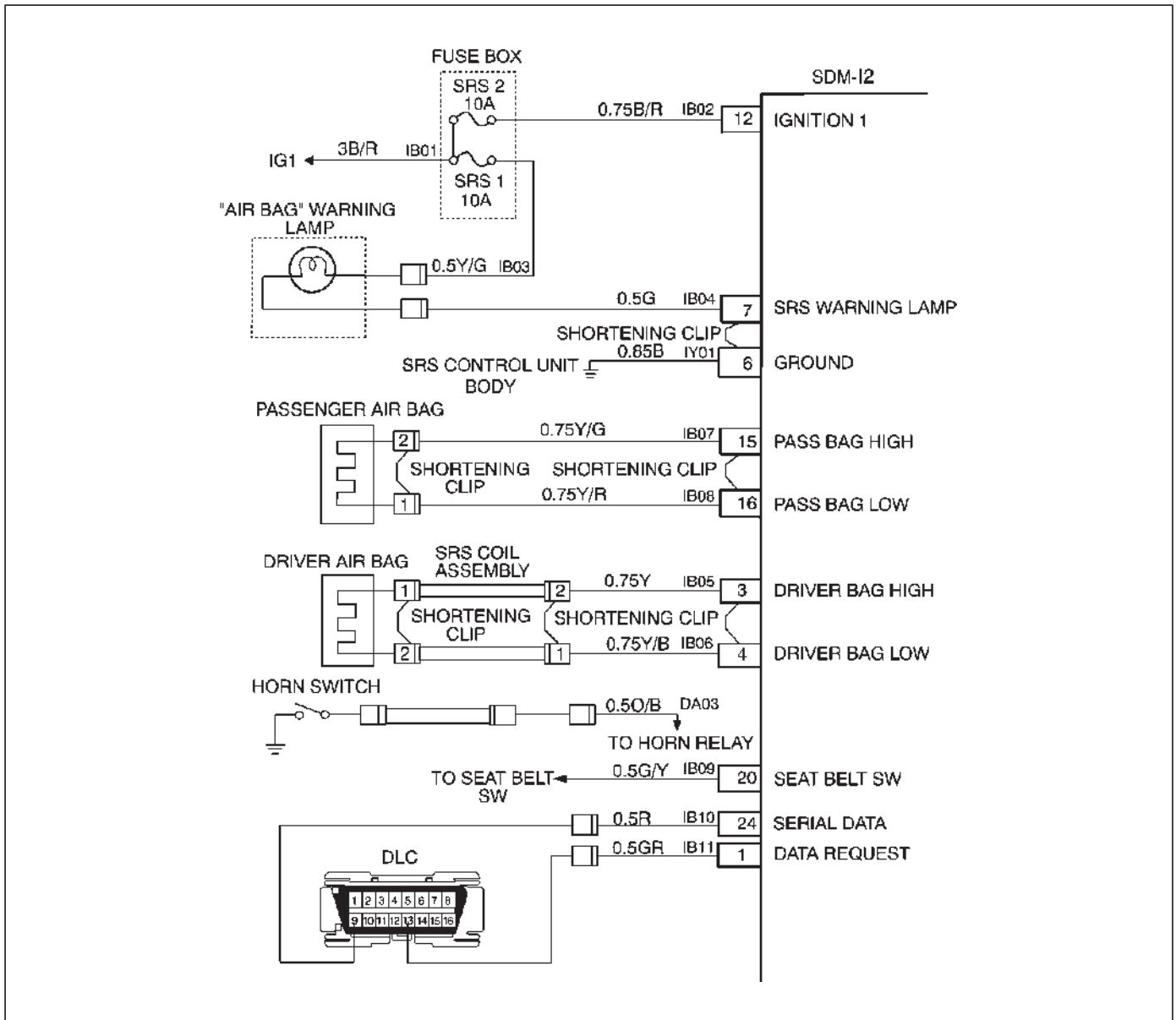
An intermittent condition is likely to be caused by a short to B+ in the driver air bag assembly circuit. Inspect CKTs IB05-YELLOW and IB06-YELLOW/BLACK carefully for cutting or chafing. If the wiring pigtail of the driver air bag assembly and SRS coil assembly is damaged, the components must be replaced. A careful inspection of CKT IB05-YELLOW and IB06-YELLOW/BLACK, including the SRS coil assembly and driver air bag assembly is essential to ensure that the replacement Sensing and Diagnostic Module (SDM) will not be damaged.

**DTC 25 Driver Deployment Loop Short To Ignition**

**CAUTION:** When Diagnostic Trouble Code (DTC) 25 has been set, it is necessary to replace the Sensing and Diagnostic Module (SDM). Setting DTC 25 will also cause DTC 71 to set. When a scan tool “CLEAR CODES” command is issued and the malfunction is no longer present, DTC 71 will remain current. Ensure that the short to voltage condition is repaired prior to installing a replacement SDM to avoid damaging the SDM.

Step	Action	Yes	No
1	Was the “SRS Diagnostic System Check” performed?	Go to Step 2	Go to the “SRS Diagnostic System Check.”
2	<ol style="list-style-type: none"> <li>When measurements are requested in this chart use J-39200 DVM with correct terminal adapter from J-35616-A.</li> <li>Ignition switch “OFF.”</li> <li>Connect scan tool data link connector. Follow directions as given in the scan tool operator’s manual.</li> <li>Ignition switch “ON.”</li> <li>Read driver sense LO.</li> </ol> Is driver sense LO more than 3.5 volts?	Go to Step 3	Go to Chart A.
3	<ol style="list-style-type: none"> <li>Ignition switch “OFF.”</li> <li>Disconnect SRS coil assembly yellow 2-pin connector at the base of the steering column. Leave passenger air bag assembly connected. Connect SRS driver / passenger load tool J-41433 and appropriate adapter to SRS coil assembly harness connector.</li> <li>Ignition switch “ON.”</li> </ol> Is driver sense LO more than 3.5 volts?	Go to Step 4	Go to Step 6
4	<ol style="list-style-type: none"> <li>Ignition switch “OFF.”</li> <li>Disconnect SDM.</li> <li>Disconnect SRS drive / passenger load tool.</li> <li>Measure resistance on SDM harness connector from terminal “3” to terminal “12” (Ignition 1).</li> </ol> Does J-39200 display “0L” (infinite)?	Go to Step 5	Replace SRS harness. Go to Step 7
5	Measure resistance on SDM harness connector from terminal “4” to terminal “12” (Ignition 1). Does J-39200 display “0L” (infinite)?	Go to Chart A.	Replace SRS harness. Go to Step 7
6	<ol style="list-style-type: none"> <li>Ignition switch “OFF.”</li> <li>Connect SRS driver / passenger load tool J-41433 and appropriate adapter J-35616-A to driver air bag assembly harness connector located of top of the steering column.</li> <li>Reconnect SRS coil assembly harness connector as the base of steering column.</li> <li>Ignition switch “ON.”</li> </ol> Is driver sense LO more than 3.5 volts?	Ignition switch “OFF.” Replace SRS coil assembly. Go to Step 7	Ignition switch “OFF.” Replace driver air bag assembly. Go to Step 7
7	<ol style="list-style-type: none"> <li>Reconnect all components, ensure all components are properly mounted.</li> <li>Ignition switch “ON.”</li> </ol> Is passenger sense LO less than 3.5 volts?	Replace SDM. Go to Step 8	Go to Chart A.
8	<ol style="list-style-type: none"> <li>Reconnect all components, ensure all components are properly mounted.</li> <li>Clear diagnostic trouble codes.</li> </ol> Was this step finished?	Repeat the “SRS Diagnostic System Check.”	Go to Step 8

DTC 26 Driver Deployment Loop Open



D09RX001

**Circuit Description:**

When the ignition switch is turned "ON", the Sensing and Diagnostic Module (SDM) will perform tests to diagnose critical malfunctions within itself. Upon passing these tests, "ignition 1", and deployment loop voltages are measured to ensure they are within their respective normal voltage ranges.

During "Continuous Monitoring" diagnostics, a fixed amount of current is following in the deployment loop. This produces proportional voltage drops in the loop. By monitoring the voltage difference between "Driver Bag High" and "Driver Bag Low", the SDM calculates the combined resistance of the driver air bag assembly, SRS coil assembly, harness wiring Circuits (CKTs) IB05-YELLOW and IB06-YELLOW/BLACK, and connector terminal contact.

**DTC Will Set When:**

The voltage difference between "Driver Bag High" terminal "3" and "Driver Bag Low" terminal "4" is above or equal to a specified value for 500 milliseconds during "Continuous Monitoring."

**Action Taken:**

SDM turns "ON" the "AIR BAG" warning lamp and sets a diagnostic trouble code.

**DTC Will Clear When:**

The voltage difference between "Driver Bag High" terminal "3" and "Driver Bag Low" terminal "4" is below a specified value for 500 milliseconds during "Continuous Monitoring."

**DTC Chart Test Description:**

Number(s) below refer to circled number(s) on the diagnostic chart:

1. This test determines whether the malfunction is in the Sensing and Diagnostic Module (SDM).
2. This test verifies proper connection of the yellow 2-pin connector at the base of the steering column.
3. This test checks for proper contact and/or corrosion of the yellow 2-pin connector at the base of the steering column.
4. This test isolates the malfunction to one side of the Supplemental Restraint System (SRS) coil assembly yellow 2-pin connector located at the base of steering column.
5. This test determines whether the open is in the wiring.
6. This test determines whether the malfunction is in the SRS coil assembly or the driver air bag assembly.

**Diagnostic Aids:**

An intermittent condition is likely to be caused by a poor connection at the driver air bag assembly harness 2-pin connector terminals "1" and "2" at the top of the steering column, SRS coil assembly harness 2-pin connection terminals "1" and "2", SDM terminals "3" and "4", or an open in Circuits(CKTs) IB05-YELLOW and IB06-YELLOW/BLACK.

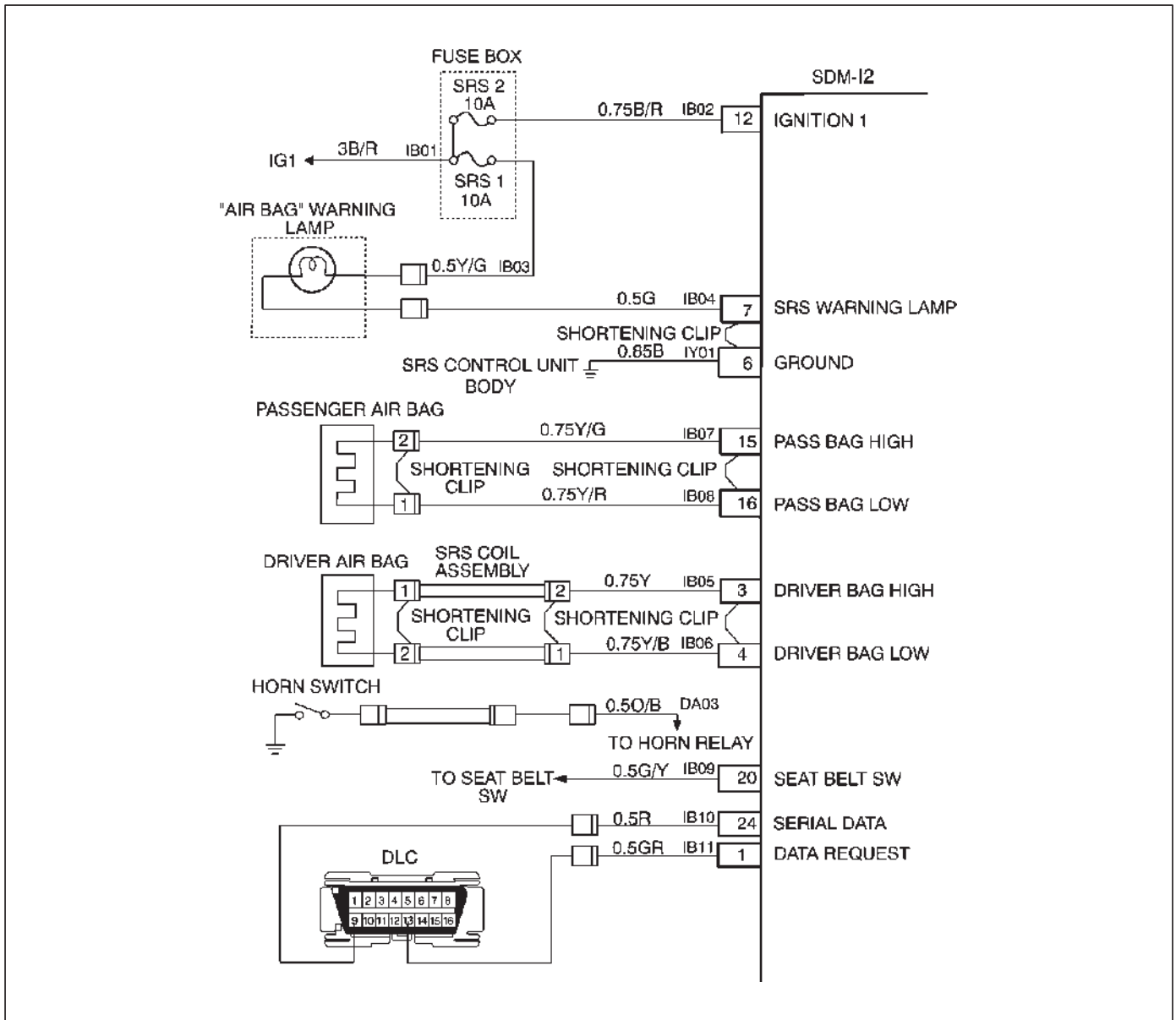
## 9J1-40 RESTRAINT CONTROL SYSTEM

### DTC 26 Driver Deployment Loop Open

Step	Action	Yes	No
1	Was the "SRS Diagnostic System Check" performed?	Go to Step 2	Go to the "SRS Diagnostic System Check."
2	1. When measurements are requested in this chart use J-39200 DVM with correct terminal adapter from J-35616-A. 2. Use scan tool data list function, read and record the driver differential voltage.  Is driver differential voltage more than 4.25 volts?	Go to Step 3	Go to Chart A.
3	1. Ignition switch "OFF." 2. Make sure the SRS coil assembly yellow 2-pin connector located at the base of steering column is seated properly.  Is the yellow 2-pin connector connected properly?	Go to Step 4	Seat driver air bag assembly 2-pin connector. Go to Step 8
4	1. Disconnect and inspect the SRS coil assembly yellow 2-pin connector located base of steering column. 2. If OK, reconnect the SRS coil assembly yellow 2-pin connector. 3. Ignition switch "ON".  Is DTC 26 current?	Go to Step 5	Ignition switch "OFF." Go to Step 8
5	1. Ignition switch "OFF." 2. Disconnect SRS coil and passenger air bag assembly, yellow 2-pin connectors located at the base of steering column and behind the glove box assembly. 3. Connect SRS driver / passenger load tool J-41433 and appropriate adapter to SRS coil and passenger air bag assembly harness connectors. 4. Ignition switch "ON."  Is DTC 26 current?	Go to Step 6	Go to Step 7
6	1. Ignition switch "OFF." 2. There has been an open circuit in the driver deployment loop. Use the high resolution ohmmeter mode of the DVM while checking CKTs IB05 YEL and IB06 YEL/BLK, and SDM connector terminal "3" AND "4" to locate the root cause.  Was a fault found?	Replace SRS harness. Go to Step 8	Go to Chart A.
7	1. Ignition switch "OFF." 2. Disconnect SRS driver / passenger load tool from SRS coil assembly harness connector. 3. Connect SRS driver / passenger load tool J-41433 on steering column. 4. Reconnect SRS coil assembly harness connector as the base of steering column. 5. Ignition switch "ON."  Is DTC 26 current?	Ignition switch "OFF." Replace SRS coil assembly, refer to in this section. Go to Step 8	Ignition switch "OFF." Replace driver air bag assembly. Go to Step 8
8	1. Reconnect all components, ensure all component are properly mounted. 2. Clear diagnostic trouble codes.  Was this step finished?	Repeat the "SRS Diagnostic System Check."	Go to Step 8



## DTC 51 Deployment Event Commanded



D09RX001

### Circuit Description:

The Sensing and Diagnostic Module (SDM) contains a sensing device which converts vehicle velocity changes to an electrical signal. The electrical signal generated is processed by the SDM and then compared to a value stored in memory. When the generated signal exceeds the stored value, the SDM will cause current to flow through the air bag assembly deploying the air bags and causing Diagnostic Trouble Code (DTC) 51 to set.

### DTC Will Set When:

The SDM detects a frontal crash, up to 30 degrees off the centerline of the vehicle, of sufficient force to warrant deployment of the air bags.

### Action Taken:

SDM turns "ON" the "AIR BAG" warning lamp records "Crash Data", and sets a diagnostic trouble code.

### DTC Will Clear When:

The SDM is replaced.

### DTC Chart Test Description:

Number(s) below refer to step number(s) on the diagnostic chart:

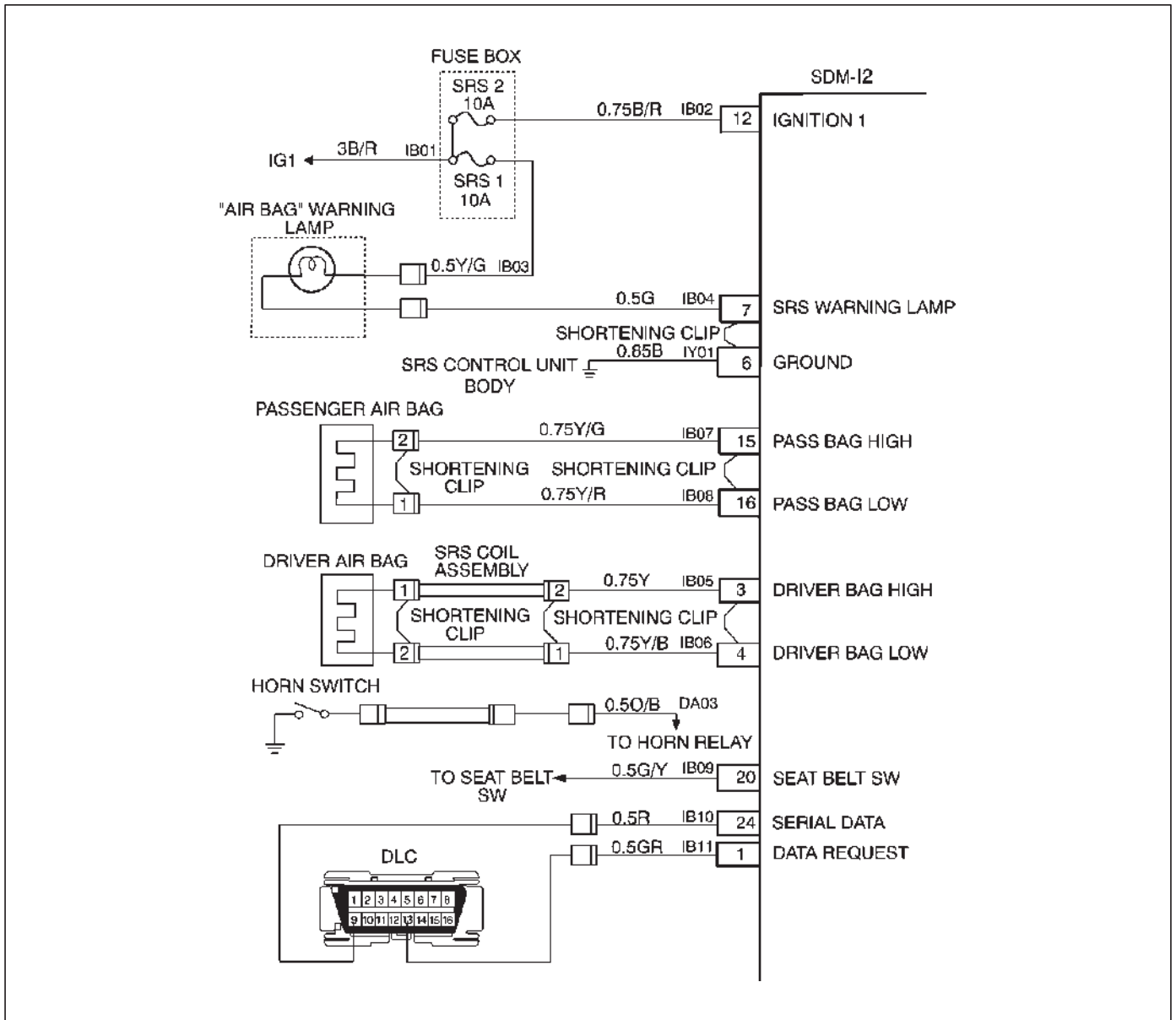
2. If air bag assembly (s) has not deployed, DTC 51 may have falsely set.
3. If DTC 51 has set with no signs of frontal impact, the diagnostic trouble code has falsely set.

**DTC 51 Deployment Event Commanded**

**WARNING: DURING SERVICE PROCEDURES. BE VERY CAREFUL WHEN HANDLING A SENSING AND DIAGNOSTIC MODULE (SDM). NEVER STRIKE OR JAR THE SDM. NEVER POWER UP THE SRS WHEN THE SDM IS NOT RIGIDLY ATTACHED TO THE VEHICLE. ALL SDM AND MOUNTING BRACKET FASTENERS MUST BE CAREFULLY TORQUED AND THE ARROW MUST BE POINTING TOWARD THE FRONT OF THE VEHICLE TO ENSURE PROPER OPERATION OF THE SUPPLEMENTAL RESTRAINT SYSTEM (SRS). THE SDM COULD BE ACTIVATED WHEN POWERED WHILE NOT RIGIDLY ATTACHED TO THE VEHICLE WHICH COULD CAUSE DEPLOYMENT AND RESULT IN PERSONAL INJURY.**

Step	Action	Yes	No
1	Was the "SRS Diagnostic System Check" performed?	Go to Step 2	Go to the "SRS Diagnostic System Check."
2	Ignition switch "OFF." Have air bag assemblies deployed?	Replace components and perform inspections as directed in "repairs and inspections required after an accident" in this section. Clear diagnostic trouble codes. Repeat the "SRS Diagnostic System Check."	Go to Step 3
3	Inspect front of vehicle and undercarriage for signs of impact. Were signs of impact found?	Replace components and perform inspections as directed in "repairs and inspections required after an accident" in this section. Clear diagnostic trouble codes. Repeat the "SRS Diagnostic System Check."	Ignition switch "OFF." Replace SDM. Reconnect all SRS system components, ensure all components are properly mounted.Repeat the "SRS Diagnostic System Check."

## DTC 53 Deployment Commanded With Deployment Loop Fault Or Energy Reserves Out Of Range



D09RX001

### Circuit Description:

The Sensing and Diagnostic Module (SDM) contains a sensing drive which converts vehicle velocity changes to an electrical signal. The electrical signal generated is processed by the SDM and then compared to a value stored in memory. When the generated signal exceeds the stored value, the SDM will cause current to flow through the air bag assembly deploying the air bags. Diagnostic Trouble Code (DTC) 53 is set accompanying with DTC 51 when a deployment occurs while an air bag assembly circuit fault is present that could possibly result in a no deployment situation in one or both air bag assemblies.

### DTC Will Set When:

The SDM detects a frontal crash, up to 30 degrees off the centerline of the vehicle, of sufficient force to warrant

deployment of the air bags and an inflator circuit fault is present.

### Action Taken:

SDM turns "ON" the "AIR BAG" warning lamp records "Crash Data", and sets a diagnostic trouble code.

### DTC Will Clear When:

The SDM is replaced. If DTC 53 is set, one or more DTCs will be set in addition to DTC 53. Malfunction(s) setting DTC(s) (other than DTC 71) must be repaired so that DTC(s) will not be set when a new SDM is installed.

### DTC Chart Test Description:

Number(s) below refer to step number(s) on the diagnostic chart:

2. If air bag assembly has not deployed, Diagnostic Trouble Code (DTC) 53 may have falsely set.

## 9J1-44 RESTRAINT CONTROL SYSTEM

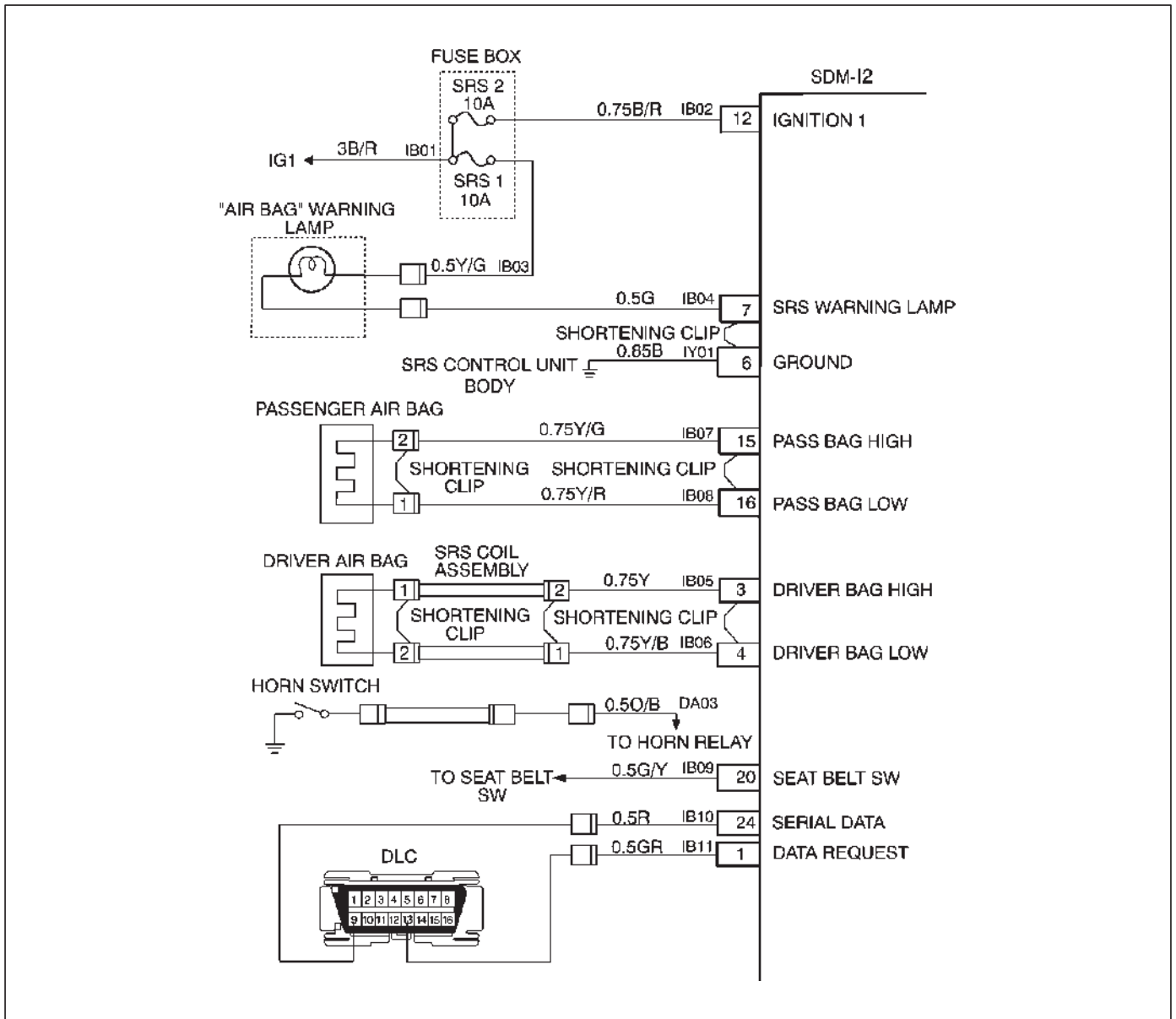
3. If DTC 53 has set with no signs of frontal impact, the diagnostic trouble code has falsely set.

### DTC 53 Deployment Commanded With Deployment Loop Fault Or Energy Reserves Out Of Range

**WARNING: DURING SERVICE PROCEDURES. BE VERY CAREFUL WHEN HANDLING A SENSING AND DIAGNOSTIC MODULE (SDM). NEVER STRIKE OR JAR THE SDM. NEVER POWER UP THE SRS WHEN THE SDM IS NOT RIGIDLY ATTACHED TO THE VEHICLE. ALL SDM AND MOUNTING BRACKET FASTENERS MUST BE CAREFULLY TORQUED AND THE ARROW MUST BE POINTING TOWARD THE FRONT OF THE VEHICLE TO ENSURE PROPER OPERATION OF THE SRS. THE SDM COULD BE ACTIVATED WHEN POWERED WHILE NOT RIGIDLY ATTACHED TO THE VEHICLE WHICH COULD CAUSE DEPLOYMENT AND RESULT IN PERSONAL INJURY.**

Step	Action	Yes	No
1	Was the "SRS Diagnostic System Check" performed?	Go to Step 2	Go to the "SRS Diagnostic System Check."
2	Ignition switch "OFF." Have air bag assemblies deployed?	Replace components and perform inspections as directed in "repairs and inspections required after an accident" in this section. Clear diagnostic trouble codes. Repeat the "SRS Diagnostic System Check."	Go to Step 3
3	Inspect front of vehicle and undercarriage for signs of impact. Were signs of impact found?	Replace components and perform inspections as directed in "repairs and inspections required after an accident" in this section. Clear diagnostic trouble codes. Repeat the "SRS Diagnostic System Check."	Ignition switch "OFF." Replace SDM. Reconnect all SRS system components, ensure all components are properly mounted. Repeat the "SRS Diagnostic System Check."

## DTC 61 Warning Lamp Circuit Failure



D09RX001

### Circuit Description:

When the ignition switch is turned "ON", battery voltage is applied to the "AIR BAG" warning lamp and to the "ignition 1" input terminal "12". The Sensing and Diagnostic Module (SDM) responds by flashing the "AIR BAG" warning lamp seven times. The SDM monitors the lamp driver output by comparing the output state at "Supplemental Restraint System (SRS) warning lamp" terminal "7" to the microprocessor commanded state. When "ignition 1" is in the specified value, and the output state Does not match the commanded state of the lamp driver for 500 milliseconds, DTC 61 is set.

### DTC Will Set When:

"Ignition 1" voltage is in the specified value and the output state at the "SRS warning lamp" terminal does not match

the commanded state of the lamp driver for 500 milliseconds. This test is run every 100 milliseconds during "Continuous Monitoring" tests and once per each ignition cycle at the beginning.

### Action Taken:

SDM attempts to turn "ON" the "AIR BAG" warning lamp and sets a diagnostic trouble code.

### DTC Will Clear When:

The ignition switch is turned "OFF."

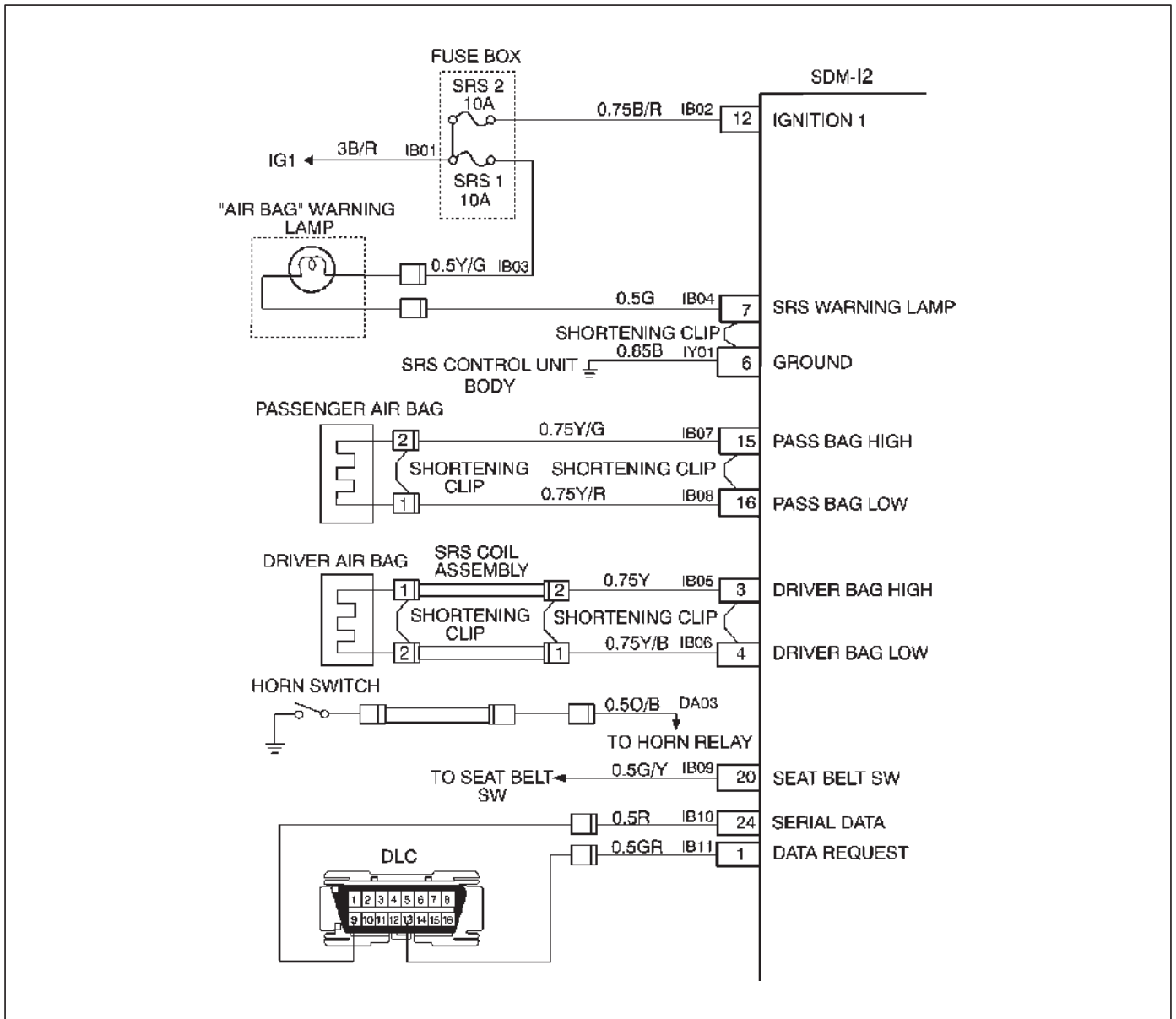
### Diagnostic Aids:

Refer to Charts B and C to diagnose warning lamp circuit malfunctions.

**DTC 61 Warning Lamp Circuit Failure**

Step	Action	Yes	No
1	Was the "SRS Diagnostic System Check" performed?	Go to Step 2	Go to the "SRS Diagnostic System Check."
2	1. Malfunctions within the "AIR BAG" warning lamp circuitry will set this diagnostic trouble code. 2. These malfunctions are addressed in the "SRS Diagnostic System Check" via Chart B and Chart C. 3. Failure to properly perform the "SRS Diagnostic System Check" may result in misdiagnosis. 4. Ignition switch "ON." 5. Clear SRS diagnostic trouble codes. Is DTC 61 SET?	Ignition switch "OFF." Go to Chart A.	Repeat the "SRS Diagnostic System Check."

**DTC 71 Internal SDM Fault**



D09RX001

**Circuit Description:**

Diagnostic Trouble Code (DTC) 71 is an indication of a potential internal Sensing and Diagnostic Module (SDM) malfunction and will set if any of the following conditions are detected:

- 1) Deployment or microprocessor energy reserve failure.
- 2) Electronically Erasable Programmable Read Only Memory failure. (EEPROM).
- 3) Random Only Memory failure. (ROM).
- 4) Random Access Memory failure. (RAM).
- 5) Calibration check sum failure.
- 6) Deployment switch faults.
- 7) Accelerometer fault.
- 8) Arming sensor fault.
- 9) Diagnostic current faults.
- 10) DTC 19
- 11) DTC 25
- 12) DTC 51

13) DTC 53

**DTC Will Set When:**

Any of the above indicated malfunctions are detected by the SDM. The malfunctions described above are tested mainly during "Continuous Monitoring" and some ones run each ignition cycle.

**Action Taken:**

SDM turns "ON" the "AIR BAG" warning lamp and sets a diagnostic trouble code.

**DTC Will Clear When:**

A scan tool "Clear Codes" commanded is received by the SDM. Some of the indicated malfunctions will only allow the "AIR BAG" warning lamp to go out. But when DTC 19, 25, 51, 53 are also set, SDM is Replaced.

**DTC 71 Internal SDM Fault**

**WARNING: DURING SERVICE PROCEDURES. BE VERY CAREFUL WHEN HANDLING A SENSING AND DIAGNOSTIC MODULE (SDM). NEVER STRIKE OR JAR THE SDM. NEVER POWER UP THE SRS WHEN THE SDM IS NOT RIGIDLY ATTACHED TO THE VEHICLE. ALL SDM AND MOUNTING BRACKET FASTENERS MUST BE CAREFULLY TORQUED AND THE ARROW MUST BE POINTING TOWARD THE FRONT OF THE VEHICLE TO ENSURE PROPER OPERATION OF THE SRS. THE SDM COULD BE ACTIVATED WHEN POWERED WHILE NOT RIGIDLY ATTACHED TO THE VEHICLE WHICH COULD CAUSE DEPLOYMENT AND RESULT IN PERSONAL INJURY.**

**CAUTION: When Diagnostic Trouble Code (DTC) 19 or 25 or 51 or 53 has been set it is necessary to Replace the SDM. Setting DTC 19 and 25 or 51 or 53 will also cause DTC 71 to set. When a scan tool “CLEAR CODES” command is issued and the malfunction is no longer present, DTC 51 or 53 and DTC 71 will remain current. Ensure that the short to voltage condition DTC 19, 25 is repaired prior to installing a Replacement SDM to avoid damaging the SDM.**

Step	Action	Yes	No
1	Was the “SRS Diagnostic System Check” performed?	Go to Step 2	Go to the “SRS Diagnostic System Check.”
2	Note SRS “Diagnostic System Check.” Is DTC 19 or 25 or 51 or 53 also set (current or history)? (Refer to notice above).	Go to DTC 19 if DTC 19 is set. Go to DTC 25 if DTC 25 is set. Go to DTC 51 if DTC 51 is set. Go to DTC 53 if DTC 53 is set.	Ignition switch “OFF.” Replace SDM. Repeat the “SRS Diagnostic System Check.”



# CONTROL SYSTEM

## CRUISE CONTROL SYSTEM

### CONTENTS

Service Precaution .....	10A-1	Removal .....	10A-4
General Description .....	10A-2	Installation .....	10A-5
Diagnosis .....	10A-2	Adjustment .....	10A-5
Brake Switch .....	10A-3	Mode Switch .....	10A-6
Removal and Installation .....	10A-3	Removal and Installation .....	10A-6
Adjustment .....	10A-3	Cruise Control Main Switch .....	10A-6
Cruise Control Unit .....	10A-3	Removal .....	10A-6
Removal .....	10A-3	Installation .....	10A-6
Installation .....	10A-3	Cruise Control Switch (Combination Switch) .....	10A-6
Cruise Actuator .....	10A-4	Removal and Installation .....	10A-6
Actuator Cable Diagram .....	10A-4		

### Service Precaution

**WARNING: THIS VEHICLE HAS A SUPPLEMENTAL RESTRAINT SYSTEM (SRS). REFER TO THE SRS COMPONENT AND WIRING LOCATION VIEW IN ORDER TO DETERMINE WHETHER YOU ARE PERFORMING SERVICE ON OR NEAR THE SRS COMPONENTS OR THE SRS WIRING. WHEN YOU ARE PERFORMING SERVICE ON OR NEAR THE SRS COMPONENTS OR THE SRS WIRING, REFER TO THE SRS SERVICE INFORMATION. FAILURE TO FOLLOW WARNINGS COULD RESULT IN POSSIBLE AIR BAG DEPLOYMENT, PERSONAL INJURY, OR OTHERWISE UNNEEDED SRS SYSTEM REPAIRS.**

**CAUTION: Always use the correct fastener in the proper location. When you replace a fastener, use ONLY the exact part number for that application. ISUZU will call out those fasteners that require a replacement after removal. ISUZU will also call out the fasteners that require thread lockers or thread sealant. UNLESS OTHERWISE SPECIFIED, do not use supplemental coatings (Paints, greases, or other corrosion inhibitors) on threaded fasteners or fastener joint interfaces. Generally, such coatings adversely affect the fastener torque and the joint clamping force, and may damage the fastener. When you install fasteners, use the correct tightening sequence and specifications. Following these instructions can help you avoid damage to parts and systems.**

### General Description

The cruise control keeps the vehicle running at a fixed speed until a signal canceling this fixed speed is received. When the main switch "AUTO CRUISE" is turned on with the vehicle in the running mode, the battery voltage is applied to the control unit. When a signal from the control switch is input to the control unit while the vehicle is in this state, the cruise control actuator is activated to operate the system. Also, while the system is operating, the "AUTO CRUISE" indicator light in the meter assembly lights up.

The cruise control system can be set while the vehicle runs at approximately 25 mph (40 km/h).

#### 1 . SET/COAST Switch Function

1. **Set Function:** When the SET/COAST switch is pressed and released with the main switch on, the speed at which the vehicle is running at that moment is stored in the memory, and the vehicle automatically runs at the speed stored.
2. **Coast-Down Function:** When the SET/COAST switch is kept on while the vehicle is running, the vehicle decelerates during that time. The speed at which vehicle is running when the control switch is turned off is stored in the memory, and the vehicle automatically returns to the stored speed.
3. **Tap-Down Function:** When the SET/COAST switch is turned on and off instantaneously while the vehicle is running, the vehicle accelerates a mile for each on/off operation. The vehicle speed at which the vehicle was running when the SET/COAST was turned off last is stored in the memory, and the vehicle automatically returns to this stored speed.

#### 2 . RESUME/ACCEL Switch Function

1. **Resume Function:** When the RESUME, ACCEL switch is turned on/off after the system is temporarily deactivated by pressing the brake or clutch pedal while the vehicle is running, the vehicle resumes, the speed stored before the system was released.
2. **Accelerate Function:** When the RESUME/ACCEL switch is kept on after the system is released completely, the vehicle accelerates its speed during that time. The vehicle speed at which the vehicle was running when the switch was turned off is stored in the memory, and the vehicle automatically returns to this speed.
3. **Tap-Up Function:** When the RESUME/ACCEL switch is turned on and off instantaneously while the vehicle is running, the vehicle decelerates a mile for each on/off operation. The vehicle speed at which the vehicle was running when the switch was turned off last is stored in the memory, and the vehicle automatically returns to this stored speed.

#### 3 . CANCEL Function

##### 1. Temporary Cancellation:

- When the brake pedal is pressed.
- When the select lever is shifted to any position other than "D", "3", "2" or "L".
- When the vehicle speed has decreased about 12.5 mph (20 km/h) or more than the stored speed.

##### 2. Complete Cancellation:

- When the starter switch or the main switch is turned off.
- When the failsafe function is activated.

### Diagnosis

Refer to the Cruise Control System Diagnosis in Wiring System section.

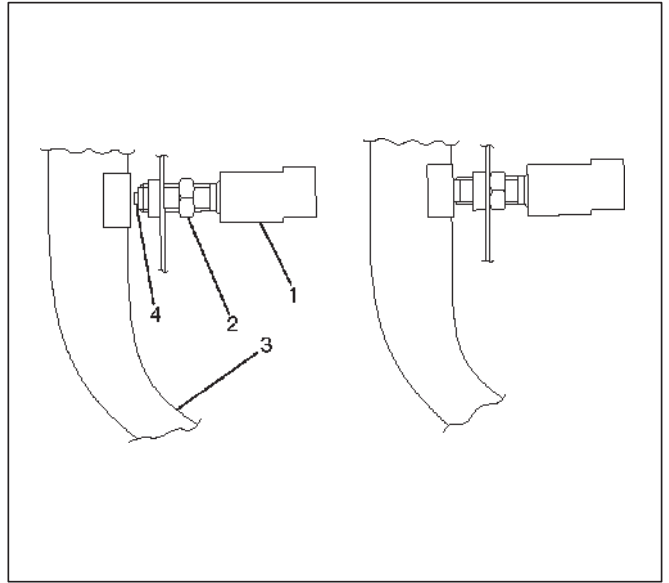
## Brake Switch

### Removal and Installation

Refer to the Brake Pedal Replacement in Brake section.

### Adjustment

1. Check that the brake pedal (3) is fully returned by pedal return spring.
2. Disconnect the switch connector.
3. Loosen the lock nut (2).
4. Rotate the brake switch (1) by hand until push rod disappears from brake switch tip (4).
5. Return the brake switch by a half turn.
6. Tighten the lock nut.
7. Connect the switch connector.

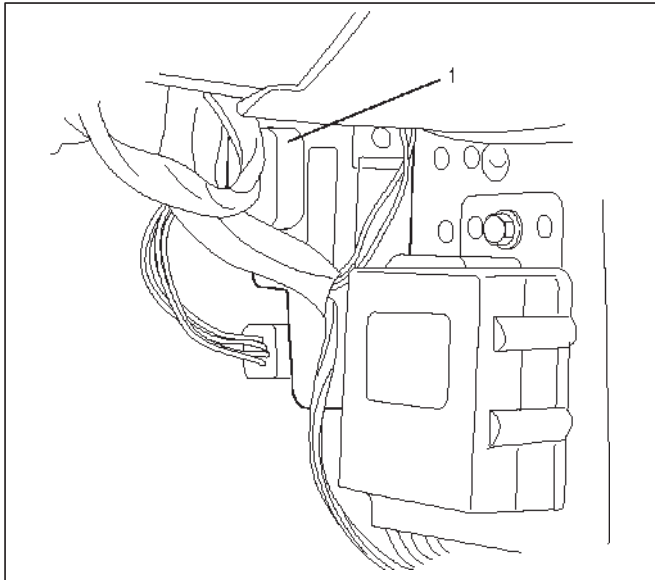


310RS028

## Cruise Control Unit

### Removal

1. Disconnect the battery ground cable.
2. Remove the dash side trim panel (RH).
3. Disconnect the connector.
4. Remove a fixing nut to remove the cruise control unit (1).



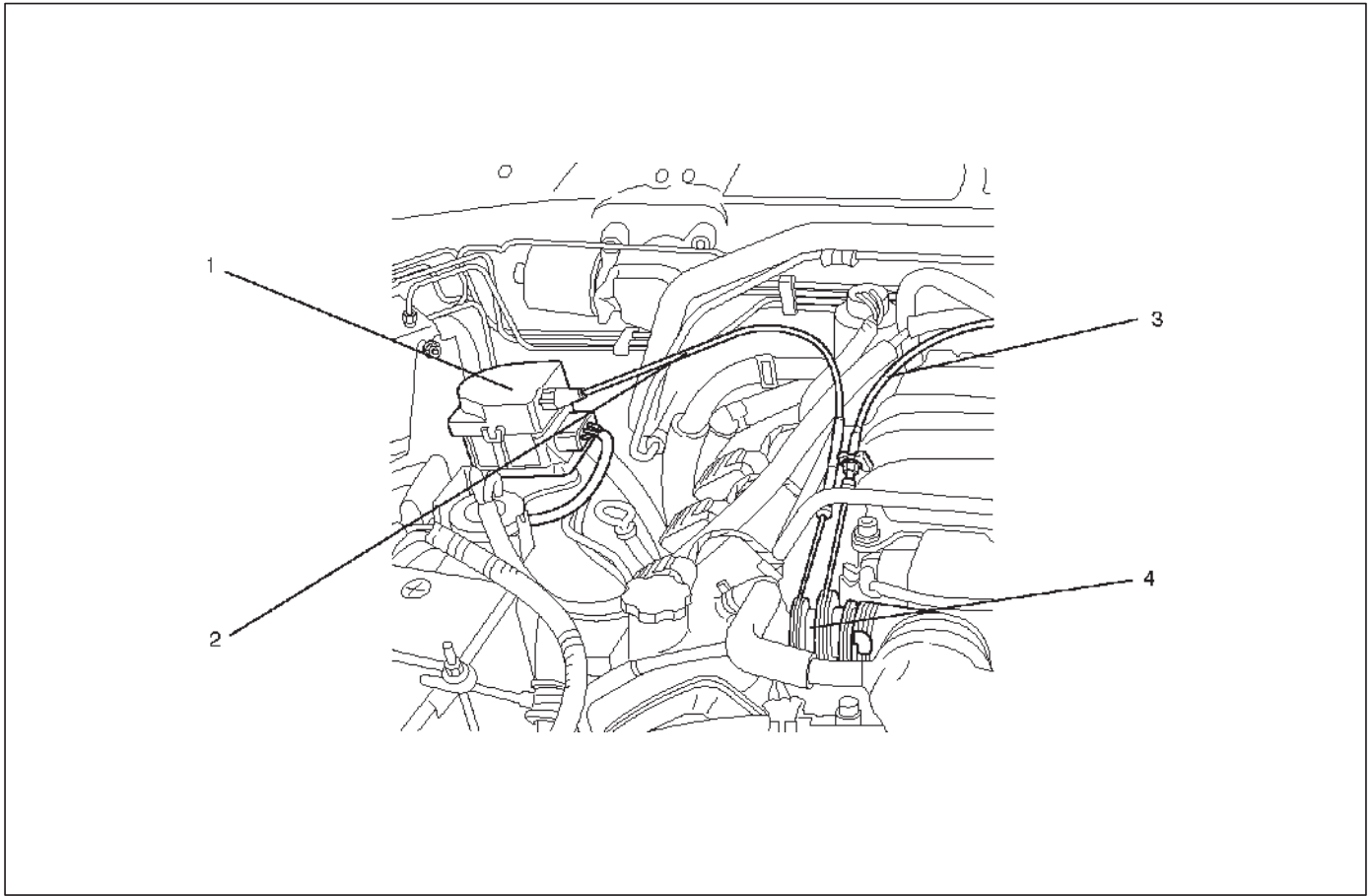
826RX009

### Installation

To install, follow the removal steps in the reverse order.

## Cruise Actuator

### Actuator Cable Diagram



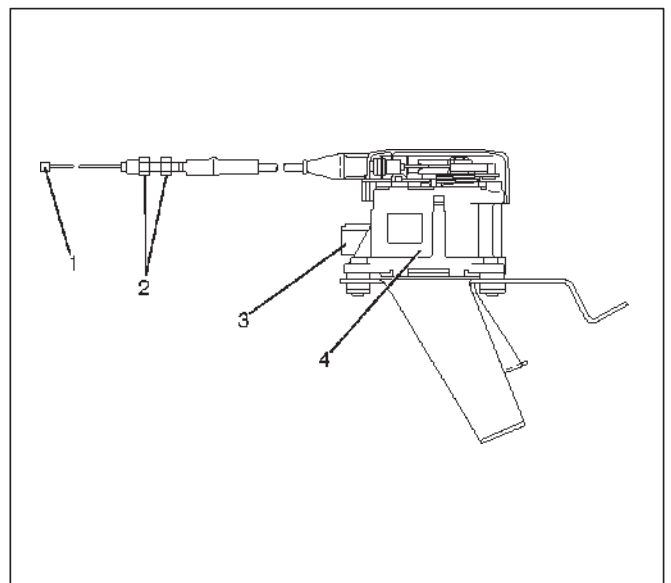
105RX001

#### Legend

- |                              |   |
|------------------------------|---|
| (1) Cruise Actuator Assembly | (3) Accelerator Cable                   |
| (2) Cruise Control Cable     | (4) Throttle Link (Cruise Control Side) |

### Removal

1. Disconnect the battery ground cable.
2. Remove the cruise actuator assembly (4).
  - Disconnect the connector (3).
  - Remove the cable end (1) from the throttle link (cruise control side).
  - Loosen two fixing nuts (2).
  - Remove three actuator assembly fixing screws.



825RW049

## Installation

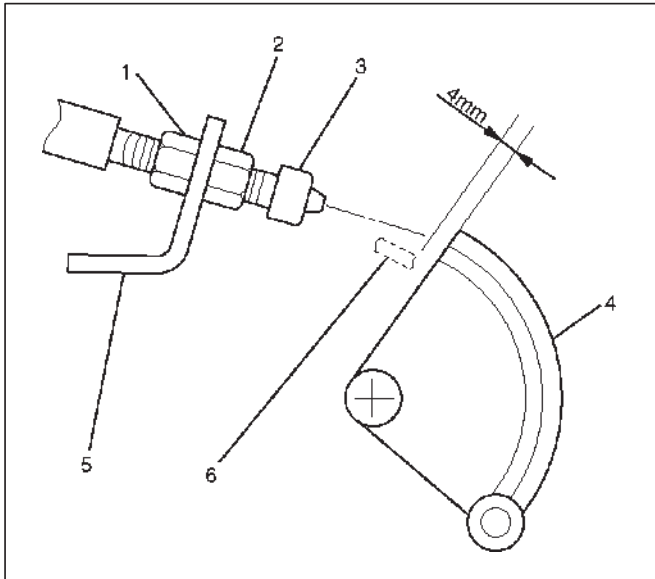
To install, follow the removal steps in the reverse order, noting the following point:

1. Take care not to bend the cable excessively.

## Adjustment

After installing the cruise actuator, the following steps must be carried out for cruise control cable adjustment.

1. Install the cruise control cable end (3) to the throttle link (4).
  2. Put the screw portion of the cable in the bracket (5).
  3. Put the nut (1) to the bracket and then tighten the nut (2).
- If the distance between the throttle link (4) and the throttle link lever (6) is out of the specified range, loosen the nut (2) to adjust it.



035RW140

## Mode Switch

### Removal and Installation

Refer to Mode Switch in Automatic Transmission section.

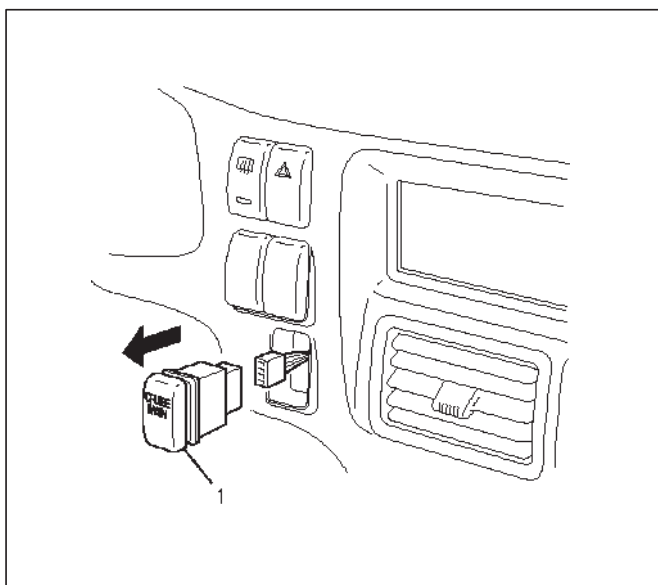
## Cruise Control Main Switch

### Removal

1. Disconnect the battery ground cable.
2. Remove the meter cluster assembly.
  - Refer to the Instrument Panel Assembly in Body Structure section.
3. Remove the cruise control main switch (1).
  - Disconnect the switch connector.
  - Push the lock from the back side of the instrument panel cluster assembly.

### Installation

To install, follow the removal steps in the reverse order.



826RX006

## Cruise Control Switch (Combination Switch)

### Removal and Installation

Refer to the Lighting Switch (Combination Switch) in Lighting System section.