

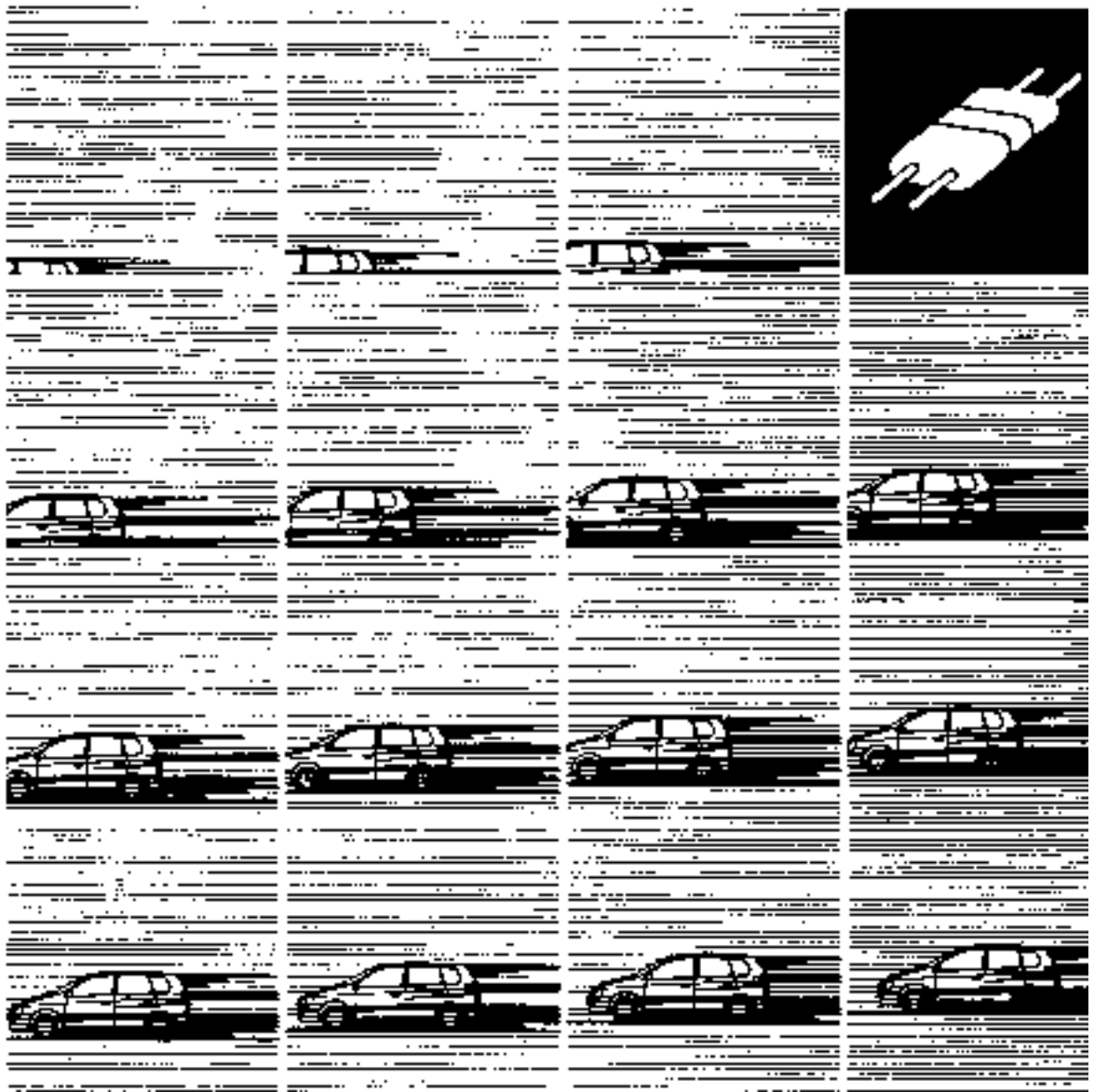

Workshop Manual

electrical wiring

SPACE STAR '99



SPACE STAR

ELECTRICAL WIRING

FOREWORD

This Electrical Wiring Manual contains information necessary for inspection and servicing of electrical wiring of Mitsubishi SPACE STAR edited in the form of wiring harness configuration diagrams and function-separated circuit diagrams. It is recommended that all service mechanics engaged in the servicing of the vehicle refer to the following publications as well as this manual.

TECHNICAL INFORMATION MANUAL
IMXE99E1

WORKSHOP MANUAL
CHASSIS GROUP
CMXE99E1

BODY REPAIR MANUAL
BMXE99E1

ENGINE GROUP
PWEE□□□□
{Looseleaf edition}

PARTS CATALOGUE
N606H509DF

All information, illustrations and product descriptions contained in this manual are current as of time of publication. We, however, reserve the right to make changes at any time without prior notice or obligation.

 **MITSUBISHI MOTOR SALES**
Europe B.V.

GROUP INDEX

00109001370

HOW TO READ THE WIRING DIAGRAMS	1
WIRING HARNESS CONFIGURATION DIAGRAMS	2
SINGLE PART INSTALLATION POSITION	3
CIRCUIT DIAGRAM	4
INDEX	

“GDI” is the trade mark which Mitsubishi Motors Corporation holds

© Mitsubishi Motors Corporation

September 1988

HOW TO USE THIS MANUAL

001 00010241

CONTENTS

The preceding page contains GROUP INDEX that lists the group title and group number.

PAGE NUMBERS

All page numbers consist of two sets of digits separated by a dash. The digits preceding the dash identify the number of the group. The digits following the dash represent the consecutive page number within the group. The page number can be found on the top left or right of each page.

OPERATION AND TROUBLESHOOTING HINTS

In the GROUP 4 circuit diagrams, the operation and troubleshooting hints are given on the previous page or following page for each circuit where necessary.

HOW TO READ THE WIRING DIAGRAMS

CONTENTS

00109401387

MODELS	1-2	HOW TO READ CIRCUIT DIAGRAMS	1-4
COMPOSITION AND CONTENTS OF WIRING DIAGRAMS	1-2	MARKINGS FOR CONNECTOR EARTHING	1-6
HOW TO READ CONFIGURATION DIAGRAMS	1-3	WIRE COLOUR CODES	1-9
		ABBREVIATION SYMBOLS	1-10

MODELS

DE10030366

Model code	Engine model	Transmission model	Fuel supply system
DG1A	LNDEL6/R6	F5MR1 (2WD-5MT)	MPI
	LNDJL6		
	LNJEL6/R6		
	LNJL6		
DG5A	LNDCI6/R6	F5M42 (2WD-5MT)	GDI
	LNDGL6		
	LNJCL6/R6		
	LNJGL6		

COMPOSITION AND CONTENTS OF WIRING DIAGRAMS

00100010366

- (1) This manual consists of wiring harness diagrams, installation locations of individual parts, circuits diagrams and index.
- (2) In each section, all specifications are listed, including optional specifications. Accordingly, some specifications may not be applicable for individual vehicles.

Section	Basic contents
Wiring harness configuration diagrams	Connector locations and harness wiring configurations on actual vehicles are illustrated.
Single part installation position	Locations are shown for each point of relays, electronic control units, sensors, solenoids, solenoid valves, diodes, inspection connectors, fusible links, fuses, etc. In the part's lists, parts are listed in alphabetical order.
Circuit diagrams	<p>Circuits from power supply to earth are shown completely, classified according to system. There is a main division into power circuits, and circuits classified by system. The circuits classified by system also include operation and troubleshooting hints.</p> <ul style="list-style-type: none"> ● Junction block The entire circuit for the junction block is described, because only the part of the junction block needed is normally shown in each circuit diagram. ● Joint connectors The internal circuits for all joint connectors are described, because only the part needed is shown in each circuit diagram. ● Power supply circuits Circuits from the battery to fusible link, dedicated fuses, ignition switch, general purpose fuses, etc. ● Circuits classified by system For each system, the circuits are shown from fuse to earth, excluding the power supply sections. ● Operation The standard operation of each system is briefly described, following the route of current flow. ● Troubleshooting hints This is a brief explanation of the inspection points that serve as hints when troubleshooting. Explanations of the circuits controlled by the electronic control unit are omitted. Refer to the related publications as required.
Index	All components used are listed by connector number and component name.

HOW TO READ CONFIGURATION DIAGRAMS

0010664075

The wiring harness diagrams clearly show the connector locations and harness routings at each site on actual vehicles.

Denotes connector No.
The same connector No. is used throughout the circuit diagrams to facilitate connector location searches.
The first alphabetical symbol indicates the location site of the connector and a number that follows is the unique number. Numbers are assigned to parts in clockwise order on the diagram.

Example: A-12 Number specific to connector (serial number)

Connector location site symbol
 A: Engine compartment
 B: Dash pane
 C: Instrument panel
 D: Floor and roof
 E: Door
 F: Luggage compartment

Denotes earth point
Same earth number is used throughout circuit diagrams to facilitate search of earth point. Refer to GROUP 3 SINGLE PART INSTALLATION POSITION – EARTH MOUNTING LOCATIONS for details of earth points.

Denotes a section covered by a corrugated tube

The mark ★ shows the standard mounting position of wiring harness.

Indicates the color of the cable tube. (If no color is recorded, it indicates that the color is black.)
 R: Red
 Y: Yellow

Indicates the device to which the connector is to be connected.

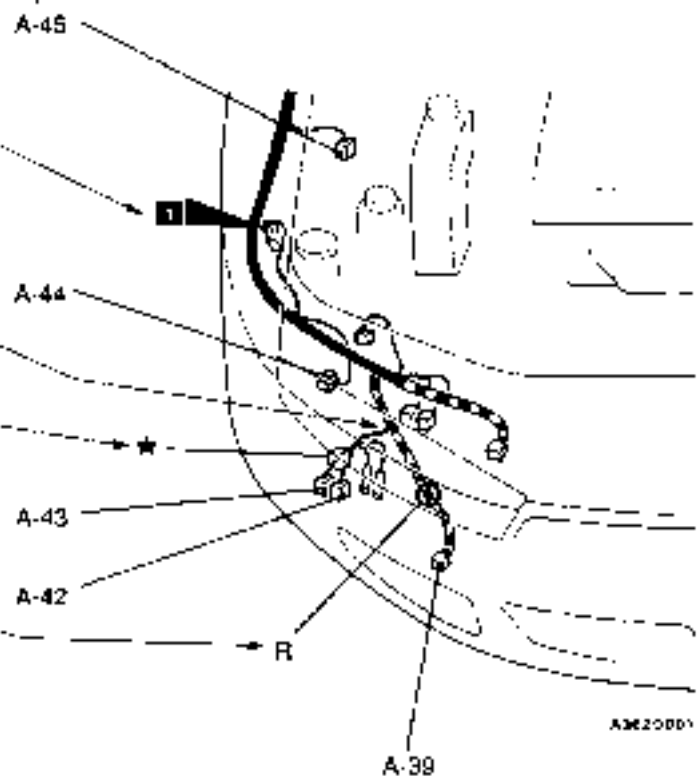

A-39 (2-B)
A-40 (1)

Front fog lamp (LH)
Horn (LO)

A-41 (1)
A-42 (2-B)

Horn (LO)
Windshield washer motor

The number of connector pins and the connector colour (except milk white) are shown for ease of retrieval.

Typical connector colours
 B: Black
 Y: Yellow
 L: Blue
 G: Green
 R: Red
 BR: Brown
 V: Violet
 O: Orange
 GR: Gray

Example: (2-B)

Connector colour (milk white if no colour is indicated)
 — Number of connector pins

HOW TO READ CIRCUIT DIAGRAMS

00160650122

The circuit of each system from fuse (or fusible link) to earth is shown. The power supply is shown at the top and the earth at the bottom to facilitate understanding of the current flow.

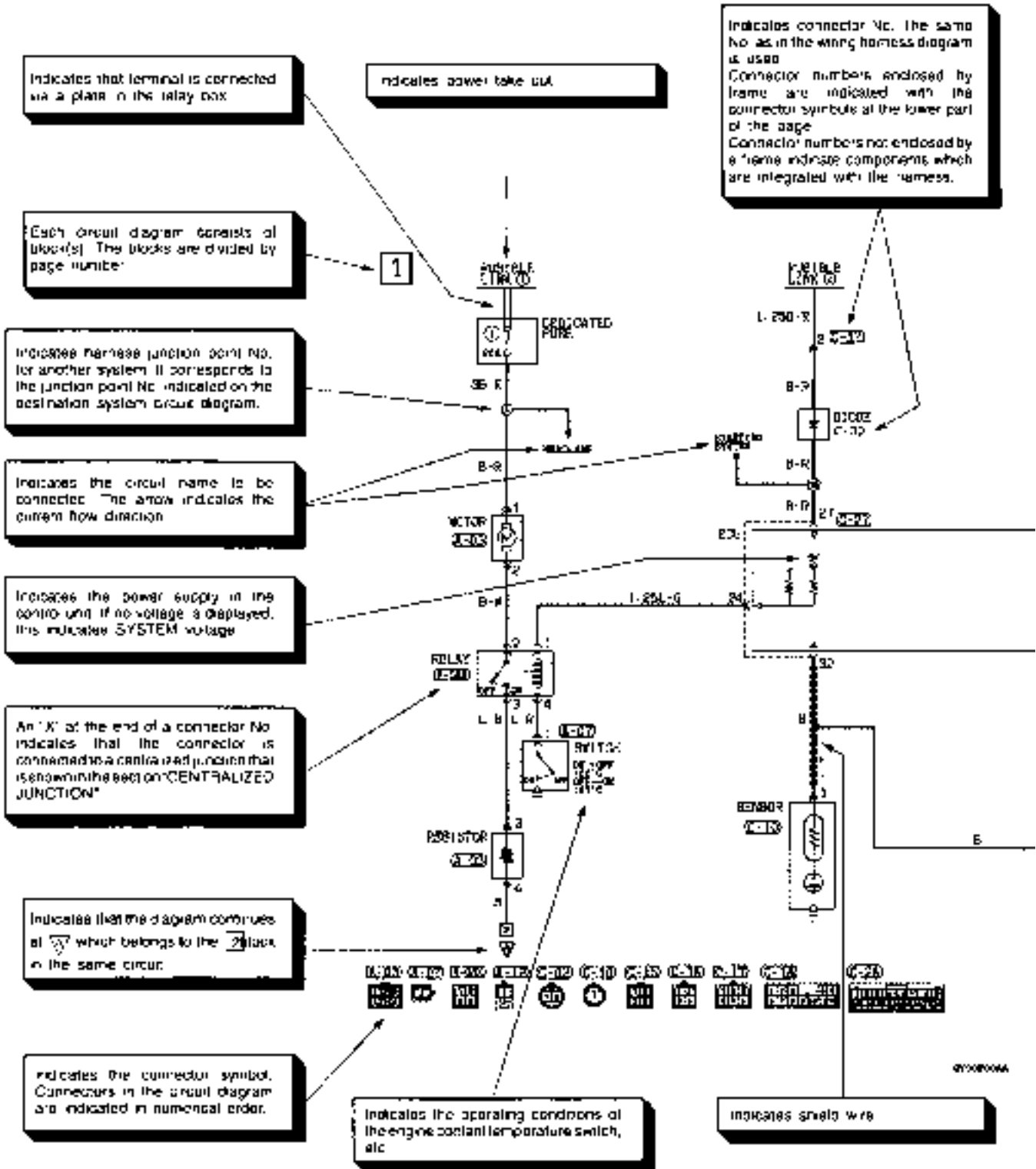

Indicates that terminal is connected via a plate in the relay box

indicates power take off

Indicates connector No. The same No. as in the wiring harness diagram is used
Connector numbers enclosed by frame are indicated with the connector symbols at the lower part of the page
Connector numbers not enclosed by a frame indicate components which are integrated with the harness.

Each circuit diagram consists of block(s). The blocks are divided by page number.

Indicates harness junction point No. for another system. It corresponds to the junction point No. indicated on the destination system circuit diagram.

Indicates the circuit name to be connected. The arrow indicates the current flow direction

Indicates the power supply in the control unit if no voltage is displayed. This indicates SYSTEM voltage

An 'X' at the end of a connector No. indicates that the connector is connected to a central junction that is shown in the section 'CENTRALIZED JUNCTION'

Indicates that the diagram continues at [symbol] which belongs to the [symbol] part in the same circuit.

Indicates the connector symbol. Connectors in the circuit diagram are indicated in numerical order.

Indicates the operating conditions of the engine coolant temperature switch, etc.

Indicates shield wire

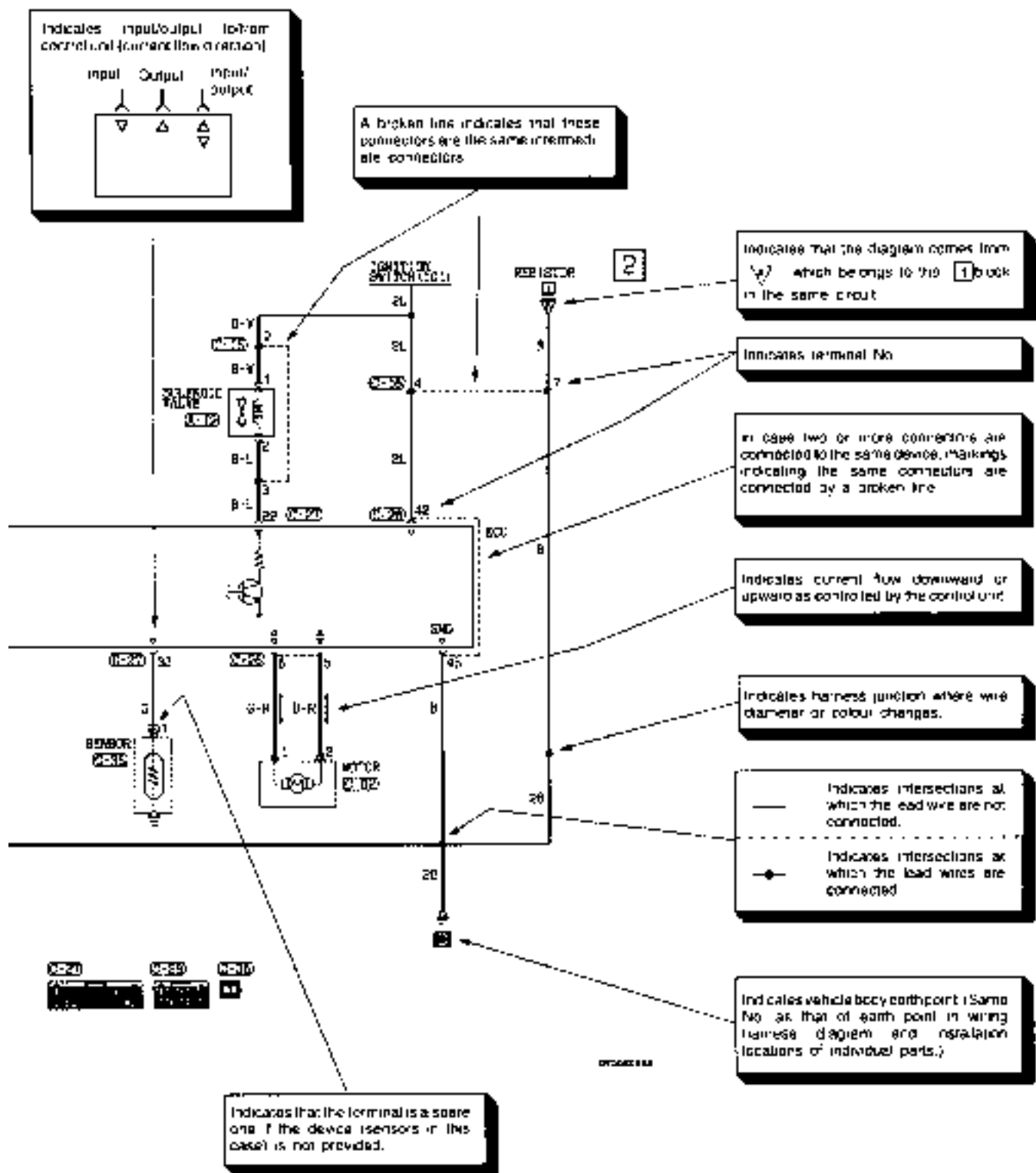

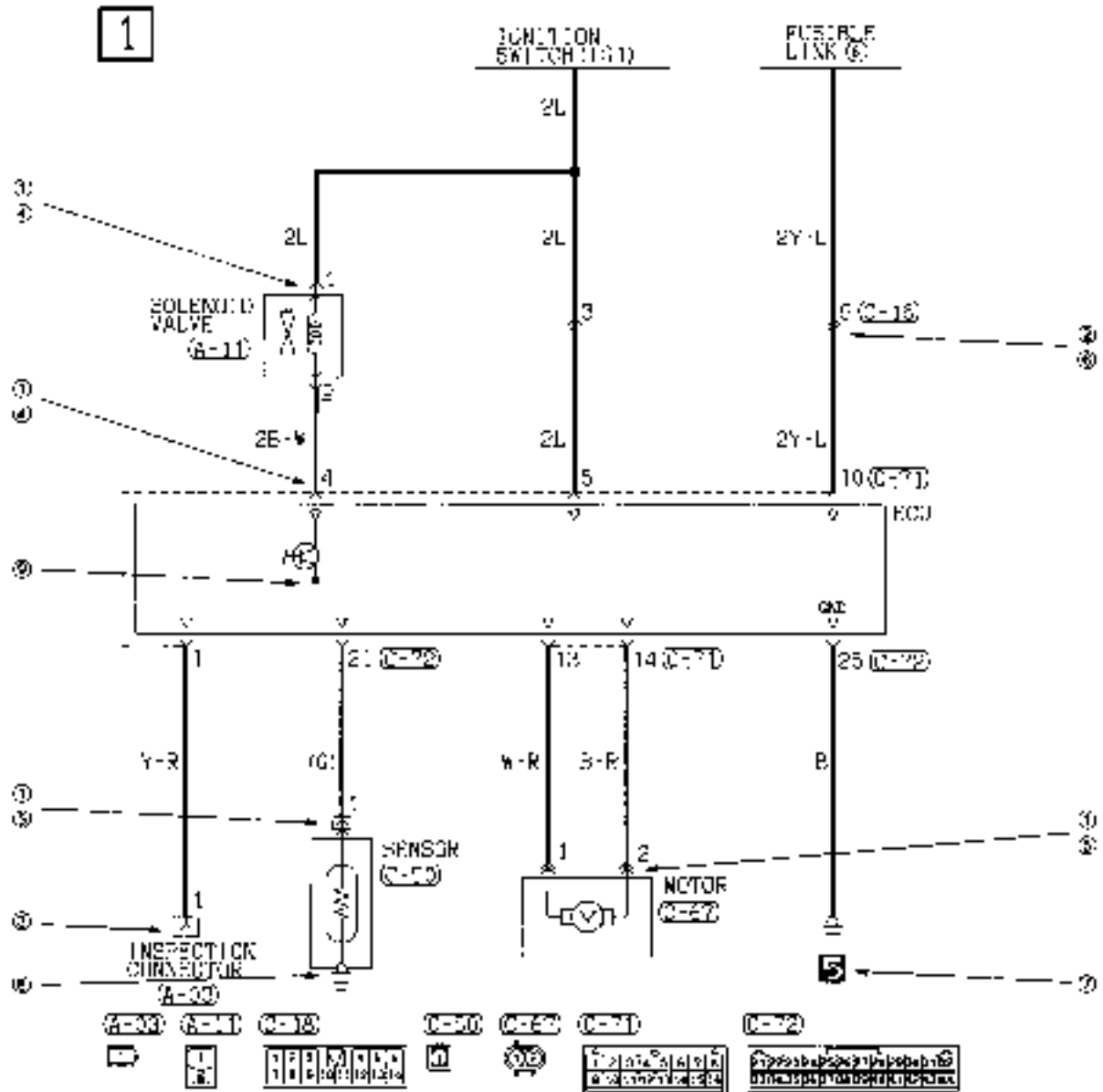

MARKINGS FOR CONNECTOR EARTHING

001 0010077

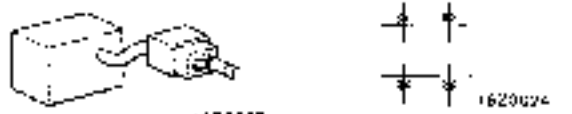

Item	No.	Connector/Earthing	Symbol	Contents
Connector and terminal marking	-		<p>Male terminal</p> <p>1620021</p>	<p>The male and female terminals are indicated as shown. The connector with male terminal(s) is called as male connector and indicated by double connector contour lines while the connector with female terminal(s) is called as female connector and indicated by single connector contour line.</p>
			<p>Male connector</p> <p>1620016</p>	
		<p>Female terminal</p> <p>1620022</p>		
		<p>Female connector</p> <p>1620017</p>		
Connector symbol marking	①	<p>Device</p>	<p>1620015</p>	<p>The symbol indicates the vehicle connector as viewed from the illustrated direction. At the connection with a device the connector symbol on the device side is shown, and for an intermediate connector, a male connector symbol is shown. For spare connectors and check connectors, no device is connected, and so the harness-side connector symbol is shown for these connectors. The details for the diagnosis connector differ from the above description. For details, refer to the "MUT-II operation instructions".</p>
	②	<p>Intermediate connector</p>	<p>1620015</p>	
	③	<p>Spare connector, check connector</p>	<p>1620017</p>	

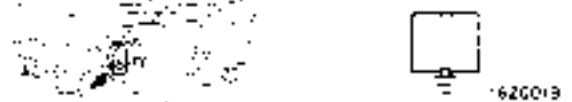
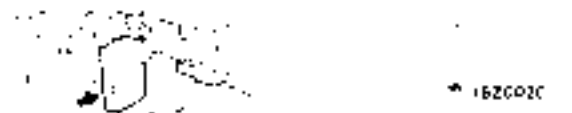
Item	No	Connector/Earthing	Symbol	Contents
Connector connector marking	2	Direct connection type		A connection between a device and connector on the harness side is either by direct insertion in the device (direct connection type) or by connection with a harness connector on the device side furnished (harness connection type). The two types are indicated as illustrated.
	3	Harness connection type		
	4	Intermediate connector		
Earth markings	7	Body earth		Earth is either by body earth, device earth or control unit interior earth. These are indicated as illustrated.
	8	Device earth		
	9	Earth in control unit		

WIRE COLOUR CODES

0010080048

Wire colours are identified by the follow colour codes.

Code	Wire colour	Code	Wire colour
B	Black	P	Pink
BR	Brown	R	Red
G	Green	SB	Sky blue
GR	Gray	SI	Silver
L	Blue	V	Violet
LG	Light green	W	White
O	Orange	Y	Yellow

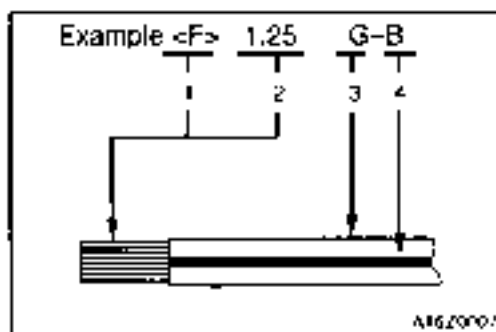

If a cable has two colours, the first of the two colour code characters indicates the basic colour (colour of the cable coating) and the second indicates the marking colour.

No	Meaning
1	<F>:Flexible wire <T>:Twisted wire
2	Wire size(mm ²)*
3	Basic colour (colour of the cable coating)
4	Marking colour

NOTE

- *: No code indicates 0.5 mm².
Cable colour code in parentheses indicates 0.3 mm².

1-10 HOW TO READ THE WIRING DIAGRAMS – Abbreviation Symbols

ABBREVIATION SYMBOLS

90190810124

The Abbreviation symbols used in wiring diagrams are defined below.

1. Abbreviation symbols used for system name

Abbreviation symbol	Meaning	Abbreviation symbol	Meaning
ABS	Anti-skid braking system	EGR	Exhaust gas recirculation
A/C	Air conditioner	MT	Manual transmission
DRL	Daytime running lamp	MPI	Multi-point injection
		SRS	Supplemental restraint system

2. Abbreviation symbols used for combination meters

Abbreviation symbol	Meaning	Abbreviation symbol	Meaning
ABS	Anti-skid braking system warning lamp	OIL	Oil pressure warning lamp
BEAM	High beam indicator lamp	R/FOG	Rear fog lamp indicator lamp
BRAKE	Brake warning lamp	SPEED	Speedometer
CHECK ENGINE	Check engine warning lamp	SRS	Supplemental restraint system warning lamp
CHG	Charging warning lamp	TACHO	Tachometer
DOOR	Door ajar warning lamp	T/GA	Engine coolant temperature gauge
F/GA	Fuel gauge	TRIP	Trip meter
F/FOG	Front fog lamp indicator lamp	TURN (LH)	Turn signal indicator (L.H.)
FUEL	Low fuel warning lamp	TURN (RH)	Turn signal indicator (R.H.)
ODO	Odometer	WASHER	Washer fluid level warning lamp

3. Abbreviation symbols used for switches and relays

Name of switches and relays	Abbreviation symbol	Operation	Name of switches and relays	Abbreviation symbol	Operation
Blower switch	LO	Blower operates at low speed	Power window switch	UP	Window closes
	ML	Blower operates at medium low speed		DOWN	Window opens
	MH	Blower operates at medium high speed		AUTO UP	Window is easily closed with one action
	HI	Blower operates at high speed		AUTO DOWN	Window is easily opened with one action
Dimmer passing switch	LO	Low beams ON	Remote controlled mirror switch	LOCK	Window locked
	HI	High beams ON		UNLOCK	Window unlocked
Doorlock actuator, door lock keycylinder switch or door lock switch	LOCK	Door locked	Room lamp switch	LH	L.H. mirror operates
	UNLOCK	Door unlocked		RH	R.H. mirror operates
Heated seat switch	LO	Normal heating	Sunroof switch	DOOR	Room lamps ON when a door is open
	HI	Rapid heating		OPEN	Sunroof slides to open
Ignition switch	ACC	When turned to the ACC (ACCESSORY) or ON position, the power circuit will start	Turn signal switch	UP	Sunroof tilts up
	IG1	Even when at the ST (START) position, the power circuit will start		CLOSE/ DOWN	Sunroof tilts down or slides to close
	IG2	When at the ST (START) position, the power circuit will not start functioning		LH	L.H. turn signal lamps ON
Lighting switch	TAIL	Position, i.e., licence plate and other illumination lamps ON	Variable intermittent wiper control switch	RH	R.H. turn signal lamps ON
	HEAD	Headlamps ON		SLOW	Pause time for intermittent operation lengthen
Others	ON	Switched on	Windshield wiper switch or rear wiper switch	FAST	Pause time for intermittent operation shorten
	OFF	Switched off		LO	Wipers operate at low speed
				HI	Wipers operate at high speed
				INT	Wipers operate intermittently

1-12 HOW TO READ THE WIRING DIAGRAMS – Abbreviation Symbols

4. Other abbreviation symbols

Abbreviation symbol	Meaning	Abbreviation symbol	Meaning
ECU	Electronic control unit	LCD	Liquid crystal display
GND	Earth	LH	Left hand
ILL	Illumination amp	LHO	L.H. drive vehicles
IND	Indicator lamp	RH	Right hand
J/B	Junction block	RHD	R.H. drive vehicles
J/C	Joint connector		

WIRING HARNESS CONFIGURATION DIAGRAMS

CONTENTS

001 09000449

OVERALL WIRING DIAGRAM

L.H. drive vehicles	2-2
R.H. drive vehicles	2-3

ENGINE COMPARTMENT

4G13 <L.H. drive vehicles>	2-4
4G93 <L.H. drive vehicles>	2-8
4G13 <R.H. drive vehicles>	2-12
4G93 <R.H. drive vehicles>	2-16

DASH PANEL

L.H. drive vehicles	2-20
R.H. drive vehicles	2-24

INSTRUMENT PANEL

L.H. drive vehicles	2-28
R.H. drive vehicles	2-29

FLOOR AND ROOF

L.H. drive vehicles	2-30
R.H. drive vehicles	2-32

DOOR

L.H. drive vehicles	2-34
R.H. drive vehicles	2-35

LUGGAGE COMPARTMENT

2-36

OVERALL WIRING DIAGRAM

00-00016364

L.H. drive vehicles

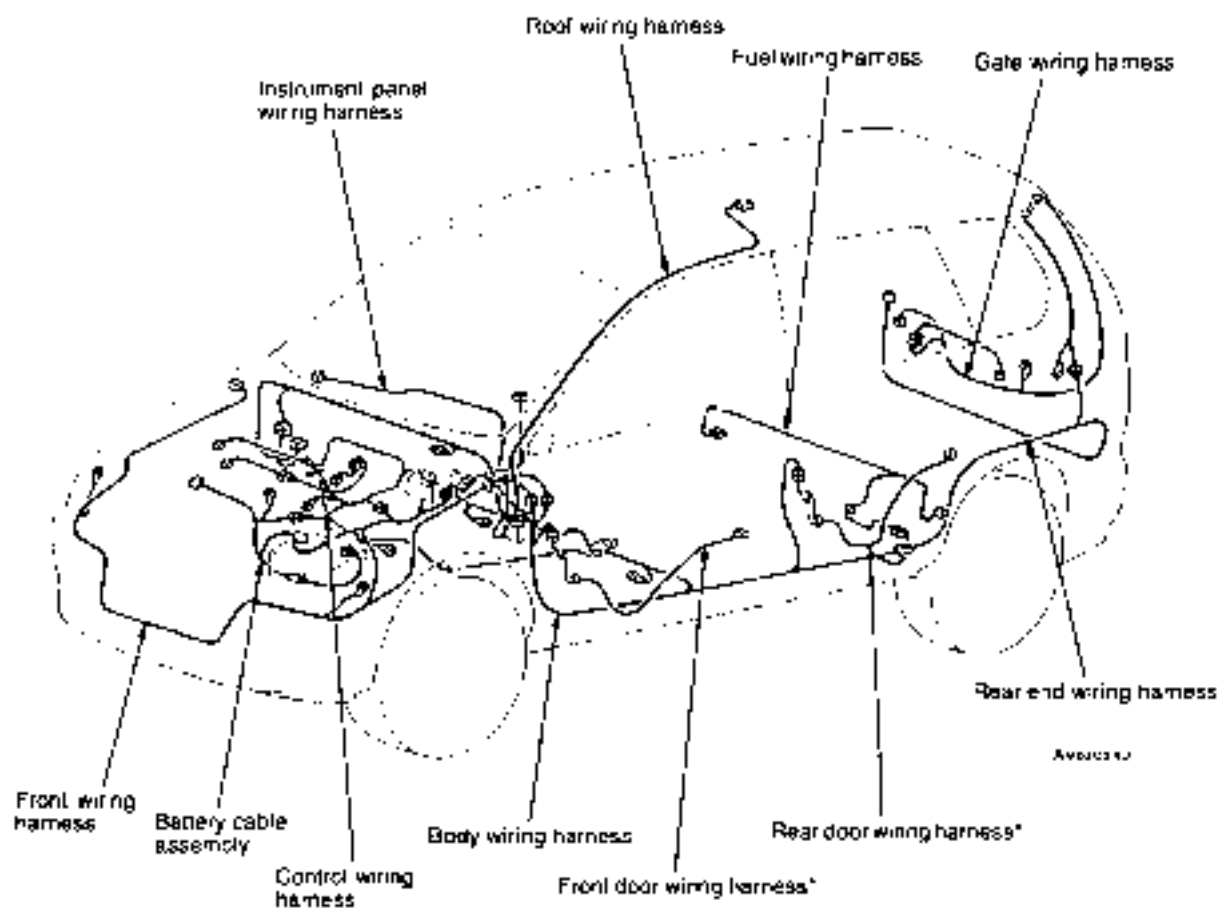

Remarks

- (1) This illustration shows only major wiring harnesses.
- (2) *: also equipped at the right side.

R.H. drive vehicles

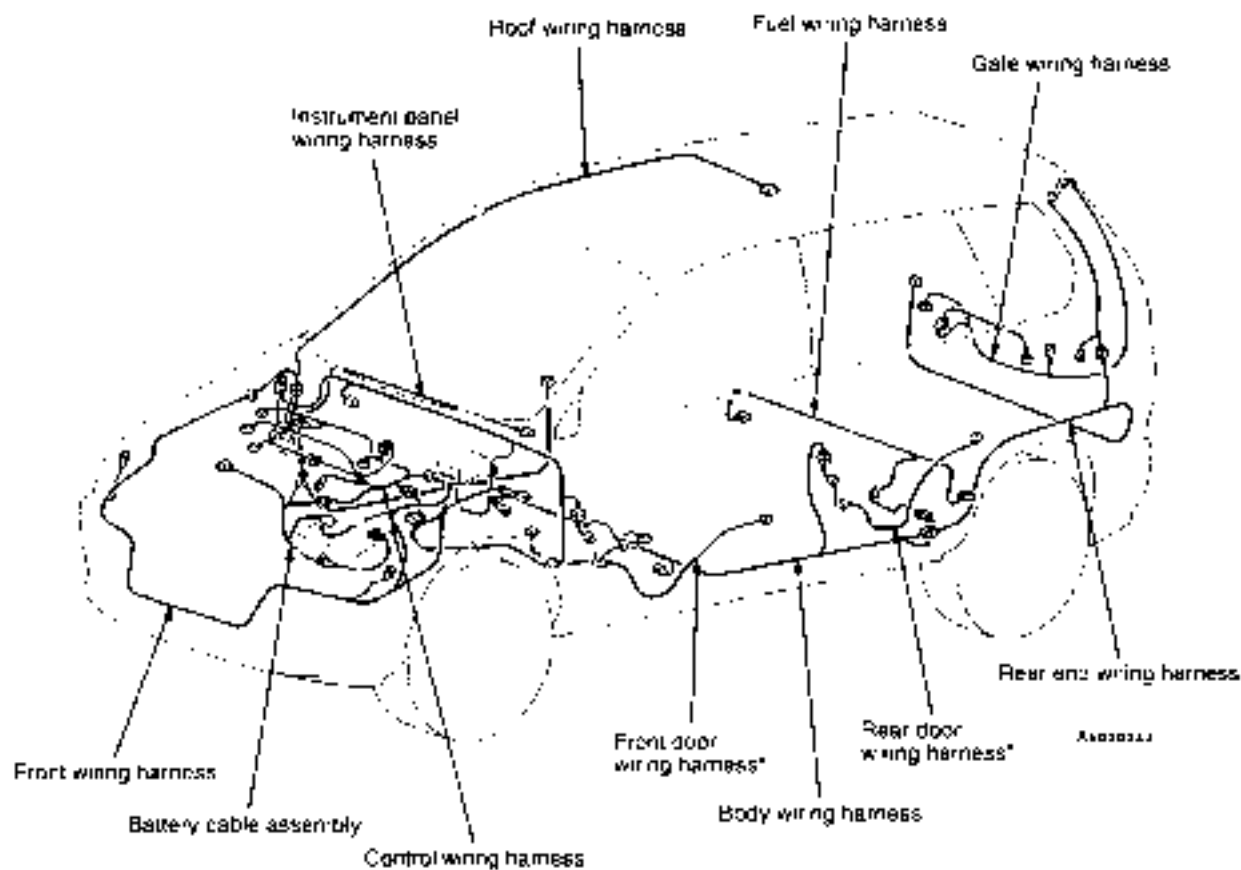

Remarks

- (1) This illustration shows only major wiring harnesses.
- (2) * also equipped at the right side.

ENGINE COMPARTMENT

80100081264

4G13 engine <L.H. drive vehicles>

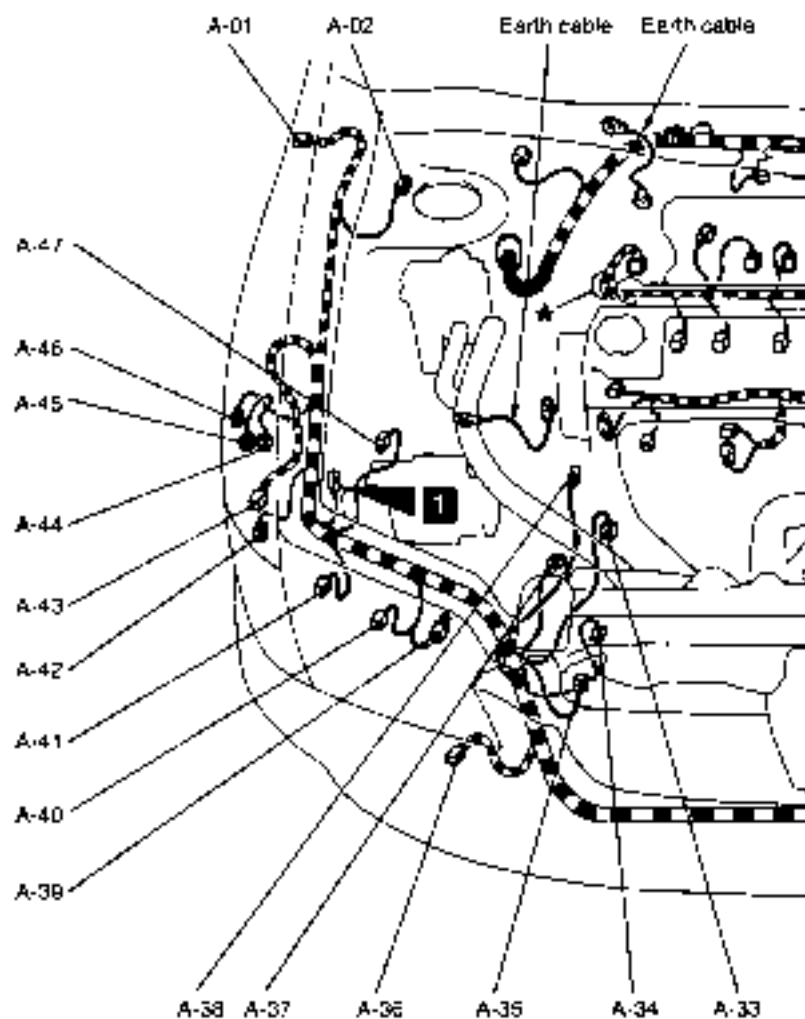
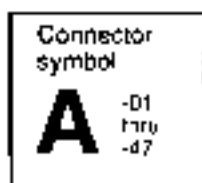

Connector color code

B: Black
 Y: Yellow
 L: Blue
 G: Green
 R: Red
 BR: Brown
 V: Violet
 O: Orange
 GR: Gray

A-01 (2-B)	Side turn signal lamp (RH)	A-17 (5)	DRL relay 1
A-02 (2-B)	Front speed sensor (RH) <ABS>	A-18 (5)	DRL relay 2
A-03X (5)	Headlamp washer relay	A-19 (2-B)	Side turn signal lamp (LH)
A-04X (4)	Alternator relay	A-20 (10-B)	Front wiring harness and DRL wiring harness combination
A-06X (5)	Horn relay	A-21 (10-B)	Front wiring harness and DRL wiring harness combination
A-08X (5)	Condenser fan relay (HI)	A-22 (2-B)	Front speed sensor (LH) <ABS>
A-09X (5)	Condenser fan relay (LO)	A-23 (10-B)	Front wiring harness and control wiring harness combination
A-10X (5)	A/C compressor relay	A-24 (2-B)	Front turn signal lamp (LH)
A-12X (5)	Headlamp relay	A-25 (3-B)	Headlamp leveling unit (LH)
A-14X (5)	Radiator fan relay		
A-15X (5)	Tail lamp relay <DRL>		
A-16 (13)	DRL-ECU		

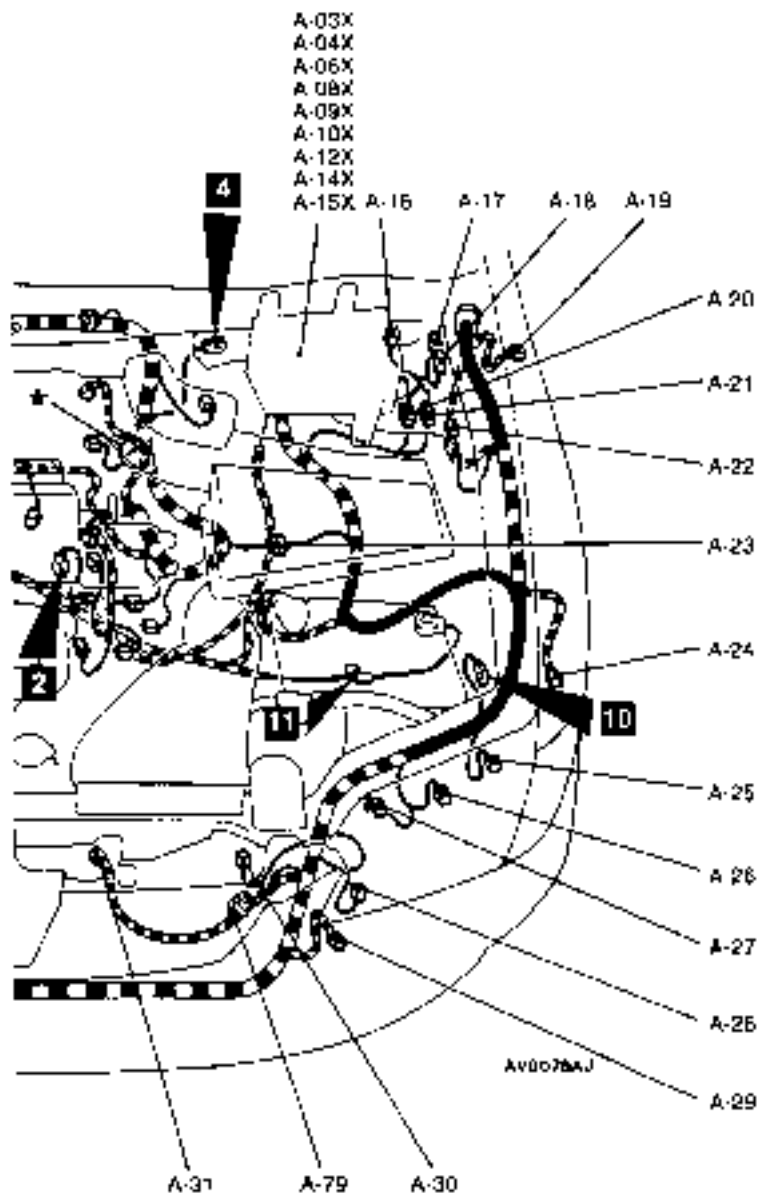

- | | | | |
|-------------|--|-------------|------------------------------------|
| A-26 (2-B) | Position lamp (LH) | A-38 (1) | Power steering oil pressure switch |
| A-27 (3-B) | Headlamp (LH) | A-39 (3-B) | Headlamp (RH) |
| A-28 (2) | Outside thermo sensor | A-40 (2-B) | Position lamp (RH) |
| A-29 (2-GR) | Front fog lamp (LH) | A-41 (3-B) | Headlamp leveling unit (RH) |
| A-30 (2-B) | Horn (LH) | A-42 (2-B) | Headlamp washer motor |
| A-31 (2-B) | Radiator fan motor | A-43 (2-B) | Front turn signal lamp (RH) |
| A-33 (2-BR) | Dual pressure switch | A-44 (2-BR) | Washer fluid level sensor |
| A-34 (4-B) | Condenser fan motor | A-45 (2-B) | Windshield washer motor |
| A-35 (2-B) | Horn (RH) | A-46 (2) | Rear washer motor |
| A-36 (2-GR) | Front fog lamp (RH) | A-47 (31-B) | ABS-ECU |
| A-37 (1-B) | A/C refrigerant temperature switch and magnetic clutch | A-79 (1-B) | Spare connector for front fog lamp |

4G13 engine <L.H. drive vehicles>

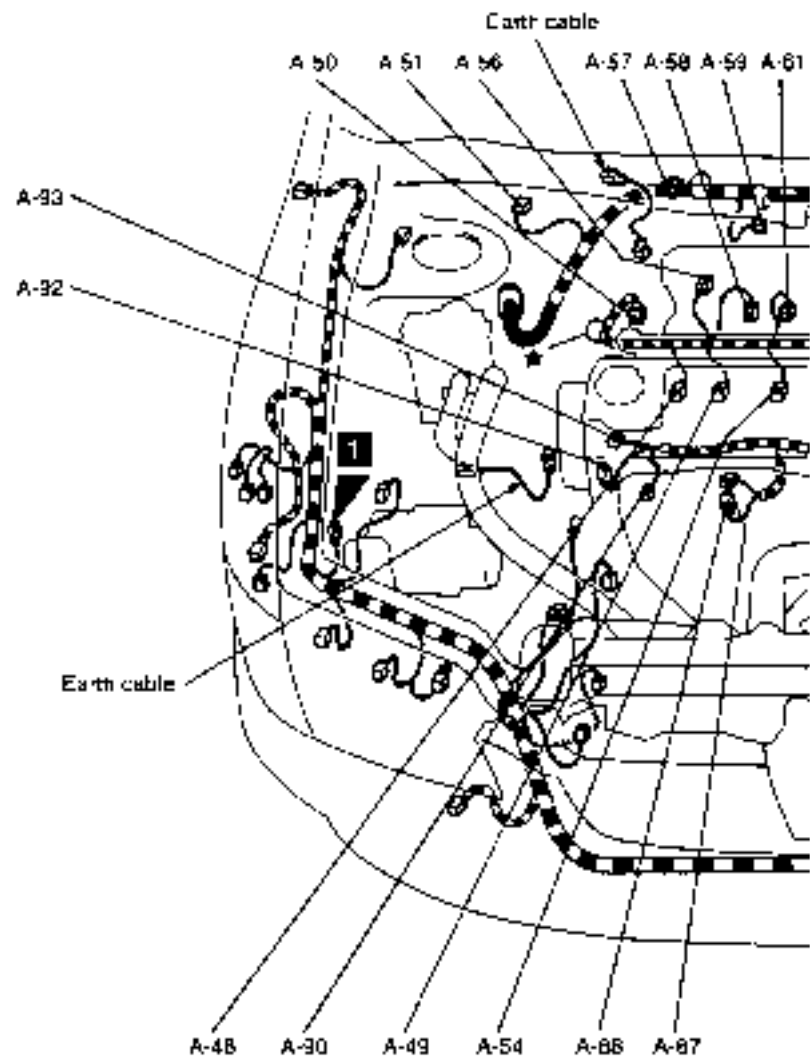
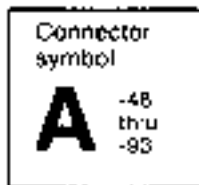

Connector color code

B: Black
 Y: Yellow
 L: Blue
 G: Green
 R: Red
 BR: Brown
 V: Violet
 O: Orange
 GR: Gray

A-48 (2-GR) Injector No. 1
 A-49 (2-GR) Injector No. 2
 A-50 (2-GR) Detonation sensor
 A-51 (5-B) Windshield wiper motor
 A-54 (2-GR) Injector No. 3
 A-56 (2-B) Intake air temperature sensor
 A-57 (1-BR) Ignition timing adjustment connector

A-58 (2-B) Purge control solenoid valve
 A-59 (3-GR) Vacuum sensor
 A-60 (2-GR) Injector No. 4
 A-61 (2-BR) EGR solenoid valve
 A-64 (1-L) Engine speed detection connector
 A-66 (4) Throttle position sensor
 A-67 (6-B) Idle speed control servo

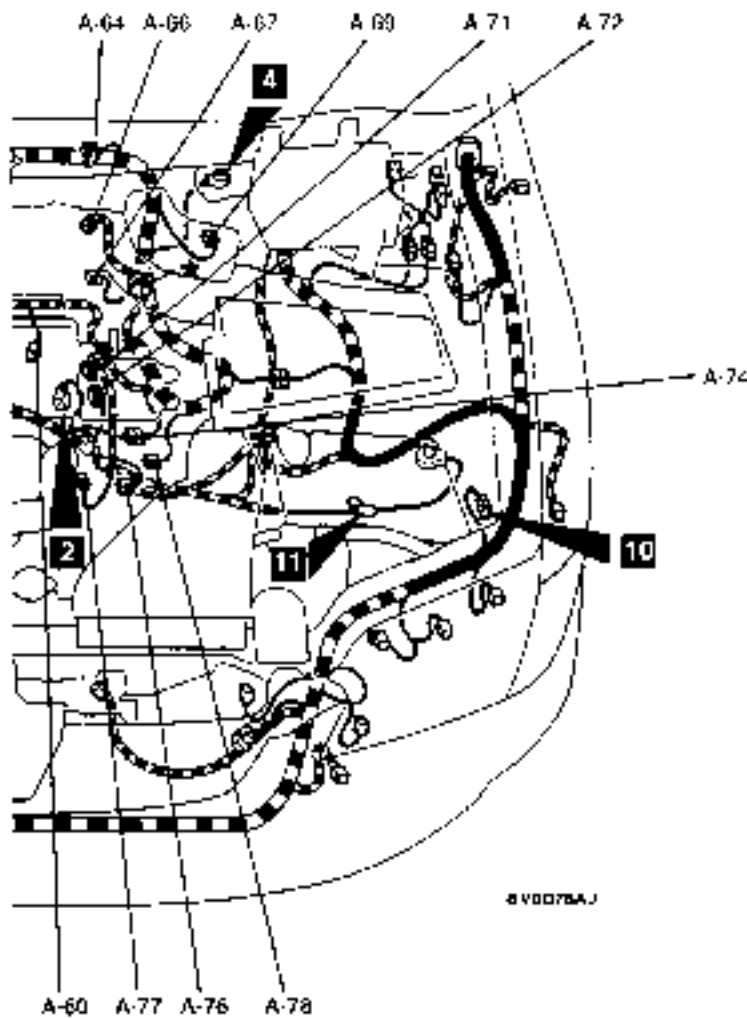

- | | | | |
|------------|---|------------|---------------------|
| A-69 (2-B) | Brake fluid level sensor | A-78 (2-G) | Back-up lamp switch |
| A-71 (3-B) | Vehicle speed sensor | A-87 (1) | Starter |
| A-72 (7-B) | Distributor assembly | A-88 (1) | Starter |
| A-74 (4-B) | Control wiring harness and battery cable assembly combination | A-90 (1-B) | Oil pressure switch |
| A-76 (2-B) | Engine coolant temperature sensor | A-92 (1) | Alternator |
| A-77 (1-B) | Engine coolant temperature gauge unit | A-93 (2-B) | Alternator |

ENGINE COMPARTMENT

80106031274

4G93 engine <L.H. drive vehicles>

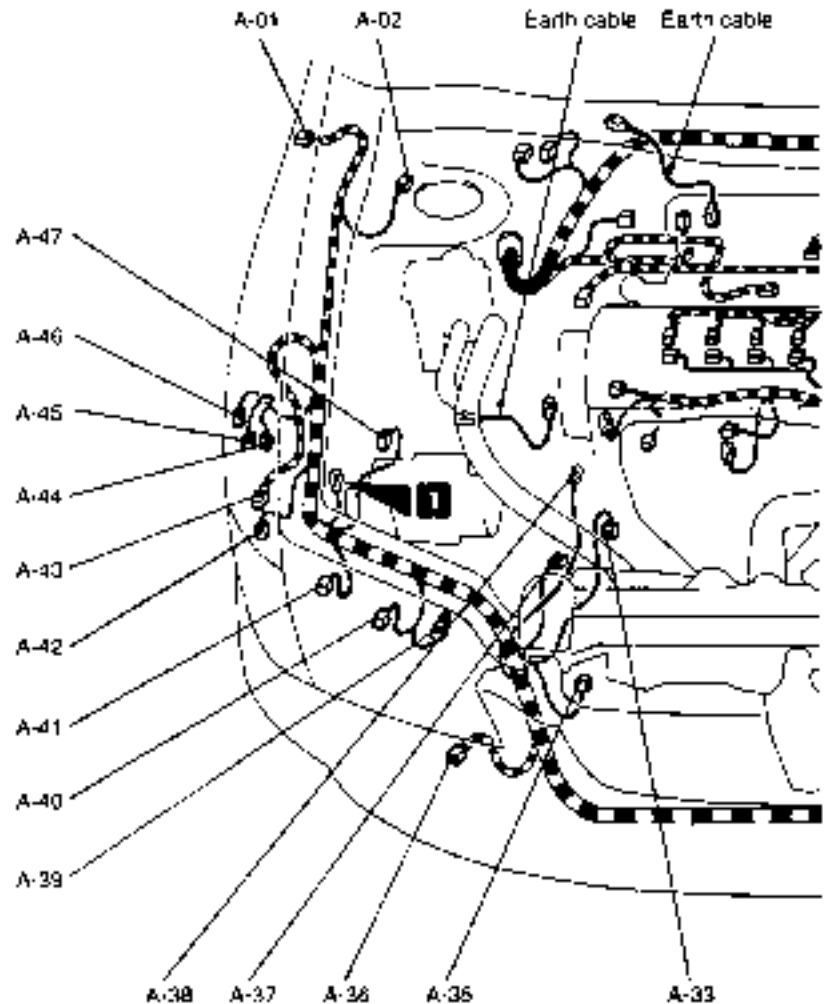
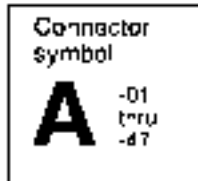

Connector color code:

B. Black
 Y. Yellow
 L. Blue
 G. Green
 R. Red
 BR. Brown
 V. Violet
 O. Orange
 GR. Gray

A-01 (2-B)	Side turn signal lamp (RH)	A-18 (5)	DRL relay 2
A-02 (2-B)	Front speed sensor (RH) <ABS>	A-19 (2-B)	Side turn signal lamp (LH)
A-03X (5)	Headlamp washer relay	A-20 (10-B)	Front wiring harness and DRL wiring harness combination
A-04X (4)	Air blower relay	A-21 (10-B)	Front wiring harness and DRL wiring harness combination
A-05X (5)	Horn relay	A-22 (2-B)	Front speed sensor (LH) <ABS>
A-07X (5)	Fan control relay	A-23 (10-B)	Front wiring harness and control wiring harness combination
A-10X (5)	A/C compressor relay	A-24 (2-B)	Front turn signal lamp (LH)
A-12X (5)	Headlamp relay		
A-15X (5)	Tail lamp relay <DRL>		
A-16 (13)	DRL-ECU		
A-17 (5)	DRL relay 1		

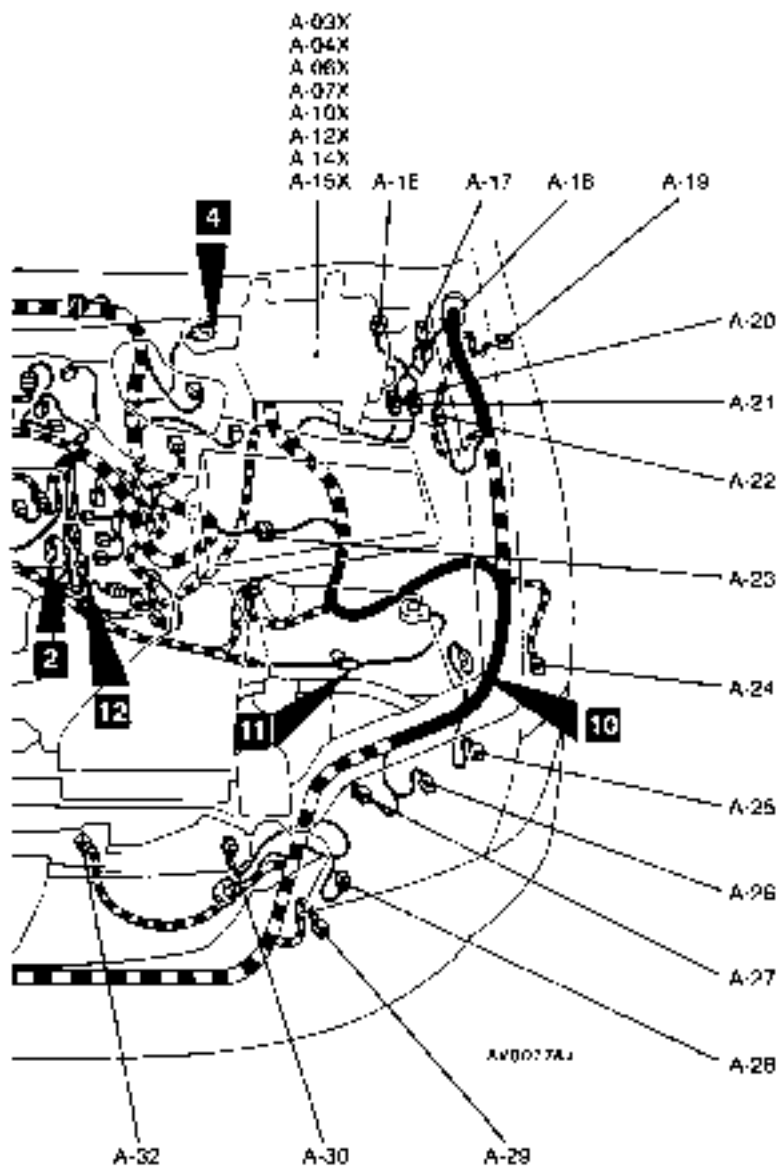

- | | | | |
|-------------|--|-------------|------------------------------------|
| A-25 (3-B) | Headlamp leveling unit (LH) | A-38 (1) | Power steering oil pressure switch |
| A-26 (2-B) | Position lamp (LH) | A-39 (3-B) | Headlamp (RH) |
| A-27 (3-B) | Headlamp (LH) | A-40 (2-B) | Position lamp (RH) |
| A-28 (2) | Outside thermo sensor | A-41 (3-B) | Headlamp leveling unit (RH) |
| A-29 (2-GR) | Front fog lamp (LH) | A-42 (2-B) | Headlamp washer motor |
| A-30 (2-B) | Horn (LH) | A-43 (2-B) | Front turn signal lamp (RH) |
| A-32 (3-GR) | Fan controller | A-44 (2-BR) | Washer fluid level sensor |
| A-33 (2-BR) | Dual pressure switch | A-45 (2-B) | Windshield washer motor |
| A-35 (2-B) | Horn (RH) | A-46 (2) | Rear washer motor |
| A-36 (2-GR) | Front fog lamp (RH) | A-47 (31-B) | ABS-ECU |
| A-37 (1-B) | A/C refrigerant temperature switch and magnetic clutch | A-79 (1-B) | Spare connector for front fog lamp |

4G93 engine <L.H. drive vehicles>

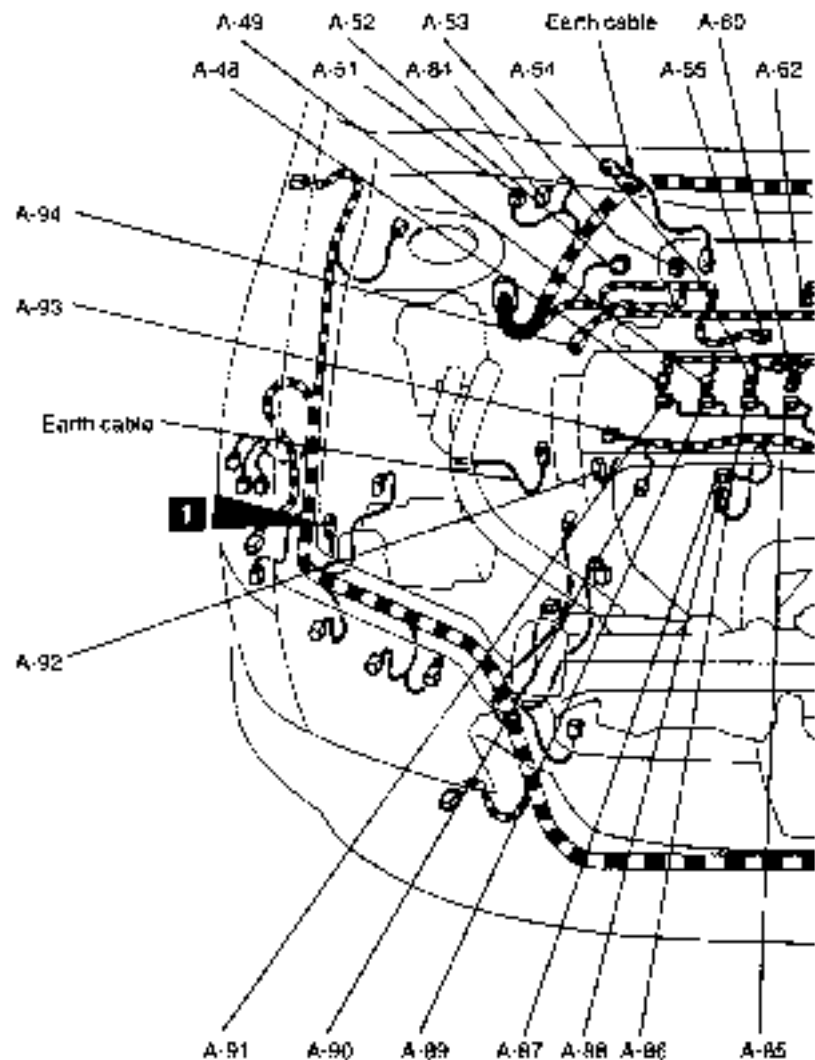
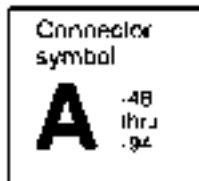

Connector color code

B. Black
 Y. Yellow
 L. Blue
 G. Green
 R. Red
 BR. Brown
 V. Violet
 O. Orange
 GR. Gray

A-48 (2-GR)	Injector No. 1	A-62 (6-B)	EGR servo
A-49 (2-GR)	Injector No. 2	A-64 (1-L)	Engine speed detection connector
A-50 (2-GR)	Detonation sensor	A-65 (6-B)	Control wiring harness and EGR wiring harness combination
A-51 (5-B)	Windshield wiper motor	A-66 (4-B)	Throttle position sensor
A-52 (26-B)	Injector driver	A-68 (4-GR)	Throttle valve control servo
A-53 (4-GR)	Injector driver control relay	A-69 (2-B)	Brake fluid level sensor
A-54 (2-GR)	Injector No. 3	A-70 (3-GR)	Brake vacuum sensor
A-55 (4-B)	Oxygen sensor	A-71 (3-B)	Vehicle speed sensor
A-58 (2-B)	Purge control solenoid valve	A-73 (7-B)	Air flow sensor
A-60 (2-GR)	Injector No. 4		

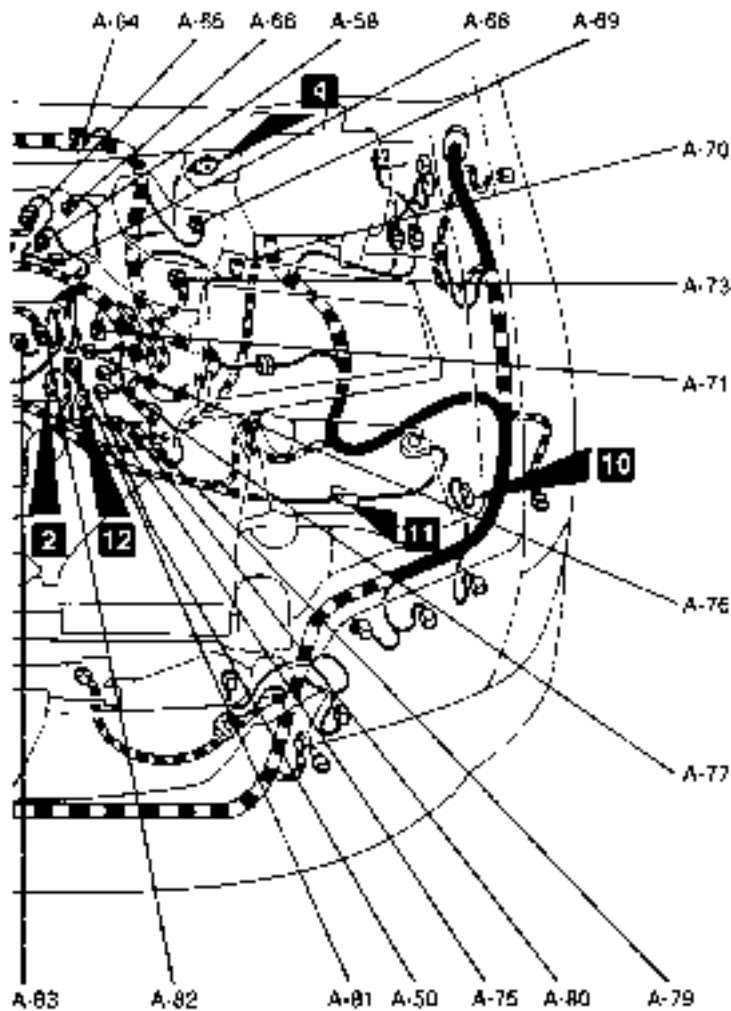

R V00774J

A-75 (6-B)	Control wiring harness and battery cable assembly combination	A-85 (3-GR)	Ignition coil 4
A-76 (2-B)	Engine coolant temperature sensor	A-86 (3-GR)	Ignition coil 3
A-77 (1-B)	Engine coolant temperature gauge unit	A-87 (1)	Starter
A-78 (2-B)	Back-up lamp switch	A-88 (1)	Starter
A-80 (2-GR)	M/T oil temperature sensor	A-89 (3-GR)	Ignition coil 2
A-81 (3-B)	Camshaft position sensor	A-90 (1-B)	Oil pressure switch
A-82 (8-B)	Control wiring harness and injector wiring harness combination	A-91 (3-GR)	Ignition coil 1
A-83 (3-B)	Fuel pressure sensor	A-92 (1)	Alternator
A-84 (8)	Accelerator pedal position sensor	A-93 (4-B)	Alternator
		A-94 (3-B)	Crank angle sensor

ENGINE COMPARTMENT

80100081206

4G13 engine <R.H. drive vehicles>

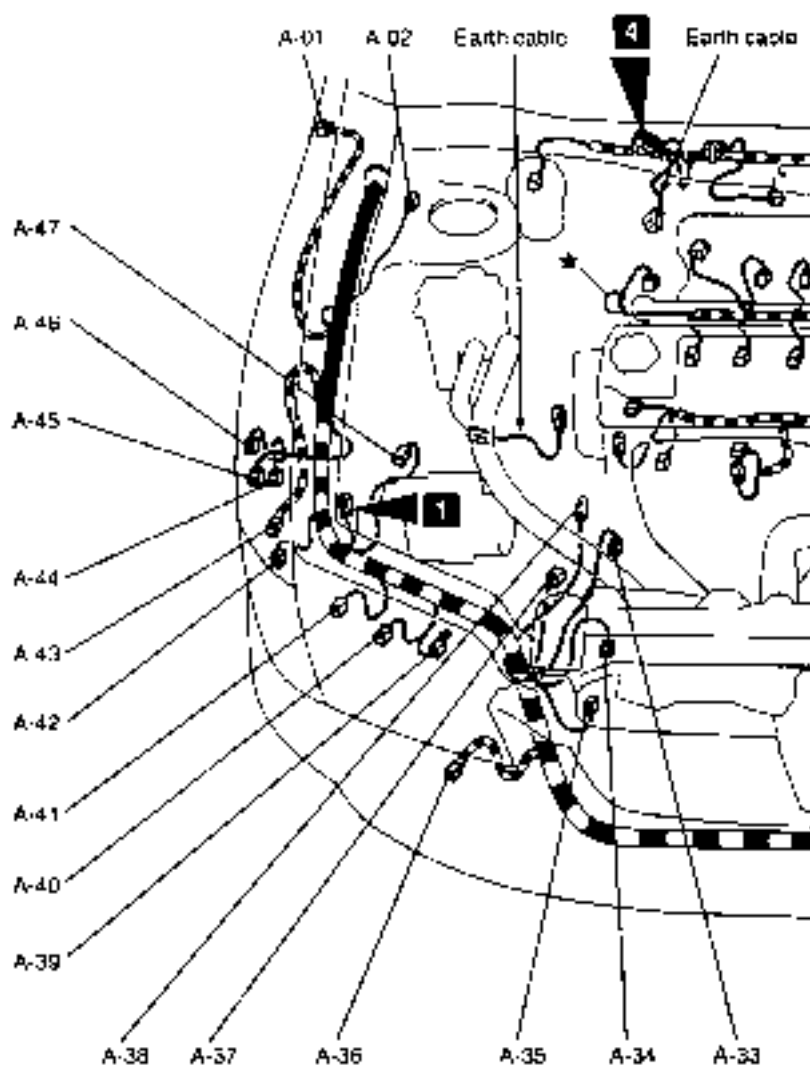
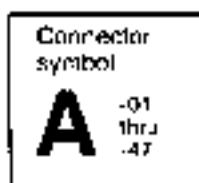

Connector color code

B: Black
 Y: Yellow
 L: Blue
 G: Green
 H: Red
 BR: Brown
 V: Violet
 O: Orange
 GR: Grey

A-01 (2-B)	Side turn signal lamp (RH)	A-19 (2-B)	Side turn signal lamp (LH)
A-02 (2-B)	Front speed sensor (RH) <ABS>	A-22 (2-B)	Front speed sensor (LH) <ABS>
A-03X (5)	Headlamp washer relay	A-23 (10-B)	Front wiring harness and control wiring harness combination
A-04X (4)	Alternator relay	A-24 (2-B)	Front turn signal lamp (LH)
A-06X (5)	Horn relay	A-25 (3-B)	Headlamp leveling unit (LH)
A-08X (5)	Condenser fan relay (HI)	A-26 (2-B)	Position lamp (LH)
A-09X (5)	Condenser fan relay (LO)	A-27 (3-B)	Headlamp (LH)
A-10X (5)	A/C compressor relay	A-28 (2)	Outside thermo sensor
A-12X (5)	Headlamp relay	A-29 (2-GR)	Front fog lamp (LH)
A-14X (5)	Radiator fan relay		

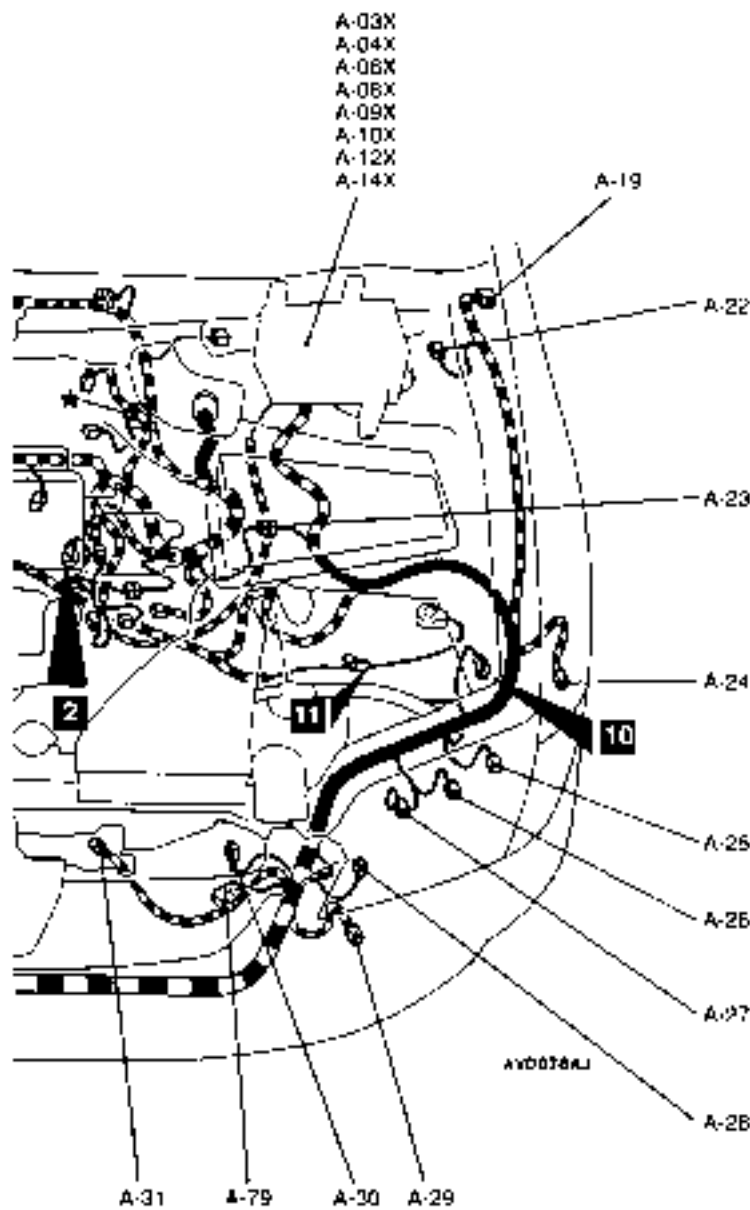

A-30 (2-B)	Horn (LH)	A-40 (2-B)	Position lamp (RH)
A-31 (2-B)	Radiator fan motor	A-41 (3-B)	Headlamp leveling unit (RH)
A-33 (2-BR)	Dual pressure switch	A-42 (2-B)	Headlamp washer motor
A-34 (4-B)	Condenser fan motor	A-43 (2-B)	Front turn signal lamp (RH)
A-35 (2-B)	Horn (RH)	A-44 (2-BR)	Washer fluid level sensor
A-36 (2-GR)	Front fog lamp (RH)	A-45 (2-B)	Windshield washer motor
A-37 (1-B)	A/C refrigerant temperature switch and magnetic clutch	A-46 (2)	Rear washer motor
A-38 (1)	Power steering oil pressure switch	A-47 (31-B)	ABS-FCU
A-39 (3-B)	Headlamp (RH)	A-79 (1-B)	Spare connector for front fog lamp

4G13 engine <R.H. drive vehicles>

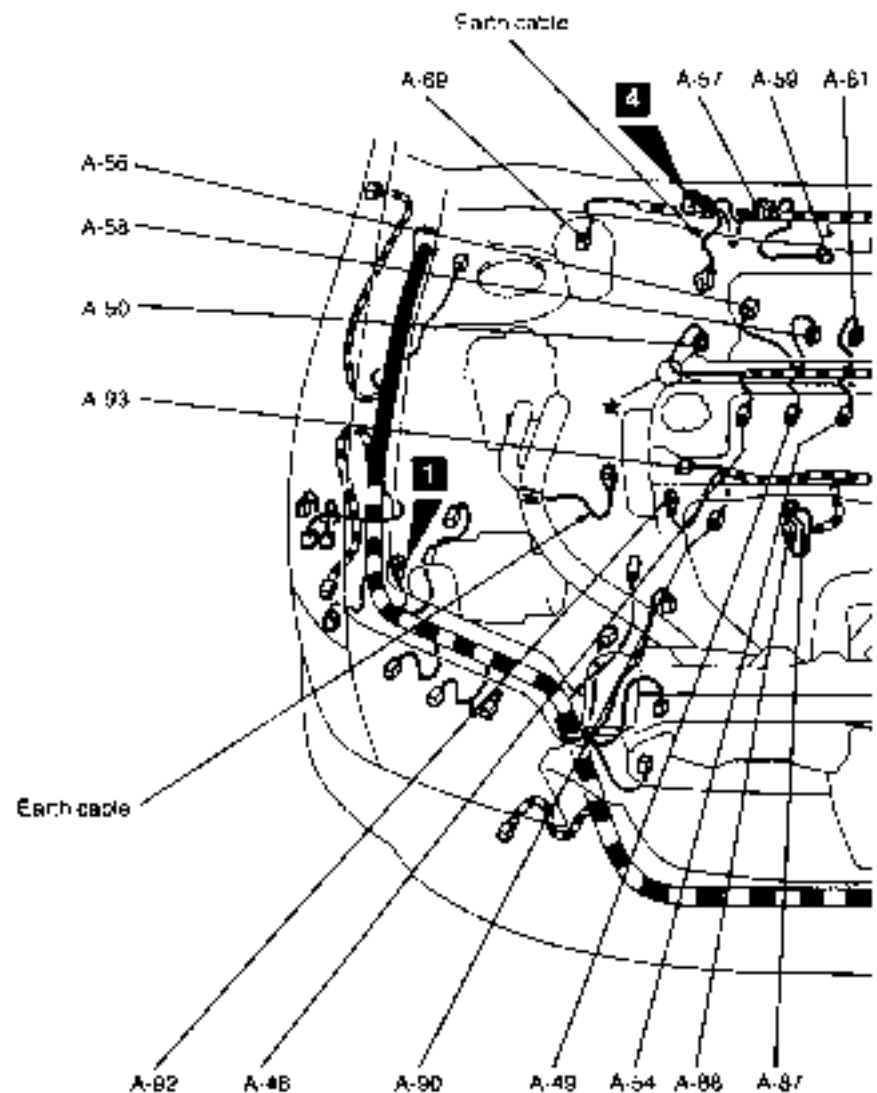
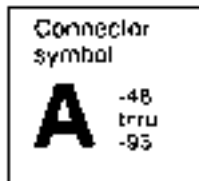

Connector color code

B: Black
 Y: Yellow
 L: Blue
 G: Green
 R: Red
 BR: Brown
 V: Violet
 O: Orange
 GR: Gray

A-48 (2-GR) Injector No. 1
 A-49 (2-GR) Injector No. 2
 A-50 (2-GR) Detonation sensor
 A-51 (5-B) Windshield wiper motor
 A-54 (2-GR) Injector No. 3
 A-56 (2-B) Intake air temperature sensor
 A-57 (1-BR) Ignition timing adjustment connector

A-58 (2-B) Purge control solenoid valve
 A-59 (3-GR) Vacuum sensor
 A-60 (2-GR) Injector No. 4
 A-61 (2-BR) EGR solenoid valve
 A-64 (1-L) Engine speed detection connector
 A-66 (4) Throttle position sensor
 A-67 (6-B) Idle speed control servo

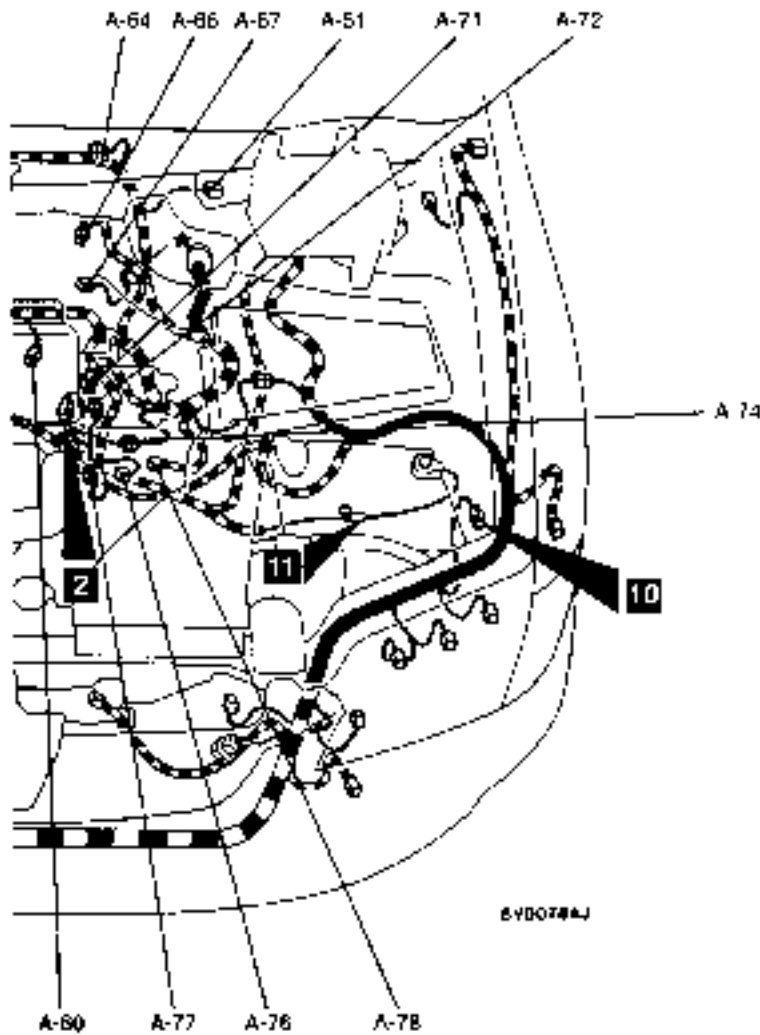

A-69 (2-B)	Brake fluid level sensor	A-78 (2-G)	Back-up lamp switch
A-71 (3-B)	Vehicle speed sensor	A-87 (1)	Starter
A-72 (7-B)	Distributor assembly	A-88 (1)	Starter
A-74 (4-B)	Control wiring harness and battery cable assembly combination	A-90 (1-B)	Oil pressure switch
A-76 (2-B)	Engine coolant temperature sensor	A-92 (1)	Alternator
A-77 (1-B)	Engine coolant temperature gauge unit	A-93 (2-B)	Alternator

ENGINE COMPARTMENT

60100081295

4G93 engine <R.H. drive vehicles>

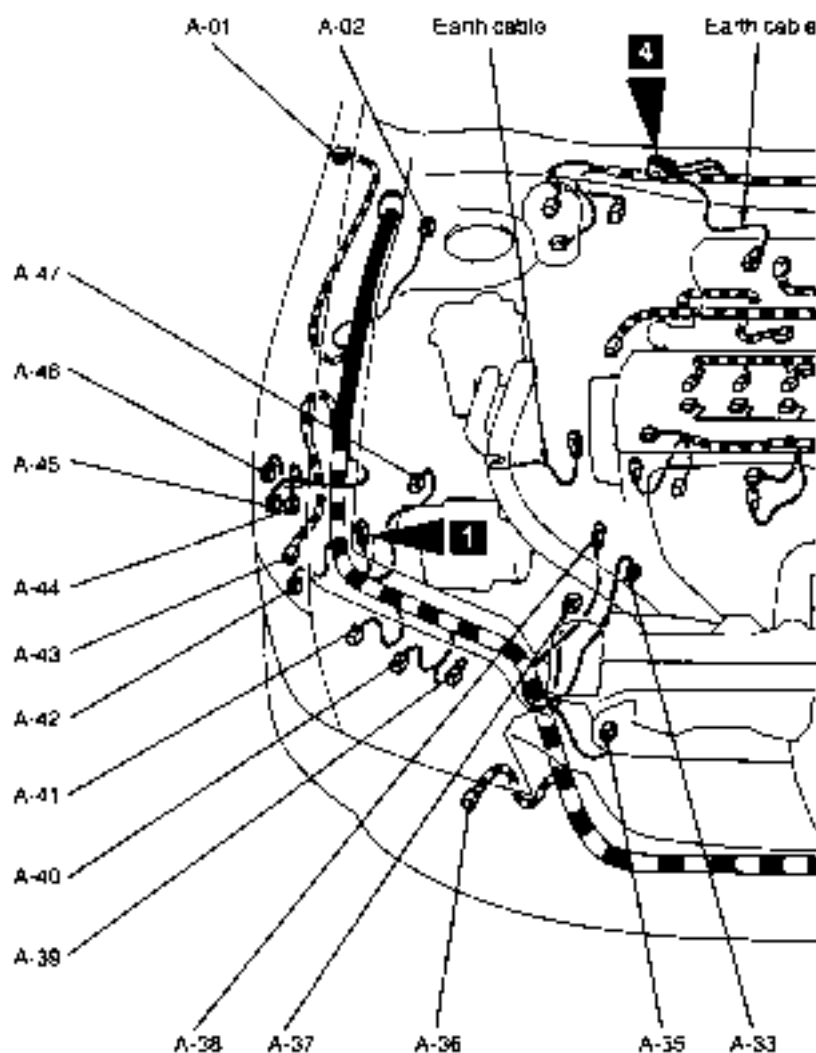

Connector color code

B: Black
 Y: Yellow
 L: Blue
 G: Green
 R: Red
 BR: Brown
 V: Violet
 O: Orange
 GR: Gray

A-01 (2-B) Side turn signal lamp (RH)
 A-02 (2-B) Front speed sensor (RH) <ABS>
 A-03X (5) Headlamp washer relay
 A-04X (4) Alternator relay
 A-06X (5) Horn relay
 A-07X (5) Fan control relay
 A-10X (5) A/C compressor relay
 A-12X (5) Headlamp relay
 A-14X (5) Radiator fan relay

A-19 (2-B) Side turn signal lamp (LH)
 A-22 (2-B) Front speed sensor (LH) <ABS>
 A-23 (10-B) Front wiring harness and control wiring harness combination
 A-24 (2-B) Front turn signal lamp (LH)
 A-25 (3-B) Headlamp leveling unit (LH)
 A-26 (2-B) Position lamp (LH)
 A-27 (3-B) Headlamp (LH)
 A-28 (2) Outside thermo sensor

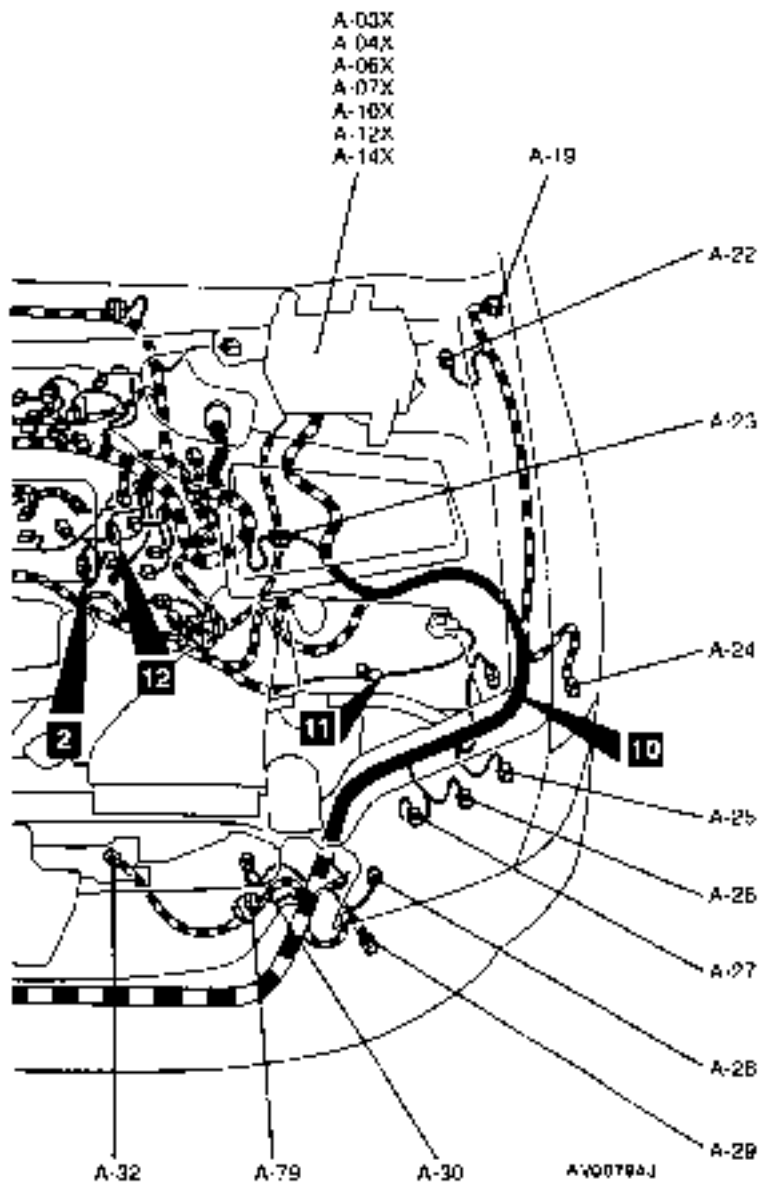

- | | | | |
|-------------|--|-------------|------------------------------------|
| A-29 (2-GR) | Front fog lamp (LH) | A-40 (2-B) | Position lamp (RH) |
| A-30 (2-B) | Horn (LH) | A-41 (3-B) | Headlamp leveling unit (RH) |
| A-32 (3-GR) | Fan controller | A-42 (2-B) | Headlamp washer motor |
| A-33 (2-BR) | Dual pressure switch | A-43 (2-B) | Front turn signal lamp (RH) |
| A-35 (2-B) | Horn (RH) | A-44 (2-BR) | Washer fluid level sensor |
| A-36 (2-GR) | Front fog lamp (RH) | A-45 (2-B) | Windshield washer motor |
| A-37 (1-B) | A/C refrigerant temperature switch and magnetic clutch | A-46 (2) | Rear washer motor |
| A-38 (1) | Power steering oil pressure switch | A-47 (31-B) | ABS-ECU |
| A-39 (3-B) | Head lamp (RH) | A-79 (1-B) | Spare connector for front fog lamp |

4G93 engine <R.H. drive vehicles>

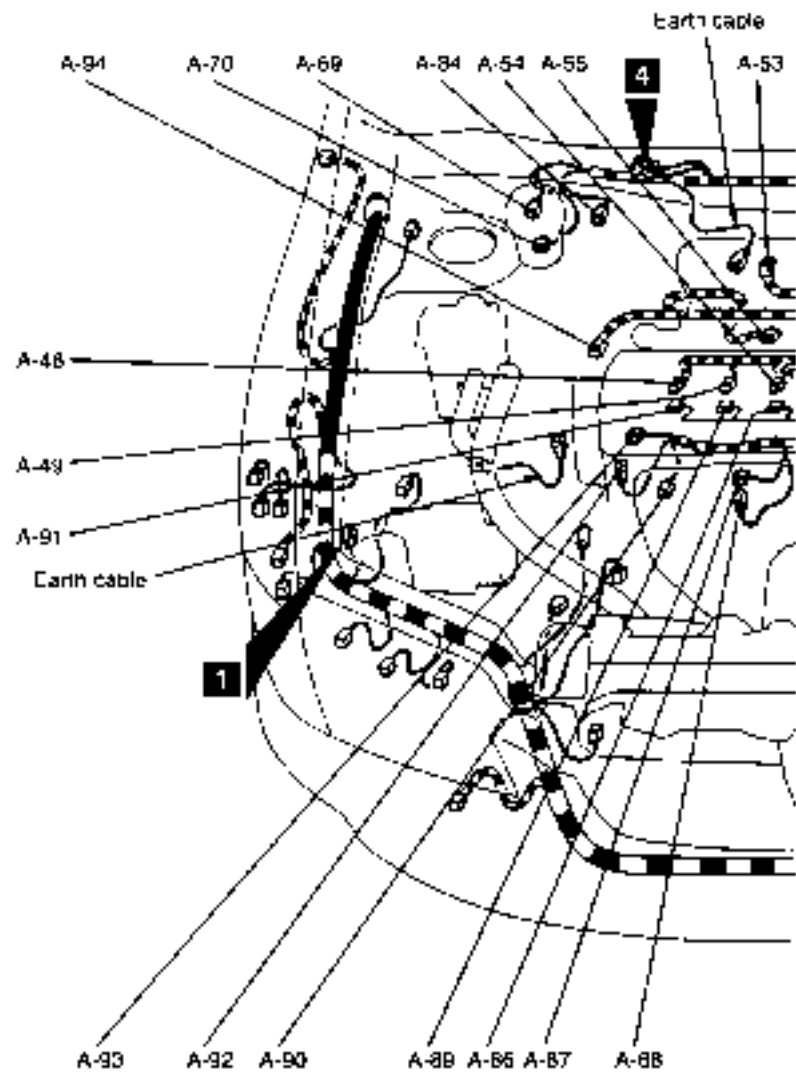
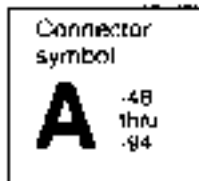

A-48 (2-GR)	Injector No. 1	A-62 (6-B)	EGR motor
A-49 (2-GR)	Injector No. 2	A-64 (1-L)	Engine speed detection connector
A-50 (2-GR)	Detonation sensor	A-65 (8-B)	Control wiring harness and EGR wiring harness combination
A-51 (5-B)	Windshield wiper motor	A-66 (4-B)	Throttle position sensor
A-52 (26-B)	Injector driver	A-68 (4-GR)	Throttle valve control motor
A-53 (4-GR)	Injector driver control relay	A-69 (2-B)	Brake fluid level sensor
A-54 (2-GR)	Injector No. 3	A-70 (3-GR)	Brake vacuum sensor
A-55 (4-B)	Oxygen sensor	A-71 (3-B)	Vehicle speed sensor
A-58 (2-B)	Purge control solenoid valve		
A-60 (2-GR)	Injector No. 4		

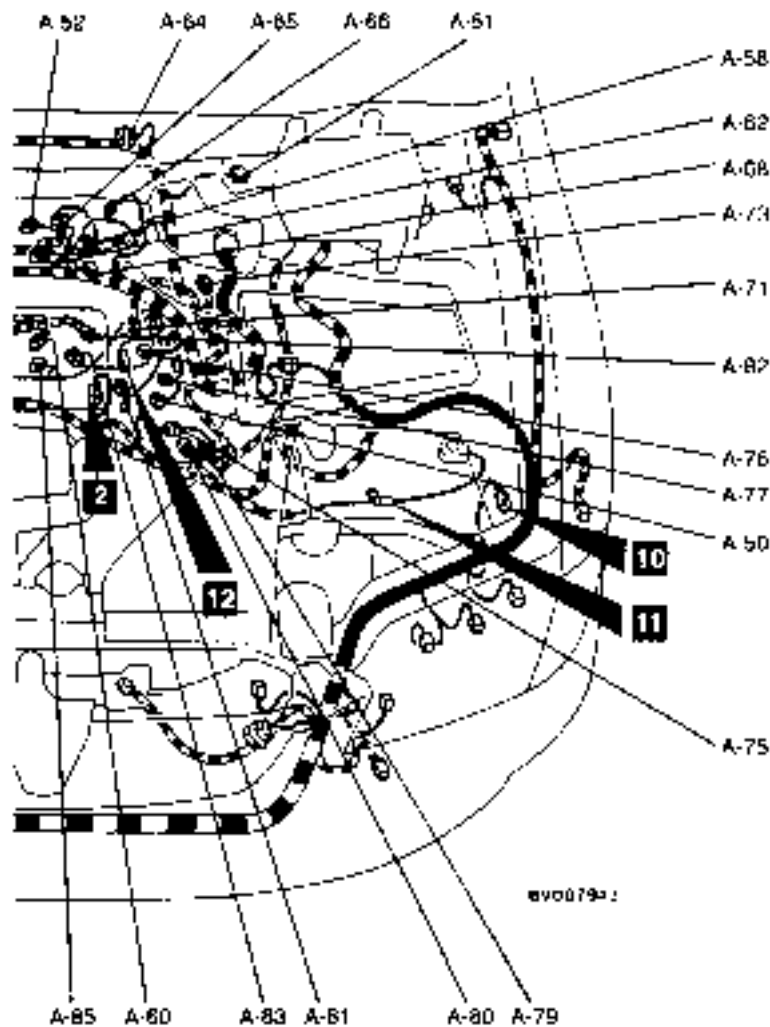

- | | | | |
|-------------|--|-------------|-----------------------------------|
| A-73 (7-B) | Air flow sensor | A-84 (8) | Accelerator pedal position sensor |
| A-75 (6-B) | Control wiring harness and battery cable assembly combination | A-85 (3-GR) | Ignition coil 4 |
| A-76 (2-B) | Engine coolant temperature sensor | A-86 (3-GR) | Ignition coil 3 |
| A-77 (1-B) | Engine coolant temperature gauge unit | A-87 (1) | Starter |
| A-78 (2-B) | Back-up lamp switch | A-88 (1) | Starter |
| A-80 (2-GR) | M/T oil temperature sensor | A-89 (3-GR) | Ignition coil 2 |
| A-81 (3-B) | Camshaft position sensor | A-90 (1-B) | Oil pressure switch |
| A-82 (8-B) | Control wiring harness and injector wiring harness combination | A-91 (3-GR) | Ignition coil 1 |
| A-83 (3-B) | Fuel pressure sensor | A-92 (1) | Alternator |
| | | A-93 (4-B) | Alternator |
| | | A-94 (3-B) | Crank angle sensor |

DASH PANEL

80100080705

L.H. drive vehicles

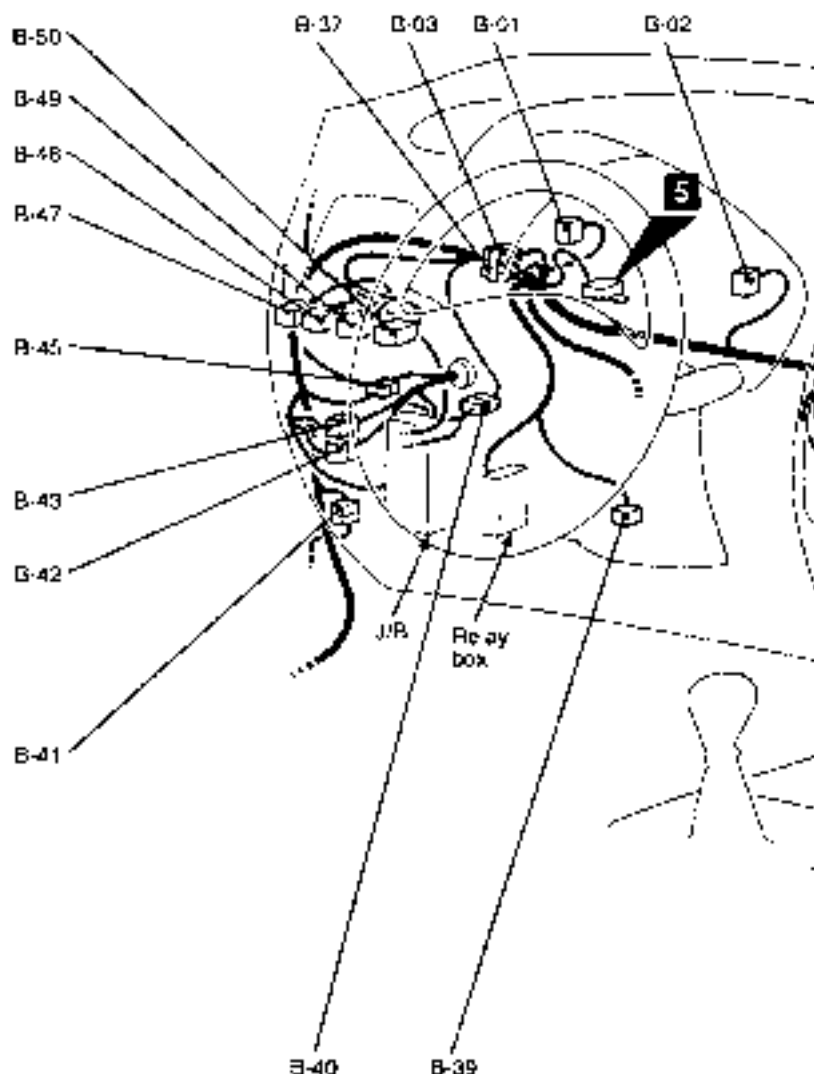

Connector color code

B Black
 Y Yellow
 L Blue
 G Green
 R Red
 BR Brown
 V Violet
 O Orange
 GR Gray

B-01 (25)	Combination meter	B-14 (12-B)	Navigation unit
B-02 (25)	Combination meter	B-15 (26-GR)	Throttle valve controller <4G93>
B-03 (2-B)	Diode (Headlamp circuit)	B-16 (4)	Automatic compressor ECU
B-04 (16)	Audio unit <Vehicles with navigation system>	B-17 (2-R)	Air bag module (squib) (Passenger's side)
B-05 (14)	Audio unit <Vehicles without navigation system>	B-18 (4)	Control wiring harness and body wiring harness combination
B-06 (12)	A/C switch	B-19 (22)	Control wiring harness and body wiring harness combination
B-07 (1-B)	Audio unit <Vehicles with navigation system>	B-20 (4-G)	Outside/inside air selection damper control motor
B-08 (16-B)	Multi center display	B-21 (22-DG)	Keyless entry receiver-ECU
B-09 (20-B)	Multi center display	B-22 (22)	Body wiring harness and front door wiring harness (Passenger's side) combination
B-10 (6)	Blower switch	B-23 (2)	Blower motor
B-11 (14)	Audio <Vehicles with navigation system>	B-24 (4)	Resistor
B-12 (1-B)	Audio <Vehicles without navigation system>		
B-13 (2)	Blower control illumination lamp		

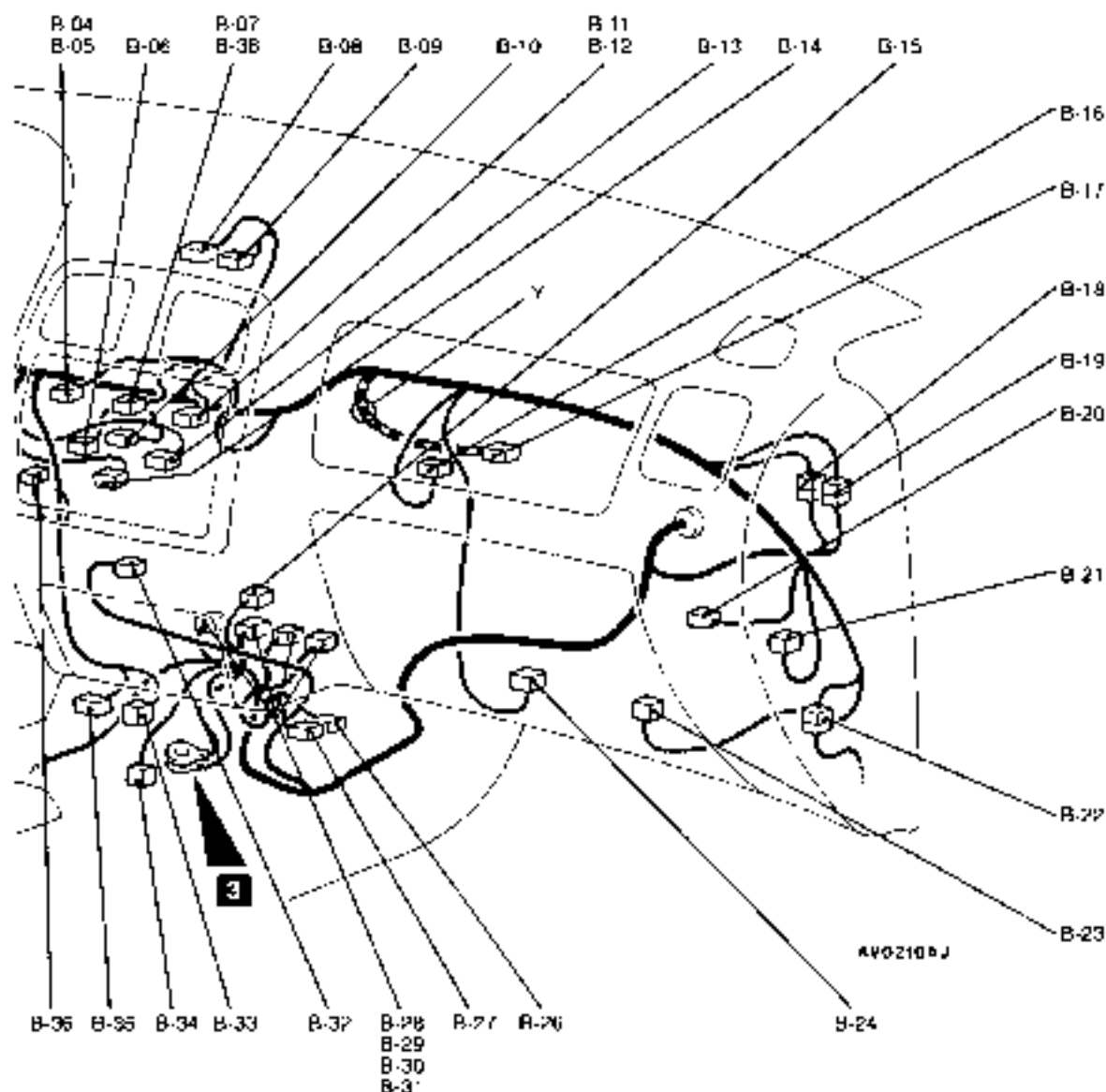

- | | | | |
|-------------|---|--------------|---|
| B-26 (4) | Engine control relay | B-40 (4) | Body wiring harness and instrument panel wiring harness combination |
| B-27 (4) | Fuel pump relay | B-41 (32) | Body wiring harness and front door wiring harness (Driver's side) combination |
| B-28 (26-Y) | Engine-ECU | B-42 (18) | Front wiring harness and body wiring harness combination |
| B-29 (16-Y) | Engine-ECU | B-43 (22-GR) | Front wiring harness and body wiring harness combination |
| B-30 (12-Y) | Engine-ECU | B-45 (10-B) | Front wiring harness and body wiring harness combination |
| B-31 (22-Y) | Engine-ECU | B-47 (10) | Fog lamp switch |
| B-32 (4) | Throttle valve control relay <4G93> | B-48 (6) | Headlamp leveling switch |
| B-33 (12) | Diagnosis connector | B-49 (12) | Remote controlled door mirror switch |
| B-34 (4) | Oxygen sensor (Front) <4G13> | B-50 (3) | Rheostat |
| B-35 (15-B) | Diagnosis connector | | |
| B-36 (12-B) | Immobilizer-ECU | | |
| B-37 (2-B) | Diode (Keyless entry system circuit) | | |
| B-38 (18) | Audio unit <Vehicles without navigation system> | | |
| B-39 (3-B) | Stop lamp switch | | |

L.H. drive vehicles

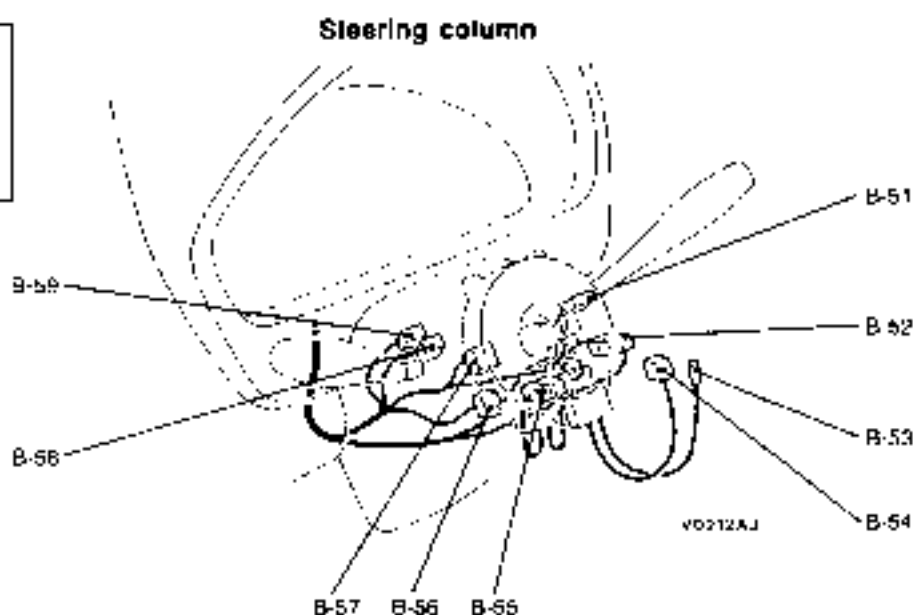
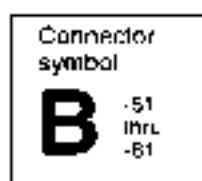

Relay box in passenger compartment

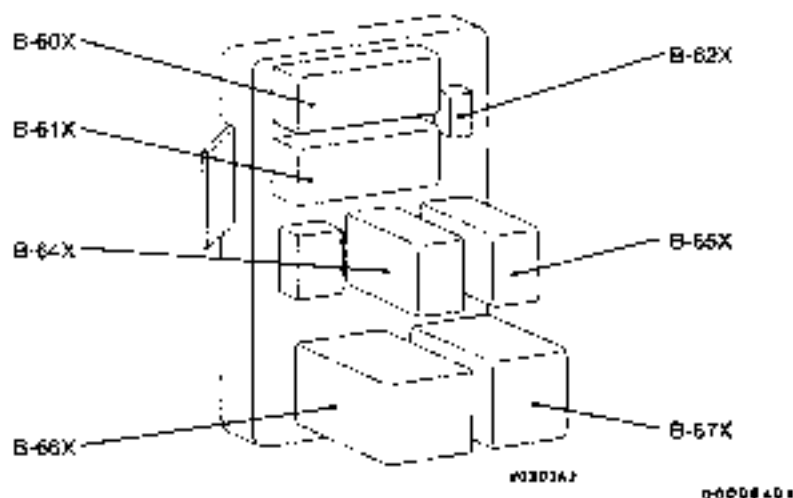

B-51 (12)	Column switch	B-59 (2)	Ignition key ring antenna
B-52 (2-R)	Lock spring <SRS>	B-60X (33)	J/C (1)
B-53 (1)	Horn switch <SRS>	B-61X (33)	J/C (2)
B-54 (2)	Air bag module (squib) (Driver's side)	B-62X (3-B)	Diode
B-55 (3)	Lock spring <SRS>	B-64X (5)	Front fog lamp relay
B-56 (10)	Column switch	B-65X (5)	Rear fog lamp relay
B-57 (6)	Column switch	B-66X (7)	Rear intermittent wiper relay
B-58 (6)	Ignition switch	B-67X (9)	Door lock ECU

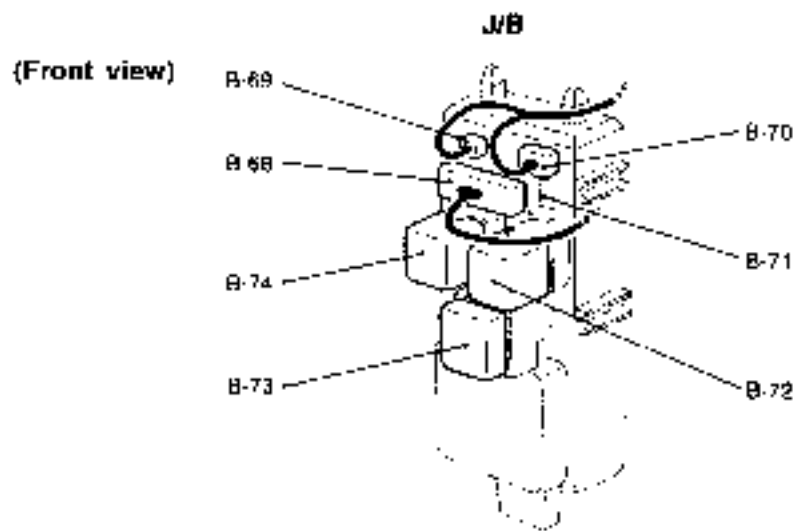

003144

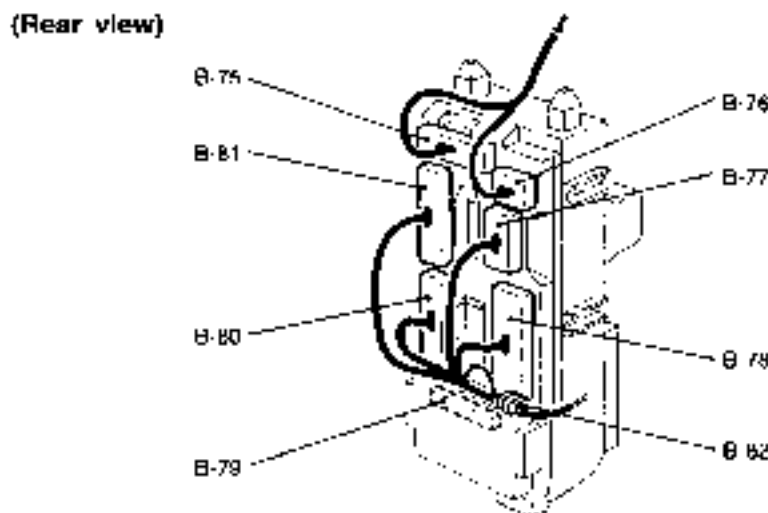

003145

00000410

Connector color code
 B Black
 Y Yellow
 L Blue
 G Green
 R Red
 BH Brown
 V Violet
 O Orange
 GR Gray

B-68 (13)	J/B and instrument panel wiring harness combination	B-75 (20)	Front wiring harness and J/B combination
B-69 (2)	J/B and roof wiring harness combination	B-76 (2)	Front wiring harness and J/B combination
B-70 (6)	J/B and roof wiring harness combination	B-77 (3)	Body wiring harness and J/B combination
B-71 (8)	No connection	B-78 (18)	Body wiring harness and J/B combination
B-72 (5)	Dofogger relay	B-79 (10)	Buzzer-ECU
B-73 (5)	Turn-signal and hazard warning flasher unit	B-80 (22)	Body wiring harness and J/B combination
B-74 (5)	Blower relay	B-81 (22)	Body wiring harness and J/B combination
		B-82 (1)	Spare connector for front fog lamp

DASH PANEL

NO10080712

R.H. drive vehicles

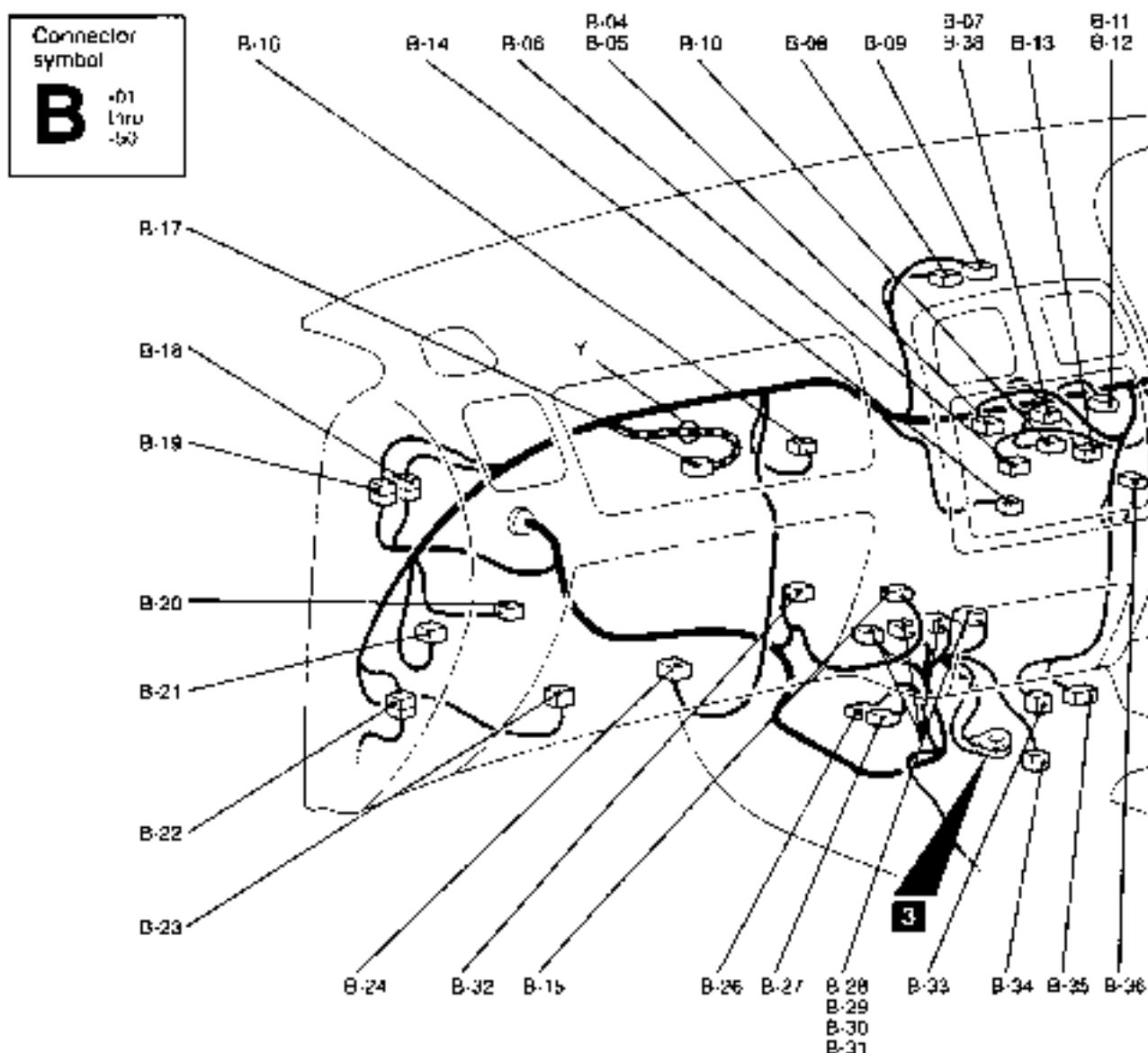

B-01 (25)	Combination meter	B-13 (2)	Blower control illumination lamp
B-02 (25)	Combination meter	B-14 (12-B)	Navigation unit
B-03 (2-B)	Diode (Headlamp circuit)	B-15 (26-GR)	Throttle valve controller <4G93>
B-04 (16)	Audio unit <Vehicles with navigation system>	B-16 (4)	Automatic compressor ECU
B-05 (14)	Audio unit <Vehicles without navigation system>	B-17 (2-R)	Air bag module (squib) (Passenger's side)
B-06 (12)	A/C switch	B-18 (4)	Control wiring harness and body wiring harness combination
B-07 (1-B)	Audio unit <Vehicles with navigation system>	B-19 (22)	Control wiring harness and body wiring harness combination
B-08 (16-B)	Multi display	B-20 (4-G)	Outside/inside air selection damper control motor
B-09 (20-B)	Multi display	B-21 (22-OG)	Keyless entry receiver ECU
B-10 (6)	Blower switch	B-22 (22)	Body wiring harness and front door wiring harness (Passenger's side) combination
B-11 (14)	Audio unit <Vehicles with navigation system>	B-23 (2)	Blower motor
B-12 (1-B)	Audio unit <Vehicles without navigation system>	B-24 (4)	Resistor

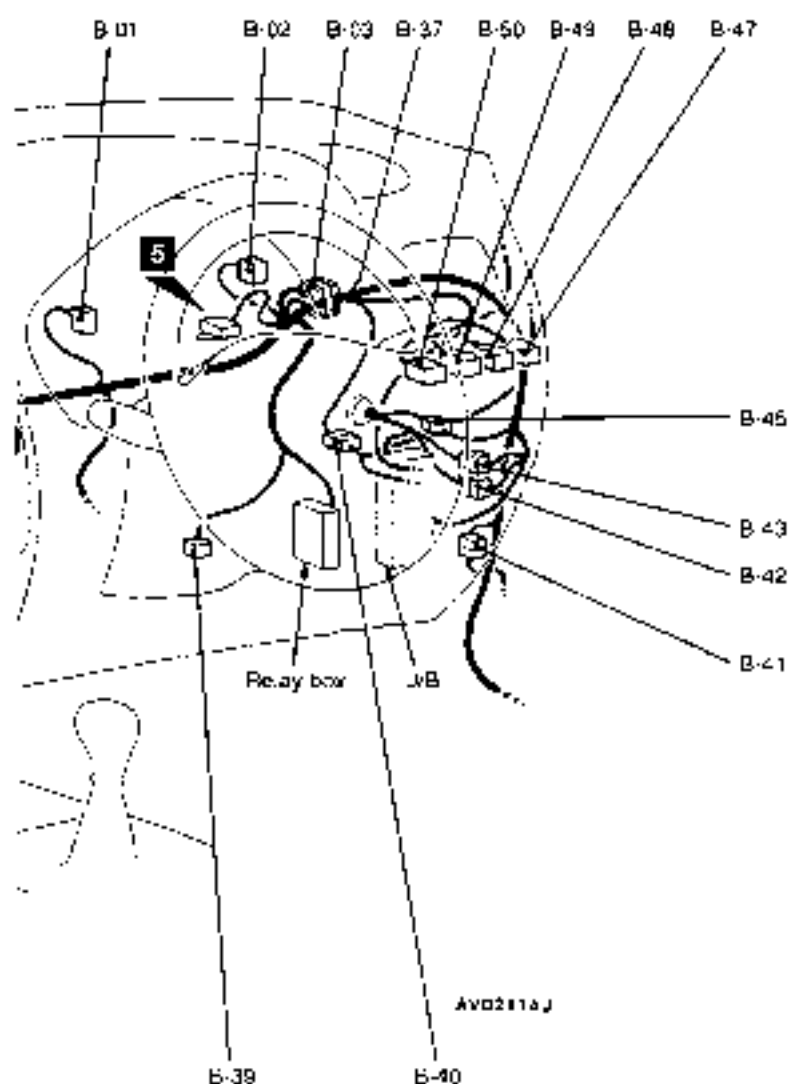

Connector color code
 B: Black
 Y: Yellow
 L: Blue
 G: Green
 R: Red
 BR: Brown
 V: Violet
 O: Orange
 GR: Gray

B-26 (4)	Engine control relay	B-40 (4)	Body wiring harness and instrument panel wiring harness combination
B-27 (4)	Fuel pump relay	B-41 (32)	Body wiring harness and front door wiring harness (Driver's side) combination
B-28 (28-Y)	Engine-ECU	B-42 (18)	Front wiring harness and body wiring harness combination
B-29 (16-Y)	Engine-ECU	B-43 (22-GR)	Front wiring harness and body wiring harness combination
B-30 (12-Y)	Engine-ECU	B-45 (10-B)	Front wiring harness and body wiring harness combination
B-31 (22-Y)	Engine-ECU	B-47 (10)	Fog lamp switch
B-32 (4)	Throttle valve control relay <4G93>	B-48 (6)	Headlamp leveling switch
B-33 (12)	Diagnosis connector	B-49 (12)	Remote controlled door mirror switch
B-34 (4)	Oxygen sensor (Front) <4G13>	B-50 (3)	Rheostat
B-35 (16-B)	Diagnosis connector		
B-36 (12-B)	Immobilizer-ECU		
B-37 (2-B)	Diode (Keyless entry system circuit)		
B-38 (16)	Audio unit (Vehicles without navigation system)		
B-39 (3-B)	Stop lamp switch		

R.H. drive vehicles

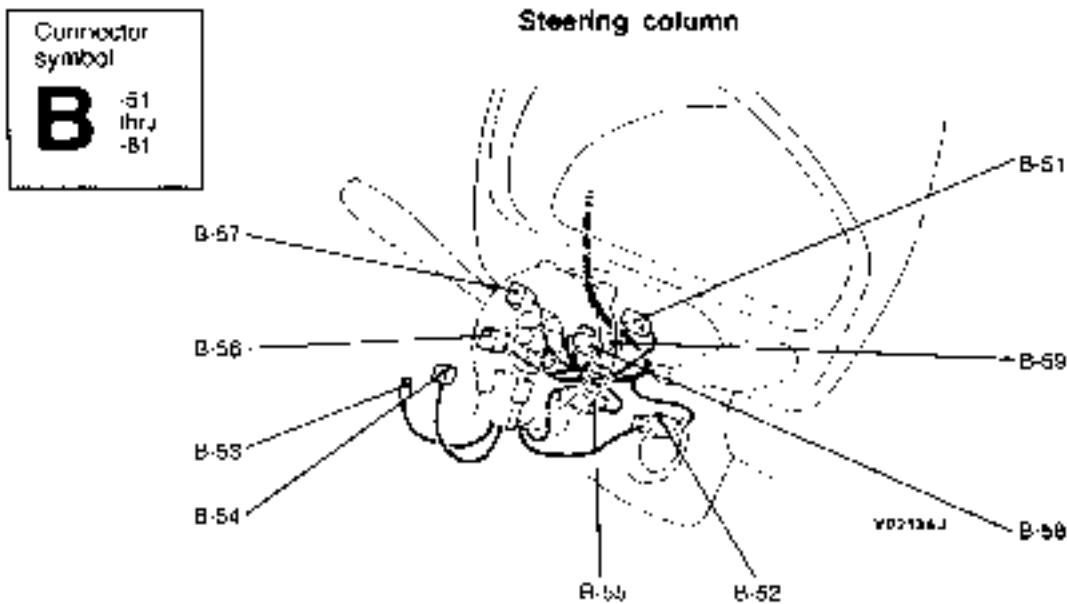

Relay box in passenger compartment

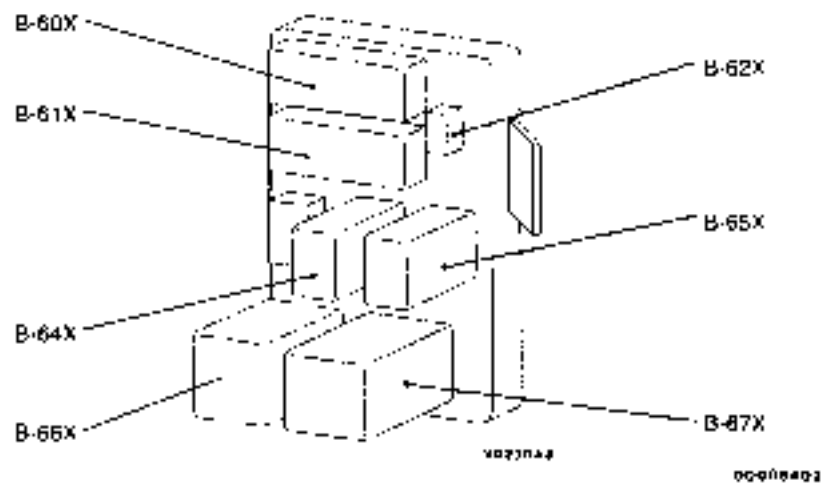

B-51 (12)	Column switch	B-59 (2)	Ignition key ring antenna
B-52 (2-R)	Clock spring <SRS>	B-60X (33)	J/C (1)
B-53 (1)	Horn switch <SHS>	B-61X (33)	J/C (2)
B-54 (2)	Air bag module (squib) (Driver's side)	B-62X (3-B)	Diode
B-55 (3)	Clock spring <SRS>	B-64X (5)	Front fog lamp relay
B-56 (10)	Column switch	B-65X (5)	Rear fog lamp relay
B-57 (6)	Column switch	B-66X (7)	Rear intermittent wiper relay
B-58 (6)	Ignition switch	B-67X (9)	Door lock ECU

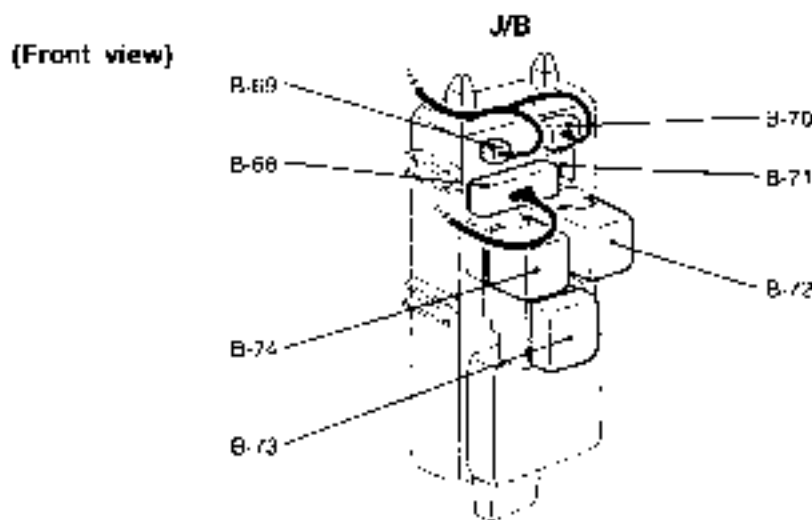

922-56J

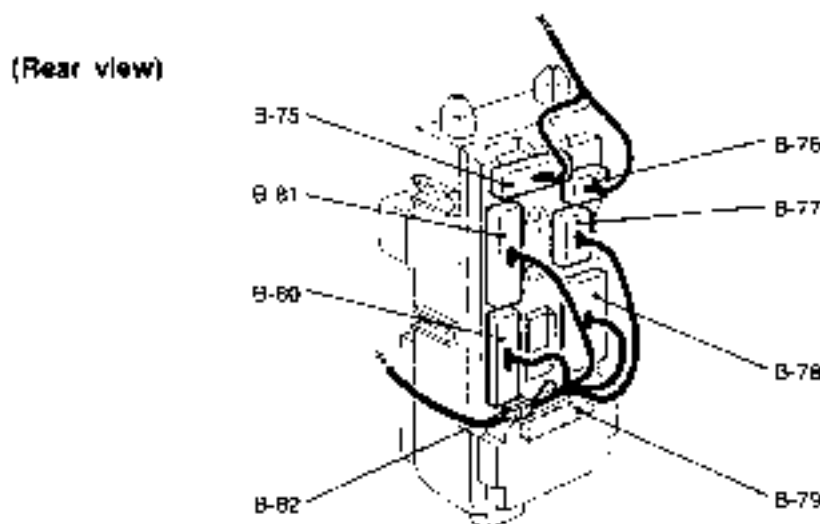

922-64J

0-00084-9

Connector color code
 B Black
 Y Yellow
 L Blue
 G Green
 R Red
 BR Brown
 V Violet
 O Orange
 GR Gray

B-68 (18)	J/B and instrument panel wiring harness combination	B-75 (20)	Front wiring harness and J/B combination
B-69 (2)	J/B and roof wiring harness combination	B-76 (2)	Front wiring harness and J/B combination
B-70 (6)	J/B and roof wiring harness combination	B-77 (3)	Body wiring harness and J/B combination
B-71 (8)	No connection	B-78 (18)	Body wiring harness and J/B combination
B-72 (5)	Defogger relay	B-79 (10)	Buzzer-ECU
B-73 (5)	Turn-signal and hazard warning flasher unit	B-80 (22)	Body wiring harness and J/B combination
B-74 (5)	Blower relay	B-81 (22)	Body wiring harness and J/B combination
		B-82 (1)	Spare connector for front fog lamp

INSTRUMENT PANEL

801090/80110

L.H. drive vehicles

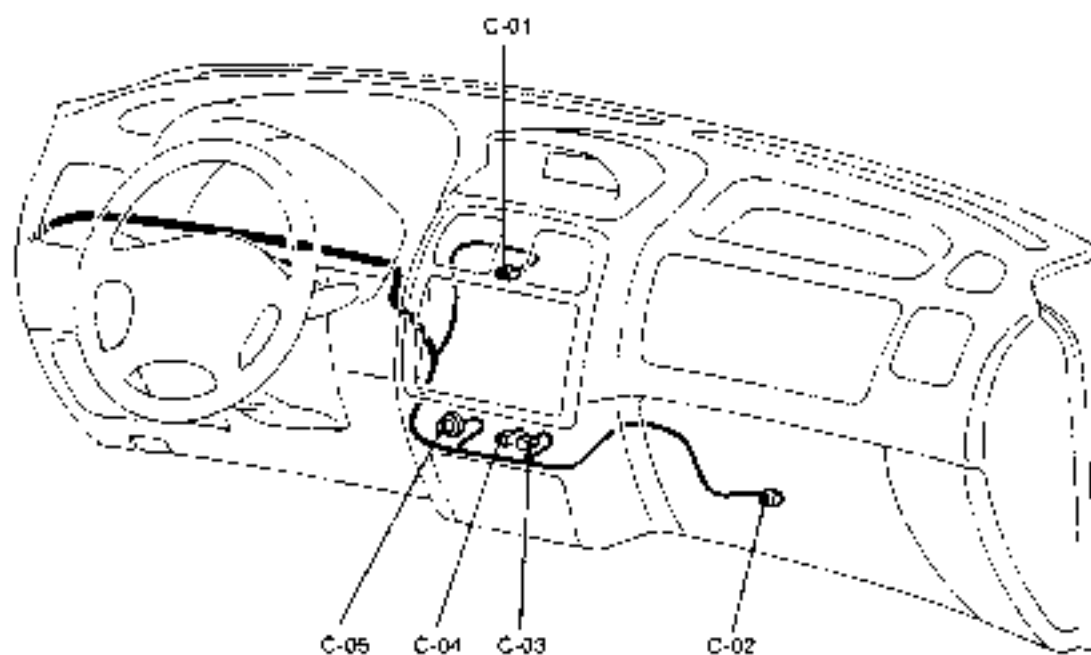
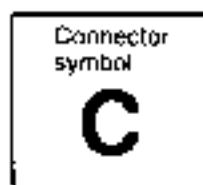

AY02 04 A.J

Connector color code

B: Black
Y: Yellow
I: Blue
G: Green
R: Red
BR: Brown
V: Violet
O: Orange
GR: Gray

C-01 (10) Hazard warning switch
 C-02 (2) Glove box lamp
 C-03 (2) Cigarette lighter

C-04 (1-B) Cigarette lighter
 C-05 (2-B) Ashtray illumination lamp

INSTRUMENT PANEL

60100000100

R.H. drive vehicles

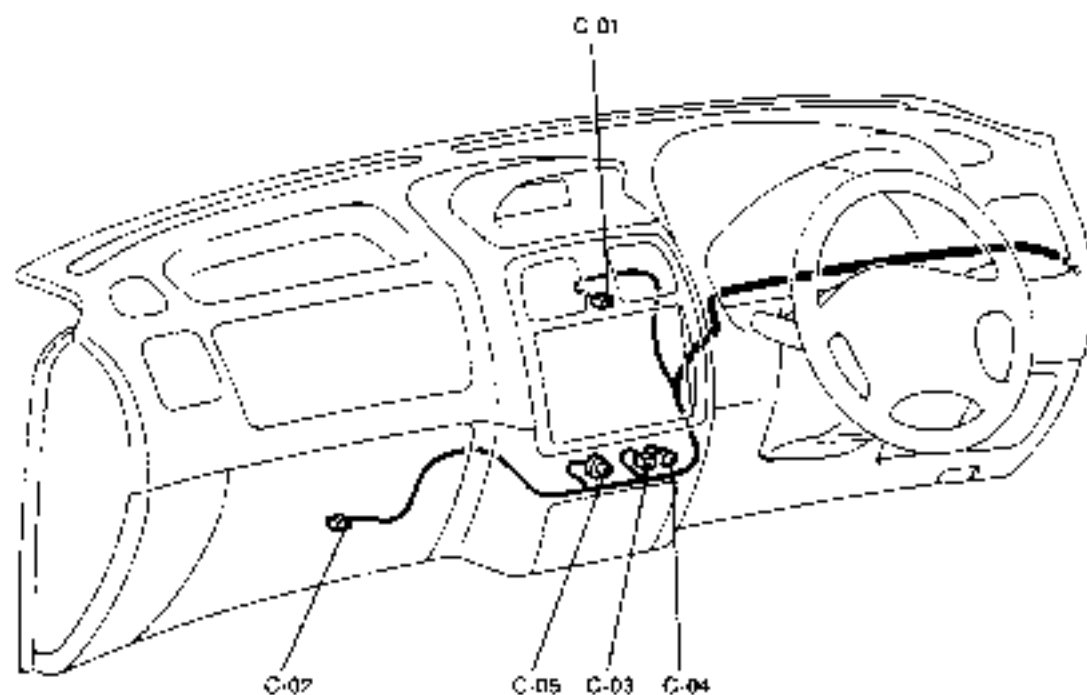
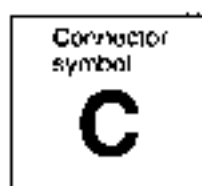

AY0100AJ

Connector color code

B. Black
 Y. Yellow
 L. Blue
 G. Green
 R. Red
 BR. Brown
 V. Violet
 O. Orange
 GR. Gray

C-01 (10) Hazard warning switch
 C-02 (2) Glove box lamp
 C-03 (2) Cigarette lighter

C-04 (1-B) Cigarette lighter
 C-05 (2-B) Ashtray illumination lamp

FLOOR AND ROOF

60100080508

L.H. drive vehicles

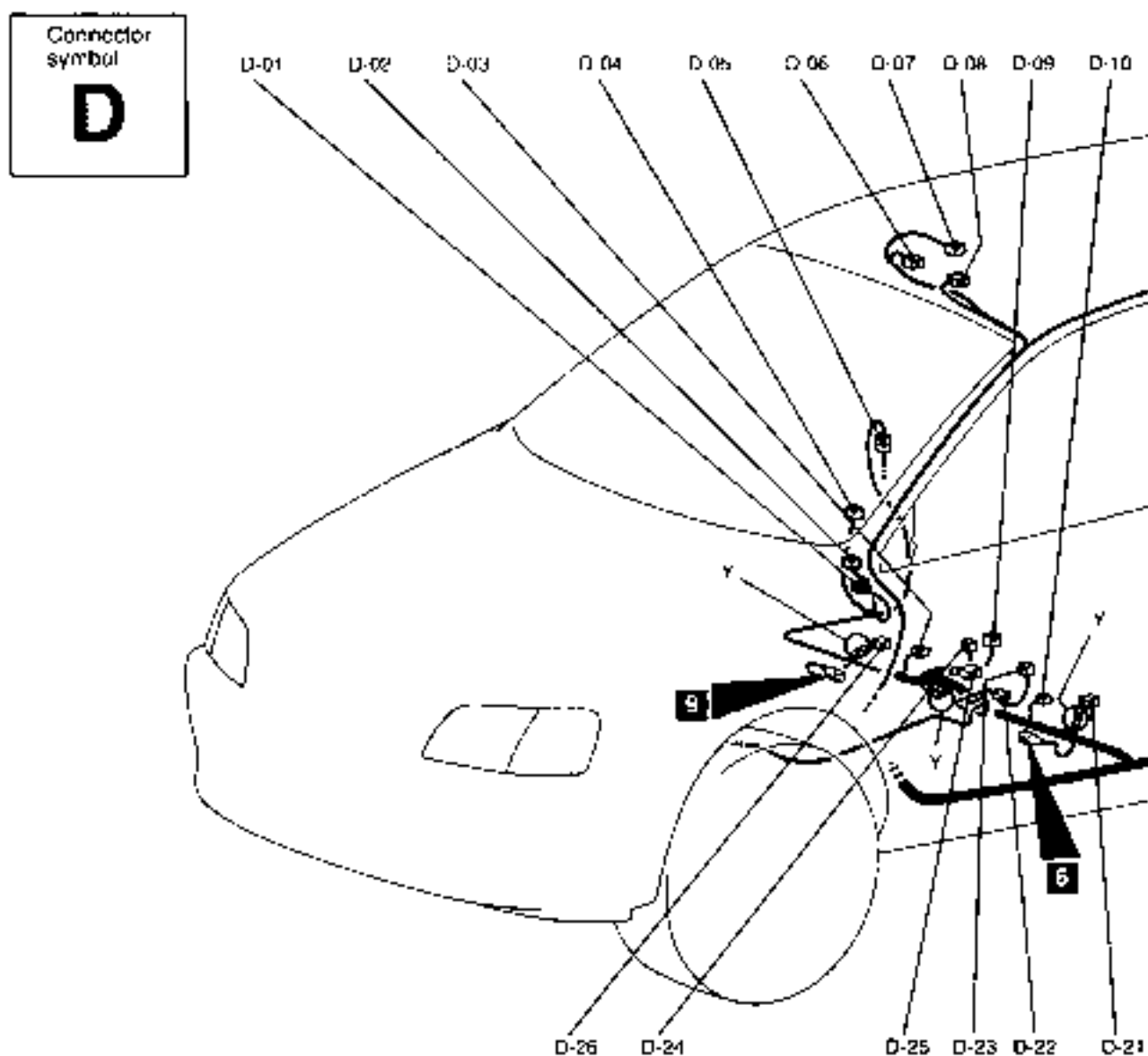

D-01 (1-B) Front door switch (Passenger's side)
 D-02 (2-R) Seat belt pretensioner (Passenger's side)
 D-03 (3-B) Heated seat (RH)
 D-04 (2-Y) Side impact sensor (RH)
 D-05 (10) Body wiring harness and rear door wiring harness (RH) combination
 D-06 (10) Sunroof ECU

D-07 (2) Sunroof motor
 D-08 (R) Room lamp and sunroof switch
 D-09 (6) Heated seat switch (RH)
 D-10 (3-B) Heated seat (LH)
 D-11 (2) Room lamp <Without sunroof>
 D-12 (2-B) Rear speed sensor (RH) <ABS>
 D-13 (5-GR) Fuel pump and gauge unit assembly
 D-14 (2-B) Rear speed sensor (LH) <ABS>

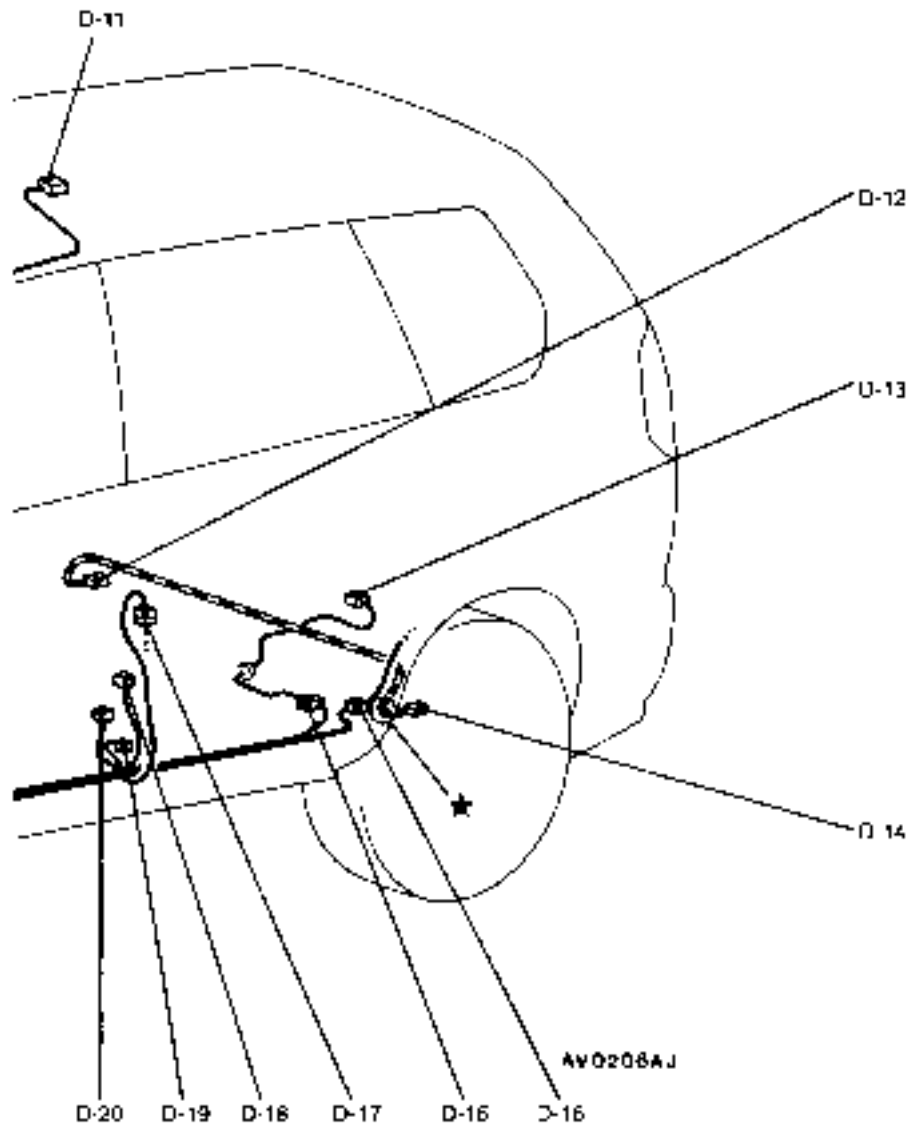

Connector color code
 B: Black
 Y: Yellow
 L: Blue
 G: Green
 R: Red
 BR: Brown
 V: Violet
 O: Orange
 GR: Gray

- | | | | |
|------------|---|-------------|--|
| D-15 (10) | Body wiring harness and fuel wiring harness combination | D-20 (2-R) | Seat belt pretensioner (Driver's side) |
| D-16 (22) | Body wiring harness and rear end wiring harness combination | D-21 (2-R) | Side air bag module (squib) (LH) |
| D-17 (10) | Body wiring harness and rear door wiring harness (LH) combination | D-22 (4-B) | Oxygen sensor (Res) <4G13> |
| D-18 (2-Y) | Side impact sensor (LH) | D-23 (6) | Heated seat switch (LH) |
| D-19 (2) | Front door switch (Driver's side) | D-24 (1-B) | Parking brake switch |
| | | D-25 (36-O) | SRS-ECU |
| | | D-26 (2-R) | Side air bag module (squib) (RH) |

FLOOR AND ROOF

N100090513

R.H. drive vehicles

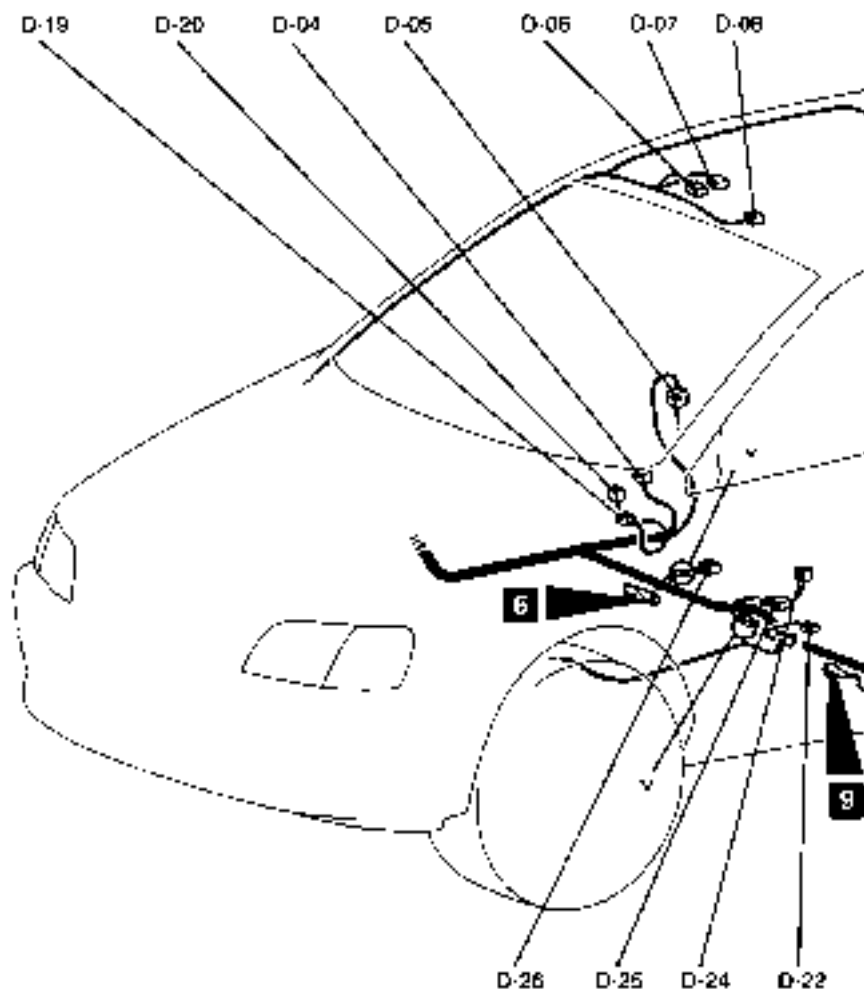
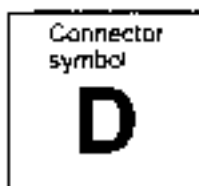

D-01 (1-B)	Front door switch (Passenger's side)	D-08 (8)	Room lamp and sunroof switch
D-02 (2-A)	Seat belt pretensioner (Passenger's side)	D-11 (2)	Room lamp <Without sunroof>
D-04 (2-Y)	Side impact sensor (RH)	D-12 (2-B)	Rear speed sensor (RH)
D-05 (10)	Body wiring harness and rear door wiring harness (RH) combination	D-13 (5-GF)	Fuel pump and gauge unit assembly
D-06 (10)	Sunroof ECU	D-14 (2-B)	Rear speed sensor (LH)
D-07 (2)	Sunroof motor	D-15 (10)	Body wiring harness and fuel wiring harness combination

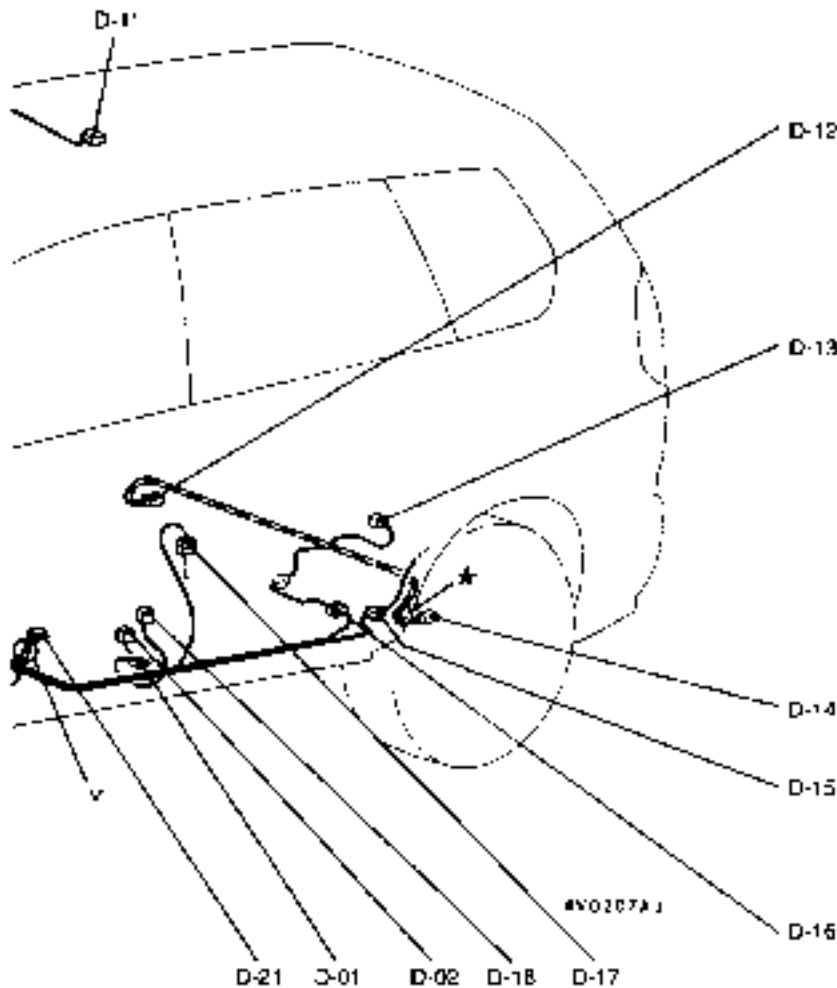

Connector color code
 B: Black
 Y: Yellow
 L: Blue
 G: Green
 R: Red
 BR: Brown
 V: Violet
 O: Orange
 GR: Gray

- | | | | |
|------------|---|-------------|--|
| D-16 (22) | Body wiring harness and rear end wiring harness combination | D-20 (2-R) | Seat belt pretensioner (Driver's side) |
| D-17 (10) | Body wiring harness and rear door wiring harness (LH) combination | D-21 (2-R) | Side air bag module (squib) (LH) |
| D-18 (2-Y) | Side impact sensor (LH) | D-22 (2-B) | Oxygen sensor (Rear) <4G13> |
| D-19 (2) | Front door switch (Driver's side) | D-23 (1-B) | Parking brake switch |
| | | D-24 (36-O) | SRS-ECU |
| | | D-25 (2-R) | Side air bag module (squib) (RH) |

DOOR

20100170165

L.H. drive vehicles

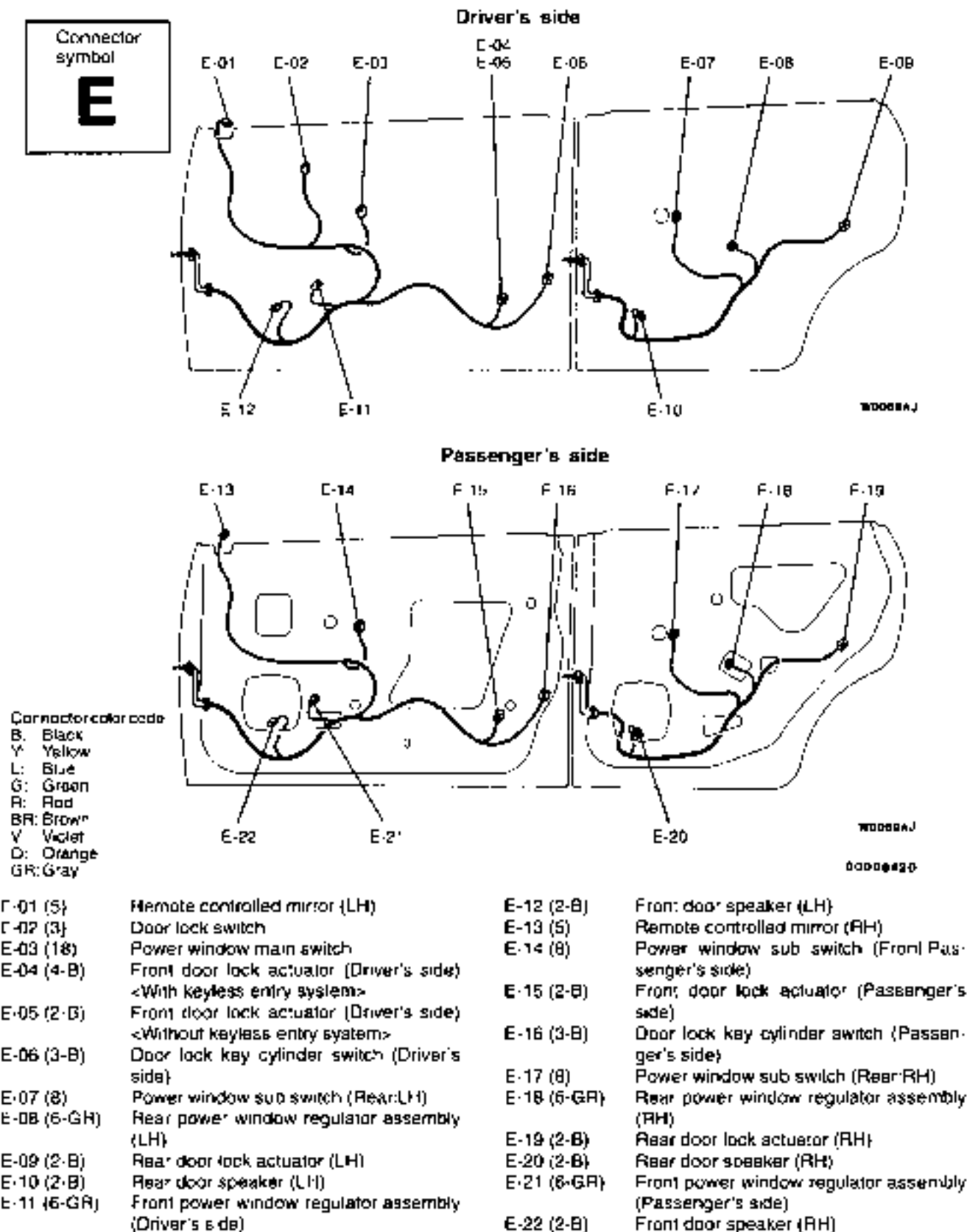

DOOR

80100140492

R.H. drive vehicles

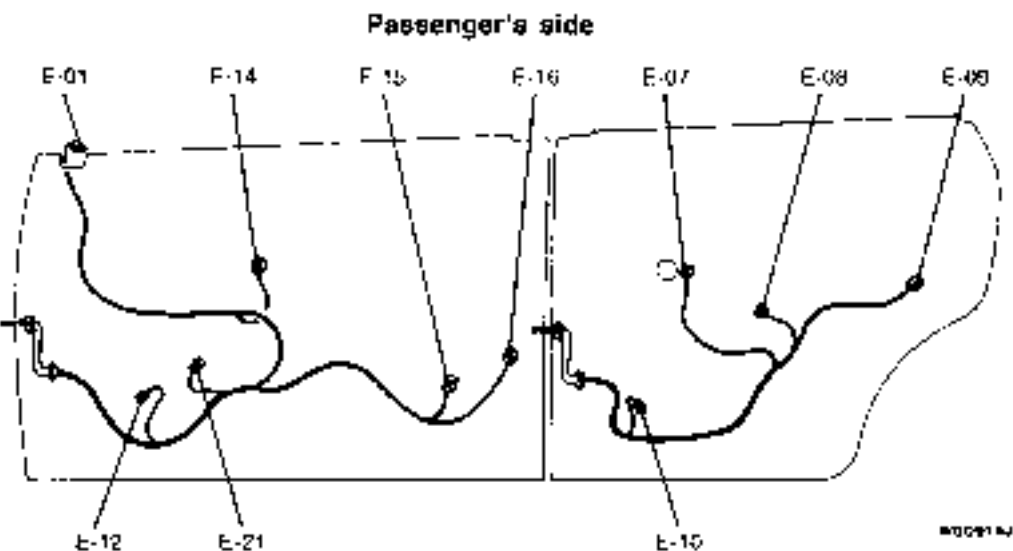
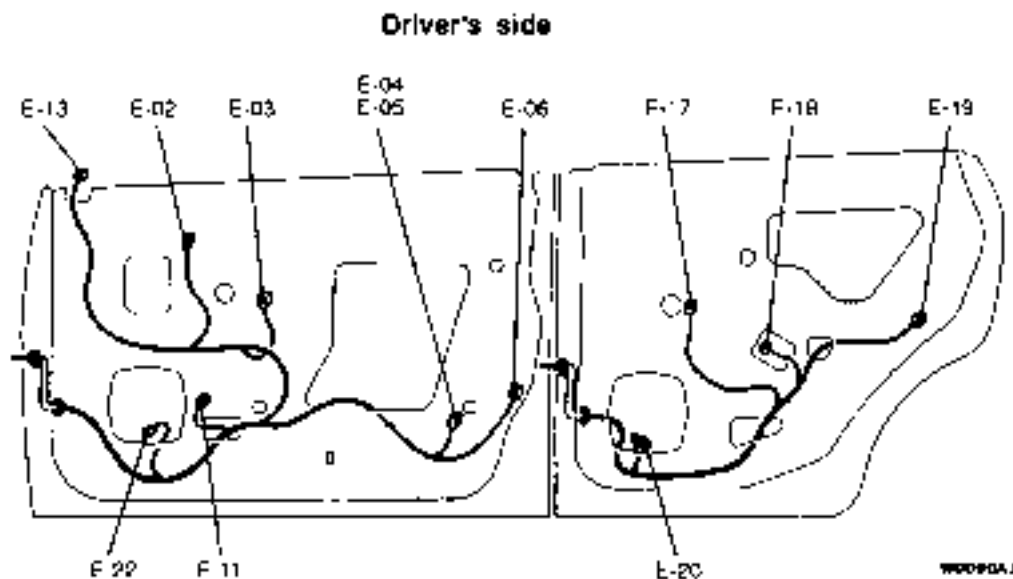

- Connector color code
- B: Black
 - Y: Yellow
 - L: Blue
 - G: Green
 - R: Red
 - BR: Brown
 - V: Violet
 - O: Orange
 - GR: Gray

E-01 (5)	Remote controlled mirror (LH)	E-12 (2-B)	Front door speaker (LH)
E-02 (3)	Door lock switch	E-13 (5)	Remote controlled mirror (RH)
E-03 (18)	Power window main switch	E-14 (8)	Power window sub switch (Front/Passenger's side)
E-04 (4-B)	Front door lock actuator (Driver's side)	E-15 (2-B)	Front door lock actuator (Passenger's side)
E-05 (2-B)	Front door lock actuator (Driver's side)	E-16 (3-B)	Door lock key cylinder switch (Passenger's side)
E-06 (3-B)	Door lock key cylinder switch (Driver's side)	E-17 (8)	Power window sub switch (Rear:RH)
E-07 (8)	Power window sub switch (Rear:LH)	E-18 (6-GR)	Rear power window regulator assembly (RH)
E-08 (6-GR)	Rear power window regulator assembly (LH)	E-19 (2-B)	Rear door lock actuator (RH)
E-09 (2-B)	Rear door lock actuator (LH)	E-20 (2-B)	Rear door speaker (RH)
E-10 (2-B)	Rear door speaker (LH)	E-21 (6-GR)	Front power window regulator assembly (Passenger's side)
E-11 (6-GR)	Front power window regulator assembly (Driver's side)	E-22 (2-B)	Front door speaker (RH)

LUGGAGE COMPARTMENT

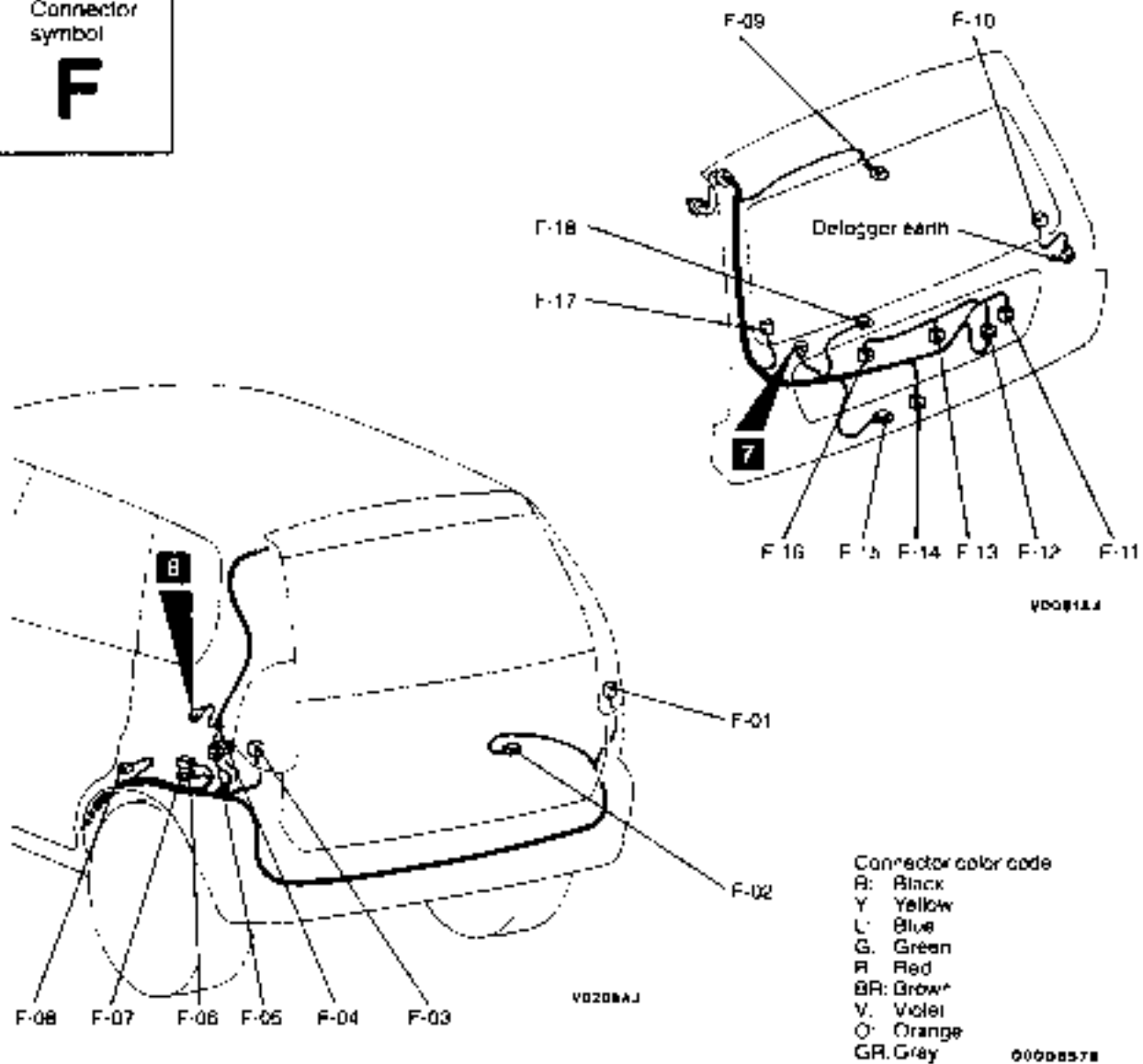
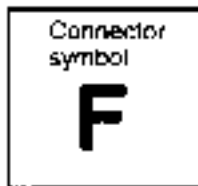

F-01 (6)	Rear combination lamp (RH)	F-10 (1)	Defogger (-)
F-02 (1-B)	Rear door switch (RH)	F-11 (3)	Rear gate lock key cylinder switch
F-03 (6)	Rear combination lamp (LH)	F-12 (2)	Gate wiring harness and licence plate lamp wiring harness combination
F-04 (8)	Rear end wiring harness and gate wiring harness combination	F-13 (2)	Licence plate lamp (RH)
F-05 (4)	Rear end wiring harness and gate wiring harness combination	F-14 (1-B)	Rear gate switch
F-06 (1)	Luggage compartment lamp	F-15 (2)	Rear gate lock actuator
F-07 (1)	Luggage compartment lamp	F-16 (2)	Licence plate lamp (LH)
F-08 (1-B)	Rear door switch (LH)	F-17 (1-B)	Defogger (+)
F-09 (2)	High mounted stop lamp	F-18 (3)	Rear wiper motor

SINGLE PART INSTALLATION POSITION

CONTENTS

7016900402

RELAY	3-2	INSPECTION CONNECTOR AND SPARE CONNECTOR	3-11
ECU	3-4	FUSIBLE LINK AND FUSE	3-12
SENSOR	3-6	EARTH CABLE	3-13
SOLENOID AND SOLENOID VALVE	3-9	EARTH	3-14
DIODE	3-10		

RELAY

7510004041 0

Name	Symbol	Name	Symbol
A/C compressor relay	B	Fuel pump relay	H
Alternator relay	B	Headlamp relay	B
Blower relay	E	Headlamp washer relay	B
Condenser fan relay (LO) <4G13>	B	Horn relay	B
Condenser fan relay (HI) <4G13>	B	Radiator fan relay <4G13>	B
Defogger relay	E	Rear fog lamp relay	F
DHL relay (1)	C	Rear intermittent wiper relay	G
DRL relay (2)	C	Tail lamp relay <DRL>	B
Injector driver control relay <4G93>	A	Throttle valve control relay <4G93>	G
Engine control relay	H	Turn-signal hazard warning flasher unit	E
Fan control relay <4G93>	B	Windshield intermittent wiper relay (built-in column switch)	D
Front fog lamp relay	F		

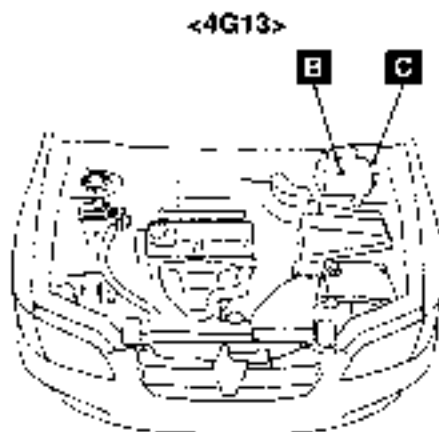

V00794J

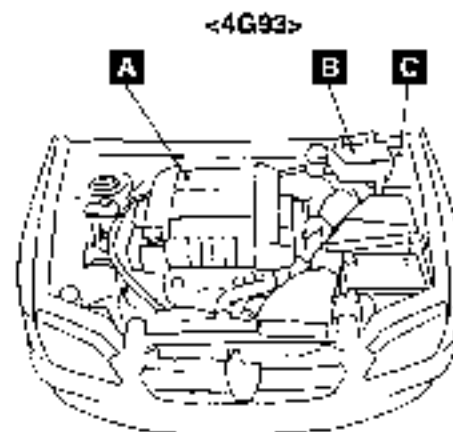

W0281AJ

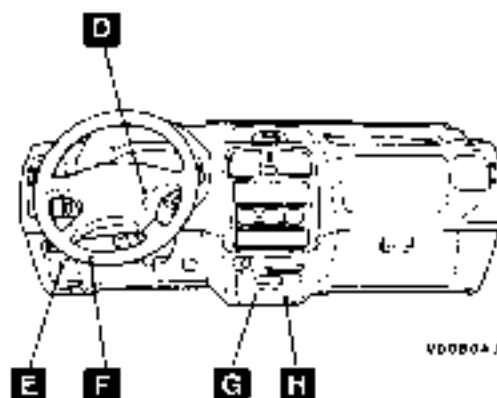

V0080AJ

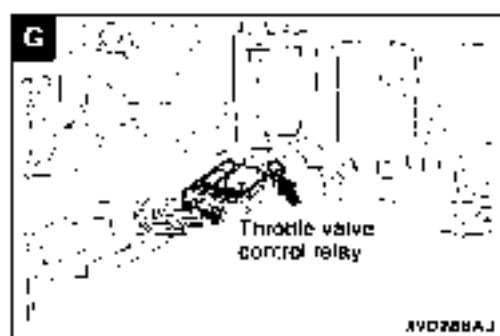
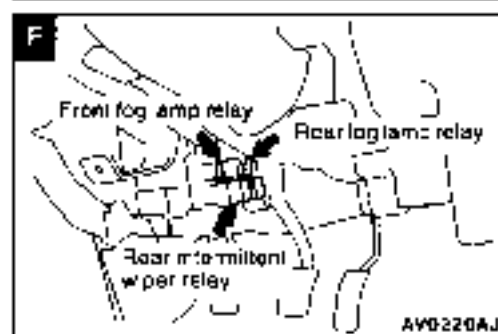
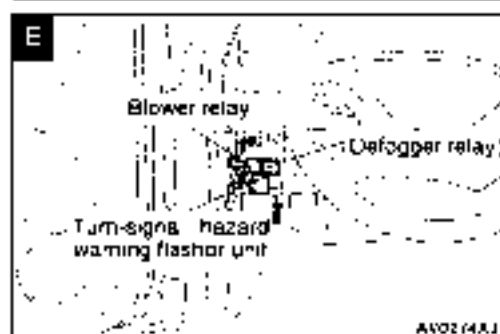
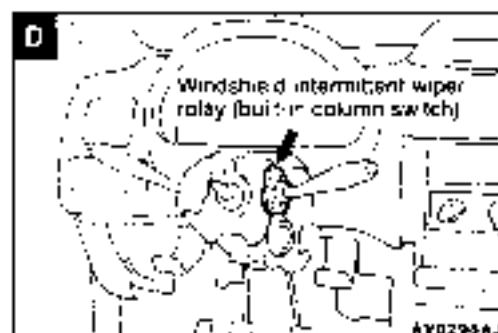
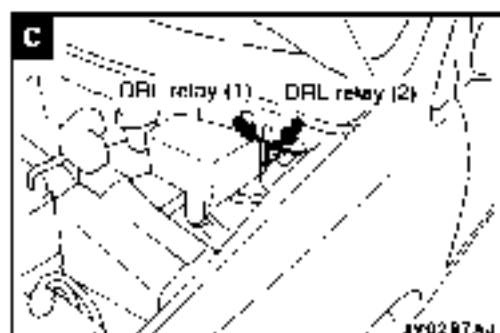
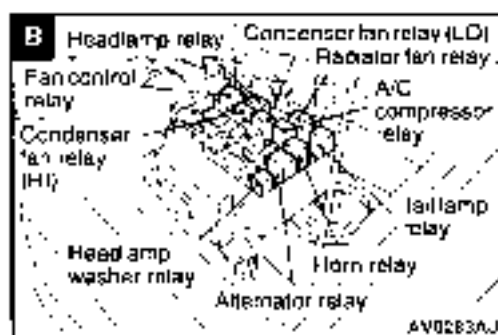
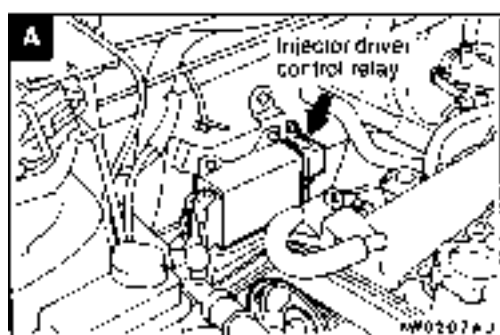

ECU

70100270228

Name	Symbol	Name	Symbol
ABS-ECU	C	Immobilizer-ECU	E
Automatic compressor ECU	F	Injector driver <4G93>	A
Buzzer-ECU	H	Keyless entry receiver-ECU	G
Door lock ECU	I	SRS-ECU	L
DRL-ECU	B	Sunroof-ECU	K
Engine ECU	J	Throttle valve controller <4G93>	J
Fan controller <4G93>	D		

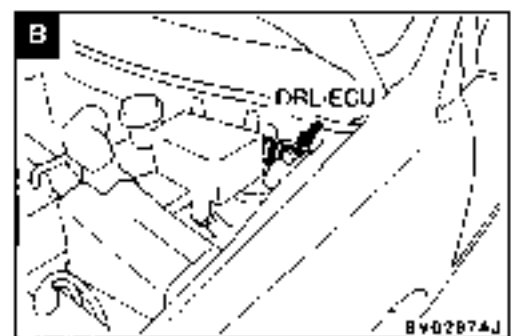
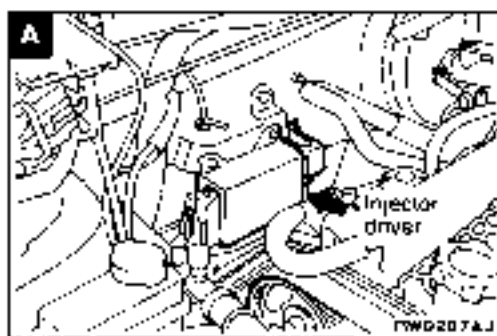
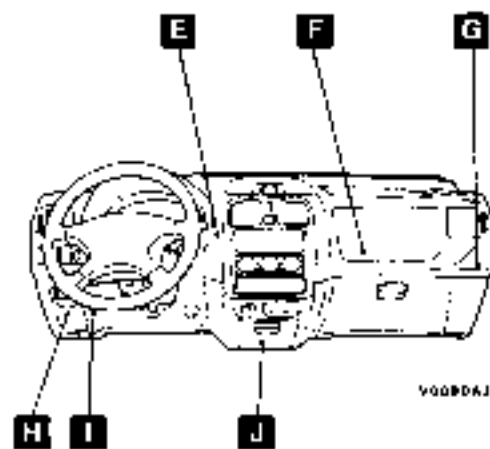
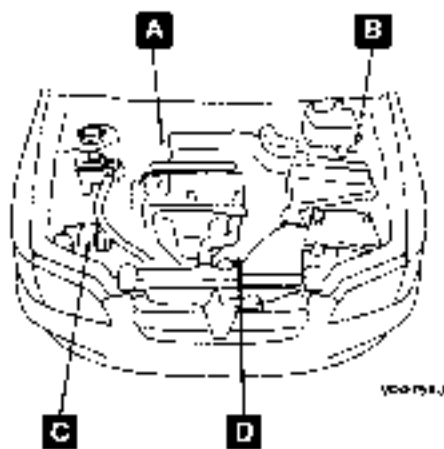

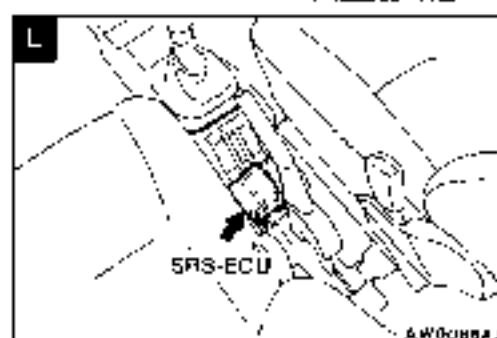
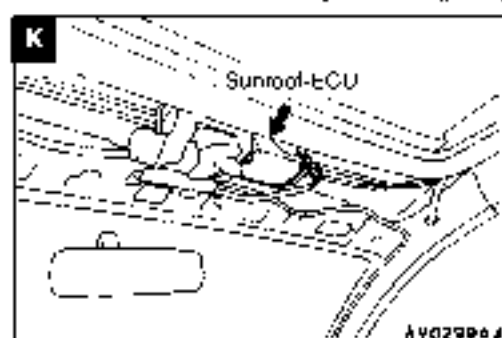
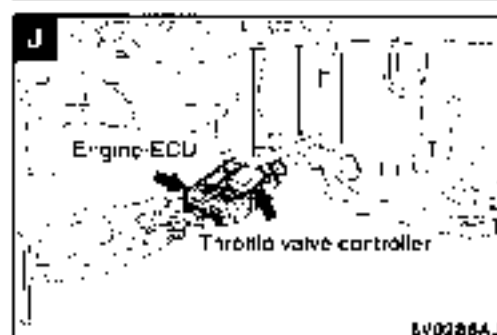
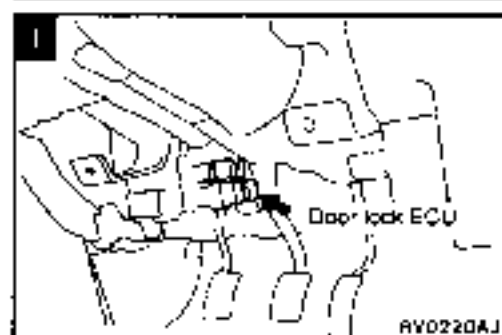
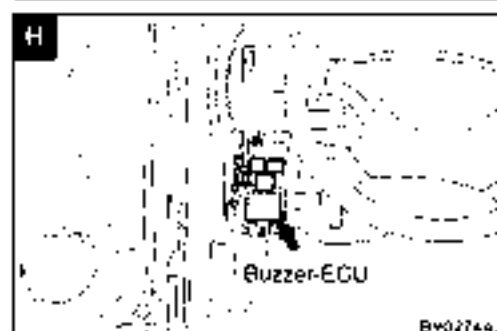
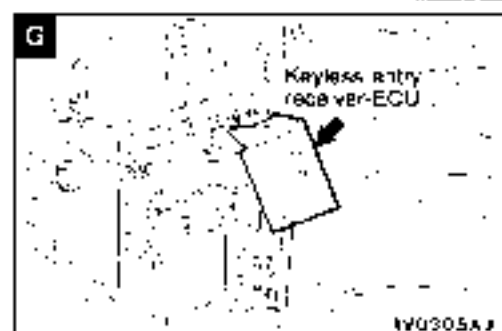
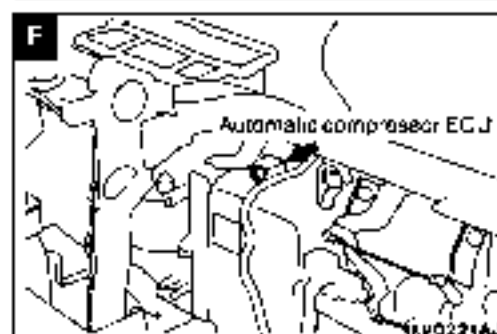
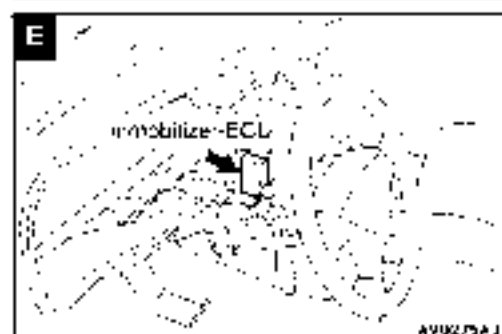
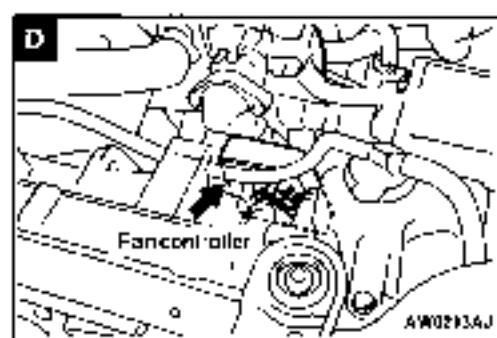
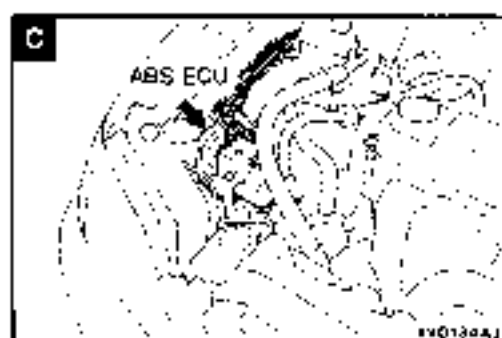

SENSOR

7010000173

Name	Symbol	Name	Symbol
Accelerator pedal position sensor <4G93>	A	Front speed sensor	P
Air flow sensor <4G93>	J	Intake air temperature sensor <4G13>	C
Air thermo sensor	O	M/T oil temperature sensor <4G93>	M
Brake vacuum sensor <4G93>	I	Outside thermo sensor	N
Camshaft position sensor <4G93>	H	Oxygen sensor <4G93>	D
Crank angle position sensor <4G93>	K	Oxygen sensor (Front) <4G13>	Q
Detonation sensor	B	Oxygen sensor (Rear) <4G13>	R
Distributor assembly (built-in crank angle sensor) <4G13>	G	Rear speed sensor	T
Engine coolant temperature sensor	C	Side impact sensor	S
		Throttle position sensor	E
			4G13
			4G93
Fuel pressure sensor <4G93>	H	Vacuum sensor <4G13>	F
			C
		Vehicle speed sensor	L

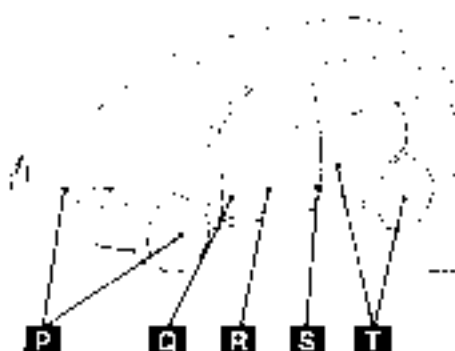
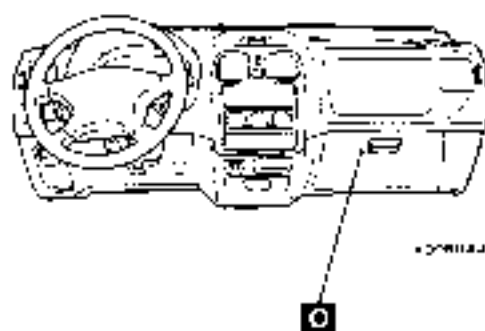
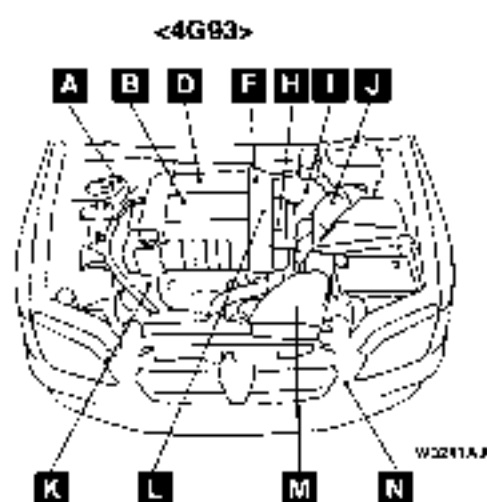
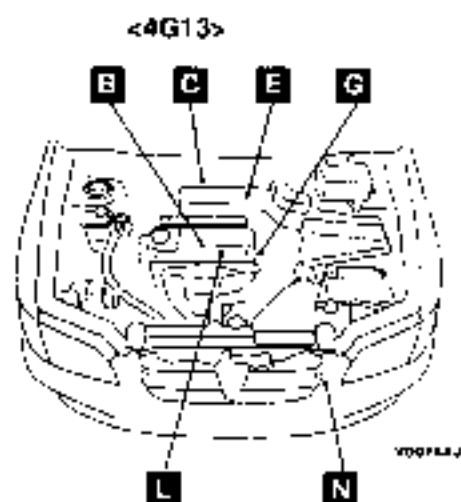

000055J

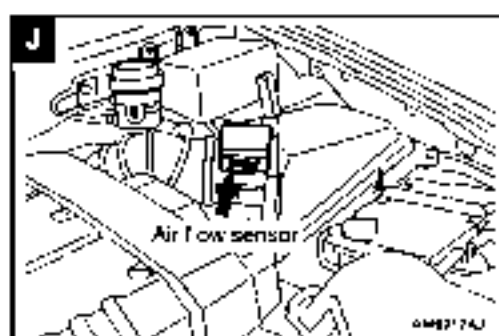
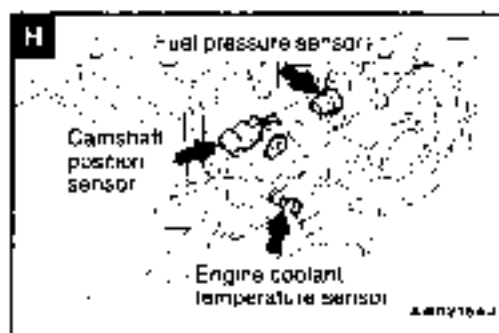
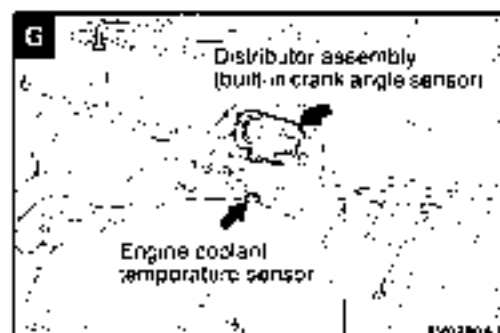
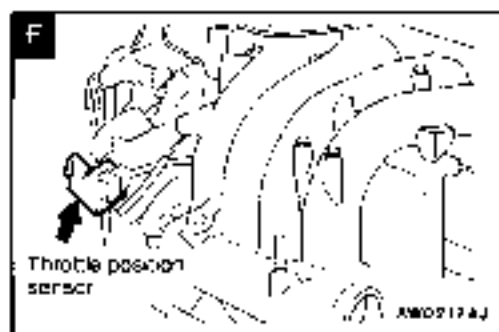
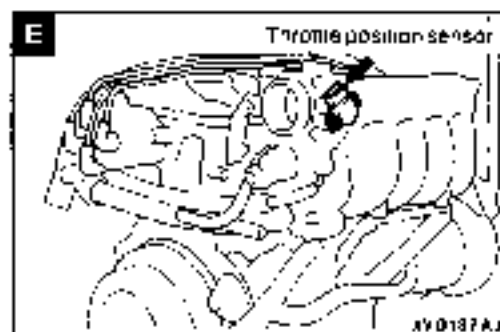
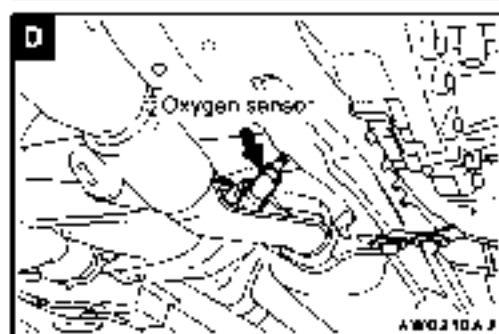
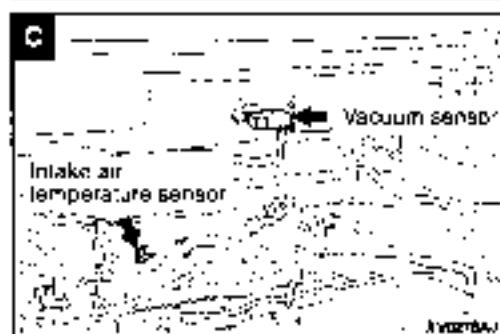
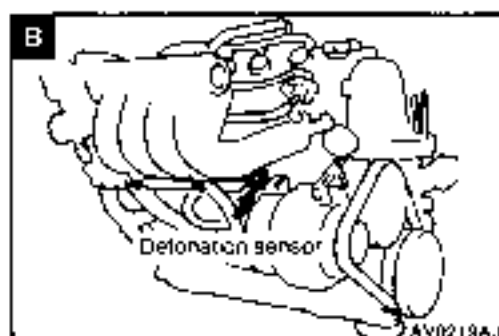

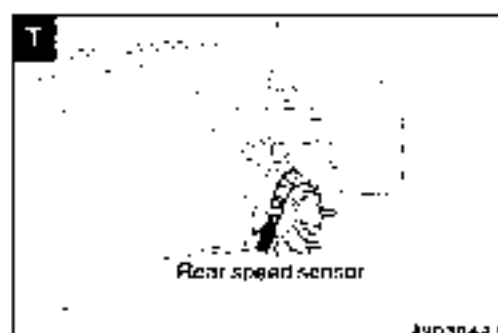
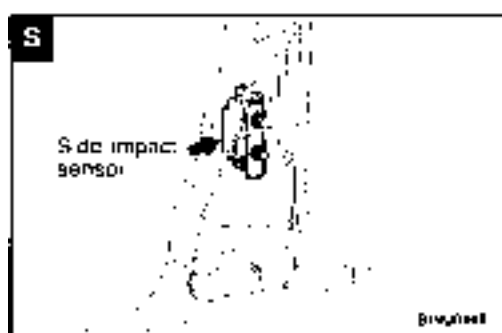
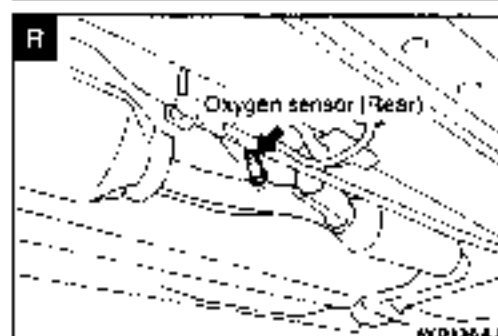
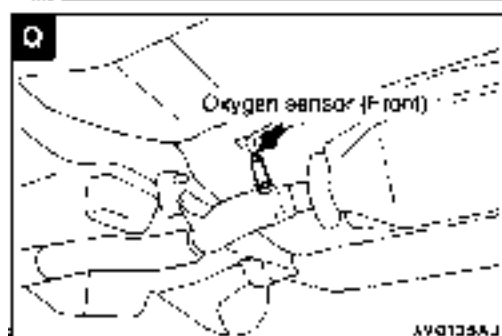
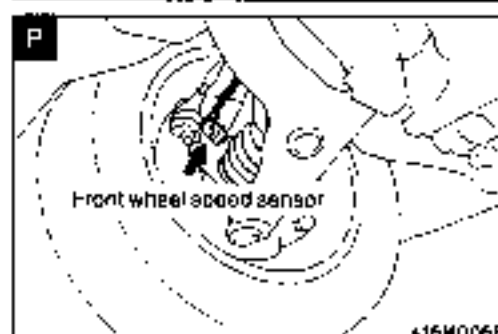
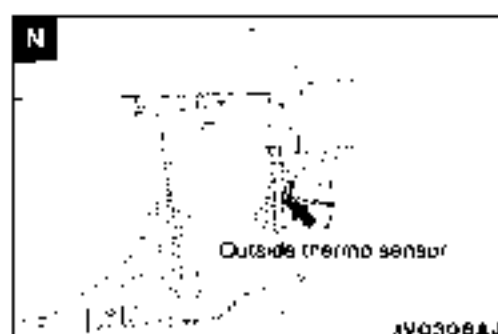
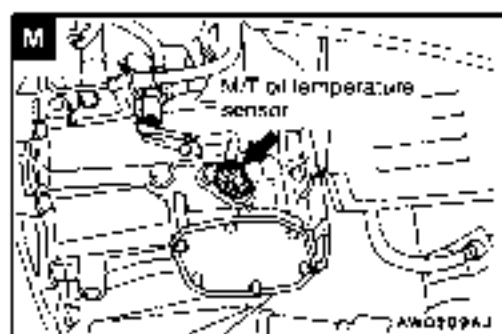
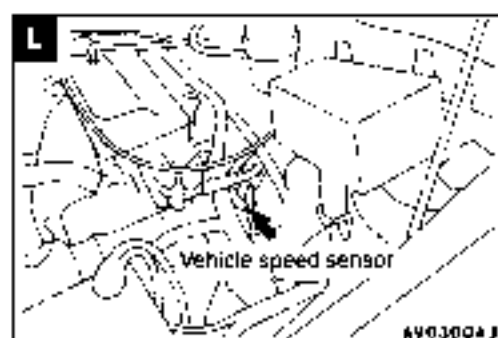
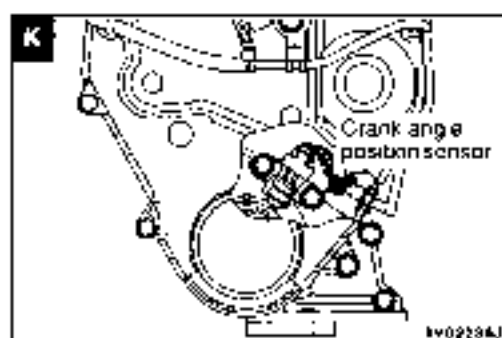

SOLENOID AND SOLENOID VALVE

70160010107

Name	Symbol	Name	Symbol
EGR solenoid valve <4G13>	A	Purge control solenoid valve 4G13	A
		4G93	B

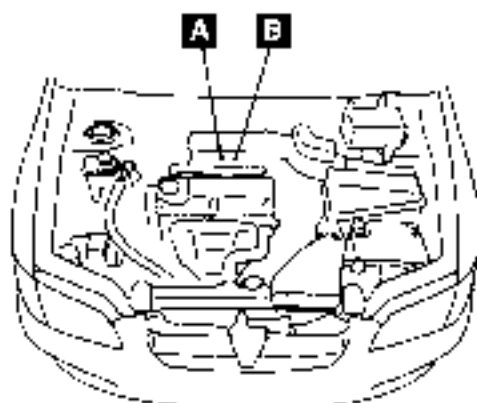

8V0075A.J

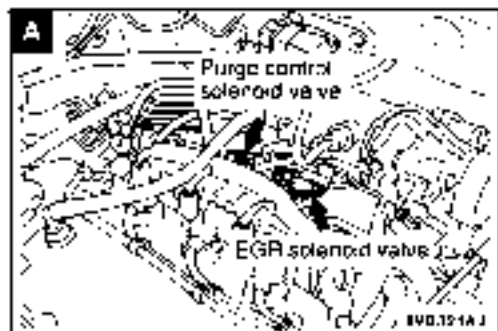

DIODE

7010096017

Name	Symbol	Name	Symbol
Diode (Electrically loaded idle-up circuit)	A	Diode (Headlamp circuit)	B
		Diode (Keyless entry system circuit)	B

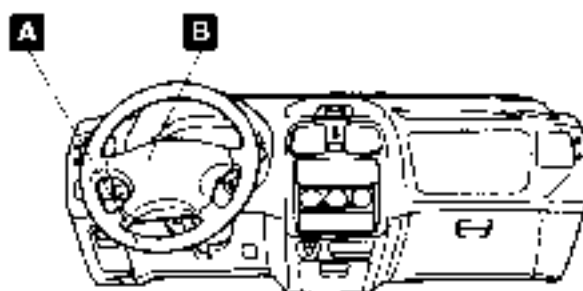

AV008DAJ

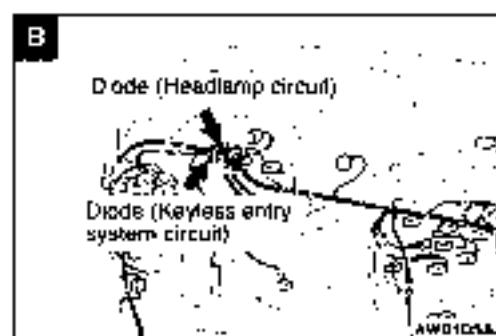

INSPECTION CONNECTOR AND SPARE CONNECTOR

7010020091

Name	Symbol	Name	Symbol
Diagnosis connector	E	Ignition timing adjustment connector	B
Diagnosis connector	E		L.H. drive vehicles
Engine speed detection connector	B		R.H. drive vehicles
	A	Spare connector for front fog lamp	C
	A	Spare connector for front fog lamp	D

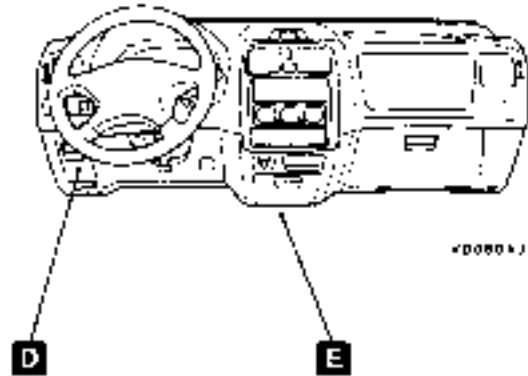
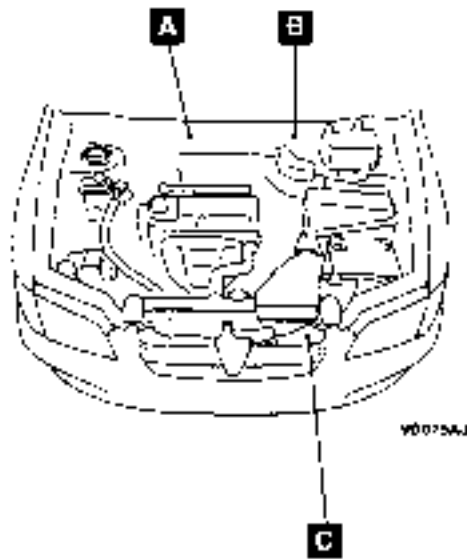

000058Z

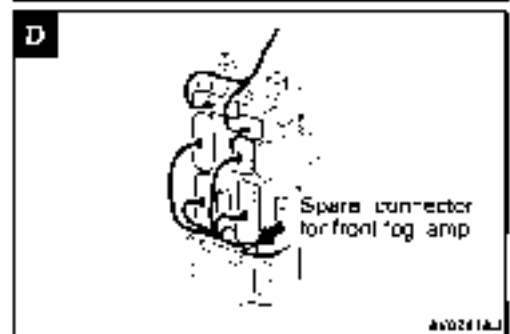
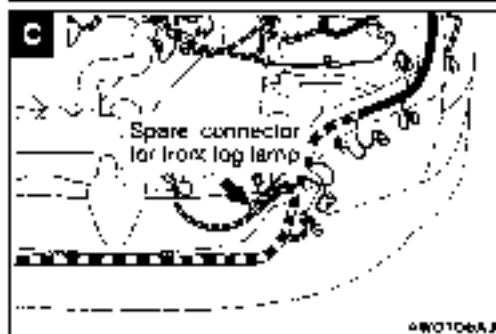
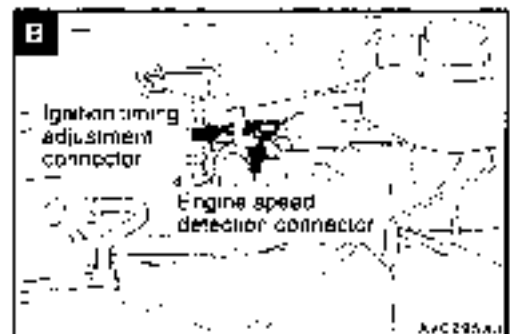
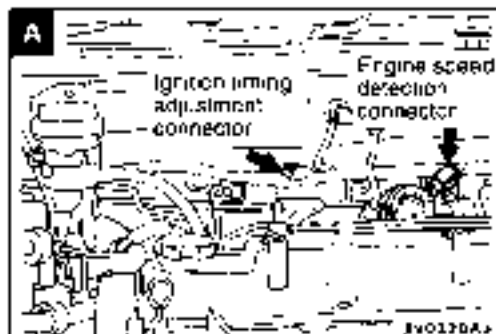

3-12 SINGLE PART INSTALLATION POSITION – Inspection Connector and Spare Connector/Fusible link and Fuse



FUSIBLE LINK AND FUSE

701 00016-004

Name	Symbol	Name	Symbol
Dedicated fuses	A	Multi-purpose fuses	B
Fusible links	A		

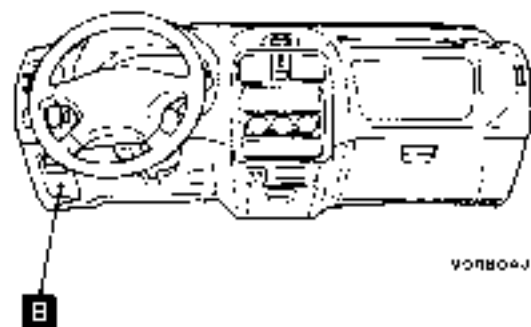
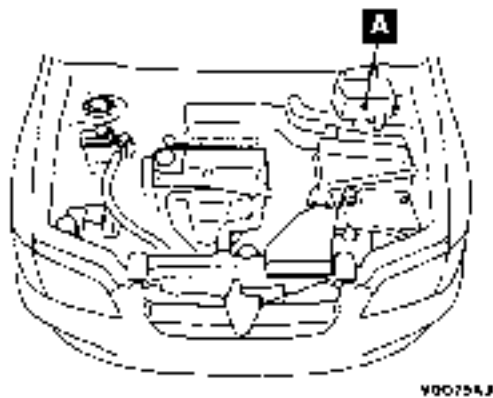

QD008563

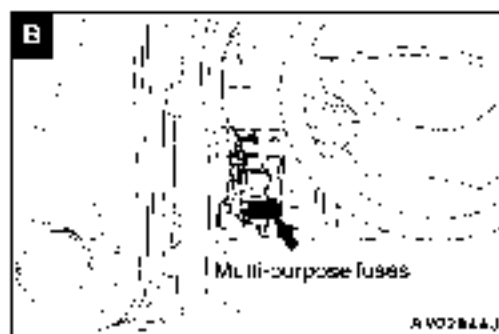
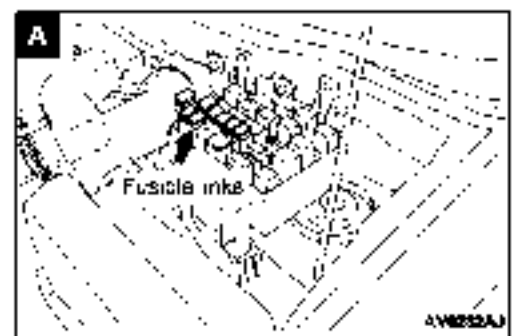
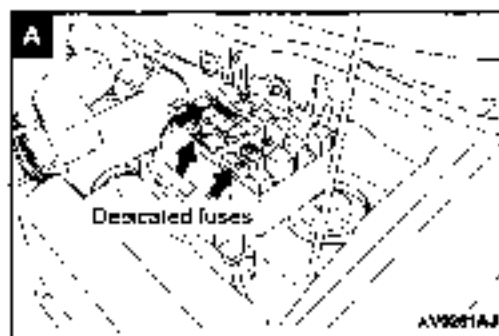

EARTH CABLE

7D100100231

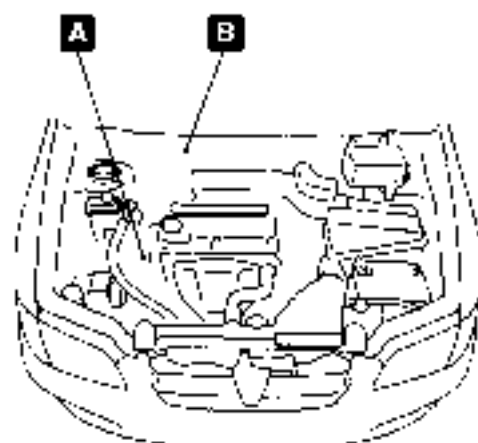

8V00754J

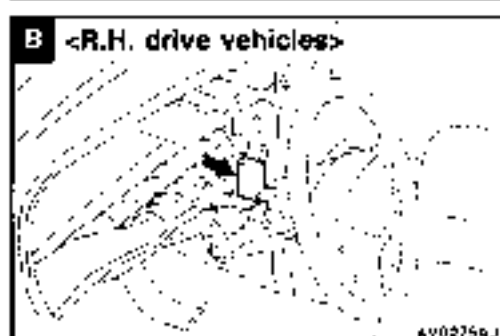
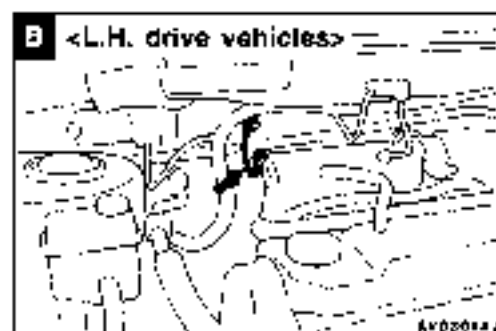
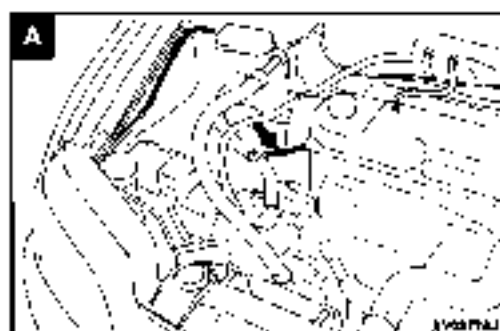

EARTH

7010039424

L.H. drive vehicles

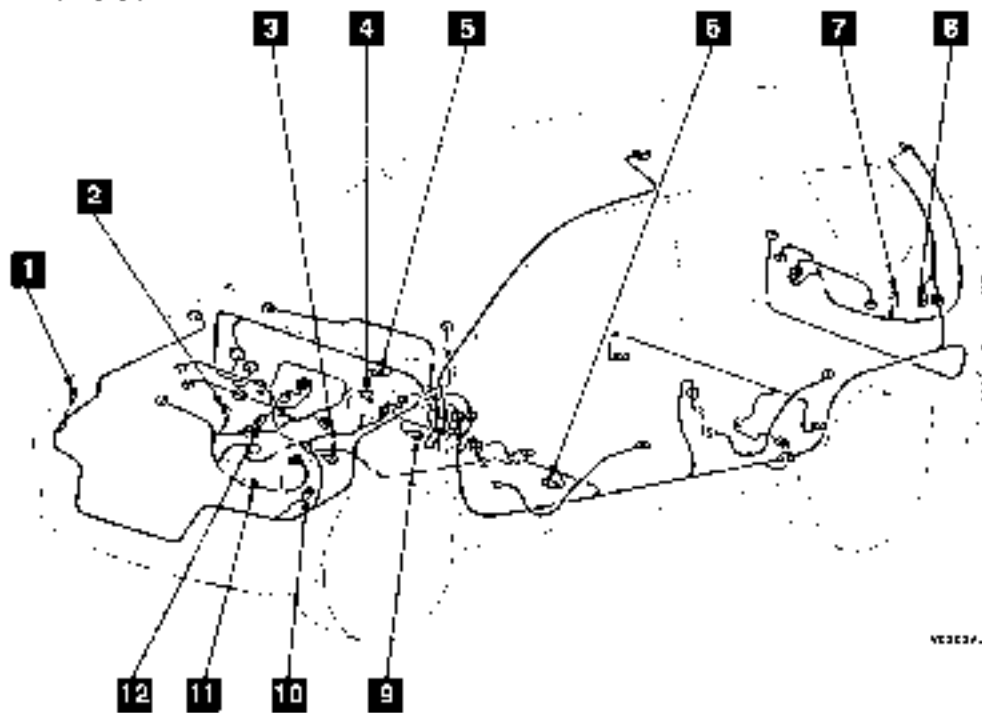

VE20274

R.H. drive vehicles

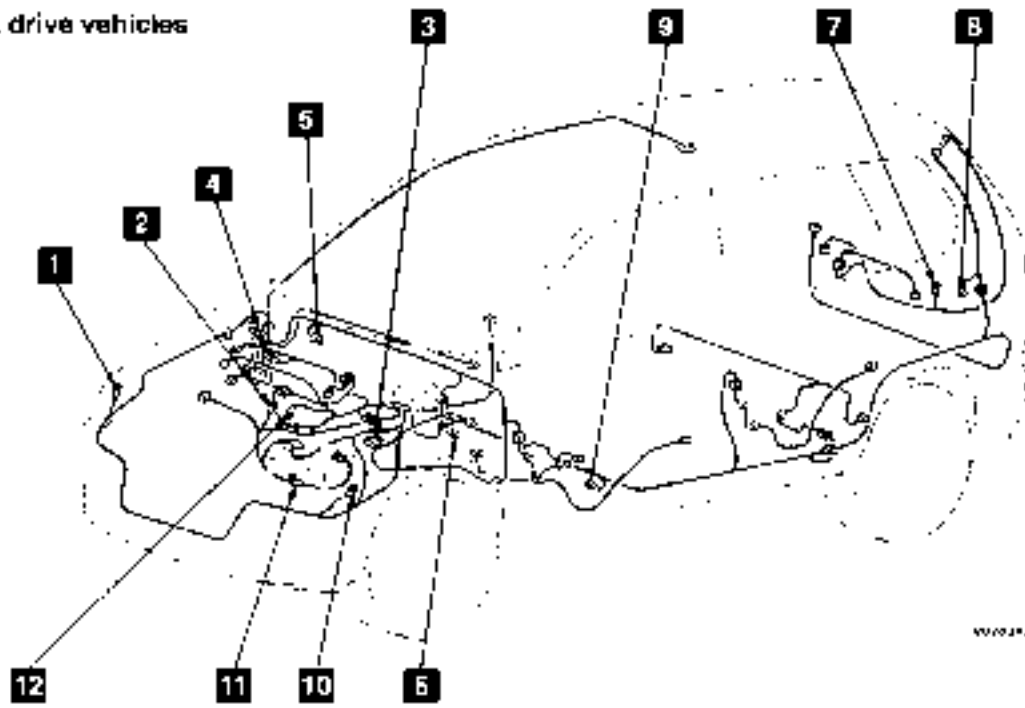

WV0274

9000544

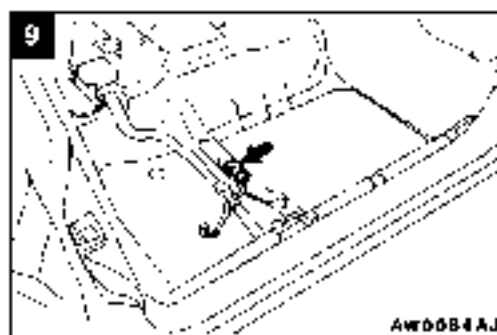
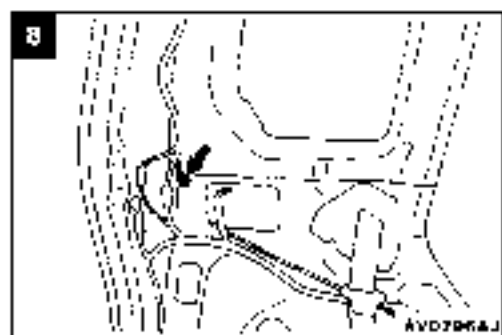
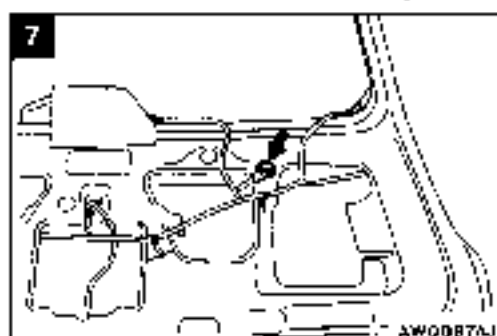
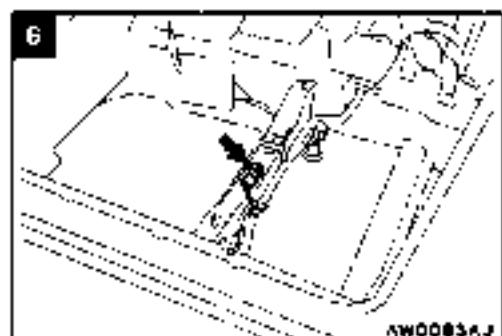
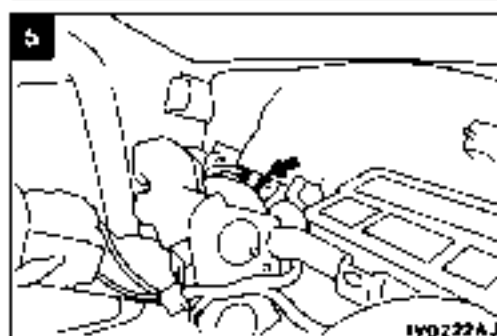
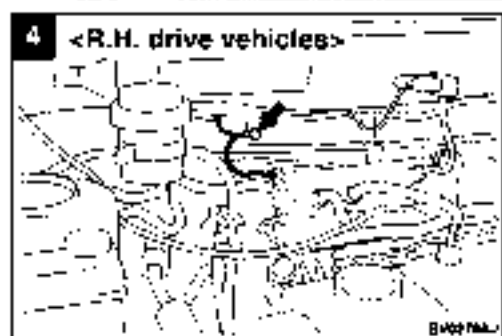
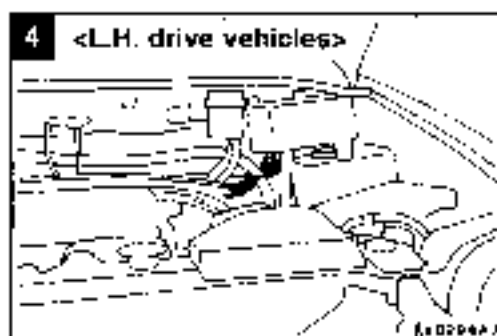
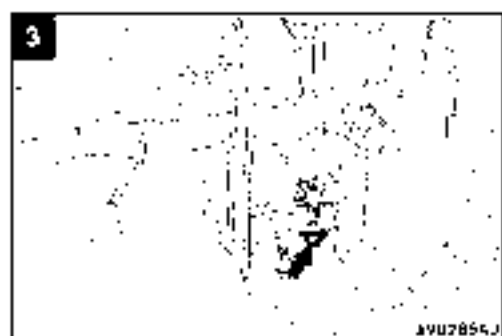
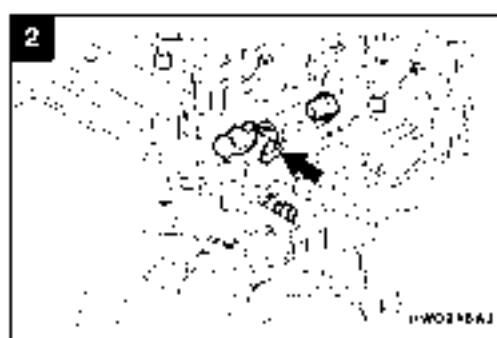
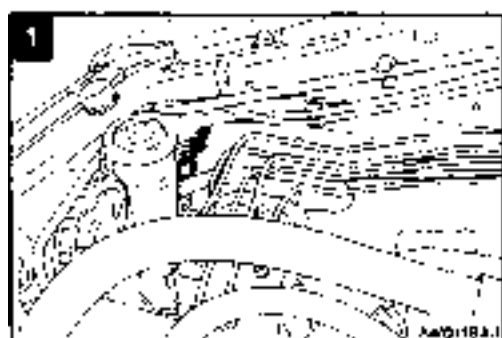

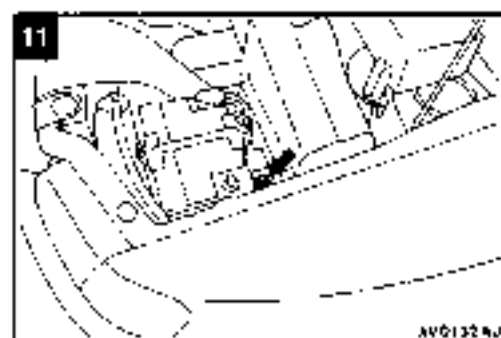
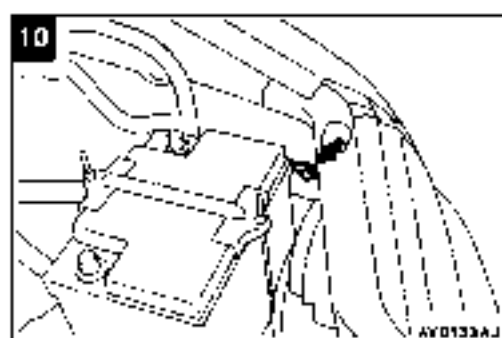

CIRCUIT DIAGRAM

CONTENTS

B01 0900444

JUNCTION BLOCK (J/B)	4-4	TAIL LAMP, POSITION LAMP, LICENCE PLATE LAMP AND LIGHTING MONITOR BUZZER	
JOINT CONNECTOR (J/C)	4-6	Vehicles without daytime running lamp	4-58
CENTRALIZED JUNCTION	4-8	Vehicles with daytime running lamp	4-62
POWER DISTRIBUTION	4-12	FRONT FOG LAMP	
STARTING SYSTEM	4-20	Vehicles without daytime running lamp	4-66
IGNITION SYSTEM		Vehicles with daytime running lamp	4-68
4G13 engine	4-22	REAR FOG LAMP	
4G93 engine	4-23	Vehicles without daytime running lamp	4-70
CHARGING SYSTEM		Vehicles with daytime running lamp	4-74
4G13 engine	4-24	ROOM LAMP AND LUGGAGE COMPARTMENT LAMP	
4G93 engine	4-25	Vehicles without keyless entry system	4-78
MPI SYSTEM		Vehicles with keyless entry system	4-80
4G13 engine	4-28	GLOVE BOX LAMP	4-82
4G93 engine	4-34	TURN-SIGNAL LAMP AND HAZARD WARNING LAMP	4-84
COOLING SYSTEM		STOP LAMP	4-87
4G13 engine	4-46	BACK-UP LAMP	4-88
4G93 engine	4-48	HORN	4-89
HEADLAMP		METER AND GAUGE	4-90
L.H. drive vehicles without daytime running lamp	4-50	OIL PRESSURE WARNING LAMP	4-94
R.H. drive vehicles	4-51	FUEL WARNING LAMP	4-94
Vehicles with daytime running lamp	4-52		
HEADLAMP LEVELING SYSTEM	4-56		

BRAKE WARNING LAMP	4-94	DEFOGGER AND DOOR MIRROR HEATER	
POWER WINDOWS	4-96	L.H. drive vehicles	4-132
CENTRAL DOOR LOCKING SYSTEM		R.H. drive vehicles	4-134
Vehicles without keyless entry system	4-102	REMOTE CONTROLLED MIRROR	4-136
Vehicles with keyless entry system	4-106	CIGARETTE LIGHTER	4-137
HEATER	4-112	MULTI CENTER DISPLAY	4-138
MANUAL AIR CONDITIONER		SUNROOF	4-144
4G13 engine	4-114	HEATED SEAT	4-148
4G93 engine	4-120	ABS	4-148
WINDSHIELD WIPER AND WASHER	4-124	SUPPLEMENTAL RESTRAINT SYSTEM	4-160
REAR WIPER AND WASHER	4-128	IMMOBILIZER SYSTEM	4-154
HEADLAMP WASHER	4-131	RHEOSTAT	4-158

NOTES

JUNCTION BLOCK (J/B)

90100020412

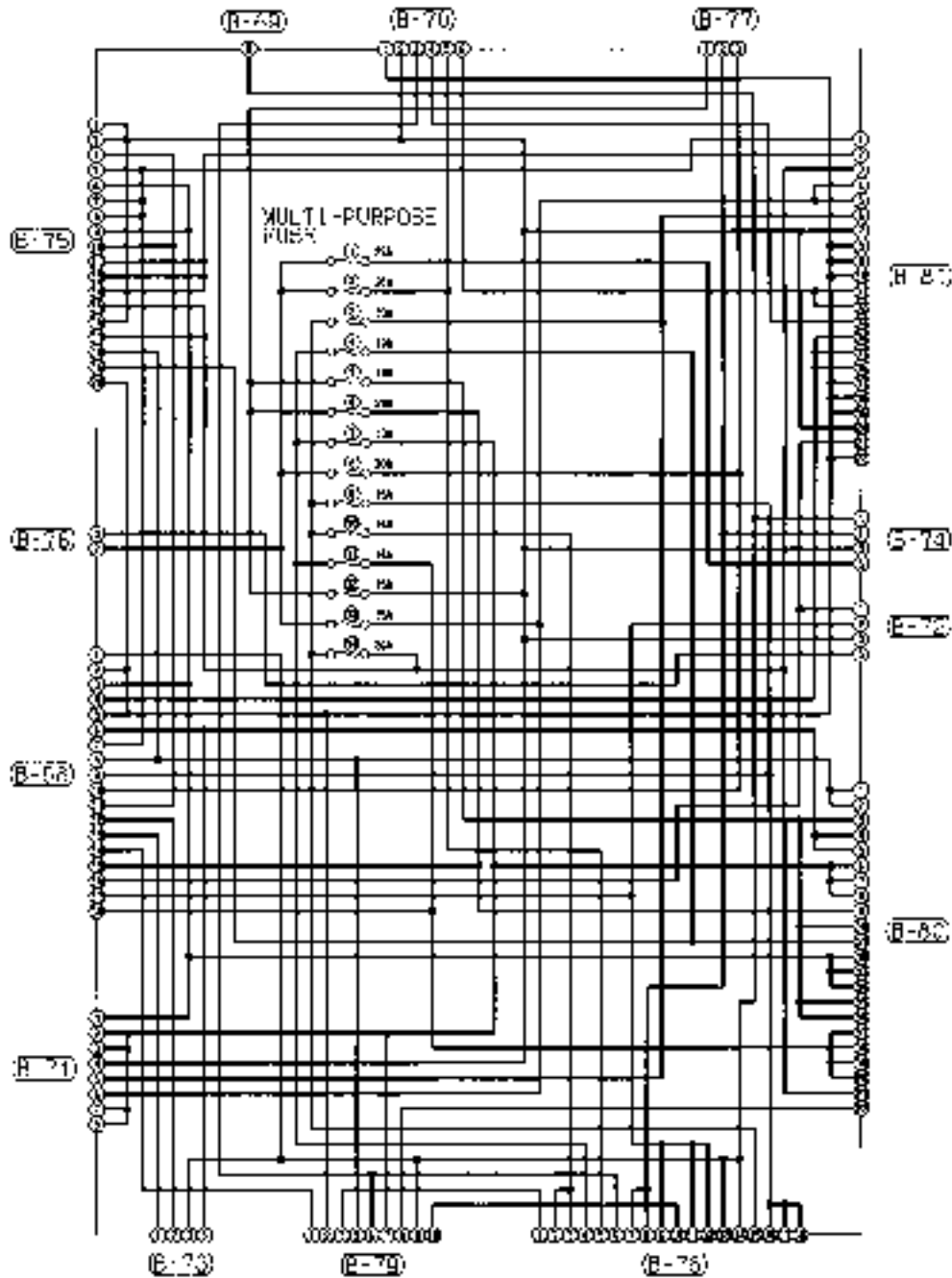

REMARK:
CONNECTOR NUMBERS ARE KEYED TO THE CONFIGURATION
DIAGRAM PAGE PANEL AND EACH CIRCUIT DIAGRAM.

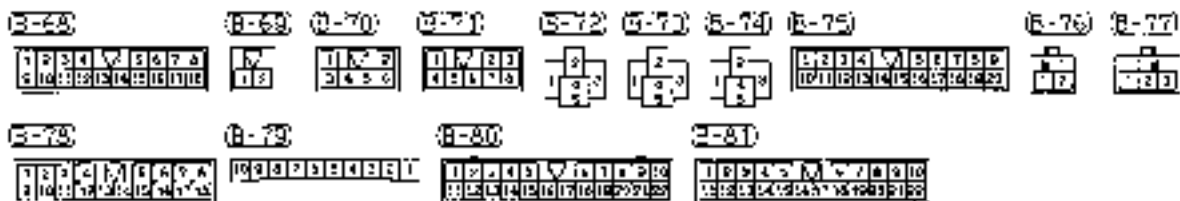

9000000000

Front side

Rear side

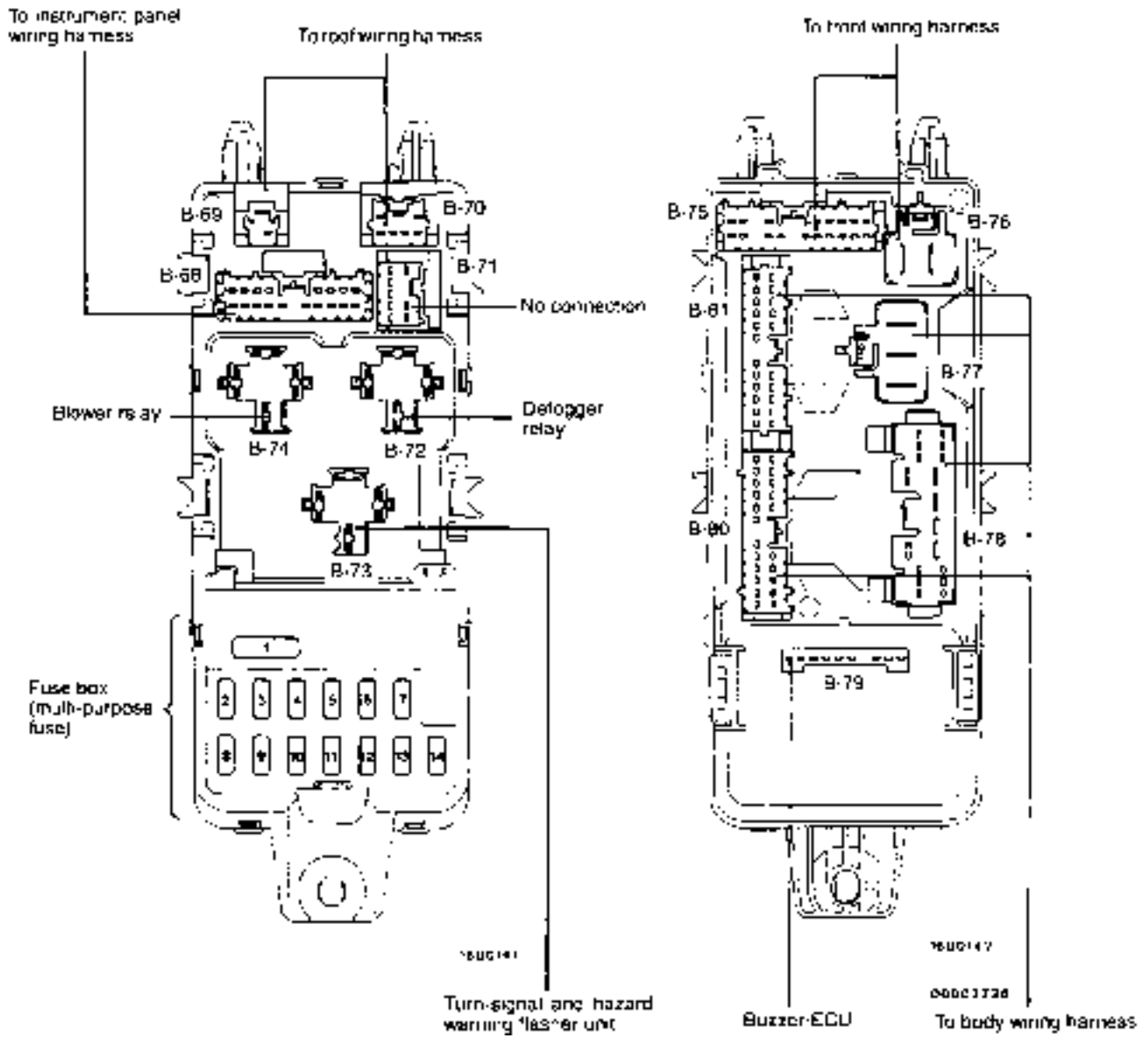

JOINT CONNECTOR (J/C)

301014281 00

IN ACTUAL VEHICLES, ANY OF THE TERMINALS CONNECTED IN J/C ARE USED. THE TERMINALS DESCRIBED IN THE CIRCUIT DIAGRAM MAY NOT BE IDENTICAL TO THOSE OF THE VEHICLES.

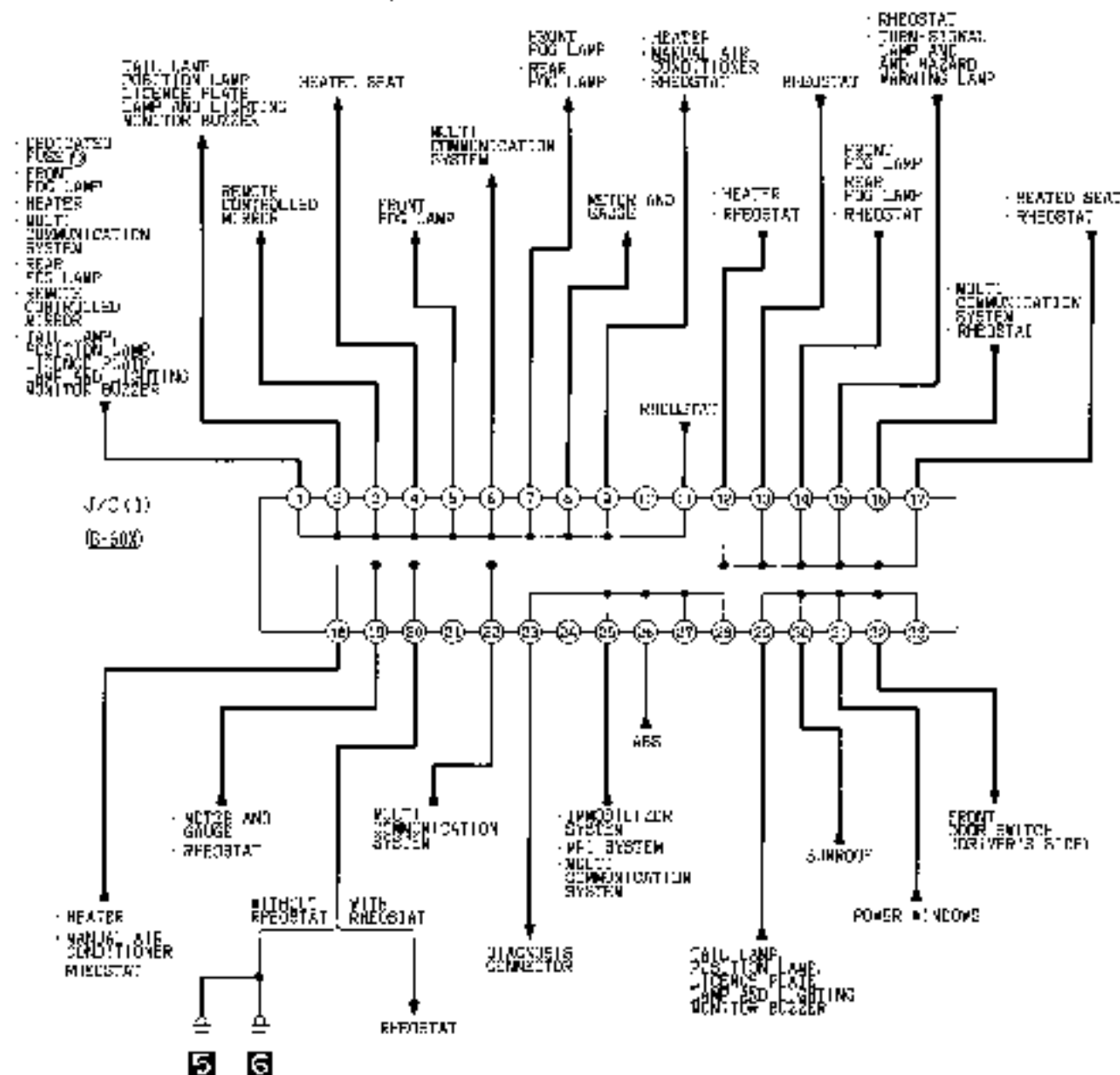

②-60X

②-61X

1	2	3	4	5	6	7	8	9	10	11	12	13	14	15	16	17	18	19	20	21	22	23	24	25	26	27	28	29	30	31	32
1	2	3	4	5	6	7	8	9	10	11	12	13	14	15	16	17	18	19	20	21	22	23	24	25	26	27	28	29	30	31	32

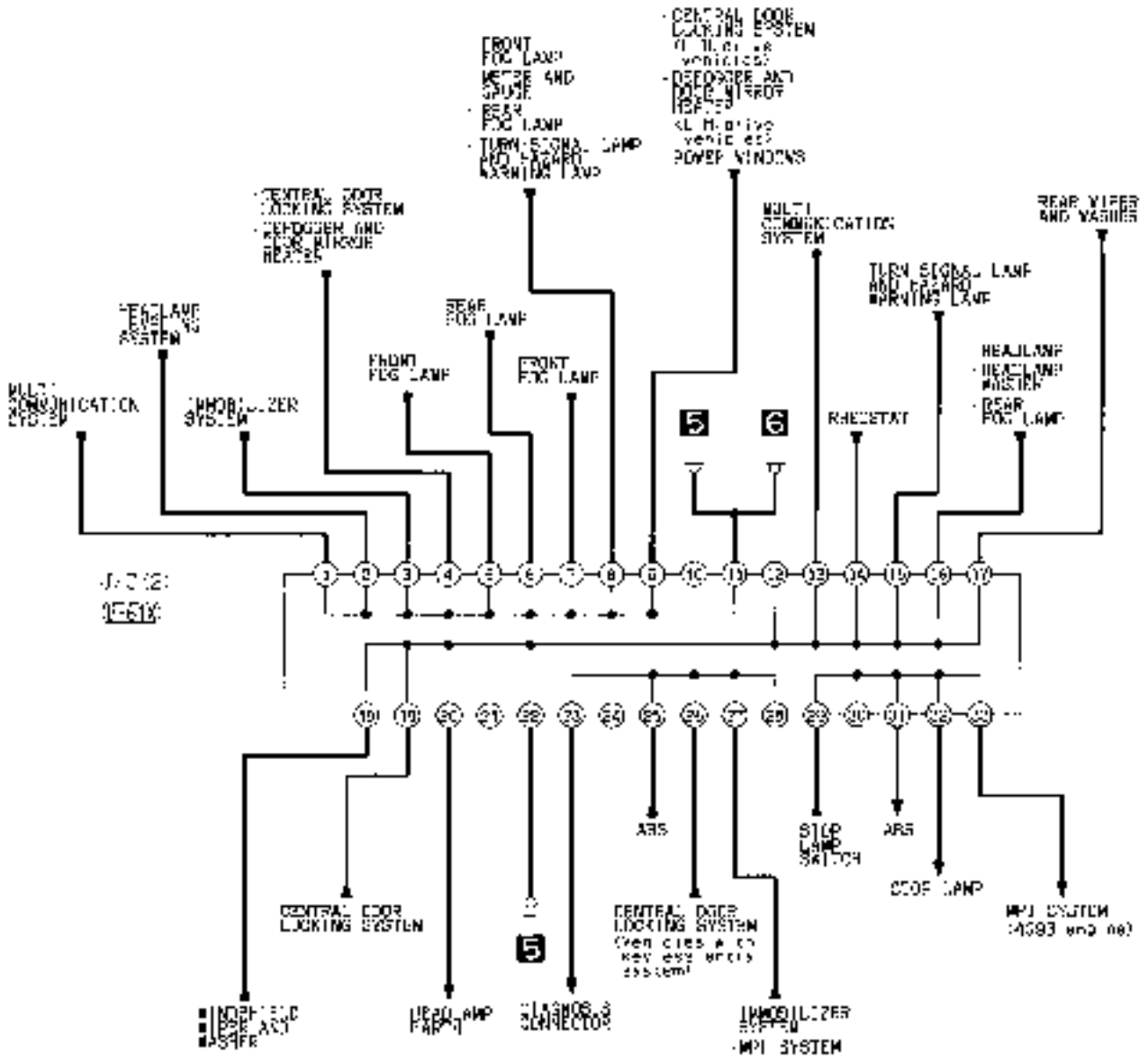

CENTRALIZED JUNCTION

10100030499

FUSIBLE LINK

No.	Circuit	Housing colour	Rated capacity (A)
1	Fusible link No. 2, 3 and dedicated fuse No. 1, 2, 3, 4, circuit <When the engine stopped> Fusible link No. 4, 5, 6, 7, 8 and dedicated fuse No. 8, 9, 10 and charging system circuit <After start of the engine>	Black	100
2	Multi-purpose fuse No. 1, 2, 13 circuit	Green	40
3	Defogger and door mirror heater circuit	Pink	30
4	ABS circuit	Red	50
5	Ignition switch circuit	Green	40
6	Headlamp washer and power window circuit	Pink	30
7	Cooling system and manual air conditioner circuit	Pink	30
8	Dedicated fuse No. 12, 13, 14, 15, head amp and rear fog lamp circuit	Green	40
9			

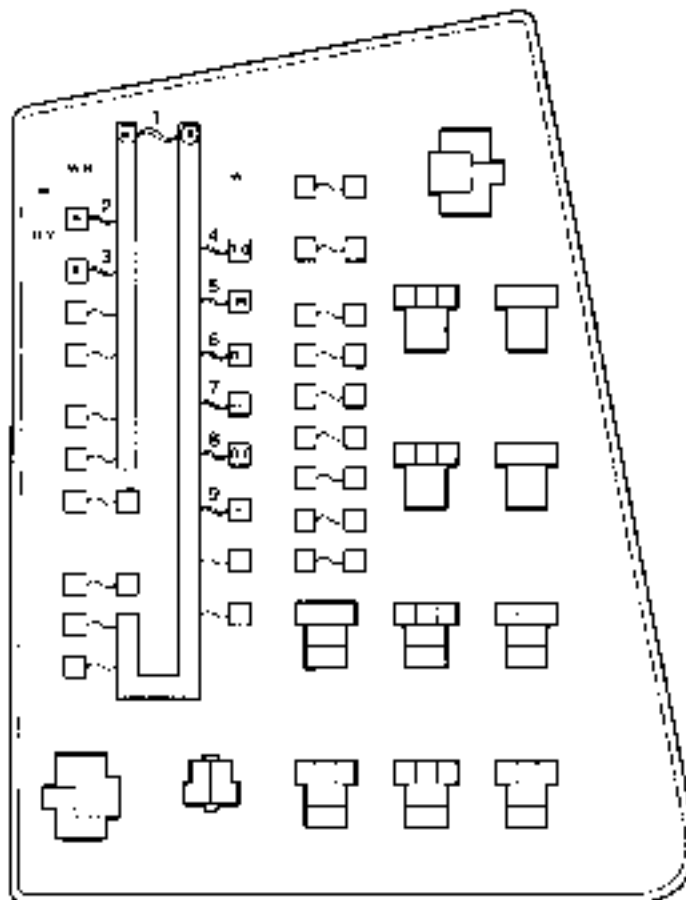

AV9239A4

DEDICATED FUSE

Power supply circuit	No.	Rated capacity (A)	Housing colour	Circuit
Battery/Alternator (Fusible link No. 1)	1	20	Yellow	Condenser fan circuit <4G13>
	2	10	Red	A/C compressor circuit
	3	10	Red	Audio circuit, door warning lamp, front fog lamp, MPI system, MUT-l power supply, rear fog lamp and room lamp and luggage compartment lamp circuit
	4	20	Yellow	Central door locking system circuit
Ignition switch ACC	5	10	Red	Audio circuit
	6	-	-	-
	7	-	-	-
Battery/Alternator (Fusible link No. 1)	8	10	Red	Charging and hazard warning circuit
	9	20	Yellow	Cooling system <4G93>, immobilizer system and MPI system circuit
	10	15	Blue	ABS, MPI system <4G93> and stop lamp circuit
	11	-	-	-
Fusible link No. 8	12	15	Blue	Front fog lamp circuit
	13	10	Red	Front fog lamp, illumination, MPI system, rheostat, tail lamp, position lamp and lighting monitor buzzer circuit
	14	10	Red	Headlamp washer, tail lamp and position lamp circuit
	15	10	Red	Headlamp leveling system circuit, high beam indicator lamp, MPI system <4G13> and rear fog lamp circuit
	16	-	-	-
-	17	-	-	-
-	18	-	-	-
-	19	-	-	-



MULTI-PURPOSE FUSE

Power supply circuit	No.	Rated capacity (A)	Housing colour	Load circuit	
Fusible link No. 2	1	25	Transparent	A/C switch (Manual air conditioner), blower motor and resistor	
	2	20	Yellow	Sunroof-ECU	
Ignition switch	ACC	3	Red	Horn and horn relay	
	IG1	4	Red	Alternator relay, back-up lamp and SRS-ECU	
	IG2	5	Red	ABS-ECU	
		6	20	Yellow	Heated seat
-	IG1	7	Red	Buzzer ass'y, combination meter and multi-center display	
	8		-	-	
	Ignition switch	ACC	9	Blue	Cigarette lighter and multi-center display
			10	Red	Keyless entry receiver ECU and remote controlled mirror switch
		IG1	11	Red	Hazard warning switch and SRS-ECU
		IG2	12	Blue	Condenser fan relay <4G13>, DAL-ECU <Vehicles with daytime running lamp>, defogger relay, blower relay, headlamp washer relay, outside/inside air selection damper control motor and radiator fan relay
Fusible link No. 2	13	15	Blue	Combination meter and rear combination lamp (Rear fog lamp)	
	14	20	Yellow	Column switch <Intermittent wiper relays>, rear intermittent wiper relay, rear wiper motor and windshield wiper motor	

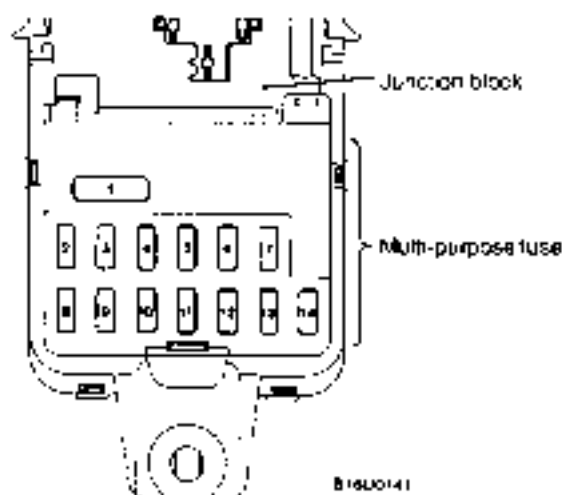

CENTRALIZED RELAY

Connector No.	Name	Connector No.	Name
A-03X	Headlamp washer relay	A-14X	Radiator fan relay <4G13>
A-04X	Alternator relay	A-15X	Tail lamp relay <DRL>
A-05X	-	B-60X	J/C (1)
A-06X	Horn relay	B-61X	J/C (2)
A-07X	Fan control relay <4G93>	B-62X	Diode (Engine circuit)
A-08X	Condenser fan relay (HI) <4G13>	B-63X	-
A-09X	Condenser fan relay (LO) <4G13>	B-64X	Front fog lamp relay
A-10X	A/C compressor relay	B-65X	Rear fog lamp relay
A-11X	-	B-66X	Rear intermittent wiper relay
A-12X	Headlamp relay	B-67X	Door lock ECU <Vehicles without keyless entry>
A-13X			

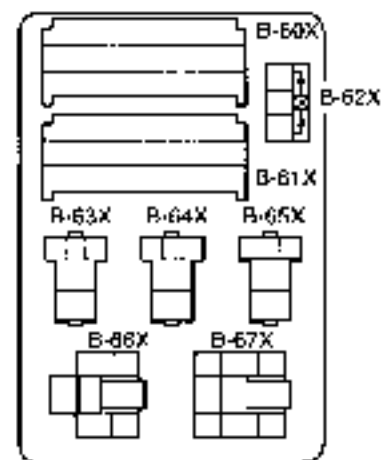
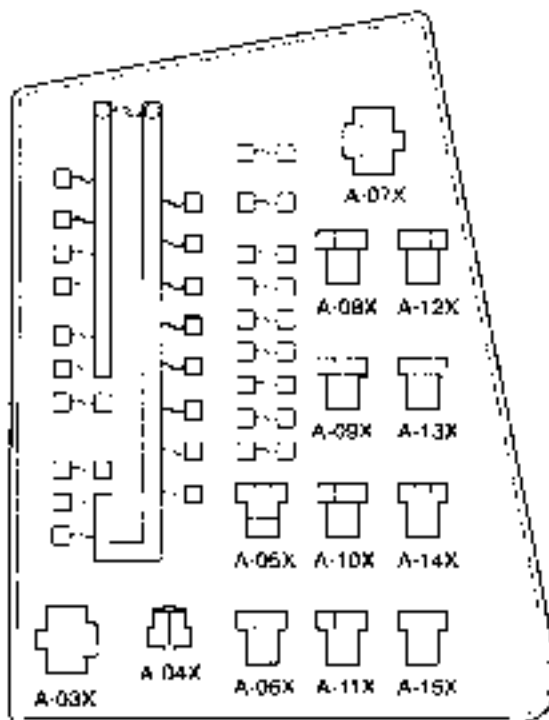

1614999

9507988.1

16008422

POWER DISTRIBUTION SYSTEM

40100640722

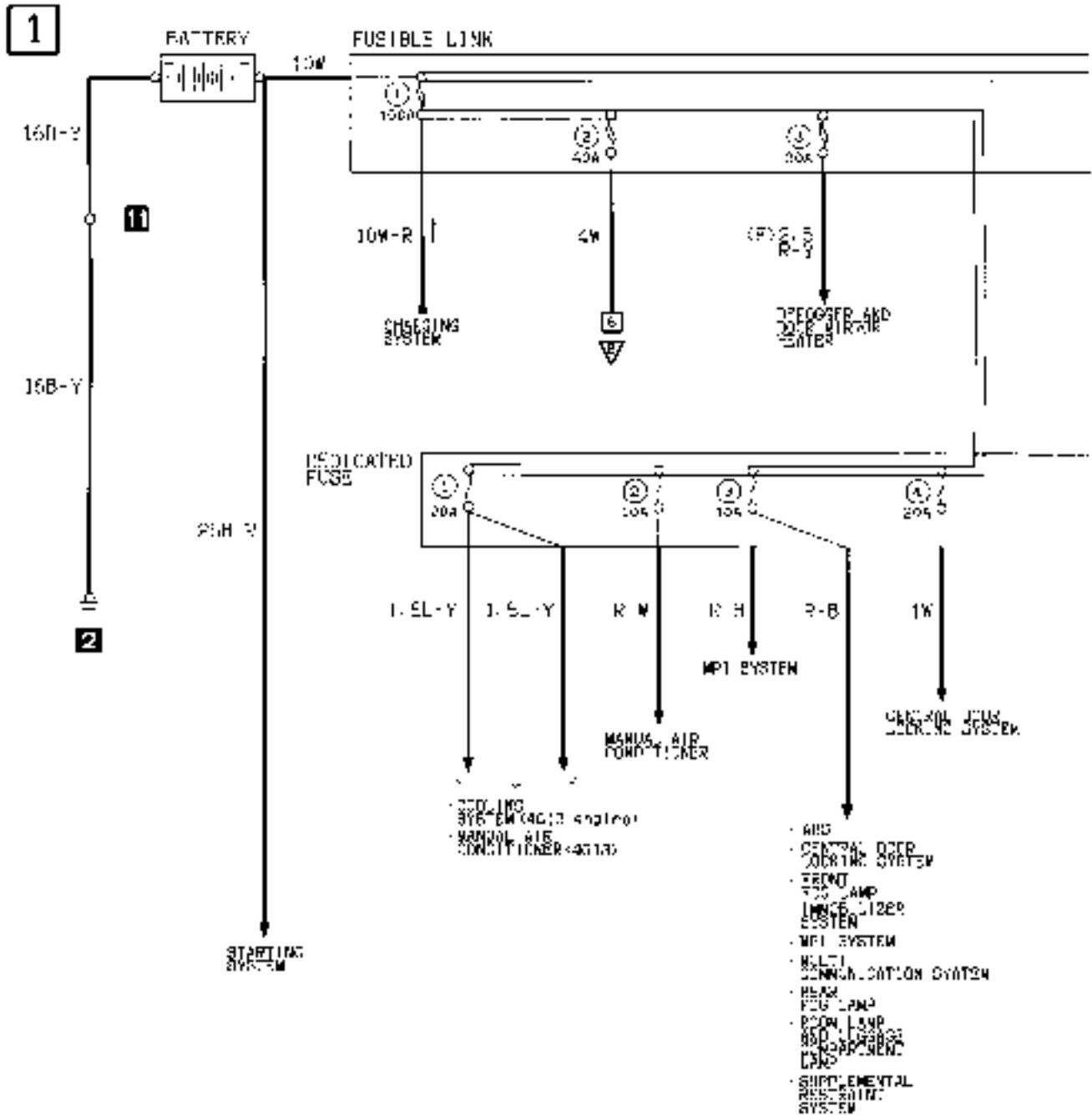

2

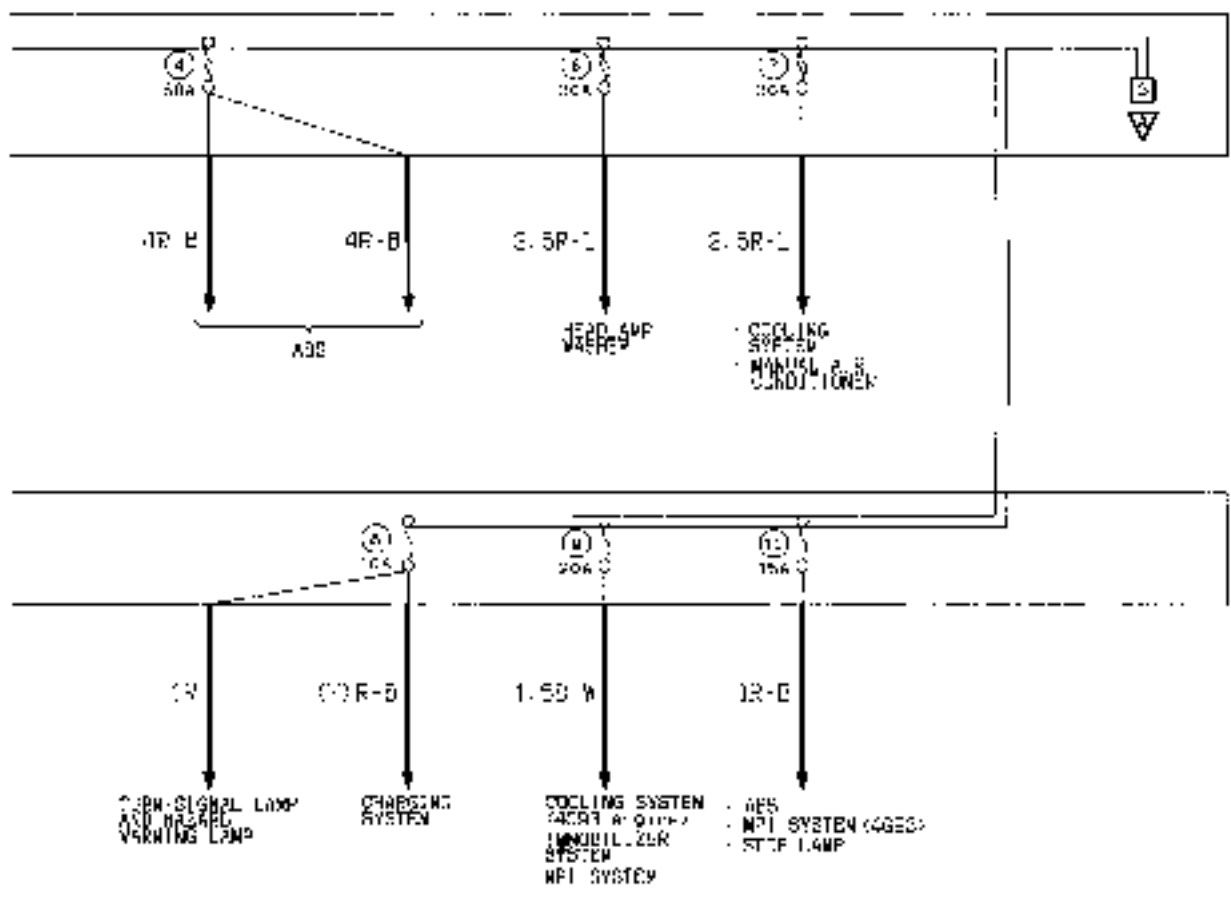

NOTE: EDITOR CODE
 B: Black G: Green L: Blue W: White Y: Yellow BB: Sky Blue
 BR: Brown O: Light Green GR: Gray R: Red P: Pink V: Violet

POWER DISTRIBUTION SYSTEM (CONTINUED)

3

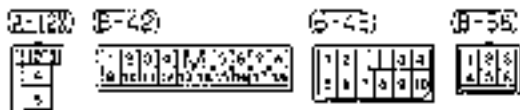
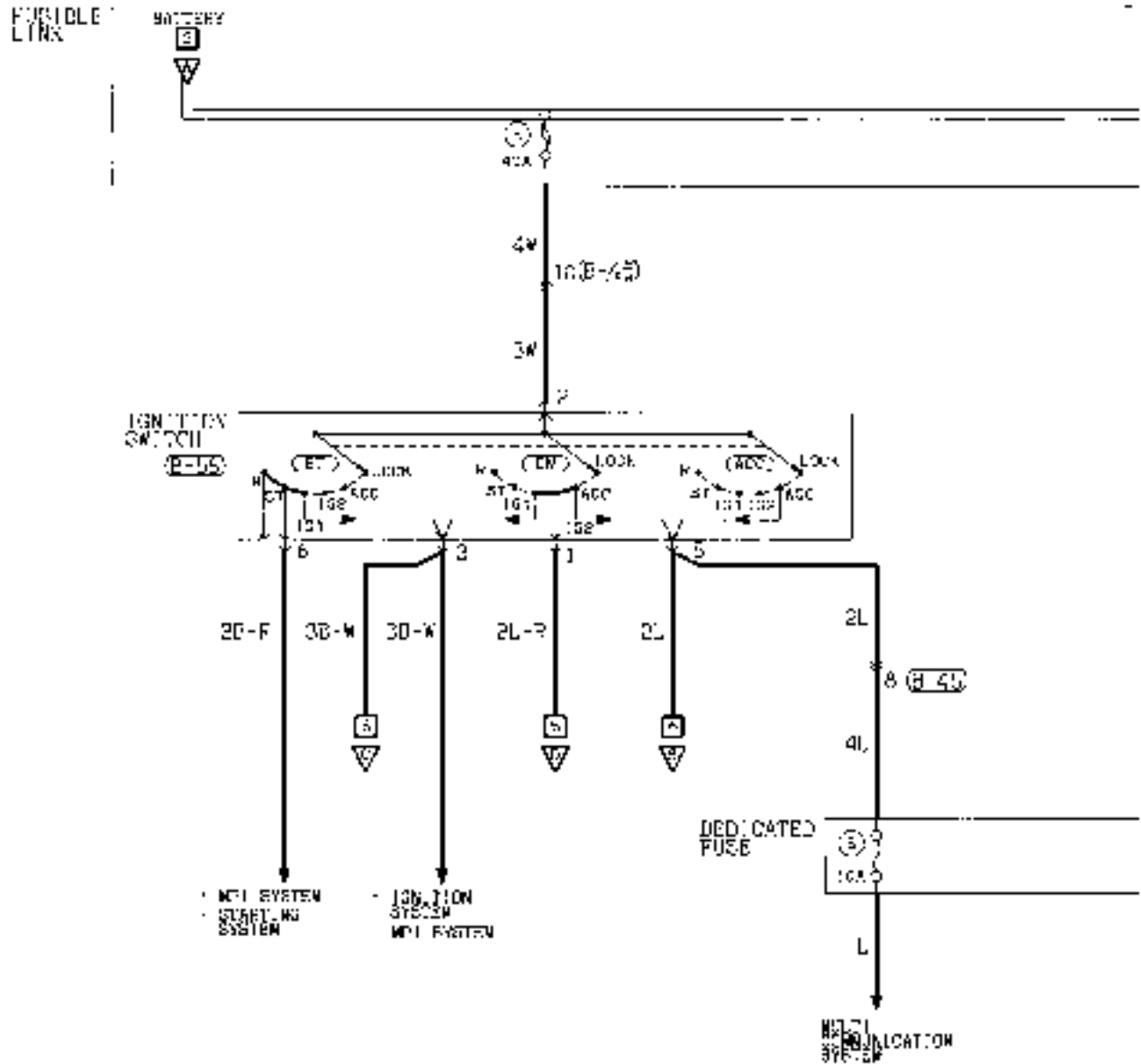

4

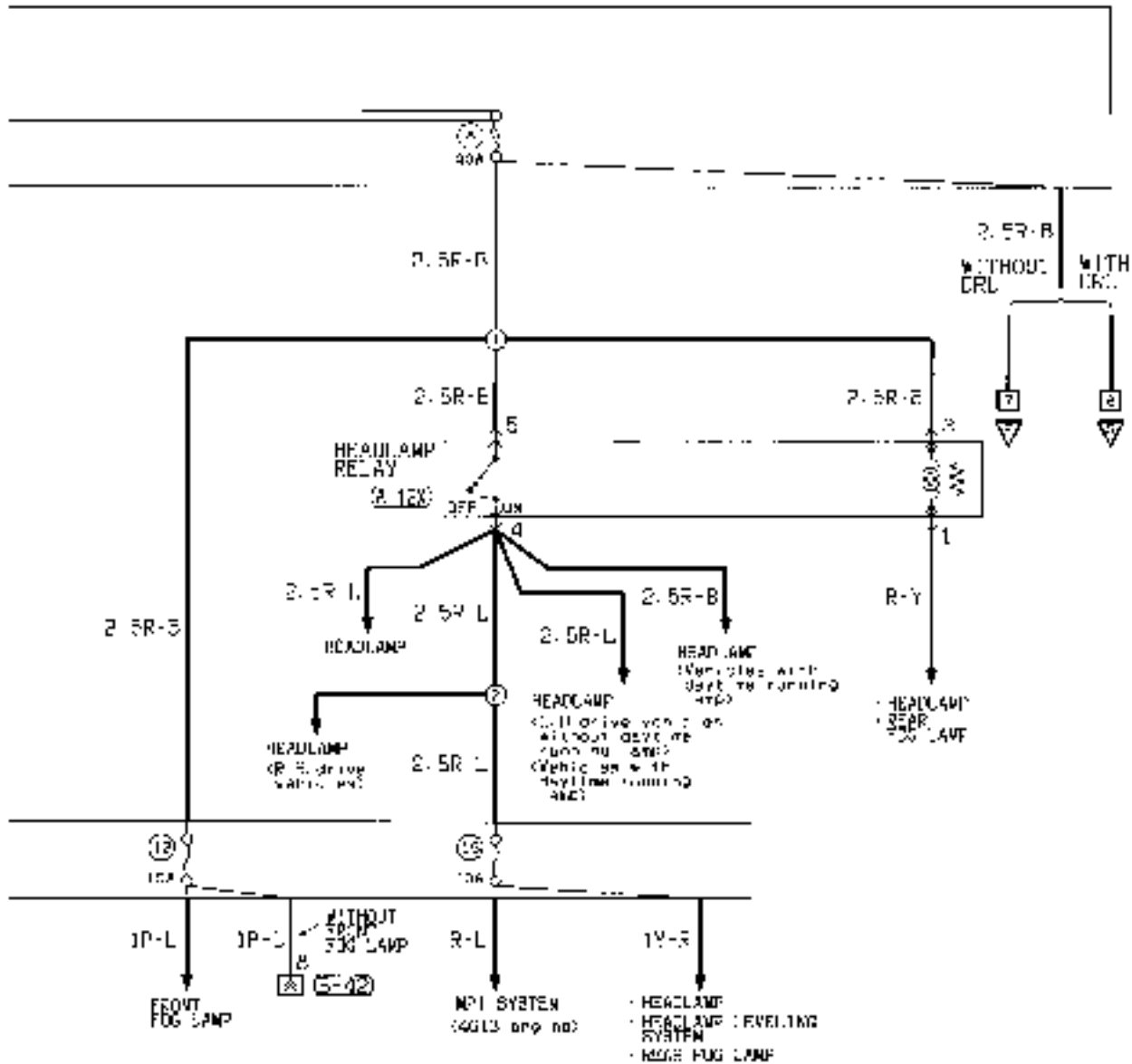

W: White, G: Green, B: Black, GR: Gray, R: Red, P: Pink, Y: Yellow, SB: Sky Blue
 BR: Brown, O: Orange, G: Light Green, L: Blue, Y: White, Y: Yellow, SB: Sky Blue

POWER DISTRIBUTION SYSTEM (CONTINUED)

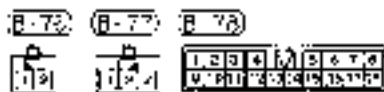
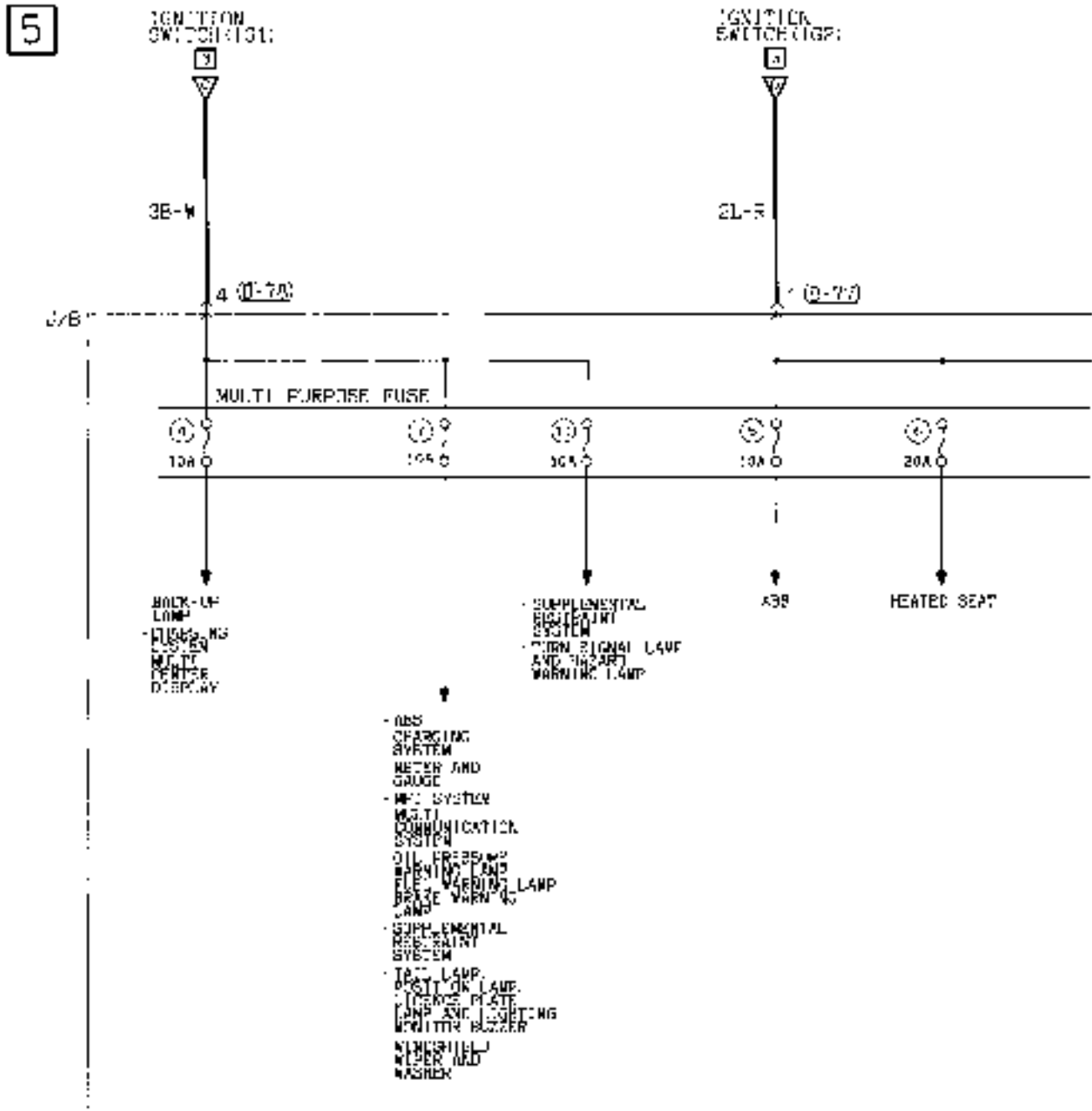

6

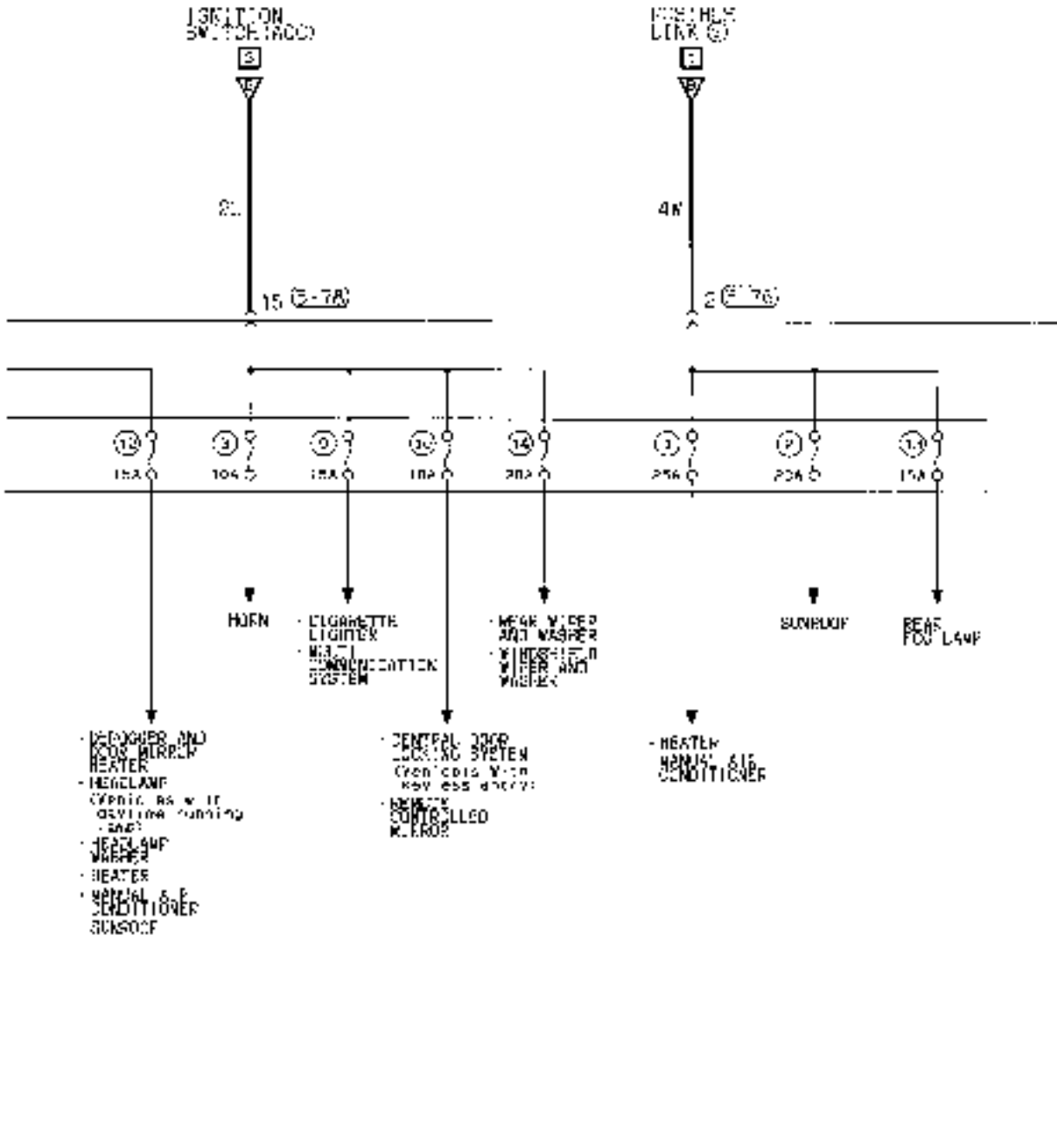

Wire colour code
 B: Blue L: Light green G: Green L: Blue Y: White y: Yellow SS: Sky blue
 BR: Brown C: Orange GR: Gray R: Red P: Pink V: Violet

POWER DISTRIBUTION SYSTEM (CONTINUED)

7

(Van dies without daytime running lamp)

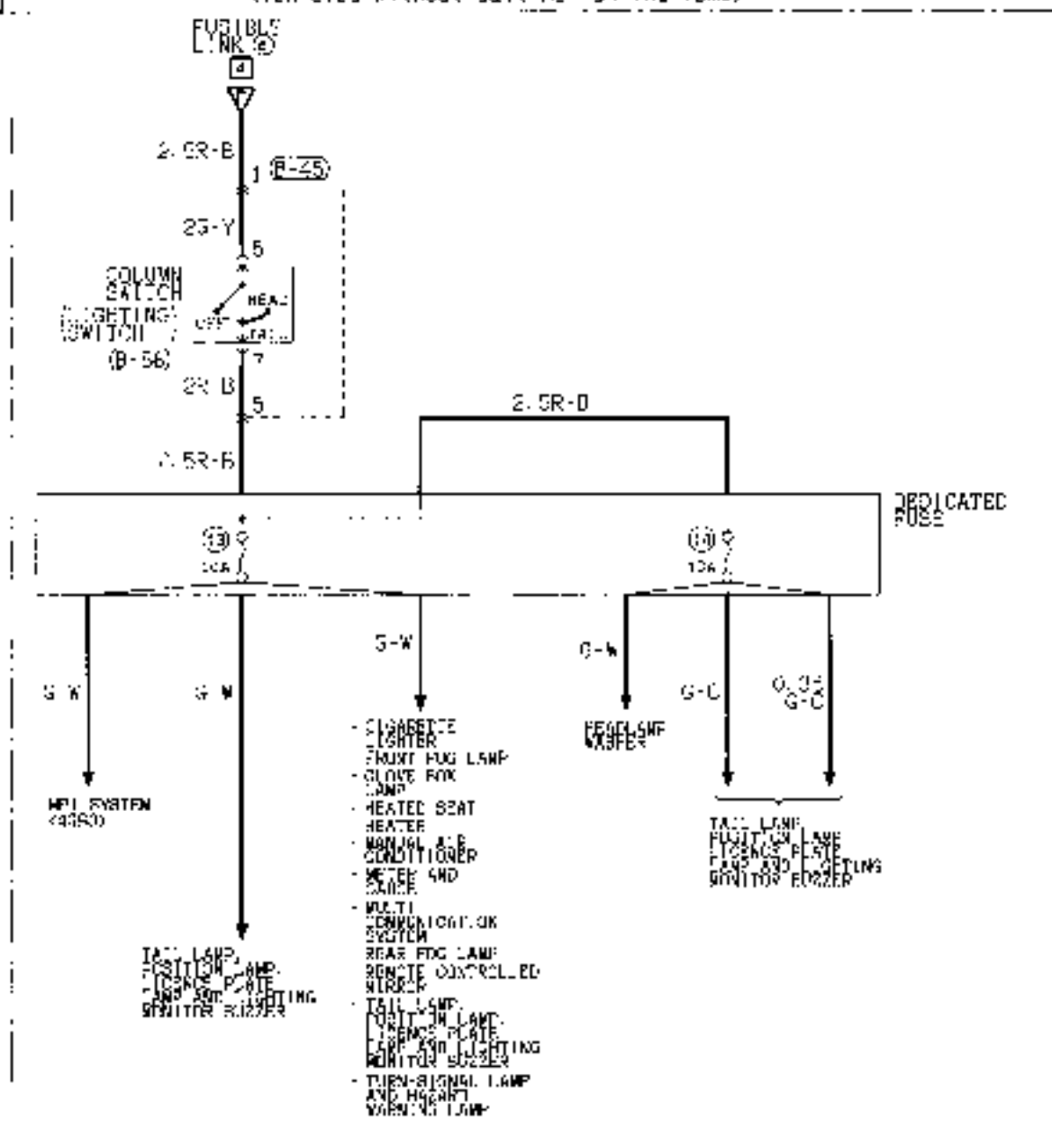

(6-25)

(B-45)

(B-50)

1	2	3	4
5	6	7	8

1	2	3	4
5	6	7	8

1	2	3	4
5	6	7	8

8

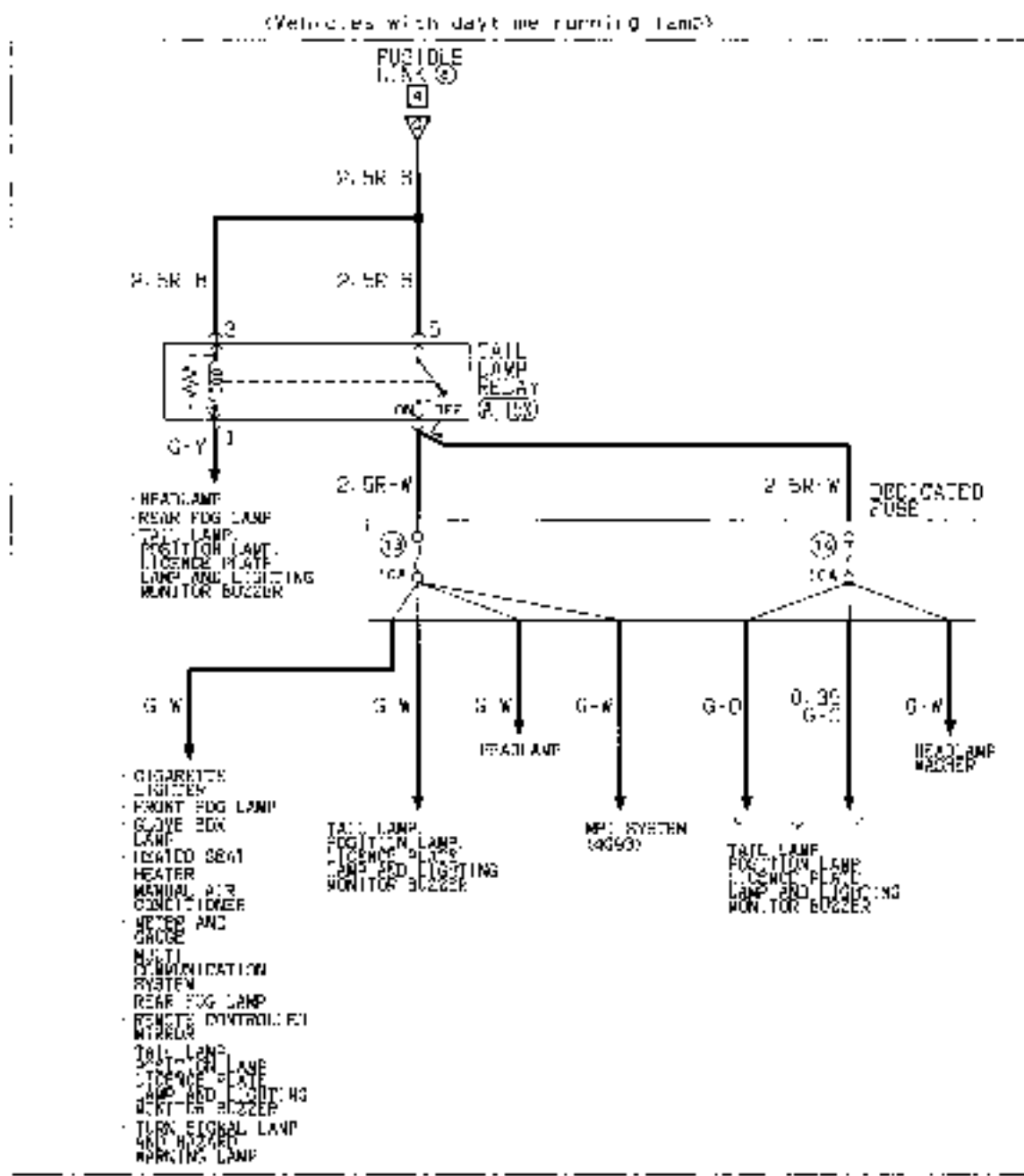

Wire colour code

B: Black	W: White	G: Green	L: Blue	M: Pink	Y: Yellow	EB: Ext. blue
BR: Brown	OR: Orange	GR: Grey	R: Red	P: Pink	V: Violet	

STARTING SYSTEM

90100050865

1

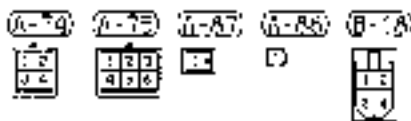
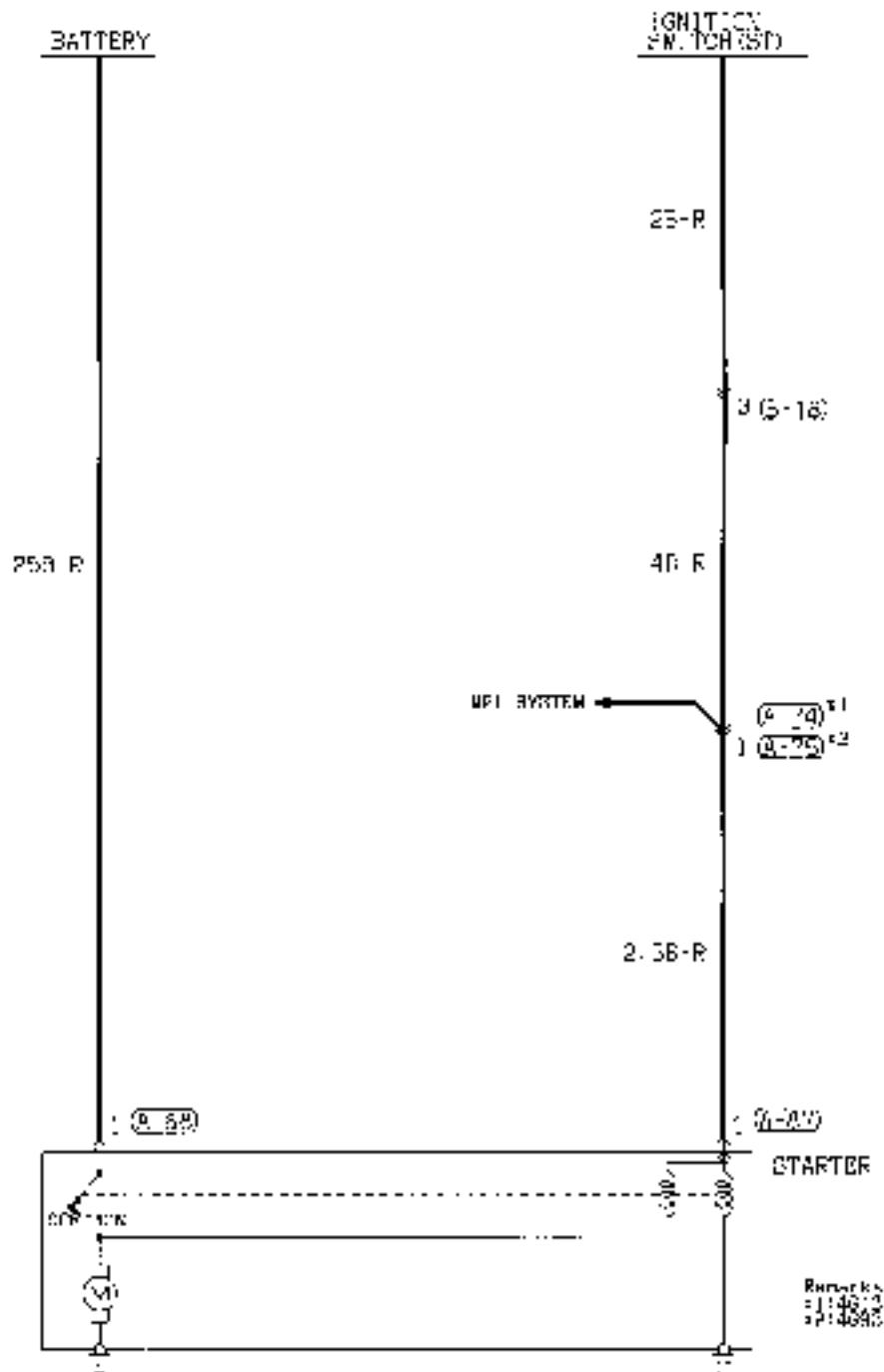

Wire colour code
 B: Black
 BR: Brown
 W: White
 V: Violet
 LG: Light green
 O: Orange
 SB: Sky blue
 G: Green
 BR: Brown
 P: Pink
 L: Light blue
 R: Red
 Y: Yellow

STARTING SYSTEM (See P. 4-20.)**OPERATION**

When the ignition switch is turned to the ST position, the starter contacts (magnet switch) turns ON and the starter motor starts turning over.

TROUBLESHOOTING HINTS

1. Starter motor does not turn over at all.
 - Check starter (coil)
 - Check battery terminals for proper contact
2. Starter motor does not stop rotating.
 - Check starter (magnet switch).

IGNITION SYSTEM

9010086011

4G13 engine

1

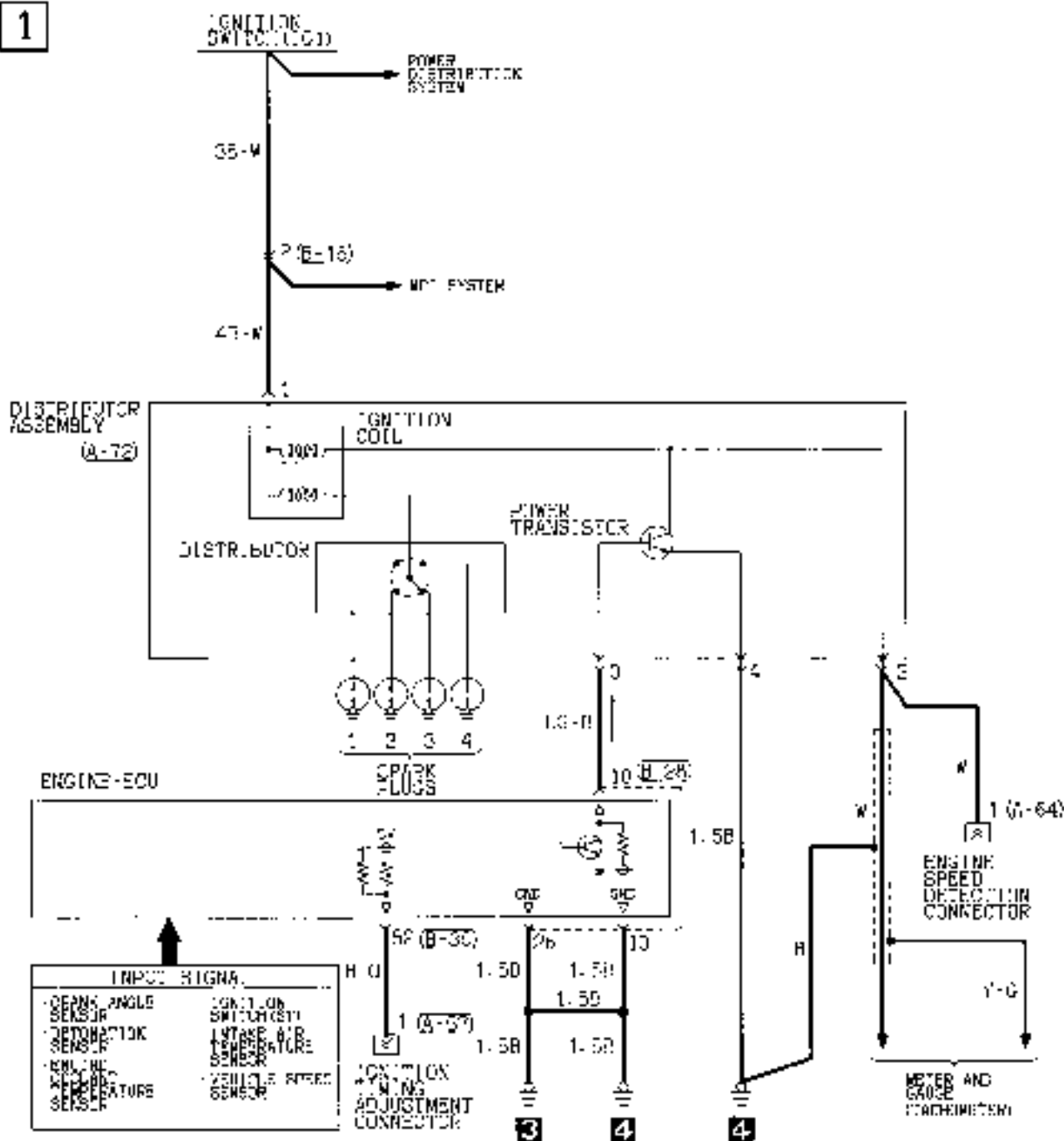

W : Yellow C-29
 B : Black L3 : Light Green G : Green L : Blue N : White Y : Yellow SS : Sky blue
 BR : Brown U : Orange GR : Gray R : Red P : Pink V : Violet

IGNITION SYSTEM

9010900926

4G93 engine

1

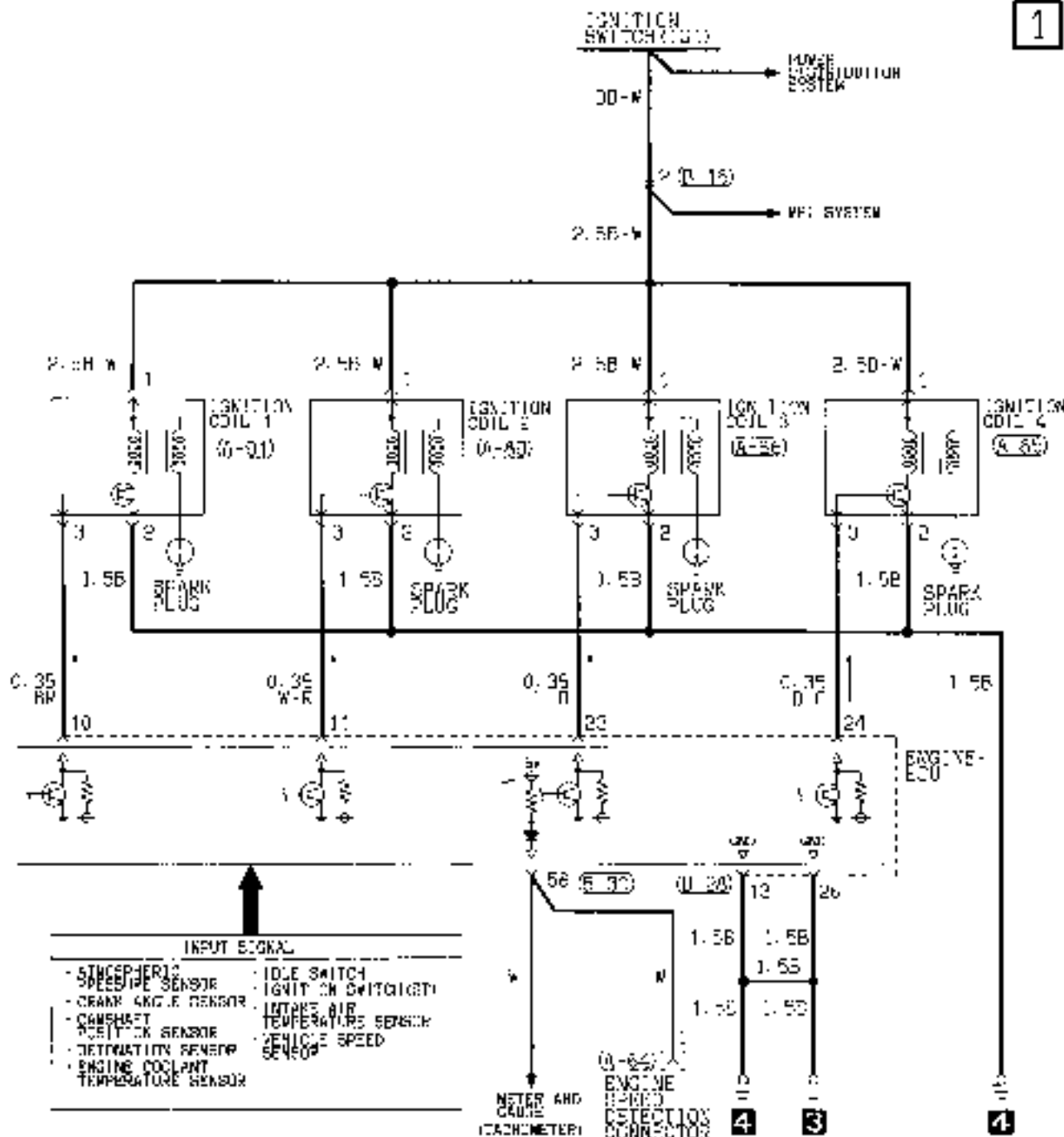

CHARGING SYSTEM

9010070790

4G13 engine

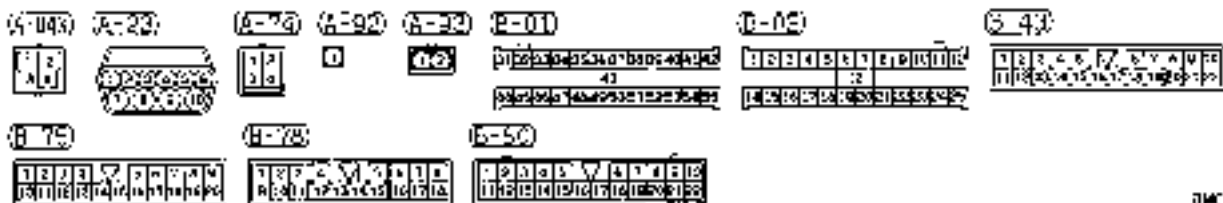
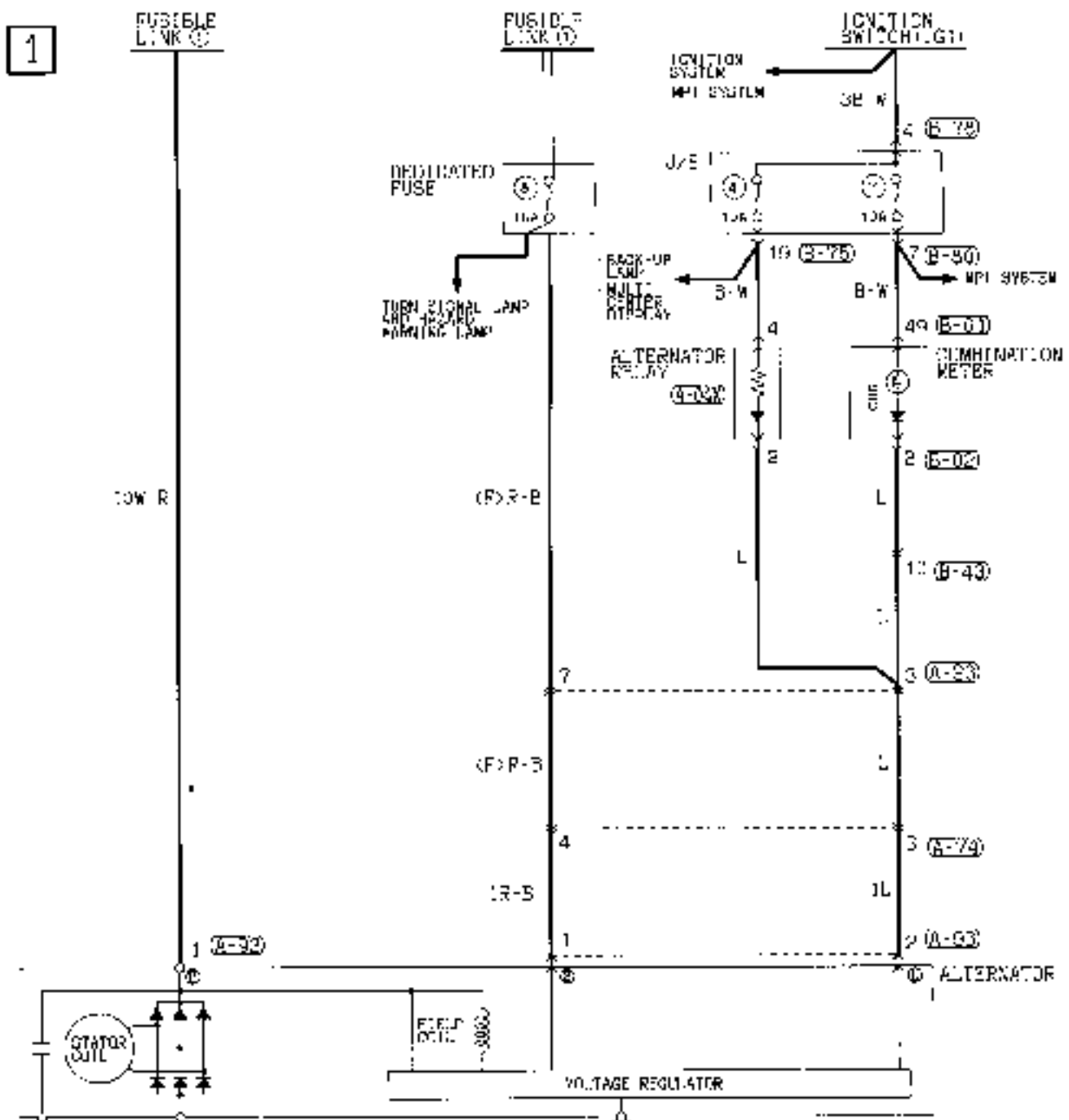

04C4E00AA

CHARGING SYSTEM

9010070808

4G93 engine

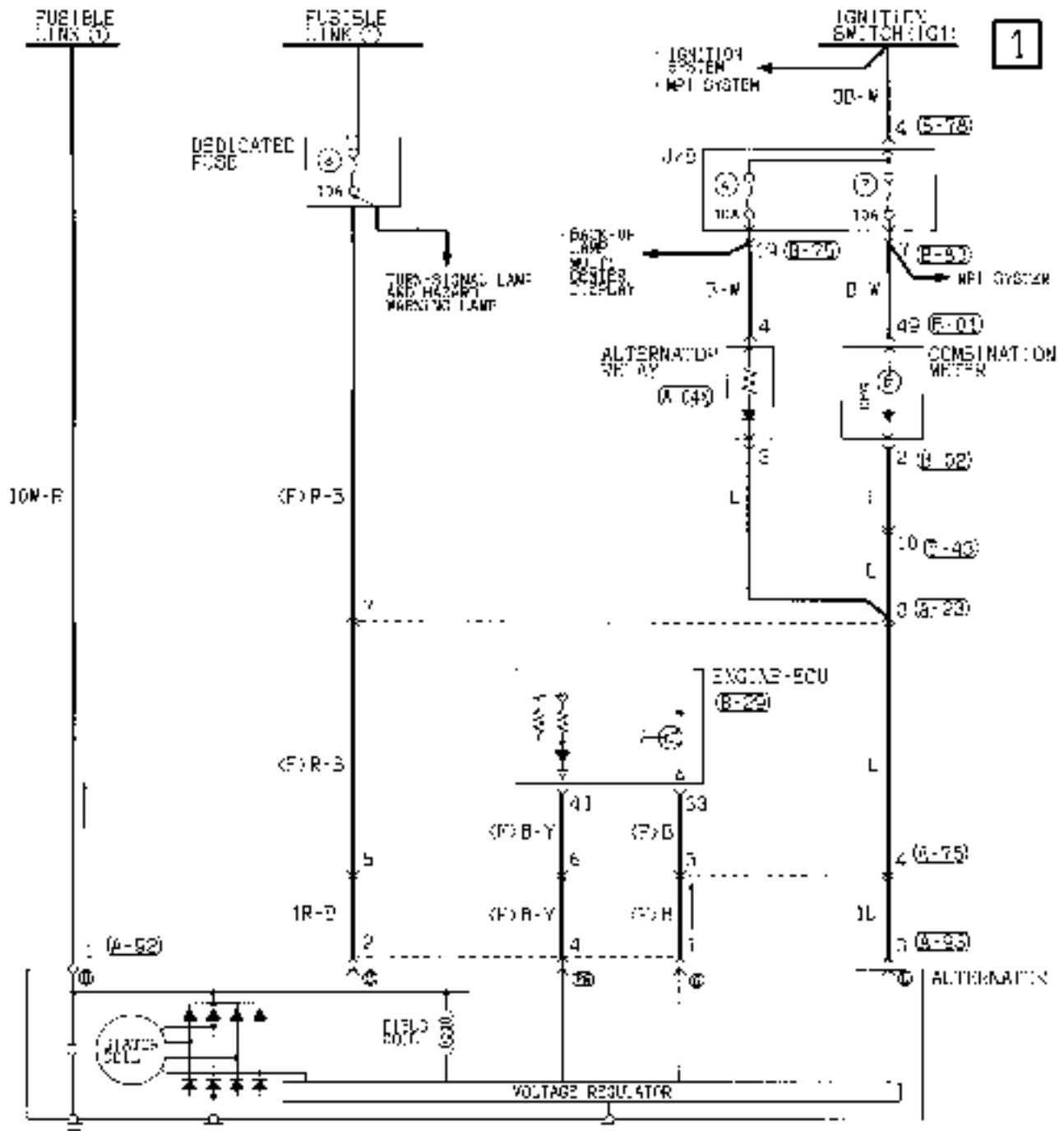

CHARGING SYSTEM (See P. 4-24, 25.)**OPERATION****When engine is stationary**

- When the ignition switch is turned to the ON position, current flows the alternator L terminal to the field coil and, at the same time, the charge warning lamp illuminates.

When engine is started and after engine has started

- When the engine is started, the charge warning lamp goes out because of the charging voltage begin applied to the alternator L terminal.
- The battery voltage being applied to the alternator S terminal is monitored by the voltage regulator. Therefore, the amount of electricity produced by the alternator is controlled by allowing and cutting off the current flowing to the field coil
- The alternator B terminal supplies power to each load.

Remark

The alternator relay is provided to back up the flow of current to the field coil when the charge warning lamp is open

TROUBLESHOOTING HINTS

1. Charging indicator lamp does not illuminate when the ignition switch is turned to ON position, before the engine starts.
 - Check multi-purpose fuse No. (7)
 - Check the bulb.
2. Charging indicator lamp fails to switch off once the engine starts.
 - Check voltage regulator of alternator.
3. Discharged or overcharged battery
 - Check voltage regulator of alternator.
4. Charge warning lamp illuminates dimly.
 - Check combination meter diode (for short).

NOTES

MPI SYSTEM

9010061419

4G13 engine

1

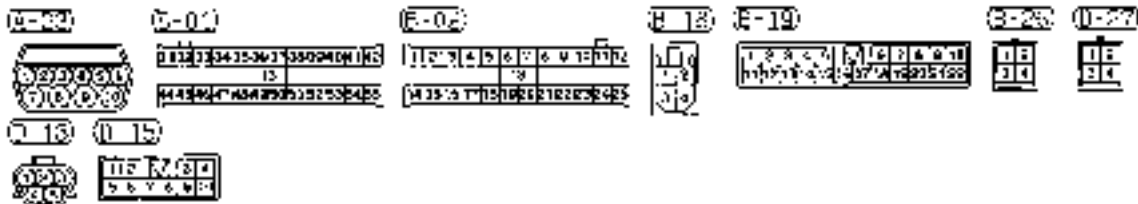
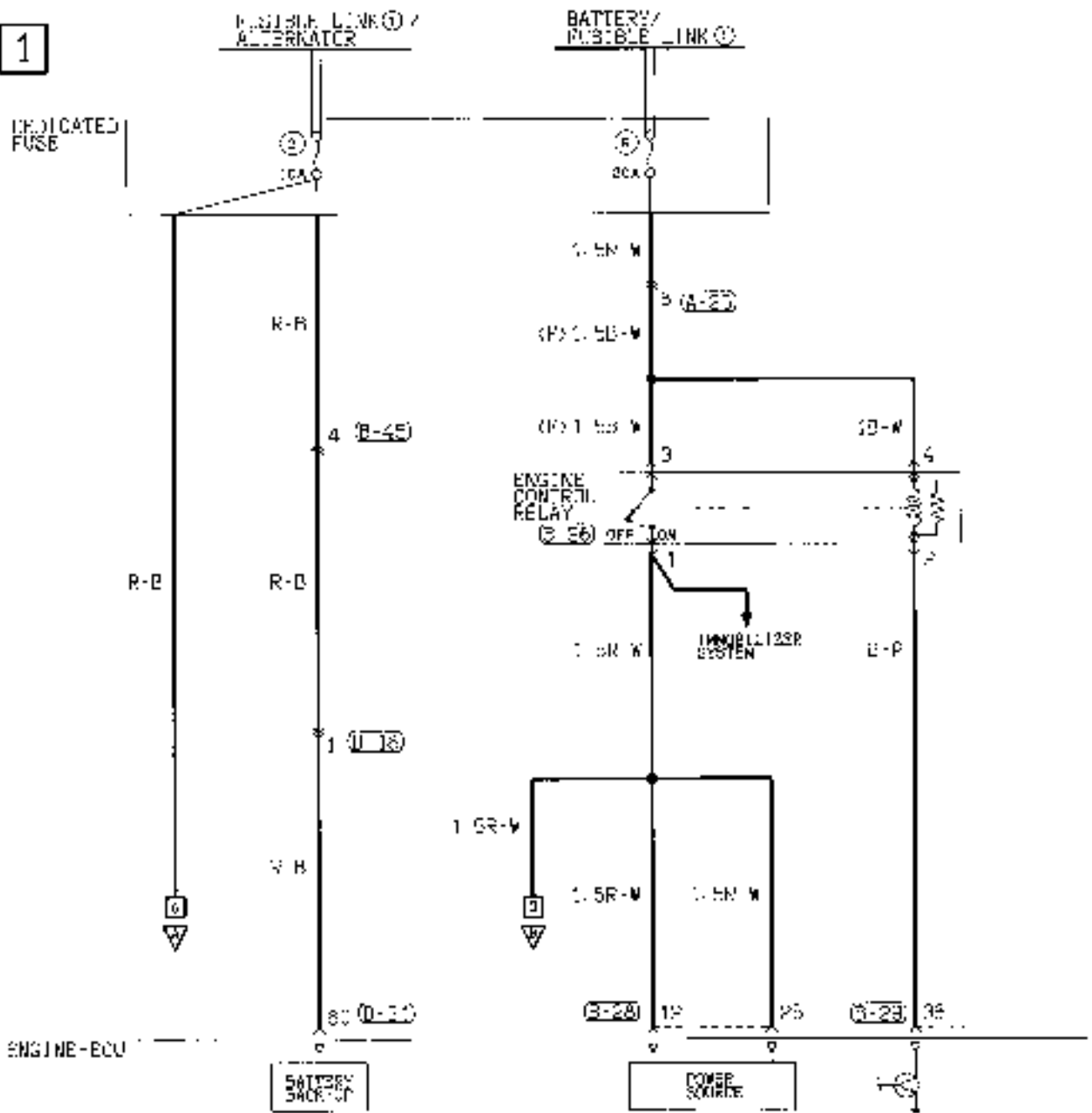

9010061419

2

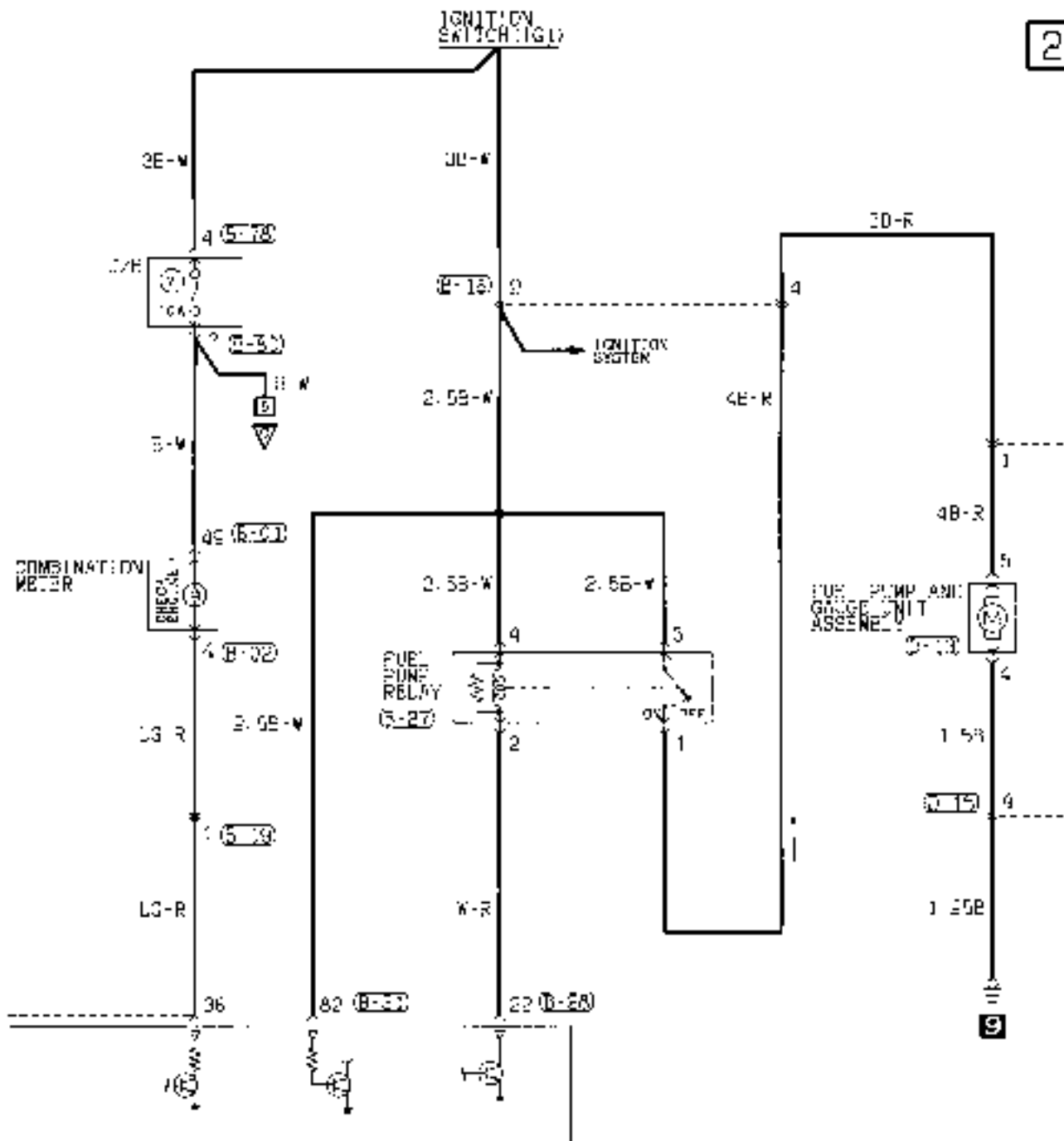

(B-26)

1	2	3	4	5	6	7	8	9	10	11	12	13	14
14	15	16	17	18	19	20	21	22	23	24	25	26	27

(B-20)

1	2	3	4	5	6	7	8	9	10	11	12	13	14
15	16	17	18	19	20	21	22	23	24	25	26	27	28

(B-3)

1	2	3	4	5	6	7	8	9	10	11	12	13	14
15	16	17	18	19	20	21	22	23	24	25	26	27	28

(B-4)

1	2	3	4
5	6	7	8

(H-78)

1	2	3	4	5	6	7	8	9	10	11	12	13	14
15	16	17	18	19	20	21	22	23	24	25	26	27	28

(H-80)

1	2	3	4	5	6	7	8	9	10	11	12	13	14
15	16	17	18	19	20	21	22	23	24	25	26	27	28

Wire color code
 B: Black LG: Light green G: Green B: Blue W: White Y: Yellow DB: Sky blue
 BR: Brown O: Orange GR: Gray R: Red P: Pink V: Violet

MPI SYSTEM <4G13 engine> (CONTINUED)

3

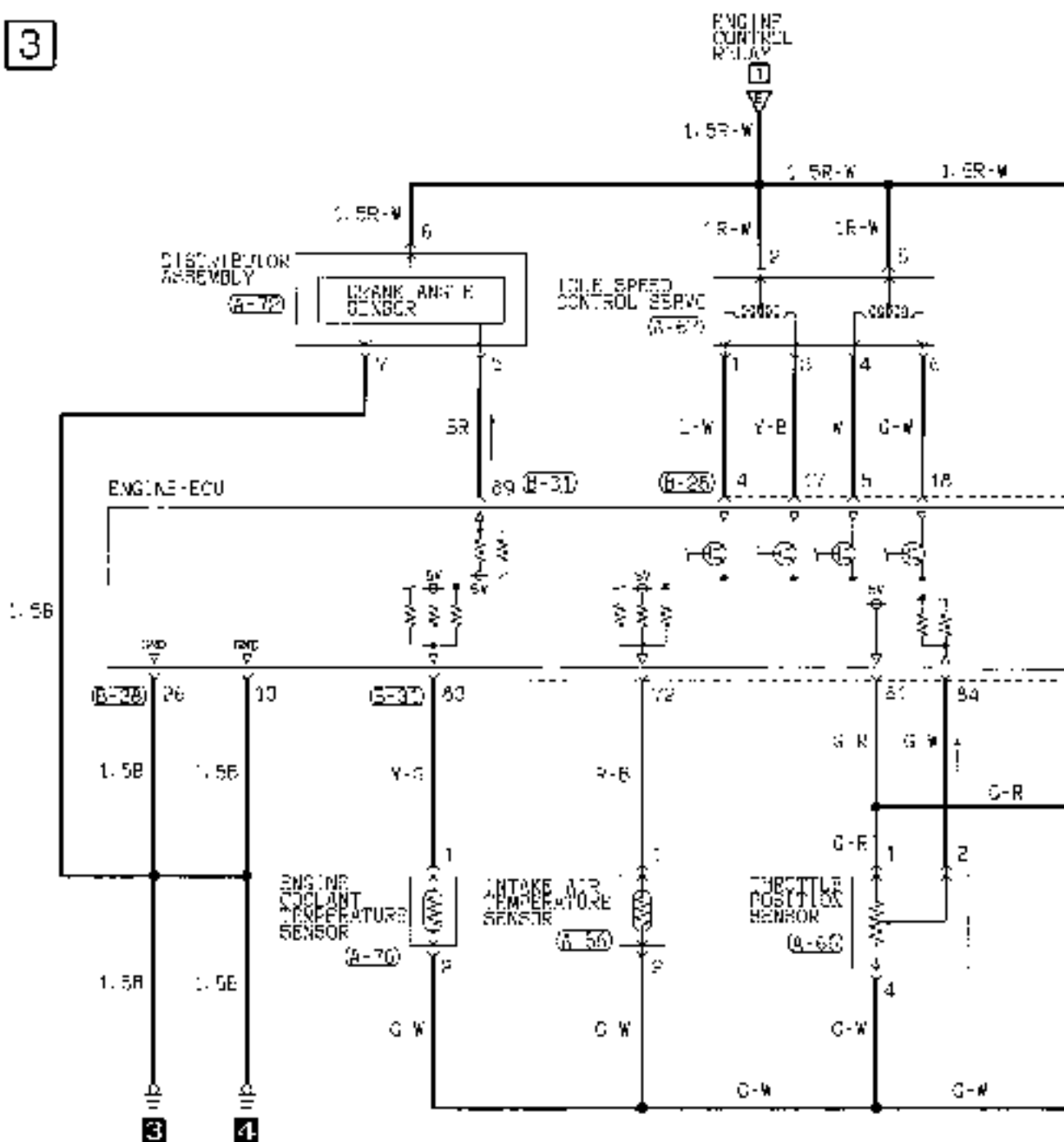

- (A-72)
- (A-49)
- (A-54)
- (A-55)
- (A-58)
- (A-53)
- (A-60)
- (A-67)
- (A-52)
- (A-57)
- (A-70)
- (A-70)

4

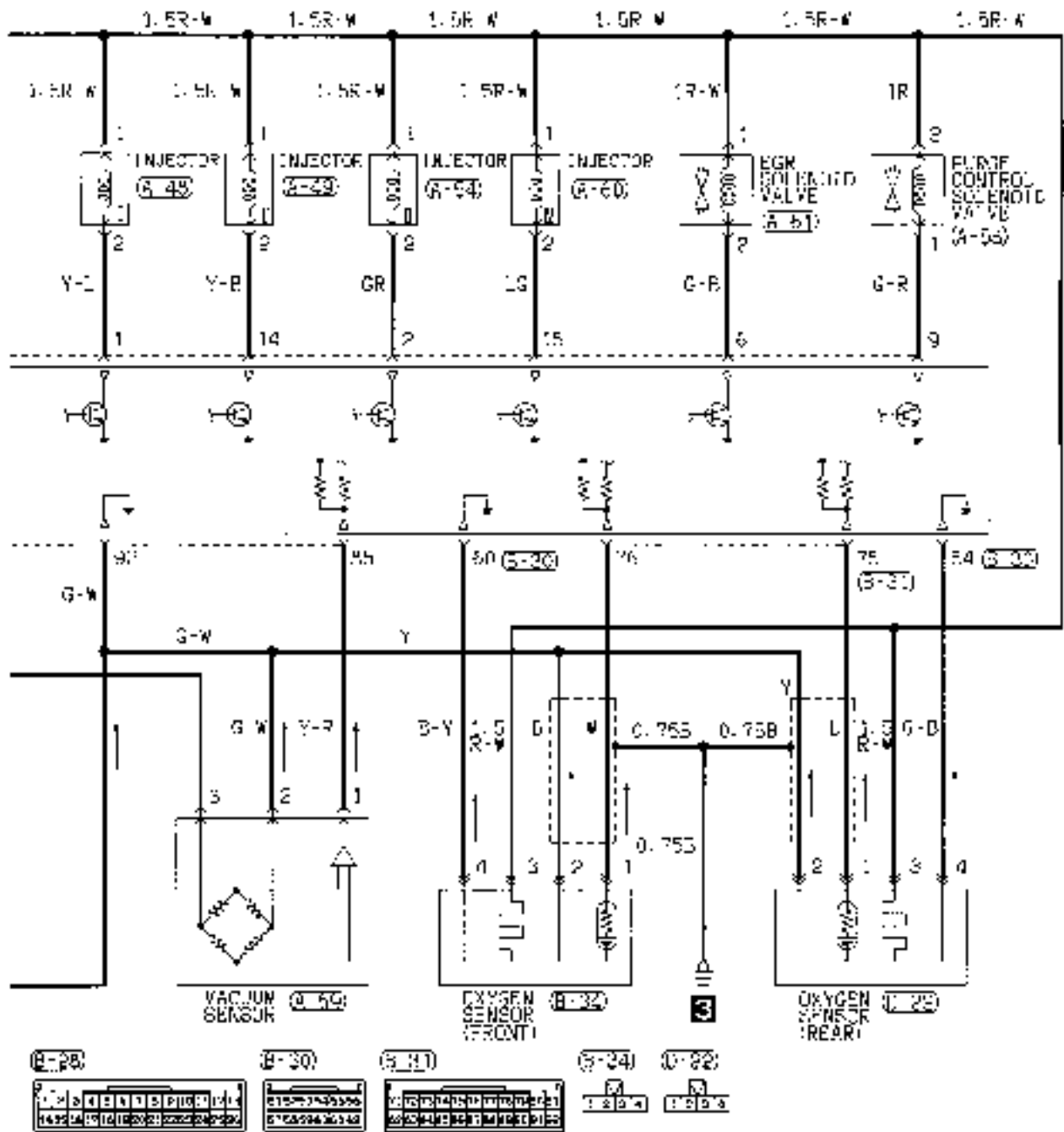

MPI SYSTEM <4G13 engine> (CONTINUED)

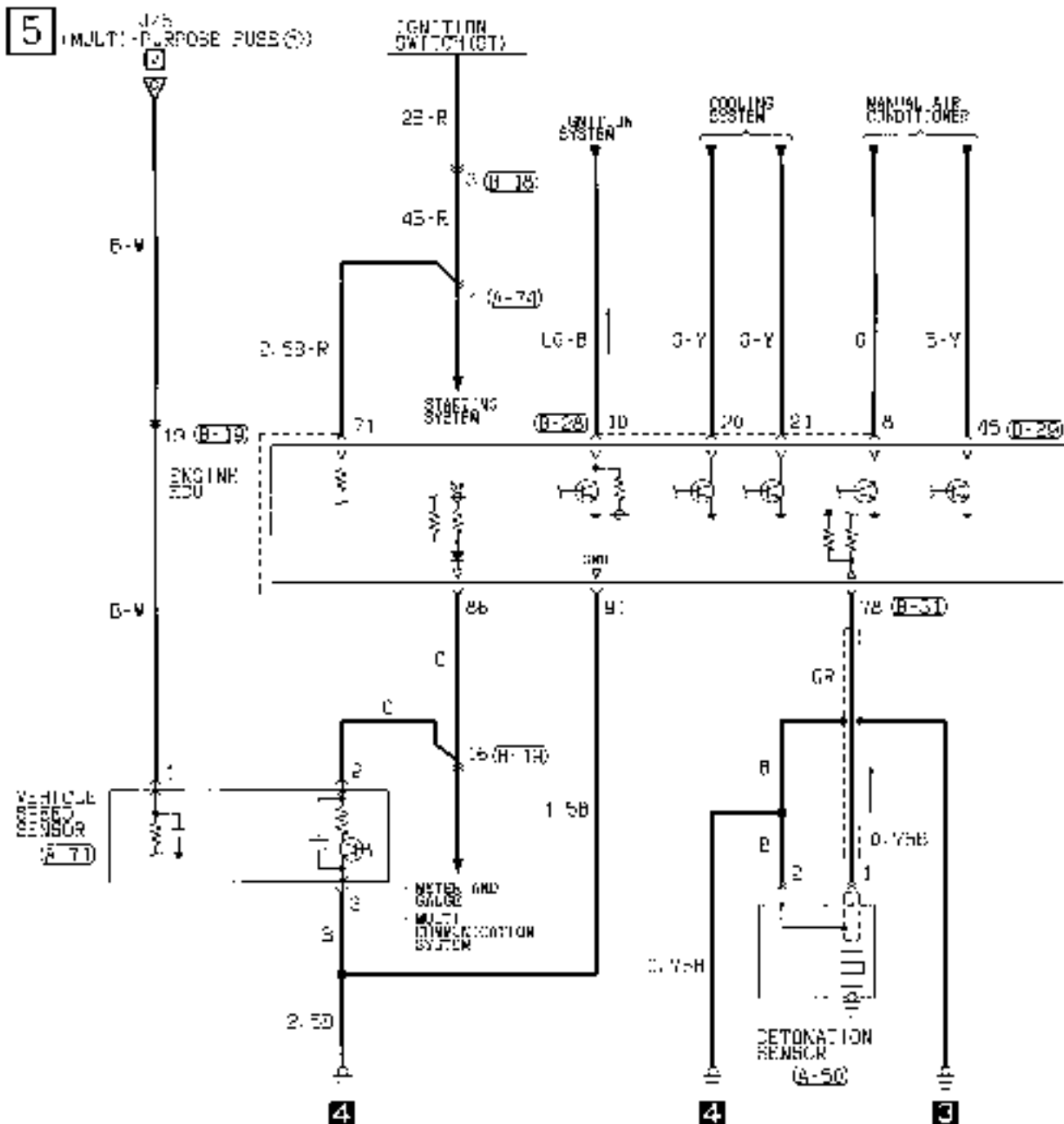

(B-25)	(B-32)	(B-50)	(B-57)	(B-71)	(B-74)	(B-99)	(B-16)	(B-19)
0000000000	1	0-2	0	10 2-3	1-3 2-4	0000000000	1 2 3	123456789010
(B-36)	(B-43)	(B-50X)	(B-57X)	(B-71X)	(B-74X)	(B-79)		
0000000000	0000000000	0000000000	0000000000	0000000000	0000000000	0000000000		
0000000000	0000000000	0000000000	0000000000	0000000000	0000000000	0000000000		

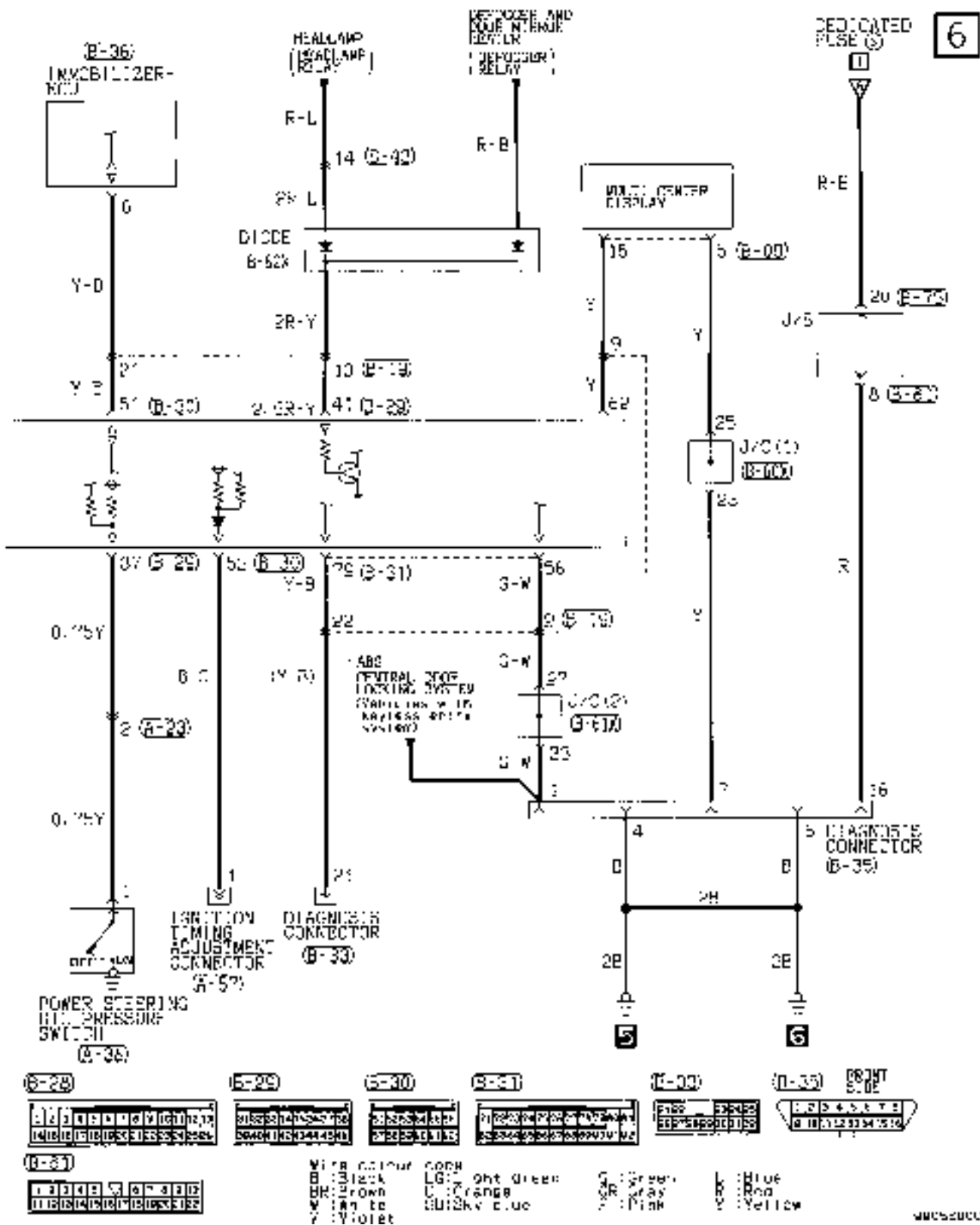

MPI SYSTEM

9010001526

4G93 engine

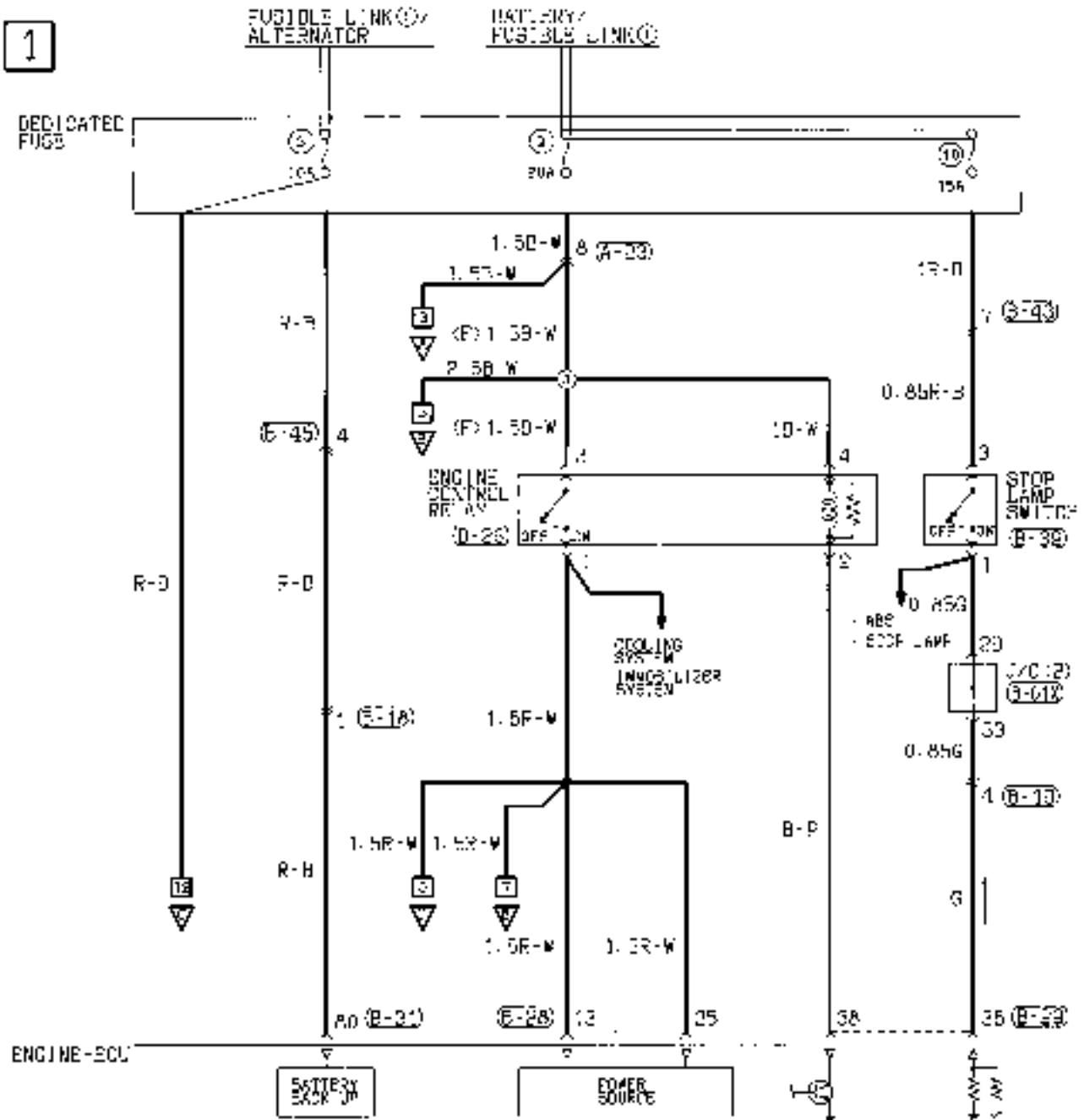

9010001526

2

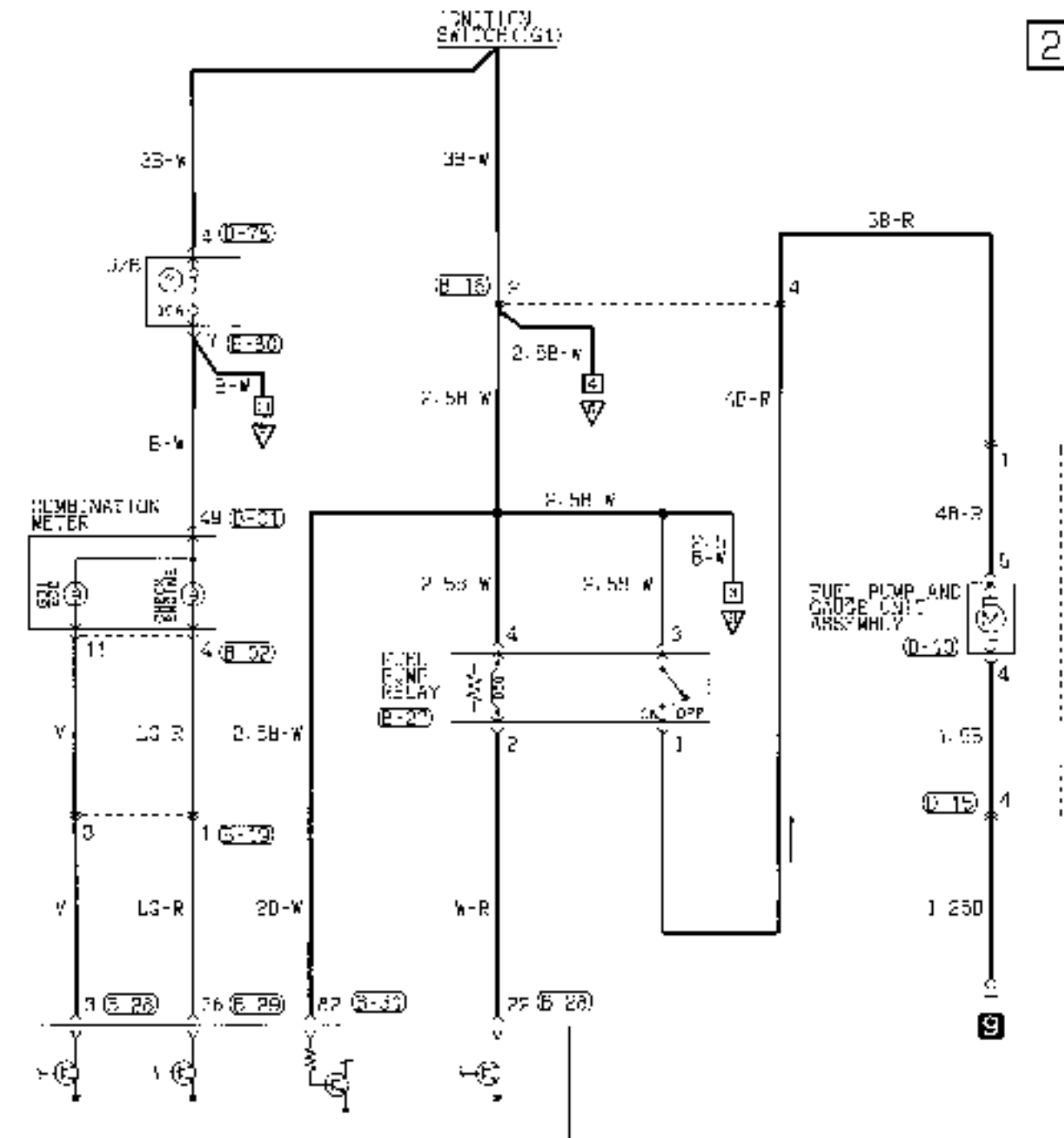

(P-20)	(P-20)	(P-20)	(P-20)	(P-20)	(P-20)
1 2 3 4 5 6 7 8 9 10 11 12	1 2 3 4 5 6 7 8 9 10 11 12	1 2 3 4 5 6 7 8 9 10 11 12	1 2 3 4 5 6 7 8 9 10 11 12	1 2 3 4 5 6 7 8 9 10 11 12	1 2 3 4 5 6 7 8 9 10 11 12
13 14 15 16 17 18 19 20 21 22 23 24	13 14 15 16 17 18 19 20 21 22 23 24	13 14 15 16 17 18 19 20 21 22 23 24	13 14 15 16 17 18 19 20 21 22 23 24	13 14 15 16 17 18 19 20 21 22 23 24	13 14 15 16 17 18 19 20 21 22 23 24

Wire colour code
 B: Black 10: Light Green G: Green L: Blue W: White Y: Yellow
 BR: Brown O: Orange GR: Gray R: Red P: Pink V: Violet
 SB: Sky blue

MPI SYSTEM <4G93 engine> (CONTINUED)

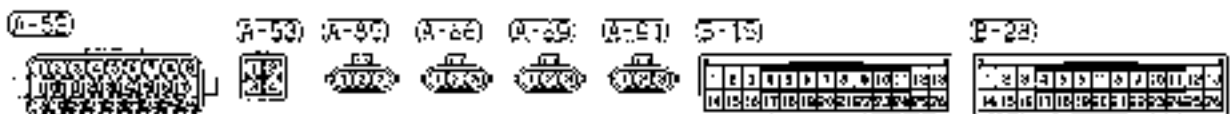
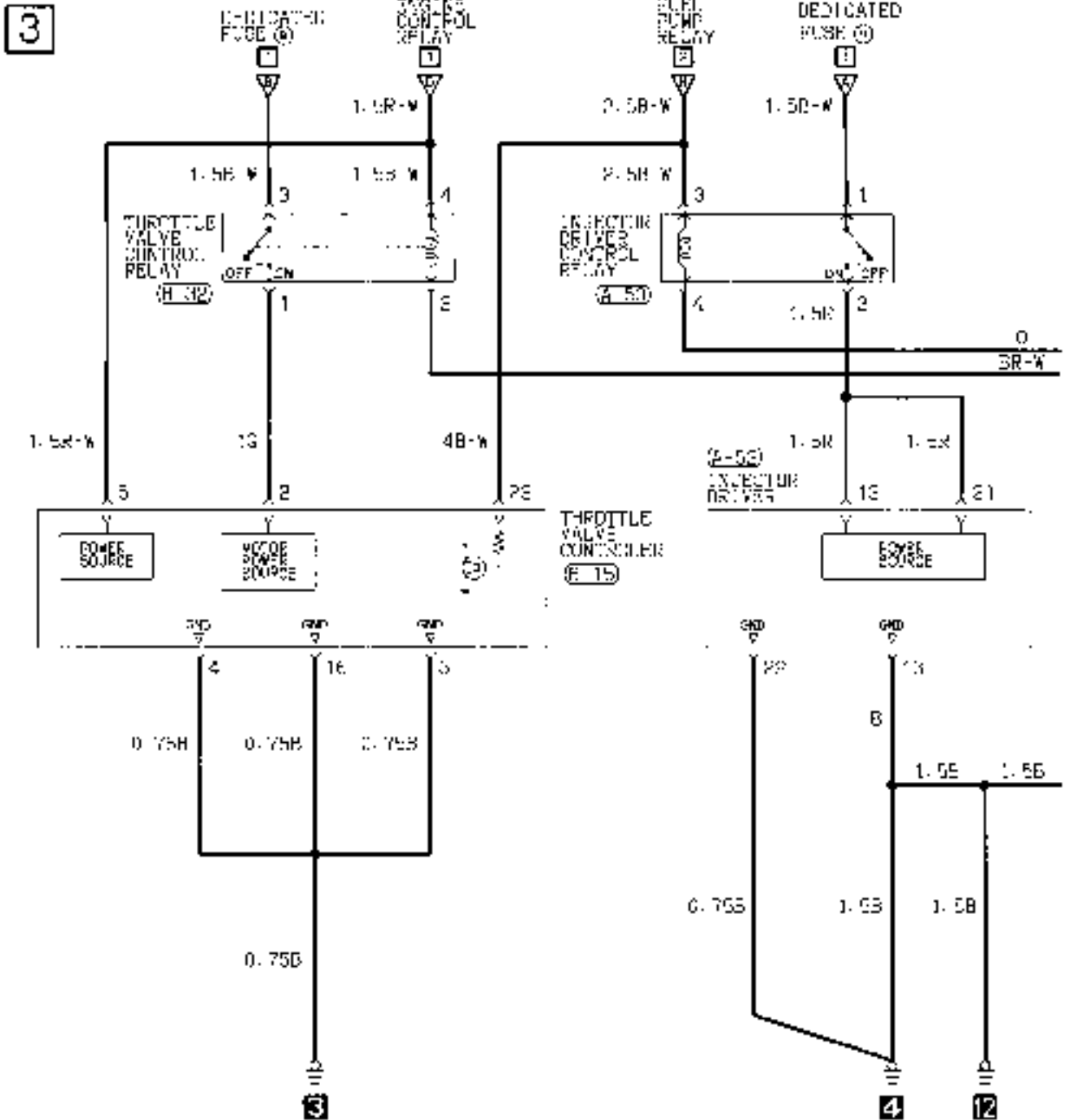

4

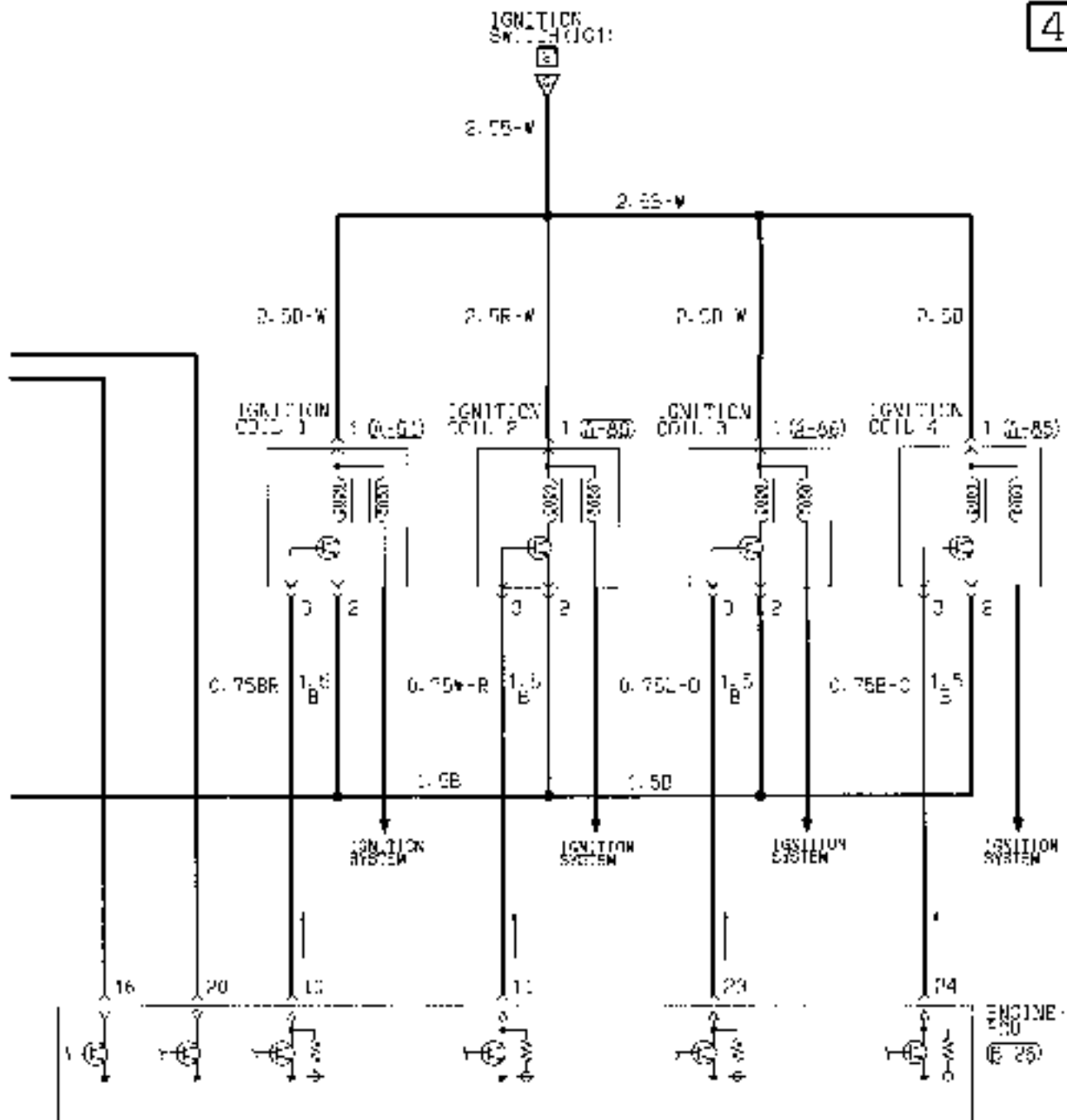

13-322



Wire color code
 B: Black LG: Light Green G: Green L: Blue W: White Y: Yellow BB: Day Blue
 BR: Brown O: Orange GR: Gray R: Red P: Pink V: Violet

MPI SYSTEM <4G93 engine> (CONTINUED)

5

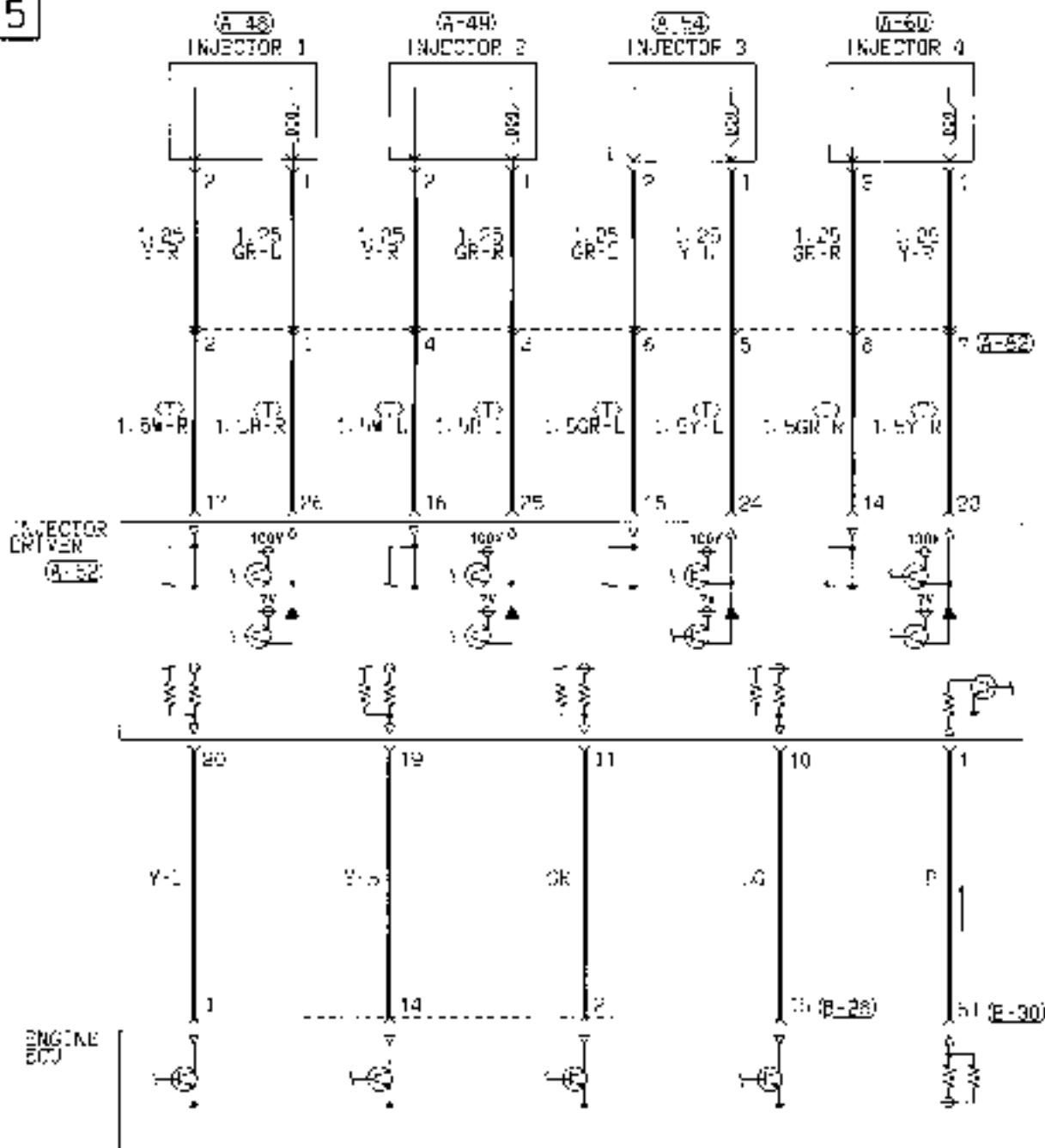

6

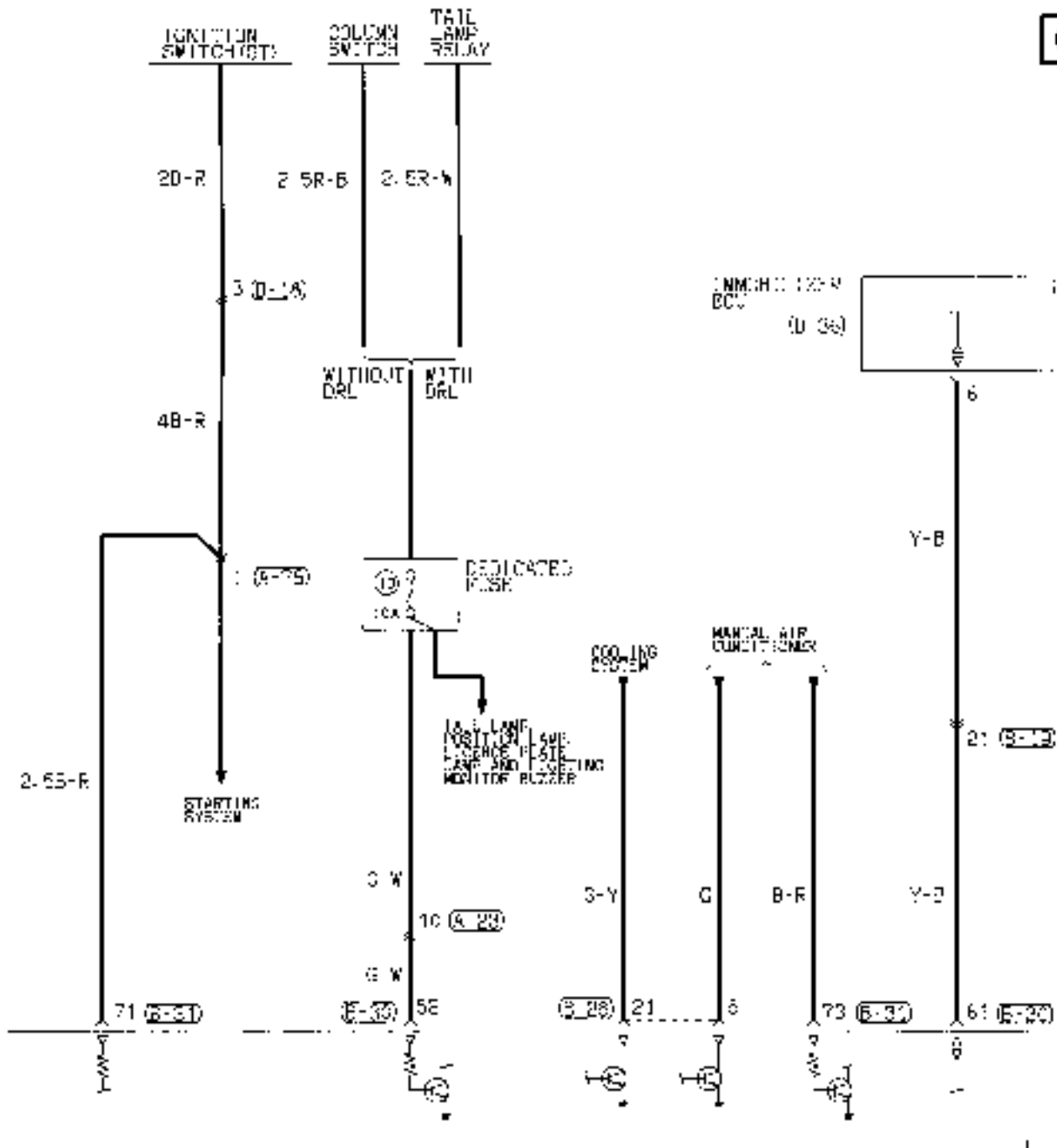

(B-25)	(B-30)	(E-31)	(E-36)
1 2 3 4 5 6 7 8 9 10 11 12	1 2 3 4 5 6 7 8 9 10 11 12	1 2 3 4 5 6 7 8 9 10 11 12 13 14 15 16 17 18 19 20 21 22 23 24 25 26 27 28 29 30 31 32 33 34 35 36 37 38 39 40 41 42 43 44 45 46 47 48 49 50 51 52 53 54 55 56 57 58 59 60 61 62 63 64 65 66 67 68 69 70 71 72 73 74 75 76 77 78 79 80 81 82 83 84 85 86 87 88 89 90 91 92 93 94 95 96 97 98 99 100	1 2 3 4 5 6
14 15 16 17 18 19 20 21 22 23 24 25 26 27 28 29 30 31 32 33 34 35 36 37 38 39 40 41 42 43 44 45 46 47 48 49 50 51 52 53 54 55 56 57 58 59 60 61 62 63 64 65 66 67 68 69 70 71 72 73 74 75 76 77 78 79 80 81 82 83 84 85 86 87 88 89 90 91 92 93 94 95 96 97 98 99 100	1 2 3 4 5 6 7 8 9 10 11 12	1 2 3 4 5 6 7 8 9 10 11 12 13 14 15 16 17 18 19 20 21 22 23 24 25 26 27 28 29 30 31 32 33 34 35 36 37 38 39 40 41 42 43 44 45 46 47 48 49 50 51 52 53 54 55 56 57 58 59 60 61 62 63 64 65 66 67 68 69 70 71 72 73 74 75 76 77 78 79 80 81 82 83 84 85 86 87 88 89 90 91 92 93 94 95 96 97 98 99 100	1 2 3 4 5 6

Wire colour code
 B: Black LG: Light Green G: Green L: Blue W: White Y: Yellow BB: Sky blue
 Br: Brown O: Orange GR: Gray R: Red P: Pink V: Violet

MPI SYSTEM <4G93 engine> (CONTINUED)

7

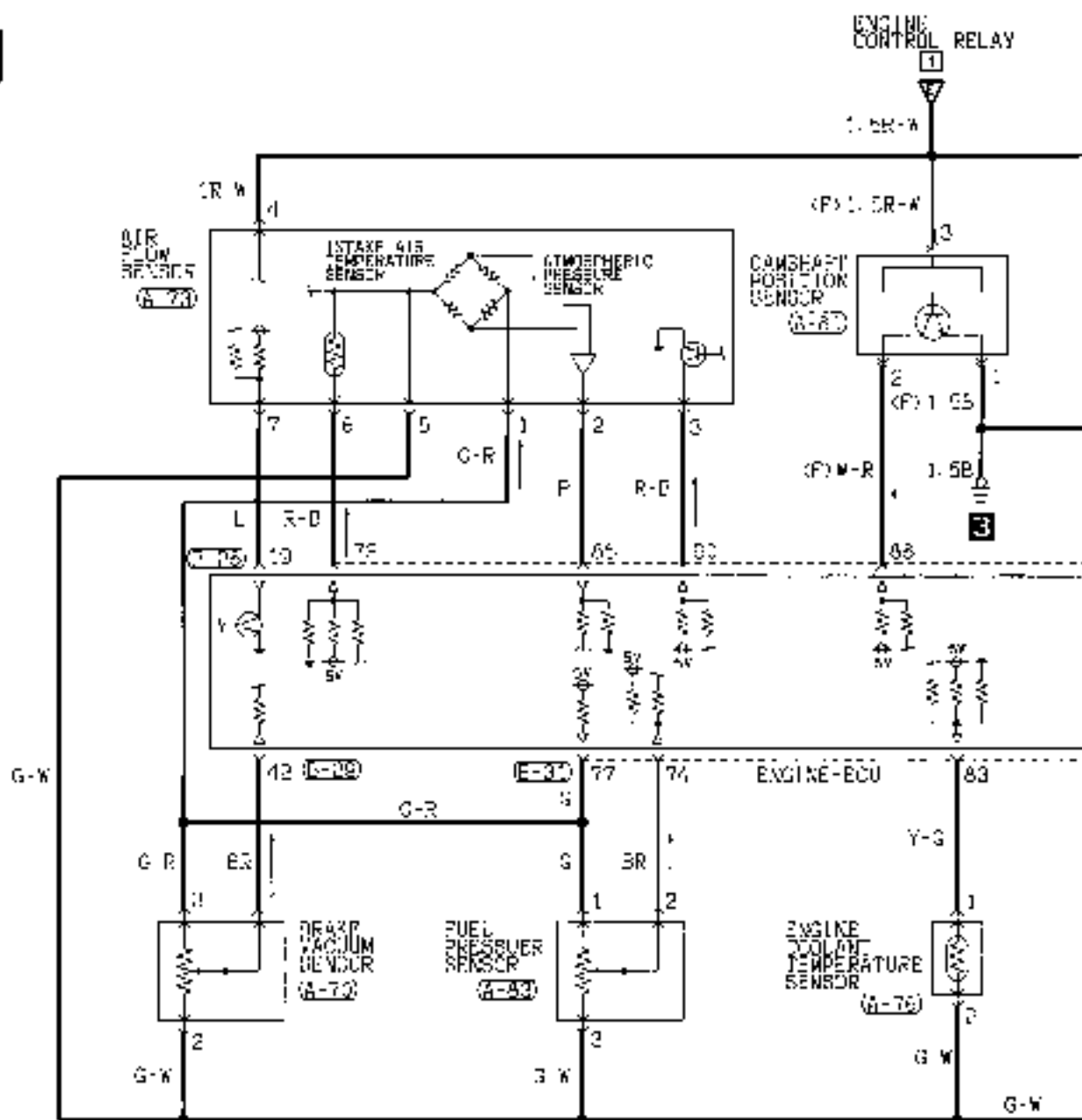

- | | | | | | | | | | | | |
|------|------|------|------|------|------|------|------|------|------|------|------|
| | | | | | | | | | | | |
| A-50 | A-55 | A-58 | A-62 | A-65 | A-76 | A-73 | A-76 | A-80 | A-81 | A-83 | A-84 |

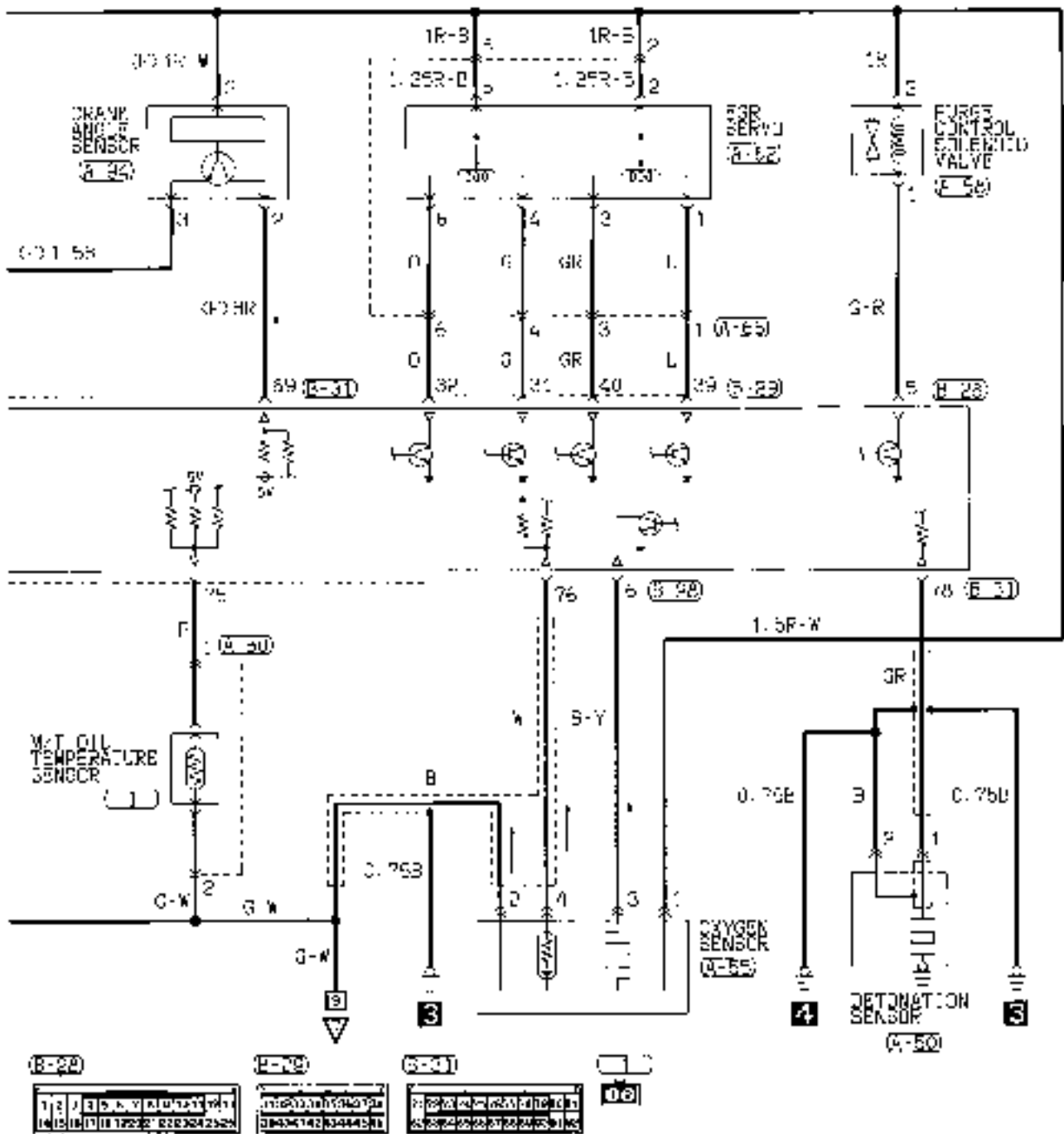

Wire colour code
 B: Blue, BR: Brown, C: Orange, G: Green, GR: Grey, L: Blue, R: Red, W: White, Y: Yellow, ZB: Sky blue
 LG: Light Green, P: Pink, V: Violet

MPI SYSTEM <4G93 engine> (CONTINUED)

9

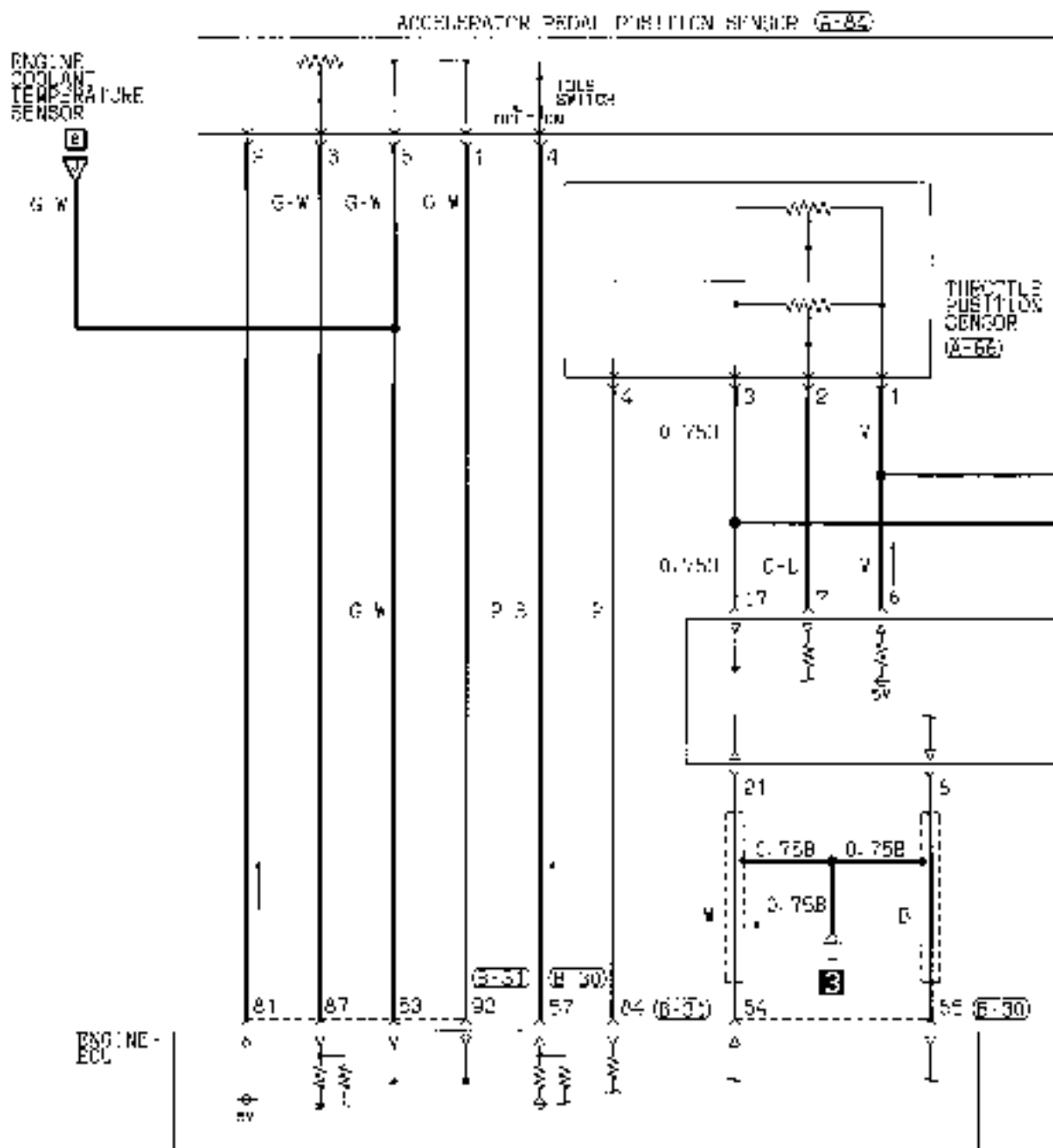

10

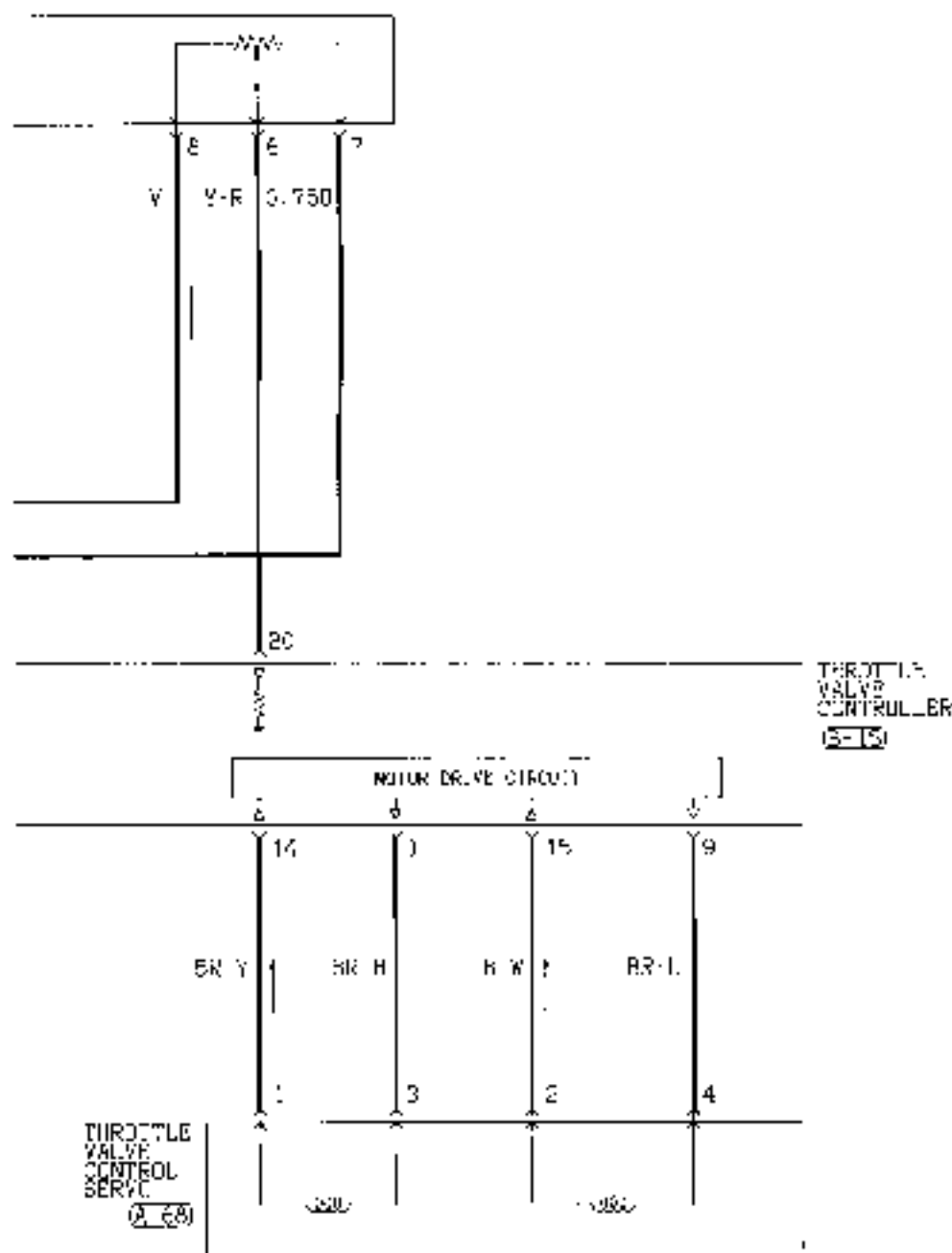

Wire colour code
 B:Black L:Light Green G:Green W:White Y:Yellow
 BR:Brown O:Orange GR:Gray R:Red P:Pink V:Violet
 SK:Sky Blue

MPI SYSTEM <4G93 engine> (CONTINUED)

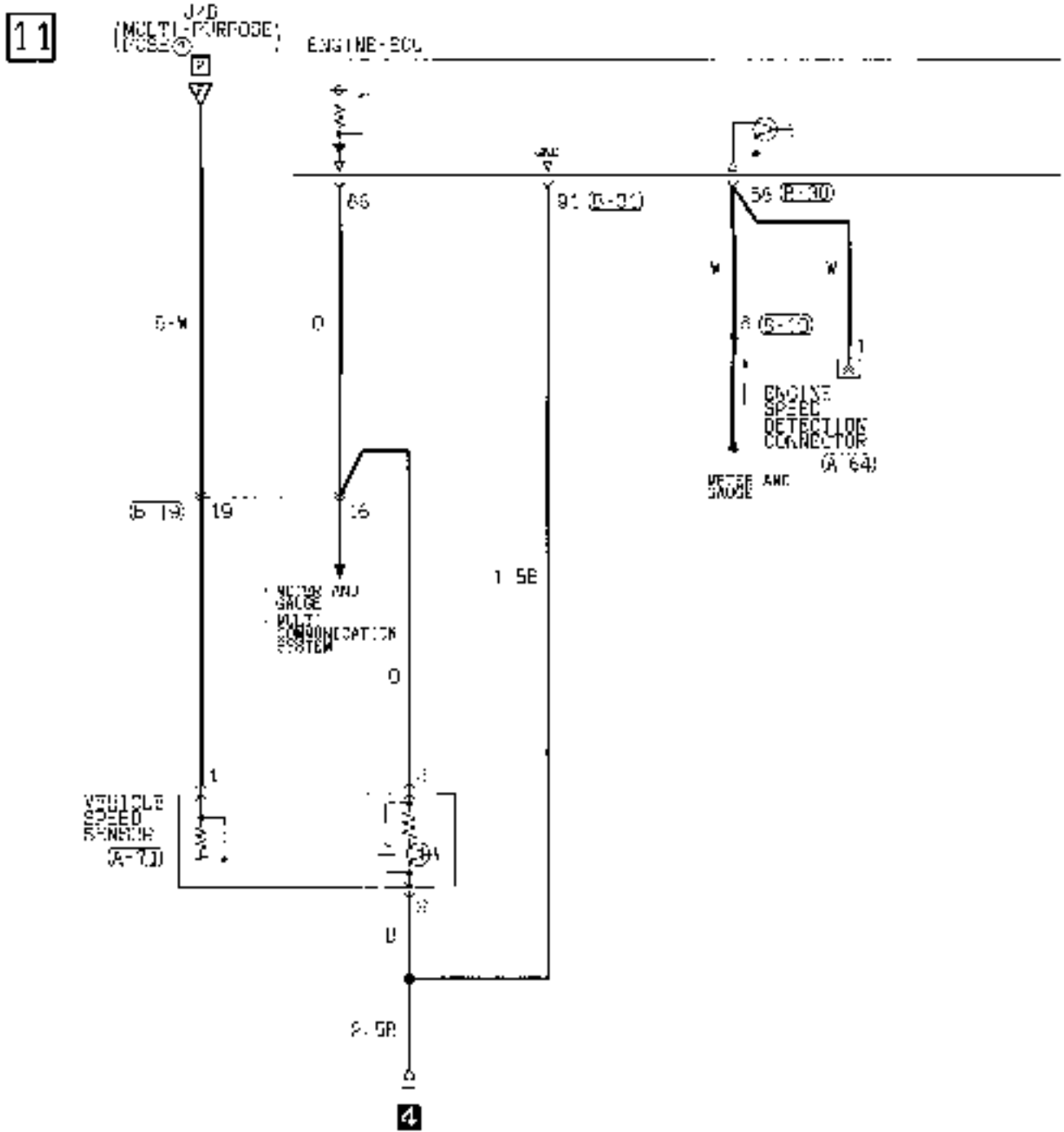

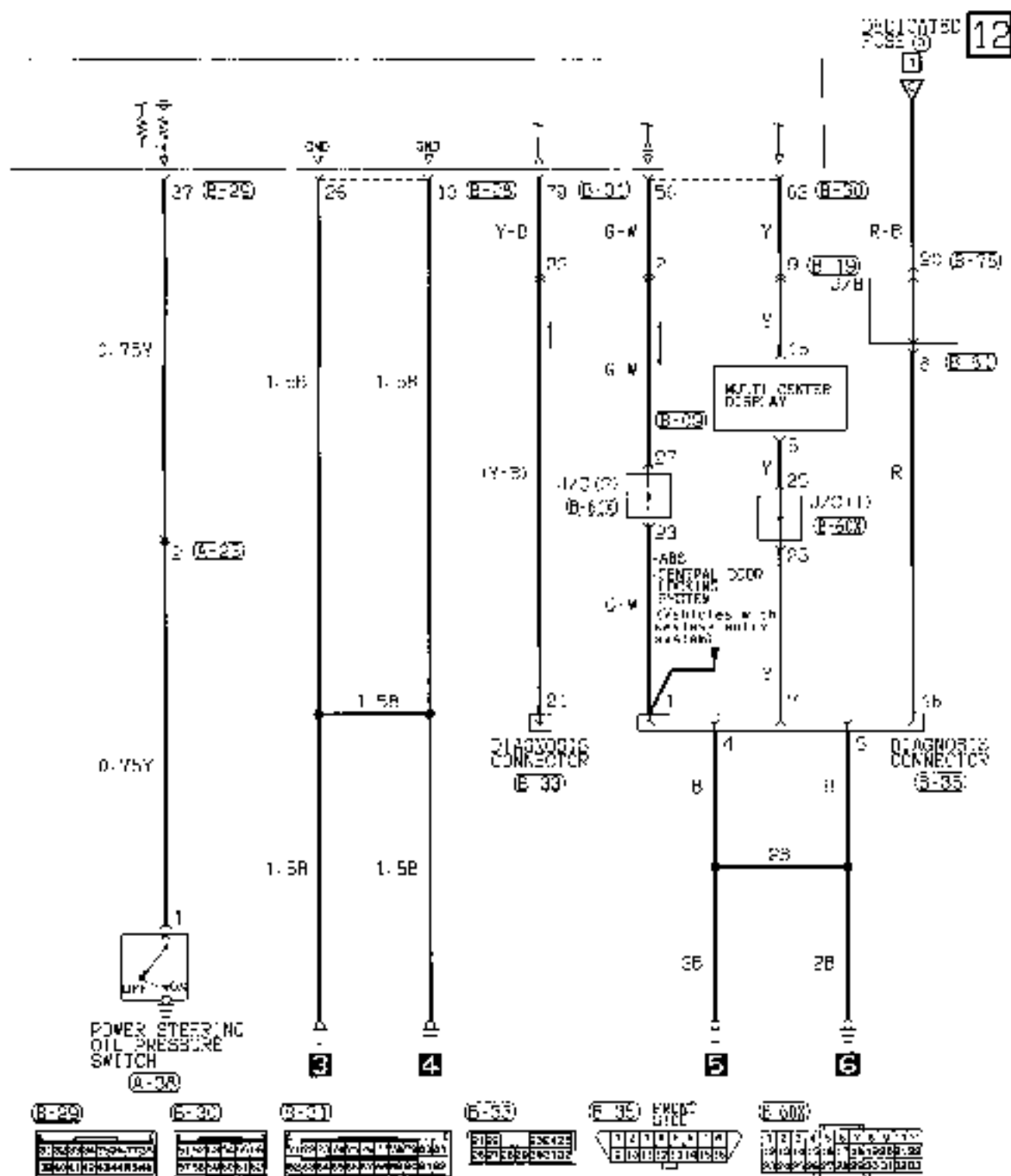

COOLING SYSTEM

90F00109746

4G13 engine

1

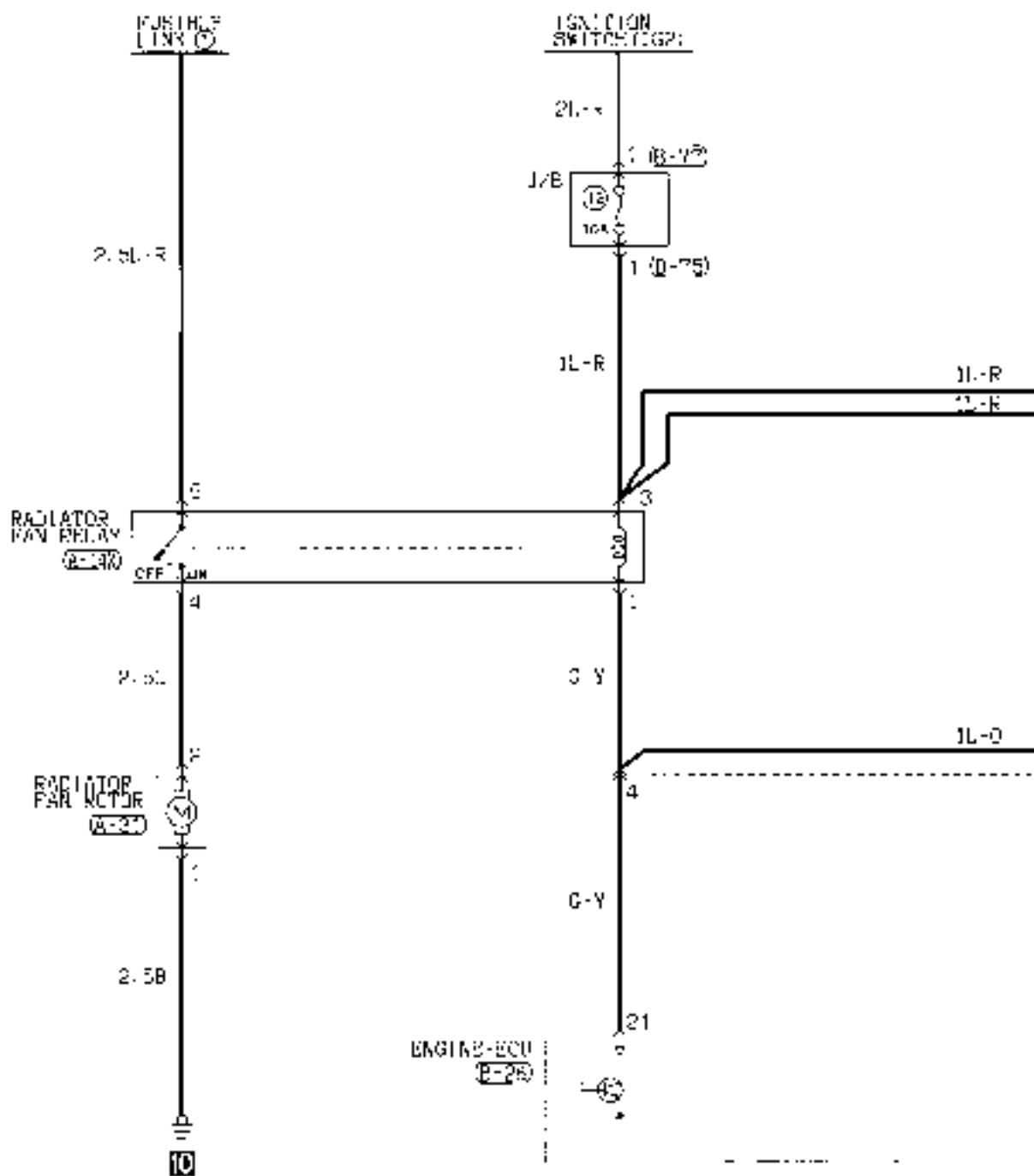

2

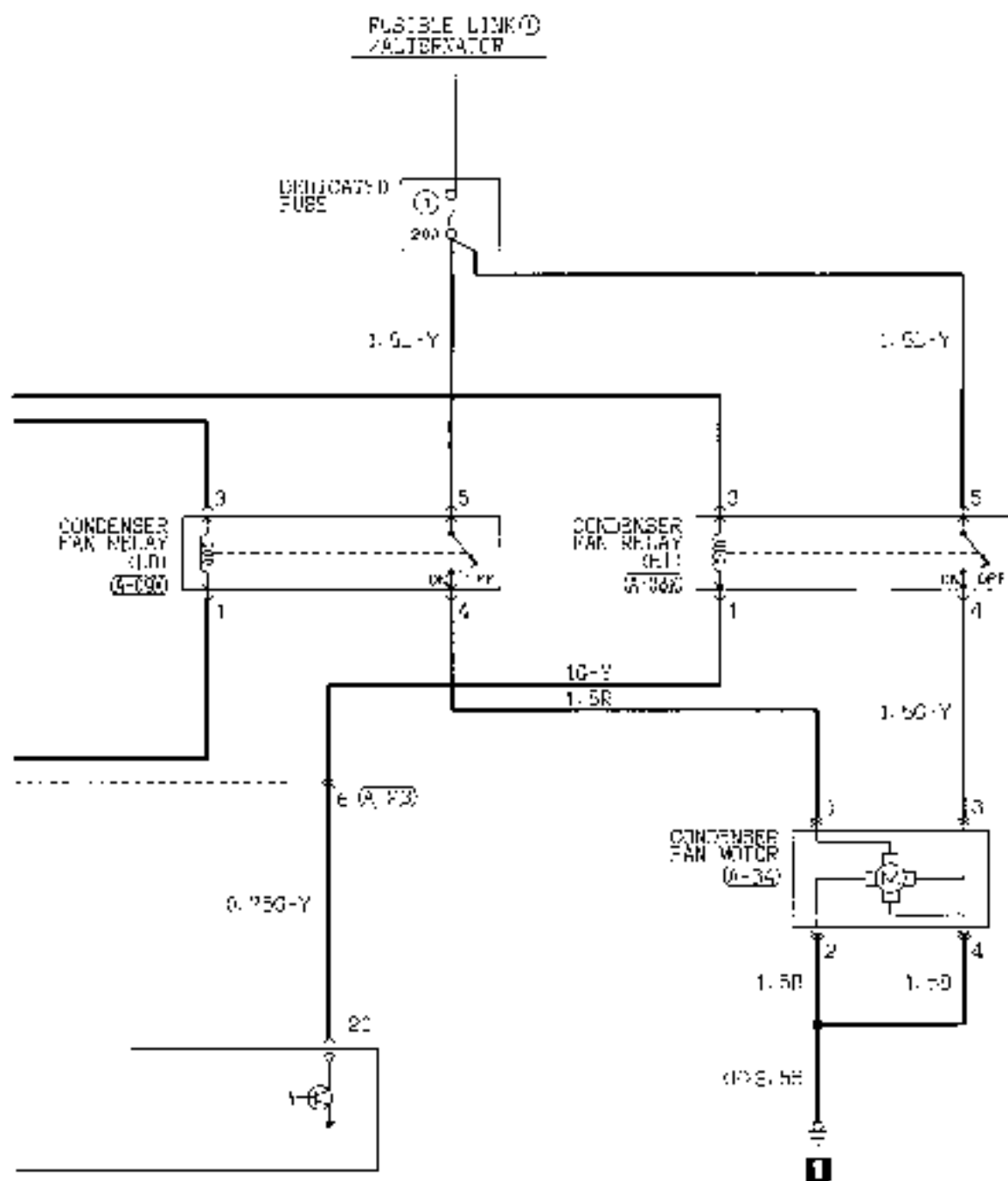

W: White Y: Yellow BB: Blue
 B: Black L: Light green G: Green L: Blue W: White Y: Yellow
 BR: Brown O: Orange GR: Gray R: Red P: Pink V: Violet

COOLING SYSTEM

091-001 007-05

4G93 engine

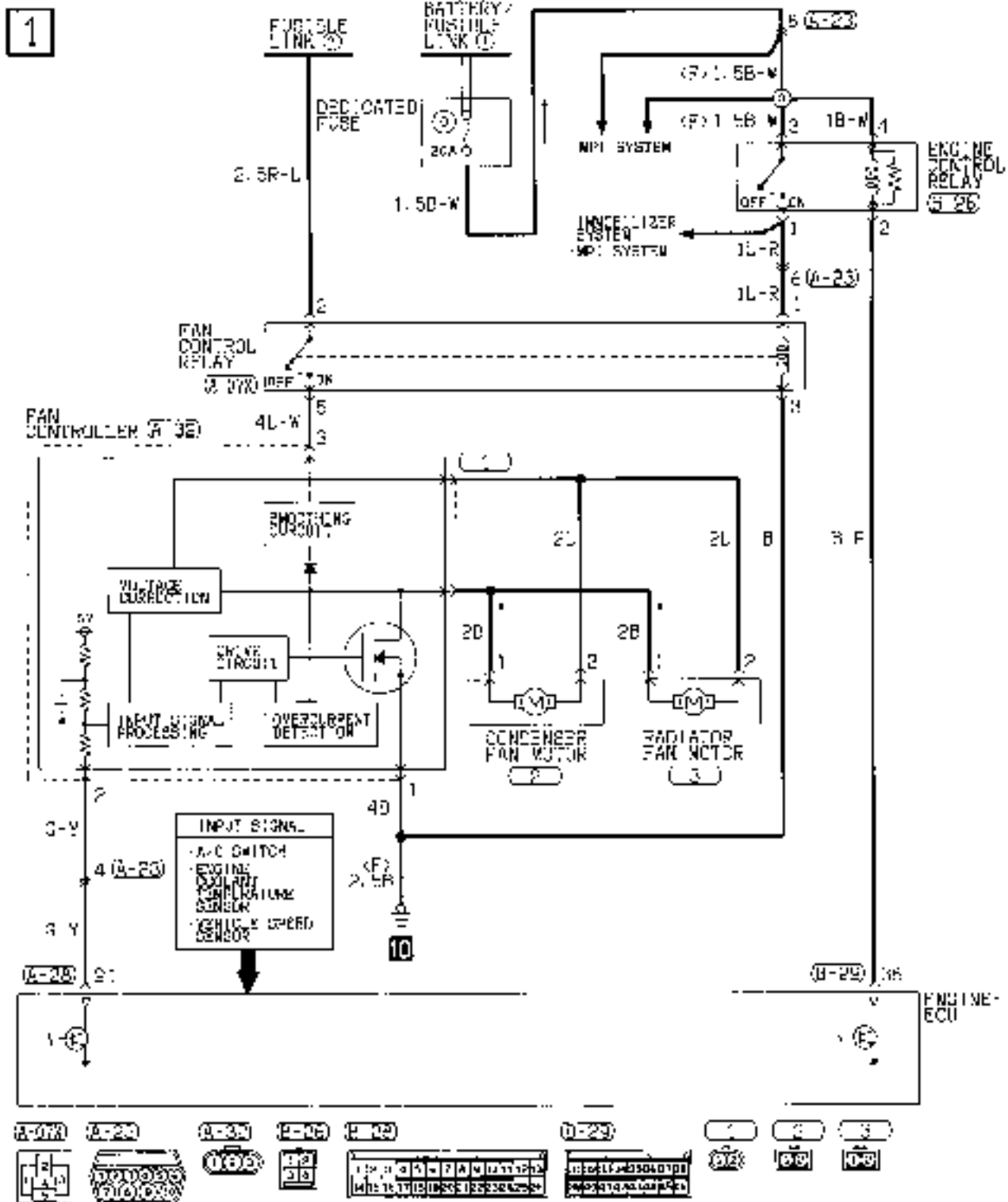

W: White G: Green B: Blue M: White Y: Yellow 39: Sky Blue
 BK: Black LG: Light Green GR: Gray R: Red P: Pink V: Violet
 LG: Light Green

091-001 007-05

HEADLAMP <Vehicles without daytime running lamp> (See P. 4-50, 51.)**OPERATION****Headlamp Relay ON Conditions**

Refer to the table below.

<Low-beam operation>

- Placing the lighting switch in the HEAD position causes the headlamp relay to be energized.
- If the dimmer/passing switch is placed in the LO position at this time, the headlamps light up in low beam.

<Upper-beam operation>

- Placing the lighting switch in the HEAD position causes the headlamp relay to be energized.
- If the dimmer/passing switch is placed in the HI position at this time, the headlamps light up in upper beam.

<Upper-beam indicator lamp>

- This lamp lights up when the upper/passing beams are on, indicating that the headlamps are on in upper beam.

<Passing operation>

- When the dimmer/passing switch is set to the "ON" position, the headlamp relay is switched ON and the upper beam of the headlamps illuminates.

TROUBLESHOOTING HINTS

1. Headlamps don't go on.
 - 1) But the tail lamps illuminate.
 - Check the headlamp relay
 - Check the lighting switch
 - 2) The tail lamps also don't illuminate.
 - Check the fusible link No. (8)
2. The low beam at both sides doesn't illuminate.
 - Check the dimmer switch LO contacts.
3. The upper beam at both sides doesn't illuminate.
 - 1) The passing signal functions OK.
 - Check the dimmer switch HI contacts.
 - 2) The passing signal doesn't function.
 - Check the dimmer switch
4. One headlamp doesn't illuminate.
 - Check the lamp bulb
5. Can't switch from low to upper beam or vice-versa.
 - Check the dimmer switch
6. Upper-beam indicator lamp does not go on.
 - 1) Headlamp upper beams are operational.
 - Check dedicated fuse No. (15).
 - Check the indicator lamp bulb.
 - 2) Headlamp upper beams doesn't illuminate.
 - Check the dimmer switch.

Lighting switch	Dimmer/passing switch	Headlamp relay
"HEAD"	—	ON
—	ON	ON

HEADLAMP

68100160153

L.H. drive vehicles without daytime running lamp

1

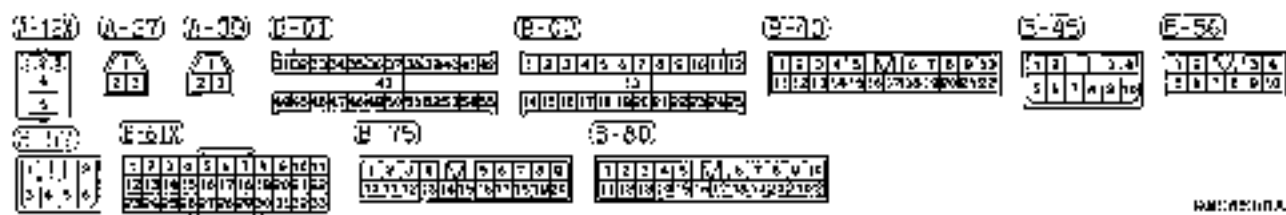
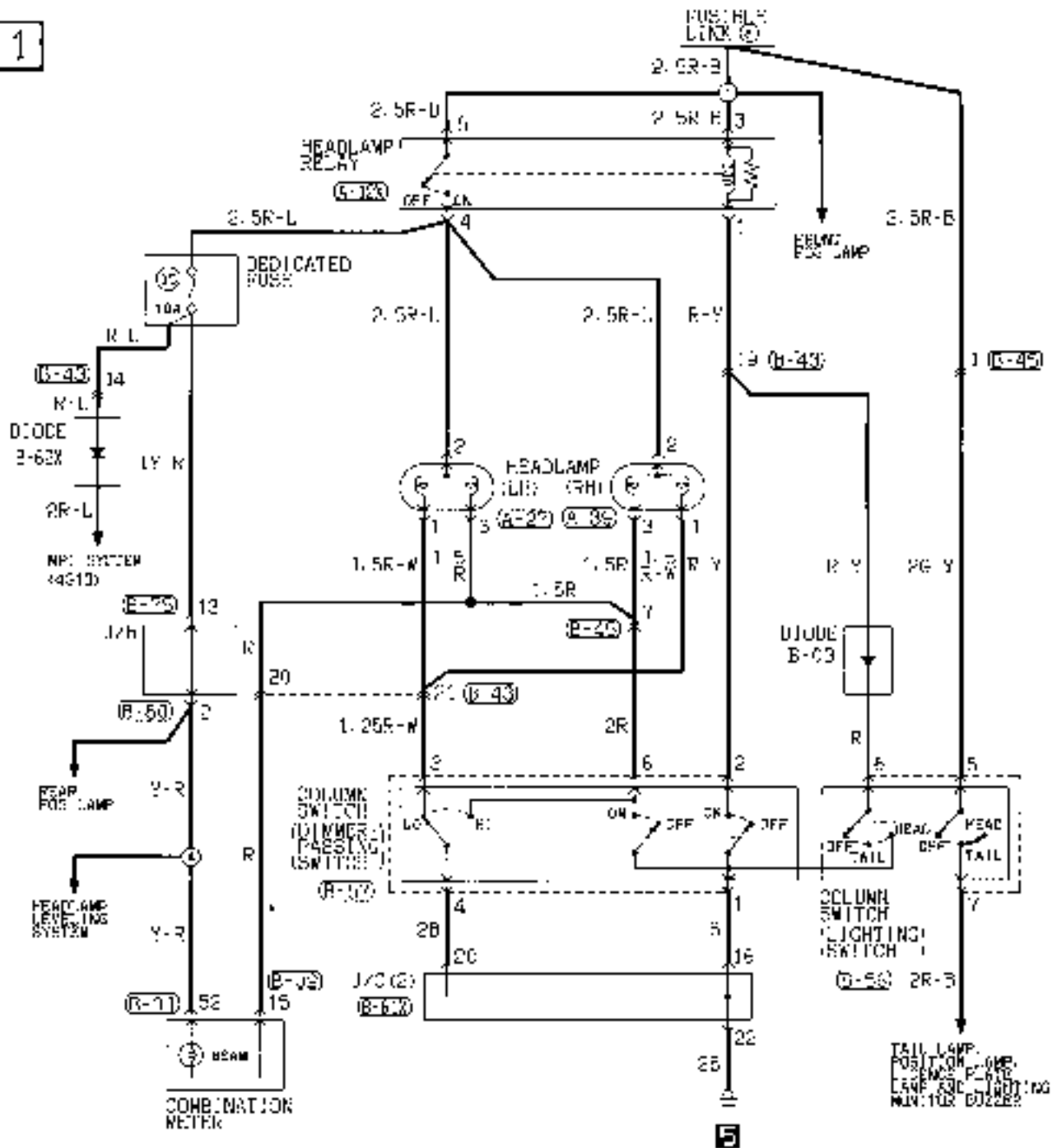

HEADLAMP

90109150700

R.H. drive vehicles

1

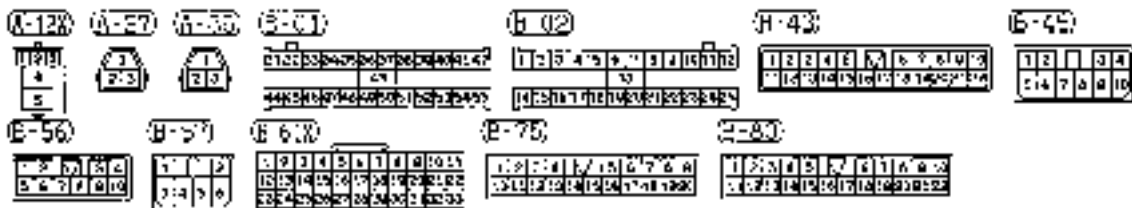
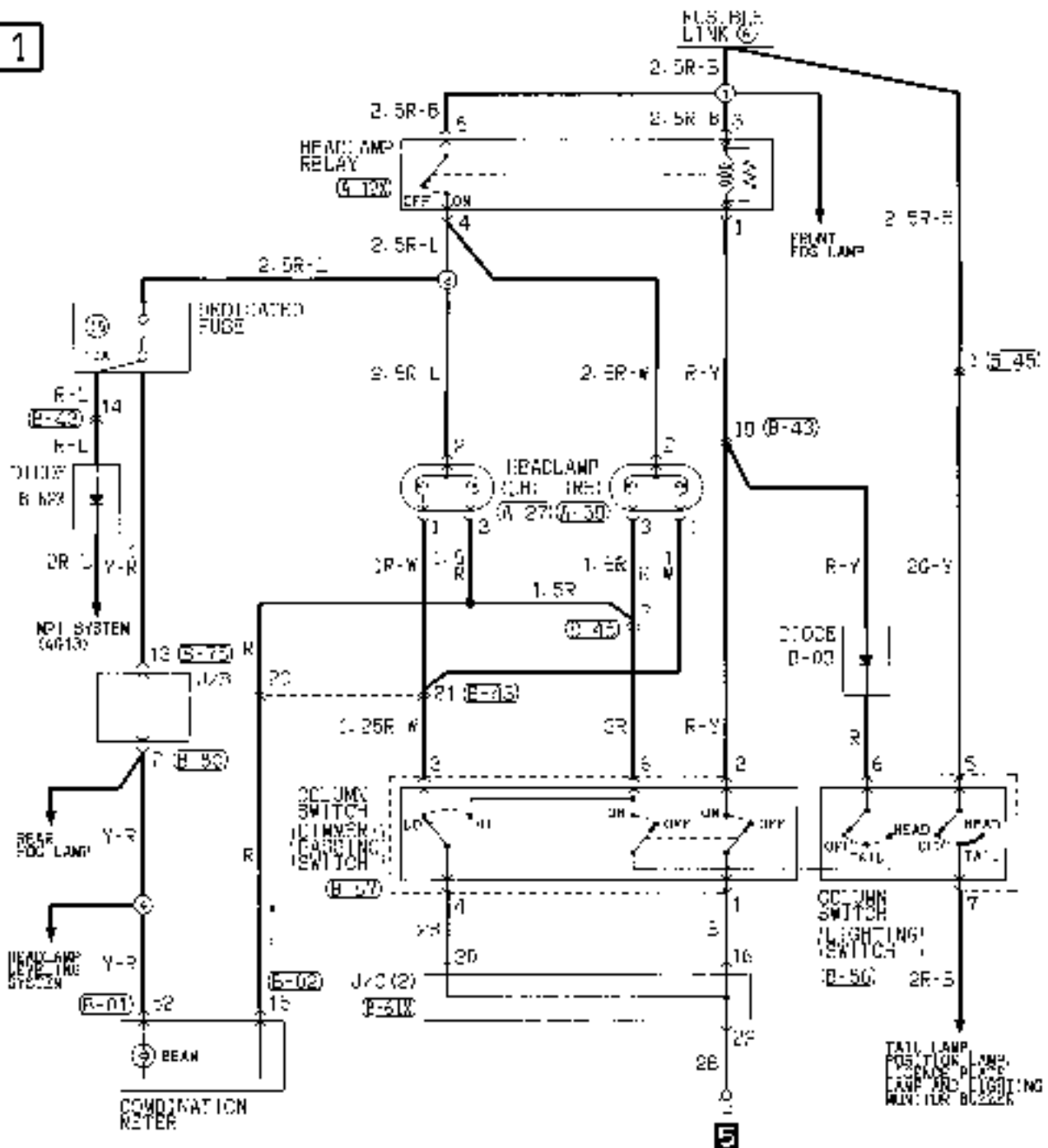

HEADLAMP

90160160777

Vehicles with daytime running lamp

1

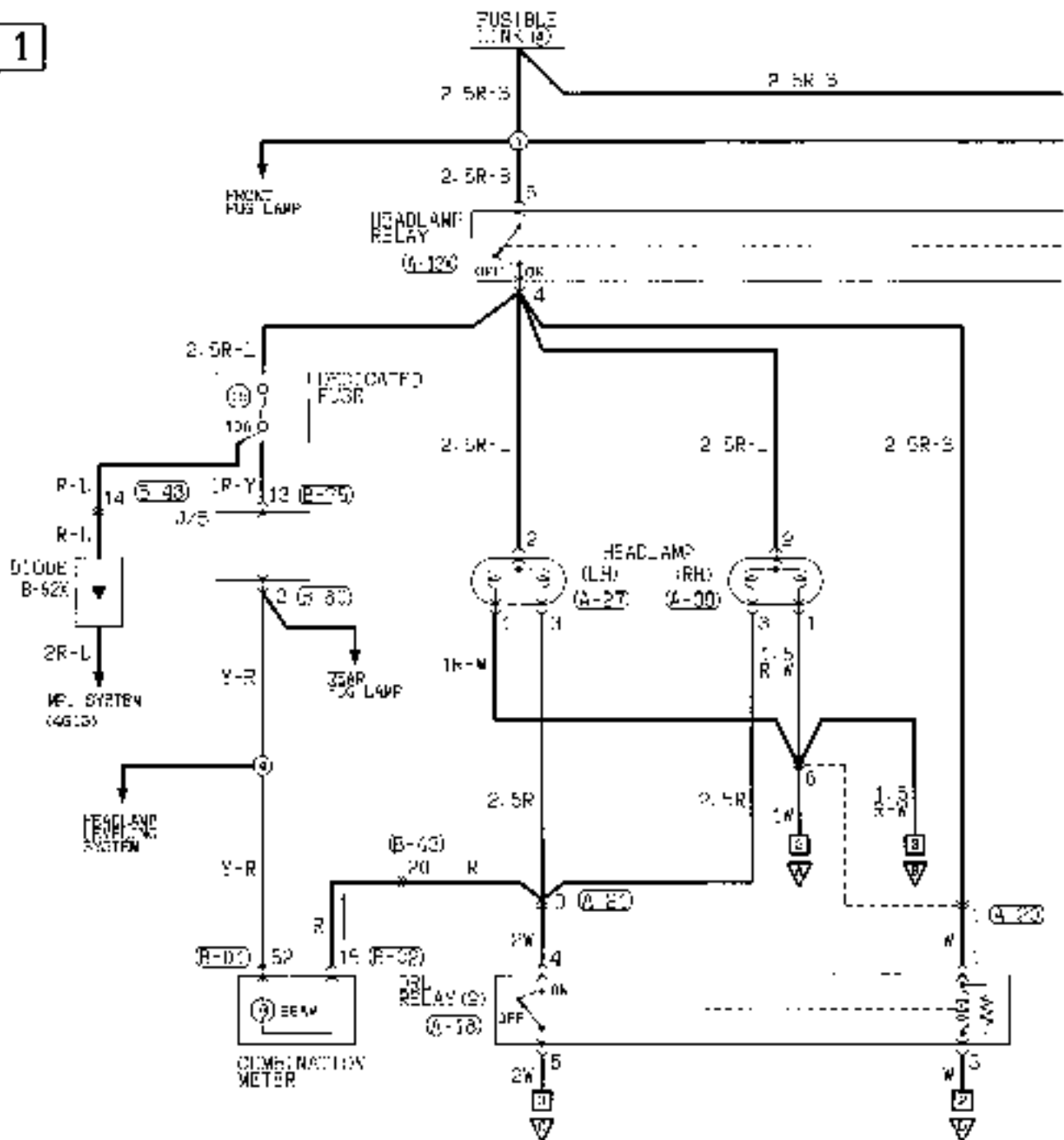

2

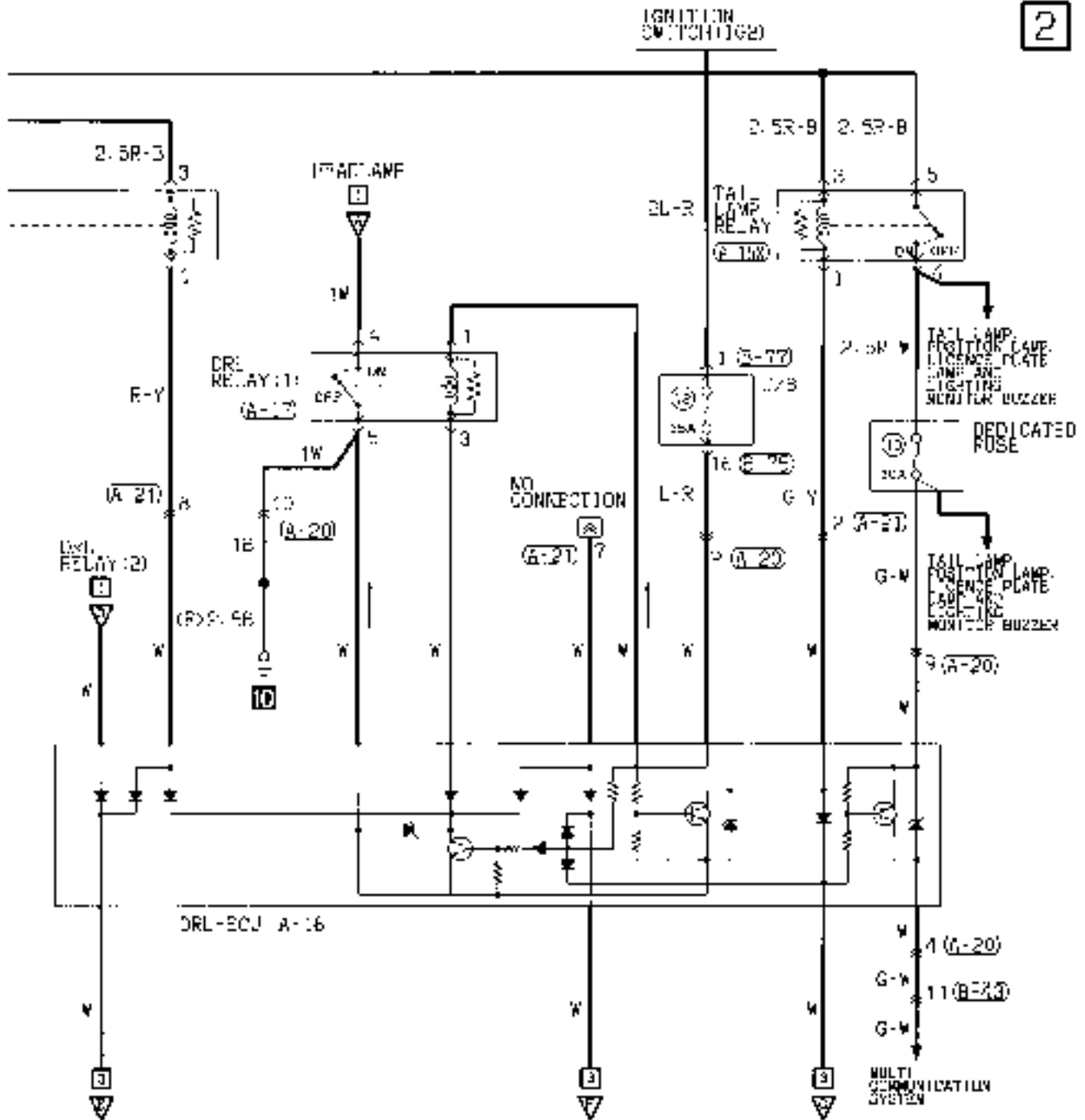

Wire color code
 B: Black G: Light green GR: Green L: Blue W: White Y: Yellow GN: Gray
 BR: Brown O: Orange GR: Gray R: Red P: Pink V: Violet

HEADLAMP <Vehicles with daytime running lamp> (CONTINUED)

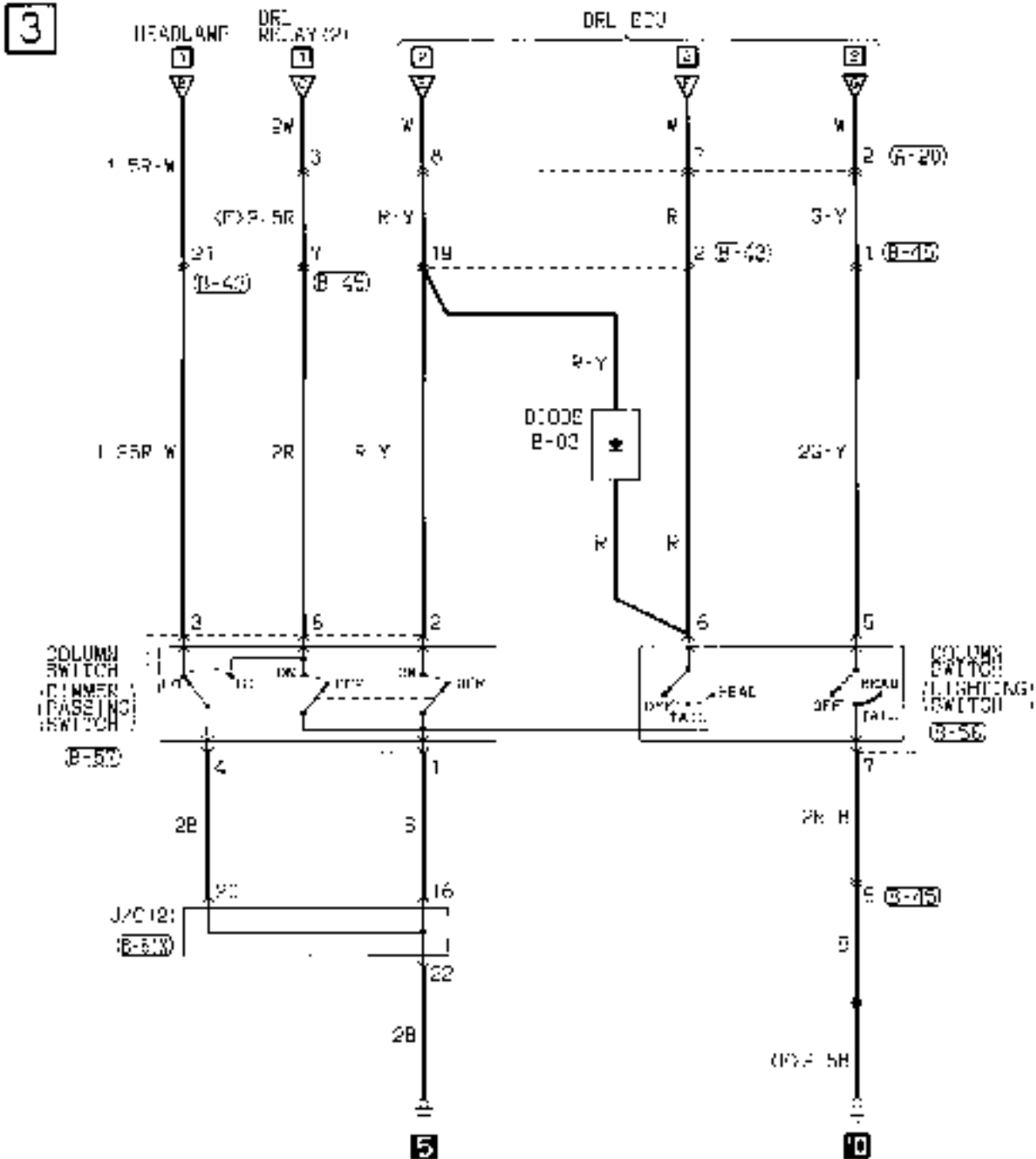

<table border="1"> <tr><td>1</td><td>2</td><td>3</td><td>4</td><td>5</td><td>6</td><td>7</td><td>8</td><td>9</td><td>10</td><td>11</td><td>12</td><td>13</td><td>14</td><td>15</td><td>16</td><td>17</td><td>18</td><td>19</td><td>20</td><td>21</td><td>22</td><td>23</td><td>24</td><td>25</td><td>26</td><td>27</td><td>28</td><td>29</td><td>30</td><td>31</td><td>32</td></tr> <tr><td>1</td><td>2</td><td>3</td><td>4</td><td>5</td><td>6</td><td>7</td><td>8</td><td>9</td><td>10</td><td>11</td><td>12</td><td>13</td><td>14</td><td>15</td><td>16</td><td>17</td><td>18</td><td>19</td><td>20</td><td>21</td><td>22</td><td>23</td><td>24</td><td>25</td><td>26</td><td>27</td><td>28</td><td>29</td><td>30</td><td>31</td><td>32</td></tr> </table>	1	2	3	4	5	6	7	8	9	10	11	12	13	14	15	16	17	18	19	20	21	22	23	24	25	26	27	28	29	30	31	32	1	2	3	4	5	6	7	8	9	10	11	12	13	14	15	16	17	18	19	20	21	22	23	24	25	26	27	28	29	30	31	32	<table border="1"> <tr><td>1</td><td>2</td><td>3</td><td>4</td><td>5</td><td>6</td><td>7</td><td>8</td><td>9</td><td>10</td><td>11</td><td>12</td><td>13</td><td>14</td><td>15</td><td>16</td><td>17</td><td>18</td><td>19</td><td>20</td><td>21</td><td>22</td><td>23</td><td>24</td><td>25</td><td>26</td><td>27</td><td>28</td><td>29</td><td>30</td><td>31</td><td>32</td></tr> <tr><td>1</td><td>2</td><td>3</td><td>4</td><td>5</td><td>6</td><td>7</td><td>8</td><td>9</td><td>10</td><td>11</td><td>12</td><td>13</td><td>14</td><td>15</td><td>16</td><td>17</td><td>18</td><td>19</td><td>20</td><td>21</td><td>22</td><td>23</td><td>24</td><td>25</td><td>26</td><td>27</td><td>28</td><td>29</td><td>30</td><td>31</td><td>32</td></tr> </table>	1	2	3	4	5	6	7	8	9	10	11	12	13	14	15	16	17	18	19	20	21	22	23	24	25	26	27	28	29	30	31	32	1	2	3	4	5	6	7	8	9	10	11	12	13	14	15	16	17	18	19	20	21	22	23	24	25	26	27	28	29	30	31	32	<table border="1"> <tr><td>1</td><td>2</td><td>3</td><td>4</td><td>5</td><td>6</td><td>7</td><td>8</td><td>9</td><td>10</td><td>11</td><td>12</td><td>13</td><td>14</td><td>15</td><td>16</td><td>17</td><td>18</td><td>19</td><td>20</td><td>21</td><td>22</td><td>23</td><td>24</td><td>25</td><td>26</td><td>27</td><td>28</td><td>29</td><td>30</td><td>31</td><td>32</td></tr> <tr><td>1</td><td>2</td><td>3</td><td>4</td><td>5</td><td>6</td><td>7</td><td>8</td><td>9</td><td>10</td><td>11</td><td>12</td><td>13</td><td>14</td><td>15</td><td>16</td><td>17</td><td>18</td><td>19</td><td>20</td><td>21</td><td>22</td><td>23</td><td>24</td><td>25</td><td>26</td><td>27</td><td>28</td><td>29</td><td>30</td><td>31</td><td>32</td></tr> </table>	1	2	3	4	5	6	7	8	9	10	11	12	13	14	15	16	17	18	19	20	21	22	23	24	25	26	27	28	29	30	31	32	1	2	3	4	5	6	7	8	9	10	11	12	13	14	15	16	17	18	19	20	21	22	23	24	25	26	27	28	29	30	31	32	<table border="1"> <tr><td>1</td><td>2</td><td>3</td><td>4</td><td>5</td><td>6</td><td>7</td><td>8</td><td>9</td><td>10</td><td>11</td><td>12</td><td>13</td><td>14</td><td>15</td><td>16</td><td>17</td><td>18</td><td>19</td><td>20</td><td>21</td><td>22</td><td>23</td><td>24</td><td>25</td><td>26</td><td>27</td><td>28</td><td>29</td><td>30</td><td>31</td><td>32</td></tr> <tr><td>1</td><td>2</td><td>3</td><td>4</td><td>5</td><td>6</td><td>7</td><td>8</td><td>9</td><td>10</td><td>11</td><td>12</td><td>13</td><td>14</td><td>15</td><td>16</td><td>17</td><td>18</td><td>19</td><td>20</td><td>21</td><td>22</td><td>23</td><td>24</td><td>25</td><td>26</td><td>27</td><td>28</td><td>29</td><td>30</td><td>31</td><td>32</td></tr> </table>	1	2	3	4	5	6	7	8	9	10	11	12	13	14	15	16	17	18	19	20	21	22	23	24	25	26	27	28	29	30	31	32	1	2	3	4	5	6	7	8	9	10	11	12	13	14	15	16	17	18	19	20	21	22	23	24	25	26	27	28	29	30	31	32	<table border="1"> <tr><td>1</td><td>2</td><td>3</td><td>4</td><td>5</td><td>6</td><td>7</td><td>8</td><td>9</td><td>10</td><td>11</td><td>12</td><td>13</td><td>14</td><td>15</td><td>16</td><td>17</td><td>18</td><td>19</td><td>20</td><td>21</td><td>22</td><td>23</td><td>24</td><td>25</td><td>26</td><td>27</td><td>28</td><td>29</td><td>30</td><td>31</td><td>32</td></tr> <tr><td>1</td><td>2</td><td>3</td><td>4</td><td>5</td><td>6</td><td>7</td><td>8</td><td>9</td><td>10</td><td>11</td><td>12</td><td>13</td><td>14</td><td>15</td><td>16</td><td>17</td><td>18</td><td>19</td><td>20</td><td>21</td><td>22</td><td>23</td><td>24</td><td>25</td><td>26</td><td>27</td><td>28</td><td>29</td><td>30</td><td>31</td><td>32</td></tr> </table>	1	2	3	4	5	6	7	8	9	10	11	12	13	14	15	16	17	18	19	20	21	22	23	24	25	26	27	28	29	30	31	32	1	2	3	4	5	6	7	8	9	10	11	12	13	14	15	16	17	18	19	20	21	22	23	24	25	26	27	28	29	30	31	32	<table border="1"> <tr><td>1</td><td>2</td><td>3</td><td>4</td><td>5</td><td>6</td><td>7</td><td>8</td><td>9</td><td>10</td><td>11</td><td>12</td><td>13</td><td>14</td><td>15</td><td>16</td><td>17</td><td>18</td><td>19</td><td>20</td><td>21</td><td>22</td><td>23</td><td>24</td><td>25</td><td>26</td><td>27</td><td>28</td><td>29</td><td>30</td><td>31</td><td>32</td></tr> <tr><td>1</td><td>2</td><td>3</td><td>4</td><td>5</td><td>6</td><td>7</td><td>8</td><td>9</td><td>10</td><td>11</td><td>12</td><td>13</td><td>14</td><td>15</td><td>16</td><td>17</td><td>18</td><td>19</td><td>20</td><td>21</td><td>22</td><td>23</td><td>24</td><td>25</td><td>26</td><td>27</td><td>28</td><td>29</td><td>30</td><td>31</td><td>32</td></tr> </table>	1	2	3	4	5	6	7	8	9	10	11	12	13	14	15	16	17	18	19	20	21	22	23	24	25	26	27	28	29	30	31	32	1	2	3	4	5	6	7	8	9	10	11	12	13	14	15	16	17	18	19	20	21	22	23	24	25	26	27	28	29	30	31	32
1	2	3	4	5	6	7	8	9	10	11	12	13	14	15	16	17	18	19	20	21	22	23	24	25	26	27	28	29	30	31	32																																																																																																																																																																																																																																																																																																																																																																						
1	2	3	4	5	6	7	8	9	10	11	12	13	14	15	16	17	18	19	20	21	22	23	24	25	26	27	28	29	30	31	32																																																																																																																																																																																																																																																																																																																																																																						
1	2	3	4	5	6	7	8	9	10	11	12	13	14	15	16	17	18	19	20	21	22	23	24	25	26	27	28	29	30	31	32																																																																																																																																																																																																																																																																																																																																																																						
1	2	3	4	5	6	7	8	9	10	11	12	13	14	15	16	17	18	19	20	21	22	23	24	25	26	27	28	29	30	31	32																																																																																																																																																																																																																																																																																																																																																																						
1	2	3	4	5	6	7	8	9	10	11	12	13	14	15	16	17	18	19	20	21	22	23	24	25	26	27	28	29	30	31	32																																																																																																																																																																																																																																																																																																																																																																						
1	2	3	4	5	6	7	8	9	10	11	12	13	14	15	16	17	18	19	20	21	22	23	24	25	26	27	28	29	30	31	32																																																																																																																																																																																																																																																																																																																																																																						
1	2	3	4	5	6	7	8	9	10	11	12	13	14	15	16	17	18	19	20	21	22	23	24	25	26	27	28	29	30	31	32																																																																																																																																																																																																																																																																																																																																																																						
1	2	3	4	5	6	7	8	9	10	11	12	13	14	15	16	17	18	19	20	21	22	23	24	25	26	27	28	29	30	31	32																																																																																																																																																																																																																																																																																																																																																																						
1	2	3	4	5	6	7	8	9	10	11	12	13	14	15	16	17	18	19	20	21	22	23	24	25	26	27	28	29	30	31	32																																																																																																																																																																																																																																																																																																																																																																						
1	2	3	4	5	6	7	8	9	10	11	12	13	14	15	16	17	18	19	20	21	22	23	24	25	26	27	28	29	30	31	32																																																																																																																																																																																																																																																																																																																																																																						
1	2	3	4	5	6	7	8	9	10	11	12	13	14	15	16	17	18	19	20	21	22	23	24	25	26	27	28	29	30	31	32																																																																																																																																																																																																																																																																																																																																																																						
1	2	3	4	5	6	7	8	9	10	11	12	13	14	15	16	17	18	19	20	21	22	23	24	25	26	27	28	29	30	31	32																																																																																																																																																																																																																																																																																																																																																																						

Wire color code
 B: Blue L: Light green G: Green W: White Y: Yellow PB: Sky blue
 BR: Brown O: Orange GR: Gray R: Red P: Pink V: Violet

HEADLAMP <Vehicles with daytime running lamp> (See P. 4-52.)**OPERATION**

Headlamp Relay ON Conditions
Refer to the table below.

<Daytime running lamp operation>

- Turning the ignition switch to the ON position causes the headlamp relay, daytime running lamp relay (I), and tail lamp relay to be energized, which causes the headlamps, tail lamps, etc. to go on.

<Low-beam operation>

- Placing the lighting switch in the HEAD position causes the headlamp relay and daytime running lamp relay (II) to be energized.
- If the dimmer/passing switch is placed in the LO position at this time, the headlamps light up in low beam.

<Upper-beam operation>

- Placing the lighting switch in the HEAD position causes the headlamp relay and daytime running lamp relay (II) to be energized.
- If the dimmer/passing switch is placed in the HI position at this time, the headlamps light up in upper beam.

<Upper-beam indicator lamp>

- This lamp lights up when the upper/passing beams are on, indicating that the headlamps are on in upper beam.

<Passing operation>

- When the dimmer/passing switch is set to the "ON" position, the headlamp relay is switched ON and the upper beam of the headlamps illuminates.

TROUBLESHOOTING HINTS

- Headlamps don't go on.
 - But the tail lamps do illuminate.
 - Check the headlamp relay.
 - Check the lighting switch.
 - The tail lamps also don't illuminate.
 - Check the fusible link No. (8).
- The low beam at both sides doesn't illuminate.
 - Check the dimmer switch LO contacts.
- The upper beam at both sides doesn't illuminate.
 - The passing signal functions OK.
 - Check the dimmer switch HI contacts.
 - The passing signal doesn't function.
 - Check the dimmer switch.
 - Check the daytime running lamp relay (II).
 - Check the daytime running lamp control unit.
- One headlamp doesn't illuminate.
 - Check the lamp bulb.
- Can't switch from low to upper beam or vice-versa.
 - Check the dimmer switch.
- With the ignition switch at the "ON" position, the headlamps' low beam does not illuminate.
 - Check the daytime running lamp relay (I).
 - Check the daytime running lamp control unit.
- Upper-beam indicator lamp does not go on.
 - Headlamp upper beams are operational.
 - Check dedicated fuse No. (15).
 - Check the indicator lamp bulb.
 - Headlamp upper beams doesn't illuminate.
 - Check the dimmer switch.

Ignition switch	Lighting switch	Dimmer/passing switch	Headlamp relay
"ON"	"OFF"	—	ON
—	"HEAD"	—	ON
—	—	"PASS"	ON

HEADLAMP LEVELING SYSTEM

9019120030

1

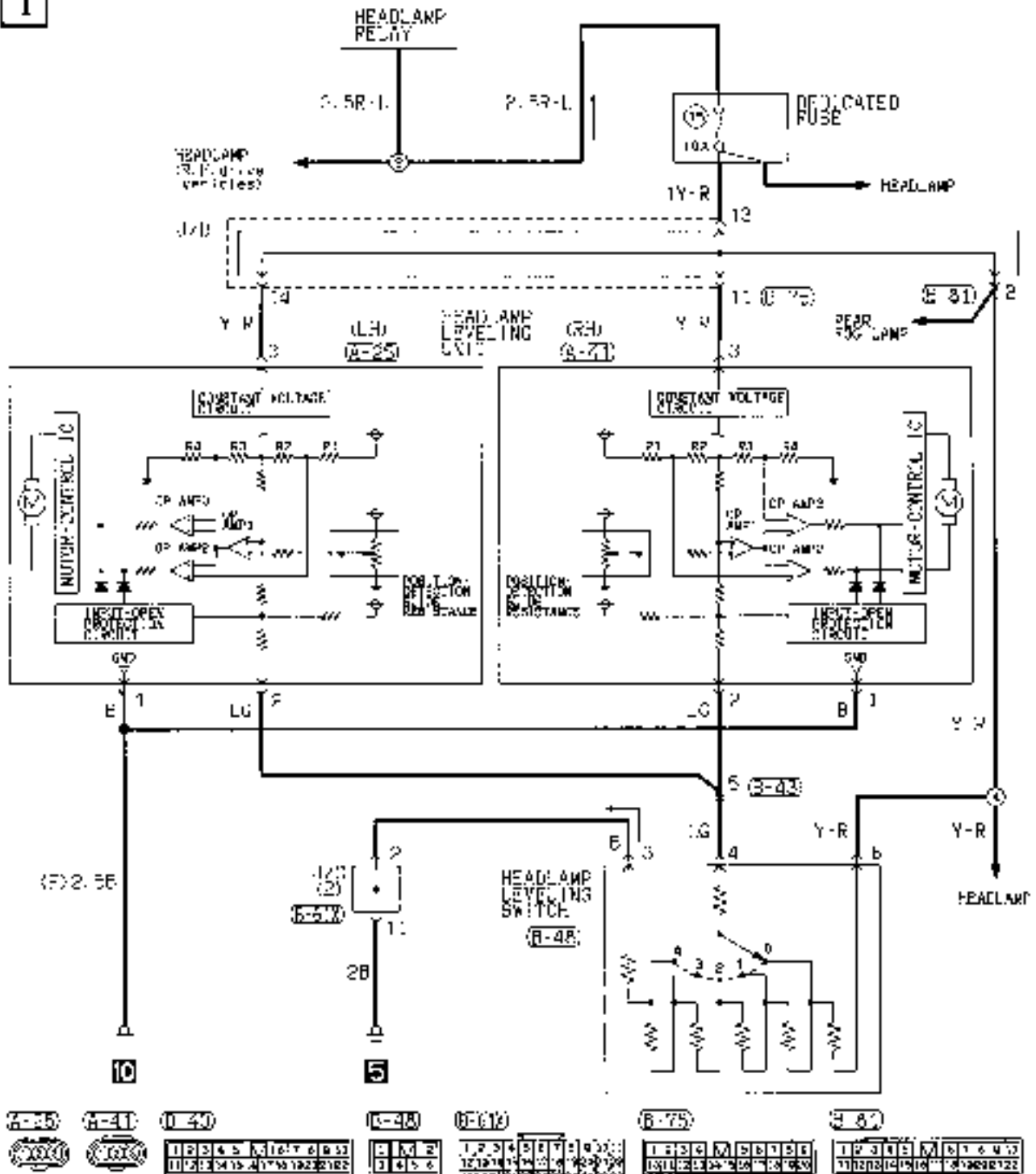

Wire colour code
 BK:Black LG:Light Green G:Green B:Blue W:White Y:Yellow GB:Sky Blue
 BR:Brown O:Orange GR:Gray R:Red P:Pink V:Violet

SW02530A

HEADLAMP LEVELING SYSTEM (See P. 4-56.)**OPERATION****1. Headlamps angle-downward operation**

- When the lighting switch is set to the "HEAD" position, the headlamp relay is switched ON, and battery voltage is applied, through the headlamp-leveling unit, to dedicated fuse No. (15).
- When the headlamp-leveling switch setting is changed from "0" to "1", the positive (+) input terminal voltage of the comparator OP AMP 1 (located within the headlamp-leveling unit) becomes greater than the negative (-) input terminal standard reference voltage value, and OP AMP 1 outputs HIGH signals to OP AMP 2 and OP AMP 3.
- As a result of these HIGH signals, OP AMP 2 outputs LOW signals and OP AMP 3 outputs HIGH signals to the motor-control IC.
- When this happens, the motor-control IC is switched ON, current flows to the motor, and the motor rotates in the forward direction.
- The rotation of the motor, after passing through the gears and the output shaft, causes the headlamp reflectors to move to a downward angle thus changing the angle of headlamp illumination.
- At this time, the position-detection sliding resistance is activated in the direction of the low resistance value, after which the OP AMP 1 negative (-) input terminal voltage value and positive (+) input terminal voltage value become equivalent, and OP AMP 2 and OP AMP 3 both output HIGH signals.
- When this happens, the motor-control IC is switched OFF and the motor stops.

NOTE

- (1) The same operation occurs if the headlamp-leveling switch is set to another position.
- (2) The input open protection circuit functions to stop the operation of the motor if there is an abnormal condition, such as damaged or disconnected wiring within the headlamp-leveling unit or of the wiring harness.

2. Headlamps angle-upward operation

- The headlamp angle-upward operation is the opposite logic of the downward operation; the motor operates in the reverse direction and then stops.

TROUBLESHOOTING HINTS

1. Absolutely no change of the headlamp angle
 - (1) The upper-beam indicator lamp illuminates.
 - Check the headlamp-leveling switch.
 - Check the headlamp-leveling unit.
 - (2) The upper-beam indicator lamp does not illuminate.
 - Check dedicated fuse No. (15).
2. There is one setting of the headlamp-leveling switch at which the headlamp angle does not change.
 - Check the headlamp-leveling switch.

TAIL LAMP, POSITION LAMP, LICENCE PLATE LAMP AND LIGHTING MONITOR BUZZER

80100176193

Vehicles without daytime running lamp

1

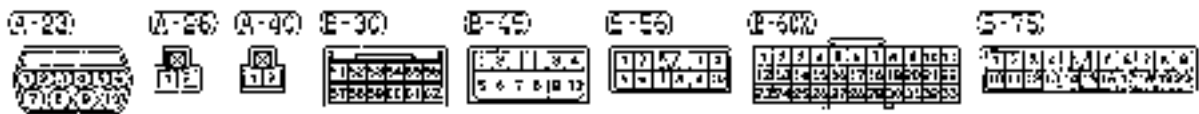
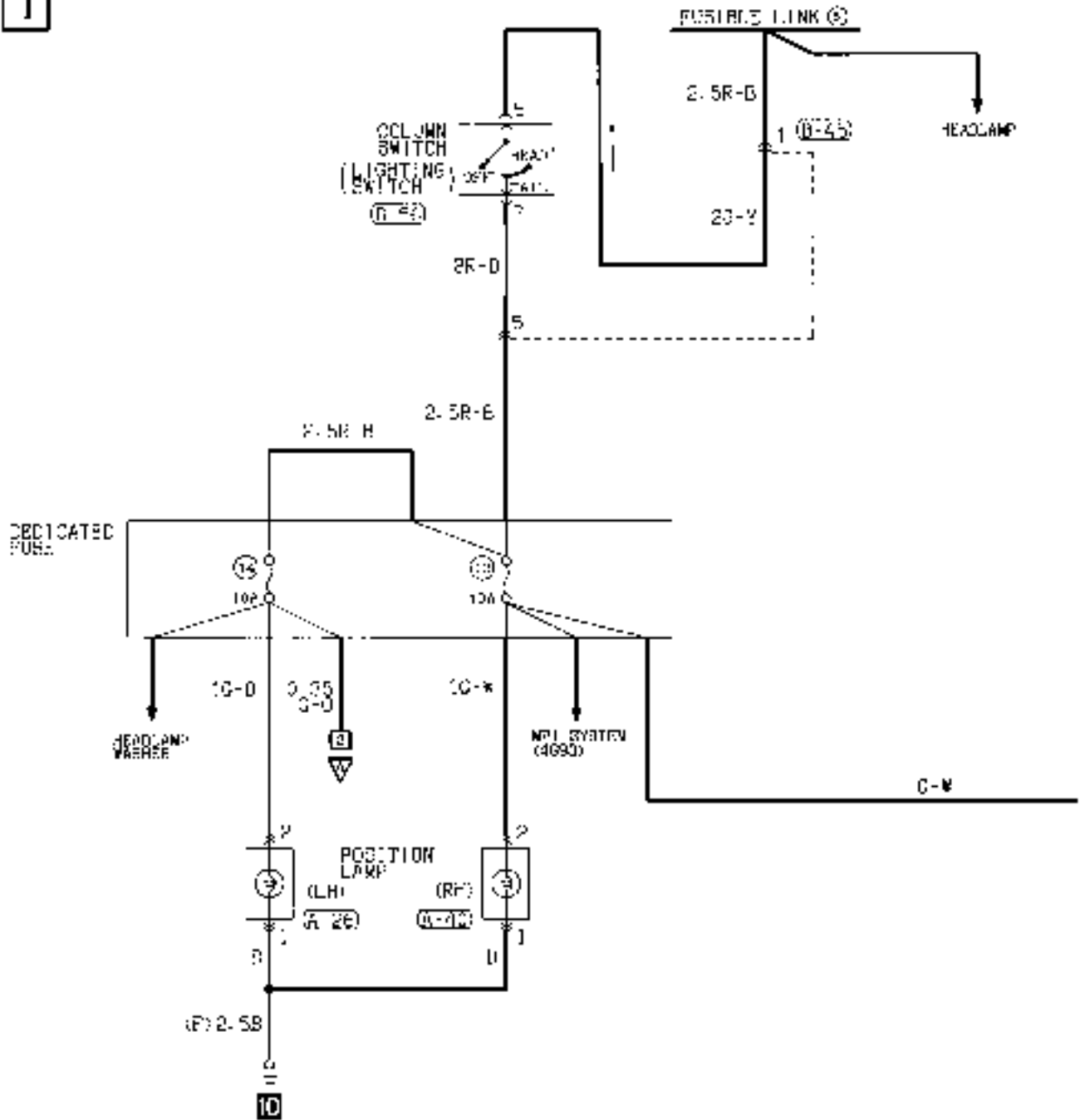

2

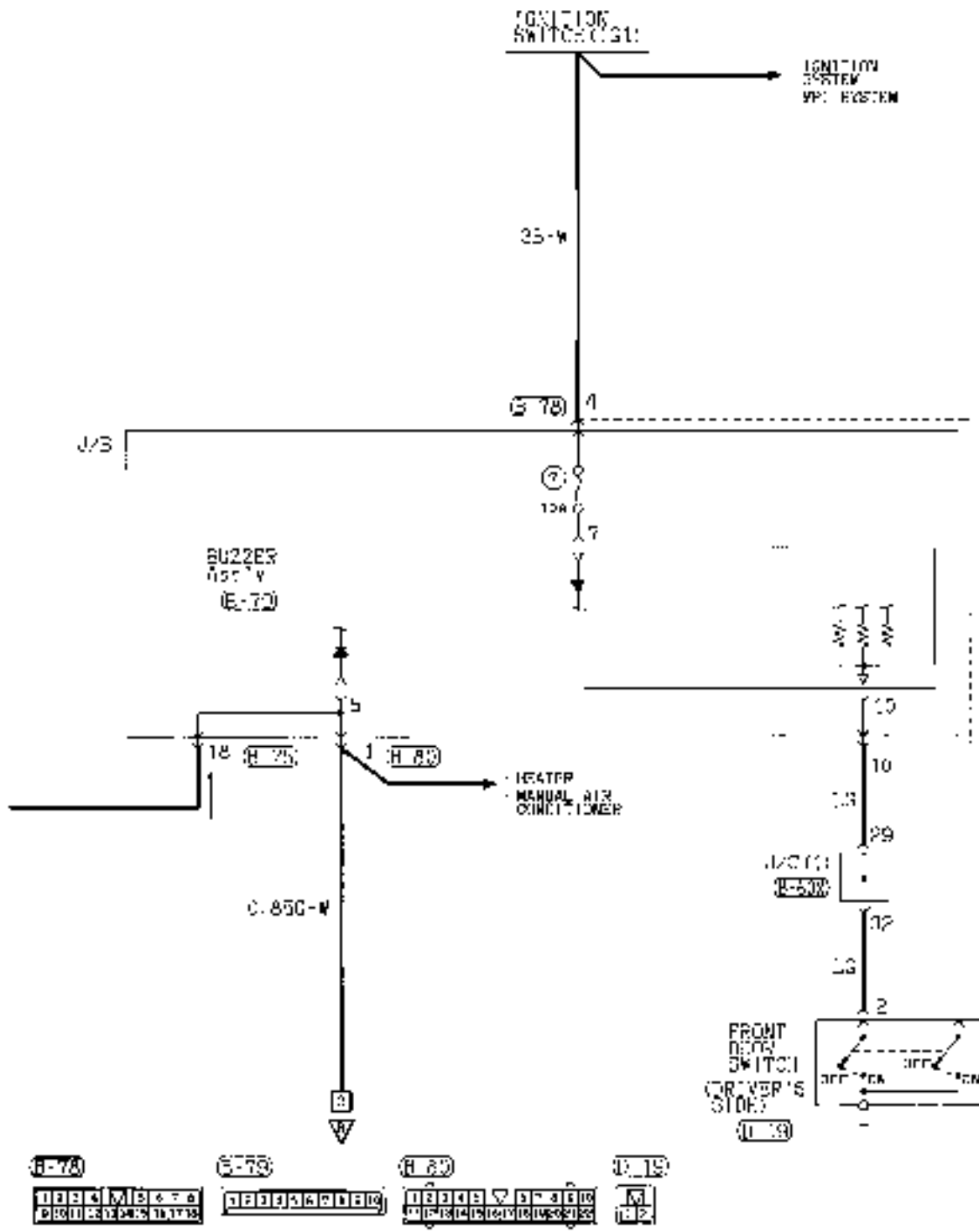

Wires to our 2003
 B: Blue
 BR: Brown
 LG: Light green
 C: Orange
 G: Green
 GR: Gray
 L: Blue
 M: Red
 W: White
 P: Pink
 Y: Yellow
 V: Violet
 2B: Sky blue

TAIL LAMP, POSITION LAMP, LICENCE PLATE LAMP AND LIGHTING MONITOR BUZZER <Vehicles without daytime running lamp> (CONTINUED)

3

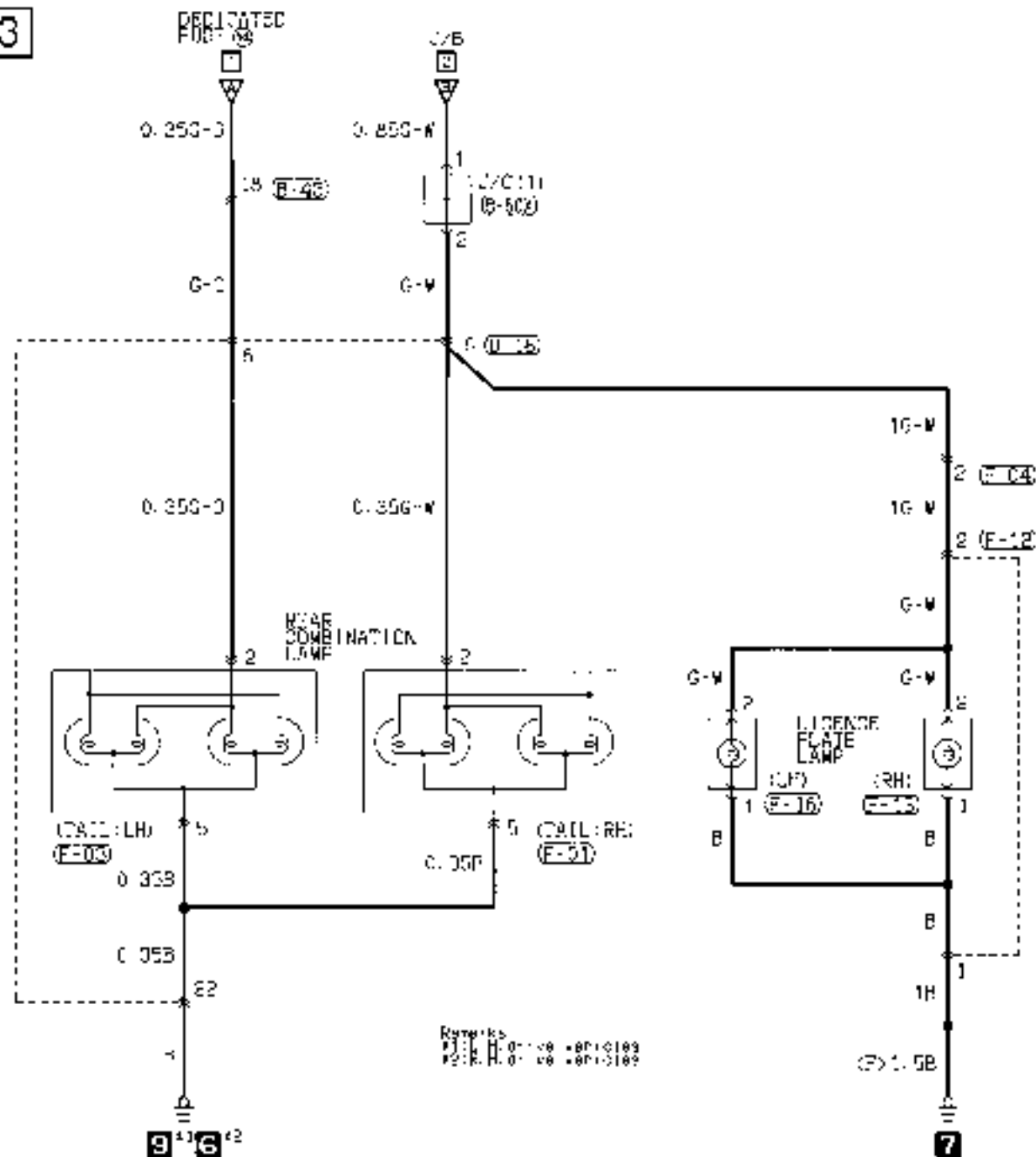

Remarks:
 F-01, F-03: for vehicles with
 F-04, F-12, F-13: for vehicles without

(F-43)	(F-48)	(R-11)	(F-01)	(F-03)	(F-04)	(F-12)	(F-13)
1 2 3 4 5 6 7 8 9 10 11 12 13 14 15 16 17 18 19 20 21 22 23 24 25 26 27 28 29 30	1 2 3 4 5 6 7 8 9 10 11 12 13 14 15 16 17 18 19 20 21 22 23 24 25 26 27 28 29 30	1 2 3 4 5 6 7 8 9 10 11 12 13 14 15 16 17 18 19 20 21 22 23 24 25 26 27 28 29 30	1 2 3 4 5 6 7 8 9 10 11 12 13 14 15 16 17 18 19 20 21 22 23 24 25 26 27 28 29 30	1 2 3 4 5 6 7 8 9 10 11 12 13 14 15 16 17 18 19 20 21 22 23 24 25 26 27 28 29 30	1 2 3 4 5 6 7 8 9 10 11 12 13 14 15 16 17 18 19 20 21 22 23 24 25 26 27 28 29 30	1 2 3 4 5 6 7 8 9 10 11 12 13 14 15 16 17 18 19 20 21 22 23 24 25 26 27 28 29 30	1 2 3 4 5 6 7 8 9 10 11 12 13 14 15 16 17 18 19 20 21 22 23 24 25 26 27 28 29 30

(F-16) Wire color code: B: Black, BR: Brown, G: Green, GR: Gray, L: Blue, R: Red, W: White, P: Pink, Y: Yellow, V: Violet, BB: Sky Blue

TAIL LAMP, POSITION LAMP, LICENCE PLATE LAMP AND LIGHTING MONITOR BUZZER (See P. 4-58, 62.)**OPERATION**

1. **Vehicles without daytime running lamp.**
 - When the lighting switch is turned to the "TAIL" or "HEAD" position, current is supplied to each lamp, causing them to illuminate.
2. **Vehicles with daytime running lamp.**
 - Placing the lighting switch in the "TAIL" or "HEAD" position causes the tail lamp relay to be energized.
If the ignition switch is turned to the "ON" position, the tail lamp relay normally is always "ON".
 - As a result, current flows by way of dedicated fuse No. (13) and No. (14) to each lamp, causing the lamp to go on.

<Lighting monitor buzzer operation>

- When the lighting switch is in the "TAIL" or "HEAD" position, if the ignition switch is turned to the "ACC" or "LOCK" position or if the ignition key is removed, the lighting monitor buzzer will sound when the driver's side door is opened as a warning to the driver.

TROUBLESHOOTING HINTS

1. No lamp go on.
 - 1) Headlamps do not go on either.
 - Check fusible link No. (8).
 - 2) Headlamps go on.
 - Check tail lamp relay
 - Check dedicated fuse No. (13) and No. (14).
2. Lighting monitor buzzer does not sound.
 - 1) Tail lamps go on.
 - Check lighting monitor buzzer
 - Check front door switch (driver's side).

TAIL LAMP, POSITION LAMP, LICENCE PLATE LAMP AND LIGHTING MONITOR BUZZER

901-00170280

Vehicles with daytime running lamp

1

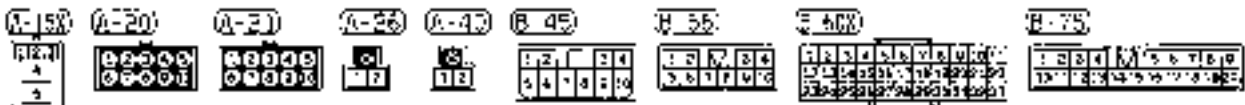
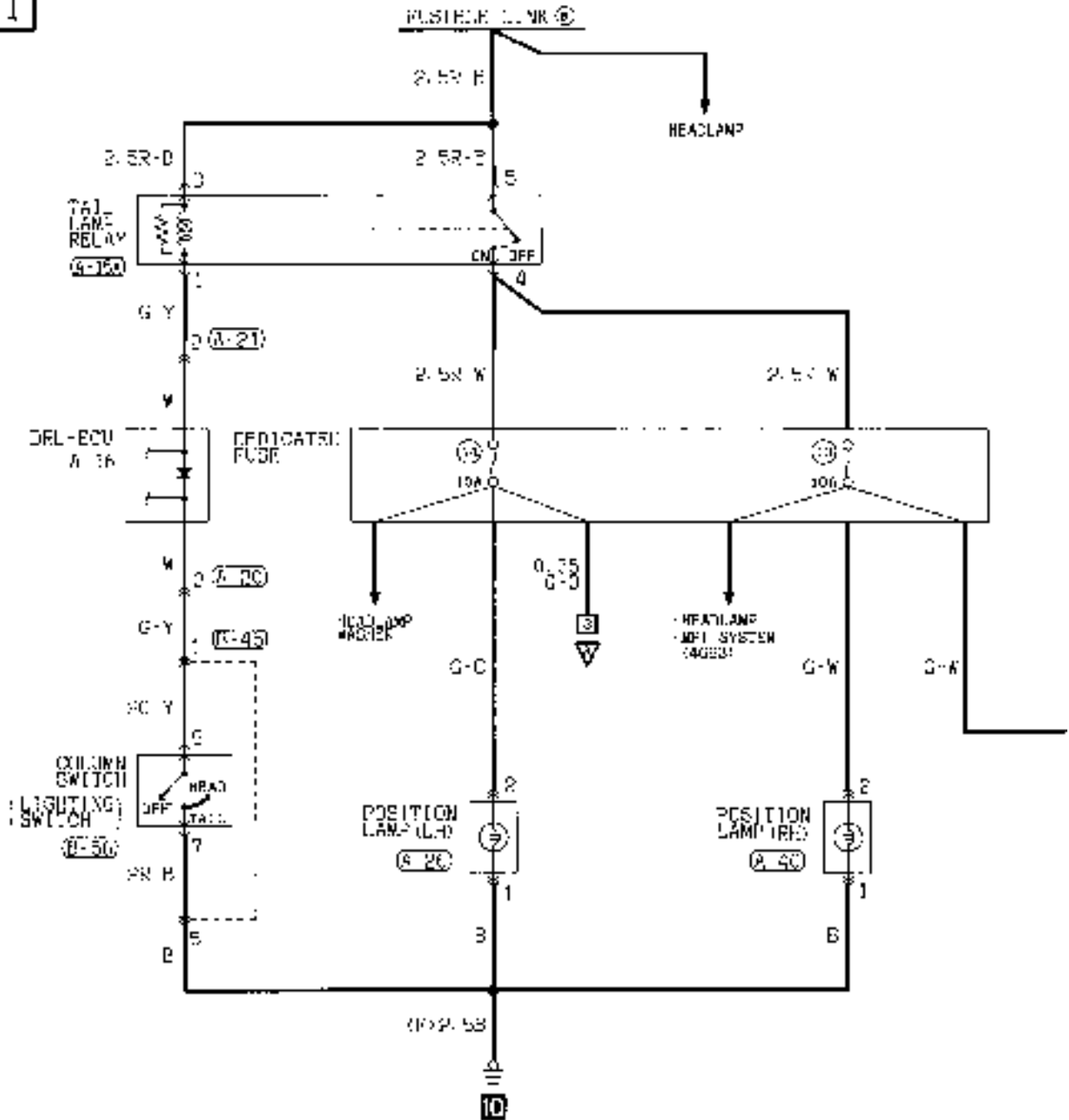

2

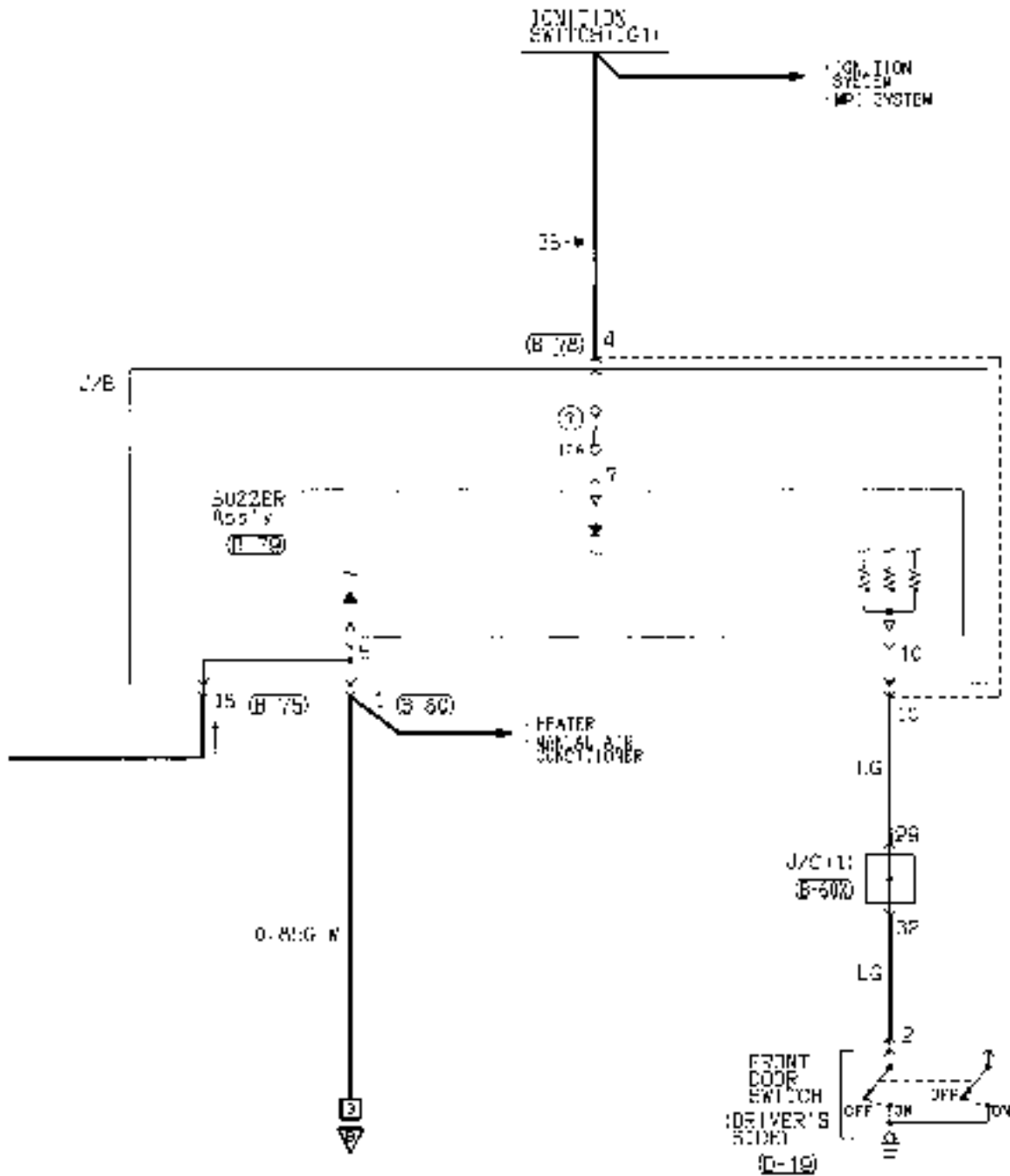

Wire color code

B:Black	LG:Light Green	G:Green	B:Blue	W:White	Y:Yellow	SB:Sky Blue
BR:Brown	O:Orange	GR:Gray	R:Red	P:Pink	V:Violet	

TAIL LAMP, POSITION LAMP, LICENCE PLATE LAMP AND LIGHTING MONITOR BUZZER <Vehicles with daytime running lamp> (CONTINUED)

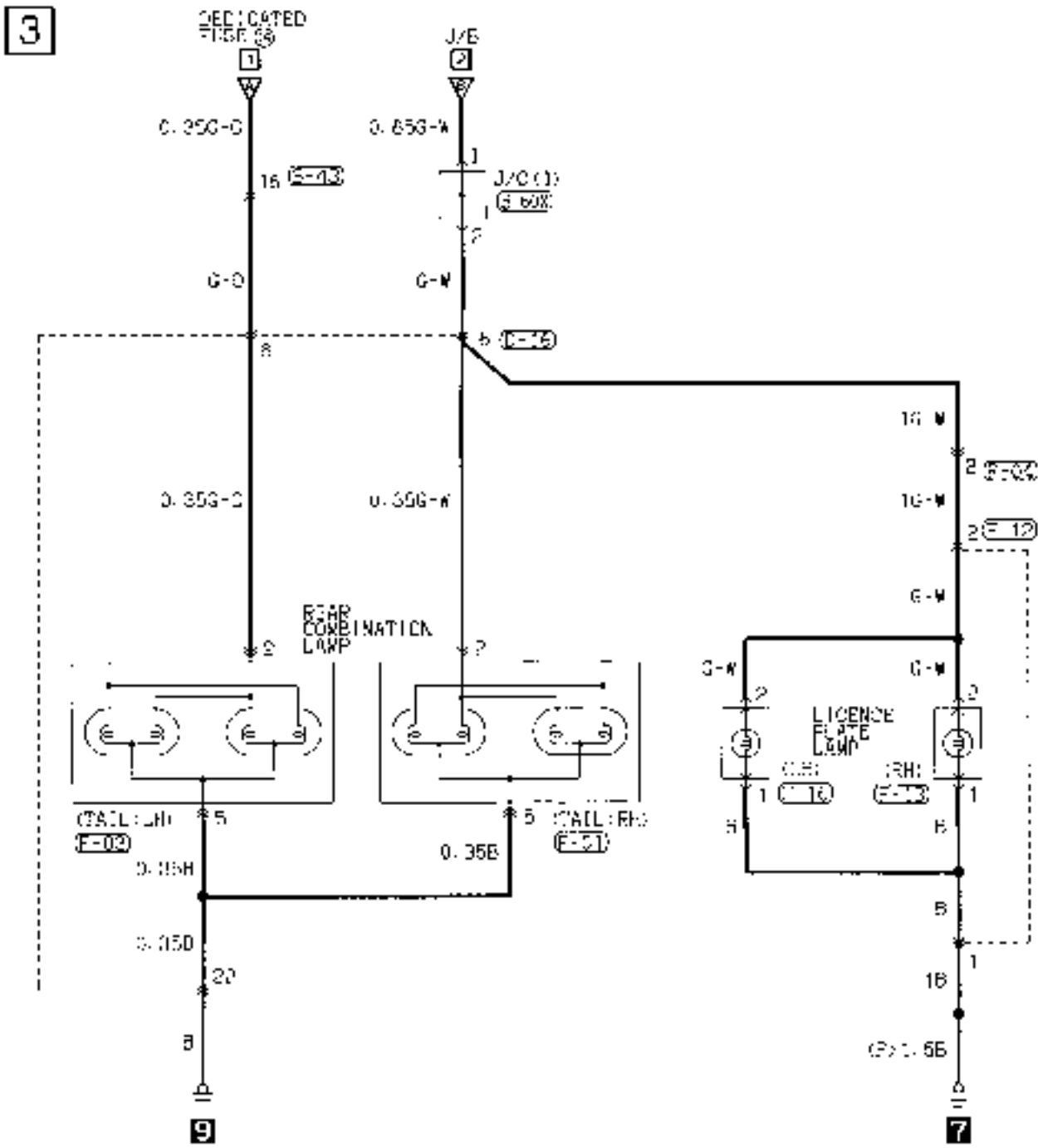

(F-02)	(F-03)	(F-04)	(F-07)	(F-08)	(F-09)	(F-12)	(F-13)
1 2 3 4 5 6 7 8 9 10 11 12 13 14 15 16 17 18 19 20 21 22	1 2 3 4 5 6 7 8 9 10 11 12 13 14 15 16 17 18 19 20	1 2 3 4 5 6 7 8 9 10 11 12 13 14 15 16 17 18 19 20	1 2 3 4 5 6 7 8	1 2 3 4 5 6 7 8	1 2 3 4 5 6 7 8	1 2 3 4	1 2 3 4

(F-16)
(F-13)

W to do our code
 B: Black G: Light green S: Green b: Blue Y: White V: Yellow SB: Sky blue
 BR: Brown O: Orange GR: Gray R: Red P: Pink Y: Yellow

FRONT FOG LAMP (See P. 4-66, 68.)**OPERATION**

1. **Vehicles without daytime running lamp.**
 - When the lighting switch is at the "TAIL" or "HEAD" position and the front fog lamp switch is turned to "ON", the front fog lamps illuminate.
2. **Vehicles with daytime running lamp.**
 - Placing the lighting switch in the "TAIL" or "HEAD" position causes the tail lamp relay to be energized. If the ignition switch is turned to the "ON" position, the tail lamp relay normally is always "ON".
 - When the front fog lamp switch is turned "ON" in this condition, the front fog lamp goes on.

TROUBLESHOOTING HINTS

1. The front fog lamp does not light up.
 - 1) The tail lamp lights up.
 - Check front fog lamp relay.
 - Check front fog lamp switch.
 - Check dedicated fuse No. (3).

FRONT FOG LAMP

90101190287

Vehicles without daytime running lamp

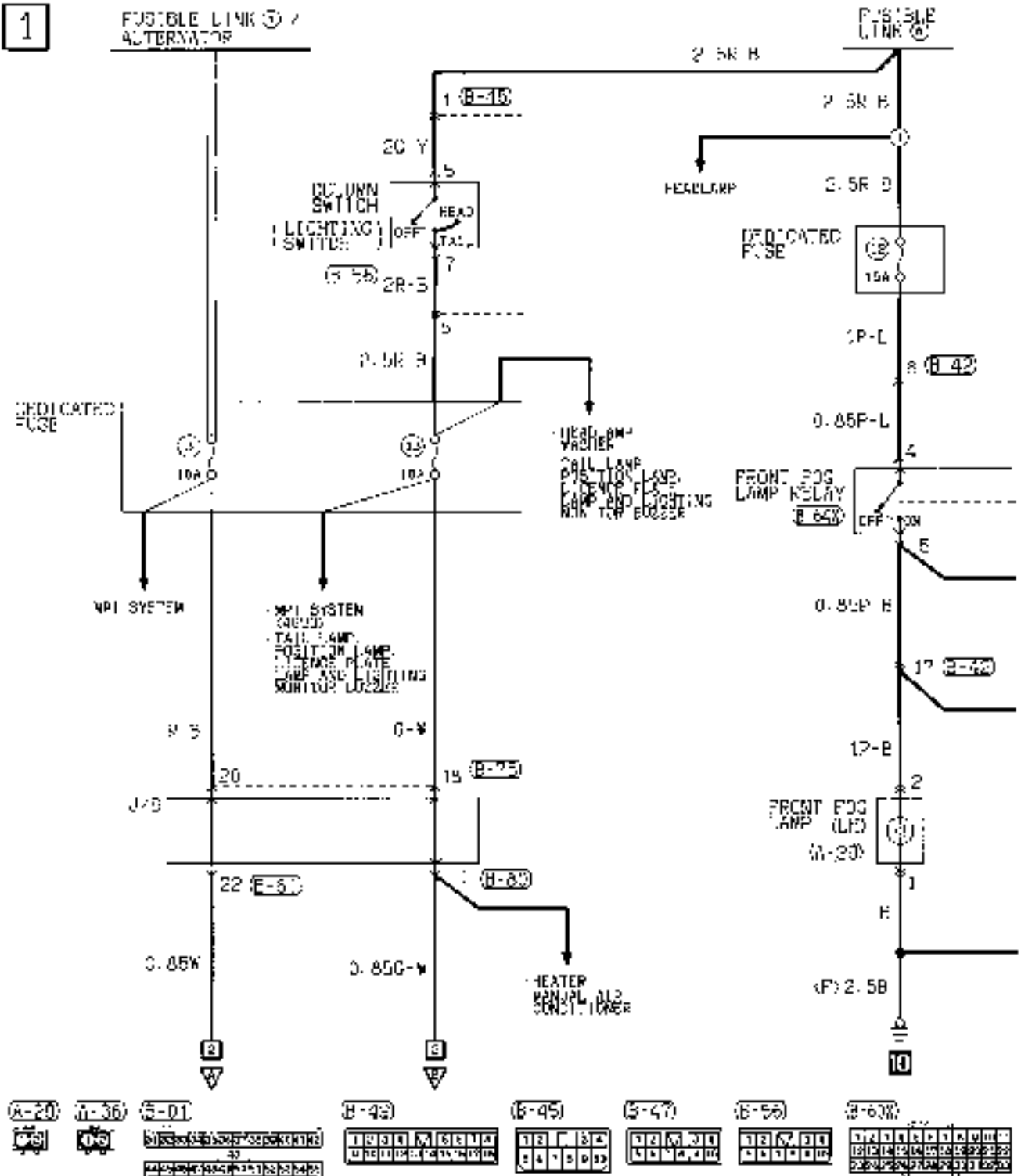

2

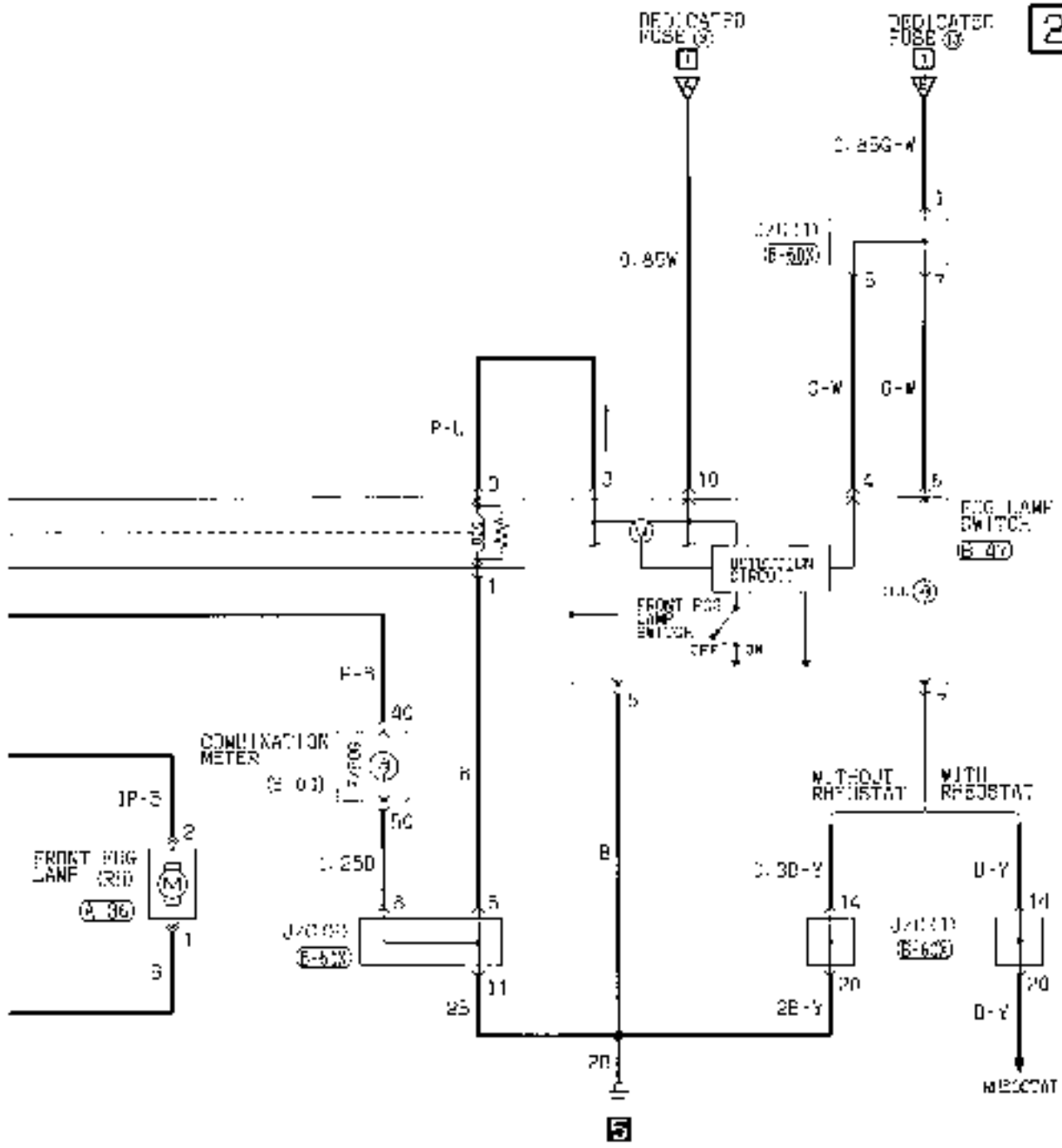

(E-36)

(E-47)

(E-03)

(E-60)

(E-62)

1	2	3	4	5	6	7	8	9	10
11	12	13	14	15	16	17	18	19	20
21	22	23	24	25	26	27	28	29	30

1	2	3	4	5	6	7	8	9	10
11	12	13	14	15	16	17	18	19	20
21	22	23	24	25	26	27	28	29	30

1	2	3	4	5	6	7	8	9	10
11	12	13	14	15	16	17	18	19	20
21	22	23	24	25	26	27	28	29	30

1	2	3	4	5	6	7	8	9	10
11	12	13	14	15	16	17	18	19	20
21	22	23	24	25	26	27	28	29	30

1	2	3	4	5	6	7	8	9	10
11	12	13	14	15	16	17	18	19	20
21	22	23	24	25	26	27	28	29	30

Wire color code
 BK:Black LG:Light green GR:Green W:White Y:Yellow SB:Sky blue
 BR:Brown O:Orange DR:Drab R:Red P:Pink V:Violet

FRONT FOG LAMP

90101100383

Vehicles with daytime running lamp

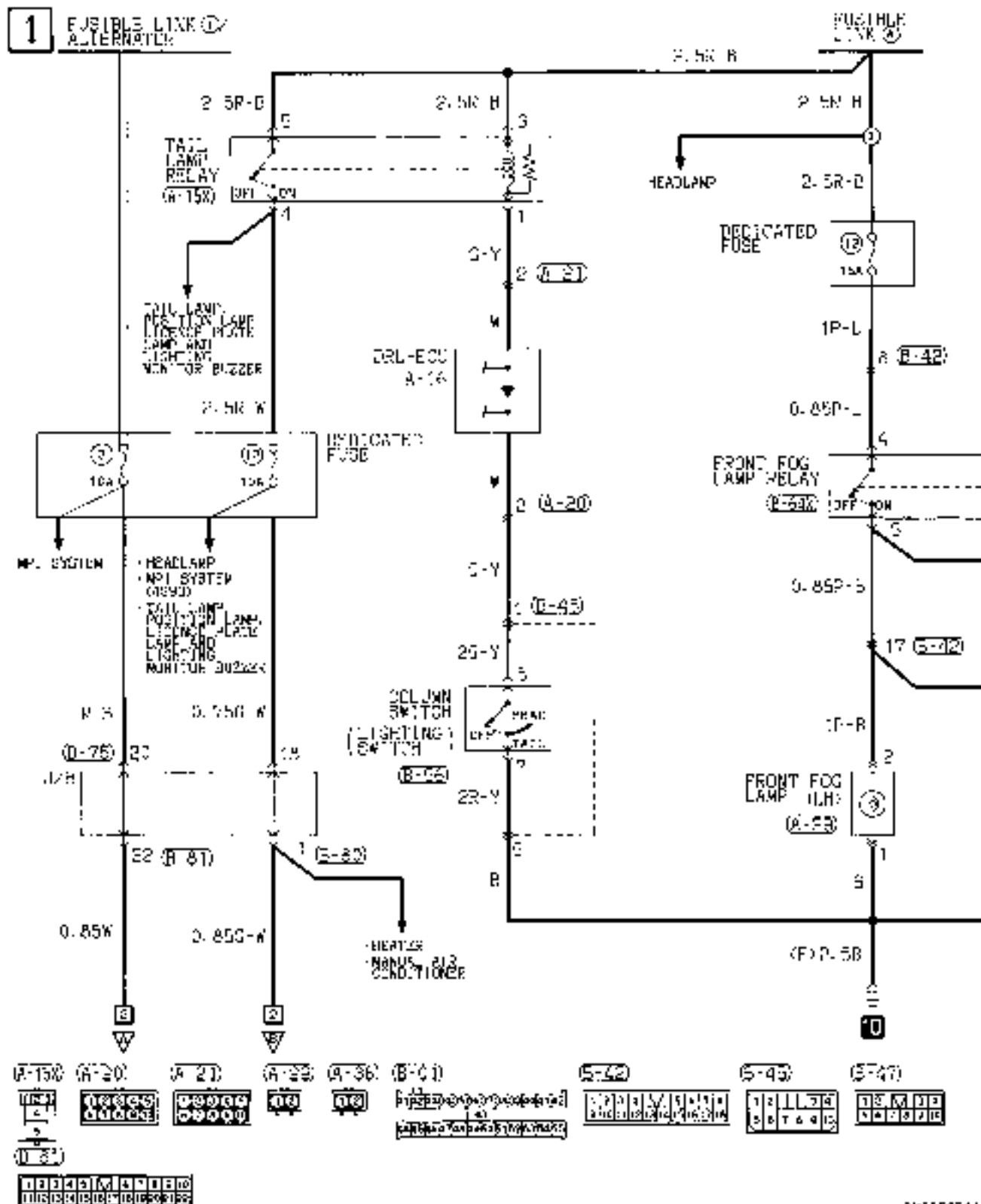

2

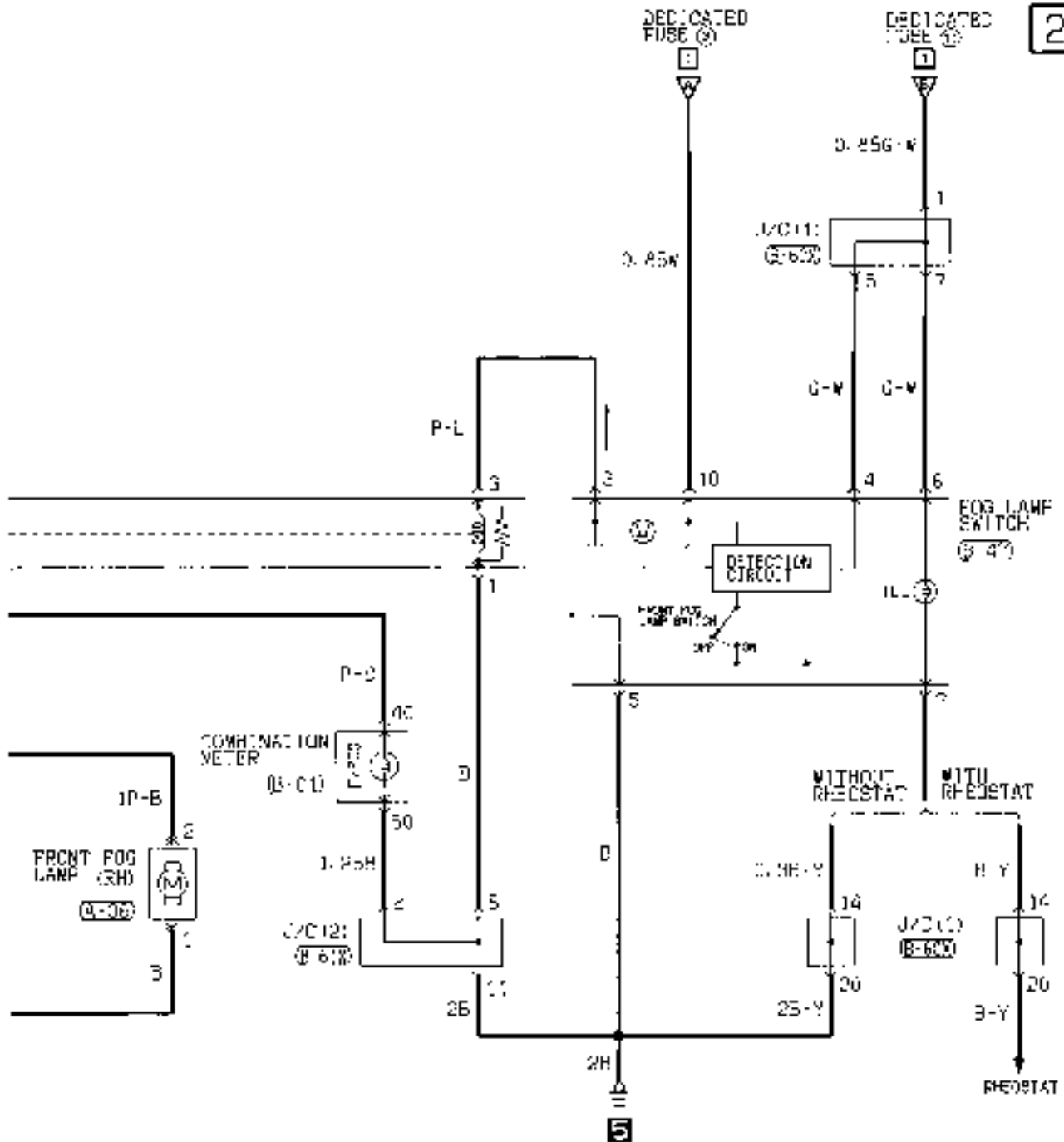

0-50	0-50G	0-50R	0-74R	0-75	0-50
1 2 3 4 5 6 7 8 9 10	1 2 3 4 5 6 7 8 9 10	1 2 3 4 5 6 7 8 9 10	1 2 3 4 5	1 2 3 4 5 6 7 8 9 10 11 12 13 14 15 16 17 18 19 20	1 2 3 4 5 6 7 8 9 10 11 12 13 14 15 16 17 18 19 20

Wire colour code
 B: Black LC: Light green G: Green R: Red W: White Y: Yellow BR: Brown D: Orange GR: Gray K: Red P: Pink V: Violet SR: S-yellow

REAR FOG LAMP

9914120348

Vehicles without daytime running lamp

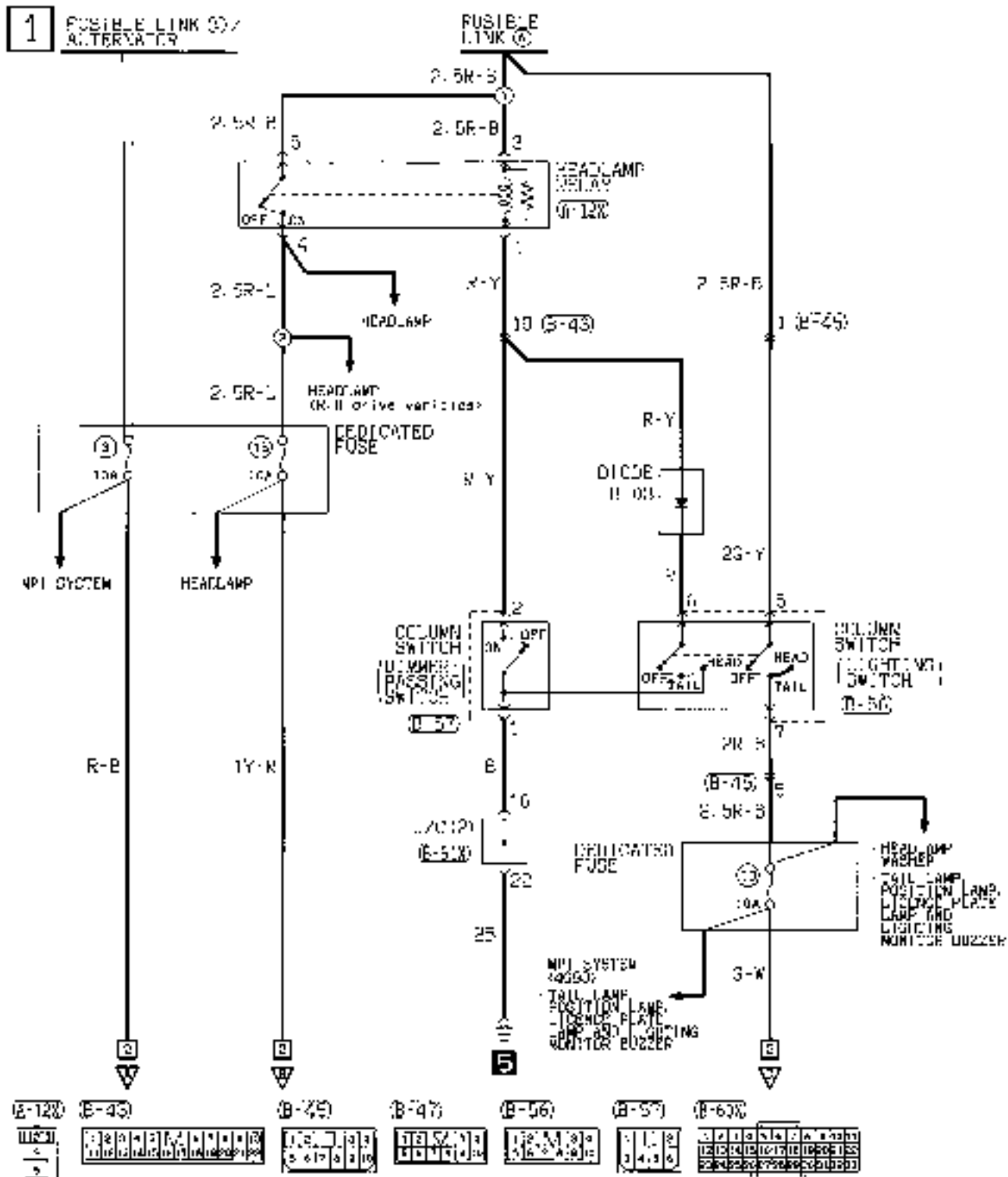

2

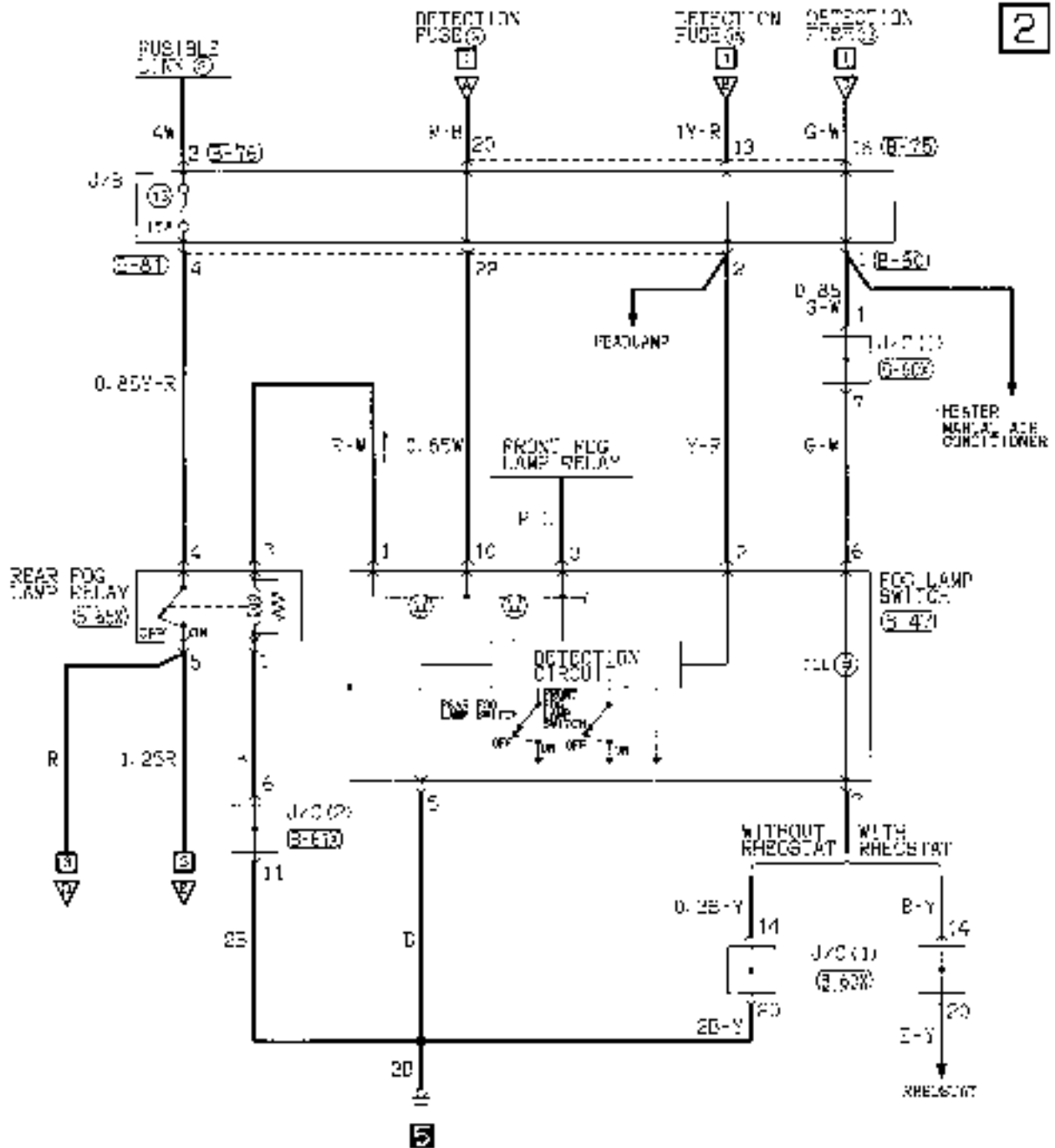

(E-5W)



(E-6W)



(E-7W)



(E-7E)



(E-8W)

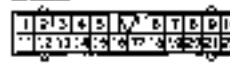

(E-8E)



Wiring color code
 B: Blue LG: Light green G: Green R: Red W: White Y: Yellow BB: Sky blue
 BR: Brown C: Orange GR: Gray P: Pink V: Violet

REAR FOG LAMP <Vehicles without daytime running lamp> (CONTINUED)

3

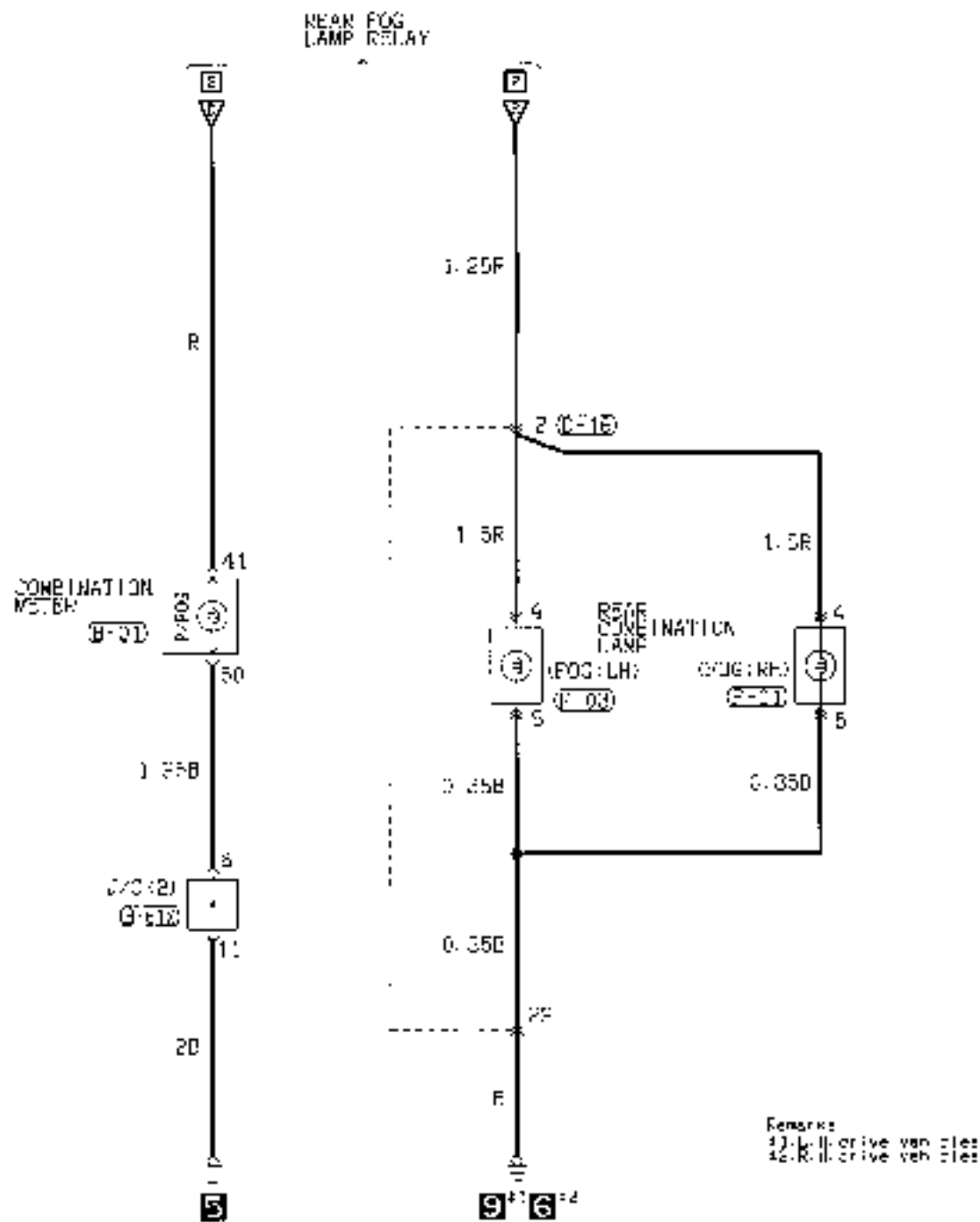

8-01

1	2	3	4	5	6	7	8	9	10	11
12	13	14	15	16	17	18	19	20	21	22
23	24	25	26	27	28	29	30	31	32	33

8-10

1	2	3	4	5	6	7	8	9	10	11
12	13	14	15	16	17	18	19	20	21	22
23	24	25	26	27	28	29	30	31	32	33

Q-16

1	2	3	4	5	6	7	8	9	10	11
12	13	14	15	16	17	18	19	20	21	22
23	24	25	26	27	28	29	30	31	32	33

F-01

1	2	3	4	5	6	7	8	9	10	11
12	13	14	15	16	17	18	19	20	21	22
23	24	25	26	27	28	29	30	31	32	33

F-03

1	2	3	4	5	6	7	8	9	10	11
12	13	14	15	16	17	18	19	20	21	22
23	24	25	26	27	28	29	30	31	32	33

Wire color code
 B: Black G: Green GR: Gray L: Blue M: White Y: Yellow BB: Sky Blue
 BR: Brown O: Orange R: Red P: Pink V: Violet

REAR FOG LAMP (See P. 4-70, 74.)**OPERATION**

Rear Fog Lamp Relay ON Conditions

<Vehicles without daytime running lamp>

Refer to the table I.

<Vehicles with daytime running lamp>

Refer to the table II.

- Placing the lighting switch in the "HEAD" position causes the rear fog lamp relay to be energized.

For vehicles with daytime running lamps, if the ignition switch is in the "ON" position, and the lighting switch is in the "OFF" position, the rear fog lamp relay will be energized.

- When the rear fog lamp switch is turned "ON" in this condition, the rear fog lamp goes on.

I

Ignition switch	Lighting switch	Rear fog lamp relay
—	"HEAD"	ON

II

Ignition switch	Lighting switch	Rear fog lamp relay
—	"HEAD"	ON
"ON"	"OFF" or "HEAD"	ON

TROUBLESHOOTING HINTS

1. The rear fog lamp does not illuminate.
 - 1) Headlamps go on.
 - Check the rear fog lamp relay
 - Check the rear fog lamp switch
 - Check the dedicated fuse No. (13)
 - 1) Headlamps do not go on, either.
 - Check the lighting switch
 - Check the fusible link No. (8).
2. The rear fog lamp at the one side does not illuminate
 - Check the lamp bulb.

REAR FOG LAMP

9410120090

Vehicles with daytime running lamp

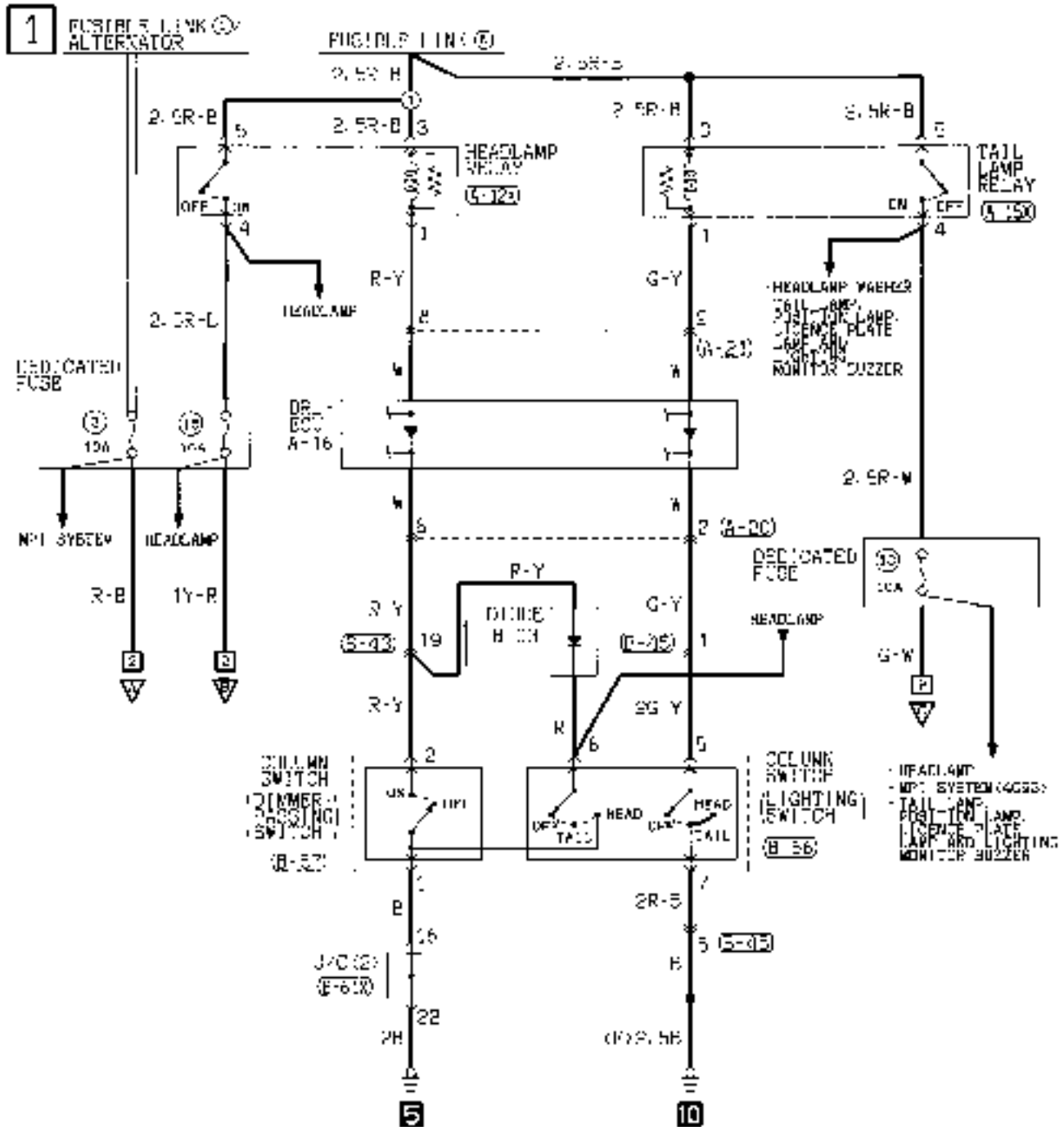

(S-12)

(S-15)

(S-20)

(S-21)

(S-43)

(S-45)

(S-47)

(S-56)

(S-57)



(S-36)



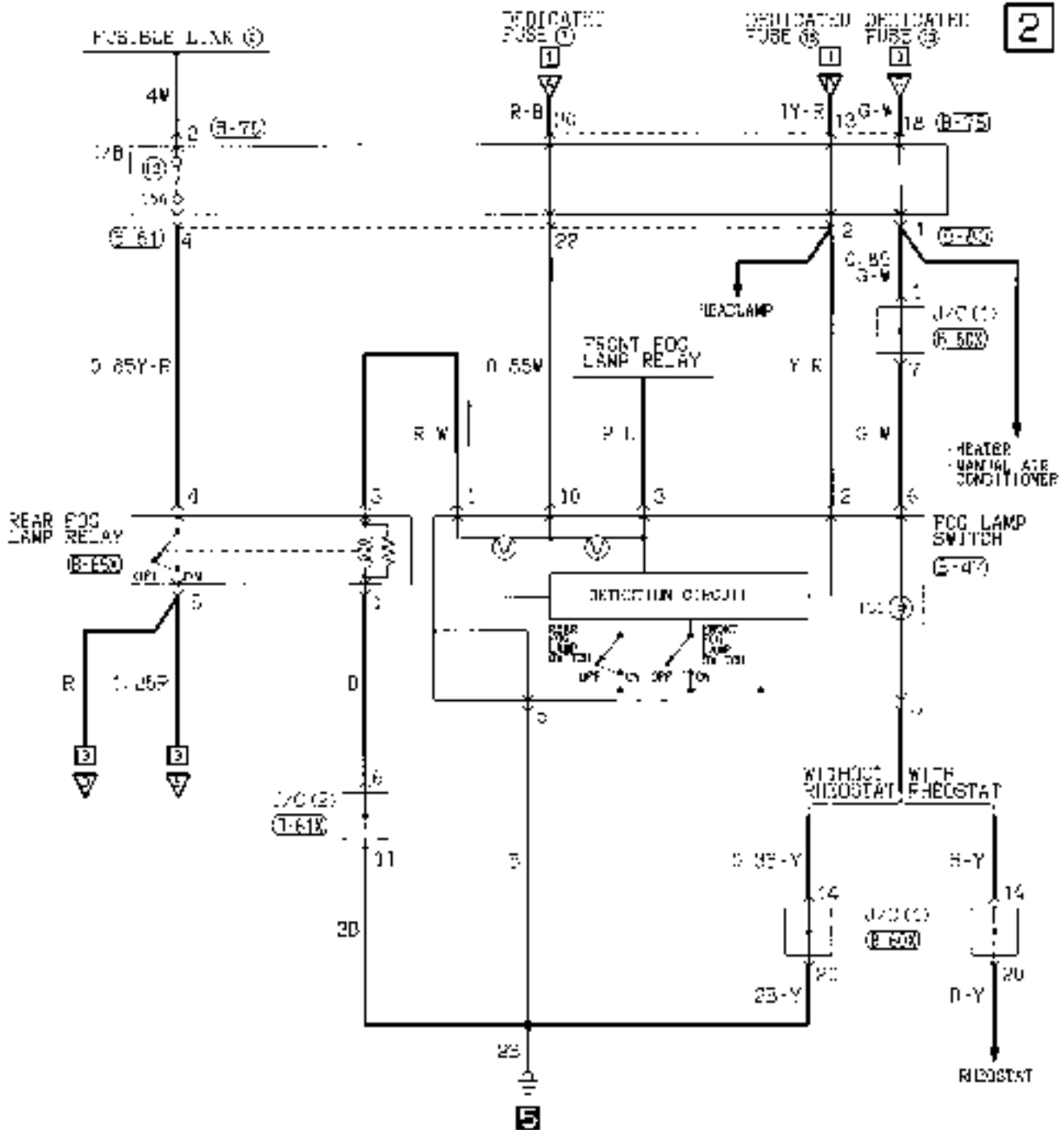

B-550

E-47

B-55K

B-75

B-76

B-50

1	2	3	4	5	6	7	8	9	10	11	12	13	14	15	16	17	18	19	20	21	22	23	24	25
1	2	3	4	5	6	7	8	9	10	11	12	13	14	15	16	17	18	19	20	21	22	23	24	25

1	2	3	4	5	6	7	8	9	10	11	12	13	14	15	16	17	18	19	20	21	22	23	24	25
1	2	3	4	5	6	7	8	9	10	11	12	13	14	15	16	17	18	19	20	21	22	23	24	25

1	2	3	4	5
1	2	3	4	5

1	2	3	4	5	6	7	8	9	10	11	12	13	14	15	16	17	18	19	20	21	22	23	24	25
1	2	3	4	5	6	7	8	9	10	11	12	13	14	15	16	17	18	19	20	21	22	23	24	25

1	2	3	4	5
1	2	3	4	5

1	2	3	4	5	6	7	8	9	10	11	12	13	14	15	16	17	18	19	20	21	22	23	24	25
1	2	3	4	5	6	7	8	9	10	11	12	13	14	15	16	17	18	19	20	21	22	23	24	25

Wire color code
 B:Black LG:Light green G:Green L:Blue W:White Y:Yellow BR:Blue
 BR:Brown C:Orange GR:Gray R:Red P:Pink V:Violet

REAR FOG LAMP <Vehicles with daytime running lamp> (CONTINUED)

3

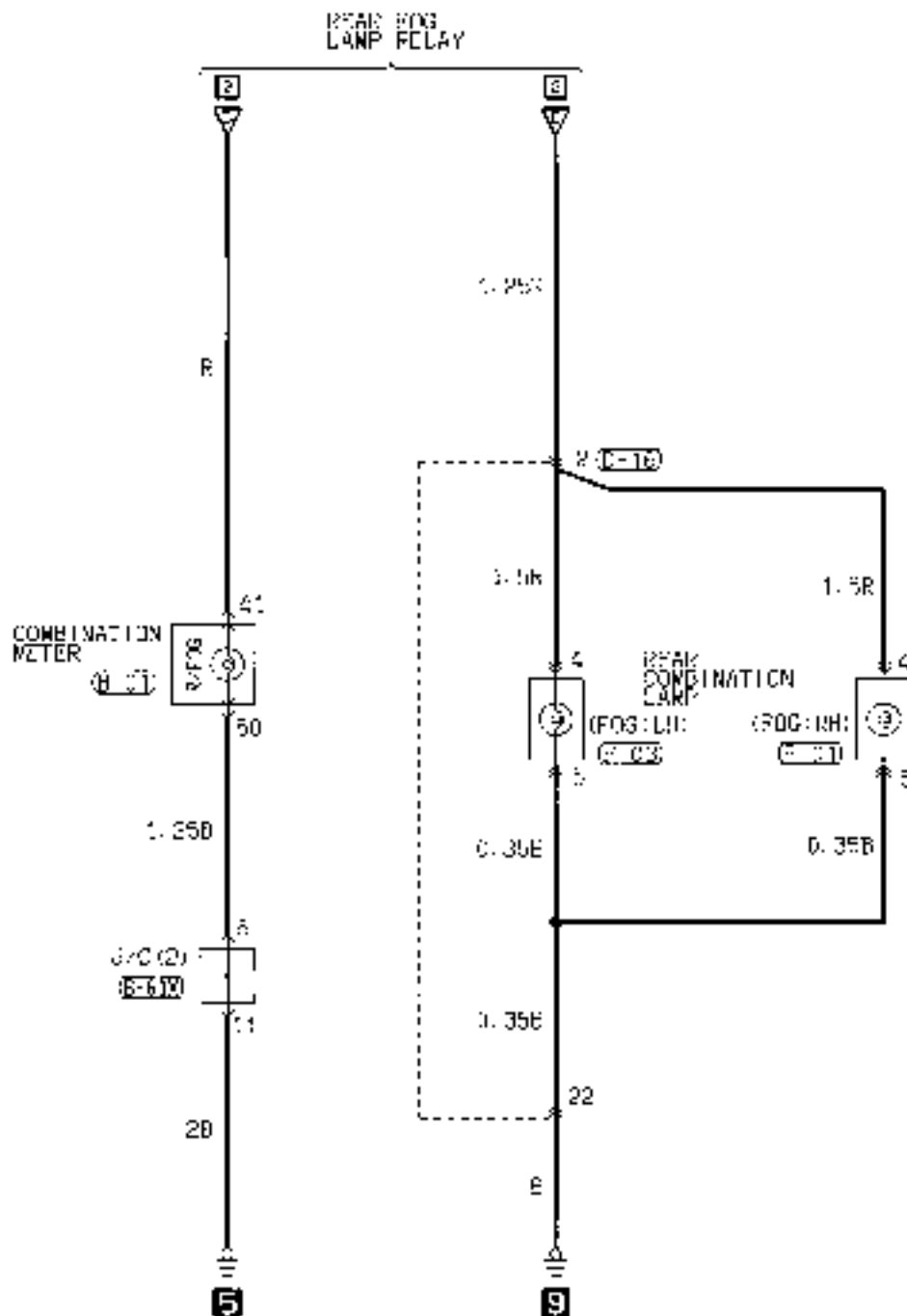

S-01	C-6-12	F-16	F-01	F-03
1 2 3 4 5 6 7 8 9 10 11 12 13 14 15 16 17 18 19 20 21 22 23 24	1 2 3 4 5 6 7 8 9 10 11 12 13 14 15 16 17 18 19 20 21 22 23 24	1 2 3 4 5 6 7 8 9 10 11 12 13 14 15 16 17 18 19 20 21 22 23 24	1 2 3 4 5 6 7 8 9 10 11 12 13 14 15 16 17 18 19 20 21 22 23 24	1 2 3 4 5 6 7 8 9 10 11 12 13 14 15 16 17 18 19 20 21 22 23 24

Wire colour code
 B : Black LG : Light Green G : Green L : Blue W : White Y : Yellow SB : Sky blue
 BR : Brown O : Orange GR : Gray K : Red P : Pink V : Violet

ROOM LAMP AND LUGGAGE COMPARTMENT LAMP (See P. 4-78, 80.)**OPERATION****<Room lamp>**

- Placing the room lamp switch in the ON position causes the room lamp to come on at all times.
- Opening any one of the doors with the room lamp switch in the DOOR position causes the room lamp to come on.
- Closing all doors causes the room lamp to go out.

<Luggage compartment lamp>

- Battery voltage is being applied at all times to the luggage compartment lamp through the dedicated fuse No. (3).
- Opening the tailgate turns ON the tailgate switch, causing the luggage compartment lamp to light up.

TROUBLESHOOTING HINTS

1. Room lamp does not come on.
 - 1) Rear fog lamp does not illuminate.
 - Check dedicated fuse No. (3).
 - 2) Room lamp does not come on when any door is opened with the room lamp switch in the DOOR position.
 - Check bulb.
 - Check room lamp switch.
 - 3) Room lamp does not come on when a door is opened with the room lamp switch in the DOOR position.
 - Check door switch (of the suspected door).
2. Luggage compartment lamp does not come on.
 - 1) Room lamp is normal.
 - Check bulb.
 - Check tailgate switch.
 - 2) Room lamp does not illuminate.
 - Check dedicated fuse No. (3).

ROOM LAMP AND LUGGAGE COMPARTMENT LAMP

9010132000

Vehicles without keyless entry system

1

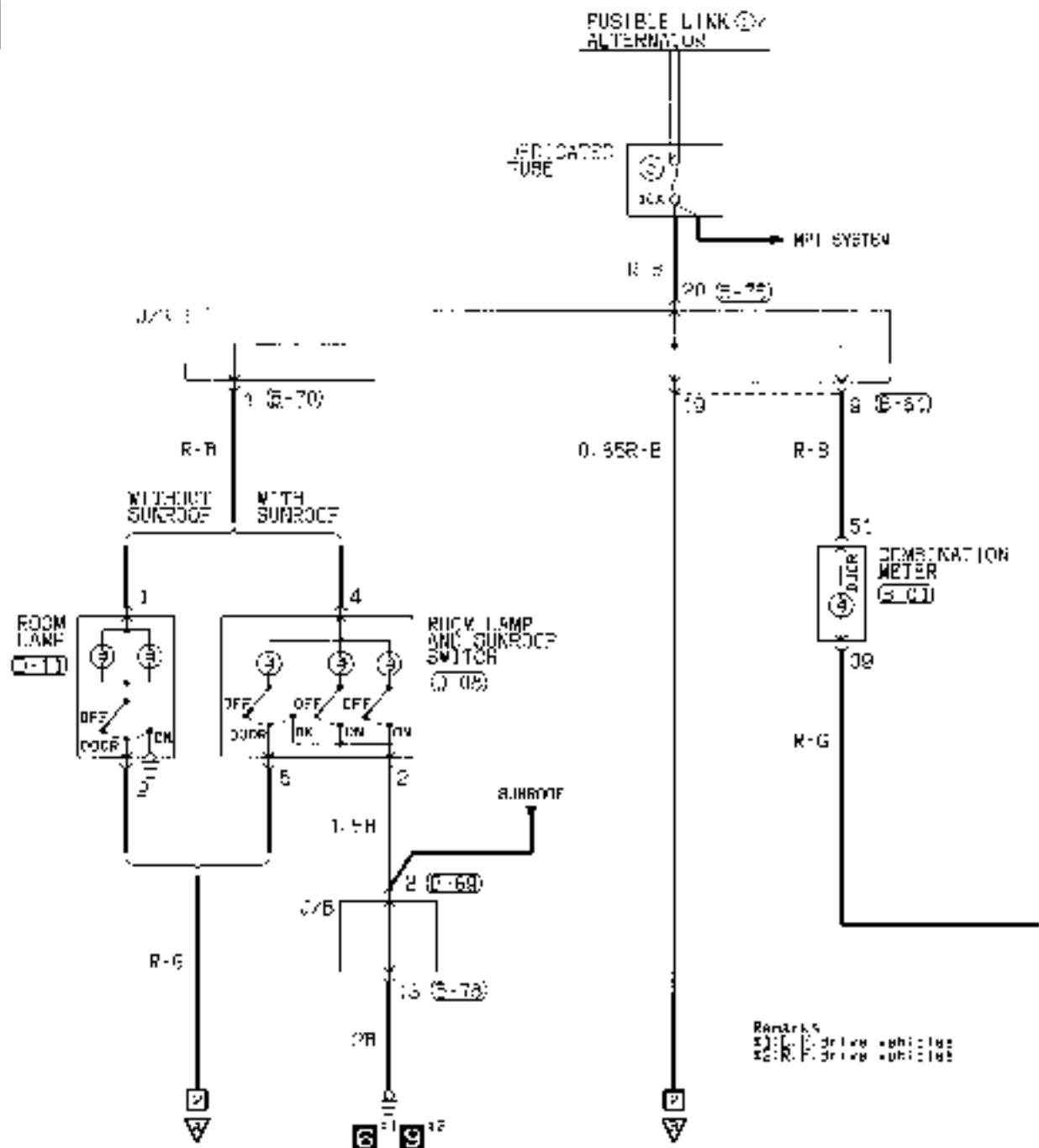

Remarks:
S: S. Drive vehicles
R: R. Drive vehicles

5-01	5-59	5-70	5-75	5-78	5-81	5-81	5-81
1 2 3 4 5 6 7 8 9 10 11 12 13 14 15 16 17 18 19 20 21 22 23 24 25 26 27 28 29 30 31 32 33 34 35 36 37 38 39 40 41 42 43 44 45 46 47 48 49 50 51 52 53 54 55 56 57 58 59 60 61 62 63 64 65 66 67 68 69 70 71 72 73 74 75 76 77 78 79 80 81 82 83 84 85 86 87 88 89 90 91 92 93 94 95 96 97 98 99 100	1 2 3 4 5 6 7 8 9 10 11 12 13 14 15 16 17 18 19 20 21 22 23 24 25 26 27 28 29 30 31 32 33 34 35 36 37 38 39 40 41 42 43 44 45 46 47 48 49 50 51 52 53 54 55 56 57 58 59 60 61 62 63 64 65 66 67 68 69 70 71 72 73 74 75 76 77 78 79 80 81 82 83 84 85 86 87 88 89 90 91 92 93 94 95 96 97 98 99 100	1 2 3 4 5 6 7 8 9 10 11 12 13 14 15 16 17 18 19 20 21 22 23 24 25 26 27 28 29 30 31 32 33 34 35 36 37 38 39 40 41 42 43 44 45 46 47 48 49 50 51 52 53 54 55 56 57 58 59 60 61 62 63 64 65 66 67 68 69 70 71 72 73 74 75 76 77 78 79 80 81 82 83 84 85 86 87 88 89 90 91 92 93 94 95 96 97 98 99 100	1 2 3 4 5 6 7 8 9 10 11 12 13 14 15 16 17 18 19 20 21 22 23 24 25 26 27 28 29 30 31 32 33 34 35 36 37 38 39 40 41 42 43 44 45 46 47 48 49 50 51 52 53 54 55 56 57 58 59 60 61 62 63 64 65 66 67 68 69 70 71 72 73 74 75 76 77 78 79 80 81 82 83 84 85 86 87 88 89 90 91 92 93 94 95 96 97 98 99 100	1 2 3 4 5 6 7 8 9 10 11 12 13 14 15 16 17 18 19 20 21 22 23 24 25 26 27 28 29 30 31 32 33 34 35 36 37 38 39 40 41 42 43 44 45 46 47 48 49 50 51 52 53 54 55 56 57 58 59 60 61 62 63 64 65 66 67 68 69 70 71 72 73 74 75 76 77 78 79 80 81 82 83 84 85 86 87 88 89 90 91 92 93 94 95 96 97 98 99 100	1 2 3 4 5 6 7 8 9 10 11 12 13 14 15 16 17 18 19 20 21 22 23 24 25 26 27 28 29 30 31 32 33 34 35 36 37 38 39 40 41 42 43 44 45 46 47 48 49 50 51 52 53 54 55 56 57 58 59 60 61 62 63 64 65 66 67 68 69 70 71 72 73 74 75 76 77 78 79 80 81 82 83 84 85 86 87 88 89 90 91 92 93 94 95 96 97 98 99 100	1 2 3 4 5 6 7 8 9 10 11 12 13 14 15 16 17 18 19 20 21 22 23 24 25 26 27 28 29 30 31 32 33 34 35 36 37 38 39 40 41 42 43 44 45 46 47 48 49 50 51 52 53 54 55 56 57 58 59 60 61 62 63 64 65 66 67 68 69 70 71 72 73 74 75 76 77 78 79 80 81 82 83 84 85 86 87 88 89 90 91 92 93 94 95 96 97 98 99 100	1 2 3 4 5 6 7 8 9 10 11 12 13 14 15 16 17 18 19 20 21 22 23 24 25 26 27 28 29 30 31 32 33 34 35 36 37 38 39 40 41 42 43 44 45 46 47 48 49 50 51 52 53 54 55 56 57 58 59 60 61 62 63 64 65 66 67 68 69 70 71 72 73 74 75 76 77 78 79 80 81 82 83 84 85 86 87 88 89 90 91 92 93 94 95 96 97 98 99 100

2

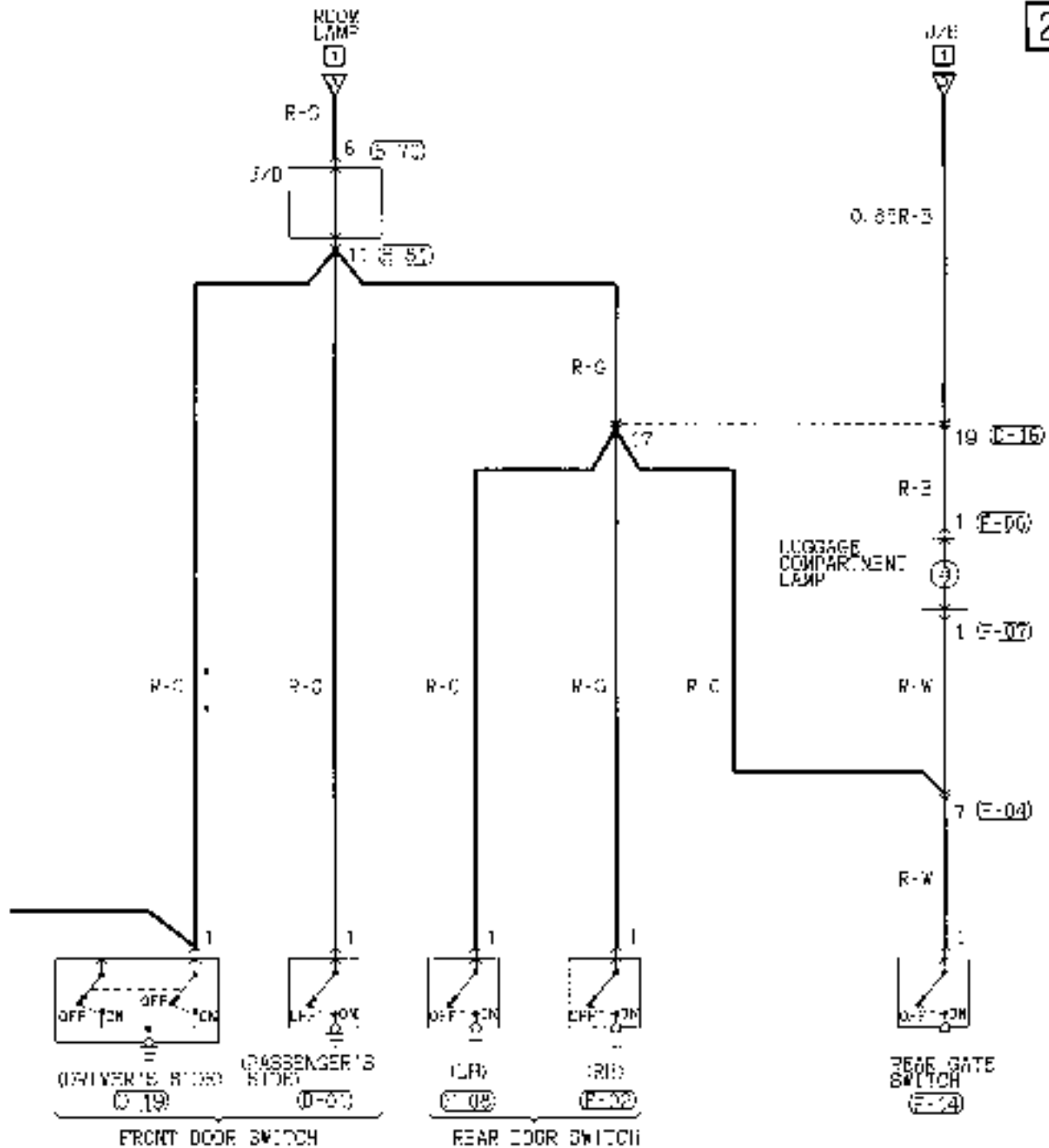

F-19	F-03	F-08	F-02	F-04	F-07	F-04	F-14
1 2 3 4 5 6 7 8 9 10 11 12	1 2 3 4 5 6 7 8 9 10 11 12	1 2 3 4 5 6 7 8 9 10 11 12	1 2 3 4 5 6 7 8 9 10 11 12	1 2 3 4 5 6 7 8 9 10 11 12	1 2 3 4 5 6 7 8 9 10 11 12	1 2 3 4 5 6 7 8 9 10 11 12	1 2 3 4 5 6 7 8 9 10 11 12

Wire color code
 B: Black LG: Light Green G: Green L: Blue W: White Y: Yellow RB: Sky blue
 Br: Brown G: Orange GR: Gray R: Red P: Pink V: Violet

ROOM LAMP AND LUGGAGE COMPARTMENT LAMP

99101320275

Vehicles with keyless entry system

1

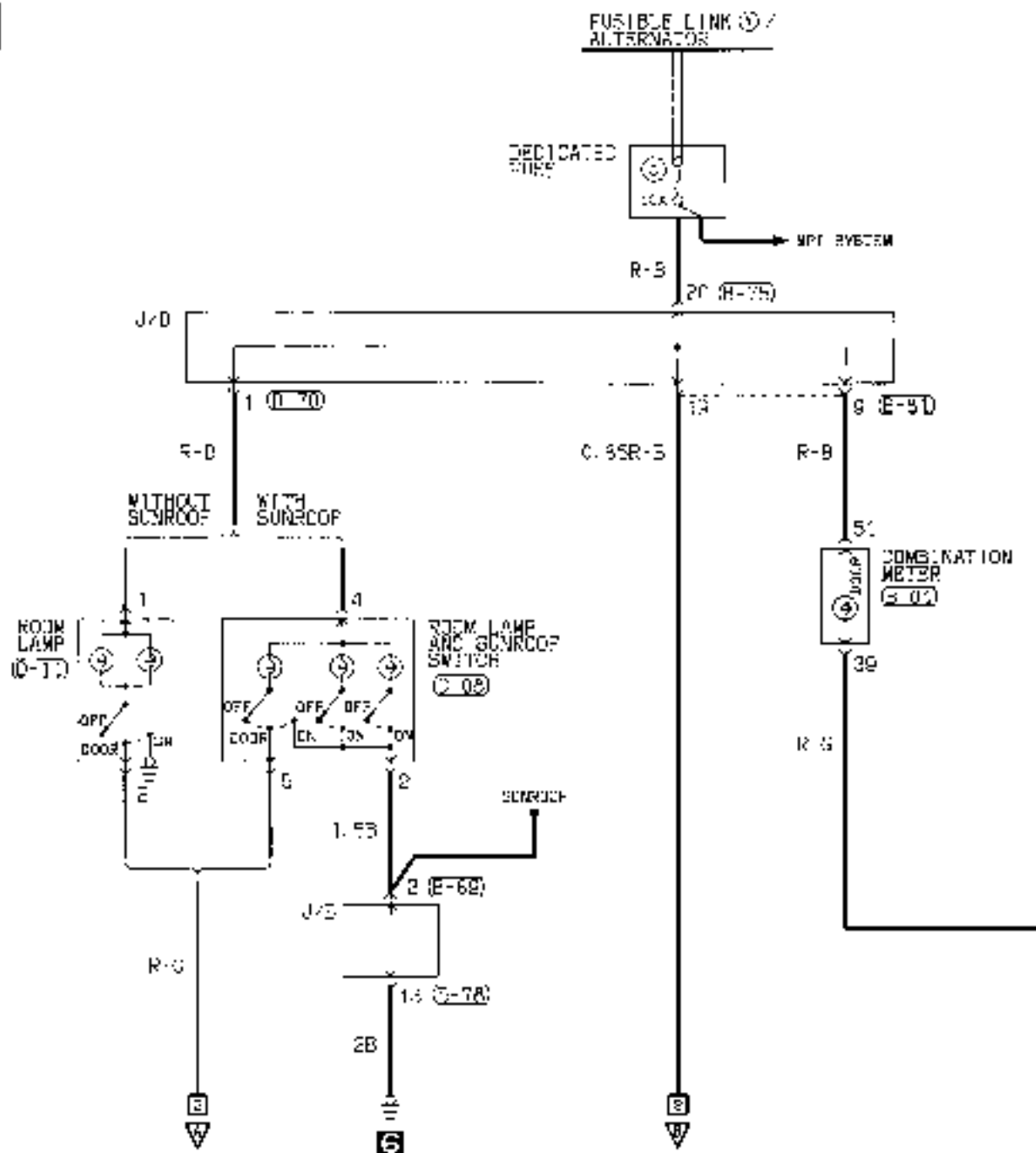

6-01

1	2	3	4	5	6	7	8	9	10	11	12	13	14	15	16	17	18	19	20	21	22	23	24	25	26	27	28	29	30	31	32	33	34	35	36	37	38	39	40	41	42	43	44	45	46	47	48	49	50	51	52	53	54	55	56	57	58	59	60	61	62	63	64	65	66	67	68	69	70	71	72	73	74	75	76	77	78	79	80	81	82	83	84	85	86	87	88	89	90	91	92	93	94	95	96	97	98	99	100
---	---	---	---	---	---	---	---	---	----	----	----	----	----	----	----	----	----	----	----	----	----	----	----	----	----	----	----	----	----	----	----	----	----	----	----	----	----	----	----	----	----	----	----	----	----	----	----	----	----	----	----	----	----	----	----	----	----	----	----	----	----	----	----	----	----	----	----	----	----	----	----	----	----	----	----	----	----	----	----	----	----	----	----	----	----	----	----	----	----	----	----	----	----	----	----	----	----	----	-----

5-69

1	2	3	4	5	6	7	8	9	10	11	12	13	14	15	16	17	18	19	20	21	22	23	24	25	26	27	28	29	30	31	32	33	34	35	36	37	38	39	40	41	42	43	44	45	46	47	48	49	50	51	52	53	54	55	56	57	58	59	60	61	62	63	64	65	66	67	68	69	70	71	72	73	74	75	76	77	78	79	80	81	82	83	84	85	86	87	88	89	90	91	92	93	94	95	96	97	98	99	100
---	---	---	---	---	---	---	---	---	----	----	----	----	----	----	----	----	----	----	----	----	----	----	----	----	----	----	----	----	----	----	----	----	----	----	----	----	----	----	----	----	----	----	----	----	----	----	----	----	----	----	----	----	----	----	----	----	----	----	----	----	----	----	----	----	----	----	----	----	----	----	----	----	----	----	----	----	----	----	----	----	----	----	----	----	----	----	----	----	----	----	----	----	----	----	----	----	----	----	-----

5-70

1	2	3	4	5	6	7	8	9	10	11	12	13	14	15	16	17	18	19	20	21	22	23	24	25	26	27	28	29	30	31	32	33	34	35	36	37	38	39	40	41	42	43	44	45	46	47	48	49	50	51	52	53	54	55	56	57	58	59	60	61	62	63	64	65	66	67	68	69	70	71	72	73	74	75	76	77	78	79	80	81	82	83	84	85	86	87	88	89	90	91	92	93	94	95	96	97	98	99	100
---	---	---	---	---	---	---	---	---	----	----	----	----	----	----	----	----	----	----	----	----	----	----	----	----	----	----	----	----	----	----	----	----	----	----	----	----	----	----	----	----	----	----	----	----	----	----	----	----	----	----	----	----	----	----	----	----	----	----	----	----	----	----	----	----	----	----	----	----	----	----	----	----	----	----	----	----	----	----	----	----	----	----	----	----	----	----	----	----	----	----	----	----	----	----	----	----	----	----	-----

5-75

1	2	3	4	5	6	7	8	9	10	11	12	13	14	15	16	17	18	19	20	21	22	23	24	25	26	27	28	29	30	31	32	33	34	35	36	37	38	39	40	41	42	43	44	45	46	47	48	49	50	51	52	53	54	55	56	57	58	59	60	61	62	63	64	65	66	67	68	69	70	71	72	73	74	75	76	77	78	79	80	81	82	83	84	85	86	87	88	89	90	91	92	93	94	95	96	97	98	99	100
---	---	---	---	---	---	---	---	---	----	----	----	----	----	----	----	----	----	----	----	----	----	----	----	----	----	----	----	----	----	----	----	----	----	----	----	----	----	----	----	----	----	----	----	----	----	----	----	----	----	----	----	----	----	----	----	----	----	----	----	----	----	----	----	----	----	----	----	----	----	----	----	----	----	----	----	----	----	----	----	----	----	----	----	----	----	----	----	----	----	----	----	----	----	----	----	----	----	----	-----

5-76

1	2	3	4	5	6	7	8	9	10	11	12	13	14	15	16	17	18	19	20	21	22	23	24	25	26	27	28	29	30	31	32	33	34	35	36	37	38	39	40	41	42	43	44	45	46	47	48	49	50	51	52	53	54	55	56	57	58	59	60	61	62	63	64	65	66	67	68	69	70	71	72	73	74	75	76	77	78	79	80	81	82	83	84	85	86	87	88	89	90	91	92	93	94	95	96	97	98	99	100
---	---	---	---	---	---	---	---	---	----	----	----	----	----	----	----	----	----	----	----	----	----	----	----	----	----	----	----	----	----	----	----	----	----	----	----	----	----	----	----	----	----	----	----	----	----	----	----	----	----	----	----	----	----	----	----	----	----	----	----	----	----	----	----	----	----	----	----	----	----	----	----	----	----	----	----	----	----	----	----	----	----	----	----	----	----	----	----	----	----	----	----	----	----	----	----	----	----	----	-----

5-81

1	2	3	4	5	6	7	8	9	10	11	12	13	14	15	16	17	18	19	20	21	22	23	24	25	26	27	28	29	30	31	32	33	34	35	36	37	38	39	40	41	42	43	44	45	46	47	48	49	50	51	52	53	54	55	56	57	58	59	60	61	62	63	64	65	66	67	68	69	70	71	72	73	74	75	76	77	78	79	80	81	82	83	84	85	86	87	88	89	90	91	92	93	94	95	96	97	98	99	100
---	---	---	---	---	---	---	---	---	----	----	----	----	----	----	----	----	----	----	----	----	----	----	----	----	----	----	----	----	----	----	----	----	----	----	----	----	----	----	----	----	----	----	----	----	----	----	----	----	----	----	----	----	----	----	----	----	----	----	----	----	----	----	----	----	----	----	----	----	----	----	----	----	----	----	----	----	----	----	----	----	----	----	----	----	----	----	----	----	----	----	----	----	----	----	----	----	----	----	-----

1-07

1	2	3	4	5	6	7	8	9	10	11	12	13	14	15	16	17	18	19	20	21	22	23	24	25	26	27	28	29	30	31	32	33	34	35	36	37	38	39	40	41	42	43	44	45	46	47	48	49	50	51	52	53	54	55	56	57	58	59	60	61	62	63	64	65	66	67	68	69	70	71	72	73	74	75	76	77	78	79	80	81	82	83	84	85	86	87	88	89	90	91	92	93	94	95	96	97	98	99	100
---	---	---	---	---	---	---	---	---	----	----	----	----	----	----	----	----	----	----	----	----	----	----	----	----	----	----	----	----	----	----	----	----	----	----	----	----	----	----	----	----	----	----	----	----	----	----	----	----	----	----	----	----	----	----	----	----	----	----	----	----	----	----	----	----	----	----	----	----	----	----	----	----	----	----	----	----	----	----	----	----	----	----	----	----	----	----	----	----	----	----	----	----	----	----	----	----	----	----	-----

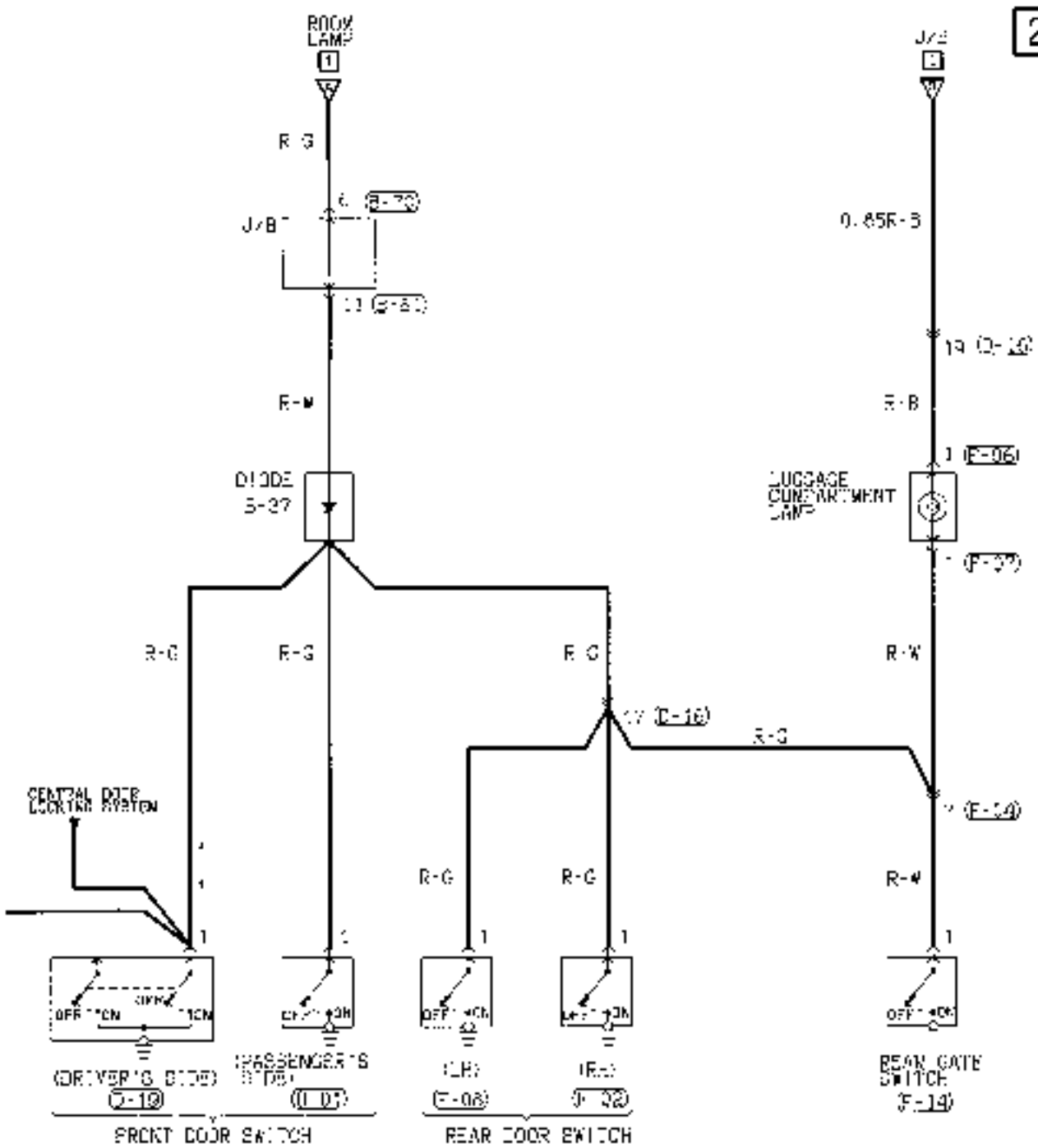

2

(F-06)	(D-11)	(Q-10)	(Q-19)	(F-08)	(F-09)	(F-06)	(F-07)	(F-08)	(F-14)
1 2 3 4 5 6 7 8	3	1 2 3 4 5 6 7 8 9 10 11 12 13 14 15 16 17 18 19	1 2	1 2	1 2 3 4	1 2	1 2	1 2 3 4	1 2

Wire colour code
 B:Black L:Light green G:Green L:Blue W:White Y:Yellow BR:Brown G:Grande GR:Gray R:Red P:Pink V:Violet

GLOVE BOX LAMP

90100220184

1

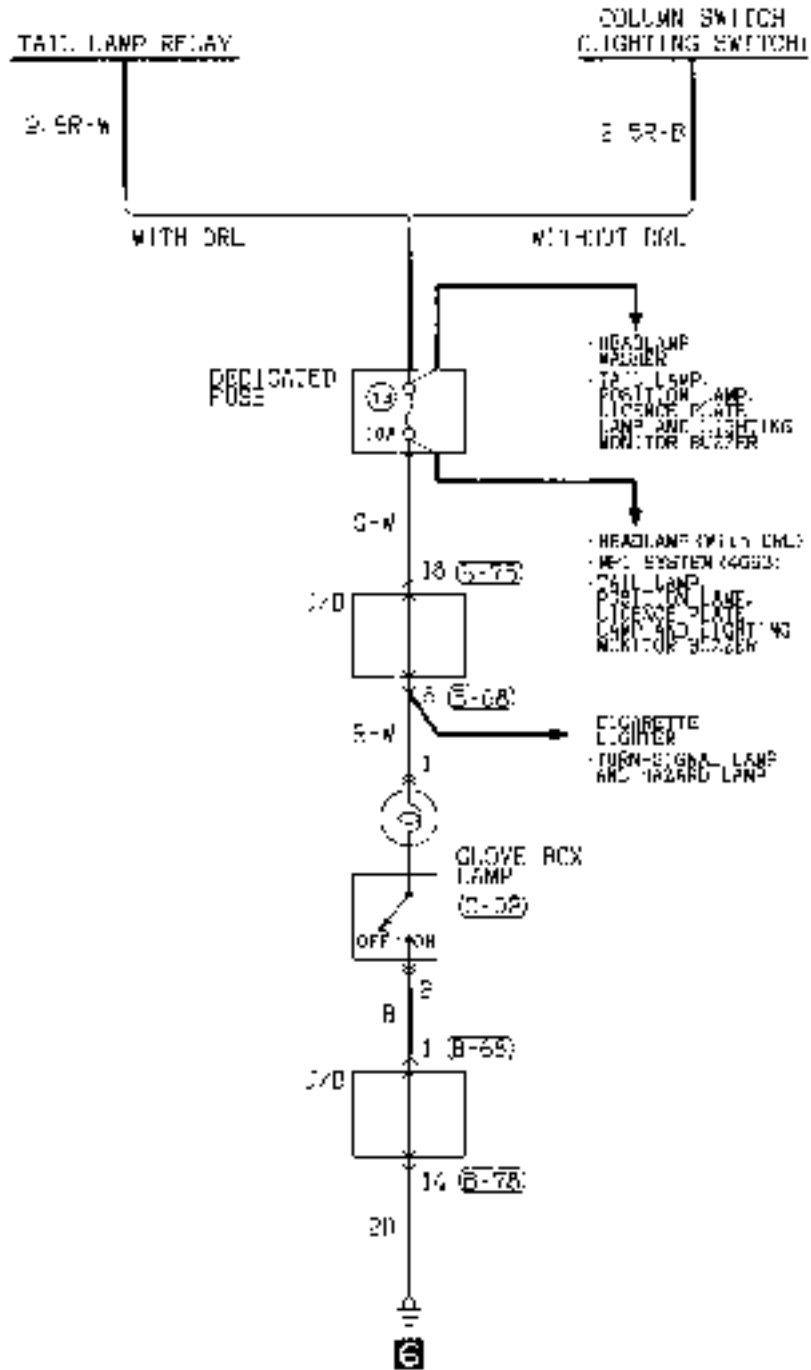

(H-28)	(H-75)	(H-78)	(C-02)
1 2 3 4 5 6 7 8 9 10 11 12 13 14 15 16 17 18	1 2 3 4 5 6 7 8 9 10 11 12 13 14 15 16 17 18 19 20	1 2 3 4 5 6 7 8 9 10 11 12 13 14 15 16 17 18 19 20	1 2 3 4 5 6 7 8 9 10 11 12 13 14 15 16 17 18 19 20

Wing colour 300C
 B: Black
 BR: Brown
 G: Green
 GR: Gray
 L: Blue
 R: Red
 W: White
 P: Pink
 Y: Yellow
 V: Violet
 BB: Sky blue

2WC&E:26A

TURN-SIGNAL LAMP AND HAZARD WARNING LAMP (See P. 4-84.)**OPERATION****<Turn-signal lamp>****1. In standard operating condition**

- When the ignition switch is placed in the ON position, battery voltage is applied through the hazard warning switch to the turn-signal and hazard warning flasher unit.
- When the turn signal switch is turned to the "LH" or "RH" position, the relay contact turns "ON" and "OFF" repeatedly due to the switching operation of the capacitor and transistor inside the flasher unit, and the turn signal lamp and the "LH" and "RH" of the turn signal indicator lamp flash.

2. When one bulb is burnt

- When either one of the turn signal lamp is burnt, the resistance of the entire lamp circuit increases, so that the time required for charging and discharging of the capacitor is shortened, causing the "ON" "OFF" cycle of the relay to become faster than standard and the number of flashes to increase.

<Hazard warning lamp>

- When the hazard warning switch is turned to the "ON" position, current flows via dedicated fuse No. (7) to the flasher unit, the flasher unit relay contacts repeatedly close and open, which results in the RH and LH turn-signal lamps, turn-signal indicator lamps and hazard warning indicator lamps flashing on and off at the same time.

Remark

- The number of times the hazard warning lamps flash on and off does not change even when one bulb is out.

TROUBLESHOOTING HINTS

1. Neither the turn-signal lamp nor hazard warning lamps operate.
 - Check hazard warning switch contacts (on power source end)
 - Check flasher unit.
2. All LH or RH turn-signal lamps do not operate.
 - (1) Hazard warning lamp is fully operational.
 - Check turn-signal switch.
3. Flashing cycle of turn signal lamps is shorter.
 - Check the lamp bulb.
 - Check flasher unit.
4. Hazard warning lamp does not operate.
 - (1) Turn-signal lamps are operational.
 - Check dedicated fuse No. (8).
 - Check hazard warning switch contacts (on hazard lamp end).

TURN-SIGNAL LAMP AND HAZARD WARNING LAMP

80100298647

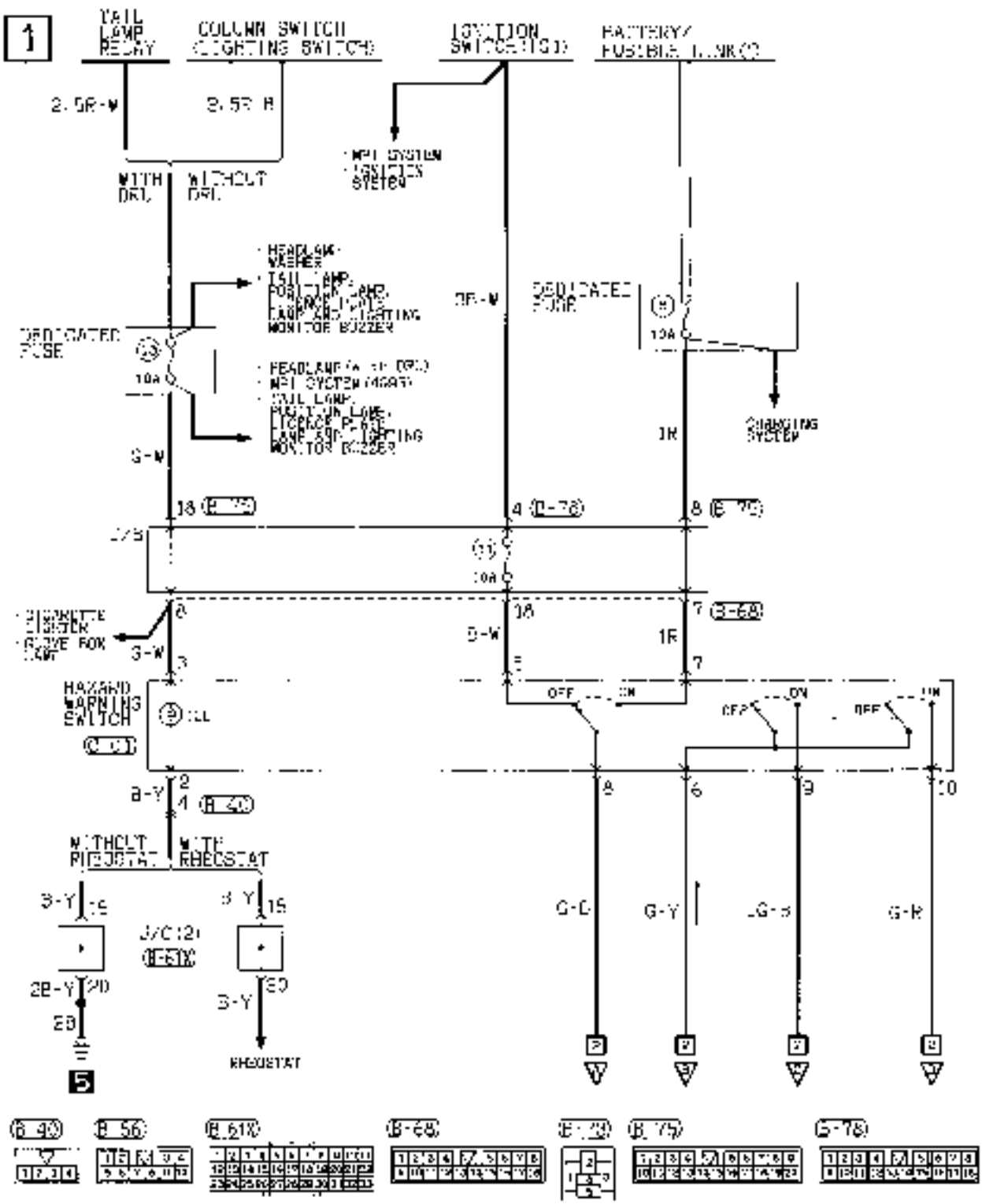

80020044

TURN-SIGNAL LAMP AND HAZARD WARNING LAMP (CONTINUED)

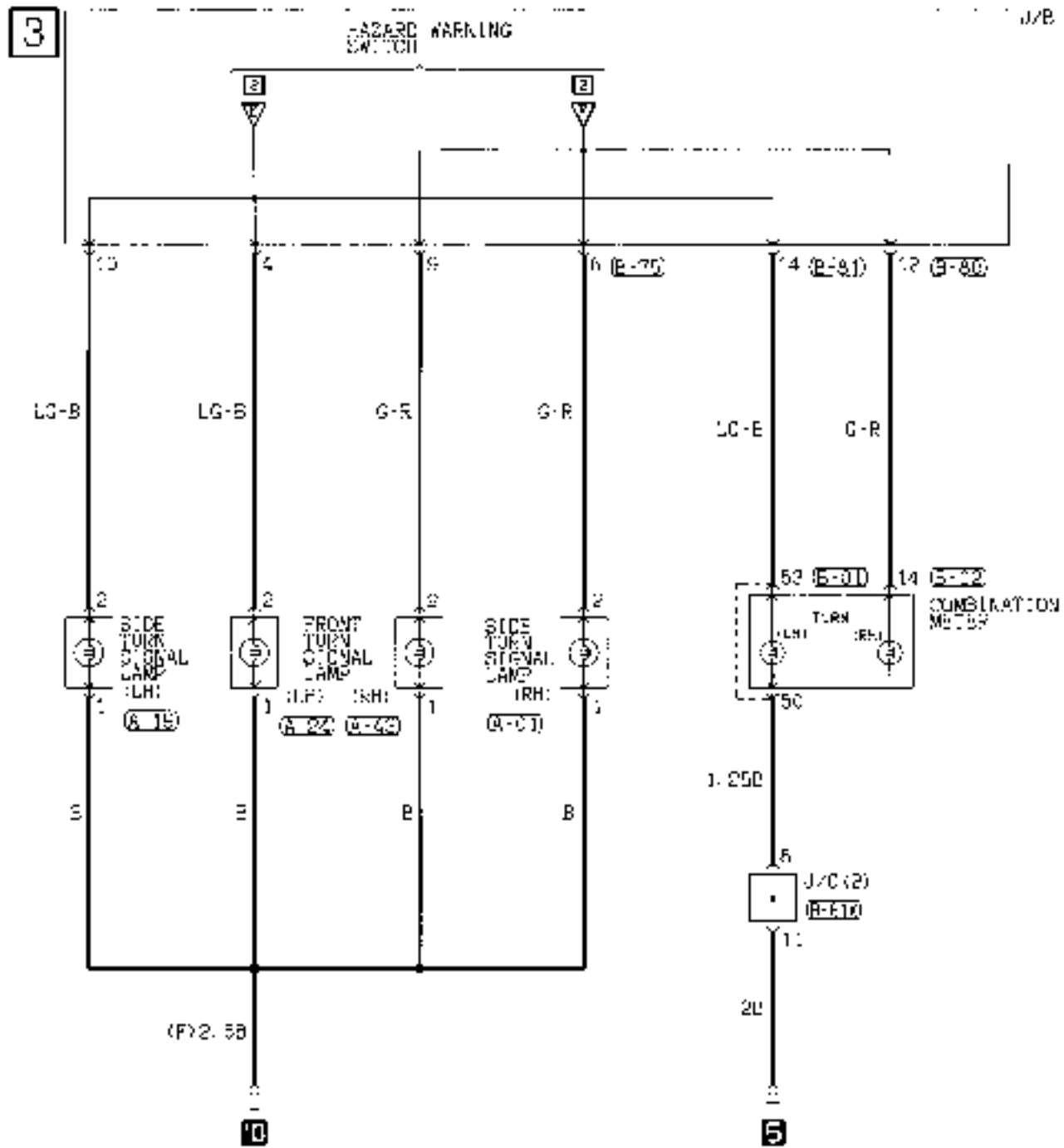

A-19	A-24	A-43	E-01	E-02	E-03	E-04	E-05	E-06	E-07	E-08	E-09	E-10	E-11	E-12	E-13	E-14	E-15	E-16	E-17	E-18	E-19	E-20	E-21	E-22	E-23	E-24	E-25	E-26	E-27	E-28	E-29	E-30	E-31	E-32	E-33	E-34	E-35	E-36	E-37	E-38	E-39	E-40	E-41	E-42	E-43	E-44	E-45	E-46	E-47	E-48	E-49	E-50	E-51	E-52	E-53	E-54	E-55	E-56	E-57	E-58	E-59	E-60	E-61	E-62	E-63	E-64	E-65	E-66	E-67	E-68	E-69	E-70	E-71	E-72	E-73	E-74	E-75	E-76	E-77	E-78	E-79	E-80	E-81	E-82	E-83	E-84	E-85	E-86	E-87	E-88	E-89	E-90	E-91	E-92	E-93	E-94	E-95	E-96	E-97	E-98	E-99	E-100
-------------	-------------	-------------	-------------	-------------	-------------	-------------	-------------	-------------	-------------	-------------	-------------	-------------	-------------	-------------	-------------	-------------	-------------	-------------	-------------	-------------	-------------	-------------	-------------	-------------	-------------	-------------	-------------	-------------	-------------	-------------	-------------	-------------	-------------	-------------	-------------	-------------	-------------	-------------	-------------	-------------	-------------	-------------	-------------	-------------	-------------	-------------	-------------	-------------	-------------	-------------	-------------	-------------	-------------	-------------	-------------	-------------	-------------	-------------	-------------	-------------	-------------	-------------	-------------	-------------	-------------	-------------	-------------	-------------	-------------	-------------	-------------	-------------	-------------	-------------	-------------	-------------	-------------	-------------	-------------	-------------	-------------	-------------	-------------	-------------	-------------	-------------	-------------	-------------	-------------	-------------	-------------	-------------	-------------	-------------	-------------	-------------	-------------	-------------	-------------	-------------	-------------	--------------

Wire colour code
 B: Black
 BR: Brown
 V: White
 Y: Yellow
 G: Green
 LG: Light green
 O: Orange
 SB: Sky Blue
 R: Red
 GR: Gray
 P: Pink
 L: Blue
 BK: Black
 Y: Yellow

STOP LAMP

9010030665

1

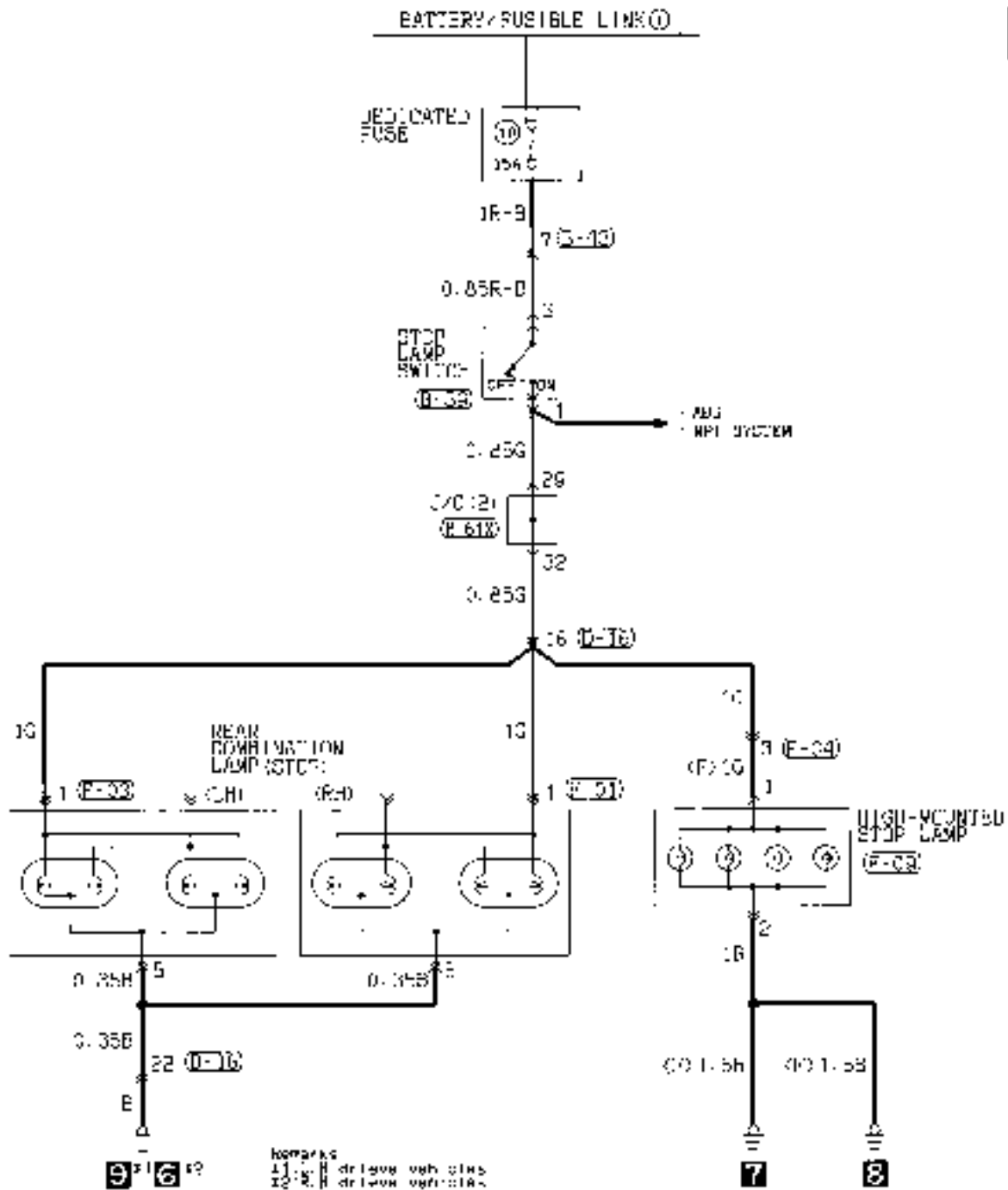

Remarks
 11: 8.1 drives veh. stop
 12: 8.1 drives veh. stop

F-39	F-40	F-41	F-42	F-43	F-44	F-45
15A	15A	15A	15A	15A	15A	15A

Wire color code
 B: Black L3: Light green G: Green L: Blue Y: Yellow SB: Sky blue
 BK: Brown O: Orange GR: Gray R: Red P: Pink V: Violet

BACK-UP LAMP

90180310632

1

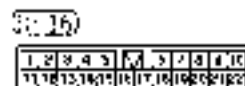
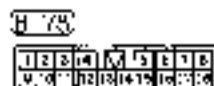
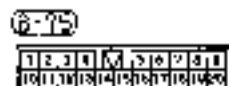
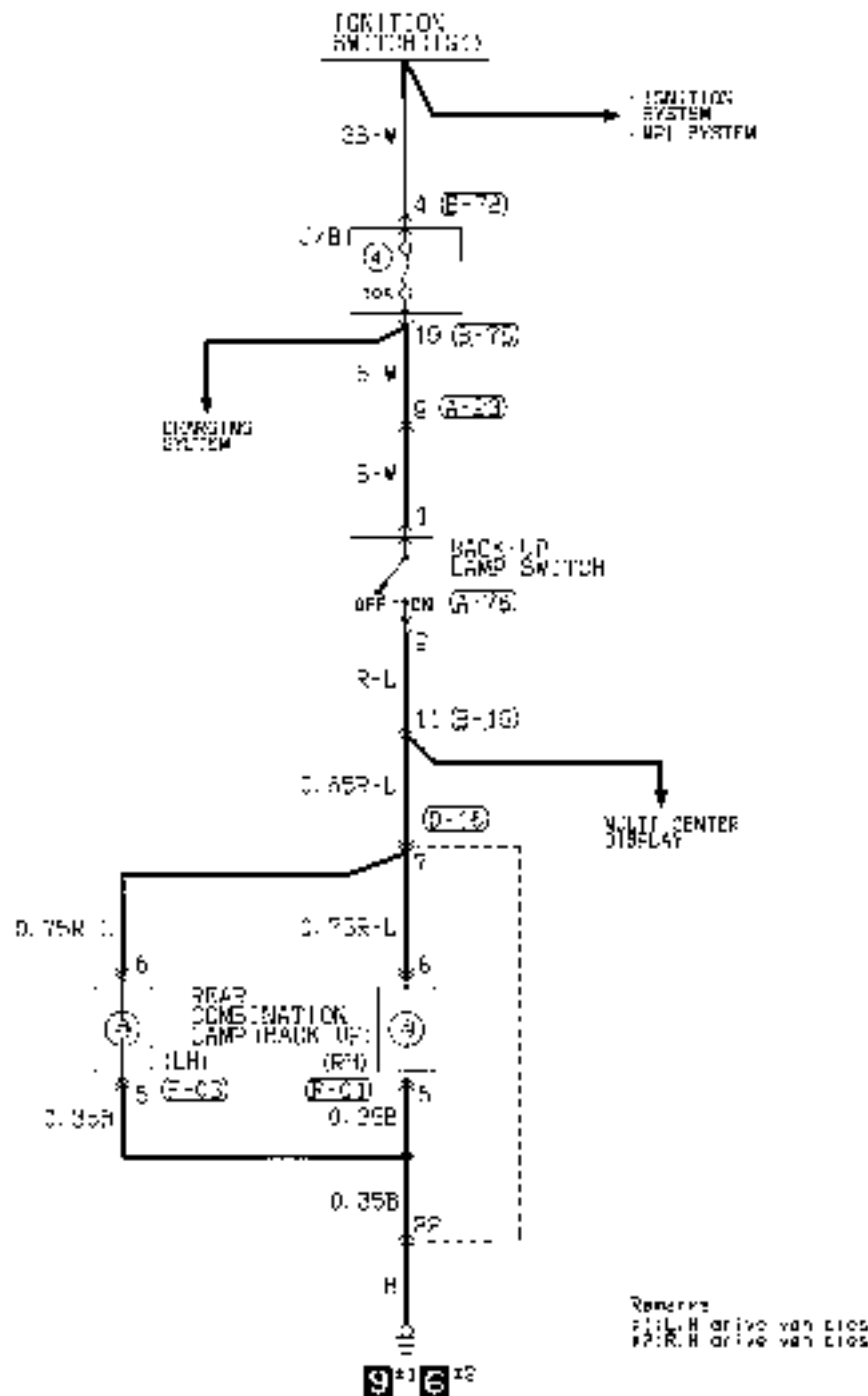

1: Blue 2: Yellow 3: Green 4: Light green 5: White 6: Pink 7: Violet 8: Black 9: Brown 10: Orange 11: Red 12: Grey
 13: Grey 14: Blue 15: Yellow 16: Green 17: Light green 18: White 19: Pink 20: Violet 21: Black 22: Brown 23: Orange 24: Red 25: Grey

2MCE02A4

HORN

90100380414

1

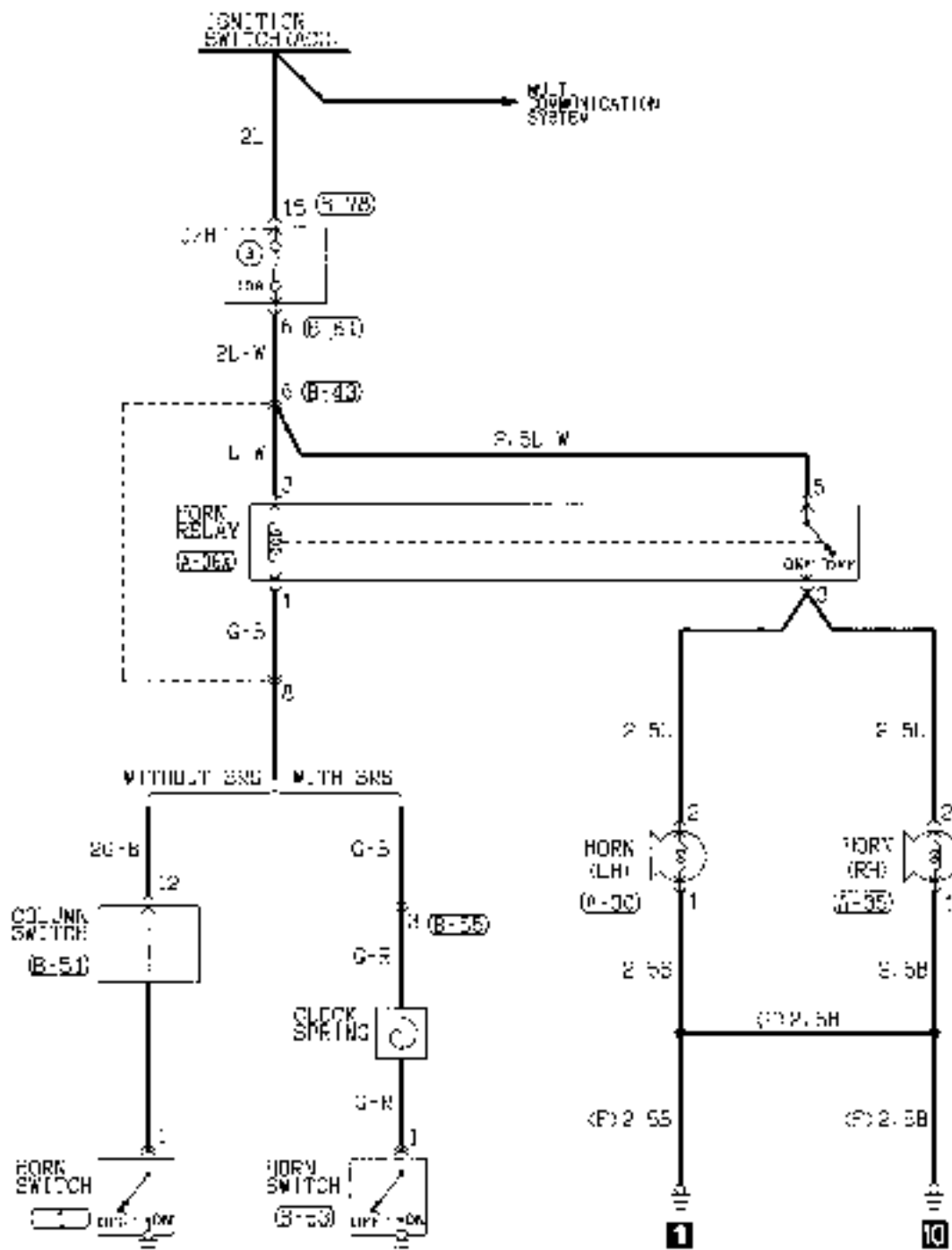

(B-2)	(B-3)	(B-30)	(B-35)	(B-43)	(B-51)	(B-53)	(B-55)	(B-78)

WIRE COLOUR CODE

B: Black	LG: Light green	G: Green	: Blue
BR: Brown	O: Orange	GR: Gray	R: Red
W: White	SB: Sky blue	P: Pink	Y: Yellow
V: Violet			

METER AND GAUGE

90100200702

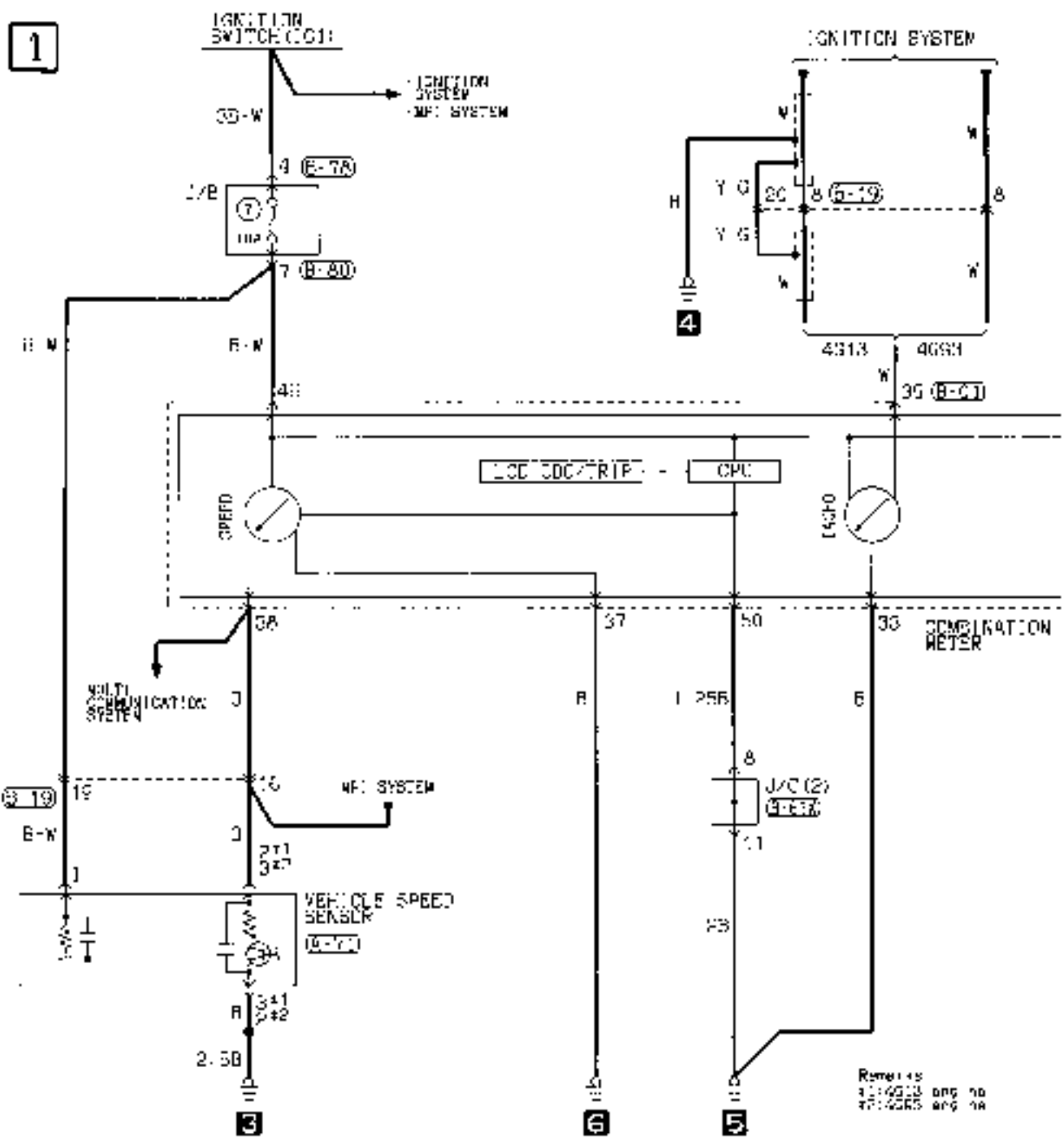

Remember
 1:1993 and 10
 2:1995 and 18

<p>(A-7) 13</p> <table border="1"> <tr><td>1</td><td>2</td><td>3</td><td>4</td><td>5</td><td>6</td><td>7</td><td>8</td><td>9</td><td>10</td><td>11</td><td>12</td><td>13</td><td>14</td><td>15</td><td>16</td><td>17</td><td>18</td><td>19</td><td>20</td><td>21</td><td>22</td><td>23</td><td>24</td><td>25</td><td>26</td><td>27</td><td>28</td><td>29</td><td>30</td><td>31</td><td>32</td><td>33</td><td>34</td><td>35</td><td>36</td><td>37</td><td>38</td><td>39</td><td>40</td><td>41</td><td>42</td><td>43</td><td>44</td><td>45</td><td>46</td><td>47</td><td>48</td><td>49</td><td>50</td><td>51</td><td>52</td><td>53</td><td>54</td><td>55</td><td>56</td><td>57</td><td>58</td><td>59</td><td>60</td><td>61</td><td>62</td><td>63</td><td>64</td><td>65</td><td>66</td><td>67</td><td>68</td><td>69</td><td>70</td><td>71</td><td>72</td><td>73</td><td>74</td><td>75</td><td>76</td><td>77</td><td>78</td><td>79</td><td>80</td><td>81</td><td>82</td><td>83</td><td>84</td><td>85</td><td>86</td><td>87</td><td>88</td><td>89</td><td>90</td><td>91</td><td>92</td><td>93</td><td>94</td><td>95</td><td>96</td><td>97</td><td>98</td><td>99</td><td>100</td></tr> </table>	1	2	3	4	5	6	7	8	9	10	11	12	13	14	15	16	17	18	19	20	21	22	23	24	25	26	27	28	29	30	31	32	33	34	35	36	37	38	39	40	41	42	43	44	45	46	47	48	49	50	51	52	53	54	55	56	57	58	59	60	61	62	63	64	65	66	67	68	69	70	71	72	73	74	75	76	77	78	79	80	81	82	83	84	85	86	87	88	89	90	91	92	93	94	95	96	97	98	99	100	<p>(A-7) 13</p> <table border="1"> <tr><td>1</td><td>2</td><td>3</td><td>4</td><td>5</td><td>6</td><td>7</td><td>8</td><td>9</td><td>10</td><td>11</td><td>12</td><td>13</td><td>14</td><td>15</td><td>16</td><td>17</td><td>18</td><td>19</td><td>20</td><td>21</td><td>22</td><td>23</td><td>24</td><td>25</td><td>26</td><td>27</td><td>28</td><td>29</td><td>30</td><td>31</td><td>32</td><td>33</td><td>34</td><td>35</td><td>36</td><td>37</td><td>38</td><td>39</td><td>40</td><td>41</td><td>42</td><td>43</td><td>44</td><td>45</td><td>46</td><td>47</td><td>48</td><td>49</td><td>50</td><td>51</td><td>52</td><td>53</td><td>54</td><td>55</td><td>56</td><td>57</td><td>58</td><td>59</td><td>60</td><td>61</td><td>62</td><td>63</td><td>64</td><td>65</td><td>66</td><td>67</td><td>68</td><td>69</td><td>70</td><td>71</td><td>72</td><td>73</td><td>74</td><td>75</td><td>76</td><td>77</td><td>78</td><td>79</td><td>80</td><td>81</td><td>82</td><td>83</td><td>84</td><td>85</td><td>86</td><td>87</td><td>88</td><td>89</td><td>90</td><td>91</td><td>92</td><td>93</td><td>94</td><td>95</td><td>96</td><td>97</td><td>98</td><td>99</td><td>100</td></tr> </table>	1	2	3	4	5	6	7	8	9	10	11	12	13	14	15	16	17	18	19	20	21	22	23	24	25	26	27	28	29	30	31	32	33	34	35	36	37	38	39	40	41	42	43	44	45	46	47	48	49	50	51	52	53	54	55	56	57	58	59	60	61	62	63	64	65	66	67	68	69	70	71	72	73	74	75	76	77	78	79	80	81	82	83	84	85	86	87	88	89	90	91	92	93	94	95	96	97	98	99	100	<p>(A-7) 13</p> <table border="1"> <tr><td>1</td><td>2</td><td>3</td><td>4</td><td>5</td><td>6</td><td>7</td><td>8</td><td>9</td><td>10</td><td>11</td><td>12</td><td>13</td><td>14</td><td>15</td><td>16</td><td>17</td><td>18</td><td>19</td><td>20</td><td>21</td><td>22</td><td>23</td><td>24</td><td>25</td><td>26</td><td>27</td><td>28</td><td>29</td><td>30</td><td>31</td><td>32</td><td>33</td><td>34</td><td>35</td><td>36</td><td>37</td><td>38</td><td>39</td><td>40</td><td>41</td><td>42</td><td>43</td><td>44</td><td>45</td><td>46</td><td>47</td><td>48</td><td>49</td><td>50</td><td>51</td><td>52</td><td>53</td><td>54</td><td>55</td><td>56</td><td>57</td><td>58</td><td>59</td><td>60</td><td>61</td><td>62</td><td>63</td><td>64</td><td>65</td><td>66</td><td>67</td><td>68</td><td>69</td><td>70</td><td>71</td><td>72</td><td>73</td><td>74</td><td>75</td><td>76</td><td>77</td><td>78</td><td>79</td><td>80</td><td>81</td><td>82</td><td>83</td><td>84</td><td>85</td><td>86</td><td>87</td><td>88</td><td>89</td><td>90</td><td>91</td><td>92</td><td>93</td><td>94</td><td>95</td><td>96</td><td>97</td><td>98</td><td>99</td><td>100</td></tr> </table>	1	2	3	4	5	6	7	8	9	10	11	12	13	14	15	16	17	18	19	20	21	22	23	24	25	26	27	28	29	30	31	32	33	34	35	36	37	38	39	40	41	42	43	44	45	46	47	48	49	50	51	52	53	54	55	56	57	58	59	60	61	62	63	64	65	66	67	68	69	70	71	72	73	74	75	76	77	78	79	80	81	82	83	84	85	86	87	88	89	90	91	92	93	94	95	96	97	98	99	100	<p>(A-7) 13</p> <table border="1"> <tr><td>1</td><td>2</td><td>3</td><td>4</td><td>5</td><td>6</td><td>7</td><td>8</td><td>9</td><td>10</td><td>11</td><td>12</td><td>13</td><td>14</td><td>15</td><td>16</td><td>17</td><td>18</td><td>19</td><td>20</td><td>21</td><td>22</td><td>23</td><td>24</td><td>25</td><td>26</td><td>27</td><td>28</td><td>29</td><td>30</td><td>31</td><td>32</td><td>33</td><td>34</td><td>35</td><td>36</td><td>37</td><td>38</td><td>39</td><td>40</td><td>41</td><td>42</td><td>43</td><td>44</td><td>45</td><td>46</td><td>47</td><td>48</td><td>49</td><td>50</td><td>51</td><td>52</td><td>53</td><td>54</td><td>55</td><td>56</td><td>57</td><td>58</td><td>59</td><td>60</td><td>61</td><td>62</td><td>63</td><td>64</td><td>65</td><td>66</td><td>67</td><td>68</td><td>69</td><td>70</td><td>71</td><td>72</td><td>73</td><td>74</td><td>75</td><td>76</td><td>77</td><td>78</td><td>79</td><td>80</td><td>81</td><td>82</td><td>83</td><td>84</td><td>85</td><td>86</td><td>87</td><td>88</td><td>89</td><td>90</td><td>91</td><td>92</td><td>93</td><td>94</td><td>95</td><td>96</td><td>97</td><td>98</td><td>99</td><td>100</td></tr> </table>	1	2	3	4	5	6	7	8	9	10	11	12	13	14	15	16	17	18	19	20	21	22	23	24	25	26	27	28	29	30	31	32	33	34	35	36	37	38	39	40	41	42	43	44	45	46	47	48	49	50	51	52	53	54	55	56	57	58	59	60	61	62	63	64	65	66	67	68	69	70	71	72	73	74	75	76	77	78	79	80	81	82	83	84	85	86	87	88	89	90	91	92	93	94	95	96	97	98	99	100	<p>(A-7) 13</p> <table border="1"> <tr><td>1</td><td>2</td><td>3</td><td>4</td><td>5</td><td>6</td><td>7</td><td>8</td><td>9</td><td>10</td><td>11</td><td>12</td><td>13</td><td>14</td><td>15</td><td>16</td><td>17</td><td>18</td><td>19</td><td>20</td><td>21</td><td>22</td><td>23</td><td>24</td><td>25</td><td>26</td><td>27</td><td>28</td><td>29</td><td>30</td><td>31</td><td>32</td><td>33</td><td>34</td><td>35</td><td>36</td><td>37</td><td>38</td><td>39</td><td>40</td><td>41</td><td>42</td><td>43</td><td>44</td><td>45</td><td>46</td><td>47</td><td>48</td><td>49</td><td>50</td><td>51</td><td>52</td><td>53</td><td>54</td><td>55</td><td>56</td><td>57</td><td>58</td><td>59</td><td>60</td><td>61</td><td>62</td><td>63</td><td>64</td><td>65</td><td>66</td><td>67</td><td>68</td><td>69</td><td>70</td><td>71</td><td>72</td><td>73</td><td>74</td><td>75</td><td>76</td><td>77</td><td>78</td><td>79</td><td>80</td><td>81</td><td>82</td><td>83</td><td>84</td><td>85</td><td>86</td><td>87</td><td>88</td><td>89</td><td>90</td><td>91</td><td>92</td><td>93</td><td>94</td><td>95</td><td>96</td><td>97</td><td>98</td><td>99</td><td>100</td></tr> </table>	1	2	3	4	5	6	7	8	9	10	11	12	13	14	15	16	17	18	19	20	21	22	23	24	25	26	27	28	29	30	31	32	33	34	35	36	37	38	39	40	41	42	43	44	45	46	47	48	49	50	51	52	53	54	55	56	57	58	59	60	61	62	63	64	65	66	67	68	69	70	71	72	73	74	75	76	77	78	79	80	81	82	83	84	85	86	87	88	89	90	91	92	93	94	95	96	97	98	99	100	<p>(A-7) 13</p> <table border="1"> <tr><td>1</td><td>2</td><td>3</td><td>4</td><td>5</td><td>6</td><td>7</td><td>8</td><td>9</td><td>10</td><td>11</td><td>12</td><td>13</td><td>14</td><td>15</td><td>16</td><td>17</td><td>18</td><td>19</td><td>20</td><td>21</td><td>22</td><td>23</td><td>24</td><td>25</td><td>26</td><td>27</td><td>28</td><td>29</td><td>30</td><td>31</td><td>32</td><td>33</td><td>34</td><td>35</td><td>36</td><td>37</td><td>38</td><td>39</td><td>40</td><td>41</td><td>42</td><td>43</td><td>44</td><td>45</td><td>46</td><td>47</td><td>48</td><td>49</td><td>50</td><td>51</td><td>52</td><td>53</td><td>54</td><td>55</td><td>56</td><td>57</td><td>58</td><td>59</td><td>60</td><td>61</td><td>62</td><td>63</td><td>64</td><td>65</td><td>66</td><td>67</td><td>68</td><td>69</td><td>70</td><td>71</td><td>72</td><td>73</td><td>74</td><td>75</td><td>76</td><td>77</td><td>78</td><td>79</td><td>80</td><td>81</td><td>82</td><td>83</td><td>84</td><td>85</td><td>86</td><td>87</td><td>88</td><td>89</td><td>90</td><td>91</td><td>92</td><td>93</td><td>94</td><td>95</td><td>96</td><td>97</td><td>98</td><td>99</td><td>100</td></tr> </table>	1	2	3	4	5	6	7	8	9	10	11	12	13	14	15	16	17	18	19	20	21	22	23	24	25	26	27	28	29	30	31	32	33	34	35	36	37	38	39	40	41	42	43	44	45	46	47	48	49	50	51	52	53	54	55	56	57	58	59	60	61	62	63	64	65	66	67	68	69	70	71	72	73	74	75	76	77	78	79	80	81	82	83	84	85	86	87	88	89	90	91	92	93	94	95	96	97	98	99	100
1	2	3	4	5	6	7	8	9	10	11	12	13	14	15	16	17	18	19	20	21	22	23	24	25	26	27	28	29	30	31	32	33	34	35	36	37	38	39	40	41	42	43	44	45	46	47	48	49	50	51	52	53	54	55	56	57	58	59	60	61	62	63	64	65	66	67	68	69	70	71	72	73	74	75	76	77	78	79	80	81	82	83	84	85	86	87	88	89	90	91	92	93	94	95	96	97	98	99	100																																																																																																																																																																																																																																																																																																																																																																																																																																																																																																																										
1	2	3	4	5	6	7	8	9	10	11	12	13	14	15	16	17	18	19	20	21	22	23	24	25	26	27	28	29	30	31	32	33	34	35	36	37	38	39	40	41	42	43	44	45	46	47	48	49	50	51	52	53	54	55	56	57	58	59	60	61	62	63	64	65	66	67	68	69	70	71	72	73	74	75	76	77	78	79	80	81	82	83	84	85	86	87	88	89	90	91	92	93	94	95	96	97	98	99	100																																																																																																																																																																																																																																																																																																																																																																																																																																																																																																																										
1	2	3	4	5	6	7	8	9	10	11	12	13	14	15	16	17	18	19	20	21	22	23	24	25	26	27	28	29	30	31	32	33	34	35	36	37	38	39	40	41	42	43	44	45	46	47	48	49	50	51	52	53	54	55	56	57	58	59	60	61	62	63	64	65	66	67	68	69	70	71	72	73	74	75	76	77	78	79	80	81	82	83	84	85	86	87	88	89	90	91	92	93	94	95	96	97	98	99	100																																																																																																																																																																																																																																																																																																																																																																																																																																																																																																																										
1	2	3	4	5	6	7	8	9	10	11	12	13	14	15	16	17	18	19	20	21	22	23	24	25	26	27	28	29	30	31	32	33	34	35	36	37	38	39	40	41	42	43	44	45	46	47	48	49	50	51	52	53	54	55	56	57	58	59	60	61	62	63	64	65	66	67	68	69	70	71	72	73	74	75	76	77	78	79	80	81	82	83	84	85	86	87	88	89	90	91	92	93	94	95	96	97	98	99	100																																																																																																																																																																																																																																																																																																																																																																																																																																																																																																																										
1	2	3	4	5	6	7	8	9	10	11	12	13	14	15	16	17	18	19	20	21	22	23	24	25	26	27	28	29	30	31	32	33	34	35	36	37	38	39	40	41	42	43	44	45	46	47	48	49	50	51	52	53	54	55	56	57	58	59	60	61	62	63	64	65	66	67	68	69	70	71	72	73	74	75	76	77	78	79	80	81	82	83	84	85	86	87	88	89	90	91	92	93	94	95	96	97	98	99	100																																																																																																																																																																																																																																																																																																																																																																																																																																																																																																																										
1	2	3	4	5	6	7	8	9	10	11	12	13	14	15	16	17	18	19	20	21	22	23	24	25	26	27	28	29	30	31	32	33	34	35	36	37	38	39	40	41	42	43	44	45	46	47	48	49	50	51	52	53	54	55	56	57	58	59	60	61	62	63	64	65	66	67	68	69	70	71	72	73	74	75	76	77	78	79	80	81	82	83	84	85	86	87	88	89	90	91	92	93	94	95	96	97	98	99	100																																																																																																																																																																																																																																																																																																																																																																																																																																																																																																																										

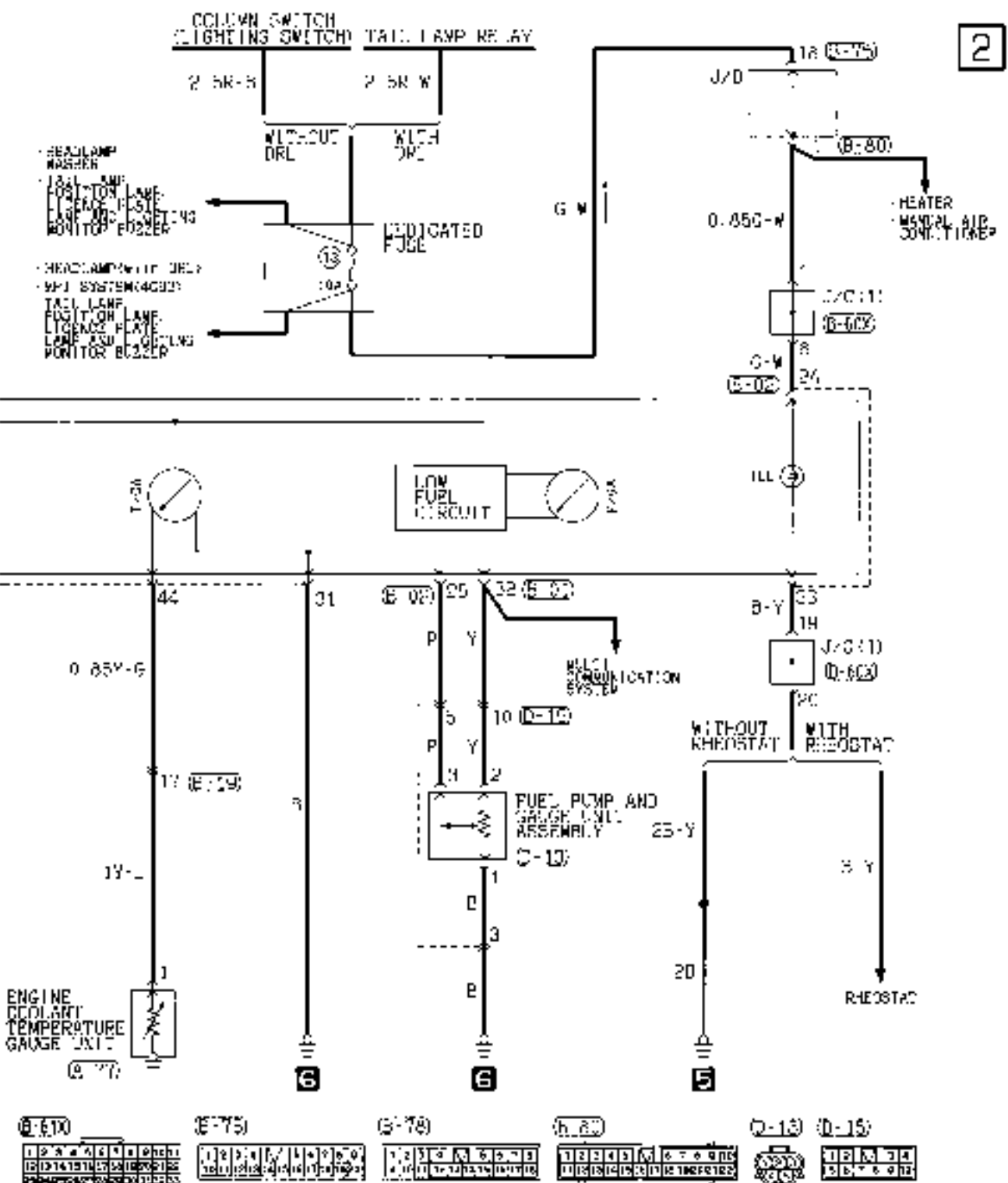

Wire colour code
 B: Black LG: Light Green G: Green L: Blue W: White Y: Yellow SB: Sky blue
 BR: Brown C: Orange GR: Gray R: Red P: Pink V: Violet

METER AND GAUGE (See P. 4-90.)**OPERATION****<Fuel gauge>**

- When the ignition switch is at the "ON" position, the fuel gauge is activated.
- When there is much fuel, the unit's resistance is small and the current flowing in the circuit is great, so the gauge's indicator indicates in the "Full" area.
- When there is little fuel, the unit's resistance is high and the current flowing in the circuit is small, so the gauge's indicator indicates in the "Empty" area.

<Engine coolant temperature gauge>

- When the ignition switch is at the "ON" position, the engine coolant temperature gauge is activated.
- When the engine coolant temperature is high, the unit's resistance is low and there is a great flow of current in the circuit, so the gauge's indicator indicates in the "H" area.
- When the engine coolant temperature is low, the unit's resistance is high and there is a small flow of current in the circuit, so the gauge's indicator indicates in the "C" area.

TROUBLESHOOTING HINTS

1. Fuel gauge does not operate, or registers incorrectly.
 - (1) The fuel gauge indicates "F" when the fuel gauge unit connector is disconnected and the "2" terminal is earthed.
 - Check fuel gauge
2. Engine coolant temperature gauge does not operate, or registers incorrectly.
 - (1) When the engine coolant temperature gauge is earthed with its connector unplugged, it registers "H".
 - Check engine coolant temperature gauge unit.
3. Meter illumination lamp does not illuminate
 - (1) Tail lamps illuminate.
 - Check rheostat.

NOTES

**OIL PRESSURE WARNING LAMP
FUEL WARNING LAMP
BRAKE WARNING LAMP**

00101180004

1

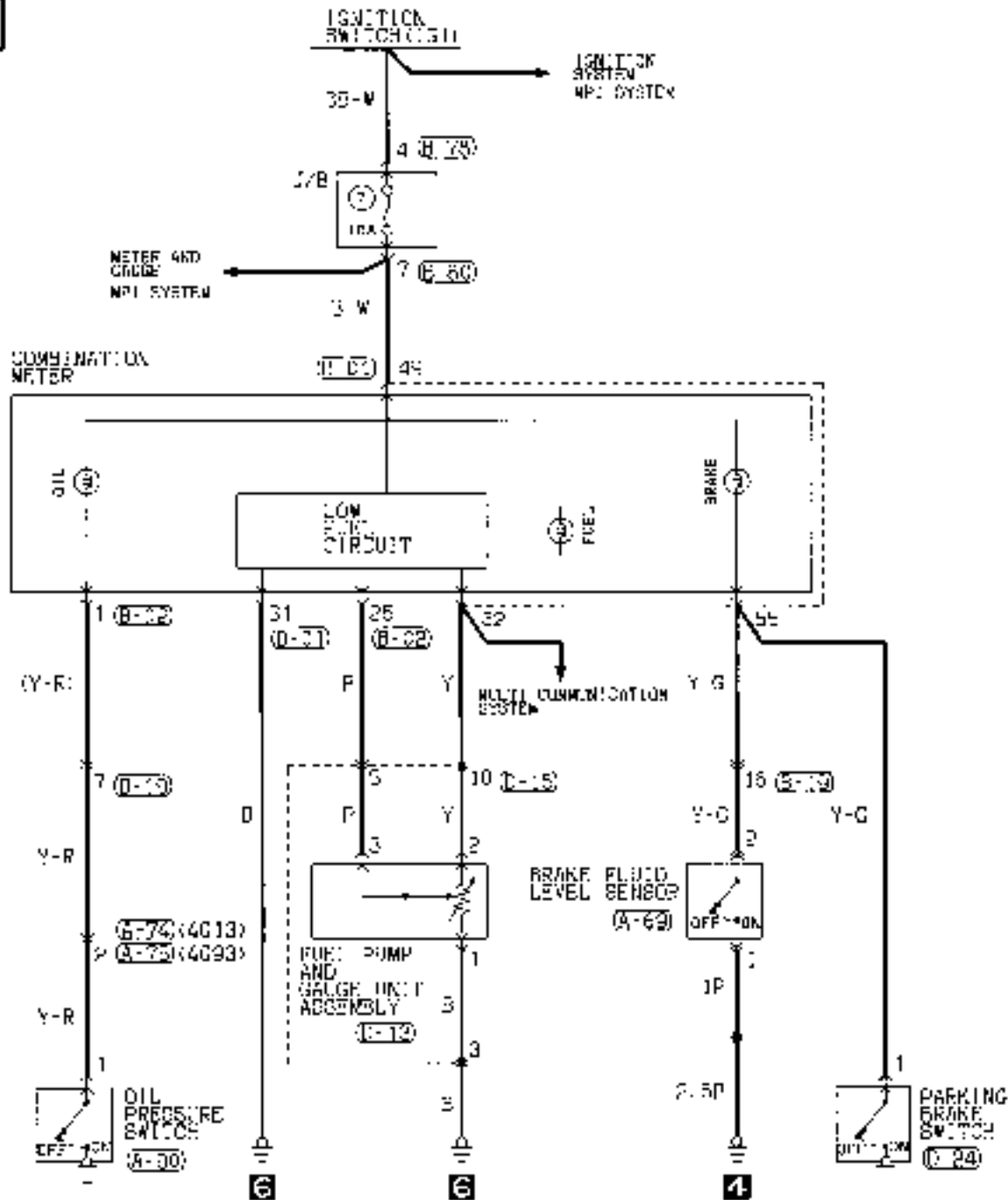

(A-30)	(A-74)	(A-75)	(A-82)	(E-12)	(E-62)	(C-24)
68	12 24	12 24	14	41	18	12 13 14 15 16 17 18 19
(A-75)	(E-12)	(E-62)	(C-24)			
12 13 14 15 16 17 18 19	12 13 14 15 16 17 18 19	12 13 14 15 16 17 18 19	12 13 14 15 16 17 18 19			

OIL PRESSURE WARNING LAMP (See P. 4-94.)

FUEL WARNING LAMP (See P. 4-94.)

BRAKE WARNING LAMP (See P. 4-94.)

OPERATION

<Oil pressure warning lamp>

- When the lubrication system fails after engine starting, resulting in the oil pressure failing to build up, the oil pressure switch turns on causing the oil pressure warning lamp to illuminate.

<Fuel warning lamp>

- When the ignition switch is at the ON position and the fuel level drops the resistance of the unit increases. When the resistance rises to a value that is higher than the specified value, the fuel warning lamp illuminates to inform the driver that the fuel level is low.

<Brake warning lamp>

- When the brake fluid level goes down below a predetermined level with the ignition switch in the ON position, the brake fluid level sensor is activated or the parking brake switch is turned on, causing the brake warning lamp to illuminate.

POWER WINDOWS

90100460227

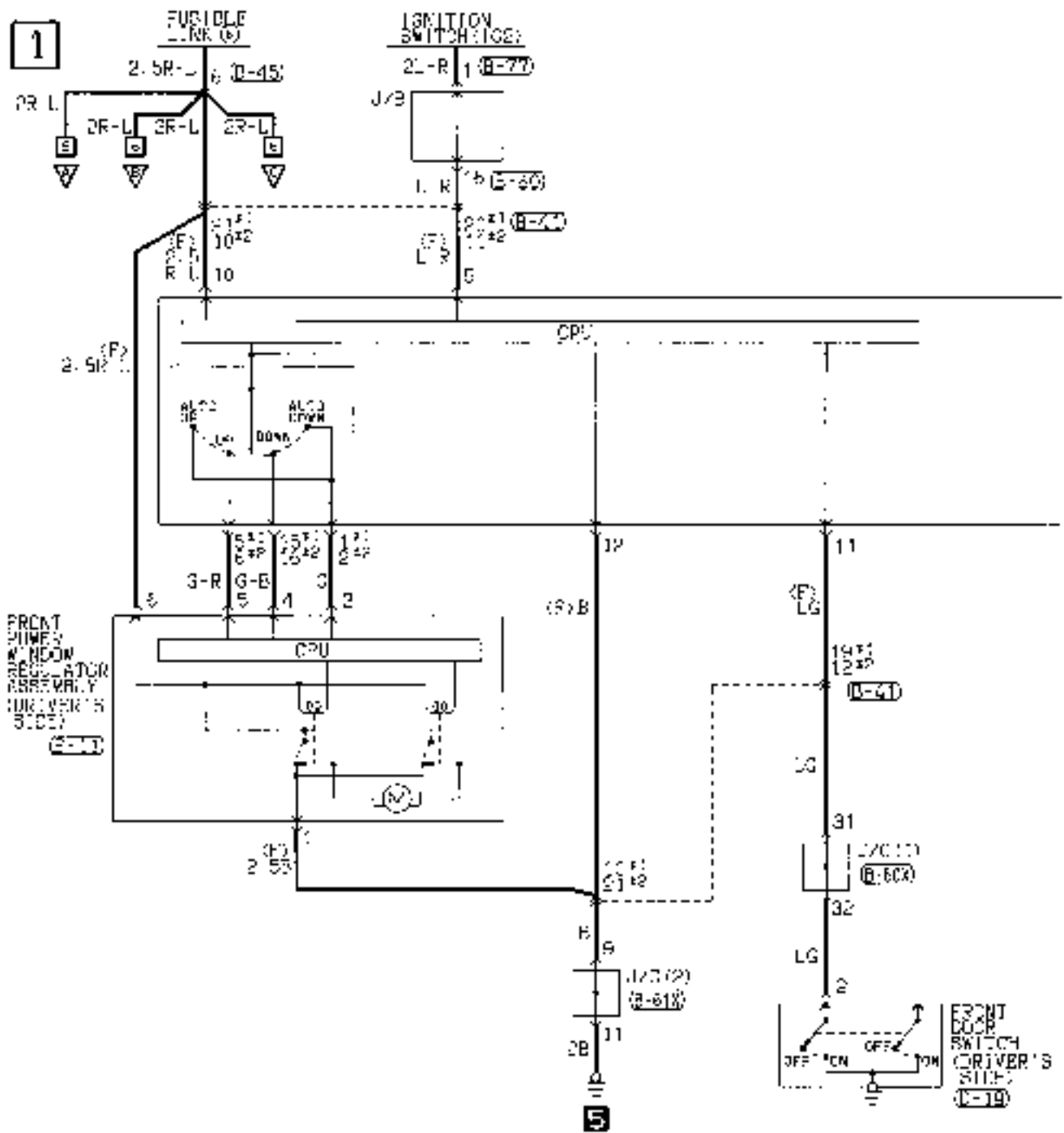

(E-22)

1	2	3	4	5	6	7	8	9	10
11	12	13	14	15	16	17	18	19	20

(E-41)

1	2	3	4	5	6	7	8	9	10
11	12	13	14	15	16	17	18	19	20

(E-45)

1	2	3	4
5	6	7	10

(E-60)

1	2	3	4	5	6	7	8	9	10	11
12	13	14	15	16	17	18	19	20	21	22
23	24	25	26	27	28	29	30	31	32	33

(E-61)

1	2	3	4	5	6	7	8	9	10	11
12	13	14	15	16	17	18	19	20	21	22
23	24	25	26	27	28	29	30	31	32	33

(E-70)

1	2	3
---	---	---

2

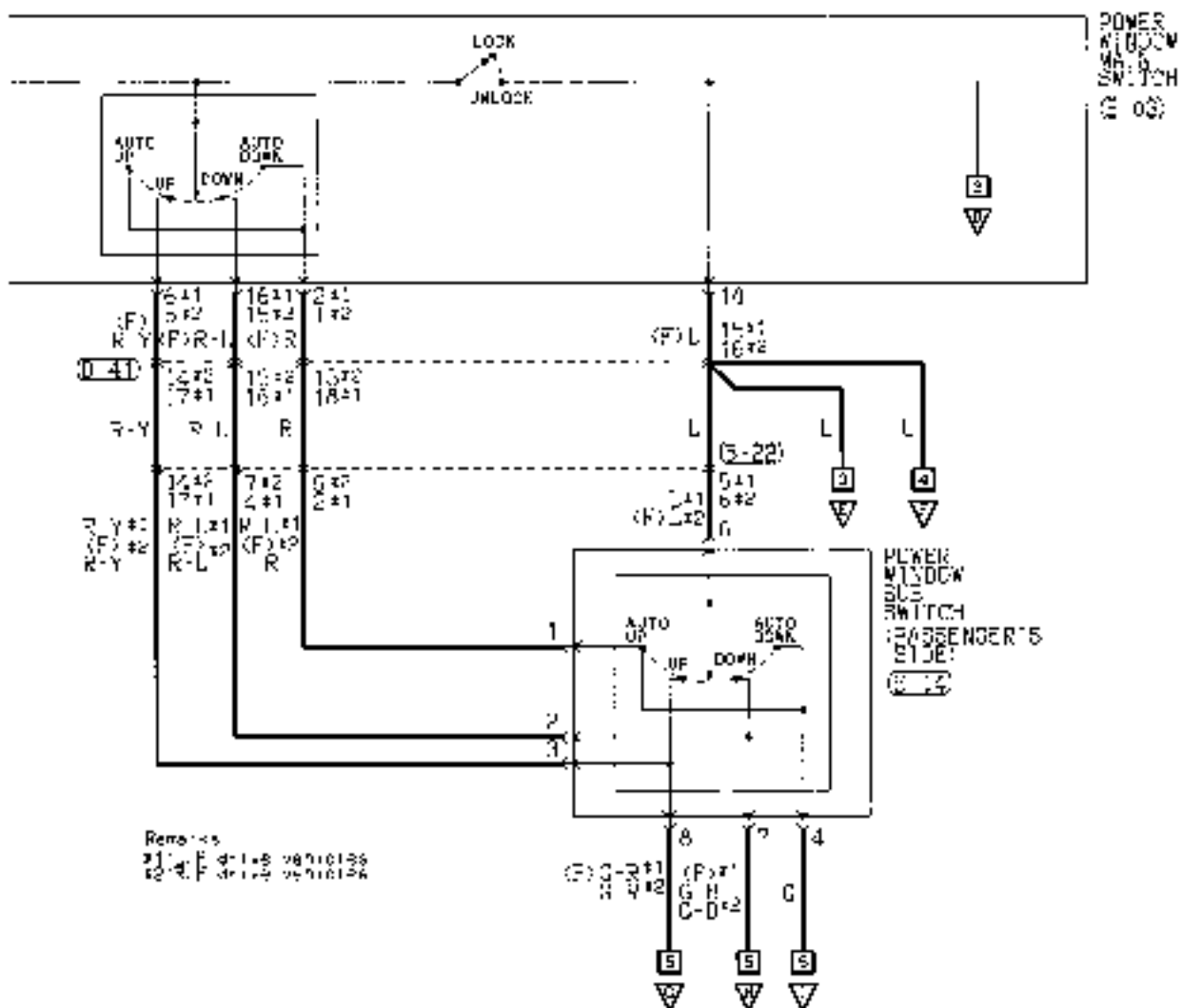

Remarks
 21-1 F 41-1 28-1 0138
 22-1 F 42-1 29-1 0138



Wire colour code
 B: Black L: Light green G: Green L: Blue W: White Y: Yellow SB: Sky blue
 Br: Brown O: Orange GR: Gray B: Red P: Pink V: Violet

POWER WINDOWS (CONTINUED)

3

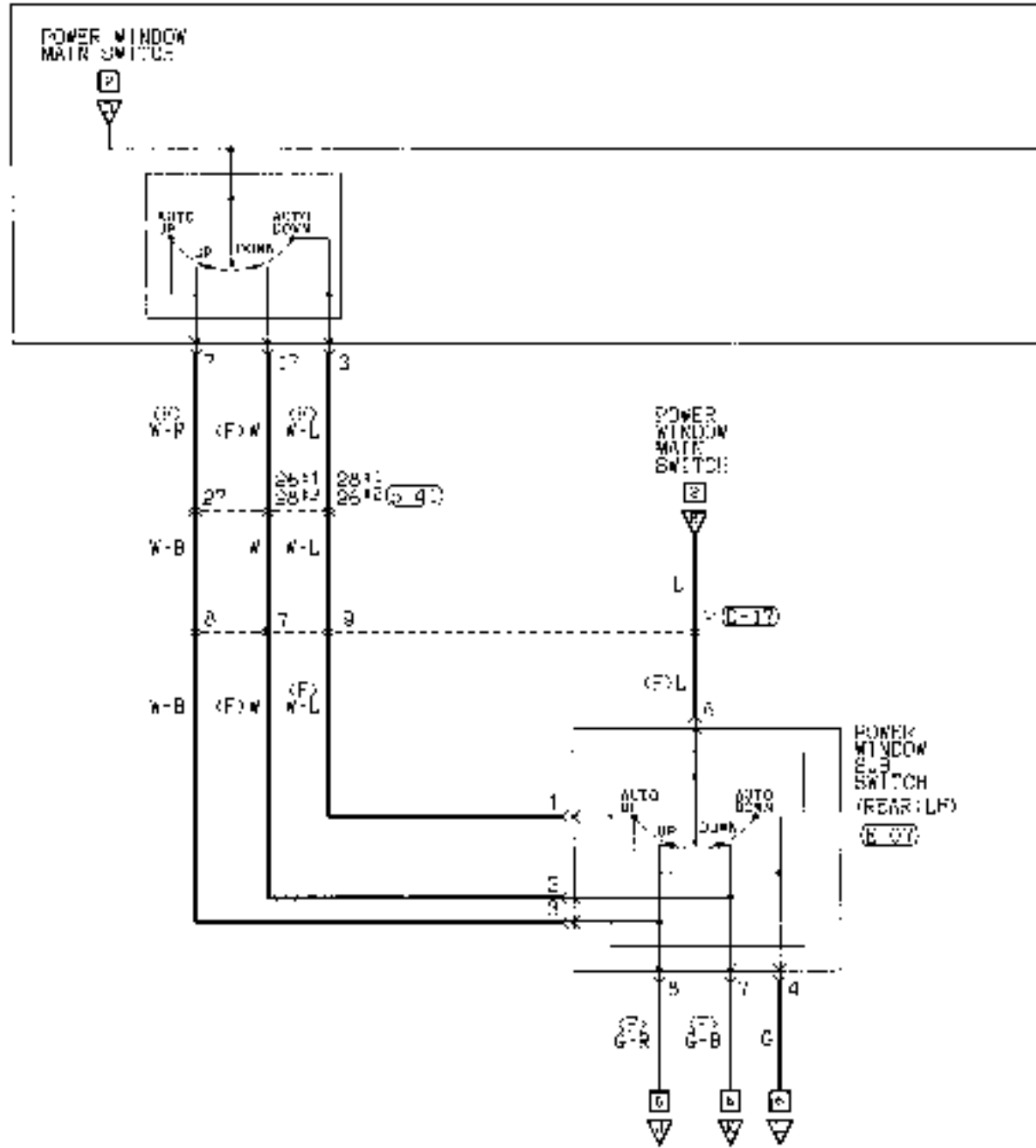

C-11

1	2	3	4	5	6	7	8	9	10
11	12	13	14	15	16	17	18	19	20
21	22	23	24	25	26	27	28	29	30

C-15

1	2	M	3	4
5	6	7	8	10

C-17

1	2	M	3	4
5	6	7	8	10

C-23

1	2	3	4	5	6	7	8	9	10
11	12	13	14	15	16	17	18	19	20
21	22	23	24	25	26	27	28	29	30

C-27

1	2	3	4
5	6	7	8

C-17

1	2	3	4
5	6	7	8

4

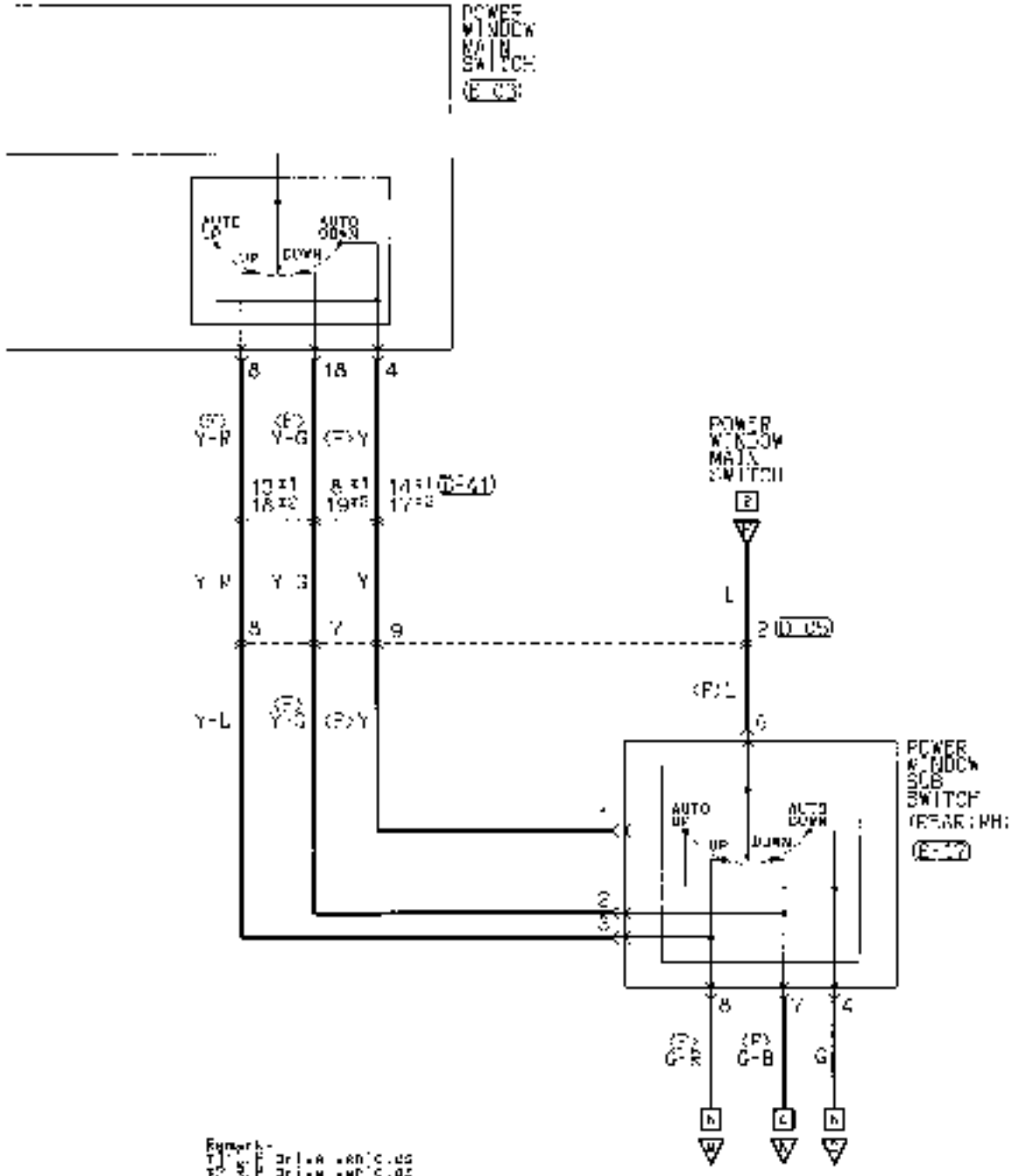

Wire colour code
 B:Black G:Light green GR:Green L:Blue W:White Y:Yellow BB:Sky blue
 BR:Brown O:Orange GR:Gray R:Red P:Pink V:Violet

POWER WINDOWS (CONTINUED)

5

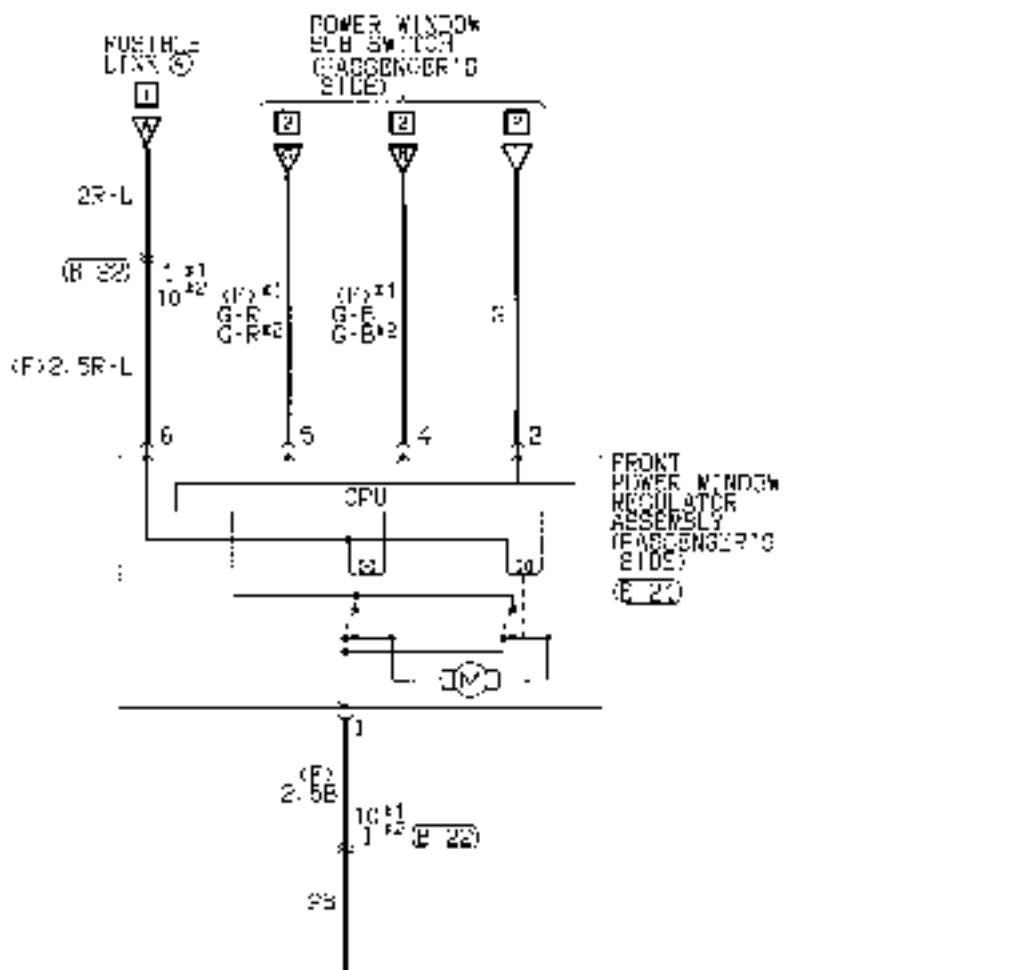

Remarks:
 11: R.H. drive veh. sides
 12: L.H. drive veh. sides



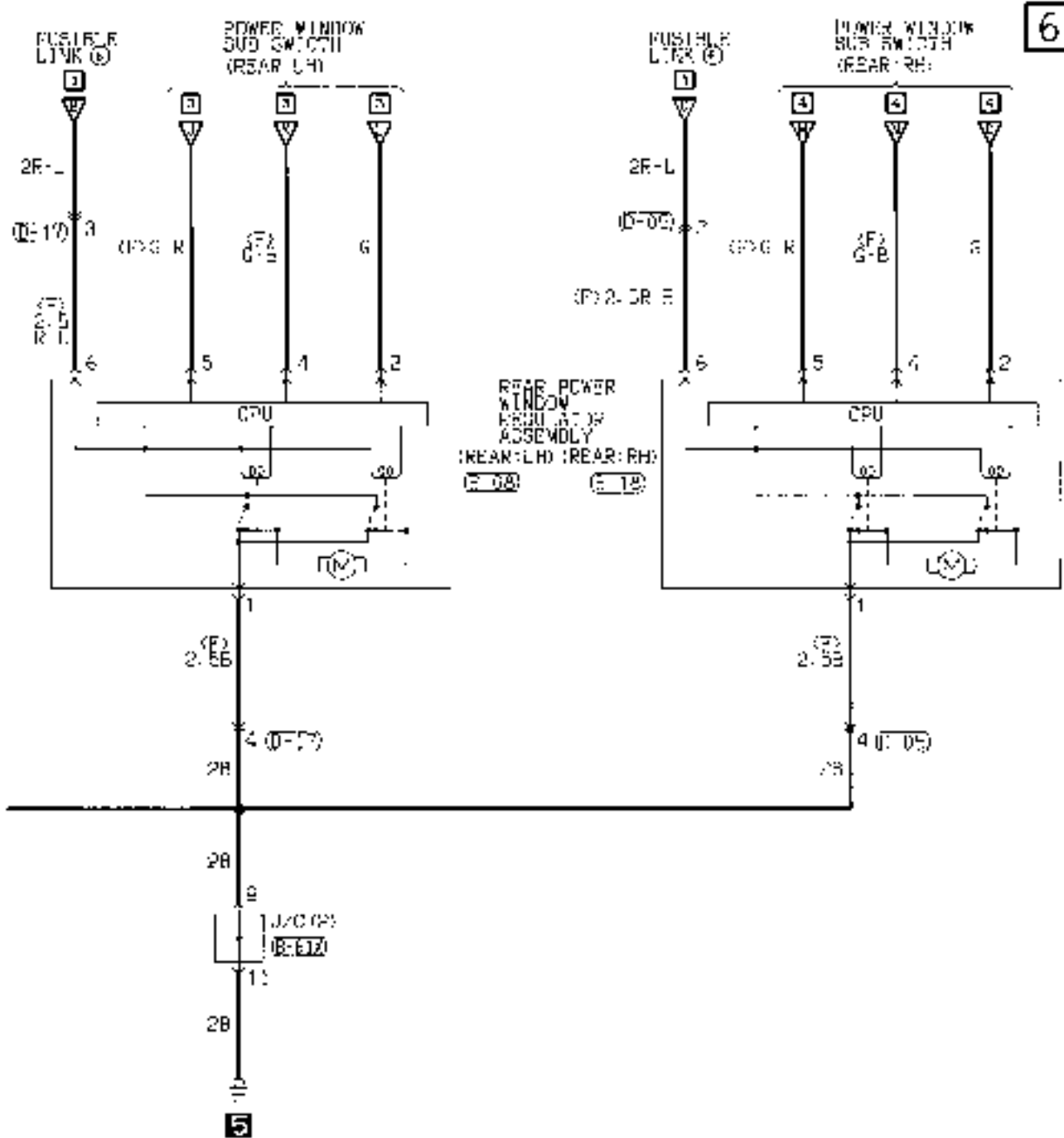

6

Wire colour code
 1: Black LD: Light green G: Green L: Blue W: White Y: Yellow SN: Sky blue
 BR: Brown D: Orange GR: Gray R: Red P: Pink V: Violet

CENTRAL DOOR LOCKING SYSTEM

90160471005

Vehicles without keyless entry system

1

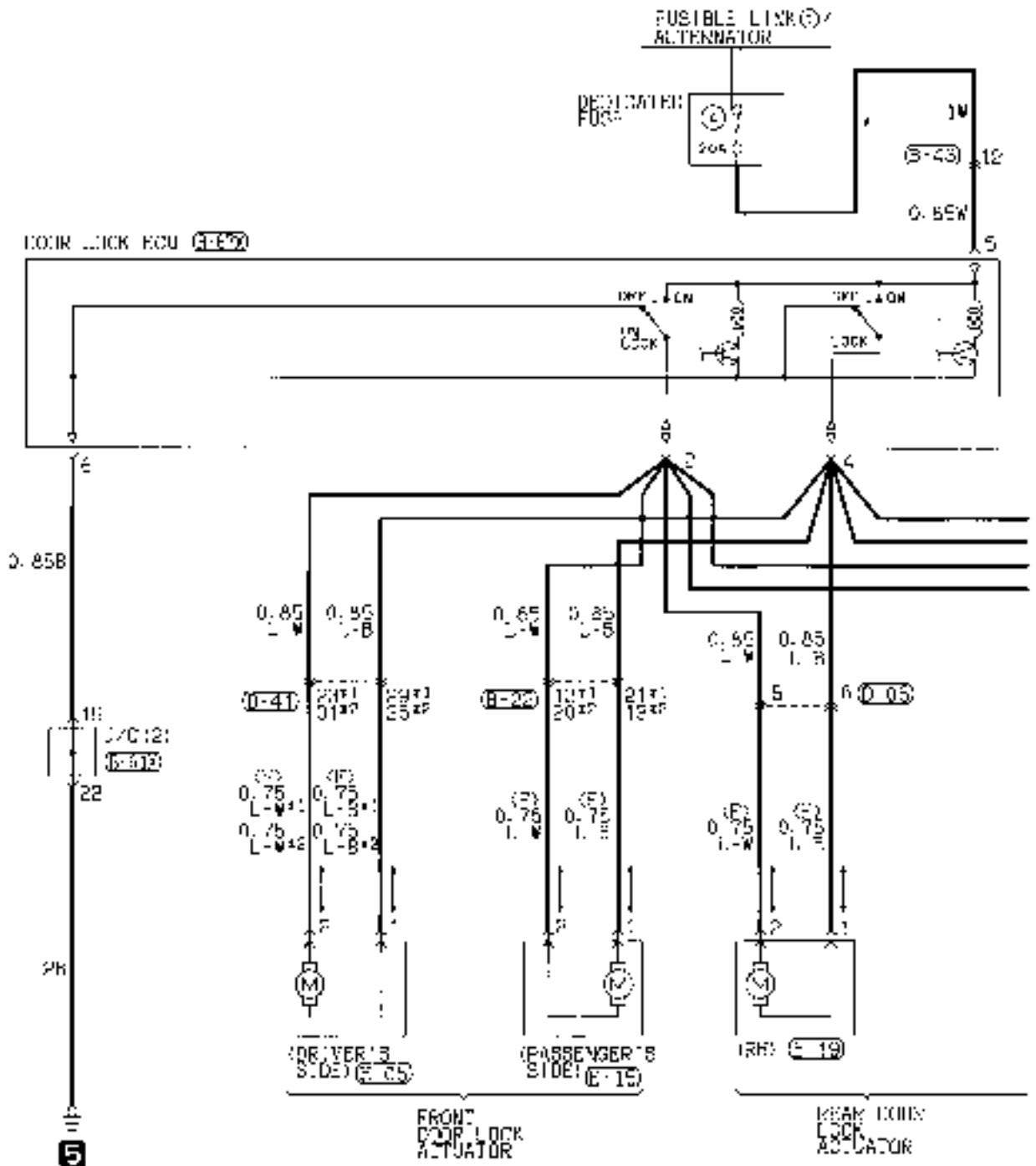

(5-22)

1	2	3	4	5	6	7	8	9	10	11	12	13	14	15	16	17	18	19	20	21	22
1	2	3	4	5	6	7	8	9	10	11	12	13	14	15	16	17	18	19	20	21	22

(5-4)

1	2	3	4	5	6	7	8	9	10	11	12	13	14	15	16	17	18	19	20	21	22
1	2	3	4	5	6	7	8	9	10	11	12	13	14	15	16	17	18	19	20	21	22

(5-43)

1	2	3	4	5	6	7	8	9	10	11	12	13	14	15	16	17	18	19	20	21	22
1	2	3	4	5	6	7	8	9	10	11	12	13	14	15	16	17	18	19	20	21	22

(5-41)

1	2	3	4	5	6	7	8	9	10	11	12	13	14	15	16	17	18	19	20	21	22
1	2	3	4	5	6	7	8	9	10	11	12	13	14	15	16	17	18	19	20	21	22

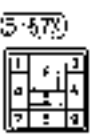

2

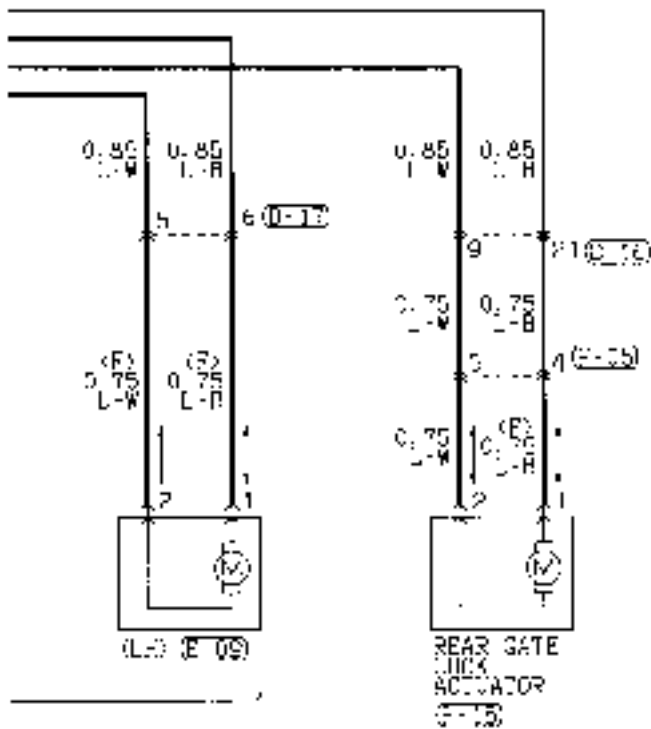

Remarks
 F1: E-drive vehicles
 F2: E-drive vehicles

00-05	00-16	00-17	00-08	00-00	00-15	00-00	00-05	00-05	
12 13 14 15 16 17 18 19 20 21 22 23 24 25 26 27 28 29 30 31 32 33 34 35 36 37 38 39 40 41 42 43 44 45 46 47 48 49 50 51 52 53 54 55 56 57 58 59 60 61 62 63 64 65 66 67 68 69 70 71 72 73 74 75 76 77 78 79 80 81 82 83 84 85 86 87 88 89 90 91 92 93 94 95 96 97 98 99 100	1 2 3 4 5 6 7 8 9 10 11 12 13 14 15 16 17 18 19 20 21 22 23 24 25 26 27 28 29 30 31 32 33 34 35 36 37 38 39 40 41 42 43 44 45 46 47 48 49 50 51 52 53 54 55 56 57 58 59 60 61 62 63 64 65 66 67 68 69 70 71 72 73 74 75 76 77 78 79 80 81 82 83 84 85 86 87 88 89 90 91 92 93 94 95 96 97 98 99 100	1 2 3 4 5 6 7 8 9 10 11 12 13 14 15 16 17 18 19 20 21 22 23 24 25 26 27 28 29 30 31 32 33 34 35 36 37 38 39 40 41 42 43 44 45 46 47 48 49 50 51 52 53 54 55 56 57 58 59 60 61 62 63 64 65 66 67 68 69 70 71 72 73 74 75 76 77 78 79 80 81 82 83 84 85 86 87 88 89 90 91 92 93 94 95 96 97 98 99 100	01 02 03 04 05 06 07 08 09 10 11 12 13 14 15 16 17 18 19 20 21 22 23 24 25 26 27 28 29 30 31 32 33 34 35 36 37 38 39 40 41 42 43 44 45 46 47 48 49 50 51 52 53 54 55 56 57 58 59 60 61 62 63 64 65 66 67 68 69 70 71 72 73 74 75 76 77 78 79 80 81 82 83 84 85 86 87 88 89 90 91 92 93 94 95 96 97 98 99 100	01 02 03 04 05 06 07 08 09 10 11 12 13 14 15 16 17 18 19 20 21 22 23 24 25 26 27 28 29 30 31 32 33 34 35 36 37 38 39 40 41 42 43 44 45 46 47 48 49 50 51 52 53 54 55 56 57 58 59 60 61 62 63 64 65 66 67 68 69 70 71 72 73 74 75 76 77 78 79 80 81 82 83 84 85 86 87 88 89 90 91 92 93 94 95 96 97 98 99 100	01 02 03 04 05 06 07 08 09 10 11 12 13 14 15 16 17 18 19 20 21 22 23 24 25 26 27 28 29 30 31 32 33 34 35 36 37 38 39 40 41 42 43 44 45 46 47 48 49 50 51 52 53 54 55 56 57 58 59 60 61 62 63 64 65 66 67 68 69 70 71 72 73 74 75 76 77 78 79 80 81 82 83 84 85 86 87 88 89 90 91 92 93 94 95 96 97 98 99 100	01 02 03 04 05 06 07 08 09 10 11 12 13 14 15 16 17 18 19 20 21 22 23 24 25 26 27 28 29 30 31 32 33 34 35 36 37 38 39 40 41 42 43 44 45 46 47 48 49 50 51 52 53 54 55 56 57 58 59 60 61 62 63 64 65 66 67 68 69 70 71 72 73 74 75 76 77 78 79 80 81 82 83 84 85 86 87 88 89 90 91 92 93 94 95 96 97 98 99 100	01 02 03 04 05 06 07 08 09 10 11 12 13 14 15 16 17 18 19 20 21 22 23 24 25 26 27 28 29 30 31 32 33 34 35 36 37 38 39 40 41 42 43 44 45 46 47 48 49 50 51 52 53 54 55 56 57 58 59 60 61 62 63 64 65 66 67 68 69 70 71 72 73 74 75 76 77 78 79 80 81 82 83 84 85 86 87 88 89 90 91 92 93 94 95 96 97 98 99 100	01 02 03 04 05 06 07 08 09 10 11 12 13 14 15 16 17 18 19 20 21 22 23 24 25 26 27 28 29 30 31 32 33 34 35 36 37 38 39 40 41 42 43 44 45 46 47 48 49 50 51 52 53 54 55 56 57 58 59 60 61 62 63 64 65 66 67 68 69 70 71 72 73 74 75 76 77 78 79 80 81 82 83 84 85 86 87 88 89 90 91 92 93 94 95 96 97 98 99 100	01 02 03 04 05 06 07 08 09 10 11 12 13 14 15 16 17 18 19 20 21 22 23 24 25 26 27 28 29 30 31 32 33 34 35 36 37 38 39 40 41 42 43 44 45 46 47 48 49 50 51 52 53 54 55 56 57 58 59 60 61 62 63 64 65 66 67 68 69 70 71 72 73 74 75 76 77 78 79 80 81 82 83 84 85 86 87 88 89 90 91 92 93 94 95 96 97 98 99 100

Wire Color Code
 B: Black G: Light green S: Green L: Blue N: White Y: Yellow EE: Spindle
 BR: Brown C: Orange GR: Gray R: Red P: Pink V: Violet

CENTRAL DOOR LOCKING SYSTEM <Vehicles without keyless entry system>
(CONTINUED)

3

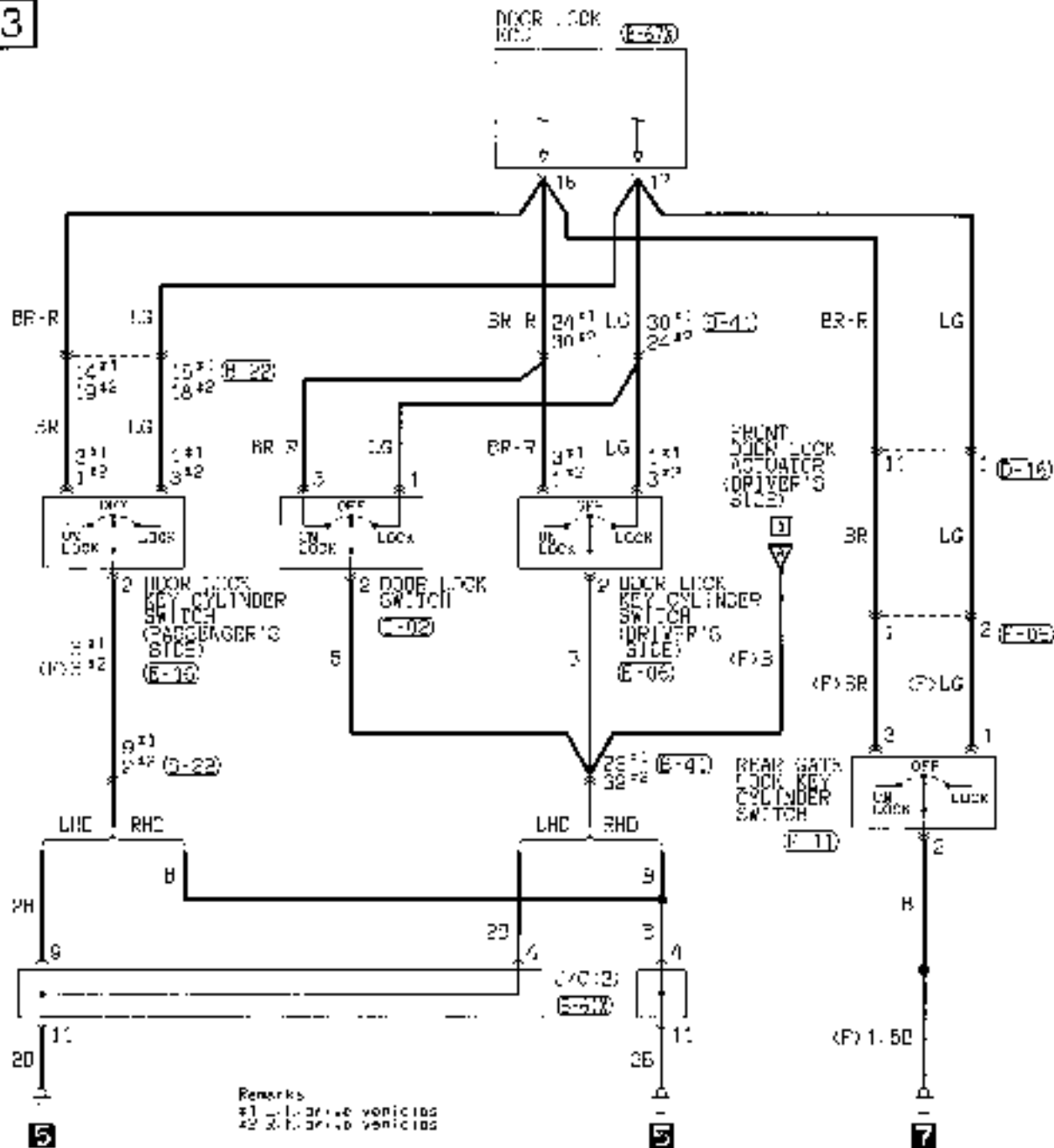

Remarks
*1 : L-Drive vehicles
*2 : R-Drive vehicles

E-22 [1][2][3][4][5][6][7][8][9][10] [11][12][13][14][15][16][17][18][19][20]	E-4 [1][2][3][4][5][6][7][8][9] [10][11][12][13][14][15][16][17][18][19][20]	E-16 [1][2][3][4][5][6][7][8][9][10] [11][12][13][14][15][16][17][18][19][20]	E-16 [1][2][3][4][5][6][7][8][9][10] [11][12][13][14][15][16][17][18][19][20]	E-02 [1][2][3][4]	E-06 [1][2][3][4]	E-10 [1][2][3][4]
E-05 [1][2][3][4]	E-01 [1][2][3][4]	Wire colour code B : Black LG : Light green G : Green L : Blue BR : Brown O : Orange GR : Gray LG : Light green W : White BB : Blue F : Pink Y : Yellow V : Violet		GM 100088A		

NOTES

CENTRAL DOOR LOCKING SYSTEM

90160471072

Vehicles with keyless entry system

1

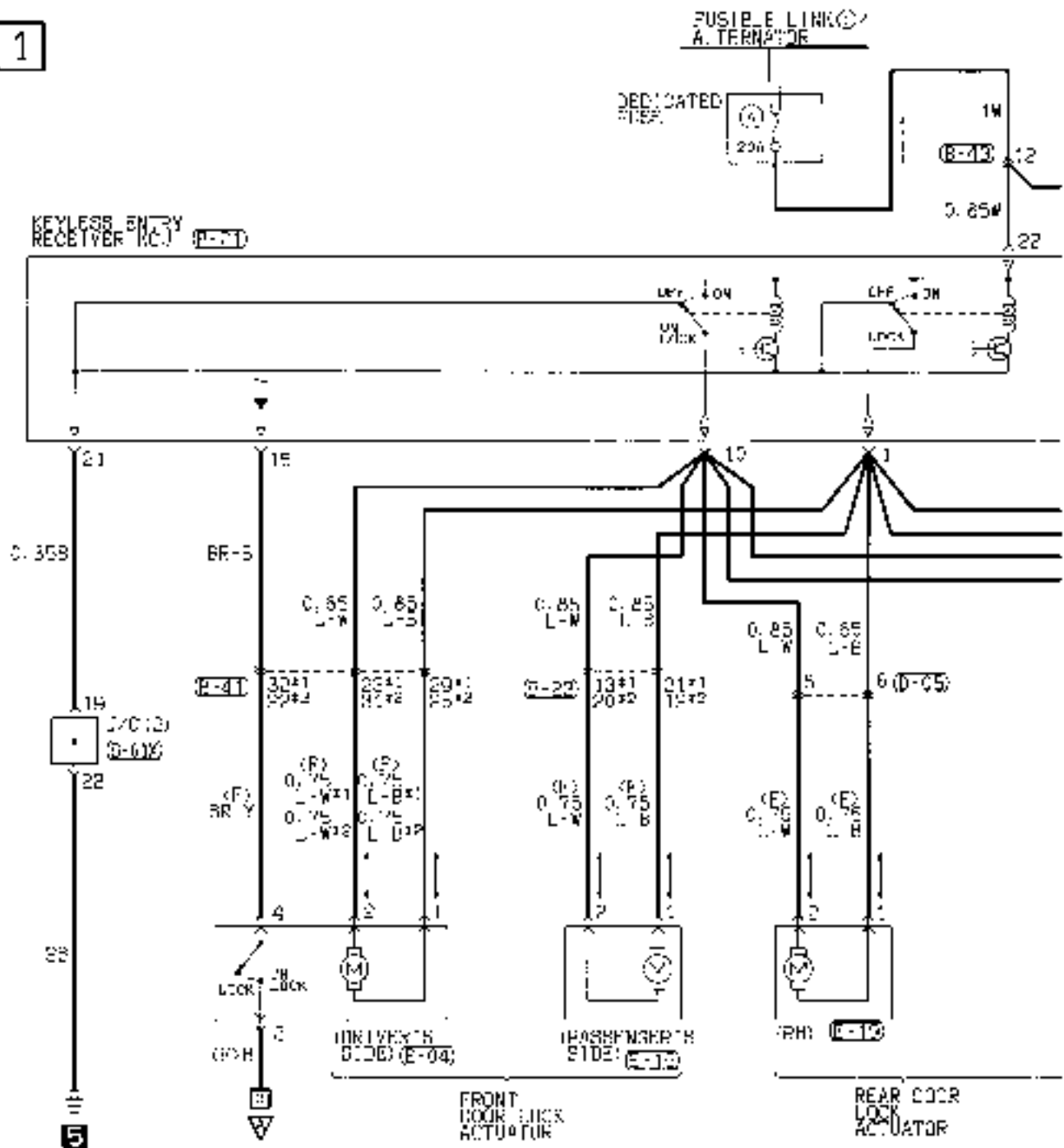

(B-21)

1	2	3	4	5	6	7	8	9	10	11	12	13	14	15	16	17	18	19	20	21	22	
23	24	25	26	27	28	29	30	31	32	33	34	35	36	37	38	39	40	41	42	43	44	45

(B-22)

1	2	3	4	5	6	7	8	9	10	11	12	13	14	15	16	17	18	19	20	21	22	23	24	25	26	27	28	29	30	31	32	33	34	35	36	37	38	39	40	41	42	43	44	45
---	---	---	---	---	---	---	---	---	----	----	----	----	----	----	----	----	----	----	----	----	----	----	----	----	----	----	----	----	----	----	----	----	----	----	----	----	----	----	----	----	----	----	----	----

(B-35) SWM

1	2	3	4	5	6	7	8	9	10	11	12	13	14	15	16	17	18	19	20	21	22	23	24	25	26	27	28	29	30	31	32	33	34	35	36	37	38	39	40	41	42	43	44	45
---	---	---	---	---	---	---	---	---	----	----	----	----	----	----	----	----	----	----	----	----	----	----	----	----	----	----	----	----	----	----	----	----	----	----	----	----	----	----	----	----	----	----	----	----

(B-41)

1	2	3	4	5	6	7	8	9	10	11	12	13	14	15	16	17	18	19	20	21	22	23	24	25	26	27	28	29	30	31	32	33	34	35	36	37	38	39	40	41	42	43	44	45
---	---	---	---	---	---	---	---	---	----	----	----	----	----	----	----	----	----	----	----	----	----	----	----	----	----	----	----	----	----	----	----	----	----	----	----	----	----	----	----	----	----	----	----	----

(B-42)

1	2	3	4	5	6	7	8	9	10	11	12	13	14	15	16	17	18	19	20	21	22	23	24	25	26	27	28	29	30	31	32	33	34	35	36	37	38	39	40	41	42	43	44	45
---	---	---	---	---	---	---	---	---	----	----	----	----	----	----	----	----	----	----	----	----	----	----	----	----	----	----	----	----	----	----	----	----	----	----	----	----	----	----	----	----	----	----	----	----

(F-16)

1	2	3	4	5	6	7	8	9	10	11	12	13	14	15	16	17	18	19	20	21	22	23	24	25	26	27	28	29	30	31	32	33	34	35	36	37	38	39	40	41	42	43	44	45
---	---	---	---	---	---	---	---	---	----	----	----	----	----	----	----	----	----	----	----	----	----	----	----	----	----	----	----	----	----	----	----	----	----	----	----	----	----	----	----	----	----	----	----	----

(F-17)

1	2	3	4	5	6	7	8	9	10	11	12	13	14	15	16	17	18	19	20	21	22	23	24	25	26	27	28	29	30	31	32	33	34	35	36	37	38	39	40	41	42	43	44	45
---	---	---	---	---	---	---	---	---	----	----	----	----	----	----	----	----	----	----	----	----	----	----	----	----	----	----	----	----	----	----	----	----	----	----	----	----	----	----	----	----	----	----	----	----

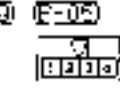

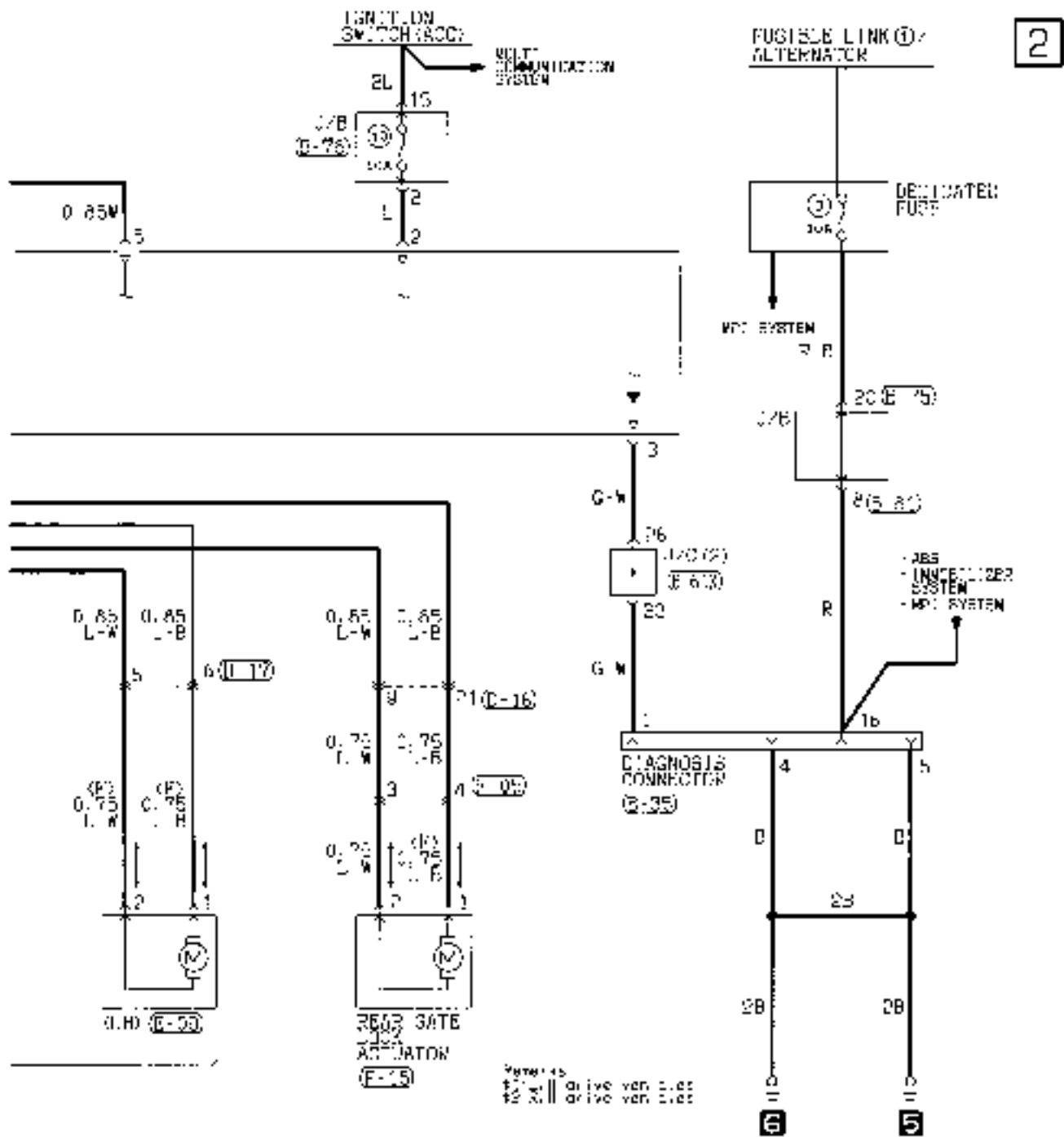

(I-17)

(I-18)

(I-19)

(I-20)

(I-28)

1	2	3	4	5	6	7	8	9	10	11	12	13	14	15	16	17	18	19	20
21	22	23	24	25	26	27	28	29	30	31	32	33	34	35	36	37	38	39	40

1	2	3	4	5	6	7	8	9	10	11	12	13	14	15	16	17	18	19	20
21	22	23	24	25	26	27	28	29	30	31	32	33	34	35	36	37	38	39	40

1	2	3	4	5	6	7	8	9	10	11	12	13	14	15	16	17	18	19	20
21	22	23	24	25	26	27	28	29	30	31	32	33	34	35	36	37	38	39	40

1	2	3	4	5	6	7	8	9	10	11	12	13	14	15	16	17	18	19	20
21	22	23	24	25	26	27	28	29	30	31	32	33	34	35	36	37	38	39	40

1	2	3	4	5	6	7	8	9	10	11	12	13	14	15	16	17	18	19	20
21	22	23	24	25	26	27	28	29	30	31	32	33	34	35	36	37	38	39	40

Wire color code
 B: Blue L: Light green G: Green C: Blue W: White Y: Yellow SB: Sky blue
 BR: Brown O: Orange GR: Gray R: Red P: Pink V: Violet

CENTRAL DOOR LOCKING SYSTEM <Vehicles with keyless entry system>
(CONTINUED)

3

KEYLESS ENTRY RECEIVER (E-21)

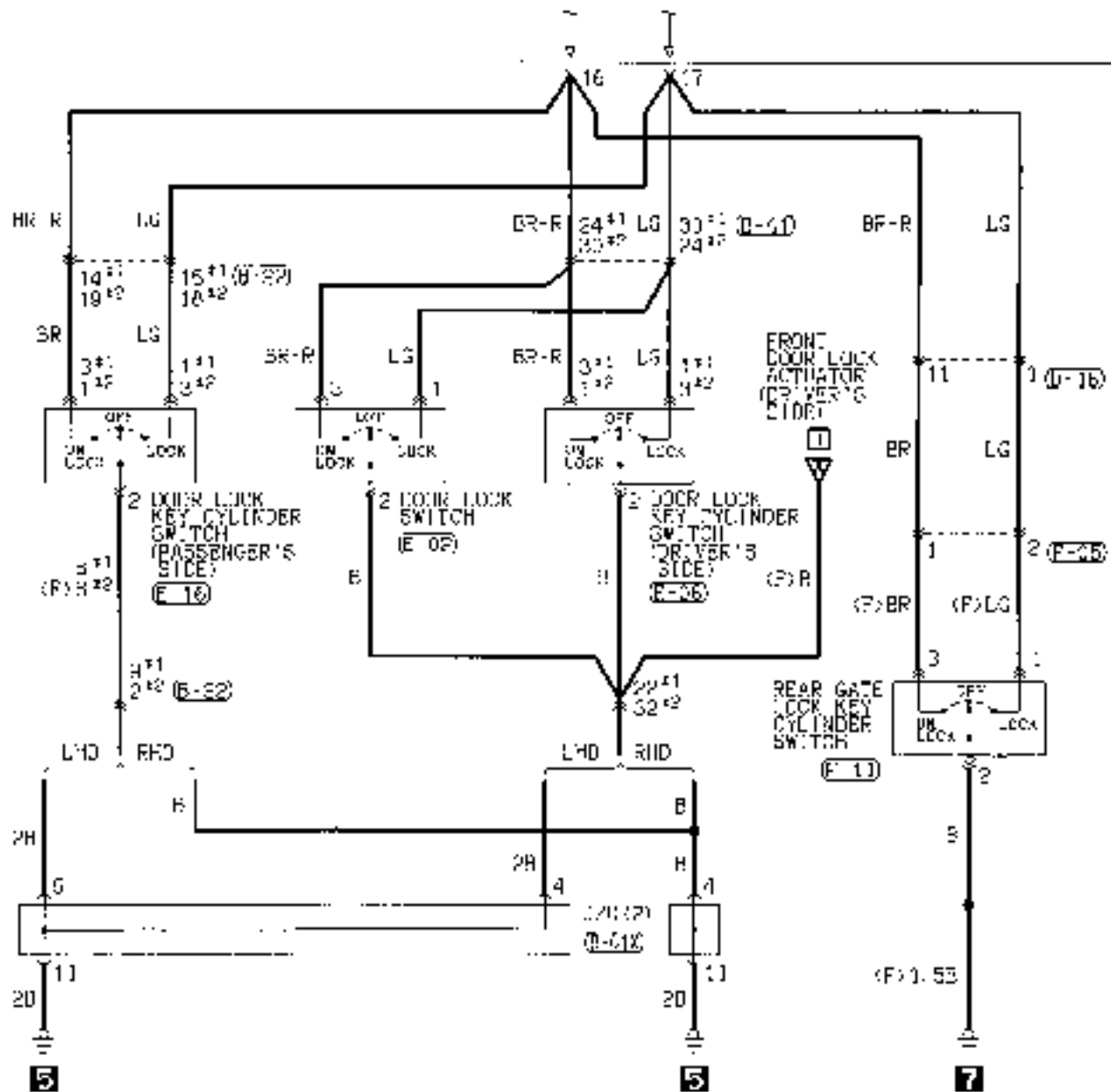

(A-01)	(A-19)	(A-24)	(A-42)	(E-01)	(E-02)	(E-21)
80	06	17	18	222010432340708360416	123456789101112	123456789101112
				3414347454250215333411	23456789101112131415	123456789101112
(E-03)	(E-04)	(E-05)	(E-06)	(E-07)	(E-08)	(E-09)
123456789101112	123456789101112	123456789101112	123456789101112	123456789101112	123456789101112	123456789101112
123456789101112	123456789101112	123456789101112	123456789101112	123456789101112	123456789101112	123456789101112

4

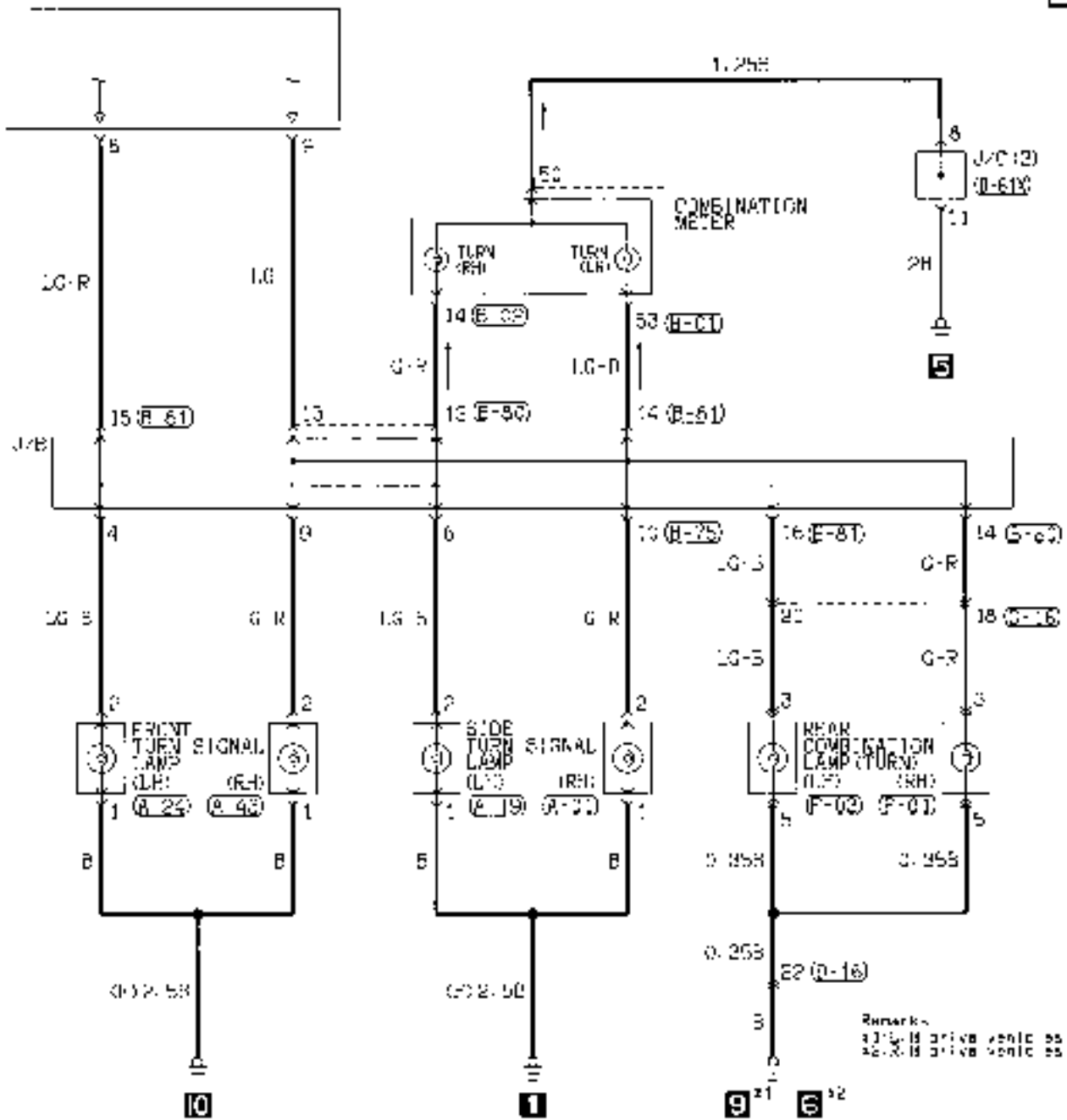

(E-24)	(E-43)	(E-19)	(E-20)	(E-25)	(E-81)
1 2 3 4 5 6 7 8 9 10 11 12 13 14 15 16 17 18 19 20 21 22 23 24 25 26 27 28 29 30	1 2 3 4 5 6 7 8 9 10 11 12 13 14 15 16 17 18 19 20 21 22 23 24 25 26 27 28 29 30	1 2 3 4 5 6 7 8 9 10 11 12 13 14 15 16 17 18 19 20 21 22 23 24 25 26 27 28 29 30	1 2 3 4 5 6 7 8 9 10 11 12 13 14 15 16 17 18 19 20 21 22 23 24 25 26 27 28 29 30	1 2 3 4 5 6 7 8 9 10 11 12 13 14 15 16 17 18 19 20 21 22 23 24 25 26 27 28 29 30	1 2 3 4 5 6 7 8 9 10 11 12 13 14 15 16 17 18 19 20 21 22 23 24 25 26 27 28 29 30

W: White
 B: Black
 BR: Brown
 LG: Light Green
 G: Green
 GR: Gray
 L: Blue
 R: Red
 W: White
 Y: Yellow
 V: Violet
 SS: Sky Blue

**CENTRAL DOOR LOCKING SYSTEM <Vehicles with keyless entry system>
(CONTINUED)**

5

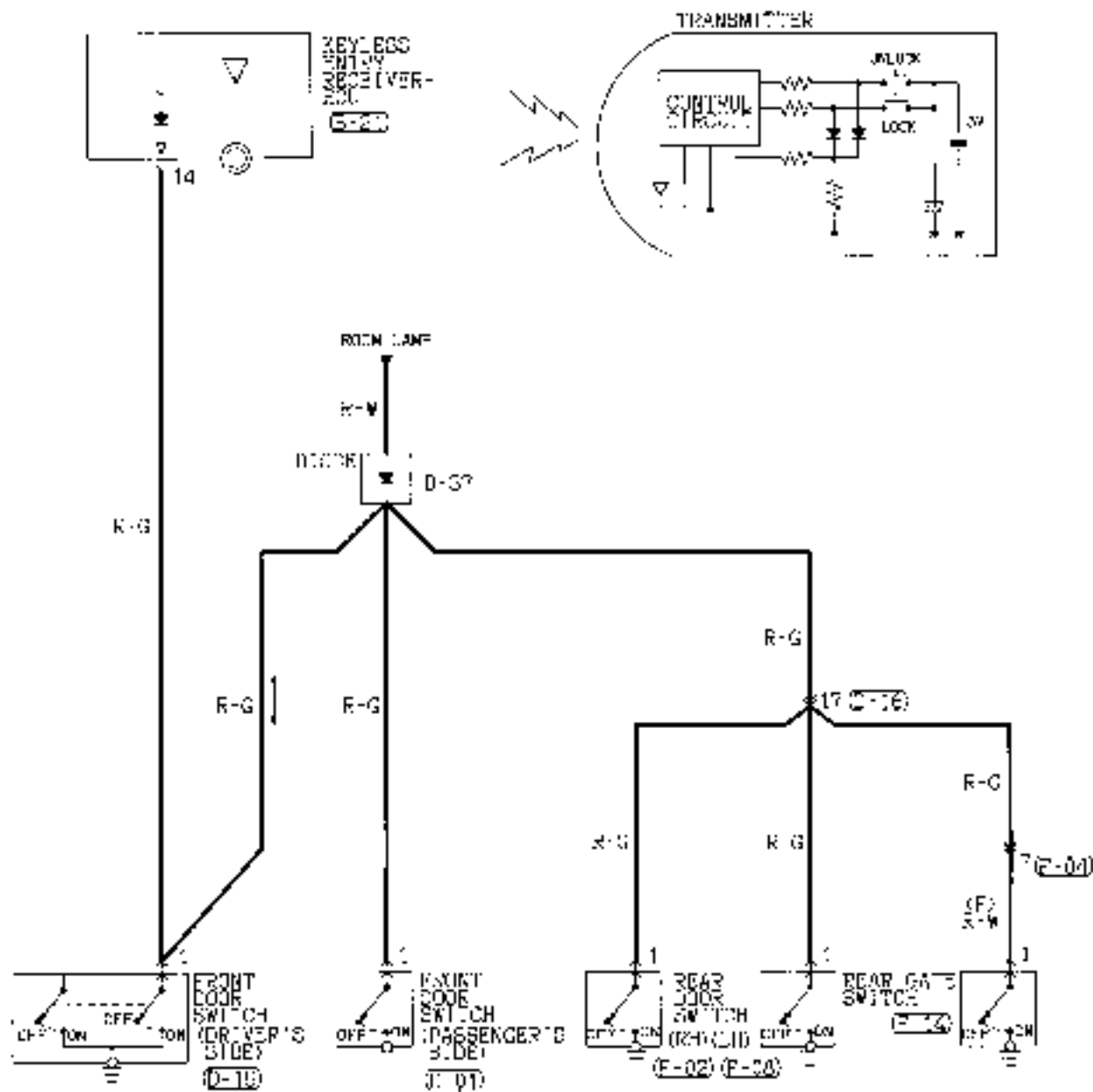

(E-22)	(D-07)	(D-18)	(D-19)	(E-02)	(E-03)	(E-04)	(D-08)	(F-14)
1 2 3 4 5 6 7 8 9 10 11 12	1 2 3 4 5 6 7 8 9 10 11 12	1 2 3 4 5 6 7 8 9 10 11 12	1 2 3 4 5 6 7 8 9 10 11 12	1 2 3 4 5 6 7 8 9 10 11 12	1 2 3 4 5 6 7 8 9 10 11 12	1 2 3 4 5 6 7 8 9 10 11 12	1 2 3 4 5 6 7 8 9 10 11 12	1 2 3 4 5 6 7 8 9 10 11 12

Wire colour code
 B : Blue L : Light green G : Green L : Blue W : White Y : Yellow DB : Sky blue
 Br : Brown O : Orange GR : Gray R : Red P : Pink V : Violet

HEATER (See P. 4-112.)**OPERATION**

- When the ignition switch is turned ON, the blower relay is energized. If the blower switch is turned ON (LO, ML, MH, or HI position) in this condition, the blower is activated through the circuit via resistor at a speed corresponding to the blower switch position.

TROUBLESHOOTING HINTS

- 1 Blower motor is energized at one switch position and not energized at another
 - Check harness and connectors between defective switch position and resistor (or blower motor in HI position)
- 2 Blower motor is energized only when switch is positioned in HI.
 - Check resistor.
- 3 Blower motor speed does not represent the switch position.
 - Check blower switch.

HEATER

9910063001 *

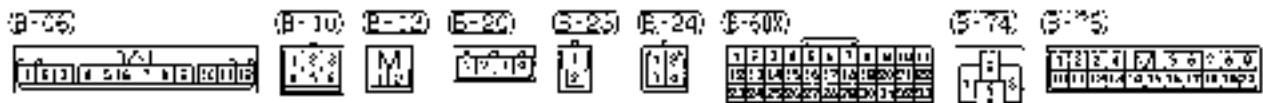
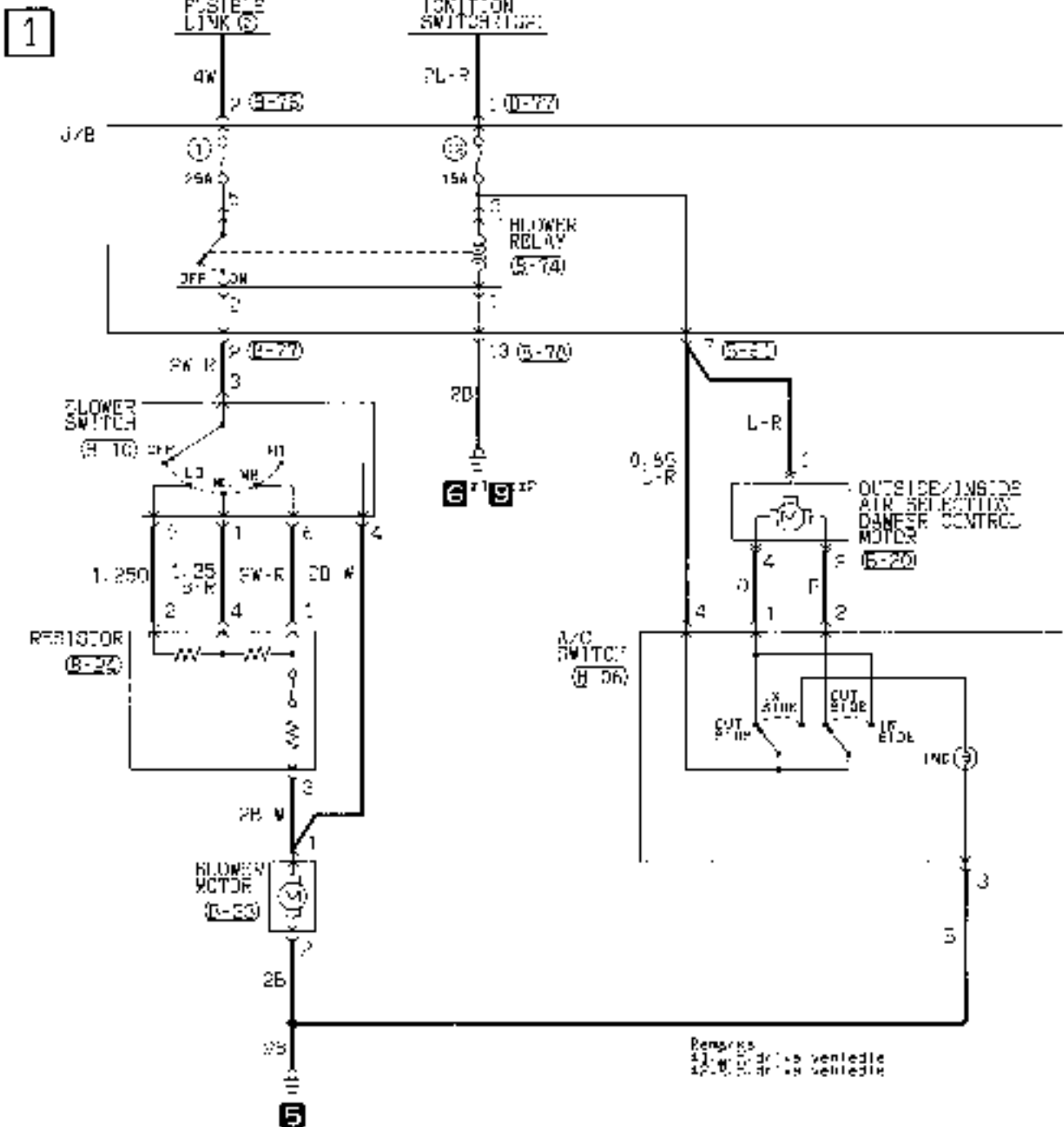

2

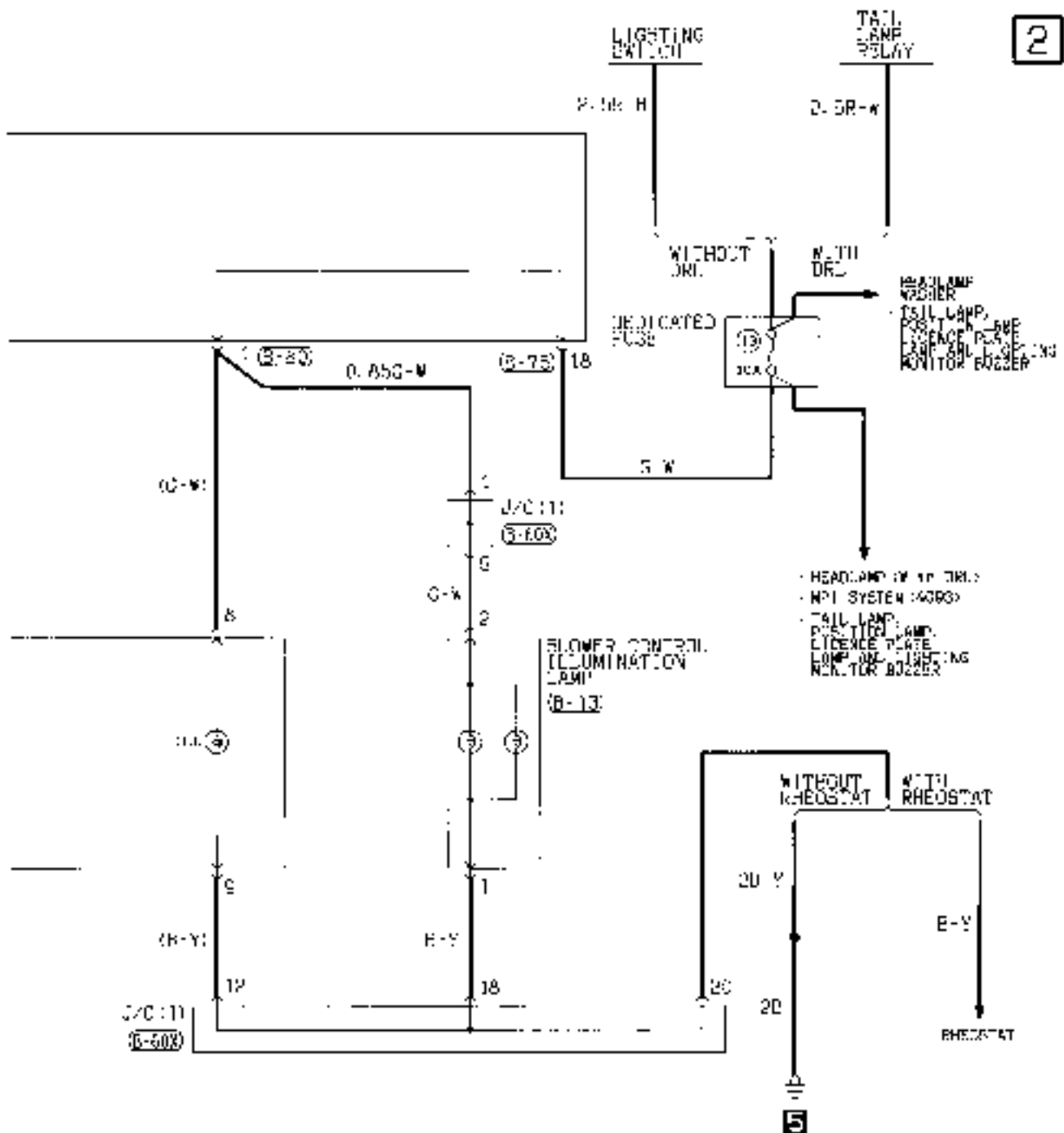

(B-23)	(B-77)	(B-78)	(B-A0)	(B-61)
1 2	1 2 3	1 2 3 4 5 6 7 8	1 2 3 4 5 6 7 8 9 10	1 2 3 4 5 6 7 8 9 10
11 12	1 2 3	1 2 3 4 5 6 7 8 9 10 11 12 13 14 15 16 17 18 19 20	1 2 3 4 5 6 7 8 9 10 11 12 13 14 15 16 17 18 19 20	1 2 3 4 5 6 7 8 9 10 11 12 13 14 15 16 17 18 19 20

Wire color code
 B: Black L: Light green G: Green L: Blue W: White Y: Yellow
 BR: Brown O: Orange GR: Gray R: Red P: Pink V: Violet
 SS: Sky blue

MANUAL AIR CONDITIONER

90100650482

4G13 engine

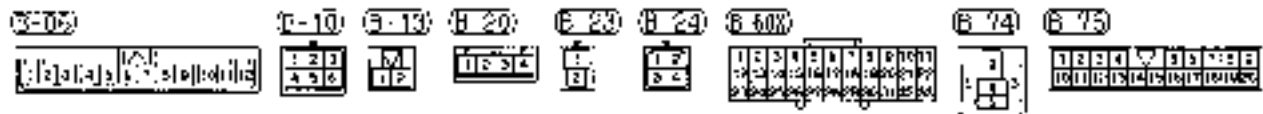
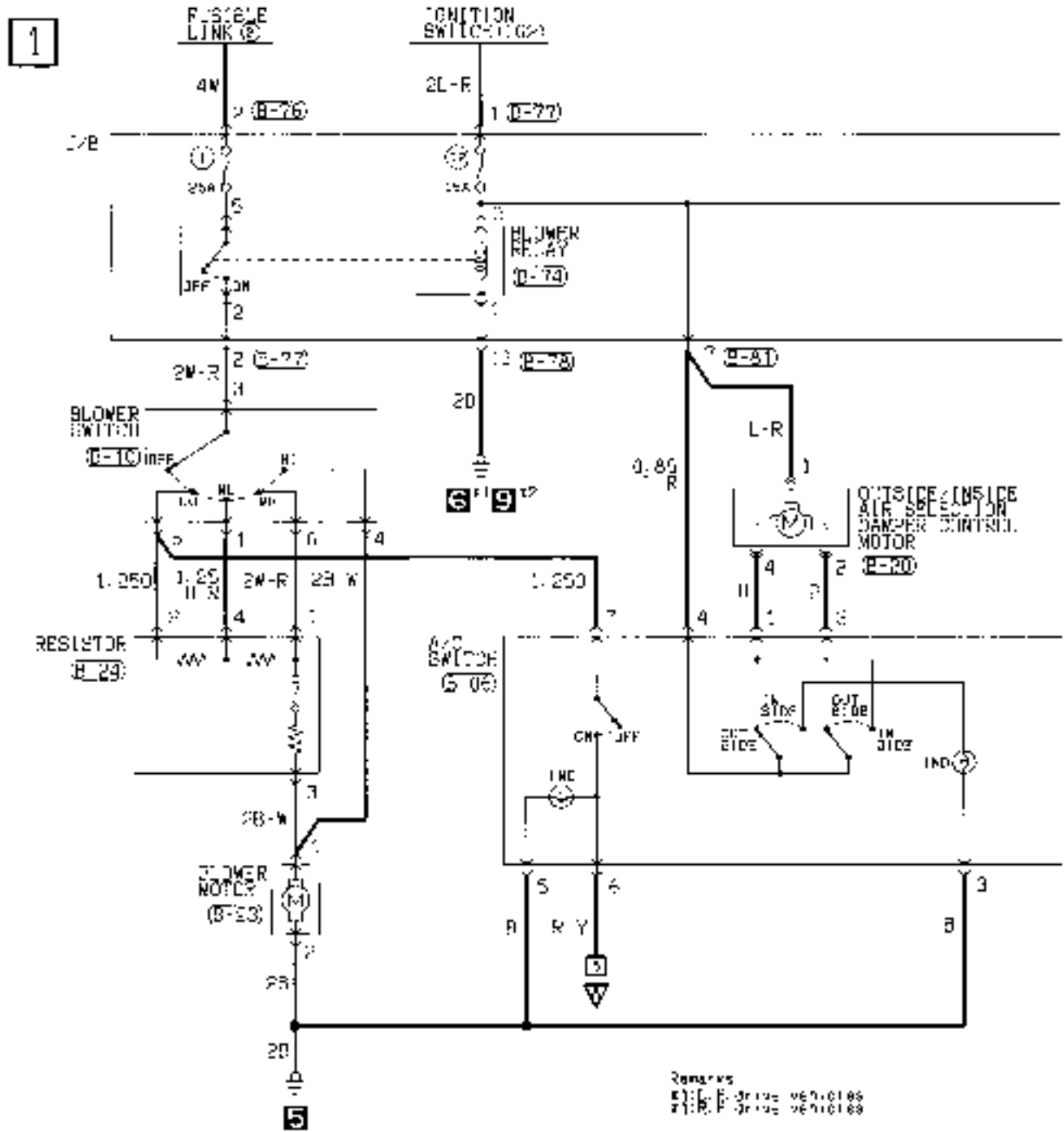

2

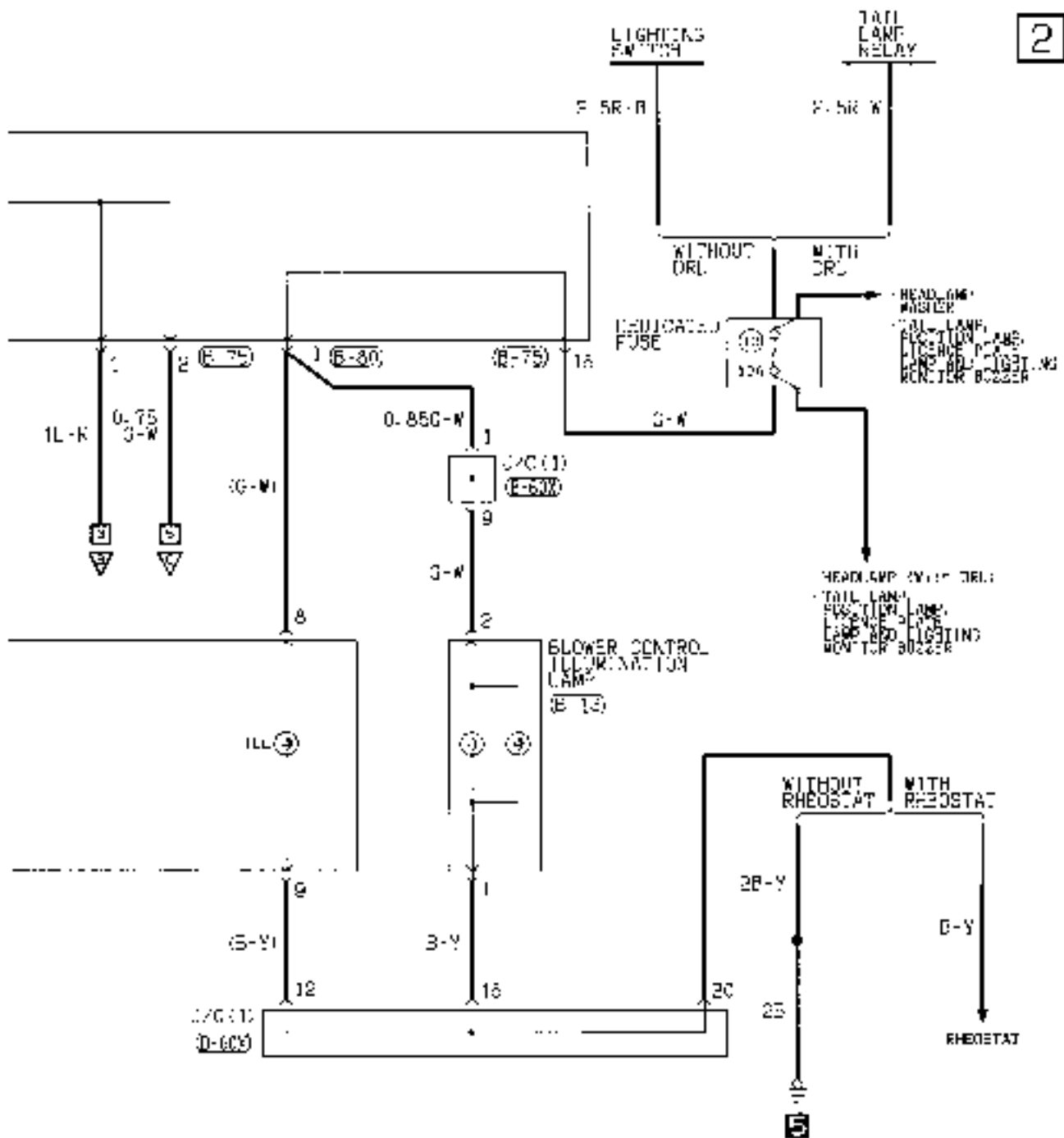

Wire color code
 B: Blue L: Light green G: Green R: Red W: White V: Violet GN: Sky blue
 BR: Brown O: Orange GR: Gray P: Pink Y: Yellow

MANUAL AIR CONDITIONER <4G13 engine> (CONTINUED)

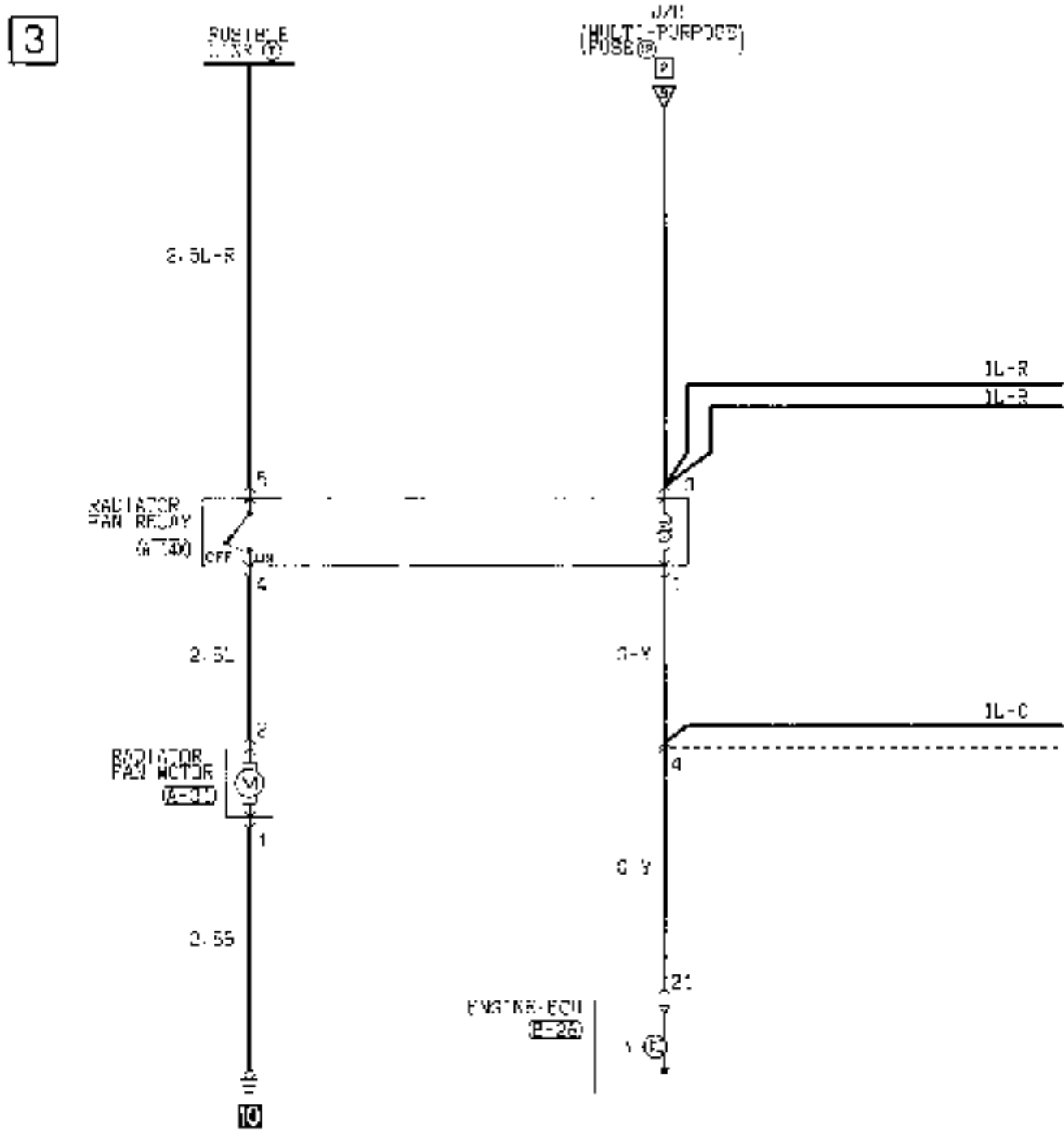

4

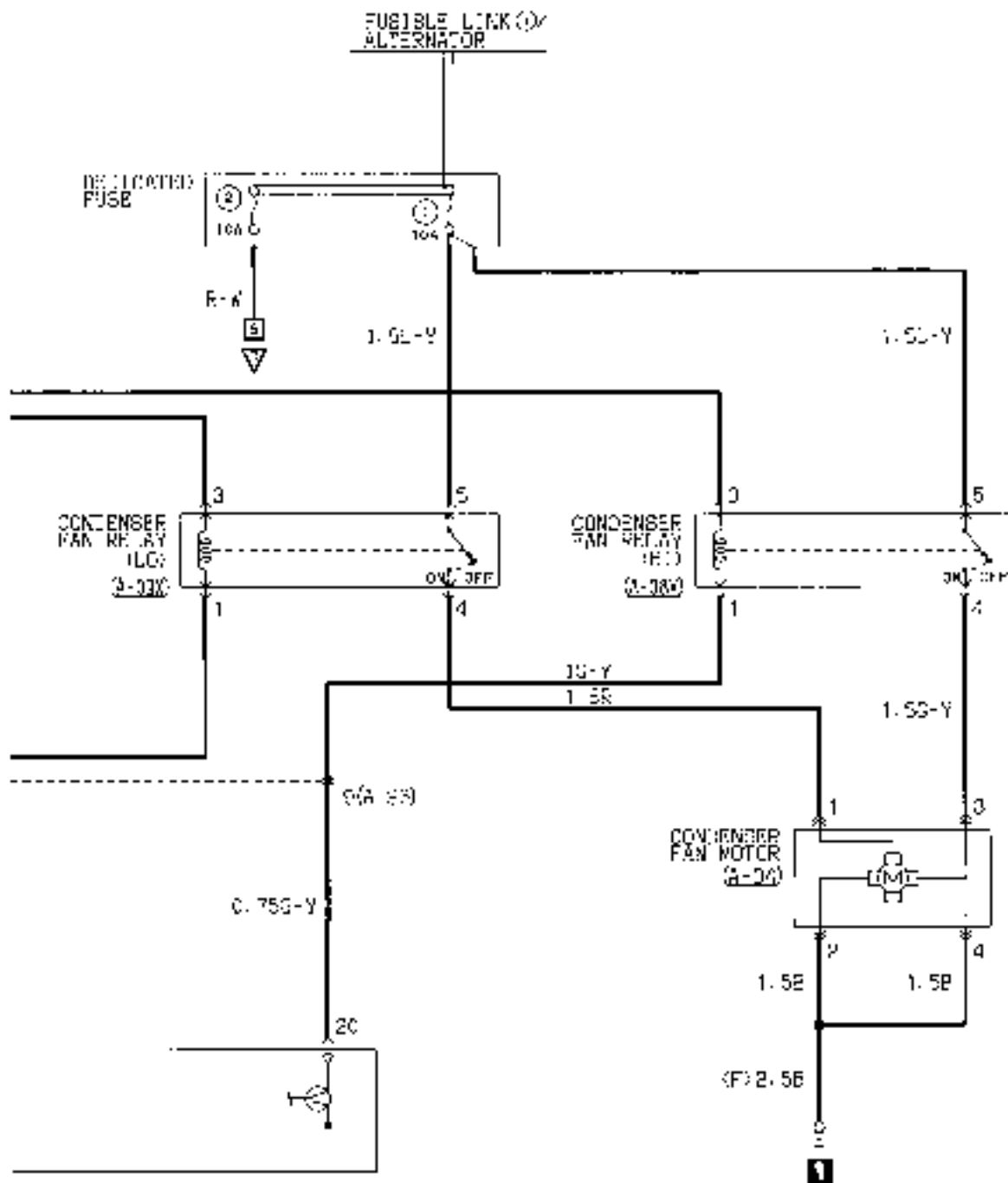

Wire colour code
 B: Black LG: Light green G: Green L: Blue W: White Y: Yellow GB: Grey blue
 BK: Brown O: Orange GR: Gray R: Red P: Pink V: Violet

MANUAL AIR CONDITIONER <4G13 engine> (CONTINUED)

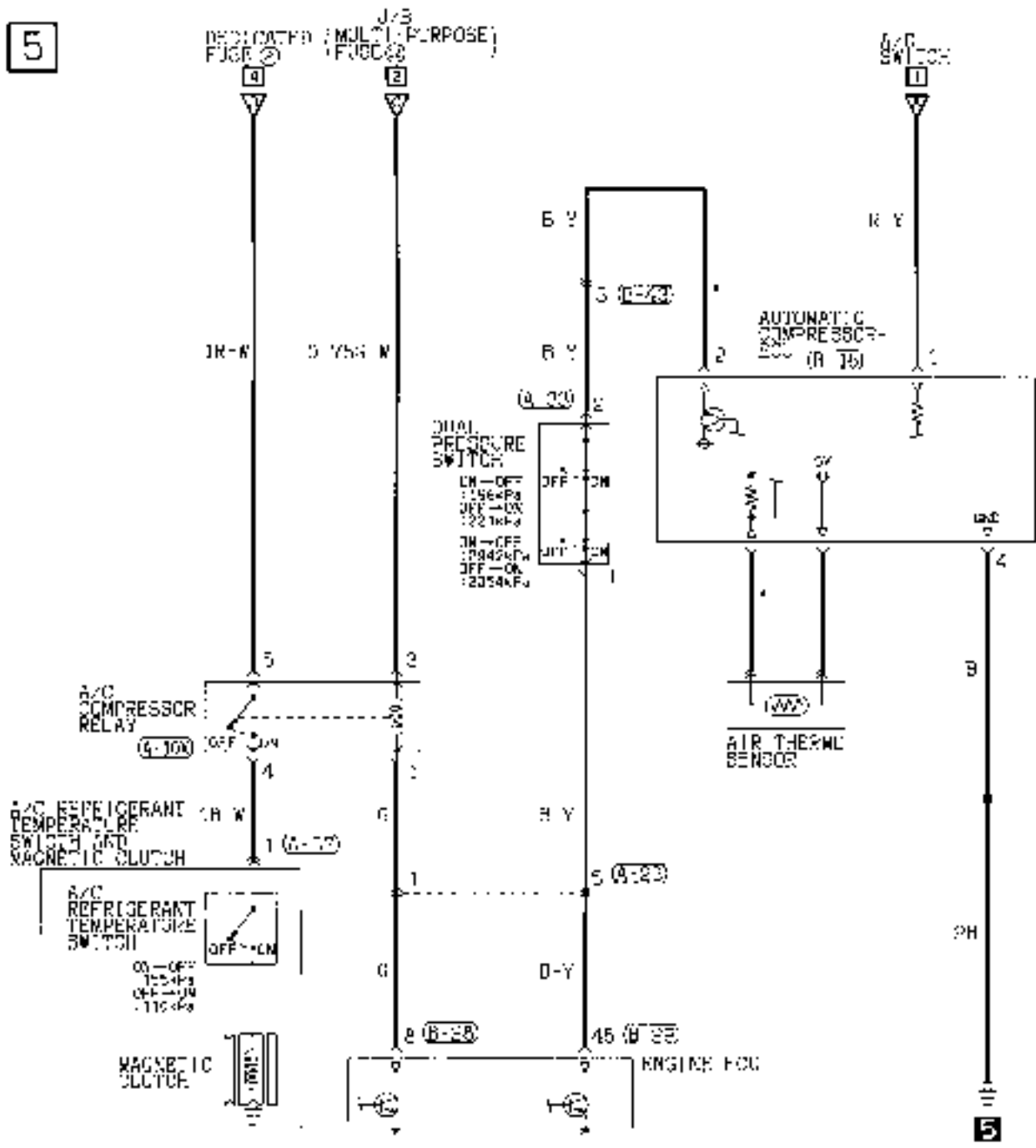

Wires color code: B: Blue, BK: Brown, LG: Light green, GR: Gray, L: Blue, R: Red, W: White, P: Pink, Y: Yellow, BR: Sky blue

NOTES

MANUAL AIR CONDITIONER

90109530540

4G93 engine

1

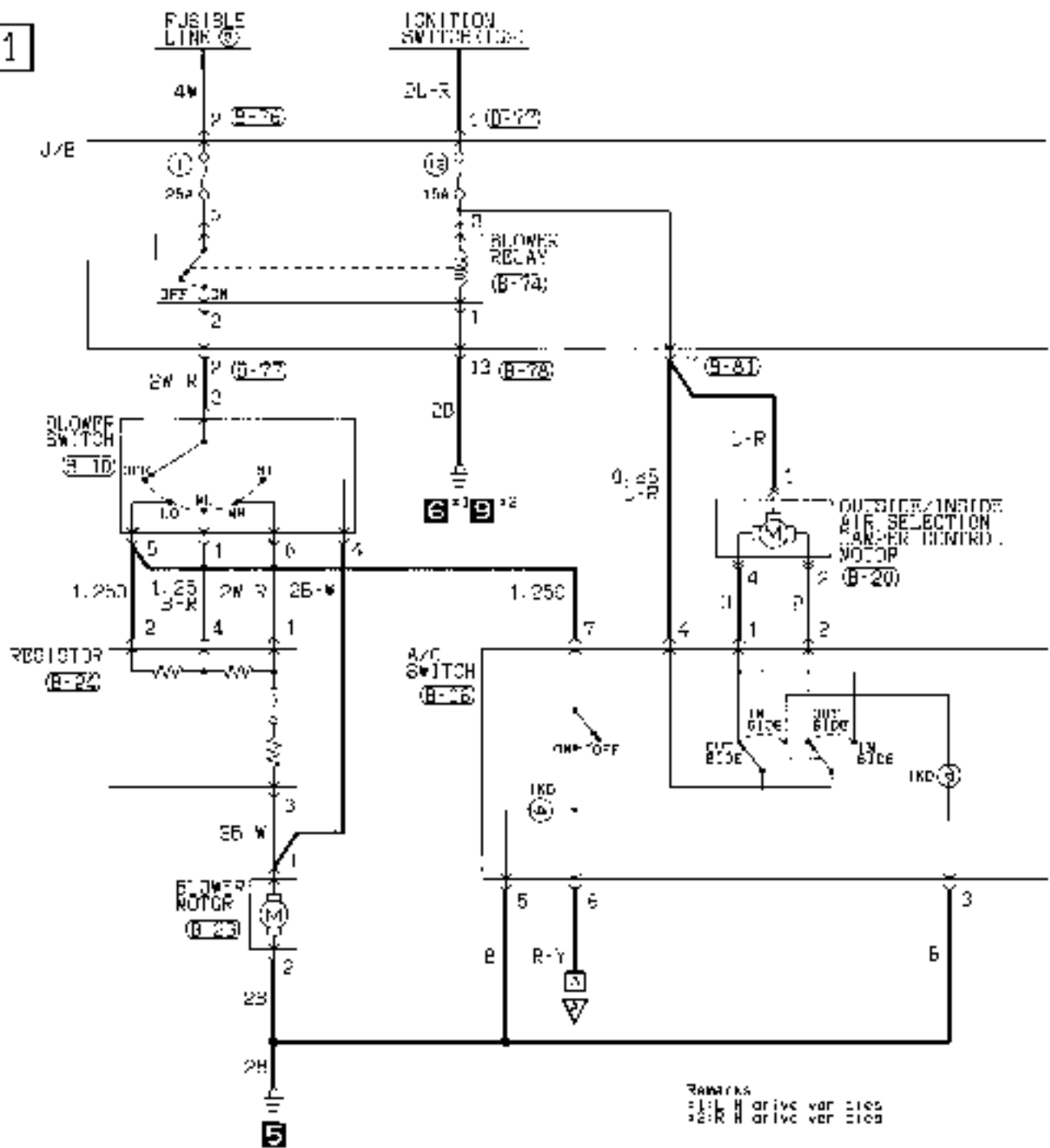

(B-25)

1	2	3	4	5	6	7	8	9	10	11	12	13	14	15	16	17	18	19	20	21	22	23	24	25	26	27	28	29	30	31	32	33	34	35	36	37	38	39	40	41	42	43	44	45	46	47	48	49	50
---	---	---	---	---	---	---	---	---	----	----	----	----	----	----	----	----	----	----	----	----	----	----	----	----	----	----	----	----	----	----	----	----	----	----	----	----	----	----	----	----	----	----	----	----	----	----	----	----	----

(B-10) (S-13)

1	2	3	4	5	6	7	8	9	10	11	12	13	14	15	16	17	18	19	20	21	22	23	24	25	26	27	28	29	30	31	32	33	34	35	36	37	38	39	40	41	42	43	44	45	46	47	48	49	50
---	---	---	---	---	---	---	---	---	----	----	----	----	----	----	----	----	----	----	----	----	----	----	----	----	----	----	----	----	----	----	----	----	----	----	----	----	----	----	----	----	----	----	----	----	----	----	----	----	----

(B-20)

1	2	3	4	5	6	7	8	9	10	11	12	13	14	15	16	17	18	19	20	21	22	23	24	25	26	27	28	29	30	31	32	33	34	35	36	37	38	39	40	41	42	43	44	45	46	47	48	49	50
---	---	---	---	---	---	---	---	---	----	----	----	----	----	----	----	----	----	----	----	----	----	----	----	----	----	----	----	----	----	----	----	----	----	----	----	----	----	----	----	----	----	----	----	----	----	----	----	----	----

(S-23)

1	2	3	4	5	6	7	8	9	10	11	12	13	14	15	16	17	18	19	20	21	22	23	24	25	26	27	28	29	30	31	32	33	34	35	36	37	38	39	40	41	42	43	44	45	46	47	48	49	50
---	---	---	---	---	---	---	---	---	----	----	----	----	----	----	----	----	----	----	----	----	----	----	----	----	----	----	----	----	----	----	----	----	----	----	----	----	----	----	----	----	----	----	----	----	----	----	----	----	----

(S-24)

1	2	3	4	5	6	7	8	9	10	11	12	13	14	15	16	17	18	19	20	21	22	23	24	25	26	27	28	29	30	31	32	33	34	35	36	37	38	39	40	41	42	43	44	45	46	47	48	49	50
---	---	---	---	---	---	---	---	---	----	----	----	----	----	----	----	----	----	----	----	----	----	----	----	----	----	----	----	----	----	----	----	----	----	----	----	----	----	----	----	----	----	----	----	----	----	----	----	----	----

(B-60)

1	2	3	4	5	6	7	8	9	10	11	12	13	14	15	16	17	18	19	20	21	22	23	24	25	26	27	28	29	30	31	32	33	34	35	36	37	38	39	40	41	42	43	44	45	46	47	48	49	50
---	---	---	---	---	---	---	---	---	----	----	----	----	----	----	----	----	----	----	----	----	----	----	----	----	----	----	----	----	----	----	----	----	----	----	----	----	----	----	----	----	----	----	----	----	----	----	----	----	----

(B-24)

1	2	3	4	5	6	7	8	9	10	11	12	13	14	15	16	17	18	19	20	21	22	23	24	25	26	27	28	29	30	31	32	33	34	35	36	37	38	39	40	41	42	43	44	45	46	47	48	49	50
---	---	---	---	---	---	---	---	---	----	----	----	----	----	----	----	----	----	----	----	----	----	----	----	----	----	----	----	----	----	----	----	----	----	----	----	----	----	----	----	----	----	----	----	----	----	----	----	----	----

(S-15)

1	2	3	4	5	6	7	8	9	10	11	12	13	14	15	16	17	18	19	20	21	22	23	24	25	26	27	28	29	30	31	32	33	34	35	36	37	38	39	40	41	42	43	44	45	46	47	48	49	50
---	---	---	---	---	---	---	---	---	----	----	----	----	----	----	----	----	----	----	----	----	----	----	----	----	----	----	----	----	----	----	----	----	----	----	----	----	----	----	----	----	----	----	----	----	----	----	----	----	----

2

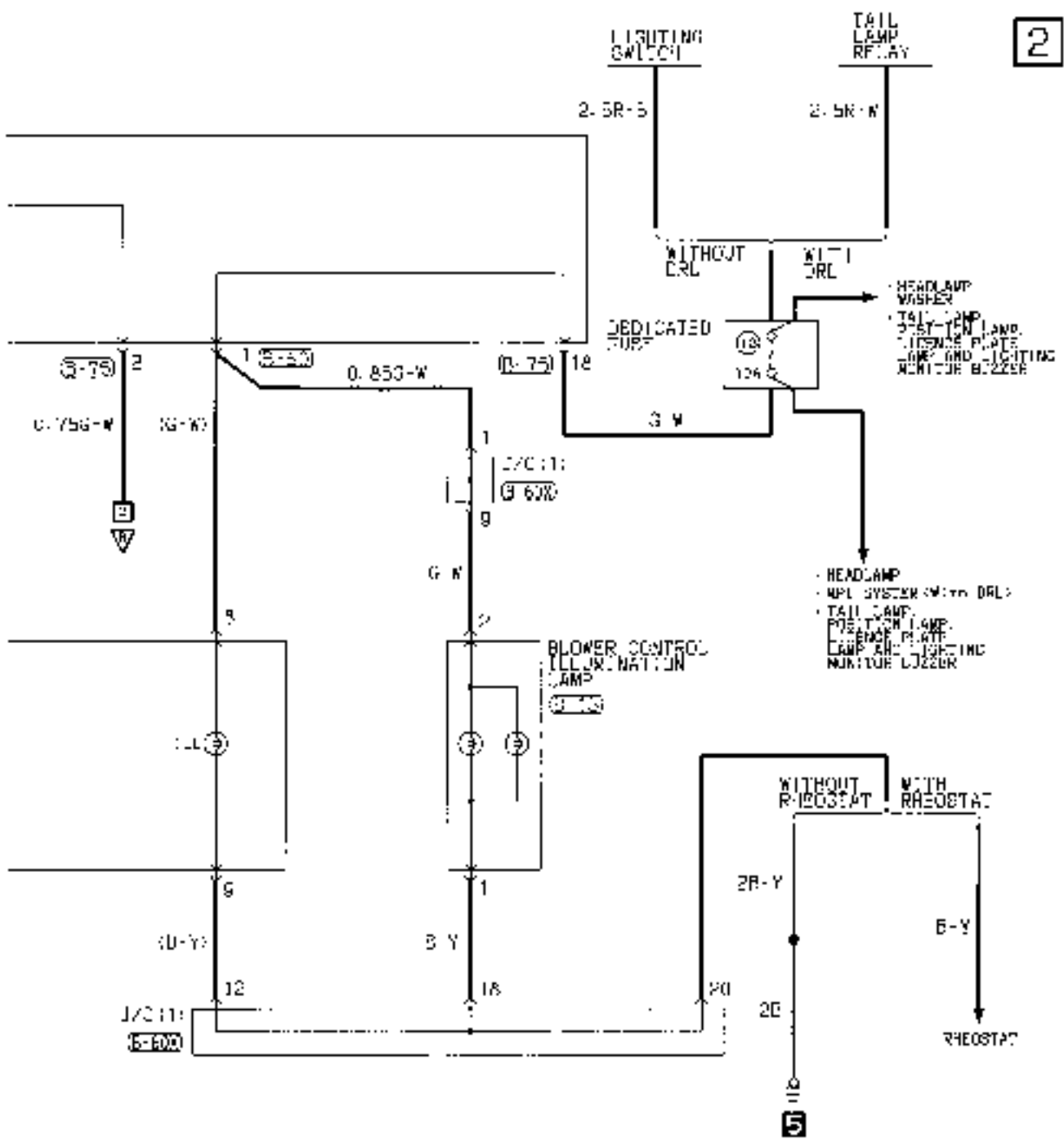

(5-76)	(5-77)	(5-78)	(5-80)	(R-81)
1 2 3 4 5 6 7 8 9 10 11 12	1 2 3 4 5 6 7 8 9 10 11 12	1 2 3 4 5 6 7 8 9 10 11 12	1 2 3 4 5 6 7 8 9 10 11 12	1 2 3 4 5 6 7 8 9 10 11 12

Wire colour code
 B: black O: light green G: Green L: blue W: white Y: Yellow BK: 5kv blue
 BR: Brown O: Orange GR: Gray R: Red P: Pink V: Violet

MANUAL AIR CONDITIONER <4G93 engine> (CONTINUED)

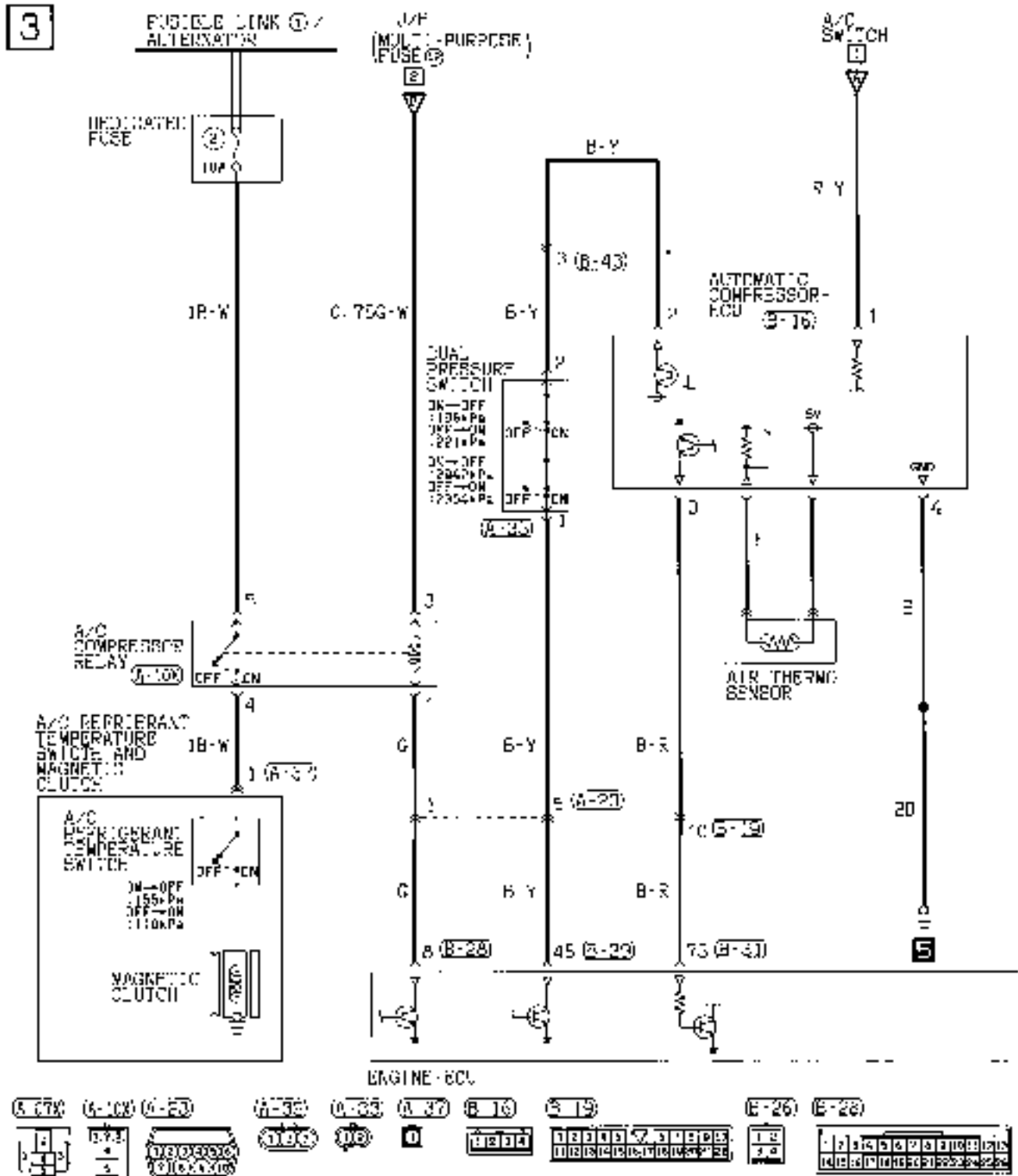

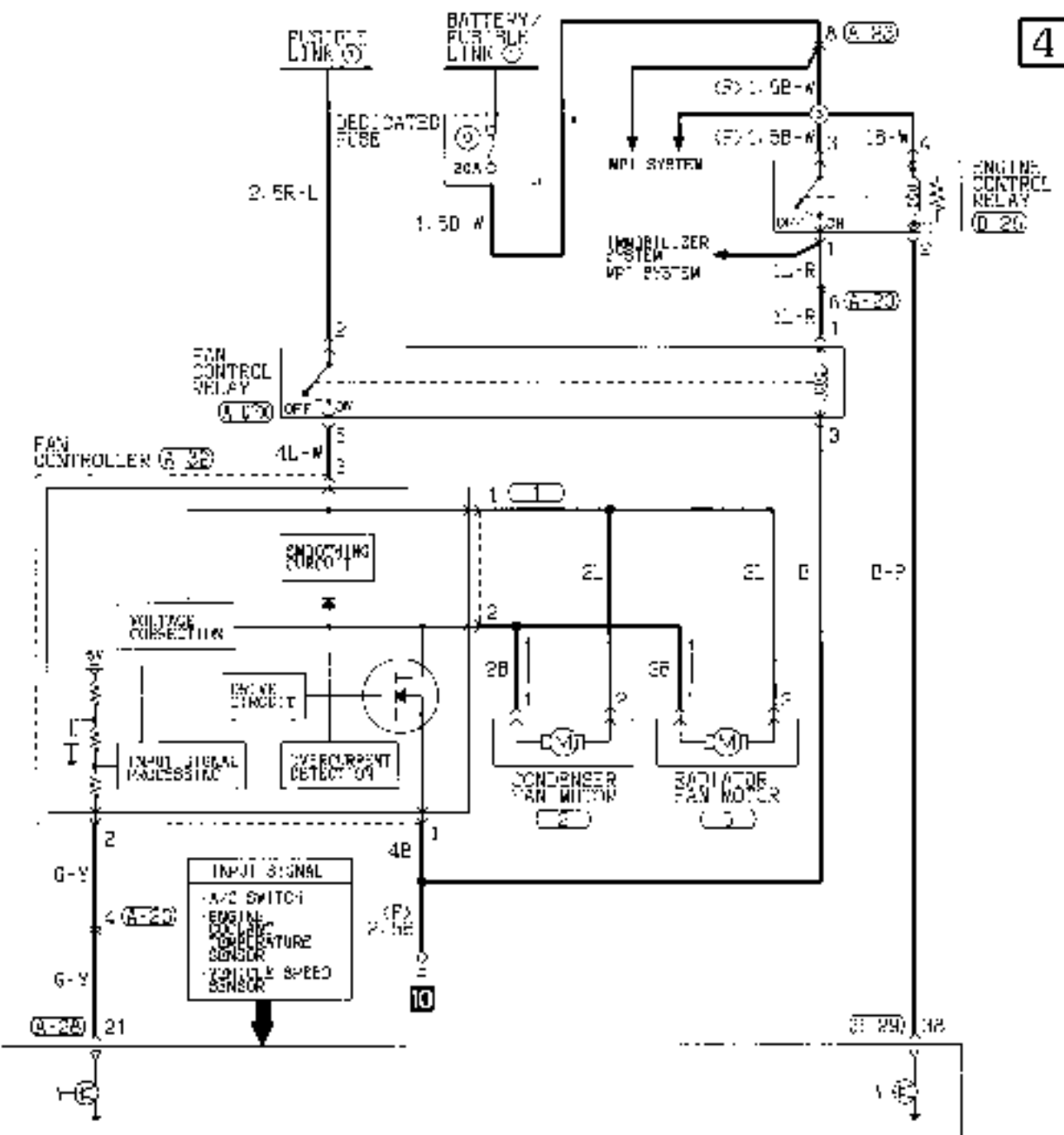

4

(E-20)

(E-11)

(E-20)

1

2

3

1	2	3	4	5	6	7	8	9	10	11	12	13	14	15	16	17	18	19	20	21	22	23	24	25	26	27	28	29	30
30	29	28	27	26	25	24	23	22	21	20	19	18	17	16	15	14	13	12	11	10	9	8	7	6	5	4	3	2	1

1	2	3	4	5	6	7	8	9	10	11	12	13	14	15	16	17	18	19	20	21	22	23	24	25	26	27	28	29	30
30	29	28	27	26	25	24	23	22	21	20	19	18	17	16	15	14	13	12	11	10	9	8	7	6	5	4	3	2	1

1	2	3	4	5	6	7	8	9	10	11	12	13	14	15	16	17	18	19	20	21	22	23	24	25	26	27	28	29	30
30	29	28	27	26	25	24	23	22	21	20	19	18	17	16	15	14	13	12	11	10	9	8	7	6	5	4	3	2	1

1	2	3	4	5	6	7	8	9	10	11	12	13	14	15	16	17	18	19	20	21	22	23	24	25	26	27	28	29	30
30	29	28	27	26	25	24	23	22	21	20	19	18	17	16	15	14	13	12	11	10	9	8	7	6	5	4	3	2	1

A: To CC, B: Blue, C: Black, D: Light green, E: Green, F: Blue, G: White, H: Yellow, I: CA, J: Sky blue
 K: Black, L: Light green, M: Green, N: Blue, O: White, P: Pink, Q: Violet
 R: Brown, S: Orange, T: Gray, U: Red, V: Pink, W: Violet

WINDSHIELD WIPER AND WASHER

99106810689

1

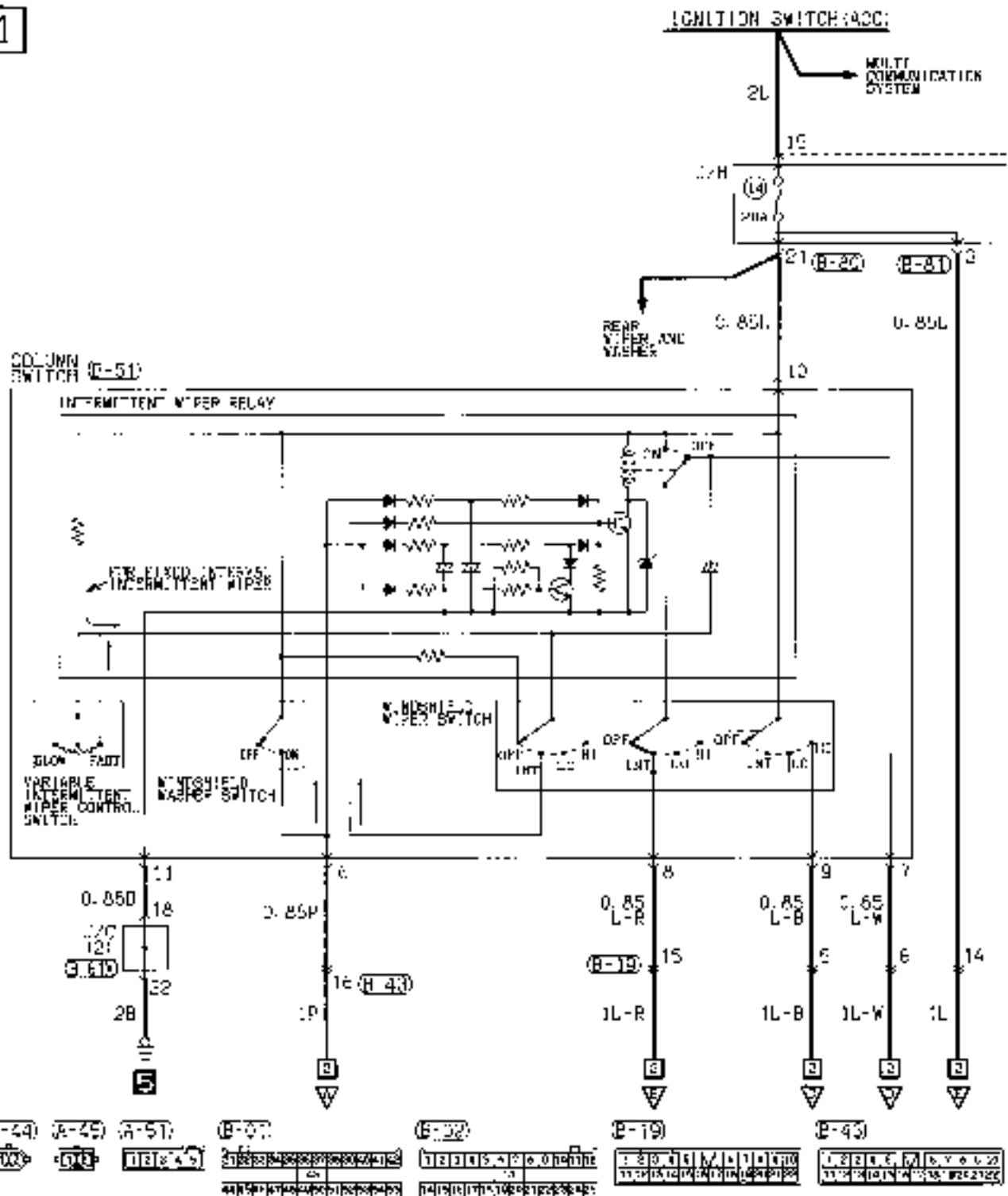

9913200AA

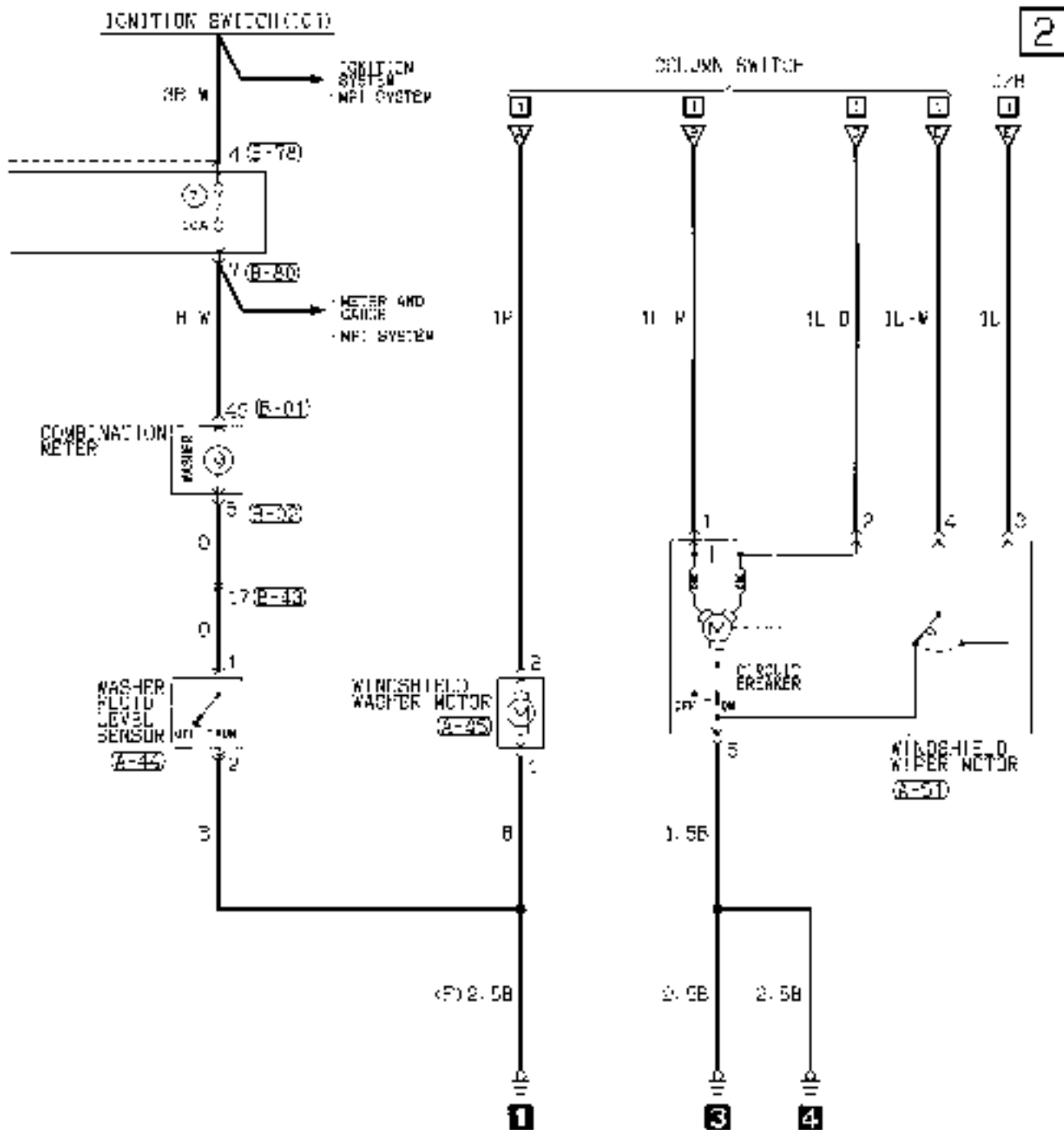

(B-51)

1	2	3	4	5	6	7	8	9	10
11	12	13	14	15	16	17	18	19	20

(B-52)

1	2	3	4	5	6	7	8	9	10
11	12	13	14	15	16	17	18	19	20

(B-78)

1	2	3	4	5	6	7	8	9	10
11	12	13	14	15	16	17	18	19	20

(B-40)

1	2	3	4	5	6	7	8	9	10
11	12	13	14	15	16	17	18	19	20

(B-01)

1	2	3	4	5	6	7	8	9	10
11	12	13	14	15	16	17	18	19	20

W:rg colour code
 B:Black LG:Light green G:Green R:Red W:White Y:Yellow SW:Sky blue
 BR:Brown O:Orange GR:Gray P:Pink V:Violet

WINDSHIELD WIPER AND WASHER (See P. 4-124.)**OPERATION****<Low-speed (and high-speed) wiper operation>**

- When the wiper switch is placed in the LO position with the ignition switch in the ACC or ON position, wipers operate continuously at low speed.
- Placing the wiper switch in the HI position causes the wipers to operate at high speed.

<Automatic wiper stopping operation>

- When the wiper switch is placed in the OFF position, the cam contacts of wiper motor caused current to flow through the automatic wiper stopping circuit allowing the wiper blades to cycle before they reach to the stop positions.

<Intermittent wiper operation>

- When the wiper switch is placed in the INT position with the ignition switch in ACC or ON position, the intermittent wiper relay is energized causing the intermittent wiper relay contacts to close and open repeatedly
- When the contacts are closed, the wiper motor is energized.
- When the wiper motor is energized, the relay contacts open, however, the cam contacts keep the wiper motor energized until the wiper blades return to their stop position.

<Washer-activated wiper operation>

- When the washer switch is turned on, the intermittent wiper relay contacts close causing wipers to cycle two to three times

TROUBLESHOOTING HINTS

1. Wipers do not operate.
 - (1) Washer is not operative, either.
 - Check multi-purpose fuse No. (14).
 - Check earth.
2. Low-speed (or high-speed) wiper operation only is inoperative.
 - Check wiper switch
3. Wipers do not stop.
 - Check wiper motor.
 - Check intermittent wiper relay
 - Check wiper switch.
4. Intermittent wiper operation is inoperative.
 - Check terminal voltage of steering-column switch (with a built-in intermittent wiper relay) with the intermittent wiper relay energized (see below)
5. The length of pause for intermittent operation cannot be varied.
 - Check variable intermittent wiper control switch
 - Check intermittent wiper relay.
6. Washer is inoperative.
 - (1) Wiper is operative on washer-activated wiper operation.
 - Check washer motor
 - (2) Washer-activated wiper operation is inoperative also.
 - Check washer switch.
7. Washer-activated wiper operation is inoperative.
 - Check intermittent wiper relay.

Terminal No	Voltage	Check
8	0V	Intermittent wiper relay or wiper switch
	System voltage	Intermittent wiper relay
	0V ↔ System voltage (alternating)	- (Normal)

REAR WIPER AND WASHER (See P. 4-126.)**OPERATION**

- When the wiper switch is placed in the ON or LO position with the ignition switch in the ACC or ON position, wipers operate continuously.

<Automatic wiper stopping operation>

- When the wiper switch is placed in the OFF position, the cam contacts of wiper motor causes current to flow through the automatic wiper stopping circuit, allowing the wiper blades to cycle before they reach to the stop positions.

<Intermittent wiper operation>

- When the wiper switch is placed in the INT position with the ignition switch in ACC or ON position, the intermittent wiper relay is energized causing the intermittent wiper relay contacts to close and open repeatedly.
- When the contacts are closed, the wiper motor is energized.
- When the wiper motor is energized, the relay contacts open, however, the cam contacts keep the wiper motor energized until the wiper blades return to their stop position.

TROUBLESHOOTING HINTS

1. Wipers do not operate.
 - (1) Washer is not operative, either.
 - Check multi-purpose fuse No. (14)
 - Check wiper switch.
2. Wipers do not stop
 - Check wiper motor
 - Check intermittent wiper relay.
 - Check wiper switch.
3. Intermittent wiper operation is inoperative.
 - While the intermittent wiper relay is being operated, check terminal voltage of the intermittent wiper relay energized (Refer to the table below)
4. Washer is inoperative
 - Check washer motor.
 - Check washer switch.

HEADLAMP WASHER (See P. 4-151)**OPERATION**

- When the headlamp washer switch is turned ON with ignition switch in ON and lighting switch in TAIL or HEAD position, the headlamp washer relay is energized causing the headlamp washer motor to start.

Terminal No.	Voltage	Check
4	0V	Intermittent wiper relay or wiper switch
	System voltage	Intermittent wiper relay
	0V ↔ System voltage (alternating)	— (Standard)

REAR WIPER AND WASHER

90180620476

1

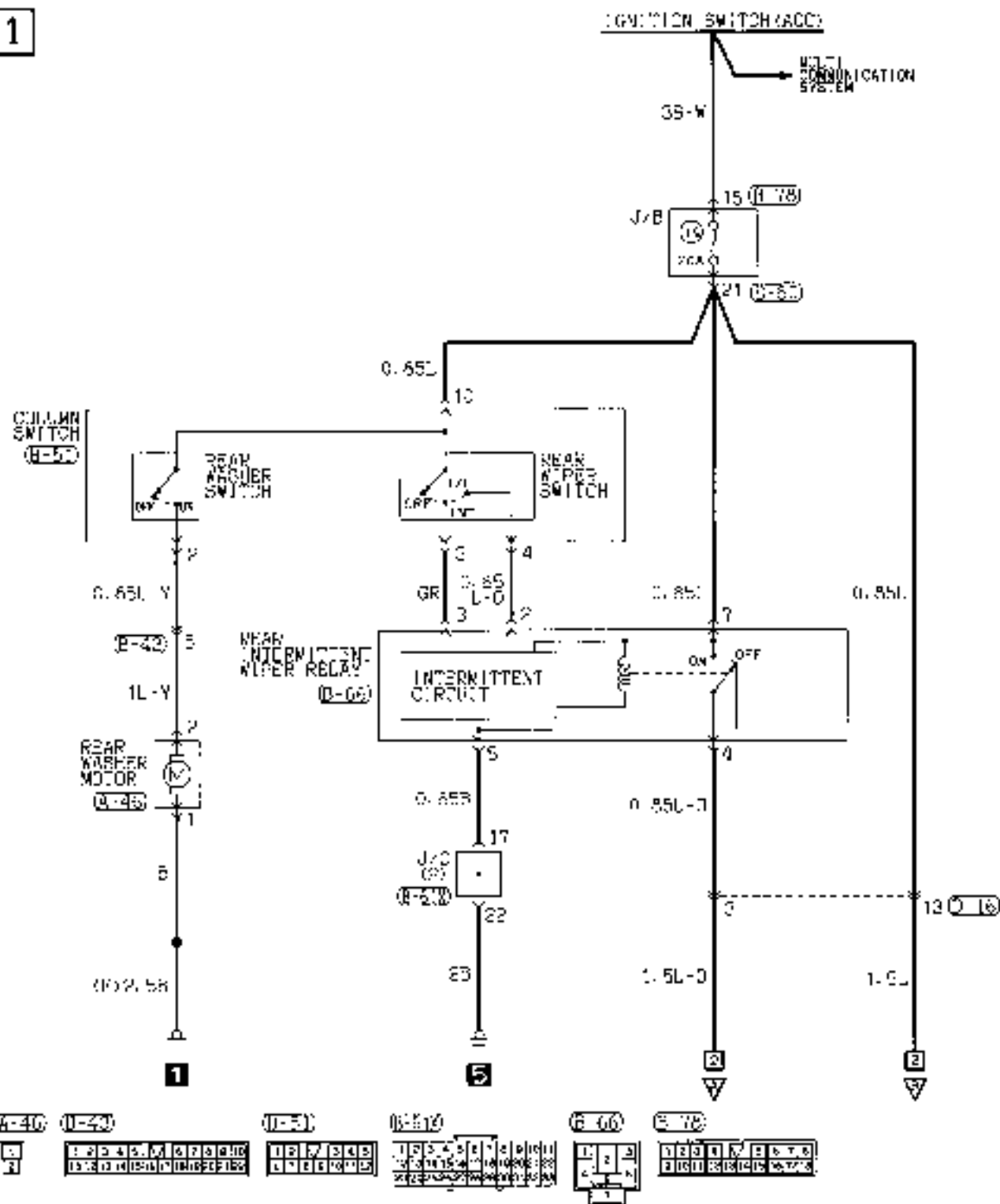

901320144

2

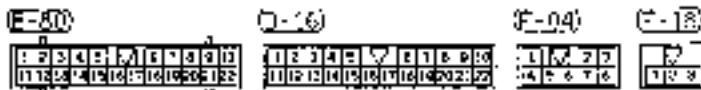
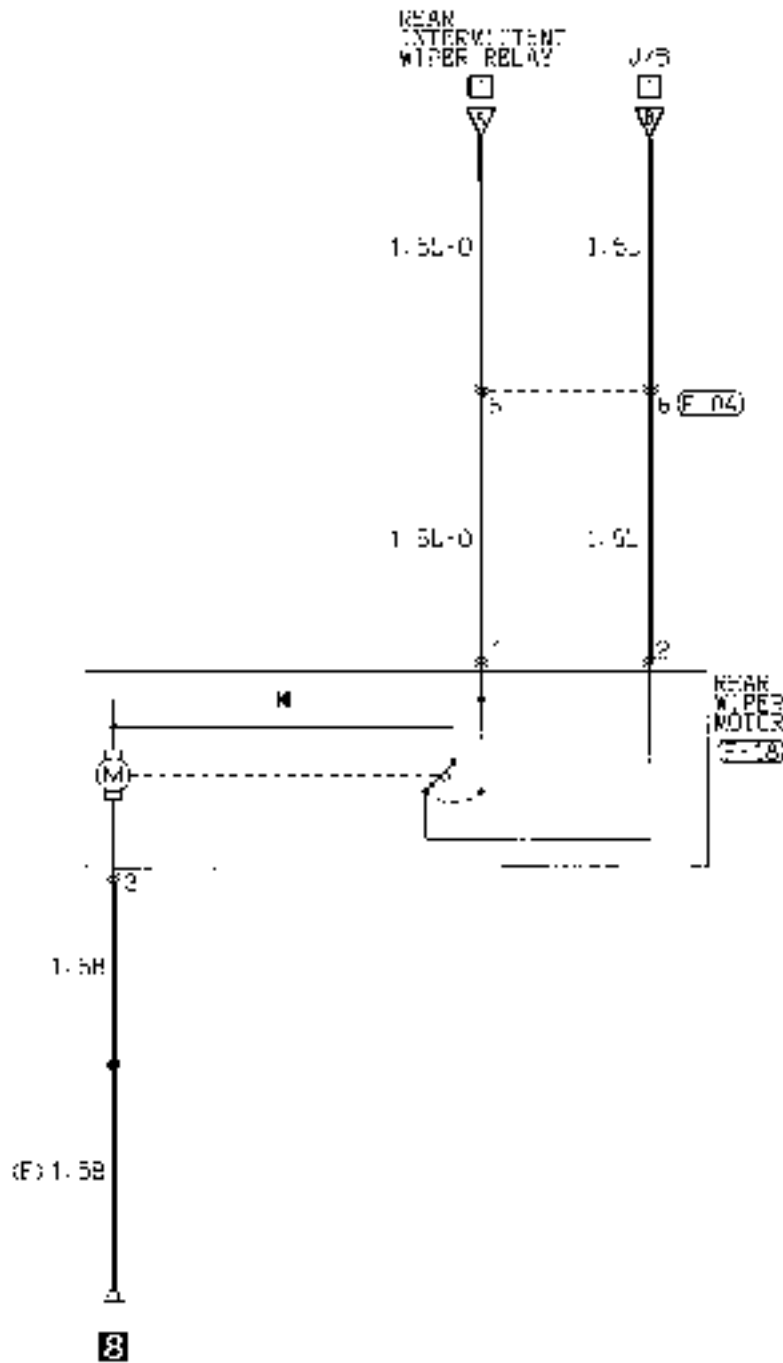

Wire color code
 B:Black G:Green GR:Gray L:Blue R:Red W:White Y:Yellow
 BR:Brown O:Orange C:Green H:Red P:Pink V:Violet
 BB:Blue

NOTES

HEADLAMP WASHER

90100630240

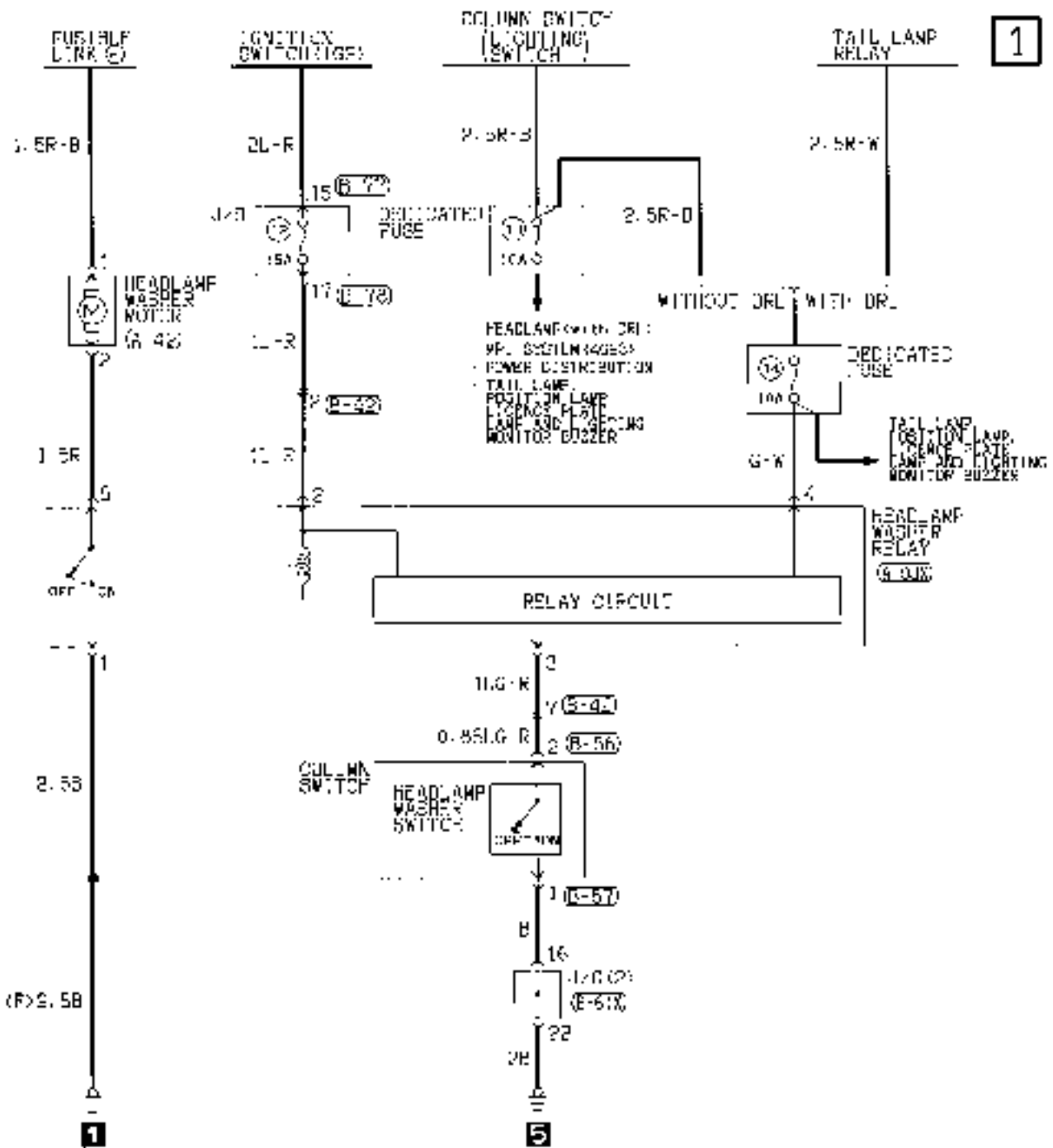

(G-42)	(G-52)	(B-22)	(G-56)	(B-57)	(B-57)	(B-77)	(B-76)

Wire colour code
 B:Black O:light green G:Green L:Blue W:White Y:Yellow SB:Sky blue
 BR:Brown O:Orange GR:Grey R:Red P:Pink V:Violet

9013E026A

DEFOGGER AND DOOR MIRROR HEATER

801 005-00119

L.H. drive vehicles

1

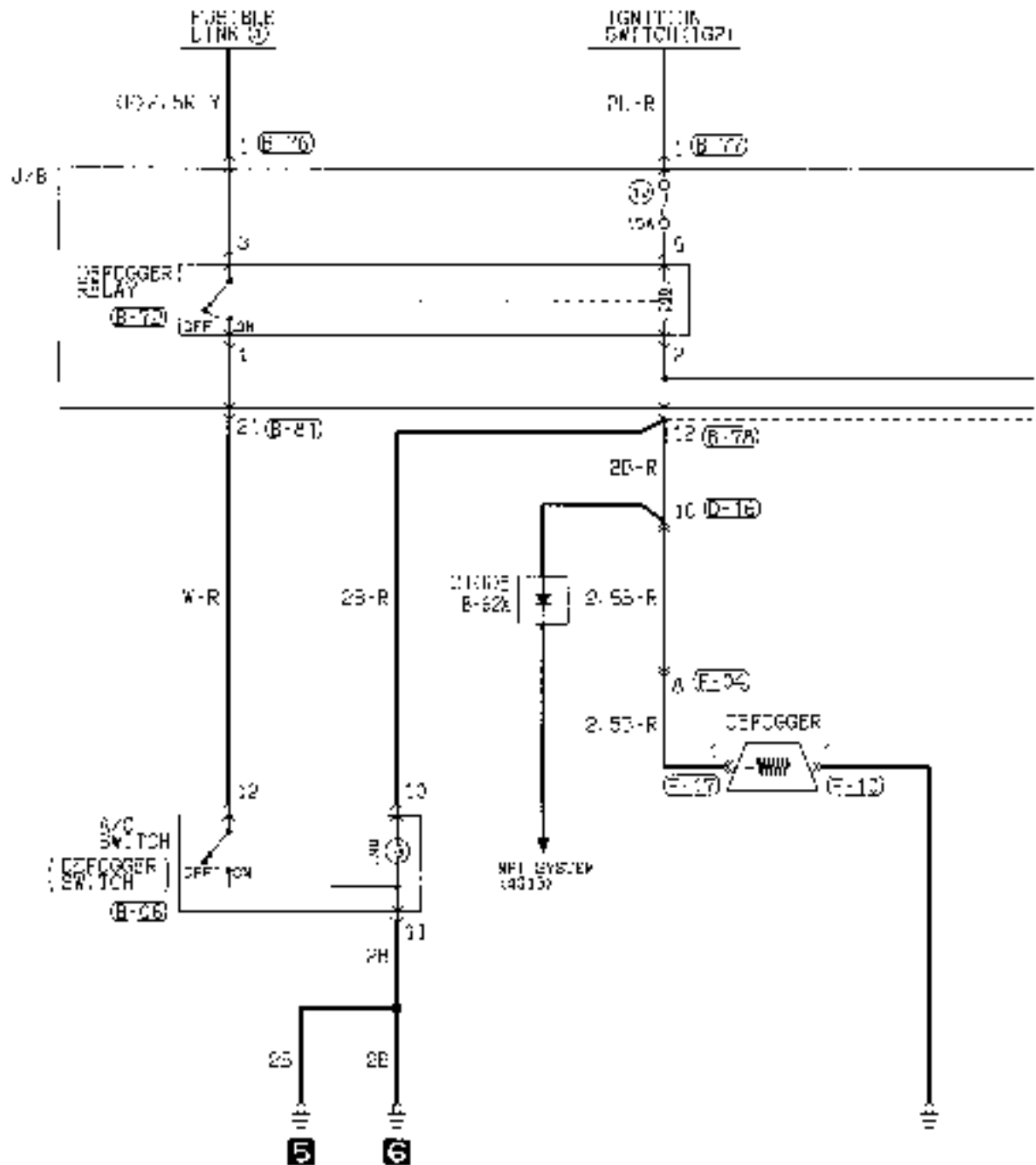

(B-66)

1	2	3	4	5	6	7	8	9	10	11	12	13	14	15	16	17	18	19	20	21	22	23	24	25	26	27	28	29	30	31	32
---	---	---	---	---	---	---	---	---	----	----	----	----	----	----	----	----	----	----	----	----	----	----	----	----	----	----	----	----	----	----	----

(B-62)

1	2	3	4	5	6	7	8	9	10	11	12	13	14	15	16	17	18	19	20	21	22	23	24	25	26	27	28	29	30	31	32
---	---	---	---	---	---	---	---	---	----	----	----	----	----	----	----	----	----	----	----	----	----	----	----	----	----	----	----	----	----	----	----

(B-41)

1	2	3	4	5	6	7	8	9	10	11	12	13	14	15	16	17	18	19	20	21	22	23	24	25	26	27	28	29	30	31	32
---	---	---	---	---	---	---	---	---	----	----	----	----	----	----	----	----	----	----	----	----	----	----	----	----	----	----	----	----	----	----	----

(B-61)

1	2	3	4	5	6	7	8	9	10	11	12	13	14	15	16	17	18	19	20	21	22	23	24	25	26	27	28	29	30	31	32
---	---	---	---	---	---	---	---	---	----	----	----	----	----	----	----	----	----	----	----	----	----	----	----	----	----	----	----	----	----	----	----

(B-72)

1	2	3	4	5	6	7	8	9	10	11	12	13	14	15	16	17	18	19	20	21	22	23	24	25	26	27	28	29	30	31	32
---	---	---	---	---	---	---	---	---	----	----	----	----	----	----	----	----	----	----	----	----	----	----	----	----	----	----	----	----	----	----	----

(B-76)

1	2	3	4	5	6	7	8	9	10	11	12	13	14	15	16	17	18	19	20	21	22	23	24	25	26	27	28	29	30	31	32
---	---	---	---	---	---	---	---	---	----	----	----	----	----	----	----	----	----	----	----	----	----	----	----	----	----	----	----	----	----	----	----

(B-70)

1	2	3	4	5	6	7	8	9	10	11	12	13	14	15	16	17	18	19	20	21	22	23	24	25	26	27	28	29	30	31	32
---	---	---	---	---	---	---	---	---	----	----	----	----	----	----	----	----	----	----	----	----	----	----	----	----	----	----	----	----	----	----	----

2

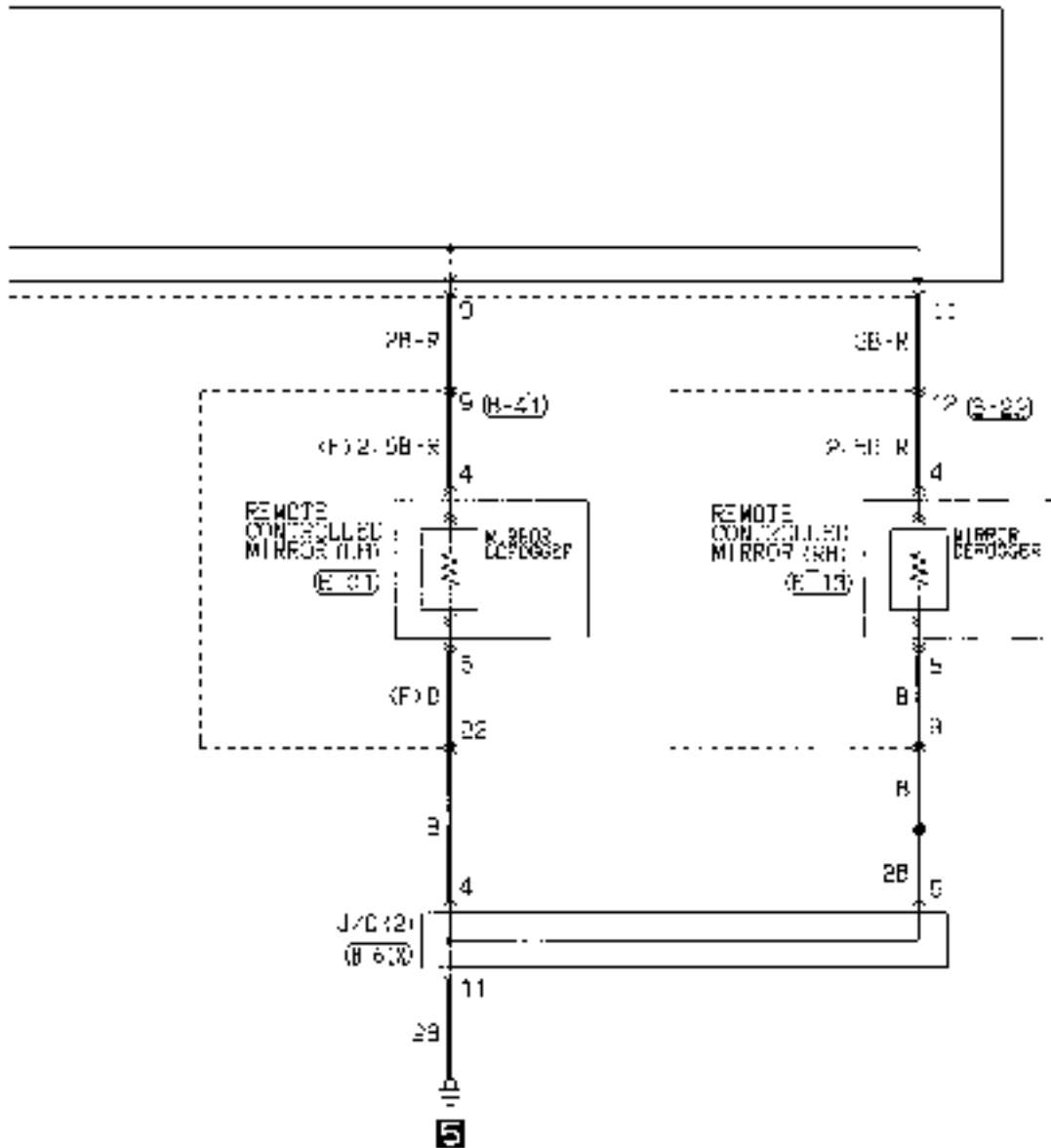

(B-78)	(B-81)	(D-16)	(F-02)	(E-13)	(F-04)	(F-10)	(F-17)
1 2 3 4 5 6 7 8 9 10 11 12 13 14 15 16	1 2 3 4 5 6 7 8 9 10 11 12 13 14 15 16 17 18 19 20	1 2 3 4 5 6 7 8 9 10 11 12 13 14 15 16 17 18 19 20	0 0 0 0 0 0	0 0 0 0 0 0	0 1 0 0 0 0	1 1	1 1

Wire colour code
 B:Black LG:Light green G:Green L:Blue W:White Y:Yellow 2B:Sky blue
 BR:Brown O:Orange GR:Gray R:Red P:Pink V:Violet

DEFOGGER AND DOOR MIRROR HEATER

90100640629

R.H. drive vehicles

1

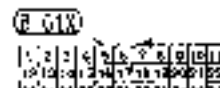
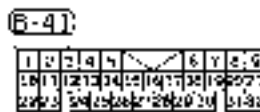
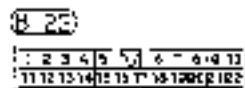
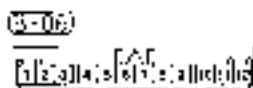
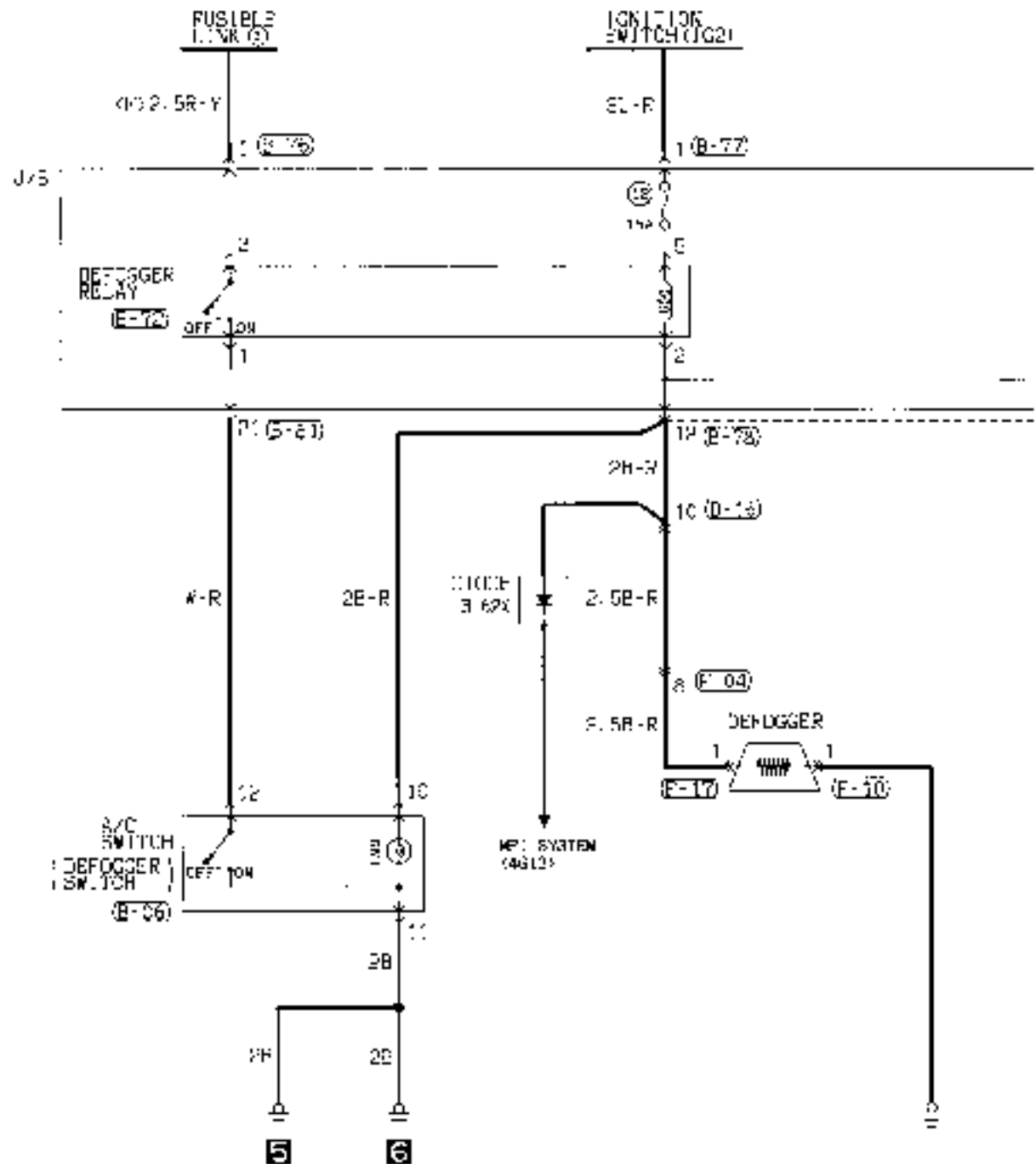

2

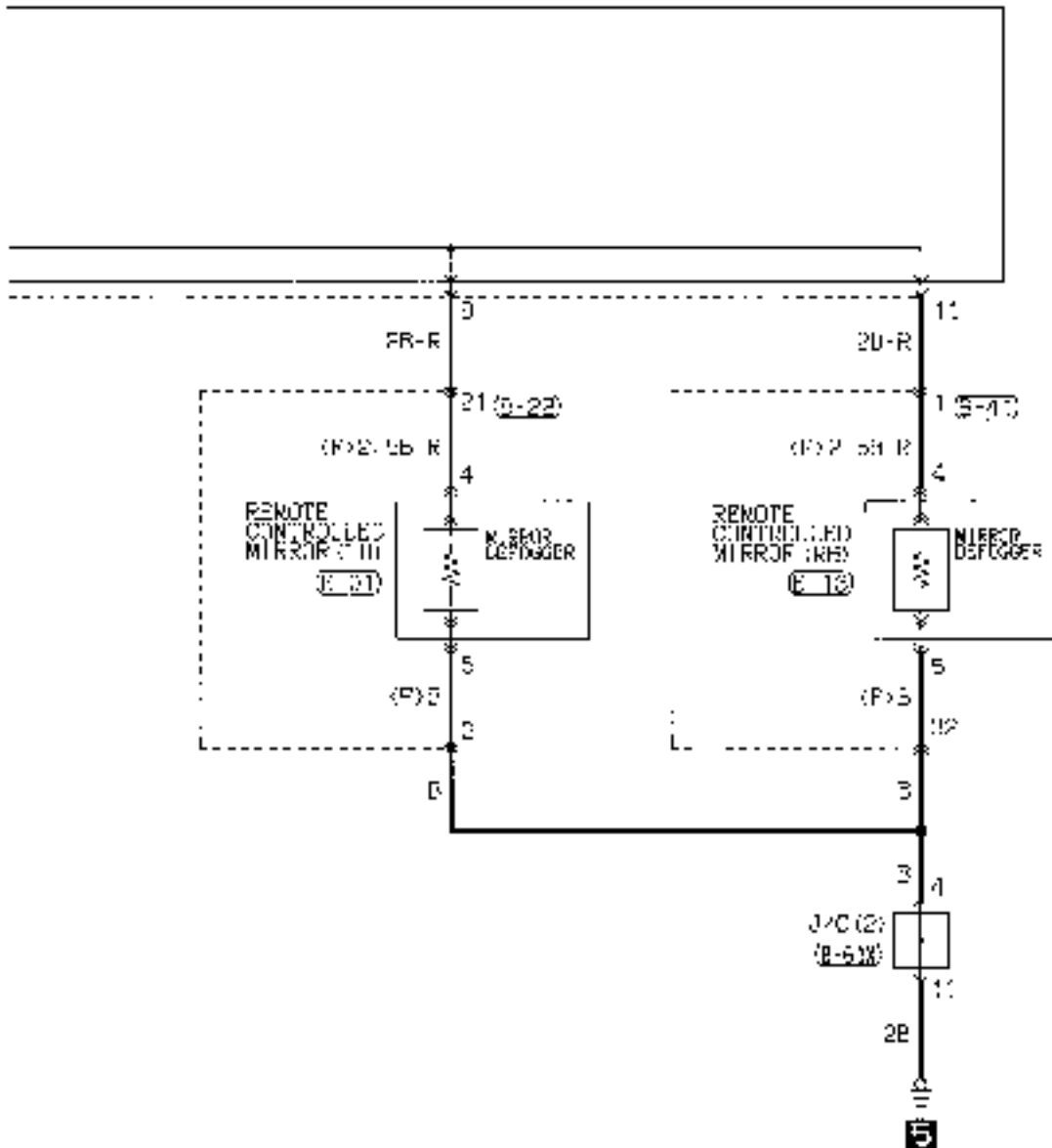

(E-21)	(E-22)	(E-13)	(E-14)	(E-51)	(E-10)	(E-17)
1 2 3 4 5 6 7 8 9 10	1 2 3 4 5 6 7 8 9 10	1 2 3 4 5 6 7 8 9 10	0 0 0 0 0 0 0 0 0 0	0 0 0 0 0 0 0 0 0 0	1 1 1 1 1 1 1 1 1 1	1 1
1 0 0 1 5 1 5 1 5 1 5	1 1 2 2 1 1 5 1 7 1 1 1 2 1 2 1 2 2	1 1 2 2 1 1 5 1 7 1 1 1 2 1 2 1 2 2			1 1 1 1 1 1 1 1 1 1	

Wire colour code
 B: Black LG: Light green G: Green L: Blue W: White Y: Yellow SB: Sky blue
 BR: Brown O: Orange GR: Gray k: Red P: Pink V: Violet

REMOTE CONTROLLED MIRROR

99100810005

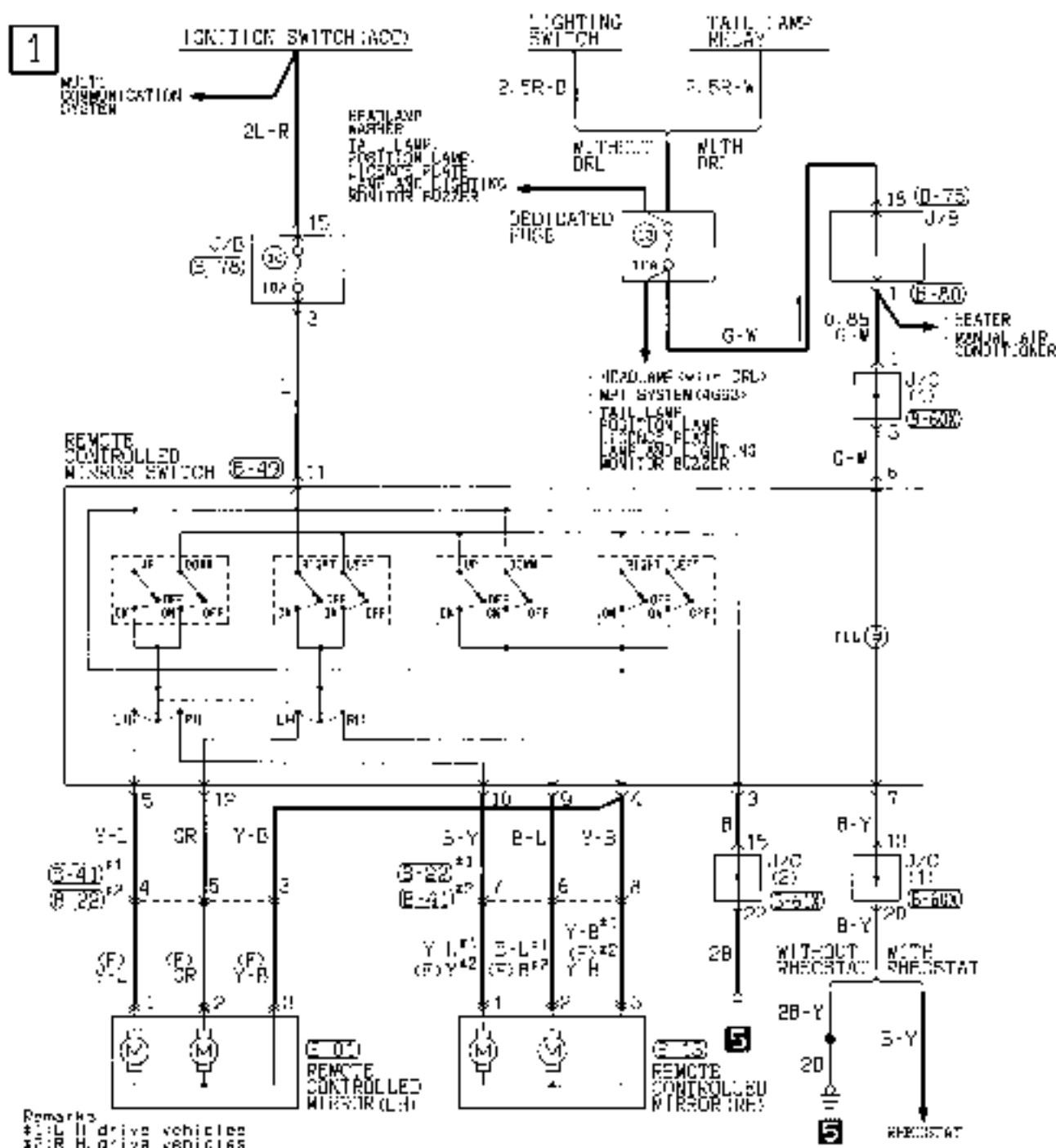

Remarks
 #1: L.H. drive vehicles
 #2: R.H. drive vehicles

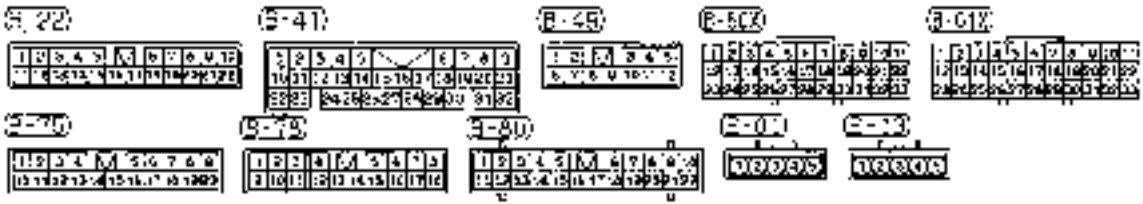

CIGARETTE LIGHTER

90100780457

1

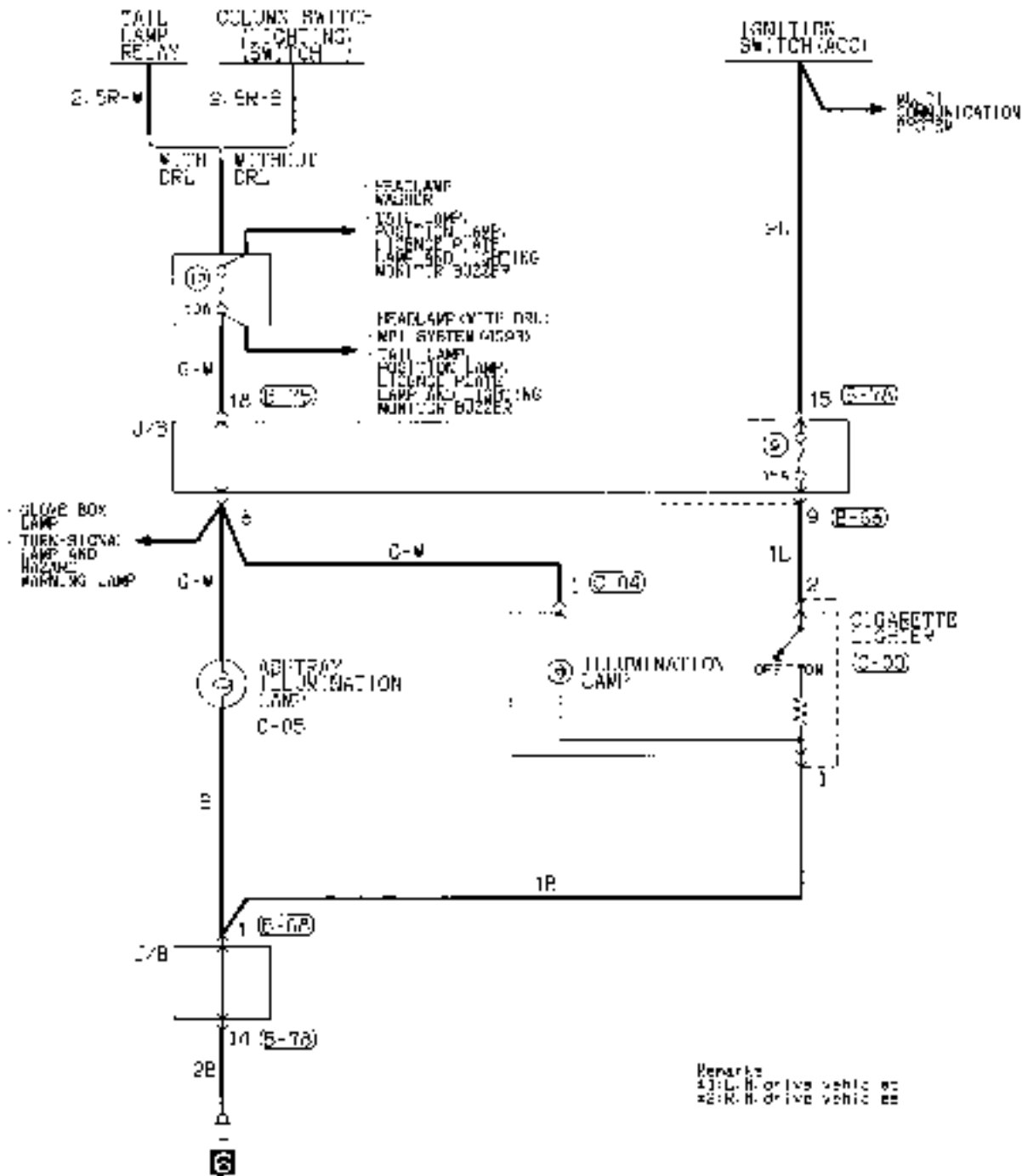

Remarks
 11: L.H. drive vehicle
 22: R.H. drive vehicle

R-60	R-75	R-78	C-00	C-04
1 2 3 4 5 6 7 8 9 10 11 12 13 14 15 16 17 18 19 20 21 22 23 24 25 26 27 28 29 30 31 32	1 2 3 4 5 6 7 8 9 10 11 12 13 14 15 16 17 18 19 20 21 22 23 24 25 26 27 28 29 30 31 32	1 2 3 4 5 6 7 8 9 10 11 12 13 14 15 16 17 18 19 20 21 22 23 24 25 26 27 28 29 30 31 32	1 2 3 4 5 6 7 8 9 10 11 12 13 14 15 16 17 18 19 20 21 22 23 24 25 26 27 28 29 30 31 32	1 2 3 4 5 6 7 8 9 10 11 12 13 14 15 16 17 18 19 20 21 22 23 24 25 26 27 28 29 30 31 32

Wire color code
 B: Black L: Light green G: Green L: Blue A: Air In Y: Yellow SB: Sky blue
 BR: Brown O: Orange GR: Gray R: Red P: Pink V: Violet

MULTI CENTER DISPLAY

90100750021

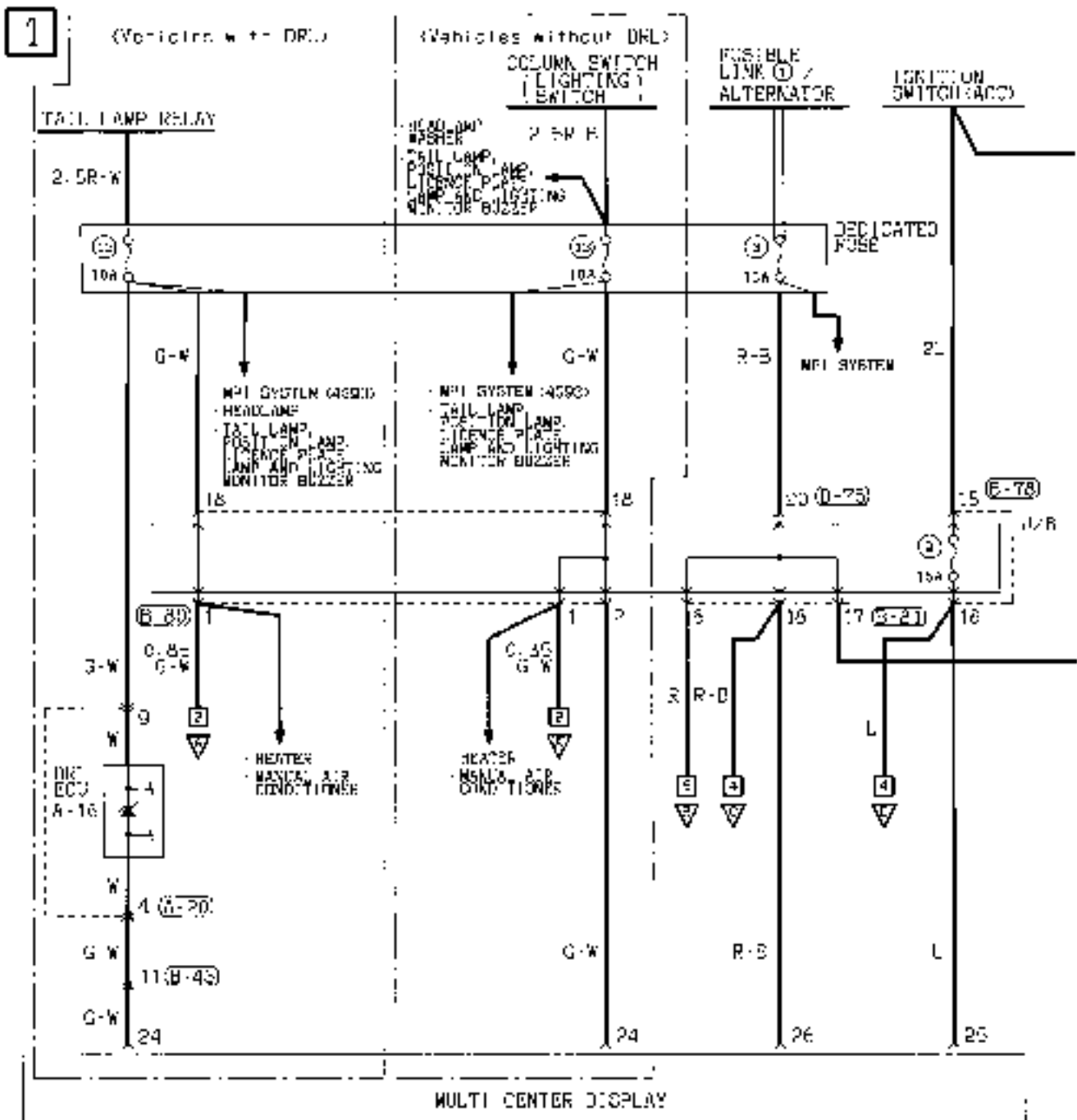

<p>(A-20)</p> <p>00000 00000</p>	<p>(C-25)</p> <p>00000 M 00000 00000 00000</p>	<p>(E-22)</p> <p>00000</p>	<p>(G-08)</p> <p>00000 00000 00000</p>	<p>(E-11)</p> <p>00000 00000</p>	<p>(E-22)</p> <p>00000 00000</p>	<p>(E-24)</p> <p>00000</p>
<p>(E-14)</p> <p>00000 00000</p>	<p>(E-25)</p> <p>00000 M 00000 00000 00000</p>	<p>(E-26)</p> <p>00000 00000</p>	<p>(E-15)</p> <p>00000 00000</p>	<p>(E-17)</p> <p>00000 00000</p>	<p>(E-10)</p> <p>00000</p>	<p>(E-12)</p> <p>00000</p>

90100750021

2

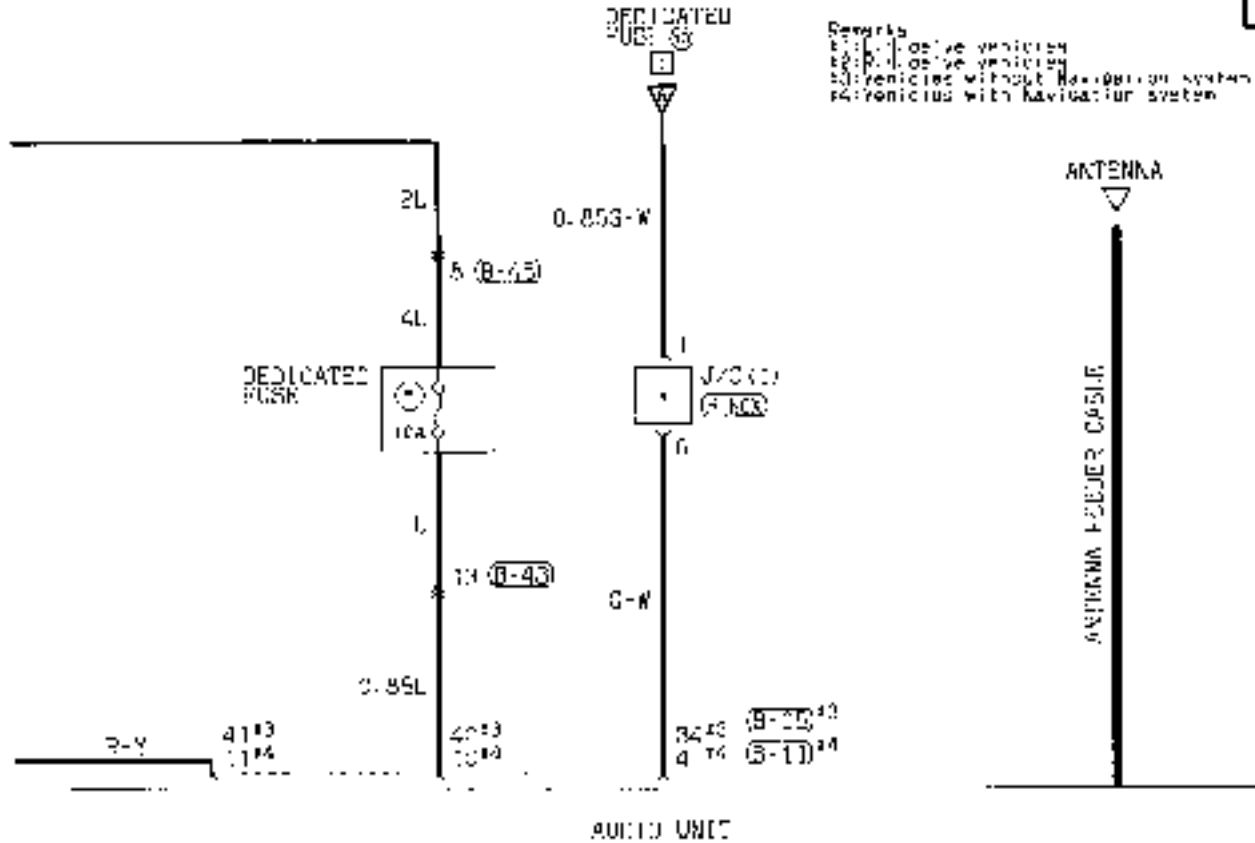

Remarks
 1: For active vehicles
 2: For passive vehicles
 3: Vehicles without Navigation System
 4: Vehicles with Navigation System

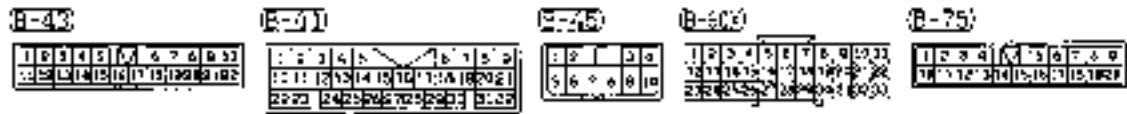
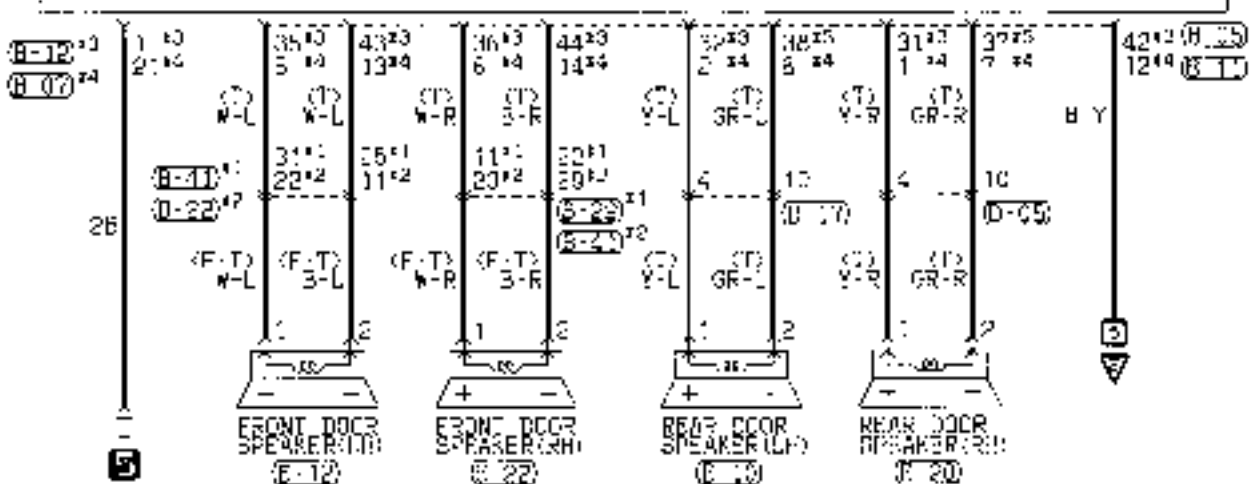

B-43 **B-75** **B-60** **B-75**

1	2	3	4	5	6	7	8	9	10	11	12
13	14	15	16	17	18	19	20	21	22	23	24

 Wire colour code
 B: Black G: Light green G: Green R: Red W: White Y: Yellow SB: Sky blue
 BK: Brown O: Orange GR: Gray R: Red P: Pink V: Violet

MULTI CENTER DISPLAY (CONTINUED)

3

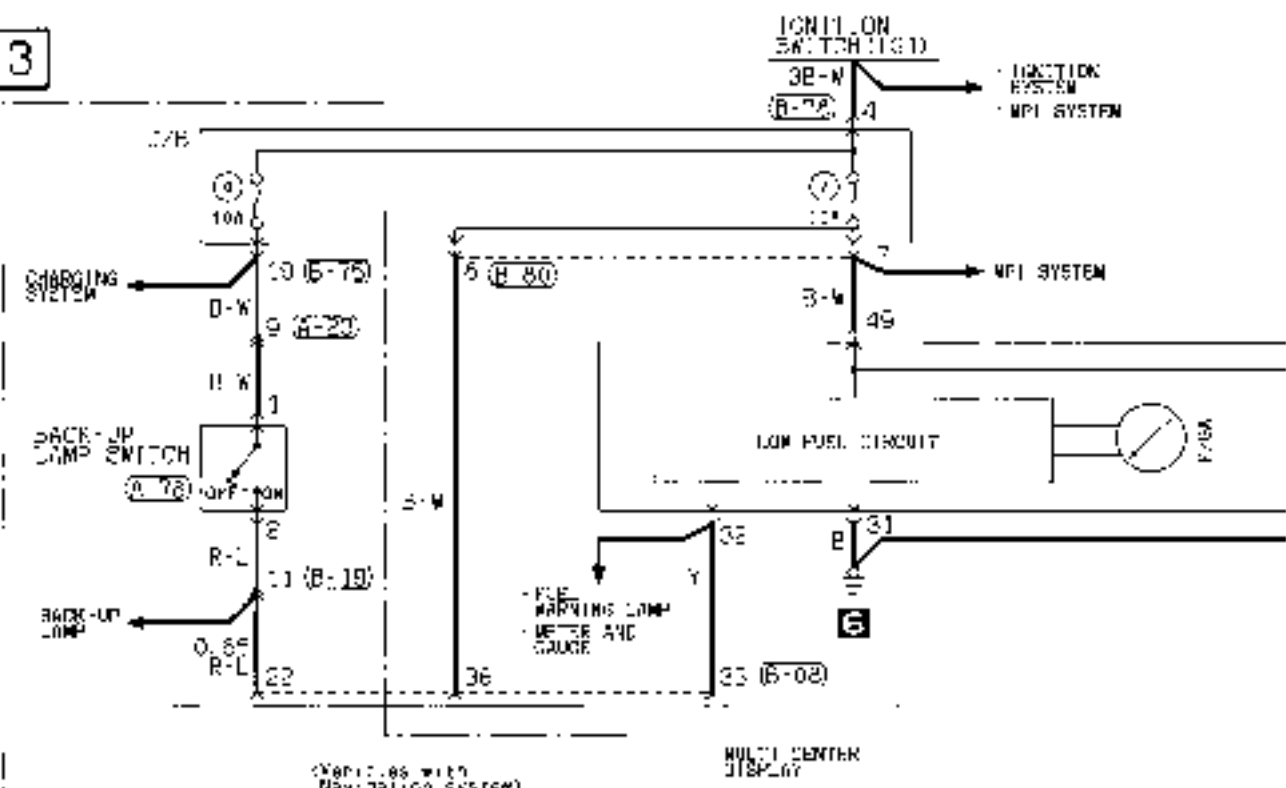

(Vehicles with Navigation System)

MULTI CENTER DISPLAY

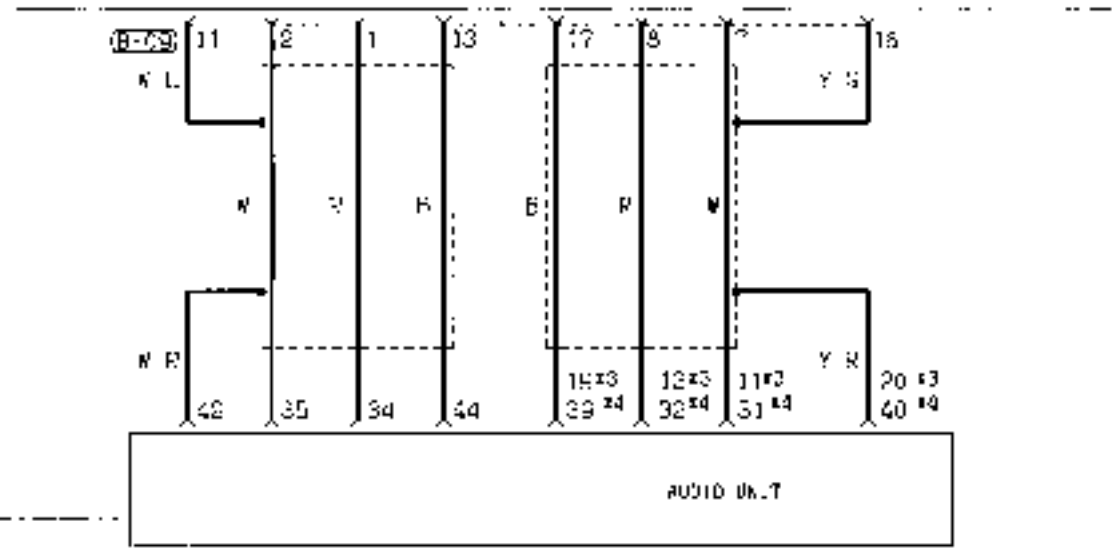

R-35 x2 R-02 x4



4

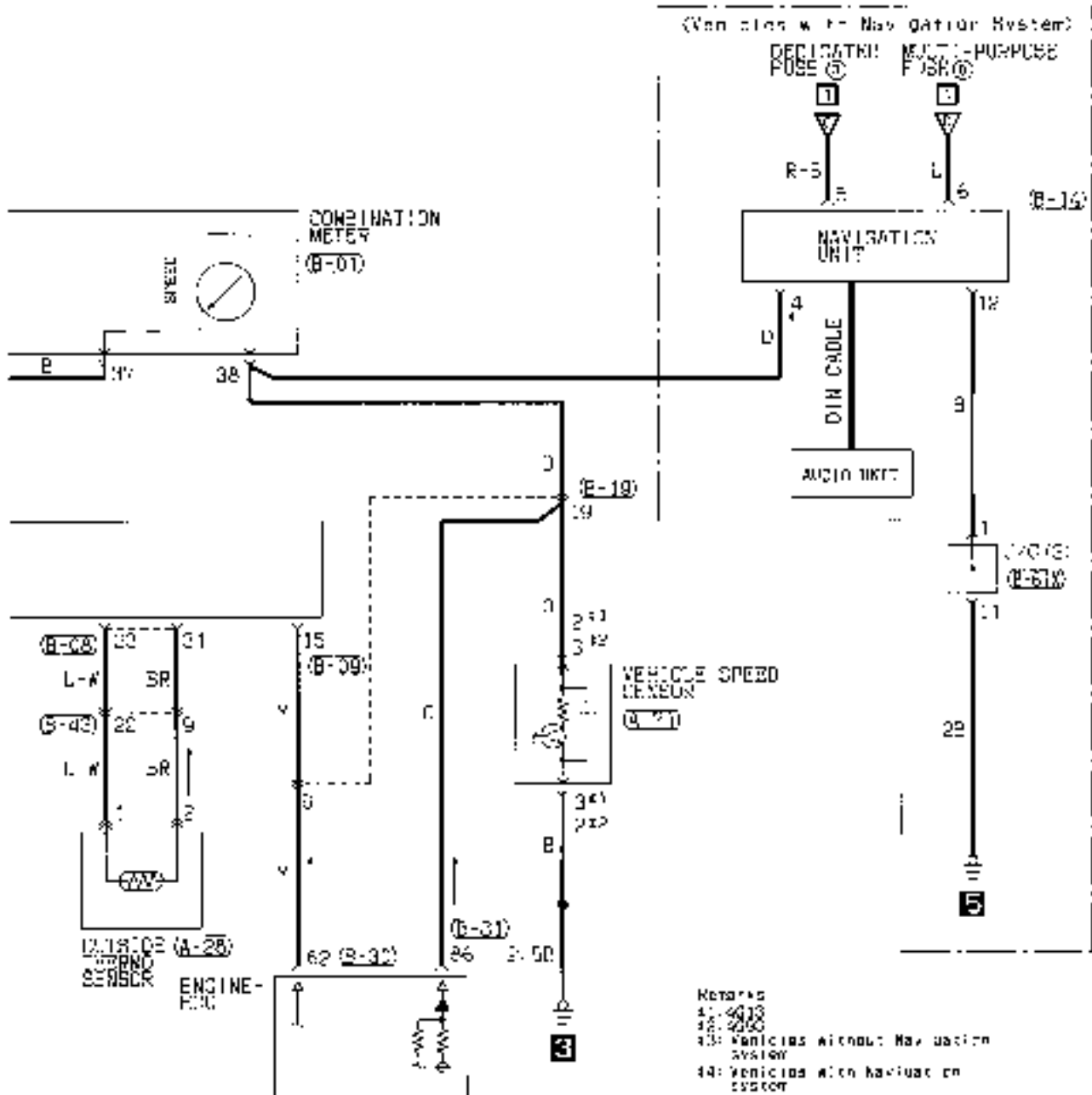

(B-07)

1	2	3	4	5	6	7	8	9	10	11	12	13	14	15	16	17	18	19	20	21	22	23	24	25	26	27	28	29	30	31	32	33	34	35	36	37	38	39	40
---	---	---	---	---	---	---	---	---	----	----	----	----	----	----	----	----	----	----	----	----	----	----	----	----	----	----	----	----	----	----	----	----	----	----	----	----	----	----	----

(B-14)

1	2	3	4	5	6	7	8	9	10	11	12	13	14	15	16	17	18	19	20	21	22	23	24	25	26	27	28	29	30	31	32	33	34	35	36	37	38	39	40
---	---	---	---	---	---	---	---	---	----	----	----	----	----	----	----	----	----	----	----	----	----	----	----	----	----	----	----	----	----	----	----	----	----	----	----	----	----	----	----

(B-19)

1	2	3	4	5	6	7	8	9	10	11	12	13	14	15	16	17	18	19	20	21	22	23	24	25	26	27	28	29	30	31	32	33	34	35	36	37	38	39	40
---	---	---	---	---	---	---	---	---	----	----	----	----	----	----	----	----	----	----	----	----	----	----	----	----	----	----	----	----	----	----	----	----	----	----	----	----	----	----	----

(B-31)

1	2	3	4	5	6	7	8	9	10	11	12	13	14	15	16	17	18	19	20	21	22	23	24	25	26	27	28	29	30	31	32	33	34	35	36	37	38	39	40
---	---	---	---	---	---	---	---	---	----	----	----	----	----	----	----	----	----	----	----	----	----	----	----	----	----	----	----	----	----	----	----	----	----	----	----	----	----	----	----

(B-31)

1	2	3	4	5	6	7	8	9	10	11	12	13	14	15	16	17	18	19	20	21	22	23	24	25	26	27	28	29	30	31	32	33	34	35	36	37	38	39	40
---	---	---	---	---	---	---	---	---	----	----	----	----	----	----	----	----	----	----	----	----	----	----	----	----	----	----	----	----	----	----	----	----	----	----	----	----	----	----	----

(B-31)

1	2	3	4	5	6	7	8	9	10	11	12	13	14	15	16	17	18	19	20	21	22	23	24	25	26	27	28	29	30	31	32	33	34	35	36	37	38	39	40
---	---	---	---	---	---	---	---	---	----	----	----	----	----	----	----	----	----	----	----	----	----	----	----	----	----	----	----	----	----	----	----	----	----	----	----	----	----	----	----

(B-31)

1	2	3	4	5	6	7	8	9	10	11	12	13	14	15	16	17	18	19	20	21	22	23	24	25	26	27	28	29	30	31	32	33	34	35	36	37	38	39	40
---	---	---	---	---	---	---	---	---	----	----	----	----	----	----	----	----	----	----	----	----	----	----	----	----	----	----	----	----	----	----	----	----	----	----	----	----	----	----	----

WIRE COLOR KEY:

- B: Black
- BR: Brown
- W: White
- V: Violet
- LG: Light Green
- OR: Orange
- SK: Sky Blue
- G: Green
- GR: Gray
- P: Pink
- BU: Blue
- RD: Red
- Y: Yellow

MULTI CENTER DISPLAY (CONTINUED)

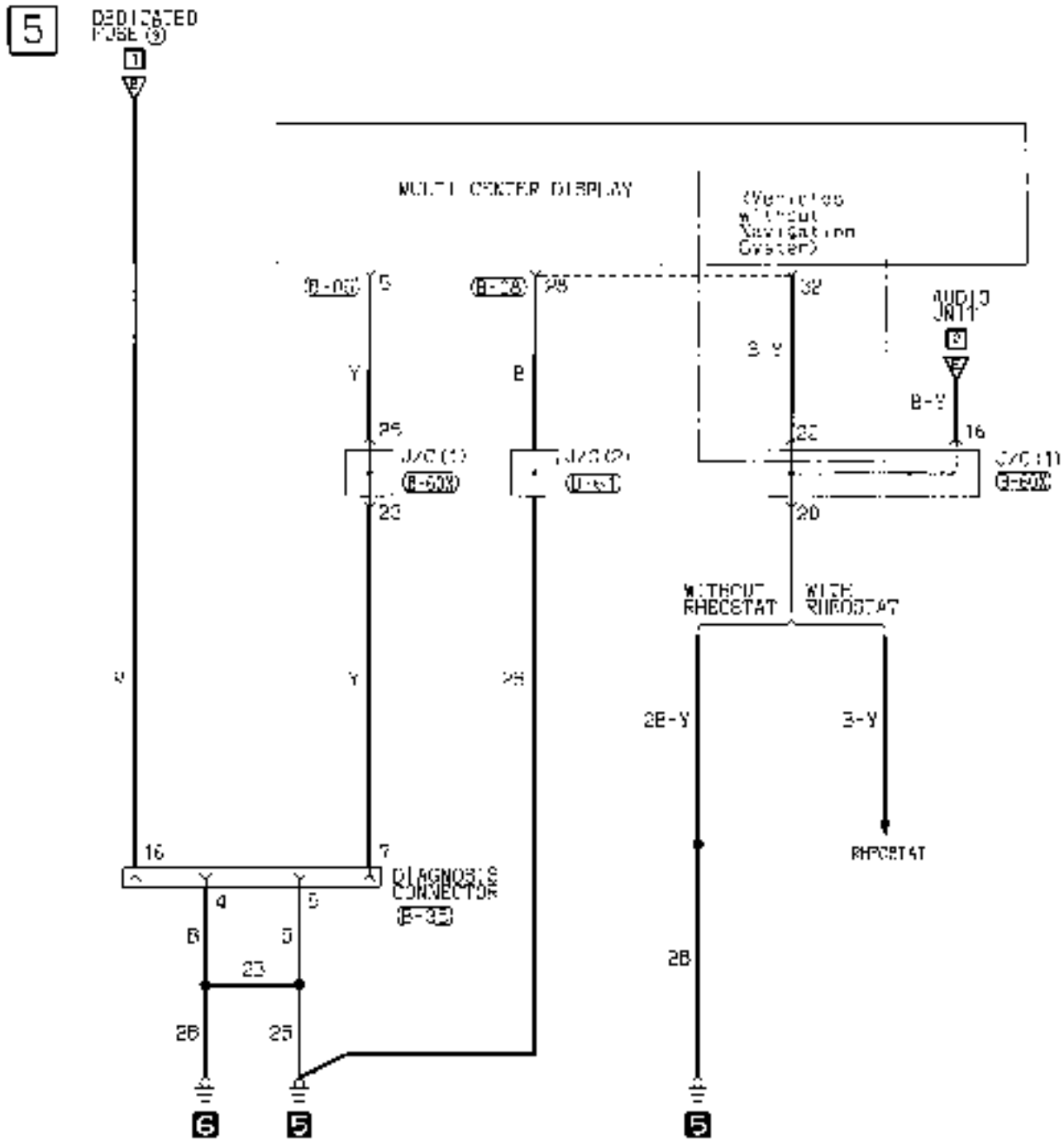

(E-35)

1	2	3	4	5	6	7	8
1	2	3	4	5	6	7	8

(B-50)

1	2	3	4	5	6	7	8	9	10
1	2	3	4	5	6	7	8	9	10

(B-35) 800P
Scale

1	2	3	4	5	6	7	8	9	10
1	2	3	4	5	6	7	8	9	10

(B-60)

1	2	3	4	5	6	7	8	9	10
1	2	3	4	5	6	7	8	9	10

(B-61)

1	2	3	4	5	6	7	8	9	10
1	2	3	4	5	6	7	8	9	10

Wire colour code

B: Blue G: Green L: Blue W: White Y: Yellow SB: 5V Blue
 BR: Brown O: Orange GR: Gray R: Red P: Pink V: Violet

NOTES

SUNROOF

40100940383

1

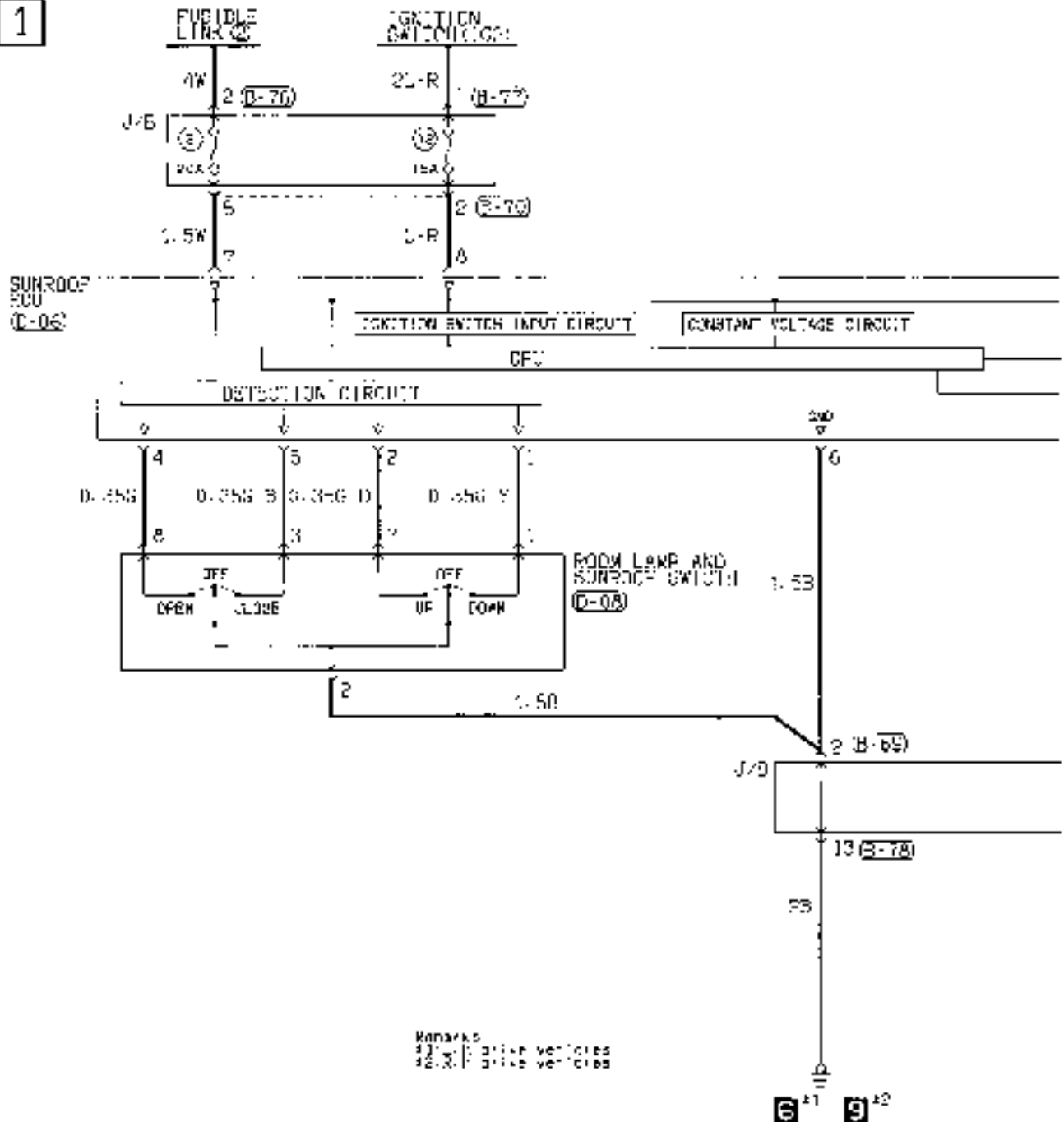

Remarks: 42: X 31: 48: 49: 50: 51: 52: 53: 54: 55: 56: 57: 58: 59: 60: 61: 62: 63: 64: 65: 66: 67: 68: 69: 70: 71: 72: 73: 74: 75: 76: 77: 78: 79: 80: 81: 82: 83: 84: 85: 86: 87: 88: 89: 90: 91: 92: 93: 94: 95: 96: 97: 98: 99: 100: 101: 102: 103: 104: 105: 106: 107: 108: 109: 110: 111: 112: 113: 114: 115: 116: 117: 118: 119: 120: 121: 122: 123: 124: 125: 126: 127: 128: 129: 130: 131: 132: 133: 134: 135: 136: 137: 138: 139: 140: 141: 142: 143: 144: 145: 146: 147: 148: 149: 150: 151: 152: 153: 154: 155: 156: 157: 158: 159: 160: 161: 162: 163: 164: 165: 166: 167: 168: 169: 170: 171: 172: 173: 174: 175: 176: 177: 178: 179: 180: 181: 182: 183: 184: 185: 186: 187: 188: 189: 190: 191: 192: 193: 194: 195: 196: 197: 198: 199: 200: 201: 202: 203: 204: 205: 206: 207: 208: 209: 210: 211: 212: 213: 214: 215: 216: 217: 218: 219: 220: 221: 222: 223: 224: 225: 226: 227: 228: 229: 230: 231: 232: 233: 234: 235: 236: 237: 238: 239: 240: 241: 242: 243: 244: 245: 246: 247: 248: 249: 250: 251: 252: 253: 254: 255: 256: 257: 258: 259: 260: 261: 262: 263: 264: 265: 266: 267: 268: 269: 270: 271: 272: 273: 274: 275: 276: 277: 278: 279: 280: 281: 282: 283: 284: 285: 286: 287: 288: 289: 290: 291: 292: 293: 294: 295: 296: 297: 298: 299: 300: 301: 302: 303: 304: 305: 306: 307: 308: 309: 310: 311: 312: 313: 314: 315: 316: 317: 318: 319: 320: 321: 322: 323: 324: 325: 326: 327: 328: 329: 330: 331: 332: 333: 334: 335: 336: 337: 338: 339: 340: 341: 342: 343: 344: 345: 346: 347: 348: 349: 350: 351: 352: 353: 354: 355: 356: 357: 358: 359: 360: 361: 362: 363: 364: 365: 366: 367: 368: 369: 370: 371: 372: 373: 374: 375: 376: 377: 378: 379: 380: 381: 382: 383: 384: 385: 386: 387: 388: 389: 390: 391: 392: 393: 394: 395: 396: 397: 398: 399: 400: 401: 402: 403: 404: 405: 406: 407: 408: 409: 410: 411: 412: 413: 414: 415: 416: 417: 418: 419: 420: 421: 422: 423: 424: 425: 426: 427: 428: 429: 430: 431: 432: 433: 434: 435: 436: 437: 438: 439: 440: 441: 442: 443: 444: 445: 446: 447: 448: 449: 450: 451: 452: 453: 454: 455: 456: 457: 458: 459: 460: 461: 462: 463: 464: 465: 466: 467: 468: 469: 470: 471: 472: 473: 474: 475: 476: 477: 478: 479: 480: 481: 482: 483: 484: 485: 486: 487: 488: 489: 490: 491: 492: 493: 494: 495: 496: 497: 498: 499: 500: 501: 502: 503: 504: 505: 506: 507: 508: 509: 510: 511: 512: 513: 514: 515: 516: 517: 518: 519: 520: 521: 522: 523: 524: 525: 526: 527: 528: 529: 530: 531: 532: 533: 534: 535: 536: 537: 538: 539: 540: 541: 542: 543: 544: 545: 546: 547: 548: 549: 550: 551: 552: 553: 554: 555: 556: 557: 558: 559: 560: 561: 562: 563: 564: 565: 566: 567: 568: 569: 570: 571: 572: 573: 574: 575: 576: 577: 578: 579: 580: 581: 582: 583: 584: 585: 586: 587: 588: 589: 590: 591: 592: 593: 594: 595: 596: 597: 598: 599: 600: 601: 602: 603: 604: 605: 606: 607: 608: 609: 610: 611: 612: 613: 614: 615: 616: 617: 618: 619: 620: 621: 622: 623: 624: 625: 626: 627: 628: 629: 630: 631: 632: 633: 634: 635: 636: 637: 638: 639: 640: 641: 642: 643: 644: 645: 646: 647: 648: 649: 650: 651: 652: 653: 654: 655: 656: 657: 658: 659: 660: 661: 662: 663: 664: 665: 666: 667: 668: 669: 670: 671: 672: 673: 674: 675: 676: 677: 678: 679: 680: 681: 682: 683: 684: 685: 686: 687: 688: 689: 690: 691: 692: 693: 694: 695: 696: 697: 698: 699: 700: 701: 702: 703: 704: 705: 706: 707: 708: 709: 710: 711: 712: 713: 714: 715: 716: 717: 718: 719: 720: 721: 722: 723: 724: 725: 726: 727: 728: 729: 730: 731: 732: 733: 734: 735: 736: 737: 738: 739: 740: 741: 742: 743: 744: 745: 746: 747: 748: 749: 750: 751: 752: 753: 754: 755: 756: 757: 758: 759: 760: 761: 762: 763: 764: 765: 766: 767: 768: 769: 770: 771: 772: 773: 774: 775: 776: 777: 778: 779: 780: 781: 782: 783: 784: 785: 786: 787: 788: 789: 790: 791: 792: 793: 794: 795: 796: 797: 798: 799: 800: 801: 802: 803: 804: 805: 806: 807: 808: 809: 810: 811: 812: 813: 814: 815: 816: 817: 818: 819: 820: 821: 822: 823: 824: 825: 826: 827: 828: 829: 830: 831: 832: 833: 834: 835: 836: 837: 838: 839: 840: 841: 842: 843: 844: 845: 846: 847: 848: 849: 850: 851: 852: 853: 854: 855: 856: 857: 858: 859: 860: 861: 862: 863: 864: 865: 866: 867: 868: 869: 870: 871: 872: 873: 874: 875: 876: 877: 878: 879: 880: 881: 882: 883: 884: 885: 886: 887: 888: 889: 890: 891: 892: 893: 894: 895: 896: 897: 898: 899: 900: 901: 902: 903: 904: 905: 906: 907: 908: 909: 910: 911: 912: 913: 914: 915: 916: 917: 918: 919: 920: 921: 922: 923: 924: 925: 926: 927: 928: 929: 930: 931: 932: 933: 934: 935: 936: 937: 938: 939: 940: 941: 942: 943: 944: 945: 946: 947: 948: 949: 950: 951: 952: 953: 954: 955: 956: 957: 958: 959: 960: 961: 962: 963: 964: 965: 966: 967: 968: 969: 970: 971: 972: 973: 974: 975: 976: 977: 978: 979: 980: 981: 982: 983: 984: 985: 986: 987: 988: 989: 990: 991: 992: 993: 994: 995: 996: 997: 998: 999: 1000



2

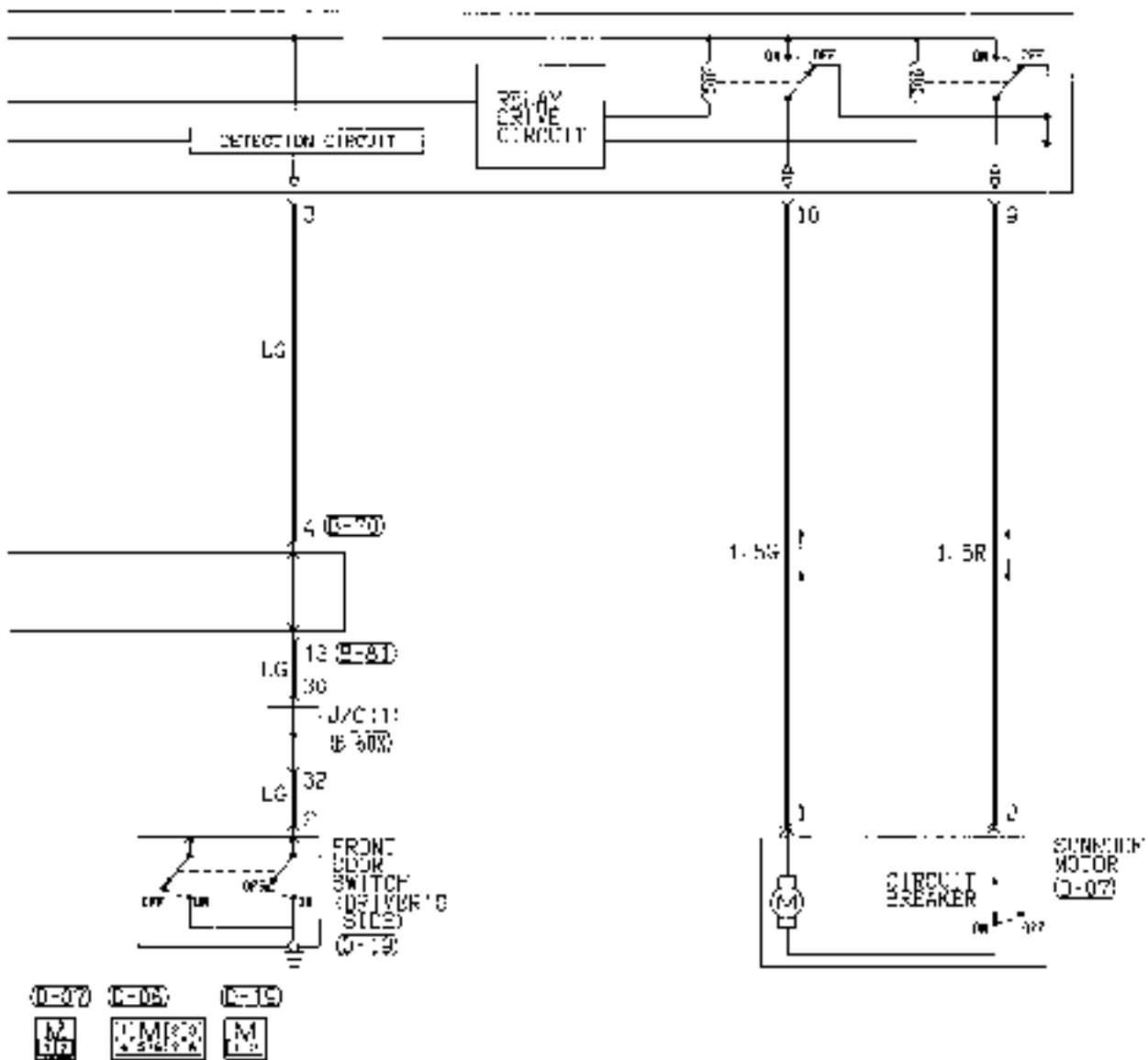

Wire color code: W: White, B: Black, BR: Brown, LG: Green, U: Orange, G: Green, GR: Grey, W: White, R: Red, P: Pink, Y: Yellow, V: Violet, GB: Gray-blue

HEATED SEAT

90101470171

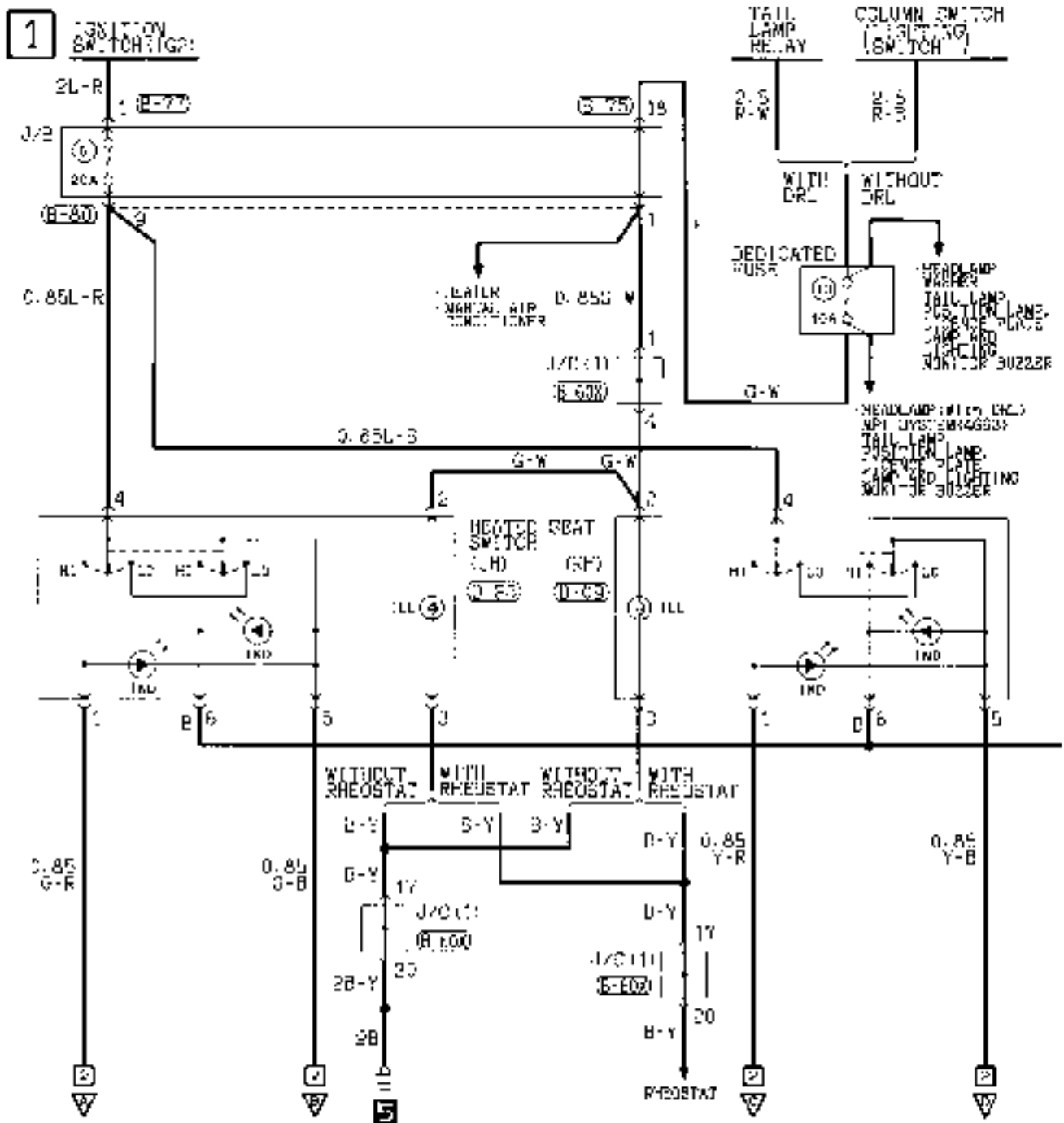

E-60

1	2	3	4	5	6	7	8	9	10	11	12
12	13	14	15	16	17	18	19	20	21	22	23
24	25	26	27	28	29	30	31	32	33	34	35

E-61

1	2	3	4	5	6	7	8	9	10	11	12
13	14	15	16	17	18	19	20	21	22	23	24
25	26	27	28	29	30	31	32	33	34	35	36

E-75

1	2	3	4	5	6	7	8	9	10	11	12
13	14	15	16	17	18	19	20	21	22	23	24
25	26	27	28	29	30	31	32	33	34	35	36

E-77

1	2	3	4	5	6	7	8	9	10	11	12
13	14	15	16	17	18	19	20	21	22	23	24
25	26	27	28	29	30	31	32	33	34	35	36

E-80

1	2	3	4	5	6	7	8	9	10	11	12
13	14	15	16	17	18	19	20	21	22	23	24
25	26	27	28	29	30	31	32	33	34	35	36

O-03

1	2	3	4	5	6	7	8	9	10	11	12
13	14	15	16	17	18	19	20	21	22	23	24
25	26	27	28	29	30	31	32	33	34	35	36

O-09

1	2	3	4	5	6	7	8	9	10	11	12
13	14	15	16	17	18	19	20	21	22	23	24
25	26	27	28	29	30	31	32	33	34	35	36

2

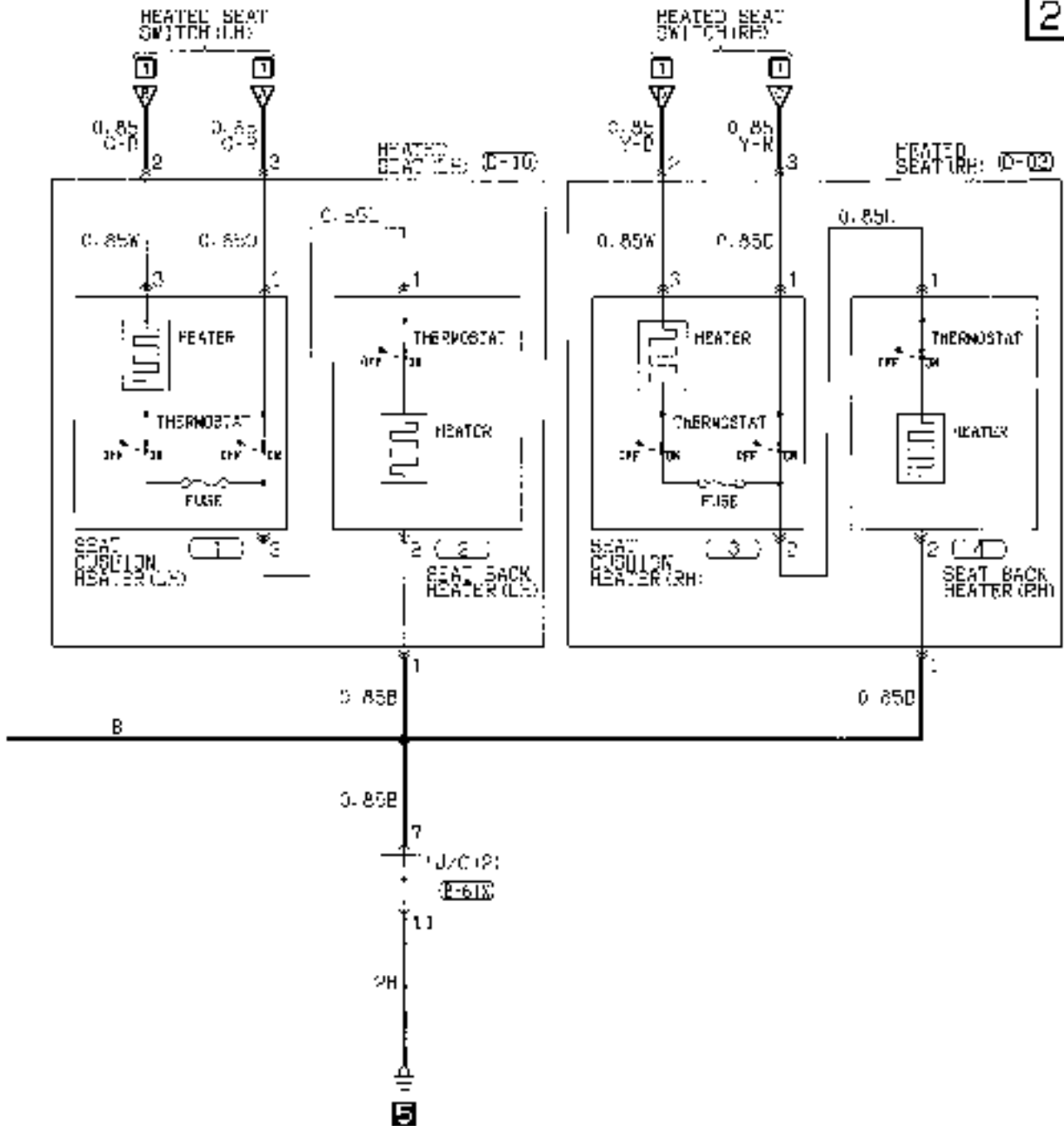

W: White G: Green C: Blue Y: Yellow SP: Sky blue
 B: Brown R: Red N: Pink V: Violet
 NR: Brown CS: Orange GR: Gray R: Red P: Pink V: Violet

ABS

90160842803

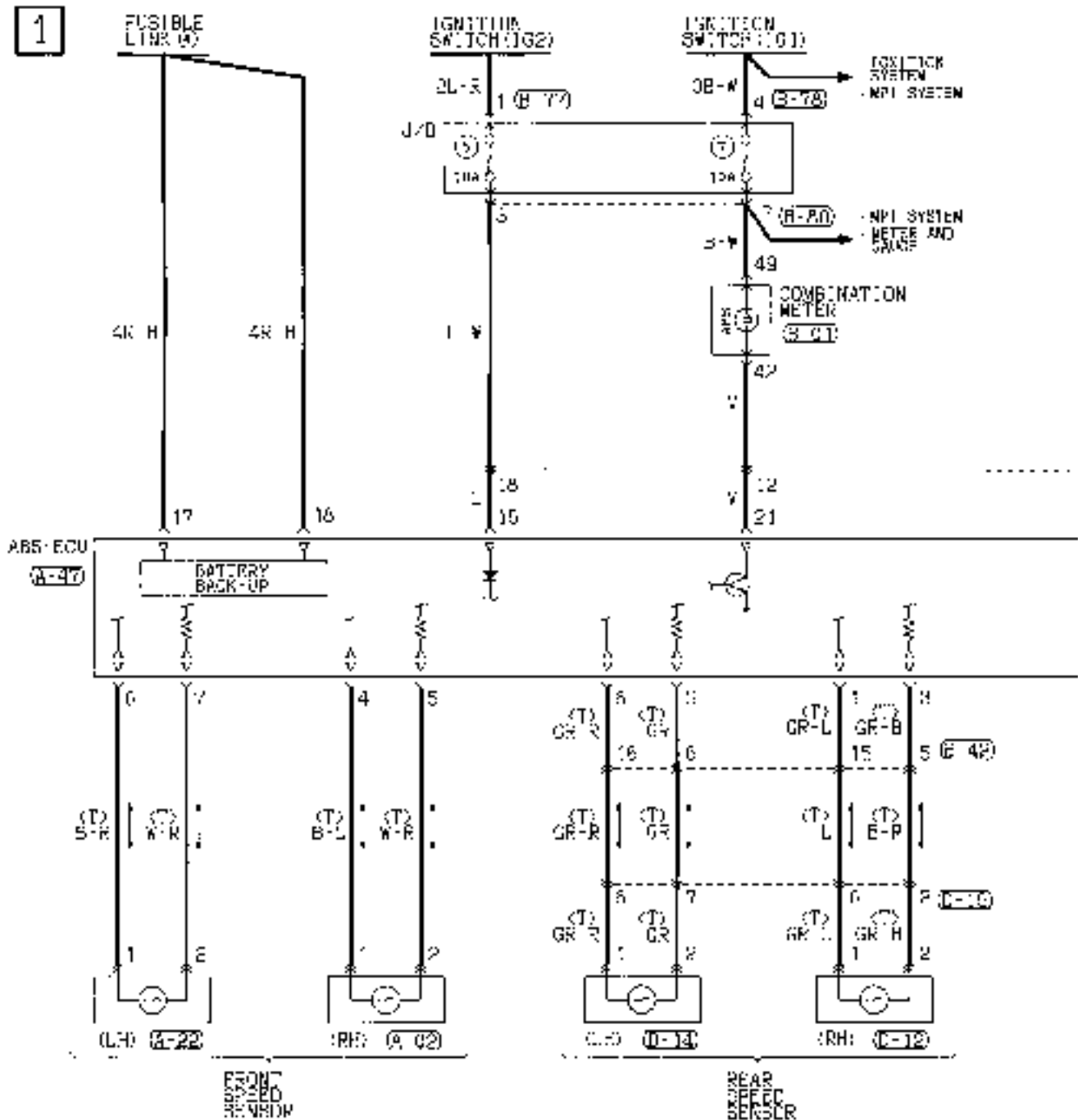

A-02 A-29 A-47



B-07

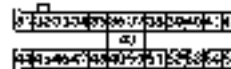

B-35 B-WF

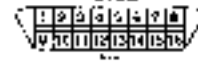

B-39 B-42

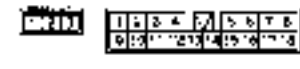

C-30



C-81



D-12



D-14



C-15



2

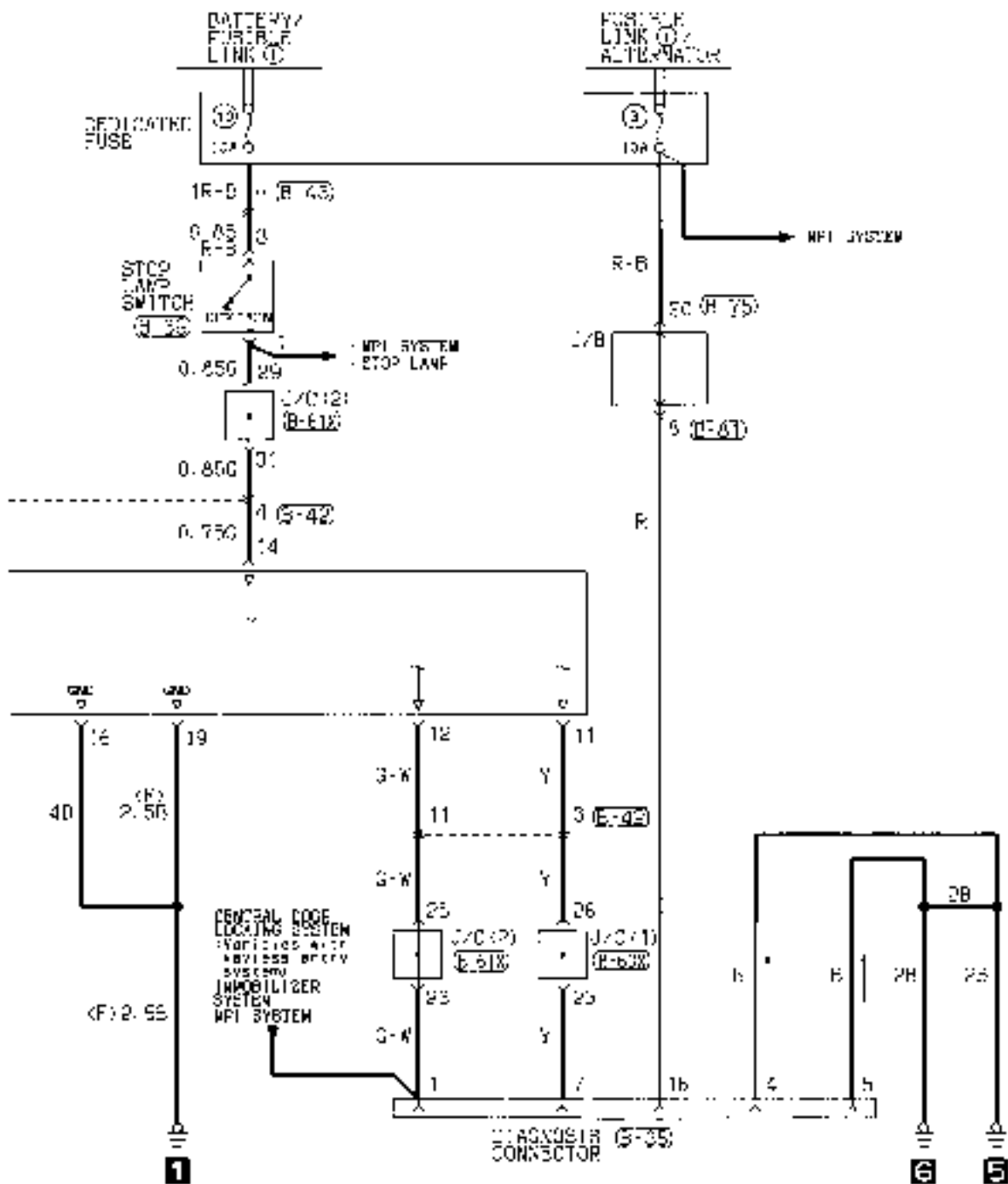

(E-43)	(E-613)	(E-75)	(E-77)	(E-78)
1 2 3 4 5 6 7 8 9 10 11 12 13 14 15 16 17 18 19 20 21 22 23 24 25 26 27 28 29 30	1 2 3 4 5 6 7 8 9 10 11 12 13 14 15 16 17 18 19 20 21 22 23 24 25 26 27 28 29 30	1 2 3 4 5 6 7 8 9 10 11 12 13 14 15 16 17 18 19 20 21 22 23 24 25 26 27 28 29 30	1 2 3 4 5 6 7 8 9 10 11 12 13 14 15 16 17 18 19 20 21 22 23 24 25 26 27 28 29 30	1 2 3 4 5 6 7 8 9 10 11 12 13 14 15 16 17 18 19 20 21 22 23 24 25 26 27 28 29 30

Wire colour code
 B: Black LG: Light green G: Green L: Blue W: White Y: Yellow SB: Sky blue
 BR: Brazer O: Orange GR: Gray R: Red P: Pink V: Violet

SUPPLEMENTAL RESTRAINT SYSTEM

9010089017

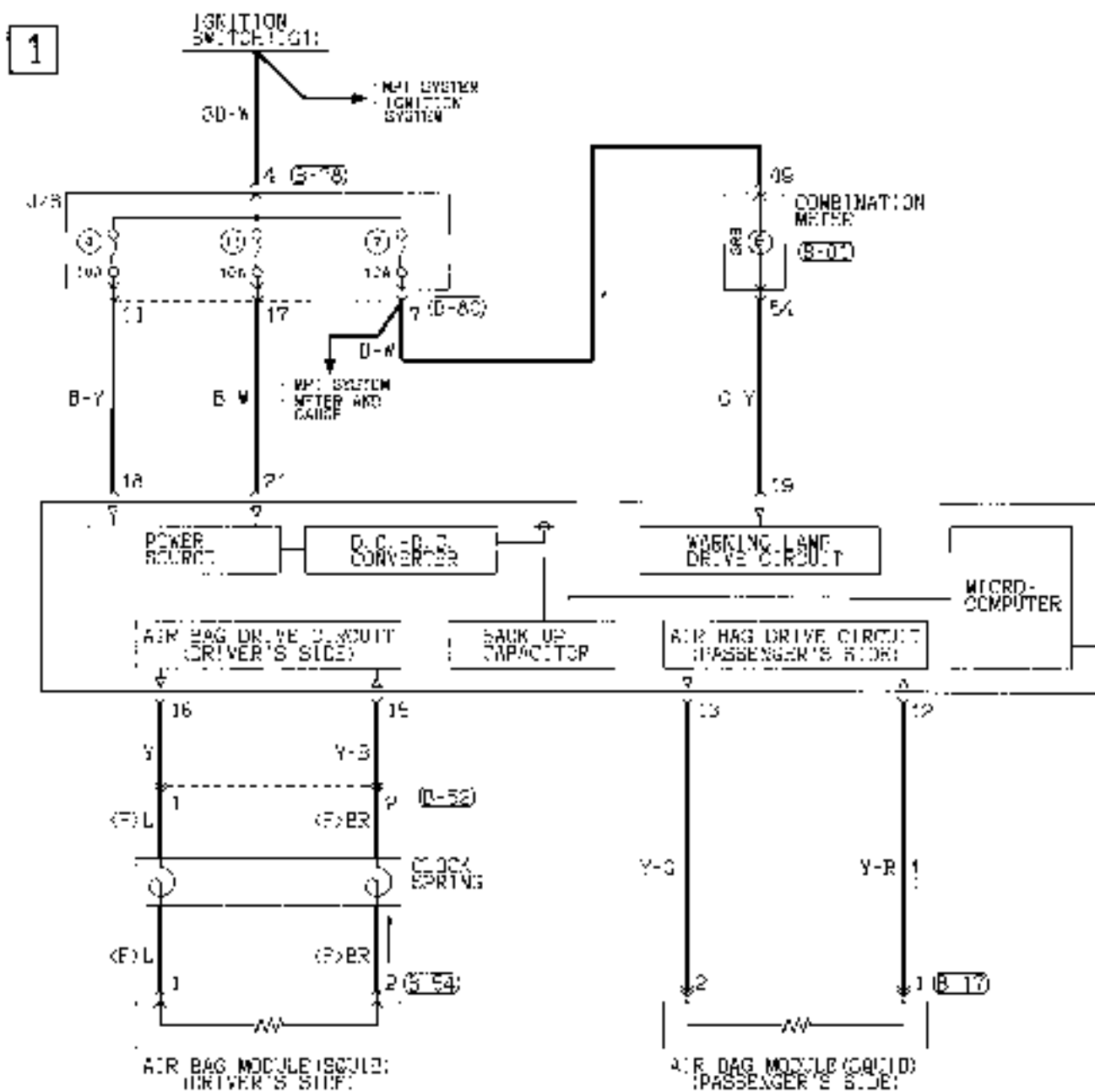

(B-01)

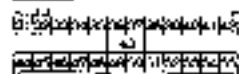

(B-17)



(B-52) FRONT SIDE

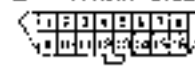

(B-54)



(B-78)



(B-80)



(B-78)



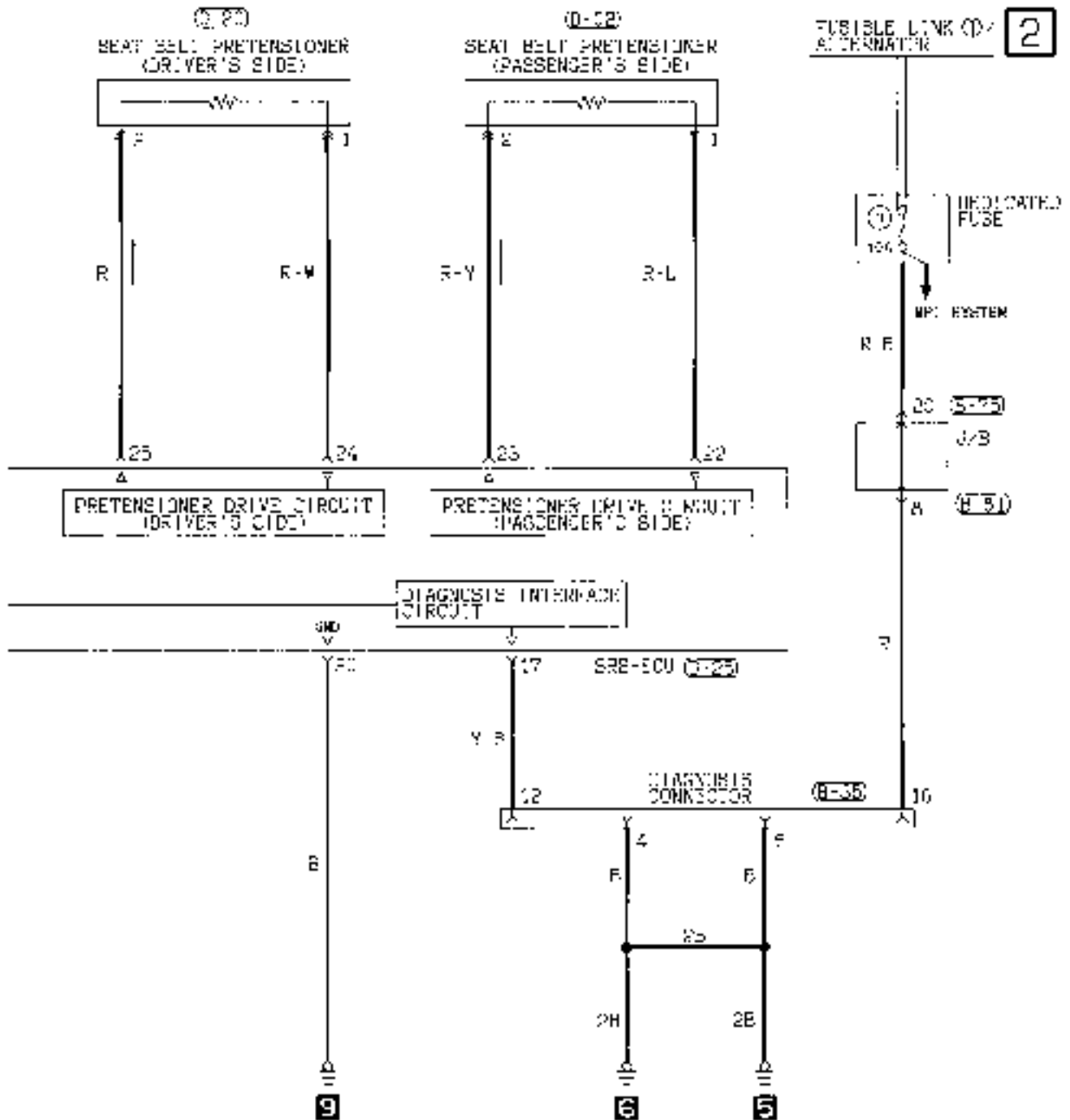

E-20	E-21	E-22	E-25
1 2 3 4 5 6 7 8 9 10 11 12 13 14 15 16 17 18 19 20	1 2 3 4 5 6 7 8 9 10 11 12 13 14 15 16 17 18 19 20	1 2 3 4	1 2 3 4 5 6 7 8 9 10 11 12 13 14 15 16 17 18 19 20 21 22 23 24 25

Wires color code
 B: Blue L: Light green G: Green L: Blue Y: Yellow V: Violet
 BR: Brown D: Drive GR: Gray R: Red P: Pink W: White

SUPPLEMENTAL RESTRAINT SYSTEM (CONTINUED)

3

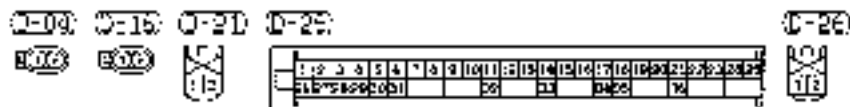
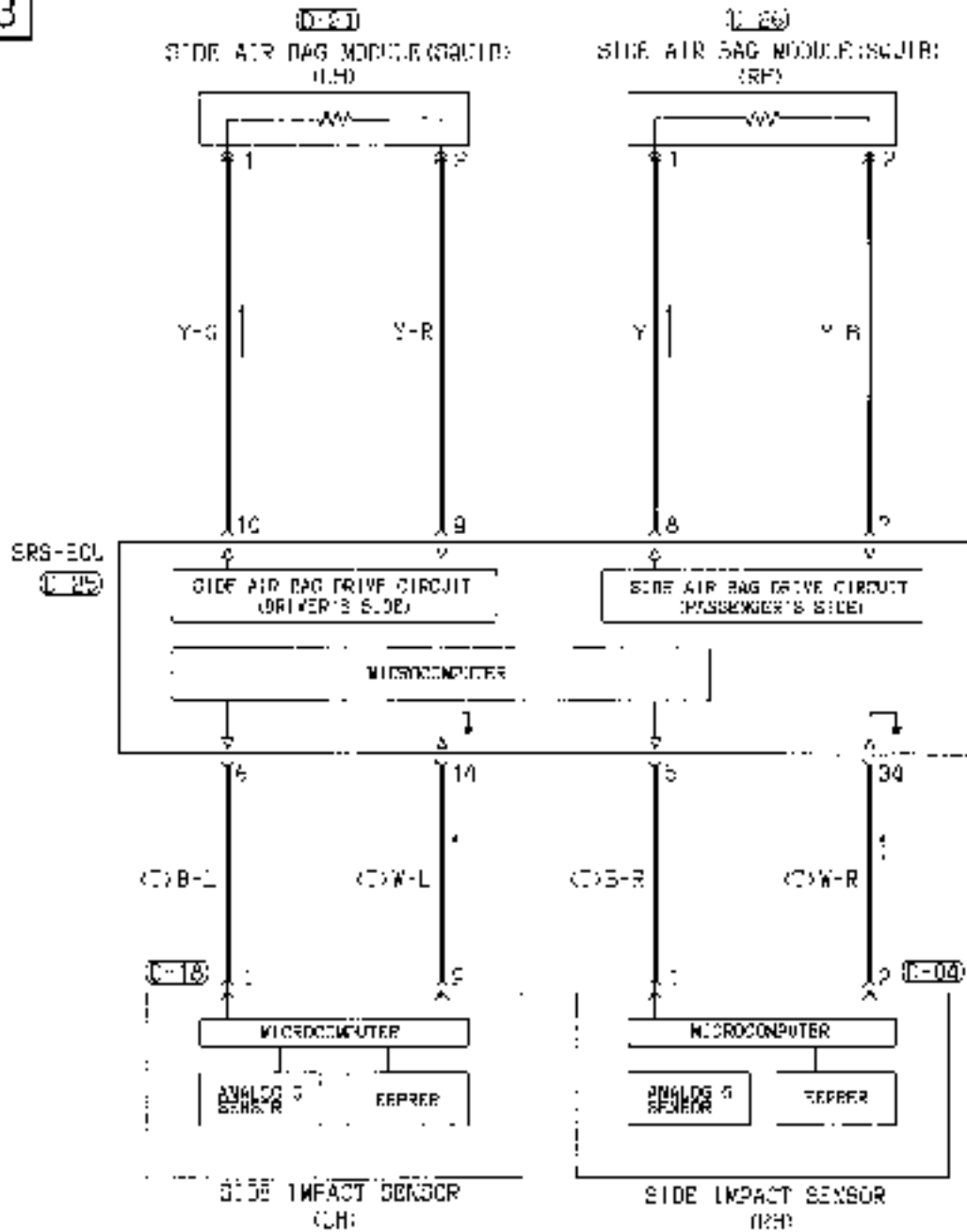

NOTES

IMMOBILIZER SYSTEM

9910130030

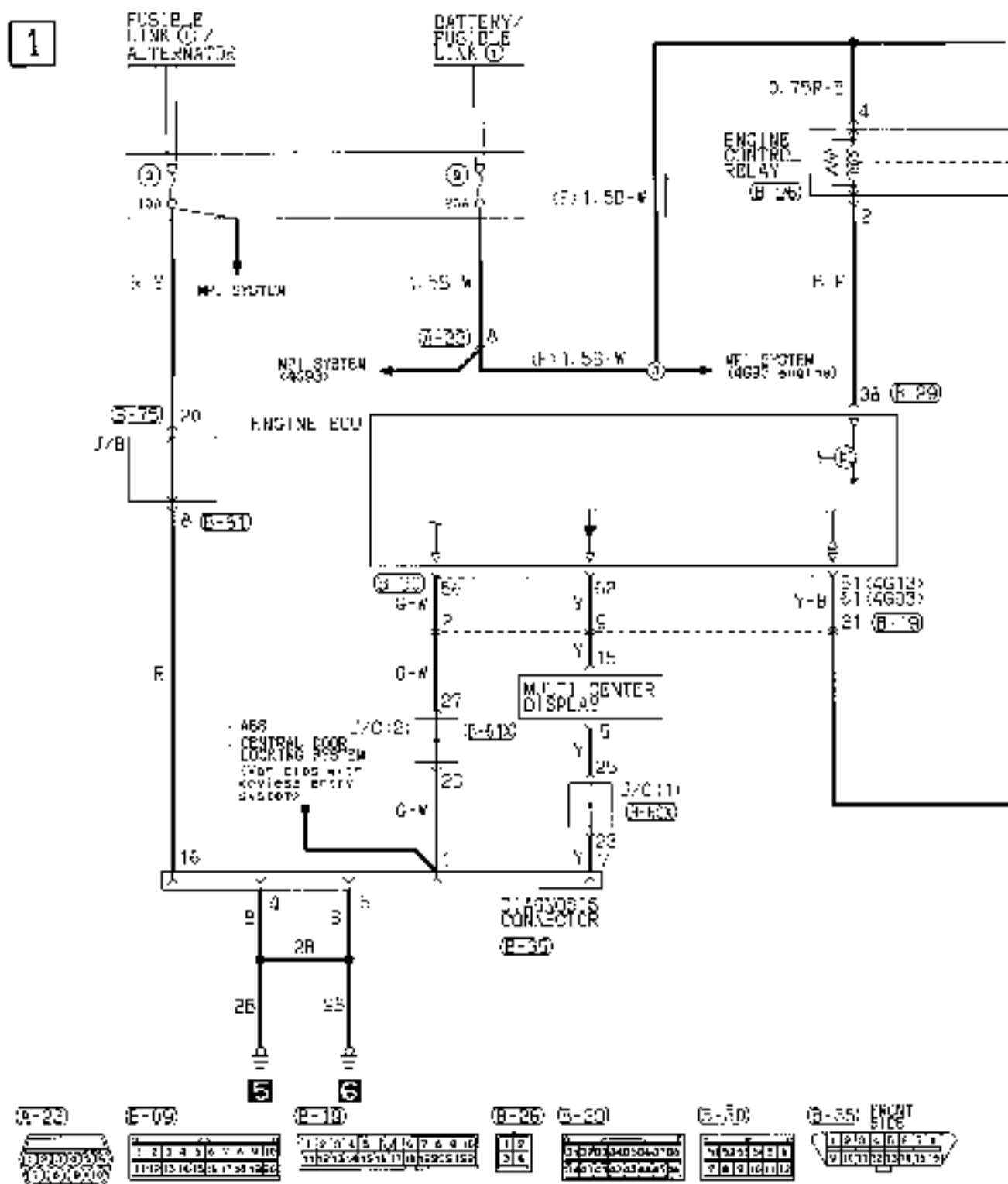

2

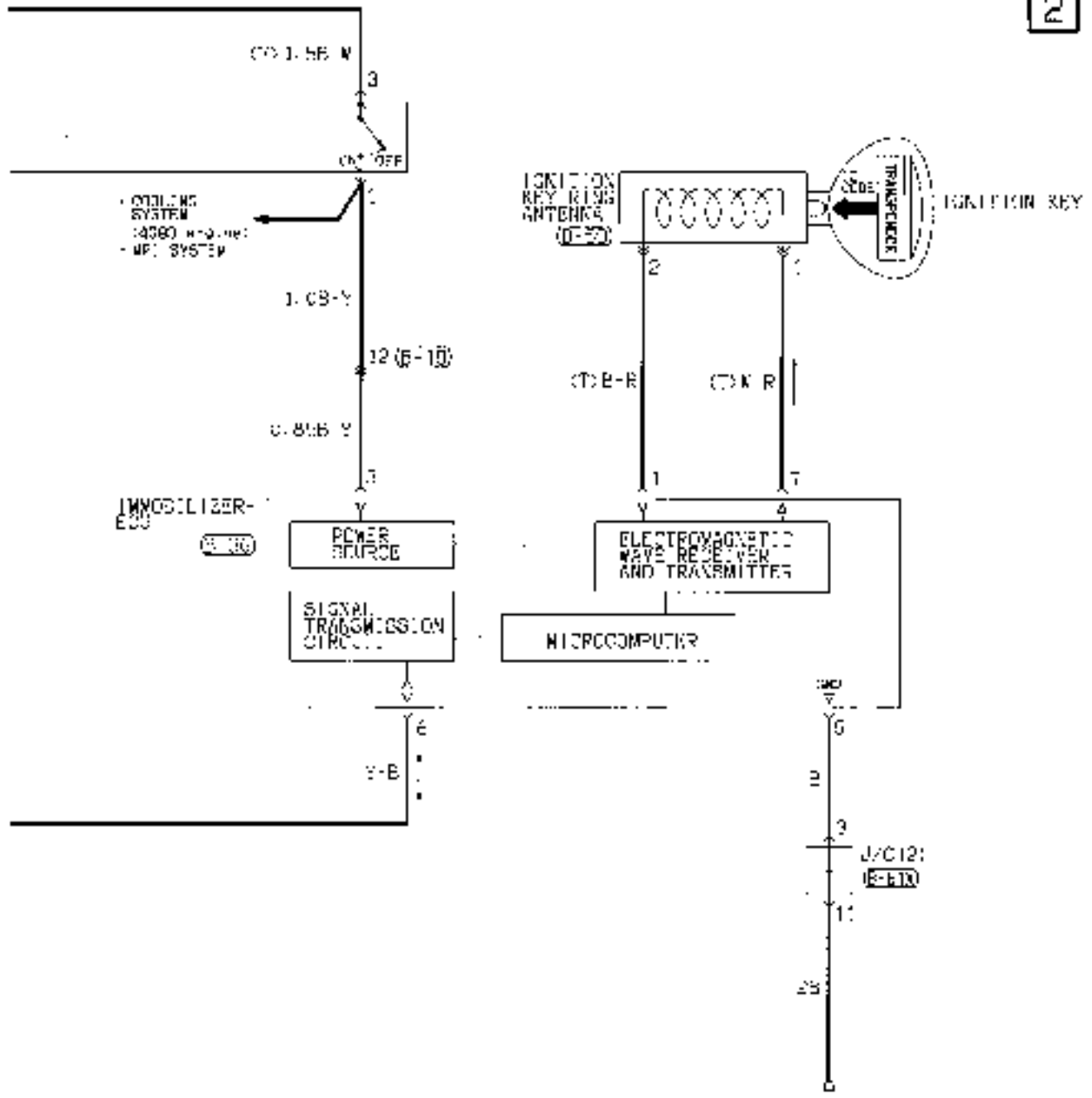

(B-36)	(B-39)	(B-60)	(B-71)	(B-75)	(B-81)
0 1 2 3 4 5 6 7 8 9 10 11 12 13 14 15 16 17 18 19 20 21 22 23 24 25 26 27 28 29 30 31 32	1 2 3 4 5 6 7 8 9 10 11 12 13 14 15 16 17 18 19 20 21 22 23 24 25 26 27 28 29 30 31 32	1 2 3 4 5 6 7 8 9 10 11 12 13 14 15 16 17 18 19 20 21 22 23 24 25 26 27 28 29 30 31 32	1 2 3 4 5 6 7 8 9 10 11 12 13 14 15 16 17 18 19 20 21 22 23 24 25 26 27 28 29 30 31 32	1 2 3 4 5 6 7 8 9 10 11 12 13 14 15 16 17 18 19 20 21 22 23 24 25 26 27 28 29 30 31 32	1 2 3 4 5 6 7 8 9 10 11 12 13 14 15 16 17 18 19 20 21 22 23 24 25 26 27 28 29 30 31 32

Wire colour code
 B : Black LP : Light green G : Green L : Blue W : White Y : Yellow GR : Grey-blue
 BR : Brown U : Orange GR : Gray R : Red P : Pink V : Violet

RHEOSTAT

8010110231

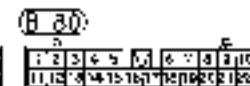
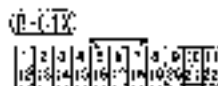
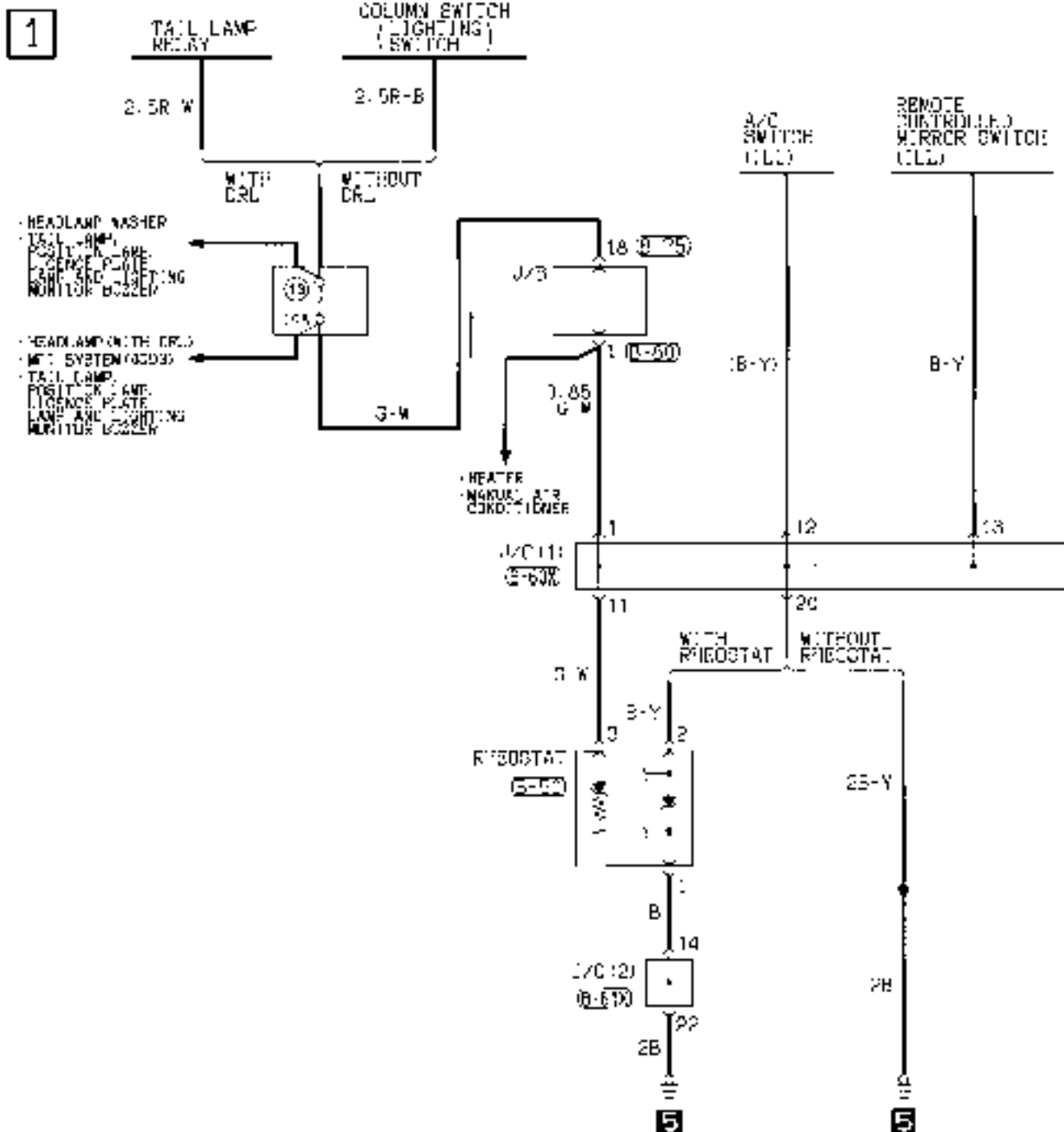

2

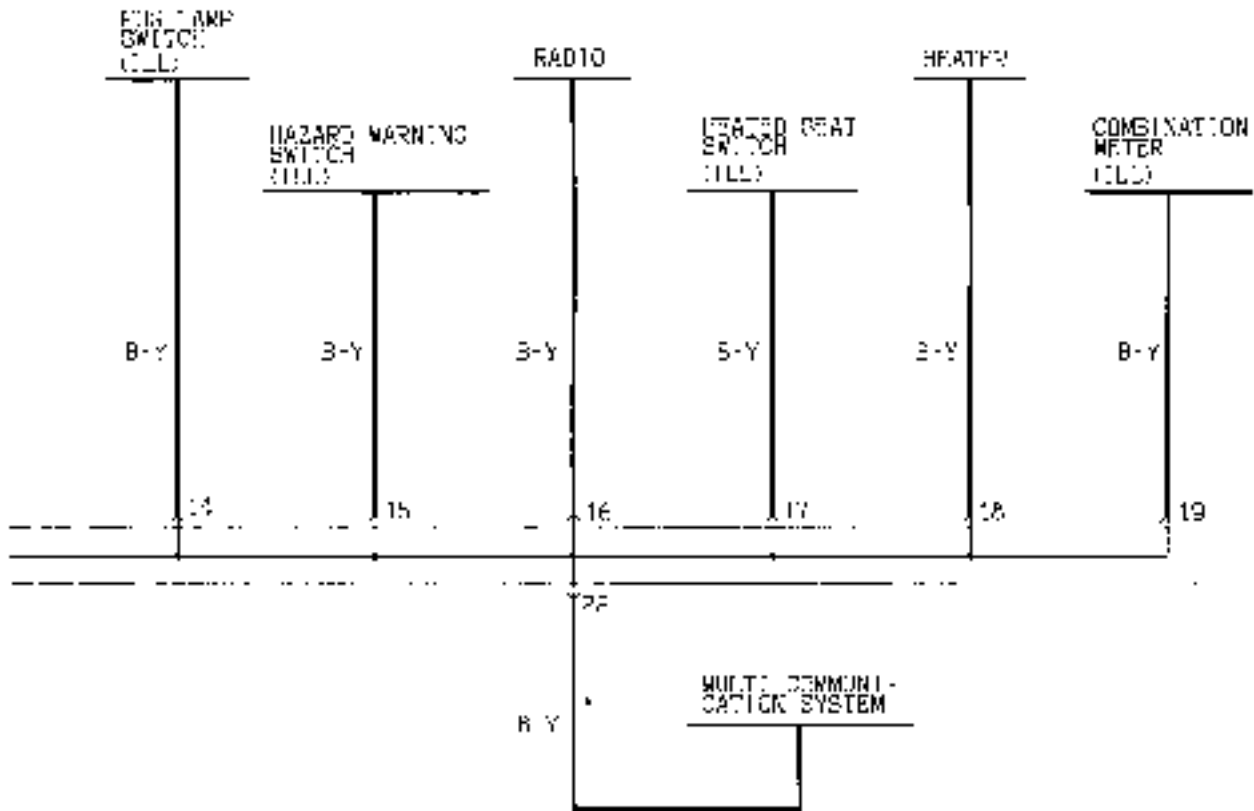

Wire color code:

B:Black LG:Light green G:Green L:Blue W:White Y:Yellow SB:Sky blue
 BK:Brown O:Orange GR:Gray R:Red P:Pink V:Violet

QV10305A3

INDEX (In order of connector No.)

M9106010106

Connector No	Parts name	Circuit diagram page	Wiring diagram page
A-01	Side turn signal lamp (RH)	4-86, 109	2-4, 8, 12, 16
A-02	Front speed sensor (RH) <ABS>	4-148	2-4, 8, 12, 16
A-03X	Headlamp washer relay	4-131	2-4, 8, 12, 16
A-04X	Alternator relay	4-24, 25	2-4, 8, 12, 16
A-06X	Horn relay	4-89	2-4, 8, 12, 16
A-07X	Fan control relay <4G93>	4-48, 123	2-8, 16
A-08X	Condenser fan relay (F O) <4G13>	4-47, 117	2-4, 12
A-09X	Condenser fan relay (HI) <4G13>	4-47, 117	2-4, 12
A-10X	A/C compressor relay	4-118, 122	2-4, 8, 12, 16
A-12X	Headlamp relay	4-15, 50, 51, 52, 70, 74	2-4, 8, 12, 16
A-14X	Radiator fan relay <4G13>	4-40, 116	2-4, 12, 16
A-15X	Tail lamp relay <DRL>	4-19, 62, 68, 74	2-4, 8
A-16	DRL ECU	4-53, 62, 74, 138	2-4, 8
A-17	DRL relay 1	4-53	2-4, 8
A-18	DRL relay 2	4-52	2-4, 8
A-19	Side turn signal lamp (LH)	4-86, 109	2-4, 8, 12, 16
A-20	Front wiring harness and DRL wiring harness combination	4-52, 53, 54, 62, 68, 74, 138	2-4, 8
A-21	Front wiring harness and DRL wiring harness combination	4-52, 53, 62, 68, 74	2-4, 8
A-22	Front speed sensor (LH) <ABS>	4-148	2-4, 8, 12, 16
A-23	Front wiring harness and control wiring harness combination	4-24, 25, 28, 33, 34, 39, 45, 47, 48, 88, 117, 118, 122, 123, 140, 154	2-4, 8, 12, 16
A-24	Front turn signal lamp (LH)	4-86, 109	2-4, 8, 12, 16
A-25	Headlamp leveling unit (LH)	4-56	2-4, 9, 12, 16
A-26	Position lamp (LH)	4-58, 62	2-5, 9, 12, 16
A-27	Headlamp (LH)	4-50, 51, 52	2-5, 9, 12, 16
A-28	Outside thermo sensor	4-140	2-5, 9, 12, 16
A-29	Front fog lamp (LH)	4-66, 68	2-5, 9, 12, 16
A-30	Horn (LH)	4-89	2-5, 9, 13, 16
A-31	Radiator fan motor <4G13>	4-46, 116	2-5, 13
A-32	Fan controller <4G93>	4-48	2-9, 16

	Connector No.	Parts name	Circuit diagram page	Wiring diagram page
A	A-33	Dual pressure switch	4-118, 122	2-5, 9, 13, 16
	A-34	Condenser fan motor <4G13>	4-47, 117	2-5, 13
	A-35	Horn (RH)	4-89	2-5, 9, 13, 16
	A-36	Front fog lamp (RH)	4-67, 69	2-5, 9, 13, 16
	A-37	A/C refrigerant temperature switch and magnetic clutch	4-118, 122	2-5, 9, 13, 16
	A-38	Power steering oil pressure switch	4-33, 45	2-5, 9, 13, 16
	A-39	Headlamp (RH)	4-50, 51, 52	2-5, 9, 13, 16
	A-40	Position lamp (RH)	4-58, 62	2-5, 9, 13, 16
	A-41	Headlamp leveling unit (RH)	4-56	2-5, 9, 13, 16
	A-42	Headlamp washer motor	4-131	2-5, 9, 13, 16
	A-43	Front turn signal lamp (RH)	4-86, 109	2-5, 9, 13, 16
	A-44	Washer fluid level sensor	4-125	2-5, 9, 13, 16
	A-45	Windshield washer motor	4-125	2-5, 9, 13, 16
	A-46	Rear washer motor	4-128	2-5, 9, 13, 16
	A-47	ABS-ECU	4-148	2-5, 9, 13, 16
	A-48	Injector No. 1	4-31, 38	2-6, 10, 14, 18
	A-49	Injector No. 2	4-31, 38	2-6, 10, 14, 18
	A-50	Detonation sensor	4-32, 41	2-6, 10, 14, 18
	A-51	Windshield wiper motor	4-125	2-6, 10, 14, 18
	A-52	Injector driver	4-36, 38	2-10, 18
	A-53	Injector driver control relay	4-36	2-10, 18
	A-54	Injector No. 3	4-31, 38	2-6, 10, 14, 18
	A-55	Oxygen sensor <4G93>	4-41	2-10, 18
	A-56	Intake air temperature sensor <4G13>	4-30	2-6, 14
	A-57	Ignition timing adjustment connector <4G13>	4-22, 23	2-6, 14
	A-58	Purge control solenoid valve	4-31, 41	2-6, 10, 14, 18
	A-59	Vacuum sensor <4G13>	4-31	2-6, 14
	A-60	Injector No. 4	4-31, 38	2-6, 10, 14, 18
	A-61	EGR solenoid valve <4G13>	4-31	2-6, 14
	A-62	EGR servo <4G93>	4-41	2-10, 18
	A-64	Engine speed detection connector	4-22, 23, 24	2-6, 10, 14, 18

Connector No.	Parts name	Circuit diagram page	Wiring diagram page
A-65	Control wiring harness and EGR wiring harness combination	4-41	2-10, 18
A-66	Throttle position sensor	4-30, 42	2-6, 10, 14, 18
A-67	Idle speed control servo <4G13>	4-30	2-6, 14
A-68	Throttle valve control servo <4G93>	4-43	2-10, 18
A-69	Brake fluid level sensor	4-94	2-7, 10, 15, 18
A-70	Brake vacuum sensor <4G93>	4-40	2-10, 18
A-71	Vehicles speed sensor	4-32, 44, 90, 141	2-7, 10, 15, 18
A-72	Distributor assembly <4G13>	4-22, 30	2-7, 15
A-73	Air flow sensor <4G93>	4-40	2-10, 19
A-74	Control wiring harness and battery cable assembly combination <4G13>	4-20, 24, 32, 94	2-7, 15
A-75	Control wiring harness and battery cable assembly combination <4G93>	4-20, 25, 39, 94	2-11, 19
A-76	Engine coolant temperature sensor	4-30, 40	2-7, 11, 15, 19
A-77	Engine coolant temperature gauge unit	4-91	2-7, 11, 15, 19
A-78	Back-up lamp switch	4-88, 140	2-7, 11, 15, 19
A-79	Spare connector for front fog lamp	-	2-5, 9, 13, 17
A-80	M/T oil temperature sensor <4G93>	4-41	2-11, 19
A-81	Camshaft position sensor <4G93>	4-40	2-11, 19
A-82	Control wiring harness and injector wiring harness combination <4G93>	4-38	2-11, 19
A-83	Fuel pressure sensor <4G93>	4-40	2-11, 19
A-84	Accelerator pedal position sensor	4-42	2-11, 19
A-85	Ignition coil 4 <4G93>	4-23, 37	2-11, 19
A-86	Ignition coil 3 <4G93>	4-23, 37	2-11, 19
A-87	Starter	4-20	2-7, 11, 15, 19
A-88	Starter	4-20	2-7, 11, 15, 19
A-89	Ignition coil 2 <4G93>	4-23, 37	2-11, 19
A-90	Oil pressure switch	4-94	2-7, 11, 15, 19
A-91	Ignition coil 1 <4G93>	4-23, 37	2-11, 19
A-92	Alternator	4-24, 25	2-7, 11, 15, 19
A-93	Alternator	4-24, 25	2-7, 11, 15, 19
A-94	Crank angle sensor <4G93>	4-41	2-11, 19

Connector No	Parts name	Circuit diagram page	Wiring diagram page
B-01	Combination meter	4-24, 25, 29, 35, 50, 51, 52, 67, 89, 72, 76, 78, 80, 86, 90, 94, 109, 125, 141, 148, 150	2-20, 24
B-02	Combination meter	4-24, 25, 29, 35, 50, 51, 52, 86, 81, 94, 109, 125	2-20, 24
B-03	Diode (Headlamp circuit)	4-50, 51, 54, 70, 74	2-20, 24
B-04	Audio unit <Vehicles with navigation system>	4-140, 141	2-20, 24
B-05	Audio unit <Vehicles without navigation system>	4-139	2-20, 24
B-06	A/C switch	4-112, 114, 120, 134	2-20, 24
B-07	Audio unit <Vehicles with navigation system>	4-139	2-20, 24
B-08	Multi center display	4-140, 142	2-20, 24
B-09	Multi center display	4-33, 45, 140, 141, 142	2-20, 24
B-10	Blower switch	4-112, 114, 120	2-20, 24
B-11	Audio unit <Vehicles with navigation system>	4-139	2-20, 24
B-12	Audio unit <Vehicles without navigation system>	4-139	2-20, 24
B-13	Blower control illumination lamp	4-113, 115, 121	2-20, 24
B-14	Navigation unit	4-141	2-20, 24
B-15	Throttle valve controller <4G93>	4-36, 43	2-20, 24
B-16	Automatic compressor ECU	4-118, 122	2-20, 24
B-17	Air bag module (squib) (Passenger's side)	4-150	2-20, 24
B-18	Control wiring harness and body wiring harness combination	4-20, 22, 23, 28, 29, 32, 34, 35, 39	2-20, 24
B-19	Control wiring harness and body wiring harness combination	4-29, 32, 33, 34, 35, 39, 44, 45, 88, 90, 91, 94, 122, 124, 140, 141, 154, 155	2-20, 24
B-20	Outside/inside air selection damper control motor	4-112, 114, 120	2-20, 24
B-21	Keyless entry receiver-ECU	4-106, 108, 110	2-20, 24
B-22	Body wiring harness and front door wiring harness (Passenger's side) combination	4-97, 100, 102, 104, 108, 108, 133, 135, 136, 139	2-20, 24
B-23	Blower motor	4-112, 114, 120	2-20, 24
B-24	Resistor	4-112, 114, 120	2-20, 24
B-26	Engine control relay	4-28, 34, 48, 123, 154	2-21, 25
B-27	Fuel pump relay	4-28, 35	2-21, 25

Connector No	Parts name	Circuit diagram page	Wiring diagram page
B-28	Engine-ECU	4-22, 23, 28, 29, 30, 32, 34, 35, 37, 38, 39, 40, 41, 45, 46, 48, 116, 118, 122, 123	2-21, 25
B-29	Engine-FCU	4-28, 32, 33, 34, 40, 41, 45, 48, 118, 122, 123, 154	2-21, 25
B-30	Engine-ECU	4-22, 23, 31, 33, 38, 39, 42, 44, 45, 140, 154	2-21, 25
B-31	Engine-ECU	4-28, 30, 31, 32, 33, 34, 35, 39, 40, 41, 42, 44, 45, 122, 141	2-21, 25
B-32	Throttle valve controller <4G93>	4-36	2-21, 25
B-33	Diagnosis connector	4-33, 45	2-21, 25
B-34	Oxygen sensor (Front) <4G13>	4-31	2-21, 25
B-35	Diagnosis connector	4-33, 45, 107, 142, 149, 151, 154	2-21, 25
B-36	Immobilizer-ECU	4-33, 39, 155	2-21, 25
B-37	Diode (Keyless entry system circuit)	4-81, 110	2-21, 25
B-38	Audio unit <Vehicles without navigation system>	4-140	2-21, 25
B-39	Stop lamp switch	4-34, 87, 149	2-21, 25
B-40	Body wiring harness and instrument panel wiring harness combination	4-84	2-21, 25
B-41	Body wiring harness and front door wiring harness (Driver's side) combination	4-98, 97, 98, 99, 102, 104, 106, 108, 133, 135, 136, 139	2-21, 25
B-42	Front wiring harness and body wiring harness combination	4-15, 86, 68, 131, 148, 149	2-21, 25
B-43	Front wiring harness and body wiring harness combination	4-24, 25, 33, 34, 50, 51, 52, 53, 54, 56, 60, 64, 70, 74, 87, 89, 102, 106, 118, 122, 124, 125, 128, 138, 139, 140, 149	2-21, 25
B-45	Front wiring harness and body wiring harness combination	4-14, 18, 28, 34, 50, 51, 54, 58, 62, 66, 69, 70, 74, 96, 139	2-21, 25
B-47	Fog lamp switch	4-67, 69, 71, 75	2-21, 25
B-48	Headlamp leveling switch	4-56	2-21, 25
B-49	Remote controlled door mirror switch	4-136	2-21, 25
B-50	Rheostat	4-156	2-21, 25
B-51	Column switch	4-89, 124, 128	2-22, 26

Connector No	Parts name	Circuit diagram page	Wiring diagram page	
B	B-52	Clock spring <SRS>	4-150	2-22, 26
	B-53	Horn switch <SRS>	4-89	2-22, 26
	B-54	Air bag module (squib) (Driver's side)	4-150	2-22, 26
	B-55	Clock spring <SRS>	4-89	2-22, 26
	B-56	Column switch	4-18, 50, 51, 54, 58, 62, 66, 68, 70, 74, 85, 131	2-22, 26
	B-57	Column switch	4-50, 51, 54, 70, 74, 131	2-22, 26
	B-58	Ignition switch	4-14	2-22, 26
	B-59	Ignition key ring antenna	4-155	2-22, 26
	B-60X	J/C (1)	4-6, 33, 45, 59, 60, 63, 64, 67, 69, 71, 75, 91, 96, 113, 115, 121, 136, 139, 142, 145, 146, 149, 154, 156	2-22, 26
	B-61X	J/C (2)	4-6, 33, 34, 45, 50, 51, 54, 56, 67, 69, 70, 71, 72, 74, 75, 76, 84, 86, 87, 90, 96, 101, 102, 104, 106, 107, 108, 109, 124, 126, 131, 133, 135, 136, 141, 142, 147, 149, 154, 155, 150	2-22, 26
	B-62X	Diode (Electrically loaded idle-up circuit)	4-33, 50, 51, 52, 132, 134	2-22, 26
	B-64X	Front fog lamp relay	4-71, 75	2-22, 26
	B-65X	Rear fog lamp relay	4-66, 68	2-22, 26
	B-66X	Rear intermittent wiper relay	4-128	2-22, 26
	B-67X	Door lock ECU	4-102, 104	2-22, 26
	B-68	J/B and instrument panel wiring harness combination	4-4, 82, 84, 85, 137	2-23, 27
	B-69	J/B and roof wiring harness combination	4-4, 78, 80, 144	2-23, 27
	B-70	J/B and roof wiring harness combination	4-4, 78, 79, 80, 81, 144, 145	2-23, 27
	B-71	No connection	4-4	2-23, 27
	B-72	Defogger relay	4-4, 132, 134	2-23, 27
	B-73	Turn-signal and hazard warning flasher unit	4-1, 85	2-23, 27
	B-74	Blower relay	4-1, 112, 114, 120	2-23, 27
	B-75	Front wiring harness and J/B combination	4-4, 24, 25, 33, 45, 46, 50, 51, 52, 53, 56, 59, 63, 66, 68, 71, 75, 78, 80, 82, 84, 86, 88, 91, 107, 109, 112, 113, 115, 121, 136, 137, 138, 140, 146, 149, 151, 154, 156	2-23, 27

Connector No	Parts name	Circuit diagram page	Wiring diagram page	
B	B-76	Front wiring harness and J/B combination	4-4, 17, 71, 75, 112, 114, 120, 132, 134, 144	2-23, 27
	B-77	Body wiring harness and J/B combination	4-4, 16, 46, 53, 96, 114, 120, 131, 132, 134, 144, 146, 148	2-23, 27
	B-78	Body wiring harness and J/B combination	4-4, 16, 17, 24, 25, 29, 35, 59, 63, 78, 80, 82, 84, 85, 88, 89, 90, 94, 107, 112, 114, 120, 125, 128, 131, 132, 134, 136, 137, 138, 140, 144, 148, 150	2-23, 27
	B-79	Buzzer-ECU	4-4, 59, 63	2-23, 27
	B-80	Body wiring harness and J/B combination	4-4, 24, 25, 29, 35, 50, 51, 52, 59, 63, 66, 68, 71, 75, 85, 86, 90, 91, 94, 96, 109, 113, 114, 121, 124, 125, 128, 136, 138, 140, 142, 146, 148, 150, 156	2-23, 27
	B-81	Body wiring harness and J/B combination	4-4, 33, 45, 56, 66, 68, 71, 75, 78, 79, 80, 81, 85, 86, 89, 109, 112, 114, 120, 124, 132, 134, 138, 145, 149, 151, 154	2-23, 27
	B-82	Spare connector for front fog lamp	-	2-23, 43
C	C-01	Hazard warning switch	4-84	2-28, 29
	C-02	Glove box lamp	4-82	2-28, 29
	C-03	Cigarette lighter	4-137	2-28, 29
	C-04	Cigarette lighter	4-137	2-28, 29
	C-05	Ashtray illumination lamp	4-137	2-28, 29
D	D-01	Front door switch (Passenger's side)	4-79, 81, 110	2-30, 32
	D-02	Seat belt pretensioner (Passenger's side)	4-151	2-30, 32
	D-03	Heated seat (RH)	4-147	2-30
	D-04	Side impact sensor (RH)	4-152	2-30, 32
	D-05	Body wiring harness and rear door wiring harness (RH) combination	4-99, 101, 102, 106, 139	2-30, 32
	D-06	Sunroof ECU	4-144	2-30, 32
	D-07	Sunroof ECU	4-145	2-30, 32
	D-08	Room lamp and sunroof switch	4-78, 80, 144	2-30, 32
	D-09	Heated seat switch (RH)	4-145	2-30
	D-10	Heated seat (LH)	4-147	2-30
	D-11	Room lamp <Without sunroof>	4-78, 80	2-30, 32

Connector No	Parts name	Circuit diagram page	Wiring diagram page	
D	D-12	Rear speed sensor (RH) <ABS>	4-148	2-30, 32
	D-13	Fuel pump and gauge unit assembly	4-29, 35, 91, 94	2-30, 32
	D-14	Rear speed sensor (LH) <ABS>	4-148	2-30, 32
	D-15	Body wiring harness and fuel wiring harness combination	4-29, 35, 91, 94, 109, 148	2-31, 32
	D-16	Body wiring harness and rear end wiring harness combination	4-60, 64, 72, 79, 81, 85, 87, 88, 103, 104, 107, 108, 109, 110, 128, 132, 134, 147	2-31, 33
	D-17	Body wiring harness and rear door wiring harness (LH) combination	4-98, 101, 103, 107, 139	2-31, 33
	D-18	Side impact sensor (LH)	4-152	2-31, 33
	D-19	Front door switch (Driver's side)	4-59, 63, 79, 81, 96, 110, 145	2-31, 33
	D-20	Seat belt pretensioner (Driver's side)	4-151	2-31, 33
	D-21	Side air bag module (squib) (LH)	4-152	2-31, 33
	D-22	Oxygen sensor (Rear) <4G13>	4-31	2-31, 33
	D-23	Heated seat switch (LH)	4-146	2-31
	D-24	Parking brake switch	4-94	2-31, 33
	D-25	SRS-ECU	4-142, 151, 152	2-31, 33
	D-26	Side air bag module (squib) (RH)	4-152	2-31, 33
E	E-01	Remote controlled mirror (LH)	4-133, 135, 136	2-34, 35
	E-02	Door lock switch	4-104, 108	2-34, 35
	E-03	Power window main switch	4-97, 99	2-34, 35
	E-04	Front door lock actuator (Driver's side) <With keyless entry system>	4-106	2-34, 35
	E-05	Front door lock actuator (Driver's side) <Without keyless entry system>	4-102	2-34, 35
	E-06	Door lock key cylinder switch (Driver's side)	4-104, 108	2-34, 35
	E-07	Power window sub switch (Rear, LH)	4-98	2-34, 35
	E-08	Rear power window regulator assembly (LH)	4-101	2-34, 35
	E-09	Rear door lock actuator (LH)	4-102, 106	2-34, 35
	E-10	Rear door speaker (LH)	4-139	2-34, 35
	E-11	Front power window regulator assembly (Driver's side)	4-96	2-34, 35
	E-12	Front door speaker (LH)	4-139	2-34, 35

Connector No.	Parts name	Circuit diagram page	Wiring diagram page	
E	E-13	Remote controlled mirror (RH)	4-133, 135, 136	2-34, 35
	E-14	Power window sub switch (Front: Passenger's side)	4-97	2-34, 35
	E-15	Front door lock actuator (Passenger's side)	4-102, 106	2-34, 35
	E-16	Door lock key cylinder switch (Passenger's side)	4-104, 108	2-34, 35
	E-17	Power window sub switch (Rear: RH)	4-99	2-34, 35
	E-18	Rear power window regulator assembly (RH)	4-101	2-34, 35
	E-19	Rear door lock actuator (RH)	4-103, 107	2-34, 35
	E-20	Rear door speaker (RH)	4-130	2-34, 35
	E-21	Front power window regulator assembly (Passenger's side)	4-100	2-34, 35
	E-22	Front door speaker (RH)	4-139	2-34, 35
F	F-01	Rear combination lamp (RH)	4-60, 64, 72, 76, 85, 87, 88, 109, 142	2-36
	F-02	Rear door switch (RH)	4-79, 81, 110	2-36
	F-03	Rear combination lamp (LH)	4-60, 64, 72, 76, 85, 87, 88, 109, 142	2-36
	F-04	Rear end wiring harness and gate wiring harness combination	4-60, 64, 79, 81, 87, 129, 132, 134, 110	2-36
	F-05	Rear end wiring harness and gate wiring harness combination	4-103, 104, 107, 108	2-36
	F-06	Luggage compartment lamp	4-79, 81	2-36
	F-07	Luggage compartment lamp	4-79, 81	2-36
	F-08	Rear door switch (LH)	4-79, 81, 110	2-36
	F-09	High mounted stop lamp	4-87	2-36
	F-10	Defogger ()	4-132, 134	2-36
	F-11	Rear gate lock key cylinder switch	4-104, 108	2-36
	F-12	Gate wiring harness and licence plate lamp wiring harness combination	4-60, 64	2-36
	F-13	Licence plate lamp (RH)	4-60, 64	2-36
	F-14	Rear gate switch	4-79, 81, 110	2-36
	F-15	Rear gate lock actuator	4-103, 107	2-36
	F-16	Licence plate lamp (LH)	4-60, 64	2-36
	F-17	Defogger (+)	4-132, 134	2-36
	F-18	Rear wiper motor	4-129	2-36

INDEX (In order of parts name)

	Parts name	Connector No	Circuit diagram page	Wiring diagram page
A	A/C compressor relay	A-10X	4-118, 122	2-4, 8, 12, 16
	A/C refrigerant temperature switch and magnetic clutch	A-37	4-118, 122	2-5, 9, 13, 16
	A/C switch	B-08	4-112, 114, 120, 134	2-20, 24
	ABS-ECU	A-47	4-148	2-5, 9, 13, 16
	Accelerator pedal position sensor	A-84	4-42	2-11, 19
	Air bag module (squib) (Driver's side)	B-54	4-150	2-22, 26
	Air bag module (squib) (Passenger's side)	B-17	4-150	2-20, 24
	Air flow sensor <4G93>	A-73	4-40	2-10, 19
	Alternator	A-93	4-24, 25	2-7, 11, 15, 19
	Alternator	A-92	4-24, 25	2-7, 11, 15, 19
	Alternator relay	A-04X	4-24, 25	2-4, 8, 12, 16
	Ashtray illumination lamp	C-05	4-137	2-28, 29
	Audio unit <Vehicles with navigation system>	B-04	4-140, 141	2-20, 24
	Audio unit <Vehicles with navigation system>	B-07	4-139	2-20, 24
	Audio unit <Vehicles with navigation system>	B-11	4-139	2-20, 24
	Audio unit <Vehicles without navigation system>	B-05	4-139	2-20, 24
	Audio unit <Vehicles without navigation system>	B-12	4-139	2-20, 24
	Audio unit <Vehicles without navigation system>	B-38	4-140	2-21, 25
	Automatic compressor ECU	B-16	4-118, 122	2-20, 24
B	Back-up lamp switch	A-78	4-88, 140	2-7, 11, 15, 19
	Blower control illumination lamp	B-13	4-113, 115, 121	2-20, 24
	Blower motor	B-23	4-112, 114, 120	2-20, 24
	Blower relay	B-74	4-4, 112, 114, 120	2-23, 27
	Blower switch	B-10	4-112, 114, 120	2-20, 24
	Body wiring harness and front door wiring harness (Driver's side) combination	B-41	4-96, 97, 98, 99, 102, 104, 106, 108, 133, 135, 136, 139	2-21, 25
	Body wiring harness and front door wiring harness (Passenger's side) combination	B-22	4-97, 100, 102, 104, 106, 108, 133, 135, 136, 139	2-20, 24
	Body wiring harness and fuel wiring harness combination	D-15	4-29, 35, 91, 94, 109, 148	2-31, 32

Parts name	Connector No.	Circuit diagram page	Wiring diagram page
B Body wiring harness and instrument panel wiring harness combination	B-40	4-84	2-21, 25
Body wiring harness and J/B combination	B-77	4-4, 16, 46, 53, 96, 114, 120, 131, 132, 134, 144, 146, 148	2-23, 27
Body wiring harness and J/B combination	B-78	4-4, 16, 17, 24, 25, 29, 35, 59, 63, 78, 80, 82, 84, 85, 88, 89, 90, 94, 107, 112, 114, 120, 125, 128, 131, 132, 134, 136, 137, 138, 140, 144, 146, 150	2-23, 27
Body wiring harness and J/B combination	B-80	4-4, 24, 25, 29, 35, 50, 51, 52, 59, 63, 66, 68, 71, 75, 85, 86, 90, 91, 94, 98, 109, 113, 114, 121, 124, 125, 128, 136, 138, 140, 142, 146, 148, 150, 156	2-23, 27
Body wiring harness and J/B combination	B-81	4-4, 33, 45, 56, 66, 68, 71, 75, 78, 79, 80, 81, 85, 88, 89, 109, 112, 114, 120, 124, 132, 134, 138, 145, 149, 151, 154	2-23, 27
Body wiring harness and rear door wiring harness (LH) combination	D-17	4-98, 101, 103, 107, 139	2-31, 33
Body wiring harness and rear door wiring harness (RH) combination	D-05	4-99, 101, 102, 106, 139	2-30, 32
Body wiring harness and rear end wiring harness combination	D-16	4-60, 64, 72, 79, 81, 85, 87, 88, 103, 104, 107, 108, 109, 110, 128, 132, 134, 142	2-31, 33
Brake fluid level sensor	A-69	4-94	2-7, 10, 15, 18
Brake vacuum sensor <4G93>	A-70	4-40	2-10, 18
Buzzer-ECU	B-79	4-4, 59, 63	2-23, 27
C Camshaft position sensor <4G93>	A-81	4-40	2-11, 19
Cigarette lighter	C-03	4-137	2-28, 29
Cigarette lighter	C-04	4-137	2-28, 29
Clock spring <SRS>	B-52	4-150	2-22, 26
Clock spring <SRS>	B-55	4-89	2-22, 26
Column switch	B-51	4-89, 124, 128	2-22, 26
Column switch	B-56	4-18, 50, 51, 54, 58, 62, 66, 68, 70, 74, 85, 131	2-22, 26
Column switch	B-57	4-50, 51, 54, 70, 74, 131	2-22, 26

Parts name	Connector No	Circuit diagram page	Wiring diagram page
C Combination meter	B-01	4-24, 25, 29, 35, 50, 51, 52, 67, 69, 72, 76, 78, 80, 86, 90, 94, 109, 125, 141, 148, 150	2-20, 24
Combination meter	B-02	4-24, 25, 29, 35, 50, 51, 52, 86, 91, 94, 109, 125	2-20, 24
Condenser fan motor <4G13>	A-34	4-47, 117	2-5, 13
Condenser fan relay (HI) <4G13>	A-09X	4-47, 117	2-4, 12
Condenser fan relay (LO) <4G13>	A-08X	4-47, 117	2-4, 12
Control wiring harness and battery cable assembly combination <4G13>	A-74	4-20, 24, 32, 94	2-7, 15
Control wiring harness and battery cable assembly combination <4G93>	A-75	4-20, 25, 39, 94	2-11, 19
Control wiring harness and body wiring harness combination	B-18	4-20, 22, 23, 28, 29, 32, 34, 35, 39	2-20, 24
Control wiring harness and body wiring harness combination	B-19	4-29, 32, 33, 34, 35, 39, 44, 45, 66, 90, 91, 94, 122, 124, 140, 141, 154, 155	2-20, 24
Control wiring harness and EGR wiring harness combination	A-65	4-41	2-10, 16
Control wiring harness and injector wiring harness combination <4G93>	A-82	4-38	2-11, 19
Crank angle sensor <4G93>	A-94	4-41	2-11, 19
D Defogger (-)	F-10	4-132, 134	2-36
Defogger (+)	F-17	4-132, 134	2-36
Defogger relay	B-72	4-4, 132, 134	2-23, 27
Detonation sensor	A-50	4-32, 41	2-6, 10, 14, 18
Diagnosis connector	B-33	4-33, 45	2-21, 25
Diagnosis connector	B-35	4-33, 45, 107, 142, 149, 151, 154	2-21, 25
Diode (Headlamp circuit)	B-03	4-50, 51, 54, 70, 74	2-20, 24
Diode (Keyless entry system circuit)	B-37	4-81, 110	2-21, 25
Diode (Electrically loaded idle-up circuit)	B-62X	4-33, 50, 51, 52, 132, 134	2-22, 26
Distributor assembly <4G13>	A-72	4-22, 30	2-7, 15
Door lock ECU	B-67X	4-102, 104	2-22, 26
Door lock key cylinder switch (Driver's side)	E-06	4-104, 108	2-34, 35
Door lock key cylinder switch (Passenger's side)	E-16	4-104, 108	2-34, 35

	Parts name	Connector No	Circuit diagram page	Wiring diagram page
D	Door lock switch	E-02	4-104, 108	2-34, 35
	DRL-ECU	A-16	4-53, 62, 74, 138	2-4, 8
	DRL relay 1	A-17	4-53	2-4, 8
	DRL relay 2	A-18	4-52	2-4, 8
	Dual pressure switch	A-33	4-118, 122	2-5, 9, 13, 16
E	EGR servo <4G93>	A-62	4-41	2-10, 16
	EGR solenoid valve <4G13>	A-61	4-31	2-6, 14
	Engine control relay	B-26	4-28, 34, 48, 123, 154	2-21, 25
	Engine coolant temperature gauge unit	A-77	4-91	2-7, 11, 15, 19
	Engine coolant temperature sensor	A-76	4-30, 40	2-7, 11, 15, 19
	Engine-ECU	B-28	4-22, 23, 28, 29, 30, 32, 34, 35, 37, 38, 39, 40, 41, 45, 46, 48, 116, 118, 122, 123	2-21, 25
	Engine-ECU	B-29	4-28, 32, 33, 34, 40, 41, 45, 48, 118, 122, 123, 154	2-21, 25
	Engine-ECU	B-30	4-22, 23, 31, 33, 38, 39, 42, 44, 45, 140, 154	2-21, 25
	Engine-ECU	B-31	4-28, 30, 31, 32, 33, 34, 35, 39, 40, 41, 42, 44, 45, 122, 141	2-21, 25
	Engine speed detection connector	A-64	4-22, 23, 24	2-6, 10, 14, 18
F	Fan control relay <4G93>	A-07X	4-48, 123	2-8, 16
	Fan controller <4G93>	A-32	4-18	2-9, 16
	Fog lamp switch	B-47	4-67, 69, 71, 75	2-21, 25
	Front door lock actuator (Driver's side) <With keyless entry system>	E-04	4-106	2-34, 35
	Front door lock actuator (Driver's side) <Without keyless entry system>	E-05	4-102	2-34, 35
	Front door lock actuator (Passenger's side)	E-15	4-102, 106	2-34, 35
	Front door speaker (LH)	E-12	4-139	2-34, 35
	Front door speaker (RH)	E-22	4-139	2-34, 35
	Front door switch (Driver's side)	D-19	4-59, 63, 79, 81, 96, 110, 145	2-31, 33
	Front door switch (Passenger's side)	D-01	4-79, 81, 110	2-30, 32
	Front fog lamp relay	B-64X	4-71, 75	2-22, 26
	Front fog lamp (LH)	A-29	4-66, 68	2-5, 9, 12, 16

	Parts name	Connector No	Circuit diagram page	Wiring diagram page
F	Front fog lamp (RH)	A-36	4-67, 69	2-5, 9, 13, 16
	Front power window regulator assembly (Driver's side)	E-11	4-96	2-34, 35
	Front power window regulator assembly (Passenger's side)	E-21	4-100	2-34, 35
	Front speed sensor (LH) <ABS>	A-22	4-148	2-4, 8, 12, 16
	Front speed sensor (RH) <ABS>	A-02	4-148	2-4, 8, 12, 16
	Front turn signal lamp (LH)	A-24	4-86, 109	2-4, 8, 12, 16
	Front turn signal lamp (RH)	A-43	4-86, 109	2-5, 9, 13, 16
	Front wiring harness and body wiring harness combination	B-42	4-15, 66, 68, 131, 148, 149	2-21, 25
	Front wiring harness and body wiring harness combination	B-43	4-24, 25, 33, 34, 50, 51, 52, 53, 54, 56, 60, 64, 70, 74, 87, 89, 102, 106, 118, 122, 124, 125, 126, 138, 139, 140, 149	2-21, 25
	Front wiring harness and body wiring harness combination	B-45	4-14, 18, 28, 34, 50, 51, 54, 58, 62, 66, 68, 70, 74, 96, 139	2-21, 25
	Front wiring harness and control wiring harness combination	A-23	4-24, 25, 28, 33, 34, 39, 45, 47, 48, 86, 117, 118, 122, 123, 140, 154	2-4, 8, 12, 16
	Front wiring harness and DRL wiring harness combination	A-20	4-52, 53, 54, 62, 68, 74, 138	2-4, 8
	Front wiring harness and DRL wiring harness combination	A-21	4-52, 53, 62, 68, 74	2-4, 8
	Front wiring harness and J/B combination	B-75	4-4, 24, 25, 33, 45, 46, 50, 51, 52, 53, 56, 59, 63, 66, 68, 71, 75, 78, 80, 82, 84, 86, 88, 91, 107, 109, 112, 113, 115, 121, 136, 137, 138, 140, 146, 149, 151, 154, 156	2-23, 27
	Front wiring harness and J/B combination	B-76	4-4, 17, 71, 75, 112, 114, 120	2-23, 27
	Fuel pressure sensor <4G93>	A-83	4-40	2-11, 19
	Fuel pump and gauge unit assembly	D-13	4-29, 35, 91, 94	2-30, 32
	Fuel pump relay	B-27	4-29, 35	2-21, 25
G	Gate wiring harness and licence plate lamp wiring harness combination	F-12	4-60, 64	2-36
	Glove box lamp	C-02	4-82	2-28, 29
H	Hazard warning switch	C-01	4-84	2-28, 29

Parts name	Connector No.	Circuit diagram page	Wiring diagram page
H Headlamp leveling switch	B-46	4-56	2-21, 25
Headlamp leveling unit (LH)	A-25	4-56	2-4, 9, 12, 16
Headlamp leveling unit (RH)	A-41	4-56	2-5, 9, 13, 16
Headlamp relay	A-12X	4-15, 50, 51, 52, 70, 74	2-4, 8, 12, 16
Headlamp washer motor	A-42	4-131	2-5, 9, 13, 16
Headlamp washer relay	A-03X	4-131	2-4, 8, 12, 16
Headlamp (LH)	A-27	4-50, 51, 52	2-5, 9, 12, 16
Headlamp (RH)	A-39	4-50, 51, 52	2-5, 9, 13, 16
Heated seat switch (LH)	D-23	4-146	2-31
Heated seat switch (RH)	D-09	4-146	2-30
Heated seat (LH)	D-10	4-147	2-30
Heated seat (RH)	D-03	4-147	2-30
High mounted stop lamp	F-09	4-87	2-36
Horn relay	A-06X	4-89	2-4, 8, 12, 16
Horn switch <SRS>	B-53	4-89	2-22, 26
Horn (LH)	A-30	4-89	2-5, 9, 13, 16
Horn (RH)	A-35	4-89	2-5, 9, 13, 16
I Idle speed control servo <4G13>	A-67	4-30	2-6, 14
Ignition coil 1 <4G93>	A-91	4-23, 37	2-11, 19
Ignition coil 2 <4G93>	A-89	4-23, 37	2-11, 19
Ignition coil 3 <4G93>	A-86	4-23, 37	2-11, 19
Ignition coil 4 <4G93>	A-85	4-23, 37	2-11, 19
Ignition key ring antenna	B-59	4-155	2-22, 26
Ignition switch	B-58	4-14	2-22, 26
Ignition timing adjustment connector <4G13>	A-57	4-22, 23	2-6, 14
Immobilizer-ECU	B-36	4-33, 39, 155	2-21, 25
Injector driver	A-52	4-36, 38	2-10, 18
Injector driver control relay	A-53	4-36	2-10, 18
Injector No. 1	A-48	4-31, 38	2-6, 10, 14, 18
Injector No. 2	A-49	4-31, 38	2-6, 10, 14, 18
Injector No. 3	A-54	4-31, 38	2-6, 10, 14, 18
Injector No. 4	A-50	4-31, 38	2-6, 10, 14, 18

	Parts name	Connector No.	Circuit diagram page	Wiring diagram page
I	Intake air temperature sensor <4G13>	A-56	4-30	2-6, 14
J	J/B and instrument panel wiring harness combination	B-68	4-4, 82, 84, 85, 137	2-23, 27
	J/B and roof wiring harness combination	B-69	4-4, 78, 80, 144	2-23, 27
	J/B and roof wiring harness combination	B-70	4-4, 78, 79, 80, 81, 144, 145	2-23, 27
	J/C (1)	B-60X	4-6, 33, 45, 59, 60, 63, 64, 67, 69, 71, 75, 91, 96, 113, 115, 121, 136, 139, 142, 145, 146, 149, 154, 156	2-22, 26
	J/C (2)	B-61X	4-6, 33, 34, 45, 50, 51, 54, 56, 57, 69, 70, 71, 72, 74, 75, 76, 84, 86, 87, 90, 96, 101, 102, 104, 106, 107, 108, 109, 124, 128, 131, 133, 135, 136, 141, 142, 147, 149, 154, 155, 156	2-22, 26
K	Keyless entry receiver-ECU	B-21	4-106, 106, 110	2-20, 24
L	Licence plate lamp (LH)	F-16	4-60, 64	2-36
	Licence plate lamp (RH)	F-13	4-60, 64	2-36
	Luggage compartment lamp	F-06	4-79, 81	2-36
	Luggage compartment lamp	F-07	4-79, 81	2-36
M	M/T oil temperature sensor <4G93>	A-30	4-41	2-11, 19
	Multi center display	B-08	4-140, 142	2-20, 24
	Multi center display	B-09	4-33, 45, 140, 141, 142	2-20, 24
N	Navigation unit	B-14	4-141	2-20, 24
	No connection	B-71	4-4	2-23, 27
O	Oil pressure switch	A-90	4-94	2-7, 11, 15, 19
	Outside thermo sensor	A-28	4-140	2-5, 9, 12, 16
	Outside/inside air selection damper control motor	B-20	4-112, 114, 120	2-20, 24
	Oxygen sensor (Front) <4G13>	B-34	4-31	2-21, 25
	Oxygen sensor (Rear) <4G13>	D-22	4-31	2-31, 33
	Oxygen sensor <4G93>	A-55	4-41	2-10, 18
P	Parking brake switch	D-24	4-94	2-31, 33
	Position lamp (LH)	A-26	4-58, 62	2-5, 9, 12, 16
	Position lamp (RH)	A-40	4-58, 62	2-5, 9, 13, 16
	Power steering oil pressure switch	A-38	4-33, 45	2-5, 9, 13, 16

	Parts name	Connector No.	Circuit diagram page	Wiring diagram page
P	Power window main switch	E-03	4-97, 99	2-34, 35
	Power window sub switch (Front Passenger's side)	E-14	4-97	2-34, 35
	Power window sub switch (Rear RH)	E-17	4-99	2-34, 35
	Power window sub switch (Rear LH)	E-07	4-98	2-34, 35
	Purge control solenoid valve	A-58	4-31, 41	2-6, 10, 14, 18
R	Radiator fan motor <4G13>	A-31	4-46, 116	2-5, 13
	Radiator fan relay <4G13>	A-14X	4-46, 116	2-4, 12, 16
	Rear combination lamp (LH)	F-03	4-60, 64, 72, 76, 85, 87, 88, 109, 142	2-36
	Rear combination lamp (RH)	F-01	4-60, 64, 72, 76, 85, 87, 88, 109, 142	2-36
	Rear door lock actuator (LH)	E-09	4-102, 106	2-34, 35
	Rear door lock actuator (RH)	E-19	4-103, 107	2-34, 35
	Rear door speaker (LH)	E-10	4-139	2-34, 35
	Rear door speaker (RH)	E-20	4-139	2-34, 35
	Rear door switch (LH)	F-08	4-79, 81, 110	2-36
	Rear door switch (RH)	F-02	4-79, 81, 110	2-36
	Rear end wiring harness and gate wiring harness combination	F-04	4-60, 64, 79, 81, 87, 129, 132, 134, 110	2-36
	Rear end wiring harness and gate wiring harness combination	F-05	4-103, 104, 107, 108	2-36
	Rear fog lamp relay	B-65X	4-66, 68	2-22, 26
	Rear gate lock actuator	F-15	4-103, 107	2-36
	Rear gate lock key cylinder switch	F-11	4-104, 108	2-36
	Rear gate switch	F-14	4-79, 81, 110	2-36
	Rear intermittent wiper relay	B-66X	4-128	2-22, 26
	Rear power window regulator assembly (LH)	E-08	4-101	2-34, 35
	Rear power window regulator assembly (RH)	E-18	4-101	2-34, 35
	Rear speed sensor (LH) <ABS>	D-14	4-148	2-30, 32
	Rear speed sensor (RH) <ABS>	D-12	4-148	2-30, 32
	Rear washer motor	A-46	4-128	2-5, 9, 13, 16
	Rear wiper motor	F-18	4-129	2-36
	Remote controlled door mirror switch	B-49	4-135	2-21, 25

	Parts name	Connector No	Circuit diagram page	Wiring diagram page
R	Remote controlled mirror (LH)	E-01	4-133, 135, 136	2-34, 35
	Remote controlled mirror (RH)	E-13	4-133, 135, 136	2-34, 35
	Resistor	D-24	4-112, 114, 120	2-20, 24
	Rheostat	B-50	4-156	2-21, 25
	Room lamp and sunroof switch	D-08	4-78, 80, 144	2-30, 32
	Room lamp <Without sunroof>	D-11	4-78, 80	2-30, 32
S	Seat belt pretensioner (Driver's side)	D-20	4-151	2-31, 33
	Seat belt pretensioner (Passenger's side)	D-02	4-151	2-30, 32
	Side air bag module (squib) (LH)	D-21	4-152	2-31, 33
	Side air bag module (squib) (RH)	D-26	4-152	2-31, 33
	Side impact sensor (LH)	D-18	4-152	2-31, 33
	Side impact sensor (RH)	D-04	4-152	2-30, 32
	Side turn signal lamp (LH)	A-19	4-86, 109	2-4, 8, 12, 16
	Side turn signal lamp (RH)	A-01	4-86, 109	2-4, 8, 12, 16
	Spare connector for front fog lamp	A-79	-	2-5, 9, 13, 17
	Spare connector for front fog lamp	B-82	-	2-23, 27
	SRS-ECU	D-25	4-142, 151, 152	2-31, 33
	Starter	A-87	4-20	2-7, 11, 15, 19
	Starter	A-88	4-20	2-7, 11, 15, 19
	Stop lamp switch	B-39	4-34, 87, 149	2-21, 25
	Sunroof ECU	D-06	4-144	2-30, 32
	Sunroof ECU	D-07	4-145	2-30, 32
T	Turn lamp relay <DRL>	A-15X	4-19, 62, 68, 74	2-4, 8
	Throttle position sensor	A-66	4-30, 42	2-6, 10, 14, 18
	Throttle valve control servo <4G93>	A-68	4-43	2-10, 18
	Throttle valve controller <4G93>	B-15	4-35, 43	2-20, 24
	Throttle valve controller <4G93>	B-32	4-35	2-21, 25
	Turn-signal and hazard warning flasher unit	B-73	4-4, 85	2-23, 27
V	Vacuum sensor <4G13>	A-59	4-31	2-8, 14
	Vehicle speed sensor	A-71	4-32, 44, 90, 141	2-7, 10, 15, 18

	Parts name	Connector No.	Circuit diagram page	Wiring diagram page
W	Washer fluid level sensor	A-44	4-125	2-5, 9, 13, 16
	Windshield washer motor	A-45	4-125	2-5, 9, 13, 16
	Windshield wiper motor	A-51	4-125	2-6, 10, 14, 18