



OWNER'S MANUAL

GRANDIS



English

## Foreword

E09200101831

Thank you for selecting a GRANDIS as your new vehicle. This owner's manual will add to your understanding and full enjoyment of the many fine features of this vehicle. It contains information prepared to acquaint you with the proper way to operate and maintain your vehicle for the utmost in driving pleasure.

MITSUBISHI MOTORS Europe B.V. reserves the right to make changes in design and specifications and/or to make additions to or improvements in this product without obligation to install them on products previously manufactured. It is an absolute requirement for the driver to strictly observe all laws and regulations concerning vehicles.

This owner's manual has been written in compliance with such laws and regulations, but some of the contents may become contradictory with later amendment of the laws and regulations.

Please leave this owner's manual in this vehicle at time of resale. The next owner will appreciate having access to the information contained in this owner's manual.

Repairs to your vehicle:  
Vehicles in the warranty period:  
All warranty repairs must be carried out by a MITSUBISHI MOTORS Authorized Service Point.

Vehicles outside the warranty period:  
Where the vehicle is repaired is at the discretion of the owner.

Throughout this owner's manual the words **WARNING** and **CAUTION** appear. These serve as reminders to be especially careful. Failure to follow instructions could result in personal injury or damage to your vehicle.



**indicates a strong possibility of severe personal injury or death if instructions are not followed.**



**means hazards or unsafe practices that could cause minor personal injury or damage to your vehicle.**

You will see another important symbol:

**NOTE: gives helpful information.**

**\*: indicates optional equipment.**

It may differ according to the sales classification; refer to the sales catalogue.

Abbreviations used in this owner's manual:

**LHD: Left-Hand Drive**

**RHD: Right-Hand Drive**

**M/T: Manual Transmission**

**A/T: Automatic Transmission**

## Information for station service

E09300101526

Fuel	Fuel tank capacity	65 litres
	Fuel requirements	<b>Petrol-powered vehicles</b> Unleaded petrol octane number (EN 228) 95 RON or higher <b>Diesel-powered vehicles</b> Cetane number (EN 590) 51 or higher Refer to the "General information" section for the fuel selection.
Engine oil	Refer to the "Maintenance" section for the selection of engine oil.	
Tyre inflation pressure	Refer to the "Maintenance" section for the tyre inflation pressure.	

**Mitsubishi Motors Europe B.V.**

© 2007 Mitsubishi Motors Corporation

**OXPE08E1**

(9290B529)

BL070680

8

# *Table of contents*

<i>Overview</i>	
<i>General information</i>	
<i>Locking and unlocking</i>	1
<i>Seat and seat belts</i>	2
<i>Instruments and controls</i>	3
<i>Starting and driving</i>	4
<i>For pleasant driving</i>	5
<i>For emergencies</i>	6
<i>Vehicle care</i>	7
<i>Maintenance</i>	8
<i>Specifications</i>	9

# Instruments and Controls (Driver's area)

E00100102645

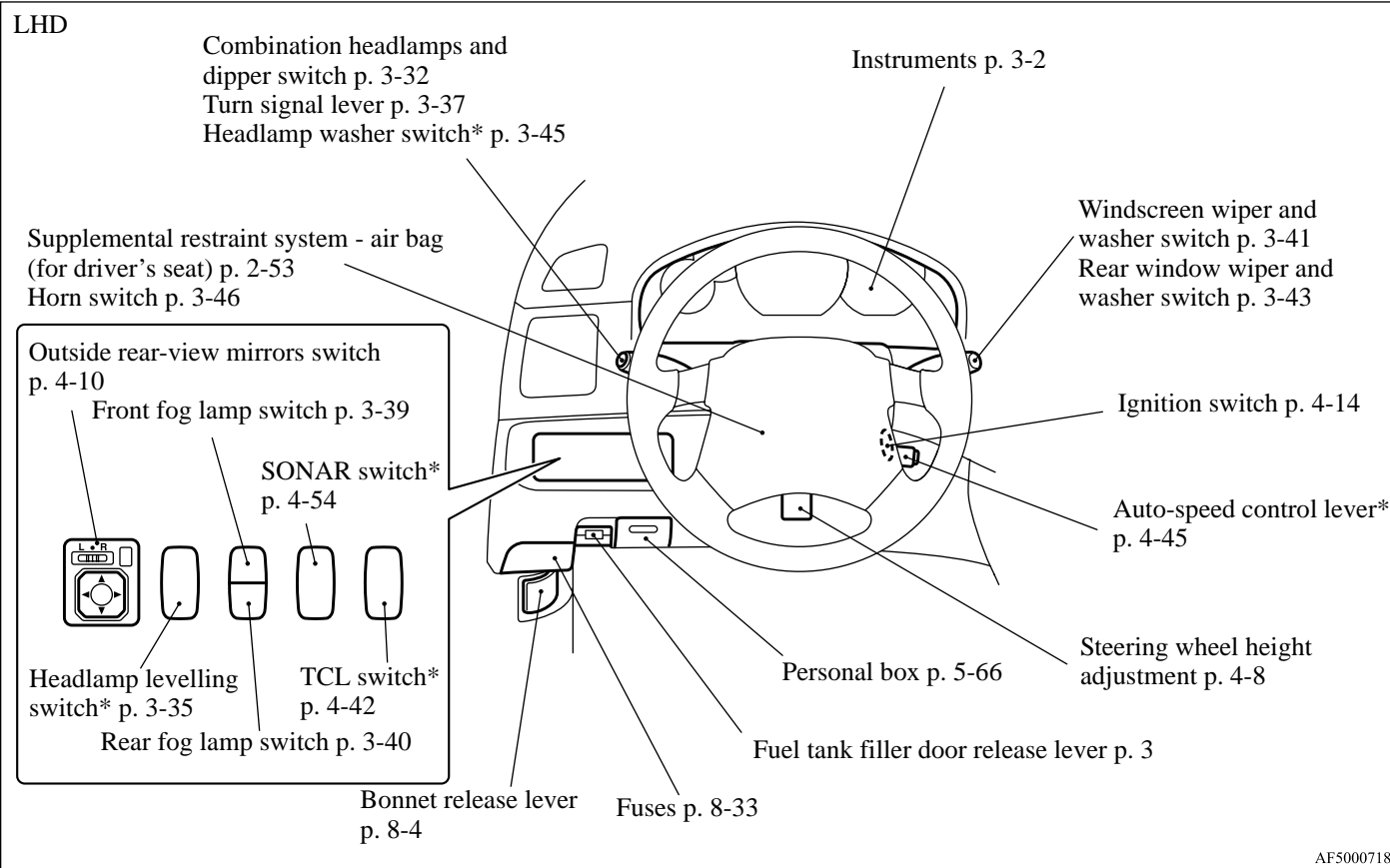

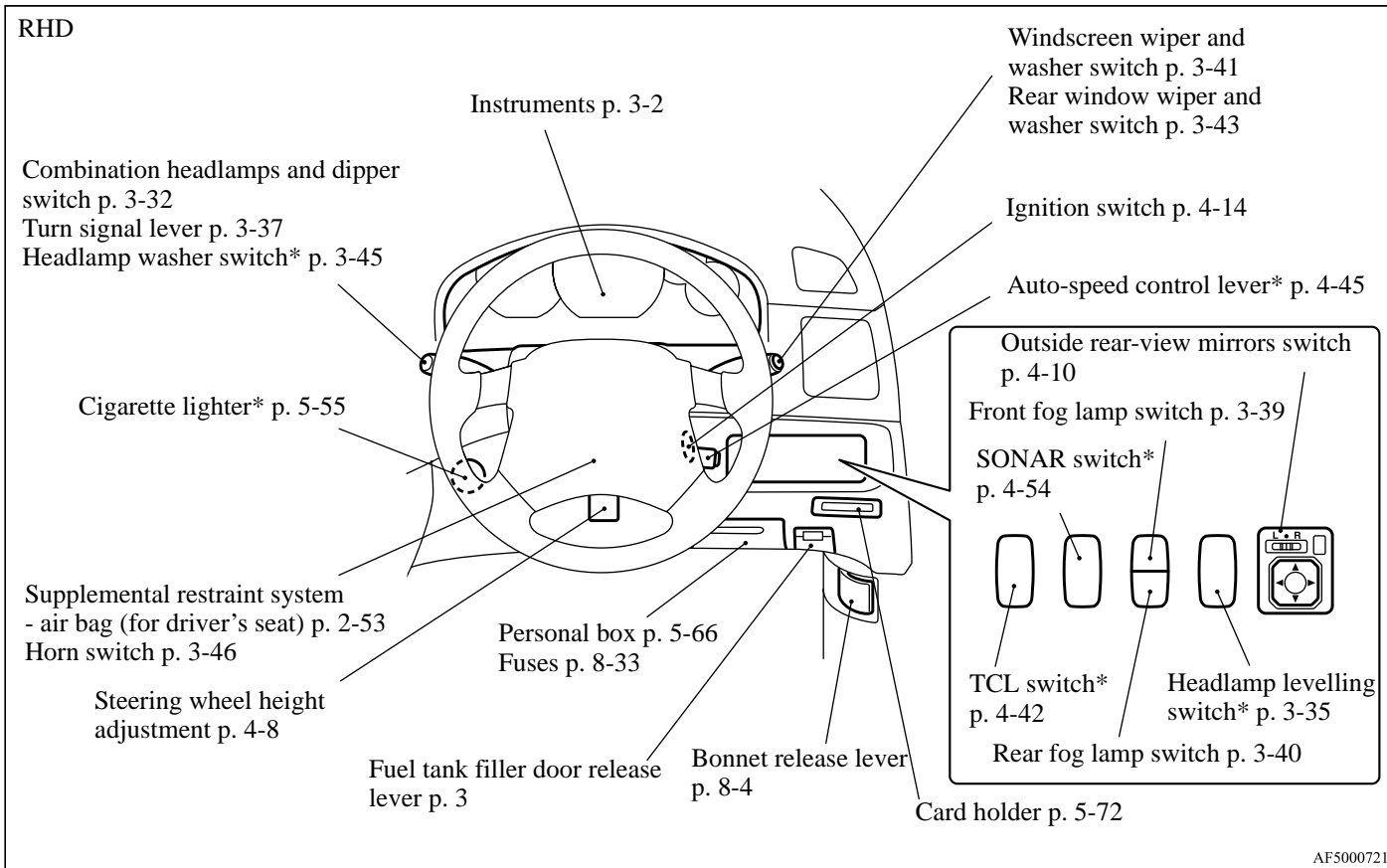

## *Instruments and Controls (Instrument panel)*

E00100102658

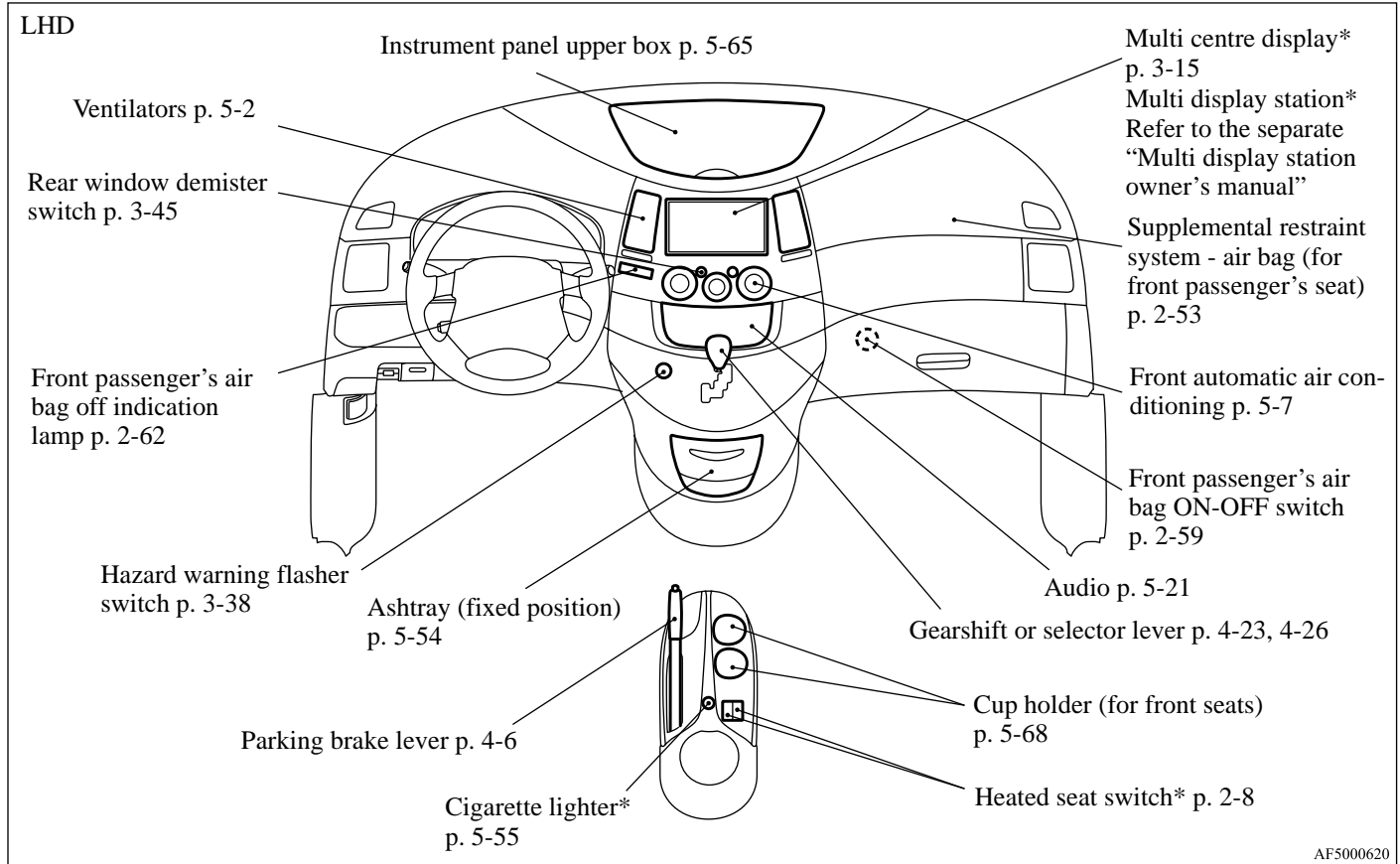

AF5000620

RHD

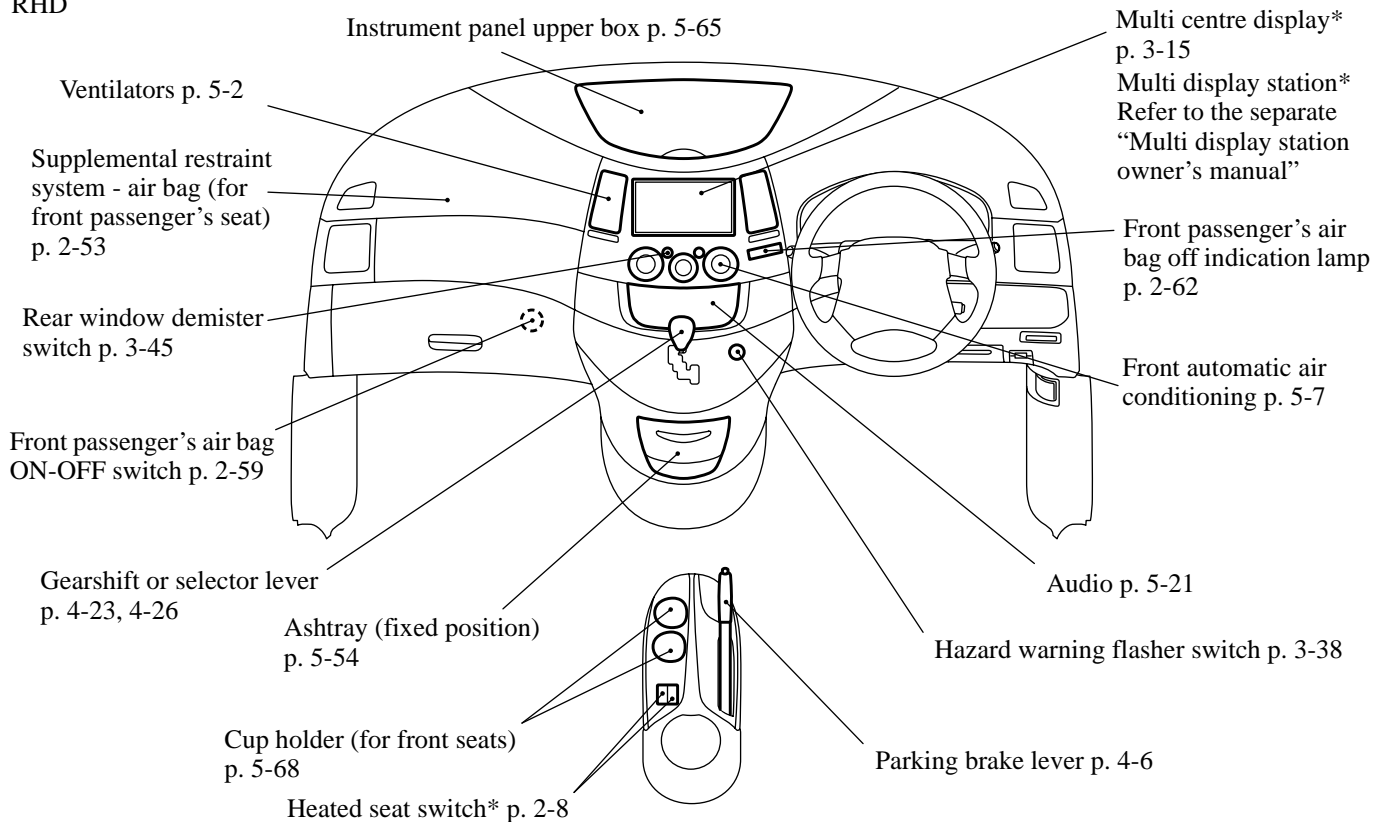

# Interior (Front area)

E00100201968

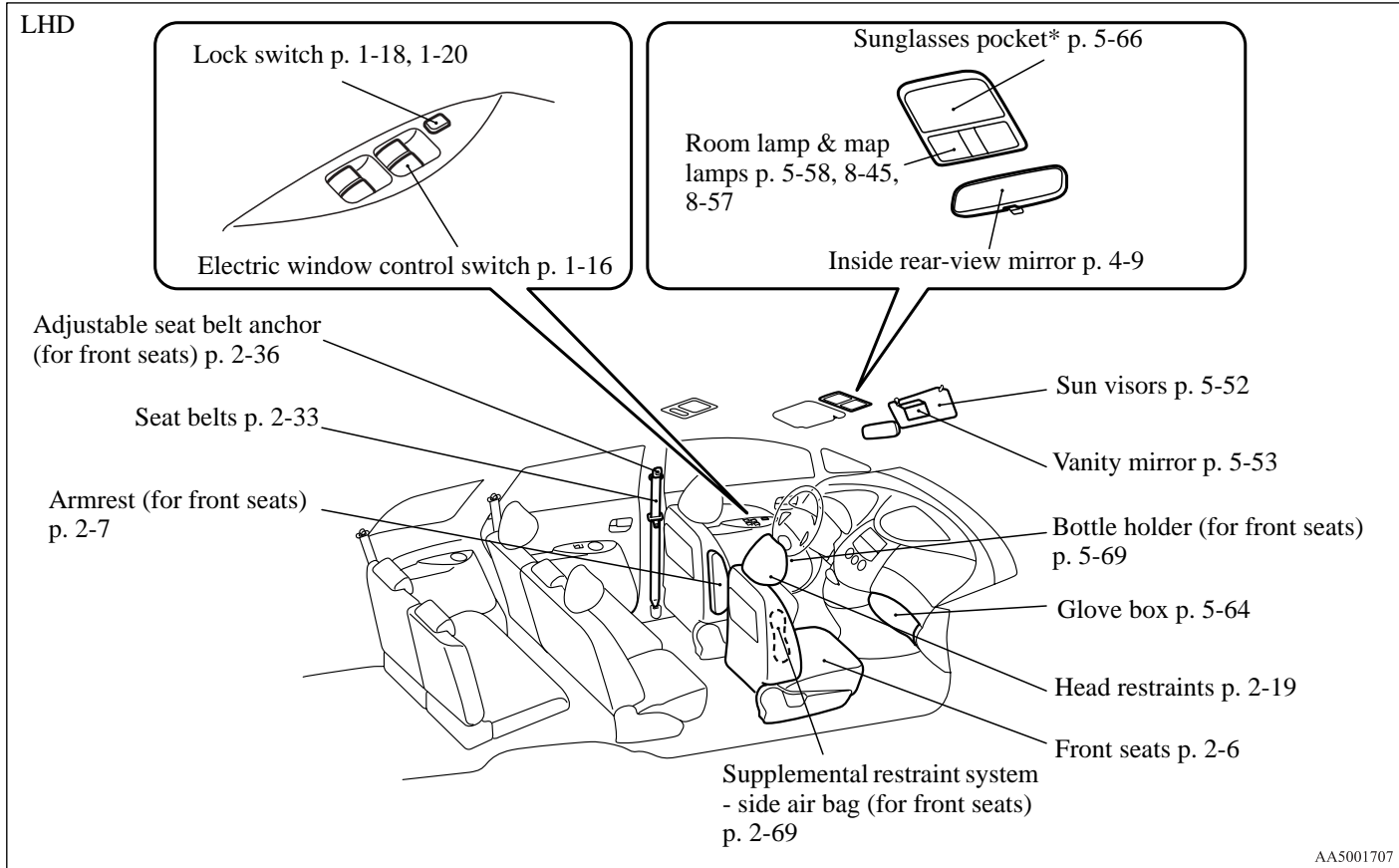



RHD

Sunglasses pocket\* p. 5-66

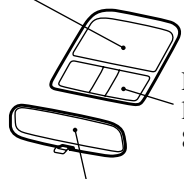

Room lamp & map lamps p. 5-58, 8-45, 8-57

Inside rear-view mirror p. 4-9

Lock switch p. 1-18, 1-20

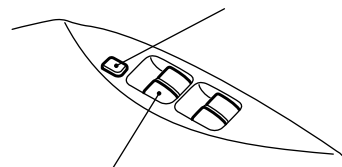

Electric window control switch p. 1-16

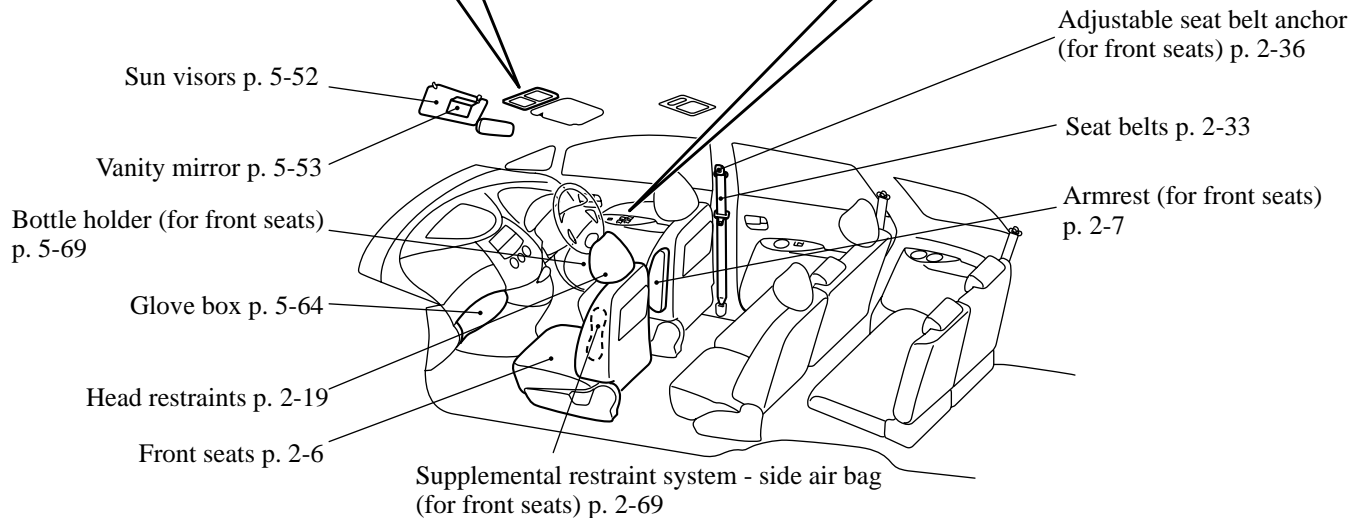

# Interior (Rear area)

E00100201971

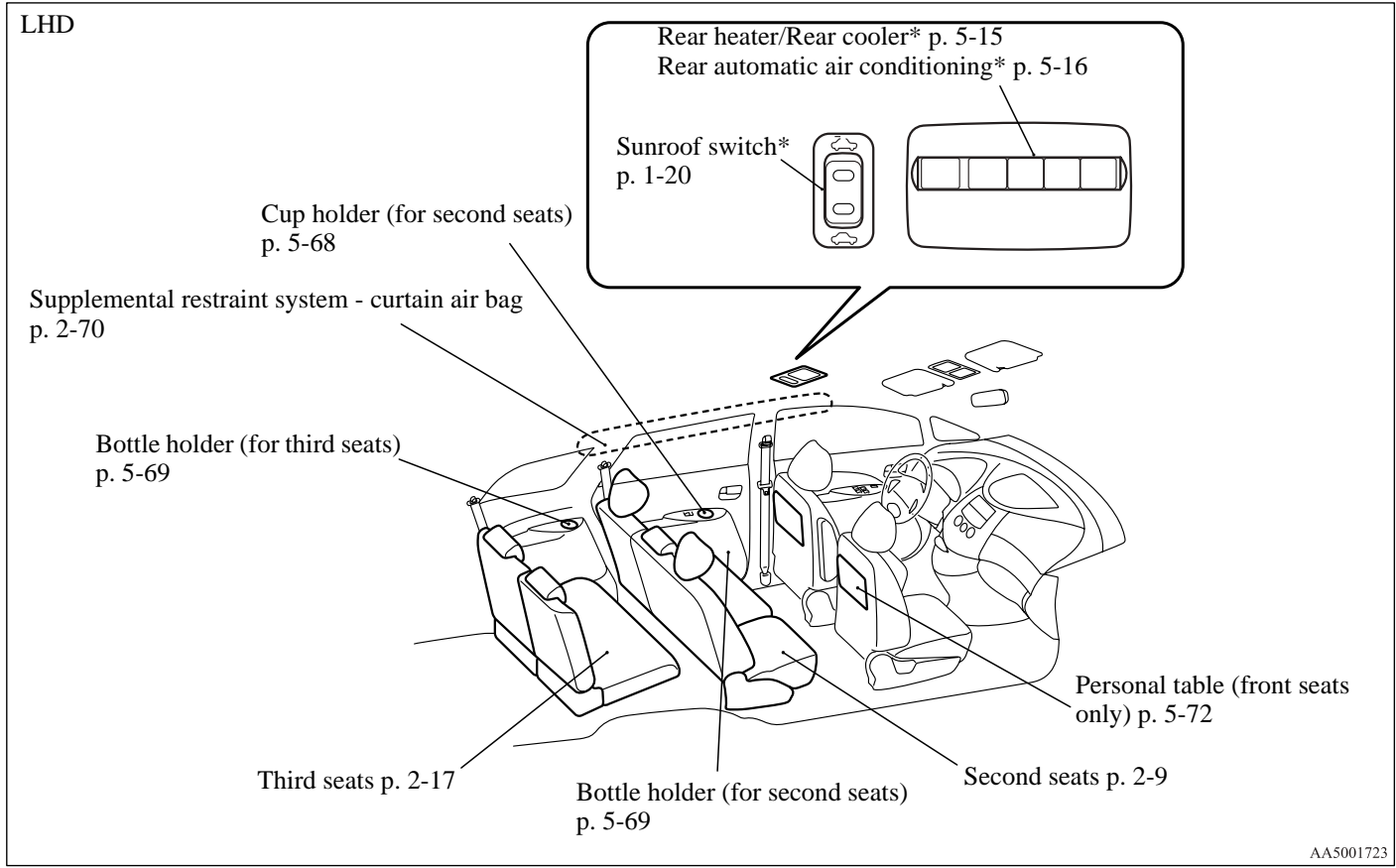

RHD

Rear heater/Rear cooler\* p. 5-15  
Rear automatic air conditioning\* p. 5-16

Sunroof switch\*  
p. 1-20

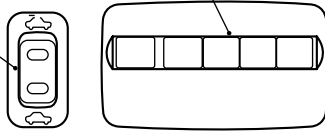

The diagram shows a rectangular sunroof switch with two arrows pointing outwards and two buttons below it. To its right is a rectangular panel with five vertical slots, representing the rear heater/cooler or automatic air conditioning controls.

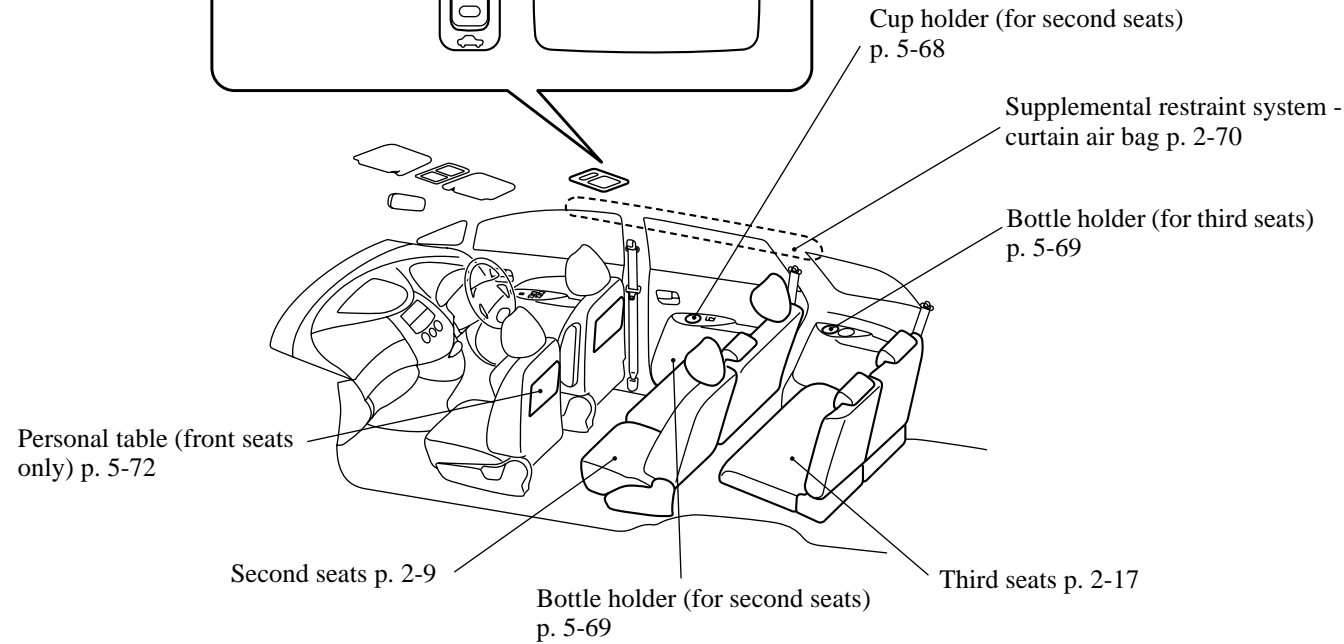

## Luggage area

E00100400833

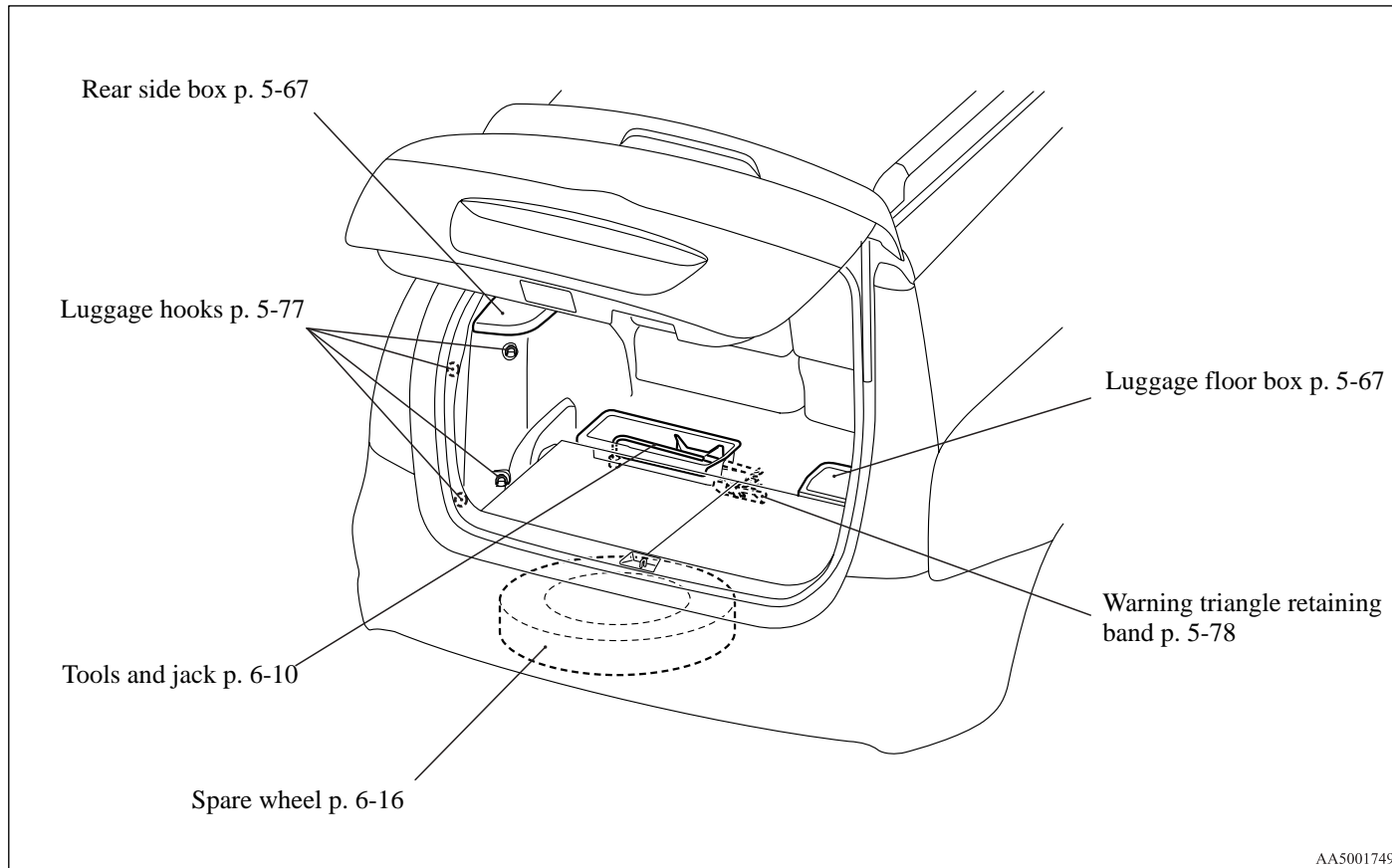

AA5001749

*Exterior*

E00100502128

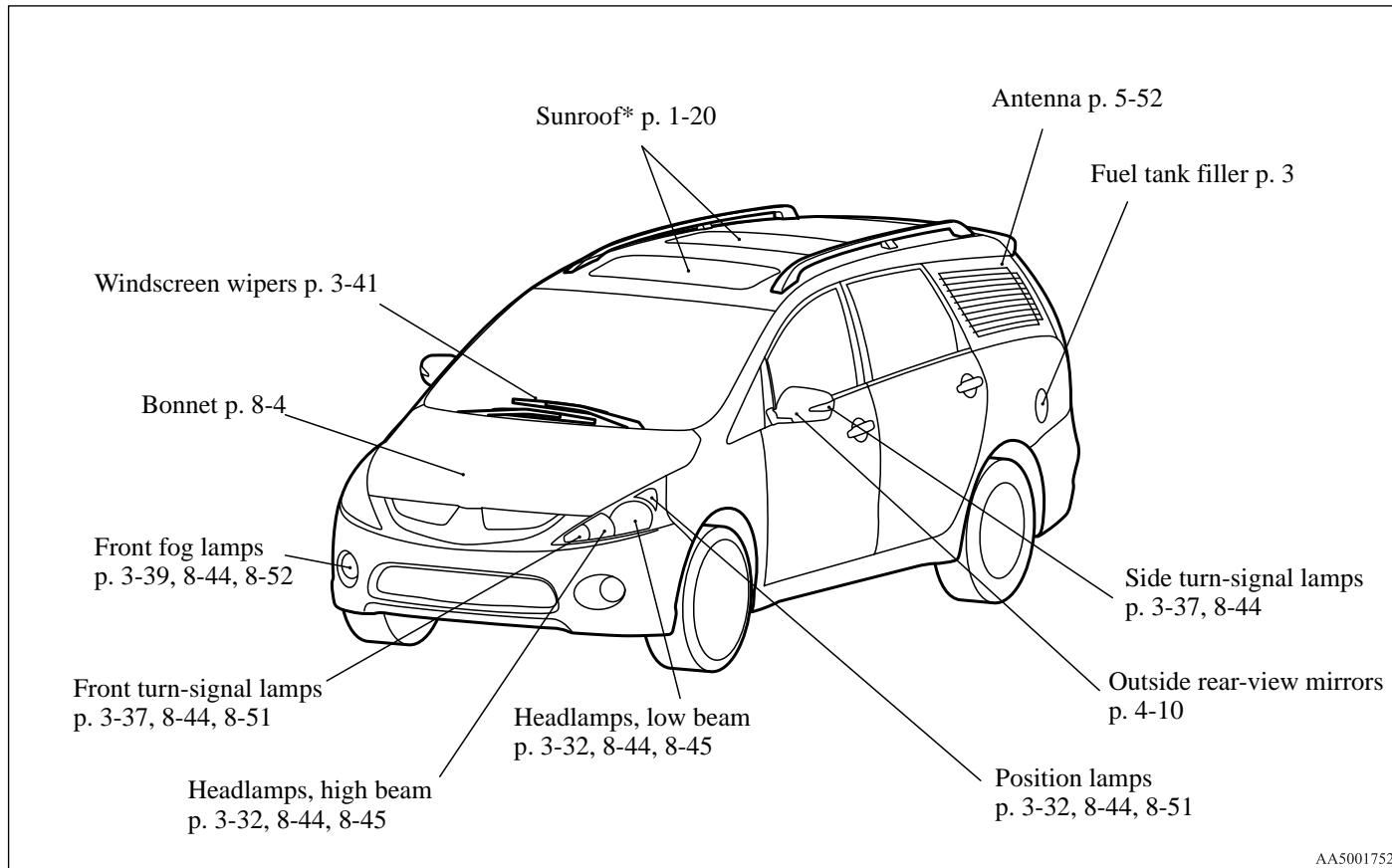

## Overview

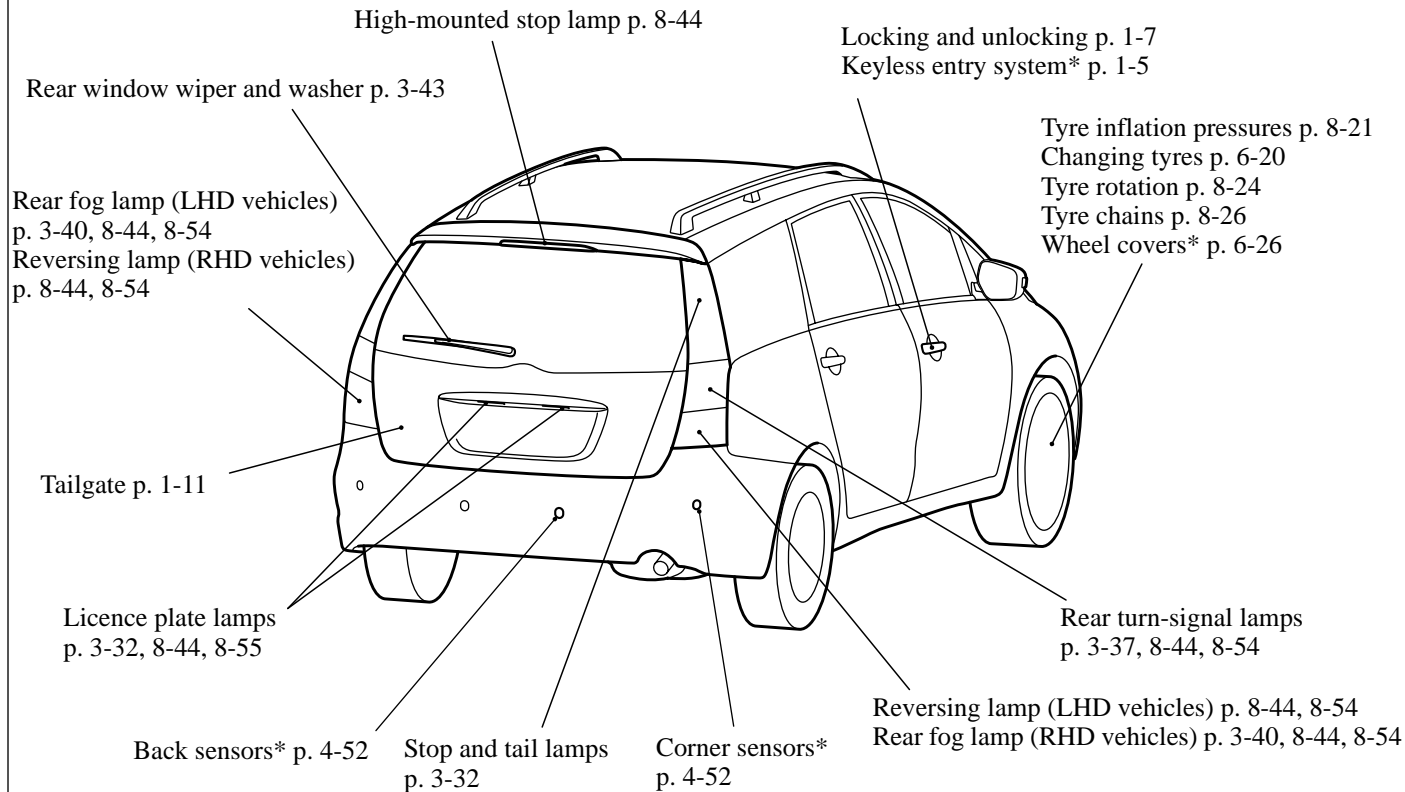

# *General information*

Fuel selection . . . . .	2
Filling the fuel tank . . . . .	3
Installation of accessories . . . . .	5
Modification/alterations to the electrical or fuel systems . . . . .	6
Genuine parts . . . . .	7
Used engine oils safety instructions and disposal information . . . . .	7

## Fuel selection

E00200101388

Recom- mended fuel	<b>Petrol-powered vehicles</b> Unleaded petrol octane number (EN228) 95 RON or higher
	<b>Diesel-powered vehicles</b> Cetane number (EN590) 51 or higher

### CAUTION

- **For petrol-powered vehicles, the use of leaded fuel can result in serious damage to the engine and catalytic converter. Do not use the leaded fuel.**
- **Diesel-powered vehicles are designed to use only diesel fuel that meets the EN 590 standard. Use of any other type of diesel fuel would adversely affect the engine's performance and durability.**

### NOTE

- Petrol-powered vehicles have the knock control system so that you can use unleaded petrol 90 RON as an emergent measure in case unleaded petrol 95 RON or higher is not available on journey, etc. In such a case, you don't need to adjust the engine specially.  
In case of using unleaded petrol 90 RON, the engine performance level is reduced.

- Repeatedly driving short distance at low speeds can cause deposits to form in the fuel system and engine, resulting in poor starting and poor acceleration. If these problems occur, you are advised to add a detergent additive to the gasoline when you refuel the vehicle. The additive will remove the deposits, thereby returning the engine to a normal condition. Be sure to use a genuine MITSUBISHI FUEL SYSTEM CLEANER. Using an unsuitable additive could make the engine malfunction. For details, please contact your MITSUBISHI MOTORS Authorized Service Point.
- Poor quality petrol can cause problems such as hard starting, stalling, engine noise and hesitation. If your experience these problems, try another brand and/or grade of petrol.  
If the check engine warning lamp flashes, have the system checked as soon as possible at a MITSUBISHI MOTORS Authorized Service Point.



## Filling the fuel tank

E00200200698

### **⚠ WARNING**

- Gasoline is highly flammable and explosive. You could be burned or seriously injured when handling it. When refuelling your vehicle, always turn the engine off and keep away from flames, sparks, and smoking materials. Always handle fuel in well-ventilated outdoor areas.
- Before removing the fuel cap, be sure to get rid of your body's static electricity by touching a metal part of the car or fuel pump. Any static electricity on your body could create a spark that ignites fuel vapour.
- Perform the whole refuelling process (opening the fuel tank filler door, removing the fuel cap, etc.) by yourself. Do not let any other person come near the fuel tank filler. If you allowed a person to help you and that person was carrying static electricity, fuel vapour could be ignited.
- Do not move away from the fuel tank filler until refuelling is finished. If you moved away and did something else (for example, cleaning your windshield) part-way through the refuelling process, you could pick up a fresh charge of static electricity.
- Be careful not to inhale fuel vapour. Fuel contains toxic substances.
- Keep the doors and windows closed while refuelling the vehicle. If they were open, fuel vapour could get into the cabin.

## Fuel tank capacity

65 litres

## Refuelling

1. Before filling with fuel, stop the engine.
2. The fuel tank filler is located on the rear left side of your vehicle.

The fuel tank filler door can be opened from inside the vehicle with the fuel tank filler door release lever located below the instrument panel.

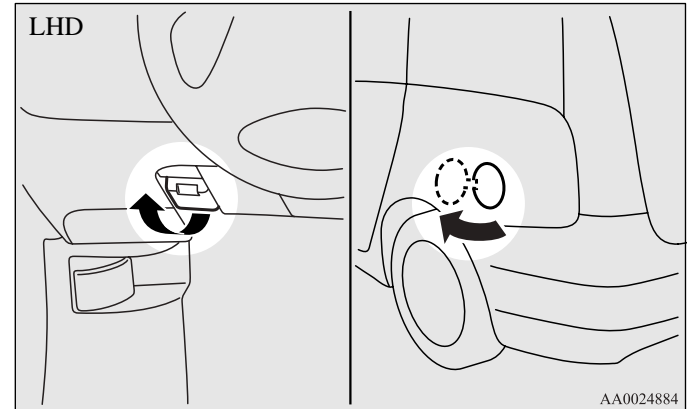

## General information

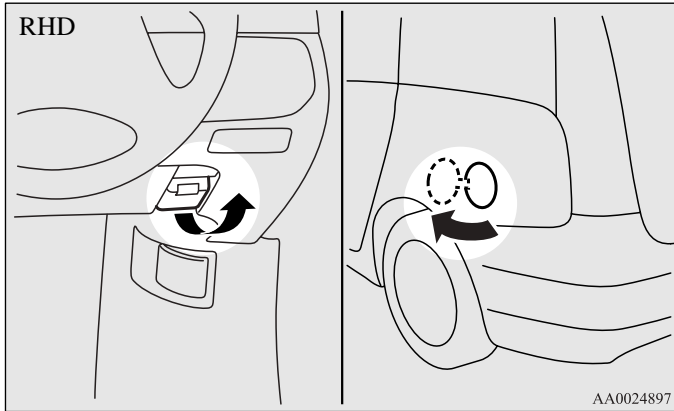

3. Open the fuel tank filler tube by slowly turning the cap anticlockwise.

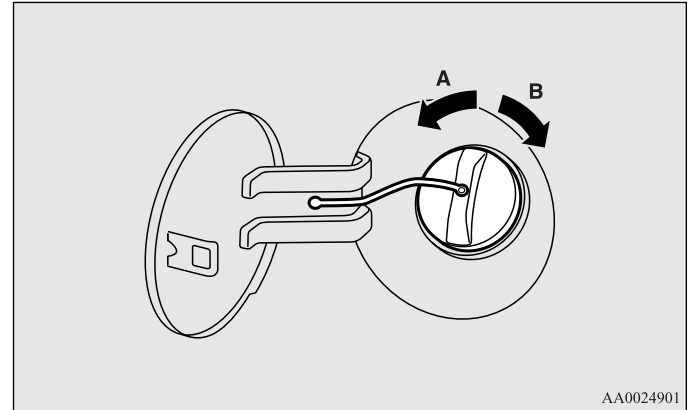

- A- Remove  
B- Close

### **⚠ CAUTION**

- Since the fuel system may be under pressure, remove the fuel tank filler tube cap slowly. This relieves any pressure or vacuum that might have built up in the fuel tank. If the cap is venting vapour or if you hear a hissing sound, wait until it stops before removing the cap. Otherwise, fuel may spray out, injuring you or others.

4. To fill with fuel correctly depends mainly on correct handling of the fuel filler gun. Do not tilt the gun. Insert the gun in the tank port as far as it goes.

### CAUTION

- A label which reads “UNLEADED FUEL ONLY” is attached to the fuel tank filler lid of vehicles which can only operate using unleaded petrol. Serious engine and catalytic converter damage will result if leaded petrol is filled into these vehicles, and consequently, this must never be attempted.

5. When the gun stops automatically, remove the gun half the way in the tank port. After the second automatic stop, do not fill with fuel any more.

### CAUTION

- To avoid fuel spillage and overfilling, do not “top-off” the fuel tank.

6. To close, turn the fuel tank filler tube cap slowly clockwise until you hear clicking sounds, then gently push the fuel tank filler door closed.

### CAUTION

- If you need to replace the fuel tank filler tube cap, use only the cap specified for your model vehicle.

## *Installation of accessories*

E00200300745

We recommend you to consult your MITSUBISHI MOTORS Authorized Service Point.

- The installation of accessories, optional parts, etc., should only be carried out within the limits prescribed by law in your country, and in accordance with the guidelines fitting instructions and warnings contained within the documents accompanying the parts or accessories.
- Improper installation of electrical components may cause an electrical fire if incorrectly fitted. Please refer to the Modification/alteration to the electrical or fuel systems section within this owner’s manual.
- Using a cellular phone or radio set inside the vehicle without an external antenna may cause electrical system interference, which could lead to unsafe vehicle operation.
- Tyres and wheels which do not meet specifications must not be used.  
Refer to the “Specifications” section for information regarding wheel and tyre sizes.

## General information

### Important points!

Due to the large number of accessory and replacement parts of different manufactures available in the market, it is not possible, not only for MITSUBISHI MOTORS, but also a MITSUBISHI MOTORS Authorized Service Point, to check whether the attachment or installation of such parts affects the driving safety of your MITSUBISHI-vehicle.

Even when such parts are officially authorized, for example by a “general operators permit” (an appraisal for the part) or through the execution of the part in an officially approved manner of construction, or when a single operation permit following the attachment or installation of such parts, it cannot be deduced from that alone, that the driving safety of your vehicles has not been affected.

Consider also that there basically exists no liability on the part of the appraiser or the official. Only in the case of parts (MITSUBISHI MOTORS original replacement or exchange parts as well as MITSUBISHI MOTORS genuine accessories) that are recommended and released by a MITSUBISHI MOTORS Authorized Service Point and that are attached or installed by a MITSUBISHI MOTORS Authorized Service Point can you assume, that optimal safety has been provided. The same also pertains to modifications of MITSUBISHI vehicles with respect to the production specifications. For your own safety, in such cases as well, you should only undertake modifications according to the recommendations of a MITSUBISHI MOTORS Authorized Service Point.

## *Modification/alterations to the electrical or fuel systems*

E00200400238

MITSUBISHI MOTORS has always manufactured safe, high quality vehicles. In order to maintain this safety and quality, it is important that any accessory that is to be fitted, or any modifications carried out which involve the electrical or fuel systems, should be carried out in accordance with MITSUBISHI MOTORS guidelines.

### **CAUTION**

- **If the wiring interferes with any part of the vehicle body work or improper installation methods are used, i.e. protective fuses not installed, etc., electronic devices may be adversely affected, possibly resulting in an electrical fire or other failures that may cause an accident.**

## *Genuine parts*

E00200500330

MITSUBISHI MOTORS has gone to great lengths to bring you a superbly crafted automobile offering the highest quality and dependability.

Use MITSUBISHI MOTORS genuine parts, designed and manufactured to maintain your MITSUBISHI MOTORS automobile at top performance. MITSUBISHI MOTORS genuine parts are identified by this mark and are available at all MITSUBISHI MOTORS Authorized Service Points.



## *Used engine oils safety instructions and disposal information*

E00200600025

### **⚠ WARNING**

- Prolonged and repeated contact may cause serious skin disorders, including dermatitis and cancer.
- Avoid contact with the skin as far as possible and wash thoroughly after any contact.
- Keep used engine oils out of reach of children.

### **Protect the environment**

It is illegal to pollute drains, water courses and soil. Use authorized waste collection facilities, including civic amenity sites and garages providing facilities for disposal of used oil and used oil filters. If in doubt, contact your local authority for advice on disposal.



# *Locking and unlocking*

Keys.....	1- 2
Electronic immobilizer (Anti-theft starting system).....	1- 3
Keyless entry system* .....	1- 5
Doors .....	1- 7
Central door locks .....	1- 9
“Child-protection” rear doors .....	1- 10
Tailgate.....	1- 11
Inside tailgate release.....	1- 15
Electric window control.....	1- 16
Sunroof*.....	1- 20

## Keys

E00300101099

The keys fit all locks.

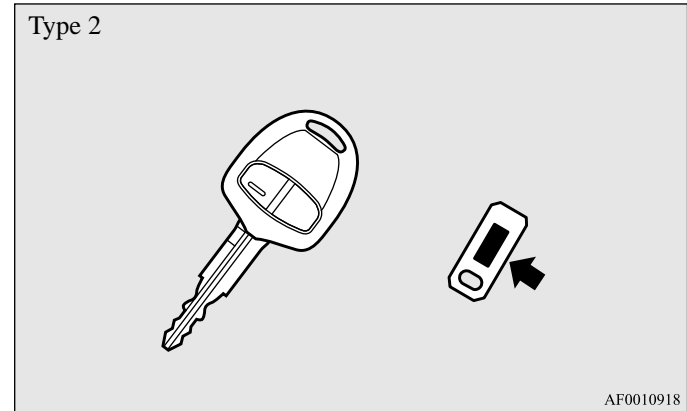
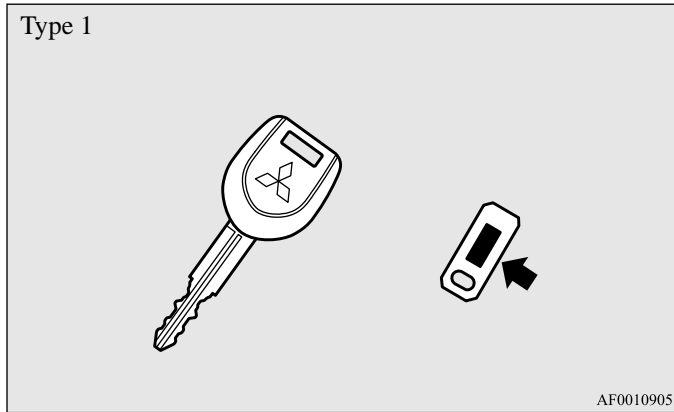

### NOTE

- The key number is stamped on the tag as indicated in the illustration.  
Make a record of the key number and store the key and key number tag in separate places, so that you can order a key in the event the original keys are lost.
- The key is a precision electronic device with a built-in signal transmitter. Please observe the following in order to prevent a malfunction.
  - Do not leave anywhere exposed to direct sunlight, for example on the dashboard.
  - Do not disassemble or modify.
  - Do not excessively bend the key or subject it to strong impact.
  - Do not expose to water.
  - Keep away from magnetic key holders.



- Keep away from audio systems, personal computers, TVs, and any other equipment that generates a magnetic field.
- Do not wash with ultrasonic cleaners or similar equipment.
- Do not leave the key where it may be exposed to high temperature or high humidity.
- The engine is designed so that it will not start if the ID code registered in the immobilizer computer and the key's ID code do not match. Refer to the section entitled "Electronic immobilizer" for details and key usage.

Keys should never be placed in areas which contain magnetic or metal objects as this may interfere with the transponder.

## *Electronic immobilizer (Anti-theft starting system)*

E00300201003

The electronic immobilizer is designed to reduce significantly the possibility of vehicle theft. The purpose of the system is to immobilize the vehicle if an invalid start is attempted. A valid start attempt can only be achieved (subject to certain conditions), using a key "registered" to the immobilizer system.

### NOTE

- In the following cases, the vehicle may not be able to receive the registered ID code from the key. This means the engine will not start even when the registered key is turned to the "START" position.
  - When the key contacts a key ring or other metallic or magnetic object (Type A)
  - When the key grip contacts metal of another key (Type B)
  - When the key contacts or is close to other immobilizing keys (including keys of other vehicles) (Type C)

In cases like these, remove the object or additional key from the vehicle key and turn the key back to the "ACC" or "LOCK" position. Then try again to start the engine. If the engine does not start, we recommend you to contact your MITSUBISHI MOTORS Authorized Service Point.

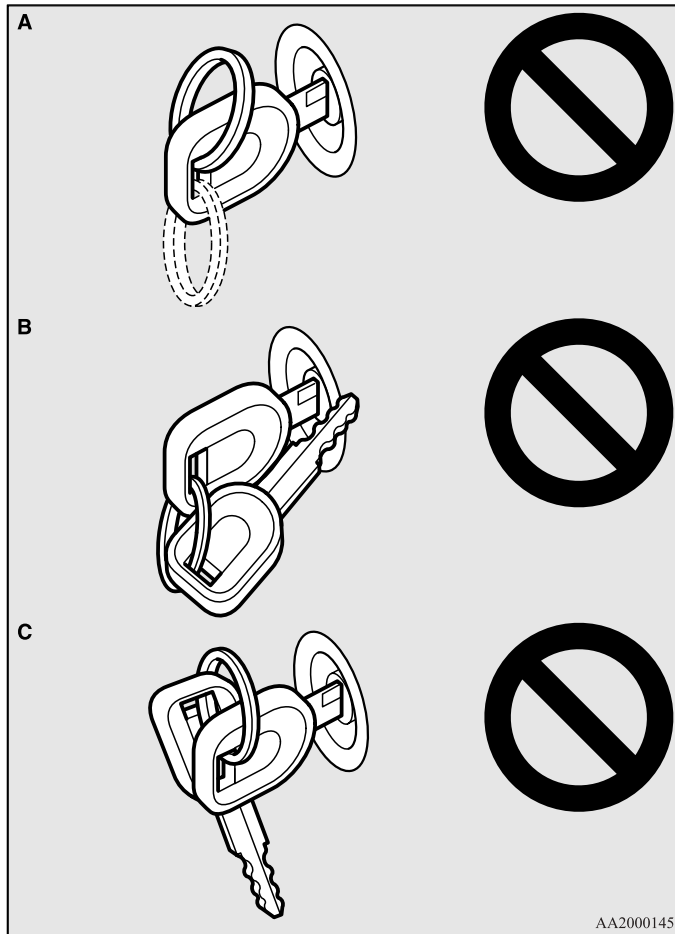

NOTE

- If you lose your key, order a key from your MITSUBISHI MOTORS Authorized Service Point as soon as possible. To obtain a replacement or extra spare key, take your vehicle and all remaining key to your MITSUBISHI MOTORS Authorized Service Point. All the keys have to be re-registered in the immobilizer computer unit. The immobilizer can register up to 8 different keys.

**⚠ CAUTION**

- Don't make any alterations or additions to the immobilizer system; alterations or additions could cause failure of the immobilizer.

## Keyless entry system\*

E00300301440

Press the remote control switch, and all doors and the tailgate will be locked or unlocked as desired. It is also possible to operate the door mirrors.

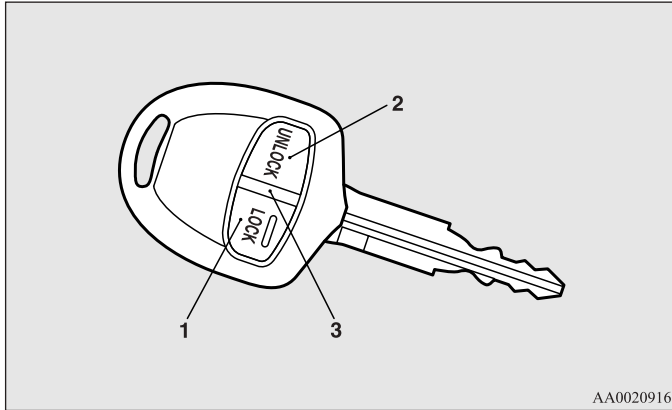

- 1- LOCK switch
- 2- UNLOCK switch
- 3- Indication lamp

### To lock

Press the LOCK switch (1). All the doors and the tailgate will be locked. If the interior lamp switch is in the middle position (DOOR) at this time, the room lamp & map lamps, the rear personal lamps, and the turn-signal lamps will blink once.

### To unlock

Press the UNLOCK switch (2). All the doors and the tailgate will be unlocked. If the interior lamp switch is in the middle position (DOOR) at this time, the room lamp & map lamps and the rear personal lamps will come on for approximately 15 seconds and the turn-signal lamps will blink twice.

### NOTE

- The indication lamp (3) comes on each time a switch is pressed.
- If the UNLOCK switch (2) is pressed and no door or tailgate is opened within approximately 30 seconds: relocking will automatically occur.
- It is possible to modify functions as follows:  
For further information, please contact your MITSUBISHI MOTORS Authorized Service Point.  
On a vehicle equipped with a Multi Display Station (MDS), the functions can be adjusted on the screen. For details, refer to a separate operation manual.
  - The time from pressing of the UNLOCK switch (2) to the moment of automatic locking can be changed.
  - The confirmation function (flashing of the turn-signal lamps) can be set to operate only when the doors and tailgate are locked or only when the doors and tailgate are unlocked.
  - The confirmation function (this indicates locking or unlocking of the doors and tailgate with the flash of the turn-signal lamps) can be deactivated.
  - The number of times the turn-signal lamps are flashed by the confirmation function can be changed.

### Operation of the outside rear-view mirrors

#### *To fold*

Within 30 seconds of locking the doors and tailgate using the LOCK switch (1), press the LOCK switch twice rapidly to fold the door mirrors.

#### *To extend*

Within 30 seconds of unlocking the doors and tailgate using the UNLOCK switch (2), press the UNLOCK switch twice rapidly to return the door mirrors to their extended positions.

#### NOTE

- The keyless entry system does not operate in the following conditions:
  - The key is left in the key cylinder.
  - The door or tailgate is open.
- The remote control switch will operate within about 4 m from the vehicle. However, the operating range of the remote control switch may change if the vehicle is located near a TV transmitting tower, power station, or radio broadcasting station.
- If either of the following problems occurs, the battery may be exhausted. Have the battery replaced by a MITSUBISHI MOTORS Authorized Service Point.
  - The remote control switch is operated at the correct distance from the vehicle, but the doors and tailgate are not locked/unlocked in response.
  - The indication lamp (3) is dim or does not come on.

- If your remote control switch is lost or damaged, please contact your MITSUBISHI MOTORS Authorized Service Point for a replacement remote control switch.
- If you wish to add remote control switch, we recommend that you contact your MITSUBISHI MOTORS Authorized Service Point.  
A maximum of 4 remote control switches are available for your vehicle.

## Doors

E00300401409

### **CAUTION**

- Make sure the doors are closed: driving with doors not completely closed is dangerous.
- Never leave children in the vehicle unattended.
- Be careful not to lock the doors while the key is inside the vehicle.

#### NOTE

- When the driver's door is open, neither the key nor the lock knob can be used to lock it.

## To lock or unlock with the key

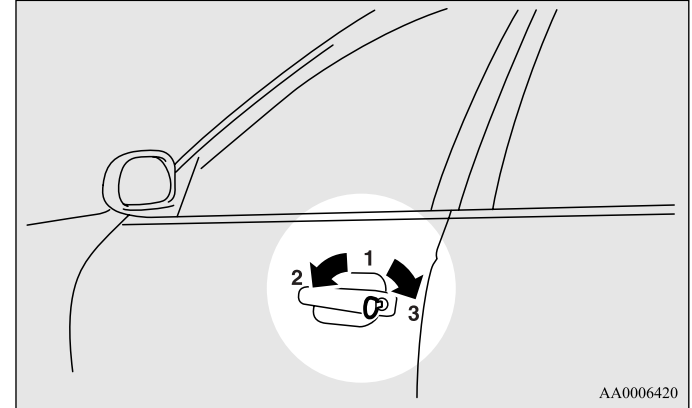

- 1- Insert or remove the key
- 2- Lock
- 3- Unlock

## Locking and unlocking

### To lock or unlock from inside the vehicle

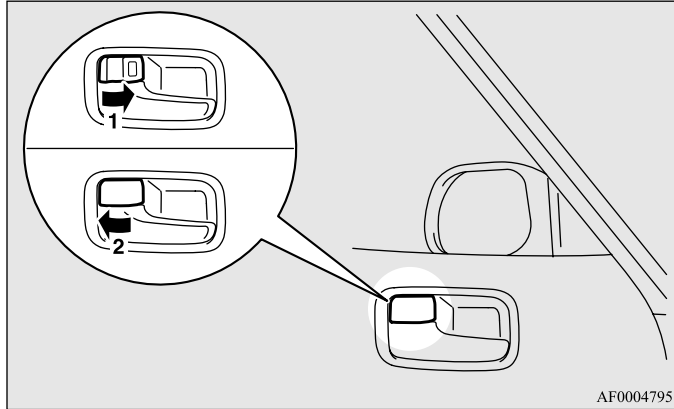

- 1- Lock
- 2- Unlock

Pull the inside door handle towards you to open the door.

#### NOTE

- The driver's door can be opened without using the lock knob by pulling on the inside door handle.  
All other doors and the tailgate are unlocked at the same time.

### To lock without using the key

#### *Front passenger's door, Rear door*

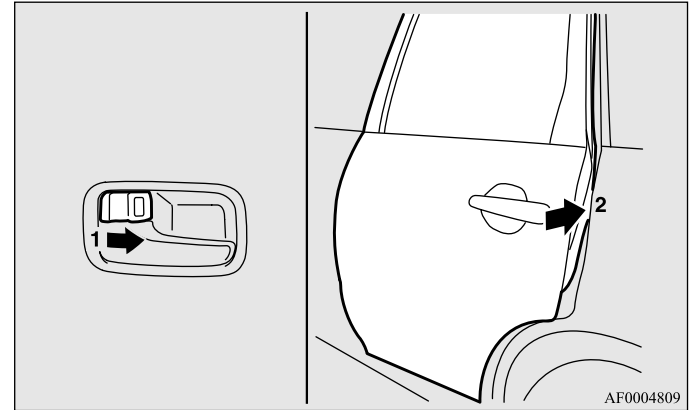

Set the inside lock knob (1) to the locked position and close the door (2).

#### NOTE

- The driver's door cannot be locked using the inside lock knob while the driver's door is opened.

## Central door locks

E00300800897

### NOTE

- Each of the doors can be locked or unlocked independently by using the inside lock knob.
- Repeated continuous operation between lock and unlock could activate the central door locking systems built-in protection circuit and prevent the system from operating. If this occurs, wait about one minute before operating the inside lock knob or the key.
- When the driver's door is open, neither the key nor the lock knob can be used to lock it.

All of the doors and the tailgate can be locked and unlocked as described hereafter.

## Driver's door with key

Turn the key in the driver's door towards the front of the vehicle to lock the doors and the tailgate, and towards the rear of the vehicle to unlock the doors and the tailgate.

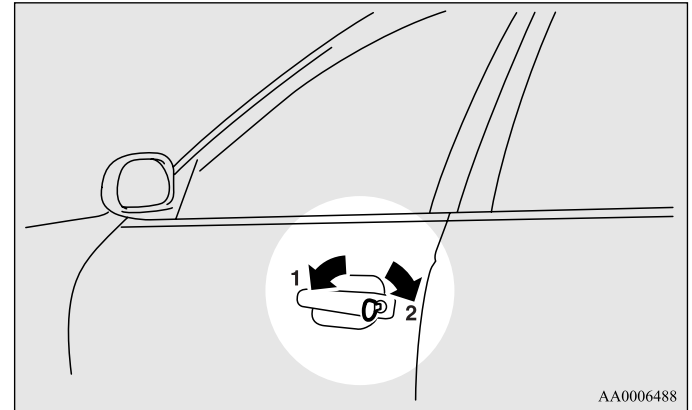

AA0006488

- 1- Lock
- 2- Unlock

## Locking and unlocking

### Driver's door with inside lock knob

Set the inside lock knob on the driver's door towards the front of the vehicle to lock the doors and the tailgate. Set it towards the rear of the vehicle to unlock the doors and the tailgate.

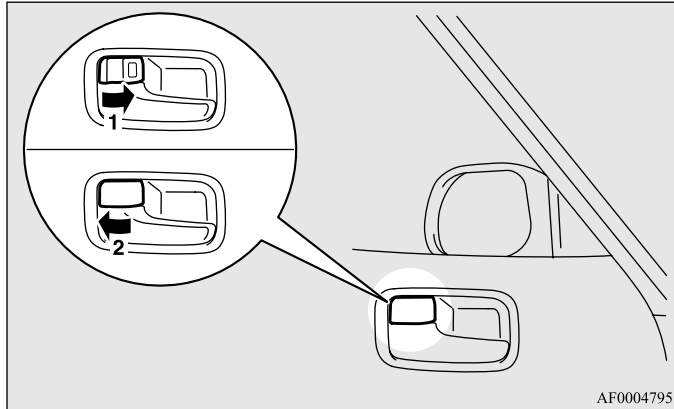

- 1- Lock
- 2- Unlock

### *“Child-protection” rear doors*

E00300900045

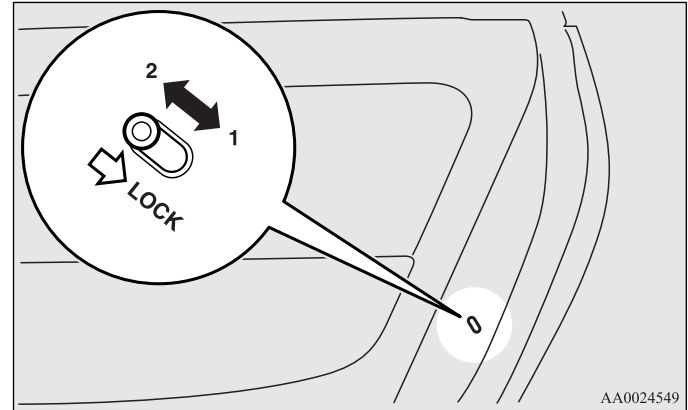

AA0024549

- 1- Lock
- 2- Free

Child protection helps prevent doors from being opened accidentally, especially when small children are in the rear seat. A lever is provided on each rear door.

If the lever is set to the locked position, the rear doors cannot be opened using the inside handle.

To open the rear door while the child protection is in use, pull the outside door handle.

If the lever is set to the “Free” position, the child protection mechanism does not function.



## Tailgate

E00301400685

### **CAUTION**

- When driving with a child in the rear seat, please use the child protection to prevent accidental door opening which may cause an accident.

### **WARNING**

- It is dangerous to drive with the tailgate open since carbon monoxide (CO) gas can enter the cabin. You cannot see or smell CO. It can cause unconsciousness and even death.
- When opening and closing the tailgate, make sure that there are no people nearby and be careful not to hit your head or pinch your hands, neck, etc.

### **CAUTION**

- Do not stand behind the exhaust pipe when loading and unloading luggage. Heat from the exhaust could lead to burns.

#### NOTE

- Locking/unlocking of the driver's door by using the key, inside lock knob (driver side) or keyless entry system (if so equipped) also locks/unlocks the tailgate.

## Locking and unlocking

### To lock or unlock from outside the vehicle (Except for vehicles with keyless entry system)

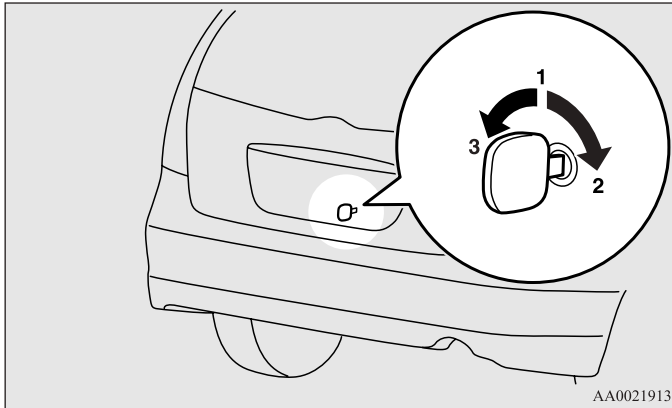

- 1- Insert (or remove) the key
- 2- Lock
- 3- Unlock

### To lock or unlock from inside the vehicle

The tailgate can be locked or unlocked by using the inside lock knob (driver side), regardless of the position of the ignition key.

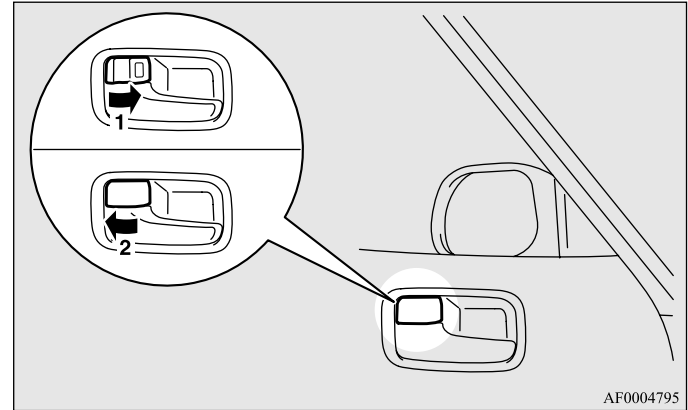

- 1- Lock
- 2- Unlock

If the tailgate is locked or unlocked by using the inside lock knob (driver side), it can still be locked or unlocked with the key.

#### NOTE

- Repeated continuous operating between lock and unlock could cause the central door locks' built-in protection circuit to prevent the system from operating. If this occurs, wait about one minute before operating the inside lock knob.

## To open

Pull the tailgate handle upward to open the tailgate.

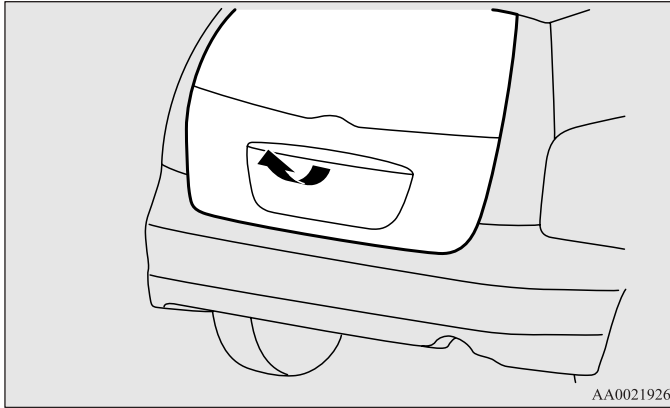

### **⚠ CAUTION**

- Make sure there is no one standing nearby when opening the tailgate.

## NOTE

- If you do not open the tailgate immediately after pulling the handle, the tailgate will automatically be relocked. If this happens, pull the handle again and lift the tailgate with the handle still pulled.
- The tailgate cannot be opened when the battery is flat or disconnected.

## To close

Pull the tailgate grip (A) downward as illustrated and release it before the tailgate closes completely. Gently slam the tailgate from the outside so that it is completely closed.

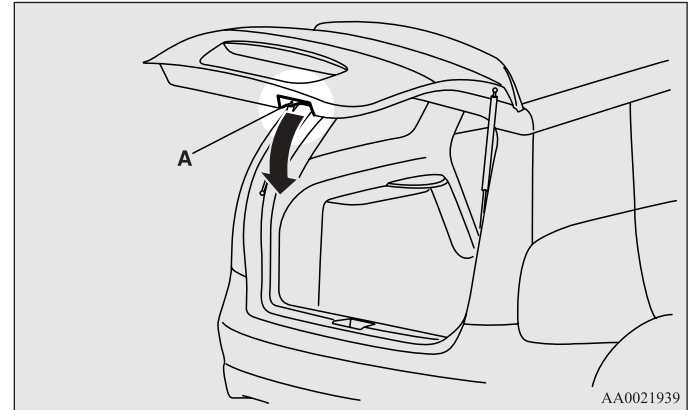

**⚠ CAUTION**

- To avoid injuring your hand or arm, do not attempt to close the tailgate without letting go off the tailgate grip.
- Before driving, make sure that the tailgate is securely closed.  
If the tailgate opens while driving the vehicle, objects stored in the luggage area could fall out onto the road.

**NOTE**

- Gas struts (B) are installed in the locations illustrated to support the tailgate. Please observe the following in order to prevent damage or faulty operation.
  - Do not hold the gas struts when closing the tailgate. Also, do not push or pull the gas struts.
  - Do not attach any plastic material, tape, etc., to the gas struts.
  - Do not tie string, etc., around the gas struts.
  - Do not hang any object on the gas struts.

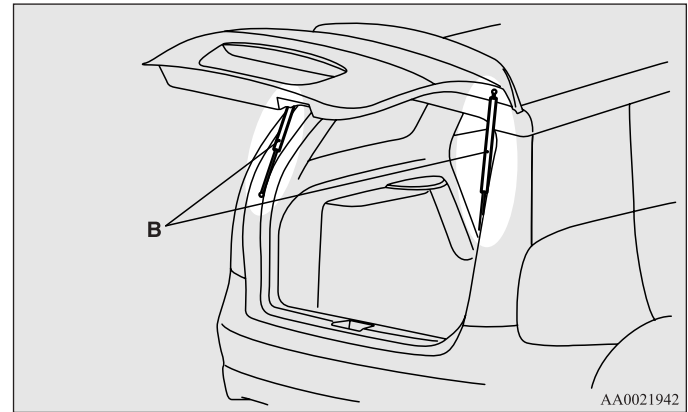

AA0021942

## Inside tailgate release

E00303400041

The inside tailgate release is designed to provide a way to open the tailgate in the case of discharged battery. The tailgate release lever (see illustration) is mounted on the tailgate.

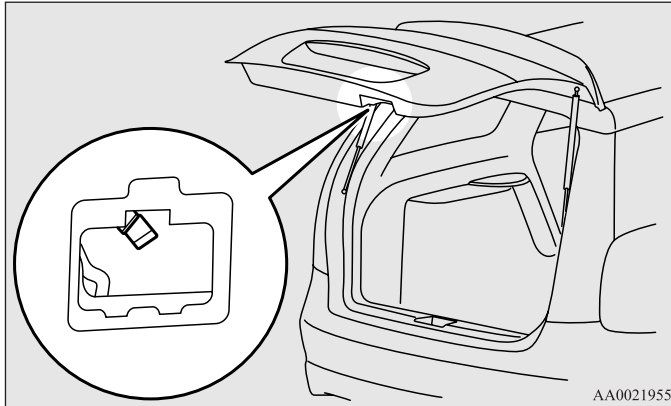

You and your family should familiarize yourselves with the location and operation of the tailgate release lever.

## To open

1. Open the lid (A) inside of the tailgate.

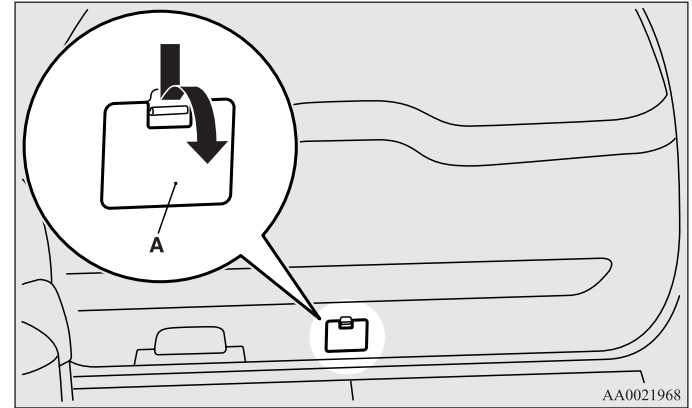

## Locking and unlocking

2. Move the lever (B) to unlock the tailgate.

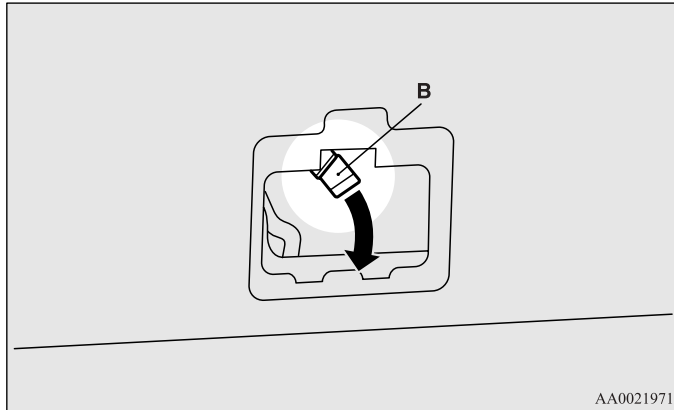

3. Push the tailgate to open the tailgate.

### **⚠ CAUTION**

- Always keep the release lever lid on the tailgate closed when driving so that your luggage cannot accidentally bump the lever and open the tailgate.

## *Electric window control*

E0030220042

The electric windows can only be operated with the ignition switch in the "ON" position.

### **Electric window control switch**

E00302300144

Each door window opens or closes while the corresponding switch is operated.

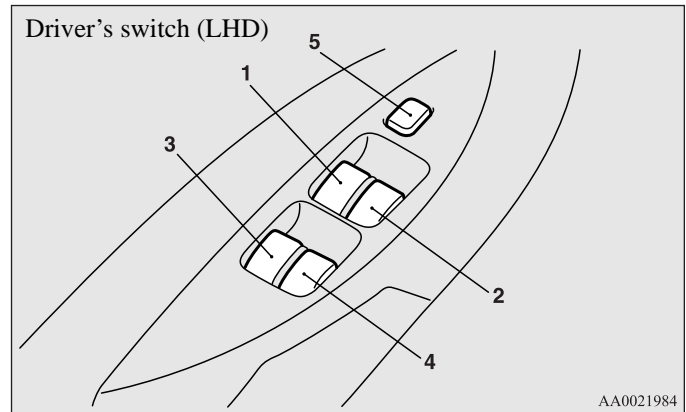

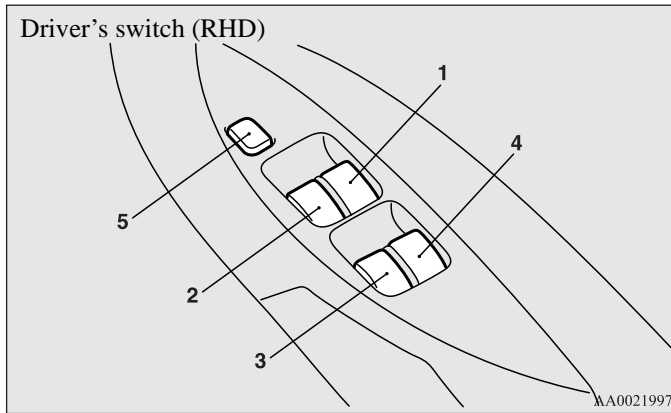

- 1- Driver's door window
- 2- Front passenger's door window
- 3- Rear left door window
- 4- Rear right door window
- 5- Lock switch

## **⚠ WARNING**

- Before operating the electric window control, make sure that nothing is capable of being trapped (head, hand, finger, etc.).
- Never leave the vehicle without removing the key.
- Never leave a child (or other person who might not be capable of safe operation of the electric window control) in the vehicle alone.

### NOTE

- Repeated operation with the engine stopped will run down the battery. Operate the window switches only while the engine is running.

### *Driver's switches*

The driver's switches can be used to operate all door windows. A window can be opened or closed by operating the corresponding switch.

Press the switch down to open the window, and pull up the switch to close it.

If the switch is fully pressed down/pulled up, the door window automatically opens/closes completely.

If you want to stop the window movement, operate the switch lightly in the reverse direction.

## Locking and unlocking

### Passenger's switches

The passenger's switches can be used to operate the corresponding passenger's door windows.

Press the switch down for opening the window, and pull up the switch for closing.

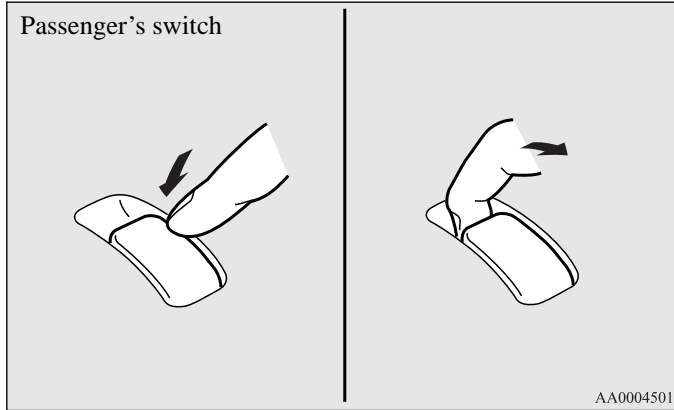

#### NOTE

- The rear door windows only open halfway.

### Lock switch

E00303100338

When this switch is operated, the passenger's switches cannot be used to open or close the door windows.

To unlock, press it once again.

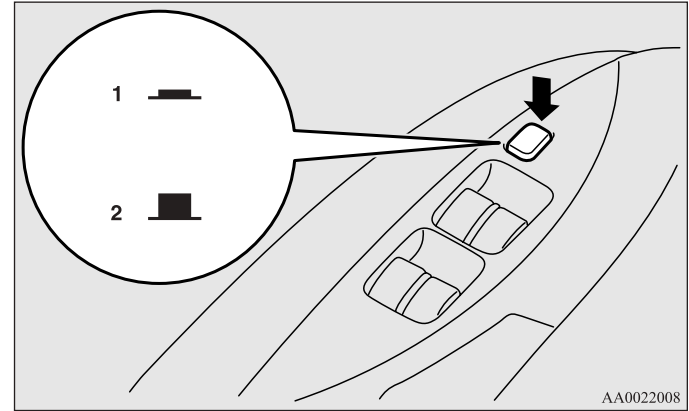

- 1- Lock
- 2- Unlock

#### NOTE

- The driver's switch can open or close any door windows.

## **⚠ WARNING**

- A child may tamper with the switch at the risk of its hands or head being trapped in the window. When driving with a child in the vehicle, please press the window lock switch to disable the passenger's switches.



NOTE

- It is possible to prevent the driver’s door switches from being used to open and close the front passenger’s door window and rear door windows while the lock switch is pressed in the “LOCK” position.  
For details, we recommend you to consult a MITSUBISHI MOTORS Authorized Service Point.

**Timer function**

E00302400086

The door windows can be opened or closed for 30 seconds after the ignition switch is turned off. If the driver’s door is opened during this period, the door window can be opened or closed for another 30 seconds.  
However, once the driver’s door is closed, the windows cannot be operated.

**Safety mechanism**

E00302500029

If a hand or head is trapped in the closing window, it will lower automatically.  
Nonetheless, make sure that nobody puts their head or hand out of the window when closing a window.  
The lowered window will become operational after a few seconds.

 <b>WARNING</b>
<ul style="list-style-type: none"> <li>● <b>If the safety mechanism is activated three or more times successively, the safety mechanism will be temporarily cancelled. If a hand or head got trapped, a serious injury could result.</b></li> </ul>

 <b>CAUTION</b>
<ul style="list-style-type: none"> <li>● <b>The safety mechanism is cancelled just before the window is fully closed. This allows the window to close completely. Therefore be especially careful that no fingers are trapped in the window.</b></li> </ul>

## Locking and unlocking

### NOTE

- The safety mechanism can be activated if the driving conditions or other circumstances cause the door windows to be subjected to a physical shock similar to that caused by a trapped hand or head.
- If the safety mechanism is activated three or more times in a row, the safety mechanism will be cancelled and the door window will not close correctly.

In such a case, the following procedure should be implemented to rectify this situation. If the window is open, repeatedly raise the appropriate window switch until that window has been fully closed. Following this, release the switch, raise the switch once again and hold it in this condition for at least one second, then release it. You should now be able to operate all windows in the normal fashion.

## Sunroof\*

E00302700496

There are two sunroofs.

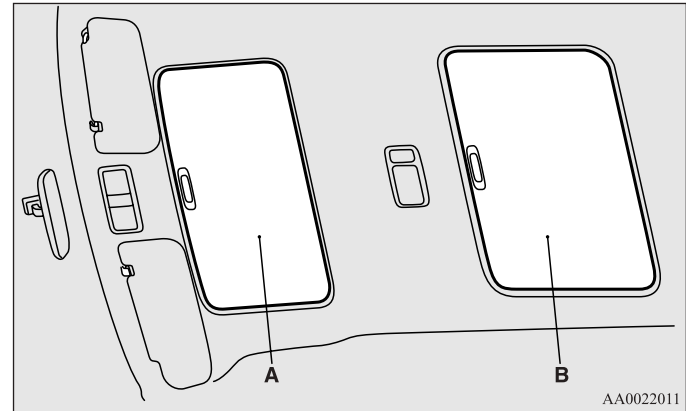

AA0022011

A- Front sunroof

B- Rear sunroof

## Front sunroof

### *To tilt up*

Push the handle (C) while pressing the button (D).

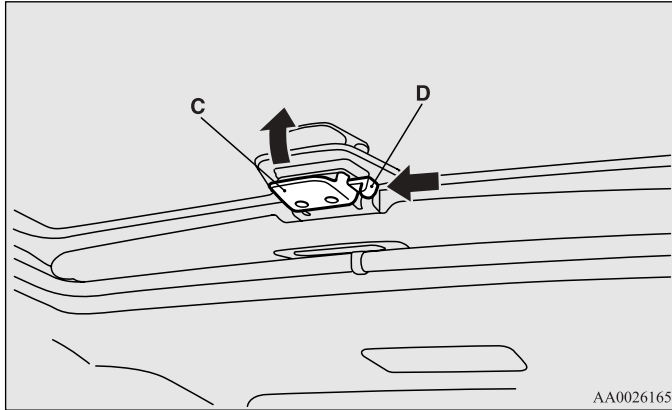

### *To tilt down*

Pull the handle, returning it to its original position and securing it in place.

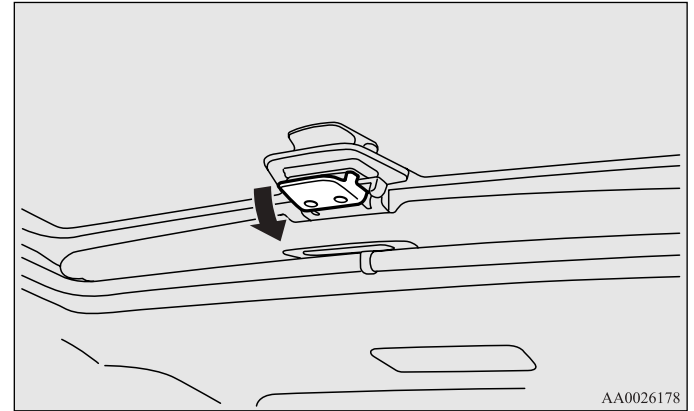

## Locking and unlocking

### Sunshade

Slide the sunshade manually to open and close it.

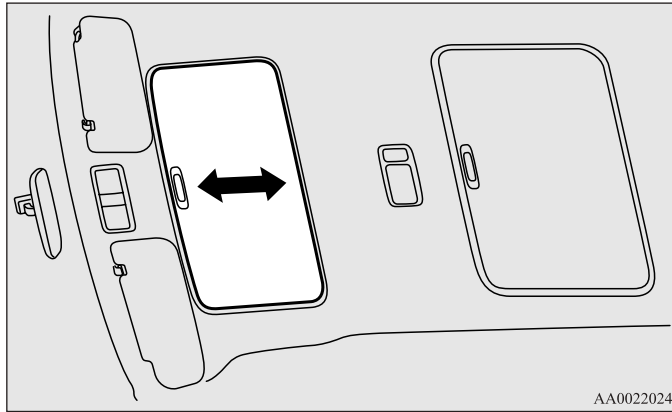

### **CAUTION**

- Be careful that hands are not trapped when closing the sunshade.

#### NOTE

- Be sure to tilt down the sunroof before closing the sunshade.
- The sunshade cannot be closed with the sunroof opened. Do not attempt to close the sunshade when the sunroof is opened.

### Rear sunroof

The rear sunroof can only be operated with the ignition switch in the “ON” position.

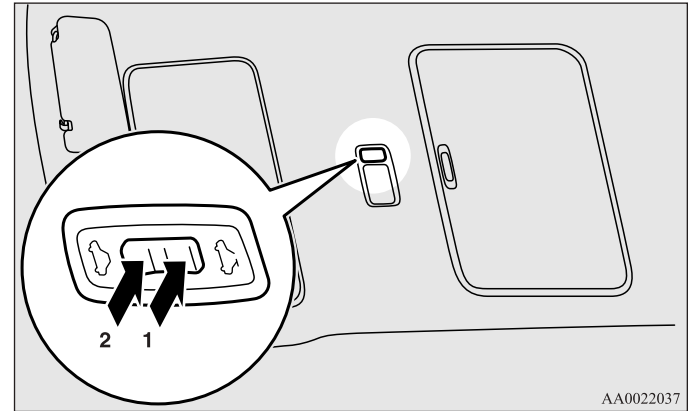

#### *To open*

The sunroof automatically opens if the switch (1) is pressed. To stop the moving sunroof, press the switch (2).

#### NOTE

- The sunroof automatically stops just before reaching the fully open position. Press the switch again to make it open fully.

#### *To close*

The sunroof automatically closes if the switch (2) is pressed. To stop the moving sunroof, press the switch (1).

### Lock switch

When this switch is operated, the sunroof switch cannot be used to open or close the sunroof.  
To unlock, press it once again.

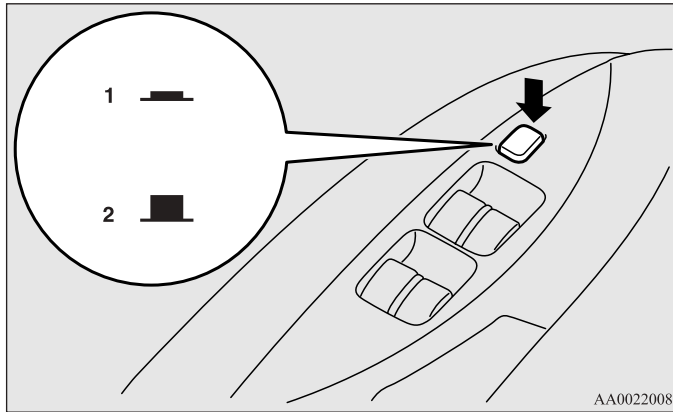

- 1- Lock
- 2- Unlock

### NOTE

- If the sunroof switch is operated with the lock switch pressed, a buzzer sounds to indicate the sunroof cannot be opened or closed.
- With the lock switch pressed, operation of the power windows with switches other than the driver's door switches is also prevented.

### Safety mechanism

If a hand or head is trapped in the closing sunroof, it will re-open automatically.  
Nonetheless, make sure that nobody sticks their head or hand out of the sunroof when opening or closing.  
The opened sunroof will become operational after a few seconds.

If the safety mechanism should be activated 5 or more times consecutively, normal closing of the sunroof will be aborted. In such an event, the following steps should be taken:

1. Press the switch (2) repeatedly to fully close the sunroof and hold the switch (2) for a period of at least 3 seconds.
2. After pressing the switch (1) to perform full opening, press the switch (2) to fully close the sunroof.

### NOTE

- The safety mechanism can be activated if the driving conditions or other circumstances cause the sunroof to be subjected to a physical shock similar to that caused by a trapped hand or head.
  - Avoiding stopping the sunroof before it reaches the opening or closing end during operations. If this should accidentally be allowed to happen, repeat the process from step 1.
3. Following this action, it should be possible to operate the sunroof in the normal manner.

## **⚠ WARNING**

- Do not put head, hands or anything else out of the sunroof opening while driving the vehicle.
- Never leave a child (or other person who might not be capable of safe operation of the sunroof switch) in the vehicle alone.
- Before operating the sunroof, make sure that nothing is capable of being trapped (head, hand, finger, etc.).

## **⚠ CAUTION**

- The safety mechanism is cancelled just before the sunroof is fully closed. This allows the sunroof to close completely. Therefore be especially careful that no fingers are trapped in the sunroof.

### NOTE

- The sunroof stops just before reaching the fully open position.  
If the vehicle is driven with the sunroof in this position, wind throbs is lower than with the sunroof fully open.
- When leaving the vehicle unattended, make sure you close the sunroof and remove the ignition key.
- Do not try to operate the sunroof if it is frozen closed (after snow fall or during extreme cold).
- Do not sit or place heavy luggage on the sunroof or roof opening edge.

- Release the switch as soon as the sunroof reaches the fully open or fully closed position.
- If the sunroof does not operate when the sunroof switch is operated, release the switch and check whether something is trapped by the sunroof. If nothing is trapped, we recommend you to have the sunroof checked.
- Depending on the models of ski carriers or roof carriers, the sunroof may contact with the carrier when the sunroof is tilted up. Be careful when tilting up the sunroof if such a ski carrier or a roof carrier is installed.
- Be sure to close the sunroof completely when washing the vehicle or when leaving the vehicle.
- Be careful, not to put any wax on the weatherstrip (black rubber) around the sunroof opening. If stained with wax, the weatherstrip cannot maintain a weatherproof seal with the sunroof.
- After washing the vehicle or after it has rained, wipe off any water that is on the sunroof before operating it.
- Operating the sunroof repeatedly with the engine stationary will run down the battery. Operate the sunroof while the engine is running.

### Sunshade

Slide the sunshade manually to open and close it.

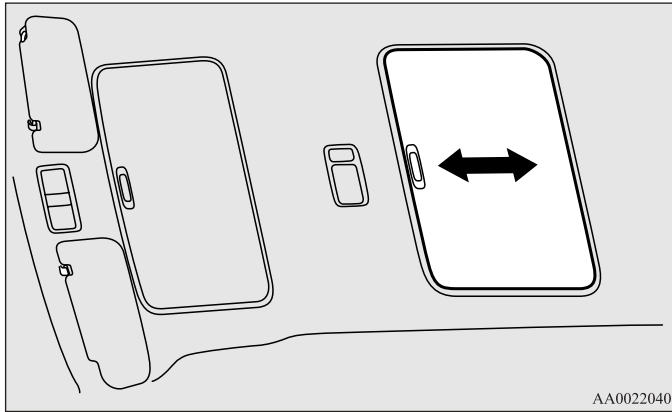

### **⚠ CAUTION**

- Be careful that hands are not trapped when closing the sunshade.

By the following operation, the sunshade will open together with the sunroof.

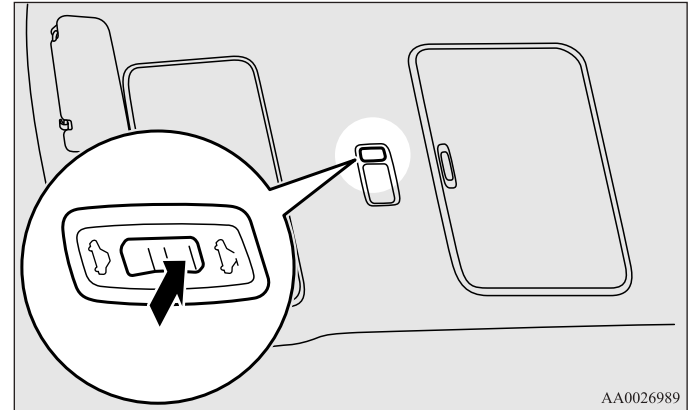

### To open

When the switch is pressed, the sunshade will open together with the sunroof.

### NOTE

- The sunshade cannot be closed with the sunroof opened. Do not attempt to close the sunshade when the sunroof is opened.





# *Seat and seat belts*

Seat . . . . .	2-	2
Seat arrangement . . . . .	2-	3
Seat adjustment . . . . .	2-	5
Front seat . . . . .	2-	6
Second seat. . . . .	2-	9
Third seat . . . . .	2-	17
Head restraints . . . . .	2-	19
Making a luggage area . . . . .	2-	21
Making a flat seat. . . . .	2-	25
Seat belts . . . . .	2-	33
Seat belt reminder/warning lamp . . . . .	2-	35
Pregnant women restraint . . . . .	2-	38
Seat belt pre-tensioner system and force limiter system . . . . .	2-	39
Child restraint. . . . .	2-	40
Seat belt inspection . . . . .	2-	52
Supplemental restraint system (SRS) - air bag . . . . .	2-	53

## Seat

E00400100992

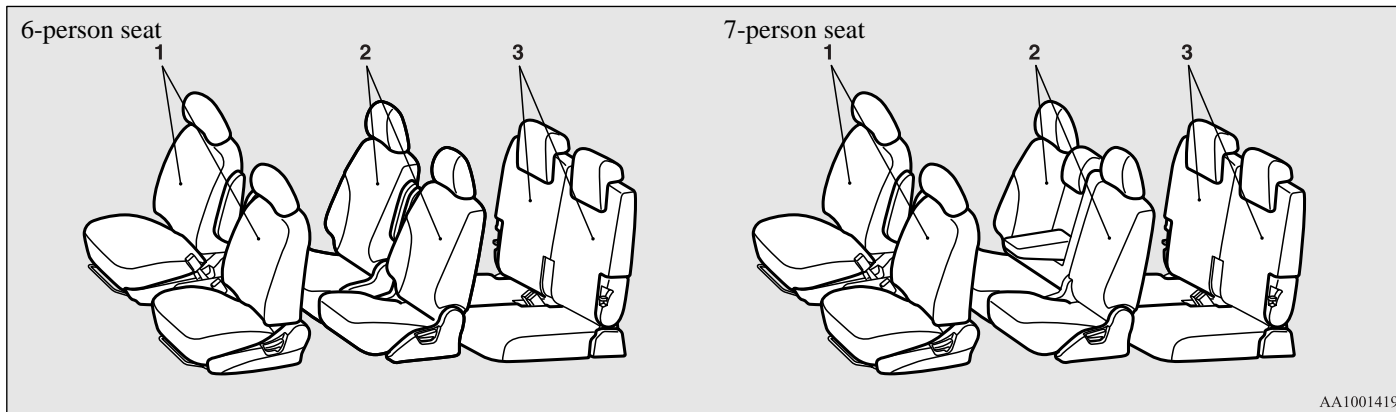

AA1001419

### 1- Front seat

- To adjust forward or backward → p. 2-6
- To recline the seatback → p. 2-6
- To adjust seat cushion height\* → p. 2-7
- Armrest → p. 2-7
- Heated seats\* → p. 2-8

### 2- Second seat

- To adjust forward or backward → p. 2-9
- To recline the seatback → p. 2-10
- Armrest → p. 2-11
- To get in and out of the third seat → p. 2-12
- Folding up the seat cushion → p. 2-13

### 3- Third seat





- To recline the seatback → p. 2-17
- Folding the seatbacks forward → p. 2-18
- Stowing the third seat → p. 2-22

## Seat arrangement

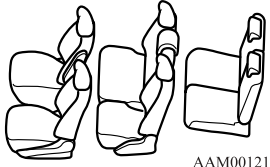
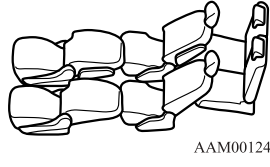
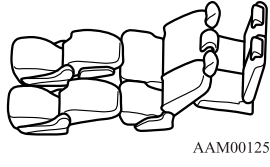
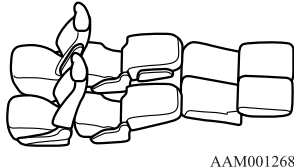
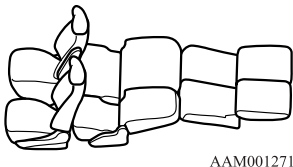
E00400200430

By operating the seats select the desired seats arrangement.

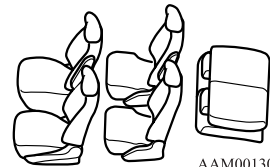
		6-person seat	7-person seat
Normal usage		 <p>AAM001200</p>	 <p>AAM001213</p>
Flat seat	With front and second seats → p. 2-26	 <p>AAM001242</p>	 <p>AAM001255</p>
	With second and third seats → p. 2-29	 <p>AAM001268</p>	 <p>AAM001271</p>

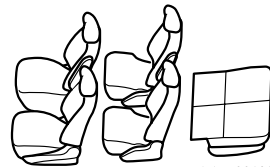
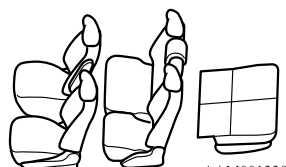
		6-person seat	7-person seat
2 How to stow large articles	Folding up the second seat cushion → p. 2-13	 <p>AAM001284</p>	 <p>AAM001297</p>
	Folding the third seat-backs forward → p. 2-18	 <p>AAM001301</p>	 <p>AAM001314</p>
	Stowing the third seat → p. 2-22	 <p>AAM001327</p>	 <p>AAM001330</p>

## Seat adjustment

E00400300402

Adjust the driver's seat so that you are comfortable and that you can reach the pedals, steering wheel, switches etc. while retaining a clear field of vision.

### **WARNING**

- Do not attempt to adjust the seat while driving. This can cause loss of vehicle control and result in an accident. After adjustments are made, ensure the seating is locked in position by attempting to move the seat forward and rearward without using the adjusting mechanism.
- It is extremely dangerous to ride in the luggage area of a vehicle. Also, the luggage area and rear seats should never be used as a play area by children. In a collision, people or children riding unrestrained in these areas are more likely to be seriously injured or killed.  
Do not allow people or children to ride in any area of your vehicle that is not equipped with seats and seat belts, and make sure that everyone travelling in your vehicle is in a seat and wearing a seat belt, or in the case of a child is strapped in a child restraint.

### **WARNING**

- To minimize the risk of personal injury in the event of a collision or sudden braking, the seatbacks should always be in the almost upright position while the vehicle is in motion. The protection provided by the seat belts may be reduced significantly when the seatback is reclined. There is greater risk that the passenger will slide under the seat belt, resulting in serious injury, when the seatback is reclined.

### **CAUTION**

- Make sure the seat is adjusted by an adult or with adult supervision for correct and safe operation.
- Do not place a cushion or the like between your back and the seatback while driving. The effectiveness of the head restraints will be reduced in the event of an accident.
- When sliding the seats, be careful not to catch your hand or foot.
- When sliding or reclining the seat rearward, pay careful attention to the rear seat passengers.

## Front seat

E0040040012

### To adjust forward or backward

E00400500491

Pull the seat adjusting lever and adjust the seat forward or backward to the desired position. After adjustment, release the adjusting lever to lock the seat in position.

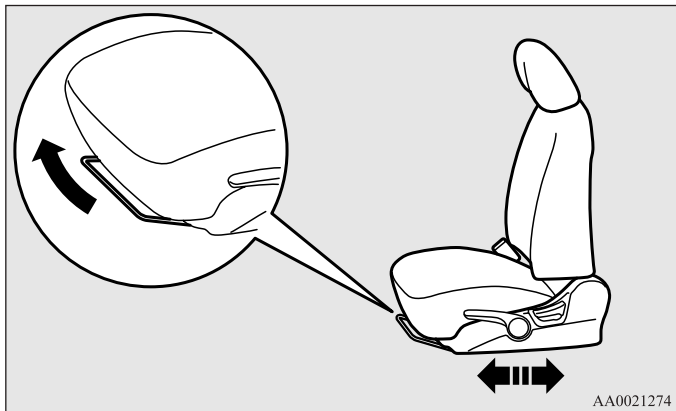

### **⚠ WARNING**

- To ensure the seat is locked securely, try to move the seat forward or backward without using the adjusting lever.

### To recline the seatback

E00400600610

In order to recline the seatback, lean forward slightly, pull the seatback lock lever up, and then lean backward to the desired position and release the lever. The seatback will lock in that position.

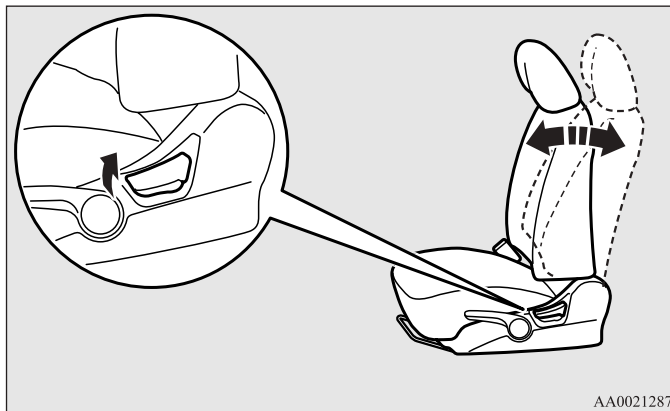

### **⚠ CAUTION**

- The reclining mechanism of the seatback is spring loaded, causing it to return to the vertical position when the lock lever is operated. When using the lever, sit close to the seatback or hold it with your hand to control its return motion.

## To adjust seat cushion height\*

E00400700608

Adjust the seat cushion height by repeatedly operating the lever.

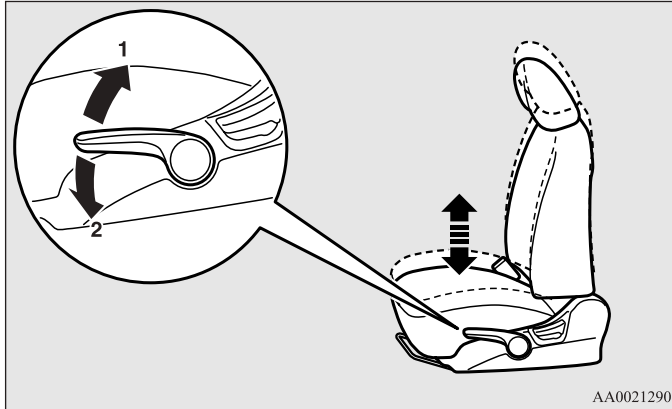

AA0021290

- 1- Raise
- 2- Lower

## Armrest

E00400900059

To adjust the armrest angle, tip the armrest forward and then raise it to the desired position.

To return the armrest to its original position, raise it backward.

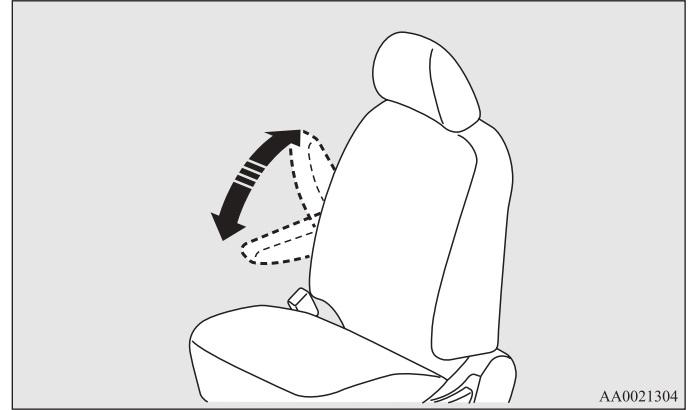

AA0021304

### NOTE

- Do not stand or sit on the armrest. It could break.

## Heated seats\*

E00401100205

The heated seats can be operated with the ignition switch in the "ON" position.

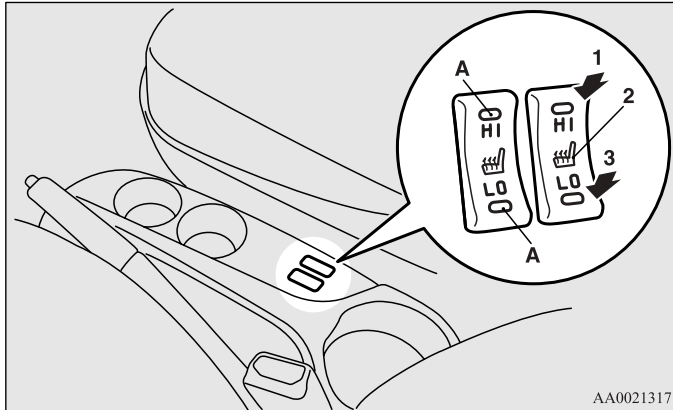

- 1- Heater high (for quick heating).
- 2- Heater off.
- 3- Heater low (to keep the seat warm).

The indication lamp (A) will illuminate while the heater is on.

### **⚠ CAUTION**

- **Operate in the high position for quick heating. Once the seat is warm, set the heater to low to keep it warm. Slight variations in seat temperature may be felt while using the heated seats. This is caused by the operation of the heater's internal thermostat and does not indicate a malfunction.**

### **⚠ CAUTION**

- **If the following types of persons use the heated seats, they might become too hot or receive minor burns (red skin, heat blisters, etc.):**
  - **Children, elderly or ill people**
  - **People with sensitive skin**
  - **Excessively tired people**
  - **People under the influence of alcohol or sleep inducing medication (cold medicine, etc.)**
- **Do not use a blanket, cushion, or other material with high heat insulation properties on the seat while using the heater; this might cause the heater element to overheat.**
- **Turn the heater off immediately if it appears to be malfunctioning during use.**

### NOTE

- **Do not place heavy objects on the seat or stick pins, needles, or other pointed objects into it.**
- **When cleaning the seat, do not use benzene, gasoline, alcohol, or other organic solvents; this might damage the surface of the seat and also the heater element.**
- **If water or any other liquid is spilled on the seat, allow it to dry thoroughly before attempting to use the heater.**



## Second seat

E00402000227

When a person is sitting in the middle seating position of the second seat in a cabin with 7-person seats, adjust the head restraints to heights at which they lock in position. Refer to “Head restraints” on page 2-19.

### NOTE

- It is possible to adjust each side of the second seats forward and backward independently of the other side, to adjust the seatback angle independently on each side, and to fold up the seat cushion independently on each side.

## To adjust forward or backward

E00402100097

Pull the seat adjusting left- or right-hand lever and adjust the seat forward or backward to the desired position. After adjustment, release the adjusting lever to lock the seat in position.

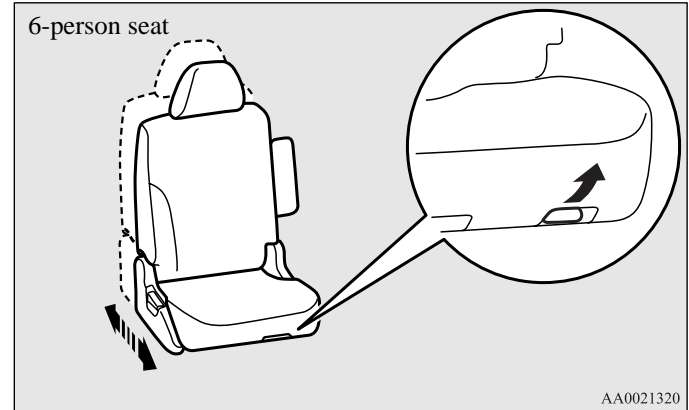

## Seat and seat belts

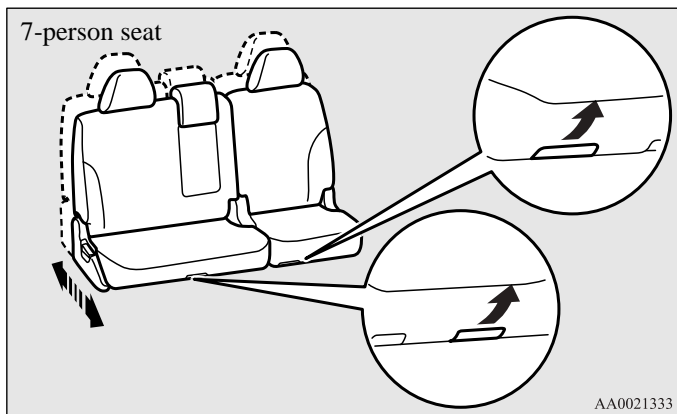

### **⚠ WARNING**

- To ensure the seat is locked securely, try to move the seat forward or backward without using the adjusting lever.

## To recline the seatback

E00402200186

In order to recline the seatback, lean forward slightly, pull the seatback lock lever up, and then lean backward to the desired position and release the lever. The seatback will lock in that position.

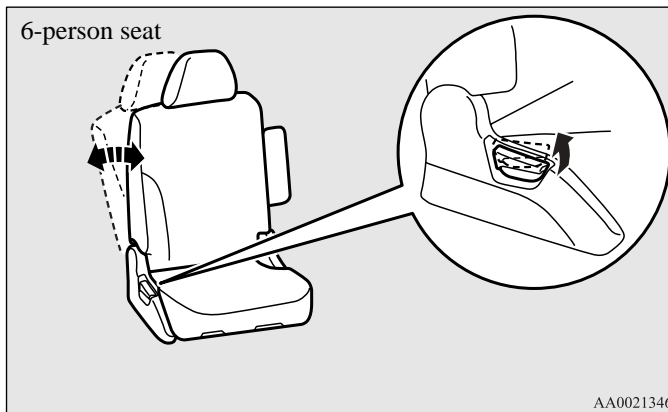

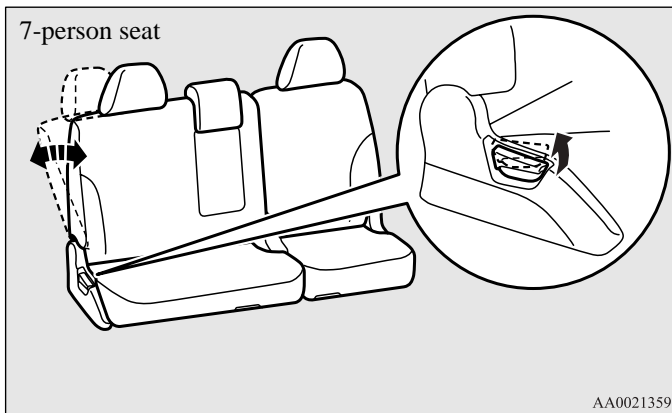

## **⚠ WARNING**

- When a person is sitting in the middle seating position of the second seat in a cabin with 7-person seats, the two sides of the second seat must have the same forward/backward position and the same seatback angle. Otherwise, the seat belt for the middle seating position may not be adequately effective in the event of hard braking or a collision.

## **⚠ CAUTION**

- The reclining mechanism of the seatback is spring loaded, causing it to return to the vertical position when the lock lever is operated. When using the lever, sit close to the seatback or hold it with your hand to control its return motion.

## Armrest

E00402400250

### *6-person seat*

To adjust the armrest angle, tip the armrest forward and then raise it to the desired position.

To return the armrest to its original position, raise it backward.

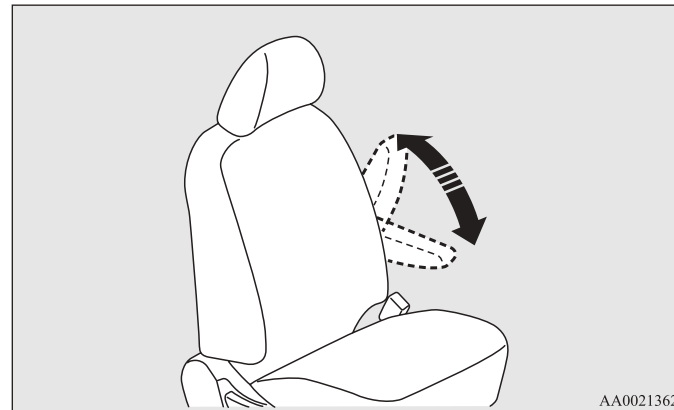

## Seat and seat belts

### 7-person seat

To use the armrest, fold it down.

To return to the original position, push it backward (into the seatback) until it is flush with the seat.

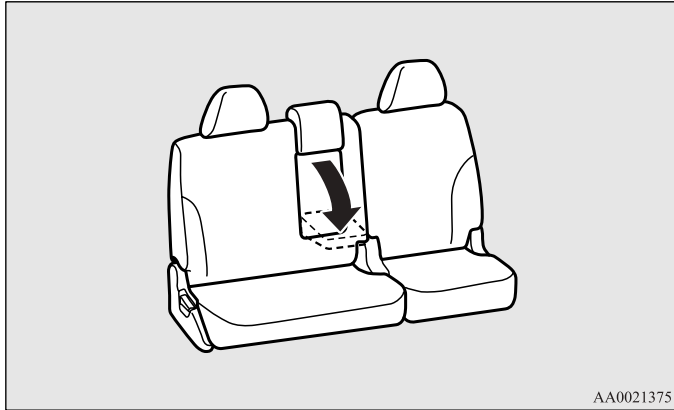

#### NOTE

- Do not stand or sit on the armrest. It could break.

### To get in and out of the third seat

E00402500222

The lever can be used to make getting in and out easier.

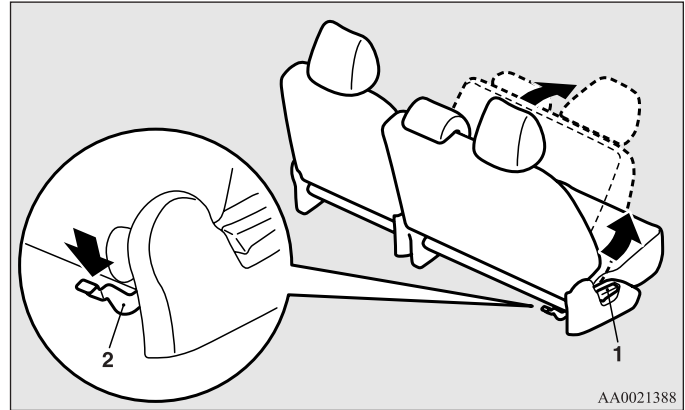

- 1- To get in or out
- 2- To get out

Fold the seatback forward, then slide the entire seat forward. To return the seat, slide the entire seat fully backward to retain it and then raise the seatback.

After returning the seat, gently try to move it forward and backward to check that it is securely retained.

**⚠ WARNING**

- Do not drive the vehicle with the seatback folded forward. The seat is not retained with the seatback in this position, so serious injuries could be suffered in the event of hard braking or a collision.

**⚠ CAUTION**

- The reclining mechanism of the seatback is spring loaded, causing it to return to the vertical position when the lock lever is operated. When using the lever, sit close to the seatback or hold it with your hand to control its return motion.
- Use a foot to operate the pedal (2).

**Folding up the seat cushion**

E00409700021

It is possible to create a luggage area by folding up the seat cushion and moving the seat forward.

**⚠ WARNING**

- Do not allow a passenger to sit on the seat or a child to play on it with the seat cushion folded up. Otherwise, serious injuries could be suffered in the event of hard braking.

**⚠ CAUTION**

- Do not stack luggage above the seatback height. Secure the luggage firmly. Otherwise, serious accidents could result due to restricted rear vision or unrestrained objects entering the passenger compartment during sudden braking.

## Seat and seat belts

### To fold

1. If the seatback is reclined, raise it to the initial locked position.  
(Refer to “To recline the seatback” on page 2-10.)
2. With the lever pulled on the side you wish to fold, fold up the seat cushion.

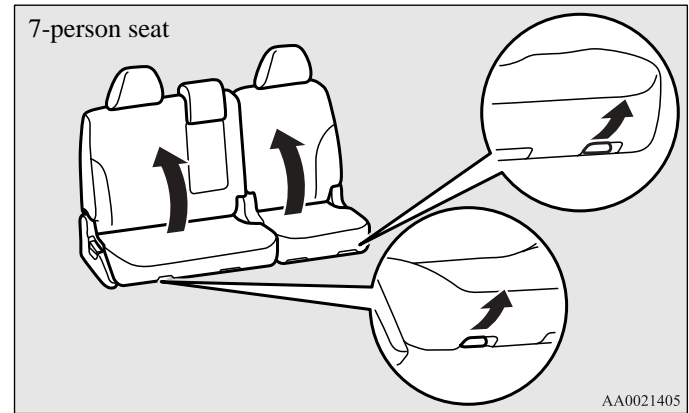
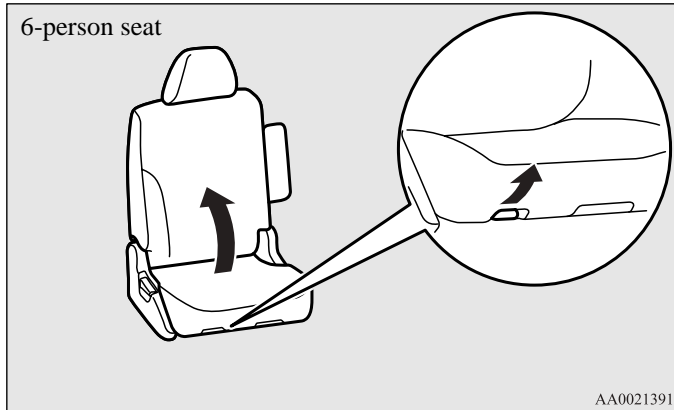

### To return

With the lever pulled, return the seat cushion to its original position.  
Then, check that the seat is securely retained.

### NOTE

- With the seat in its forward most position, the seat cushion cannot be returned to its original position.

***To adjust the seat forward or backward with the seat cushion folded up***

Adjust the seat forward or backward with the lever pulled. After making the adjustment, gently try to move it forward and backward to check that it is securely retained.

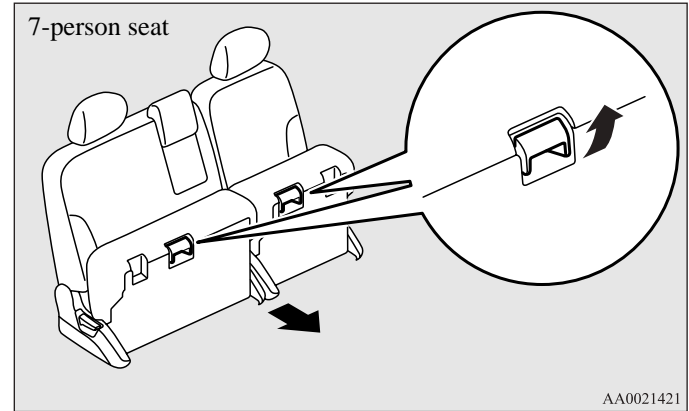
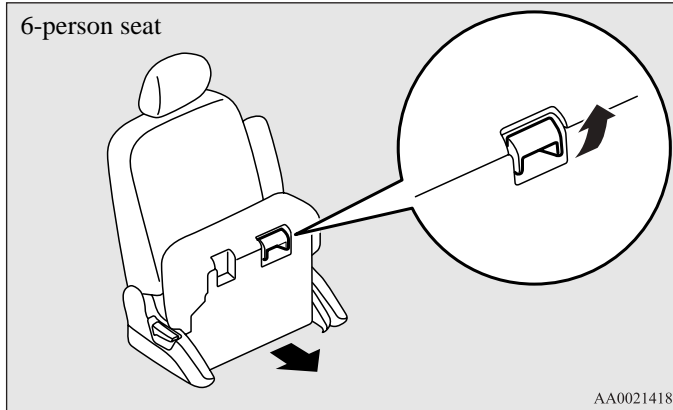

**NOTE**

- The seat can slide further forward only when the seat cushion is folded up.

## Seat and seat belts

### *To adjust the seat cushion angle*

E00410300014

If, while raising the seat cushion, you release the lever when the seat cushion reaches some desired angle, the seat cushion will be held at that angle.

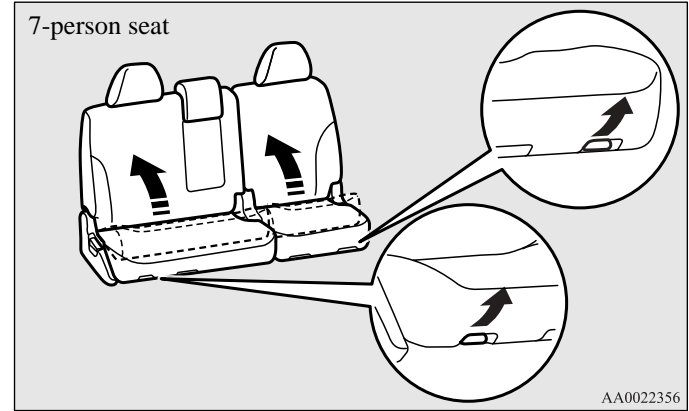
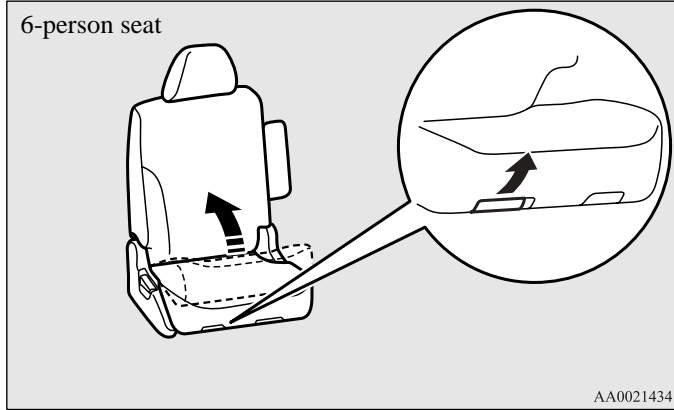



## Third seat

E00402700208

When sitting in the third seat, adjust the head restraints to heights at which they lock in position. Refer to “Head restraints” on page 2-19.

### To recline the seatback

E00402800140

In order to recline the seatback, lean forward slightly, pull the seatback lock lever up, and then lean backward to the desired position and release the lever. The seatback will lock in that position.

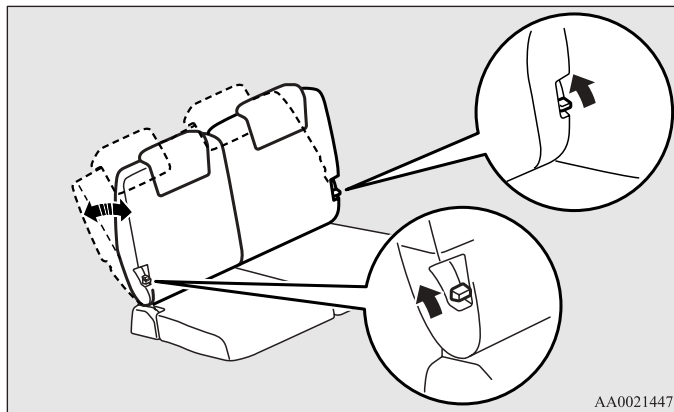

#### NOTE

- It is possible to adjust the seatback angle independently on each side of the seats.

### **⚠ CAUTION**

- The reclining mechanism of the seatback is spring loaded, causing it to return to the vertical position when the lock lever is operated. When using the lever, sit close to the seatback or hold it with your hand to control its return motion.

## Folding the seatbacks forward

E00402900024

Larger objects can be loaded into the vehicle if a seatback is folded forwards.

### **⚠ WARNING**

- The luggage area in the rear of the vehicle should never be used as a play area by children. Children should be seated with seat belts fastened when the vehicle is in motion. Be sure that the rear seatbacks are returned to their fully upright position and locked in place.

### **⚠ CAUTION**

- Do not stack luggage above the seatback height. Secure the luggage firmly. Otherwise, serious accidents could result due to restricted rear vision or unrestrained objects entering the passenger compartment during sudden braking.

### *To fold*

Pull the belt (A) behind the seatback that you wish to fold, then tilt the seatback forwards until it locks.

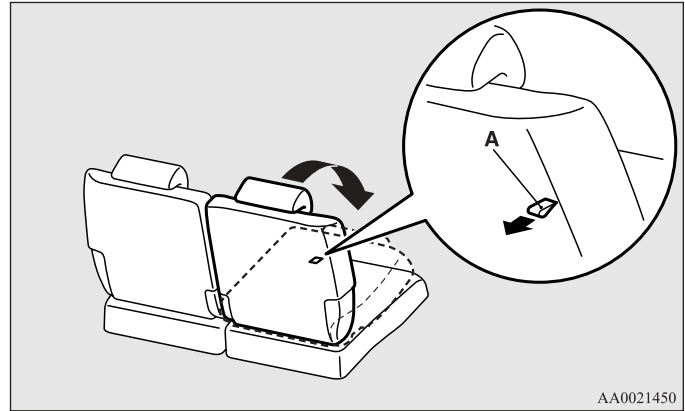

### *To return*

1. Pull the belt (A) behind the seatback which is desired to be raised, then raise the seatback until it locks securely into place.
2. Push lightly on the seatback to confirm that it has actually been secured.

## Head restraints

E00403300953

### **⚠ WARNING**

- Driving without the head restraints in place can cause you and your passengers serious injury or death in an accident. To reduce the risk of injury in an accident, always make sure the head restraints are installed and properly positioned when the seat is occupied.
- Never place a cushion or similar device on the seat-back. This can adversely affect head restraint performance by increasing the distance between your head and the restraint.

### To adjust height

Adjust the head restraint height so that the centre of the restraint is as close as possible to eye level to reduce the chances of injury in the event of collision. Any person too tall for the restraint to reach their seated eye level, should adjust the restraint as high as possible.

To raise the head restraint, move it upward. To lower the restraint, move it downward while pushing the height adjusting knob (A) in the direction of the arrow. After adjustment, push the head restraint downward and make sure that it is locked.

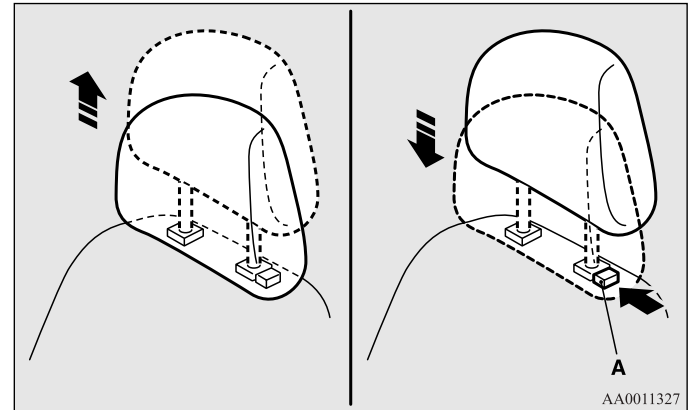

## Seat and seat belts

### To remove

Lift the head restraint with the height adjusting knob (A) pushed in.

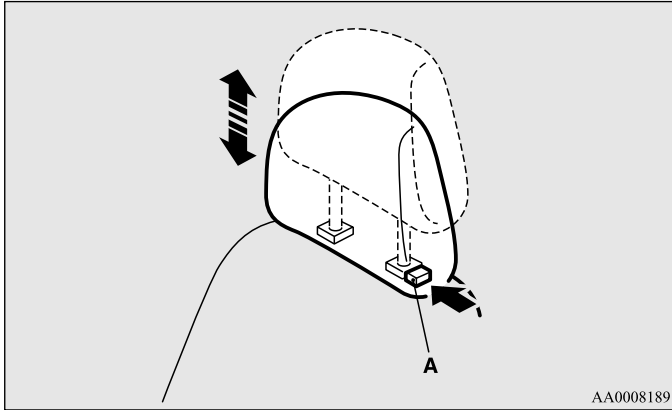

### To install

Confirm that the head restraint is facing the correct direction, and then insert it into the seatback while pressing the height adjusting knob (A) in the direction indicated by the arrows.

## **CAUTION**

- Confirm that the height adjusting knob (A) is correctly adjusted as shown in the illustration, and also lift the head restraints to ensure that they do not come out of the seatback.

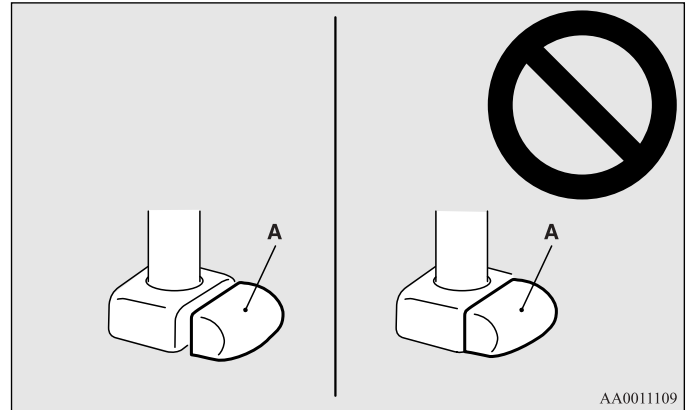

**⚠ CAUTION**

- The head restraints for the seats differ in shape and size. When installing head restraints, make sure the head restraints are fitted in their respective seats. Failure to do so could cause serious injury if involved in an accident.

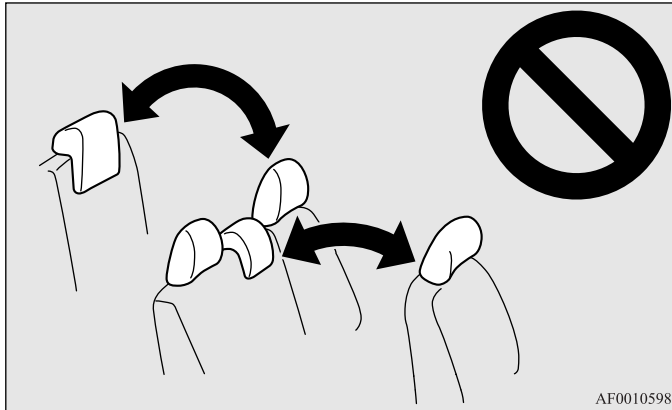
***Making a luggage area***

E00403400039

**⚠ WARNING**

- If required, always operate the seating before the vehicle is in motion.
- After seat operations are made, ensure the seating is locked in position by attempting to move the seat and seatback forward and rearward without using the adjusting mechanism.
- The luggage area in the rear of the vehicle should never be used as a play area by children. Children should be seated with seat belts fastened when the vehicle is in motion. Be sure that the rear seatbacks are returned to their fully upright position and locked in place.

2

**⚠ CAUTION**

- Do not stack luggage above the seatback height. Secure the luggage firmly. Otherwise, serious accidents could result due to restricted rear vision or unrestrained objects entering the passenger compartment during sudden braking.
- Make sure that the seat is operated by an adult. If it is operated by a child, an unexpected accident might occur.
- When folding or storing the seat, be sure not to catch your hand or leg.

## Stowing the third seat

E00404100020

The third seat can be stowed under the floor to create a luggage area.

### NOTE

- Each side of the third seats can be stowed independently of the other.

### To stow

1. Remove the head restraints from the third seats.  
(Refer to “Head restraints” on page 2-19.)
2. Fold the seatback forward and make sure it is securely retained against the seat cushion.  
(Refer to “Folding the seatbacks forward” on page 2-18.)

### NOTE

- The seatback cannot be retained if any object is trapped between the seatback and seat cushion.
- If the seatback is not retained against the seat cushion when the seat is stowed, it may get caught on the floor and prevent the seat from being returned to its original position.

3. Pull the belt (A) on the back of the seat cushion until it clicks.

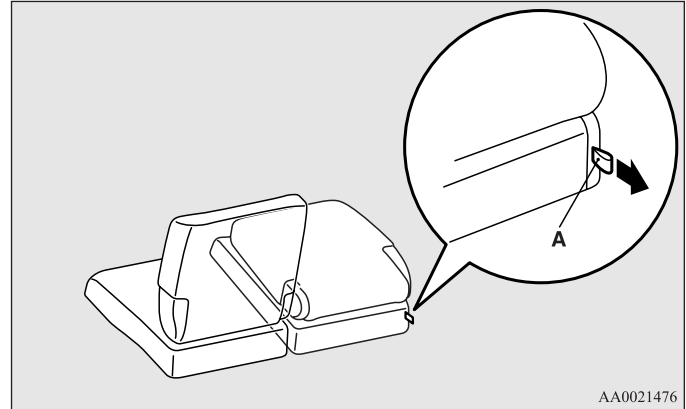

4. Tip the entire seat backward. Hold the handle (B) on the back of the seat cushion and lower the seat into the floor.

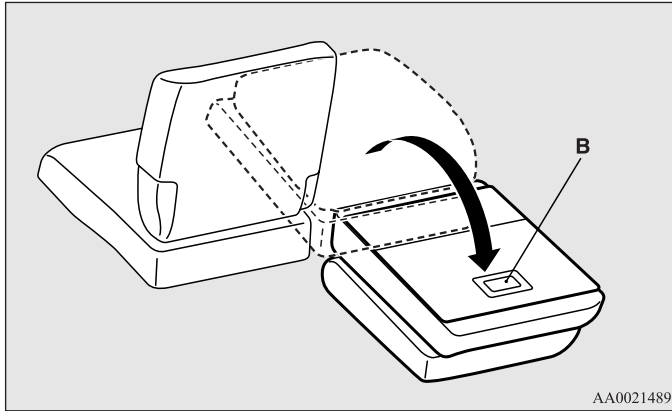

### **⚠ CAUTION**

- When stowing the seat, hold it with your hands and lower it slowly. Unless you hold the seat securely, it may suddenly tip under its own weight, trapping your hands.
- Do not pull the belt while a person is sitting on the seat. The seat could tip backward, resulting in an accident.

### NOTE

- The removed third seat head restraints (C) can be fitted together and stored in the cargo net in the luggage area. (Refer to “Cargo net” on page 5-78.)

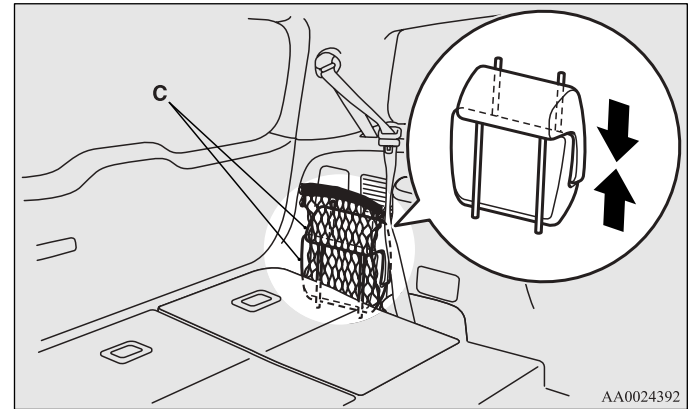

## Seat and seat belts

### To return

1. Use the handle (B) to lift the entire seat. Slowly tip the seat forward, then push it until it locks securely in position.

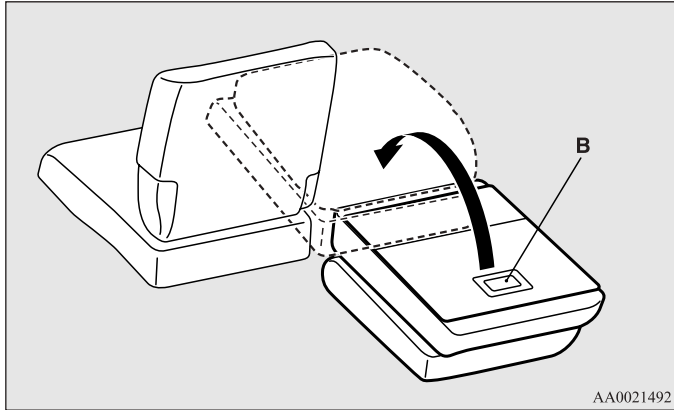

2. Pull the belt (D) on the back of the seatback. With the belt pulled, raise the seatback to its original position.

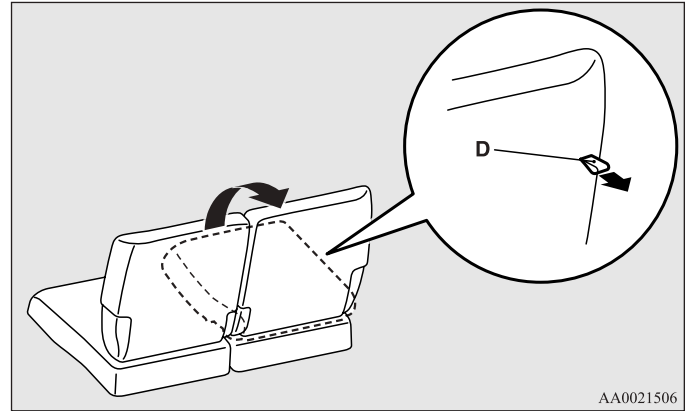

3. After raising the seatback to its original position, push lightly on it to confirm that it has been secured.
4. Install the head restraints.



## Making a flat seat

E00404300064

By removing the head restraints and fully reclining the seat-backs of the seats, one large flat seat is achieved.

### **⚠ WARNING**

- **Never drive with luggage or passengers on the flat seat. This is highly dangerous.**  
In a collision, people or children riding unrestrained in these areas are more likely to be seriously injured or killed.
- Do not allow people or children to ride in any area of your vehicle that is not equipped with seats and seat belts, and make sure that everyone travelling in your vehicle is in a seat and wearing a seat belt, or in the case of a child is strapped in a child restraint.
- In the interest of their safety, children should not be allowed to adjust the seats.

### **⚠ CAUTION**

- **To make a flat seat, stop the vehicle in a safe place.**
- **Make sure that the seat is adjusted by an adult.**  
If it is adjusted by a child, an unexpected accident might occur.
- **When sliding the seat, be sure not to catch your hand or leg.**
- **Do not walk around on top of the seats after they have been laid flat.**
- **To ensure the seats are locked securely, attempt to move them back and forth.**
- **Do not jump on, or impact the seatbacks heavily.**
- **To raise the seatback, sit on the seat and put a hand on the seatback and raise slowly. Never have a child do this operation, or an unexpected accident may result.**

## With front and second seats

E0040440023

### NOTE

- Retract the personal table to its original position before performing the following steps.  
(Refer to “Personal table” on page 5-72.)

1. Remove the head restraints from the front seats, and raise the armrest.  
(Refer to “Head restraints” on page 2-19 and “Armrest” on page 2-7, 2-11.)

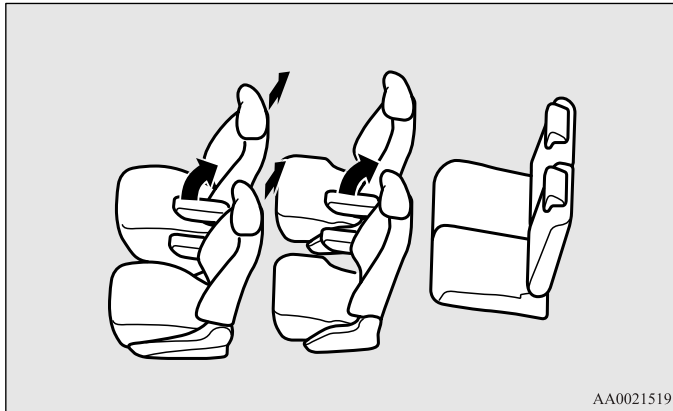

2. Slide the second seats to the fully backward position.  
(Refer to “To adjust forward or backward” on page 2-9.)

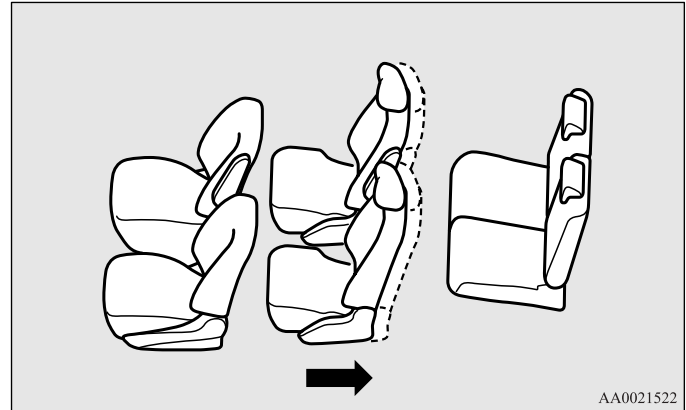

3. Adjust the second seat cushions to the highest angle.  
(Refer to “To adjust the seat cushion angle” on page 2-16.)

- Slide the front seats to the fully forward position, then tip their seatbacks backward.  
(Refer to “To adjust forward or backward” on page 2-6 and “To recline the seatback” on page 2-6.)

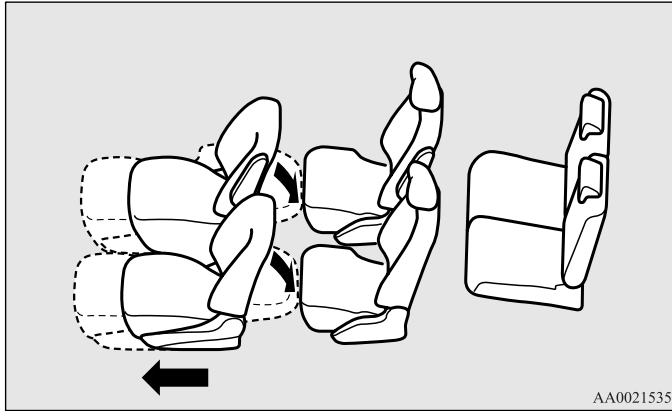

- Tip the seatbacks of the second seats backward.  
(Refer to “To recline the seatback” on page 2-10.)

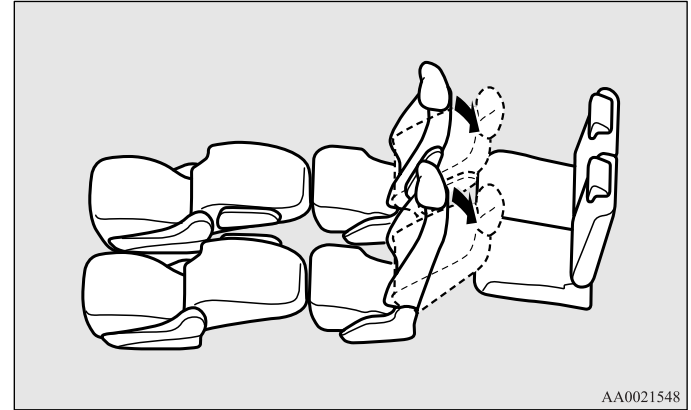

## Seat and seat belts

6. The flat seat configuration is now complete.  
To return the seats to the normal position, reverse the above procedure.

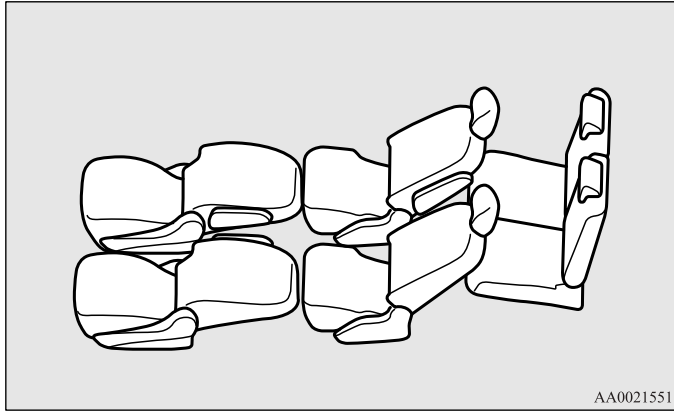

## NOTE

- The removed head restraints (A) can be fitted together and stored in the cargo net in the luggage area. (Refer to “Cargo net” on page 5-78.)

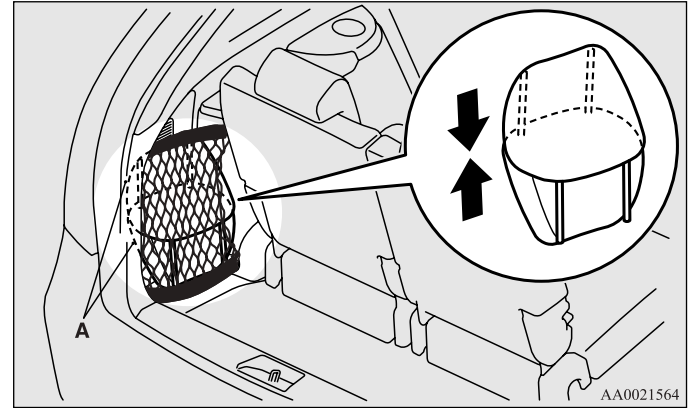

## With second and third seats

E00404500024

### NOTE

- Retract the personal table to its original position before performing the following steps.  
(Refer to “Personal table” on page 5-72.)
1. Remove the head restraints from the second and third seats, and raise the armrest.  
(Refer to “Head restraints” on page 2-19 and “Armrest” on page 2-7, 2-11.)

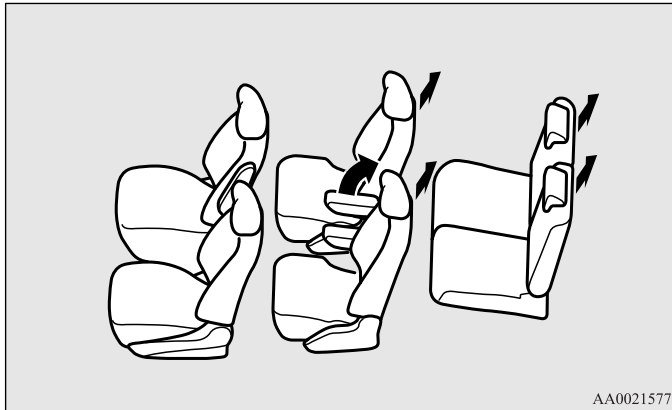

2. Slide the front seats to the fully forward position.  
(Refer to “To adjust forward or backward” on page 2-6.)

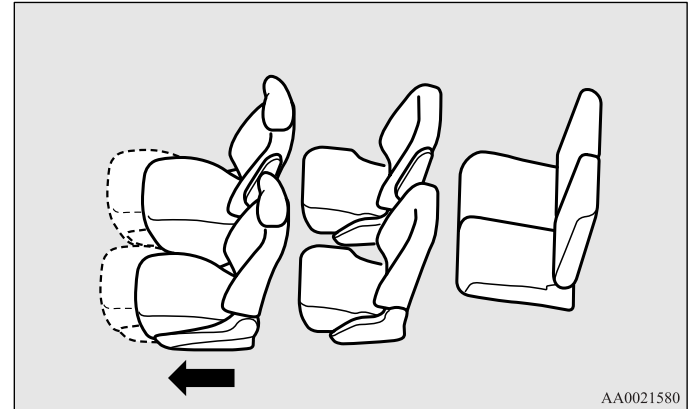

## Seat and seat belts

3. Slide the second seats to the fully forward position.  
(Refer to “To adjust forward or backward” on page 2-9.)

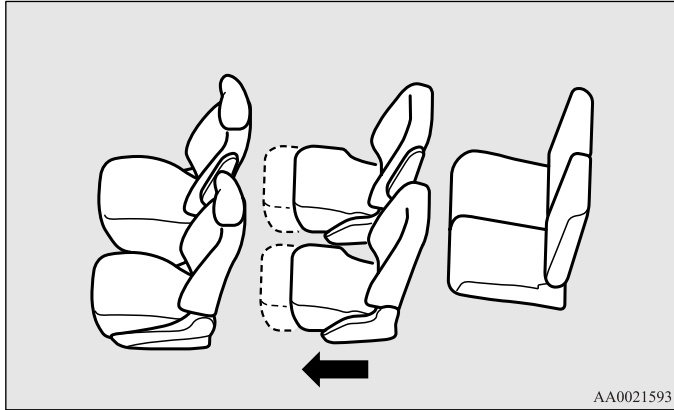

4. Tip the seatbacks of the second seats backward.  
(Refer to “To recline the seatback” on page 2-10.)

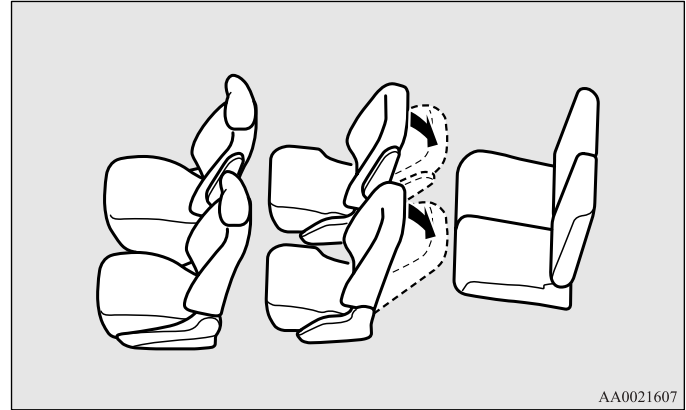

5. Tip the seatbacks of the third seats backward.  
(Refer to “To recline the seatback” on page 2-17.)

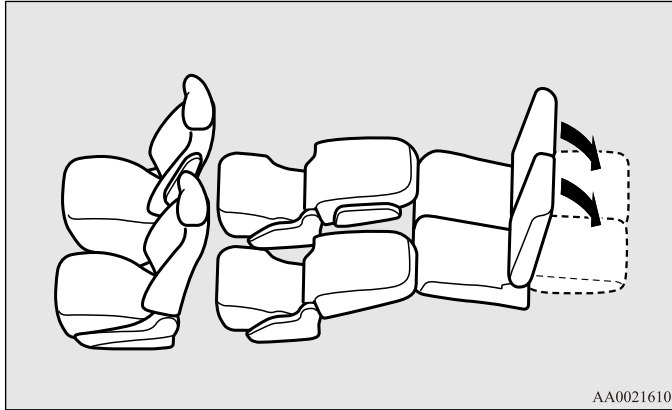

6. Move the front seats backward until they touch the second seats. Lock them in that position. The flat seat configuration is now complete.  
To return the seats to their normal positions, reverse the above procedure.

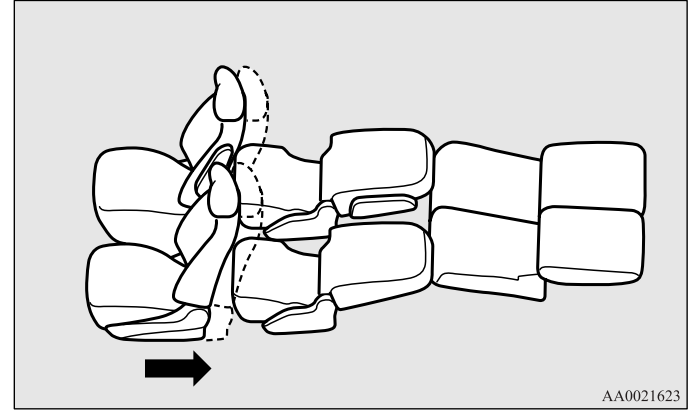

## Seat and seat belts

### NOTE

- You can store the head restraints (A) removed from the second seat (except the middle seating position) by inserting their rods between the tipped third seat and the wall of the luggage area on the right side.

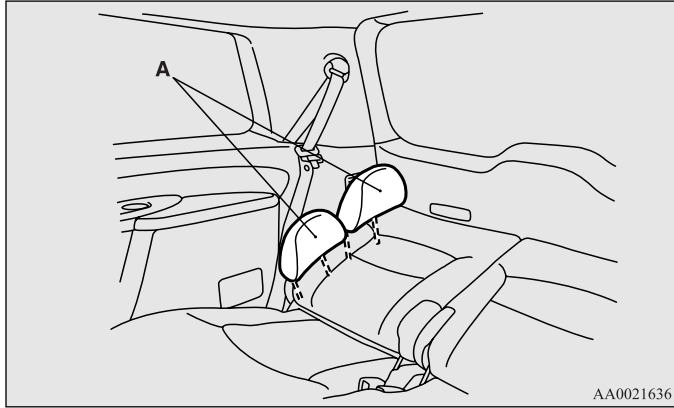

- The head restraints (B) removed from the third seat and the second seat (the middle seating position) can be fitted together and stored in the cargo net in the luggage area.

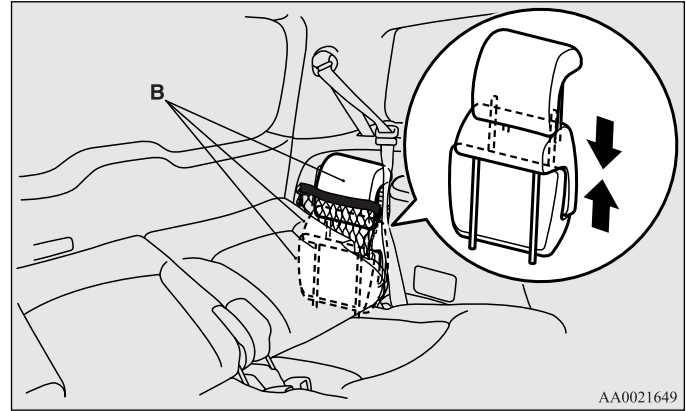



## Seat belts

E00404800593

To protect you and your passengers in the event of an accident, it is the most important that the seat belts be worn correctly when you drive.

The front seat belts have a pre-tensioner system. These belts are used the same way as a conventional seat belt.

Refer to “Seat belt pre-tensioner system and force limiter system” on page 2-39.

### **WARNING**

- **Always place the shoulder belt over your shoulder and across your chest. Never put it behind you or under your arm.**
- **One seat belt should be used by only one person. Doing otherwise can be dangerous.**
- **The seat belt will provide its wearer with maximum protection if the recliner seatback is placed in fully upright position. When the seatback is reclined, there is greater risk that the passenger will slide under the belt, especially in a forward impact accident, and may be injured by the belt or by striking the instrument panel or seatbacks.**
- **Seat belts should always be worn by every adult who drives or rides in this vehicle, and by all children who are large enough to wear seat belts properly.**
- **Remove any twists when using the belt.**
- **No modifications or additions should be made by the user which will either prevent the seat belt adjusting devices from operating to remove slack, or prevent the seat belt assembly from being adjusted to remove slack.**
- **To reduce risk of serious or fatal injury in an accident, including the deploying driver air bag, the driver should adjust the driver’s seat to the rear most position that still allows good visibility and good control of the steering wheel, the brake and accelerator, and vehicle controls.**

## **⚠ WARNING**

- Never hold a child in your arms or on your lap when riding in this vehicle, even if you are wearing your seat belt. To do so risks severe or fatal injury to your child in a collision or sudden stop.
- Always adjust the belt to a snug fit.



## **3-point type seat belt (with emergency locking mechanism)**

E00404900754

This type of belt requires no length adjustment. Once worn, the belt adjusts itself to the movement of wearer, but in the event of a sudden or strong shock, the belt automatically locks to hold the wearer's body.

### *To fasten*

1. Pull the seat belt out slowly while holding the latch plate.

### **NOTE**

- When the seat belts cannot be pulled out in a locked condition, pull the belts once forcefully and then return them. After that, pull the belts out slowly once again.
2. Insert the latch plate into the buckle until a “click” is heard.

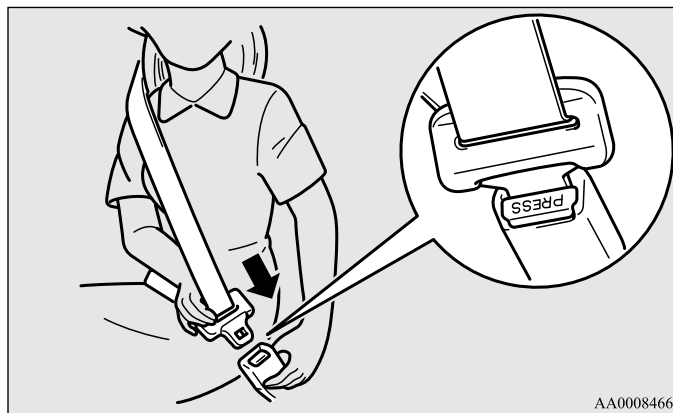

## **⚠ WARNING**

- Never wear the lap portion of the belt across your abdomen. During accidents it can press sharply against abdomen and increase the risk of injury.
- The seat belts must not be twisted when worn.

3. Pull the belt slightly to adjust slackness as desired.

### *To unfasten*

Hold the latch plate and push the button on the buckle.

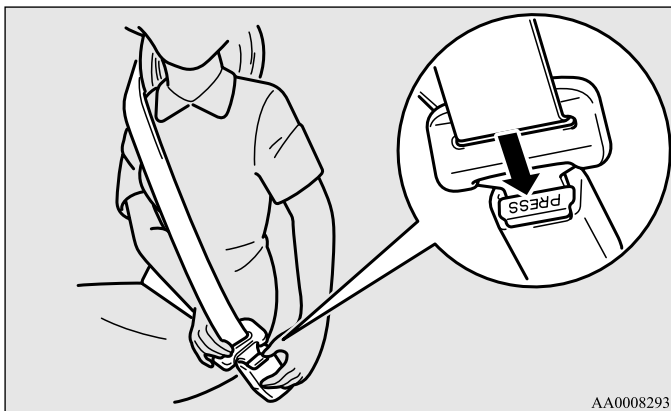

### NOTE

- As the belt retracts automatically, keep the latch plate held while retracting so that the belt stows slowly. Failure to do this could damage the vehicle.

## Seat belt reminder/warning lamp

E0040980022

A tone and warning lamp are used to remind the driver and front passenger to fasten the seat belt.

### NOTE

- For the front passenger seat, the warning function works only while a person is sitting on the seat.

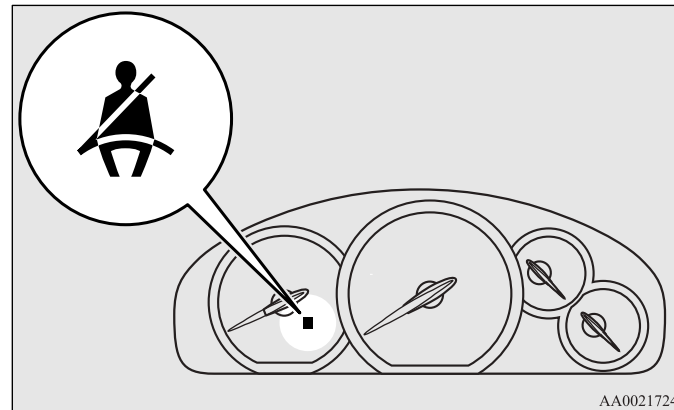

## Seat and seat belts

When the ignition key is turned to the “ON” position, the warning lamp will come on and a tone will sound for about 6 seconds. If the front seat belt remains unfastened approximately 1 minute later, the warning lamp will flash and the tone sound intermittently (each 12 seconds) when the vehicle is driven. If the passenger subsequently unfastens the seat belt while driving, the warning lamp and tone will issue further warnings. And if the seat belt remains unfastened, the warning lamp and tone will issue further warnings each time the vehicle starts moving from a stop. When the seat belt is fastened, the warnings will stop.

### **⚠ WARNING**

- In order to reduce the risk of serious or fatal injury in an accident, always wear your own seat belt. Do not allow anyone to ride in your vehicle unless he or she is also seated and wearing a seat belt. Children should additionally be restrained in a secure child restraint system.

### NOTE

- When luggage is placed on the front passenger seat, a sensor in the seat cushion may, depending on the weight and position of the luggage, cause the warning tone to sound and the warning lamp to come on.

## Adjustable seat belt anchor (front seats)

E00405000433

The seat belt anchor height can be adjusted. Move the seat belt anchor (A) down with the lock knob (B) depressed. To move the anchor up, slide it without depressing the lock knob.

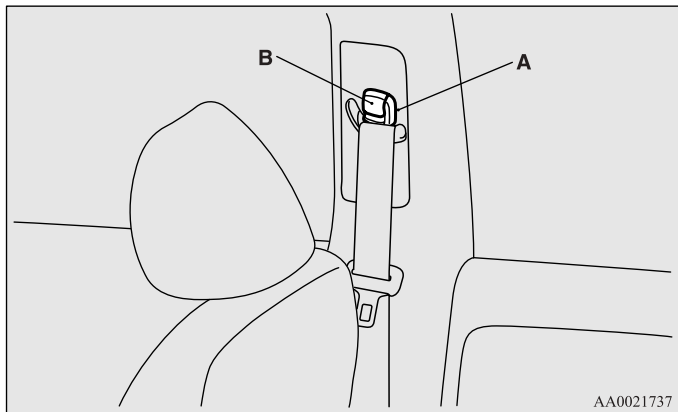

### **⚠ WARNING**

- When adjusting the seat belt anchor, set it at a position that is sufficiently high so that the belt will make full contact with your shoulder but will not touch your neck.
- Adjust the shoulder belt anchor only when the vehicle is not in motion.
- Make sure the anchor is securely locked in position after adjusting it.

## Rear seat belt storage

E00405300045

When the second (except centre) and third seat belts are not in use, store them as shown in the illustrations.

The openings in the front and rear of the holder (A) can be used for storage.

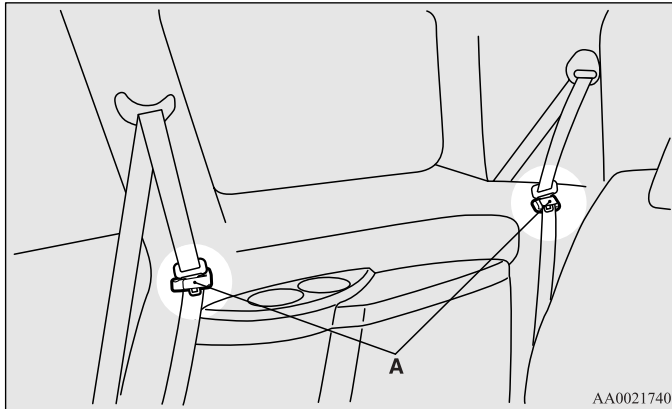

After passing the belt through the rear notch (B), insert the plate into the front notch (C).

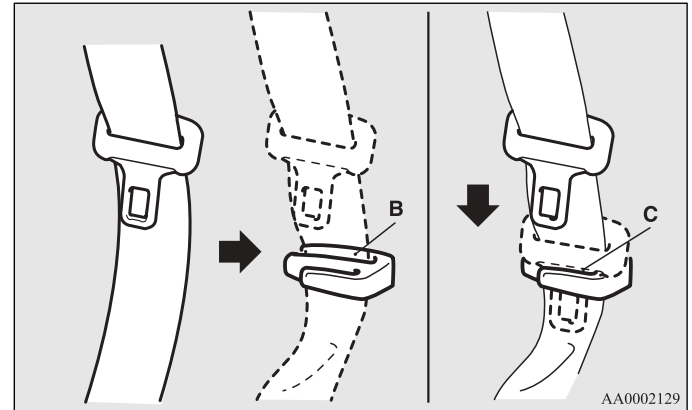

## Seat and seat belts

Insert the third seat's buckle into the pocket on the seat cushion.

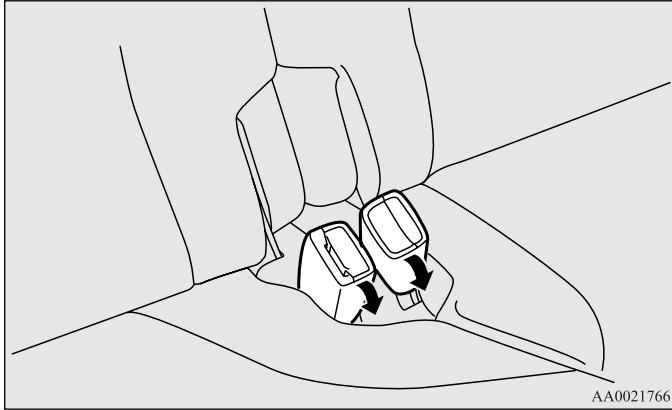

## *Pregnant women restraint*

E00405600123

### **⚠ WARNING**

- Seat belts work for everyone, including pregnant women. Pregnant women should use the available seat belts. This will reduce the likelihood of injury to both the woman and the unborn child. The lap belt should be worn across the thighs and as snug against the hips as possible, but not across the waist. Consult your doctor if you have any additional questions or concerns.

## Seat belt pre-tensioner system and force limiter system

E0040570052

The driver's seat and front passenger's seat each have a seat belt equipped with a pre-tensioner system.

### Pre-tensioner system

E00405800923

The pre-tensioner system will retract their respective seat belts instantaneously, thus maximizing the seat belt's effectiveness, if there is a frontal impact severe enough to injure the driver and/or front passenger and the ignition switch is in the "ON" or "START" position.

The seat belt pre-tensioner includes the following components:

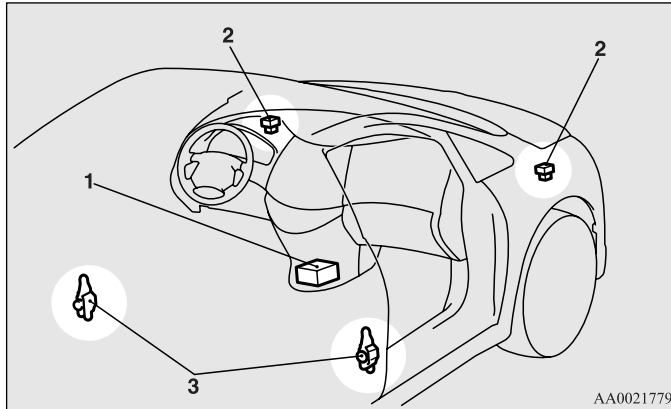

- 1- Air bag control unit
- 2- Front impact sensor
- 3- Seat belt pre-tensioner

## **⚠ WARNING**

- To obtain the best results from your pre-tensioner seat belt, make sure you have adjusted your seat correctly and wear your seat belt properly.

## **⚠ CAUTION**

- Installation of audio equipment or repairs in the vicinity of the pre-tensioner seat belts or floor console must be performed in line with MITSUBISHI guidelines. It is important to do so because the work could affect the pre-tensioner systems.
- If you need to scrap the vehicle, please consult a MITSUBISHI MOTORS Authorized Service Point. It is important to do so because unexpected activation of the pre-tensioner seat belts could cause injuries.

### NOTE

- The pre-tensioner seat belts will be activated if the vehicle suffers a severe frontal impact, even if the seat belts are not worn.
- The pre-tensioner seat belts are designed to work only once. After the pre-tensioner seat belts have been activated, we recommend you to replaced by a MITSUBISHI MOTORS Authorized Service Point.

## SRS warning lamp

E00405900038

This warning lamp is shared by the SRS air bags and the pretensioner seat belts.

Refer to “SRS warning lamp” on page 2-76.

## Force limiter system

E00406000023

In the event of a collision, each force-limiter system will effectively absorb the load applied to the seat belt so as to minimize the impact to the passenger.

## Child restraint

E00406401226

When transporting children in your vehicle, some type of child restraint system should always be used according to the size of the child. This is required by law in most countries.

The regulations concerning driving with children in the front seat may differ from country to country. You are advised to comply with the relevant regulations.

### **WARNING**

- **When possible, put children in the rear seat. Accident statistics indicate that children of all sizes and ages are safer when properly restrained in the rear seat rather than in the front seat.**
- **Holding a child in your arms is no substitute for a restraint system. Failure to use a proper restraint system can result in severe or fatal injury to your child.**
- **Each child restraint device or fixing is to be used only by one child.**
- **When attaching a child restraint to the rear seat, place the front seatbacks in the upright position. Otherwise, the child could be seriously injured in the event of hard braking or a collision.**



### Caution for installing the child restraint on vehicle with front passenger air bag

The label shown here is attached on vehicles with front passenger air bag.

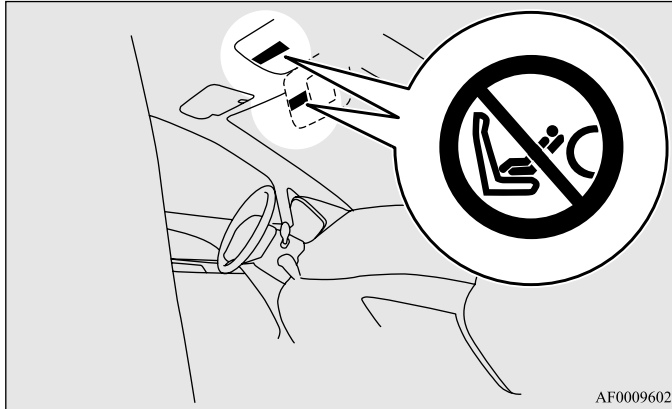

### **⚠ WARNING**

- **Extreme Hazard!**  
Do not use a rearward facing child restraint on a seat protected by an air bag in front of it!

### **⚠ WARNING**

- **A REARWARD FACING CHILD RESTRAINT must NOT be used in the front passenger seat if the front passenger's air bag has not been deactivated.** The force of an inflating air bag could kill or cause serious injuries to the child. A rearward facing child restraint should be used in the rear seat.



## Seat and seat belts

### NOTE

- If you have a rearward facing child restraint system that cannot be fitted to any seat other than the front passenger seat, be sure to turn OFF the front passenger's air bag ON-OFF switch before using it. (Refer to "To turn an air bag off" on page 2-60.)



### **⚠ WARNING**

- **A FORWARD FACING CHILD RESTRAINT should be used in the rear seat whenever possible; if used in the front seat, adjust the seat to the most rearward position.**



## Infants and small children

E00406600579

When transporting infants and small children in your vehicle, follow the instruction given below.

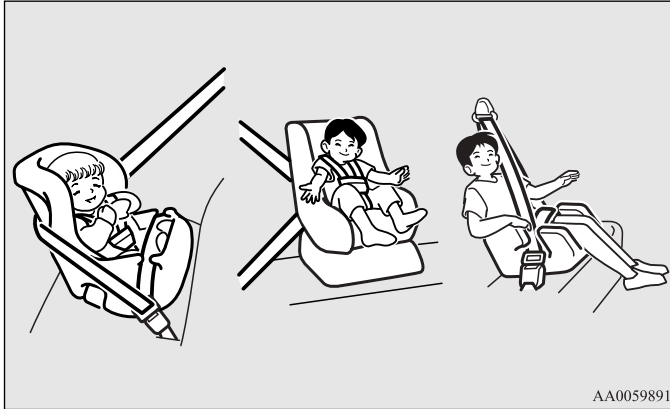

### *Instruction:*

- For small infants, an infant carrier should be used. For small children whose height when seated allows the shoulder belt to lie in contact with the face or the throat, a child seat should be used.
- The child restraint system should be appropriate for your child's weight and height and properly fit the vehicle. For a higher degree of safety: **THE CHILD RESTRAINT SYSTEM SHOULD BE INSTALLED IN THE REAR SEAT.**

## **⚠ WARNING**

- When installing a child restraint system, refer to the instructions provided by the manufacturer of the restraint system. Failure to do so can result in severe or fatal injury to your child.
- After installation, push and pull the child restraint system back and forth, and side to side, to see that it is positively secured. If the child restraint system is not installed securely, it may cause injury to the child or other occupants in the case of accident or sudden stops.
- When the child restraint system is not in use, keep your child or infant seat secured with the seat belt or remove it from the vehicle in order to prevent injury to your child.

### NOTE

- Before purchasing a child restraint system, try installing it in the rear seat to make sure there is a good fit. Because of the location of the seat belt buckles and the shape of the seat cushion, it may be difficult to securely install some manufacturer's child restraint systems.

If the child restraint system can be pulled forward or to either side easily on the seat cushion after the seat belt has been tightened, choose another manufacturer's child restraint system.

Depending on the seating position in the vehicle and the child restraint system that you have, the child restraint can be attached using one of the following 2 locations:

- To the lower anchorage in the rear seat **ONLY** if the child restraint has ISOFIX mountings (See page 2-49).
- To the seat belt (See page 2-51).

## Older children

E00406700192

Children who have outgrown the child restraint system should be seated in the rear seat and wear combination lap shoulder belt.

The lap portion of the belt should be snug and positioned low on the abdomen so that it is below the top of the hip-bone. Otherwise, the belt could intrude into the child's abdomen during an accident and cause injury.

### **⚠ WARNING**

- **Children who are not buckled up can be thrown out of the vehicle in an accident.**
- **Children who are not buckled up can strike other people in the vehicle in an accident.**
- **A child should never be left unattended in your vehicle. When you leave the vehicle, take the child with you.**

## Suitability for various seating positions

### 6-person seat

Mass Group	Seating Position				
	Front Passenger		Rear Outboard	Intermediate Outboard	
	Activated Air Bag	Deactivated Air Bag* <sup>1</sup>		Left side	Right side
0 - Up to 10 kg (0-9 months)	X	X	U	U	U
0+ - Up to 13 kg (0-2 years)	X	L* <sup>2</sup>	U, L* <sup>2</sup>	U, L* <sup>2</sup>	U, L* <sup>2</sup>
I - 9 to 18 kg (9 months-4 years)	L* <sup>3</sup>	L* <sup>3</sup>	U, L* <sup>3</sup>	U, L* <sup>3</sup>	U, L* <sup>3</sup>
II & III - 15 to 36 kg (4-12 years)	L* <sup>4</sup>	L* <sup>4</sup>	U, L* <sup>4</sup>	U, L* <sup>4</sup>	U, L* <sup>4</sup>

\*<sup>1</sup>: With front passenger's air bag deactivated by means of front passenger's air bag ON-OFF switch

#### Key of letters to be inserted in the above table:

- U- Suitable for "universal" category restraints approved for use in this mass group.
- UF- Suitable for forward-facing "universal" category restraints approved for use in this mass group.
- L- Suitable for particular child restraints (MITSUBISHI MOTORS genuine parts).
- B- Built-in restraint approved for this mass group.
- X- Seat position not suitable for children in this mass group.

## Seat and seat belts

### L (Genuine part information)

	Genuine parts No.	ECE No.
*2	MZ312807	E1-04301146
*3	MZ312745	E1-04301136
	MZ313045	E1-04301133
*4	MZ312808	E1-04301148

#### NOTE

- The above suitability table applies to retention of child restraints using seat belts.
- When MITSUBISHI MOTORS genuine part No. MZ313045 is used on the intermediate outboard seat, it can also be retained by means of ISOFIX child restraint mountings.
- There is no applicable MITSUBISHI MOTORS Genuine Parts to the Mass Group “0- Up to 10 kg (0-9 months)”.

MITSUBISHI MOTORS Europe B.V. reserves the right to changes without any prior announcement.  
For detail information, consult your MITSUBISHI MOTORS Authorized Service Point.

**7-person seat**

Mass Group	Seating Position					
	Front Passenger		Rear Outboard	Intermediate Outboard		Intermediate Centre
	Activated Air Bag	Deactivated Air Bag* <sup>1</sup>		Left side	Right side	
0 - Up to 10 kg (0-9 months)	X	X	U	U	U	X
0+ - Up to 13 kg (0-2 years)	X	L* <sup>2</sup>	U, L* <sup>2</sup>	U, L* <sup>2</sup>	U, L* <sup>2</sup>	L* <sup>2</sup>
I - 9 to 18 kg (9 months-4 years)	L* <sup>3</sup>	L* <sup>3</sup>	U, L* <sup>3</sup>	U, L* <sup>3</sup>	U, L* <sup>3</sup>	L* <sup>3</sup>
II & III - 15 to 36 kg (4-12 years)	L* <sup>4</sup>	L* <sup>4</sup>	U, L* <sup>4</sup>	U, L* <sup>4</sup>	U, L* <sup>4</sup>	X

\*<sup>1</sup>: With front passenger's air bag deactivated by means of front passenger's air bag ON-OFF switch

**Key of letters to be inserted in the above table:**

- U- Suitable for “universal” category restraints approved for use in this mass group.
- UF- Suitable for forward-facing “universal” category restraints approved for use in this mass group.
- L- Suitable for particular child restraints (MITSUBISHI MOTORS genuine parts).
- B- Built-in restraint approved for this mass group.
- X- Seat position not suitable for children in this mass group.

## Seat and seat belts

### L (Genuine part information)

	Genuine parts No.	ECE No.
*2	MZ312807	E1-04301146
*3	MZ312745	E1-04301136
	MZ313045	E1-04301133
*4	MZ312808	E1-04301148

#### NOTE

- The above suitability table applies to retention of child restraints using seat belts.
- When MITSUBISHI MOTORS genuine part No. MZ313045 is used on the intermediate outboard seat, it can also be retained by means of ISOFIX child restraint mountings.
- There is no applicable MITSUBISHI MOTORS Genuine Parts to the Mass Group “0- Up to 10 kg (0-9 months)”.

MITSUBISHI MOTORS Europe B.V. reserves the right to changes without any prior announcement.  
For detail information, consult your MITSUBISHI MOTORS Authorized Service Point.



## Installing a child restraint system to the lower anchorage (ISOFIX child restraint mountings)

E00408900042

Your vehicle's second seat is fitted with lower anchorages for attaching a child restraint system with ISOFIX mountings.

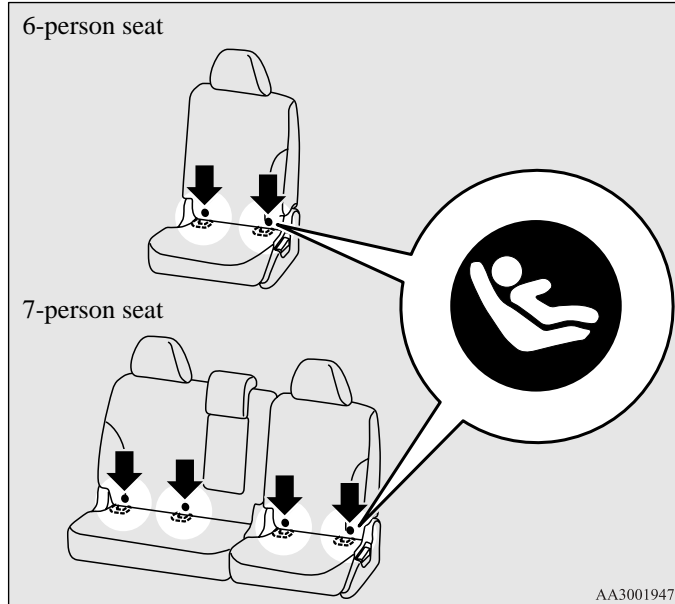

## Child restraint system with ISOFIX mountings

E00409000486

The child restraint system is designed only for seats that incorporate lower anchorages. Retain the child restraint system using the lower anchorages.

It is not necessary to retain the child restraint system using the vehicle's seat belts. Only a MITSUBISHI MOTORS genuine child restraint system can be used.

Genuine parts No.: MZ313045

ECE No.: E1-03301133

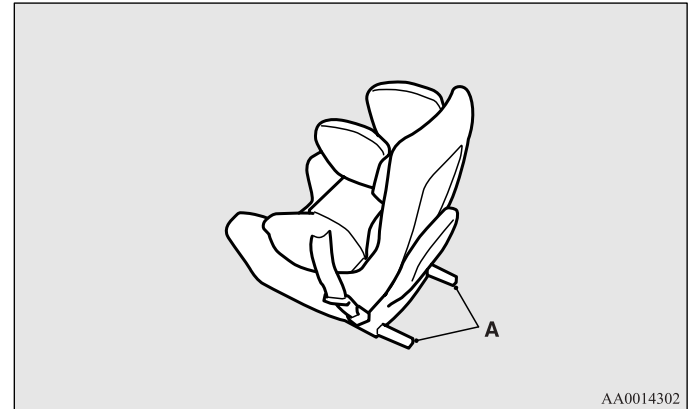

A: Child restraint system connectors

## **⚠ WARNING**

- If a child restraint system other than a MITSUBISHI MOTORS genuine one is used, it may not be properly retained and the child could be seriously injured as a result. Use only a MITSUBISHI MOTORS genuine child restraint system.

### *To install*

## **⚠ WARNING**

- If there is any foreign material in or around the connectors, remove it before installing the child restraint system. Also, make sure the seat belt is away from, not looped through or otherwise interfering with, the child restraint system. If foreign matter is not removed and/or the seat belt interferes with the child restraint system, the child restraint system will not be secured properly and could move forward in the event of sudden braking or a collision, seriously injuring the child and possibly other vehicle occupants.
- Use the top tether strap when fitting a child restraint system with ISOFIX mountings. Otherwise, the child could be seriously injured in the event of hard braking or a collision.
- When the vehicle is moving do not adjust the seat where the child restraint system is installed.

1. Slide the second seats to the fully backward position. (Refer to “To adjust forward or backward” on page 2-9.)
2. Open the gap a little between the seat cushion (A) and the seatback (B) with your hand to locate the lower anchorages (C).

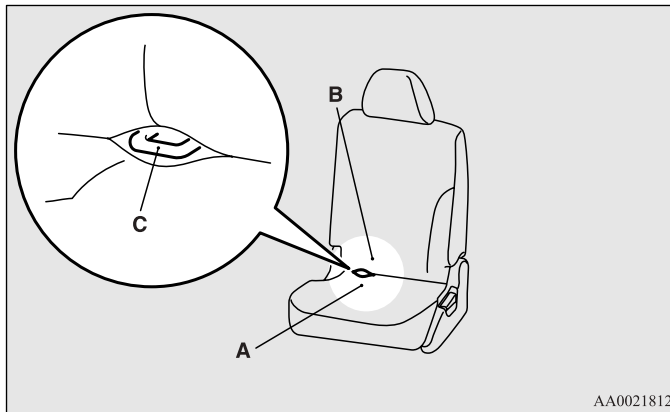

AA0021812

3. Push the child restraint system's connectors into the lower anchorages (C) in accordance with the instructions provided by the child restraint system's manufacturer.
4. Remove the head restraint from the location in which you wish to install a child restraint.

5. Latch the tether strap hook (D) of the child seat to the tether anchor (E) and tighten the top tether strap hook so it is securely fastened.

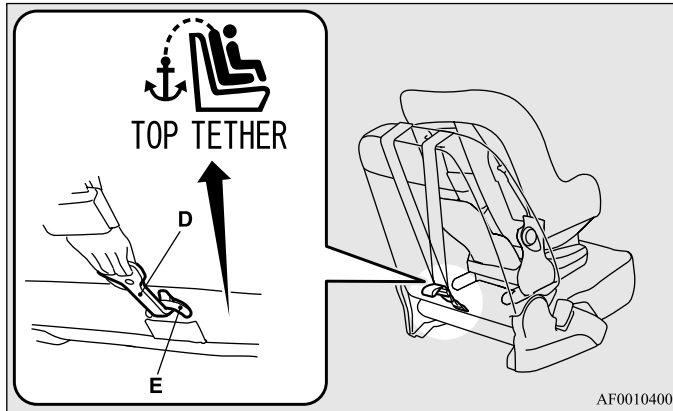

6. Push and pull the child restraint system in all directions to be sure it is firmly secured.

### **To remove**

Remove the child restraint in accordance with the instructions provided by the child restraint system's manufacturer.

## **Installing a child restraint system to a 3-point type seat belt (with emergency locking mechanism)**

E00408700297

For safety, you are advised to install the child restraint system using a 3-point type seat belt with emergency/automatic locking mechanism. If you cannot avoid installing it using another type of seat belt, follow the instructions given below.

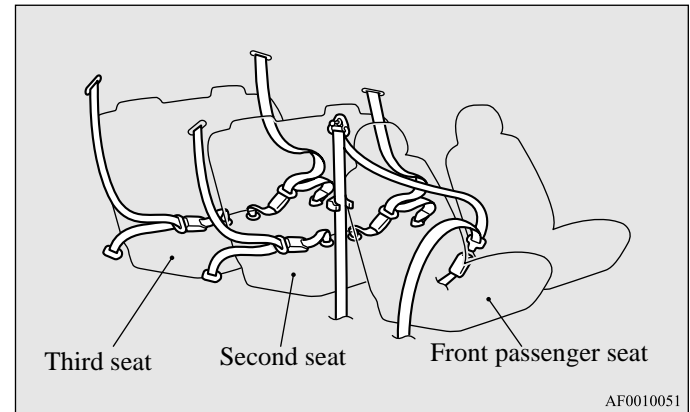

### **Installation:**

1. Fasten the seat belt to secure the child restraint system. Make sure you hear a “click” when you insert the latch plate in the buckle.
2. Remove all slack by using the locking clip.
3. Push and pull the child restraint in all directions to be sure it is secure.

## **⚠ WARNING**

- For some types of child restraint, the locking clip (A) should be used to help avoid personal injury during a collision or sudden manoeuvre. It must be fitted and used in accordance with the child restraint manufacturer's instructions. The locking clip must be removed when the child restraint is removed.

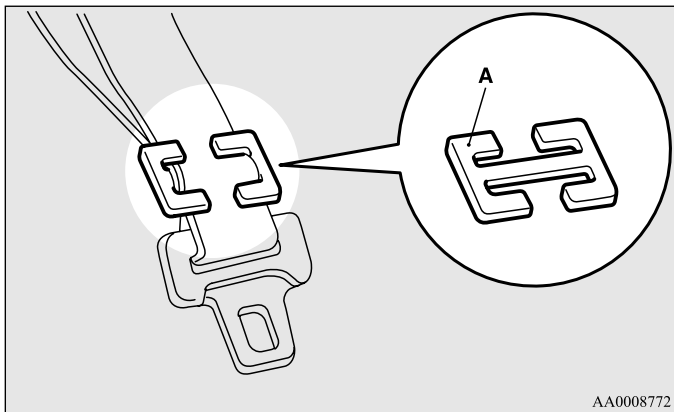

AA0008772

## *Seat belt inspection*

E00406300550

- Check the belts for cuts, worn or frayed webbing and for cracked or deformed metallic parts. Replace the belt assembly if detectable.
- A dirty belt should be cleaned with neutral detergent in warm water. After rinsing in water, let it dry in the shade. Do not attempt to bleach or re-dye the belts because this affects their characteristics.

## **⚠ WARNING**

- We recommend you to have all seat belt assemblies including retractors and attaching hardware inspected after any collision. We recommend that seat belt assemblies in use during a collision be replaced unless the collision was minor and the belts show no damage and continue to operate properly.
- Do not attempt to repair or replace any part of the seat belt assemblies; we recommend you to have this work done by a MITSUBISHI MOTORS Authorized Service Point. Incorrect repair or replacement could reduce the effectiveness of the belts and could result in serious injury in the event of a collision.
- Once the pre-tensioner has activated, it cannot be re-used. It must be replaced together with the retractor.

## ***Supplemental restraint system (SRS) - air bag***

E00407201377

The information written in this supplemental restraint system (SRS) section contains important points concerning the driver, front passenger, side and curtain air bags.

The SRS driver and front passenger air bags are designed to supplement the primary protection of the driver and front passenger side seat belt systems by providing those occupants with protection against head and chest injuries in certain moderate-to-severe frontal collisions.

The SRS driver and front passenger air bags employ a dual stage air bag system. The SRS driver and front passenger air bag is controlled by the impact sensors (at the front of the vehicle and near the center of the vehicle at floor level) and the driver's seat position sensor. The SRS front passenger air bag is controlled by the impact sensors.

The SRS side air bags are designed to supplement the seat belts and provide the driver and front passenger with protection against chest and abdomen injuries in certain moderate-to-severe side impact collisions.

The SRS curtain air bags are designed to supplement the seat belts and provide the driver and passenger with protection against head injuries in certain moderate-to-severe side impact collisions.

The SRS is NOT a substitute for the seat belts; for maximum protection in all types of crashes and accidents, seat belts should ALWAYS be worn by everyone who drives or rides in this vehicle. (With infants and small children in child restraints and older children buckled in the rear seat.)

### **⚠ WARNING**

- **IT IS VERY IMPORTANT TO ALWAYS PROPERLY WEAR YOUR SEAT BELT, EVEN WITH AN AIR BAG:**
  - **Seat belts help keep the driver and passenger properly positioned, which reduces injury risk in all collisions, and reduces the risk of serious or fatal injuries when the air bags inflate.**  
**During sudden braking just before a collision, an unrestrained or improperly restrained driver or passenger can move forward into direct contact with or within close proximity to the air bag which may then deploy during the collision.**  
**The initial stage of air bag inflation is the most forceful which could cause serious or fatal injuries if the occupant contacts it at this stage.**
  - **Seat belts reduce the risk of injury in roll-overs, rear impact collisions, and in lower-speed frontal collisions, because driver's and passenger's air bags are not designed to inflate in those situations.**
  - **Seat belts reduce the risk of being thrown from your vehicle in a collision or roll-over.**

## **⚠ WARNING**

- **IT IS VERY IMPORTANT TO BE PROPERLY SEATED.**

A driver or front passenger too close to the steering wheel or instrument panel during air bag deployment can be killed or seriously injured.

Air bags inflate very fast, and with great force.

If the driver and front passenger are not properly seated and restrained, the air bags may not protect you properly, and could cause serious or fatal injuries when it inflates.

- Before driving, adjust the driver's seat as far back as possible while still maintaining complete control of the vehicle.
- Before driving, adjust the front passenger seat as far back as possible.
- Make sure all vehicle occupants are always properly restrained using the available seat belts.
- With seat belts properly fastened, the driver and passenger should sit well back and upright without leaning against the window or door.

## **⚠ WARNING**

- Do not sit on the edge of the seat, or lean head or chest close to the steering wheel or instrument panel. Do not put feet or legs on or against the instrument panel.
- Place all infants and small children in the rear seat and properly restrained using an appropriate child restraint system. The rear seat is the safest for infants and children.

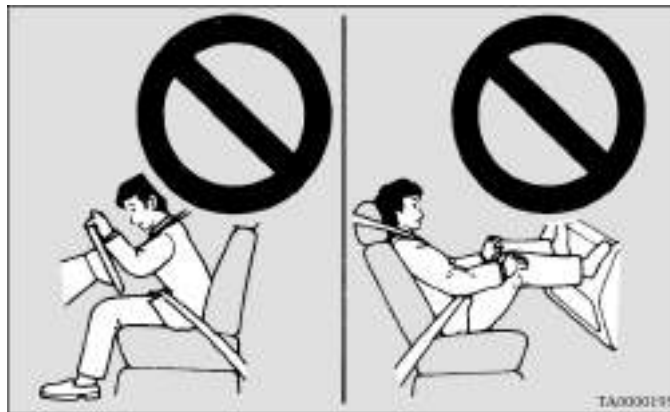

**⚠ WARNING**

- Infants and small children should never be unrestrained, stand up against the instrument panel or held in your arms or on your lap. They could be seriously injured or killed in a collision, including when the air bag inflates. They should be properly seated in the rear seat in an appropriate child restraint system. See the “Child restraint” section in this owner’s manual.

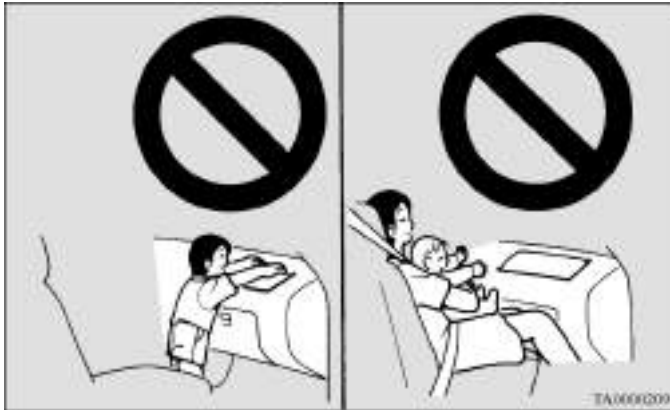
**⚠ WARNING**

- A REARWARD FACING CHILD RESTRAINT must NOT be used in the front passenger seat if the front passenger’s air bag has not been deactivated. The force of an inflating air bag could kill or cause serious injuries to the child. A rearward facing child restraint should be used in the rear seat.



## Seat and seat belts

### NOTE

- If you have a rearward facing child restraint system that cannot be fitted to any seat other than the front passenger seat, be sure to turn OFF the front passenger's air bag ON-OFF switch before using it. (Refer to "To turn an air bag off" on page 2-60.)



### **⚠ WARNING**

- A FORWARD FACING CHILD RESTRAINT should be used in the rear seat whenever possible; if they must be used in the front passenger seat, adjust the seat to the most rearward position. Failure to do so could kill or cause serious injuries to the child.



### **⚠ WARNING**

- Older children should be seated in the rear seat, properly wearing the seat belt, with an appropriate booster seat if needed.



## Caution for installing the child restraint on vehicle with front passenger air bag

The label shown here is attached on vehicles with front passenger air bag.

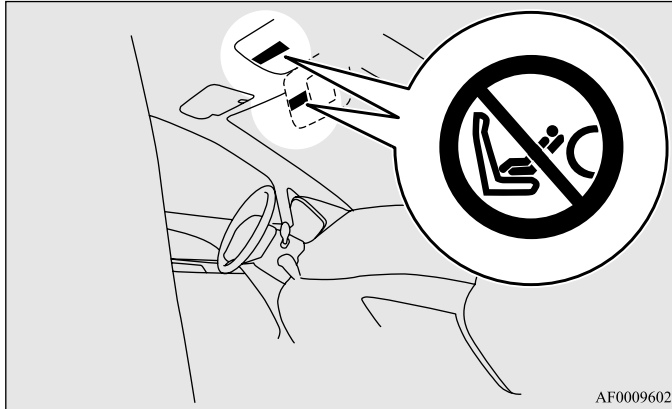

### **⚠ WARNING**

#### ● Extreme Hazard!

**Do not use a rearward facing child restraint on a seat protected by an air bag in front of it!**

## How the supplemental restraint system works

E00407300935

The SRS includes the following components:

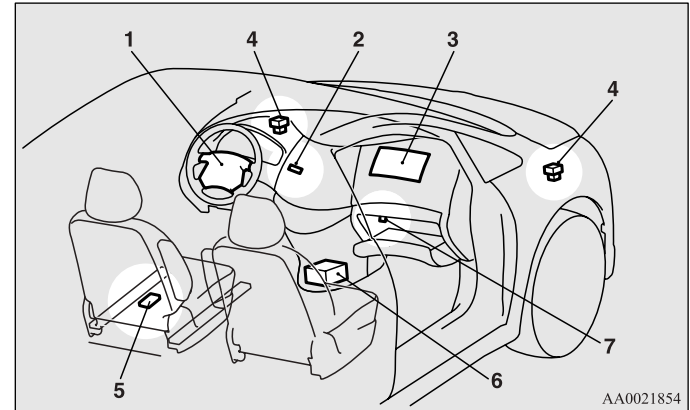

- 1- Air bag module (Driver)
- 2- Front passenger's air bag off indication lamp
- 3- Air bag module (Passenger)
- 4- Front impact sensors
- 5- Driver's seat position sensor
- 6- Air bag control unit
- 7- Front passenger's air bag ON-OFF switch

## Seat and seat belts

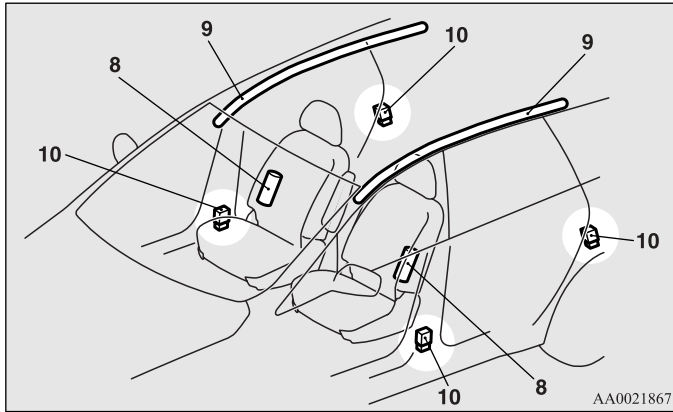

- 8- Side air bag modules
- 9- Curtain air bag modules
- 10- Side impact sensors

The air bags will operate only when the ignition switch is in the "ON" or "START" position.

When the impact sensors detect an impact of sufficient frontal or side force, an automated circuit ignites materials in the inflator to generate gas and inflate the air bags.

The air bags deployment produces a sudden, loud noise, and releases some smoke and powder, but these conditions are not injurious, and do not indicate a fire in the vehicle. People with respiratory problems may feel some temporary irritation from chemicals used to produce the deployment; open the windows after air bag deployment, if safe to do so.

The air bags deflate very rapidly after deployment, so there is little danger of obscured vision.

The time required from the sensors detecting an impact to deflation of the air bags after deployment is shorter than a blink of an eye.

### **CAUTION**

- **Air bags inflate at an extremely rapid speed. In certain situations, contact with inflating air bags can result in abrasions, light cuts, bruises, and the like.**

## Driver's seat position sensor

E00409900052

In order to detect the fore-aft position of the driver's seat, the driver's seat position sensor is attached to the seat rail.

In the event of a problem in the driver's seat position sensor, the SRS warning lamp comes on.

### **⚠ WARNING**

- If the SRS warning lamp comes on, we recommend you to have the vehicle inspected by a MITSUBISHI MOTORS Authorized Service Point as soon as possible.
- Please observe the following instructions to ensure that the driver's seat position sensor can sense the seat position correctly. Otherwise, the dual stage air bags may not operate correctly.
  - Adjust the seat to the correct position, and sit correctly with your back against the seatback. Refer to "Front seat" on page 2-6.
  - Do not have the seatback reclined more than necessary when driving.
  - Do not place metallic objects or luggage under the seat.
- If the vehicle suffers a severe impact, we recommend you to have the sensor inspected by a MITSUBISHI MOTORS Authorized Service Point as soon as possible.

## Front passenger's air bag ON-OFF switch

E00410100126

The front passenger's air bag ON-OFF switch can be used to disable the front passenger's air bag. If you have a rearward facing child restraint system that cannot be fitted to any seat other than the front passenger seat, be sure to turn OFF the front passenger's air bag ON-OFF switch before using it. (Refer to "To turn an air bag off" on page 2-60.)

Front passenger's air bag ON-OFF switch is located in the glove box.

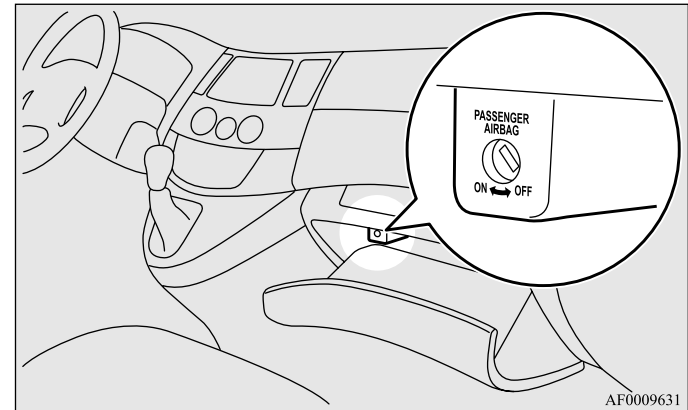

AF0009631

## **⚠ WARNING**

- **To reduce risk of serious or fatal injury:**
  - Always remove the key from the ignition switch before operating an air bag ON-OFF switch. Failure to do so could adversely affect the air bag performance.
  - Wait at least 60 seconds to operate the air bag ON-OFF switch after turning the ignition switch from “ON” position to “LOCK” position. The air bag SRS system is designed to retain enough voltage to deploy the air bag.
  - Always remove the key from an air bag ON-OFF switch after operating that switch. Failure to do so could lead to improper position of the air bag ON-OFF switch.

### *To turn an air bag off*

E00410600118

To turn an air bag off, follow these steps:

1. Insert the key into the key opening of the appropriate air bag ON-OFF switch, and turn that air bag ON-OFF switch to the “OFF” position.
2. Remove the key from the key opening of that air bag ON-OFF switch.
3. Insert the key into the ignition switch, and turn the ignition to “ON” position.

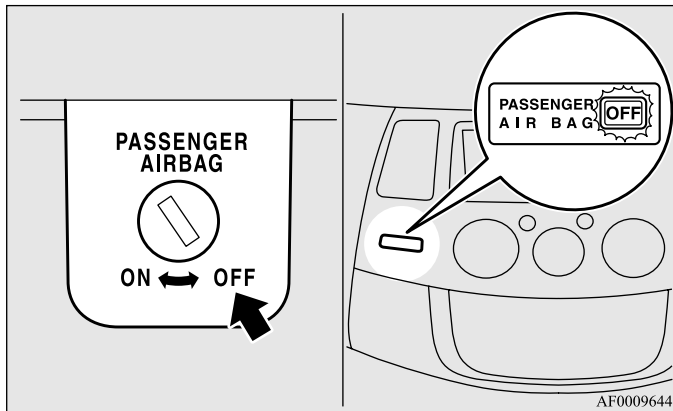

That air bag off indication lamp, with the word “OFF” (depending upon which air bag has been turned off) should illuminate. That will tell you that air bag is OFF, and will NOT deploy. (Refer to “Front passenger’s air bag off indication lamp” on page 2-62.)

That air bag will remain OFF, and will NOT deploy, until it is again turned ON.

## **⚠ WARNING**

- **To reduce risk of serious or fatal injury:**
  - **If the indicator does not come on when the front passenger's air bag ON-OFF switch is turned OFF, do not fit a rearward facing child restraint system to the front passenger seat.**
  - **Do not turn OFF the front passenger's air bag ON-OFF switch except when a rearward facing child restraint system is fitted to the front passenger seat.**

### *To turn an air bag on*

E0041070089

To turn an air bag on, follow these steps:

1. Insert the key into the key opening of the appropriate air bag ON-OFF switch, and turn that air bag ON-OFF switch to "ON" position.
2. Remove the key from the key opening of that air bag ON-OFF switch.
3. Insert the key into the ignition switch, and turn the ignition to "ON" position.

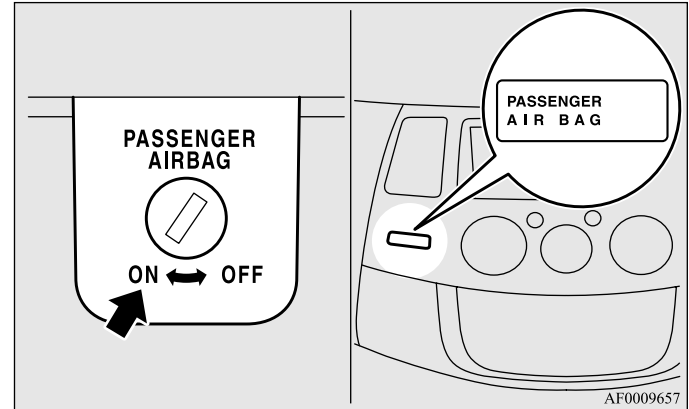

That air bag off indication lamp, with the word "OFF" (depending upon which air bag has been turned back on) should not illuminate.

## Seat and seat belts

That air bag will remain ON, and will be ready to deploy, until it is again turned OFF.

### **⚠ WARNING**

- To reduce risk of serious or fatal injury:
  - Turn ON the front passenger's air bag ON-OFF switch immediately after removing a rearward facing child restraint system from the front passenger seat.
  - If the indicator remains on when the front passenger's air bag ON-OFF switch is turned ON, do not allow anyone to sit on the front passenger seat.

## Front passenger's air bag off indication lamp

E00410200156

The front passenger's air bag off indicator is located in the instrument panel.

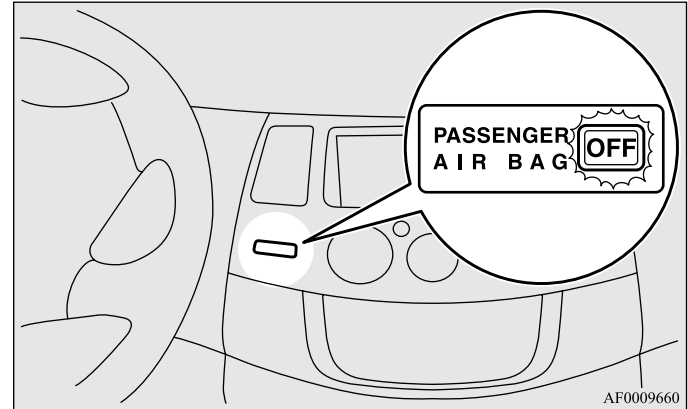

The indicator normally comes on when the ignition switch is turned to the "ON" position, and goes off a few seconds later. When the front passenger's air bag ON-OFF switch is turned OFF, the indicator will stay on to show that the passenger front air bag is not operational.

When the front passenger's air bag ON-OFF switch is turned ON, the indicator goes off to show that the front passenger's air bag is operational.

## **⚠ WARNING**

- **If the indicator behaves in any of the following ways, there may be a fault in the air bag system. We recommend you to have the vehicle inspected by a MITSUBISHI MOTORS Authorized Service Point as soon as possible.**
  - **The indicator does not come on when the front passenger's air bag ON-OFF switch is turned OFF.**
  - **The indicator stays on when the front passenger's air bag ON-OFF switch is turned ON.**
- **Do not fit any accessory that makes the indicator impossible to see, and do not cover the indicator with a sticker. You would not be able to verify the status of the passenger air bag system.**

## Driver's and passenger's front air bag system

E00407400356

The driver's air bag is located under the padded cover in the middle of the steering wheel. The front passenger's air bag is contained in the instrument panel above the glove box.

The driver's air bag inflates at two different rates according to the fore-aft position of the driver's seat and the severity of the impact.

The front passenger's air bag deploys at the same time as the driver's air bag, even if the passenger seat is not occupied, and inflates at two different rates according to the severity of the impact.

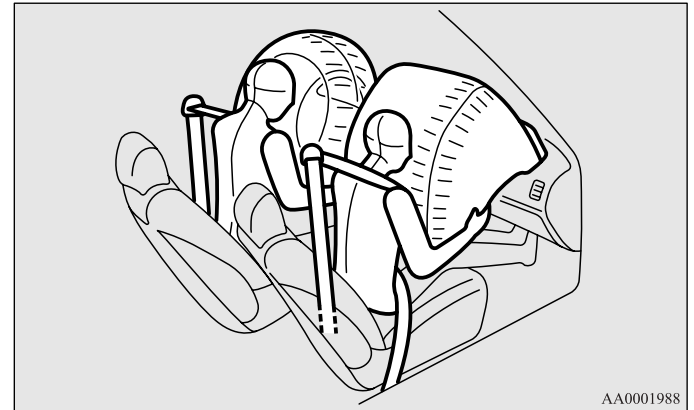

AA0001988

## Deployment of front air bags

E00407501064

*The front air bags ARE DESIGNED TO DEPLOY when...*

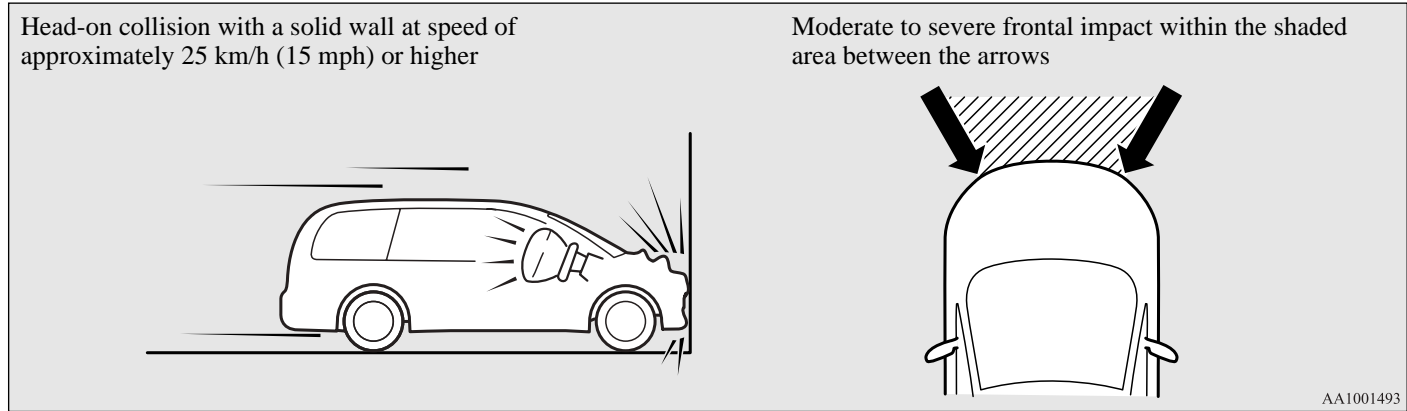

The front air bags are designed to deploy when the vehicle suffers a moderate to severe frontal impact. A typical condition is shown in the illustration.

The front air bags will deploy if the severity of impact is above the designed threshold level, comparable to an approximately 25 km/h (15 mph) collision when impacting straight into a solid wall that does not move or deform. If the severity of the impact is below the above threshold level, the front air bags may not deploy. However, this threshold speed will be considerably higher if the vehicle strikes an object that absorbs the impact by either deforming or moving (for example, another stationary vehicle, pole or a guard rail).

Because frontal collisions can easily move you out of position, it is important to always properly wear your seat belts. Your seat belts will help keep you in a safe distance from the steering wheel and instrument panel during the initial stages of air bag deployment. The initial stage of air bag inflation is the most forceful, and can possibly cause serious or fatal injuries. Moreover, the seat belts in your vehicle are your primary means of protection in a collision. The SRS (Supplemental Restraint System) air bags are designed to provide additional protection. Therefore, for your safety and the safety of all occupants, be sure to always properly wear your seat belts.



***The front air bags MAY NOT DEPLOY when...***

With certain types of frontal collisions, the vehicle's body structure is designed to absorb the shock to help protect the occupants from harm. (The vehicle body's front area may deform significantly as it absorbs the impact.) Under such circumstances, the front air bags may not deploy irrespective of the deformation and damage to the vehicle body.

Examples of some typical conditions are shown in the illustration.

Because the front air bags do not protect the occupant in all types of frontal collisions, be sure to always properly wear your seat belts.

Collision with a utility pole, tree or other narrow objects

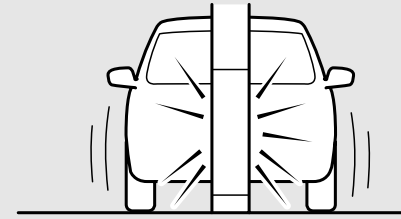

Vehicle slides under the rear body of a truck

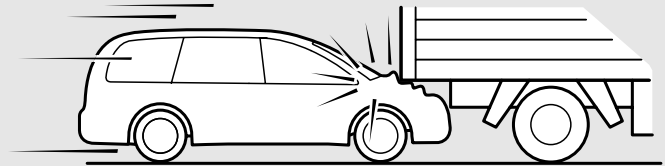

Oblique frontal impacts

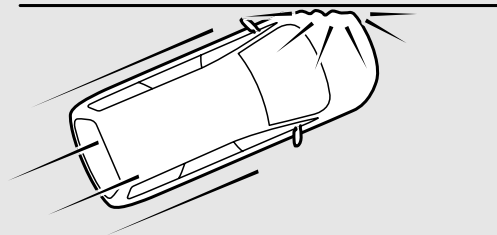

AA2000594

## Seat and seat belts

### ***The front air bags ARE NOT DESIGNED TO DEPLOY when...***

The front air bags are not designed to deploy in conditions where they cannot typically provide protection to the occupant. Such conditions are shown in the illustration.

Because the front air bags do not protect the occupant in all types of collisions, be sure to always properly wear your seat belts.

Rear end collisions

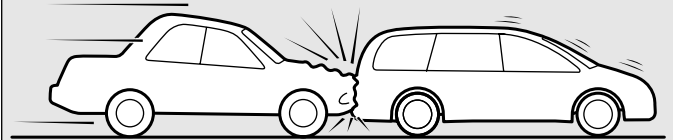

Side collisions

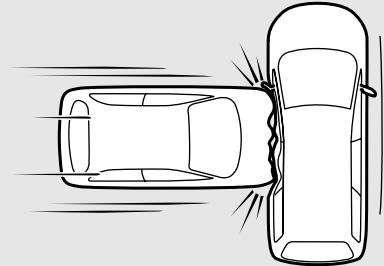

Vehicle rolls onto its side or roof

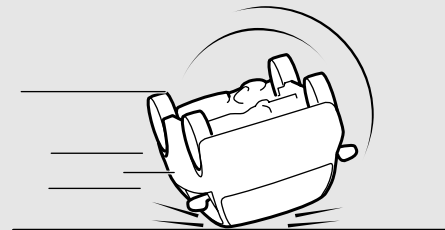

AA2000608

***The front air bags MAY DEPLOY when...***

The front air bags may deploy if the bottom of the vehicle suffers a moderate to severe impact (undercarriage damage). Examples of some typical conditions are shown in the illustration.

Because the front air bags may deploy in certain types of unexpected impacts as shown in the illustration that can easily move you out of position, it is important to always properly wear your seat belts. Your seat belts will help keep you in a safe distance from the steering wheel and instrument panel during the initial stages of air bag deployment. The initial stage of air bag inflation is the most forceful and can possibly cause serious or fatal injuries if you contact it at this stage.

Collision with an elevated median/island or kerb

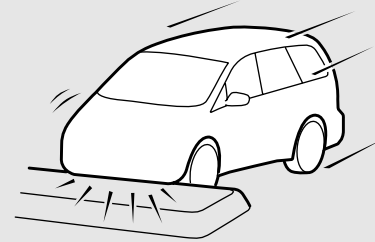

Vehicle travels over a deep hole/pothole

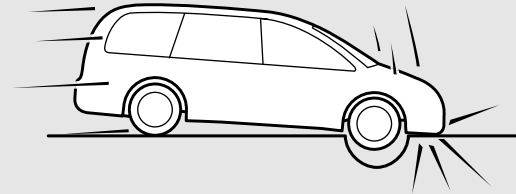

Vehicle drives down a steep slope and hits the ground

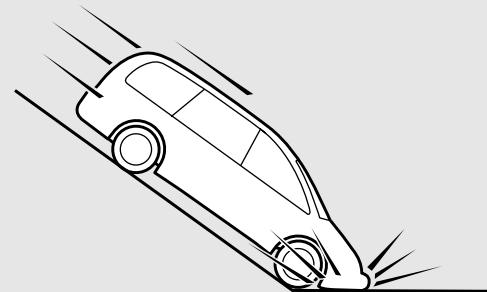

AA2000611

## **⚠ WARNING**

- Do not attach anything to the steering wheel padded cover, such as trim material, badges, etc. It might strike and injure an occupant if the air bag inflates.
- Do not set anything on, or attach anything to, the instrument panel above the glove box. It might strike and injure an occupant if the air bag inflates.

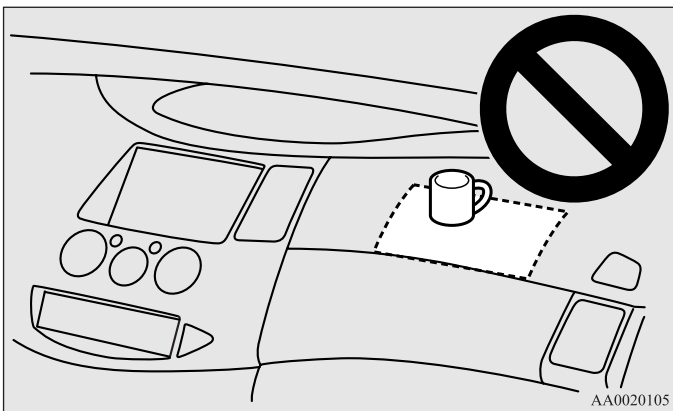

## **⚠ WARNING**

- Do not attach accessories to, or put them in front of, the windscreen. These objects could restrict the air bag inflation, or strike and injure an occupant if the air bags inflate.

## **⚠ WARNING**

- Do not put packages, pets or other objects between the air bags and the driver or front passenger. It could affect air bag performance, or could cause injury when the air bag inflates.
- Right after the air bag inflation, several air bag system components will be hot. Do not touch them; you could be burned.
- The air bag system is designed to work only once. Once the air bags have deployed, they will not work again. They must promptly be replaced, and we recommend you to have the entire air bag system inspected by a MITSUBISHI MOTORS Authorized Service Point.

## Side air bag system

E0040760055

The side air bags (A) are contained in the driver and front passenger seatbacks.

The side air bag is designed to inflate only on the side of the vehicle that is impacted, even with no passenger in the front seat.

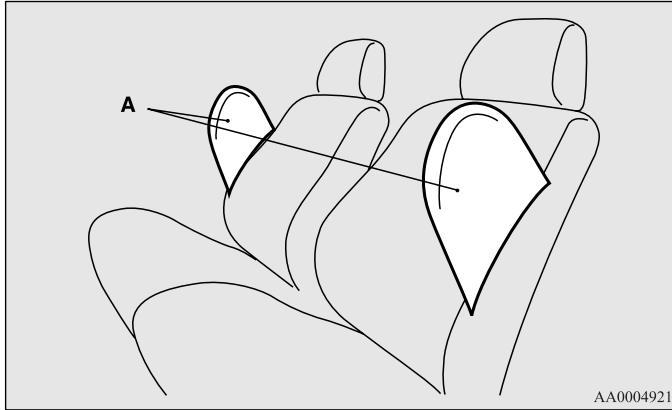

The label shown here is attached to the seatbacks with a side air bag.

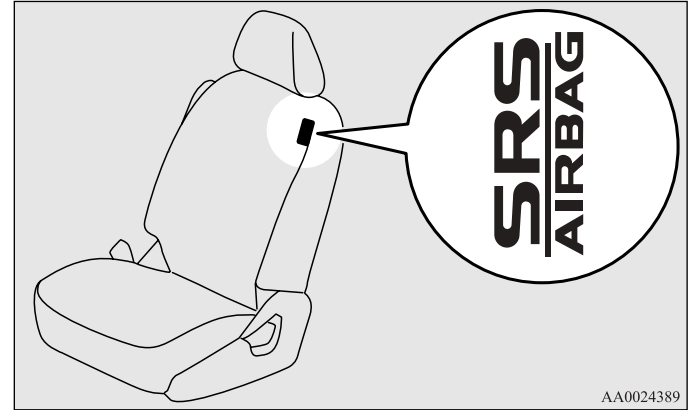

## Curtain air bag system

E0040910038

The curtain air bags are contained in the front pillars and roof side rail. The curtain air bag is designed to inflate only on the side of the vehicle that is impacted, even with no passenger in the front seat or second seat.

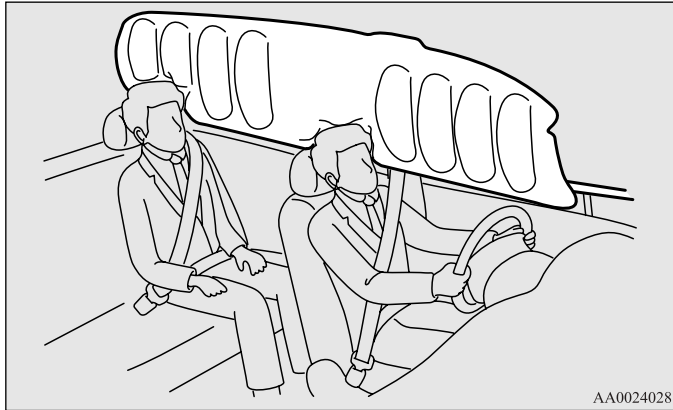

## Deployment of side air bags and curtain air bags

E00407700649

***The side air bags and curtain air bags ARE DESIGNED TO DEPLOY when...***

The side air bags and curtain air bags are designed to deploy when the vehicle suffers a moderate to severe side impact to the middle of the passenger compartment.

The typical condition is shown in the illustration.

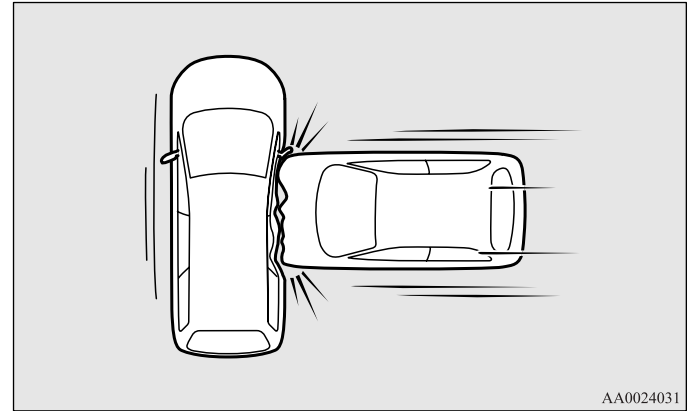

The seat belts in your vehicle are your primary means of protection in a collision. The SRS (Supplemental Restraint System) side air bags and curtain air bags are designed to provide additional protection. Therefore, for your safety and the safety of all occupants, be sure to always properly wear your seat belts.

***The side air bags and curtain air bags MAY NOT DEPLOY when...***

With certain types of side collisions, the vehicle's body structure is designed to absorb the shock to help protect the occupants from harm. (The vehicle body's side area may deform significantly as it absorbs the impact.) Under such circumstances, the side air bags and curtain air bags may not deploy irrespective of the deformation and damage to the vehicle body. Also, depending on the location of the impact, the side air bags and curtain air bags may not deploy simultaneously. Examples of some typical conditions are shown in the illustration.

Because the side air bags and curtain air bags do not protect the occupant in all types of side collisions, be sure to always properly wear your seat belts.

Side impacts in an area away from the passenger compartment

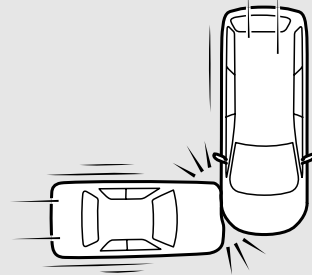

Motorcycle or other similar small vehicle collides with the side of vehicle

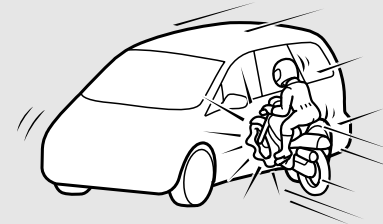

Collision with a utility pole, tree or other narrow object

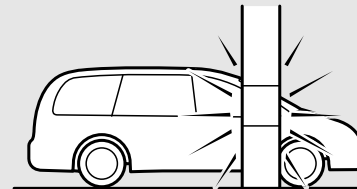

AA2000624

Oblique side impacts

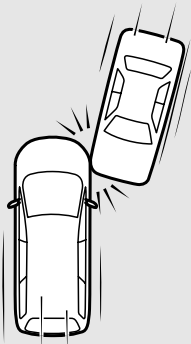

Vehicle rolls onto its side or roof

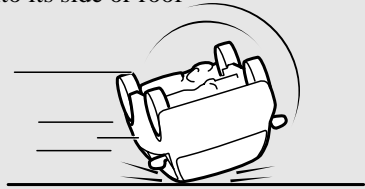

AA3001022

***The side air bags and curtain air bags ARE NOT DESIGNED TO DEPLOY when...***

The side air bags and curtain air bags are not designed to deploy in conditions where they cannot usually provide protection to the occupant. Typical conditions are shown in the illustration.

Head-on collisions

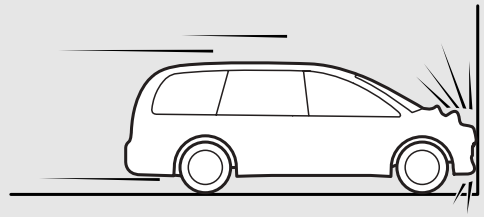

Rear end collisions

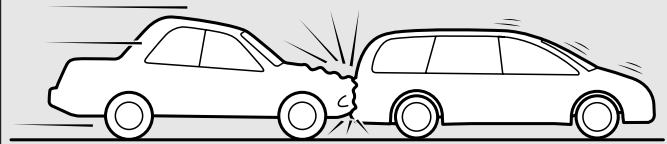

AA3001035



Because the side air bags and curtain air bags do not protect the occupant in all types of collisions, be sure to always properly wear your seat belts.

## **⚠ WARNING**

- The side air bags and curtain air bags are designed to supplement the driver and passenger seat belts in certain side impacts. Seat belts should always be worn properly, and the driver and passenger should sit well back and upright without leaning against the window or door.

## **⚠ WARNING**

- The side air bags and curtain air bags inflate with great force. The driver and passenger should not put their arms out the window, and should not lean against the door, in order to reduce risk of serious or possibly fatal injury from the deploying side air bags and curtain air bags.



**⚠ WARNING**

- Do not allow a child to kneel on the passenger seat facing the passenger's side door, since the side air bags and curtain air bags inflate with great force. Otherwise, the child may be killed or seriously injured.

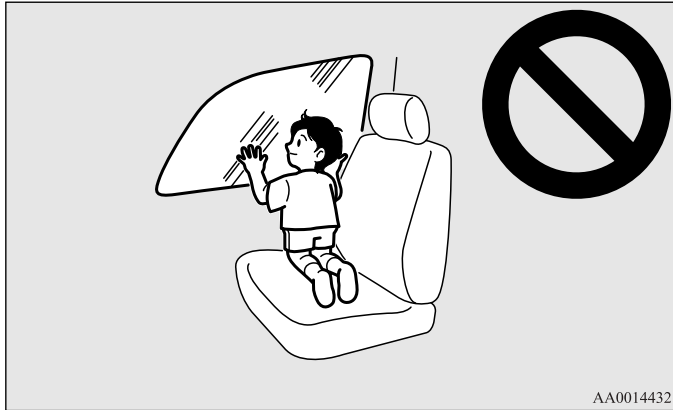

**⚠ WARNING**

- Do not allow any second seat occupant to hold onto the seatback of either front seat, in order to reduce risk of injury from the deploying side air bags. Special care should be taken with children.
- Do not place any objects near or in front of the seatback of either front seat. They could interfere with proper side air bag inflation, and also could cause injury if thrown free by side air bag deployment.
- Do not place stickers, labels or additional trim on the seatback of either front seat. They could interfere with proper side air bag inflation.
- Do not install seat covers on seats with side air bags. Do not re-cover the seats with side air bags. They could interfere with proper side air bag inflation.

**⚠ WARNING**

- Do not attach a microphone (A) or any other device or object around the part where the curtain air bags activate such as on the windscreen, side door glass, front and rear pillars and roof side or assist grips. When the curtain air bags inflate, the microphone or other device or object will be hurled with great force or the curtain air bags may not activate correctly, resulting in death or serious injury.

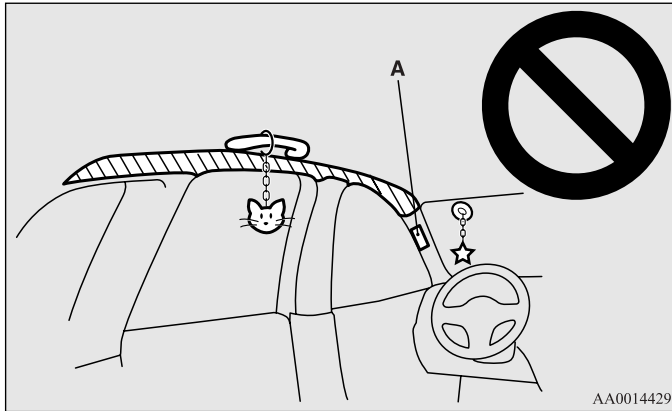
**⚠ WARNING**

- Do not put a hanger or any heavy or pointed object on the coat hook.  
If the curtain air bag was activated, any such item could be propelled away with great force and could prevent the curtain air bag from inflating correctly. Hang clothes directly on the coat hook (without using a hanger).  
Make sure there are no heavy or sharp objects in the pockets of clothes that you hang on the coat hook.
- Do not allow the child to lean against or close to the front door even if the child is seated in a child restraint system.  
The child's head should also not be leaned against or be close to the area where the side air bags and curtain air bags are located. It is dangerous if the side air bags and curtain air bags inflate.  
Failure to follow all of these instructions could lead to serious or fatal injury to the child.
- We recommend work around and on the side air bags and curtain air bags system to be done by a MITSUBISHI MOTORS Authorized Service Point. Improper work could result in inadvertent deployment of side air bags and curtain air bags, or could render side air bags and curtain air bags inoperative; either situation could result in serious injury.

## SRS warning lamp

E00407800653

There is a supplemental restraint system (“SRS”) warning lamp on the instrument panel. The system checks itself and the lamp tells you if there is a problem. When the ignition key is turned to the “ON” or “START” position, the warning lamp should illuminate for several seconds and then should go out. This means the system is ready. If an SRS air bags or pre-tensioner seat belt is not operating properly, the warning lamp comes on and stays on.

The SRS warning lamp is shared by the following:

- Driver’s air bag
- Front passenger’s air bag
- Side air bags
- Curtain air bags
- Seat belt pre-tensioners
- Driver’s seat position sensor
- Front passenger’s air bag ON-OFF switch

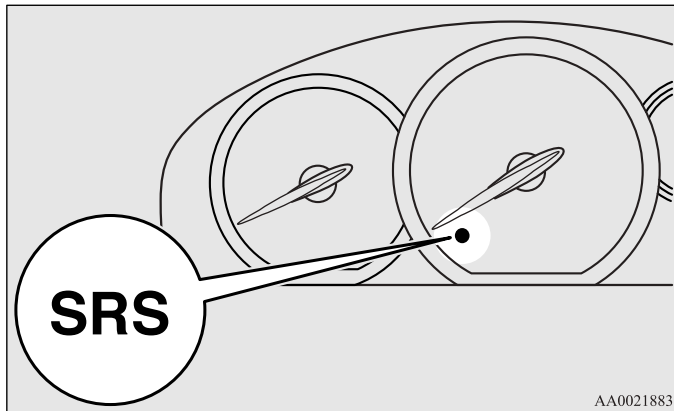

AA0021883

## **WARNING**

- **If any of the following conditions occurs, the SRS and/or seat belt pre-tensioners are not working properly, and we recommend you to have it inspected by a MITSUBISHI MOTORS Authorized Service Point immediately.**
  - **The SRS warning lamp does not illuminate when you start the vehicle.**
  - **The SRS warning lamp does not go out after several seconds.**
  - **The SRS warning lamp illuminates while driving.**

## SRS servicing

E00407900726

**⚠ WARNING**

- We recommend any maintenance performed on or near the components of the SRS to be performed by a MITSUBISHI MOTORS Authorized Service Point.

Improper work on the SRS components or wiring could result in inadvertent deployment of the air bags, or could render the SRS inoperative; either situation could result in serious injury.

- Do not modify your steering wheel, seat belt retractor or any other SRS components. For example, replacement of the steering wheel, or modifications to the front bumper or body structure can adversely affect SRS performance and lead to possible injury.
- If your vehicle has received any damage, we recommend you to have the SRS inspected to ensure it is in proper working order.
- Do not modify your front seats, centre pillar and centre console.

It can adversely affect SRS performance and lead to possible injury.

Also, if you have found any tear or open seam in the seat fabric at the portion near the side air bag, we recommend you to have the seat inspected.

- If you have found any scratch, crack or damage to the portion of the front and rear pillars and roof side rail, you should have the SRS inspected by a MITSUBISHI MOTORS Authorized Service Point.

## NOTE

- When you transfer ownership of the vehicle to some other person, we urge you to alert the new owner that it is equipped with the SRS and refer that owner to the applicable section in this owner's manual.
- If you junk or scrap the vehicle, we urge you to first take the vehicle to a MITSUBISHI MOTORS Authorized Service Point so that the SRS can be rendered safe.



# *Instruments and controls*

Instruments . . . . .	3- 2
Indicator and warning lamps . . . . .	3- 8
Indicator lamps . . . . .	3- 9
Warning lamps . . . . .	3- 10
Multi centre display . . . . .	3- 15
Combination headlamps and dipper switch . . . . .	3- 32
Headlamp levelling . . . . .	3- 35
Turn/Lane-change signals . . . . .	3- 37
Hazard warning flasher switch . . . . .	3- 38
Fog lamp switch . . . . .	3- 39
Wiper and washer switch . . . . .	3- 41
Headlamp washer switch* . . . . .	3- 45
Rear window demister switch . . . . .	3- 45
Horn switch . . . . .	3- 46

## Instruments

E00500100137

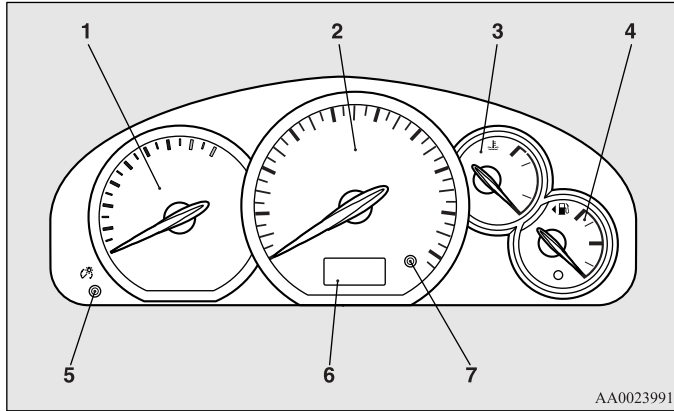

AA0023991

- 1- Tachometer
- 2- Speedometer
- 3- Water temperature gauge
- 4- Fuel gauge
- 5- Daytime dipper button
- 6- Odometer/Tripmeter
- 7- Tripmeter reset button

## Speedometer

E00500200154

### Indication for km/h

The speedometer indicates the vehicle's speed in kilometers per hour (km/h).

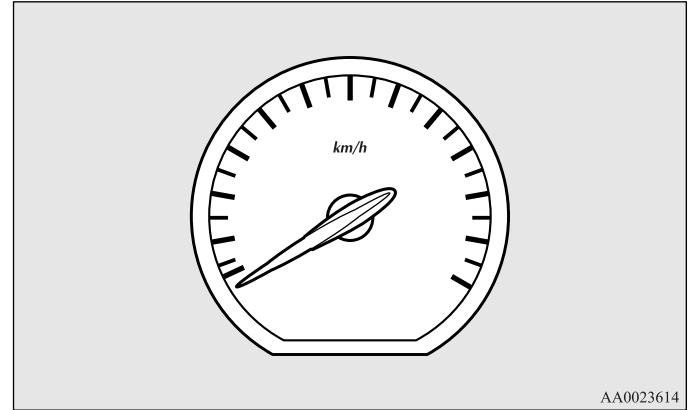

AA0023614



**Indication for km/h and mph**

The speedometer indicates the vehicle's speed in miles per hour (mph) and kilometers per hour (km/h).

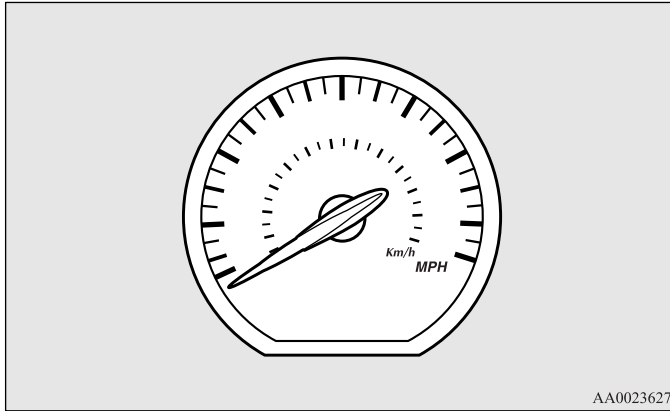
**Tachometer**

E00500300139

The tachometer indicates the engine speed (r/min). The tachometer can help you obtain more economical driving and also warns you of excessive engine speeds.

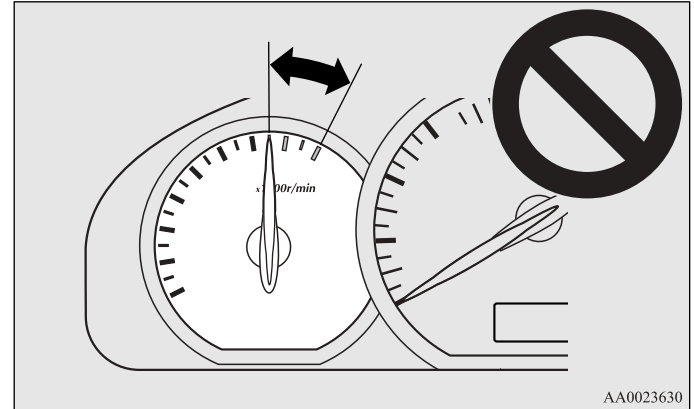
**⚠ CAUTION**

- When driving, watch the tachometer to make sure that the engine speed indication does not rise into the red zone (excessive engine rpm).

## Odometer/Tripmeter

E00500600897

When the ignition key is turned to the “ON” position, odometer and tripmeter indications are given.

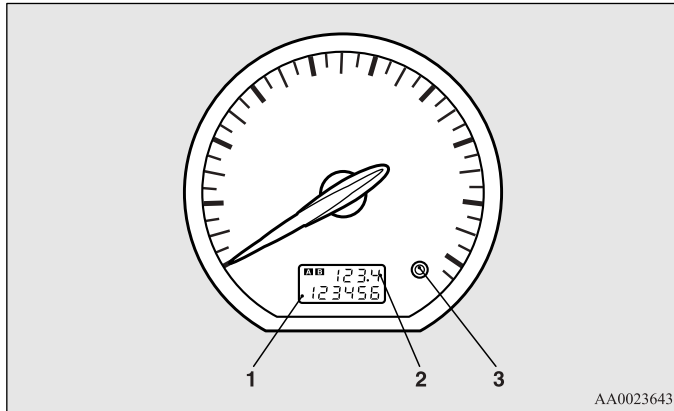

- 1- Odometer
- 2- Tripmeter
- 3- Reset button

### *Odometer*

The odometer indicates the total distance the vehicle has travelled.

### *Tripmeter*

The tripmeter indicates the distance travelled during a particular trip or period.

There are two tripmeter displays: TRIP **A** and **B**.

TRIP **A** can be used to measure the distance travelled since the current trip began. At the same time, TRIP **B** can be used to measure the distance from an intermediate location.

Every time the reset button (3) is pressed lightly (less than 1 second), tripmeter indications (TRIP **A** and **B**) are changed.

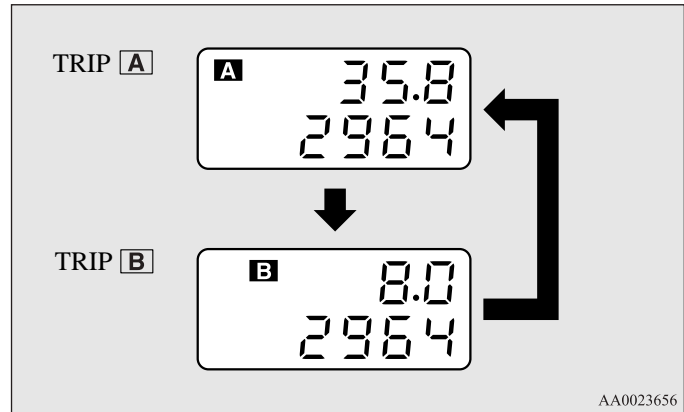

### **To reset the tripmeter**

To return the display to “0”, press the reset button for more than 1 second. Only the currently displayed value will be reset. If TRIP **A** is displayed, for example, only TRIP **A** will be reset.

## NOTE

- Display TRIP **A** and **B** each have a maximum distance of 999.9 km (999.9 miles).
- Even when the ignition switch has been turned to the “LOCK” position, pressing the tripmeter reset button causes the odometer/tripmeter indication to appear for approximately 30 seconds.
- When disconnecting the battery terminal for a long time, the memory of tripmeter display TRIP **A** and **B** are cleared, and the display returns to “0”.

## Fuel gauge

E00500700481

The fuel gauge indicates the fuel level in the fuel tank when the ignition switch is “ON”.

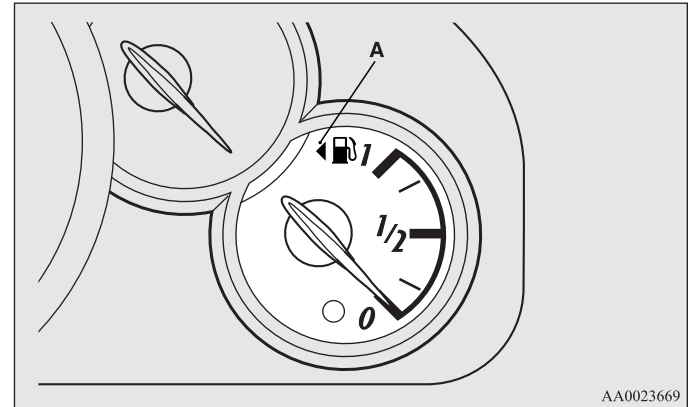

- 1- Full
- 0- Empty

**⚠ CAUTION**

- For petrol-powered vehicles, do not drive with an extremely low fuel level; running out of fuel could cause damage to the catalytic converter.

**Fuel lid mark**

The fuel lid mark (A) indicates that the fuel tank filler door is located on the left side of the vehicle (Refer to “Filling the fuel tank” on page 3).

## Instruments and controls

### Low fuel warning lamp

E00508100638

The warning lamp (A) comes on when the fuel level is getting low (approx. 10 liters) with the ignition switch in the “ON” position. Refuel as soon as possible.

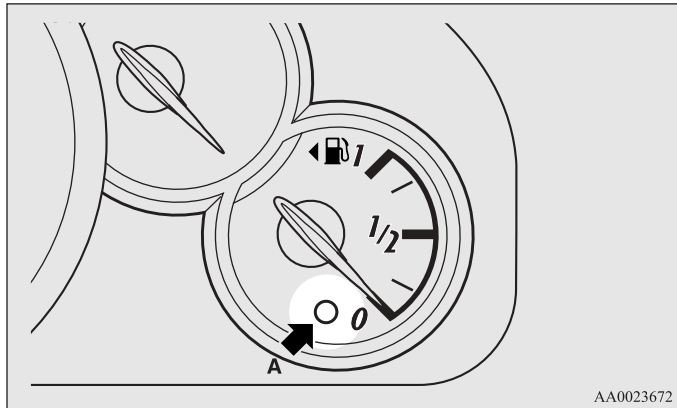

#### NOTE

- On inclines or curves, due to the movement of fuel in the tank, the low fuel warning lamp may indicate incorrectly.

### Water temperature gauge

E00500800118

The water temperature gauge indicates the engine coolant temperature when the ignition switch is “ON”.

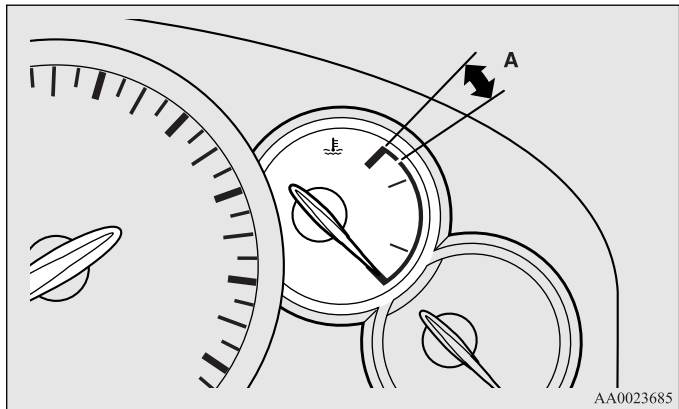

#### **⚠ CAUTION**

- If the indication needle enters the zone (A) while the engine is running, it indicates that the engine is possibly overheating. Immediately park your vehicle in a safe place and make the necessary corrections. (Refer to “Engine overheating” on page 6-7.) While driving, care should always be taken to maintain the normal operating temperature.

## Daytime dipper button

E0050880026

By pressing the daytime dipper button, you can change the brightness of the backlighting in meters and instrument panel.

### NOTE

- The brightness can be adjusted among 4 levels in accordance with the on/off condition of the tail lamps.

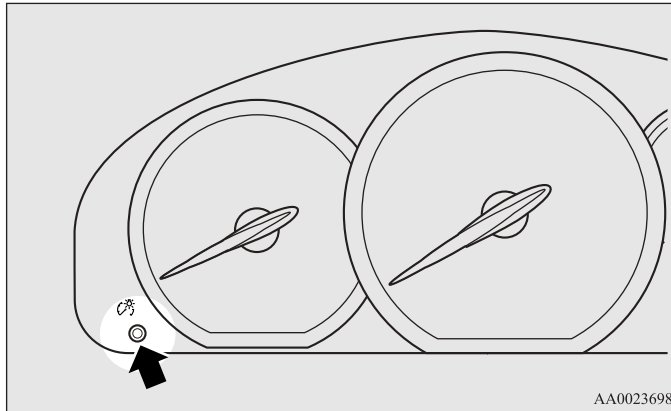

### NOTE

- The meter brightness is memorized and maintained even if the ignition switch is turned to the “LOCK” position.

## Indicator and warning lamps

E00501501337

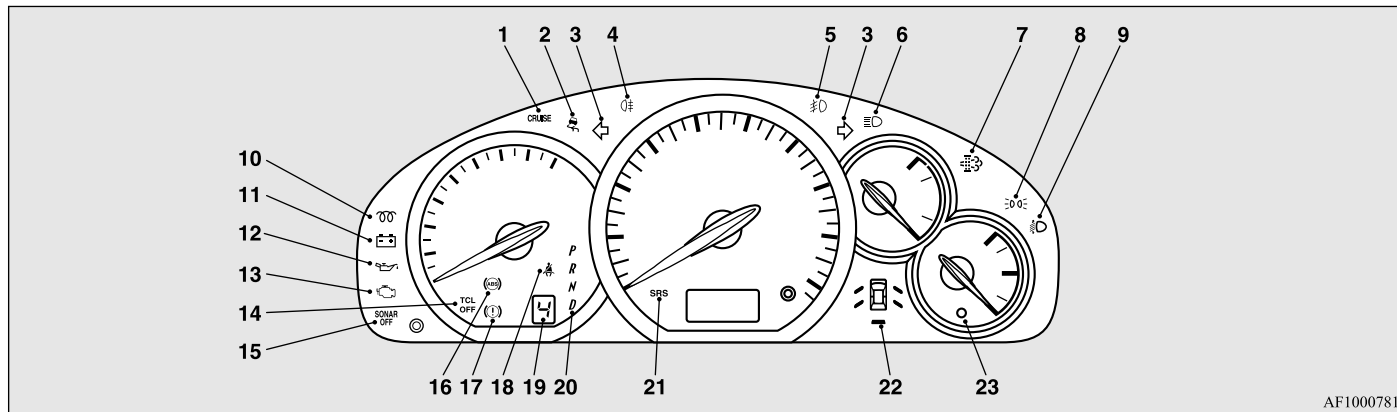

AF1000781

- 1- CRUISE indication lamp\* → p. 4-46
- 2- ASC indication lamp\* → p. 4-43
- 3- Turn-signal indication lamps/Hazard warning indication lamps → p. 3-9
- 4- Rear fog lamp indication lamp → p. 3-9
- 5- Front fog lamp indication lamp → p. 3-9
- 6- High-beam indication lamp → p. 3-9
- 7- Diesel particulate filter (DPF) warning lamp (diesel-powered vehicles)\* → p. 4-21
- 8- Position lamp indication lamp → p. 3-9
- 9- Automatic headlamp levelling warning lamp\* → p. 3-35
- 10- Diesel preheat indication lamp (diesel-powered vehicles) → p. 3-9
- 11- Charge warning lamp → p. 3-13
- 12- Oil pressure warning lamp → p. 3-14
- 13- Check engine warning lamp → p. 3-11
- 14- TCL OFF indication lamp\* → p. 4-43
- 15- SONAR OFF indication lamp\* → p. 4-57
- 16- Anti-lock brake system (ABS) warning lamp → p. 4-38
- 17- Brake warning lamp → p. 3-10
- 18- Seat belt reminder/warning lamp → p. 2-35
- 19- Sports mode indication lamp (vehicles with A/T) → p. 4-32
- 20- Selector lever position indication lamps (vehicles with A/T, "N" indication lamp is used also as A/T warning lamp) → p. 4-28
- 21- Supplemental restraint system (SRS) warning lamp → p. 2-76
- 22- Door-ajar warning lamp → p. 3-14
- 23- Low fuel warning lamp → p. 3-6

## Indicator lamps

E00501600012

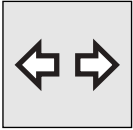

### Turn-signal indication lamps/Hazard warning indication lamps

E00501700169

These indication lamps blink on and off when a turn-signal lamp is operating.

#### NOTE

- If the blinking is too fast, the cause may be a faulty turn-signal connection or a blown lamp bulb.

When the hazard warning lamp switch is pressed, all turn-signal lamps will flash on and off continuously.

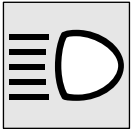

### High-beam indication lamp

E00501800160

This indication lamp illuminates when the high beam is used.

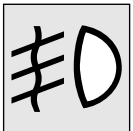

### Front fog lamp indication lamp

E00501900321

This lamp illuminates while the front fog lamps are on.

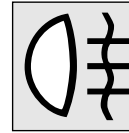

### Rear fog lamp indication lamp

E00502000101

This lamp illuminates while the rear fog lamp is on.

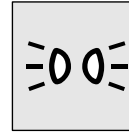

### Position lamp indication lamp

E00508900102

This lamp illuminates with the lamp switch at “ $\equiv$ ” or “ $\equiv$ ” position

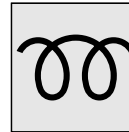

### Diesel preheat indication lamp (diesel-powered vehicles)

E00502300061

This indication lamp illuminates when the ignition switch is placed in the “ON” position. As the glow plug becomes hot, the lamp goes out and the engine can be started. If it does not go off after a few seconds, we recommend you to have the vehicle checked.

#### NOTE

- If the engine is cold, the diesel preheat indication lamp is on for a longer time.
- When the engine has not been started within about 5 seconds after the diesel preheat indication lamp went out, return the ignition switch to the “LOCK” position. Then, turn the switch to the “ON” position to preheat the engine again.

- When the engine is warm, the diesel preheat indication lamp does not come on even if the ignition switch is placed in the “ON” position.



## Warning lamps

E00502400017

### Brake warning lamp

E00502501015

This lamp illuminates when the ignition switch is turned “ON”, and the lamp goes off after a few seconds.

Always make sure that the lamp goes out before beginning to drive.

With the ignition switch “ON”, the brake warning lamp illuminates under the following conditions:

- When the parking brake lever has been engaged.
- When the brake fluid level in the reservoir falls to a low level.

### **⚠ CAUTION**

- **If either of the situations described below occurs, there is a risk of reduced brake effectiveness. Stop the vehicle in a safe place to have it checked.**
  - **The brake warning lamp does not illuminate when the parking brake is applied or does not turn off when the parking brake is released.**
  - **The brake warning lamp remains illuminated during driving.**



**⚠ CAUTION**

- If the brake warning lamp comes on at the same time as the ABS warning lamp, the brake force distribution function may not be working, so hard braking could make the vehicle unstable. Avoid hard braking and high-speed driving. Stop the vehicle in a safe place and we recommend you to consult a **MITSUBISHI MOTORS** Authorized Service Point.
- The vehicle should be brought to a halt in the following manner when brake performance has deteriorated.
  - Depress the brake pedal harder than usual.  
Even if the brake pedal moves down to the very end of its possible stroke, keep it pressed down hard.
  - Should the brakes fail, use engine braking to reduce your speed and slowly pull the parking brake lever to park your vehicle.  
Depress the brake pedal to operate the stop lamp (brake lamp) to alert the vehicles behind you.

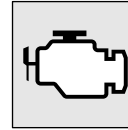
**Check engine warning lamp (petrol-powered vehicles)**

E00502600501

This lamp is a part of an onboard diagnostic system which monitors the emissions, engine and automatic transmission control systems.

If a problem is detected in one of these systems, this lamp illuminates or flashes.

Although your vehicle will usually be drivable and not need towing, we recommend you to have the system checked as soon as possible.

This lamp will also illuminate for a few seconds when the ignition key is turned to the “ON” position. If it does not go off after a few seconds, we recommend you to have the vehicle checked.

**⚠ CAUTION**

- Prolonged driving with this lamp on may cause further damage to the emission control system. It could also affect fuel economy and drivability.
- If the lamp does not illuminate when the ignition key is turned to the “ON” position, we recommend you to have the system checked.

**⚠ CAUTION**

- If the lamp illuminates or flashes while the engine is running, avoid driving at high speeds and we recommend you to have the system checked.  
During vehicle operation with the lamp illuminated or flashing, the vehicle may not accelerate when you depress the accelerator pedal.  
When the vehicle is stationary with the lamp illuminated or flashing, you must depress the brake pedal more firmly than usual since the engine idling speed is higher than usual and the vehicle with an A/T has a stronger tendency to creep forward.

NOTE

- The engine electronic control module accommodating the onboard diagnostic system has various fault data (especially about the exhaust emission) stored.  
This data will be erased if a battery cable is disconnected which will make a rapid diagnosis difficult. Do not disconnect a battery cable when the check engine warning lamp is ON.

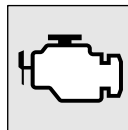

**Check engine warning lamp (diesel-powered vehicles)**

E00502600628

This lamp is a part of an onboard diagnostic system which monitors the emissions control systems.

If a problem is detected in one of these systems, this lamp illuminates.

Although your vehicle will usually be drivable and not need towing, we recommend you to have the system checked as soon as possible.

This lamp will also illuminate for a few seconds when the ignition key is turned to the “ON” position. If it does not go off after a few seconds, we recommend you to have the vehicle checked.

**⚠ CAUTION**

- Prolonged driving with this lamp on may cause further damage to the emission control system. It could also affect fuel economy and drivability.
- If the lamp does not illuminate when the ignition key is turned to the “ON” position, we recommend you to have the system checked.

**⚠ CAUTION**

- If the lamp illuminates while the engine is running, avoid driving at high speeds and we recommend you to have the system checked.  
During vehicle operation with the lamp illuminated, the vehicle may not accelerate when you depress the accelerator pedal.  
When the vehicle is stationary with the lamp illuminated, you must depress the brake pedal more firmly than usual since the engine idling speed is higher than usual.

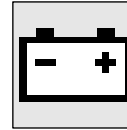
**Charge warning lamp**

E00502700300

This lamp illuminates when the ignition key is turned “ON”, and the lamp goes off after the engine has started.

**⚠ CAUTION**

- If it illuminates while the engine is running, there is a problem in the charging system. In this case, immediately park your vehicle in a safe place and we recommend you to have it checked.

**NOTE**

- The engine electronic control module accommodating the onboard diagnostic system has various fault data (especially about the exhaust emission) stored.  
This data will be erased if a battery cable is disconnected which will make a rapid diagnosis difficult. Do not disconnect a battery cable when the check engine warning lamp is ON.



## Oil pressure warning lamp

E00502800330

This lamp illuminates when the ignition key is turned “ON”, and the lamp goes off after the engine has started. If it illuminates while the engine is running, the oil pressure is too low.

If the warning lamp illuminates while the engine is running, turn the engine off and have it inspected.

### **⚠ CAUTION**

- If this lamp illuminates when the engine oil level is not low, have it inspected.
- This warning lamp does not indicate the amount of oil in the crankcase. This must be determined by checking the oil level on the dipstick, while the engine is switched off.
- If you continue driving with low engine oil level or with this warning lamp illuminated, engine seizure may occur.

#### NOTE

- The oil pressure warning lamp should not be treated as an indication of the engine’s oil level. The oil level must be checked using the dipstick.



## Door-ajar warning lamp

E00503300417

This lamp illuminates when a door or tailgate is either open or incompletely closed.

If the vehicle speed reaches approximately 8 km/h (5 mph) with a door or the tailgate open or incompletely closed, the warning lamp flashes 8 times and a buzzer simultaneously sounds 8 times as a warning.

### **⚠ CAUTION**

- Before moving your vehicle, check that the warning lamp is OFF.

#### NOTE

- On vehicles with keyless entry system, the lamp remains illuminated for a certain period and then goes out automatically to prevent complete discharge of the battery. Refer to “Lamps (room lamps, etc.) auto-cutout function” on page 5-63.
- It is possible to change the buzzer setting for either of the following types of operation. For further information, we recommend you to consult a MITSUBISHI MOTORS Authorized Service Point.
  - No buzzer operation (buzzer disabled)
  - Continuous buzzer operation

## *Multi centre display*

E00503600120

### **WARNING**

- When operating the system for a prolonged period, make sure the vehicle is parked in a well ventilated area to avoid the accumulation of toxic fumes inside and outside of the passenger compartment.

### **CAUTION**

- The driver should not operate the display while the vehicle is in motion.
- When operating the system, stop the vehicle in a safe area.

When the ignition switch is in the “ACC” position, the digital clock is displayed in the multi centre display. When the ignition switch is in the “ON” position, the momentary fuel consumption and outside temperature are displayed besides the digital clock.

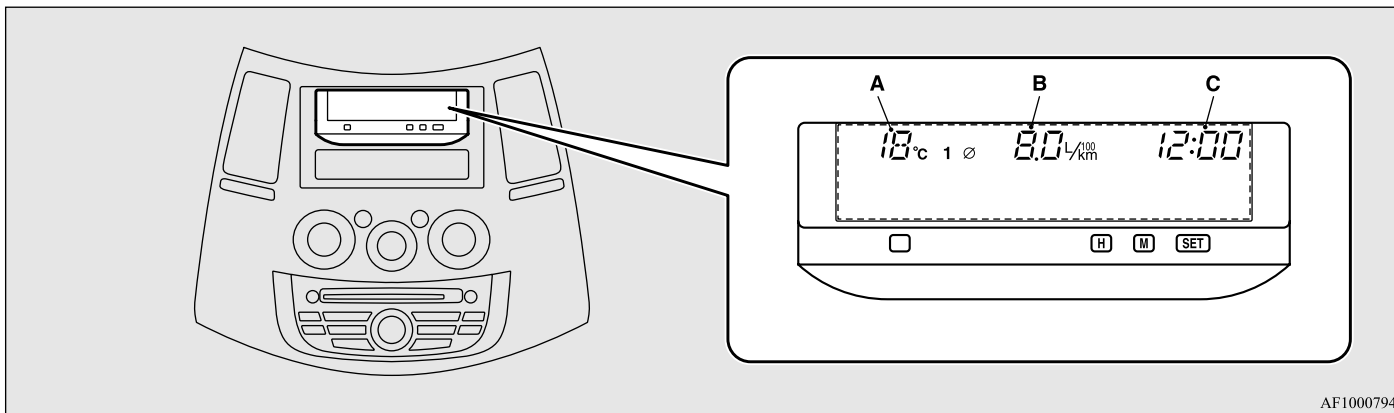

AF1000794

- A- Outside temperature → p. 3-20
- B- Driving information → p. 3-21
- C- Digital clock → p. 3-17

#### NOTE

- The display unit (ex. km or mile) and brightness can be changed as desired. (Refer to “Display brightness adjustment” on page 3-27 and “Display unit selection” on page 3-29.) When the system cannot provide a definite value for momentary fuel consumption/average fuel consumption/driving range/average speed, it is displayed as “---”.
- The figure of the display varies according to the conditions under which a vehicle is travelling (road conditions, the manner in which the vehicle is being driven, etc.).

Observe display for reference because the figure of the display may differ from the actual figure.

## Digital clock

E00503700118

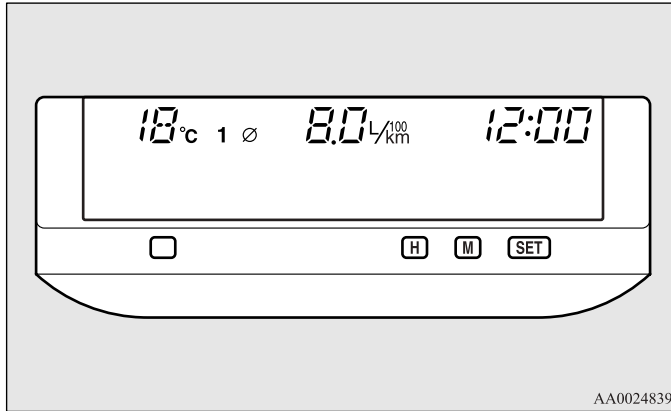

AA0024839

Following modes are available for digital clock adjustment:

- For vehicles with MITSUBISHI MOTORS genuine audio automatic mode and manual mode
- Except for vehicles with MITSUBISHI MOTORS genuine audio manual mode only

Select the automatic mode or the manual mode by performing the following operations:

1. Enter the function setup mode by pushing the “MENU” button.

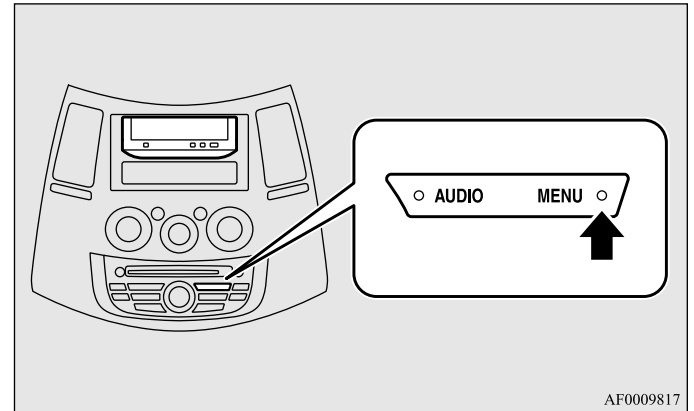

AF0009817

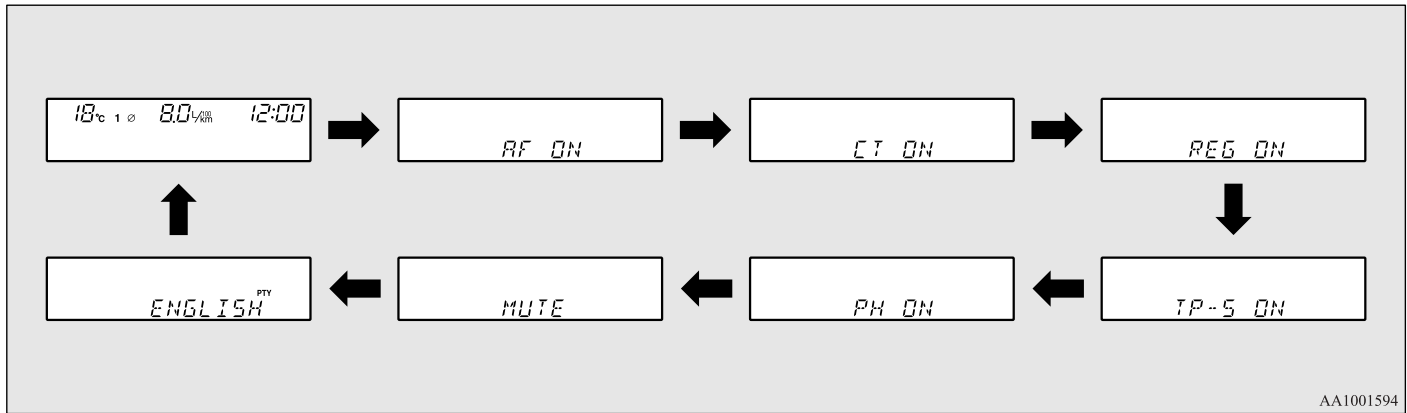

AA1001594

- 3
- Press the “MENU” button repeatedly to select the CT (Clock Time) mode.  
The order is: AF → CT → REG → TP-S → PH → MUTE (with PH OFF, this mode is not displayed) → Language of PTY display → Function setup mode OFF (Refer to “Function setup mode” on page 5-35.)

NOTE

- Although “PH” and “MUTE” appear on the display, the PH and MUTE functions are inoperative.



3. Make your selection by pressing the “▶▶” button or the “◀◀” button.

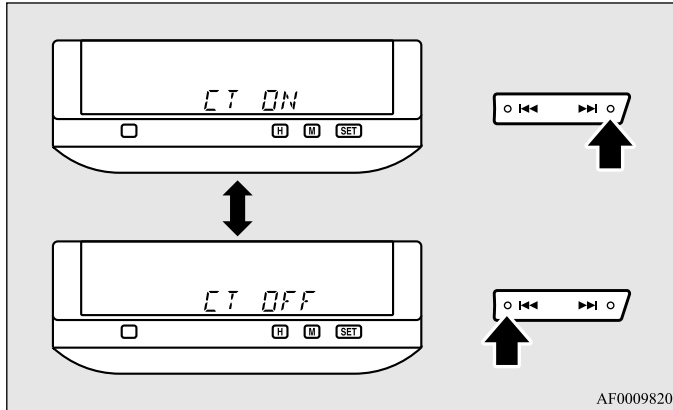

▶▶ - CT ON (Automatic mode)

◀◀ - CT OFF (Manual mode)

#### NOTE

- After selecting a mode, you can leave the function setup mode by taking either of the following steps:
  - Press the “MENU” button for at least 2 seconds.
  - Make no entry for 7 seconds.

#### Automatic mode (For vehicles with MITSUBISHI MOTORS genuine audio)

The automatic mode can set the local time automatically by using the signal from the local RDS stations. In this mode, CT (A) is shown in the display. Refer to “Radio data system (RDS)” on page 5-29.

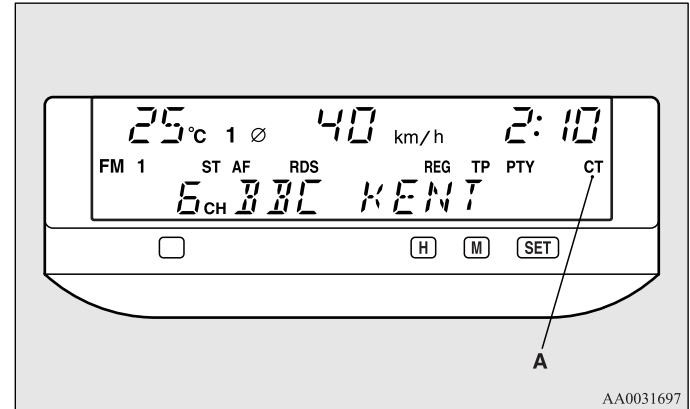

### Manual mode

The manual mode is also available in case the “Automatic mode” shows the incorrect time when the adjacent local RDS stations are located in a different time zone. Refer to “Radio data system (RDS)” on page 5-29.

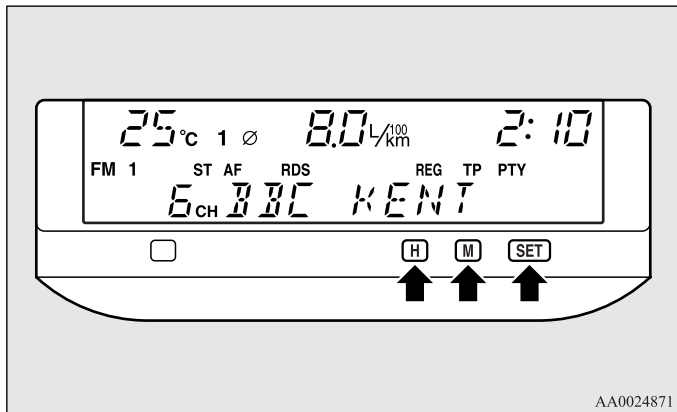

Set the time by pressing the various buttons as described below.

- H- To adjust the hour
- M- To adjust the minutes
- SET- To reset the minutes to zero
- 10:30-11:29...Changes to 11:00
- 11:30-12:29...Changes to 12:00

### Outside temperature

E0050390019

This value shows the outside temperature of the vehicle. If the outside air temperature drops below approx. 3 °C, the alarm sounds and the outside air temperature figure flashes for about 10 seconds.

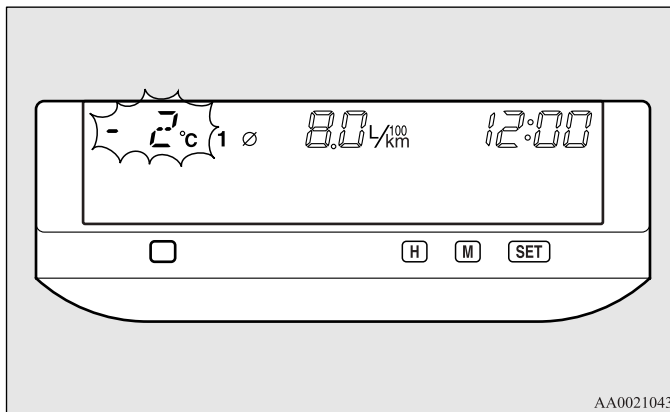

### **CAUTION**

- There is a danger the road might be icy, even when the outside air temperature figure is not flashed, so please take care when driving.

## NOTE

- The outside temperature can be displayed from -40 °C to 50 °C.
- The outside temperature displayed may differ from the actual temperature on account of surrounding conditions, driving conditions, etc.
- When the outside temperature is below -40 °C or over 50 °C, the display will remain -40 °C or 50 °C.

**Driving information**

E00509000041

***For vehicles with MITSUBISHI MOTORS genuine audio***

The momentary fuel consumption, average fuel consumption, driving range and average speed can be displayed. When the ignition switch is turned “ON”, the display shows the 4 items sequentially and returns to the original display that is shown before the ignition switch was last turned “OFF”.

## NOTE

- If the “DISP” button is pressed while the display is scrolling through the sequence mentioned above, the display stops scrolling and shows the item that was shown before the ignition switch was last turned to the “OFF” position.

***Except for vehicles with MITSUBISHI MOTORS genuine audio***

Only the momentary fuel consumption can be displayed. Refer to “Momentary fuel consumption” on page 3-22.

## Instruments and controls

### Change of driving information (For vehicles with MIT-SUBISHI MOTORS genuine audio)

E0050910068

Every time the “DISP” button is pressed lightly (less than 5 seconds), the display can be changed.

Momentary fuel consumption → Average fuel consumption →  
Driving range → Average speed

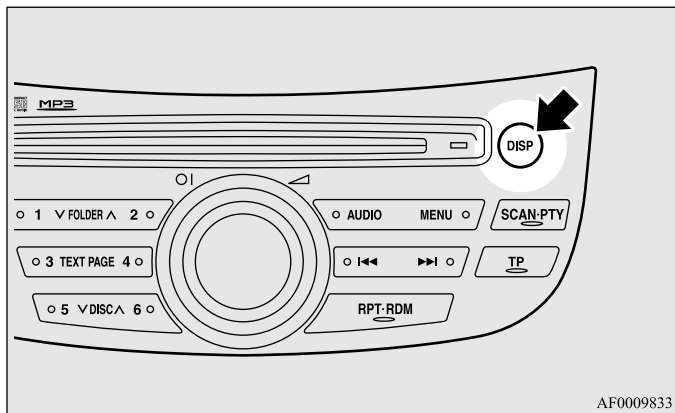

### Momentary fuel consumption

E00509200014

This value shows the momentary fuel consumption (in L/100km, km/L or mpg). Calculation and indication of the value begin when the vehicle speed rises above 6 km/h (4 mph).

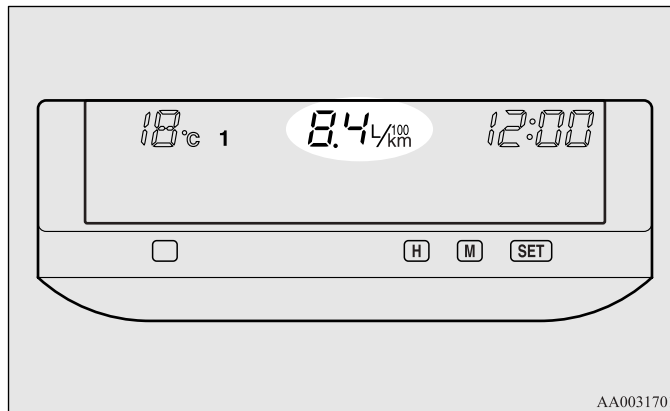

### Average fuel consumption

E00509300060

This value shows the average fuel consumption (in L/100 km, km/L or mpg).

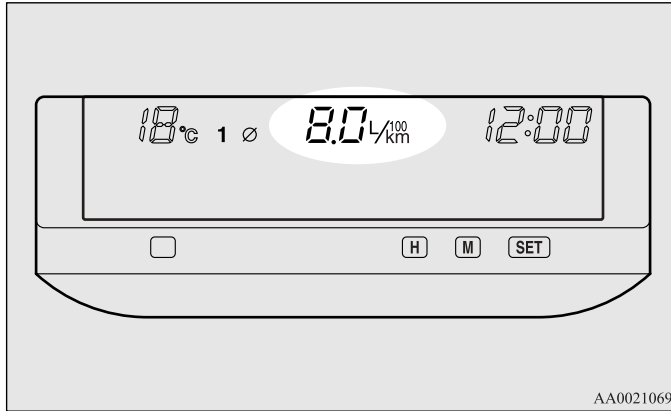

#### NOTE

- When the ignition switch is turned on, the average fuel consumption which was being displayed when the ignition switch was previously turned off will be displayed once again.
- Average fuel consumption varies according to the conditions under which a vehicle is travelling (road conditions, the manner in which the vehicle is being driven, etc.). Observe this display for reference because the fuel consumption display may differ from the actual fuel consumption.

### To reset the display

You can switch from the automatic reset mode to the manual reset mode by performing the following operations:

1. Press and hold down button (A), then press the “SET” button (B) within 1 second, and a buzzer will sound and the reset mode will be changed.

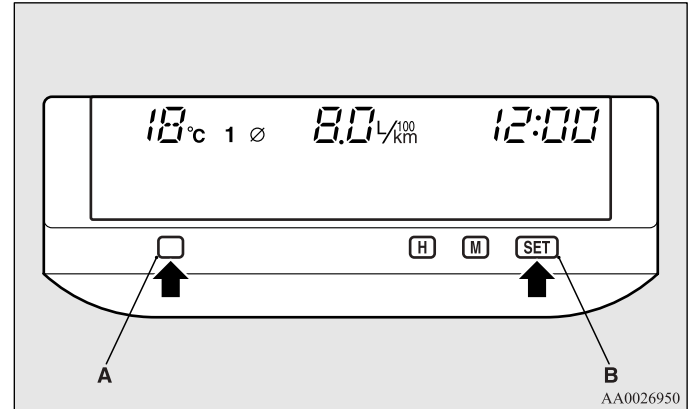

## Instruments and controls

- The name of the newly selected mode will flash, then the display will return to its original indications.

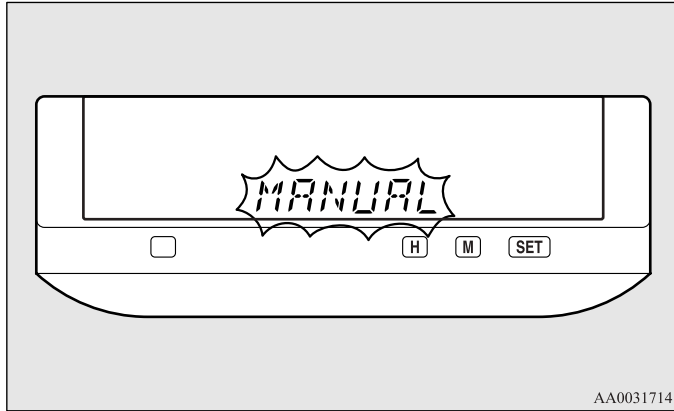

- The status of the selected mode will be shown on the display.

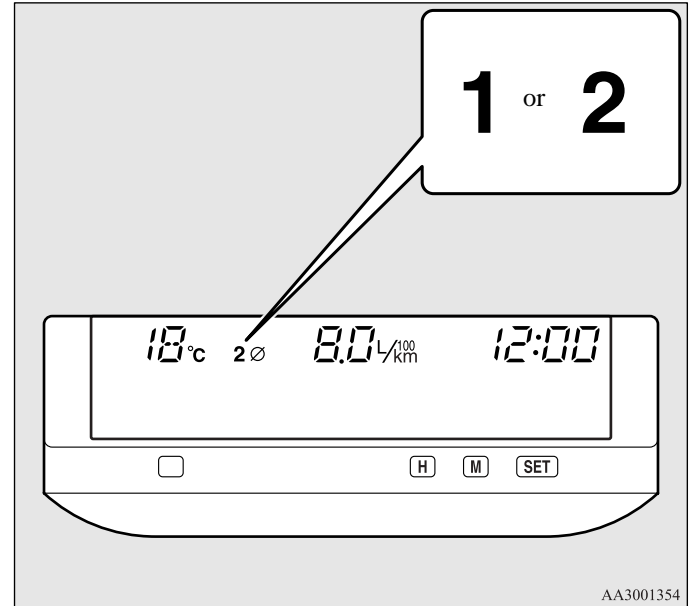

- Automatic reset mode
- Manual reset mode

- Automatic reset mode

When 4 hours have passed after the ignition switch is turned to the “OFF” or “ACC” position, the display is automatically reset. It then shows “---”.

- Manual reset mode

If you reset the display at the time when you want to start the measurements, average fuel consumption from that point of time can be displayed.

Push the “DISP” button for more than 5 seconds.

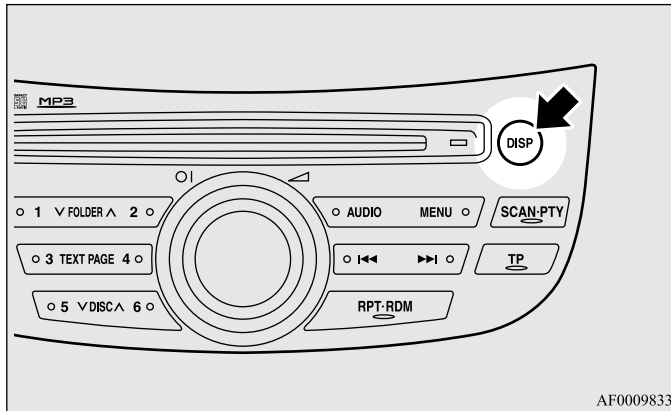

### NOTE

- While the ignition switch is in the “ON” position, the automatic reset mode is permanently selected. If you wish to make continuous measurements, select the manual mode.

### Driving range

E00509400016

This value shows the distance (in km or miles) that can be driven on the fuel remaining in the fuel tank.

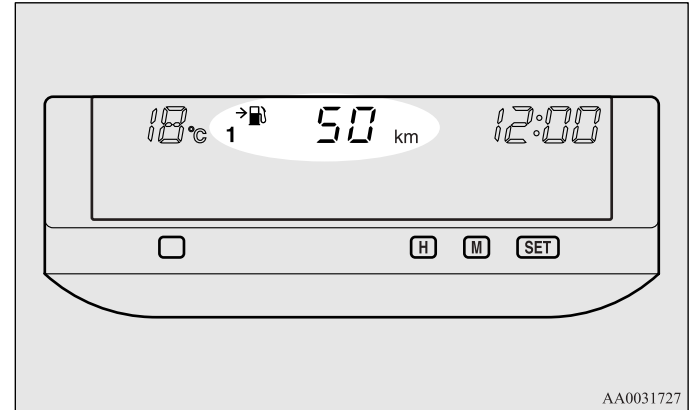

### NOTE

- If the driving range drops below 50 km (30 miles) while the driving range is displayed, the display shows “---”. When this occurs, top up the fuel tank as soon as possible.
- The driving range varies depending on road conditions, the manner of driving and other related factors. Consequently, the display should be used only as a guide. It is recommended to add fuel as soon as the low fuel warning lamp in the instrument cluster illuminates. (Refer to “Low fuel warning lamp” on page 3-6.)
- Refueling will update the driving range indication.
- The driving range displayed is based on previous fuel consumption data. Disconnecting the battery cable will result in the deletion of existing fuel consumption data, which will affect the unit’s calculations.
- The driving range figure can occasionally increase if the vehicle is stopped on an incline. This is because the fuel has moved in the tank because of the incline and is not considered as a fault.

### Average speed

E00509500062

This value shows the average speed (in km/h or mph) since the display was reset. Refer to “To reset the display” on page 3-23.

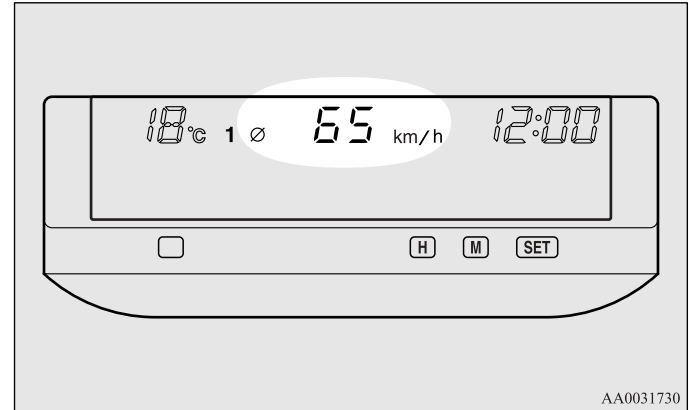



- Automatic reset mode

When 4 hours have passed after the ignition switch is turned to the “OFF” or “ACC” position, the display is automatically reset. It then shows “---”.

- Manual reset mode

If you reset the display at the time when you want to start the measurements, average speed from that point of time can be displayed.

To reset the display, push the “DISP” button for about 5 seconds or more.

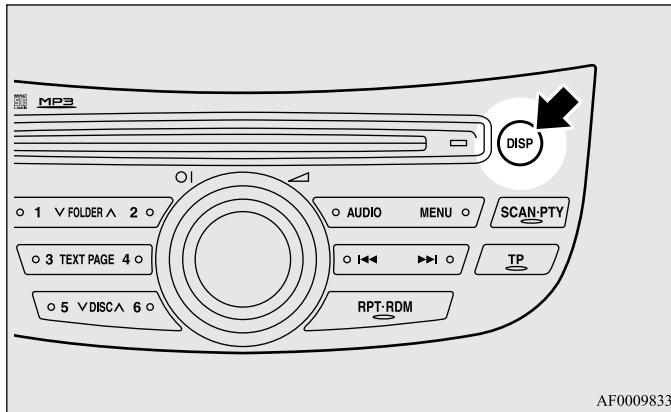

### NOTE

- While the ignition switch is in the “ON” position, the automatic reset mode is permanently selected. If you wish to make continuous measurements, select the manual mode.

### Display brightness adjustment

E00509600018

1. Press and hold down button (A), then press the “H” button (B) within 1 second. A buzzer will sound, and the system will allow adjustment of the display brightness.

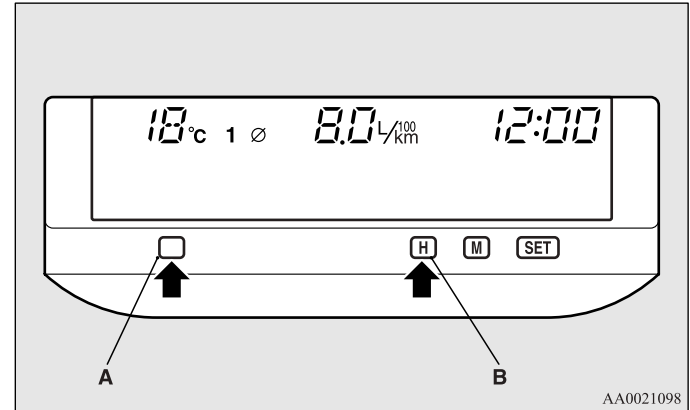

## Instruments and controls

- Adjust the brightness by pressing the “H” button (B) or “M” button (C).

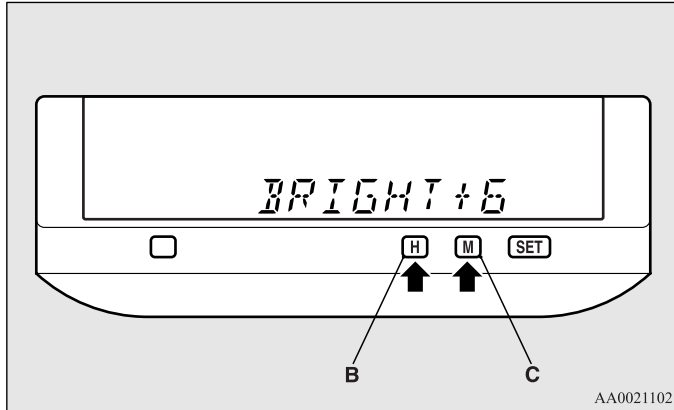

- Press the “SET” button (D) to determine the setting. The display will return to the original display item.

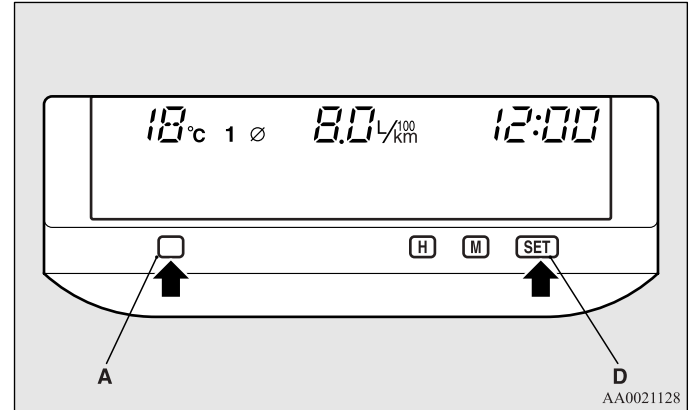

- H- Decrease brightness  
M- Increase brightness

### NOTE

- To cancel the brightness adjusting procedure before completion, press the button (A).
- If the “SET” button (D) is not pressed for about 15 seconds or longer in the middle of the adjustment, the currently selected brightness is set automatically. Then, the display returns to the original display item.

### Display unit selection

E00509700051

It is possible to change the units in which distance, fuel consumption, and time are displayed.

#### NOTE

- Except for vehicles with MITSUBISHI MOTORS genuine audio, only the unit of momentary fuel consumption can be changed to km or miles.
1. Press and hold down button (A), then press the “M” button (B) within 1 second. A buzzer will sound, and the system will allow units to be changed.

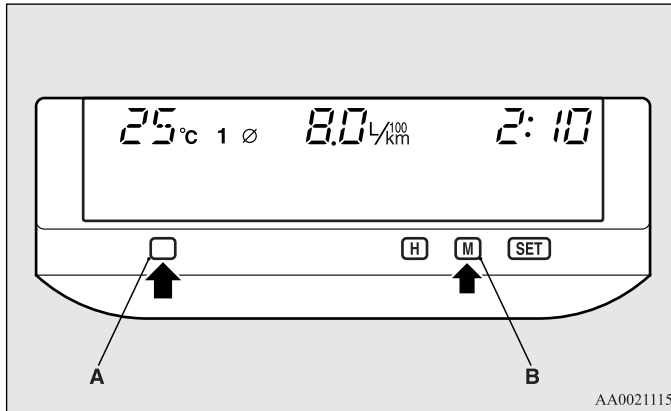

2. Use the “H” button (C) or “M” button (B) to select the desired speed unit, then press the “SET” button (D) to enter the setting.

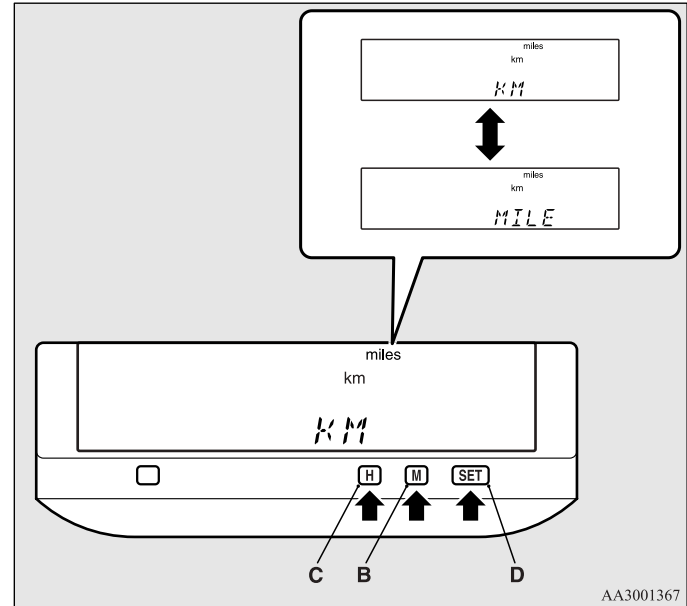

H - km  
M - mile

## Instruments and controls

3. If the km unit was selected in step 2, the fuel consumption unit must be subsequently selected using the “H” button (C) or “M” button (B).

Use the “H” button (C) or “M” button (B) to select the desired fuel consumption unit, then press the “SET” button (D) to enter the setting.

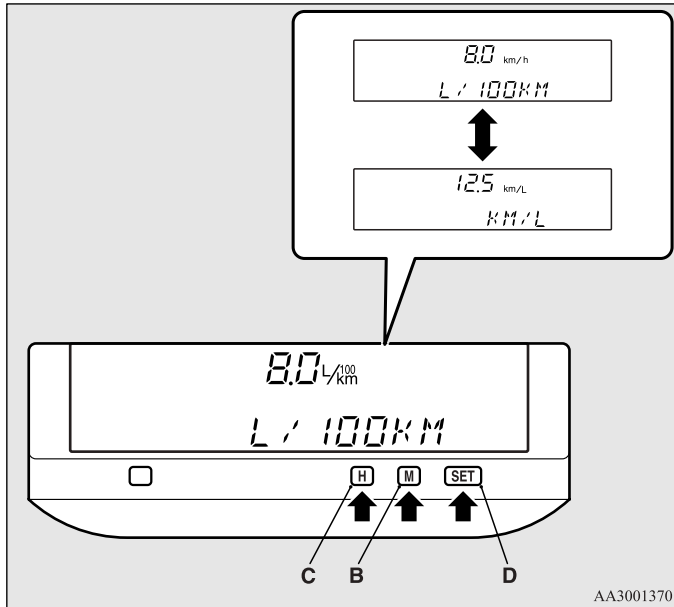

H - L/100km

M - km/L

4. When you have finished setting the fuel consumption unit (or if you selected miles in step 2), the system will require you to proceed to select, using the “H” button (C) or “M” button (B), whether times should be displayed in the 12-hour format or in the 24-hour format. The currently selected format will be displayed.

Use the “H” button (C) or “M” button (B) to choose your desired time display format, and then press the “SET” button (D) to enter the setting.

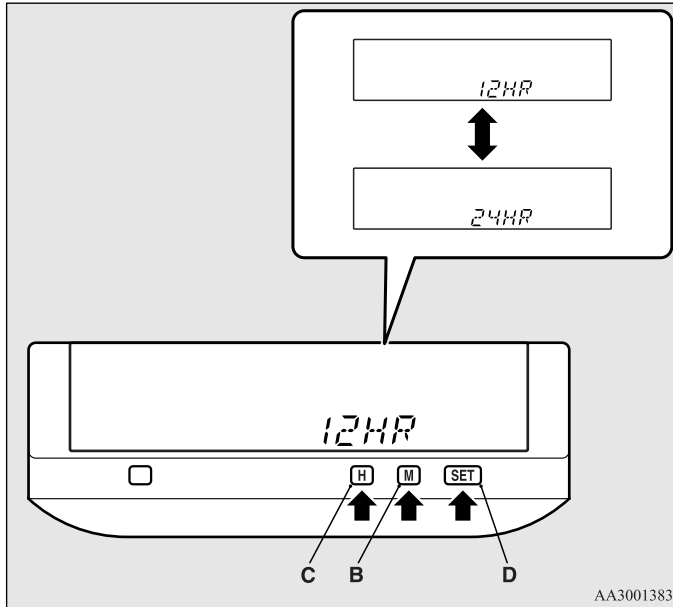

H - 12-hour format

M - 24-hour format

5. The display will return to the original display item.

#### NOTE

- If you selected the mile unit in step 2, the speed and fuel consumption units will be as follows.
  - Speed: mph (miles per hour)
  - Fuel consumption: mpg (miles per gallon)
- To cancel the unit setting procedure before completion, press the button (A).

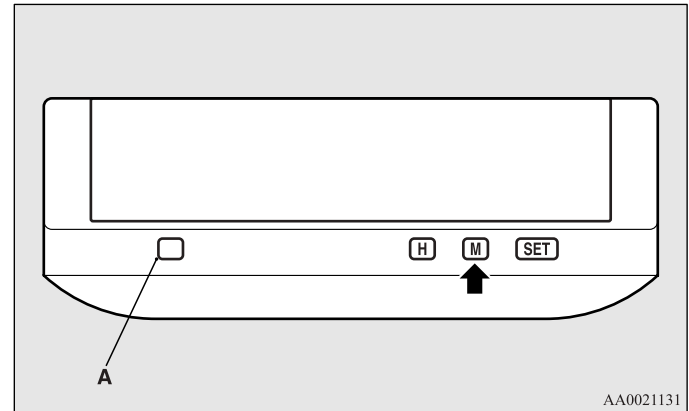

- The outside temperature and digital clock are not shown during the unit selecting procedure.
- If the “SET” button is not pressed for about 15 seconds or longer in the middle of the selection, the currently selected unit is set automatically. Then, the display returns to the original display item.

## Combination headlamps and dipper switch

E00506000776

### Headlamps

Rotate the switch to turn on the lamps.

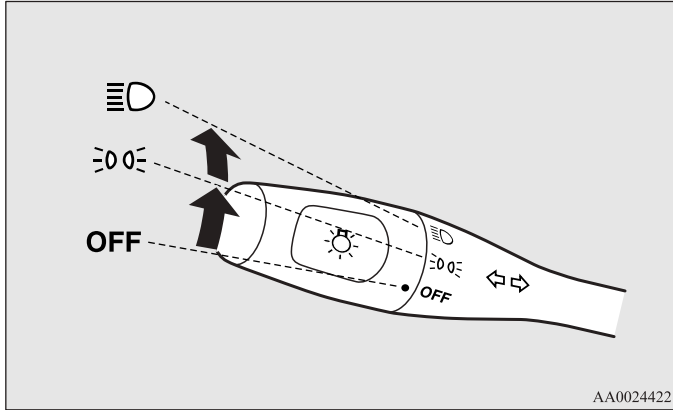

OFF	All lamps off
☰☽☻	Position, tail, licence plate and instrument panel lamps on
☰☽☻☽	Headlamps and other lamps go on



### NOTE

- Do not leave the headlamps and other lamps on for a long while the engine is stationary. A run-down battery could result.
- When it rains, or when the vehicle has been washed, the inside of the lens sometimes becomes foggy. This is the same phenomenon as when window glass mists up on a humid day, and does not indicate a functional problem. When the lamp is switched on, the heat will remove the fog. However, if water gathers inside the lamp, we recommend you to have it checked.



### [Vehicles with Daytime Running Lamp]

When the ignition switch is in the “ON” position and the lamp switch is set to the “OFF” position, the low beam of the headlamps, tail lamps, etc., will illuminate.



## Lamps (headlamps, fog lamps, etc.) auto-cutout function

- If the key is turned to “LOCK” or “ACC” position or removed from the ignition switch and the lamps will stay on for about 3 minutes without opening the driver’s door while the lamp switch in the “” position, automatically turn off.
- If the key is turned to “LOCK” or “ACC” position or removed from the ignition switch and the driver’s door is opened within 3 minutes while the lamp switch in the “” position, a buzzer will sound to warn the driver that the lamps have not been turned off, and these lamps will automatically turn off.

### NOTE

- The lamp auto-cutout will not function when the lamp switch is in the “” position.
- When the key has been turned to either the “LOCK” or “ACC” position or removed from the ignition switch with the lamp switch in the “” position, and the lamp switch is turned to the “OFF” position within approximately 3 minutes, the auto-cutout function will not be activated. (Even if the lamp switch is again turned to the “” position, the lamps will not go off automatically; the lamps will remain on as normal.)

### *When you want to keep the lamps on*

- Turn the switch in the “OFF” position to switch off all lamps while the key is in the “LOCK” or “ACC” position or remove the key from the ignition switch.
- Turn on the lamps with the switch in the “” or “” position again, then the lamps will remain on.

### NOTE

- It is possible to disable the lamps auto-cutout function. For further information, we recommend you to consult a MITSUBISHI MOTORS Authorized Service Point.

## Lamp monitor buzzer

E00506100012

If the driver’s door is opened when the key is in the “LOCK” or “ACC” position or removed from the ignition switch while the lamps are on, a buzzer will sound to remind the driver to turn off the lamps. When the lamp auto-cutout function acts, the buzzer will stop automatically. When this function does not act, turn off the lamp switch to stop the buzzer.

## Dipper (High/Low beam change)

E00506200114

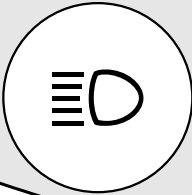
When the lamp switch is in the “” position, the beam changes from high to low (or low to high) each time the lever is pulled to (1). While the high beam is on, the high beam indicator lamp in the instrument cluster will also illuminate.

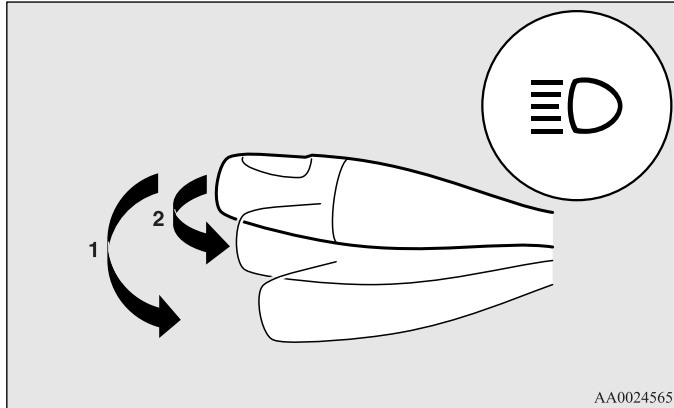

## Headlamp flasher

E00506300027

The high beams flash when the lever is pulled slightly to (2), and will go off when it is released.

When the high beam is on, the high beam indicator lamp in the instrument cluster will also illuminate.

### NOTE

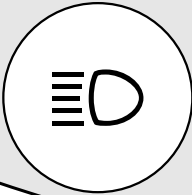
- The high beams can also flash when the lamp switch is OFF.
- If you turn the lamps off with the headlamps set to high-beam illumination, the headlamps are automatically returned to their low-beam setting when the lamp switch is next turned to the “” position.



## Headlamp levelling

E00506400594

### Headlamp levelling switch\*

#### *Except for vehicles with discharge headlamps*

The angle of the headlamp beam varies depending upon the load carried by the vehicle.

The headlamp levelling switch can be used to adjust the headlamp illumination distance (when the lower beam is illuminated) so that the headlamps' glare does not distract the drivers of approaching vehicles.

Set the switch (referring to the following table) to the appropriate position according to the number of people and the load in the vehicle.

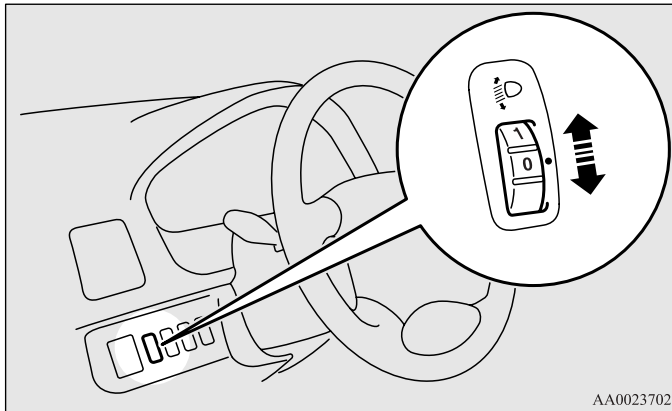

AA0023702

### <6-person seat>

Vehicle condition					
Switch position	“0”	“1”	“2”	“3”	“4”

●: 1 person

▨: Full luggage loading

Switch position 0- Driver only/Driver + 1 front passenger

Switch position 1- Driver + 1 front passenger + 2 third seat passengers

Switch position 2- All passengers

Switch position 3- All passengers + Full luggage loading

Switch position 4- Driver + Full luggage loading

<7-person seat>

Vehicle condition					
Switch position	"0"	"1"	"2"	"3"	"4"

●: 1 person

▨: Full luggage loading

Switch position 0- Driver only/Driver + 1 front passenger

Switch position 1- Driver + 1 front passenger + 2 third seat passenger

Switch position 2- All passengers

Switch position 3- All passengers + Full luggage loading

Switch position 4- Driver + Full luggage loading

## Automatic headlamp levelling\*

### Vehicles with discharge headlamps

This function automatically adjusts the illumination distance of the headlamps according to the number of people and the load in the vehicle.

When the ignition switch is in the "ON" position and the lamp switch is in the "☰D" position, the illumination distance of the headlamps is automatically adjusted when the vehicle is stopped or travelling at a constant speed.

### Automatic headlamp levelling warning lamp

The automatic headlamp levelling warning lamp should illuminate when the ignition switch is turned "ON", and should go off in a few seconds.

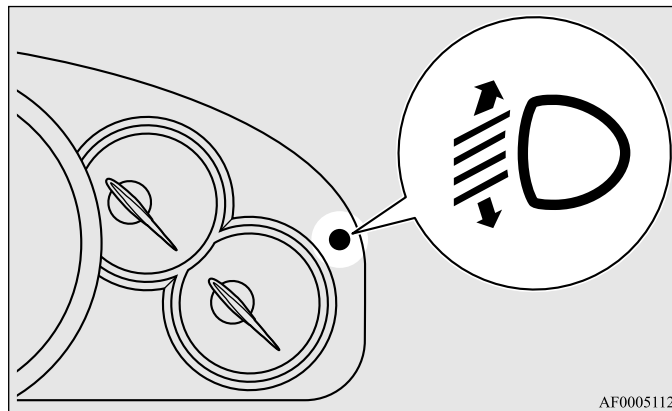

AF0005112

## **⚠ CAUTION**

- If the warning lamp stays on or does not illuminate when the ignition switch is turned “ON”, it indicates that the automatic headlamp levelling device is not functioning.  
We recommend you to have your vehicle inspected.

## *Turn/Lane-change signals*

E00506500393

The turn-signal lamps flash when the switch is operated (with the ignition switch “ON”). At the same time, the turn signal indicator flashes.

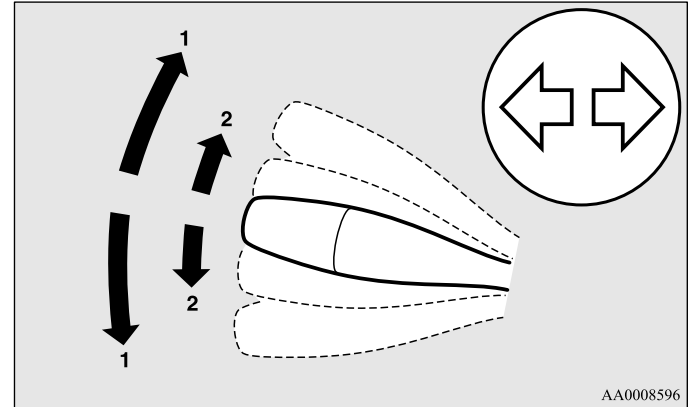

### 1- Turn-signals

When making a normal turn, use position (1). The lever will return automatically when cornering is completed.

There are times when the lever will not return after cornering. This occurs when the steering wheel is turned only slightly.

In such cases, return the lever by hand.

### 2- Lane-change signals

When changing lanes, use position (2). It will return to the neutral position when released.

NOTE

- If the lamp flashes unusually quickly, the bulb in a turn-signal lamp may have burned out. We recommend you to have the vehicle inspected.
- It is possible to activate the following functions. For further information, we recommend you to consult a MIT-SUBISHI MOTORS Authorized Service Point.  
On a vehicle equipped with a Multi Display Station (MDS), the functions can be adjusted on the screen. For details, refer to a separate operation manual.
  - Sounding of a buzzer as the turn-signal lamps flash
  - Flashing of the turn-signal lamps and the indication lamp in the meter when the lever is operated with the ignition switch in the “ACC” position

## *Hazard warning flasher switch*

E00506600567

Use the hazard warning flasher switch when the vehicle has to be parked on the road for any emergency. The hazard warning flashers can always be operated, regardless of the position of the ignition key.

Push the switch to turn on the hazard warning flashers; push the switch again to turn them off. When this switch is operated, all turn-signal lamps flash continuously, as do the turn-signal indication lamps in the instrument cluster.

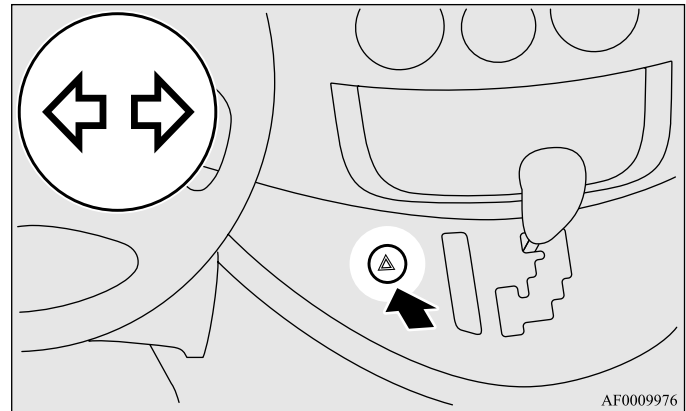

## Fog lamp switch

E0050670018

### NOTE

- If the lamps are kept flashing for a long time, the battery will be discharged, resulting in hard engine starting or no start condition.
- It is possible to cause a buzzer to sound in time with flashing of the turn-signal lamps. For further information, we recommend you to consult a MITSUBISHI MOTORS Authorized Service Point.

On a vehicle equipped with a Multi Display Station (MDS), the functions can be adjusted on the screen. For details, refer to a separate operation manual.

### Front fog lamp switch

E00508300050

The front fog lamps can be operated when the headlamps or tail lamps are turned on. Push the switch to turn on the front fog lamps, push the switch again to turn them off.

The indicator lamp in the instrument cluster will illuminate while the front fog lamps are on.

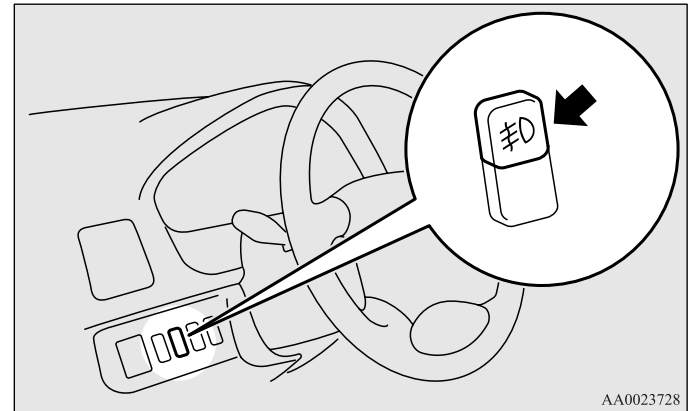

AA0023728

### NOTE

- The front fog lamps are automatically turned off when the headlamps and tail lamps turn off. To turn on the front fog lamps again, push the switch again when the headlamps or tail lamps are turned on.

## Instruments and controls

- In case of vehicles with Daytime Running Lamp, the front fog lamps can be operated even if the lamp switch is set to the “OFF” position, because the low beam of the headlamps, tail lamps, etc. illuminate when the ignition key is at the “ON” position.

### Rear fog lamp switch

E00508400237

The rear fog lamp can be operated when the headlamps or front fog lamps are on. Push the switch to turn on the rear fog lamp, and push the switch again to turn it off.

The indication lamp in the instrument cluster will illuminate while the rear fog lamp is on.

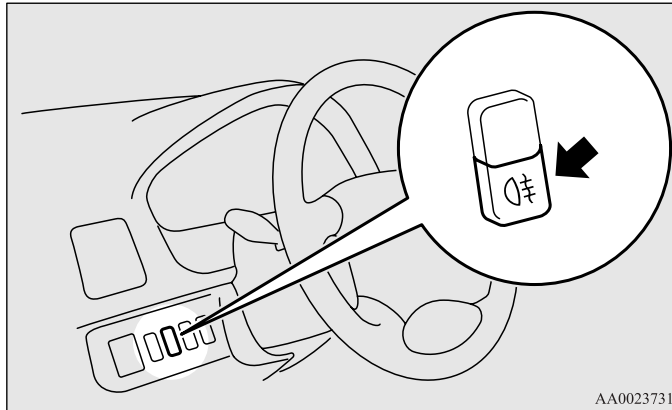

### NOTE

- The rear fog lamp is automatically turned off when the headlamps and front fog lamps are turned off. To turn on the rear fog lamp again, push the switch again when the headlamps or front fog lamps are on.
- In case of vehicles with Daytime Running Lamp, the rear fog lamp can be operated even if the lamp switch is set to the “OFF” position, because the low beam of the headlamps, tail lamps, etc. illuminate when the ignition key is at the “ON” position.

## Wiper and washer switch

E00507101162

The windscreen wiper and washer can be operated with the ignition switch in the “ON” or “ACC” position. Move the switch to operate the windscreen wipers or spray the washer fluid.

### Windscreen wipers

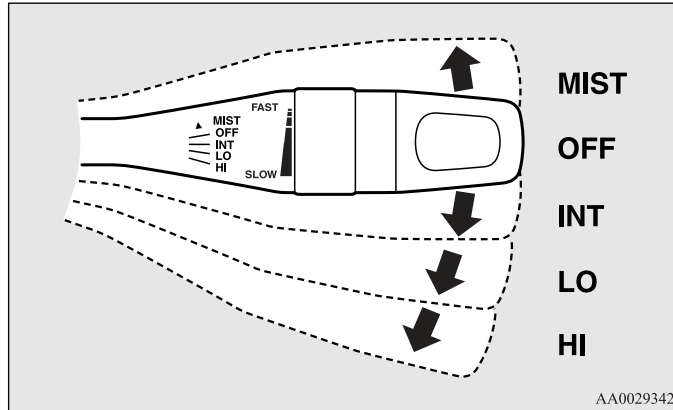

- MIST- Misting function  
The wipers will operate once.
- OFF- Off
- INT- Speed sensitive intermittent operation  
The intermittent intervals will change with the speed of the vehicle.
- LO- Slow
- HI- Fast

### NOTE

- The speed-sensitive-operation function of the windscreen wipers can be deactivated. For further information, we recommend you to consult a MITSUBISHI MOTORS Authorized Service Point. On a vehicle equipped with a Multi Display Station (MDS), the functions can be adjusted on the screen. For details, refer to a separate operation manual.

### To adjust intermittent intervals

With the lever in the “INT” (speed sensitive intermittent operation) position, the intermittent intervals can be adjusted by turning the knob (A).

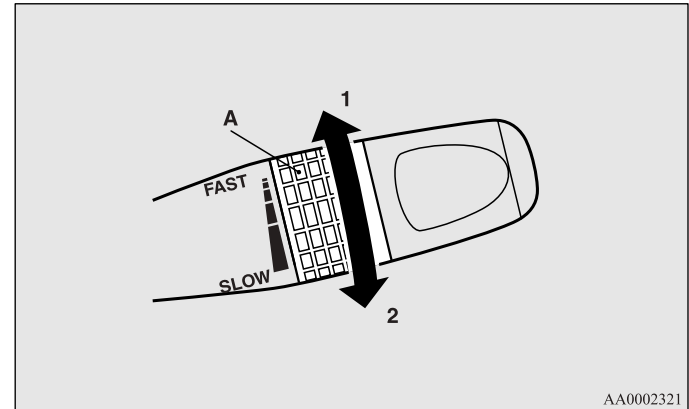

- 1- Fast  
2- Slow

## Instruments and controls

### *Misting function*

Move the lever in the direction of the arrow and release, and the wipers will operate once.

Use this function when you are driving in mist or drizzle.

If the lever is held in the upward position (MIST), the wipers continue operating until the lever is released.

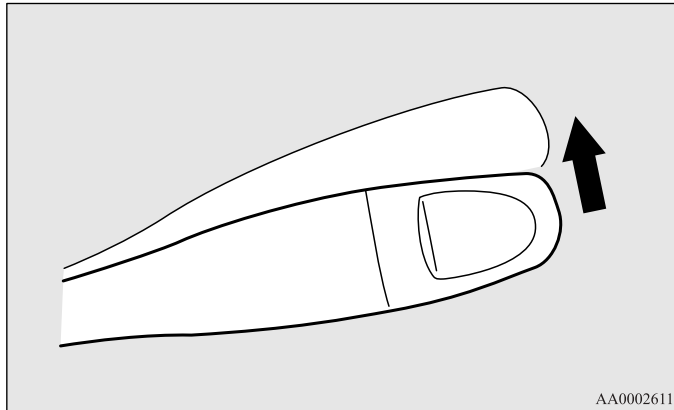

### Windscreen washer

E00507200531

The washer fluid will be sprayed onto the windscreen by pulling the lever towards you. The wipers operate automatically several times while the washer fluid is being sprayed.

On a vehicle equipped with the headlamp washer, the headlamp washer operates together with the windscreen washer the first time the windscreen washer is used if the headlamps are on.

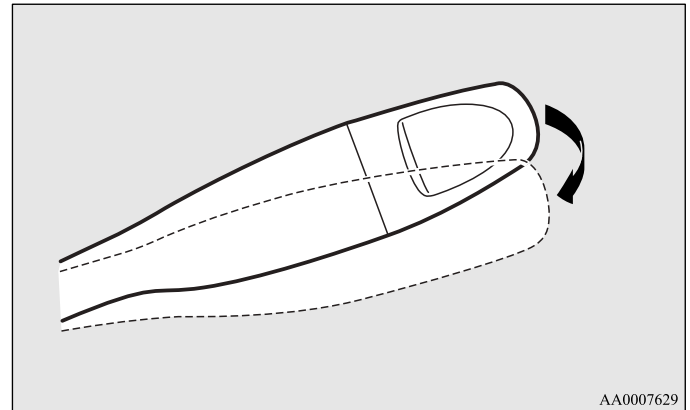

### **⚠ CAUTION**

- If the washer is used in cold weather, the washer fluid sprayed against the glass may freeze resulting in poor visibility. Heat the glass with the defroster or demister before using the washer.



## NOTE

- It is possible to spray washer fluid without activating the wipers. To do so, hold the lever in the pulled position and turn the ignition switch to the “ON” or “ACC” position.
- It is possible to cause the wipers never to operate when washer fluid is sprayed. For further information, we recommend you to consult a MITSUBISHI MOTORS Authorized Service Point.

On a vehicle equipped with a Multi Display Station (MDS), the functions can be adjusted on the screen. For details, refer to a separate operation manual.

## Rear window wiper and washer

E00507300460

The rear window wiper and washer switch can be operated with the ignition switch in the “ON” or “ACC” position. Turn the knob, and the rear window wiper will operate.

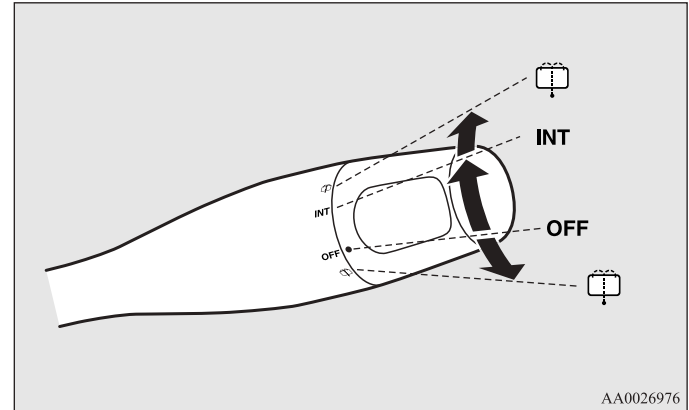

INT - The wiper operates continuously for several seconds then operates intermittently at intervals of about every 8 seconds

OFF - Off



- The washer fluid will be sprayed onto the rear window when the knob is turned fully in either direction.

The wipers operate automatically several times while the washer fluid is being sprayed

### NOTE

● To ensure a clear rearward view, the wiper performs a number of continuous operations either when the switch is moved to the “INT” position or when the gearshift lever (M/T) or the selector lever (A/T) is moved to the “R” position while the switch is in the “INT” position. Following this continuous operation, the wiper will automatically switch to intermittent operation.

● It is possible to spray washer fluid without activating the wiper. To do so, hold the knob at the end of the lever in the “” position and turn the ignition switch to the “ON” or “ACC” position.

● It is possible to activate the following functions. For further information, we recommend you to consult a **MITSUBISHI MOTORS** Authorized Service Point.

On a vehicle equipped with a Multi Display Station (MDS), the functions can be adjusted on the screen. For details, refer to a separate operation manual.

- Adjustment of the interval for intermittent operation
- Causing the wipers to switch to continuous operation when the knob at the end of the lever is turned to the “INT” position twice within approximately 1 second
- Changing intermittent wiper operation to continuous wiper operation
- Causing the wiper never to operate when washer fluid is sprayed

## Precautions to observe when using wipers and washers

E00507600014

- If the moving wipers become blocked by ice or other deposits on the glass, the motor may burn out even if the wiper switch is turned to OFF. If obstruction occurs, park your vehicle in a safe place, turn off the ignition, and clean the deposits from the glass so that the wipers operate smoothly.
- Do not use the wipers when the glass is dry. They may scratch the glass surface or the blades may prematurely wear out.
- Before using the wipers in cold weather, check that the wiper blades are not frozen onto the glass. The motor may burn out if the wipers are used with the blades frozen onto the glass.
- Avoid using the washer continuously for more than 20 seconds. Do not operate the washer when the fluid reservoir is empty. Otherwise, the motor may burn out.
- Periodically check the level of washer fluid in the reservoir and refill if required. During cold weather, add a recommended washer solution that will not freeze in the washer reservoir. Failure to do so could result in loss of washer function and frost damage to the system components.

## Headlamp washer switch\*

E00507800120

The headlamp washer can be operated when the ignition switch is in the “ON” or “ACC” position and the headlamps are on.

Push the button once and the washer fluid will be sprayed on to the headlamps.

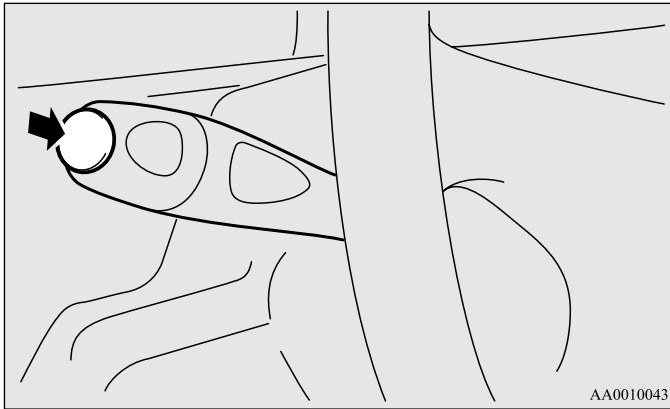

### NOTE

- If the ignition switch is in the “ON” or “ACC” position and the headlamps are on, the headlamp washer operates together with the windscreen washer the first time the windscreen washer lever is pulled.
- Check the headlamp washers periodically to confirm that the washer fluid is being sprayed properly on to the headlamp lenses.

## Rear window demister switch

E00507900176

The rear window demister switch can be operated with the ignition switch in the “ON” position.

Push the switch to turn on the rear window demister. It will be turned off automatically in about 20 minutes. To turn off the demister within about 20 minutes, push the switch again.

The indicator lamp (A) will illuminate while the demister is on.

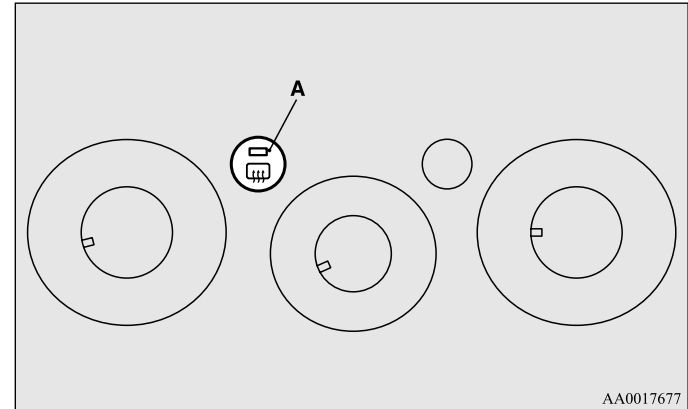

### NOTE

- When the rear window demister switch is pressed, the outside rearview mirrors are defogged or defrosted. Refer to “Heated mirrors” on page 4-14.
- The demister switch is not to melt snow but to clear mist. Remove snow before use of the demister switch.

## Instruments and controls

- To avoid unnecessary discharge of the battery, do not use the rear window demister during starting of the engine or when the engine is not running. Turn the demister off immediately after the window is clear.
- When cleaning the inside of the rear window, use a soft cloth and wipe gently along the heater wires, being careful not to damage the wires.
- Do not allow objects to touch the inside of the rear window glass, damaged or broken wires may result.

## *Horn switch*

E0050800099

Pressing the “” mark on the steering wheel, causes the horn to sound.

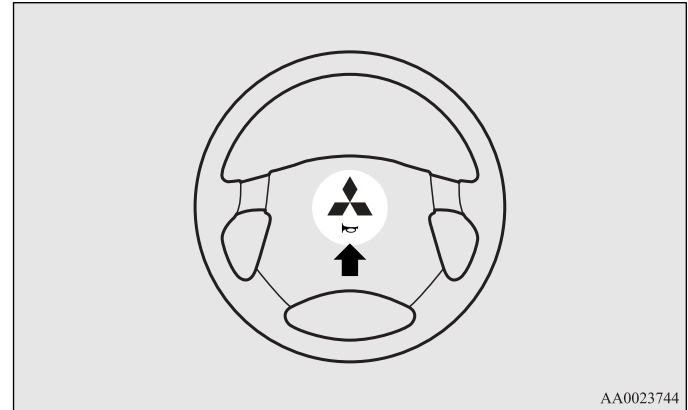

# *Starting and driving*

Economical driving . . . . .	4- 2	Active stability control (ASC)*. . . . .	4- 41
Driving, alcohol and drugs. . . . .	4- 3	Auto-speed (cruise) control*. . . . .	4- 45
Safe driving techniques . . . . .	4- 3	Corner sensor system* . . . . .	4- 51
Running-in recommendations . . . . .	4- 5	Cargo loads . . . . .	4- 57
Parking brake . . . . .	4- 6	Trailer towing . . . . .	4- 60
Parking . . . . .	4- 7		
Steering wheel height adjustment . . . . .	4- 8		
Inside rear-view mirror . . . . .	4- 9		
Outside rear-view mirrors . . . . .	4- 10		
Ignition switch . . . . .	4- 14		
Steering wheel lock . . . . .	4- 17		
Starting . . . . .	4- 18		
Diesel particulate filter (DPF)* . . . . .	4- 21		
Manual transmission . . . . .	4- 23		
Automatic transmission INVECS-II			
Sports Mode 4A/T (Intelligent & Innovative			
Vehicle Electronic Control System II) . . . . .	4- 26		
Braking . . . . .	4- 35		
Anti-lock brake system (ABS). . . . .	4- 36		
Power steering system . . . . .	4- 40		

### *Economical driving*

E00600100372

For economical driving, there are some technical requirements that have to be met. The prerequisite for low fuel consumption is a properly adjusted engine. In order to achieve longer life of the vehicle and the most economical operation, we recommend you have the vehicle checked at regular intervals in accordance with the service standards.

Fuel economy and generation of exhaust gas and noise are highly influenced by personal driving habits as well as the particular operating conditions. The following points should be observed in order to minimize wear of brakes, tyres and engine as well as to reduce environmental pollution.

#### **Starting**

Avoid rapid acceleration and sudden starts; such operation will result in higher fuel consumption.

#### **Shifting**

Shift only at an appropriate speed and engine speed. Always use the highest gear possible.

#### **City traffic**

Frequent starting and stopping increases the average fuel consumption. Use roads with smooth traffic flow whenever possible. When driving on congested roads, avoid use of a low gear at high engine speeds.

#### **Idling**

The vehicle consumes fuel even during idling. Avoid extended idling whenever possible.

#### **Speed**

The higher the vehicle speed, the more fuel consumed. Avoid driving at full speed. Even a slight release of the accelerator pedal will save a significant amount of fuel.

#### **Tyre inflation pressure**

Check the tyre inflation pressures at regular intervals. Low tyre inflation pressure increases road resistance and fuel consumption. In addition, low tyre pressures adversely affect tyre wear and driving stability.

#### **Load**

Do not drive with unnecessary articles in the luggage compartment. Especially during city driving where frequent starting and stopping is necessary, the increased weight of the vehicle will greatly affect fuel consumption. Also avoid driving with unnecessary luggage, etc., on the roof; the increased air resistance will increase fuel consumption.

#### **Cold engine starting**

Starting of a cold engine consumes more fuel. Unnecessary fuel consumption is also caused by keeping a hot engine running. After the engine is started, commence driving as soon as possible.

#### **Air conditioning**

The use of the air conditioning will increase the fuel consumption.

## *Driving, alcohol and drugs*

E00600200012

Drunk driving is one of the most frequent causes of accidents. Your driving ability can be seriously impaired even with blood alcohol levels far below the legal minimum. If you have been drinking, don't drive. Ride with a designated non-drinking driver, call a cab or a friend, or use public transportation. Drinking coffee or taking a cold shower will not make you sober.

Similarly, prescription and nonprescription drugs affect your alertness, perception and reaction time. Consult with your doctor or pharmacist before driving while under the influence of any of these medications.

### **⚠ WARNING**

#### **● NEVER DRINK AND DRIVE.**

**Your perceptions are less accurate, your reflexes are slower and your judgment is impaired.**

## *Safe driving techniques*

E00600300202

Driving safety and protection against injury cannot be fully ensured. However, we recommend that you pay extra attention to the following:

### **Seat belts**

Before starting the vehicle, make sure that you and your passengers have fastened your seat belts.

## Floor mats

### **⚠ WARNING**

- **Keep floor mats clear of the pedals by correctly laying floor mats that are suitable for the vehicle. To prevent the floor mats from slipping out position, securely retain them using the hook etc. Note that laying a floor mat over a pedal or laying one floor mat on top of another can obstruct pedal operation and lead to a serious accident.**

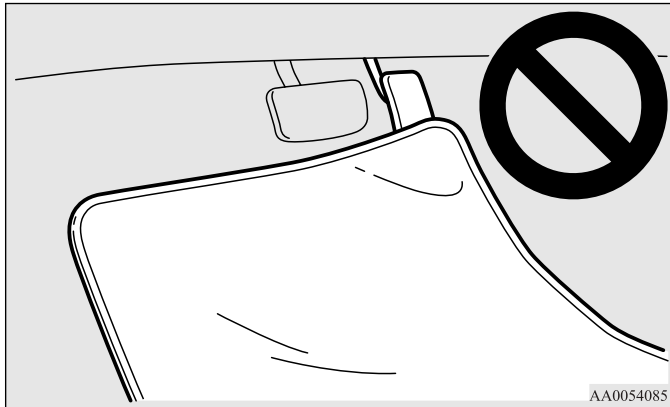

## Carrying children in the vehicle

- Never leave your vehicle unattended with the key in the ignition and children inside the vehicle. Children may play with the driving controls and this could lead to an accident.
- Make sure that infants and small children are properly restrained in accordance with the laws and regulations, and for maximum protection in case of an accident.
- Prevent children from playing in the luggage compartment. It is quite dangerous to allow them to play there while the vehicle is moving.

## Loading luggage

When loading luggage, be careful not to load above the height of seats. This is dangerous not only because rearward vision will be obstructed, but also the luggage may be projected into the passenger compartment under hard braking.



## Running-in recommendations

E00600400694

During the running-in period for the first 1,000 km (620 miles), it is advisable to drive your new vehicle using the following precautions as a guideline to aid long life as well as future economy and performance.

- Do not race the engine at high speeds.
- Avoid rapid starting, accelerating, braking and prolonged high-speed running.
- Keep to the running-in speed limit shown below.  
Please note that the legal speed limits displayed must be adhered to.
- Do not exceed loading limits.
- Refrain from towing a trailer.

### Vehicles with M/T

#### 5 M/T

Shift point	Speed limit
1st gear	30 km/h (19 mph)
2nd gear	60 km/h (37 mph)
3rd gear	95 km/h (59 mph)
4th gear	120 km/h (75 mph)
5th gear	155 km/h (96 mph)

#### 6 M/T

Shift point	Speed limit
1st gear	25 km/h (16 mph)
2nd gear	40 km/h (25 mph)
3rd gear	65 km/h (40 mph)
4th gear	90 km/h (56 mph)
5th gear	115 km/h (71 mph)
6th gear	130 km/h (81 mph)

### Vehicles with A/T

Shift point	Speed limit
1st gear	25 km/h (16 mph)
2nd gear	75 km/h (47 mph)
3rd gear	115 km/h (71 mph)
4th gear	165 km/h (103 mph)

## Parking brake

E00600500666

To park the vehicle, first bring it to a complete stop, fully engage the parking brake, and then move the gearshift lever to 1st (on an uphill) or Reverse (on a downhill) position, for vehicles with M/T or set the selector lever to “P” (PARK) position on A/T vehicles.

### To apply

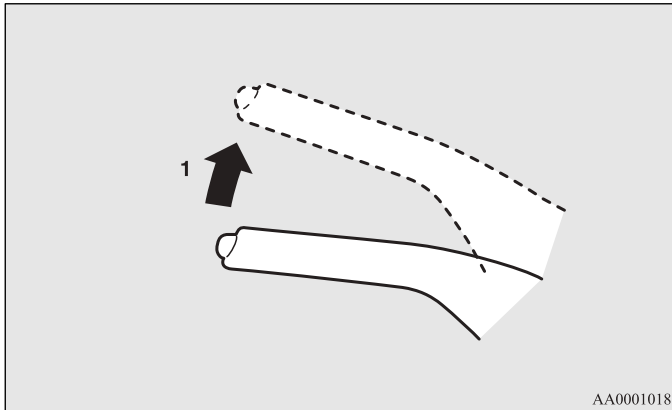

- 1- Pull the lever up without pushing the button at the end of hand grip.

### To release

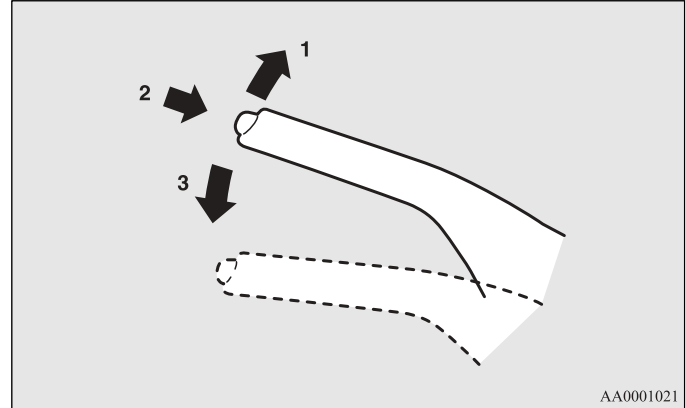

- 1- Pull the lever up slightly.
- 2- Push the button at the end of hand grip.
- 3- Push the lever downward.

## Parking

E00600600830

When parking on a hill, apply the parking brake and turn the front wheels towards the kerb on a downhill grade, away from the kerb on an uphill grade.

### CAUTION

- Before driving, be sure that the parking brake is fully released and brake warning lamp is off. If a vehicle is driven without releasing the parking brake, the brake will be overheated, resulting in ineffective braking and possible brake failure.
- When you intend to apply the parking brake, firmly press the brake pedal to bring the vehicle to a complete stop before pulling the parking brake lever. Pulling the parking brake lever with the vehicle moving could make the rear wheels lock up, thereby making the vehicle unstable.
- If the brake warning lamp does not extinguish when the parking brake is fully released, the brake system may be abnormal. For details, refer to “Brake warning lamp” on page 3-10.

### Parking on a hill

To prevent the vehicle from rolling into the street, follow these procedures:

#### *Parking on a downhill slope*

Turn the front wheels towards the kerb and move the vehicle forward until the kerb side wheel gently touches the kerb.

Set the parking brake and place the gearshift lever into the “R” (Reverse) position (with M/T) or the selector lever into the “P” (PARK) position (with A/T).

If necessary, apply chocks to wheels.

#### *Parking on an uphill slope*

Turn the front wheels away from the kerb and move the vehicle back until the kerb side wheel gently touches the kerb.

Set the parking brake and place the gearshift lever into the 1st position (with M/T) or the selector lever into the “P” (PARK) position (with A/T).

If necessary, apply chocks to wheels.

### NOTE

- If your vehicle is equipped with A/T, be sure to apply the parking brake before moving the selector lever to the “P” (PARK) position. If you move the selector lever to the “P” (PARK) position before applying the parking brake, it may be difficult to disengage the selector lever from the “P” (PARK) position when next you drive the vehicle, requiring application of a strong force to the selector lever to move from the “P” (PARK) position.

## Starting and driving

### Parking with the engine running

Never leave the engine running while you take a short sleep/rest. Also, never leave the engine running in a closed or poorly ventilated place. Leaving the engine running risks injury or death from accidentally moving the gearshift lever (M/T) or selector lever (A/T) or the accumulation of toxic exhaust fumes on the passenger compartment.

### Where you park

Your front bumper can be damaged if you scrape it over kerbs or parking stop blocks. Be careful when travelling up or down steep slopes where your bumper can scrape the road.

#### **⚠ WARNING**

- Do not park your vehicle in areas where combustible materials such as dry grass or leaves can come in contact with the hot exhaust, since fire could occur.

### When leaving the vehicle

Always remove the key from the ignition switch and lock all doors and the tailgate when leaving the vehicle unattended. Always try to park your vehicle in a well lit area.

### Steering wheel height adjustment

E00600700121

To adjust the steering wheel height, release the tilt lock lever while holding the steering wheel by hand, and raise or lower the steering wheel to the desired height.

After adjustment, securely lock the lever by pulling it upward.

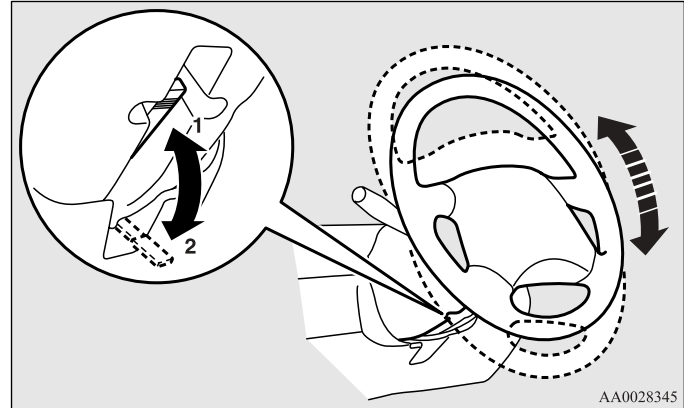

1- Locked

2- Release

#### **⚠ WARNING**

- After adjusting to the desired height, check to be sure that the lever is locked.
- Do not attempt to adjust the steering wheel while you are driving the vehicle.

**⚠ WARNING**

- When releasing the tilt lock lever, move it to the release position (2) and hold the steering wheel by hand to prevent it falling to the lowest position.

***Inside rear-view mirror***

E00600800425

Adjust the rear-view mirror only after making any seat adjustments so you have a clear view to the rear of the vehicle.

**⚠ WARNING**

- Do not attempt to adjust the rear-view mirror while driving. This can be dangerous. Always adjust the mirror before driving.

Adjust the rear-view mirror to maximize the view through the rear window.

**To adjust the vertical mirror position**

It is possible to move the mirror up and down to adjust its position.

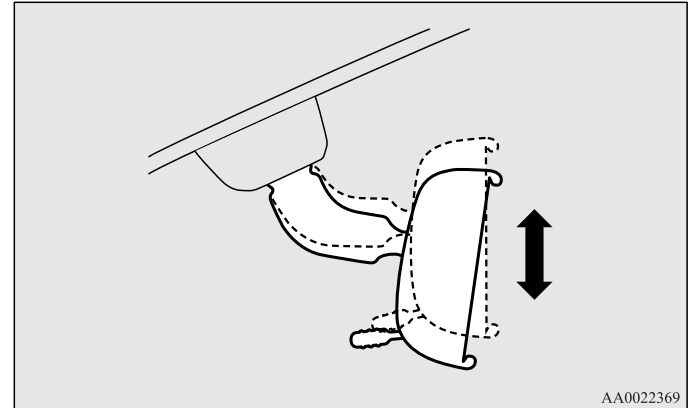

## To reduce the glare

The lever (A) at the bottom of the mirror can be used to adjust the mirror to reduce the glare from the headlamps of vehicles behind you during night driving.

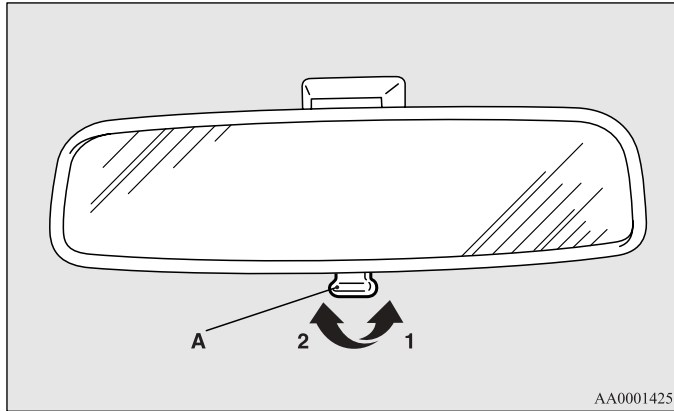

- 1- Normal
- 2- Anti-glare

## Outside rear-view mirrors

E00600900455

On the driver's seat side, a compound curved-surface mirror if so equipped is used, while on the front passenger's seat side, a single curved-surface mirror is used.

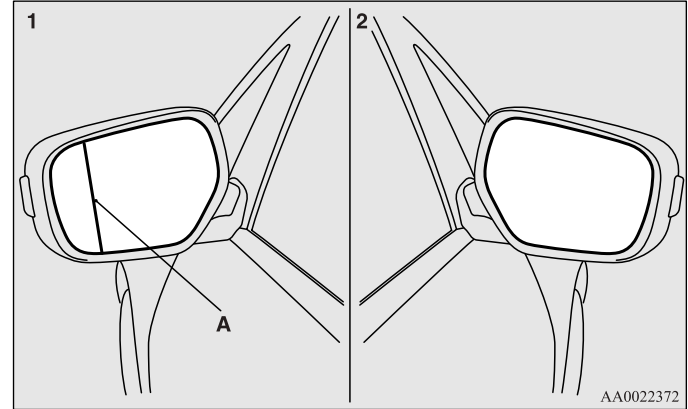

- 1- Compound curved-surface mirror
- 2- Single curved-surface mirror

While the single curved-surface mirror has a fixed curvature, the compound curved-surface mirror has different curvatures between the inner and outer sides of the boundary line (A). The inner side of the boundary line provides the same vision as that available from an ordinary door mirror. However, the outer side of the boundary line provides a wider vision than an ordinary door mirror.

**⚠ WARNING**

- The sense of distance that you get from an object you see on the inner side of the mirror boundary line differs from the sense of distance that you get from an object you see on the outer side.

An object you see on the outer side of the boundary line of the mirror will look farther away than actually is (farther away than if you see in a normal flat mirror) as compared with an object you see on the inner side.

**To adjust the mirror position**

E00601000134

The outside rear-view mirrors can be operated when the ignition switch is in the “ON” or “ACC” position.

**⚠ WARNING**

- Do not attempt to adjust the rear-view mirrors while driving. This can be dangerous.  
Always adjust the mirrors before driving.
- Your vehicle is equipped with convex type mirrors. Please take into consideration. Objects you see in the mirror will look smaller and farther away compared to a normal flat mirror.  
Do not use this mirror to estimate distance of following vehicles when changing lanes.

## Starting and driving

Place the lever (A) to the same side as the mirror whose adjustment is desired.

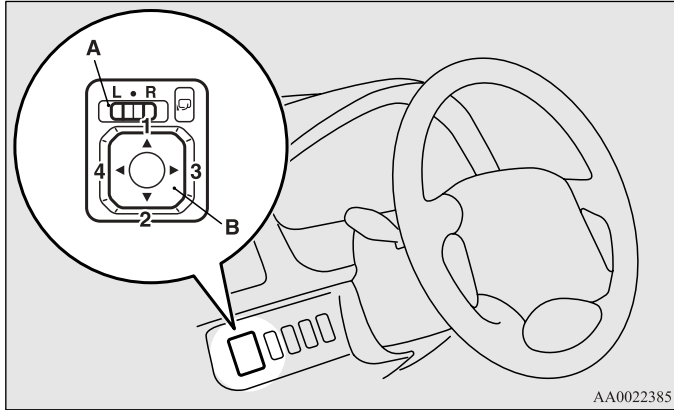

L- Left outside mirror adjustment  
R- Right outside mirror adjustment

### NOTE

- After adjustment, return the lever to (·) position.

Press the switch (B) to the left, right, up or down to adjust the mirror position.

- 1- Up
- 2- Down
- 3- Right
- 4- Left

## To fold the mirror

E00601100441

The outside mirror can be folded in towards the side window to prevent damage when parking in narrow areas.

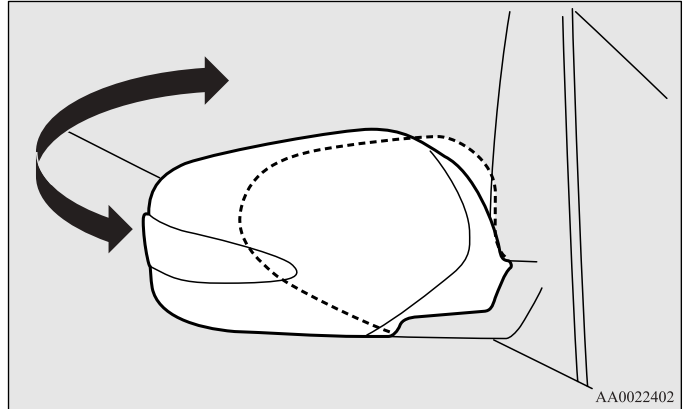



### ***Mirror retractor switch***

When entering a restricted space, outside mirrors can be folded away by pressing a switch inside the vehicle.

Push the switch to fold the mirrors to the rear.

To bring mirrors back into the original position, push the switch again.

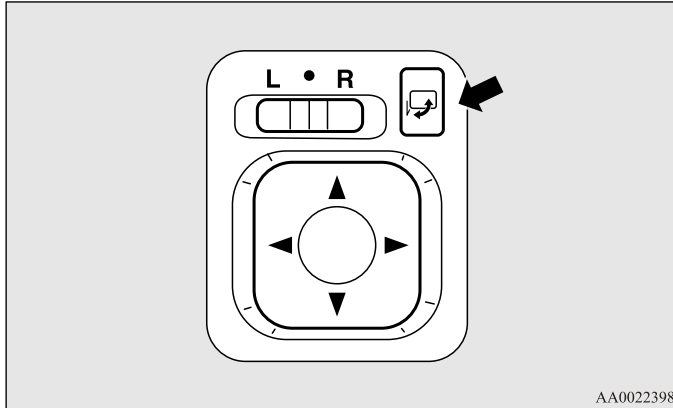

The mirrors can be extended and retracted for 30 seconds after the ignition switch is turned to the “LOCK” position.

Either the mirror switch in the cabin or the remote controller of the keyless entry system (if so equipped) can be used.

For information on the keyless entry system, refer to page 1-5.

### **NOTE**

- It is also possible to fold and return the mirrors by hand.
- When freezing has occurred and mirrors fail to operate as intended, please refrain from repeated pushing of the retractor switch as this action can result in burn-out of the mirror motor circuits.

### ***Automatic extension of mirrors***

If the engine is stopped and started with the mirrors retracted, the mirrors automatically extend for safety when the vehicle speed reaches 30 km/h (19 mph).

### **NOTE**

- If the mirrors are retracted manually or using the mirror switch after the engine is started, they do not extend automatically. Use the mirror switch to extend the mirrors, or turn the ignition switch to the “LOCK” position to activate the automatic extension function.

## Heated mirrors

E0060120077

When the rear window demister switch is pressed, the outside rear-view mirrors are demisted or defrosted. Current will flow through the heater element inside the mirrors, thus clearing away frost or condensation.

The indicator lamp (C) will illuminate while the demister is on. The heater will be turned off automatically in about 20 minutes.

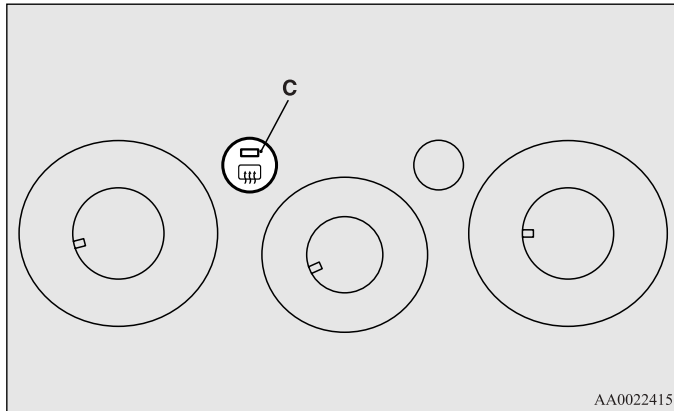

## Ignition switch

E00601401076

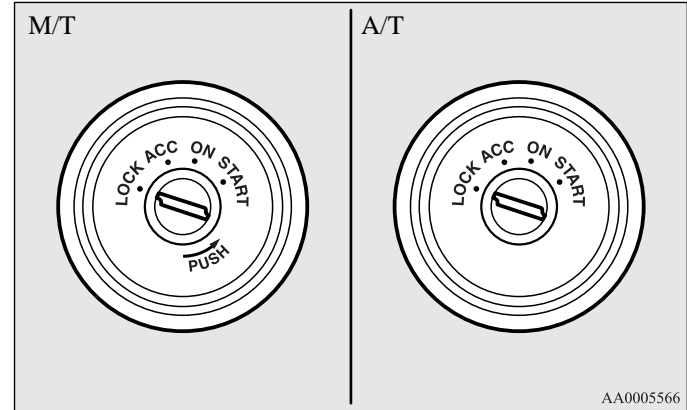

### LOCK

The engine is stopped and the steering wheel locked. The key can be inserted and removed only when the switch is in this position.

### ACC

The engine is stopped, but the electrical devices such as the radio and cigarette lighter can be operated.

### ON

The engine is running, and all the vehicle's electrical devices can be operated.

### START

The starter motor operates. After the engine has started, release the key and it will automatically return to the "ON" position.

**NOTE**

- This vehicle is equipped with ignition switch illumination.
  - The ignition switch illumination comes on while the driver's door is opened and remains on for about 30 seconds after the driver's door is closed.
  - [On vehicles with keyless entry system]  
When you get out of the vehicle and remove the ignition key, it will be illuminated for about 30 seconds.

However, it will go off even while the illumination comes on if the ignition switch is set to "ON" position.

- For vehicles equipped with the Daytime Running Lamp, when the ignition switch is in the "ON", the headlamp low beams etc. are turned on.  
Refer to "Headlamps" on page 3-32.
- Your vehicle is equipped with an electronic immobilizer. To start the engine, the ID code which the transponder inside the key sends must match the one registered to the immobilizer computer. (Refer to "Electronic immobilizer (Anti-theft starting system)" on page 1-3.)

**To remove the key**

For vehicles with M/T, when removing the key, push in the key at the "ACC" position and keep it depressed until it is turned to the "LOCK" position, then remove the key.

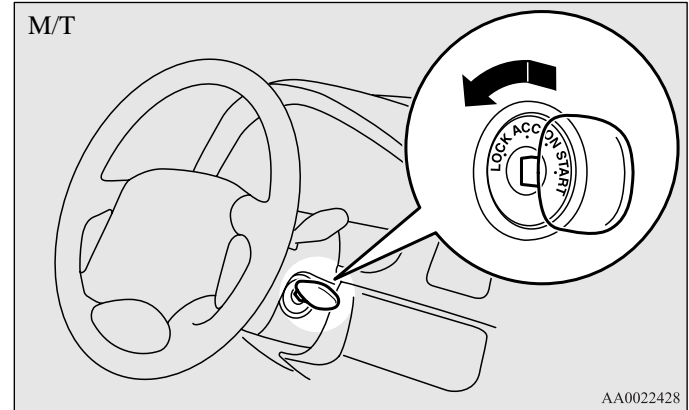

## Starting and driving

For vehicles with A/T, when removing the key, first set the selector lever to the “P” (PARK) position, and then turn the key to the “LOCK” position, then remove the key.

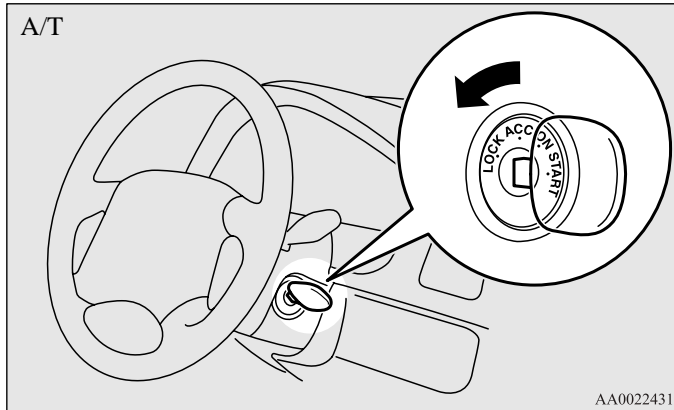

## **⚠ CAUTION**

- Do not remove the ignition key from the ignition switch while driving. The steering wheel will locked, causing loss of control.
- If the engine is stopped while driving, the brake servomechanism will cease to function and braking efficiency will deteriorate. Also, the power steering system will not function and it will require greater manual effort to operate the steering.
- Do not leave the key in the “ON” position for a long time when the engine is not running, doing so will cause the battery to be discharged.
- Do not turn the key to the “START” position when the engine is running, doing so could damage the starter motor.

## Steering wheel lock

E00601500083

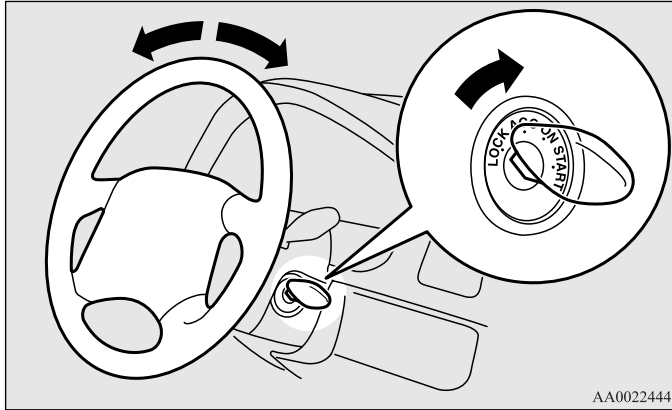

AA0022444

### To lock

Remove the key at the “LOCK” position.  
Turn the steering wheel until it is locked.

### To unlock

Turn the key to the “ACC” position while moving the steering wheel slightly.

## **CAUTION**

- Remove the key when leaving the vehicle.

### NOTE

- If the front wheels are turned, the anti-theft lock may sometimes make it difficult to turn the key from “LOCK” to “ACC”. Firmly turn the steering wheel to the left or to the right as you turn the key.

## Starting

E00601600693

### Tips for starting

- Do not operate the starter motor continuously for anything longer than 10 seconds; doing so could run down the battery. If the engine does not start, turn the ignition switch back to “LOCK”, wait a few seconds, and then try again. Trying repeatedly with the starter motor still turning will damage the starter mechanism.
- If the engine cannot be started because the battery is weak or dead, refer to the “Emergency starting” section for instructions on starting the engine.
- The engine is well warmed up if the coolant temperature gauge needle starts to move (the engine speed decreases). Extended warming-up operation will result in excessive fuel consumption.

### **WARNING**

- Never run the engine in a closed or poorly ventilated area any longer than is needed to move your vehicle in or out of the area. Carbon monoxide gases are odourless and can be fatal.

### **CAUTION**

- Never attempt to start the engine by pushing or pulling the vehicle. Especially in the A/T, since the structure is different from a M/T, it is not possible to start the engine by using this technique. Never attempt this or it could damage the A/T.
- Do not run the engine at high rpm or drive the vehicle at high speed until the engine has had a chance to warm up.
- Release the ignition key as soon as the engine starts to avoid damaging the starter motor.
- If your vehicle is equipped with a turbocharger, do not stop the engine immediately after high-speed or uphill driving. First allow the engine to idle to give the turbocharger a chance to cool down.

## Starting the engine (petrol-powered vehicles)

E00601701239

This vehicle is equipped with an electronically controlled fuel injection system which is automatically controlled. When starting the engine, do not depress the accelerator pedal.

### Normal conditions

The starting procedure is as follows:

1. Insert the ignition key and fasten the seat belt.
2. Make sure the parking brake is applied.
3. Depress and hold the brake pedal.
4. Fully depress the clutch pedal (M/T).
5. On vehicles with M/T, place the gearshift lever in the “N” (Neutral) position.

On vehicles with A/T, make sure the selector lever is in the “P” (PARK) position.

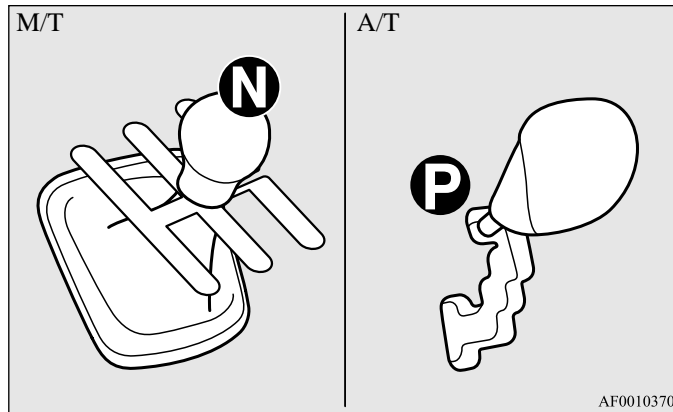

6. After turning the ignition key to the “ON” position, make certain that all warning lamps are functioning properly before starting the engine.
7. Turn the ignition key to the “START” position without depressing the accelerator pedal, and release it when the engine starts.

### At extreme cold ambient temperature

If the engine won't start, depress the accelerator pedal about halfway while cranking the engine. Once the engine starts, release the accelerator pedal.

## **CAUTION**

- When starting the engine, make sure that you press on the brake pedal. At extreme cold ambient temperature move your foot to the brake pedal immediately after the engine has started.

## Starting and driving

### *Flooded engine*

If the engine was flooded during starting, first operate the starter for 5 to 6 seconds while fully depressing the accelerator pedal, then start the engine without depressing the accelerator pedal.

### *Using the MIVEC engine*

The MIVEC engine automatically switches its intake-valve control between a low-speed mode and a high-speed mode in accordance with driving conditions for maximum engine performance.

#### NOTE

- To protect the engine, the high-speed mode may not be selected while the engine coolant temperature is low. In such a case, the engine revolutions do not rise to over 5,000 rpm even if the accelerator pedal is depressed.

## Starting the engine (diesel-powered vehicles)

E00601701242

1. Insert the ignition key and fasten the seat belt.
2. Make sure the parking brake is applied.
3. Depress and hold the brake pedal.
4. Fully depress the clutch pedal.
5. Place the gearshift lever in the “N” (Neutral) position.

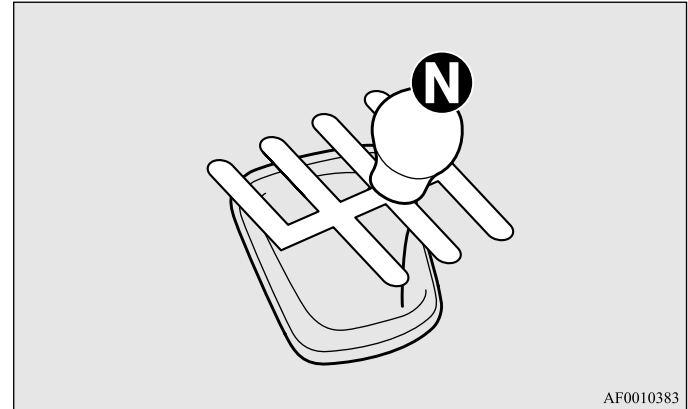

AF0010383

6. Turn the ignition key to the “ON” position.  
The diesel preheat indication lamp will first illuminate, and then after a short time go out, indicating that preheating is completed.



## NOTE

- If the engine is cold, the diesel preheat indication lamp is on for a longer time.
- When the engine has not been started within about 5 seconds after the diesel preheat indication lamp went out, return the ignition key to the “LOCK” position. Then, turn the key to the “ON” position to preheat the engine again.
- When the engine is warm, the diesel preheat indication lamp does not come on even if the ignition key is placed in the “ON” position.  
Start the engine by turning the ignition key right to the “START” position.

7. Turn the ignition key to the “START” position without depressing the accelerator pedal, and release it when the engine starts.

## NOTE

- A ticking noise may be heard after starting the engine. This is not an abnormal condition. The noise will disappear after a short time of engine running.  
If the ticking noise continues after the engine is warmed up, we recommend you to have your vehicle checked.

***Diesel particulate filter (DPF)\****

E0061980069

The diesel particulate filter (DPF) is a device that captures most of the particulate matter (PM) in the exhaust emissions of the diesel engine. The DPF automatically burns away trapped PM during vehicle operation. Under certain driving conditions, however, the DPF is not able to burn away all of the trapped PM and, as a result, an excessive amount of PM accumulates inside.

** WARNING**

- The DPF reaches very high temperatures. Do not park your vehicle in areas where combustible materials such as dry grass or leaves can come in contact with the hot exhaust system since fire could occur.

** CAUTION**

- Do not use any type of fuel or engine oil that is not specified for your vehicle. Also, do not use any moisture-removing agent or other fuel additive. Such substances could have a detrimental effect on the DPF.  
Refer to “Fuel selection” on page 2 and “Engine oil” on page 8-7.

## NOTE

- To minimize the likelihood of excessive accumulation of PM, try to avoid driving for long periods at low speeds and repeatedly driving short distances.

## DPF warning lamp

The DPF warning lamp comes on in the event of an abnormality in the DPF system. Provided the DPF system is working normally, the DPF warning lamp comes on when the ignition switch is turned to the “ON” position and goes off a few seconds later.

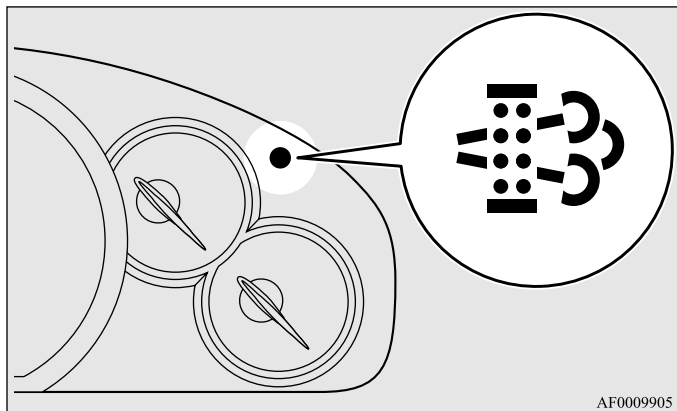

## If the DPF warning lamp comes on during vehicle operation

Steady illumination of the DPF warning lamp shows that the DPF has not been able to burn away all of the trapped PM and that, as a result, an excessive amount of PM has accumulated inside. To enable the DPF to burn away the PM, try to drive the vehicle as follows:

- With the gearshift lever in the 4th or 5th gear position, drive more than 15 minutes at a speed of at least 60 km/h (37 mph) and engine revolutions of at least 2,000 rpm.

If the DPF warning lamp subsequently stays on, contact your MITSUBISHI MOTORS Authorized Service Point.

### **⚠ CAUTION**

- You do not have to continuously drive exactly as indicated above. Always strive to drive safely in accordance with road conditions.

## If the DPF warning lamp and check engine warning lamp come on during vehicle operation

When the DPF warning lamp and check engine warning lamp come on, this indicates an abnormality in the DPF system. Have the system inspected by a MITSUBISHI MOTORS Authorized Service Point.

### **⚠ CAUTION**

- Continuing to drive when the DPF warning lamp and check engine warning lamp remain on could result in engine trouble and DPF damage.

## Manual transmission

E00602000173

The shift pattern is shown on the gearshift lever knob. Be sure to always fully depress the clutch pedal before attempting to shift the lever.

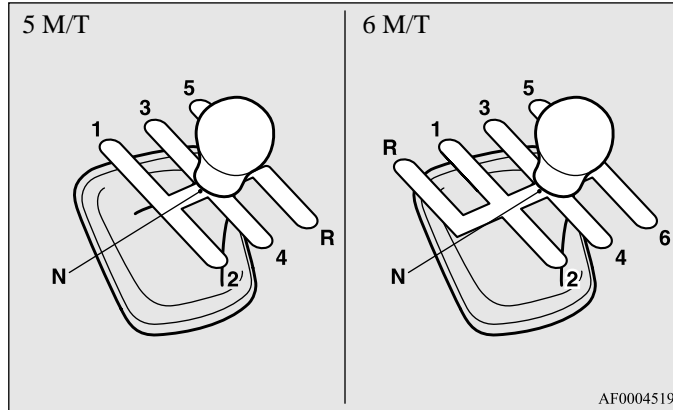

AF0004519

### **⚠ CAUTION**

- Do not move the gearshift lever into reverse while the vehicle is moving forward; doing so will damage the transmission.
- Do not rest your foot on the clutch pedal while driving as this will cause premature clutch wear or damage.

### NOTE

- If it is hard to shift into 1st, depress the clutch pedal again; the shift will then be easier to make.

### Moving the gearshift lever to the “R” (Reverse) position

#### **⚠ CAUTION**

- Do not move the gearshift lever to the “R” (Reverse) position while the vehicle is moving forward. This could damage the transmission.

#### *Vehicles equipped with 5-speed manual transmission*

To shift into the “R” (Reverse) position from 5th gear, move the gearshift lever to the “N” (Neutral) position, and then move it to the “R” (Reverse) position.

## Starting and driving

### *Vehicles equipped with 6-speed manual transmission*

Pull up the pull-ring (A), then move the gearshift lever to the “R” (Reverse) position with the pull-ring still pulled.

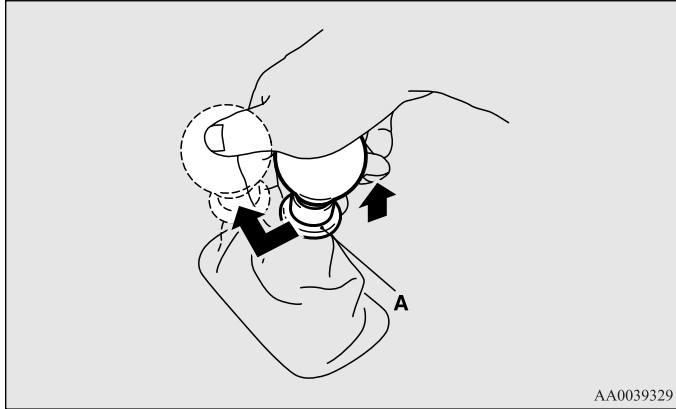

The pull-ring will return to its original position when you return the gearshift lever to the “N” (Neutral) position.

### **⚠ CAUTION**

- If the pull-ring will not return from the pulled-up position, we recommend you to have your vehicle inspected.

## Changing gears

E0061060022

Always use care to change the gear with the vehicle speed matched to the engine speed. Proper shifting will improve fuel economy and prolong engine life.

Avoid shifting down at high speed, as this may cause excessive engine speed (the tachometer needle into the red zone) and damage the engine.

### **⚠ CAUTION**

- Do not pull up the pull-ring (A) when moving the gearshift lever to any position other than the “R” (Reverse) position. If you always pulled up the pull-ring (A) when moving the gearshift lever, you could unintentionally move the gearshift lever to the “R” (Reverse) position and cause an accident and/or a problem in the transmission.

## Economical driving speed

E00610700443

The following shift points are recommended to assist fuel economy. The driver may vary these points to suit driving conditions and load.

### 5 M/T

Shift point	Speed limit
1st gear to 2nd gear	30 km/h (19 mph)
2nd gear to 3rd gear	55 km/h (34 mph)
3rd gear to 4th gear	85 km/h (53 mph)
4th gear to 5th gear	115 km/h (71 mph)

### 6 M/T

Shift point	Speed limit
1st gear to 2nd gear	10 km/h (6 mph)
2nd gear to 3rd gear	25 km/h (16 mph)
3rd gear to 4th gear	35 km/h (22 mph)
4th gear to 5th gear	50 km/h (31 mph)
5th gear to 6th gear	65 km/h (40 mph)

## Possible driving speed

E00610800431

### 5 M/T

Shift point	Speed limit
1st gear	50 km/h (31 mph)
2nd gear	90 km/h (56 mph)
3rd gear	140 km/h (87 mph)
4th gear	185 km/h (115 mph)

5th gear is an overdrive ratio and its use reduces engine speed below that of the 4th gear. Use 5th gear whenever vehicle speed allows, for maximum fuel economy.

### 6 M/T

Shift point	Speed limit
1st gear	35 km/h (22 mph)
2nd gear	65 km/h (40 mph)
3rd gear	95 km/h (59 mph)
4th gear	135 km/h (84 mph)
5th gear	170 km/h (106 mph)

The 4th, 5th and 6th gears have overdrive ratios and their use reduces the engine speeds below those of the 3rd, 4th and 5th gear, respectively. Use the 4th, 5th or 6th gear whenever the vehicle speed allows, for maximum fuel economy.

## Automatic transmission INVECS-II Sports Mode 4A/T (Intelligent & Innovative Vehicle Electronic Control System II)

E00603200068

Designed for optimum control and equipped with adaptive control capabilities, the electronically controlled transmission optimally matches gear shifts to almost all driving and road conditions.

### **⚠ CAUTION**

- This system is strictly intended to provide supplementary functions. When travelling downhill under certain conditions or immediately after starting off when the A/T is cold, no automatic shiftdown may be made. The driver should shiftdown to a lower gear to use engine braking. Try to drive safely at all time.

### NOTE

- During running-in period or immediately after reconnection of the battery cable, there may be a case where gear shifts are not made smoothly. This does not indicate a faulty transmission. Gear shifts will become smooth after the transmission has been shifted several times by the electronic control system.

## Selector lever operation

E00603300131

The transmission has 4 forward gears and 1 reverse gear. The individual gears are selected automatically, depending on the position of the gear selector lever, the speed of the vehicle and the position of the accelerator pedal.

The selector lever (A) has 2 gates; the main gate (B) and the manual gate (C).

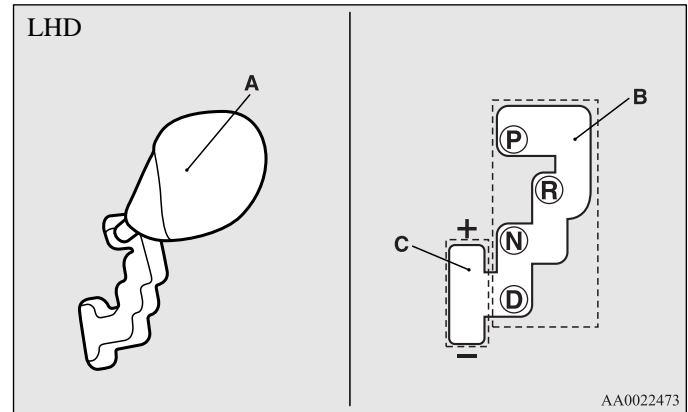

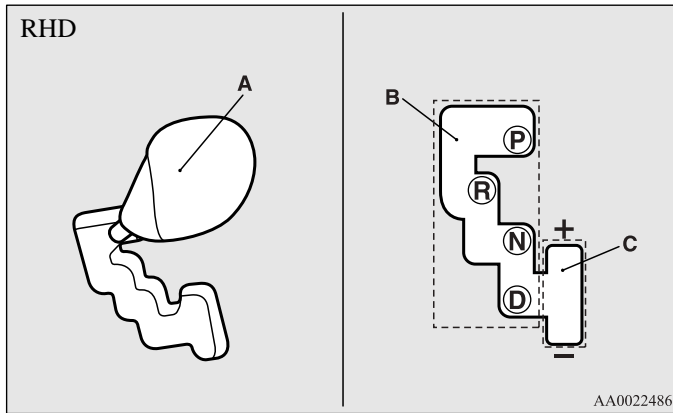

NOTE

- In the main gate, selector lever has 4 positions.
- For information on manual gate operation, please refer to “Sports mode” on page 4-30.

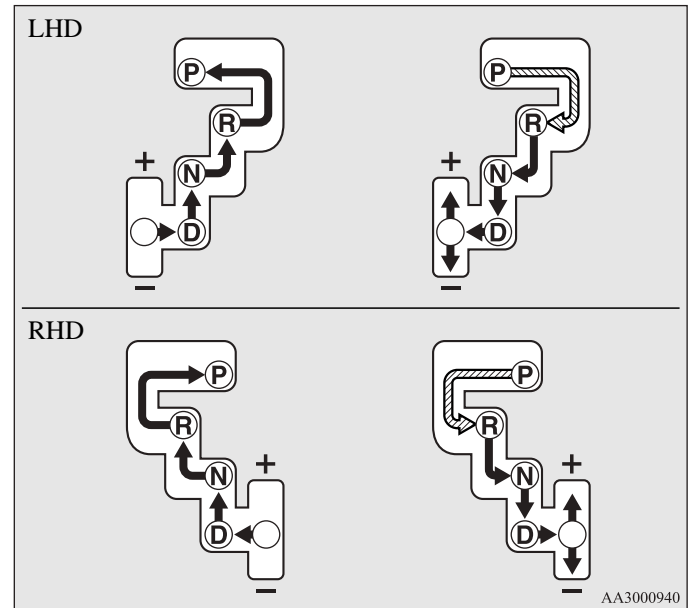

⬇	Depress the brake pedal while moving the selector lever through the gate.
⬇	Move the selector lever through the gate.

## **⚠ WARNING**

- Always depress the brake pedal when shifting the selector lever into a gear from the “P” (PARK) or “N” (NEUTRAL) position.

When beginning to drive, do not shift the selector lever from the “P” (PARK) or “N” (NEUTRAL) position while depressing the accelerator pedal, doing so is dangerous because the vehicle will “jump” forward or backward.

### NOTE

- To avoid erroneous operation, move the selector lever firmly into each position and briefly hold it there. Always check the position shown by the selector lever position indicator lamp after moving the selector lever.
- If the brake pedal is not depressed and held, the shift-lock device activates to prevent the selector lever from being moved from the “P” (PARK) position.
- For a shift indicated by  in the illustration, depress the brake pedal before moving the selector lever. If you attempt to move the selector lever before depressing the brake pedal, the selector lever may become immovable.

## Selector lever position indication lamps/“N” indication lamp

E00603500452

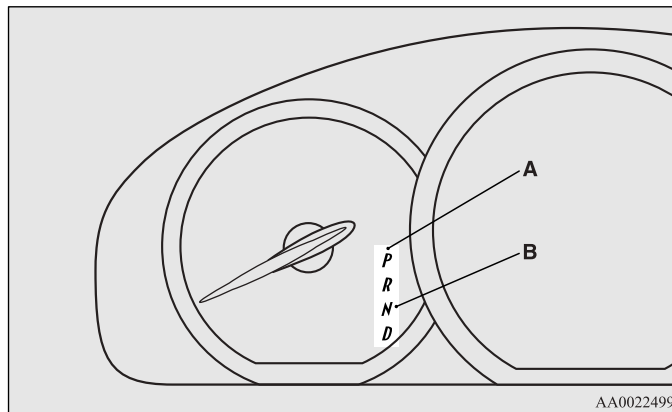

### A- Selector lever position indication lamps

When the ignition switch is turned to the “ON” position, the indication lamps in the instrument panel come on to show the position of the selector lever (i.e. “PARK”, “DRIVE”, “REVERSE”, etc.).

### B- “N” indication lamp

When the “N” indication lamp blinks with the “D” (DRIVE) position or “Sports mode” selected, the A/T may be malfunctioning.



## **CAUTION**

- If a malfunction occurs in the A/T while driving, the “N” indication lamp will blink.

In this case, immediately park your vehicle in a safe place and follow these procedure:

(The “N” indication lamp warning function does not operate with the selector lever in the “P” (PARK), “R” (REVERSE) or “N” (NEUTRAL) position.)

[The “N” indication lamp blinks rapidly (twice per second)]

The automatic transmission fluid is overheating.

Park your vehicle in a safe place but do not turn off the engine. Move the selector lever to the “P” (PARK) position and open the bonnet. Keep the engine idling.

After a while, move the selector lever to the “D” (DRIVE) position and confirm that the “N” indication lamp stops blinking. It is safe to continue driving if the “N” indication lamp no longer blinks.

If the “N” indication lamp continues blinking or blinks intermittently, we recommend you to have your vehicle inspected.

[The “N” indication lamp blinks slowly (once per second)]

The A/T safety device may be operating due to a malfunction.

We recommend you to have your vehicle inspected as soon as possible.

## Selector lever positions (Main gate)

E00603800077

### “P” *PARK*

This position locks the transmission to prevent the vehicle from moving. The engine can be started in this position.

### “R” *REVERSE*

Move the lever to this position only after the vehicle has come to a complete stop.

## **CAUTION**

- Never shift into the “P” (PARK) or “R” (REVERSE) position while the vehicle is in motion. If the lever is shifted into the “P” (PARK) or “R” (REVERSE) position while the vehicle is in motion, the transmission may be damaged.

### “N” *NEUTRAL*

At this position the transmission is disengaged. It is the same as the neutral position on a M/T, and should be used when the vehicle is stationary for an extended length of time during driving, such as in a traffic jam.

## **WARNING**

- Never move the selector lever to the “N” (NEUTRAL) position while driving. A serious accident could occur since you could accidentally move the lever into the “P” (PARK) or “R” (REVERSE) position or you will lose engine braking.

## **⚠ WARNING**

- On a gradient the engine should be started in the “P” (PARK) position, not in the “N” (NEUTRAL) position.
- Always keep your right foot on the brake pedal when the vehicle is in “N” (NEUTRAL), or when shifting into or out of “N” (NEUTRAL), to minimize the risk of loss of control.

### **“D” DRIVE**

This position is for normal driving. The transmission automatically selects a suitable gear for your speed and acceleration. Engine braking is automatically applied when necessary, depending on road conditions.

Please refer to “Uphill/downhill driving” on page 4-33.

### **Sports mode**

E00603900775

Whether the vehicle is stationary or in motion, sports mode is selected by pushing the selector lever from the “D” (DRIVE) position into the manual gate (A). To return to “D” range operation, push the selector lever back into the main gate (B).

In sports mode, gear shifts can be made rapidly simply by moving the selector lever backwards and forwards. In contrast to a M/T, the sports mode allows gear shifts with the accelerator pedal depressed.

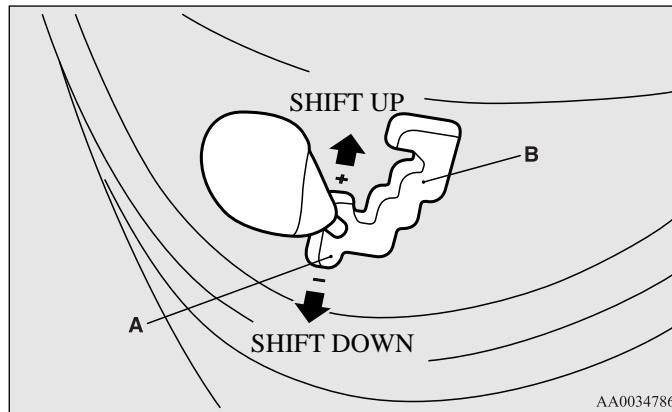

#### **+ (SHIFT UP)**

Push the lever forward once to shift up one gear.

#### **- (SHIFT DOWN)**

Pull the lever backwards once to shift down one gear.

**⚠ CAUTION**

- In sports mode, the upward shift from the 1st to 2nd gear is made automatically while the upward shifts to the 3rd and 4th gears are made by the driver. The driver must execute upward shifts in accordance with prevailing road conditions, taking care to keep the engine speed below the red zone.
- By rapidly moving the selector lever backwards (SHIFT DOWN) twice, it is possible to skip one gear, i.e., 3rd to 1st or 4th to 2nd. Since sudden engine braking and/or rapid acceleration can cause loss of traction, however, downshifts must be made carefully in accordance with the vehicle's speed.

**NOTE**

- In sports mode, only the 4 forward gears can be selected. To reverse or park the vehicle, move the selector lever to the “R” (REVERSE) or “P” (PARK) position as required.
- To maintain good running performance, the transmission may refuse to perform an upshift when the selector lever is moved to the “+ (SHIFT UP)” position at certain vehicle speeds. Also, to prevent over-revving of the engine, the transmission may refuse to perform a downshift when the lever is moved to the “- (SHIFT DOWN)” position at certain vehicle speeds.
- In sports mode, downward shifts are made automatically when the vehicle slows down. When the vehicle stops, 1st gear is automatically selected.
- When driving away on a slippery road, push the selector lever forward into the “+ (SHIFT UP)” position. This causes the transmission to shift into the 2nd gear which is better for smooth driving away on a slippery road. Push the selector lever to the “- (SHIFT DOWN)” side to shift back to the 1st gear.
- Move the selector lever gently between the manual and main gates and between positions in the manual gate. Undue force could damage the selector lever.

### Sports mode indicator lamp

E00612300010

In sports mode, the currently selected position is indicated on the instrument panel.

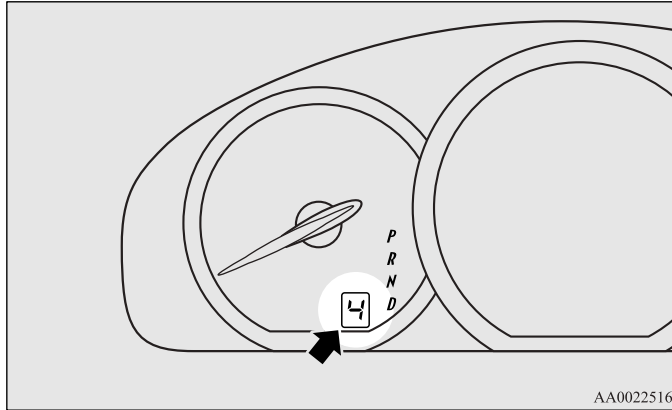

#### NOTE

- When sports mode is selected, the “D” indicator lamp goes off.

### Operation of the A/T

E00604200065

#### **CAUTION**

- Before selecting a gear with the engine running and the vehicle stationary, fully depress the brake pedal to prevent the vehicle from creeping.  
The vehicle will begin to move as soon as the gear is engaged, especially when the engine speed is high, at fast idle or with the air conditioning operating, the brakes should only be released when you are ready to drive away.
- Depress the brake pedal with the right foot at all times.  
Using the left foot could cause driver movement delay in case of an emergency.
- To prevent sudden acceleration, never race the engine when shifting from the “P” (PARK) or “N” (NEUTRAL) position.
- Operating the accelerator pedal while the other foot is resting on the brake pedal will affect braking efficiency and may cause premature wear of brake pads.  
Do not race the engine with brake pedal pressed.  
This can damage the transmission.  
Also, when the vehicle is stationary, the engine revolutions may not rise to the same revolutions as measured in normal starting even if the accelerator pedal is depressed while the brake pedal is being pressed.

## Passing acceleration

E00604500055

To gain extra acceleration in “D” (DRIVE) position (when passing another vehicle) push the accelerator to the floor. The A/T will automatically downshift.

### NOTE

- In sports mode, downshifts do not take place when the accelerator is depressed all the way to the floor.

## Uphill/downhill driving

E00610500018

### DRIVING UPHILL

The transmission may not upshift to a higher gear if the computer determines the current speed cannot be maintained once a higher gear is engaged.

For smoother vehicle performance, if you release the throttle while climbing a steep grade, the transmission may not upshift. This is normal, as the computer is temporarily preventing shifting. After reaching the top of the hill, normal gear shift function will resume.

### DRIVING DOWNHILL

When travelling down steep grades, the computer may automatically select a lower gear. This function assists engine braking efforts, reducing the need for using the brakes.

## Waiting

E00604600069

For short waiting periods, such as at traffic signals the vehicle can be left in gear and held stationary with the service brake. For longer waiting periods with the engine running, the selector lever should be placed in the “N” (NEUTRAL) position.

### CAUTION

- Never hold the vehicle stationary while in gear on a hill with the accelerator; always apply the parking brake and/or service brake.
- Unexpected acceleration may occur if the selector lever is in a position other than “P” (PARK) or “N” (NEUTRAL).  
Prior to moving off after having stopped the vehicle, make sure that the selector lever is in “D” (DRIVE) or “Sports mode” position.

### *Parking*

E00604700233

To park the vehicle, first bring it to a complete stop, fully engage the parking brake, and then move the selector lever to the “P” (PARK) position.

If you are going to leave the vehicle unattended, always switch off the engine and remove the ignition key.

#### NOTE

- On a slope, be sure to apply the parking brake before moving the selector lever to the “P” (PARK) position. If you move the selector lever to the “P” (PARK) position before applying the parking brake, it may be difficult to disengage the selector lever from the “P” (PARK) position when next you drive the vehicle, requiring application of a strong force to the selector lever to move from the “P” (PARK) position.

### *When the A/T makes no speed change*

E00604800351

If the transmission does not change speeds while driving, or your vehicle does not pick up enough speed when starting on an uphill slope, it may be that there is something unusual happening in the transmission, causing a safety device to activate. We recommend you to have your vehicle checked as soon as possible.

1. If your vehicle has difficulty moving uphill, shift the selector lever into 2nd gear of the sports mode.  
This method might not work depending on the type of transmission malfunction.
2. Once the vehicle is moving on a level road, move the selector lever back to “D” (DRIVE).

#### NOTE

- When the “N” indication lamp in the instrument panel blinks, it means that there is an abnormal condition in the transmission. Refer to “Selector lever position indication lamps/“N” indication lamp” on page 4-28.

## Braking

E00607000888

All the parts of the brake system are critical to safety. We recommend you to have the vehicle checked at regular intervals according to the service booklet.

### **CAUTION**

- **Avoid driving habits that cause heavy braking and never “ride” the brakes by resting your foot on the brake pedal while driving. It causes brake overheating and fade.**

### Brake system

The service brake is divided into two brake circuits so that when one brake circuit fails, the other is available to stop the vehicle. In this situation, even if the brake pedal moves down to the very end of its possible stroke, keep it pressed down hard; stop driving as soon as possible and have the brake system repaired.

### Power brakes

Your vehicle is equipped with power brakes for more braking force with less brake pedal effort.

Your brakes are designed to operate at full capacity, even if the power assist is not being used.

If the power assist is not being used, the effort needed to press the brake pedal is greater.

If you should lose the power assist for some reason, the brakes will still work.

If the power brake unit or either of the two brake hydraulic systems stops working properly, the rest of the brake system will still work, but the vehicle will not slow down as quickly.

You will know this has happened if you find you need to press the brake down further, or harder when slowing down or stopping, or if the brake warning lamp comes on.

### **WARNING**

- **Never coast downhill with the engine OFF. Keep the engine running whenever your vehicle is in motion. If you turn off the engine while driving, the power brake booster will stop working and your brakes will not work as well.**
- **If the power assist is lost or if either brake hydraulic system stops working properly, have your vehicle checked immediately.**

### Warning lamp

The brake warning lamp illuminates to indicate a fault in the braking system. Read “Brake warning lamp” on page 3-10.

### When brakes are wet

Check the brake system while driving at a low speed immediately after starting, especially when the brakes are wet, to confirm they work normally.

A film of water can be formed on the brake discs and prevent normal braking after driving in heavy rain or through large puddles, or after the vehicle is washed. If this occurs, dry the brakes out by driving slowly while lightly depressing the brake pedal.

## When driving downhill

It is important to take advantage of the engine braking by shifting to a lower shift position while driving on steep downhill roads in order to prevent the brakes from overheating.

### **⚠ WARNING**

- Do not leave any objects near the brake pedal or let a floor mat slide under it; doing so could prevent the full pedal stroke that would be necessary in an emergency. Make sure that the pedal can be operated freely at all times. Make sure the floor mat is securely held in place.

## Brake pads

- With new brake pads, avoid where possible sudden full application of the brakes for the first 200 km (124 miles) of driving.
- The disc brakes are provided with a warning device which emits a shrieking metallic sound while braking if the brake pads have reached their limit.  
If you hear this sound, have the brake pads replaced.

### **⚠ WARNING**

- Driving with worn brake pads will make it harder to stop, and can cause an accident.

## *Anti-lock brake system (ABS)*

E00607100560

Environmental conditions can have an effect on braking. During sudden braking when there is snow, ice, oil, water etc. on the road surface, a skid may occur. In this situation, steering control and braking effectiveness is reduced and the stopping distance is increased. The vehicle may also go into an uncontrolled spin.

The ABS helps prevent the wheels from locking during braking, thus maintaining directional stability, ensuring controllability and providing optimum braking force.

## Driving hints

- With ABS fitted, steering during sudden braking (when the ABS functions) differs slightly from when the brakes are not being applied.  
Steer the vehicle carefully in these conditions.
- Always maintain the same distance from the vehicle in front of you as you would for a vehicle not equipped with ABS.  
Compared with vehicles not fitted with ABS, your vehicle may require a longer stopping distance in the following cases:
  - Driving on gravel or snow-covered roads.
  - Driving with tyre chains installed.
  - Driving on roads where the road surface is pitted or has other differences in surface height.
  - Driving on bumpy roads or other poor driving surfaces.



- Operation of ABS is not restricted to situations where brakes are applied suddenly. This system may also operate to prevent wheel lock when you are driving over man-holes, steel road-work plates, or the vehicle is driven over steps or level differences in the road, road markings, or other surfaces which are difficult for the wheels to grip.
- When the ABS is activated, you may feel the brake pedal pulsating and hear a characteristic noise. Also at this time, it may feel as if the pedal attempts to resist being depressed.

**In this situation, to let the ABS work for you, just hold the brake pedal down more firmly. Do not pump the brake. This will result in reduced braking performance.**

## **CAUTION**

- **Even the ABS cannot prevent the natural laws of physics from acting on the vehicle. It cannot for instance avoid accidents that may result from excessive speed on bends or following another vehicle too closely or aquaplaning. It should remain the driver's task to observe safety precautions to judge speeds and brake applications correctly in such conditions.**
- **Be sure to use tyres of the same type and size on 4 wheels.**  
If tyre types or sizes are mixed, ABS may not function normally.
- **Never install a limited slip differential, which is not a MITSUBISHI MOTORS genuine part, as the ABS may not function normally.**  
We recommend to consult a MITSUBISHI MOTORS Authorized Service Point.

## ABS warning lamp

E00607200721

The ABS warning lamp should illuminate when the ignition switch is turned "ON", and should go off in a few seconds.

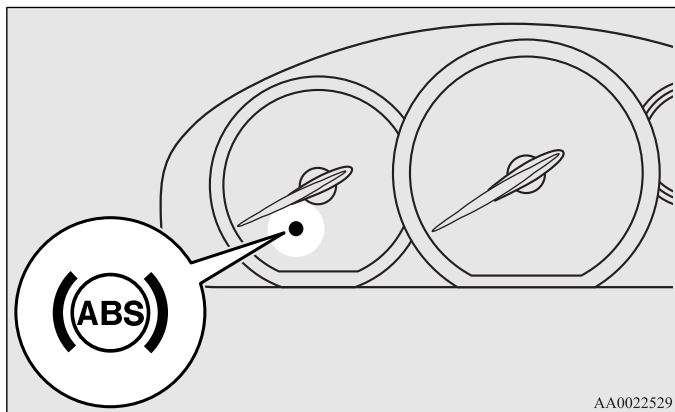

4

### **⚠ CAUTION**

- If the warning lamp stays on or does not illuminate when you start the vehicle, it indicates that the ABS is not functioning and that only the standard brake system is in operation. (In this condition the standard hydraulic brake system will still function.) We recommend you to consult a MITSUBISHI MOTORS Authorized Service Point.

## If the warning lamp illuminates while driving

E00607300940

### *If only the ABS warning lamp illuminates*

- Avoid hard braking and high-speed driving. Stop the vehicle in a safe place. Restart the engine and check to see whether the lamp goes out after a few minutes driving; if it then remains off during driving, there is no problem. However, if the lamp does not go out, or if it lights up again when the vehicle is driven, we recommend you to consult a MITSUBISHI MOTORS Authorized Service Point.
- The ABS warning lamp can illuminate if the battery voltage is insufficient when the engine is started. In this case, it does not indicate an ABS fault. Charge the battery by allowing the engine to idle for a while. If the battery has been charged but the ABS warning lamp continues to illuminate or illuminates intermittently, we recommend you to consult a MITSUBISHI MOTORS Authorized Service Point.

### *If the ABS warning lamp and brake warning lamp illuminate at the same time*

- The ABS and brake force distribution function may not work, so hard braking could make the vehicle unstable. Avoid hard braking and high-speed driving. Stop the vehicle in a safe place and we recommend you to consult a MITSUBISHI MOTORS Authorized Service Point.

## NOTE

- Immediately after the vehicle starts moving after engine start up, a whining sound of the motor will be heard from the engine compartment. If the brake pedal is depressed at that moment, a brake pedal pulsating is felt. This pulsation is due to the self-diagnosis operation of the ABS and does not indicate a malfunction.
- After driving on snowy roads, remove any snow and ice which may have become adhered to the wheel areas. When doing this, be careful not to damage the wheel speed sensors (A) and cables located at each wheel on vehicles equipped with an ABS.

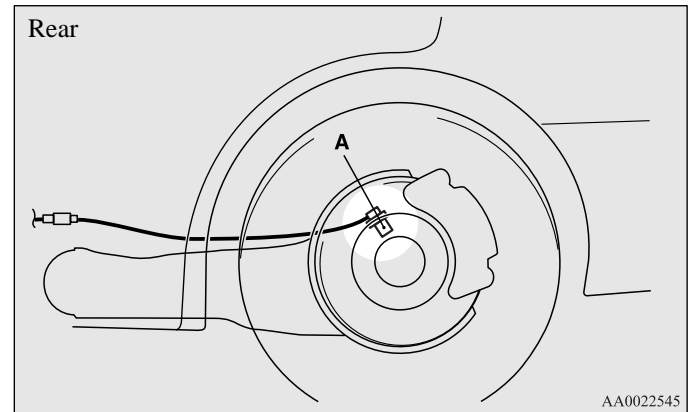
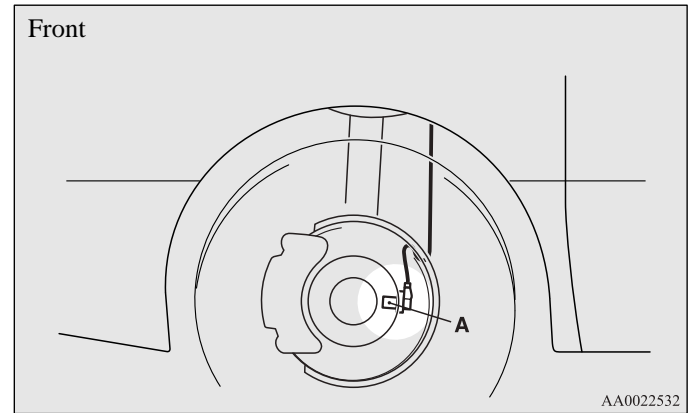

## Starting and driving

- The ABS becomes operative after the vehicle has accelerated to a speed in excess of approximately 10 km/h (6 mph). It stops operating when the vehicle decelerates to a speed below approximately 5 km/h (3 mph).

## *Power steering system*

E00607400127

When the engine is stopped, the power steering system will not function and it will require greater manual effort to operate the steering wheel. Keep this in mind in particular when towing the vehicle. Never turn off the engine while driving. Periodically check the power steering fluid level.

### **CAUTION**

- **Do not hold the steering wheel in the fully turned position (either left or right), for longer than 10 seconds.  
This can cause damage to the power steering system.**

## Active stability control (ASC)\*

E00611700118

The active stability control (ASC) takes overall control of the anti-lock brake system, traction control function and stability control function to help maintain the vehicle's control and traction. Please read this section in conjunction with the page on the anti-lock brake system, traction control function and stability control function.

Anti-lock brake system (ABS) → p. 4-36

Traction control function → p. 4-42

Stability control function → p. 4-43

### CAUTION

- Do not over-rely on the ASC. Even when the ASC is operating, there are limits to the system and its ability to maintain control and traction. Reckless driving may lead to accidents. Always drive carefully, taking account of the road conditions.
- Be sure to use the same specified type and size of tyre on all 4 wheels. Otherwise, there is a possibility that the ASC will not work properly.

### NOTE

- In the following situation, a click is heard from the engine compartment. However, this is only the sound of ASC being checked.
  - After turning the ignition switch to the “ON” position.
  - After your vehicle is driven a short distance after starting the engine.
- Some vibration will be felt in the vehicle body and a whining sound of the motor will be heard from the engine compartment when the ASC functions. This is a normal result of the ASC operation and does not indicate a malfunction.
- The ASC does not operate while the ABS warning lamp is illuminated.

## Traction control function

E00611800050

On slippery surfaces, the traction control function prevents the drive wheels from excessive spinning, thus helping the vehicle to start moving from a stop. It also provides sufficient driving force and steering performance as the vehicle turns at accelerated speeds.

### **⚠ CAUTION**

- When driving a vehicle on a snowy or icy road, be sure to install snow tyres and drive the vehicle at moderate speeds.
- When a tyre such as a compact spare tyre, which is different in size from the standard tyre, has been installed, make sure that the traction control function is turned off.

### NOTE

- When moving out of mud, sand or fresh snow, pressing the accelerator pedal may not allow the engine speed to increase.  
If this happens and the vehicle remains stuck as a result, turn the TCL switch OFF. The vehicle will then be easier to extricate.
- When climbing or beginning to climb a steep slope, turn the TCL switch OFF if the traction control function reduces the engine speed excessively.

## *TCL switch*

E00611900048

The traction control function automatically goes on, when the ignition switch is turned to the “ON” position. To deactivate the traction control function, press the TCL switch. To reactivate the traction control function, press the TCL switch again. MITSUBISHI MOTORS recommends to normally keep the traction control function on.

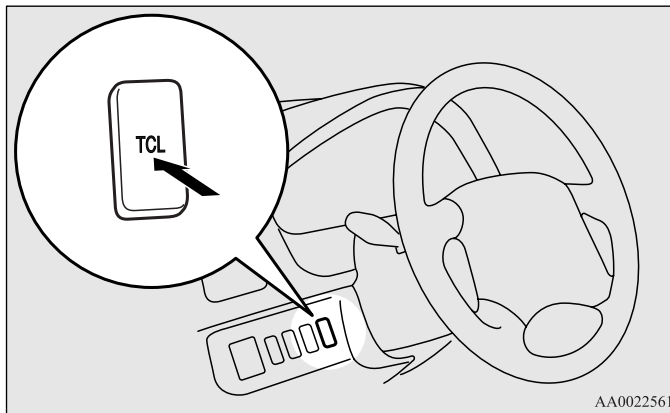

## Stability control function

E0061200088

The stability control function is designed to help maintain the vehicle's control in slippery conditions, or during rapid steering manoeuvres. It works by controlling the engine output and the brake on each wheel.

### NOTE

- The stability control function operates at speeds of about 30 km/h (19 mph) or higher.

## ASC indication lamp, TCL OFF indication lamp

E00612100089

The traction control function and stability control function share the same indication lamp.

The indication lamps should illuminate when the ignition switch is turned to the "ON" position, and should go off after a few seconds. Always make sure that the lamp goes out before beginning to drive.





If one or both indication lamps stay on or do not illuminate when the ignition switch is turned to the "ON" position, we recommend you to consult a MITSUBISHI MOTORS Authorized Service Point.

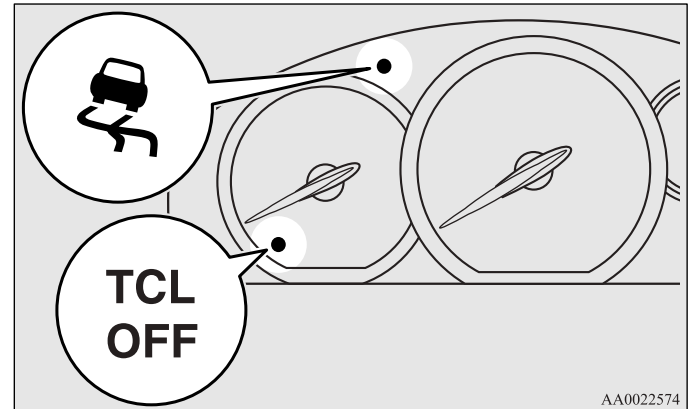

 indication lamp blinks when the ASC is operating.



 indication lamp is illuminated when the traction control function is off.



## ⚠ CAUTION

- When the  indication lamp blinks, ASC is operating, which means that the road is slippery or that your vehicle's wheels are slipping excessively. If this happens, drive slower with less accelerator input.
- If a malfunction occurs in the device, the  and  indication lamps will continuously illuminate. Park your vehicle in a safe place and stop the engine. Then, start the engine again and check whether the  and  indication lamps go out.

If the  and  indication lamps remain on even after your vehicle is driven a short distance after starting the engine, we recommend you to consult a MITSUBISHI MOTORS Authorized Service Point.

- If continuous brake control (on a slippery surface, for example) causes the temperature of the braking system to increase excessively, the traction control function (working by controlling the brake on each wheel) will be suspended to protect the braking system. [The traction control function (working by controlling the engine output) will operate. Normal operation of the vehicle will not be affected.] At this time, the  indication lamp will blink to inform the driver that the traction control function (working by controlling the brake on each wheel) is suspended. If the vehicle is stopped and the  indication lamp goes off, the traction control function (working by controlling the brake on each wheel) will start operating again.

## ⚠ CAUTION

- If the vehicle is towed with the ignition switch in the “ON” position and only the front wheels or only the rear wheels raised off the ground, the traction control function may operate, resulting in an accident. When towing the vehicle with the front wheels raised, keep the ignition switch in the “LOCK” or “ACC” position. When towing the vehicle with the rear wheels raised, keep the ignition switch in the “ACC” position. Refer to “Towing” on page 6-28.

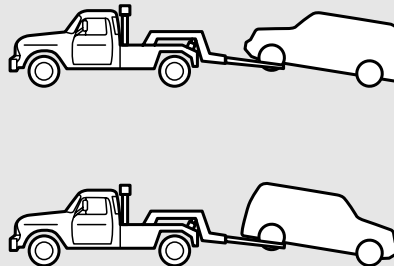

AA0029674



## Auto-speed (cruise) control\*

E00609100391

Auto-speed control is an automatic speed control system. It lets you keep the same driving speed, auto-speed control can be used at about 40 km/h (25 mph) or more. It is especially useful for highway driving. Auto-speed control does not work at speeds below about 40 km/h (25 mph).

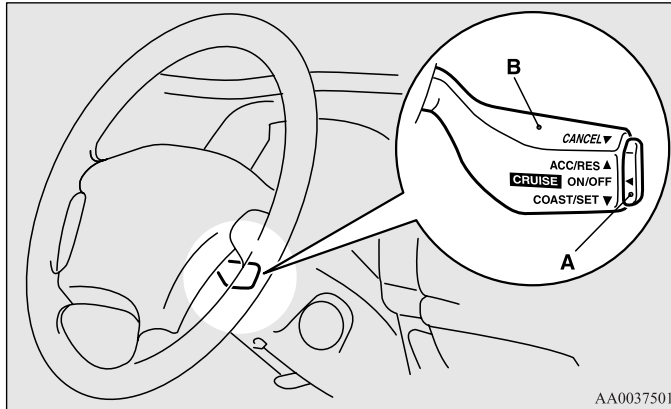

A- Main switch

B- Auto-speed control lever

### **⚠ CAUTION**

- For safety reasons, deactivate the cruise control system using the main switch (A) when you are not using the auto-speed control system. (Refer to “To deactivate” on page 4-50.)

### **⚠ CAUTION**

- Auto-speed control is not recommended when driving conditions will not allow you to stay at the same speed, such as in heavy traffic or on roads that are winding, icy, snow-covered, wet, or slippery, or on a steep downhill.
- For vehicles with M/T, if you shift to “N” (Neutral) position in auto-speed control mode without pressing the clutch first, the engine will run too fast and might be damaged.

### NOTE

- Auto-speed control may not be able to keep your speed on uphill or downhill.
- Your speed may drop on a steep uphill. You must use the accelerator pedal if you want to stay at your set speed.
- Your speed may increase to more than the set speed on a steep downhill. You must use the brake to control your speed. If your speed increases too much, turn off the auto-speed control. (Refer to “To deactivate” on page 4-50.)

## CRUISE indication lamp

E00609200161

This lamp comes on when the auto-speed control is activated by operation of the auto-speed control main switch.

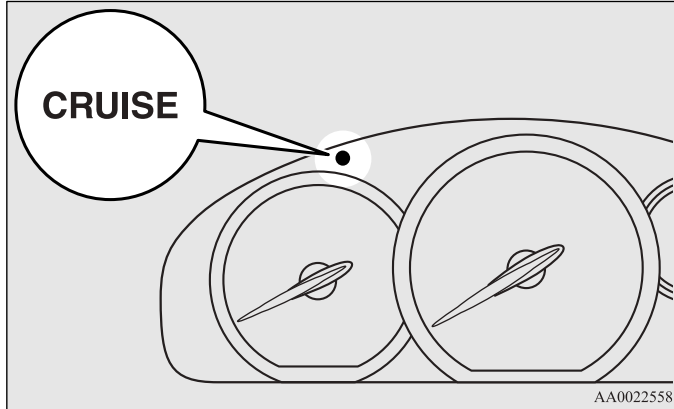

## To activate

E00609300595

1. Push the main switch (A) at the end of the auto-speed control lever.

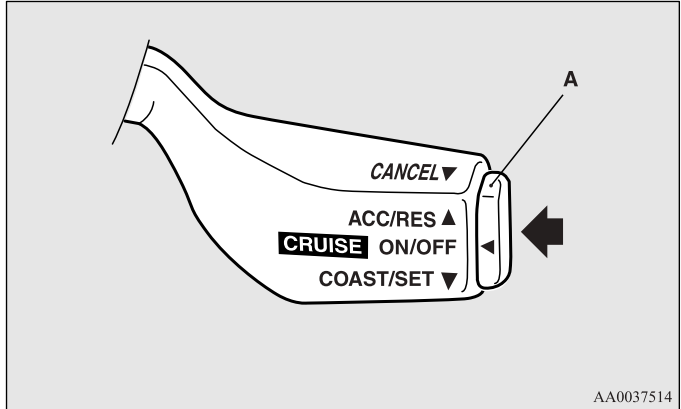

2. Pull the lever (B) down while driving at the desired speed.

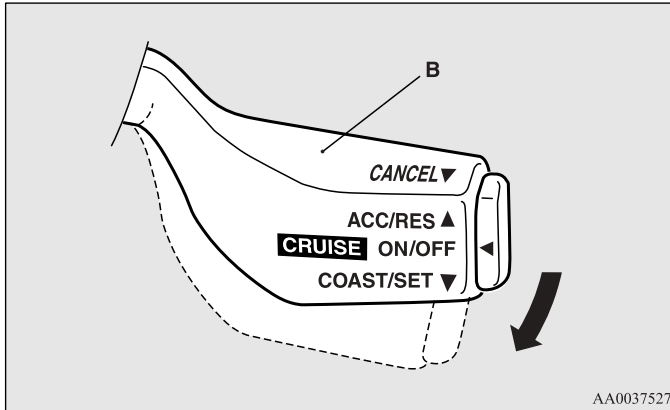

#### NOTE

- If the main switch is on when the ignition switch is turned to “LOCK” or “ACC” position, auto-speed control will be on automatically the next time you start the engine. The CRUISE indication lamp will also come on. You will need to reset the speed however, if you want to use auto-speed control.
- If the battery voltage is insufficient, the memory data for the main switch will be erased. As a result, the CRUISE indication lamp may not come on when you restart the engine. If this happens, push in the main switch once again to activate the system.
- On diesel-powered vehicles, it is not possible to set the vehicle speed while driving in 1st gear.

## To increase the set speed

E00609400323

There are 2 ways to increase the set speed.

### *Auto-speed control lever*

Pull the auto-speed control lever up and hold it while driving at the set speed, and you will increase gradually. When you reach your desired speed, release the switch. Your cruising speed is now set.

To increase your speed in small amounts, press the auto-speed control lever up for less than 1 second and release it. Each time you press the lever up, your vehicle will go about 1.6 km/h (1 mph) faster.

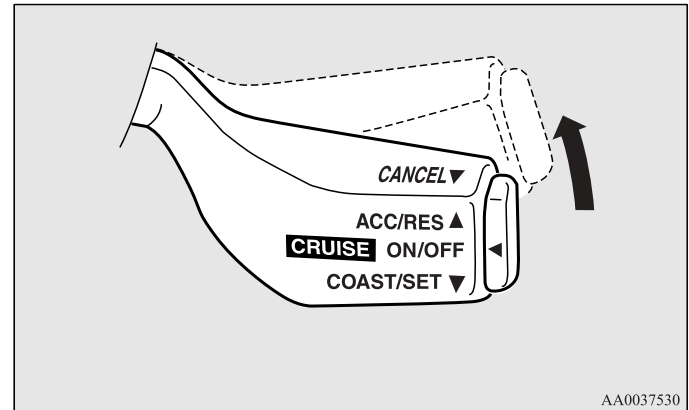

## Starting and driving

### *Accelerator pedal*

Use the accelerator pedal to reach your desired speed and then pull the auto-speed control lever down.

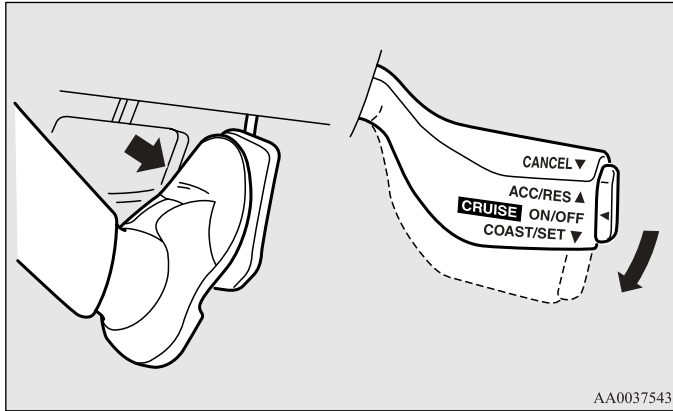

### **To decrease the set speed**

E00609500278

There are 2 ways to reduce the set speed.

#### *Auto-speed control lever*

Pull the auto-speed control lever down and hold it while driving at the set speed, and you will slow down gradually. When your desired low speed is reached, release the switch.

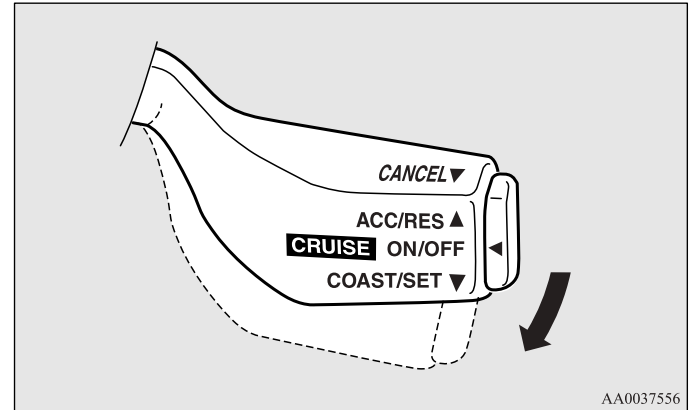

To slow down in small amounts, press the auto-speed control lever down for less than 1 second and release it. Each time you press the lever down, your vehicle will slow down by about 1.6 km/h (1 mph).

### ***Brake pedal***

Use the brake pedal (which disengages the auto-speed control), then pull the auto-speed control lever down momentarily to set a new desired cruise speed.

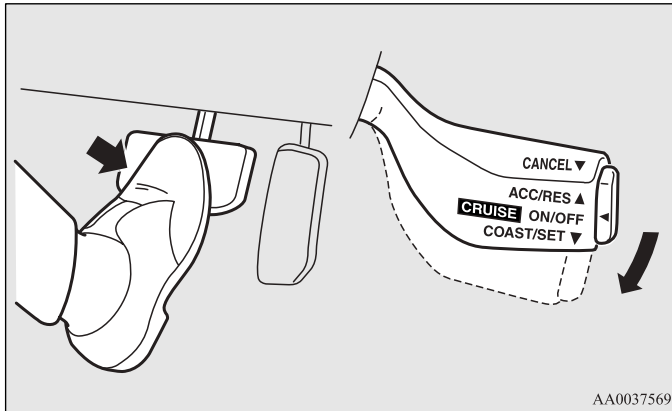

### **To accelerate for passing**

E00609600019

Press the accelerator pedal as you would normally. When you release the pedal, you will return to your set speed.

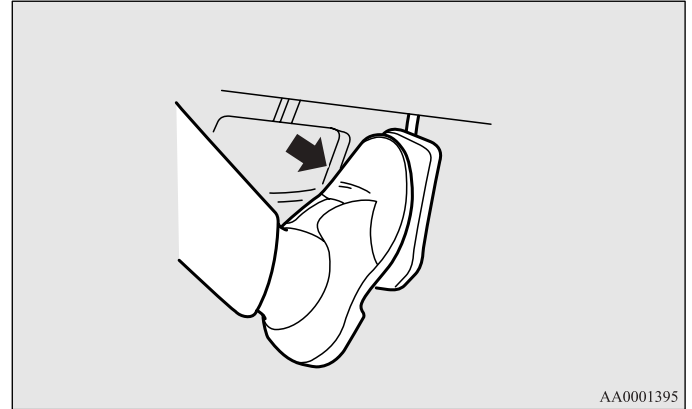

## To deactivate

E00609700599

The auto-speed control can be turned off as follows:

- Push the main switch (A) at the end of the lever. (Main switch OFF)
- Pull the auto-speed control lever (B) towards you.
- Depress the brake pedal.

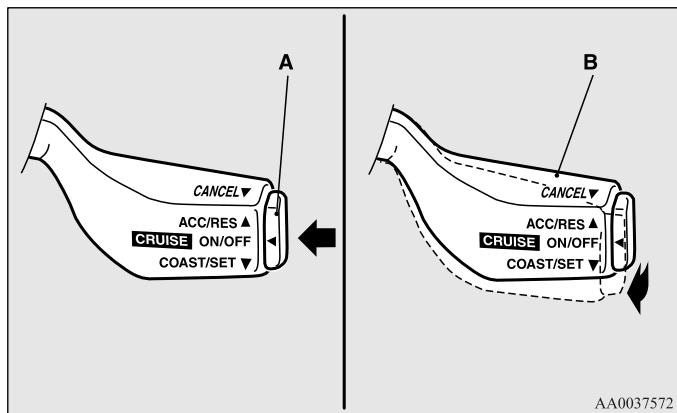

The auto-speed control is turned off automatically in any of the following ways.

- By pressing the clutch pedal down (for vehicles with M/T).
- When your speed decreases to about 15 km/h (9 mph) or less below the set speed because of a hill, etc. (for petrol-powered vehicles)
- When your speed decreases to about 40 km/h (25 mph) or less.

- When the active stability control (ASC) starts operating (if so equipped). Refer to “Active stability control (ASC)” on page 4-41.

## **⚠ WARNING**

- For vehicles with A/T, although the auto-speed control will be disengaged when shifting to the “N” (NEUTRAL) position, never move the selector lever to the “N” (NEUTRAL) position while driving. You would have no engine braking and could cause a serious accident.

## To resume the set speed

E00609800271

If the speed memory has not been erased, resume the previously set speed by pulling the auto-speed control lever up while driving at a speed of about 40 km/h (25 mph) or higher.

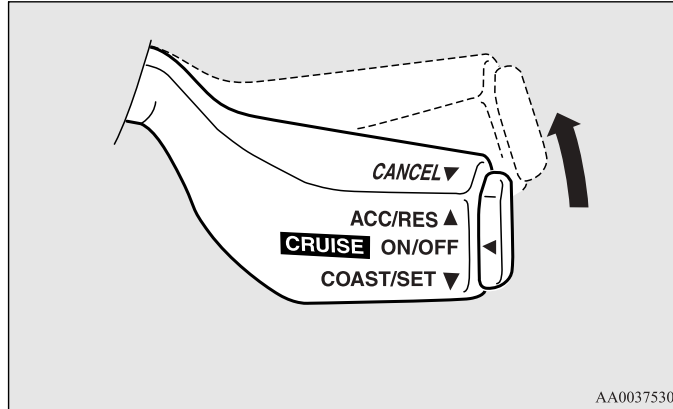

Under either of the following conditions, however, using the switch does not allow you to resume the previously set speed. In these situations, repeat the speed setting procedure:

- The ignition switch is turned OFF.
- The main switch is turned OFF.

## Corner sensor system\*

E00615500039

This system operates when you are backing the vehicle. It uses corner and back sensors to detect an obstacle and sounds a buzzer to inform you of the approximate distance to the obstacle.

### **⚠ CAUTION**

- The corner sensor system assists you in determining the approximate distance between the vehicle and an obstacle located behind the vehicle. It has limitations in terms of detectable areas and objects, and may not properly detect some objects. Therefore, do not place excessive confidence in the corner sensor system, and operate the vehicle as carefully as you would a vehicle without this system.
- Make sure to check the surroundings with your own eyes to ensure safety. Do not operate the vehicle by relying on the corner sensor system alone.

## Obstacle detection areas

E00615600199

The detection areas of the corner and back sensors are limited to those shown in the illustration. Moreover, the sensors are unable to detect low or thin objects or objects near the rear bumper. Thus, make sure to check the surroundings as you operate the vehicle in a safe manner.

### Corner and back sensor locations

There are two corner sensors (A) at the corners of the rear bumper, and two back sensors (B) in the centre of the rear bumper.

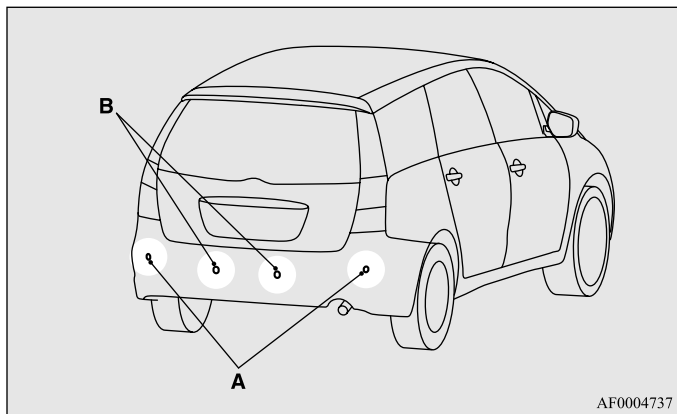

## Corner sensor system detection areas

Depending on whether the vehicle is equipped with a towbar, you can change the corner sensor system between the standard mode and the towbar mode. The towbar mode changes the system to exclude the area in which the towbar is mounted from the detection areas.

### Vehicles without a towbar

The detection areas are within approximately 50 cm (A) from the corner sensors, 100 cm (B) from the back sensors, and 60 cm (C) or less from the ground surface, excluding the area approximately 10 cm (D) from the ground surface.

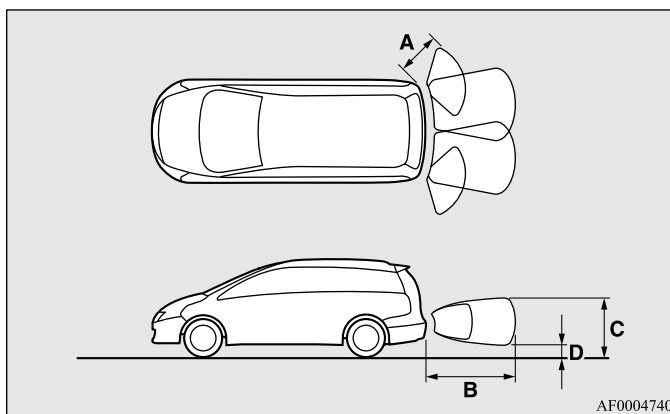



### Vehicles with a towbar

The detection areas are within approximately 50 cm (A) from the corner sensors, 100 cm (B) from the back sensors, and 60 cm (C) or less from the ground surface, excluding the area approximately 10 cm (D) from the ground surface. The non-detection areas (E) are within approximately 20 cm (F) from the bumper.

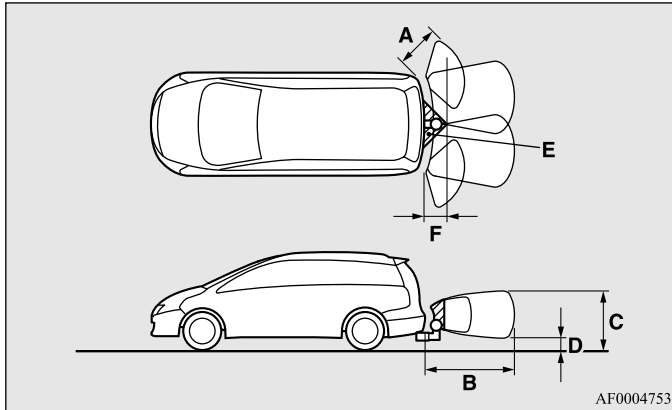

### NOTE

- If the rear bumper has been exposed to an impact, the corner or back sensors may fail and prevent the system from functioning properly. We recommend you to have your vehicle inspected.
- The sensors do not detect objects located in the area directly below or near the bumper. If the height of an object is lower than the mounted position of the corner or back sensors, the sensors may not continue detecting it even if they detected it initially.

For information on how to change the detection areas, please refer to “Changing the detection areas” on page 4-56.

### **CAUTION**

- **The corner sensor system may not operate properly under the following conditions:**
  - The sensors or surroundings are covered with ice, snow, or mud.
  - The sensors are frozen.
  - The system receives ultrasonic noise from other sources (the horns of other vehicles, motorcycle engines, brakes, radios, pouring rain, splashing water, tyre chains, etc.).
  - The sensors are extremely hot or cold (while the vehicle is parked for a long period of time under a blazing sun or in cold weather).
  - The vehicle tilts significantly.
  - The vehicle is driven on a rough road (with a bumpy, gravel, hilly, or grassy surface).
  - The vehicle is too close to an obstacle.
  - The sensors or surroundings have been wiped by hand, or stickers or accessories have been attached.
- **The corner sensor system may not properly detect the following:**
  - Objects that are thin, such as wire nets or ropes.
  - Objects that absorb sound waves, such as snow.
  - Objects that are shaped with a sharp angle.
  - Objects with a smooth surface, such as glass.
  - Objects that are low, such as kerbstones.

## Starting and driving

### NOTE

- The buzzer may sound lower than the normal warning sound when the corner sensor system is receiving ultrasonic noise from other sources, but this is not a malfunction. The buzzer will stop sounding and the system will return to normal operation after the noise is no longer received.

### To operate

E00615700204

To operate the system while the ignition switch is “ON”, move the selector lever to the “R” (REVERSE) position on an A/T vehicle, or move the gearshift lever into reverse on a M/T vehicle. To stop the operation, push the SONAR switch.

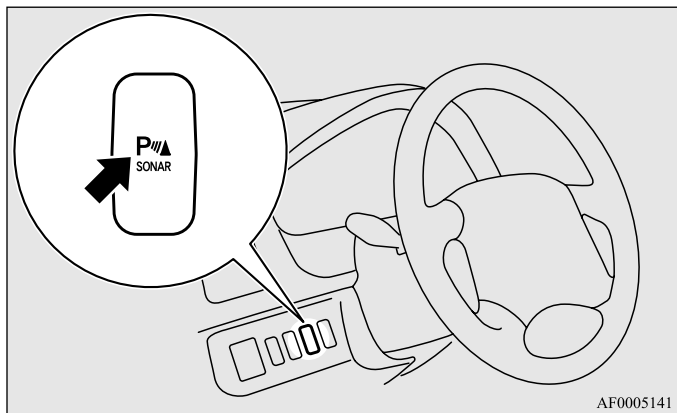

The SONAR OFF indication lamp will illuminate to indicate that the system has stopped operating.

It will flash in case there is a malfunction in the system. For details, refer to “SONAR OFF indication lamp” on page 4-57.

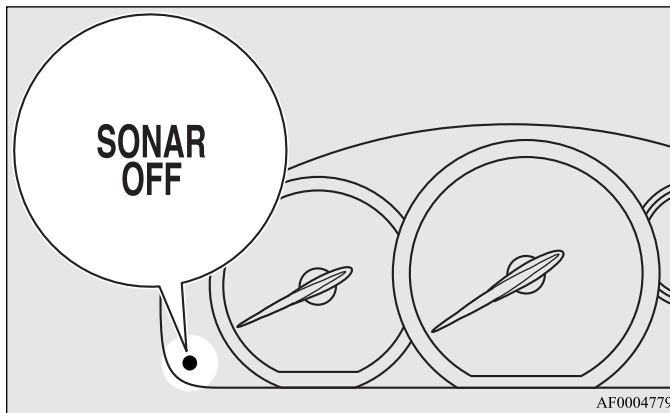

To return the system to the operating state, push the SONAR switch again. When the system returns to the operating state, the buzzer sounds once and the SONAR OFF indication lamp turns off.

### NOTE

- The SONAR OFF indication lamp flashes once when the ignition switch is turned “ON”.

The warning buzzer sounds when the system detects an obstacle during operation.

#### NOTE

- After pushing the SONAR switch, corner sensor system operation differs according to the detection area setting.
  - Setting when towbar is not equipped  
When the selector lever is moved to the “R” (REVERSE) position, the corner sensor system will operate even if corner sensor system operation was stopped by pushing the SONAR switch.
  - Setting when towbar is equipped  
When corner sensor system operation was stopped by pushing the SONAR switch, the corner sensor system will not operate until the engine has been stopped even if the selector lever is moved to the “R” (REVERSE) position.  
To resume corner sensor system operation, push the SONAR switch or stop and restart the engine, and then move the selector lever to the “R” (REVERSE) position.

#### **Warning for obstacles**

If there is an obstacle behind the vehicle, a warning buzzer sounds to indicate the distance between the vehicle and the obstacle.

#### **Corner sensor**

Vehicle to obstacle distance	Warning sound cycle
Approx. 50 to 40 cm	Intermittent
Approx. 40 to 25 cm	Fast intermittent
Within approx. 25 cm	Continuous

#### **Back sensor (vehicles without a towbar)**

Vehicle to obstacle distance	Warning sound cycle
Approx. 150 to 80 cm	Intermittent
Approx. 80 to 40 cm	Fast intermittent
Within approx. 40 cm	Continuous

#### **Back sensor (vehicles with a towbar)**

Vehicle to obstacle distance	Warning sound cycle
Approx. 150 to 120 cm	Intermittent
Approx. 120 to 60 cm	Fast intermittent
Within approx. 60 cm	Continuous

**⚠ CAUTION**

- **The distances given are to be used for reference only, as errors may be caused by various factors, such as temperature, humidity, or the shape of the obstacles.**

*Changing the detection areas*

E0061580087

The detection areas can be changed as follows:

**Vehicles with a towbar**

While the operation of the system is stopped at the SONAR switch, push the SONAR switch approximately 3 seconds or more, and release it. The buzzer sounds twice to indicate that the detection area has been changed.

**Vehicles without a towbar**

While the operation of the system is stopped at the SONAR switch, push the SONAR switch approximately 3 seconds or more, and release it. The buzzer sounds once to indicate that the detection area has been changed.

**NOTE**

- The detection area will not change if you keep the SONAR switch pushed for 10 seconds or more.

## SONAR OFF indication lamp

E0061590033

In case there is a malfunction in the corner sensor system, the SONAR OFF indication lamp will flash and the warning buzzer will sound for approximately 5 seconds. Even after the buzzer has stopped sounding, the indication lamp will continue flashing until the system reverts to the normal state. We recommend you to have your vehicle inspected.

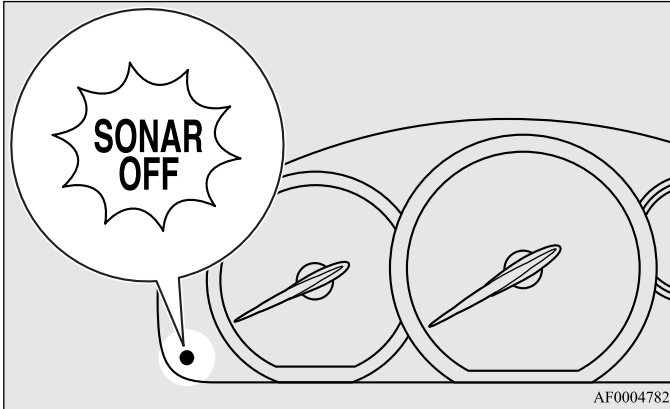

## Cargo loads

E00609900634

### Cargo loads precautions

#### **⚠ CAUTION**

- Do not load cargo or luggage higher than the top of the seatback. Be sure that your cargo or luggage cannot move once your vehicle is moving. Having either the rear view blocked, or your cargo being thrown inside the cabin if you suddenly have to brake can cause a serious accident or injury.
- Load heavy cargo or luggage in the front of the vehicle. If the load in the back of the vehicle is too heavy, steering may become unstable.

## Loading a roof carrier\*

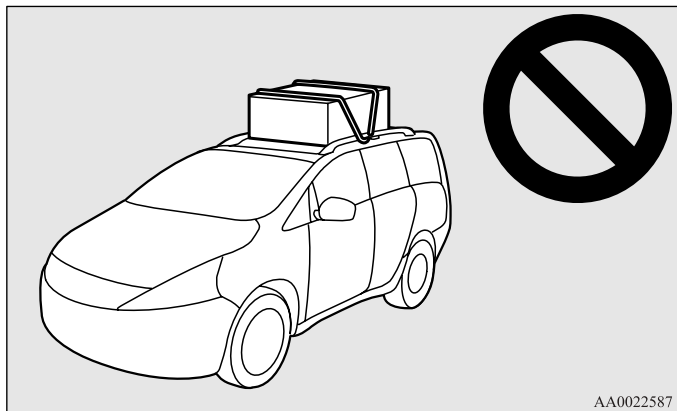

### **⚠ CAUTION**

- Do not load luggage directly onto the roof. Use a roof carrier that properly fits your vehicle. For installation, refer to the instruction manual accompanying the roof carrier.

#### NOTE

- We recommend you to use a genuine MITSUBISHI roof carrier, since the brackets to be used have a special shape. For details, we recommend you to consult a MITSUBISHI MOTORS Authorized Service Point.

## Roof carrier mounting brackets\*

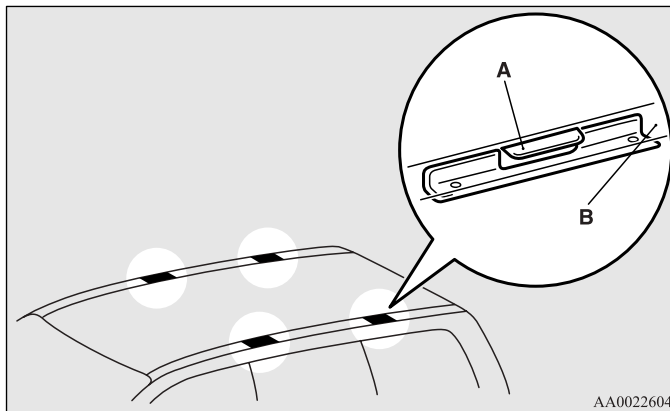

When installing the roof carrier, use the brackets (A). The brackets (A) are located under each roof drip moulding (B).

#### NOTE

- We recommend you to use a genuine MITSUBISHI roof carrier, since the brackets to be used have a special shape. For details, we recommend you to consult a MITSUBISHI Authorized Service Point.

## Roof carrier precaution

### **CAUTION**

- **Make sure that the weight of the luggage does not exceed the allowable roof load.**  
If the allowable roof load is exceeded, this may cause damage to the vehicle.  
The roof load is the total allowable load on the roof (the weight of the roof carrier plus the weight of luggage placed on the roof carrier).  
For specific figures, please refer to “Maximum roof load” on page 9-8.
- **When luggage is loaded onto the vehicle, please make sure to drive slowly and avoid excessive maneuvers such as sudden braking or quick turning.**  
In addition, place the luggage on the carrier so that its weight is distributed evenly with the heaviest items on the bottom. Do not load items that are wider than the roof carrier.  
The additional weight on the roof could raise the vehicle’s centre of gravity and affect vehicle handling characteristics.  
As a result, driving errors or emergency maneuvers could lead to a loss of control and result in an accident.

### **CAUTION**

- **Before driving and after travelling a short distance, always check the load to make sure it is securely fastened to the roof carrier.**  
Check periodically during your travel that the load remains secure. If the load is not secure, it could fall from the vehicle and damage your vehicle, another vehicle or create road hazard.

#### NOTE

- To prevent wind noise or reduction in fuel economy, remove the roof carrier when not in use.
- Before using an automatic car wash, check with the attendant to determine if the roof carrier should be removed.
- Be sure that adequate clearance is maintained for raising the sunroof (if so equipped) and/or the tailgate when installing a roof carrier.

## Trailer towing

E00610000172

In order to tow a trailer with your vehicle, have a trailer towing device mounted that meets all relevant regulations in your area. Consult a MITSUBISHI MOTORS Authorized Service Point. The regulations concerning the towing of a trailer may differ from country to country. You are advised to obey the regulations in each area.

### **⚠ CAUTION**

● **Danger of Accident!**

A towing bar should be fitted according to MITSUBISHI MOTORS guidelines.

#### NOTE

- If you are going to tow a trailer, pay careful attention to the following points.

### **Maximum towable weight with brake and maximum trailer-nose weight**

Never exceed the maximum towable weight with brake and the maximum trailer-nose weight as listed in the specifications. (Refer to page 9-8)

If you tow a trailer at an altitude of more than 1,000 m above sea-level, reduce your weight by 10 % of the gross combination weight for every increase of 1,000 m above sea-level, as the engine output is lowered owing to decrease in atmospheric pressure.

## Towing bar mounting specifications

See the following table for fixing points (A) for the towing bar.

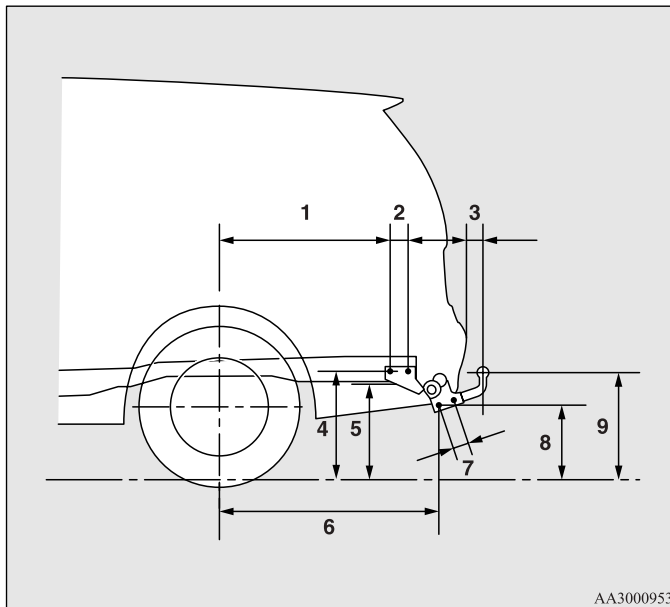



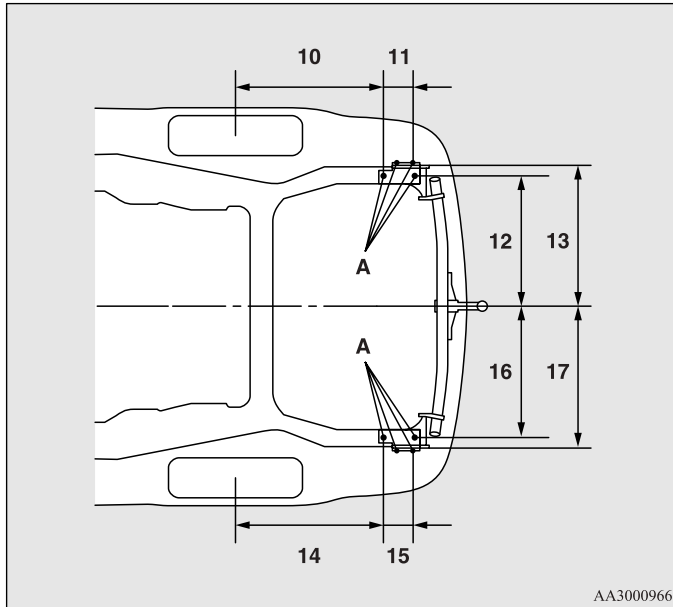

1	720 mm
2	76 mm
3	75 mm
4	435 mm
5	383 mm
6	926 mm
7	60 mm
8	292 mm
9	430 mm
10	661 mm
11	142 mm
12	590 mm
13	639 mm
14	661 mm
15	142 mm
16	590 mm
17	639 mm

Item 4, 5, 8 or 9: at kerb weight

#### NOTE

- The value of item 4, 5, 8 or 9 is applicable to unladen vehicles. These values can also be varied depending on the tyre size, optional equipment and suspension conditions.

### Operating hints

- Do not let the clutch slip (vehicles with M/T only) and do not increase the engine speed more than necessary when starting.
- Be sure that the driving speed does not exceed the 100 km/h (62 mph) for trailer operation.  
It is also recommended that you obey the local regulations in case driving speed with a trailer is limited to less than 100 km/h (62 mph).
- To prevent shocks from the overrun brake, depress the brake pedal lightly at first and then more strongly.
- To make full use of engine braking, change to a lower gear before descending a slope.
- The body, brakes, clutch, and chassis will be under additional strain when towing a trailer.
- The heavier weight and higher rolling and air resistance will increase fuel consumption.

### ***Additional precautions for vehicles equipped with A/T***

The 2nd gear (in sports mode) is recommended on slopes or at low speed. Use the 1st gear (in sports mode) in mountainous areas in order to make better use of engine braking and to assist the brake system. However, be sure that the speed does not exceed the maximum speed limit for the selected gear.

## *For pleasant driving*

Ventilators . . . . .	5-	2
Front automatic air conditioning . . . . .	5-	7
Rear heater*/Rear cooler* . . . . .	5-	15
Rear automatic air conditioning* . . . . .	5-	16
Important operation tips for the air conditioning . . . . .	5-	19
Air purifier (with deodorizing function) . . . . .	5-	20
LW/MW/FM electronic tuning radio with		
CD player . . . . .	5-	21
Error codes . . . . .	5-	47
Handling of compact discs . . . . .	5-	49
Antenna . . . . .	5-	52
Sun visors . . . . .	5-	52
Vanity mirror . . . . .	5-	53
Ashtray . . . . .	5-	54
Cigarette lighter* . . . . .	5-	55
Accessory socket* . . . . .	5-	57
Interior lamps . . . . .	5-	58
Storage spaces . . . . .	5-	63
Cup holder . . . . .	5-	68
Bottle holder . . . . .	5-	69
Card holder* . . . . .	5-	72
Personal table . . . . .	5-	72
Tonneau cover* . . . . .	5-	73

Coat hooks . . . . .	5-	77
Luggage hooks . . . . .	5-	77
Cargo net . . . . .	5-	78
Warning triangle retaining bands . . . . .	5-	78

● For details on a vehicle equipped with a Multi Display Station (MDS), refer to a separate operation manual.

## Ventilators

E00700100461

### Front ventilators

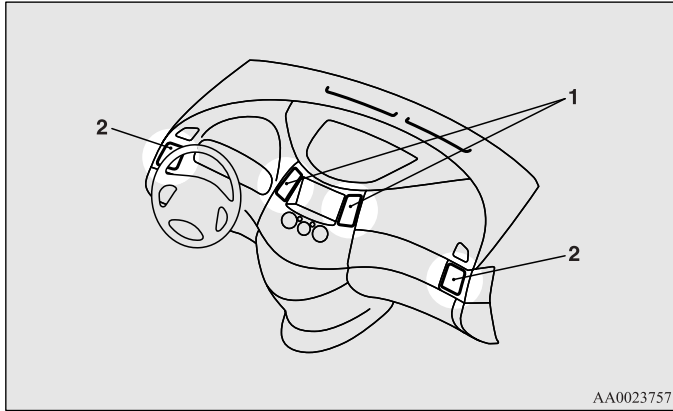

- 1- Centre ventilators
- 2- Side ventilators

#### NOTE

- Do not place beverages on top of the instrument panel. If they splash into the air conditioning ventilators, they could damage the system.

### Rear ventilators\*

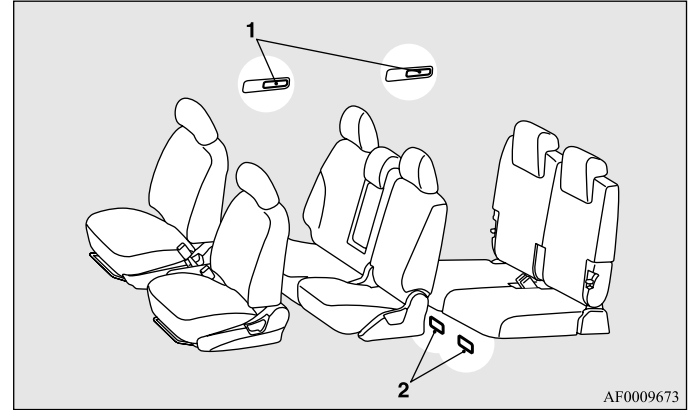

- 1- Roof ventilators
- 2- Rear floor ventilators  
(from under the third seat)

## Air flow and direction adjustments

E00700200101

### Front ventilators

The ventilator can be opened and closed with the dial (A).

(≡) - Open

(☒) - Close

Adjust the direction of the air flow by moving the knob (B).

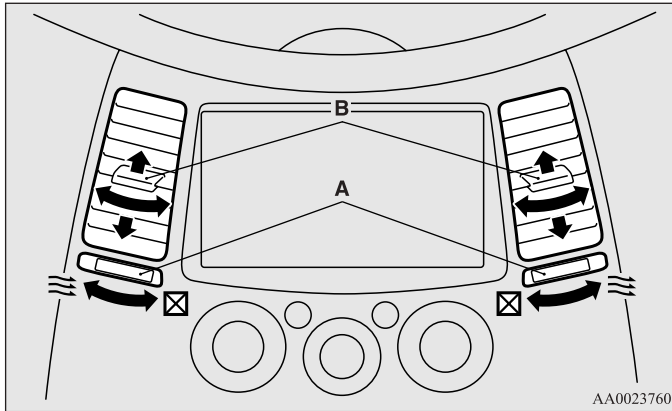

### Rear ventilators (roof ventilators only)

Adjust the direction of the air flow by moving the knob (A).

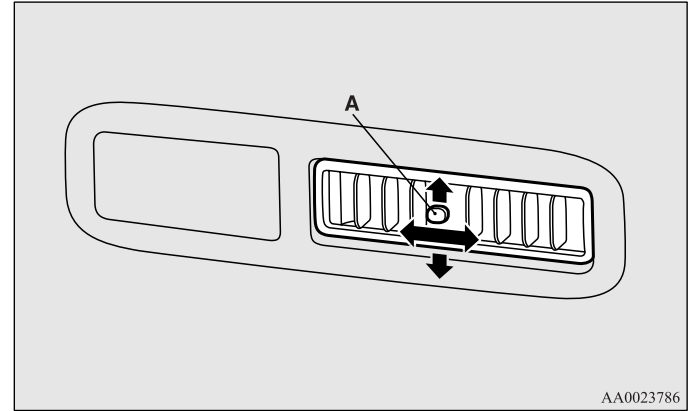

### NOTE

- The cool air from the ventilators may appear as a mist. This is due to moist air being suddenly cooled by the air conditioning. This will clear after a few moments.

## For pleasant driving

### Changing the front mode selection

E00700300522

To change the position and amount of air flowing from the ventilators, turn the mode selection dial. (Refer to “Mode selection dial” on page 5-10).

These symbols are used in the next several illustrations to demonstrate the quantity of air coming from the ventilators.

→ : Small amount of air from the ventilators

➔ : Medium amount of air from the ventilators

➤ : Large amount of air from the ventilators

### Face position

Air flows only to the upper part of the passenger compartment.

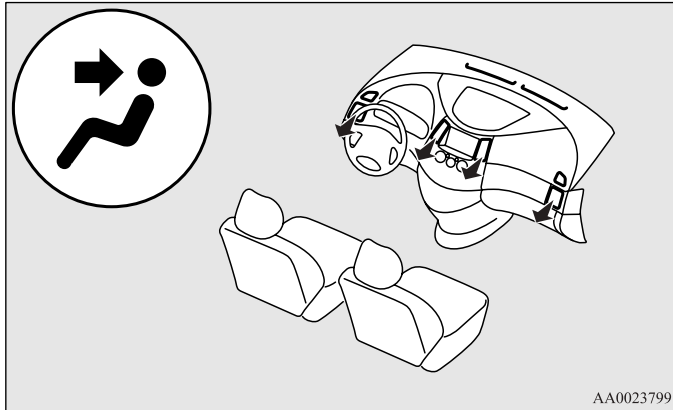



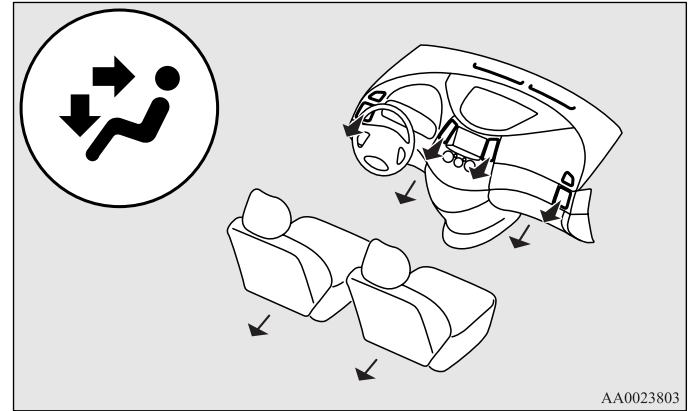

### Foot/Face position

Air flows to the upper part of the passenger compartment, and flows to the leg area.



### NOTE

- With the mode selection dial between the “” and “” positions, air flows mainly to the upper part of the passenger compartment. With the mode selection dial between the “” and “” positions, air flows mainly to the leg area.

**Foot position**

Air flows mainly to the leg area.

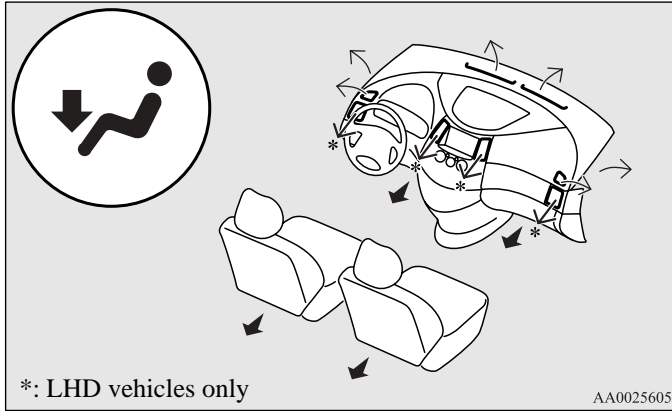



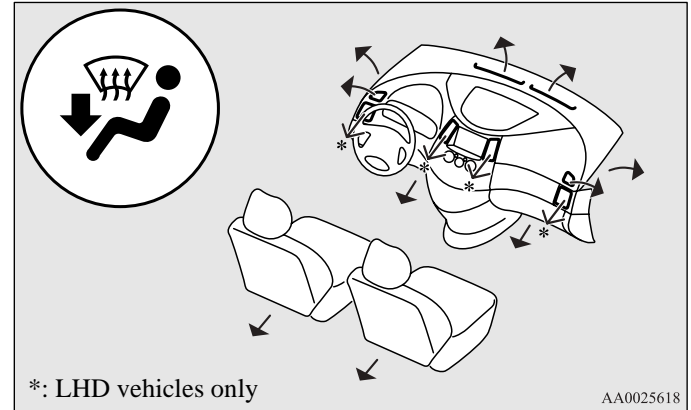

**Foot/Demister position**

Air flows to the leg area, the windscreen and the door windows.



**NOTE**

- With the mode selection dial between the “” and “” positions, air flows mainly to the leg area. With the mode selection dial between the “” and “” positions, air flows mainly to the windscreen and door windows.

## For pleasant driving

### *Demister position*

Air flows mainly to the windscreen and the door windows.

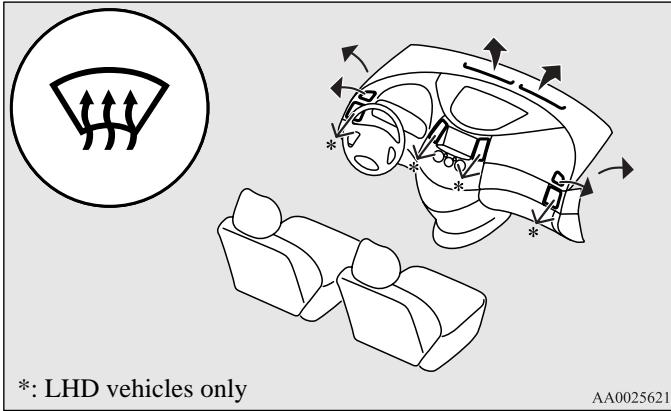

## Changing the rear mode selection (vehicles with rear automatic air conditioning)

E00700400086

To change the amount of air flowing from the ventilators, slide the temperature control lever.

### *When the temperature is set to the minimum*

Air flows from the roof ventilators.

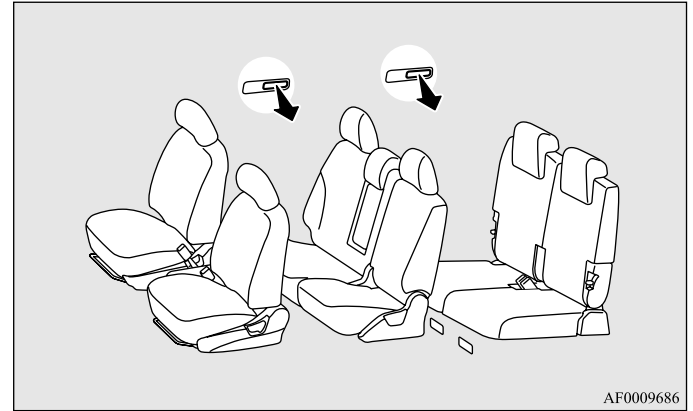



**When the temperature is set to the maximum**

Air flows from the third seat floor ventilators.

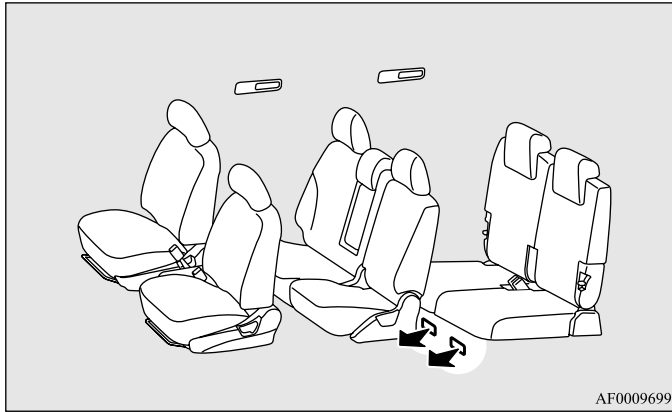

**NOTE**

- With the air temperature set within a range from the minimum to the maximum, air flows to the leg area and to the upper part of the passenger compartment. Moving the temperature control lever rightward causes more air to flow to the leg area. Moving it leftward causes more air to flow to the upper part of the passenger compartment. (Refer to “Temperature control lever” on page 5-18.)

**Front automatic air conditioning**

E00702400048

The air conditioning can only be used while the engine is running.

**Control panel**

E00702500544

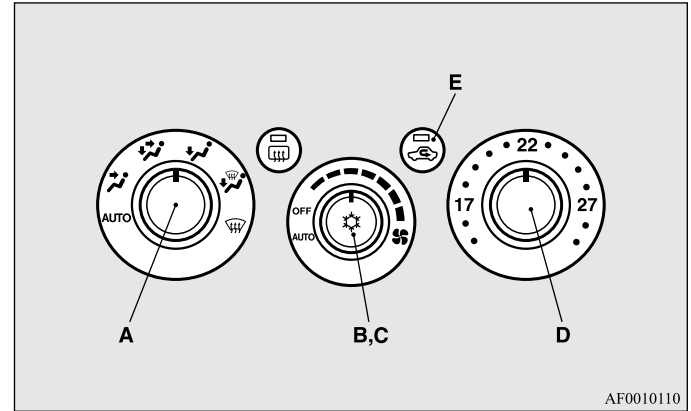

- A- Mode selection dial
- B- Blower speed selection dial
- C- Air conditioning switch
- D- Temperature control dial
- E- Air selection switch

## For pleasant driving

### NOTE

- There is a photo sensor (F) and interior air temperature sensor (G) inside the vehicle. Never place anything on top of these sensors, since doing so will prevent them from functioning properly.

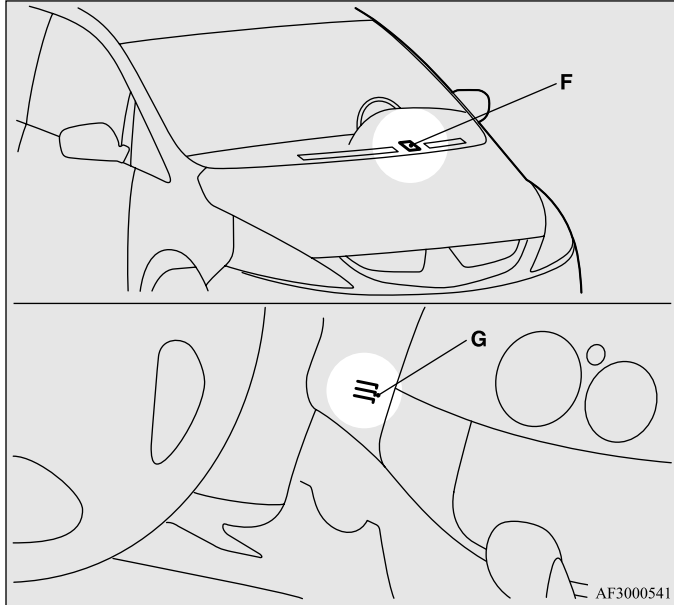

F- Photo sensor\*

G- Interior air temperature sensor

### Blower speed selection dial

E00702800127

Select the blower speed by turning the blower speed selection dial clockwise or anticlockwise. The blower speed will gradually increase as the dial is turned to the right. When the blower speed selection dial is set to the “OFF” position, all fan-driven airflow will stop.

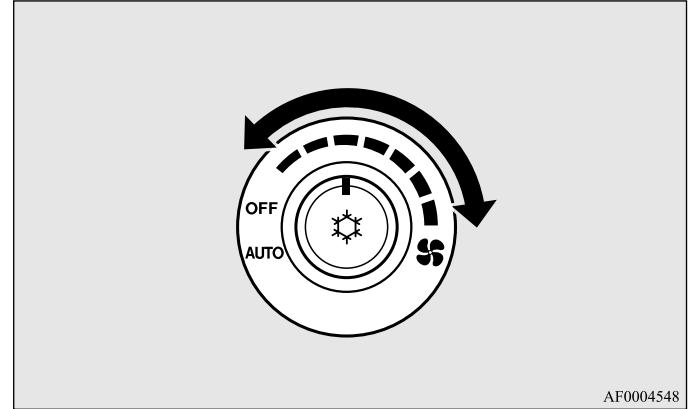

### Temperature control dial

E00703000360

Turn the temperature control dial clockwise to make the air warmer. Turn it anticlockwise to make the air cooler.

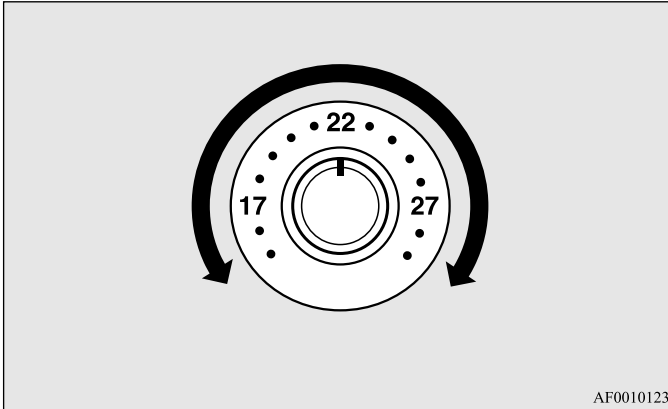

AF0010123

### NOTE

- While the engine coolant temperature is low, the temperature of the air from the heater will be cool/cold until the engine warms up, even if you have selected warm air with the dial.
- When the temperature is set to the highest or the lowest, the air selection and the air conditioning will be automatically changed as follows.  
Also, manually operated after an automatic changeover, manual operation will be selected.
  - Quick Heating (When the temperature is set to the highest setting)  
Outside air will be introduced and the air conditioning will stop.
  - Quick Cooling (When the temperature is set to the lowest setting)  
Inside air will be recirculated and the air conditioning will operate.

## For pleasant driving

### Mode selection dial

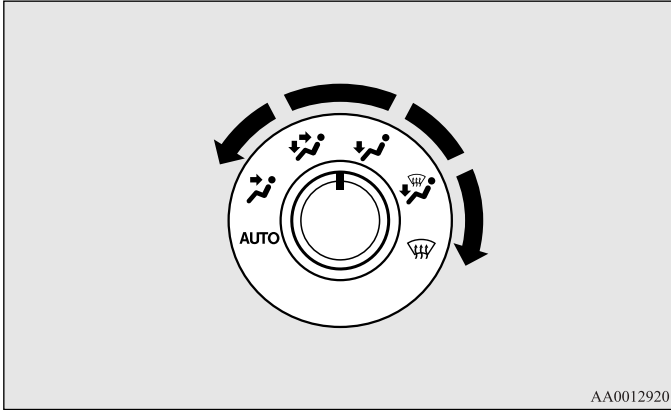

E00703200418

To change the position and amount of air flowing from the ventilators, turn the mode selection dial. (Refer to “Changing the front mode selection” on page 5-4.)



5

### **CAUTION**

- When using the mode selection dial between the “” and “” positions, prevent fogging by pressing the air selection switch to select outside air. (Refer to “Air selection switch” on page 5-10.)

### Air selection switch

E00703400511

To change the air selection, simply press the air selection switch.

- Outside air { Indication lamp (A) is OFF }  
Outside air is introduced into the passenger compartment.
- Recirculated air { Indication lamp (A) is ON }  
Air is recirculated inside the passenger compartment.

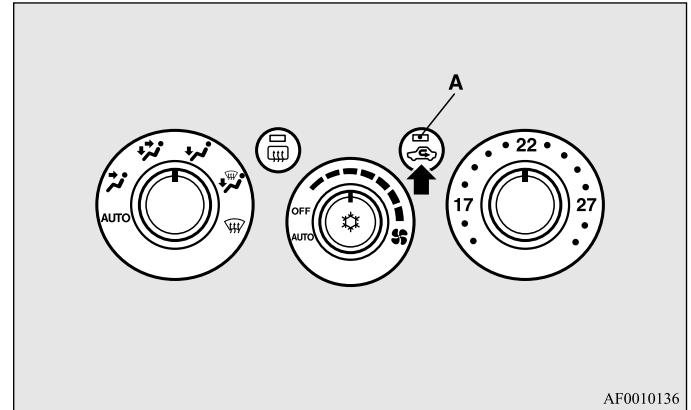

## **⚠ CAUTION**

- Normally, use the outside position to keep the windscreen and side windows clear and quickly remove fog or frost from the windscreen. If high cooling performance is desired, or if the outside air is dusty or otherwise contaminated, use the recirculation position. Switch to the outside position periodically to increase ventilation so that the windows do not become fogged up.
- Use of the recirculation position for extended time may cause the windows to fog up.

### NOTE

- When the mode selection dial or the blower speed selection dial is set to the “AUTO” position again after manual operation, the air selection switch will also be automatically controlled.

## *Air conditioning switch*

E00703500785

Push the switch, and the air conditioning compressor will turn on. The air conditioning indication lamp (A) will come on.

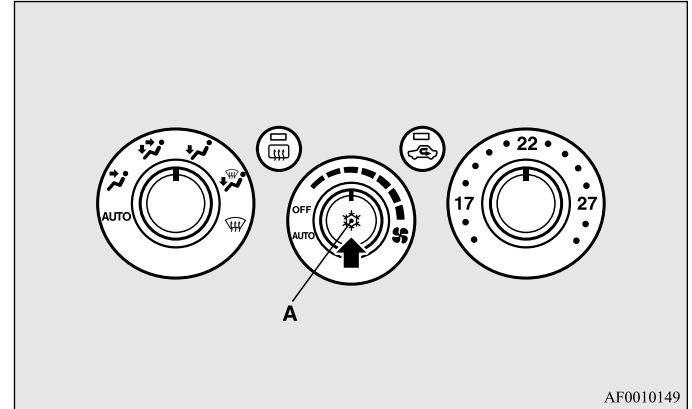

AF0010149

Push the switch again and the air conditioning compressor will stop and the indication lamp (A) goes off.

## **⚠ CAUTION**

- When using the air conditioning, the idling speed may slightly increase as the air conditioning compressor is switched on/off automatically. While the vehicle with an A/T is stationary, fully depress the brake pedal to prevent the vehicle from creeping.

NOTE

- If a problem is detected in the air conditioning system, the air conditioning operation indication lamp (A) blinks. Press the air conditioning switch once to turn it off, then once more to turn it back on. If the air conditioning operation indication lamp (A) does not blink for a while, there is nothing wrong. If it starts to blink again, we recommend you to have it checked.
- Sometimes, for example after using a high-pressure car wash, the condenser can get wet, and the operation indication lamp (A) blinks temporarily. In this case there is nothing wrong. Wait for a while, press the air conditioning switch once to turn the system off, then once more to turn it back on. Once the water evaporates, the blinking will stop.

## Operating the system in automatic mode

E00704100557

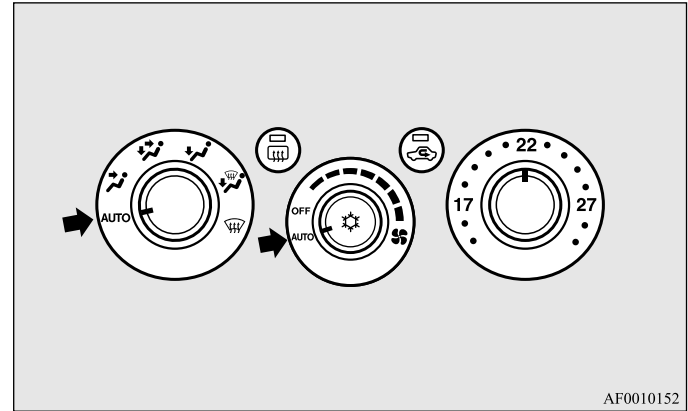

In normal conditions, use the system in the AUTO mode and follow these procedures:

1. Set the blower speed selection dial to the “AUTO” position.
2. Select the temperature control dial to the desired temperature. The temperature can be set within a range of 15 to 29. The temperature will gradually increase as the dial is turned to the right.
3. Set the mode selection dial to the “AUTO” position.
4. Push the air conditioning switch to operate the air conditioning. When the air conditioning operates, the indication lamp (⚙️) in the dial will come on.

The outlet port (except “”), recirculation/outside air select and blower speed, and ON/OFF of air conditioning will be controlled automatically.

To stop the system, turn the blower speed selection dial to the “OFF” position.

#### NOTE

- Set the temperature at about 22 under normal conditions.
- While the engine coolant temperature is low, the temperature of the air from the heater will be cool/cold until the engine warms up, even if you have selected warm air with the dial. To prevent the windscreen and windows from fogging up, the ventilator mode will be changed to “” and the blower speed will be reduced.
- If the blower speed selection dial, air conditioning switch, mode selection dial, or air selection switch is operated while the system is operating in the AUTO mode, the activated function overrides the corresponding function of automatic control. All other functions remain under automatic control.

## Operating the system in manual air mode



E00704200011

Blower speed and ventilator mode may be controlled manually by setting the blower speed selection dial and the mode selection dial to the desired positions. To return to automatic operation, set the dials to the “AUTO” position.

### *Demisting of the windscreen and door windows*

E00704300546

 <b>CAUTION</b>
<ul style="list-style-type: none"> <li>● For safety, make sure you have a clear view through all the windows.</li> </ul>

To remove frost or mist from the windscreen and door windows, use the mode selection dial (“” or “”).

## For pleasant driving

### For ordinary demisting

Use this setting to keep the windscreen and door windows clear of mist, and to keep the leg area heated (when driving in rain or snow).

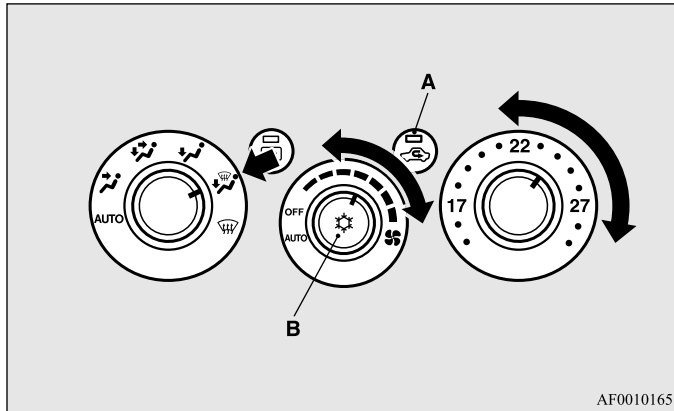

1. Set the air selection switch (A) to the outside position.
2. Set the mode selection dial to the "OFF" position.
3. Select your desired blower speed by turning the blower speed selection dial.
4. Select your desired temperature by turning the temperature control dial.
5. Push the air conditioning switch (B).

### For quick demisting

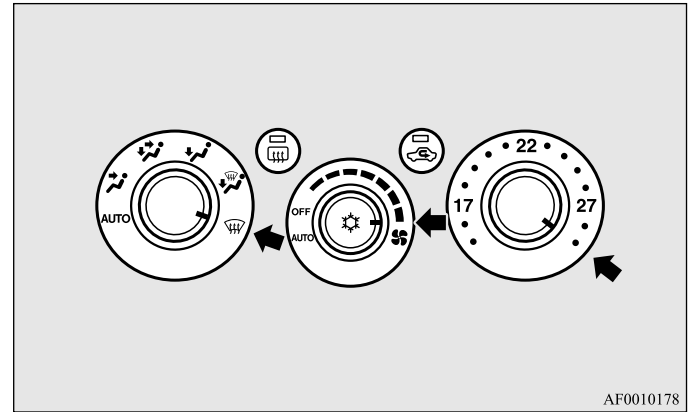

1. Set the mode selection dial to the "OFF" position.
2. Set your blower to the maximum speed.
3. Set the temperature to the highest position.

### NOTE

- While the mode selection dial is set to the "OFF" position, the air conditioning will operate automatically and the outside air position will also be selected automatically.
- Do not set the temperature control dial to the max. cool position. Cool air will blow against the window glasses and form mist on them.



## Rear heater\*/Rear cooler\*

E00719900016

The rear heater/rear cooler can only be used while the engine is running.

### NOTE

- Cooling with rear cooler is not possible when the front air conditioning (cooling and dehumidifying functions) is not operating. Be sure to activate the front air conditioning (cooling and dehumidifying functions) before activating the rear air conditioning.  
When the front air conditioning is not operating, only fan operation without cooling is possible.

### Control panel

E00720000017

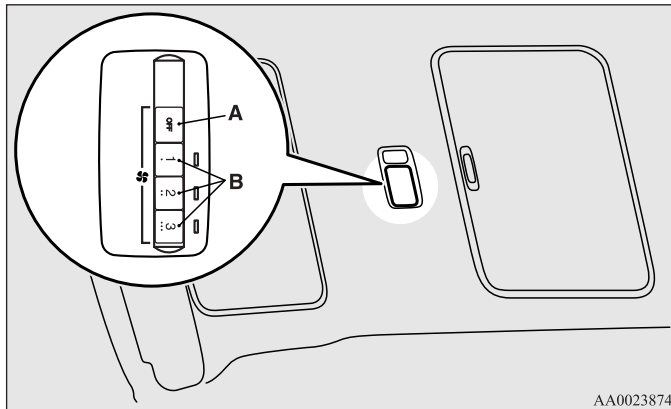

AA0023874

A- OFF switch

B- Blower speed selection switch

## Blower speed selection switch

E007202000077

### Rear heater

When the blower speed selection switch is pressed, the heater starts operating. When the “OFF” switch (A) is pressed, it stops.

The indication lamp (B) for the selected blower speed illuminates.

### Rear cooler

When the blower speed selection switch is pressed, the cooler (cooling and dehumidifying functions) starts operating. When the “OFF” switch (A) is pressed, it stops.

The indication lamp (B) for the selected blower speed illuminates.

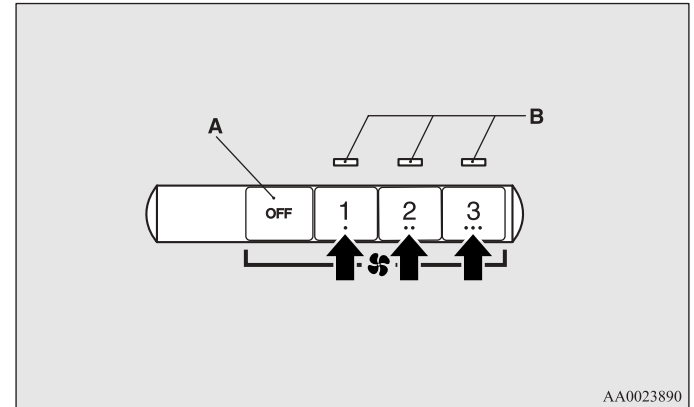

AA0023890

NOTE

- The blower speed is memorized when the engine is shut down. If the battery is disconnected and reconnected however, the memory is erased and the blower speed is automatically set to the “OFF” position.

***Rear automatic air conditioning\****

E00705900028

The air conditioning can only be used while the engine is running.

While the front air conditioning is on, rear air conditioning is also possible.

NOTE

- Cooling is not possible when the front air conditioning (cooling and dehumidifying functions) is not operating. Be sure to activate the front air conditioning (cooling and dehumidifying functions) before activating the rear air conditioning. When the front air conditioning is not operating, only fan operation without cooling is possible.

## Control panel

E0070600055

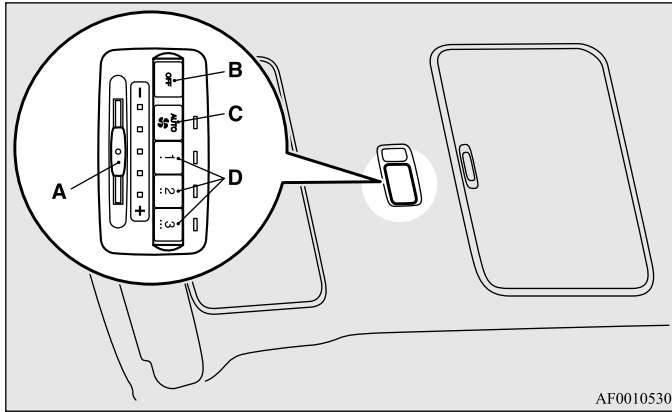

AF0010530

- A- Temperature control lever
- B- OFF switch
- C- AUTO switch
- D- Blower speed selection switch

## Blower speed selection switch

E0070630061

When the blower speed selection switch or “AUTO” switch is pressed, the air conditioning (cooling and dehumidifying functions) starts operating. When the “OFF” switch (A) is pressed, it stops.

The indication lamp (B) for the selected blower speed illuminates.

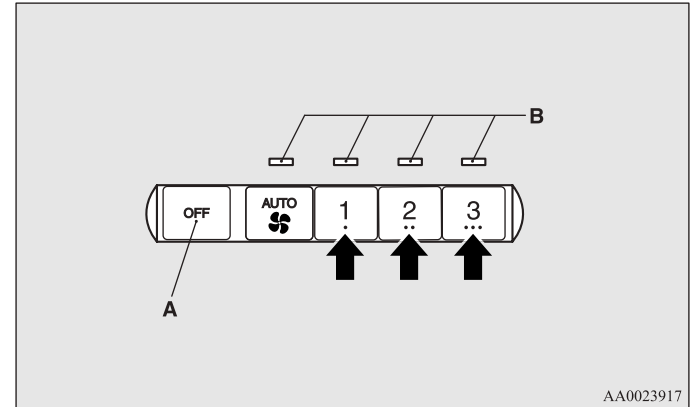

AA0023917

### NOTE

- The blower speed is memorized when the engine is shut down.

If the battery is disconnected and reconnected however, the memory is erased and the blower speed is automatically set to the “OFF” position.

## For pleasant driving

### Temperature control lever

E00706400059

The temperature control lever is used to adjust the air temperature.

Move it rightward to increase the temperature and leftward to reduce the temperature.

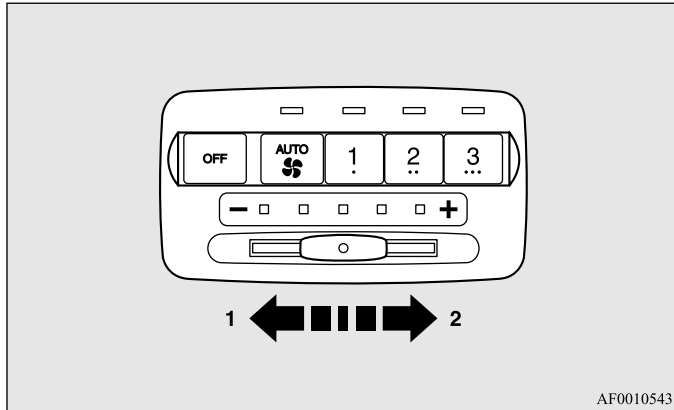

- 1- Low
- 2- High

#### NOTE

- The mode changes in accordance with the air temperature. (Refer to “Changing the rear mode selection” on page 5-6.)
- When the engine coolant temperature is extremely low (for example, in extremely cold weather), moving the temperature control lever has no effect on the air temperature.

## Operating the system in automatic mode

E00706800066

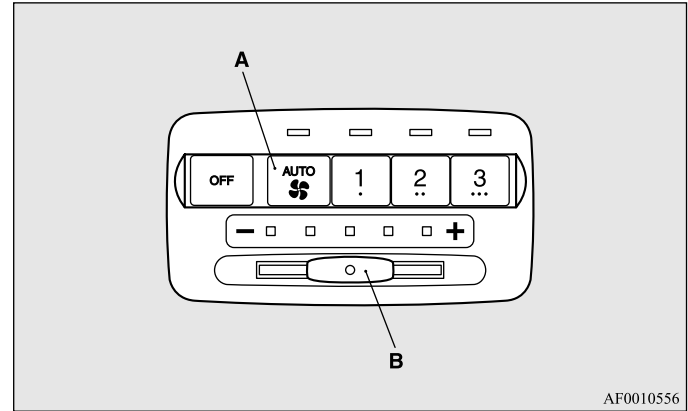

1. Press the “AUTO” switch (A).
2. Set the desired temperature using the temperature control lever (B). The temperature can be set within a range from the minimum to the maximum.

#### NOTE

- Adjust the temperature to the desired level using the temperature control lever (centred for reference).
- When the engine coolant temperature is extremely low (for example, in extremely cold weather), moving the temperature control lever has no effect on the air temperature.

## Operating the system in manual mode

E00706900067

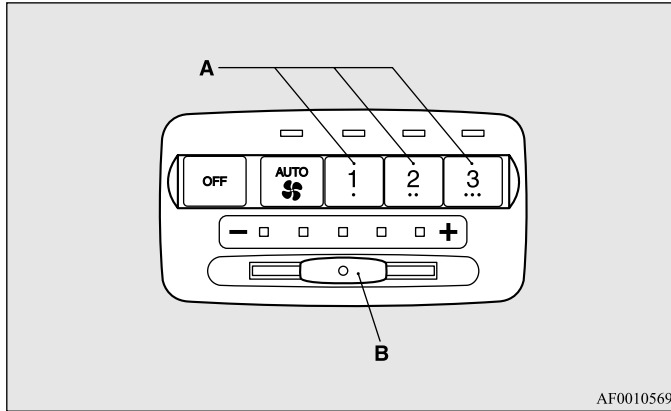

AF0010569

Set the blower speed selection switch (A) and temperature control lever (B) as desired. If the system is operating in the AUTO mode, the new settings will override automatic control.

## *Important operation tips for the air conditioning*

E00708300658

- Park the vehicle in the shade.  
Parking in the hot sun will make the vehicle interior extremely hot, and it will require more time to cool the interior.  
If it is necessary to park in the sun, open the windows for the first few minutes of air conditioning operation to expel the hot air.
- Close the windows when the air conditioning is in use.  
The entry of outside air through open windows will reduce the cooling efficiency.
- Too much cooling is not good for the health. The inside air temperature should only be 5 to 6 °C below the outside air temperature.
- When operating the system, make sure the air intake, which is located in front of the windscreen, is free of obstructions such as leaves and snow. Leaves collected in the air-intake plenum may reduce air flow and plug the plenum water drains.

## **Air conditioning system refrigerant and lubricant recommendations**

If the air conditioning seems less effective than usual, the cause might be a refrigerant leak. We recommend you to have the system inspected.

The air conditioning system in your vehicle must be charged with the refrigerant HFC-134a and the lubricant SUN-PAG56. Use of any other refrigerant or lubricant will cause severe damage which will result in the need to replace your vehicle's entire air conditioning system. The release of refrigerant into the atmosphere should be prevented.

It is recommended that the refrigerant be recovered and recycled for further use.

## **During a long period of disuse**

The air conditioning should be operated for at least five minutes each week, even in cold weather. This is to prevent poor lubrication of the compressor internal parts and to maintain the air conditioning in the best operating condition.

## ***Air purifier (with deodorizing function)***

E00708400301

An air filter is incorporated into the air conditioning system to remove pollen, dust, tobacco smells, and exhaust smells from the air.

The air filter's ability to collect pollen and dirt is reduced as it becomes dirty, so replace it periodically. For the maintenance interval, refer to the "SERVICE BOOKLET".

### **NOTE**

- Operation in certain conditions such as driving on a dusty road and frequent use of the air conditioning can lead to reduction of service life of the filter. When the air flow rate suddenly drops or when the windscreen or windows start to fog up easily, the air filter requires replacement. We recommend you to have it checked.

## *LW/MW/FM electronic tuning radio with CD player*

E00708501019

The audio system can be used when the ignition switch is in the “ON” or “ACC” position.

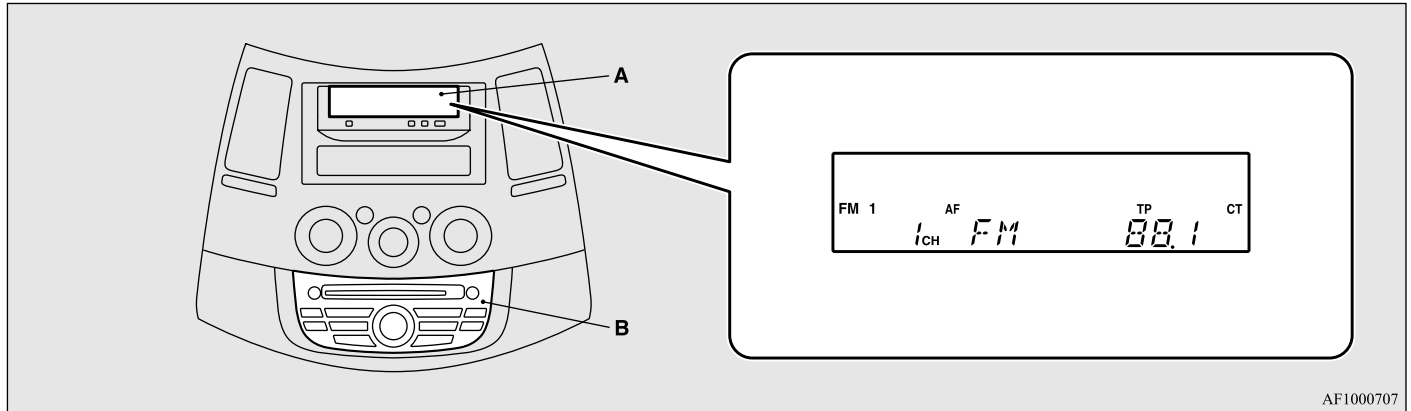

AF1000707

- A- Display window
- B- Audio system

**NOTE**

- The MITSUBISHI genuine CD autochanger can be connected to this audio system.  
The CD autochanger can be operated by the switch of the audio body. Refer to “To listen to a CD” on page 5-39.
- To listen to the audio system while the engine is stopped, turn the ignition key to the “ACC” position.
- If a cellular phone is used inside the vehicle, it may create noise from the audio equipment. This does not mean that anything is wrong with your audio equipment. In such a case, use the cellular phone at a place as far as possible from the audio equipment.
- If foreign objects or water get into the audio equipment, or if smoke or a strange odour comes from it, immediately turn off the audio system and have it checked. Never try to repair it by yourself. Avoid continuous usage without inspection by a qualified person.



## Volume and tone control panel

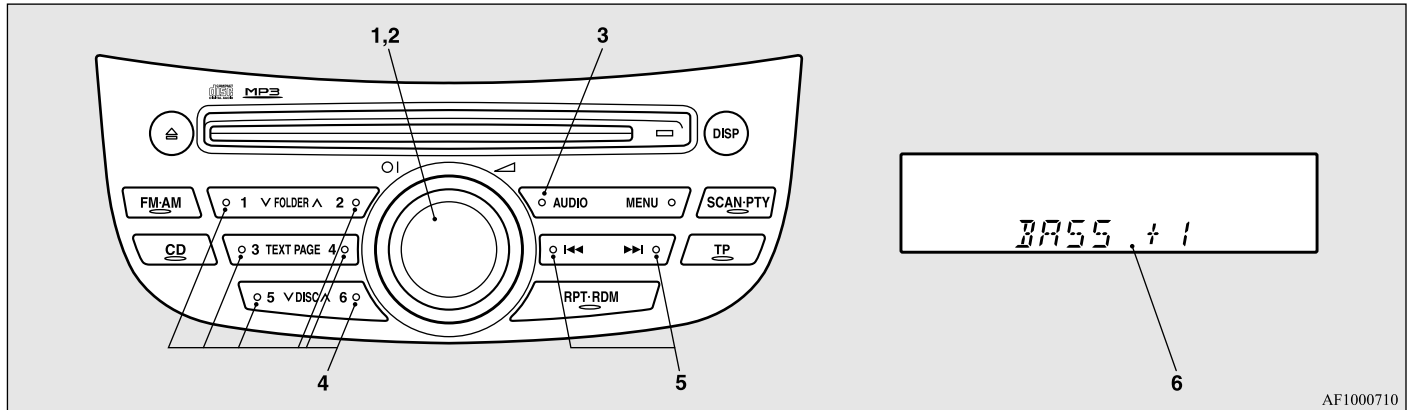

- 1- PWR (On-Off) switch
- 2- VOL (Volume control) knob
- 3- AUDIO button
- 4- Memory select buttons
- 5- Audio adjust button
- 6- Display

## For pleasant driving

### To adjust the volume

E0070870069

#### ***VOL (Volume control)***

Turn the VOL knob (2) clockwise to increase the volume; anti-clockwise to decrease the volume. The status will be displayed in the display (6).

### To adjust the tone

E00708800640

Press the AUDIO button (3) to select BASS → TRE → FADE → BAL → Audio adjust mode off. The status will be displayed in the display (6).

#### ***BASS (Bass tone control)***

Press the audio adjust button (5) either ◀◀ or ▶▶ to select the desired bass tone quality.

#### ***TRE (Treble tone control)***

Press the audio adjust button (5) either ◀◀ or ▶▶ to select the desired treble tone quality.

#### ***FADE (Front/Rear balance control)***

Press the audio adjust button (5) either ◀◀ or ▶▶ to balance the volume of sound from the front and the rear speakers.

#### ***BAL (Left/Right balance control)***

Press the audio adjust button (5) either ◀◀ or ▶▶ to balance the volume of sound from the left and the right speakers.

#### NOTE

- Audio adjust mode will be canceled when radio or CD operation is performed or no adjustment is performed for more than 7 seconds.

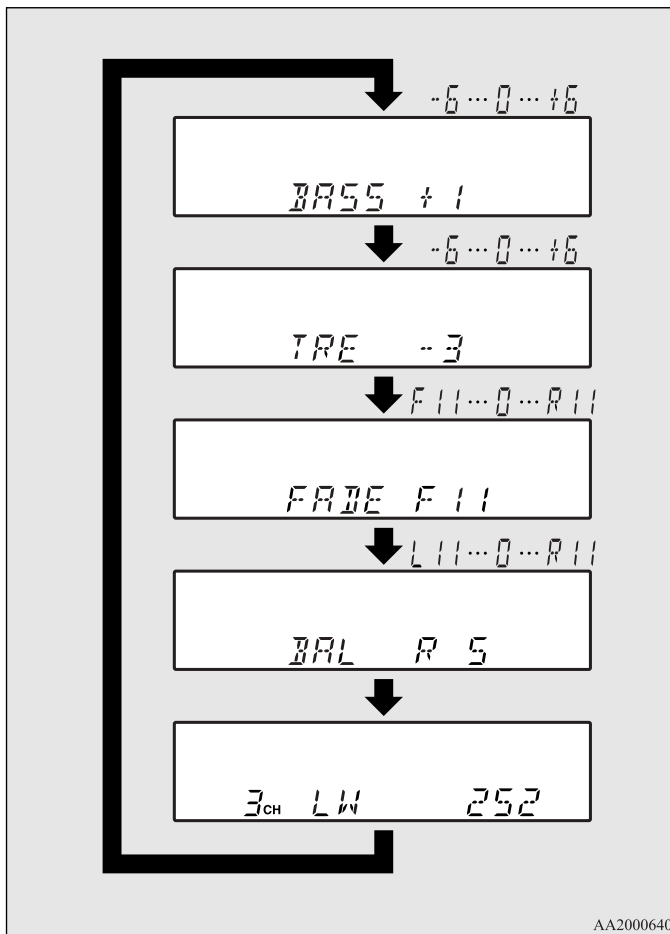

AA2000640

***To enter audio tone settings into the memory***

It is possible to enter the audio adjustment condition (BASS, TRE, FADE, BAL) into the memory.

1. Make the desired adjustments in the audio adjust mode. Refer to “To adjust the tone” on page 5-24.
2. In the audio adjust mode, press and hold one of the memory select buttons (4) [1-6]. When you hear a bleep, the memorization is complete. The display will show the button number [SOUND1-SOUND6] for which the settings were memorized.
3. In future, when you gently press the memory select button in the audio adjust mode, the audio adjustment condition memorized for that button will take effect.

## Radio control panel and display

E00708900713

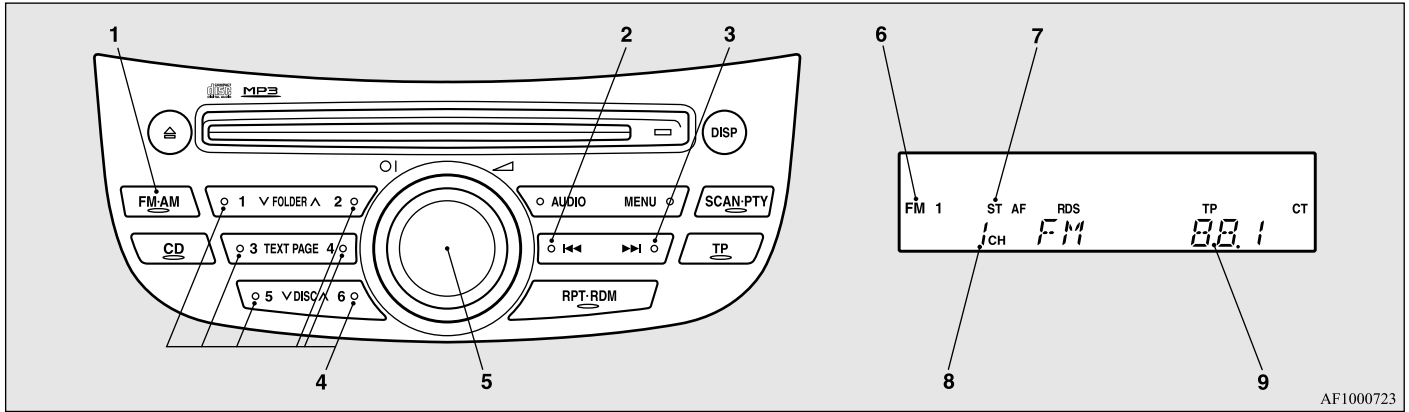

AF1000723

- 1- AM/FM (FM/MW/LW selection) button
- 2- TUNE/SEEK (Down-step/Down-seek) button
- 3- TUNE/SEEK (Up-step/Up-seek) button
- 4- Memory select buttons
- 5- PWR (On-Off) switch
- 6- FM (FM1/FM2/FM3) indicators
- 7- ST (Stereo) indicator
- 8- Preset memory number display
- 9- Frequency display window

## To listen to the radio

E00709000678

1. Press the PWR switch (5) to turn the audio system on and off. The system turns on in the last mode used.
2. Press the AM/FM button (1) to select the desired band.
3. Press the TUNE/SEEK button (2 or 3) to turn to a station, or press one of the memory select buttons (4) to recall a station memorised for that button.

## To tune the radio

E00709100565

### Automatic tuning

After keeping the TUNE/SEEK button (2 or 3) depressed until it beeps, release the button, and the selected station reception will start.

### Manual tuning

The frequency changes every time the TUNE/SEEK button (2 or 3) is pressed. Press the button to select the desired station.

## To enter frequencies into the memory

E00716100785

### Manual setting

You can assign to the memory select buttons (4) a maximum of 18 stations in the FM band (6 FM1, 6 FM2 and 6 FM3 stations) and 6 stations each in the MW and LW band. (Stations already assigned to the memory select buttons are replaced by any newly assigned stations.)

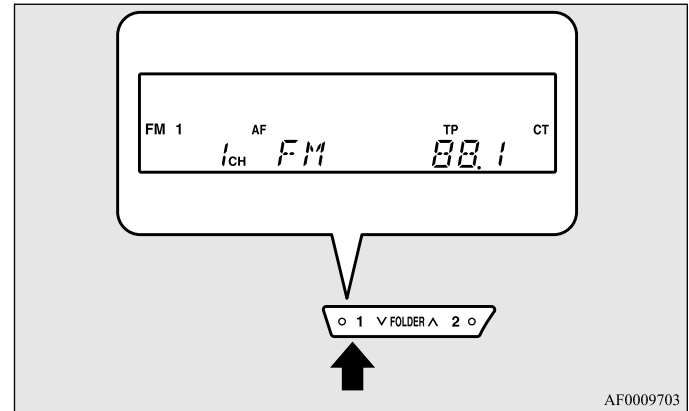

AF0009703

## For pleasant driving

Follow the steps described below.

1. Press either the TUNE/SEEK button (2 or 3) to tune the frequency to be entered in the memory.
2. Press one of the memory select buttons (4) for 2 seconds or longer. The sound will be momentarily interrupted while the frequency is being entered into the memory. The number of the button corresponding to the entry in the memory and the frequency are displayed.
3. The preset memory setting is retrieved by pressing the button and then releasing it within 2 seconds.

## Automatic setting

With the method, all manually set stations in the band currently selected for reception are replaced with stations in the same band that are automatically selected in order of signal strength. The radio automatically selects 6 stations in the FM band (FM3 station only) and 6 stations each in the MW and LW band.

Follow the steps described below.

1. With the radio mode selected, hold down the AM/FM button (1) for 2 seconds or longer. The 6 stations with the best signal strength will automatically be assigned to the memory select buttons (4), with the lowest-frequency station being assigned to the lowest-number button.
2. When you subsequently press a memory select button to select a channel number, the radio will begin receiving the station assigned to that number.

## NOTE

- If you press the AM/FM button (1) for 2 seconds or longer while tuning in the FM1 or FM2 band, the radio will automatically switch to the FM3 band, where the automatic seeking/storing will be activated.

## Radio data system (RDS)

E00709200247

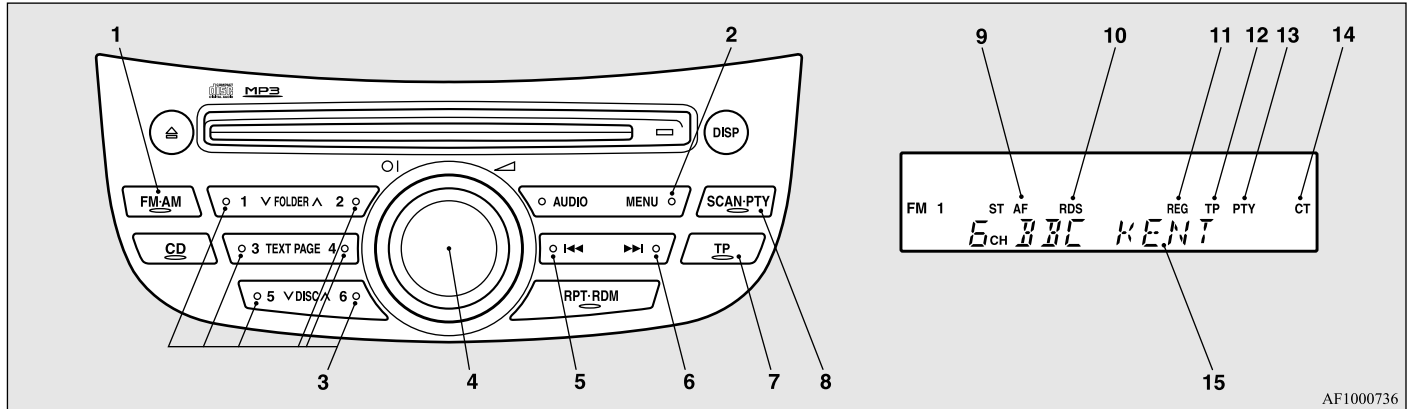

AF1000736

- 1- AM/FM (FM/MW/LW selection) button
- 2- Menu button
- 3- Memory select buttons
- 4- PWR (On-Off) switch
- 5- TUNE/SEEK (Down-step/Down-seek) button
- 6- TUNE/SEEK (Up-step/Up-seek) button
- 7- TP (Traffic program) button
- 8- PTY (Program type) button
- 9- AF (Alternative frequencies) indicator
- 10- RDS (Radio data system) indicator
- 11- REG (Regional program) indicator
- 12- TP (Traffic program identification) indicator
- 13- PTY (Program type) indicator
- 14- CT (Clock time) indicator
- 15- Frequency display window

## For pleasant driving

RDS uses PI (program identification) signal and AF (alternative frequency) list transmitted in addition to the normal FM broadcasting programs, and picks up the FM stations that are transmitting the same program from the EON (enhanced other network) and automatically tunes to the station with the strongest signal intensity.

Therefore, you can continue listening to one program in, for example, a long distance driving without retuning to the other station transmitting the same program when you are leaving the service area of the currently receiving station.

The RDS radio also features the limited reception of the program types, the break-in reception of the traffic announcement and emergency broadcast, and the limited/unlimited reception of the regional programs.

### *AF (Alternative Frequencies) function*

E00720900016

The AF function finds a station broadcasting the same program and selects the station with the strongest signal of AF lists.

The AF function is turned on (with the AF indicator (9) shown on the display) at all times unless you manually switch it off.

The AF function can be turned ON and OFF.  
Refer to “Function setup mode” on page 5-35.

### *CT (Clock Time) function*

E00721000014

The clock can be set automatically by using the signal from the local RDS stations. Refer to “Digital clock” on page 3-17.

### *REG (Regional) function*

E00721100015

REG function limits to receive the stations broadcasting regional programs.

Regional programming and regional networks are organized differently depending on the country or area (they may be changed according to the hour, state, or broadcast area), so if you don't want to receive the regional programs automatically, you can set up REG ON not to receive regional programs.

The REG function can be turned ON and OFF.  
Refer to “Function setup mode” on page 5-35.

### *PI (Program Identification) search function*

E00721200016

When travelling long distance and the recalled preset station is weak, the radio searches another frequency broadcasting the same programming with the same PI code in AF list.

If there are no frequencies broadcasting the same programming, the radio searches a frequency broadcasting the regional programming. The radio succeeds in searching the regional programming, then the display shows the REG indicator (11). If the radio does not succeed in searching the regional programming, the radio returns to the recalled preset station.

### *PTY (Program type)*

E00721300192

RDS broadcasts are classified according to program type (PTY) as follows. Use the TUNE/SEEK button (5 or 6) to select your desired PTY.



1. NEWS
2. AFFAIRS (Current affairs)
3. INFO (Information)
4. SPORT
5. EDUCATE (Education)
6. DRAMA
7. CULTURE
8. SCIENCE
9. VARIED
10. POP M (Pop music)
11. ROCK M (Rock music)
12. EASY M (Easy music)
13. LIGHT M (Light classics)
14. CLASSICS
15. OTHER M (Other music)
16. WEATHER (Weather information)
17. FINANCE
18. CHILDREN
19. SOCIAL
20. RELIGION
21. PHONE IN
22. TRAVEL
23. LEISURE
24. JAZZ
25. COUNTRY
26. NATION M (National music)
27. OLDIES
28. FOLK M (Folk music)
29. DOCUMENT

To search for a broadcast of desired program type:

1. Press the PTY button (8).
2. Press the TUNE/SEEK button (5 or 6) for less than 1 second at a time to select your desired PTY.
3. Two seconds after a desired PTY has been selected, the radio will begin to search for a broadcast of your selected PTY. During search, the selected PTY on the display blinks and the radio will begin to search for a broadcast of your selected PTY.
4. When the radio picks up a station with your desired PTY, the display will show the name of the station.

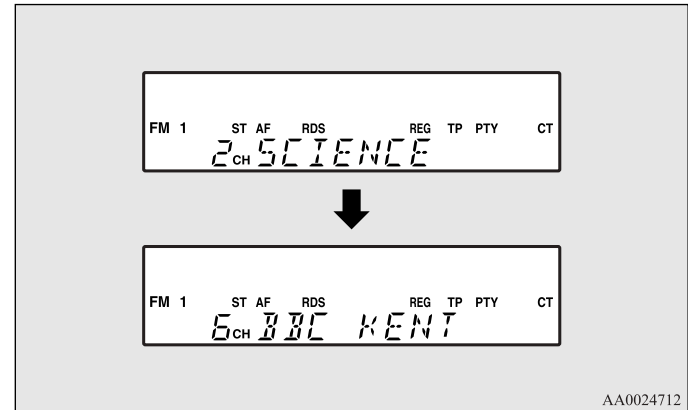

NOTE

- If the TUNE/SEEK button (5 or 6) is pressed for more than 1 second, the radio will try to find out another broadcast of the same program type as currently selected.
- If no station is found with your desired PTY, the display will show “EMPTY” for about 5 seconds and the radio will return to the previous station.

***How to enter PTYs in the memory***

E00721400122

As many as 6 PTYs can be entered in the memory.

Follow the steps described below.

1. Press either the TUNE/SEEK button (5 or 6) to tune the PTY to be entered in the memory.
2. Press one of the memory select buttons (3) for 2 seconds or longer. The sound will be momentarily interrupted while the PTY is being entered into the memory. The number of the button corresponding to the entry into the memory and the PTY are displayed.
3. The preset memory setting is retrieved by pressing the button and then releasing it within about 2 seconds.

***To change the language of PTY display***

E00721500181

You can select your favourite language among English, French, German, Swedish, Spanish and Italian.

1. Press the “MENU” button (A) to select the language of PTY display mode.  
Refer to “Function setup mode” on page 5-35.
2. Press the audio adjust button (B) to select a language.

NOTE

- After selecting a mode, you can leave the function setup mode by taking either of the following steps:
  - Press the “MENU” button for at least 2 seconds.
  - Make no entry for 7 seconds.

E00721600179

### Traffic information

The radio will automatically tune in to traffic information broadcasts while receiving FM broadcasts or playing compact discs.

To select this function, follow the instructions below.

1. Press the TP button (7). The display will show “TP” (12). If the RDS data can be read, the display will show “RDS” (10). If not, the display will show “NO RDS” for about 5 seconds.
2. If the radio detects traffic information on either the station currently selected or another station, the display will show “TRAF INF” for 5 seconds followed by a 2-second indication of the frequency. Then, it will show the name of the station broadcasting the traffic information to which you will listen. The volume level is set separately for listening to normal audio programs and for listening to traffic information. The volume level will therefore change automatically to that set when traffic information was last received. When the traffic information broadcast is over, the radio will return to the previously received program and to the corresponding volume level.
3. Press the TP button (7) to return to the previous condition.

#### NOTE

- While “TP” is illuminated, the radio stops only at TP stations even if the TUNE/SEEK button (5 or 6) is pressed.

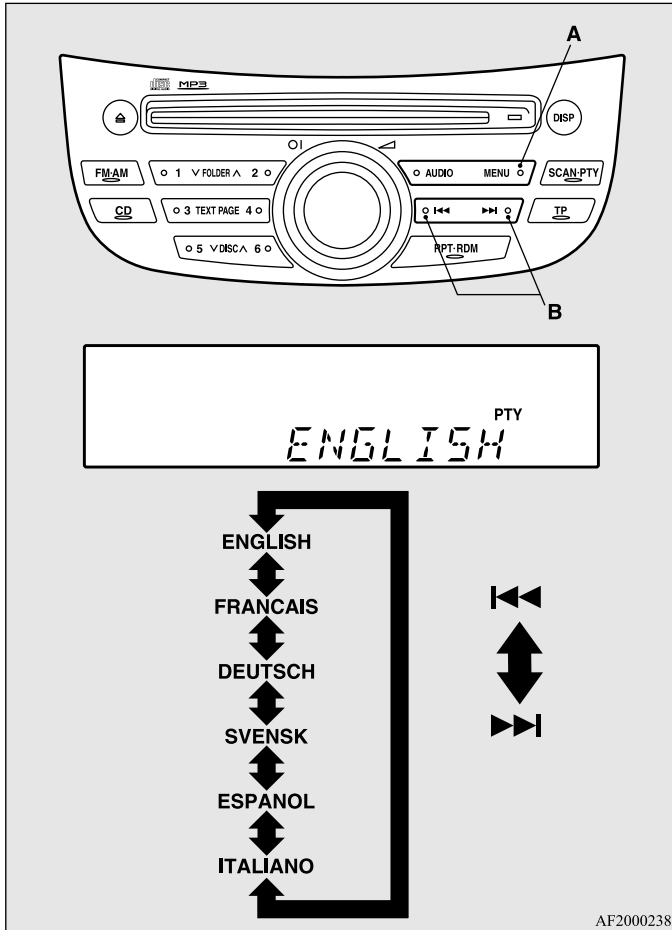

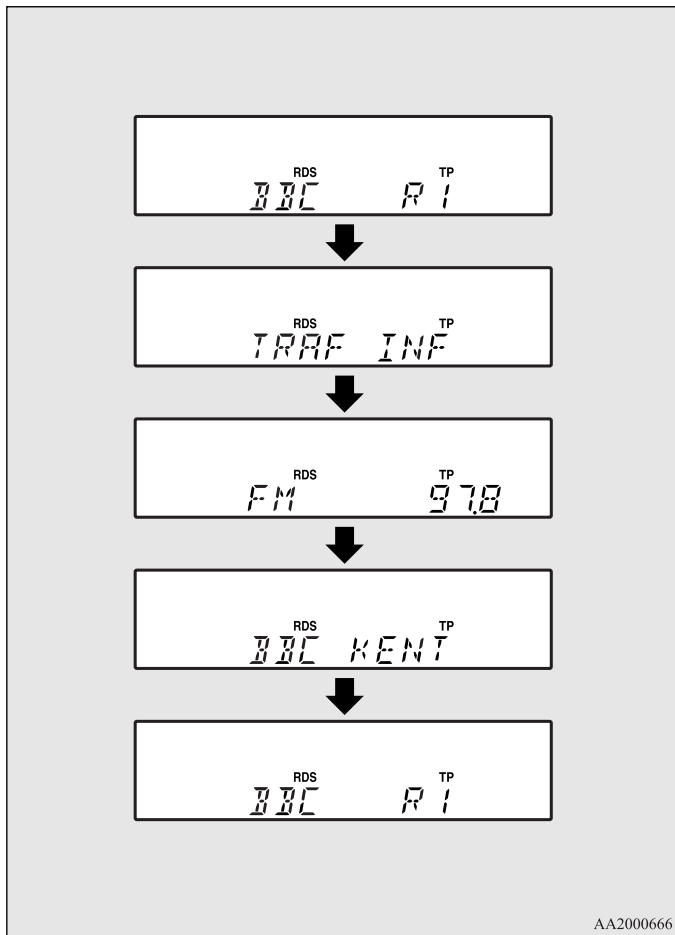

AA2000666

### TP (Traffic information Program) search function

E00721800012

The traffic information program standby function is turned on (with the TP indicator (12) shown on the display) and after about 45 seconds since the RDS indicator (10) turns off due to weak signal or the tuning station is changed over from a TP station to a station which does not broadcast traffic information, the sound will beep 5 times and seeks out a TP station in all frequencies automatically.

The TP search function can be turned ON and OFF.

Refer to "Function setup mode" on page 5-35.

## Emergency broadcasts

E00721700011

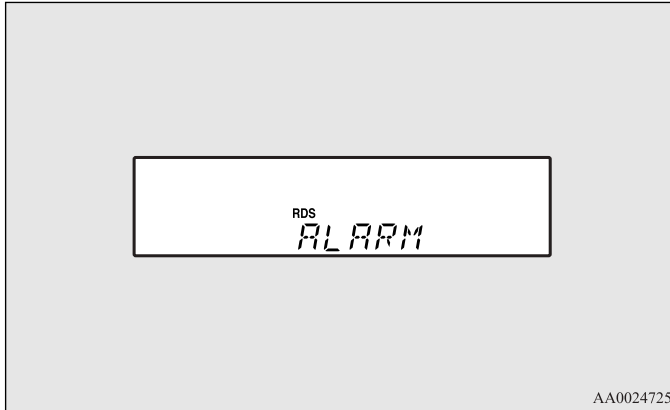

AA0024725

If an emergency broadcast is caught while receiving a FM broadcast or playing back a compact disc with the ignition switch in “ACC” or “ON” position, the display will show “ALARM” and the emergency broadcast will interrupt the current program. The volume level is set separately for listening to normal audio programs and for listening to emergency broadcasts. The volume level will therefore change automatically to that set when an emergency broadcast or traffic information broadcast was last received. When the emergency broadcast is over, the radio will return to the previously received program and to the corresponding volume level.

## Function setup mode

E00722500175

It is possible to change the following functions:

- AF
- CT
- REG
- TP-S
- Language of PTY display

1. Press the “MENU” button to select the function setup mode.

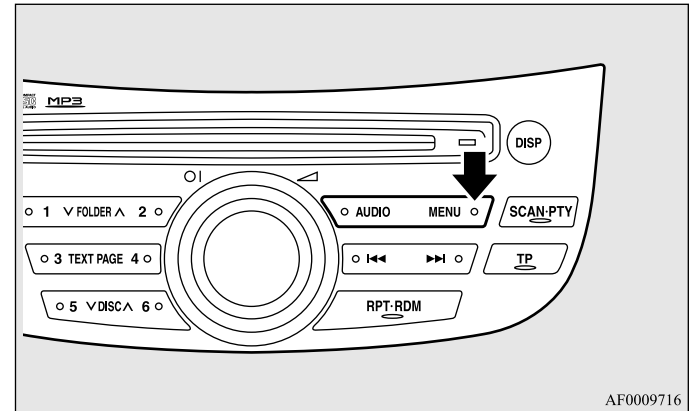

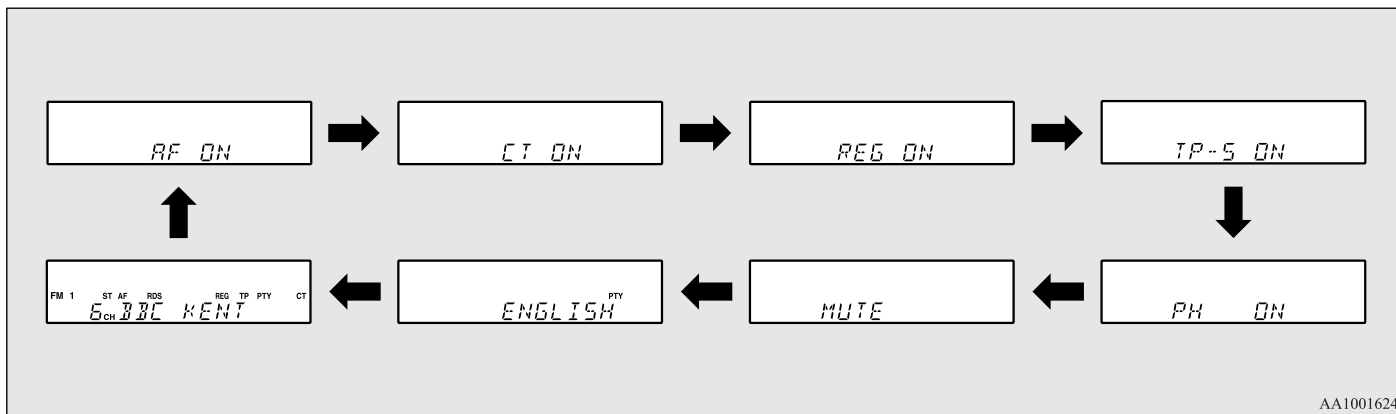

AA1001624

- 5
2. Press the “MENU” button repeatedly to select the mode you wish to change. The order is: AF → CT → REG → TP-S → PH → MUTE → Language of PTY display → Function setup mode OFF.

NOTE

- Although “PH” and “MUTE” appear on the display, the PH and MUTE functions are inoperative.

3. Select the desired setting for each mode to be turned ON and OFF as shown below.  
The setting will be shown on the display.

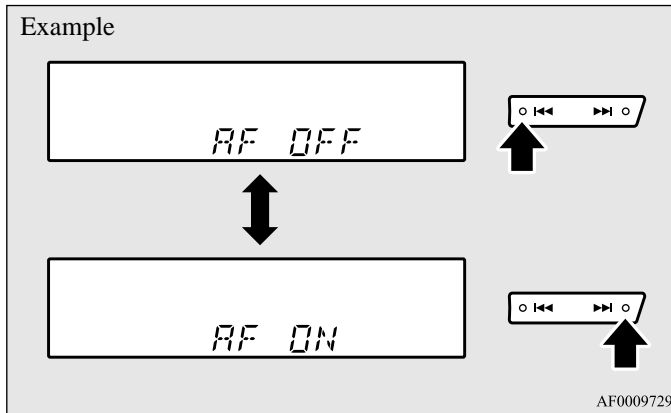

#### NOTE

- After selecting a mode, you can leave the function setup mode by taking either of the following steps:
  - Press the “MENU” button for at least 2 seconds.
  - Make no entry for 7 seconds.
- For instructions on setting the language of PTY display, refer to “To change the language of PTY display” on page 5-32.

## CD control panel and display

E00709500673

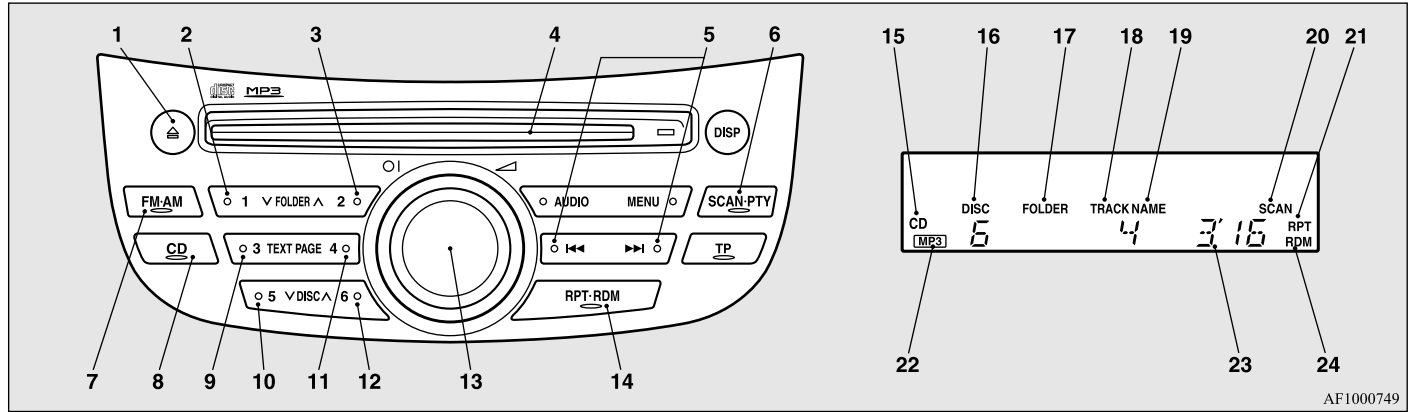

5

- 1- CD eject button
- 2- FOLDER (Folder down) button
- 3- FOLDER (Folder up) button
- 4- Disc loading slot
- 5- TRACK (Track down/up) button
- 6- SCAN button
- 7- AM/FM (FM/MW/LW selection) button
- 8- CD (CD mode changeover) button
- 9- TEXT (Title display) button
- 10- DISC (Disc down) button\*
- 11- PAGE (Title scroll) button
- 12- DISC (Disc up) button\*
- 13- PWR (On-Off) switch
- 14- RPT/RDM (Repeat/Random) button
- 15- CD indicator

- 16- DISC indicator\*
- 17- FOLDER indicator
- 18- TRACK indicator
- 19- NAME indicator
- 20- SCAN indicator
- 21- RPT (Repeat) indicator
- 22- MP3 indicator
- 23- Track play time display
- 24- RDM (Random) indicator

\* Operates when equipped with a CD autochanger.

AF1000749



## To listen to a CD

E00709601004

### With a CD player

1. Insert the disc with the label facing up.  
When a disc is inserted, the CD indicator (16) will come on and the CD player will begin playing even if the radio is being used. The CD player will also start playback when the CD button (8) is pressed with a disc in the player even if the radio is being used.

### NOTE

- If the system is equipped with a CD autochanger, the system switches between the CD player mode and the CD autochanger mode each time the CD button (8) is pressed.
2. To adjust the volume and tone, refer to “To adjust the volume” on page 5-24 and “To adjust the tone” on page 5-24.

### NOTE

- When an 8 cm compact disc is used, the adapter is not needed for playback. Insert the disc in the centre of the disc-loading slot.
- For information concerning the handling of compact discs, refer to “Handling of compact discs” on page 5-49.

### *To fast-forward/fast-reverse the disc*

To fast-forward or fast-reverse the disc, press the TRACK button (5).

#### **Fast-forward**

You can fast-forward the disc by pressing the ►► side of the TRACK button (5). While the button is kept pressed, the disc will be fast-forwarded.

#### **Fast-reverse**

You can fast-reverse the disc by pressing the ◀◀ side of the TRACK button (5). While the button is kept pressed, the disc will be fast-reversed.

### NOTE

- When you have fast-forwarded/fast-reversed the disc, the playing-time may be shown with deviation.

## For pleasant driving

### To listen an MP3 CD

This CD player allows you to play MP3 (MPEG Audio Layer-3) files recorded on CD-ROMs, CD-Rs (recordable CDs), and CD-RWs (rewritable CDs) in ISO9660 Level 1/Level 2, Joliet, and Romeo formats. Each disc may have a maximum of 16 trees, 100 folders, and 255 files per disc. During MP3 playback, the unit can display ID3 tag information. For information concerning ID3 tag, refer to “CD text and MP3 title display” on page 5-44.

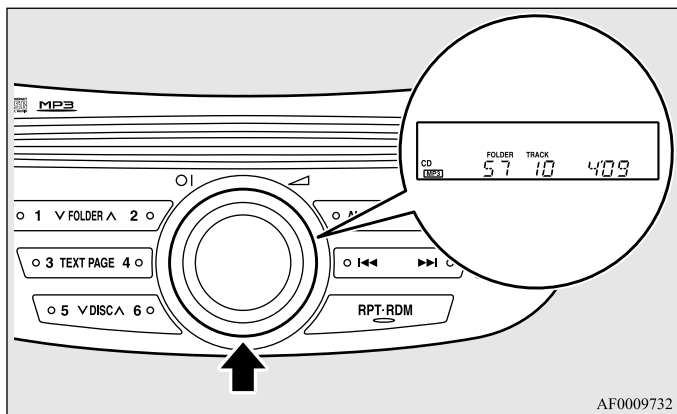

1. Insert a disc containing MP3 files into the slot.
2. Press the CD button (8) for 2 seconds or longer to switch to MP3 CD mode from normal music CD mode. The display shows “READING”, then playback will begin. The folder number and the track number will appear on the display.

### NOTE

- While listening to a disc on which both CD-DA (CD-Digital Audio) and MP3 files have been recorded, you can switch between reading of the CD-DA, reading of the MP3 files, and AUX (auxiliary input) by pressing the CD button for 2 seconds or longer (until you hear a beep).
- With a disc that contains both CD-DA and MP3 files, the CD-DA are automatically played first.
- The playback sound quality differs depending on the encoding software and the bit rate. For details, refer to the user manual of your encoding software.
- Depending on file/folder configurations on a disc, it may take some time before playback starts.
- MP3 encode software and writing software are not supplied to this unit.
- You may encounter trouble in playing an MP3 or displaying the information of MP3 files recorded with certain writing software or CD recorders (CD-R/RW drivers).
- If you record too many folders or files other than MP3 onto a disc, it may take some time before playback starts.
- This unit does not record MP3 files.
- For information concerning CD-Rs/RWs, refer to “Notes on CD-Rs/RWs” on page 5-51.

### **!** CAUTION

- Attempting to play a file not in the MP3 format which has the “.mp3” file name may produce noise from the speakers and speaker damage, and can damage your hearing.

**Folder selection order/MP3 file playback order (Example)**

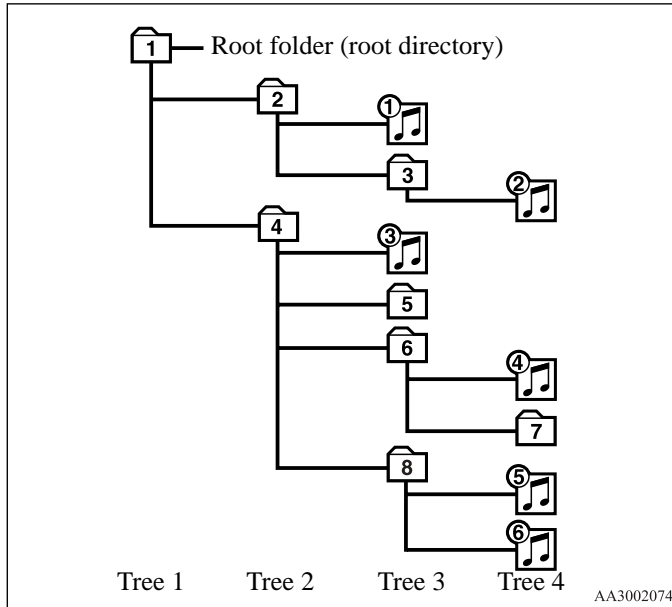

**Folder selection**

In the order

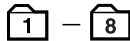

**File selection**

In the order



**To select a desired folder (MP3 CDs only)**

You can select your desired folder by pressing the FOLDER buttons (2 or 3).

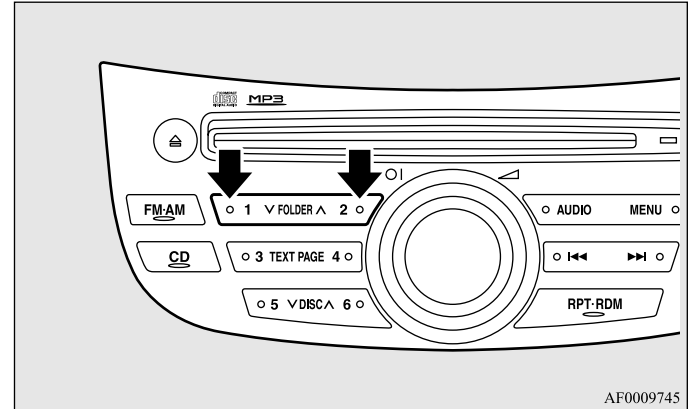

**Folder up**

Press the FOLDER button (3) until the desired folder number appears on the display.

**Folder down**

Press the FOLDER button (2) until the desired folder number appears on the display.

## For pleasant driving

### *To select a desired track*

You can select your desired track by using the TRACK button (5).

#### **Track up**

Press the ►| side of the TRACK button (5) repeatedly until the desired track number appears on the display.

#### **Track down**

Press the |◀◀ side of the TRACK button (5) repeatedly until the desired track number appears on the display.

#### **NOTE**

- Pressing the |◀◀ side of the TRACK button (5) once during the song will cause the CD player to restart playback from the beginning of the song.

### *To repeat a track*

Press the RPT/RDM button (14) briefly while the track is playing. “RPT” will appear on the display. To exit the repeat mode, press the RPT/RDM button two times.

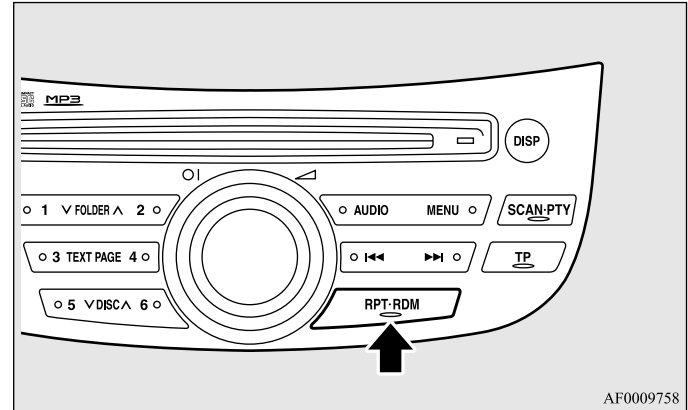

#### **NOTE**

- The repeat mode will be canceled by pressing the TRACK button (5), the SCAN button (6) or CD eject button (1).
- With a disc that contains both CD-DA and MP3 files, the repeat mode causes only files of the same format (CD-DA only or MP3 files only) to be repeated.

### To change the order of tracks for playback

#### Random playback for a disc (music CDs only)

Press the RPT/RDM button (14) briefly. “RDM” will appear on the display. Tracks on the currently selected disc will be played in a random sequence.

To exit the random mode, press the RPT/RDM button again.

#### Random playback for all folders on a disc (MP3 CDs only)

Press the RPT/RDM button (14) briefly. “RDM” will appear on the display. Tracks in the currently selected disc will be played in a random sequence. To exit the random mode, press the RPT/RDM button again.

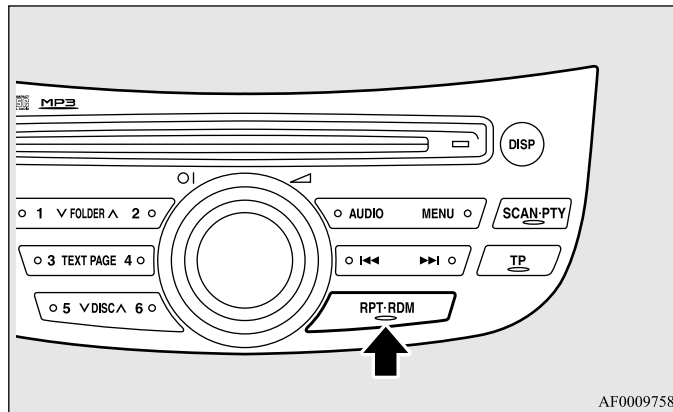

#### NOTE

- The random mode will be canceled by pressing the SCAN button (6) or the CD eject button (1).
- With a disc that contains both CD-DA and MP3 files, the random mode causes only files of the same format (CD-DA only or MP3 files only) to be played in a random sequence.

## For pleasant driving

### *To find the start of each track on a disc for playback*

Press the SCAN button (6). “SCAN” will appear on the display and the CD player will play back the first 10 seconds of each track on the selected disc.

The track number will blink while the scan mode is selected. To exit the scan mode, press the SCAN button again.

### NOTE

- Once all tracks on the disc have been scanned, playback of the disc will restart from the beginning of the track that was playing when scanning started.
- The scan mode will be canceled by selecting radio or CD operation and pressing the RPT/RDM button (14), the TRACK button (5) or the CD eject button (1).
- With a disc that contains both CD-DA and MP3 files, the scan mode causes only files of the same format (CD-DA only or MP3 files only) to be played.

### *To eject a disc*

When the CD eject button (1) is pressed, the disc automatically stops and is ejected. The system automatically switches to radio mode.

### *CD text and MP3 title display*

E00725000298

This CD player can display CD text and MP3 titles including ID3 tag information.

#### CD text

The CD player can display disc and track titles for discs encoded with disc and track title information. Press the TEXT button (9) repeatedly to make selections in the following sequence: disc name → track name → normal display mode.

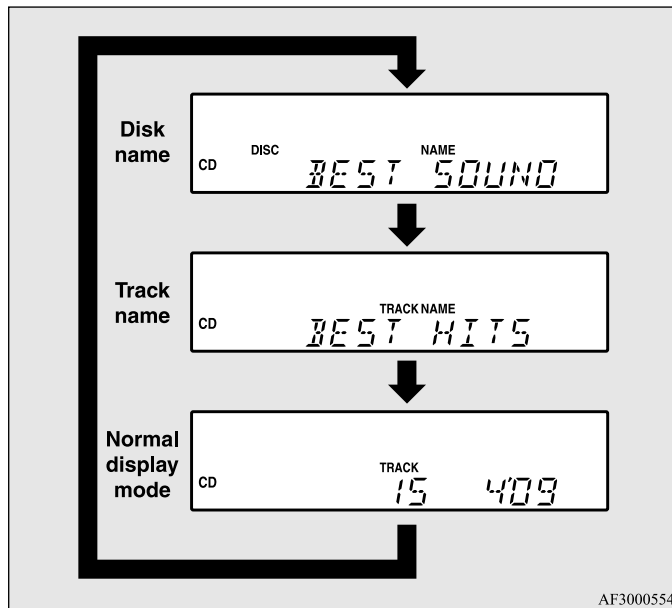

### NOTE

- The display can show up to 10 characters. If a disc name or track name has more than 10 characters, press the PAGE button (11) to view the next 10 characters.
- When there is no title information to be displayed, the display shows “NO TITLE”.
- Characters that the CD player cannot display are shown as an asterisk.

### MP3 title

The CD player can display folder and track titles for discs encoded with folder and track information. Press the TEXT button (9) for less than 1 second repeatedly to make selections in the following sequence: folder name → track name → normal display mode.

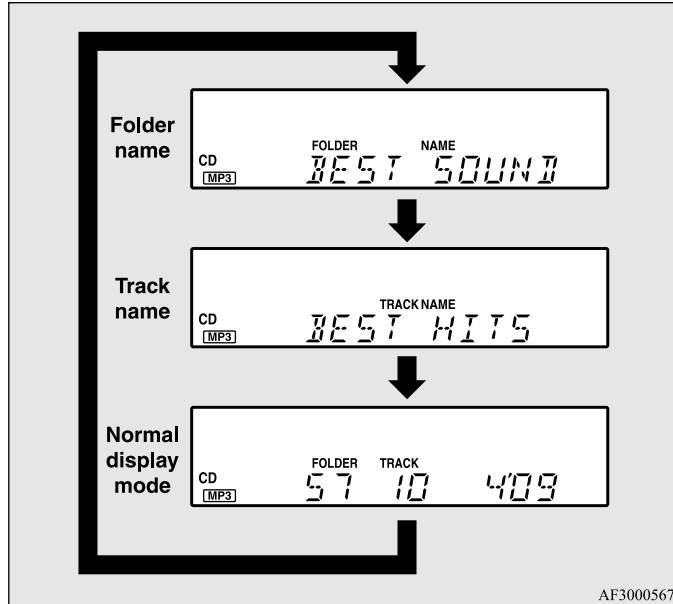

### ID3 tag information

The CD player can display ID3 tag information for files that have been recorded with ID3 tag information.

1. Press the TEXT button (9) for 2 seconds or longer to switch to the ID3 tag information. "TAG" indicator will appear on the display.
2. Then press the DISP button for less than 1 second repeatedly to make selections in the following sequence: album name → track name → artist name → normal display mode.

### NOTE

- To return from ID3 tag information to the folder name, press the TEXT button (9) again for 2 seconds or longer.
- When there is no title information to be displayed, the display shows "NO TITLE".
- The display can show up to 10 characters. If a folder name, track name, or item of ID3 tag information has more than 10 characters, press the PAGE button (11) to view the next 10 characters.
- Folder names and track names can each be displayed up to a length of 10 characters. Items of ID3 tag information can each be displayed up to a length of 10 characters.
- Characters that the CD player cannot display are shown as an asterisk.

## For pleasant driving

### With a CD autochanger

1. Press the CD button (11), and the CD autochanger mode will be selected, starting playback.
2. To adjust the volume and tone, refer to “To adjust the volume” on page 5-24 and “To adjust the tone” on page 5-24.
3. To stop the CD player, turn off the power by pressing the PWR switch (13) or switch to the radio mode by pressing the AM/FM button (7).
4. For information concerning the handling of compact discs, refer to “Handling of compact discs” on page 5-49.

### To select a desired disc (CD autochanger only)

You can select by using the DISC button (10 or 12).

#### Disc up

Press the DISC button (12) until the desired disc is reached. The disc indicator (16) will display the selected disc number.

#### Disc down

Press the DISC button (10) until the desired disc is reached. The disc indicator (16) will display the selected disc number.



## Error codes

E00710100695

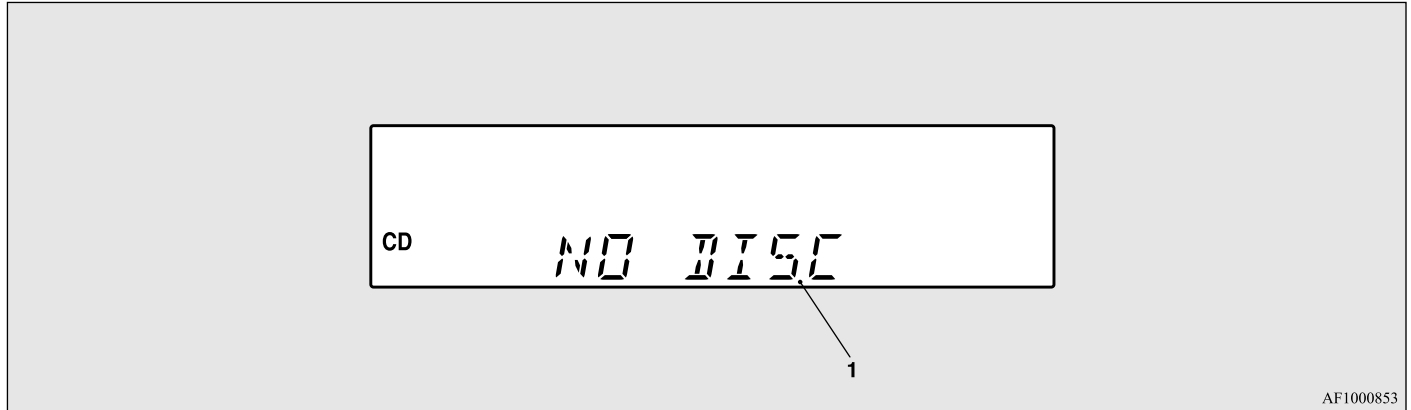

AF1000853

If an error code (1) appears in the display window, take action in accordance with the table below.

Error display	Problem	Description	
EJ	No magazine inserted	Magazine is not in changer.	Insert magazine into changer.
NO DISC	No disc inserted	Disc is not in CD player.	Insert disc.
E 01	Focus error	Disc is not loaded correctly, or condensation on disc.	Insert disc with label facing up. Remove moisture from disc.
E 02	Disc error	Disc is dirty, scratched, or deformed; or excessive vehicle vibration.	Clean or replace disc. Retry when vibrations stop.
E 03	Mechanism error	Loading or eject error. Pick-up is out of position.	Eject disc and reload. If disc will not eject, have the equipment inspected by an authorized MITSUBISHI MOTORS dealer.

**For pleasant driving**

Error display	Problem	Description	
E HOT	High temperature	Internal protection against high temperatures.	Allow radio to cool by waiting about 30 minutes.
E	Communication or power supply error	Communication error between external device and audio equipment. Power supply error of external device.	Consult an authorized MITSUBISHI MOTORS dealer.

## Handling of compact discs

E00723000193

- Use only the type of compact discs that have the mark shown in the illustration below. (Playback of CD-R or CD-RW discs may cause problems.)



- The use of special shaped, damaged compact discs (like cracked discs) or low-quality compact discs (like warped discs or burrs on the discs) such as those shown will damage the CD player.

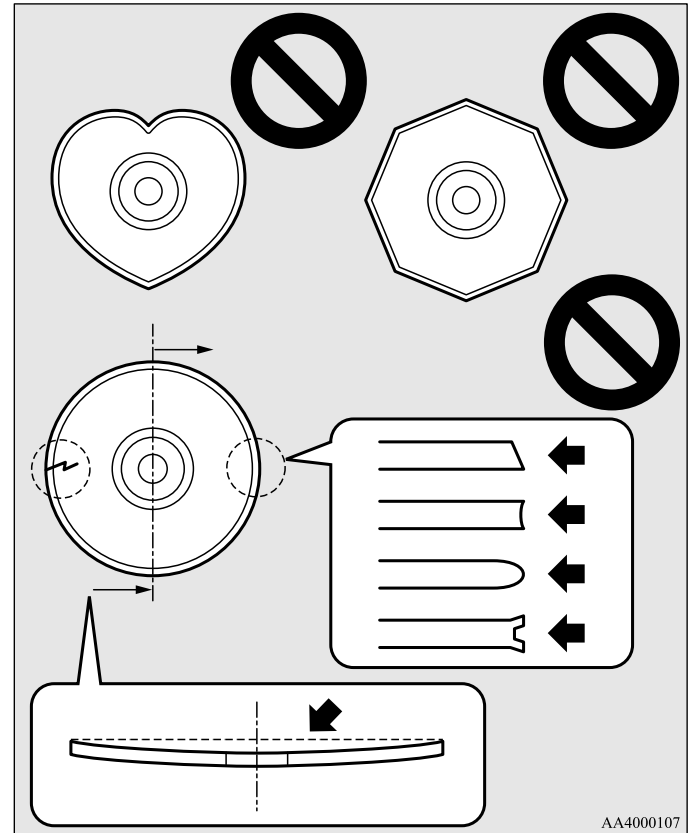

## For pleasant driving

- In the following circumstances, moisture can form on discs and inside the audio system, preventing normal operation.
  - When there is high humidity (for example, when it is raining).
  - When the temperature suddenly rises, such as right after the heater is turned on in cold weather.

In this case, wait until the moisture has had time to dry out.

- When the CD player is subjected to violent vibrations, such as during off-road driving, the tracking may not work.
- When storing compact discs, always store them in their separate cases. Never place compact discs in direct sunlight, or in any place where the temperature or humidity is high.
- Never touch the flat surface of the disc where there isn't a label. This will damage the disc surface and could affect the sound quality. When handling a compact disc, always hold it by the outer edge and the centre hole.

- To clean a disc, use a soft, clean, dry cloth. Wipe directly from the centre hole towards the outer edge. Do not wipe in a circle. Never use any chemicals such as benzine, paint thinner, a disc spray cleaner, or an anti-static agent on the disc.

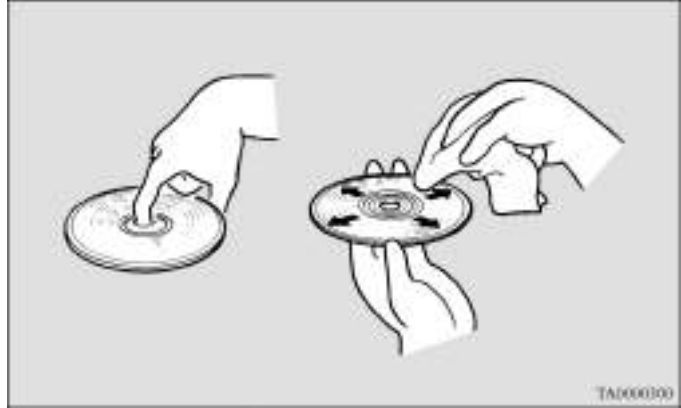

- Do not use a ball point pen, felt pen, pencil, etc. to write on the label surface of the disc.

- Do not put additional labels (A) or stickers (B) on compact discs. Also, do not use any compact disc on which a label or sticker has started to peel off or any compact disc that has stickiness or other contamination left by a peeled-off label or sticker. If you use such a compact disc, the CD player may stop working properly and you may not be able to eject the compact disc.

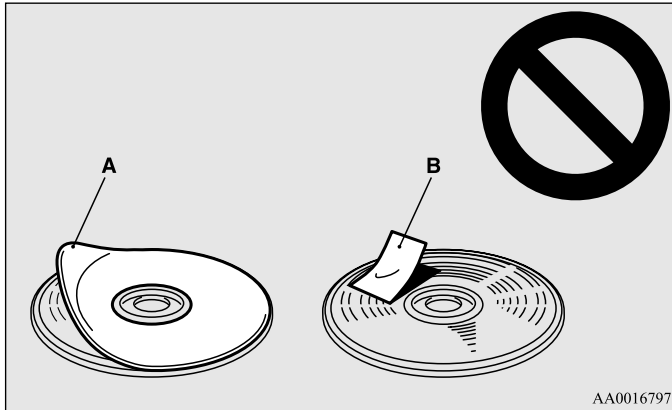

## Notes on CD-Rs/RWs

E00725100026

- You may have trouble playing back some CD-R/RW discs recorded on CD recorders (CD-R/RW drives), either due to their recording characteristics or dirt, fingerprints, scratches, etc. on the disc surface.
- CD-R/RW discs are less resistant to high temperatures and high humidity than ordinary music CDs. Leaving them inside a vehicle for extended periods may damage them and make playback impossible.
- The unit may not successfully play back a CD-R/RW that was made by the combination of writing software, a CD recorder (CD-R/RW drive) and a disc if they are incompatible with one another.
- This player cannot play the CD-R/RW discs if the session is not closed.
- This player cannot play CD-R/RW discs which contain other than CD-DA or MP3 data (Video CD, etc.).
- Be sure to observe the handling instructions for the CD-R/RW disc.

### **⚠ WARNING**

- Operating the CD player in a manner other than specifically instructed herein may result in hazardous radiation exposure. Do not remove the cover and attempt to repair the CD player by yourself. There are no user serviceable parts inside. In case of malfunction, we recommend you to have it checked.

## Antenna

E0071050064

### Glass antenna

The antenna wire is printed in the left rear quarter window glass.

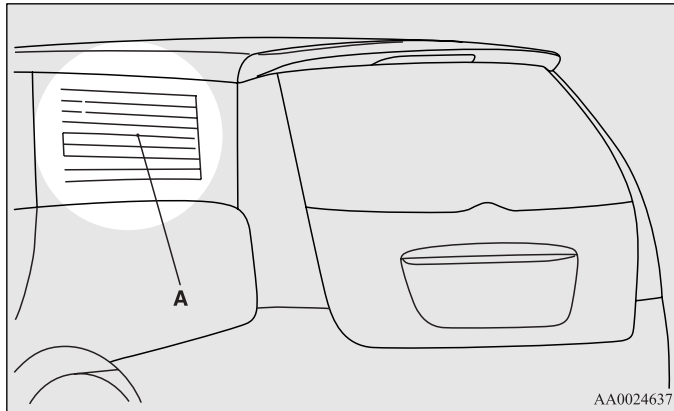

AA0024637

A- Antenna wire

### NOTE

- When cleaning the rear quarter window glass, use a soft cloth along the antenna wire to keep it from damaging.

## Sun visors

E00711200680

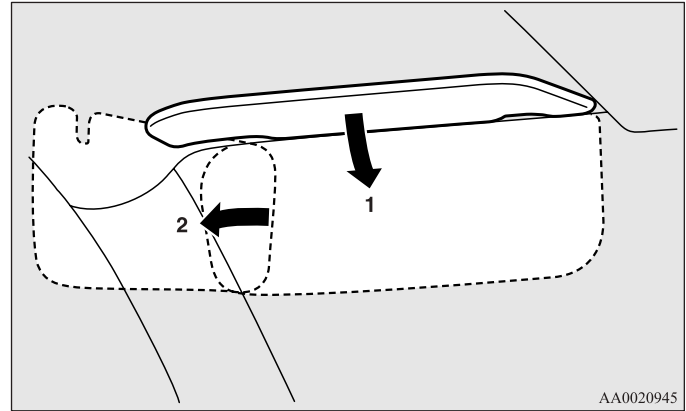

AA0020945

- 1- To eliminate front glare
- 2- To eliminate side glare

## Card holder

Cards can be slipped into the holder (A) on the back of the sun visor.

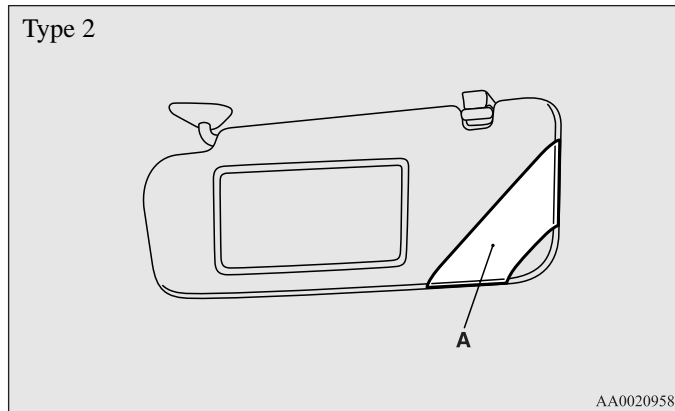
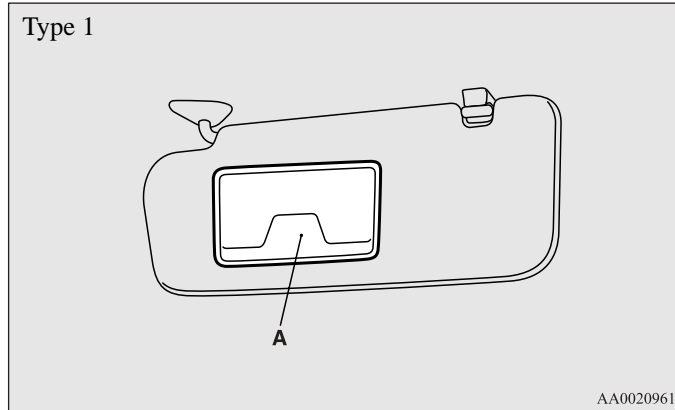

## Vanity mirror

E00711300102

### Type 1

A vanity mirror is fitted to the back of the sun visor.

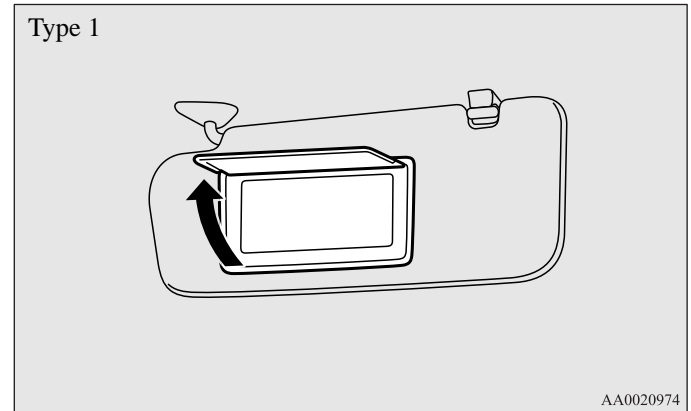

## Type 2

A vanity mirror is fitted to the back of the sun visor. Operating the lid of the vanity mirror will automatically turn on the mirror lamp (A).

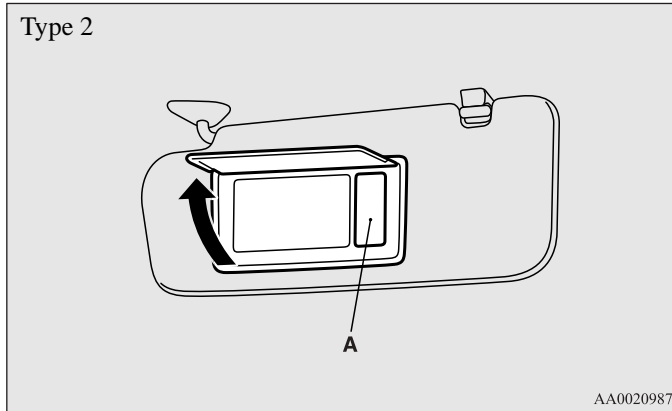

### **⚠ CAUTION**

- If the lid of vanity mirror with lamp is kept open for prolonged periods of time, the vehicle's battery will be discharged.

## Ashtray

E00711400480

### **⚠ CAUTION**

- Put out matches and cigarettes before they are placed in the ashtray.
- Don't put papers and other things that burn into your ashtrays. If you do, cigarettes or other smoking materials could set them on fire, causing damage.
- Always close the ashtray. If left open, other cigarette butts in the ashtray may be rekindled.

To use the ashtray, pull open the lid.

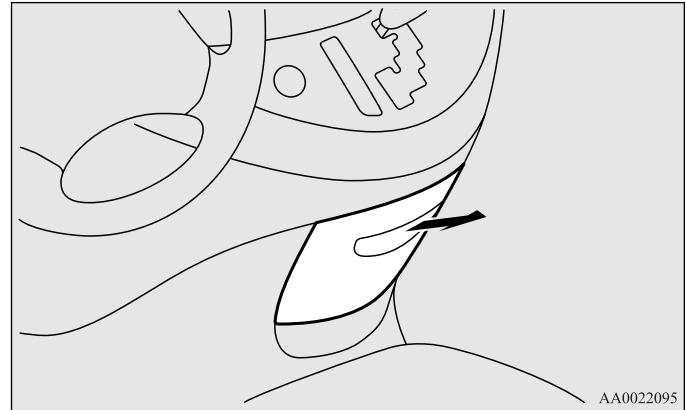



## *Cigarette lighter\**

E00711500869

To remove the ashtray, pull it out while pressing the stopper (A).

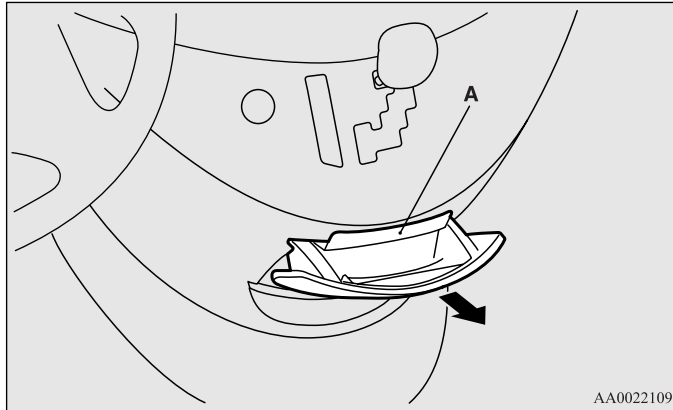

The cigarette lighter can be used while the ignition switch is in either "ON" or "ACC".

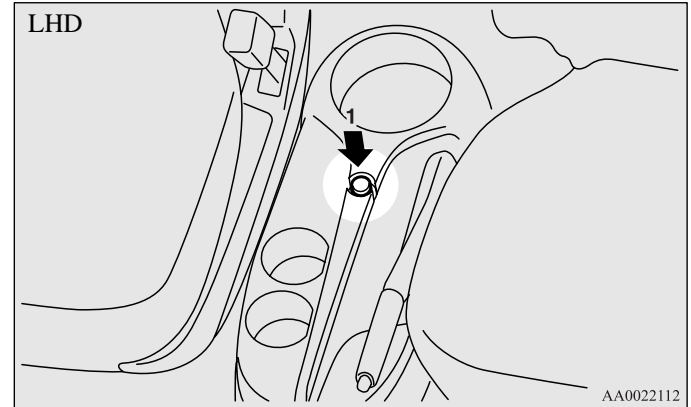

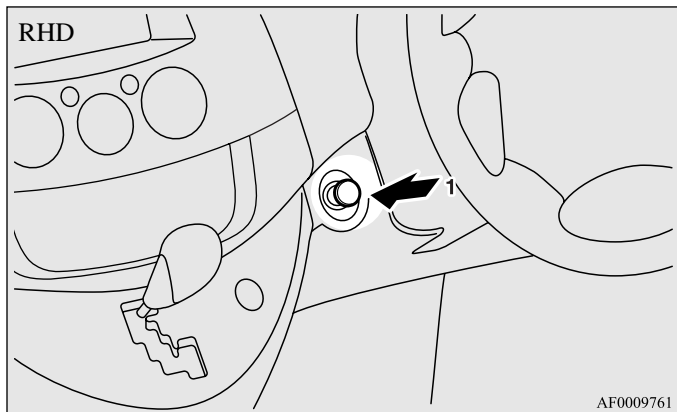

1- Push all the way in.

The lighter will automatically return to its original position with a “click” when ready. Pull it out for use.

After use, insert the lighter to its original position in the socket.

#### NOTE

- Do not leave the cigarette lighter removed from its socket, because the socket might become clogged by foreign material and be short-circuited.

#### **⚠ CAUTION**

- Do not touch heating element or lighter housing, hold the knob only to prevent burns.
- Do not allow children to operate or play with the cigarette lighter as burns may occur.

#### **⚠ CAUTION**

- Something is wrong with the cigarette lighter if it does not pop back out within approximately 30 seconds of being pushed in.  
Leaving the cigarette lighter pushed in for an extended period could cause fire. If it does not pop out by itself, we recommend you to have it checked.
- Do not leave the cigarette lighter pushed in or insert the cigarette lighter from another vehicle. Otherwise, the lighter may overheat and cause fire.
- It is recommended that only the lighter be inserted in its socket.  
Use of “plug-in” type accessories may damage the socket and result in poor retention of the lighter.
- When the cigarette lighter socket is used as a power source for an electric appliance, be sure that the electric appliance operates at 12 V and has an electric capacity of 120 W or less. In addition, long use of the electric appliance without running the engine may run down the battery.

## Accessory socket\*

E00711600684

The accessory socket can be used while the ignition switch is in either the "ON" or "ACC" position. Pull out the plug (A) or open the lid (B) to uncover the socket. Use it to plug in an electrical device.

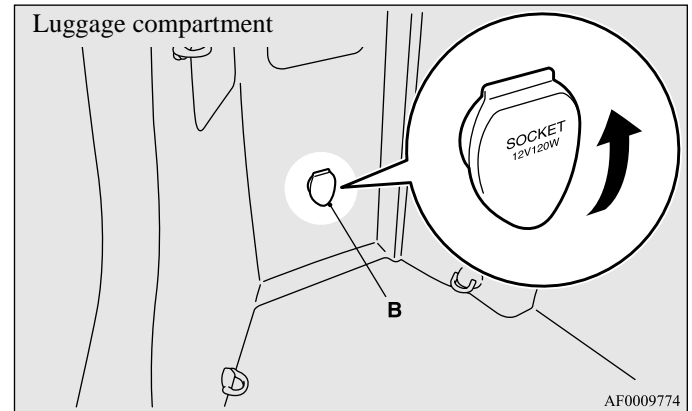
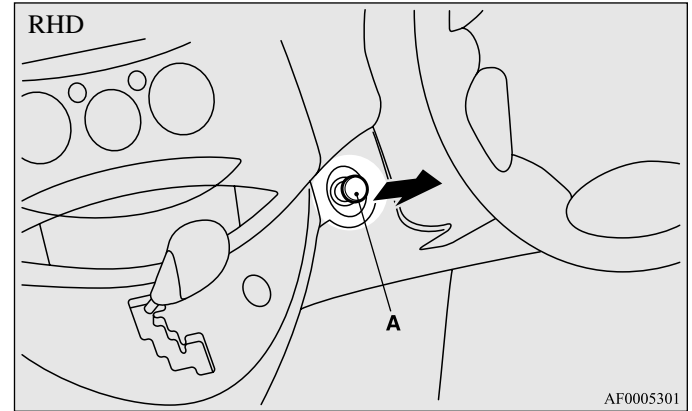
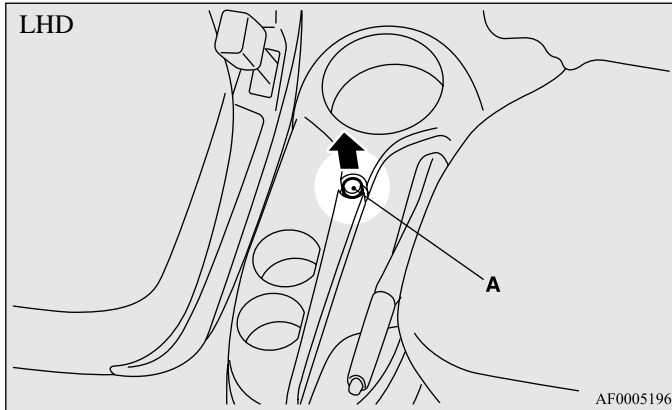

**⚠ CAUTION**

- Be sure to use a “plug-in” type accessory operating at 12 V and at 120 W or less.  
When using both sockets at the same time, make sure that electrical accessories are 12 V accessories and that the total power consumption does not exceed 120 W.
- When the accessory socket is not in use, be sure to put on the plug or close the lid, because the socket might become clogged by foreign material and be short-circuited.

NOTE

- Long use of the electric appliance without running the engine may run down the battery.

*Interior lamps*

E00712000500

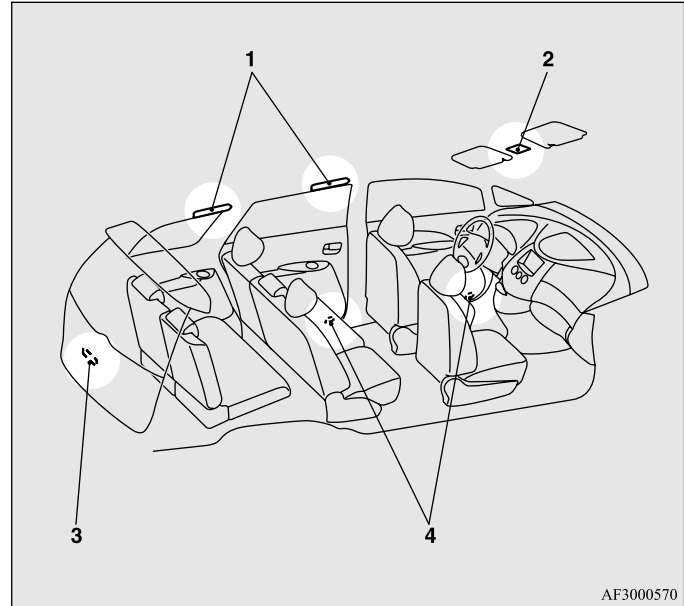

AF3000570

- 1- Rear personal lamps
- 2- Interior lamp switch  
Room lamp & map lamps
- 3- Luggage compartment lamp
- 4- Door lamps

## NOTE

- If you leave the lamps on without running the engine, you will run down the battery. Before you leave the vehicle, make sure that all the lamps are off.

## Interior lamp switch

E00717300263

The interior lamp switch can be used to turn the room lamp & map lamps and rear personal lamps on and off.

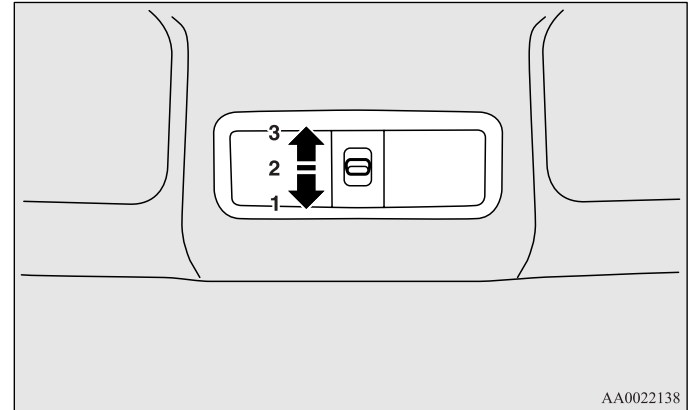

AA0022138

- 1 (○) - The room lamp & map lamps and rear personal lamps are off regardless of opening and closing of the doors and tailgate.

## NOTE

- When the room lamp & map lamp switch is in the “ON” position, the interior lamp switch cannot be used to turn off the room lamp & map lamps.

## For pleasant driving

2 (DOOR) - The room lamp & map lamps and rear personal lamps go on when a door or the tailgate is opened. When all doors and tailgate are closed, the room lamp & map lamps and rear personal lamps are illuminated and dimmed gradually for 15 seconds and then go out.

However, the lamp goes out immediately without being dimmed in the following cases:

- The doors and tailgate are closed and the ignition switch is turned to the “ON” position.
- All doors and tailgate are locked using the key mechanism of the driver’s door, the lock knob of the driver’s door, or the remote control switch of the keyless entry system (if so equipped).

### NOTE

- On vehicles with keyless entry system, if the ignition key is removed with the doors and tailgate closed, the room lamp & map lamps and rear personal lamps are dimmed gradually for 15 seconds and then go out.

The dimming period is also adjustable.

For further information, we recommend you to consult a MITSUBISHI MOTORS Authorized Service Point.

On a vehicle equipped with a Multi Display Station (MDS), the functions can be adjusted on the screen. For details, refer to a separate operation manual.

- When the room lamp & map lamp switch is in the “ON” position, closing the doors and tailgate does not cause the room lamp & map lamps to go off.

3 (⌘) - The room lamp & map lamps and rear personal lamps are on regardless of opening and closing of the doors and tailgate.

## Room lamp & map lamps

E0071740020

With the doors and tailgate closed and the interior lamp switch in the “DOOR” position, pressing the lens (A) makes the room lamp & map lamps come on and pressing the lens again makes them go off.

If any of the doors or the tailgate is opened, the room lamp & map lamps come on. When it is subsequently closed, the room lamp & map lamps gradually dim for 15 seconds and then go off.

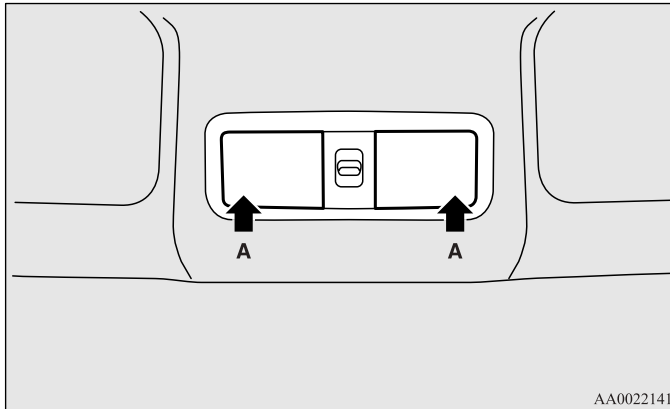

### NOTE

- Even with the interior lamp switch in the “○” position, it is possible to turn on the room lamp & map lamps by pressing the lens (A).
- With a door or the tailgate open or the interior lamp switch in the “☞” position, the room lamp & map lamps remain on even when the lens (A) is pressed.

## Rear personal lamps

E00712600216

With the doors and tailgate closed and the interior lamp switch in the “DOOR” position, pressing the lens (A) makes the lamp come on and pressing the lens again makes it go off.

If any of the doors or the tailgate is opened, the lamps come on. When it is subsequently closed, the lamps gradually dim for 15 seconds and then go off.

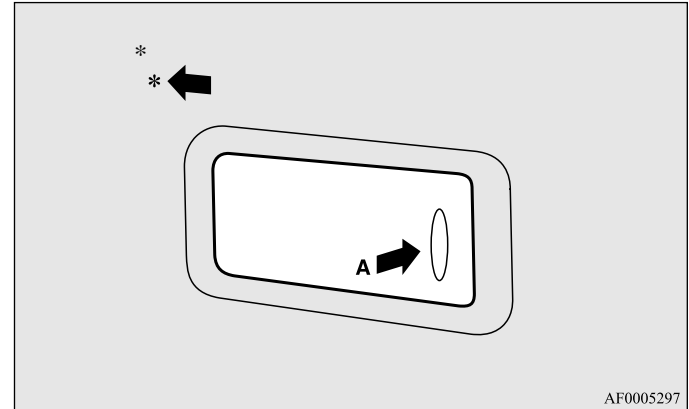

\*: Front of the vehicle

### NOTE

- With the interior lamp switch in the “○” position, the lamp remains off even when the lens (A) is pressed or one of the doors or the tailgate is opened.

For pleasant driving

## Luggage compartment lamp

E00712700031

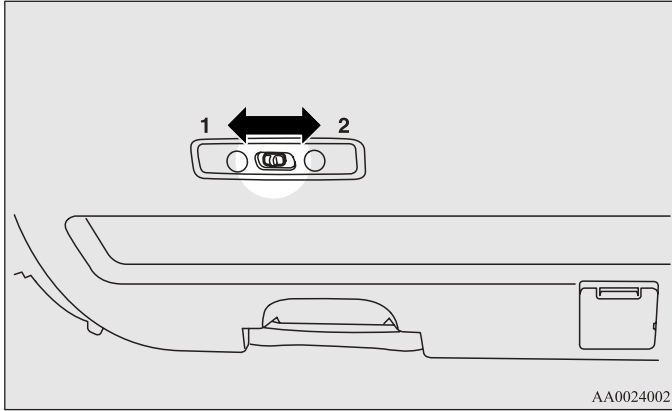

AA0024002

- 1- The lamp goes out.
- 2- The lamp illuminates when the tailgate is opened and goes out when it is closed.

## Door lamps

E00717500021

Each door lamp comes on when the relevant door is opened and goes off when the door is closed.

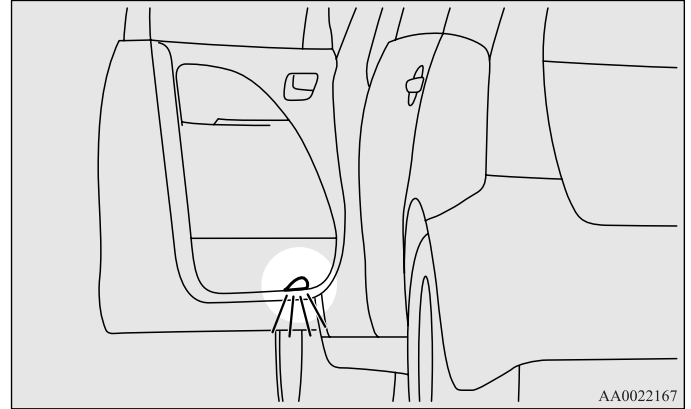

AA0022167



## Storage spaces

E00713100928

### Lamps (room lamps, etc.) auto-cutout function (vehicles with keyless entry system)

E00712900293

If any of the interior lamps are left switched on with the ignition key in any position other than “ON” or “ACC”, it goes off automatically after approximately 30 minutes to prevent complete discharge of the battery.

The lamp comes on again if the ignition key is turned to the “ON” or “ACC” position, any door or tailgate is opened and closed, or the keyless entry remote control is operated.

#### NOTE

- The interior lamp auto-cut function can be deactivated. We recommend you to consult a MITSUBISHI MOTORS Authorized Service Point for detailed information and assistance.  
On a vehicle equipped with a Multi Display Station (MDS), the functions can be adjusted on the screen. For details, refer to a separate operation manual.

### CAUTION

- **Never leave lighters, cans of carbonated drink, and spectacles in the cabin when parking the vehicle in hot sunshine. The cabin will become extremely hot, so lighters and other flammable items may catch fire and unopened drink cans (including beer cans) may rupture. The heat may also deform or crack plastic spectacle lenses and other spectacle parts that are made of plastic.**
- **Keep the lids of storage spaces closed while driving the vehicle. A lid or the contents of a storage space could otherwise cause injuries.**

#### NOTE

- Do not leave valuables in any storage space when leaving the vehicle.

## For pleasant driving

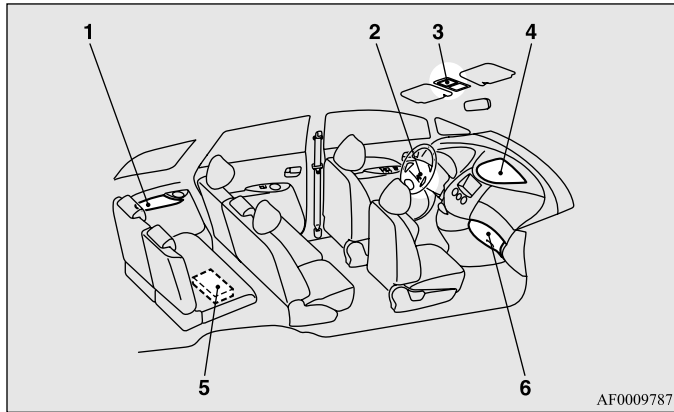

- 1- Rear side box
- 2- Personal box
- 3- Sunglasses pocket\*
- 4- Instrument panel upper box
- 5- Luggage floor box
- 6- Glove box

## Glove box

E00717600471

The glove box can be locked and unlocked using the key.

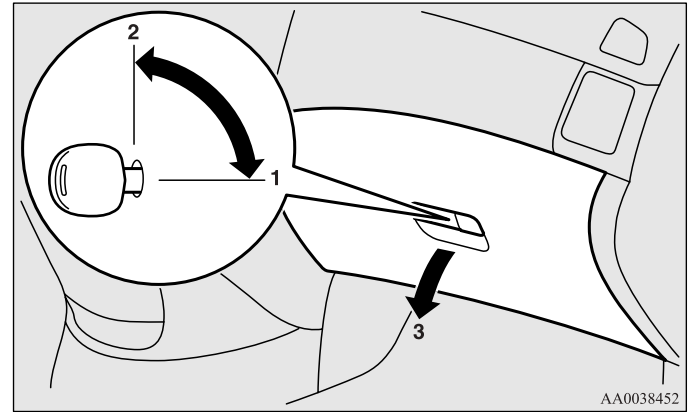

- 1- To lock
- 2- To unlock
- 3- To open, pull the lever

## NOTE

- When the lamp switch is in the “☀️” or “☞” position, the glove box lamp illuminates.
- The owner’s manual can be stored in the upper area (A) of the glove box.

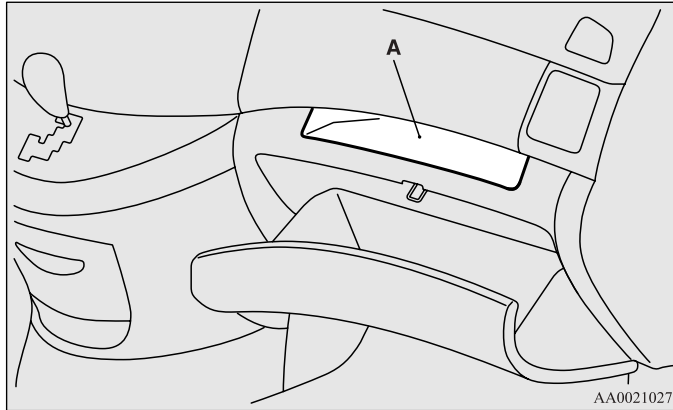

## Instrument panel upper box

E00717700023

To open, push the button.

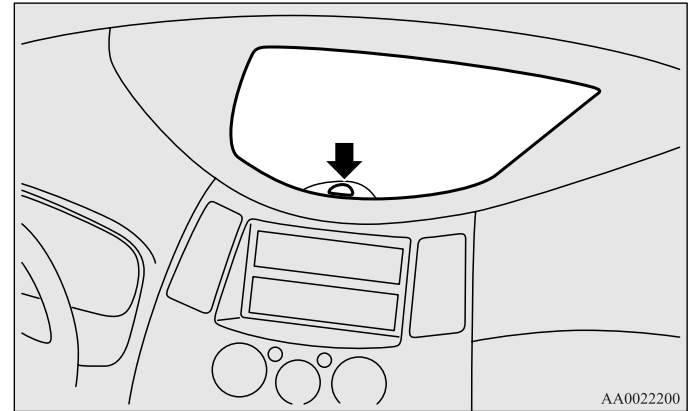

For pleasant driving

## Personal box

To open, pull the lid (A).

E0071800023

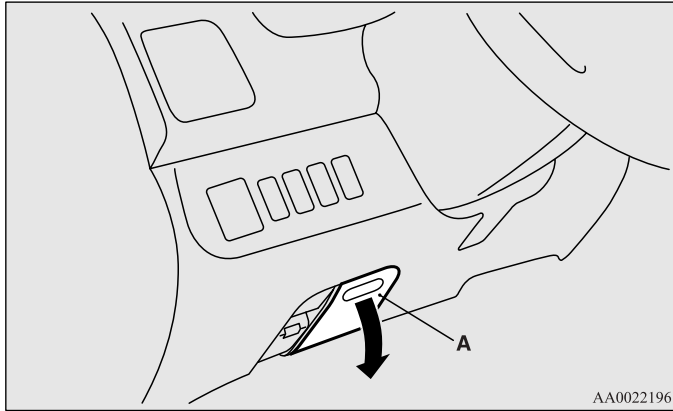

AA0022196

## Sunglasses pocket\*

To open, push the lid.

E00718600218

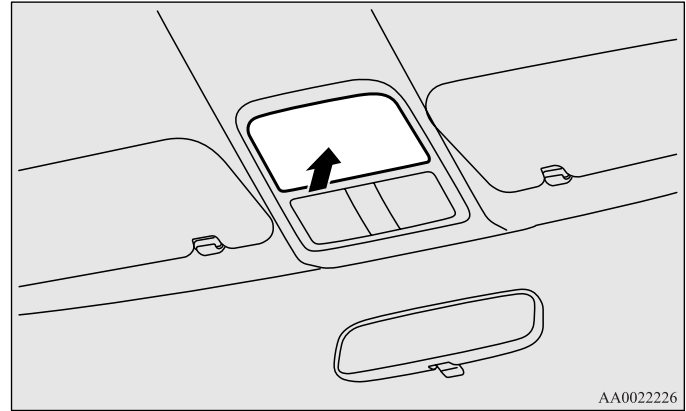

AA0022226

### **CAUTION**

- The holder should not be used to store anything heavier than sunglasses. These objects could drop out and lead to a collision.

### NOTE

- The holder may not be able to accommodate every possible size and shape of sunglasses; it is advisable to check compatibility before use.

## Rear side box

E00718100024

The rear side box is located on the left side of the third seat. Open the lid to use it.

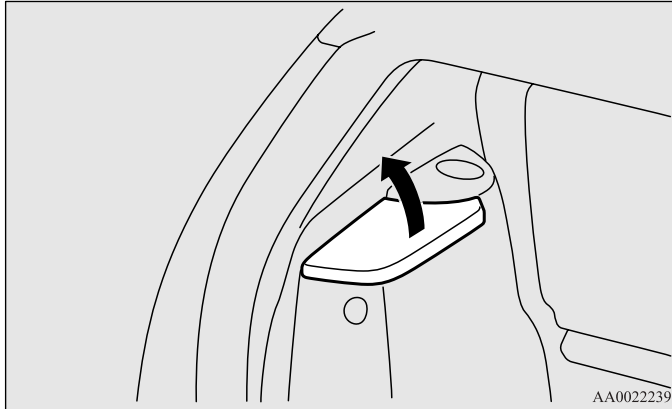

## Luggage floor box

E00718700020

The box for storing articles is located inside the luggage compartment.

To access it, stow the right side part of the third seat and lift the floor mat (A).

(Refer to “Stowing the third seat” on page 2-22.)

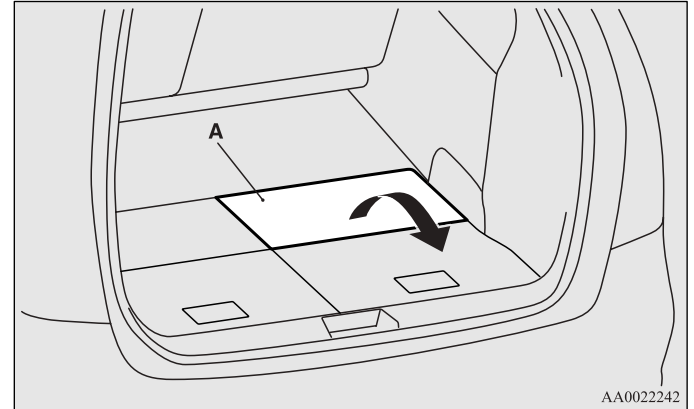

For pleasant driving

## Cup holder

E00714500150

### **⚠ CAUTION**

- Do not drink beverages while driving the vehicle; doing so could distract you and result in an accident.
- Beverages can spill owing to vibration or other movement during vehicle operation or owing to opening and closing of the rear doors. Be careful not to get scalded by a hot beverage if it spills.

### For the front seat

The cup holder is located in front of the floor console.

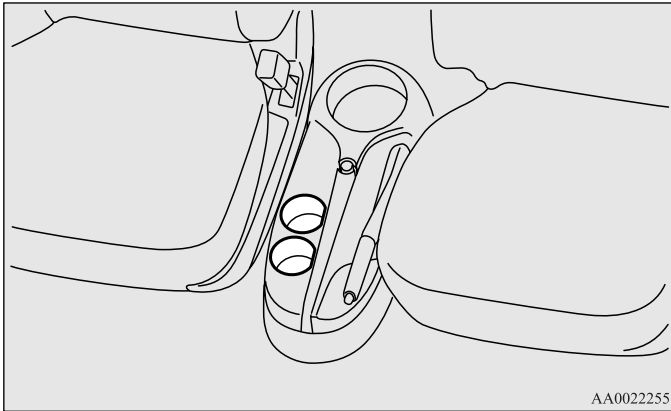

### For the second seat

E00718900019

The cup holders are provided at both sides.

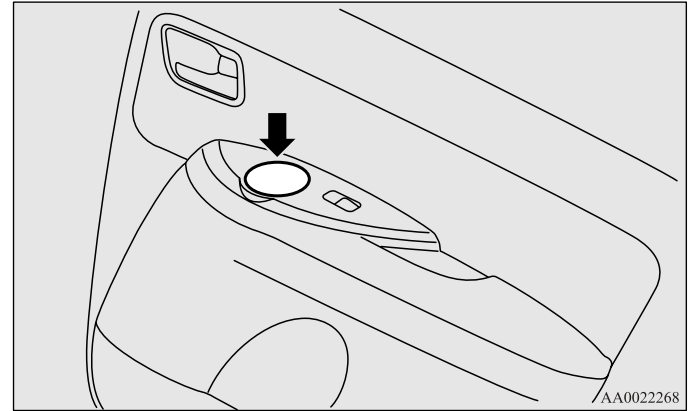

***Bottle holder***

E0071820025

**For the third seat**

E0071900017

The cup holder is provided at the right side.  
The back hole is for the cup holder.

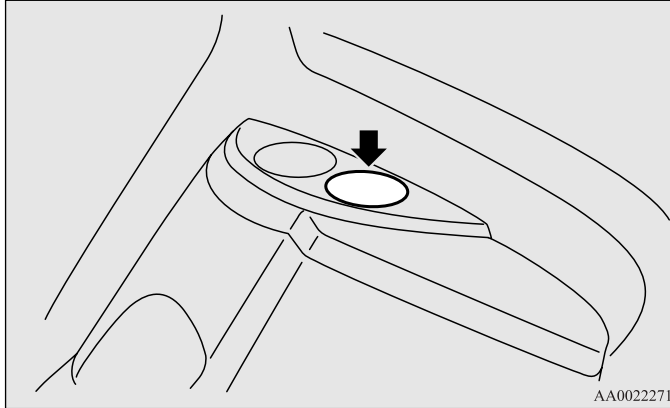
**⚠ CAUTION**

- Do not drink beverages while driving the vehicle; doing so could distract you and result in an accident.
- Beverages can spill owing to vibration or other movement during vehicle operation. Be careful not to get scalded by a hot beverage if it spills.

**NOTE**

- Make sure the cap of any plastic bottle to be placed in a bottle holder is tightly closed.
- The bottle holders may not accommodate bottles of certain shapes and sizes.

For pleasant driving

### For the front seat

The bottle holders are provided at both sides.

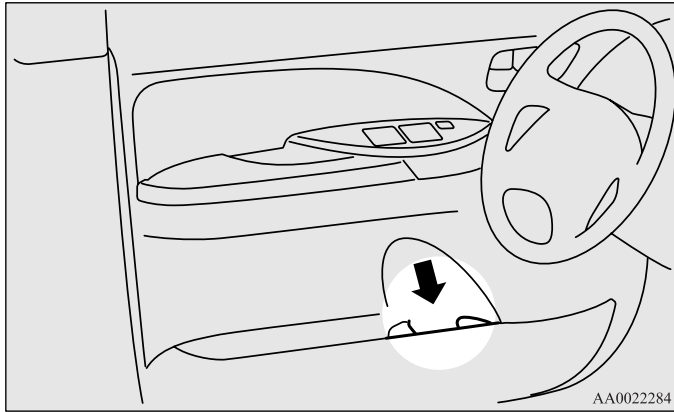

### For the second seat

The bottle holders are provided at both sides.

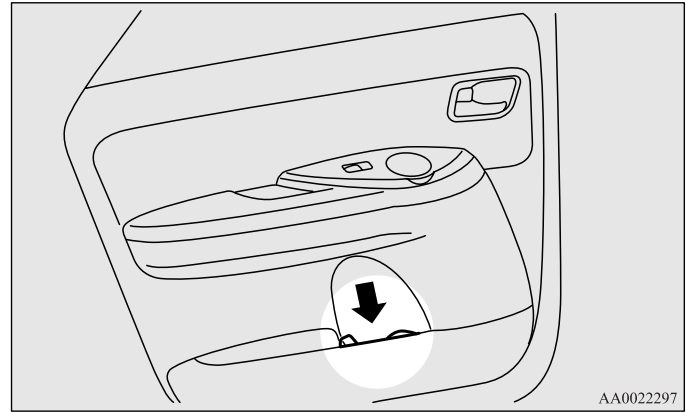



### For the third seat

The bottle holders are provided at both sides.

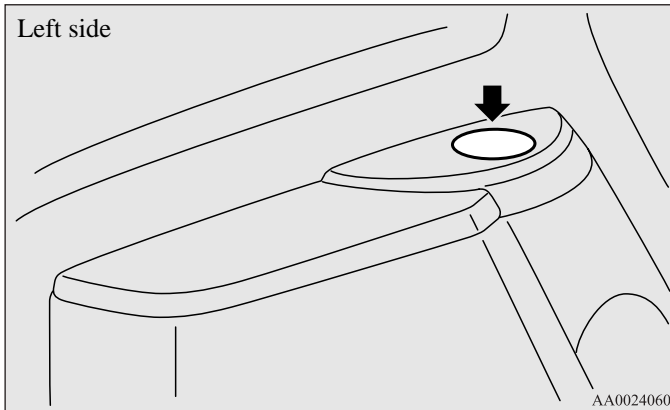
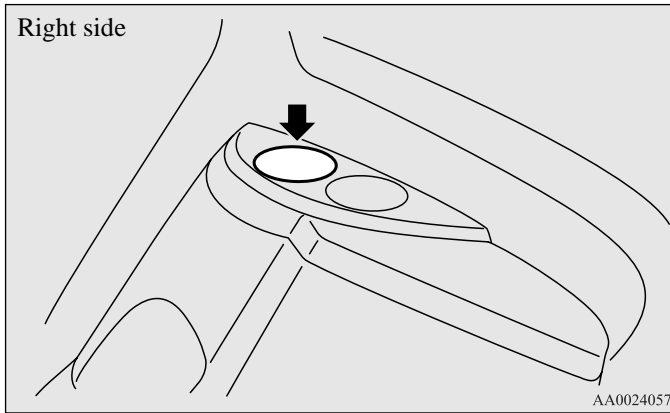

### NOTE

- On the right side, the front hole is for the bottle holder.

## Card holder\*

E0071880021

To store a card, insert it into the card holder until you hear a click. To remove the card, give it a push. It will come out automatically.

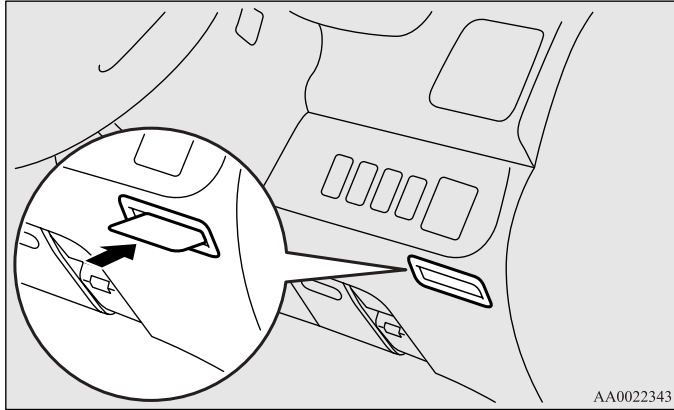

### NOTE

- The card holder can hold up to 3 cards.
- Do not insert receipts and other thin pieces of paper.

## Personal table

E0071530012

To use the personal table, push the button (A) and pull the table up until it locks in position.

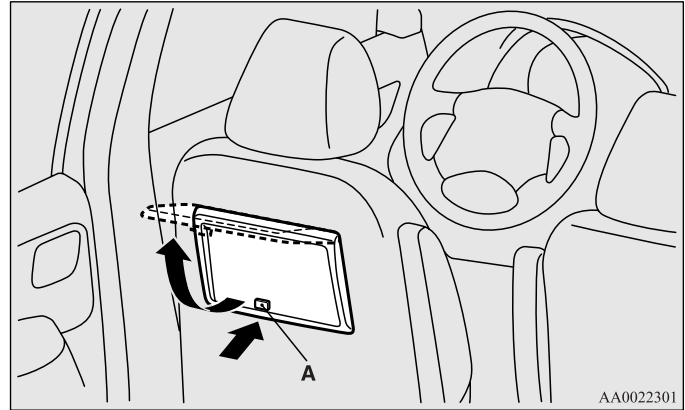

## **⚠ WARNING**

- **Keep the table retracted while driving the vehicle. The table could otherwise cause an accident in the event of hard braking or a collision.**
- **When retracting the table, push it until a click is emitted from the vicinity of the button. Confirm that the table is securely retained.**

## Tonneau cover\*

E00715500346

### NOTE

- Make sure the table is level before using it.
- Do not place luggage weighing a total of 4 kg or more on the table.
- Keep the table retracted when you are not using it.

### To install

1. Remove the tonneau cover, which is stowed in the luggage area, from its storage bag.
2. Stow the third seat.  
(Refer to “Stowing the third seat” on page 2-22.)
3. Move the sliders (A) outward to the positions where they click, then check that they are securely locked in position.

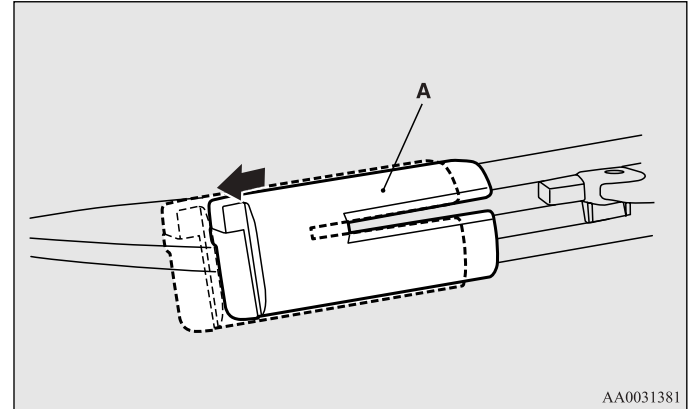

## For pleasant driving

4. Move one of the sliders (A) towards the inside of the vehicle, and fit the protruding portion (B) into the installation hole (C). Move the opposite slider in the same fashion.

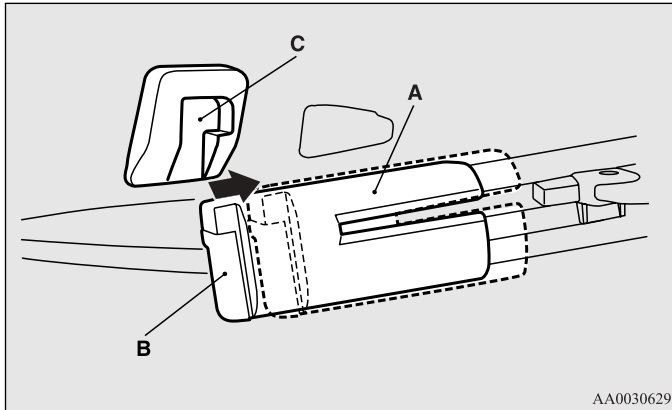

## NOTE

- After installing the position, gently shake the entire tonneau cover to make sure it is securely retained.

## To use

1. Draw out the cover retracted by spring and insert it in the mounting grooves (D).



- Adjust the position of the second seat as necessary, then attach the hooks (E) to the bottom of the head restraint. (Refer to “To adjust forward or backward” on page 2-9 and “To recline the seatback” on page 2-10.)

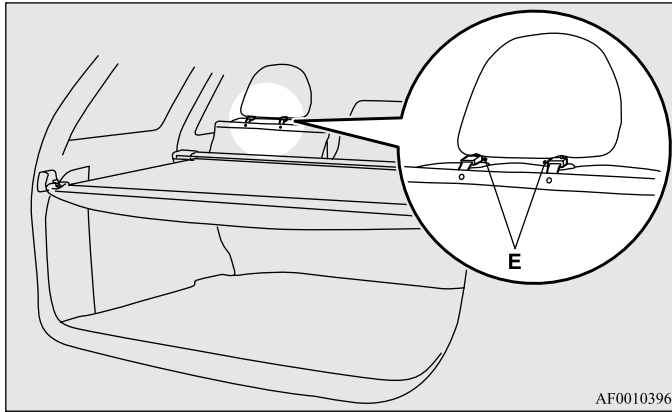

AF0010396

**NOTE**

- Do not weight the tonneau cover with a piece of luggage.

**To remove**

- Remove the cover from the mounting grooves, and the cover will be rolled back into the retracted position.
- Remove the hooks from the head restraint.
- Move one of the sliders (A) towards the inside of the vehicle, and lift it to remove the tonneau cover.

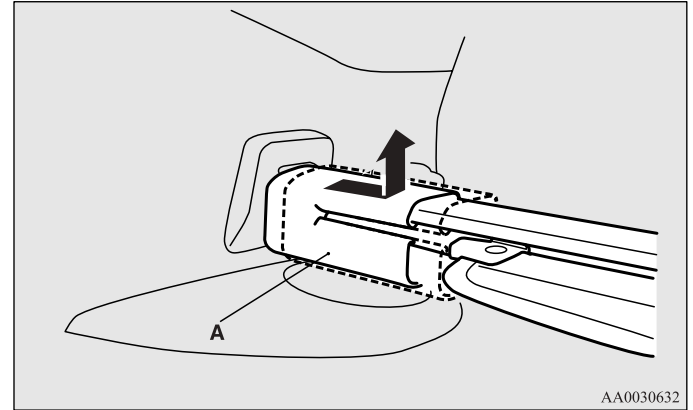

AA0030632

## For pleasant driving

### To store

1. Press the button (F) on the back of each slider, and move the sliders inward.

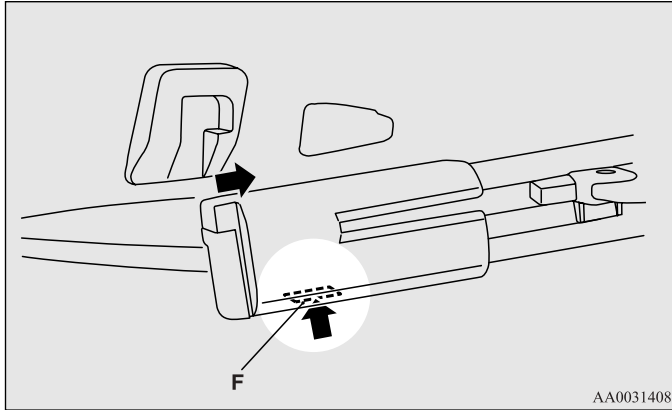

2. Return the third seat to its original position.  
(Refer to “Stowing the third seat” on page 2-22.)

3. Put the tonneau cover in its storage bag and stow it in the luggage area.

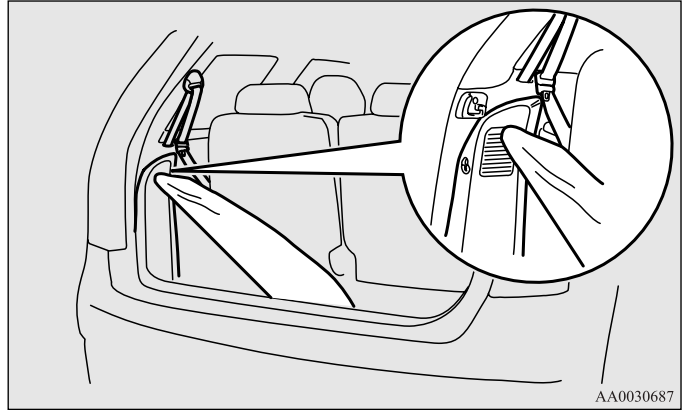

### **⚠ CAUTION**

- Be sure to stow the tonneau cover in the illustrated position. Unless stowed in the correct position, the tonneau cover could touch the seatbelts and damage them.

## Coat hooks

E00725600034

There are two hooks on the rear pillar for use in hanging clothes.

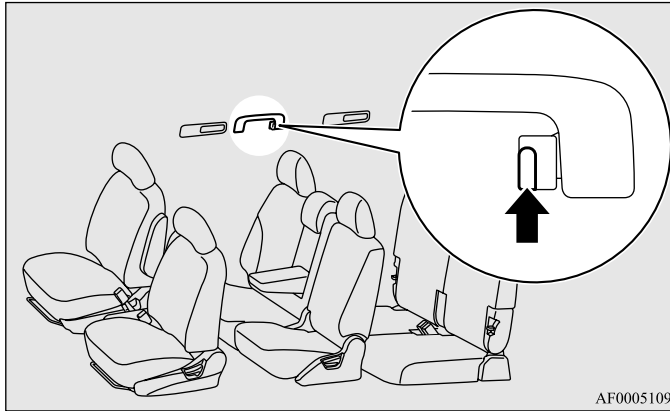

### **⚠ WARNING**

- Do not put a hanger or any heavy or pointed object on the coat hook. If the curtain air bag was activated, any such item could be propelled away with great force and could prevent the curtain air bag from inflating correctly. Hang clothes directly on the coat hook (without using a hanger). Make sure there are no heavy or sharp objects in the pockets of clothes that you hang on the coat hook.

## Luggage hooks

E00715700090

There are 4 luggage hooks at the sides of the luggage area. Use them when you wish to tie luggage down.

### **⚠ CAUTION**

- Be sure to tie luggage down securely. Otherwise, hard braking could cause luggage to be thrown into the passenger area, resulting in an accident.

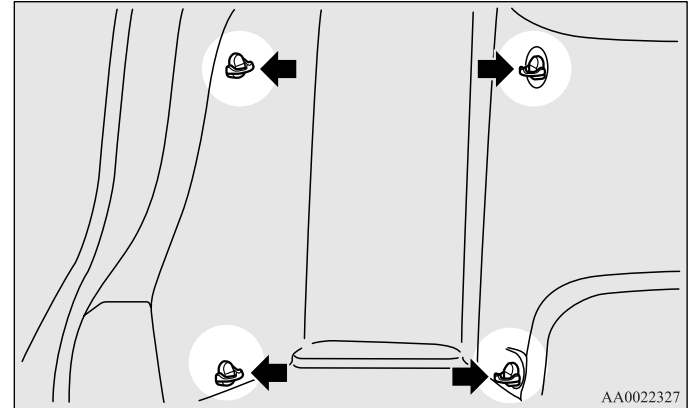

## Cargo net

E0071580020

To use, attach the net to the hooks according to the illustration. The cargo net is used to cover light articles in the luggage compartment to prevent them from tumbling.

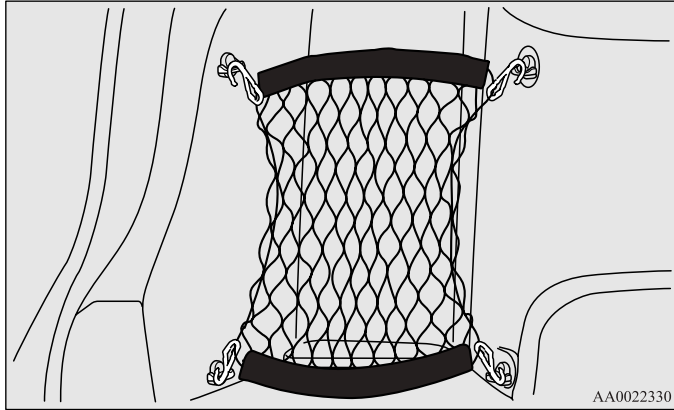

## Warning triangle retaining bands

E00715200079

Band (B) to be used for retaining a warning triangle can be accessed with the third seat stowed and the luggage floor board (A) raised. (Refer to “Stowing the third seat” on page 2-22.)

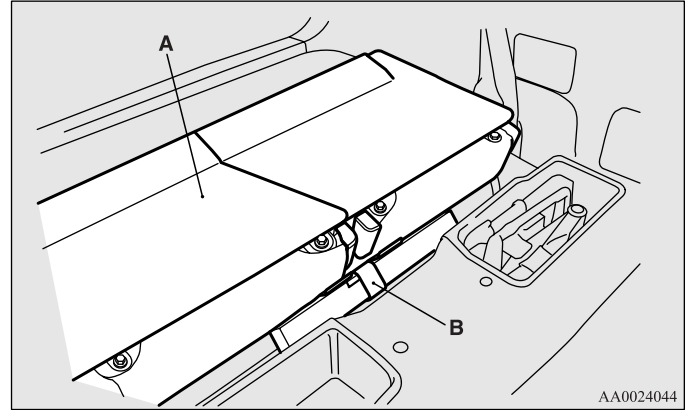

### NOTE

- Some warning triangles may not fit fully into the storage space and may thus be damaged by the third seat.



## *For emergencies*

If the vehicle breaks down . . . . .	.6-	2
Emergency starting . . . . .	.6-	2
Engine overheating . . . . .	.6-	7
Tools and jack . . . . .	.6-	10
Jacking up the vehicle . . . . .	.6-	13
Spare wheel . . . . .	.6-	16
How to change a tyre . . . . .	.6-	20
Towing . . . . .	.6-	28
Operation under adverse driving conditions . . . .	.6-	35

## *If the vehicle breaks down*

E00800100606

If the vehicle breaks down on the road, move it to the shoulder and use the hazard warning flashers.

Refer to “Hazard warning flasher switch” on page 3-38.

### **If the engine stops/fails**

Vehicle operation and control are affected if the engine stops.

Before moving the vehicle to a safe area be aware of the following:

- The brake booster becomes inoperative and the pedal effort will increase. Press down the brake pedal harder than usual.
- Since the power steering pump is no longer operative, the steering wheel feels heavy when turning it. Turn the wheel with more effort than usual.

## *Emergency starting*

E00800501216

If the engine cannot be started because the battery is weak or dead, the battery from another vehicle can be used with jumper cables to start the engine.

### **⚠ WARNING**

- **To start the engine by use of jumper cables from another vehicle, perform the correct procedures according to the instruction manual. Incorrect procedures could result in a fire or explosion or damage to the vehicles.**

1. Get the vehicles close enough so the jumper cables can reach, but be sure the vehicles aren't touching each other. If they are, it could cause a ground connection you don't want. The vehicle will not start, and the bad grounding could damage the electrical systems.

### **⚠ CAUTION**

- **Check the other vehicle. It must have a 12-volt battery. If the other system isn't 12-volt, shorting can damage both vehicles.**

- You could be injured if the vehicles move. Set the parking brake firmly on each vehicle. Put an automatic transmission in "P" (PARK) or a manual transmission in "N" (Neutral). Turn off the ignition switch.

## **⚠ WARNING**

- Turn off the ignition on both vehicles beforehand. Use care to make sure that the cables or your clothes are never caught by the fan or drive belt. Personal injury could result.

### NOTE

- Turn off all lamps, heater and other electrical loads. This will avoid sparks and help save both batteries.
- Make sure battery electrolyte is at the proper level. Refer to "Battery" on page 8-16.

## **⚠ WARNING**

- If electrolyte fluid is not visible, or appears to be frozen, Do Not Attempt Jump Starting! A battery might rupture or explode if the temperature is below the freezing point or if it is not filled to the proper level.

- Connect the booster battery.

### **Petrol-powered vehicles**

Connect one end of one jumper cable to the positive (+) terminal of the discharged battery (A), and the other end to the positive (+) terminal of the booster battery (B).

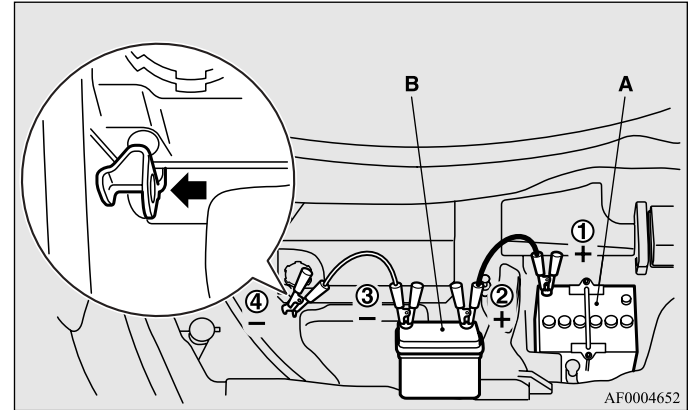

## For emergencies

### Diesel-powered vehicles (except for diesel particulate filter models)

Lift up the front of the engine cover to release the three grommets (A). Then, pull the engine cover towards you to release the grommet (B) and remove the cover.

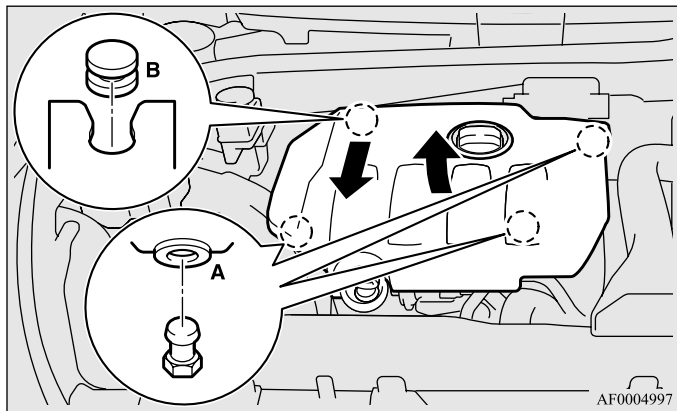

### Diesel-powered vehicles (for diesel particulate filter models)

Lift up the engine cover to release the five grommets (A) and remove the cover.

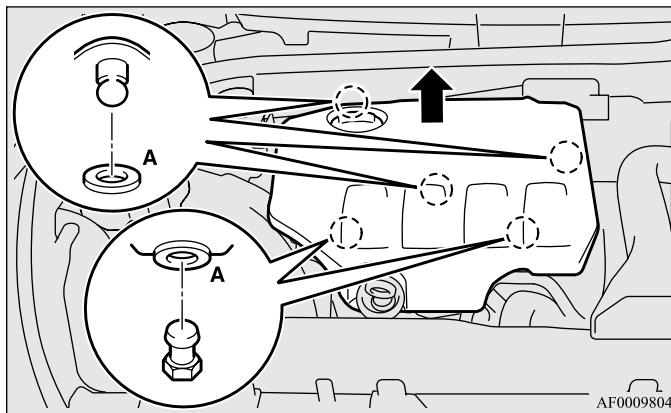

Connect one end of one jumper cable to the positive (+) terminal of the discharged battery (A), and the other end to the positive (+) terminal of the booster battery (B).

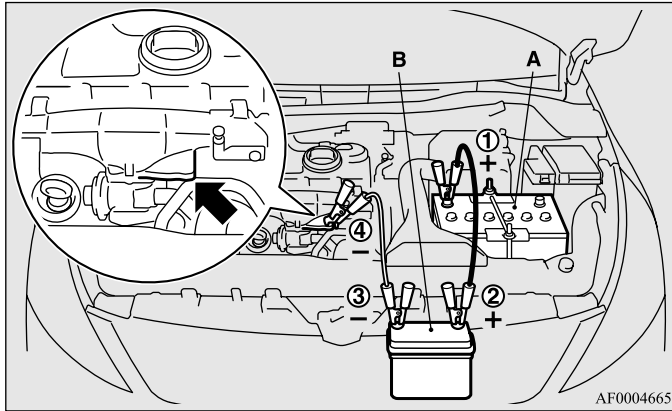

5. Connect one end of the other jumper cable to the negative (-) terminal of the booster battery, and the other end to the engine block of the vehicle with the discharged battery at the point farthest from the battery.

#### NOTE

- Open the cover before connecting the jumper cable to the positive (+) terminal of the battery. (Refer to “Battery” on page 8-16.)

### **⚠ WARNING**

- Be sure to observe the connecting sequence of ① → ② → ③ → ④.
- Make sure that the connection ④ is made to the appointed position (shown in the illustration). If the connection is made directly to the negative side of the battery, the inflammable gases generated from the battery might catch fire and explode.
- When connecting the jumper cable, do not connect the positive (+) cable to the negative (-) terminal. Otherwise sparks might cause explosion of the battery.

### **⚠ CAUTION**

- Use care not to get the jumper cable caught in the cooling fan or other rotating part in the engine compartment.
- Use care not to pinch the wiring harness with the clamps when connecting the jumper cables.
- Use the proper cables suitable for the battery size. Otherwise heat damage to the cables could result.
- Check the jumper cables for damage and corrosion before use.

## For emergencies

6. Start the engine in the vehicle which has the booster battery, let the engine idle a few minutes, then start the engine in the vehicle with the discharged battery.

### **⚠ CAUTION**

- Keep the engine of the vehicle giving assistance running.

7. After the engine is started, disconnect the cables in the reverse order.

### **⚠ WARNING**

- Charging the battery while it is installed in the vehicle might cause the battery to catch fire and explode. Or damage to the vehicle could result. If it has to be charged in that condition for unavoidable reasons, disconnect the vehicle side negative (-) terminal connected to the battery.
- Keep sparks, cigarettes and flames away from the battery because the battery may produce an explosion.
- Use adequate ventilation when charging or using the battery in an enclosed space.
- Remove all the caps before charging the battery.

### **⚠ WARNING**

- Electrolyte is corrosive diluted sulphuric acid. If electrolyte (battery acid) comes into contact with your hands, eyes, clothes and the painted surface of your vehicle, it should be thoroughly flushed with water. If electrolyte gets in your eyes, flush them with water immediately and thoroughly, and get prompt medical attention.

### **⚠ CAUTION**

- Do not attempt to start the engine by pulling or pushing the vehicle. It could damage your vehicle.
- Always wear protective eye goggles when working near the battery.
- Keep the battery out of the reach of children.

#### NOTE

- If the vehicle is put in motion without fully charging the battery, it might cause the loss of smooth engine operation and the anti-lock brake warning lamp to illuminate. Refer to “Anti-lock brake system (ABS)” on page 4-36.

## Engine overheating

E00800601305

If the water temperature gauge indication remains in the overheating zone for a long time, the engine may be overheating. If this occurs, take the following corrective measures:

1. Stop the vehicle in a safe place.
2. Check whether steam is coming from the engine compartment.

[If steam does not come from the engine compartment]  
With the engine still running, raise the bonnet to ventilate the engine compartment.

[If steam is coming from the engine compartment]  
Stop the engine, and when the steam stops, raise the bonnet to ventilate the engine compartment. Restart the engine.

3. Confirm that the radiator fan is turning. If the fan is not turning, stop the engine immediately and have it checked.

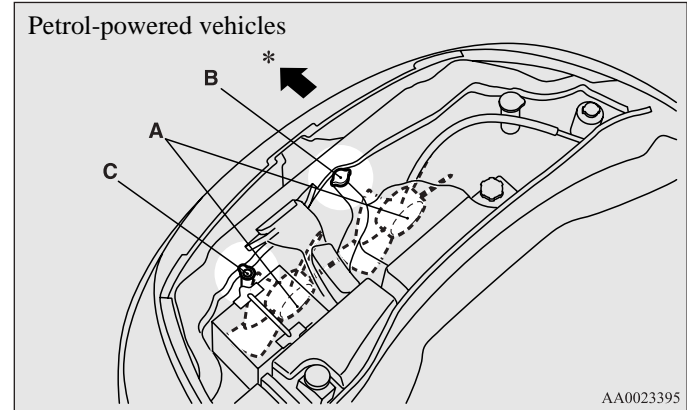

### **⚠ WARNING**

- Do not open the bonnet while steam is coming from the engine compartment. It could cause steam or hot water to spurt out, causing burns. Hot water could spurt out even when there is no steam coming out, and some parts will be very hot. Be very careful when opening the bonnet.
- Be careful of hot steam, which could be blowing off the reserve tank cap.
- Do not attempt to remove the radiator cap (petrol-powered vehicles) or reserve tank cap (diesel-powered vehicles) while the engine is hot.

## For emergencies

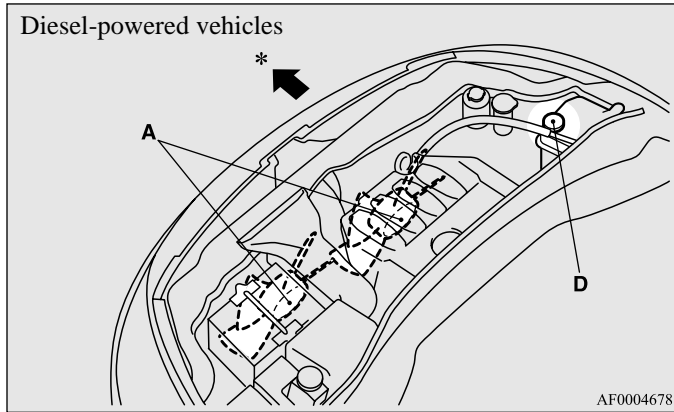

- A- Cooling fans
- B- Radiator cap
- C- Reserve tank
- D- Reserve tank cap
- \* : Front of the vehicle

4. After the engine coolant temperature has dropped to the normal temperature, stop the engine.

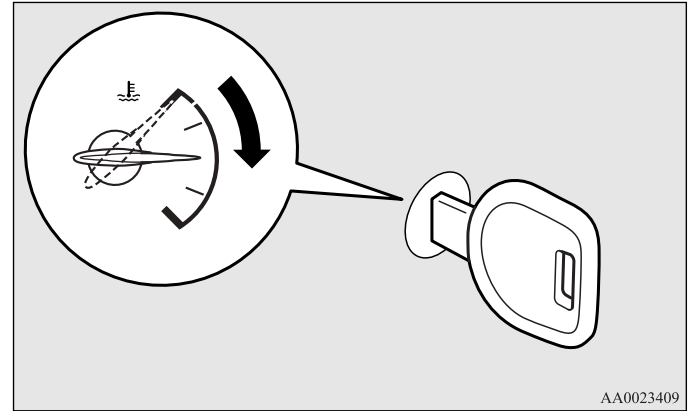

## **⚠ WARNING**

- Be careful not to get your hands or clothes caught in the cooling fan.



5. Check the coolant level in the reserve tank.

#### Petrol-powered vehicles

The reserve tank lid (A) is equipped with a dipstick.

Remove the dipstick and wipe it with a clean cloth. Reinsert the dipstick as far as it goes. Remove the dipstick and read the coolant level, which should always be within the range indicated.

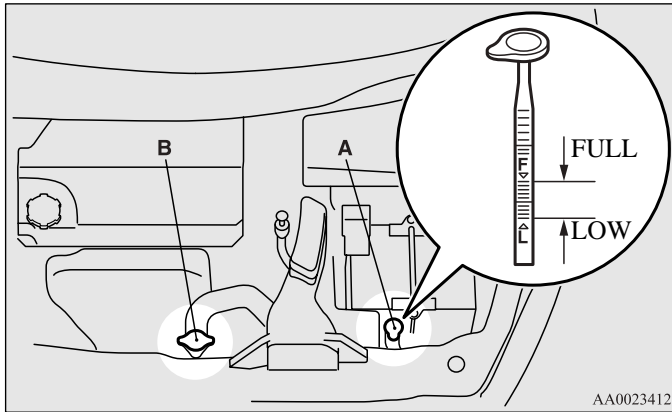

AA0023412

#### ⚠ WARNING

- If there is none, make sure that the engine has cooled down before removing the radiator cap (B), because hot steam or boiling water otherwise will gush from the filler port and may scald you.

#### Diesel-powered vehicles

The coolant level in this tank should be kept between the "LOW" and "FULL" marks.

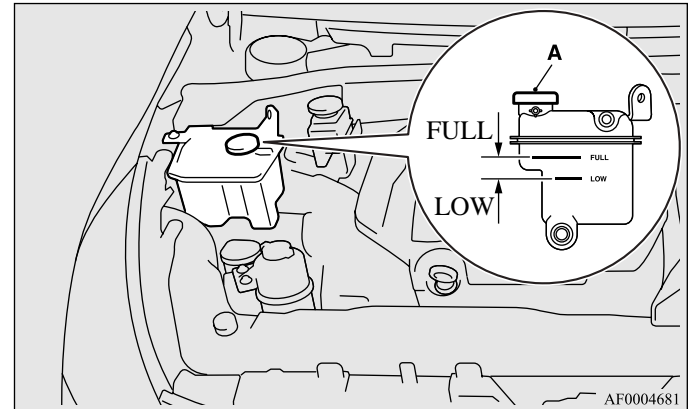

AF0004681

#### ⚠ WARNING

- If there is none, make sure that the engine has cooled down before removing the reserve tank cap (A), because hot steam or boiling water otherwise will gush from the filler port and may scald you.

## For emergencies

6. Add coolant to the radiator and/or reserve tank if necessary (refer to the “Maintenance” section).

### **⚠ CAUTION**

- **Do not add coolant while the engine is hot. Suddenly adding cold coolant could damage the engine. Wait for the engine to cool down, then add coolant a little at a time.**

7. Examine the radiator hoses for coolant leakage and the drive belt for looseness or damage.  
If there is anything wrong with the cooling system or drive belt, we recommend you to have it checked and repaired.

## *Tools and jack*

E00800900864

### **Storage**

The tools and jack are stored under the third seat. The storage location of the tools and jack should be remembered in case of an emergency.

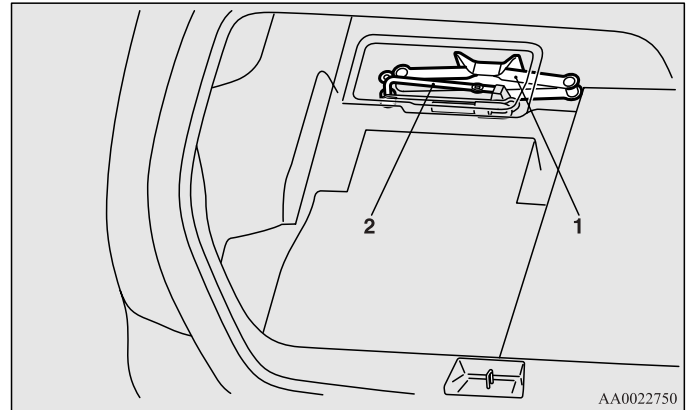

- 1- Jack
- 2- Tools

## Tools

E00801900092

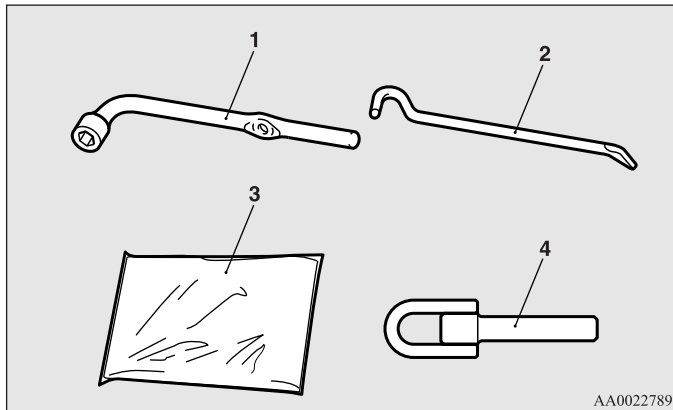

AA0022789

- 1- Wheel nut wrench
- 2- Bar
- 3- Vinyl sheet
- 4- Towing hook

### NOTE

- Use the vinyl sheet to wrap the standard wheel that is removed in the event of wheel replacement.

## **⚠ CAUTION**

- Do not let children touch the vinyl sheet. If the vinyl sheet got wrapped around a child's nose or mouth, it could cause suffocation.

## Jack

E00802000074

### To remove

1. Stow the third seat.  
(Refer to “Stowing the third seat” on page 2-22.)
2. Raise the luggage floor board.

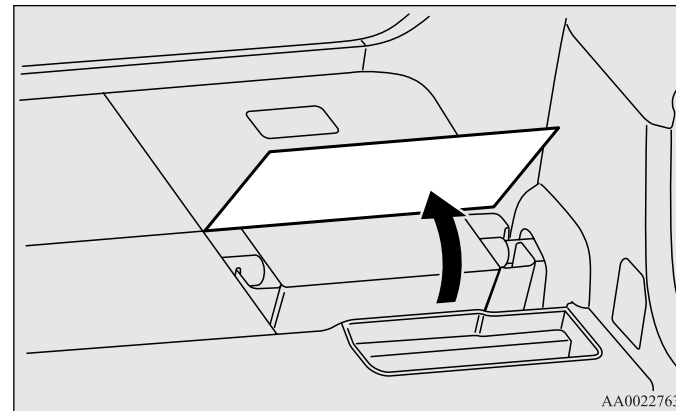

AA0022763

## For emergencies

3. Retract the jack, then remove it from its storage location.

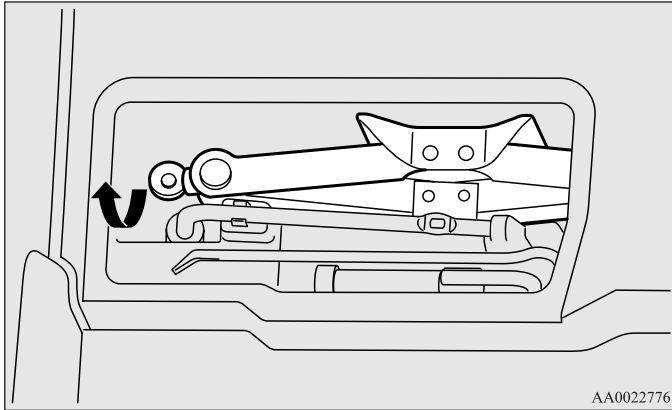

## To store

1. Retract the jack, then return it to its original position.

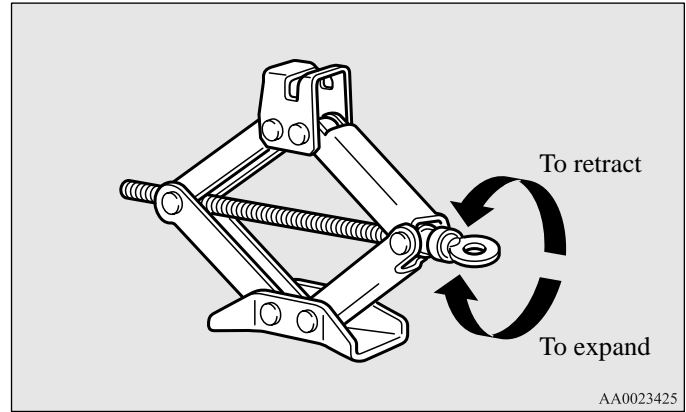

2. Expand the jack to lock it securely in place.
3. Return the luggage floor board to its original position.

## Jacking up the vehicle

E00801000992

1. Park the vehicle on level and stable ground.
2. Set the parking brake firmly.
3. On vehicles with manual transmission, turn the ignition key to the "LOCK" position, move the gearshift lever to the "R" (Reverse) position.  
On vehicles with automatic transmission, move the selector lever to the "P" (PARK) position, turn the ignition key to the "LOCK" position.
4. Turn on the hazard flashers and set up a warning triangle, flashing signal lamp, etc., at an adequate distance from the vehicle, and have all your passengers leave the vehicle.

5. To prevent the vehicle from rolling when it is raised on the jack, place a chock or block (A) at the tyre that is diagonally opposite from the tyre (B) you are changing.

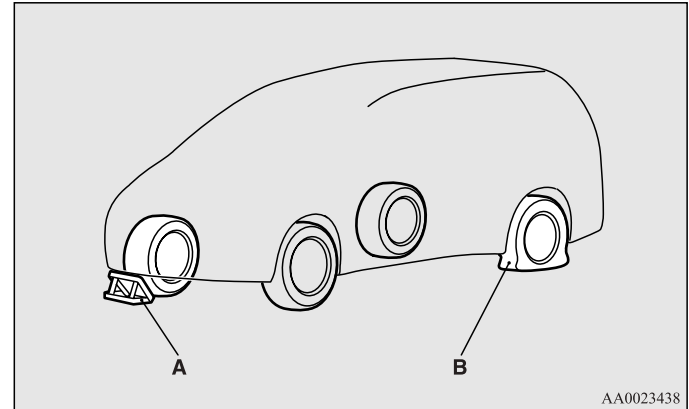

### **⚠ WARNING**

- Be sure to apply a chock to the correct tyre when jacking up the vehicle. If the vehicle moves while jacked up, the jack could slip out of position, leading to an accident.

### NOTE

- The chock shown in the illustration does not come with your vehicle. It is recommended that you keep one in the vehicle for use if needed.
- If a chock is not available, use a stone or any other object that is large enough to hold the wheel in position.

## For emergencies

- Place the jack under one of the jacking points (C) shown in the illustration. Use the jacking point closest to the tyre you wish to change.

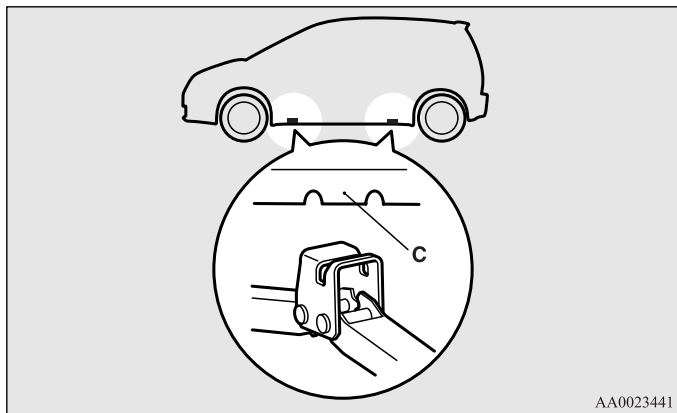

- Rotate the jack by hand until the flange portion (D) fits in the groove (E) at the top of the jack.

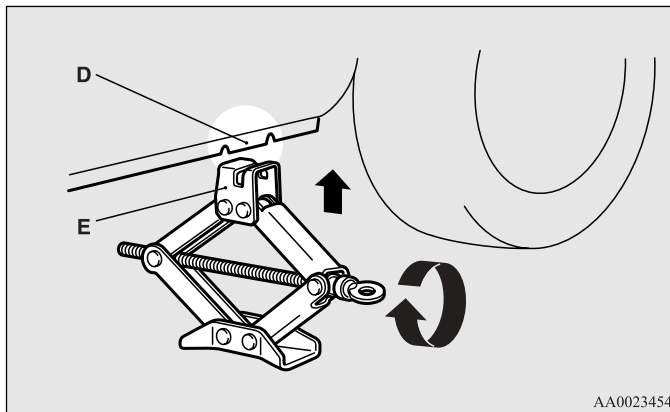

- Remove the wheel nut wrench and bar from under the third seat. (Refer to “Tools and jack” on page 6-10.)

## **⚠ WARNING**

- Set the jack only at the positions shown here. If the jack is set at a wrong position, it could dent your vehicle or the jack might fall over and cause personal injury.
- Do not use the jack on a tilted or soft surface. Otherwise, the jack might slip and cause personal injury. Always use the jack on a flat, hard surface. Before setting the jack, make sure there are no sand or pebbles under the jack base.

9. Insert the bar (F) into the wheel nut wrench (G). Then put the end of the bar into the shaft's jack end, as shown in the illustration.

Slowly rotate the wheel nut wrench until the tyre is raised slightly off the ground surface.

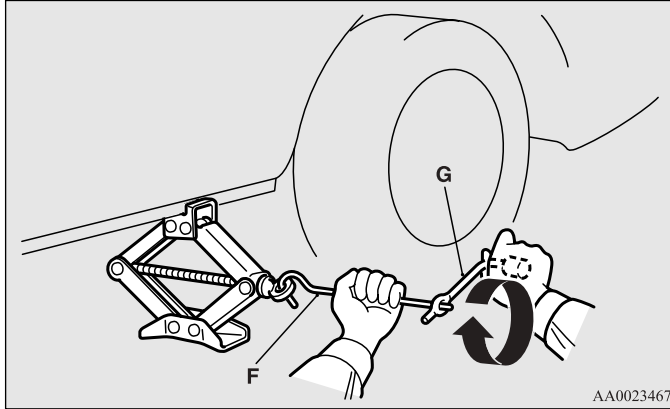

## **⚠ WARNING**

- Stop jacking up the vehicle as soon as the tyre is raised off the ground. It is dangerous to raise the vehicle any higher.
- Do not get under your vehicle while using the jack.
- Do not bump the raised vehicle or leave it sitting on the jack for a long time. Both are very dangerous.
- Do not use a jack except the one that came with your vehicle.
- The jack should not be used for any purpose other than to change a tyre.

## **⚠ WARNING**

- No one should be in your vehicle when using the jack.
- Do not start or run the engine while your vehicle is on the jack.
- Do not turn the raised wheel. The tyres still on the ground could turn and make your vehicle fall off the jack.

## *Spare wheel*

E00801101176

Check the air pressure of the spare tyre frequently and make sure it is ready for emergency use at any time.

Maintaining the spare wheel at the highest specified air pressure will ensure that it can always be used under any conditions (city/high-speed driving, varying load weight, etc.).

The spare wheel is stored under the rear of the body.

### **Compact spare wheel**

The compact spare tyre is designed to save space in the luggage compartment and its lighter weight makes it easier to use if a flat tyre occurs.

### **⚠ CAUTION**

- The compact spare tyre is not as good as a standard tyre in controllability and stability. When the compact spare tyre is used, avoid quick starts, sudden braking and sharp steering.
- Avoid driving through automatic vehicle washers and over obstacles that could possibly damage the vehicle's undercarriage. Because the compact spare wheel is smaller than the original wheel, the ground clearance is slightly reduced.
- The compact spare wheel is specifically designed for your vehicle and it should not be used on any other vehicle.

### **⚠ CAUTION**

- The pressure should be periodically checked and maintained at the specified pressure while the tyre is stowed.

Driving with an insufficient tyre pressure can lead to an accident. If you have no choice but to drive with an insufficient tyre pressure, keep your speed down and inflate the tyre to the correct pressure as soon as possible. (Refer to "Tyre inflation pressures" on page 8-21.)

- The compact spare wheel is for temporary use only and should be removed as soon as the original wheel can be repaired or replaced.
- The vehicle must not be driven at speeds in excess of 80 km/h (50 mph) while using the compact spare wheel.



## **⚠ CAUTION**

- Do not use tyre chain with your compact spare wheel. Because of the smaller tyre size, a tyre chain will not fit properly. This could cause damage to the wheel and result in loss of the chain.  
If a front tyre becomes flat when using tyre chains, first replace a rear wheel with the compact spare wheel and then use the removed rear wheel to replace the flat front wheel so that you can continue to use the chains.

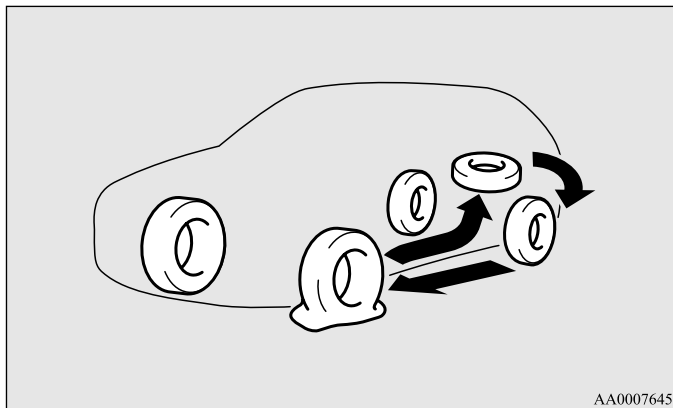

## **⚠ CAUTION**

- The compact spare tyre should not be used on any other wheels, nor should standard tyres, snow tyres, wheel covers or trim rings be used with the compact spare wheel. If such use is attempted, damage to these items or other vehicle components may occur.
- Upon installation of the compact spare tyre, the overall vehicle height is slightly lowered as the tyre is smaller in diameter than the standard tyre. When passing over the projections on the road, use care not to drive the vehicle with the same feeling as used in driving with the standard tyre on.
- Do not install more than one compact spare wheel at the same time.
- When the tread wear indicators appear, the tyre must be replaced.  
Refer to “Wheel condition” on page 8-23.

### NOTE

- The wheel hanger is designed for a compact spare wheel only. It cannot be used for storage of any other kind of wheel.  
Store any wheel with a punctured tyre in the luggage area.
- Check that the compact spare wheel is not loose by trying to joggle it with your hands or feet. If it is loose, the wheel hanger or hook may be deformed. Store the wheel inside the luggage area, and have it repaired.

## For emergencies

### To remove

1. Open the tailgate and remove the lid of the hanger mounting bolt with the bar.

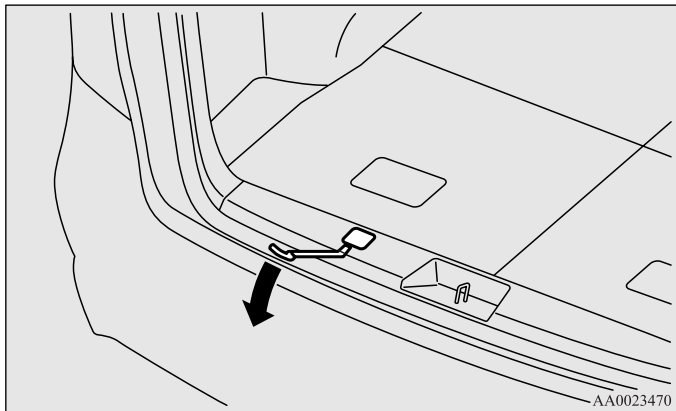

2. Loosen the hanger mounting bolt with the wheel nut wrench.

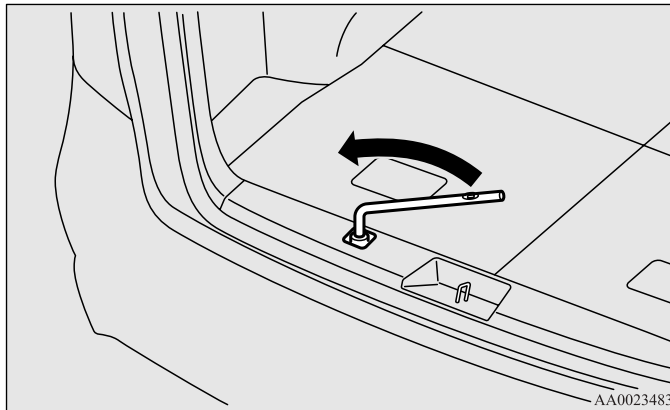

### **⚠ CAUTION**

- If you loosen the hanger mounting bolt too much, the holder will come free and the spare wheel will fall down. Pay close attention to the bolt while loosening it.

3. Unlock the hanger (A) from the holder (B) by lifting the part that is shown by the arrow in the drawing. Lower it to remove the spare wheel.

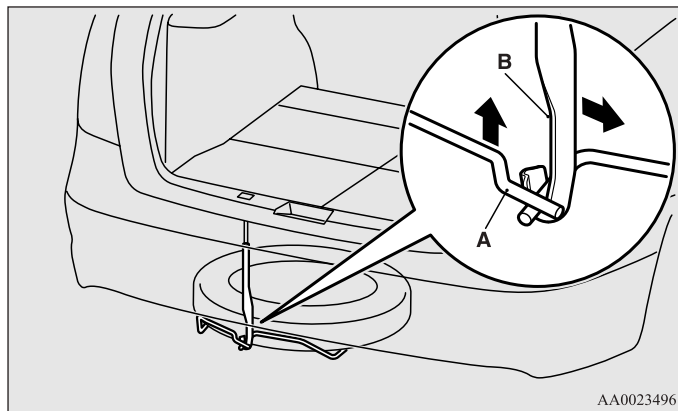

### **⚠ CAUTION**

- When removing the hanger from the holder or hooking the hanger onto the holder, hold the hanger securely to avoid dropping it on your feet.

### To install

1. Set the spare wheel onto the centre of the hanger (A).
2. Raise the hanger and hook it onto the holder (B).

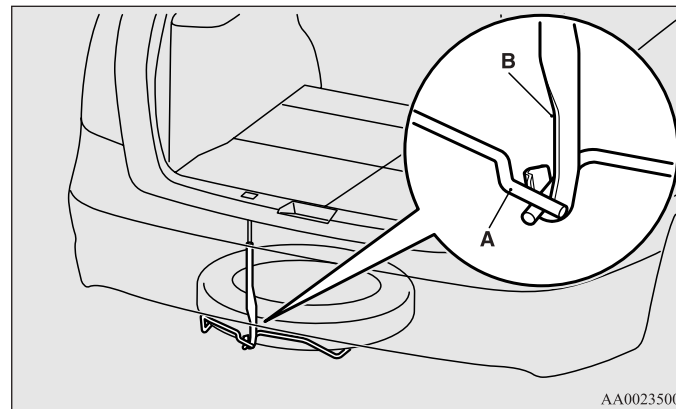

### **⚠ CAUTION**

- Do not hang the holder in any position other than the hanger's correct position. The holder could scratch the vehicle body, and the spare wheel could fall down, resulting in an accident.

## For emergencies

3. Tighten the holder mounting bolt securely with the wheel nut wrench.

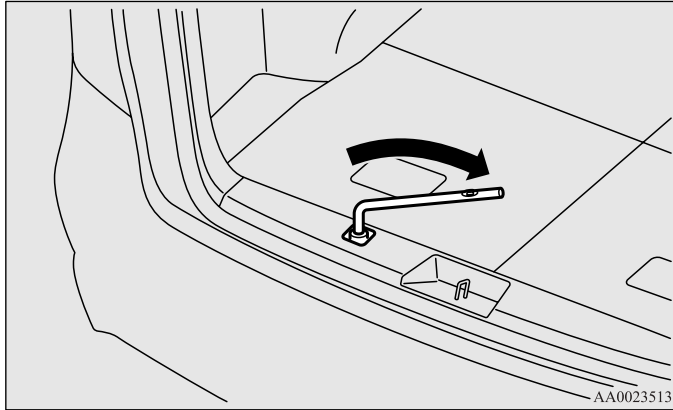

4. Fit the cover over the hanger mounting bolt.
5. After tightening the bolt, try joggling the spare wheel to confirm that there is no play in the hanger.

## *How to change a tyre*

E00801201542

Before changing a tyre, first stop your vehicle in a safe, flat location.

1. Park the vehicle on level and stable ground.
2. Set the parking brake firmly.
3. On vehicles with manual transmission, turn the ignition key to the “LOCK” position, move the gearshift lever to the “R” (Reverse) position.  
On vehicles with automatic transmission, move the selector lever to the “P” (PARK) position, turn the ignition key to the “LOCK” position.
4. Turn on the hazard flashers and set up a warning triangle, flashing signal lamp, etc., at an adequate distance from the vehicle, and have all your passengers leave the vehicle.

5. To prevent the vehicle from rolling when it is raised on the jack, place a chock or block (A) at the tyre that is diagonally opposite from the tyre (B) you are changing.

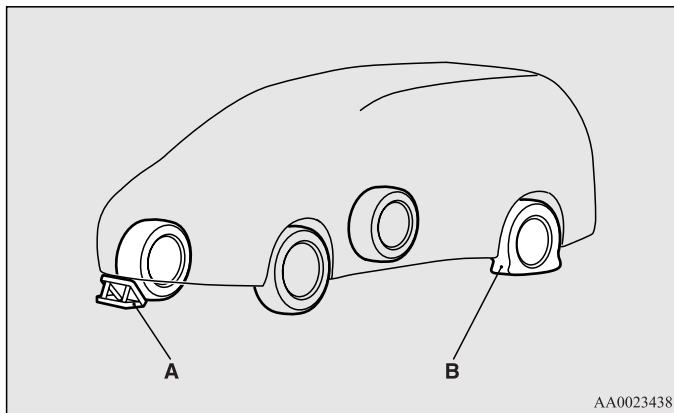

AA0023438

## **⚠ WARNING**

- Be sure to apply a chock to the correct tyre when jacking up the vehicle. If the vehicle moves while jacked up, the jack could slip out of position, leading to an accident.

### NOTE

- The chock shown in the illustration does not come with your vehicle. It is recommended that you keep one in the vehicle for use if needed.
- If a chock is not available, use a stone or any other object that is large enough to hold the wheel in position.

6. Get the spare wheel, jack, and wheel nut wrench ready.

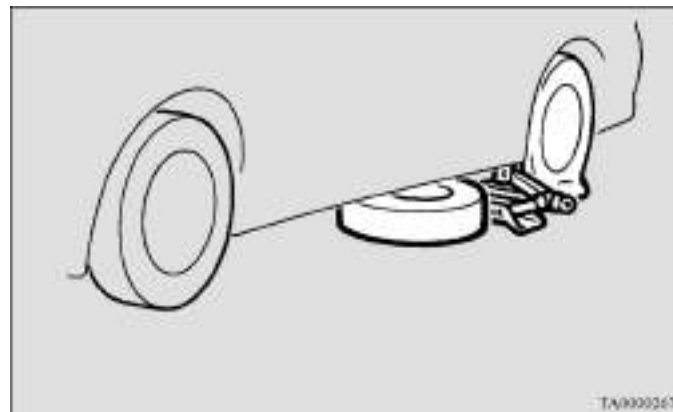

TA000036T

### NOTE

- Put the spare wheel under the vehicle body near the jack. This makes it safer if the jack slips out of position.

## For emergencies

- On vehicles with wheel covers, first remove the covers (refer to “Wheel covers” on page 6-26). Then loosen the wheel nuts with the wheel nut wrench. Do not remove the wheel nuts yet.

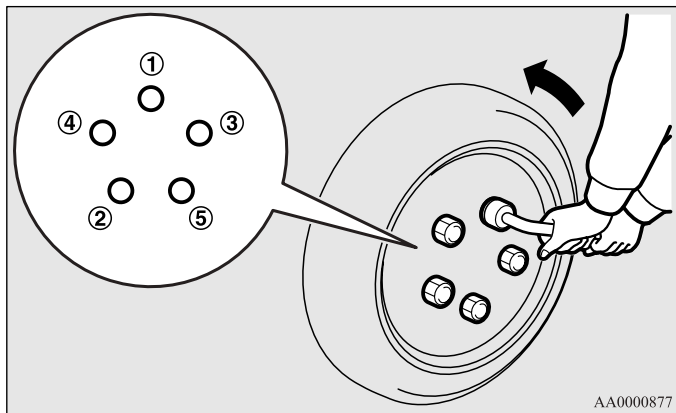

- Find the jacking point closest to the flat tyre (refer to “Jacking up the vehicle” on page 6-13). Then position the jack and raise the vehicle until the tyre is slightly off the ground.
- Remove the wheel nuts with the wheel nut wrench, then take the wheel off.

- Clean out any mud, etc. on the hub surface (C), hub bolts (D) or in the installation holes (E) in the wheel, and then mount the spare tyre.

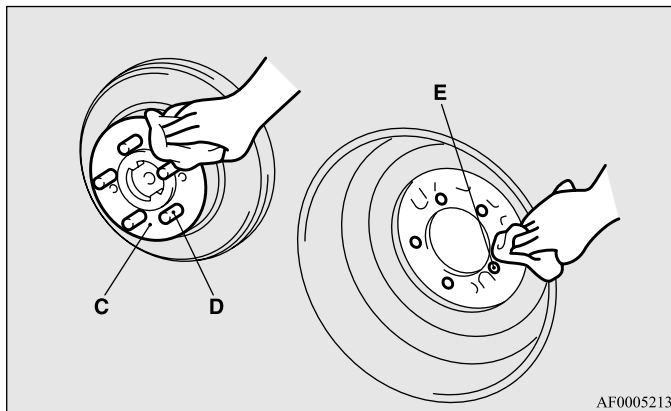

### **⚠ CAUTION**

- Handle the wheel carefully when changing the tyre, to avoid scratching the wheel surface.

**⚠ WARNING**

- Mount the spare wheel with the valve stem (F) facing outboard. If you cannot see the valve stem (F), you have installed the wheel backwards. Operating the vehicle with the spare wheel installed backwards can cause vehicle damage and result in an accident.

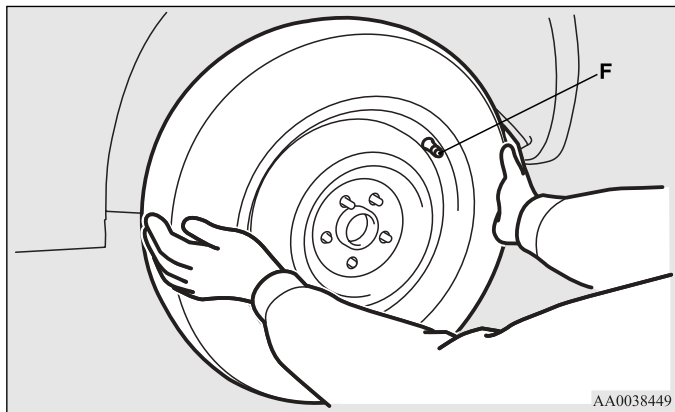

11. Finger-tighten the wheel nuts. (Turn them clockwise.)

**Vehicle with steel wheels**

Tighten the wheel nuts until the tapered parts of the wheel nuts make light contact with the seats of the wheel holes and the wheel is not loose. Tighten the wheel nuts in the same way with a compact spare wheel.

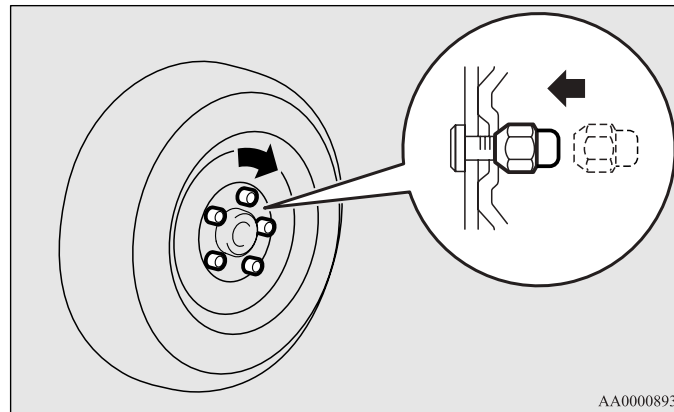

## For emergencies

### Vehicle with aluminium wheels

With a normal wheel, tighten the wheel nuts until the flanges of the wheel nuts touch the wheel and the wheel is not loose.

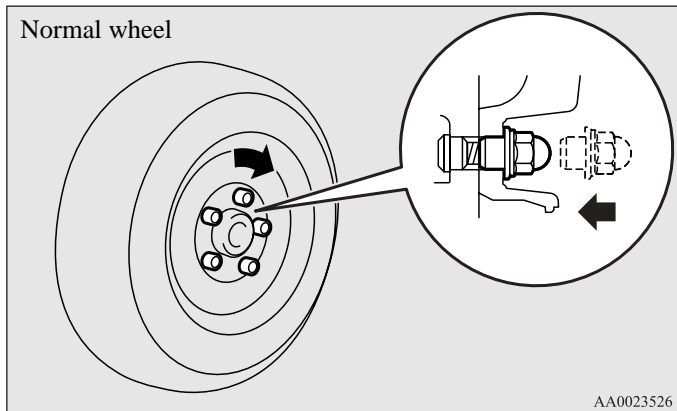

With a compact spare wheel, tighten the wheel nuts until the tapered parts of the wheel nuts make light contact with the seats of the wheel holes and the wheel is not loose.

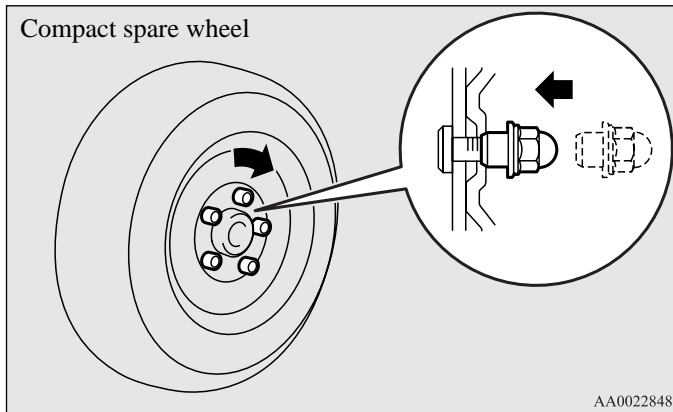

### **⚠ CAUTION**

- Never apply oil to either the wheel bolts or the nuts or they will tighten too much.

### NOTE

- Flange nuts can be temporarily used on the spare wheel, but return to the original wheel and tyre as soon as possible.
- If all four aluminium wheels are changed to steel wheels, use tapered nuts.



12. Lower the vehicle slowly and then tighten the nuts in the order shown in the illustration until each nut has been tightened to the torque listed here.

Tightening torque

88 to 108 Nm

(Achieved by applying a force of 350 to 420 N at the end of the wheel nut wrench supplied with the vehicle)

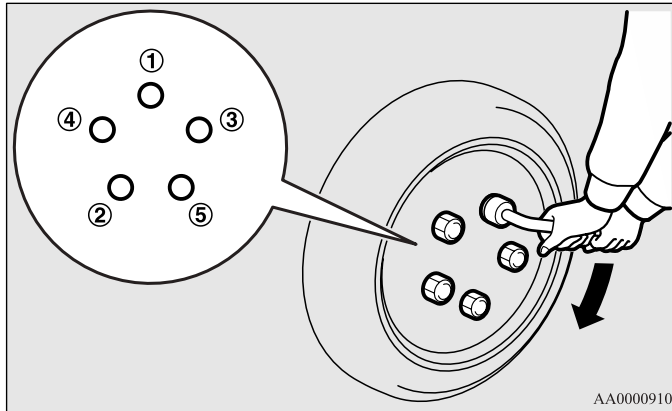

**⚠ CAUTION**

- Never use your foot or a pipe extension for extra force in the wheel nut wrench. If you do so, you will tighten the nut too much.

13. Lower and remove the jack, then store the jack and chock.

14. Wrap the removed wheel in the vinyl sheet and store it in the luggage area.  
Have your damaged tyre repaired as soon as possible.

**NOTE**

- The vinyl sheet is stored under the third seat together with the tools and jack. (Refer to “Tools and jack” on page 6-10.)



**⚠ WARNING**

- When storing the removed wheel, raise the left- and right-hand parts of the third seat seatback and stand the wheel upright. If you leave the space configured as a luggage area when storing the wheel, serious injuries could occur in the event of a collision.

## For emergencies

15. Check your tyre inflation pressure. The correct pressures are shown on the door label. See the illustration.

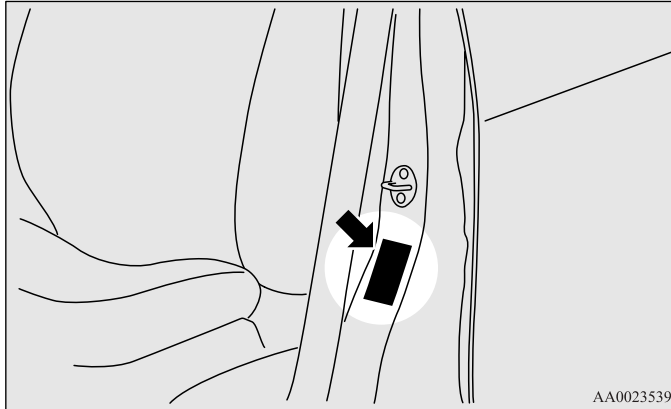

## **⚠ CAUTION**

- Do not mix one type of tyre with another or use a different size from the one listed. This would cause early wear and poor handling.

## Wheel covers\*

E00801300041

### *To remove*

1. Wrap the tip of the bar with a cloth, insert it deeply into the notch provided in the wheel cover, and use it to lever up the cover a little.

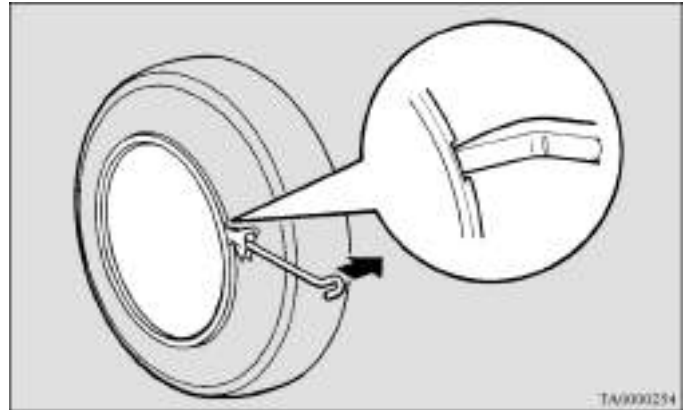

## **⚠ CAUTION**

- The tyre pressure should be periodically checked and maintained at the specified pressure while the tyre is stowed.
- The compact spare tyre is to be used only temporarily when the standard tyre is damaged. Repair the damaged tyre as soon as possible and use it to replace the compact spare tyre.
- After changing the tyre and driving the vehicle about 1,000 km (620 miles), retighten the wheel nuts to make sure that they have not come loose.
- If the steering wheel vibrates when driving after changing the tyre, we recommend you to have the tyres checked for balance.

2. With the cover raised a little, pry it off completely using the jack bar. Insert the jack bar under the cover, and move it around the circumference, prying the cover away from the wheel little by little as you move the bar around.

## NOTE

- The wheel cover is made of plastic; take care when prying it off.

### CAUTION

- Use the jack bar until the wheel cover comes completely off. If you try to use your hands, they may be hurt by the edge of the wheel cover.

### To install

1. Align the wheel nuts with the wheel cover mounting holes, and align the air valve (A) of the tyre with the notch (B) in the wheel cover.

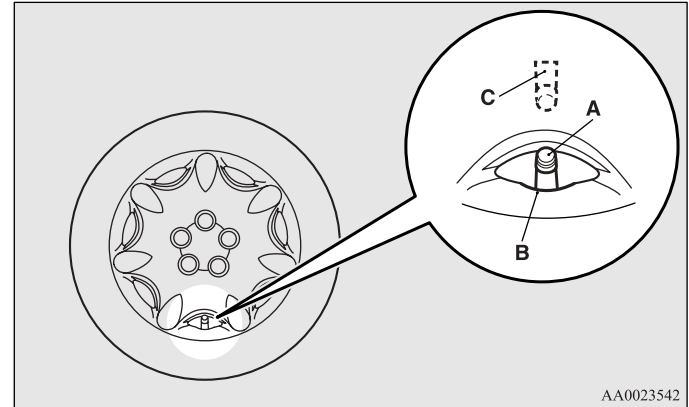

## NOTE

- Full wheel covers have a symbol mark (C) provided on the reverse side to show the air valve location. Before installing the wheel cover to the wheel, make sure that the opening with the symbol mark is correctly aligned with the air valve.

## For emergencies

2. Press the bottom part (D) of the wheel cover onto the wheel.
3. Gently press both sides (E) of the wheel cover and hold them in place with your knees.
4. Gently tap around the circumference of the wheel cover at the top (F), then press the wheel cover into place.

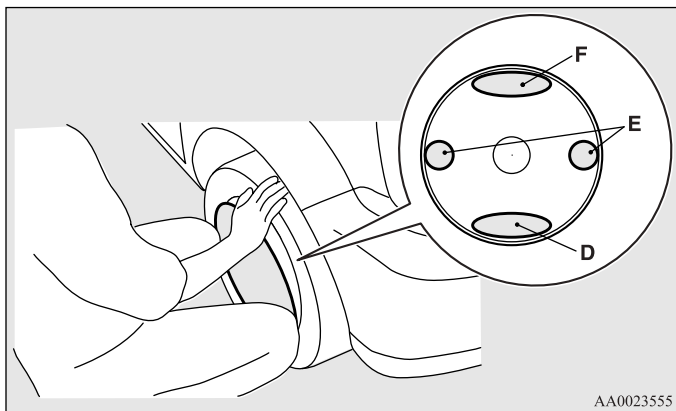

## NOTE

- Before installing the wheel cover, make sure the tabs on the back are correctly fitted on the rings. If the tabs are not correctly fitted on the rings, the wheel cover may come off. If the tabs are broken, do not install the wheel cover.

## Towing

E00801501688

### If your vehicle needs to be towed

If towing is necessary, we recommend you to have it done by your MITSUBISHI MOTORS Authorized Service Point or a commercial tow truck service.

In the following cases, transport the vehicle using a tow truck.

- The engine runs but the vehicle does not move or abnormal noise is produced.
- Inspection of the vehicle's underside reveals that oil or some other fluid is leaking.

If a wheel gets stuck in a ditch, do not try to tow the vehicle. Please contact your MITSUBISHI MOTORS Authorized Service Point or a commercial tow truck service for assistance.

Only when you cannot receive a towing service from a MITSUBISHI MOTORS Authorized Service Point or commercial tow truck service, tow your vehicle carefully in accordance with the instructions given in "Emergency towing" in this part. The regulations concerning towing may differ from country to country. It is recommended that you obey the regulations of the area where you are driving your vehicle.

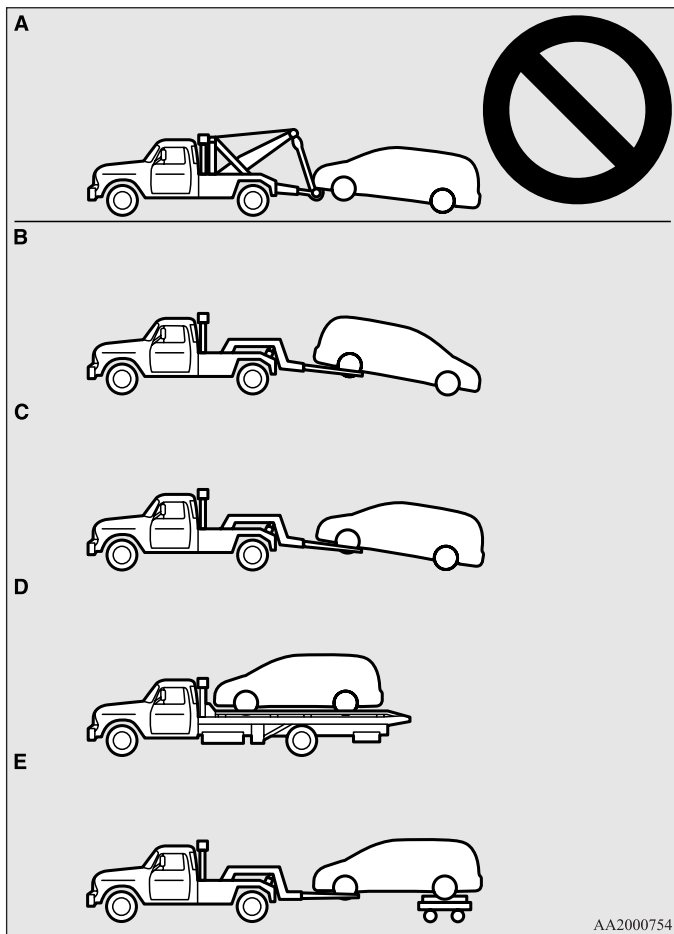

## Towing the vehicle by a tow truck

### **⚠ CAUTION**

- This vehicle must not be towed by a tow truck using sling lift type equipment (Type A) as illustrated. Using a sling lift will damage the bumper and front end.
- If the transmission is malfunctioning or damaged, transport the vehicle with the driving wheels on a carriage (Type C, D or E) as illustrated.
- If you tow an A/T vehicle with the driving wheels on the ground (Type B) as illustrated, make sure that the towing speed and distance given below are never exceeded, causing damage to the transmission.  
Towing speed: 50 km/h (31 mph)  
Towing distance: 30 km (19 miles)

For the towing speed and the towing distance, follow the local driving laws and regulations.

## For emergencies

### ***Towing with rear wheels off the ground (Type B)***

Place the gearshift lever in the “N” (Neutral) position (M/T) or the selector lever in the “N” (NEUTRAL) position (A/T). Turn the ignition key to the “ACC” position and secure the steering wheel in a straight ahead position with a rope or tie-down strap. Never place the ignition key in the “LOCK” position when towing.

#### **⚠ CAUTION**

- Never tow an A/T vehicle with the rear wheels up (and the front wheels on the ground) when the automatic transmission fluid level is low. This may cause serious and expensive damage to the transmission.

### ***Towing with front wheels off the ground (Type C)***

Release the parking brake.

Place the gearshift lever in the “N” (Neutral) position (M/T) or the selector lever in the “N” (NEUTRAL) position (A/T).

#### **⚠ CAUTION**

- [For vehicles equipped with the Active stability control (ASC) system]  
If the vehicle is towed with the ignition key in to the “ON” position and only the front wheels or only the rear wheels raised off the ground, the traction control system may operate, resulting in an accident.

### **Emergency towing**

If towing service is not available in an emergency, your vehicle may be temporarily towed by a rope secured to the towing hook.

In case of your vehicle is to be towed by another vehicle or your vehicle tows another vehicle, pay careful attention to the following points.

***If your vehicle is to be towed by another vehicle***

1. Take out the towing hook, wheel nut wrench and jack bar.  
(Refer to “Tools and jack” on page 6-10.)
2. Cover the tip of the jack bar with a cloth, then use it to remove the cover (A) that is located on the front bumper.

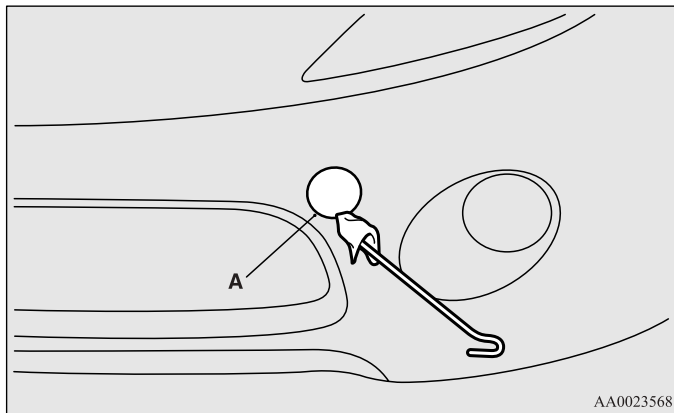

3. Use the wheel nut wrench (B) to securely mount the towing hook (C).

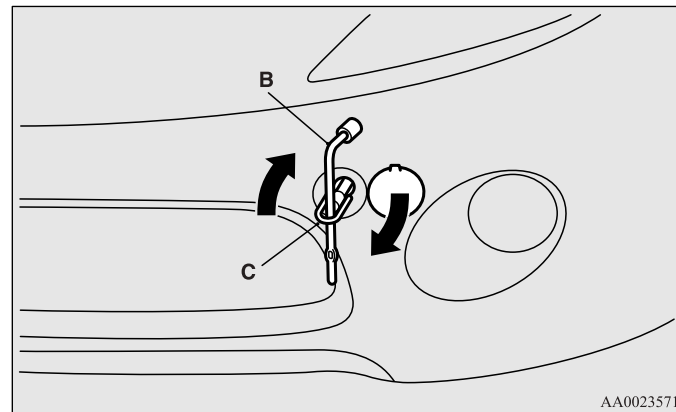

## For emergencies

4. Secure the tow rope to the front towing hook.

### **CAUTION**

- Do not tow the vehicle with the rope at an excessive diagonal angle.

#### NOTE

- To avoid deforming or otherwise damaging the vehicle body when hooking the rope onto the towing hook, observe the following instructions:
  - Mount the towing hook securely.
  - Do not attach the rope to any part of the vehicle other than the towing hook.
  - Do not drive in a way that subjects the towing hook to significant physical shock.

5. Keep the engine running.

If the engine is not running, turn the ignition key to the “ACC” or “ON” position to unlock the steering wheel.

### **CAUTION**

- When the engine is not running, the brake booster and power steering pump do not operate. This means higher brake depression force and higher steering effort are required. Therefore, vehicle operation is more difficult than usual.
- Do not leave the key in the “LOCK” position or do not remove the ignition key from the ignition switch while driving. The steering wheel will lock, causing loss of control.

6. Place the gearshift lever in the “N” (Neutral) position (M/T) or the selector lever in the “N” (NEUTRAL) position (A/T).
7. Turn on the hazard warning lamps if required by law. (Follow the local driving laws and regulations.)
8. During towing make sure that close contact is maintained between the drivers of both vehicles, and that the vehicles travel at low speed.

### **WARNING**

- To prevent entry of exhaust gas from the towing vehicle, set your air selection switch to the recirculation position.



## **⚠ CAUTION**

- The person in the vehicle being towed must pay attention to the brake lamps of the towing vehicle and make sure the rope never becomes slack.
- Avoid sudden braking, sudden acceleration and sharp turning; such operation could cause damage to the towing hooks or the tow rope.  
People in the vicinity could be injured as a result.
- When towing or being towed down a long slope, the brakes may overheat reducing the effectiveness. In this situation, have your vehicle transported by a tow truck.
- When the vehicle with A/T is to be towed by another vehicle with all wheels on the ground, make sure that the towing speed and distance given below are never exceeded, causing damage to the transmission.  
Towing speed: 50 km/h (31 mph)  
Towing distance: 30 km (19 miles)

For the towing speed and the towing distance, follow the local driving laws and regulations.

9. When towing is finished, remove the towing hook and store it in the specified location. (Refer to “Tools and jack” on page 6-10.)

When installing the cover on the bumper, align the tab (D) with the notch (E) in the bumper and press the cover securely into place.

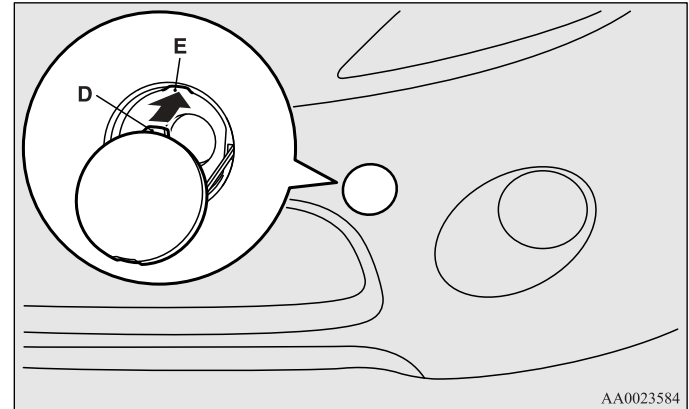

## For emergencies

### *If your vehicle tows another vehicle*

The rear towing hook (A) is located as shown in the illustration. Secure the tow rope to the rear towing hook.

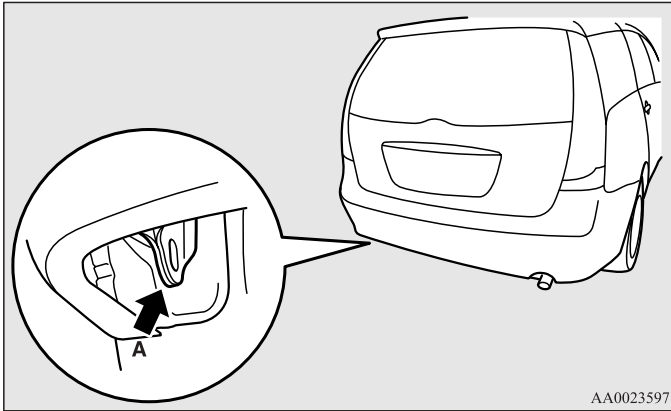

#### NOTE

- Using any part other than the designated towing hook (A) could result in damage to vehicle body.

#### NOTE

- Your vehicle should only be used to tow another vehicle if the weight of the other vehicle is less than your vehicle.

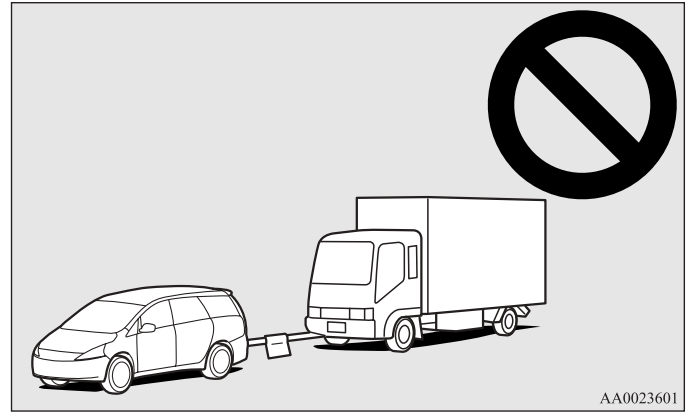

## Operation under adverse driving conditions

E00801701404

### If your vehicle becomes stuck in sand, mud or snow

If the vehicle becomes stuck in snow, sand, or mud, it can often be moved by a rocking motion. Move the selector lever alternately between the Sports mode and “R” (REVERSE) position (with M/T, between 1st and Reverse), while applying slight pressure to the accelerator pedal.

Avoid racing the engine or spinning the wheels. Prolonged efforts to free a stuck vehicle may result in overheating and transmission failure. Allow the engine to idle for a few minutes to let the transmission cool between rocking attempts.

If the vehicle remains stuck after several rocking attempts, seek other assistance.

### **WARNING**

- When attempting to rock your vehicle out of a stuck position, be sure that the area around the vehicle is clear of people and physical objects. The rocking motion may cause the vehicle to suddenly launch forward or backward, causing injury or damage to nearby people or objects.

### On a flooded road

- Avoid flooded roads. Water could enter the brake discs, resulting in temporarily ineffective brakes. In such cases, lightly depress the brake pedal to see if the brakes operate properly. If they do not, lightly depress the pedal several times while driving in order to dry the brake pads.
- When driving in rain or on a road with many puddles a layer of water may form between the tyres and the road surface.

This reduces a tyre’s frictional resistance on the road, resulting in loss of steering stability and braking capability.

To cope with this, observe the following items:

- (a) Drive your vehicle at a slow speed.
- (b) Do not drive on worn tyres. Always maintain the specified tyre inflation pressures.

## For emergencies

### On a snow-covered or frozen road

- When driving on a snow-covered or frozen road, it is recommended that you use snow tyres or tyre chains. Refer to the “Snow tyres” and “Tyre chains” sections.
- Avoid high-speed operation, sudden acceleration, abrupt brake application and sharp cornering.
- Depressing the brake pedal during travel on snowy or icy roads may cause tyre slippage and skidding. When traction between the tyres and the road is reduced the wheels may skid and the vehicle cannot readily be brought to a stop by conventional braking techniques. Braking will differ, depending upon whether you have anti-lock brakes (ABS). As your vehicle is equipped with anti-lock brakes (ABS), brake by pressing the brake pedal hard, and keeping it pressed.
- Allow extra distance between your vehicle and the vehicle in front of you, and avoid sudden braking.

### On bumpy or rutted road

Drive as slow as possible when driving on bumpy or rutted roads.



### **CAUTION**

- **The impact on tyres and/or wheels driving on a bumpy or rutted road can damage the tyre and /or wheel.**

## *Vehicle care*

Vehicle care precautions . . . . .7-	2
Cleaning the interior of your vehicle . . . . .7-	3
Cleaning the exterior of your vehicle. . . . .7-	4

## *Vehicle care precautions*

E00900100261

In order to maintain the value of your vehicle, it is necessary to perform regular maintenance using the proper procedures. Always maintain your vehicle in compliance with any environmental pollution control regulations. Carefully select the materials used for washing, etc., to be sure that they do not contain corrosives. If in doubt, we recommend you to consult a specialist for selection of these materials.

### **CAUTION**

- **Cleaning products can be dangerous. Some are poisonous. Others can burst into flame if you strike a match or drop them on a hot part of the vehicle. Some are dangerous if you breathe their fumes in a closed space. When you use anything in a container to clean your vehicle, always follow the instructions and always open your vehicle doors or windows when you're cleaning the inside. Never use the following to clean your vehicle:**
  - Gasoline
  - Paint Thinner
  - Benzine
  - Turpentine
  - Naphtha
  - Lacquer Thinner
  - Carbon Tetrachloride
  - Nail Polish Remover
  - Acetone
- **These are all dangerous, and can damage your vehicle.**

## Cleaning the interior of your vehicle

E00900200031

After cleaning the interior of your vehicle with water, cleaner or similar, wipe and dry in a shady, well-ventilated area.

### CAUTION

- Do not use organic substances (solvents, kerosine, alcohol, gasoline, etc.) or alkaline or acidic solutions. These chemicals can cause discolouring, staining or cracking of the surface.
- If you use cleaners or polishing agents, make sure their ingredients do not include the substances mentioned above.

#### NOTE

- Always read the instructions on the cleaner label.

### Plastic, vinyl leather, fabric and flocked parts

E00900300146

1. Gently wipe off with gauze or other soft cloth soaked with a 3 % aqueous solution of neutral detergent.
2. Dip cloth in fresh water and wring out well. Using this cloth, wipe off the detergent thoroughly.

#### NOTE

- Do not use the cleaners, conditioners, and protectants containing silicons or wax. Such products may cause annoying reflections and obscure vision.

## Upholstery

E00900500063

1. To maintain the value of your new vehicle, handle the upholstery carefully and keep the interior clean. Use a vacuum cleaner and brush to clean the seats. If stained, vinyl and synthetic leather should be cleaned with an appropriate cleaner, and cloth fabrics can be cleaned with either upholstery cleaner or a 3 % solution of neutral detergent in lukewarm water.
2. Clean the carpeting with a vacuum cleaner and remove any stains with carpet cleaner. Oil and grease can be removed by lightly dabbing with a clean colourfast cloth and stain remover.

## Genuine leather\*

E00900600208

1. Lightly wipe off with gauze or other soft cloth soaked with a 5 % aqueous solution of neutral detergent for wool.
2. Dip cloth in fresh water and wring it out well. Using this cloth, wipe off the detergent thoroughly.
3. Apply leather protecting agent to the genuine leather surface.

#### NOTE

- If genuine leather is wet with water or is washed in water, wipe off water as quickly as possible with a dry, soft cloth.
- Slight stains on genuine leather may be removed with leather cleaner as well.
- The genuine leather surface may be damaged if a nylon brush or synthetic fibre is rubbed hard against it.
- Organic solvents such as benzine, alcohol and gasoline, acid or alkaline solvents may discolour the genuine leather surface. Be sure to use neutral detergents.

## Vehicle care

- Dirty genuine leather seat may mildew. Be very careful about oil stains and remove them quickly.
- The genuine leather surface may harden and shrink if it is exposed to direct rays of the sun for long hours. When your vehicle is parked, place it in the shade as much as possible.
- When the temperature of the vehicle interior rises in summer, vinyl products left on the genuine leather seat may deteriorate and stick to the seat.

## *Cleaning the exterior of your vehicle*

E00900700182

If the following is left on your vehicle, it may cause corrosion, discolouration and stains, wash the vehicle as soon as possible.

- Seawater, anti-freeze for road use.
- Soot and dust, iron powder from factories, chemical substance (acids, alkalis, coal-tar, etc.).
- Droppings from birds, carcasses of insects, tree sap, etc.

## Washing

E00900901123

Chemicals contained in the dirt and dust picked up from the road surface can damage the paint coat and body of your vehicle if left in prolonged contact.

Frequent washing and waxing is the best way to protect your vehicle from this damage. This will also be effective in protecting it from environmental elements such as rain, snow, salt air, etc.

Do not wash the vehicle in direct sunlight. Park the vehicle in the shade and spray it with water to remove dust. Next, using an ample amount of clean water and a car washing brush or sponge, wash the vehicle from top to bottom.

Use a mild car washing soap if necessary. Rinse thoroughly and wipe dry with a soft cloth. After washing the vehicle, carefully clean the joints and flanges of the doors, bonnet, etc., where dirt is likely to remain.



### **CAUTION**

- When washing the under side of your vehicle or wheel, be careful not to injure your hands.



## **⚠ CAUTION**

- Refrain from using a car wash as its brushes may scratch the paint surface, causing it to lose its gloss. Scratches will be especially visible on darker coloured vehicles.
- Never spray or splash water on the electrical components in the engine compartment, as this may adversely affect engine starting. Exercise caution also when washing the underbody; be careful not to spray water into the engine compartment.
- Some types of hot water washing equipment apply high pressure and heat to the vehicle. They may cause heat distortion and damage to the vehicle resin parts and may result in flooding of the vehicle interior. Therefore; observe the following.
  - Maintain a good distance of approx. 50 cm or more between the vehicle body and the washing nozzle.
  - When washing around the door glass, hold the nozzle at a distance of more than 50 cm and at right angles to the glass surface.
- Using an automatic car wash, pay attention to the following items, referring to the operation manual or consulting a car wash operator. If the following procedure is not followed, it could result in damage to your vehicle.
  - The outside mirrors are retracted.
  - The rear wiper arm assembly is taped or removed.
  - If your vehicle is equipped with a rear deflector or roof rails, consult a car wash operator before using the car wash.

## **⚠ CAUTION**

- After washing the vehicle, drive the vehicle slowly while lightly depressing the brake pedal several times in order to dry out the brakes. Leaving the brakes wet could result in reduced braking performance. Also, there is a possibility that they could freeze up or become inoperative due to rust, rendering the vehicle unable to move.

### *During cold weather*

The salt and other chemicals spread on the roads in some areas in winter can have a harmful effect on the vehicle body. You should therefore wash the vehicle as often as possible in accordance with our care-instructions. It is recommended to have a preservative applied and the underfloor protection checked before and after the cold weather season.

After washing your vehicle, wipe off all waterdrops from the rubber parts around the doors to prevent the doors from freezing.

### NOTE

- To prevent freezing of the weatherstripping on the doors, bonnet, etc., they should be treated with silicone spray.

## Waxing

E00901000339

Waxing the vehicle will help prevent the adherence of dust and road chemicals to the paintwork. Apply a wax solution after washing the vehicle, or at least once every three months to assist displacing of water.

Do not wax your vehicle in direct sunlight. You should wax after the surfaces have cooled.

### CAUTION

- **Waxes containing high abrasive compounds should not be used. Such waxes remove rust and stain effectively from the paintwork but they are harmful to the lustre of the painted surface.**  
Further, they are harmful to glossy surfaces such as grille, garnish, mouldings, etc.
- **Do not use petrol or paint thinners to remove road tar or other contamination to the vehicle surface.**
- **Do not apply wax on the areas having black mat coating as it can cause uneven discolouration, patches, blurs, etc. If stained with wax, immediately wipe off with a piece of soft cloth and warm water.**
- **On vehicles with the sunroof, be careful when waxing the area around the sunroof opening, not to put any wax on the weatherstrip (black rubber). If stained with wax, the weatherstrip cannot maintain a weatherproof seal with the sunroof.**

## Polishing

E00901100011

The vehicle should only be polished if the paintwork has become stained or lost its lustre. Matt-finish parts and plastic bumpers must not be polished, polishing these parts will stain them or damage their finish.

## Damaged paint

E00901200012

Small cracks and scratches in the paint coat should be touched up as soon as possible with MITSUBISHI touch-up paint to prevent corrosion.

Check body areas facing the road or the tyres carefully for damage to the paint coat caused by flying stones, etc. The paint code number for your vehicle can be found on the vehicle information code plate in the engine compartment.

## Cleaning plastic parts

E00901300417

Use a sponge or chamois leather.

If a car wax adheres on a grey or black rough surface of the bumper, moulding or lamps, the surface becomes white. In such a case, wipe it off using lukewarm water and soft cloth or chamois leather.

### CAUTION

- **Do not use a scrubbing brush or other hard tools as they may damage the plastic part surface.**
- **Do not use wax containing compound (polishing powder) which may damage the plastic part surface.**

## CAUTION

- Do not bring the plastic parts into contact with gasoline, light oil, brake fluids, engine oils, greases, paint thinners, and sulphuric acid (battery electrolyte) which may stain, crack or discolour the plastic parts.  
If they touch the plastic parts, wipe them off with soft cloth, chamois or the like and an aqueous solution of neutral detergent then immediately rinse the affected parts with water.

### Chrome parts

E00901400014

In order to prevent spots and corrosion of chrome parts, wash with water, dry thoroughly, and apply a special protective coating. This should be done more frequently in winter.

### Aluminium wheels\*

E00901500275

1. Remove dirt using a sponge while sprinkling water on the wheel.
2. Use neutral detergent on any dirt that cannot be removed easily with water.  
Rinse off the neutral detergent after washing the wheel.
3. Dry the wheel thoroughly using a chamois leather or a soft cloth.

## CAUTION

- Do not use a brush or other hard implement on the wheels.  
Doing so could scratch the wheels.
- Do not use any cleaner that contains an abrasive substance or is acidic or alkaline. Doing so could cause the coating on the wheels to peel or become discoloured or stained.
- Do not directly apply hot water using a steam cleaner or by any other means.
- Contact with seawater and road deicer can cause corrosion. Rinse off such substances as soon as possible.

### Window glass

E00901600045

The window glass can normally be cleaned using only a sponge and water.

Glass cleaner can be used to remove oil, grease, dead insects, etc. After washing the glass, wipe dry with a clean, dry, soft cloth. Never use the same cloth to wipe the window glass as would be used to wipe the paintwork; wax from the painted surfaces could adhere to the glass and reduce its transparency and visibility.

#### NOTE

- To clean the inside of the tailgate window, always use a soft cloth and wipe the window glass along the demister heater element so as not to cause damage.

## Wiper blades

E00901700017

Use a soft cloth and glass cleaner to remove grease, dead insects, etc., from the wiper blades. Replace the wiper blades when they no longer wipe properly. (Refer to page 8-29.)

## Cleaning the sunroof\*

E00901800018

Clean the inside of the sunroof with a soft cloth. Hard deposits should be wiped away with a cloth dipped in warm, neutral detergent solution. Wipe away the solution with a sponge dipped in fresh water.

### NOTE

- The surface treatment on the inside of the glass may be removed if hard cloth or organic solvent (benzine, thinner, etc.) is used.

## Engine compartment

E00902100265

Clean the engine compartment at the beginning and end of winter. Pay particular attention to flanges, crevices and peripheral parts where dust containing road chemicals and other corrosive materials might collect.

If salt and other chemicals are used on the roads in your area, clean the engine compartment at least every three months.

Never spray or splash water on the electrical components in the engine compartment, as this may cause damage.

Do not bring the nearby parts, the plastic parts and so on into contact with sulphuric acid (battery electrolyte) which may crack, stain or discolour them.

If they are in contact, wipe off with soft cloth, chamois or the like and an aqueous solution of neutral detergent then immediately rinse the affected parts with plenty of water.

# *Maintenance*

Service precautions . . . . .	8- 2
Catalytic converter . . . . .	8- 3
Bonnet . . . . .	8- 4
Engine oil . . . . .	8- 7
Engine coolant . . . . .	8- 10
Automatic transmission fluid* . . . . .	8- 13
Washer fluid . . . . .	8- 14
Brake fluid/Clutch fluid* . . . . .	8- 14
Power steering fluid . . . . .	8- 15
Battery . . . . .	8- 16
Tyres . . . . .	8- 21
Clutch pedal free play* . . . . .	8- 27
Brake pedal free play . . . . .	8- 28
Parking brake lever stroke . . . . .	8- 28
Wiper blades . . . . .	8- 29
General maintenance . . . . .	8- 31
For cold and snow weather . . . . .	8- 32
Fuse links . . . . .	8- 33
Fuses . . . . .	8- 33
Replacement of lamp bulbs . . . . .	8- 43

## Service precautions

E01000100328

Adequate care of your vehicle at regular intervals serves to preserve the value and appearance as long as possible.

Maintenance items as described in this owner's manual can be performed by the owner.

Maintenance items as described in this Owner's Manual can be performed by the owner.

We recommend you to have the periodic inspection and maintenance performed by a MITSUBISHI MOTORS Authorized Service Point or another specialist. In the event a malfunction or other problem is discovered, we recommend you to have it checked and repaired. This section contains information on inspection maintenance procedures that you can do yourself. Follow the instructions and cautions for each of the various procedures.

### **WARNING**

- Be extremely cautious when working around the battery. It contains poisonous and corrosive sulphuric acid.
- Do not get under your vehicle with just the body jack supporting it. Always use automotive jack stands.
- Improper handling of components and materials used in the vehicle can endanger your personal safety. We recommend you to consult a specialist for necessary information.

### **WARNING**

- When checking or servicing the inside of the engine compartment, make sure the engine is switched off and has had a chance to cool down.
- If it is necessary to do work in the engine compartment with the engine running, be especially careful that your clothing, hair, etc., does not become caught by the fan, drive belts, or other moving parts.
- The fan may turn on automatically even if the engine is not running; turn the ignition key to "LOCK" position and remove the key to ensure safety while you work in the engine compartment.
- Do not smoke, cause sparks or allow open flames around fuel or battery. The fumes are flammable.

## Catalytic converter

E01000200752

For ordinary use, there are no particular precautions except that of using unleaded petrol.

The exhaust gas scavenging devices used with the catalytic converter are extremely efficient for the reduction of noxious gases. The catalytic converter is installed in the exhaust system.

It is important to keep the engine properly tuned to ensure proper catalyst operation and prevent possible catalyst damage.

### CAUTION

- **Damage to the catalytic converter can result if your vehicle is not kept in proper operating condition. In the event of an engine malfunction particularly involving engine misfire or other apparent loss of performance have your vehicle serviced promptly. Continued operation of your vehicle with a severe overheated condition may result in possible damage to the converter and vehicle.**

### WARNING

- **As with any vehicle, do not park or operate this vehicle in areas where combustible materials such as dry grass or leaves can come in contact with the hot exhaust since fire could occur.**
- **Paint should not be applied to the catalytic converter.**

The catalytic converter itself gets hot quickly, and may be damaged if overheated. The following points should be noted in order to prevent the ignition of unburned petrol within the catalytic converter.

- Use **UNLEADED PETROL ONLY** of the type recommended in “Fuel selection” on page 2.
- Do not drive with an extremely low fuel level; running out of fuel could cause damage to the catalytic converter.
- Do not try to start the engine by pushing the vehicle. If the battery is weak or discharged, use another battery to start the engine.
- Do not idle the engine with any spark plug wires disconnected or removed such as performing diagnostic tests.
- Do not idle the engine for prolonged periods during very rough idle or malfunctioning operating conditions.
- Do not race the engine when turning off the ignition switch. This will cause the catalytic converter to be damaged due to contact with unburnt fuel.
- Stop driving the vehicle if you think the performance is noticeably low, or that there is unnecessary engine rotation, or any other engine trouble, such as with the ignition, etc.

If it is impractical to stop driving immediately, reduce the speed and drive for only a short time. We recommend you to have your vehicle inspected as soon as possible.

## Maintenance

- In unusual situations involving grossly malfunctioning engine operation, a burnt smell may indicate severe and abnormal catalyst overheating. If this occurs, the vehicle should be stopped in a safe place, the engine switched off and the vehicle allowed to cool. Once the engine is cool, a service, including a tune-up to manufacturer's specifications, should be obtained immediately.

## Bonnet

E01000301095

### To open

Pull the release lever towards you to unlock the bonnet.

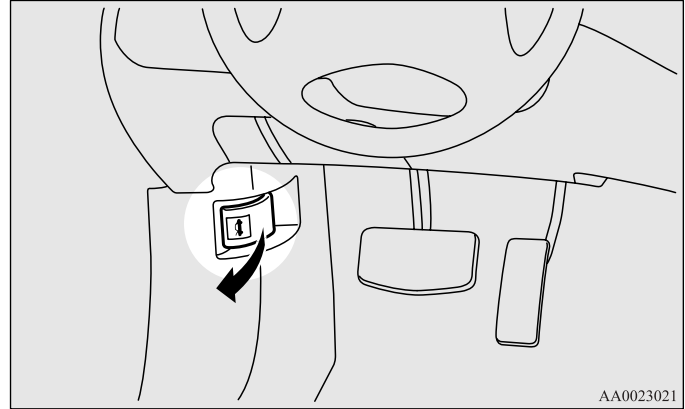

AA0023021



Raise the bonnet while pressing the safety lock.

**NOTE**

- Only open the bonnet when the wipers are in the parked position. Failure to do so may cause bonnet damage.

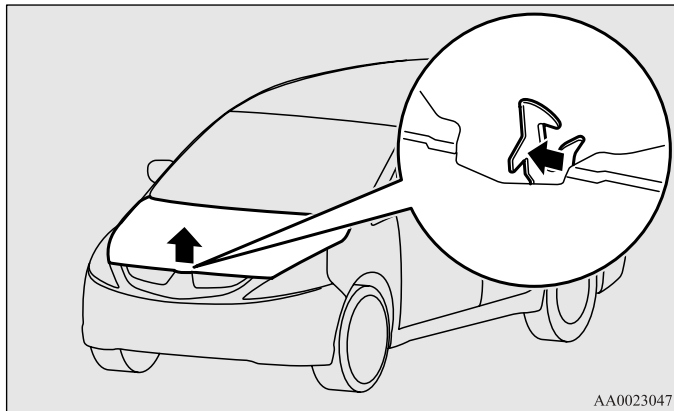

Support the bonnet by inserting the support bar in its slot.

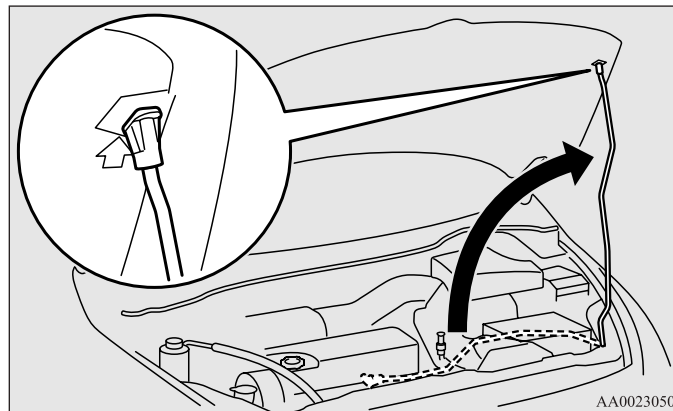
**⚠ CAUTION**

- Note that the support bar may disengage the bonnet if the open bonnet is lifted by a strong wind.
- Always insert the support bar into the hole provided specifically for this purpose. Supporting the bonnet at any other location could result in the support bar slipping out and lead to an accident.

## Maintenance

### To close

Unlatch the support bar and clip it in its holder.  
Slowly lower the bonnet to a position about 30 cm above the closed position, then let it drop.

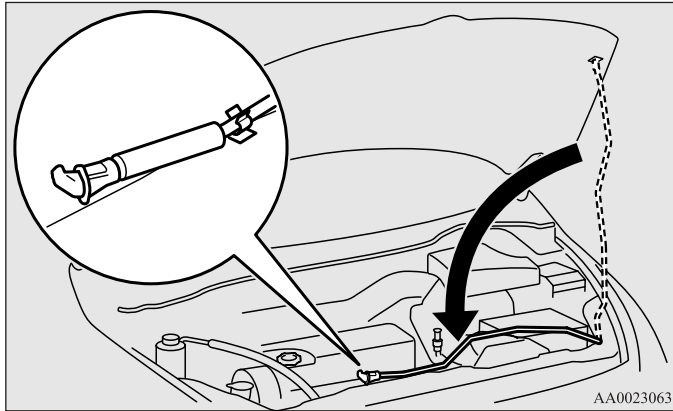

### NOTE

- If this does not close the bonnet, release it from a slightly higher position.
- Do not press down the bonnet hard with a hand as it may damage the bonnet.

### **⚠ CAUTION**

- Be careful that hands or fingers are not trapped when closing the bonnet.
- Before driving, make sure that the bonnet is securely locked. An incompletely locked bonnet can suddenly open while driving. This can be extremely dangerous.

# Engine oil

E01000401139

## To check and refill engine oil

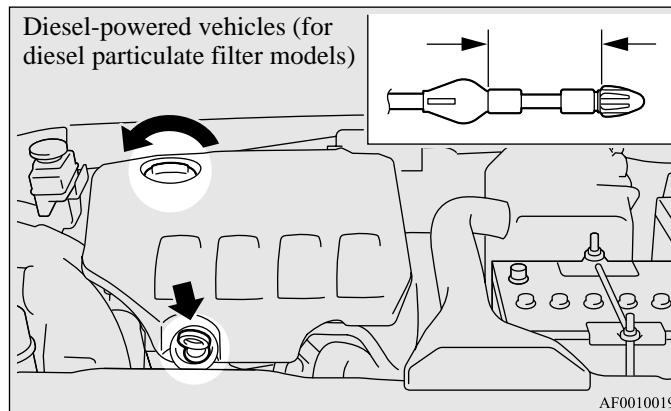
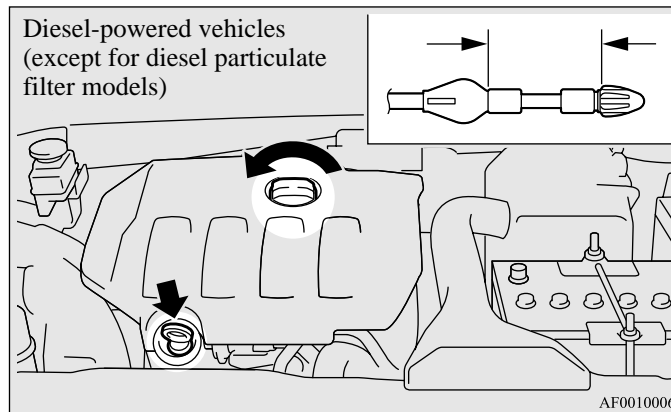
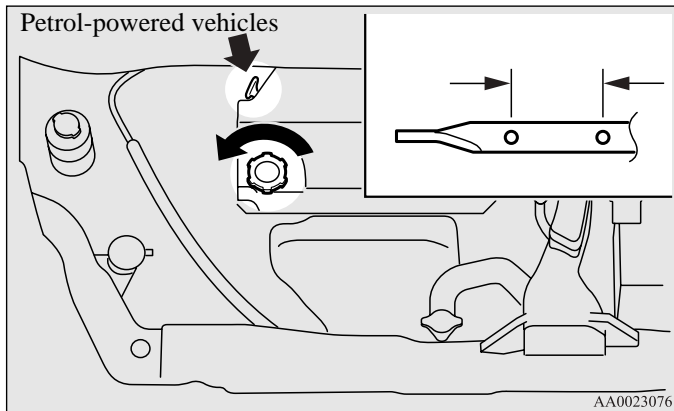

## Maintenance

The engine oil used has a significant effect on the engine's performance, service life and startability. Be sure to use oil of the recommended quality and appropriate viscosity.

All engines consume a certain amount of oil during normal operation, and engine oil consumption is greatly influenced by payload, engine speed, etc. Therefore, it is important to check the oil level at regular intervals or before starting a long trip.

This check must be made with the engine warm but not running. Park the vehicle on a level surface, stop the engine, and then wait a few moments to allow the engine oil in circulation to return to the oil pan to ensure accurate measurement.

Remove the dipstick and wipe it with a clean cloth. Reinsert the dipstick as far as it goes. Remove the dipstick and read the oil level, which should always be within the range indicated.

If the oil level is below the specified limit, remove the cap located on the cylinder head cover and add enough oil to raise the level to within the specified range.

Be sure to use the specified engine oil and do not mix various types of oil. Also, avoid mixing different makes of oil together if possible.

After adding oil, close the cap securely.

Use only the recommended oils with an ACEA or API classification as specified in this manual.

### NOTE

- Engine oil consumption is greatly influenced by payload, engine speed, etc. It may reach 1.0 lit./1,000 km depending on style of driving.

- The engine oil will deteriorate rapidly if the vehicle is subjected to severe conditions (for example, repeated operation on rough roads, in mountainous regions, on roads with many uphill and downhill gradients, or over short distances). Consequently, the oil will require earlier replacement.
- For handling of used engine oils, refer to page 7.

## Selection of engine oil

### Petrol-powered vehicles

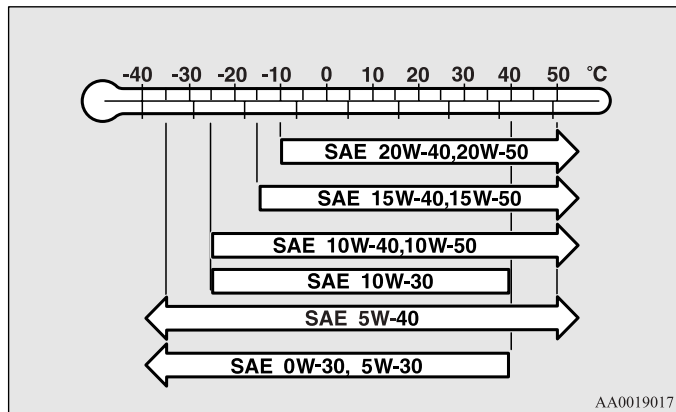

1. Select engine oil of the proper SAE viscosity number according to the atmospheric temperature.  
SAE 0W-30, 5W-30, and 5W-40 engine oils can only be used if they meet ACEA A3/B3, A3/B4 or A5/B5 and API SG (or higher) specifications.
2. Use engine oil conforming to the following classification:
  - API classification: “For service SG” or higher
  - ILSAC certificated oil
  - ACEA classification: “For service A1/B1, A3/B3, A3/B4 or A5/B5”

### NOTE

- Use of additives is not recommended since they may reduce the effectiveness of additives already included in the engine oil. It may result in failure of the mechanical assembly.

### Diesel-powered vehicles

Use engine oil conforming to the following classification:

- Vehicles with DPF= “VW 50700”
- Vehicles without DPF= “VW 50501/50601/50700”

### NOTE

- Use of additives is not recommended since they may reduce the effectiveness of additives already included in the engine oil. It may result in failure of the mechanical assembly.

## Engine coolant

E01000500960

### To check the coolant level

A translucent coolant reserve tank is located in the engine compartment.

#### *Petrol-powered vehicles*

Check the coolant level in the reserve tank. The reserve tank lid (B) is equipped with a dipstick.

Remove the dipstick and wipe it with a clean cloth. Reinsert the dipstick as far as it goes. Remove the dipstick and read the coolant level, which should always be within the range “F” (FULL) or “L” (LOW) while the engine is cold.

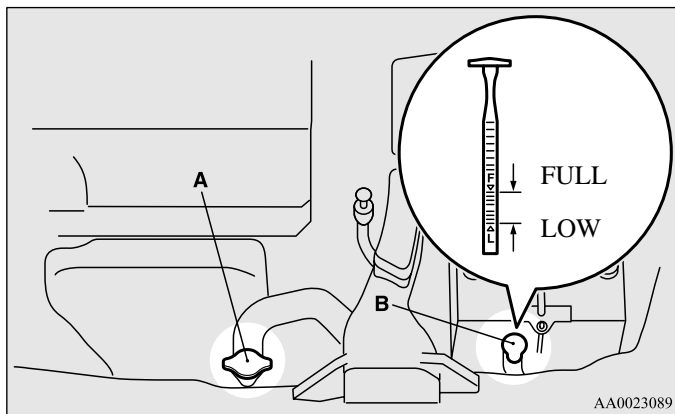

### To add coolant

The cooling system is a closed system and normally the loss of coolant should be very slight. A noticeable drop in the coolant level could indicate leakage. If this occurs, we recommend you to have the system checked as soon as possible.

If the level should drop below the “L” (LOW) level on the dipstick, add coolant to the reserve tank.

Also, if the reserve tank is completely empty, remove the radiator cap (A) and add coolant until the level reaches the filler neck.

### **▲ WARNING**

- Do not open the radiator cap while the engine is hot. The coolant system is under pressure and any hot coolant escaping could cause severe burns.

### *Anti-freeze*

The engine coolant contains an ethylene glycol anti-corrosion agent. The cylinder head and water pump housing are cast aluminium alloy, and periodic changing of the engine coolant is necessary to prevent corrosion of these parts.

Use “DIA QUEEN SUPER LONG LIFE COOLANT” or equivalent.

MITSUBISHI Genuine Coolant has excellent protection against corrosion and rust formation of all metals including aluminium and can avoid blockages in the radiator, heater, cylinder head, engine block, etc.

Because of the necessity of this anti-corrosion agent, the coolant must not be replaced with plain water even in summer. The required concentration of anti-freeze differs depending on the expected ambient temperature.

Ambient temperature (minimum) °C	-15	-20	-25	-30	-35	-50
Anti-freeze concentration %	30	35	40	45	50	60

### **⚠ CAUTION**

- Do not use alcohol or methanol anti-freeze or any engine coolants mixed with alcohol or methanol anti-freeze. The use of an improper anti-freeze can cause corrosion of the aluminium components.
- For effective anti-corrosion and anti-freeze performance, keep the anti-freeze concentration within the range of 30 to 60 %.  
Concentrations exceeding 60 % will result in a reduction of both the anti-freeze and cooling performance thus adversely affecting the engine.
- Do not top up with water only.  
Water by itself reduces the rust-protective and anti-freeze qualities of the coolant and has a lower boiling point. It can also cause damage to the cooling system if it should freeze. Do not use tapwater, as it can cause corrosion and rust formation.

### ***Diesel-powered vehicles***

The coolant level in this tank should be kept between the “LOW” and “FULL” marks when measured while the engine is cold.

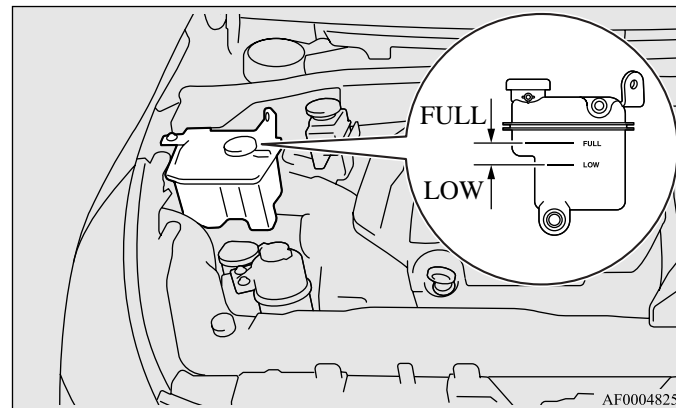

## To add coolant

The cooling system is a closed system and normally the loss of coolant should be very slight. A noticeable drop in the coolant level could indicate leakage. If this occurs, we recommend you to have the system checked as soon as possible.

If the level should drop below the “LOW” level on the reserve tank, open the lid and add coolant.

### **⚠ WARNING**

- Do not open the reserve tank cap while the engine is hot. The coolant system is under pressure and any hot coolant escaping could cause severe burns.

## Anti-freeze

The engine coolant contains an ethylene glycol anti-corrosion agent. The cylinder head and water pump housing are cast aluminium alloy, and periodic changing of the engine coolant is necessary to prevent corrosion of these parts.

Use only “BASF Glysantin Alu Protect Premium/G30”.

It has excellent protection against corrosion and rust formation of all metals including aluminium and can avoid clogs in the radiator, heater, cylinder head, engine block, etc.

Because of the necessity of this anti-corrosion agent, the coolant must not be replaced with plain water even in summer.

The anti-freeze must fill 50 % concentration coolant in all temperature conditions.

### **⚠ CAUTION**

- Do not use alcohol or methanol anti-freeze or any engine coolants mixed with alcohol or methanol anti-freeze. The use of an improper anti-freeze can cause corrosion of the aluminium components.
- Do not top up with water only.  
Water by itself reduces the rust-protective and anti-freeze qualities of the coolant and has a lower boiling point. It can also cause damage to the cooling system if it should freeze. Do not use tapwater, as it can cause corrosion and rust formation.

## During cold weather

If the temperatures in your area drop below freezing, there is the danger that the coolant in the engine or radiator could freeze and cause severe damage to the engine and/or radiator. Add a sufficient amount of anti-freeze to the coolant to prevent it from freezing.

The engine coolant mixture used at the factory provides protection against freezing for temperatures as low as approximately  $-30^{\circ}\text{C}$ . The concentration should be checked before the start of cold weather and anti-freeze added to the system if necessary.



## Automatic transmission fluid\*

E01000600134

The proper amount of automatic transmission fluid is essential to the life and operation of the automatic transmission. Either insufficient fluid or excessive fluid could cause transmission trouble. The transmission fluid filler port cap is equipped with a dipstick. Use the following procedure to check the fluid level.

### Procedure for checking the fluid level

1. Check the fluid level after the vehicle has been driven enough to warm up the transmission fluid.
2. Park the vehicle on a flat, level surface and apply the parking brake.
3. With the engine idling and the brake pedal fully depressed, move the transmission selector lever through all the positions from the “P” (PARK) to “D” (DRIVE), stopping momentarily at each position.
4. Move the selector lever to the “P” (PARK) position.
5. Remove the dipstick and wipe it with a clean lint-free cloth.
6. Reinsert the dipstick as far as it goes.

7. Remove dipstick and read the oil level.

The fluid level should always be between the two marks on the dipstick.

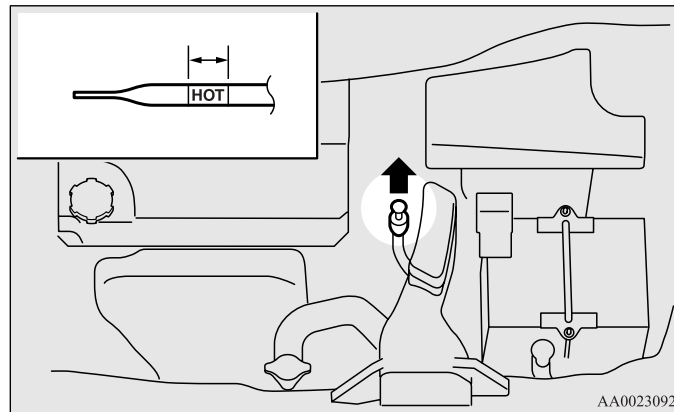

### **⚠ WARNING**

- Do not spill the fluid onto a hot exhaust manifold during topping up or inspection, or a fire may occur.

### Recommended fluid

Use only “DIA QUEEN ATF SP III” transmission fluid to ensure optimum transmission performance.

## Washer fluid

E01000700164

Check the float (A) is between the “FULL” and “EMPTY” on the washer fluid reservoir.

If the level is low, replenish the container with washer fluid.

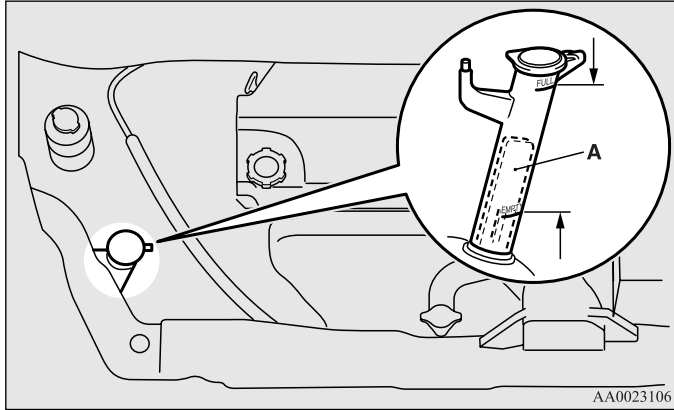

AA0023106

### NOTE

- The washer fluid container serves the windscreen, rear window and headlamps\*.

### During cold weather

To ensure proper operation of the washers at low temperatures, use a fluid containing an anti-freezing agent.

## Brake fluid/Clutch fluid\*

E01000800501

The brake fluid and the clutch fluid share reservoir tank.

### To check the fluid level

The fluid level must be between the “MAX” and “MIN” marks on the reservoir.

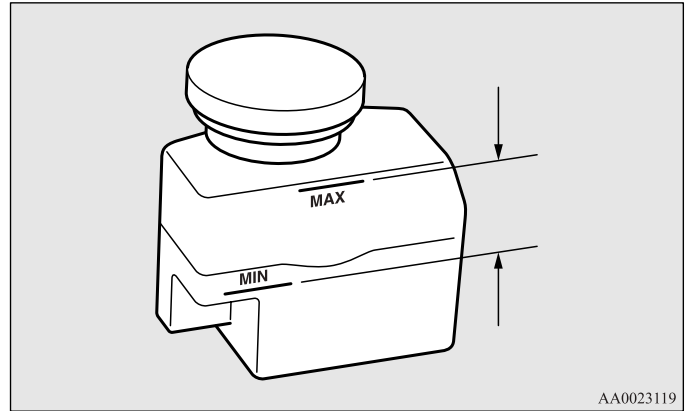

AA0023119

The fluid level is monitored by a float. When the fluid level falls below the “MIN” mark, the brake fluid warning lamp lights up.

The fluid level falls slightly with wear of the brake pads, but this does not indicate any abnormality.

If the fluid level falls markedly in a short length of time, it indicates leaks from the brake system.

If this occurs, we recommend you to have the vehicle checked.

## Fluid type

Use brake fluid conforming to DOT3 or DOT4 from a sealed container. The brake fluid is hygroscopic. Too much moisture in the brake fluid will adversely affect the brake system, reducing the brake performance.

### **⚠ CAUTION**

- Take care in handling brake fluid as it is harmful to the eyes, may irritate your skin and also damage to painted surfaces.
- Use only the specified brake fluid.  
Do not mix or add different brand of brake fluid to prevent chemical reaction.  
Do not let any petroleum-based fluid touch, mix with, or get into the brake fluid.  
This will damage the seals.
- Keep the reservoir tank cap closed to prevent the brake fluid from deteriorating except maintenance.
- Clean the filler cap before removing and close the cap securely after maintenance.

## Power steering fluid

E01001100413

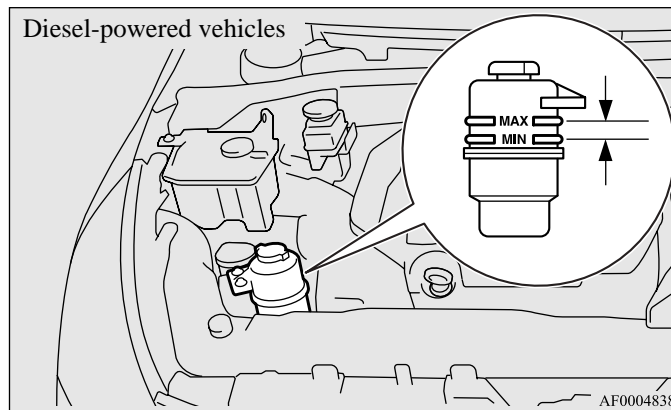
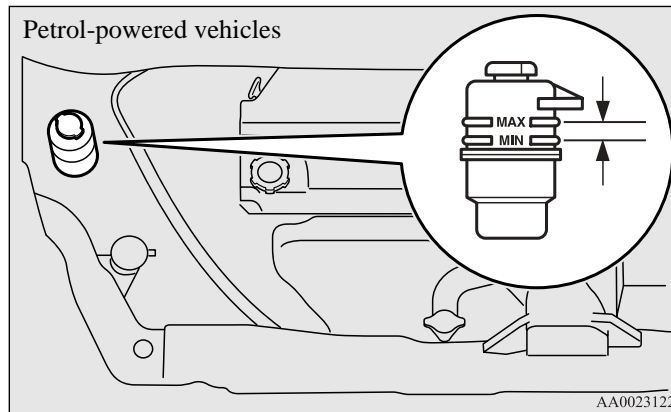

### To check the fluid level

Check the fluid level in the reservoir while the engine is idling. Check to make certain that the power steering fluid level is always between the “MAX” and “MIN” level markings on the fluid reservoir and refill the fluid, if necessary.

### Recommended fluid

Use “Genuine MITSUBISHI Power Steering Fluid” or “ATF DEXRON III / DEXRON II”.

## *Battery*

E01001201277

The condition of the battery is very important for quick starting of the engine and proper functioning of the vehicle’s electrical system. Regular inspection and care are especially important in cold weather.

### NOTE

- After replacing the battery, the electronic control system data for the automatic transmission, etc., will be erased. As a result, shift shocks may occur. Shift shocks will become smoother after several changes in speed.
- Memory data for settings made by the user may be erased when the battery is replaced. If this happens, establish the settings again using the relevant procedures.

## Checking battery electrolyte level

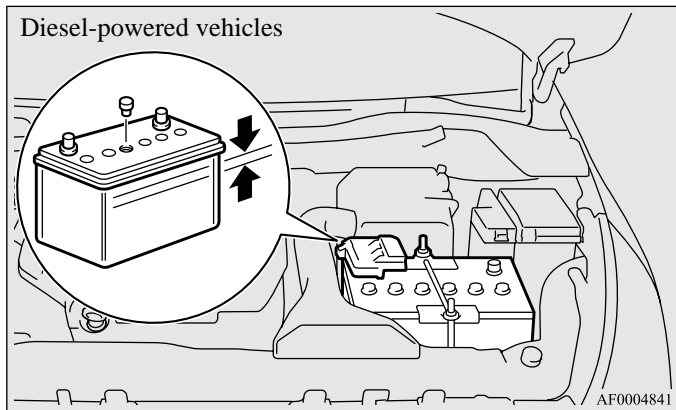
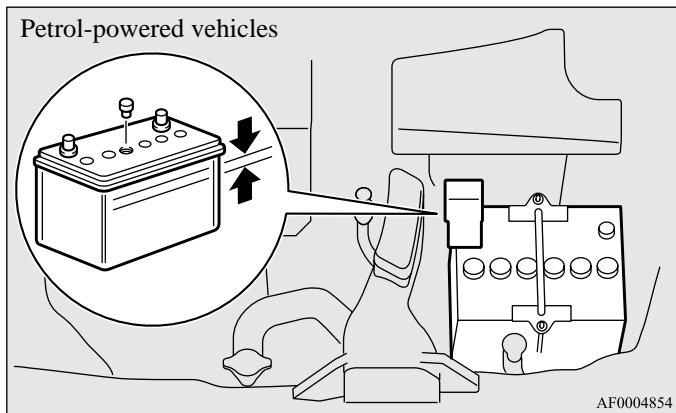

The electrolyte level must be between the specified limit on the outside of the battery. Replenish with distilled water as necessary.

The inside of the battery is divided into several compartments; remove the cap from each compartment and fill to the upper mark. Do not over-replenish beyond the upper mark because spillage during driving could cause damage.

Check the electrolyte level at least once every four weeks, depending on the operating conditions.

If the battery is not used, it will discharge by itself with time. Check it once every four weeks and charge with low current as necessary.

## Maintenance

### During cold weather

The capacity of the battery is reduced at low temperatures. This is an inevitable result of its chemical and physical properties. This is why a very cold battery, particularly one that is not fully charged anyway, will only deliver a fraction of the starter current which is normally available.

We recommend you to have the battery checked before the start of cold weather and, if necessary, have it charged or replaced. This does not only ensures reliable starting, but a battery which is kept fully charged also has a longer life.

### Disconnection and connection

To disconnect the battery cable, stop the engine, first disconnect the negative (-) terminal and then the positive (+) terminal. When connecting the battery, first connect the positive (+) terminal and then the negative (-) terminal.

### NOTE

- Open the terminal cover (A) before disconnecting or connecting the positive (+) terminal of the battery.
- Loosen the nut (B), and then disconnect the battery cable from the positive (+) terminal.

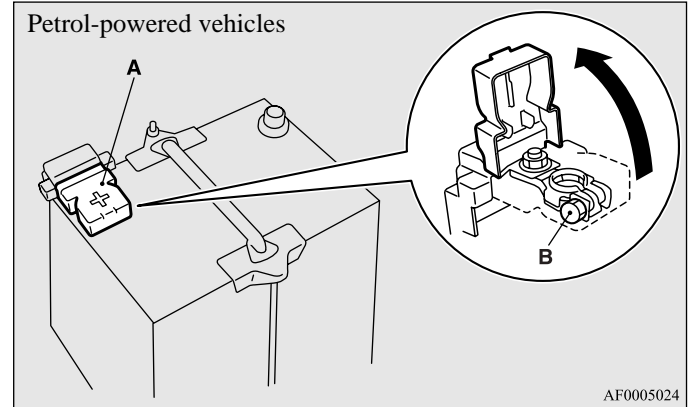

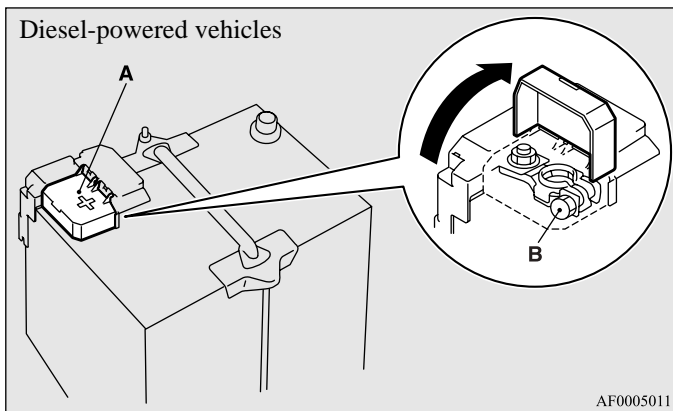

## **⚠ WARNING**

- Keep sparks, cigarettes, and flames away from the battery because the battery could explode.
- The battery electrolyte is extremely caustic. Do not allow it to come in contact with your eyes, skin, clothing, or the painted surfaces of the vehicle. Spilt electrolyte should be flushed immediately with ample amounts of water. Irritation to eyes or skin from contact with electrolyte requires immediate medical attention.
- Ventilate when charging or using the battery in an enclosed space.

## **⚠ CAUTION**

- Never disconnect the battery with the ignition switch in the “ON” position; doing so could damage the vehicle’s electrical components.
- Never short-circuit the battery; doing so could cause it to overheat and be damaged.
- Always wear protective eye goggles when working near the battery.
- If the battery is to be quickcharged, first disconnect the battery cables.
- In order to prevent a short circuit, be sure to disconnect the negative (–) terminal first.
- Keep it out of reach of children.
- Do not bring the nearby parts, the plastic parts and so on into contact with sulphuric acid (battery electrolyte) which may crack, stain or discolour them. If they are in contact, wipe off with soft cloth, cham-  
ois or the like and an aqueous solution of neutral detergent then immediately rinse the affected parts with plenty of water.

### NOTE

- Keep the terminals clean. After the battery is connected, apply terminal protection grease. To clean the terminals, use lukewarm water.
- Check to see if the battery is securely installed and cannot be moved during travel. Also check each terminal for tightness.
- When the vehicle is to be left unused for a long period of time, remove the battery and store it in a place where the battery fluid will not freeze. The battery should be stored only in a fully charged condition.



## Tyres

E01001300213

### **WARNING**

- Driving with tyres that are worn, damaged or improperly inflated can lead to loss of control or blowout of the tyres which can result in a collision with serious or fatal injury.

### Tyre inflation pressures

E01001401413

#### Petrol-powered vehicles

Item	Tyre size	Up to 4 passengers		Max. load		At trailer towing	
		Front	Rear	Front	Rear	Front	Rear
Normal tyre	215/60R16 95H	2.1 bar (210 kPa), 2.3 bar (230 kPa)*	2.1 bar (210 kPa), 2.6 bar (260 kPa)*	2.1 bar (210 kPa)	2.4 bar (240 kPa)	2.1 bar (210 kPa)	2.4 bar (240 kPa)
	215/55R17 94V	2.3 bar (230 kPa), 2.3 bar (230 kPa)*	2.3 bar (230 kPa), 2.7 bar (270 kPa)*	2.3 bar (230 kPa)	2.4 bar (240 kPa)	2.3 bar (230 kPa)	2.5 bar (250 kPa)
Compact spare tyre	T135/90D16 102M	4.2 bar (420 kPa)				—	

\*: Above 160 km/h (99 mph)

**Diesel-powered vehicles**

Item	Tyre size	Up to 4 passengers		Max. load		At trailer towing	
		Front	Rear	Front	Rear	Front	Rear
Normal tyre	215/60R16 95H	2.3 bar (230 kPa), 2.4 bar (240 kPa)*	2.1 bar (210 kPa), 2.7 bar (270 kPa)*	2.3 bar (230 kPa), 2.4 bar (240 kPa)*	2.4 bar (240 kPa), 2.7 bar (270 kPa)*	2.3 bar (230 kPa)	2.4 bar (240 kPa)
	215/55R17 94V	2.3 bar (230 kPa), 2.4 bar (240 kPa)*	2.3 bar (230 kPa), 2.8 bar (280 kPa)*	2.3 bar (230 kPa), 2.4 bar (240 kPa)*	2.5 bar (250 kPa), 2.7 bar (270 kPa)*	2.3 bar (230 kPa)	2.5 bar (250 kPa)
Compact spare tyre	T135/90D16 102M	4.2 bar (420 kPa)					

\*: Above 160 km/h (99 mph)

Check the tyre inflation pressure of all the tyres while they are cold; if insufficient or excessive, adjust to the specified value. After the tyre inflation pressure has been adjusted, check the tyres for damage and air leaks. Be sure to put caps on the valves.

## Wheel condition

E01001800638

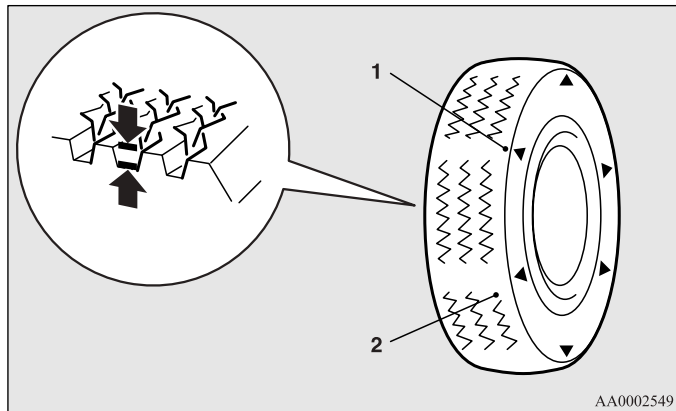

AA0002549

- 1- Location of the tread wear indicator
- 2- Tread wear indicator

Check the tyres for cuts, cracks and other damage. Replace the tyres if there are deep cuts or cracks. Also check each tyre for pieces of metal or pebbles.

The use of worn tyres can be very dangerous because of the greater chance of skidding or hydroplaning. The tread depth of the tyres must exceed 1.6 mm in order for the tyres to meet the minimum requirement for use.

If there are tread wear indicators on the tyres, they will appear in six places on the surface of the tyre as the tyre wears, thereby indicating that the tyre no longer meets the minimum requirement for use. When these wear indicators appear, the tyres must be replaced with new ones.

Check that the wheel nuts are tightened correctly. Refer to the section entitled “For emergencies” for information concerning replacement of the tyres.

### NOTE

- The mark and the location of the tyre tread wear indicators are different depending on tyre manufacturers.

## Replacing tyres and wheels

E01007200285

### **⚠ CAUTION**

- **Avoid using different size tyres from the one listed and the combined use of different types of tyres, as this can affect driving safety. Refer to “Tyres and wheels” on page 9-12.**
- **Even if a wheel has the same rim size and offset as the specified type of wheel, its shape may prevent it from being fitted correctly. We recommend you to consult a specialist before using wheels that you have.**

## Tyre rotation

E01001900958

Tyre wear varies with vehicle conditions, road surface conditions and individual driver's driving habits. To equalize the wear and help extend tyre life, it is recommended to rotate the tyres immediately after discovery of abnormal wear, or whenever the wear difference between the front and rear tyres is recognizable.

When rotating tyres, check for uneven wear and damage. Abnormal wear is usually caused by incorrect tyre pressure, improper wheel alignment, out of balance wheel, or severe braking. We recommend you to have it checked to determine the cause of irregular tread wear.

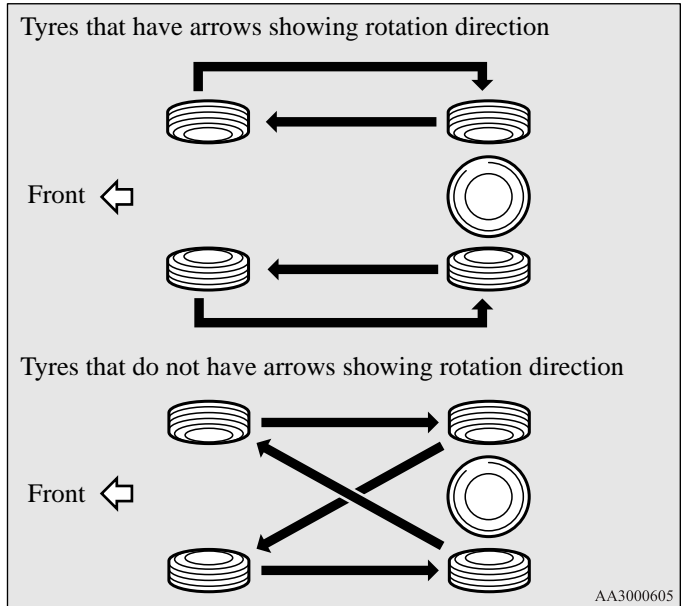

### **⚠ CAUTION**

- A compact spare tyre can be fitted temporarily in place of a tyre that has been removed during the tyre rotation. However, it must not be included in the regular tyre rotation sequence.

## **⚠ CAUTION**

- If the tyres have arrows (A) indicating the correct direction of rotation, swap the front and rear wheels on the left hand side of the vehicle and the front and rear wheels on the right hand side of the vehicle separately. Keep each tyre on its original side of the vehicle. When fitting the tyres, make sure the arrows point in the direction in which the wheels will turn when the vehicle moves forward. Any tyre whose arrow points in the wrong direction will not perform to its full potential.

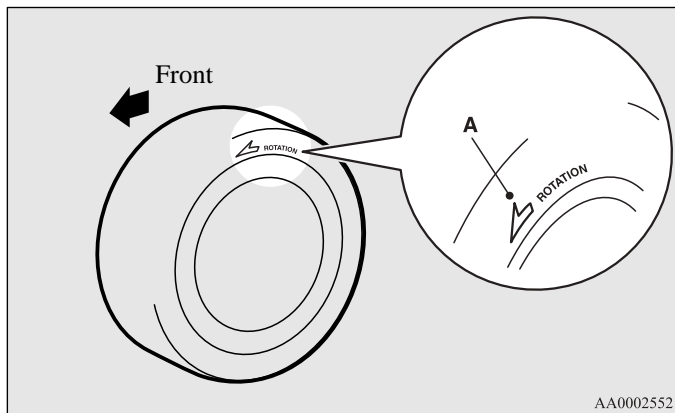

AA0002552

## **⚠ CAUTION**

- Avoid the combined use of different types of tyres. Using different types of tyres can affect vehicle performance and safety.

### Snow tyres

E01002000725

The use of snow tyres is recommended for driving on snow and ice. To preserve driving stability, mount snow tyres of the same size and tread pattern on all four wheels.

Snow tyres worn more than 50 % are no longer suitable for use as snow tyres.

Snow tyres which do not meet specifications must not be used.

## **⚠ CAUTION**

- Observe permissible maximum speed for your snow tyres and the legal speed limit.

### NOTE

- The laws and regulations concerning snow tyres (driving speed, required use, type, etc.) vary. Find out and follow the laws and regulations in the area you intend to drive.
- If flange nuts are used on your vehicle, change to tapered nuts when steel wheels are used.

## Tyre chains

E01002101130

If tyre chains have to be used, ensure that they are fitted only on the drive wheels (front).

Use only tyre chains which are designed for use with the tyres mounted on the vehicle: use of the incorrect size or type of chain could result in damage to the vehicle body.

Before fitting tyre chains, We recommend you to consult a MITSUBISHI MOTORS Authorized Service Point.

Tyre size	Wheel size	Max chain height [mm]
215/60R16	16x6.5 JJ	9
215/55R17	17x7.0 J	

The speed limit for tyre chain is 50 km/h (31 mph) and remove the tyre chains as soon as possible on snow free roads.

### **WARNING**

- **DO NOT use a jack when fitting the chains, as in the conditions, the tyres may slip on the icy road causing the vehicle to slip off the jack.**

### **CAUTION**

- **Practice fitting the chains before you need them. Don't expect help from other people in the cold.**
- **Choose a clear straight stretch of road where you can pull off and still be seen while you are fitting the chains.**
- **Do not fit chains before you need them. This will wear out your tyres and the road surface.**
- **After driving around 100-300 metres, stop and retighten the chains.**
- **Care should be taken with extremes of steering lock to prevent possible contact between the chains and the vehicle body.**
- **Drive carefully and do not exceed 50 km/h (31 mph). Remember, fitting chains is not going to stop accidents from happening.**
- **When tyre chains are installed, take care that they do not damage the disc wheel or body.**
- **Do not install a tyre chain on an emergency wheel which is compact in size. If one of the front wheels has punctured, replace it with one of the rear wheels and install the compact spare wheel in that place before fitting a tyre chain.**

## **⚠ CAUTION**

- An aluminium wheel can be damaged by a tyre chain while driving. When fitting a tyre chain on an aluminium wheel, take care that any part of the chain and fitting cannot be brought into contact with the wheel.
- Remove the wheel covers before installing the tyre chains, otherwise they may be damaged by the tyre chain. (Refer to “wheel covers” on page 6-26.)
- When installing or removing a tyre chain, take care that hands and other parts of your body are not injured by the sharp edges of the vehicle body.
- Install the chains only on the front tyres and tighten them as tightly as possible with the ends securely fastened.

## NOTE

- The laws and regulations concerning the use of tyre chains vary. Find out and follow the laws and regulations in driving area. In most countries, it is prohibited by the law to use tyre chains on roads without snow.

## *Clutch pedal free play\**

E01002200163

Press down the clutch pedal with your fingers until initial resistance is felt.

This distance should be within the specified range.

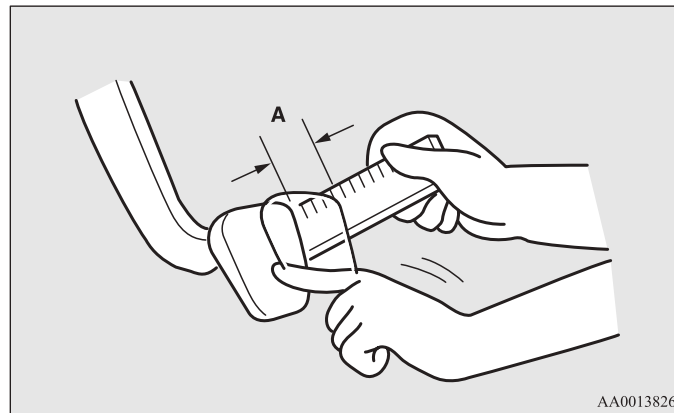

AA0013826

A- Free play: 4 to 13 mm

If the clutch pedal free play is not within the standard range, we recommend you to have it checked.

## Brake pedal free play

E01002300210

Stop the engine, depress the brake pedal several times, and press down the pedal with your fingers until initial resistance is felt. This distance should be within the specified range.

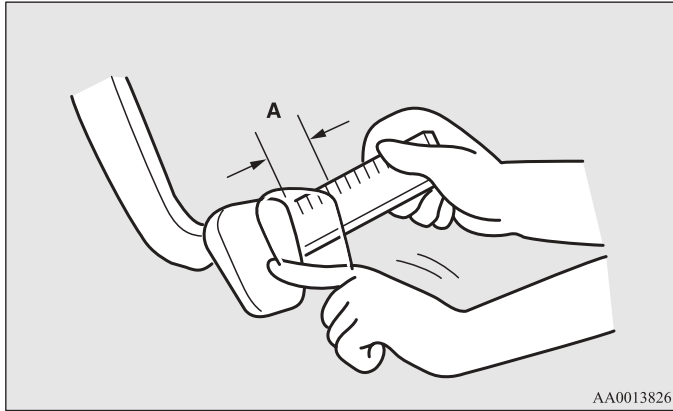

A- Free play: 3 to 8 mm

If the brake pedal free play is not within the standard range, we recommend you to have it checked.

## Parking brake lever stroke

E01005800362

Pull the parking brake lever up to check the number of “clicks” that the ratchet makes. One click represents a lever movement of one notch. The lever should move the specified number of notches for normal brake application.

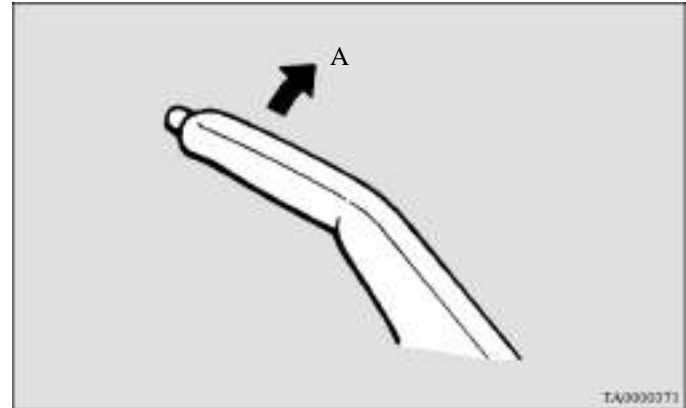

A- Parking brake lever stroke: 5 to 6 notches  
(Parking brake adjustment when pulled with the force of 200 N)

If the parking brake lever stroke is out of the standard range, we recommend you to have it checked.

### **⚠ WARNING**

- Continued operation of the vehicle with the parking brake lever or pedal out of adjustment may result in the vehicle moving when unattended.



## Wiper blades

E01002600398

If the blades are frozen to the windscreen or rear window, do not operate the wipers until the ice has melted and the blades are freed, otherwise the wiper motor may be damaged.

### Wiper blade rubber replacement

#### Windscreen wiper blades

1. Lift the wiper arm off the windscreen.
2. Pull the wiper blade (A) downward to remove it completely from the wiper arm (B).

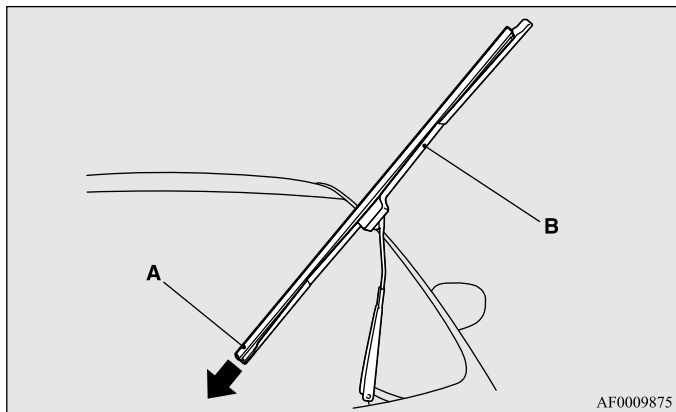

#### NOTE

- Do not allow the wiper arm to fall onto the windscreen; it could damage the glass.

3. Attach retainers (C) to a new wiper blade.

Refer to the illustration to ensure that the retainers are correctly aligned as you insert them into the groove.

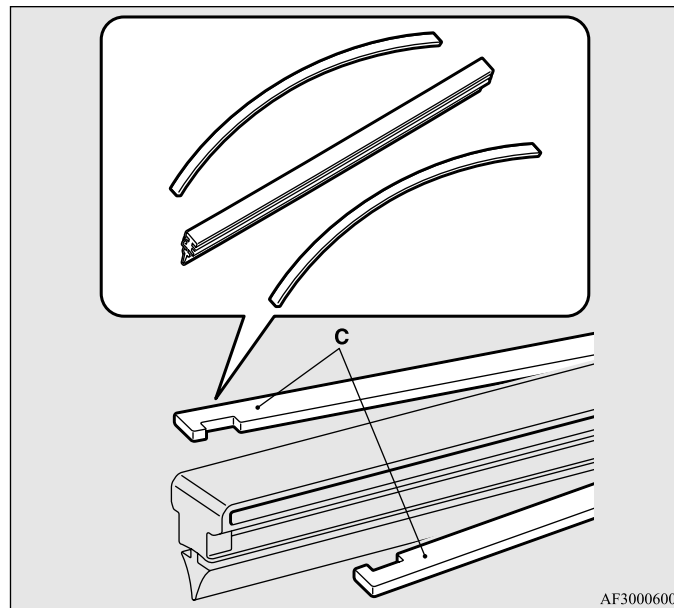

#### NOTE

- If retainers are not supplied with the new wiper blade, use the retainers from the old blade.
4. Position the wiper blade stopper (D) as shown and insert the blade into the wiper arm (B) from the lower end of the arm.

## Maintenance

- Slide the wiper blade (A) until it contacts the end of the wiper arm (B).

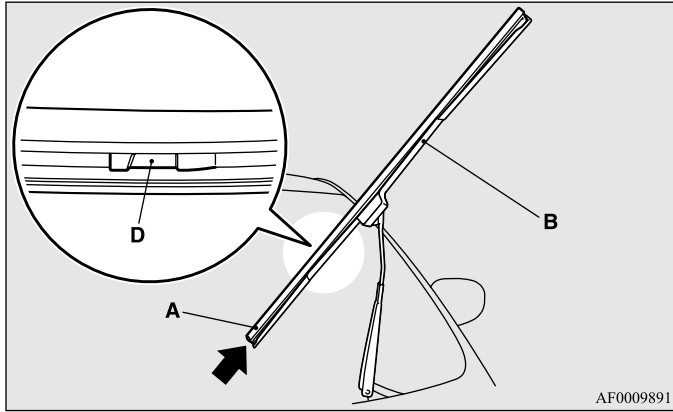

### NOTE

- After installation, gently pull up and down on the wiper blade to make sure the stopper is securely engaged.

## Rear window wiper blades

- Lift the wiper arm off the window glass.
- Pull the wiper blade downward to disengage it from the stopper (A) at the end of the wiper arm. Pull the wiper blade further to remove it.
- Slide a new wiper blade through the hook (B) on the wiper arm.

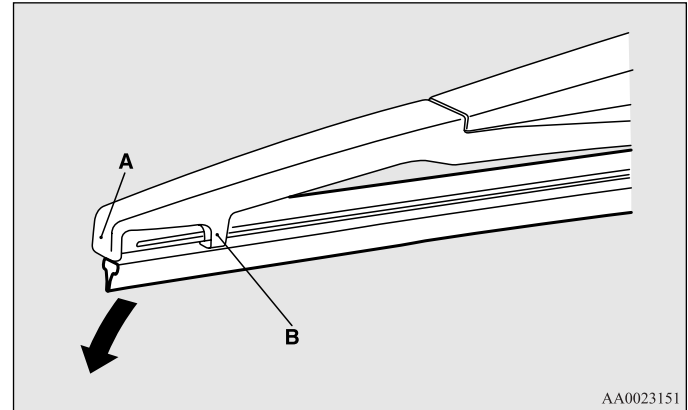

### NOTE

- Do not allow the wiper arm to fall onto the window glass; it could damage the glass.

4. Firmly insert the retainer (C) into the groove (D) in the wiper blade.

Refer to the illustration to ensure that the retainers are correctly aligned as you insert them into the groove.

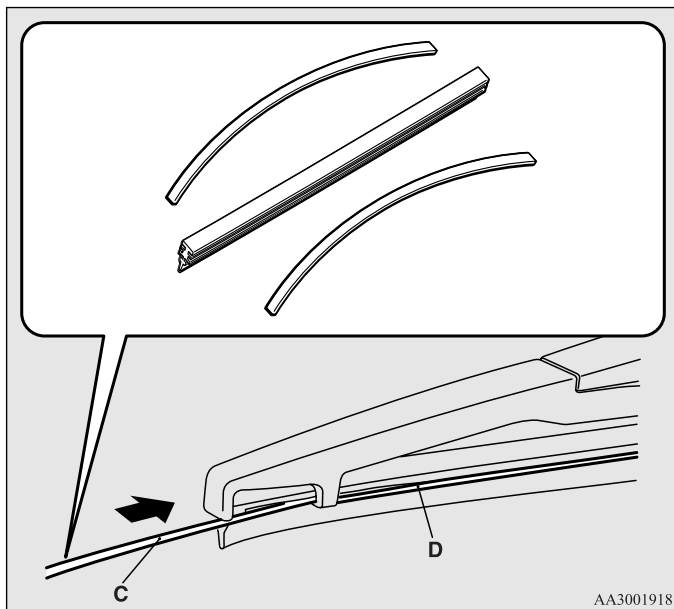

#### NOTE

- If a retainer is not supplied with the new wiper blade, use the retainer from the old blade.

## General maintenance

E01002700256

### Fuel, engine coolant, oil and exhaust gas leakage

Look under the body of your vehicle to check for fuel, engine coolant, oil and exhaust gas leaks.

#### **⚠ WARNING**

- If you see a suspicious fuel leak or if you smell fuel, do not operate the vehicle; we recommend you to call for assistance.

### Exterior and interior lamp operation

Operate the combination lamp switch to check that all lamps are functioning properly.

If the lamps do not illuminate, the probable cause is a blown fuse or defective lamp bulb. Check the fuses first. If there is no blown fuse, check the lamp bulbs.

For information regarding the inspection and replacement of the fuses and the lamp bulbs, refer to “Fuses” on page 8-33 and “Replacement of lamp bulbs” on page 8-43.

If the fuses and bulbs are all OK, we recommend you to have your vehicle checked and repaired.

## Maintenance

### **Meter, gauge and indicator/warning lamps operation**

Run the engine to check the operation of all meters, gauges, and indicator/warning lamps.

If there is anything wrong, we recommend you to have your vehicle inspected.

### **Hinges and latches lubrication**

Check all latches and hinges, and lubricate if necessary by first cleaning and then applying multipurpose grease.

## *For cold and snow weather*

E01002800286

### **Ventilation slots**

The ventilation slots in front of the windscreen should be kept clear of leaves or brushed clear after a heavy snowfall, so that the operation of the heating and ventilation systems will not be impaired.

### **Weatherstripping**

To prevent freezing of the weatherstripping on the doors, bonnet, etc., they should be treated with silicone grease.

### **Additional equipment**

It is a good idea to carry a shovel or a short-handled spade in the vehicle during the winter so that you can clear away snow if you get stranded. A small hand-brush for sweeping snow off the vehicle and a plastic scraper for the windscreen and rear window are also useful.

## *Fuse links*

E01002900173

The fuse links will melt to prevent a fire if a large current attempts to flow through certain electrical systems. In case of a melted fuse link, we recommend you to have your vehicle inspected.

## *Fuses*

E01003001729

### **Fuse block location**

To prevent damage to the electrical system due to short-circuiting or overloading, each individual circuit is provided with a fuse.

There are fuse blocks in the passenger compartment and in the engine compartment.

### ***Passenger compartment***

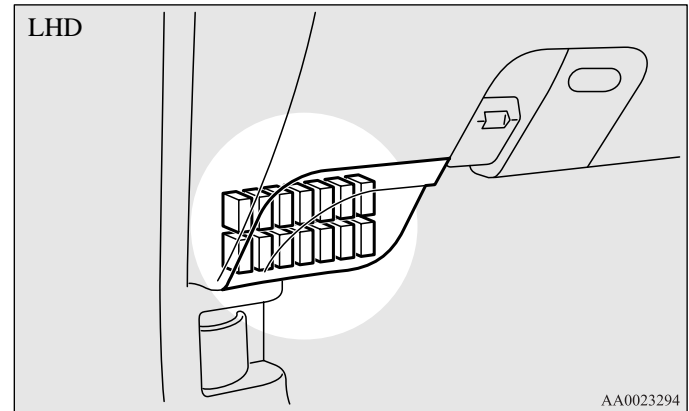

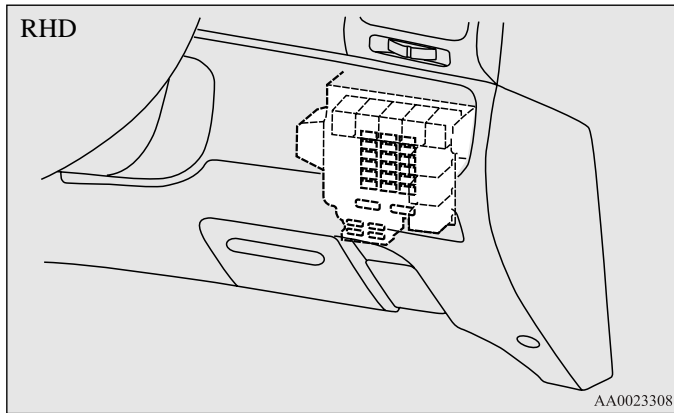

The fuse block in the passenger compartment is located behind the fuse box lid (LHD vehicles) or the personal box (RHD vehicles) in front of the driver's seat at the position shown in the illustration.

### *Engine compartment*

In the engine compartment, the fuse block is located as shown in the illustration.

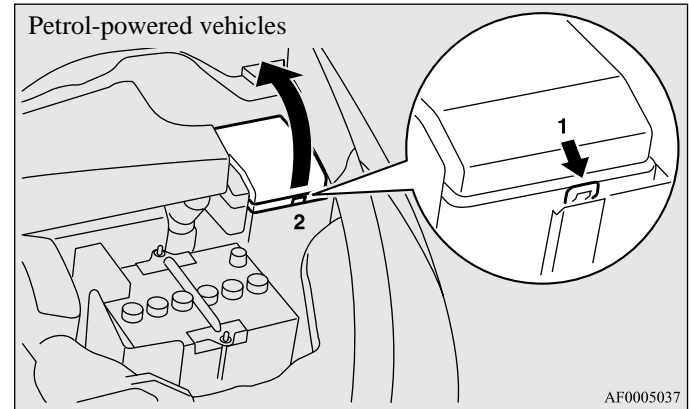

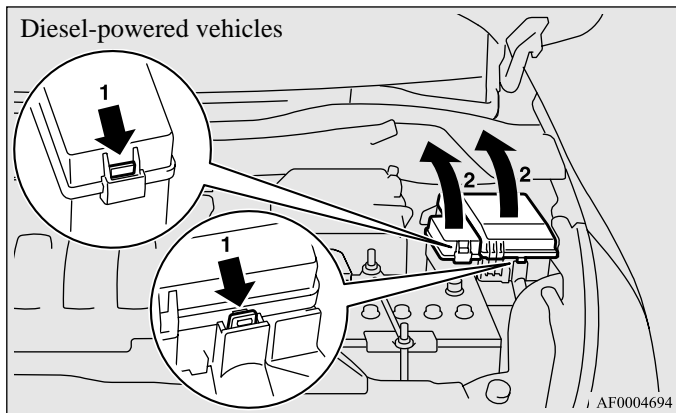

- 1- Push the knob.
- 2- Remove the cover.

## Fuse load capacity

The fuse capacity and the name of the electrical systems protected by the fuses are indicated at the fuse box lid (LHD vehicles) or the personal box (RHD vehicles) and on the inside of the fuse block cover for fuses located in the engine compartment.

### *Passenger compartment fuse location table*

#### NOTE

- Spare fuses are contained in the fuse box lid (LHD vehicles) or the personal box lid (RHD vehicles). Always use a fuse of the same capacity for replacement.



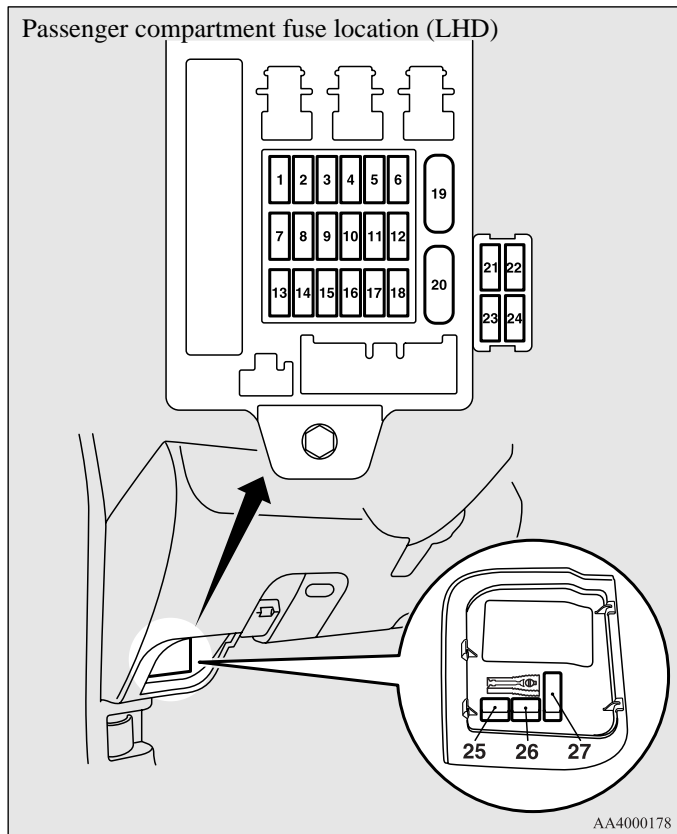



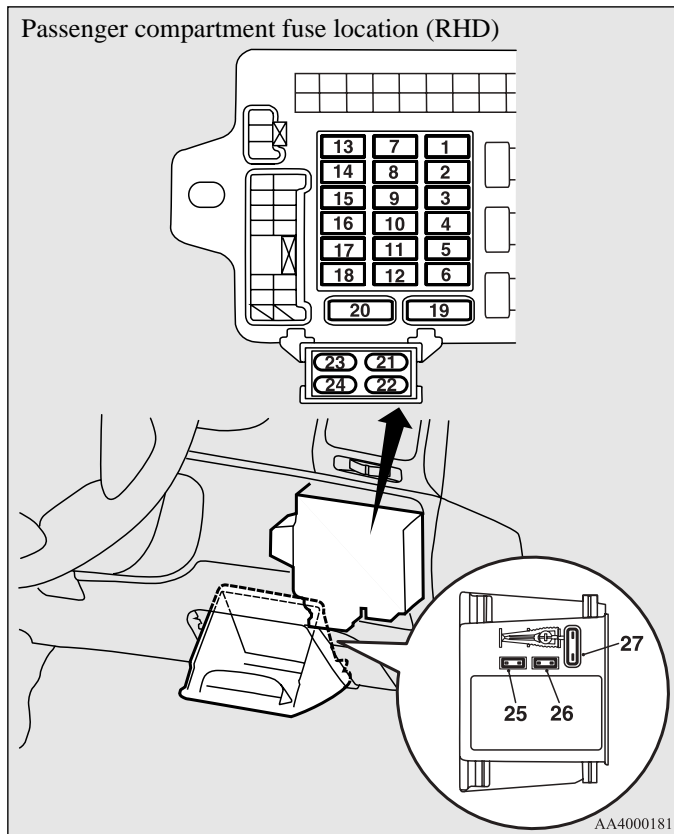









Passenger compartment fuse location (LHD)







Passenger compartment fuse location (RHD)





No.	Symbol	Electrical system	Capacity
1		Ignition coil	10 A
2		Gauge	7.5 A
3		Reversing lamp	7.5 A
4		Cruise control	7.5 A
5		Relay	7.5 A
6		Heated door mirror	7.5 A
7		Windscreen wiper	30 A
8		Engine control	7.5 A
9		Cigarette lighter	15 A
10	—	—	—
11		Outside rear-view mirrors	7.5 A
12		Engine control	7.5 A
13	—	—	—
14		Rear window wiper	15 A
15		Central door locks	15 A
16		Rear fog lamp	10 A
17	—	—	—
18	—	—	—
19		Heater	30 A
20		Rear window demister	30 A

No.	Symbol	Electrical system	Capacity
21		Sunroof	20 A
22		Heated seat	20 A
23		Rear air conditioning	20 A
24		Starter	10 A
25	—	Spare fuse	30 A
26	—	Spare fuse	20 A
27	—	Spare fuse	30 A

- Some fuses may not be installed on your vehicle, depending on the vehicle model or specifications.
- The table above shows the main equipment corresponding to each fuse.

The fuse box does not contain spare 7.5 A, 10 A and 15 A fuses. If a fuse of one of these capacities blows, replace it temporarily by borrowing the one that matches from:

**7.5 A: Outside rear-view mirrors**

**10 A: Radio (Engine compartment)**







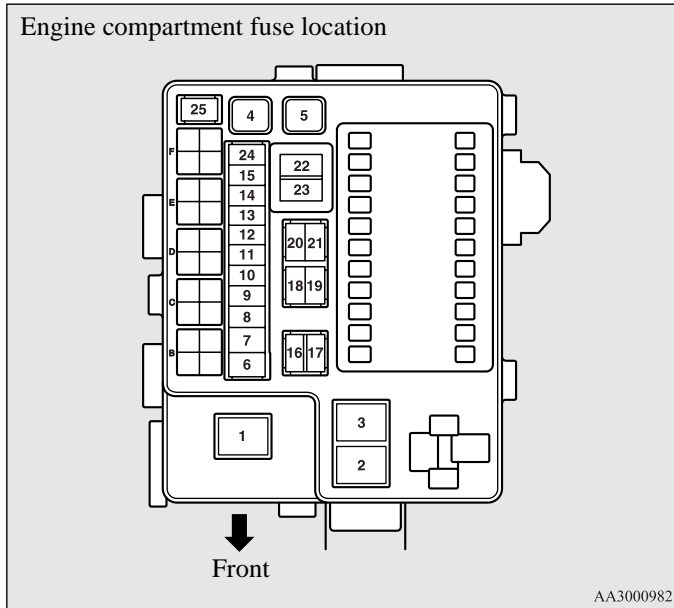





**15 A: Cigarette lighter**

Replace the borrowed fuse as soon as possible.

Engine compartment fuse location table



No.	Symbol	Electrical system	Capacity
1	—	—	_* <sup>1</sup>
		Battery	60 A* <sup>2</sup>
2		Radiator fan motor	50 A* <sup>1</sup>
			40 A* <sup>2</sup>
3		Anti-lock braking system	30 A
4		Anti-lock braking system	40 A
5		Electric window system	40 A
6		Front fog lamps	15 A
7		AC power supply	15 A* <sup>1</sup>
		Accessory socket	
		Accessory socket	15 A* <sup>2</sup>
8		Horn	10 A
9		Engine control	20 A* <sup>1</sup>
			10 A* <sup>2</sup>
10		Air conditioning	10 A
11	STOP	Stop lamps	15 A
12		Horn	15 A* <sup>1</sup>
		Wiper deicer	
	—	—	_* <sup>2</sup>

No.	Symbol	Electrical system	Capacity
13		Alternator	7.5 A* <sup>1</sup>
		Starter	25 A* <sup>2</sup>
14		Hazard warning flasher	10 A
15	A/T	Automatic transmission	20 A* <sup>1</sup>
	—	—	_* <sup>2</sup>
16		Headlamp high beam (right)	10 A
17		Headlamp high beam (left)	10 A
18		Headlamp low beam (right)	10 A* <sup>3</sup>
			20 A* <sup>4</sup>
19		Headlamp low beam (left)	10 A* <sup>3</sup>
			20 A* <sup>4</sup>
20		Tail lamp (right)	7.5 A
21		Tail lamp (left)	7.5 A
22		Back up	15 A
23		Radio	10 A
24		Fuel pump	15 A
25		Electric tailgate	30 A

\*<sup>1</sup>: Petrol-powered vehicles





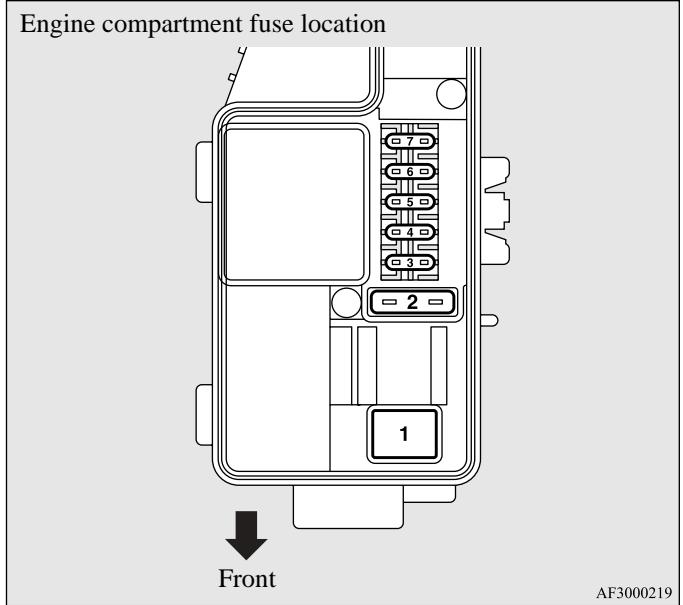

\*<sup>2</sup>: Diesel-powered vehicles

\*<sup>3</sup>: Halogen lamp : 55 W (H1)

\*<sup>4</sup>: Discharge lamp : 35 W (D2R)

**Engine compartment fuse location  
(diesel-powered vehicles only)**



No.	Symbol	Electrical system	Capacity
1		Condenser fan	30 A
2		Engine control	30 A
3		Control flap	10 A
4		Glow relay	10 A
5		Valve block	10 A
6		Immobilizer	7.5 A
7		Heating pipe	10 A

- Some fuses may not be installed on your vehicle, depending on the vehicle model or specifications.
- The table above shows the main equipment corresponding to each fuse.

**Identification of fuse**

7.5 A	Brown
10 A	Red
15 A	Blue
20 A	Yellow
25 A	Transparent
30 A	Green (fuse type) / Pink (fusible link type)
40 A	Green
50 A	Red
60 A	Yellow (fusible link type)

**Fuse replacement**

1. Before replacing a fuse, always turn off the electrical circuit concerned and place the ignition switch in the “LOCK” position.

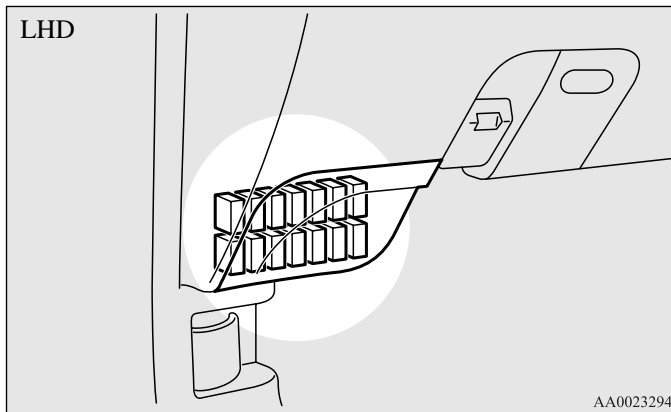

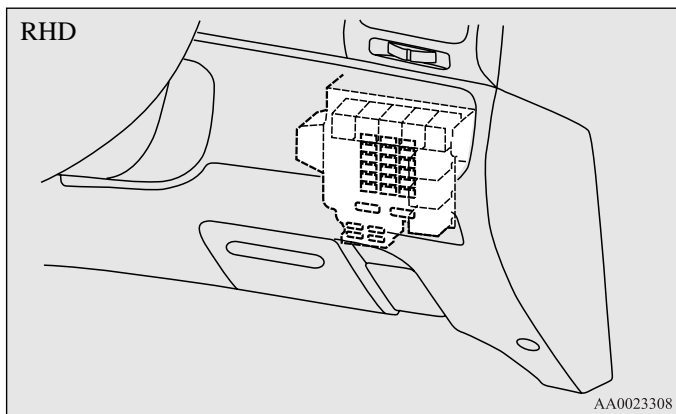

2. Remove the fuse puller from the fuse box lid or personal box.

**[LHD vehicles]**

Pull the fuse box lid (A) to remove it.

Remove the fuse puller (B) from the fuse box lid (A).

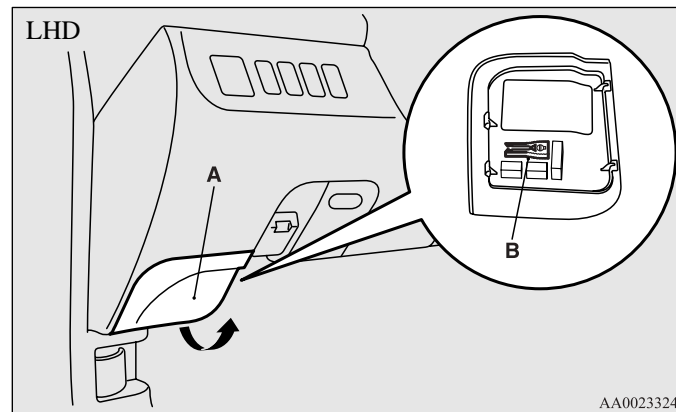

## Maintenance

### [RHD vehicles]

Open the personal box and pull the personal box towards you while lifting it up to remove.

Remove the fuse puller (B) from the personal box lid (A).

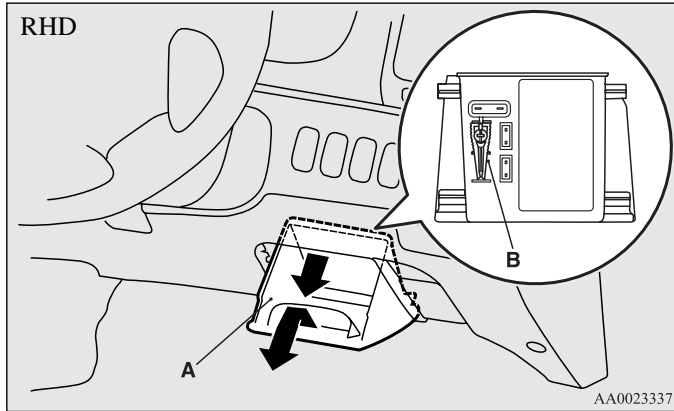

3. Referring to the fuse load capacity table, check the fuse pertaining to the problem.

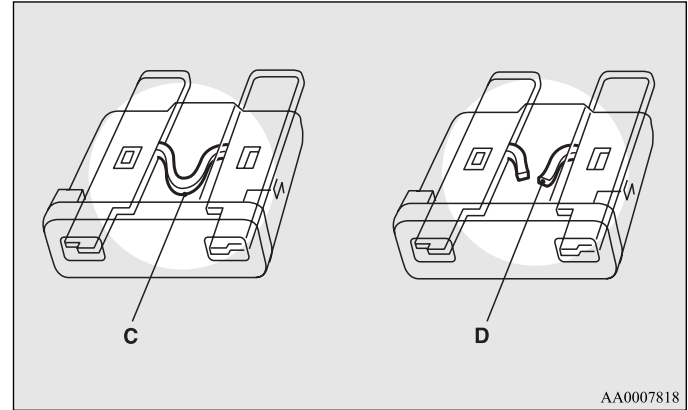

- C- Fuse is OK
- D- Blown fuse

### NOTE

- If any system does not function but the fuse corresponding to that system is normal, there may be a fault in the system elsewhere. We recommend you to have your vehicle checked.

4. Insert a new fuse of the same capacity by using the fuse puller and insert the fuse at the same place in the fuse block.

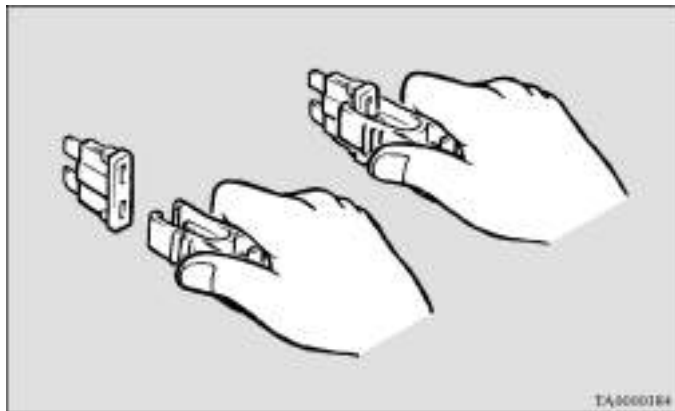

### **⚠ CAUTION**

- If the newly inserted fuse blows again after a short time, we recommend you to have the electrical system checked to find the cause and rectify it.
- Never use a fuse with a capacity larger than that specified or any substitute, such as wire, foil, etc.; doing so will cause the circuit wiring to heat up and could cause a fire.

## **Replacement of lamp bulbs**

E01003100622

Before replacing a bulb, ensure the lamp is off. Do not touch the glass part of the new bulb with your bare fingers; the skin oil left on the glass will evaporate when the bulb gets hot and the vapor will condense on the reflector and dim the surface.

### **⚠ CAUTION**

- Bulbs are extremely hot immediately after being turned off.  
When replacing a bulb, wait for it to cool sufficiently before touching it. You could otherwise be burnt.

### NOTE

- If you are unsure of how to carry out the work as required, we recommend you to consult a specialist.
- Be careful not to scratch the vehicle body when removing a lamp and lens.
- When it rains, or when the vehicle has been washed, the inside of the lens sometimes becomes foggy. This is the same phenomenon as when window glass mists up on a humid day, and does not indicate a functional problem. When the lamp is switched on, the heat will remove the fog. However, if water gathers inside the lamp, we recommend you to have it checked.

## Bulb capacity

E01003200043

When replacing a bulb, use a new bulb with the same wattage and colour.

### Outside

E01003301487

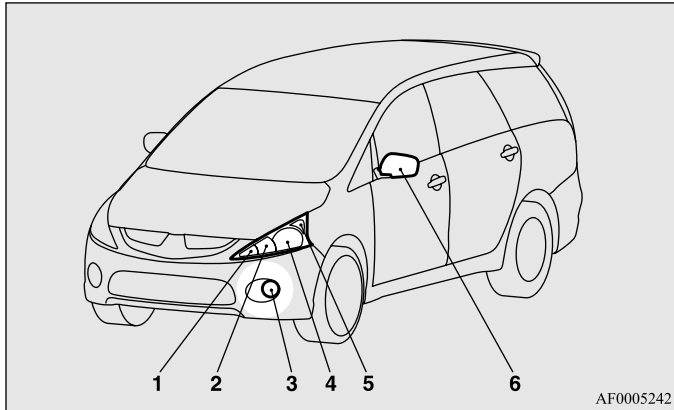

- 1- Front turn-signal lamps: 21 W (W21W)
- 2- Headlamps, high beam: 65 W (H9)
- 3- Front fog lamps: 51 W (HB4)
- 4- Headlamps, low beam  
Halogen lamp: 55 W (H1)  
Discharge lamp: 35 W (D2R)
- 5- Position lamps: 5 W (W5W)
- 6- Side turn-signal lamps

Codes in parentheses indicate bulb types.

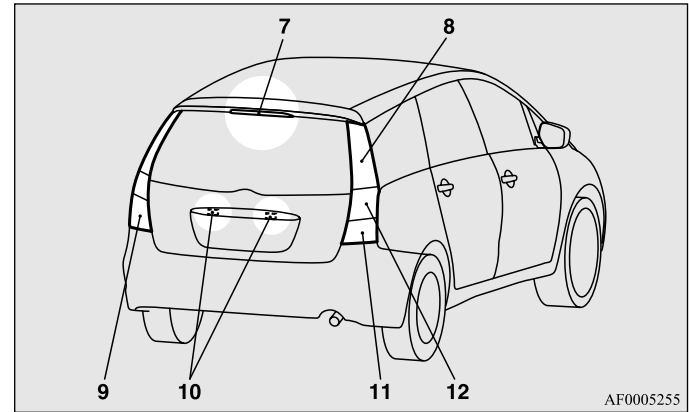

- 7- High-mounted stop lamp
- 8- Stop and tail lamps
- 9- Rear fog lamp (LHD vehicles): 21 W (W21W)  
Reversing lamp (RHD vehicles): 21 W (W21W)
- 10- Licence plate lamps: 5 W (W5W)
- 11- Reversing lamp (LHD vehicles): 21 W (W21W)  
Rear fog lamp (RHD vehicles): 21 W (W21W)
- 12- Rear turn-signal lamps: 21 W (WY21W)

Codes in parentheses indicate bulb types.

### NOTE

- The side turn-signal lamps, stop and tail lamps and high-mounted stop lamp use LEDs rather than bulbs. For repair and replacement, we recommend you to consult a specialist.



**Inside**

E01003400986

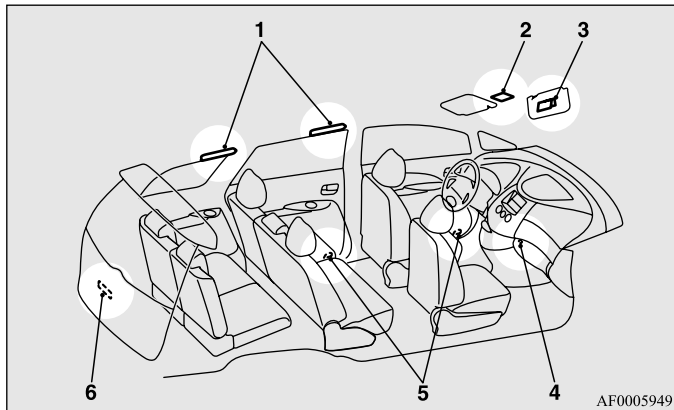

AF0005949

- 1- Rear personal lamps: 8 W
- 2- Room lamp & map lamps: 8 W
- 3- Vanity mirror lamps\*: 3 W
- 4- Glove box lamp: 1.4 W
- 5- Door lamps: 3.4 W
- 6- Luggage compartment lamp: 5 W

**Headlamps**

E01003500929

**Replacement of low beam (halogen lamp type)**

1. Pull out the connector (B) while pressing the tab (A). Turn the cap (C) anticlockwise and remove it.

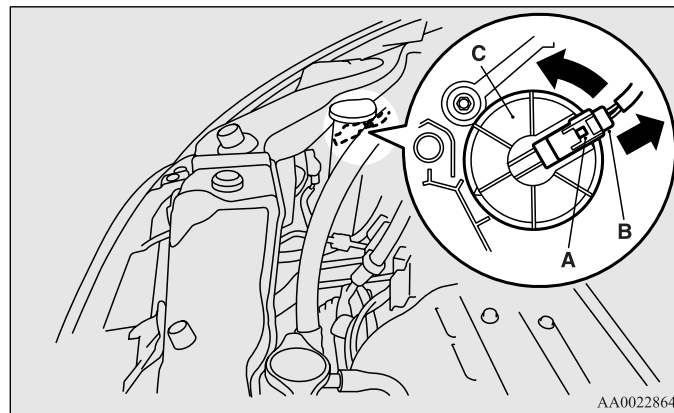

AA0022864

## Maintenance

2. Pull the socket (D) off the bulb.

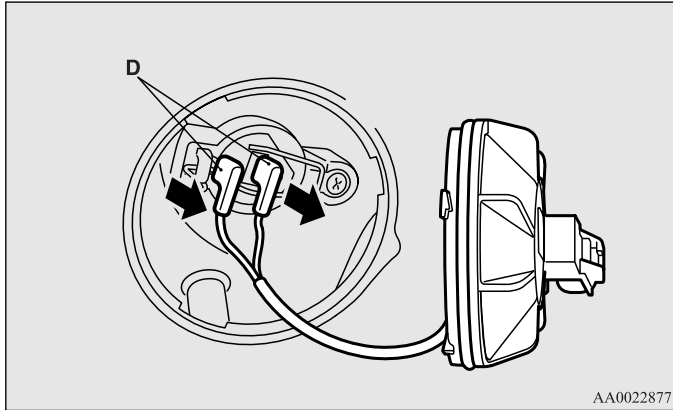

3. Unhook the spring (E), which secures the bulb, and remove the bulb.

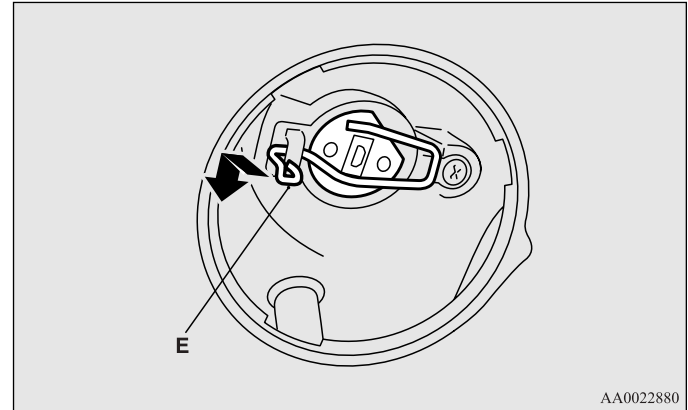

**⚠ CAUTION**

- Handle halogen lamp bulb with care. The gas inside halogen lamp bulb is highly pressurized, so dropping, knocking, or scratching a halogen lamp bulb can cause it to shatter.
- Never hold the halogen lamp bulb with a bare hand, dirty glove, etc.  
The oil from your hand could cause the bulb to break the next time the headlamps are operated. If the glass surface is dirty, it must be cleaned with alcohol, paint thinner, etc., and refit it after drying it thoroughly.

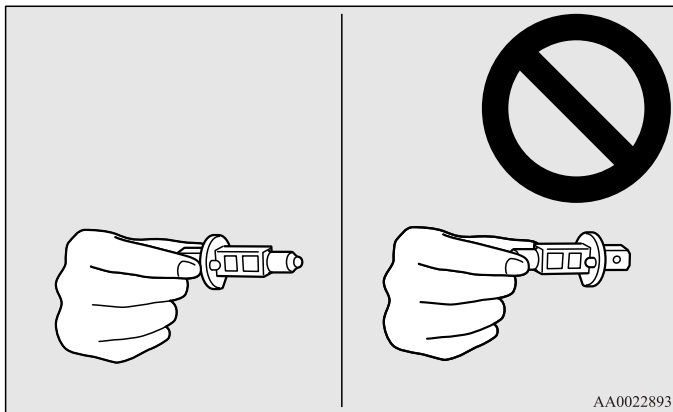
**Replacement of low beam (discharge lamp type)**

Do not attempt to disassemble or repair discharge headlamps, and do not attempt to replace their bulbs.

**⚠ CAUTION**

- A high voltage is present in the power circuit and in the bulbs and bulb terminals. To avoid the risk of an electric shock, contact by a MITSUBISHI MOTORS Authorized Service Point whenever repair or replacement is necessary.

## Maintenance

### *Replacement of high beam Petrol-powered vehicles*

1. Pull out the connector (B) while pressing the tab (A). Turn the cap (C) anticlockwise and remove it.

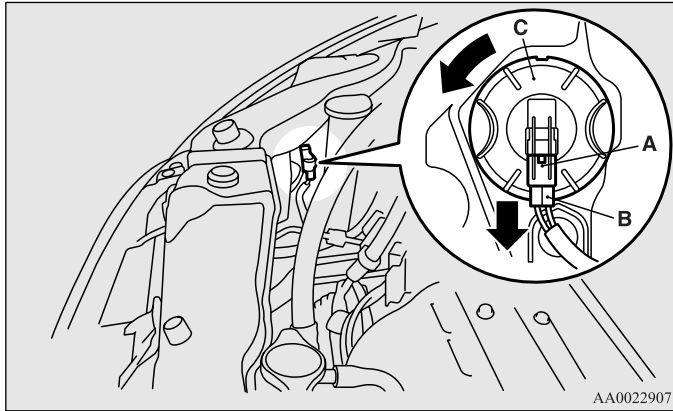

### *Diesel-powered vehicles*

1. Remove the bolt (A) to remove the power steering reservoir tank (B).

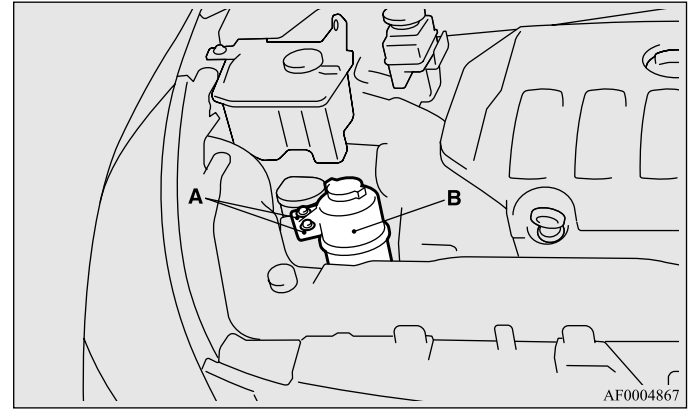

Pull out the connector (D) while pressing the tab (C). Turn the cap (E) anticlockwise and remove it.

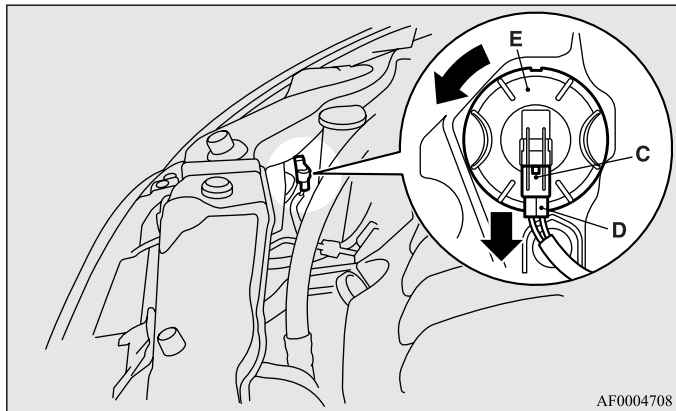

2. Turn the bulb socket (D) anticlockwise to remove it.

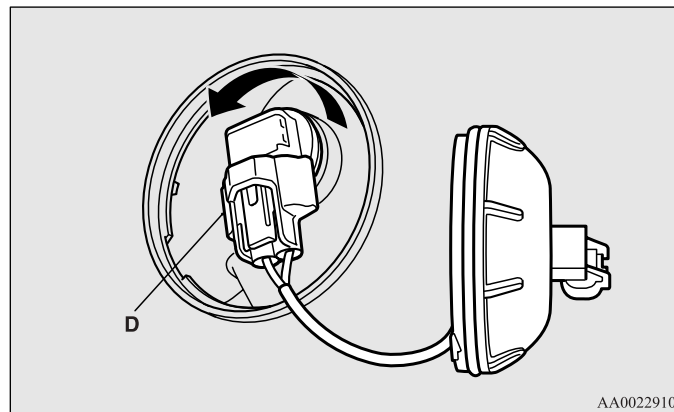

## Maintenance

3. Depress the tab (E) on the harness connector and pull the harness connector to remove the bulb.

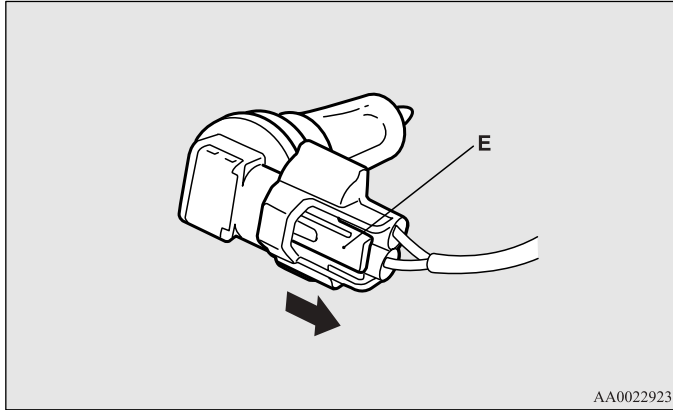

## **⚠ CAUTION**

- Handle halogen lamp bulb with care. The gas inside halogen lamp bulb is highly pressurized, so dropping, knocking, or scratching a halogen lamp bulb can cause it to shatter.
- Never hold the halogen lamp bulb with a bare hand, dirty glove, etc.  
The oil from your hand could cause the bulb to break the next time the headlamps are operated. If the glass surface is dirty, it must be cleaned with alcohol, paint thinner, etc., and refit it after drying it thoroughly.

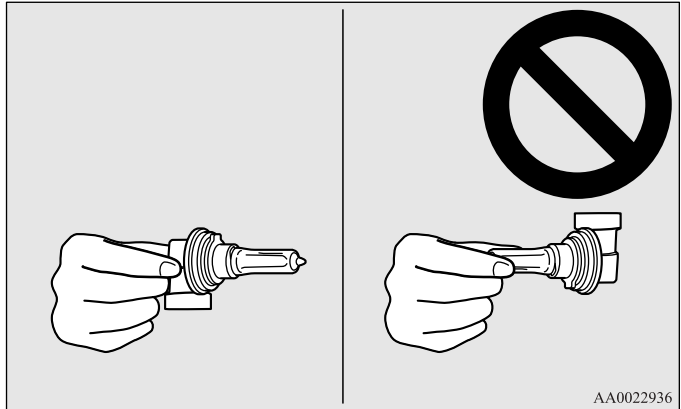

## Position lamps

E01003700279

Have the position lamps bulbs replaced by a MITSUBISHI MOTORS Authorized Service Point.

## Front turn-signal lamps

E01003800081

Turn the bulb socket anticlockwise to remove it. And remove the bulb from the socket by pulling it out.

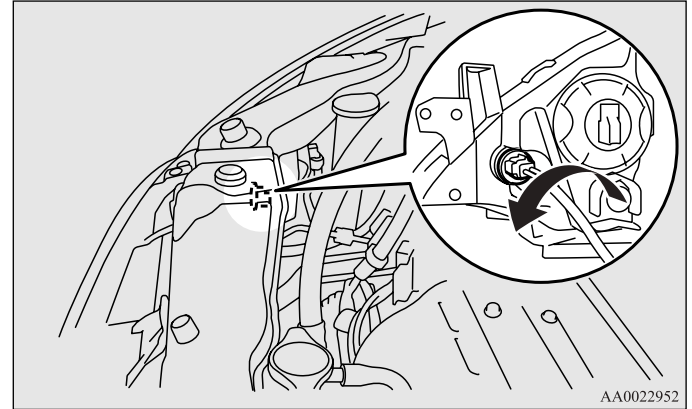

## Front fog lamps

1. Remove the 4 clips (A), then pull off the cover (B).

E0100400527

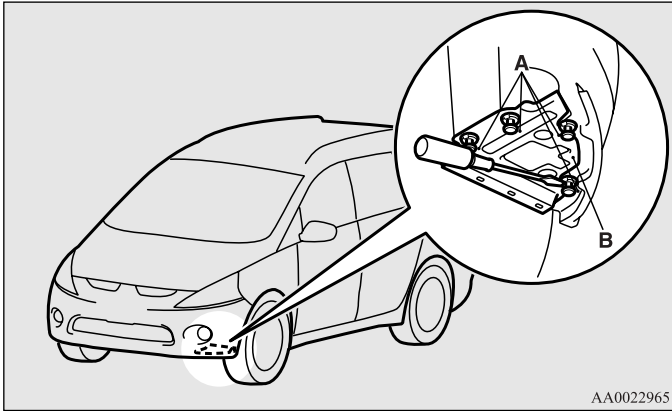

2. Depress the tab (C) on the harness connector and pull the harness connector (D) to remove it.

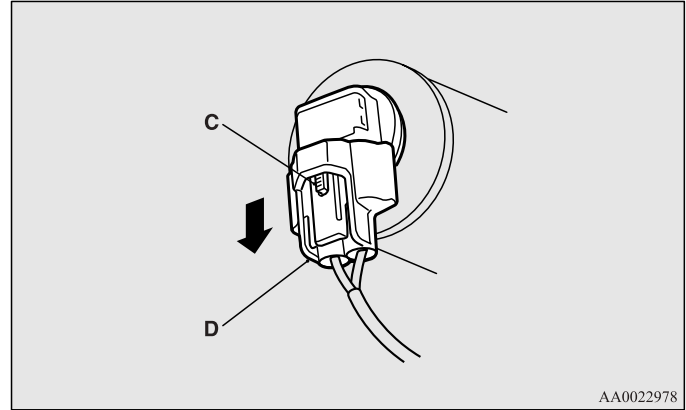



3. Remove the entire socket and bulb assembly (E) by turning it anticlockwise.

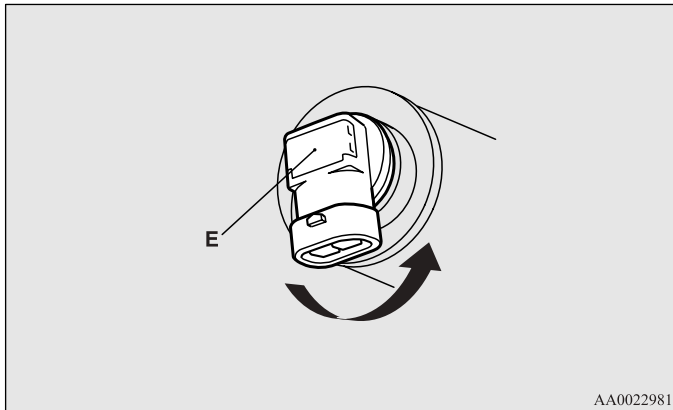

AA0022981

### **⚠ CAUTION**

- Handle halogen lamp bulb with care. The gas inside halogen lamp bulb is highly pressurized, so dropping, knocking, or scratching a halogen lamp bulb can cause it to shatter.
- Never hold the halogen lamp bulb with a bare hand, dirty glove, etc.  
The oil from your hand could cause the bulb to break the next time the fog lamps are operated. If the glass surface is dirty, it must be cleaned with alcohol, paint thinner, etc., and refit it after drying it thoroughly.

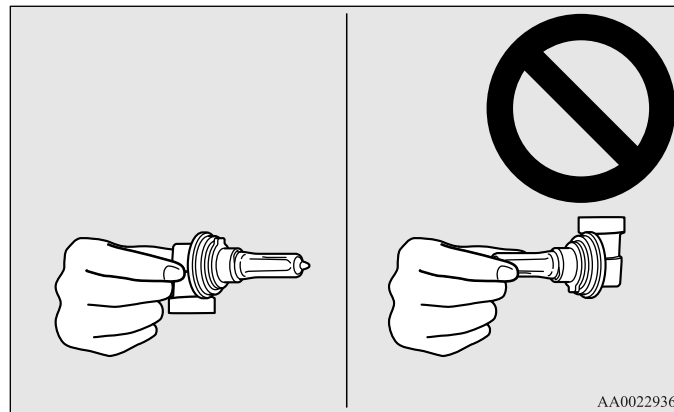

AA0022936

## Rear combination lamps

E01004200082

1. Insert a straight blade (or minus) screwdriver with a cloth over its tip into the notch at the bottom of the lid of the lamp whose bulb you wish to replace. Use it to lever off the lid.

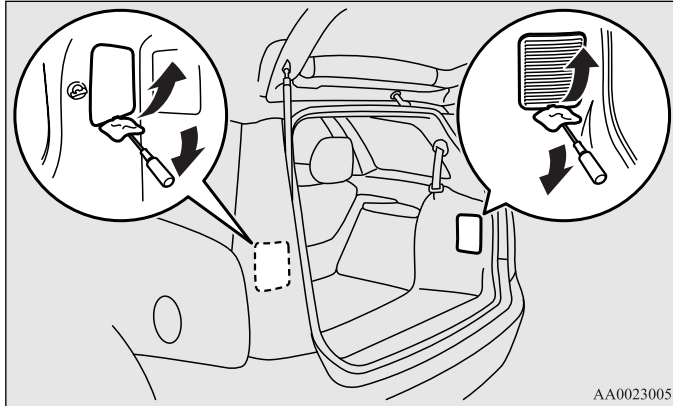

2. Turn the socket anticlockwise and remove it. Withdraw the bulb from the socket.

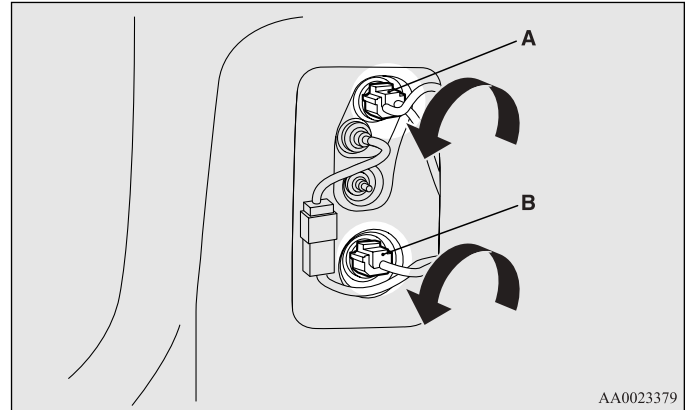

- A- Rear turn-signal lamp
- B- Rear fog lamp (driver's side)  
Reversing lamp (passenger's side)

## NOTE

- When installing the lid, make sure the 2 tabs (C) are aligned with the holes on the vehicle side.

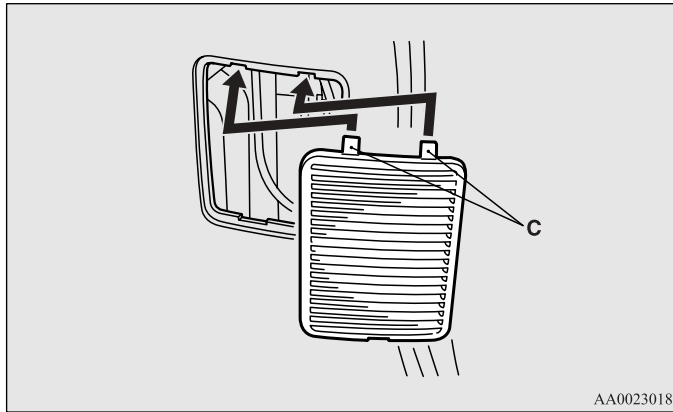

## Licence plate lamps

E0100460099

1. Insert a straight blade (or minus) screwdriver into the lamp assembly and pry gently to remove it.

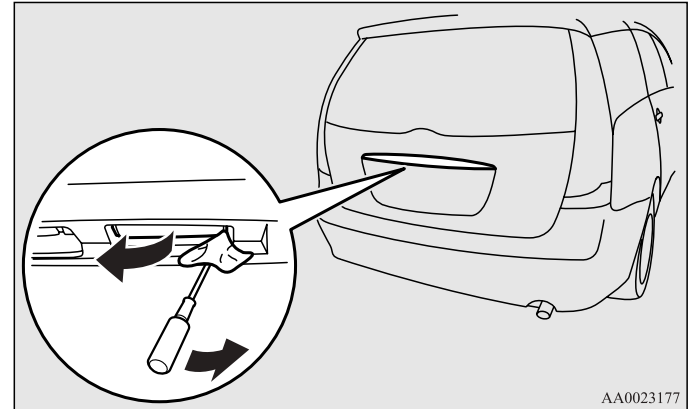

## NOTE

- Wrap a piece of cloth around the tip of the screwdriver in order to avoid scratching the lens and the body.

## Maintenance

2. Remove the socket by turning it anticlockwise, and then remove the bulb by pulling it out.

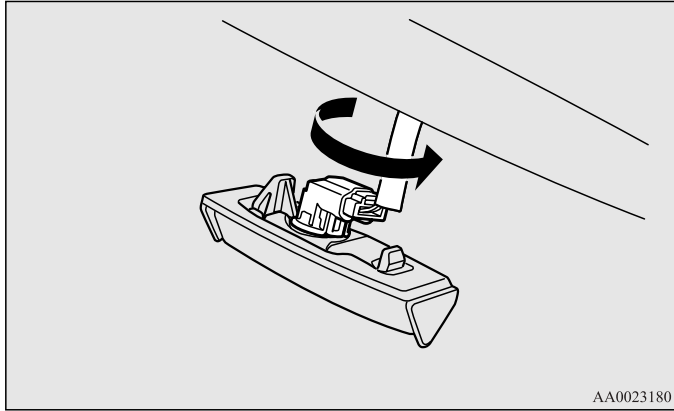

## NOTE

- When installing the lamp, insert tab (A) first, then align and insert tab (B).

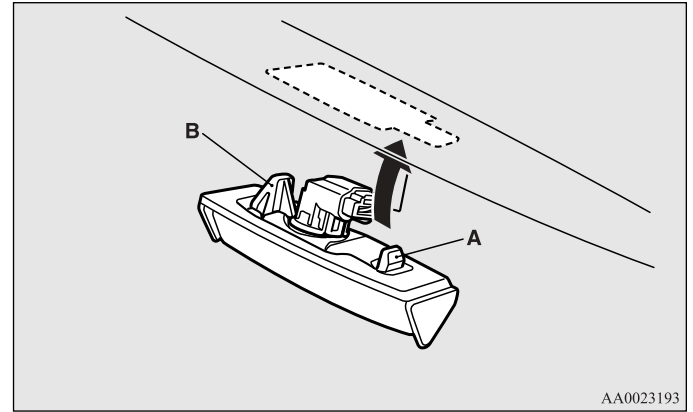

## Room lamp & map lamps

E01004700087

Insert a straight blade (or minus) screwdriver into the lens and pry gently to remove it.

Remove the bulb from the lamp holder.

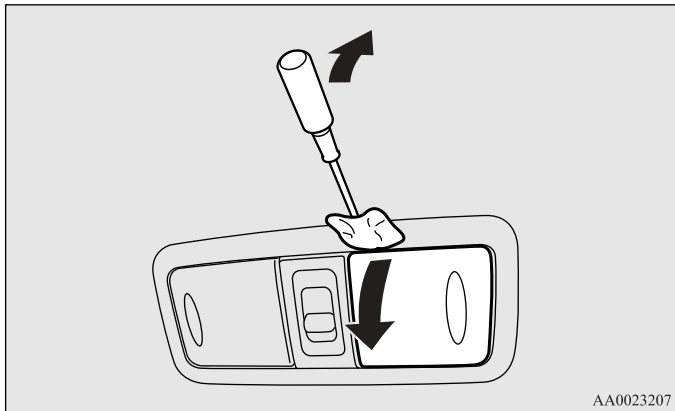

### NOTE

- Wrap a piece of cloth around the tip of the screwdriver in order to avoid scratching the lens.

### NOTE

- When installing the lens, align the tab on the lens with the hole on the vehicle side.

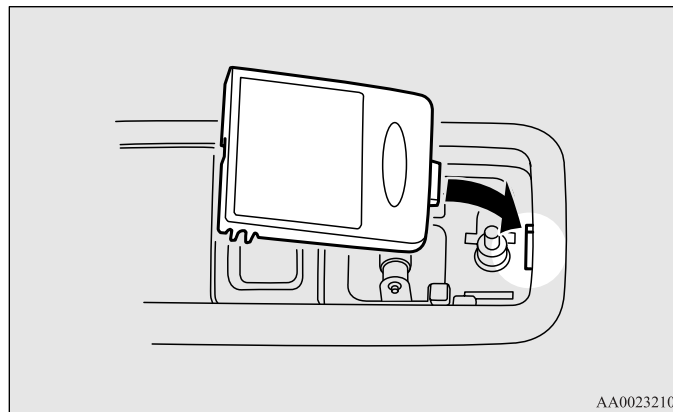

## Maintenance

### Rear personal lamps

E01005200034

Insert a straight blade (or minus) screwdriver into the notch of the lens and pry gently to remove it.

Remove the bulb from the lamp holder.

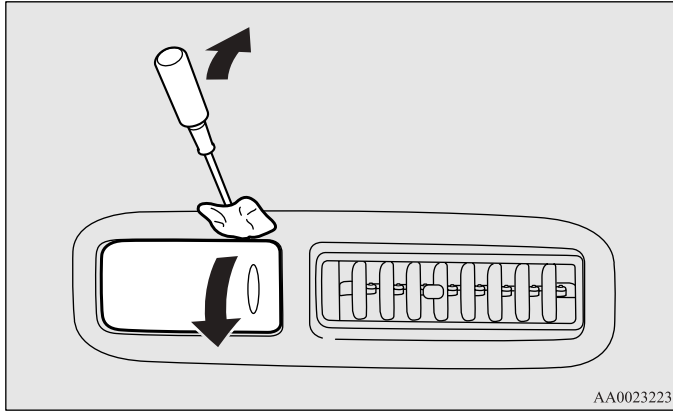

#### NOTE

- Wrap a piece of cloth around the tip of the screwdriver in order to avoid scratching the lens.
- When replacing a bulb, keep the interior lamp switch in the “○” (OFF) position.

#### NOTE

- When installing the lens, align the tab on the lens with the hole on the vehicle side.

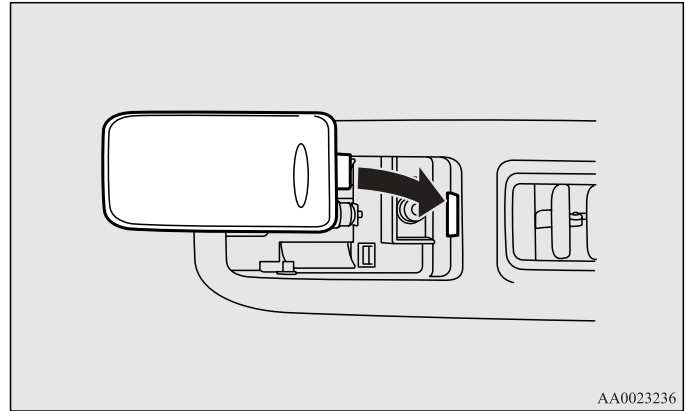

## Luggage compartment lamp

E01005300051

Insert a straight blade (or minus) screwdriver into the notch of the lens and pry gently to remove it.  
Remove the bulb from the lamp holder.

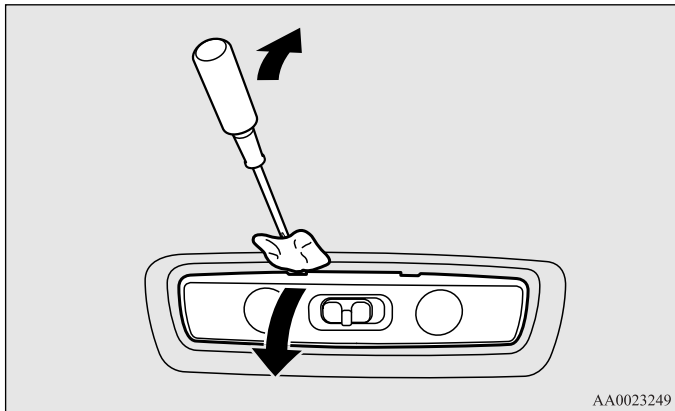

### NOTE

- Wrap a piece of cloth around the tip of the screwdriver in order to avoid scratching the lens.

## Door lamps

E01005400023

Insert a straight blade (or minus) screwdriver into the lens and pry gently to remove it.  
Remove the bulb from the lamp holder.

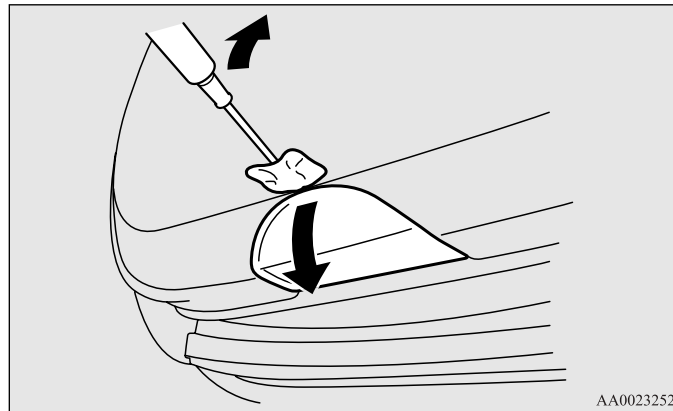

### NOTE

- Wrap a piece of cloth around the tip of the screwdriver in order to avoid scratching the lens.

## Maintenance

### NOTE

- When installing the lens, align the 2 tabs on the lens with the holes on the vehicle side.

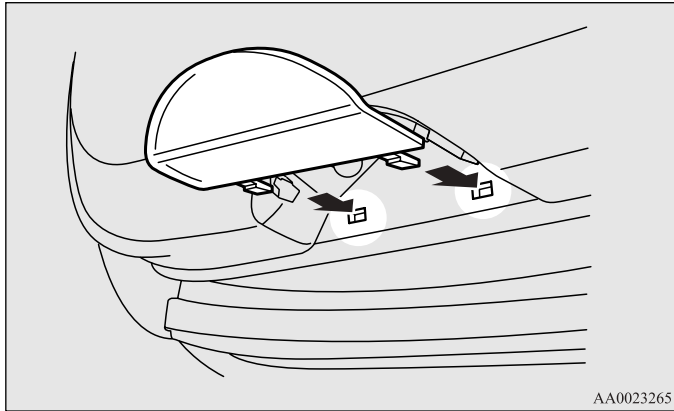

## Glove box lamp

E01006100027

Pull out the bulb.

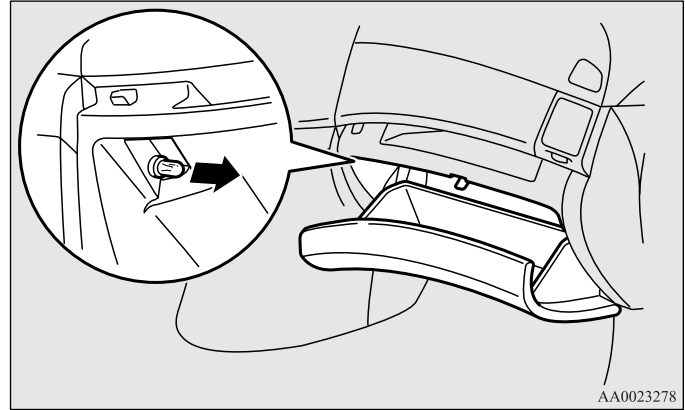



## Vanity mirror lamps\*

E01006200028

Insert a straight blade (or minus) screwdriver into the notch of the lens and pry gently to remove it.

Remove the bulb from the lamp holder.

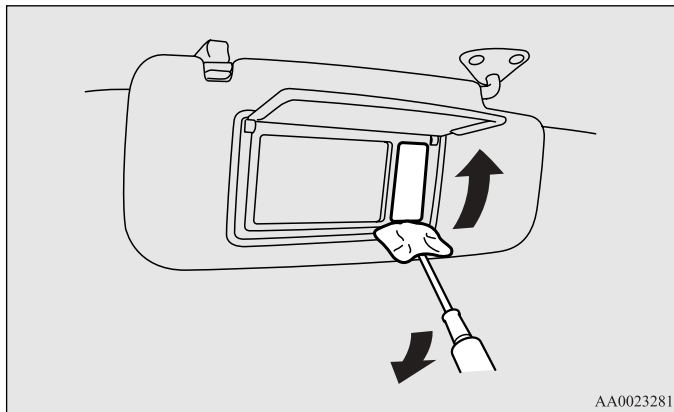

### NOTE

- Wrap a piece of cloth around the tip of the screwdriver in order to avoid scratching the lens.

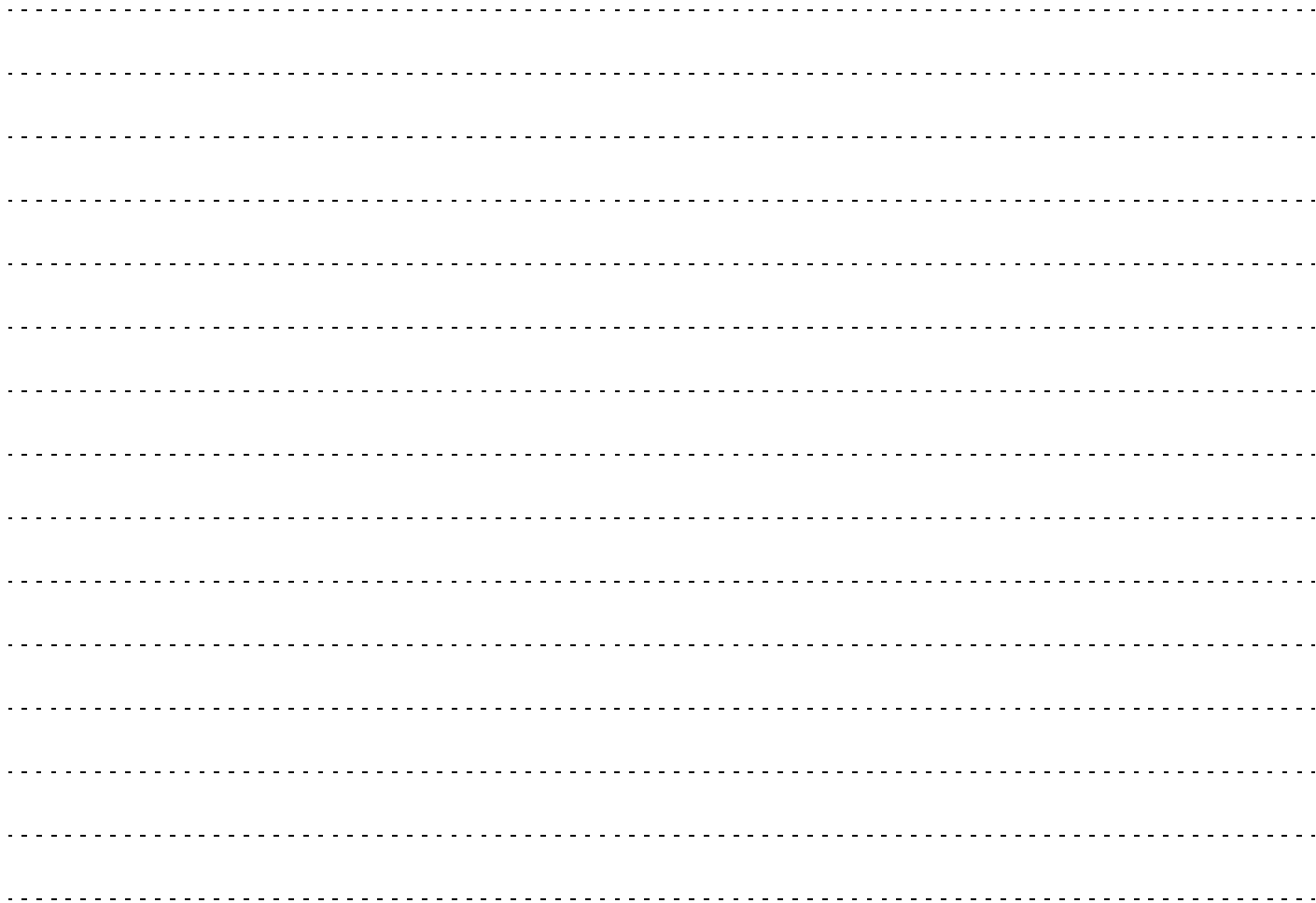

# *Specifications*

Vehicle labeling . . . . .	9- 2
Vehicle dimensions . . . . .	9- 5
Vehicle performance . . . . .	9- 7
Vehicle weight . . . . .	9- 8
Engine specifications . . . . .	9- 9
Transmission specifications . . . . .	9- 10
Electrical system . . . . .	9- 11
Tyres and wheels . . . . .	9- 12
Other specifications . . . . .	9- 13
Fuel consumption . . . . .	9- 14
Notes regarding diesel fuel . . . . .	9- 15
Capacities . . . . .	9- 16

## Vehicle labeling

E01100101573

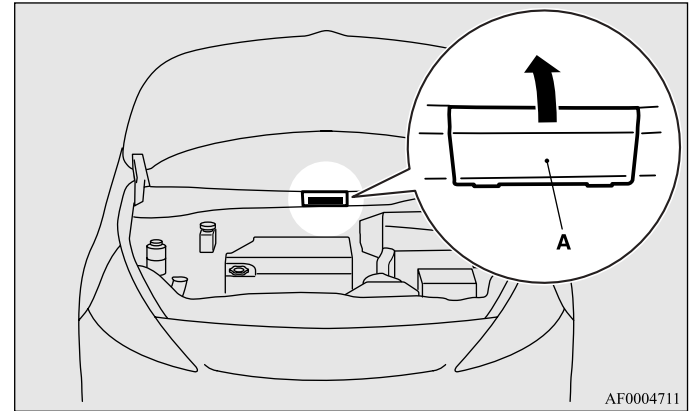
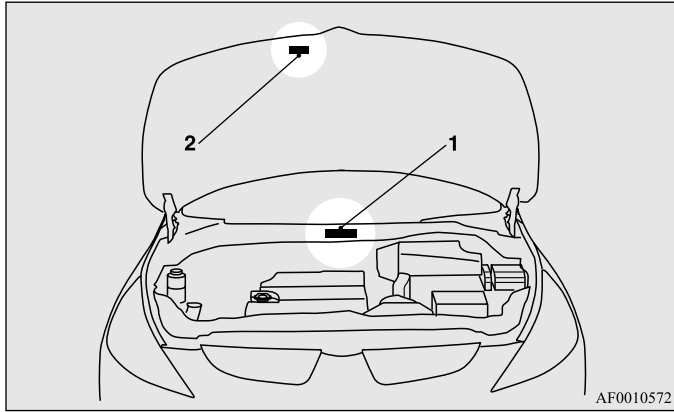

### 1- Vehicle identification number

The vehicle number is stamped inside the bulkhead as shown in the illustration.

Remove the cover (A) to check the vehicle number.

## 2- Vehicle information code plate

The plate shows model code, engine model, transmission model and body colour code, etc.

Please use this number when ordering replacement parts.

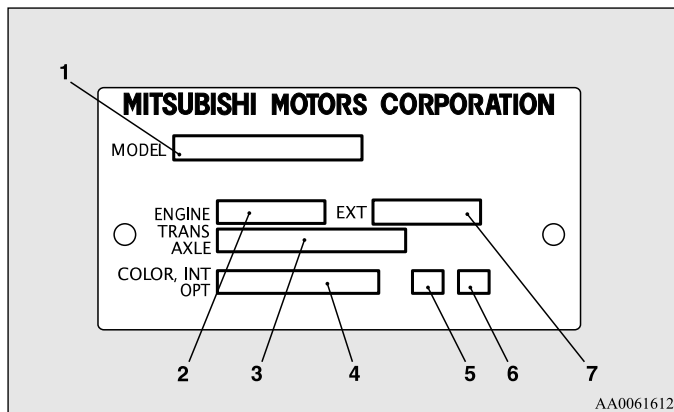

- 1- Model code
- 2- Engine model code
- 3- Transmission model code
- 4- Body colour code
- 5- Interior code
- 6- Option code
- 7- Exterior code

## Vehicle identification number plate (RHD vehicles only)

This is stamped on the number plate riveted to the left front corner of the instrument panel pad. It is visible from outside of the vehicle through the windscreen.

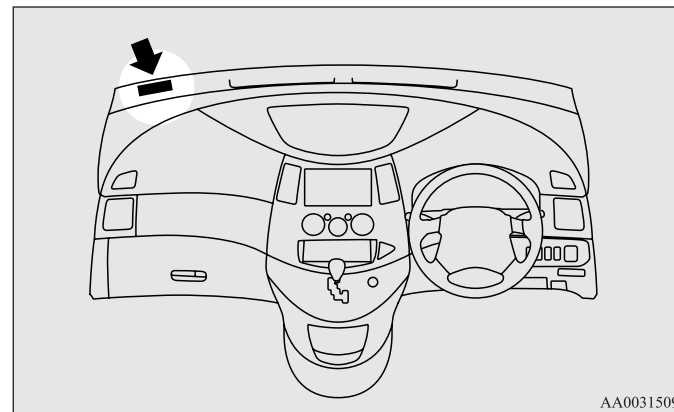

## Specifications

### Engine number

The engine number is stamped on the engine cylinder block as shown in the illustration.

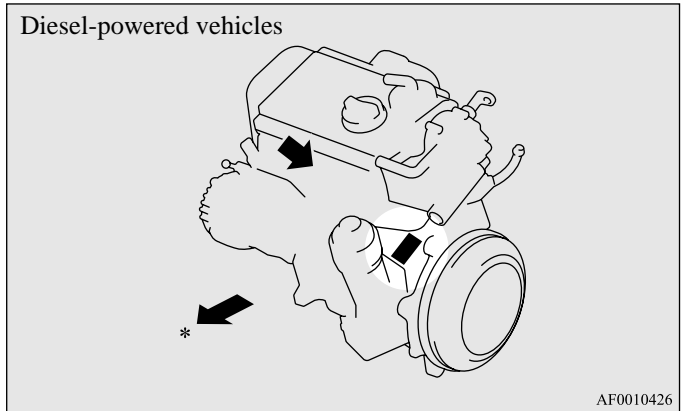
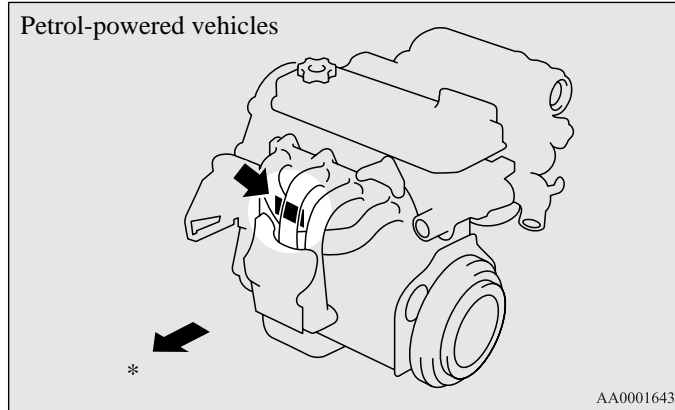

\*: Front of the vehicle

## Vehicle dimensions

E01100201301

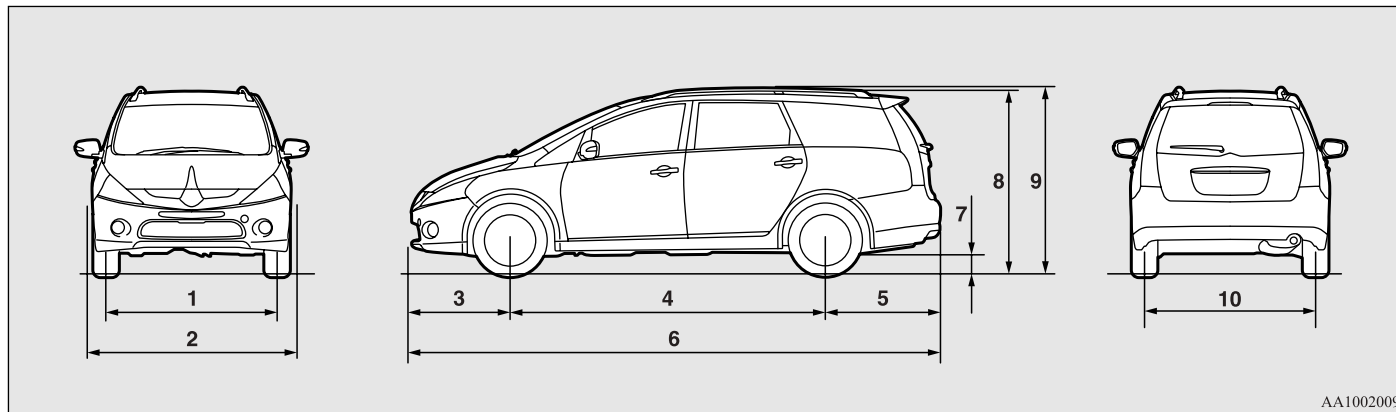

AA1002009

1	Front track	1,550 mm
2	Overall width	1,795 mm
3	Front overhang	900 mm
4	Wheel base	2,830 mm
5	Rear overhang	1,035 mm
6	Overall length	4,765 mm
7	Ground clearance (unladen)	155 mm, 165 mm* <sup>1</sup>

## Specifications

8	Overall height (unladen)	Without roof rails	1,655 mm, 1,665 mm* <sup>1</sup>
		With roof rails	1,690 mm, 1,700 mm* <sup>1</sup>
9		With sport type roof rails	1,670 mm, 1,680 mm* <sup>1</sup>
10	Rear track		1,555 mm

\*<sup>1</sup>: Vehicles with high ground suspensions



*Vehicle performance*

E01100301113

Item		Petrol-powered vehicles		Diesel-powered vehicles
		M/T	A/T	
Maximum speed		200 km/h (124 mph)	190 km/h (118 mph)	195 km/h (121 mph)
Minimum turning radius	Body	6.1 m		
	Wheel	5.8 m		

## *Vehicle weight*

E01100402225

Item		Petrol-powered vehicles				Diesel-powered vehicles (except for DPF models)		Diesel-powered vehicles (for DPF models)	
		M/T		A/T		6 persons	7 persons	6 persons	7 persons
		6 persons	7 persons	6 persons	7 persons				
Kerb weight (kg)	Without optional parts	1,625	1,645	1,635	1,655	1,690	1,710	1,700	1,720
	With full optional parts	1,695	1,715	1,705	1,725	1,760	1,780	1,770	1,790
Maximum gross vehicle weight (kg)		2,250, 2,335*		2,250, 2,335*		2,335, 2,420*		2,345, 2,430*	
Maximum axle weight (kg)	Front	1,100		1,100		1,160		1,170	
	Rear	1,190, 1,305*		1,190, 1,305*		1,215, 1,330*		1,215, 1,330*	
Maximum towable weight (kg)	With brake	1,600		1,800		2,000			
	Without brake	570							
Maximum trailer-nose weight (kg)		85							
Maximum roof load (kg)	Without roof rails	65							
	With roof rails	80							

\*: In case of trailer towing

**NOTE**

- Trailer specifications indicate the manufacturer's recommendation.

*Engine specifications*

E01100601334

Item	Petrol-powered vehicles	Diesel-powered vehicles (except for DPF models)	Diesel-powered vehicles (for DPF models)
Engine type	Four-cylinder, in line, water cooled, four-cycle, single overhead camshaft	Four-cylinder, in line, water cooled, four-cycle, double overhead camshaft with intercooler and turbocharger	
Engine model	4G69	BSY	BWC
Total displacement	2,378 cc	1,968 cc	
Bore	87.0 mm	81.0 mm	
Stroke	100.0 mm	95.5 mm	
Compression ratio	9.5	18.0	
Valve clearance	Intake	0.20 mm (hot)	Automatically
	Exhaust	0.30 mm (hot)	Automatically
Firing order	1-3-4-2	1-3-4-2	
Maximum output (EEC net)	121 kW/6,000 r/min	100 kW/4,000 r/min	103 kW/4,000 r/min
Maximum torque (EEC net)	217 Nm/4,000 r/min	310 Nm/1,750 r/min	

*Transmission specifications*

E01100701061

Item	Petrol-powered vehicles		Diesel-powered vehicles
	M/T	A/T	6 M/T
1st gear ratio	3.583	2.842	3.538
2nd gear ratio	1.947	1.529	2.045
3rd gear ratio	1.266	1.000	1.366
4th gear ratio	0.970	0.712	0.974
5th gear ratio	0.767	—	0.897
6th gear ratio	—	—	0.790
Reverse gear ratio	3.363	2.480	3.831
Final gear ratio	4.312	4.406	4.058 (1st to 4th), 3.450 (5th to 6th and reverse)

*Electrical system*

E01100801192

Item		Petrol-powered vehicles	Diesel-powered vehicles
Voltage		12 V	12 V
Battery	Type (JIS)	75D23L	95D31L
	Capacity (5HR)	52 Ah	64 Ah
Alternator capacity		110 A	140 A
Spark plug type	NGK	LZFR6AI	—

*Tyres and wheels*

E01100901337

Tyre		215/60R16 95H	215/55R17 94V*
Wheel	Size	16x6 1/2 JJ (Steel)	17x7 J (Aluminium)*
	Offset	46 mm	

\*: Optional equipment

*Other specifications*

E01101000628

Item		Petrol-powered vehicles	Diesel-powered vehicles
Fuel system	Fuel control	Electric controlled injection	Direct injection
	Fuel pump	Electric motor type	Electric motor type
Clutch		Dry single disc clutch with diaphragm spring, hydraulic action	
Steering system		Rack and pinion type, power assisted	
Suspension	Front	Independent type, MacPherson strut, coil spring	
	Rear	Independent type, semi-trailing arm, coil spring	
Service brakes	Type	Hydraulic, dual diagonal circuit with power assistance and anti-lock brake system with electronic brake force distribution function	
	Front	Ventilated disc brakes	
	Rear	Drum in disc brakes	
Parking brakes		Parking brake acts mechanically on rear wheels	

## *Fuel consumption*

E01101100355

Item			Combined		Urban conditions	Extra-urban conditions
			CO <sub>2</sub> (g/km)	Fuel consumption (L/100 km)	Fuel consumption (L/100 km)	Fuel consumption (L/100 km)
Standard	Petrol-powered vehicles	M/T	221.2	9.3	12.6	7.3
		A/T	234.3	9.9	13.2	8.0
	Diesel-powered vehicles (except for DPF models)		175.0	6.6	8.4	5.6
	Diesel-powered vehicles (for DPF models)		175.0	6.6	8.5	5.6
Full option	Petrol-powered vehicles	M/T	223.3	9.4	12.8	7.4
		A/T	236.6	10.0	13.3	8.1
	Diesel-powered vehicles (except for DPF models)		175.0	6.6	8.4	5.6
	Diesel-powered vehicles (for DPF models)		175.0	6.6	8.5	5.6

### NOTE

- The results given do not express or imply any guarantee of the fuel consumption of the particular vehicle. The vehicle itself has not been tested and there are inevitably differences between individual vehicles of the same model. In addition, this vehicle may incorporate particular modifications. Furthermore, the driver's style and road and traffic conditions, as well as the extent to which the vehicle has been driven and the standard of maintenance, will all affect its fuel consumption.



## *Notes regarding diesel fuel*

E01101400055

Due to the separation of paraffin, the fluidity of the fuel decreases considerably as the temperature falls. Because of this fact there are two kinds of fuel: “summer” and “winter”.

This must be considered in winter use.

When travelling abroad, find out in advance about the fuels served in local service stations.

# Capacities

E01101301686

## Petrol-powered vehicles

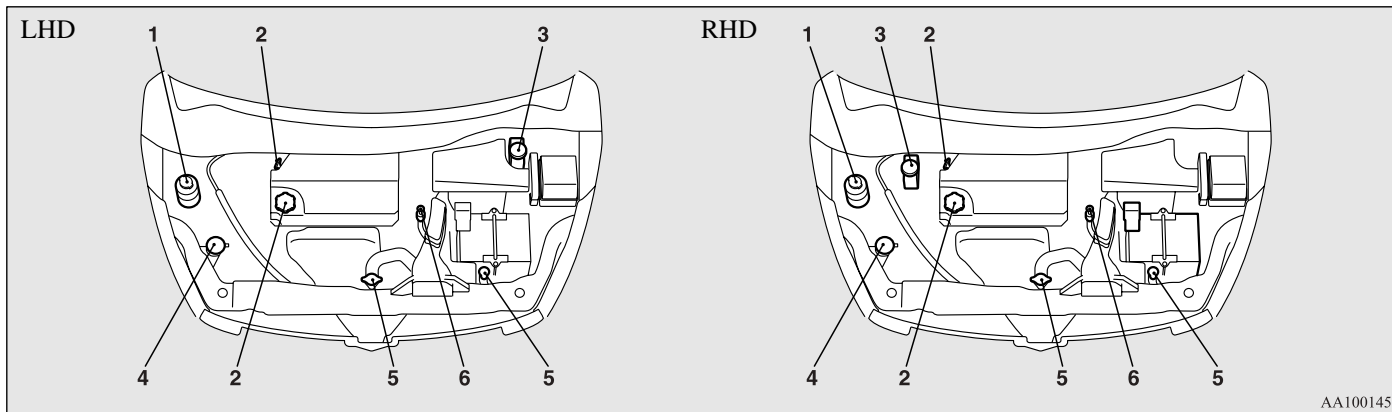

AA1001451

No.	Item		Quantity	Lubricants
1	Power steering fluid		1.0 litre	Genuine MITSUBISHI Power Steering Fluid or ATF DEXRON III / DEXRON II
2	Engine oil	Oil pan	4.0 litres	Refer to page 8-7
		Oil filter	0.3 litre	
3	Brake fluid		As required	Brake fluid DOT 3 or DOT 4
	Clutch fluid			
4	Washer fluid		4.5 litres	—

No.	Item	Quantity	Lubricants
5	Engine coolant [includes 0.6 litre in the reserve tank]	8.0 litres* <sup>1</sup> , 9.5 litres* <sup>2</sup>	DIA QUEEN SUPER LONG LIFE COOLANT or equivalent
6	Automatic transmission fluid	7.7 litres	DIA QUEEN ATF SP III
7	Manual transmission oil	2.2 litres	DiaQueen NEW MULTI GEAR OIL API classification GL-3, SAE 75W-80
8	Refrigerant (air conditioning)	440 - 480 g* <sup>3</sup> , 730 - 770 g* <sup>4</sup>	HFC-134a

\*1: Vehicles without rear heater and rear automatic air conditioning

\*2: Vehicles with rear heater or rear automatic air conditioning

\*3: Vehicles without rear cooler and rear automatic air conditioning

\*4: Vehicles with rear cooler or rear automatic air conditioning

#### NOTE

- Points requiring routine inspection or replenishment such as the engine oil, coolant, washer fluid and brake/clutch fluid are marked white for easy identification.

## Specifications

### Diesel-powered vehicles (except for DPF models)

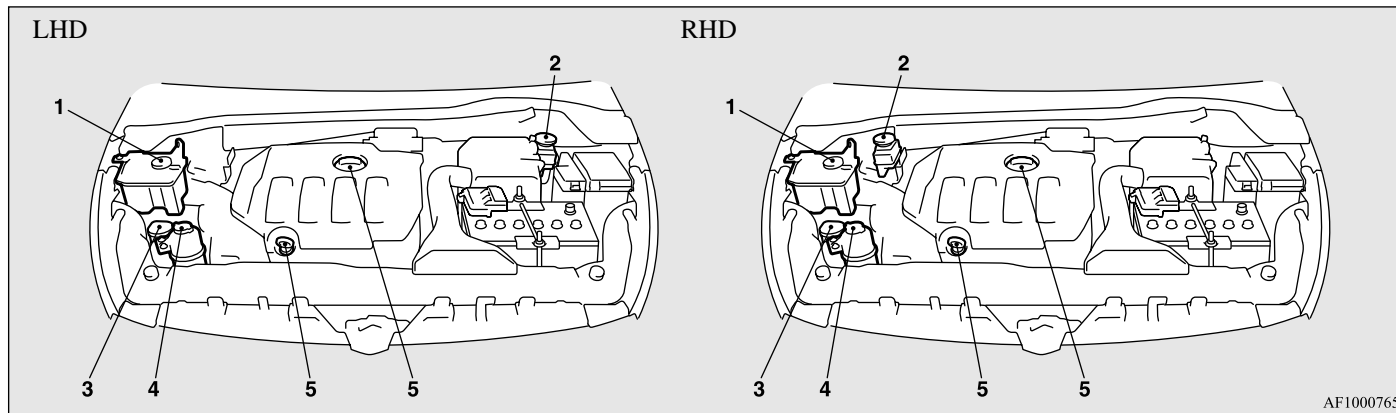

AF1000765

No.	Item	Quantity	Lubricants
1	Engine coolant [includes 0.7 litre in the reserve tank]	8.0 litres* <sup>1</sup> , 9.5 litres* <sup>2</sup>	BASF Glysantin Alu Protect Premium/G30
2	Brake fluid Clutch fluid	As required	Brake fluid DOT 3 or DOT 4
3	Washer fluid	4.5 litres	—
4	Power steering fluid	1.0 litre	Genuine MITSUBISHI Power Steering Fluid or ATF DEXRON III / DEXRON II
5	Engine oil		Refer to page 8-7
	Oil pan	3.7 litres	
	Oil filter	0.3 litre	

\*1: Vehicles without rear heater and rear automatic air conditioning

\*2: Vehicles with rear heater or rear automatic air conditioning

No.	Item	Quantity	Lubricants
6	Manual transmission oil	2.0 litres	DiaQueen NEW MULTI GEAR OIL API classification GL-3, SAE 75W-80
7	Refrigerant (air conditioning)	440 - 480 g* <sup>3</sup> , 730 - 770 g* <sup>4</sup>	HFC-134a

\*<sup>3</sup>: Vehicles without rear cooler and rear automatic air conditioning

\*<sup>4</sup>: Vehicles with rear cooler or rear automatic air conditioning

## Specifications

### Diesel-powered vehicles (for DPF models)

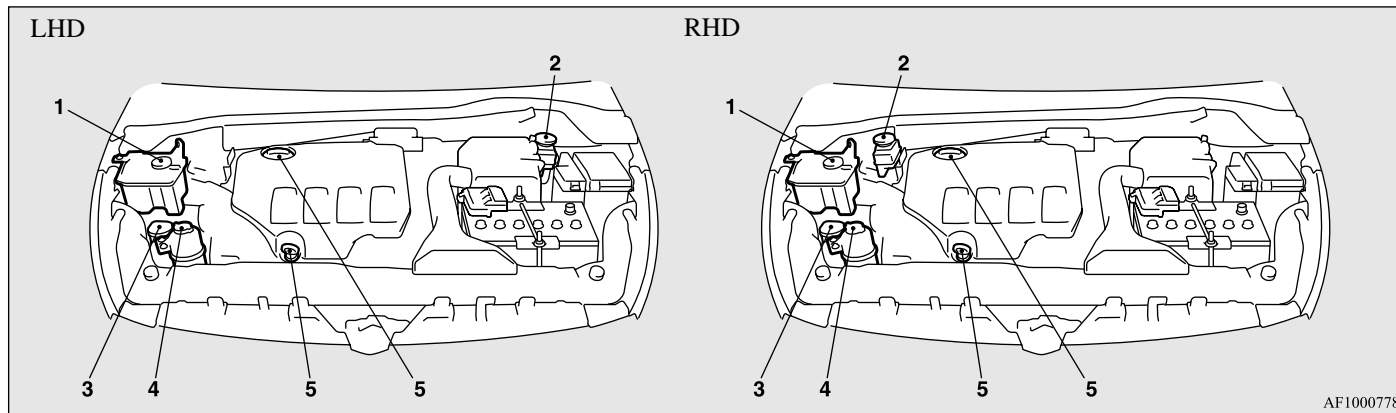

AF1000778

No.	Item	Quantity	Lubricants
1	Engine coolant [includes 0.7 litre in the reserve tank]	8.0 litres* <sup>1</sup> , 9.5 litres* <sup>2</sup>	BASF Glystantin Alu Protect Premium/G30
2	Brake fluid Clutch fluid	As required	Brake fluid DOT 3 or DOT 4
3	Washer fluid	4.5 litres	—
4	Power steering fluid	1.0 litre	Genuine MITSUBISHI Power Steering Fluid or ATF DEXRON III / DEXRON II
5	Engine oil	Oil pan 3.7 litres	Refer to page 8-7
		Oil filter 0.3 litre	

\*1: Vehicles without rear heater and rear automatic air conditioning

\*2: Vehicles with rear heater or rear automatic air conditioning

No.	Item	Quantity	Lubricants
6	Manual transmission oil	2.0 litres	DiaQueen NEW MULTI GEAR OIL API classification GL-3, SAE 75W-80
7	Refrigerant (air conditioning)	440 - 480 g* <sup>3</sup> , 730 - 770 g* <sup>4</sup>	HFC-134a

\*<sup>3</sup>: Vehicles without rear cooler and rear automatic air conditioning

\*<sup>4</sup>: Vehicles with rear cooler or rear automatic air conditioning





---

**A**

---

Accessory socket 5-57  
 Accessory (Installation) 5  
 Active skid control (ASC) system 4-41  
 Active stability control system (ASC)  
   Indication lamp 4-43  
 Additional equipment 8-32  
 Air bag 2-53  
 Air conditioning  
   Front automatic air conditioning 5-7  
   Important operation tips for the air conditioning 5-19  
   Rear automatic air conditioning 5-16  
 Air purifier (with deodorizing function) 5-20  
 Antenna  
   Glass antenna 5-52  
 Anti-lock brake system (ABS) 4-36  
   Warning lamp 4-38  
 Armrest 2-7, 2-11  
 Ashtray 5-54  
 Audio  
   Error codes 5-47  
   Handling of compact discs 5-49  
   LW/MW/FM electronic tuning radio with CD player 5-21  
 Automatic headlamp levelling 3-36  
 Automatic headlamp levelling warning lamp 3-36  
 Automatic transmission  
   Fluid 8-13, 9-16  
   Selector lever operation 4-26

Sports mode 4-30  
 Auto-speed (cruise) control 4-45  
   Indication lamp 4-46

---

**B**

---

Battery 8-16  
   Charge warning lamp 3-13  
   Discharged battery (Emergency starting) 6-2  
   Specification 9-11  
 Bonnet 8-4  
 Bottle holder 5-69  
 Brake  
   Anti-lock brake 4-36  
   Braking 4-35  
   Fluid 8-14, 9-16  
   Parking brake 4-6  
   Parking brake stroke 8-28  
   Pedal free play 8-28  
   Power brakes 4-35  
   Warning lamp 3-10  
 Bulb capacity 8-44

---

**C**

---

Capacities 9-16  
 Card holder 5-53, 5-72  
 Cargo loads 4-57  
 Cargo net 5-78  
 Catalytic converter 8-3  
 Central door locks 1-9

## Alphabetical index

Charge warning lamp 3-13  
Chassis number 9-2  
Check engine warning lamp 3-11, 3-12  
Child restraint 2-40  
Child-protection rear doors 1-10  
Cigarette lighter 5-55  
Cleaning  
    Exterior of your vehicle 7-4  
    Interior of your vehicle 7-3  
    Plastic, vinyl leather, etc 7-3  
Clutch  
    Fluid 8-14, 9-16  
    Pedal free play 8-27  
Coat hooks 5-77  
Combination headlamps and dipper switch 3-32  
Compact spare wheel 6-16  
Coolant (engine) 8-10, 9-16  
Corner sensor system 4-51  
Cup holder 5-68

---

## D

---

Daytime dipper button 3-7  
Demister (rear window) 3-45  
Diesel particulate filter (DPF) 4-21  
Diesel preheat indication lamp 3-9  
Dimensions 9-5  
Dipper (High/Low beam change) 3-34  
Door lamps 5-62  
    Bulb capacity 8-45

    Replacement 8-59  
Doors  
    Central door locks 1-9  
    Child-protection 1-10  
    Lock and unlock 1-7  
Driving, alcohol and drugs 4-3

---

## E

---

Economical driving 4-2  
Electric window control 1-16  
Electrical system 9-11  
Electronic immobilizer (Anti-theft starting system) 1-3  
Emergency starting 6-2  
Engine  
    Coolant 8-10, 9-16  
    MIVEC 4-20  
    Number 9-4  
    Oil 8-7  
    Oil and oil filter 9-16  
    Overheating 6-7  
    Specifications 9-9  
    Used engine oils safety instructions and disposal information 7  
    Water temperature gauge 3-6  
Engine specifications 9-9  
Error codes 5-47  
Exterior and interior lamp operation 8-31

---

## F

---

### Fluid

- Automatic transmission fluid 8-13, 9-16
- Brake fluid 8-14, 9-16
- Clutch fluid 8-14, 9-16
- Engine coolant 8-10, 9-16
- Power steering fluid 8-15, 9-16
- Washer fluid 8-14, 9-16
- Fluid capacities and lubricants 9-16
- For cold and snow weather 8-32
- Front automatic air conditioning 5-7
- Front fog lamps
  - Bulb capacity 8-44
  - Indication lamp 3-9
  - Replacement 8-52
  - Switch 3-39
- Front seat 2-6
- Front turn-signal lamps
  - Bulb capacity 8-44
  - Replacement 8-51
- Fuel
  - Filling the fuel tank 3
  - Fuel gauge 3-5
  - Fuel selection 2
  - Low fuel warning lamp 3-6
  - Modification/alterations to the electrical or fuel systems 6
  - Tank capacity 3
- Fuel consumption 9-14

- Fuse links 8-33
- Fuse load capacity 8-35
- Fuse replacement 8-40
- Fuses 8-33

---

## G

---

- Gauges 3-2, 3-8
- General maintenance 8-31
- General vehicle data 9-5
- Genuine leather 7-3
- Genuine parts 7
- Glove box 5-64
- Glove box lamp
  - Bulb capacity 8-45
  - Replacement 8-60

---

## H

---

- Handling of compact discs 5-49
- Hazard warning flasher switch 3-38
- Head restraints 2-19
- Headlamp levelling 3-35
- Headlamp levelling dial switch 3-35
- Headlamps
  - Bulb capacity 8-44
  - Headlamp flasher 3-34
  - Replacement 8-45
  - Switch 3-32
- Heated mirrors 4-14
- Heated seats 2-8

## Alphabetical index

High-beam indication lamp 3-9  
Hinges and latches lubrication 8-32  
Horn switch 3-46

---

### I

---

If the vehicle breaks down 6-2  
Ignition switch 4-14  
Indicator and warning lamps 3-8  
Indicator lamps 3-9  
Inside rear-view mirror 4-9  
Inside tailgate release 1-15  
Installation of accessories 5  
Instrument panel upper box 5-65  
Instruments 3-2  
Interior lamp switch 5-59  
Interior lamps 5-58

---

### J

---

Jack 6-11  
    Storage 6-10  
Jacking up the vehicle 6-13  
Jump starting (Emergency starting) 6-2

---

### K

---

Keyless entry system 1-5  
Keys 1-2

---

### L

---

Labeling 9-2

Lamp monitor buzzer 3-33  
Lamps (headlamps, fog lamp, etc.) auto-cutout function 3-33  
Leakage (Fuel, engine coolant, oil and exhaust gas) 8-31  
Licence plate lamps  
    Bulb capacity 8-44  
    Replacement 8-55  
Low fuel warning lamp 3-6  
Lubricants 9-16  
Luggage compartment lamp 5-62  
    Bulb capacity 8-45  
    Replacement 8-59  
Luggage floor box 5-67  
Luggage hooks 5-77  
LW/MW/FM electronic tuning radio with CD player 5-21

---

### M

---

Making a flat seat 2-25  
Manual transmission 4-23  
    Oil 9-16  
Mirror  
    Inside rear-view mirror 4-9  
    Outside rear-view mirrors 4-10  
MIVEC engine 4-20  
Modification/alterations to the electrical or fuel systems 6  
Multi centre display 3-15

---

### N

---

Notes regarding diesel fuel 9-15

---

**O**

---

Odometer 3-4  
 Oil  
     Engine oil 8-7  
     Manual transmission oil 9-16  
 Oil pressure warning lamp 3-14  
 Operation under adverse driving conditions 6-35  
 Other specifications 9-13  
 Outside rear-view mirrors 4-10  
 Overheating 6-7

---

**P**

---

Parking 4-7  
     Parking brake 4-6  
     Parking brake stroke 8-28  
 Personal box 5-66  
 Personal table 5-72  
 Position lamps  
     Bulb capacity 8-44  
     Indication lamp 3-9  
     Replacement 8-51  
 Power brakes 4-35  
 Power steering  
     Fluid 8-15, 9-16  
     System 4-40  
 Precautions to observe when using wipers and washers 3-44  
 Pregnant women restraint 2-38  
 Puncture (Tyre changing) 6-20

---

**R**

---

Radio  
     LW/MW/FM electronic tuning radio with CD player 5-21  
 Rear automatic air conditioning 5-16  
 Rear combination lamps  
     Bulb capacity 8-44  
     Replacement 8-54  
 Rear cooler 5-15  
 Rear fog lamp  
     Bulb capacity 8-44  
     Indication lamp 3-9  
     Replacement 8-54  
     Switch 3-40  
 Rear heater 5-15  
 Rear personal lamps 5-61  
     Bulb capacity 8-45  
     Replacement 8-58  
 Rear side box 5-67  
 Rear turn-signal lamps  
     Bulb capacity 8-44  
     Replacement 8-54  
 Rear window demister switch 3-45  
 Rear-view mirror  
     Inside 4-9  
     Outside 4-10  
 Replacement of lamp bulbs 8-43  
 Reversing lamps  
     Bulb capacity 8-44

## Alphabetical index

Replacement 8-54  
Roof carrier precaution 4-59  
Room lamp & map lamps 5-61  
    Bulb capacity 8-45  
    Replacement 8-57  
Running-in recommendations 4-5

---

### S

---

Safe driving techniques 4-3  
Seat  
    Adjustment 2-5  
    Armrest 2-7, 2-11  
    Front seat 2-6  
    Head restraints 2-19  
    Heated seats 2-8  
    Making a flat seat 2-25  
    Second seat 2-9  
    Third seat 2-17  
Seat arrangement 2-3  
Seat belt 2-33  
    Adjustable seat belt anchor (front seats) 2-36  
    Child restraint 2-40  
    Force limiter system 2-40  
    Inspection 2-52  
    Pregnant women restraint 2-38  
    Pre-tensioner system 2-39  
    Rear seat belt storage 2-37  
    Seat belt reminder/warning lamp 2-35  
Second seat 2-9

Service precaution 8-2  
Skid control function 4-41  
Snow tyres 8-25  
Spare wheel 6-16  
Spark plug 9-11  
Specifications 9-2  
Speedometer 3-2  
Starting 4-18  
Steering  
    Power steering fluid 8-15, 9-16  
    Power steering system 4-40  
    Steering wheel height adjustment 4-8  
    Steering wheel lock 4-17  
Storage spaces 5-63  
Sun visors 5-52  
Sunglasses pocket 5-66  
Sunroof 1-20  
Supplemental restraint system 2-53  
    How the supplemental restraint system works 2-57  
    Servicing 2-77  
    Warning lamp 2-76

---

### T

---

Tachometer 3-3  
Tailgate 1-11  
Tank capacity 3  
Third seat 2-17  
Tonneau cover 5-73  
Tools 6-11

Storage 6-10  
 Towing 6-28  
 Traction control function 4-41  
     TCL switch 4-42  
 Traction control system (TCL)  
     Indication lamp 4-43  
 Trailer towing 4-60  
 Transmission  
     Automatic transmission 4-26  
     Fluid 8-13, 9-16  
     Manual transmission 4-23  
     Oil 9-16  
     Specifications 9-10  
 Tripmeter 3-4  
 Turn-signal indication lamps 3-9  
 Turn/Lane-change signals 3-37  
 Tyres 8-21  
     How to change a tyre 6-20  
     Inflation pressures 8-21  
     Rotation 8-24  
     Size (tyre and wheel) 9-12  
     Snow tyres 8-25  
     Tyre chains 8-26  
     Wheel condition 8-23

---

**U**

---

Used engine oils safety instructions and disposal information 7

---

**V**

---

Vanity mirror 5-53  
 Vanity mirror lamps  
     Bulb capacity 8-45  
     Replacement 8-61  
 Vehicle care precautions 7-2  
 Vehicle dimensions 9-5  
 Vehicle identification number plate 9-3  
 Vehicle information code plate 9-3  
 Vehicle labeling 9-2  
 Vehicle performance 9-7  
 Vehicle weight 9-8  
 Ventilators 5-2

---

**W**

---

Warning lamps 3-10  
 Warning triangle retaining bands 5-78  
 Washer  
     Fluid 8-14, 9-16  
     Switch 3-41, 3-43  
 Washing 7-4  
 Water temperature gauge 3-6  
 Waxing 7-6  
 Weatherstripping 8-32  
 Weight 9-8  
 Wheel  
     Covers 6-26  
     Specification 9-12

## Alphabetical index

### Wiper

Rear window 3-43

Windscreen 3-41

Wiper blades 8-29



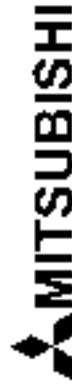

MITSUBISHI ELECTRIC CORPORATION  
4-10-1, TEMPA  
1-6-20-00000001 TEL: 00520 4789111111  
TEL: 00520 47891111 FAX: 00520 47891111

### DECLARATION of COMPLIANCE

We, MITSUBISHI ELECTRIC CORPORATION, BIRMINGHAM, hereby declare  
that we are responsible for the following product conforms to the Essential  
Requirements of the EMC and LVD (CE) 73/23/EEC and European Directive  
89/339/EEC in a manner which is in accordance with the appropriate requirements of the  
relevant standards in the UK market.

Body : Inverter System

Model / Case Number : IMR01501

Dimensions (mm) (L x W x H) : 1000 x 1000 x 1200 (mm)  
P.S. No. (S) (J) : 2001-000

EMC : EN 55014-000, EN 55014-001

EN 50148-3, EN 50148-02

Safety : EN 60900, 1998

Year of affixing CE marking : 2003

Lot : 02 / 20,000

Signature :

Name : Katsuo Katsuna

Title and position : Manager, Quality Control Engineering Dept. 1  
Technical Control Engineering Dept. 1.

---

**CE08910**

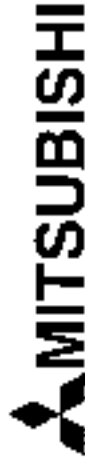

MITSUBISHI ELECTRIC CORPORATION  
MINELI WORKS  
106-2172-004-4662-01 MINELI WORKS, 670-0677-3074  
TEL: 81 792 98 8966 FAX: 81 792 563482

## DECLARATION of CONFORMITY

We, **MITSUBISHI ELECTRIC CORPORATION, MINELI WORKS** of the above address, hereby declare, at our sole responsibility, that the following product conforms to the Essential Requirements of the Radio and Telegraphic Equipment Terminal Equipment Directive 89/336/EEC in accordance with the tests conducted to the appropriate requirements of the relevant standards, as listed herewith.

Product : Immobiliser System

Model/Type Number : IM3323 02

Directive and Standards used : Radio : EN 300 330-1 V1.3.1 (12-2002)  
- EN 300 330-2 V1.1.1 (06-2001)  
EMC : EN 301 489-1 V1.4.1 (06-2002)  
: EN 301 489-2 V1.4.1 (08-2002)  
Safety : EN 60966 1998

Year of affixing CE marking : 2005

**CE0891**

Signature : *K. Kobayashi*

Name : Kazuhira Kobayashi

Position : Manager, Chassis Control Engineering Group A  
Electronic Control Engineering Dept

Date : May 31, 2005

**OMRON**

OMRON Corporation  
604 ORENDOCKA - ORISA  
KOMAGI-CITY  
AKSHI  
497-0001 JAPAN  
TEL: 011-658-764170  
FAX: 011-658-764178

## DECLARATION of CONFORMITY

We, **OMRON Corporation** of the above address, hereby declare, at our sole responsibility, that the following product conforms to the Essential Requirements of the Radio and Telecommunications Terminal Equipment Directive (90/25/EEC) in accordance with the tests conducted to the appropriate requirements of the relevant standards, as listed herewith.

**Product :** Keyless Entry System for Vehicle

**Model/Type Number :** GRD-407M-A \*, GRD-528M-A \*, and GRD-571M-A for Transmitter,  
GRD-410M-B \*, GRC-500M \*, GRD-581M-B \* and GRC-507M for Receiver.

**Directive and Standards used :** Radio : EN300 220-1 V1.3.1 (2006-06) EN300 220-3 V1.1.1 (2006-06)  
EMC : EN301 489-1 V1.4.1 (2006-06) EN301 489-3 V1.4.1 (2006-06)  
Safety : EN 60955: 1998

**Year of affixing CE marking :** 2003

**Model/Type Number :** GRD-518M-A for Transmitter  
GRC-223M-3C for Receiver

**Directive and Standards used :** Radio : EN300 220-1 V1.3.1 (2006-06) EN300 220-3 V1.1.1 (2006-06)  
EMC : EN301 489-1 V1.3.1 (2006-06) EN301 489-3 V1.3.1 (2006-06)

**Year of affixing CE marking :** 2002

Signature :



Name :

Takao Matsui

Position :

General Manager

Date :

September 18, 2003

**CE 08910**









