

RR 1884E

LOCATION OF ELECTRICAL EQUIPMENT

- | | |
|---|--|
| <ul style="list-style-type: none"> 1. Battery 2. Air conditioning compressor 3. Horns 4. Oil pressure switch 5. Water temperature switch 6. Electronic distributor 7. Alternator 8. Starter motor 9. Coil 10. Relays 11. Wiper motor-front screen 12. Relays/delay units 13. Heater 14. Window lift motor (front right hand door) 15. Door lock actuator (front right hand door) 16. Electronic control unit 17. Relays 18. Parking brake warning light switch 19. Window lift motor (front left hand door) 20. Door lock actuator (front left hand door) | <ul style="list-style-type: none"> 21. Seat adjustment fusebox 22. Seat motor-relay 23. Inertia switch 24. Window lift motor (rear left hand door) 25. Door lock actuator (rear left hand door) 26. Electrical in-tank fuel pump 27. Window lift motor (rear right hand door) 28. Door lock actuator (rear right hand door) 29. Wiper motor-rear screen 30. Radio aerial amplifier 31. Fuel filler flap lock actuator |
|---|--|

For full information on fuel injection related items-see fuel injection section of manual.

To identify individual relays (items 10, 12, 17 and 22) see relays in Electrical Section of Manual.

FAULT DIAGNOSIS

SYMPTOM	POSSIBLE CAUSE	CURE
<p>A-Battery in low state of charge</p>	<ol style="list-style-type: none"> 1. Broken or loose connection in alternator circuit 2. Current voltage regulator not functioning correctly 3. Slip rings greasy or dirty. 4. Brushes worn, not fitted correctly or wrong type 5. Fan belt broken 	<ol style="list-style-type: none"> 1. Examine the charging and field circuit wiring. Tighten any loose connections, repair/replace broken leads. Examine the battery connection. 2. Check/fit new unit 3. Clean 4. Fit new brushes 5. Fit new belt
<p>B-Battery overcharging leading to burnt out bulbs and trequent need for topping-up</p>	<ol style="list-style-type: none"> 1. Current voltage regulator not functioning correctly 	<ol style="list-style-type: none"> 1. Fit new unit
<p>C-Lamps giving insufficient illumination</p>	<ol style="list-style-type: none"> 1. Battery discharged 2. Bulbs discoloured through prolonged use 3. Fan belt broken 	<ol style="list-style-type: none"> 1. Charge the battery from independent supply or by a long period of daylight running. 2. Fit new bulb 3. Fit new belt
<p>D-Lamps light when switched on but fade out</p>	<ol style="list-style-type: none"> 1. Battery discharged 	<ol style="list-style-type: none"> 1. Charge the battery from an independent supply or by a long period of daylight running
<p>E-Lights flicker</p>	<ol style="list-style-type: none"> 1. Loose connection 	<ol style="list-style-type: none"> 1. Tighten/clean
<p>F-Failure of lights</p>	<ol style="list-style-type: none"> 1. Battery discharged 2. Loose broken connection 3. Fan belt broken 	<ol style="list-style-type: none"> 1. Charge the battery from an independent supply or by a long period of daylight running 2. Locate and rectify 3. Fit new belt

SYMPTOM	POSSIBLE CAUSE	CURE
<p>S-Starter motor lacks power or fails to turn engine</p>	<ol style="list-style-type: none"> 1. Stiff engine 2. Battery discharged 3. Broken or loose connection in starter circuit 4. Greasy or dirty slip rings. 5. Brushes worn, not fitted correctly or wrong type 6. Brushes sticking in holders or incorrectly tensioned. 7. Starter pinion jammed in mesh with flywheel 	<ol style="list-style-type: none"> 1. Locate cause and remedy 2. Charge the battery either by a long period of daytime running or from independent electrical supply 3. Check and tighten all battery, starter and starter switch connections and check the cables connecting these units for damage 4. Clean 5. Fit new brushes 6. Rectify 7. Remove starter motor and Investigate
<p>H-Starter noisy</p>	<ol style="list-style-type: none"> 1. Starter pinion or flywheel teeth chipped or damaged 2. Starter motor loose on engine 3. Armature shaft bearing 	<ol style="list-style-type: none"> 1. Fit new components 2. Rectify, checking pinion and the flywheel for damage 3. Fit new bearing
<p>I-Starter operates but does not crank the engine</p>	<ol style="list-style-type: none"> 1. Pinion of starter does not engage with the flywheel 	<ol style="list-style-type: none"> 1. Check operation of starter solenoid. If correct, remove starter motor and investigate
<p>L-Starter pinion will not disengage from the flywheel when the engine is running</p>	<ol style="list-style-type: none"> 1. Starter pinion jammed in mesh with the flywheel 	<ol style="list-style-type: none"> 1. Remove starter motor and investigate

SYMPTOM	POSSIBLE CAUSE	CURE
<p>-Engine will not start</p>	<ol style="list-style-type: none"> 1. The starter will not turn the engine due to a discharged battery 2. The starter will not turn due to incorrect gear selection. 3. Sparking plugs faulty. dirty or incorrect plug gaps 4. Defective coil or distributor 5. A fault in the low tension wiring circuit 6. Faulty amplifier 7. Air gap out of adjustment 8. Fuel system fault 	<ol style="list-style-type: none"> 1. Recharge battery by running the car for a long period during daylight or from an independent electrical supply 2. Select 'P' or 'N' 3. Rectify' fit new plugs 4. Carry out ignition checks. Fit a new coil or distributor 5. Examine all the ignition cables and check that the terminals are secure and not corroded. 6. Check/fit new component if necessary. 7. Adjust 8. See Fuel System Section.
<p>M-Engine misfired stalls</p>	<ol style="list-style-type: none"> 1. Faulty sparking plugs 2. Air gap incorrectly set 3. Distributor cap cracked 4. Faulty pick-up or reductor 5. Excessive wear in distributor shaft brushes, etc. 6. Rotor arm and flash shield cracked or showing signs of tracking 	<ol style="list-style-type: none"> 1. Rectify 2. Adjust 3. Fit new cap 4. Fit new components 5. Fit a new components 6. Fit new component

SYMPTOM	POSSIBLE CAUSE	CURE
<p>N&Frequent recharging of the battery necessary</p>	<ol style="list-style-type: none"> 1. Alternator inoperative 2. Loose or corroded connections 3. Slipping fan belt 4. Voltage regulator faulty 5. Excessive use of the starter motor 6. Vehicle operation confined largely to night driving 7. Abnormal accessory load 8. Internal discharge of the batten, 	<ol style="list-style-type: none"> 1. Check the brushes, cables and connections or fit a new alternator 2. Examine all connections especially the battery terminals and ground cables 3. Adjust 4. Fit new component 5. In the hands of the operator, advise 6. In the hands of the operator, advise 7. Superfluous electrical fittings such as extra lamps, etc. 8. Fit new battery
<p>P-Alternator not charging correctly</p>	<ol style="list-style-type: none"> 1. Slipping fan belt 2. Voltage control not operating correctly 3. Greasy, charred or glazed slip rings 4. Brushes worn, sticking or oily 5. Shorted, open or burnt-out field coils 	<ol style="list-style-type: none"> 1. Adjust 2. Rectify/ fit new component 3. Clean 4. Rectify/fit new brushes 5. Fit new field coils
<p>Q-Alternator noisy</p>	<ol style="list-style-type: none"> 1. Worn, damaged or defective bearings 2. Cracked or damaged pulley 3. Alternator out of alignment 4. Alternator loose in mounting 5. Excessive brush noise 	<ol style="list-style-type: none"> 1. Fit new bearings 2. Fit new pulley 3. Rectify 4. Rectify 5. Check for rough or dirty slip rings, badly seating brushes, incorrect brush tension, loose brushes and loose field magnets. Rectify/fit new components
<p>R-Poor performance of horns</p>	<ol style="list-style-type: none"> 1. Low voltage due to discharged battery 2. Bad connections in wiring 3. Loose mounting nut 4. A faulty horn 	<ol style="list-style-type: none"> 1. Recharge 2. Carefully inspect all connections and horn push 3. Rectify 4. Fit new horn

SYMPTOM	POSSIBLE CAUSE	CURE
S-Central door locking does not operate (on all doors)	<ol style="list-style-type: none"> 1. Battery discharged 2. Control unit in driver's door lock actuator faulty 3. Loose or broken connection in driver's door 4. Blown fuse 	<ol style="list-style-type: none"> 1. Recharge 2. Fit new unit 3. Locate and rectify 4. Rectify
T-Central door locking does not operate (on one door only)	<ol style="list-style-type: none"> 1. Loose or broken connection 2. Lock actuator failure 3. Faulty lock 4. Mechanical linkages disconnected 	<ol style="list-style-type: none"> 1. Locate and rectify 2. Fit new actuator 3. Rectify 4. Locate and rectify
U-Window lift will not operate	<ol style="list-style-type: none"> 1. Motor failure 2. Loose or broken connection 3. Faulty switch 4. Mechanical linkage faulty 	<ol style="list-style-type: none"> 1. Fit new motor 2. Locate and rectify 3. Fit new switch 4. Rectify
V-Exterior mirrors fail to operate	<ol style="list-style-type: none"> 1. Loose or broken connection 2. Faulty switch 3. Mirror motor failure 	<ol style="list-style-type: none"> 1. Locate and rectify 2. Fit new switch 3. Fit new motor

ELECTRICAL EQUIPMENT

DESCRIPTION

The electrical system is Negative ground, and it is most important to ensure correct polarity of the electrical connections at all times. Any incorrect connections made when reconnecting cables may cause irreparable damage to the semi-conductor devices used in the alternator and regulator. Incorrect polarity would also seriously damage any transistorized equipment such as radio and tachometer etc.

WARNING: During battery removal or before carrying out any repairs or maintenance to electrical components always disconnect the battery negative lead first. If the positive lead is disconnected with the negative lead in place, accidental contact of the wrench to any grounded metal part could cause a severe spark, possibly resulting in personal injury. Upon installation of the battery the positive lead should be connected first.

ALTERNATOR - LUCAS A13380

The alternator is a three phase, field sensed unit. The rotor and stator windings produce three phase alternating current, AC, which is rectified to direct current, DC. The electronic voltage regulator unit controls the alternator output voltage by high frequency switching of the rotor field circuit. Use only the correct Range Rover replacement fan belt. Occasionally check that the engine and alternator pulleys are accurately aligned.

It is essential that good electrical connections are maintained at all times. Of particular importance are those in the charging circuit (including those at the battery) which should be occasionally inspected to see that they are clean and tight. In this way any significant increase in circuit resistance can be prevented.

Do not disconnect battery cables while the engine is running or damage to the semi-conductor devices may occur. It is also inadvisable to break or make any connections in the alternator charging and control circuits while the engine is running.

The Model 15TR electronic voltage regulator employs micro-circuit techniques resulting in improved performance under difficult service conditions. The whole assembly is encapsulated in silicone rubber and housed in an aluminium heat sink, ensuring complete protection against the adverse effects of temperature, dust, and moisture etc.

The regulating voltage is set during manufacture to give the required regulating voltage range of 14.2 \pm 0.2 volts, and no adjustment is necessary. The only maintenance needed is the occasional check on terminal connections and wiping with a clean dry cloth.

The alternator system provides for direct connection of a charge (ignition) indicator warning light, and eliminates the need for a field switching relay or warning light control unit. As the warning lamp is connected in the charging circuit, lamp failure will cause loss of charge. Lamp should be checked regularly and a spare carried.

When using rapid charge equipment to re-charge the battery, the battery must be disconnected from the vehicle.

ALTERNATOR

Remove and refit

Removing

1. Disconnect battery ground lead.
2. Disconnect leads from alternator.

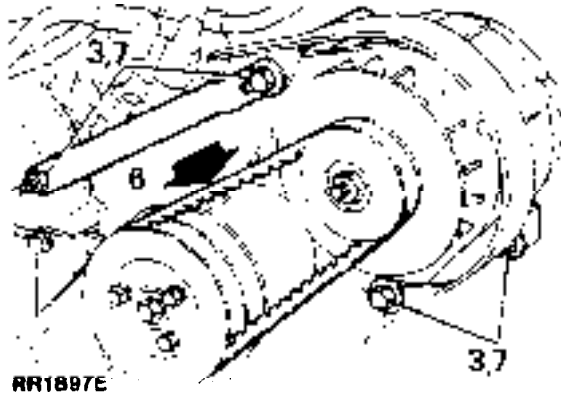

3. Loosen alternator fixings, pivot alternator inwards and remove drive belt.
4. Remove three mounting bolts and lift the alternator clear of the engine.

Refitting

5. Fit the alternator and mounting bolts.

NOTE: The fan guard is attached to the front fixing and the adjustment bracket bolt.

6. Fit the drive belt and adjust the belt tension.
7. Tighten the mounting bolts and the adjustment bracket securing nut.
8. Connect the wiring leads to the alternator.
9. Connect the battery.

ALTERNATOR DRIVE BELT

Adjust

1. Loosen the alternator fixings and the adjustment link.
2. Pivot the alternator to give the required belt tension.
3. Belt tension should be 4 to 6mm (0.19 to 0.25 in) at the point indicated by the bold arrow.

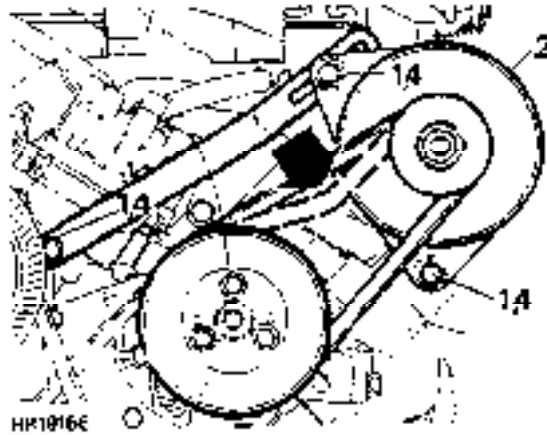

4. Tighten the alternator fixing bolts and the adjustment link.

NOTE: Check adjustment after running engine at fast idle speed for 3 to 5 minutes if a new belt has been fitted.

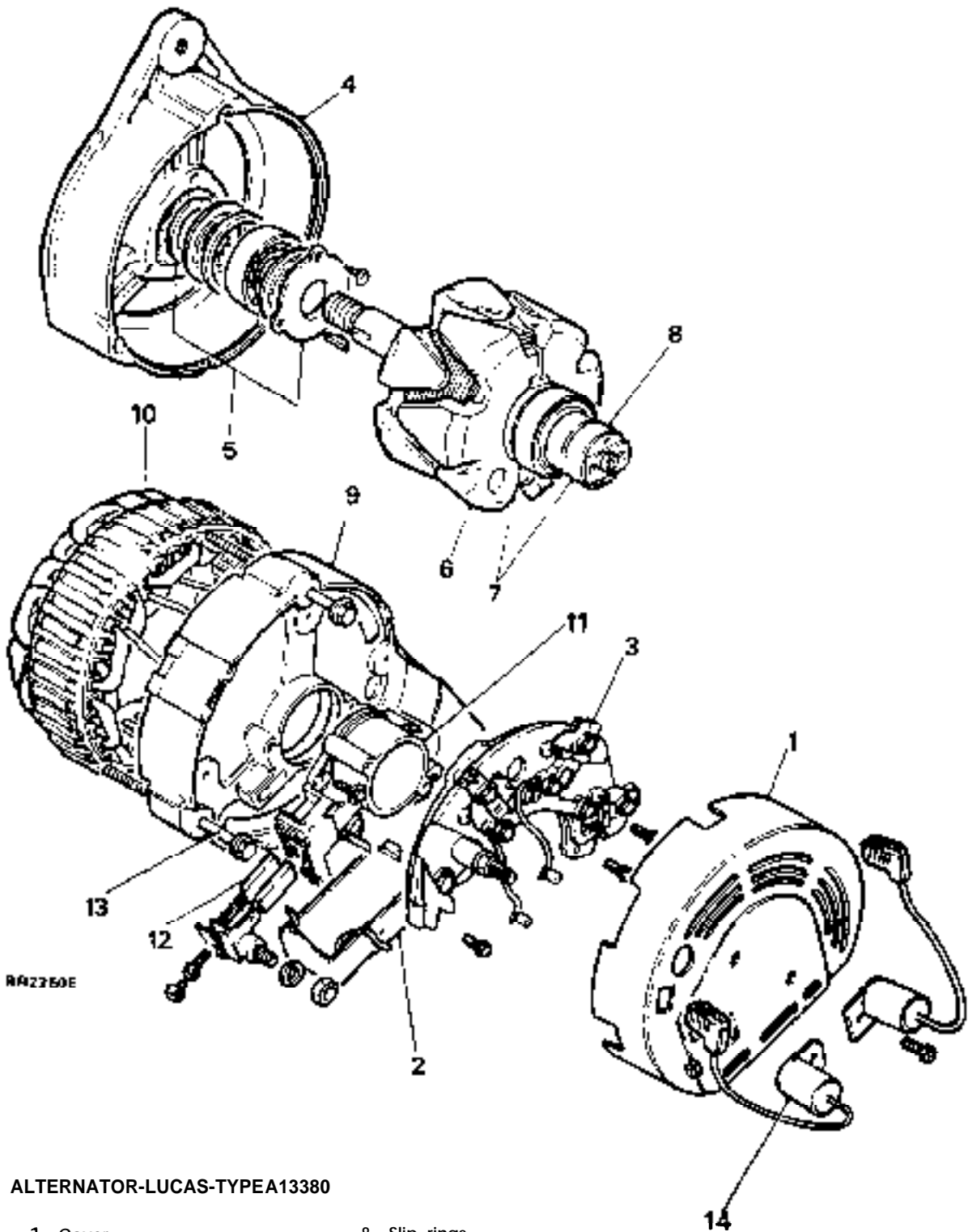

ALTERNATOR-LUCAS-TYPEA13380

- | | |
|--------------------------|---------------------------|
| 1. Cover | 8. Slip rings |
| 2. Regulator | 9. Slip ring end bracket |
| 3. Rectifier | 10. Stator |
| 4. Drive end bracket | 11. Brush box |
| 5. Bearing assembly | 12. Brushes |
| 6. Rotor | 13. Through bolts (three) |
| 7. Slip ring end bearing | 14. Suppressors |

ALTERNATOR-LUCAS-TYPE A133/80

Sequence of connections

Overhaul

Including Test (Bench)

NOTE: Alternator charging circuit-The ignition warning light is connected in series with the alternator field circuit. Bulb failure would prevent the alternator charging, except at very high engine speeds, therefore, the bulb should be checked before suspecting an alternator failure.

Precautions

Battery polarity is **NEGATIVE GROUND**, which must be maintained at all times.

No separate control unit is fitted; instead a voltage regulator of micro-circuit construction is incorporated on the slip ring end bracket, inside the alternator cover.

Battery voltage is applied to the alternator output cable even when the ignition is switched off, the battery must be disconnected before commencing any work on the alternator. The battery must also be disconnected when repairs to the body structure are being carried out using electric welding equipment.

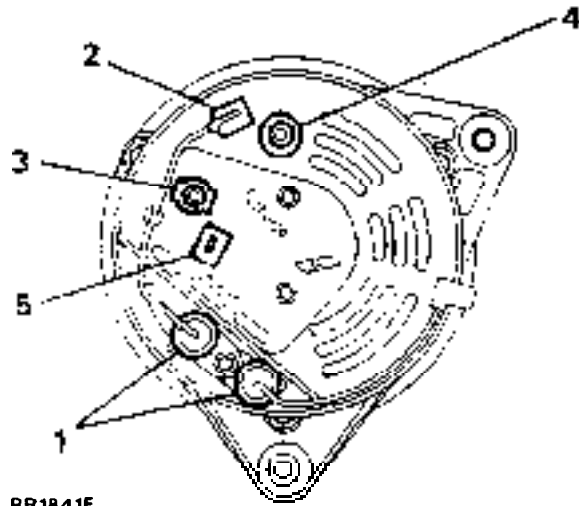

RR1841E

- 1 Suppression capacitors (two)
2. Positive suppression terminal
3. IND terminal
4. + output terminal
5. Sensing terminal

ALTERNATOR TESTING

Charging system check

1. Check the battery is in good condition, with an open circuit voltage of at least 12.6 V. Recharge or fit a charged substitute battery to carry out test.
2. Check drive belt adjustment and condition. Rectify as necessary.
3. Check battery connections are clean and tight.
4. Check alternator connections are clean and tight.
5. Ensure that there is no continuous drain on battery due, for example, to interior, underhood or door edge lamps being left on.

Alternator test

The following instructions refer to the use of suitable test- equipment using a carbon pile rheostat.

6. Connect test equipment referring to the manufacturer's instructions.
7. Start engine and run at 3000 rev/min without accessory load.
8. Rotate the carbon pile load control to achieve the greatest output (amps) without allowing voltage to fall below 12.0 V. A reading of 80 amps, minus 10% to allow for EFI and Ignition loss, should be obtained.
9. Run engine at 3000 rev/min, switch selector to regulator test, read voltmeter. A reading of 13.6 to 14.4 V should be obtained.
10. Switch selector to diode/stator test, switch on headlamps to load alternator. Raise engine speed to 3000 rev/min, read voltmeter. The needle must be within the 'OK' range.

NOTE: See also charging circuit resistance test, page 13.

Testing-alternator removed

11. Withdraw the connectors from the alternator.
12. Remove the alternator.
13. Disconnect the suppressor and remove the alternator cover.

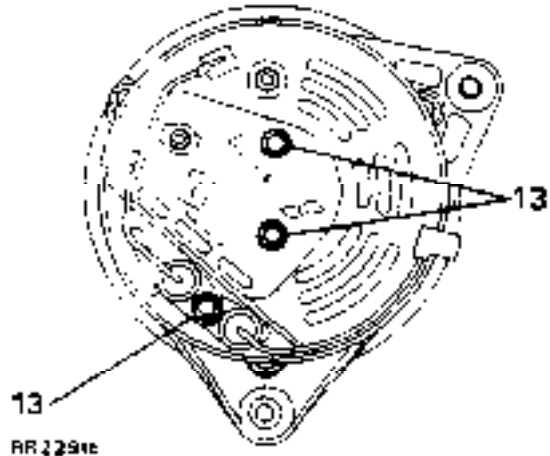

14. Disconnect the lead and remove the rectifier assembly.
15. Note the arrangement of the brush box connections and remove the screws securing the regulator to the brush box and withdraw. This screw also retains the inner brush mounting plate in position.
16. Remove the screw retaining the outer brush box in position and withdraw both brushes.
17. Check brushes for wear by measuring length of brush protruding beyond brush box moulding. If length is 10mm (0.4 in) or less, fit new brushes.
18. Check that brushes move freely in holders. If brush is sticking, clean with a mineral spirit moistened cloth or polish sides of brush with fine file.
19. Check brush spring pressure using push-type spring gauge. Gauge should register 136 to 279g (5 to 10 oz) when brush is pulled back until face is flush with housing. If reading is outside these limits, fit a new brush assembly.
20. Remove the two screws securing the brush box to the slip ring end bracket and lift off the brush box assembly.
21. Securely clamp alternator in a vice and release the stator winding cable ends from the rectifier by applying a hot soldering iron to the terminal tags of the rectifier. Pry out the cable ends when the solder melts.

22. Remove the two remaining screws securing the rectifier assembly to the slip ring end bracket and lift off the rectifier assembly. Further dismantling of the rectifier is not required.
23. Check the diodes. Connect the test equipment as shown and test each diode in turn, note whether lamp lights, then reverse test lead connections. The lamp should light in one direction only. Renew the rectifier assembly if a faulty diode is diagnosed.

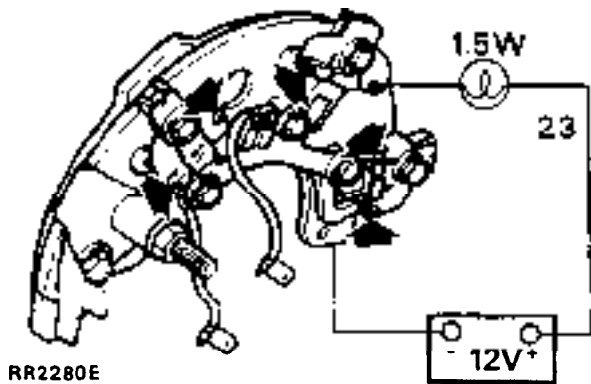

24. Remove the slip ring end bracket bolts and lift off the bracket.
25. Connect a 12 volt battery and a 36 watt test lamp to two of the stator connections. Repeat the test replacing one of the two stator connections with the third. If test lamp fails to light in either test, fit a new stator.

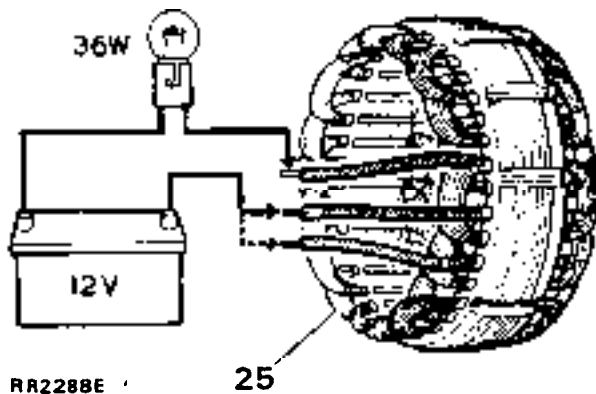

26. Using a 110 volt a.c. supply and a 15 watt test lamp, test for insulation between any one of the three stator connections and stator laminations. If test lamp lights, fit a new stator.

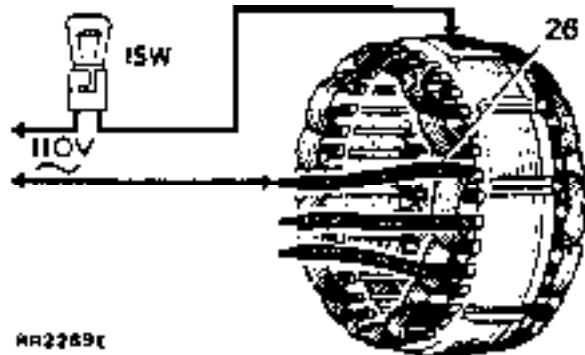

27. Clean surfaces of slip rings using a solvent moistened cloth.
28. inspect slip ring surfaces for signs of burning; remove burn marks using very fine sandpaper. On no account should emery cloth or similar abrasives be used, or any attempt made to machine the slip rings.
29. Note the position of the stator output leads in relation to the alternator fixing lugs, and lift the stator from the drive end bracket.
30. Connect an ohmmeter to the slip rings. A reading of 2.6 ohms should be recorded.

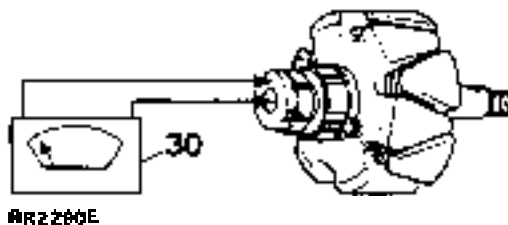

31. Using a 110 volt a.c. supply and a 15 watt test lamp, test for insulation between one of the slip rings and one of the rotor poles. If the test lamp lights, fit a new rotor.

32. To separate the drive end bracket and rotor, remove the shaft nut, washers, woodruff key and spacers from the shaft.
33. Remove bearing retaining plate by removing the three screws. Using a press, drive the rotor shaft from the drive end bearing.
34. If necessary, to remove the slip rings or the slip ring end bearing on the rotor shaft, unsolder the outer slip ring connection and gently pry the slip ring off the shaft, repeat the procedure for the inner slip ring connection. Using a suitable extraction tool, withdraw the slip ring bearing from the shaft.

Reassembling

35. Reverse the dismantling procedure, noting the following points.
 - (a) Use Shell Alvania 'RA' to lubricate bearings.
 - (b) When refitting slip ring end bearing, ensure it is fitted with open side facing rotor.
 - (c) Use Fry's H.T.3 solder on slip ring field connections.
 - (d) When refitting rotor to drive end bracket, support inner track of bearing. Do not use drive end bracket to support bearing when fitting rotor.
 - (e) Tighten through-bolts evenly.
 - (f) Fit brushes into housings before fitting brush moulding.
 - (g) Tighten shaft nut to the correct torque, see Torque Values.
 - (h) Refit regulator pack to brush moulding.
36. Reconnect the leads between the regulator, brush box and rectifier.
37. Refit the alternator.

Testing in position

Charging circuit resistance test.

1. Connect a low range voltmeter between the alternator terminal marked + and the positive terminal of the battery.

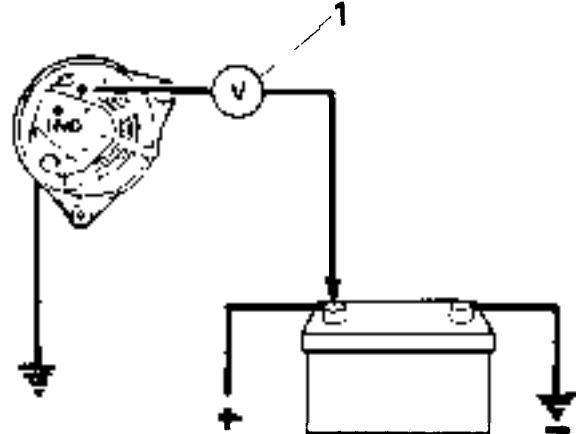

RR2317E

2. Switch on the headlamps and start the engine. Set the throttle to run at approximately 3000 rev/min. Note the voltmeter reading.
3. Transfer the voltmeter connections to the frame of the alternator and the negative terminal of the battery, and again note the voltmeter reading.

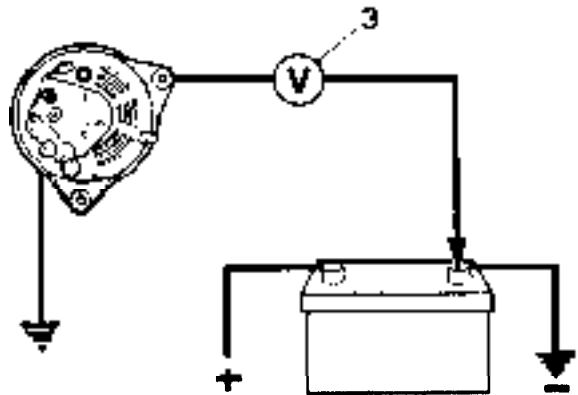

RR2318E

4. If the reading exceeds 0.5 volt on the positive side or 0.25 volt on the negative side, there is a high resistance in the charging circuit which must be traced and remedied.

BATTERY

Remove and refit

WARNING: During battery removal or before carrying out any repairs or maintenance to electrical components always disconnect the battery negative lead first. If the positive lead is disconnected with the negative lead in place, accidental contact of the wrench to any grounded metal part could cause a severe spark, possibly resulting in personal injury. Upon installation of the battery the positive lead should be connected first.

Removing

1. Disconnect battery ground lead followed by the disconnection of the positive lead.
2. Release the four nuts securing the battery bracket in position.
3. Remove the bracket from the studs.
4. Remove the battery.

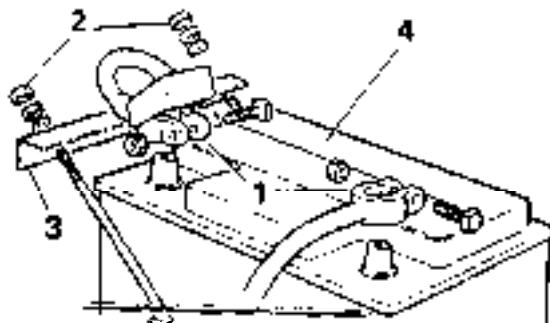

RR689M

Refitting

5. Reverse the removal procedure.

NOTE: Coat the battery clamps and terminals with petroleum jelly before refitting.

HORNS

Remove and refit

Removing

1. Disconnect the battery negative lead.
2. Remove radiator grille.
3. Remove the nut and withdraw the horn.
4. Disconnect the electrical leads.
5. Remove the plain and serrated washer.

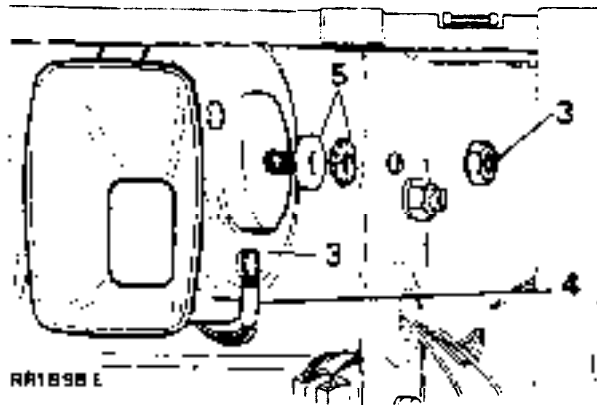

RR1898 E

NOTE: Twin horns are fitted. An identification letter is stamped on the front outer rim of the horn; 'H'-high note, 'L'-low note.

Refitting

NOTE: When refitting the horn ensure that the stud location is pushed firmly to the back of the elongated slot to prevent the horn fouling the radiator grille.

6. Reverse removal procedure.

DISTRIBUTOR-LUCAS 35 DLM8

SERVICE PARTS

- 1. Cap
- 2. HT brush and spring
- 3. Rotor arm
- 4. Insulation cover
- 5. Pick-up module and base plate assembly
- 6. Vacuum unit
- 7. Amplifier module
- 8. 'O'-ring oil seal
- 9. Gasket

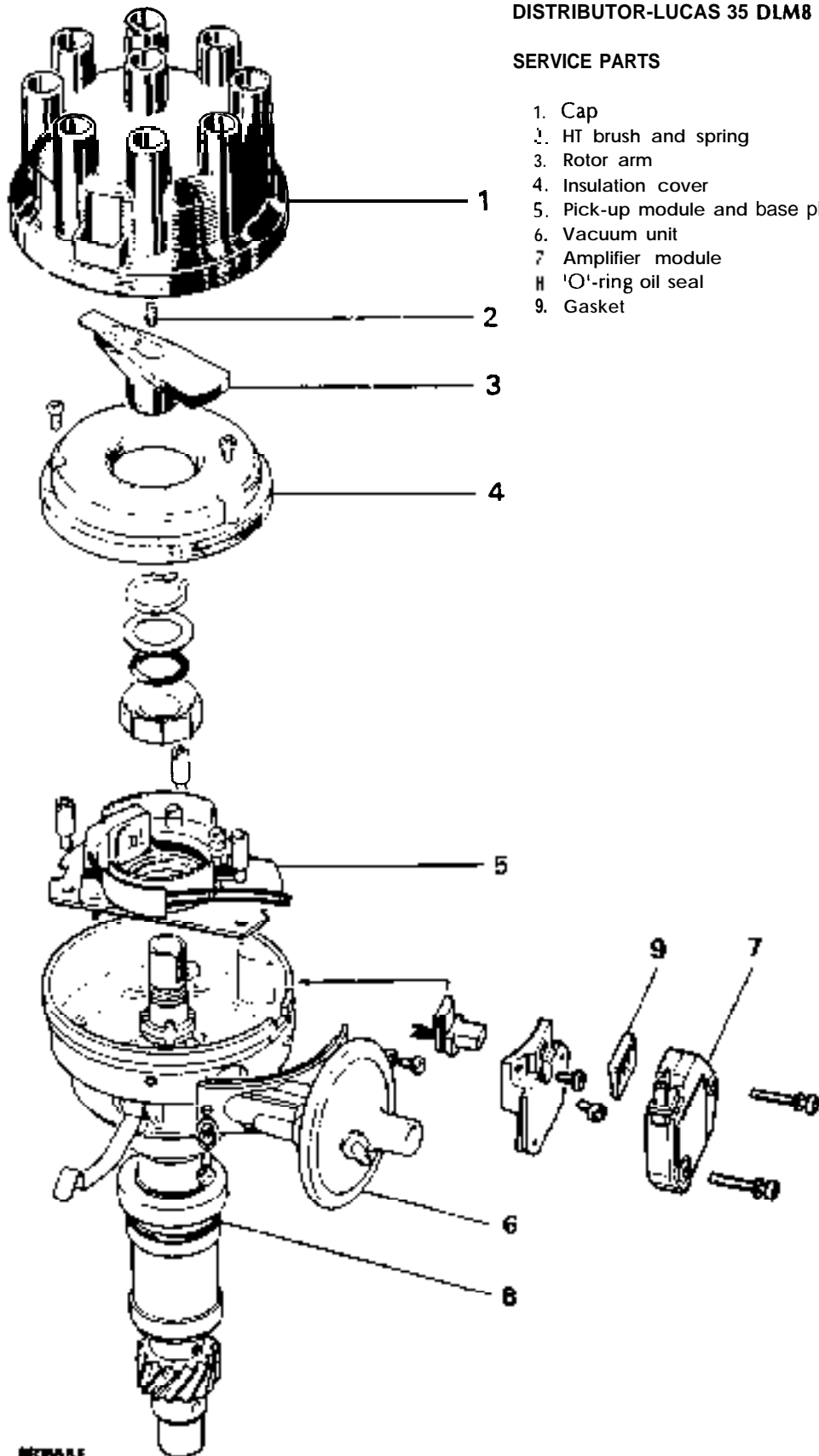

ELECTRONIC IGNITION

A Lucas 35DLM8 distributor is employed. This has a conventional vacuum advance unit and centrifugal automatic advance mechanism.

A pick-up module, in conjunction with a rotating timing reluctor inside the distributor body, generates timing signals. These are applied to an electronic ignition amplifier module mounted on the side of the distributor body.

NOTE: The pick-up air gap is factory set. Do not adjust the gap unless the pick-up is being changed or the base plate has been moved. Use a non-ferrous feeler gauge to set the air gap.

DISTRIBUTOR

Remove and refit

Removing

1. Disconnect the battery negative lead.
2. Disconnect the vacuum hose.
3. Remove the distributor cap.
4. Disconnect low tension lead from the coil.
5. Mark distributor body in relation to centre line of rotor arm.

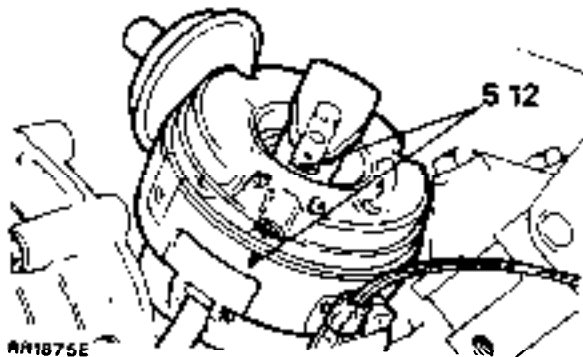

6. Add alignment marks to distributor and front cover.

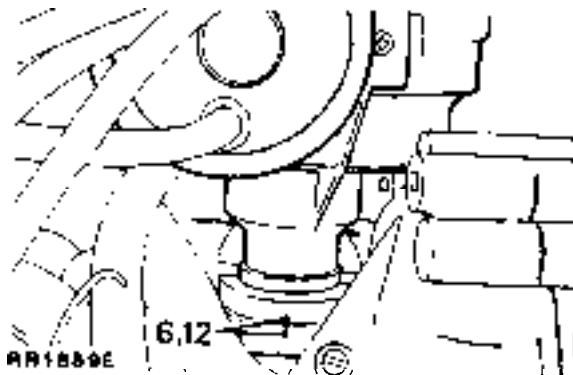

NOTE: Marking distributor enables refitting in exact original position, but if engine is turned while distributor is removed, complete ignition timing procedure must be followed.

7. Release the distributor clamp and remove the distributor.

Refitting

NOTE: If a new distributor is being fitted, mark body in same relative position as distributor removed.

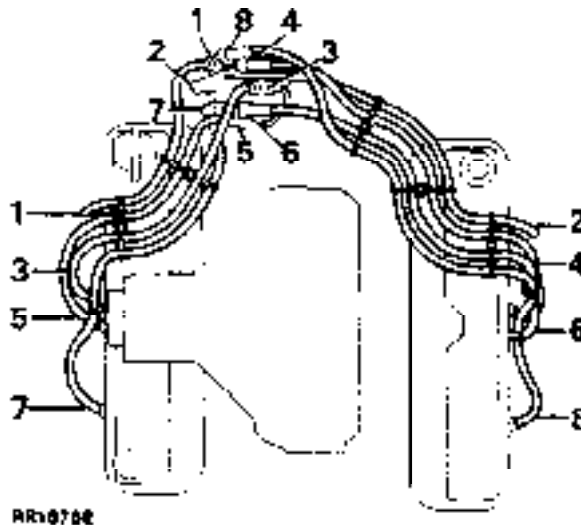

8. Leads for distributor cap should be connected as illustrated.

Figures 1 to 8 inclusive indicate plug lead numbers.

RH-Right hand side of engine, when viewed from the rear.

LH-Left hand side of engine, when viewed from the rear.

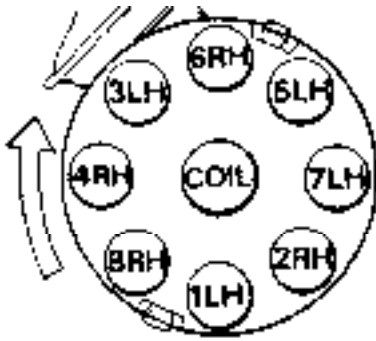

RR95184M

9. If engine has not been turned while distributor has been removed, proceed as follows (items 10 to 17). Alternatively proceed to instruction 18.
 10. Fit new 'O' ring seal to distributor housing.
 11. Turn distributor drive until centre line of rotor arm is 30° counter-clockwise from mark made on top edge of distributor body.
 12. Fit distributor in accordance with alignment markings.
- NOTE:** It may be necessary to align oil pump drive shaft to enable distributor drive shaft to engage in slot.
13. Fit clamp and bolt. Secure distributor in exact original position.
 14. Connect vacuum hose to distributor and low tension lead to coil.
 15. Fit distributor cap.
 16. Reconnect battery.
 17. Using suitable electronic equipment, set the ignition timing, see IGNITION TIMING-Adjust.
 18. If, with distributor removed, engine has been turned it will be necessary to carry out the following procedure.
 19. Set engine-No. 1 piston to static ignition timing figure (see Engine Tuning Data- Section 05) on compression stroke.
 20. Turn distributor drive until rotor arm is approximately 30° counter-clockwise from number one sparking plug lead position on cap.

21. Fit distributor to engine.
22. Check that centre line of rotor arm is now in line with number one sparking plug lead on cap. Reposition distributor if necessary.
23. If distributor does not seat correctly in front cover, oil pump drive is not engaged. Engage by lightly pressing down distributor while turning engine.
24. Fit clamp and bolt leaving both loose at this stage.
25. Set the ignition timing statically to 6° B.T.D.C.
26. Connect the vacuum hose to the distributor.
27. Fit low tension lead to coil.
28. Fit distributor cap.
29. Reconnect the battery.
30. Using suitable electronic equipment set the ignition timing, see IGNITION TIMING-Adjust.

DISTRIBUTOR-LUCAS 35DLM8

Overhaul

DISTRIBUTOR CAP

1. Unclip and remove the cap
2. Fit a new cap if known to be faulty.
3. Clean the cap and HT brush with a lint free cloth.

ROTOR ARM

4. Pull rotor arm from shaft.
5. Fit a new rotor arm if known to be faulty.

INSULATION COVER (Flash shield)

6. Remove cover, secured by three screws.
7. Fit a new cover if known to be faulty.

VACUUM UNIT

8. Remove two screws from vacuum unit securing bracket, disengage vacuum unit connecting rod from pick-up base plate connecting peg, and withdraw vacuum unit from distributor body.

Continued

AMPLIFIER MODULE

9. Remove two screws and withdraw the module.
10. Remove the gasket.
11. Remove two screws securing the cast heatsink and remove the heatsink.

WARNING: The amplifier module is a sealed unit containing Beryllia. This substance is extremely dangerous if handled. Do not attempt to open or crush the module.

PICK-UP AND BASE PLATE ASSEMBLY

12. Use circlip pliers to remove the circlip retaining the reluctor on rotor shaft.
13. Remove the flat washer and then the 'O' ring recessed in the top of the reluctor.
14. Gently withdraw the reluctor from the shaft, taking care not to damage the teeth.

NOTE: Coupling ring fitted beneath reluctor.

15. Remove three support pillars and cable grommet. Lift out the pick-up and base plate assembly.

NOTE: Do not disturb the two barrel nuts securing the pick-up module, otherwise the air gap will need re-adjustment.

16. Fit a new pick-up and base plate assembly if module is known to be faulty, otherwise check pick-up winding resistance (2k-5k ohm).

RE-ASSEMBLY

17. This is mainly a reversal of the dismantling procedure, noting the following points:

LUBRICATION

Apply clean engine oil:

- a. A spot into the rotor spindle before fitting rotor arm.

Apply Omnilube 2 (or equivalent) grease.

- b. Auto advance mechanism.
- c. Pick-up plate centre bearing.
- d. Pre tilt spring and its rubbing area (pick-up and base plate assembly).
- e. Vacuum unit connecting peg (pick-up and base plate assembly).
- f. The connecting peg hole in vacuum unit connecting rod.

FITTING PICK-UP AND BASE PLATE ASSEMBLY

18. Pick-up leads must be prevented from fouling the rotating reluctor. Both leads should be located in plastic guide as illustrated. Check during re-assembly.

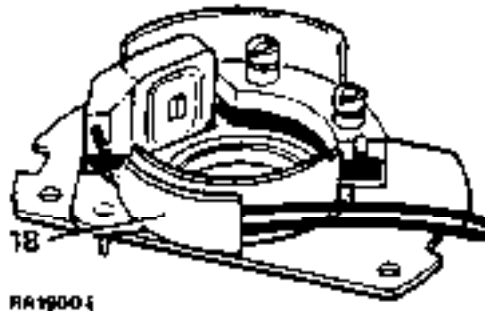

REFITTING RELUCTOR

19. Slide reluctor as far as it will go on rotor shaft then rotate reluctor- until it engages with the coupling ring beneath the pick-up base plate. The distributor shaft, coupling ring and reluctor are 'keyed' and rotate together. Fit the 'O' ring, flat washer and retaining circlip.

PICK-UP AIR GAP ADJUSTMENT

20. The air gap between the pick-up limb and reluctor teeth must be set within the specified limits, using a non-ferrous feeler gauge.

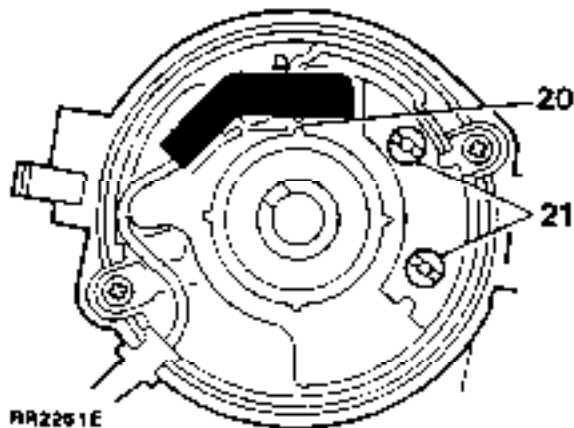

21. If adjustment is necessary, slacken the two barrel nuts to set the air gap. See Engine Tuning Data.

NOTE: When the original pick-up and base plate assembly has been refitted the air gap should be checked, and adjusted if necessary.

When fitting a new assembly the air gap will require adjusting to within the specified limits.

AMPLIFIER MODULE

22. Before fitting the module, apply MS4 Silicone grease or equivalent heat-conducting compound to the amplifier module backplate, the seating face on distributor body and both faces of the heatsink casting.

IGNITION COIL

Remove and refit

Removing

1. Disconnect the battery negative terminal.
2. Disconnect the High Tension and Low Tension electrical leads from the Ignition coil.

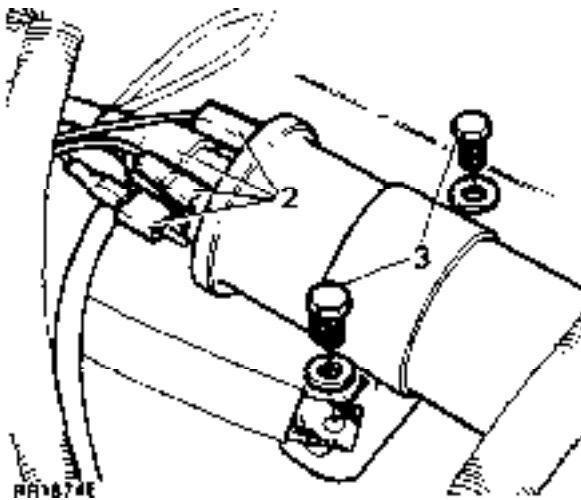

3. Remove the two bolts securing the coil to the valance.

NOTE: A ground strap is located under one of the bolts.

4. Remove the coil from the engine compartment.

Refitting

5. Reverse the removal instructions.

NOTE: Ensure that the bolting location for the ground strap is free from paint and grease. Coat the area around the bolt with Petroleum Jelly.

IGNITION TIMING

Adjust

1. It is essential that the following procedures are adhered to. Inaccurate timing can lead to serious engine damage and additionally create failure to comply with emission regulations. If the engine is being checked in the vehicle, the air conditioning compressor must be disengaged.
2. On initial engine build, or if the distributor has been disturbed for any reason, the ignition timing must be set statically to 6° B.T.D.C. (This sequence is to give only an approximation in order that the engine may be started) ON NO ACCOUNT MUST THE ENGINE BE STARTED BEFORE THIS OPERATION IS CARRIED OUT.

Equipment required

Calibrated Tachometer
Stroboscopic lamp

3. Couple stroboscopic timing lamp and tachometer to engine following the manufacturer's instructions.
4. Disconnect the vacuum hose from the distributor.
5. Start engine, with no load and not exceeding 3,000 rev/min run engine until normal operating temperature is reached. (Thermostat open). Check that the normal idling speed falls within the tolerance specified in the data section.
6. Idle speed for timing purposes must not exceed 800 rev/min.
7. With the distributor clamping bolt loosened turn distributor until the timing flash coincides with the timing pointer and the correct timing mark on the rim of the torsional vibration damper as shown in the engine tuning section.

Continued

8. Retighten the distributor clamping bolt securely. Recheck timing in the event that retightening has disturbed the distributor position.
9. Refit vacuum hose.
10. Disconnect stroboscopic timing lamp and tachometer from engine.

LUCAS CONSTANT ENERGY IGNITION SYSTEM 35DLM8-PRELIMINARY CHECKS

Inspect battery cables and connections to ensure they are clean and tight. Check battery state of charge it in doubt as to its condition.

Inspect all L.T. connections to ensure that they are clean and tight. Check the H.T. leads are correctly positioned and not shorting to ground against any engine components. The wiring harness and individual cables should be firmly fastened to prevent chaffing.

PICK-UP AIR GAP

Check the air gap between pick-up limb and retractor teeth, using a non-ferrous gauge, see 'Engine Tuning Data'.

NOTE: The gap is set initially at the factory and will only require adjusting if tampered with or when the pick-up module is replaced.

TEST 1:

H.T. Sparking

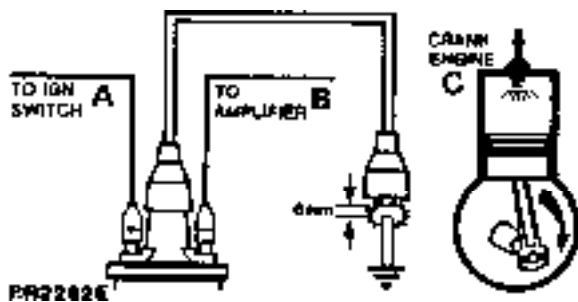

Remove coil/distributor H.T. lead from distributor cover and hold approximately 6mm (0.25 in) from the engine block, using suitable insulated pliers. Switch the ignition 'On' and operate the starter. Regular sparking indicates fault in H.T. distribution, plugs, timing or fuelling, proceed to Test 6. If no spark or weak spark occurs proceed to Test 2.

Test 2:

L.T. Voltage

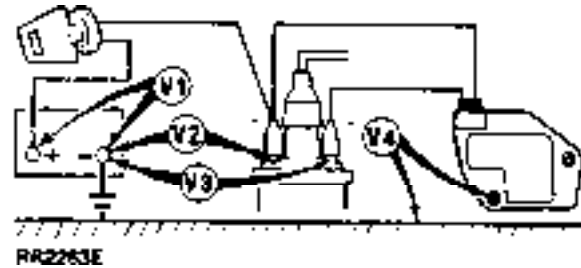

Switch the ignition 'On' - engine stationary.

- (a) Connect voltmeter to points in the circuit indicated by V1 to V4 and make a note of the voltage readings.
- (b) Compare voltages obtained with the specified values listed below:

EXPECTED READINGS

- | | |
|----|-----------------------------------|
| V1 | More than 12 volts. |
| V2 | 1 volt maximum below volts at V1. |
| V3 | 1 volt maximum below volts at V1. |
| V4 | 0 volt - 0.1 volt. |
- (c) If all readings are correct proceed to Test 3.
 - (d) Check incorrect reading(s) with chart to identify area of possible faults, i.e. faults listed under heading SUSPECT and rectify.
 - (e) If coil and amplifier is suspected, disconnect L.T. lead at coil, repeat V3. If voltage is still incorrect, fit new coil. If voltage is now correct, check L.T. lead, if satisfactory fit new amplifier.
 - (f) If engine will not start proceed to Test 3.

1	2	3	4	SUSPECT
L	.	.	*	DISCHARGED BATTERY
*	L	L	*	IGN. SWITCH AND/OR WIRING
*	.	L	.	COIL OR AMPLIFIER
.	*	*	H	AMPLIFIER GROUND

KEY

- Expected Voltage
- H Voltage higher than expected
- L Voltage lower than expected

TEST 3:

Amplifier Switching

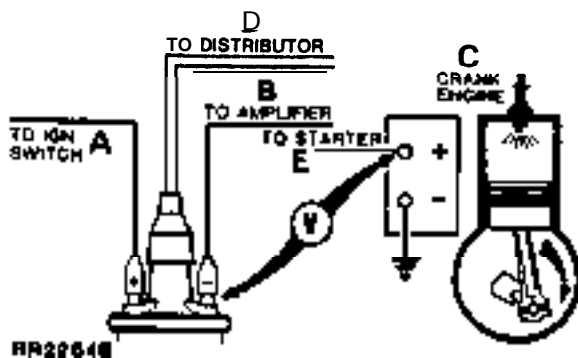

Connect the voltmeter between battery positive (+ve) terminal and H.T. coil negative (-ve) terminal, the voltmeter should register 0 volts.

Switch the ignition 'On', the voltmeter should still register 0 volts.

Crank the engine, the voltmeter reading should increase when cranking, in which case proceed to Test 5.

If there is no increase in voltage during cranking proceed to Test 4.

TEST 4:

Pick-up Coil Resistance

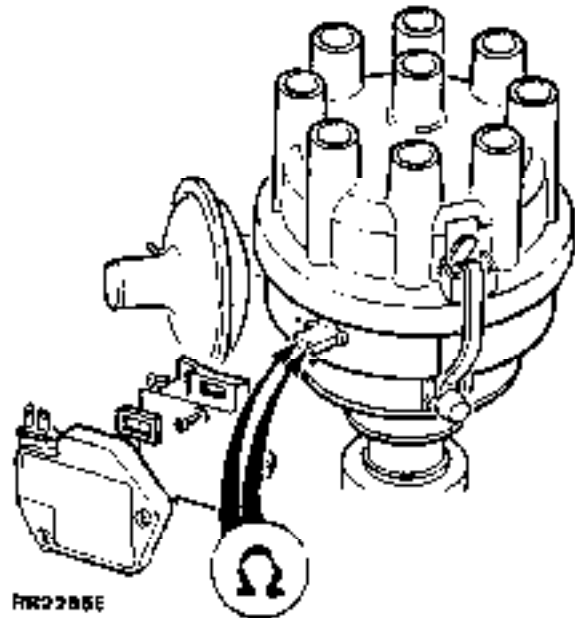

FIG 2285E

Remove the amplifier.

Connect the ohmmeter leads to the two pick-up terminals in the body of the distributor.

The ohmmeter should register between 2k and 5k ohm if pick-up is satisfactory. If ohmmeter reading is correct, check all connections between pick-up and amplifier, if satisfactory, fit new amplifier. If the engine still does not start carry out Test 5.

Change the pick-up if ohmmeter reading is incorrect. If the engine still does not start proceed to Test 5.

Continued

TEST 5:

Coil H.T. Sparking

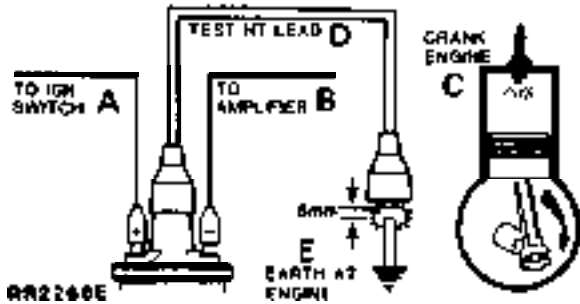

Remove existing coil/distributor H.T. lead and fit test H.T. lead to coil tower. Using suitable insulated pliers, hold free end about 6mm (0.25 in) from the engine block and crank the engine. There should be good H.T. sparking.

If weak or no sparking, fit new coil repeat test.

H.T. sparking good, repeat test with original H.T. lead. If sparking is good carry out Test 6.

If weak or no sparking, fit new H.T. lead, if engine will not start carry out Test 6.

TEST 6:

Rotor Arm

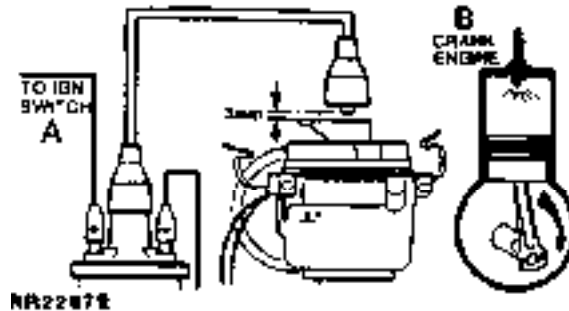

Remove distributor cover. Disconnect coil H.T. lead from cover, using insulated pliers hold about 3mm (0.13 in) above rotor arm electrode and crank the engine.

There should be no H.T. sparking between rotor and H.T. lead. If satisfactory carry out Test 7.

If H.T. sparking occurs, an earth fault on rotor arm is indicated. Fit new rotor arm. If engine will not start carry out Test 7.

TEST 7:

Visual and H.T. Cable Checks

Examine:	Should be:
1. Distributor Cover	Clean, dry, no tracking marks
2. Coil Top	Clean, dry, no tracking marks.
3. H.T. Cable Insulation	Must not be cracked, chafed or perished
4. H.T. Cable Continuity	Must not be open circuit
5. Sparking Plugs	Clean, dry, and set to correct gap

NOTE:

1. Reluctor	Must not foul pick-up or leads
2. Rotor and Insulation Cover	Must not be cracked or show signs of tracking marks

HEADLAMP ASSEMBLY/SEALED BEAM UNIT

Remove and refit

Removing

1. Disconnect the battery negative lead.
2. Remove the radiator grille - see Body Section 76.
3. Remove three crosshead screws and the headlamp retaining rim.

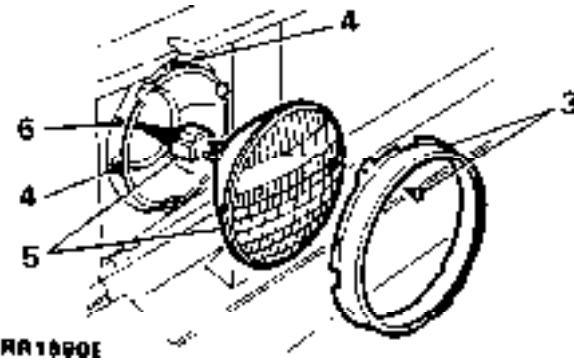

4. DO NOT disturb the two adjusting screws.
5. Withdraw the sealed beam unit and disconnect the wiring plug from the rear of the unit.
6. Remove three securing screws, pry away the grommet and withdraw the headlamp bowl.

Refitting

7. Reverse removal procedure.

HEADLAMP ALIGNMENT

Headlamp beam setting should only be carried out by qualified person using suitable beam setting equipment.

1. Turn the top adjusting screw counter-clockwise to lower the beam, clockwise to raise the beam.
2. Turn the side adjusting screw counter-clockwise to move the beam to the left, clockwise to move the beam to the right.

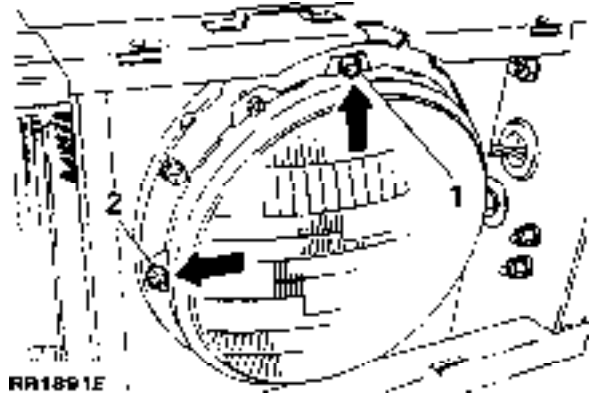

AUXILIARY DRIVING LAMP-RH AND LH

Remove, refit and adjust

Bulb replacement

1. Disconnect the battery negative lead.
2. The auxiliary driving lamp securing nut is located beneath the front fender adjacent to the front body fixing. Access to the lamp is gained through the front wheel arch.
3. Disconnect the electrical plug.
4. Remove the single nut and washer.

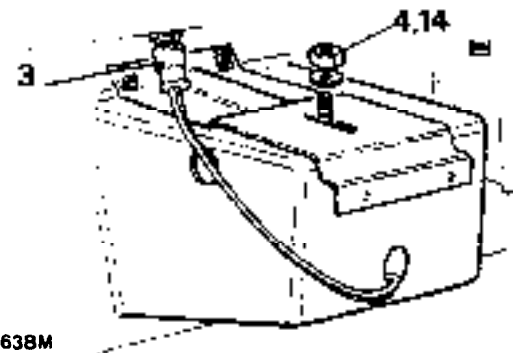

5. From the front of the vehicle, maneuver the lamp and remove it from the spoiler opening.
6. Remove the two screws securing the cover to the rear of the lamp.
7. Withdraw the cover.
8. Disconnect the lucar connector.
9. Release the spring clip securing the bulb to the lamp unit.
10. Remove the bulb.

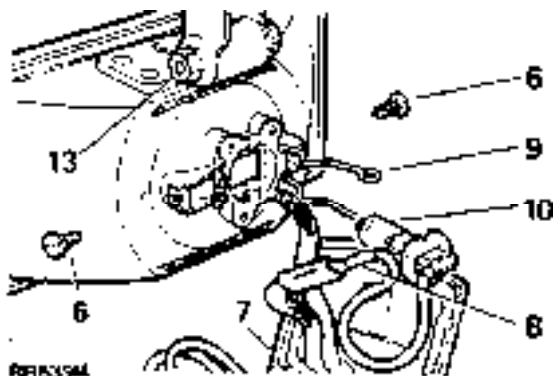

RFR15394L

Refitting

11. Fit a new bulb ensuring that the two notches on the bulb body locate with the registers on the lamp unit.
12. Reverse the removal procedure.

Adjusting

The correct adjustment is beam horizontal (parallel to the ground) and parallel to the vehicle axis.

13. Loosen the lamp adjusting bolt to lower or raise the beam.
14. Loosen the lamp securing bolt to move the beam to left or right.
15. Tighten fixing bolts to the correct torque, see Torque Values.

SIDELIGHT AND FLASHER LAMP ASSEMBLY-RH AND LH AND BULB**Remove and refit****Removing**

1. Open the hood and disconnect the battery negative lead.
2. Remove the two screws and plain washers securing the lamp assembly.
3. Lift the assembly away sufficiently to gain access to the rear of the lamp.
4. Remove the waterproof cover.
5. Depress the two retaining clips and withdraw the bulb holder.

6. Remove the required bulb. The direction indicator bulb is located in the upper section of the bulb holder, the side lamp bulb in the lower.
7. Disconnect the multi-plug to remove the complete assembly.

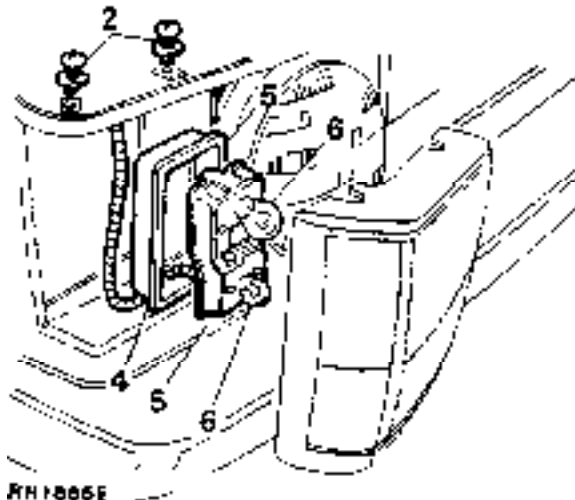

RFR1506E

Refitting

8. Reverse the removal procedure, ensuring the waterproof cover is located correctly.

TAIL, STOP, REVERSE AND FLASHER LAMP ASSEMBLY-RH AND LH**Remove and refit****Removing**

1. Disconnect the battery negative lead.
2. Remove the four lens retaining screws.
3. Remove lens.
4. Remove sealing rubber, if required.

NOTE: To remove the sealing rubber complete it is necessary to remove the side marker lens.

5. Remove the bulbs.
6. Remove the four screws securing the lamp unit to the body.
7. Remove the two through-screws from the reflector side, which also secure the lamp unit to the body.
8. Ease the lamp unit forward and disconnect leads at moulded connectors.

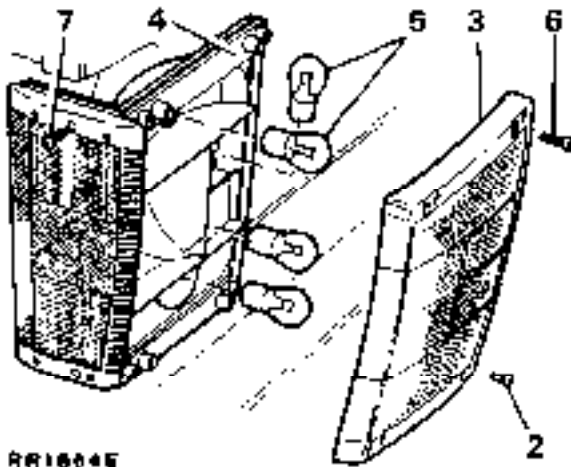

RR1804E

UNDER HOOD LAMP ASSEMBLY

Remove and refit

Removing

1. Disconnect the battery negative lead.
2. Remove the two securing screws.
3. Remove the lamp glass.
4. Pull the five-watt 'wedge' type bulb from the bulb holder.

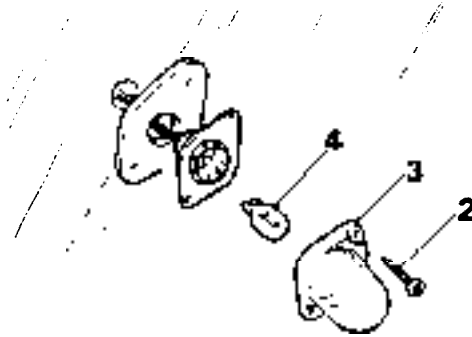

RR483M

Refitting

9. Reverse the removal procedure.

REFLECTORS/SIDE MARKER LAMP ASSEMBLY -RH AND LH BULB

Remove and refit

Removing

1. Remove the four screws securing the lens.
2. Remove the lens.
3. Remove the bulb.

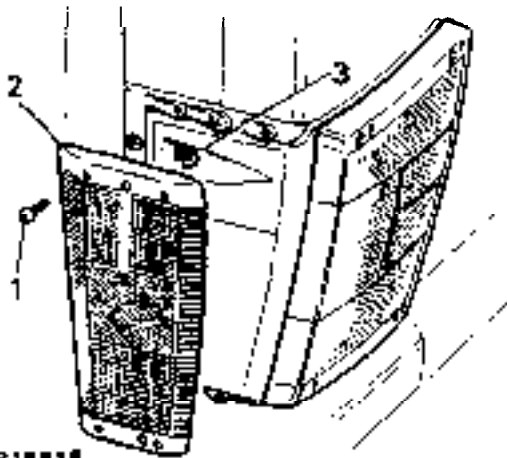

RR1503E

5. Disconnect the electrical leads located below the hood lamp switch attached to the inner fender.
6. Pull the rubber grommet off the leads and pull the lamp and leads up through the hood stiffener 'channel'.

Refitting

7. Reverse operations 1 to 6.

NOTE: A piece of bent wire will be needed to pull the electrical leads out of the channel exit hole when fitting a new lamp assembly.

NOTE: To remove the rubber seal completely it is necessary to remove the tail light lens.

Refitting

4. Reverse the removal procedure.

**HEATER/VENTILATION AND AIR CONDITIONING
CONTROL PANEL****Bulb replacement**

The heater/ventilation control panel is illuminated by four 12-volt 1.2 watt 'wedge' type (capless) bulbs. In the event of a bulb failure a replacement bulb can be fitted as follows:

1. Pull the five finger tip knobs off the control levers.
2. Remove the two screws at the top of the panel.
3. Carefully ease the panel away from the centre console only as far as the electrical leads will permit.
4. Pull the appropriate bulb holder out of the rear of the panel.
5. Pull the bulb from the holder.
6. Fit a new bulb and push the bulb holder firmly back into its location at the rear of the panel.

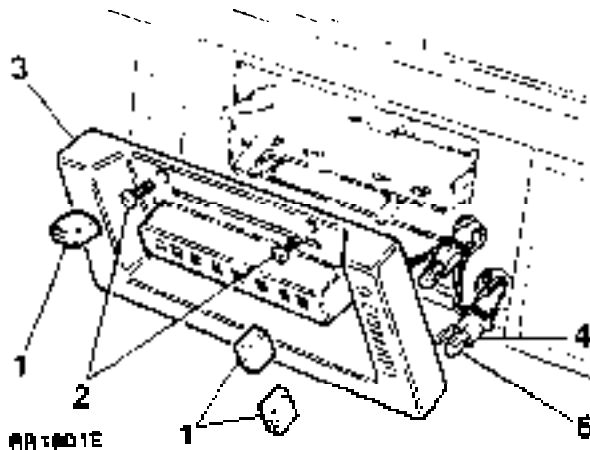
**Refitting**

7. Ensuring that the electrical leads do not become trapped between the panel console and operating levers, refit the panel.

DOOR EDGE LAMPS/PUDDLE LAMPS

Incorporated into the front door assemblies are door edge lamps and puddle lamps, these are located on the door edge and bottom of the door. The lamps are activated by the courtesy light switches when either front door is opened and will immediately switch off when both doors are closed.

Remove and refit**Removing**

1. Ensure the side door glass is fully closed.
2. Disconnect the battery negative lead.
3. Remove the interior door handle and arm rest/door pull from the door.
4. Carefully release the interior door trim pad from the inner door panel.
5. Peel back the lower half of the plastic vapour barrier.
6. Disconnect the door edge lamp and puddle lamp two pin electrical plugs within the door, accessible through the lower centre and outer openings of the inner door panel.
7. Release the door edge lamp electrical leads from the retaining clips.
8. Remove the lens and pry the lamps out of the door and withdraw the electrical leads.

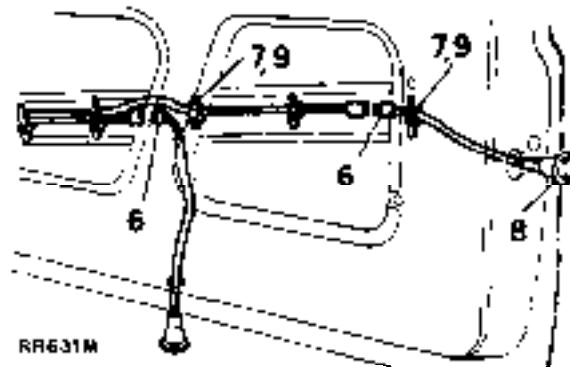
**Refitting**

9. Reverse the removal procedure.

NOTE: Ensure the door lamp wiring harness is securely clipped to the lower stiffener plate within the door to prevent damage occurring to the electrical leads when the door glass is in its lowest position.

DOOR EDGE LAMPS/PUDDLE LAMPS

Bulb replacement

1. Disconnect the battery negative lead.
2. Carefully pry out the lamp lens.
3. Withdraw the lamp body from the door ONLY as far as the electrical leads will permit.
4. Pull the bulb from the holder.

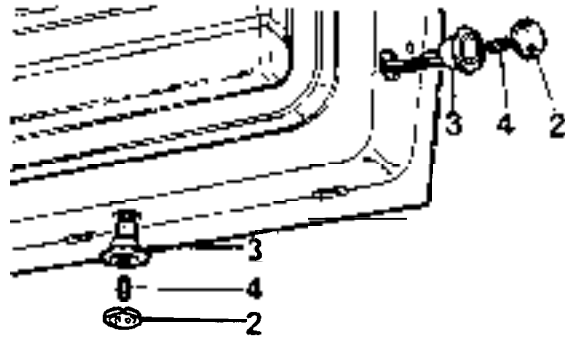

RR2120E

5. Fit a new the bulb and refit the lamp lens.
6. Push the lamp into the door. The correct bulb type is a 12-volt 5-watt capless.

AUTOMATIC GEAR SELECTOR-PANEL ILLUMINATION

Bulb replacement

1. Disconnect the battery negative lead.
2. Unclip the cover from the top of the gear selector knob.
3. Remove the circlip retaining the detent button.
4. Withdraw the detent button.
5. Remove the lower circlip above the gear selector knob securing nut.
6. Remove the securing nut.
7. Withdraw the serrated washer.

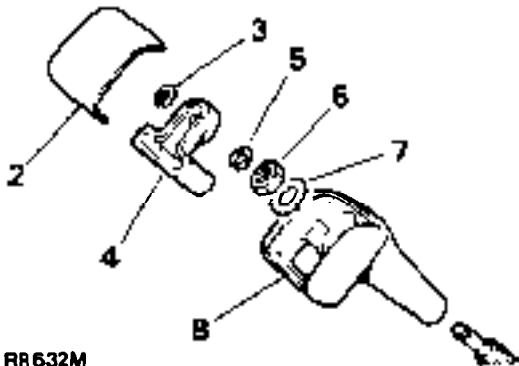

RR632M

8. Slide the selector knob off the shaft.
9. Carefully pry the inset panel out of the floor mounted console, complete with -selector illumination panel and ash tray.
10. The two illumination bulbs are located on the reverse side of the illumination panel.
11. Pull the appropriate bulb holder from its location.
12. if necessary, to facilitate easier removal of the bulb holders, remove the four screws securing the illumination panel to the outer surround panel.

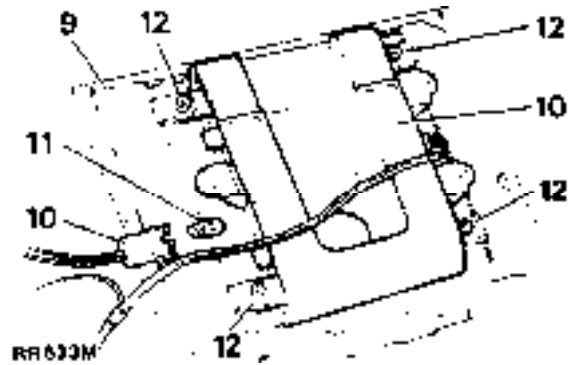

RR633M

13. Pull the bulb from the holder. The correct bulb type is a 24-volt 5-watt 'wedge' base (capless).

Refitting

14. Reverse the removal procedure ensuring that the electrical leads beneath the floor mounted console do NOT become trapped between mating surfaces.
15. To prevent damage to the gear selector knob on reassembly do NOT overtighten the retaining nut, see Torque Values.

LICENSE PLATE LAMP ASSEMBLY AND BULB

Remove and refit

Removing

1. Disconnect the battery negative lead.
2. Remove the two self-tapping screws and washers.
3. Detach the lamp assembly.
4. Disconnect the bulb holder and remove the bulb.

NOTE: Carefully pull the electrical leads out of the bottom of the lower tailgate panel to reveal the snap connectors.

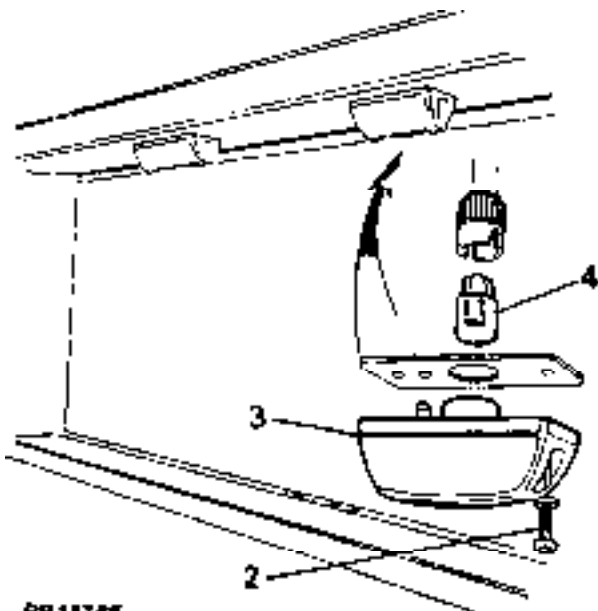

RR1176E

5. Disconnect the electrical connections located at the bottom of the lower tailgate.
6. Remove the bulb holder.
7. Carefully pull the electrical leads up through the inside of the lower tailgate panels.

Refitting

8. Reverse the removal procedure. The correct bulb 'type' is a 12-volt, 5 watt wedge base (capless).

INTERIOR ROOF LAMPS

Remove and refit

The interior roof lamps are operated automatically via the side door and tailgate courtesy switches or by an independent switch located on the auxiliary switch panel.

Removing

1. Disconnect the battery negative lead.
2. Remove the lens from the courtesy lamp by pressing upward and turning it counter-clockwise.
3. Withdraw bulb from spring clip holder.
4. Remove screws securing lamp base to roof panel.
5. Lower the lamp to reveal the cable snap connections.
6. Disconnect the electrical connections.

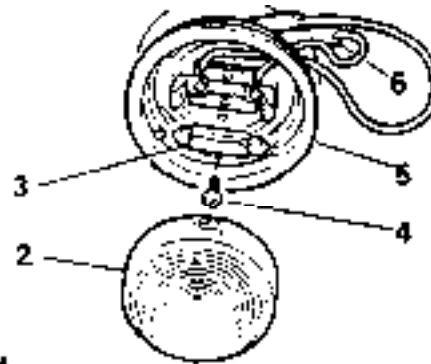

RR4B3M

Refitting

7. Reverse the removal procedure.

INTERIOR ROOF LAMPS CIRCUIT DELAY

Remove and refit

The roof lamp circuit incorporates a delay function which is designed to allow the lamps to remain on for 12 to 18 seconds after either of the front doors are closed.

NOTE; Switching on the ignition (with both doors closed) will immediately over-ride this feature, switching the interior lamps off.

Removing

1. Disconnect the battery negative lead.
2. Remove the six screws securing the lower dash panel.
3. Lower the dash panel to gain access to the red delay unit attached to the steering column support bracket.
4. Remove the delay unit by pushing the unit up off its retaining bracket, to clear the steering column support bracket.
5. Pull the red multi-plug off the delay unit.

Refitting

6. Reverse the removal operations.

STARTER MOTOR-LUCAS M78R

Remove and refit

Removing

1. Place the vehicle on a suitable hoist.
2. Disconnect the battery negative lead.
3. Disconnect the leads from the solenoid and starter motor and remove the exhaust heat shield.
4. Remove the two bolts securing the starter motor to the flywheel housing.
5. Remove the starter motor from underneath the vehicle.

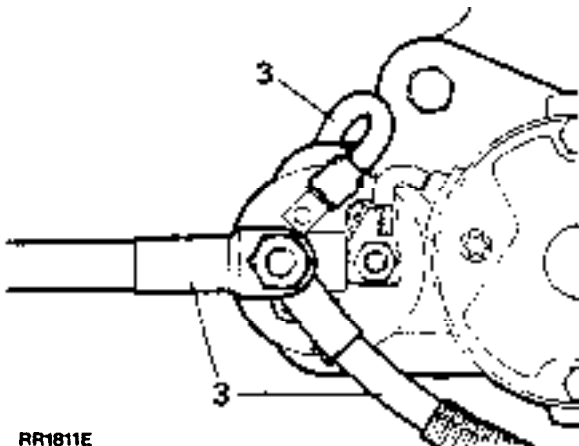

RR1811E

Refitting

6. Reverse the removal procedure.

STARTER MOTOR-Lucas M78R

Overhaul

Dismantling

1. Remove the starter motor.
2. Remove the braid between the starter and the solenoid terminal.
3. Remove the solenoid fixing screws.
4. Withdraw the solenoid body.
5. Lift and remove the solenoid plunger.
6. Remove two nuts and two screws from the commutator end bracket.
7. Remove the commutator end bracket.
8. Remove the grommet from the yoke.
9. Lift the brushbox assembly clear of the armature.
10. Remove the brush springs.
11. Unclip and remove the ground brushes.
12. Remove the insulating plate.
13. Withdraw the brushes and bus bar.
14. Remove the armature from the yoke.
15. Remove the yoke.
16. Remove the intermediate bracket.
17. Loosen and remove the through bolts from the drive end bracket.
18. Remove the sun and planet gears.
19. Push out the drive shaft sprocket assembly from the drive end bracket.
20. Carefully tap the thrust collar from over the jump ring back towards the drive.
21. Pry the snap ring from its locating groove.
22. Remove the drive assembly from the drive shaft.

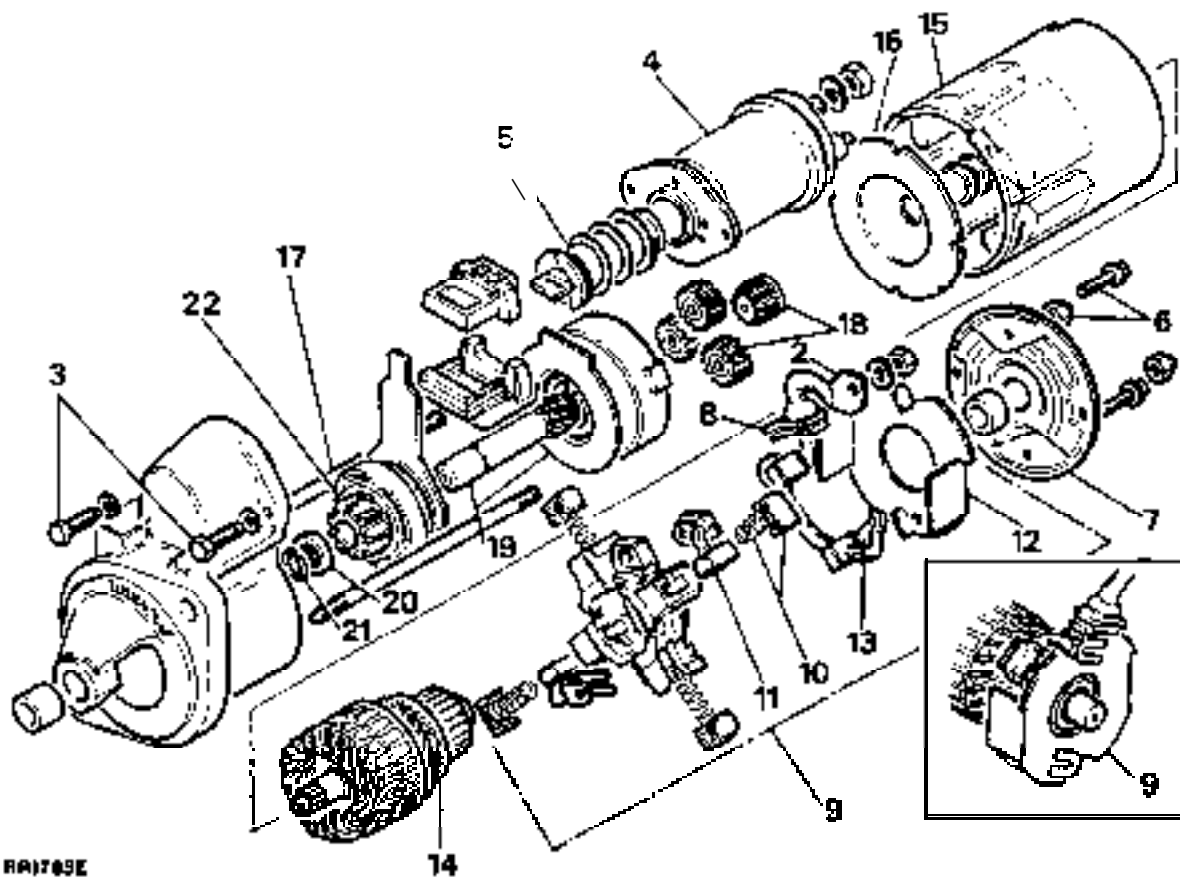

Inspecting

Solenoid

23. Check the continuity and resistance value of windings by connecting an ohmmeter as shown.

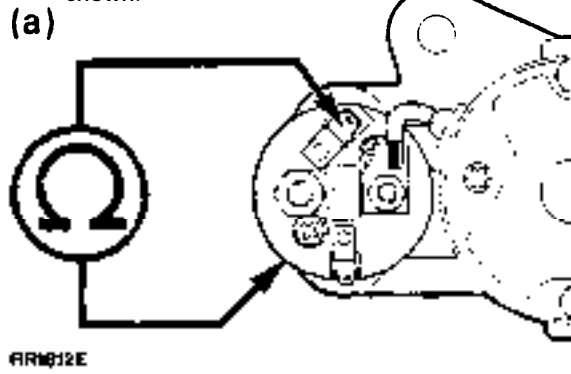

(a) Resistance value should be: 1.074 ± 0.035 ohms

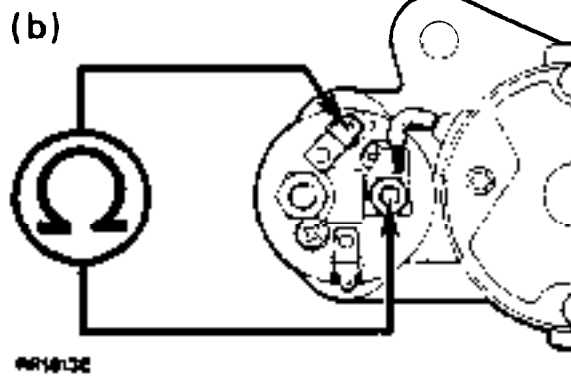

(b) Resistance value should be: 0.298 ± 0.015 ohms

If test results are unsatisfactory replace the solenoid.

If results are correct proceed to 24.

24. Check the contacts by connecting an ohmmeter as shown. Solenoid plunger removed, ohmmeter should read infinity.

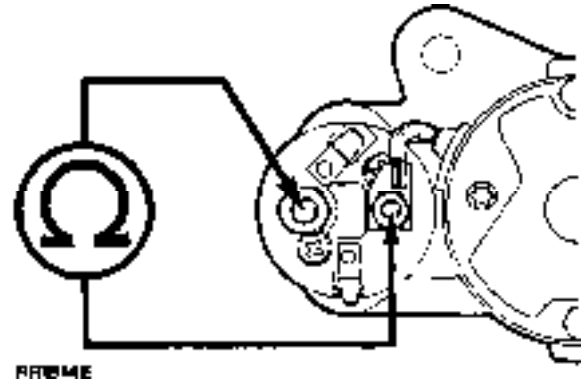

Solenoid plunger operated by hand, ohmmeter should read zero. If test results are unsatisfactory, replace the solenoid. If results are correct proceed to 25.

25. Check operation of spring for freedom of movement.

Brush gear

26. Check brush springs and ensure that the brushes move freely in their holders. Clean the brushes with a solvent moistened cloth, if required.

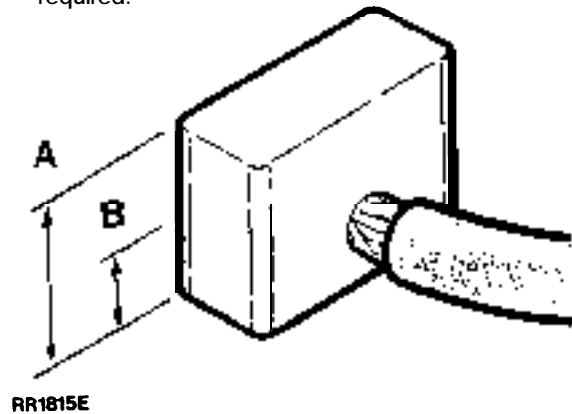

Brush length new, Dimension A is 9mm (0.354 in). Minimum brush length, Dimension B is 3.5mm (0.138 in).

Armature

27. Check the armature insulation using suitable test equipment. Connect the tester between any one commutator segment and the shaft. The method illustrated uses a 1 10V, 15W test lamp. If the lamp illuminates the armature is faulty, and a replacement component is required.

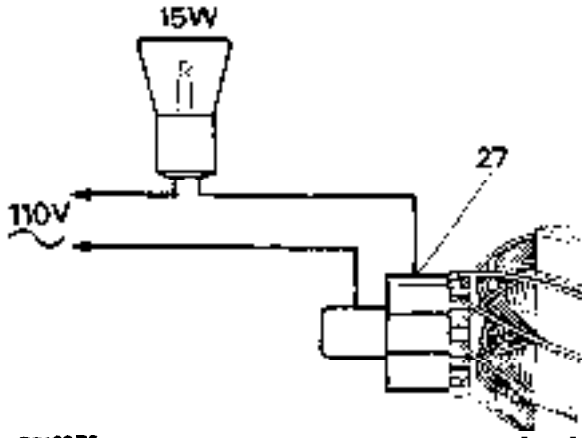

RR1927E

28. If necessary, the commutator may be machined, providing a finished surface can be obtained without reducing the diameter below 28.8mm (1.13 in), otherwise a new commutator must be fitted. Finish the surface with fine emery cloth. Do not undercut the insulation slots.

Drive assembly

29. Test the roller clutch. The pinion should rotate in **one** direction only, independent of the clutch body. Replace the unit if unsatisfactory or if teeth are damaged or worn.

Bearings

30. Fit new the bearing bushes if there is evidence of armature fouling magnets or if there is perceptible side play between the shaft and bush.

31. Drive end/intermediate end bracket: press **out** the bush using a suitable press **and** mandrel.
32. Press the new bush in, ensuring that on the drive end bracket, the bush is flush with the casting.
33. Commutator end bracket; thread a 9/16" Whitworth or suitable similar tap firmly into the bush. Extract the bush with the tap using a power press in reverse.

NOTE: Soak new bushes in engine oil for thirty minutes before fitting.

Reassembly

34. Reverse the instructions 1 to 22. Smear the teeth and operating collar of the roller clutch with Shell Retinax 'A' grease. Smear the pivot lever of the drive assembly with Mobil 22 grease. Smear the drive shaft sun and planet gears with Rocol BRB1200 grease.
35. Tighten all the fixings to the correct torque-see Torque Values.

FUSE BOX

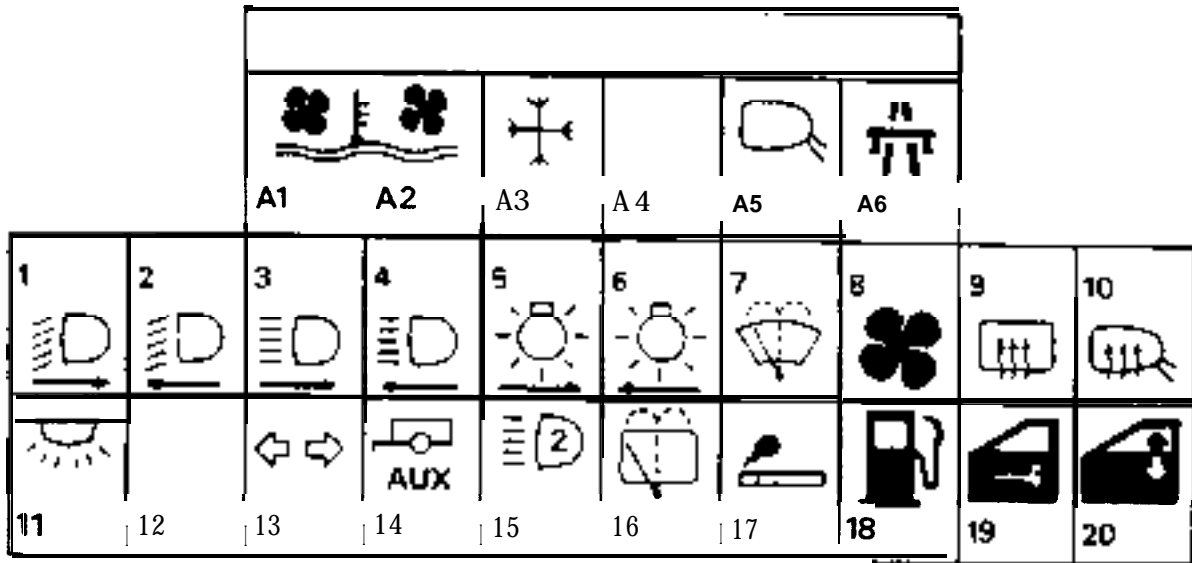

RR 1759E

FUSE NO.	COLOUR CODE	FUSE VALUE	CIRCUIT SERVED	IGNITION KEY CONTROLLED
----------	-------------	------------	----------------	-------------------------

MAIN FUSE PANEL

1	Brown	7.5 amp	RH headlamp low beam and power wash	
2	Brown	7.5 amp	LH headlamp low beam	
3	Brown	7.5 amp	RH headlamp high beam	
4	Brown	7.5 amp	LH headlamp high beam	
5	Tan	5 amp	RH parking lights and instrument illumination	
6	Tan	5 amp	LH parking lights and radio illumination	
7	Blue	15 amp	Front wash/wiper motors	AUX
8	Yellow	20 amp	Heating/air conditioning motor	AUX
9	White	25 amp	Heated rear screen	IGN
10	Violet	3 amp	Mirror heaters	IGN
11	Blue	15 amp	Audio warning unit, headlamp flash, door, hood and internal lamps, radio, clock, horns, hazard switch, key 'IN' switch and emission maintenance reminder	
12		---	Not used	
13	Blue	15 amp	Low coolant monitor, stop and reverse lamps, direction indicators, instruments, bulb check, low oil monitor, screen wash fluid monitor, interior lamp delay unit and speed transducer	IGN
14	Blue	15 amp	Auxiliary feed trailer	
15	Blue	15 amp	Auxiliary driving lamps	
16	Red	10 amp	Rear wash/wipe motor	AUX
17	Yellow	20 amp	Cigar lighters (front and rear), gear selector illumination	IGN
18	Red	10 amp	Fuel pump	IGN
19	Red	10 amp	Central locking	
20	White	25 amp	Window lifts	AUX

NOTE: Radio/Cassette combination. An in-line type 5 amp fuse is incorporated in the power input lead of the unit.

AUXILIARY FUSE PANEL-(A)

A1	Yellow	20 amp	Air conditioning fan	IGN
A2	Yellow	20 amp	Air conditioning fan	IGN
A3	Tan	5 amp	Air conditioning compressor clutch	IGN
A4			Spare	
A5	Violet	3 amp	Electric mirror motors	IGN
A6	Brown	7.5 amp	Cruise control	IGN

NOTE: Sunroof fuse is a 20 amp blade type fuse and is located on the side of the sunroof main relay. See pages 77-78 for relay location.

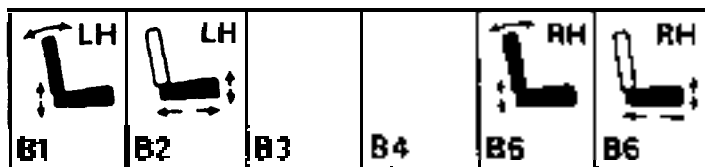

RR1760E

AUXILIARY FUSE BOX (B)-Located under the front left-hand seat

FUSE NO	COLOUR CODE	FUSE VALUE	CIRCUIT SERVED
B1	Green	30 amp	Seat recline
B2	Green	30 amp	Seat base
B3	----	----	Spare
B4	----	----	Spare
B5	Green	30 amp	Seat recline
B6	Green	30 amp	Seat base

FUSE BOX-Main and Auxiliary

Remove and refit

Removing

1. Disconnect the battery negative lead.
2. Remove the clip-on fuse box cover.
3. Remove the fuses from the main and auxiliary fuse boxes.
4. Remove the single screw securing the top auxiliary fuse box to the fuse box surround.
5. Unclip the opposite end of the fuse box.
6. Remove the two screws securing the main fuse box to the lower centre dash panel.
7. Withdraw the auxiliary fuse box surround.
8. Maneuver the main and auxiliary fuse box to enable them to be withdrawn through the fuse box opening.
9. Remove the leads from the fuse boxes, by inserting a small screwdriver into each fuse socket to depress the small retaining tab on the back of the lucar connections, withdraw the leads from the rear of the fuse box.

Refitting

10. Reverse the removal instructions ensuring that all leads are refitted to the correct fuse socket (refer to main circuit diagram).

NOTE: When refitting the leads to the fuse box, the retaining tabs on the back of the lucar connectors must be in their raised position to prevent the leads being pushed out of the rear of the fuse box when the fuse is refitted.

RELAYS-Identification

incorporated in the vehicle electrical circuits are several relays, some of which are located behind the lower dash panel attached to the steering column support bracket. Relays are also located in the engine compartment attached to the closure panel. these relays are accessible having removed the black protective cover. The remaining relays are located beneath both front seats.

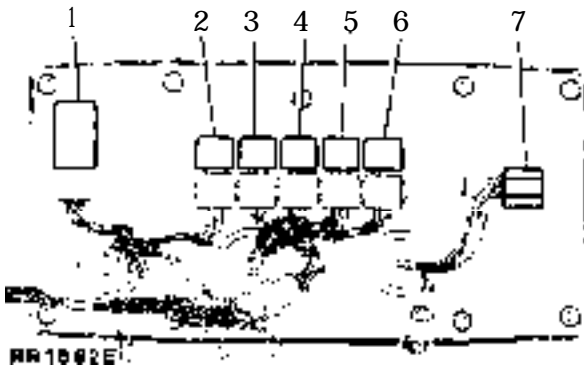

RR1002E

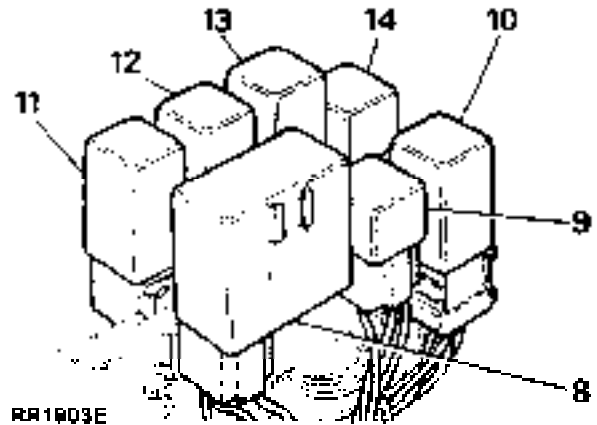

RR1003E

Closure panel viewed from the engine compartment, with protective cover removed.

Steering column mounted relays viewed with the lower dash panel removed.

Relay	Circuit Diagram Item Number	Colour
1. Headlamp wash timer unit	17. Main circuit diagram	Black
2. Heated rear window	65. Main circuit diagram	Natural
3. Starter solenoid relay	6. Main circuit diagram	Natural
4. Compressor clutch	11. Air conditioning diagram	Natural
5. Condenser fan	9. Air conditioning diagram	Natural
6. Air conditioning/heater	5. Air conditioning diagram	Natural
7. Stowage position	Not used	-----
8. Rear wiper delay	139. Main circuit diagram	Black
9. ignition load relay	1. Main circuit diagram	Black
10. Front wiper delay	14. Main circuit diagram	Red
11. Flasher/Hazard unit	74. Main circuit diagram	Blue
12. Voltage sensitive switch	71. Main circuit diagram	Yellow
13. Interior lamp delay	100. Main circuit diagram	Red
14. Auxiliary lamp relay	87. Main circuit diagram	Natural
15. Seat adjustment relay	4. Seat adjustment diagram	Natural
16. Main EFI relay	22. EFI circuit diagram	Natural
17. Fuel pump relay	21. EFI circuit diagram	Natural

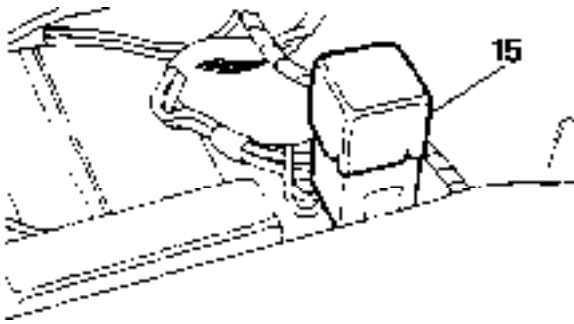

RR1028E

Seat adjustment relay located beneath the left hand front seat adjacent to fuse box (B).



RR1902E

Main EFI (black terminal block) and fuel pump relays (blue terminal block) mounted beneath right hand front seat.

NOTE: Refer to fuel injection section of manual for full information on E.F.I. relays.

RELAYS-(Mounted on the engine compartment closure panel).

Remove and refit

Removing

1. Lift the hood.
2. Disconnect the battery negative lead.
3. Remove the bolt securing the relay protective cover, located on the front of the engine compartment closure panel.
4. Remove the cover.

5. Pull the appropriate relay off its multi-plug.

Refitting

6. Reverse the removal procedure.

RELAYS-(Mounted on the steering column support bracket)

Remove and refit

Removal.

1. Disconnect the battery negative lead.
2. Remove the six screws securing the lower fascia panel.
3. Lower the dash panel, disconnect the electric leads from the dimming control switch and remove the fascia panel.
4. Locate the appropriate relay on the relay mounting bracket, carefully pull the relay off the multi-plug.

Refitting

5. Reverse the removal procedure.

RELAYS-(Floor mounted beneath front seats)

Remove and refit

Removing

1. Position seat to gain access to the required relay.
2. Disconnect the battery negative lead.
3. Carefully pull the relay off the multi-plug.

Refitting

4. Reverse the removal procedure.

AUXILIARY SWITCH PANEL

The auxiliary switch panel contains four 'push-push' type switches which incorporate integral symbols for identification.

(The first and sixth switch openings are fitted with blank covers, which are removable, to facilitate the fitting of extra switches if required).

The symbols are illuminated by two bulbs which become operational when the vehicle lights are on.

The heated rear screen switch (5) is provided with an individual warning light, illuminated when the switch is operated.

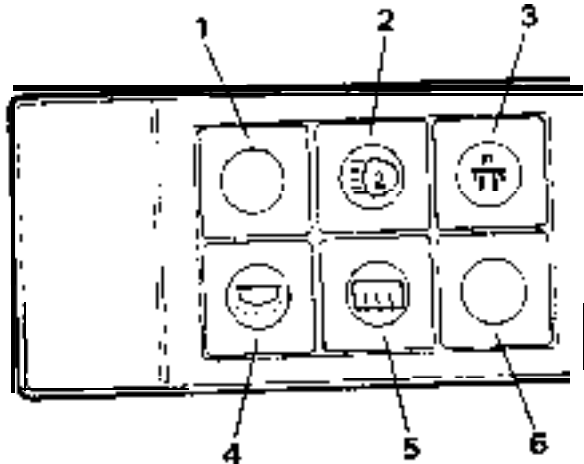

RR1B46 E

- 1. Blank.
- 2. Auxiliary driving lamps.
- 3. Cruise control master switch.
- 4. Interior and tailgate lamps.
- 5. Heated rear screen.
- 6. Blank.

AUXILIARY SWITCH PANEL

Remove and refit

Removing

- 1. Disconnect the battery negative lead.
- 2. Carefully pry the auxiliary switch panel surround away from the centre console.
- 3. Withdraw the switch panel as far as the electrical leads will permit.
- 4. Unclip the multi-plugs at the rear of the switches by depressing the retaining lugs.
- 5. Pull the plugs from the switches.
- 6. Remove the switch assembly complete.

NOTE: If necessary each individual switch can now be removed as follows.

- 7. Depress the small retaining lugs on the top and bottom of the switch and push the switch(es) through the front of the switch surround.

Refitting

- 8. Reverse the removal procedure.

NOTE: To aid identification and location of multi-plug to switch, a coloured plastic tab is attached to each body which corresponds with an appropriate coloured multi-plug. The switches if removed, should always be refitted in their original position.

Auxiliary switch panel/heated rear screen warning light warning light

Bulb replacement (switch 5)

1. Disconnect the battery negative lead.
2. Carefully pry the switch panel surround away from the centre console.
3. Unclip the multi-plug from the rear of the switch and disconnect the plug.

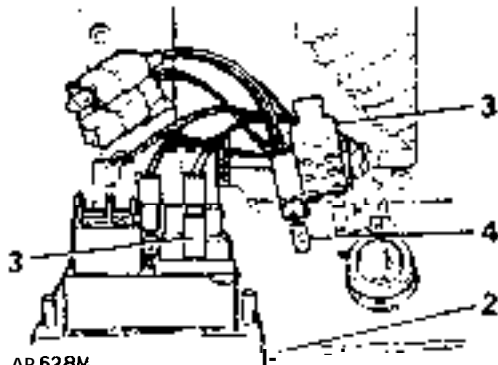

AR 628M

4. The warning light bulb is located in the multi-plug and is removed by pulling the bulb from its location.
5. Fit a new bulb and refit the multi-plug.
6. Press the auxiliary switch panel back into the centre console. The correct bulb type is an amber 12-volt 1.2-watt 'wedge' base (capless).

Auxiliary switch panel illumination

To replace either bulb

The auxiliary panel green illumination bulbs are located in the interior lamp/heated rear screen and multi-plugs, each bulb is positioned in the centre of a group of four switches.

1. Disconnect the battery negative lead.
2. Carefully pry the switch panel surround away from the centre console to give access to the multi-plugs at the rear of the switches.

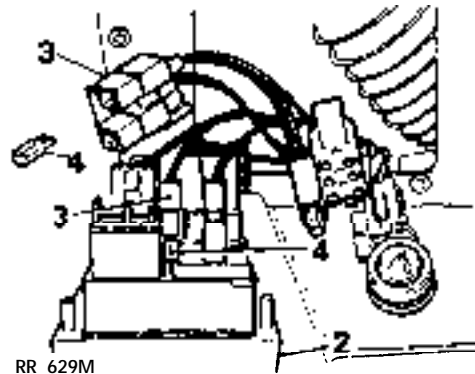

RR 629M

3. Unclip and pull the multi-plugs from the rear of the appropriate switch.
4. Pull the green illumination bulb from its location.
5. Fit a new bulb and refit the multi-plug.
6. Press the auxiliary panel surround 'back into the centre console.

The correct bulb type is a 12-volt 1.2-watt 'wedge' base (capless).

STEERING COLUMN CONTROLS

The steering column switch layout is as follows:

LEFT HAND CONTROLS

Lower switch - Main lighting switch
Upper switch - High and low beam, direction indicators and horn.

RIGHT HAND CONTROLS

Lower switch - Rear screen programmed wash/wipe.
Upper switch - Windscreen programmed wash/wipe.

STEERING WHEEL

The following operations for steering column controls show the steering wheel removed, this is for clarity only, and is not a necessary part of the procedure. If steering wheel removal is required, refer to steering wheel remove and refit on page 21 Section 57 carefully observing the spiral cassette instructions.

STEERING COLUMN SHROUD

Certain operations within the electrical section necessitate removal of the steering column shroud. Unless removal of both sides of the shroud is required, remove ONLY the side necessary for access.

Remove and refit

Removing

1. Disconnect the battery negative lead.
2. Remove the lower dash panel.
3. Disconnect the electrical connections to either the master lighting switch or the rear screen wash wipe switch. (Disconnect both if removing the complete shroud).
4. Left hand shroud - remove three securing screws and remove the shroud over the indicator/high beam switch.
5. Right hand shroud - remove three securing screws and remove the shroud over the windscreen wash wipe switch.
6. To facilitate reassembly remove the screw securing the two halves of the shroud together from one side only.

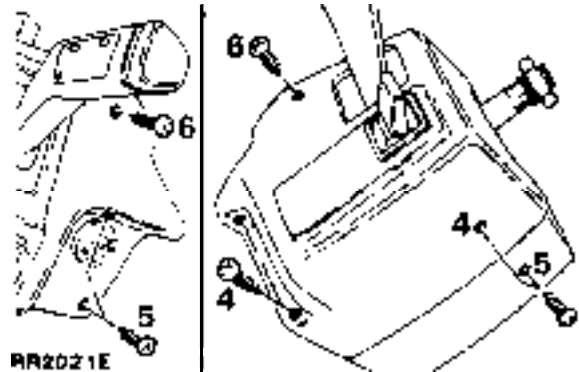

Refitting

7. If both sides of the shroud have been removed ensure that the plate on the steering column is correctly located in the slot in the shroud.
8. Reverse the removal procedure.

MAIN LIGHTING SWITCH

REAR SCREEN PROGRAMMED WASH WIPE SWITCH

Remove and refit

Removing

1. Remove the steering column shroud from the required side.
2. Disconnect cables at snap connectors.
3. Push the two spring clips locating the switch inwards and remove the switch from its mounting.

Refitting

4. Reverse the removal procedure.

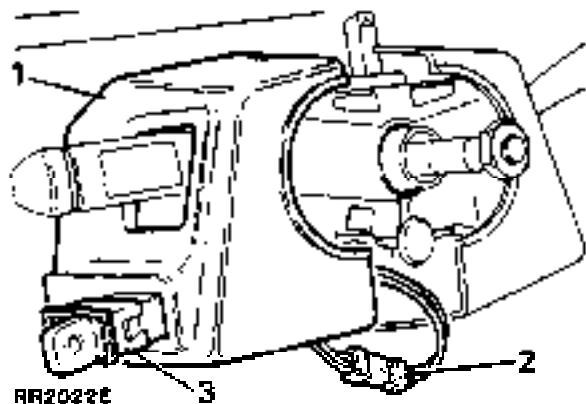

WINDSCREEN PROGRAMMED WASH WIPE SWITCH**HIGH AND LOW BEAM, DIRECTION INDICATORS AND HORN SWITCH**

Remove and refit

Removing

1. Remove the steering column shroud from the required side.
2. Release the appropriate retaining clip and pull the fibre optic guide from the housing.

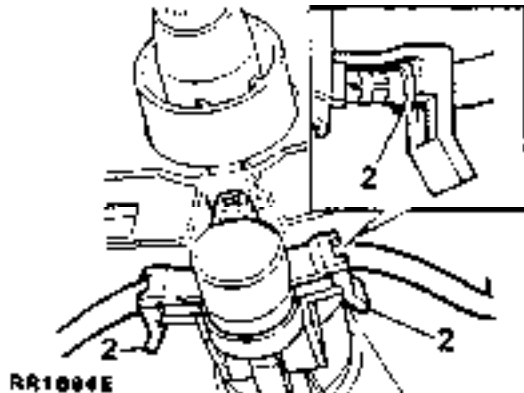

3. Depress the retainers at the top and bottom of the switch and pull combined switch assembly away from the steering column switch housing.

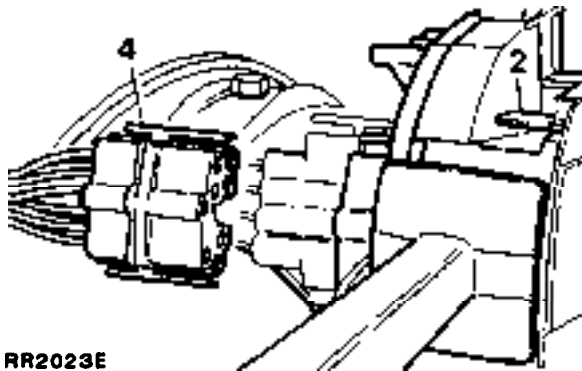

4. Lighting, indicator and horn switch: release the two harness multi-plugs from the back of the switch and remove the switch assembly.
Wiper and washer switch: release the harness multi-plug from the back of the switch and remove the switch assembly.

Refitting

5. Reverse the removal procedure.

HAZARD WARNING SWITCH BULB REPLACEMENT

Remove and refit

Removing

1. Disconnect the battery negative lead.
2. Pull the hazard switch cover upwards and remove it to gain access to the bulb.

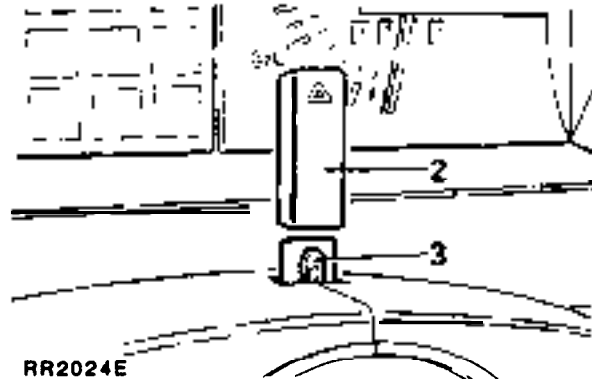

3. Remove the bulb by pulling it upwards. A piece of rubber tubing or adhesive tape attached to the bulb may facilitate removal and refitting.

Refitting

4. Locate the bulb in its holder and reverse instructions 1 to 3.
The correct bulb is a 12V, 1.2 watt 'wedge' base (capless).

COLUMN SWITCH ILLUMINATION BULB REPLACEMENT

Remove and refit

Removing

1. Disconnect the battery negative lead.
2. Remove the left hand side steering column shroud.
3. Working behind the column switch housing twist the bulb holder through 90° and withdraw.
4. Remove the bulb.

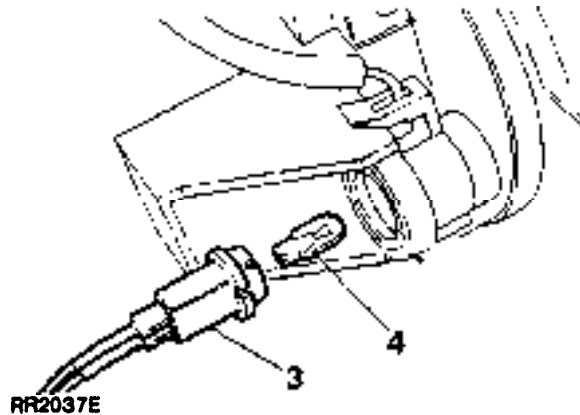

RR2037E

Refitting

5. Reverse the removal procedure. The correct bulb type is a 12-volt, 1.2-watt 'wedge' base (capless).

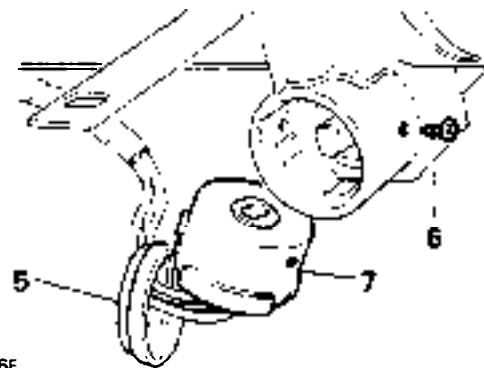

RR1966E

6. Remove the single screw securing the ignition/starter switch to the housing.
7. Withdraw the switch.

Refitting

8. Reverse the removal procedure.

DOOR PILLAR SWITCH

Remove and refit

Removing

1. Disconnect the battery negative lead.
2. Remove the screw securing the switch to door pillar.
3. Withdraw switch.
4. Disconnect electrical lead from connector blade.

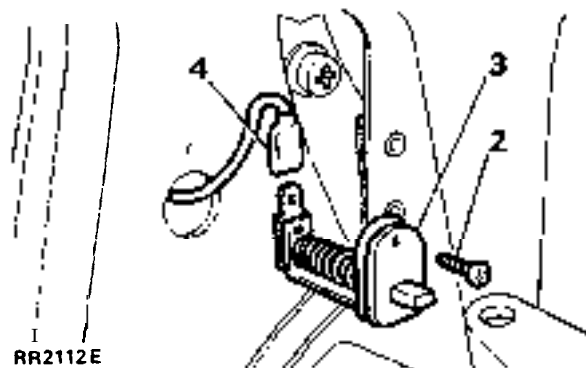

RR2112E

Refitting

5. Reverse removal procedure.

REAR TAILGATE SWITCH

Remove and refit

Removing

1. Disconnect the battery negative lead.
2. Remove the single screw securing the switch to the tailgate opening.
3. Withdraw the switch.
4. Disconnect the electrical lead.

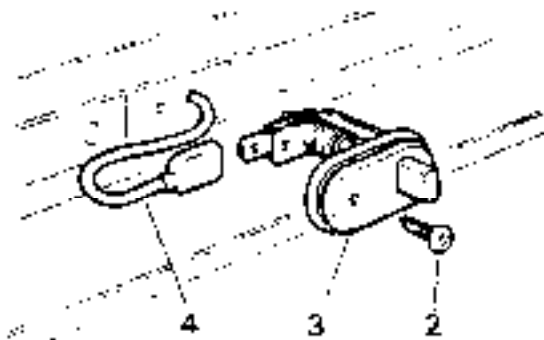

RR1857M

Refitting

5. Reverse the removal procedure.

UNDER HOOD ILLUMINATION SWITCH

Remove and refit

Removing

1. Disconnect the battery negative lead.
2. Remove the single screw securing the switch to the cowl panel.
3. Withdraw the switch.
4. Disconnect the electrical lead.

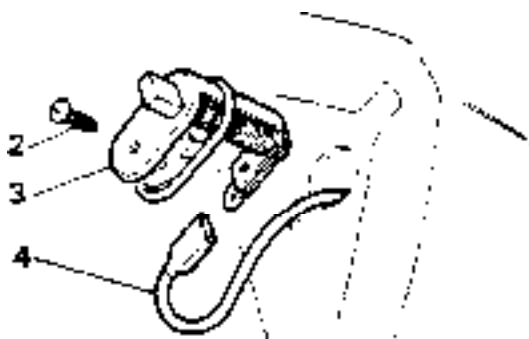

RR499M

Refitting

5. Reverse the removal procedure.

CIGAR LIGHTER-radio housing

Remove and refit

Removing

1. Disconnect the battery negative lead.
2. Remove the High/Low range gear knob.
3. Remove the main gearbox knob. See Automatic gear selector panel illumination.
4. Remove the glove box liner and release the parking brake cable from the parking brake lever, pry the inset panel out of the floor mounted console. Pull the two illumination bulbs from the selector panel.
5. Release the glove box from its four floor mounted fixings.
6. Raise the front of the glove box and console assembly and ease the unit away from the radio housing.

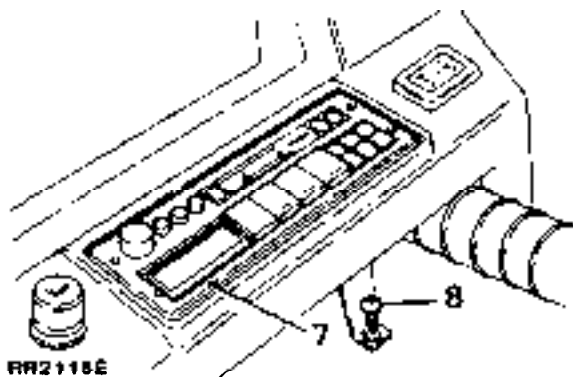

RR2115E

7. Remove the radio, referring to the Manufacturer's instructions for removal and installation.
8. Remove the single screw securing the housing to the top of the gearbox tunnel.
9. Pull the housing away from the lower dash panel.
10. Disconnect the electrical leads at the rear of the cigar lighter.
11. Remove the push in switch from the lighter outer body.
12. Depress the outer plastic surround where denoted by the arrows and push the outer body through the surround.
13. Maneuver the plastic surround and remove it from the radio housing.

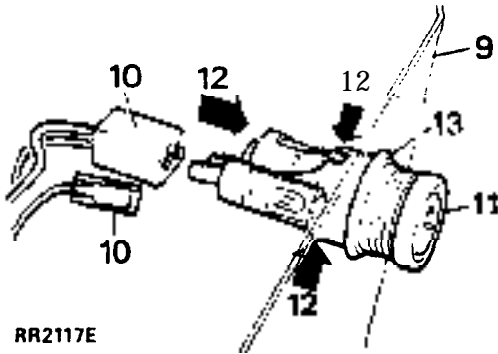

RR2117E

CIGAR LIGHTER ILLUMINATION -Bulb replacement

14. Remove the bulb holder from the plastic surround.
15. Pull the bulb from the holder. The correct bulb type is a 12V 1.2-watt wedge base (capless).

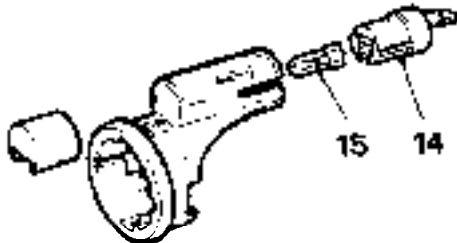

RR2118E

Refitting

16. Reverse the removal procedure.

CIGAR LIGHTER-Glove Box

The rear cigar lighter is located in the bottom of the glove box, access to the rear of the lighter is gained through heater/air vent duct below the rear ashtray.

Follow instructions 13 to 16 of CIGAR LIGHTER - radio housing, to remove the lighter from the glove box.

REVERSE LIGHT SWITCH-START INHIBITOR SWITCH/NEUTRAL SAFETY SWITCH

Automatic gearbox

Remove and refit

The reverse light switch is an integral part of the start inhibitor switch and is located on the left hand side of the gearbox above the front of the gearbox sump and is accessible from beneath the vehicle.

Removing

1. Drive the vehicle onto a suitable hoist.
2. Disconnect the battery negative lead.
3. Disconnect the multi-plug.
4. Release the clamp bolt and remove the clamp.
5. Withdraw the switch from its location.

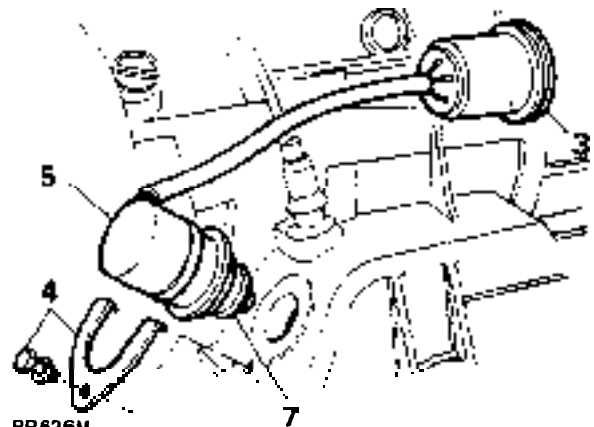

RR626M

Refitting

6. Reverse the removal instructions.
7. Fit a NEW 'O' ring to the switch.

OIL PRESSURE WARNING SWITCH

Remove and refit

Removing

1. Disconnect the battery negative lead.
2. Disconnect the electrical lead from the switch.
3. Unscrew the switch unit.
4. Remove switch and sealing washer.

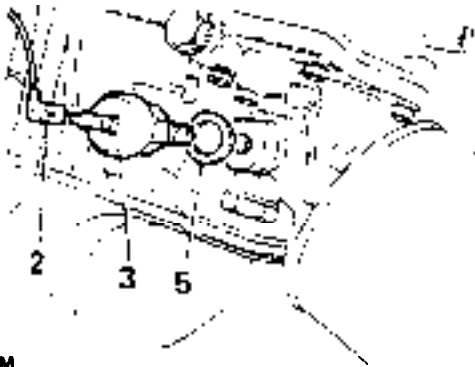

RR513M

Refitting

5. Reverse the removal procedure, using a NEW sealing washer.

COOLANT TEMPERATURE TRANSMITTER

Remove and refit

Removing

1. Disconnect the battery negative lead.
2. Disconnect the electrical lead from the transmitter.
3. Remove the transmitter from the inlet manifold.

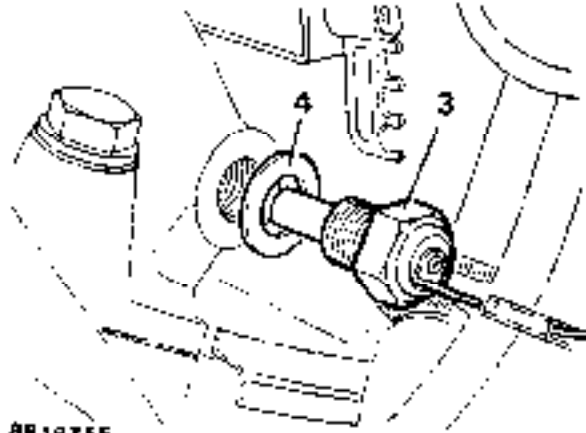

RR1975E

Refitting

4. Reverse the removal procedure, using a NEW sealing washer.

STOP LIGHT SWITCH

Remove and refit

Removing

1. Disconnect the battery negative lead.
2. Remove the lower dash panel.
3. Depress the foot brake.
4. Remove the rubber protector from switch (where fitted).
5. Remove the hexagon nut.
6. Withdraw the switch.
7. Disconnect the electrical leads.

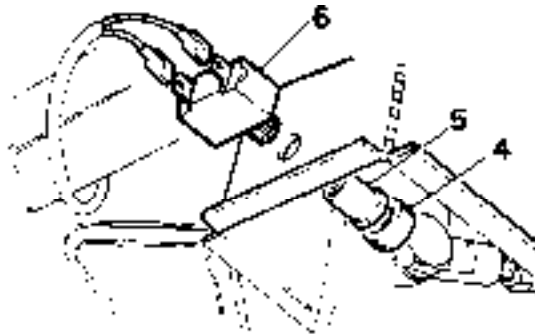

RR509M

Refitting

8. Reverse the removal procedure.

PARKING BRAKE WARNING SWITCH

Remove and refit

Removing

1. Disconnect the battery negative lead.
2. Apply the parking brake.
3. To gain access to the warning switch located on the side of the parking brake mounting bracket, it is necessary to remove the glove box liner.
4. Remove the four screws securing the glove box liner and lift out the liner.
5. Carefully pull the rear warm air flow hose away from the side of the parking brake mounting bracket to give access to the two screws securing the switch in position.
6. Remove the two screws.
7. Maneuver the switch around the front of the parking brake mounting bracket and disconnect the electrical lead.
8. Withdraw the switch.

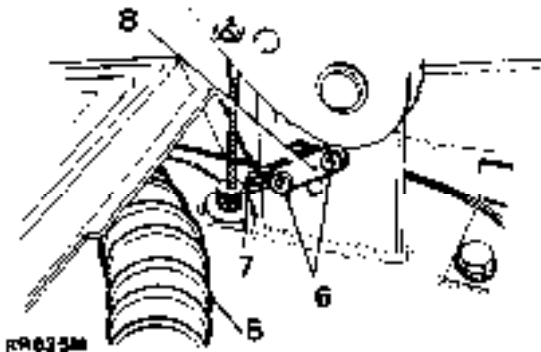

Refitting

9. Reverse the removal procedure.

EXTERIOR DRIVING MIRRORS

1. The mirror housing is hinged vertically and should be set in one of the two fixed angle positions provided to suit the respective left or right side mirror location.

2. Additionally, for safety and convenience, the mirror housing is designed to fold completely forwards or rearwards against the vehicle body.

Adjusting

3. Fine adjustment is controlled by an electric motor inside the mirror housing. This is operated by two controls fitted in the dash panel. To adjust, select left or right hand mirror. Move the head of the finger tip control to the left, right, up or down as required.
4. The mirror also incorporates a demist facility, activated by operation of the rear window demist switch.

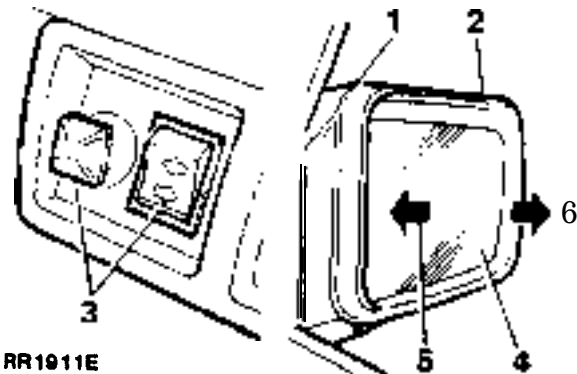

RR1911E

Replacing the mirror glass

5. Press the inner (wider) end of the glass inwards to its full extent.
6. Insert the fingers under the outer (narrower) end of the glass, and pull outwards until the glass is released from its four retaining clips.
7. Disconnect the two demister leads attached to the back of the glass unit.
8. To replace the glass, locate the inner (wider) end of the glass in the mirror housing first.

Continued

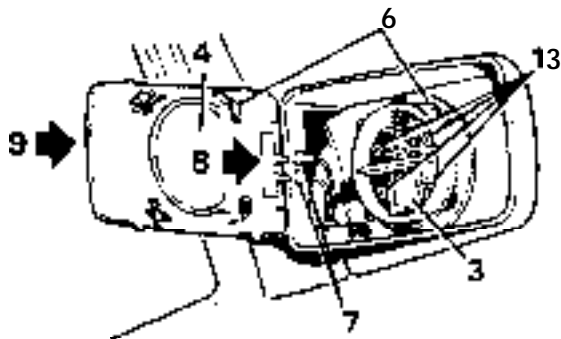

RR2038E

9. Carefully press the outer (narrower) end of the glass Inwards until it is safely held by its four retaining clips.
10. Reset the fine adjustment as required.

EXTERIOR DRIVING MIRRORS

ELECTRIC MOTORS

Remove and refit

Removing

71. Disconnect the battery negative lead.
72. Remove the mirror glass, as described in items 5 to 7.
73. Remove the four self-tapping screws securing the motor assembly to the mirror body.
74. Maneuver the motor assembly to reveal the electrical connections on the rear of the motor.
75. Pull the leads from the rear of the motor assembly.

Refitting

76. Reverse operations 71 to 75, ensuring that the electrical leads are correctly refitted (see electric mirror, circuit diagram).

EXTERIOR DRIVING MIRRORS

CONTROL SWITCHES

Remove and refit

17. Disconnect the battery negative lead.
18. Carefully pry the switch retaining panel out of the dash panel.
19. Withdraw the panel only as far as the electrical leads will permit.

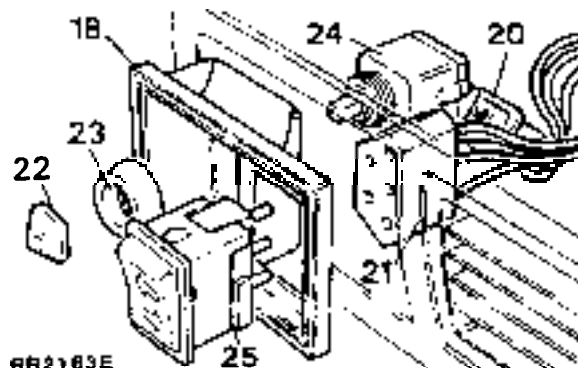

RR2163E

20. Pull the multi-plug from the rear of the fingertip controlled mirror switch.
21. Disconnect the multi-plug at the rear of the selector switch and remove the panel.
22. Carefully pry off the fingertip button at the operating end of the switch.
23. Unscrew the black plastic retaining collar securing the switch.
24. Remove the switch from the panel noting the position of the locating hole in the panel retaining clip
25. Depress the two spring clips securing the selector switch and push it through the panel.

Refitting

26. Reverse operations 17 to 25.

EXTERIOR DRIVING MIRRORS

COMPLETE ASSEMBLY

Remove and refit

Removing

27. Disconnect the battery negative lead.
28. Carefully pry off the interior finisher plate to reveal the three securing screws and electric wiring.
29. Disconnect the two electrical plugs (one two pin, one three pin).
30. Supporting the exterior mirror assembly remove the three securing screws (with plain and spring washer).
31. Pull the inner mounting plate away from the inner door frame complete with the two retaining clips.
32. Detach the mirror assembly from the outer door frame.
33. Remove the sealing rubber.

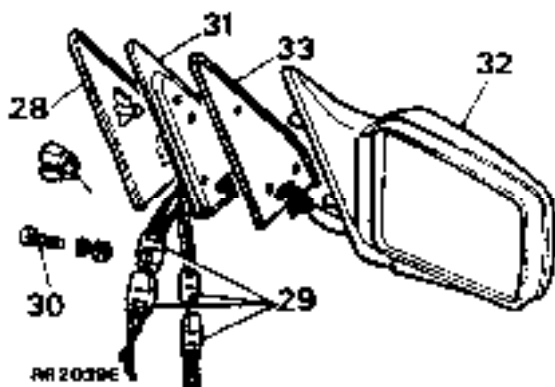

Refitting

34. Reverse the operations 27 to 33.

NOTE: To prevent damage to the electrical wiring do not push the leads down inside the door casing.

CLOCK

Remove and refit

Removing

1. Disconnect the battery negative terminal.
2. Carefully pry the clock out of the dash panel to reveal the electrical connections.

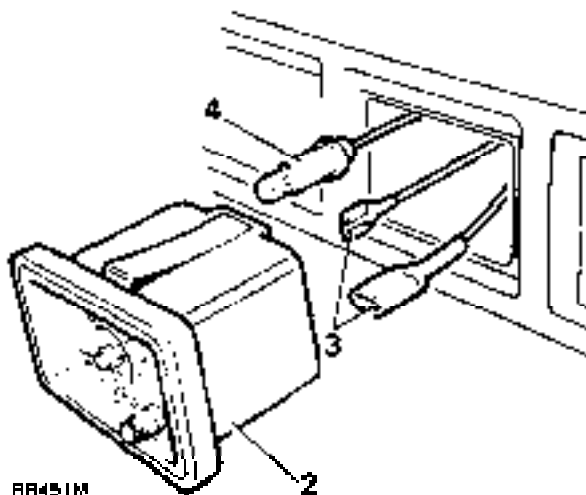

3. Disconnect the two electrical leads.
4. Remove the illumination lead complete with holder and bulb.

NOTE: The clock is illuminated by a 2-watt bayonet type bulb.

Refitting

5. Reverse the removal procedure.

INSTRUMENT BINNACLE WARNING LIGHT SYMBOLS



Trailer connected-flashes with direction indicators (green)



Symbol (not used) will illuminate on initial bulb check



Direction indicator- left turn / right turn (green)



Brake pad wear (amber)



Seat belt (red)



Brake fluid pressure failure, AP system/Brake fluid level, Lucas Girling system/Transmission park brake on (red)



Headlamp high beam on (blue)



Engine oil pressure, low (red)
Flashing - engine oil level low



Electronic fuel injection warning lamp (red) indicates failure of air flow sensor, throttle potentiometer, water temperature thermistor, or Lambda sensor



Ignition on/No charge indicator (red)



Low coolant (red)



Automatic gearbox oil temperature high (red)



Fuel indicator, low (amber)



Low wash fluid (amber)



RR2044E

The differential lock warning light, (located on the radio console) and the fifteen segments of the warning light panel within the binnacle will all be illuminated when the ignition key is turned to the 'ignition On II' position as an initial check to ensure that all bulbs are operational. All bulbs, except for the 'Brake Failure/ Transmission Parking Brake'-'Engine Oil Pressure' and 'Ignition On' symbols will go out automatically.

The 'Engine Oil Pressure' and 'Ignition On' symbols will remain on when the ignition key is turned to the engine crank position 'III' and extinguished when the engine is running.

The 'Brake Failure/Transmission Parking Brake' symbol will extinguish when the parking brake lever is released.

NOTE: Should the ignition key be turned directly to the engine crank position the bulb check procedure will be overridden.

A photo transistor incorporated into the Instrument binnacle senses ambient light levels. During normal ambient daylight levels the warning light panel will glow at normal intensity. When ambient light levels decrease, the photo transistor senses the reduction and lowers the intensity of the warning light panel accordingly.

PANEL AND WARNING LIGHT-bulb replacement

1. Disconnect the battery negative terminal.
2. Unclip the back of the cowl from the instrument binnacle to give access to the panel and warning light bulbs in the back of the instrument case.
3. Remove the appropriate bulb holder unit by rotating it counter-clockwise and withdrawing it.

NOTE: The "No Charge/Ignition On" warning light, identified by its-red coloured bulb holder, is of a higher wattage and is the only bulb which can be pulled from its holder and replaced independently.

4. Fit a new bulb holder unit and rotate clockwise to lock in position. The correct bulb type is a 1.2 watt bulb/holder unit, except the ignition bulb which is 2 watt wedge base type.
5. Refit the cowl and reconnect the battery.

NOTE: If difficulty is experienced in changing bulbs, due to the limited space available the instrument binnacle fixings should be removed to enable the binnacle to be raised above the dash as far as other connections permit. See 'Instrument Binnacle Removal' below for details of binnacle mounting bracket fixing.

INSTRUMENT BINNACLE

Remove and refit

Remove

1. Disconnect the battery negative terminal.
2. Remove the lower dash panel by releasing the six retaining screws.
3. Remove the four nuts (with spring and plain washers) from under the top dash rail which secure the instrument binnacle to the vehicle.
4. Unclip the binnacle cowl, from the rear, to provide access to the speedometer cable.
5. Disconnect the speedometer cable from the speedometer drive on the back of the instrument case.
6. Remove the two large multi-plugs from the printed circuit, and the single plug from the warning lamp control unit.

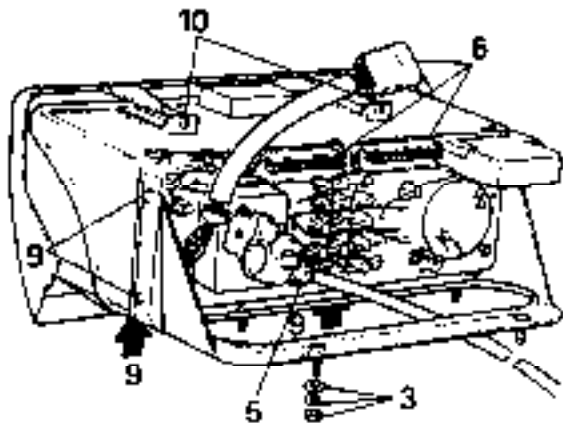

RR1809E

7. Lift the instrument binnacle from the top dash rail and transfer it to the workbench.

Refitting

8. Reverse the removal instructions 1 to 7.

Removing instrument pack

9. Having removed the instrument binnacle from the vehicle, detach the binnacle mounting bracket. This is secured to the instrument case by two screws and to the bottom of the binnacle bezel by two smaller screws.
10. Remove the two screws retaining the top of the bezel to the front housing and detach the bezel.
11. Separate the instrument case from the binnacle housing by releasing the two wire clips.
12. Detach the curved lens from the binnacle housing by releasing the wire clip at the top.

Refitting instrument pack to binnacle

13. Reverse removal instructions 9 to 12.

Removing printed circuit, multi-function unit and photo transistor

NOTE: Ensure all warning light and panel illumination bulb holders are removed before removing the printed circuit. Note the position of the no charge warning light (red holder).

14. Remove the two tachometer nuts (with washers) to release the printed circuit connecting tags.
15. Remove the four nuts (with washers) securing the fuel and temperature gauges to release the printed circuit from the fixing studs.

16. Release the two retaining screws and carefully remove the multi-function unit. Using a pair of tweezers or a fine screwdriver, lift the printed circuit out of its location and extract the rubber contact pad.

NOTE: If fitting a new multi-function unit the new rubber contact pad supplied **MUST** be installed under the printed circuit to ensure correct contact pressure.

17. Remove the two harness connectors, retained by four screws, to release the printed circuit tags.
18. Twist the photo transistor counter clockwise to disengage from the binnacle housing. Remove the five screws securing the single multi-plug wiring connections. Note the position of the leads for reassembly.
19. Carefully ease the printed circuit from its four locating pegs.

Refitting the printed circuit, multi-function unit and photo transistor

20. Reverse the removal procedure items 14 to 19.
21. Ensure that the fuel and temperature gauge mounting studs are correctly located before pressing the printed circuit on to its four locating pegs.

Removing tachometer

22. Carefully pry the needle shroud from the tachometer and disconnect the fibre optic element underneath the shroud.
23. Remove the two nuts (with washers) at the back of the instrument case which retains the tachometer and release the printed circuit tags.
24. Loosen the four nuts retaining the fuel and temperature gauges and carefully maneuver the tachometer from the front of the instrument case.

Continued

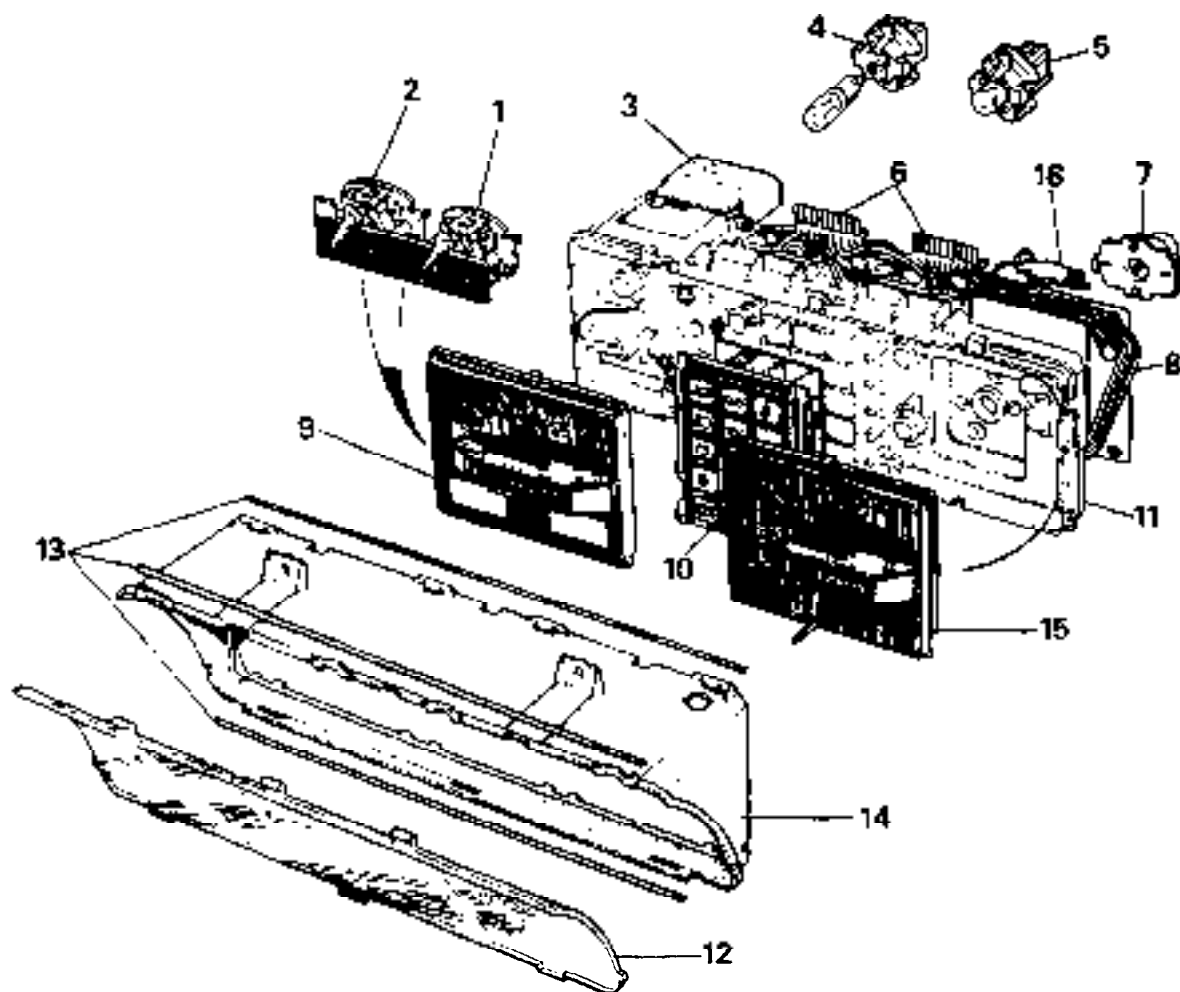

RR 2271E

instrument Pack

- | | |
|--|---|
| <ul style="list-style-type: none"> 1. Fuel gauge 2. Temperature gauge 3. Voltage stabiliser 4. Ignition warning bulb (with separate red holder unit) 5. Panel/warning lights bulb/holder 6. Printed circuit input tags (for harness connection) 7. Speedometer drive unit 8. Printed circuit | <ul style="list-style-type: none"> 9. Tachometer 10. Warning lights panel. 11. instrument case (front) 12. Curved lens 13. Wire connecting clips 14. Binnacle housing 15. Speedometer 16. Photo transistor - automatic dimming - warning lights |
|--|---|

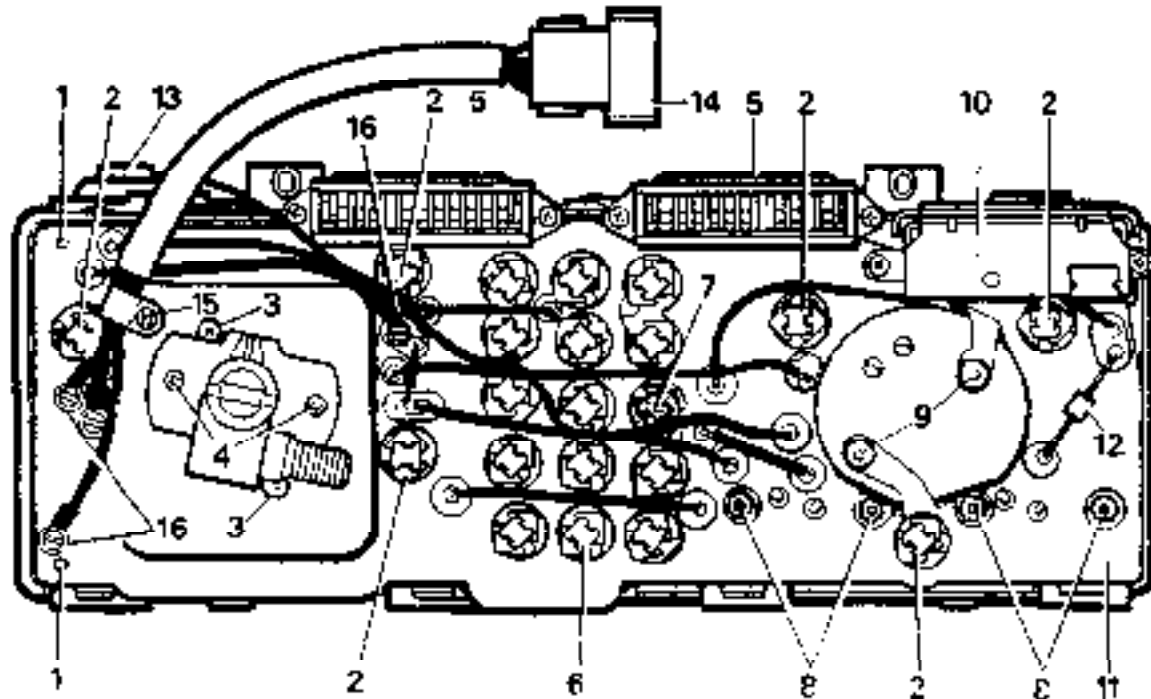

RR272E

Instrument case (back)

- | | |
|--|--|
| 1. Locating pegs | 9. Tachometer securing nuts |
| 2. Panel light bulbs | 10. Multi-function unit |
| 3. Speedometer securing screw | 11. Printed circuit |
| 4. Speedometer drive securing screws | 12. Pull-up resistor-high temperature gearbox oil |
| 5. Harness connectors | 13. Photo transistor |
| 6. Warning light bulbs (14) | 14. Single multi-plug |
| 7. No charge warning light bulb (red holder) | 15. Single multi-plug securing screw |
| 8. Temperature and fuel gauge unit securing nuts | 16. Single multi-plug wiring connecting screws (5) |

PRINTED CIRCUIT HARNESS CONNECTIONS

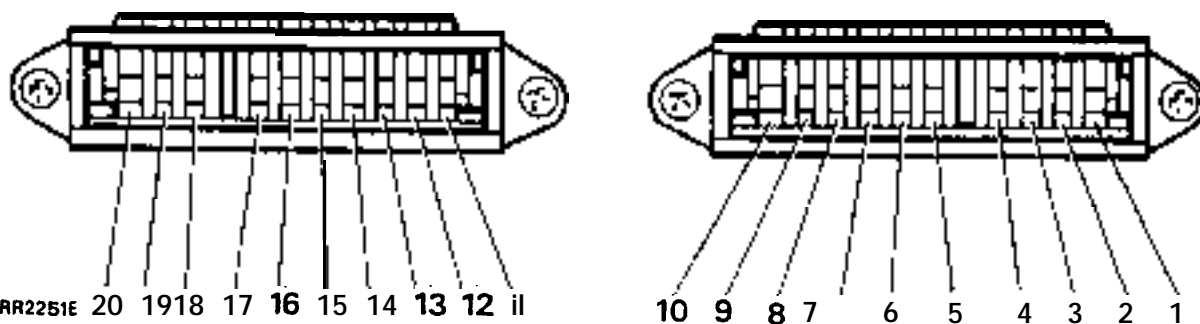

RR2251E

Sequence of connections looking towards the back of instrument case.

CIRCUIT SERVED

Tacho signal	1
Ignition switch 12V +	2
Low coolant input	3
Ground-VE	4
Ignition warning light	5
Low oil level/pressure warning light	6
High beam warning light	7
Ground from bulb check unit	8
Trailer warning light	9
Direction indicators warning light	10
Seat belts warning light	11
E.F.I. warning light	12
Temperature warning light (automatic gearbox)	13
Low wash fluid warning light	14
Not used	15
12V + from bulb check unit	16
Brake fail warning light	17
Panel illumination bulbs (6 off)	18
Low fuel warning light	19
Low coolant warning light	20

NOTE: The following 21 to 25 are connected at the single multiplug located behind the binnacle

Brake pad wear warning light	21
'P' symbol (initial bulb check only)	22
Fuel tank unit and fuel gauge	23
Temperature gauge	24
Photo transistor	25

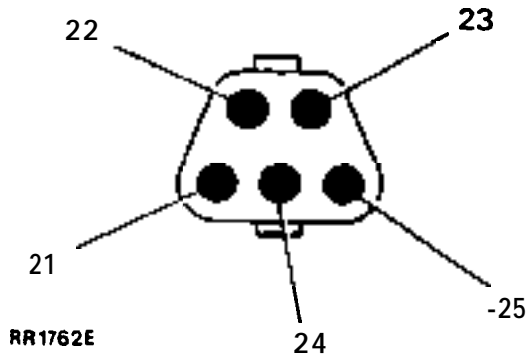

Sequence of pin connections viewed on the binnacle harness plug.

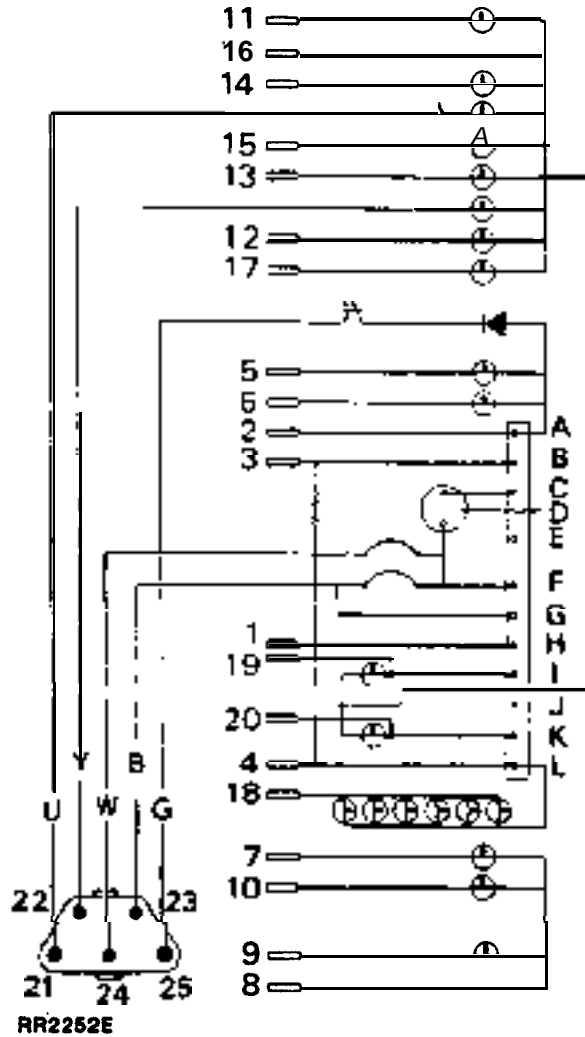

MULTI-FUNCTION UNIT

- A. 12V + supply
- B. Input to low coolant circuit
- C. Tachometer drive
- D. Tachometer
- E. Spare
- F. 1 OV + stabilised
- c. Input to fuel tank unit - stabilised
- H. Tachometer signal
- I. Low fuel warning light
- I. Spare
- K. Low coolant warning light
- L. Ground

Refitting the tachometer

- 25. Reverse the removal procedure, items 22 to 24.

Removing fuel and temperature gauge unit

- 26. Carefully pry the needle shroud from the tachometer and disconnect the fibre optic element underneath the shroud.
- 27. Remove the two nuts (with washers) retaining the tachometer and release the printed circuit taps.
- 28. Remove the four nuts (with washers) retaining the fuel and temperature gauges and carefully maneuver the tachometer, fuel and temperature gauge unit **from** the front of the instrument case.

Refitting the fuel and temperature gauges

- 29. Locate the fuel and temperature gauge unit in the instrument **panel** but do not fit the washers and nuts at **this** stage.
- 30. Feed the fibre optic element through the opening in the tachometer then locate the tachometer in the instrument panel.
- 31. Position **the** printed circuit tags over the two tachometer studs, fit the washers and fit and tighten the retaining nuts.
- 32. Fit the washers to the four fuel and temperature gauge studs and fit and tighten the retaining nuts.

Removing the speedometer and speedometer drive unit

- 33. Carefully pry the needle shroud from the element underneath the shroud.
- 34. Remove the two hexagonal headed screws (with washers) at the back of the instrument case which retain the speedometer.

- 35. Carefully remove the speedometer from the front of the instrument case.
- 36. To release the speedometer drive unit, remove the two self-tapping screws securing it to the back of the instrument case.

Refitting the speedometer and speedometer drive unit

- 37. Reverse the removal procedure items 33 to 36.

WARNING LAMP CONTROL UNIT

-see also page 69

Remove and refit

Removing

- 1. Disconnect the battery negative terminal.
- 2. Release the six screws securing the lower dash panel below the steering column.
- 3. Lower the dash panel and disconnect the multi-plug from **the** rheostat switch.
- 4. Pull the warning lamp control unit from the spring clip on the underside of the dash panel and disconnect the three multi-plugs from the unit.
- 5. Remove the warning lamp control unit from the vehicle.



RR1805E 1

Refitting

- 6. Reverse the removal procedure ensuring that the multi-plugs and unit are securely pushed into position.

**INSTRUMENT ILLUMINATION ELECTRONIC
DIMMING CONTROURHEOSTAT**

The electronic dimming control switch is located on the lower dash panel adjacent to the steering column. Rotate the control upwards to fully illuminate the instruments and downwards to reduce intensity.

The dimming control unit also controls the clock, heater and cigar lighter illumination.

Remove and refit

Removing

1. Disconnect the battery.
2. Remove the lower dash panel by releasing the six securing screws.
3. Disconnect the dimming control multi-plug.
4. Remove the two screws securing the dimmer control switch to the under-side of the lower dash panel.

Reiitting

Reverse operations 1 to 4.

SPEEDOMETER CABLE

Remove and refit

Removing

1. Disconnect the battery negative lead.
2. Remove the lower dash panel (beneath the steering column) by releasing six retaining screws.
3. Unclip the back of the cowl from the instrument binnacle to give access to the speedometer drive.
4. Disconnect the cable from the speedometer drive.
5. Withdraw the cable and grommet through the bulkhead.
6. Working underneath the vehicle, disconnect the cable at the speed transducer.
7. Release the cable from the retaining clips.

8. To remove the shorter cable, disconnect it from the speed transducer and remove the single nut and clamp securing the cable to the speedometer drive housing at the rear of the transfer box.

Refitting

9. Reverse instructions 1 to 8.

WINDOW LIFT SWITCHES

Remove and refit

Removing

1. Disconnect the battery negative lead.
2. Carefully pry the window lift switch surround away from the front of the glove box.
3. Disconnect the multi-plug at the rear of the switch(es).
4. Apply pressure to the rear of the switch to push it through the surround.

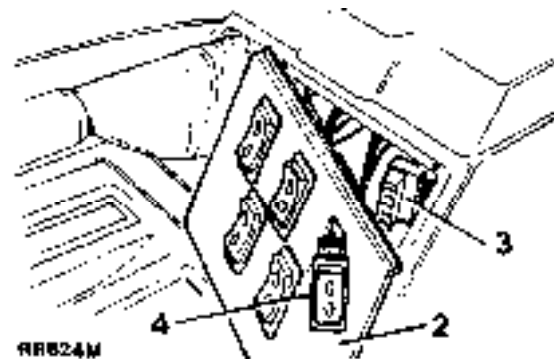

Refitting

5. Reverse the removal procedure.

WINDOW LIFT MOTOR-Front doors

Remove and refit

Removing

1. Ensure that the side door glass is in its fully closed position and secure it with adhesive tape.
2. Disconnect the battery.
3. Detach the arm-rest/door-pull finisher to reveal the two securing screws.
4. Remove the two screws (with plain washers) to enable the arm-rest/door-pull to be detached from the inner door panel.
5. Remove the interior door handle finisher button to reveal the screw retaining the handle surround.
6. Remove the screw and detach the handle surround from the inner door panel.
7. Detach the inner door trim pad by inserting a screwdriver between the trim pad and inner door panel gently prising out the nine plastic securing clips from their respective holes in the inner door panel. Tape perimeter to prevent scratches.
8. Disconnect the two radio speaker connections behind the trim pad, remove the trim pad complete with speaker.

NOTE: At this stage the speaker can be removed by releasing the four nuts (with plain washers) located on the back of the trim pad.

9. Peel back the front top corner of the plastic vapour barrier to reveal the window lift motor.
10. Release the window lift motor wiring harness from the three retaining clips to allow the harness to be pulled out of the opening at the front of the inner door panel.
11. Disconnect the window lift motor multi-plug from the main door harness.

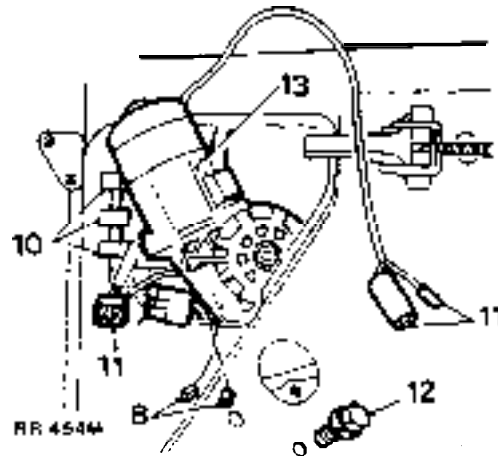

12. Supporting the motor, remove the three securing bolts.
13. Withdraw the motor through the top front opening of the door.

Refitting

14. Reverse operations 1 to 13.

NOTE: Ensure that the drive gear is engaged and correctly aligned with the window lift linkage before fitting the securing bolts.

WINDOW LIFT MOTOR-Rear doors

Remove and refit

Removing

15. Ensure the side door glass is in its fully closed position and secure it with adhesive tape.
16. Disconnect the battery.
17. Remove the arm-rest/door-pull finisher to reveal the two securing screws.
18. Remove the two screws (with plain washers) and detach the arm-rest/door-pull from the inner door panel. To enable the arm-rest/door-pull to be removed from the door, the window operating switch multi-plug must be disconnected from the rear of the switch.

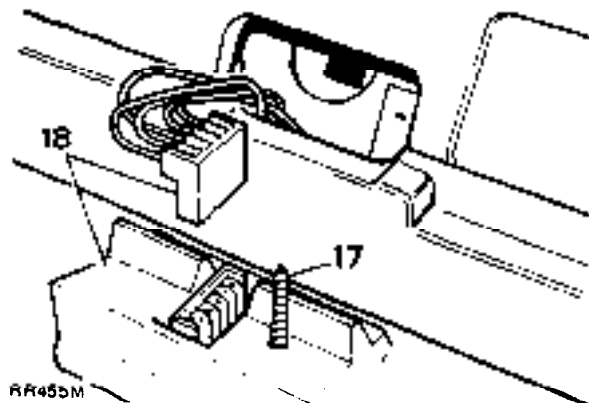

NOTE: At this stage the window operating switch can be removed by applying a little pressure to the rear of the switch to push it through the door-pull handle.

19. Remove the interior handle finisher button to reveal the screws retaining the handle surround.
20. Remove the screw and detach the handle surround from the door trim pad.
21. Remove the door trim pad by inserting a screwdriver between the trim pad and inner door panel, gently prying out the six plastic securing clips from their respective holes in the inner door panel.
22. Carefully detach the bottom half of the vapour barrier to reveal the window lift motor.
23. Release the lift motor wiring harness from the retaining clips.
24. Disconnect the lift motor harness snap connections from the main door harness.
25. Supporting the lift motor release the three bolts securing the motor to the inner door panel.
26. Withdraw the lift motor from the lower opening in the inner door panel.

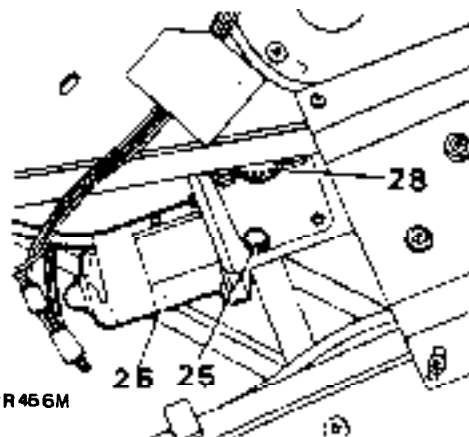

Refitting

27. Reverse operations 15 to 26.
28. Ensure the lift motor drive gear is engaged and correctly aligned with the window lift linkage before fitting the securing bolts.

ELECTRICALLY OPERATED CENTRAL DOOR LOCKING SYSTEM

An electrically operated central door locking system is fitted as standard equipment.

Locking or unlocking the drivers door from outside by key operation, or from inside by sill knob automatically locks or unlocks all four doors and the fuel filler flap.

Front and rear passenger doors can be independently locked or unlocked from inside the vehicle by sill knob operation but can be overridden by further operation of the driver's door locking control.

On rear doors only, a child safety lock is provided which can be mechanically pre-set to render the interior door handles inoperative.

failure of an actuator will not affect the locking of the remaining three doors or the fuel filler flap. The door with the inoperative actuator can still be locked or unlocked manually, but not the fuel filler flap.

NOTE: The actuator units contain non-serviceable parts. if a fault should occur replace the unit concerned with a new one.

Before carrying out any maintenance work disconnect the battery negative lead.

FRONT DOOR ACTUATOR UNITS

Remove and refit

Removing

1. Ensure the window is in its fully closed position.
2. Remove the arm-rest/door-pull finisher to reveal the two retaining screws.
3. Remove the interior door handle finisher button to reveal the screw retaining the handle surround.

4. Release the screw and remove the handle surround from the interior door trim pad.
5. Release the door trim pad by inserting a screwdriver between the trim pad and the inner door panel, carefully prying out the nine plastic clips from their respective holes around the edges of the trim pad.
6. Disconnect the two speaker connections inside the door and remove the door trim pad complete with speaker.
7. Peel back the top of the plastic vapour barrier at the rear of the inner door panel to expose the lock actuator unit.
8. Remove the four screws (with plain washers) securing the lock actuator mounting plate to the inner door panel.
9. Release the clip retaining the electrical cable.
10. Maneuver the actuator assembly to detach the operating rod 'eye' from the hooked end of the actuator link on the door lock.

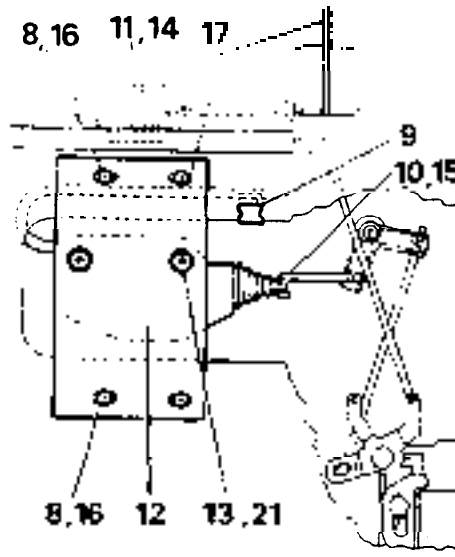

RR369M

11. Withdraw the actuator assembly from the door until the electrical cable is pulled out of its channel sufficiently to expose the connectors which can then be detached.
12. Remove the actuator assembly from the door.

13. The actuator unit may be changed if necessary by removing the two rubber mounted screws which secure it to the mounting plate.

Refitting

14. Locate the actuator assembly in the inner door panel and fit the electrical cable connectors. The cable, and connectors, are pulled back into the channel from the front end and the cable clip refitted.
15. Maneuver the actuator assembly to engage the operating rod 'eye' on the hooked actuator link.
16. Loosely fit the actuator mounting plate to the inner door panel with the four screws, setting the mounting plate in the centre of the slotted holes.
17. Ensure that manual operation of the sill locking control is not restricted by the operation of the actuator operating rod and vice versa, resetting the mounting plate as necessary.
18. Reconnect the vehicle battery.
19. Check that electrical operation of the door lock occurs when the sill locking control is moved through half of its total movement. Reset the mounting plate if necessary and tighten the four screws.

NOTE: The above adjustment ensures that the full tolerance on the switching operation is utilised.

REAR DOOR ACTUATOR UNITS

Remove and refit

instructions as for front doors with the following exceptions:

20. No radio speaker is involved.
21. The electrical cable and plug is retained and is immediately accessible through the large opening in the door.

22. instruction 19 does not apply to rear actuator units which are not fitted with switches.

NOTE: If necessary the lock actuator may be detached from its mounting plate to facilitate the removal of the lock actuator from the connector rod inside the door panel.

FUEL FILLER FLAP ACTUATOR UNIT

Remove and refit

Removing

1. Remove six screws and withdraw the closure panel, situated in the tool stowage area.
2. Ensure that the actuator is in the unlocked position and the fuel filler flap is open.
3. Release two screws and maneuver the actuator unit clear of its mounting.

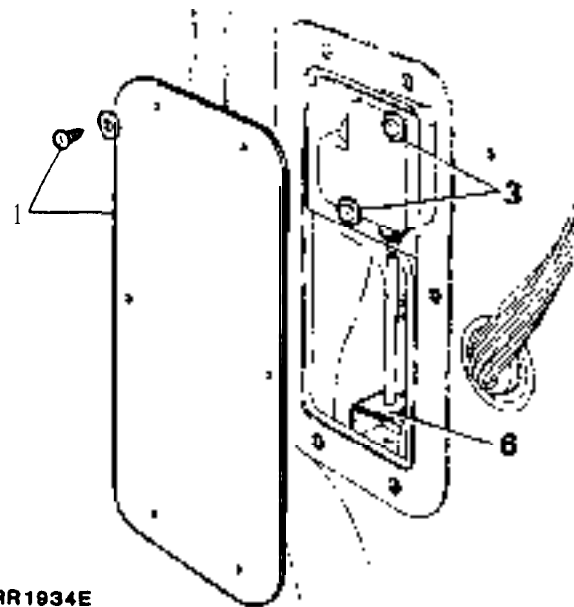

RR1934E

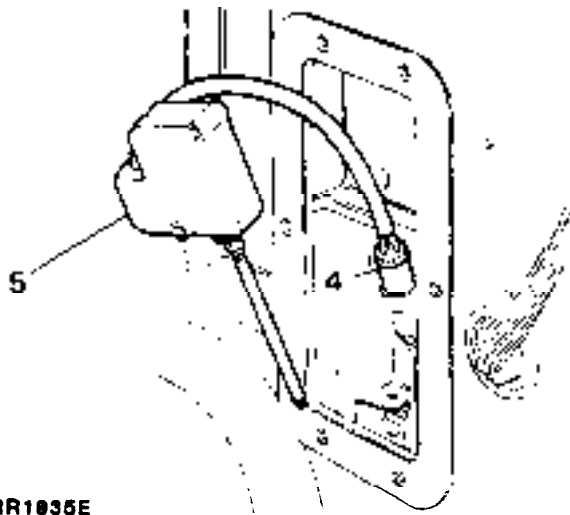

RR1035E

4. Disconnect the wiring plug.
5. Withdraw the actuator.

Refitting

6. Reverse the removal procedure. The actuator mounting holes in the body are elongated. Adjust the position of the actuator to ensure that the rod will pass through the guide brackets without fouling.
7. Check the operation of the central locking system.

FUEL TANK GAUGE UNIT

Remove and refit

Service tool-RO 600964 Locking wrench.

Removing

1. Disconnect the battery negative lead.
2. Remove the fuel tank, referring to the instructions on page 38, Fuel Injection System, Section 19.
3. Using service tool RO 600964 release the tank unit locking ring.
4. Remove the gauge unit and sealing washer.

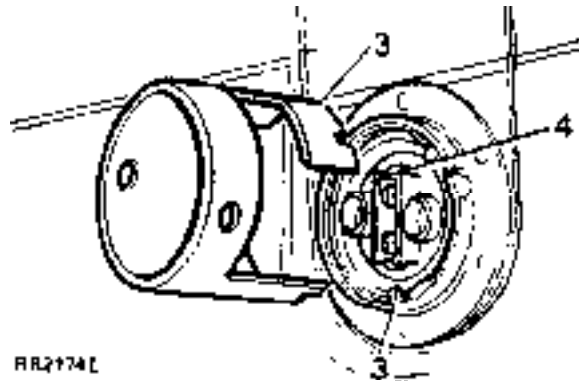

RR2174L

Refitting

5. Coat the mating faces with Bostik 772 adhesive and fit a NEW sealing washer. Locate the gauge unit in the tank ensuring that the notch in the outer edge of the gauge unit locates with tire register in the gauge opening of the tank.
6. Retighten the locking ring.
7. Refit the fuel tank.

TRAILER SOCKET-OPTION

Incorporated in the vehicle electrical circuit is a facility for fitting a seven pin trailer lighting socket. The pick-up point is located behind the right hand rear tail light cluster and is accessible by removing the tail light assembly.

The pick-up point consists of a seven pin pre-wired plug, a separate auxiliary fused line feed and reverse light lead.

CAUTION: The fitting of the trailer socket and its associated wiring **MUST** be carried out by a qualified vehicle electrician.

1. Disconnect the battery.
2. Remove the rear tail light assembly and disconnect the electrical plug.

Pre-wired plug • Part No. PRC4143

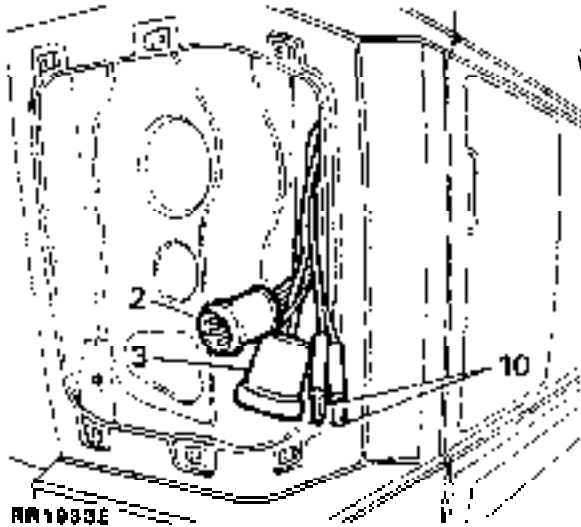

RR1033E

- Remove the protective cap from the trailer pick-up point plug.

NOTE: Cable colours in this plug correspond to the main circuit diagram. The red/yellow is a spare unused wire.

- Feed the seven core cable Part No. PRC4143 (fitted with a pre-wired plug to one end-suitable for connection to pick-up point) down between the inner and outer body panels through the rear light opening.
- Feed the cable alongside the existing rear lighting harness.
- Pull the cable through the opening between the chassis side member and fuel tank.
- Fit two retaining clips to the cable and secure it to the rear end cross member.
- Connect the electrical leads to the vehicle trailer socket. (Refer to current trailer wiring regulations).
- Secure trailer socket to the tow bar.
- If it is necessary to provide a line feed and reverse light feed, provision is made for this by the presence of two extra leads in the rear light opening.

Electrical lead identification

Single leads • item 10

pink/white

- Pink** • Fused auxiliary line feed.
- Green/Brown** • Reverse light feed.

BLUE

- Yellow • Left indicator.
- Green • Right indicator.
- ~~Red/Yellow~~ • Spare, unused.
- White • Ground.
- Brown • Right-hand tail lights.
- Black • Left-hand tail lights.
- Red • Stop lamps.

- Refit rear tail light.
- Reconnect the battery.

DIFFERENTIAL LOCK WARNING LAMP ASSEMBLY/BULB REPLACEMENT

Remove and refit

Removing

- Carefully pry the warning lamp out of the radio console.
- Remove the two wiring connectors and withdraw the lamp assembly, if required.
- Squeeze the sides of the lamp body to enable the lens surround to be slid back along the body.

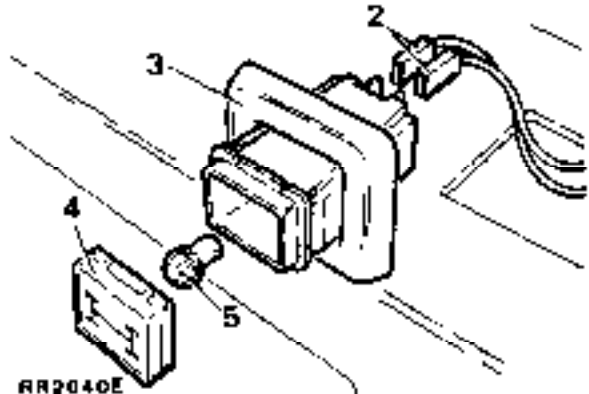

RR2040E

- Remove the amber lens.
- Remove the bayonet fitting bulb.

Refitting

- Reverse the removal procedure.

The correct bulb type is a 12-volt, 2-watt bayonet fitting.

AUDIBLE WARNING UNIT

The audible warning unit will sound with varying notes to warn the driver of the following conditions:

- (a) Intermittent high and low notes for a period of 4 to 8 seconds:
 - key in ignition position 'I' and driver's seat belt unfastened.
- (b) Interrupted low note:
 - drivers door open with key in switch but not in ignition position.
- (c) Rapidly repeated low note:
 - vehicle lights on and driver's door open with key removed from ignition switch.
- (d) Constant high note:
 - vehicle ignition switched on with transfer gearbox lever in neutral.

Remove and refit

Removing

1. Disconnect the battery negative lead.
2. Remove the steering column shroud.
3. Remove the under dash panel.
4. Disconnect the multi-pin plug.
5. Remove two securing screws and withdraw the audible warning unit.

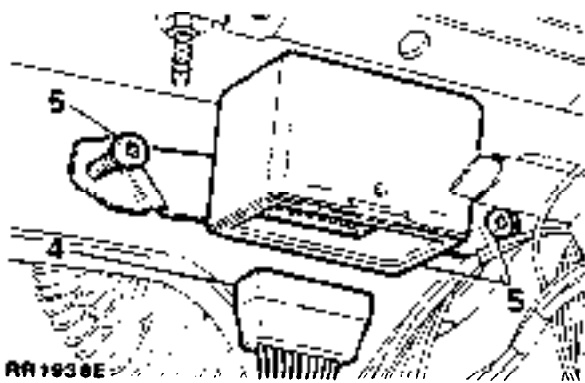

Refitting

6. Reverse the removal procedure.

LOW OIL LEVEL SENSOR UNIT

The low oil level sensor unit is fitted into the right hand side of the engine sump.

Remove and refit

NOTE: Ensure that the oil level is below the sensor before removal

Removing

1. Disconnect the battery negative lead.
2. Disconnect the wiring connector.

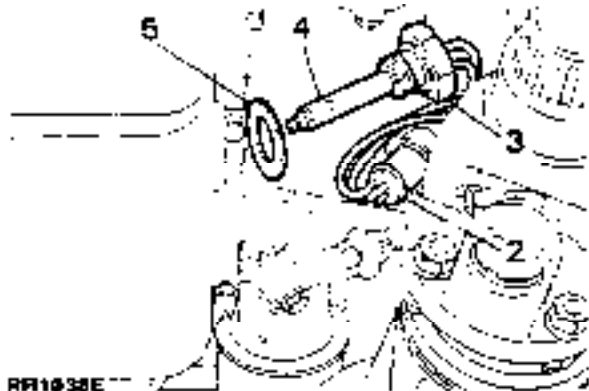

3. Remove the brass securing nut.
4. Withdraw the sensor unit.

Refitting

5. Fit a new sealing washer.
6. Reverse the removal procedure.
7. Top up the engine oil level. Run the engine and check for leaks around the sensor unit.

LOW OIL LEVEL WARNING LOGIC UNIT

When the ignition is switched 'ON' the warning lamp in the binnacle will flash for 10 to 20 seconds if low oil level is detected. The unit will not repeat the warning until the ignition is again switched 'ON'.

If the ignition is switched 'ON' within 15 to 30 seconds of the **preceeding** sequence, the warning lamp will not operate.

Remove and refit

Removing

1. Disconnect the battery negative lead.
2. Remove the lower dash panel.
3. Disconnect the wiring at the multi-plug.
4. Remove the securing screws and withdraw the logic control unit.

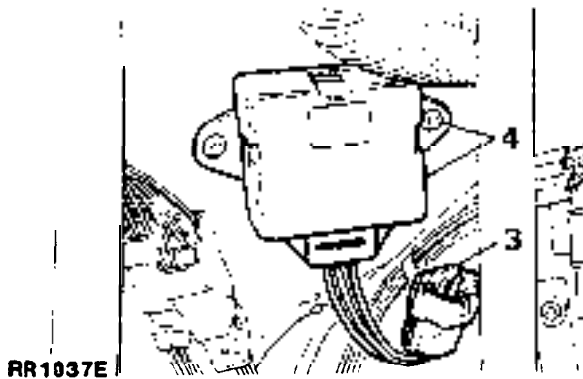

RR1037E

Refitting

5. Reverse the removal procedure.

FRONT SEAT ADJUSTMENT MOTORS

Remove and refit

Four electric motors **mounted beneath each front seat** control the fore and aft movement, the cushion height front and rear, and the angle of recline of the seat. Adjustment is possible with either front door open, or with ignition switched ON.

Removing

1. Position **the** seat to give access to the motors.
2. Disconnect the battery negative lead.
3. Remove the seat base trim.
4. Remove two securing screws from each side of the required motor.

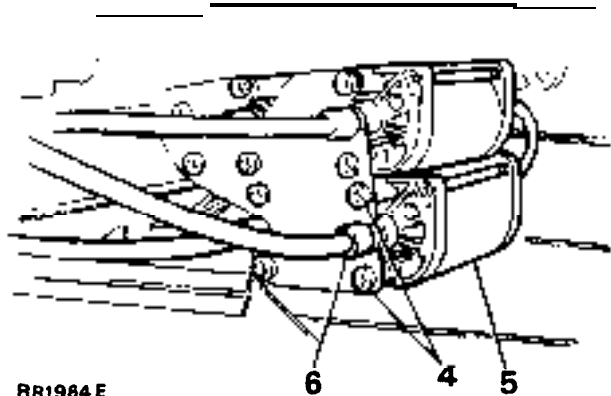

RR1984 E

5. Withdraw the motor from its **mounting**.
6. Disconnect the drive cables by unscrewing the ferrule.
7. Disconnect the wires from the multi-plug **and remove the motor**.

Refitting

8. Reverse the removal procedure.
9. Check the seat adjustment for correct operation.

SEAT ADJUSTMENT CONTROL SWITCH

Remove and refit

Removing

1. Disconnect the battery negative lead.
2. Pry the two finger tip controls from the top of the switch housing.
3. Removing the switch housing cover by lightly depressing the sides of the cover to disengage the clips. Remove the diaphragm fitted to later models.
4. Remove two crosshead screws and washers and lift the switch assembly to gain access to the two multiplugs.
5. Disconnect the multiplugs and withdraw the switch assembly.

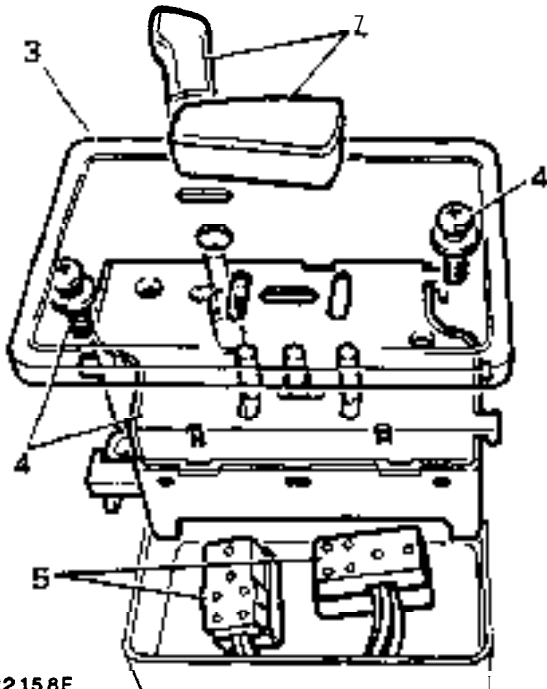

RR2158E

Refitting

6. Reverse instructions 1 to 5.

NOTE: If switch housing removal is required it is necessary to remove the seat to gain access to the two securing screws- see Body Section 76.

RADIO ANTENNA AMPLIFIER

Remove and refit

Removing

1. Disconnect the battery negative lead.
2. Lower or remove the rear headlining.
3. Remove the electrical leads and the antenna lead to the radio.
4. Remove two screws and withdraw the amplifier unit.

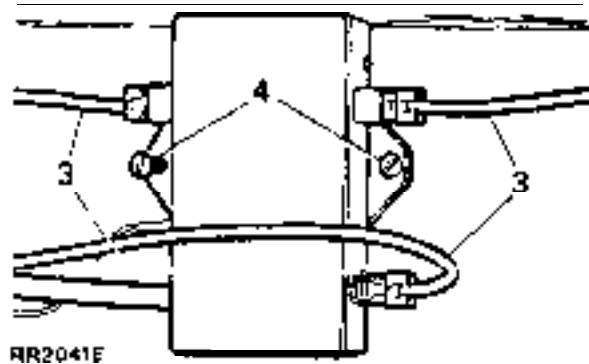

RR2041E

Refitting

5. Reverse the removal procedure.

ELECTRICAL EQUIPMENT-CIRCUIT DIAGRAMS

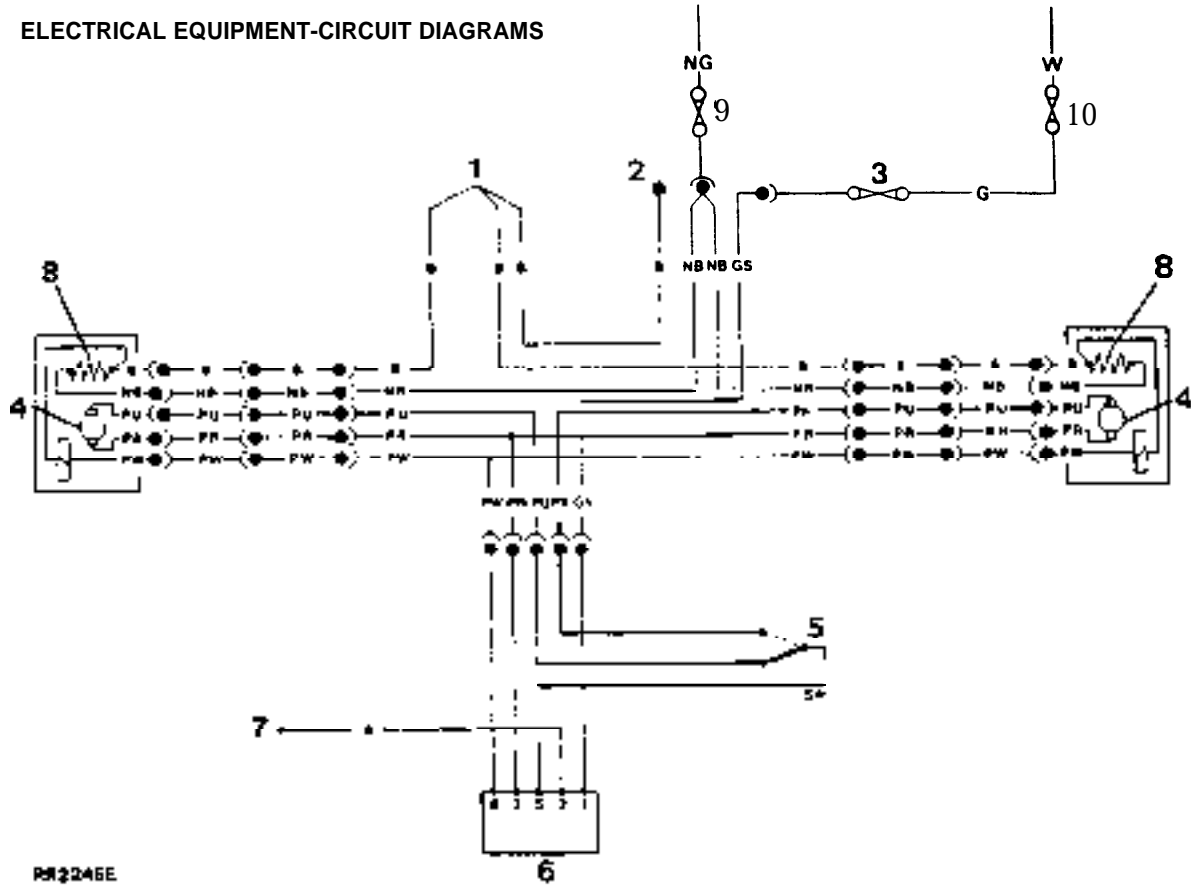

PR2246E

ELECTRIC MIRRORS -
Circuit diagram

- | | |
|----------------------------|---|
| 1. Clinch | 8. Mirror heating elements - active with heated rear screen |
| 2. Main cable connections | 9. Fuse 10 - heating elements |
| 3. Fuse A5 - mirror motors | 10. Fuse 13 |
| 4. Mirror motors | |
| 5. Change over switch | |
| 6. Mirror control switch | |
| 7. Ground - via main cable | |

CABLE COLOUR CODE

- B Black
- U Blue
- N Brown
- G Green
- S Grey
- O Orange
- K Pink
- P Purple
- R Red
- W White
- Y Yellow

The last letter of a colour code denotes the tracer.

WINDOW LIFTS AND DOOR LOCKS-**Circuit diagram**

1. Main cable connections
NK: (+) Battery feed - central locking
WO: (+) Key position 1 - window lift
B: (-) Ground
2. Clinches
3. Switch unit-central door locking (drivers door)
4. Fuel flap actuator
5. Lock unit-central door locking (front passenger door)
6. Window lift motor L/H front
7. Window lift motor R/H front
8. isolator switch
9. Window lift switch L/H front
10. Window lift switch R/H front
11. Window lift switch L/H rear
12. Window lift switch R/H rear
13. Window lift motor L/H rear
14. Window lift motor R/H rear
15. Window lift switch L/H rear door
16. Window lift switch R/H rear door
17. Lock unit central door locking L/H rear door
18. Lock unit central door locking R/H rear door
19. Rocker switch operating levers

CABLE COLOUR CODE

B Black	G Green	K Pink	W White
U Blue	S Grey	P Purple	Y Yellow
h! Brown	0 Orange	R Red	

The last letter of a **colour** code denotes the tracer.

WINDOW LIFTS AND DOOR LOCKS-
Circuit diagram

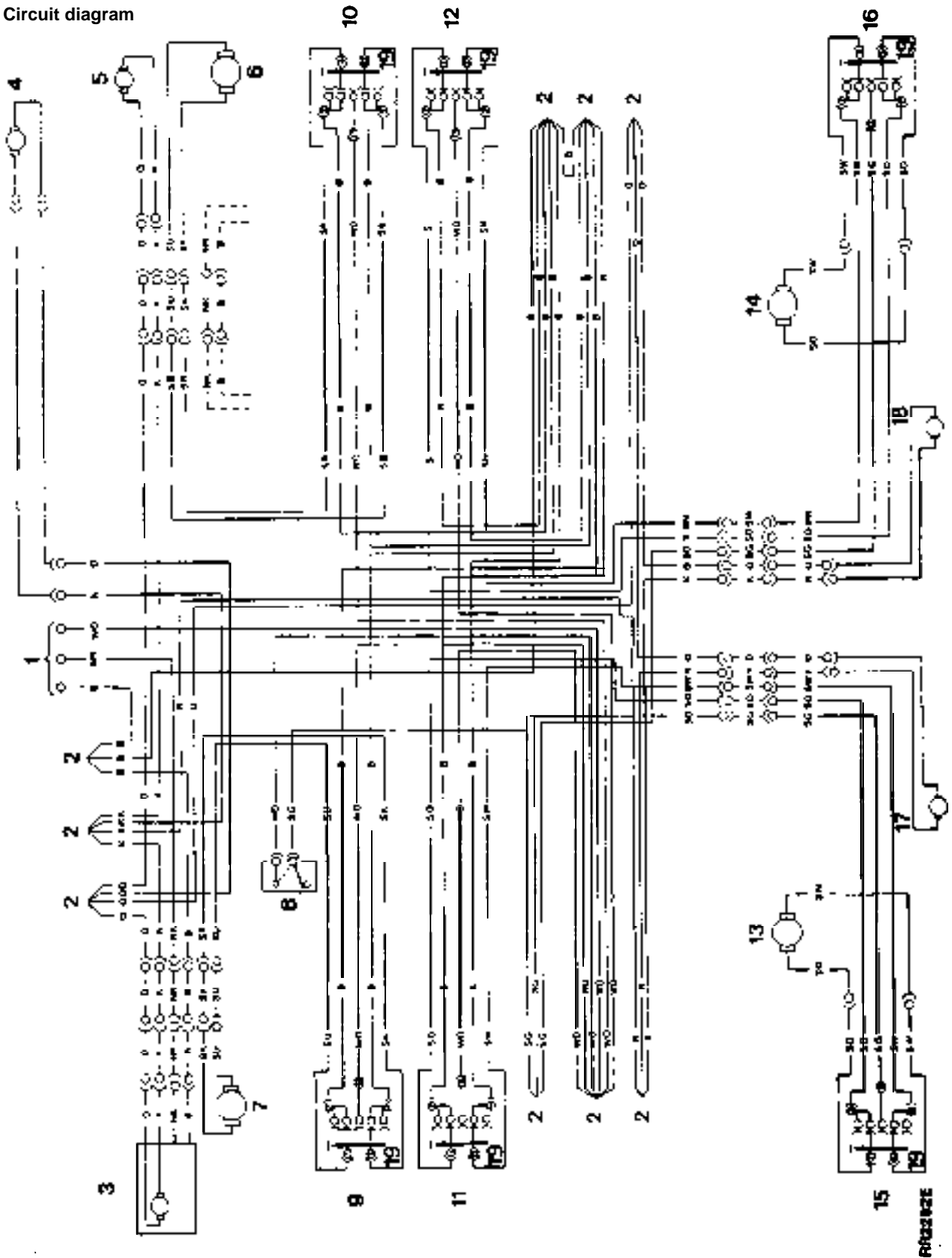

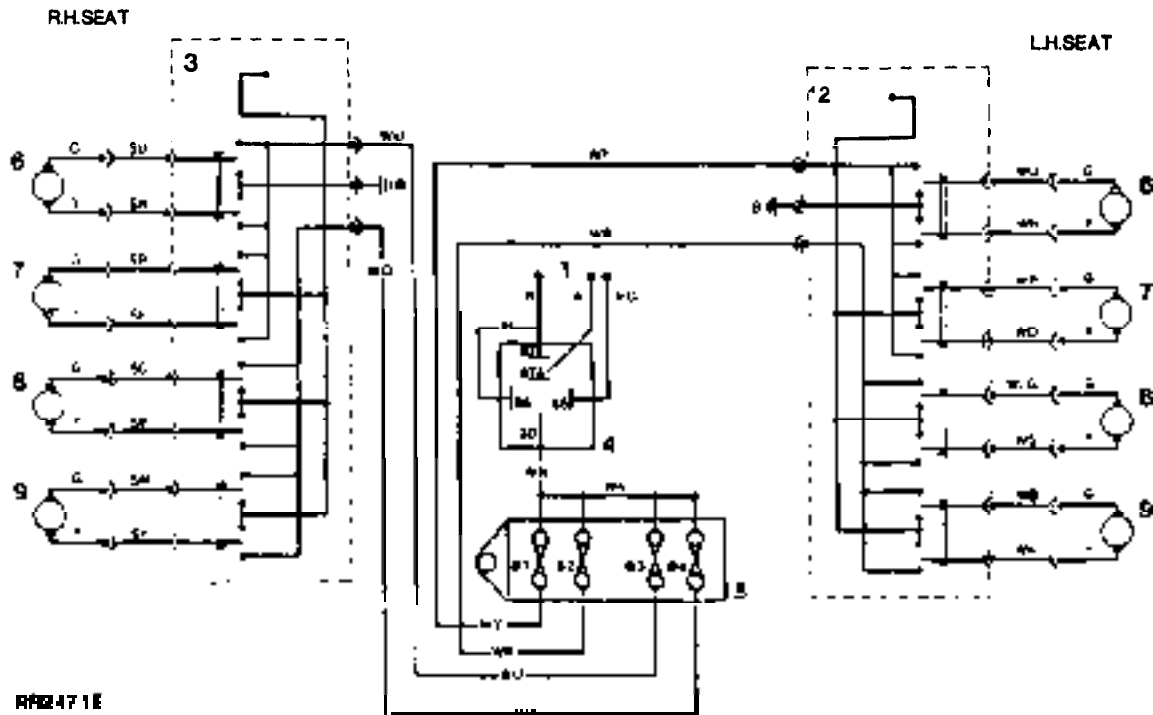

RF2471E

SEATADJUSTMENT-
Circuit diagram

1. Main connections - Item 126 on main circuit diagram.
Brown - Live positive feed
White - Ignition positive feed
Purple/Orange - Door switch
2. Driver's seat control.
3. Passenger seat control.
4. Load control relay.
5. Auxiliary fuse box (B).
6. Seat recline motor.
7. Seat height (rear) motor.
8. Seat base adjust motor.
9. Seat height (front) motor.

CABLE COLOUR CODE

- B Black
- U Blue
- N Brown
- C Green
- O Orange
- P Purple
- R Red
- W White
- Y Yellow

The last letter of a colour code denotes the tracer.

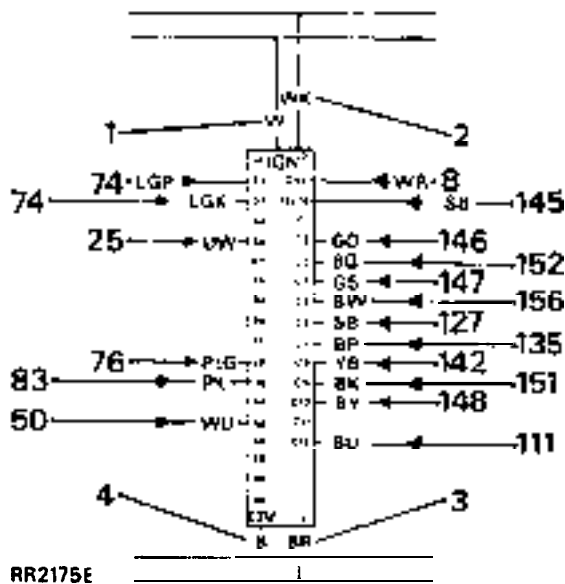

**WARNING LAMP CONTROL UNIT-
Circuit diagram**

1. W- White: Ignition feed
2. WK-White/pink: Common positive side for negative switched lamps
3. BR-Black/red: Common negative side for positive switched lamps
4. B-Black: Earth

See main circuit diagram for key.

Description

Ignition ON will initiate the bulb check for 12 ± 4 secs.

If the engine is cranked during bulb check, the check will terminate in 0.75 ± 0.25 secs.

In normal ambient light the warning lamps will operate at full brightness at the end of the bulb check period, and change to reduced brightness within 20 secs. Note that the ignition and oil warning lamps will not reduce in brightness.

If a fault is suspected check the warning lamp bulbs and the continuity of the circuits before changing the warning lamp control unit.

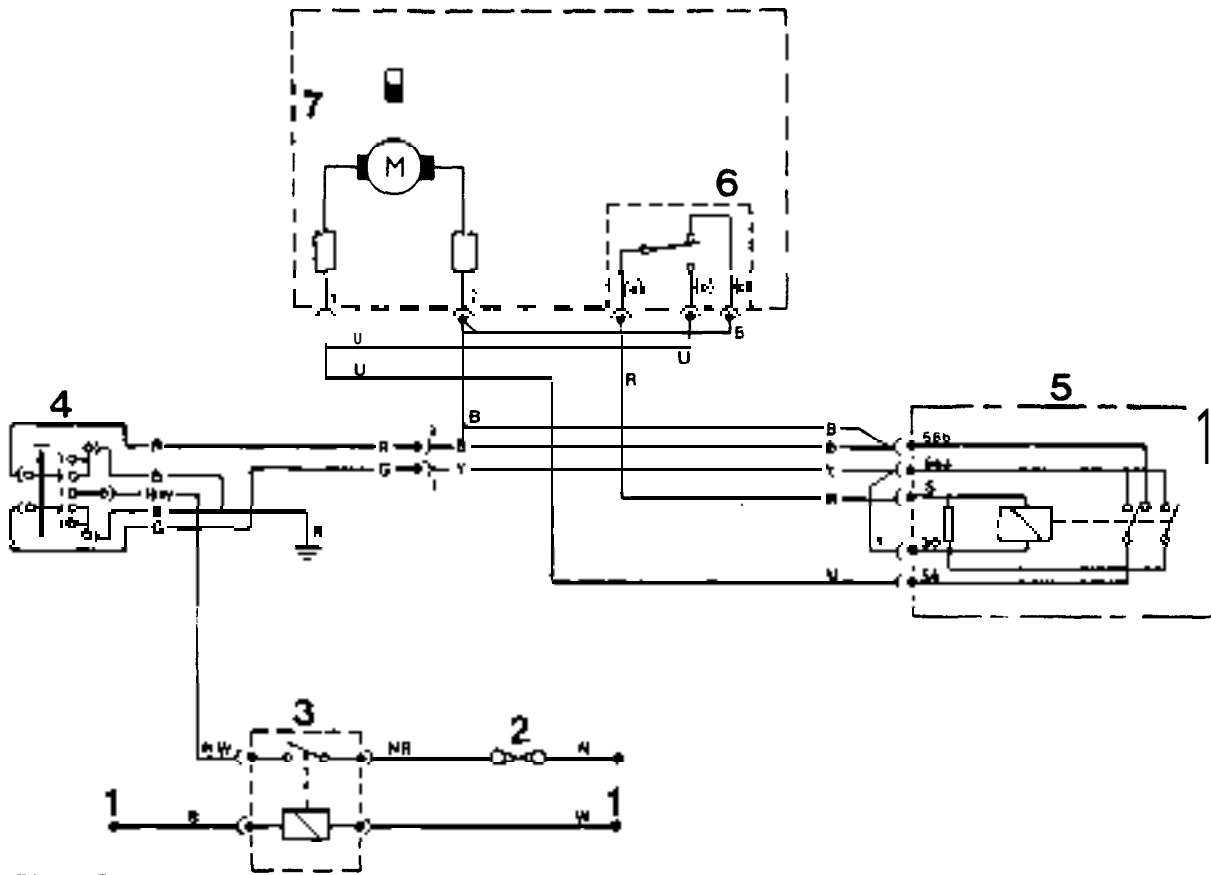

RR2321E

SUNROOF - Circuit diagram

- 1. Main harness connections
 - Brown - live positive feed
 - White - ignition positive feed
 - Black - ground
- 2. Fuse
- 3. Auxiliary relay
- 4. Operating switch
- 5. Stepper relay
- 6. Micro-switch - motor switching:
 - Contact (a) and (c) - CLOSED
 - Contact (a) and (b) - OPEN/TILT
- 7. Drive motor

CABLE COLOUR CODE

- B Black
- U Blue
- N Brown
- G Green
- R Red
- W White
- Y Yellow

The last letter of a colour code denotes the tracer colour

**MAIN CIRCUIT DIAGRAM • 1987 Model Year
- RR2947E & RR2948E**

- | | |
|--|---|
| 1. Ignition load relay | 51. Fuel gauge |
| 2. Battery | 52. Fuel gauge sender unit |
| 3. Terminal post | 53. Water temperature gauge |
| 4. Starter solenoid | 54. Water temperature sender unit |
| 5. Starter motor | 55. Fuse 11 |
| 6. Starter relay | 56. Horn switch |
| 7. Starter inhibit switch | 57. RH horn |
| 8. Ignition switch | 58. LH horn |
| 9. Tachometer | 59. Under hood illumination switch |
| 10. Ignition warning lamp | 60. Under hood light |
| 11. Alternator | 61. Clock |
| 12. Fuse 7 | 62. Fuse 19 |
| 13. Front wipe/wash switch | 63. Fuse 20 |
| 14. Front wipe delay unit | 64. Pick-up point central locking/window lift |
| 15. Front wiper motor | 65. Heated rear window relay |
| 16. Front wash pump | 66. Fuse 9 |
| 17. Headlamp wash timer unit | 67. Radio aerial amplifier |
| 18. Headlamp wash pump | 68. Heated rear screen |
| 19. Main lighting switch | 69. Heated rear screen switch |
| 20. Fuse 6 | 70. Heated rear screen warning lamp |
| 21. Fuse 5 | 71. Voltage sensitive switch |
| 22. LH side lamp | 72. Fuse 13 |
| 23. LH tail lamp | 73. Hazard switch |
| 24. LH license plate lamp | 74. Flasher unit |
| 25. High beam dimmer/flash switch | 75. Direction indicator switch |
| 26. Radio illumination | 76. Hazard/indicator warning lamp |
| 27. RH side lamp | 77. LH rear indicator lamp |
| 28. RH tail lamp | 78. LH front indicator lamp |
| 29. RH license plate lamp | 79. LH side repeater lamp |
| 30. Rheostat | 80. RH side repeater lamp |
| 31. Fuse 3 | 81. RH front indicator lamp |
| 32. Fuse 4 | 82. RH rear indicator lamp |
| 33. Fuse 1 | 83. Trailer warning lamp |
| 34. Fuse 2 | 84. Fuse 15 |
| 35. Not used | 85. Stop lamp switch |
| 36. Not used | 86. Reverse lamp switch |
| 37. Switch illumination (2 off) | 87. Auxiliary lamp relay |
| 38. Cigar lighter illumination (2 off) | 88. LH stop lamp |
| 39. Heater illumination (4 off) | 89. RH stop lamp |
| 40. Clock illumination | 90. LH reverse lamp |
| 41. Automatic gear selector illumination (2 off) | 91. RH reverse lamp |
| 42. Instrument illumination (6 off) | 92. LH auxiliary lamp |
| 43. Not used | 93. RH auxiliary lamp |
| 44. Not used | 94. Auxiliary lamp switch |
| 45. Not used | 95. Fuse 17 |
| 46. LH low beam | 96. Dash cigar lighter |
| 47. RH low beam | 97. Glove box cigar lighter |
| 48. LH high beam | 98. LH interior lamp |
| 49. RH high beam | 99. RH interior lamp |
| 50. High beam warning lamp | 100. Interior lamp delay unit |

- 101. LH door edge lamp
- 102. RH door edge lamp
- 103. LH puddle lamp
- 104. RH puddle lamp
- 105. interior lamp switch
- 106. LH rear door switch
- 107. RH rear door switch
- 108. Tailgate switch
- 109. LH front door switch
- 110. RH front door switch
- 111. Differential lock warning lamp
- 112. Differential lock switch
- 113. Oil pressure/level warning lamp
- 114. Oil pressure switch
- 115. Fuse 18
- 116. Inertia switch
- 117. Fuel pump
- 118. Ignition coil
- 119. Capacitor
- 120. Distributor
- 121. EFI Harness plug
- 122. Radio choke
- 123. Radio fuse
- 124. Radio
- 125. Four speakers
- 126. Electric seats pick up point
- 127. Seat belt warning Lamp
- 128. "Key-in" switch
- 129. Speed transducer, see Cruise Control
- 130. Resistor
- 131. Audible warning unit
- 132. Transfer box neutral switch
- 133. Seat buckle switch
- 134. Ignition connection points
- 135. Automatic transmission **oil temperature** warning lamp
- 136. Automatic transmission oil temperature switch
- 137. Fuse 16
- 138. Rear wash wipe switch
- 139. Rear wipe delay unit
- 140. Rear wiper motor
- 141. Rear screen wash pump
- 142. Low screen wash fluid level warning lamp
- 143. Low screen wash switch
- 144. Low coolant switch
- 145. Multi-function unit and binnacle

- 146. Low coolant level warning lamp
- 147. Low fuel level warning lamp
- 148. E.F.I. warning lamp
- 149. Low oil level logic unit
- 150. Low oil level probe
- 151. Not used - will illuminate on initial bulb check
- 152. Parking brake/brake fail warning lamp
- 153. Parking brake warning switch
- 154. Brake fail warning switch
- 155. Brake pad wear warning lamp
- 156. Brake pad wear sensors
- 157. Warning lamp control unit
- 158 Heater/air conditioning connections
- 159. Fuse 6
- 160. Cruise control connection points
- 161. Coil negative, engine speed signal to ECU

CABLE COLOUR CODE

- B Black
- U Blue
- N Brown
- G Green
- S Grey
- L Light
- O Orange
- K Pink
- P Purple
- R Red
- W White
- Y Yellow

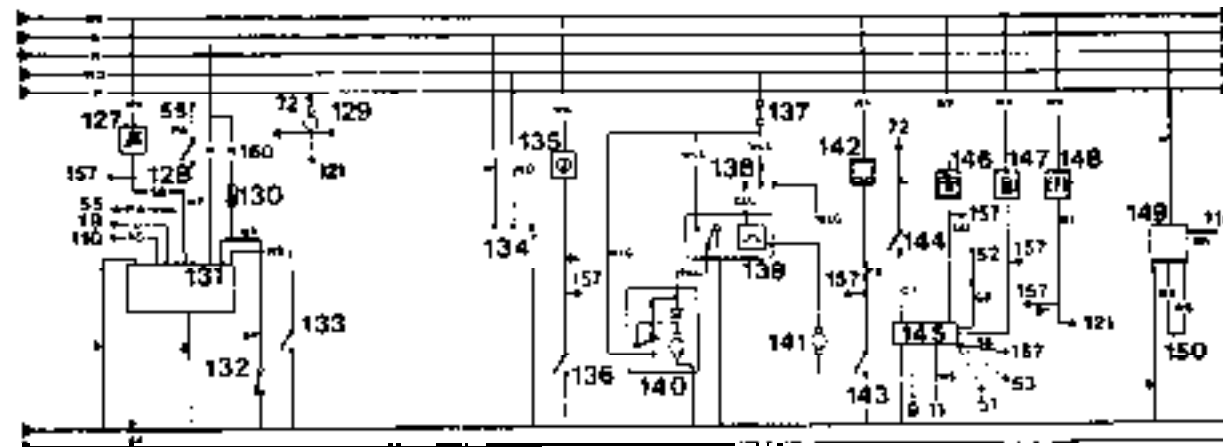
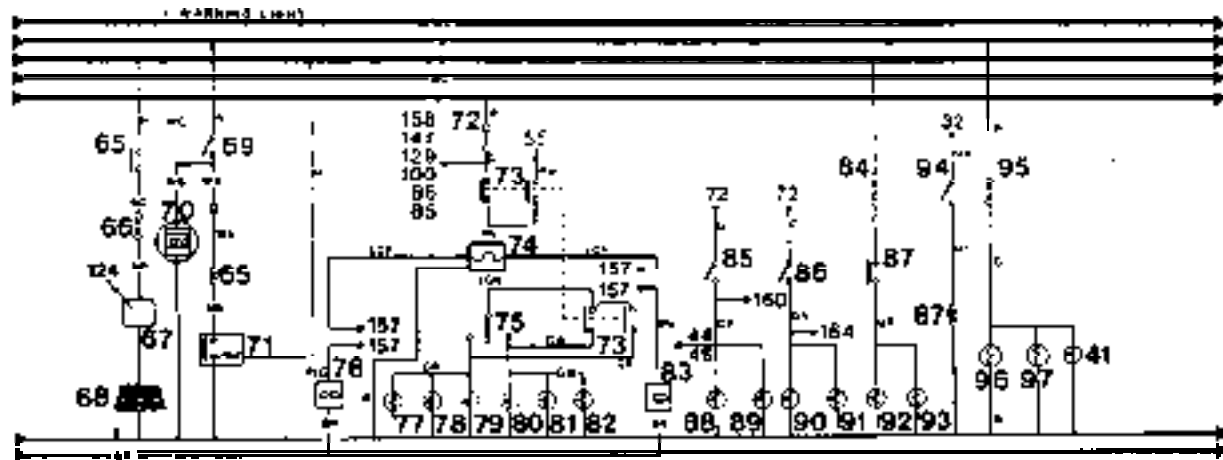
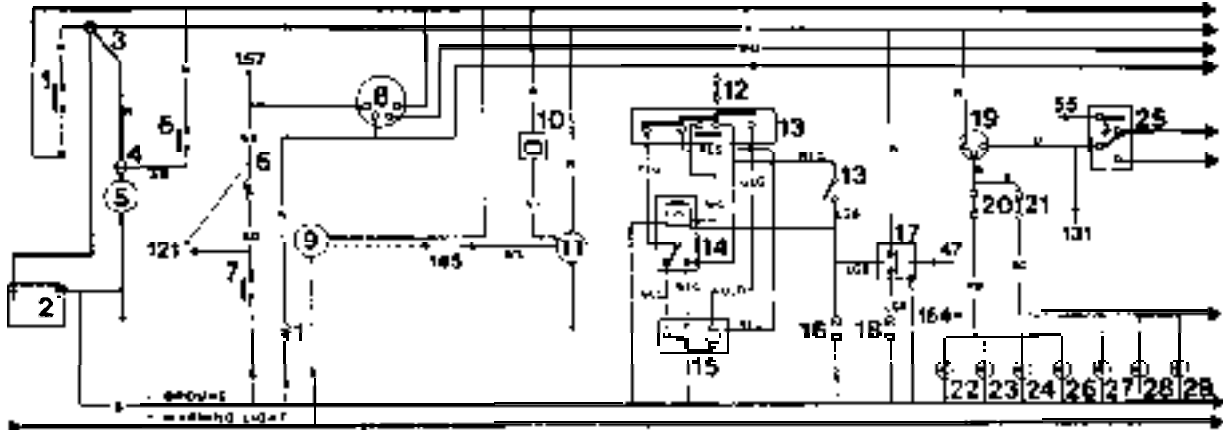

RR2947E

ELECTRICAL EQUIPMENT - CIRCUIT DIAGRAMS
 • 1988 Model year

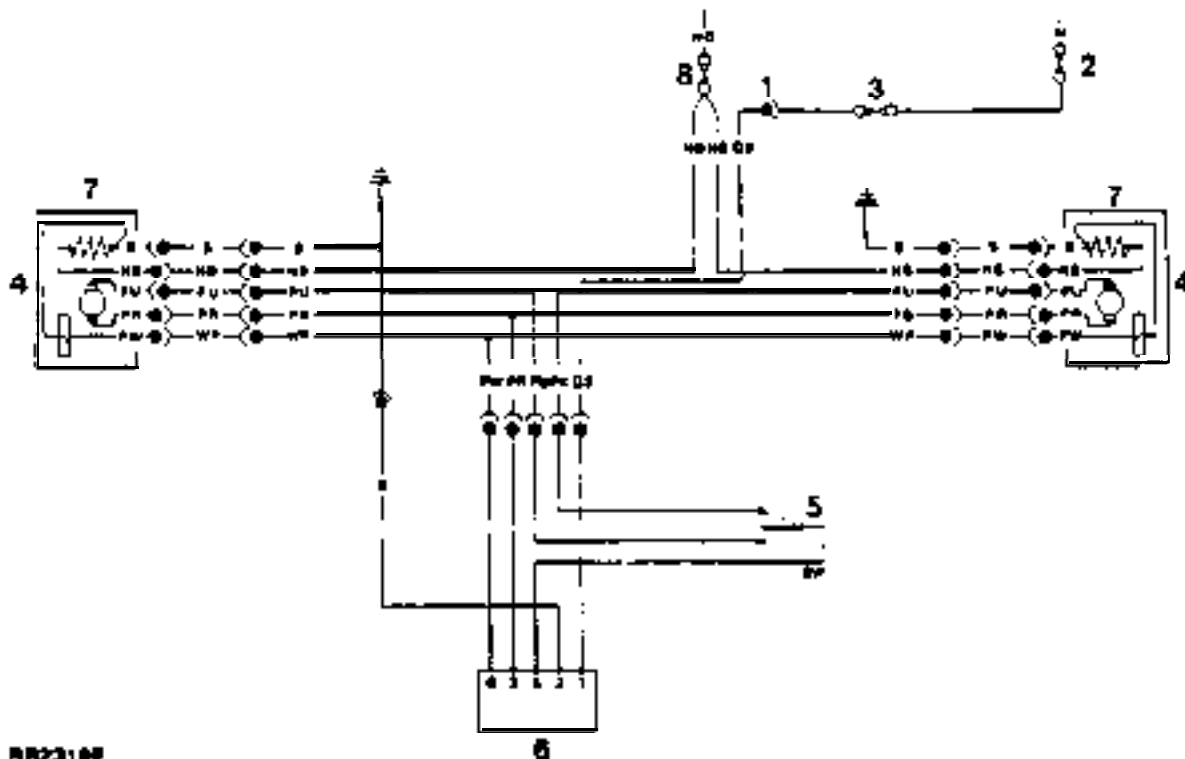

RR2310E

ELECTRIC MIRRORS -
 Circuit diagram

- | | |
|----------------------------------|---|
| 1. Auxiliary fuse box connection | 7. Mirror heating elements - active with heated rear screen |
| 2. Fuse 13 | 8. Fuse 10 - heating elements |
| 3. Fuse AS - mirror motors | |
| 4. Mirror motors | |
| 5. Change over switch | |
| 6. Mirror control switch | |

CABLE COLOUR CODE

- B Black
- U Blue
- N Brown
- G Green
- S Grey
- O Orange
- K Pink
- P Purple
- R Red
- W White
- Y Yellow

The last letter of a colour code denotes the tracer.

AUXILIARY SWITCH PANEL

The auxiliary switch panel contains four 'push-push' type switches which incorporate integral symbols for identification.

(The sixth switch opening is fitted with a blank cover, which is removable, to facilitate the fitting of an extra switch if required).

The symbol in segment 1 will illuminate initially when turning the ignition on but will go out after a few seconds. The warning light is designed to illuminate at 52,500 and 105,000 miles when critical emission maintenance intervals are reached.

The symbols are illuminated by two bulbs which become operational when the vehicle lights are on.

The heated rear screen switch (5) is provided with an individual warning light, illuminated when the switch is operated.

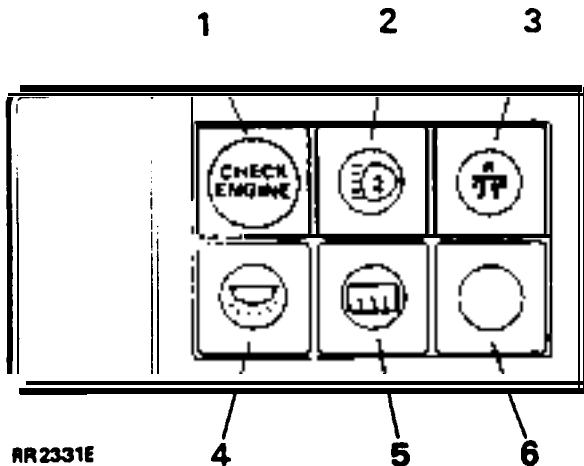

RR2331E

1. Emission maintenance reminder warning light.
2. Auxiliary driving lamps.
3. Cruise control master switch.
4. Interior and tailgate lamps.
5. Heated rear screen.
6. B l a n k .

AUXILIARY SWITCH PANEL

Remove and refit

Removing

1. Disconnect the battery negative lead.
2. Carefully pry the auxiliary switch panel surround away from the centre console.
3. Withdraw the switch panel as far as the electrical leads will permit.
4. Unclip the multi-plugs at the rear of the switches by depressing the retaining lugs.
5. Pull the plugs from the switches.
6. Remove the switch assembly complete.

NOTE: If necessary each individual switch can now be removed as follows.

7. Depress the small retaining lugs on the top and bottom of the switch and push the switch(es) through the front of the switch surround.

Refitting

8. Reverse the removal procedure.

NOTE: To aid identification and location of multi-plug to switch, a coloured plastic tab is attached to each body which corresponds with an appropriate coloured multi-plug. The switches if removed, should always be refitted in their original position.

NOTE: Refer to page 38 of Section 86, for bulb replacement procedure.

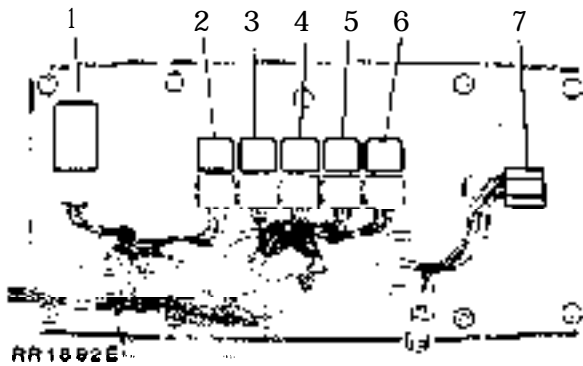

RR1892E
Closure panel viewed from the engine compartment, with protective cover removed.

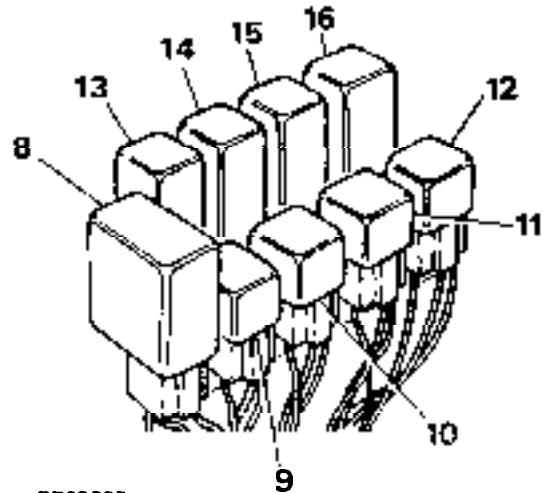

RR2303E

Steering column mounted relays viewed with the lower dash panel removed.

Relay	Circuit Diagram Item Number
1. Headlamp wash timer unit	17. Main circuit diagram
2. Heated rear window	65. Main circuit diagram
3. Starter solenoid relay	6. Main circuit diagram
4. Compressor clutch	11. Air conditioning diagram
5. Condenser fan	9. Air conditioning diagram
6. Air conditioning/heater	5. Air conditioning diagram
7. Stowage position	Not used
8. Rear wiper delay	139. Main circuit diagram
9. Ignition load relay	1. Main circuit diagram
10. Window lift relay	64(a). Main circuit diagram
11. Seat adjustment relay	126(a). Main circuit diagram
12. Auxiliary lamp relay	87. Main circuit diagram
13. Flasher/hazard unit	74. Main circuit diagram
14. Interior lamp delay	100. Main circuit diagram
15. Voltage sensitive switch	71. Main circuit diagram
16. Front wiper delay	14. Main circuit diagram
17. Seat adjustment relay	4. Seat adjustment diagram
18. Main EFI relay	22. EFI circuit diagram
19. Fuel pump relay	21. EFI circuit diagram
20. Sunshine roof auxiliary relay	3. Sunroof circuit diagram

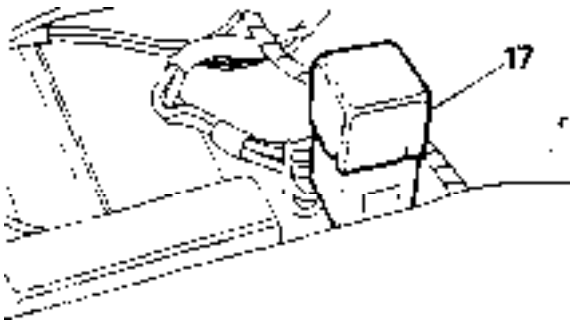

RR2304E

Seat adjustment relay located beneath the left hand front seat adjacent to fuse box (B).

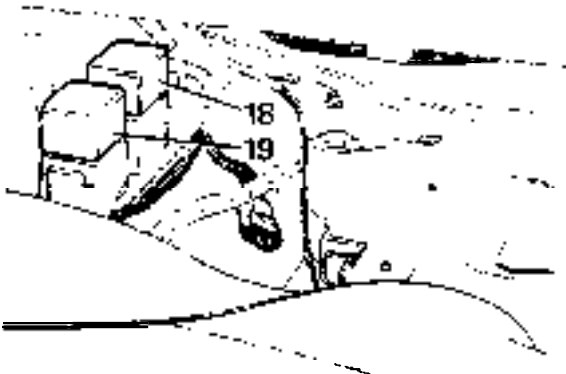

RR2305E

Main EFI (black terminal block) and fuel pump relays (blue terminal block) mounted beneath right hand front seat.

NOTE: Refer to fuel injection section of manual for full information on E.F.I. relays.

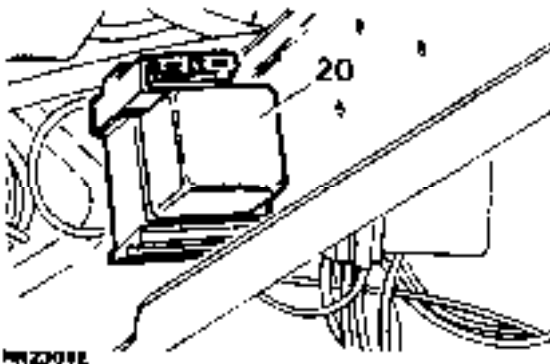

Sunshine roof auxiliary relay located on side of the steering column support bracket located behind the lower dash panel.

RELAYS-(Mounted on the engine compartment closure panel).

Remove and refit

Removing

1. Lift the hood
2. Disconnect the battery negative lead.
3. Remove the bolt securing the relay protective cover, located on the front of the engine compartment closure panel.
4. Remove the cover.
5. Pull the appropriate relay off its multi-plug.

Refitting

6. Reverse the removal procedure.

RELAYS-(Mounted on the steering column support bracket)

Remove and refit

Removal.

1. Disconnect the battery negative lead.
2. Remove the six screws securing the lower fascia panel.
3. Lower the dash panel, disconnect the electric leads from the dimming control switch and remove the fascia panel.
4. Locate the appropriate relay on the relay mounting bracket, carefully pull the relay off the multi-plug.

Refitting

5. Reverse the removal procedure.

RELAYS-(Floor mounted beneath front seats)

Remove and refit

Removing

1. Position seat to gain access to the required relay.
2. Disconnect the battery negative lead.
3. Carefully pull the relay off the multi-plug.

Refitting

4. Reverse the removal procedure.

MAIN CIRCUIT DIAGRAM - 1988 Model Year
• RR2949E & RR2950E

- | | |
|--|---|
| 1. Ignition load relay | 51. Fuel gauge |
| 2. Battery | 52. Fuel gauge sender unit |
| 3. Terminal post | 53. Water temperature gauge |
| 4. Starter solenoid | 54. Water temperature sender unit |
| 5. Starter motor | 55. Fuse 11 |
| 6. Starter relay | 56. Horn switch |
| 7. Starter inhibit switch | 57. RH horn |
| 8. Ignition switch | 58. LH horn |
| 9. Tachometer | 59. Under hood illumination switch |
| 10. Ignition warning lamp | 60. Under hood light |
| 11. Alternator | 61. Clock |
| 12. Fuse 7 | 62. Fuse 19 |
| 13. Front wipe/wash switch | 63. Fuse 20 |
| 14. Front wipe delay unit | 64. Pick-up point central locking/window lift |
| 15. Front wiper motor | 64. (a) Window lift relay |
| 16. Front wash pump | 65. Heated rear window relay |
| 17. Headlamp wash timer unit | 66. Fuse 9 |
| 18. Headlamp wash pump | 67. Radio aerial amplifier |
| 14. Main lighting switch | 68. Heated rear screen |
| 20. Fuse 6 | 69. Heated rear screen switch |
| 21. Fuse 5 | 70. Heated rear screen warning lamp |
| 22. LH side lamp | 71. Voltage sensitive switch |
| 23. LH tail lamp | 72. Fuse 13 |
| 24. License plate lamp (2 off) | 73. Hazard switch |
| 25. High beam dimmer/flash switch | 74. Flasher unit |
| 26. Radio illumination | 75. Direction indicator switch |
| 27. RH side lamp | 76. Hazard/indicator warning lamp |
| 28. RH tail lamp | 77. LH rear indicator lamp |
| 29. Not used | 78. LH front indicator lamp |
| 30. Rheostat | 79. Pick up point - electric mirrors |
| 31. Fuse 3 | 80. Fuse 10 |
| 32. Fuse 4 | 81. RH front indicator lamp |
| 33. Fuse 1 | 82. RH rear indicator lamp |
| 34. Fuse 2 | 83. Trailer warning lamp |
| 35. Not used | 84. Fuse 15 |
| 36. Not used | 85. Stop lamp switch |
| 37. Switch illumination (2 off) | 86. Reverse lamp switch |
| 38. Cigar lighter illumination (2 off) | 87. Auxiliary lamp relay |
| 39. Heater illumination (4 off) | 88. LH stop lamp |
| 40. Clock illumination | 89. RH stop lamp |
| 41. Automatic gear selector illumination (2 off) | 90. LH reverse lamp |
| 42. Instrument illumination (6 off) | 91. RH reverse lamp |
| 43. Not used | 92. LH auxiliary lamp |
| 44. Not used | 93. RH auxiliary lamp |
| 45. Not used | 94. Auxiliary lamp switch |
| 46. LH low beam | 95. Fuse 17 |
| 47. RH low beam | 96. Dash cigar lighter |
| 48. LH high beam | 97. Glove box cigar lighter |
| 49. RH high beam | 98. LH interior lamp |
| 50. High beam warning lamp | 99. RH interior lamp |
| | 100. Interior lamp delay unit |

- 101. LH door edge lamp
- 102. RH door edge lamp
- 103. LH puddle lamp
- 104. RH puddle lamp
- 105. Interior lamp switch
- 106. LH rear door switch
- 107. RH rear door switch
- 108. Tailgate switch
- 109. LH front door switch
- 110. RH front door switch
- 111. Differential lock warning lamp
- 112. Differential lock switch
- 113. Oil pressure/level warning lamp
- 114. Oil pressure switch
- 115. Fuse 18
- 116. Inertia switch
- 117. Fuel pump
- 118. Ignition coil
- 119. Capacitor
- 120. Distributor
- 121. EFI Harness plug
- 122. Not used
- 123. Radio fuse
- 124. Radio
- 125. Four speakers
- 126. Electric seats pick up point
- 126. (a) Electric seat relay
- 127. Seat belt warning lamp
- 128. "Key-in" switch
- 129. Speed transducer, see Cruise Control
- 130. Resistor
- 131. Audible warning unit
- 132. Transfer box neutral switch
- 133. Seat buckle switch
- 134. Sunroof connection points (option)
- 135. Automatic transmission oil temperature warning lamp
- 136. Automatic transmission oil temperature switch
- 137. Fuse 16
- 138. Rear wash wipe switch
- 139. Rear wipe delay unit
- 140. Rear wiper motor
- 141. Rear screen wash pump
- 142. Low screen wash fluid level warning lamp
- 143. Low screen wash switch
- 144. Low coolant switch
- 145. Multi-function unit and binnacle

- 146. Low coolant level warning lamp
- 147. Low fuel level warning lamp
- 148. E.F.I. warning lamp
- 149. Low oil level logic unit
- 150. Low oil level probe
- 151. Not used - will illuminate on initial bulb check
- 152. Parking brake/brake fluid loss warning lamp
- 153. Parking brake warning switch
- 154. Brake fluid loss warning switch
- 155. Brake pad wear warning lamp
- 156. Brake pad wear sensors
- 157. Warning lamp control unit
- 158. Heater/air conditioning connections
- 159. Fuse 8
- 160. Cruise control connection points
- 161. Coil negative, engine speed signal to ECU
- 162. Emission maintenance reminder
- 163. Check engine warning lamp
- 164. Trailer pick up point
- 165. Fuse 14

CABLE COLOUR CODE

- | | |
|---|--------|
| B | Black |
| U | Blue |
| N | Brown |
| G | Green |
| S | Grey |
| L | Light |
| O | Orange |
| K | Pink |
| P | Purple |
| R | Red |
| W | White |
| Y | Yellow |

MAIN CIRCUIT DIAGRAM - RR2949E & RR2950E

Alphabetical key

- 11. Alternator
- 131. Audible warning unit
- 41. Automatic gear selector illumination (2 off)
- 136. Automatic transmission oil temperature switch
- 135. Automatic transmission oil temperature warning lamp
- 87. Auxiliary lamp relay
- 94. Auxiliary lamp switch
- 2. Battery
- 154. Brake fluid loss warning switch
- 156. Brake pad wear sensors
- 155. Brake pad wear warning lamp
- 119. Capacitor
- 163. Check engine warning lamp
- 38. Cigar lighter illumination (2 off)
- 61. Clock
- 40. Clock illumination
- 161. Coil negative, engine speed signal to ECU
- 160. Cruise control connection points
- 96. Dash cigar lighter
- 112. Differential lock switch
- 111. Differential lock warning lamp
- 75. Direction indicator switch
- 120. Distributor
- 121. EFI Harness plug
- 148. EFI warning lamp
- 126. Electric seats pick up point
- 126. (a) Electric seat relay
- 162. Emission maintenance reminder
- 74. Flasher unit
- 16. Front wash pump
- 14. Front wiper delay unit
- 13. Front wiper/wash switch
- 15. Front wiper motor
- 51. Fuel gauge
- 52. Fuel gauge sender unit
- 117. Fuel pump
- 33. Fuse 1
- 34. Fuse 2
- 31. Fuse 3
- 32. Fuse 4
- 21. Fuse 5
- 20. Fuse 6
- 12. Fuse 7
- 159. Fuse 8
- 66. Fuse 9
- 80. Fuse 10
- 55. Fuse 11
- 72. Fuse 13
- 165. Fuse 14
- 84. Fuse 15
- 137. Fuse 16
- 95. Fuse 17
- 115. Fuse 18
- 62. Fuse 19
- 63. Fuse 20
- 97. Glove box cigar lighter
- 73. Hazard switch
- 76. Hazard/indicator warning lamp
- 18. Headlamp wash pump
- 17. Headlamp wash timer unit
- 68. Heated rear screen
- 69. Heated rear screen switch
- 70. Heated rear screen warning lamp
- 65. Heated rear window relay
- 39. Heater illumination (4 off)
- 158. Heater/air conditioning connections
- 25. High beam dimmer/flash switch
- 50. High beam warning lamp
- 56. Horn switch
- 118. Ignition coil
- 1. Ignition load relay
- 8. Ignition switch
- 10. Ignition warning lamp
- 116. Inertia switch
- 42. Instrument illumination (6 off)
- 100. Interior lamp delay unit
- 105. Interior lamp switch
- 128. "Key-in" switch
- 92. LH auxiliary lamp
- 101. LH door edge lamp
- 109. LH front door switch
- 78. LH front indicator lamp
- 48. LH high beam
- 58. LH horn
- 98. LH interior Lamp
- 24. License plate lamp (2 off)
- 46. LH low beam
- 103. LH puddle lamp
- 106. LH rear door switch
- 77. LH rear indicator lamp
- 90. LH reverse lamp
- 22. LH side lamp
- 88. LH stop lamp
- 23. LH tail lamp
- 146. Low coolant level warning lamp
- 144. Low coolant switch
- 147. Low fuel level warning lamp
- 149. Low oil level logic unit
- 150. Low oil level probe
- 142. Low screen wash fluid level warning lamp
- 143. Low screen wash switch
- 19. Main lighting switch
- 145. Multi-function unit and binnacle
- 114. Oil pressure switch
- 113. Oil pressure/level warning lamp
- 153. Parking brake warning switch
- 152. Parking brake/brake fluid loss warning lamp
- 79. Pick up point - electric mirrors
- 64. Pick-up point central locking/window lift
- 124. Radio
- 67. Radio aerial amplifier
- 123. Radio fuse
- 26. Radio illumination

- 125. Radio speakers (4 off)
- 141. Rear screen wash pump
- 138. Rear wash wipe switch
- 139. Rear wipe delay unit
- 140. Rear wiper motor
- 130. Resistor
 - 86. Reverse lamp switch
- 93. RH auxiliary lamp
- 102. RH door edge lamp
- 110. RH front door switch
 - 81. RH front indicator lamp
- 49. RH high beam
- 57. RH horn
- 99. RH interior lamp
- 47. RH low beam
- 104. RH puddle lamp
- 107. RH rear door switch
 - 82. RH rear indicator lamp
- 91. RH reverse lamp
- 27. RH side lamp
- 89. RH stop lamp
- 28. RH tail lamp
- 30. Rheostat
- 127. Seat belt warning lamp
- 133. Seat buckle switch
- 129. Speed transducer, see Cruise Control
 - 7. Starter inhibit switch
 - 5. Starter motor
 - 6. Starter relay
 - 4. Starter solenoid
- 85. Stop lamp switch
- 134. Sunroof connection points (option)
 - 37. Switch illumination (2 off)
 - 9. Tachometer
- 108. Tailgate switch
 - 3. Terminal post
- 164. Trailer pick up point
 - 83. Trailer warning lamp
- 132. Transfer box neutral switch
- 59. Under hood illumination switch
- 60. Under hood light
- 71. Voltage sensitive switch
- 157. Warning lamp control unit
- 53. Water temperature gauge
- 54. Water temperature sender unit
- 64. (a) Window lift relay

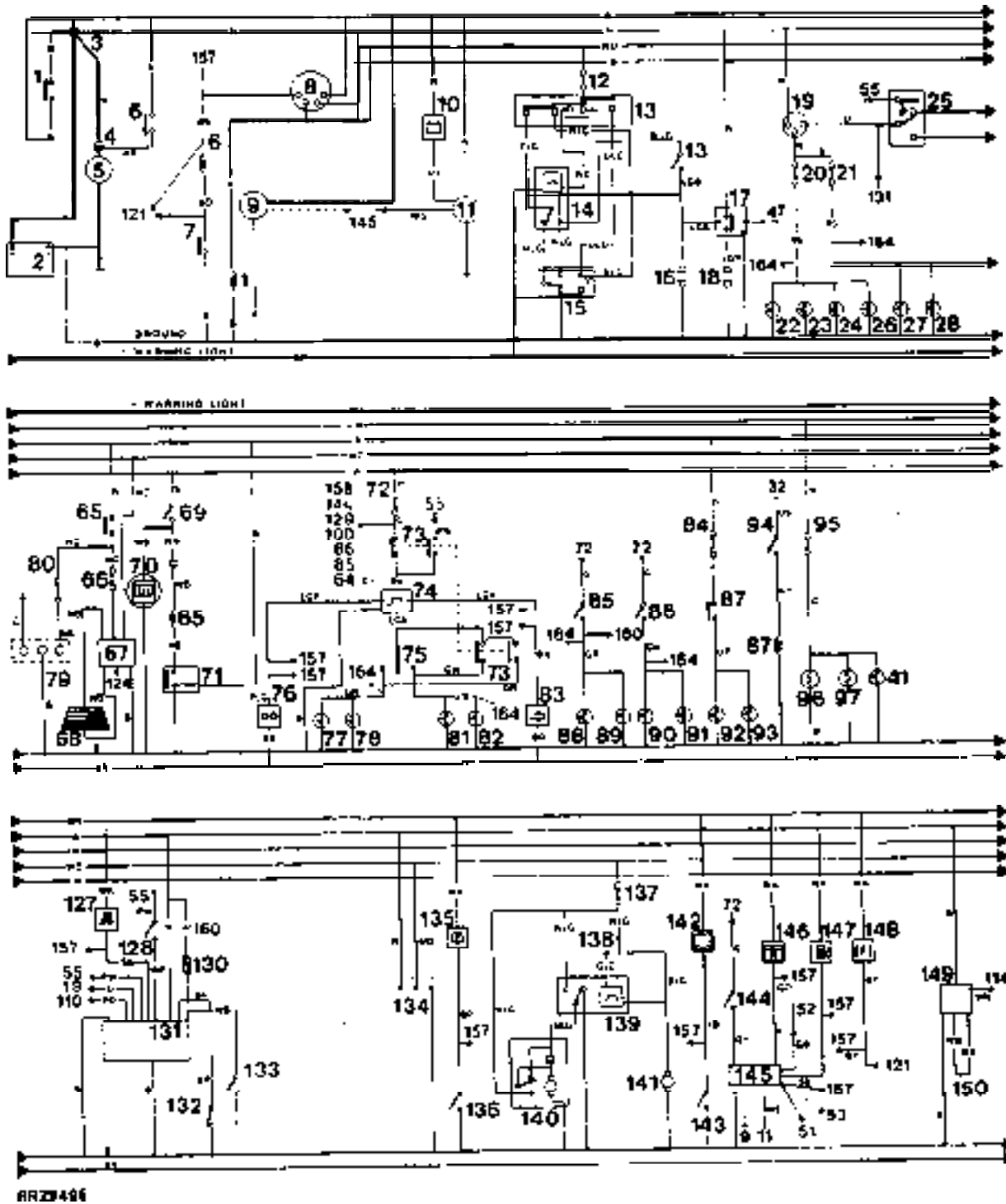

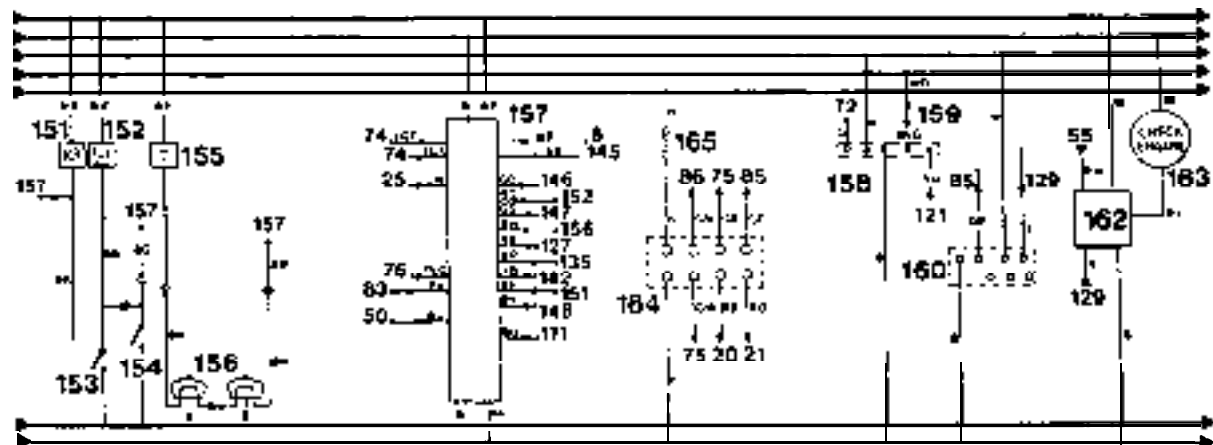
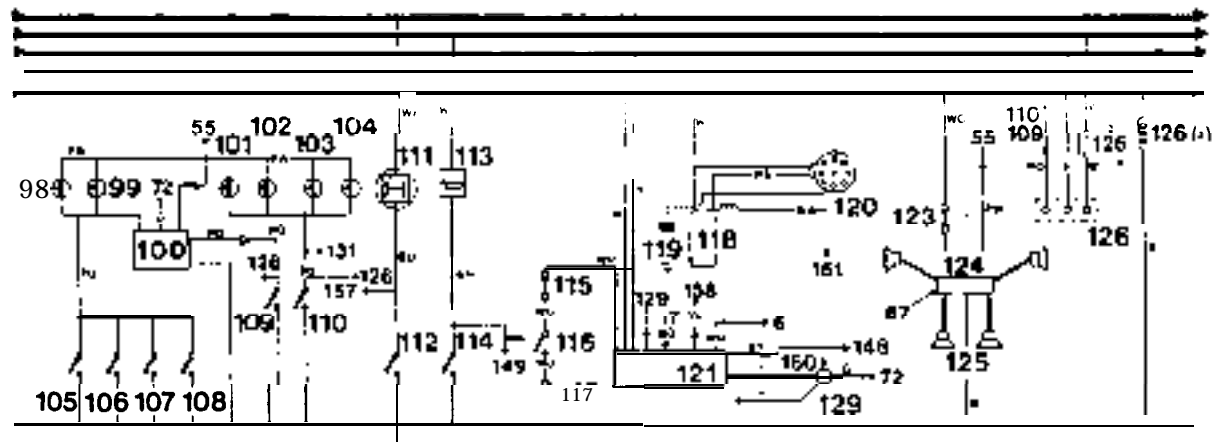
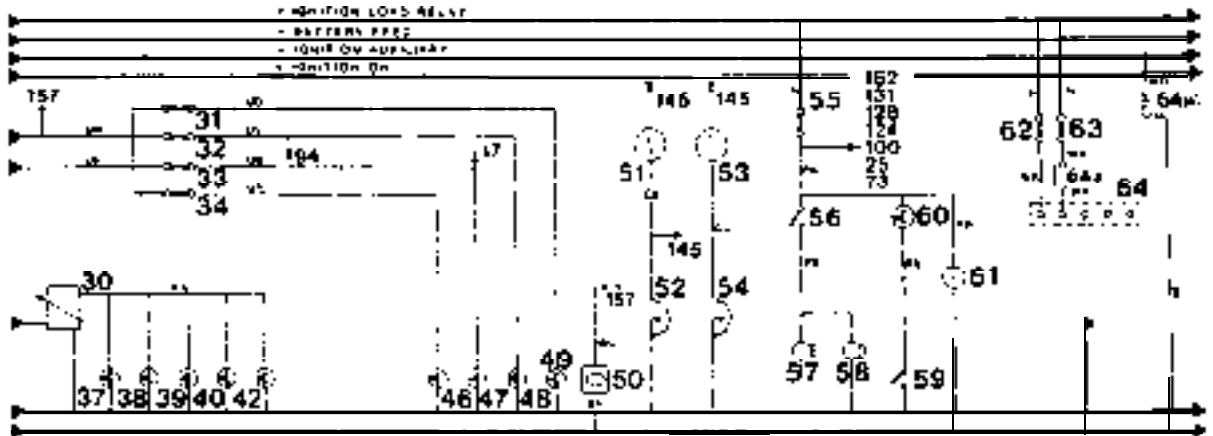

RR2950E

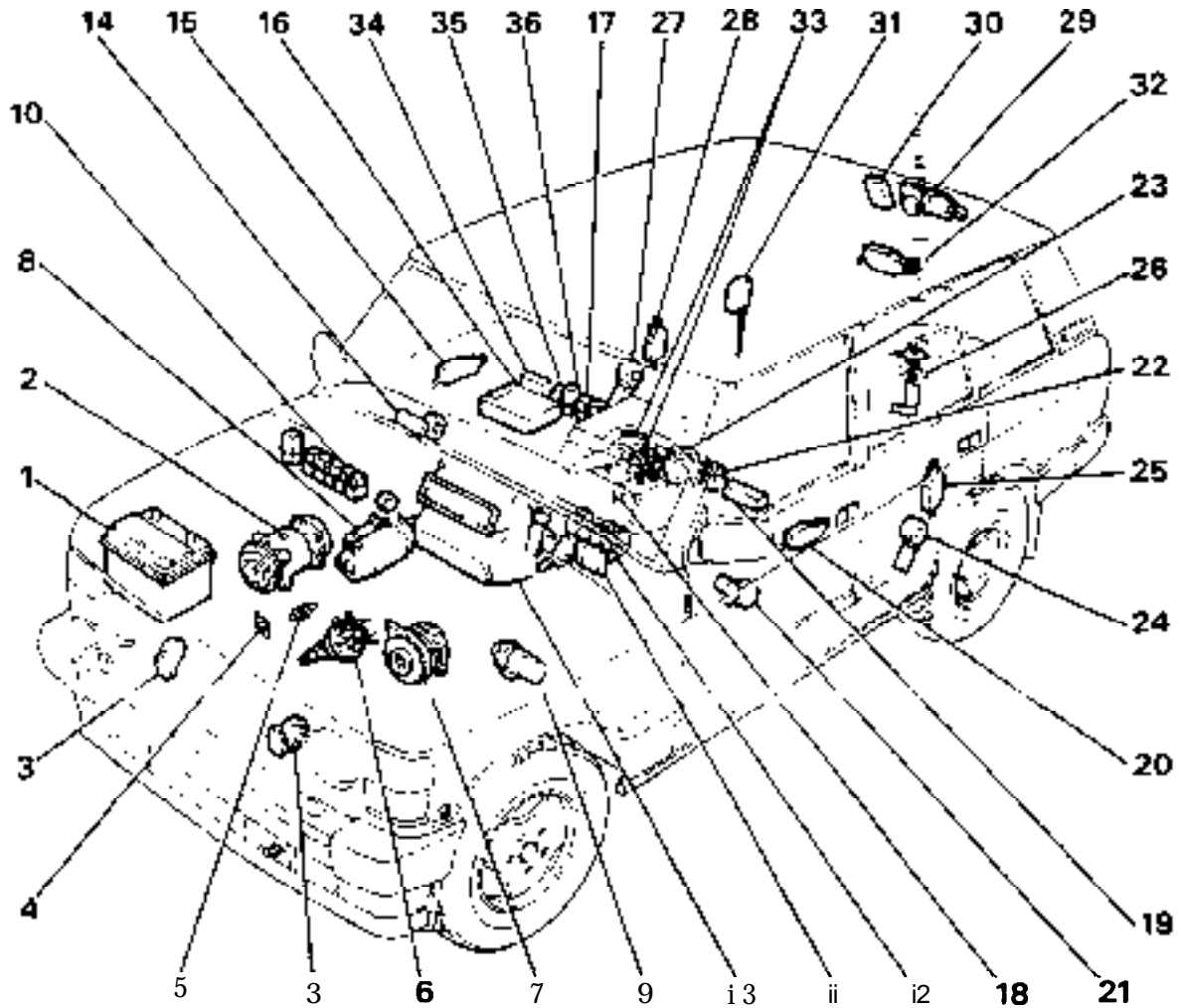

RR2671E

**LOCATION OF ELECTRICAL EQUIPMENT
• 1989 MODEL YEAR**

- 1. Battery
- 2. Air conditioning compressor
- 3. Horns
- 4. Oil pressure switch
- 5. Water temperature switch
- 6. Electronic distributor
- 7. Alternator
- 8. Starter motor
- 9. Coil
- 10. Relays
- 11. Wiper motor-front screen
- 12. Relays/delay units
- 13. Heater
- 14. Window lift motor (front right hand door)
- 15. Door lock actuator (front right hand door)
- 16. Electronic control unit (EFI)
- 17. EFI relays (two)
- 18. Parkbrake warning light switch
- 19. Seat adjustment fusebox
- 20. Door lock actuator (front left hand door)
- 21. Window lift motor (front left hand door)

- 22. Seat adjustment relays (two)
- 23. Inertia switch
- 24. Window lift motor (rear left hand door)
- 25. Door lock actuator (rear left hand door)
- 26. Electrical in-tank fuel pump
- 27. Window lift motor (rear right hand door)
- 28. Door lock actuator (rear right hand door)
- 29. Wiper motor-rear screen
- 30. Radio aerial amplifier
- 31. Fuel filler flap lock actuator
- 32. Tailgate lock actuator
- 33. Window lift relays and one touch control unit
- 34. Emission maintenance reminder
- 35. Cruise control relay (neutral lockout)
- 36. Condenser fan timer unit

For full information on fuel injection related items-see Fuel Injection Section of manual.

To identify individual relays see relays in Electrical Section of Manual.

FUSE BOX

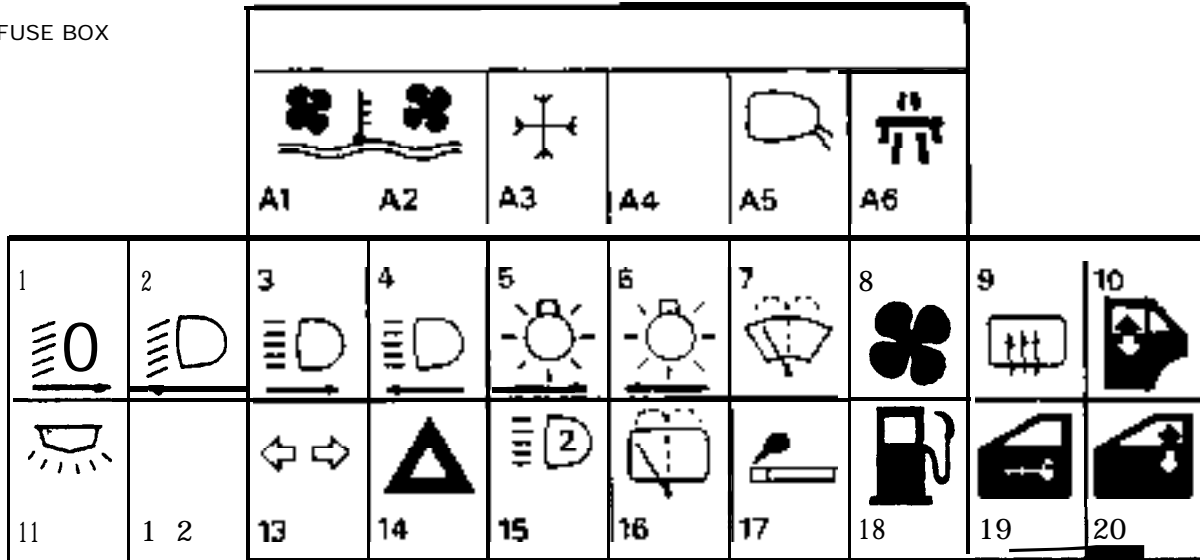

RR2474E

FUSE NO.	COLOUR CODE	FUSE VALUE	CIRCUIT SERVED	IGNITION KEY CONTROLLED
----------	-------------	------------	----------------	-------------------------

MAIN FUSE PANEL

1	Brown	7.5 amp	RH headlamp low beam and power wash	Ign
2	Brown	7.5 amp	LH headlamp low beam	Ign
3	Brown	7.5 amp	RH headlamp high beam	Ign
4	Brown	7.5 amp	LH headlamp high beam, auxiliary lamp switch	Ign
5	Tan	5 amp	RH parking lights and instrument illumination	
6	Tan	5 amp	LH parking lights and radio illumination	
7	Blue	15 amp	Front wash/wiper motors, seat relay, window lift relay, antennae amplifier	Aux
8	Green	30 amp	Heater/air con. motor	Aux
9	White	25 amp	Heated rear screen	Ign
10	Green	30 amp	Window lifts rear	Aux
11	Blue	15 amp	Interior light delay, clock, radio, under hood illumination, audible warning unit, cruise control, key in switch, emission maintenance reminder, seat connection	
12	--	---	NOT USED	
13	Blue	15 amp	Direction indicators, stop and reverse lights, electric mirrors, low coolant, low oil, heated jets, interior lamp delay, heater/air con relay, audible warning unit, neutral resistor	Ign
14	Yellow	20 amp	Hazard lights, horn, headlamps flash, alarm	
15	Blue	15 amp	Auxiliary driving lamps	
16	Red	10 amp	Rear wash/wipe motor, heated rear screen switch	Ign
17	Yellow	20 amp	Cigar lighters (front and rear), gear selector illumination	Ign
18	Red	10 amp	Fuel pump	Ign
19	Red	10 amp	Central door locking	
20	Green	30 amp	Electric window lifts front	Aux

NOTE: Radio Cassette combination. An in-line 5 amp fuse is incorporated in the power input lead of the unit.

AUXILIARY FUSE PANEL - (A)

A1	Yellow	20 amp	Air conditioning fan	IGN
A2	Yellow	20 amp	Air conditioning fan	IGN
A3	Tan	5 amp	Air conditioning compressor clutch	IGN
A4			Spare	
A5	Violet	3 amp	Electric mirror motors	IGN
A6	Brown	7.5 amp	Cruise control	IGN

AUXILIARY FUSE BOX

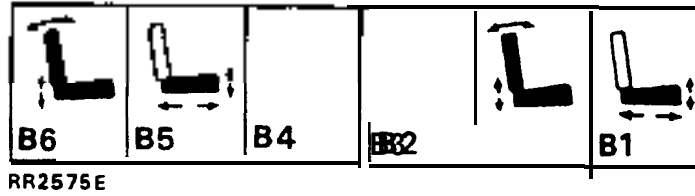

AUXILIARY FUSE BOX (B) - Located under the front left-hand seat

FUSE NO	COLOUR CODE	FUSE VALUE	CIRCUIT SERVED
B1	Green	30 amp	Drivers seat base/height front
B2	Green	30 amp	Drivers seat recline/height rear
B3	----	----	Spare
B4	----	----	S p a r e
B5	Green	30 amp	Passengers seat base/height front
B6	Green	30 amp	Passengers seat recline/height rear

ADDITIONAL FUSES

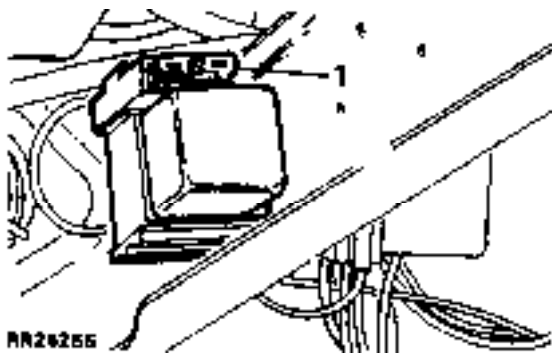

Sunroof fuse (1) is a 20 amp, yellow, blade type located on the side of the sunroof main relay

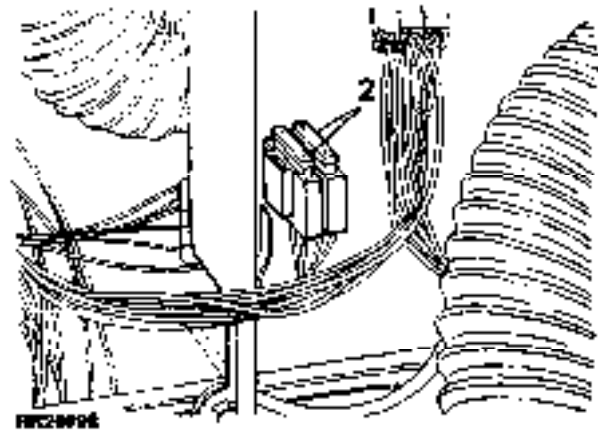

Heated front screen (2) has two 25 amp white, blade type fuses mounted adjacent to the bank of steering column mounted relays. Pull fuse holder off its mounting blade to gain access to fuses.

RELAYS-Identification

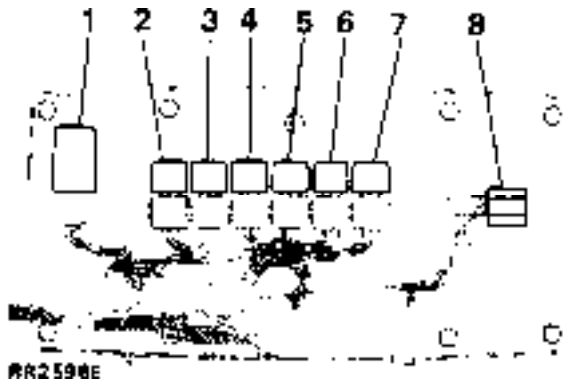

Closure panel viewed from the engine compartment, with protective cover removed.

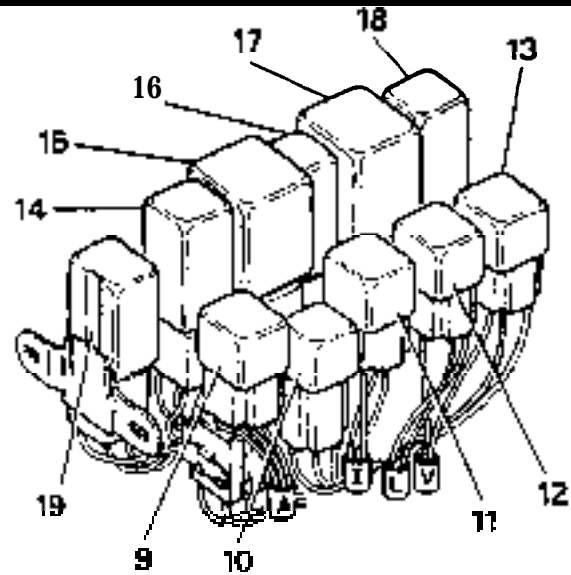

RR2599E Steering column mounted relays viewed with the lower dash panel removed.

Relay/delay/timer unit	Circuit Diagram item number	Colour
1. Headlamp wash timer unit	17. Main circuit	Black
2. Heated rear window relay	65. Main circuit	Natural
3. Starter solenoid relay	6. Main circuit	Natural
4. Compressor clutch relay	11. Air conditioning	Natural
5. Condenser fan relay	9. Air conditioning	Natural
6. Air conditioning/heater relay	5. Air conditioning	Natural
7. Fresh air solenoid relay	10. Air conditioning	Natural
8. Stowage position	- Not used	----
9. Auxiliary lamp relay	87. Main	Natural
10. Heated front screen relay	3. Heated front screen	Black
11. Ignition load relay	1. Main	Natural
12. Headlamp relay	26. Main	Natural
13. Heater/air con. relay	168. Main	Natural
14. Rear wiper delay	139. Main	Blue
15. Interior lamp delay	100. Main	Red
16. Flasher/hazard unit	74. Main	Black
17. Voltage sensitive switch	71. Main	Yellow
18. Front wiper delay-	14. Main	Red
19. Heated front screen timer unit	2. Heated front screen	Grey
20. Seat adjustment relays - two	5,6. Seat adjustment	Natural
21. Main EFI relay	22. EFI	Silver
22. Fuel pump relay	21. EFI	Silver
23. Cruise control relay	16. Cruise control	Natural
24. Condenser fan unit	23. Air conditioning	Green
25. Rear window lift relay	13. Window lift	Natural
26. Front window lift relay	14. Window lift	Natural
27. Window lift one touch unit	1. Window lift	Black
28. Sunroof auxiliary relay	3. Sunroof	Natural

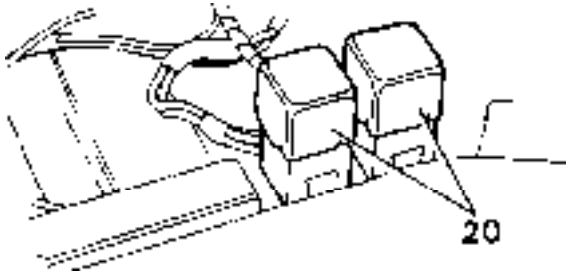

RR2602E

Seat adjustment relays (load control) located beneath the left hand front seat adjacent to fuse box (B).

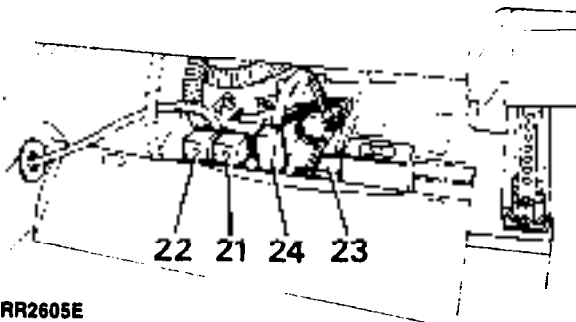

RR2605E

EFI (black terminal block) and fuel pump relays (blue terminal block) mounted beneath right hand front seat.

Condenser fan timer unit (24) mounted beneath right hand front seat.

Cruise control relay (23)

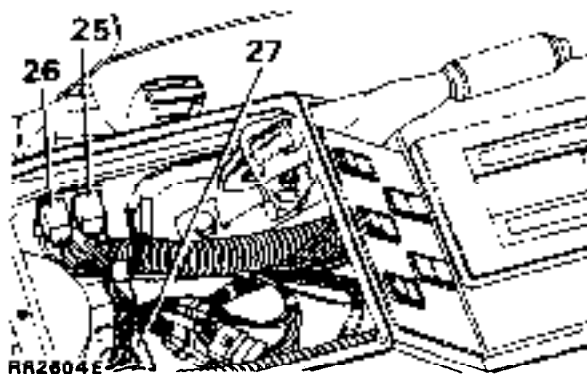

RR2604E

Front (black terminal block) and rear (blue terminal block) window relays. One touch control unit (27) is located inside the glove box, accessible by removing glove box liner.

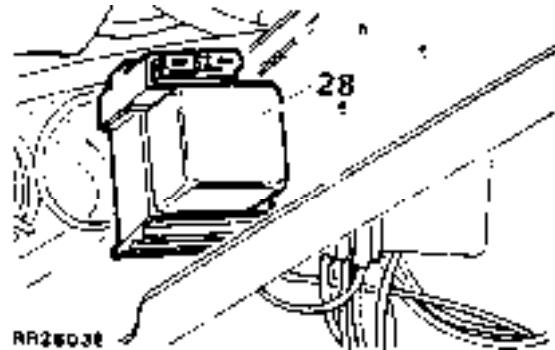

RR2603E

Sunshine roof auxiliary relay located on side of the steering column support bracket located behind the lower dash panel (Left hand drive shown).

Relays - interim condition (early 1989 models)

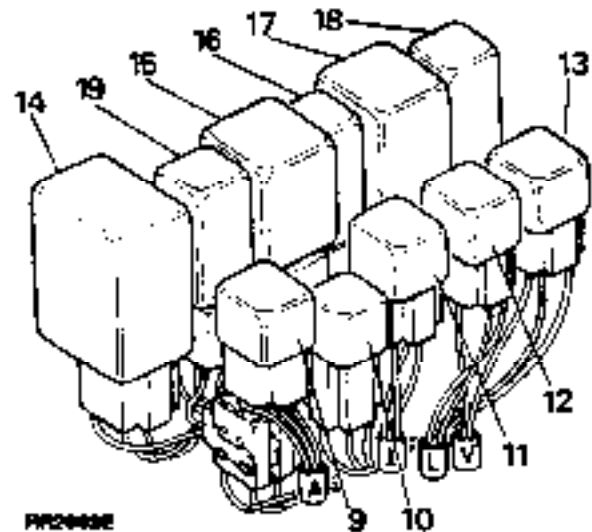

RR2603E

Steering column mounted relays viewed with the lower dash panel removed.

**ELECTRICALLY OPERATED CENTRAL DOOR
LOCKING SYSTEM**

The central door locking system now includes an actuator unit to lock the upper tailgate.

Locking or unlocking the drivers door from outside by key operation, or from inside by sill knob automatically locks or unlocks all four doors, the upper tailgate and the fuel filler flap.

Front and rear passenger doors can be independently locked or unlocked from inside the vehicle by sill knob operation but can be overridden by further operation of the driver locking control.

On rear doors only a child safety lock is provided which can be mechanically pre-set to render the interior door handles inoperative.

Failure of an actuator will not affect the locking of the remaining three doors, tailgate or fuel filler flap. The door/tailgate with the inoperative actuator can still be locked or unlocked manually, but not the fuel filler flap.

It is also possible to override the tailgate central locking by use of the key.

NOTE: The door lock actuator units contain non-serviceable parts. If a fault should occur replace the unit concerned with a new one.

Before carrying out any maintenance work disconnect the battery.

UPPER TAILGATE ACTUATOR UNIT

Remove and refit

Removing

1. Remove two screws and the trim covering to gain access to the actuator.
2. Disconnect the electrical connection.
3. Remove the two actuator retaining screws.
4. Manouver the actuator assembly to detach the operating rod 'eye' from the actuator link to the lock.
5. Withdraw the tailgate actuator unit.

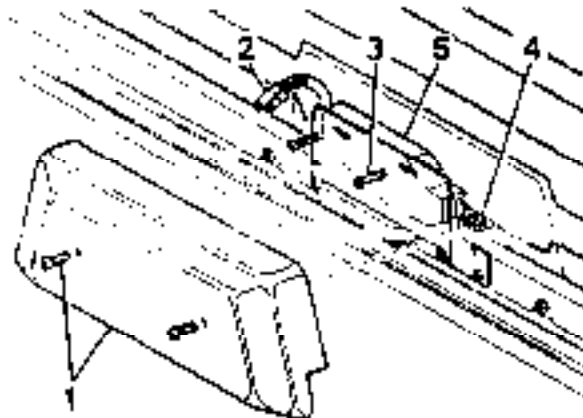

RR2570E

Refitting

6. Reverse the removal procedure.
7. Check the operation of the central locking system.

AUXILIARY SWITCH PANEL

The auxiliary switch panel contains the Emission maintenance reminder warning light, four 'push-push' type switches and a single touch switch for the heated front screen.

The switches incorporate integral symbols for identification. The symbols are illuminated when the vehicle lights are on.

The heated front (6) and rear (5) screen switches are provided with individual warning lights, illuminated when the switch is operated.

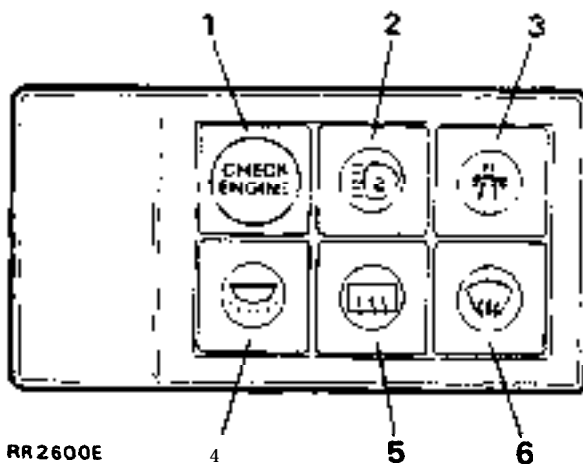

1. Emission maintenance reminder warning light.
2. Auxiliary driving lamps
3. Cruise control master switch
4. interior and tailgate lamps
5. Heated rear screen
6. Heated front screen

HEATED FRONT SCREEN

The heated front screen will operate when the switch is operated with engine running. The timer unit, see Relays-identification, will provide a preset time cycle of 7 1/2 minutes \pm 20%.

Switching off the ignition, or further operation of the heated front screen switch during the cycle will switch off the screen and cancel, reset and switch off the timer unit.

AUDIBLE WARNING UNIT

1989 model year vehicles feature ignition override of headlamps, i.e. headlamps will be switched off when ignition is switched off.

Therefore the rapidly repeated low tone described under AUDIBLE WARNING UNIT, section 86, page 62, is deleted.

ALTERNATOR HEAT SHIELD

Remove and refit

Removing

1. Disconnect the battery negative lead.
2. Remove the fixing screw to rocker cover.
3. Remove nut from alternator rear mounting bolt. Remove heat shield.

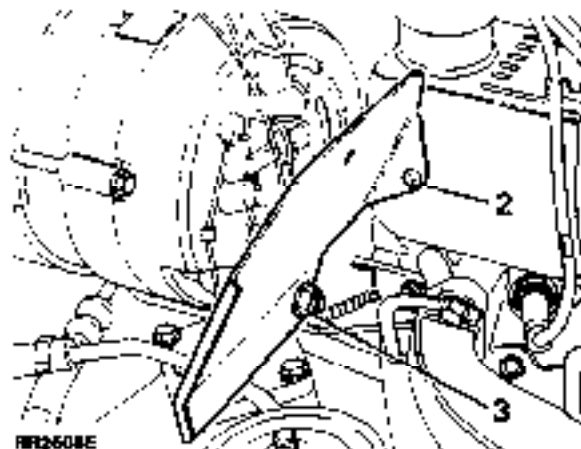

Refitting

4. Reverse removal procedure, check and adjust drive belt tension if required.

ELECTRICAL EQUIPMENT - CIRCUIT DIAGRAMS
 . 1989 Model year

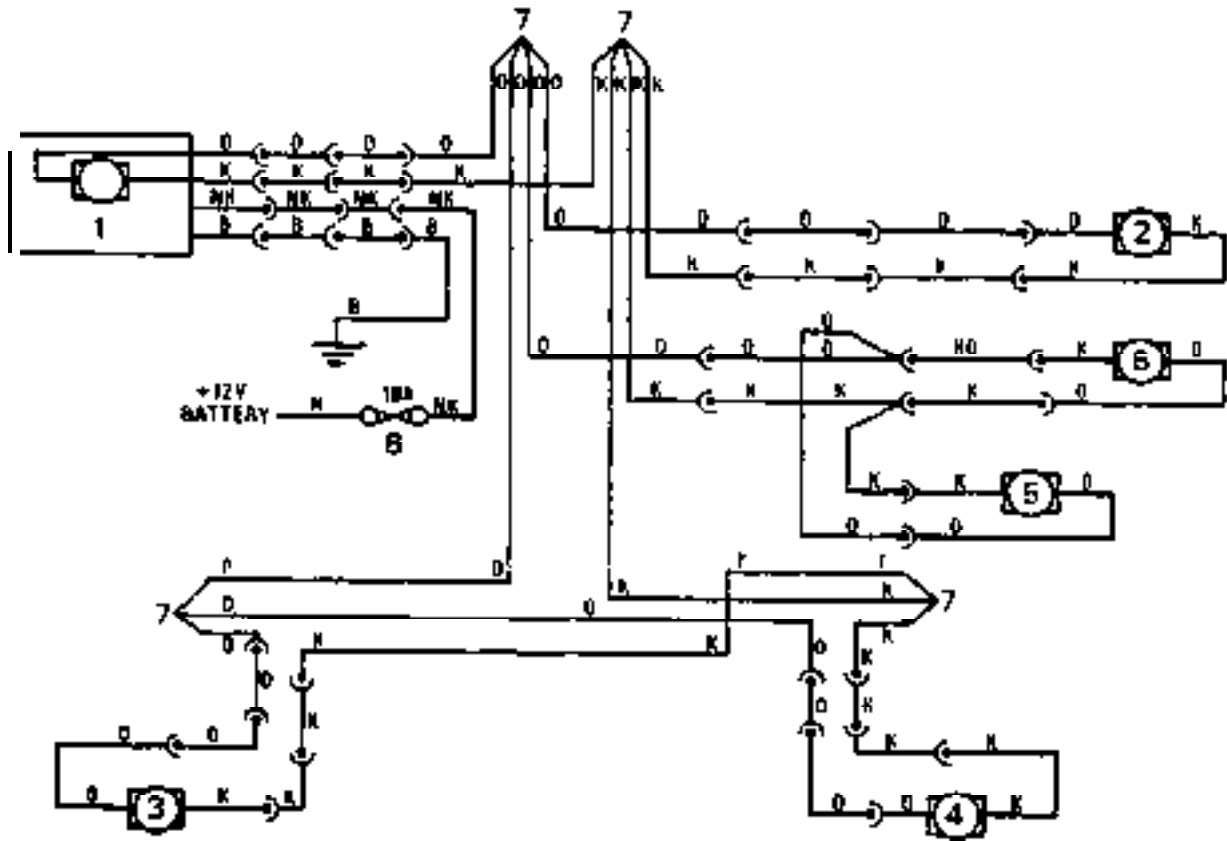

RR2545E

CENTRAL DOOR LOCKING
 . Circuit diagram RR2545E

- 1. Switch/lock unit drivers door
- 2. Lock unit front passenger door
- 3. Lock unit-left hand rear door
- 4. Lock unit-right hand rear door
- 5. Fuel flap actuator
- 6. Lock unit-tailgate
- 7. Clinches
- 8. Fuse 19

Cable colour code

B	Black	L	Light	P	Purple	U	Blue
G	Green	N	Brown	R	Red	W	White
K	Pink	O	Orange	s	Grey	Y	Yellow

The last letter of a colour code denotes the tracer.

ELECTRIC SEAT ADJUSTMENT

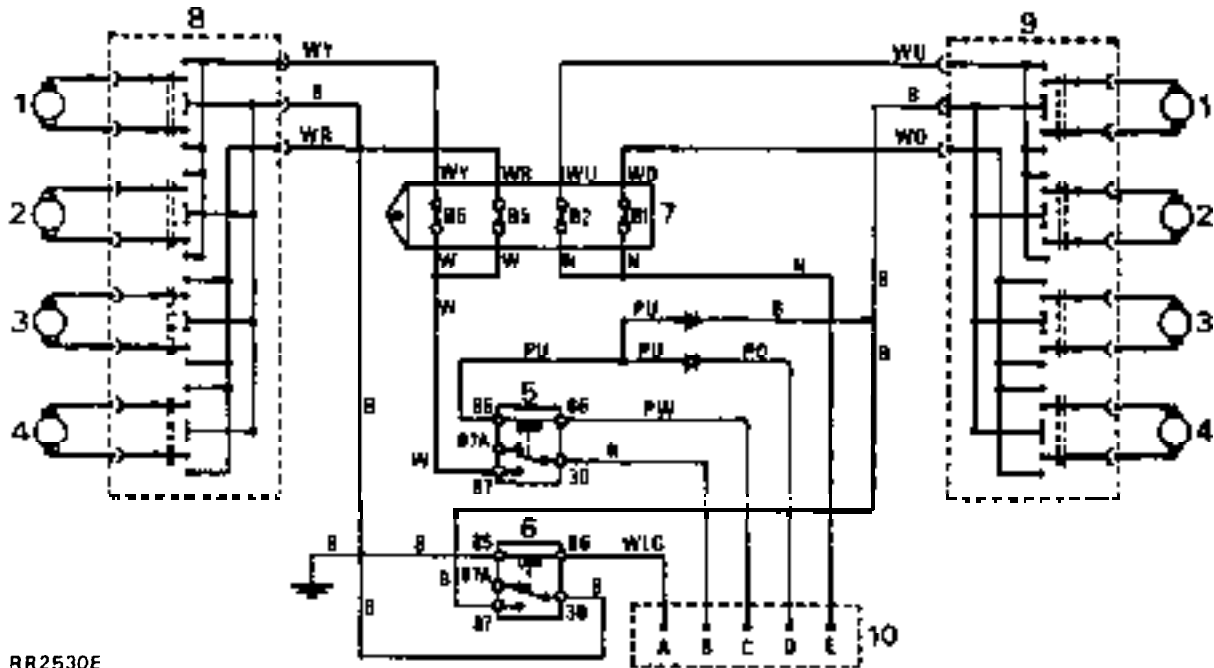

RR2530E

Circuit diagram - RR2530E

1. Seat recline motor
2. Seat height (rear) motor
3. Seat base adjust motor
4. Seat height (front) motor
5. Load relay-from driver's door courtesy switch
6. Load relay-fused auxiliary feed controlled
7. Auxiliary fuse box (B)
8. Driver's seat control
9. Passenger's seat control
10. Main cable connections:
 - A: Fused auxiliary feed
 - B: Battery feed
 - C: Fused 12 volt
 - D: Courtesy switch earth
 - E: Battery feed

Cable colour code

B Black	G Green	P Purple	Y Yellow
U Blue	S Grey	R Red	L Light
N Brown	O Orange	W White	

The last letter of a colour code denotes the tracer.

ELECTRIC MIRRORS

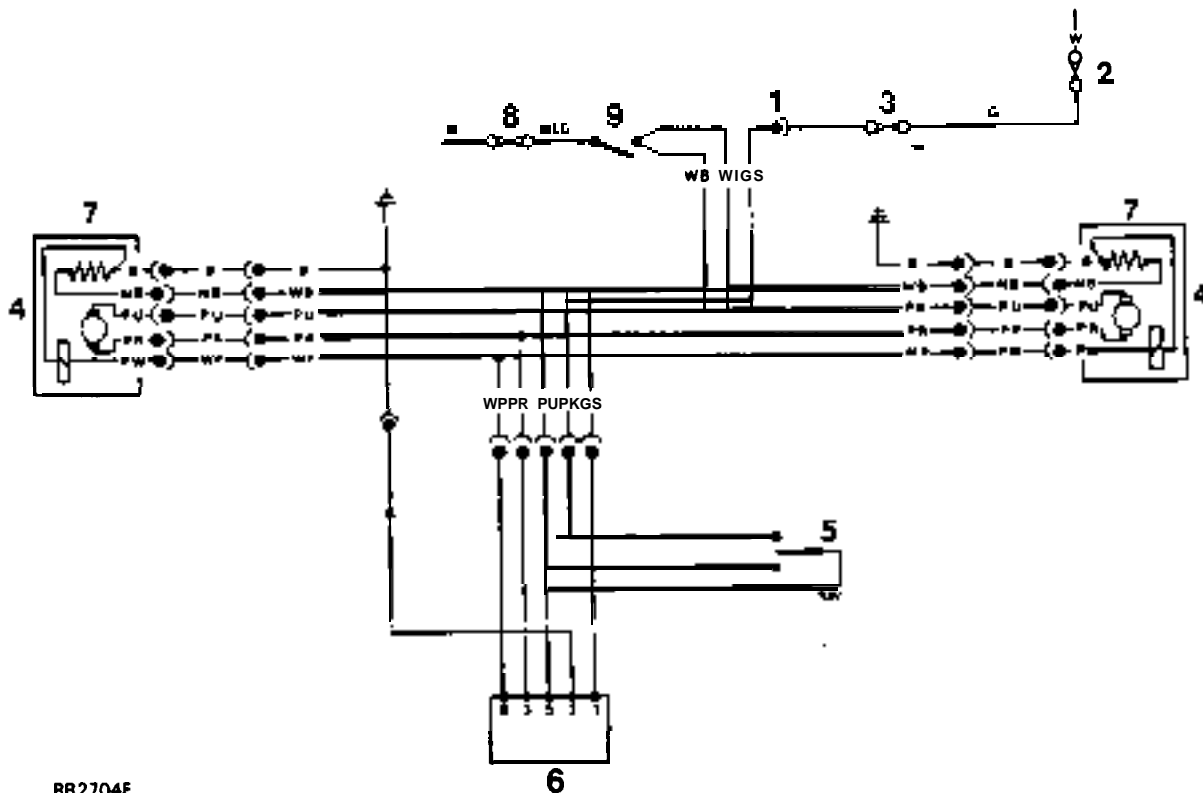

RR2704E

Circuit diagram - RR2704E

- | | |
|-----------------------------------|--|
| 1. Auxiliary fuse box connection. | 6. Mirror control switch. |
| 2. Fuse 13. | 7. Mirror heating elements - active with heated rear screen. |
| 3. Fuse A5 - mirror motors. | 8. Fuse 16 - heating elements. |
| 4. Mirror motors. | 9. Heated rear screen switch. |
| 5. Change over switch. | |

ELECTRIC WINDOW LIFT

Circuit diagram - RR2531E

- | | |
|---|--|
| 1. One touch control unit-drivers window | 11. Window lift switch in LH rear door |
| 2. Window lift motor-drivers window | 12. Window lift switch in RH rear door |
| 3. Window lift motor-front passengers side | 13. Relay-rear windows |
| 4. Window lift motor LH rear | 14. Relay-front windows |
| 5. Window lift motor RH rear | 15. Clinches |
| 6. Window lift switch drivers window | 16. Main cable fuses |
| 7. Window lift switch front passengers window | - a: Fuse 10 |
| 8. Window lift switch LH rear door | - b: Fuse 20 |
| 9. Window lift switch RH rear door | - c: Fuse 7 |
| 10. Isolator switch | |

Cable colour code

B Black	L Light	P Purple	U Blue
G Green	N Brown	R Red	W White
K Pink	O Orange	S Grey	Y Yellow

The last letter of a colour code denotes the tracer.

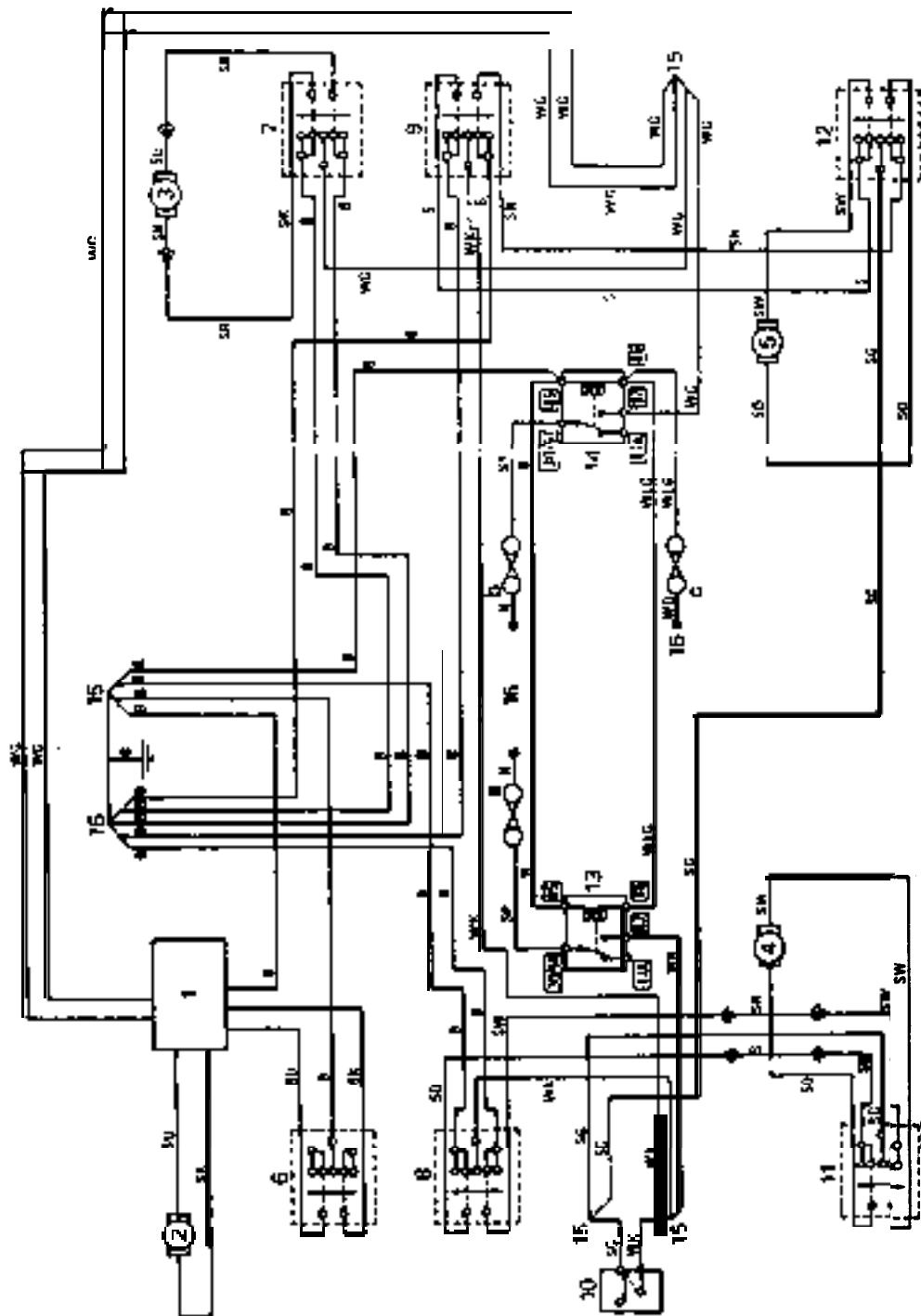

RR2531E

HEATED FRONT SCREEN

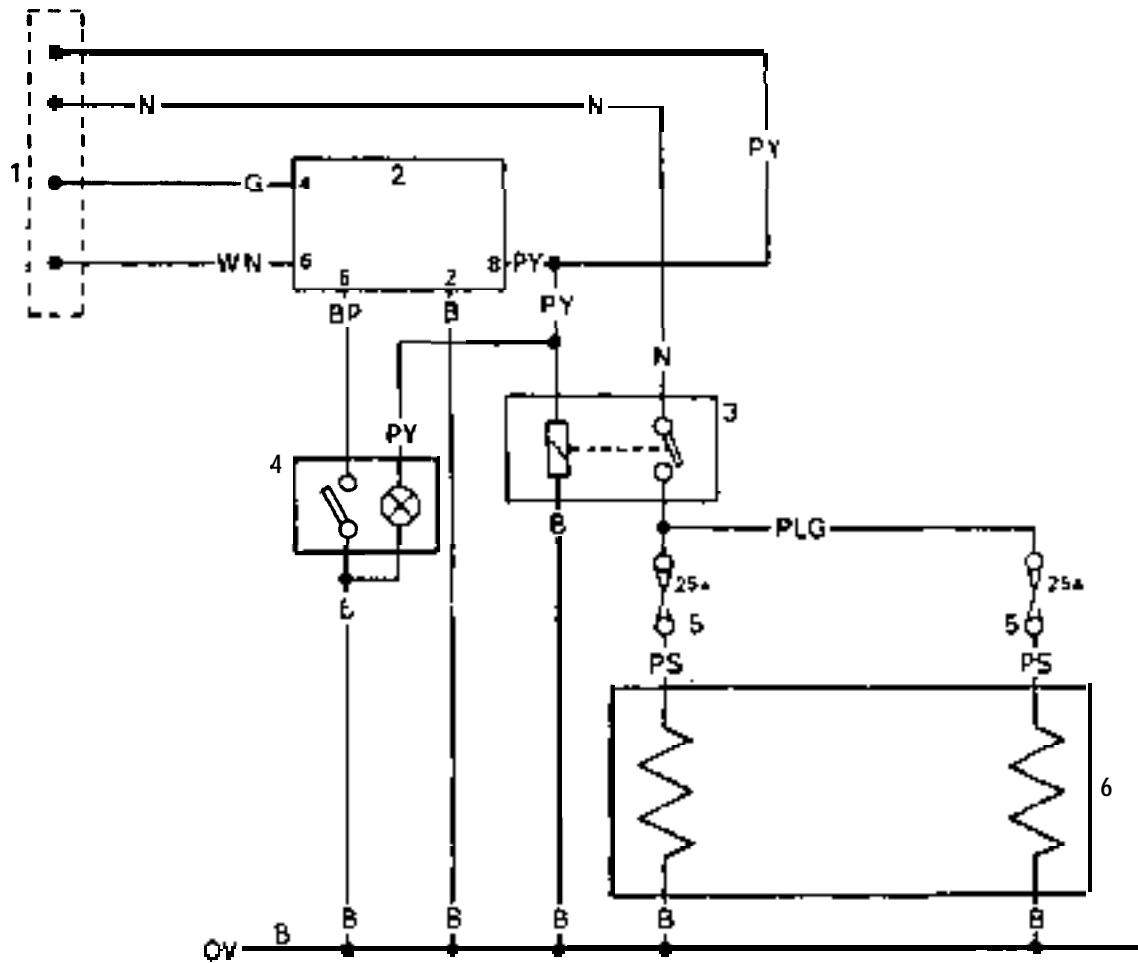

RR2593E

Circuit diagram • **RR2593E**

- 1. Main harness connections
 - Brown - live positive feed
 - Green - ignition positive feed
 - Purple/yellow - EFI harness plug
 - White/brown - oil pressure switch
 - Black - earth
- 2. Timer unit
- 3. Load relay
- 4. Switch/warning light
- 5. In line fuses - 25 Amp.
- 6. Heated front screen

Cable colour code

B	Black	L	Light	P	Purple	U	Blue
G	Green	N	Brown	R	Red	W	White
K	Pink	O	Orange	S	Grey	Y	Yellow

The last letter of a colour code denotes the tracer.

MAIN CIRCUIT DIAGRAM - 1989 Model Year - RR2951E & RR2952E
Numerical key

- | | |
|--|---|
| 1. Ignition load relay | 51. Fuel gauge |
| 2. Battery | 52. Fuel gauge sender unit |
| 3. Terminal post | 53. Water temperature gauge |
| 4. Starter solenoid | 54. Water temperature sender unit |
| 5. Starter motor | 55. Fuse 11 |
| 6. Starter relay | 56. Horn switch |
| 7. Starter inhibit switch | 57. RH horn |
| 8. Ignition switch | 58. LH horn |
| 9. Tachometer | 59. Under hood illumination switch |
| 10. Ignition warning lamp | 60. Under hood light |
| 11. Alternator | 61. Clock |
| 12. Fuse 7 | 62. Fuse 19 |
| 13. Front wiper/wash switch | 63. Fuse 20 |
| 14. Front wiper delay unit | 64. Pick-up point central locking/window lift |
| 15. Front wiper motor | 65. Heated rear window relay |
| 16. Front wash pump | 66. Fuse 9 |
| 17. Headlamp wash timer unit | 67. Radio aerial amplifier |
| 18. Headlamp wash pump | 68. Heated rear screen |
| 19. Main lighting switch | 69. Heated rear screen switch |
| 20. Fuse 6 | 70. Heated rear screen warning lamp |
| 21. Fuse 5 | 71. Voltage sensitive switch |
| 22. LH side lamp | 72. Fuse 13 |
| 23. LH tail lamp | 73. Hazard switch |
| 24. License plate lamp (2 off) | 74. Flasher unit |
| 25. High beam dimmer/flash switch | 75. Direction indicator switch |
| 26. Headlamp relay | 76. Hazard/indicator warning lamp |
| 27. RH side lamp | 77. LH rear indicator lamp |
| 28. RH tail lamp | 78. LH front indicator lamp |
| 29. Not used | 79. Pick up point - electric mirrors |
| 30. Rheostat | 80. Fuse 10 |
| 31. Fuse 3 | 81. RH front indicator lamp |
| 32. Fuse 4 | 82. RH rear indicator lamp |
| 33. Fuse 1 | 83. Trailer warning lamp |
| 34. Fuse 2 | 84. Fuse 15 |
| 35. Not used | 85. Stop lamp switch |
| 36. Not used | 86. Reverse lamp switch |
| 37. Switch illumination (2 off) | 87. Auxiliary lamp relay |
| 38. Cigar lighter illumination (2 off) | 88. LH stop lamp |
| 39. Heater illumination (4 off) | 89. RH stop lamp |
| 40. Clock illumination | 90. LH reverse lamp |
| 41. Automatic gear selector illumination (2 off) | 91. RH reverse lamp |
| 42. Instrument illumination (6 off) | 92. LH auxiliary lamp |
| 43. Column switch illumination | 93. RH auxiliary lamp |
| 44. Not used | 94. Auxiliary lamp switch |
| 45. Not used | 95. Fuse 17 |
| 46. LH low beam | 96. Dash cigar lighter |
| 47. RH low beam | 97. Glove box cigar lighter |
| 48. LH high beam | 98. LH interior lamp |
| 49. RH high beam | 99. RH interior lamp |
| 50. High beam warning lamp | 100. Interior lamp delay unit |

- | | |
|--|---|
| <ul style="list-style-type: none"> 101. RH door edge lamp 102. RH puddle edge lamp 103. LH door edge lamp 104. LH puddle lamp 105. Interior lamp switch 106. LH rear door switch 107. RH rear door switch 108. Tailgate switch 109. RH front door switch 110. LH front door switch 111. Not used 112. Fuse 14 113. Oil pressure/level warning lamp 114. Oil pressure switch 115. Fuse 18 116. Inertia switch 117. Fuel pump 118. Ignition coil 119. Capacitor 120. Distributor 121. EFI Harness plug 122. Not used 123. Radio fuse 124. Radio 125. Six speakers 126. Seats pick up point 127. Seat belt warning lamp 128. "Key-in" switch 129. Speed transducer, see Cruise Control 130. Resistor 131. Audible warning unit 132. Transfer box neutral switch 133. Seat buckle switch 134. Sunroof connection points (option) 135. Automatic transmission oil temperature warning lamp 136. Automatic transmission oil temperature switch 137. Fuse 16 138. Rear wash wipe switch 139. Rear wipe delay unit 140. Rear wiper motor 141. Rear screen wash pump 142. Low screen wash fluid level warning lamp 143. Low screen wash switch 144. Low coolant switch 145. Multi-function unit and binnacle | <ul style="list-style-type: none"> 146. Low coolant level warning lamp 147. Low fuel level warning lamp 148. E.F.I. warning lamp 149. Low oil level logic unit 150. Low oil level probe 151. Not used - will illuminate on initial bulb check 152. Parking brake/brake fluid loss warning lamp 153. Parking brake warning switch 154. Brake fluid loss warning switch 155. Brake pad wear warning lamp 156. Brake pad wear sensors 157. Warning lamp control unit 158. Heater/air conditioning connections 159. Fuse 8 160. Cruise control connection points 161. Coil negative, engine speed signal to ECU 162. Emission maintenance reminder 163. Check engine warning lamp 164. Trailer pick up point 165. Alarm connection points 166. Heated washer jets 167. Thermostat-heated jets 168. Heater/air con. relay 169. Heated screen pick up point |
|--|---|

CABLE COLOUR CODE

B	Black
U	Blue
N	Brown
G	Green
s	Grey
L	Light
O	Orange
K	Pink
P	Purple
R	Red
W	White
Y	Yellow

MAIN CIRCUIT DIAGRAM - 1989 Model Year -
RR2951E & RR2952E

Alphabetical key

- 165. Alarm connection points
- 11. Alternator
- 131. Audible warning unit
- 41. Automatic gear selector illumination (2 off)
- 136. Automatic transmission oil temperature switch
- 135. Automatic transmission oil temperature warning lamp
- 87. Auxiliary lamp relay
- 94. Auxiliary lamp switch
- 3. Battery
- 154. Brake fluid loss warning switch
- 156. Brake pad wear sensors
- 155. Brake pad wear warning lamp
- 114. Capacitor
- 163. Check engine warning lamp
- 38. Cigar lighter illumination (2 off)
- 61. Clock
- 40. Clock illumination
- 161. Coil negative engine speed signal to ECU
- 43. Column switch illumination
- 160. Cruise control connection points
- 96. Dash cigar lighter
- 75. Direction indicator switch
- 120. Distributor
- 121. EFI Harness plug
- 148. EFI warning lamp
- 162. Emission maintenance reminder
- 74. Flasher unit
- 16. Front wash pump
- 14. Front wipe delay unit
- 13. Front wipe/wash switch
- 15. Front wiper motor
- 51. Fuel gauge
- 52. Fuel gauge sender unit
- 117. Fuel pump
- 33. Fuse 1
- 34. Fuse 2
- 31. Fuse 3
- 32. Fuse 4
- 21. Fuse 5
- 20. Fuse 6
- 12. Fuse 7
- 159. Fuse 8
- 66. Fuse 9
- 80. Fuse 10
- 55. Fuse 11
- 72. Fuse 13
- 112. Fuse 14
- 84. Fuse 15
- 137. Fuse 16
- 95. Fuse 17
- 115. Fuse 18
- 62. Fuse 19
- 63. Fuse 20
- 97. Glove box cigar lighter
- 73. Hazard switch
- 76. Hazard/indicator warning lamp
- 18. Headlamp wash pump
- 17. Headlamp wash timer unit
- 169. Heated front screen connections
- 68. Heated rear screen
- 69. Heated rear screen switch
- 70. Heated rear screen warning lamp
- 65. Heated rear window relay
- 166. Heated washer jets
- 39. Heater illumination (4 off)
- 158. Heater/air conditioning connections
- 168. Heater/air con. relay
- 35. High beam dimmer/flash switch
- 50. High beam warning lamp
- 56. Horn switch
- 118. Ignition coil
 - 1. Ignition load relay
 - 8 Ignition switch
- 10. Ignitron warning lamp
- 116. Inertia switch
- 42. Instrument illumination (6 off)
- 100. Interior lamp delay unit
- 105. Interior lamp switch
- 128 "Key-in" switch
 - 92. LH auxiliary lamp
- 103. LH door edge lamp
- 110. LH front door switch
 - 78. LH front indicator lamp
- 48. LH high beam
- 58. LH horn
- 98. LH interior lamp
- 24. License plate lamp (2 off)
- 46. LH low beam
- 104. LH puddle lamp
- 106. LH rear door switch
- 77. LH rear indicator lamp
- 90. LH reverse lamp
- 22. LH side lamp
- 88. LH stop lamp
- 23. LH tail lamp
- 146. Low coolant level warning lamp
- 144. Low coolant switch
- 147. Low fuel level warning lamp
- 149. Low oil level logic unit
- 150. Low oil level probe
- 142. Low screen wash fluid level warning lamp
- 143. Low screen wash switch
 - 19. Main lighting switch
- 145. Multi-function unit and binnacle
- 14. Oil pressure switch
- 113. Oil pressure/level warning lamp
- 153. Parking brake warning switch
- 152. Parking brake/brake fluid loss warning lamp
 - 79. Pick up point - electric mirrors
- 64. Pick-up point central locking/window lift
- 124. Radio
 - 67. Radio aerial amplifier
- 123. Radio fuse
- 125. Radio speakers (6 off)
- 141. Rear screen wash pump
- 138. Rear wash wipe switch

- 139. Rear wiper delay unit
- 140. Rear wiper motor
- 130. Resistor
 - 86. Reverse lamp switch
- 53. RH auxiliary lamp
- 101. RH door edge lamp
- 109. RH front door switch
 - 81. RH front indicator lamp
- 49. RH high beam
- 57. RH horn
- 99. RH interior lamp
- 47. RH low beam
- 102. RH puddle lamp
- 107. RH rear door switch
 - 82. RH rear indicator lamp
 - 91. RH reverse lamp
- 27. RH side lamp
- 89. RH stop lamp
- 28. RH tail lamp
- 30. Rheostat
- 127. Seat belt warning lamp
- 133. Seat buckle switch
- 126. Seats nick up point
- 129. Speed transducer, see Cruise Control
 - 7. Starter inhibit switch
 - 5. Starter motor
 - 6. Starter relay
 - 4. Starter solenoid
- 85. Stop lamp switch
- 134. Sunroof connection points (option)
 - 37. Switch illumination (2 off)
- 9. Tachometer
- 108. Tailgate switch
 - 3. Terminal post
- 167. Thermostat - heated jets
- 164. Trailer pick up point
 - 83. Trailer warning lamp
- 132. Transfer box neutral switch
 - 59. Under hood illumination switch
- 60. Under hood light
- 71. Voltage sensitive switch
- 157. Warning lamp control unit
- 53. Water temperature gauge
- 54. Water temperature sender unit

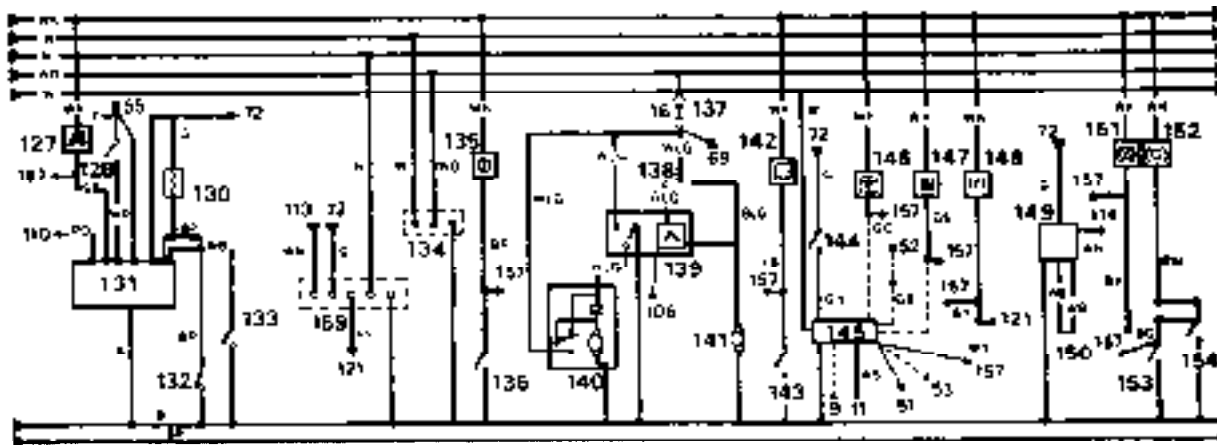
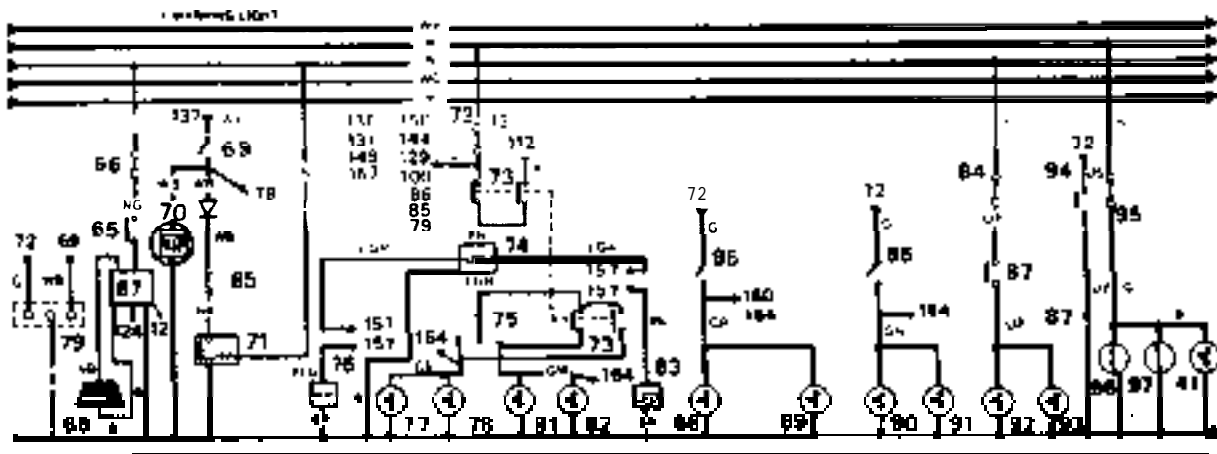
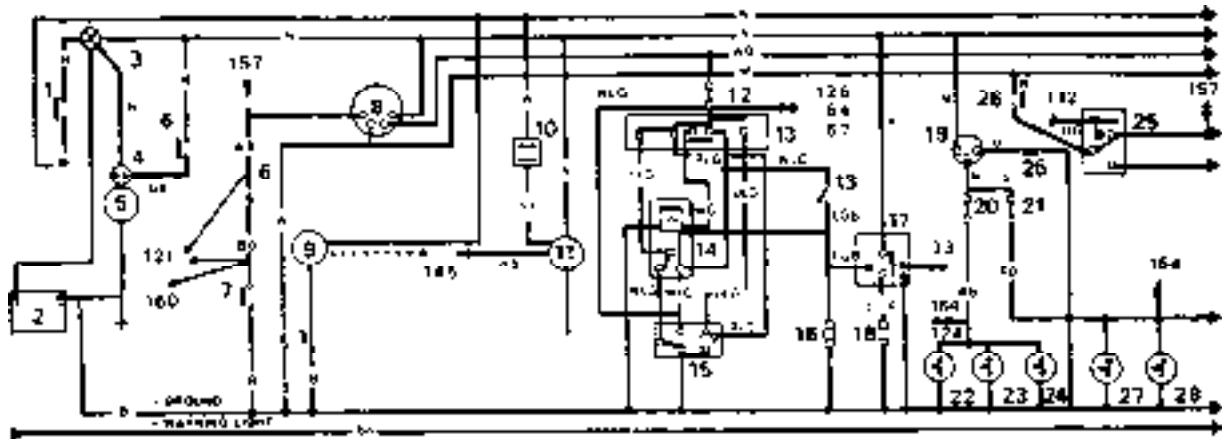

RR2951E

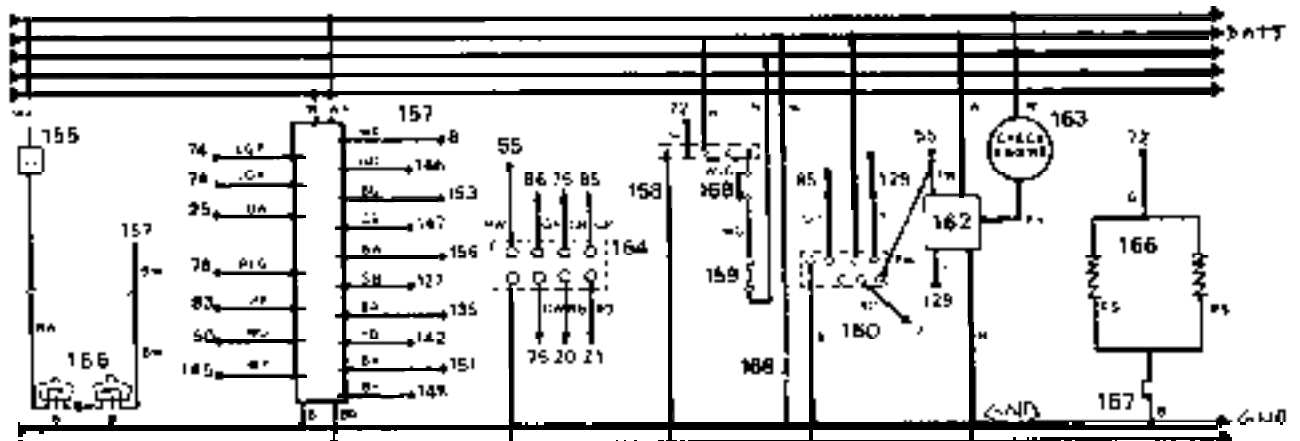
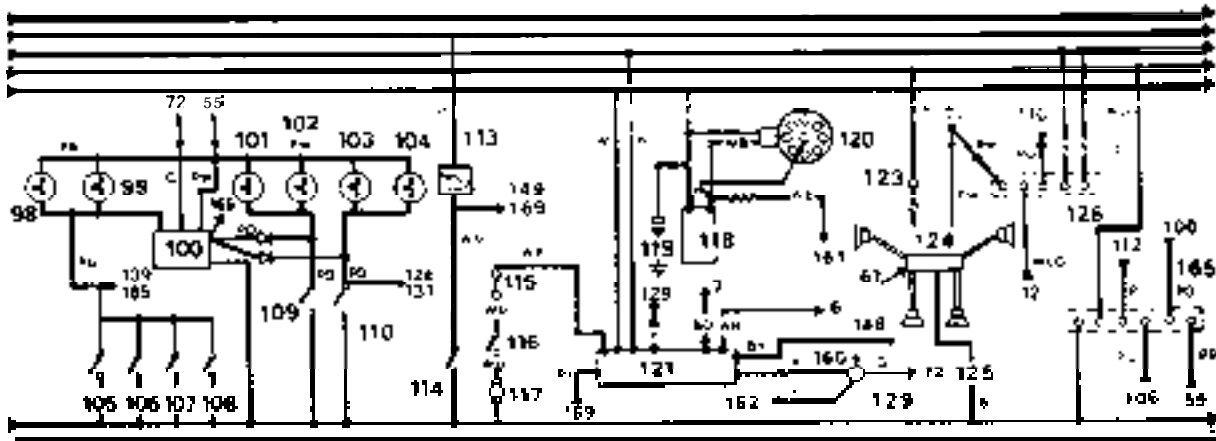
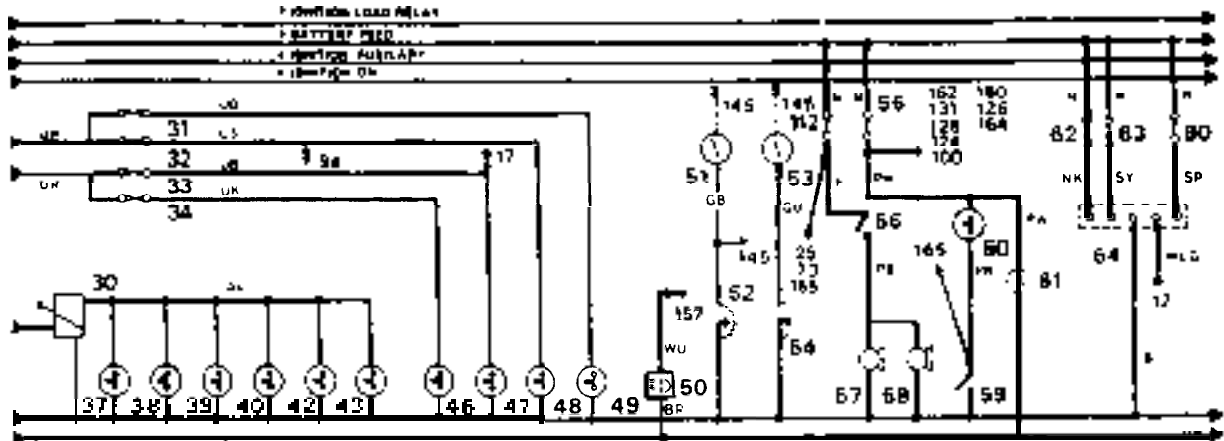

RR2952E

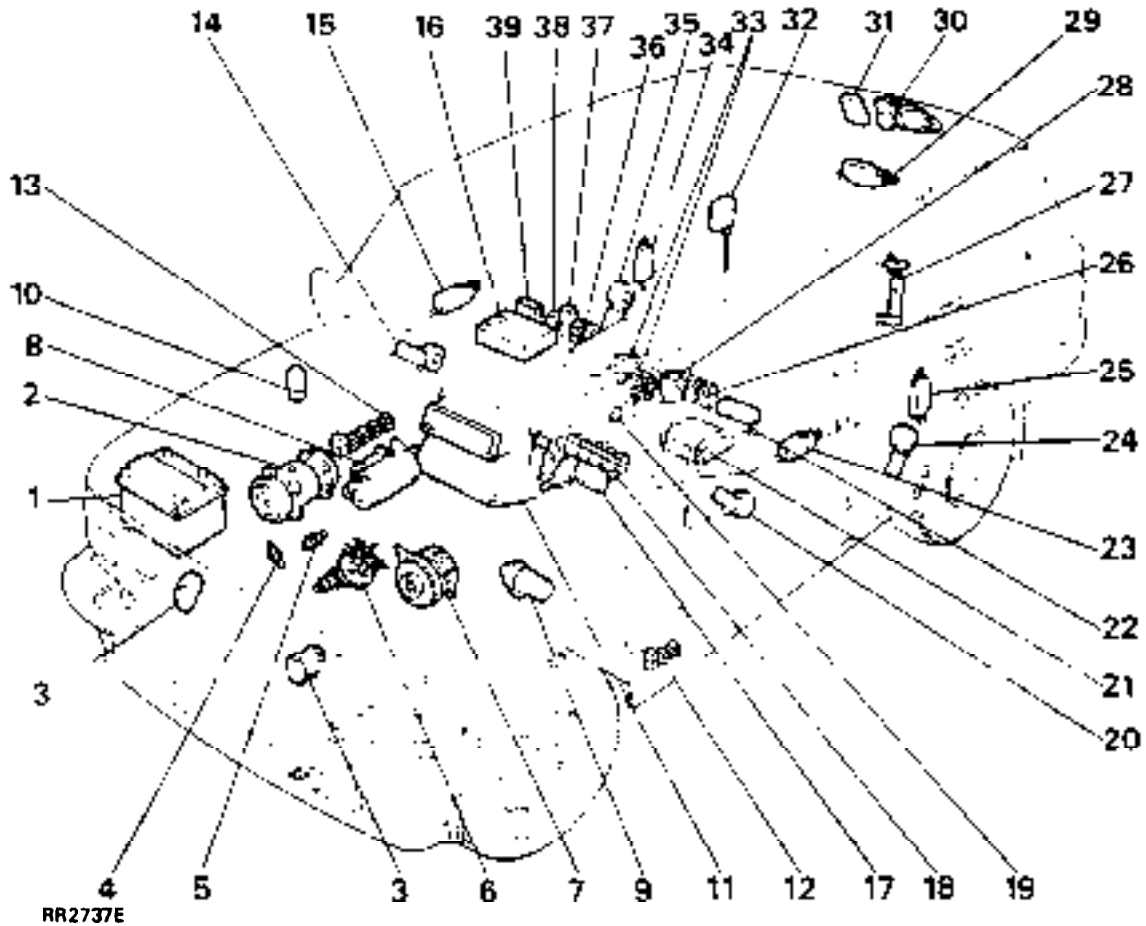

LOCATION OF ELECTRICAL EQUIPMENT - 1990 MODEL YEAR

- | | |
|--|---|
| <ul style="list-style-type: none"> 1. Battery 2. Air conditioning compressor 3. Horns 4. Oil pressure switch 5. Water temperature switch 6. Electronic distributor 7. Alternator 8. Starter motor 9. Coil 10. Headlamp wash timer unit 11. Heater 12. Relays/flasher units 13. Air con relays/diode unit 14. Window lift motor (front RH door) 15. Door lock actuator (front RH door) 16. Electronic control unit (EFI) 17. Wiper motor - front screen 18. Relays/delay units 19. Park brake warning light switch | <ul style="list-style-type: none"> 20. Window lift motor (front LH door) 21. Electronic control unit and relays (ABS) 22. Seat adjustment fusebox 23. Door lock actuator (front LH door) 24. Window lift motor (rear LH door) 25. Door lock actuator (rear LH door) 26. Seat adjustment relays - two 27. Electrical in-tank fuel pump 28. Inertia switch 29. Tailgate lock actuator 30. Wiper motor - rear screen 31. Radio aerial amplifier 32. Fuel filler flap lock actuator 33. Window lift relays and one touch control unit 34. Door lock actuator (rear RH door) 35. Window lift motor (rear RH door) 36. EFI relays (two) 37. Condenser fan timer unit 38. Cruise control relay 39. Emission maintenance reminder |
|--|---|

RELAYS, DELAY UNITS, TIMER UNITS, DIODE PACK • Identification

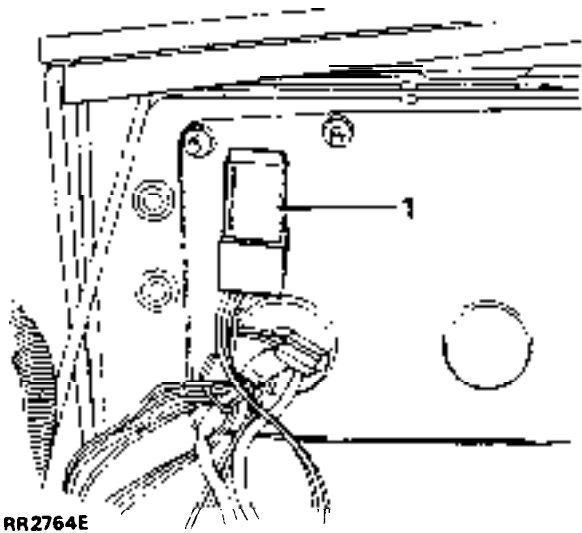

RR2764E

Closure panel viewed from the engine bay compartment, with protective cover removed.

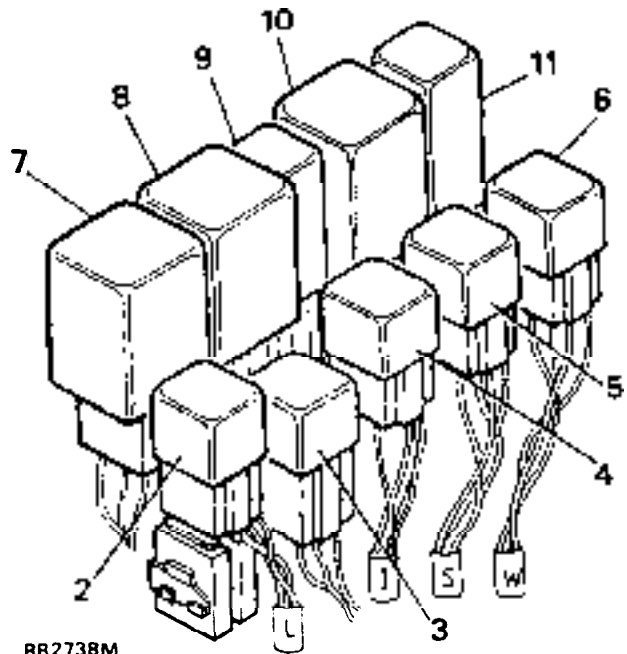

RR2738M

Steering column mounted relays viewed with the lower dash panel removed.

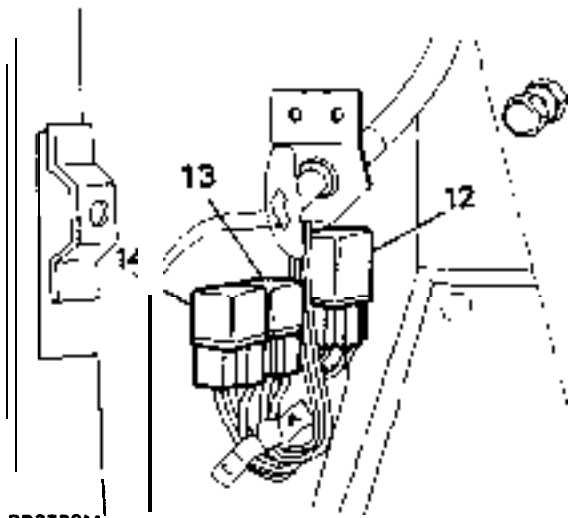

RR2739M

RR2739M shows relays mounted in left hand side of footwell, trim panel removed.

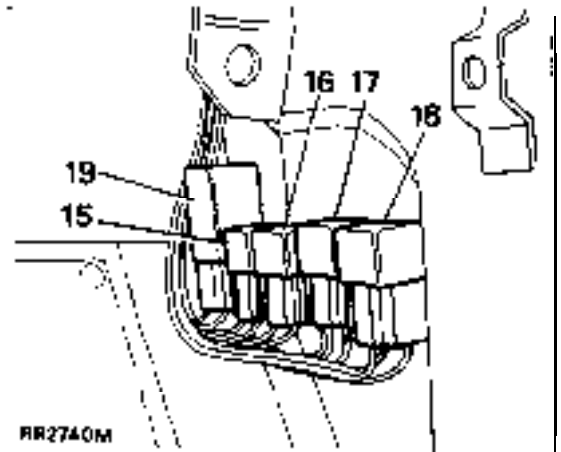

RR2740M

RR2740M shows relays mounted in right hand side of footwell, trim panel removed.

Relay/delay/timer/diode unit	Circuit diagram item number	Colour
1. Headlamp wash timer unit	18. Main	Black
2. Headlamp relay	16. Main	Natural
3. Heated front screen relay	3. Heated front screen	Black
4. Ignition load relay	1. Main	Natural
5. Starter solenoid relay	6. Main	Natural
6. Heated rear window relay	64. Main	Natural
7. Rear wiper delay	139. Main	Blue
8. Interior lamp delay/timer	99. Main	Red
9. Heated front screen timer unit	2. Heated front screen	Crey
10. Voltage sensitive switch	70. Main	Yellow
11. Front wiper delay	14. Main	Red
12. Flasher/hazard unit	73. Main	Blue
13. Fog lamp relay	86. Main	Natural
14. Sunroof auxiliary relay	3. Sunroof	Natural
15. Air con./heater relay	175. Main	Natural
16. Compressor clutch relay	11. Air conditioning	Natural
17. Heater/air con. load relay	5. Air conditioning	Natural
18. Condenser fan relay	9. Air conditioning	Natural
19. Air con. diode pack	1. Air conditioning	Orange
20. Seat adjustment relays - two	5 & 6. Seat adjustment	Natural
21. Main EFI relay	13. EFI	Silver
22. Fuel pump relay	21. EFI	Silver
23. Cruise control relay	16. Cruise control	Natural
24. Condenser fan timer unit	33. EFI	Green
25. Rear window lift relay	13. Window lift	Natural
26. Front window lift relay	14. Window lift	Natural
27. Window lift one touch unit	1. Window lift	Black
28. Gear selector illumination relay	40a Main	Natural

NOTE: See Brakes, Section 70 for details of ABS relays

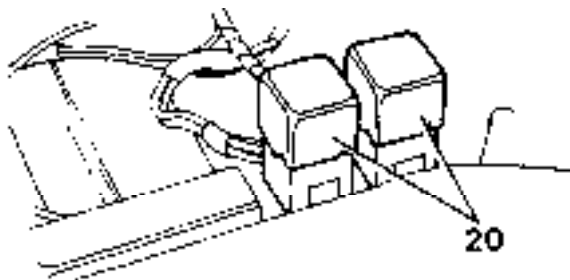

RR2602E

Seat adjustment relays (load control) located beneath the left hand front seat adjacent to fuse box (B).

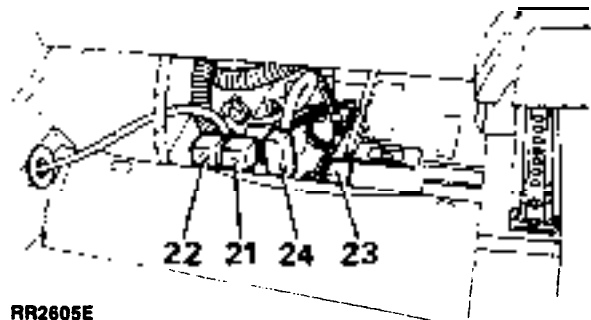

RR2605E

EFI (black terminal block) and fuel pump relays (blue terminal block) mounted beneath right hand front seat (21 and 22).

Condenser fan timer unit (24) mounted beneath right hand front seat.

Cruise control relay (23).

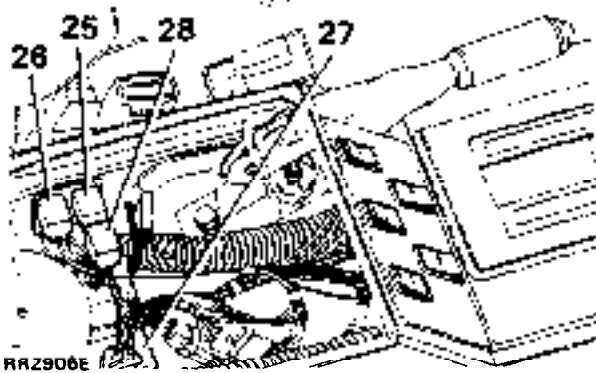

RR2906E shows relays located inside the glove box, accessible by removing the glove box liner. Front (black terminal block) and rear (blue terminal block) window relays (25 and 26) window lift one touch control unit (27). Gear shift illumination relay (28).

AUXILIARY SWITCH PANEL

The auxiliary panel contains five 'push-push' and one single push switch which incorporate integral symbols for identification.

The symbols are illuminated by two bulbs which become operational when the vehicle lights are on.

The heated front (6) and rear (5) screen switches are also provided with individual warning lights, illuminated when the switches are operated.

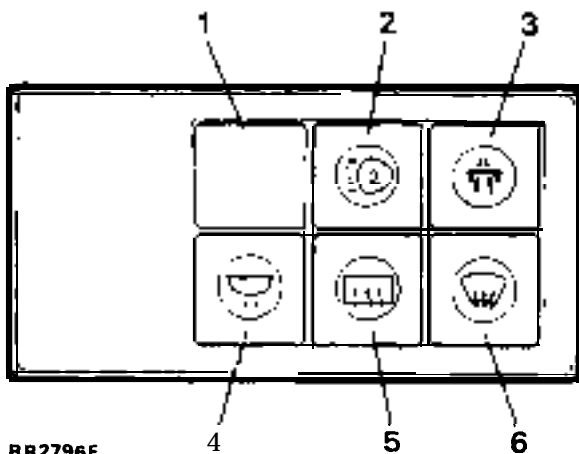

RR2796E

- 1. Blank.
- 2. Front fog lamps.
- 3. Cruise control.
- 4. Interior and tailgate lamps.
- 5. Heated rear screen.
- 6. Heated front screen.

HIGH LEVEL STOP LAMP

Remove and refit

Remove

- 1. Disconnect the battery negative lead.

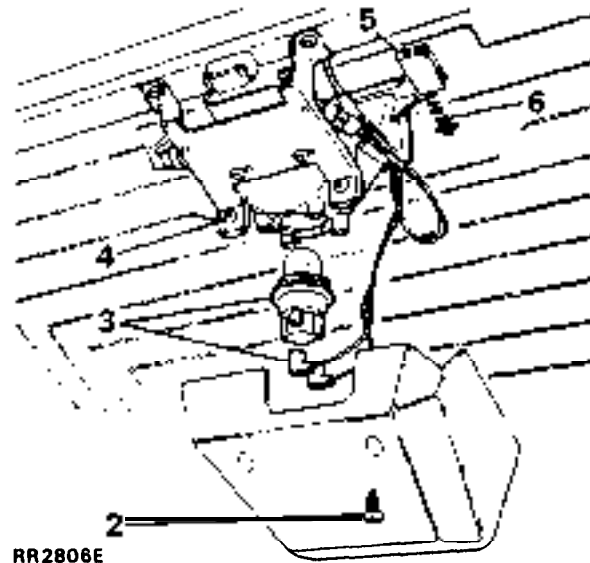

RR2806E

- 2. Remove the two cover retaining screws and remove the cover.
- 3. Disconnect the electrical leads to the bulb holder. Remove the bulbholder and the bulb with a counter clockwise twist.
- 4. Remove the two mounting plate to brake light screws.
- 5. Observe position of stop lamp on the rear screen. Carefully release the assembly tabs on the stop lamp from the rear screen mountings.
- 6. Slide the stop lamp out.

Refit

- 7. Renew the bulb if necessary, the correct bulb is a 12V, 21 watt, bayonet type.
- 8. Reverse the removal instructions.

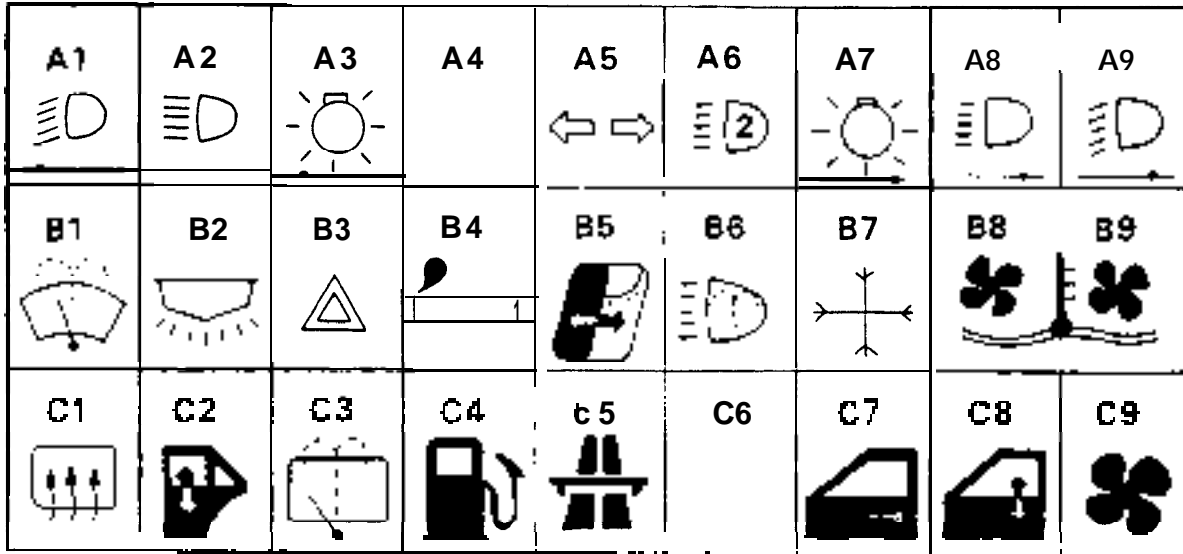















RR2697E

FUSE BOX - RR2697M

FUSE No.	COLOUR CODE	RATING AMPS	IGN. KEY POSITION	FUNCTION
A1	Red	10	II	LH low beam
A2	Red	10	II	LH high beam, auxiliary lamp relay
A3	Tan	5	0	LH parking lamps, radio ill., trailer pickup
A4	---	---	---	Not used
A5	Yellow	20	II	Direction ind., resistor, heated jets, thermo., heated front screen timer, air con. low coolant, low oil, speed transducer, interior lamp delay, reverse lights, stop lights, audible warning unit
A6	Red	10	II	Fog lamps (from low beam)
A7	Tan	5	0	RH parking lamps, rheostat controlled instrument/switch illumination, trailer pick up
A8	Red	10	II	RH high beam
A9	Red	10	II	RH low beam
B1	Yellow	20	I	Front wash/wipe, seat relays, window lift relays, antenna amplifier
B2	Yellow	20	0	interior light, clock, underhood ill., elec. seat relays, radio, door lamps, key in switch, audible warning
B3	Yellow	20	0	Hazard switch, alarm, headlamp dip/flash, horns
B4	Yellow	20	II	Cigar lighters
B5	Yellow	20	II	Sunroof motor
B6	Yellow	20	II	Headlamp wash
B7	Tan	5	II	Air conditioning compressor clutch
B8	Yellow	20	II	Air conditioning/radiator cooling fan
B9	Yellow	20	II	Air conditioning/radiator cooling fan
C1	Green	30	II	Heated rear screen (voltage switch controlled)
c2	Green	30	II	Window lifts - rear
c3	Red	10	II	Rear wash wipe motor, heated rear screen relay, mirror heaters
C4	Red	10	II	Fuel pump
c5	Red	10	II	Mirror motors, cruise control
C6	---	---	---	Not used
c7	Blue	15	0	Central locking
C8	Green	30	II	Window lifts - front
C9	Green	30	II	Heater/air conditioning motor

INSTRUMENT BINNACLE WARNING LIGHT SYMBOLS

-  Direction indicator - left turn (green)
-  Direction indicator - right turn (green)
-  Headlamp high beam on (blue)
-  Brake pad wear (amber)
-  Trailer connected - flashes with direction indicators (green)
-  EFI warning light (red)
-  Brake fluid pressure failure/low fluid level, transmission handbrake on (red)
-  Low screenwash fluid (amber)
-  ABS warning light (red)
-  Automatic gearbox oil or transfer box temperature high (red)
-  Emission maintenance reminder
-  Seat belt (red)
-  Ignition on/low charge (red)
-  Engine oil pressure low (red)
-  Low coolant (red)

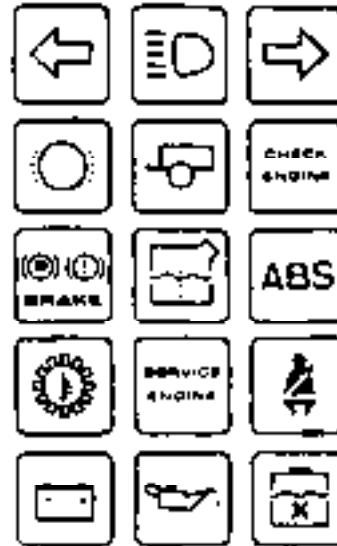

RR2803E

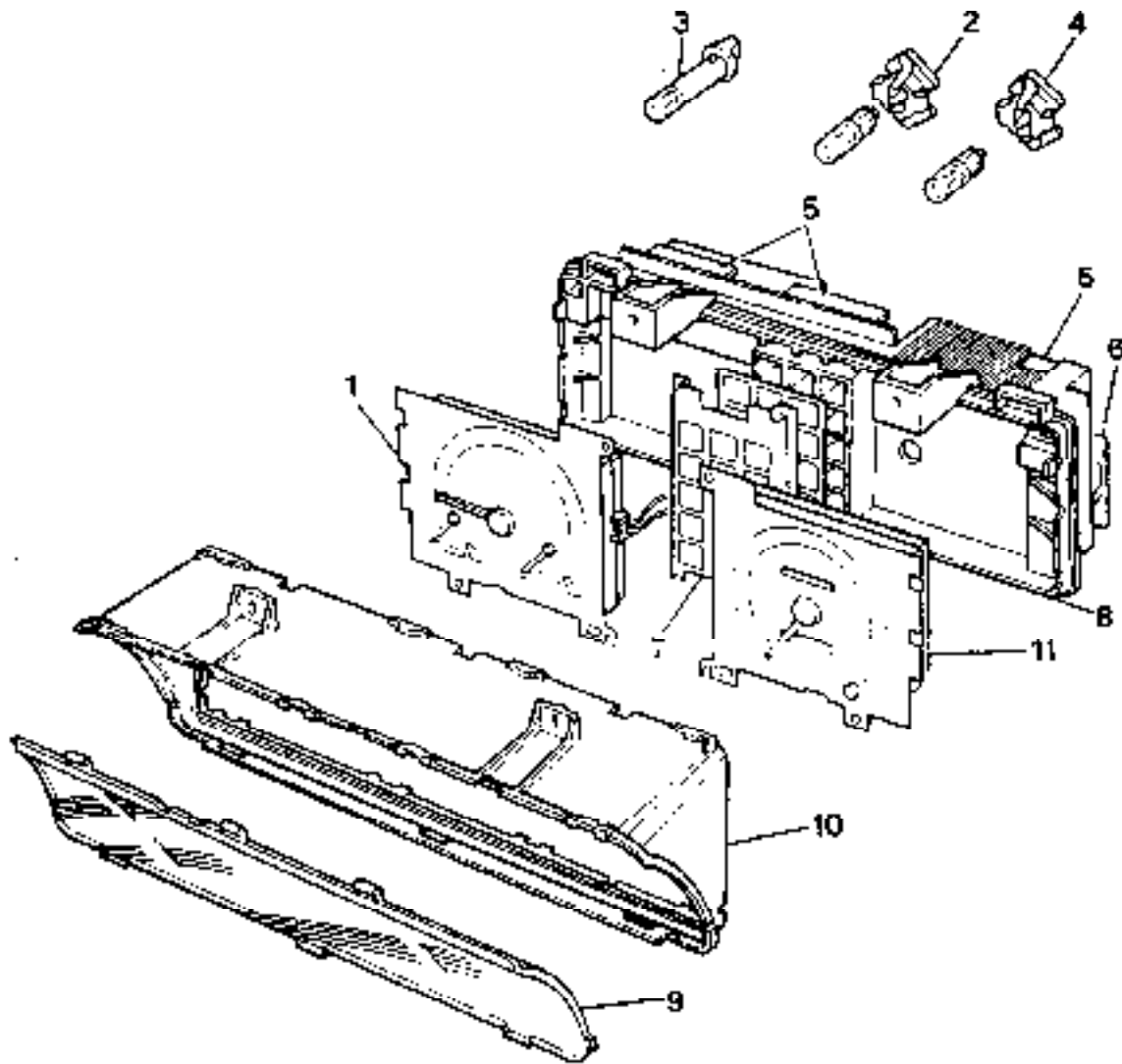

RR2732M

Instrument pack

1. Tachometer, fuel and temperature gauge.
2. Ignition warning bulb (with separate blue holder unit)
3. Panel illumination bulb and holder.
4. Warning lights bulb and holder.
5. Printed circuit input tags (for harness connection).
6. Printed circuit.
7. Warning light panel.
8. Instrument case (front).
9. Curved lens.
10. Binnacle housing.
11. Speedometer.

INSTRUMENT BINNACLE

A revised instrument pack is fitted to 1990 model year vehicles. An electronic speedometer is fitted, deleting the requirement for a speedometer cable between speed transducer and speedometer. The instruments are restyled to improve the clarity of graphics.

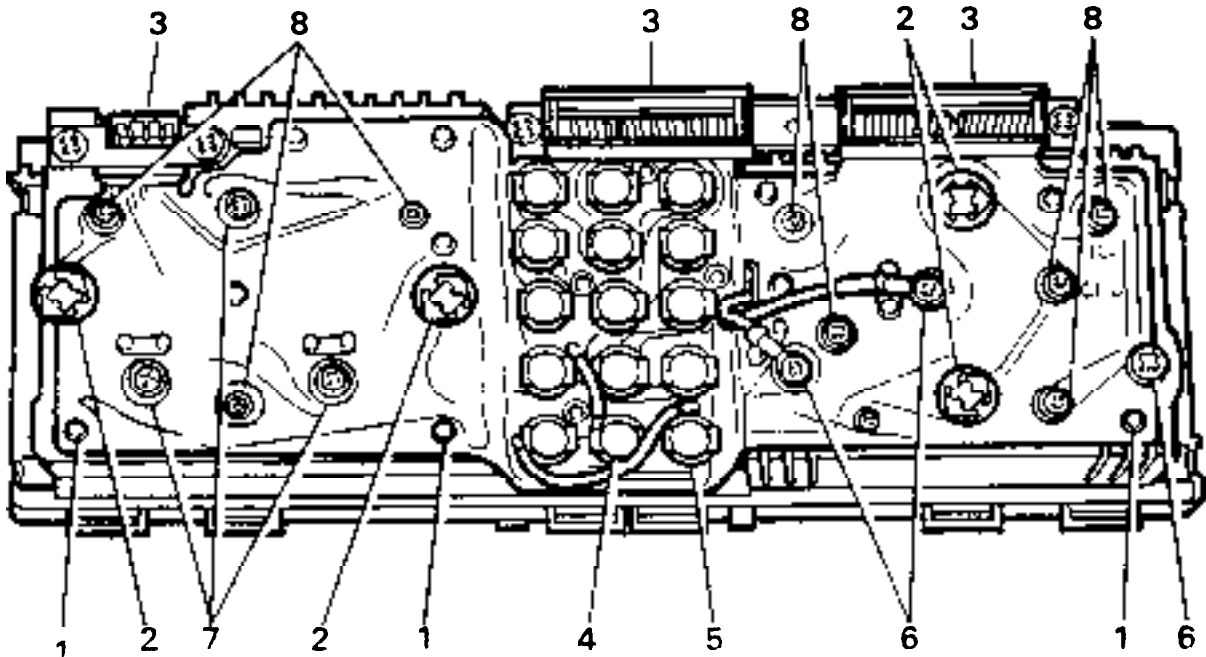

RR2733M

instrument case (back)

1. Printed circuit locating pegs.
2. Panel illumination bulbs - 4.
3. Harness connectors.
4. Warning light bulbs.
5. No charge warning light bulb (blue holder).
6. Tachometer/fuel/temperature gauge securing screws - 3.
7. Speedometer securing screws - 3.
8. Printed circuit securing screws 8.

PRINTED CIRCUIT HARNESS CONNECTIONS

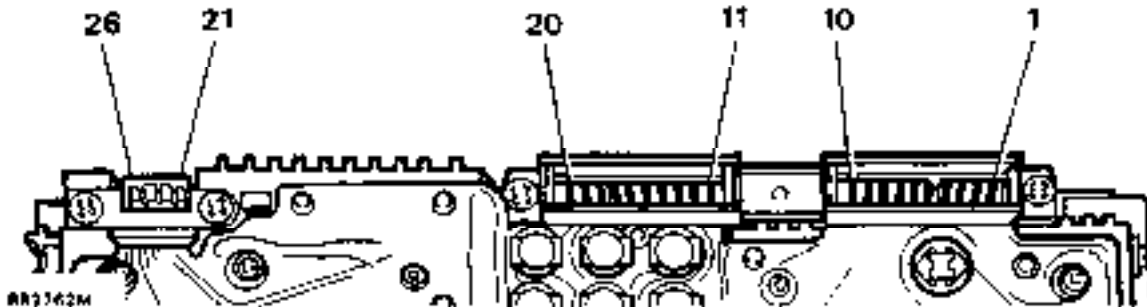

RR27342M

Sequence on connections looking towards the BACK of the instrument case

RENEWAL OF PANEL AND WARNING LIGHTS

1. Disconnect the battery negative lead.
2. Unclip the back of the cowl from the instrument binnacle to give access to the panel and warning light bulbs in the back of the instrument case.
3. Remove the appropriate bulb holder unit by rotating it anti-clockwise and withdrawing it.

NOTE: The 'No Charge/Ignition On' warning light, identified by its BLUE coloured bulb holder, is a 2 watt capless type.

4. Fit a new bulb and rotate the bulb holder clockwise to lock in position. The correct bulb type is: warning lights, 1.4 watt capless type, panel illumination, 3 watt capless type.
5. Refit the cowl and refit the battery negative lead.

NOTE: If difficulty is experienced in changing bulbs due to the limited space available the instrument binnacle fixings should be removed to enable the binnacle to be raised above the fascia as far as other connections permit. See 'Instrument Binnacle - remove and refit' below for details of binnacle mounting bracket fixing.

INSTRUMENT BINNACLE

Remove and refit

Remove

1. Disconnect the battery negative lead.
2. Remove the lower fascia by releasing the six retaining screws.
3. Remove the four nuts (with spring and plain washers) from under the top fascia rail which secure the instrument binnacle to the vehicle.
4. Unclip the binnacle cowl from the rear, and remove.
5. Disconnect the two multi-plugs and the single plug from the printed circuit connectors.
6. Lift the instrument binnacle from the top fascia rail and transfer it to the workbench.

Refitting

7. Reverse the removal instructions 1 to 6.

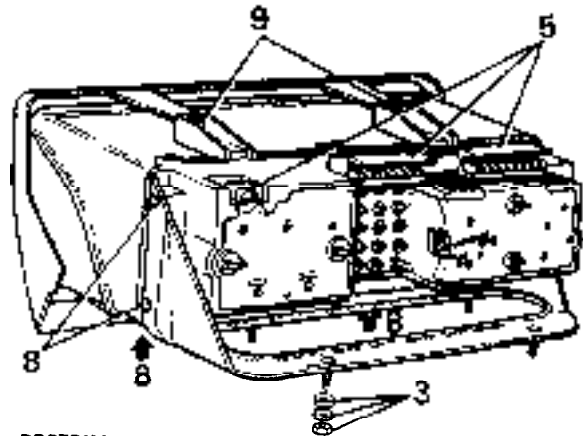

RR2731M

REMOVING INSTRUMENT PACK

8. Having removed the instrument binnacle from the vehicle, detach the binnacle mounting bracket. This is secured to the instrument case by two screws and to the bottom of the binnacle bezel by two smaller screws.
9. Remove the two screws retaining the top of the bezel to the front housing and detach the bezel.
10. Detach the curved lens from the binnacle housing by depressing four tabs and easing the top of the lens out, the depressing three tabs and easing the lower edge of the lens out of its location.
11. Separate the instrument case from the binnacle housing by releasing the upper and lower locating tabs in turn.

Refitting Instrument Pack to Binnacle

12. Reverse removal instructions 9 to 11.

CIRCUIT SERVED

Numbers refer to pin number on instrument pack circuit diagram RR2735M

Coolant temperature	1
Low coolant input	2
Ignition switch 12V +	3
Ignition warning light	4
Oil pressure warning light	5
Fuel tank unit	6
Transmission oil temperature	7
Cold start warning (diesel)	8
12V+ ignition	9
Tachometer signal	10
Brake fail/handbrake warning light	11
Brake pad wear warning light	12
Low wash fluid	13
Direction indicator - left	14
Zero volts from dimmer	15
Main beam warning light	16
Trailer warning light	17
Direction indicator - right	18
EFI warning light	19
ABS warning light	20
Seat belt warning light	21
Low coolant check	22
Speed signal	23
Photo transistor	24
Panel illumination bulbs (4)	25
Earth -ve	26

Instrument pack

Key

- A. Speedometer
- B. Tachometer
- C. Temperature gauge
- D. Fuel gauge
- E. Low fuel warning unit
- F. Low fuel warning light
- G. Low coolant warning light
- H. Low coolant warning unit

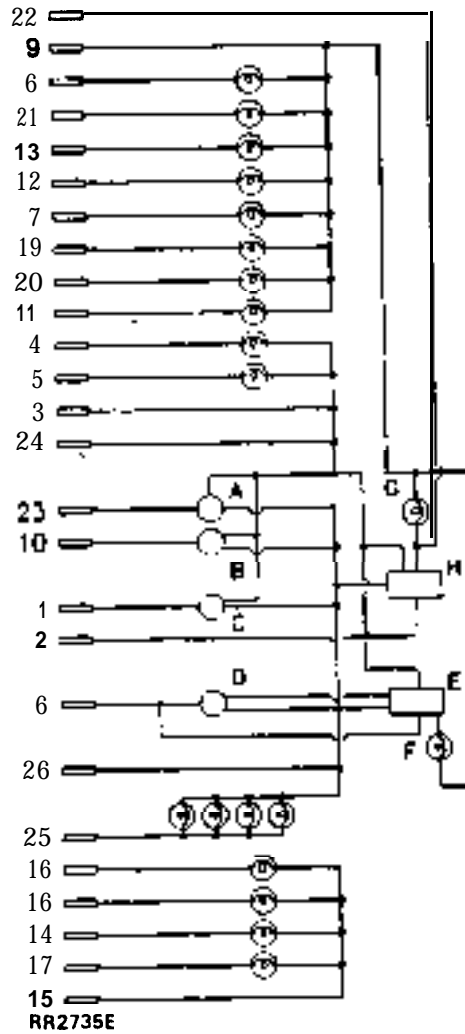

RR2735E

Removing Tachometer, Fuel and Temperature Gauge Unit

NOTE: The tachometer, fuel and temperature gauges are replaced as a unit if necessary.

13. Remove the two panel illumination bulb holders.
14. Remove the three larger screws retaining the tachometer, fuel and temperature gauges. Note the position of the black and white leads secured by two of the screws.
15. Carefully manoeuvre the unit from the front of the instrument case.

Refitting the Tachometer, Fuel and Temperature Gauge Unit

16. Reverse the removal procedure, items 13 to 15.

Removing the speedometer

17. Remove the two panel illumination bulb holders.
18. Remove the three larger screws securing the speedometer.
19. Carefully remove the speedometer from the front of the instrument case.

Refitting the speedometer

20. Reverse the removal procedure items 16 to 18.

Removing the Printed Circuit

21. Remove the Speedometer and Tachometer units as described above. Remove all warning light bulbs before removing the printed circuit. Note the position of the no charge warning light, identified by its blue coloured bulb holder.
22. Remove the two harness connectors, retained by four screws to release the printed circuit tags and the input plug.
23. Remove the eight screws and plain washers securing the printed circuit.
24. Carefully ease the printed circuit from its locating pegs.

Refitting the printed circuit

25. Reverse the removal procedure, items 21 to 24.

CENTRAL DOOR LOCKING - two point

The central door locking system on four door models is now activated from both driver's and passenger's doors. A switch/lock actuator is fitted in both front doors. The system is controlled by an electronic unit situated on the steering column support bracket.

CENTRAL DOOR LOCK CONTROL UNIT

Remove and refit

Removing

1. Disconnect the battery negative lead.
2. Remove the lower fascia panel.
3. Disconnect the harness multi-plug.
4. Remove the securing screws.
5. Remove the control unit.

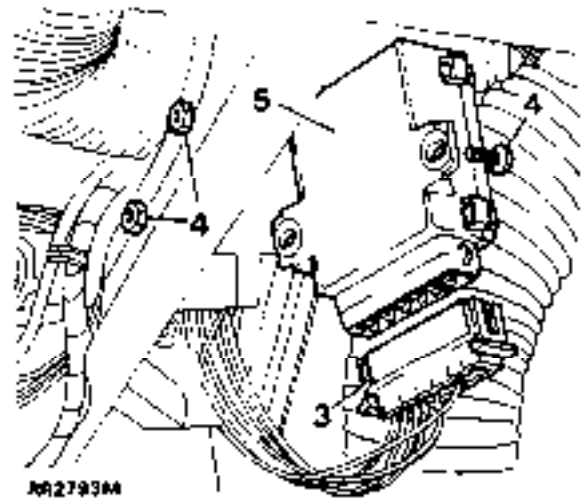

Refitting

6. Reverse the removal procedure.

ELECTRIC MIRRORS

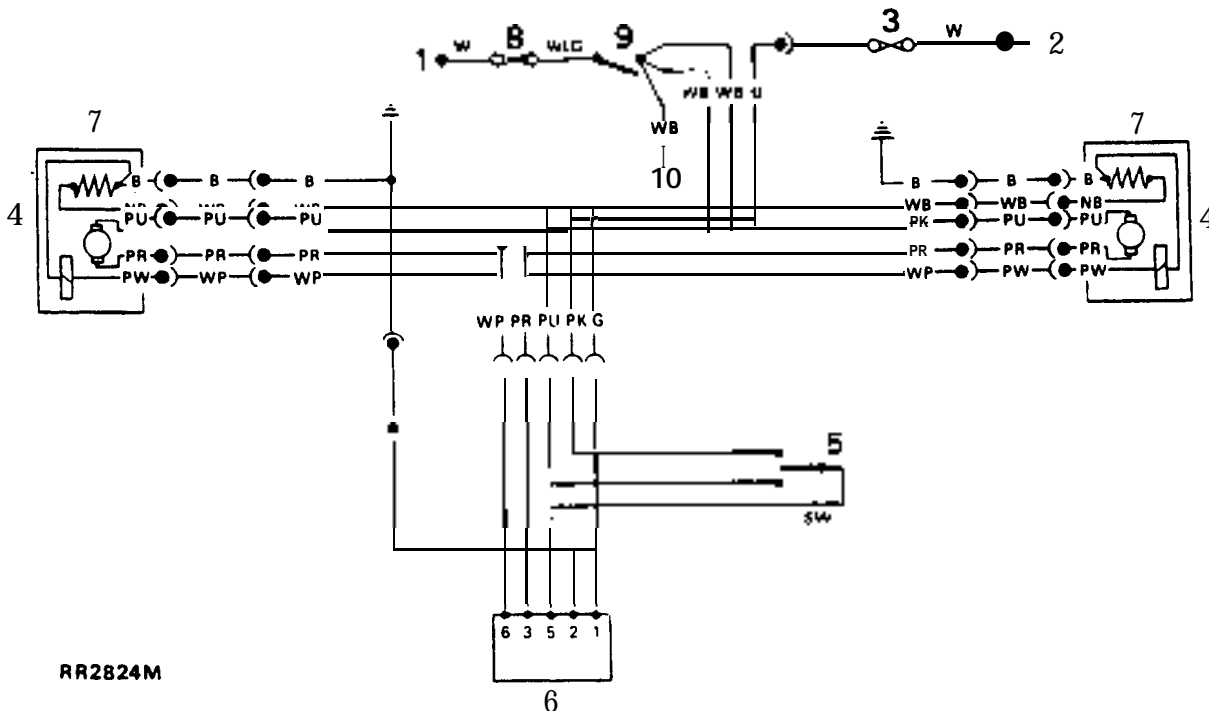

RR2824M

Circuit diagram - RR2824M

- | | |
|--|---|
| <ul style="list-style-type: none"> 1. Ignition 12V. 2. Ignition load relay. 3. Fuse C5 - mirror motors. 4. Mirror motors. 5. Change over switch. 6. Mirror control switch. | <ul style="list-style-type: none"> 7. Mirror heating elements - active with heated rear screen. 8. Fuse C3 - heating elements. 9. Heated rear screen switch. 10. Feed to heated screen relay. |
|--|---|

ELECTRIC WINDOW LIFT

Circuit diagram - RR2531E

- | | |
|---|--|
| <ul style="list-style-type: none"> 1. One touch control unit-drivers window 2. Window lift motor-drivers window 3. Window lift motor-front passengers side 4. Window lift motor LH rear 5. Window lift motor RH rear 6. Window lift switch drivers window 7. Window lift switch front passengers window 8. Window lift switch LH rear door 9. Window lift switch RH rear-door 10. Isolator switch | <ul style="list-style-type: none"> 11. Window lift switch in LH rear door 12. Window lift switch in RH rear door 13. Relay-rear windows 14. Relay-front windows 15. Clinches 16. Main cable fuses <ul style="list-style-type: none"> - a: Fuse C2 - b: Fuse CL? - c: Fuse B1 |
|---|--|

Cable colour code

B Black	L Light	P Purple	U Blue
ci Green	N Brown	R Red	W White
K Pink	O Orange	S Grey	Y Yellow

The last letter of a colour code denotes the tracer.

CENTRAL DOOR LOCKING

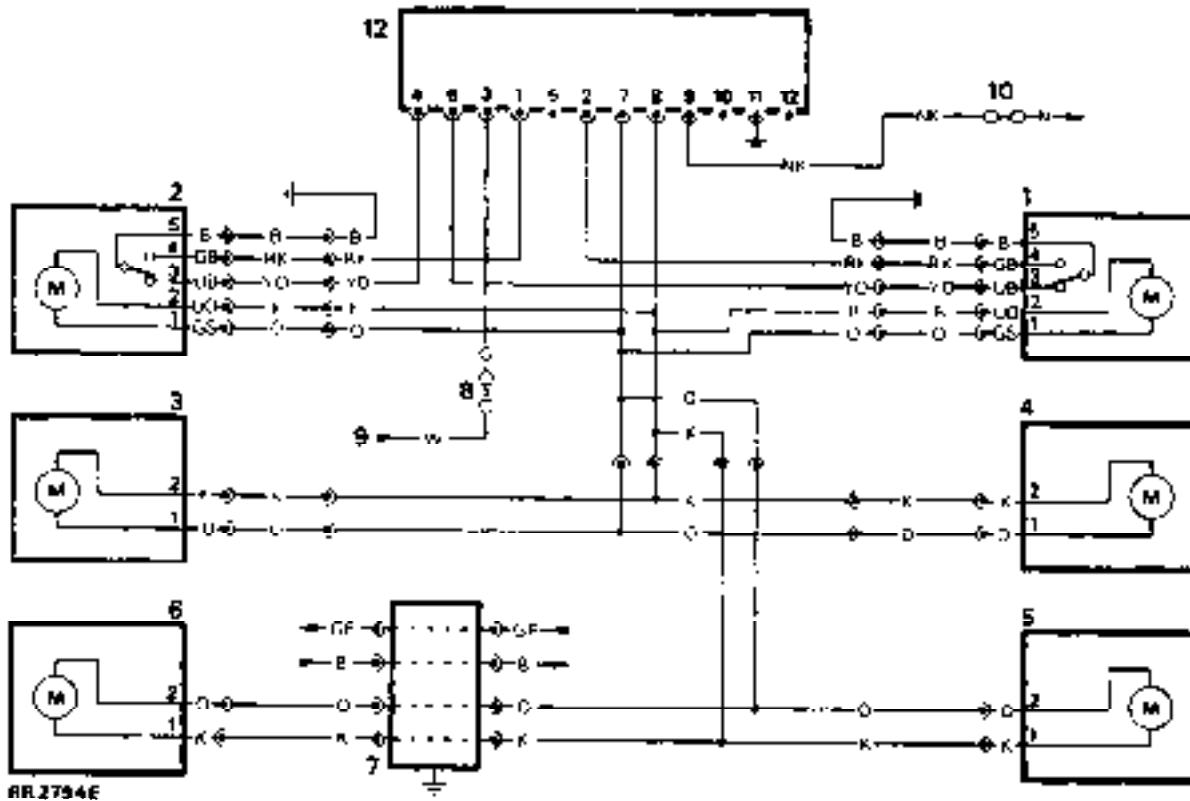

RR2794E

Circuit diagram - RR2794E

1. Switch/lock unit right hand front door
2. Switch/lock unit left hand front door
3. Lock unit left hand rear door relay
4. Lock unit right hand rear door
5. Fuel flap actuator
6. Lock unit tailgate
7. Suppressor
8. Fuse A5
9. Feed from ignition load relay
10. Fuse C7
11. Battery 12V +ve
12. Central door locking control unit

Cable colour code

B	Black	L	Light	P	Purple	U	Blue
G	Green	N	Brown	R	Red	W	White
K	Pink	O	Orange	S	Grey	Y	Yellow

SUNROOF/AUTOMATIC GLARE CONTROL MIRROR CIRCUIT DIAGRAM

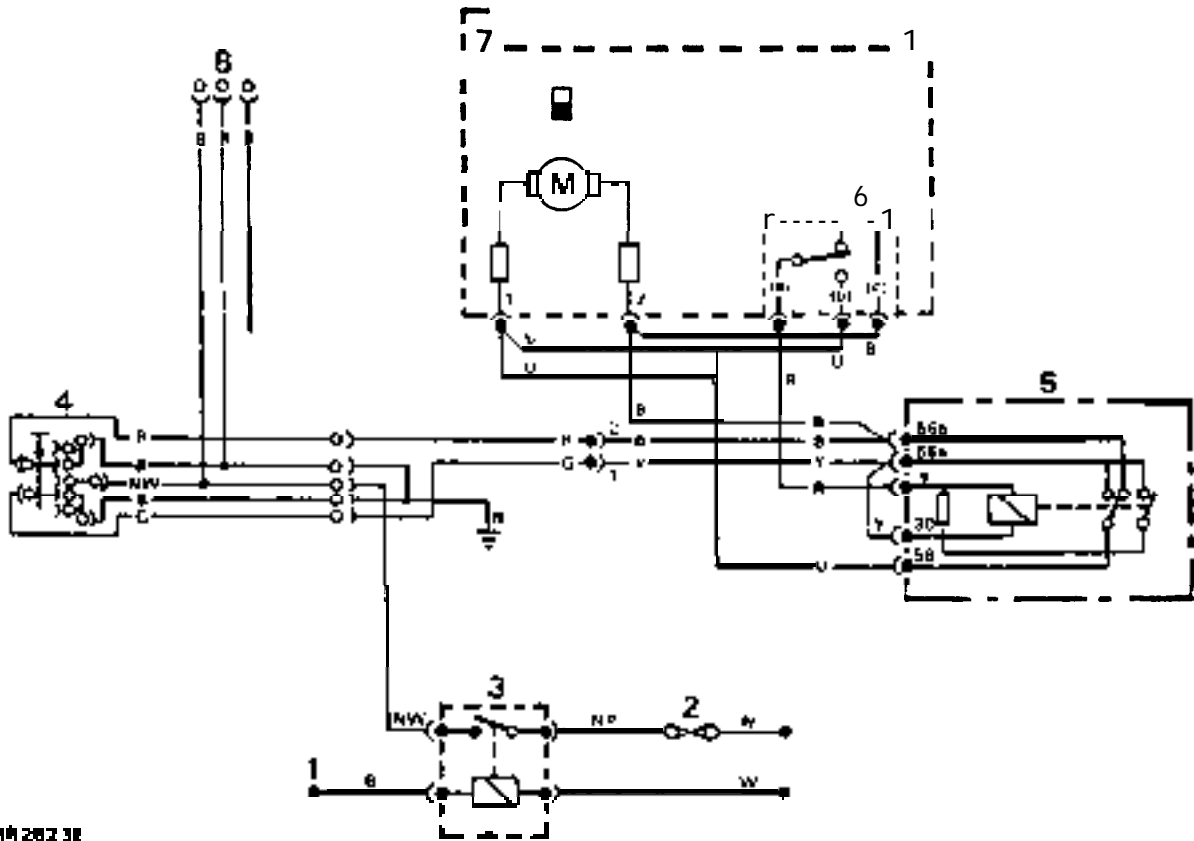

MM 2823 3E

1. Main harness connections
Brown - live positive feed
White - ignition positive feed
Black - ground
2. Fuse B5
3. Auxiliary relay
4. Operating switch
5. Stepper relay
6. Micro-switch - motor switching:
 Contact (a) and (c) - CLOSED
 Contact (a) and (b) - OPEN/TILT
7. Drive motor
8. Mirror

CABLE COLOUR CODE

B	Black
U	Blue
N	Brown
P	Purple
G	Green
R	Red
W	White
Y	yellow

The last letter of a colour code denotes the tracer colour.

MAIN CIRCUIT DIAGRAM - 1990 Model Year - RR2945E & RR2946E

Numerical key

- | | |
|---|---|
| 1. Ignition load relay | 50. Fuel gauge |
| 2. Battery | 51. Fuel gauge sender unit |
| 3. Terminal post | 52. Water temperature gauge |
| 4. Starter solenoid | 53. Water temperature sender unit |
| 5. Starter motor | 54. Fuse B2 |
| 6. Starter relay | 55. Horn switch |
| 7. Starter inhibit switch | 56. RH horn |
| 8. Ignition switch | 57. LH horn |
| 4. Tachometer | 58. Under hood illumination switch |
| 10. Ignition warning lamp | 59. Under hood light |
| 11. Alternator | 60. Clock |
| 12. Fuse B1 | 61. Fuse C7 |
| 13. Front wipe/wash switch | 62. Fuse C2 |
| 14. Front wipe delay unit | 63. Pick-up point central locking/window lift |
| 15. front wiper motor | 64. Heated rear window relay |
| 16. Headlamp relay | 65. Fuse C1 |
| 17. Front wash pump | 66. Radio aerial amplifier |
| 1A Headlamp wash timer unit | 67. Heated rear screen |
| 19. Headlamp wash pump | 68. Heated rear screen switch |
| 20. Main lighting switch | 69. Heated rear screen warning lamp |
| 21. Fuse A3 | 70. Voltage sensitive switch |
| 22. Fuse A7 | 71. Fuse A5 |
| 23. LH side lamp | 72. Hazard switch |
| 24. LH tail lamp | 73. Flasher unit |
| 25. LH license plate lamp | 74. Direction indicator switch |
| 25a. RH license plate lamp | 75. LH indicator warning lamp |
| 26. High beam dimmer/flash switch | 75a. RH indicator warning lamp |
| 27. RH side lamp | 76. LH rear indicator lamp |
| 28. RH tail lamp | 77. LH front indicator lamp |
| 29. Rheostat | 78. Not used |
| 30. Fuse A8 | 79. Not used |
| 31. Fuse A2 | 80. RH front indicator lamp |
| 32. Fuse A9 | 81. RH rear indicator lamp |
| 33. Fuse A1 | 02. Trailer warning lamp |
| 34. Fuse B6 | 83. Fuse A6 |
| 35. Not used | 84. Stop lamp switch |
| 36. Switch illumination (2 off) | 85. Reverse lamp switch |
| 37. Cigar lighter illumination (2 off) | 86. Front fog lamp relay |
| 38. Heater illumination (4 off) | 87. LH stop lamp |
| 39. Clock illumination | 88. RH stop lamp |
| 40. Auto gear selector illumination (2 off) | 89. LH reverse lamp |
| 40a. Auto gear selector illumination relay. | 90. RH reverse lamp |
| 41. Instrument illumination (4 off) | 91. LH front fog lamp |
| 42. Column switch illumination | 92. RH front fog lamp |
| 42. Not used | 93. Front fog lamp switch |
| 43. Not used | 94. Fuse B4 |
| 44. Fuse B3 | 95. Dash cigar lighter |
| 45. LH low beam | 96. Glove box cigar lighter |
| 46. RH low beam | 97. Front interior lamp |
| 47. LH high beam | 98. Rear interior lamp |
| 48. RH high beam | 99. Interior lamp delay unit |
| 49. High beam warning lamp | |

- 100. LH door edge lamp
- 101. LH puddle lamp
- 102. RH door edge lamp
- 103. RH puddle lamp
- 104. Interior lamp switch
- 105. LH rear door switch
- 106. RH rear door switch
- 107. Tailgate switch
- 108. LH front door switch
- 109. RH front door switch
- 110. Heated washer jets
- 111. Thermostat heated jets
- 112. Oil pressure/level warning lamp
- 113. Oil pressure switch
- 114. Fuse C4
- 115. Inertia switch
- 116. Fuel pump
- 117. Ignition coil
- 118. Capacitor
- 119. Distributor
- 120. EFI Harness plug
- 121. Speed transducer
- 122. Trailer nick up point
- 123. Radio fuse
- 124. Radio and six speakers
- 125. Sun roof relay
- 125a. Fuse B5
- 126. Alarm pick up point
- 127. Seat belt warning lamp
- 128. 'Key-in switch'
- 129. Resistor
- 130. Audible warning unit
- 131. Seat buckle switch
- 132. Transfer box neutral switch
- 133. Heated front screen pick up point
- 134. Sunroof connection point (option)
- 135. Auto transmission and transfer box oil temperature warning lamp
- 136. Auto transmission oil temperature switch
- 136a. Transfer box oil temperature switch
- 137. Fuse C3
- 138. Rear wash wipe switch
- 139. Rear wipe delay unit
- 140. Rear wiper motor
- 141. Rear screen wash pump
- 142. Low screen wash fluid level warning lamp
- 143. Low screen wash switch
- 144. Low coolant switch
- 145. Electronic speedo and instrument controls
- 146. Low coolant level warning lamp
- 147. Low fuel level warning lamp
- 148. E.F.I. warning lamp
- 149. Low oil level logic unit
- 150. Low oil level probe
- 151. Not used
- 152. ABS warning lamp
- 153. Parking brake/brake fluid loss warning lamp
- 153a. Brake fluid level warning switch
- 154. Park brake warning switch
- 155. Brake pad wear warning lamp
- 156. Brake pad wear sensors
- 157. Warning lamp control unit
- 158. Check engine warning lamp
- 159. Emission maintenance reminder unit
- 160. Heater/air conditioning connections
- 161. Fuse C9
- 162. Coil negative (engine RPM input to ECU)
- 163. Ignition load relay (+)
- 164. Battery feed (+)
- 165. Ignition auxiliary (+)
- 166. Ignition on (+)
- 167. Earth (-)
- 166. Warning lights supply common earth (-)
- 169. Warning lights supply (+)
- 170. Electric seats pick up point
- 171. Fuse C5
- 172. Fuse B8
- 173. Fuse C8
- 174. Electric mirrors pick up point
- 175. Heater/air conditioning relay
- 176. Cruise control connection points
- 177. Fuse B9
- 178. Condenser fan relay
- 179. Fuse B7
- 180. ABS pick up point

CABLE COLOUR CODE

- B Black
- U Blue
- N Brown
- G Green
- S Grey
- L Light
- O Orange
- K Pink
- P Purple
- R Red
- W White
- Y Yellow

MAIN CIRCUIT DIAGRAM - 1990 Model Year - RR2945E & RR2946E

Alphabetical key

- | | |
|--|--|
| 180. ABS pick up point | 44. Fuse B3 |
| 152. ABS warning lamp | 94. Fuse B4 |
| 126. Alarm pick up point | 125a. Fuse B5 |
| 11. Alternator | 34. Fuse B6 |
| 130. Audible warning unit | 179. Fuse B7 |
| 40. Auto gear selector illumination (2 off) | 172. Fuse B8 |
| 40a. Auto gear selector illumination relay. | 177. Fuse B9 |
| 135. Auto transmission and transfer box oil temperature warning lamp | 65. Fuse C1 |
| 136. Auto transmission oil temperature switch | 62. Fuse C2 |
| 2. Battery | 137. Fuse C3 |
| 164. Battery feed (+) | 114. Fuse C4 |
| 153a. Brake fluid loss warning switch | 171. Fuse C5 |
| 155. Brake pad wear warning lamp | 61. Fuse C7 |
| 156. Brake pad wear sensors | 173. Fuse C8 |
| 118. Capacitor | 161. Fuse C9 |
| 163. Check engine warning lamp | 96. Glove box cigar lighter |
| 37. Cigar lighter illumination (2 off) | 72. Hazard switch |
| 60. Clock | 16. Headlamp relay |
| 3Y. Clock illumination | 19. Headlamp wash pump |
| 162. Coil negative (engine RPM input to ECU) | 18. Headlamp wash timer unit |
| 42. Column switch illumination | 133. Heated front screen pick up point |
| 178. Condenser fan relay | 68. Heated rear screen switch |
| 176. Cruise control connection points | 64. Heated rear window relay |
| 95. Dash cigar lighter | 69. Heated rear screen warning lamp |
| 74. Direction indicator switch | 67. Heated rear screen |
| 119. Distributor | 110. Heated washer jets |
| 148. E.F.I. warning lamp | 38. Heater illumination (4 off) |
| 120. EFI Harness plug | 175. Heater/air conditioning relay |
| 167. Earth (+) | 160. Heater/air conditioning connections |
| 174. Electric mirrors pick up point | 26. High beam dimmer/flash switch |
| 170. Electric seats pick up point | 49. High beam warning lamp |
| 145. Electronic speedo and instrument controls | 55. Horn switch |
| 159. Emission maintenance reminder | 165. Ignition auxiliary (+) |
| 73. Flasher unit | 117. Ignition coil |
| 86. Front fog lamp relay | 1. Ignition load relay |
| 93. Front fog lamp switch | 163. Ignition load relay (+) |
| 97. Front interior lamp | 166. Ignition on (+) |
| 17. Front wash pump | 8. Ignition switch |
| 13. Front wipe/wash switch | 10. Ignition warning lamp |
| 14. Front wipe delay unit | 115. Inertia switch |
| 15. Front wiper motor | 41. Instrument illumination (4 off) |
| 51. Fuel gauge sender unit | 104. Interior lamp switch |
| 50. Fuel gauge | 99. Interior lamp delay unit |
| 116. Fuel pump | 128. 'Key-in switch' |
| 33. Fuse A1 | 100. LH door edge lamp |
| 31. Fuse A2 | 108. LH front door switch |
| 21. Fuse A3 | 91. LH front fog lamp |
| 71. Fuse A5 | 77. LH front indicator lamp |
| 83. Fuse A6 | 47. LH high beam |
| 30. Fuse A8 | 57. LH horn |
| 22. Fuse A7 | 75. LH indicator warning lamp |
| 32. Fuse A9 | 25. LH license plate lamp |
| 12. Fuse B1 | 45. LH low beam |
| 54. Fuse B2 | 101. LH puddle lamp |
| | 105. LH rear door switch |

- 76. LH rear indicator lamp
- 89. LH reverse lamp
- 23. LH side lamp
- 87. LH stop lamp
- 24. LH tail lamp
- 146. Low coolant level warning lamp
- 144. Low coolant switch
- 147. Low fuel level warning lamp
- 150. Low oil level probe
- 149. Low oil level logic unit
- 143. Low screen wash switch
- 142. Low screen wash fluid level warning lamp
- 20. Main lighting switch
- 151. Not used - will illuminate on initial bulb check
- 113. Oil pressure switch
- 112. Oil pressure/level warning lamp
- 154. Park brake warning switch
- 153. Parking brake/brake fluid loss warning lamp
- 63. Pick-up point central locking/window lift
- 102. RH door edge lamp
- 109. RH front door switch
- 92. RH front fog lamp
- 80. RH front indicator lamp
- 48. RH high beam
- 56. RH horn
- 75a. RH indicator warning lamp
- 25a. RH license plate lamp
- 46. RH low beam
- 103. RH puddle lamp
- 106. RH rear door switch
- 81. RH rear indicator lamp
- 90. RH reverse lamp
- 27. RH side lamp
- 88. RH stop lamp
- 28. RH tail lamp
- 66. Radio aerial amplifier
- 124. Radio and six speakers
- 123. Radio fuse
- 98. Rear interior lamp
- 141. Rear screen wash pump
- 138. Rear wash wipe switch
- 139. Rear wipe delay unit
- 140. Rear wiper motor
- 129. Resistor
- 85. Reverse lamp switch
- 29. Rheostat
- 127. Seat belt warning lamp
- 131. Seat buckle switch
- 121. Speed transducer
- 7. Starter inhibit switch
- 5. Starter motor
- 6. Starter relay
- 4. Starter solenoid
- 84. Stop lamp switch
- 125. Sun roof relay
- 134. Sunroof connection point (option)
- 36. Switch illumination (2 off)
- 9. Tachometer
- 107. Tailgate switch
- 3. Terminal post
- 111. Thermostat heated jets
- 122. Trailer pick up point
- 82. Trailer warning lamp
- 136a. Transfer box oil temperature switch
- 132. Transfer box neutral -switch
- 58. Under hood illumination switch
- 59. Under hood light
- 70. Voltage sensitive switch
- 157. Warning lamp control unit
- 168. Warning lights supply common earth (-)
- 169. Warning lights supply (+)
- 53. Water temperature sender unit
- 52. Water temperature gauge temperature warning lamp

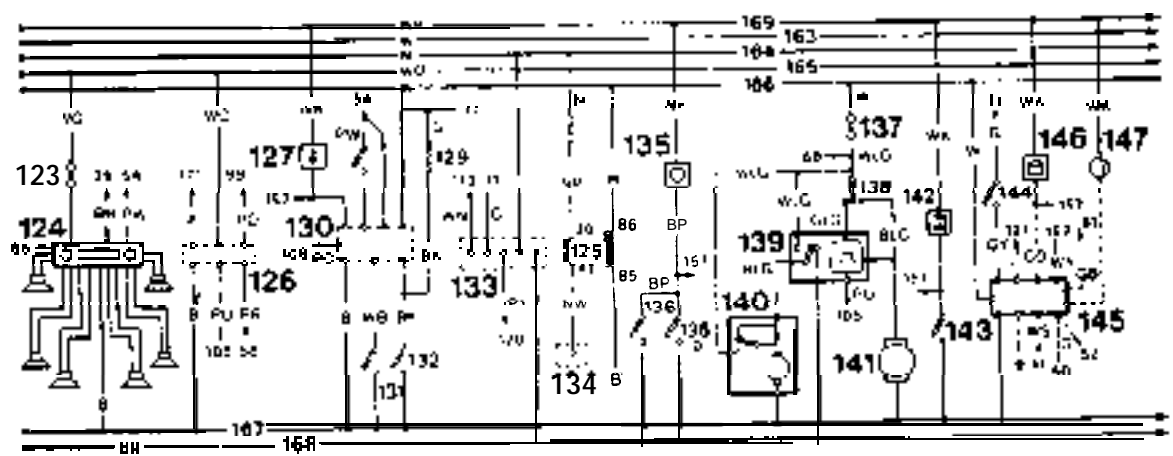
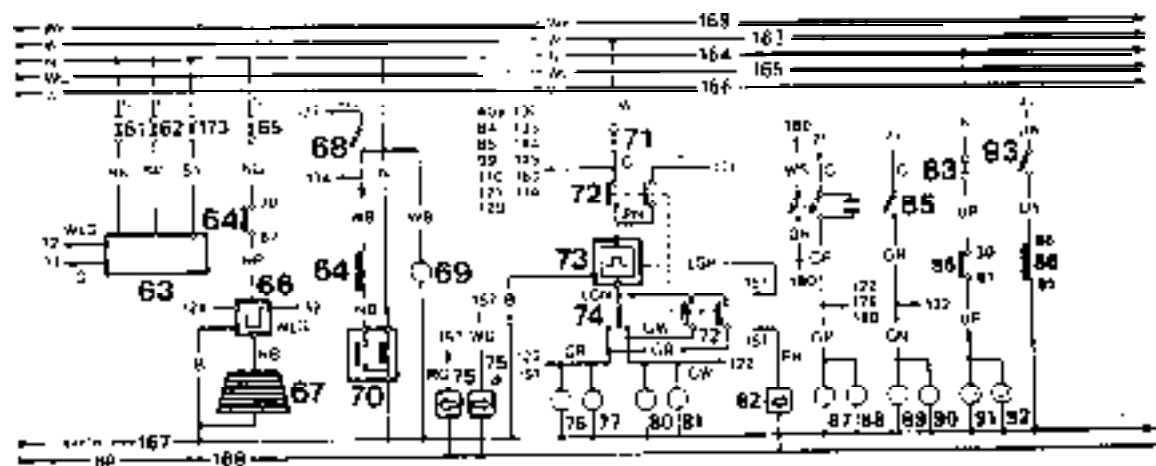
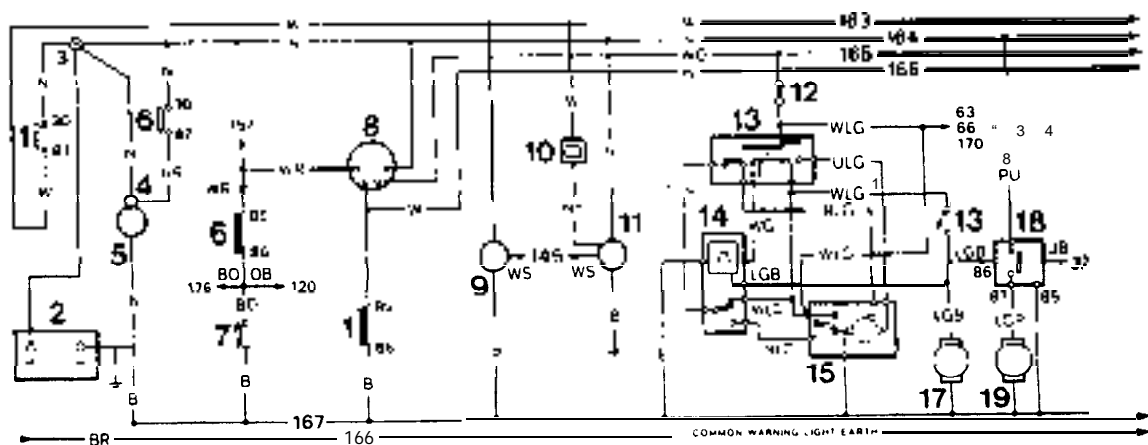

RR2945E -REVISED, SEPT. 90

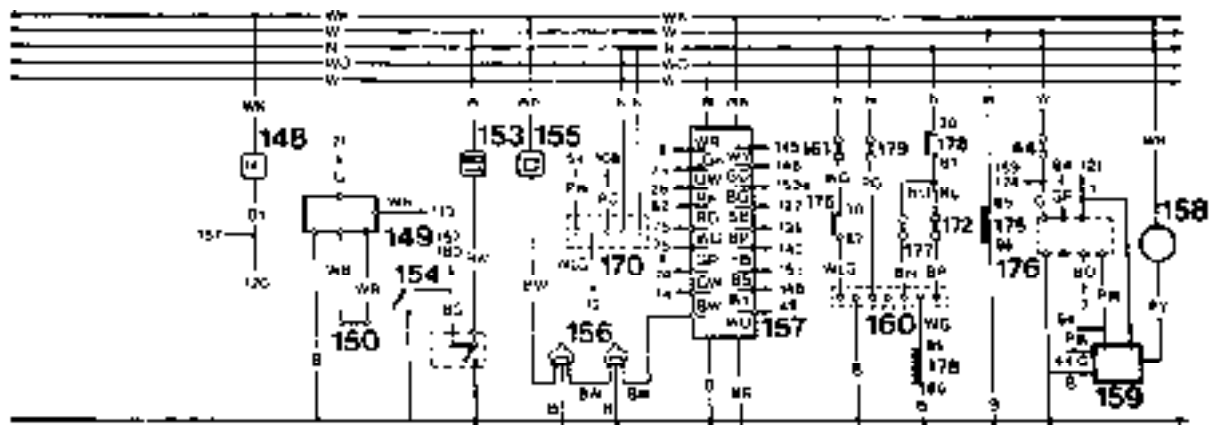
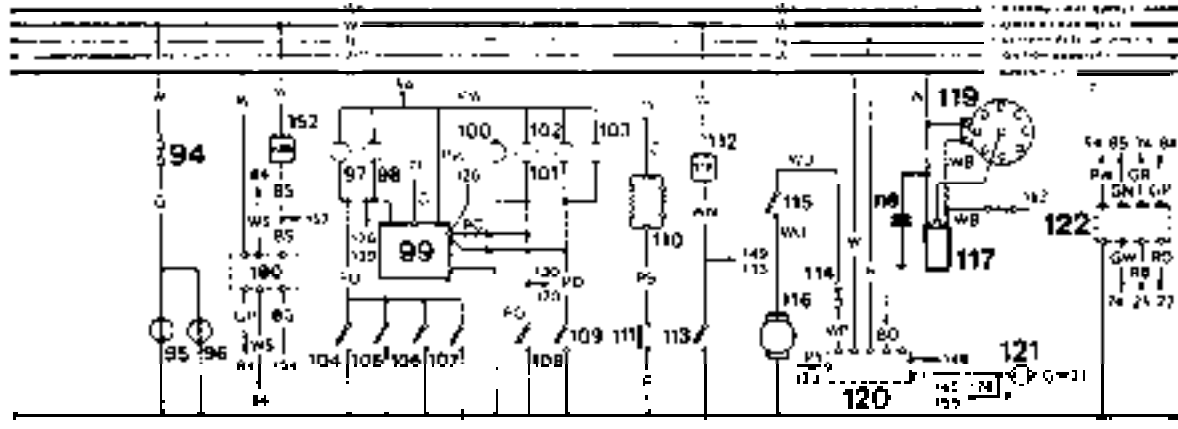
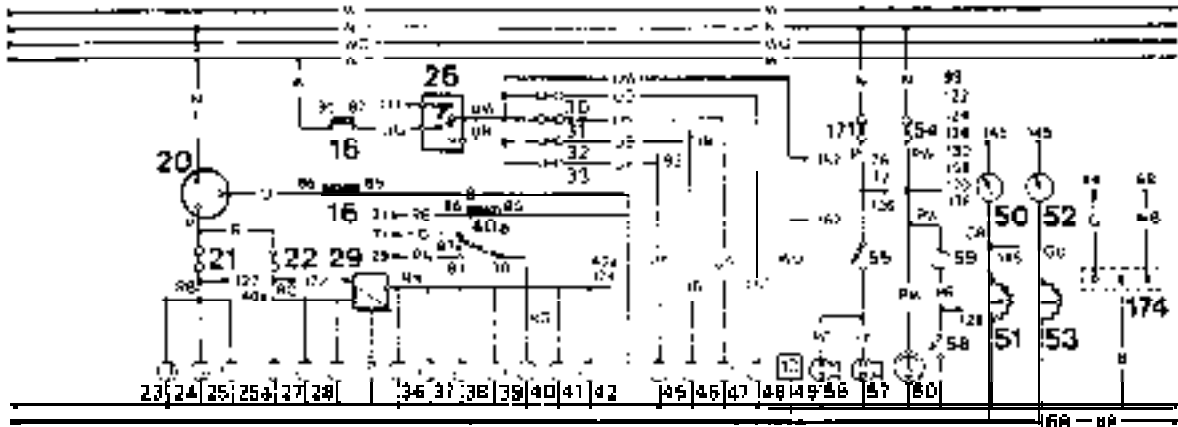

1

2

3

4

5

6

7



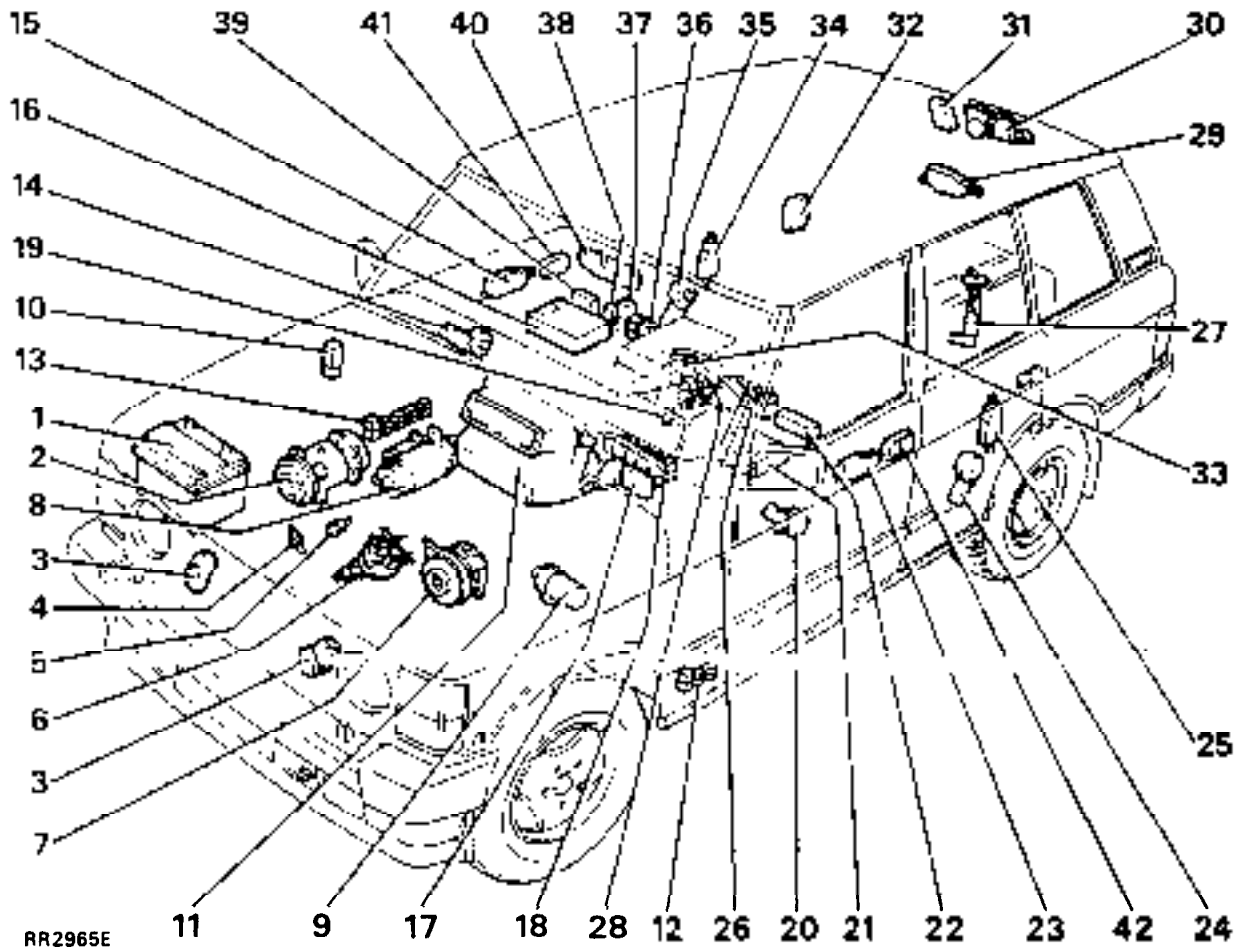











8



LOCATION OF ELECTRICAL EQUIPMENT • 1991 MODEL YEAR

- | | |
|--|---|
| 1. Battery | 22. Seat adjustment fusebox |
| 2. Air conditioning compressor | 23. Door lock actuator (front LH door) |
| 3. Horns | 24. Window lift motor (rear LH door) |
| 4. Oil pressure switch | 25. Door lock actuator (rear LH door) |
| 5. Water temperature switch | 26. Seat adjustment relays • two |
| 6. Electronic distributor | 27. Electrical in-tank fuel pump/sender unit |
| 7. Alternator | 28. Inertia switch |
| 8. Starter motor | 29. Tailgate lock actuator |
| 9. Coil | 30. Wiper motor • rear screen |
| 10. Headlamp wash timer unit | 31. Radio aerial amplifier |
| 11. Heater | 32. Fuel filler flap release actuator |
| 12. Relays/flasher units | 33. Window lift relays and one touch control unit |
| 13. Air con relays/diode unit | 34. Door lock actuator (rear RH door) |
| 14. Window lift motor (front RH door) | 35. Window lift motor (rear RH door) |
| 15. Door lock actuator (front RH door) | 36. EFI relays (two) |
| 16. Electronic control unit (EFI) | 37. Condenser fan timer unit |
| 17. Wiper motor • front screen | 38. Cruise control relay |
| 18. Relays/delay units | 39. Emission maintenance reminder |
| 19. Park brake warning light switch | 40. Glare control mirror |
| 20. Window lift motor (front LH door) | 41. RH door lock heater |
| 21. Electronic control unit and relays (ABS) | 42. LH door lock heater |

INSTRUMENT BINNACLE WARNING LIGHT SYMBOLS

-  Direction indicator - left turn (green)
-  Direction indicator - right turn (green)
-  Headlamp high beam on (blue)
-  Brake pad wear (amber)
-  Trailer connected - flashes with direction indicators (green)
-  EFI warning light (amber) - 1991 model year change
-  Brake fluid pressure failure/low fluid level, transmission handbrake on (red)
-  Low screenwash fluid (amber)
-  ABS warning light (red)
-  Automatic gearbox oil or transfer box temperature high (red)
-  Emission maintenance reminder
-  Seat belt (red)
-  Ignition on/low charge (red)
-  Engine oil pressure low (red)
-  Low coolant (red)

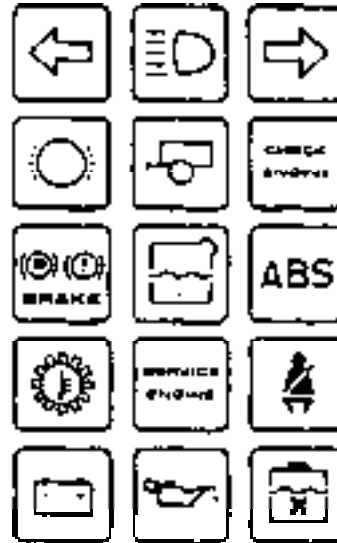

RR2803E

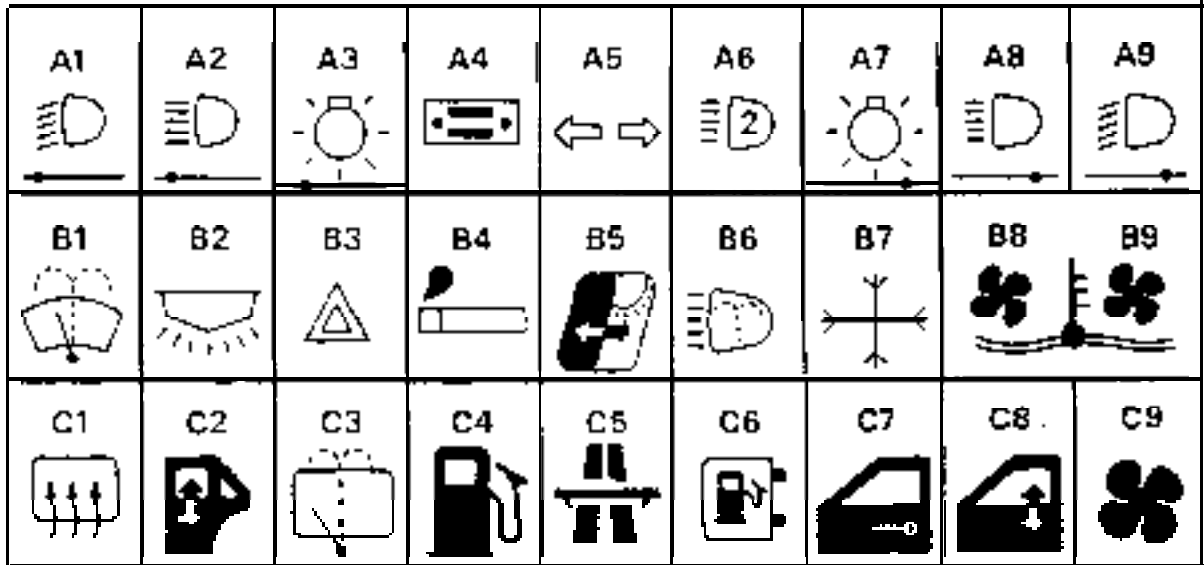

RR2918M

FUSE BOX - RR2918M

FUSE No.	COLOUR CODE	RATING AMPS	IGN. KEY POSITION	FUNCTION
A1	Red	10	II	LH low beam, front fog lamp relay
A2	Red	10	II	LH high beam, auxiliary lamp relay
A3	Tan	5	0	LH parking lamps, trailer pickup
A4	Blue	15	I	Radio, CD player
A5	Yellow	20	II	Direction ind., resistor, heated jets, thermo., heated front screen timer, air con. low coolant, low oil, speed transducer, interior lamp delay, reverse lights, stop lights, audible warning unit, glare control mirror
A6	Red	10	II	Fog lamps (from low beam)
A7	Tan	5	0	RH parking lamps, rheostat controlled instrument/switch illumination, trailer pick up
A8	Red	10	II	RH high beam
A9	Red	10	II	RH low beam
B1	Yellow	20	I	Front wash/wipe, seat relays, window lift relays, antenna amplifier
B2	Yellow	20	0	Interior light, clock, underhood ill., elec. seat relays, radio, door lamps, key in switch, audible warning, door lock heater
B3	Yellow	20	0	Hazard switch, alarm, headlamp dip/flash, horns
B4	Yellow	20	II	Cigar lighters
B5	Yellow	20	II	Sunroof motor
B6	Yellow	20	II	Headlamp wash
B7	Tan	5	II	Air conditioning compressor clutch
B8	Yellow	20	II	Air conditioning/radiator cooling fan
B9	Yellow	20	II	Air conditioning/radiator cooling fan
C1	Green	30	II	Heated rear screen (voltage switch controlled)
c2	Green	30	II	Window lifts - rear
c3	Red	10	II	Rear wash wipe motor, heated rear screen relay, mirror heaters
c4	Red	10	II	Fuel pump
C5	Red	10	II	Mirror motors, cruise control
C6	Tan	5	0	Fuel filler flap
c7	Blue	15	0	Central locking
C8	Green	30	II	Window lifts - front
C9	Green	30	II	Heater/air conditioning motor

CD PLAYER WITH POWER AMPLIFIERS

Circuit diagram - RR2941E

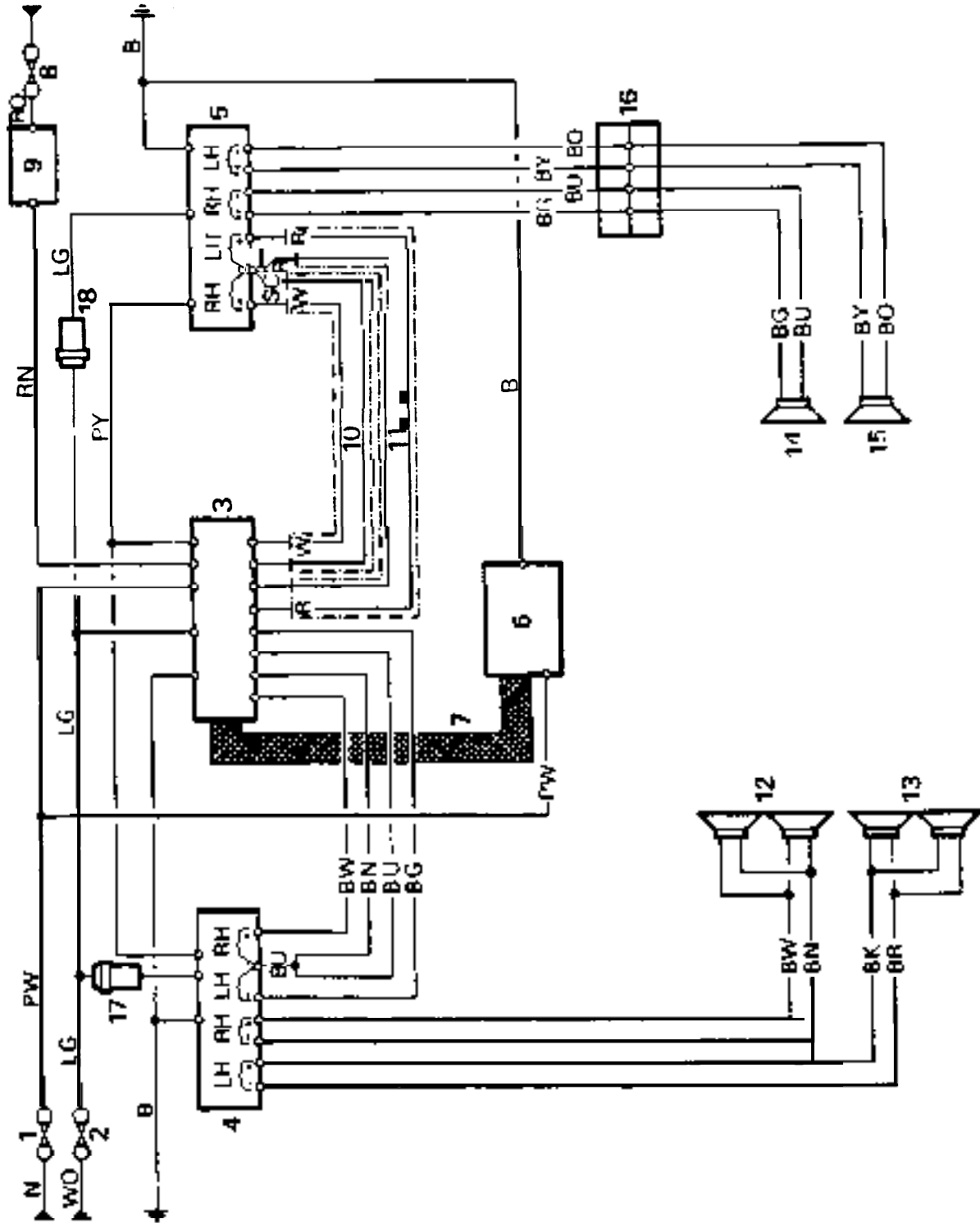

RR2941E

CD PLAYER WITH POWER AMPLIFIERS

Circuit diagram - RR2941E

1. Fuse B2
2. Fuse B4
3. Radio - head unit
4. Front power amplifier
5. Rear power amplifier
6. CD auto changer
7. Data link cable
8. Fuse A7
9. Rheostat
10. Screened cable, RH rear speaker signal
11. Screened cable, LH rear speaker signal
13. RH front door speaker
13. LH front door speaker
14. RH rear speaker
15. LH rear speaker
16. In-line connector, sub-woofer cross-over unit
17. 4 amp in-line fuse, front amplifier
18. 4 amp in-line fuse, rear amplifier

NOTE: SCK denotes screen

Cable colour code

B Black	L Light	P Purple	U Blue
G Green	N Brown	R Red	W White
K Pink	O Orange	S Grey	Y Yellow

The last letter of a colour code denotes the tracer.

HEATED FRONT SCREEN

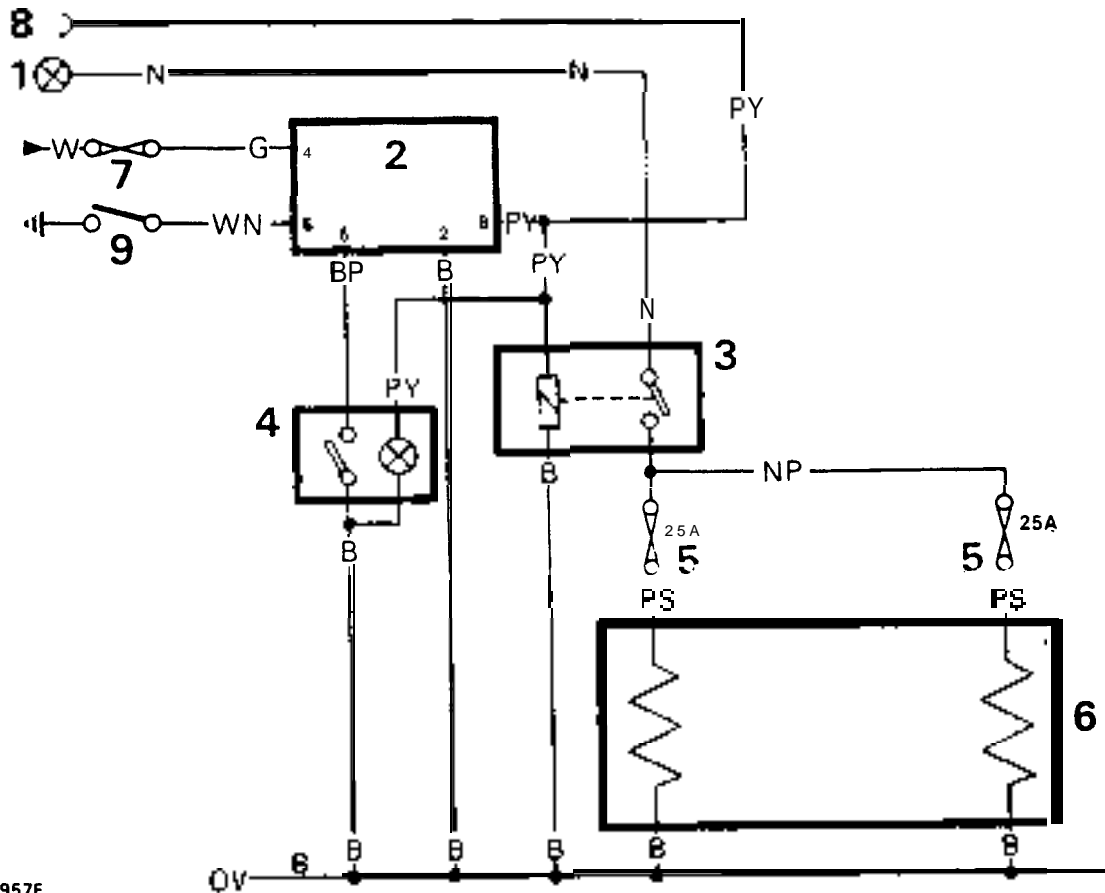

RR2957E

Circuit diagram - RR2957E

- | | |
|---------------------------|------------------------|
| 1. Terminal post | 7. Fuse A5 |
| 2. Timer unit | 8. EFI ECU pin 8 |
| 3. Load relay | 9. Oil pressure switch |
| 4. Switch/warning light | |
| 5. In line fuses - 25 Amp | |
| 6. Heated front screen | |

Cable colour code

B Black	L Light	P Purple	U Blue
G Green	N Brown	R Red	W White
K Pink	O Orange	S Grey	Y Yellow

The last letter of a colour code denotes the tracer.

ELECTRIC SEAT ADJUSTMENT

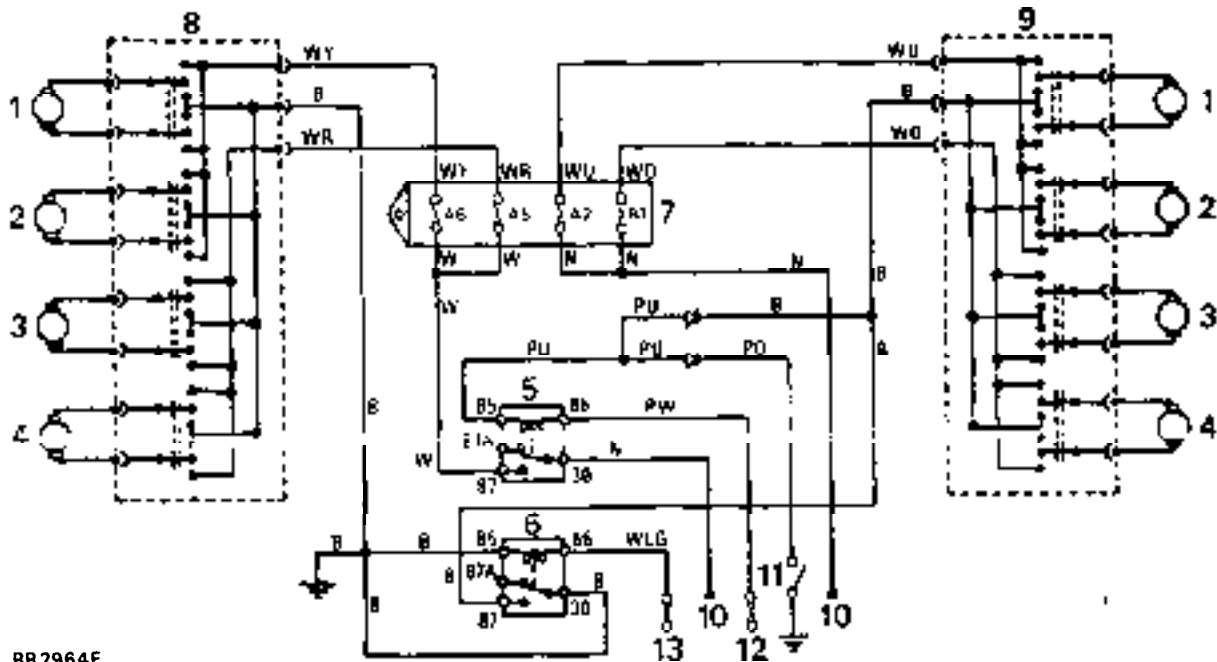

RR2964E

Circuit diagram • RR2530E

1. Seat recline motor
2. Seat height (rear) motor
3. Seat base adjust motor
4. Seat height (front) motor
5. Load relay-from driver's door courtesy switch
6. Load relay-fused auxiliary feed controlled
7. Auxiliary fuse box (B)
8. Driver's seat control
9. Passenger's seat control
10. Terminal post
11. Drivers door switch
12. Fuse B2
13. Fuse B1

Cable colour code

B Black	L Light	P Purple	U Blue
G Green	N Brown	R Red	W White
K Pink	O Orange	S Grey	Y Yellow

The last letter of a colour code denotes the tracer.

DOOR LOCKS/FUEL FILLER FLAP

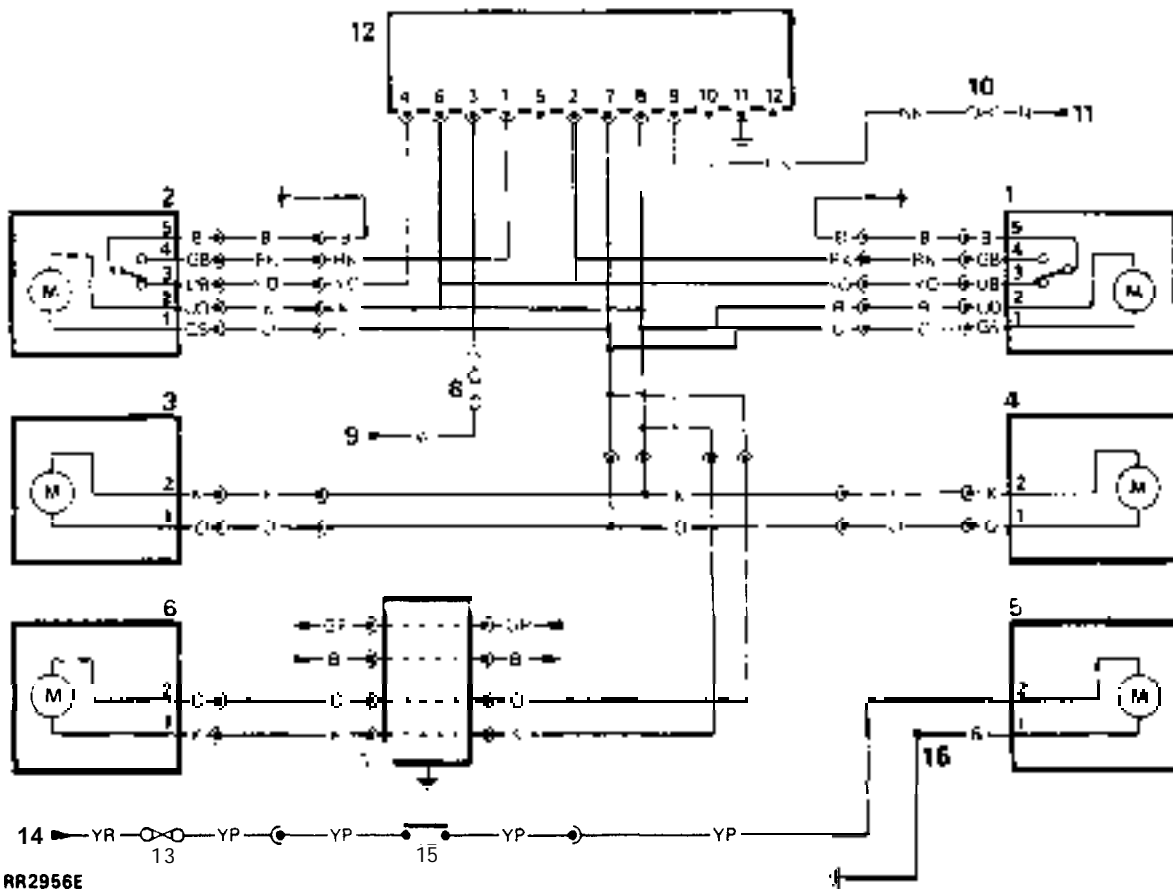

RR2956E

Circuit diagram - RR2956E

- | | |
|---|---|
| 1. Switch/lock unit right hand front door | 13. Fuse C6 |
| 2. Switch/lock unit left hand front door | 14. feed from ignition load relay - pin 87A |
| 3. Lock unit left hand rear door relay | 15. Fuel flap release switch |
| 4. Lock unit right hand rear door | 16. Fuel tank filler pipe ground |
| 5. Fuel flap actuator | |
| 6. Lock unit tailgate | |
| 7. Suppressor | |
| 8. Fuse A5 | |
| 9. Feed from ignition load relay - pin 87 | |
| 10. Fuse C7 | |
| 11. Battery 12V +ve | |
| 12. Central door locking control unit | |

Cable colour code

B Black	L Light	P Purple	U Blue
G Green	N Brown	R Red	W White
K Pink	O Orange	S Grey	Y Yellow

SUNROOF/AUTOMATIC GLARE CONTROL MIRROR

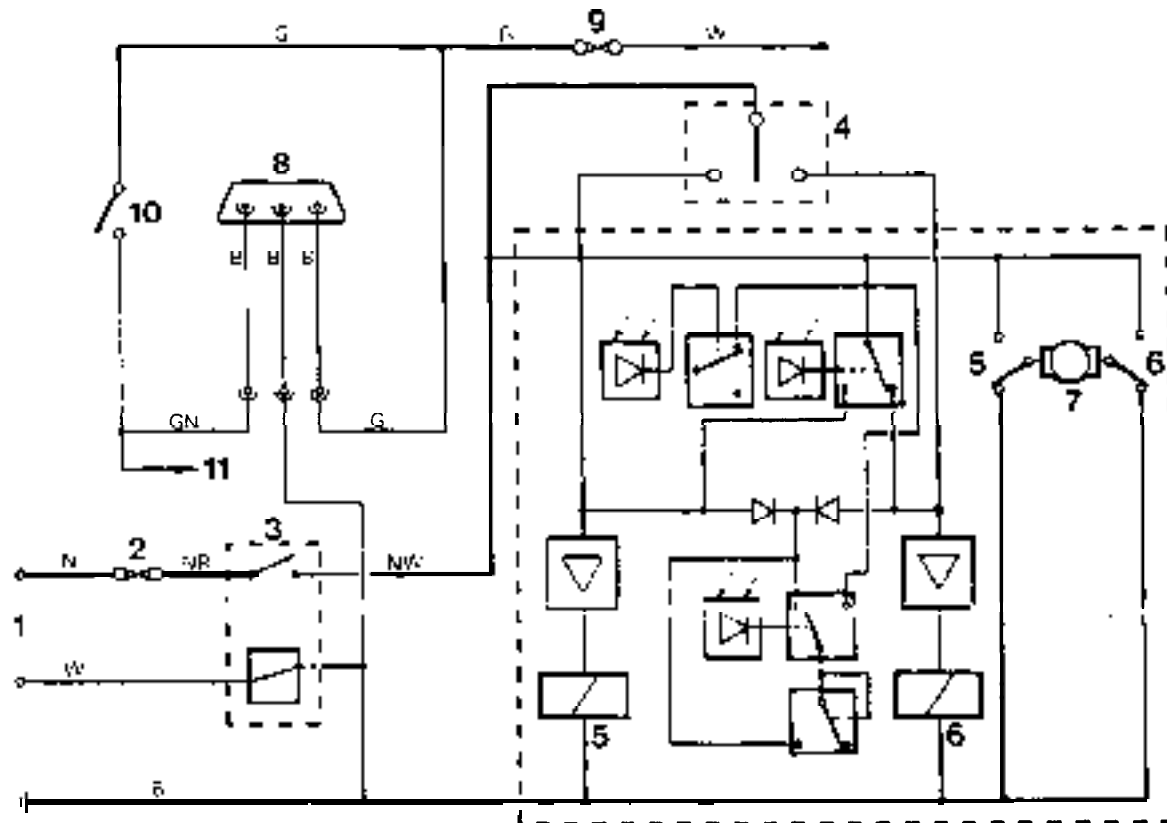

RR2958E

Circuit diagram • RR2958E

1. Main harness connections
Brown - live positive feed
White - ignition positive feed
Black - ground
2. Fuse B5
3. Auxiliary relay
4. Operating switch
5. Relay - tilt, open to closed
 - slide, closed to open
6. Relay - slide, open to closed
 - tilt, closed to open
7. Drive motor
8. Mirror connection
9. Fuse A5
10. Reverse lamps switch
11. Reverse lamps

CABLE COLOUR CODE

B	Black
U	Blue
N	Brown
P	Purple
G	Green
R	Red
W	White
Y	yellow

The last letter of a colour code denotes the tracer colour.

----- Denotes component enclosure

MAIN CIRCUIT DIAGRAM - RR2942E & RR2943E**Numerical key**

1. Ignition load relay
2. Battery
3. Terminal post
4. Starter solenoid
5. Starter motor
6. Starter relay
7. Starter inhibit switch
8. Ignition switch
9. Tachometer
10. Ignition warning lamp
11. Alternator
12. Fuse B1
13. Front wipe/wash switch
14. Front wipe delay unit
15. Front wiper motor
16. Headlamp relay
17. Front wash pump
18. Headlamp wash timer unit
19. Headlamp wash pump
20. Main lighting switch
21. Fuse A3
22. Fuse A7
23. LH side lamp
24. LH tail lamp
25. LH license plate lamp
- 25a. RH license plate lamp
26. High beam dimmer/flash switch
27. RH side lamp
28. RH tail lamp
29. Rheostat
30. Fuse A8
31. Fuse A2
32. Fuse A9
33. Fuse A1
34. Fuse B6
35. Window lift connections
36. Switch illumination (2 off)
37. Cigar lighter illumination (2 off)
38. Heater illumination (4 off)
39. Clock illumination
40. Auto gear selector illumination (2 off)
- 40a. Auto gear selector illumination relay.
41. Instrument illumination (4 off)
42. Column switch illumination
42. Not used
43. Not used
44. Fuse B3
45. LH low beam
46. RH low beam
47. LH high beam
48. RH high beam
49. High beam warning lamp
50. Fuel gauge
51. Fuel gauge sender unit
52. Water temperature gauge
53. Water temperature sender unit
54. Fuse B2
55. Horn switch
56. RH horn
57. LH horn
58. Under hood illumination switch
59. Under hood light
60. Clock
61. Fuse C7
62. Fuse C2
63. Central door locking unit
64. Heated rear window relay
65. Fuse C1
66. Radio aerial amplifier
67. Heated rear screen
66. Heated rear screen switch
69. Heated rear screen warning lamp
70. Voltage sensitive switch
71. Fuse A5
72. Hazard switch
73. Flasher unit
74. Direction indicator switch
75. LH indicator warning lamp
- 75a. RH indicator warning lamp
76. LH rear indicator lamp
77. LH front indicator lamp
78. Not used
79. Not used
80. RH front indicator lamp
81. RH rear indicator lamp
82. Trailer warning lamp
83. Fuse A6
84. Stop lamp switch
85. Reverse lamp switch
86. Front fog lamp relay
87. LH stop lamp
88. RH stop lamp
89. LH reverse lamp
90. RH reverse lamp
91. LH front fog lamp
92. RH front fog lamp
93. Front fog lamp switch
94. Fuse B4
95. Dash cigar lighter
96. Glove box cigar lighter
97. Front interior lamp
98. Rear interior lamp
99. Interior lamp delay unit

- | | |
|--|---|
| <ul style="list-style-type: none"> 100. LH door edge lamp 101. LH puddle lamp 102. RH door edge lamp 103. RH puddle lamp 104. Interior lamp switch 105. LH rear door switch 106. RH rear door switch 107. Tailgate switch 108. LH front door switch 109. RH front door switch 110. Heated washer jets 111. Thermostat heated jets 112. Oil pressure/level warning lamp 113. Oil pressure switch 114. Fuse C4 115. Inertia switch 116. Fuel pump 117. Ignition coil 118. Capacitor 119. Distributor 120. EFI Harness plug 121. Speed transducer 122. Trailer nick up point 123. Fuse A4 124. Radio and six speakers 125. Sun roof relay 125a. Fuse B5 126. Alarm pick up point 127. Seat belt warning lamp 128. 'Key-in switch' 129. Resistor 130. Audible warning unit 131. Seat buckle switch 132. Transfer box neutral switch 133. Condenser fan motors 134. Sunroof connection point (option) 135. Auto transmission and transfer box oil temperature warning lamp 136. Auto transmission oil temperature switch 136a. Transfer box oil temperature switch 137. Fuse C3 138. Rear wash wipe switch 139. Rear wipe delay unit 140. Rear wiper motor 141. Rear screen wash pump 142. Low screen wash fluid level warning lamp 143. Low screen wash switch 144. Low coolant switch 145. Electronic speedo and instrument controls 146. Low coolant level warning lamp 147. Low fuel level warning lamp 148. E.F.I. warning lamp | <ul style="list-style-type: none"> 149. Low oil level logic unit 150. Low oil level probe 151. Compressor clutch relay 152. ABS warning lamp 153. Parking brake/brake fluid loss warning lamp 153a. Brake fluid level warning switch 154. Park brake warning switch 155. Brake pad wear warning lamp 156. Brake pad wear sensors 157. Warning lamp control unit 158. Check engine warning lamp 159. Emission maintenance reminder unit 160. Diode pack fair con) 161. Fuse C9 162. Coil negative (engine RPM input to ECU) 163. Ignition load relay (+) 164. Battery feed (+) 165. Ignition auxiliary (+) 166. Ignition on (+) 167. Earth (-) 168. Warning lights supply common earth (-) 169. Warning lights supply (+) 170. Fuse C6 171. Fuse C5 172. Fuse B8 173. Fuse C8 174. Fuel filler flap release 175. Heater/air conditioning relay 176. Cruise control connection points 177. Fuse B9 178. Condenser fan relay 179. Fuse B7 180. ABS ECU 181. Front amplifier audio 182. Rear amplifier audio 183. Electric seat relays 184. Heated front screen timer unit 185. Electric mirror elements 186. Glare control mirror |
|--|---|

CABLE COLOUR CODE

- | | |
|----------|--------|
| B | Black |
| U | Blue |
| N | Brown |
| G | Green |
| S | Grey |
| L | Light |
| O | Orange |
| K | Pink |
| P | Purple |
| R | Red |
| W | White |
| Y | Yellow |

Note: The following items are now incorporated into the main harness assembly, ABS, air conditioning, CD player, electric mirrors, door locks, heated front screen and window lift. These items are shown on the main circuit diagram as a box containing the relevant number, or indicated by an arrow and the item number. Refer to the appropriate circuit diagram for details of these items.

MAIN CIRCUIT DIAGRAM - RR2942E & RR2943E

Alphabetical key

- | | |
|--|--|
| 180. ABS ECU | 71. Fuse A5 |
| 180. ABS pick up point | 83. Fuse A6 |
| 152. ABS warning lamp | 22. Fuse A7 |
| 126. Alarm pick up point | 30. Fuse A8 |
| 11. Alternator | 32. Fuse A9 |
| 130. Audible warning unit | 12. Fuse B1 |
| 40. Auto gear selector illumination (2 off) | 54. Fuse B2 |
| 40a. Auto gear selector illumination relay. | 44. Fuse B3 |
| 135. Auto transmission and transfer box oil temperature warning lamp | 94. Fuse B4 |
| 736. Auto transmission oil temperature switch | 125a. Fuse B5 |
| 2. Batter) | 34. Fuse B6 |
| 164. Battery feed (+) | 179. Fuse B7 |
| 153a. Brake fluid loss warning switch | 172. Fuse B8 |
| 155. Brake pad wear warning lamp | 177. Fuse BY |
| 156. Brake pad wear sensors | 65. Fuse C1 |
| 118. Capacitor | 62. Fuse C2 |
| 63. Central door locking unit | 137. Fuse C3 |
| 163. Check engine warning lamp | 114. Fuse C4 |
| 37. Cigar lighter illumination (2 off) | 171. Fuse C5 |
| 60. Clock | 170. Fuse C6 |
| 39. Clock illumination | 61. Fuse C7 |
| 163. Coil negative (engine RPM input to ECU) | 173. Fuse C8 |
| 42. Column switch illumination | 161. Fuse C9 |
| 151. Compressor clutch relay | 186. Glare control mirror |
| 133. Condenser fan motors | 96. Glove box cigar lighter |
| 178. Condenser fan relay | 72. Hazard switch |
| 176. Cruise control connection points | 16. Headlamp relay |
| 95. Dash cigar lighter | 19. Headlamp wash pump |
| 160. Diode pack (air con) | 18. Headlamp wash timer unit |
| 74. Direction indicator switch | 184. Heated front screen timer Unit |
| 119. Distributor | 68. Heated rear screen switch |
| 148. E.F.I. warning lamp | 64. Heated rear window relay |
| 120. EFI Harness plug | 69. Heated rear screen warning lamp |
| 167. Earth (+) | 67. Heated rear screen |
| 185. Electric mirror elements | 110. Heated washer jets |
| 183. Electric seat relays | 38. Heater illumination (4 off) |
| 145. Electronic speedo and instrument controls | 175. Heater/air conditioning relay |
| 159. Emission maintenance reminder | 160. Heater/air conditioning connections |
| 73. Flasher unit | 26. High beam dimmer/flash switch |
| 181. Front amplifier audio | 49. High beam warning lamp |
| 86. Front fog lamp relay | 55. Horn switch |
| 93. Front fog lamp switch | 165. Ignition auxiliary (+) |
| 97. Front interior lamp | 117. Ignition coil |
| 17. Front wash pump | 1. Ignition load relay |
| 13. Front wipe/wash switch | 163. Ignition load relay (+) |
| 14. Front wipe delay unit | 166. Ignition on (+) |
| 15. Front wiper motor | 8. Ignition switch |
| 174. Fuel filler flap release | 10. Ignition warning lamp |
| 51. Fuel gauge sender unit | 115. Inertia switch |
| 50. Fuel gauge | 41. Instrument illumination (4 off) |
| 116. Fuel pump | 104. Interior lamp switch |
| 33. Fuse A1 | 99. Interior lamp delay unit |
| 31. Fuse A2 | 128. 'Key-in switch' |
| 21. Fuse A3 | 100. LH door edge lamp |
| 123. Fuse A4 | 108. LH front door switch |

- 91. LH front fog lamp
- 77. LH front indicator lamp
- 47. LH high beam
- 57. LH horn
- 75. LH indicator warning lamp
- 25. LH license plate lamp
- 45. LH low beam
- 101. LH puddle lamp
- 105. LH rear door switch
- 76. LH rear indicator lamp
- 89. LH reverse lamp
- 23. LH side lamp
- 87. LH stop Lamp
- 24. LH tail lamp
- 146. Low coolant level warning lamp
- 144. Low coolant switch
- 147. Low fuel level warning lamp
- 150. Low oil level probe
- 149. Low oil level logic unit
- 143. Low screen wash switch
- 142. Low screen wash fluid level warning lamp
- 20. Main lighting switch
- 151. Not used - will illuminate on Initial bulb check
- 113. Oil pressure switch
- 112. Oil pressure/level warning lamp
- 154. Park brake warning switch
- 153. Parking brake/brake fluid loss warning lamp
- 182. Rear amplifier audio
- 102. RH door edge lamp
- 109. RH front door switch
- 92. RH front fog lamp
- 80. RH front indicator lamp
- 48. RH high beam
- 56. RH horn
- 75a. RH indicator warning lamp
- 25a. RH license plate lamp
- 46. RH low beam
- 103. RH puddle lamp
- 106. RH rear door switch
- 81. RH rear indicator lamp
- 90. RH reverse lamp
- 27. RH side lamp
- 88. RH stop lamp
- 28. RH tail lamp
- 66. Radio aerial amplifier
- 124. Radio and six speakers
- 123. Radio fuse
- 182. Rear amplifier audio
- 98. Rear interior lamp
- 141. Rear screen wash pump
- 138. Rear wash wipe switch
- 139. Rear wipe delay unit
- 140. Rear wiper motor
- 129. Resistor
- 85. Reverse lamp switch
- 29. Rheostat
- 127. Seat belt warning lamp
- 131. Seat buckle switch
- 121. Speed transducer
- 7. Starter inhibit switch
- 5. Starter motor
- 6. Starter relay
- 4. Starter solenoid
- 84. Stop lamp switch
- 125. Sun roof relay
- 134. Sunroof connection point (option)
- 36. Switch illumination (2 off)
- 9. Tachometer
- 107. Tailgate switch
- 3. Terminal post
- 111. Thermostat heated jets
- 132. Trailer pick up point
- 82. Trailer warning lamp
- 136a. Transfer box oil temperature switch
- 133. Transfer box neutral switch
- 58. Under hood illumination switch
- 59. Under hood light
- 70. Voltage sensitive switch
- 157. Warning lamp control unit
- 168. Warning lights supply common earth (-)
- 169. Warning lights supply (+)
- 53. Water temperature sender unit
- 52. Water temperature gauge temperature warning lamp
- 35. Window lift connections

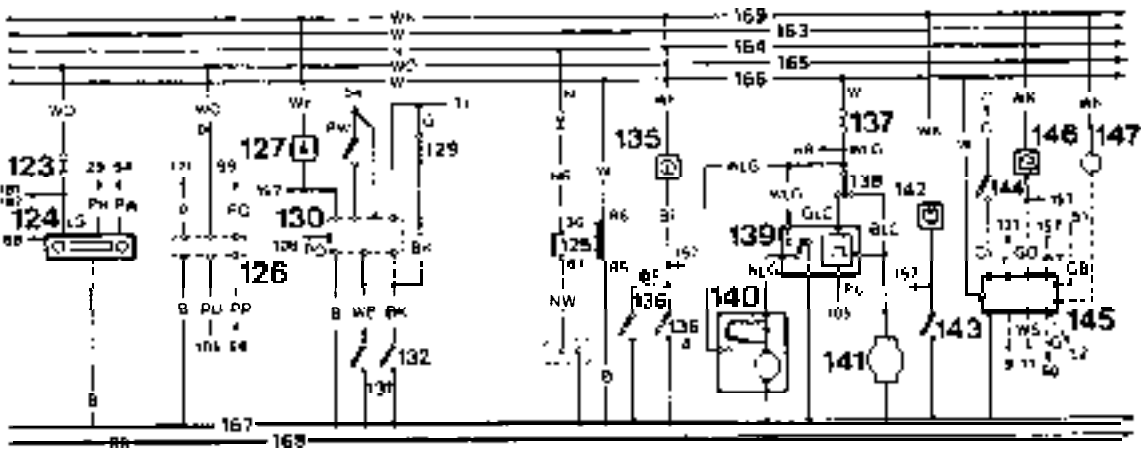
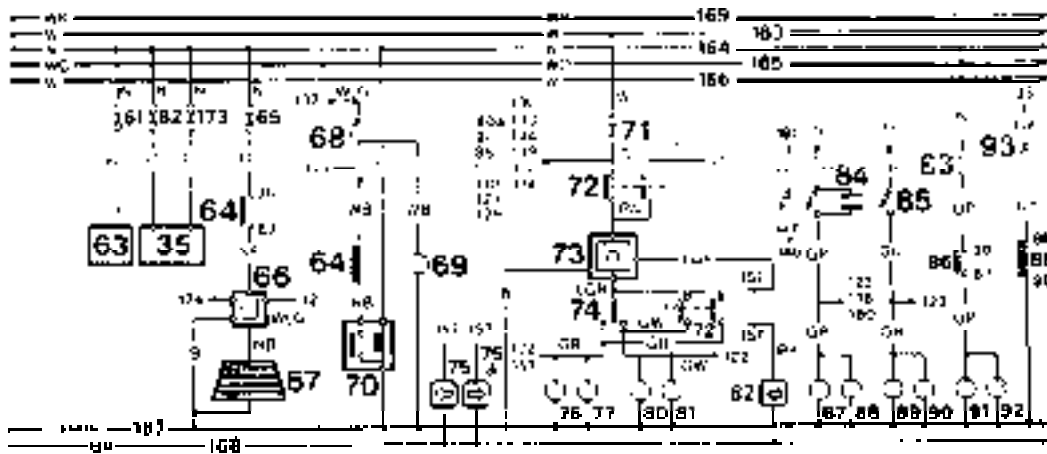
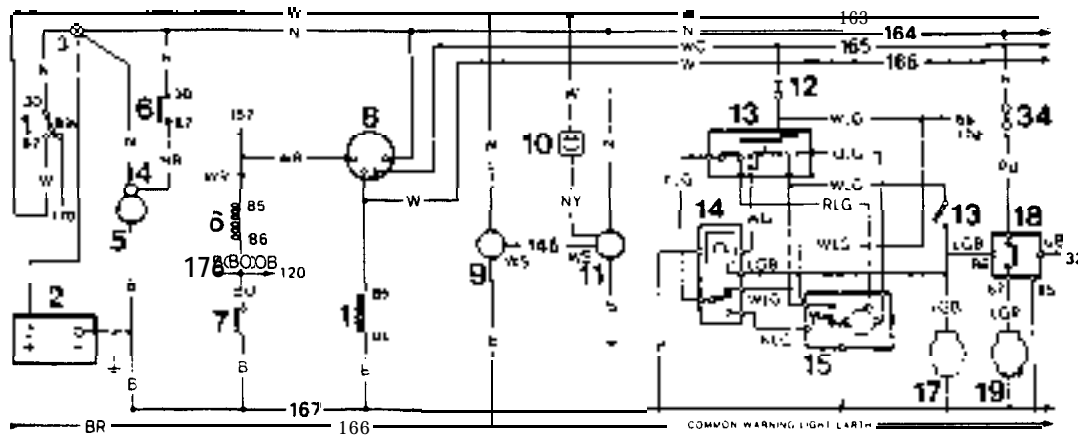

RR2942E

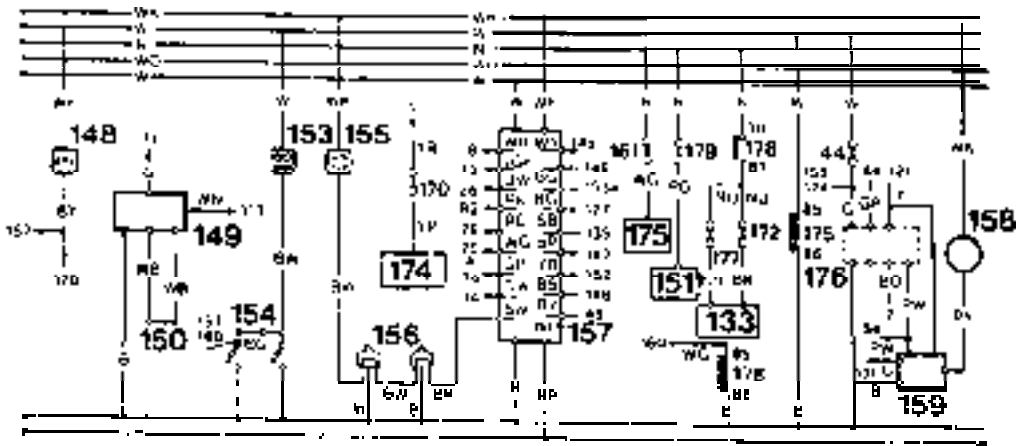
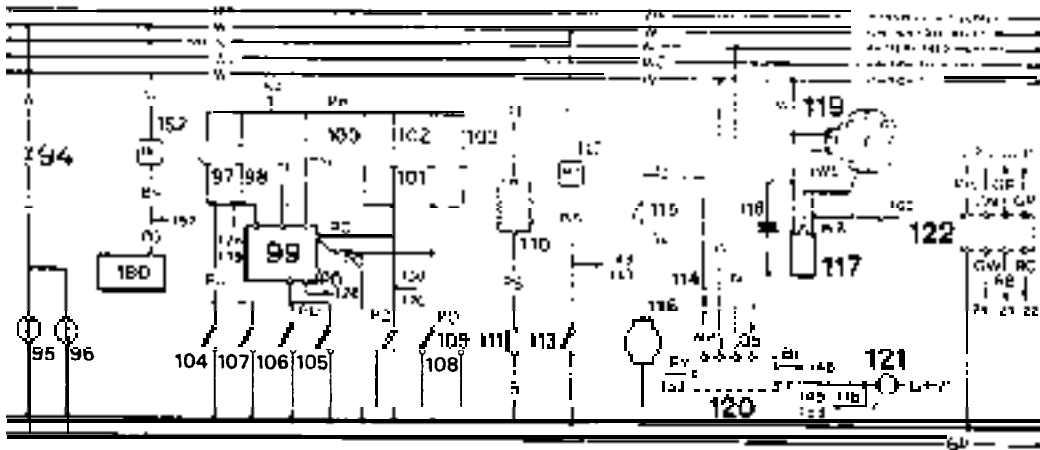
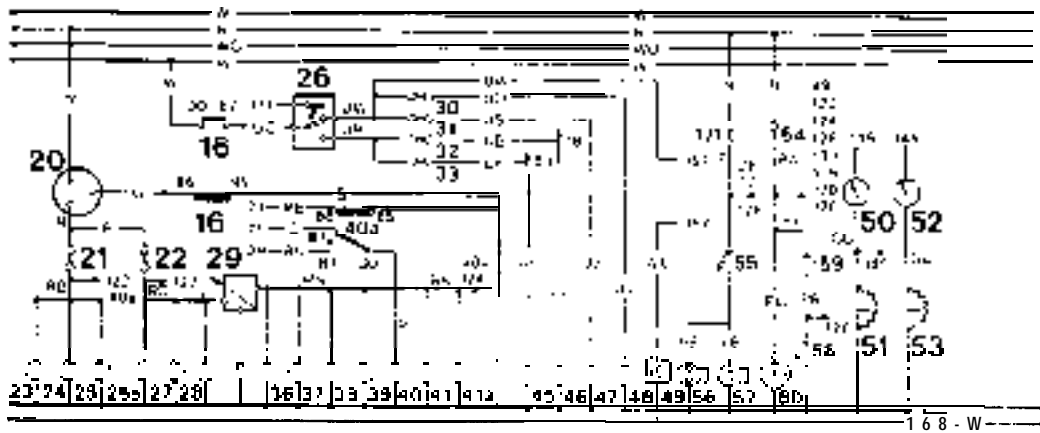

RR2943E

3
2

1

1

1

1