



Electrical Troubleshooting manual

Elektrische diagnoseprocedure-handboek

Manuel de dépannage électrique

**Handbuch zur fehlersuche bei
elektrischen Bauteilen**

**Manuale per l'individuazione
dei guasti elettrici**

Manual de localizacion de averías eléctricas

Manual de diagnóstico de averias eléctricas



RANGE ROVER

1999 Models onward

Contents

Section	Title
I	Introduction
A1	Sequential Multipoint Fuel Injection (SFI-Vol)
A6	Diesel
B1	Starting and Charging
B5	Cruise Control
D6	Transfer Gearbox
B7	Automatic Gearbox
C1	Ignition and Shift Interlock
D1	Anti-Lock Brake System
O3	Data Link Connector
E1	Instruments
F2	Warnings and Indicators
E5	Horns
E6	Radio
E9	Navigation System
F3	Wash/Wipe
F6	Heated Front Screen
F9	Heated Rear Screen
G1	Electromechanical Rear View Mirror
H1	Headlamps
H4	Side Lamps
H5	Stop Lamps
H8	Direction Indicator Lamps
H7	Reversing Lamps
H8	Fog/Guard Lamps
J1	Interior Lamps
J2	Cigar Lighter/Clock/Accessory Socket
K3	Heating and Ventilation (without A/C)
K4	Heating and Ventilation (with A/C)
L1	Power Windows
L4	Sunroof
M1	Power Seats
M0	Power Mirrors
M4	Memory Seats
M6	Heated Seats
M7	Memory Mirrors
N1	Supplementary Restraint System (SRS)
P1	Trailer Auxiliary Socket
S1	Air Suspension
S3	Security-Central Locking
Y1	Power Distribution
Y2	Fuse Details
Y5	Relay Distribution
Z4	Component Location Table
Z5	Component Location Views
Z6	Connection Views
Z8	Harness Routing
Z9	Index

Publication Part No. LRL0329 ENG (3rd Edition)
 © 2001 Land Rover



CIRCUIT DIAGRAMS

- Circuit diagrams are arranged so that current flow is from the top of the diagram (current source) to the bottom of the diagram (ground).
- Only those components that work together in the circuit are shown. If only part of a component is used in the circuit, then only that part of the component is shown.
- Remember:



TERMINAL NUMBER	DESIGNATION
50	Battery voltage: Ignition Switch in position III
30	Battery voltage: supplied constantly
15	Battery voltage: Ignition Switch in position II or III
R	Battery voltage: Ignition Switch in positions I, II
31	Ground

See Introduction (I) for additional circuit diagram symbols.

DIAGNOSIS

- If the diagram is accompanied by text:
 - Read the Circuit Operation before proceeding with the electrical diagnosis.
 - Read the Troubleshooting Hints before performing the System Diagnosis.
 - Tests follow the System Diagnosis
 - When performing the System Diagnosis, be certain that all components disconnected in previous steps are reconnected unless otherwise directed.

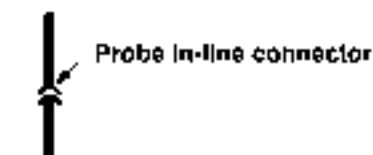
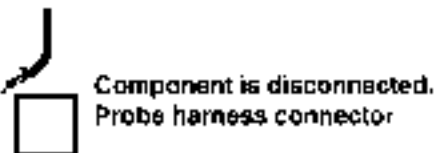
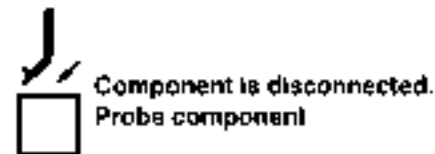
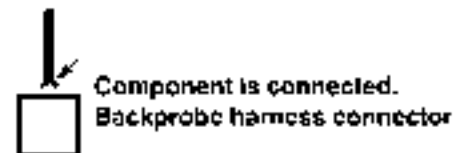
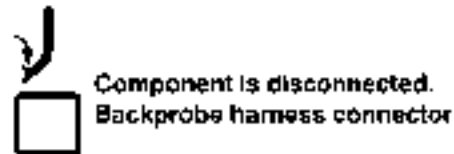

INTRODUCTION

This manual is intended for use by trained Land Rover technicians as an aid to diagnosing electrical concerns.

This manual is organized into sections, with most sections containing circuit diagrams. Each section has a unique alpha-numeric code that will normally remain the same from year to year. For example, the Headlights circuit is in Section H1, with the first page of the section numbered H1-1. The following pages of this section will be numbered H1-2, H1-3, H1-4, etc. The manual does not contain any information concerning removal, repair or overhaul of electrical components or harnesses. These details are contained in the Workshop Manual. The following information forms the basis of the troubleshooting routines:

- Circuit Diagrams
- System Diagnosis Flow Charts
- Component Location Table
- Component Locations Views

Additional information, such as Circuit Operation, is also contained in the manual to aid in your understanding of how the different circuits operate.

DESCRIPTION OF MANUAL

Circuit Operation And Diagram

The Circuit Operation information at the beginning of the section will give you an overview of how the circuit works.

The Circuit Diagrams should always be your starting point in using this Electrical Troubleshooting Manual. The diagram shows the electrical current paths when a circuit is operating properly. It is essential to understand how a circuit should work before trying to figure out why it doesn't. Diagrams are shown with the Ignition Switch in the OFF position and other switches in the OFF or 'at rest' position.

Notes are provided after certain switches to clarify switch positions. Abbreviations found in the notes are explained in the Abbreviation Table found in the SYMBOLS section of this chapter.

Circuit Diagrams (schematics) break the entire electrical system into individual circuits. Electrical components that work together are shown together.

Each diagram is arranged so current flows from positive, at the top of the page, to ground, at the

bottom of the page. The 'power' labels at the top of a fuse show when the Battery, Main Light Switch, or Ignition Switch supplies power to that fuse.

Wires that connect to another circuit are shown with an arrowhead pointing in the direction of current flow. The name of the circuit that shares the wiring is provided for reference.

Wire Colour charts are no longer provided on each circuit page. One chart is provided in the SYMBOLS section of this chapter.

'See Fuse Details' means there are more connections to other circuits that are not shown. All such shared circuits are shown on the Fuse Details diagrams. 'See Ground Distribution' means there are more shared ground circuits which are shown on the Ground Distribution diagrams.

No attempt is made on the diagrams to represent components and wiring as they physically appear on the car. For example, a long length of wire is treated no differently in a diagram from one which is only a few centimeters long. The number of cavities for each connector is listed in the Component Location Table rather than illustrated. Similarly, switches and other components are shown as simply as possible, with regard to function only.

Power Distribution

The Power Distribution diagrams are found in Section Y1. These diagrams show how voltage is supplied from the positive Battery terminal to the various circuits in the vehicle.

The individual Circuit Diagrams begin with a fuse or the Ignition Switch. Power Distribution shows the wiring from the Battery to the Fuse Boxes, the Ignition Switch, the Main Lighting Switch, and any circuit fuses not located in a Fuse Box.

Fuse Details

The Fuse Details diagrams are found in Section Y2. These diagrams show all the wiring between each fuse in the Fuse Boxes and the components connected to the output of the fuse. The Fuse Details diagrams are extremely helpful in locating a short circuit that causes a fuse to blow. These diagrams also aid in troubleshooting an inoperative circuit by showing a second circuit using the same fuse. If the second circuit works, then the fuse and certain wires of the inoperative circuit are good.

Ground Distribution

The Ground Distribution diagrams are found in Section Y6. These diagrams show which components share each ground point. This information can often be a time-saver when troubleshooting a poor ground.

For example, if the Fuel Pump does not run, you may suspect an open in its circuit to ground. However, if the Number Plate Lamps work, and they share the same ground point as the Fuel Pump, you know that the ground and the wire up to the common splice are good. You have learned this just by inspecting the diagram and knowing the vehicle's symptoms.

Connector Views

Connector Views are provided in section Z6. All connectors with 2 terminals or more will be shown. Pin-out tables with the appropriate wire colours will also be shown.

Component Location Table

A Component Location Table can be found in Section Z4. Except for the location of obvious components like the Left Head light, the table lists the location of every component, connector and ground point depicted in the Circuit Diagrams. The table also gives references to Component Location Views located in Section Z5 and cross references to Workshop Manual remove and refit procedure sections. The number of cavities in each connector and the connector colour is also listed. Wires may not be used in all connector cavities.

TROUBLESHOOTING TECHNIQUE

The following five-step troubleshooting procedure is recommended.

(1) Verify the Problem

Check the operation of the circuit to be sure you understand the problem. Do not begin disassembly or testing until you have narrowed down the possible causes.

(2) Analyze the Circuit Diagram (schematic)

Analyze the diagram. Check circuits that share the wiring with the problem circuit. The names of shared circuits are often given on each Circuit Diagram to aid troubleshooting. Shared power and ground circuits can be found in the Power and Ground Distribution sections. Try to operate the shared circuits. If these circuits work, then the shared wiring is OK. The cause must be within the wiring used only by the problem circuit. If several circuits fail at the same time, chances are the power (fuse) or ground circuit is faulty.

(3) Find the Cause

- Narrow down the possible causes
- Before you replace a component, check power, signal, and ground wires at the component harness connector.

(4) Repair the Problem

Once the specific problem is identified, make the repair. Be sure to use the correct tools and safe procedures.

(5) Check the Repair

Check the operation of the repaired circuit in all modes to make sure you fixed the entire problem. If the problem was a blown fuse, be sure to test all of the circuits on that fuse. Make sure no new problems are present.

TEST EQUIPMENT

Where applicable, Land Rover recommended testers should be used.

Voltmeter and Test Light

Use a voltmeter or test light to check for voltage. While a test light shows whether or not voltage is present, a voltmeter indicates how much voltage there is.

CAUTION: A number of circuits include solid-state devices. Voltages in these circuits should be tested only with a 10-megohm or higher impedance

digital multimeter. Never use a test light on circuits that contain solid-state devices. Damage to the device may result.

On circuits without solid-state devices, a test light may be used to check for voltage. A test light is made up of a 12-volt bulb with a pair of leads attached. After grounding one lead, touch the other lead to various points along the circuit where voltage should be present. The bulb will come on if the voltage at the point being tested is greater than 5 volts.

Self-powered Test Light and Ohmmeter

Use a self-powered test light or ohmmeter to check for continuity. The ohmmeter shows how much resistance there is between two points along a circuit. Low resistance means good continuity.

CAUTION: Never use a self-powered test light on circuits that contain solid-state devices. Damage to those devices may result.

Diodes and solid-state devices in a circuit can make an ohmmeter give a false reading. To find out if a component is affecting a measurement, take one reading, reverse the leads, and take a second reading. If the readings differ, the component is affecting the measurement.

Circuits that contain solid-state devices should only be tested with a 10-megohm or higher impedance digital multimeter.

A self-powered test light consists of a light bulb, battery, and two leads. If the leads are touched together, the bulb will go on.

A self-powered test light is only used on an unpowered circuit. First, disconnect the battery or remove the fuse that feeds the circuit you are working on. Select two points along the circuit through which there should be continuity. Connect one lead of the self-powered test light to each point. If there is continuity, the test light's circuit will be completed and the bulb will go on.

Fused Jumper Wire

Use a fused jumper wire to bypass an open circuit. A fuse jumper wire is made up of an in-line fuse holder connected to a set of test leads. Never use a jumper wire across any load. This direct battery short will blow the fuse.

The following symbol represents a fused jumper:



SYMBOLS

The abbreviations and symbols explained here are used throughout the manual, it is necessary to know what they mean in order to use the diagrams effectively.

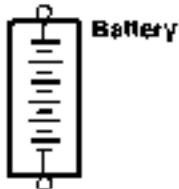
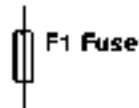
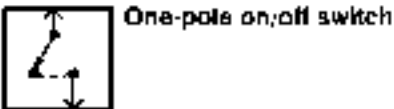
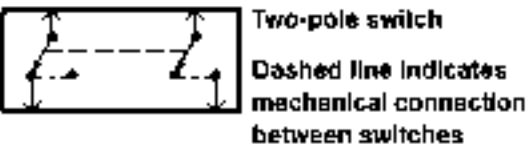
**Battery****F1 Fuse****MF2 Maxi-Fuse****One-pole on/off switch****Two-pole switch**

Dashed line indicates mechanical connection between switches

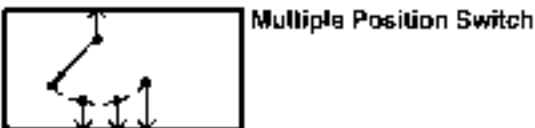
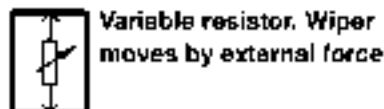
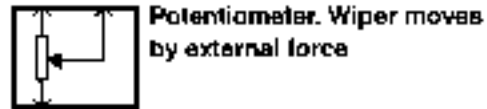
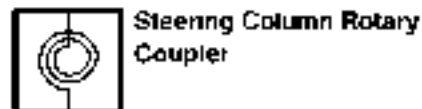
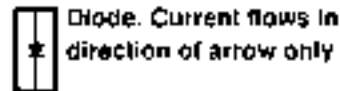
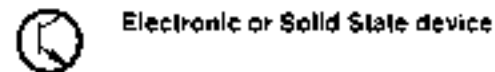
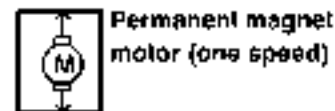
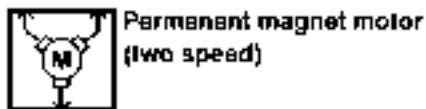
**Multiple Position Switch****Variable resistor. Wiper moves by external force****Potentiometer. Wiper moves by external force****Steering Column Rotary Coupler****Diode. Current flows in direction of arrow only****LED****Bulb****Electronic or Solid State device****Permanent magnet motor (one speed)****Permanent magnet motor (two speed)**

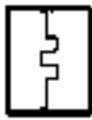
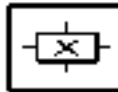
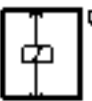
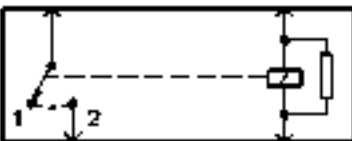
**Heating Element****Antenna****Loudspeaker or horn****Hall Effect Sensor****Coil****Solenoid****Relay**

Switch is drawn into the closed position when current flows through coil

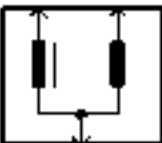
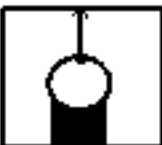
**Ignition Coil****Steering Column
Horn Brush/
Slip Ring**

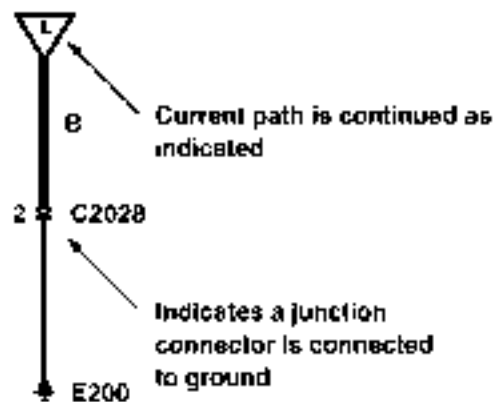
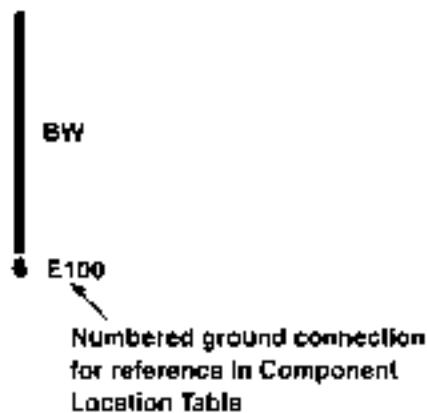
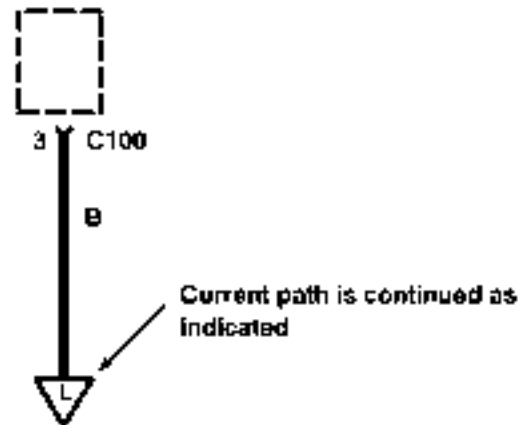
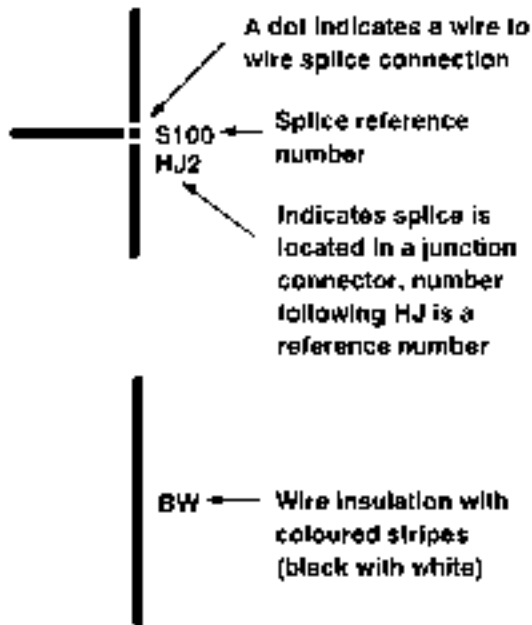
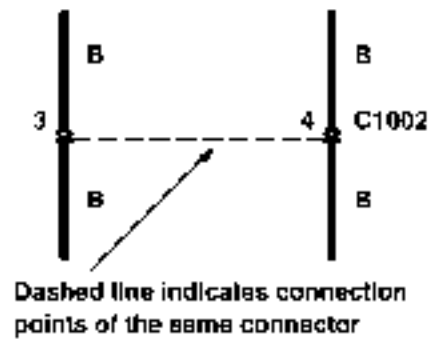
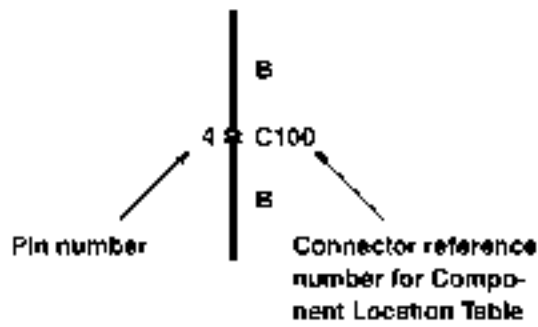

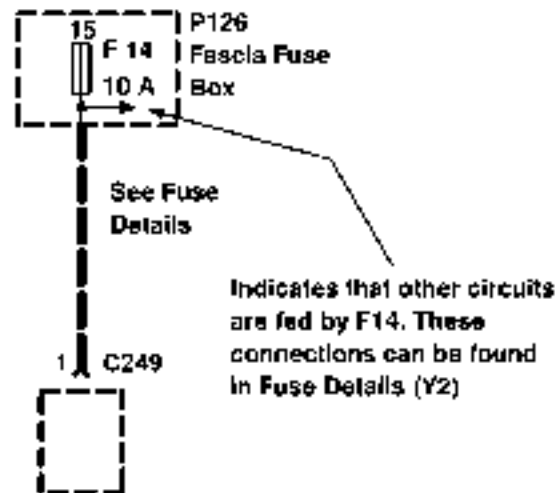
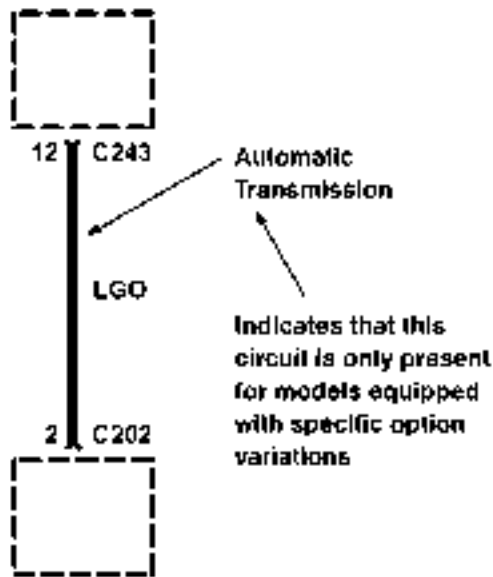
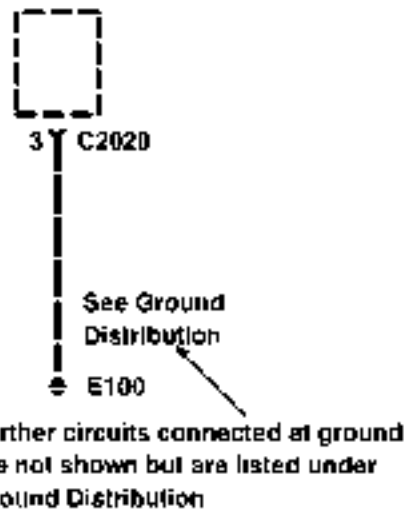
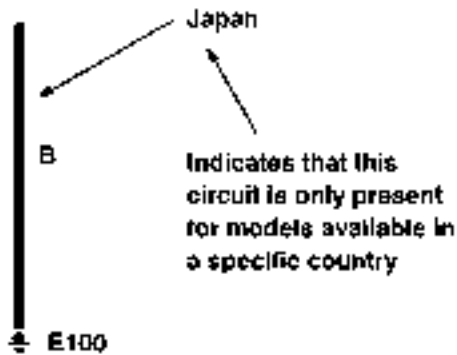
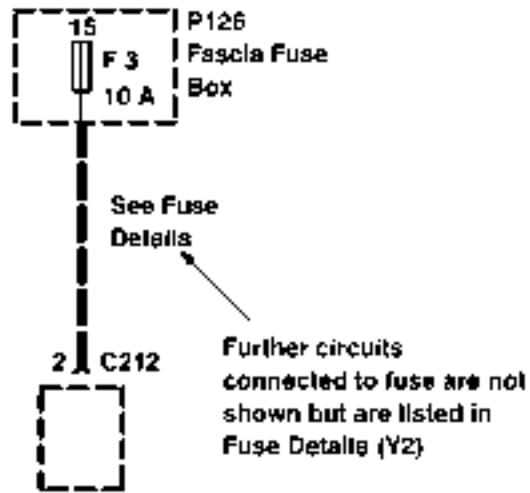
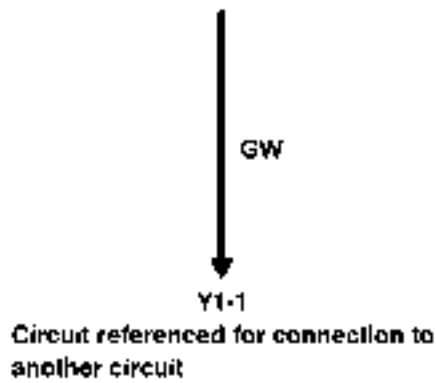

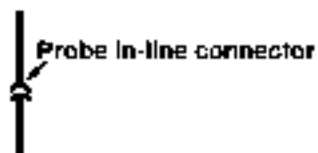
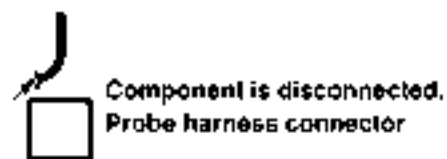
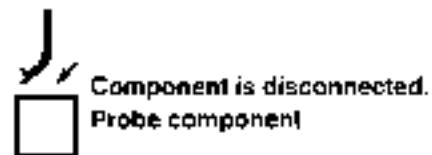
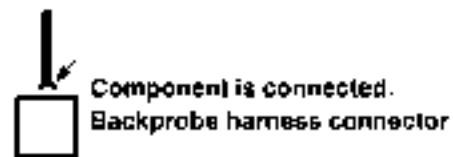
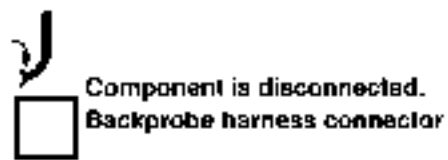
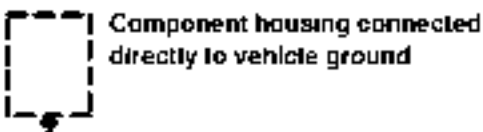
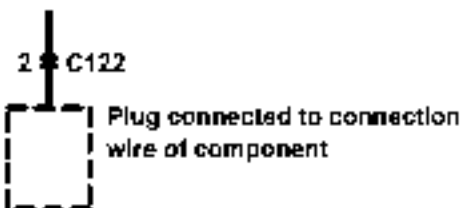
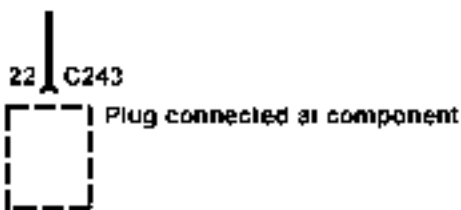
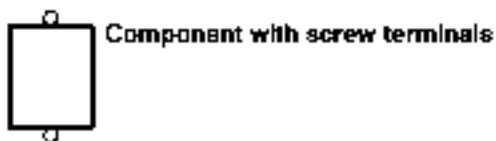
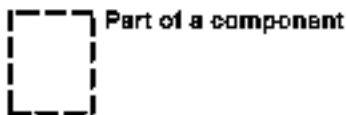
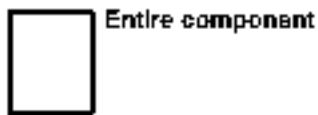

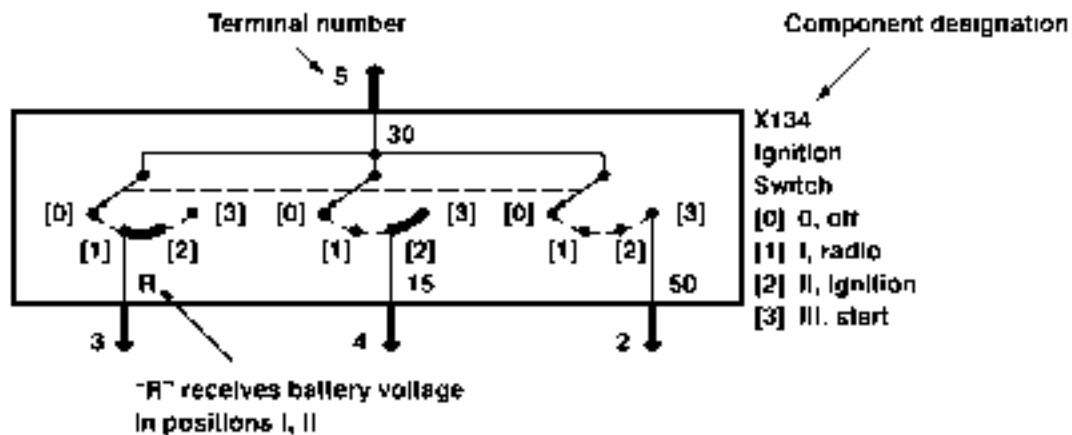

Terminal number	Designation	Terminal number	Designation
50	Battery voltage: Ignition Switch in position III	X	Switched battery voltage through the ignition load relay or accessory relay; ignition switch is in position I or II.
30	Battery voltage: supplied constantly	49	Flasher unit input
15	Battery voltage: Ignition Switch in position II or III	49a	Flasher unit output
R	Battery voltage: Ignition Switch in positions I, II	50	Start
31	Ground	56a	High beam
		56b	Low beam
		56d	Headlamp flash
		58	Side lamps
		85	End of relay coil
		86	Start of relay coil
		87	Relay contact
		87a	Relay contact

Definition of Vehicle Component Codes

All components are identified by a letter followed by an arbitrary number assigned to the component. The letter assigned to the component indicates the type of component.

B	Bulbs, Heated Screens, Mirror Demisters, Cigar Lighters, and Heated Washer Jets
K	Relays, Solenoids, Speakers, and Resistors
M	Motors
P	Fuse Boxes and Fusible Links
X	Switches and Sensors
Z	Electronic Control Units, Modules, Shields, Diodes, and Capacitors

Wire Colours

All wires are identified by letters which indicate a certain colour. Wire colour and size will only be shown once if it does not change throughout the circuit. The following chart explains the wire colour abbreviations.

Wire Colour Chart

B - Black	P - Purple
G - Green	R - Red
K - Pink	S - Grey
L - Light	U - Blue
N - Brown	W - White
O - Orange	Y - Yellow

Previous and Next Arrows

Schematic pages which follow another schematic page of the same chapter will have an arrow in the upper left hand corner. There is no arrow on the first schematic page of a chapter. Schematic pages which are followed by another schematic page will have an arrow in the lower right hand corner. If the page is the last page of the chapter, there will be a square instead of an arrow.

Page Qualifiers

Schematic pages which are specific to certain model, option or country variations will have a small "Qualifier" after the Previous Arrow in the upper left hand corner. For example, a section might contain pages specific to petrol engines and some pages specific to diesel engines. "Petrol" will be shown in the upper left hand corner of petrol specific pages, and "Diesel" will be shown in the upper left hand corner of diesel specific pages.

Circuit Qualifiers

Certain abbreviations are used throughout the **Electrical Troubleshooting Manual** as circuit qualifiers. The following list explains all abbreviations used as qualifiers in the **Circuit Diagrams**.

ABS	Anti-Lock Braking System
CPU	Central Processing Unit
LHD	Left Hand Drive
RHD	Right Hand Drive
NAS	North American Specification
A/C	Air Conditioning
SFI-V8	Sequential Multiport Fuel Injection (SFI-V8)
MY	Model Year

Switch Positions

Certain abbreviations are used throughout the **Electrical Troubleshooting Manual** as Switch Position notes. The following list explains all abbreviations used as Switch Position notes in the **Circuit Diagrams**.

< 100° **Less than 100°**

> 100° **More than 100°**

Connector, Ground, and Splice Identification:

Connectors, Grounds, and Splices are identified by a letter followed by a number. Connectors are identified by C, grounds by E, and splices by S.

SUFFIX:

A	For Different Option Variations
B	For Different Option Variations
L	Left Side of Vehicle only
R	Right Side of Vehicle only
P	Petrol Engine only
D	Diesel Engine only

CIRCUIT OPERATION**Sensors****Knock Sensors (X309, X310)**

The Knock Sensor is a 'Piezo-electric accelerometer,' i.e. it produces an output voltage proportional to mechanical vibration produced by the engine. The Engine Control Module (ECM) (Z132) receives the signal, filters out any noise and calculates if the engine is knocking. Due to the cam and crank signals supplying information regarding the position of the engine in its cycle, the ECM (Z132) can work out exactly which cylinder is knocking and retards the ignition on that particular cylinder until the knock disappears. It then advances the ignition again to find the optimum ignition point for that cylinder for those conditions (i.e. fuel type, air temperature etc.). The ECM (Z132) will be able to adjust cylinder timing for knock simultaneously, so that all eight cylinders could have different advance angles at the same time.

Engine Coolant Temperature Sensor (X126)

The sensor contains two thermistors with negative temperature co-efficients, i.e. the resistance of the metal strips varies with temperature. The Engine Coolant Sensor (X126) signal is vital to correct engine operation, as the injected fuel quantity is dependant upon the engine temperature, i.e. richer mixture at low temperatures.

Crankshaft Position Sensor (X250)

The Engine Control Module (ECM) (Z132) uses the signal produced by the Crankshaft Position (CKP) Sensor to determine the exact position of the crankshaft to enable accurate ignition and fuel injection timing. The ECM also determines engine speed at any particular instance through the analysis of the frequency of fluctuations induced in the CKP sensor as the teeth of the reluctor ring pass by the sensor tip.

Camshaft Position Sensor (Z262)

The CMP sensor is a Hall effect sensor which produces four pulses for every two engine revolutions. The signal is used in two areas: injector timing corrections for fully sequential fuelling and active knock control.

Camshaft operation is essential to continue normal ignition, i.e. actuate the Fuel Injectors in the normal sequential order, timing the injection correctly with respect to top dead centre.

In this way the sequential fueling will either be correct, or one engine revolution out of synchronisation.

Mass Air Flow Sensor (X105)

The Mass Air Flow Sensor (X105) utilizes a 'hot film' element contained in the intake air tube to monitor the mass flow of the air stream drawn into the engine. It contains two sensing elements, one element is controlled at ambient temperature, while the other is heated to 200 °C/ 390 °F above the ambient temperature. The air flow passes the heated element and cools it down, therefore lowering the resistance of the hot film element. In order to maintain a constant temperature the circuit to the heated element has to supply more current. The measured air mass flow is used by the ECM (Z132) to determine fuel quantity to be injected in order to maintain a stoichiometric air/fuel mixture for optimum engine performance and low emissions.

Throttle Position Sensor (X171)

This sensor is a variable resistor which determines throttle angle position and angular velocity. The signal is used by the ECM (Z132) to calculate fuel injection duration under various operating conditions. The closed idle switch position is used for idle speed control in conjunction with road speed. Failure of the Throttle Position Sensor (X171) will result in poor idle and lack of throttle response. If the Throttle Position Sensor (X171) fails in the 'closed' mode then the engine will only revolve up to 1740 rpm when the ECM (Z132) will initiate 'over run fuel cut-off'.

Heated Oxygen Sensors (X139, X160, X289, X290)

The Heated Oxygen Sensor consists of a ceramic body of zirconium and yttrium which is coated with gas-permeable platinum. If the sensor reaches sufficiently high temperatures (above 350 °C/660 °F) it generates a voltage which is proportional to the oxygen content in the exhaust stream in comparison with the ambient oxygen content. From this value the ECM (Z132) can adjust the injected fuel quantity that is to achieve the correct air/fuel ratio. This reduces the emissions of Carbon Monoxide (CO), Hydrocarbons (HC) and oxides of Nitrogen (NOX) to acceptable levels.

Presently, two heated oxygen sensors are used, one in each exhaust down pipe just before the catalyst.

In the event of sensor failure, the system will default to 'open loop' operation and fuelling will be calculated using signals from the remaining ECM inputs. The fault is indicated by illumination of the malfunction indicator lamp (MIL). ECM diagnostics also uses heated oxygen sensors to detect catalyst damage, misfire and fuel system faults.

North American vehicles have two extra heated oxygen sensors mounted one after each catalyst.

These are used to determine whether the catalysts are operating efficiently.

Idle Air Control Valve (M112)

The Idle Air Control Valve (M112) controls the idle speed of the engine by moving the plunger a set distance, known as a step. Fully open is zero steps and fully closed is 180 steps. The motor moves each step by sequentially changing the polarity to each of the two coils.

Ignition Coils (Z261)

The electronic ignition system is fitted with two coil pack units which are directly driven by the Electronic Control Module (ECM) (Z132) and operates using the 'wasted spark' principle. Each coil pack contains two ignition coils. The circuit to each coil is completed via switching within the ECM (Z132), allowing the coil to charge up and then fire. It produces sparks in two cylinders simultaneously, one cylinder on the compression stroke and one on the exhaust stroke.

Coil pack 1 feeds cylinders 2, 3, 5 and 8.

Coil pack 2 feeds cylinders 1, 6, 4 and 7.

The resistance of the spark plug in the compression stroke is higher than that in the exhaust stroke and hence more spark energy is dissipated in the compression stroke.

Coil failure will result in a lack of ignition, which may result in an engine misfire in the related cylinder(s). An engine misfire is indicated by the illumination of the Malfunction Indicator Lamp (MIL).

Injector/Injectors

The fuel injection system used is a 'Sequential Multipoint' fuel injection (SFI) system (i.e. one injector for each cylinder (compared to 'single point' injection or throttle body injection which uses one injector only)).

A fuel injector consists of a small solenoid, which is actuated by the ECM (Z132), allowing fuel to pass into the combustion chamber. Due to the fuel pressure in the rail and the shape of the injector orifice, the fuel is injected into the cylinder in a fine spray to aid combustion.

Relays

The engine management system uses four relays:

- Starter motor
- ECM (Z132) power supply (main relay)
- Ignition coil
- Fuel pump

All the above relays are located within the engine compartment fusebox.

Main Relay

The main relay supplies power to the ECM (Z132) with a splice that feeds the fuel injectors and Mass Air Flow (MAF) sensor.

The relay is controlled by the ECM (Z132). This enables the ECM (Z132) to remain powered up after the ignition signal is removed. When the ignition signal is removed the ECM (Z132) will record all temperature sensor readings and will drive the Idle Air Control Valve (IACV) (M112) to the fully open position.

This is known as the 'ECM (Z132) power down routine'. Failure of this relay will mean the ECM (Z132) will not power up and therefore the engine will not start.

Ignition Coil Relay

The ignition coil relay is controlled by the Body Electrical Control Module (BeCM). The BeCM receives confirmation from the anti-theft immobiliser that an approved ignition key has been inserted. On approval, the BeCM will provide a ground to the ignition coil relay.

When the ignition switch is turned from position 0 to position II and an approved ignition key is inserted a power supply is sent to the ignition coils, evaporative emission canister purge valve and heated oxygen sensor (HO2S). When the ignition is switched off, power supply to the ignition coils, evaporative emission canister purge valve and HO2S is cut immediately.

Starter Motor Relay

The starter motor relay is controlled by the ignition switch and is only energised when the switch is in position III (engine crank).

Releasing the ignition key after cranking the engine cuts the power supply to the relay and switches off the starter motor.

Fuel Pump Relay

The fuel pump relay is controlled by the ECM (Z132). The ECM controls the fuel pump relay ground. When the ECM senses that the ignition relay is energised the ECM will provide a ground for the fuel pump relay. The power from the relay supplies the fuel pump, which primes the fuel system. The fuel pump relay is only energised until a fuel pressure of between 2.3 - 2.5 Bar is reached.

Engine Control Module (ECM) (Z132)

The ECM (Z132) is located in an underbonnet 'E-Box' mounted on the LH side of the engine bay bulkhead and is cooled by a dedicated fan. If the ECM (Z132) itself is not working, the entire engine management system will cease to operate: no fuel, sparks, tachn reading, etc.

Secondary Air Injection Pump (M166)

At engine start the Secondary Air Injection Pump (M166) is activated if the engine coolant temperature is below 55 °C.

With the ignition On and with the contacts of the Main Relay in the Engine Compartment Fusebox (P125a) closed the ECM (Z132) provides an earth path for the Secondary Air Injection Pump Relay. If the coil is energised and the contacts of the Secondary Air Injection Pump Relay are closed the Secondary Air Injection Pump (M166) starts to operate.

The Secondary Air Injection Pump (M166) remains operational for a period determined by the ECM (Z132) and depends on the time needed for engine coolant to reach the required temperature.

Secondary Air Injection Valve (K237)

When the contacts of the main relay are closed voltage is fed to the Secondary Air Injection Valve (K237) via Fuse 26 in the Engine Compartment Fuse Box (P125a).

The ECM provides the earth path for the valve at the same time it switches the Secondary Air Injection Pump (M166) on. When the valve is energised a vacuum is provided to the operation control parts on both of the vacuum operated valves at the exhaust manifold. This allows pressurised air from the Secondary Air Injection Pump (M166) to pass through the exhaust manifolds for combustion.

If the engine has reached its operating temperature the earth path for the Secondary Air Injection Pump Relay and the Secondary Air Injection Valve is switched off.

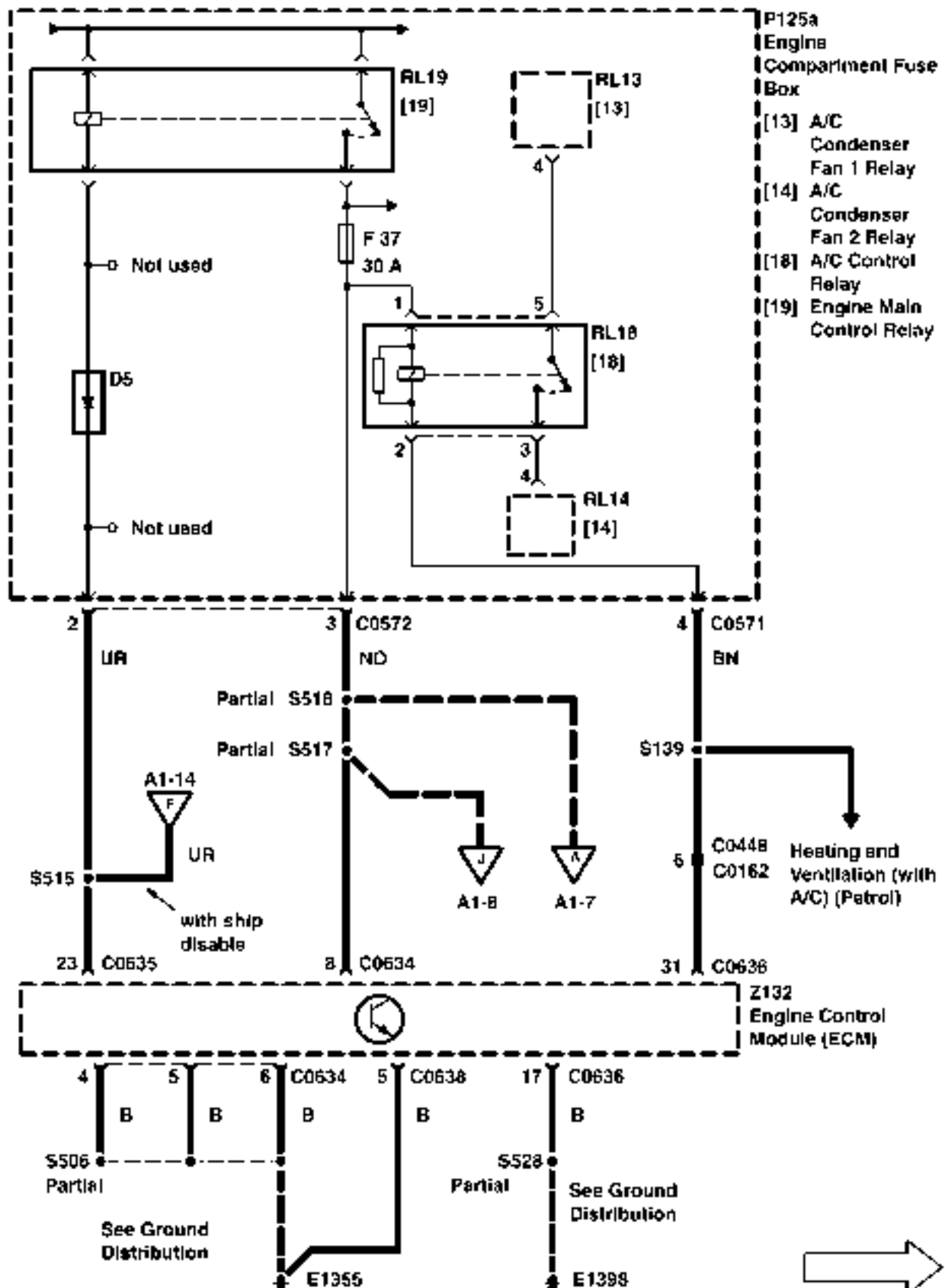

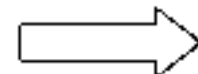
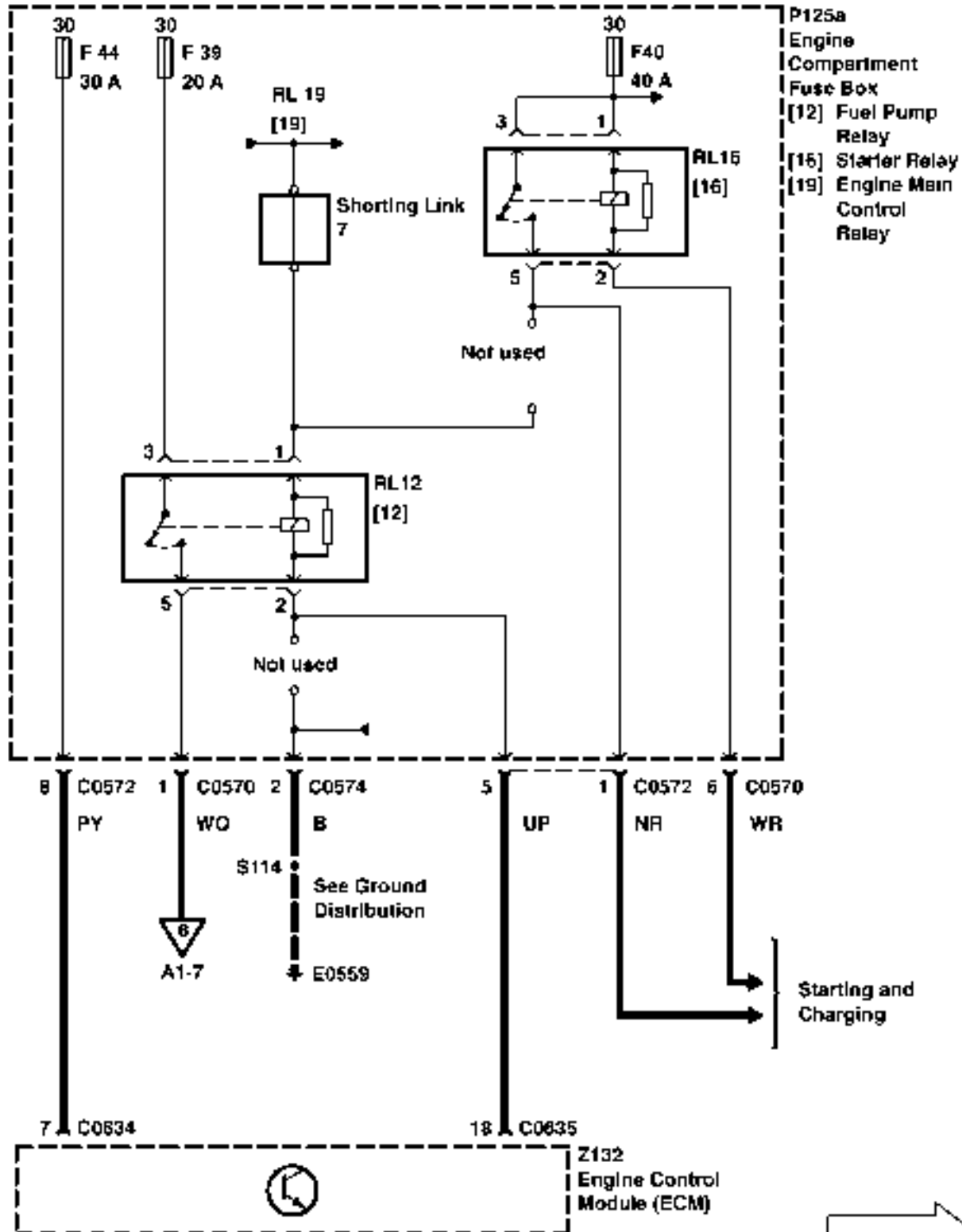

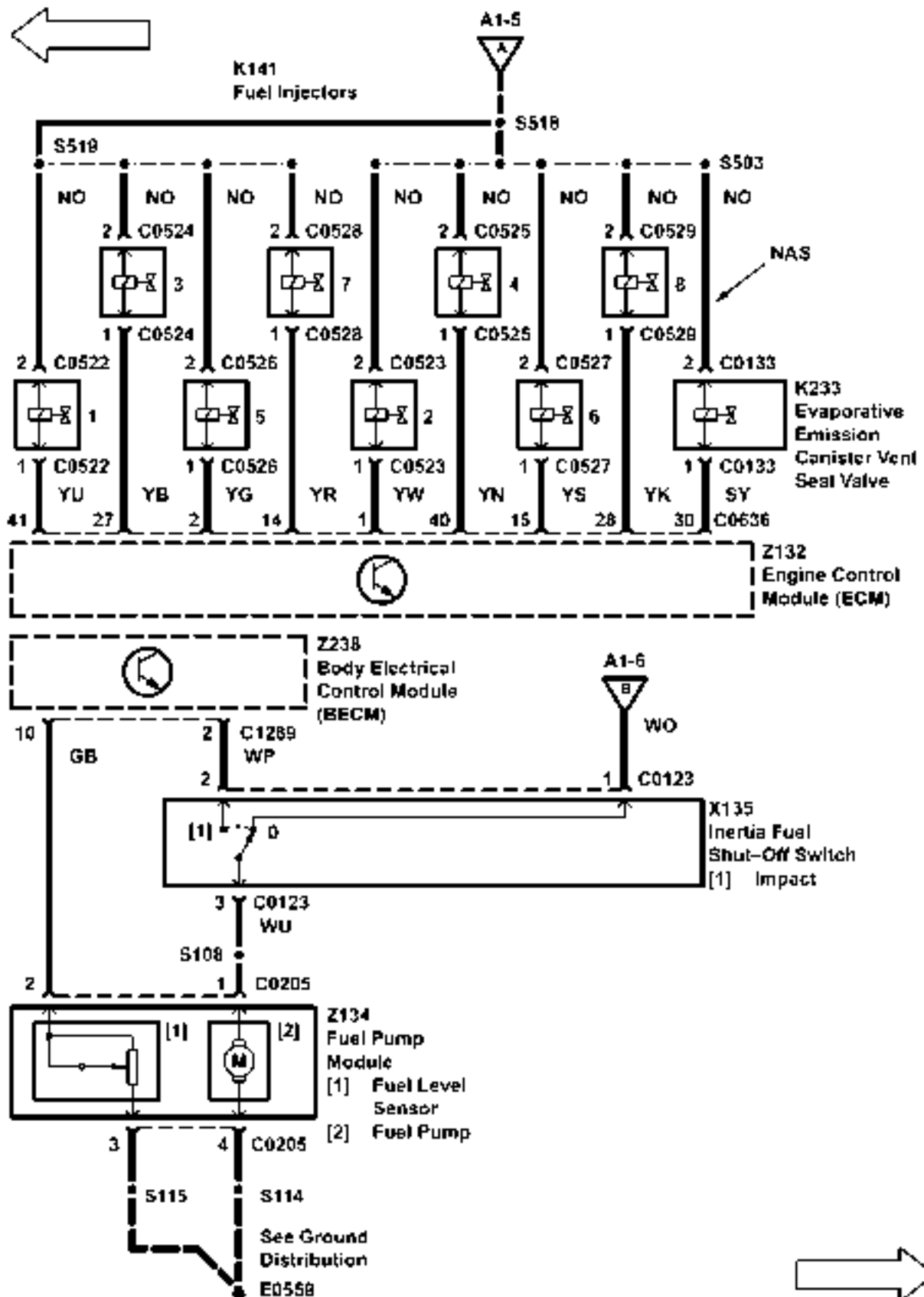

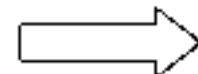
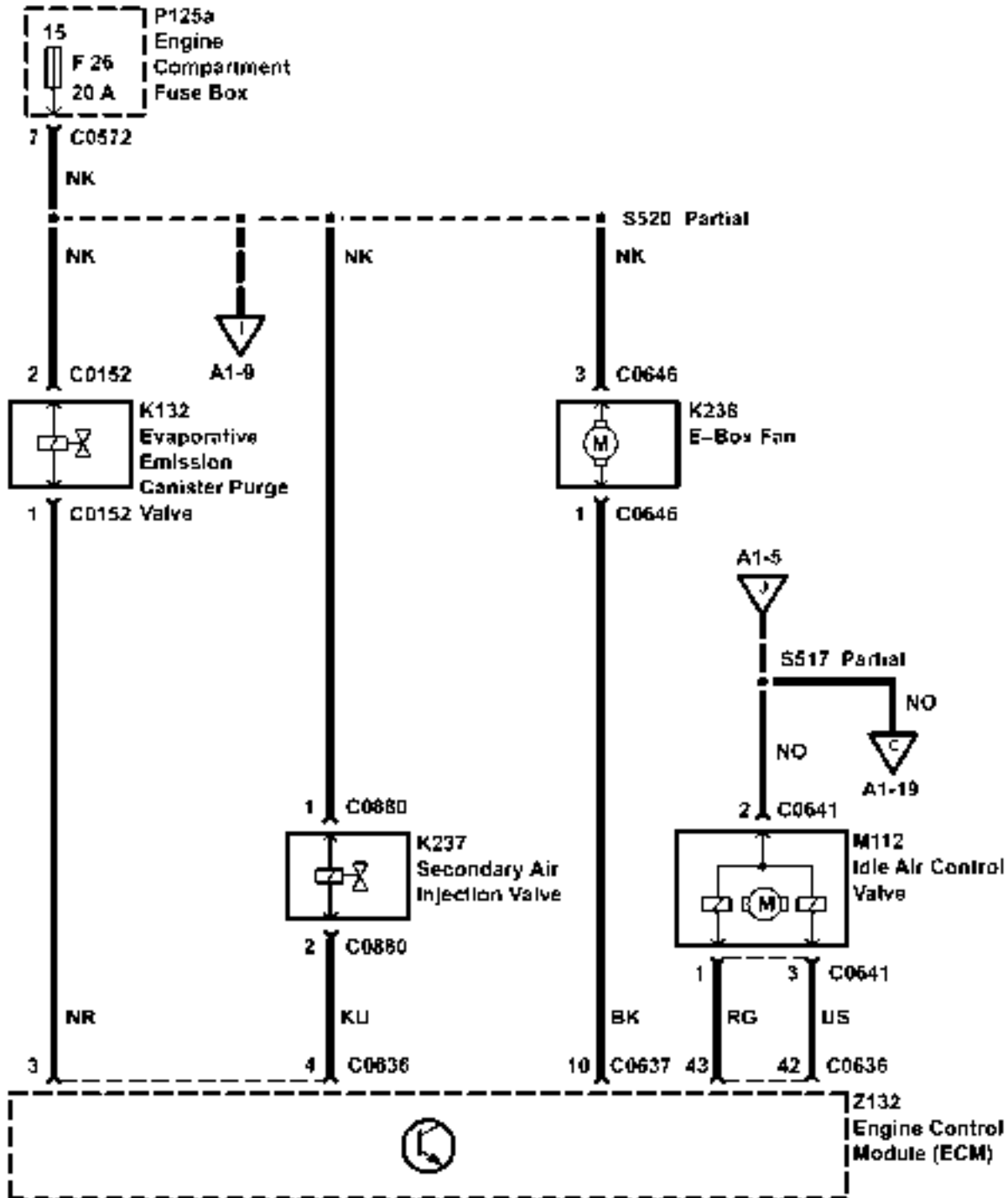
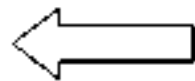

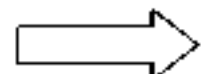
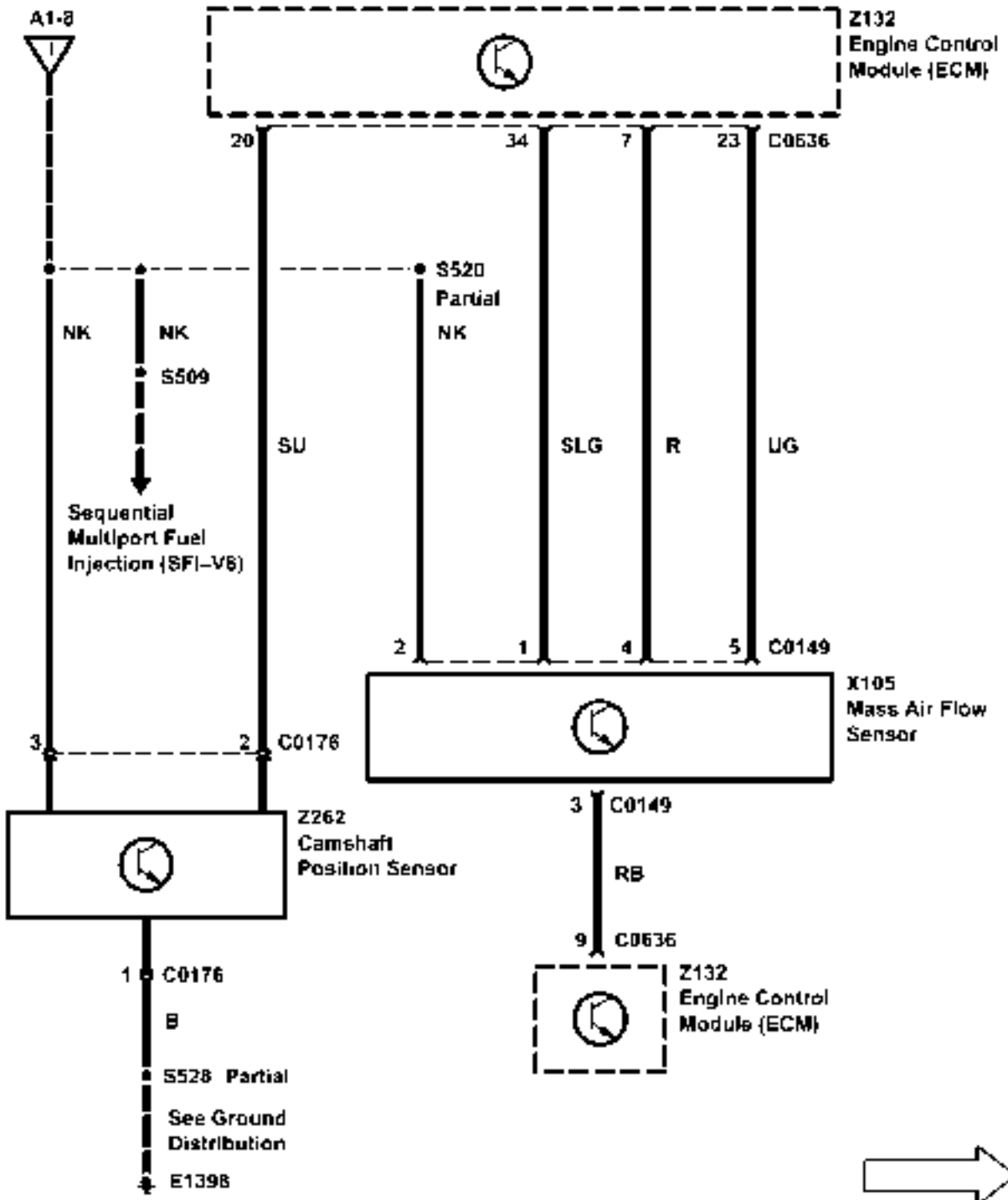
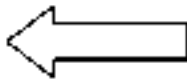

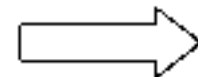
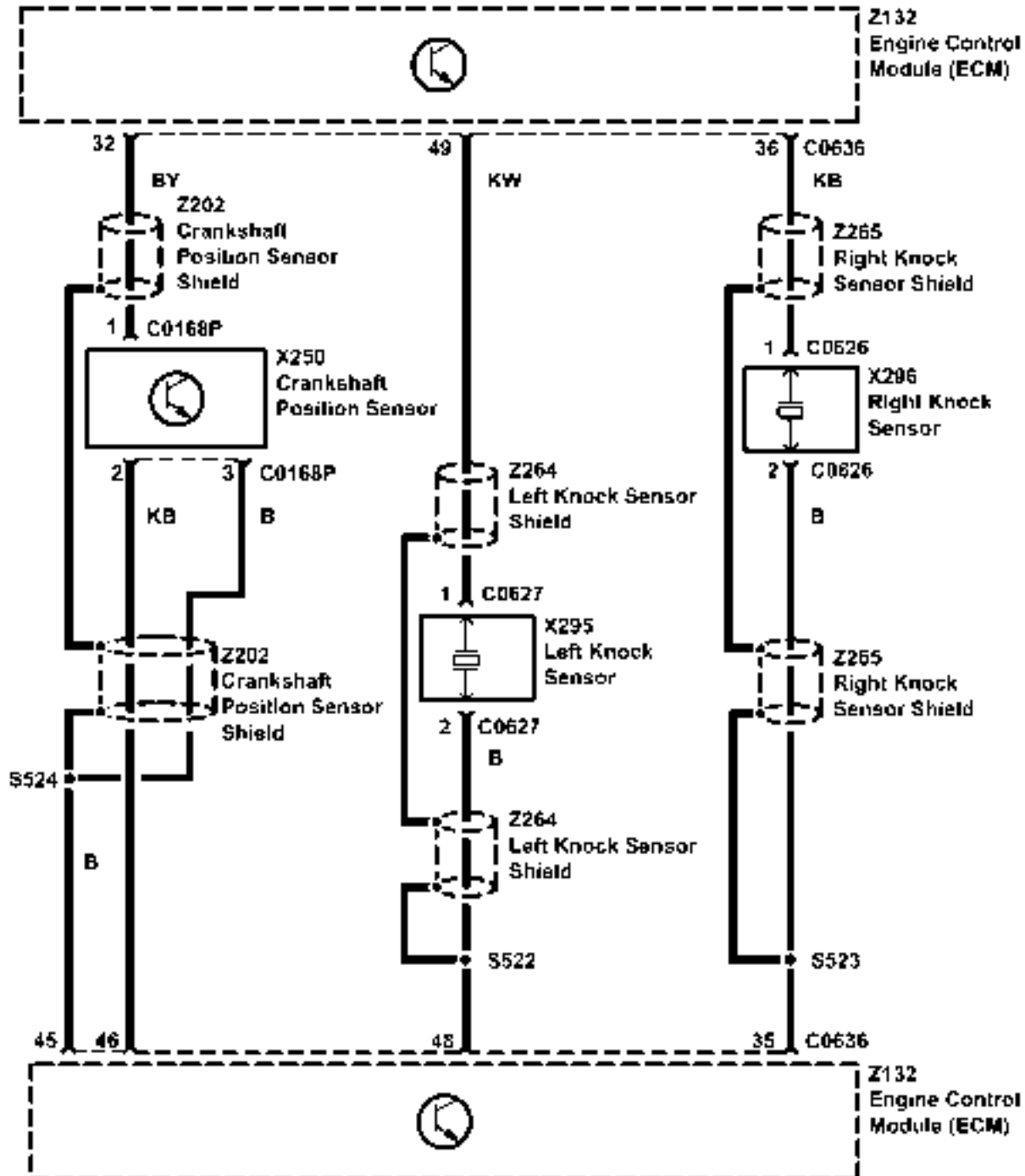

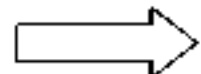
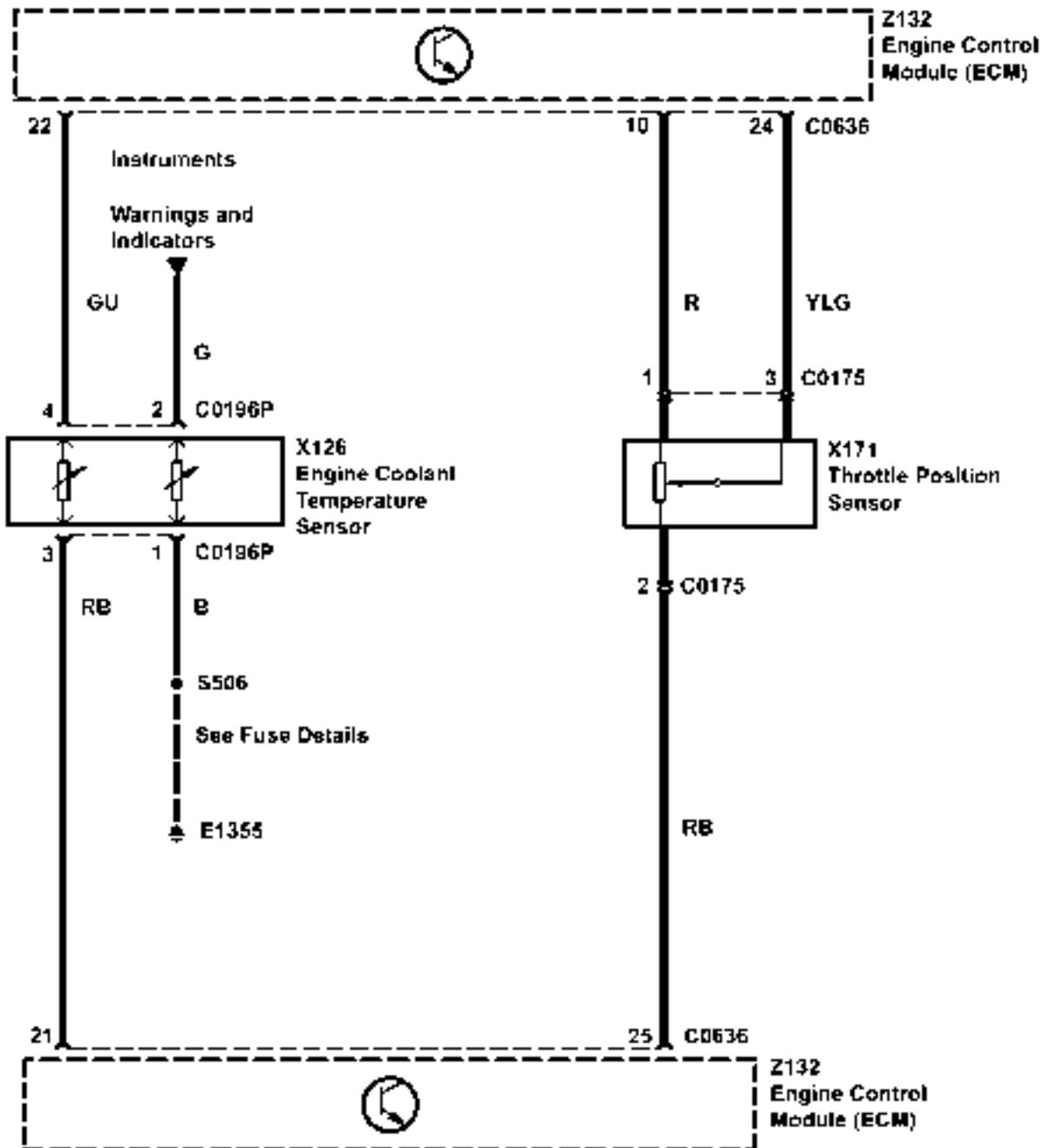

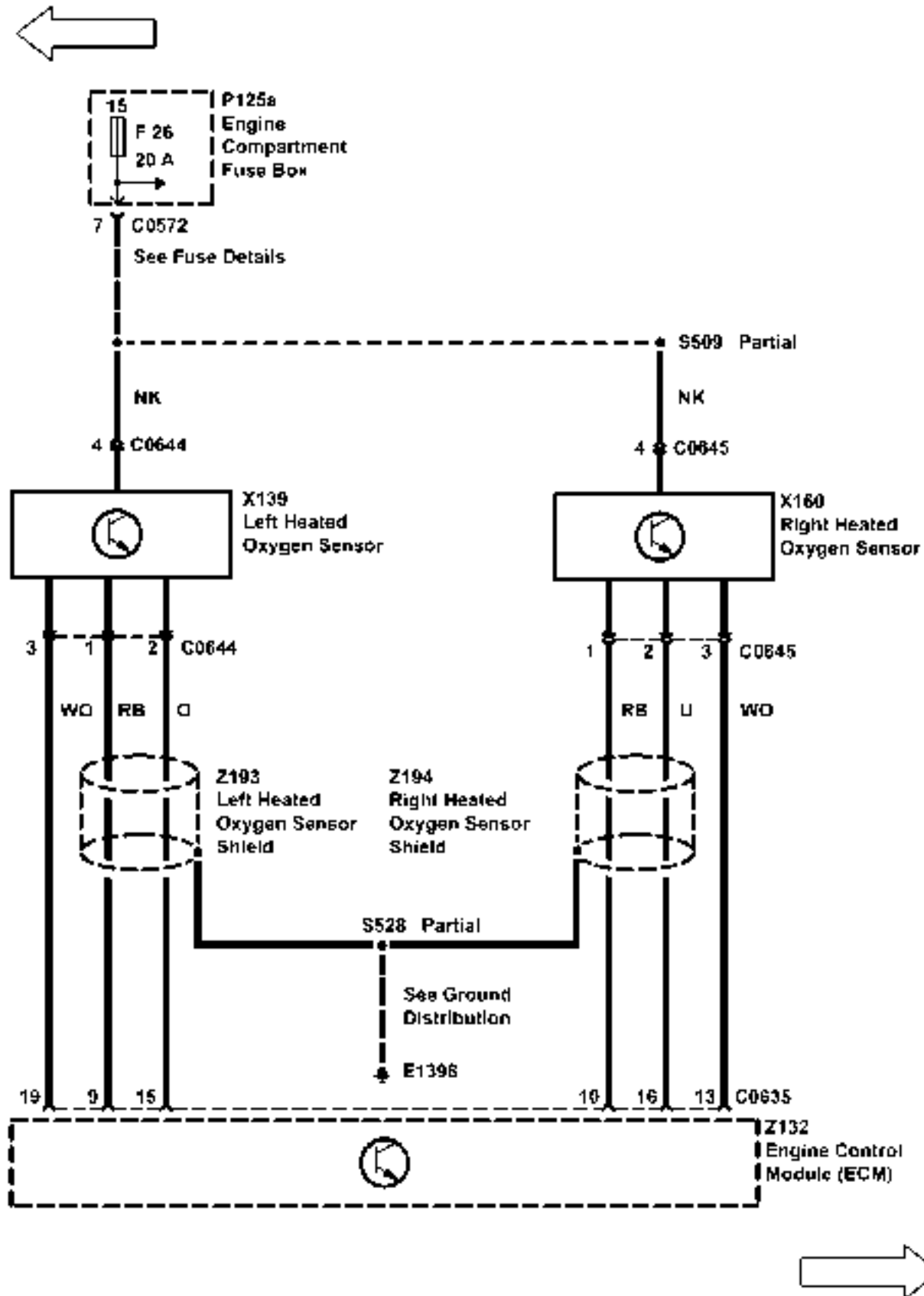

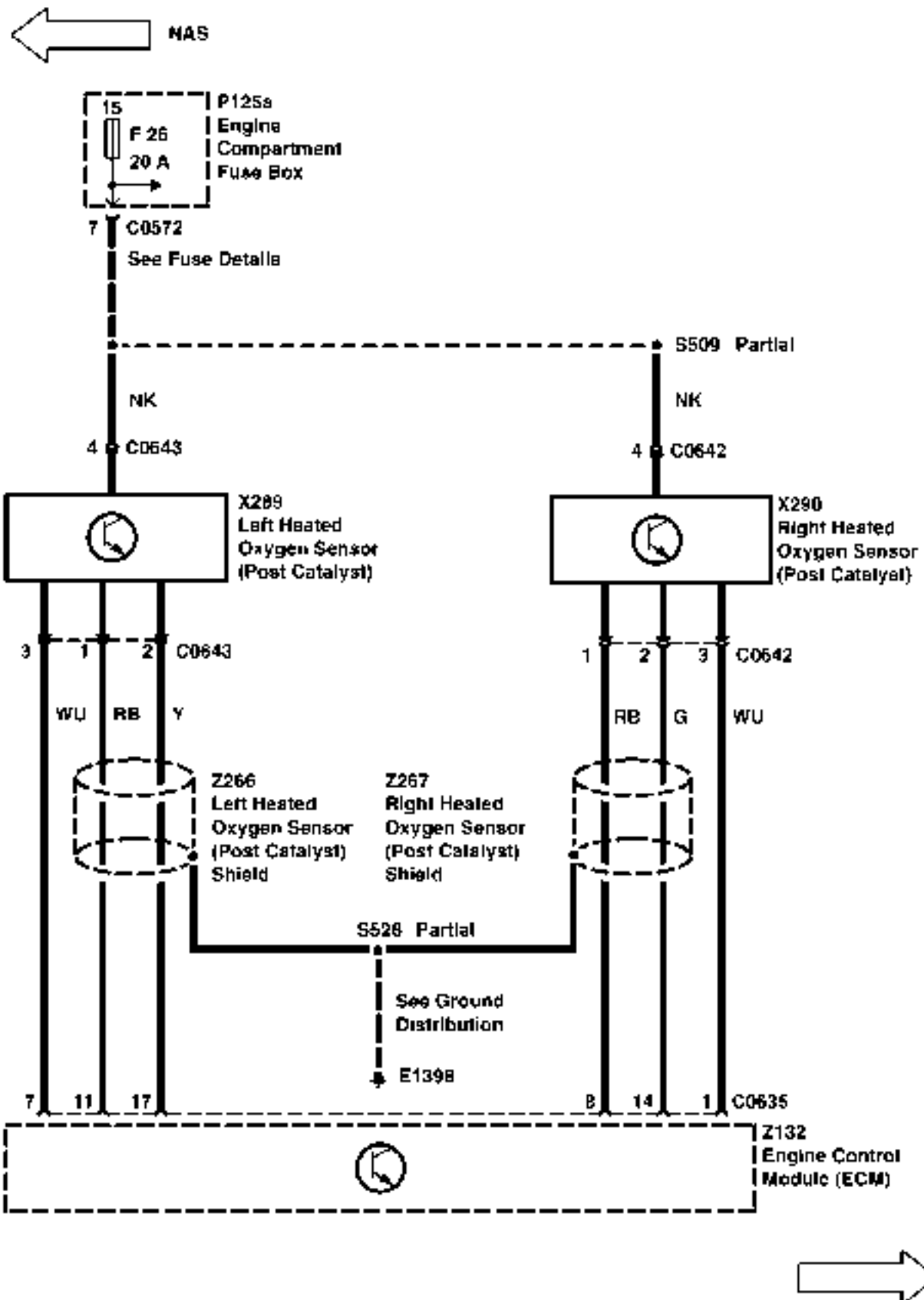

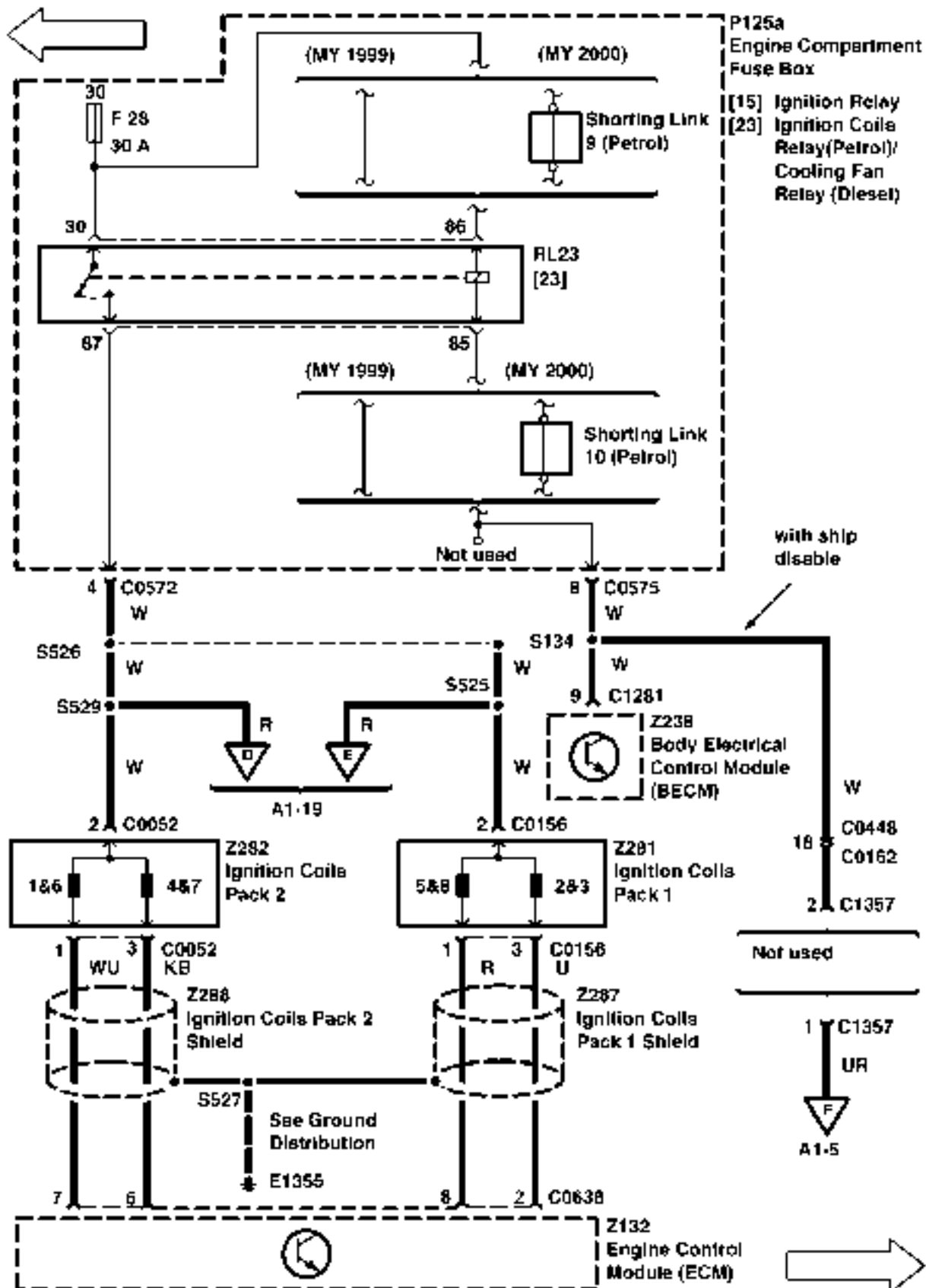

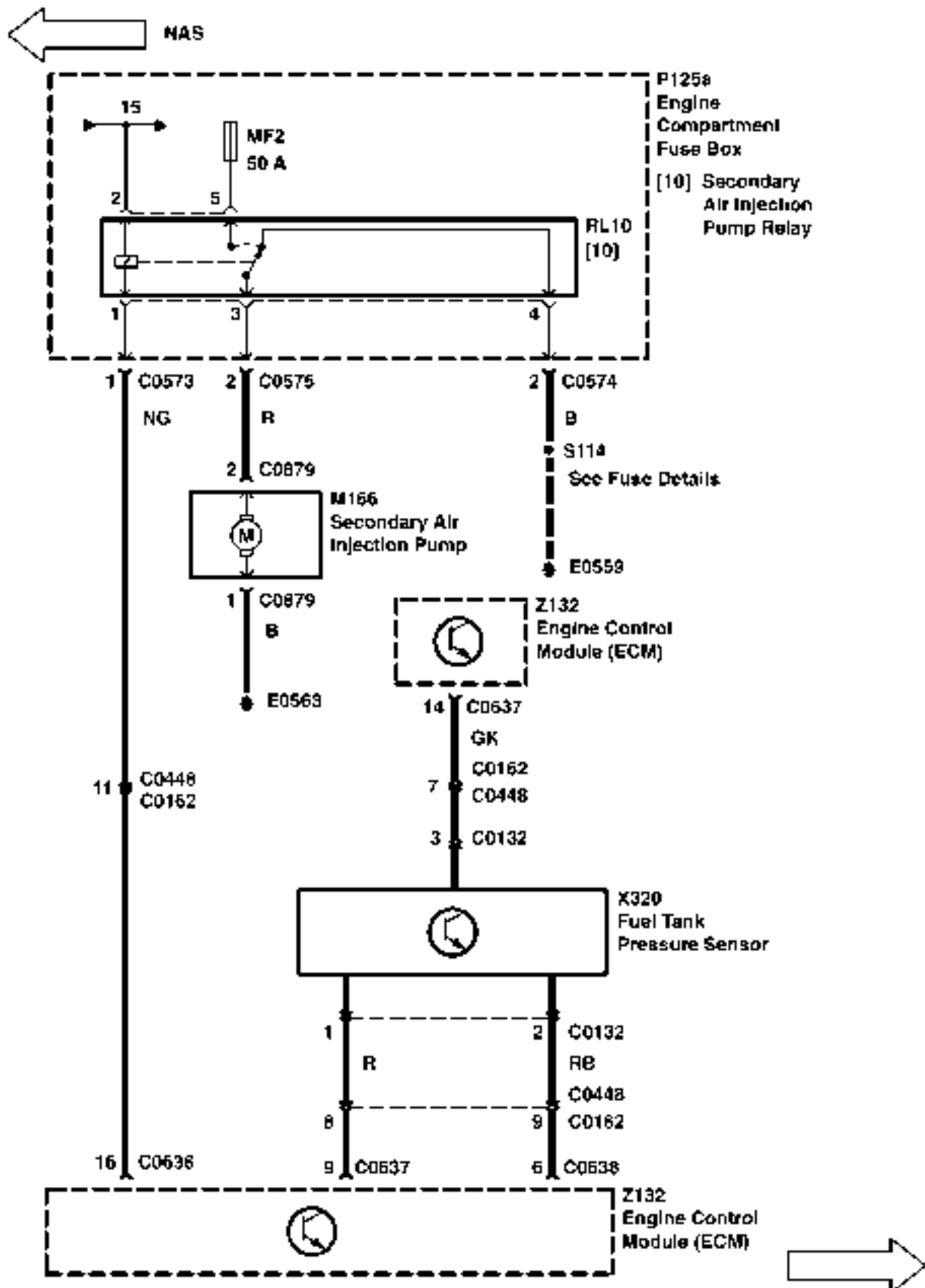

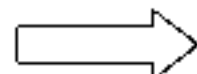
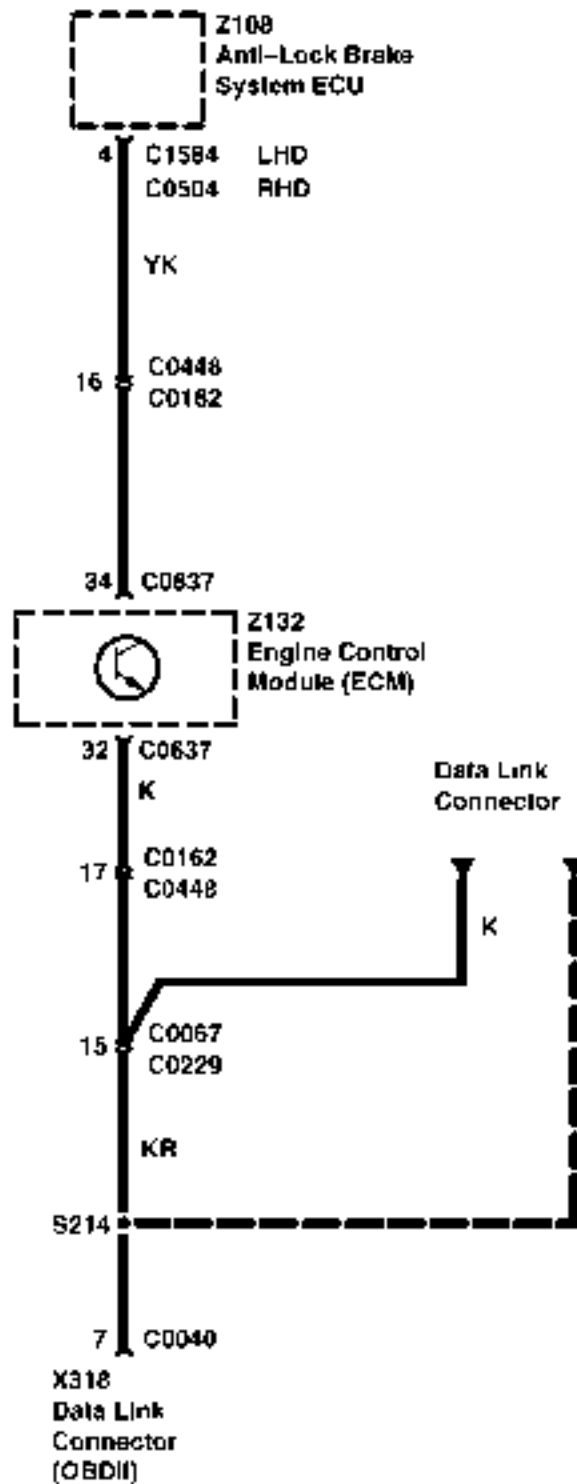
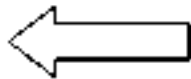

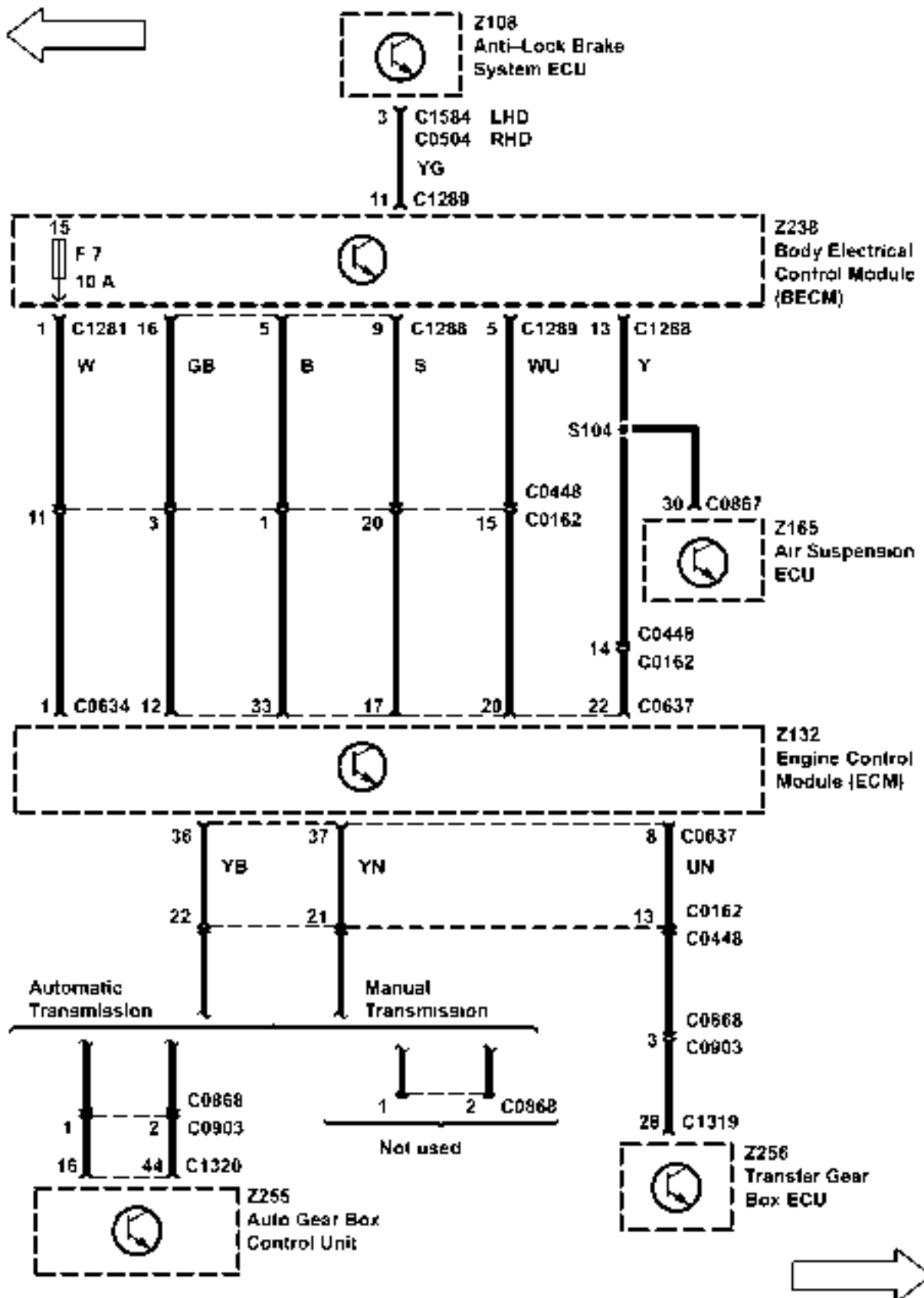

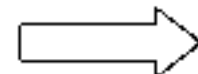
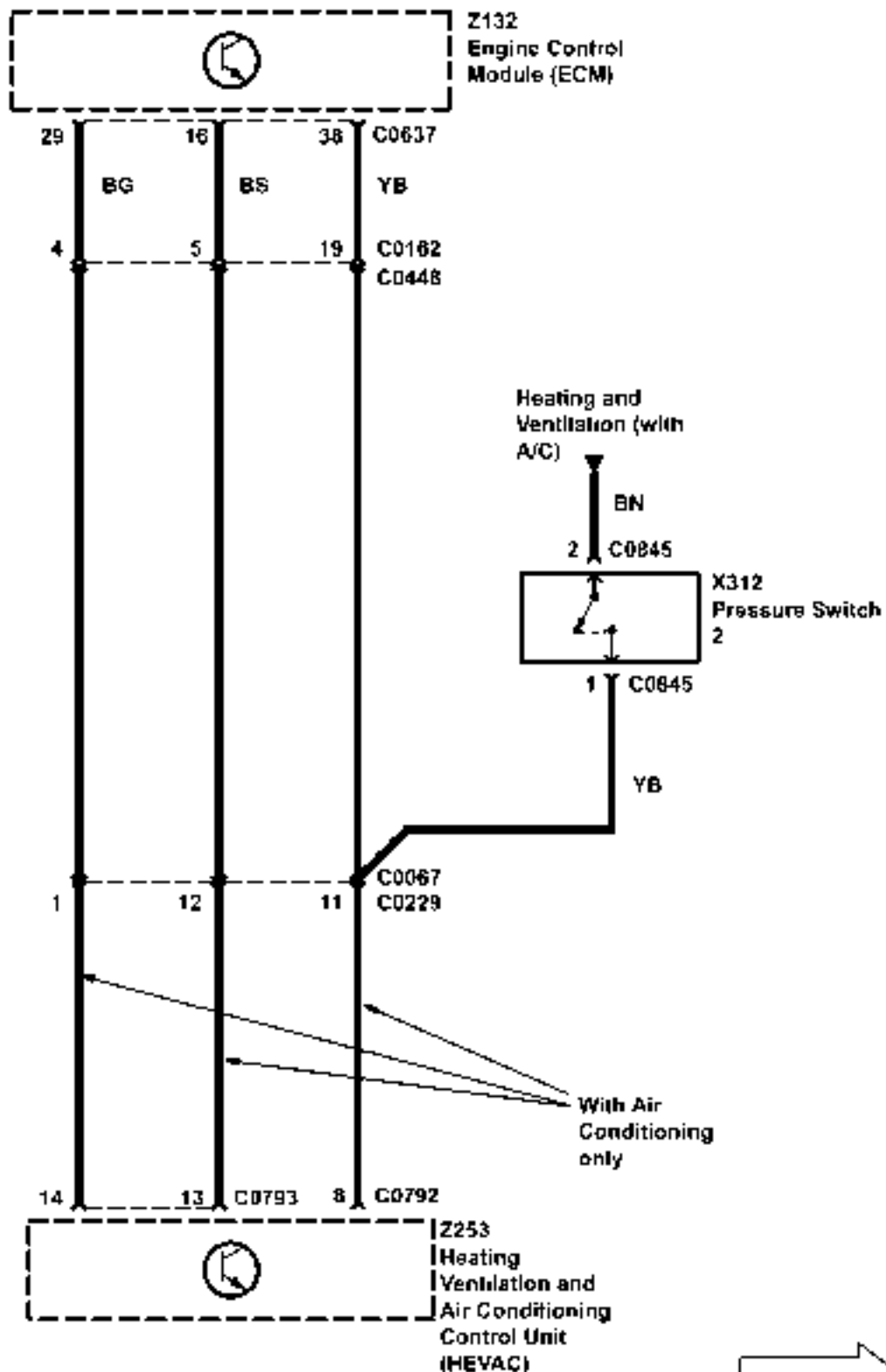

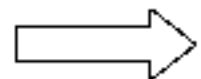
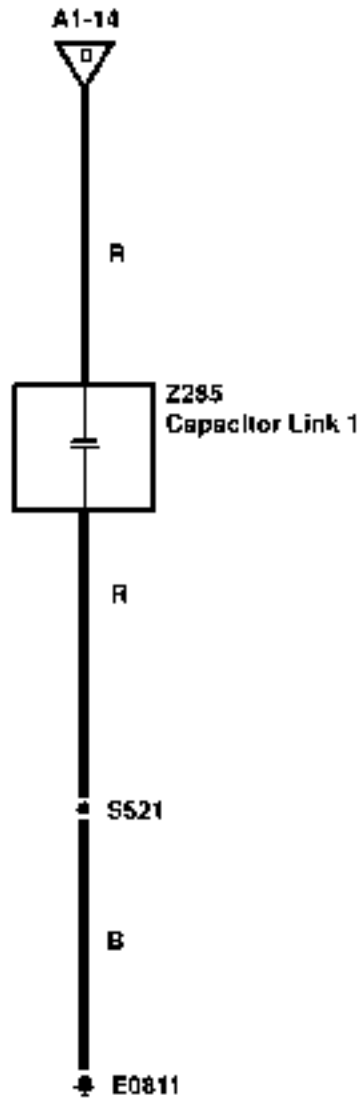
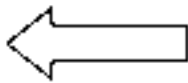

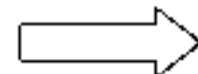
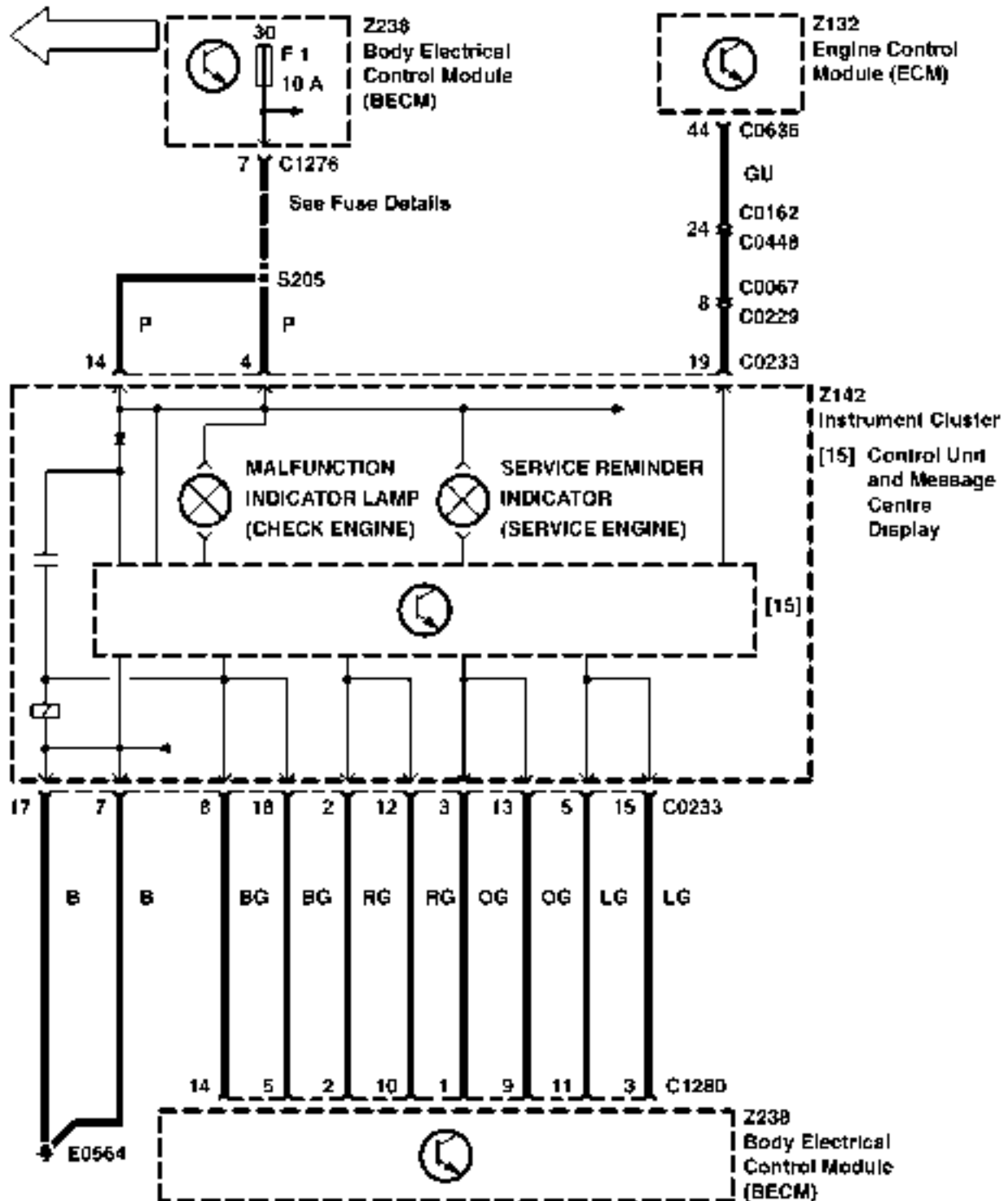

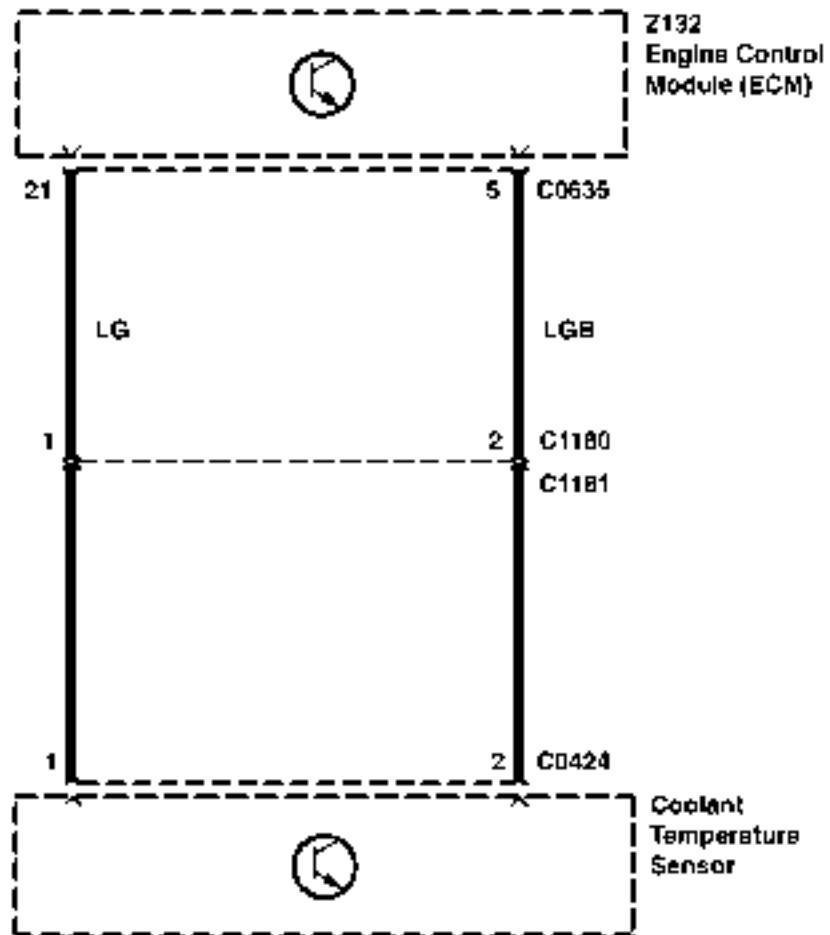
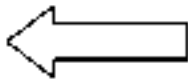

CIRCUIT DIAGRAMS

- Circuit diagrams are arranged so that current flow is from the top of the diagram (current source) to the bottom of the diagram (ground).
- Only those components that work together in the circuit are shown. If only part of a component is used in the circuit, then only that part of the component is shown.
- Remember:



TERMINAL NUMBER	DESIGNATION
50	Battery voltage: Ignition Switch in position III
30	Battery voltage: supplied constantly
15	Battery voltage: Ignition Switch in position II or III
R	Battery voltage: Ignition Switch in positions I, II
31	Ground

See Introduction (I) for additional circuit diagram symbols.

DIAGNOSIS

- If the diagram is accompanied by text:
 - Read the Circuit Operation before proceeding with the electrical diagnosis.
 - Read the Troubleshooting Hints before performing the System Diagnosis.
 - Tests follow the System Diagnosis
 - When performing the System Diagnosis, be certain that all components disconnected in previous steps are reconnected unless otherwise directed.

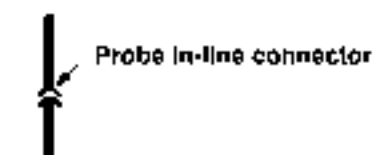
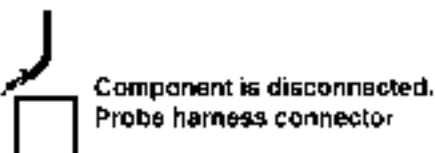
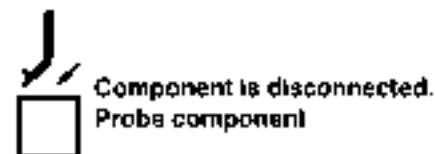
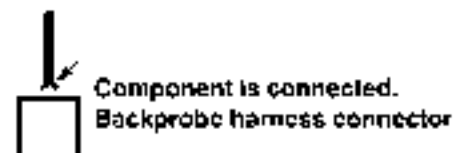
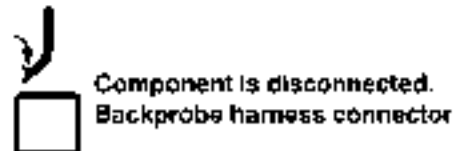

CIRCUIT OPERATION

Sensors

Engine Speed Sensor (X255)

The engine speed signal is crucial to the system, as the information from the sensor is used in virtually all of the strategies within the 'DDC' (Digital Diesel Electronics) and its Engine Control Module (ECM) (Z132). Through this sensor, the ECM (Z132) knows if the engine is turning, how fast it is turning and approximately where the engine is in its cycle. The sensor is of the 'Hall effect' type, which sends out a pulse to the ECM (Z132) every time a 'tooth' is sensed on the flywheel (the flywheel has six 'teeth'). If the sensor fails, then the warning lamp is activated and the ECM (Z132) enters a 'limp home' mode where the ECM (Z132) looks at the signal from the needle lift sensor in one of the injectors. The needle lift sensor gives one pulse per injection, i.e. one pulse per twelve engine speed sensor pulses. The response of the ECM (Z132) to changes in engine parameters will therefore be considerably slower, and a higher idle speed is initiated to try to compensate at low engine speeds.

Needle Lift Sensor (X318)

The engine has six diesel fuel injectors, one of which has a sensing element at the tip which informs the ECM (Z132) exactly when the injector fires (the 'beginning of injection' signal). The ECM (Z132) uses this to correct the injection timing and also to back up the engine speed signal in case that sensor fails. If this sensor fails, the warning lamp will switch on and the vehicle will enter 'limp home' mode with reduced engine power/performance and lack of throttle response (as there is a lack of feedback on the injection timing).

Engine Coolant Temperature Sensor (X126)

This sensor is a 'thermistor' (a temperature dependent resistor) where the voltage output varies in proportion to coolant temperature. The ECM (Z132) uses this information in many strategies, i.e. to correct the injected fuel quantity and timing (especially during cold starts), length of glow plug timing, etc. The sensor is located in the top of the engine block. In case of a failure, the warning lamp is not activated and the ECM (Z132) selects a substitute value of 50°C for glow plug and injection timing and uses the fuel temperature to correct the fuel quantity, glow plug timing will not be correct possibly resulting in long crank times in cold weather

as well as slight fuelling effects. These symptoms may not be noticeable.

Mass Air Flow Sensor (X105)

The Mass Air Flow Sensor (X105) is a hot film sensor which has a heated surface maintained by an electrical current at a constant temperature. With cool air flowing past the sensor, the volume of air drawn into the intake manifold is measured by the electrical current required to keep the temperature of the hot film sensor constant. This data is used to calculate the injected fuel volume and the rate of Exhaust Gas Recirculation (EGR).

The intake air temperature is measured by a thermistor with a negative temperature coefficient and measures the actual temperature of the turbo booster air entering the engine. The ECM (Z132) uses this information, in conjunction with the manifold absolute pressure sensor, to determine the volume of air being drawn into the engine.

Boost Pressure Sensor

The boost pressure sensor signal is used in conjunction with the air temperature signal to calculate volume air flow into the engine. The sensor is located on the rear bulkhead, with the pressure tap just after the charge air cooler. If the sensor fails a substitute value of 400 hPa is used by the ECM (Z132), producing a reduction in power due to a fuel quantity limiting to 21 mg/stroke.

Throttle Position Sensor (X171)

The DDE system is a 'Drive by Wire' system, i.e. the throttle pedal does not directly control a throttle disc or the amount of fuel injected into the engine, but accelerator movements or 'drivers request' are sensed and the information is passed to the ECM (Z132). The ECM (Z132) calculates the maximum allowable fuel quantity from the air flow into the engine, engine speed, temperature, etc. It also includes information from strategies such as smoke limitation, active surge damping, automatic gear change, fuel reduction, etc. to calculate the final figure. When driving, if the 'drivers request' signal is smaller than the maximum allowable quantity then the requested quantity is injected. However, if the requested quantity is greater than the maximum allowable, then the latter quantity is injected rather than the driver's demand. Therefore the Throttle Position Sensor (X171) is very important to the system. It is located within the pedal, close to the pedal assembly itself. The unit consists of a potentiometer and has three outputs:

1. Throttle Position – pin 37 ECM (Z132)

The sensor outputs the pedal position to the ECM (Z132), which uses the information as described above.

2. Idle Position Switch – pin 25 ECM (Z132)

The sensor has a separate idle position switch which informs the ECM (Z132) of the pedal status in the form of a simple on/off signal. This information is used by the ECM (Z132) to implement 'idle speed control' and other strategies i.e. 'overrun fuel shut-off'.

3. Kick Down Switch.

This switch is currently not used.

Fuel Temperature Sensor

A thermistor is also located inside the injection pump. The fuel temperature sensor signal is used to adjust the quantity of injected fuel, especially during temperature extremes. The signal is also used to back up the Engine Coolant Temperature Sensor (X126). If this sensor fails, the ECM (Z132) uses a

substitute value of 60°C and only slight effects on fueling may possibly be noted.

Fuel Quantity Feedback Sensor

Located within the injection pump, this sensor sends the ECM (Z132) information regarding the actual quantity of fuel injected. Failure of the sensor or corrupted signals will illuminate the warning lamp and cause the engine to stall or not start. A second check, a plausibility check against the needle lift sensor, also takes place.

Fuel Quantity Actuator

Once again located within the injection pump, this is a moving magnet actuator, failure of which will cause the engine to stall or not start as the ECM (Z132) will activate the Fuel Shut-Off Solenoid (K111).

Injection Timing (Solenoid Valve Injection Timing Device (K229))

This is another actuator within the injection pump. The ECM (Z132) receives a signal from the needle lift sensor and attempts to correct the injection timing accordingly. If a change does not occur, then the ECM (Z132) assumes a fault exists, activates the warning lamp and reduces the quantity of injected fuel.

Fuel Shut-Off Solenoid (K111)

The Fuel Shut-Off Solenoid (K111) shuts the engine down if the ECM (Z132) detects a major fault. Failure of the valve itself does not activate the warning lamp, although if a short circuit occurs, the engine will shut down.

Cruise Control

Due to the DDE system being drive by wire, a cruise control feature is supplied in the ECM (Z132) itself. Activation is via the steering wheel switches to a converter box and on a single line to the ECM (Z132). Failure of the signal results in cruise control not working.

Brake Switches

The ECM (Z132) has two brake inputs, each of opposite polarity. Comparison of the polarity states provides the ECM (Z132) with a brake sense (i.e. if switch 1 high and switch 2 low going to switch 1 low and switch 2 high) and so cancels cruise control. If both switches are the same polarity, the ECM (Z132) senses a fault and does not allow cruise control.

Vehicle Speed Signal

The ECM (Z132) takes this signal from the Anti-Lock Brake System ECU (Z108) and uses the information for cruise control and 'active surge damping'. Failure of the signal results in cruise disallowed and temporary lack of surge damping (i.e. hard acceleration will cause the vehicle to surge slightly). After 10 sec. a substitute value of 150 km/h

is used. Surging will reduce so as to be hardly noticeable.

Theft Alarm

The ECM (Z132) has a simple on/off input regarding the theft alarm. The ECM (Z132) will not allow the engine to start once activated and will kill the engine if activated up to 300 RPM (programmable). Over 300 RPM, the engine is unaffected.

Relays

The DDE engine management system on the diesel vehicles uses four relays.

ECM (Z132) power supply (main relay, glow plug relay, starter motor relay and fuel pump relay). Two are located in the fuse box and two in the ECM (Z132) box behind the battery.

Main Relay

Located in the ECM (Z132) box, this relay supplies the power feed to the ECM (Z132). It is controlled via the Ignition Switch (X274) in position II.

Glow Plug Relay (Z135)

The Glow Plug Relay (Z135) takes a feed directly from the battery and on initialisation via the ECM (Z132), supplies current to each of the six glow plugs (one per cylinder) to aid cold starting. The glow time is controlled via the ECM (Z132) which also monitors the relay and illuminates the glow plug indicator lamp for the duration of the glow time. This relay is relatively large and is located with the main relay next to the ECM (Z132).

Starter Motor Relay

This relay is also ignition key controlled - activated with the key in the ignition III position only. Releasing the key after cranking cuts supply to the relay and switches off the starter motor.

Fuel Pump Relay

The fuel pump relay is pulled in when the starter motor is activated, the earth path provided by the alternator output. When the engine is running, the starter motor is deactivated, supplying an earth path while the generator supplies a feed i.e. a polarity reversal.

ECM (Z132)

If the ECM (Z132) itself is not working, the entire engine management system will cease to operate, i.e. no fuel, tach reading, etc.

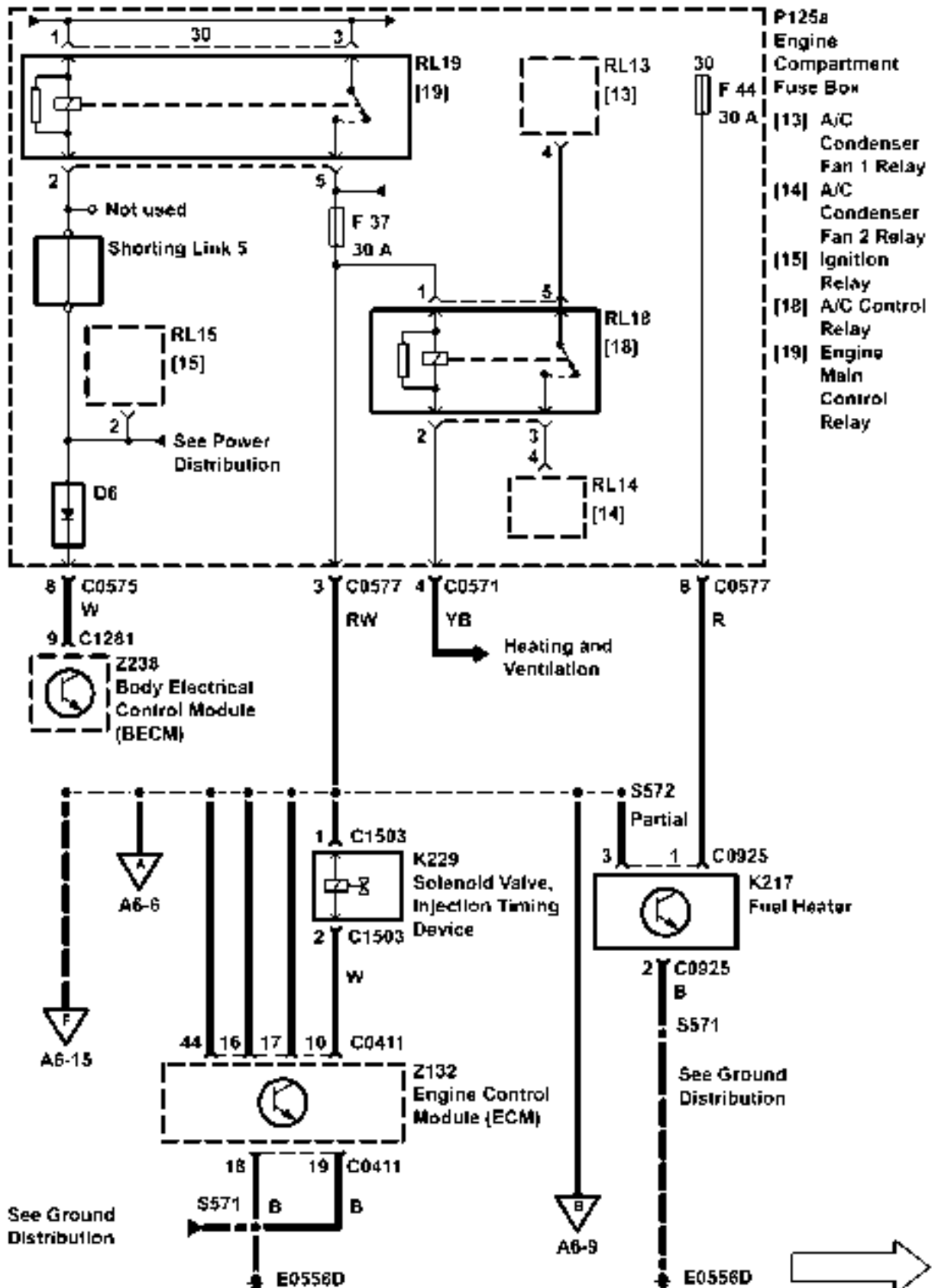

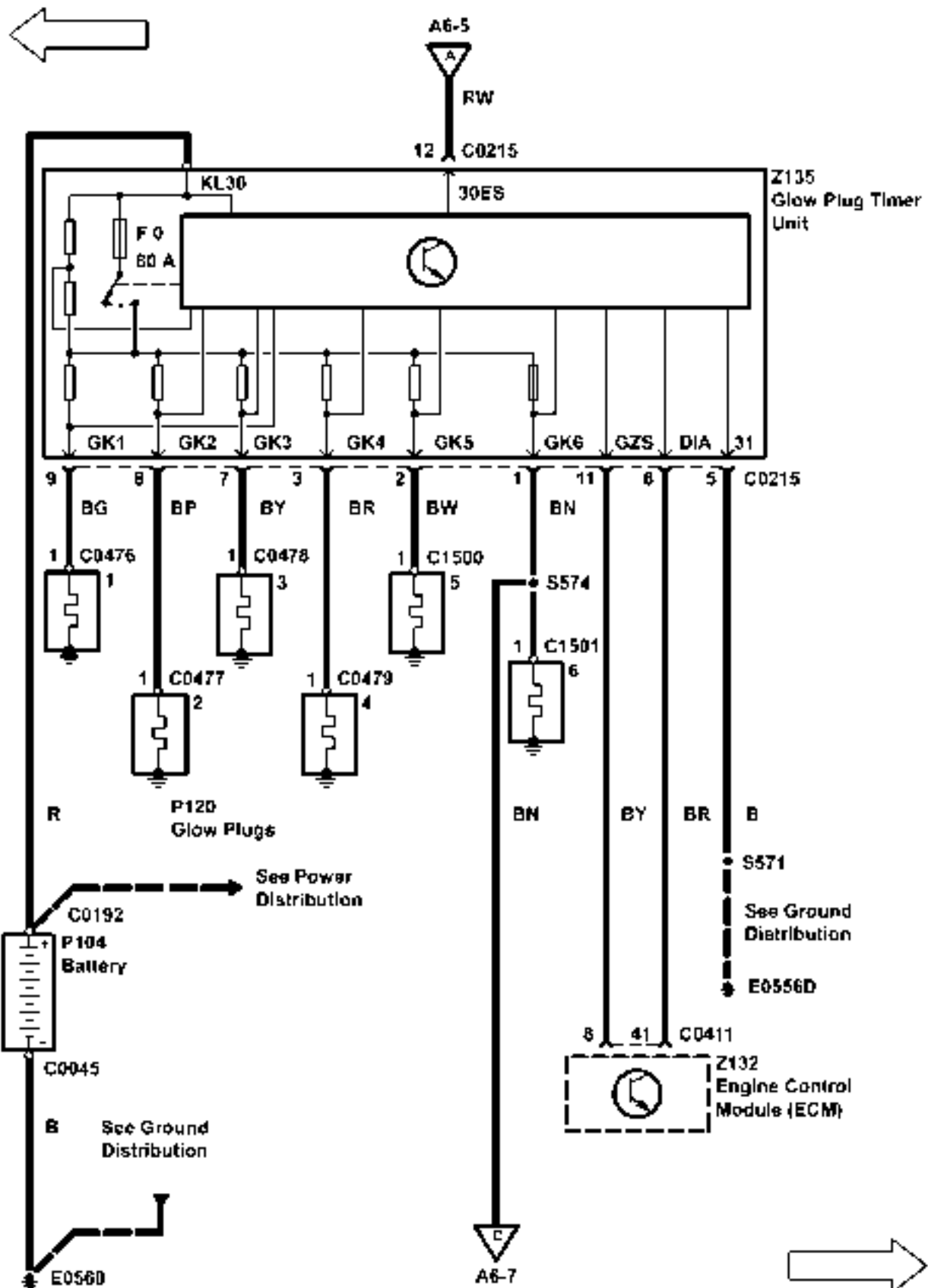

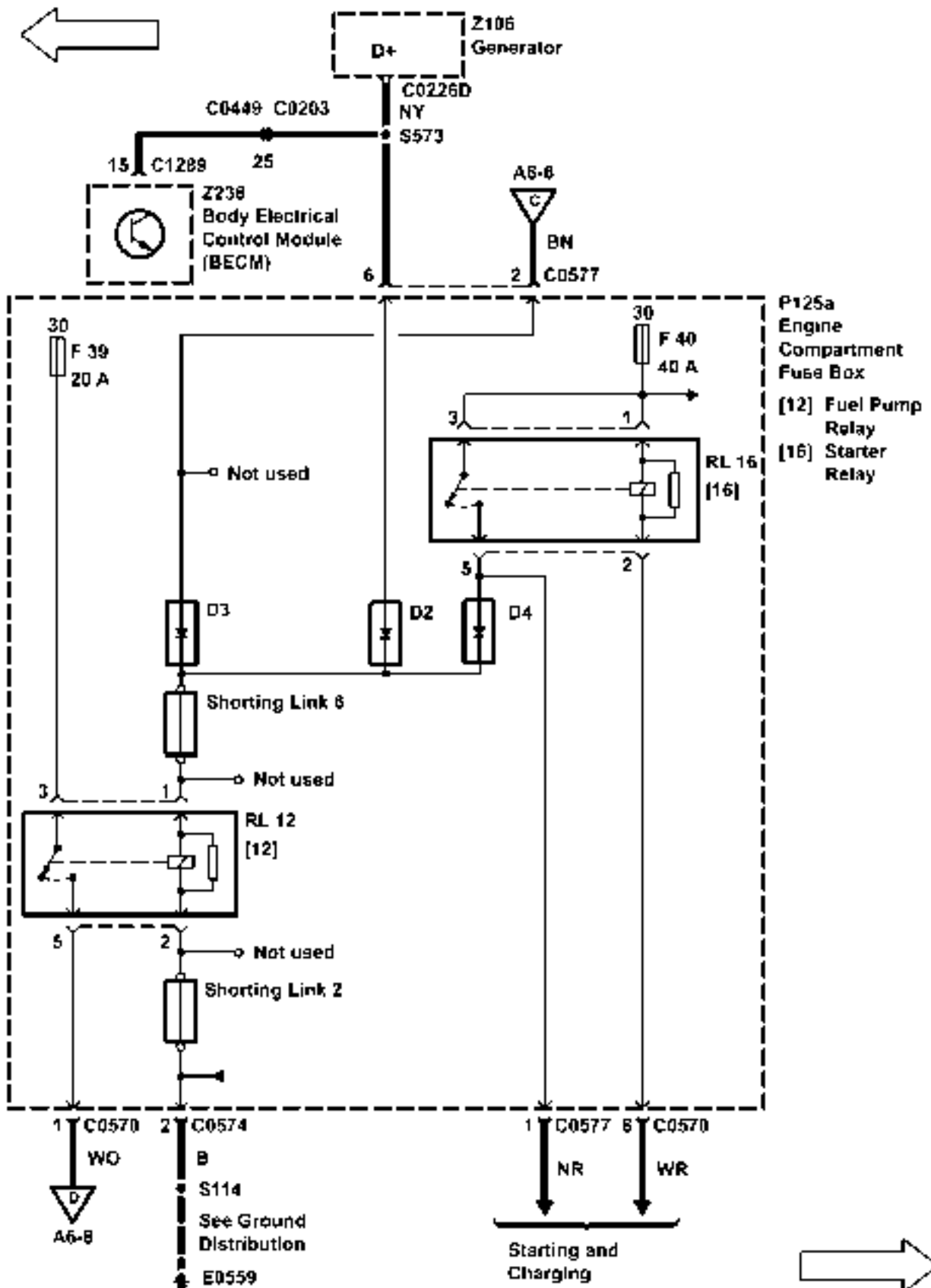

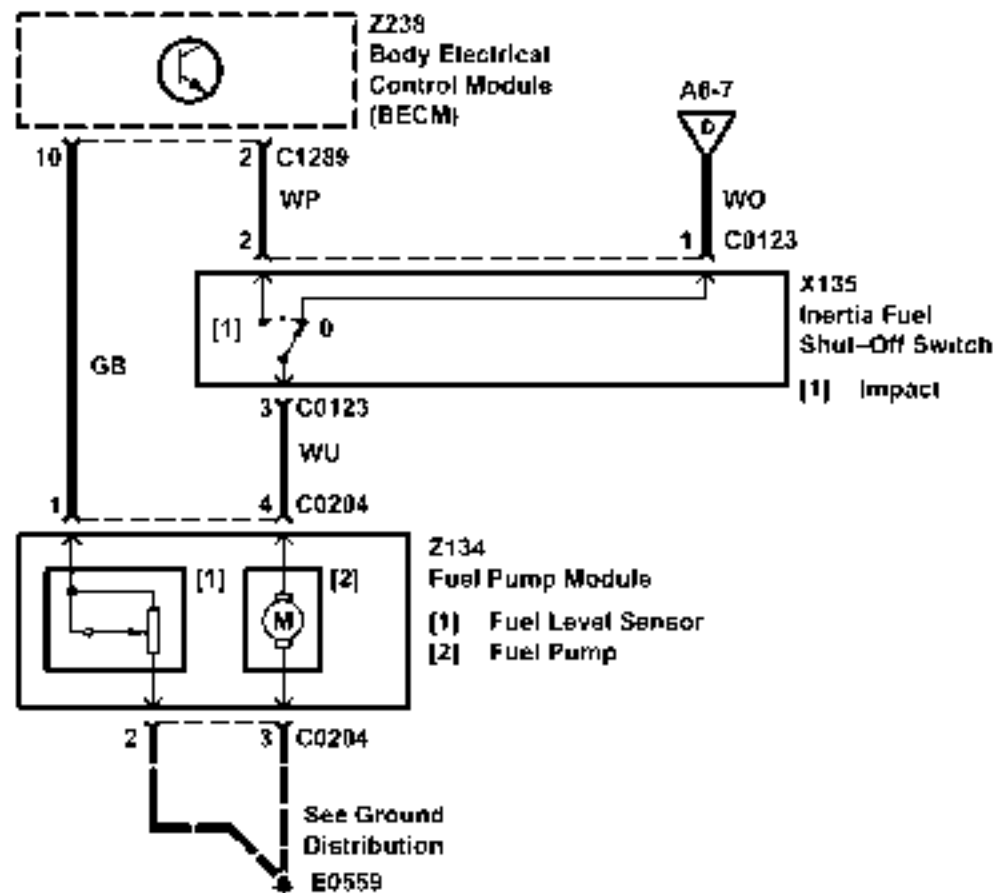
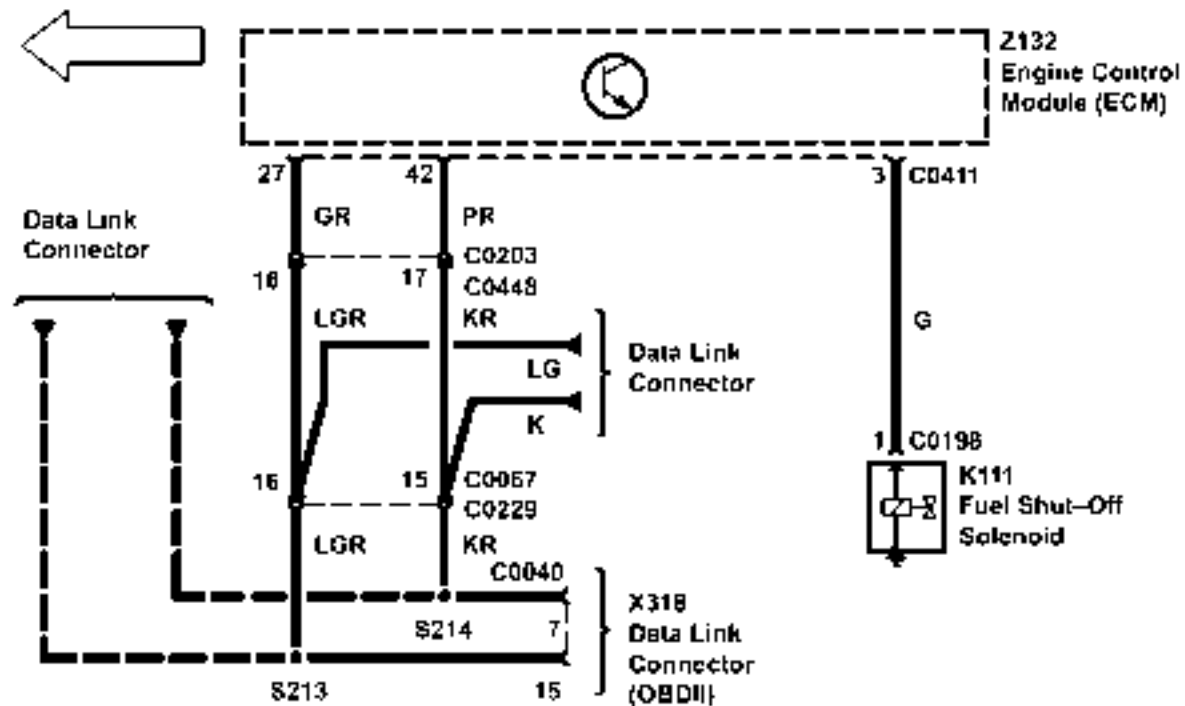

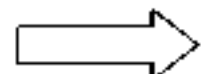
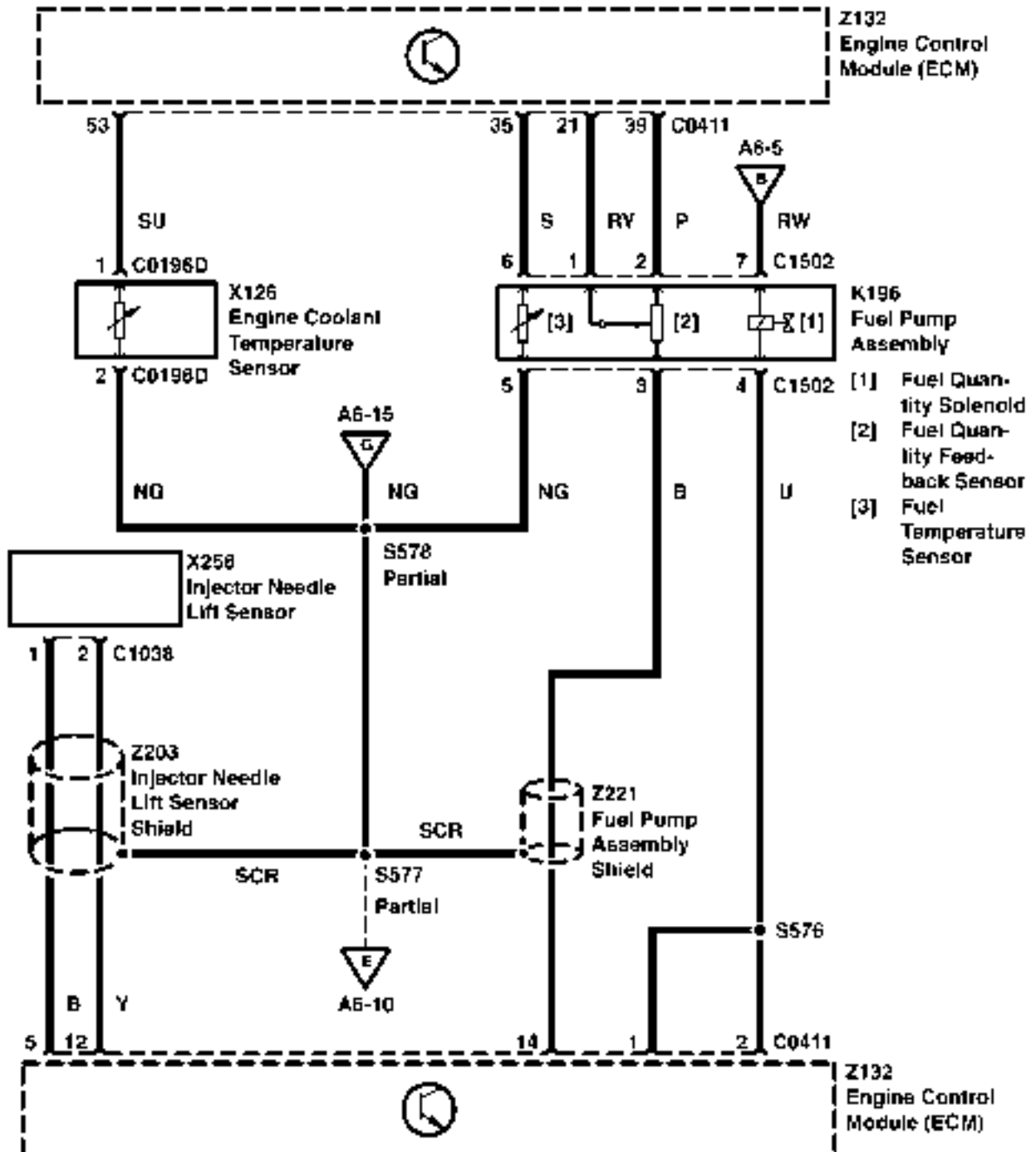
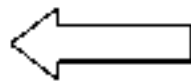

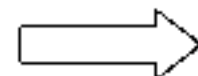
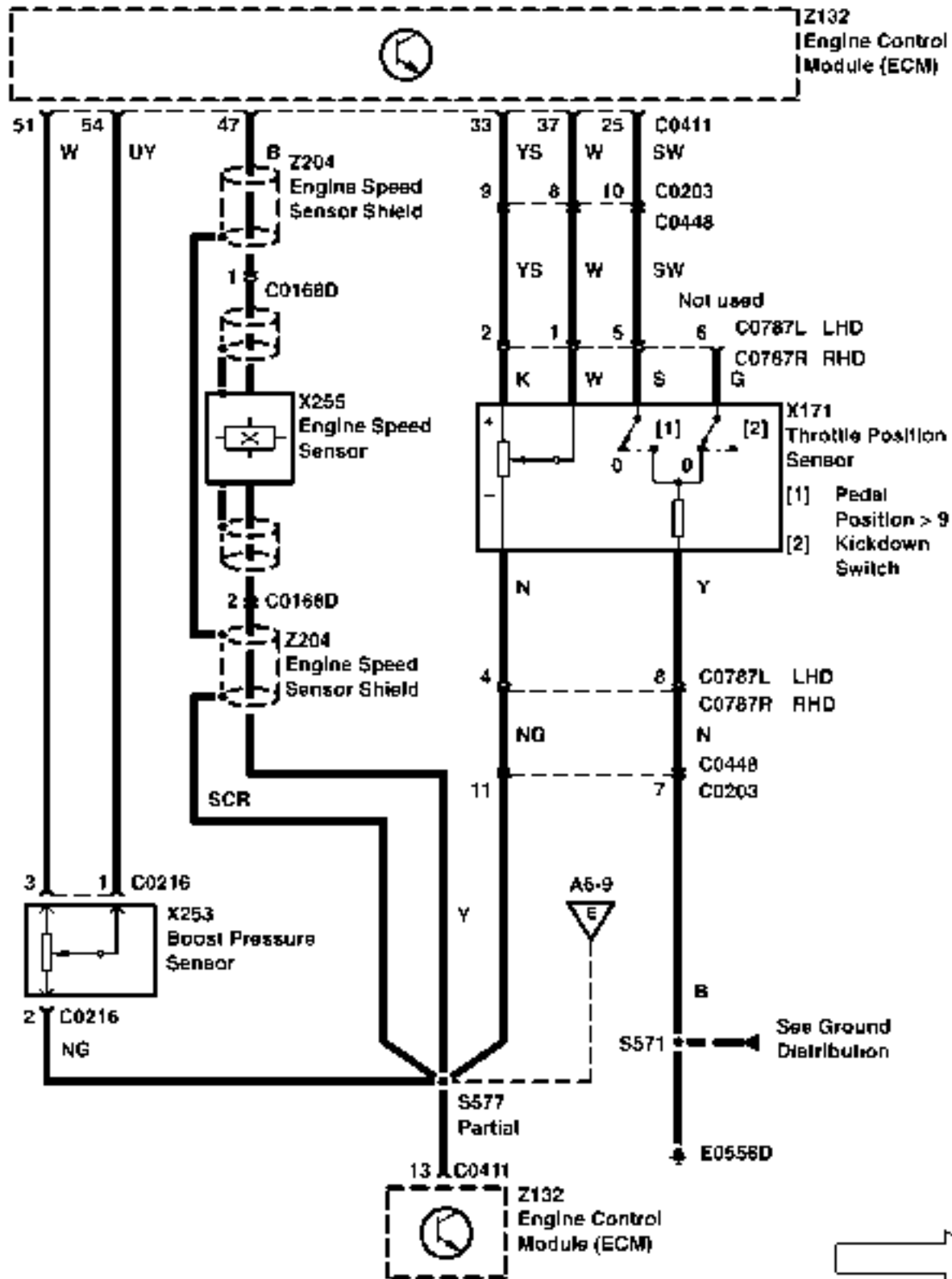
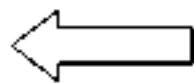

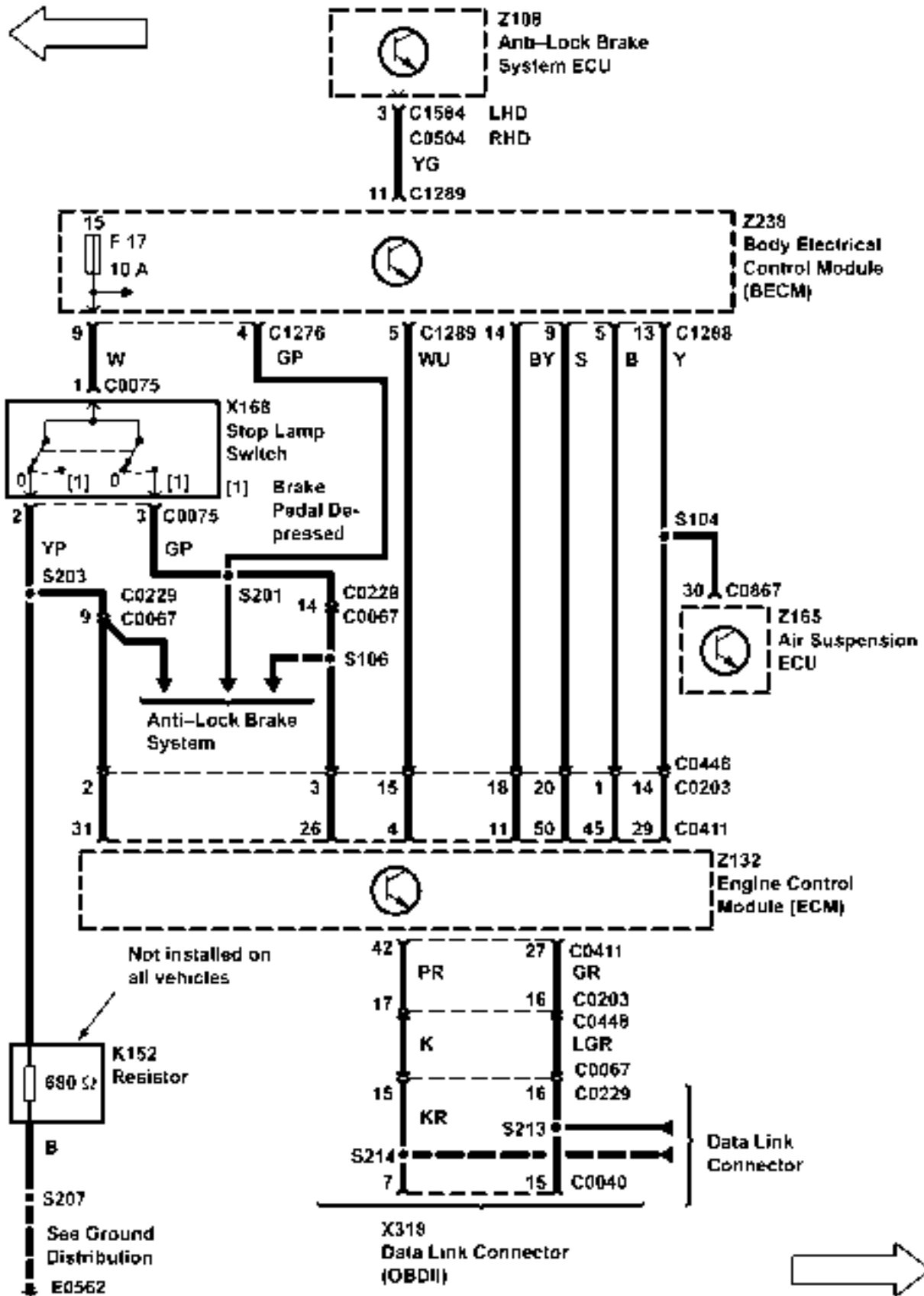

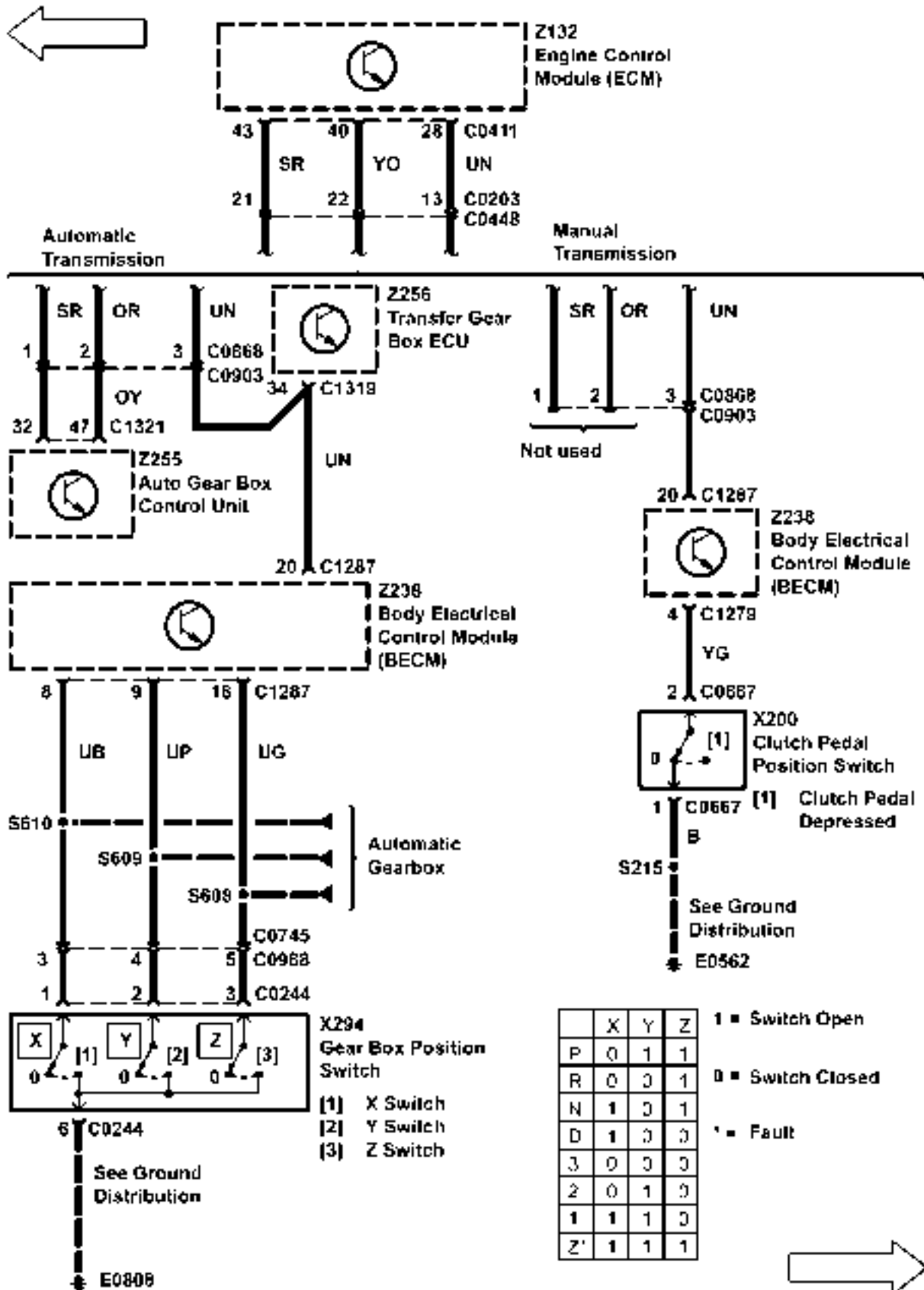

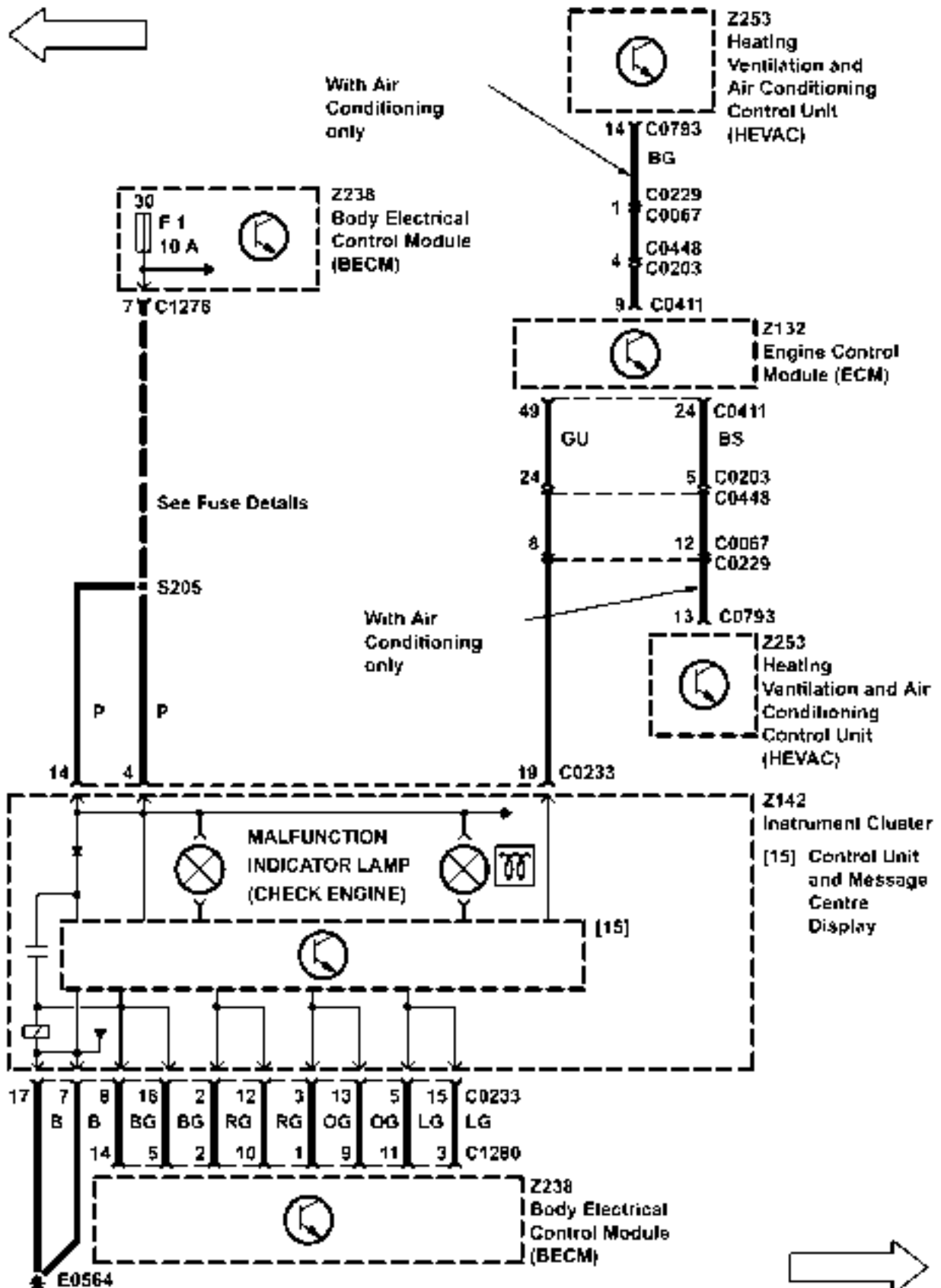

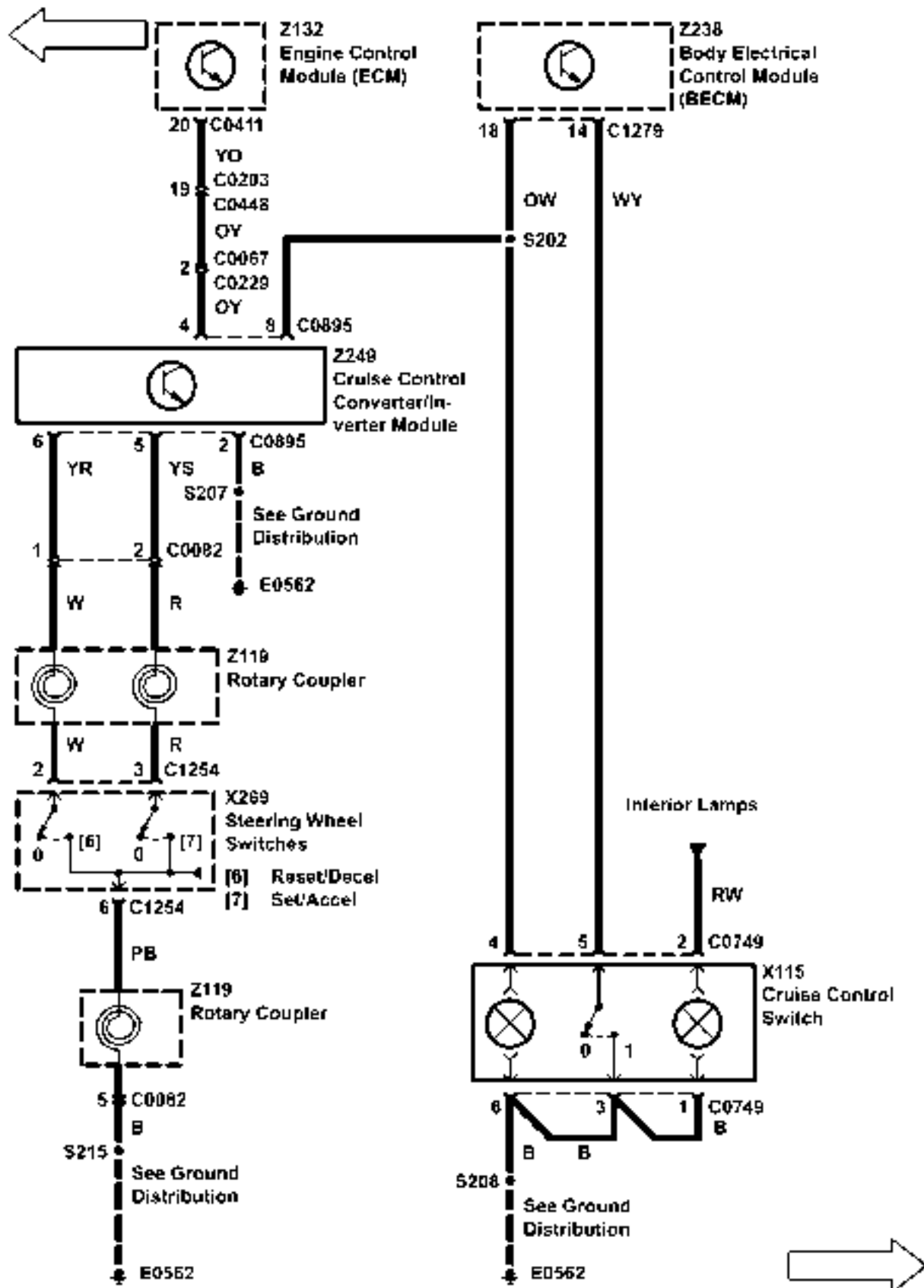

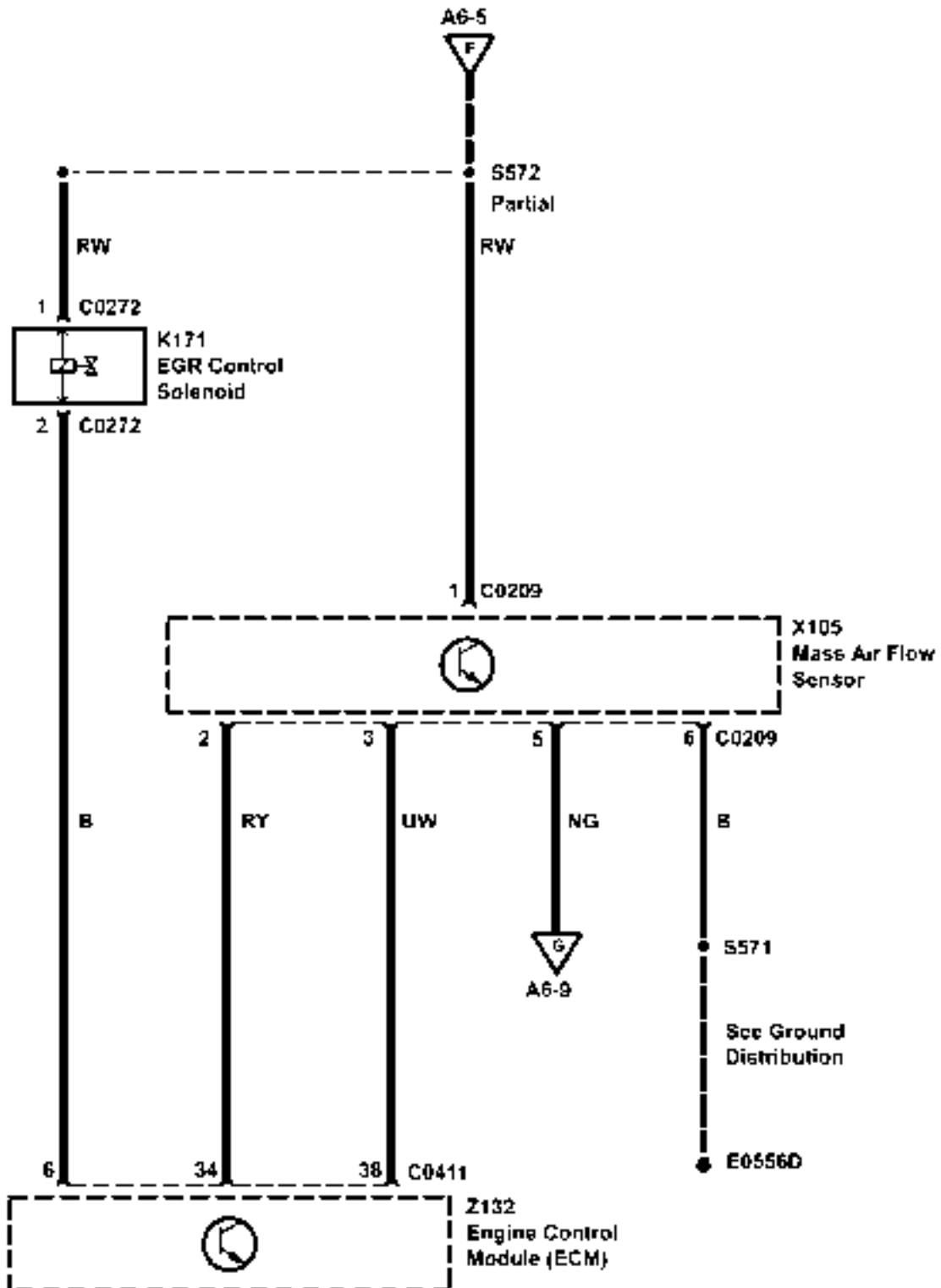
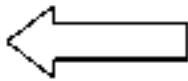

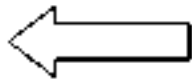

(MY 2000)

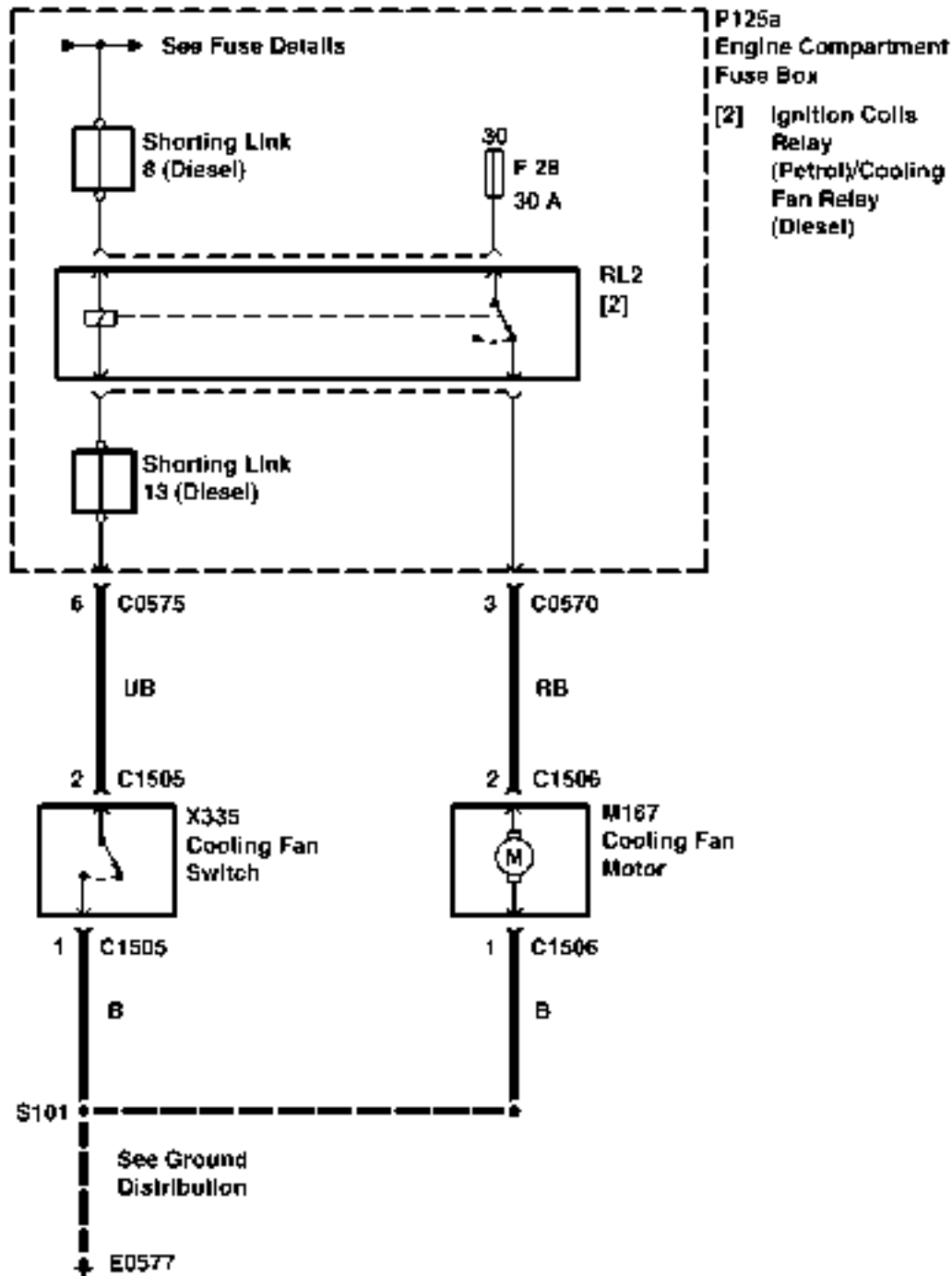

CIRCUIT OPERATION**Starting System**

When the Ignition Switch (X274) is switched to position III, the BeCM (Z238) grounds the starter solenoid relay inside the Engine Compartment Fuse Box (P125) which then energizes, applying battery voltage to the Starter Solenoid (K136) and Starter (M134).

Charging System

When the Ignition Switch (X274) is in position II, the BeCM (Z238) turns the charge warning light on via the datalink connection to the Instrument Pack (Z142).

When the Generator (Z106) starts to produce power, the BeCM (Z238) gets an input signal on Pin 15 and turns off the charge warning light.

For the Diesel engine this signal is also used as an input signal for the fuel pump relay inside the Engine Compartment Fusebox (P125) to make sure that the Fuel Pump (M103) is only supplied with power when the engine is running.

If the Generator (Z106) fails to produce power, the charge warning light remains illuminated.

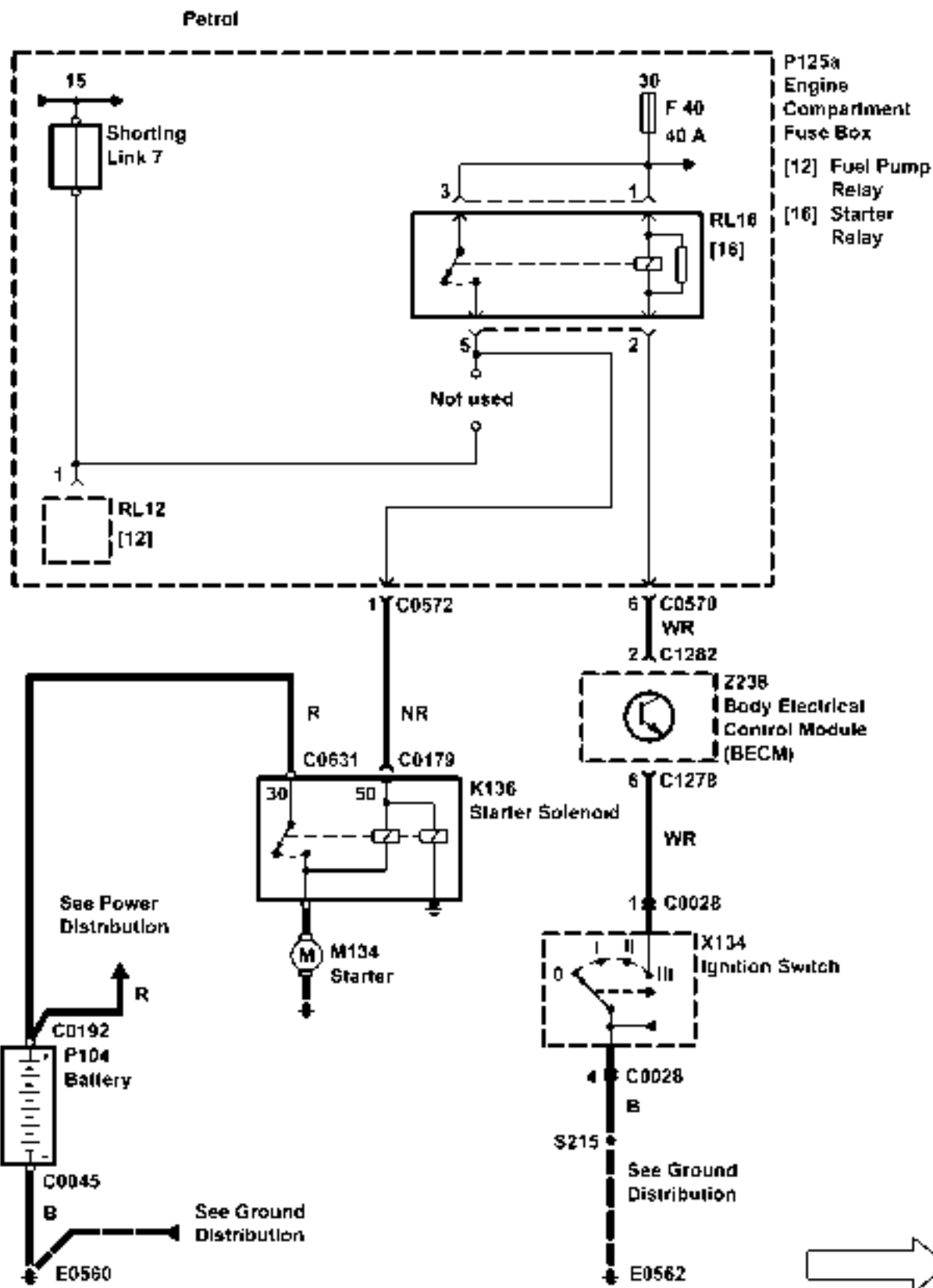

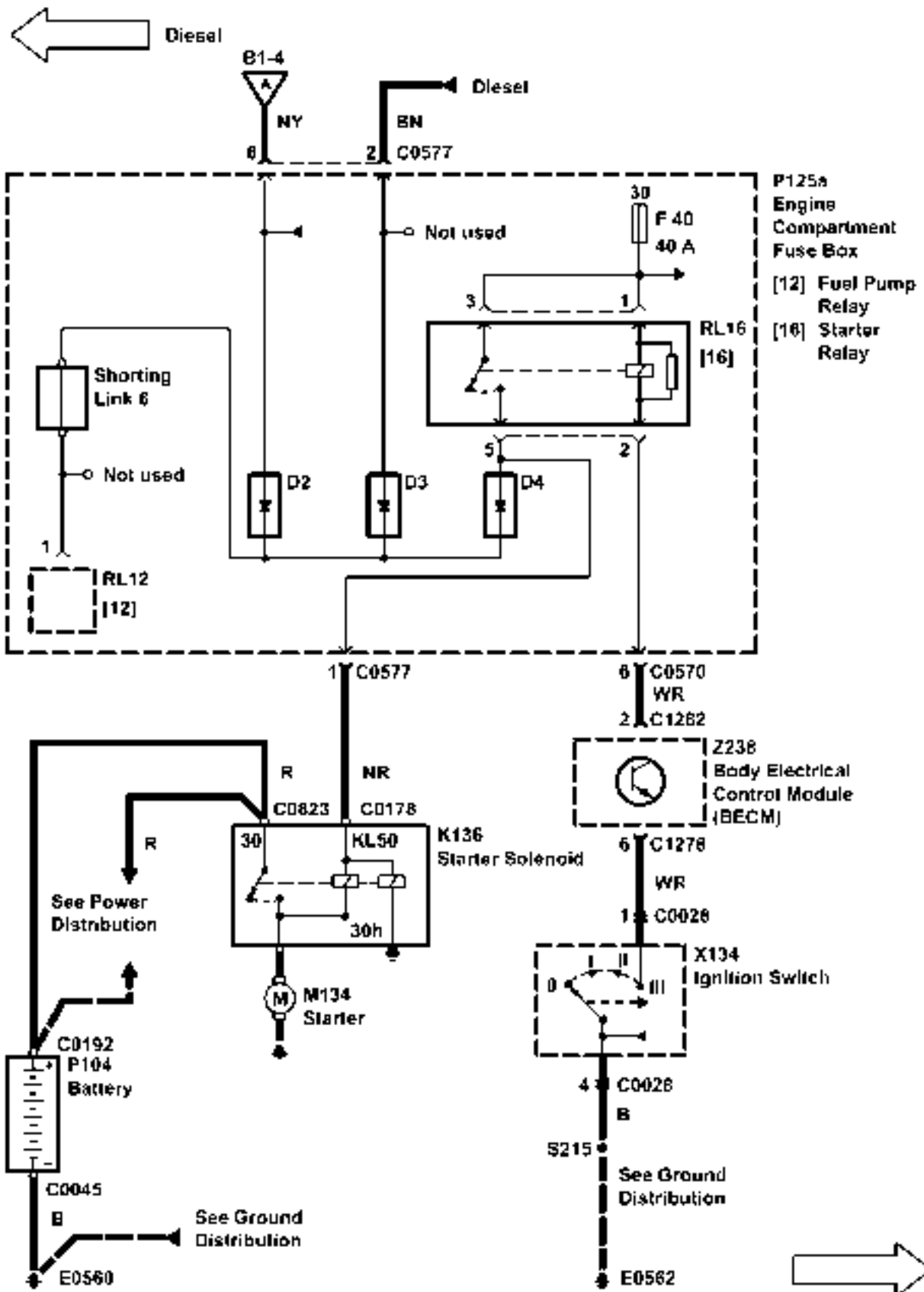

B1 STARTING AND CHARGING

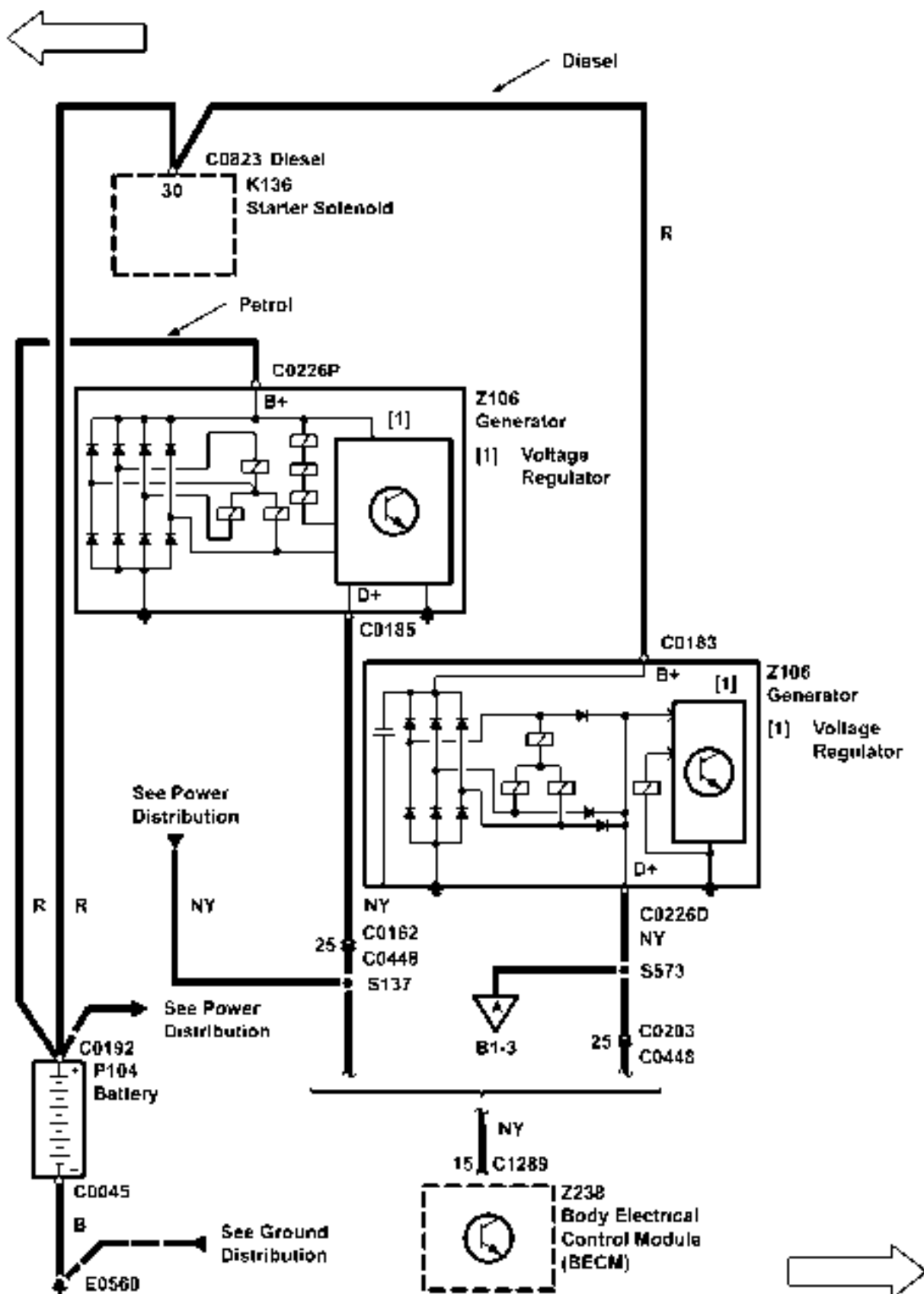

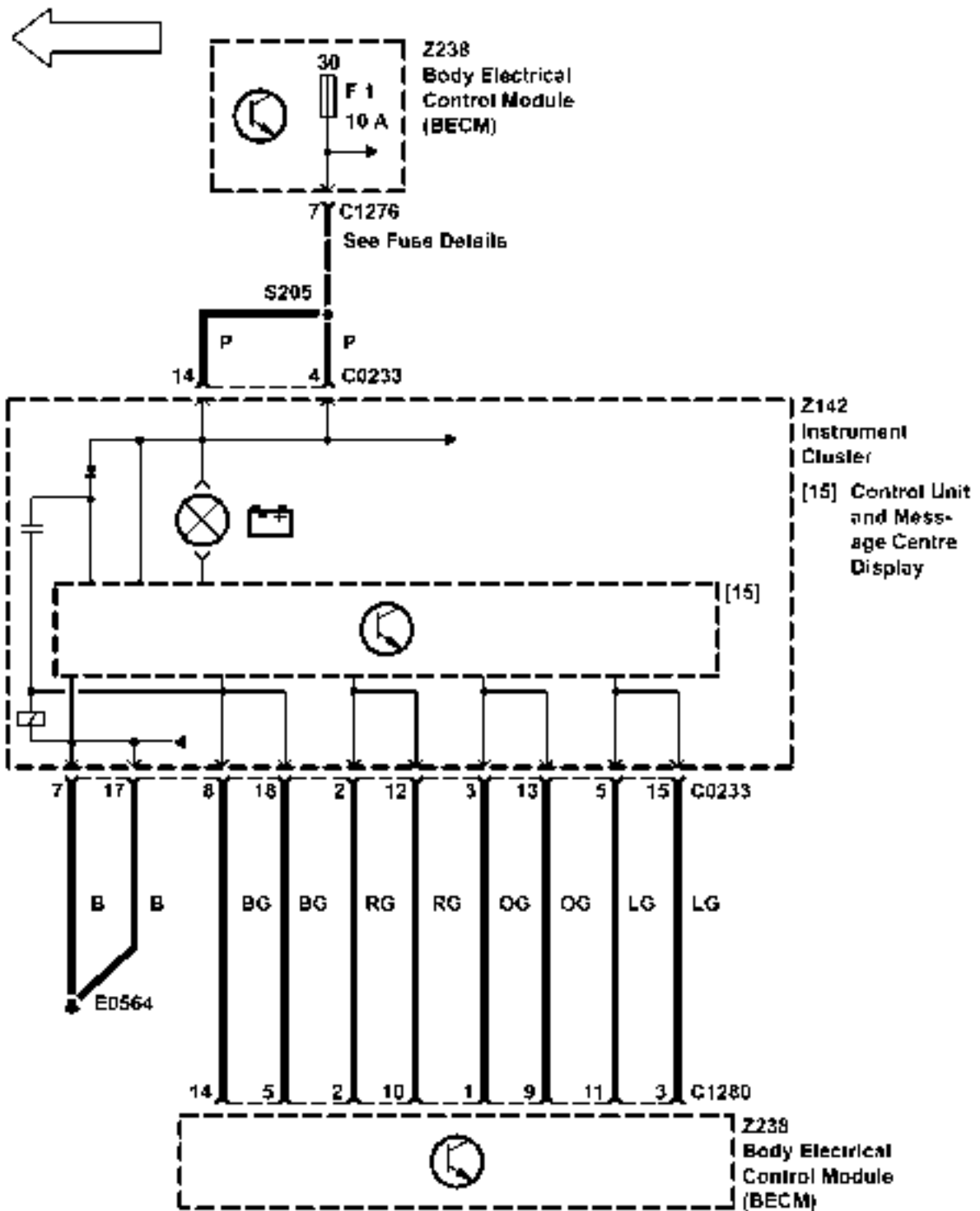

TROUBLESHOOTING HINTS

1. If the charge warning light does not light with the engine off and the Ignition Switch (X274) in position I, check the bulb. If ok, check BeCM (Z238), Instrument Pack (Z142) and the datalink between them.

SYSTEM DIAGNOSIS

2. If the Starter Solenoid (K136) does not click and the engine does not crank, do Test A.
3. If the Starter Solenoid (K136) clicks but the engine does not crank or cranks slowly, do Test B.
4. If the charge warning light stays lit with the engine running, and the Generator (Z106) is ok, do Test C.

Test A

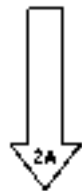
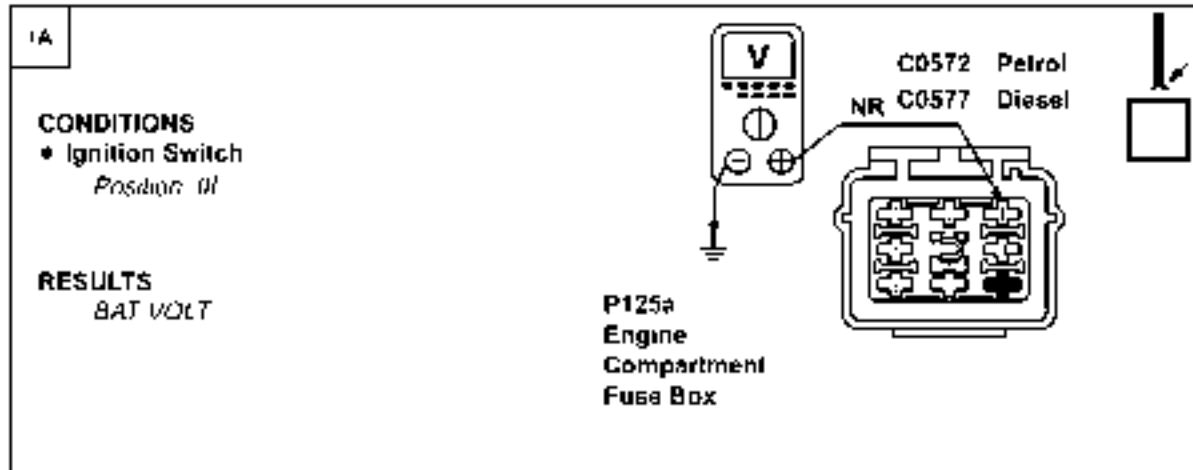

PROBLEM CAUSE

- NR Wire
- Starter Solenoid

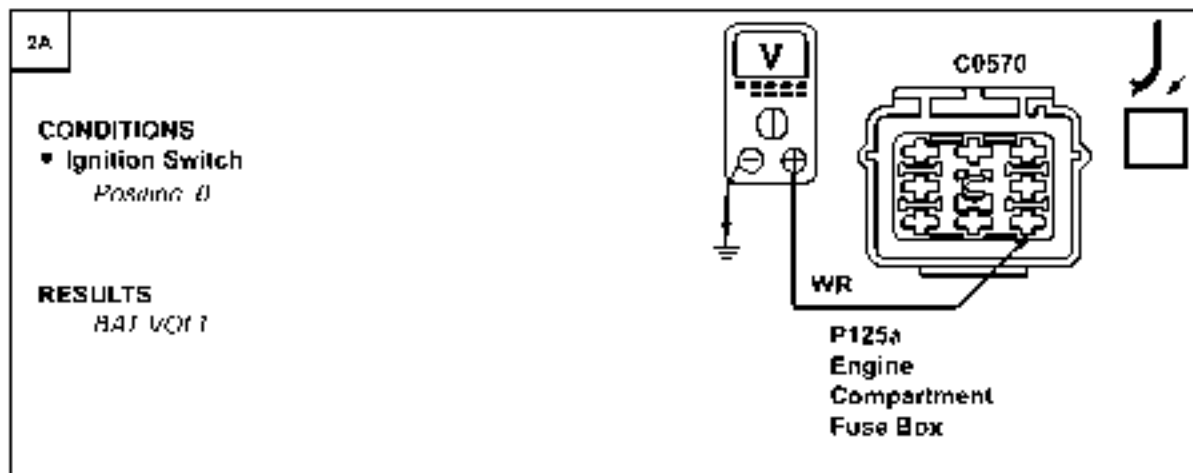

PROBLEM CAUSE

- Engine Compartment Fuse Box
- Starter Solenoid Relay



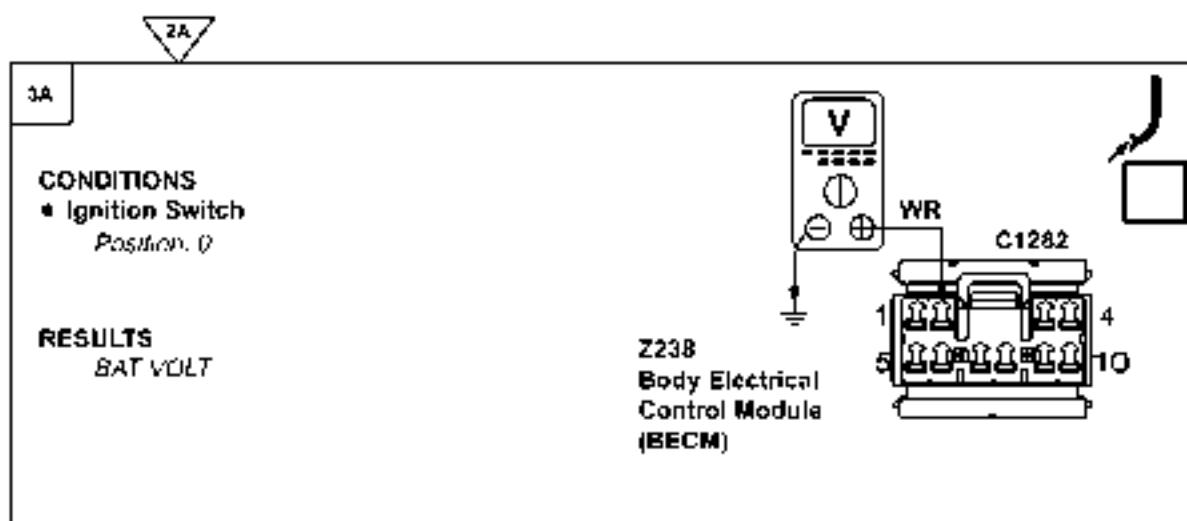

PROBLEM CAUSE

- WR Wire



PROBLEM CAUSE

- Body Electrical Control Module (BECM)
- Ignition Switch
- WR Wire
- B Wire

Test B

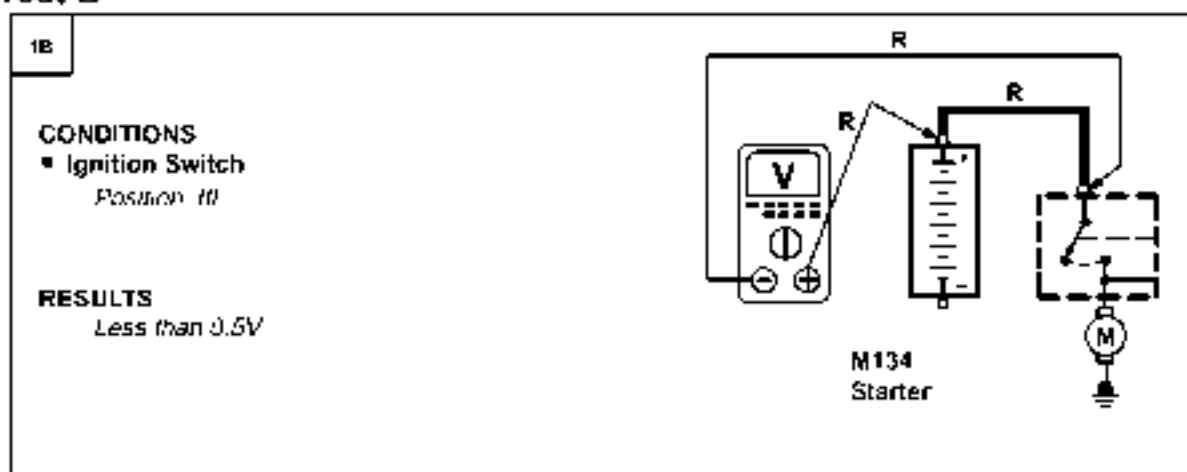

PROBLEM CAUSE

- R Wire
- Battery Terminal Connection
- Starter Solenoid (K136) terminal connection



1B

2B

CONDITIONS

- Ignition Switch
Position III

RESULTS
Less than 0.5V



PROBLEM CAUSE

- B Wire
- Ground Connections
- Battery Terminal Connection



PROBLEM CAUSE

- Starter
- Starter Solenoid

Test C

1C

CONDITIONS

- Ignition Switch
Position II
- Engine running

RESULTS
8.41 VOLT



PROBLEM CAUSE

- NY Wire



PROBLEM CAUSE

- Body Electrical Control Module (BECM)
- Instrument Cluster

CIRCUIT OPERATION

Petrol Engine

For vehicles equipped with a manual transmission, cruise control can only be activated when the Cruise Control Switch (X115) is depressed, the transfer gear box is in Hi range, and the clutch pedal is not depressed. Also, the BeCM (Z238) will deactivate cruise control if the engine rpm rises above $5000 \pm 10\%$, due to the possibility of selecting gears manually without the use of the clutch.

For vehicles equipped with an automatic transmission, cruise control can only be activated when the Cruise Control Switch (X115) is depressed, the transfer gear box is in Hi range, and the transmission is in one of the forward gears.

With the Cruise Control Switch (X115) on, a ground signal is applied to C1279/Pin 14 of the BeCM (Z238). The BeCM (Z238) then supplies signal voltage via its Pin 18 to the Converter/Inverter (Z249) to Pin 6 of the Cruise Control ECU (Z121); and to the "Operation" bulb of the Cruise Control Switch (X115). The transfer gearbox Hi range status from the Transfer Gear Box ECU (Z256) is applied to C1287/Pin 3 of the BeCM (Z238). The X, Y, and Z switch status (PRND321 position information) from the gearbox position switch is applied to C1287/Pins 8, 9, and 18 of the BeCM (Z238). The clutch pedal position input is applied to C1279/Pin 4 and the engine speed input C1288/Pin 9 of the BeCM (Z238). When the transfer gearbox is in Hi range, a forward gear is selected and the Cruise Control Switch (X115) is on, the BeCM (Z238) supplies voltage via C1276/Pin 1 and the Brake Switch/Vent Valve (X112) to the Cruise Control ECU (Z121) Pin 1, which then "knows" that cruise control can be operated.

When cruise control is activated and a cruise speed is set, the Cruise Control ECU (Z121) applies voltage through the OU wire and ground through the OR wire to operate the Cruise Control Vacuum Pump (M103) motor. The Cruise Control ECU (Z121) applies ground through the OK wire to close the normally open solenoid valve in the pump. The pump applies vacuum to the actuator.

SET/ACCEL

To set a cruise speed, the Cruise Control Switch (X115) must be on and vehicle speed must exceed 28 mph (45 km/h). When the SET/ACCEL Switch is depressed under these conditions, the

Converter/Inverter (Z249) is supplied with a ground signal. This signal is "converted" to a voltage signal and is transmitted via the SY wire to the Cruise Control ECU (Z121) terminal 4, causing the vacuum pump to operate. When the SET/ACCEL Switch is released, the signal is removed from terminal 4, signalling the ECU to set the speed.

RES/DECEL

When the RES/DECEL Switch is depressed, a signal is applied via the RY wire to terminal 2 of the Cruise Control ECU (Z121). This tells the ECU (Z121) to disengage the system and the vehicle slows down. When the switch is depressed a second time, the signal is again applied to the ECU (Z121) and the vehicle returns to the previously set speed.

Speed Input

Terminal 15 of the Cruise Control ECU (Z121) receives the Vehicle Speed output signal from the BeCM (Z238) through the Y or YR wire. The BeCM (Z238) receives the vehicle speed signal from the Anti-lock Brake System ECU (Z106). The signal is a pulsing voltage and its frequency changes with vehicle speed.

System Disable

The cruise control system can be disabled in one of four ways:

1. The Cruise Control Switch (X115) is put in the **0** position, removing the BeCM (Z238) power from the Cruise Control ECU (Z121) and vacuum pump, and erasing the set speed memory.
2. The **RES/ON/OFF** Switch is depressed, signalling the Cruise Control ECU (Z121) via the Inverter/Converter (Z249) to disengage the system.
3. The brake pedal is depressed and a vacuum valve in the Switch Vent Valve opens (X112). This vents vacuum to the actuator valve and releases the throttle.
4. The Voltage applied to the Cruise Control ECU (Z121) (terminal 1) is interrupted, causing the Cruise Control ECU (Z121) to turn off the vacuum pump and re-energize the vacuum solenoid valve. This voltage path is interrupted when:
 - The brake pedal is depressed. With the brake pedal depressed, the Brake Switch Vent Valve (X112) moves to position 1 and the circuit is interrupted.
 - The transfer gear box is not in H range.
 - The vehicle speed does not exceed 28 mph (45 km/h).
 - The vehicle is not in a forward gear (P, R, or N) (Automatic Transmission).
 - The clutch pedal is depressed (Manual Transmission).
 - The engine rpm rises above 5000 ± 10% (Manual Transmission).

The BeCM (Z238), which monitors these signals, will then remove power from C1279:Pin 18.

Diesel Engine

For vehicles equipped with a manual transmission, cruise control can only be activated when the Cruise Control Switch (X115) is depressed and the clutch pedal is not depressed. The Diesel Engine Control Module (Z132) will not allow the engine to overspeed if a cruise control speed is requested that is beyond the capability of the engine's speed range.

For vehicles equipped with an automatic transmission, cruise control can only be activated when the Cruise Control Switch (X115) is depressed, the transfer gear box is in H range, and the transmission is in one of the forward gears.

With the Cruise Control Switch (X115) on, a ground signal is applied to C1279:Pin 14 of the BeCM (Z238). The X, Y, and Z switch status (PRND321 position information) from the gearbox position switch is applied to C1287:Pins 8, 9, and 18 of the BeCM (Z238). The clutch pedal position input is applied to C1279:Pin 4 and the engine speed input is applied to C1288:Pin 9 of the BeCM (Z238). The BeCM (Z238) then supplies voltage, via its Pin 18 to the Inverter/Converter (Z249) and to the 'Operation' bulb of the Cruise Control Switch (X115).

The Cruise Control Converter/Inverter Module (Z249) supplies the Engine Control Module (Z132) via its pin 4 with a voltage signal to 'switch on' the cruise circuit. For the Diesel Engine, the Engine Control Module (Z132) controls the cruise circuit as the Cruise Control ECU (Z121) does for the Petro Engine. The Engine Control Module (Z132) is also responsible for the acceleration/deceleration of the vehicle.

SET/ACCEL

To set a cruise speed, the Cruise Control Switch (X115) must be on and vehicle speed must exceed 28 mph (45 km/h). When the SET/ACCEL Switch is depressed under these conditions, the Inverter/Converter (Z249) is supplied with a ground signal. This signal is transmitted via the OY wire to the Engine Control Module (ECM) (Z132) causing the vehicle to accelerate. When the SET/ACCEL Switch is released, the signal is removed signalling the Engine Control Module (ECM) (Z132) to set the speed.

RES

When the RES Switch is depressed, a signal is applied to the ECM (Z132) and the vehicle will return to the previously set speed.

Speed Input

The BeCM (Z238) receives the vehicle speed signal from the Anti-lock Brake System ECU (Z108). The BeCM (Z238) then provides the vehicle speed signal to the Engine Control Module (ECM) (Z132). This signal is a pulsing voltage and its frequency changes with the vehicle speed.

System Disable

The cruise control system can be disabled in two ways:

1. The Cruise Control Switch (X115) is put in the 0 position, causing the BeCM (Z238) to remove power from the Engine Control Module (ECM) (Z132) and erasing the set speed memory.
2. The Voltage applied via the Inverter/Converter (Z249) to the Engine Control Module (ECM) (Z132) terminal 20 is interrupted, causing the Engine Control Module (ECM) (Z132) to disengage the system. This voltage path is interrupted when:
 - The brake pedal is depressed. The Engine Control Module (ECM) (Z132) has two Stop Lamp Switch (X168) inputs, each of opposite polarity. The ECM (Z132) compares the polarity states to determine when the brake pedal has been depressed.
 - The vehicle speed does not exceed 28mph (45 km/h).
 - The vehicle is not in a forward gear (P, R, or N) (Automatic Transmission).

- The clutch pedal is depressed (Manual transmission)

The BeCM (Z238), which monitors these signals, will then remove power from C1279/Pin 18.

Road Test

CAUTION DO NOT ENGAGE CRUISE CONTROL WHEN VEHICLE IS BEING USED IN LOW TRANSFER GEARS.

WARNING: The use of cruise control is not recommended on winding, snow covered or slippery roads, or in heavy traffic conditions where constant speed cannot be maintained.

1. Start the engine and depress the Cruise Control Switch (X115) to activate the cruise control system. Accelerate to approximately 30 mph (50 km/h) and press the SET/ACCEL Switch. Immediately release the switch and remove foot from the accelerator pedal. The vehicle should maintain the speed at which the SET/ACCEL Switch was pressed.
2. Press the SET/ACCEL Switch and hold it at that position. The vehicle should accelerate smoothly until the switch is released. The vehicle should now maintain the new speed at which the SET/ACCEL Switch was released.
3. Press the RES/DECEL Switch while the vehicle is in the cruise control mode. The cruise control should disengage. Slow to approximately 35 mph (55 km/h) and press the RES/DECEL Switch. Immediately release the switch and remove foot from the accelerator. The vehicle should smoothly accelerate to the previously set speed. Increase speed using the accelerator pedal. Releasing the pedal should return the vehicle to the previously set speed.
4. Depressing the brake pedal should immediately disengage the cruise control system and return the vehicle to driver's control of accelerator pedal. Press the RES/DECEL Switch and the vehicle should accelerate to the previously set speed without operation of the accelerator pedal.
5. Press the RES/DECEL Switch and allow the vehicle to decelerate to below 26 mph (42 km/h). Press the RES/DECEL Switch and remove foot from the accelerator pedal. The vehicle should smoothly adjust to the previously memorized speed.
6. Press the SET/ACCEL Switch below 26 mph (45 km/h) and the cruise control system should remain disengaged. Accelerate the vehicle above 26 mph (45 km/h), press the RES/DECEL Switch and remove foot from the accelerator pedal. The vehicle should smoothly adjust to the previously memorized speed.
7. Pressing the Cruise Control Switch (X115) should immediately disengage the cruise control

system and erase the previously set speed from Cruise Control ECU (Z121)/Engine Control Module (ECM) (Z132) memory.

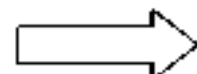
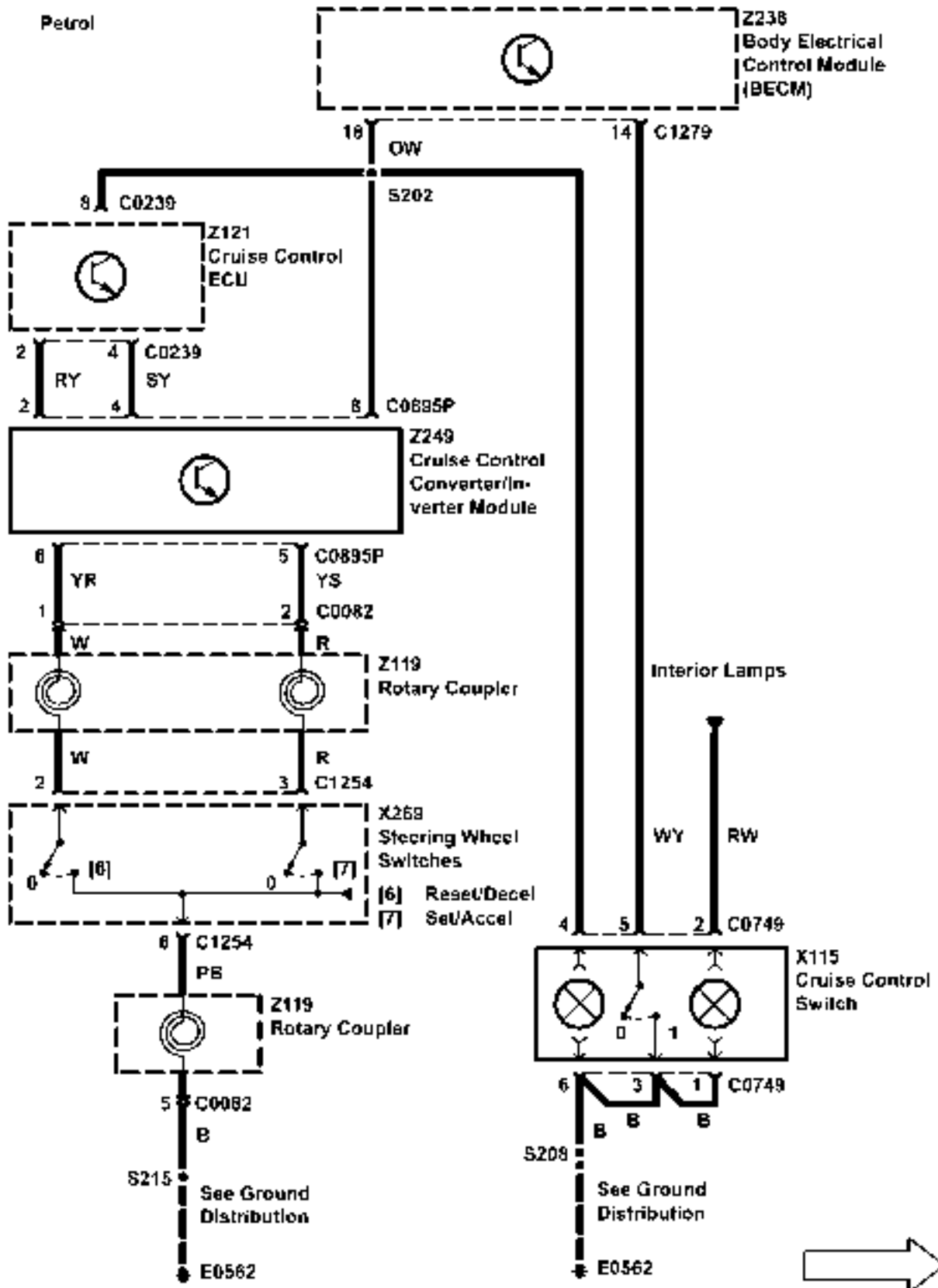

B5 CRUISE CONTROL (PETROL)

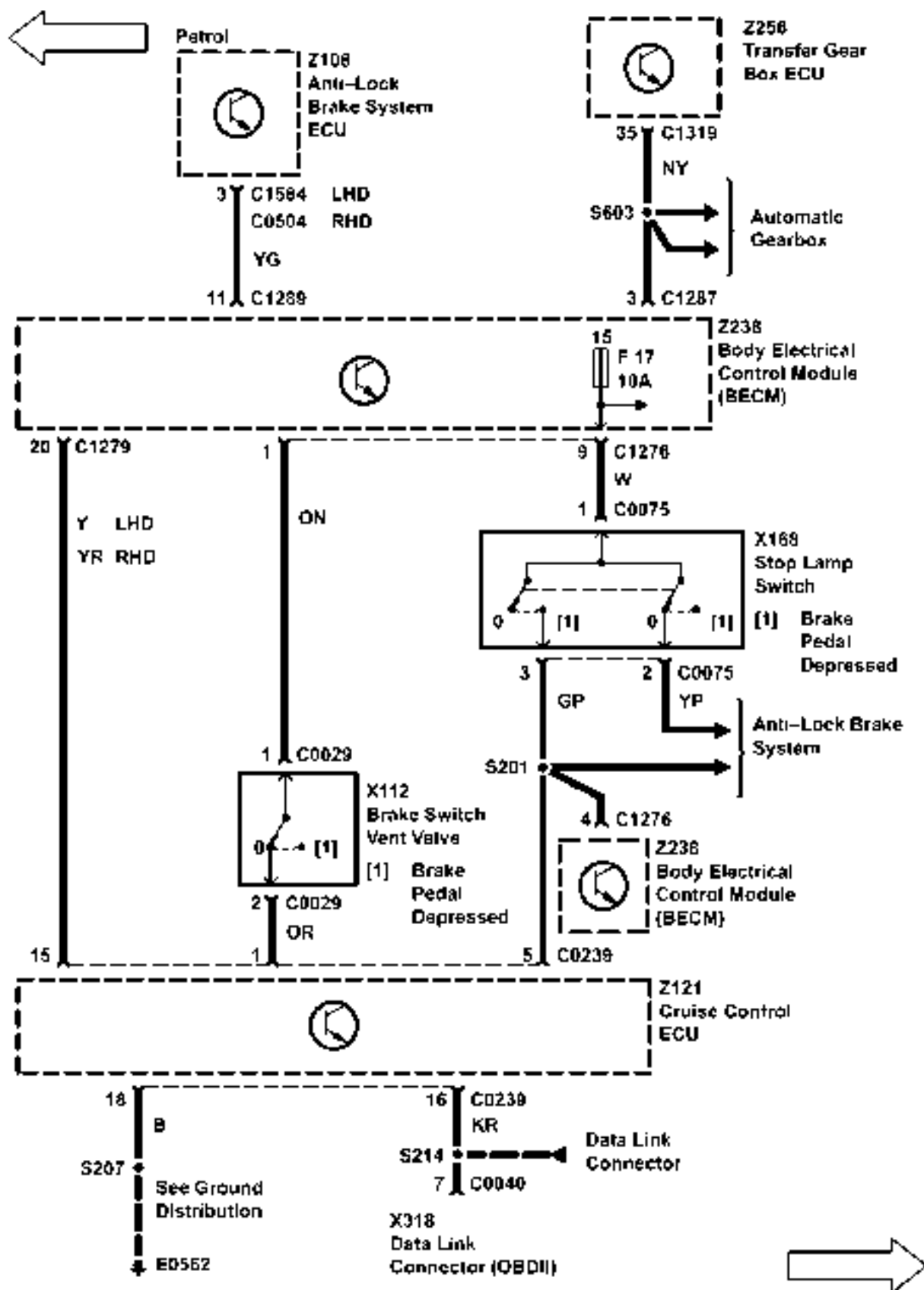

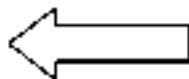

Petrol

	X	Y	Z
P	0	1	1
R	0	0	1
N	1	0	1
D	1	0	0
3	0	0	0
2	0	1	0
1	1	1	0
Z	1	1	1

1 = Switch Open

0 = Switch Closed

* = Fault

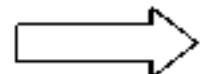
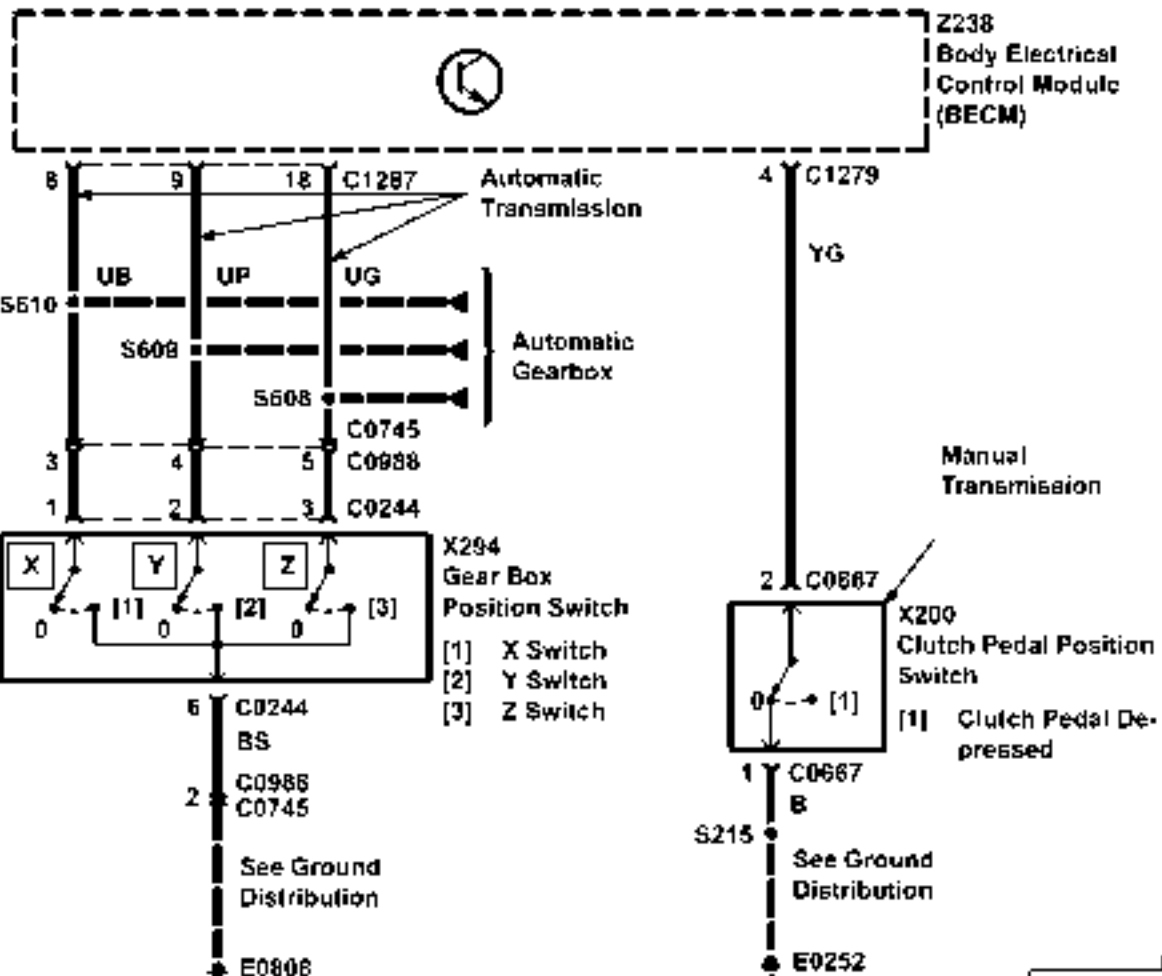
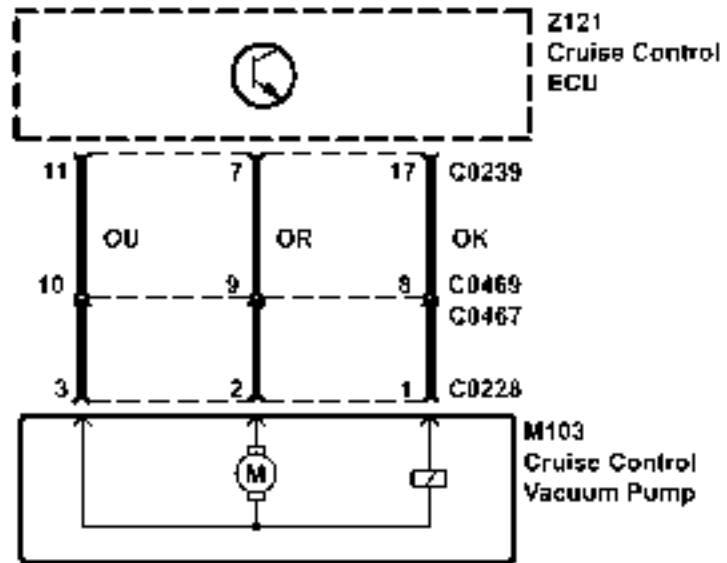

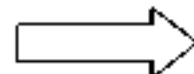
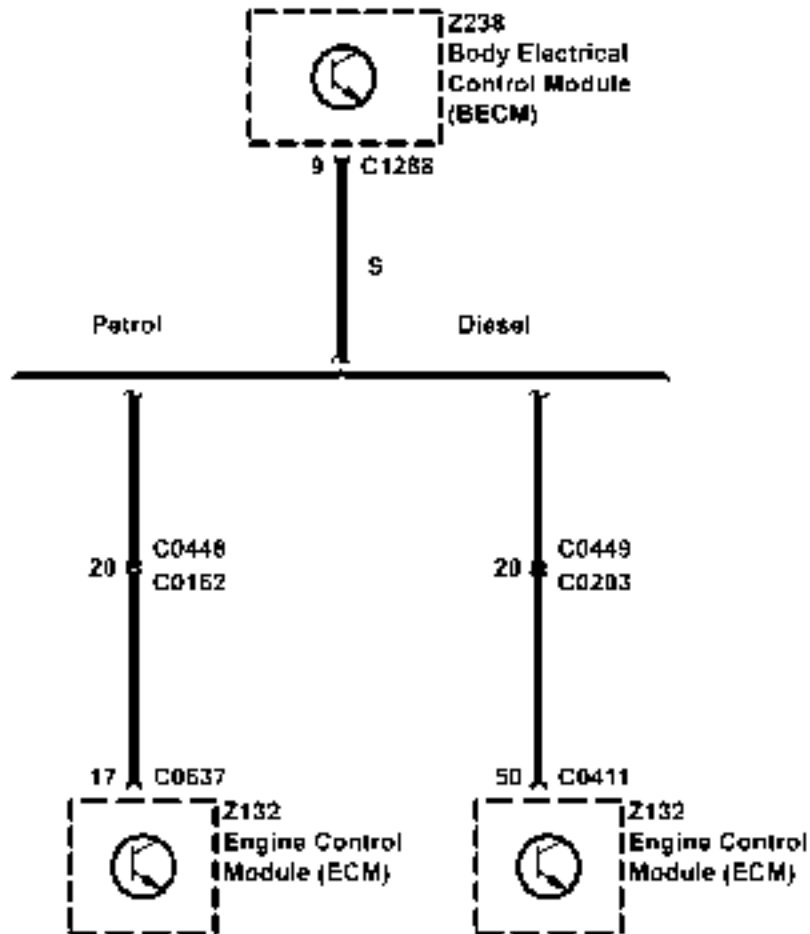
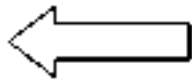

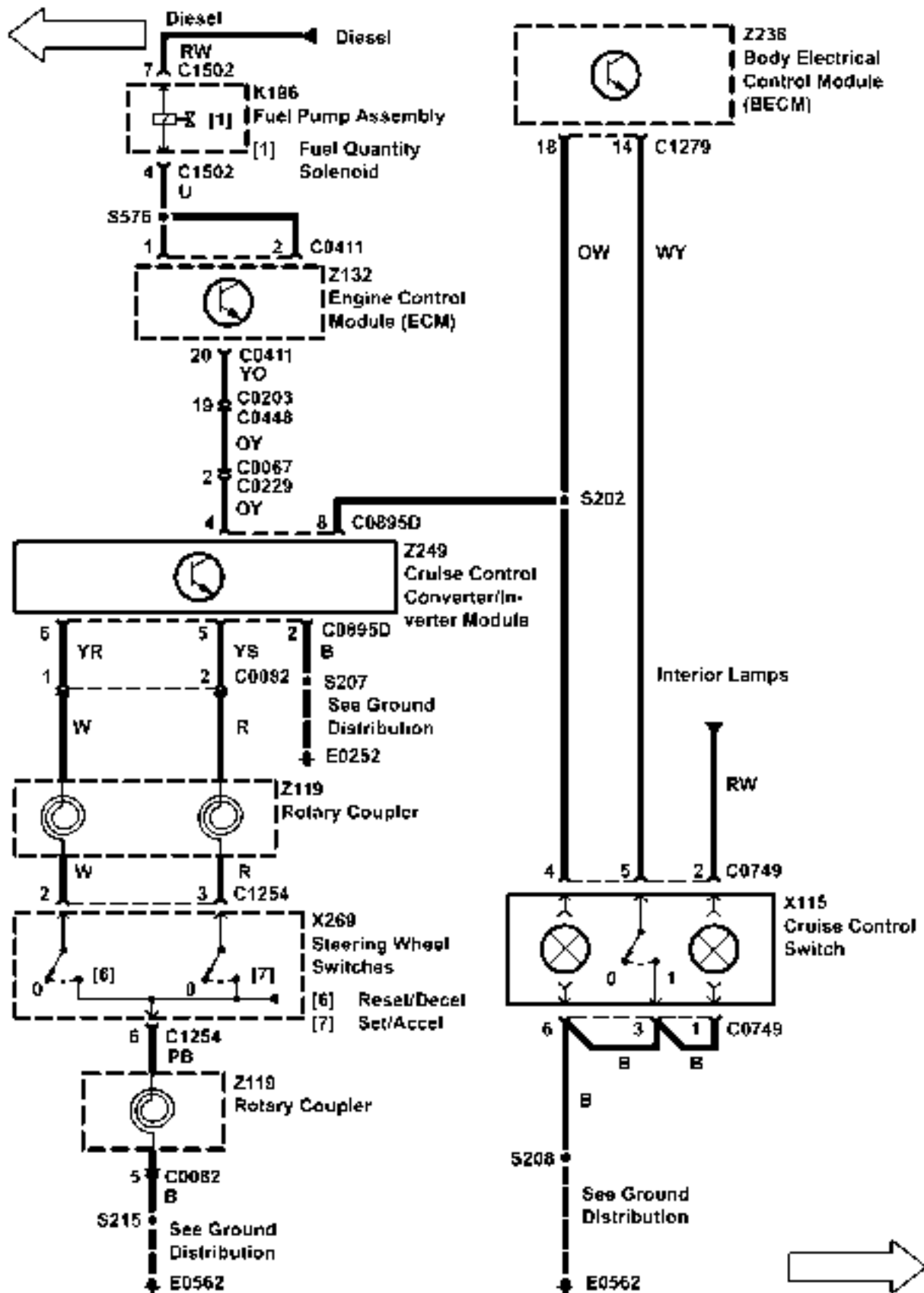

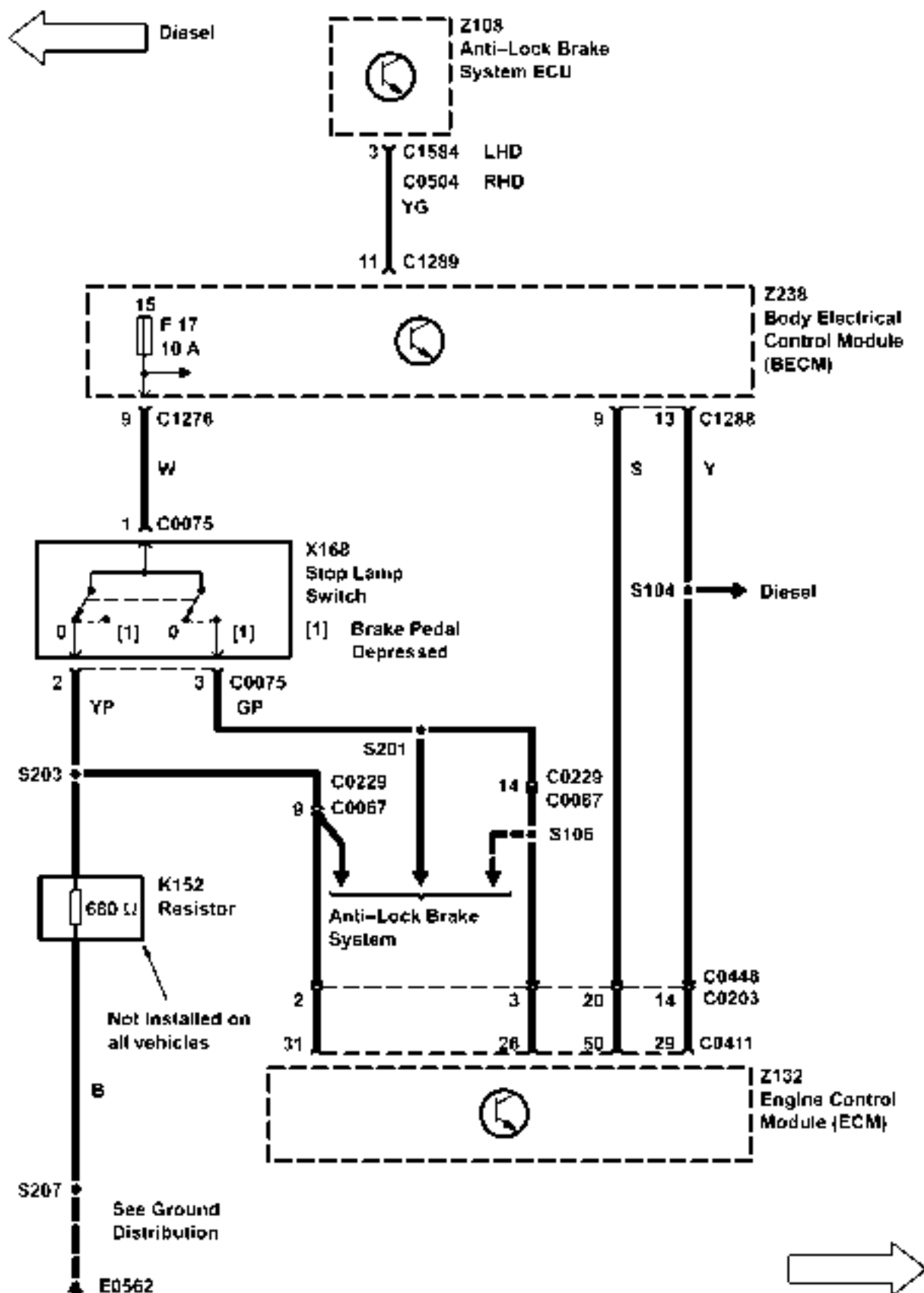

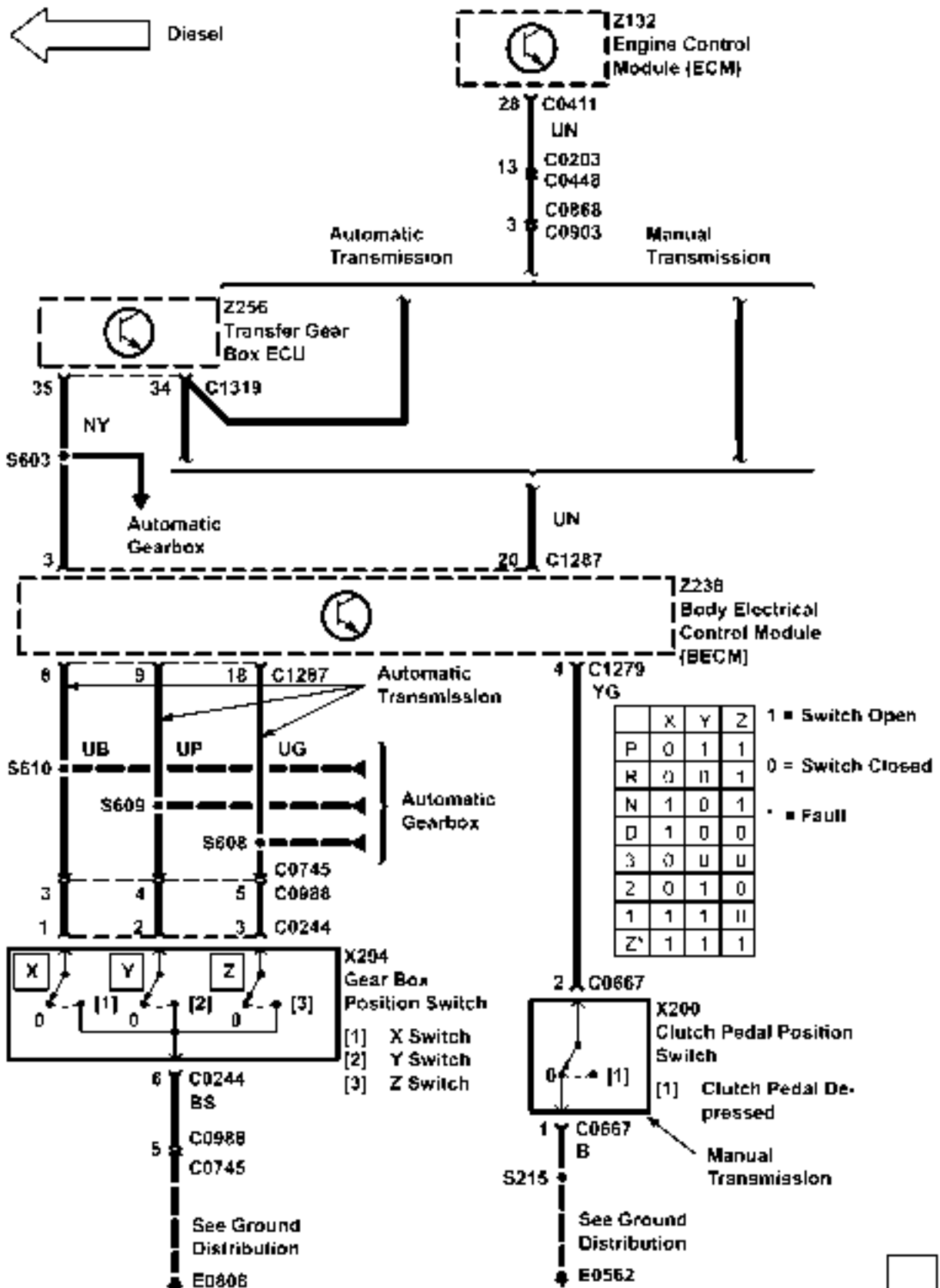

TROUBLESHOOTING HINTS

5. If the interior lights operate but the cruise control switch light does not illuminate, check the bulb, B wire and RW wire. If the cruise control system operates but the cruise control switch light does not illuminate, check bulb and OW wire.
6. Inspect vacuum hoses for kinks and restrictions.
7. Inspect actuator linkage for restrictions and adjustment.
8. Check the following two input signals to the BeCM (Z238): Signal from Clutch Pedal Position Switch (X200) for vehicles equipped with a manual transmission, or the X, Y and Z switch signals from the Gearbox Position Switch (X294) for vehicles equipped with an automatic transmission.
9. For vehicles equipped with a Petrol Engine, check the following input signal to the BeCM (Z238): Transfer box in Hi range signal from Transfer Gear Box ECU (Z256).
10. For vehicles equipped with a Diesel engine, check the Stop Lamp Switch (X168) inputs to the Engine Control Module (ECM) (Z132).
11. **Note:** For vehicles equipped with a manual transmission, cruise control can only be activated when the Cruise Control Switch (X115) is depressed, the transfer gear box is in Hi range (Petrol only), and the clutch pedal is not depressed. Also, the BeCM (Z238) will deactivate cruise control if the engine rpm rises above 5000 +/- 10 percent, due to the possibility of selecting manual without the use of the clutch (Petrol only). For vehicles equipped with an automatic transmission, cruise control can only be activated when the Cruise Control Switch (X115) is depressed, the transfer gear box is in Hi range (Petrol only), and the transmission is in one of the forward gears. The Transfer Gear Box ECU (Z256) provides the BeCM (Z238) with transfer gear box Hi range status. The Transfer Gear Box Position Switch (X294) provides the BeCM (Z238) with X, Y, Z switch status (PRND321 position information).

SYSTEM DIAGNOSIS

1. If the cruise control system does not operate correctly and the vehicle is equipped with a Petrol Engine, do Test A.

2. If the cruise control system does not operate correctly and the vehicle is equipped with a Diesel Engine, do Test E.

Test A

1A	<p>CONDITIONS</p> <ul style="list-style-type: none"> • Ignition Switch <i>Position: II</i> • Cruise Control Switch <i>On</i> <p>RESULTS <i>Within 1.5V of battery voltage</i></p>	<p style="text-align: center;">Z121 Cruise Control ECU</p>
----	---	--

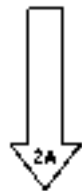

GO TO TEST B

2A	<p>CONDITIONS</p> <ul style="list-style-type: none"> • Ignition Switch <i>Position: 0</i> <p>RESULTS <i>Less than 1 ohm</i></p>	<p style="text-align: center;">Z121 Cruise Control ECU</p>
----	--	--



PROBLEM CAUSE

- B Wire



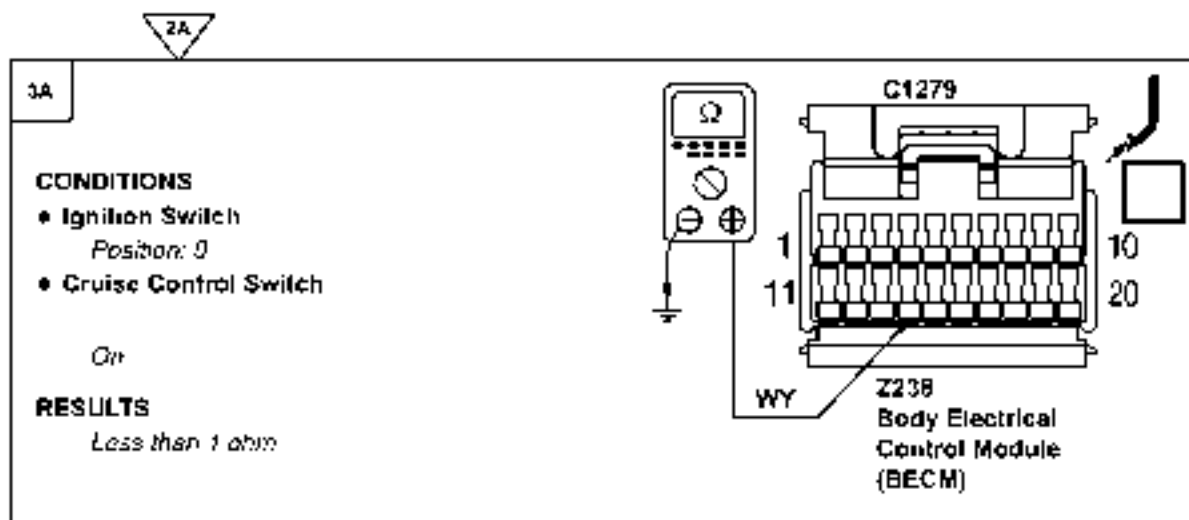

PROBLEM CAUSE

- WY Wire
- B Wire
- Cruise Control Switch



PROBLEM CAUSE

- OW Wire
- Body Electrical Control Module (BECM)

Test B

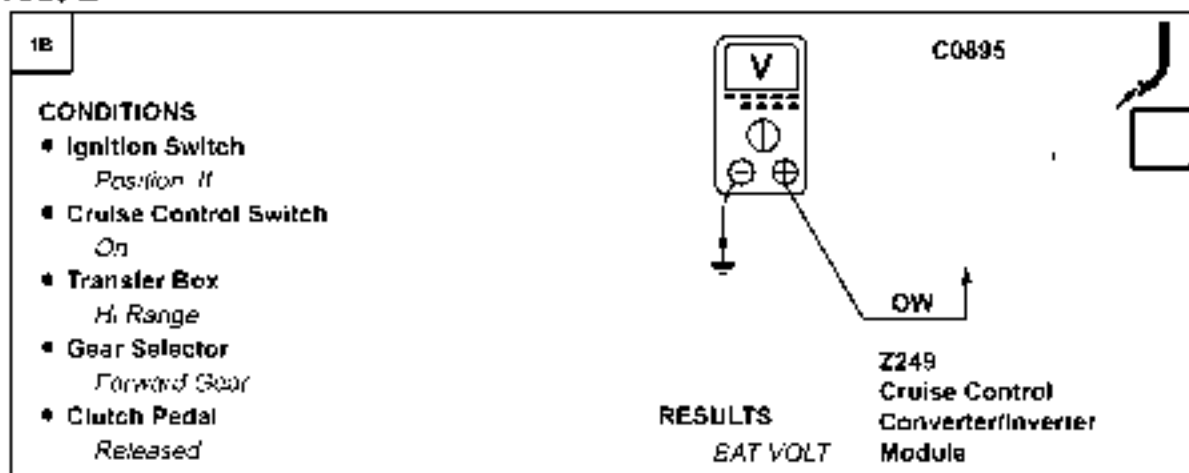

PROBLEM CAUSE

- OW Wire



1B

2B

CONDITIONS

- Ignition Switch
Position: 0
- Cruise Control Switch
On

RESULTS

- Steering Wheel Switches
RES:DECEL Switch

<i>On</i>	=	BAT VOLT
<i>Off</i>	=	0V

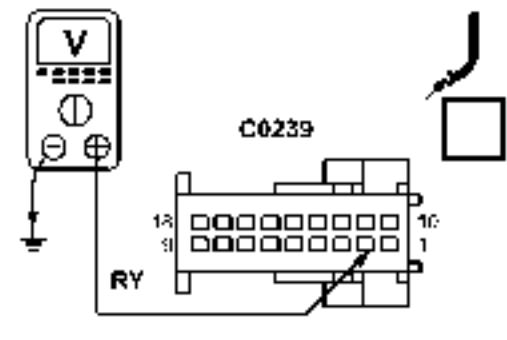

Z121
Cruise Control ECU



GO TO TEST C

3B

CONDITIONS

- Ignition Switch
Position: 0

RESULTS

- Steering Wheel Switches
RES:DECEL Switch

<i>On</i>	=	<i>Less than 1 ohm</i>
<i>Off</i>	=	<i>More than 10K ohms</i>

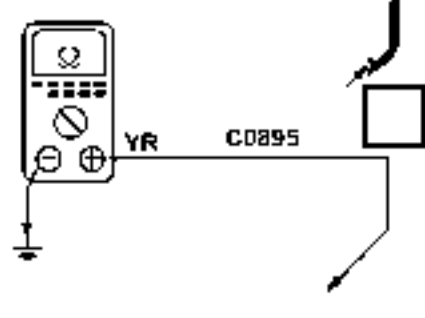

Z249
Cruise Control
Converter/Inverter
Module



- PROBLEM CAUSE**
- YR, W Wire
 - B, PB Wire
 - Steering Wheel Switches
 - Rotary Coupler



- PROBLEM CAUSE**
- Cruise Control Converter/ Inverter Module

Test C

1C	<p>CONDITIONS</p> <ul style="list-style-type: none"> • Ignition Switch <i>Position: II</i> • Cruise Control Switch <i>On</i> <p>RESULTS</p> <ul style="list-style-type: none"> • Steering Wheel Switches <i>SET/ACCEL Switch</i> <table style="width: 100%;"> <tr> <td style="width: 50%;">On</td> <td style="width: 50%;">= 5AT VOLT</td> </tr> <tr> <td>Off</td> <td>= 0 V</td> </tr> </table>	On	= 5AT VOLT	Off	= 0 V	
On	= 5AT VOLT					
Off	= 0 V					

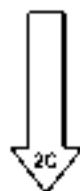

GO TO TEST D

2C	<p>CONDITIONS</p> <ul style="list-style-type: none"> • Ignition Switch <i>Position: G</i> <p>RESULTS</p> <ul style="list-style-type: none"> • Steering Wheel Switches <i>SET/ACCEL Switch</i> <table style="width: 100%;"> <tr> <td style="width: 50%;">On</td> <td style="width: 50%;">= Less than 1 ohm</td> </tr> <tr> <td>Off</td> <td>= More than 10K ohms</td> </tr> </table>	On	= Less than 1 ohm	Off	= More than 10K ohms	
On	= Less than 1 ohm					
Off	= More than 10K ohms					



PROBLEM CAUSE

- YS,R Wire
- Rotary Coupler



PROBLEM CAUSE

- Cruise Control Converter/Inverter Module

- Steering Wheel Switches

Test D

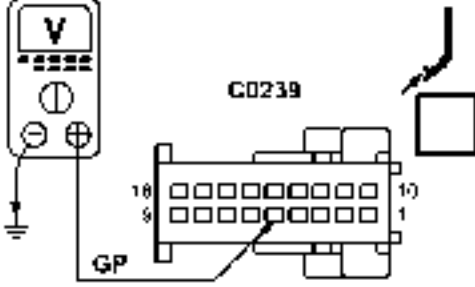
1D	<p>CONDITIONS</p> <ul style="list-style-type: none"> • Ignition Switch <i>Position: II</i> <p>RESULTS</p> <ul style="list-style-type: none"> • Brake Pedal <table style="margin-left: 20px;"> <tr> <td><i>Depressed</i></td> <td>=</td> <td><i>BAT VOLT</i></td> </tr> <tr> <td><i>Released</i></td> <td>=</td> <td><i>0 V</i></td> </tr> </table> 	<i>Depressed</i>	=	<i>BAT VOLT</i>	<i>Released</i>	=	<i>0 V</i>	 <p>Z121 Cruise Control ECU</p>
<i>Depressed</i>	=	<i>BAT VOLT</i>						
<i>Released</i>	=	<i>0 V</i>						



PROBLEM CAUSE

- GP Wire
- W Wire
- Stop Lamp Switch

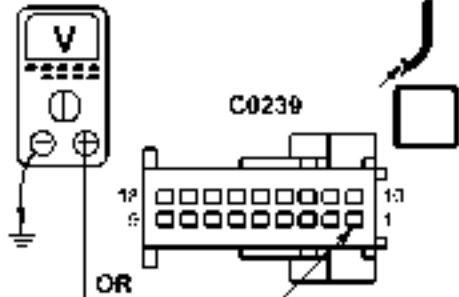

2D

2D	<p>CONDITIONS</p> <ul style="list-style-type: none"> • Ignition Switch <i>Position: II</i> • Cruise Control Switch <i>On</i> • Transfer Box <i>Hi Range</i> • Gear Selector <i>Forward Gear</i> <p>RESULTS</p> <ul style="list-style-type: none"> • Brake Pedal <table style="margin-left: 20px;"> <tr> <td><i>Depressed</i></td> <td>=</td> <td><i>0 V</i></td> </tr> <tr> <td><i>Released</i></td> <td>=</td> <td><i>BAT VOLT</i></td> </tr> </table> 	<i>Depressed</i>	=	<i>0 V</i>	<i>Released</i>	=	<i>BAT VOLT</i>	 <p>Z121 Cruise Control ECU</p>
<i>Depressed</i>	=	<i>0 V</i>						
<i>Released</i>	=	<i>BAT VOLT</i>						



PROBLEM CAUSE

- OR, ON Wire
- Brake Switch Vent Valve
- Body Electrical Control Module (BECM)



3D

20

30

CONDITIONS

- Ignition Switch
Position: II
- Turn a drive wheel by hand

RESULTS

- = 5V with ignition position II
- = 2.5V approx. with wheels turning

Z121
Cruise Control ECU



PROBLEM CAUSE

- Y, YR Wire
- Body Electrical Control Module (BECM)



40

CONDITIONS

- Ignition Switch
Position: II
- Cruise Control Switch
On
- Transfer Gearbox
Hi Range
- Gear Selector
Forward Gear
- Brake Pedal
Released

RESULTS

- Cruise Control Vacuum Pump
Operates

Z121
Cruise Control ECU



PROBLEM CAUSE

- OU, OR Wire
- Cruise Control Vacuum Pump



4D

3D

CONDITIONS

- Ignition Switch
Position: 0
- Cruise Control Switch

On
- Transfer Gearbox
Hi Range
- Gear Selector
Forward Gear
- Brake Pedal
Released

RESULTS

- Cruise Control Vacuum Pump

*Operates
Valve Closes
Throttle Opens Valve*

**Z121
Cruise Control
ECU**



PROBLEM CAUSE

- OK Wire
- Cruise Control Vacuum Pump



PROBLEM CAUSE

- Cruise Control ECU

Test E

1E

CONDITIONS

- Ignition Switch
Position: II
- Cruise Control Switch
On
- Gear Selector
Forward Gear
- Clutch Pedal
Released

RESULTS

BAT VOLT

**Z249
Cruise Control
Converter/Inverter
Module**



GO TO TEST F

1E

2E

CONDITIONS

- Ignition Switch
Position: 0

RESULTS

- Less than 1 ohm

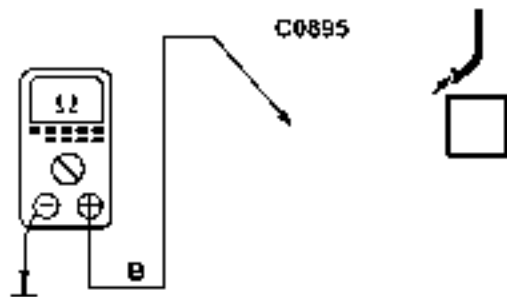

C0895

Z249
Cruise Control
Converter/Inverter
Module



PROBLEM CAUSE

- B Wire



3E

CONDITIONS

- Ignition Switch
Position: 0
- Cruise Control Switch

On

RESULTS

- Less than 1 ohm

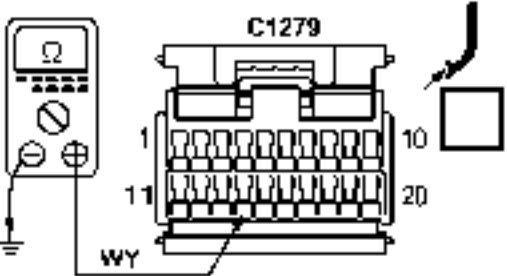

C1279

Z238
Body Electrical
Control Module
(BECM)



PROBLEM CAUSE

- WY Wire
- B Wire
- Cruise Control Switch



PROBLEM CAUSE

- OW Wire
- Body Electrical Control Module (BECM)

Test F

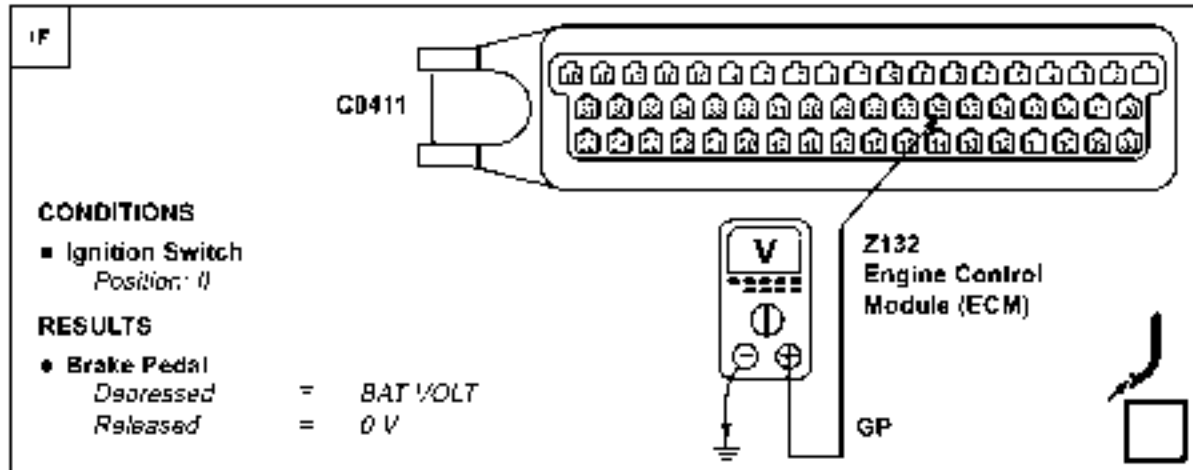

OK PROBLEM CAUSE

- GB Wire
- Stop Lamp Switch

OK

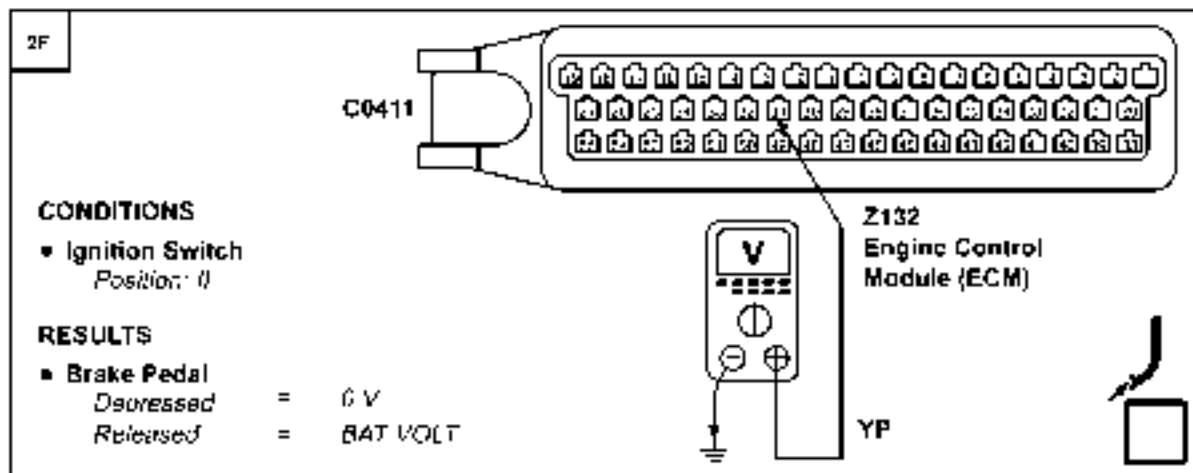

OK PROBLEM CAUSE

- YP Wire
- Stop Lamp Switch

OK



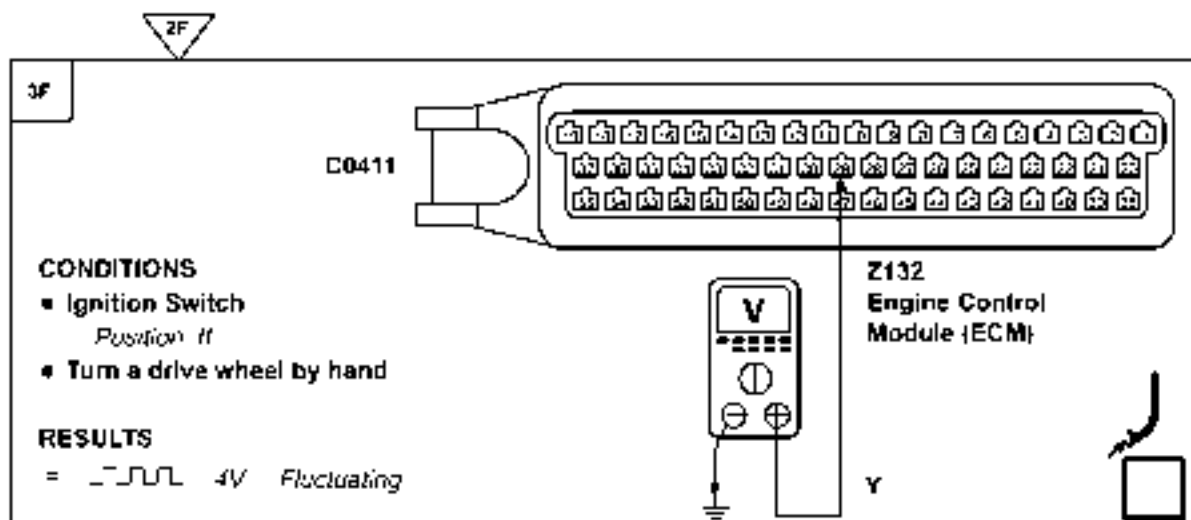

PROBLEM CAUSE

- Y, YG Wire
- Body Electrical Control Module (BECM)

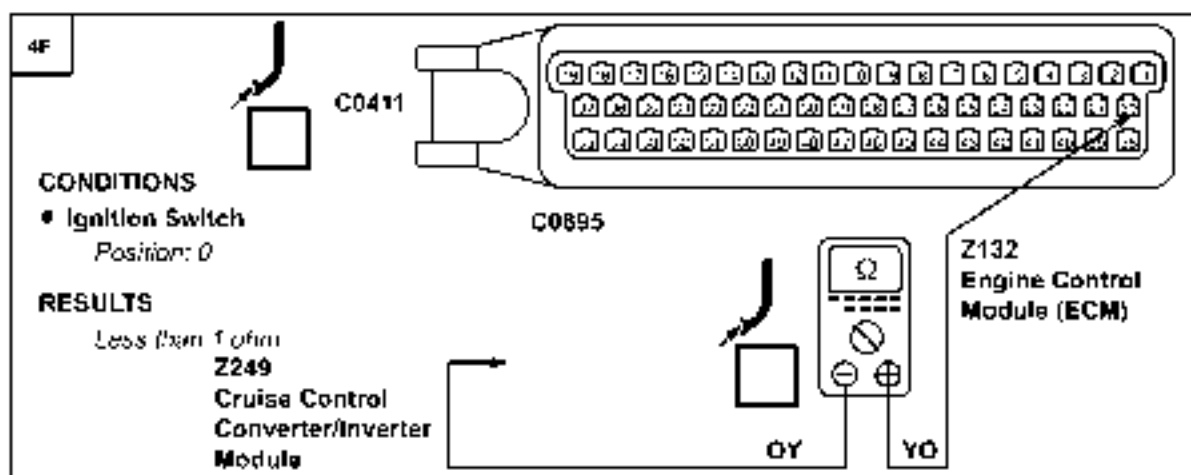

PROBLEM CAUSE

- OY, YO Wire



4F

3F

C0895

Z249
Cruise Control
Converter/Inverter
Module

CONDITIONS

- Ignition Switch
Position: 0

RESULTS

- Steering Wheel Switches
RES/DECEL Switch

<i>On</i>	= Less than 1 ohm
<i>Off</i>	= More than 10K ohms



PROBLEM CAUSE

- YR, W Wire
- B, PB Wire
- Rotary Coupler

- Steering Wheel Switches



6F

C0895

Z249
Cruise Control
Converter/Inverter
Module

CONDITIONS

- Ignition Switch
Position: 0

RESULTS

- Steering Wheel Switches
SET/ACCEL Switch

<i>On</i>	= Less than 1 ohm
<i>Off</i>	= More than 10K ohms



PROBLEM CAUSE

- YS, R Wire
- Rotary Coupler

- Steering Wheel Switches



PROBLEM CAUSE

- Cruise Control Converter/Inverter Module

- Body Electrical Control Module (BECM)

CIRCUIT OPERATION

Interface to transfer motor inside Transfer Box (X313)

The Transmission Gearbox Control Unit (Z256) has a seven wire interface to the Transfer Motor inside the Transfer Box (X313) consisting of the four motor position switches, the ground for the switches and the drives to move the motor one way or the other.

Motor Position Switches—pins 17, 32, 33, 7

The Transmission Gearbox Control Unit (Z256) reads the position of the motor in the form of a binary Gray Code.

So the Transmission Gearbox Control Unit (Z256) can find out in which gear the Transfer Box (X313) is in and where the motor should move to, to engage the desired range. If the Transfer Box (X313) moves outside the normal modes (e.g. Left of High) then the Transmission Gearbox Control Unit (Z256) can move the motor back to the correct position.

Motor Position Switch ground—pin 19

The switches on the transfer box motor are referenced to pin 19, i.e. if there is a problem with the harness to pin 19 then the Transmission Gearbox Control Unit (Z256) will not be able to assess where the transfer motor is and so will not move the motor.

Motor drive Clockwise (pins 25, 26) and Counter Clockwise (pins 1, 2)

The Transmission Gearbox Control Unit (Z256) receives signals from the motor position switches, the drivers request, the vehicle speed and the transmission neutral signal and, when the parameters are correct, powers the motor from one mode to another via the motor drives. This is actually a single wire interface for each direction which is split down to two wires at the Transmission Gearbox Control Unit (Z256) to help pass the current (through two pins rather than one). If there is a problem with either the motor drives or the harness, then the motor will not move and a range change will not be possible.

Vehicle Speed Sensor—pins 13, 30

The Transmission Gearbox Control Unit (Z256) senses how fast the vehicle is travelling, compares this speed to the value stored in the memory and decides if a range change is allowed. Presently the shift speeds are set at 5 mph High to Low and Low to High on vehicles with an automatic transmission

and 15 mph Low to High on vehicles with a manual transmission.

Interface to BeCM (Z238)

High, Low and Neutral Status Lamps—pins 35, 14, 36

The Transmission Gearbox Control Unit (Z256) informs the BeCM (Z238), which informs the Instrument Pack (Z142), about the range the vehicle is in via three status lamps.

When a range change is requested, the desired range will flash up on the display (i.e. "HIGH") and continue flashing until the range change is achieved. When complete, the range message will switch to constant and be displayed for a few seconds.

If a range change is requested and not all of the conditions are satisfied then the desired range message will flash and continue flashing until all of the parameters are satisfied or the request is removed.

If the transfer box neutral is selected then, after a five second safety delay, the Transfer Box (X313) moves to neutral and the display shows "NEUTRAL".

The High and Low status lamp signals also pass information to the H-Gate and the Auto Gear Box Control Unit (Z255).

Interface to Engine Control Module (ECM) (Z132)

On North American Specification (NAS) vehicles, the inability of the Transfer Gear Box ECU (Z258) to move into the High range is flagged over the fault output line. A fault will also be flagged in the event of a speed sensor failure or incorrect transfer motor position information. The Malfunction Indicator Lamp (MIL) will illuminate if a fault is recorded on two successive journeys.

Neutral Switch (X293) or Clutch Switch—pin 34

A shift between ranges is possible when the transmission is in neutral. The Transmission Gearbox Control Unit (Z256) senses this via a Park/Neutral Switch (X293) on automatic transmission vehicles and via either a clutch switch or a lever neutral switch on manual transmission vehicles. This signal is passed via the BeCM (Z238).

Interface to "H-Gate"—pin 35, 15 (automatic transmission only)

The H-Gate gets the range information via a High and Low status signal from the output of the Transmission Gearbox Control Unit (Z256), e.g. when the vehicle is in High then the High side of the 'H' is illuminated. When a range change to Low is requested, the Low side of the 'H' starts to flash whilst the High side stays constant. When Low range is obtained then the flashing light on the Low side changes to constant and the High side light goes off.

If a range change is requested and not all of the conditions are satisfied, then the current range will stay illuminated and the desired range will flash and continue flashing until all of the parameters are satisfied or the request is removed.

If the gear lever is placed in the neutral position for the gearbox and the transfer box then, after a five second safety delay, the transfer box moves to neutral and the lights on both side of the 'H' are extinguished.

Interface to Auto Gear Box Control Unit (Z255) — pin 35

The High/Low signal to the Auto Gear Box Control Unit (Z255) comes from the High range status lamp. If the Auto Gear Box Control Unit (Z255) does not receive the range information, then an incorrect gear change mode could be selected, i.e. Manual rather than Sport in High range and vice versa in Low range. Also, the shift strategy is different between the Economy modes of High and Low and so poor shift quality could result.

Automatic Selector Park Interlock

When the gear selector lever is in the park position, the shift interlock solenoid is deenergized and prevents the selector from being moved to another gear. To free the selector the Ignition Switch (X134) must be in position II and the brake pedal must be depressed.

Current is then supplied to the solenoid through the PK wire via fuse 1:1. The solenoid is grounded using the B wire to the console ground E0208.

The solenoid is now energised, freeing the selector. The solenoid is energised continuously whilst the selector lever is in any position other than park and the Ignition Switch (X134) is in position II.

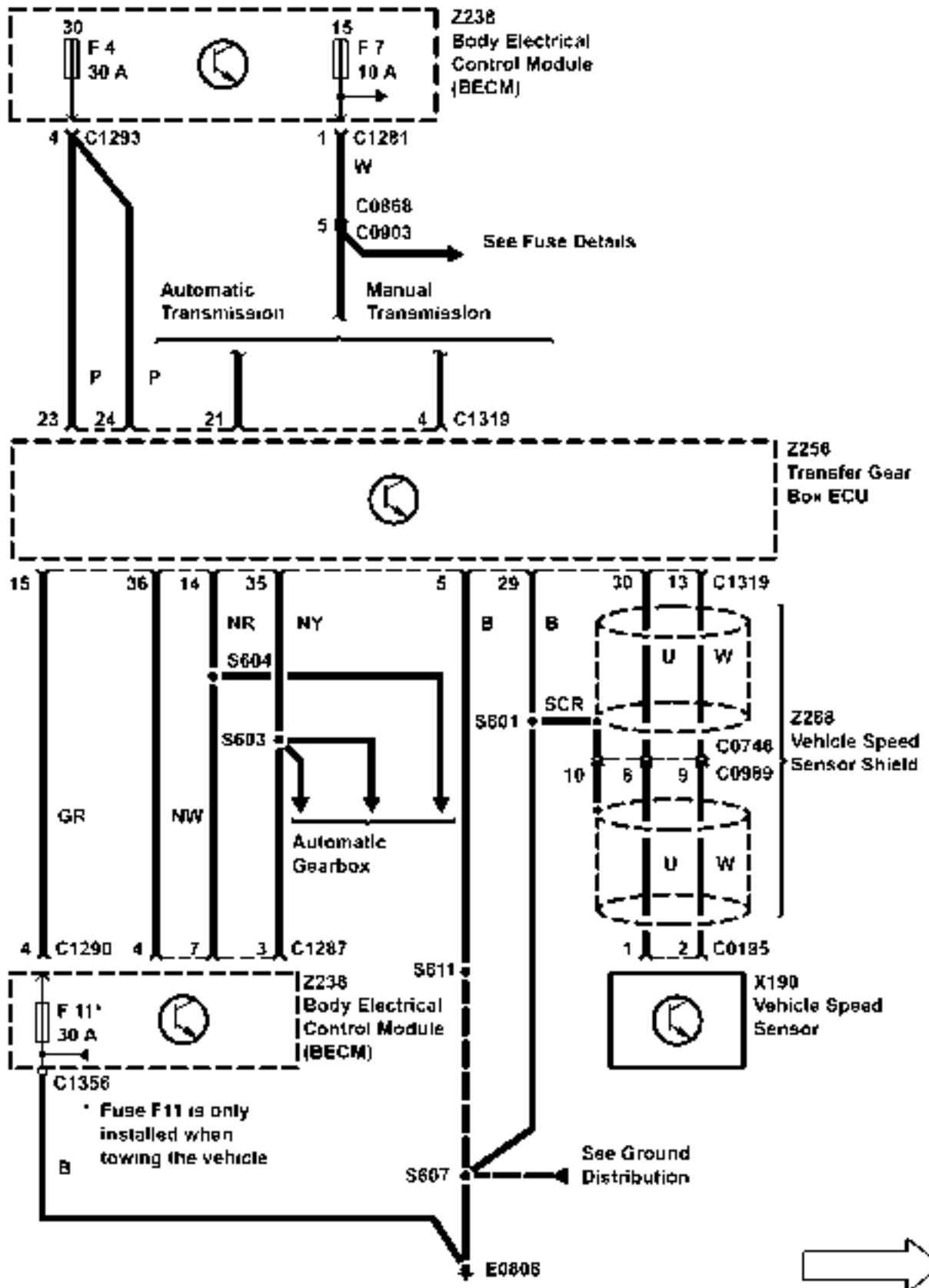

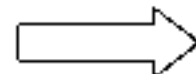
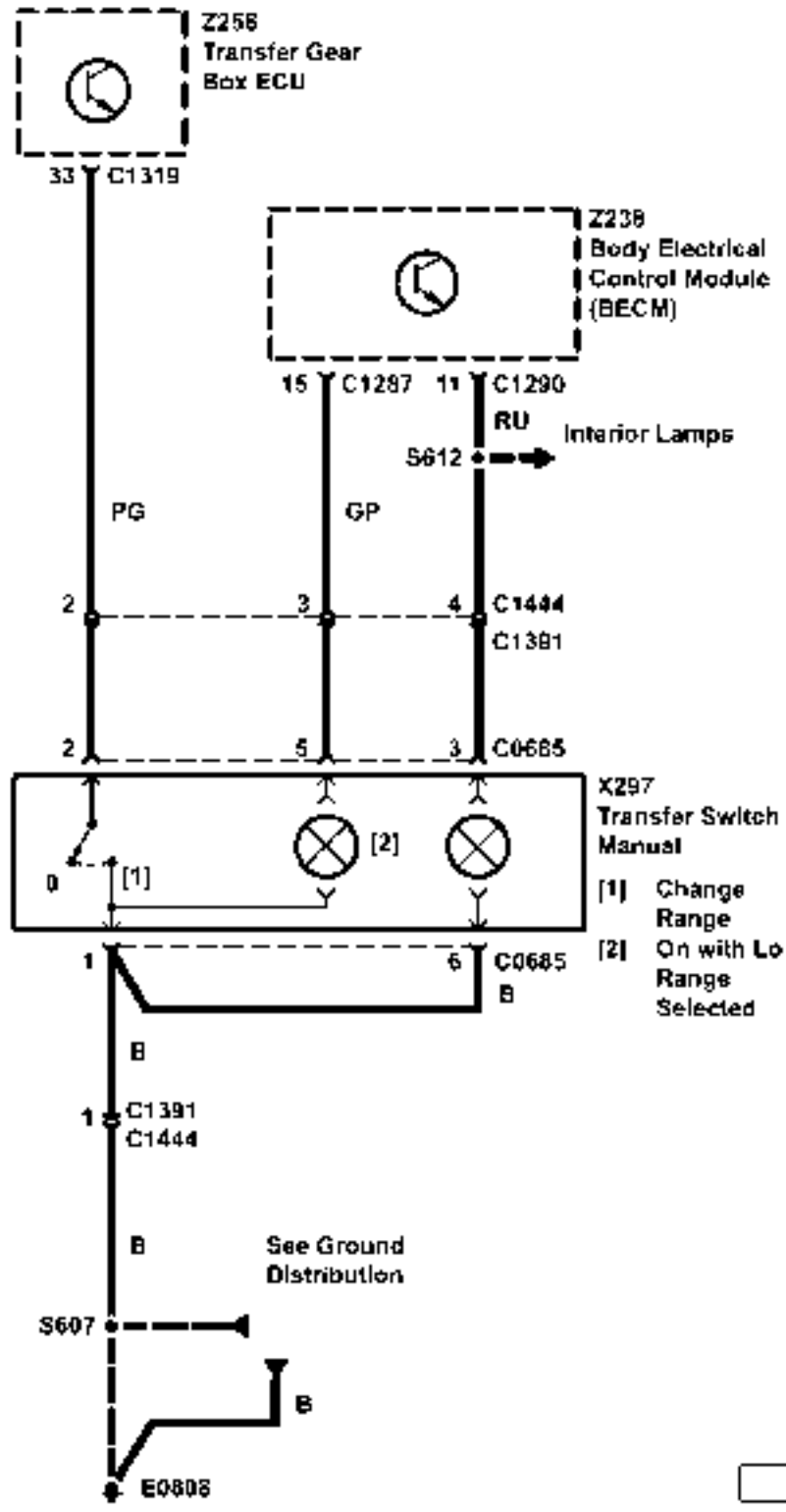

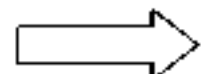
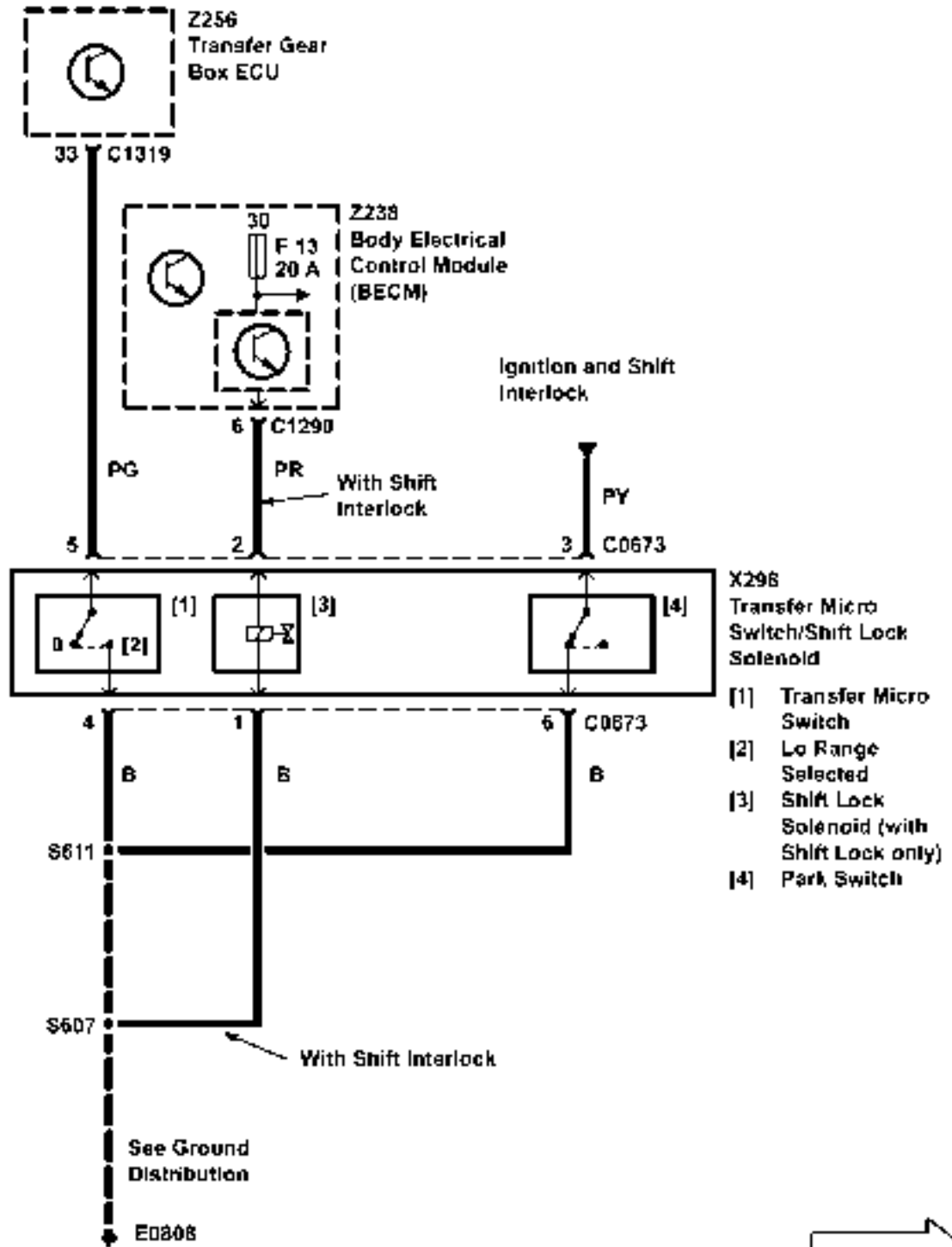

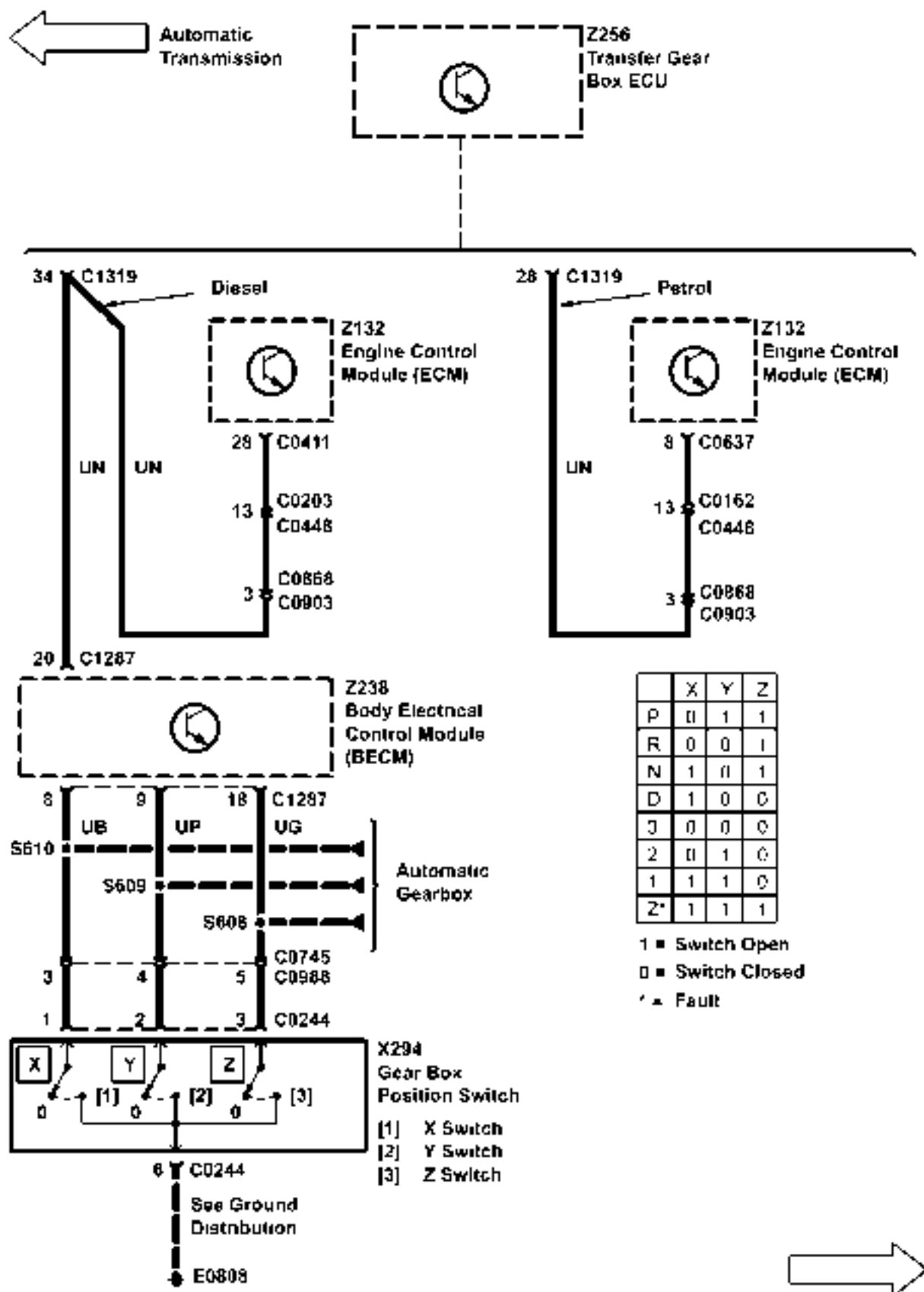

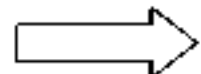
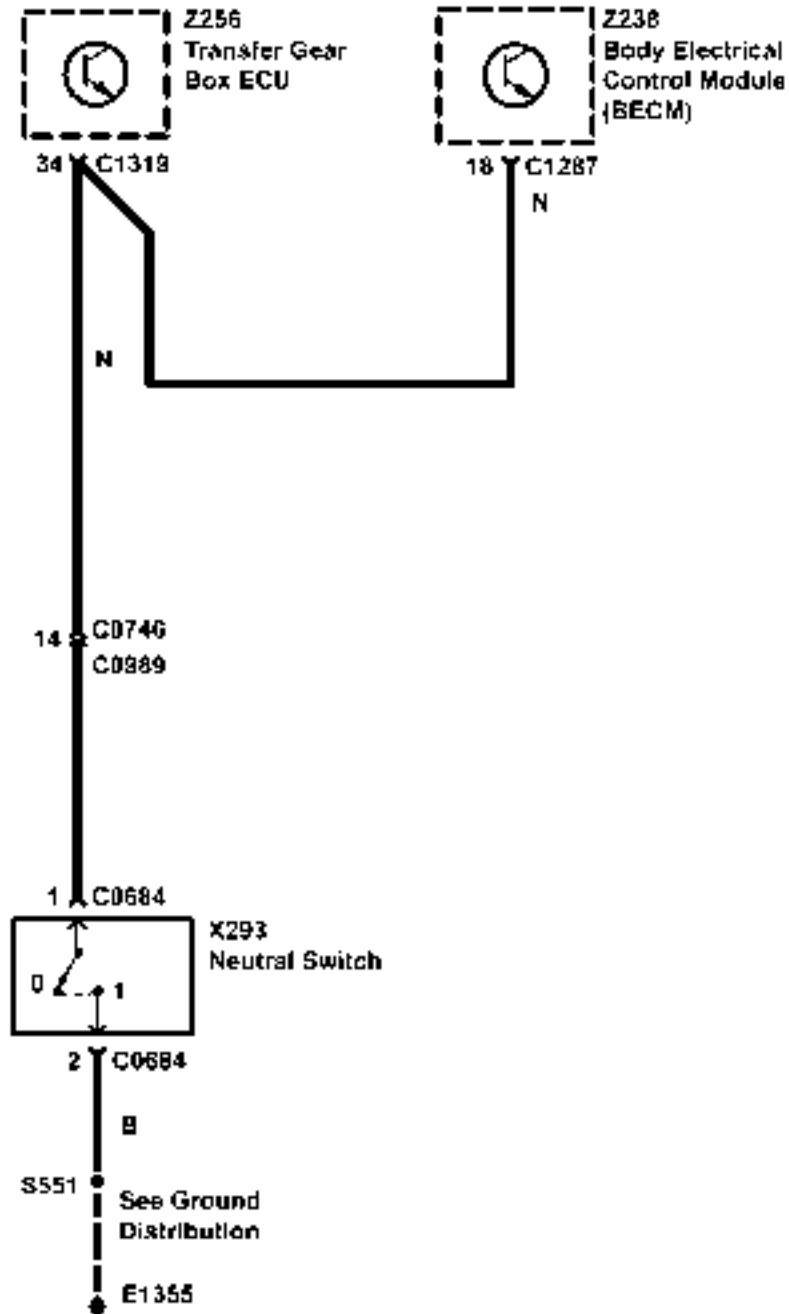

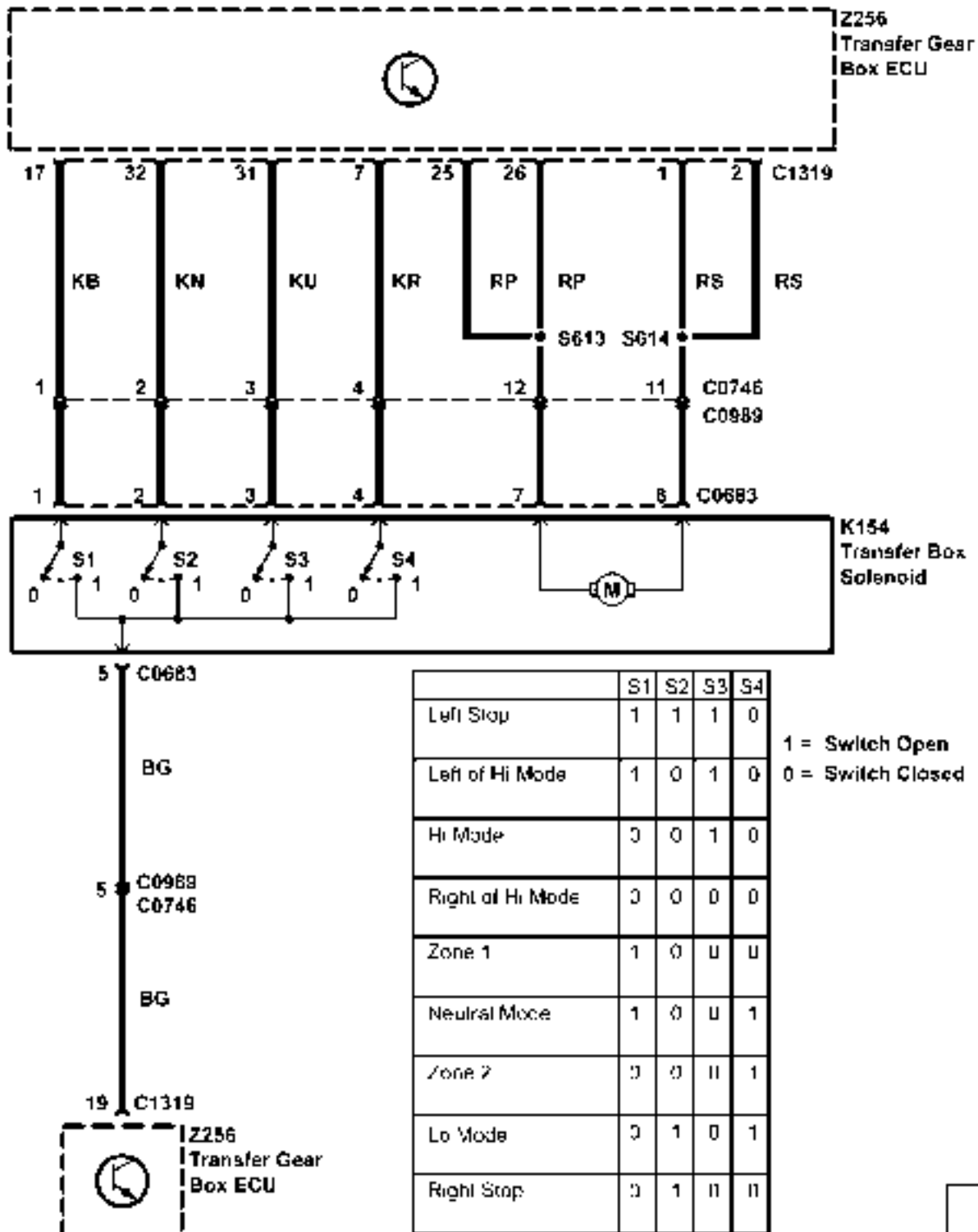
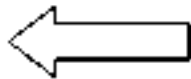

CIRCUIT OPERATION

Economy, Sport and Manual Modes

The Auto Gearbox Control Unit (Z255) has various different driving modes available, with Economy being selected automatically on start up. When the vehicle is in High range, Sport mode can be selected. This will make gear changes more sensitive to throttle movement, thereby shifting down earlier and holding lower gears longer than the Economy mode. If the vehicle is in Low range, Manual mode can be selected. This will make the gearbox change into the selected gear as quickly as possible and hold on to that gear at all speeds.

Interface to Petrol Engine Control Module (ECM) (Z132)

The Auto Gearbox Control Unit (Z255) uses engine torque, engine speed and throttle angle signals from the ECM (Z132) to calculate which gear is required. The Auto Gearbox Control Unit supplies gear selection information to the solenoid valves which will then engage the correct gear. A torque reduction signal is sent from the Auto Gearbox Control Unit to the ECM which will retard the ignition point on each cylinder. This reduces engine power during gear changes. The combination of retarded ignition and reduced engine power delivers a smoother gear change.

Information about engine speed, engine torque, throttle angle and torque reduction is received from the ECM (Z132) by the Auto Gear Box Control Unit (Z255) via CAN bus 'high' and 'low' line on pins 16 and 44.

Interface to Diesel Engine Control Module (ECM) (Z132)

Engine speed is received by the Auto Gearbox Control Unit (Z255) on pin 3, the throttle angle on pin 47. The torque reduction signal is sent to the ECM from the Auto Gearbox Control Unit (Z255) via pin 32.

Interface to Auto Gear Box Control Unit (Z255) Gear Box Position Switch – pins 14, 33, 50, Diesel (pins 8, 36, 37 Petrol)

The Gearbox Position Switch (X294) is mounted on the side of the gearbox and contains 3 internal switches. The switches are connected to the Auto

Gearbox Control Unit (Z255) via pins 50, 14 and 33 for diesel (pins 8, 36, 37 for petrol). By analysing the status of these 3 switches, the Auto Gearbox Control Unit (Z255) calculates which gear the vehicle is in.

If a fault occurs with the switch, the Auto Gearbox Control Unit (Z255) may try to override driver requests and select a different gear.

Solenoid Valves – pins 5, 6, 19, 24, 42 Diesel (pins 5, 30, 32, 33, 53 Petrol)

The Auto Gearbox Control Unit (Z255) has control over 4 solenoid valves: MV1, MV2, torque converter lock up and pressure regulator. These are all supplied via pin 19 diesel (pin 53 petrol), which is activated via a relay in the Auto Gearbox Control Unit (Z255) itself.

MV1 – pin 5 Diesel (pin 30 Petrol), MV2 – pin 24 Diesel (pin 33 Petrol)

When the driver selects 'D' (drive), the Auto Gearbox Control Unit (Z255) controls gear selection via two solenoid valves. If a fault occurs with one or both of the valves, a different gear than the one selected will result.

If the Auto Gear Box Control Unit (Z255) defaults the gearbox, the common supply to all the solenoid valves is removed and the gearbox mechanically shifts either to third gear, if the vehicle is stationary, or fourth, if moving.

MV2 is also used to prevent the driver from selecting reverse gear when the vehicle is moving forward at speeds greater than 8 km/h and from disengaging reverse gear at speeds greater than 6 km/h.

This function is known as "Reverse Safely" and will not be available if MV2 is non-operational and/or the gearbox is in default mode.

Torque Converter Lock-Up Solenoid – pin 42 Diesel (pin 32 Petrol)

The torque converter slips to allow smooth operation of the gearbox. Lock-Up occurs when the vehicle reaches a speed of 45 mph or above in either third or fourth gears.

Pressure Regulator Solenoid – pin 6 Diesel (pin 5 Petrol)

Gearshift quality is controlled by modulating the pressure regulator which is controlled by the Auto Gearbox Control Unit (Z255). When energised the solenoid is in the closed position. If a failure occurs, then the regulator only allows mechanical gear change between third and fourth gears.

Output Shaft Speed Sensor – pins 2, 38, 20 Diesel (pins 42, 14, 15 Petrol)

The automatic gearbox system incorporates an output shaft speed sensor which provides an input to the Auto Gearbox Control Unit (Z255) on pin 2 diesel (pin 42 petrol) and pin 38 diesel (pin 14 petrol) with a screen over the cable attached to pin 20 diesel (pin 15 petrol). It is important that this signal is screened correctly.

MES 1 and 2 – pins 16, 31 Diesel (pins 25, 51 Petrol)

The two Manual/Economy/Sport (MES) lines indicate to the BeCM (Z238) which mode has been selected or if a fault within the transmission has occurred.

Interface to Transmission Gearbox Control Unit (Z256)

High/Low Range Signal – pin 46 Diesel (pin 13 Petrol)

The High/Low signal is used by the Auto Gearbox Control Unit (Z255) to select the correct mode on application of the "MES" switch. Also, the gear shift points and strategies are very different in the different ranges.

Interface to H-Gate – pin 29 Diesel (pin 45 Petrol)

The H-Gate sensor module (Z254) displays selected gear information from the Gearbox Position Switch (X294), ratio information from the Transmission Gearbox Control Unit (Z256) and mode information from Auto Gearbox Control Unit (Z255). The H-Gate receives a signal from the ignition switch when it is turned to position II on a W wire. This is supplied via fuse 6 and is grounded to the console ground E08015 via a B wire.

Information on the selected gear is received from the Gearbox Position Switch (X294) on UB, UP and UG wires. These three lines also provide a feed to the Auto Gearbox Control Unit (Z255) and the BeCM (Z238).

Information on the gearbox mode (sport or manual) is received on a YG wire and a YR wire. These two lines also go to the BeCM (Z238).

The Transmission Gearbox Control Unit (Z256) high status is received on a NY wire. The low status is received on the NR wire. These two lines also go to the Transmission Gearbox Control Unit (Z256) and the BeCM (Z238).

The illumination signal is on a RU wire.

The mode request is on the UO wire. This is sent from the H-gate Sensor Module (Z254) to the Auto Gearbox Control Unit (Z255). The line is activated and deactivated by pressing the momentary action MODE button. The line is active at all times.

Gearbox Oil Cooler – Diesel

The gearbox cooling process relies mainly on ram air entering through an aperture in the LH side of the bumper moulding and is dispersed over the oil cooler. The cooled oil is fed back to the automatic gearbox via the return pipe, which is located parallel to the feed pipe on the LH side of the automatic gearbox.

A small electric fan is fitted to the front of the oil cooler to cool the gearbox oil during long periods of elevated gearbox oil temperatures i.e. during extended idle in drive or low speed towing. A gearbox oil temperature switch is fitted adjacent to the warning light switch on the oil cooler. This switch monitors the gearbox oil temperature. When the gearbox oil temperature reaches $95\text{ }^{\circ}\text{C} \pm 3\text{ }^{\circ}\text{C}$ the switch provides the ground for the oil cooler relay located in the engine compartment fusebox.

The relay receives a power supply on pin 86 from shoring link 8 (J792) in the engine compartment fusebox. The ground for the relay pin 85 is provided through the gearbox oil temperature switch. The relay therefore will not energise unless the gearbox oil temperature switch reaches its defined limit of $95\text{ }^{\circ}\text{C} \pm 3\text{ }^{\circ}\text{C}$.

A separate power supply is connected to the relay pin 30 from fuse F26 (30A). When the gearbox oil temperature switch energises the relay, power is routed via relay pin 87 to the electric fan located on the front of the oil cooler.

As gearbox oil temperature decreases the oil temperature switch deactivates the relay by breaking the relay coil ground circuit. As the ground circuit for the relay is interrupted, the power supply is disconnected.

The ground for both the gearbox oil temperature switch and the electric fan is via a ground point (E0557).

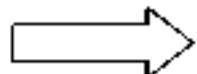
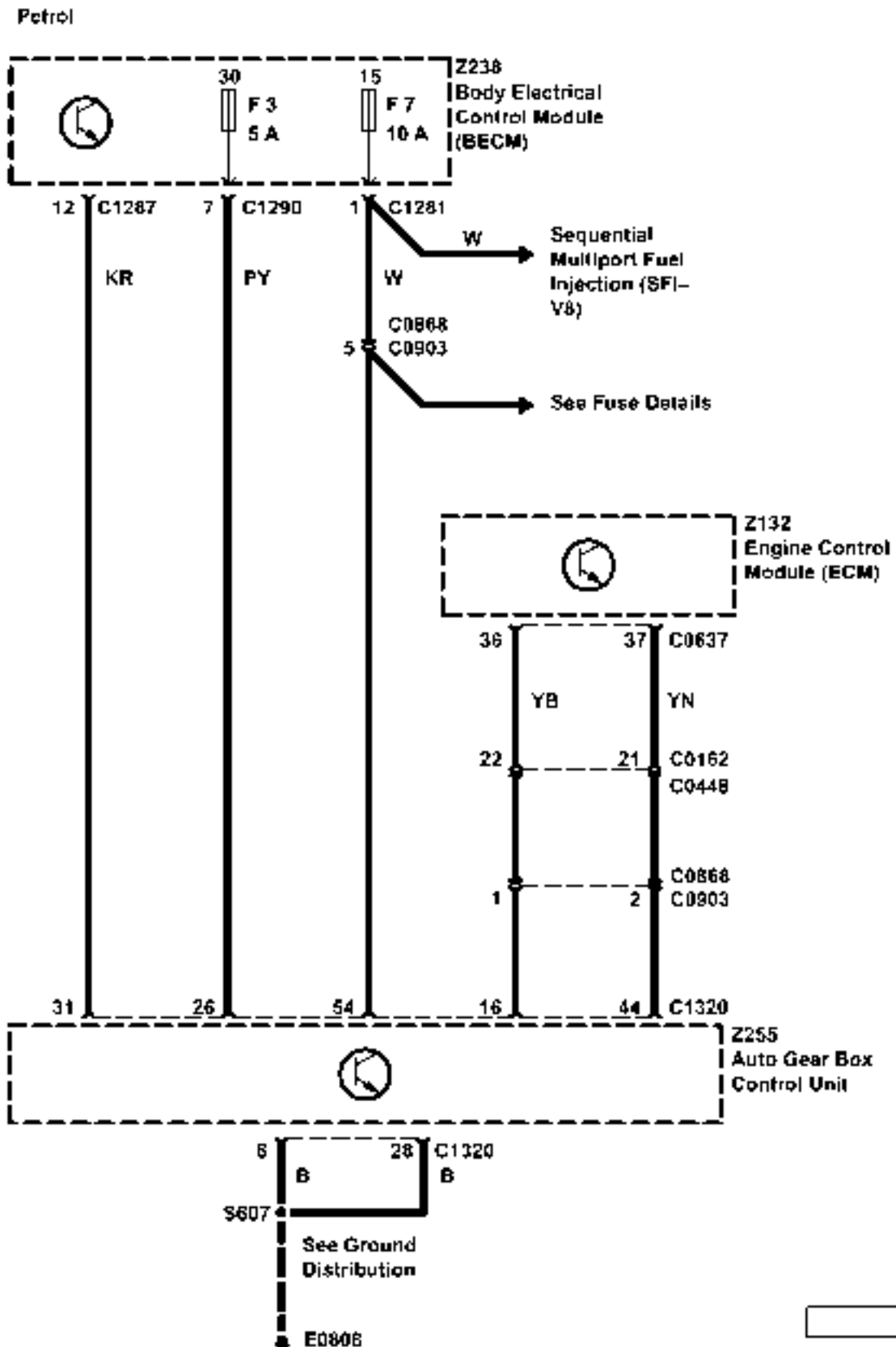

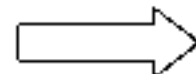
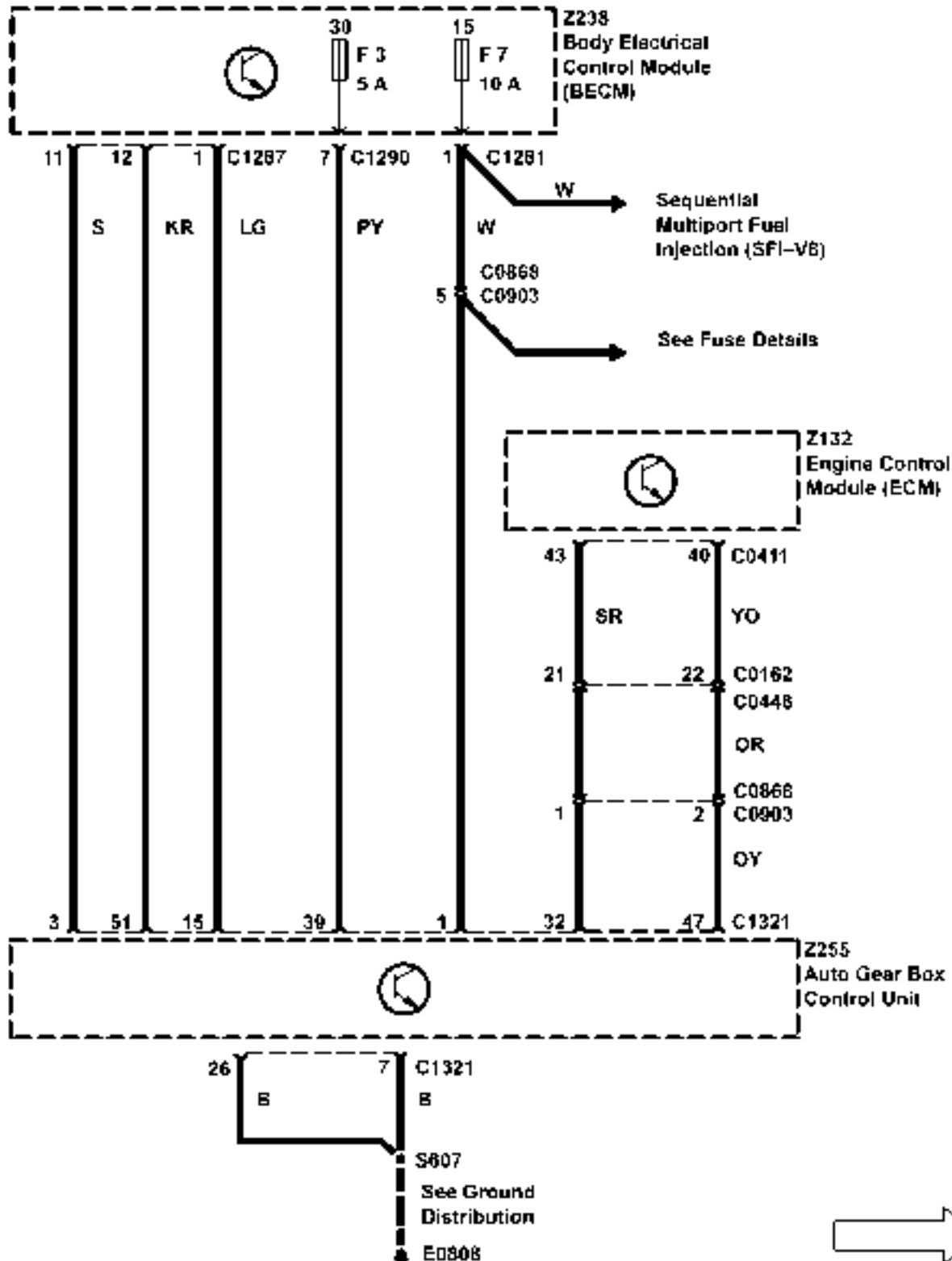
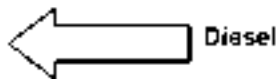

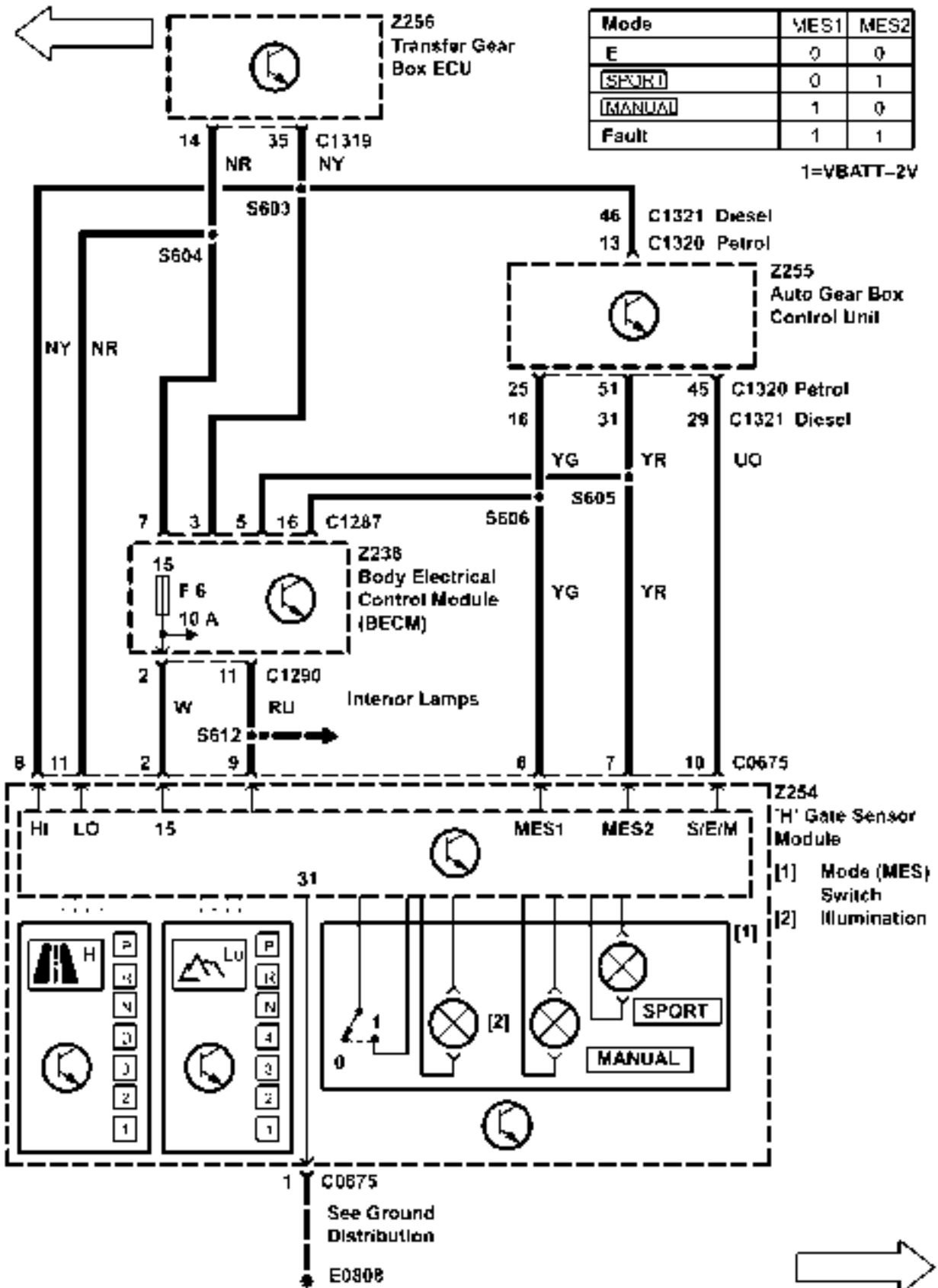

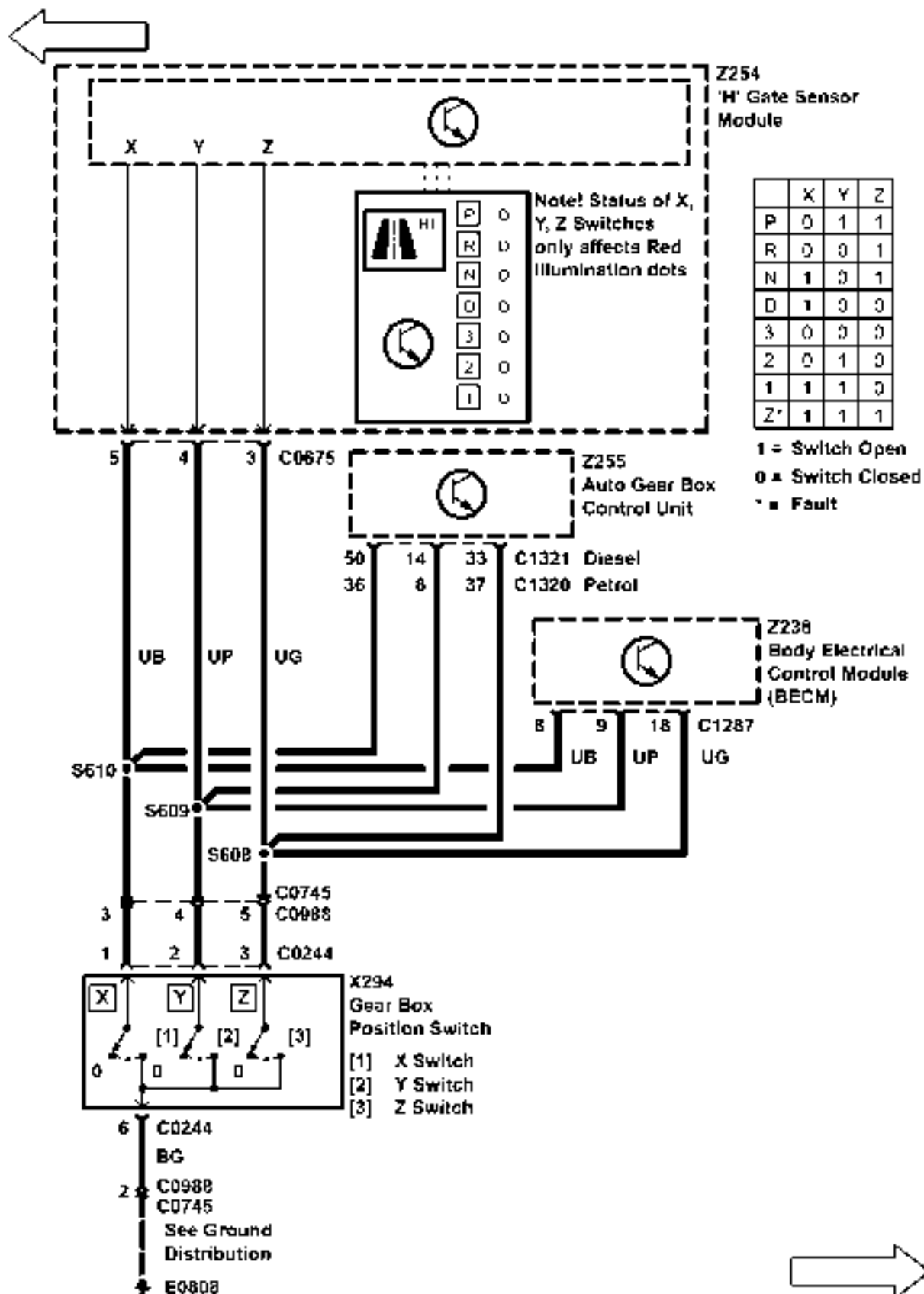

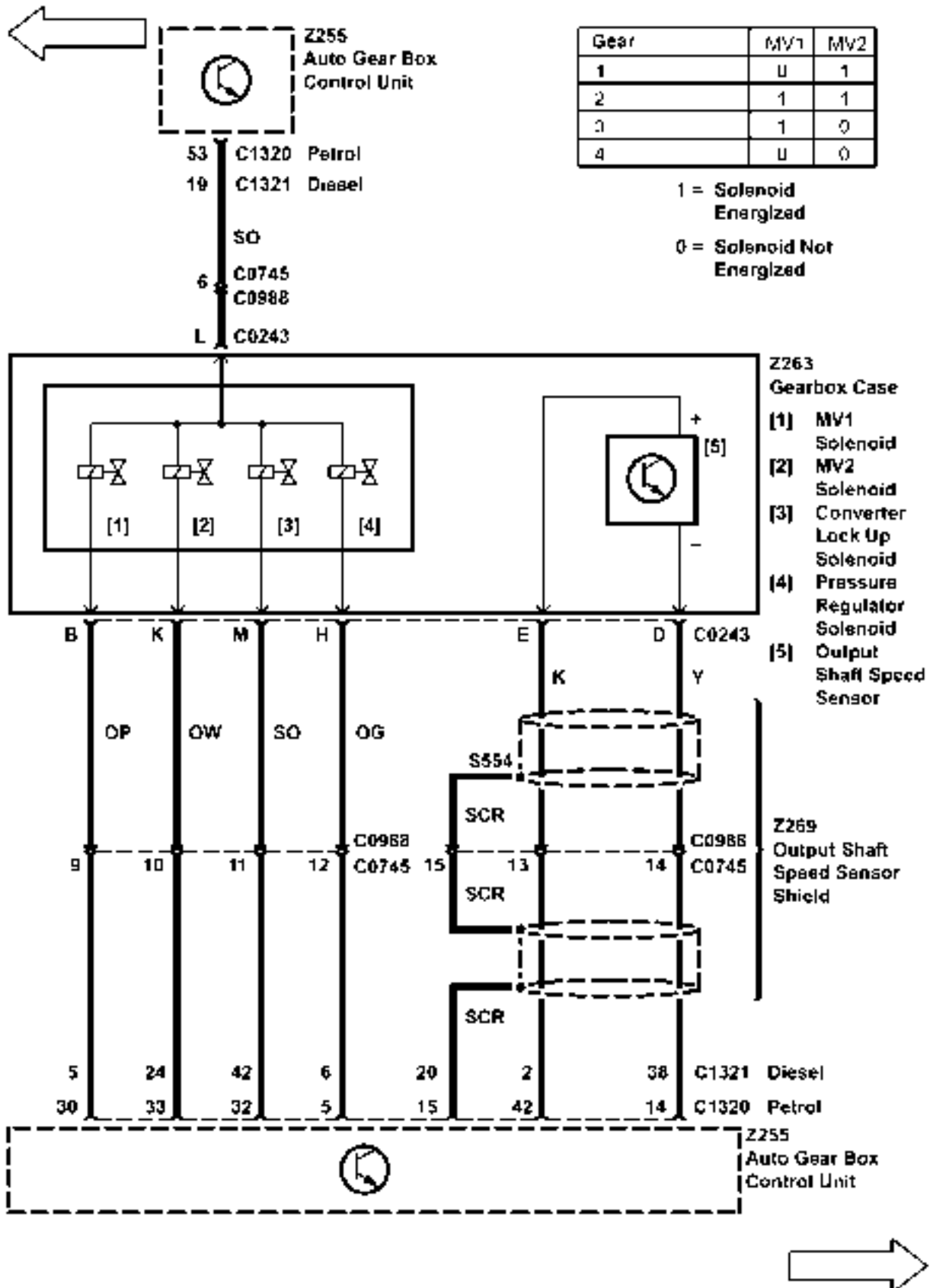

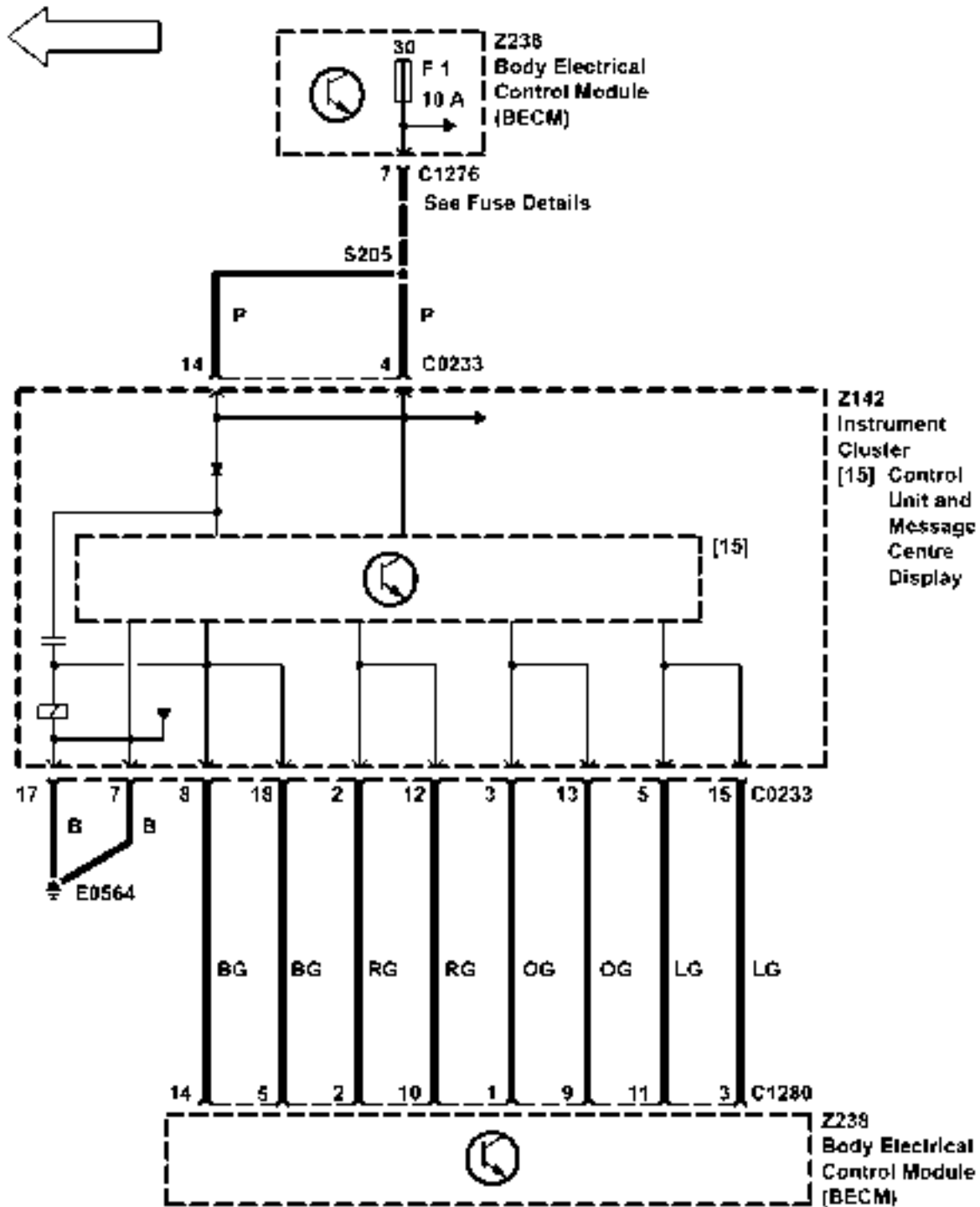

Circuit Operation**Selector Interlock**

The Gear Selector Lever may only be moved out of the Park position when the ignition is on and the brake pedal is depressed. The Shift Lock Solenoid shall be energised continuously whilst the Ignition is on and the Gear Selector Lever is in a position other than Park or Neutral.

Ignition Key Interlock

The Ignition Key Lock Solenoid shall at all times prevent removal of the Key from the Ignition Switch unless the Gear Selector Lever is in the Park position.

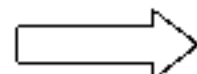
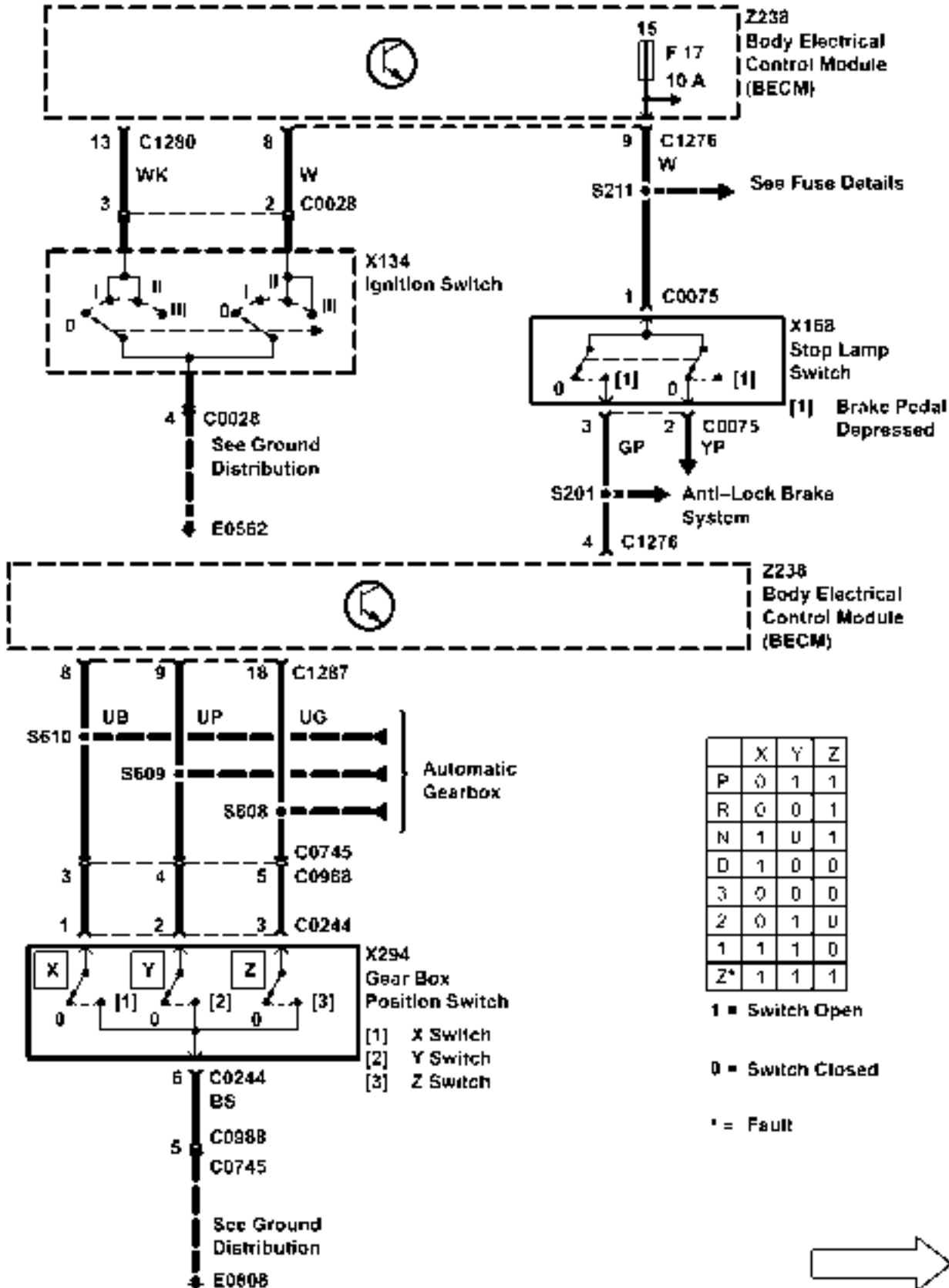

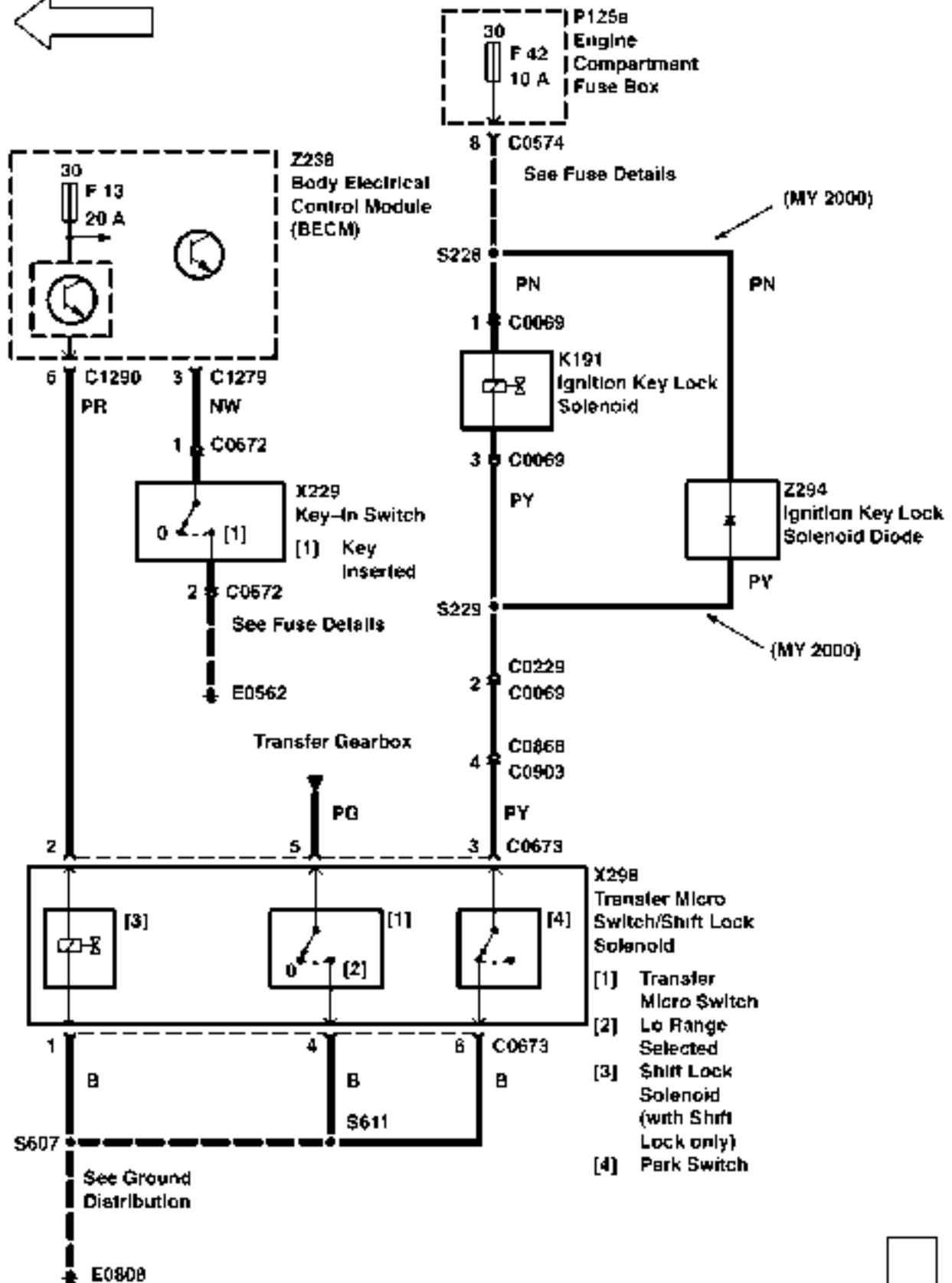
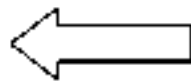

CIRCUIT DIAGRAMS

- Circuit diagrams are arranged so that current flow is from the top of the diagram (current source) to the bottom of the diagram (ground).
- Only those components that work together in the circuit are shown. If only part of a component is used in the circuit, then only that part of the component is shown.
- Remember:

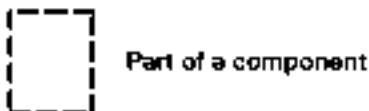

TERMINAL NUMBER	DESIGNATION
50	Battery voltage: Ignition Switch in position III
30	Battery voltage: supplied constantly
15	Battery voltage: Ignition Switch in position II or III
R	Battery voltage: Ignition Switch in positions I, II
31	Ground

See Introduction (I) for additional circuit diagram symbols.

DIAGNOSIS

- If the diagram is accompanied by text:
 - Read the Circuit Operation before proceeding with the electrical diagnosis.
 - Read the Troubleshooting Hints before performing the System Diagnosis.
 - Tests follow the System Diagnosis
 - When performing the System Diagnosis, be certain that all components disconnected in previous steps are reconnected unless otherwise directed.

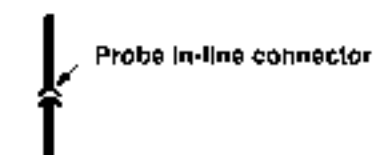
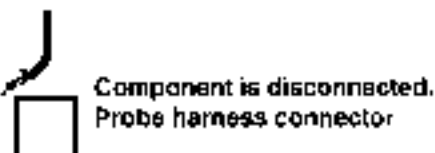
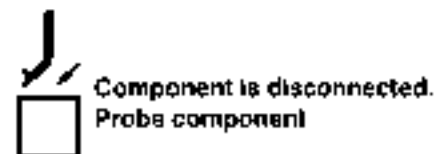
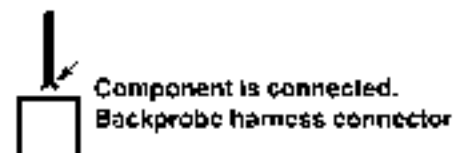
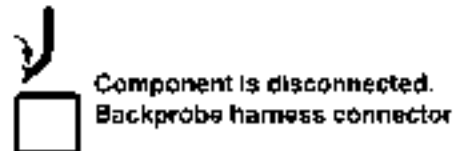

CIRCUIT OPERATION

The Anti-lock Braking System (ABS) prevents wheel lock-up during braking. This enables the driver to maintain vehicle stability and steering control while braking.

The Electronic Traction Control (ETC) system prevents wheel slip to maintain optimum traction on slippery surfaces. Up to 99 Model Year, ETC operates only on the rear wheels at vehicle speeds below 50 km/h (30 mph). From 99 Model Year, ETC operates on all four wheels at vehicle speeds below 100 km/h (62.5 mph).

Anti-lock Braking System Electronic Control Unit (ECU) (Z108)

The ABS ECU (Z108) is a computer that controls ABS operation by permanently monitoring the vehicle's four wheel speeds when the ignition switch is in position I. If an impending wheel lock-up is detected during this monitoring, the ABS ECU will apply voltage to the applicable inlet and outlet valve solenoids contained in the ABS Booster Unit (Z103). Operation of the solenoid valves regulates the pressure applied to the brake caliper and prevents wheel lock-up.

ETC is an extension to the ABS ECU. In addition to monitoring the wheel speeds for lock-up, the ABS ECU also monitors wheel speeds for wheel slip (i.e. wheel speed faster than vehicle speed). When wheel slip is detected, the ABS ECU will apply braking pressure to the slipping wheel(s), causing the wheel speed to slow to vehicle speed and torque to be transferred to the non-slipping wheel(s). The ABS ECU applies the brake by operating the applicable inlet and outlet solenoid valves in the ABS Booster Unit.

The ABS ECU has diagnostic capabilities that allow it to detect faults that may impair the system's efficiency. If a fault occurs, the ECU adopts a default strategy which illuminates the ABS or the TC warning light in the instrument cluster (Z142) and stores a fault code in its memory to aid system troubleshooting. When an ABS fault has been detected, the message ABS FAULT may also be displayed in the instrument cluster message centre. When an ETC fault has been detected, the message TRACTION FAILURE is displayed and on the first detected fault a single audible chime sounds. Fault codes stored in the ECU memory can be retrieved using Testbook or a universal scan tool.

The ABS ECU also performs a bulb check of the warning lights when the ignition switch is first turned to position I. The ABS warning light is illuminated for 1 second, extinguished for 0.5 seconds and illuminated again until the ECU receives an input speed of 7 km/h (5 mph) from all four wheel speed sensors (X137, X140, X1153, X161) and is then extinguished. The TC warning light is illuminated for 3 seconds and then extinguished. If a system fault is detected during the bulb check the ABS or the TC warning light remain illuminated.

When ETC is activated, the TC warning light illuminates, a single audible chime sounds and on earlier models, the message TRACTION is displayed. The message and warning light extinguish after 2 seconds minimum or when ETC is de-activated. If ETC is continuously or repeatedly active and there is a risk of the brakes overheating the ABS ECU disables the ETC. To advise the driver of the disablement, the ETC warning light flashes for 10 seconds minimum, a single audible chime sounds and the message TRACTION OVERHEAT is displayed. The ABS ECU restores ETC availability after allowing time for the brakes to cool.

ABS Booster Unit (Z103)

The ABS Booster Unit (Z103) contains 2 isolation solenoid valves and 4 pairs of solenoid control valves which are grounded through the harness. When the ETC is filled, the booster unit also contains an additional 2 solenoid valves. The pairs of solenoid control valves each include a fluid pressure inlet and outlet valves that control ABS braking to one wheel.

The Anti-Lock Brake System ECU (Z108) operates these valves by applying battery voltage to them. The valves are designed to decrease, hold or increase pressure to retain wheel rotation and optimum braking.

The 2 isolation valves consist of 2 solenoid valves that control fluid inlet and outlet. Their function is to disconnect or isolate the master cylinder from the servo cylinder and to connect the servo cylinder to the reservoir return during ABS functions.

Wheel Speed Sensors (X137, X140, X158, X161)

A wheel speed sensor is located at each wheel. The speed sensors generate an AC voltage signal as a toothed ring rotates past the stationary sensor pickup. The Anti-Lock Brake System ECU (Z108) calculates the wheel speed by measuring the frequency of the AC voltage signal generated by the sensors.

ABS Hydraulic Pump (M102)

The hydraulic boost for the system is provided by the ABS Hydraulic Pump (M102) which is controlled by the ABS Pump Relay (K102) and the ABS Pressure Switch Unit (Z104).

The Pressure Switch unit incorporates three electro-mechanical switches. The first operates the pump, two more illuminate the low pressure condition and signal that ABS and ETC functions should be curtailed. The Hydraulic Pump includes a hydraulic accumulator and non-return valve, as well as a pressure relief valve to protect the system.

When low pressure occurs in the brake system a switch in the pressure switch unit closes to ground the coil of the pump relay. The pump relay now energizes and applies battery voltage from the fuse to the hydraulic pump through the closed relay contacts. The hydraulic pump runs to increase pressure in the hydraulic accumulator. When sufficient pressure is developed in the system, the pressure switch opens to de-energize the pump relay and to turn off the hydraulic pump.

ABS Warning Lamp

The Anti-Lock Brake System ECU (Z108) sends signals to the BCM which then controls the illumination of the ABS warning lamp. The BCM also controls the display of the system messages.

Solenoid Valve Relay

This is energized by the ABS ECU and sends voltage back to the part of the same ECU which controls the solenoid valves in the booster. When the ABS ECU detects a fault that requires a complete system shutdown, the relay is de-energized.

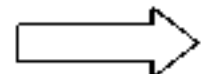
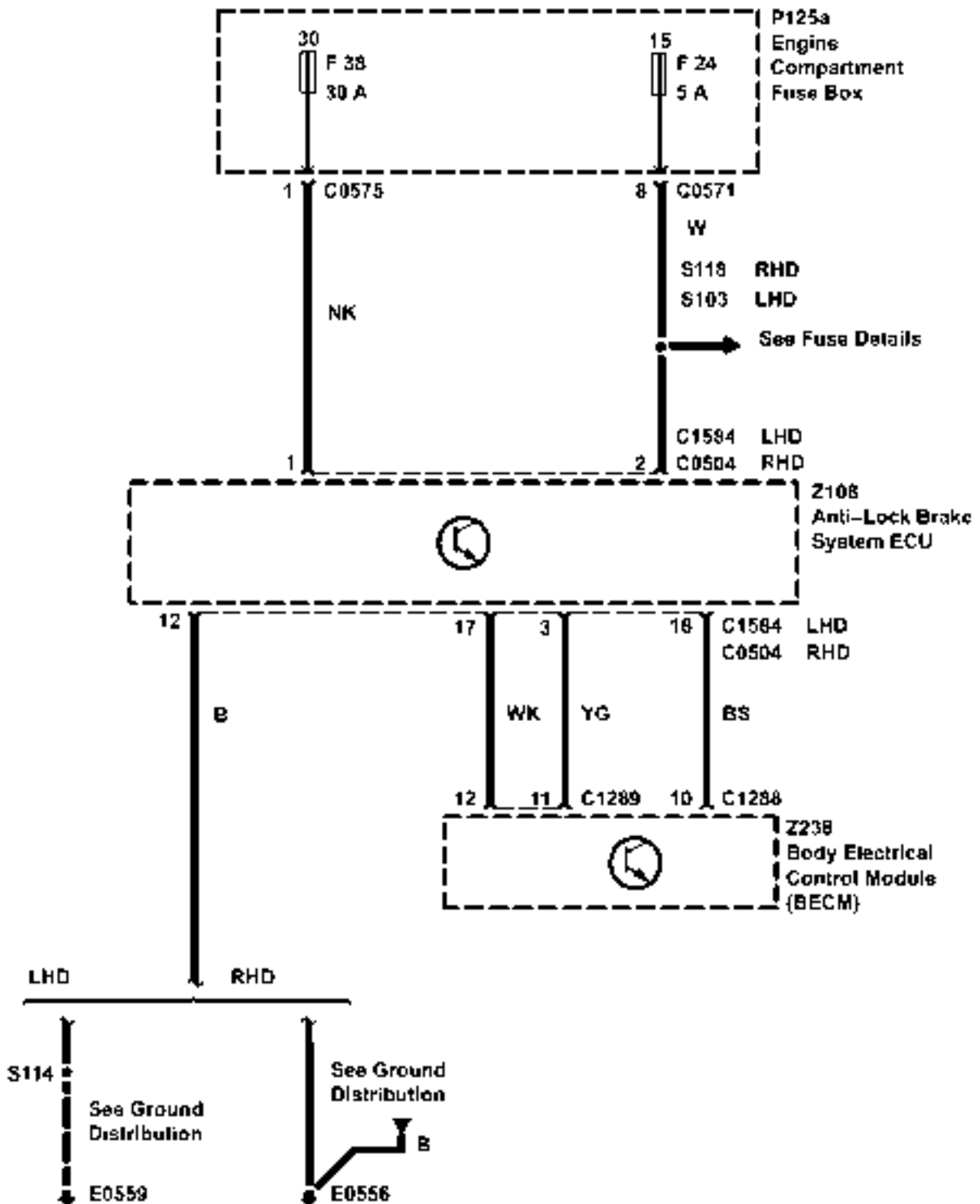

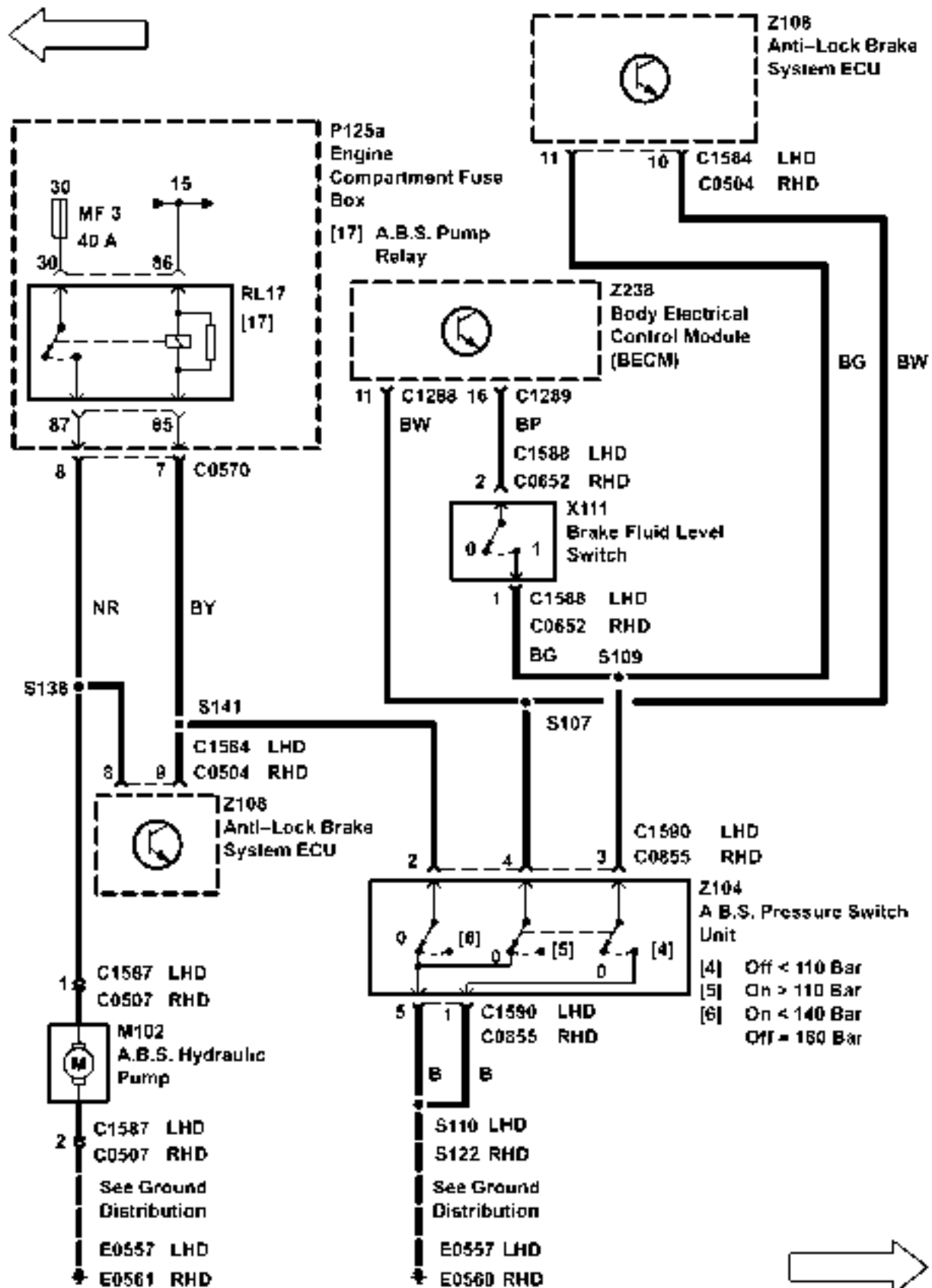

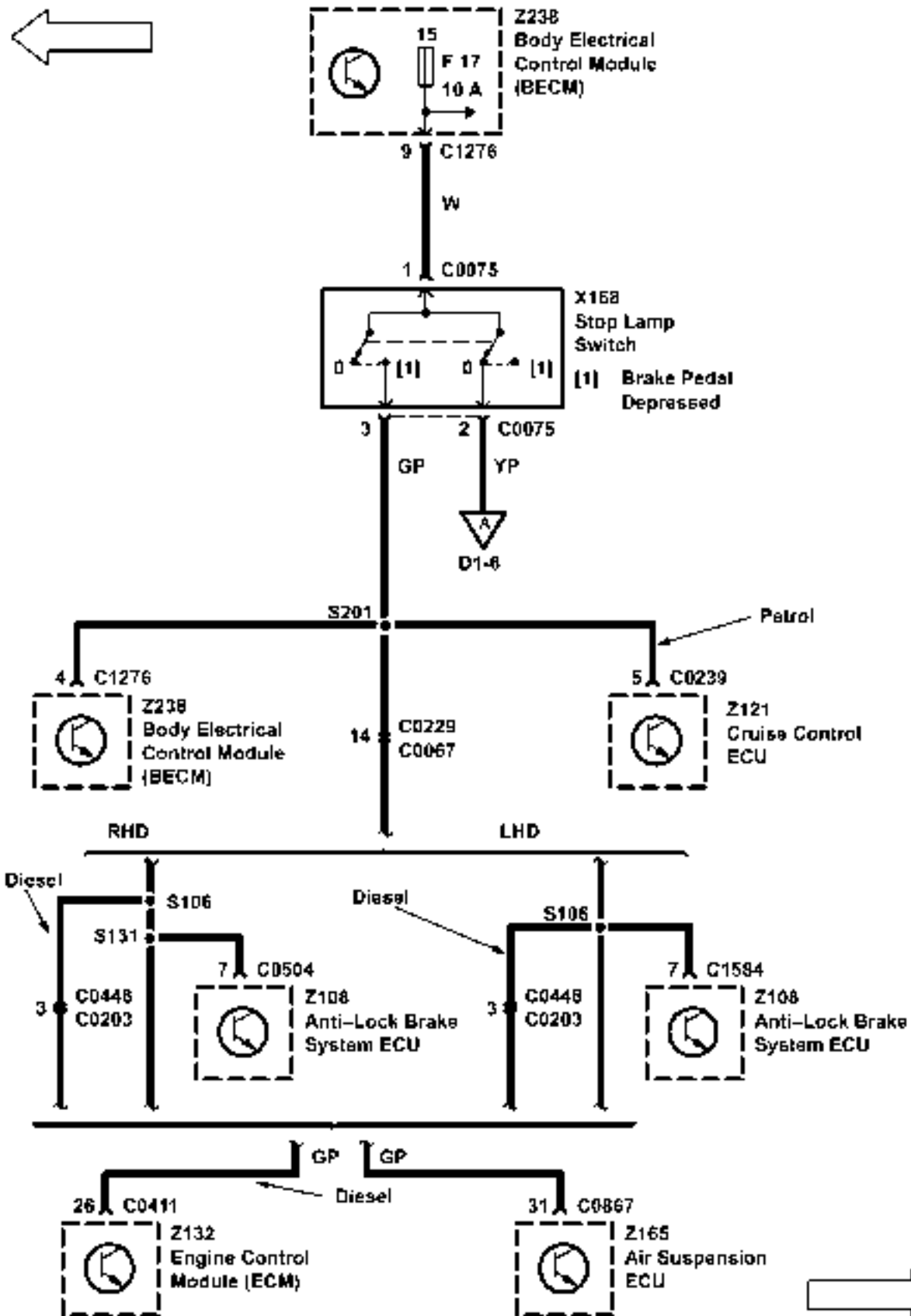

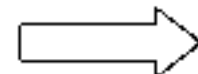
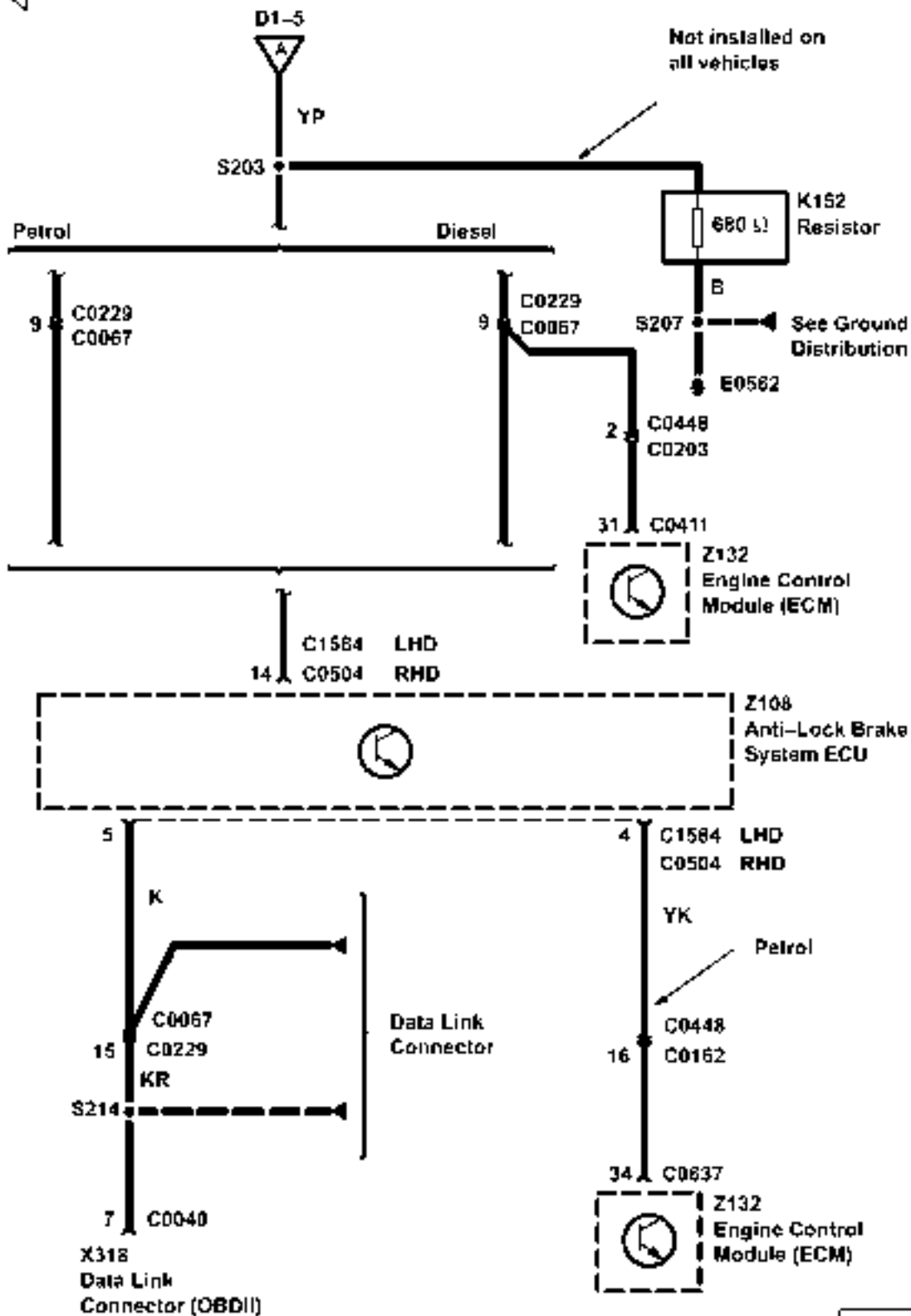

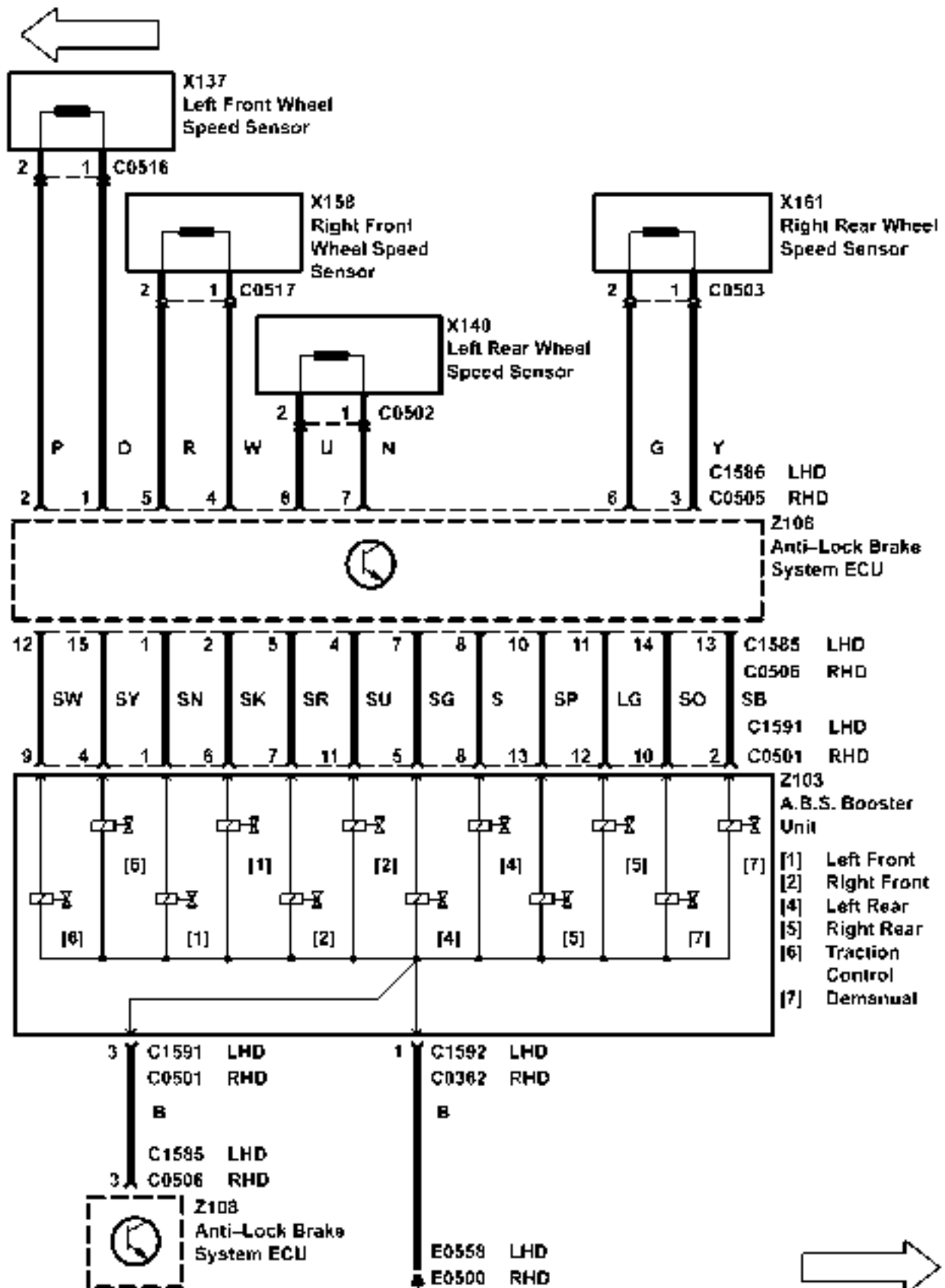

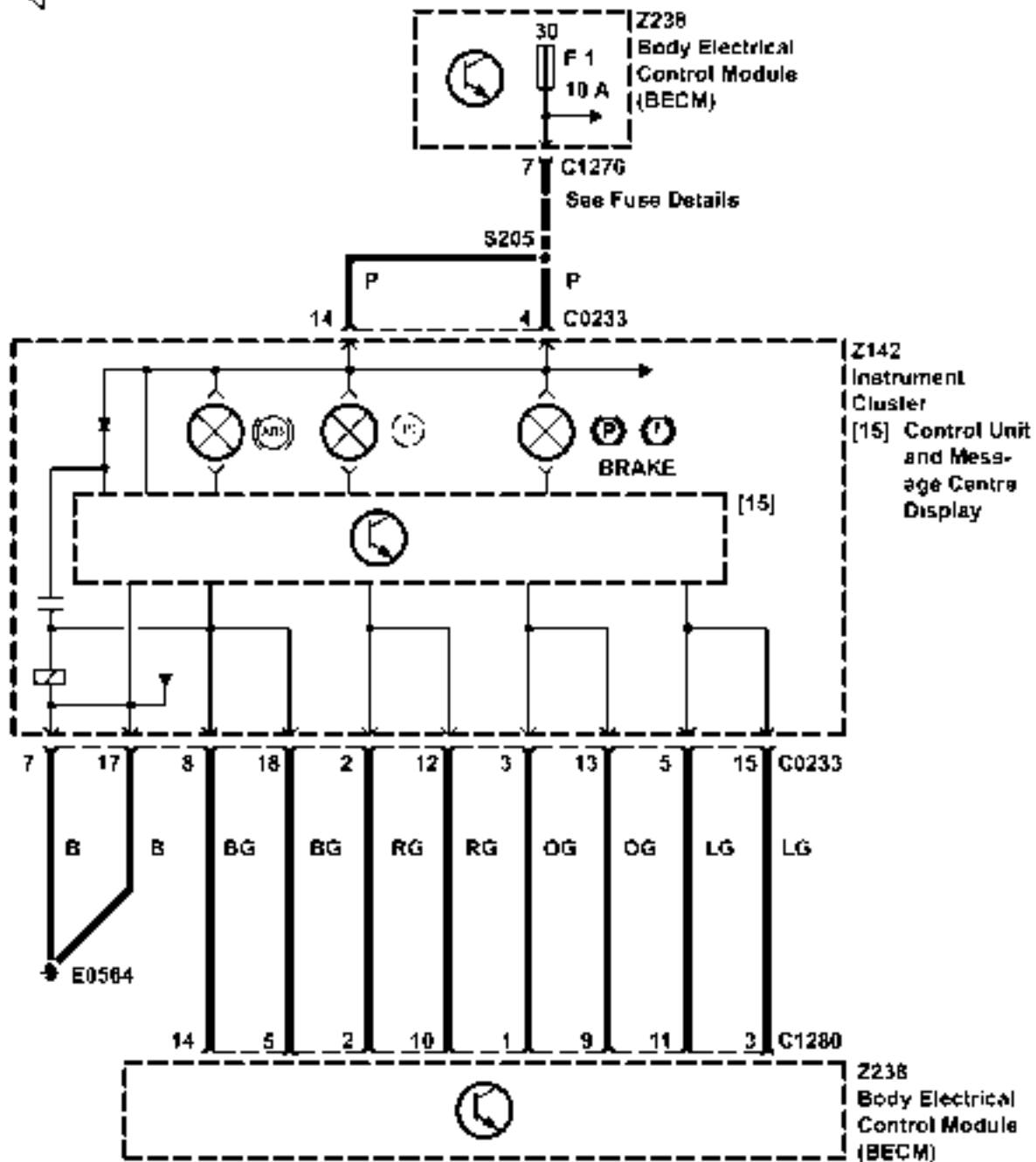
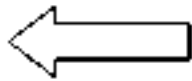

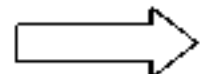
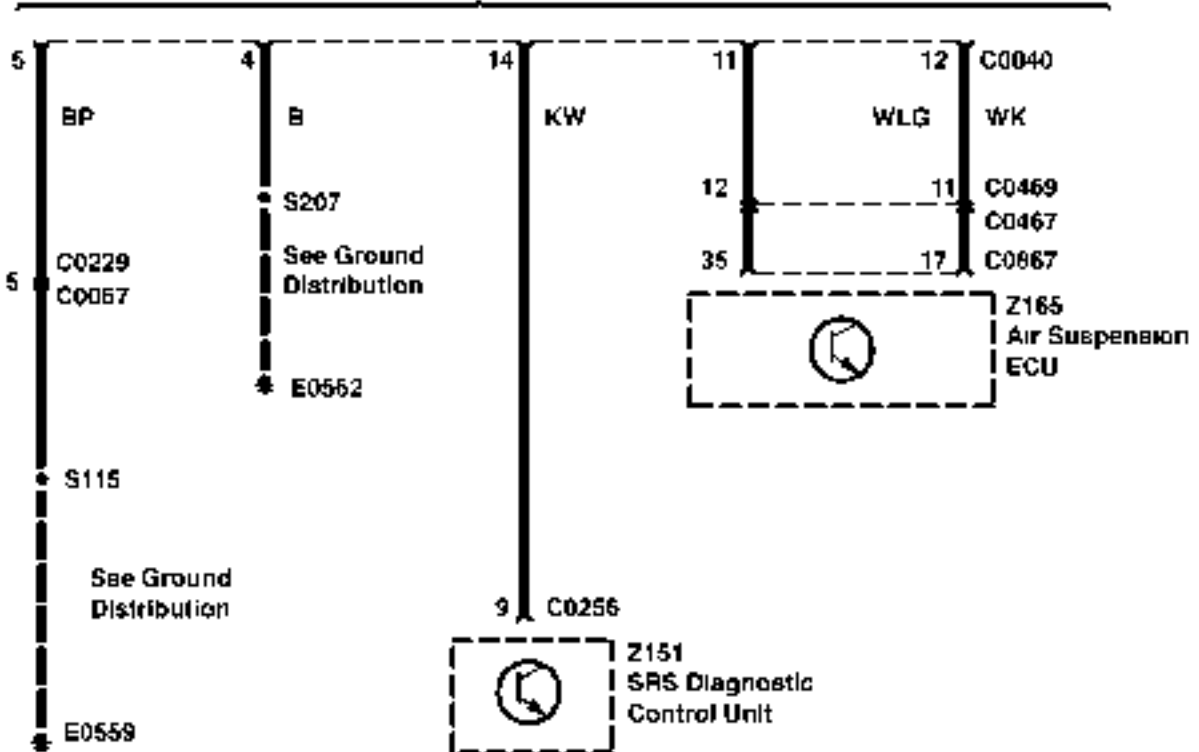
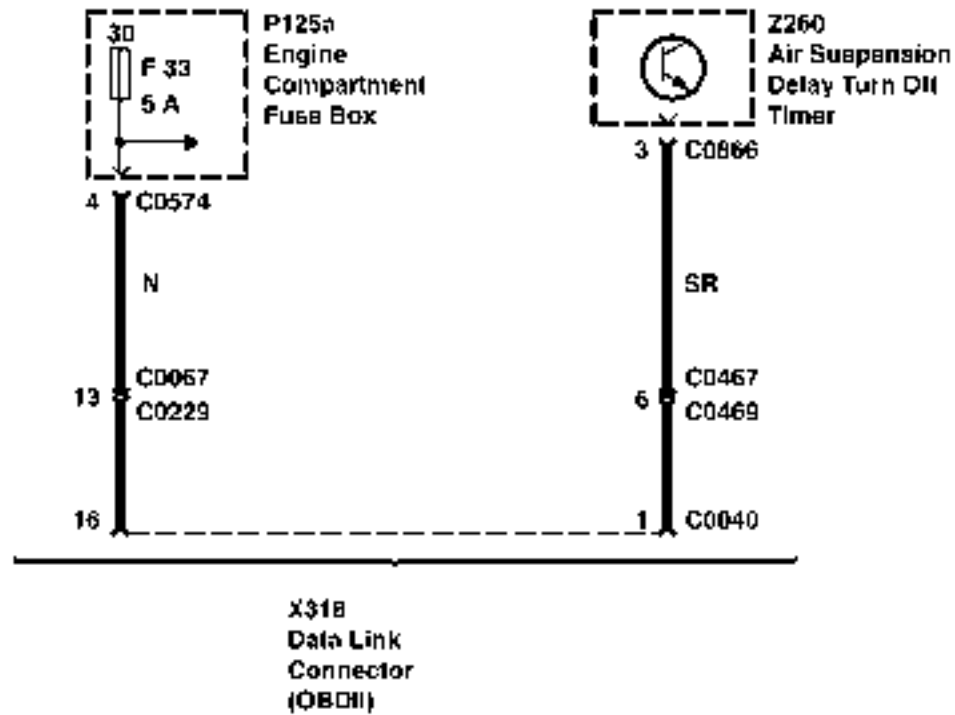

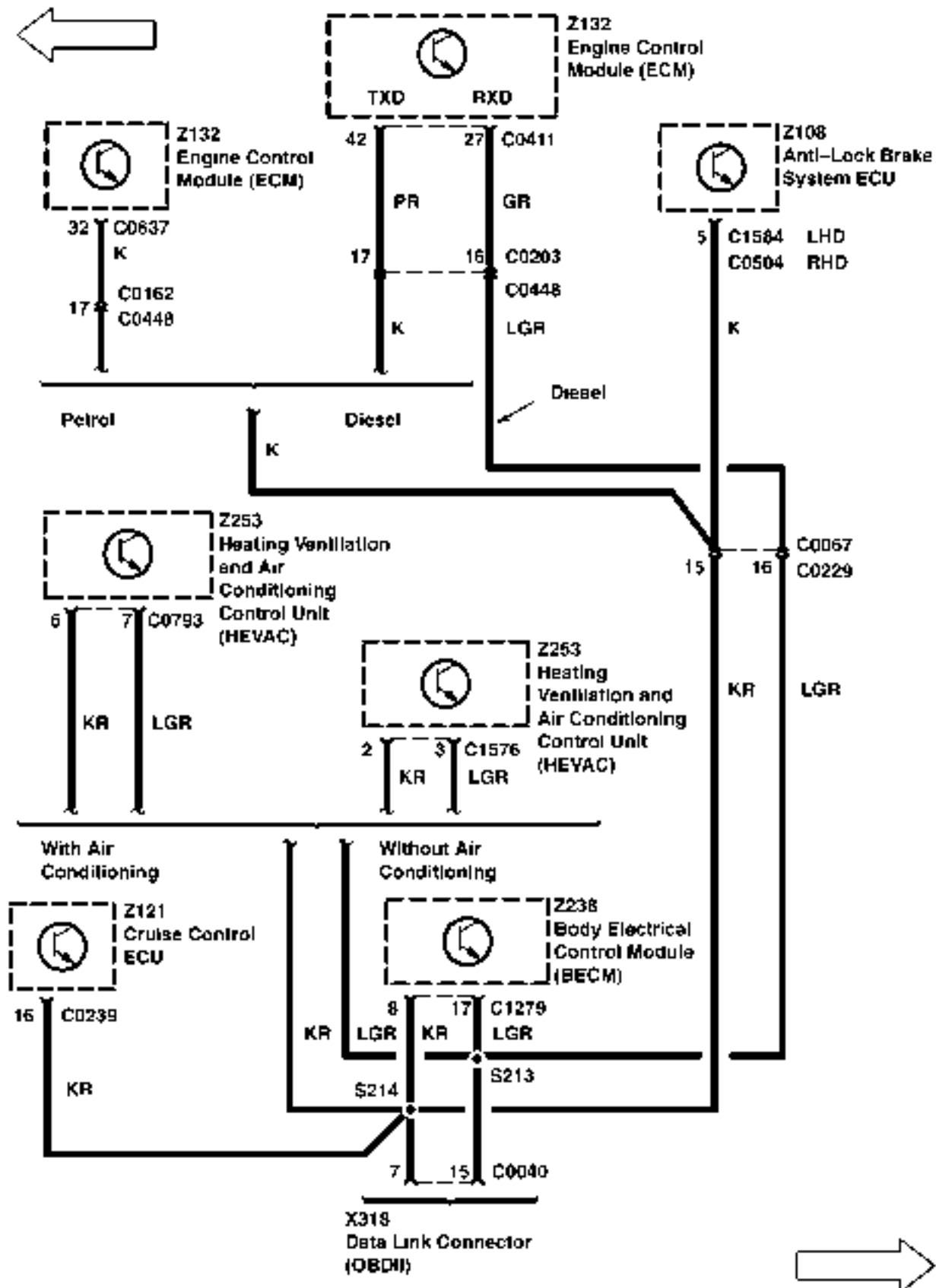

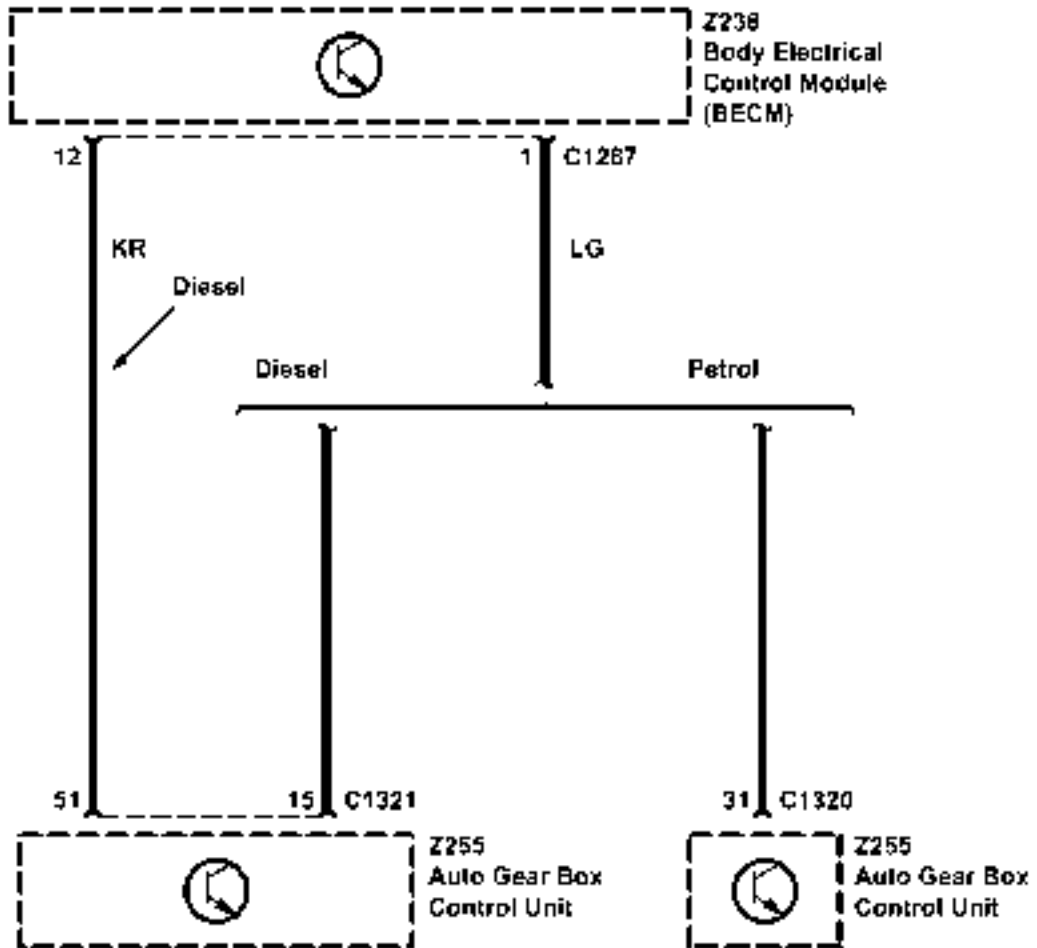
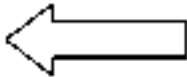

CIRCUIT OPERATION

Engine Coolant Temperature Gauge

The engine coolant temperature gauge sensor has the capability to sense from -40°C to $+130^{\circ}\text{C}$. Petrol and Diesel resistance values are different.

Both Petrol and Diesel sensors are interfaced to the Instrument Cluster (Z142) via the BeCM (Z238). The resistance value then being represented by an A/D data transfer generating the required angular deflection on this gauge. [A/D = Analog to Digital]

Fuel Gauge

When the fuel tank level is low (E), the resistance value of the gauge sensor is 270Ω for petrol and diesel engines. As the fuel level increases, the resistance of the sensor decreases. When the fuel tank is full, the resistance value of the sensor for petrol engines is 19Ω and for diesel engines 25.8Ω . When the fuel gauge sensors resistance value increases to 175Ω (9 liters/2.25 US gallons), the low fuel warning light will illuminate to warn of the fuel status. Both Petrol and Diesel sensors are interfaced to the Instrument Cluster (Z142) via the BeCM (Z238). The resistance values then being represented by an A/D data transfer generating the required angular deflection on the gauge.

Speedometer

The signal to activate the gauge is originated at the ABS wheel sensors, transmitted to the ABS ECU (Z108) which then puts out a usable signal to the Instrument Cluster (Z142) of 8000 pulses per mile or 4972 pulses per kilometer. The signal is also transmitted to other ECU's such as the Engine Control Module (ECM) (Z132) and the Cruise Control ECU (Z121).

Tachometer

The tachometer will display the engine speed in R.P.M. It will derive the engine speed from the engine speed pulse train transmitted from the Engine Control Module (ECM) (Z132).

The pulse rate for petrol engines will be 4 pulses per engine revolution.

The pulse rate for diesel engines will be 3 pulses per engine revolution.

Audible Warning

Receipt of an audible warning request signal from a vehicle parameter/message condition shall cause the BeCM (Z238) to generate the required number of warning tones. The actuator/sounder unit is located at the rear of the Instrument Cluster (Z142).

See message listing for categories/priority and levels of audible warnings.

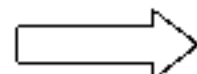
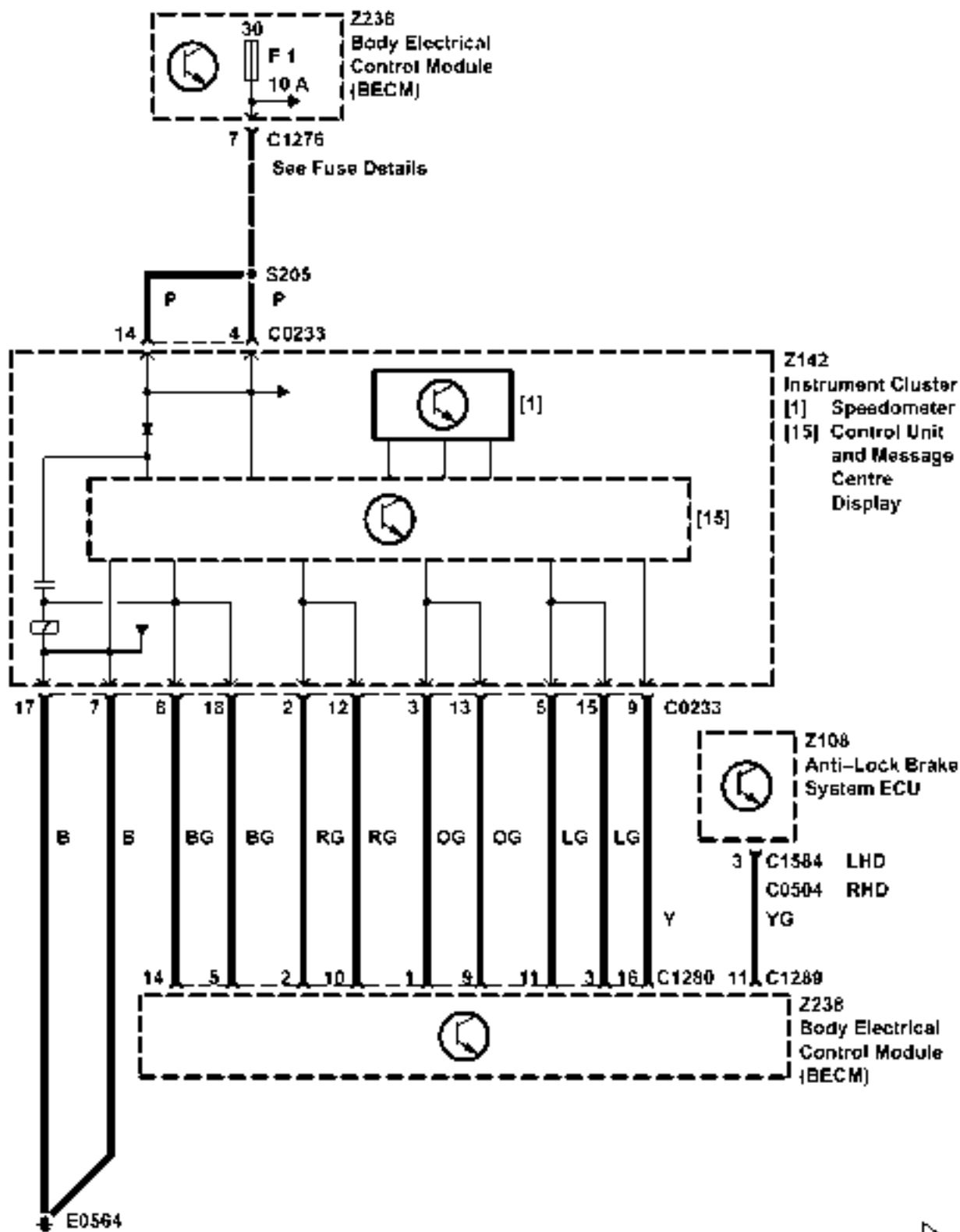

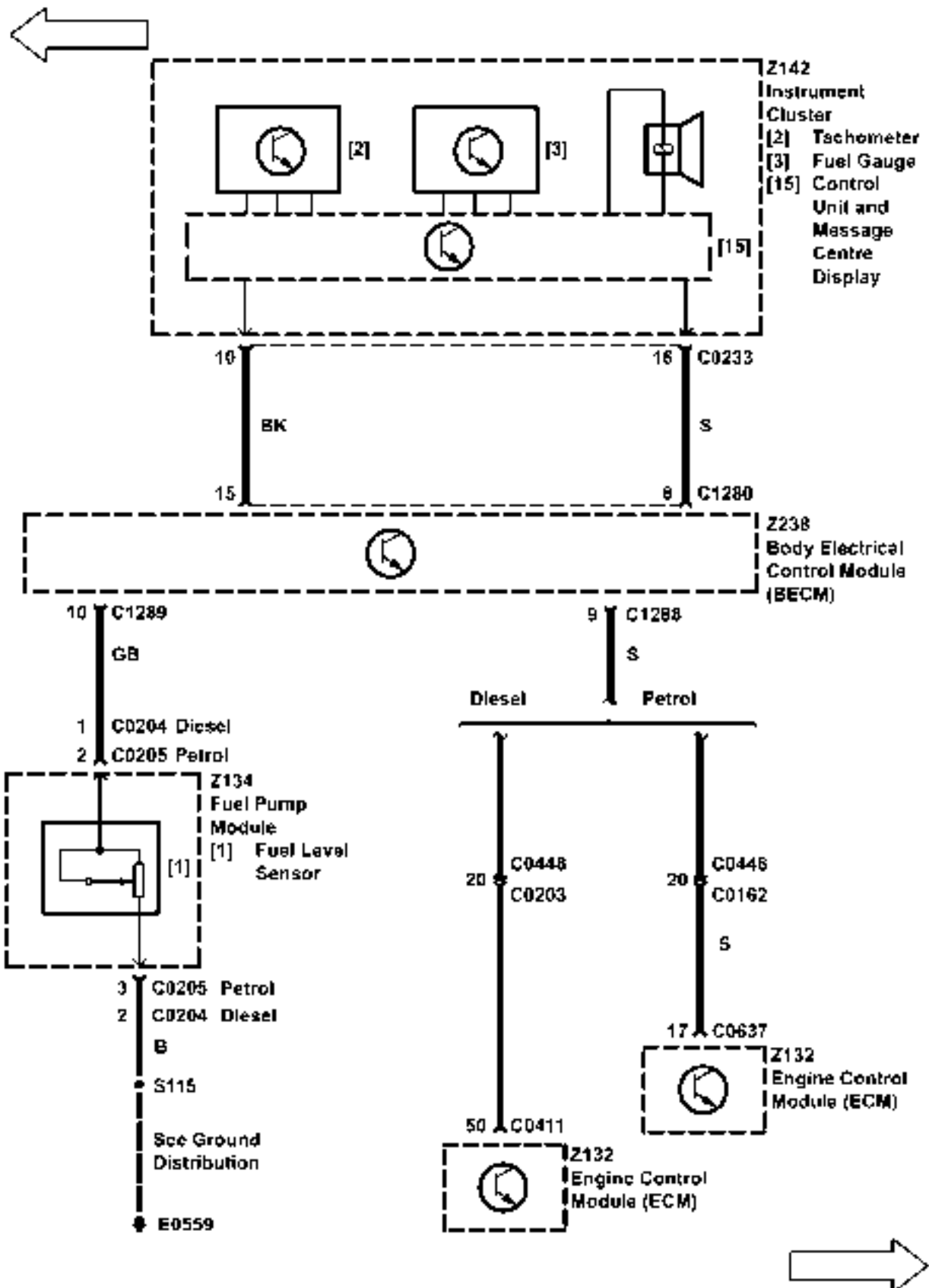

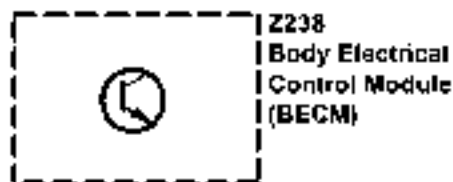
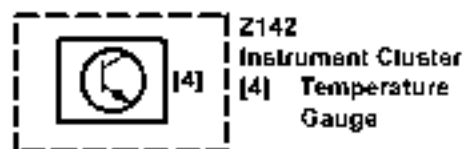
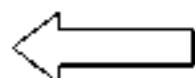

19 C1289
G

Petrol

Diesel

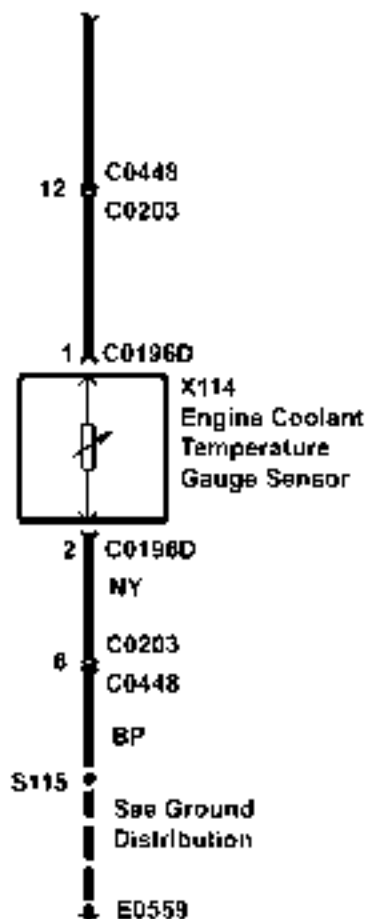
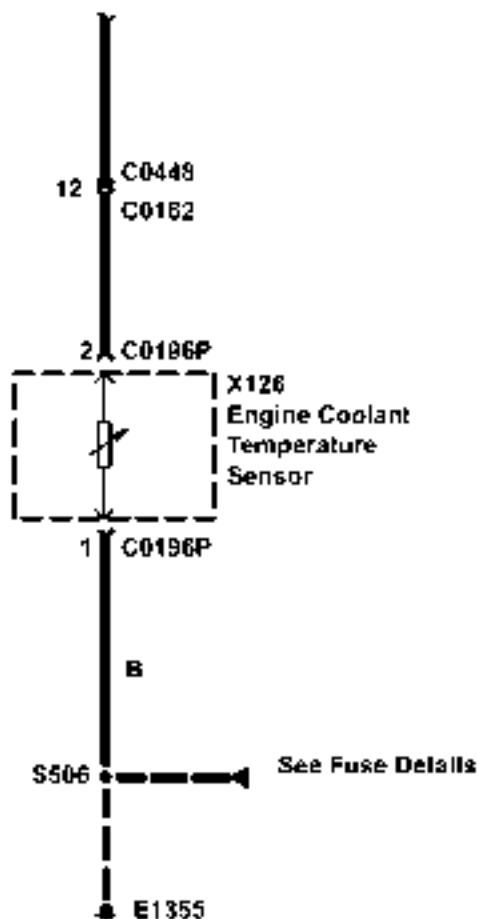

CIRCUIT OPERATION

All warning indicators are controlled by Data sent to the Instrument Cluster (Z142) from the Body Electrical Control Module (BeCM) (Z238). All data is transmitted via the serial data lines. The BeCM (Z238) will provide data based upon input from various sensors.

Some warning lights may also be accompanied by a message which will appear in the message centre display on the instrument pack.

Service Reminder Indicator (SERVICE ENGINE)

Illuminates briefly (for 3 seconds) as a bulb check when the Ignition switch is turned to position II.

Illuminates continuously when the vehicle reaches 50,000 miles (80,500 km) approx.

Low Fuel Warning Indicator

Illuminates briefly (for 4 seconds) as a bulb check when the Ignition Switch is turned to position II.

When the fuel gauge sensors resistance value increases to 175 Ω (9 liters/2.25 US gallons), the low fuel warning light will illuminate to warn of the fuel status. Both Petrol and Diesel sensors are interfaced to the Instrument Cluster (Z142) via the BeCM (Z238).

High Temperature Warning Indicator

Illuminates briefly (for 4 seconds) as a bulb check when the Ignition switch is turned to position II.

The engine coolant temperature gauge sensor has the capability to sense from -40°C to +130°C. Petrol and Diesel resistance values are different.

Both Petrol and Diesel sensors are interfaced to the Instrument Cluster (Z142) via the BeCM (Z238).

Malfunction Indicator Lamp (CHECK ENGINE)

Illuminates briefly when the Ignition Switch is turned to position II as a bulb check and extinguishes when the engine is running. Illumination at any other times indicates an engine fault.

Both Petrol and Diesel Engine Control Modules (Z132) are interfaced to the Instrument Cluster (Z142) via the BeCM (Z238).

Oil Pressure Warning Indicator

Illuminates as a bulb check when the Ignition switch is turned to position I, and extinguishes when the engine is running.

The Oil Pressure Switch (X149) is closed with Low Oil Pressure.

Both Petrol and Diesel switches are interfaced to the Instrument Cluster (Z142) via the BeCM (Z238).

ABS Warning Indicator

This light illuminates for approximately 1 second when the Ignition switch is turned to position II and then briefly extinguishes before coming on again. The warning indicator will then remain illuminated until the vehicle is driven above approximately 5 mph (7 km/h). If the light does not extinguish or illuminates again then a fault has occurred with the ABS system.

If the light remains illuminated once a speed of 5 mph (7 km/h) has been reached, or subsequently illuminates whilst driving, a fault has been detected by the self-monitoring system. The message centre will display 'ABS FAULT'.

The ABS System is interfaced to the Instrument Cluster (Z142) via the BeCM (Z238).

ETC Warning Indicator (TC)

Illuminates for 3 seconds after the Ignition switch is turned on and the ABS and traction control systems have completed their self-checks.

Whilst driving, the TC light will illuminate (for a minimum of 2 seconds) whenever traction control is active, the light extinguishing as soon as traction control ceases. The light flashing (for at least 10 seconds) indicates that the system has been over-used. It will be available again once the system components have cooled.

If the light illuminates continuously a fault with the system is indicated.

The ABS System is interfaced to the Instrument Cluster (Z142) via the BeCM (Z238).

Brake Warning Indicator

Illuminates for 3 seconds as a bulb check when the Ignition switch is turned to position II and also illuminates when the handbrake is applied and the Ignition switch is in position II.

The light should extinguish when the handbrake is fully released or after the bulb check if the handbrake is off. If the light illuminates whilst driving a fault is indicated.

NOTE: If the vehicle has been standing for some time it may take up to 40 seconds before the light extinguishes (in this case ABS and TC warning lights will also be illuminated).

The Brake System and Handbrake Switch (X101) are interfaced to the Instrument Cluster (Z142) via the BeCM (Z238).

Cruise Active Indicator

When the Cruise Control System has been activated the indicator will be illuminated. The Cruise System is interfaced to the Instrument Cluster (Z142) via the BeCM (Z238).

Charge Warning Indicator

Illuminates as a bulb check when the Ignition switch is turned to position I and extinguishes when the engine is running and the Generator (Z106) is producing normal power. If the Generator (Z106) is not producing normal power or the Generator (Z106) stops turning the indicator will illuminate.

Both Petrol and Diesel Generators (Z106) are interfaced to the Instrument Cluster (Z142) via the BeCM (Z238).

Fasten Seat Belt Indicator

Illuminates for 0 seconds when the Ignition switch is turned to position II. When the driver's seat belt is buckled, the indicator turns off.

The Driver's Seat Belt Switch (X120) is interfaced to the Instrument Cluster (Z142) via the BeCM (Z238).

Air Suspension Indicator

Illuminates as a bulb check when the ignition switch is turned to position II and remains illuminated until 2 seconds after the engine has started.

In addition, the light will illuminate whilst driving whenever 'High' or 'Extended' ride heights are selected and also if a fault with the air suspension system is detected.

The air suspension system is interfaced to the Instrument Cluster (Z142) via the BeCM (Z238).

Lights "ON" Indicator

This light illuminates when the sidelights and/or headlights are switched on. It will not illuminate when parking lights or headlight delay are in operation.

The Main Light Switch is interfaced to the Instrument Cluster (Z142) via the BeCM (Z238).

Direction Indicators

The left or right warning indicator flashes in time with the corresponding left or right direction indicator lamps whenever they are operated. A warning indicator flashing twice the normal speed indicates that a direction indicator lamp bulb has failed (the message centre will indicate which bulb is faulty). If a trailer is connected and a rear indicator lamp bulb fails then the message will not be displayed. When the hazard switch is pressed, both warning indicators will illuminate in conjunction with the indicator lamps.

The Direction Indicator switches are interfaced to the Instrument Cluster (Z142) via the BeCM (Z238).

Main Beam Indicator

This indicator illuminates whenever the main beam headlights are on.

The Main Beam Switch is interfaced to the Instrument Cluster (Z142) via the BeCM (Z238).

Trailer Indicator

This indicator is only operative when a trailer is connected to the vehicle via a multi-pin socket. The indicator flashes in conjunction with the vehicle direction indicator lamps, thus confirming that the trailer indicator lamps are operating correctly. In the event of a failure of a trailer direction indicator lamp the warning indicator will not illuminate.

The Trailer Auxilliary Socket is interfaced to the Instrument Cluster (Z142) via the BeCM (Z238).

Glow Plug Indicator

This indicator illuminates when the Engine Control Module (Z132) activates the Glow Plug Timer Unit (Z135).

The Engine Control Module (Z132) is interfaced to the Instrument Cluster (Z142) via the BeCM (Z238).

Catalyst Warning Indicator (Japan Only)

This indicator illuminates when a fault in the catalyst system is detected.

The Catalyst Overheat Sensors (X299, X300) and the Catalyst Amplifier (X301) are interfaced to the Instrument Cluster (Z142) via the BeCM (Z238).

Audible Warning

Receipt of an audible warning request signal from a vehicle parameter/message condition shall cause the BeCM (Z238) to generate the required number of warning tones. The actuator/sounder unit is located at the rear of the Instrument Cluster (Z142).

See message listing for categories/priority and levels of audible warnings.

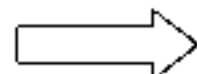
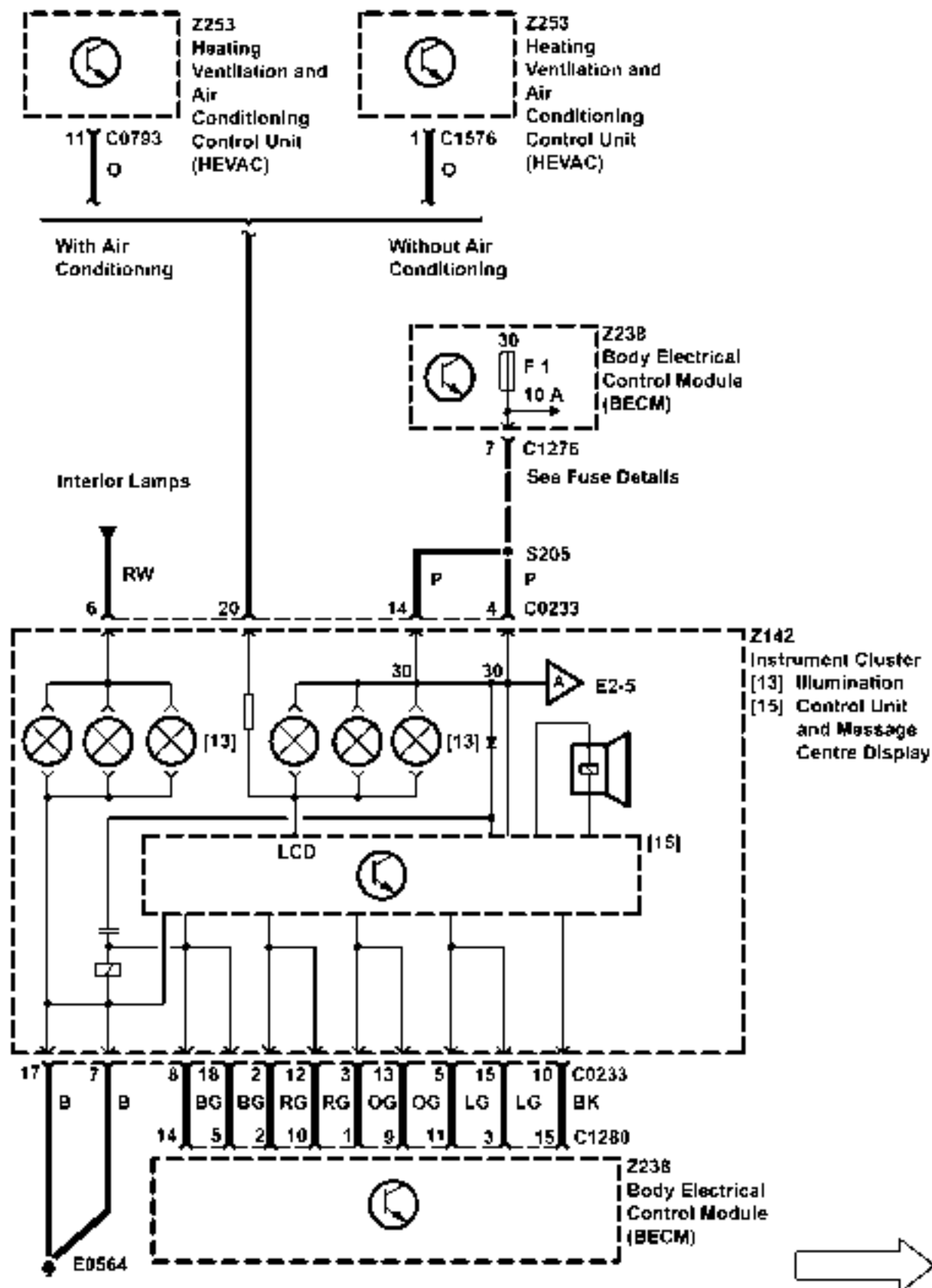

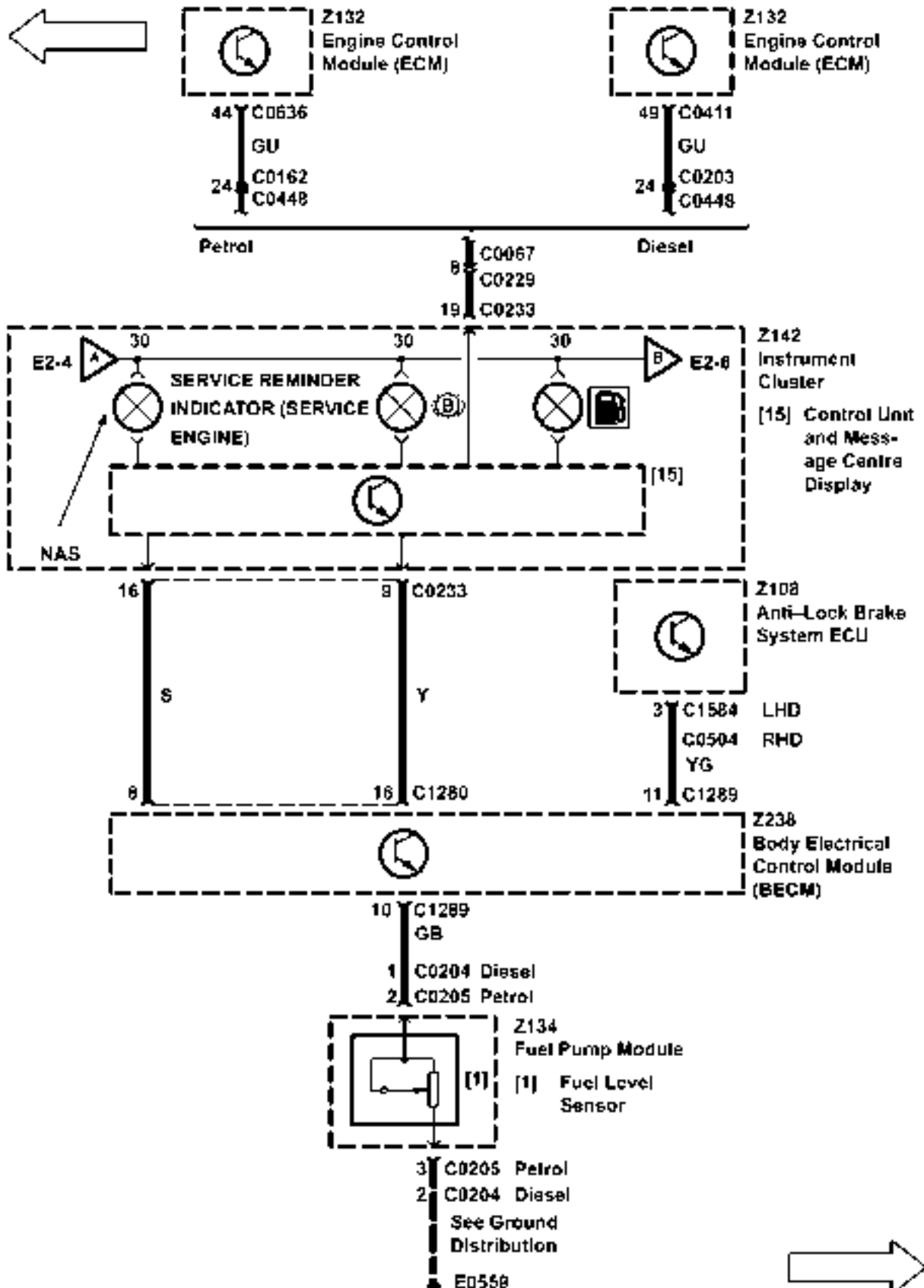

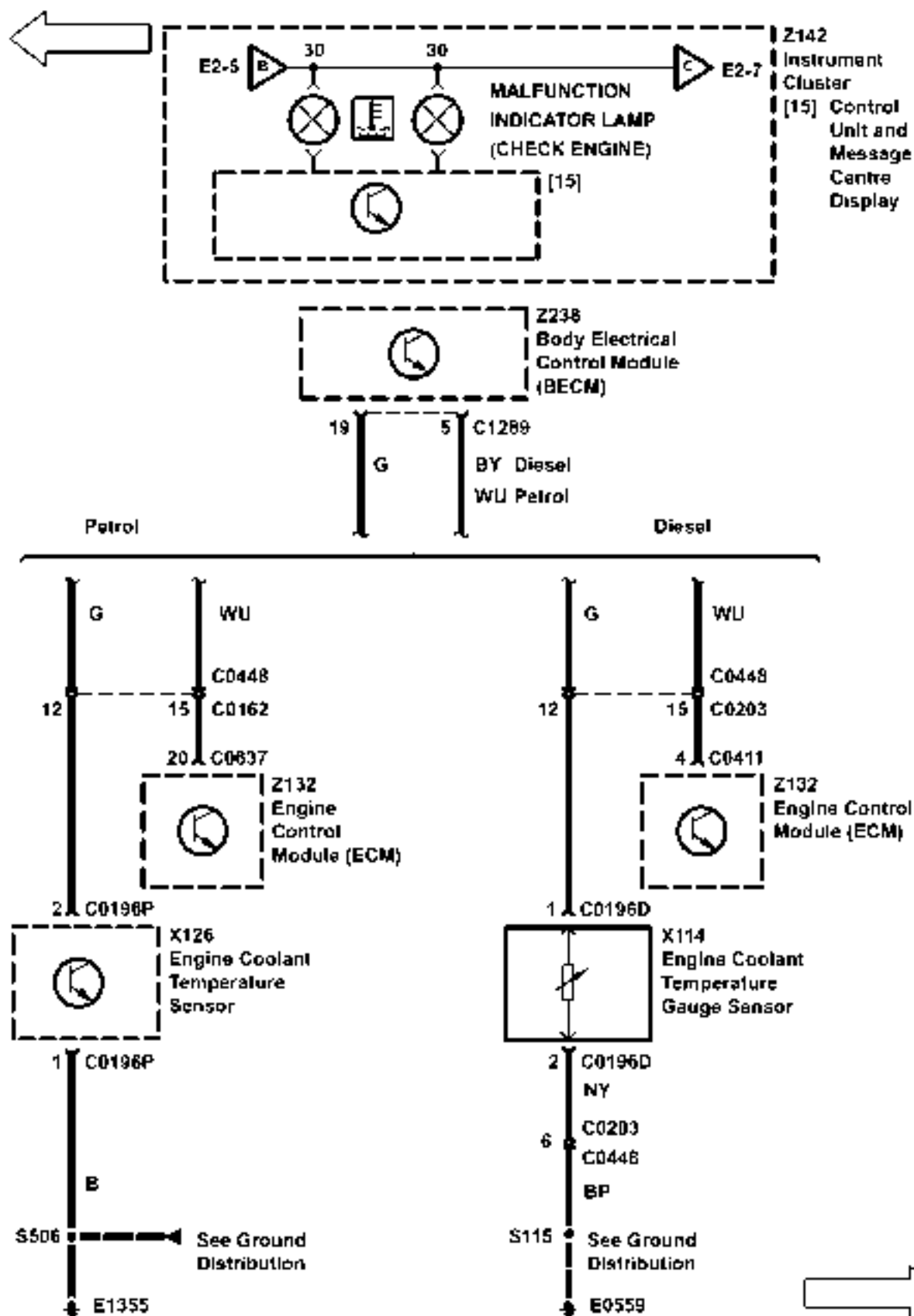

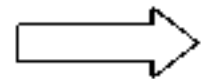
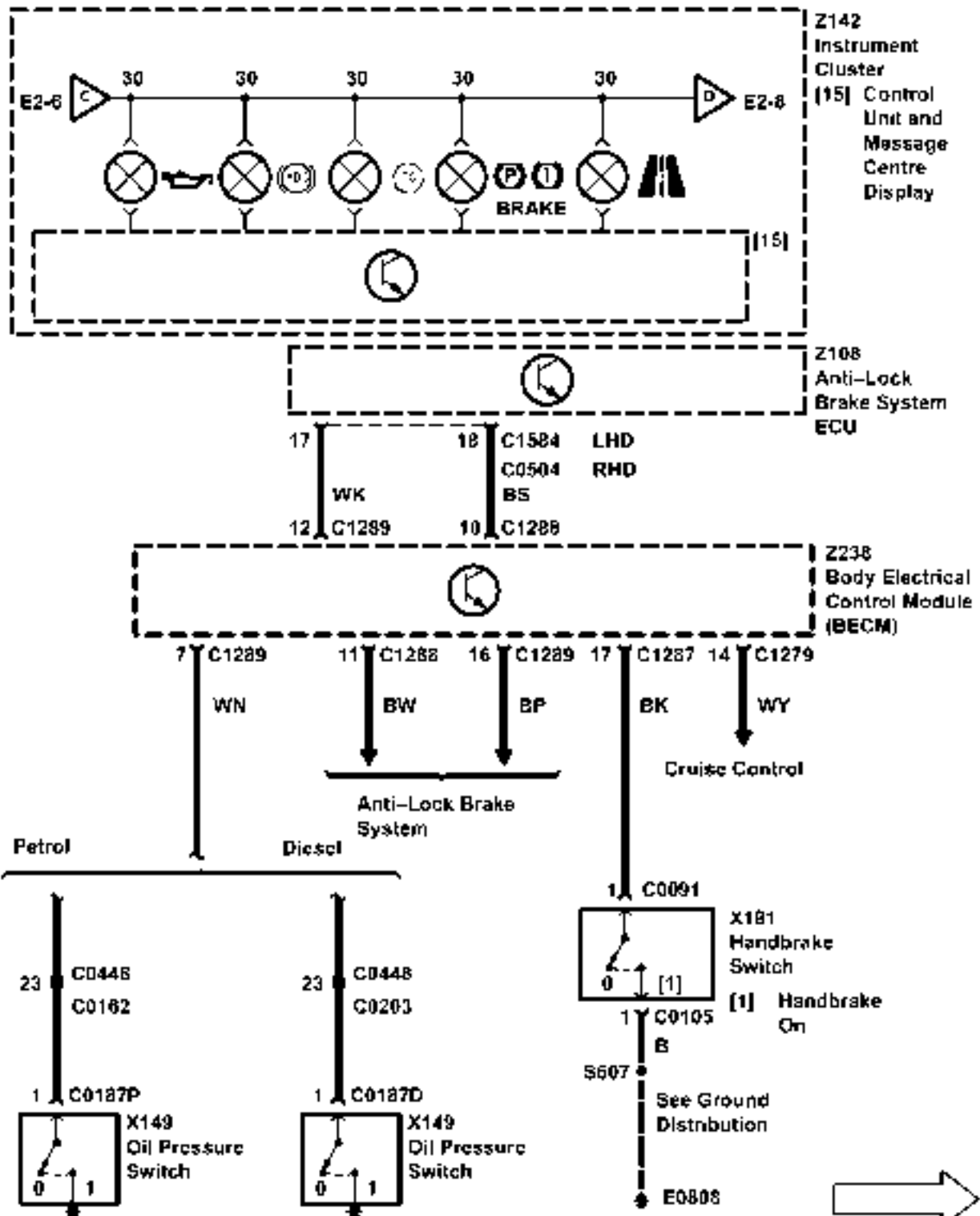
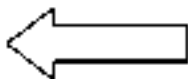

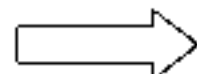
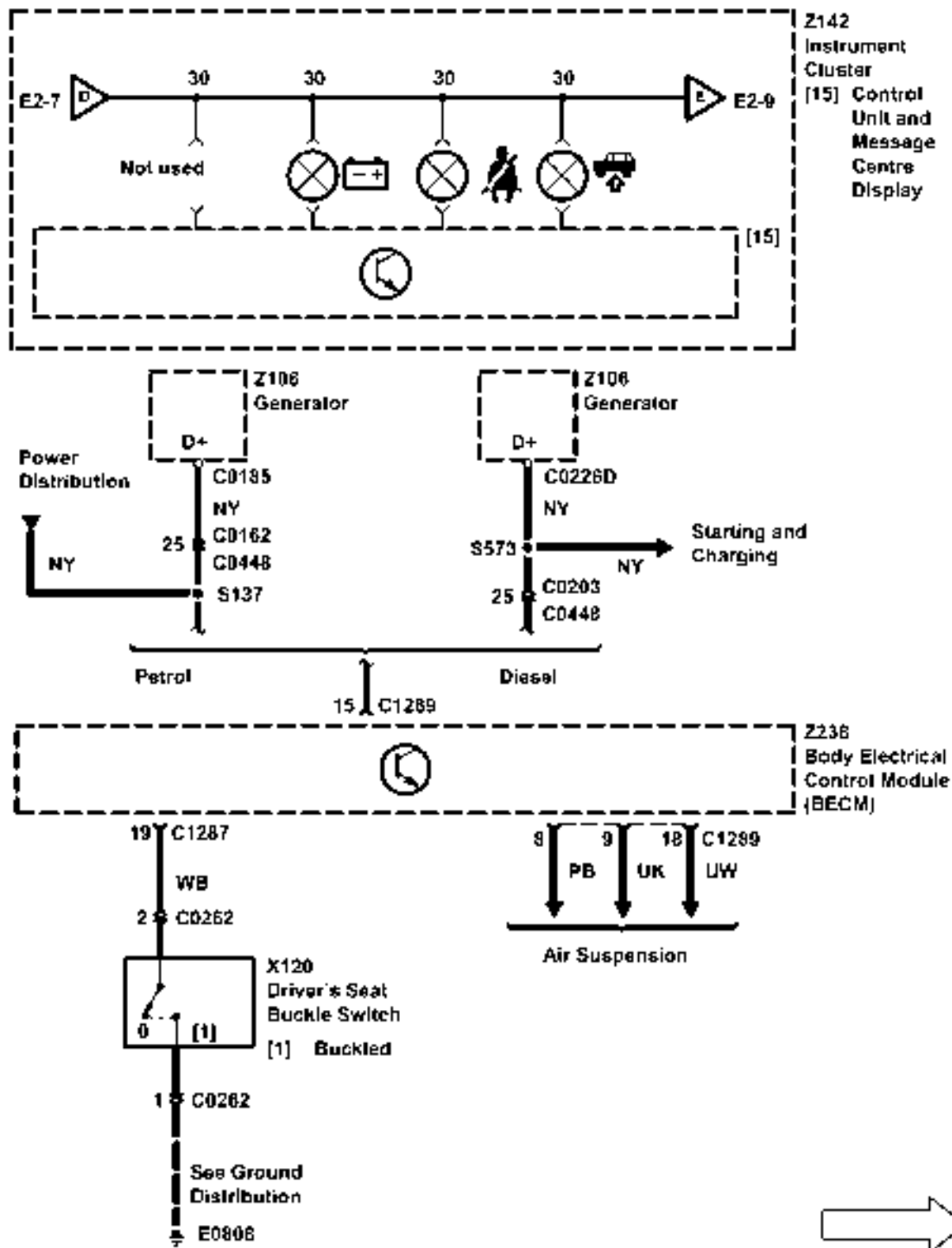
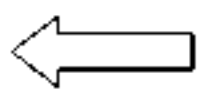

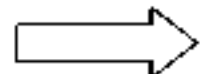
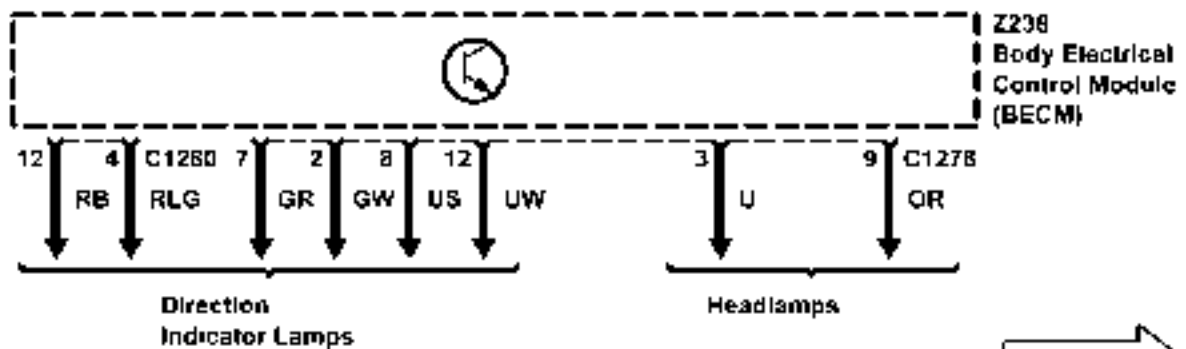
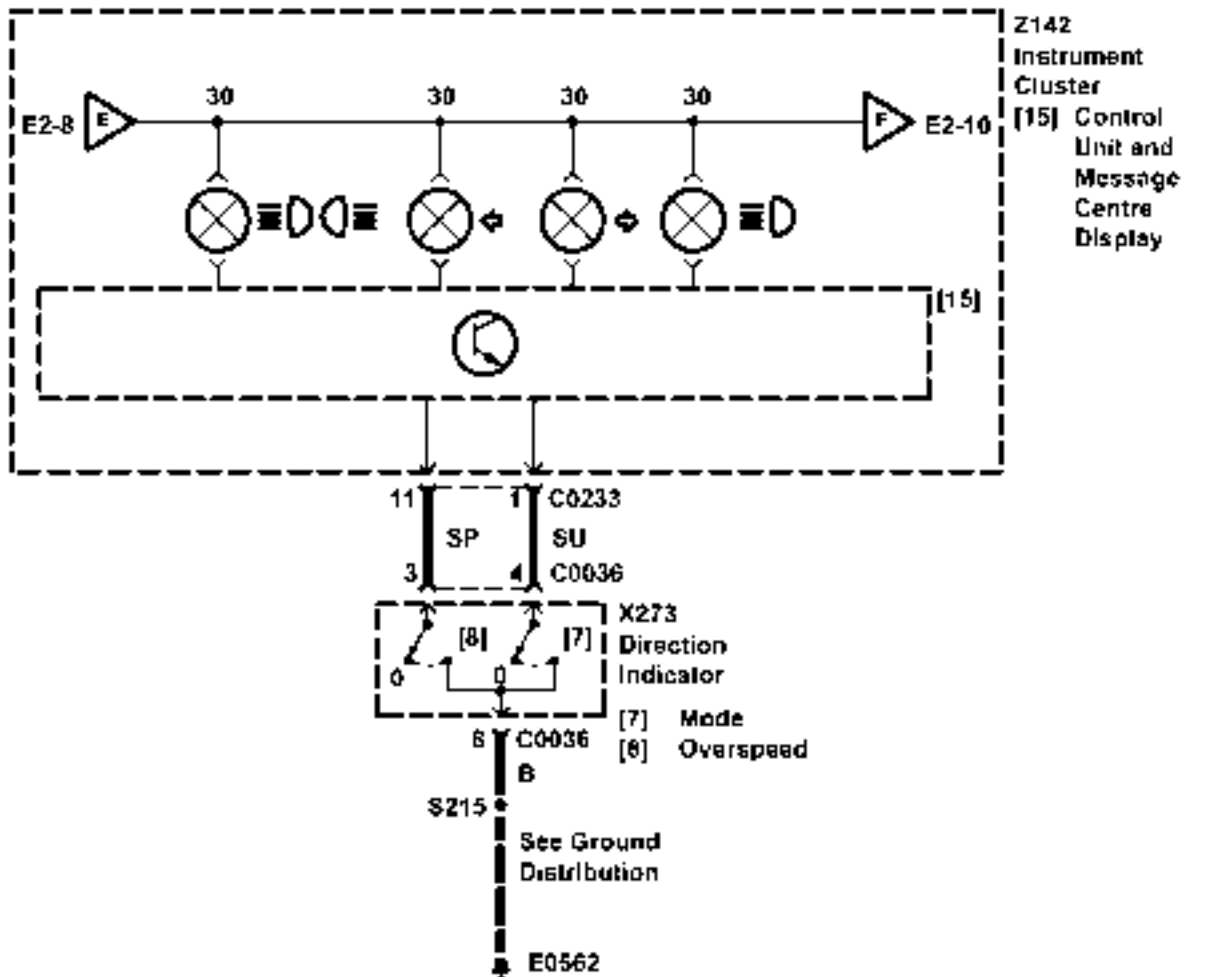
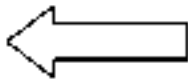

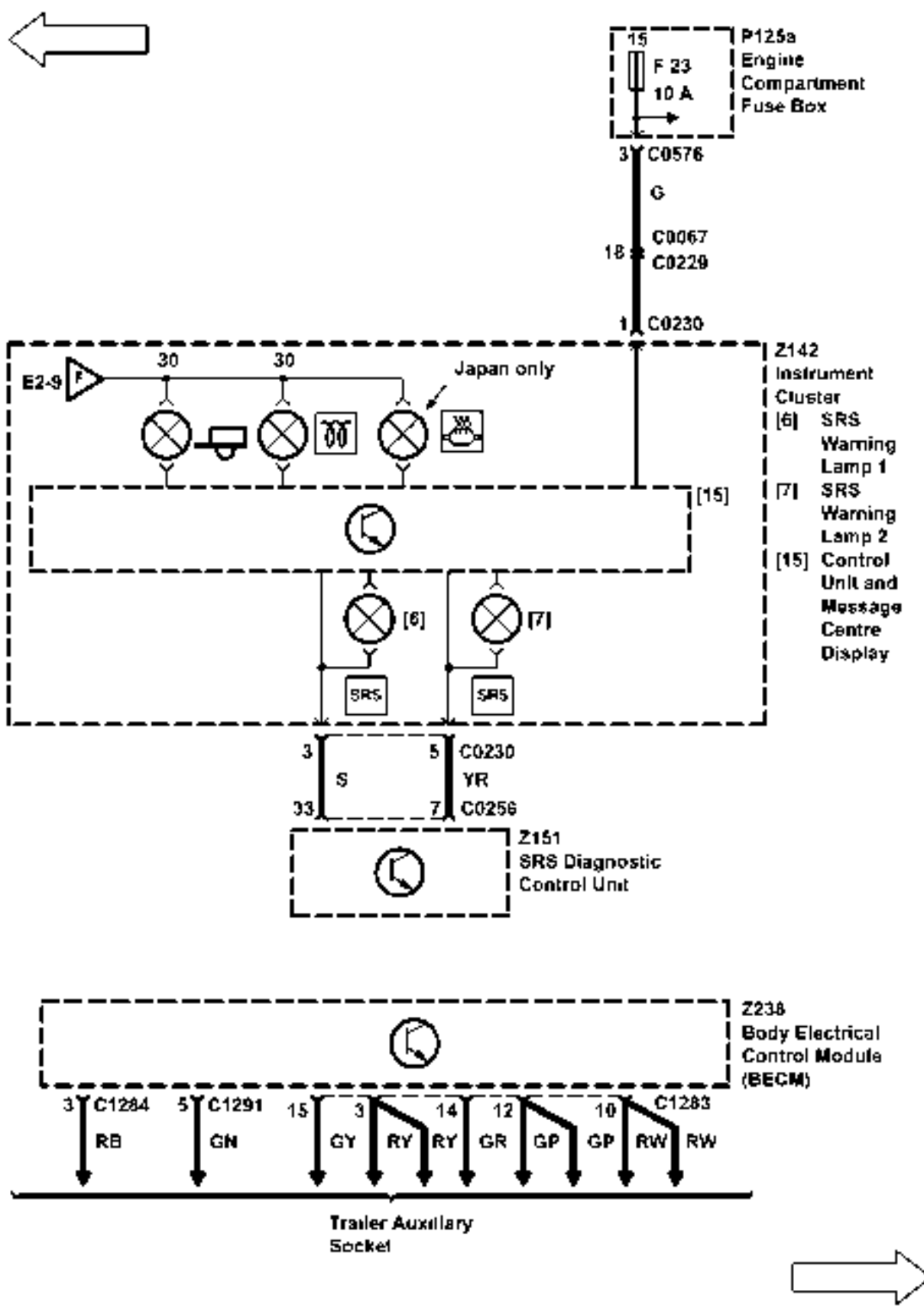

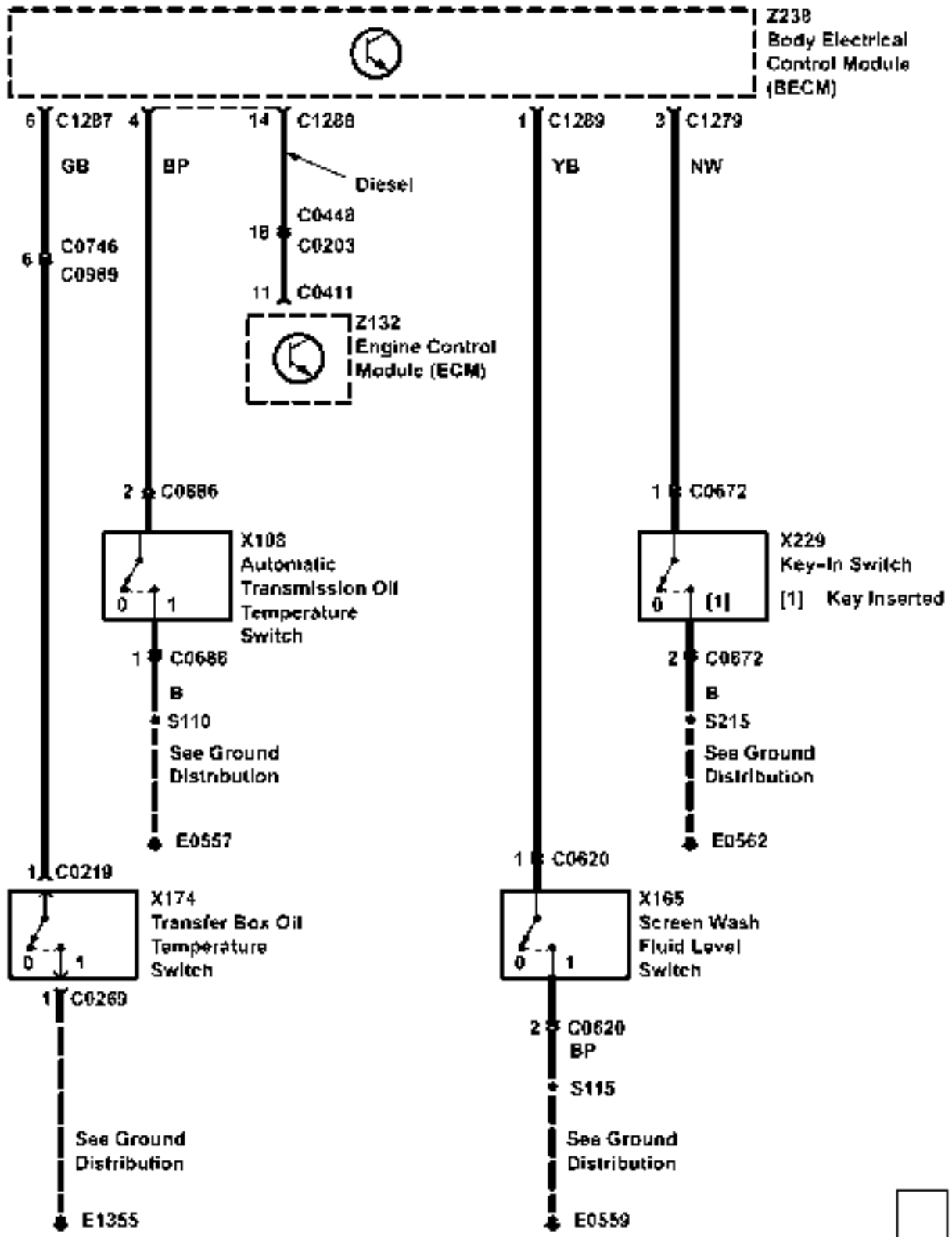
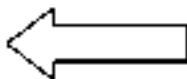

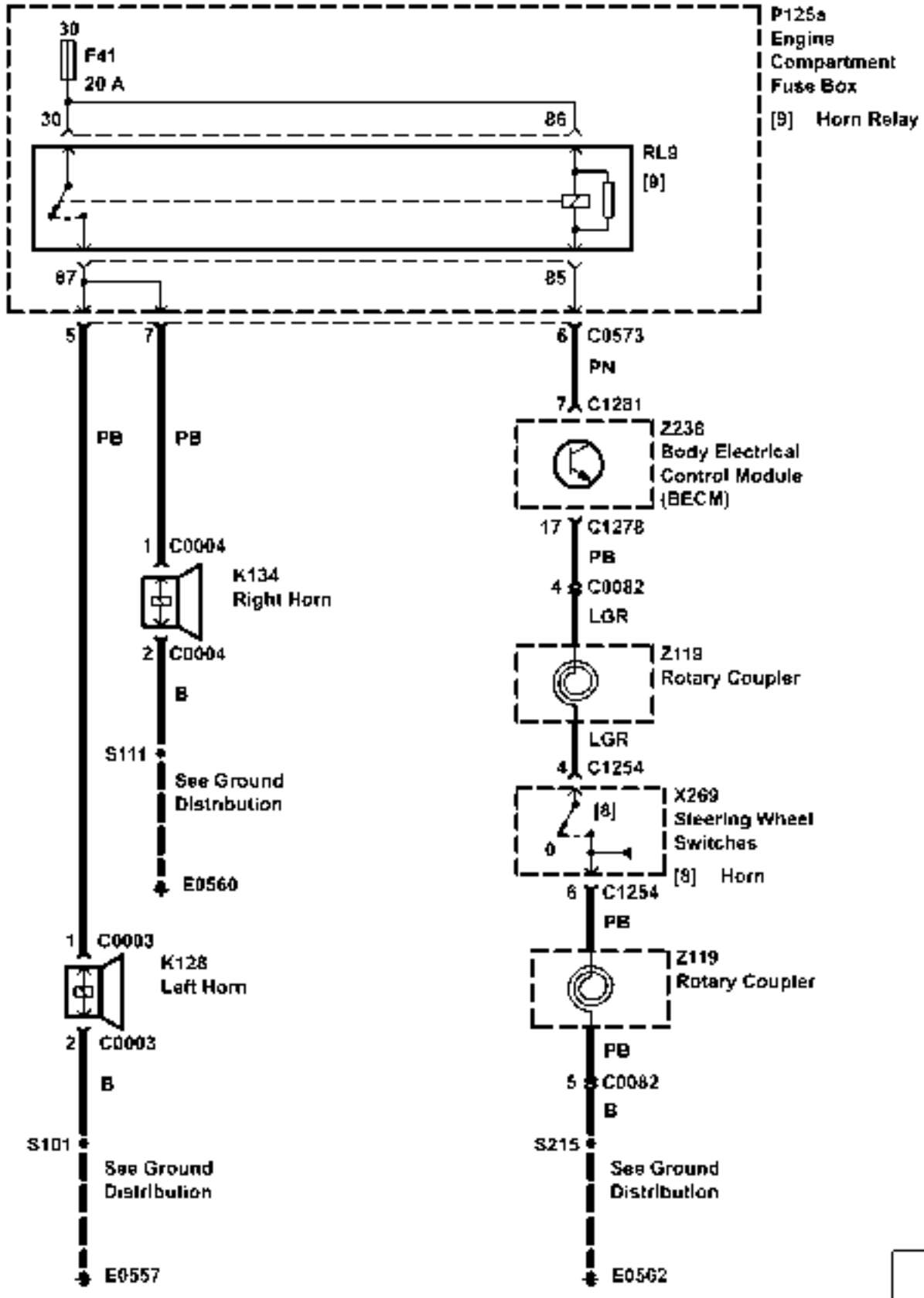

CIRCUIT OPERATION

Battery Voltage is provided to the radio at all times through the P wire. In addition to the anti-theft feature, this input voltage keeps the preset station memory alive. Whenever battery power to the unit is lost, the anti-theft code must be entered and the preset stations must be reprogrammed.

When the Radio (Z111) and the ignition are turned on, the voltage signal through the WK wire to the control head "wakes up" the unit. The Radio (Z111) plays, the LCD display comes on and the control buttons illuminate. On some models, when the park lamps or head amps are turned on, a voltage signal is sent through the RW wire to dim the LCD display and control buttons for night driving.

Radio (Z111) signals are received via a coaxial cable from the side screens and antenna amplifiers. The amplifiers filter and boost the signal from the side screen, using power supplied on WO wires whenever the Ignition Switch (X274) is in position I or II.

The CD Changer (Z114) is permanently supplied with power through the P wire via the radio and a DIN cable.

For the new Range Rover, three levels of factory fitted in-car entertainment are available:

The mid-low line radio has the following features: Electronically Tuned AM/FM cassette radio (Z111), RH antenna amplifier (Z178) for AM/FM signals and 6, 8 or 10 speakers.

The high line (NA/JAPAN) radio has the following features: Electronically tuned AM/FM cassette radio (Z111), RH antenna amplifier (Z178) for AM/FM signals, LH antenna amplifier (Z177) for FM signals only, 4 door speaker amplifiers (Z241, Z242, Z245, Z246), a subwoofer amplifier (Z176), a CD changer (Z114) and 10 speakers plus a subwoofer speaker (K146).

Subwoofer

The subwoofer amplifies frequencies between 20 and 150 Hz to give an enhanced bass sound.

Subwoofer Amplifier

The Subwoofer (K146) is supplied with power and ground from the Subwoofer Amplifier (Z176) via two separate channels which consist of 4 BWB wires. The subwoofer amplifier (Z176) is permanently

supplied with power on the P wire, but it is only switched on when the radio supplies a signal on the SB wire.

Speaker Amplifier

The Speaker Amplifiers (Z241, Z242, Z245, Z246) are situated in the 4 doors and are supplied with permanent power via the P wire. They are switched on when the radio sends a signal on the SB wire.

The speaker amplifiers (Z241, Z242, Z245, Z246) have one channel for the bass speakers (K202, K203, K209, K220) and a second for the midrange speakers (K200, K201, K211, K212) and tweeter speakers (K197, K198) (front doors only). The tweeter incorporates a capacitor to filter the signals.

Side Screen Antenna

The antenna is printed into the rear side screen. For NAS and Japan, the element is fitted in both rear side screens. This is referred to as a diversity antenna system. Other markets have a single element in the right hand screen only. Diversity reception means that as vehicle movement results in loss of signal due to reflections from buildings (known as multipath distortion), the radio will switch to the antenna receiving the strongest signal. This results in less interference and better stereo performance.

Antenna Amplifier

Antenna amplifiers are in the LH and RH side of the luggage compartment behind trim panel. The FM and AM amplifier would be located on the right hand side, and the FM only amplifier is located on the left hand side.

Speakers

Trim level 1/2 – The lowmidline radio is equipped with 6, 8 or 10 speakers fitted in the doors. The midrange speakers (K200, K201, K211, K212) are filtered by capacitors in the wires (K239, K240, K247, K248) and the tweeter speakers (K197, K198) filter the signals by built-in capacitors.

Trim level 3 – The high line is equipped with 10 speakers like the trim level 1/2, but they all receive power and ground via 4 additional speaker amplifiers. The signals for the tweeter speakers (K197, K198) are filtered by their internal capacitors similar to the mid/low line tweeters.

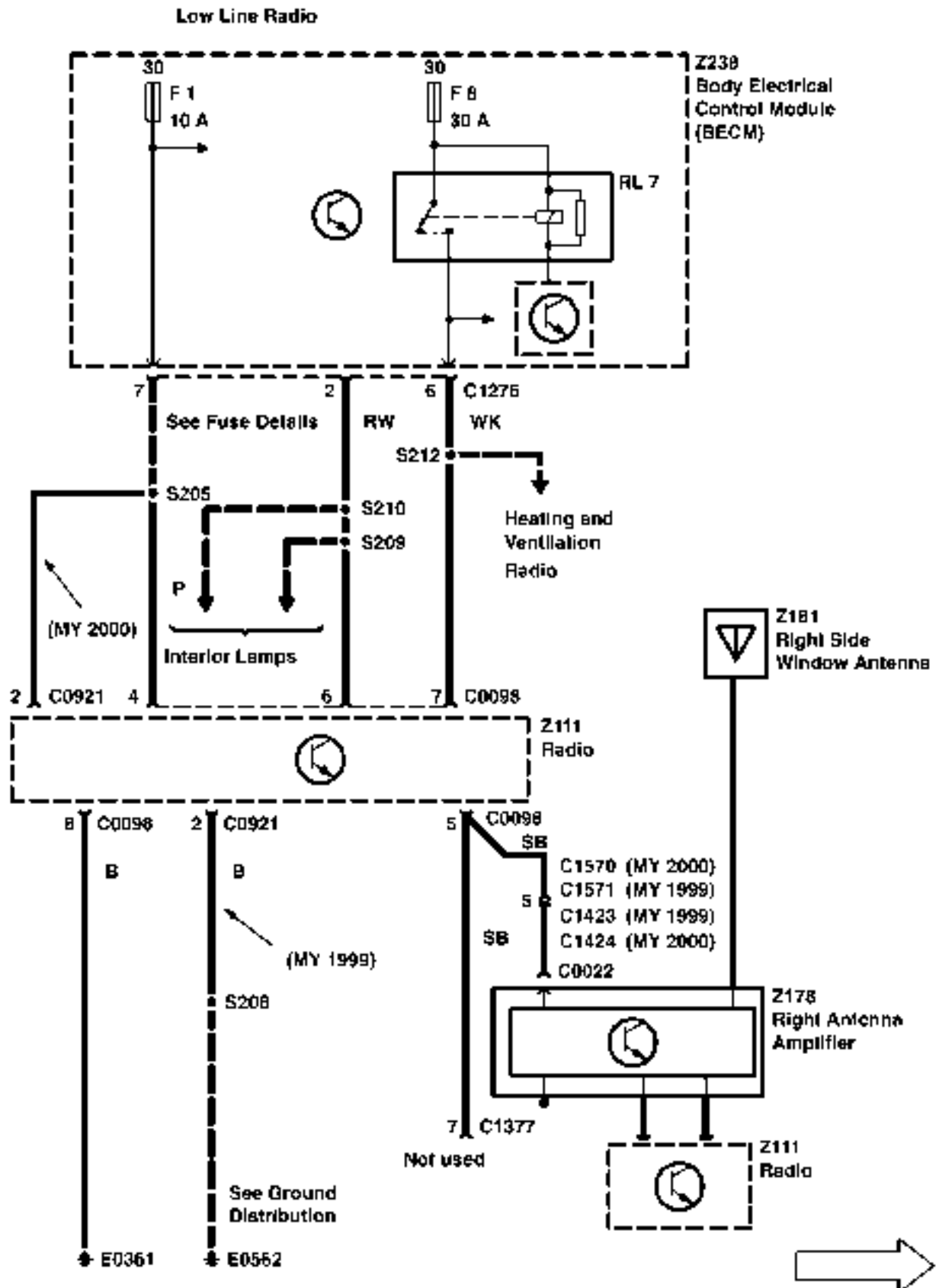

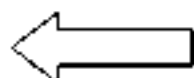

Low Line Radio

* (MY 1999)

** (MY 2000)

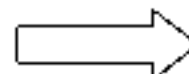
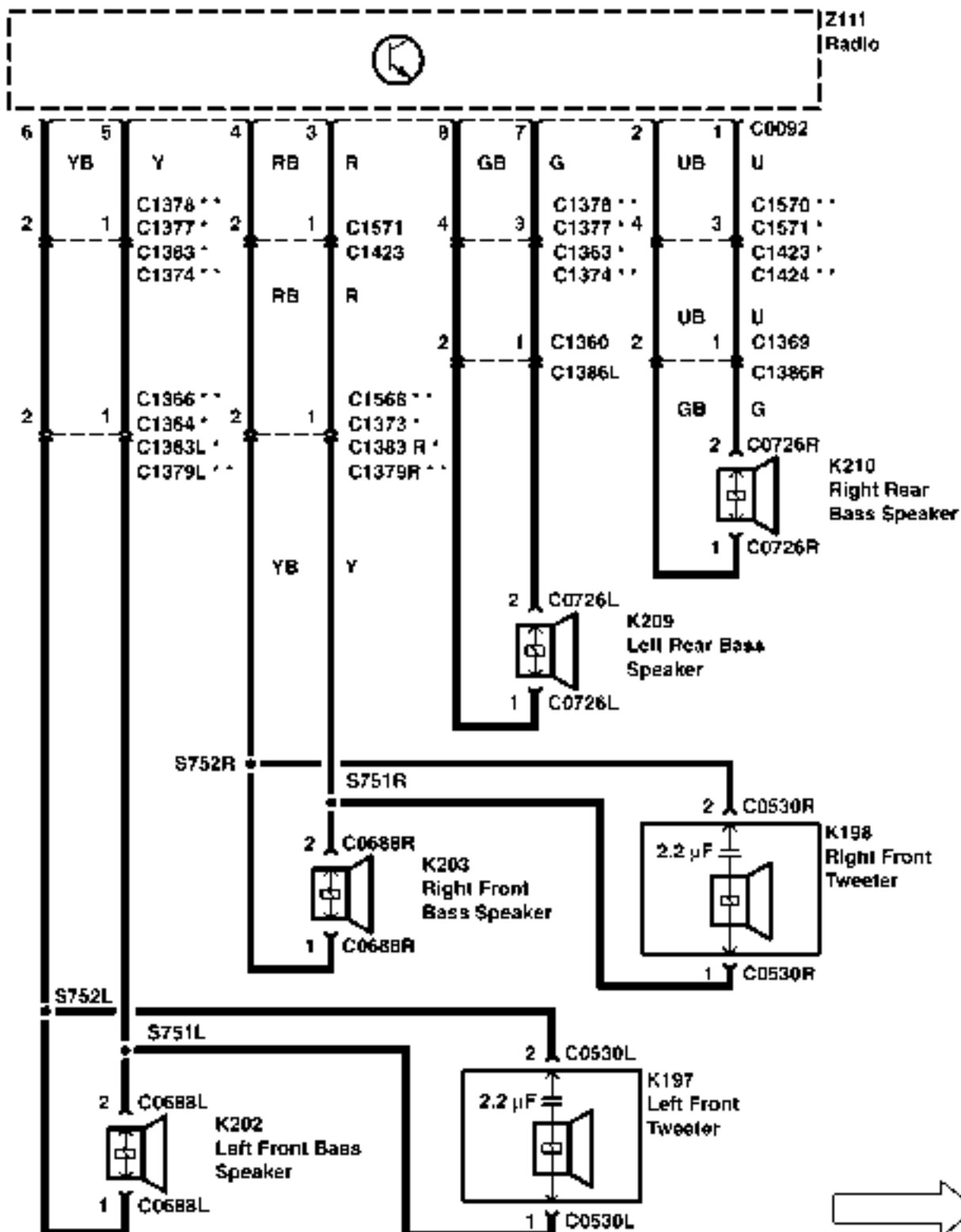

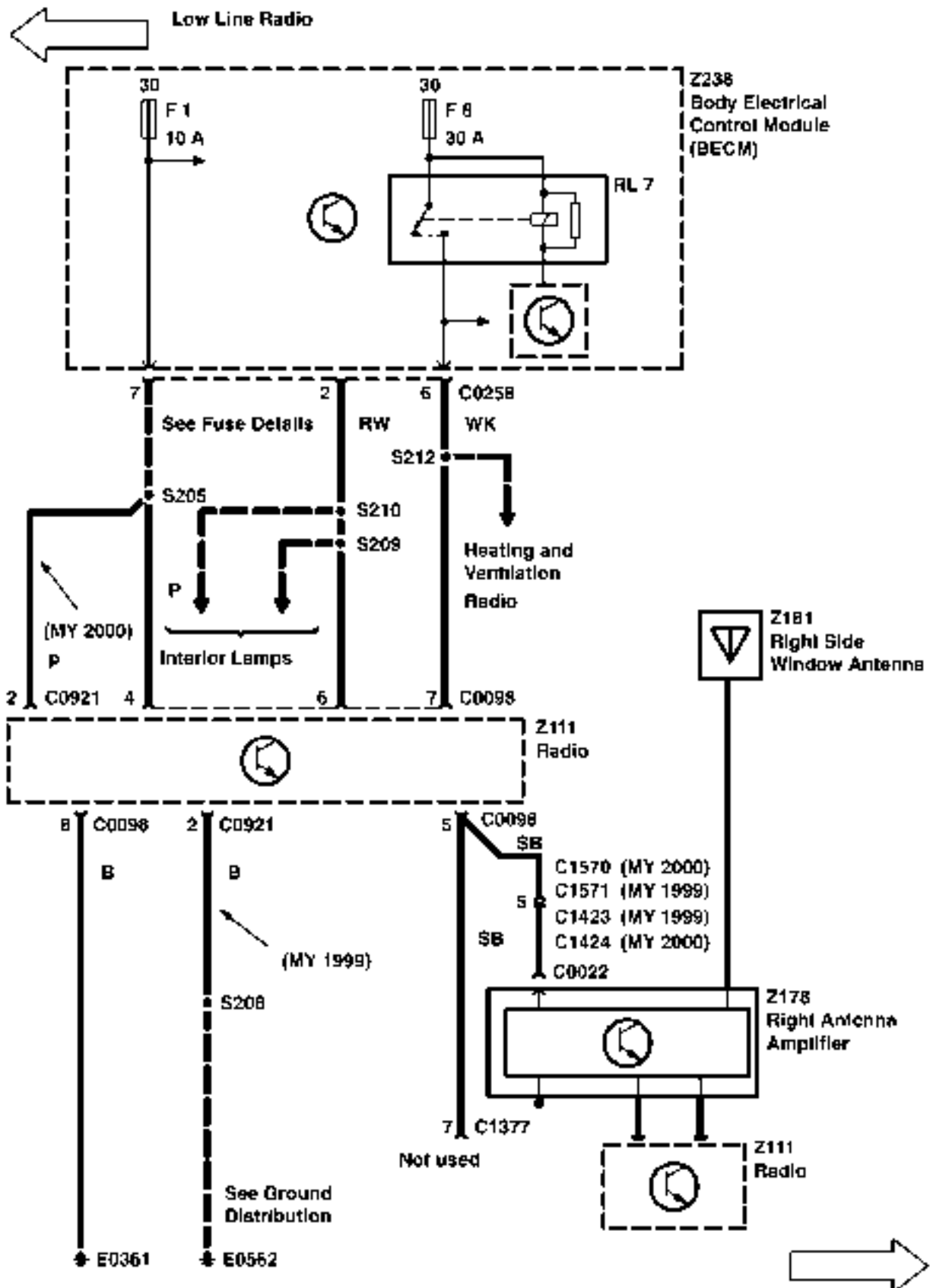

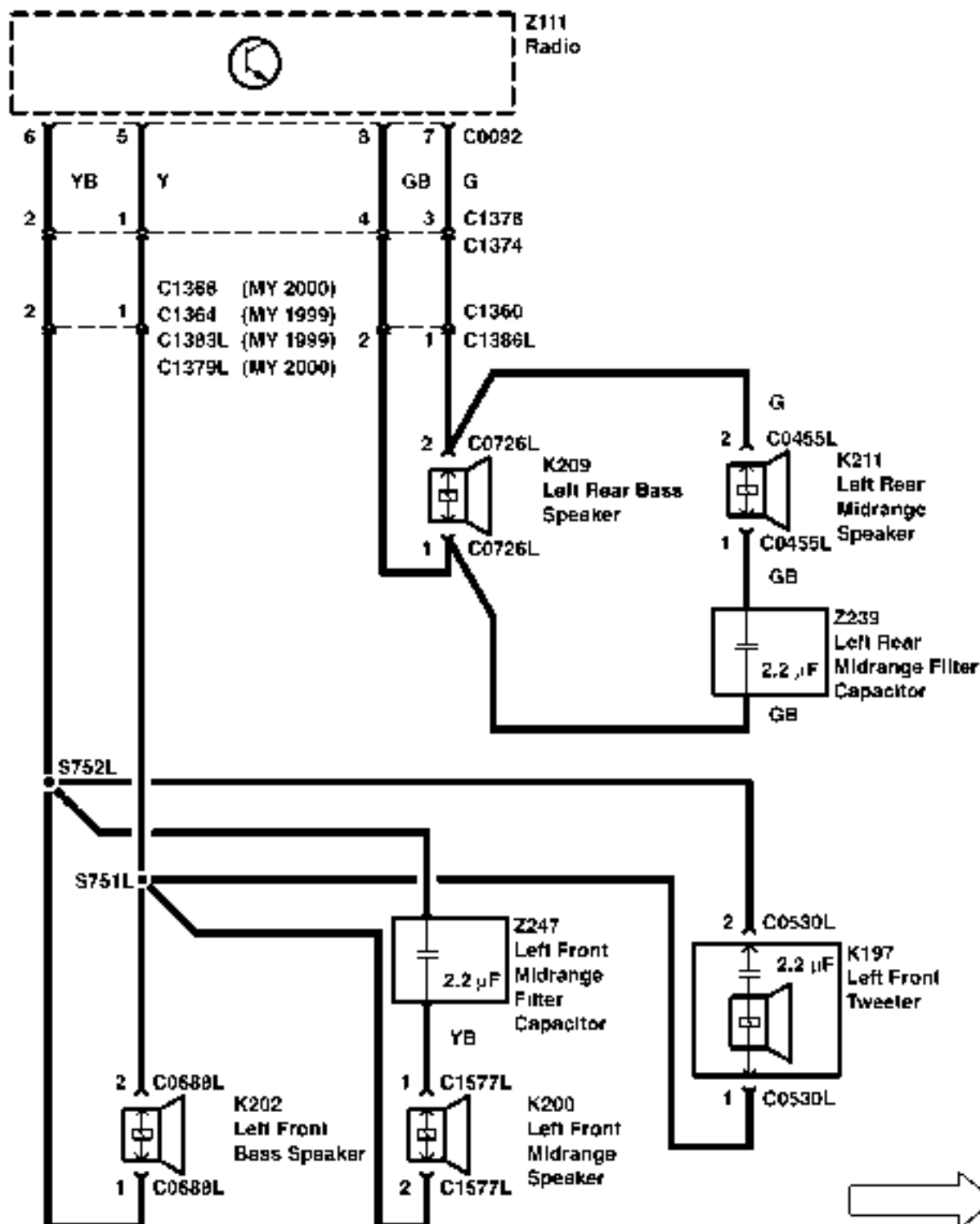

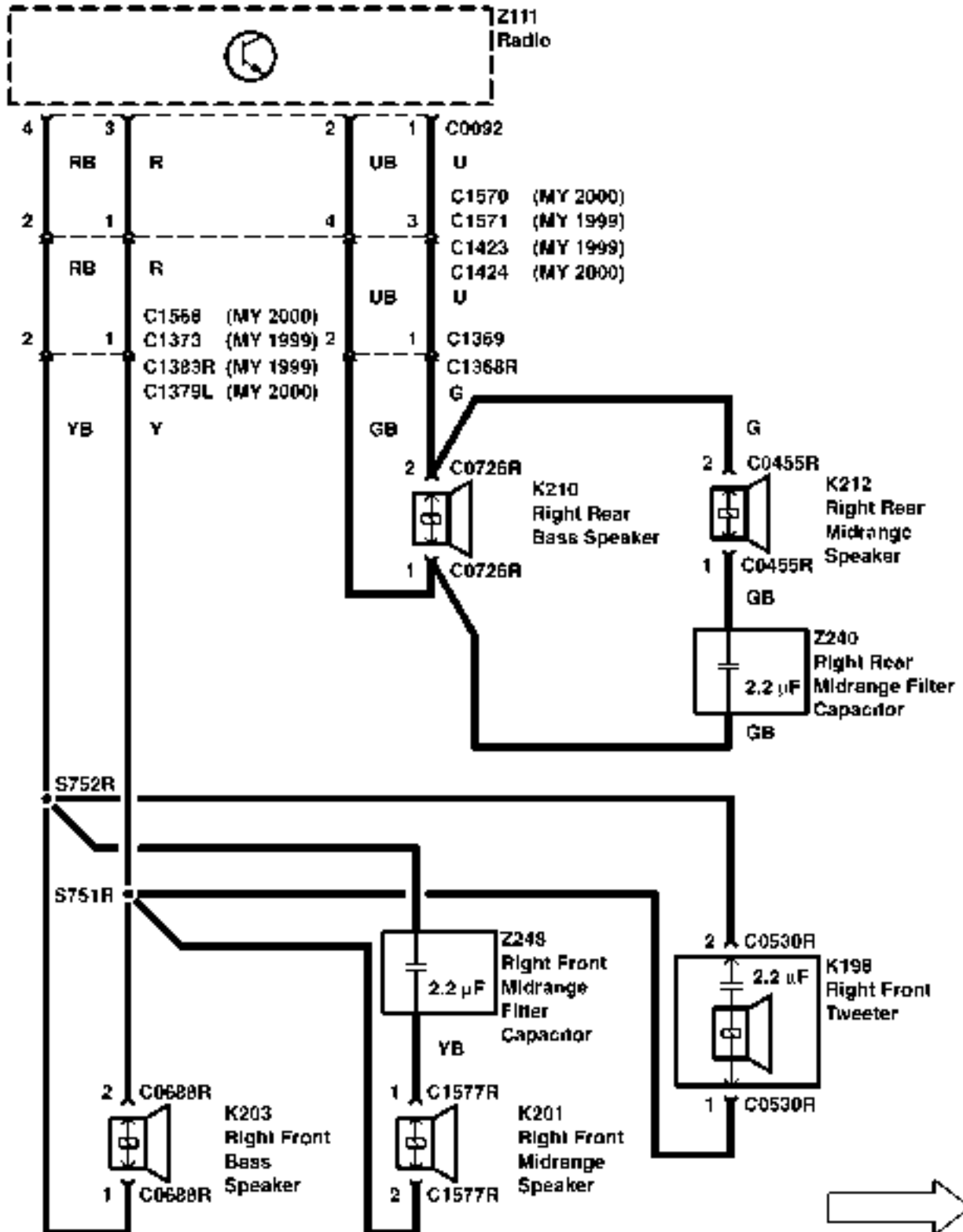
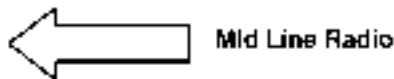

← High Line Radio

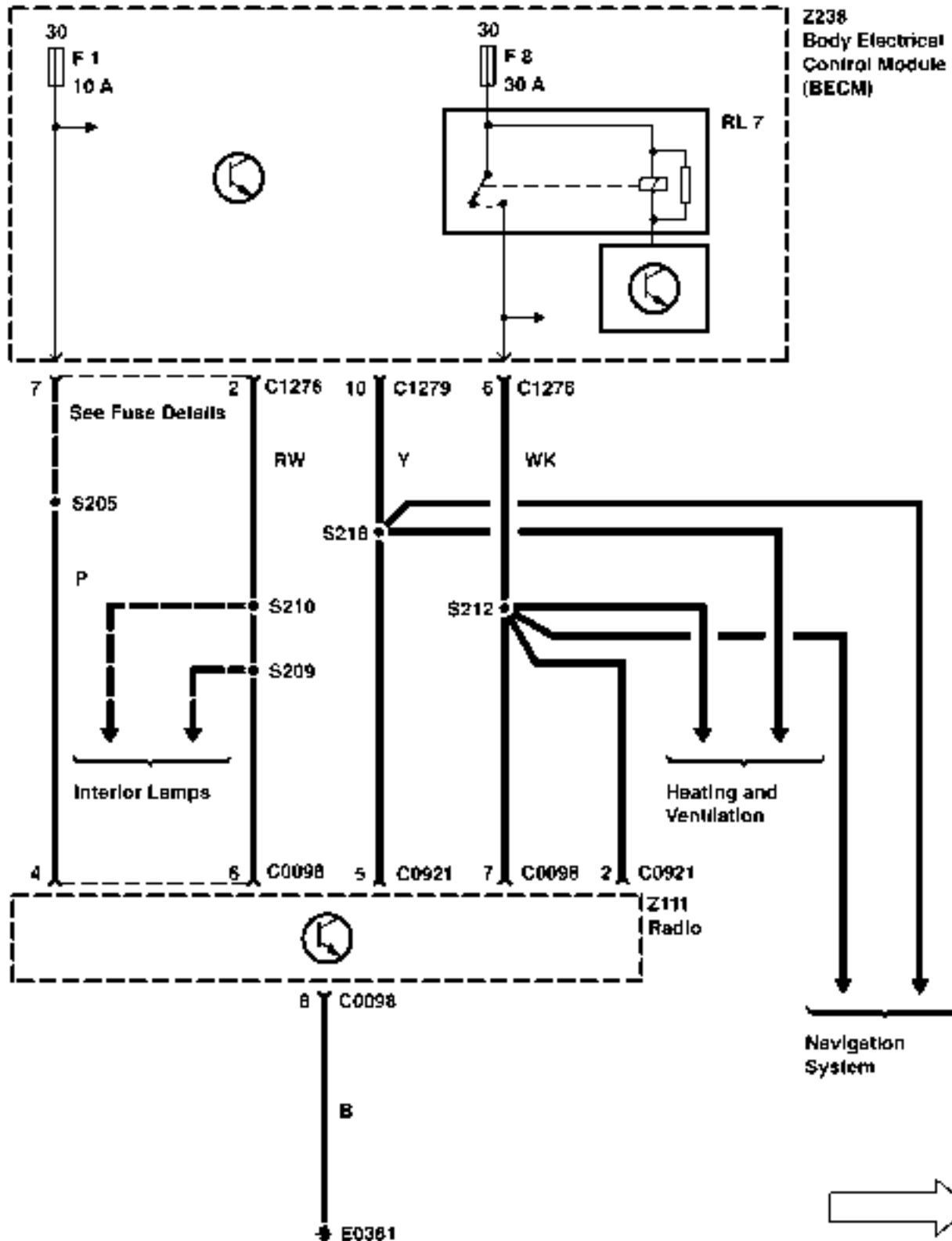

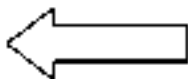

Radio (High Line)

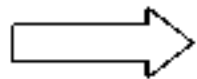
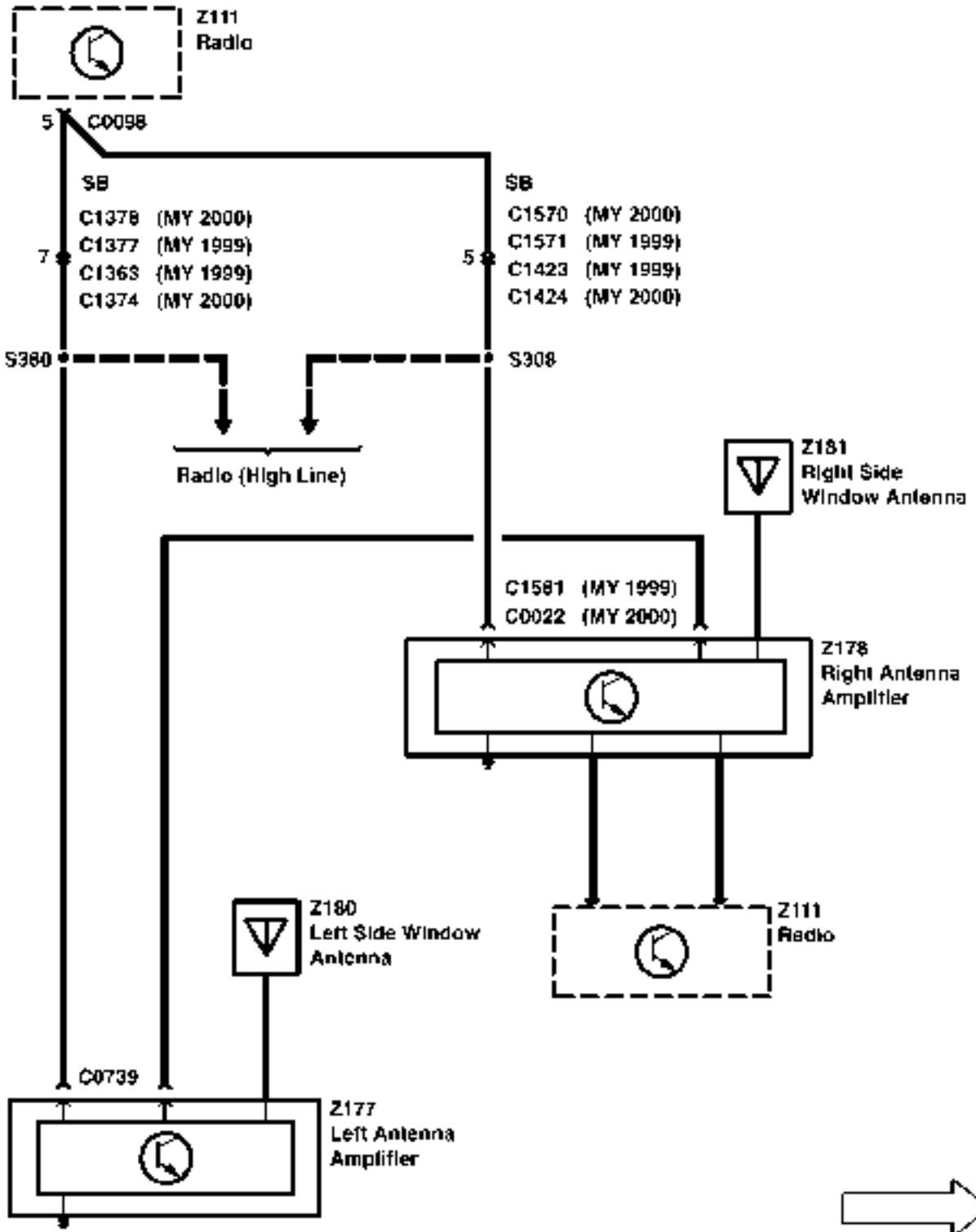

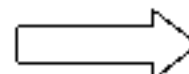
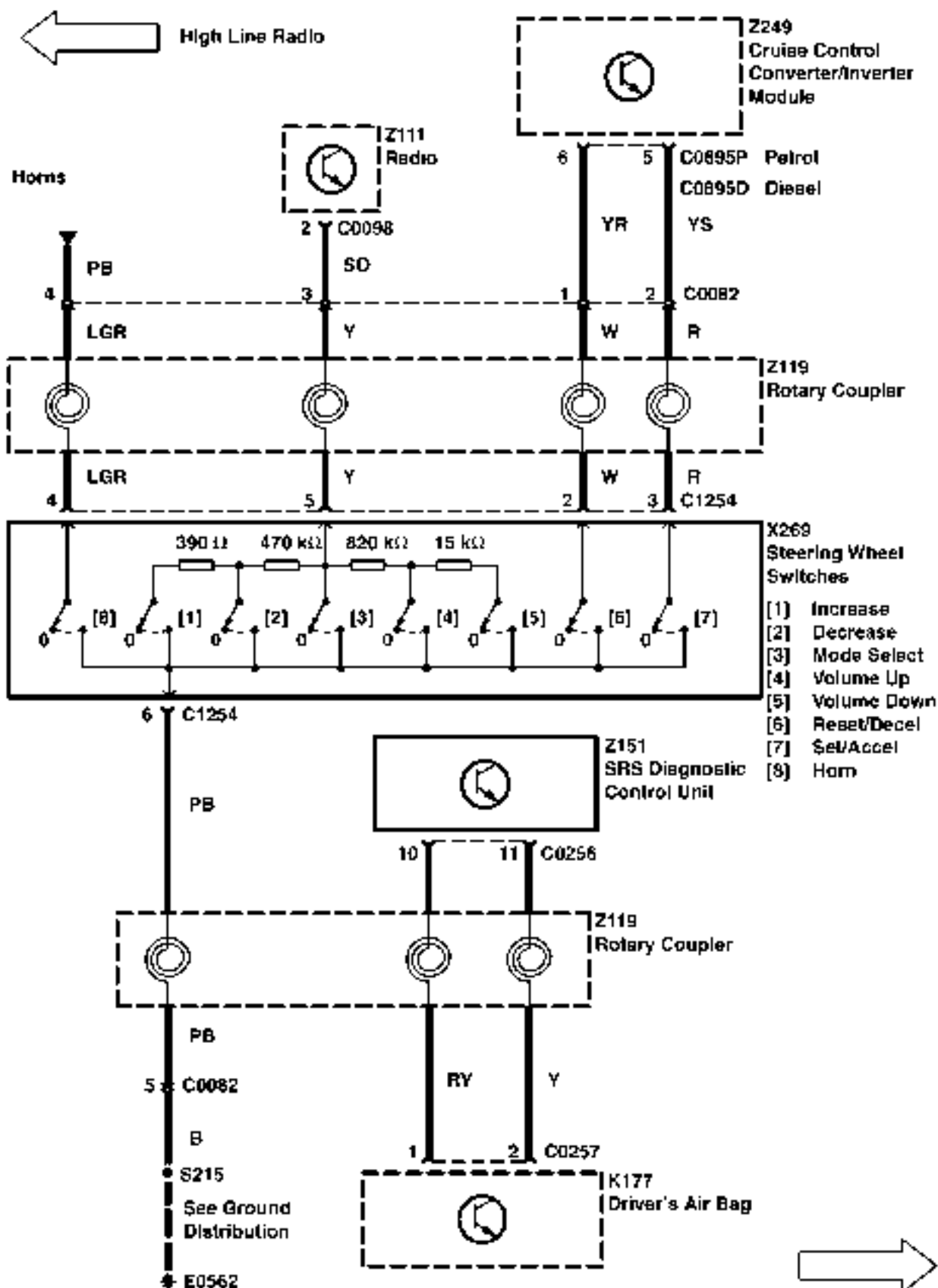

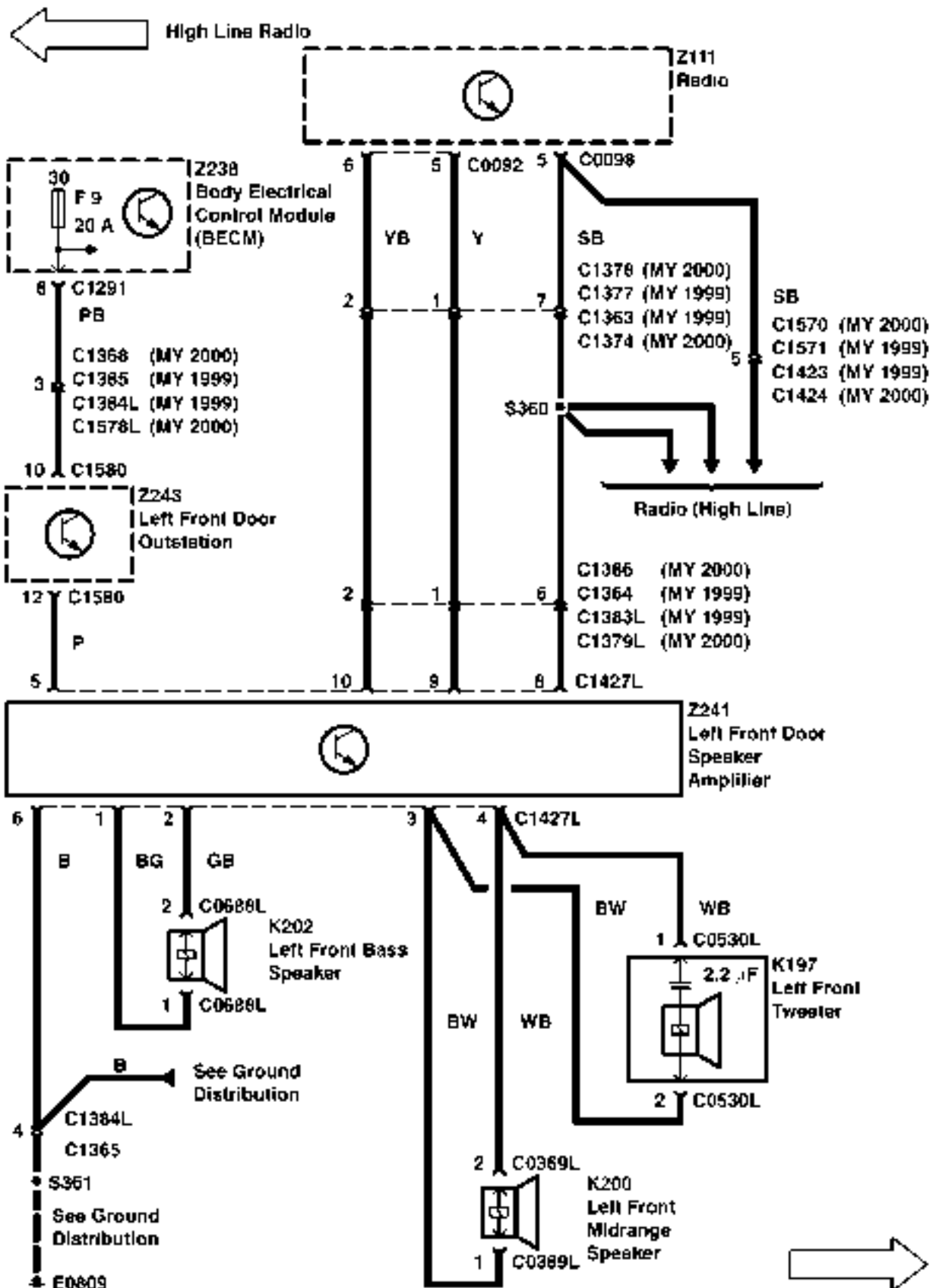

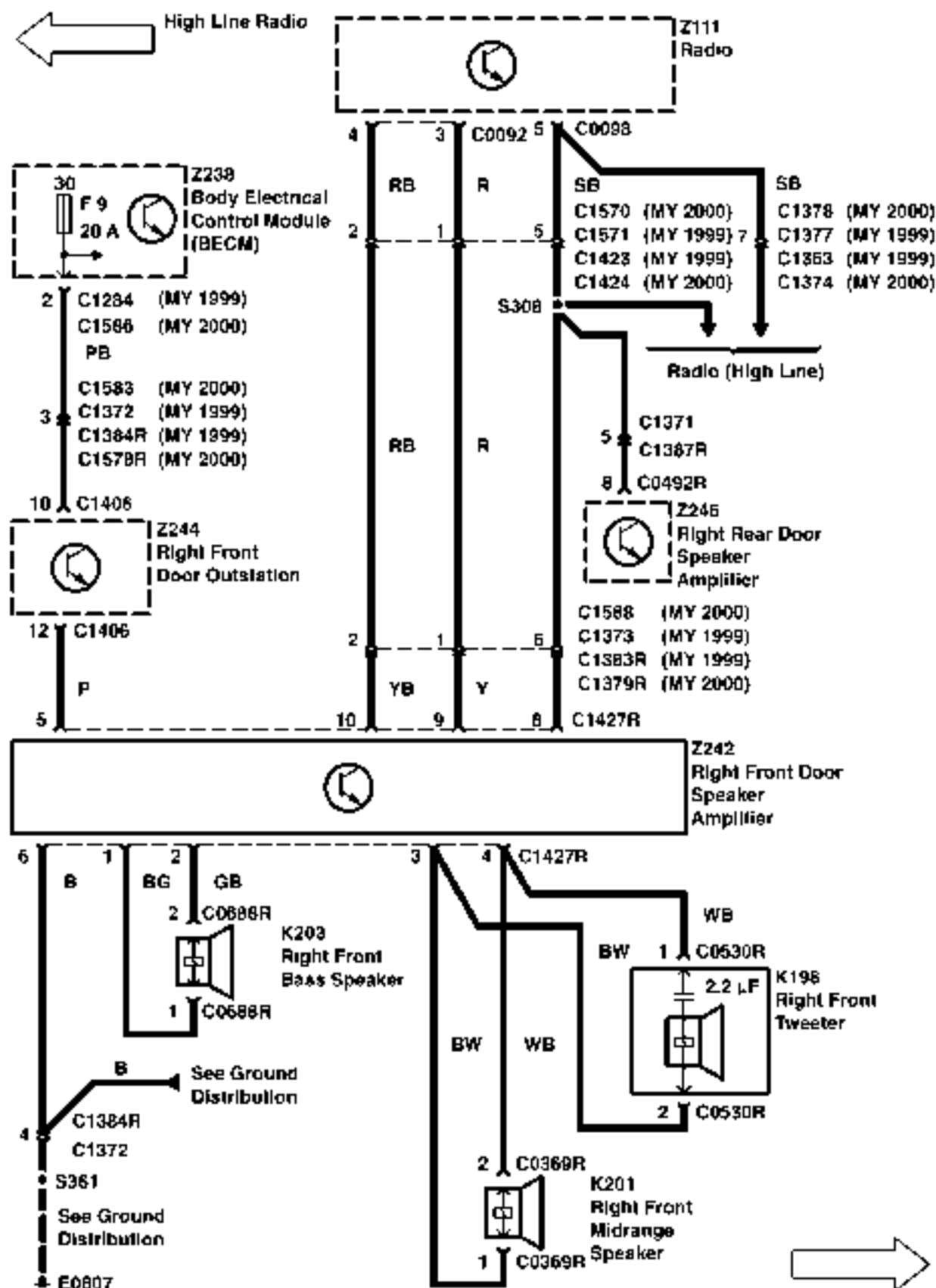

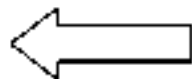

High Line Radio

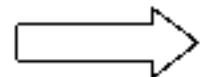
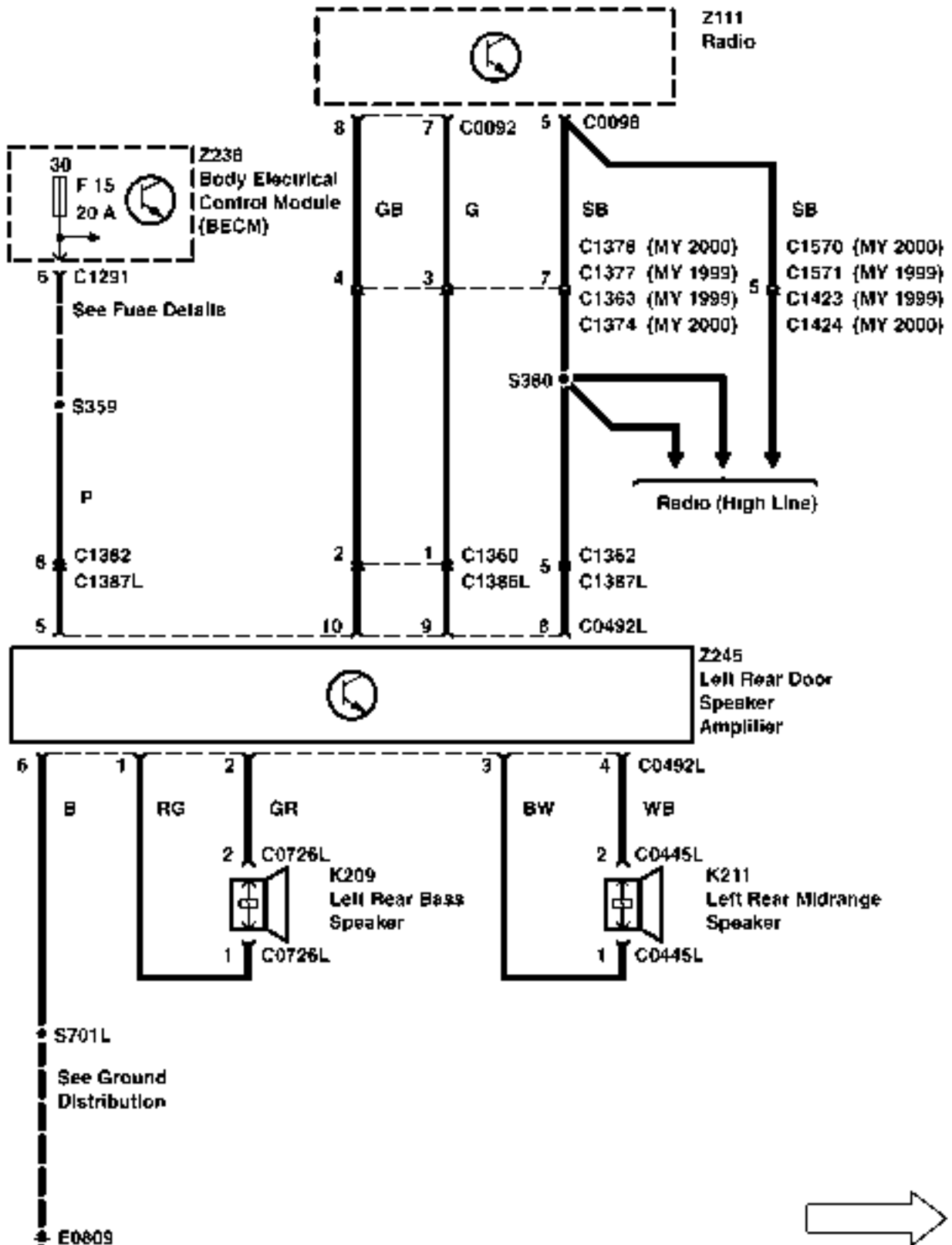

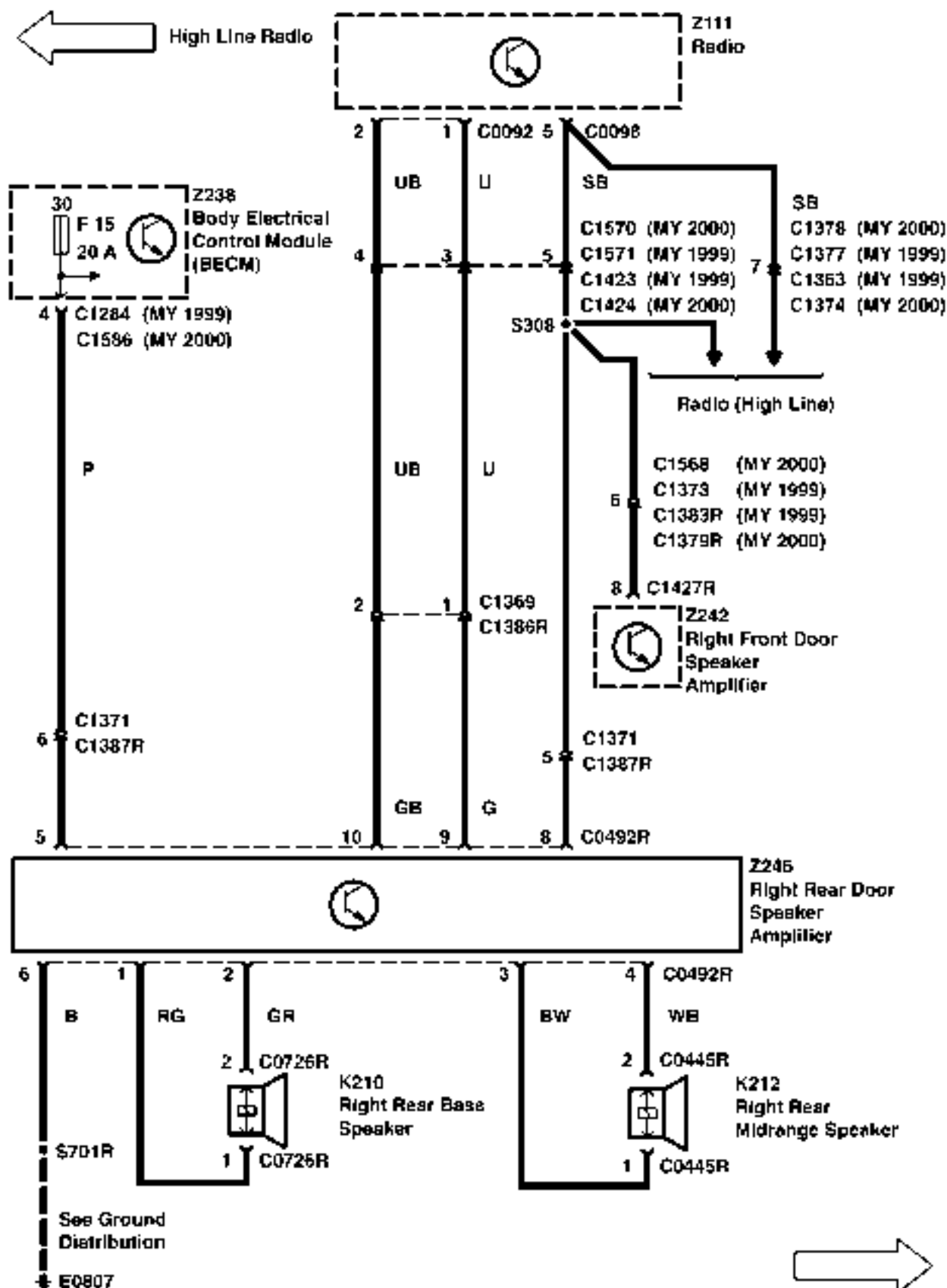

← High Line Radio

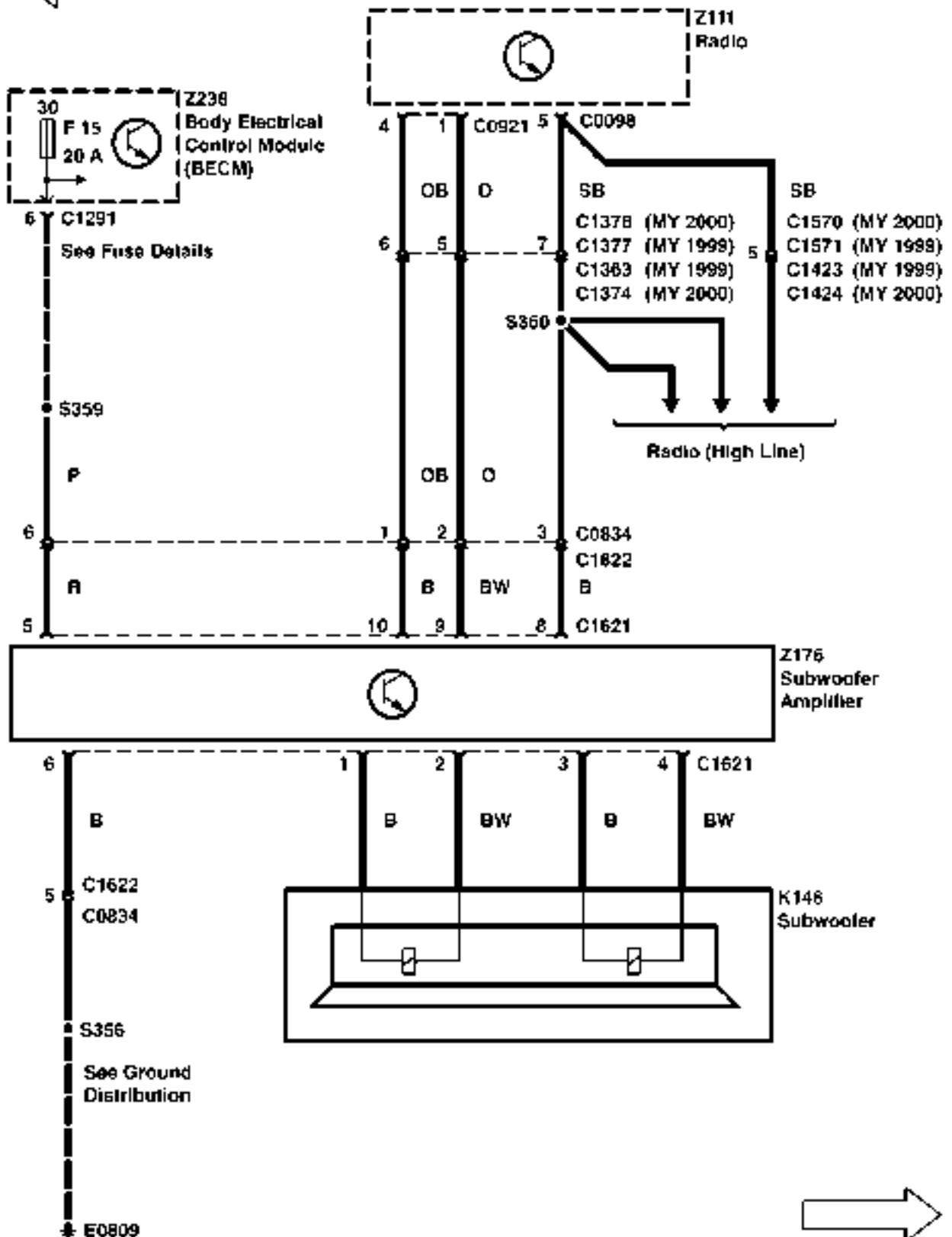

→

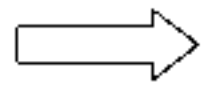
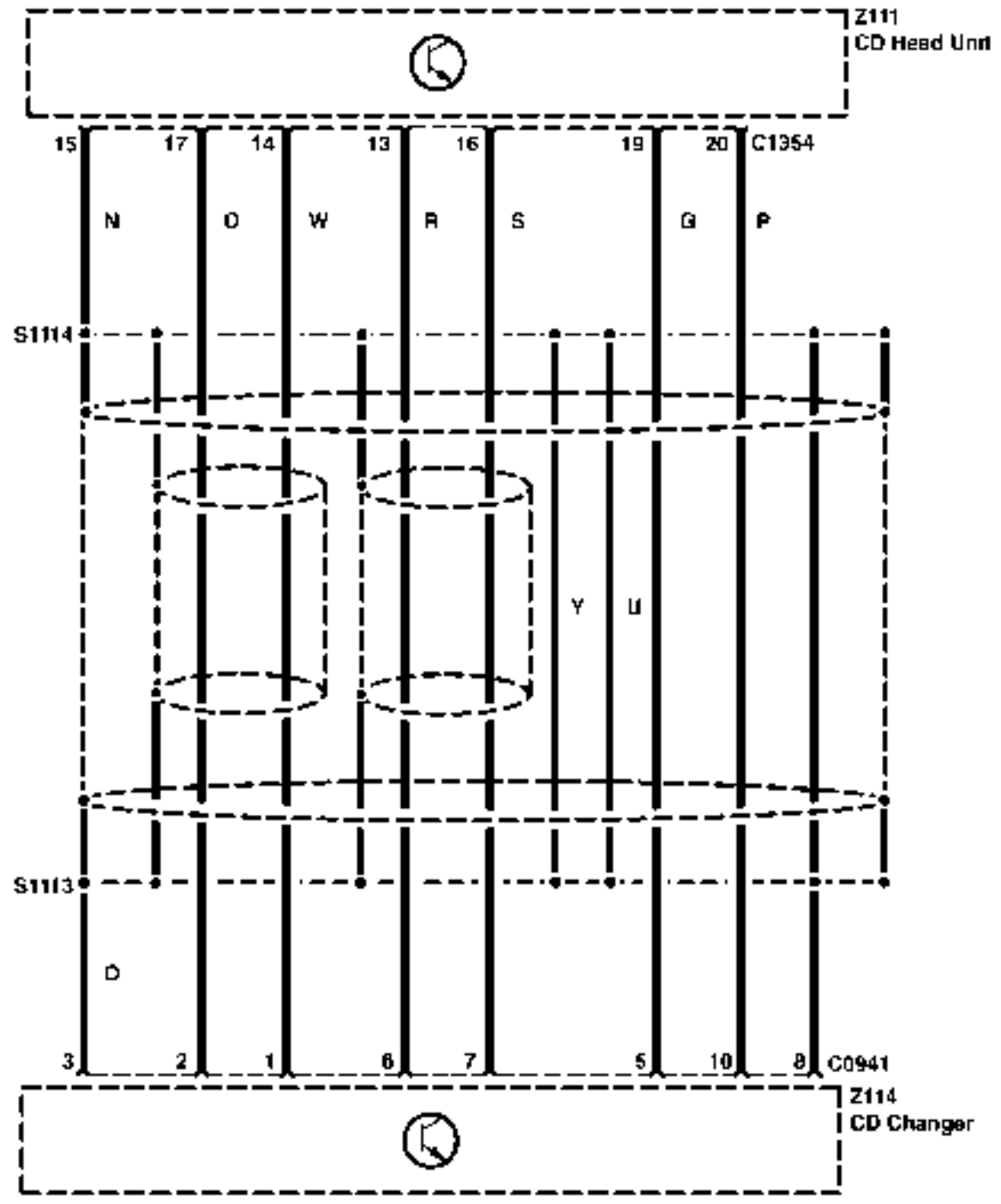
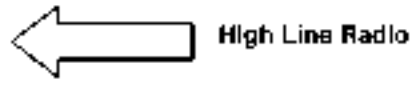

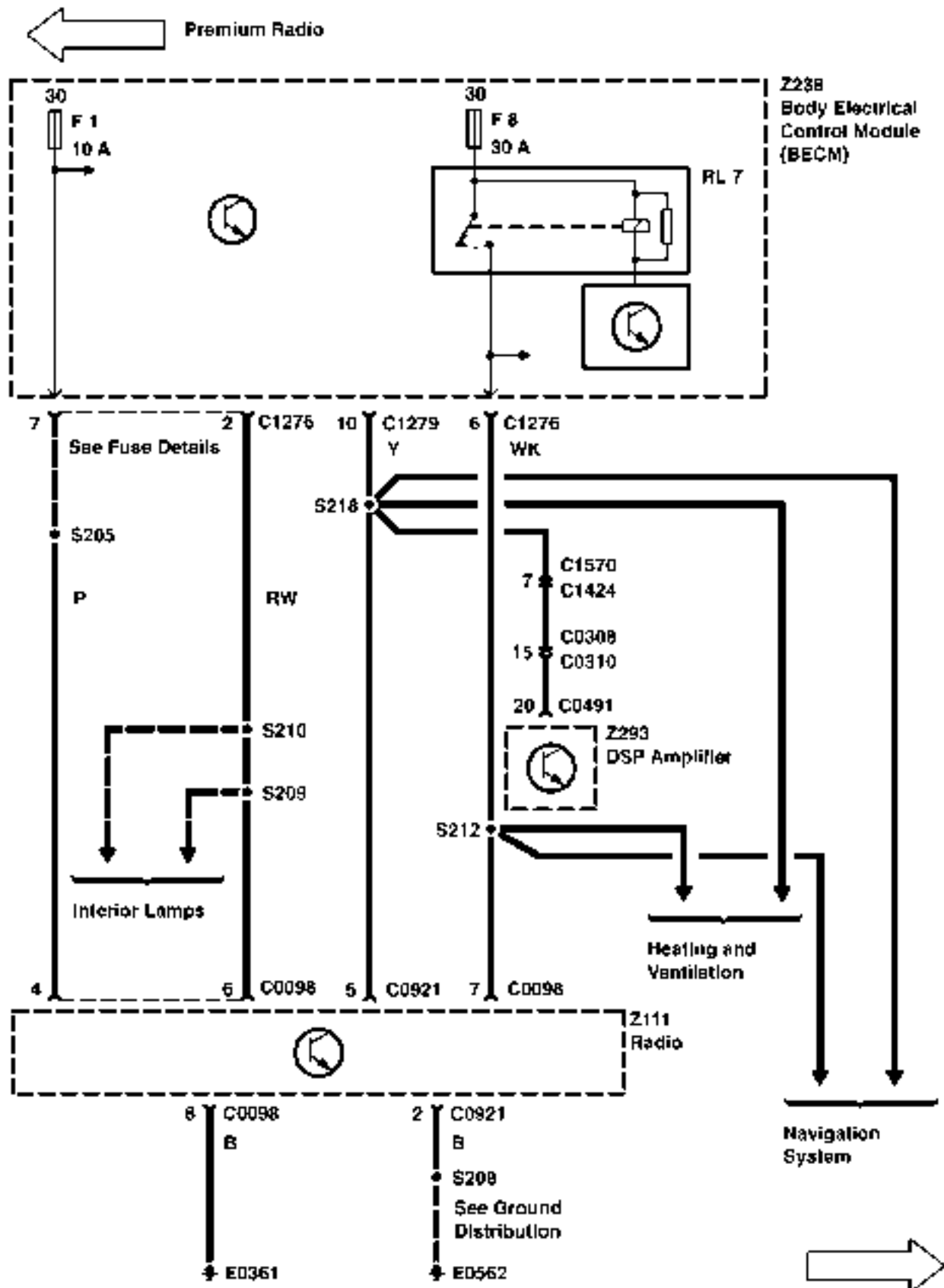

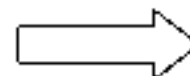
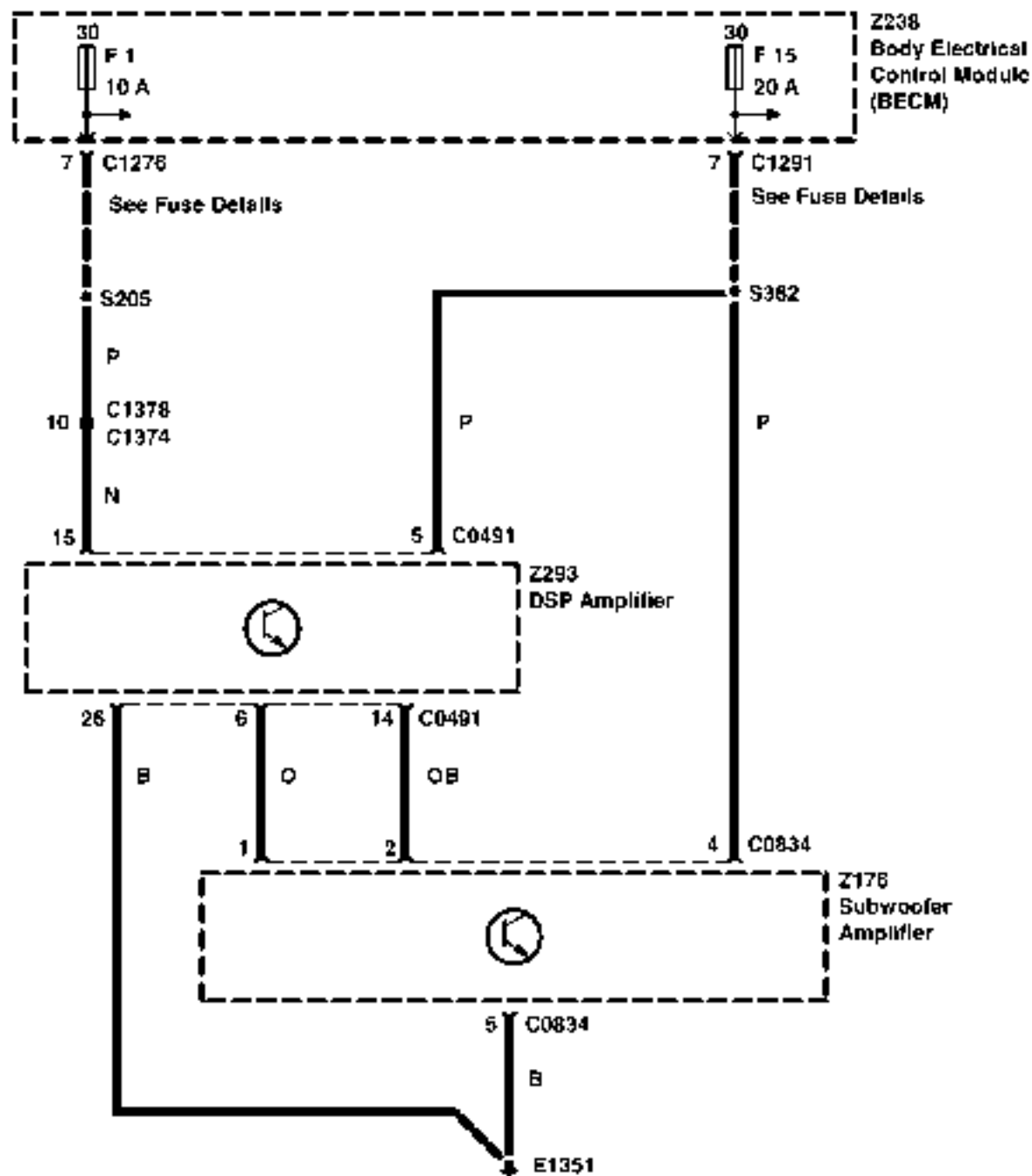

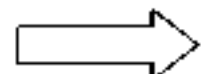
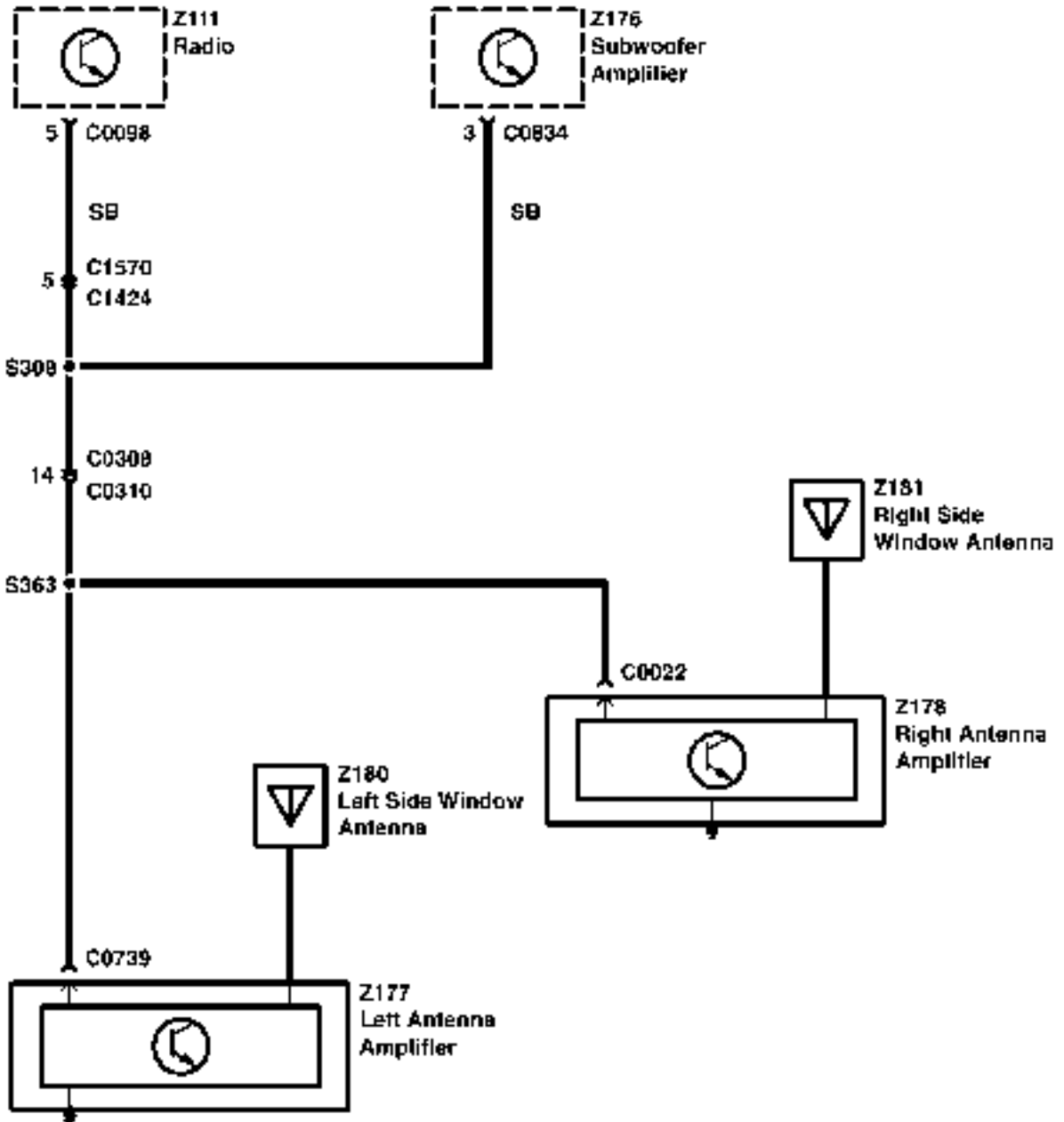

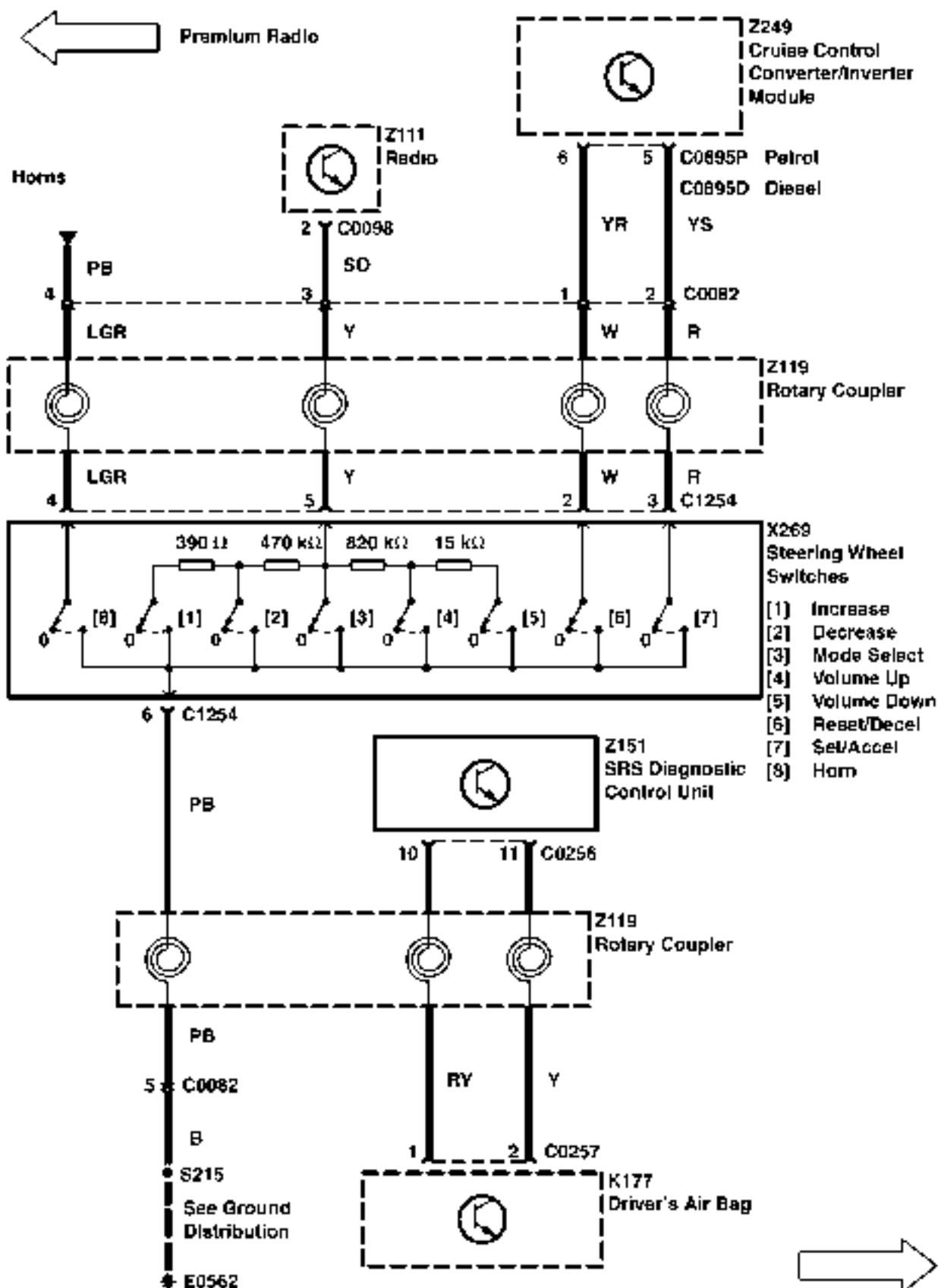

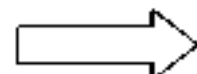
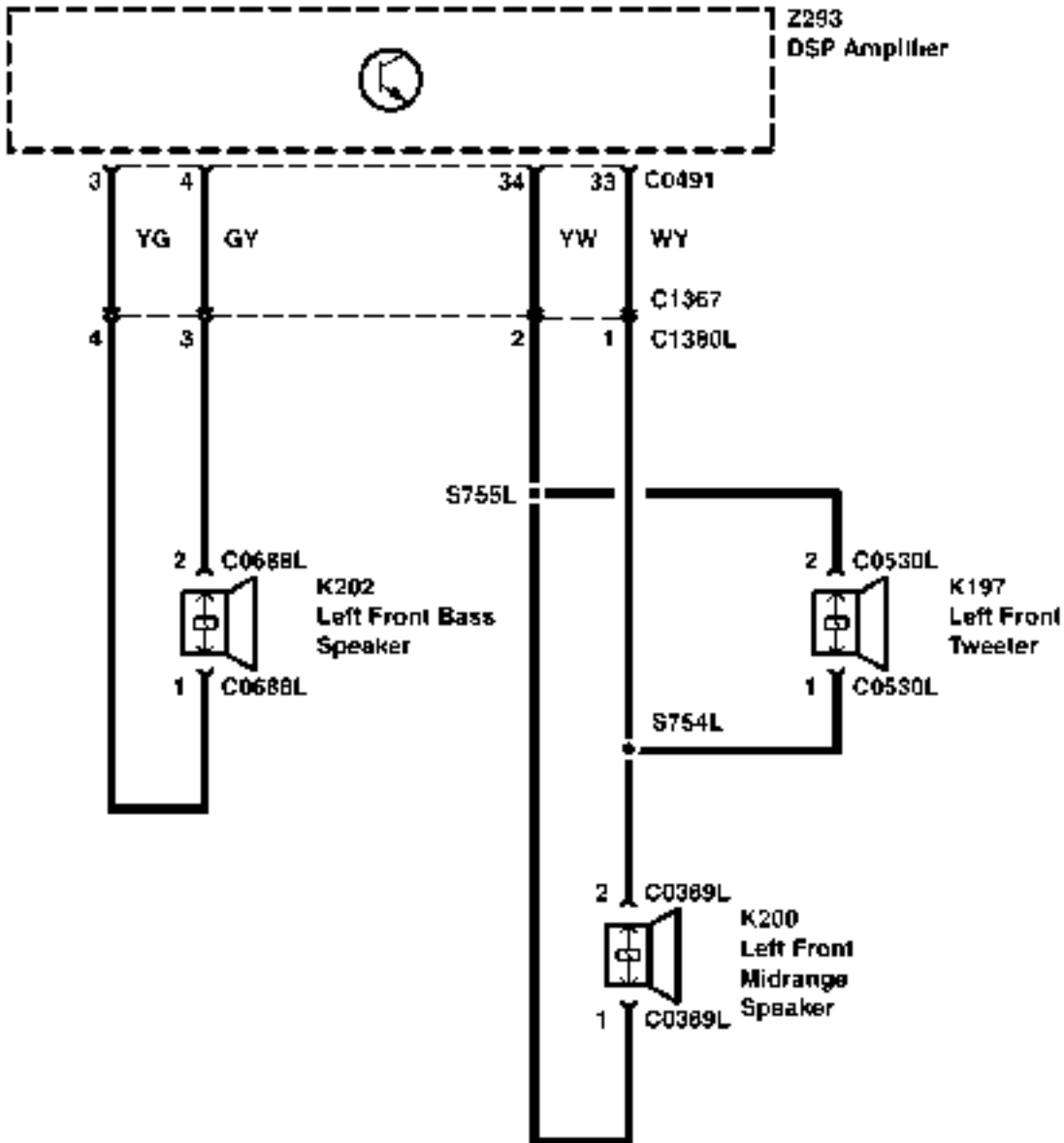

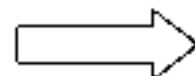
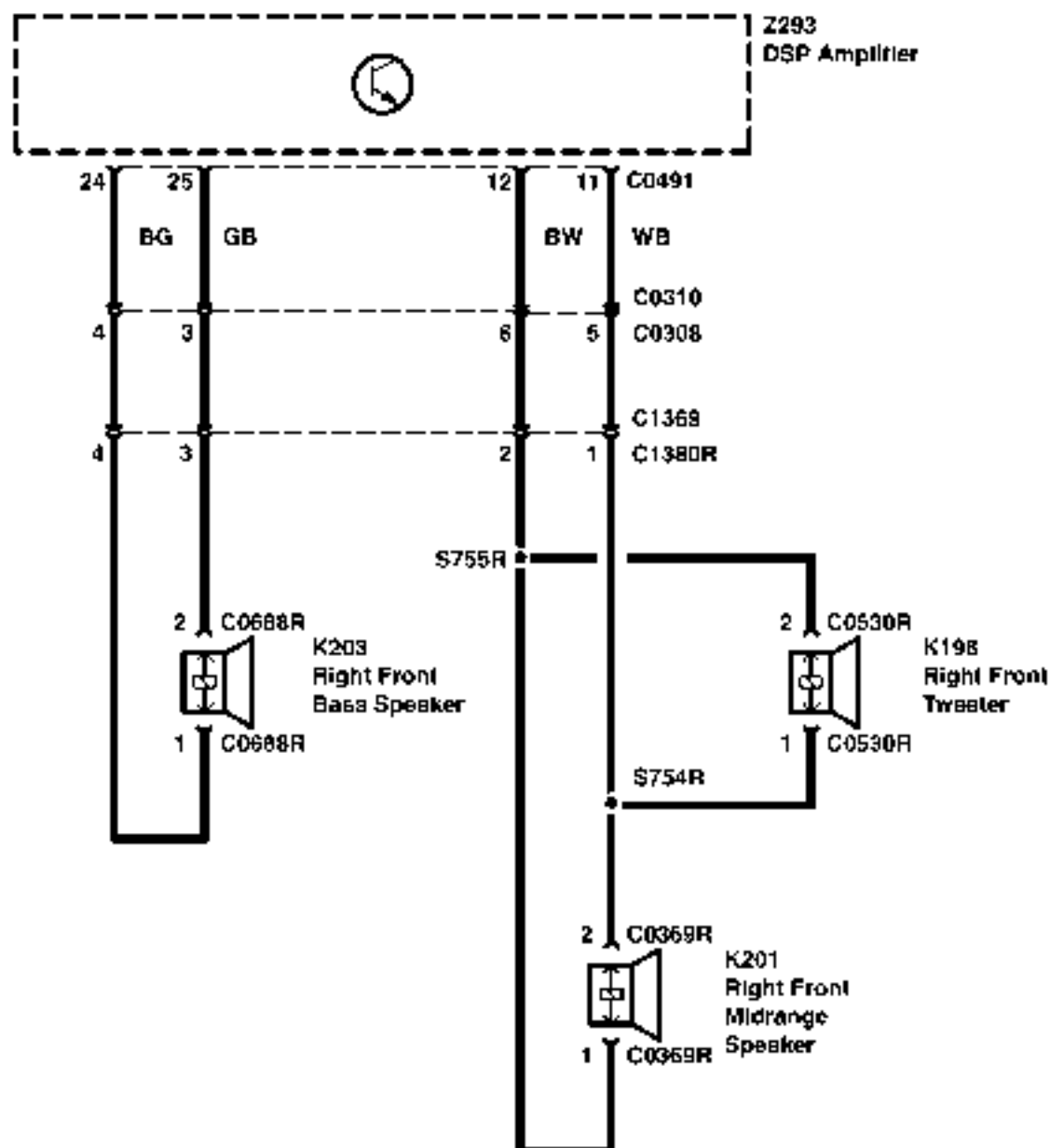

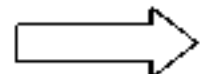
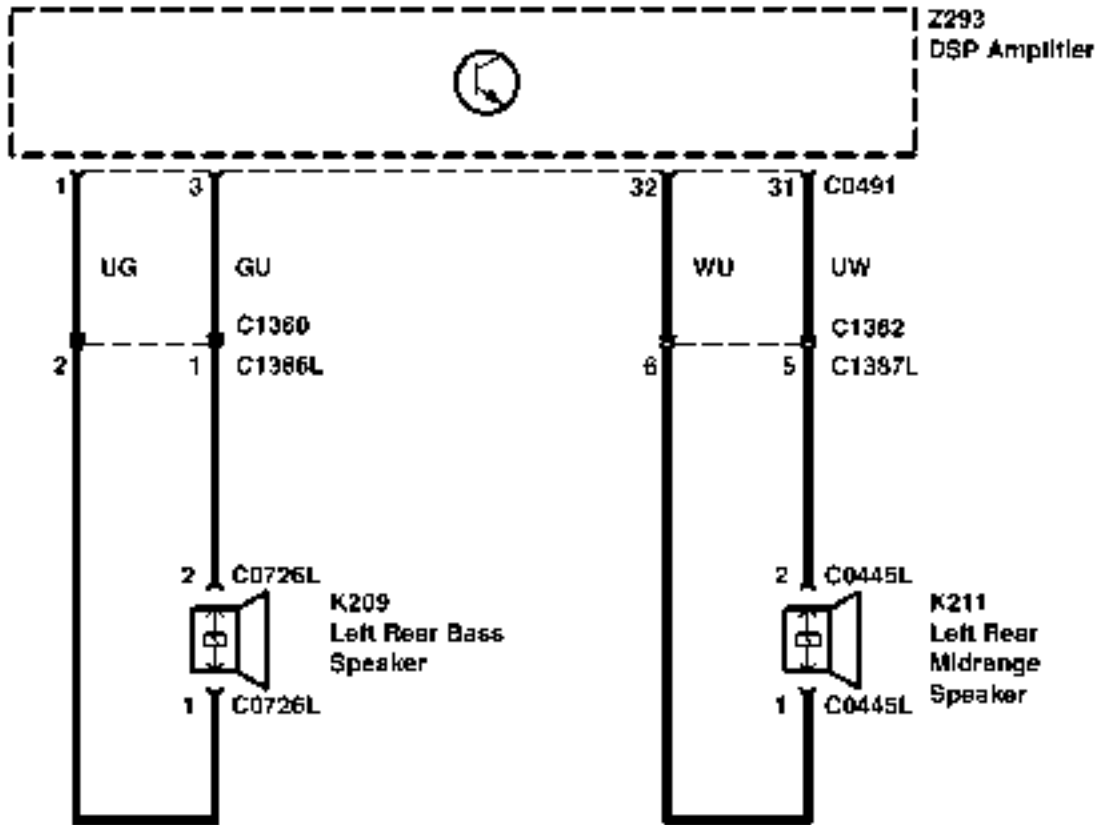

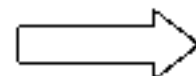
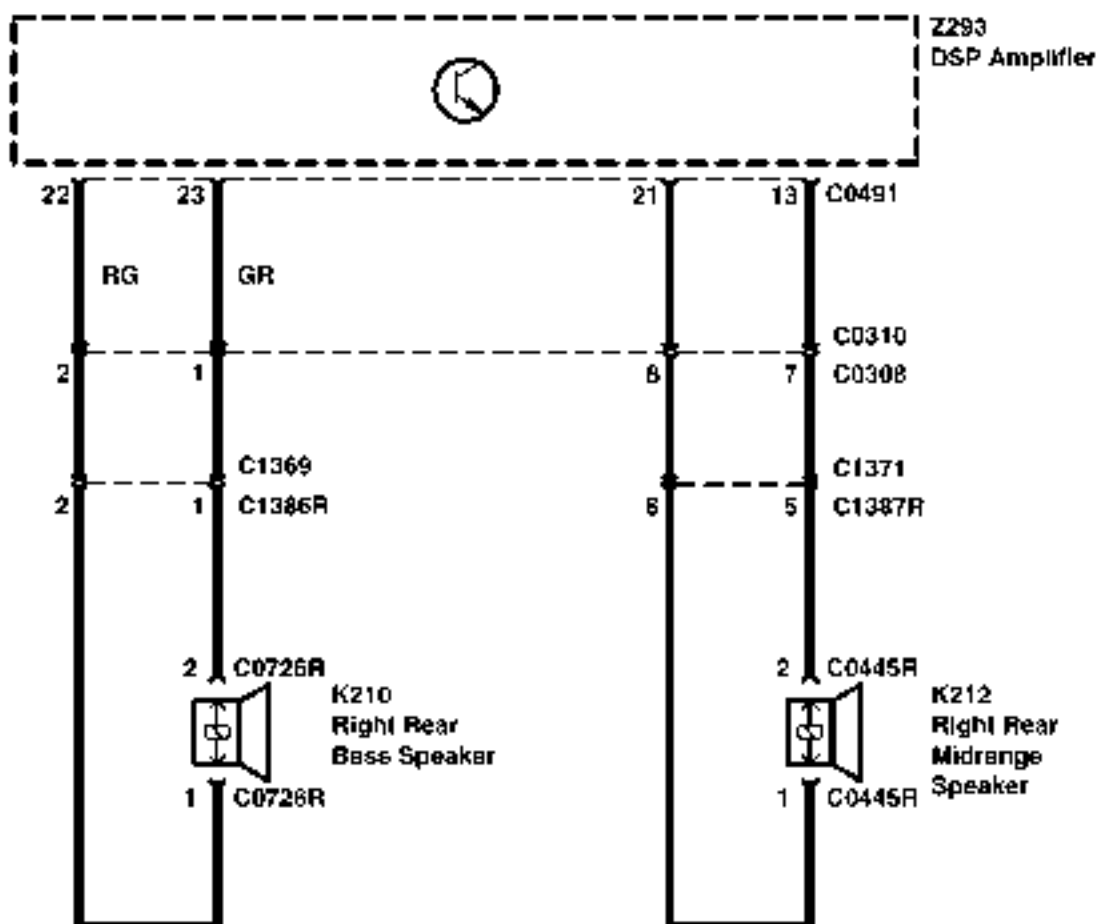

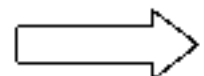
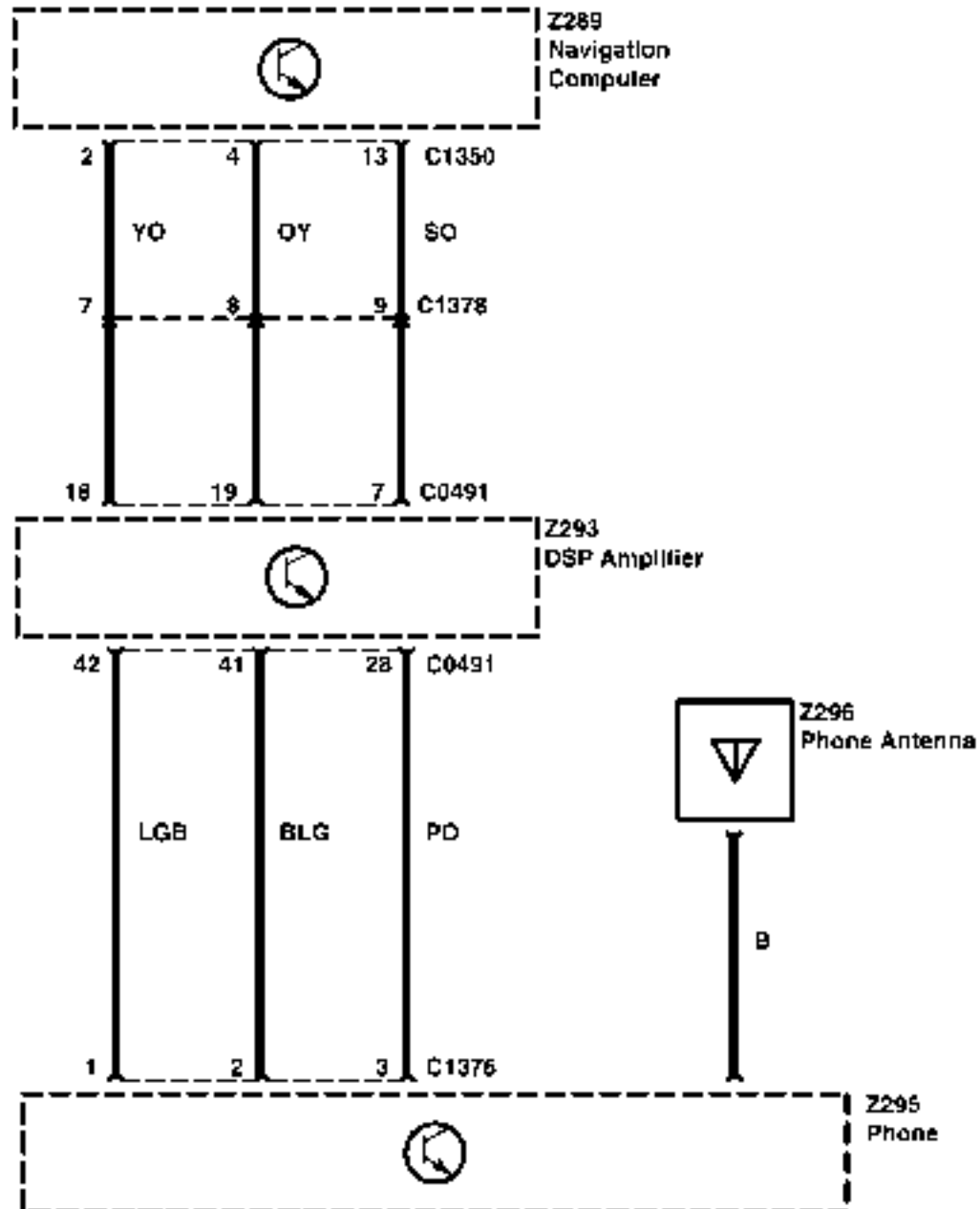

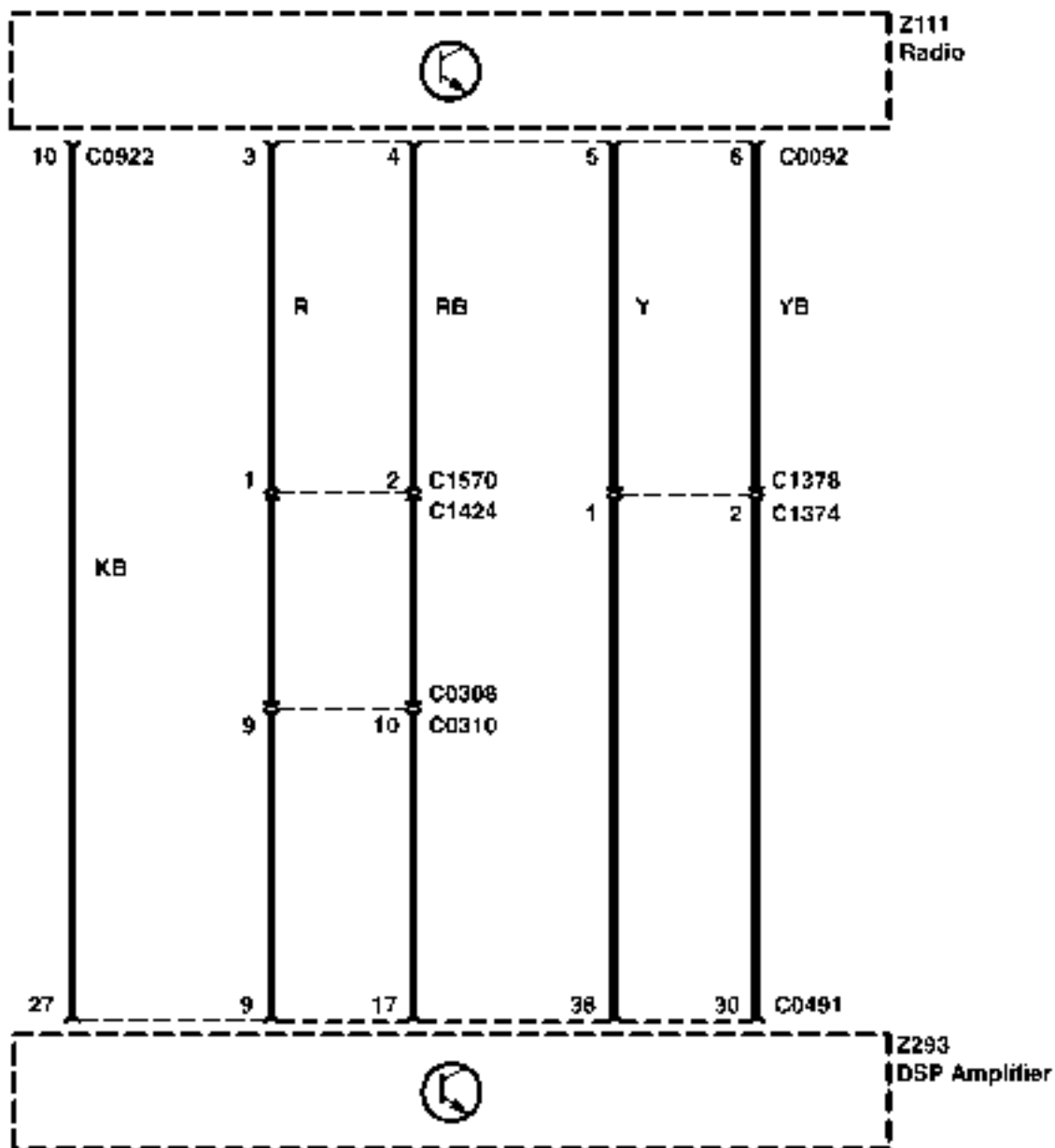

CIRCUIT OPERATION

The following components make up the navigation system:

- Navigation Computer (Z289)
- GPS Receiver (Z290)
- GPS Antenna (Z292)
- Display and Control Unit (Z291)

Navigation Computer (Z289):

The Navigation Computer (Z289) is located in the right hand side of the luggage compartment, attached to a bracket. The Navigation Computer (Z289) is the main component in the navigation system and receives input from the BECM (Z238) and the GPS Receiver (Z290). The Navigation Computer (Z289) contains a solid state piezo gyro which measures the motion in the vehicle around its vertical axis. The gyro operates on the principle known as the Coriolis force (Refer to the workshop manual for detailed operation).

Using the inputs from the BECM (Z238), the GPS Receiver (Z290) and the gyro sensor, the Navigation Computer (Z289) can determine the vehicle's current position, direction and speed.

The Navigation Computer (Z289) also houses the CD-ROM drive. This drive is used to read map data from country specific CD's and also to load updated software into the computer.

Global Positioning System (GPS) Receiver (Z290)

The GPS Receiver (Z290) is located in the right hand side of the luggage compartment underneath the parcel tray support panel. The GPS Receiver (Z290) receives information from 1 to 9 satellites at any one time via the GPS Antenna (Z292).

The GPS Receiver (Z290) fulfills the following functions:

- Calculation of position, direction and speed
- Collection and storage of data
- Real-time clock

The GPS Receiver (Z290) communicates with the Navigation Computer (Z289) via a serial link. The Navigation Computer (Z289) can also extract configuration and status information from the GPS Receiver (Z290) via this link.

GPS Antenna (Z292)

The GPS Antenna (Z292) is located underneath the air intake plenum and is connected to the GPS Receiver (Z290) via a single co-axial cable and passes signals received from the GPS satellites to the GPS Receiver (Z290) for processing.

It is possible for the antenna to lose the signals from the satellites in hilly or tree lined areas, built up areas with tall buildings, multi-storey car parks, garages, tunnels, bridges and during heavy rain/thunderstorms. When the signal is lost, the navigation computer will continue to give guidance using memory mapped data from the CD map until the signal is restored.

Display and Control Unit (Z291)

The Display and Control Unit (Z291) is located in the centre of the fascia. The unit comprises of a colour Liquid Crystal Display (LCD) screen and controls to operate the navigation functions. The Display and Control Unit (Z291) comprises four control switches, one rotary press menu control and one status LED. A photosensor is used to control the brightness of the screen in day and night time conditions (Refer to the workshop manual for detailed operation).

Diagnostics Mode

The navigation system may be put into a on-board diagnostics mode (service mode) by selecting the 'settings' menu from the main menu then pushing and holding the menu key for about 10 seconds. The service mode has four main functions:

1. To check that components are fitted and to determine their Hardware/software levels.
2. To perform a quick 'health check' of the major input signals to the system.
3. To check for correct operation of the display and control unit keys.
4. To check the status of the GPS reception.

Selecting the on-board monitor item from the service mode menu causes the version info to be displayed. The screen displays the software and hardware level of the display and control unit together with the diagnostics and bus index. The supplier of the unit is also displayed as a number code defined by BMW. The system queries the display and control unit before displaying the information on the screen. If the unit responds with

Software Hardware levels this implies that the component is connecting to at least power (ground) and K-bus.

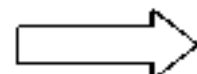
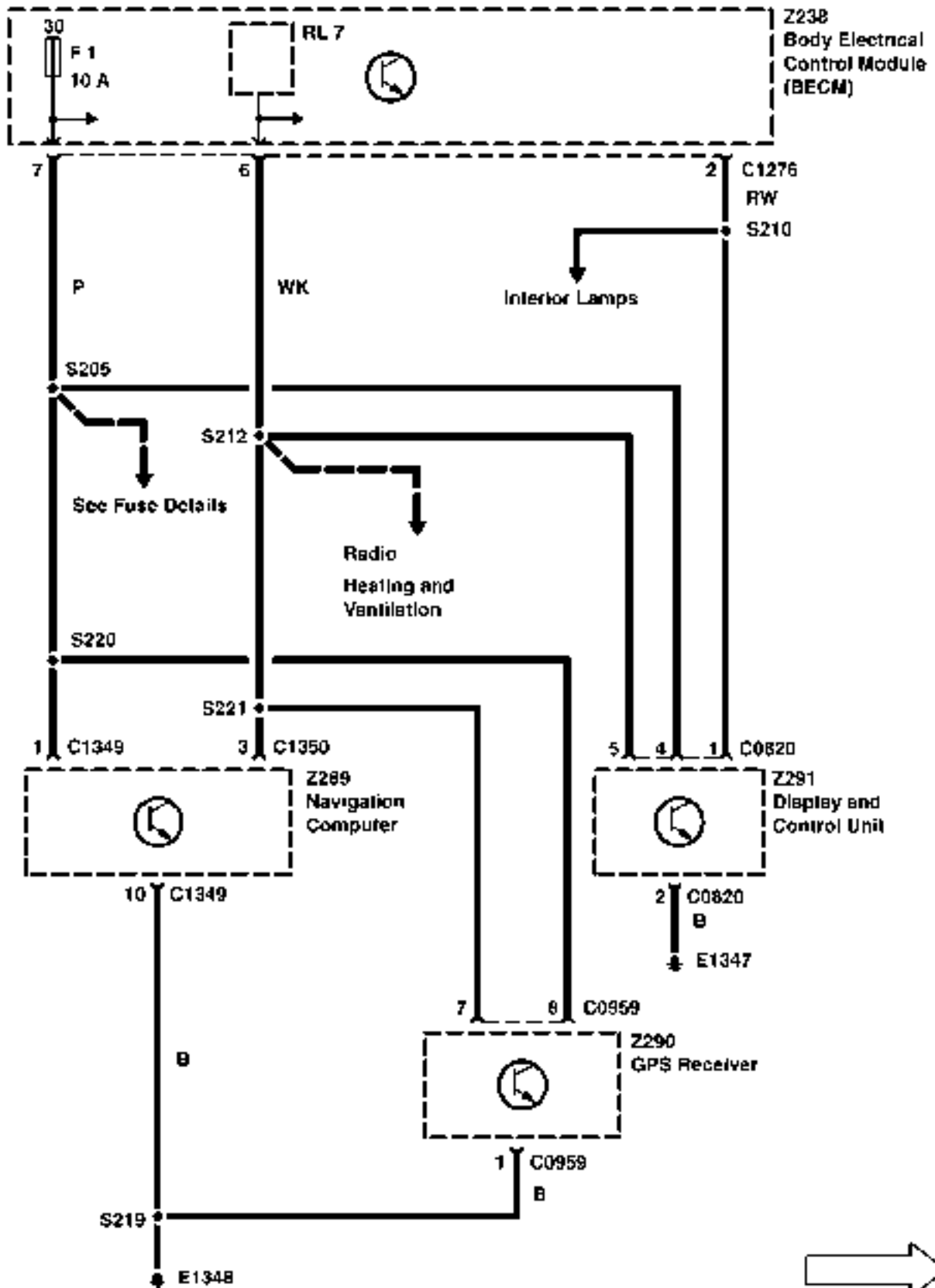

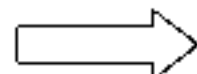
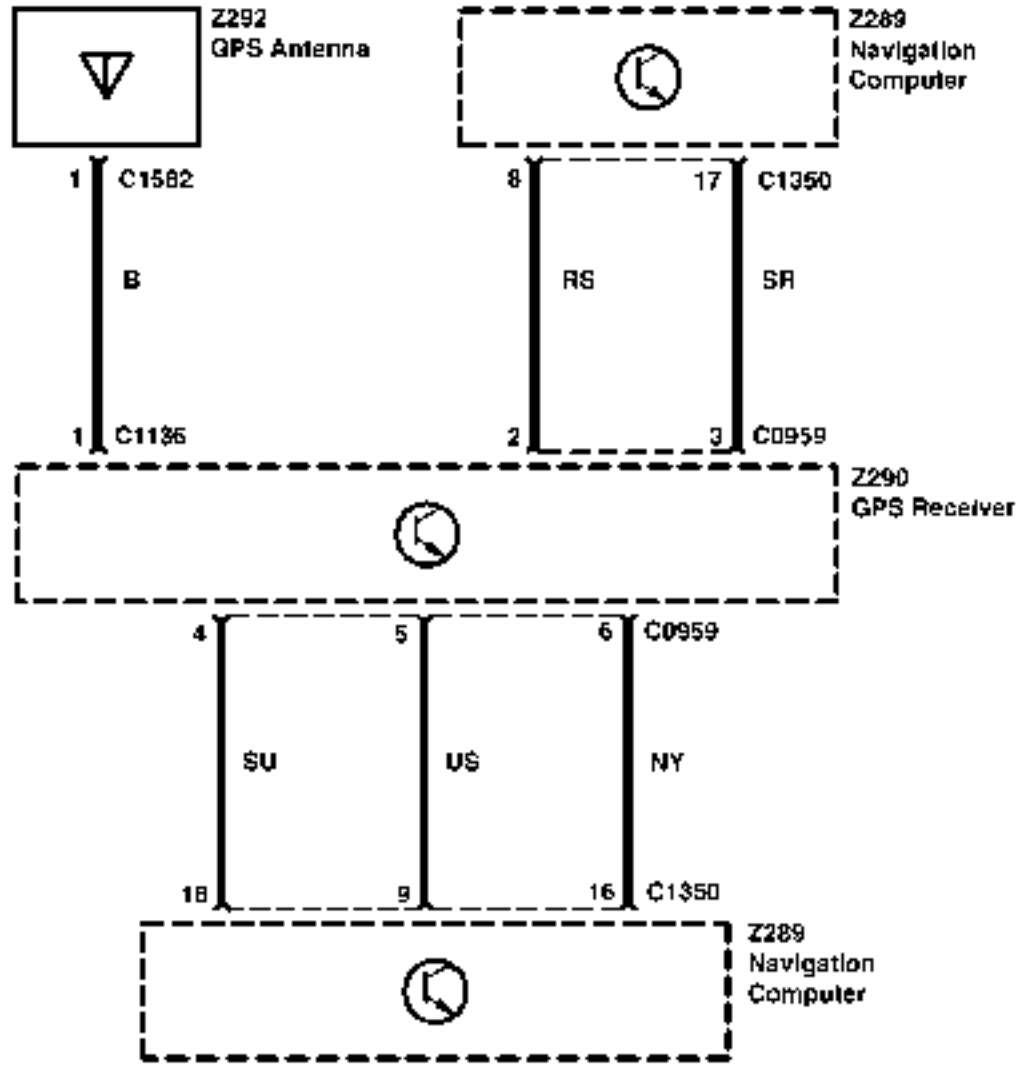

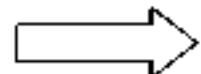
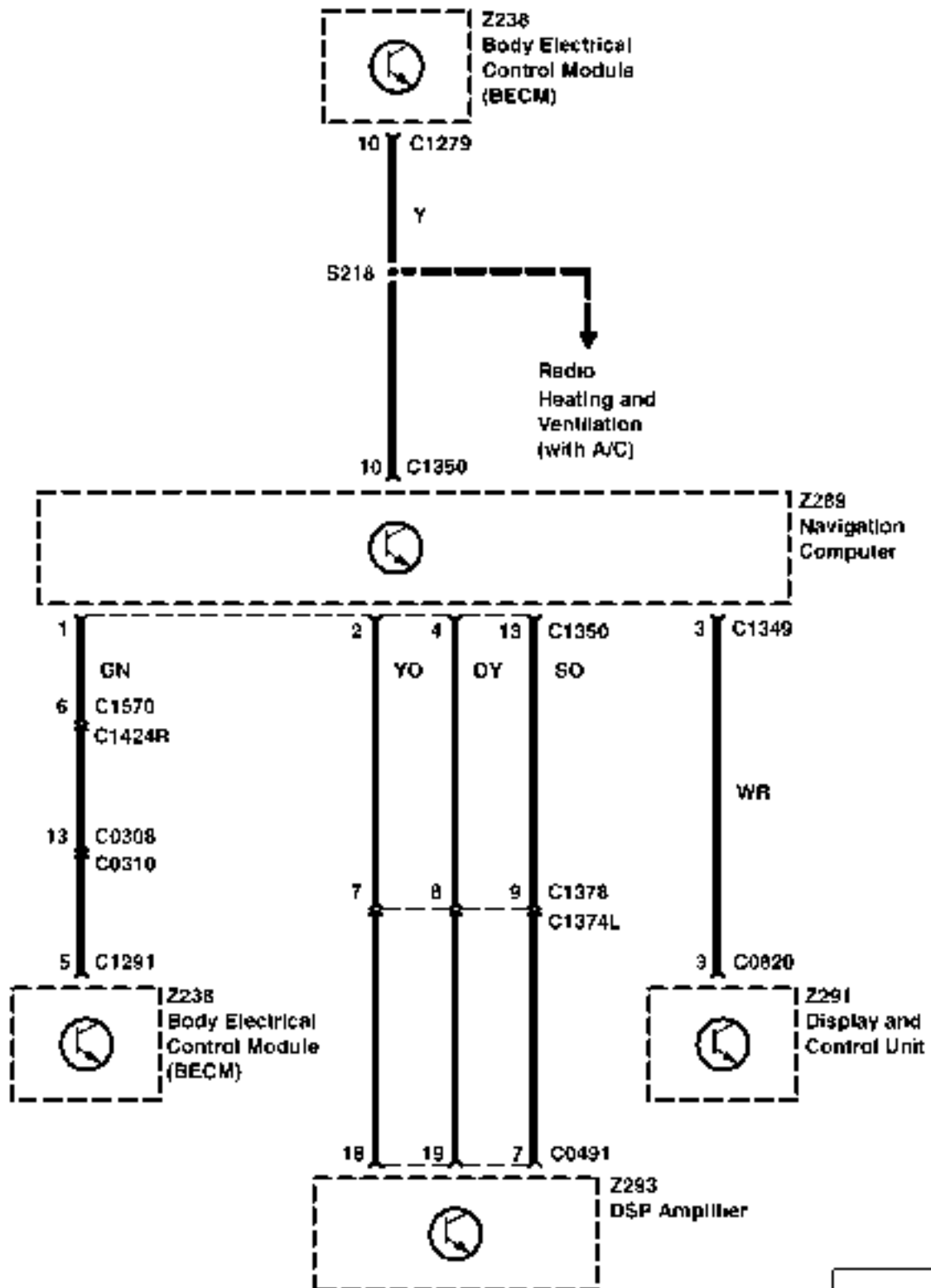
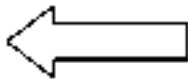

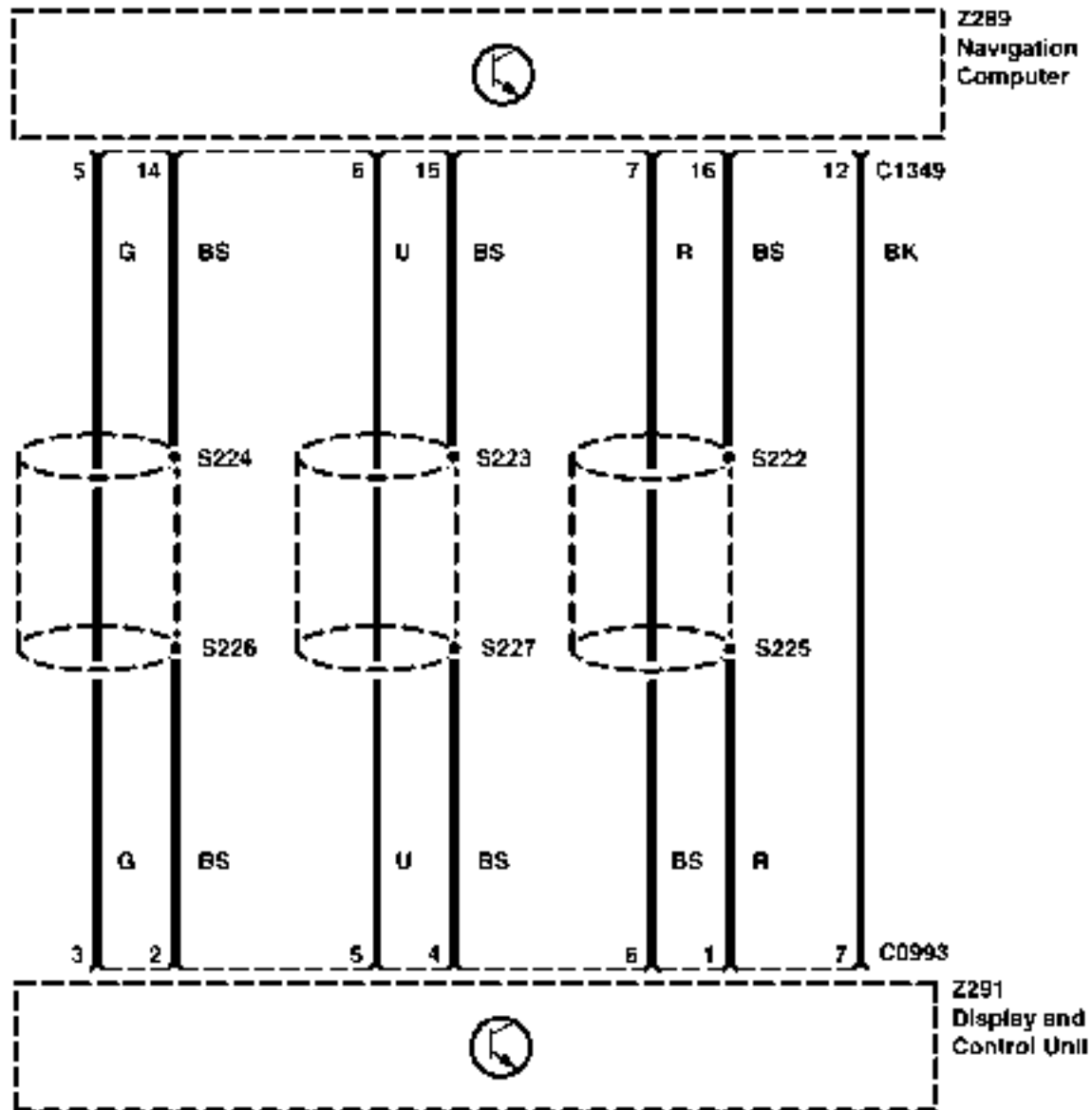
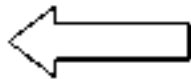

CIRCUIT OPERATION

Front Wipers

The front wipers will only operate with auxiliary or ignition on, except when auxiliary and ignition are both turned off. The wipers will continue to operate until they reach the park position. If the engine is cranked while the wipers are on, then the wiper operation will be suspended until cranking is released.

Flick Wipe Operation

When the flick wipe switch is operated, the wiper will operate in the slow wipe mode until the switch is released.

Intermittent Operation

When the wiper control stalk is moved to the intermittent position, the wipers will perform one wipe of the screen at slow speed and then wait for N seconds before doing another wipe etc. The value of N is determined by the position of the wipe delay potentiometer. When the potentiometer is in the far left position the time delay is 2 seconds. Each movement of the potentiometer to the right doubles the time delay, up to a maximum of 32 seconds.

Slow Speed Operation

When the wiper control stalk is moved to the slow position, the wipers will operate continuously at slow speed.

Fast Speed Operation

When the wiper control stalk is moved to the fast position, the wipers will start operating at fast speed immediately and will continue to do so until fast speed is switched off.

Front Screen Programmed Wash/Wipe

If the wash/wipe switch is operated, the front screen wash motor will operate for 1.5 seconds or for the duration the switch is held on, whichever is the longer.

The slow front wipe will be operated for 0.5 seconds after the switch is closed and will continue to operate until three full wipes have been completed after the wash motor has ceased it's operation.

Rear Wiper

Intermittent Operation

When the rear wiper stalk is moved to the "on" position, then the rear wiper will perform two complete wipes and stop in the park position. After

that, its operation will vary depending on the selected mode of the front wipers.

Reverse Gear Wiping

If reverse gear is selected while auxiliary or ignition is on and a front wiper function is selected, then the rear wiper will operate as well.

If reverse gear is selected while the front wipers are off (or performing a wash/wipe cycle), then the rear wiper will operate in the mode indicated by the rear wiper switch.

Rear Screen Programmed Wash/Wipe

If the rear wash/wipe switch is operated, the rear screen wash motor will operate for 1.5 seconds or for as long as the switch is held on, whichever is the longer. The rear wipe will be operated 0.5 seconds after the switch closed and will continue to operate until three full wipes have been completed after the washer motor has ceased it's operation.

Wiper Operation With Speed Dependency On

If the vehicle has speed dependent wipers, the wiper adapts its speed to the vehicle speed.

The speed barrier, where the wipers move between a faster or slower operation, is 2 mph.

Headlight Wash/Wipe

If the headlight switch is in the on position, the first and every alternate operation of the front screen wash switch will activate the headlight wash/wipe motor, which will operate for 2 seconds, regardless of the length of time the switch is pressed.

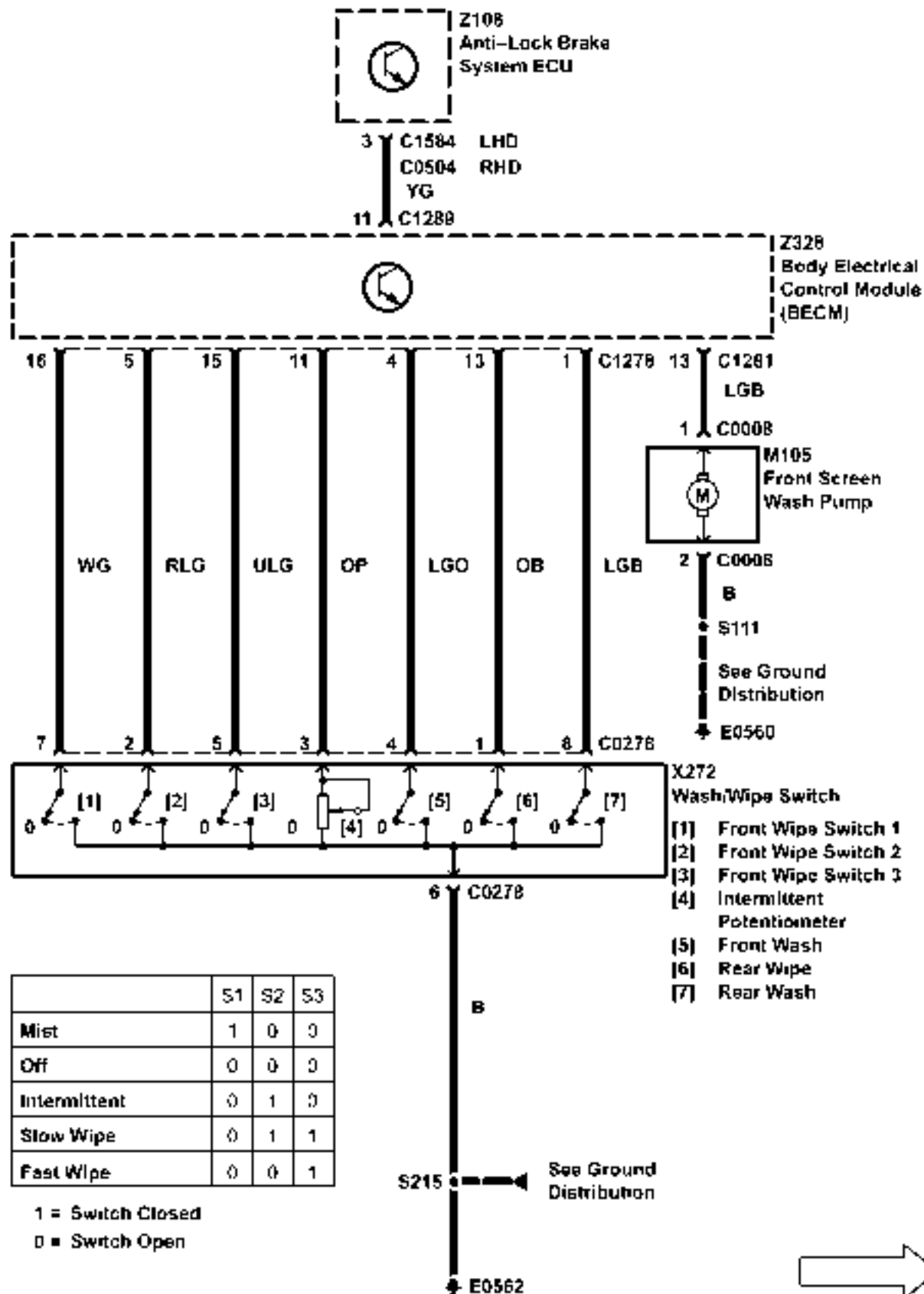

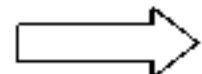
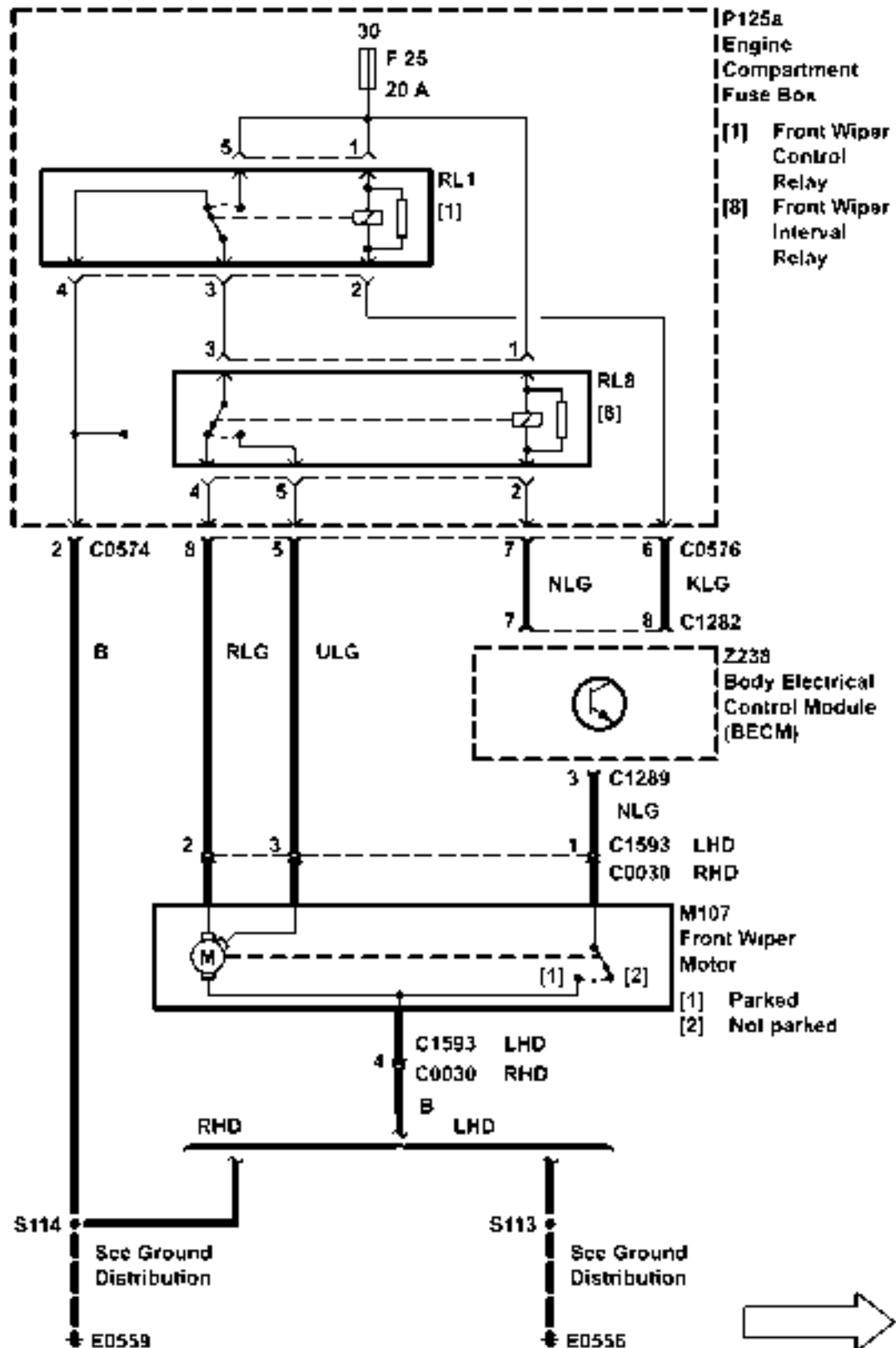
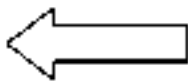

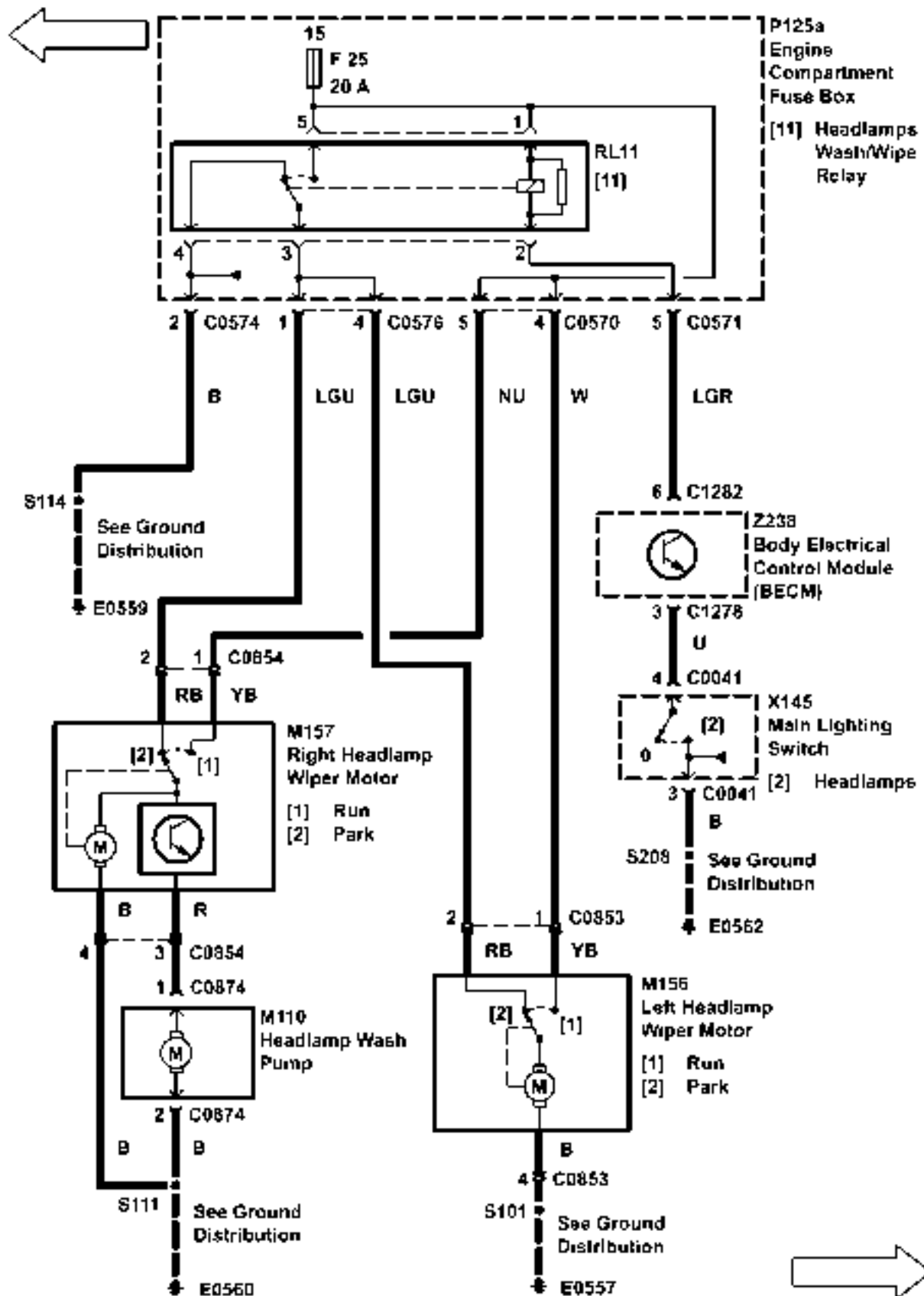

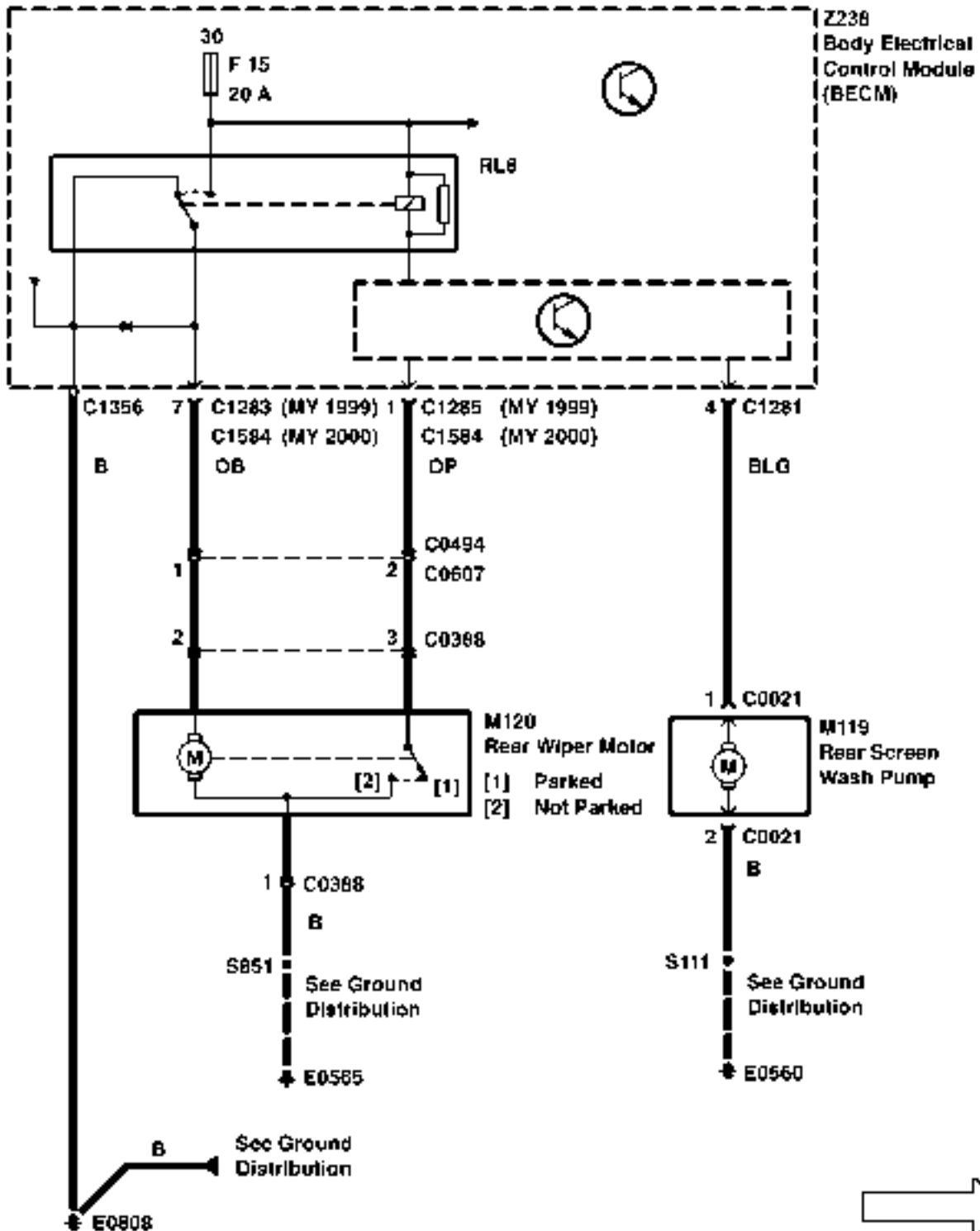
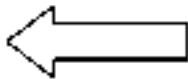

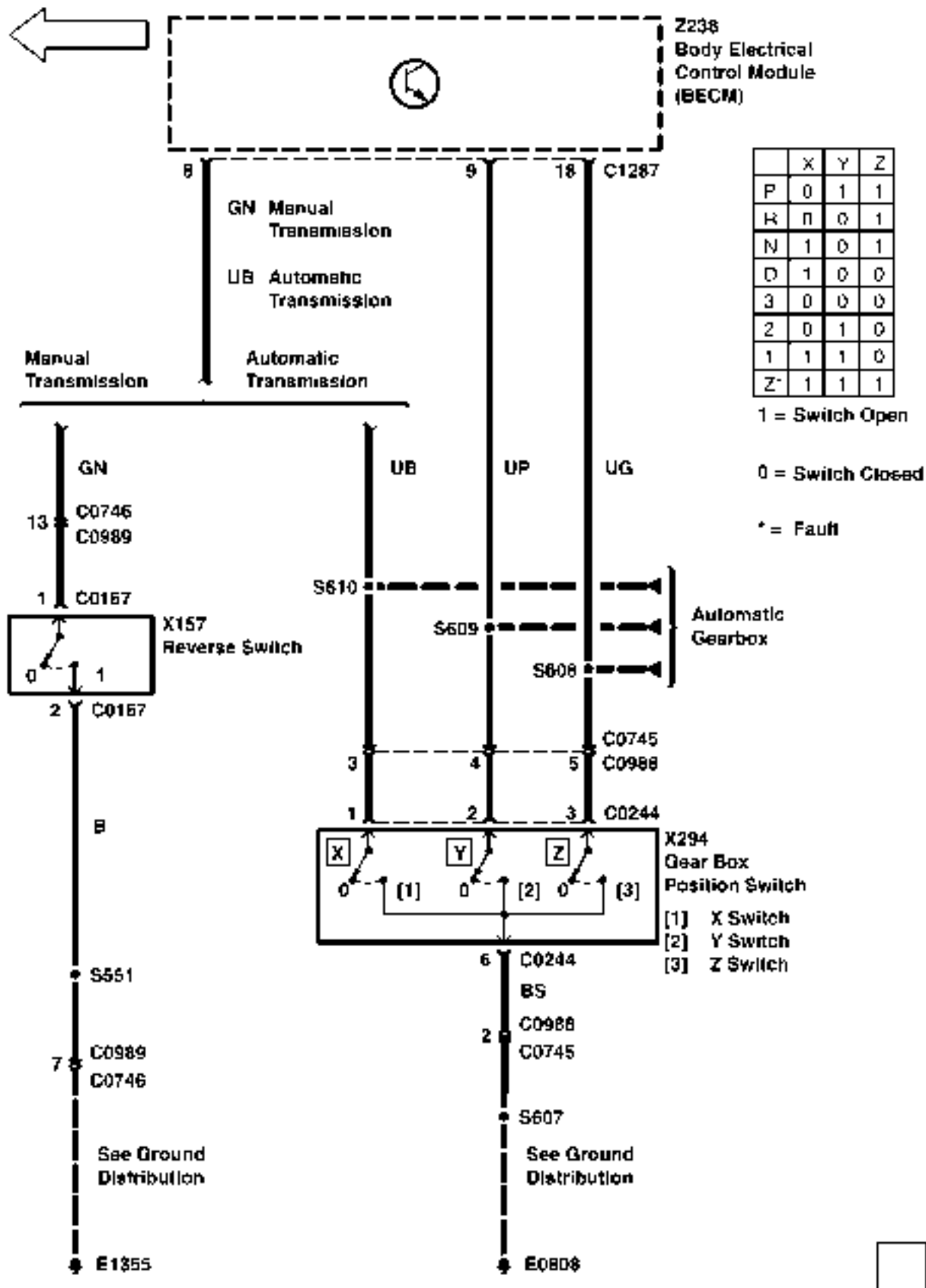

CIRCUIT OPERATION

This operates only with the engine running, which is determined by the HEVAC panel. In the off state, the signal is at 12 volts. When the Heated Front Windscreen is activated, the signal is switched to 0 volts. This provides the ground required for relay 5 to be pulled in, as there is an ignition feed on the other side of the coil provided by relay 15. This relay energises one half of the heated screen elements.

Once relay 5 has been energised, a 12 volt signal is provided to the coil of relay 4. The other side of the coil is connected directly to ground, thereby energising the relay and switching on the other half of the elements.

There is also a feed spliced from the harness which provides the petrol Engine Control Module with a signal that tells the unit there will be a large electrical load turned on/off.

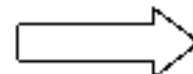
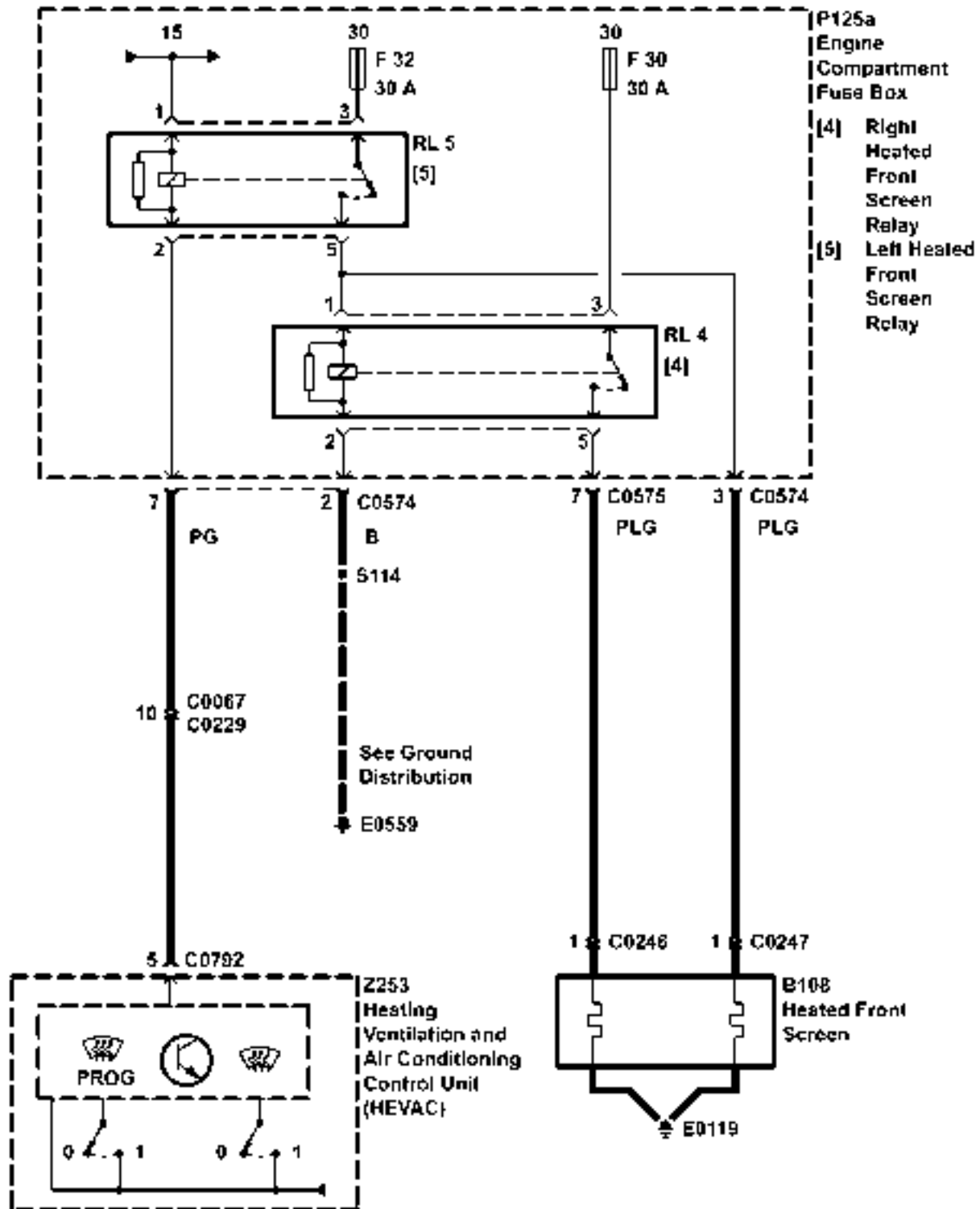

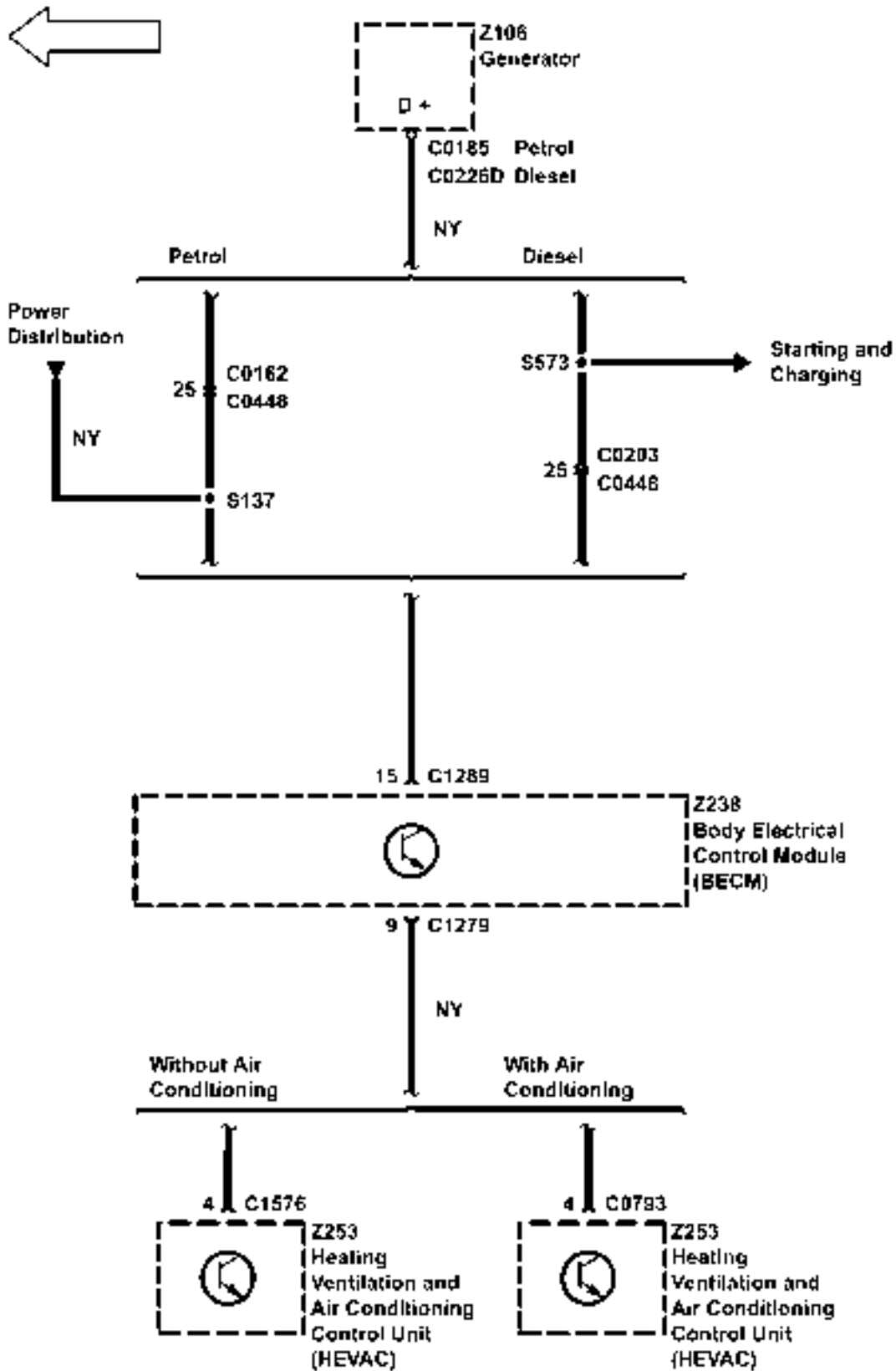

CIRCUIT OPERATION

The rear screen heater will reflect the state of the heated rear screen input from the HEVAC unit at any time while the BeCM (Z23B) is in the active mode. This signal is normally 12V and 0V when active (Active Low).

The HEVAC unit will control all timing functions related in the rear screen heater.

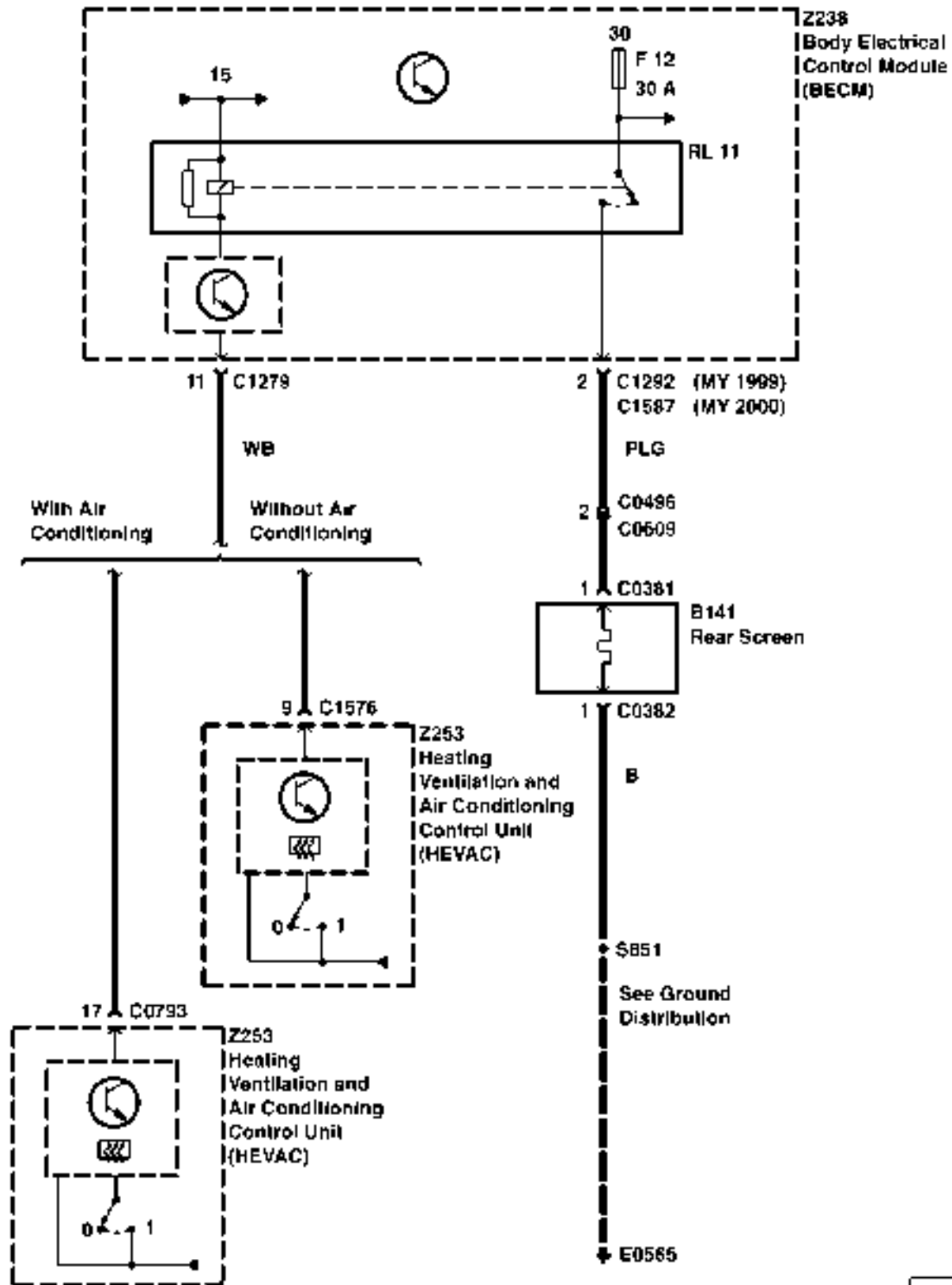

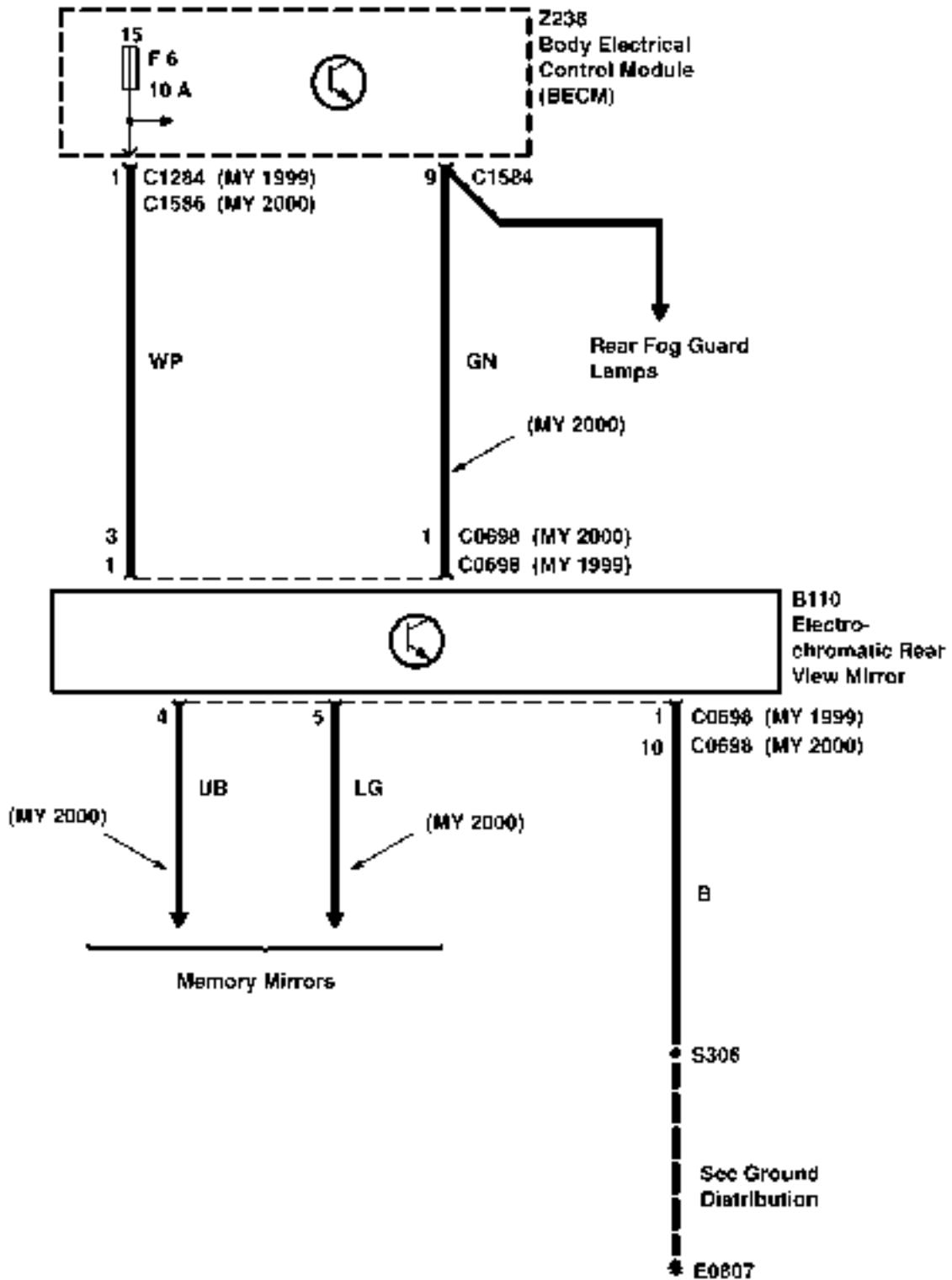

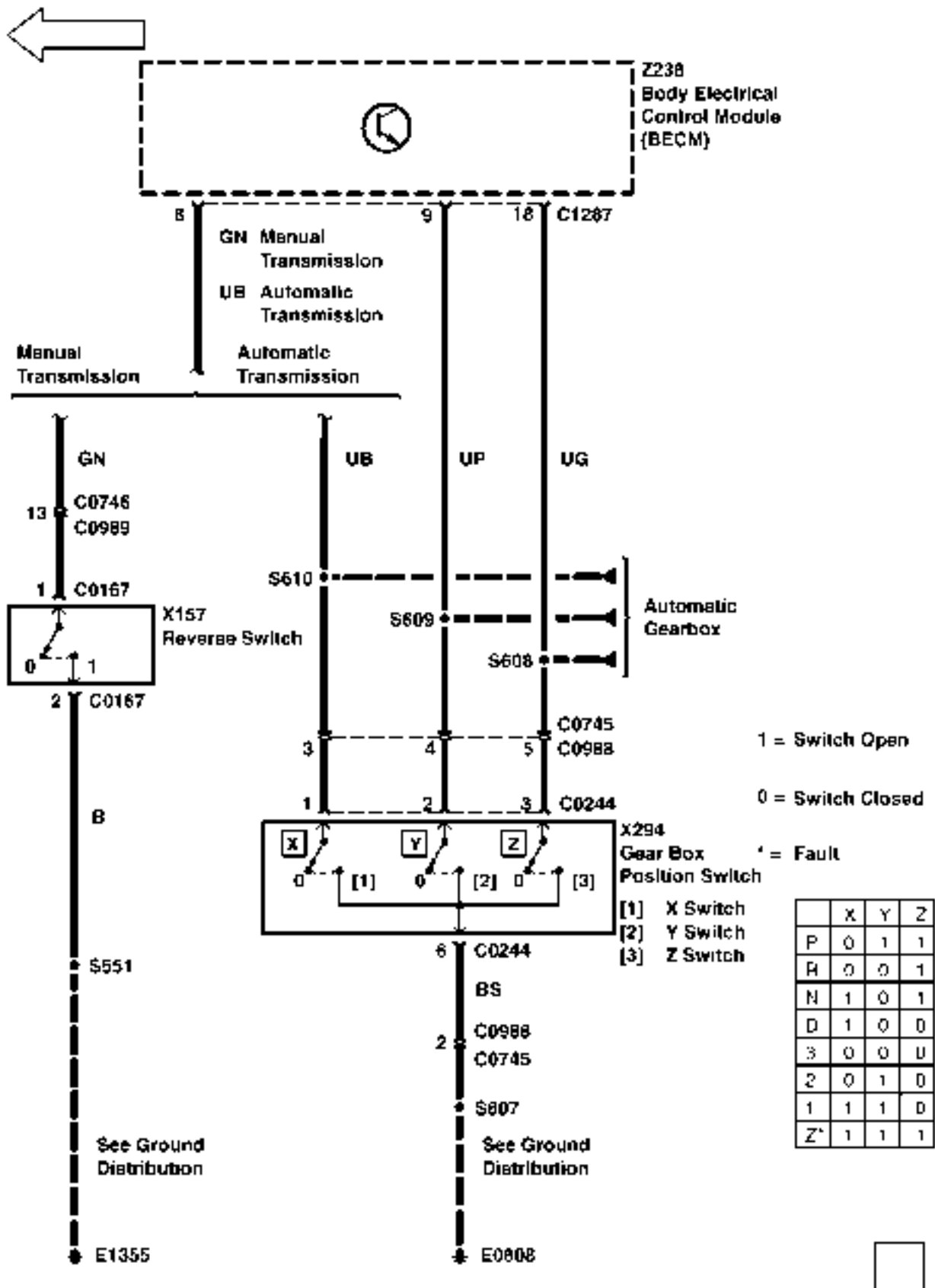

CIRCUIT OPERATION

Dipped Beam Headlamps

Operation of the headlamp switch will activate the LH and RH dipped beam headlamps, regardless of the state of the ignition switch.

Headlamp Delay

The term 'headlamp' used throughout this section is assumed to be either dipped beam or main beam, as selected by the main beam changeover switch. This switch will continue to function for the duration of the delay period.

The headlamps will operate when the headlamp switch is set to the headlamp position, regardless of the status of the ignition switch.

If the ignition switch is turned off and the key removed whilst the headlamps are on, and the headlamp switch is subsequently turned off with a dwell of less than 1 second in the side lamp position, then a 25 second headlamp delay will be initiated.

If the ignition switch is turned off and the key removed while the headlamps are on and the headlamp switch is subsequently turned to the side lamp position for greater than 1 second then the headlamps will be switched off and parking lamps will remain on until the headlamp switch is turned off or turned back to the headlamp position.

The headlamp delay may be cancelled immediately at any time while it's active (master lighting switch in the off position) by the following actions.

- Insertion of the ignition key or selection of auxiliary ignition (all exterior lamps will be extinguished).
- Turning the headlamp switch to the side lamp position. In this case the exterior lamps will immediately revert to parking lamps mode.
- Turning the headlamp switch to the headlamps position. In this case the headlamps and normal side lamps (i.e. not parking lamps) will be active.

Main Beam/Side lamp Warning lamps

The main beam warning lamp will be activated whenever the main beam lamps are on, regardless of the state of the ignition switch. The side lamp warning lamp will be active whenever the side lamp switch is on and the side lamps are operating in side lamp mode, but not when the key is removed and the parking lamp mode is on.

Main Beam Headlamps

The main beam change over switch has a momentary action, which will cause the headlamps to switch between dipped and main beam on each operation.

Operation of the main beam changeover switch, while the dipped beam headlamps are activated and the front fog lamps are inactive, will cause the dipped beam lamps to be extinguished and both main beam 1 and main beam 2 lamps to be illuminated.

Operation of the main beam changeover switch, while both dipped beam and front fog lamps are active, will cause the dipped beam lamps to be extinguished and the main beam 1 lamps to be illuminated.

Daytime Running lamps

This feature is a requirement for vehicles for the Canadian, Norwegian, Swedish and Finnish markets.

On these vehicles, with the engine running, daytime running loads will be active regardless of the state of any switches.

This feature will in no way effect the operation of any of the other lighting systems.

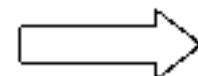
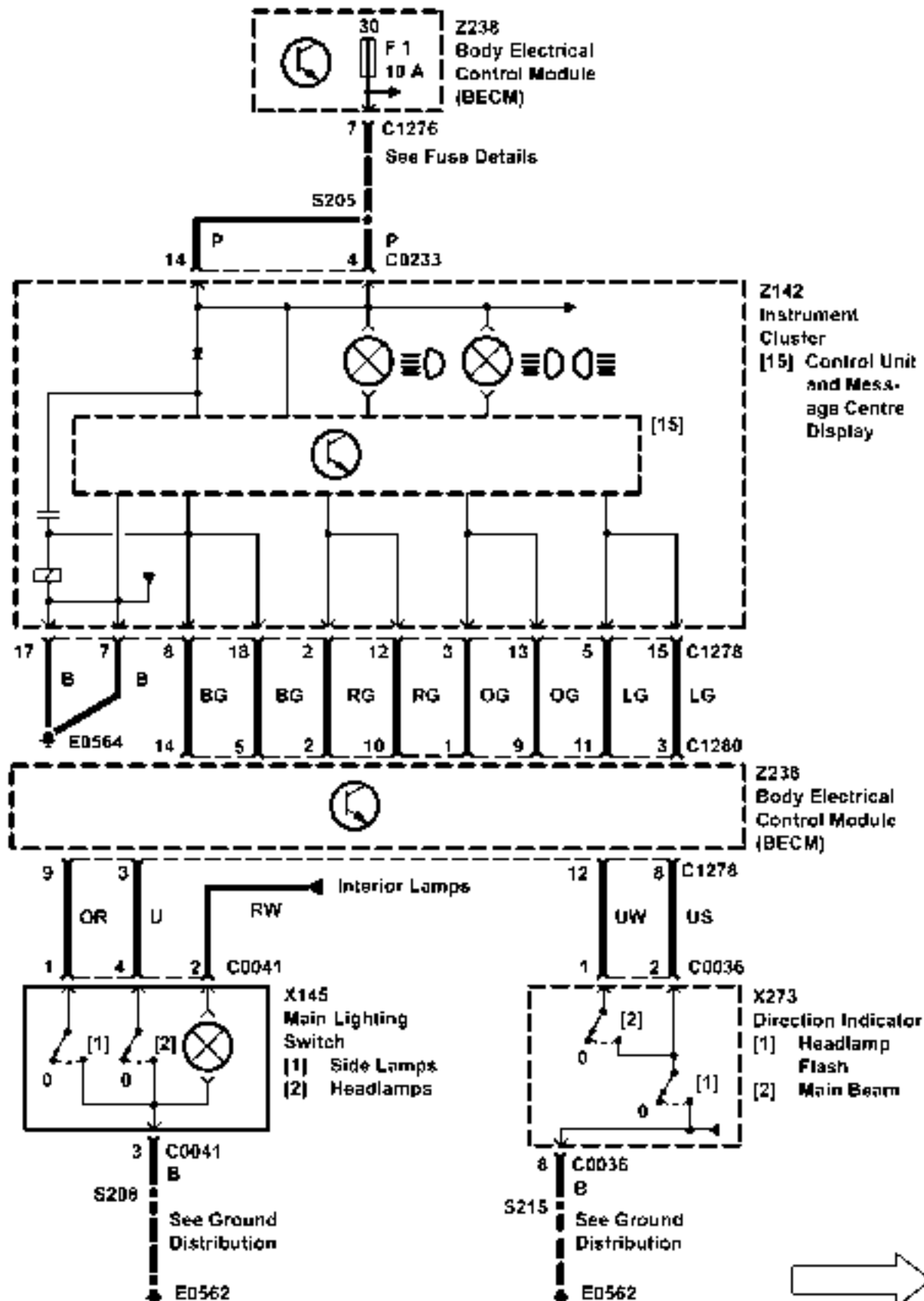

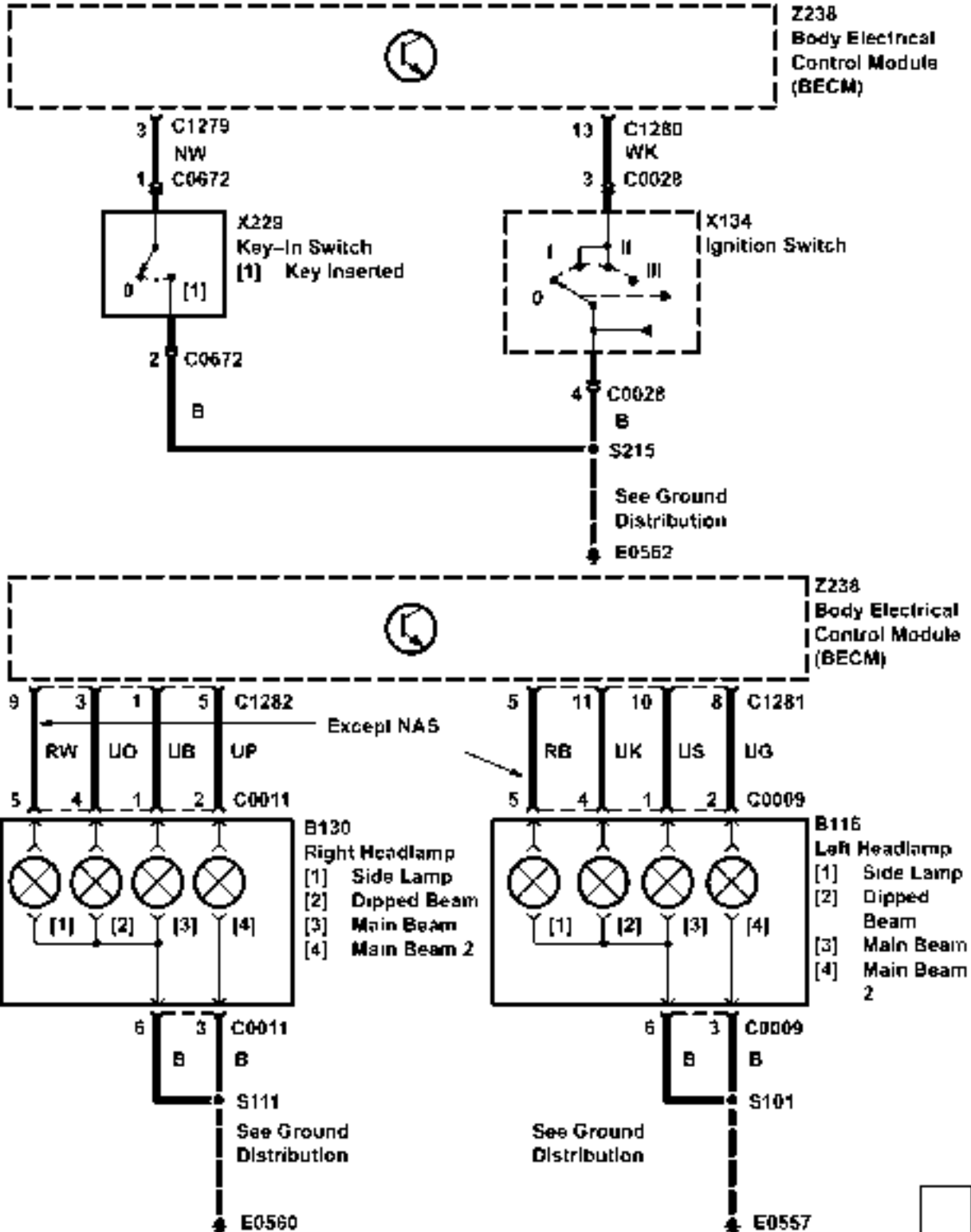

CIRCUIT OPERATION**Side lamps:**

Activation of the side lamp switch - when the ignition key is in, when the ignition is on - or when the head lamp switch is on, will result in the operation of the following: front LH and RH side lamps - rear LH and RH side lamps - number plate lamps, lamps on warning lamp and the rear door switch pack illumination.

The following lamps will also operate through the activation of the side lamp switch:

Clock fascia switch pack, console switch pack, gear select assembly, instrument pack, front cigar lighter, Hevac panel switches and I.C.E. (remote telephone dial), when fitted.

Parking lamps:

With the ignition and auxiliary off - the key out and the headlamp switch in the side lamp position, the parking lamps will be activated according to the position of the direction indicator switch as follows:

- ◆ If the indicator switch is in the central position then all the side lamps will be on.
- ◆ If the indicator switch is in the RH position, then the front right and rear right side lamps will be on.
- ◆ If the indicator switch is in the LH position then the front left and rear left side lamps will be on.

If the headlamp switch is set to the head lamp position, then normal side lamps will operate in conjunction with the headlamps.

Side lamp Warning lamps:

The side lamp warning lamp will be active whenever the side lamp switch is on and the side lamps are operating in side lamp mode, but not when the key is removed and the parking lamp mode is on.

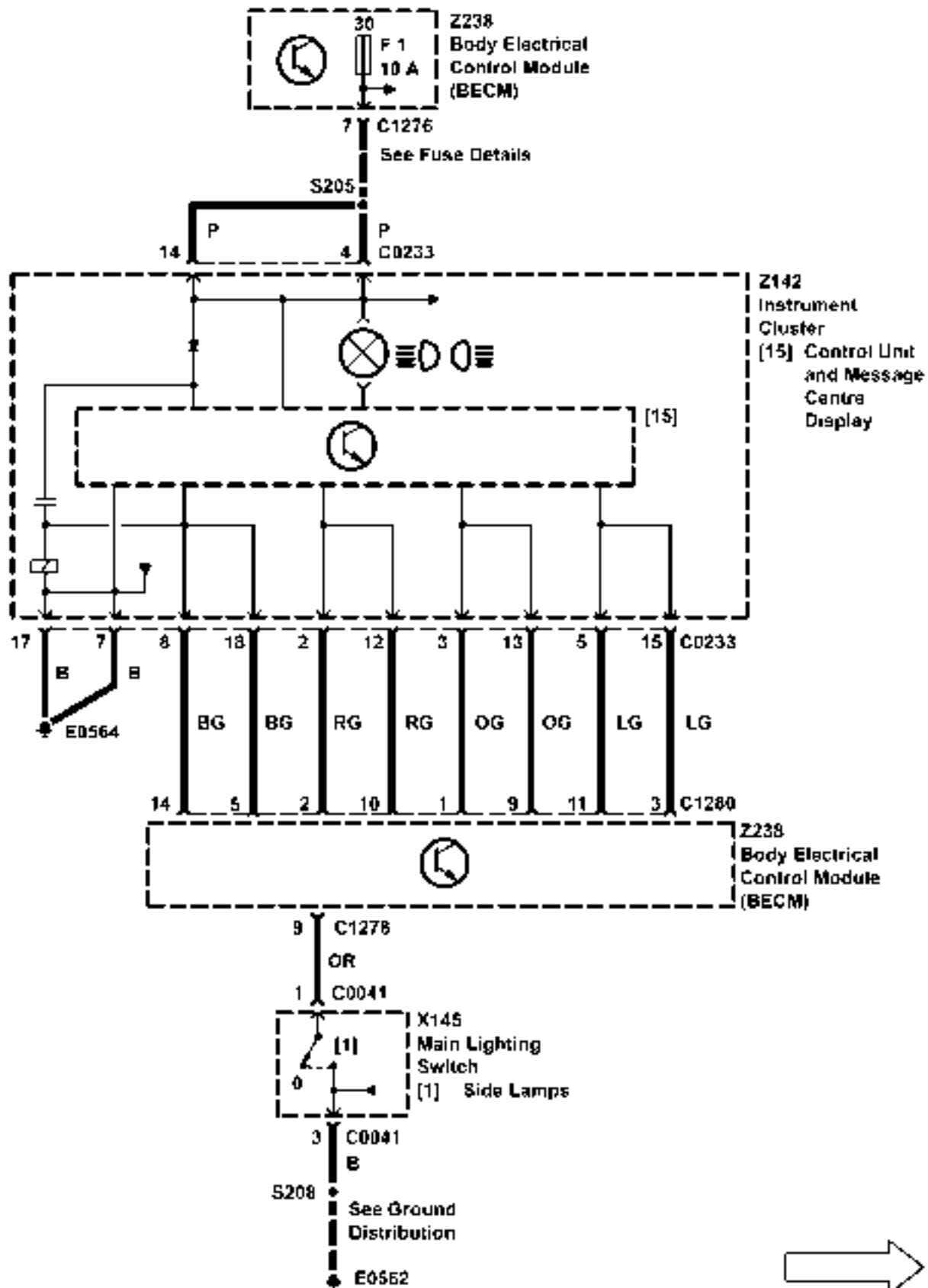

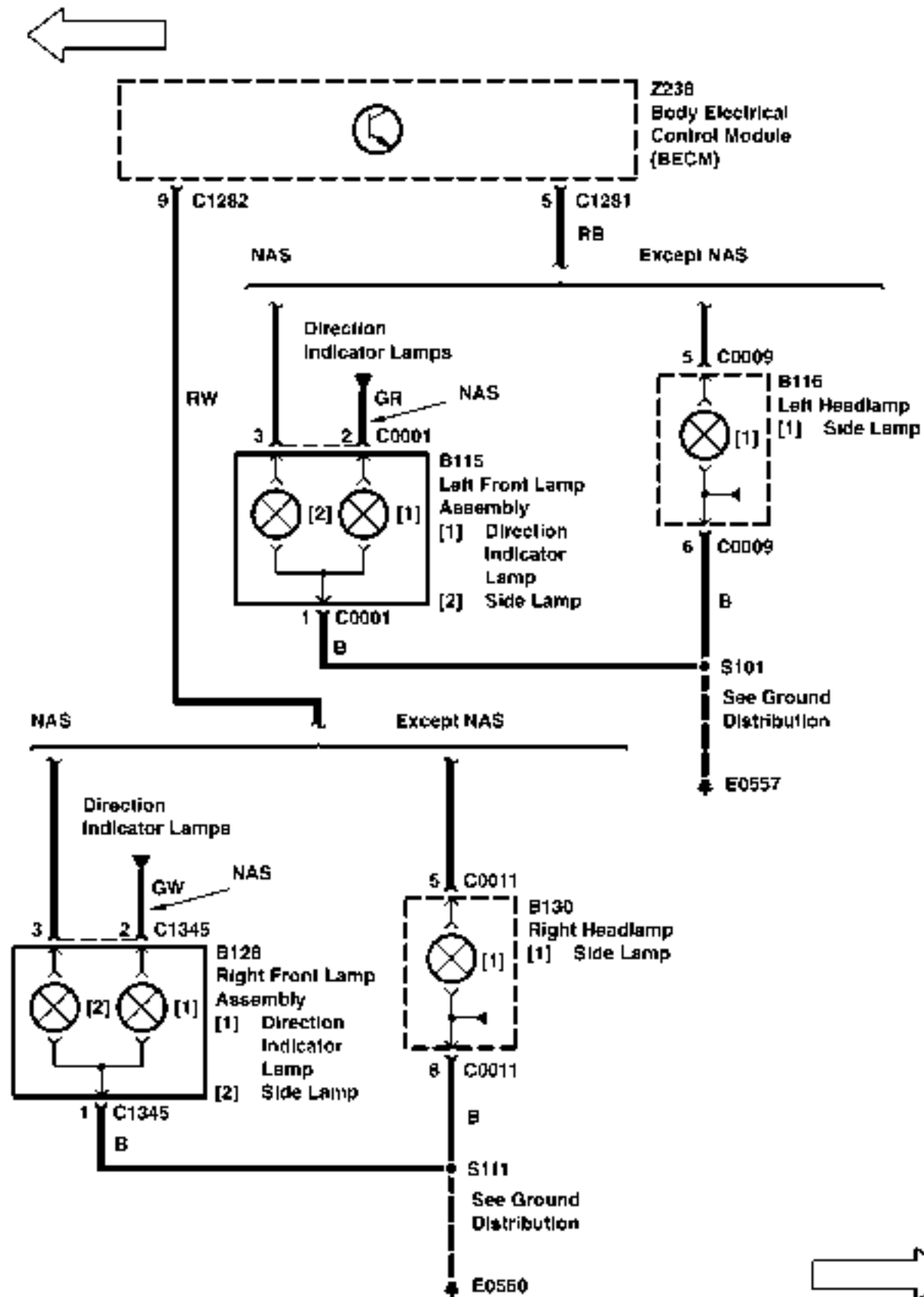

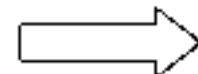
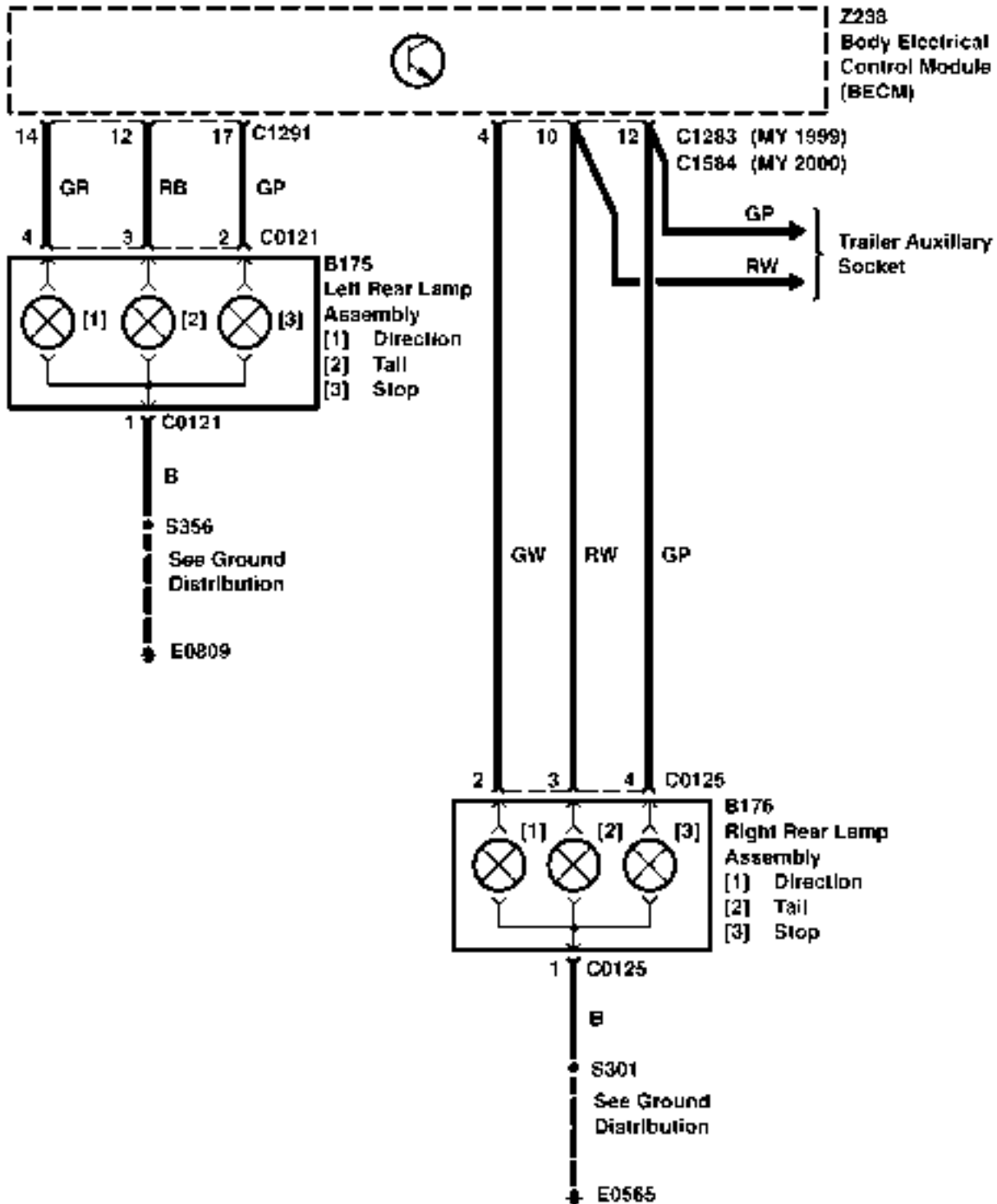
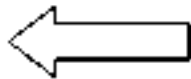

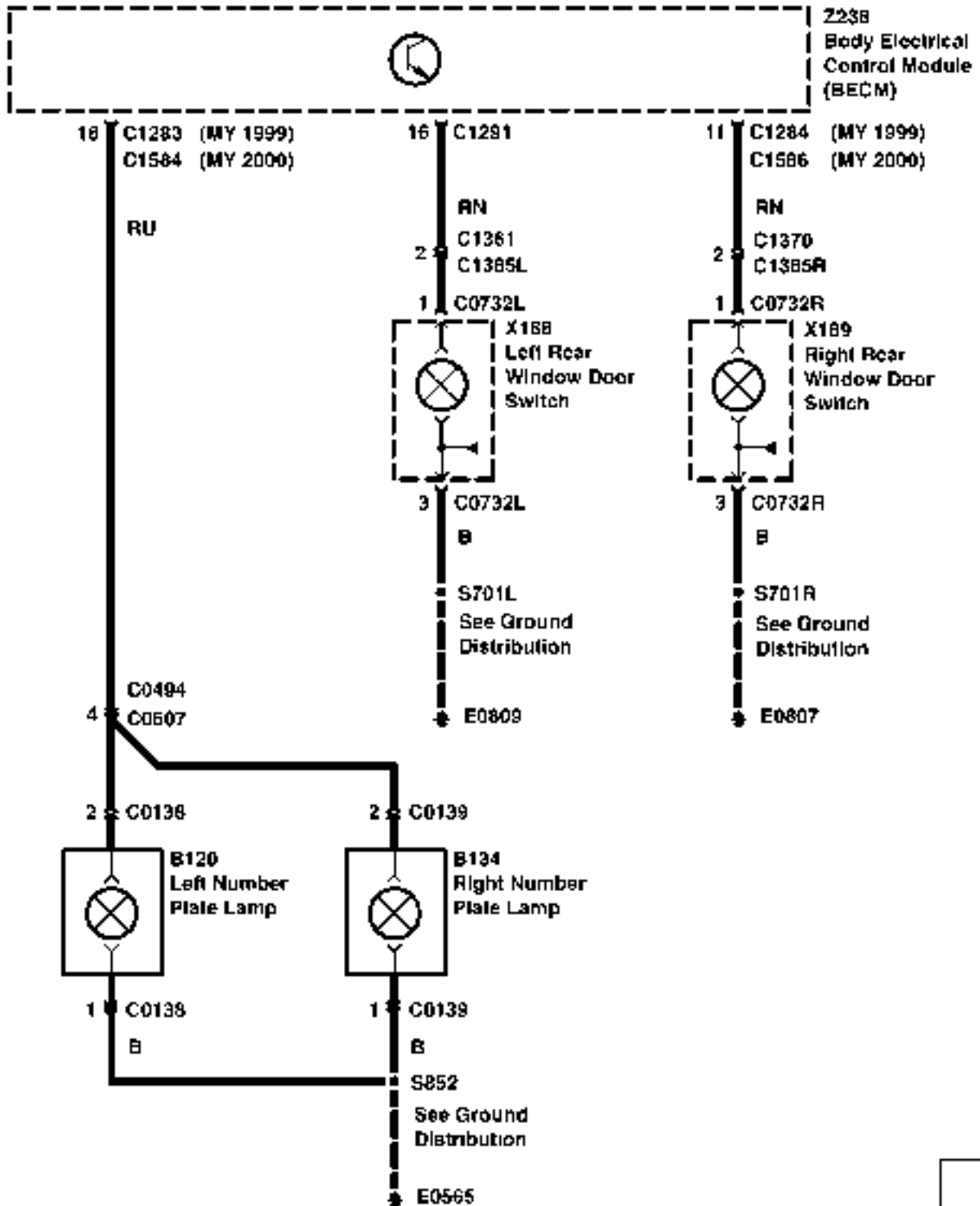
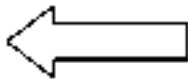

CIRCUIT DIAGRAMS

- Circuit diagrams are arranged so that current flow is from the top of the diagram (current source) to the bottom of the diagram (ground).
- Only those components that work together in the circuit are shown. If only part of a component is used in the circuit, then only that part of the component is shown.
- Remember:



TERMINAL NUMBER	DESIGNATION
50	Battery voltage: Ignition Switch in position III
30	Battery voltage: supplied constantly
15	Battery voltage: Ignition Switch in position II or III
R	Battery voltage: Ignition Switch in positions I, II
31	Ground

See Introduction (I) for additional circuit diagram symbols.

DIAGNOSIS

- If the diagram is accompanied by text:
 - Read the Circuit Operation before proceeding with the electrical diagnosis.
 - Read the Troubleshooting Hints before performing the System Diagnosis.
 - Tests follow the System Diagnosis
 - When performing the System Diagnosis, be certain that all components disconnected in previous steps are reconnected unless otherwise directed.

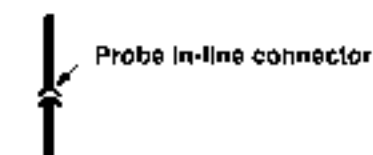
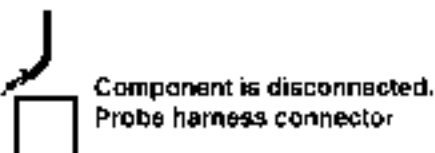
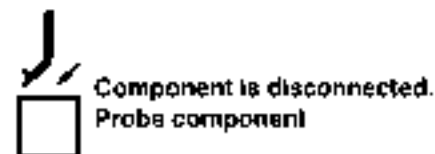
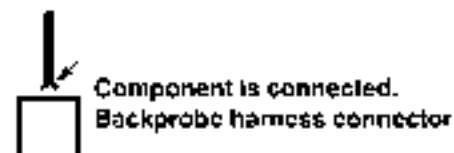
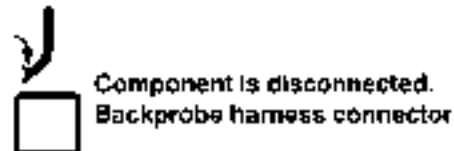

CIRCUIT OPERATION**Brake lamps**

The brake lamps (including the high mounted stop lamp when fitted) are operated when the brake switch is closed provided the ignition is switched on.

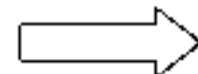
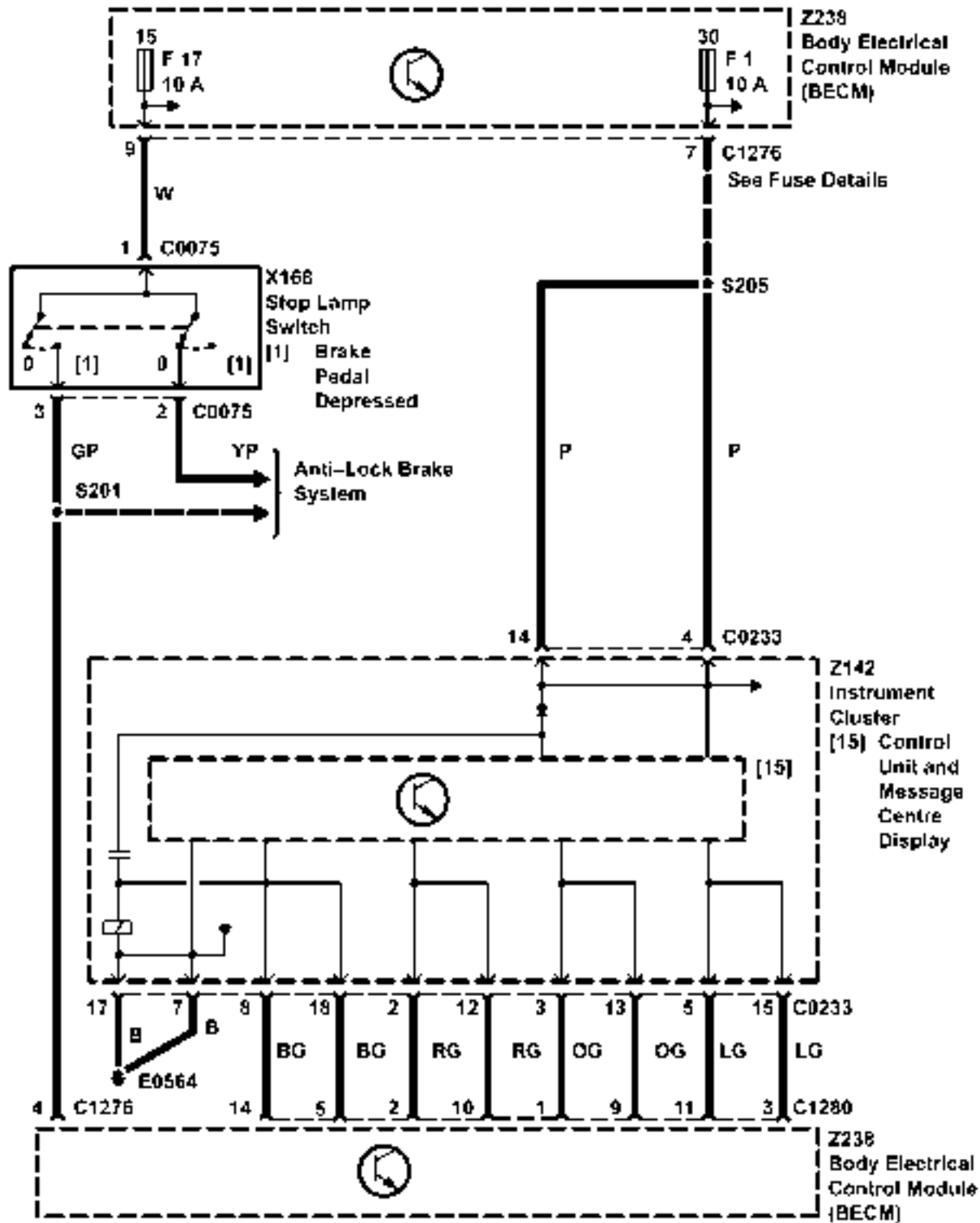

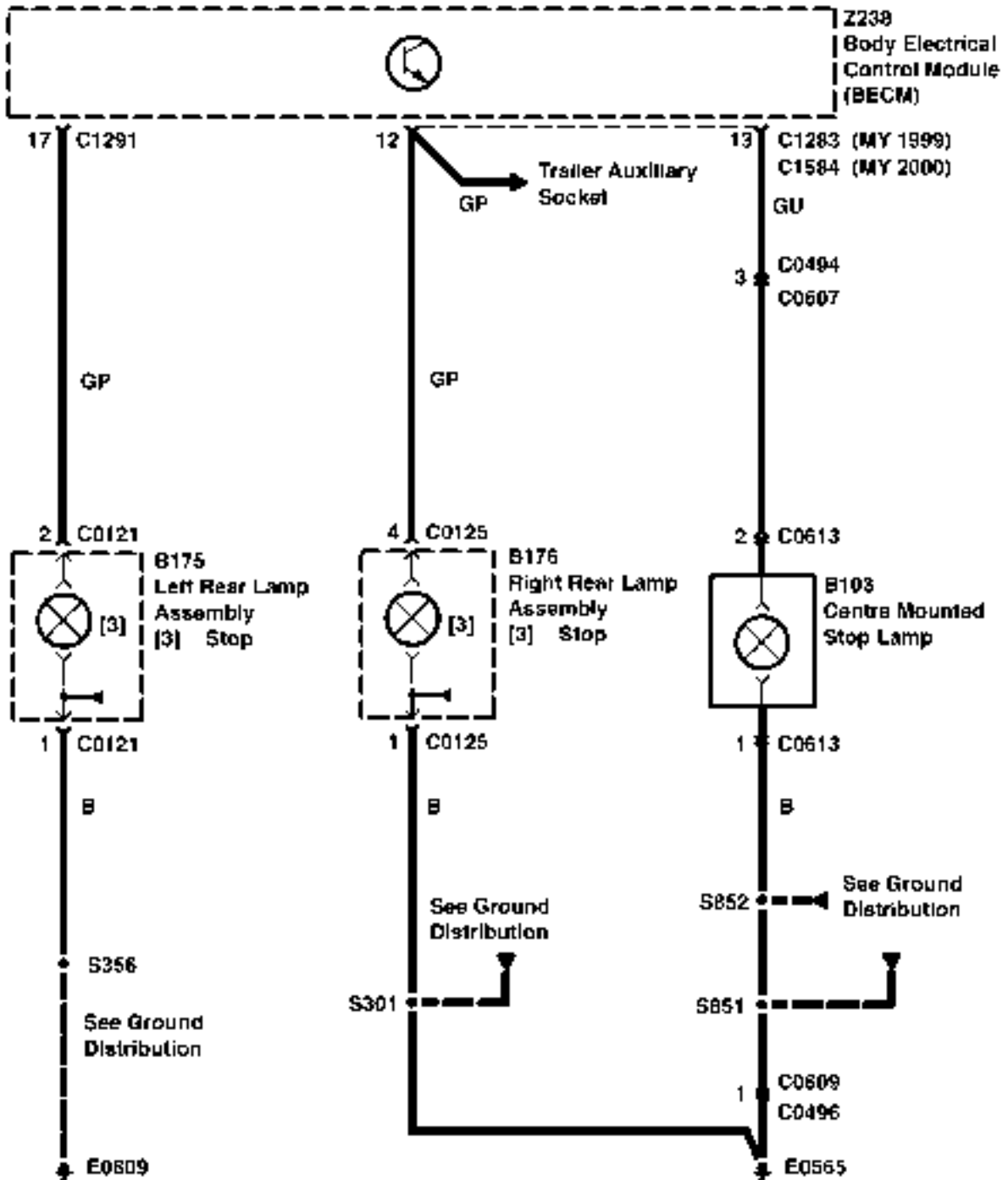
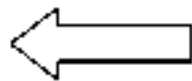

CIRCUIT DIAGRAMS

- Circuit diagrams are arranged so that current flow is from the top of the diagram (current source) to the bottom of the diagram (ground).
- Only those components that work together in the circuit are shown. If only part of a component is used in the circuit, then only that part of the component is shown.
- Remember:



TERMINAL NUMBER	DESIGNATION
50	Battery voltage: Ignition Switch in position III
30	Battery voltage: supplied constantly
15	Battery voltage: Ignition Switch in position II or III
R	Battery voltage: Ignition Switch in positions I, II
31	Ground

See Introduction (I) for additional circuit diagram symbols.

DIAGNOSIS

- If the diagram is accompanied by text:
 - Read the Circuit Operation before proceeding with the electrical diagnosis.
 - Read the Troubleshooting Hints before performing the System Diagnosis.
 - Tests follow the System Diagnosis
 - When performing the System Diagnosis, be certain that all components disconnected in previous steps are reconnected unless otherwise directed.

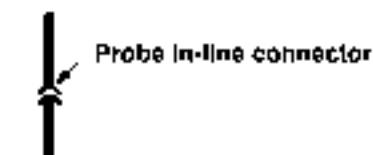
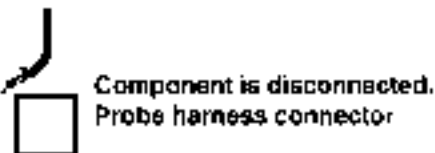
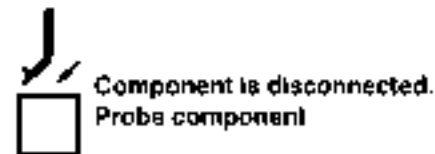
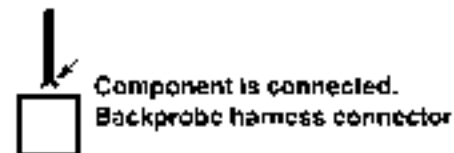
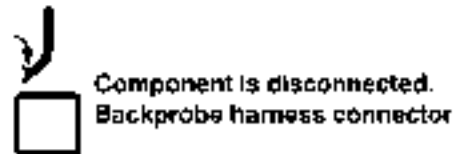

CIRCUIT OPERATION**Hazard lamps**

When the hazard warning switch is operated, all indicator bulbs, side repeaters and the hazard switch illumination bulb will operate at the specified rate regardless of the ignition switch position. The indicator warning lamps within the instrument pack will also operate under this condition.

If the parking switch is operated and the ignition is on, all indicator bulbs, side repeaters, warning lamps and the hazard switch bulb will flash at the specified rate.

In addition to the operation of the indicator bulbs there will be an audible tick generated by the BCM, timed to match the bulb illumination in the instrument pack.

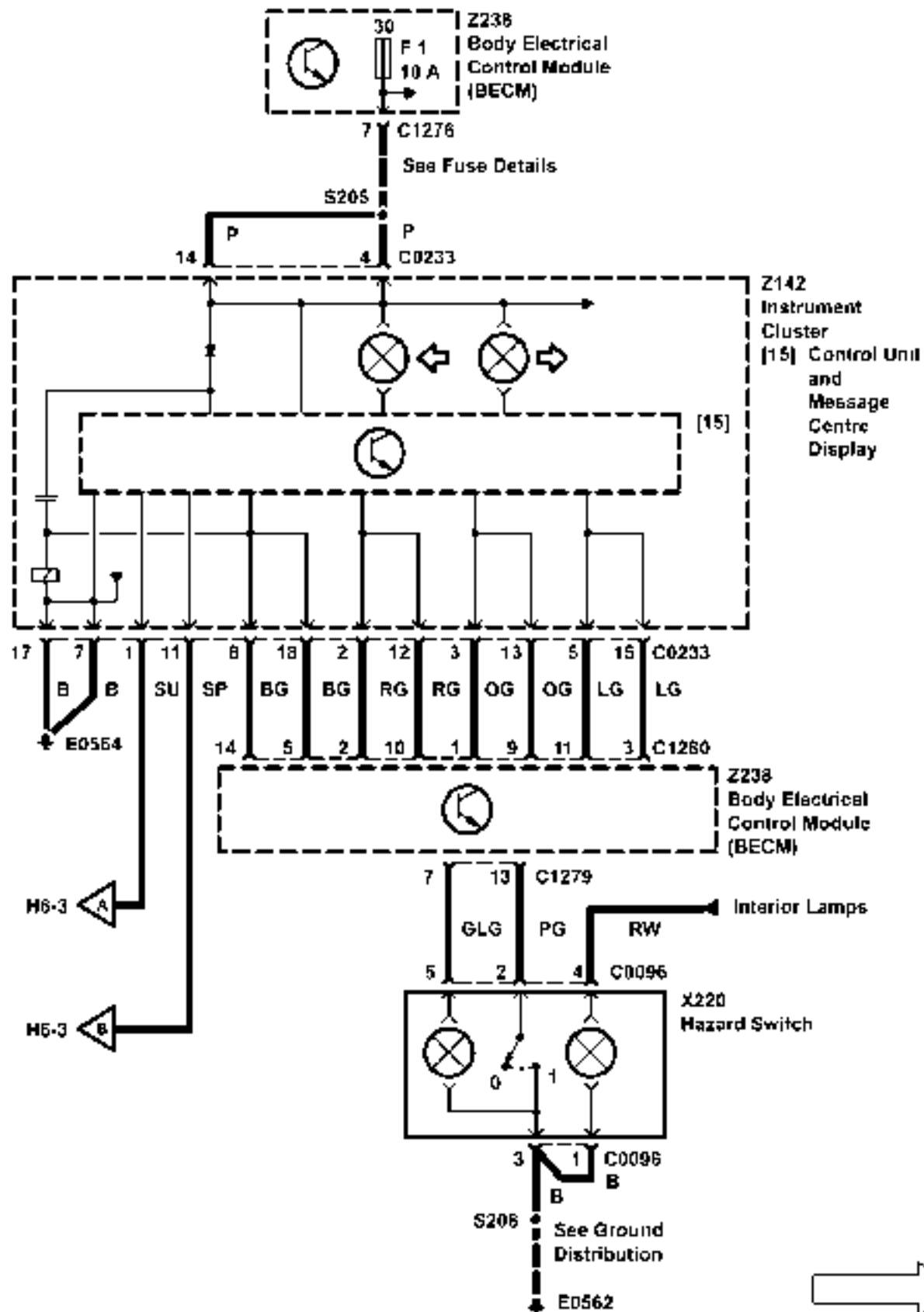

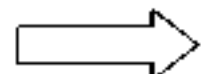
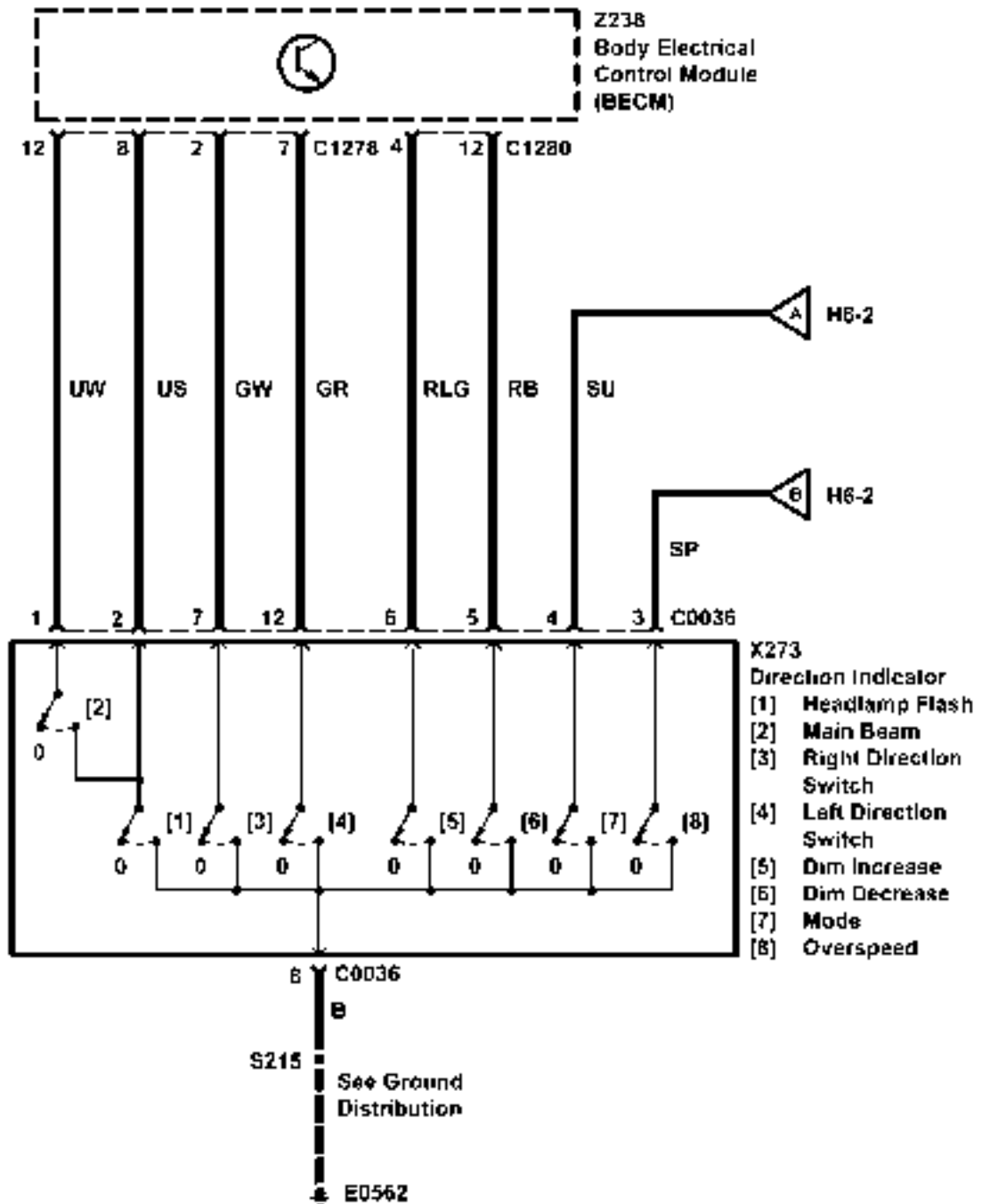
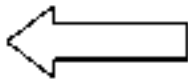

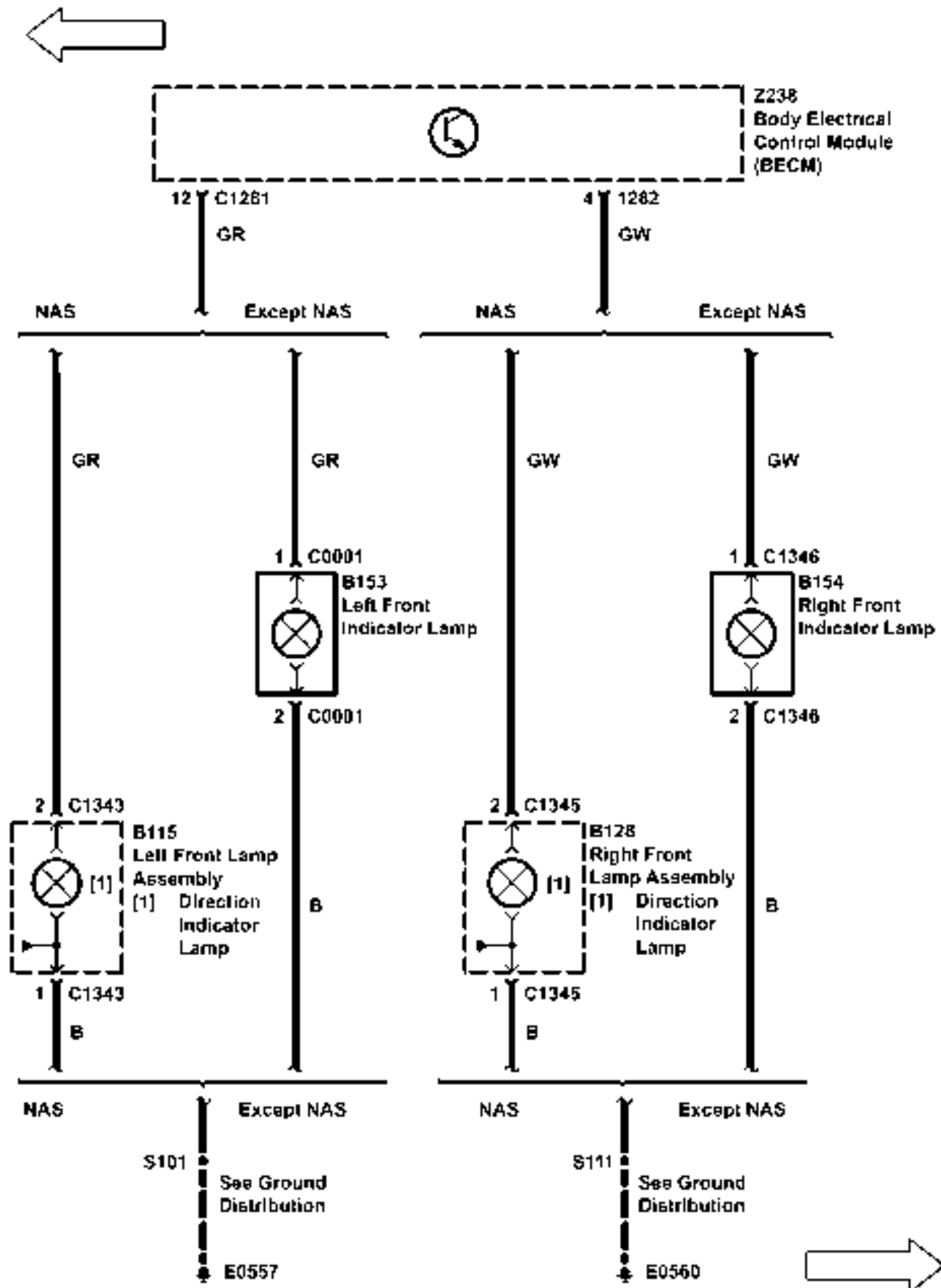

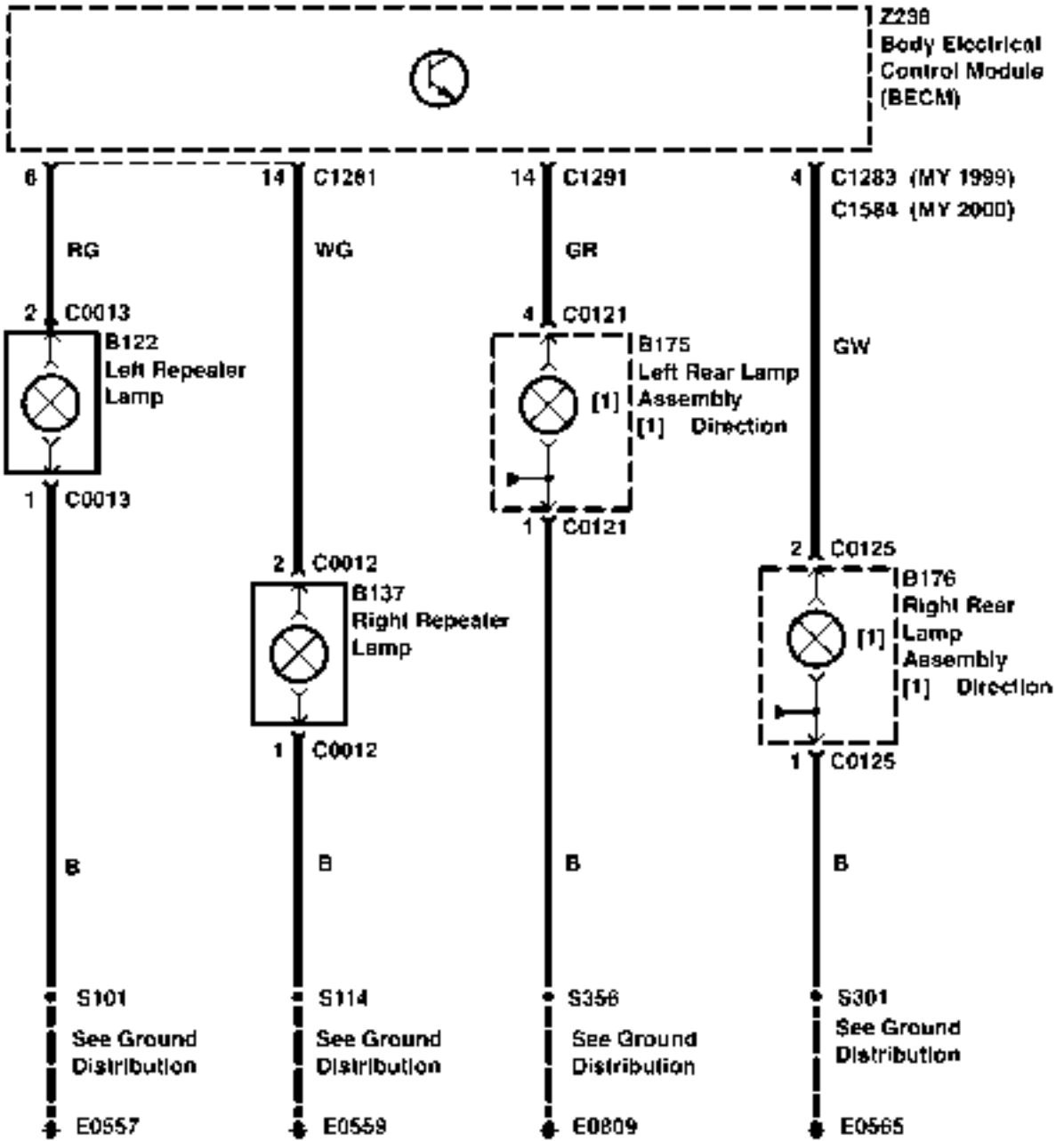

CIRCUIT DIAGRAMS

- Circuit diagrams are arranged so that current flow is from the top of the diagram (current source) to the bottom of the diagram (ground).
- Only those components that work together in the circuit are shown. If only part of a component is used in the circuit, then only that part of the component is shown.
- Remember:

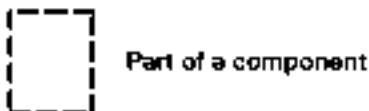

TERMINAL NUMBER	DESIGNATION
50	Battery voltage: Ignition Switch in position III
30	Battery voltage: supplied constantly
15	Battery voltage: Ignition Switch in position II or III
R	Battery voltage: Ignition Switch in positions I, II
31	Ground

See Introduction (I) for additional circuit diagram symbols.

DIAGNOSIS

- If the diagram is accompanied by text:
 - Read the Circuit Operation before proceeding with the electrical diagnosis.
 - Read the Troubleshooting Hints before performing the System Diagnosis.
 - Tests follow the System Diagnosis
 - When performing the System Diagnosis, be certain that all components disconnected in previous steps are reconnected unless otherwise directed.

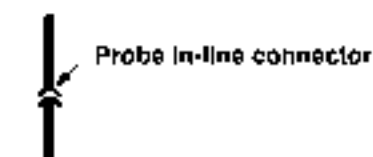
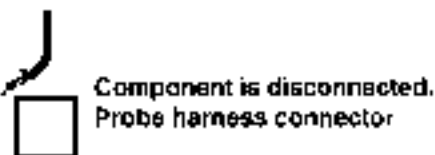
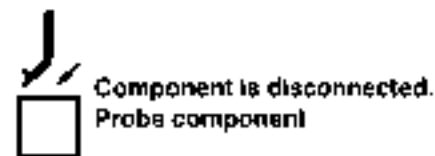
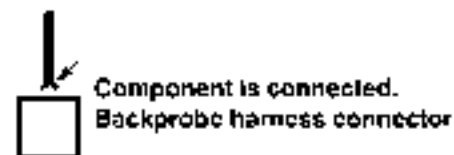
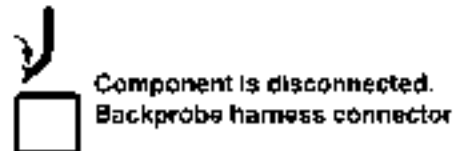

CIRCUIT OPERATION**Reversing lamps:**

With the ignition on and the gear selector lever moved to the reverse position both reverse lamps will activate

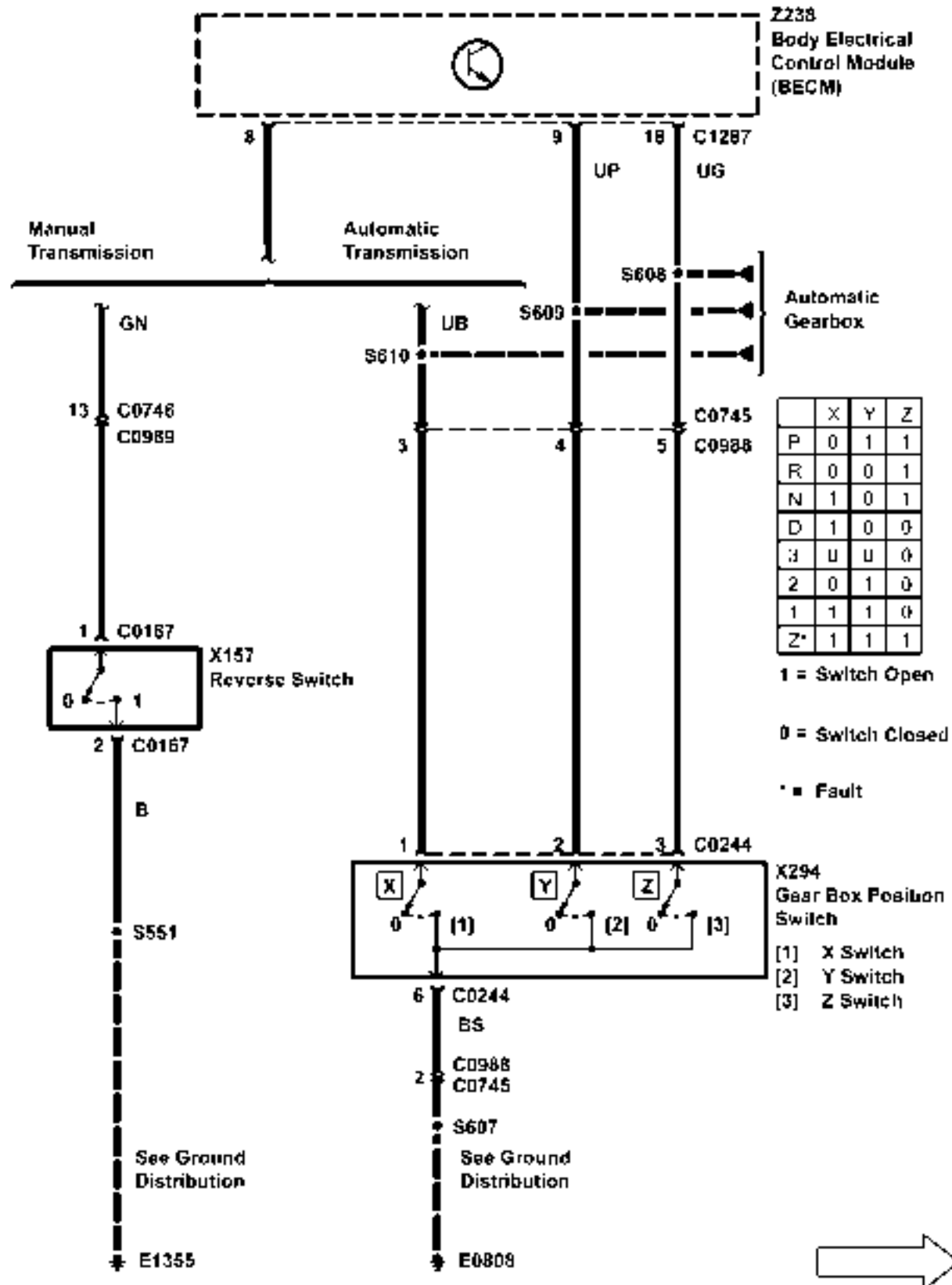

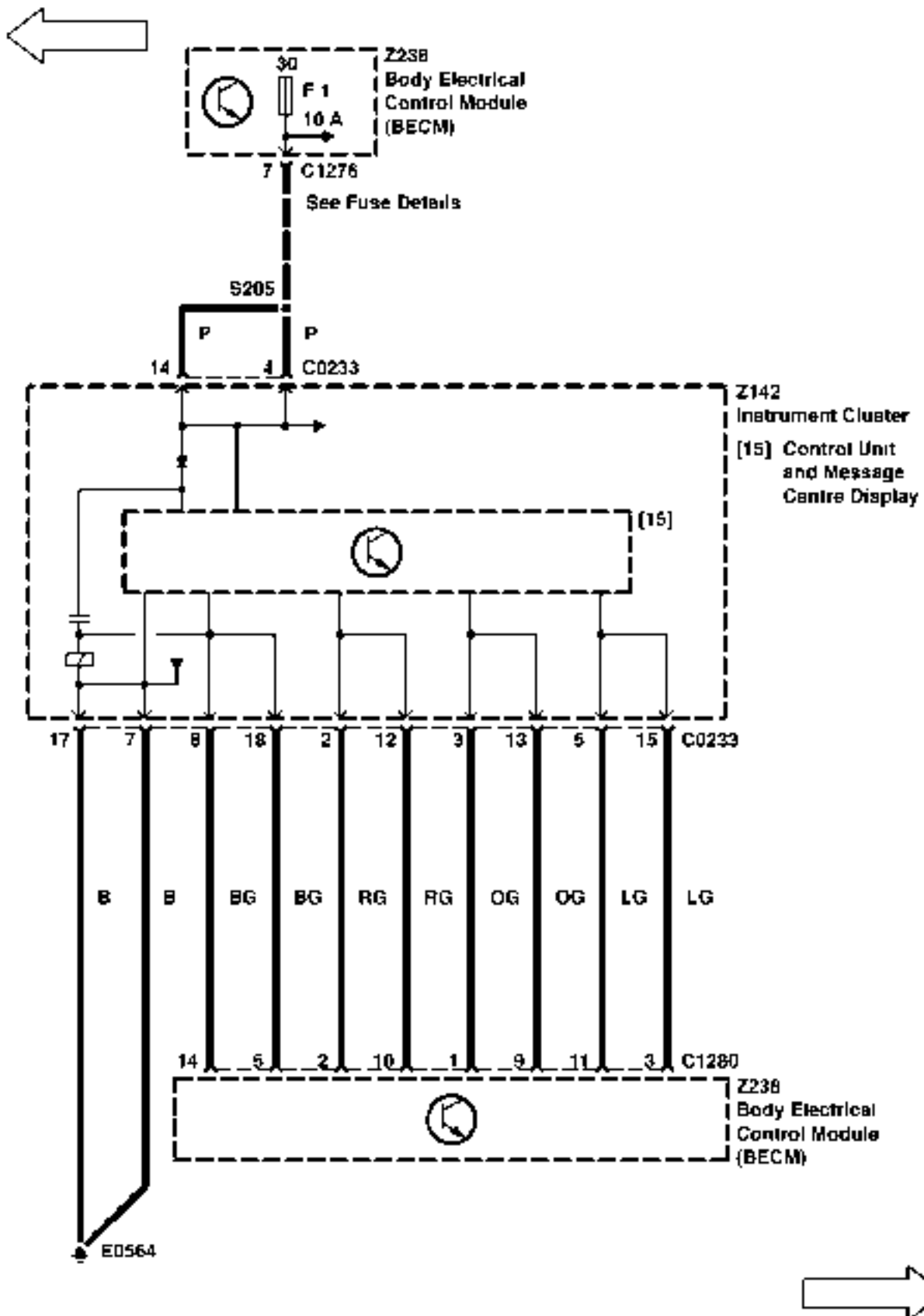

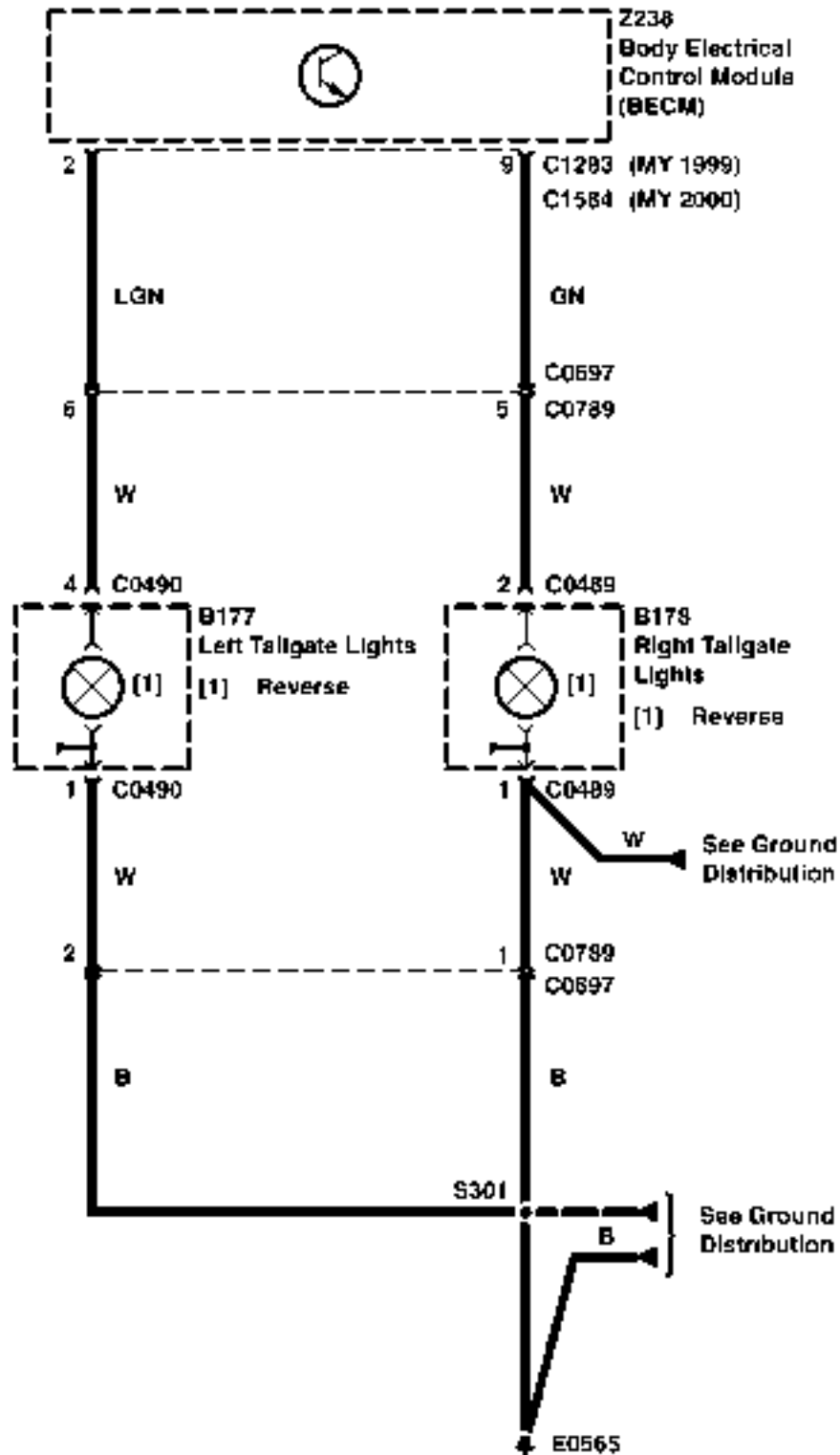
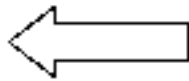

CIRCUIT OPERATION**Front Fog lamps**

With the ignition switch and side lamp or headlamp switch on, a momentary operation of the front fog lamp switch will activate the front fog lamps. A further momentary operation of the fog lamp switch, or switching off of the headlamps/side lamps or ignition will cause the front fog lamps to be extinguished.

N.B. The front fog lamps will always be inactive when the ignition is turned on.

Rear Fog lamps

With the ignition on, the headlamp switch on or front fog lamps on, a momentary operation of the rear fog lamp switch will activate the rear fog lamps. Operation of the rear fog lamps will also activate a bulb within the fog lamp switch. A further momentary operation of the fog lamp switch, switching off the headlamps and front fog lamps, or switching off the ignition, will cause the rear fog lamps to switch off.

N.B. The rear fog lamps will always be inactive when the ignition is turned on.

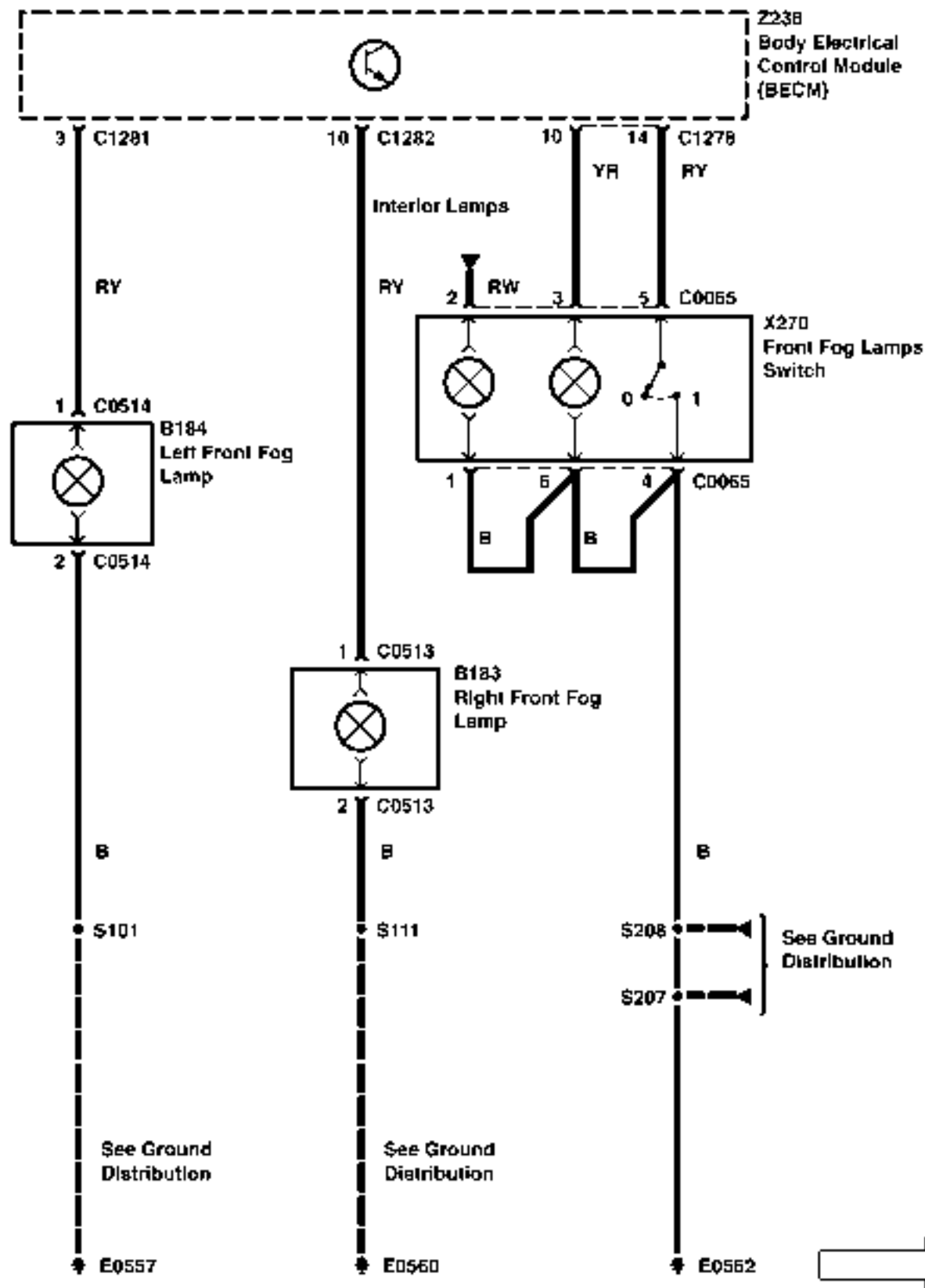

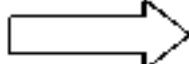
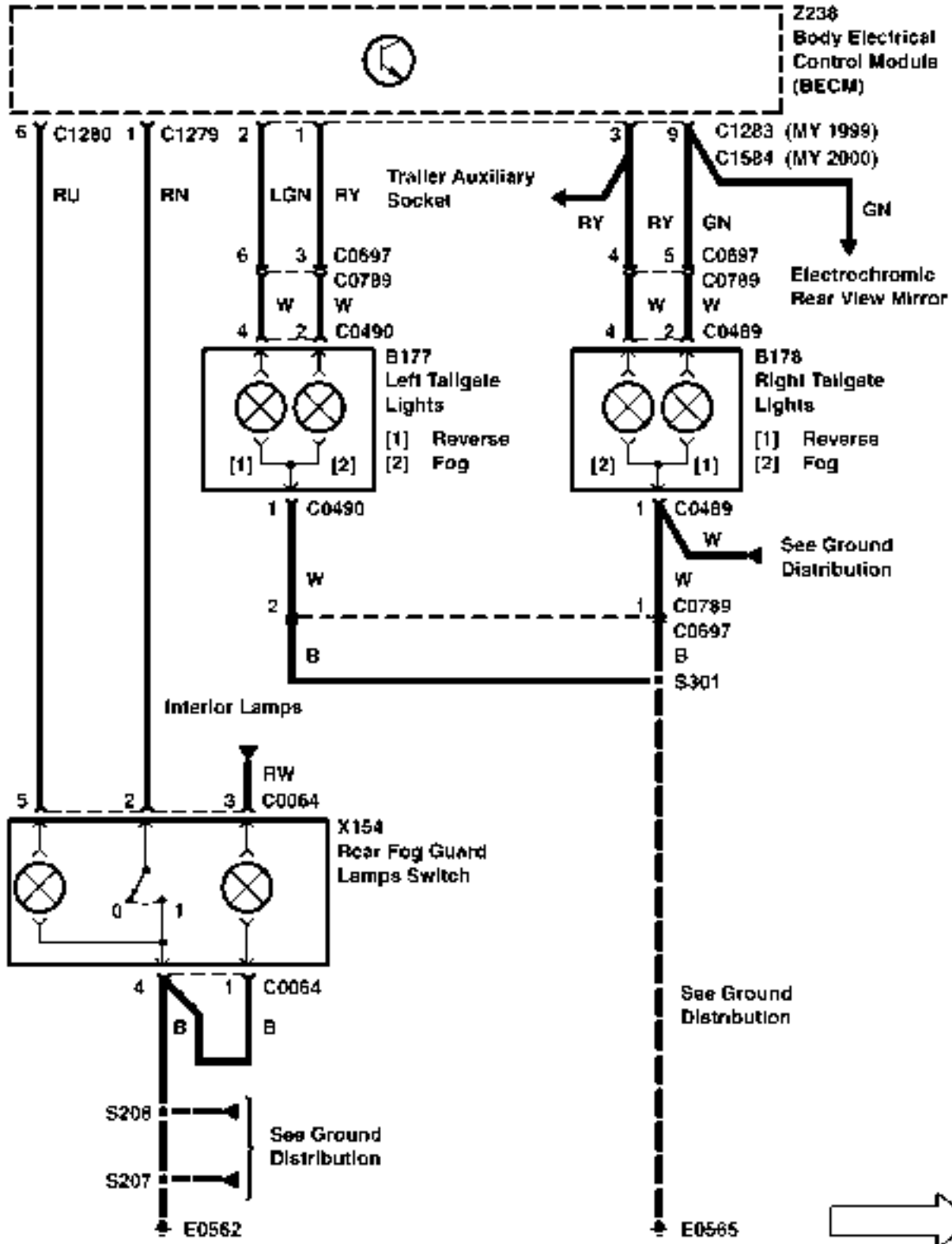
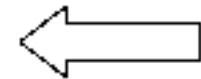

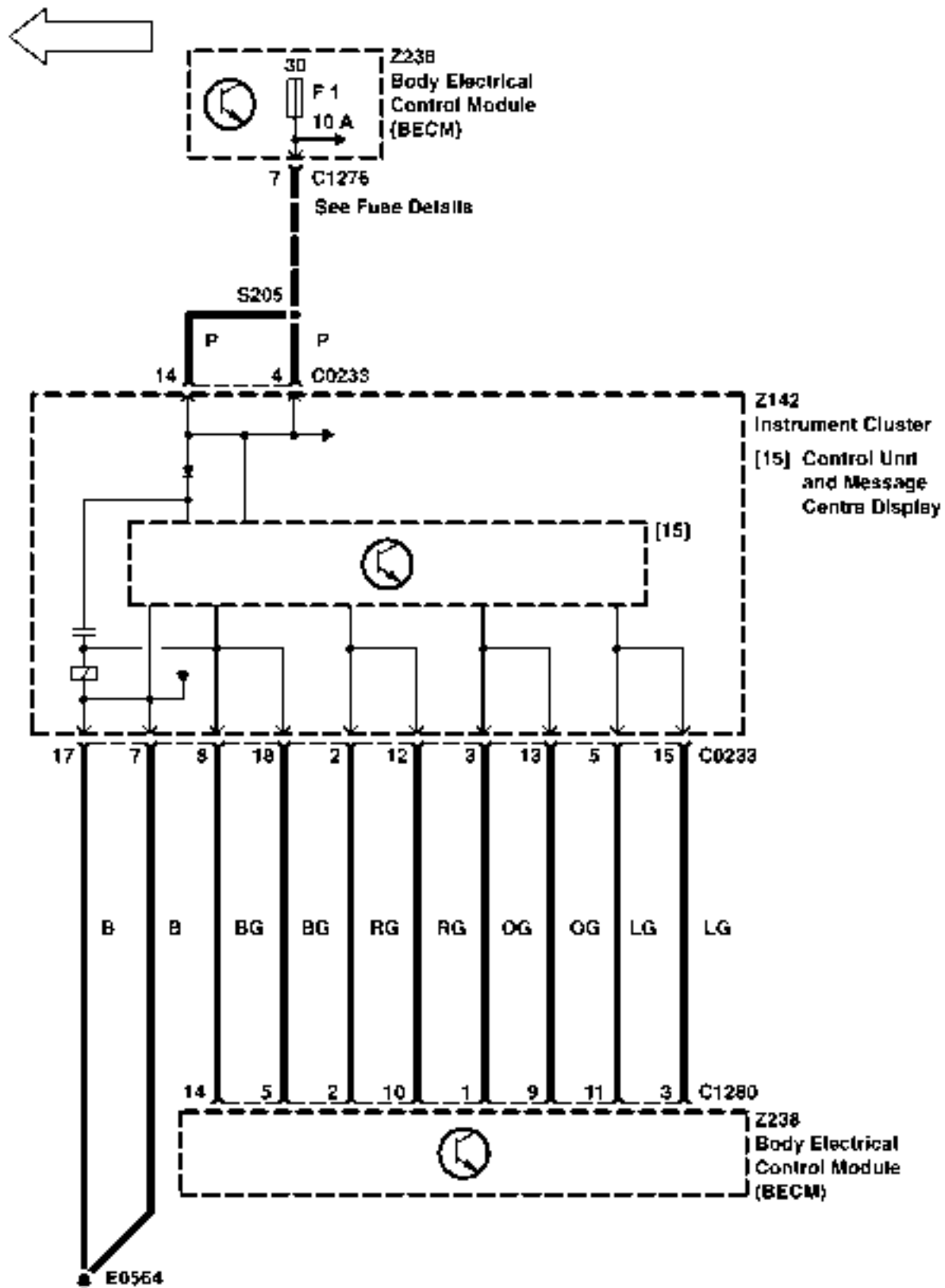

CIRCUIT OPERATION

Courtesy lamps

Automatic courtesy lamp facility enabled

With the tailgate or any of the four doors opened the illumination level of the following lamps will fade on over a period of approximately 11.5 seconds.

- front courtesy lamp
- rear left courtesy lamp
- rear right courtesy lamp
- load space lamps
- front left footwell lamp
- front right footwell lamp
- ignition ring illumination
- rear right footwell lamp
- rear left footwell lamp

If any door is left open, the lamps will fade out after a time of approximately 10 minutes. During the 10 minute time out, if any other door is opened the timer will be reset.

If all doors are closed prior to the end of this 10 minute period then all specified lamps will fade out after a delay of 15 seconds.

If the ignition is switched on before the end of the 15 second time out period, the specified lamps will begin to fade out after a delay of 1 second.

If the ignition is then switched off and no door opened, the 15 second time out of the lamps will not be resumed.

If an unlock signal is received from the remote key or if a key unlock is received from either of the front doors while all the doors are closed, then the courtesy lamps will fade to on in 0.5 seconds and begin a 15 second time out period.

If any of the doors or the tailgate are opened during this delay then the time out period will be restarted.

If all the doors are closed and a lock signal is received from the remote key or either of the front door CDL switches while the courtesy lamps are in their 15 second time out period, then the time delay will be cancelled and the lamps immediately faded out.

Automatic courtesy lamp facility disabled

Whenever the main courtesy lamp switch is operated for greater than 2 seconds, the automatic courtesy lamp feature will switch between the enabled and disabled mode upon release of the switch. At the

same time as 'Int Lamps off' 'Int Lamps auto'

message will be displayed on the instrument pack.

This extended switch operation will also extinguish the courtesy lamps if the button has been depressed for 2 seconds, causing the system to switch from the automatic to disabled mode, but otherwise will have no effect on their state. While the automatic courtesy lamp facility is disabled, the courtesy lamps may only be switched on and off by momentary activation of the main courtesy lamp switch. The change of lamp state will occur on release of the switch.

Panel Dimmer:

Operation of the panel dimmer switch, with the side lamps on, will alter the level of panel illumination between approximately 6 and 94%. Depressing the switch momentarily will cause the illumination to increase or decrease to the next level. Holding the switch closed will cause the illumination to ramp towards fully on or fully off.

The illumination level selected will be stored in the BCM's non-volatile memory whenever the driver's seat store sequence is completed successfully, provided the side lamp switch is on. If the side lamp switch is not on and a successful memory store sequence is completed, then the previously stored illumination level will remain unchanged.

Puddle lamps

With any door open and the automatic courtesy lamp feature enabled, the puddle lamp within the relevant door will be illuminated, either until the door is closed or a time period of approximately 10 minutes has elapsed. If any puddle lamp is on, momentary operation of the courtesy lamp master switch will extinguish all puddle lamps on release of the switch.

Further operation of the switch or reopening a door (if automatic courtesy lamps are enabled) will again activate the puddle lamps for those doors that are open. If the courtesy lamp switch is held on for longer than 2 seconds, the automatic operation of the puddle lamps from the door open switches will switch between enabled and disabled.

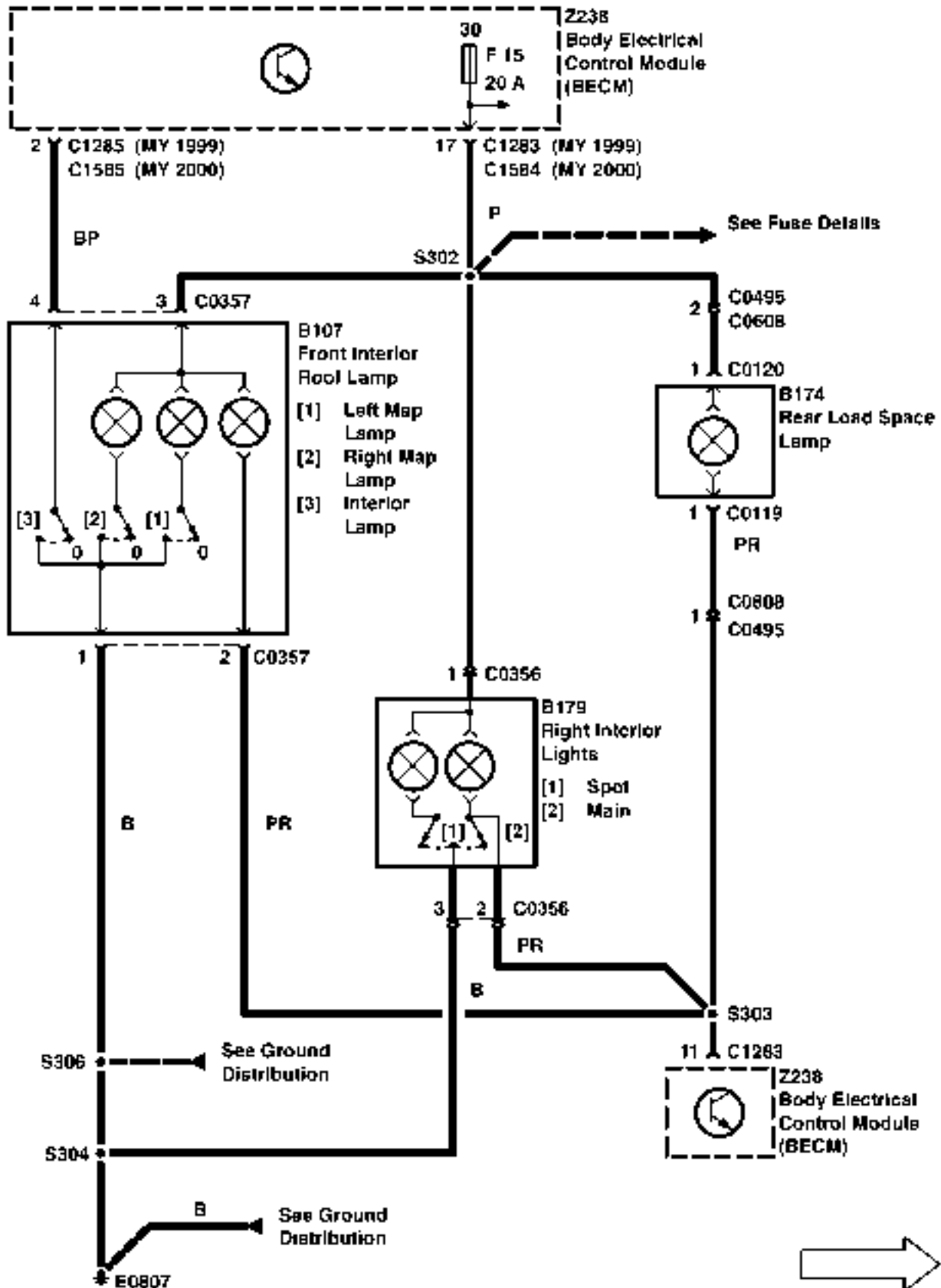

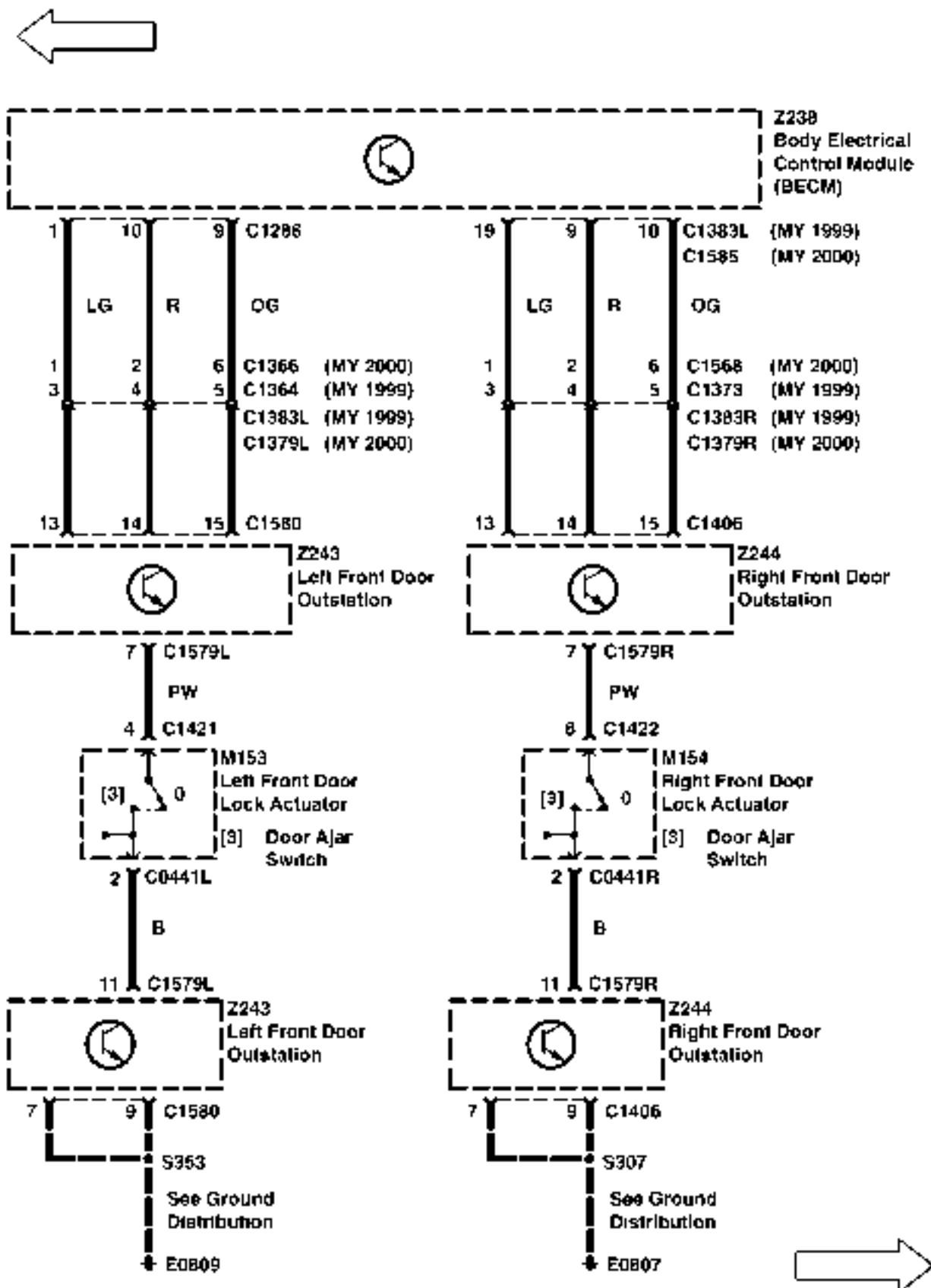

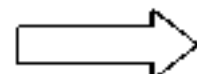
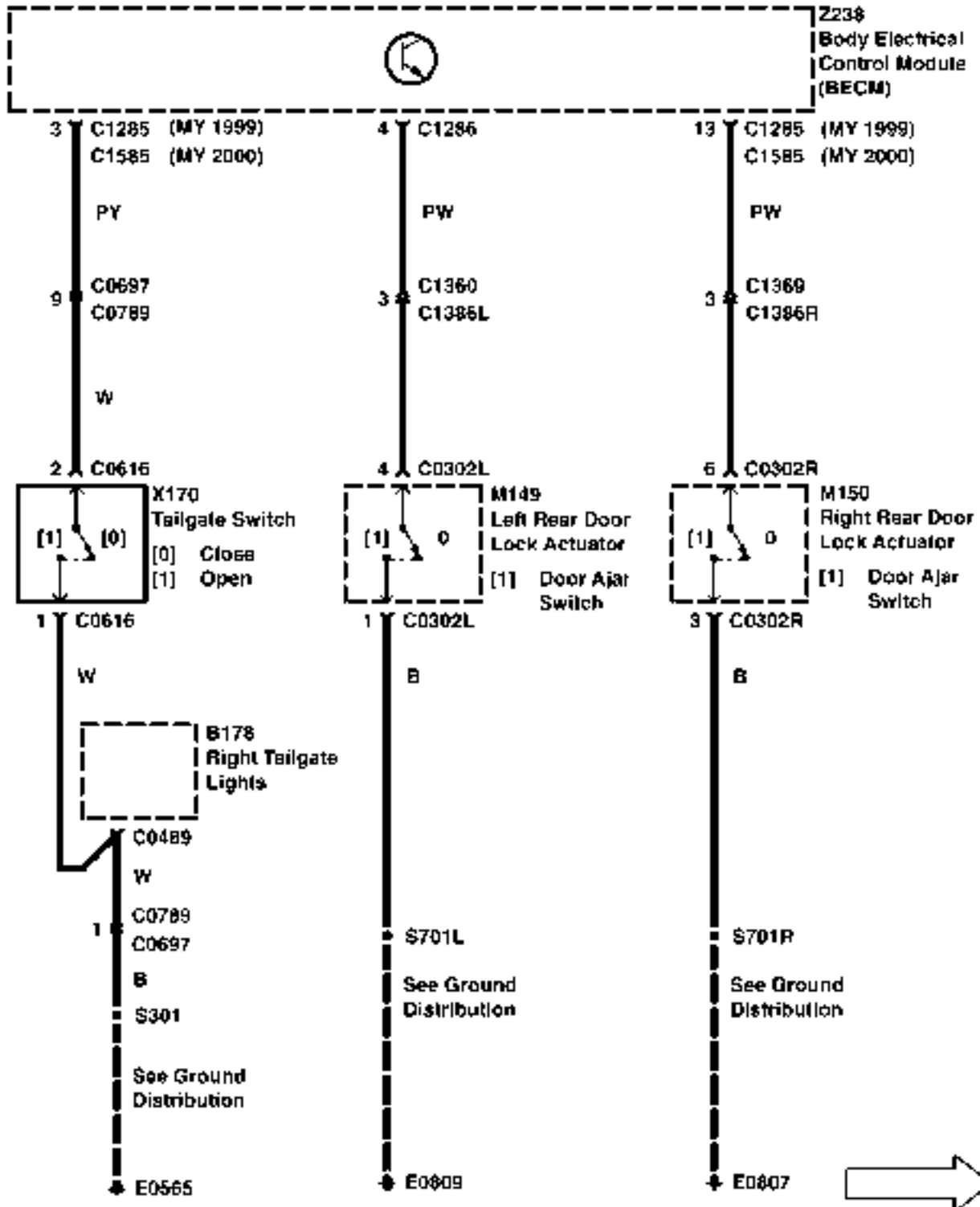
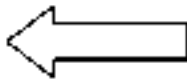

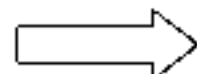
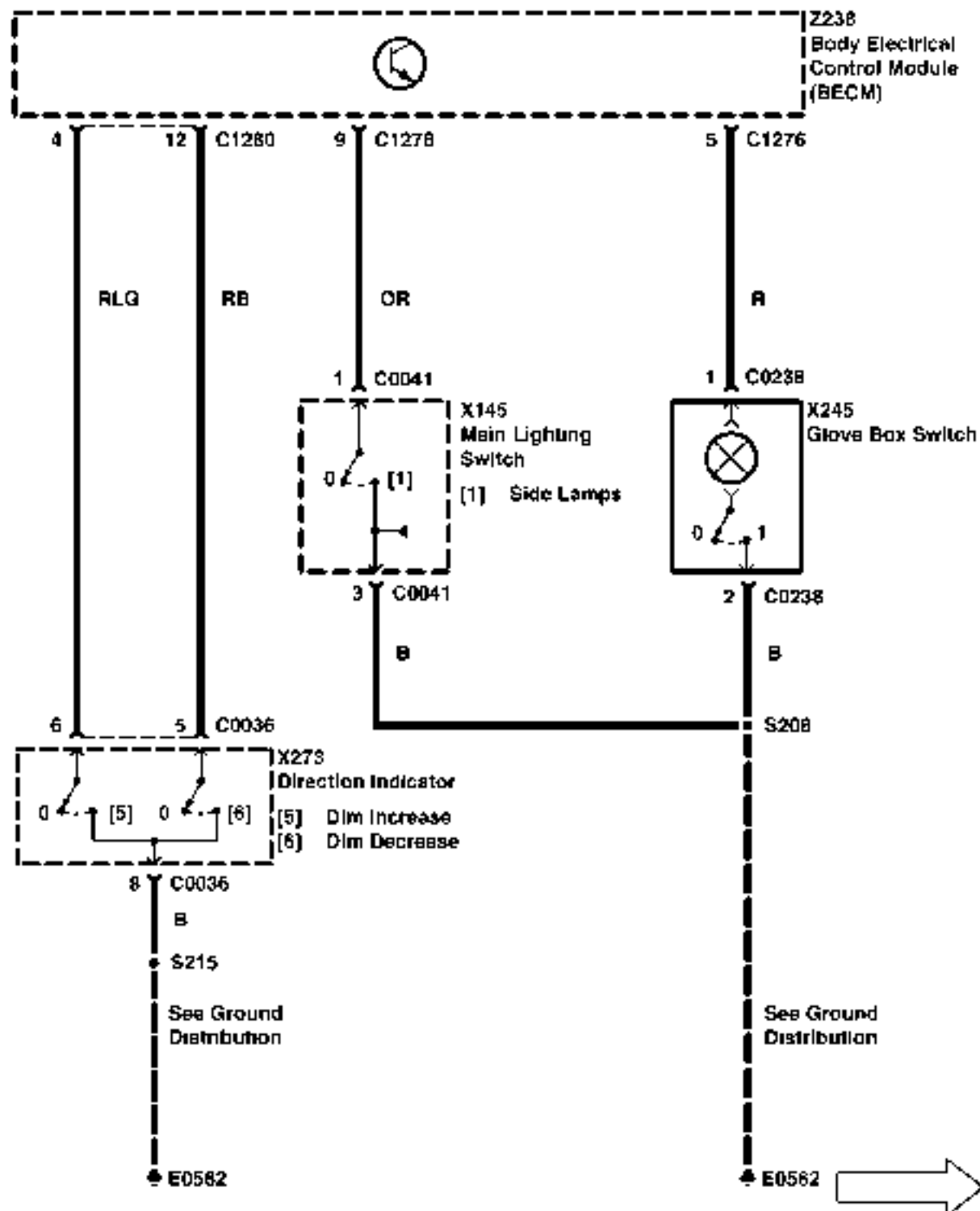
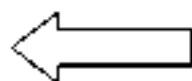

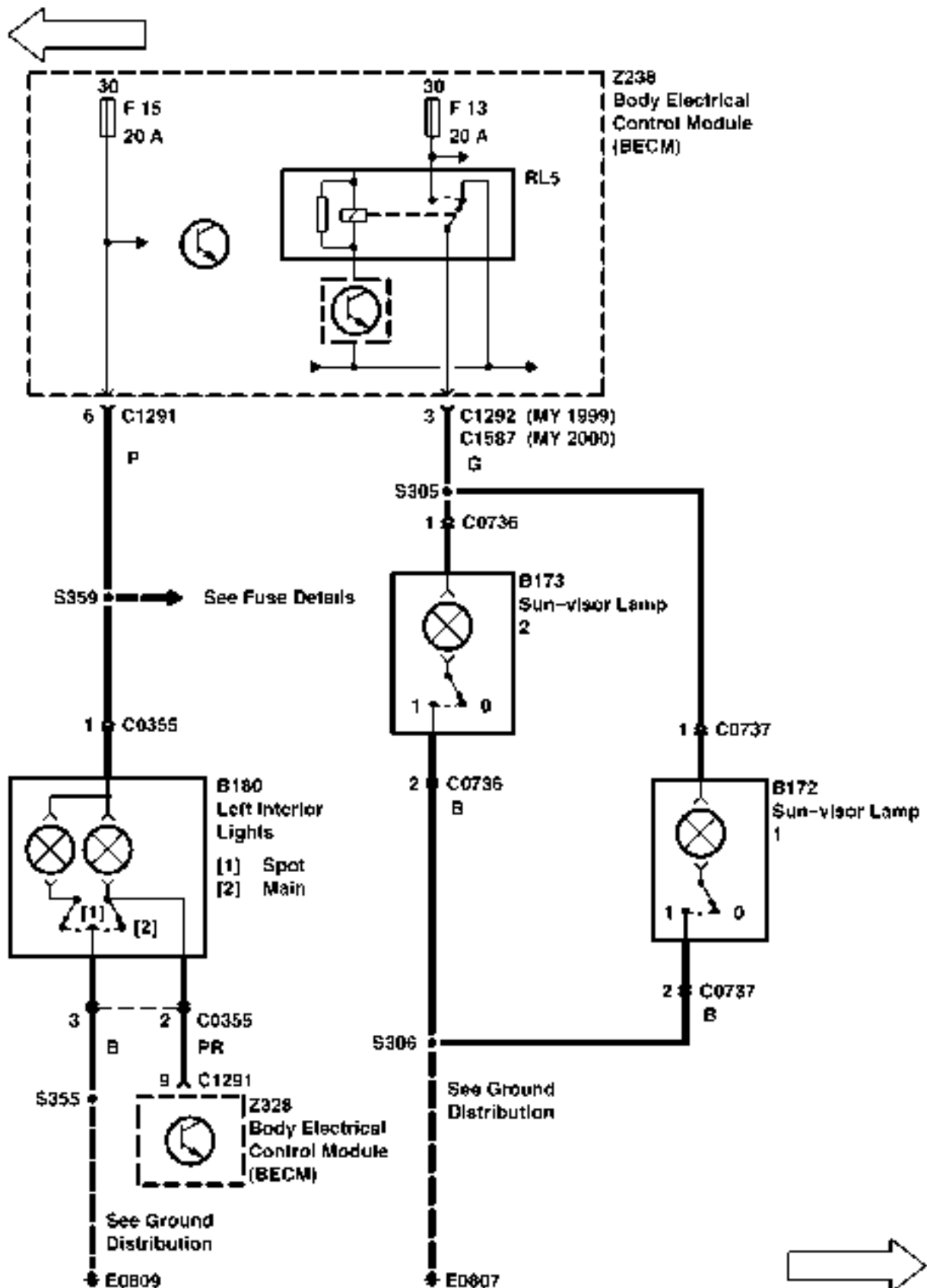

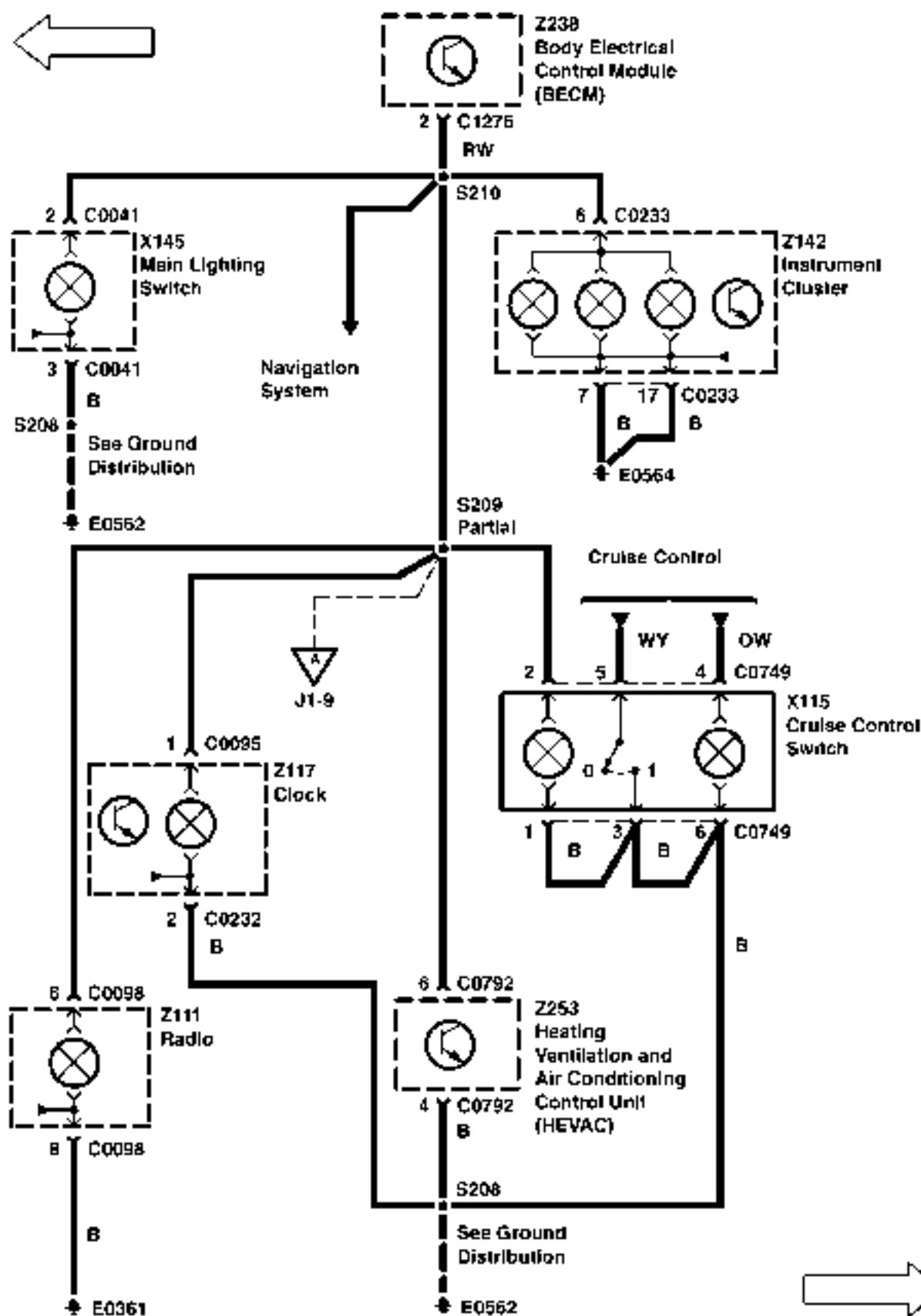

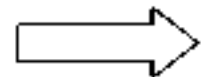
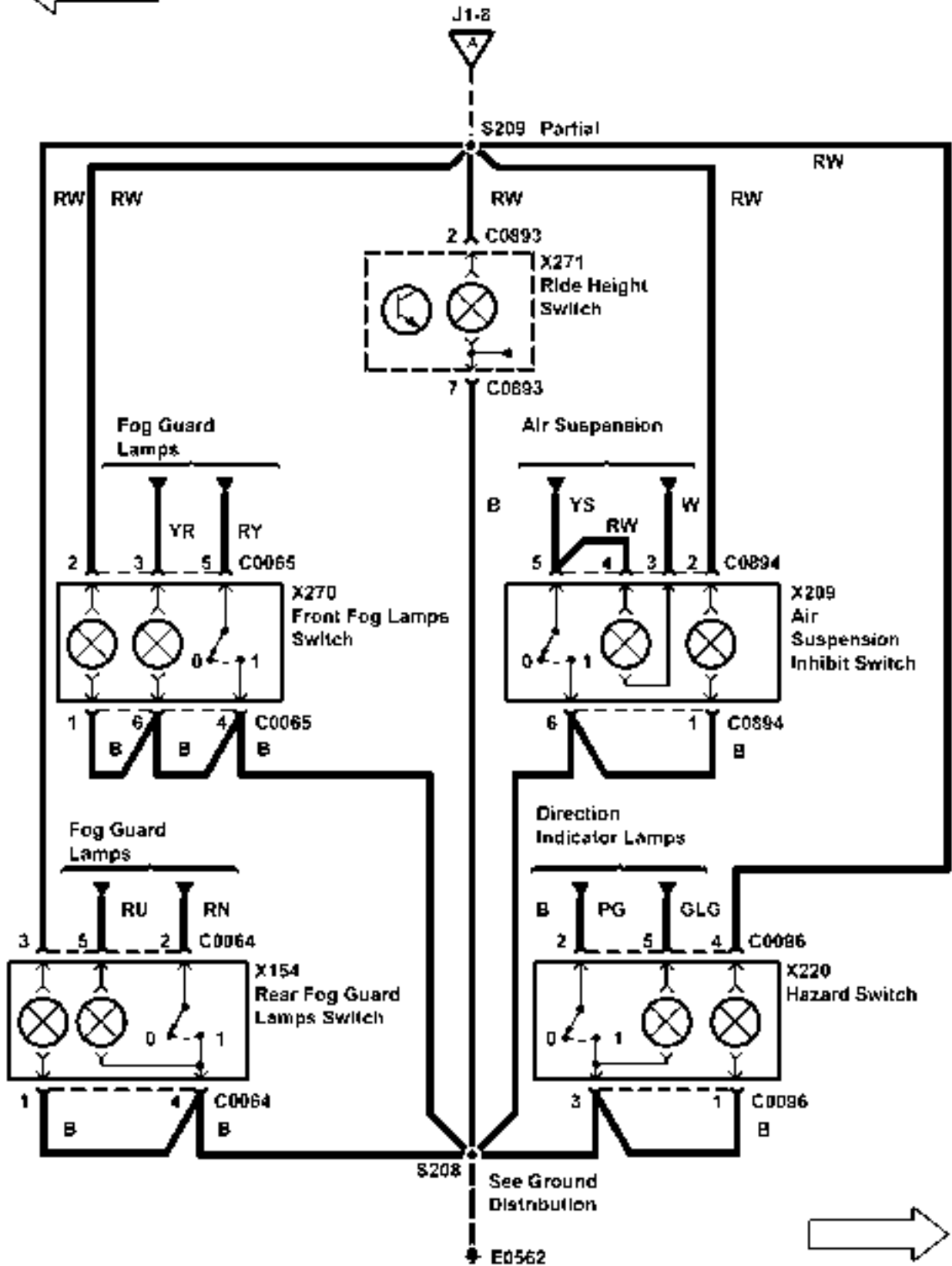
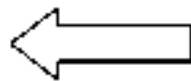

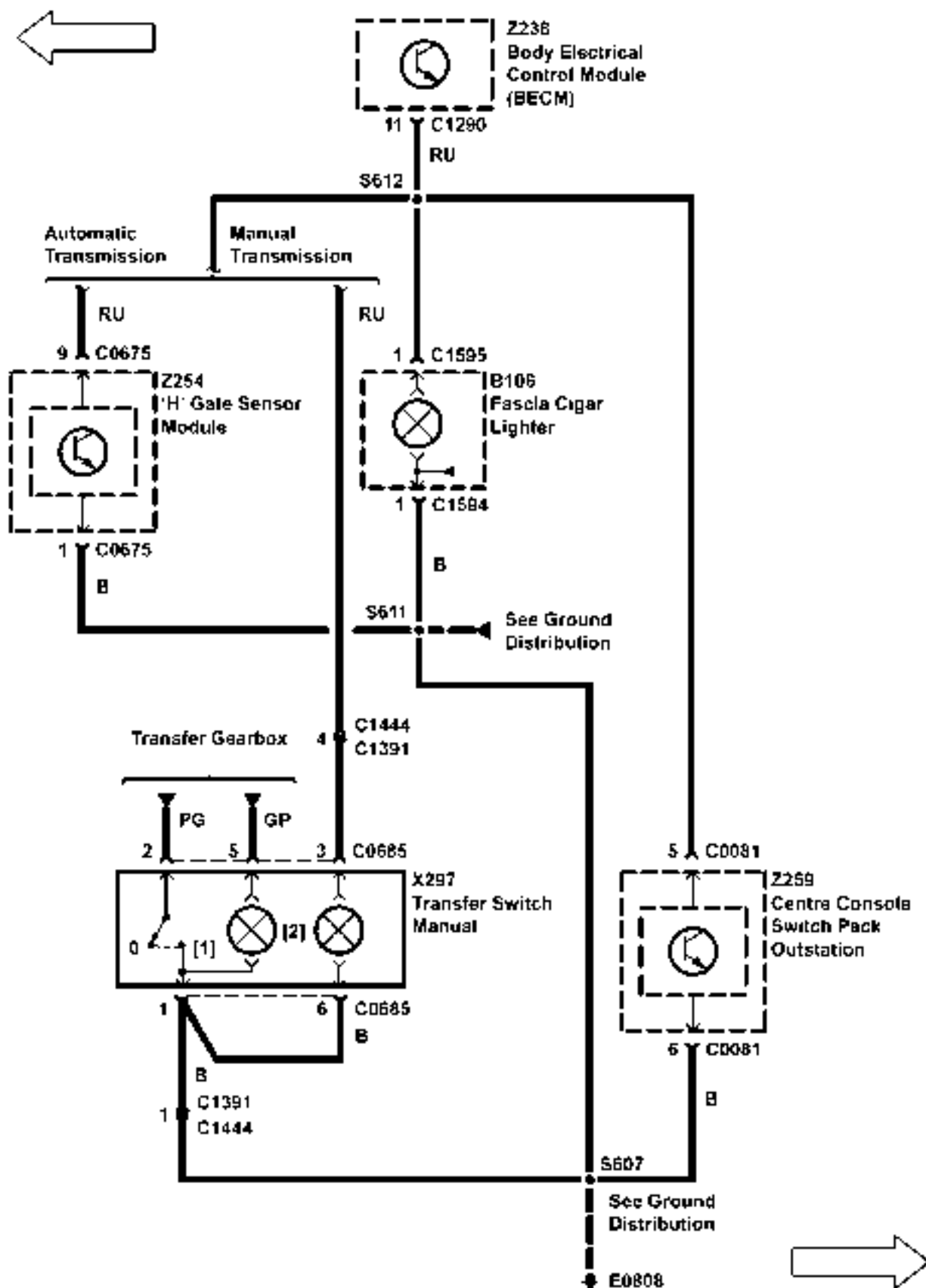

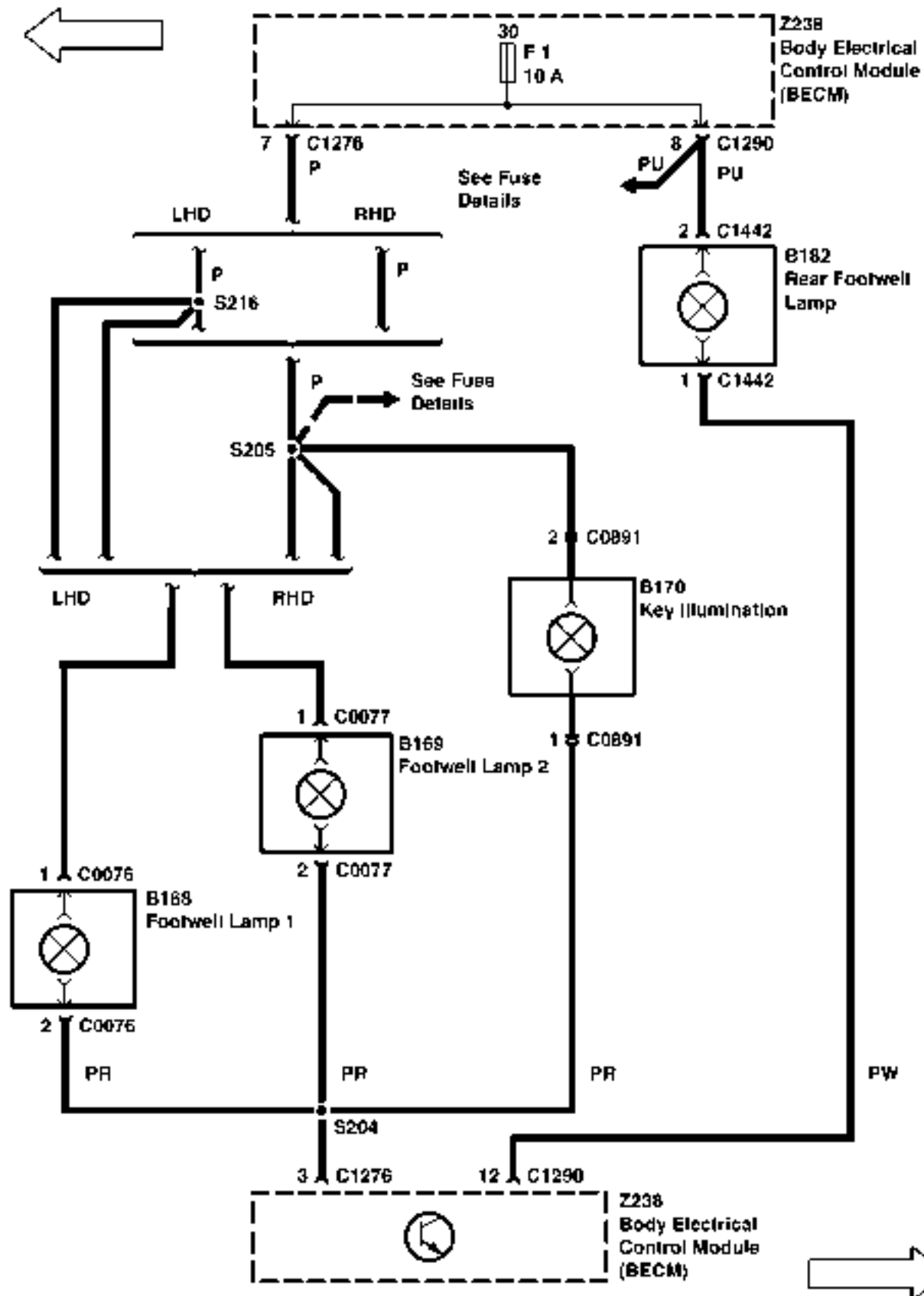

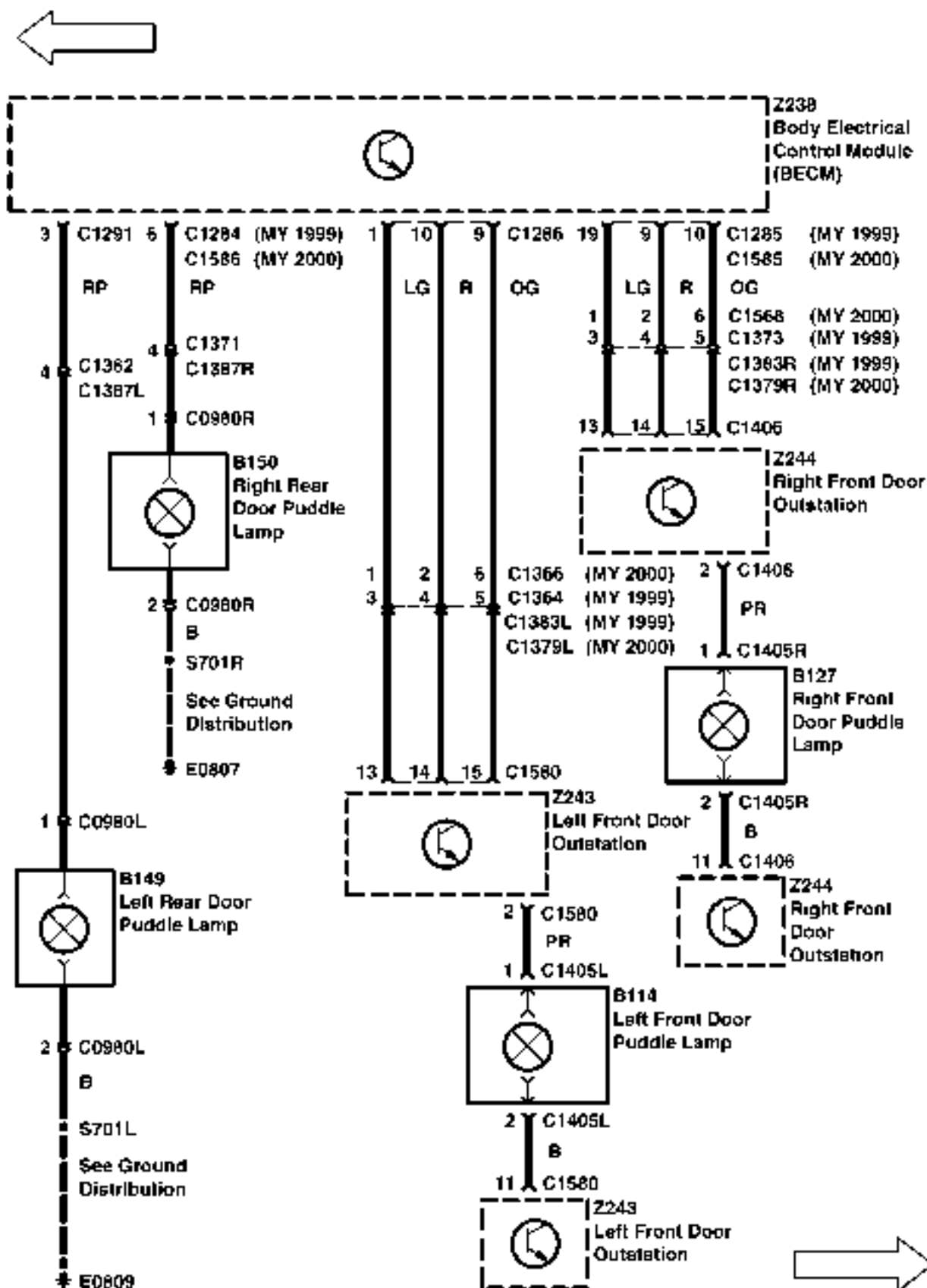

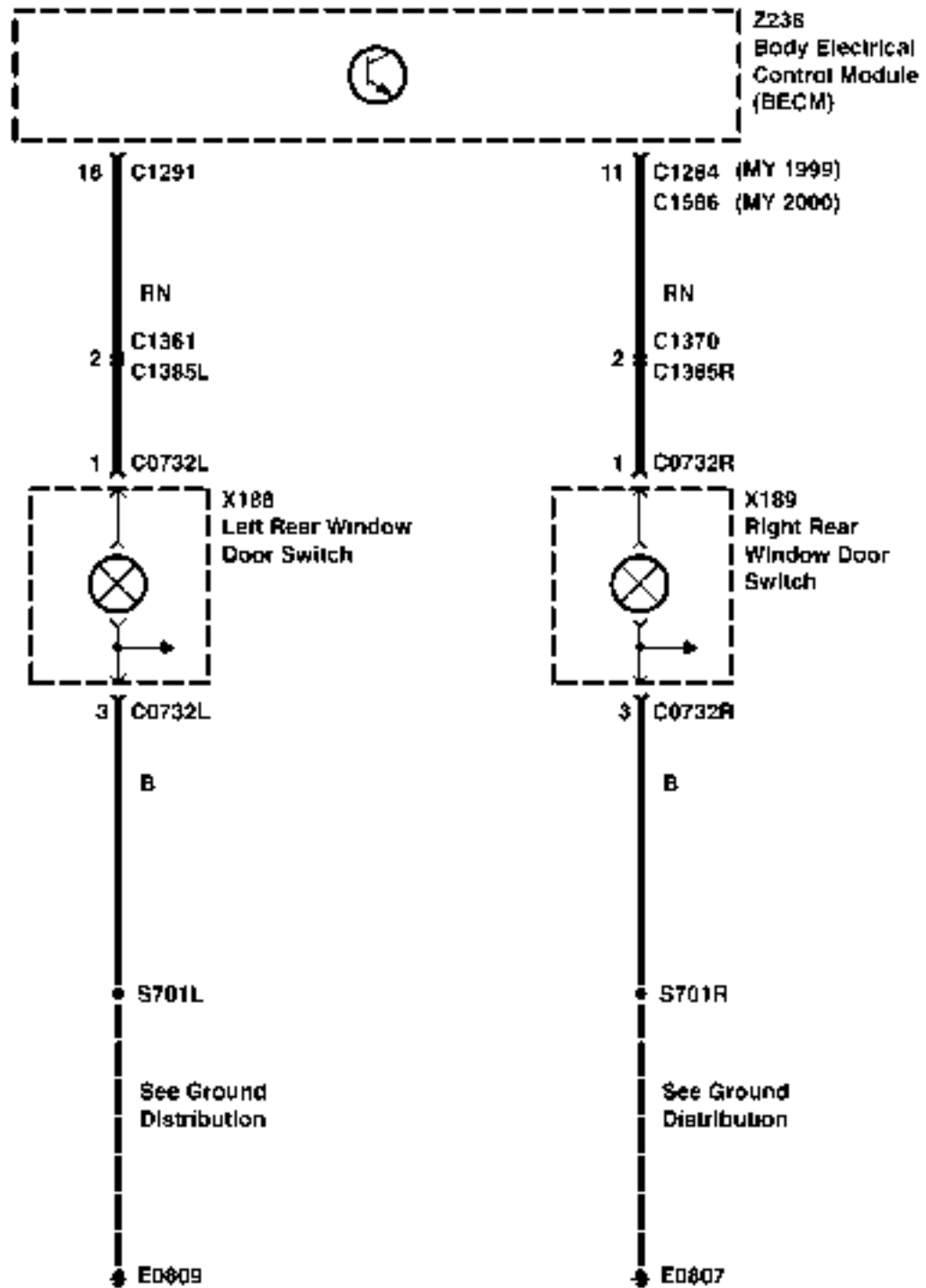
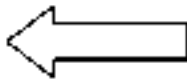

CIRCUIT DIAGRAMS

- Circuit diagrams are arranged so that current flow is from the top of the diagram (current source) to the bottom of the diagram (ground).
- Only those components that work together in the circuit are shown. If only part of a component is used in the circuit, then only that part of the component is shown.
- Remember:



TERMINAL NUMBER	DESIGNATION
50	Battery voltage: Ignition Switch in position III
30	Battery voltage: supplied constantly
15	Battery voltage: Ignition Switch in position II or III
R	Battery voltage: Ignition Switch in positions I, II
31	Ground

See Introduction (I) for additional circuit diagram symbols.

DIAGNOSIS

- If the diagram is accompanied by text:
 - Read the Circuit Operation before proceeding with the electrical diagnosis.
 - Read the Troubleshooting Hints before performing the System Diagnosis.
 - Tests follow the System Diagnosis
 - When performing the System Diagnosis, be certain that all components disconnected in previous steps are reconnected unless otherwise directed.

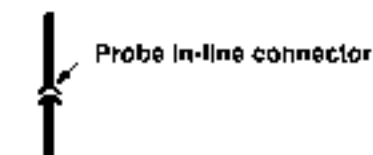
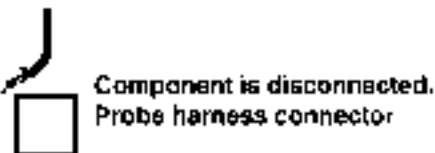
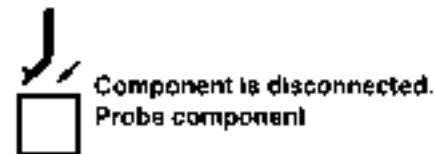
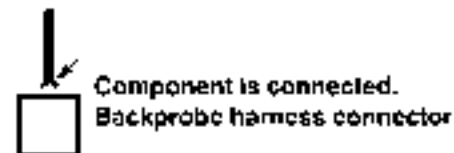
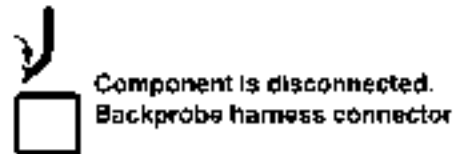

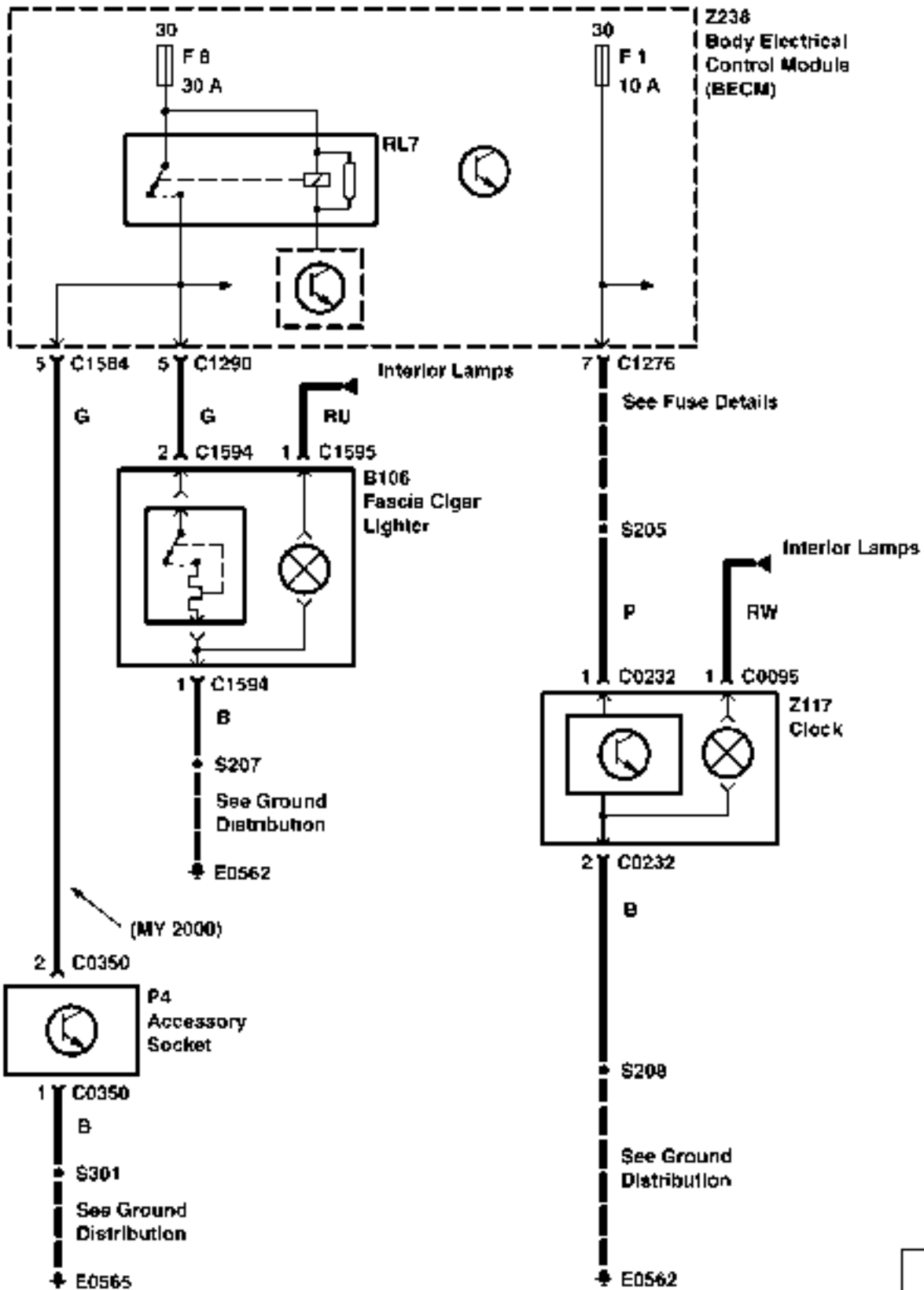

CIRCUIT DIAGRAMS

- Circuit diagrams are arranged so that current flow is from the top of the diagram (current source) to the bottom of the diagram (ground).
- Only those components that work together in the circuit are shown. If only part of a component is used in the circuit, then only that part of the component is shown.
- Remember:



TERMINAL NUMBER	DESIGNATION
50	Battery voltage: Ignition Switch in position III
30	Battery voltage: supplied constantly
15	Battery voltage: Ignition Switch in position II or III
R	Battery voltage: Ignition Switch in positions I, II
31	Ground

See Introduction (I) for additional circuit diagram symbols.

DIAGNOSIS

- If the diagram is accompanied by text:
 - Read the Circuit Operation before proceeding with the electrical diagnosis.
 - Read the Troubleshooting Hints before performing the System Diagnosis.
 - Tests follow the System Diagnosis
 - When performing the System Diagnosis, be certain that all components disconnected in previous steps are reconnected unless otherwise directed.

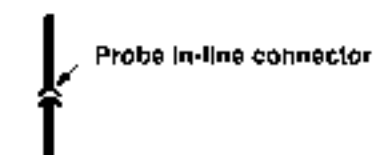
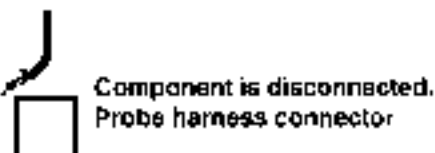
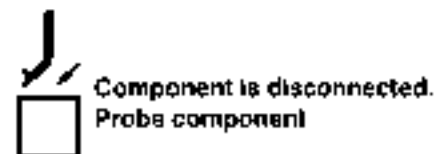
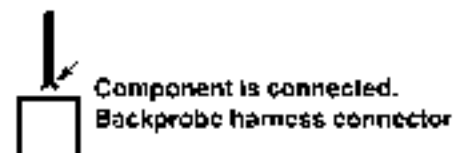
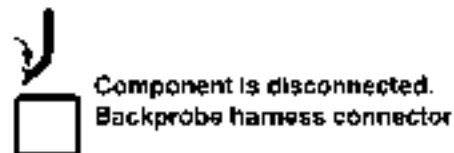

CIRCUIT OPERATION**Ignition position 1 (Accessories)**

This feed is obtained from the BeCM via fuse 8 and is shared with the Radio, Front cigar lighter and car phone (if fitted). The Ignition 1 is essential to the control panel as it provides power to the ECU although no functions or display on the LCD are possible.

Ignition position 2

This feed is obtained from the BeCM via fuse 35.

Ground Connection

This feed runs down to a spliced joint, joining the main earth run down to fascia earth point E0552.

Dimmer Line

This Pulse Width Modulated signal is provided by the BeCM.

LCD Dimmer line

This line is a input to the HEVAC and the signal is a inverse Pulse Width Modulated signal which is determined by the instrument pack.

Alternator Charge signal

This signal is given to the HEVAC ECU to inform it that the engine is running. This signal is active low.

Diagnostic K line

This line is used to communicate with the diagnostic equipment (TESTBOOK) and is normally held at 12V when not active.

Left/Right Recirculation motors

These motors control the flaps on the blower motor modules. The flaps should be in one of two positions, either fully open or fully closed.

Left/Right Blower modules

The blowers have a permanent 12V feed to them. The speed of the motors is determined by the control lines which go to the motors. The motors also provide a voltage feedback to the HEVAC ECU to determine the actual voltage at the motors but also to show if there are any faults.

Left/Right Blend and Distribution Motors

These motors are controlled by the HEVAC ECU which provides power to the motors, which in turn report back their actual positions to the HEVAC ECU.

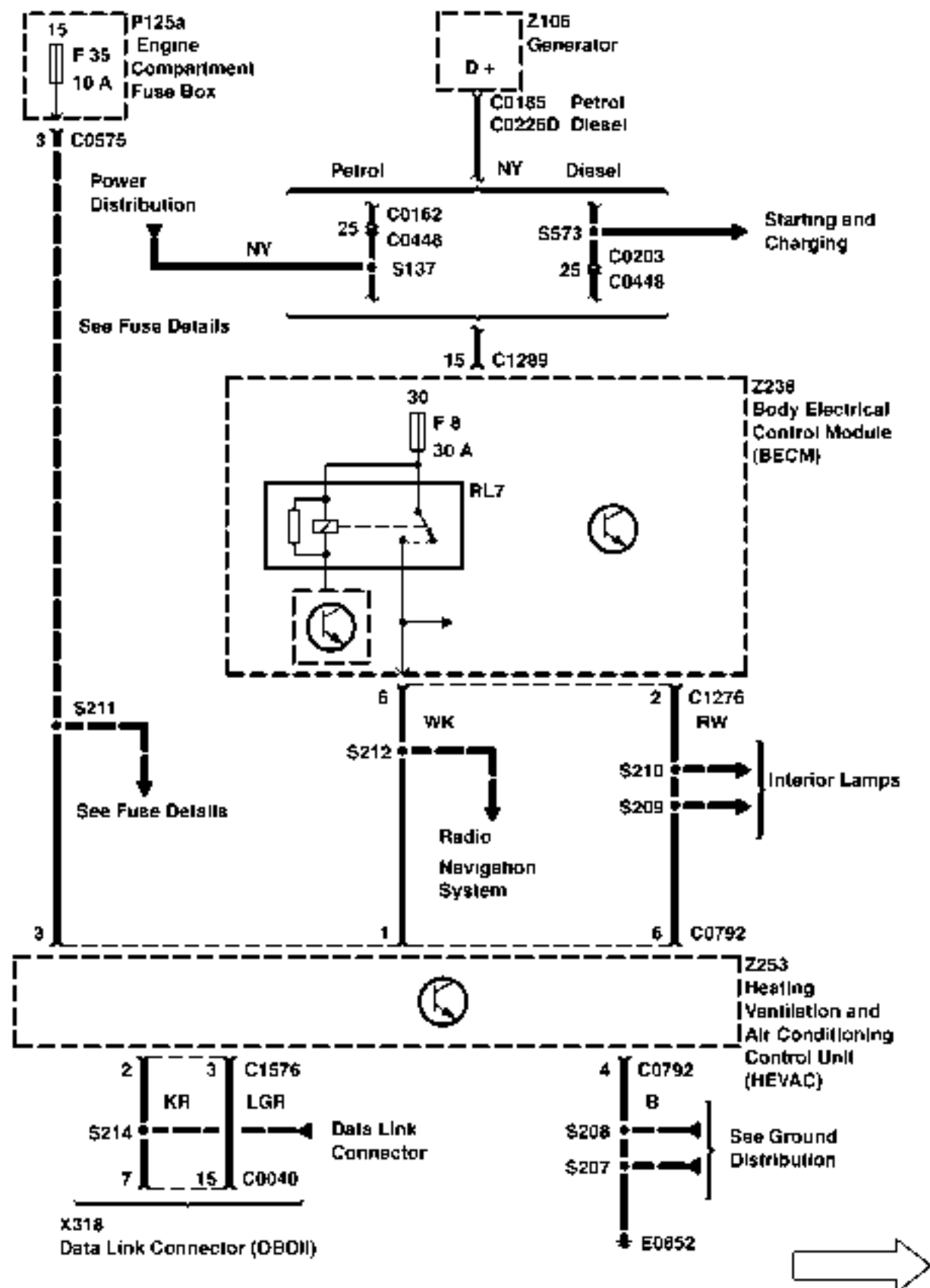

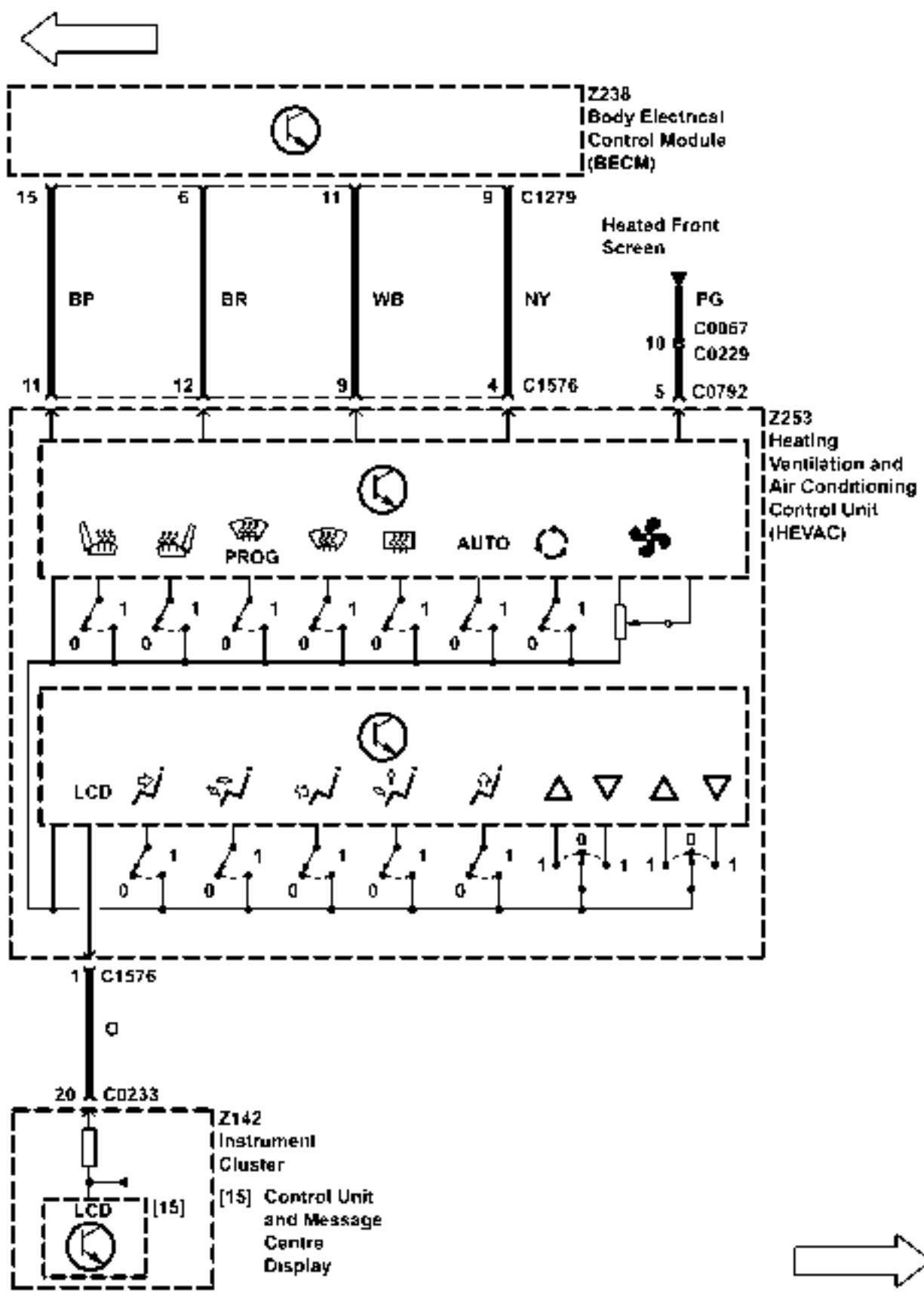

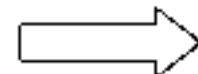
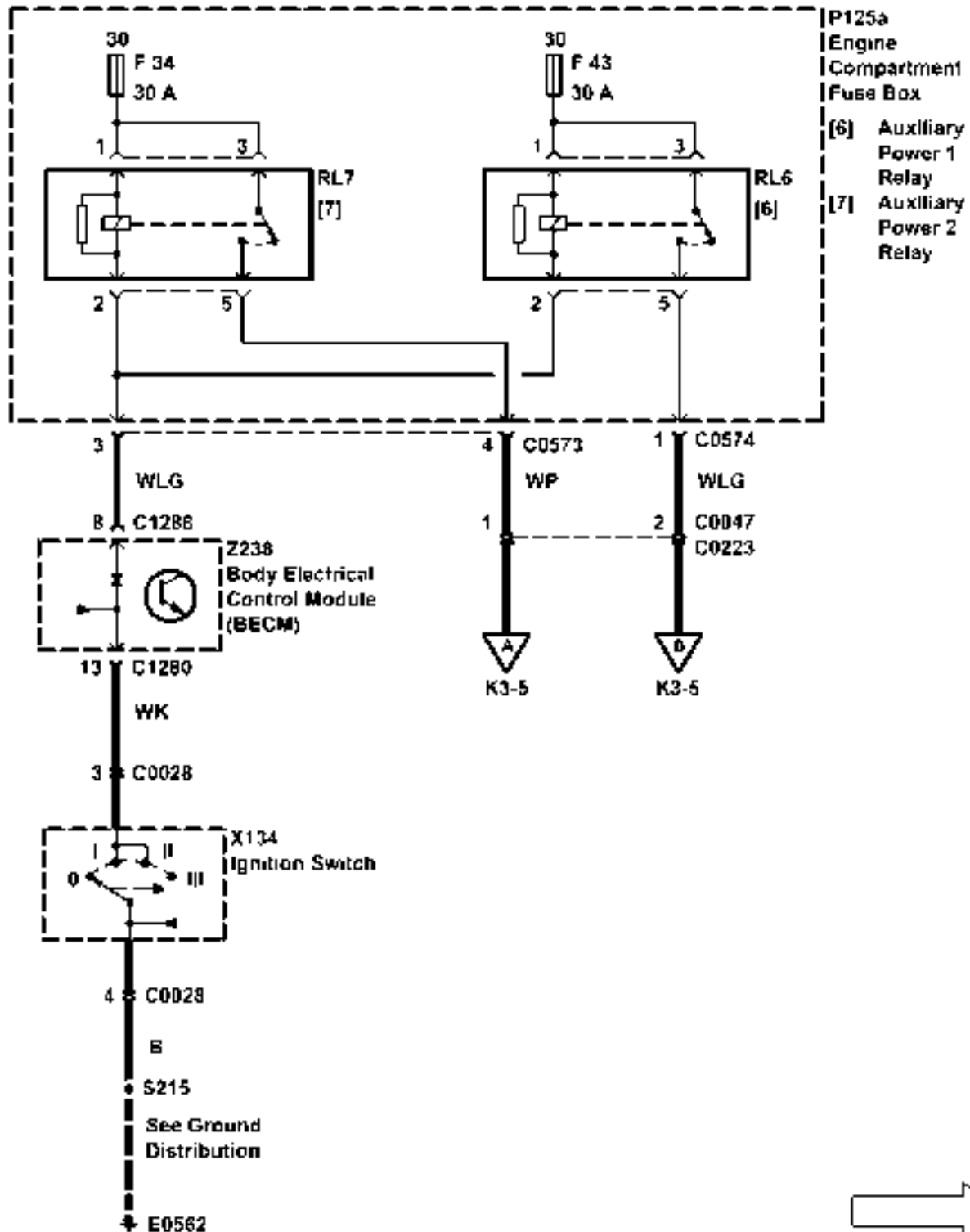
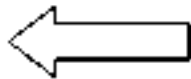

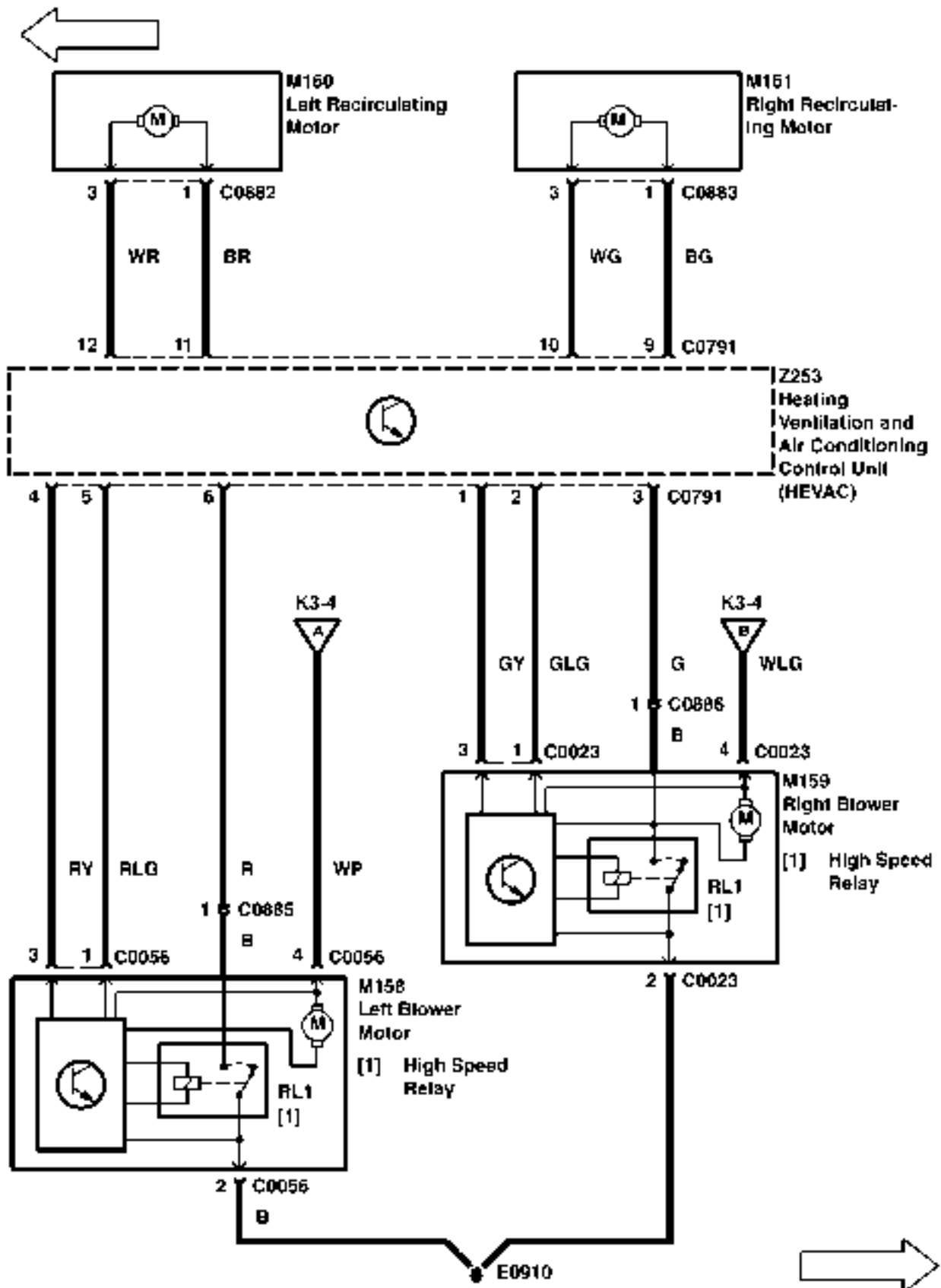

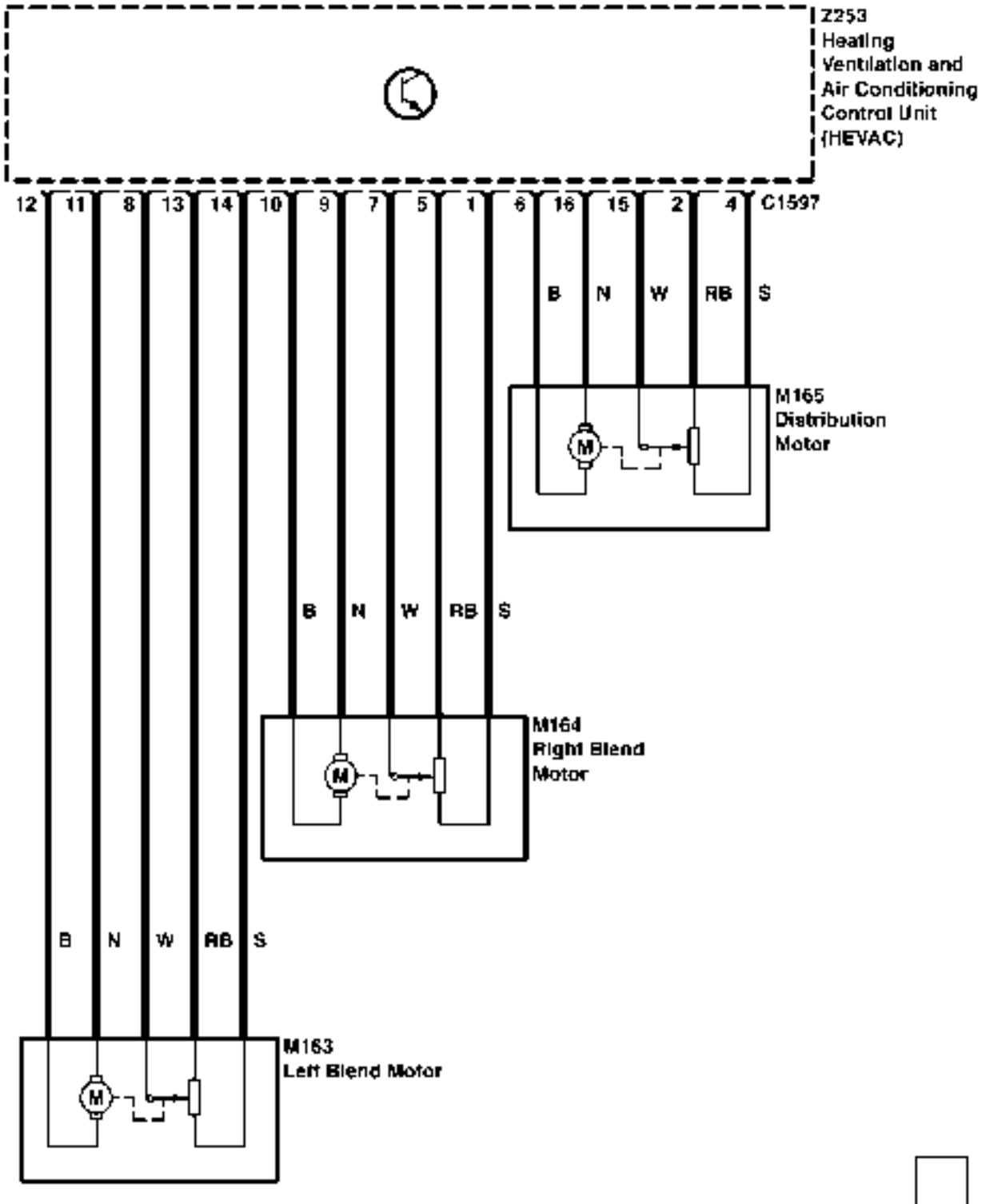
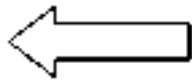

CIRCUIT OPERATION

Ignition position 1 (Accessories)

This feed is obtained from the BeCM via fuse 8 and is shared with the Radio, Front cigar lighter and car phone (if fitted). The Ignition 1 is essential to the control panel as it provides power to the ECU although no functions or display on the LCD are possible.

Ignition position 2

This feed is obtained from the BeCM via fuse 35.

Battery feed

This feed is obtained from the fuse box via fuse 42.

Ground Connection

This feed runs down to a spliced joint, joining the main earth run down to fascia earth point E0562.

Dimmer Line

This Pulse Width Modulated signal is provided by the BeCM.

LCD Dimmer line

This line is a input to the HEVAC and the signal is a inverse Pulse Width Modulated signal which is determined by the instrument pack.

Compressor Clutch

The clutch line provides a 12 volt power feed to the compressor clutch via a pressure switch 1.

Condenser Fans

The HEVAC panel provides a signal normally at 12 volts for 'off' condition and 0 volts for the 'on' condition, which in the case of petrol vehicles is fed into the ECM and diesel vehicles directly onto the coil of relay 18. In line is the Air-Conditioning pressure switch 2, which turns the fans on/off.

When relay 18 is energised, it provides connection between relays 13 and 14 (fan 1 and 2) in series or parallel with each other. This is dependent upon the state of the air-conditioning pressure switch 1.

For the petrol option, when the signal enters the ECM, the ECM will switch the output on/off to the fusebox. The ECM will switch the output on sometimes for engine cooling reasons even though the engine has been turned off.

Aspirator

There are two parts of this sensor, one of which is a fan which draws cabin air onto the temperature sensor. The temperature sensor then sends the signal back to the HEVAC ECU.

Ambient Sensor

This sensor measures the temperature of the external air flow into the vehicle.

The ambient temperature sensor is located behind the LH side of the vehicle in front of the condenser. The revised location improves the response time of the sensor. The new HEVAC software will not update the ambient temperature sensor readings unless the vehicle is traveling over approximately 15 mph (25 km/h). The HEVAC software will therefore not automatically correct temperature readings when a faulty ambient temperature sensor is renewed.

Temperature	Resistance (Ohms)
-20° C (-4° F)	94.5 K
-10° C (14° F)	54.3 K
0° C (32° F)	32.1 K
10° C (50° F)	19.7 K
20° C (68° F)	12.5 K
30° C (86° F)	8.1 K
40° C (104° F)	5.4 K

Heater Core Sensor

This sensor measures the engine coolant temperature within the fascia area.

Evaporator Sensor

This sensor is located within the evaporator unit and, by providing feedback to the HEVAC ECU, prevents it from freezing.

Alternator Charge signal

This signal is given to the HEVAC ECU to inform it that the engine is running. This signal is active low.

Diagnostic K line

This line is used to communicate with the diagnostic equipment (TESTBOOK) and is normally held at 12V when not active.

Road Speed

This signal is fed into the HEVAC ECU.

Solar Sensor

This sensor provides the HEVAC ECU with the power of the sun's solar load and allows the system to compensate accordingly.

A/C Request

This signal is active low and sends a request to the ECM to switch on the air-conditioning system.

A/C Grant

This signal is active low and sends a signal to the HEVAC ECU to acknowledge the request signal and that it is ready for the load to be switched on by the HEVAC system.

Pressure switch 1 (Trinary switch)

This switch is in parallel with two components, the condenser fans and the compressor clutch which are both normally short circuit. If the pressure is too high or too low, the switch will open and cut the feed to the clutch to prevent damage to the system. With the third setting, at a specific pressure the switch is shorted and changes the condenser fan mode from series to parallel.

Pressure switch 2 (Single switch)

The switch is normally open circuit. At a specific pressure, the switch is shorted and allows the condenser fans to turn on.

Left/Right Recirculation motors

These motors control the flaps on the blower motor modules. The flaps should be in one of two positions, either fully open or fully closed.

Left/Right Blower modules

The blowers have a permanent 12V feed to them. The speed of the motors is determined by the control lines which go to the motors. The motors also provide a voltage feedback to the HEVAC ECU to determine the actual voltage at the motors but also to show if there are any faults.

Left/Right Blend and Distribution Motors

These motors are controlled by the HEVAC ECU which provides power to the motors, which in turn report back their actual positions to the HEVAC ECU.

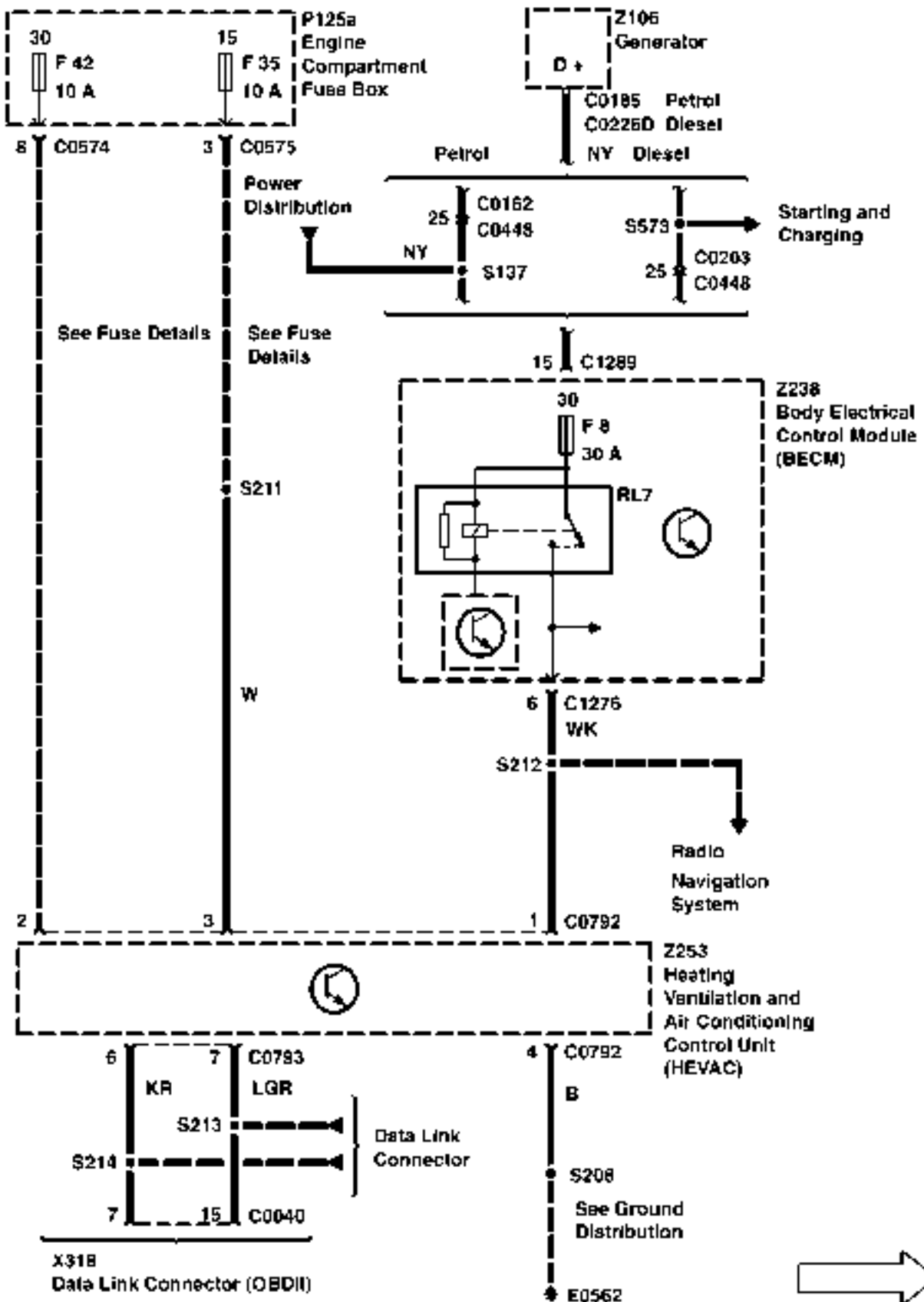

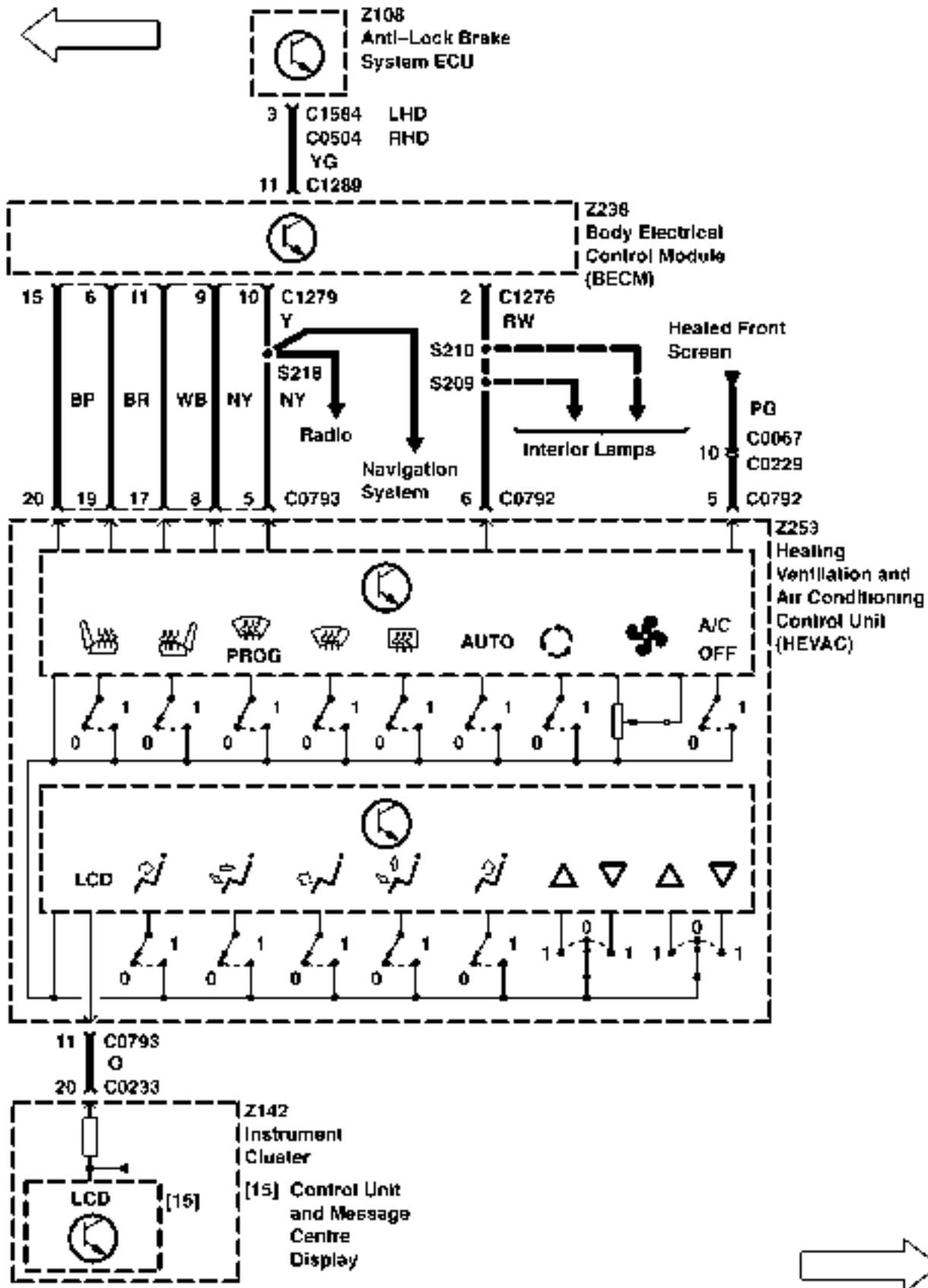

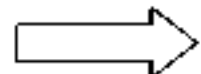
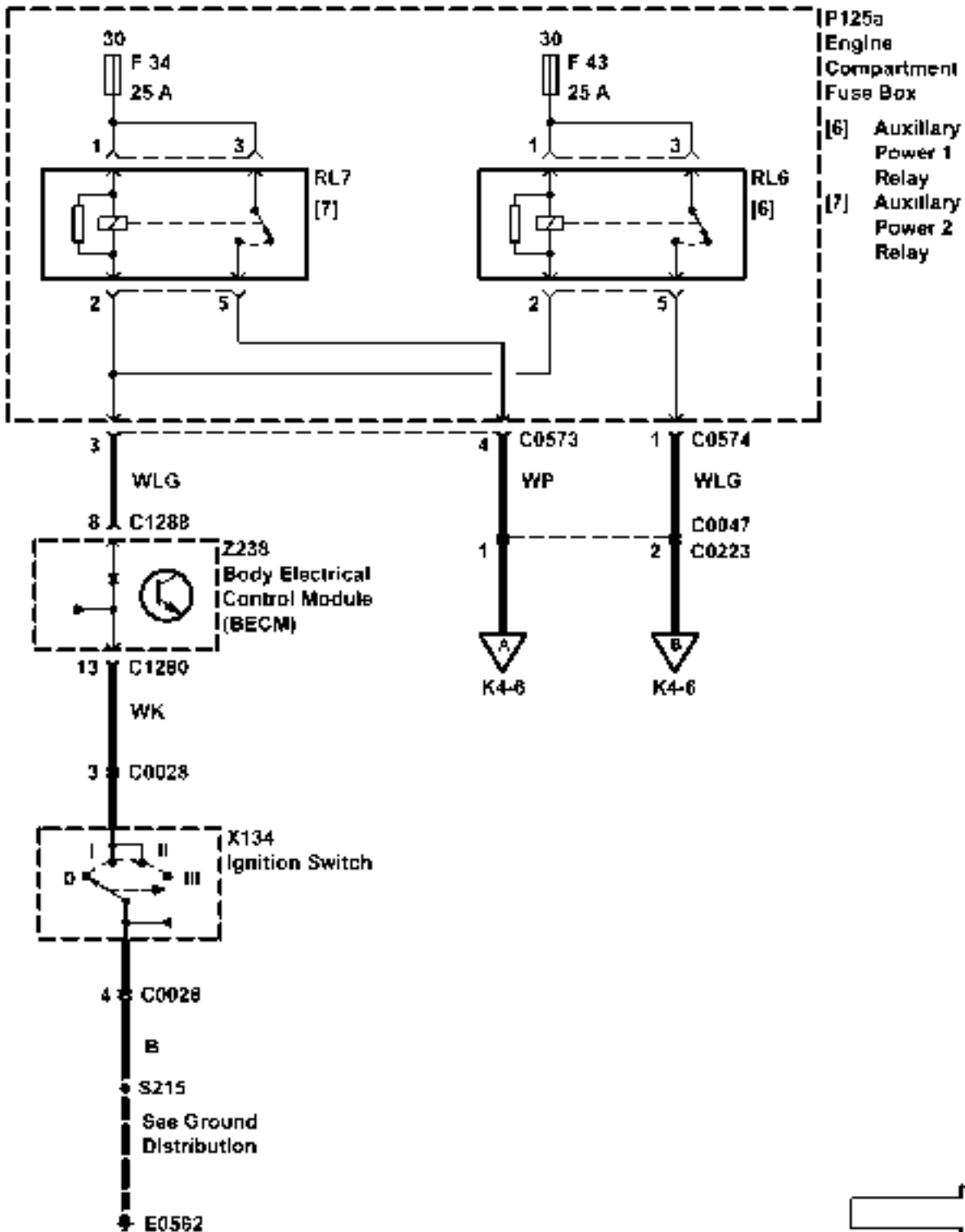
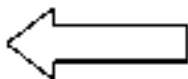

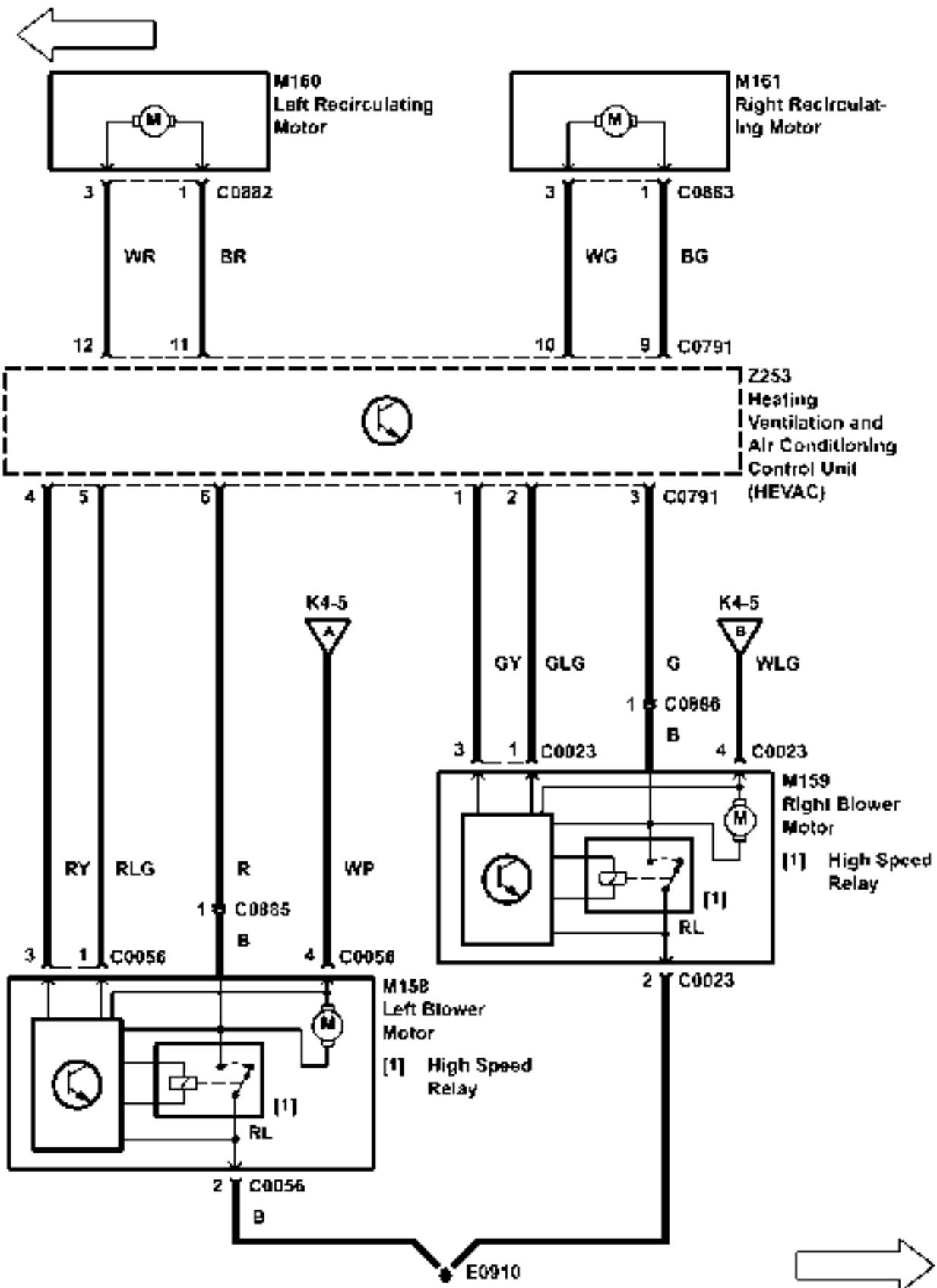

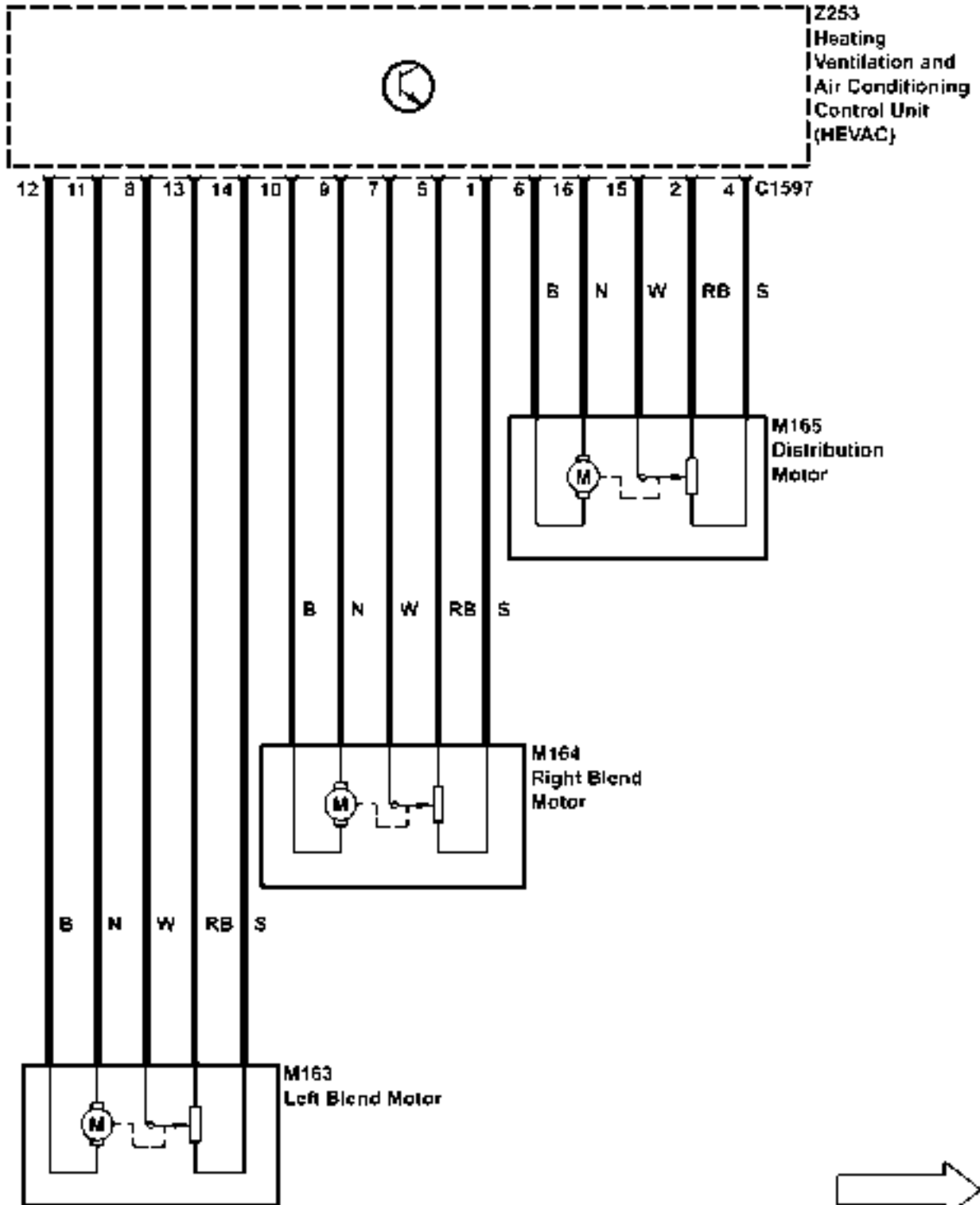
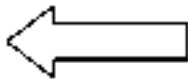

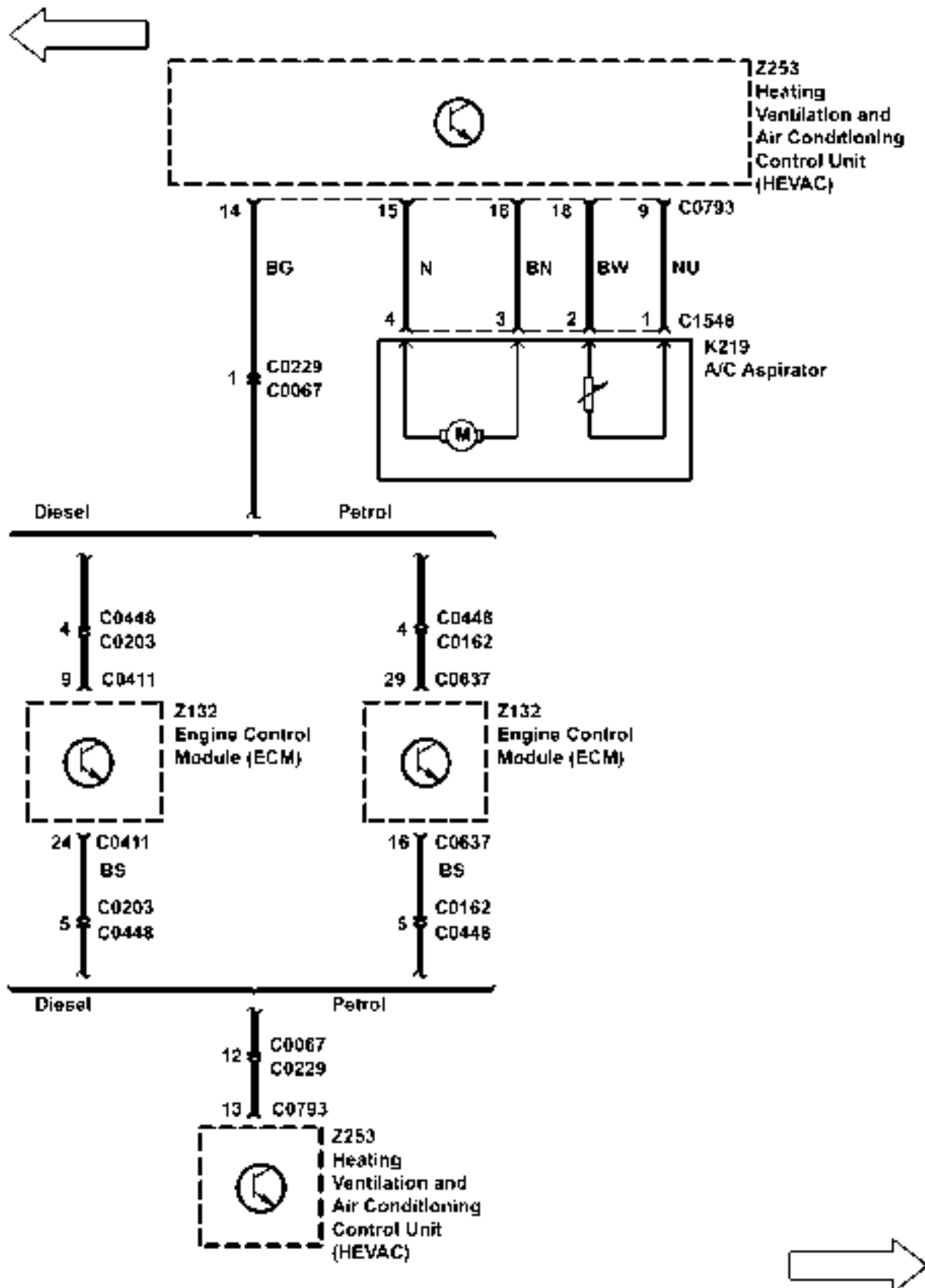

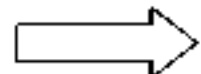
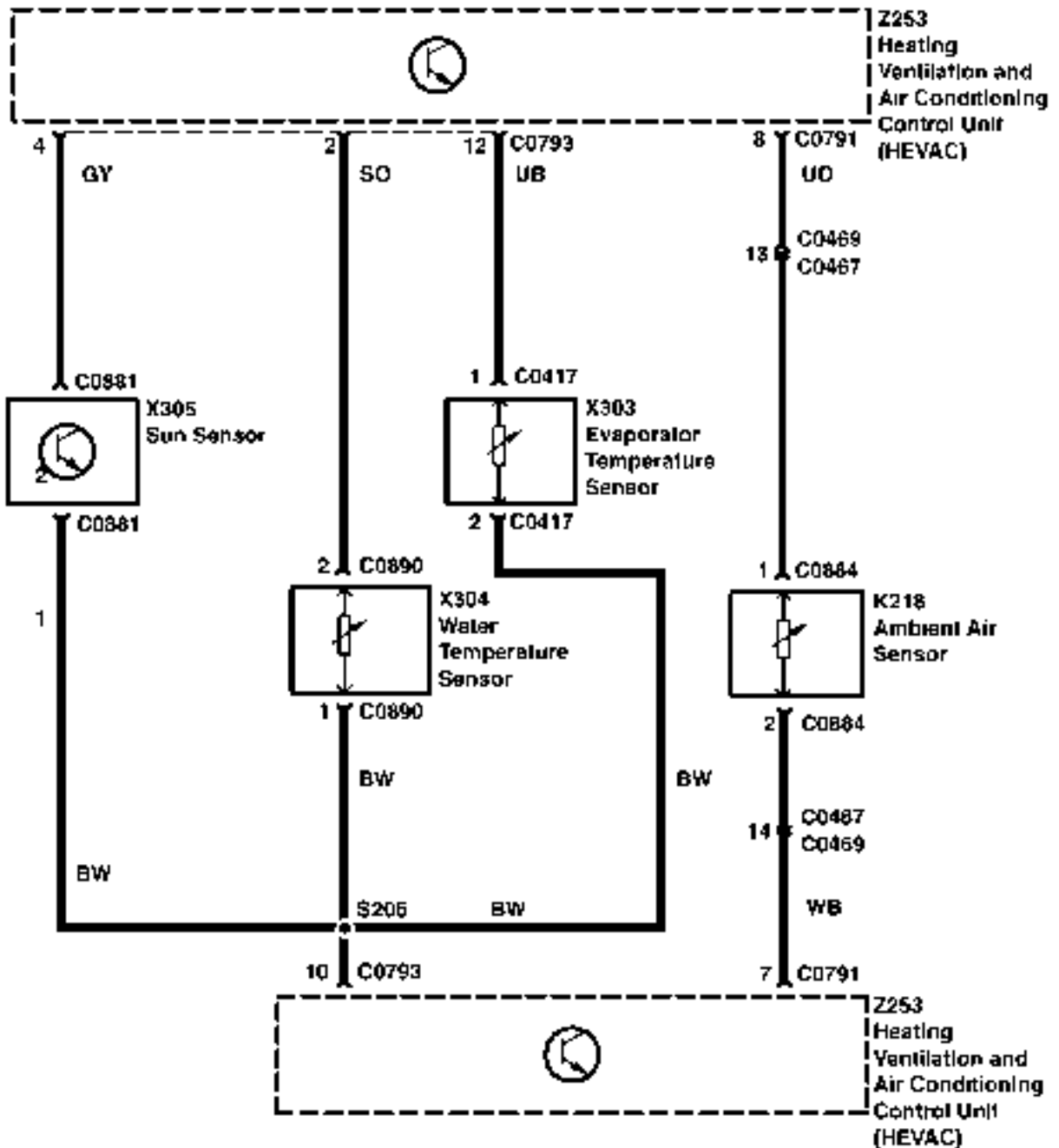

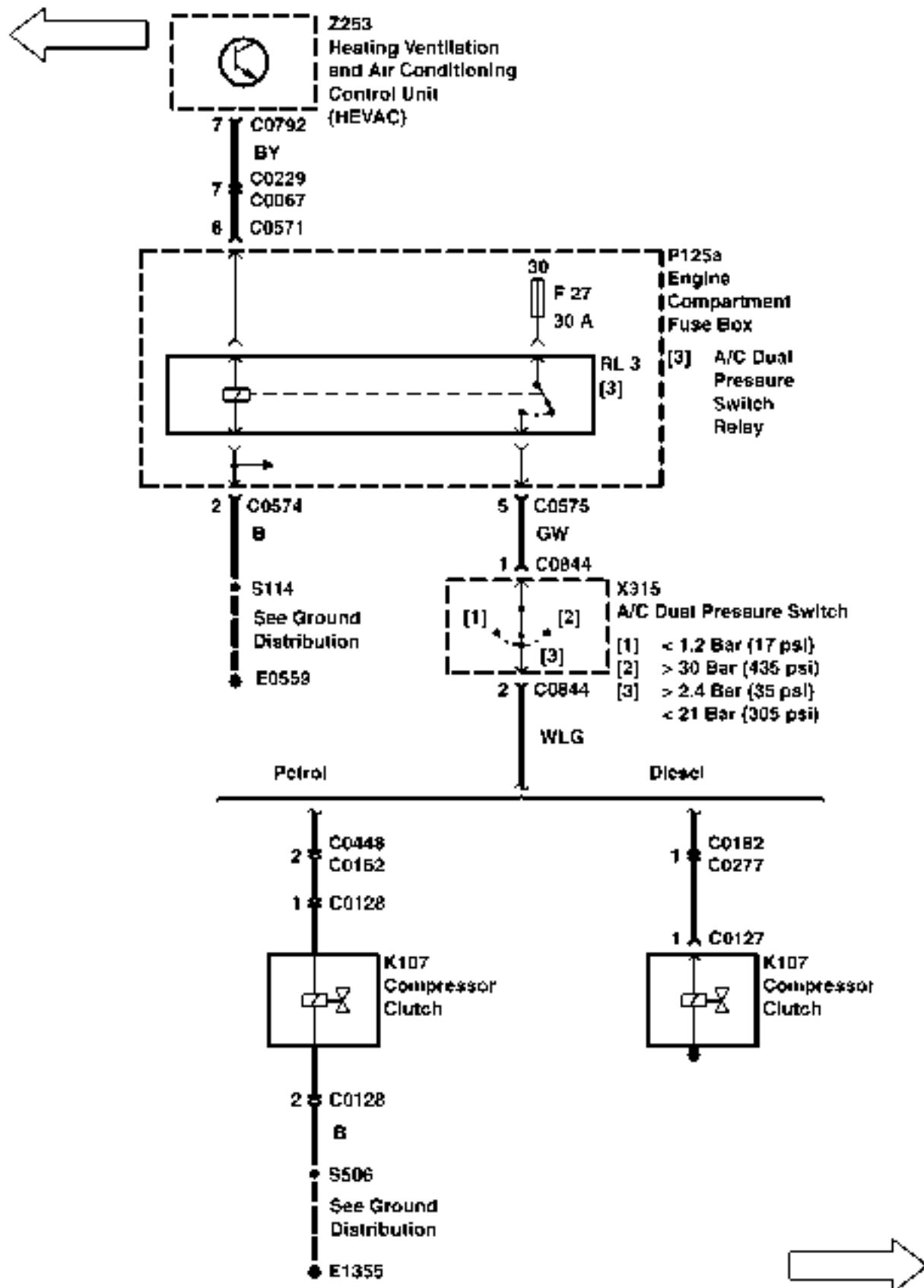

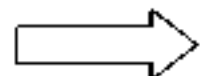
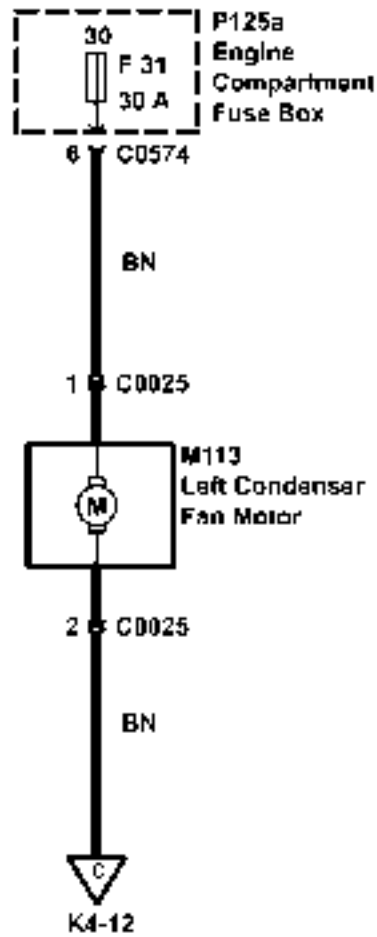
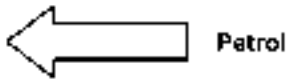

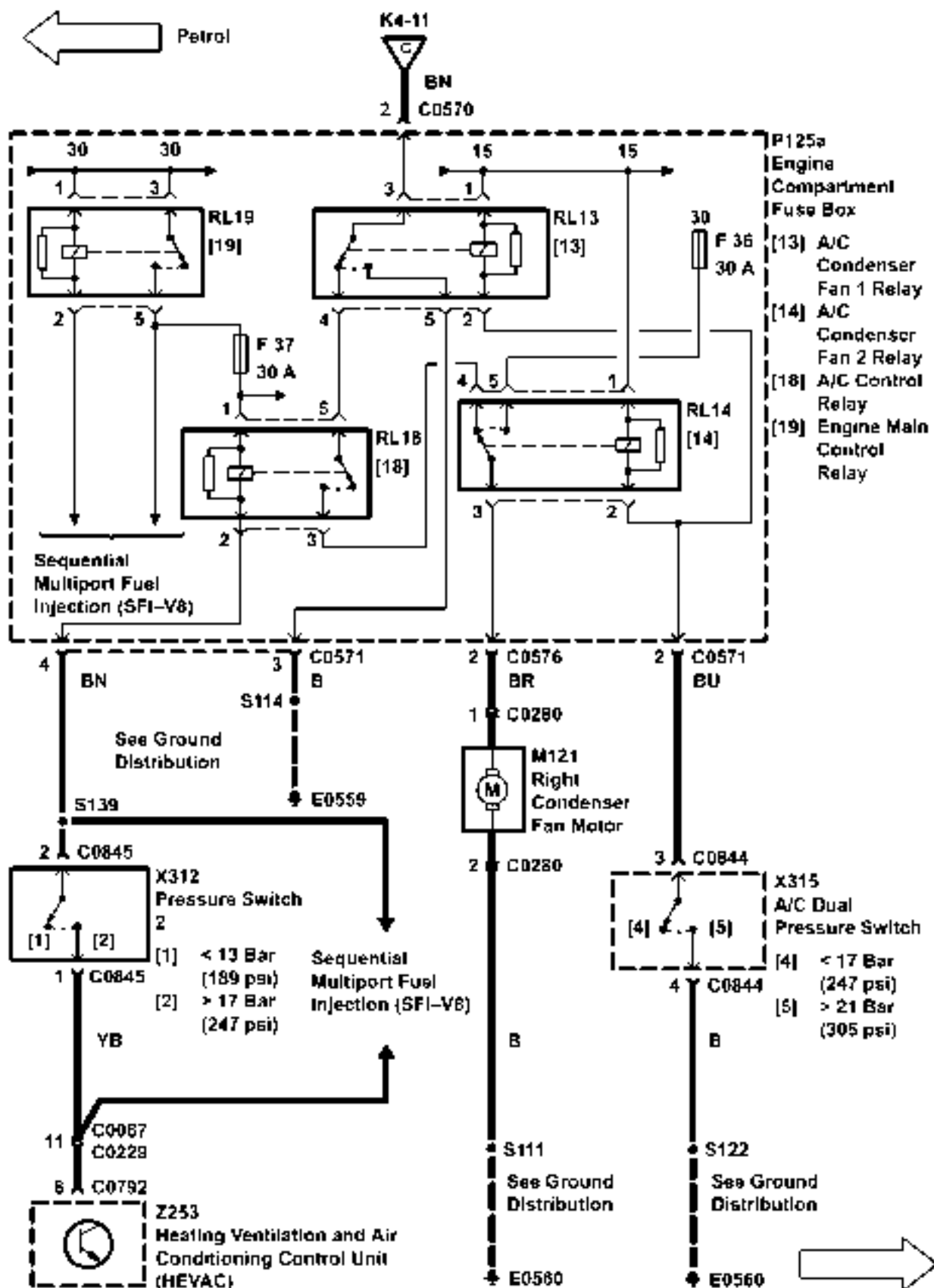

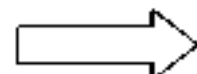
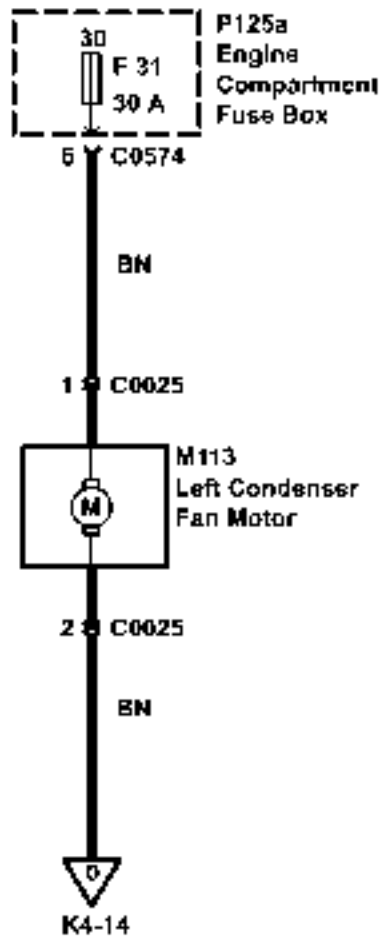
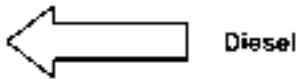

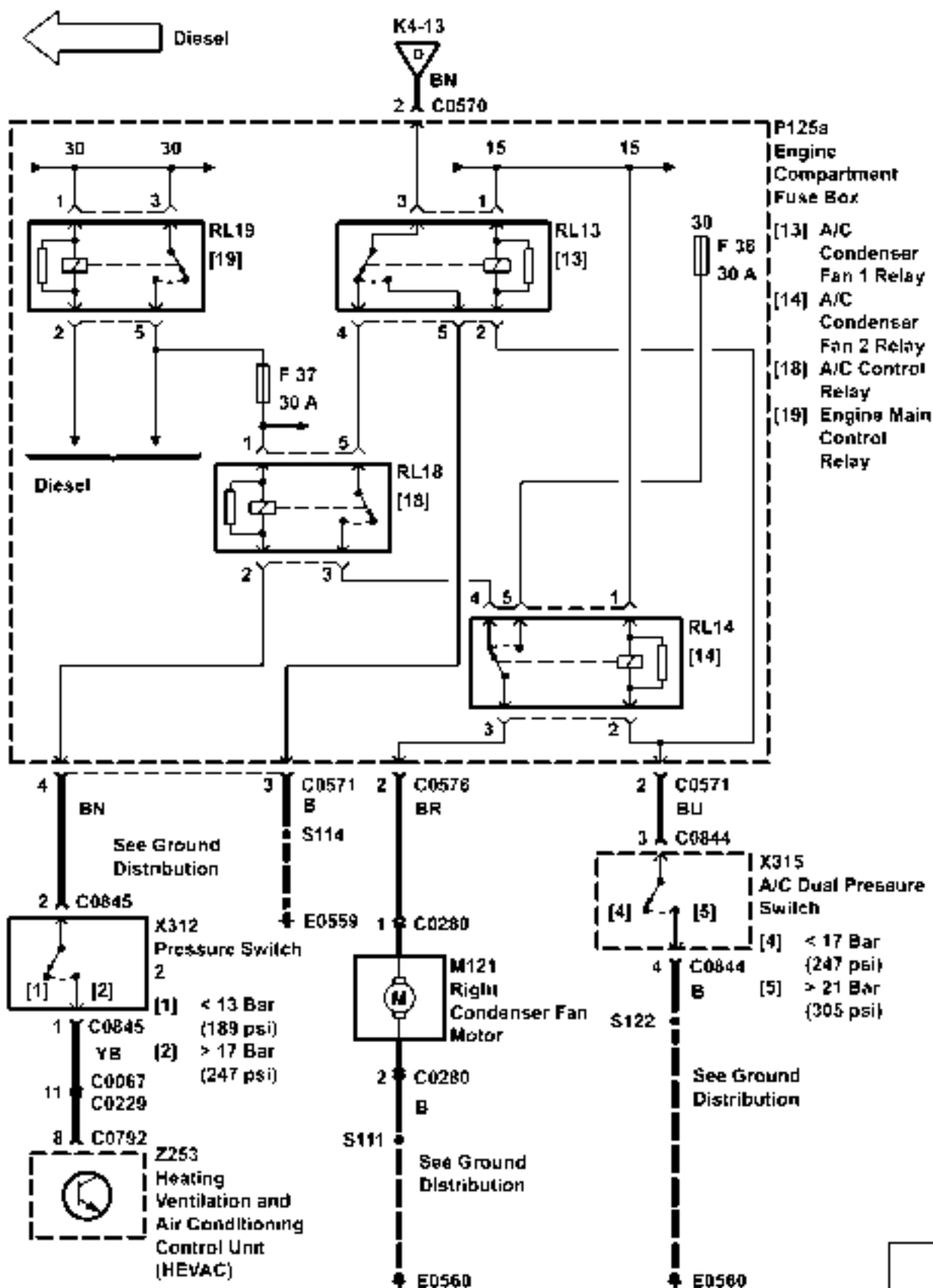

CIRCUIT OPERATION

The window lift system will provide one touch or inch mode on all windows and will have the anti-trap function (when initialised) on close.

Initialised window operation

Selection of any* aperture switch, in either direction, for less than 0.4 seconds shall initiate the "one touch" mode of operation. That aperture will be driven in the direction selected until a trap (obstruction) is detected (close only) or the motor stalls. This mode will be cancelled by the operation of the associated switch in the opposite direction. If the associated aperture switch is operated in the opposite direction then the window will be driven in that direction according to the requirements for one touch/inch mode operation.

* Rear window one touch up is a programmable feature.

Selection of any aperture switch for greater than 0.4 seconds will cause that aperture to operate in the "inch mode". The aperture will move in the selected direction until a trap (obstruction) is detected (close only), the limit of travel is reached or the switch is released.

All windows will operate independently from each other and may operate in parallel. In case of conflict between switches, those in the centre console switch pack will have priority.

The window lift system will only be active under the following conditions:

- while auxiliary is on, i.e. the window system will not be active during crank. Any one touch operations will be cancelled when ignition 1 turns off during crank,
- for the first 45 seconds after auxiliary has been switched off, the one touch up and down functions will not be available during this time period. If, during the above 45 second time period, the drivers door is opened, the window system will remain active for a further 45 seconds from the door opening or until the door is closed again, whichever is sooner. If during either of the 45 second time periods a door lock signal is received, then the timer will be cancelled and therefore the window lift system will no longer be active.

The rear windows can be prevented from being operated from their local switch by the rear inhibit switch in the centre console. In the event of a centre console serial link failure being detected, the local rear window switches will default to inhibited.

Operation of the driver's window down switch will cause the driver's window to move in the down direction until the switch is released (unless in the one touch mode), the up switch is operated or until a stall condition is detected (i.e. the window is fully open).

Operation of the driver's window up switch will cause the window to operate in the close direction until the switch is released (unless in the one touch mode), the window down switch is operated, a trap condition is detected, or until the motor stalls (i.e. the window is fully closed).

Market Deviations:

a) USA/Canada/Germany

The system will only be active when the auxiliary (ignition 1) is on or for the time between switching the auxiliary feed off and opening either of the front doors, but not exceeding 45 seconds.

b) Australia: One touch operation will only be available for the driver's window.

c) Germany: The back off distance from a trap condition will be 200mm.

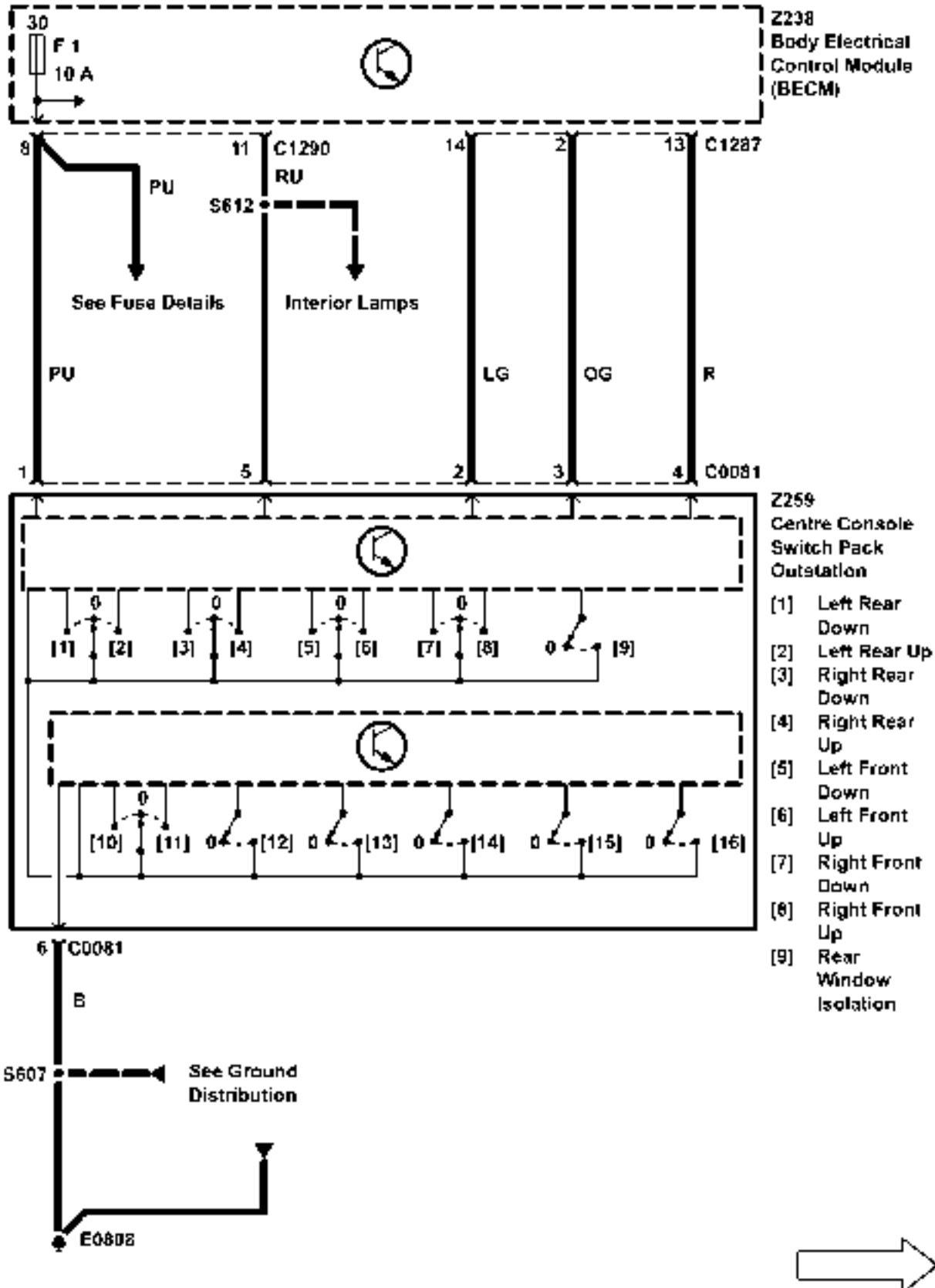

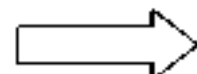
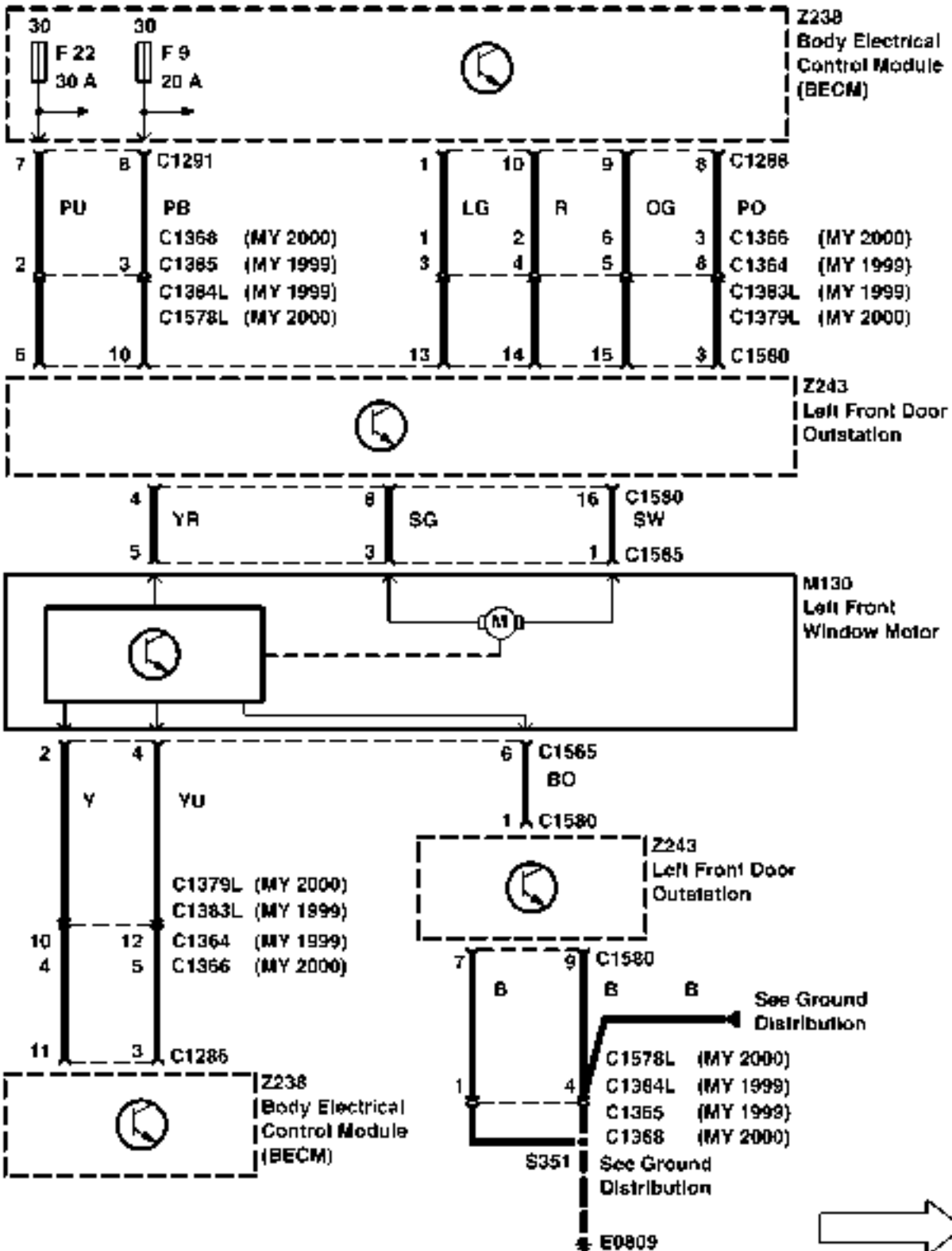
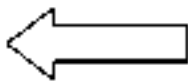

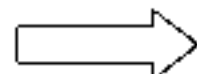
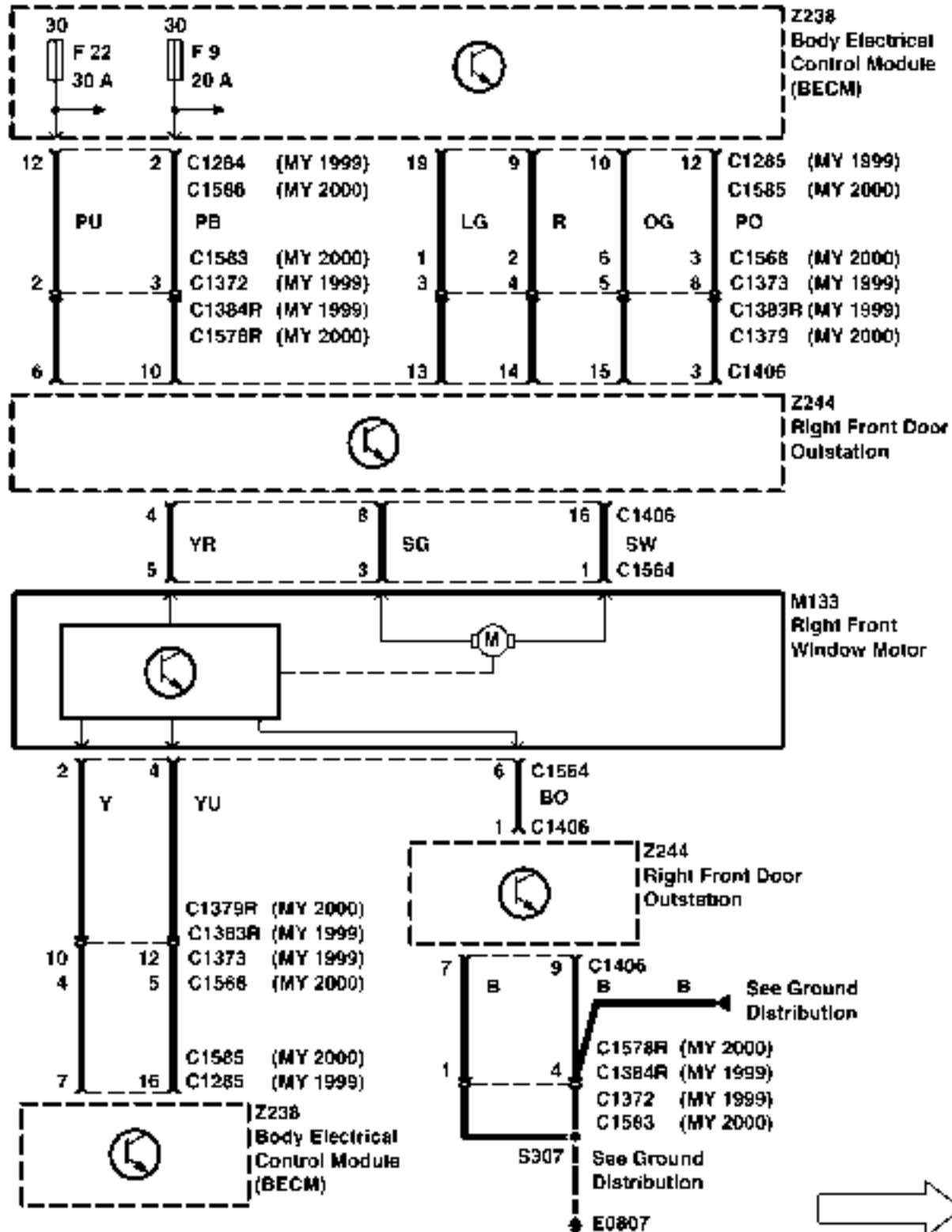
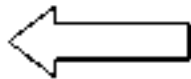

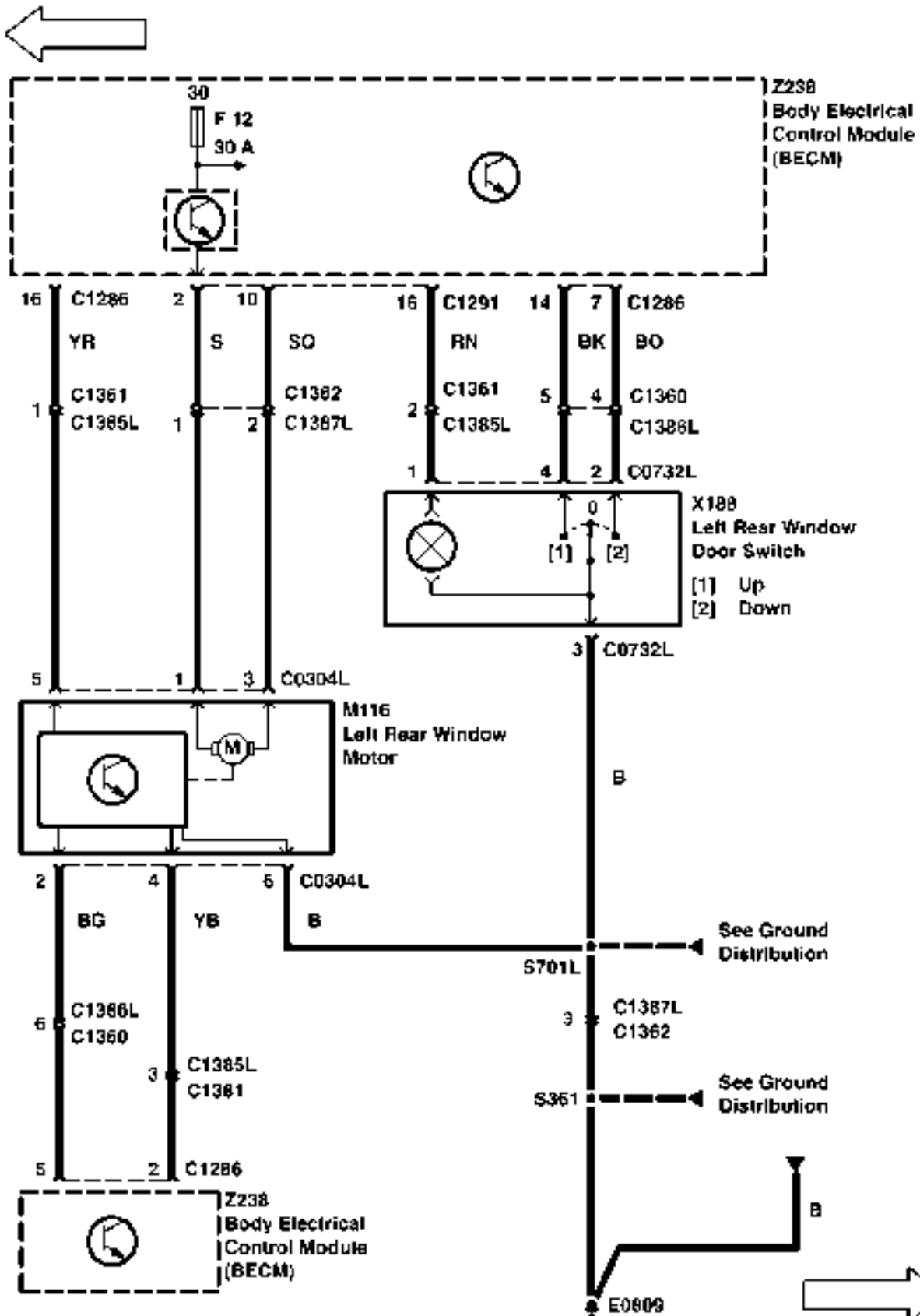

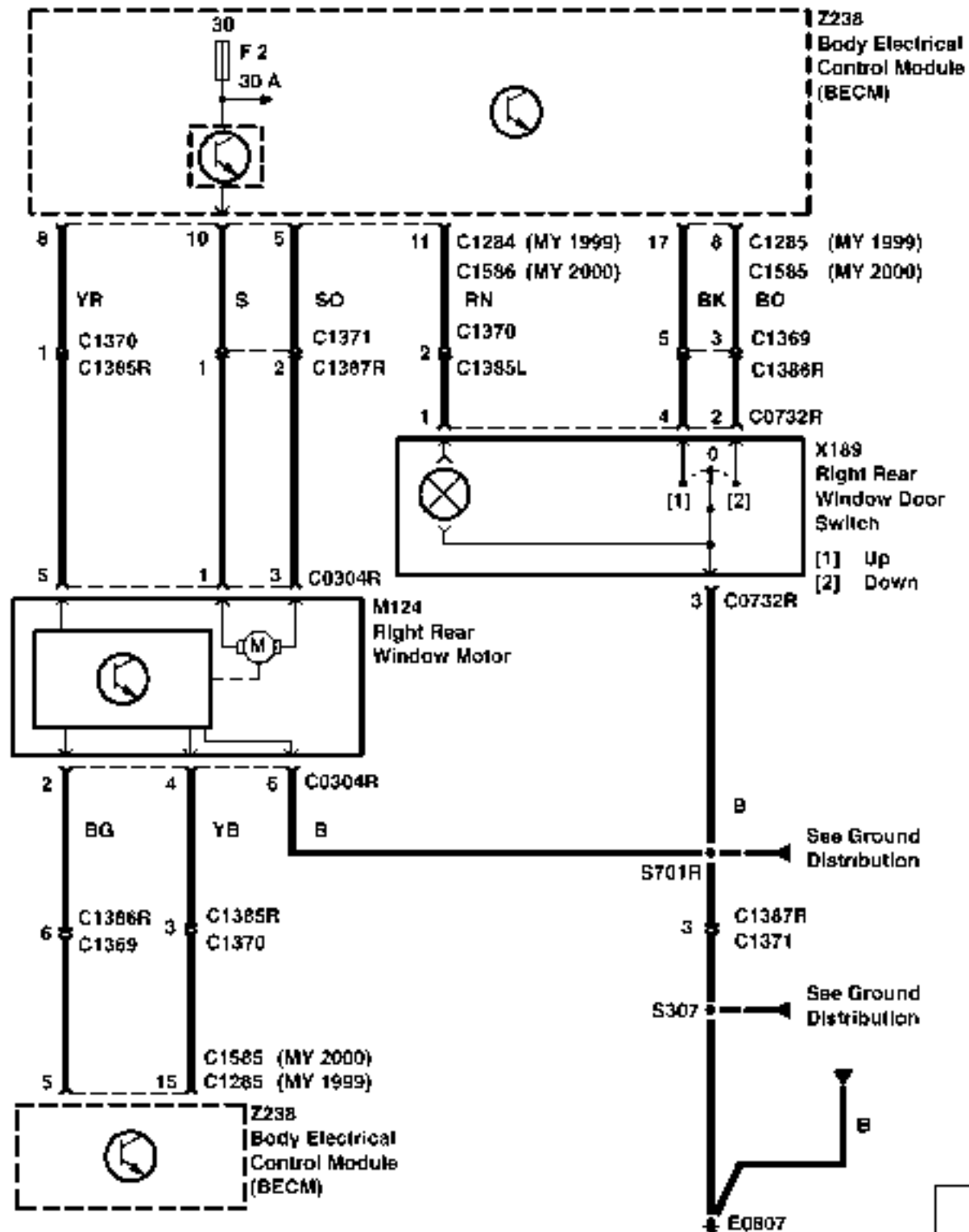
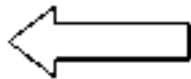

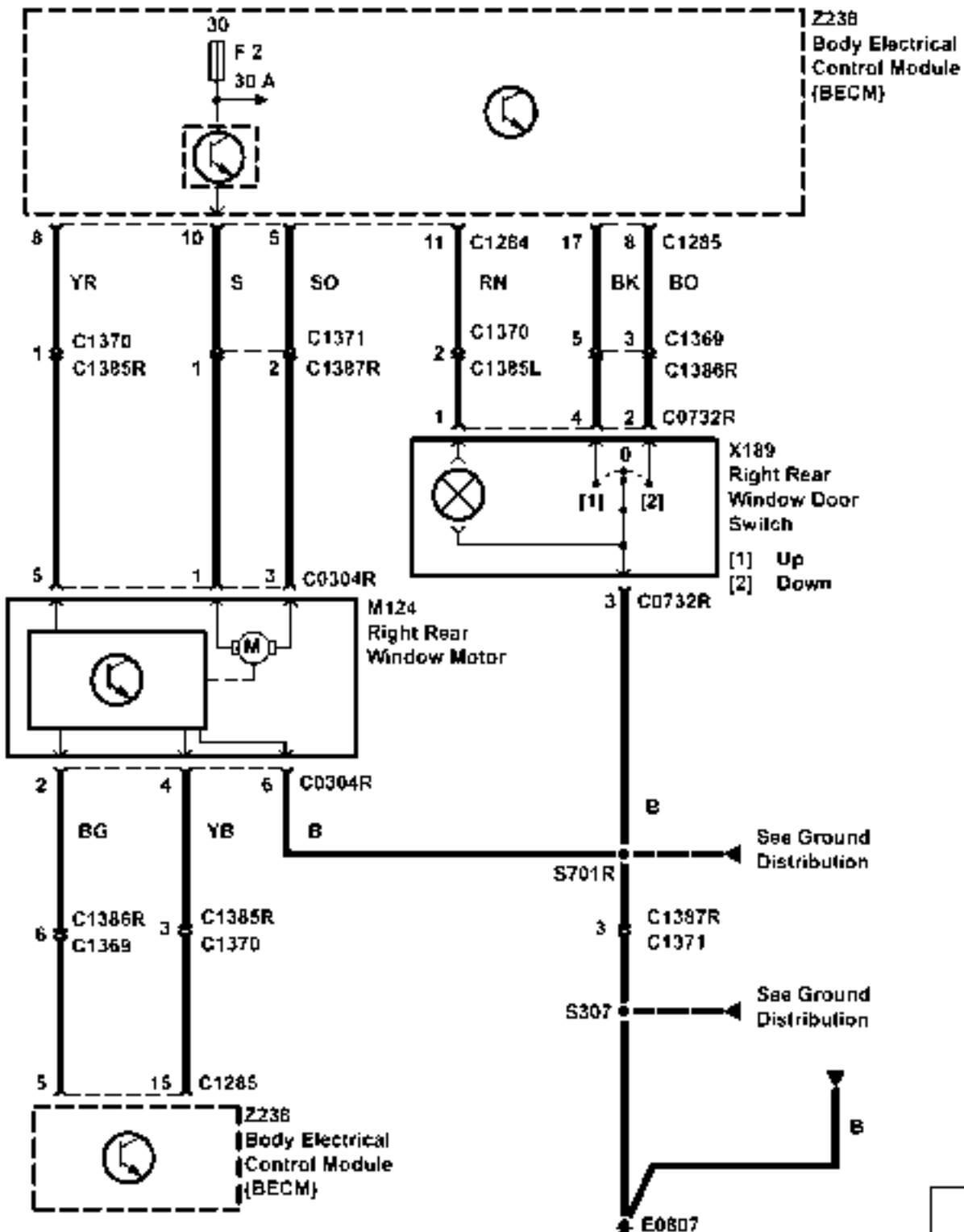
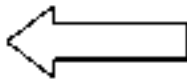

CIRCUIT OPERATION

The sunroof can operate in either slide or tilt mode. To change from one mode to the other, the sunroof must be in the closed position, the switch released and then repressed.

The sunroof functions will be active if the ignition is selected or for the first 45 seconds after it has been switched off provided that no door lock signal is received, in which case the timer will be cancelled.

The sunroof slide function will operate in one of two modes, one touch, or dead man's handle. One touch mode is initiated when the sunroof switch is operated for less than 400ms. Dead man's handle mode is initiated when the sunroof switch is operated for 400ms or more. Further operation of either sunroof switch during the one shot mode will cause the sunroof to stop operation.

The sunroof tilt function will operate in deadman's handle mode only.

There will be trap detection on sunroof close and on tilt close, but not on opening operations.

If a trap is detected whilst the sunroof is closing from the slide position then the sunroof will back off 20cm or until the motor stalls. If a trap is detected whilst the sunroof is closing from the tilt position then the sunroof will back off to the fully tilt open position. These conditions will also activate a message on the instrument pack which will be accompanied by three audible beeps.

With the sunroof in the closed or partially tilted open position, operation of the sunroof forward switch will cause the roof to operate in the tilt open direction. This will continue until the switch is released, or until a stall condition is detected.

If the sunroof back switch is operated while the sunroof is in the tilt open position, the roof will operate in the tilt close direction. This will continue until the switch is released, a trap is detected or until the sunroof is in the closed position.

If the sunroof back switch is operated with the sunroof in the closed or partially open position, the sunroof will operate in the open direction. This movement will continue until the switch is released (unless in the one touch mode), the sunroof forward switch is operated, or a stall condition is detected.

With the sunroof in an open position, operation of the sunroof forward switch will cause the sunroof to operate in the close direction. This will continue until the switch is released (unless in the one touch mode), the sunroof back switch is operated, a trap is

detected, or until the sunroof is in the fully closed position.

The heated rear window will be inhibited for the duration of any sunroof operation.

Market Deviations

USA/Canada The system will only be active when the auxiliary or ignition feeds are on, or for the time between switching the ignition feed off and opening either of the front doors.

Australia the system will only be active when the ignition switch is in the auxiliary, the ignition or the crank position, or for 45 seconds after the key is removed from the ignition switch.

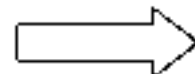
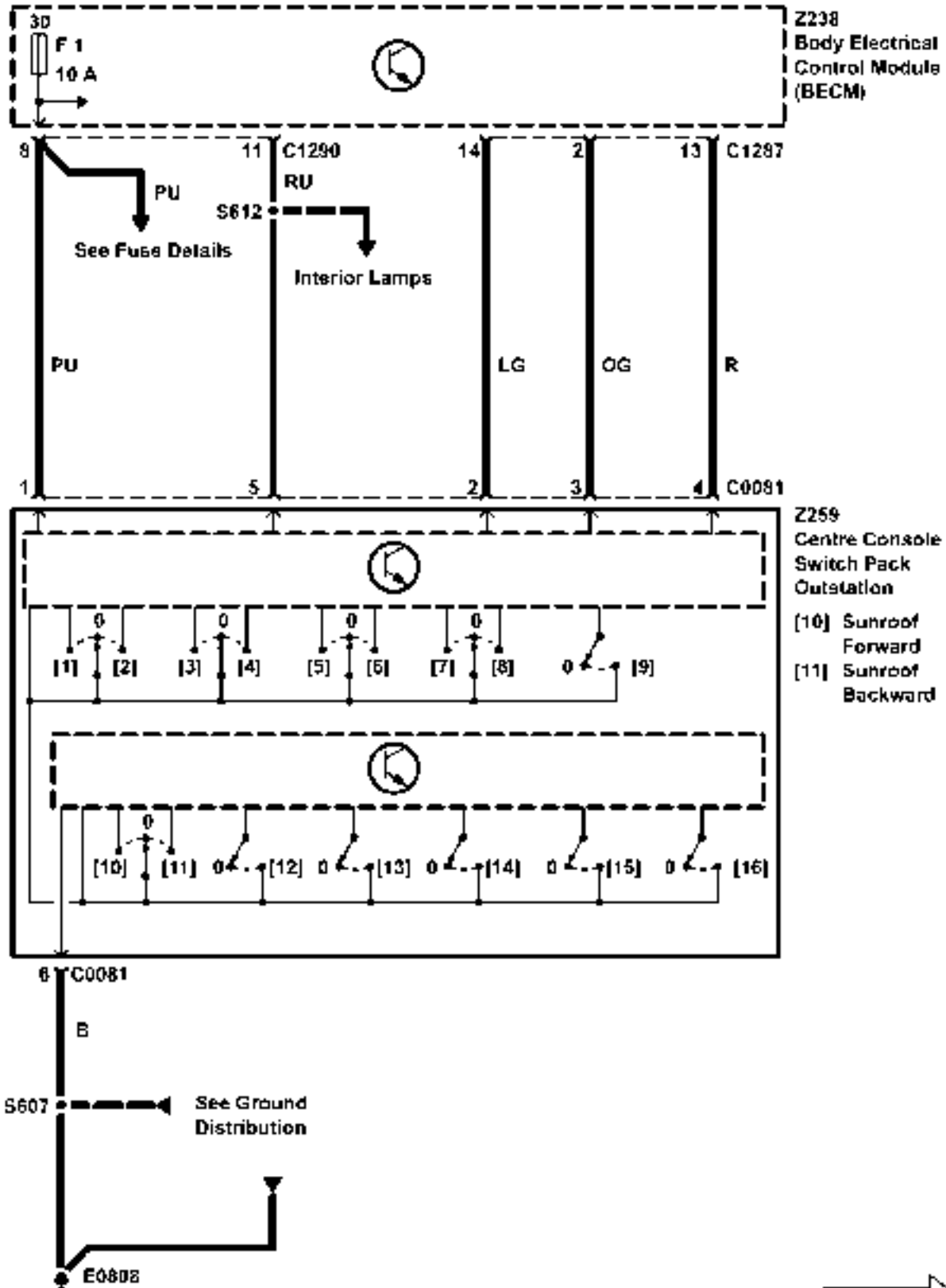

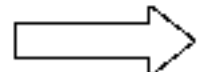
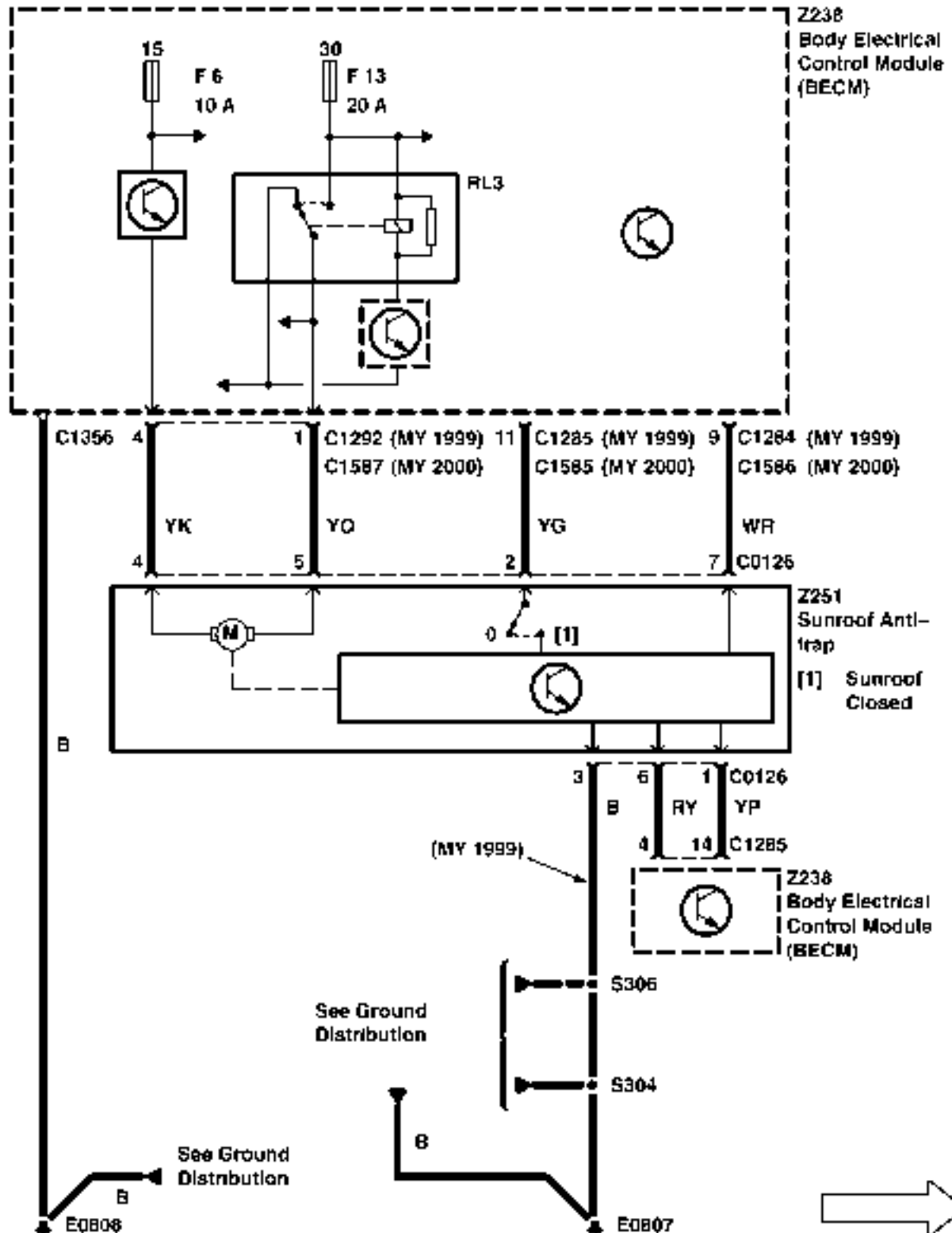

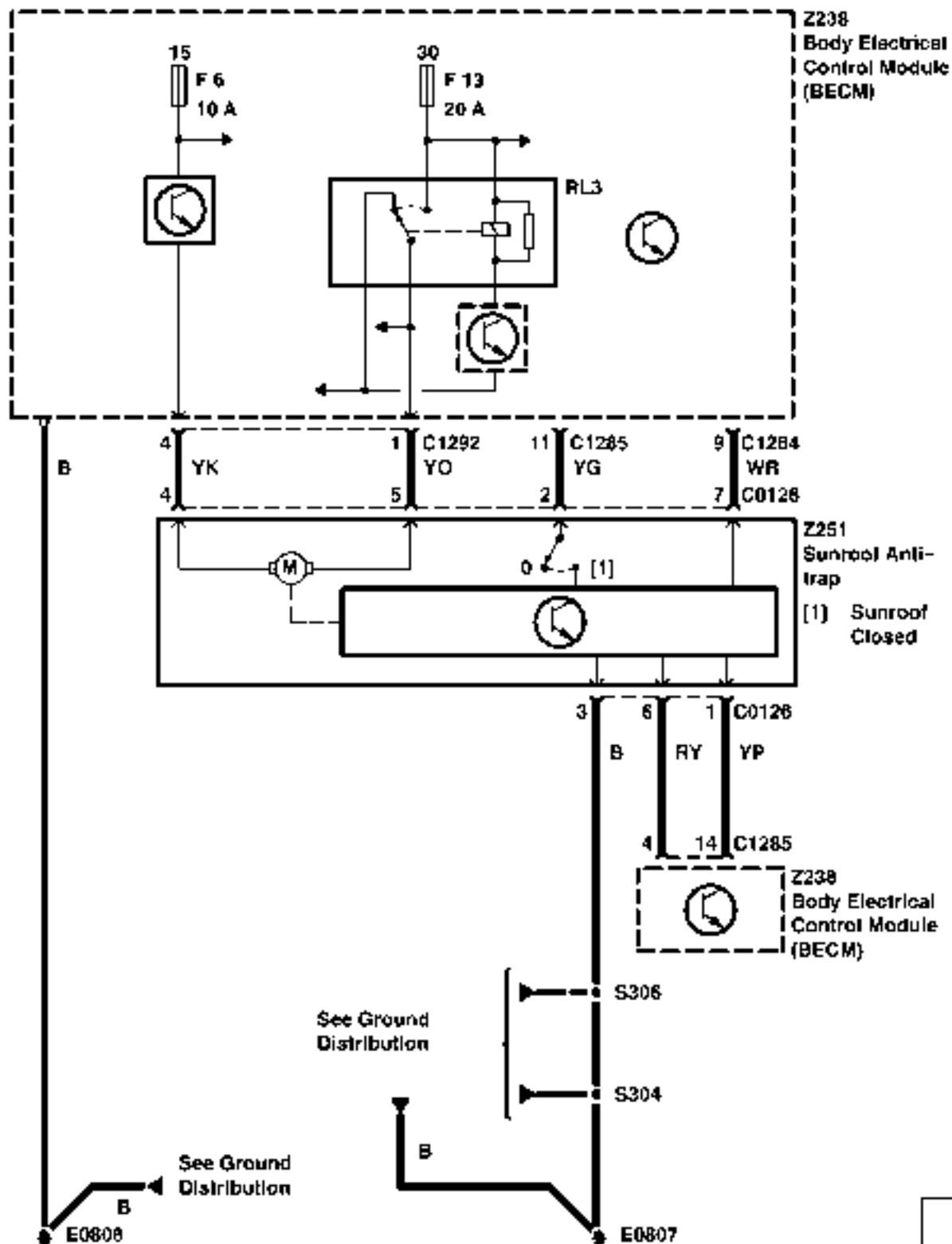
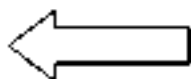

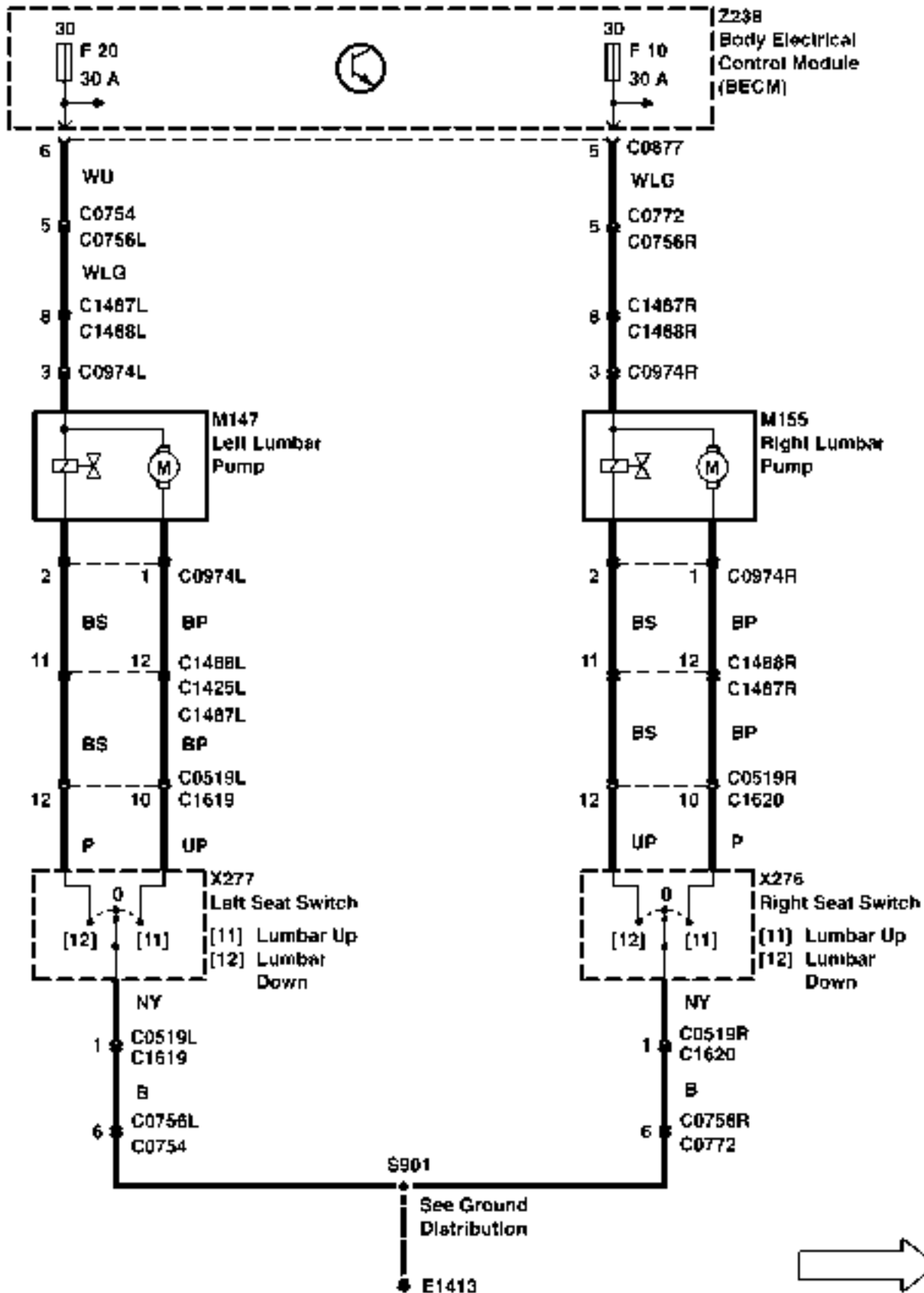

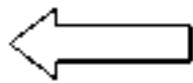

Power Seats
(Left)

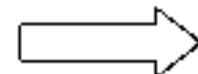
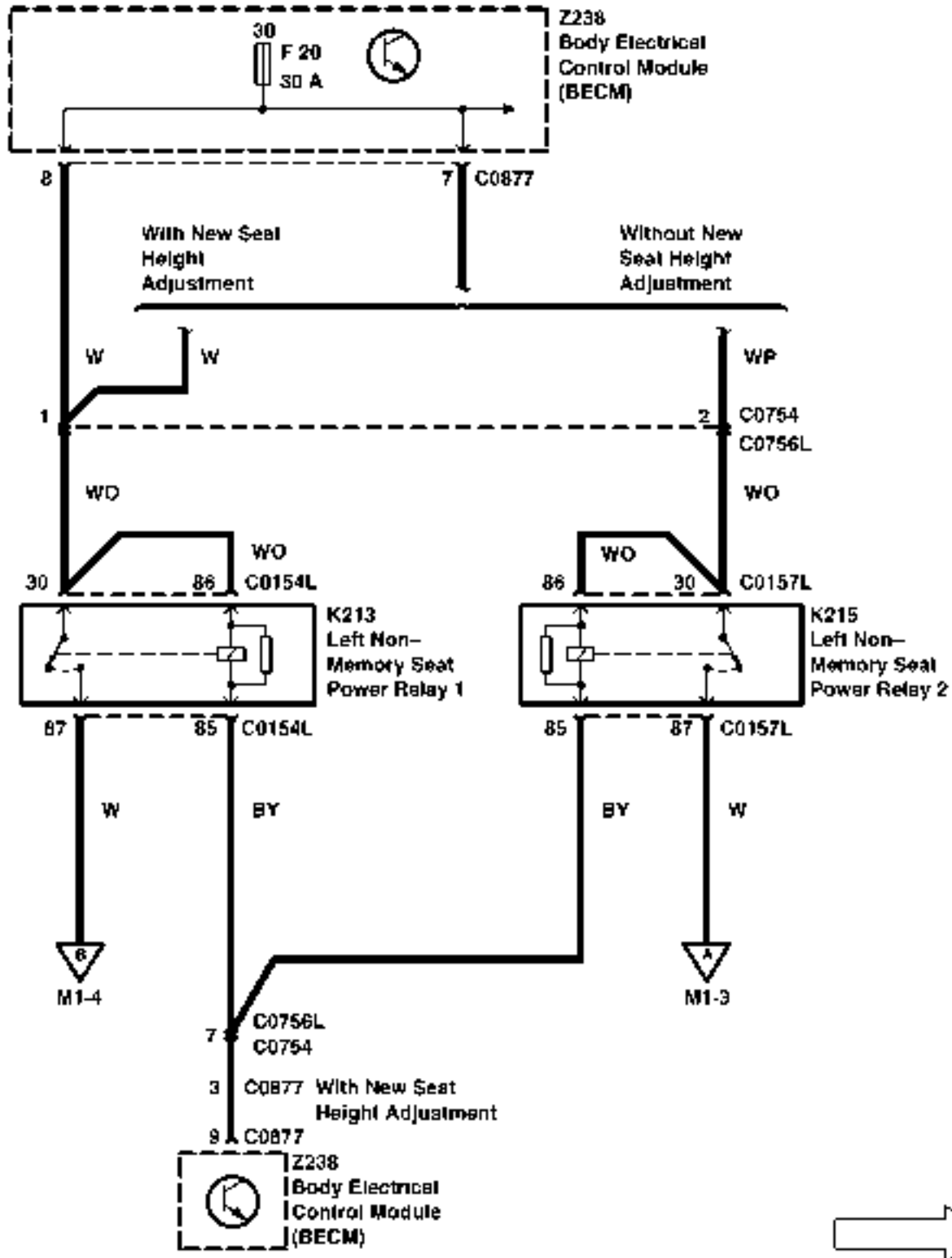



Power Seats
(Left)

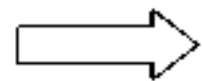
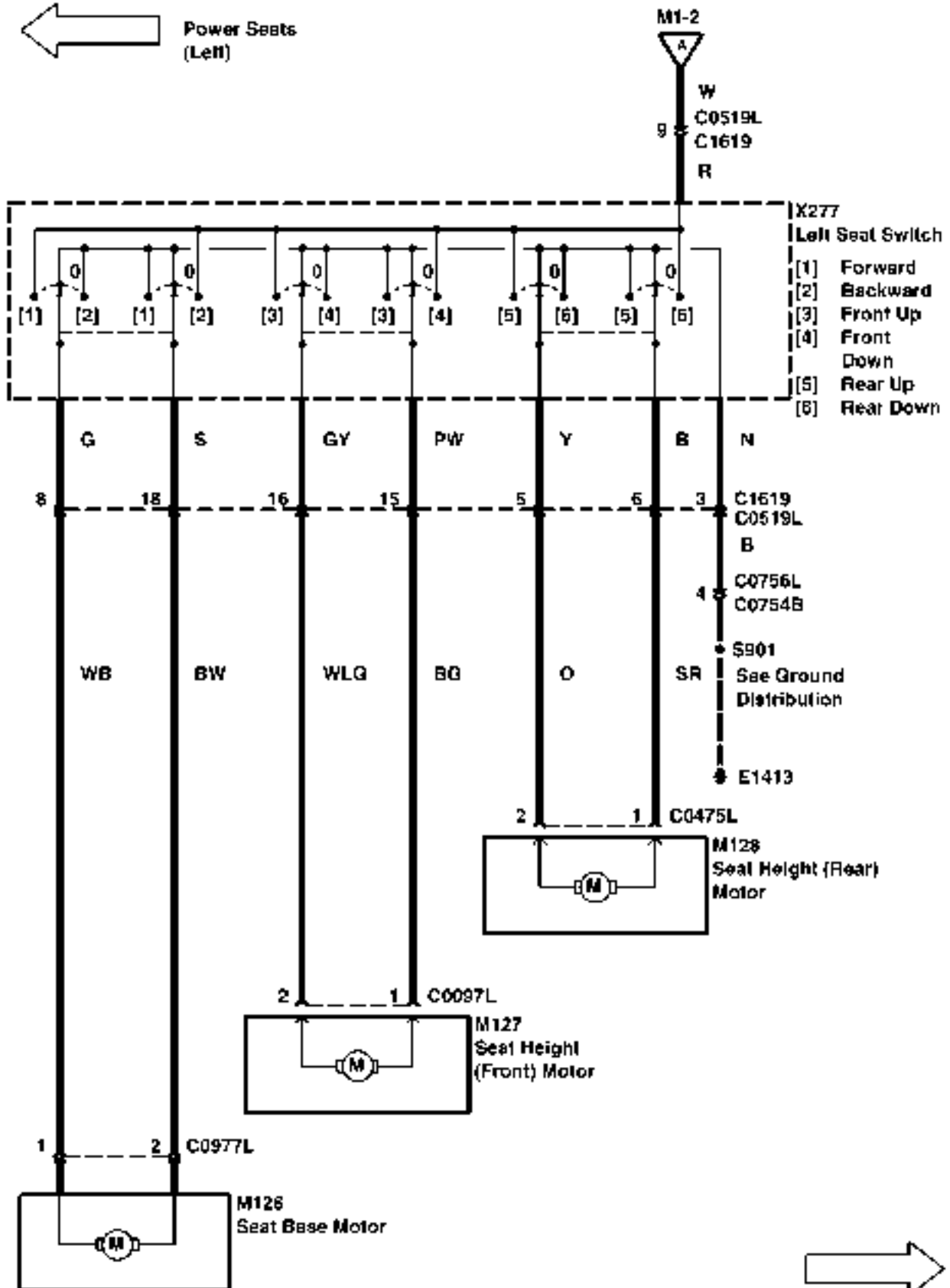

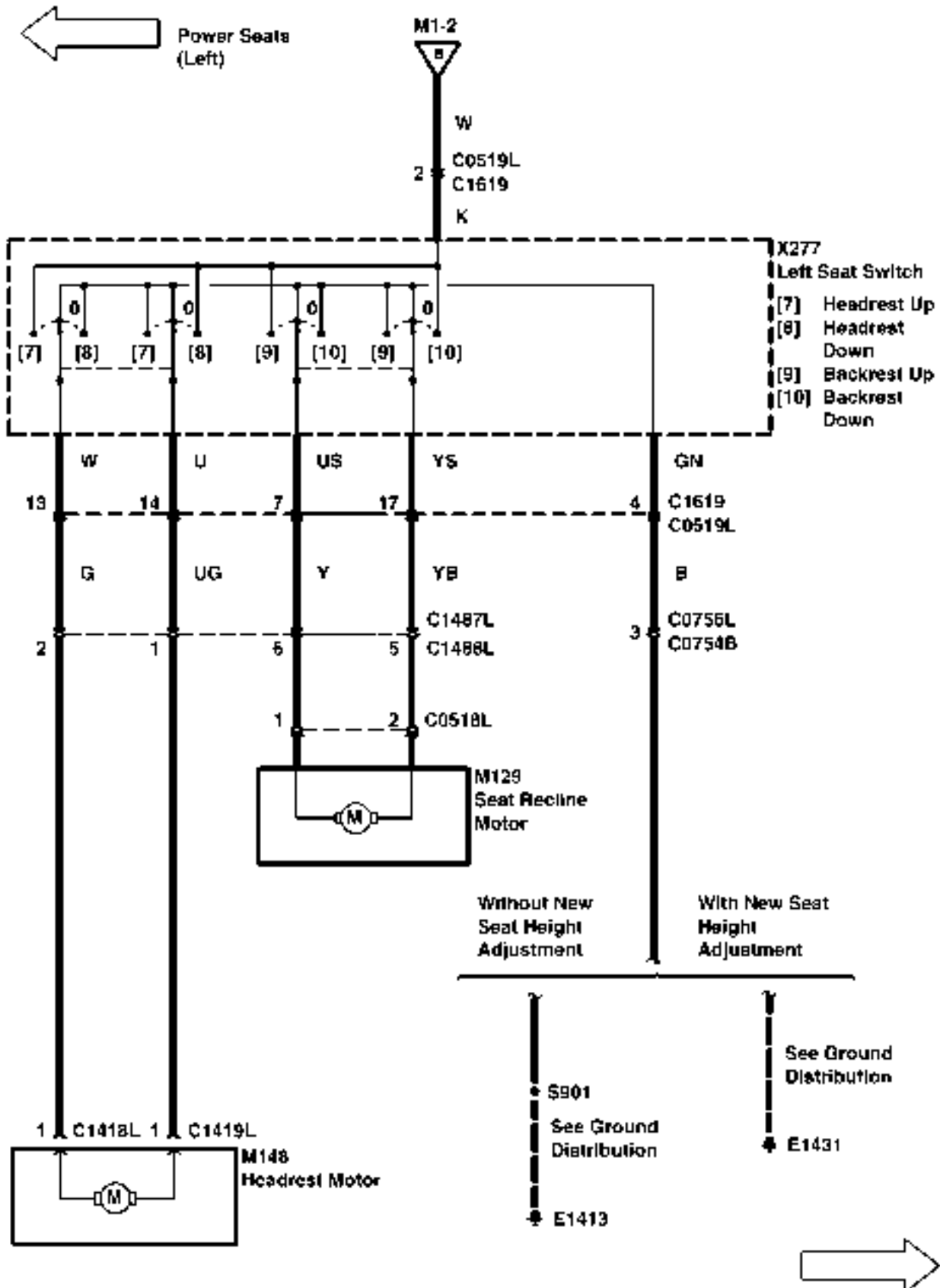

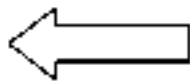

Power Seats
(Right)

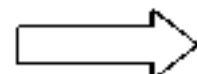
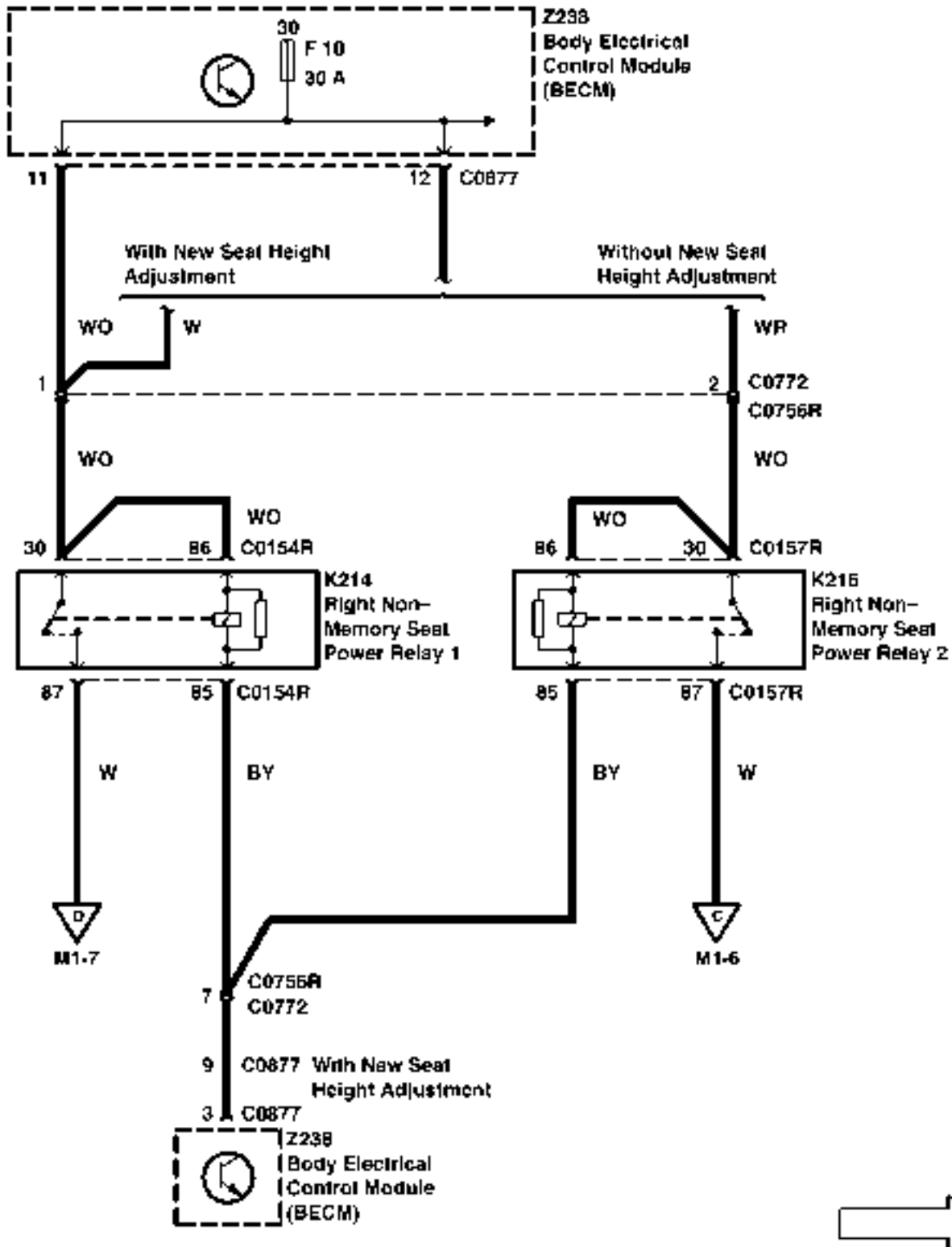

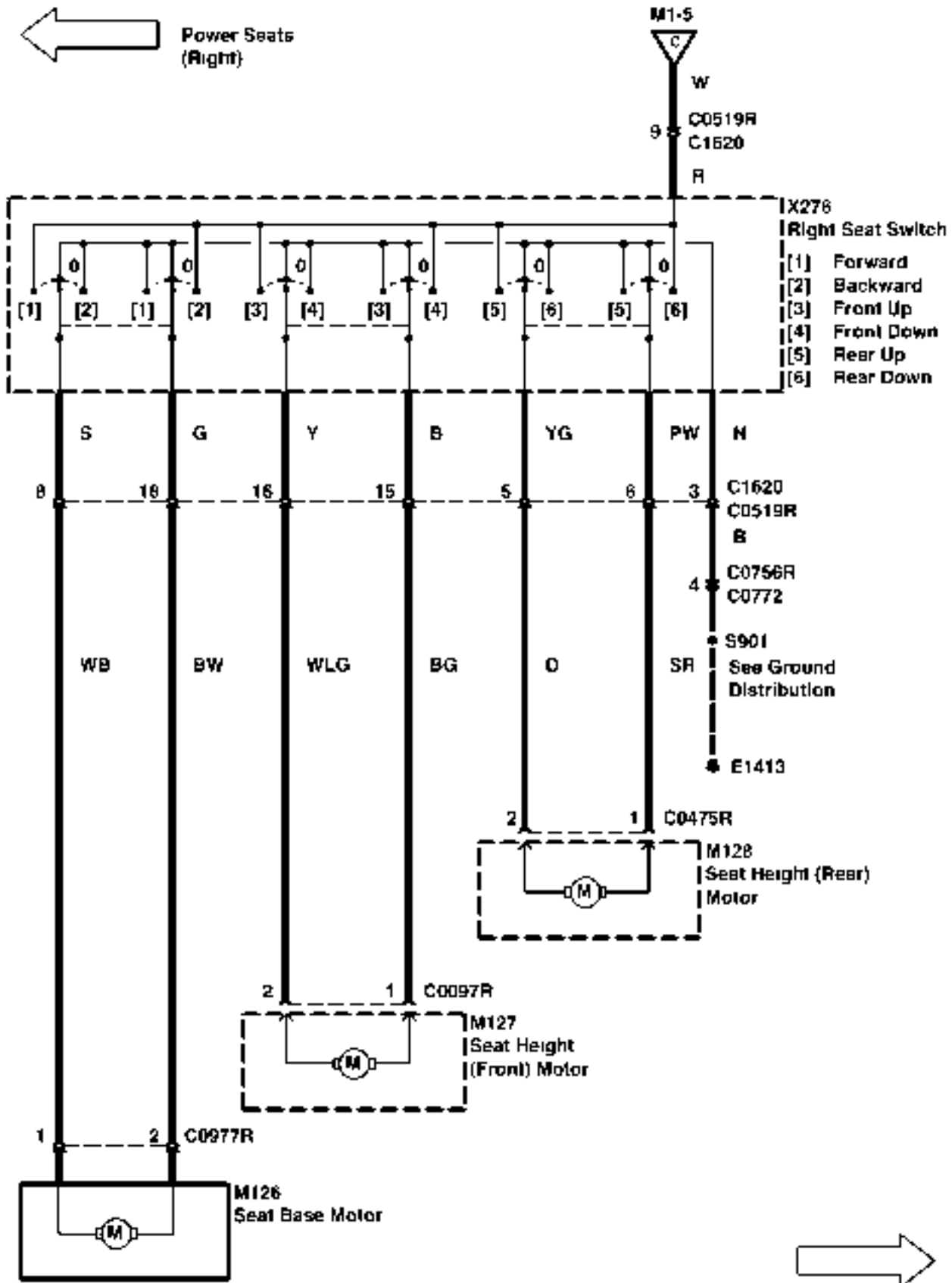

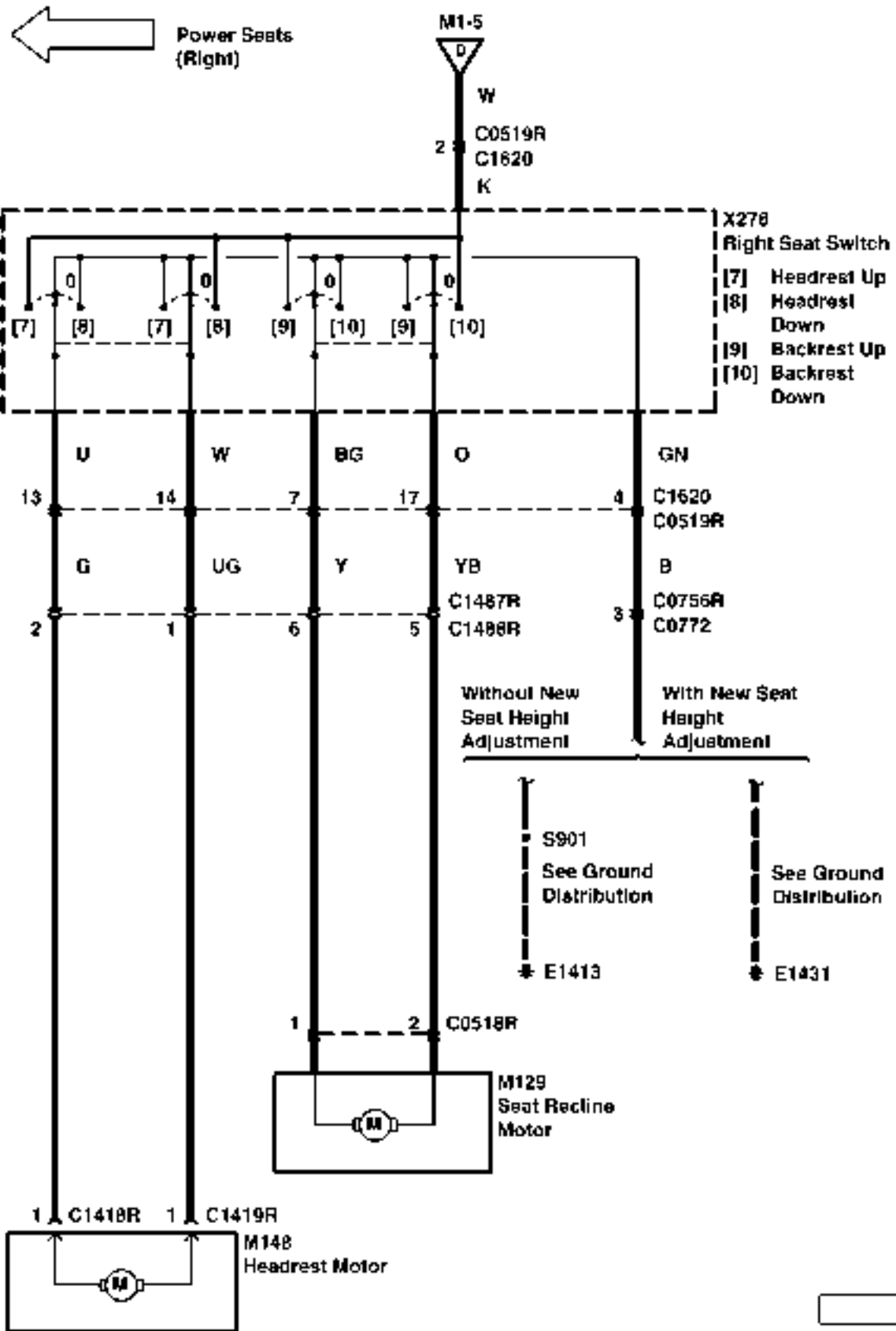

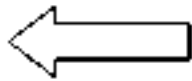

Seat Height
Adjuster

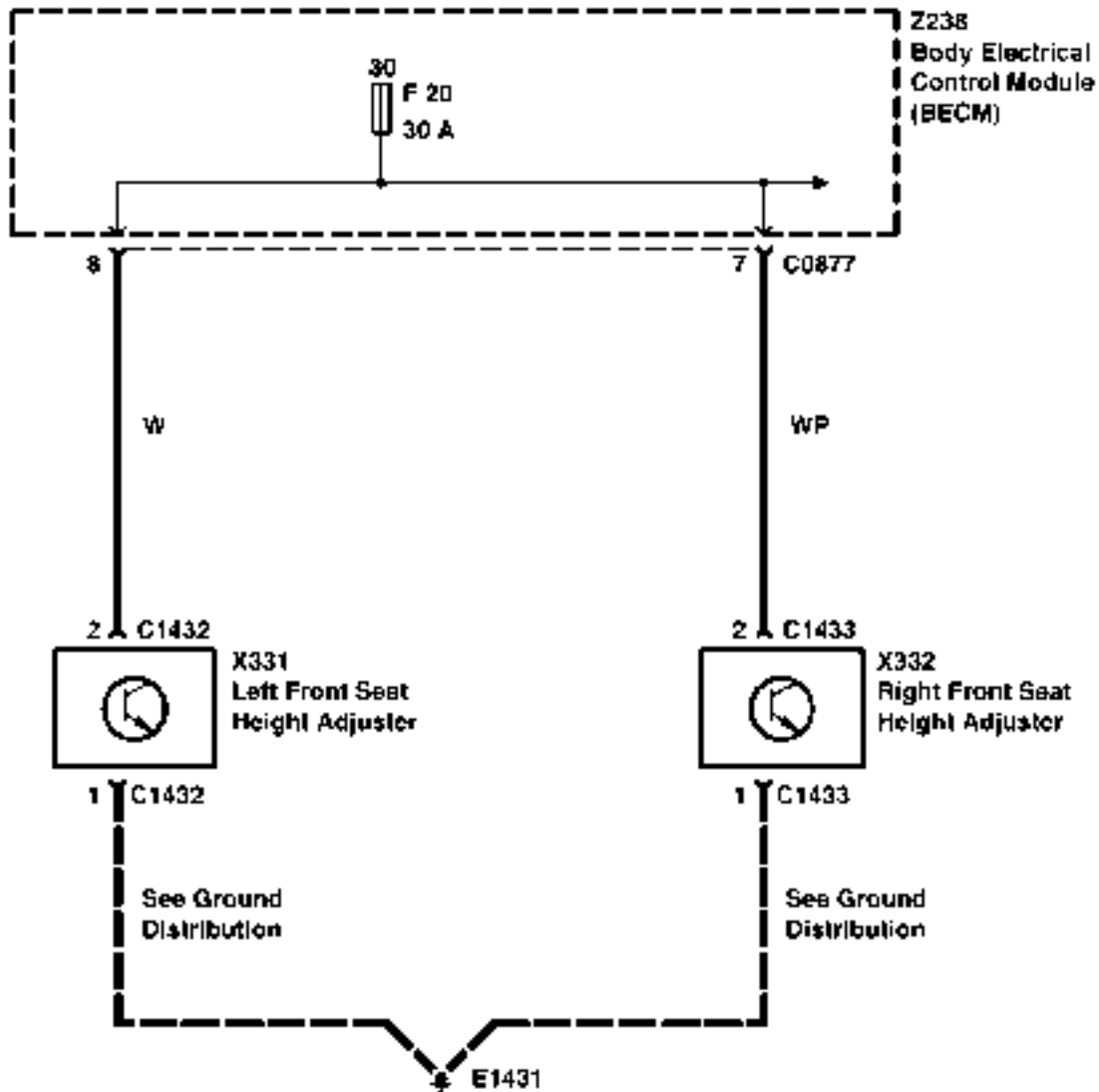

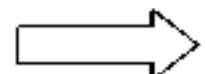
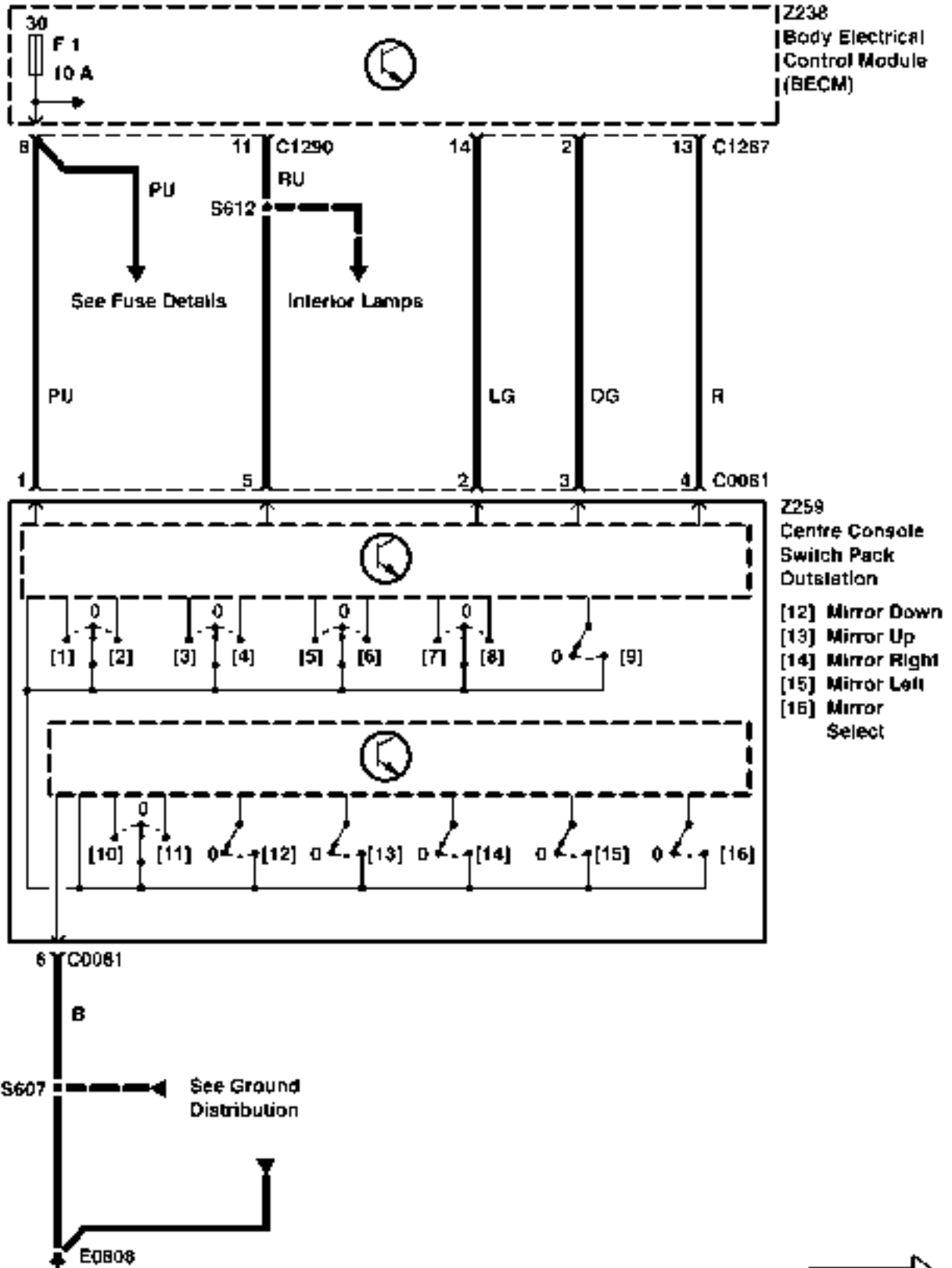

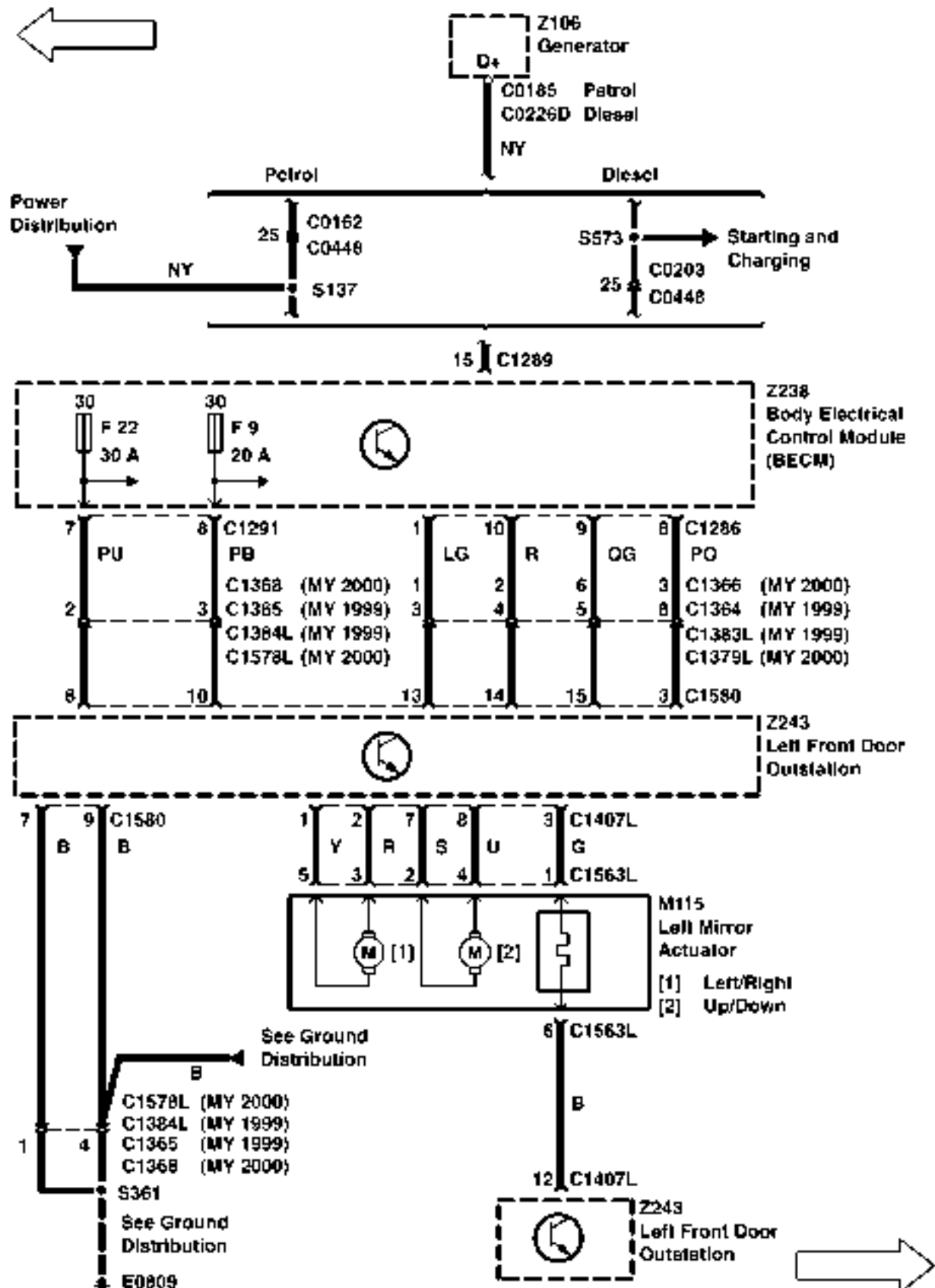

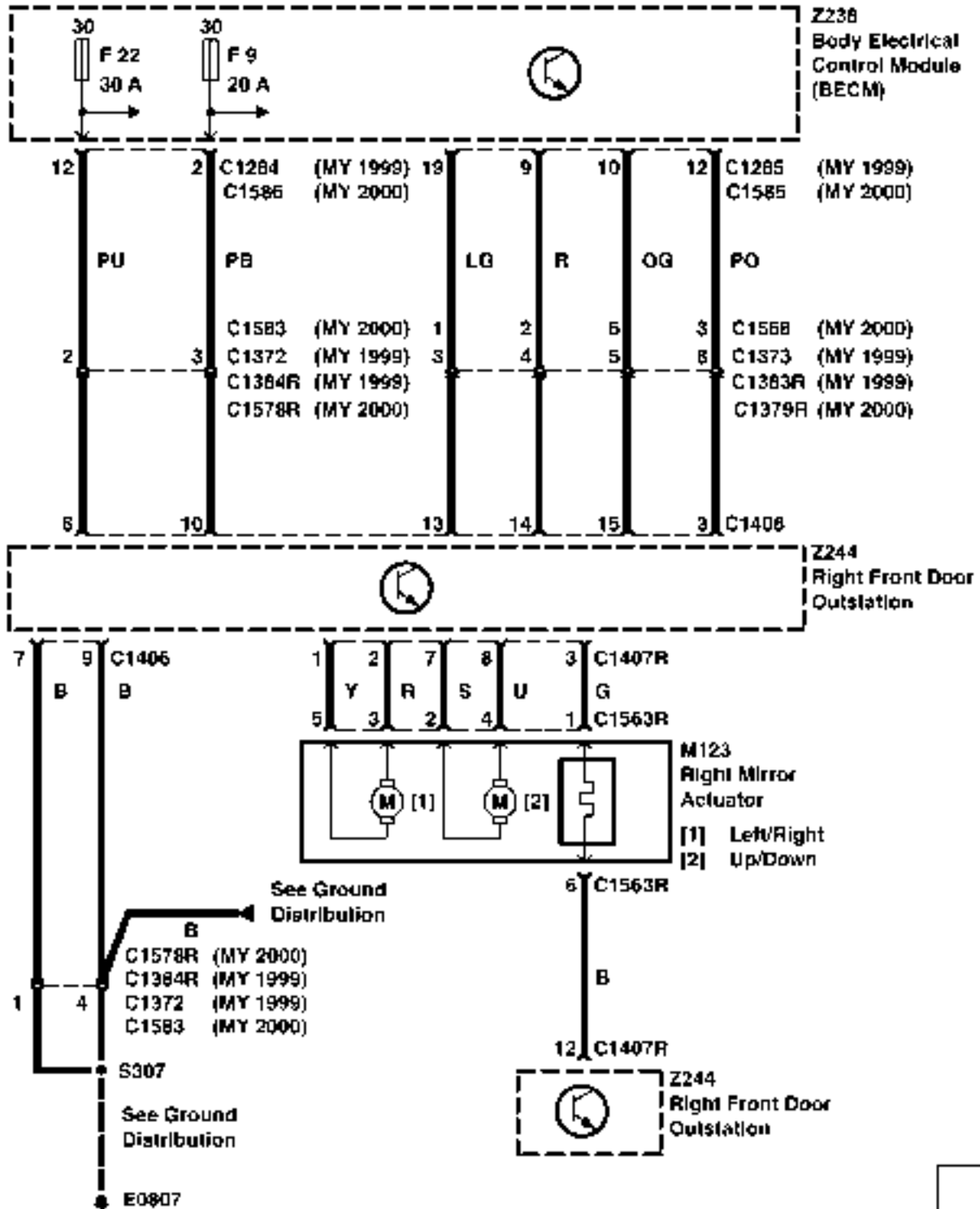
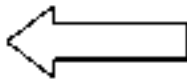

CIRCUIT DIAGRAMS

- Circuit diagrams are arranged so that current flow is from the top of the diagram (current source) to the bottom of the diagram (ground).
- Only those components that work together in the circuit are shown. If only part of a component is used in the circuit, then only that part of the component is shown.
- Remember:



TERMINAL NUMBER	DESIGNATION
50	Battery voltage: Ignition Switch in position III
30	Battery voltage: supplied constantly
15	Battery voltage: Ignition Switch in position II or III
R	Battery voltage: Ignition Switch in positions I, II
31	Ground

See Introduction (I) for additional circuit diagram symbols.

DIAGNOSIS

- If the diagram is accompanied by text:
 - Read the Circuit Operation before proceeding with the electrical diagnosis.
 - Read the Troubleshooting Hints before performing the System Diagnosis.
 - Tests follow the System Diagnosis
 - When performing the System Diagnosis, be certain that all components disconnected in previous steps are reconnected unless otherwise directed.

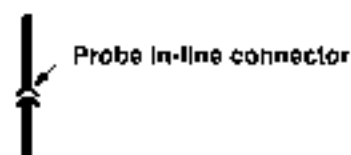
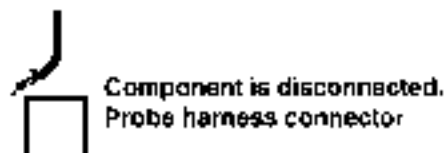
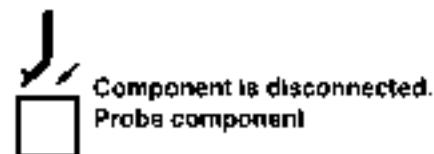
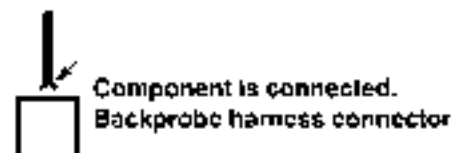
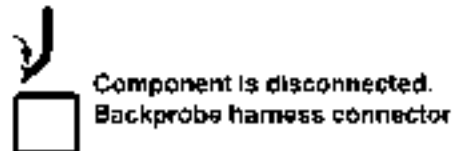

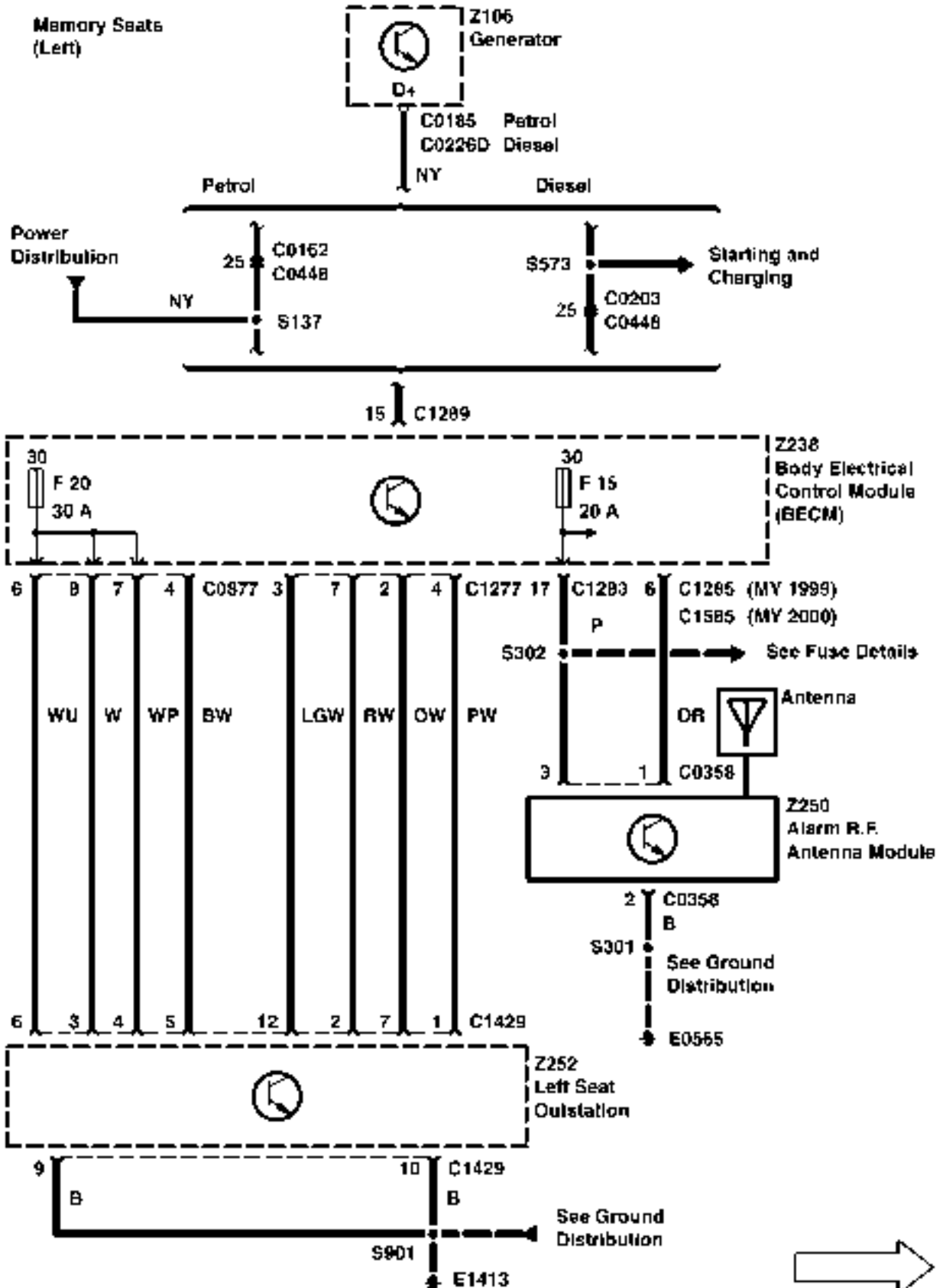



Memory Seats (Left)

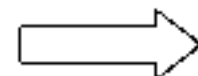
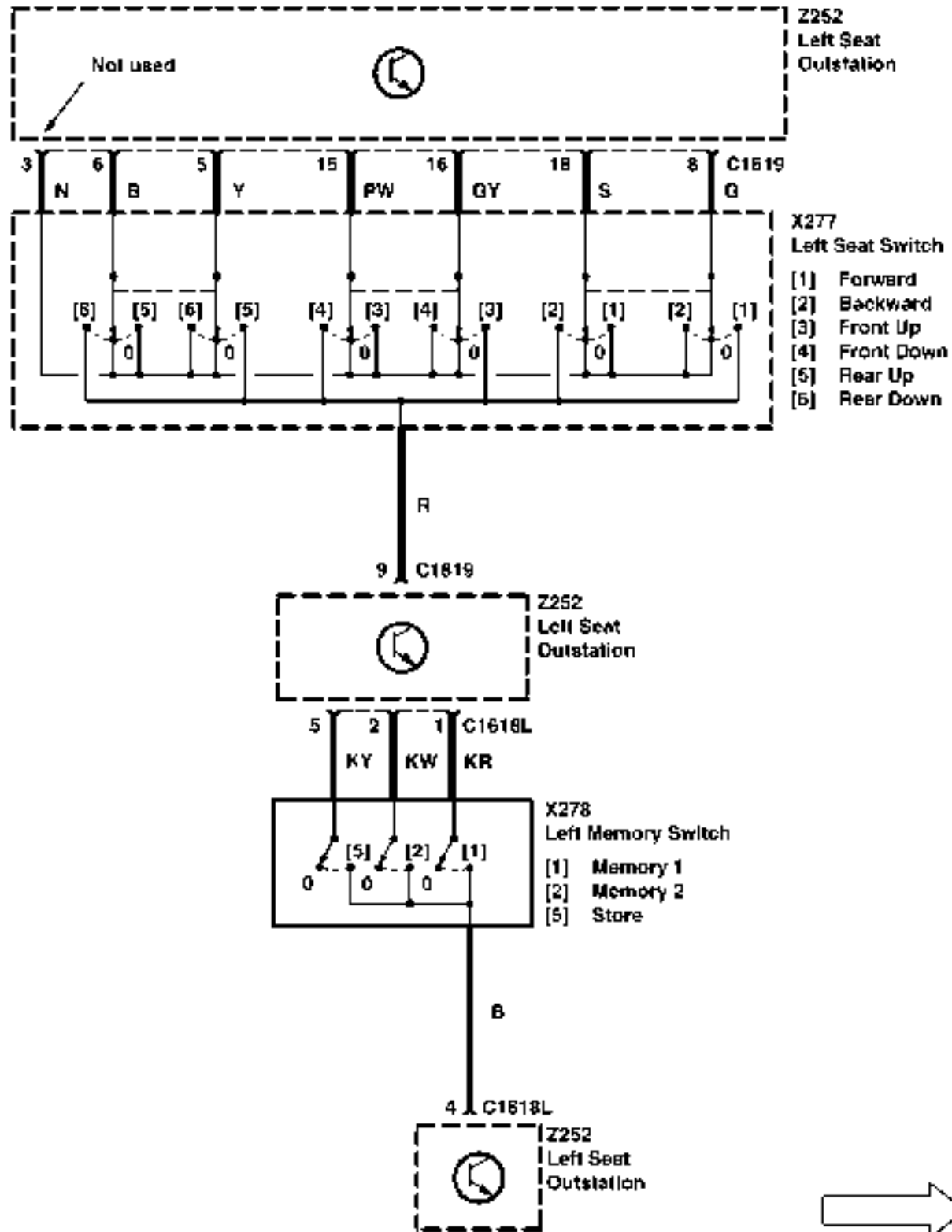

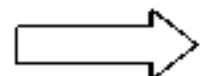
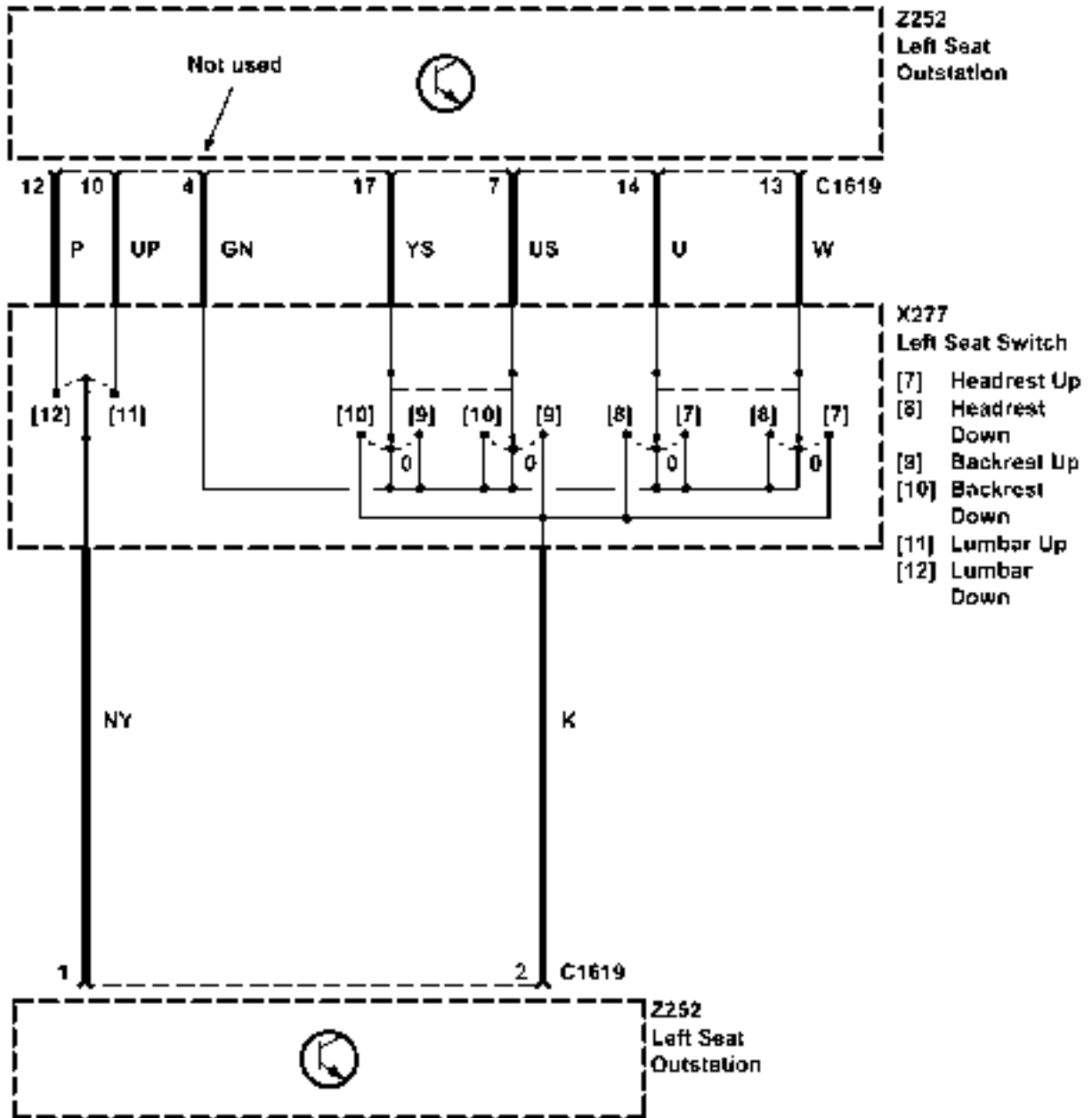

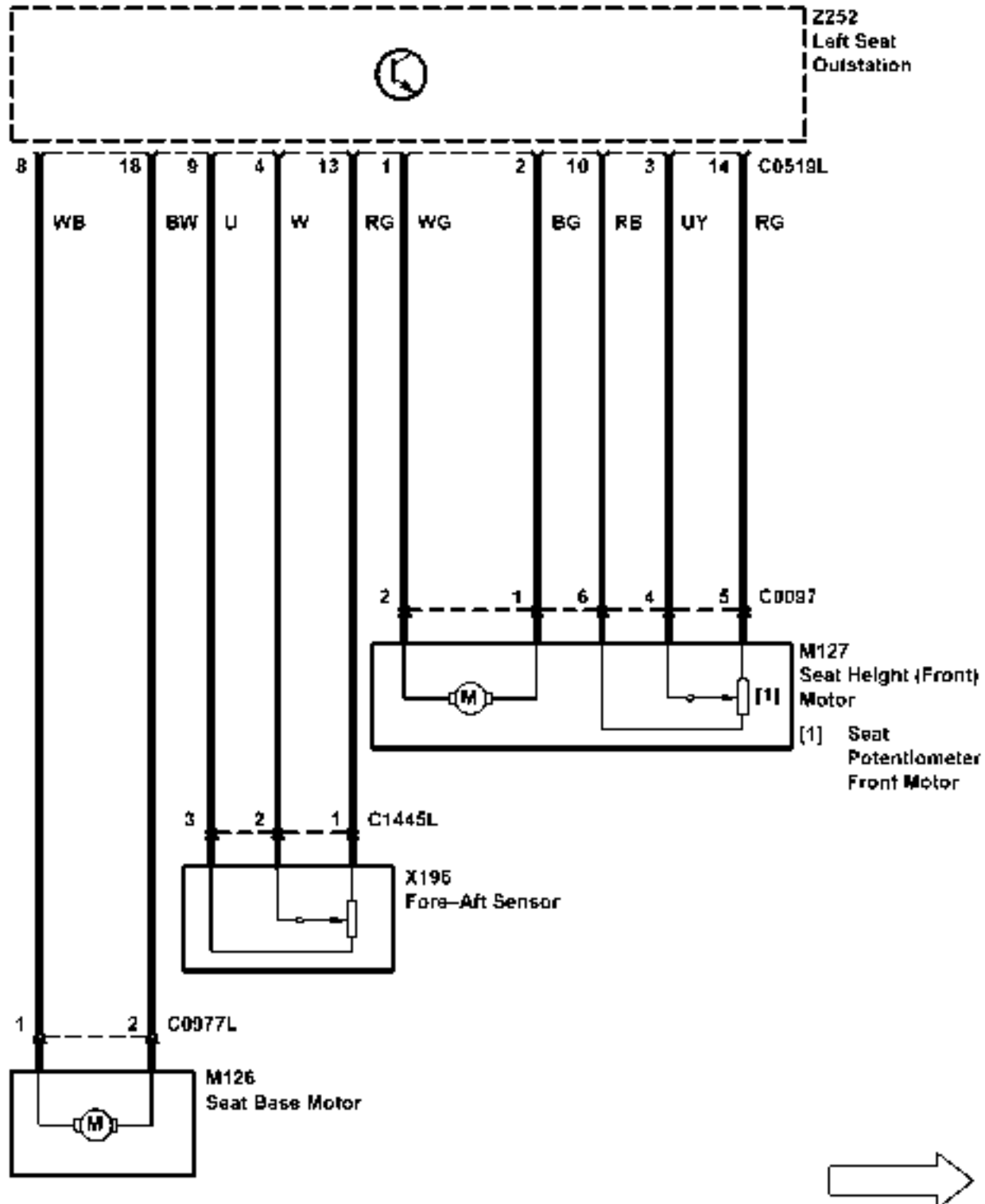

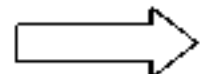
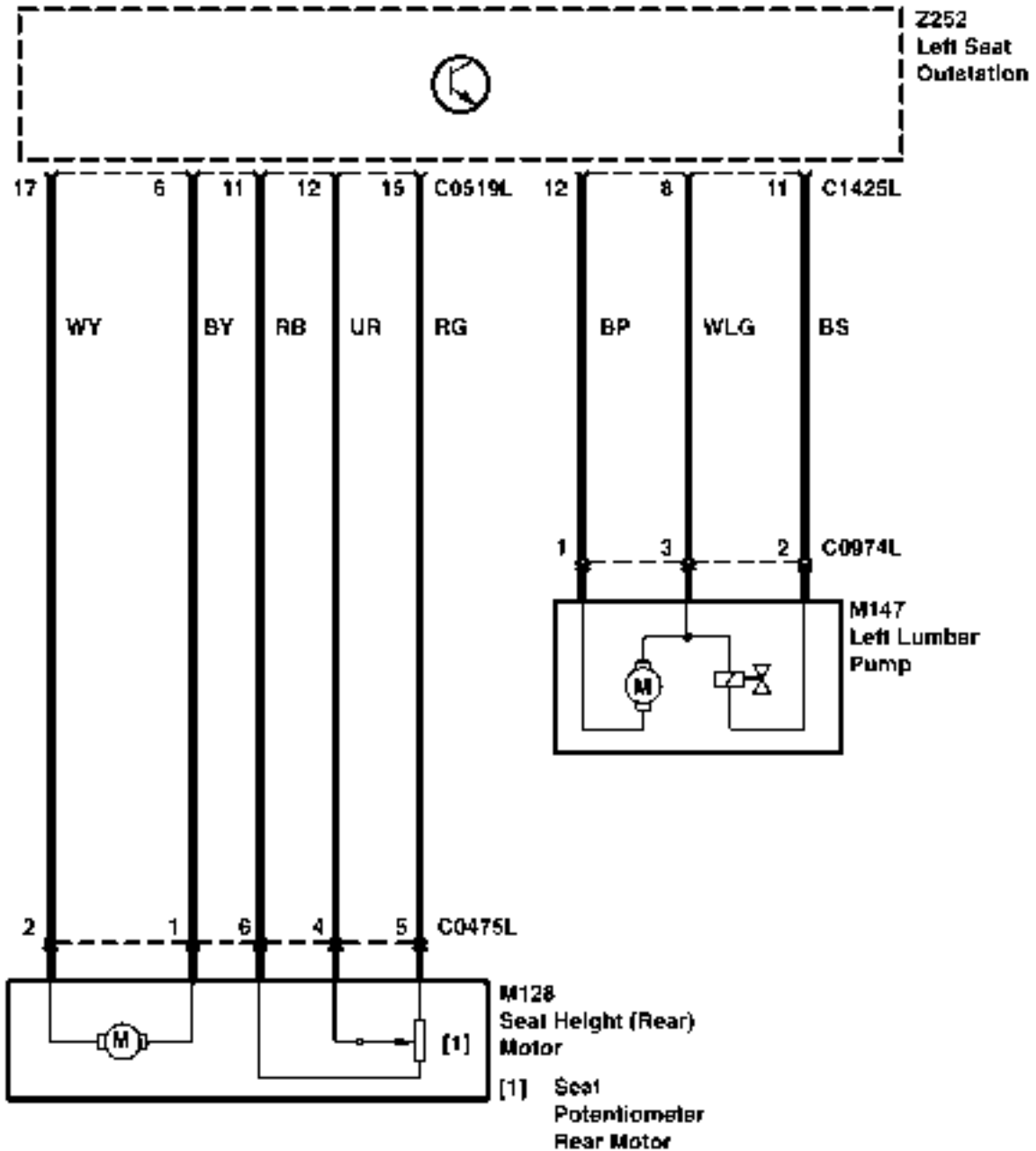

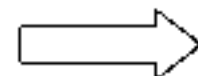
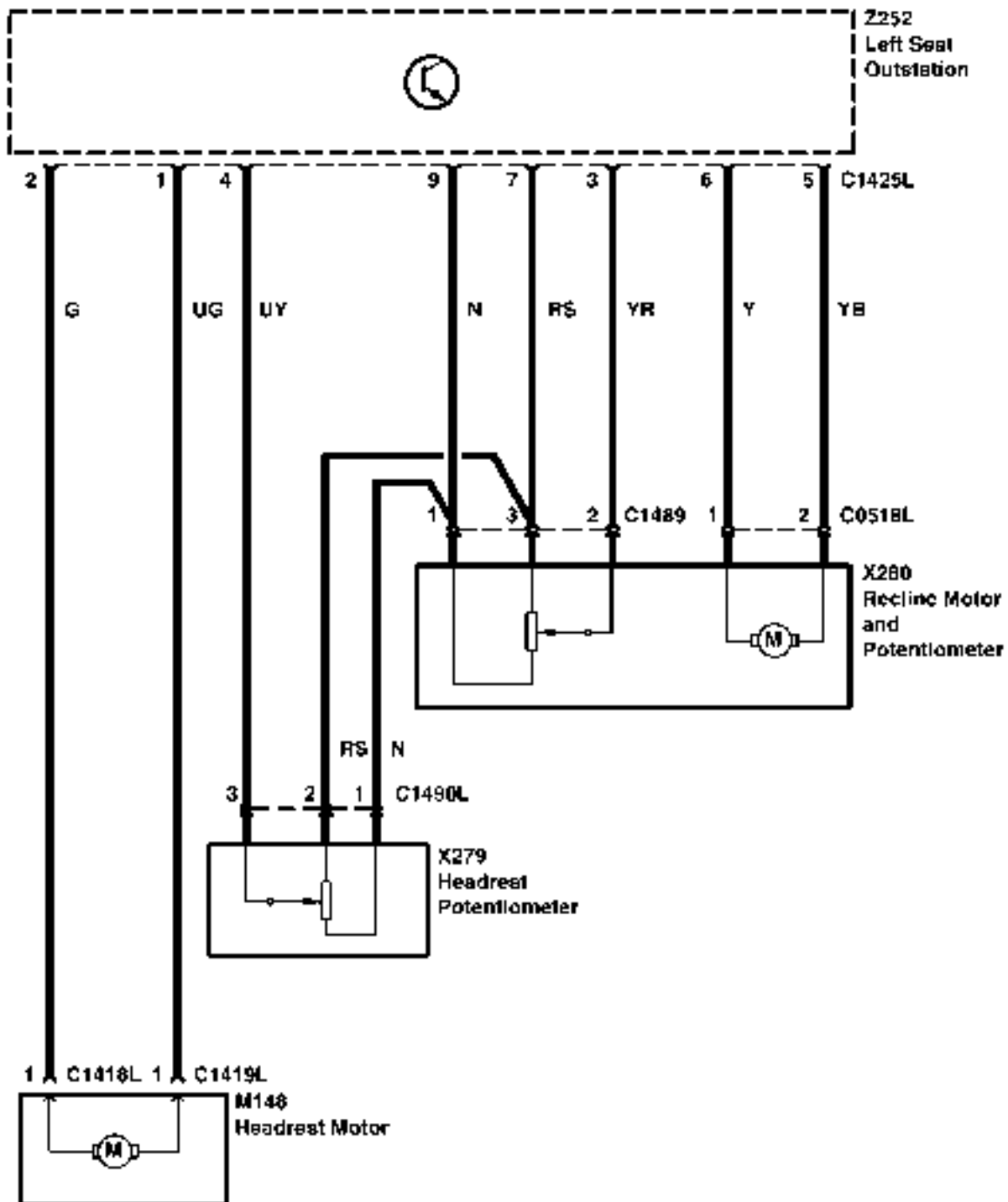

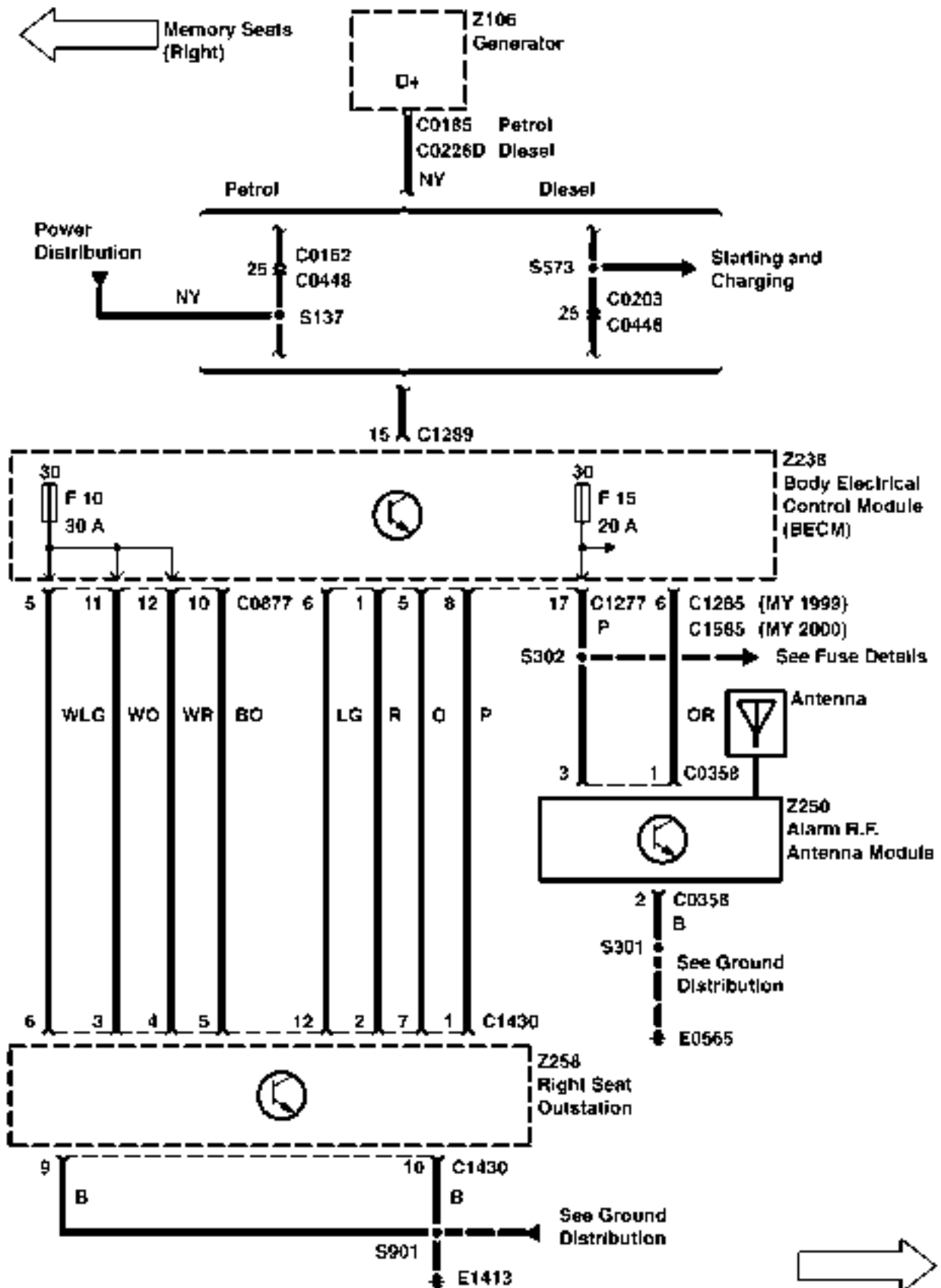

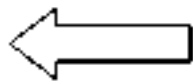

Memory Seats (Right)

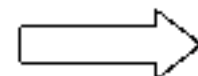
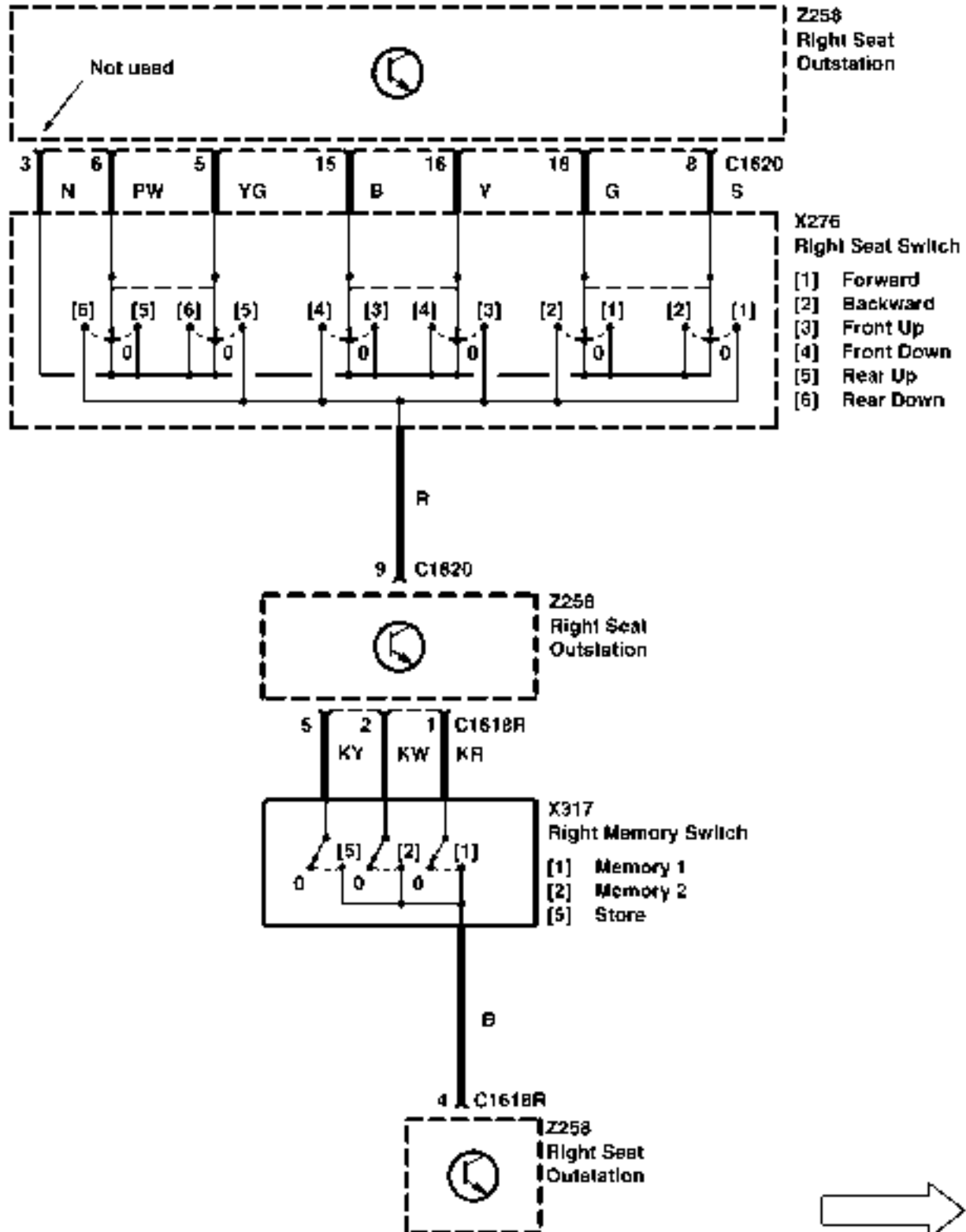

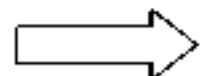
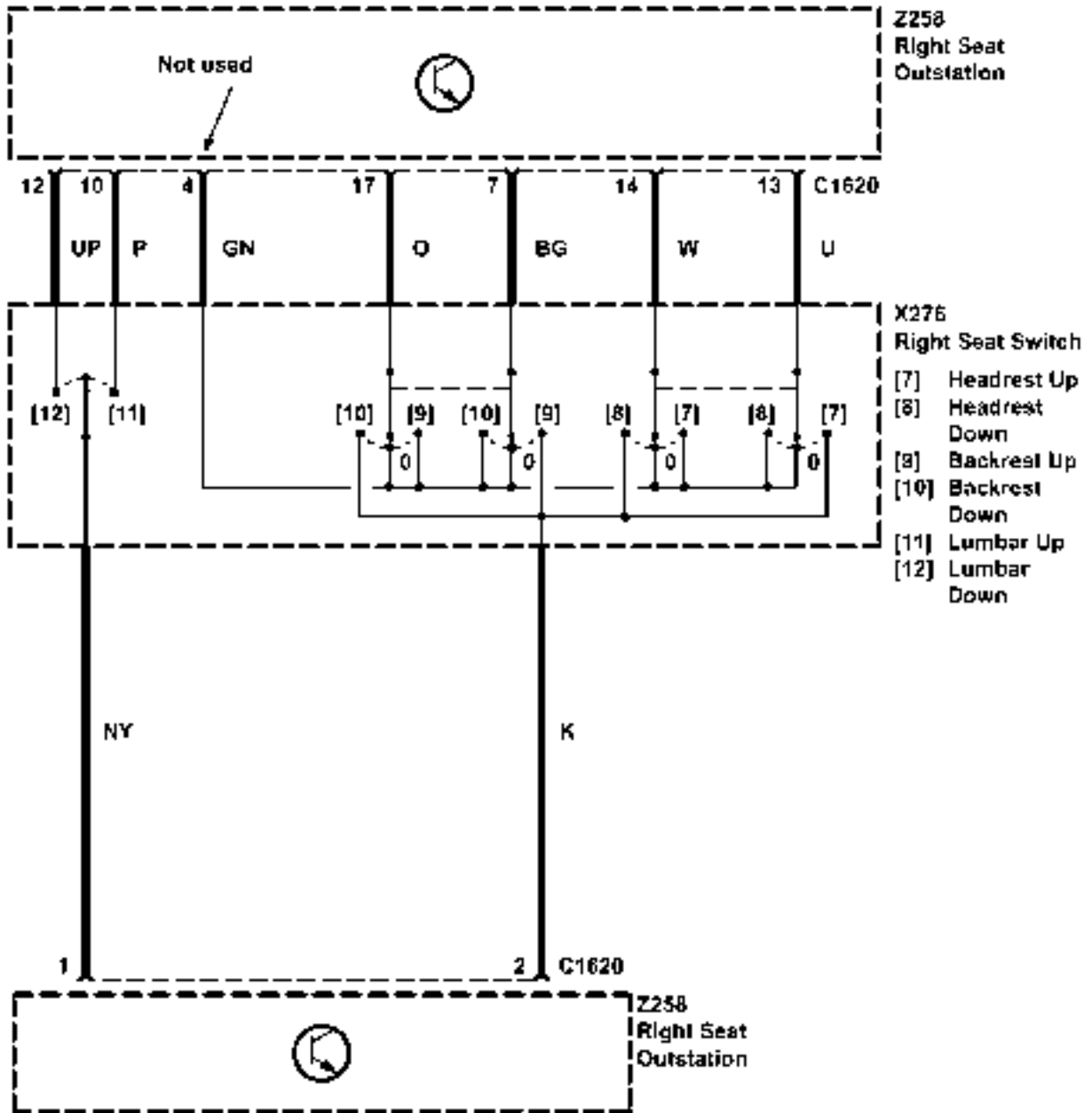

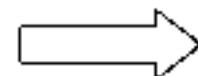
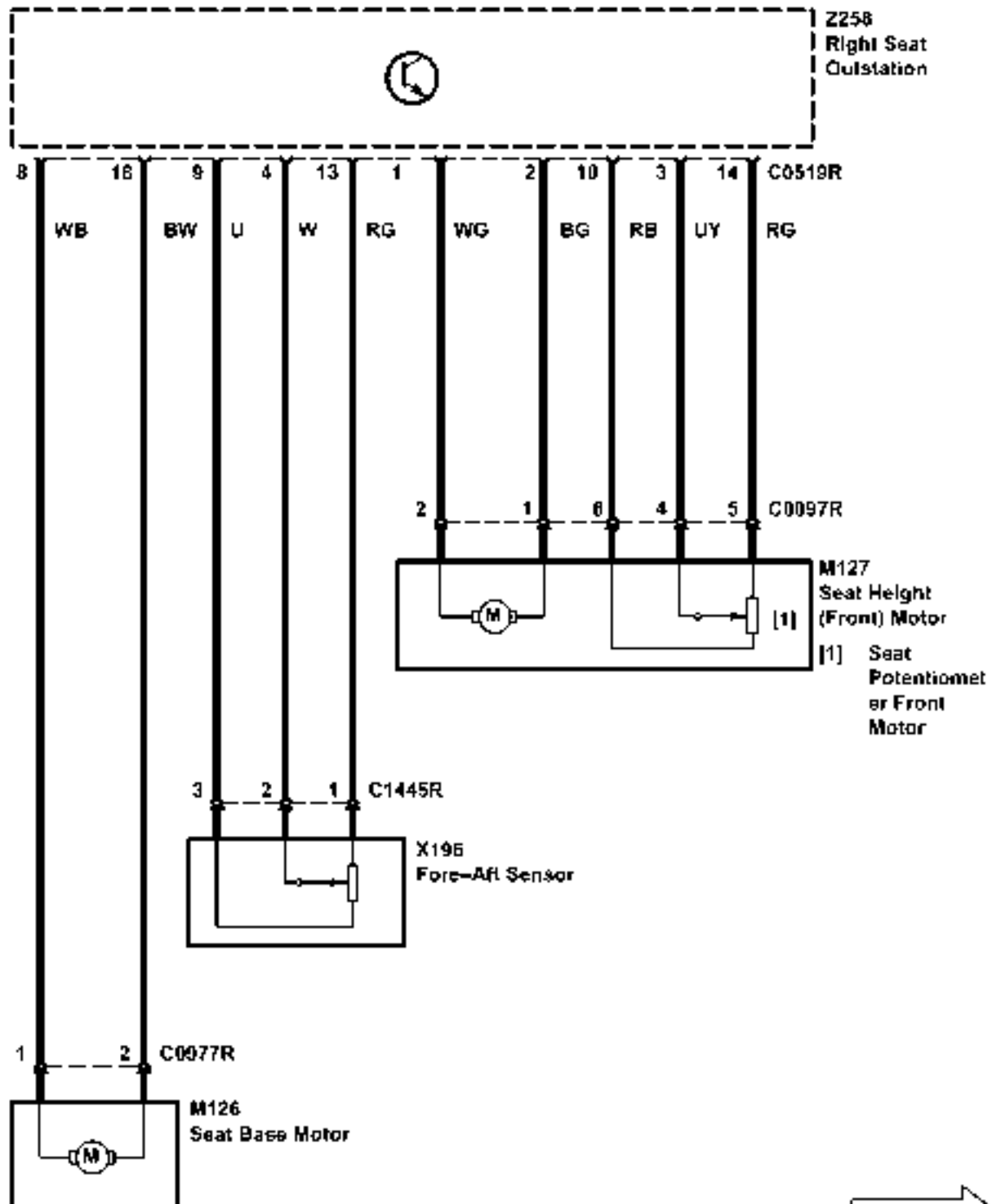

← Memory Seats (Right)

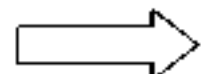
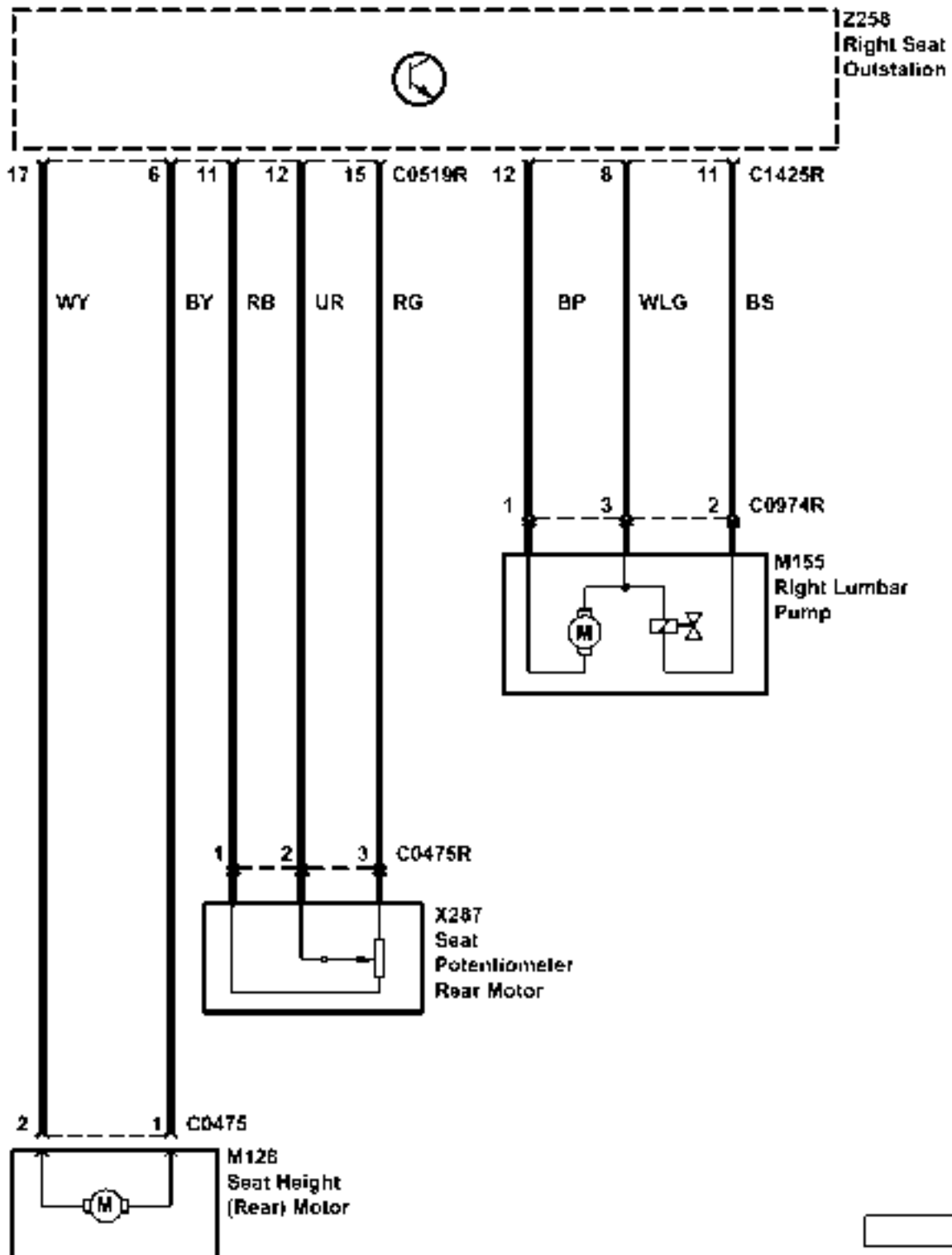

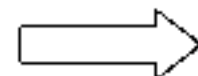
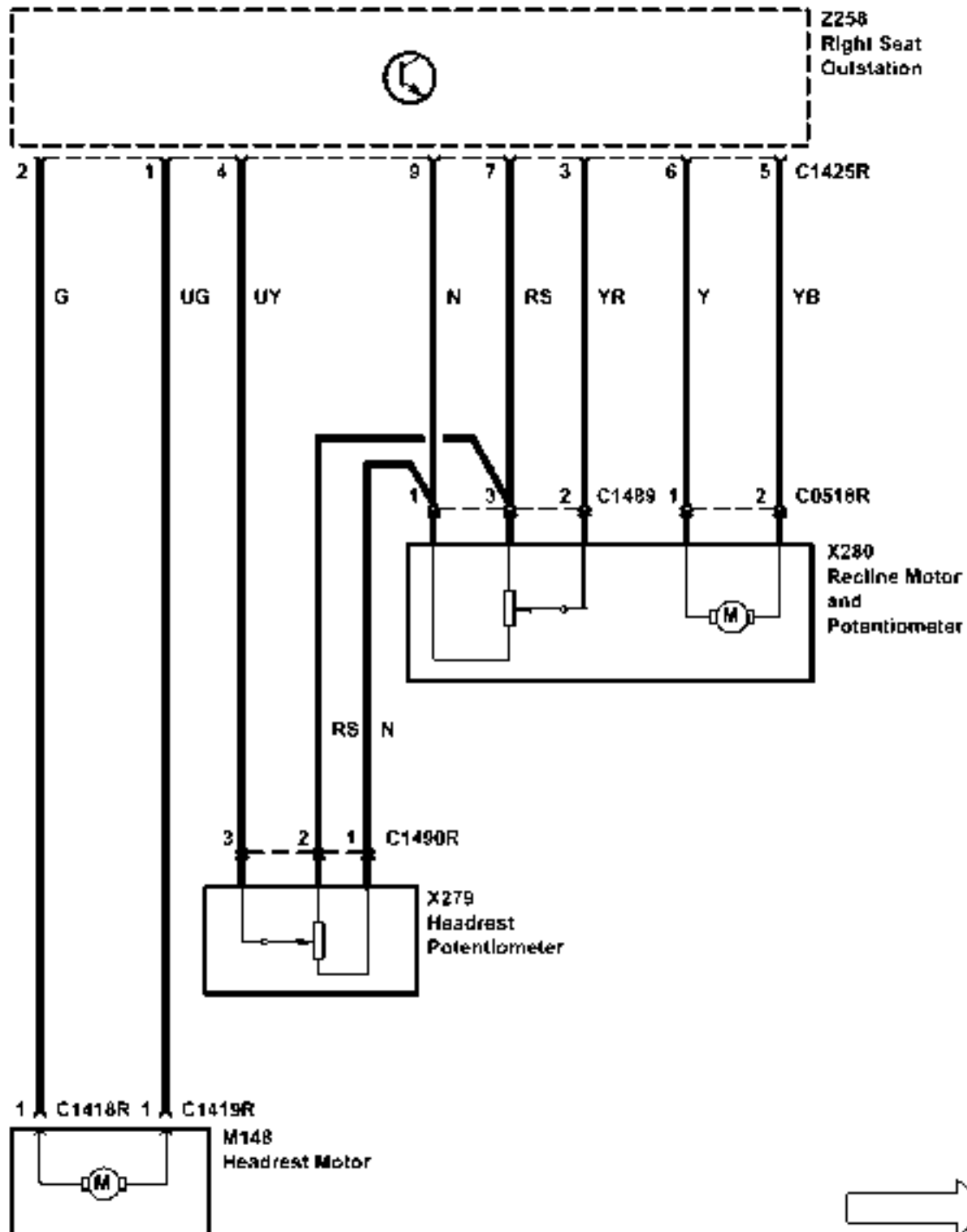

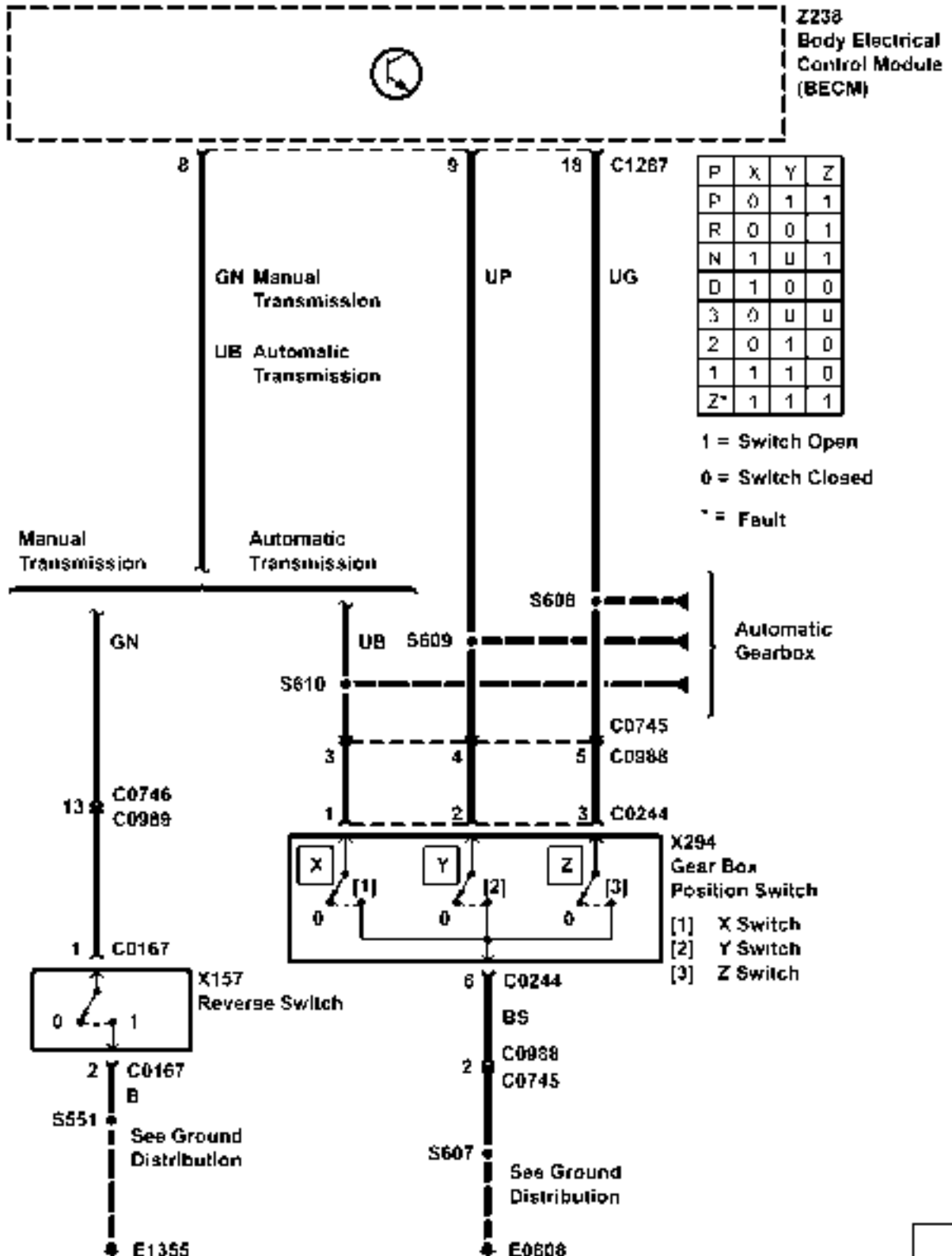
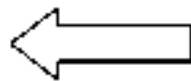

CIRCUIT OPERATION

Driver and passenger seat heaters are temperature regulated by a thermal switch located in each seat. The seat heaters will only operate while the engine is running and, once selected, remain energised until selected off or until the ignition is turned off.

Seat heater activation is initiated by pressing the appropriate switch on the HEVAC ECU. Provided the engine is running, the HEVAC ECU transfers the request to the BeCM by switching the applicable output from V_{batt} to ground for the duration that the switch is pressed. On receipt of the seat heater request, the BeCM switches the appropriate seat heater output from ground to V_{batt}. To prevent current overload, the BeCM inhibits the seat heater output if both rear windows and the sunroof are operated together, or if an uninitialised rear window or sunroof are operated.

The seat heater power output from the BeCM passes through the thermal switch and the heating elements in the seat cushion and seat squab, to ground. The temperature of the heating elements is regulated by the opening and closing of the thermal switch.

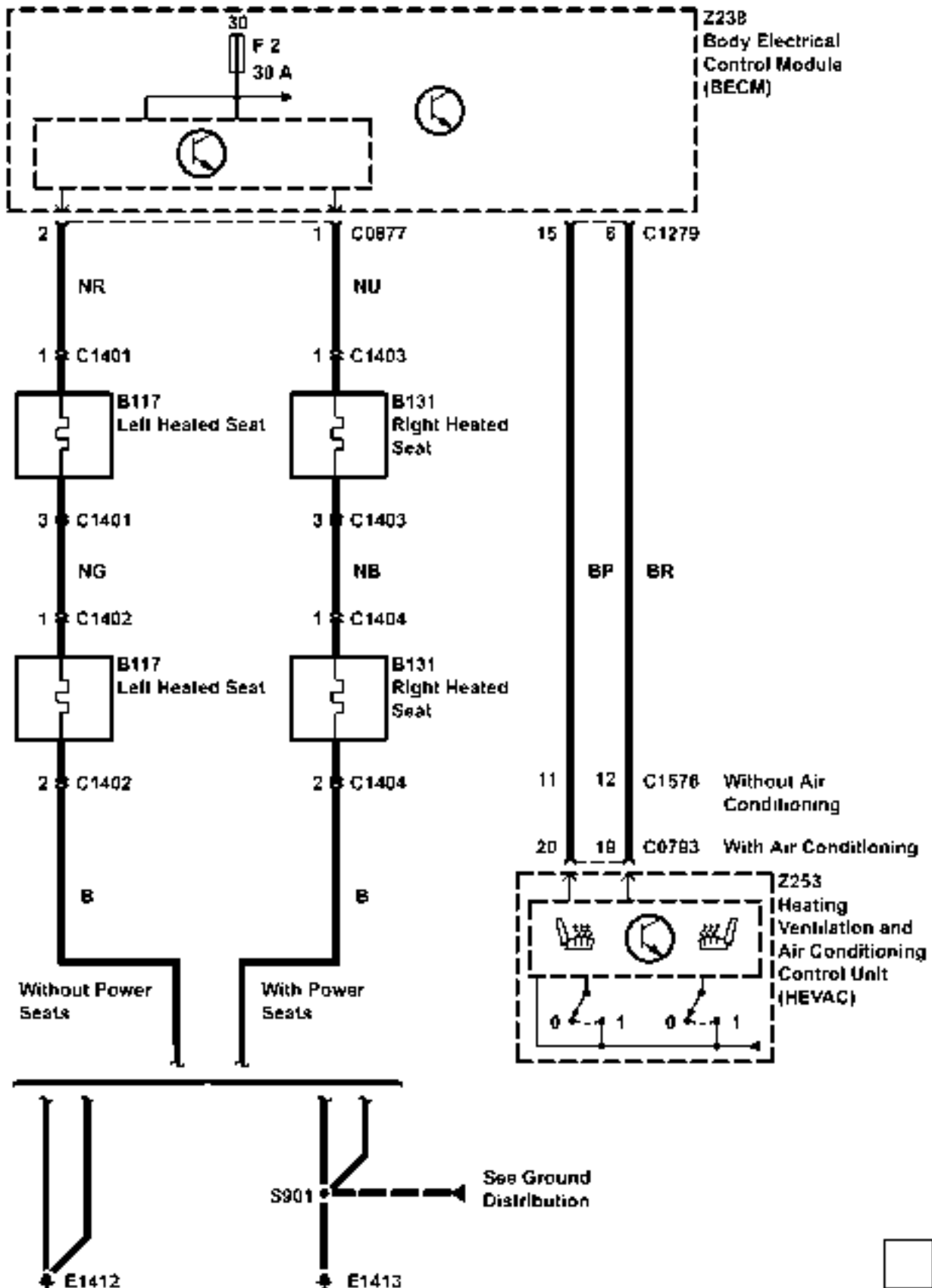

CIRCUIT OPERATION

General

The following combinations of seat and mirror adjustment method will be available:

3. Memory driver's seat, memory passenger seat and memory mirrors.
4. Memory driver's seat, electric passenger's seat and memory mirrors.
5. Mechanically adjusted driver's and passenger's seats, electric mirrors.

The memory mirror system will store the horizontal and vertical position of each mirror. Storage and recall functions will be controlled by the driver's memory seat control switches, each seat memory position having a mirror memory position associated with it.

Memory mirror enable and one touch enable will occur under the same conditions as memory seat enable and one touch enable.

Reverse dip position

Reverse mirror dipping will be enabled when the presence of a driver's side seat memory outstation is detected.

If a driver's seat memory store sequence is executed whilst auxiliary is selected and the transmission is in reverse, then the stored mirror position will be the position that the mirrors will dip to when reverse gear is next selected and that memory number is currently recalled. To protect against accidental setting, the mirror position will only be stored if it has been altered since reverse was selected and a message on the instrument pack will inform the driver that the mirror position has been stored.

The function may be toggled on and off by holding the memory store button for at least 2 seconds whilst in reverse gear with auxiliary or ignition selected.

Successful logging of the function will be accompanied by the message "Mirror dip on"/"Mirror dip off" as described in the message parameter table.

Successful logging of the function will result in the mirrors moving immediately to the dipped/dipped position as appropriate.

Storing a new reverse dip position will automatically toggle the function on.

Vehicles fitted with automatic transmission will have a 0.5 sec delay following the selection of reverse gear prior to the mirror dip position being recalled.

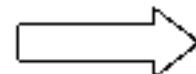
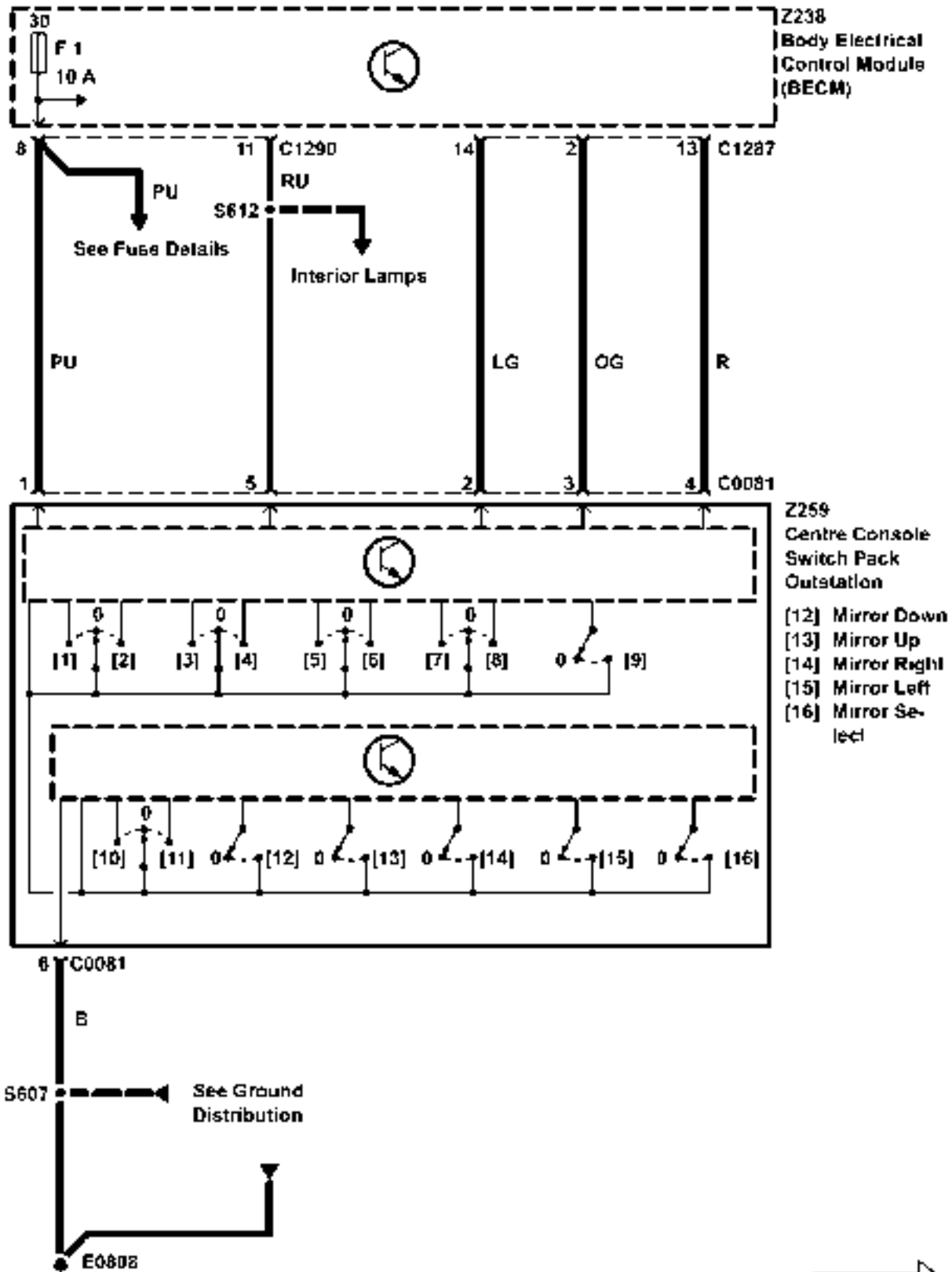

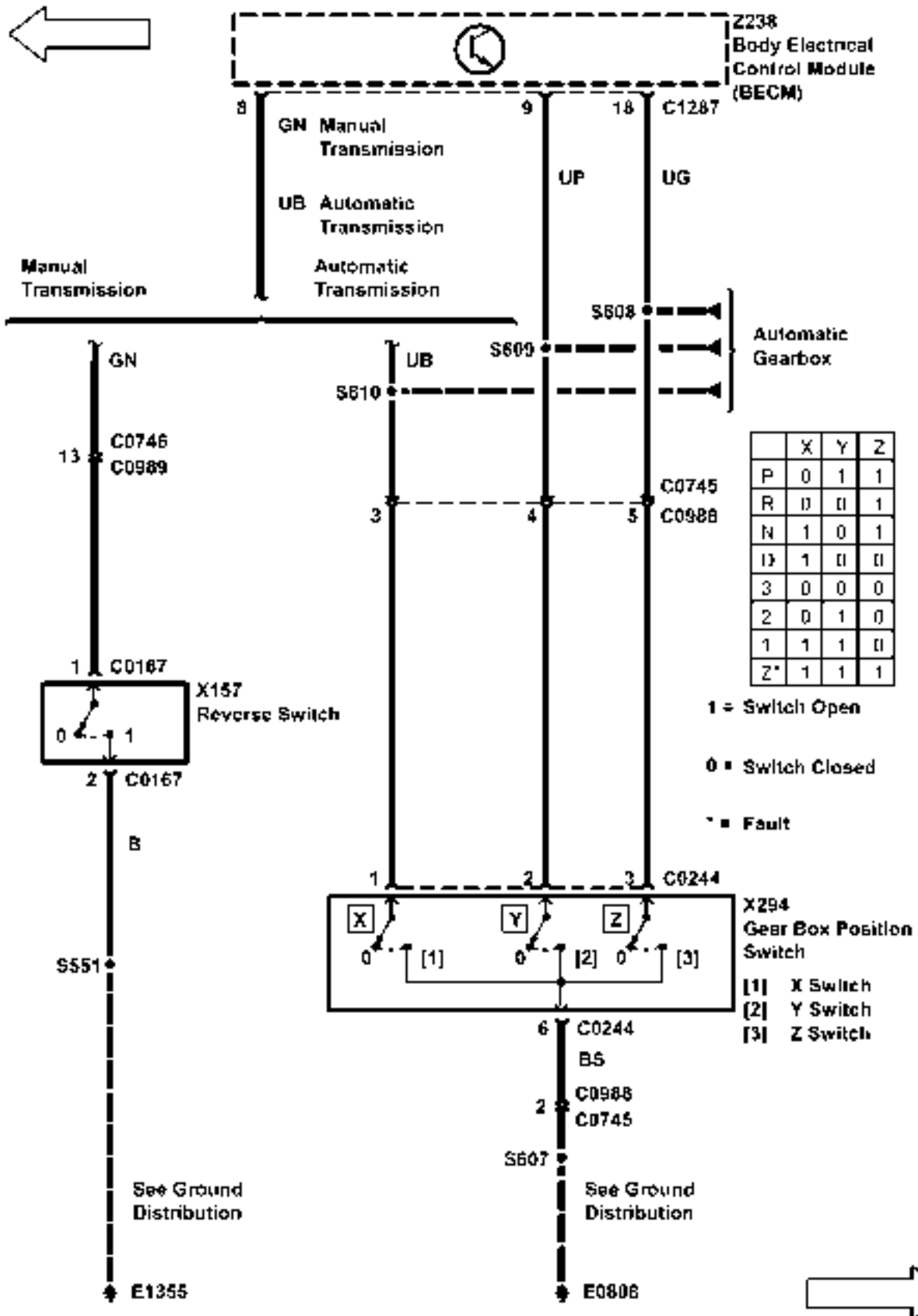

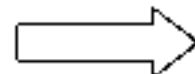
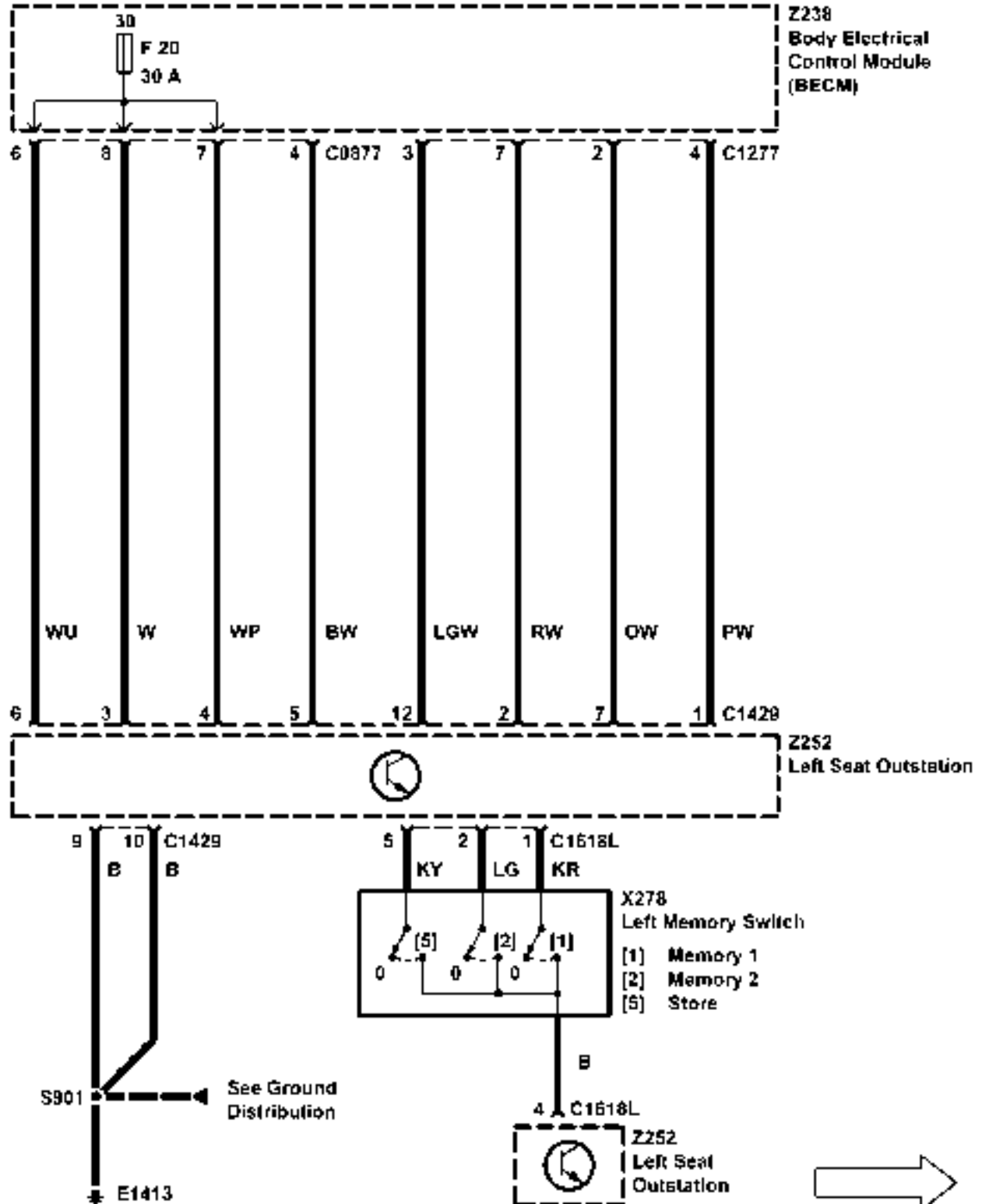

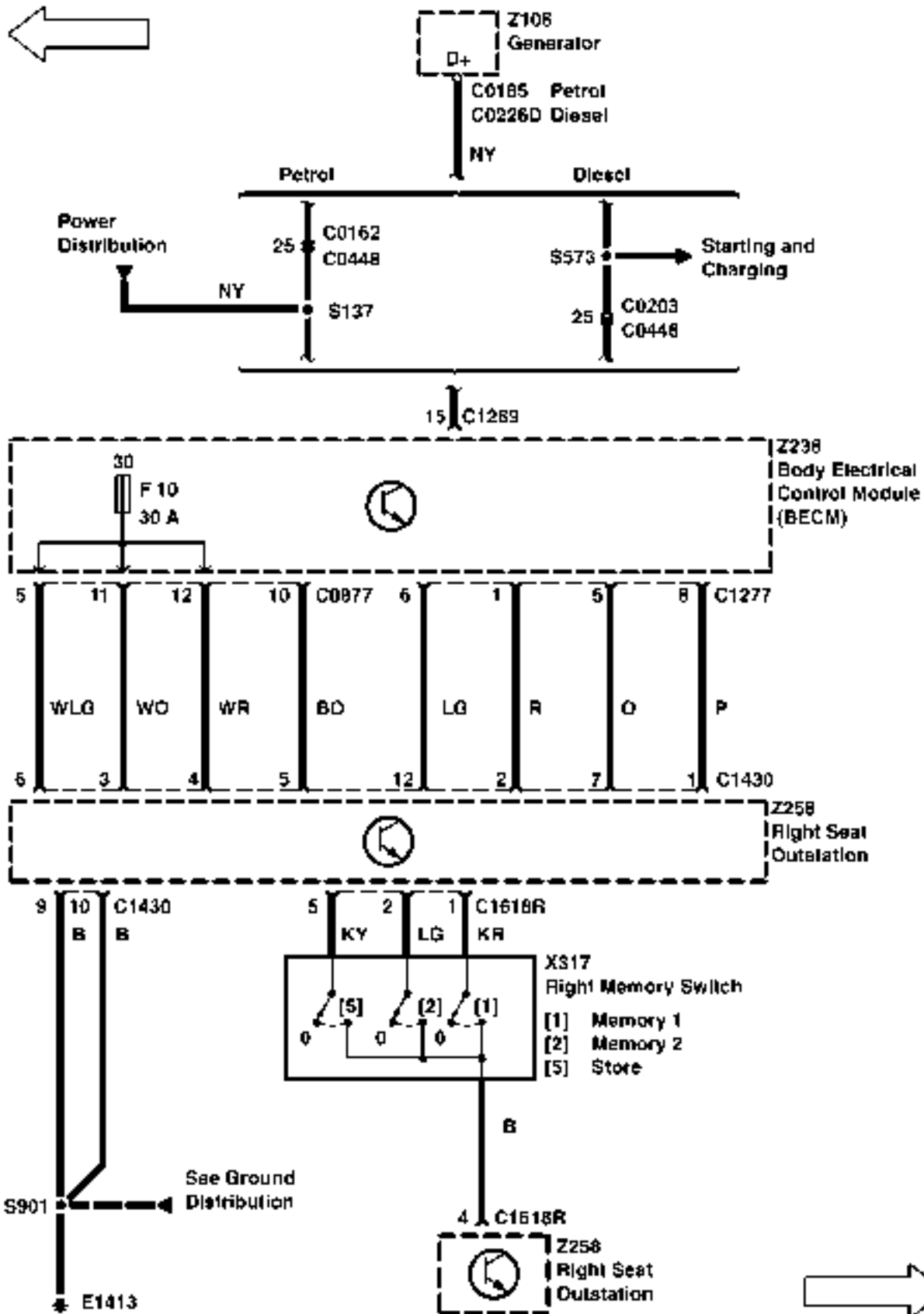

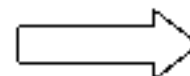
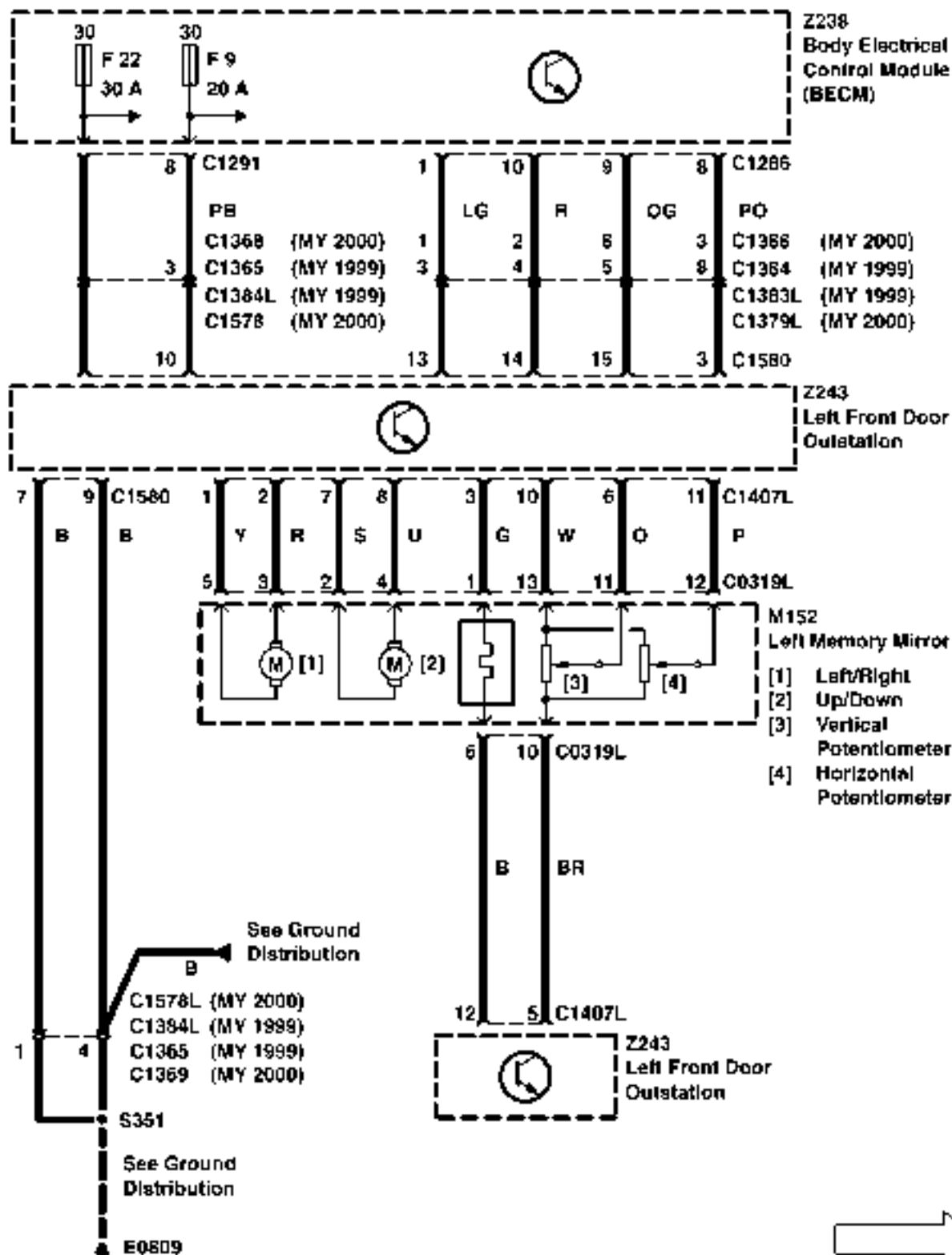
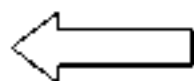

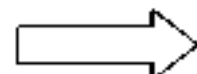
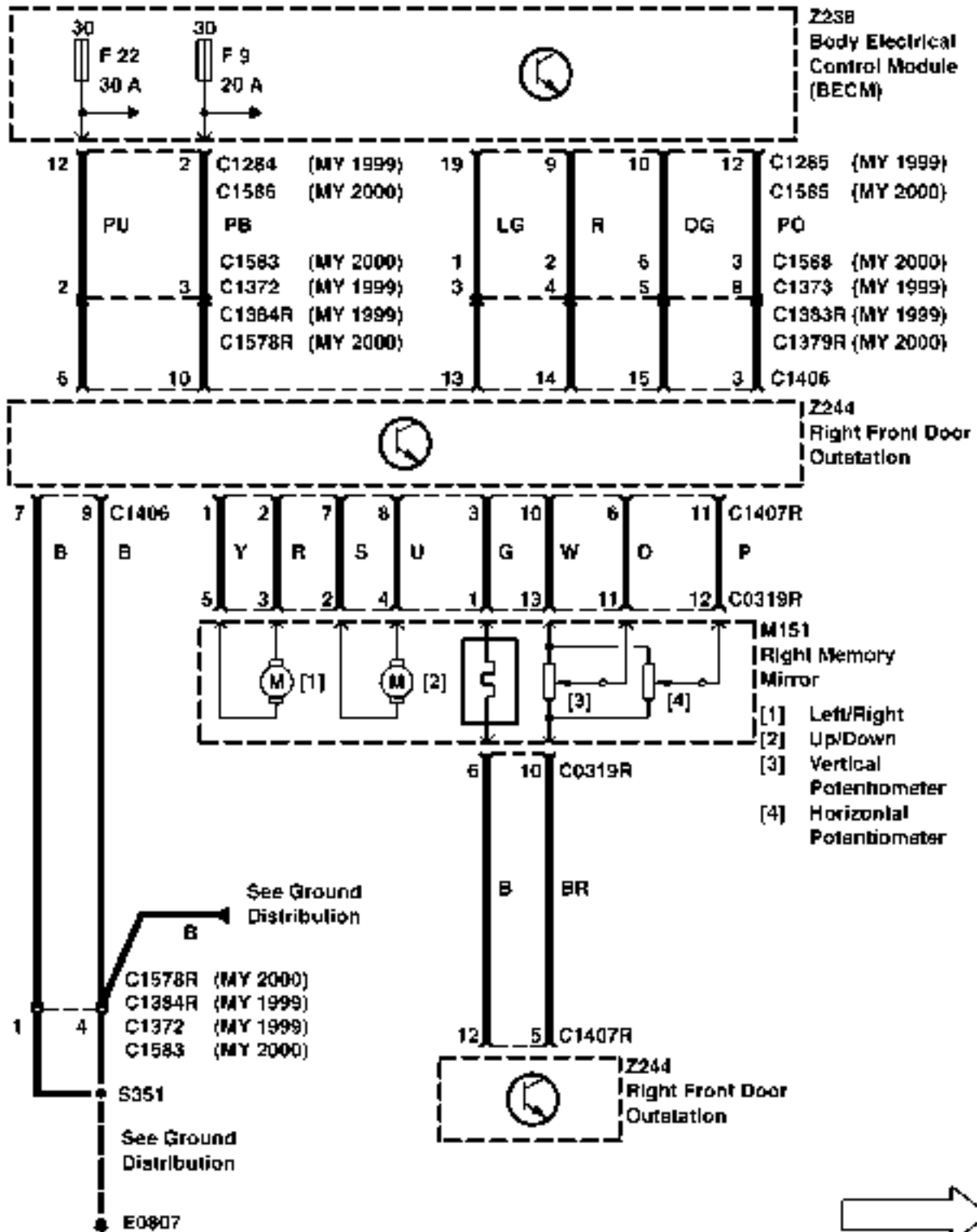
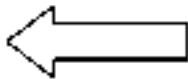

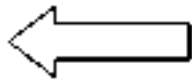

(MY 2000)
With Electrochromatic
Door Mirrors

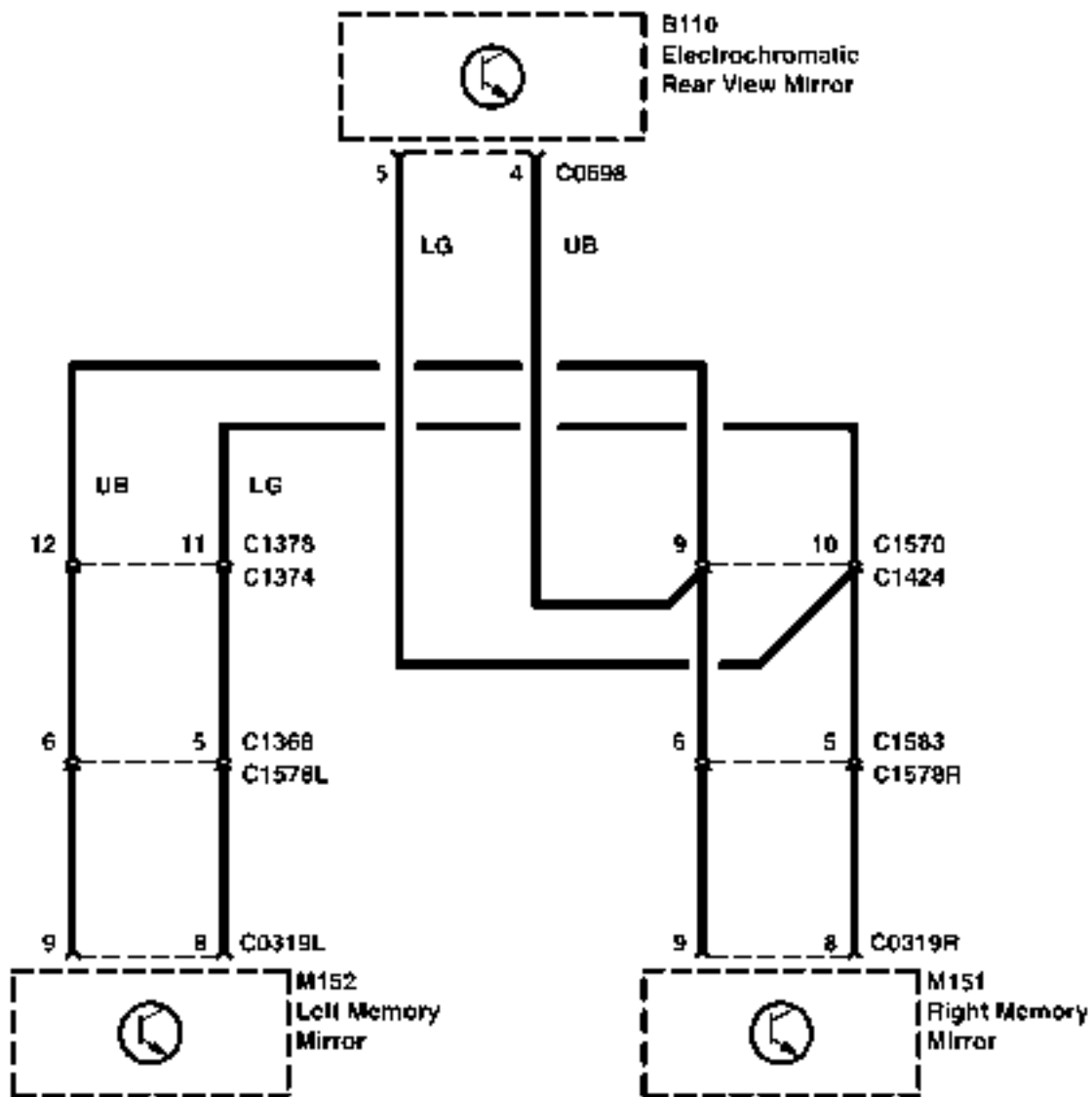

CIRCUIT OPERATION

The Supplementary Restraint System (SRS) provides enhanced passive protection for the driver and front passenger in the event of a serious collision.

SRS Diagnostic Control Unit (Z151)

The power supply to the SRS Diagnostic Control Unit (Z151) is fed via fuse 23 in the engine compartment fuse box when the ignition is turned to position II. The SRS warning lamp in the Instrument Cluster (Z142) will be illuminated for a period of approximately 5 seconds after the ignition switch is turned to position II, while the SRS Diagnostic Control Unit (Z151) performs a system integrity check. If a fault should be detected, the relevant fault code will be stored in the SRS Diagnostic Control Unit (Z151) memory and the warning lamp will remain illuminated for the remainder of the ignition cycle.

The SRS Diagnostic Control Unit (Z151) monitors the following components during the power-up phase and for the complete ignition cycle:

- Accelerometers
- Sailing sensor
- SRS Diagnostic Control Unit (Z151) microprocessor
- Front airbags
- Side airbags
- Seatbelt pre-tensioners
- Front crash sensors (NAS only)
- SRS warning lamps

The SRS Diagnostic Control Unit (Z151) contains a main sensor which is the primary device for detecting the presence of a crash condition and a sailing sensor which is used for confirmation of a crash condition. This confirmation signal is provided to prevent unintentional detonation of SRS system components. In the event of a frontal or front angled collision, both sensors exceed the trigger values stored in the SRS Diagnostic Control Unit (Z151) memory, electronic switches are activated which allow electrical current to be supplied to the airbags and seatbelt pre-tensioners. The airbags and seatbelt pre-tensioners are then activated by a control signal from the SRS Diagnostic Control Unit (Z151).

Warning:

Only fully trained and authorised personnel should be allowed to work with SRS components.

Unintentional detonation of an SRS system component or the consequent failure of a component in a crash condition may cause serious injury.

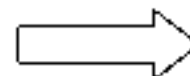
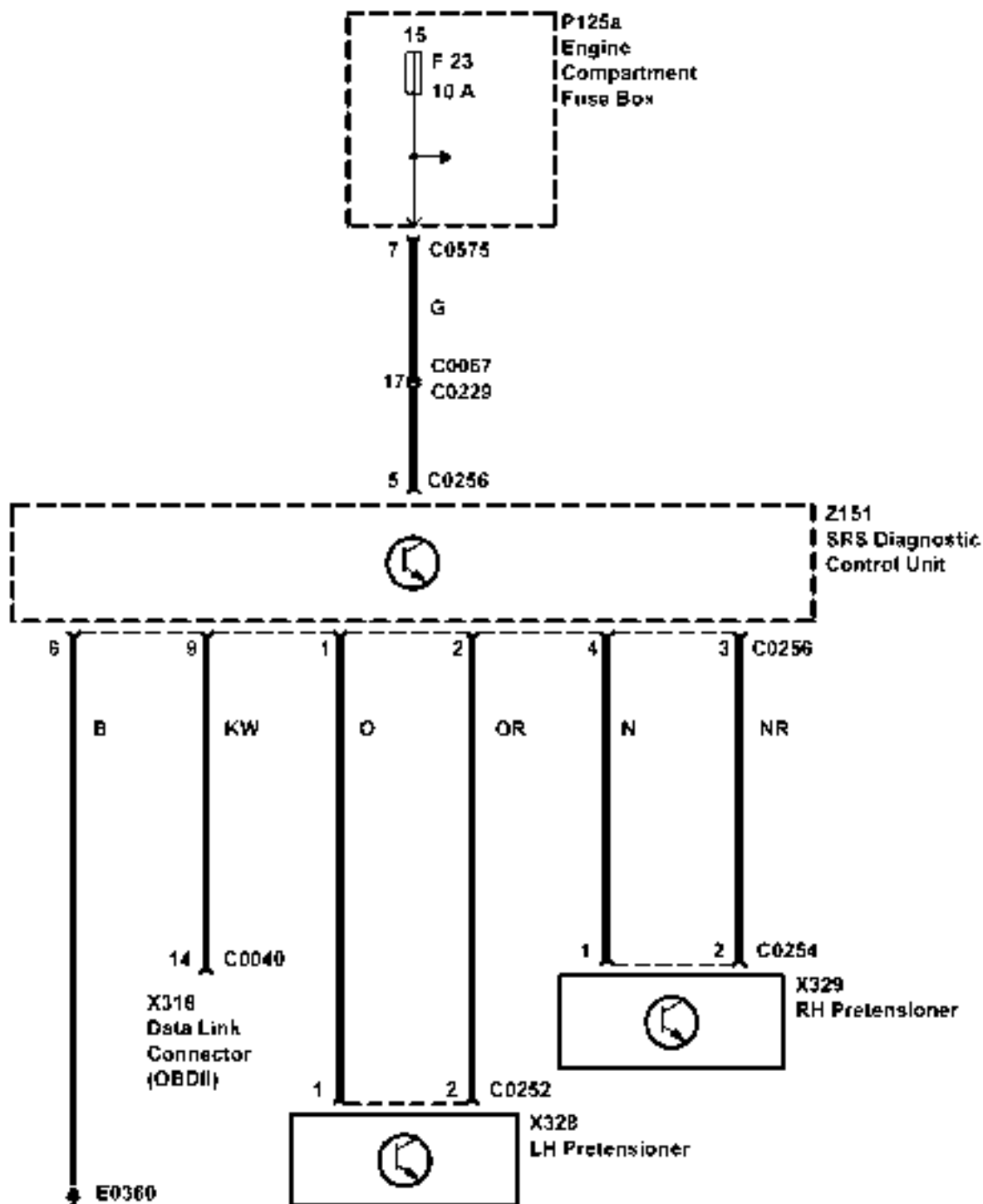

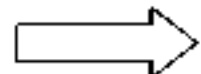
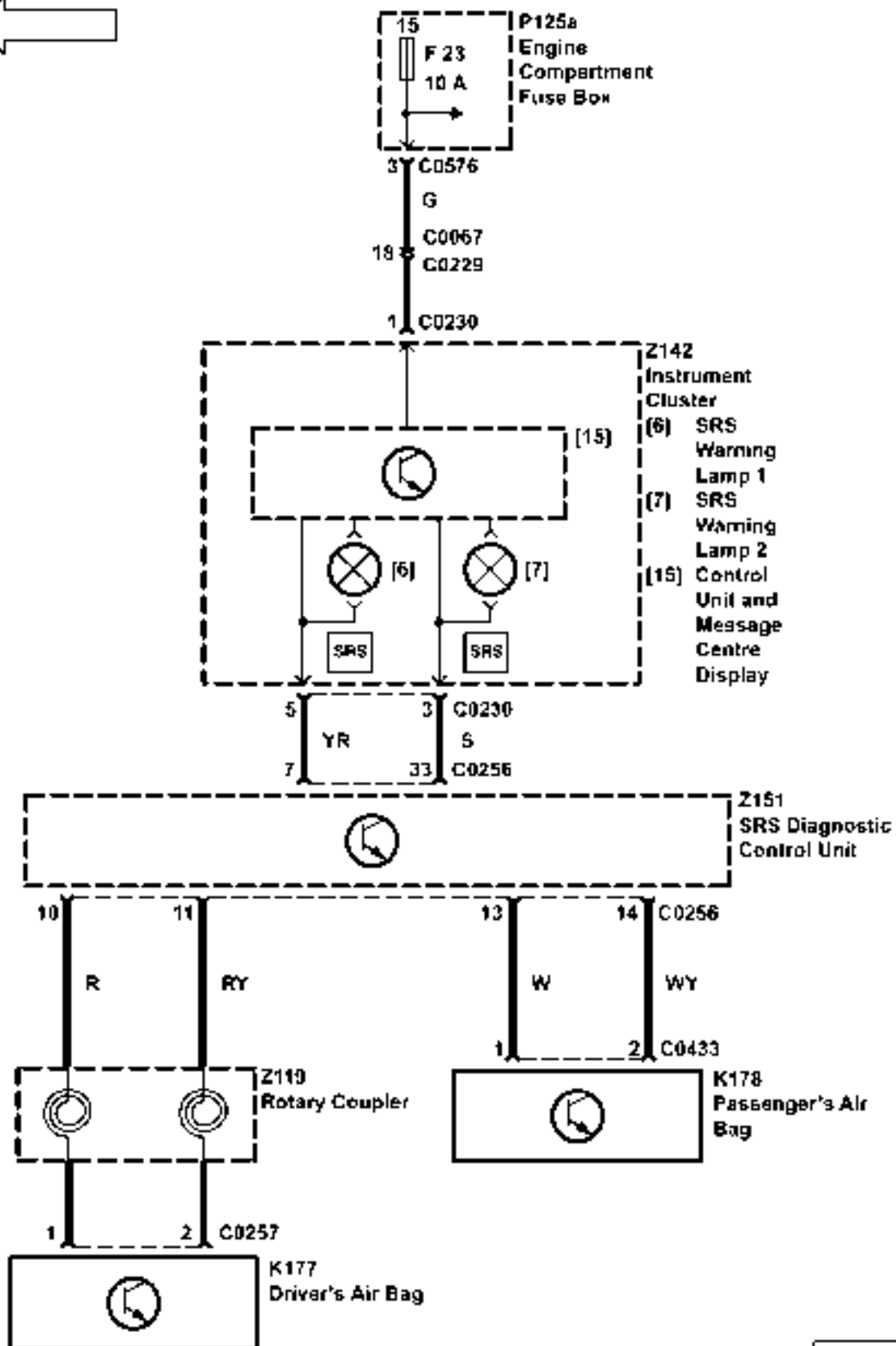
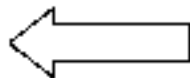

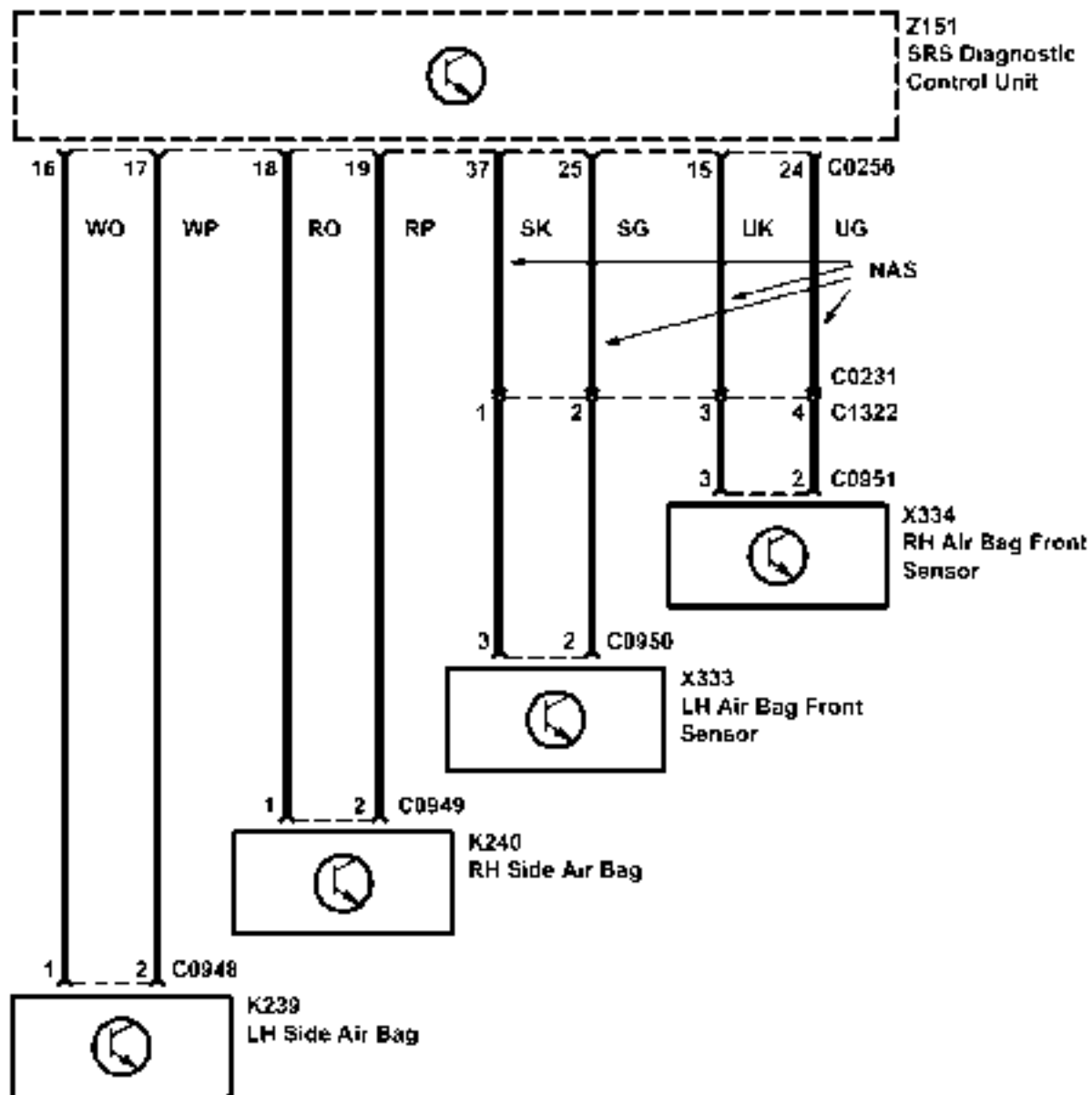
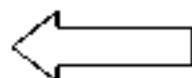

CIRCUIT OPERATION

Accommodation within the system has been made for the addition of a trailer lighting system to consist of 2 side lamps, 2 fog lamps, 2 reverse lamps, 2 brake lamps, 1 LH indicator and 1 RH indicator.

In addition to these loads, there is also a provision for a 10 amp battery feed to the trailer.

Bulb Failure Diagnosis With Trailer

The diagnosis of external bulb failures will be modified by the presence of a trailer as follows:

Brake lamps

- Diagnosis of the RH vehicle and trailer lamps will only detect a failure of all the filaments.
- Diagnosis of the LH vehicle (brake light) is unaffected.

Rear side lamps

- Diagnosis of the LH rear side lamps will only detect the failure of both the vehicle filament and the trailer filament.
- Diagnosis of the RH rear side lamps will only detect the failure of both the vehicle filament and the trailer filament.

Reverse lamps

- Diagnosis of the RH vehicle reverse light and the LH and RH trailer reverse lamps will only detect failure of all of the filaments.
- Diagnosis of the LH vehicle reverse light is unaffected.

Fog lamps

- Diagnosis of the RH vehicle rear fog light and the LH and RH trailer fog lamps will only detect failure of all of the filaments.
- Diagnosis of the LH vehicle rear fog light is unaffected.

Direction Indicators

The indicator warning lamp and trailer warning lamp will diagnose the status of the vehicle's rear filaments, and trailer direction indicator filaments according to the following table.

Indicator w/l	Trailer w/l	Vehicle filament	Trailer filament
Flash	Flash	Good	Good
Flash	Extinguished	Good	Fail/not fitted
Flash	Flash	Fail	Good
Flash w/ double rate	Extinguished	Fail	Fail/not fitted

In the case of hazard light operation with trailer lamps fitted, the failure of a trailer direction indicator light will cause the trailer warning light to flash at double rate, while the direction indicator light will flash at the 'standard' rate.

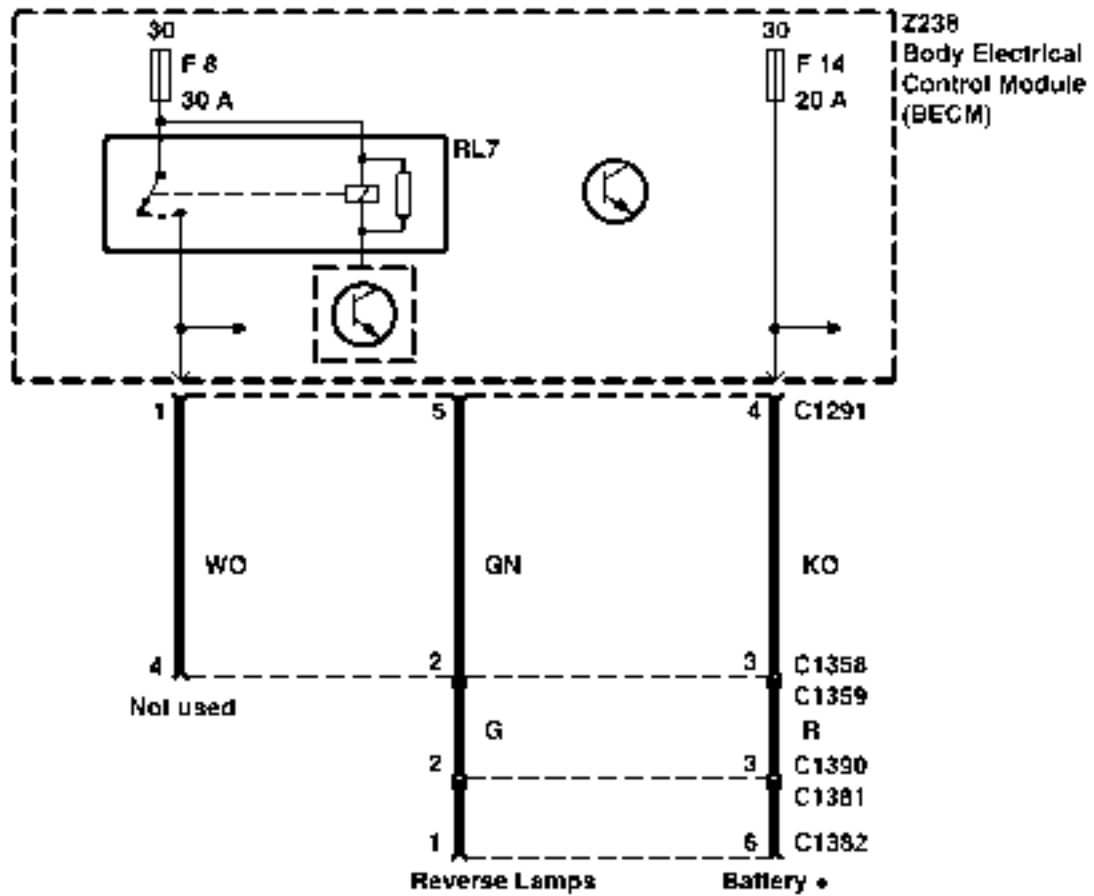

X172 Trailer Auxiliary Socket

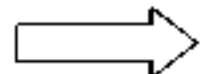
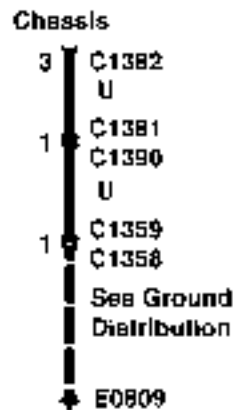

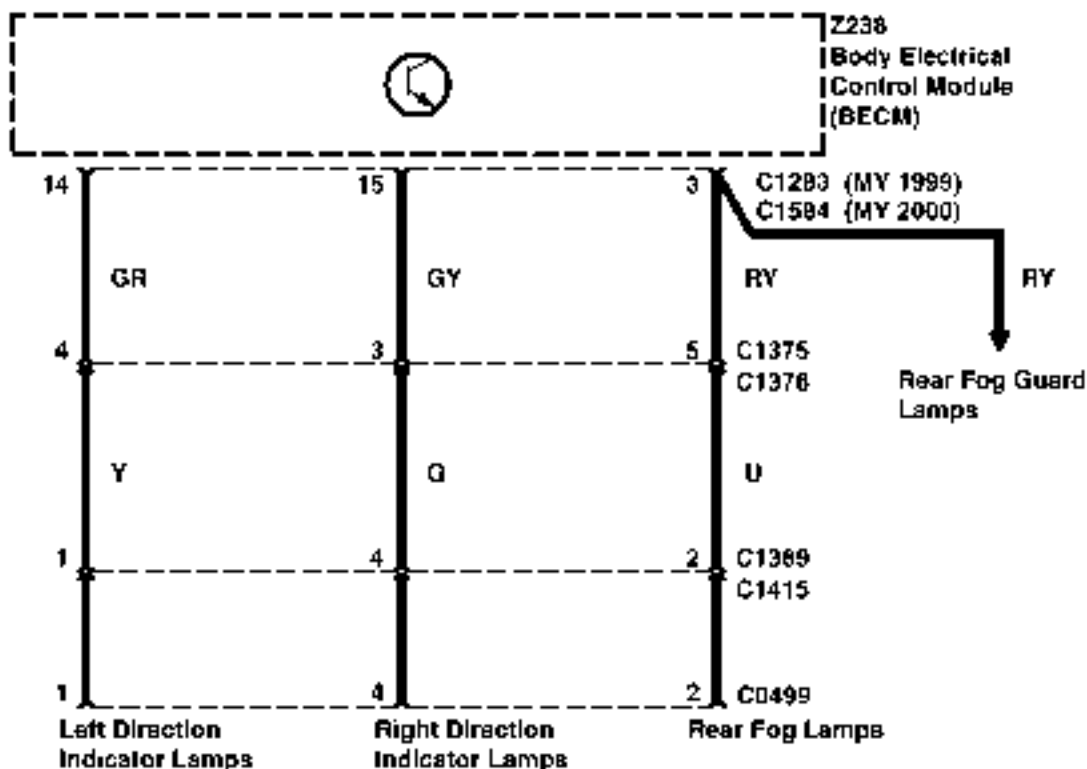
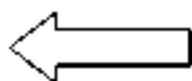

X286 Trailer Main Socket

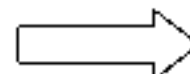
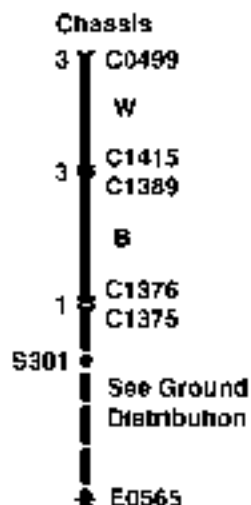

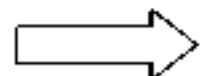
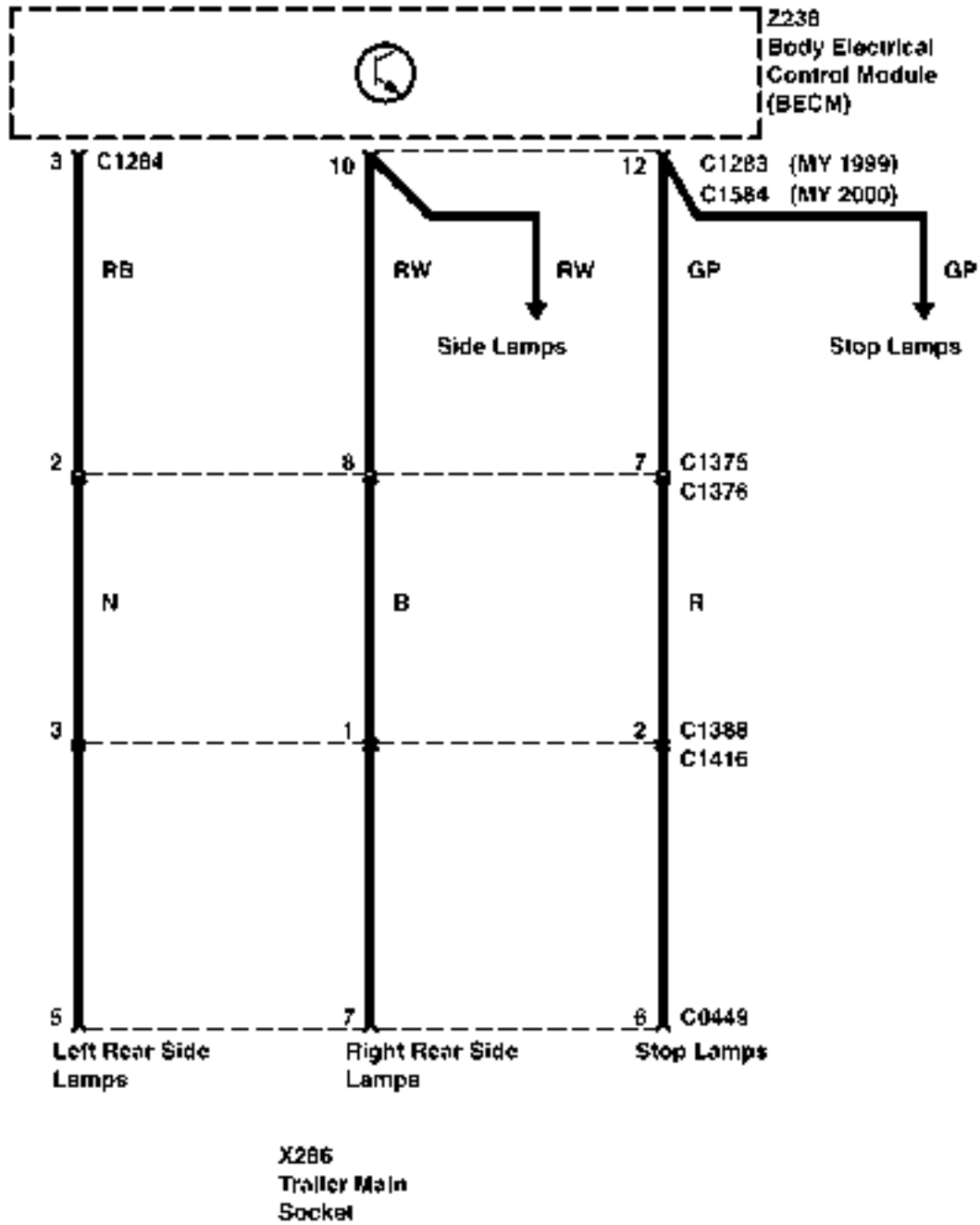
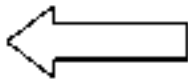

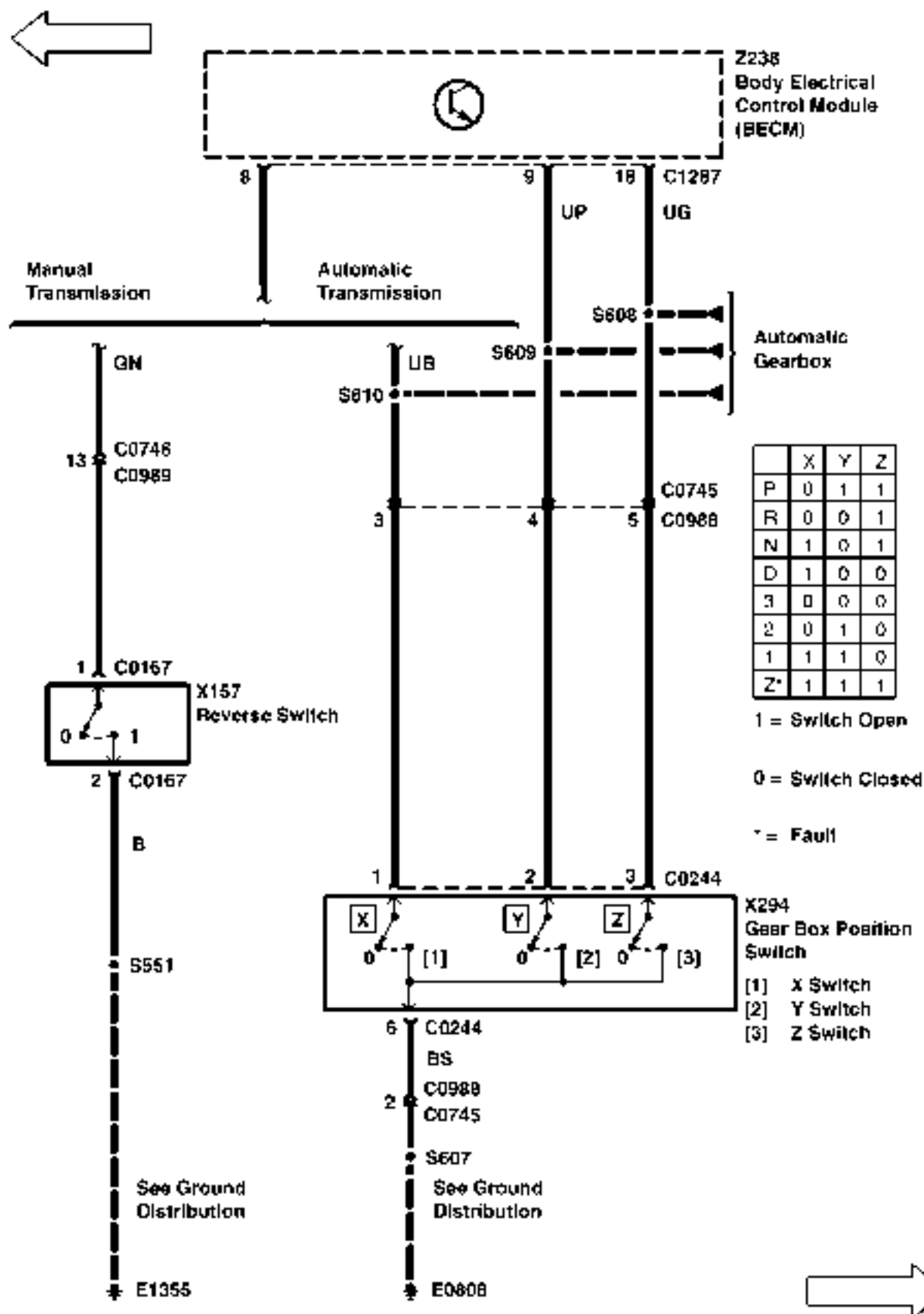

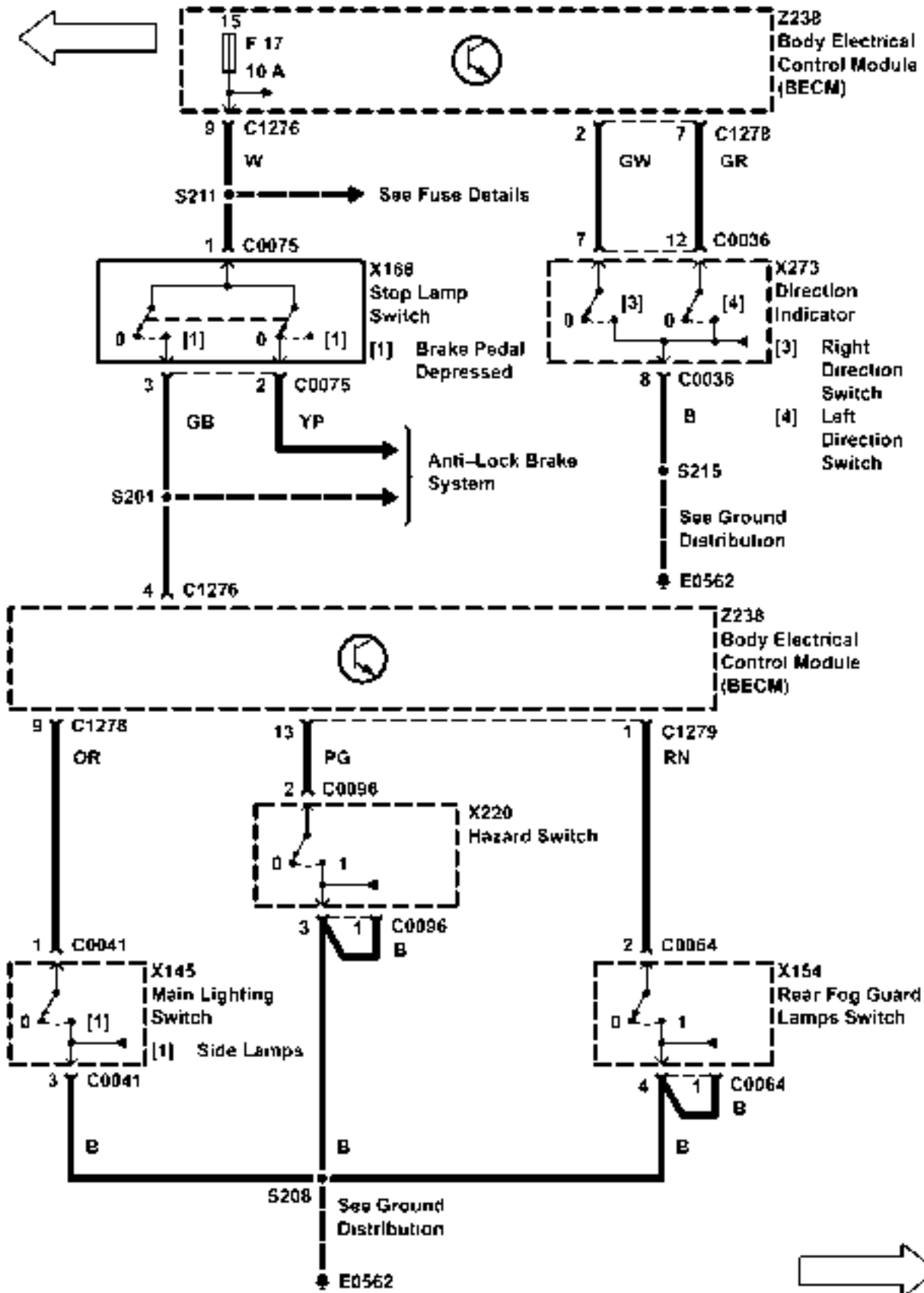

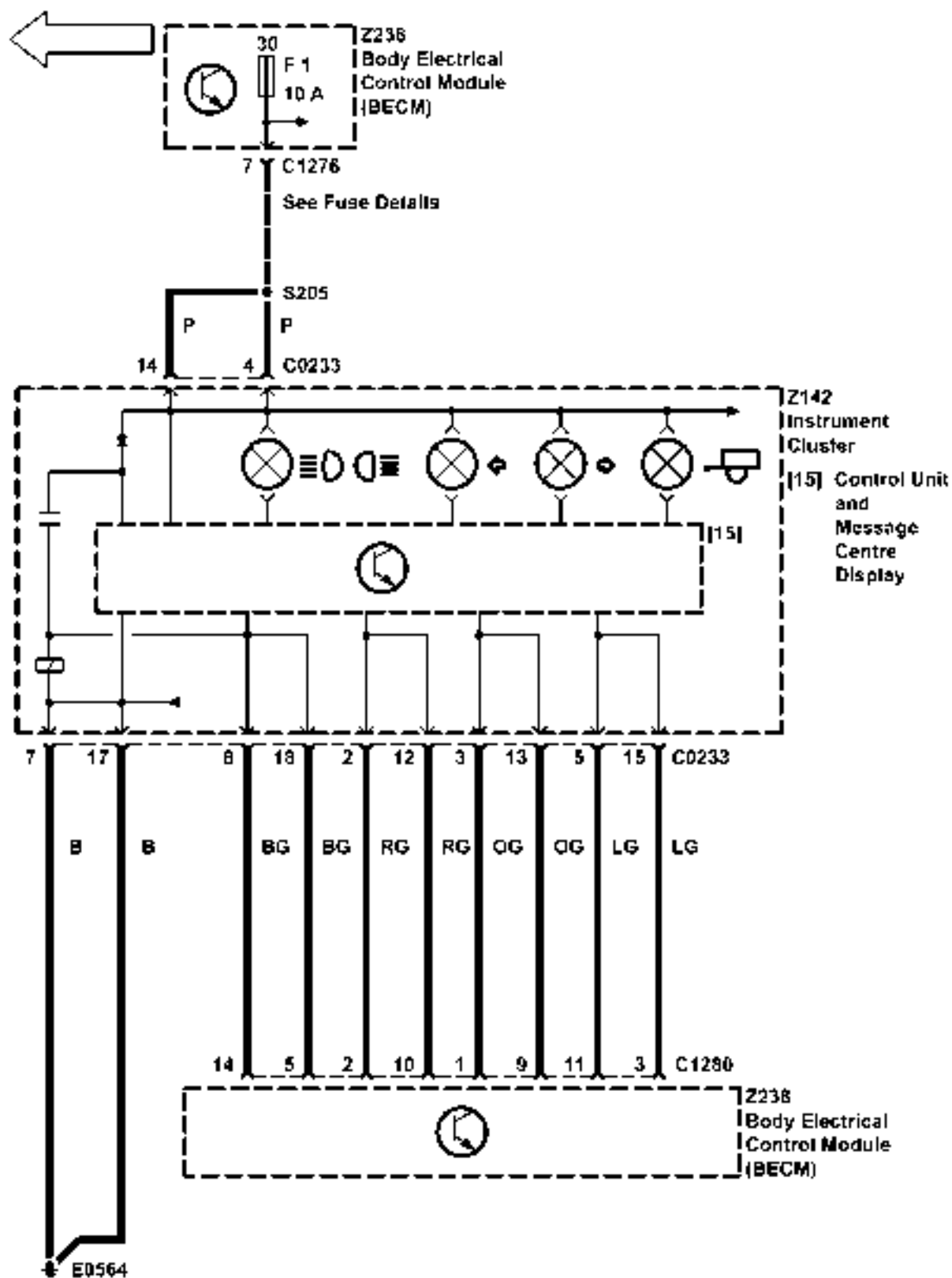

CIRCUIT OPERATION

The Electronic Air Suspension (EAS) is designed to maintain the selected vehicle height under varying loads. This is achieved by adjusting the quantity of air within the air springs located next to each wheel. It should be noted that the system is not intended to control the roll or dive of the vehicle whilst cornering or braking. The accuracy of height control achieved is sufficient to ensure that no additional driver controlled means of adjusting the Head amp beam is required to compensate for different vehicle loading conditions.

The system can operate in any one of five heights or modes. Access, Low Profile, Standard Profile, High Profile and Extended Profile. All heights with the exception of Extended Profile can be selected by the driver using the ride height switches on the fascia. When Inhibit is selected (indicated by the Inhibit switch (the H-lamp being illuminated), automatic height changes between Standard and Low Profile are disabled. It is recommended that Standard Profile Inhibit mode is selected whenever a trailer is being towed.

The ride height of the vehicle is displayed to the driver by the LEDs in the ride height display adjacent to the ride height switches on the fascia. The LED for the current ride height is continuously illuminated whenever the engine is running. When a height change is taking place, the LED for the new target height flashes and the LED for the old height remains continuously illuminated until the new target height is reached whereupon the old height LED is extinguished and the new height LED is continuously illuminated.

It should be noted that if any of the side doors or the tailgate are open when the vehicle speed is less than 5 mph (8 km/h) all height changes are suspended until the doors and tailgate are closed. If a door has been open for more than 30 seconds, then the system will need 'reminding' of the new height after the door has been closed. This condition is indicated by the LEDs for the old and new heights both being continuously illuminated.

Application of the footbrake also causes any height changes to be suspended whilst it is pressed. If the footbrake has been applied continuously for more than 3 minutes, then height changes are allowed to resume.

The ride height of the vehicle is correctly maintained only whilst the engine is running. To compensate for any changes in load after parking (e.g. driver or passengers getting out) the EAS system will lower

the vehicle to the height of the lowest corner after the last door is closed. Furthermore, if the vehicle should develop a lean due to temperature effects or air leakage whilst parked, the EAS system is automatically re-powered every few hours to allow limited corrections to the height to be achieved.

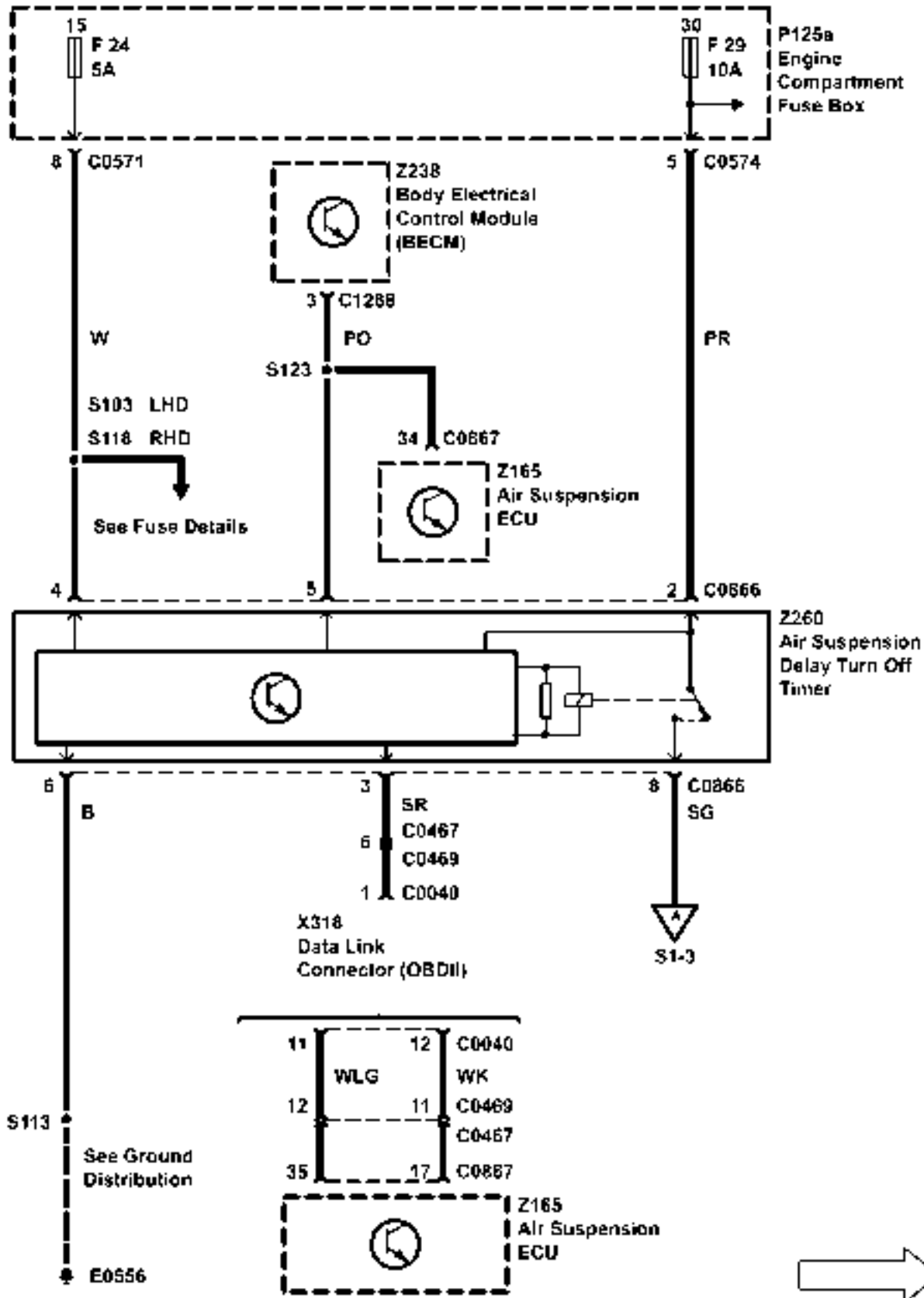

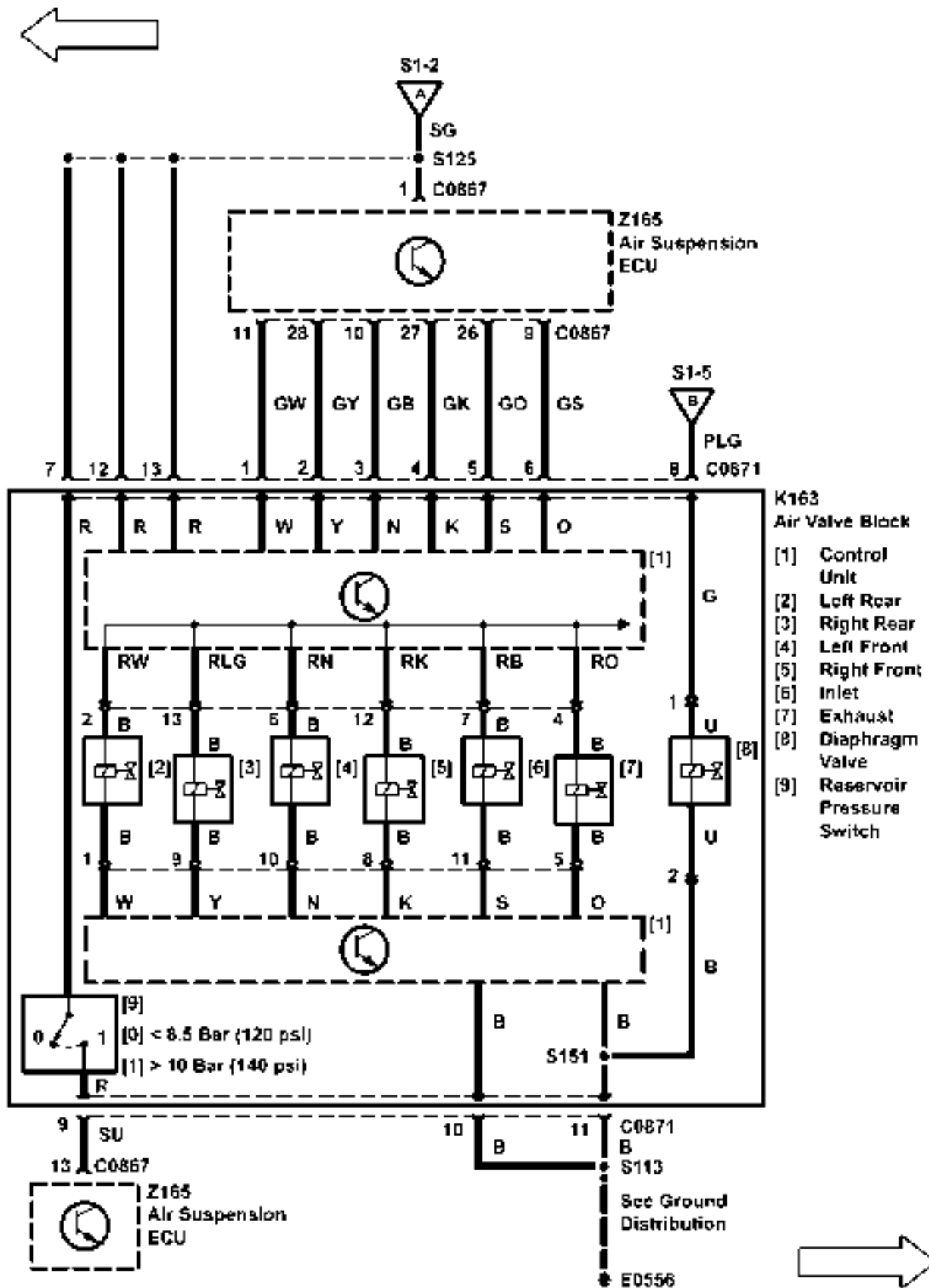

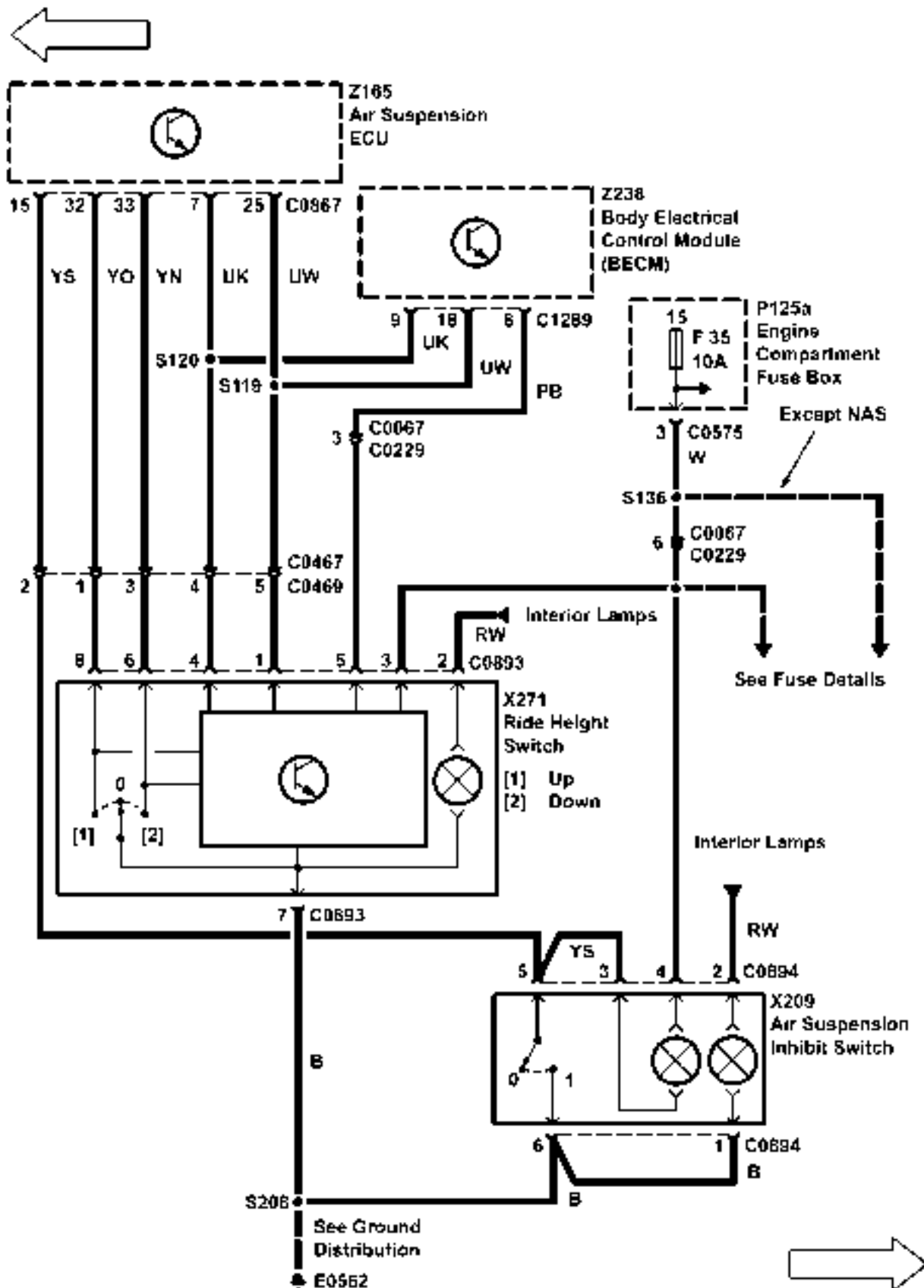

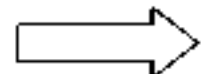
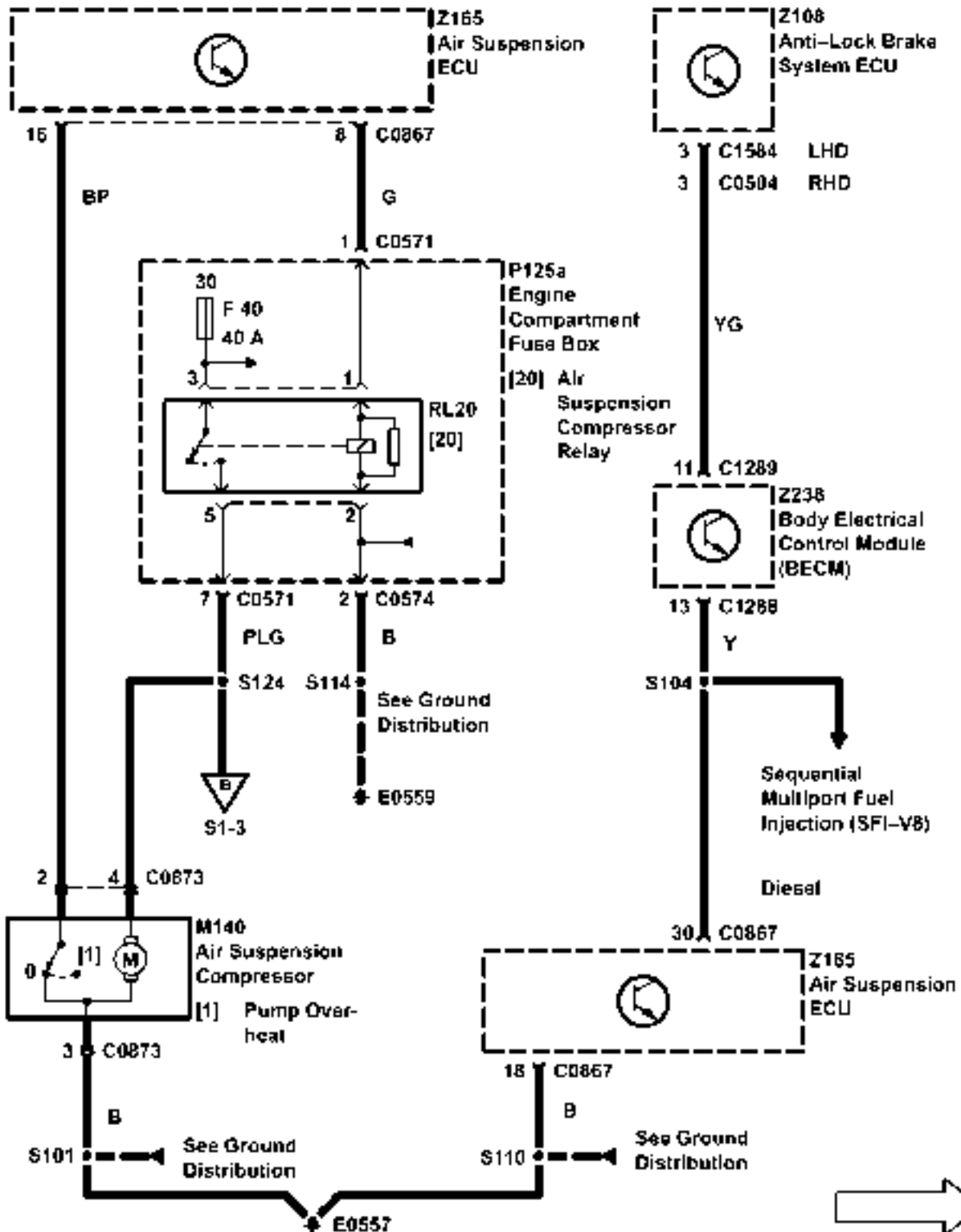
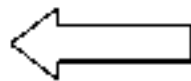

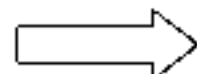
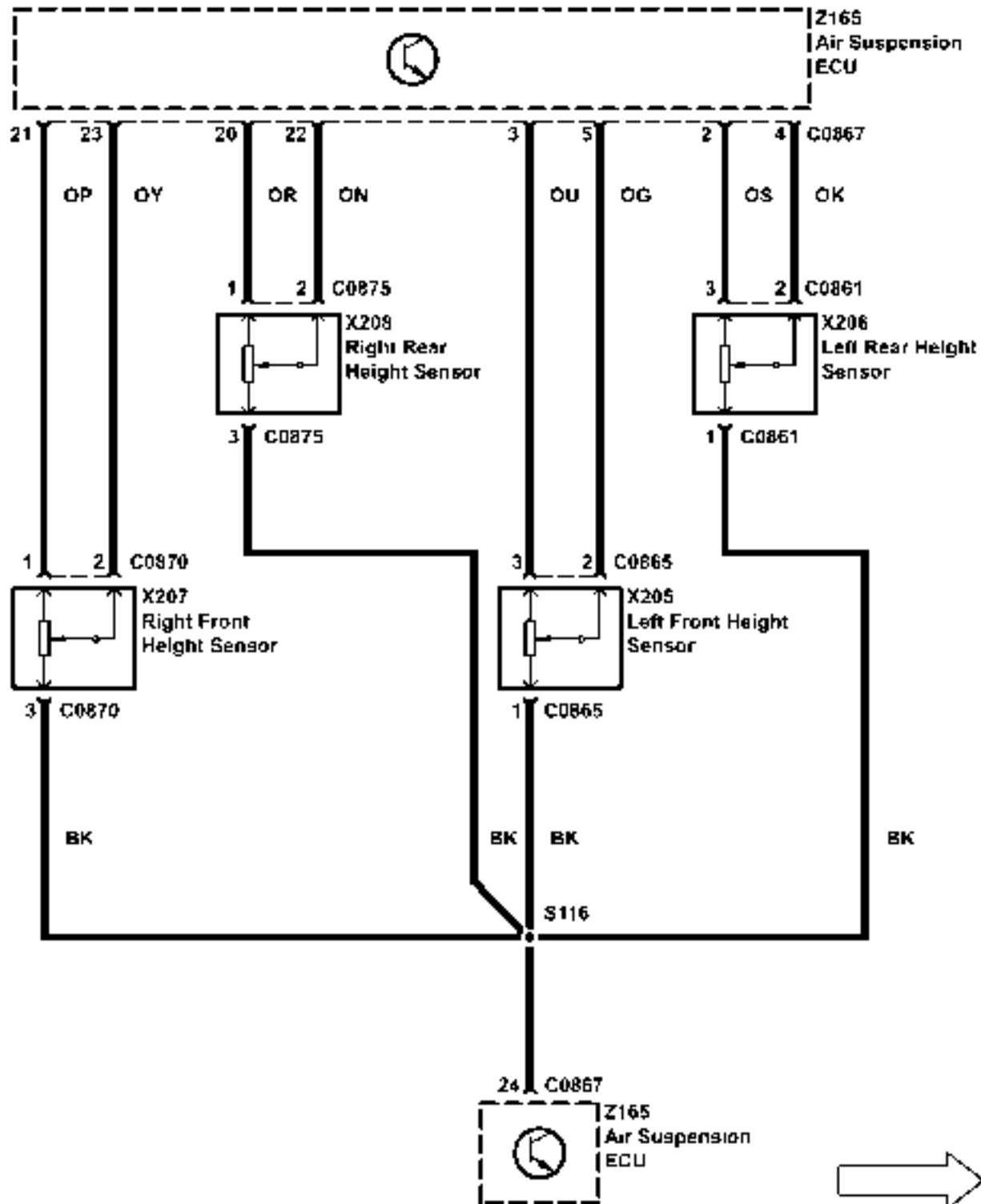
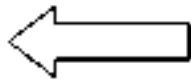

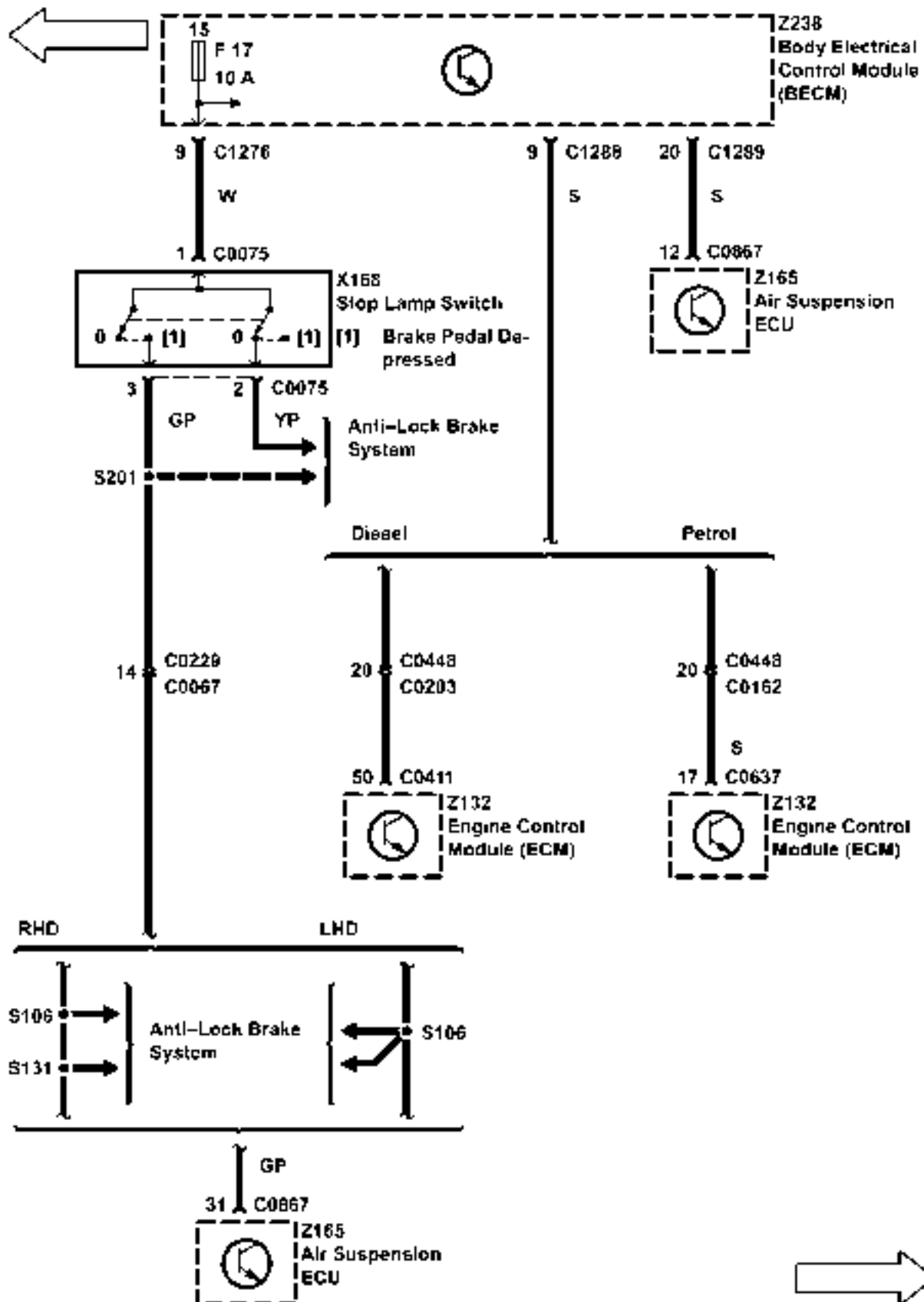

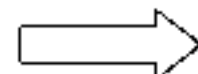
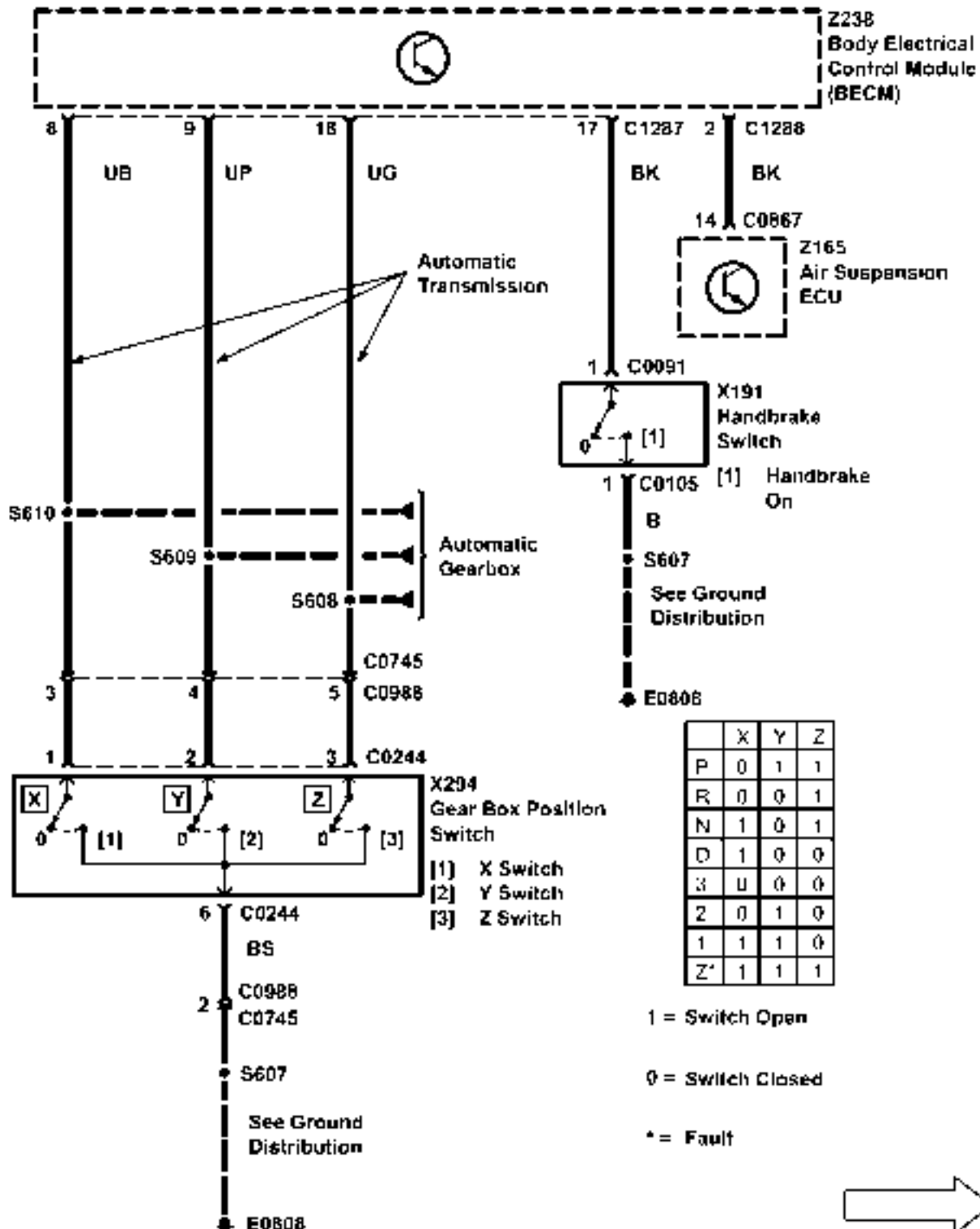
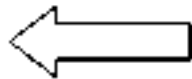

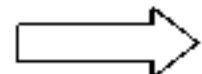
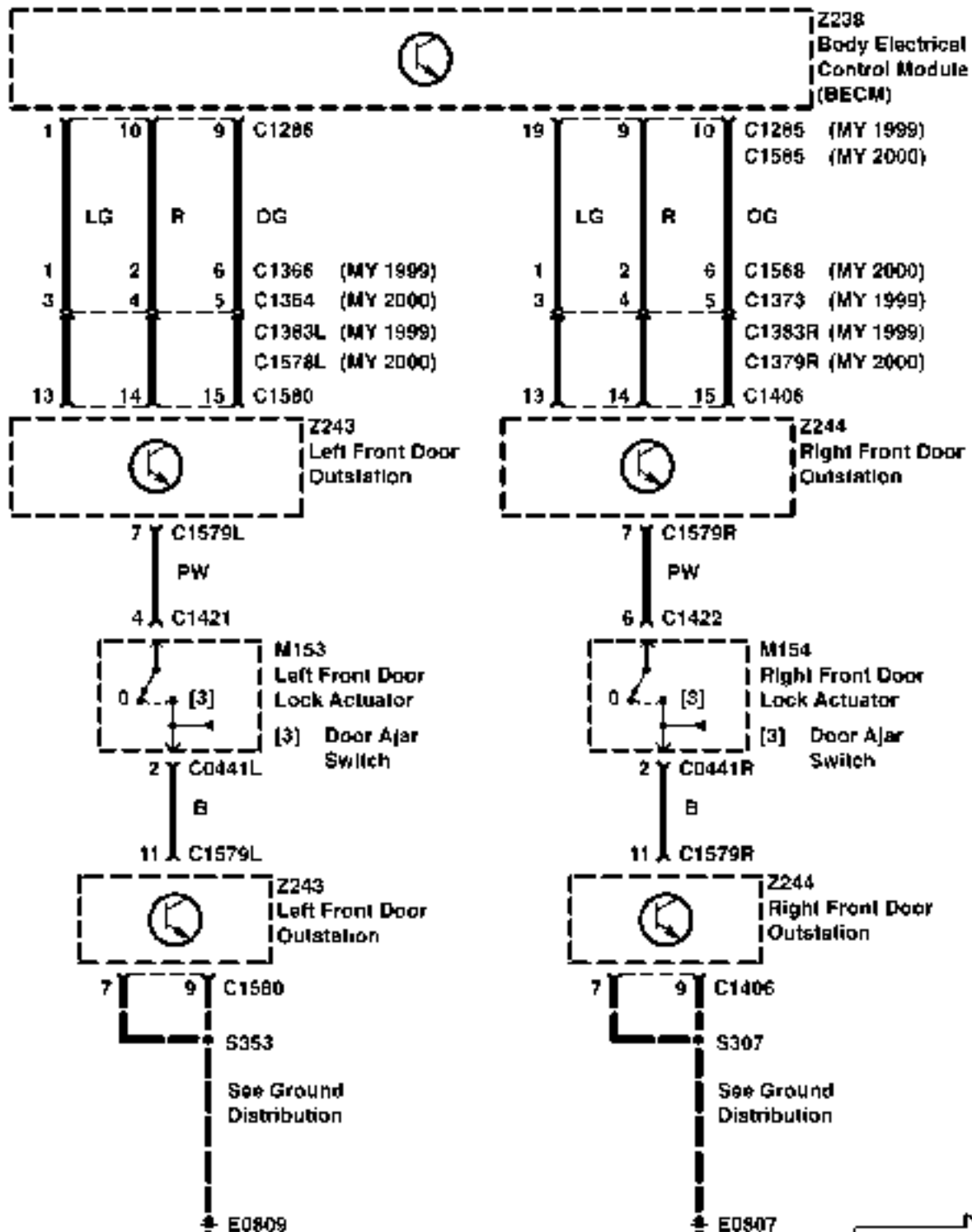
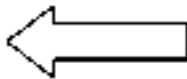

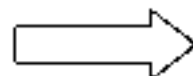
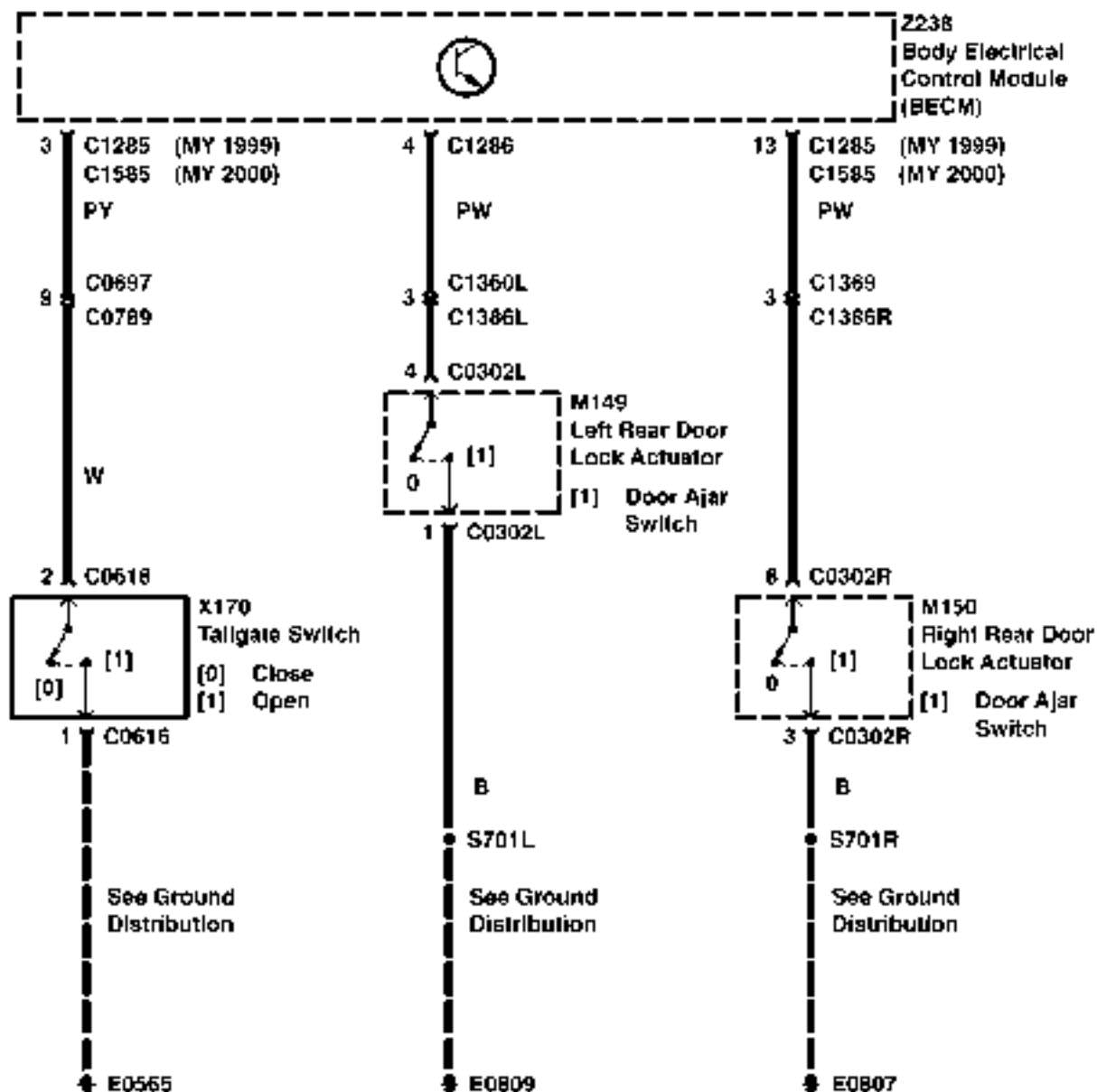

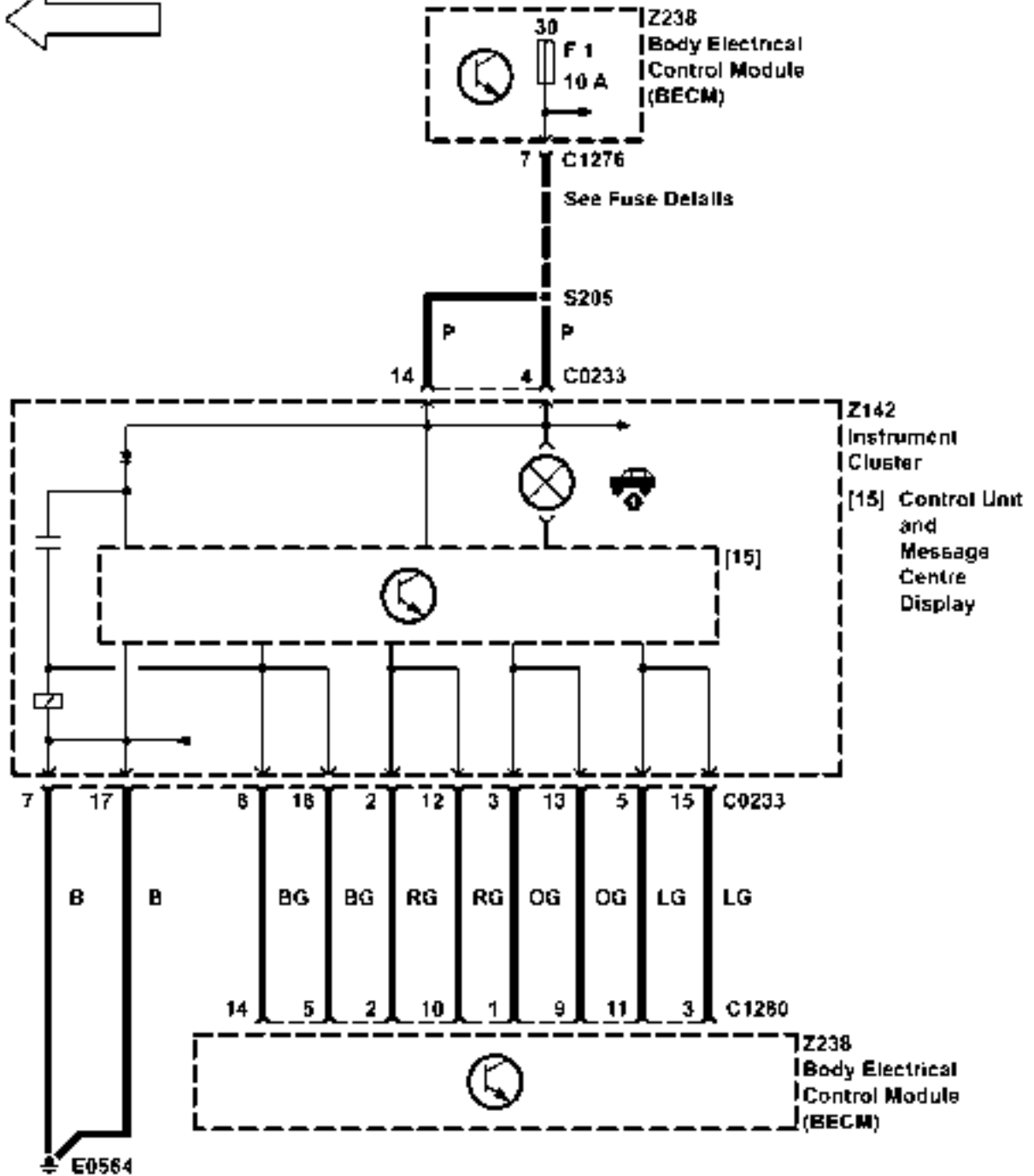
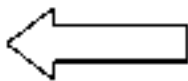

CIRCUIT OPERATION

Basic Overview – Central Door Locking

All new Range Rover models feature Central Door Locking.

All four doors and the tailgate can be locked and unlocked through operation of the central locking system, which can be operated by:

- Pressing down, or lifting up, either of the front door sill buttons.
- Turning the key clockwise (to lock), or turning the key anti-clockwise (to unlock) with the key in the driver's door lock.
- Pressing the 'lock' button, or pressing the 'unlock' button, on the remote handset.

The new Range Rover is also equipped with a 'Superlocking' feature. When the vehicle is 'Superlocked', it is impossible to unlock any of the doors from inside the vehicle by lifting any of the sill buttons.

Basic Overview – Alarm

All new Range Rovers are equipped with a sophisticated integrated security system.

The alarm system offers the following forms of protection:

- Perimeter protection against unauthorised opening of any of the hinged 'slam' panels.
- Engine crank inhibit against unauthorised engine crank.
- Electronic engine immobilisation against unauthorised engine start.
- Volumetric protection against intrusion into the passenger compartment.

Basic Overview – Lazy Locking

An additional feature of the new Range Rover's security system is Lazy Locking.

Lazy Locking enables the driver to close any open glass panel (window or sunroof) from outside the car using either the key or the remote handset.

Lazy Locking can be carried out either when locking or superlocking the vehicle, or when the vehicle is already in a locked state.

N.B. Activation of a lazy locking sequence will be dependent on market requirements.

General

The vehicle locking and security system comprises the following components:

- 'C' type latches on the passenger doors incorporating central door locking, superlocking and slam locking facilities.
- An external key barrel on the driver's door, allowing central door locking, superlocking and unlocking with mechanical override via key (excluding superlocking) in the event of a power failure.
- Separately controlled central door locking actuators on tailgate and fuel filler flap.
- Ultrasonic movement detector, located over the LH 'B' post.
- Passive Immobilisation Coil (Z270) (Not on all vehicles).
- Under bonnet mounted alarm klaxon (Not on all vehicles).
- Battery Backed Up Alarm Sounder (Z272) (Not on all vehicles).
- Radio Frequency remote key allowing locking, superlocking, unlocking and lazy locking.
- Inertia switch allowing unlocking in the event of a crash.
- Security LED to indicate the 'alarm active' state.

Remote Handset Operation

The handset has two buttons, lock/superlock and unlock. The operation is as follows:

- Lock – single press of lock button.
- Superlock – double press of lock button (within 1 second)
- Unlock – single press of unlock button from either locked or superlocked
- Lazy lock – press and hold lock button for more than 1 second.
- (NB Hold on second press if superlock required as well.)
- Lazy Seats – press unlock button for more than 1 second
- (NB This will unlock as well.)

Locking operation

There are six different ways to lock a new Range Rover. These are:

• Sill Locking

Depressing either of the front door sill buttons with both front doors closed will result in all the doors and the tailgate locking, and the vehicle entering a sill locked state.

In this state the alarm remains inactive (provides no protection), with no LED flash.

Sill locking can be achieved independently of key-in and ignition switch status.

• Slam Locking:

Depressing either of the front door sill buttons with either front door open will result in all the doors and the tailgate locking and the vehicle entering a slam locked state.

Following a slam locking operation, the alarm will enter the perimeter mode, engine crank will be disabled and electronic engine immobilisation will be activated.

Attempting to slam lock the vehicle with either the key in the ignition, or the ignition on, will cause unlocking of all the doors.

• Key Locking

A single turn of the key towards the front of the vehicle will result in all the doors and tailgate locking.

The alarm will enter the perimeter mode, engine crank will be disabled and electronic engine immobilisation will be activated.

• Key Superlocking

A double turn of the key in a clockwise direction (i.e. towards the front of the vehicle) within 2 seconds, provided the doors, tailgate and bonnet are closed, will result in all the doors being superlocked.

The alarm will enter the perimeter mode, engine crank will be disabled and electronic engine immobilisation will be activated.

• Remote Locking

A single press of the lock button on the remote handset will result in all the doors and the tailgate locking.

The alarm will enter the perimeter mode, engine crank will be disabled and electronic engine immobilisation will be activated.

• Remote Superlocking

A double press of the lock button on the remote handset within 2 seconds, provided the doors, tailgate and bonnet are closed, will result in all the doors being superlocked (subject to Ultrasonic Lock around – see Ultrasonic Sensor).

Providing all the windows are closed, the perimeter and volumetric alarm will be set. If all the windows are not closed, then only the perimeter alarm will be set.

Engine crank will be disabled and electronic engine immobilisation will be activated.

Lazy Locking

Lazy locking can be carried out when either locking or superlocking, or when the vehicle is already in a locked state, by either holding the key turned to the lock position or by holding the remote handset lock button pressed for more than one second.

This will cause all the open windows to start closing simultaneously. Closure of the windows will be followed by closure of the sunroof.

Dependent upon market requirements, lazy locking will either operate in one-shot mode, or in dead man's handle mode.

- In one-shot mode, the windows and sunroof will continue to close even after the key has been released from the lock position, or the lock button on the remote handset has been released.
- In dead man's handle mode, closure of the windows and sunroof will only continue for as long as the key is held to the lock position, or the lock button is pressed on the remote handset. In this case, failure of any of the apertures to be fully closed upon release of the key/button will result in a mislock.

Mislock

A mislock condition is indicated by either two short "beeps" from the alarm sounder, or by three short flashes of the courtesy lights, depending on the market legislation.

Partial Arming Of The Perimetric Alarm

If the perimetric alarm is armed with one (or more) of the doors, or the tailgate, or the bonnet open, then the remaining panels are all protected by the alarm. If any of the open panels are subsequently closed, then they too will be protected by the alarm.

Security LED

The security LED has two functions:

- Firstly, for the initial ten seconds after a lock request, it provides visual confirmation of the lock status.
- Secondly, after this confirmation period, it acts as a deterrent to any theft attempt (flashing at a slower rate).

Volumetric Protection

Volumetric protection, (protection of the vehicle's interior), is provided by an **Ultrasonic Sensor** and an **Ultrasonic detector**.

If the vehicle has been successfully superlocked with the key, then provided all the windows are closed, a single press on the remote transmitter lock button will activate the ultrasonics. There is a 5 second settling period before movement can be detected.

Audible/Visual Warnings

When an intrusion is detected, the Alarm Sounder (Z171) will sound and visual indicators will flash. The output from the sounder is either pulsed or a continuous tone, depending on market legislation. If the output is pulsed, then its status will be synchronised with that of the visual indicators.

The lamps used for external visual indication are dependent upon market legislation, but will be either Hazards, or Side and Tail, or Dip and Tail.

Two different types of Alarm Sounders are available:

1. Normal Alarm Klaxon (Alarm Sounder (Z171))
2. Battery Backed Up Alarm Sounder (Z272)

The Battery Backed Up Alarm Sounder (Z272) is an alarm sounder which contains its own internal battery. When the ignition is on, the internal battery is charged via an ignition feed. If either the connector is removed or the wires to it are cut, then the sounder will sound for 4-5 minutes.

To disconnect the Battery Backed Up Alarm Sounder (Z272):

- Turn Ignition On (Pos. III).
- Turn Ignition Off.
- Disconnect within 17 seconds.

To silence if triggered:

- Connect.
- Disarm Alarm.
- Turn Ignition On (Pos. III).

Alarm Triggering

The perimeter alarm will be triggered by any of the doors opening, the tailgate opening, the bonnet opening, the ignition key being inserted, the ignition being turned on, or the inertia switch being tripped.

The volumetric alarm will be triggered by any movement within the passenger compartment.

The alarm will be triggered a maximum of three times during any set/unset period. Any further triggers after this will be ignored.

ENGINE IMMOBILISATION FUNCTION

The engine will be immobilised whenever the alarm is armed or the alarm enters the Passive Immobilisation mode (regardless of whether or not the theft alarm is armed). There are two methods of Engine Immobilisation featured.

1. Engine Crank Disable
2. Electronic Engine Immobilisation

The electronic engine immobilisation is controlled jointly by the engine management system's Electronic Control Module and the BeCM.

If a crank signal is detected when the engine is immobilised, the 'Engine Immobilised' message will be transmitted to the instrument pack, and it will not be possible to start the engine.

Engine Immobilisation (Petrol)

The BeCM immobilises the engine by transmitting an engine immobilise code to the ECM. The code is not sent when the engine is immobilised.

Engine Immobilisation (Diesel)

The electronic engine immobilisation feature fitted to the diesel engine derivatives is different to the system fitted to the petrol versions.

The BeCM immobilises the engine by holding the engine immobilise output high. The output will be low when the engine is immobilised.

Passive Immobilisation

The following conditions will passively immobilise the vehicle:

- 30 seconds after ignition has been turned off and the driver's door has been opened.
- 30 seconds after ignition has been turned off, the key removed, and the driver's door has been opened.
- 10 minutes after ignition has been turned off and the key removed (without opening the driver's door).
- The handset becomes desynchronised (or with an improperly functioning Handset).

The vehicle can be mobilised by any of the following methods:

- Turn the ignition on (The handset must be functioning properly and within close proximity to the key).
- Press unlock button on the handset.
- Enter EKA code.

NOTE: The vehicle will remain immobilised by attempting to turn the ignition on with the handset detached from the key ring (or with an improperly functioning handset).

If the handset becomes desynchronised (or is functioning improperly), the engine will be passively immobilised. If an attempt is made to start the engine, the message "Engine Disabled Press Remote" will be displayed on the message centre. To mobilise the engine the EKA code must be entered and the handset (when functioning properly) resynchronised.

Passive Immobilisation Coil (Z270)

A magnetic field is generated by the passive Immobilisation Coil (Z270) contained in the steering column. This field excites a receiving coil in the handset causing it to transmit a mobilisation signal to the BeCM. If the BeCM does not receive this signal from the handset, the vehicle will remain immobilised.

Handset Transmitter Resynchronisation

The Theft Alarm Unit (Z163) will remain synchronised with the handset unless:

- The handset's batteries have been removed.
- The vehicle's battery has been disconnected.

NOTE: All handsets must be resynchronised when the vehicle's battery has been disconnected.

A handset may be resynchronised by performing a key kick, or unlock, on either front door with a 30 seconds of performing a remote lock, superlock, or unlock function. The BeCM uses the change of state of the CDL Switch to initiate resynchronisation.

Emergency Key Access (EKA)

EKA is used to disarm the theft alarm and mobilise the vehicle in the event of a handset failure. This is possible through a series of locks and unlocks with the key in the driver's door lock cylinder. With the vehicle locked and the alarm armed, turn the key the required number of times according to the following sequence:

1. To enter the first digit, turn the key the required number of times to the unlock position.
2. To enter the second digit, turn the key the required number of times to the lock position.
3. To enter the third digit, turn the key the required number of times to the unlock position.
4. To enter the fourth digit, turn the key the required number of times to the lock position.
5. Turn the key to the unlock position to unlock the doors, disarm the alarm, and mobilise the vehicle.

NOTE: The key must be fully turned to the rest and lock/unlock position each time.

After 5 wrong attempts, you must wait 10 minutes.

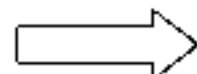
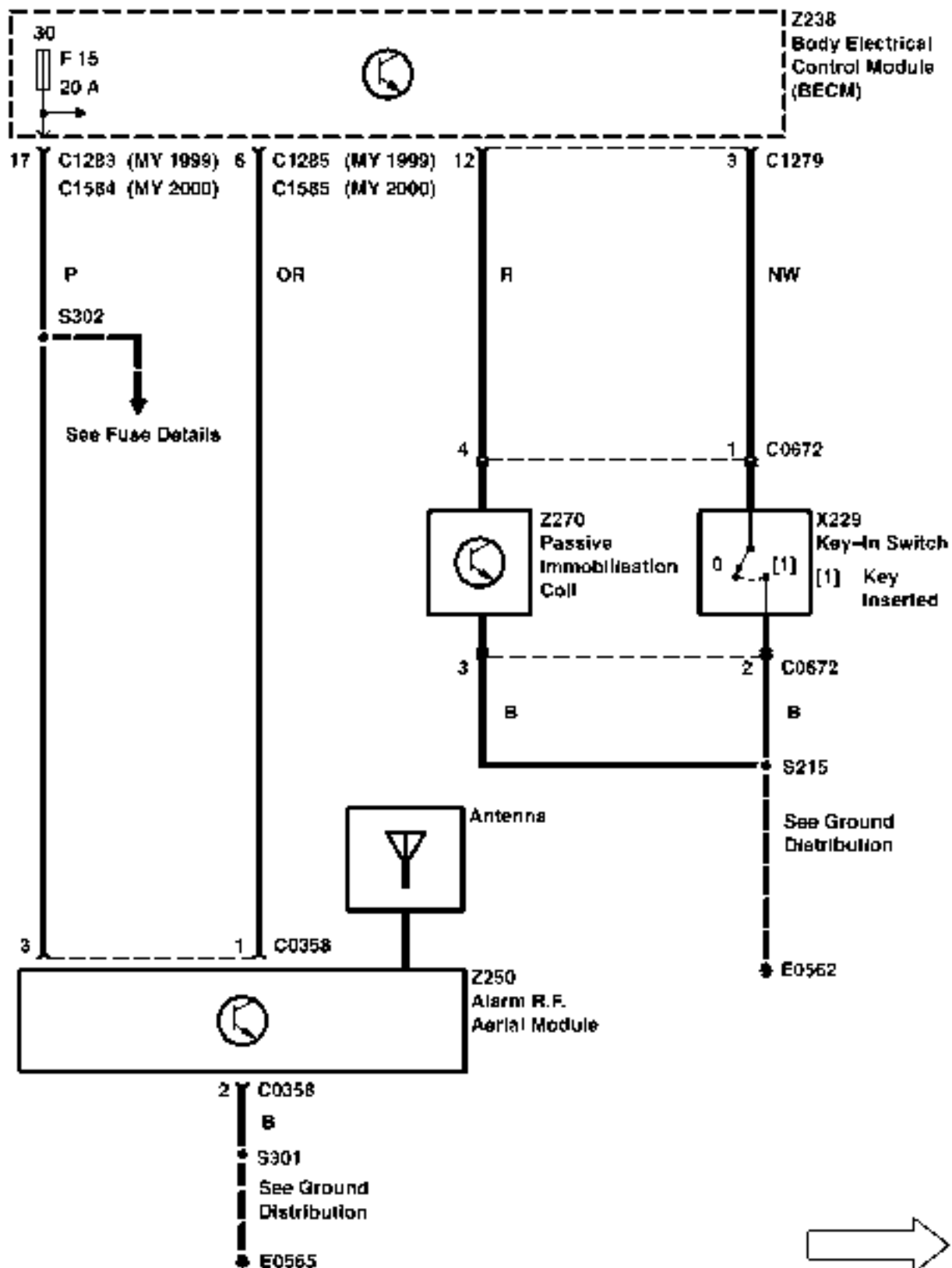

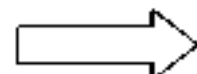
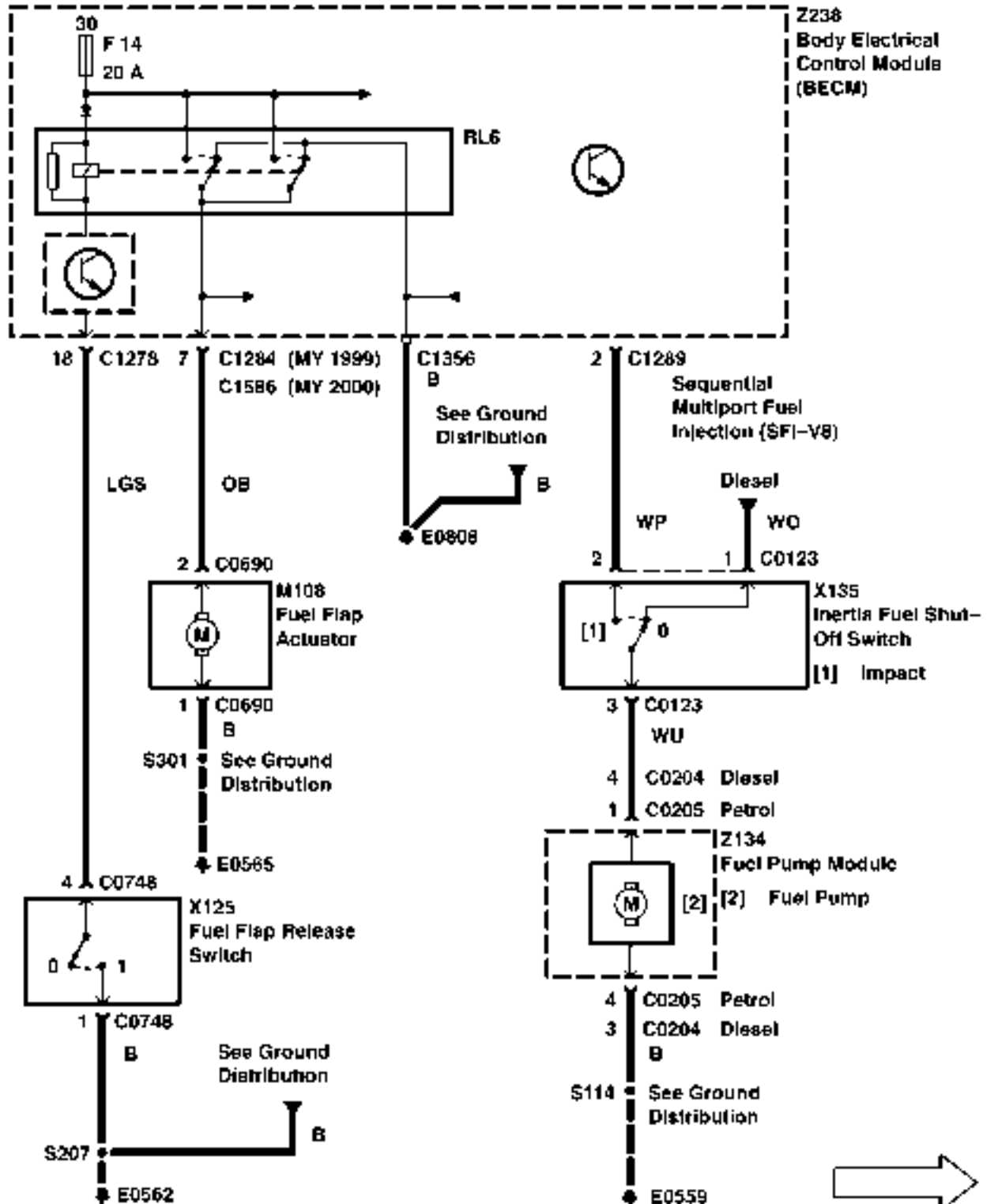
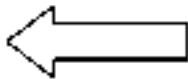

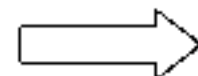
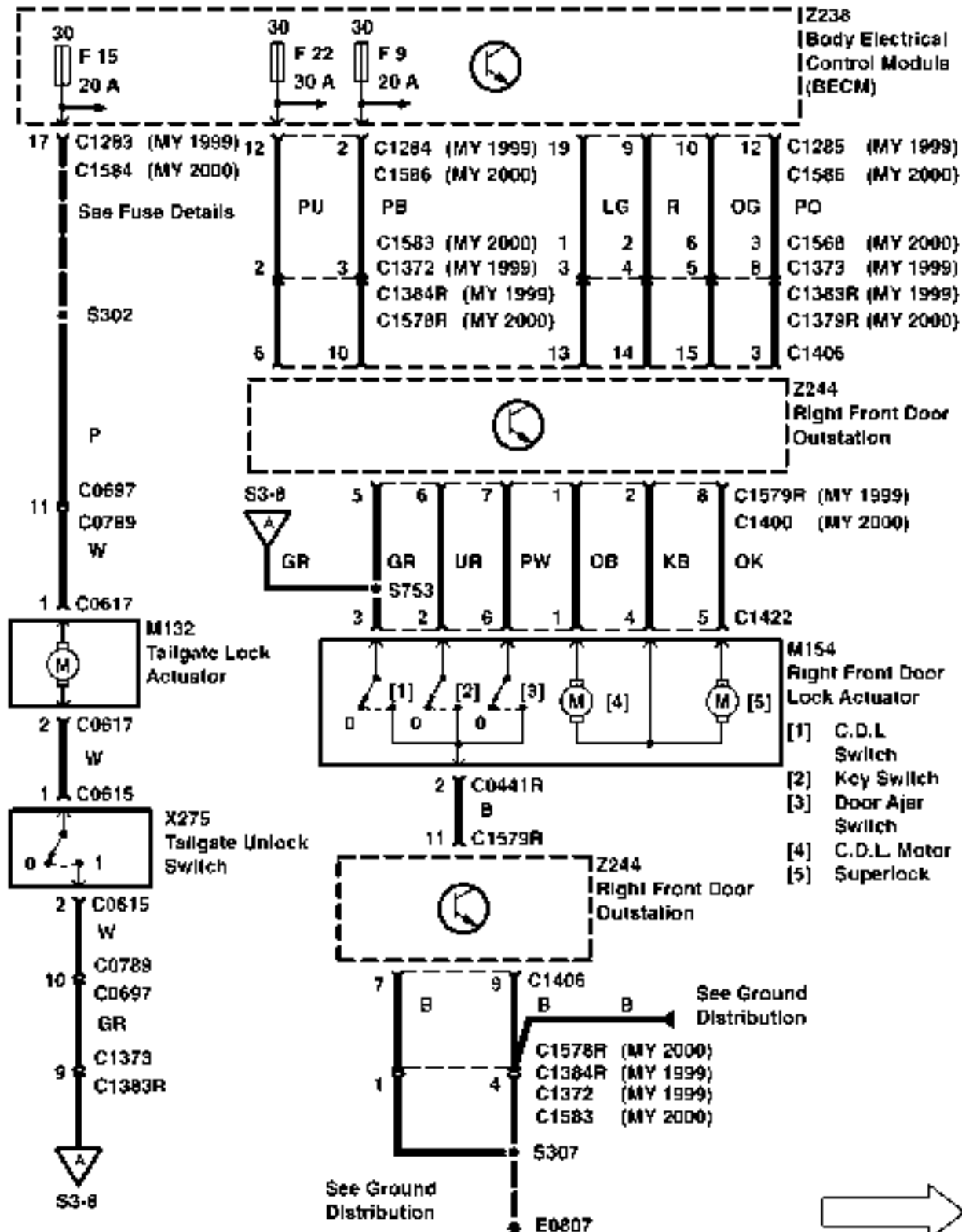
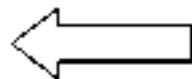

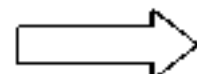
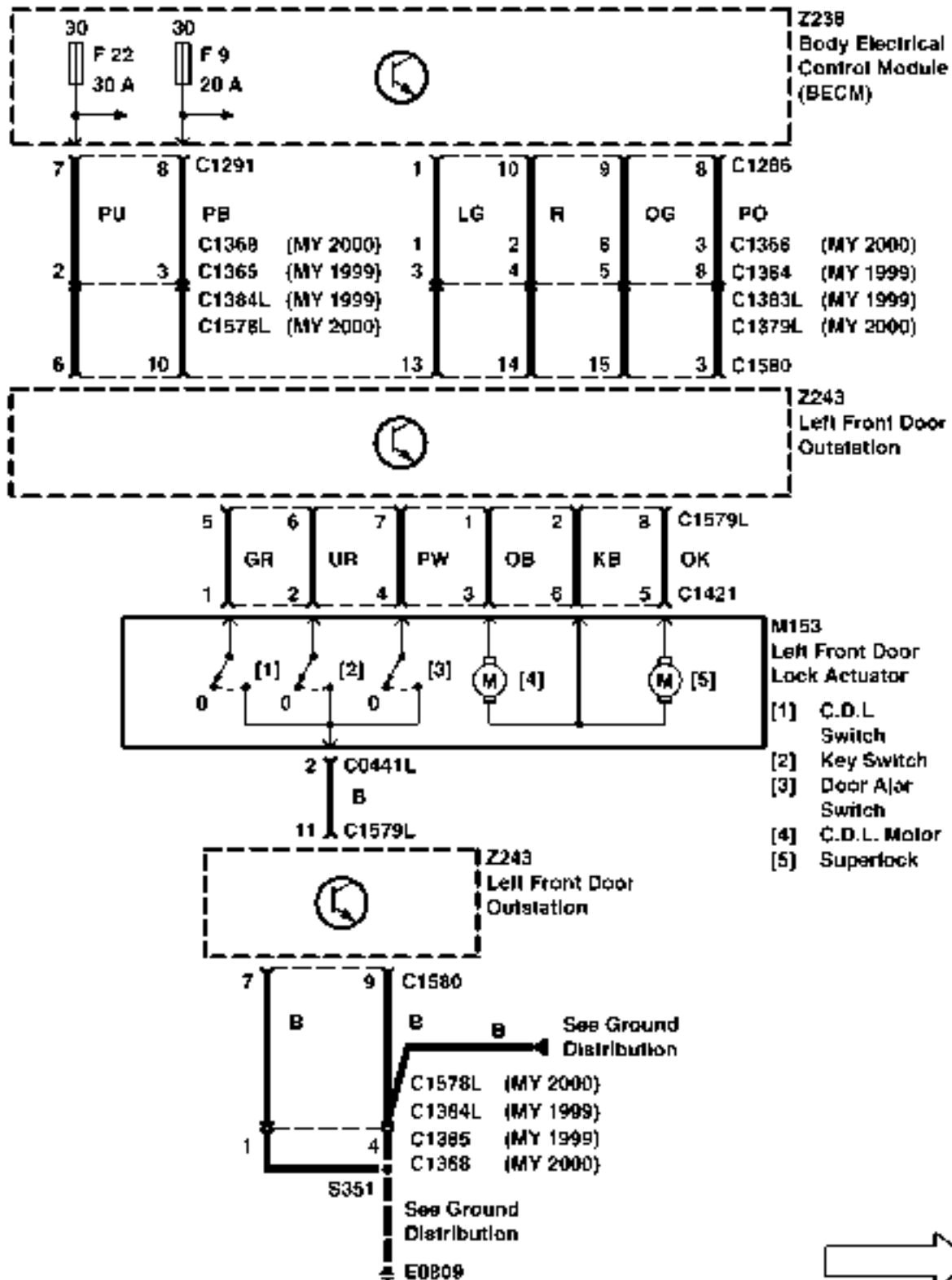
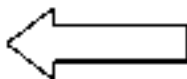

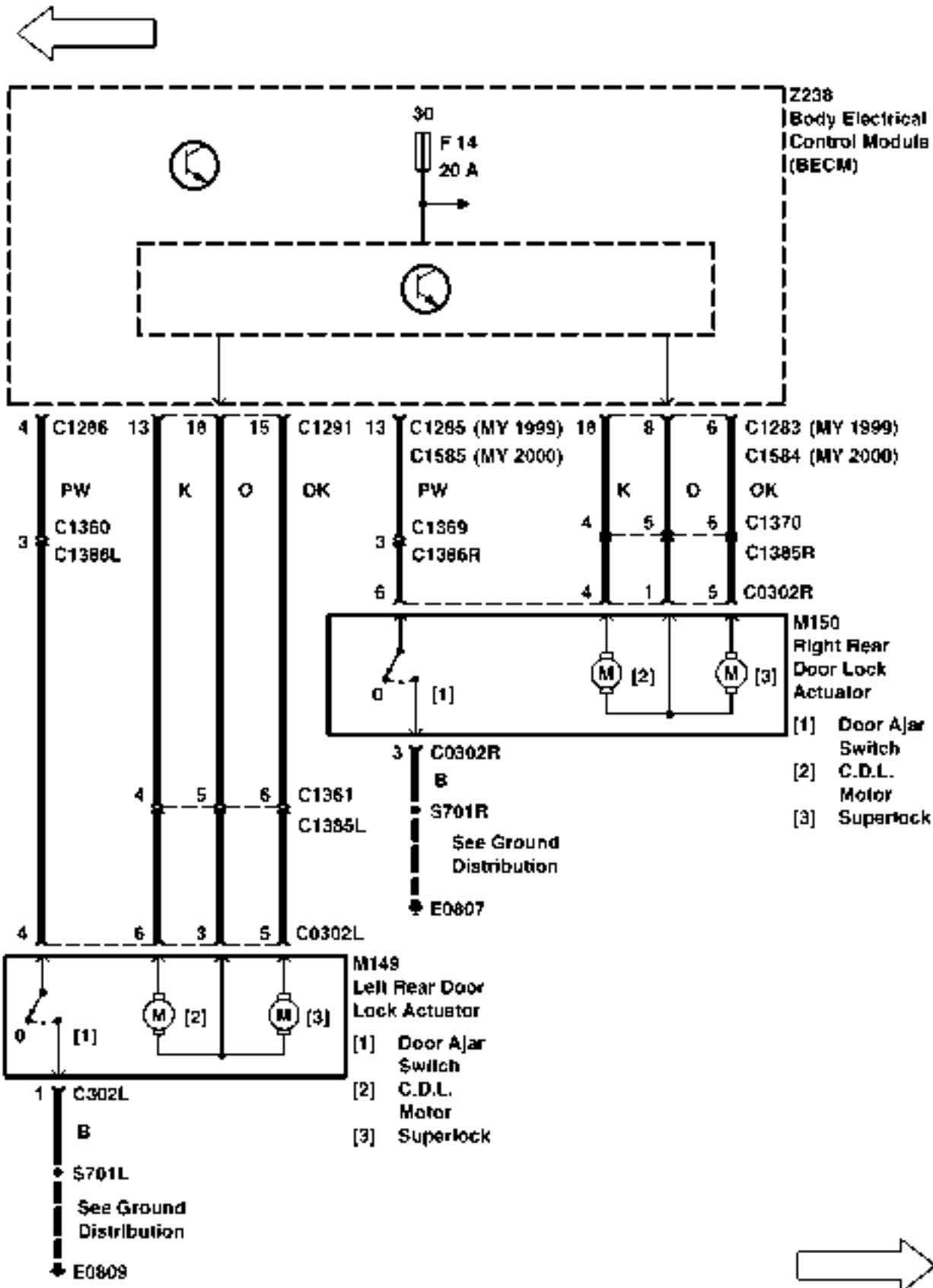

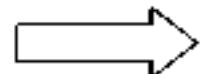
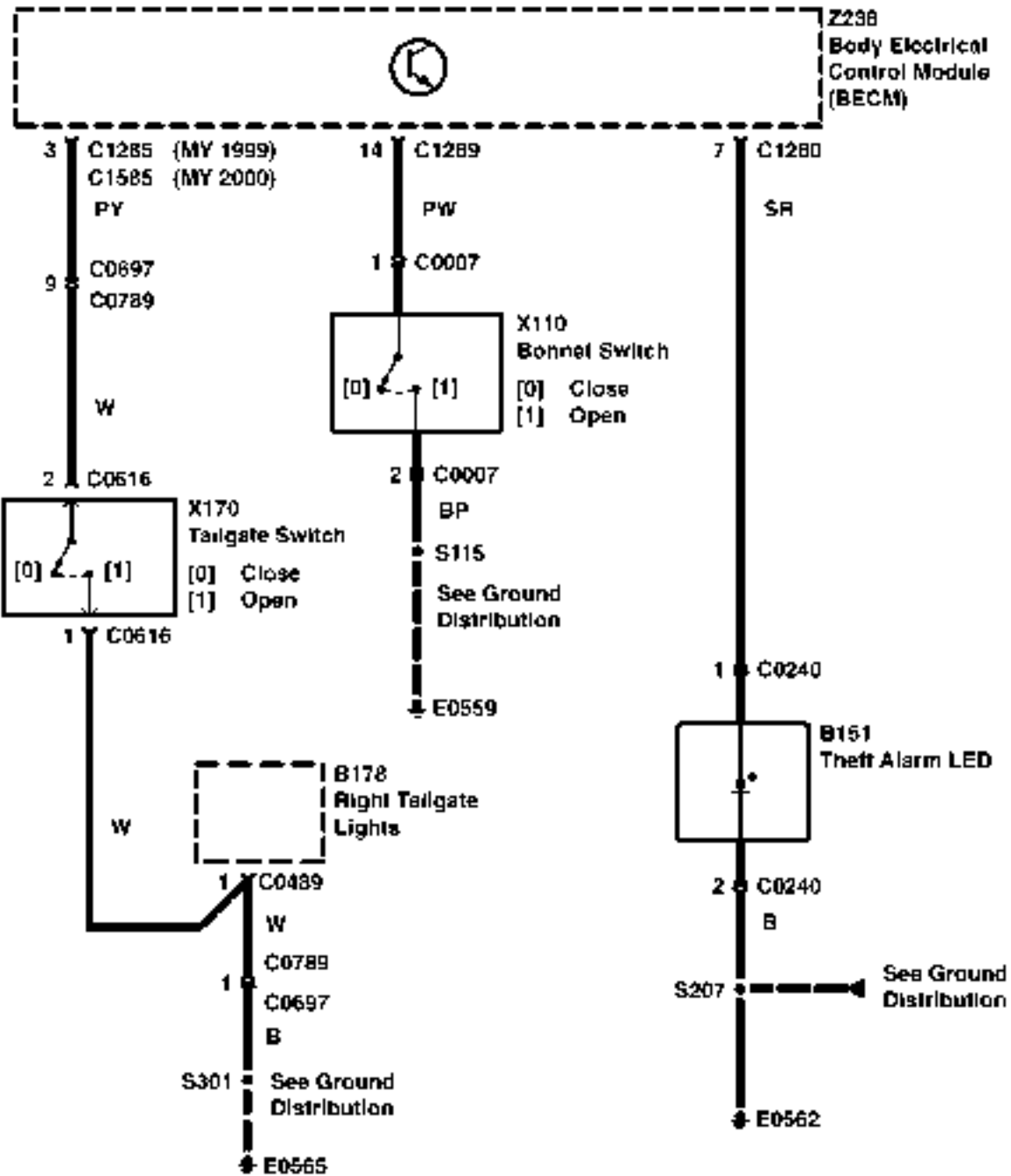

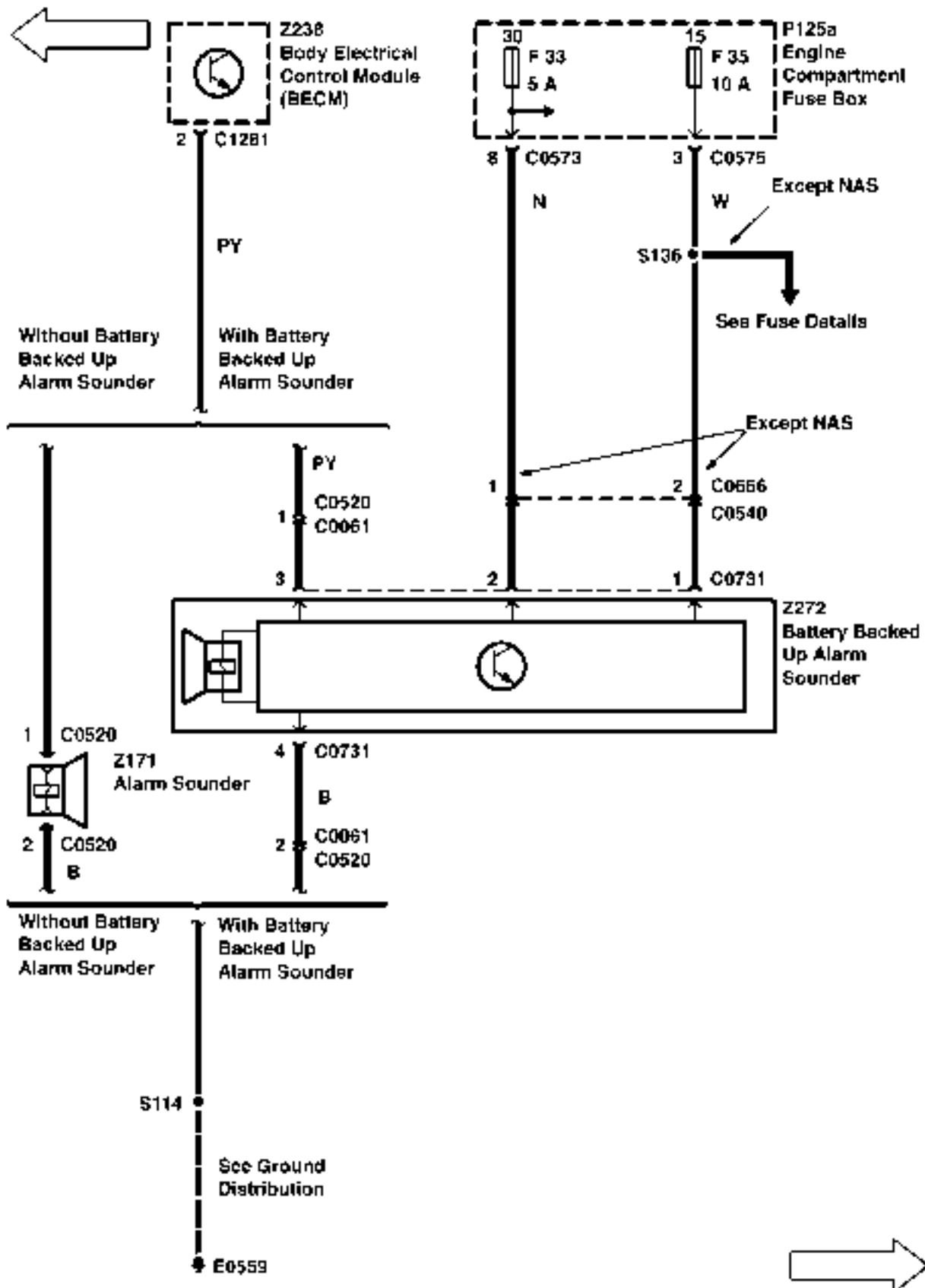

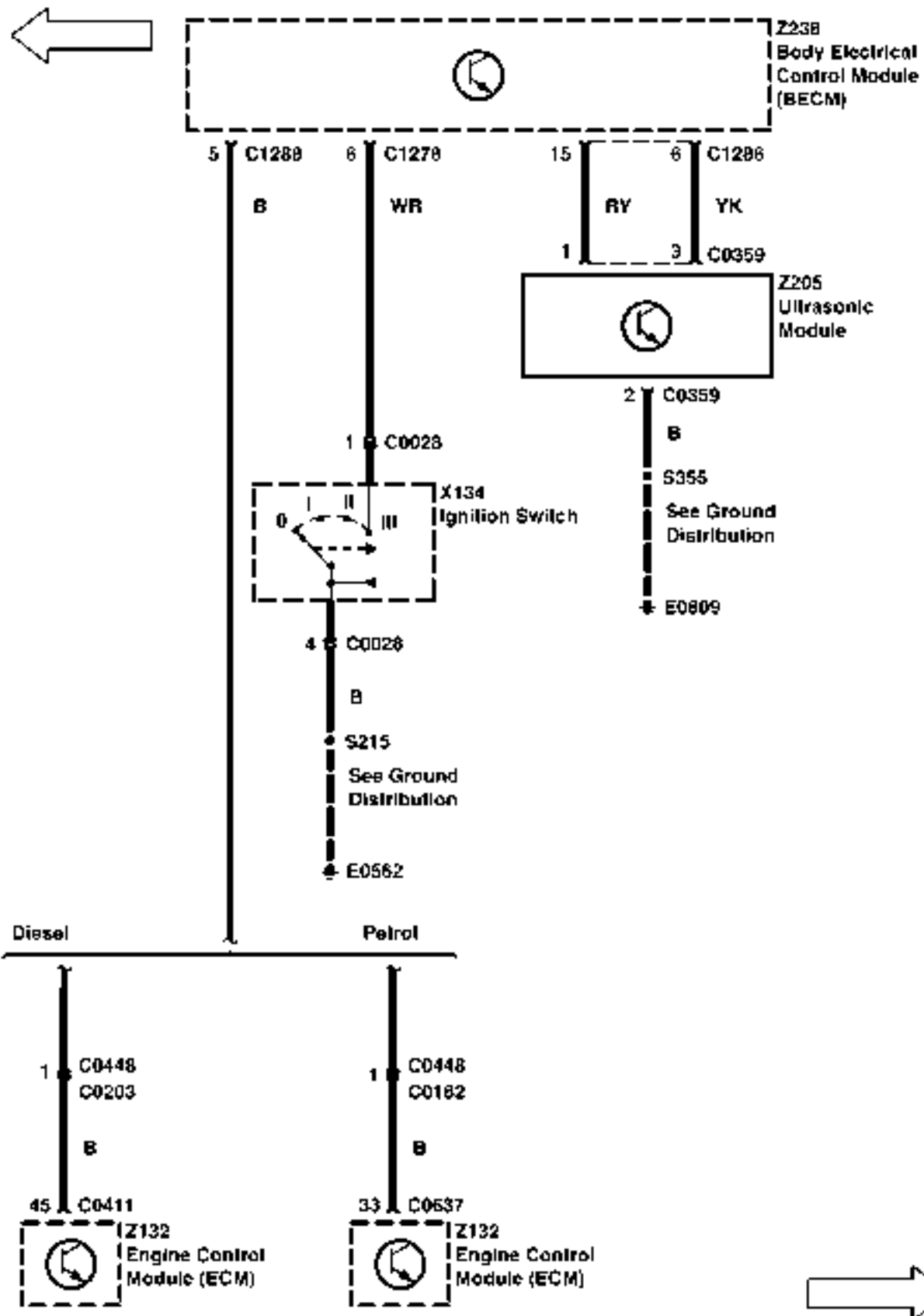

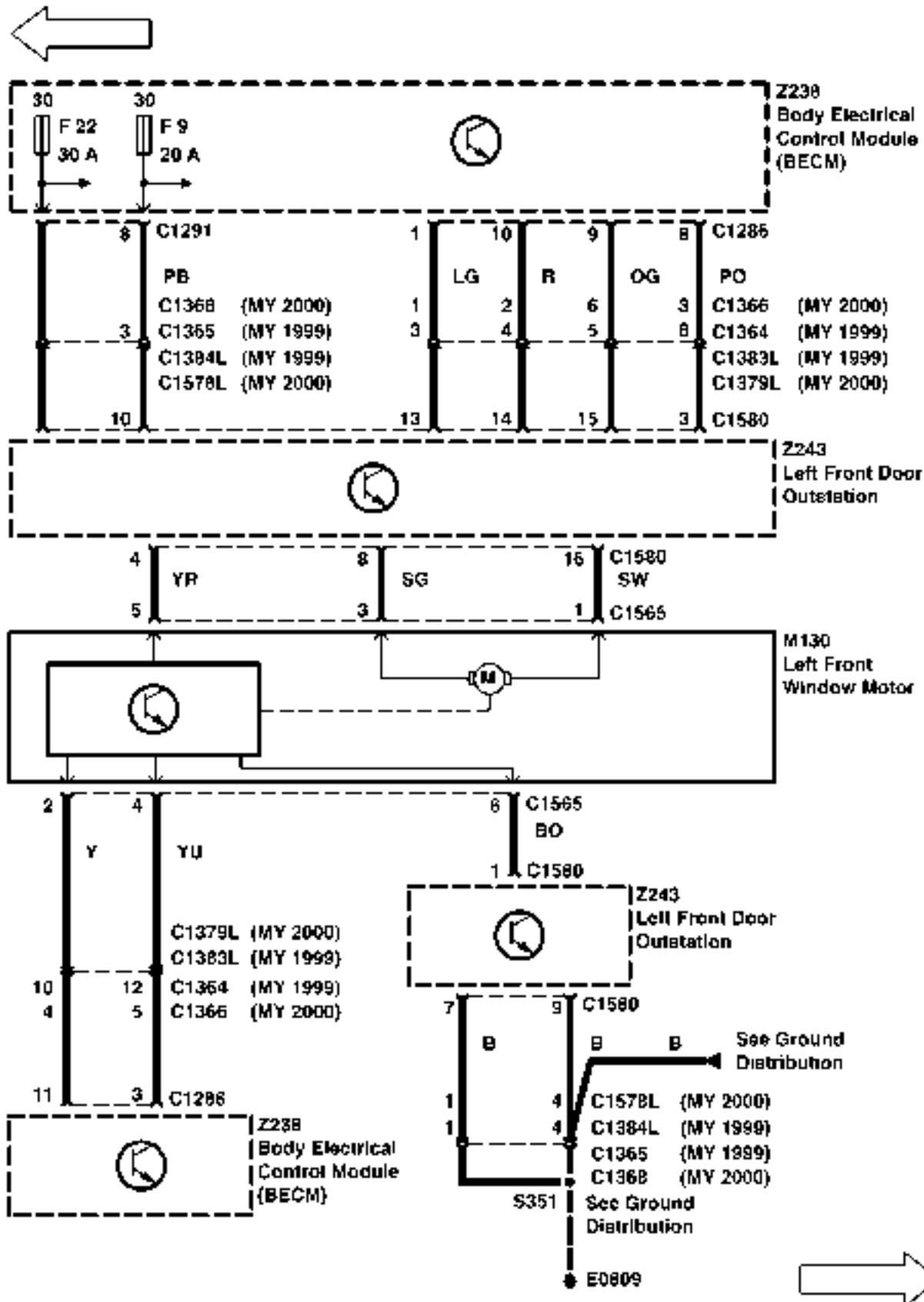

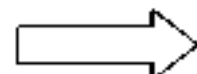
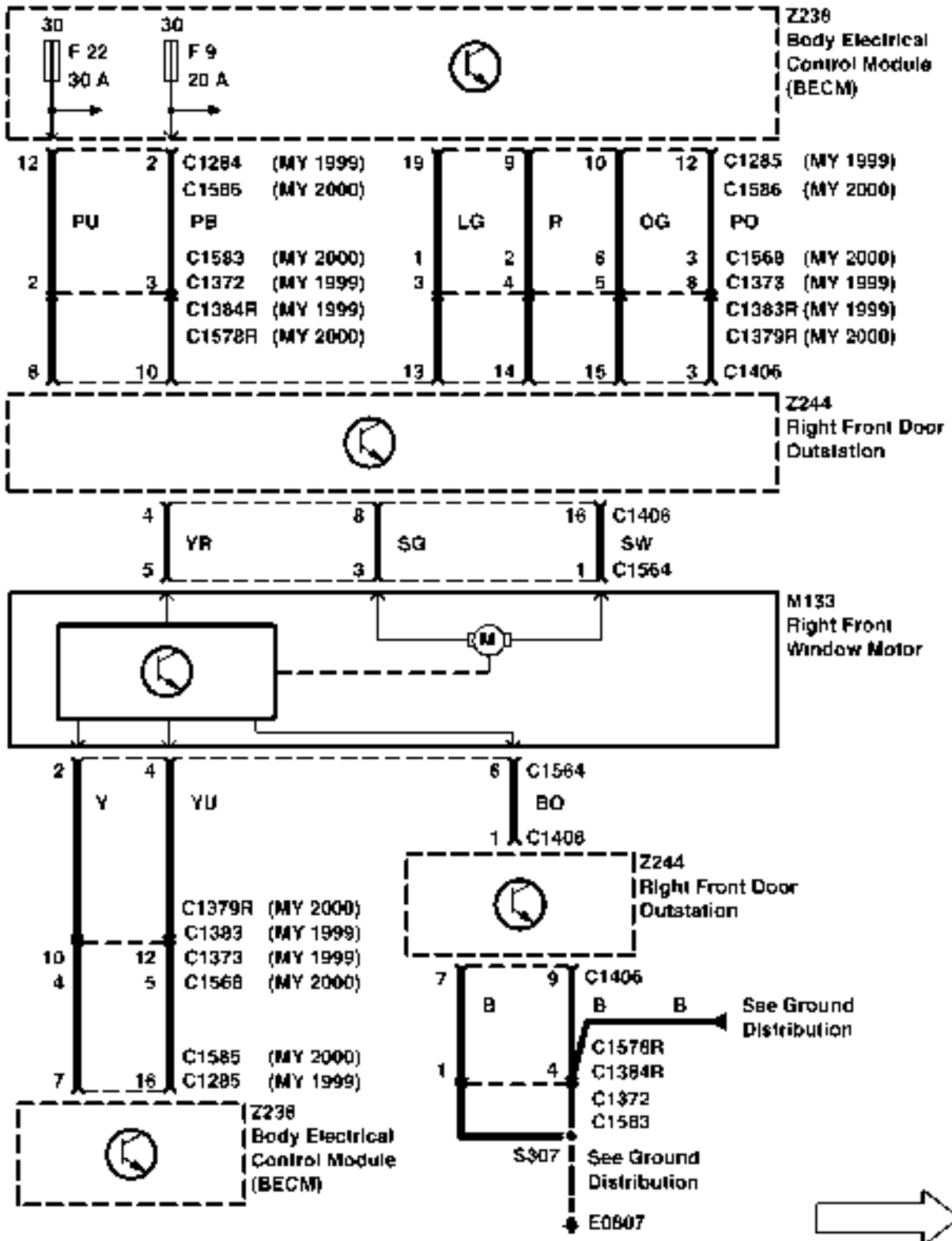
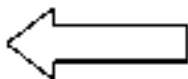

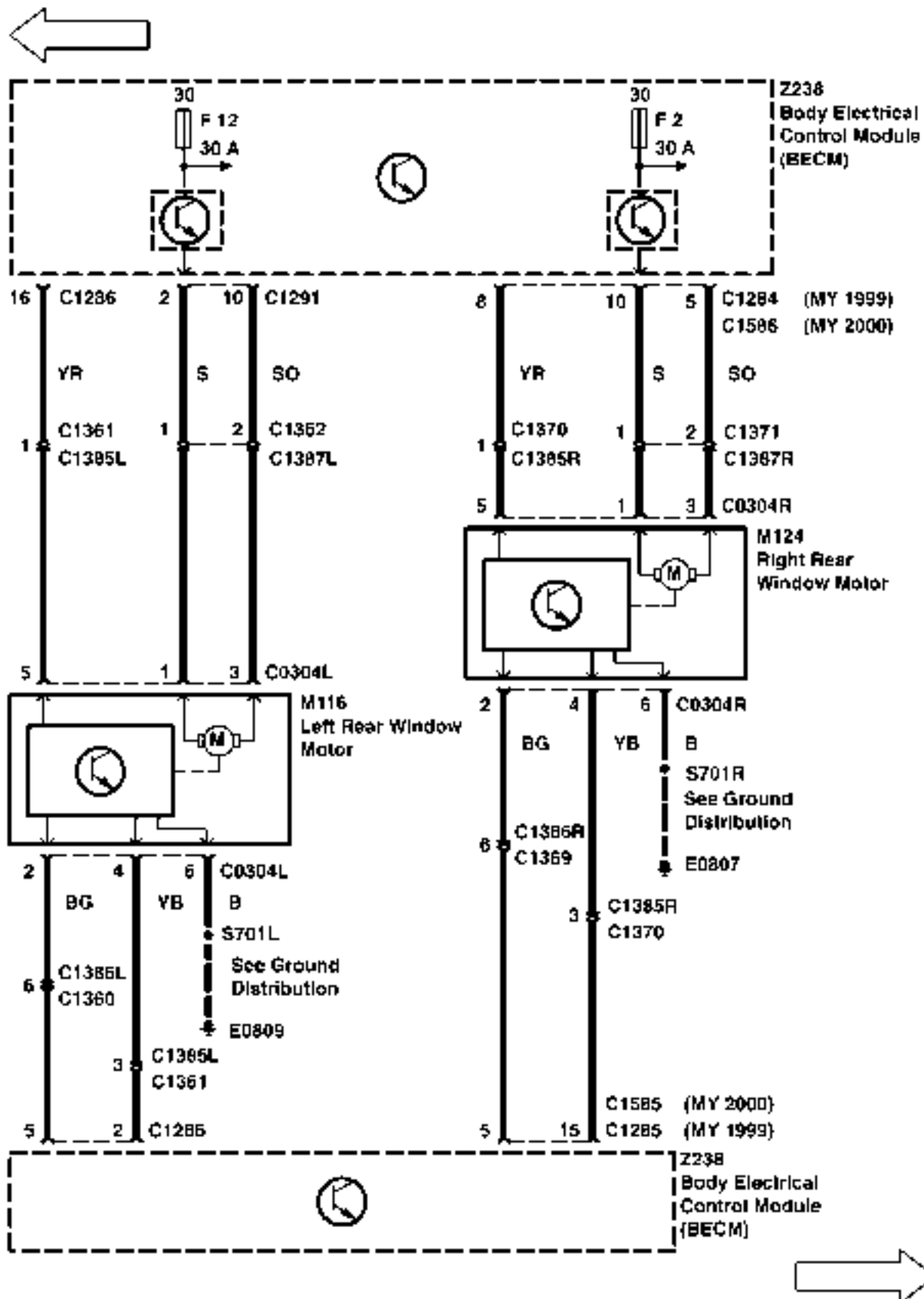

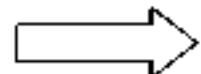
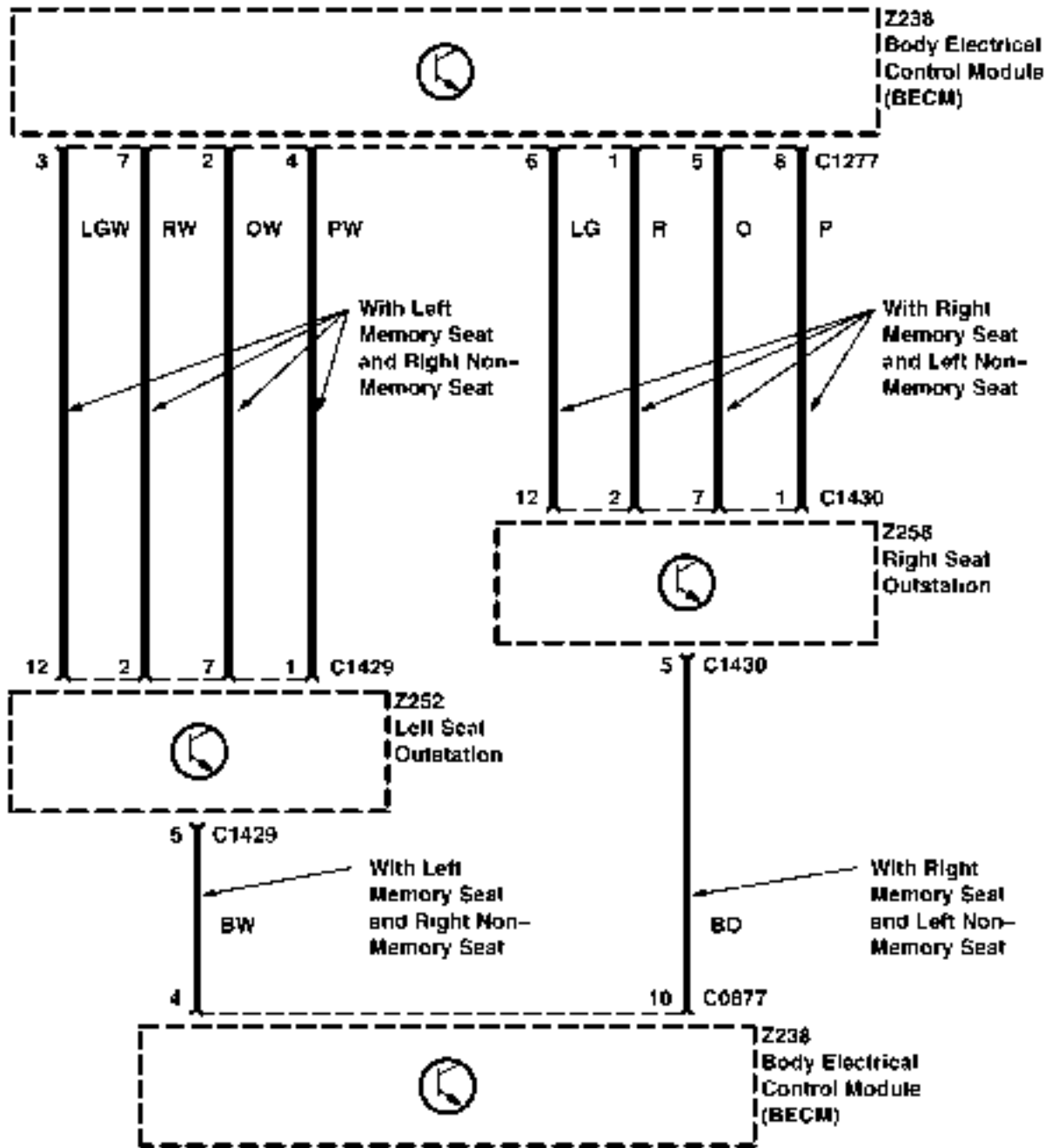
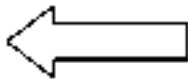

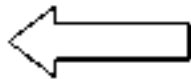

Interior Lamps

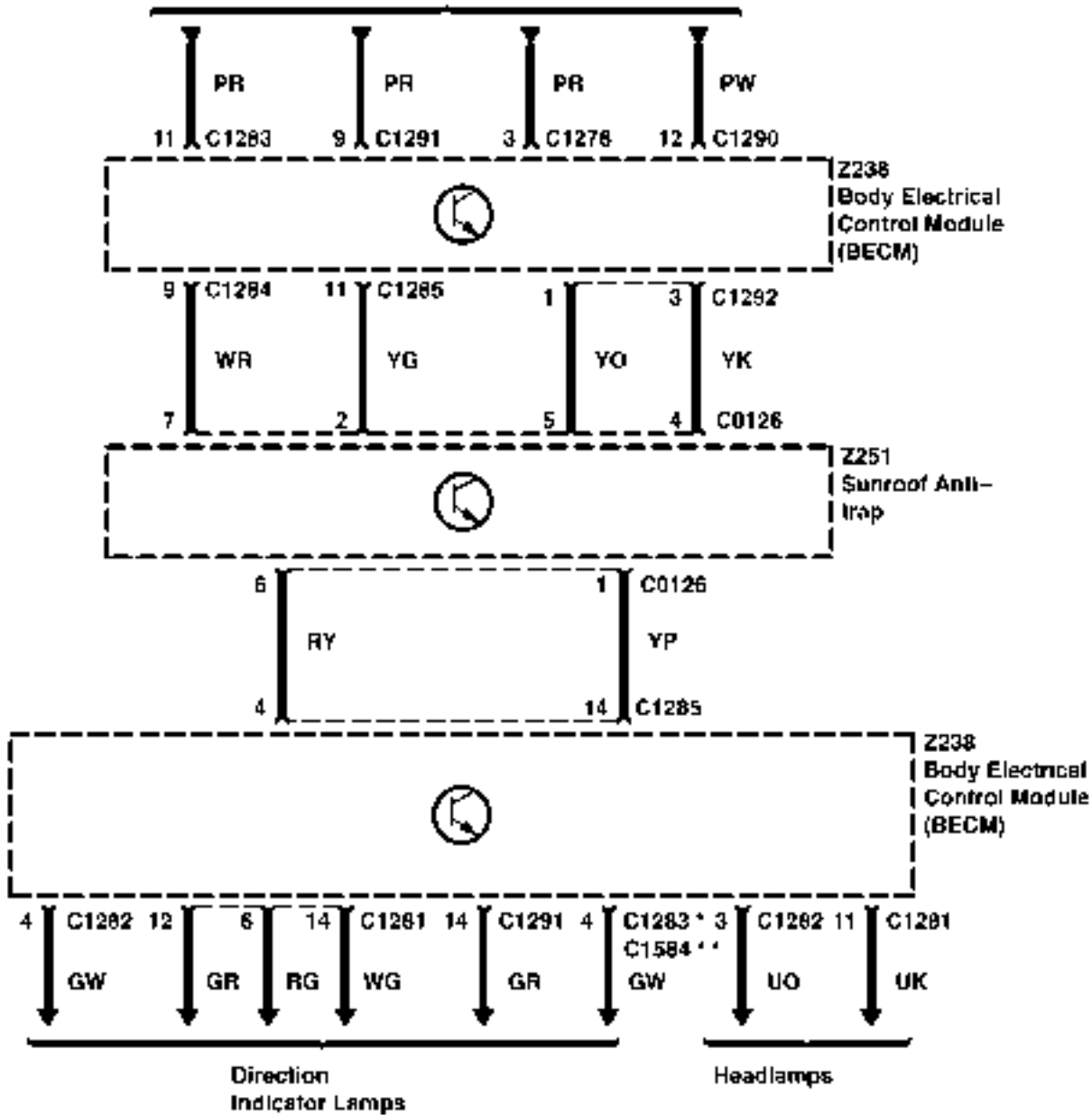

* (MY 1999)

** (MY 2000)

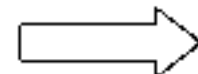

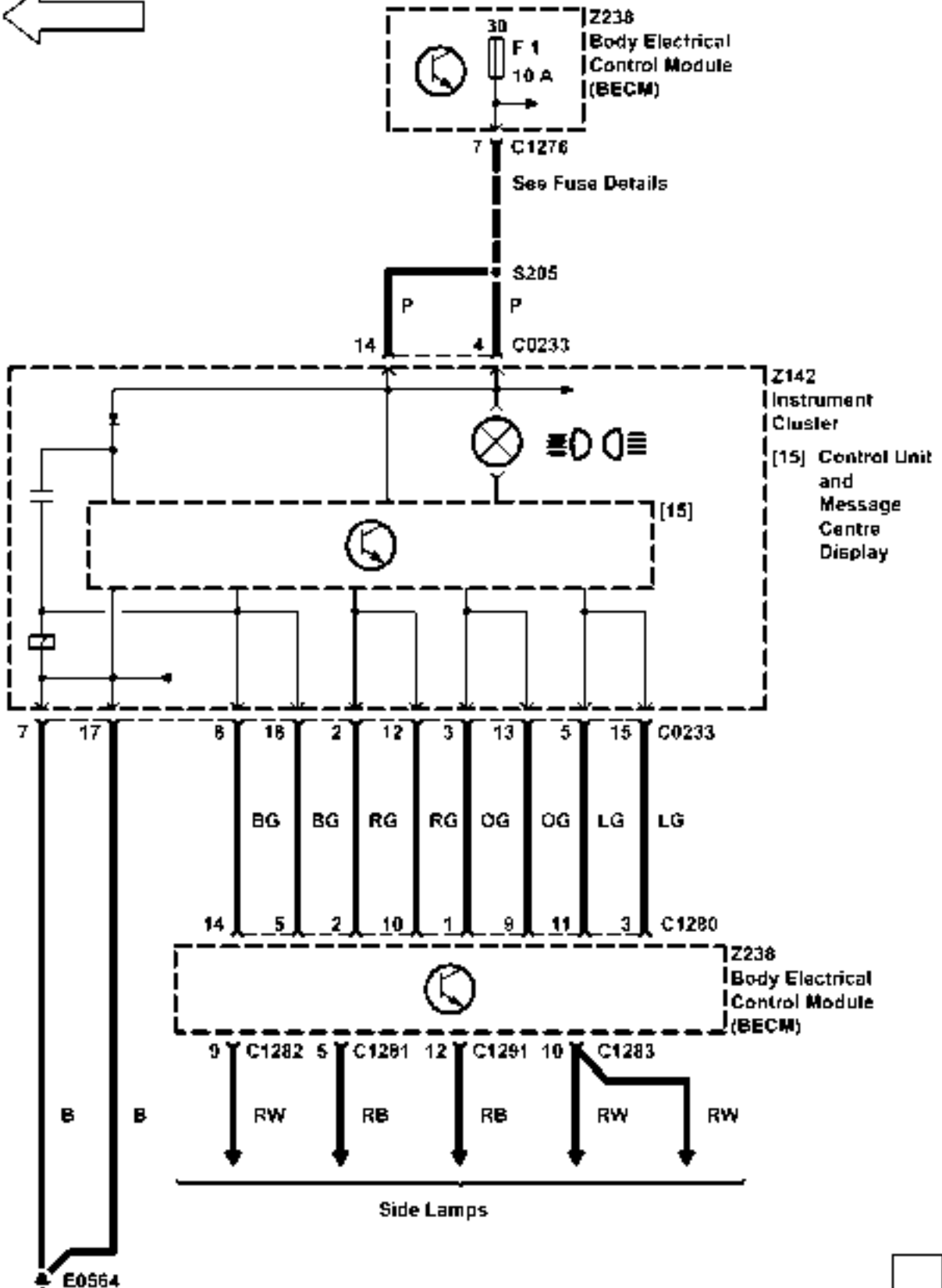
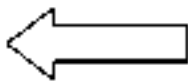

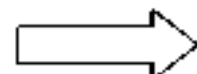
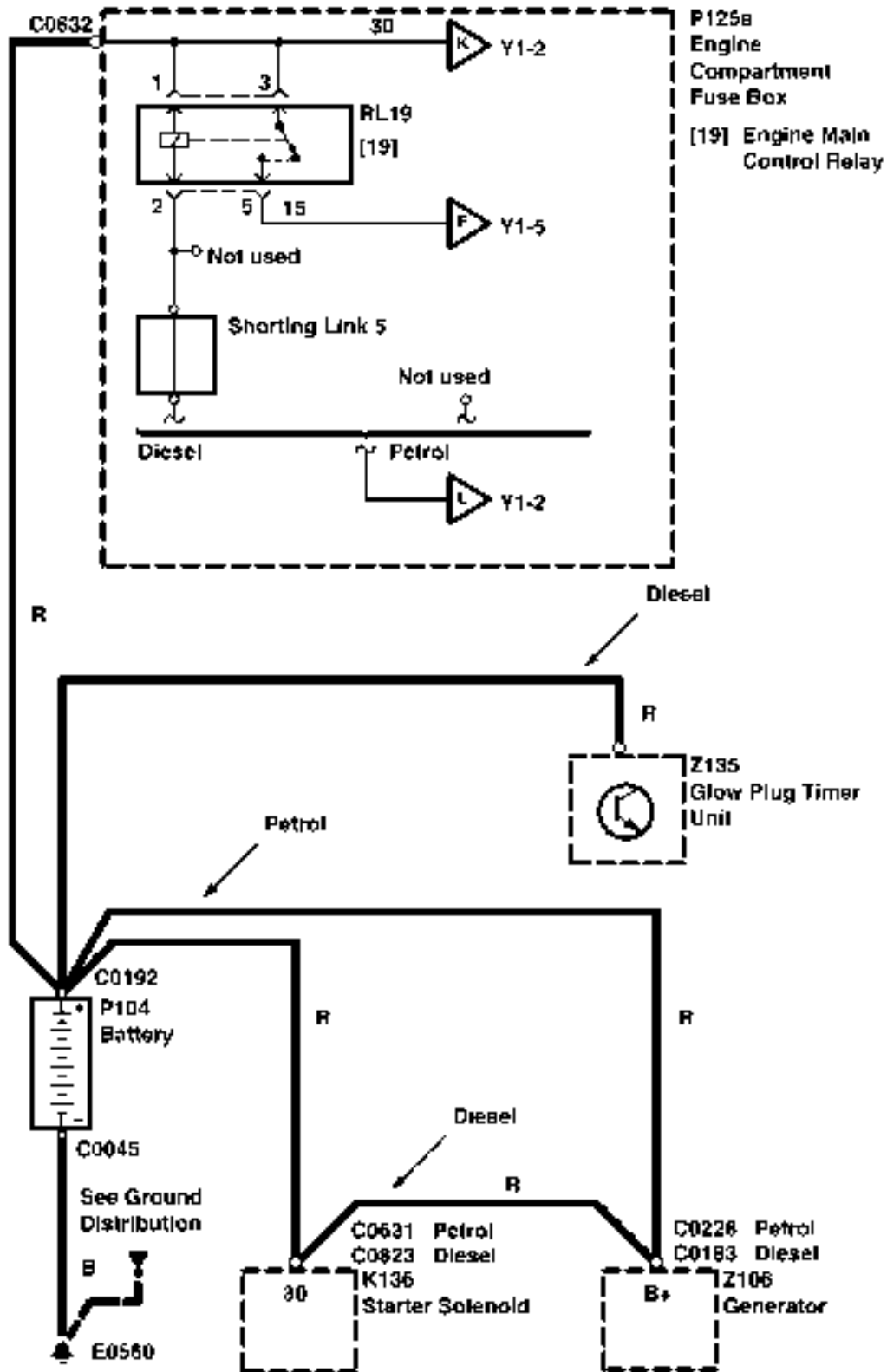

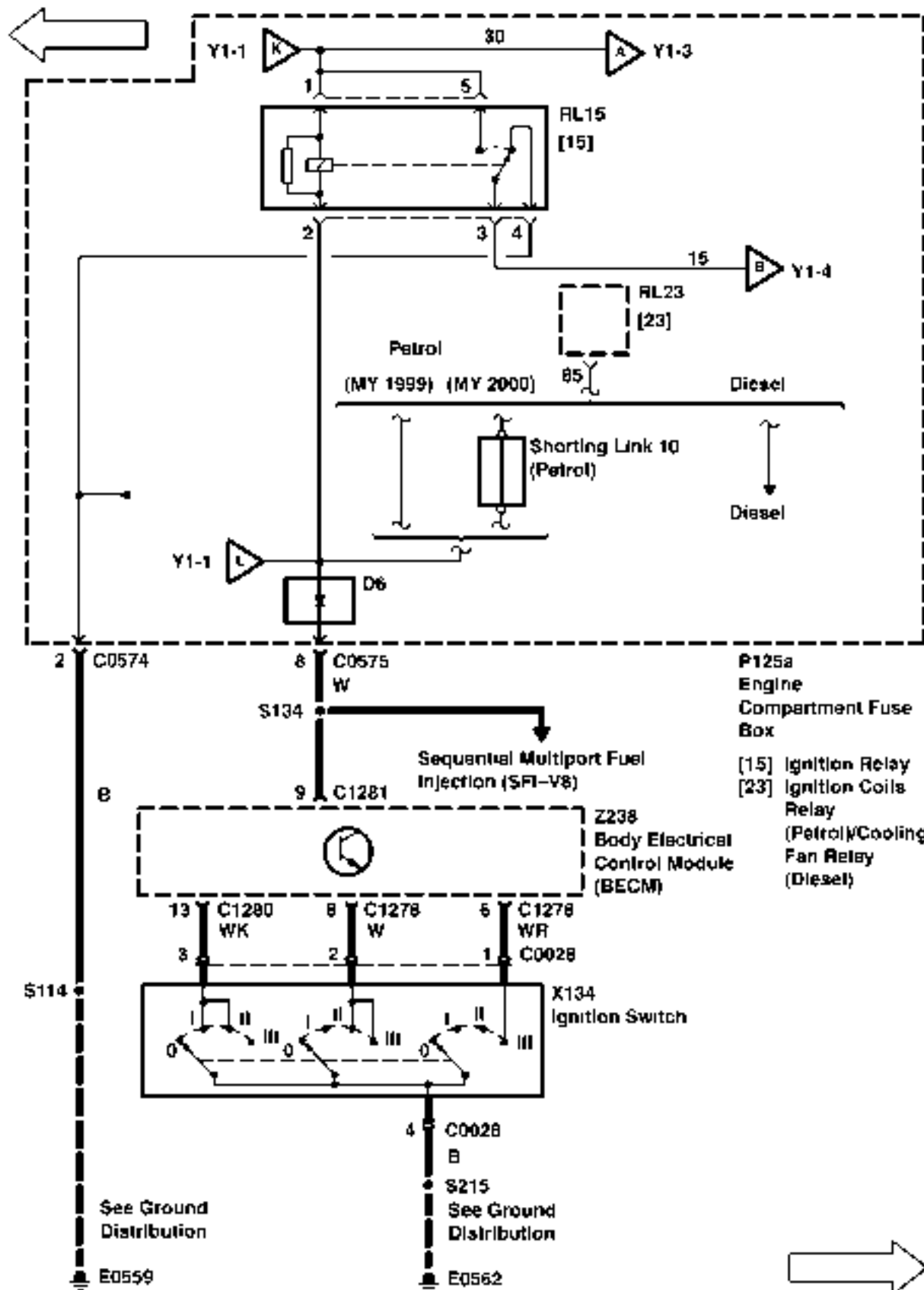

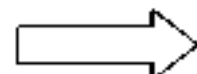
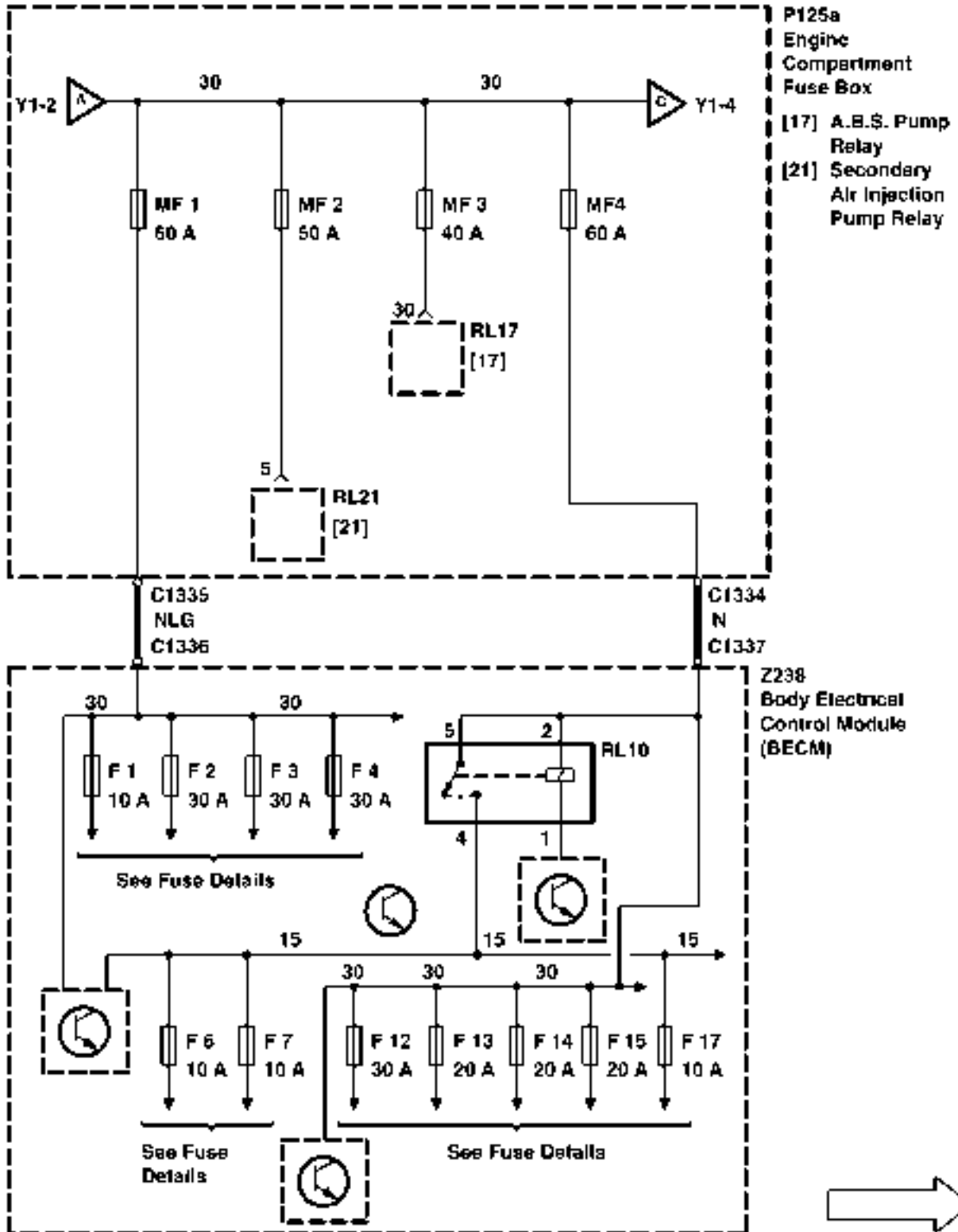
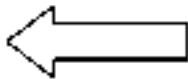

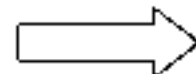
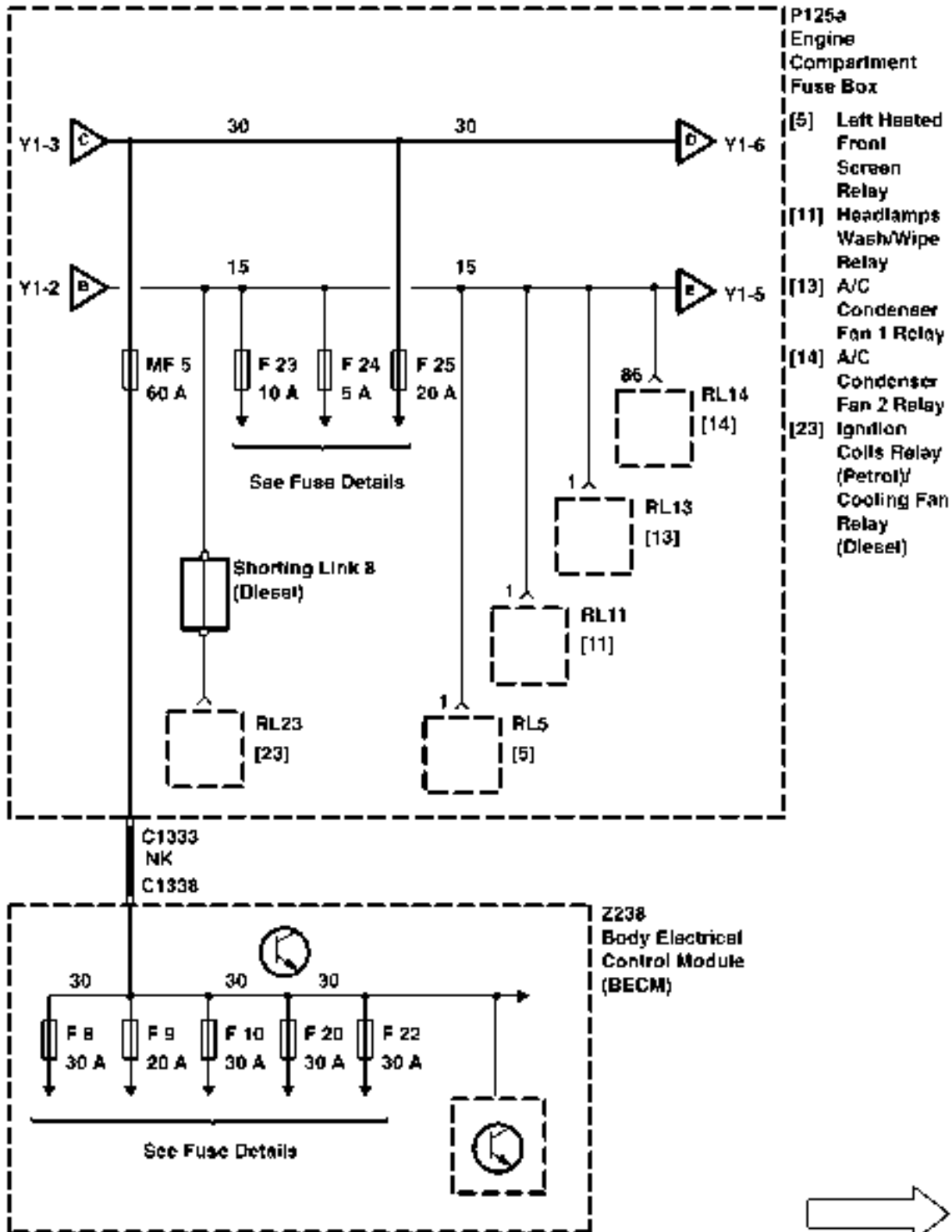

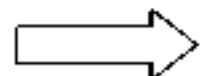
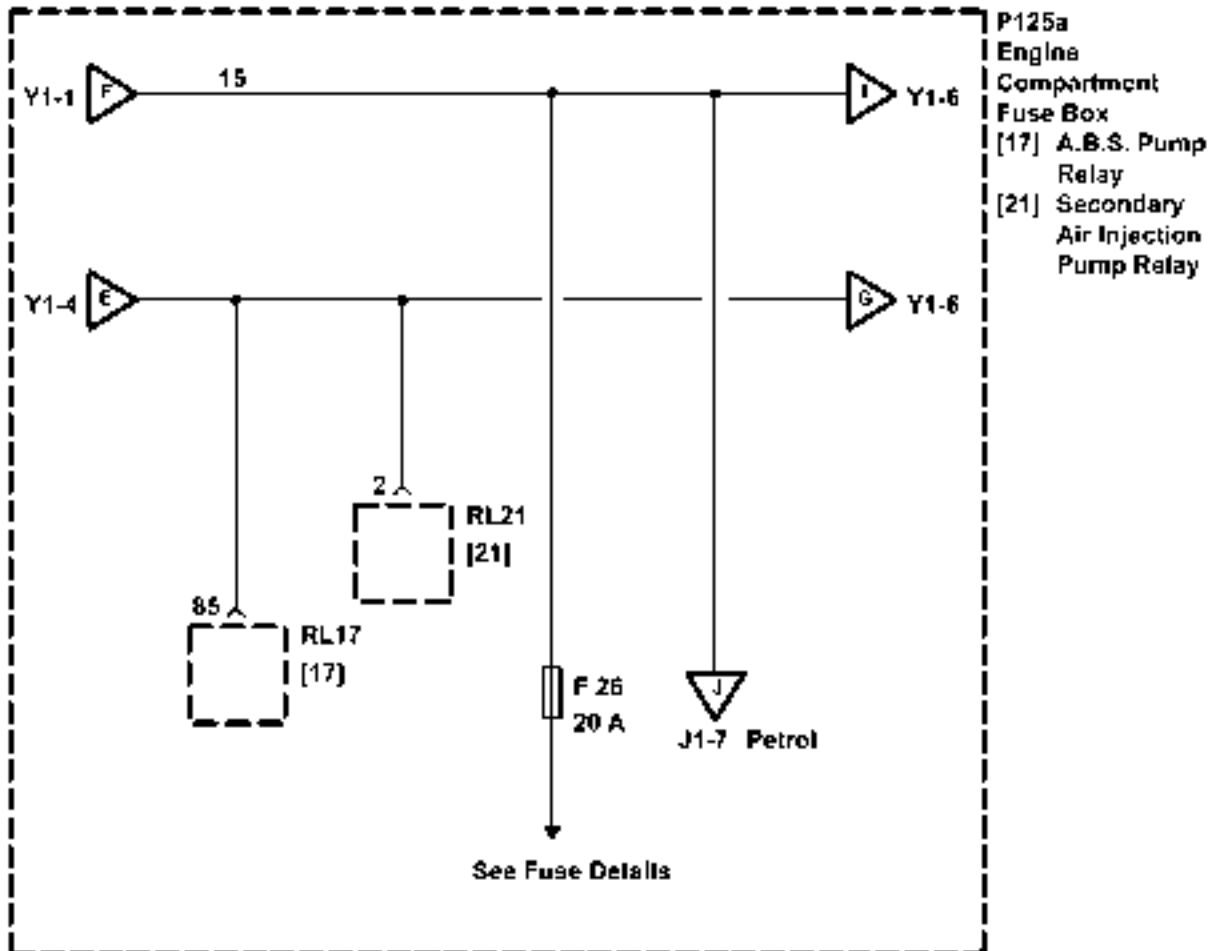
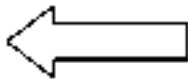

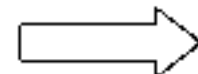
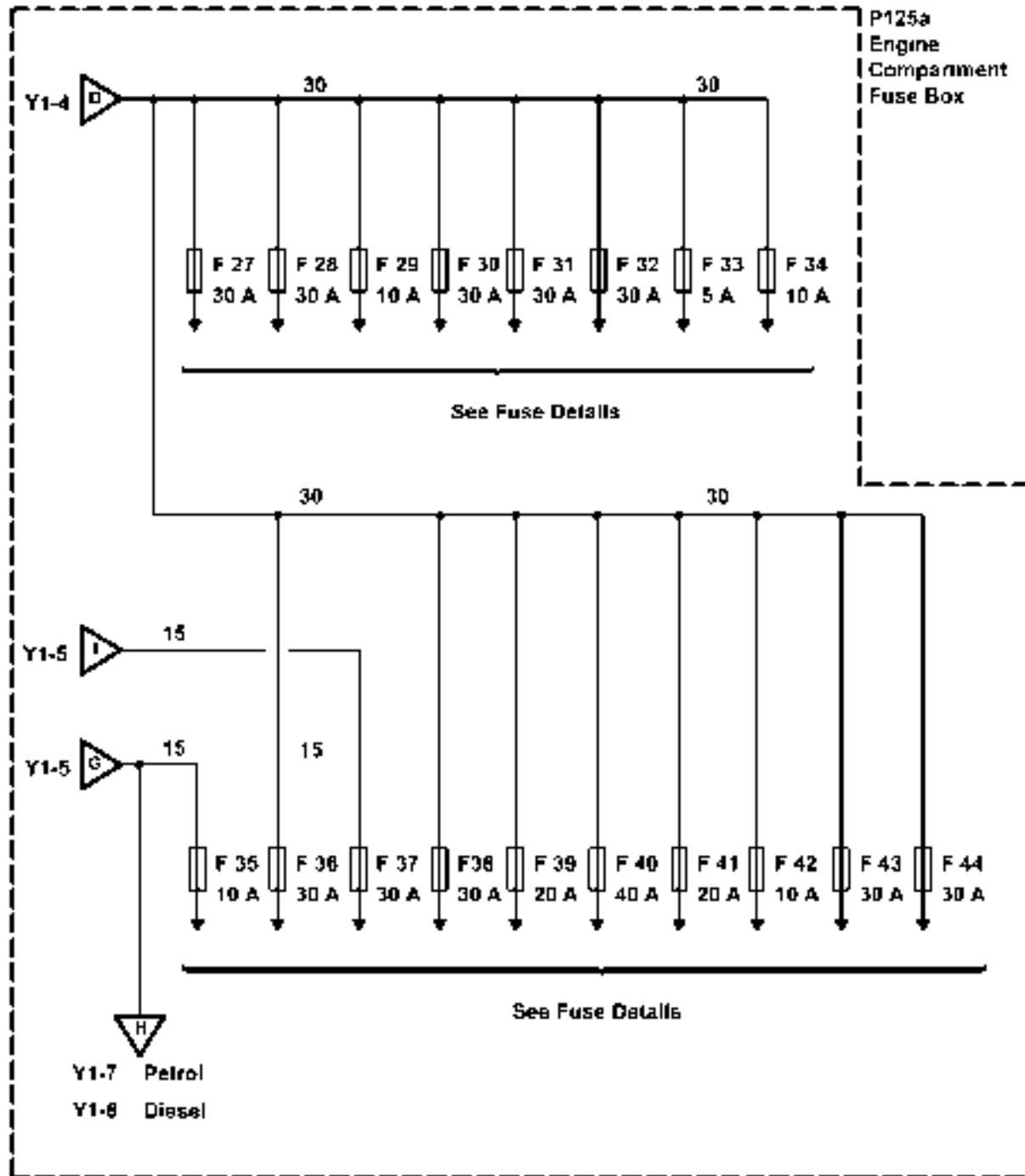
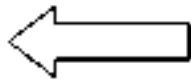

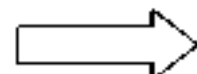
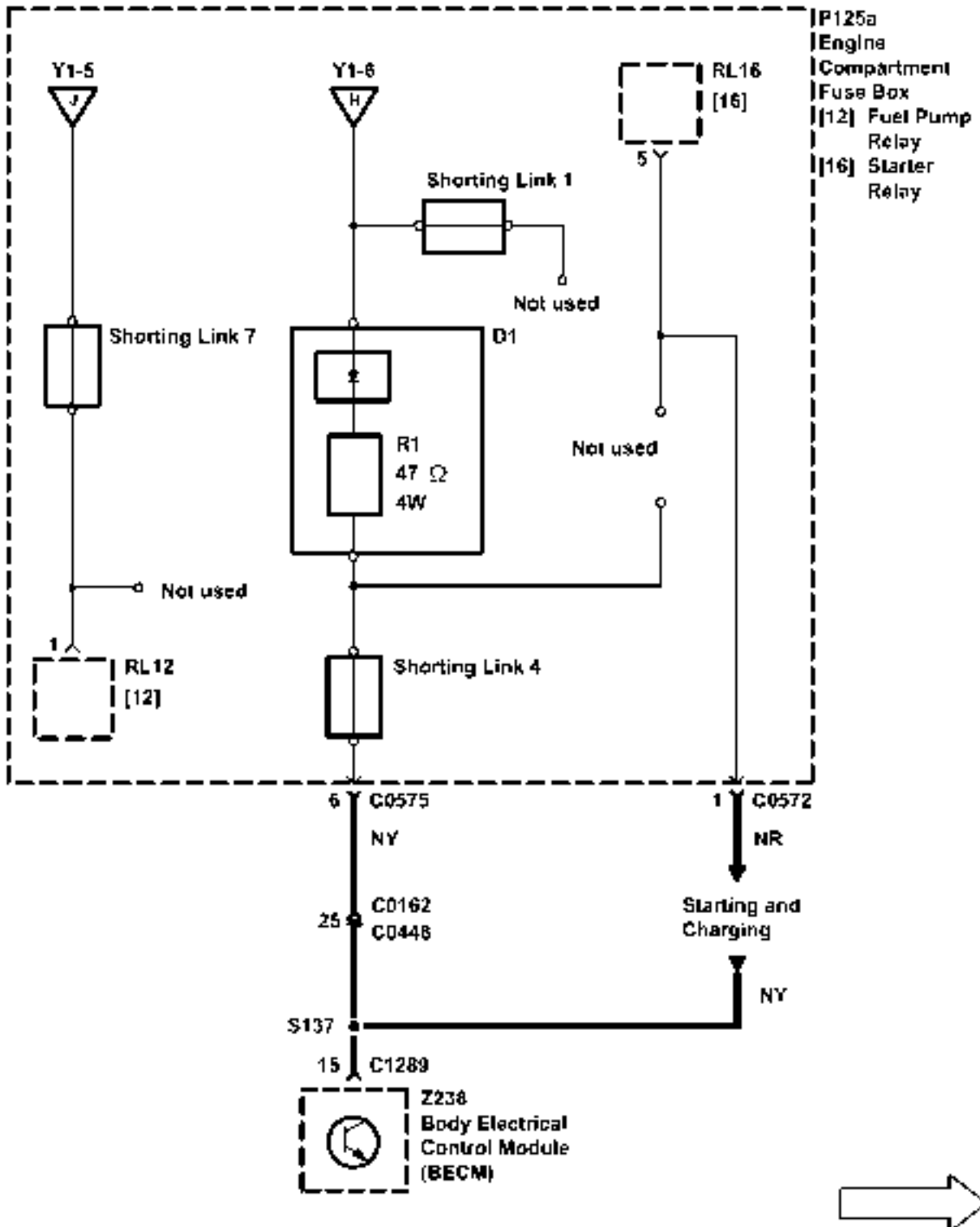
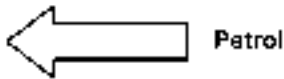

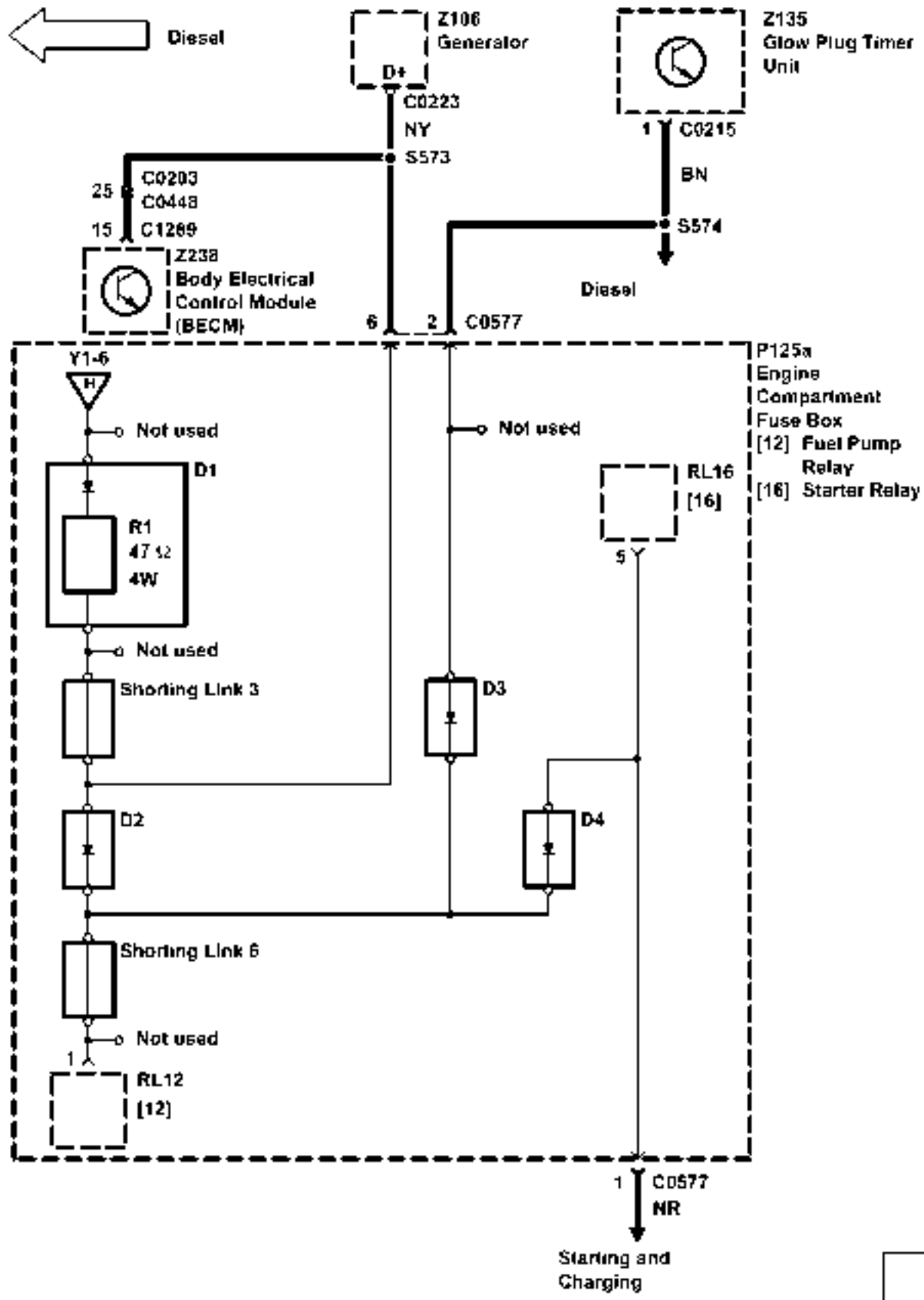

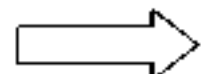
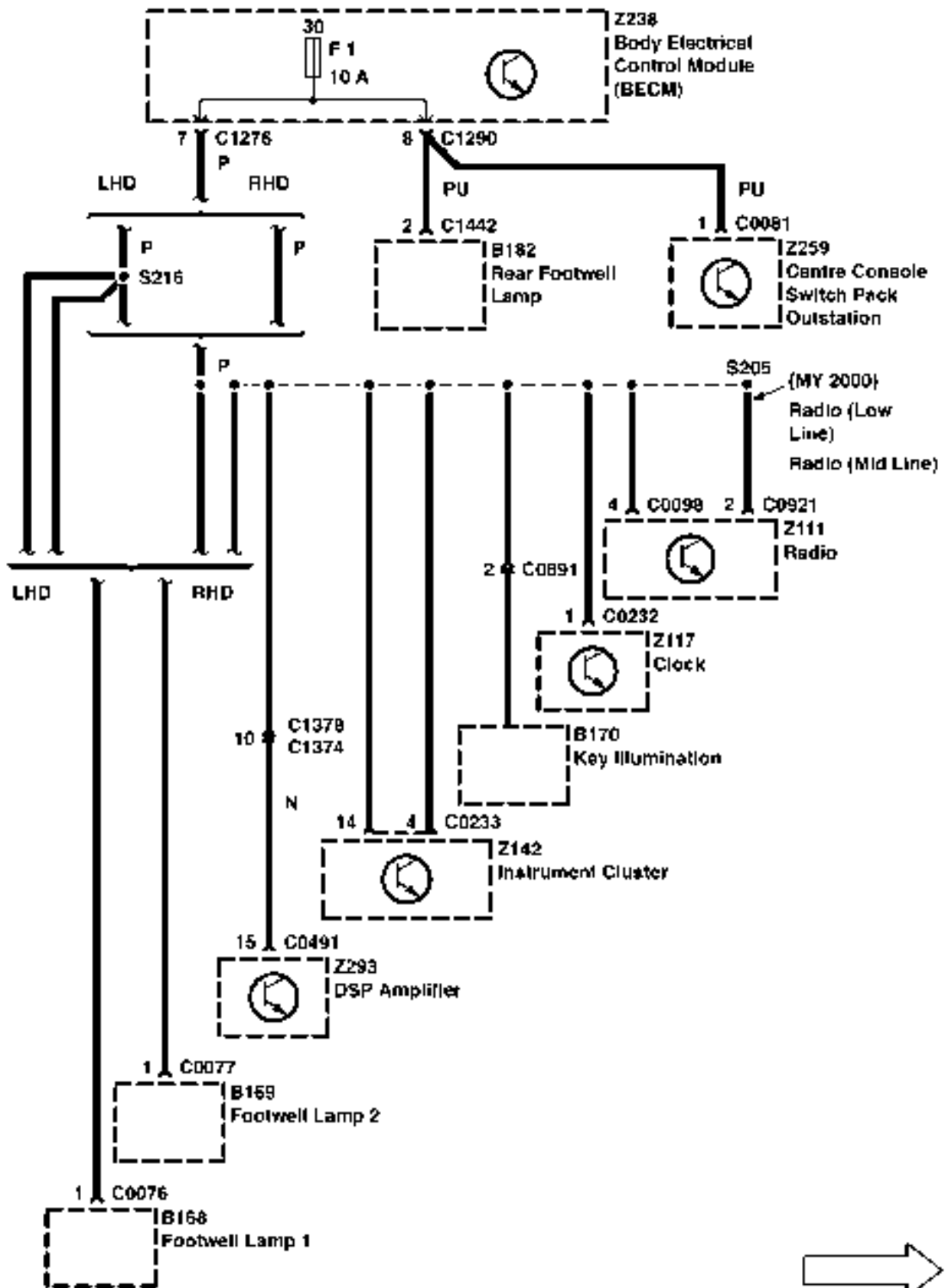

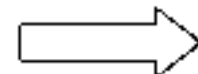
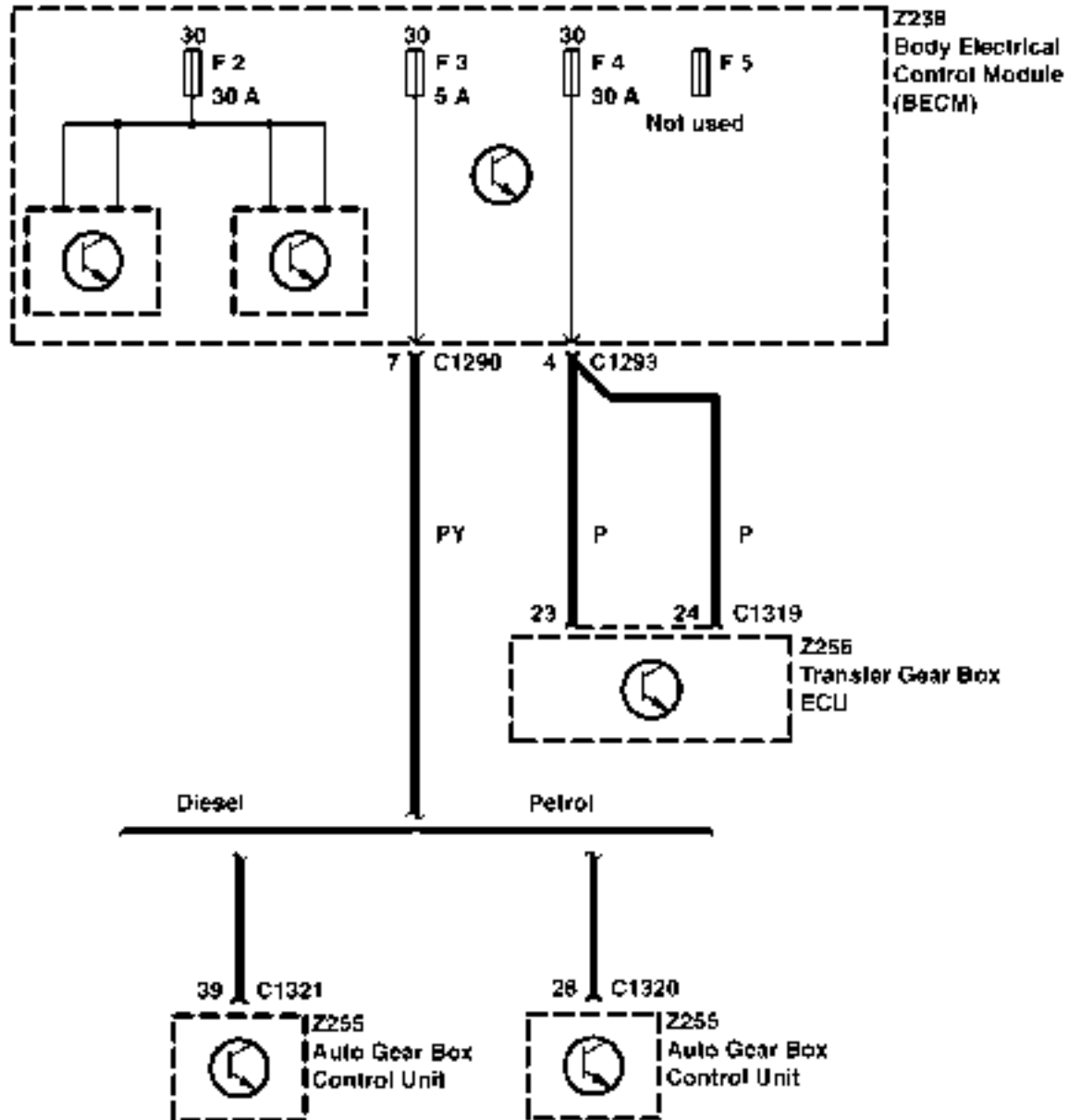
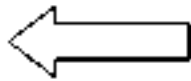

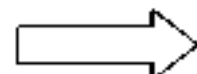
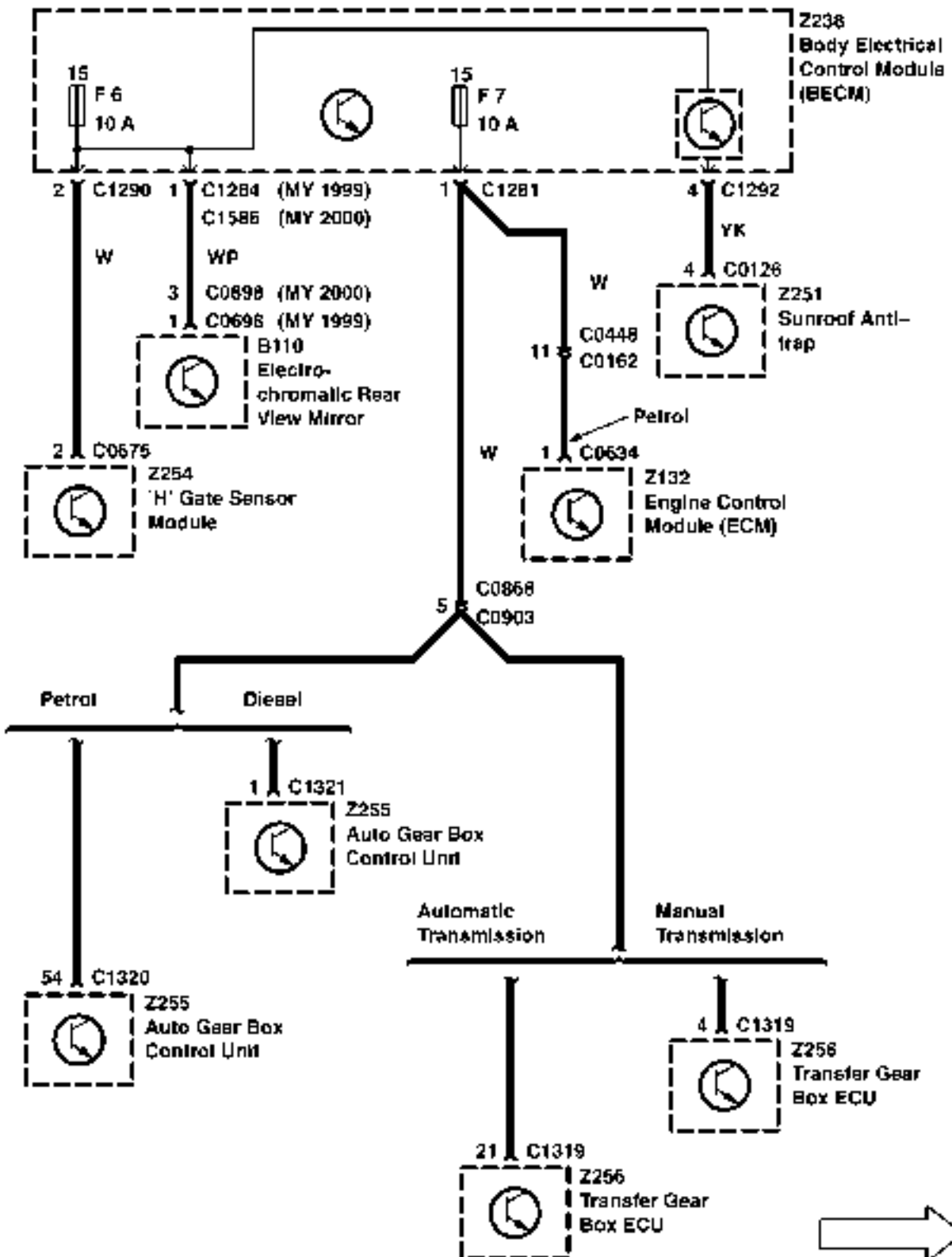
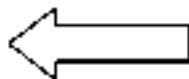

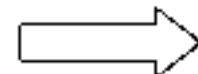
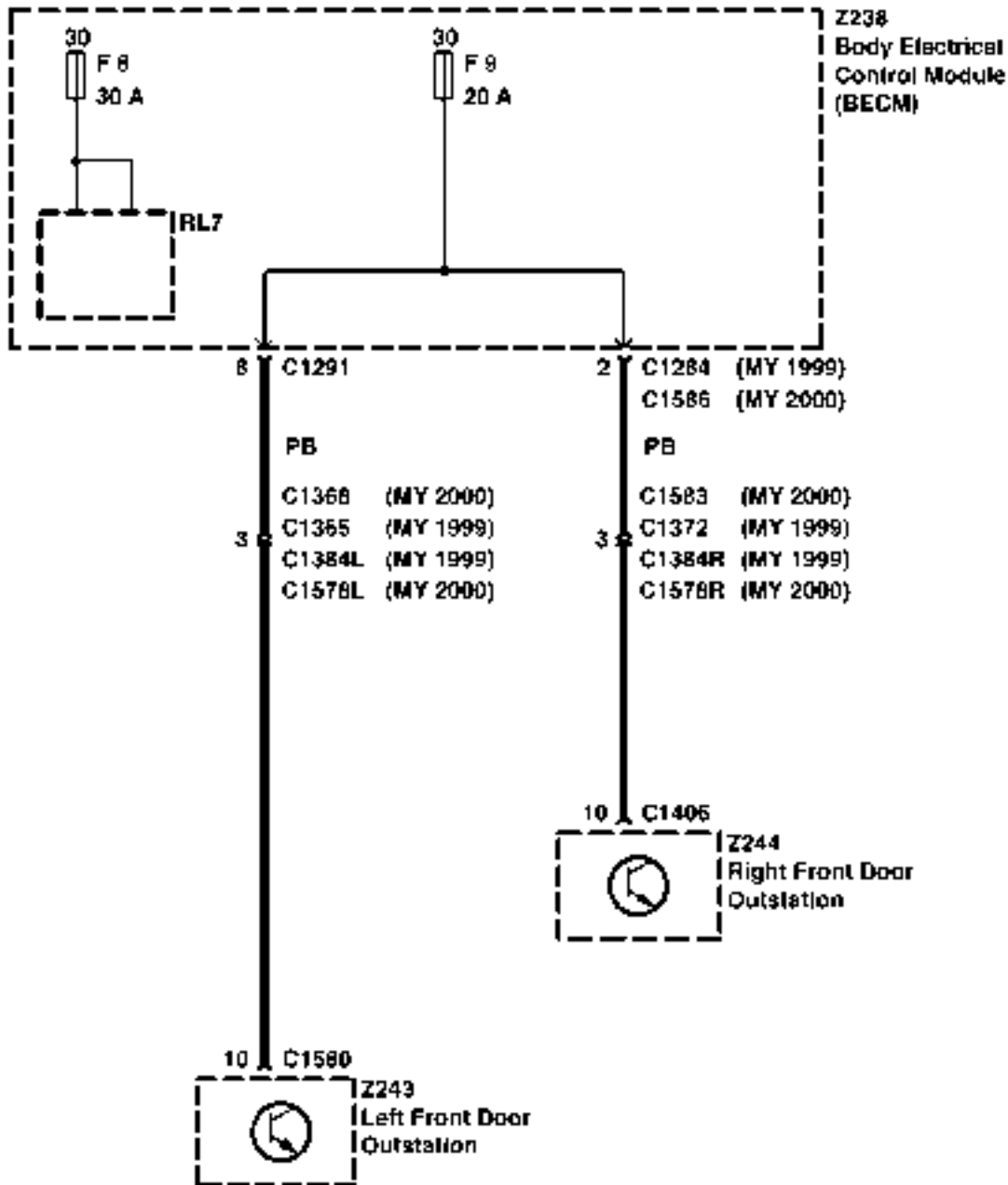
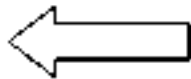

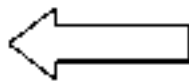

* Fuse F11 is only installed when towing the vehicle

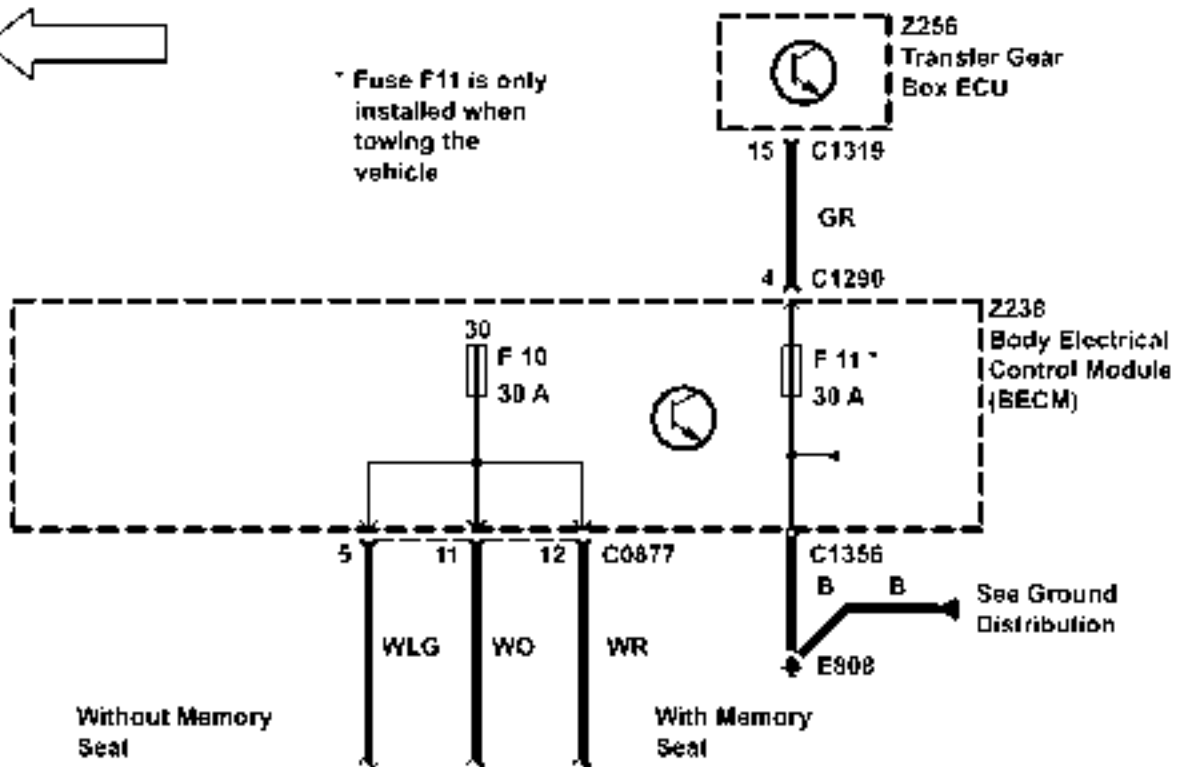

Without Memory Seat

With Memory Seat

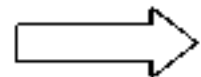
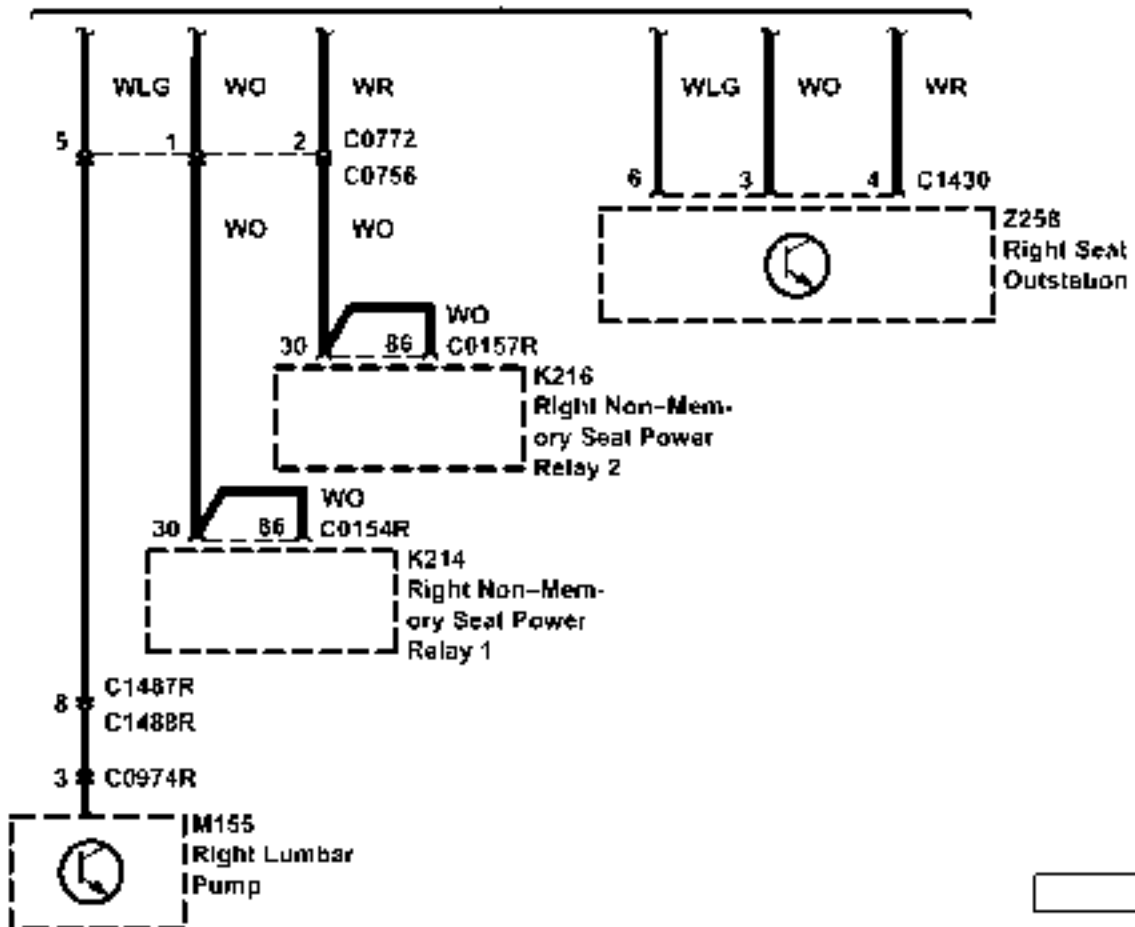

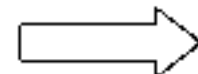
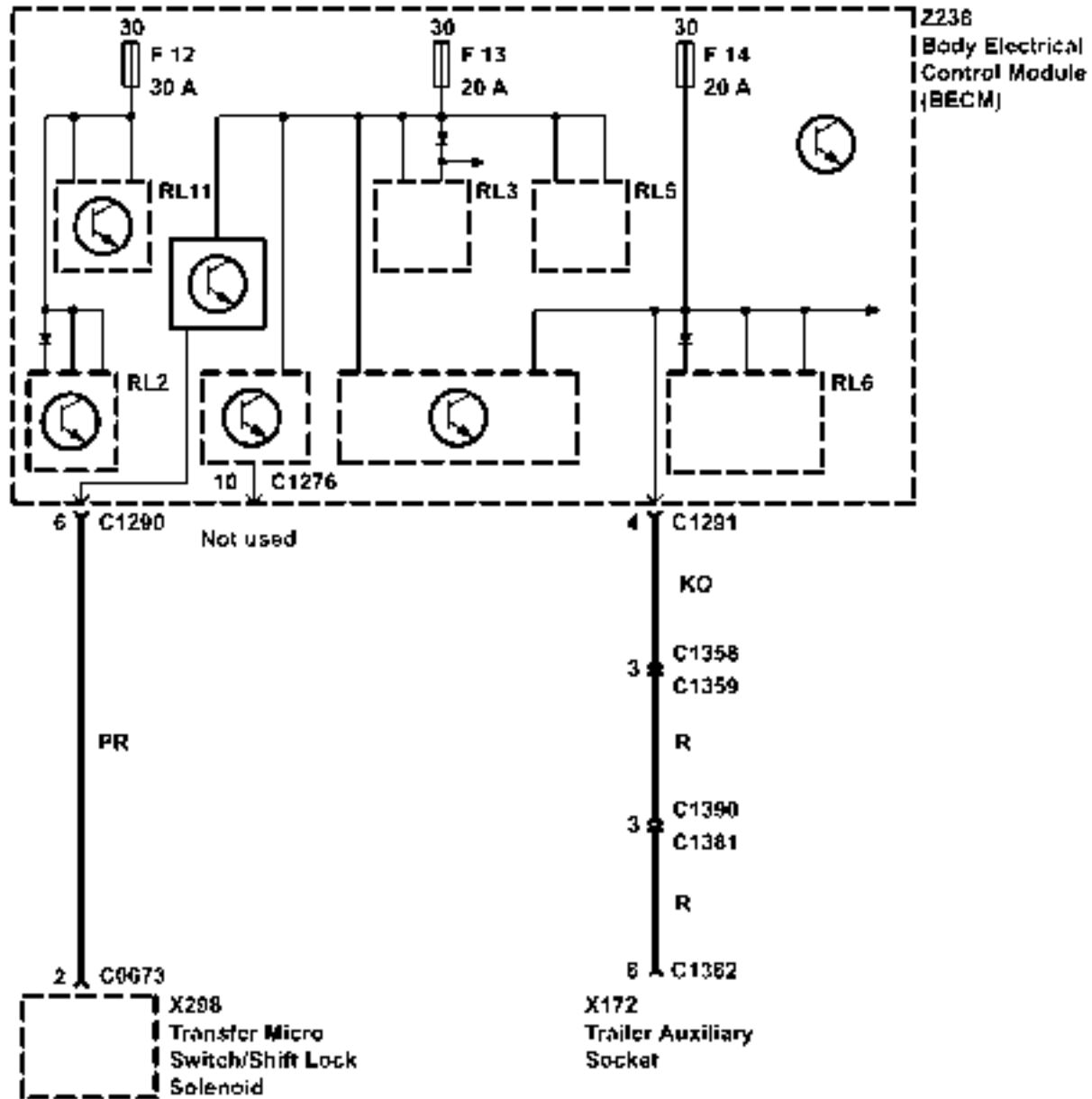
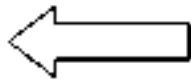

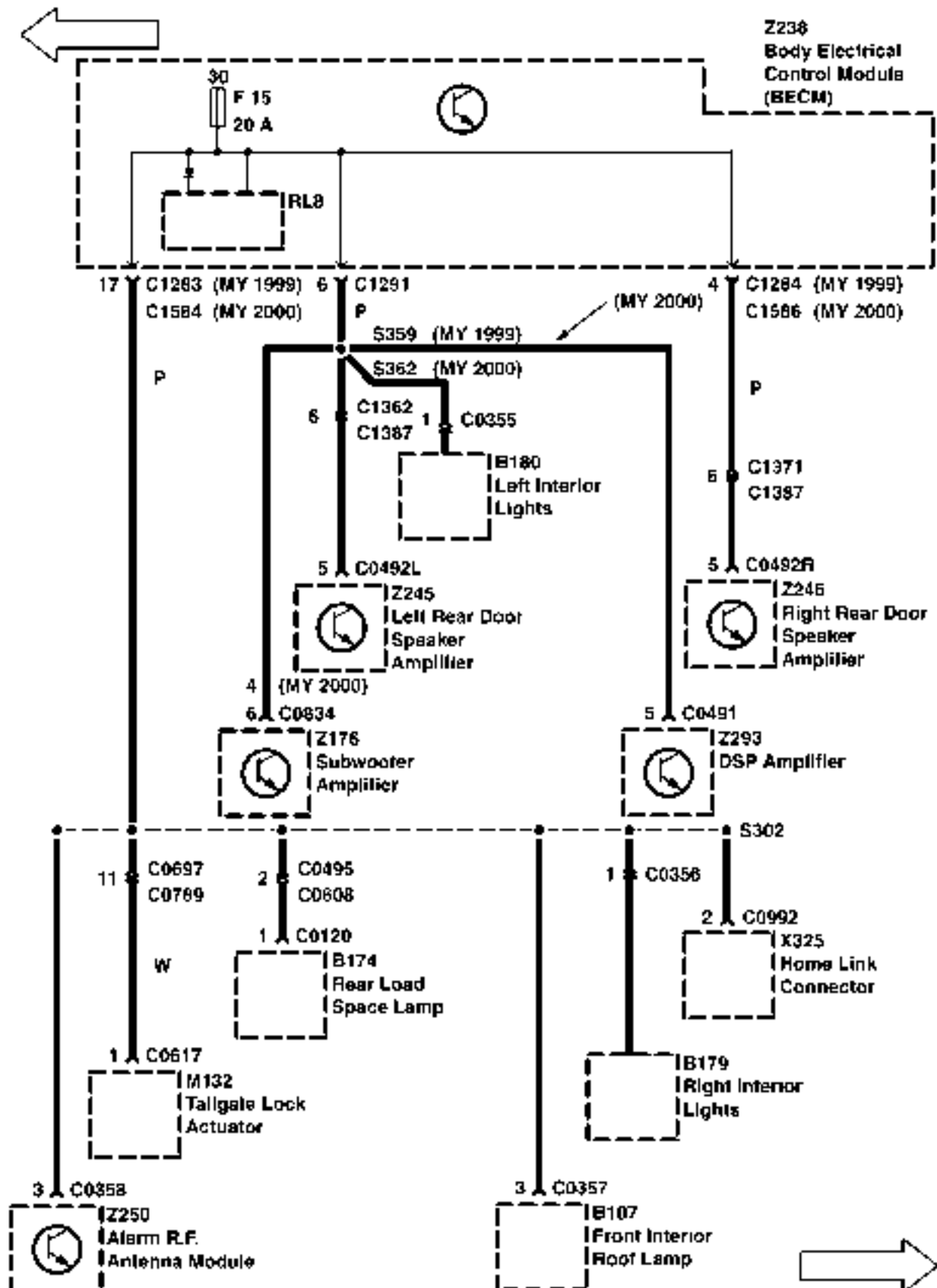

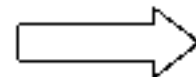
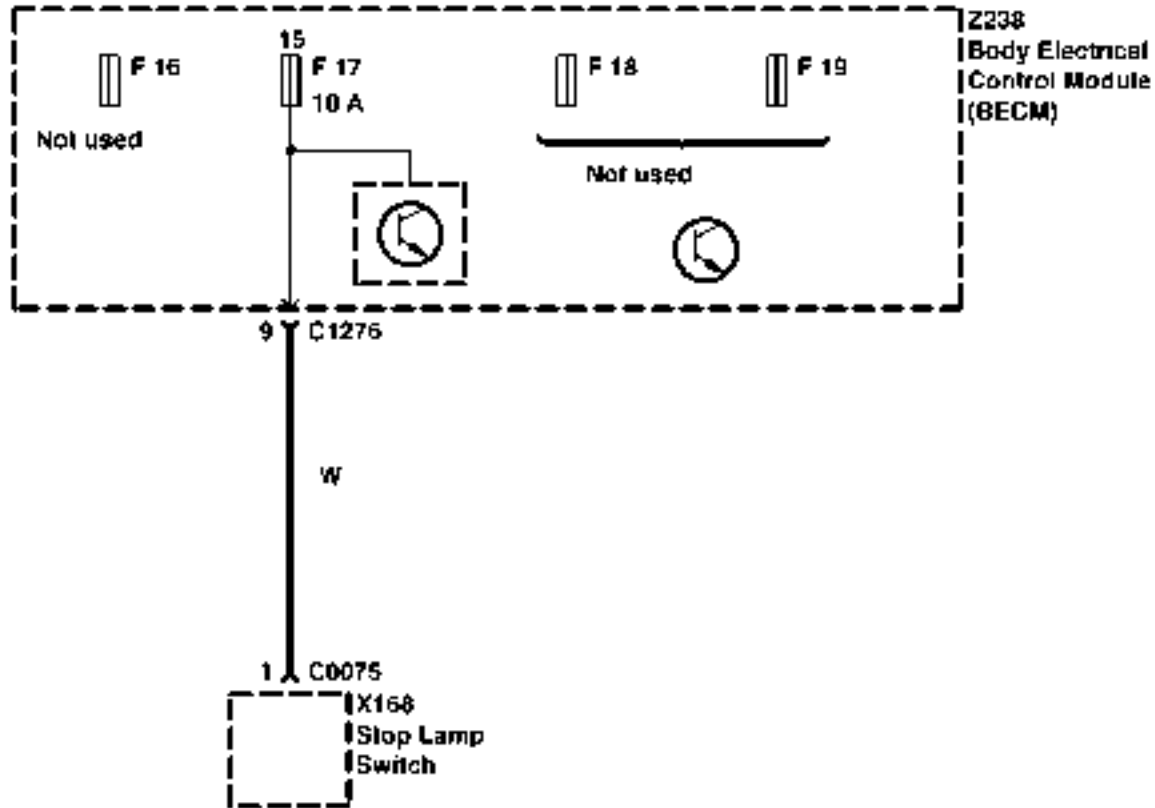

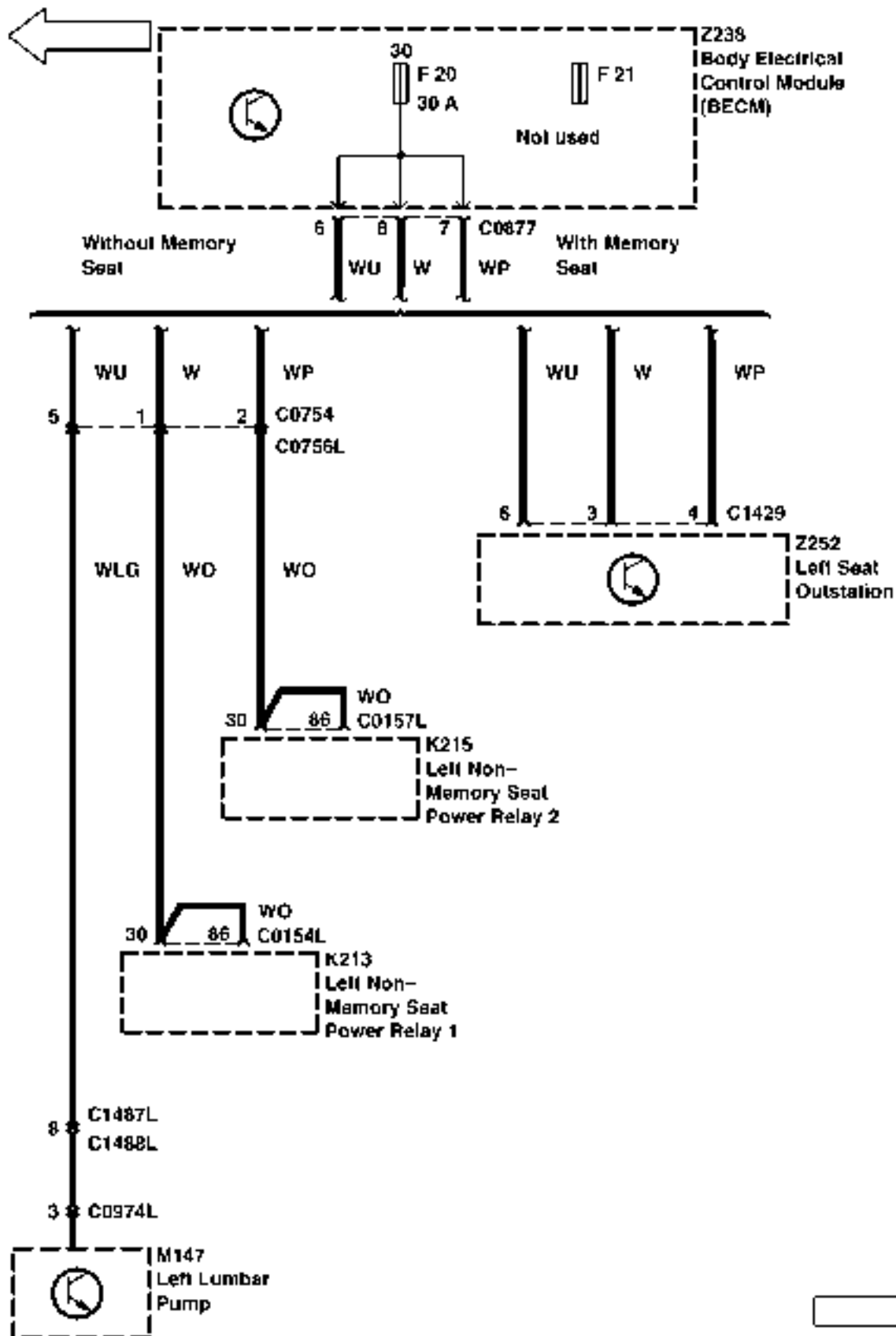

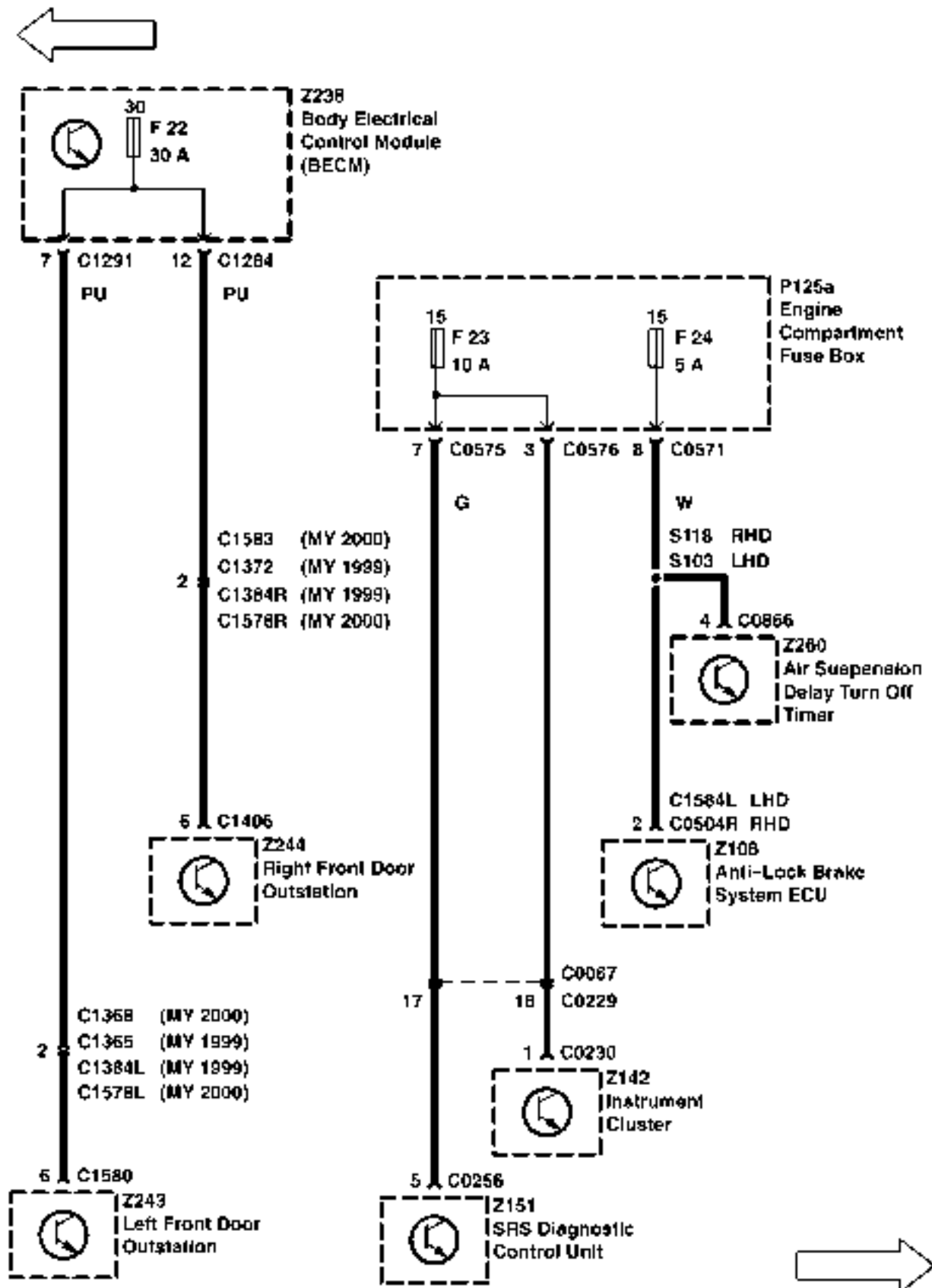

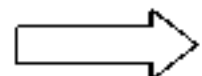
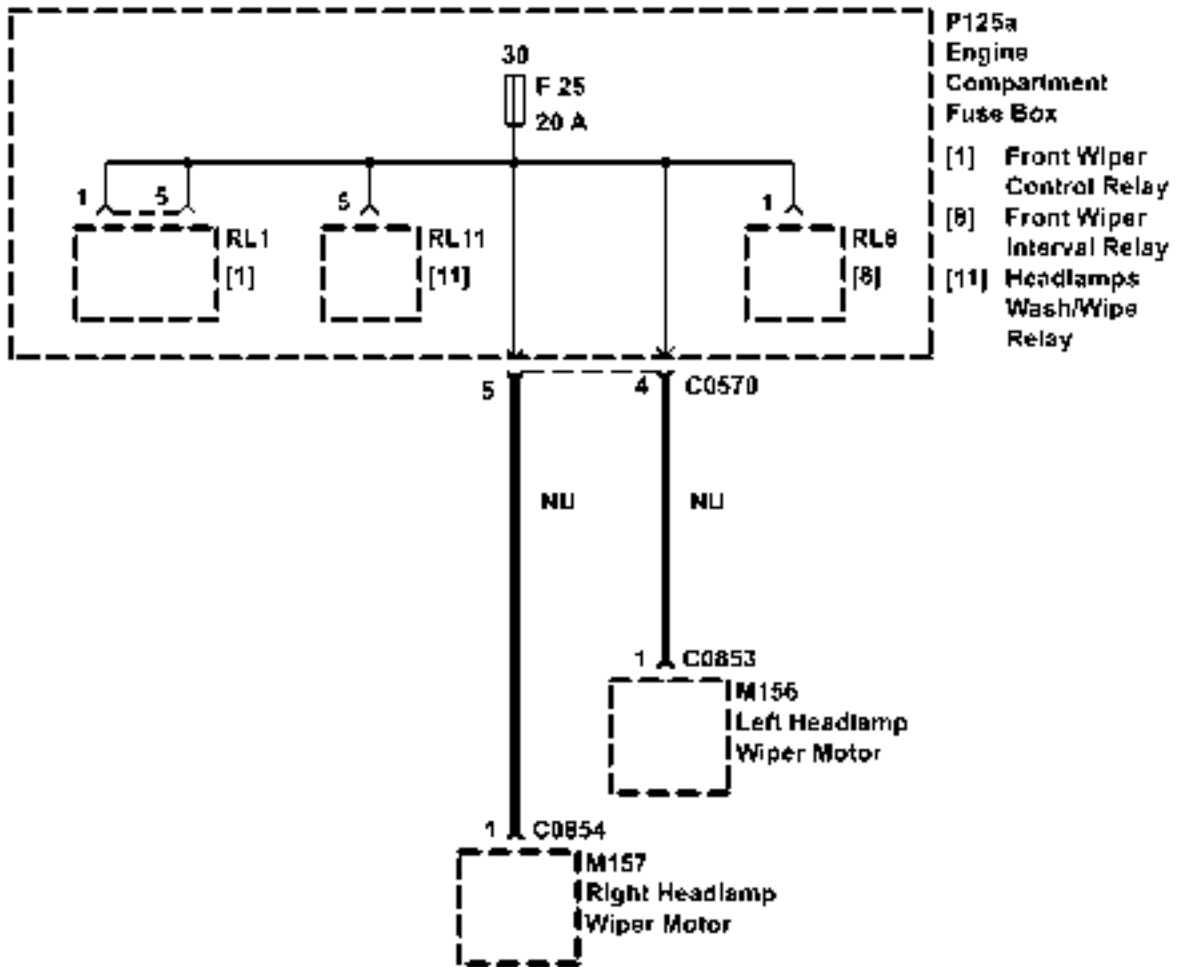
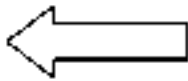

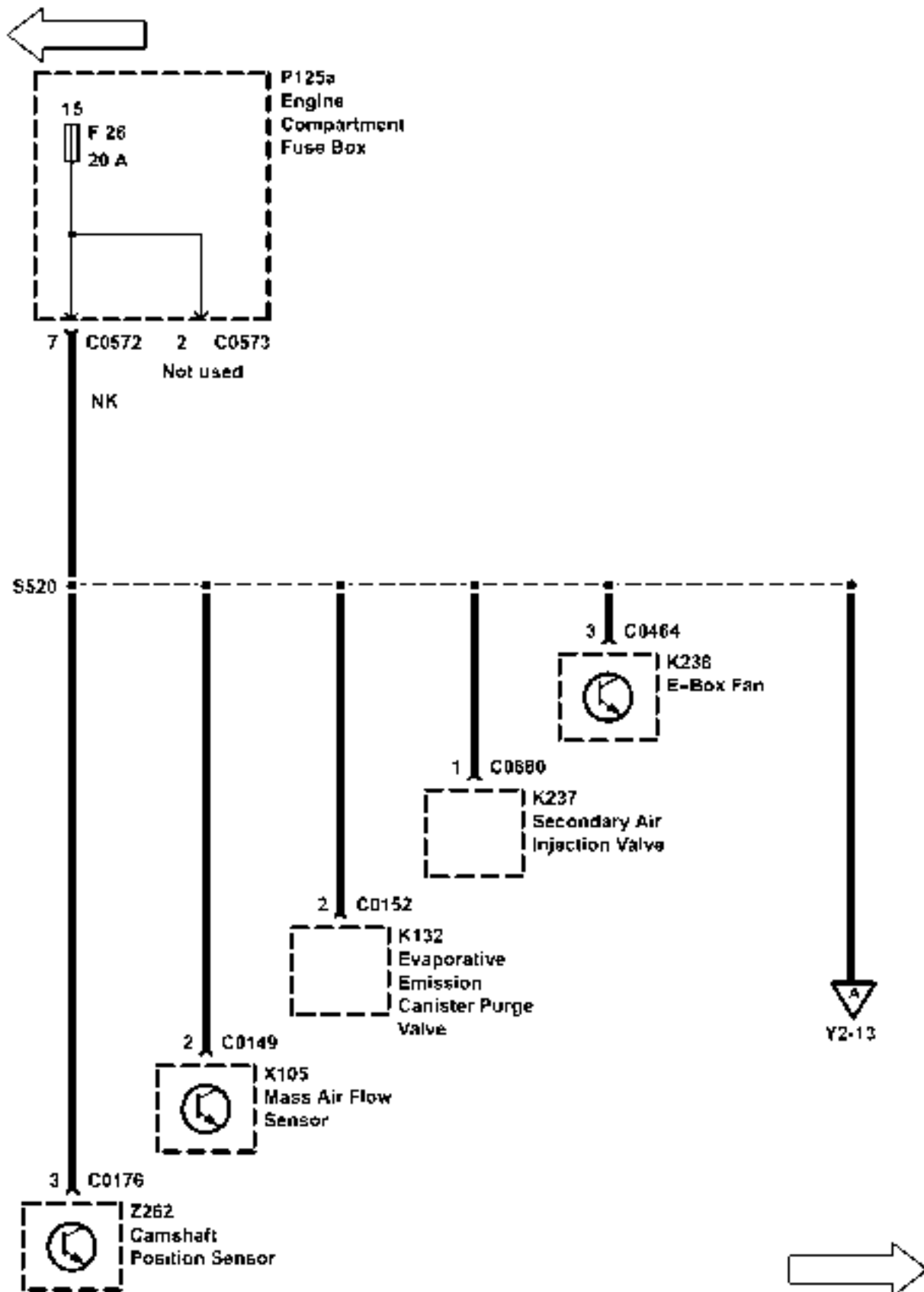

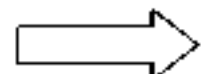
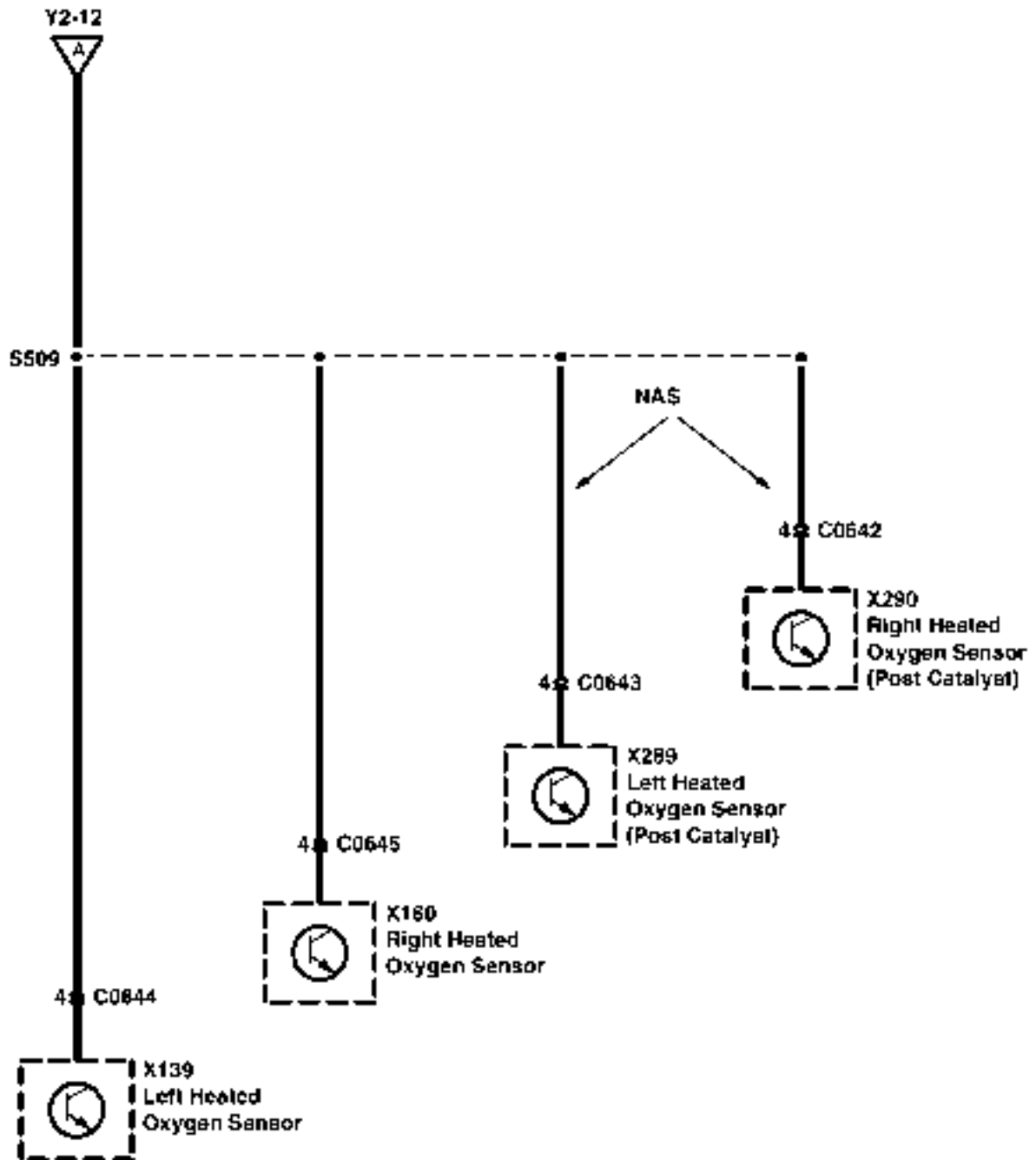
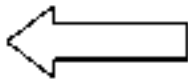

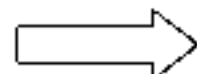
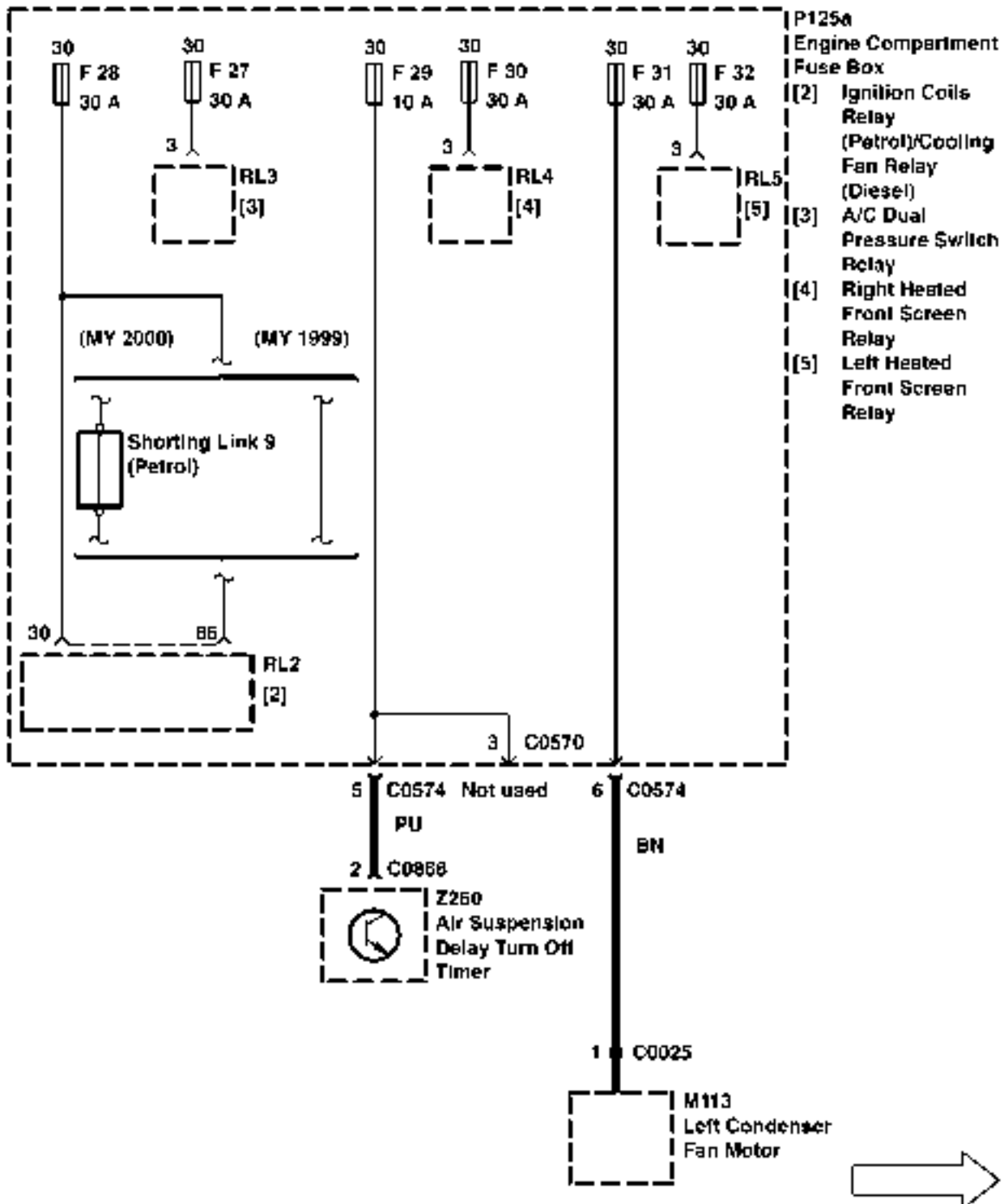
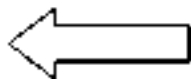

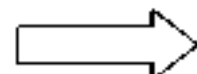
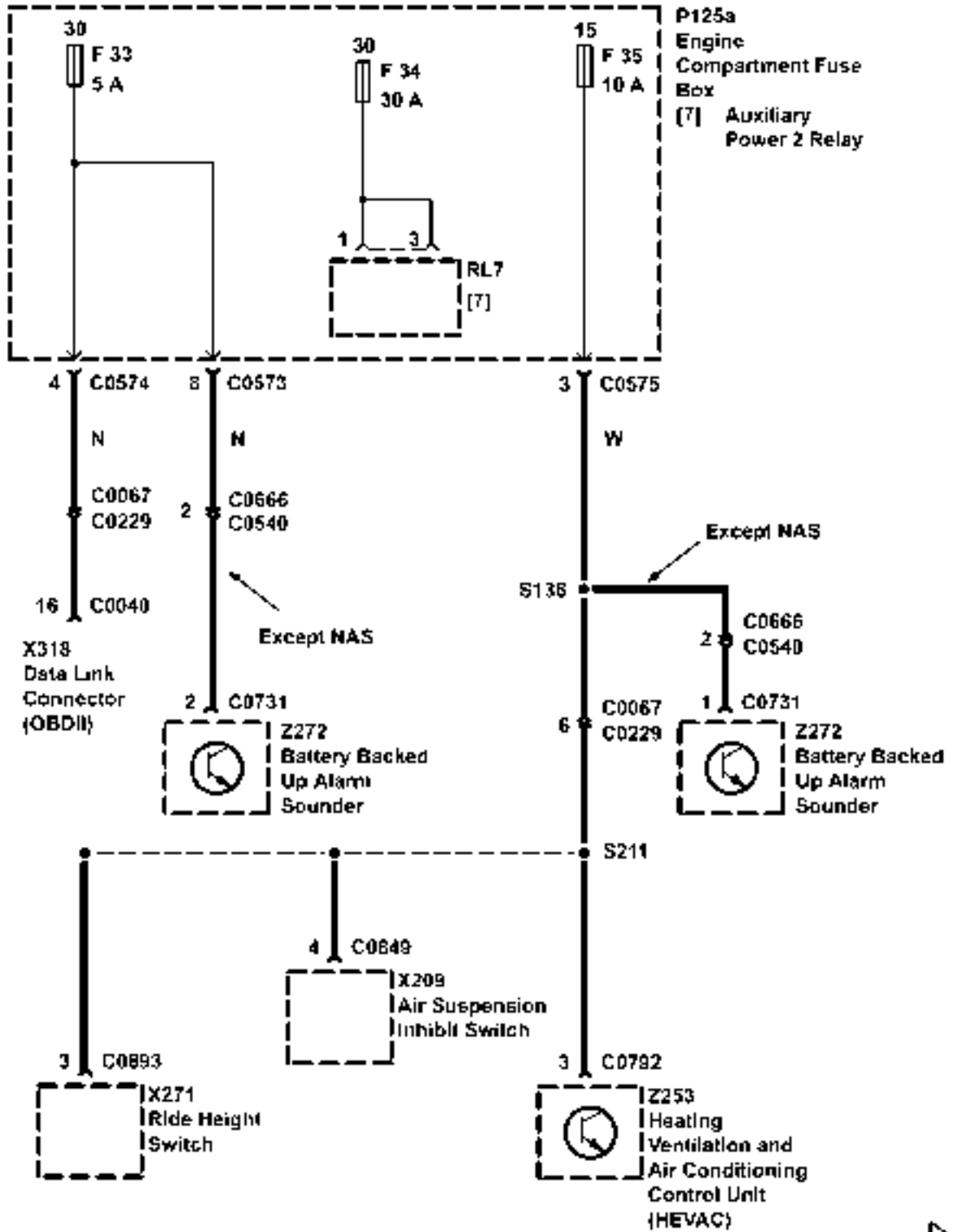

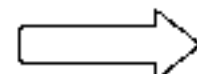
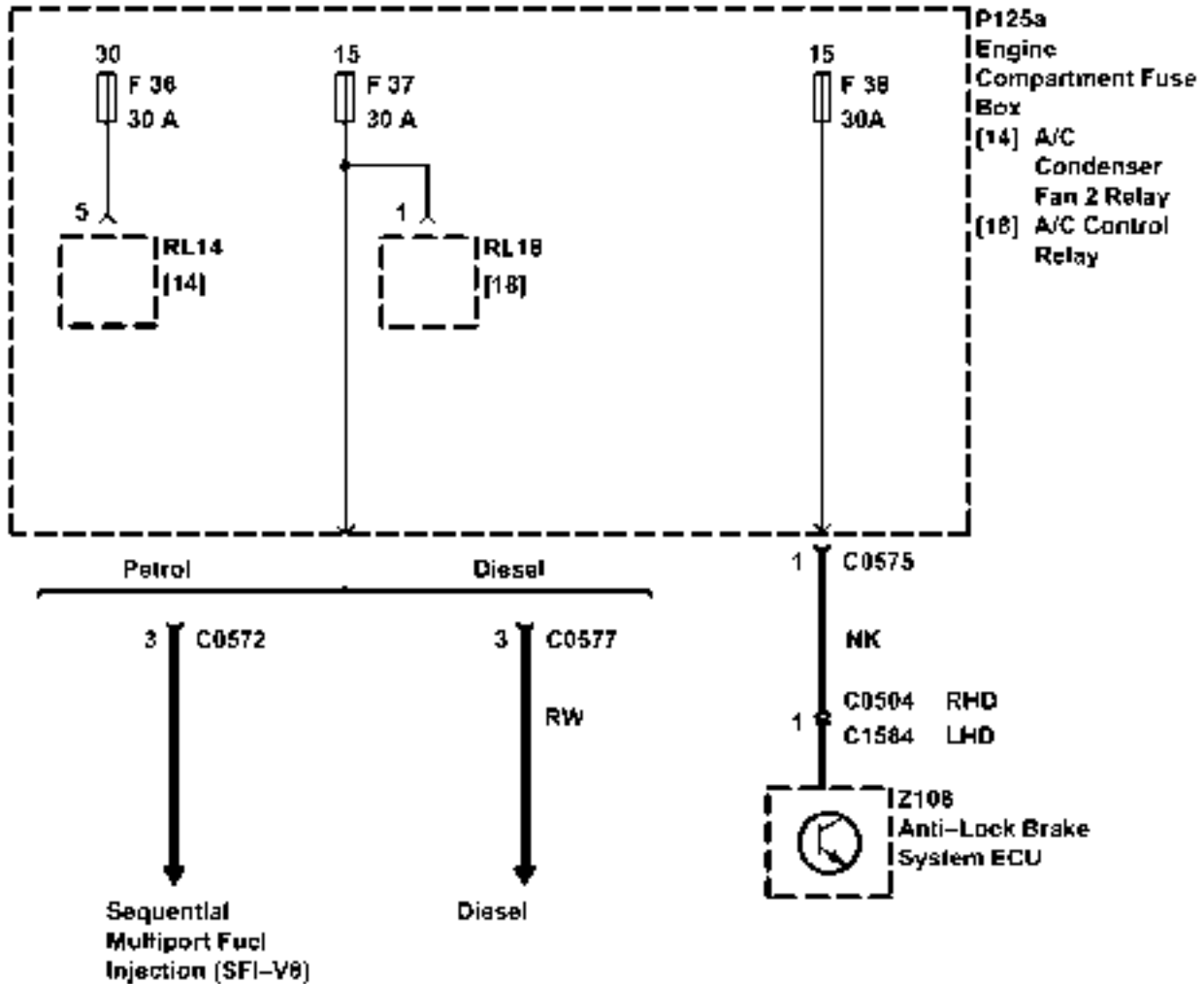
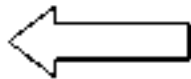

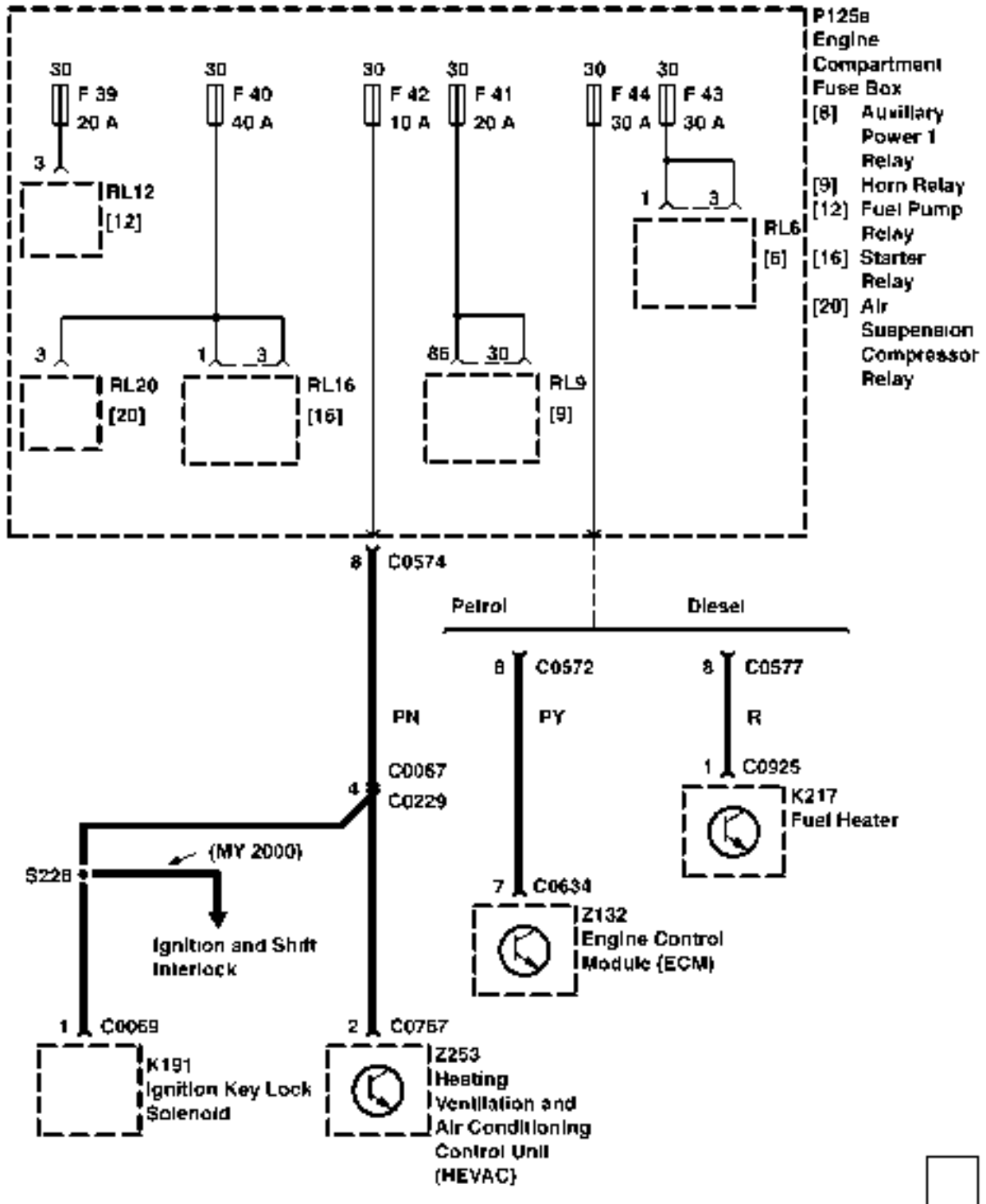
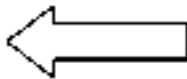

CIRCUIT DIAGRAMS

- Circuit diagrams are arranged so that current flow is from the top of the diagram (current source) to the bottom of the diagram (ground).
- Only those components that work together in the circuit are shown. If only part of a component is used in the circuit, then only that part of the component is shown.
- Remember:



TERMINAL NUMBER	DESIGNATION
50	Battery voltage: Ignition Switch in position III
30	Battery voltage: supplied constantly
15	Battery voltage: Ignition Switch in position II or III
R	Battery voltage: Ignition Switch in positions I, II
31	Ground

See Introduction (I) for additional circuit diagram symbols.

DIAGNOSIS

- If the diagram is accompanied by text:
 - Read the Circuit Operation before proceeding with the electrical diagnosis.
 - Read the Troubleshooting Hints before performing the System Diagnosis.
 - Tests follow the System Diagnosis
 - When performing the System Diagnosis, be certain that all components disconnected in previous steps are reconnected unless otherwise directed.

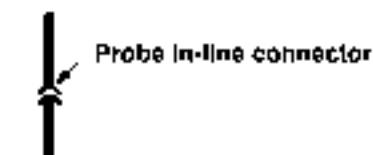
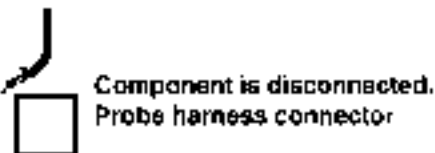
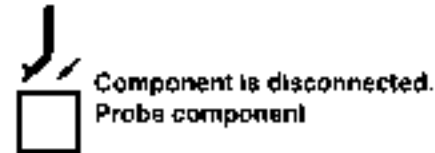
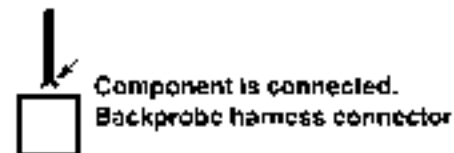
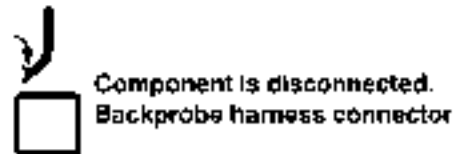

GROUND AND SPLICE INDEX

Ground	Page		
E0119	Y5-2	S122	Y5-11
E0360	Y5-2	S207	Y5-14
F0361	Y5-2	S209	Y5-13,14
C0500	Y5-2	S215	Y5-12
E0556	Y5-3	S218	Y5-20
E0556 D	Y5-6	S301	Y5-16
C0557	Y5-5	S304	Y5-18
C0558	Y5-2	S306	Y5-18
E0559	Y5-9	S307	Y5-19
E0560	Y5-11	S355	Y5-22
E0561	Y5-5	S356	Y5-22
E0562	Y5-14	S361	Y5-23
E0563	Y5-15	S506	Y5-25
E0563	Y5-15	S521	Y5-24
E0564	Y5-15	S527	Y5-25
E0565	Y5-16,17	S528	Y5-27
E0807	Y5-18,19	S530	Y5-24
E0808	Y5-21	S551	Y5-26
E0809	Y5-22,23	S571	Y5-6
E0810	Y5-24	S607	Y5-20,21
E0811	Y5-24	S611	Y5-20
E0822	Y5-11	S701R	Y5-19
E0910	Y5-24	S701L	Y5-23
F1347	Y5-29	S851	Y5-17
E1348	Y5-29	S852	Y5-17
C1351	Y5-30	S901	Y5-28
E1355	Y5-25		
E1398	Y5-27		
C1412	Y5-28		
E1413	Y5-28		
E1431	Y5-31		
E1547	Y5-11		
Splice	Page		
S101	Y5-4, 5		
S110	Y5-5		
S111	Y5-10,11		
S113	Y5-3		
S114	Y5-9		
S115	Y5-7		

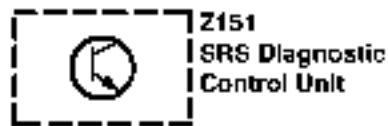
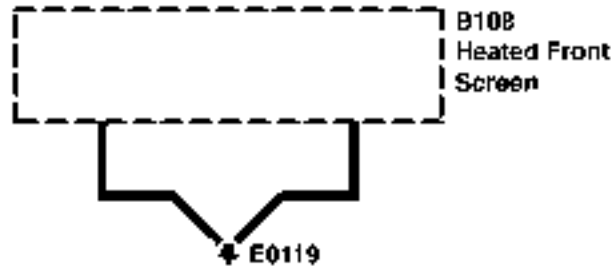

6 Y C0256

B

E0360



8 Y C0098

B

E0361

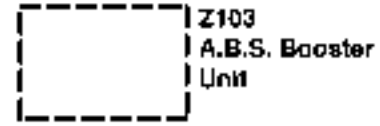

1 Y C1592 LHD
1 C0362 RHD

B

E0500 RHD
E0538 LHD

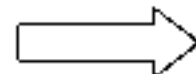

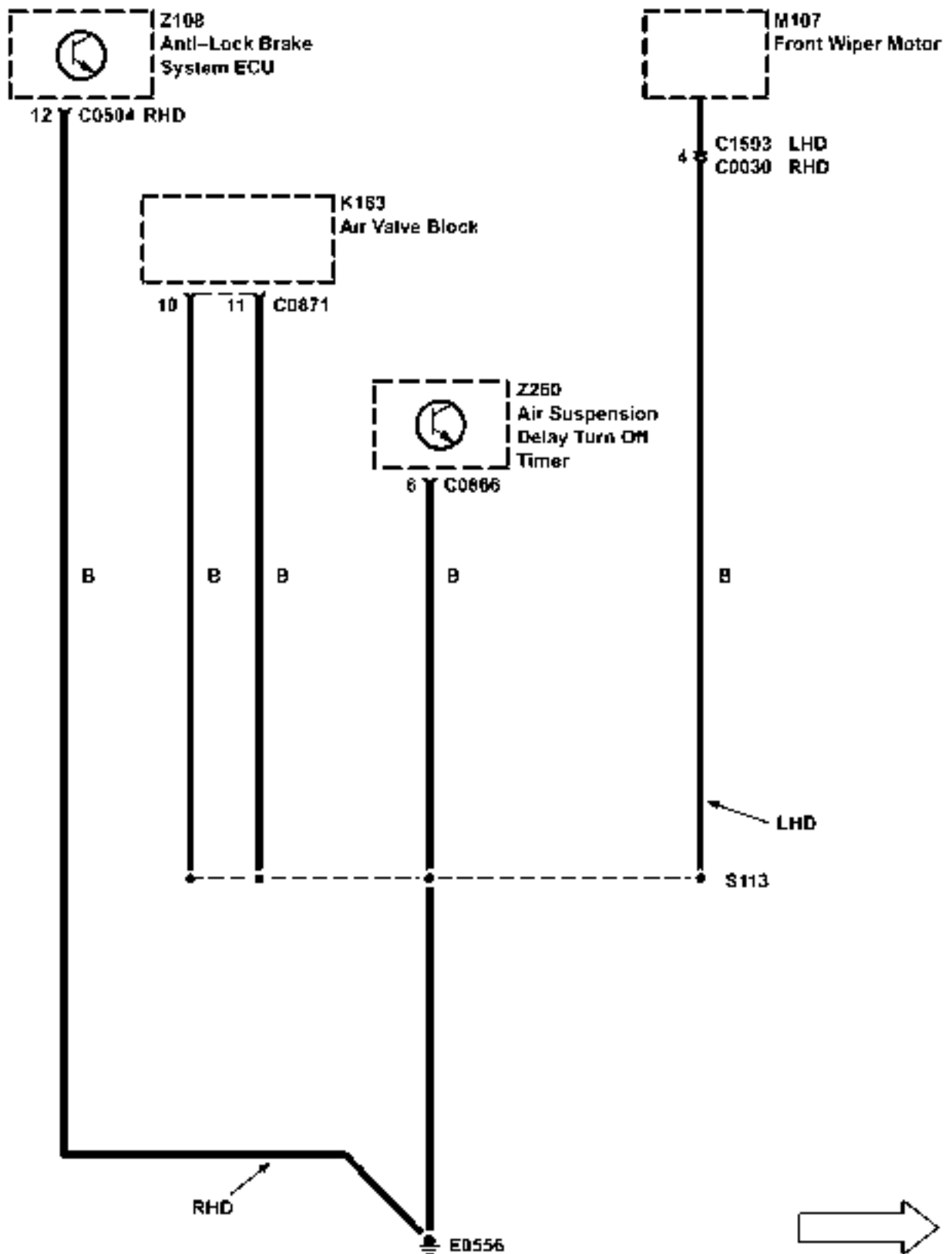

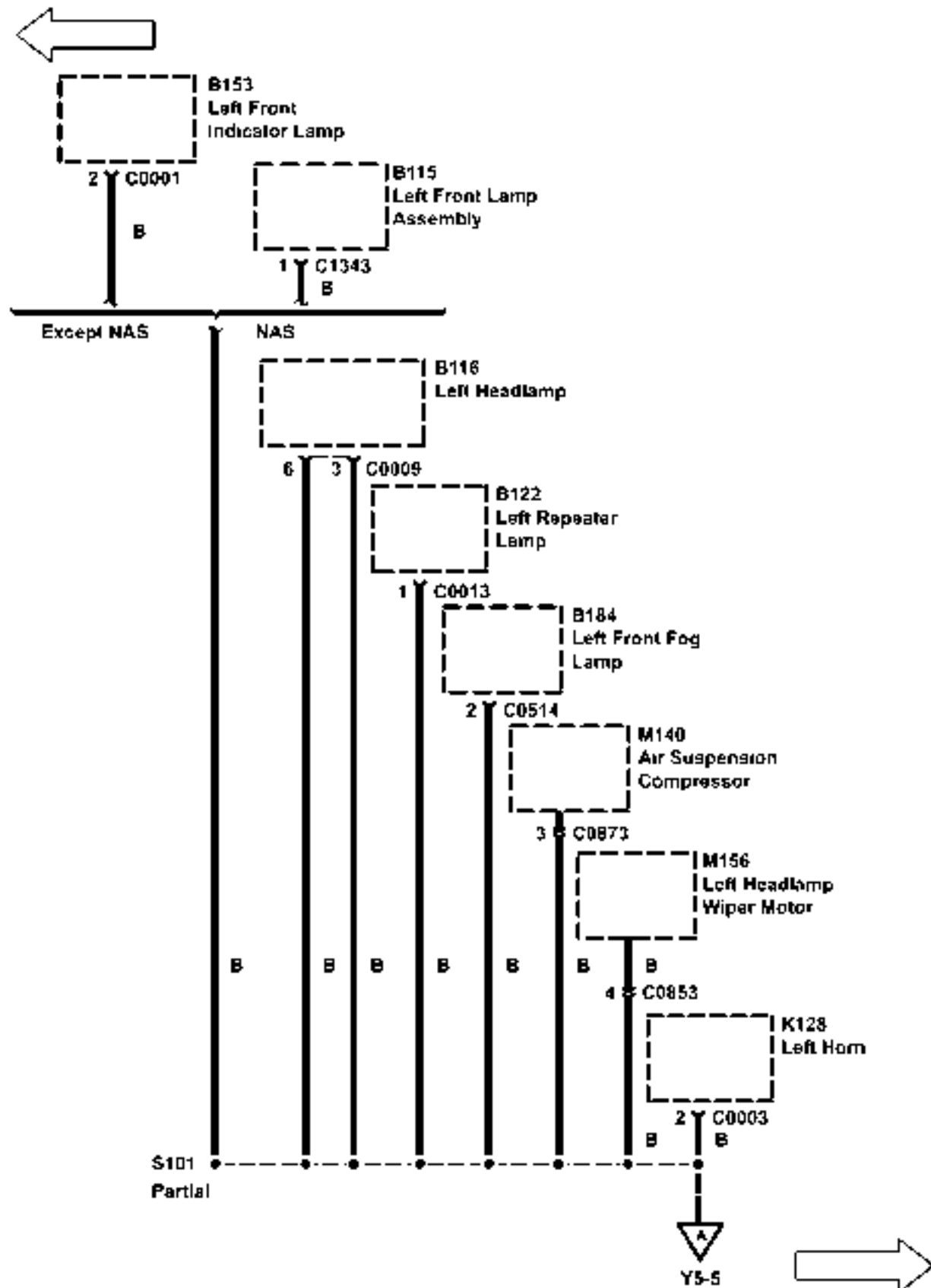

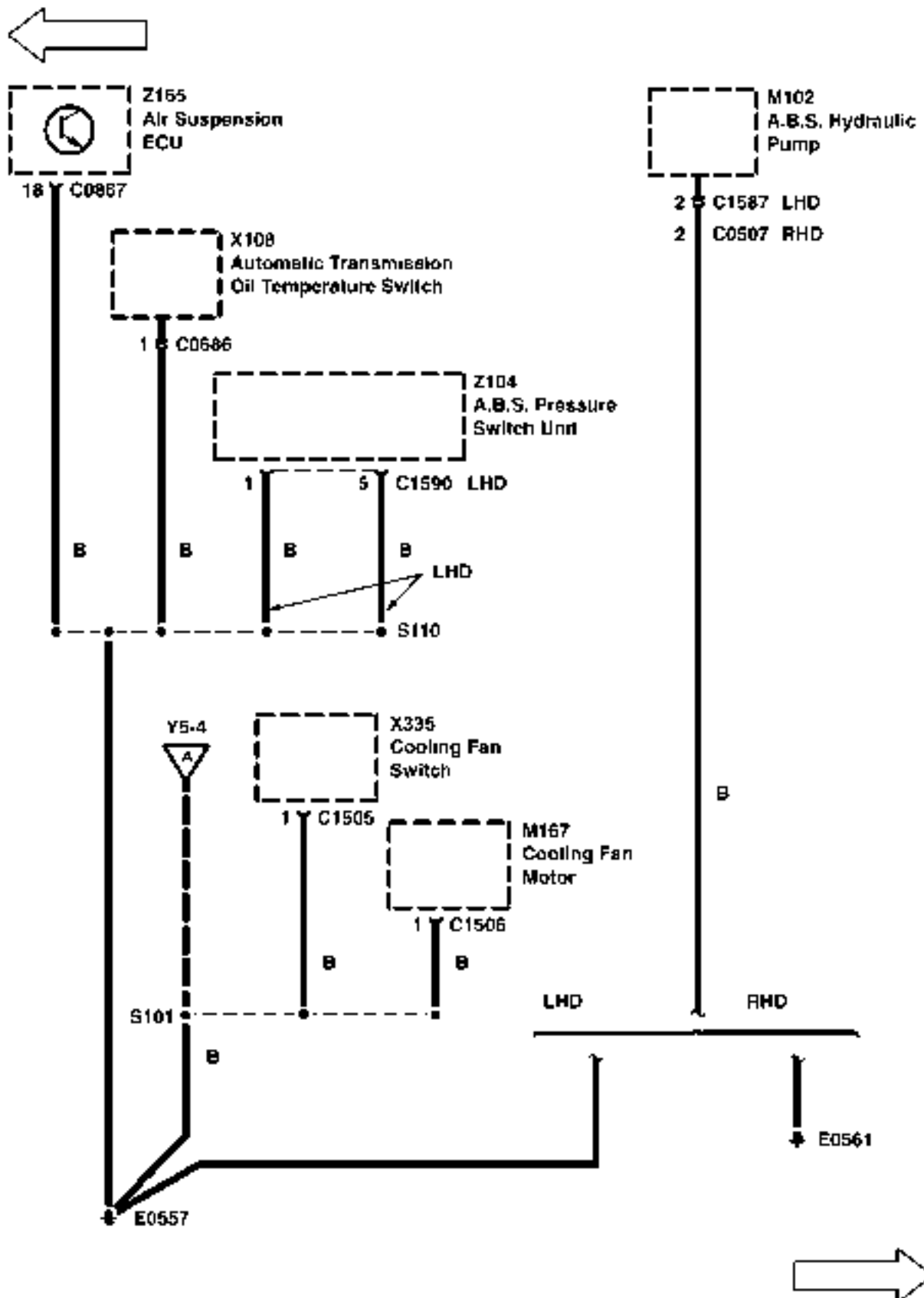

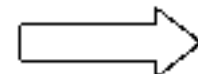
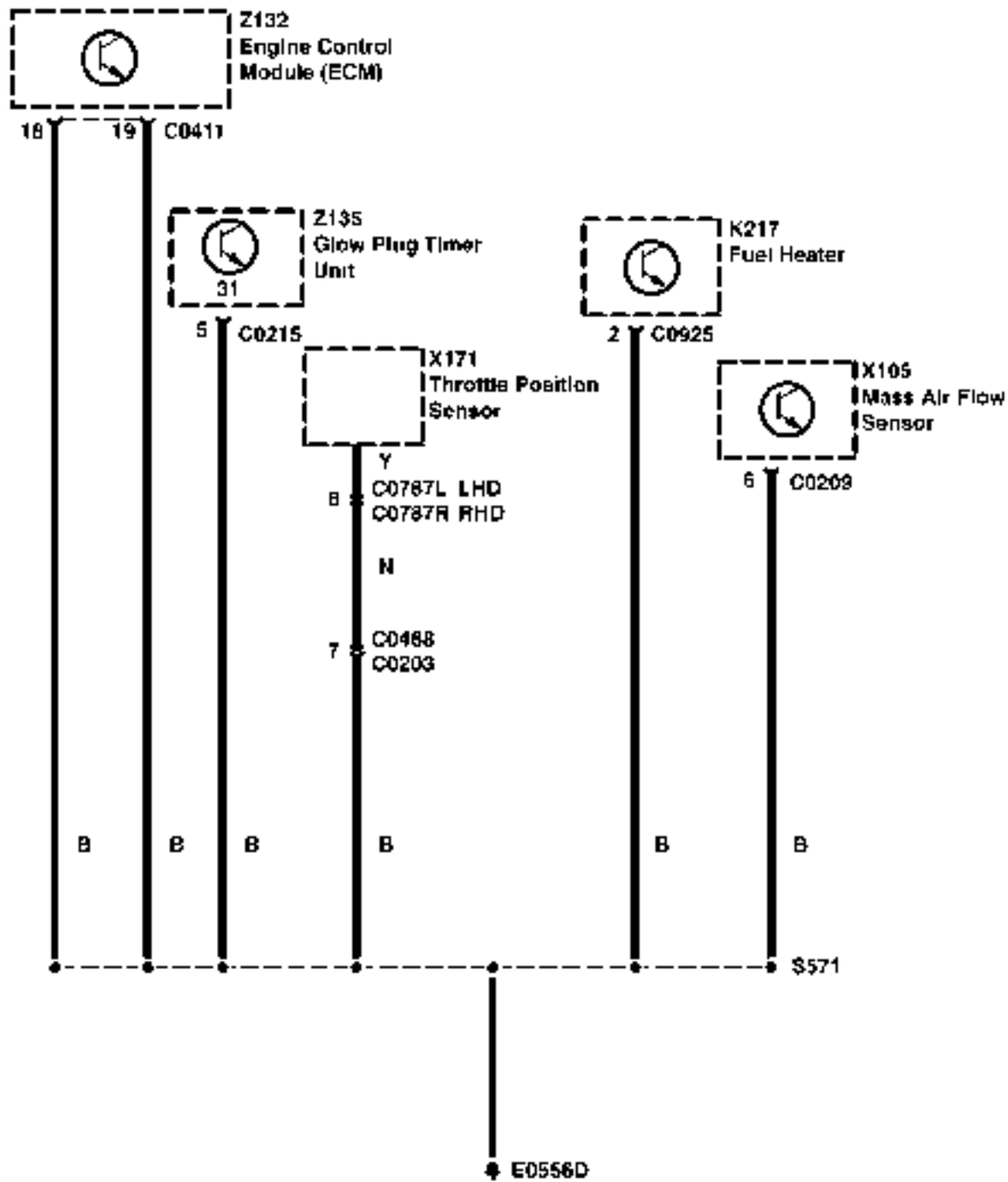
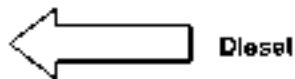

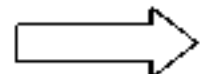
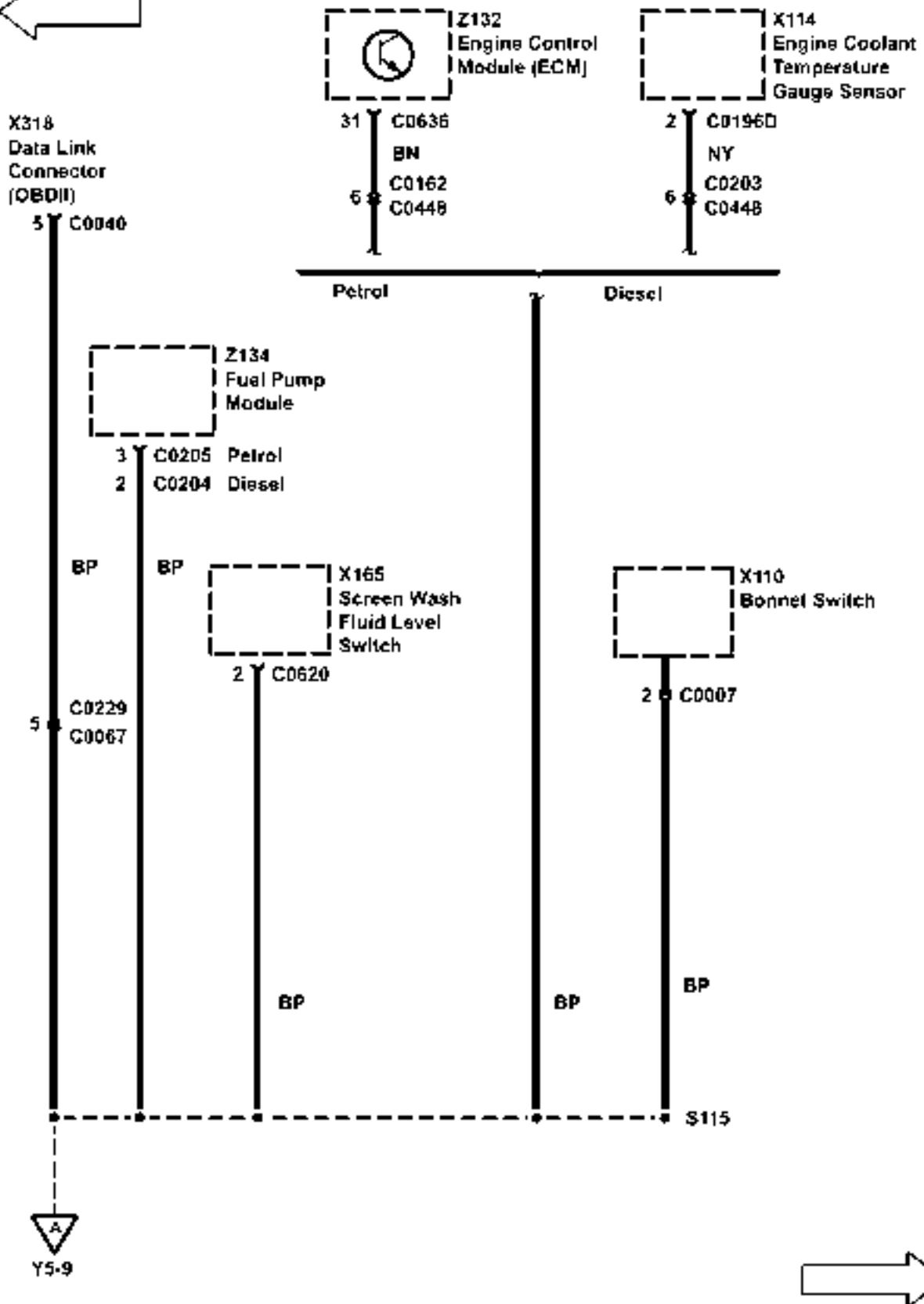

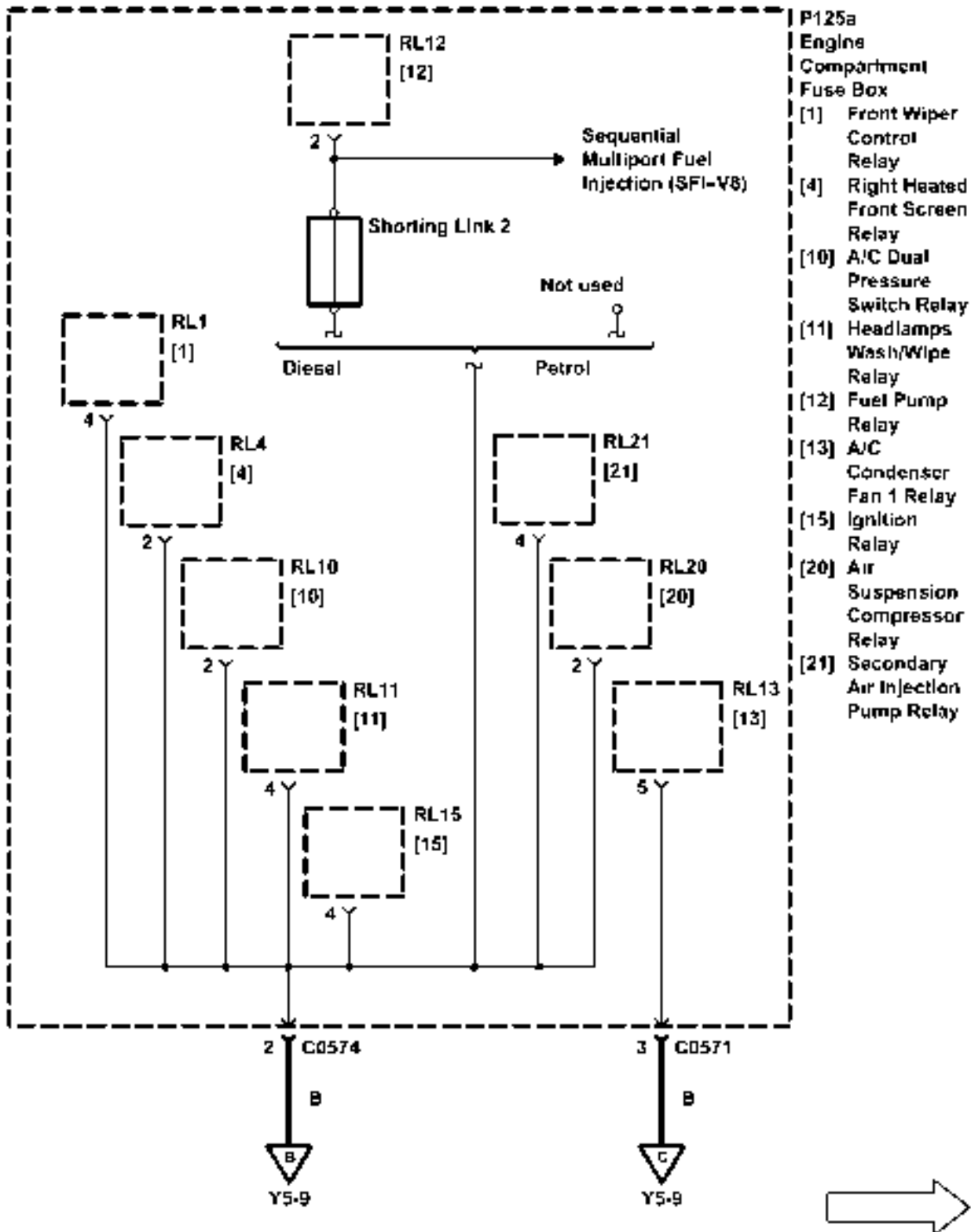
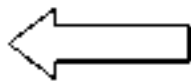

- P125a
 Engine
 Compartment
 Fuse Box
- [1] Front Wiper Control Relay
 - [4] Right Heated Front Screen Relay
 - [10] A/C Dual Pressure Switch Relay
 - [11] Headlamps Wash/Wipe Relay
 - [12] Fuel Pump Relay
 - [13] A/C Condenser Fan 1 Relay
 - [15] Ignition Relay
 - [20] Air Suspension Compressor Relay
 - [21] Secondary Air Injection Pump Relay

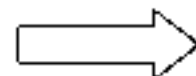

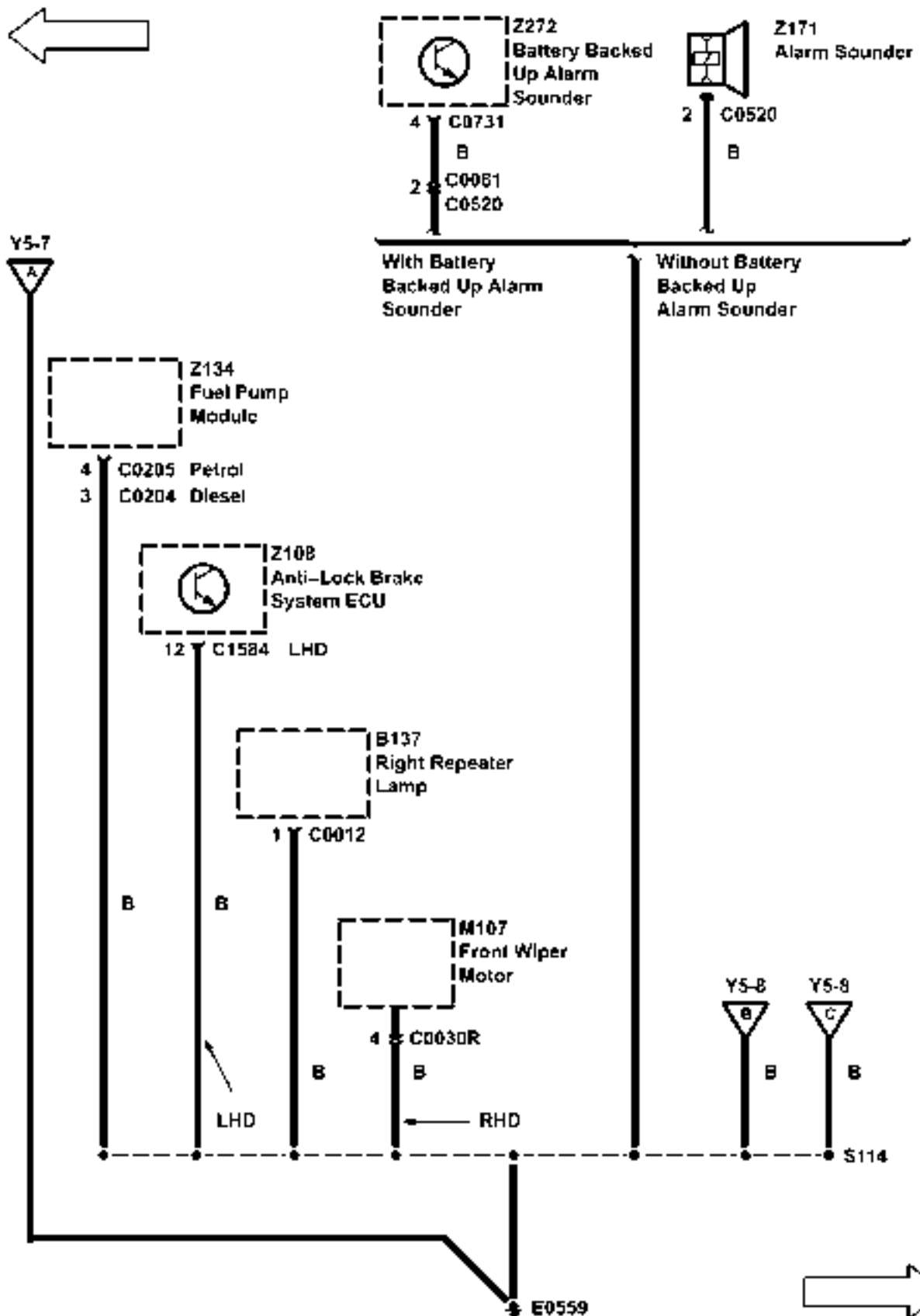

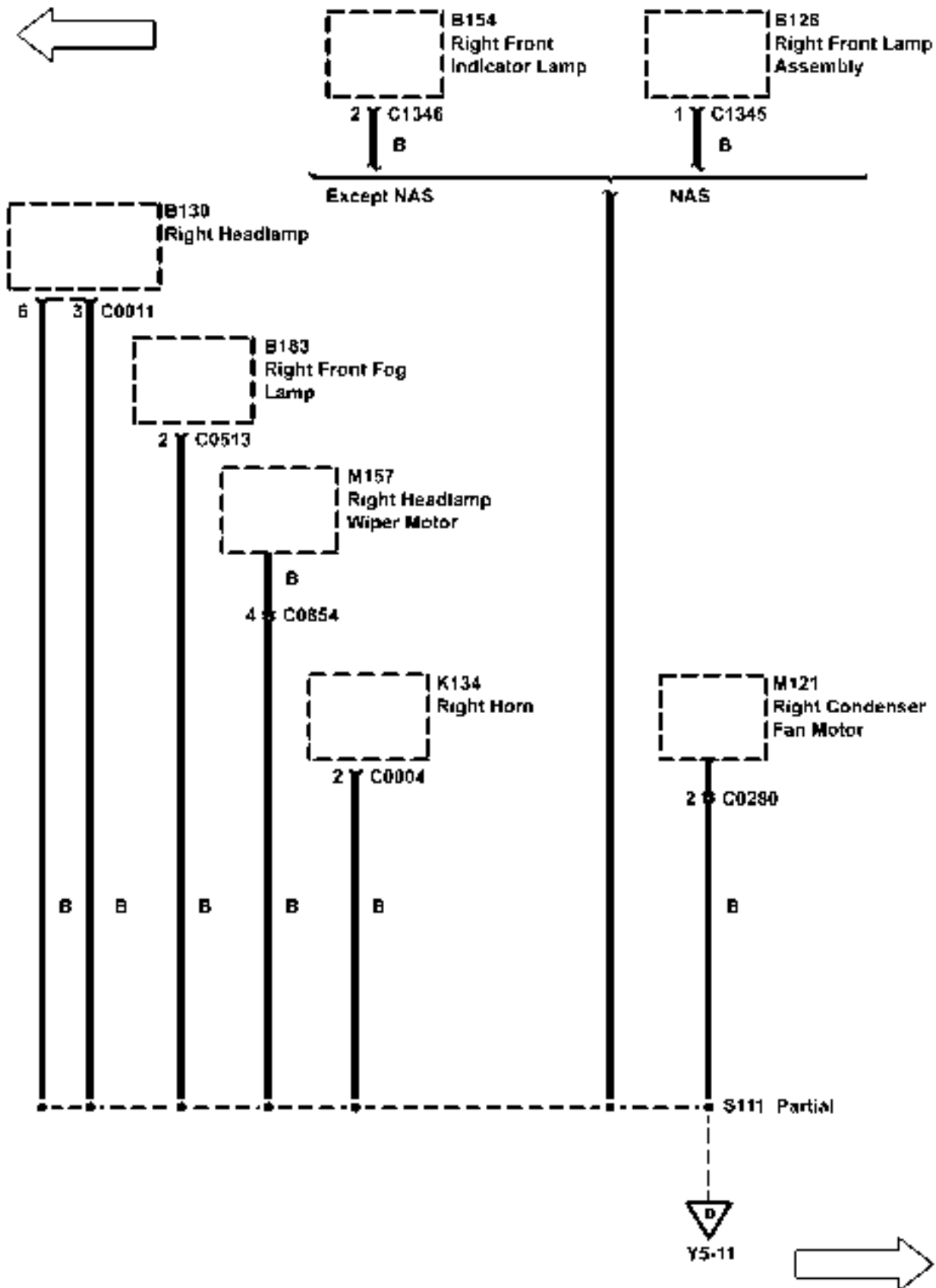

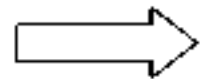
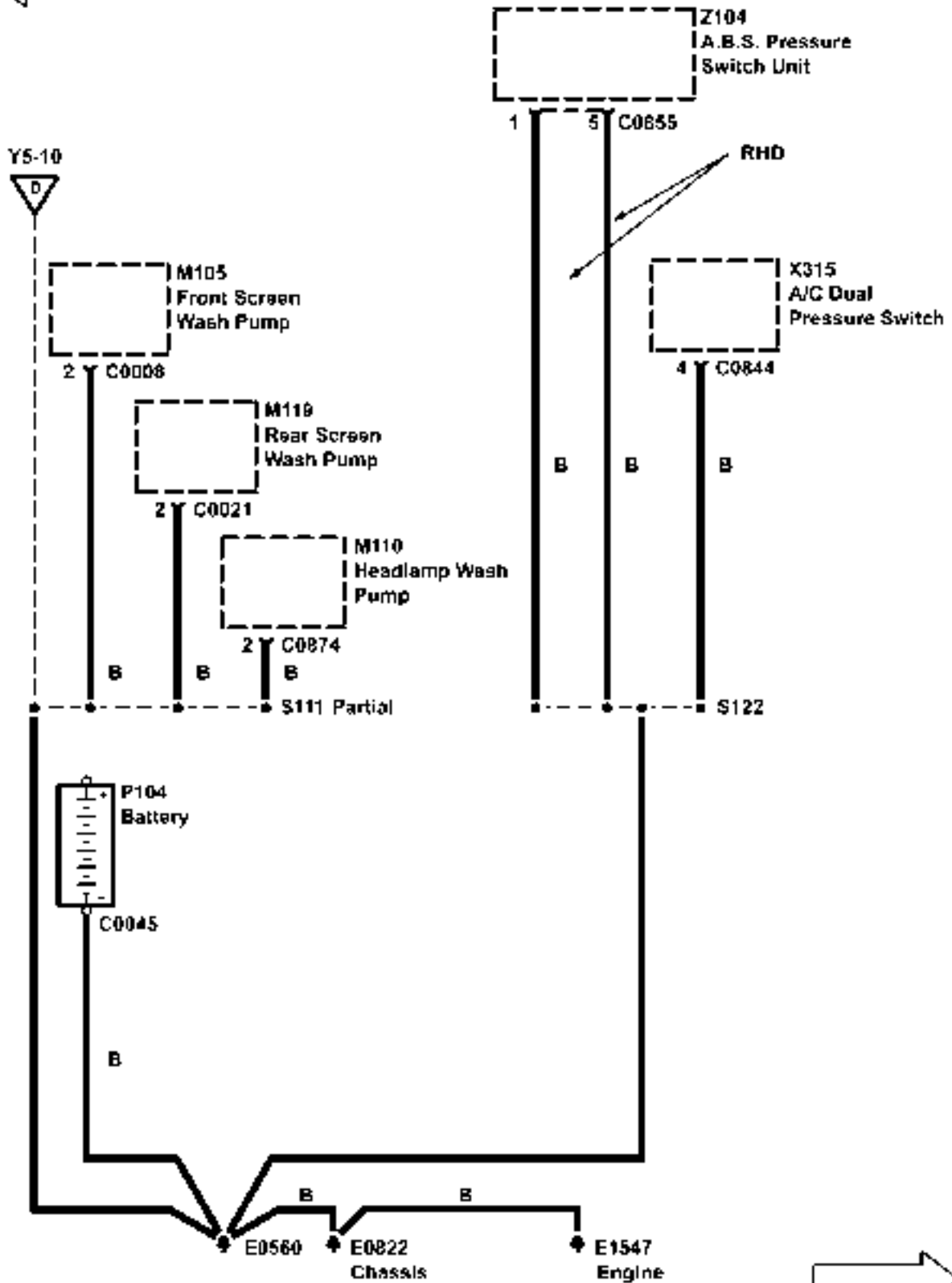
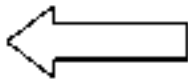

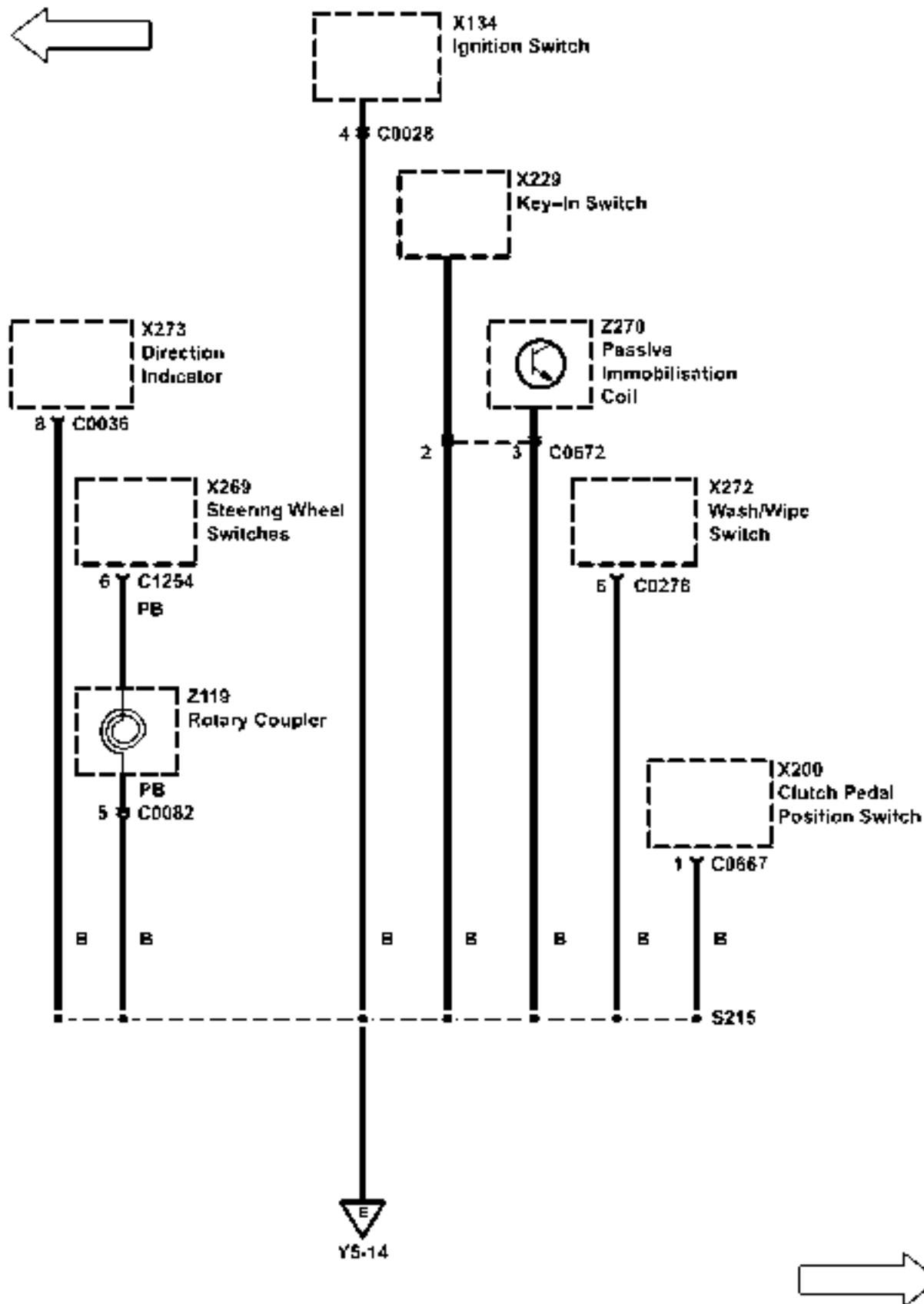

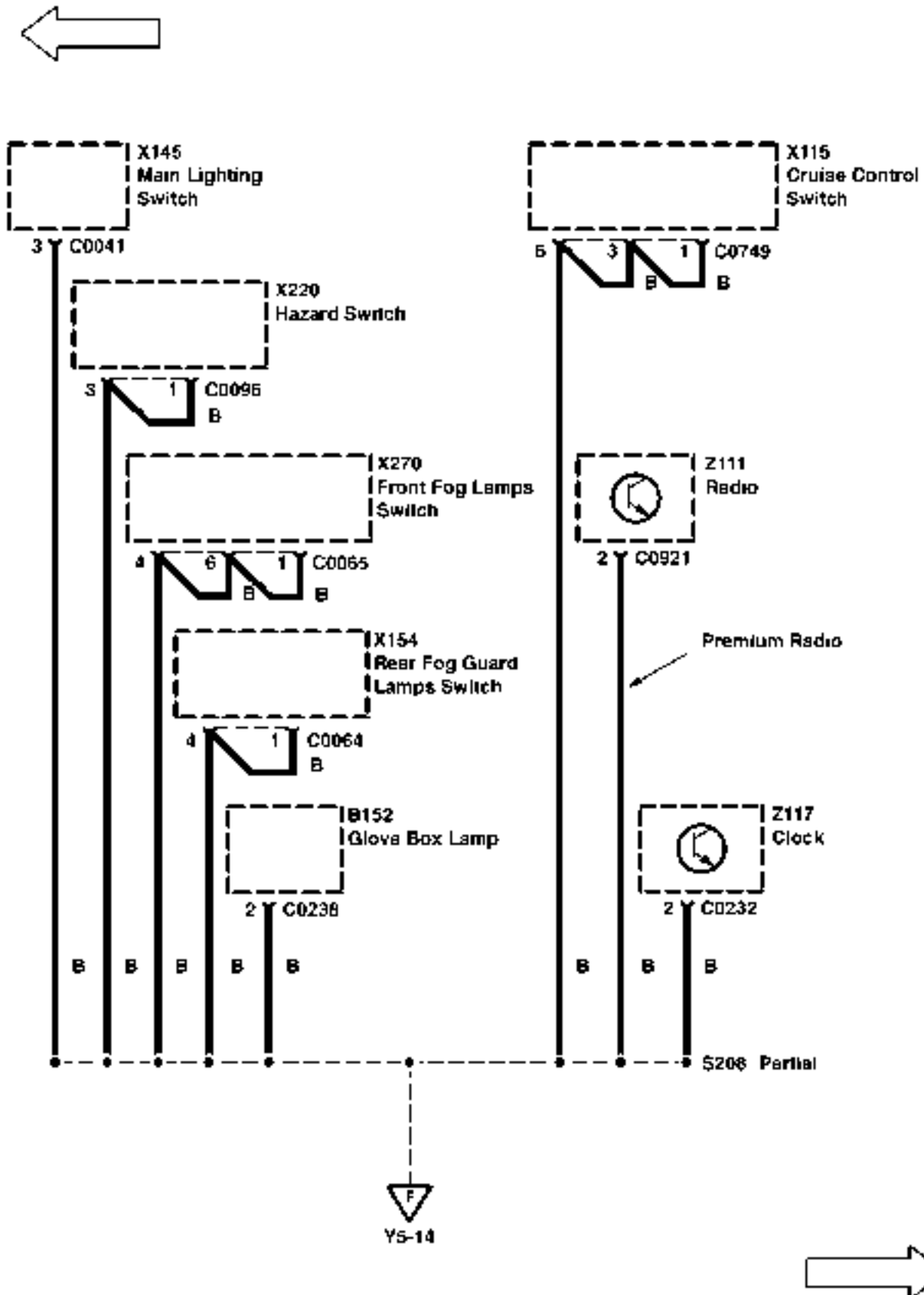

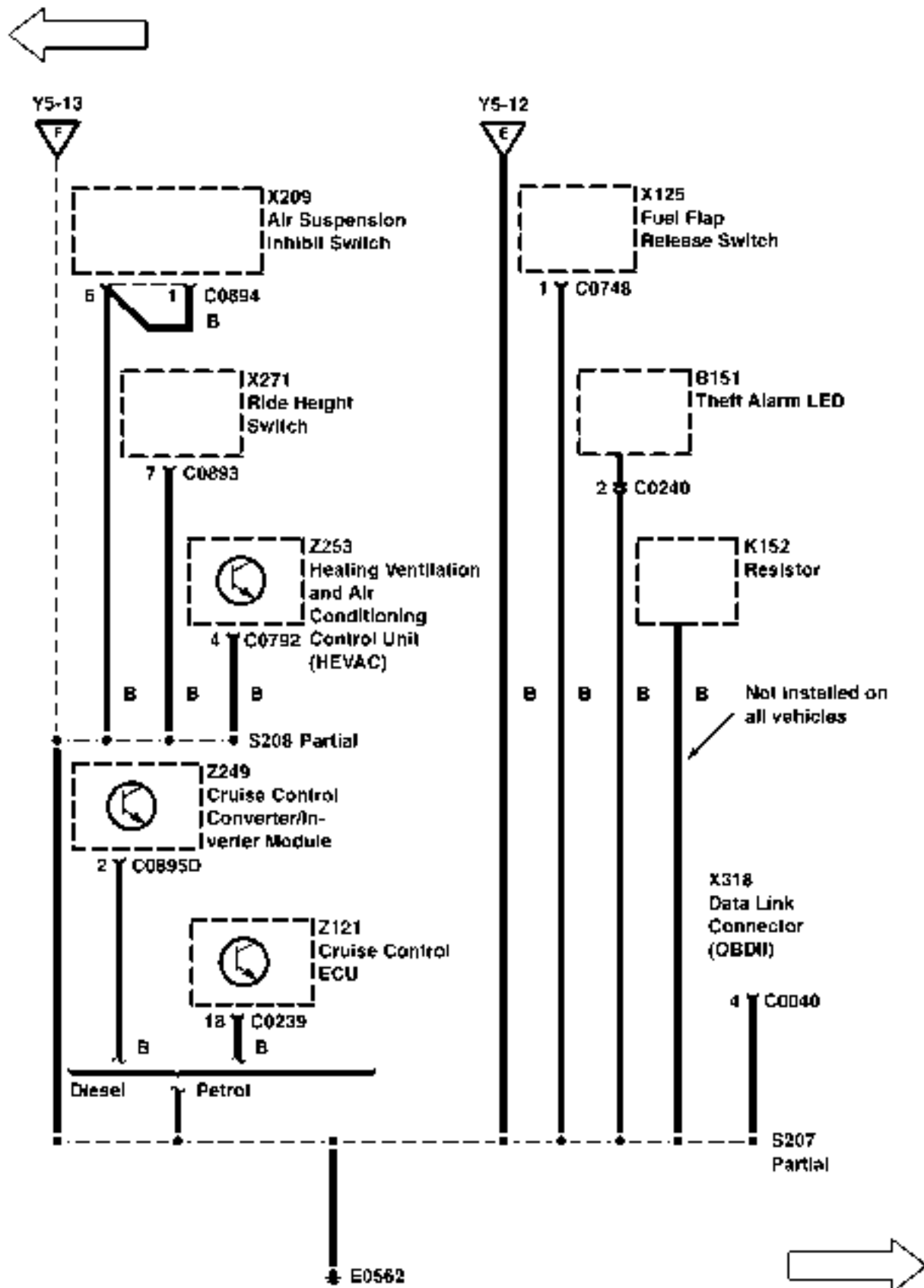

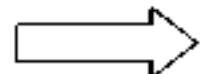
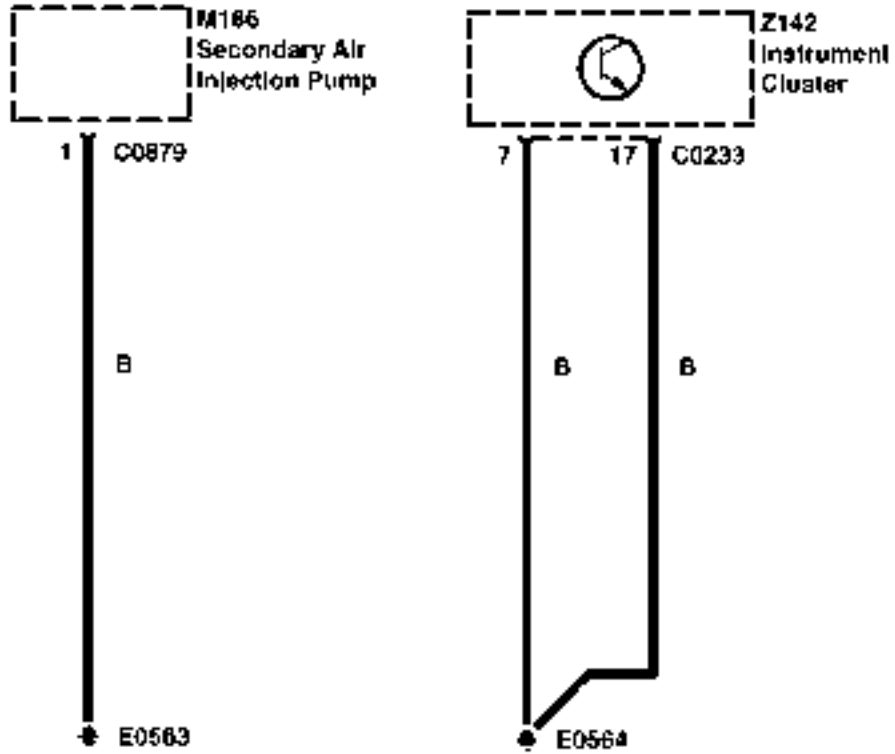
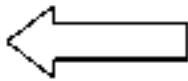

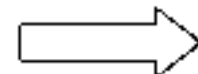
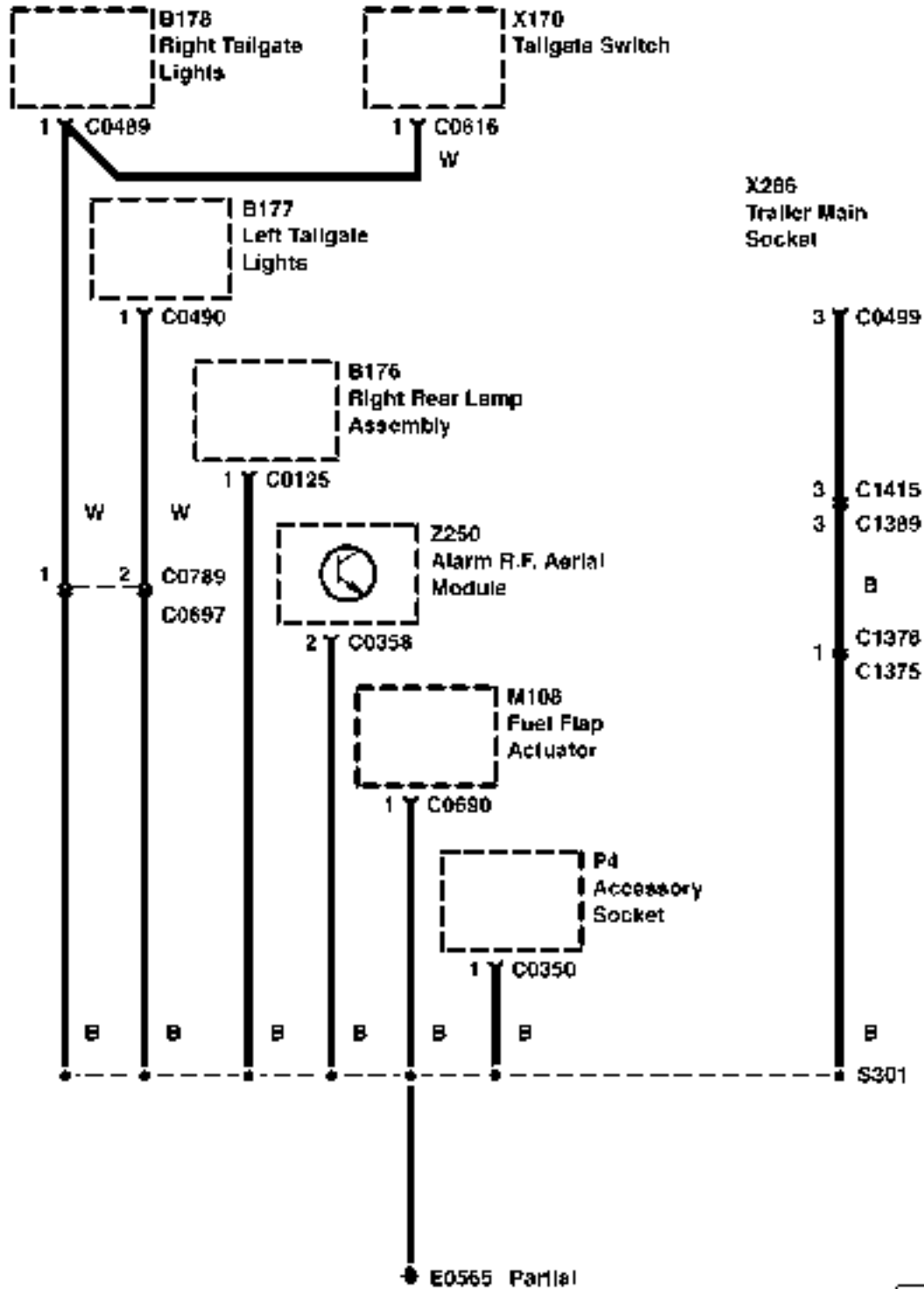
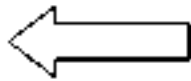

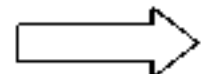
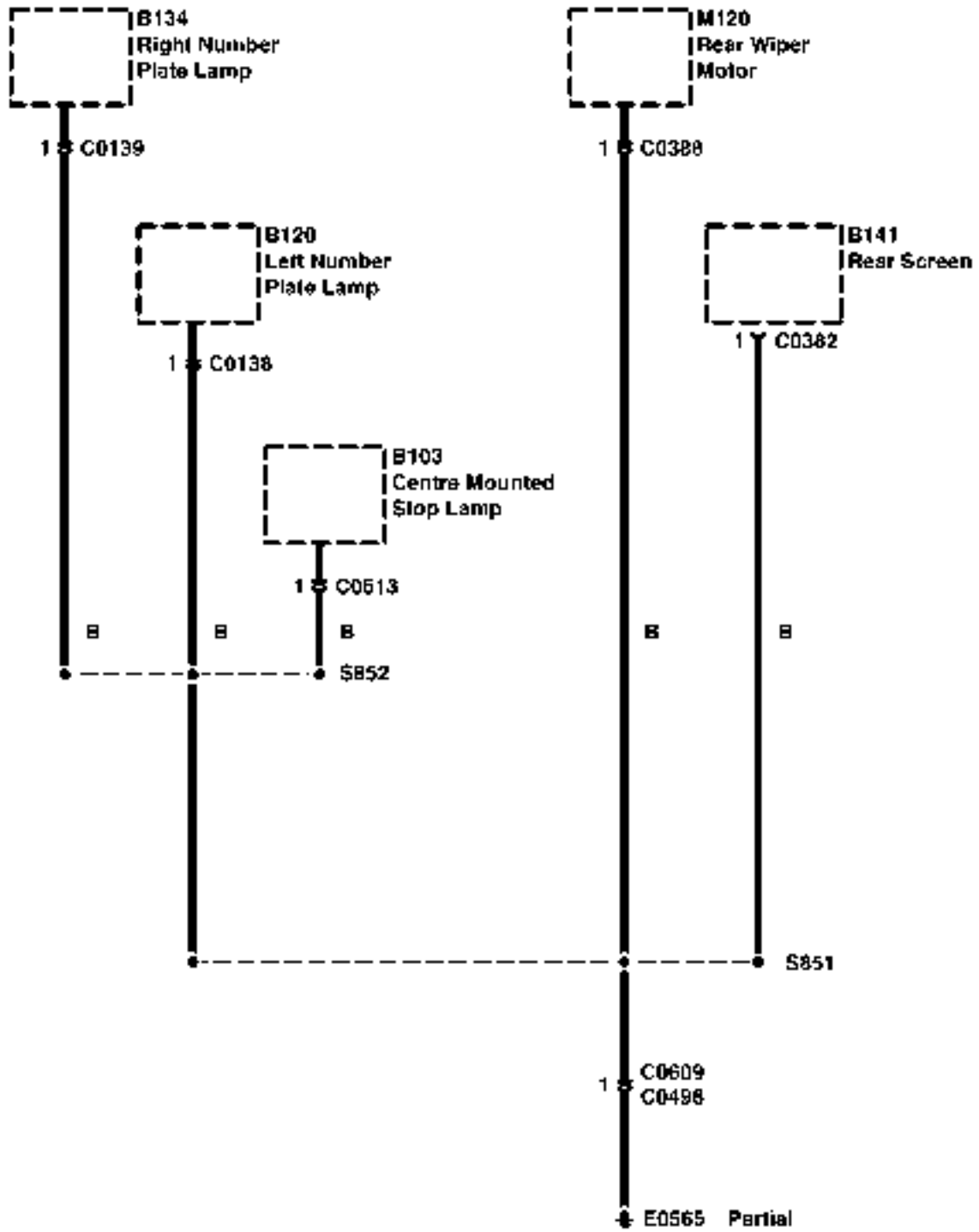
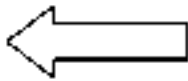

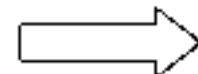
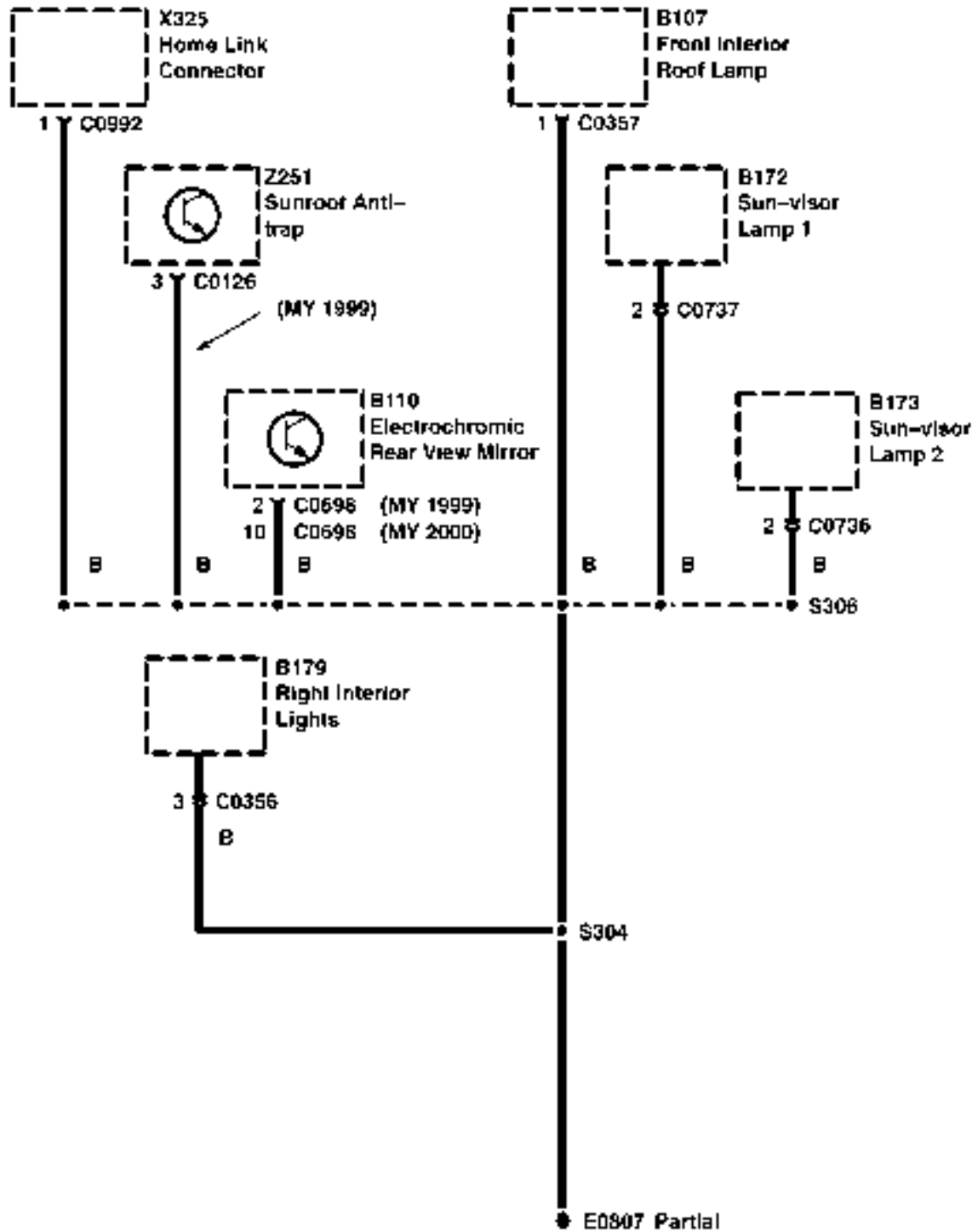
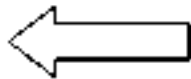

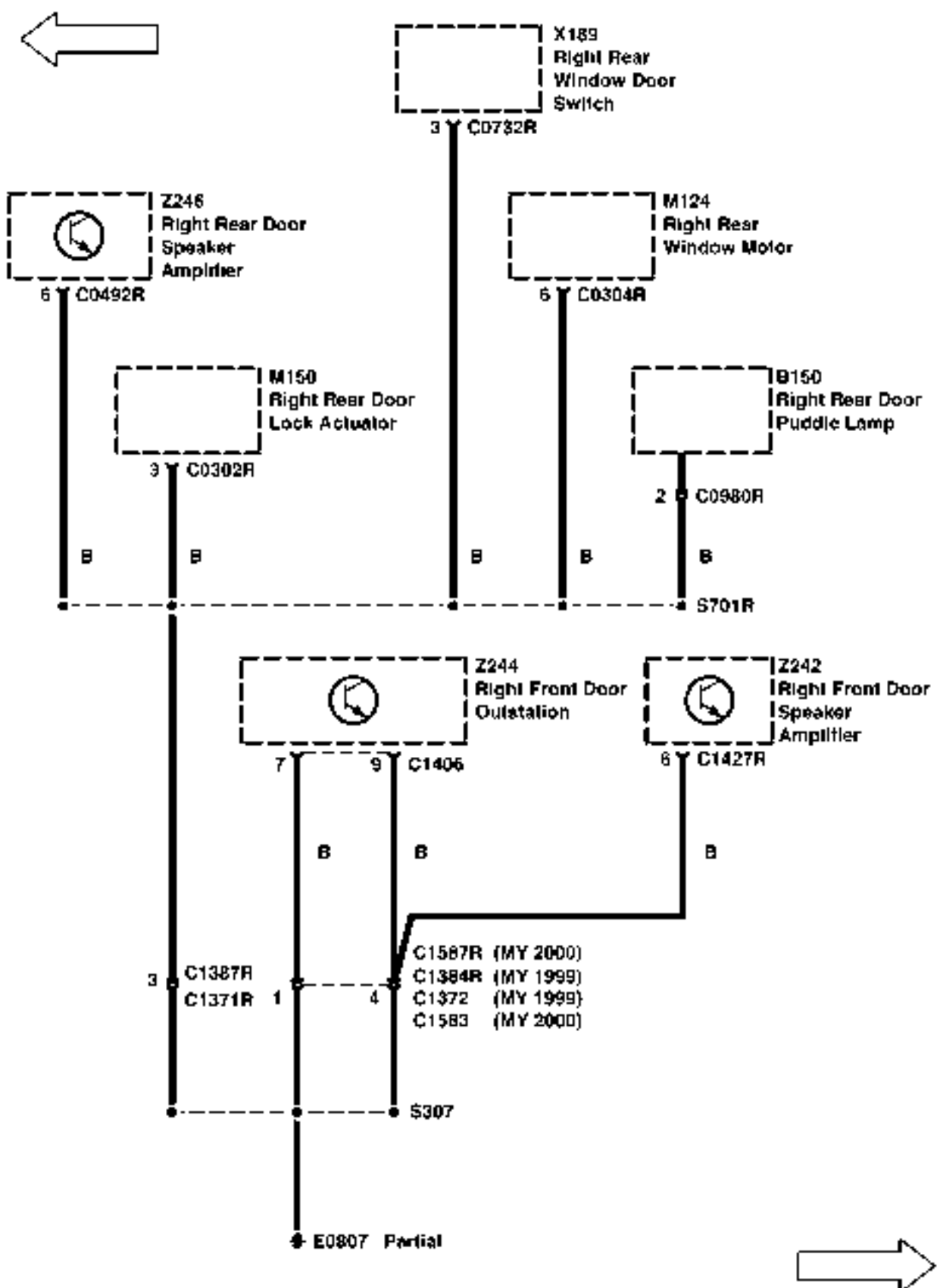

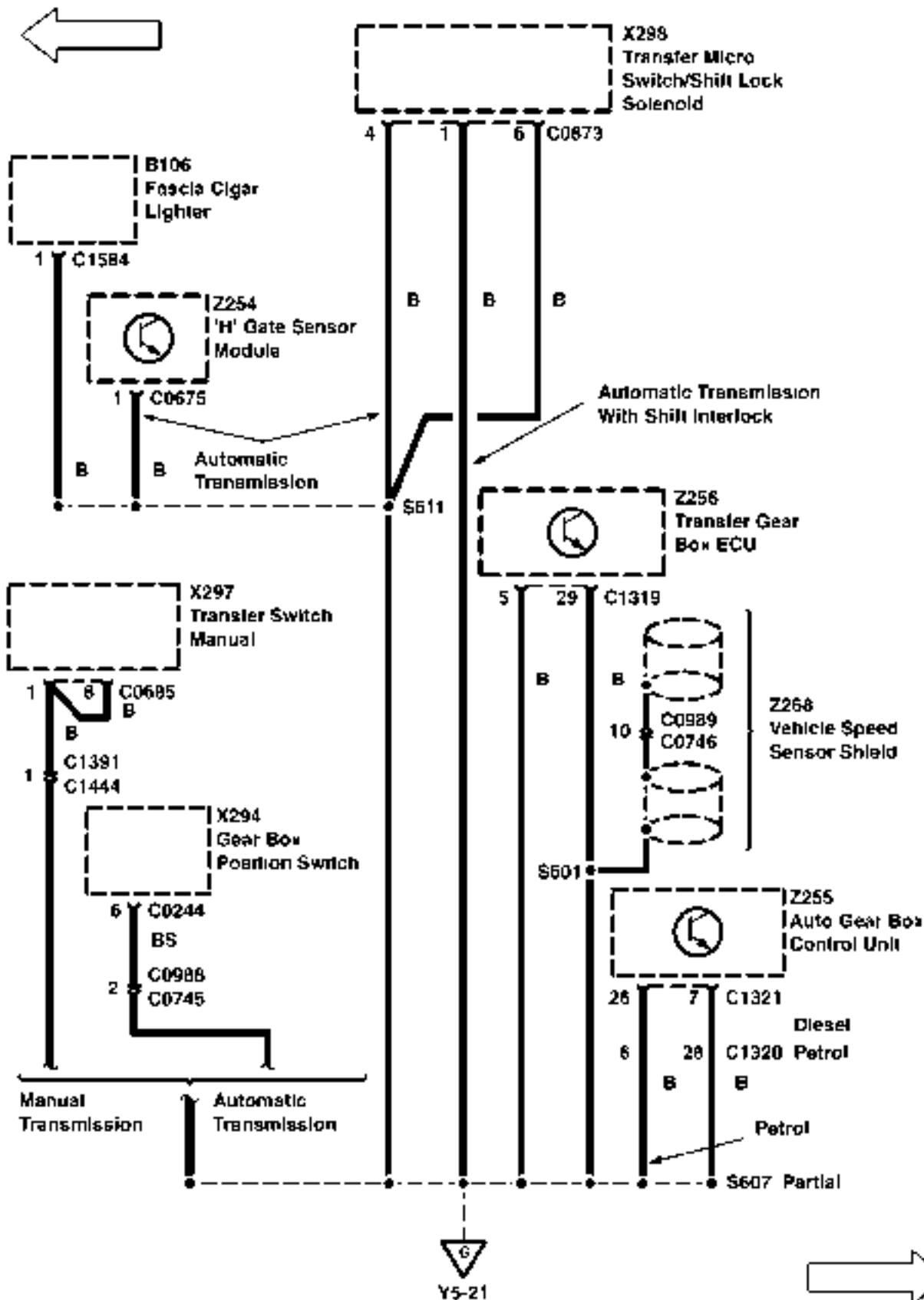

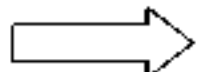
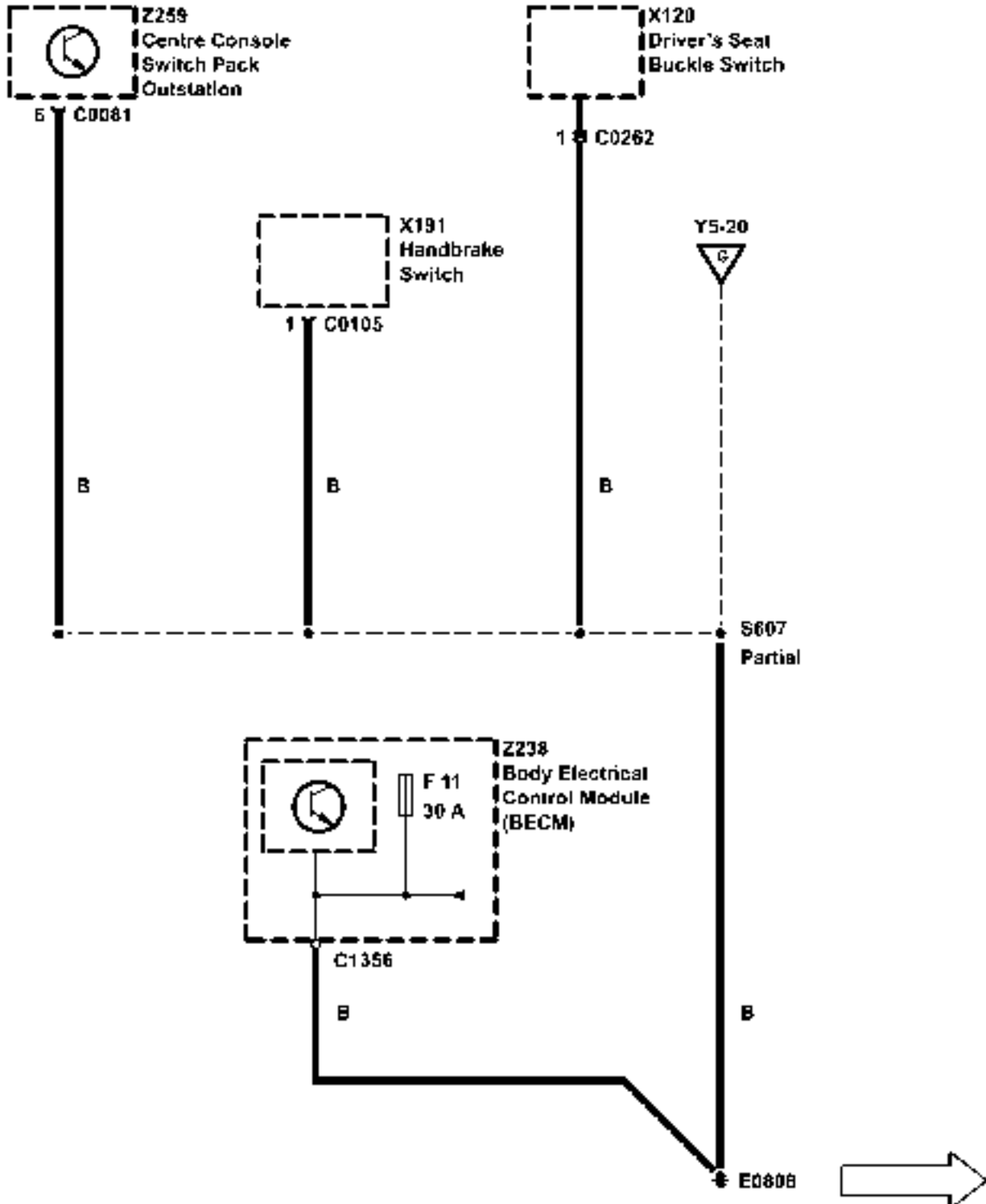
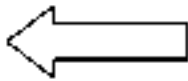

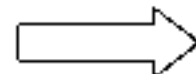
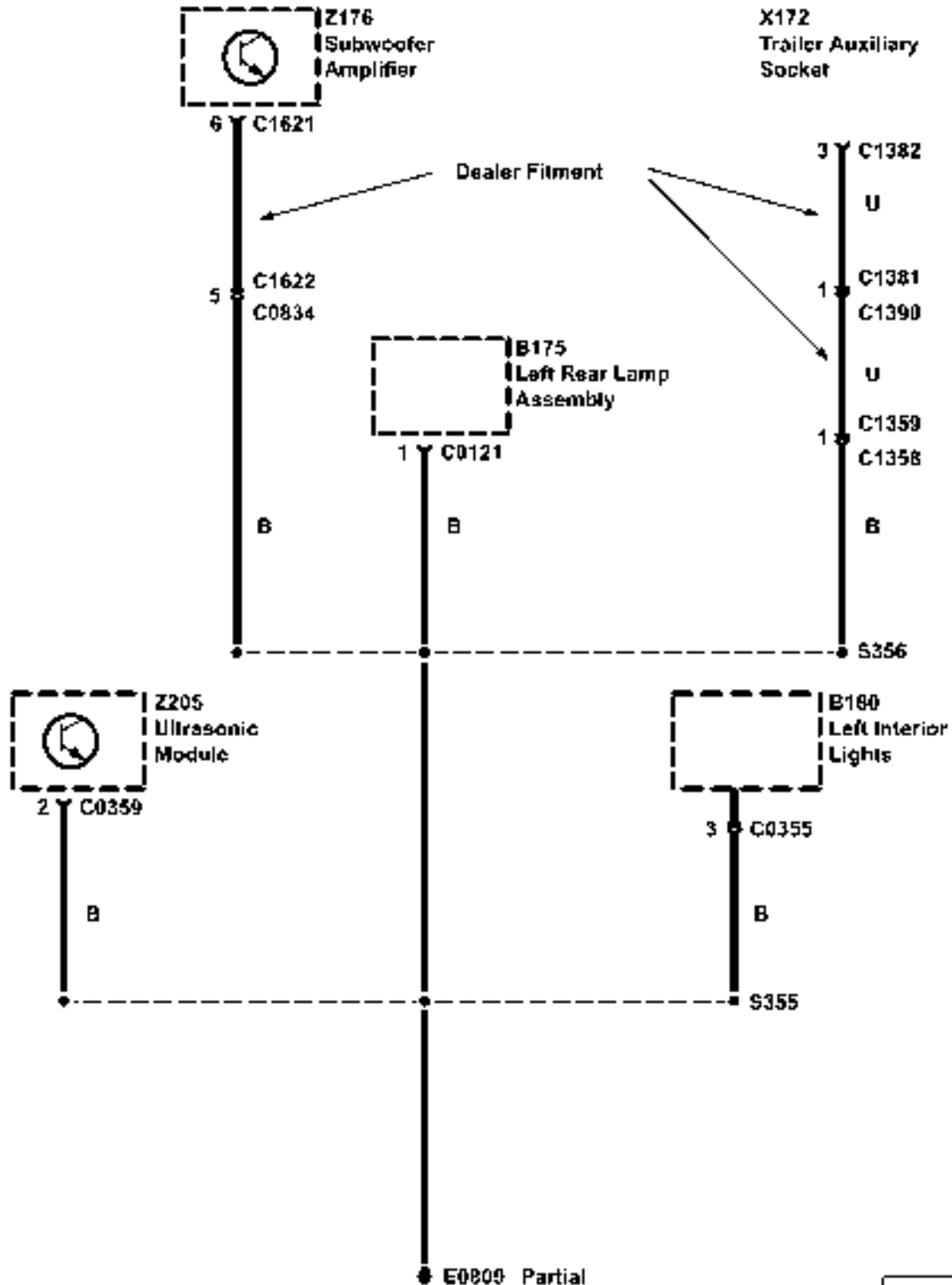
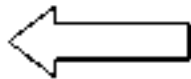

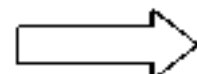
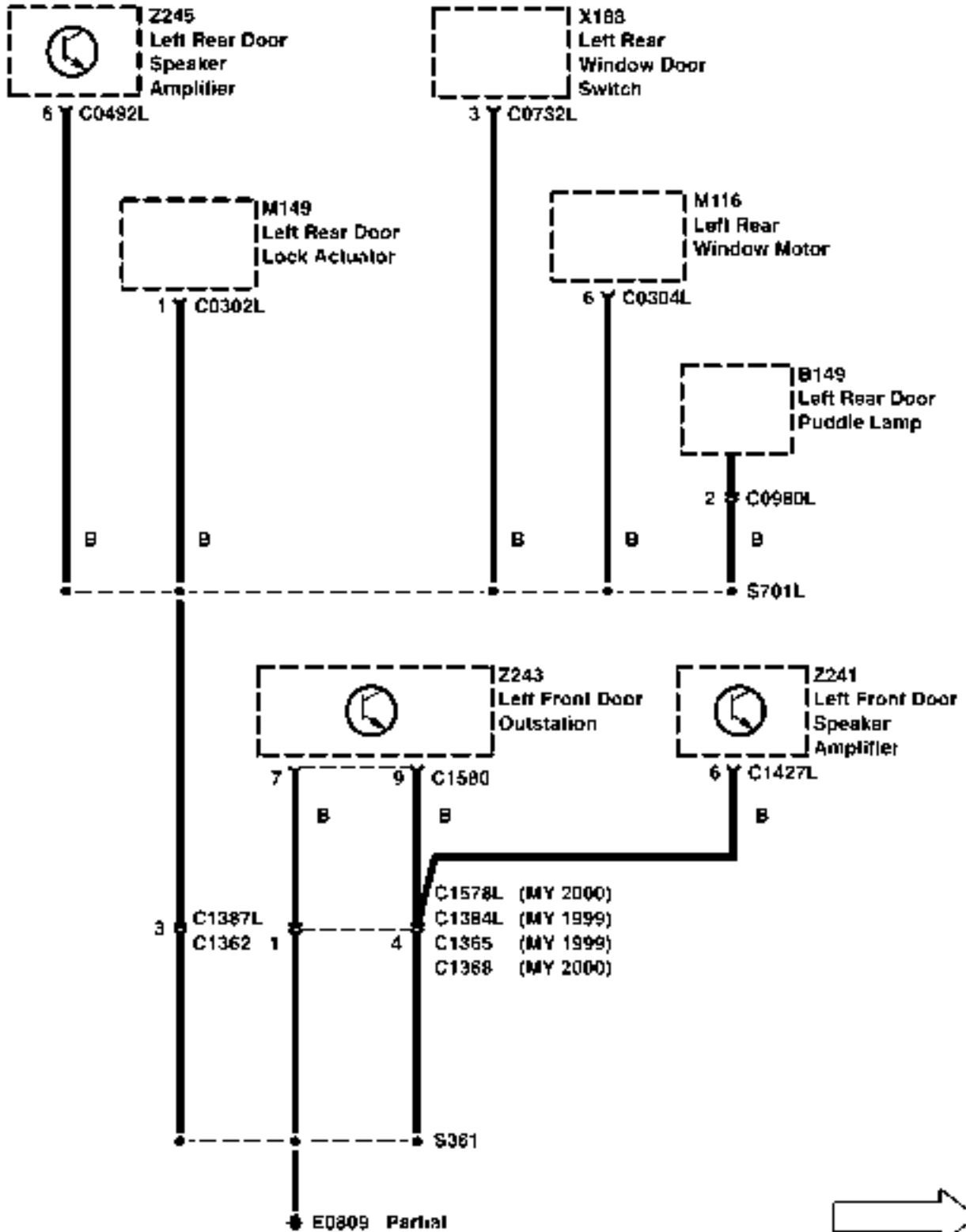
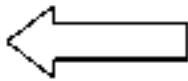

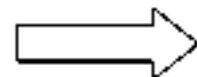
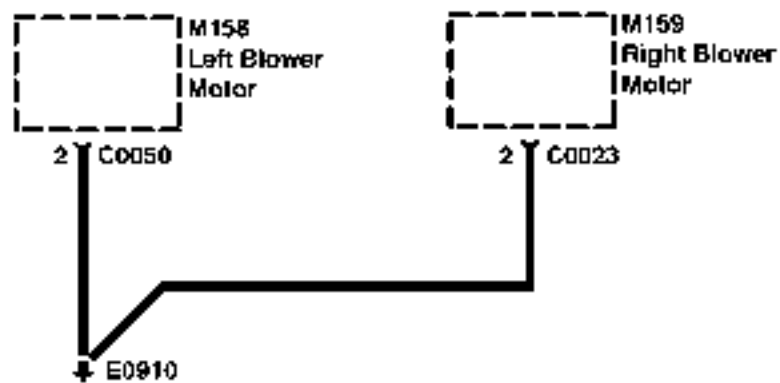
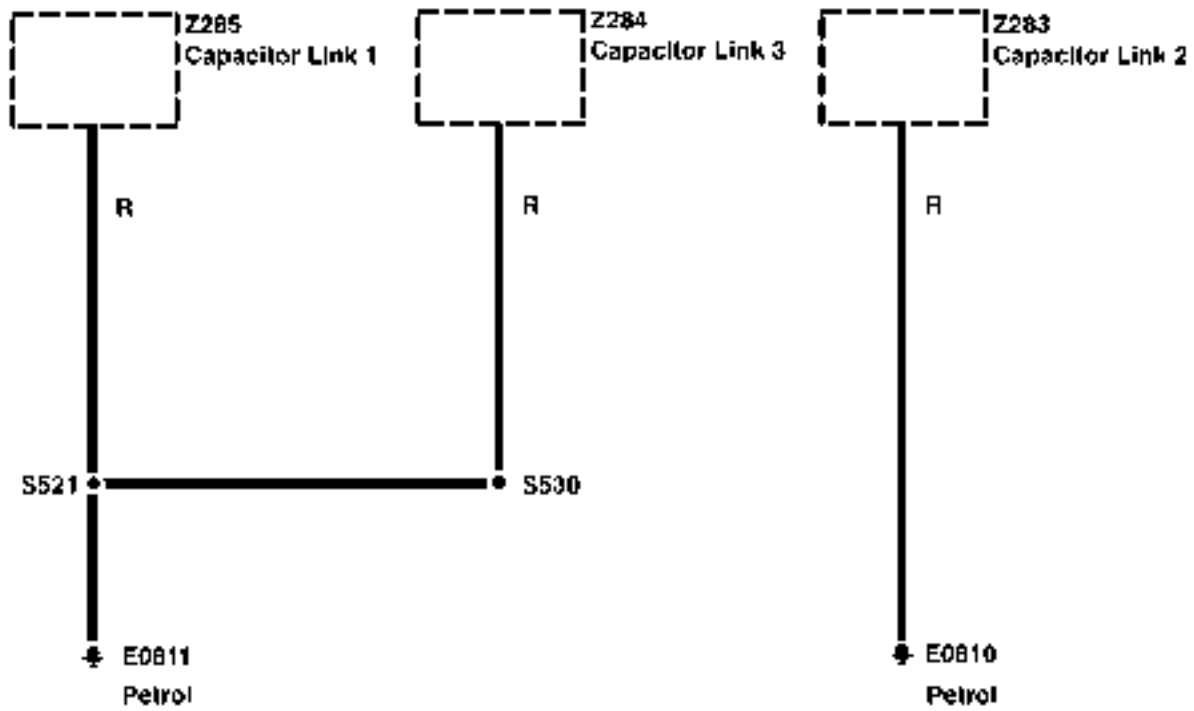



Petrol

All SCR cables are not connected at the component end.

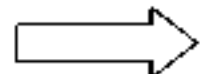
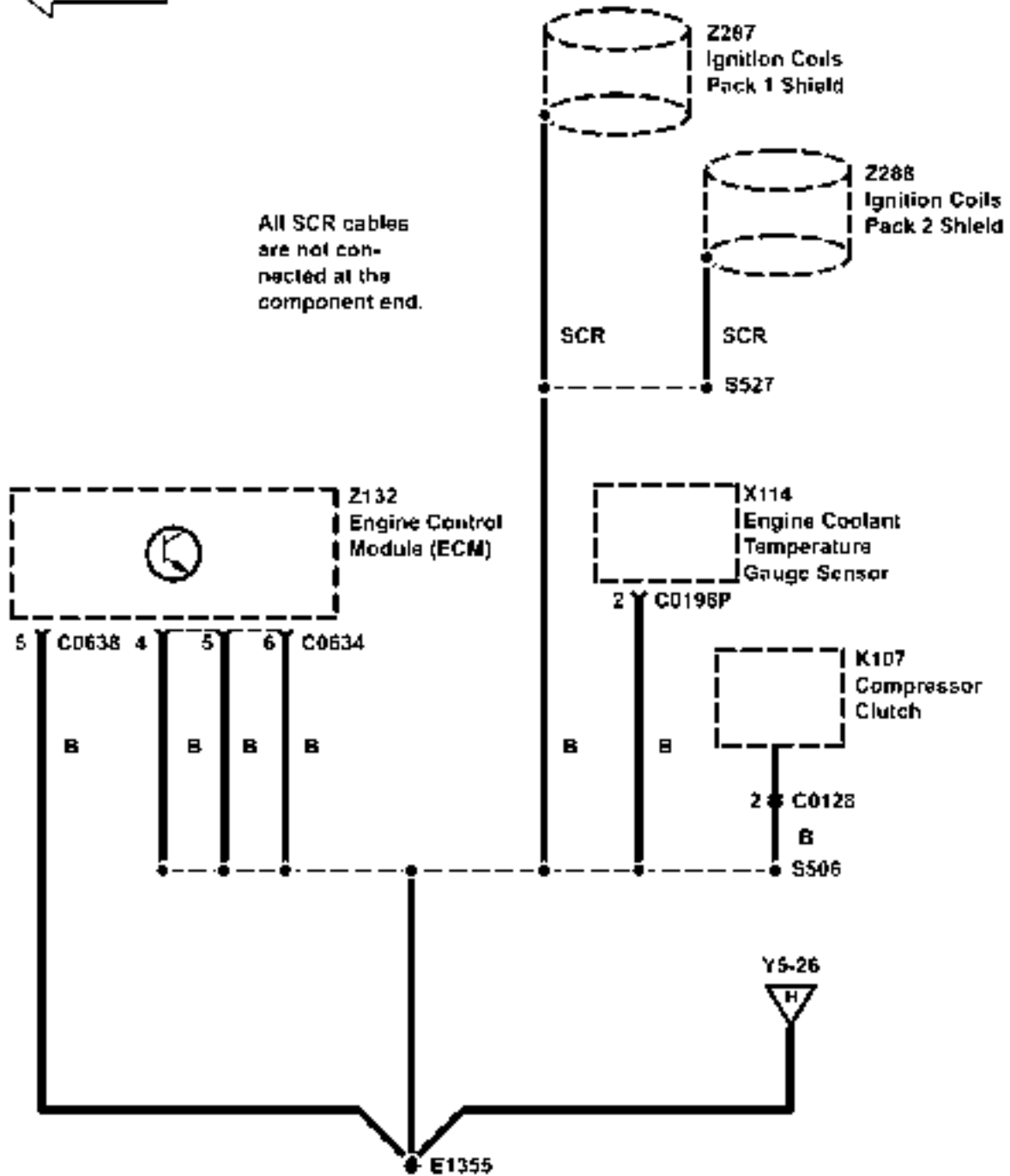

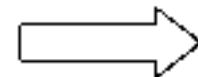
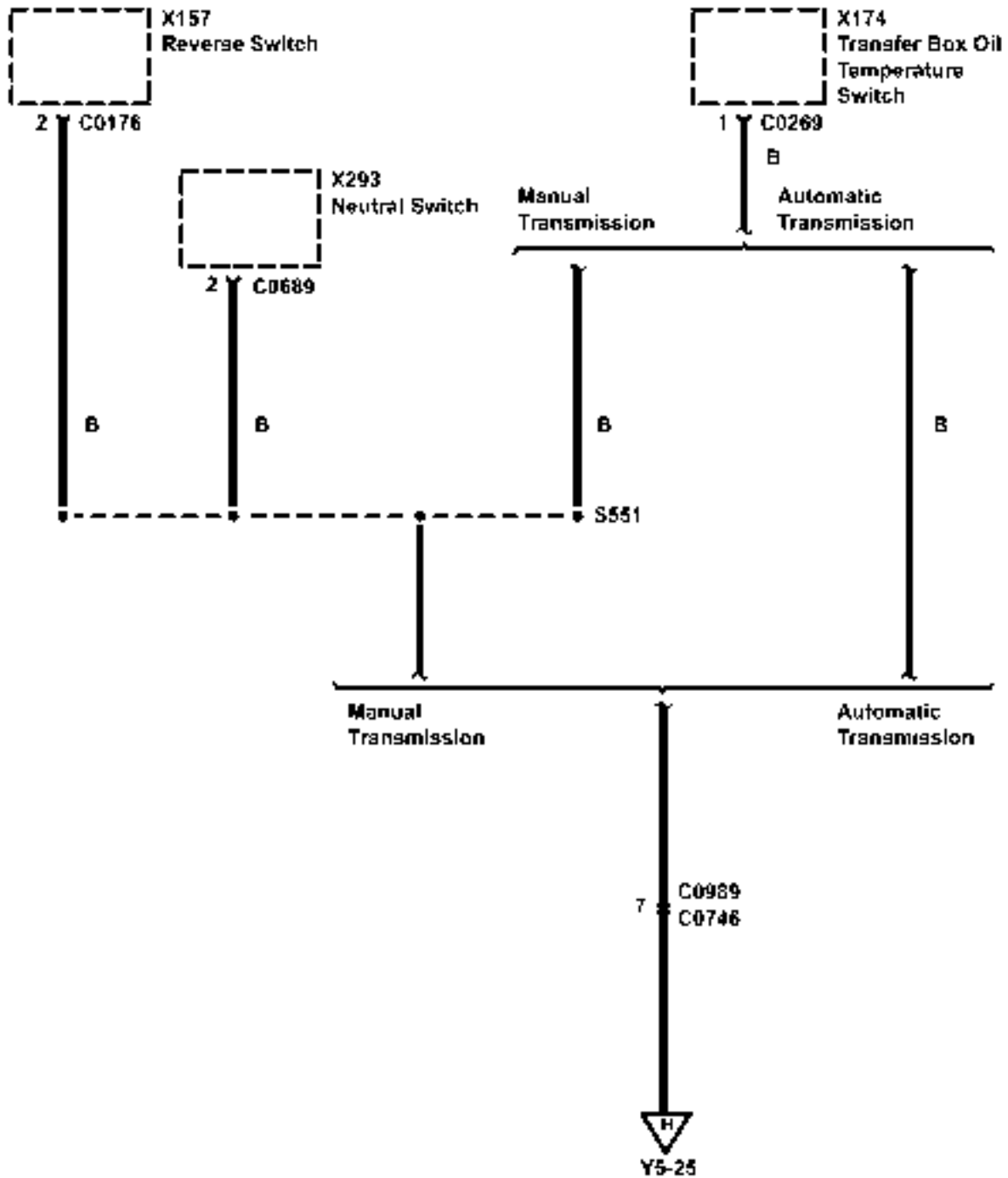
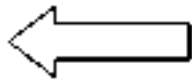

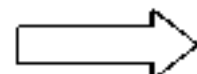
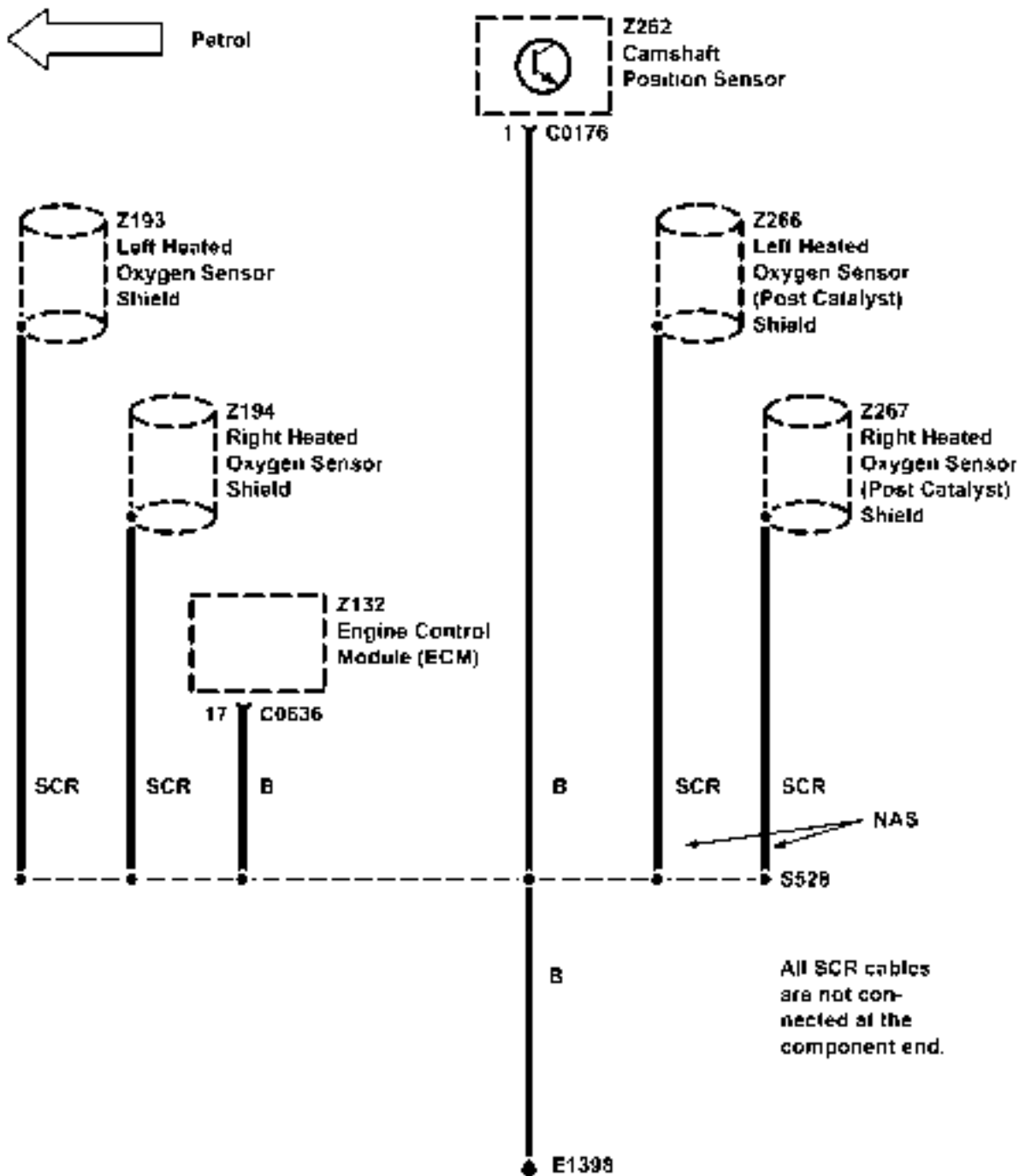

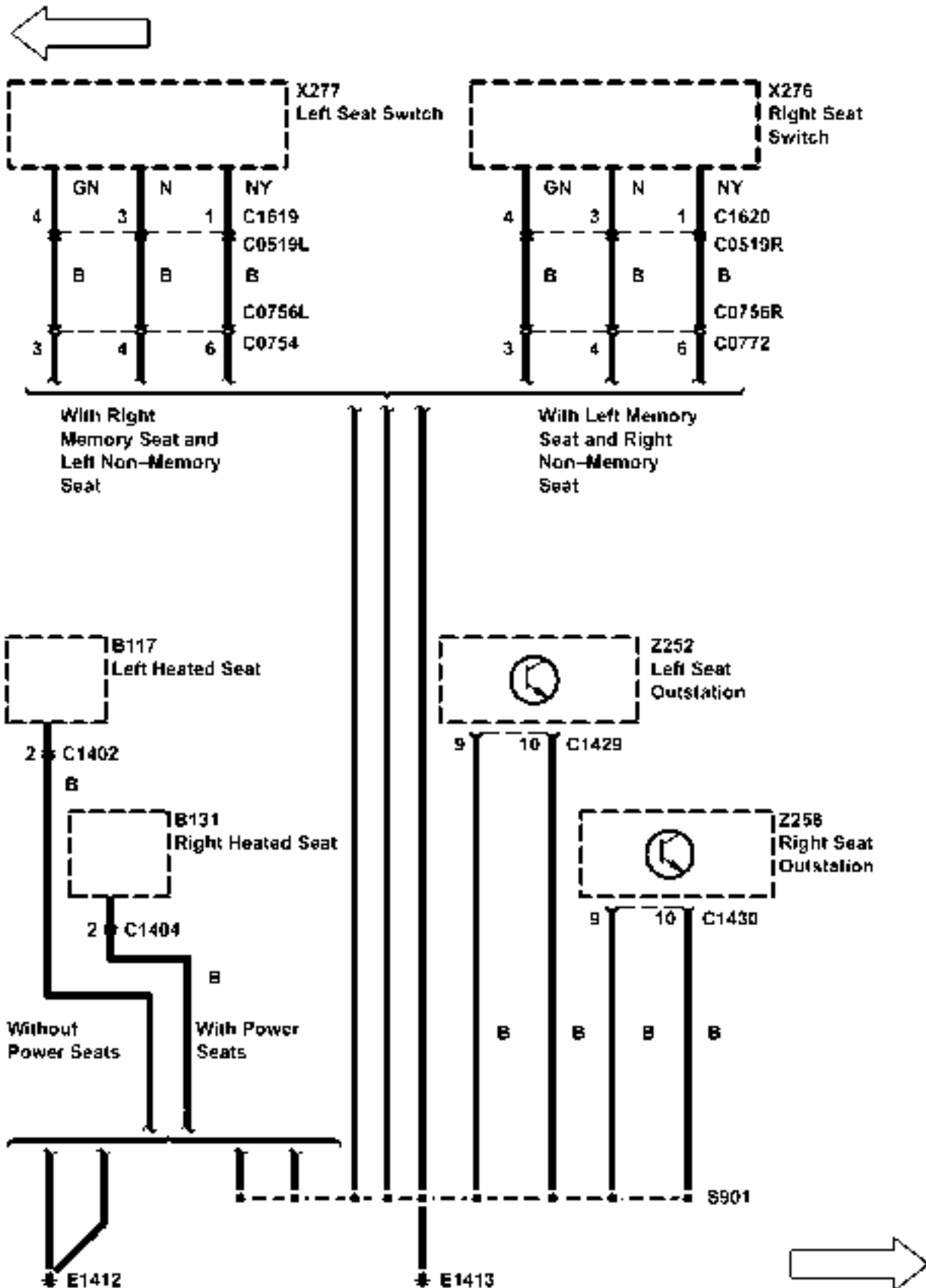

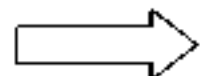
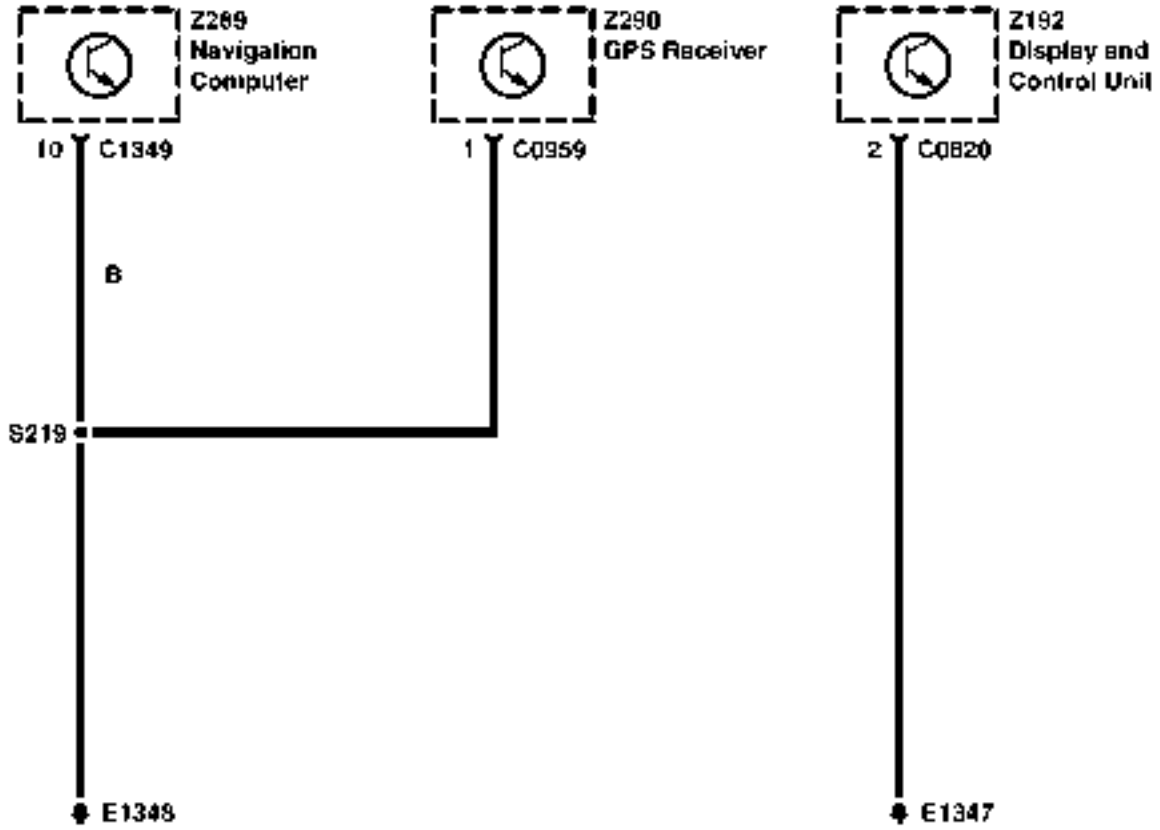
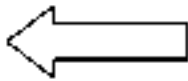

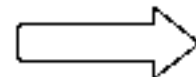
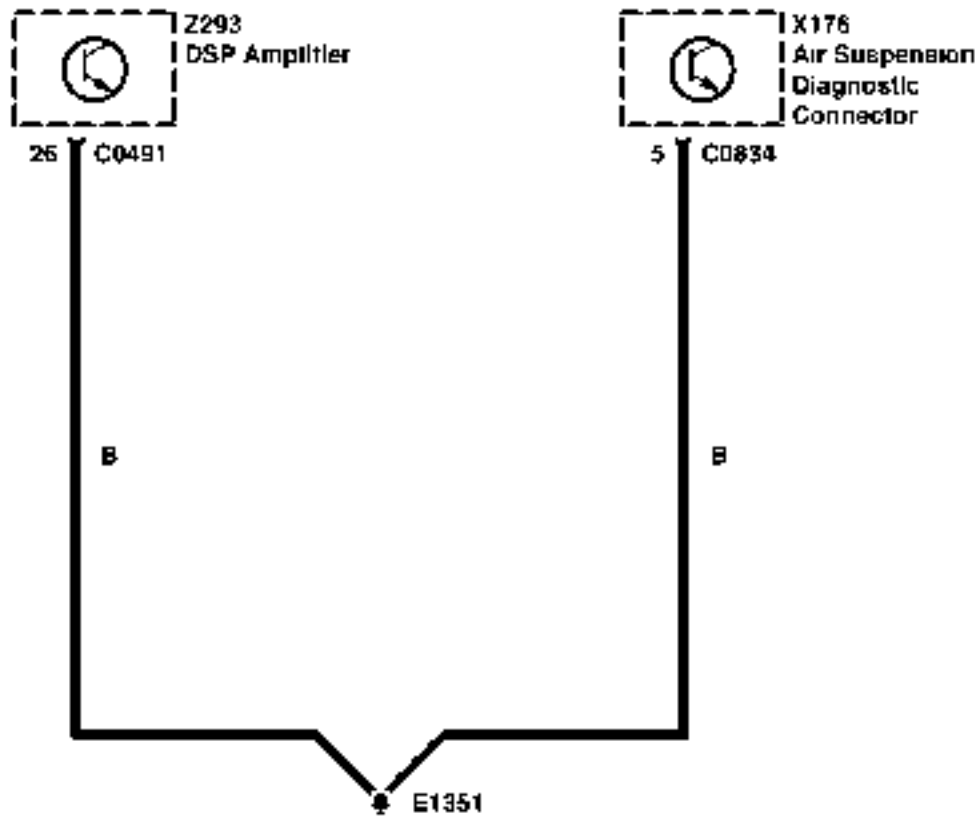

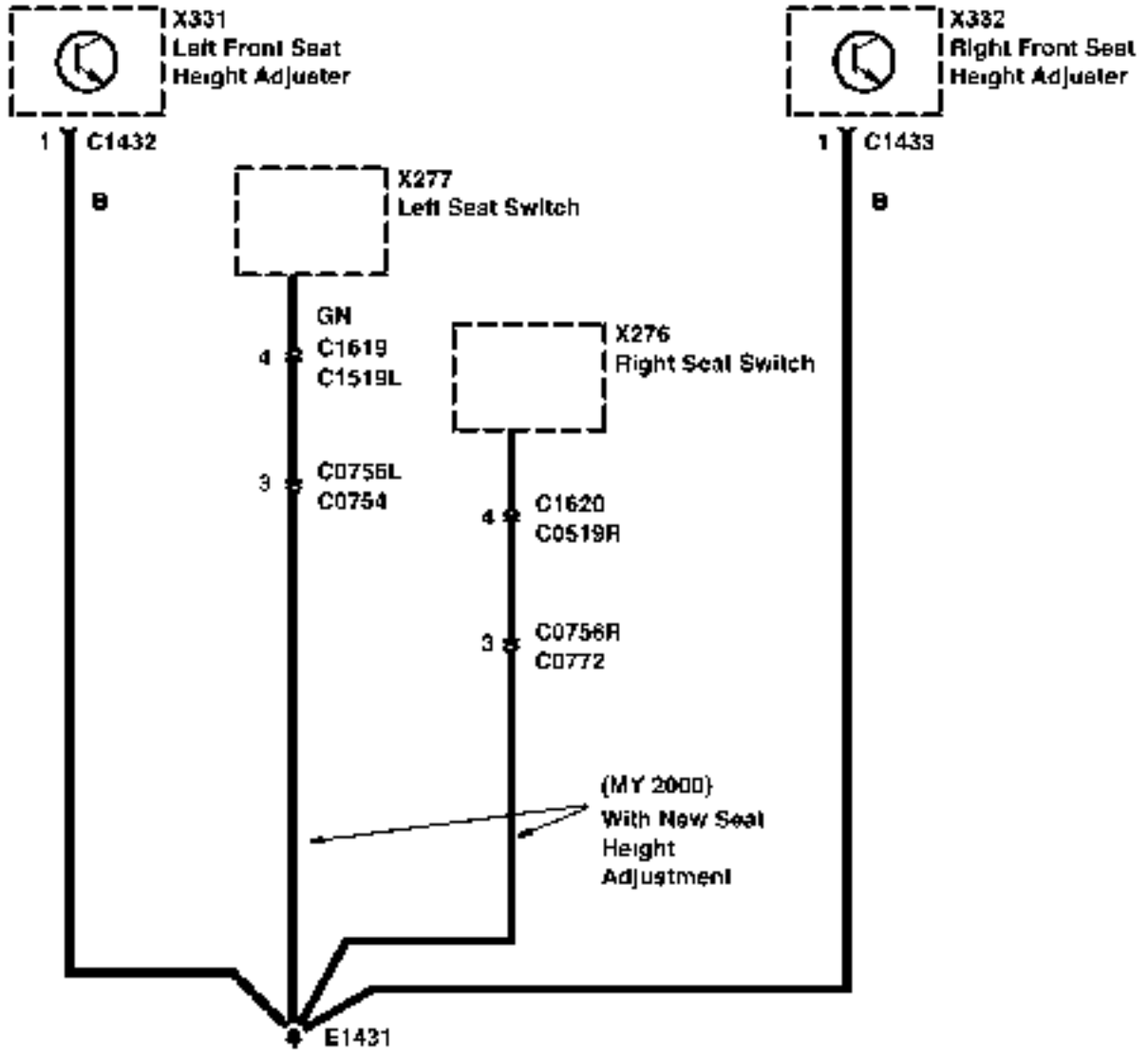
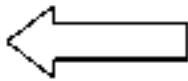

CIRCUIT DIAGRAMS

- Circuit diagrams are arranged so that current flow is from the top of the diagram (current source) to the bottom of the diagram (ground).
- Only those components that work together in the circuit are shown. If only part of a component is used in the circuit, then only that part of the component is shown.
- Remember:



TERMINAL NUMBER	DESIGNATION
50	Battery voltage: Ignition Switch in position III
30	Battery voltage: supplied constantly
15	Battery voltage: Ignition Switch in position II or III
R	Battery voltage: Ignition Switch in positions I, II
31	Ground

See Introduction (I) for additional circuit diagram symbols.

DIAGNOSIS

- If the diagram is accompanied by text:
 - Read the Circuit Operation before proceeding with the electrical diagnosis.
 - Read the Troubleshooting Hints before performing the System Diagnosis.
 - Tests follow the System Diagnosis
 - When performing the System Diagnosis, be certain that all components disconnected in previous steps are reconnected unless otherwise directed.

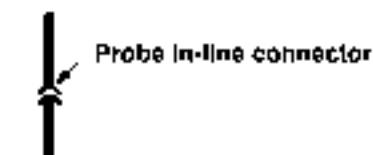
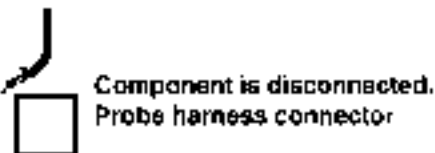
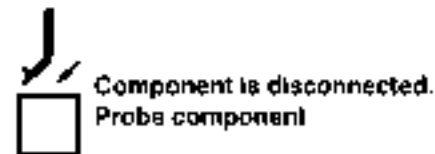
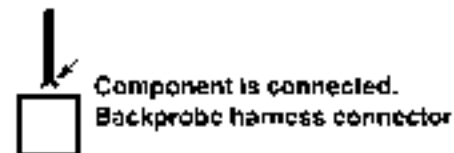
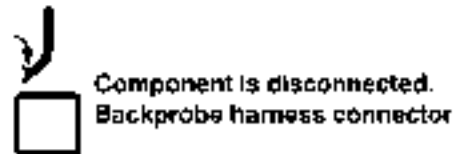

For views of the connectors which are attached to the component refer to the connector table.

Component	Location	Manual
ABS Booster Unit (Z103)	driver's side of engine compartment	70
ABS Hydraulic Pump (M102)	driver's side of engine compartment	70
ABS Pressure Switch Unit (Z104)	driver's side of engine compartment	70
A/C Aspirator (K219)	centre of fascia	82
A/C Dual Pressure Switch (X315)	behind LH side of front bumper	82
Accessory Socket (P4)	RH rear of vehicle	86
Air Bag Diagnostic Connector (X226)	passenger's footwell	75
Air Suspension Compressor (M140)	LH rear of engine compartment	60
Air Suspension Delay Turn Oil Timer (Z260)	beneath LH front seat	60
Air Suspension ECU (Z166)	beneath LH front seat	60
Air Suspension Inhibit Switch (X209)	centre of fascia	60
Air Valve Block (K163)	LH side of engine compartment	60
Alarm R.F. Antenna Module (Z250)	RH side of luggage compartment	86
Alarm Sounder (/171)	RH side of engine compartment	86
Ambient Air Sensor (K218)	LH front of vehicle in front of condenser	82
Anti Lock Brake System ECU (Z108)	beneath fascia on passenger's side of bulkhead	70
Auto Gear Box Control Unit (/255)	beneath LH front seat	44
Auto Gear Box Control Unit (Z256)	beneath LH front seat	44
Automatic Transmission Oil Temperature Switch (X106)	LH front of engine compartment	44
Battery (P104)	RH front of engine compartment	86
Battery Backed Up Alarm Sounder (Z272)	RH side of engine compartment	86
Body Electrical Control Module (BeCM) (Z238)	beneath RH front seat	76
Bonnet Switch (X110)	RH front of engine compartment rear right horn	86
Bowl Pressure Sensor (X253)	LH rear of engine compartment	19
Brake Fluid Level Switch (X111)	driver's side of engine compartment	70
Brake Switch Vent Valve (X112)	behind driver's side of fascia on brake pedal support	70
Camshaft Position Sensor (Z262)	LH front of engine	19
Capacitor Link 1 (Z285)	LH side of engine	12
Capacitor Link 3 (/284)	LH rear corner of engine compartment	12
Capacitor Link 2 (Z283)	LH side of engine	12
CD Changer (Z114)	LH rear of luggage compartment	86
CD Head Unit (Z111)	centre of fascia	86

Component	Location	Manual
Centre Console Switch Puck Outstation (Z259)	in centre console	86
Centre Mounted Stop Lamp (B103)	lower centre of rear screen	86
Clock (Z117)	centre of fascia	88
Clutch Pedal Position Switch (X200) (Diesel)	behind driver's side of fascia (lower dash panel removed)	19
Clutch Pedal Position Switch (X200) (Petrol)	behind driver's side of fascia (lower dash panel removed)	19
Compressor Clutch (K107) (Diesel)	RH front of engine	82
Compressor Clutch (K107) (Petrol)	LH front of engine	82
Cooling Fan Motor (M167)	LH front corner of engine compartment	44
Crankshaft Position Sensor (X250)	LH rear of engine	19
Cruise Control Converter/Inverter Module (Z49) (Diesel)	behind RH side of fascia right of steering column	19
Cruise Control Converter/Inverter Module (Z249) (Petrol)	behind RH side of fascia right of steering column	19
Cooling Fan Switch (X335)	LH front corner of engine compartment	44
Cruise Control ECU (Z121)	behind RH side of fascia right of steering column	19
Cruise Control Switch (X115)	centre of fascia	19
Cruise Control Vacuum Pump (M103)	LH rear corner of engine compartment	19
Data Link Connectors (X318)	passenger's footwell	86
Diaphragm Valve (K220)	LH side of engine compartment	60
Diaphragm Valve (X302)	LH side of engine compartment	60
Differential Lock Switch (X238)	LH rear corner of engine compartment	86
Direction Indicator (X273)	left of steering column	86
Display and Control Unit (Z291)	centre of fascia	87
Distribution Motor (M165)	beneath centre of fascia	82
Driver's Air Bag (K177)	driver's side on steering wheel	75
Driver's Seat Buckle Switch (X120)	inside driver's seat belt buckle assembly	86
DSP Amplifier (Z293)	LH side of luggage compartment	86
EGR Control Solenoid (K171)	front LH wing in beneath engine compartment fuse box	86
Electrochromatic Rear View Mirror (B110)	top centre of front screen	76
Engine Compartment Fuse Box (P125a)	RH side of engine compartment	86
Engine Control Module (ECM) (Z132) (Diesel)	RH side of engine compartment behind battery	19
Engine Control Module (ECM) (Z132) (Petrol)	RH side of engine compartment	19

Component	Location	Manual
Engine Coolant Temperature Gauge Sensor (X114) (Diesel)	LH side of engine	88
Engine Coolant Temperature Sensor (X126) (Diesel)	LH side of engine	19
Engine Coolant Temperature Sensor (X126) (Petrol)	LH side of engine	19
Engine Fuel Temperature Sensor (X128)	LH side of engine	19
Engine Speed Sensor (X255)	lower LH rear of engine	19
Evaporative Emission Canister Purge Valve (K132)	LH side of engine compartment	17
Evaporative Emission Canister Vent Seal Valve (K233) (NA5)	LH rear corner of engine compartment	86
Evaporator Temperature Sensor (X303)	RH side of heater evaporator unit	82
Fascia Cigar Lighter (B106)	in centre console	86
Footwell Lamp 1 (B168)	passenger's footwell	86
Footwell Lamp 2 (B169)	driver's footwell	86
Fore-Aft Sensor (X196)	underside of respective front seat	70
Front Fog Lamps Switch (X270)	centre of fascia	86
Front Interior Roof Lamp (B107)	front centre of roof	86
Front Screen Wash Pump (M105)	behind RH side of front bumper	84
Front Wiper Motor (M107)	LH rear corner of engine compartment	84
Fuel Flap Actuator (M106)	RH side of luggage compartment	86
Fuel Flap Release Switch (X125)	top LH side of fascia	80
Fuel Heater (K217)	LH rear of engine compartment	19
Fuel Injectors (K141) (Petrol)	top of engine	19
Fuel Pump Assembly (K195) (Diesel)	LH side of engine	19
Fuel Pump Module (Z134)	top of fuel tank	19
Fuel Shut Off Solenoid (K111)	LH side of engine	19
Fuel Tank Pressure Sensor (X320)	top of fuel tank	19
Gearbox Case (Z283)	LH side of transmission	44
Gear Box Position Switch (X294)	LH side of transmission	44
Generator (Z100) (Diesel)	LH front of engine	86
Generator (Z106) (Petrol)	top RH side of engine	86
Glove Box Lamp (B152)	behind glovebox	86
Glow Plugs (P120)	LH side of engine	19
Glow Plug Timer Unit (Z135)	RH front of engine compartment behind battery	19
GPS Receiver (Z290)	RH side of luggage compartment behind parcel tray support panel	87

Component	Location	Manual
GPS Antenna (Z292)	lower RH side of windscreen	87
H Gate Sensor Module (Z254)	in centre console	44
Handbrake Switch (X191)	beneath centre console on handbrake lever	70
Hazard Switch (X220)	centre of fascia	86
Headlamp Wash Pump (M110)	behind RH side of front bumper	84
Headrest Motor (M148)	RH side of seat squab frame	78
Headrest Potentiometer (X279)	RH side of seat squab frame	78
Heating Ventilation and Air Conditioning Control Unit (HEVAC) (Z253)	centre of fascia	80
Home Link Connector (X325)	front centre of roof	86
Idle Air Control Valve (M112)	LH side of engine	18
Ignition Coils Pack 1 (Z281)	LH rear of engine	86
Ignition Coils Pack 2 (Z282)	LH rear of engine	86
Ignition Key Lock Solenoid (K191)	right of steering column	86
Ignition Key Lock Solenoid Diode (Z294)	right of steering column in LHD Fascia Wiring Harness	86
Ignition Switch (X134)	left side of steering column	86
Inertia Fuel Shut-Off Switch (X135)	behind RH footwell trim panel	19
Injector Needle Lift Sensor (X258)	LH side of engine	19
Instrument Cluster (Z142)	driver's side of fascia	88
Intake Air Temperature Sensor (X311) (Diesel)	top LH side of engine on intake manifold	19
Intake Air Temperature Sensor (X311) (Petrol)	LH side of engine compartment on air cleaner	19
Key-In Switch (X229)	right of steering column	86
Key Illumination (B170)	right of steering column	86
Left Antenna Amplifier (Z177)	LH side of luggage compartment behind trim panel	86
Left Blend Motor (M153)	beneath centre of fascia	82
Left Blower Motor (M158)	behind driver's side of fascia (lower dash panel removed)	80
Left Condenser Fan Motor (M113)	behind front grille	82
Left Front Bass Speaker (K202)	front door trim panel – lower	86
Left Front Door Lock Actuator (M153)	in top rear of LH front door	76
Left Front Door Outstation (Z243)	behind front door trim panel	86
Left Front Door Puddle Lamp (B114)	underside of front door	86
Left Front Door Speaker Amplifier (Z241)	behind front door trim panel	86
Left Front Fog Lamp (B184)	behind LH side of front bumper	86

Component	Location	Manual
Left Front Height Sensor (X205)	beneath LH side of vehicle on chassis	60
Left Front Indicator Lamp (B153)	LH front of vehicle	86
Left Front Indicator Lamp (B153)	LH front of vehicle	86
Left Front Lamp Assembly (B115)	LH front of vehicle	86
Left Front Midrange Filter Capacitor (Z247)	behind front door trim panel in left front midrange speaker	86
Left Front Midrange Speaker (K200)	front door trim panel – centre	86
Left Front Seat Height Adjuster (X331)	beneath LH front seat	78
Left Front Tweeter (K197)	front door cheater panel	86
Left Front Wheel Speed Sensor (X137)	behind LH front wheel	70
Left Front Window Motor (M130)	behind front door trim panel	86
Left Headlamp (B116)	LH front of vehicle	86
Left Headlamp Wiper Motor (M156)	LH front of vehicle	84
Left Heated Oxygen Sensor (Post Catalytic) (X289)	on left intermediate pipe	19
Left Heated Oxygen Sensor (X139)	on left exhaust downpipe	19
Left Horn (K128)	LH front of engine compartment	86
Left Interior Lights (B180)	LH centre of headlining	86
Left Knock Sensor (X295)	lower LH side of engine	19
Left Lumbar Pump (M147)	RH side of seat squab frame	78
Left Memory Mirror (M152)	LH front door	76
Left Memory Switch (X278)	on side of respective front seat	78
Left Mirror Actuator (M115)	LH front door	76
Left Non-Memory Seat Power Relay 1 (K213)	underside of LH front seat	78
Left Non-Memory Seat Power Relay 2 (K215)	underside of LH front seat	78
Left Number Plate Lamp (B120)	rear of vehicle, or tailgate	86
Left Rear Bass Speaker (K209)	rear door trim panel – lower	86
Left Rear Door Lock Actuator (M149)	in top of LH rear door	76
Left Rear Door Puddle Lamp (B149)	underside of rear door	86
Left Rear Door Speaker Amplifier (Z245)	behind rear door trim panel	86
Left Rear Height Sensor (X206)	beneath LH side of vehicle on chassis	60
Left Rear Lamp Assembly (B175)	LH rear of vehicle	86

Component	Location	Manual
Left Rear Midrange Filter Capacitor (Z239)	behind rear door trim panel in left rear midrange speaker	86
Left Rear Midrange Speaker (K211)	rear door trim panel – centre	86
Left Rear Wheel Speed Sensor (X140)	behind LH rear wheel	70
Left Rear Window Door Switch (X198)	rear door trim panel	86
Left Rear Window Motor (M116)	behind rear door trim panel	84
Left Recirculating Motor (M160) (Diesel)	behind driver's side of fascia (lower dash panel removed)	80
Left Recirculating Motor (M160) (Petrol)	behind driver's side of fascia (lower dash panel removed)	80
Left Reflector Lamp (B122)	LH front side of vehicle	86
Left Seat Outstation (Z252)	underside of LH front seat	78
Left Seat Switch (X277)	at LH side of LH front seat	78
Left Tailgate Lights (B177)	LH rear of vehicle	86
LH Air Bag Front Sensor (X333)	LH front of vehicle	75
LH Pretensioner (X328)	in lower part of LH B-post	75
LH Side Air Bag (K329)	beneath LH front seat	75
Main Lighting Switch (X145)	centre of fascia	86
Mass Air Flow Sensor (X105) (Diesel)	LH side of engine compartment	86
Mass Air Flow Sensor (X105) (Petrol)	LH side of engine compartment	19
Navigation Computer (Z289)	RH side of luggage compartment	87
Neutral Switch (X290)	LH side of transmission	37
Oil Pressure Switch (X149) (Diesel)	lower LH side of engine	12
Oil Pressure Switch (X149) (Petrol)	lower RH side of engine	12
Passenger's Air Bag (K178)	top of fascia, passenger's side	76
Passive Immobilisation Coil (Z270)	underside of steering column	86
Phone (Z295)	LH side of luggage compartment	86
Phone Antenna (Z296)	LH side of luggage compartment	86
Pressure Switch 2 (X312)	behind LH side of front bumper	82
Rear Fog Guard Lamps Switch (X154)	centre of fascia	86
Rear Footwell Lamp (B182)	beneath cubby box liner	86
Rear Load Space Lamp (B174)	rear of luggage compartment	86
Rear Screen (B141)	rear of vehicle	76
Rear Screen Wash Pump (M119)	behind RH side of front bumper	84
Rear Wiper Motor (M120)	top centre of front screen behind trim panel	84
Recline Motor and Potentiometer (X293)	LH side of seat scabb frame	78

Component	Location	Manual
Resistor (K152)	behind driver's side of fascia	86
Reverse Switch (X157)	behind LH footwell trim panel	37
RH Air Bag Front Sensor (X334)	RH front of vehicle	75
RH Pretensioner (X329)	in lower part of RH B-post	75
RH Side Air Bag (K240)	beneath RH front seat	75
Ride Height Switch (X271)	centre of fascia	00
Right Antenna Amplifier (Z178)	RH side of luggage compartment behind trim panel	86
Right Blend Motor (M164)	beneath centre of fascia	82
Right Blower Motor (M159)	behind RH side of fascia (lower dash panel removed)	80
Right Condenser Fan Motor (M121)	behind front grille	82
Right Front Bass Speaker (K203)	front door trim panel – lower	86
Right Front Door Lock Actuator (M154)	in top rear of RH front door	80
Right Front Door Outstation (Z244)	behind front door trim panel	86
Right Front Door Puddle Lamp (B127)	underside of front door	86
Right Front Door Speaker Amplifier (Z242)	behind front door trim panel	86
Right Front Fog Lamp (B183)	behind RH side of front bumper	86
Right Front Height Sensor (X207)	beneath RH side of vehicle on chassis	00
Right Front Indicator Lamp (B154)	RH front of vehicle	86
Right Front Lamp Assembly (B128)	RH front of vehicle	86
Right Front Midrange Filter Capacitor (Z249)	behind front door trim panel in right front midrange speaker harness	86
Right Front Midrange Speaker (K201)	front door trim panel – centre	86
Right Front Seat Height Adjuster (X332)	beneath RH front seat	78
Right Front Tweeter (K198)	front door cheater panel	86
Right Front Wheel Speed Sensor (X158)	behind RH front wheel	70
Right Front Window Motor (M133)	behind front door trim panel	86
Right Headlamp (B130)	RH front of vehicle	86
Right Headlamp Wiper Motor (M157)	RH front of vehicle	84
Right Heated Oxygen Sensor (Post Catalyst) (X290)	on right exhaust intermediate pipe	19
Right Heated Oxygen Sensor (X160)	on right exhaust downpipe	19
Right Horn (K134)	RH front of engine compartment	86
Right Interior Lights (B179)	RH centre of headlining	86

Component	Location	Manual
Right Knuck Sensor (X298)	lower RH side of engine	19
Right Lumbar Pump (M155)	RH side of seat squab frame	78
Right Memory Mirror (M151)	RH front door	76
Right Memory Switch (X317)	on side of respective front seat	78
Right Mirror Actuator (M123)	RH front door	76
Right Non-Memory Seat Power Relay 1 (K214)	underside of RH front seat	78
Right Non-Memory Seat Power Relay 2 (K216)	underside of RH front seat	78
Right Number Plate Lamp (B134)	rear of vehicle, on tailgate	86
Right Rear Bass Speaker (K210)	rear door trim panel – lower	86
Right Rear Door Lock Actuator (M150)	in top of RH rear door	76
Right Rear Door Puddle Lamp (B150)	underside of rear door	86
Right Rear Door Speaker Amplifier (Z246)	behind rear door trim panel	86
Right Rear Height Sensor (X208)	beneath RH side of vehicle on chassis	60
Right Rear Lamp Assembly (B176)	RH rear of vehicle	86
Right Rear Midrange Filter Capacitor (Z240)	behind rear door trim panel in right rear midrange speaker harness	86
Right Rear Midrange Speaker (K212)	rear door trim panel – centre	86
Right Rear Wheel Speed Sensor (X101)	behind RH rear wheel	60
Right Rear Window Door Switch (X169)	rear door trim panel	86
Right Rear Window Motor (M124)	behind rear door trim panel	86
Right Recirculating Motor (M161)	behind passenger's side of fascia (lower dash panel removed)	80
Right Repeater Lamp (B137)	RH front side of vehicle	86
Right Seat Outstation (Z258)	underside of RH front seat	78
Right Seat Switch (X276)	at RH side of RH front seat	86
Right Tailgate Lights (B178)	RH rear of vehicle	86
Rotary Coupler (Z119)	top of steering column	86
Screen Wash Fluid Level Switch (X165)	behind RH side of front bumper	84
Seat Base Motor (M120) (with Memory)	underside of respective front seat	78
Seat Base Motor (M126) (without Memory)	underside of respective front seat	78
Seat Height (Front) Motor (M127) (with Memory)	underside of respective front seat	78
Seat Height (Front) Motor (M127) (without Memory)	underside of respective front seat	78

Component	Location	Manual
Seat Height (Rear) Motor (M128) (with Memory)	underside of respective front seat	78
Seat Height (Rear) Motor (M128) (without Memory)	underside of respective front seat	78
Seat Potentiometer Front Motor (X288)	underside of respective front seat	78
Seat Potentiometer Rear Motor (X287)	underside of respective front seat	78
Seat Recline Motor (M129)	underside of respective front seat	78
Secondary Air Injection Pump (M166)	RH front of engine compartment	17
Secondary Air Injection Valve (K237)	LH side of engine	17
Solenoid Valve, Injection Timing Device (K229)	LH front of engine	19
SRS Diagnostic Control Unit (Z151)	beneath centre console	75
SRS Diagnostic Control Unit (Z151)	beneath centre console	76
Starter (M134) (Diesel)	lower LH rear of engine	86
Starter (M134) (Petrol)	lower RH rear of engine	86
Starter Solenoid (K136) (Diesel)	lower LH rear of engine	86
Starter Solenoid (K136) (Petrol)	lower RH rear of engine	86
Steering Wheel Switches (X269)	on steering wheel	86
Stop Lamp Switch (X168)	behind driver's side of fascia on brake pedal support	86
Subwoofer (K146)	LH side of luggage compartment	86
Subwoofer Amplifier (Z176)	LH rear of luggage compartment	86
Sunvisor Lamp 1 (B172)	RH front of roof	86
Sunvisor Lamp 2 (B173)	LH front of roof	86
Sunroof Anti-trap (Z251)	front centre of roof	76
Sunroof Motor (M131)	front centre of roof	76
Sun Sensor (X305)	top centre of fascia	82
Tailgate Lock Actuator (M132)	centre of tailgate	86
Tailgate Switch (X170)	centre of tailgate	86
Tailgate Unlock Switch (X275)	centre of tailgate behind trim panel	86
Theft Alarm LED (B151)	top centre of fascia	86
Throttle Position Sensor (X171) (Diesel)	behind driver's side of fascia on brake pedal support	19
Throttle Position Sensor (X171) (Petrol)	LH side of engine	19
Trailer Auxiliary Socket (X172)	beneath centre rear of vehicle	86
Trailer Main Socket (X286)	beneath centre rear of vehicle	86
Transfer Box Oil Temperature Switch (X174)	on transfer box	41
Transfer Box Solenoid (K154)	on transfer box	41

Component	Location	Manual
Transfer Gear Box ECU (Z256)	beneath LH front seat	41
Transfer Micro Switch/Shift Lock Solenoid (X298) (Automatic Transmission)	beneath centre console	41
Transfer Switch Manual (X297) (Manual Transmission)	centre of fascia	41
Ultrasonic Module (Z205)	top of LH B-post	86
Vehicle Speed Sensor (X190)	on transfer box	41
Wash/Wipe Switch (X272)	right of steering column	84
Water Temperature Sensor (X304)	RH side of heater evaporator unit	82
Connector	Location	View
C0001 (2-B)	LH front of vehicle on left front indicator lamp	79
C0003 (2-B)	LH front corner of engine compartment near left front lamp assembly on left horn	80
C0004 (2-B)	RH front of engine compartment on right horn	82
C0007 (2-B)	RH front of engine compartment near right horn to bonnet switch	82
C0008 (2-R)	behind RH side of front bumper on front screen wash pump	127
C0009 (6-B)	LH front of vehicle on left headlamp	79
C0011 (6-B)	RH front of engine compartment on right headlamp	70
C0012 (2-B)	RH front side of vehicle on right repeater lamp	112
C0013 (2-B)	LH front side of vehicle on left repeater lamp	111
C0021 (2-B)	behind RH side of front bumper on rear screen wash pump	127
C0022 (1-B)	RH side of luggage compartment on right antenna amplifier	4
C0023 (4-N)	behind passenger's side of fascia on right blower motor	53
C0025 (2-B)	behind front grille to left condenser fan motor	126
C0026 (4-W)	right of steering column to ignition switch	61
C0029 (2-W) (RHD)	centre of roof on brake switch vent valve	145
C0029 (2-W) (LHD)	centre of roof on brake switch vent valve	86
C0030 (4-B)	lower RH side of windscreen to front wiper motor	169
C0036 (12-B)	left of steering column on direction indicator	61
C0040 (16-S)	passenger's footwell on data link connector (OBD II)	46
C0041 (4-W) (RHD)	behind centre of fascia on main lighting switch	159
C0041 (4-W) (LHD)	behind centre of fascia on main lighting switch	59
C0045 (1-)	RH front corner of engine compartment on battery	114
C0047 (2-)	behind RH footwell trim panel	44
C0052 (3-B)	LH rear of engine on ignition coil pack 2	116
C0056 (4-N) (RHD)	behind LH side of fascia on left blower motor	172
C0056 (4-N) (LHD)	behind LH side of fascia on left blower motor	50
C0061 (2-B)	LH side of engine compartment to battery backed up alarm sounder	149
C0064 (6-W) (RHD)	behind centre of fascia on rear fog guard lamps switch	159
C0064 (6-W) (LHD)	behind centre of fascia on rear fog guard lamps switch	59
C0065 (6-W) (RHD)	behind centre of fascia on front fog lamps switch	159
C0065 (6-W) (LHD)	behind centre of fascia on front fog lamps switch	58
C0067 (18-W)	behind RH footwell trim panel	44
C0069 (3-W)	right of steering column to ignition key lock solenoid	61
C0075 (3-W) (RHD)	behind LH side of fascia on stop lamp switch	145

Connector	Location	View
C0075 (3-W) (LHD)	behind LH side of fascia on stop lamp switch	86
C0076 (2-W) (RHD)	passenger's footwell on footwell lamp 1	169
C0076 (2-W) (LHD)	passenger's footwell on footwell lamp 1	46
C0077 (2-W)	behind LH side of fascia on footwell lamp 2	63
C0081 (R-U)	beneath centre console on centre console switch pack outstation	51
C0082 (6-W)	right of steering column to rotary coupler	62
C0091 (1-B)	beneath centre console on handbrake switch	47
C0092 (8-N) (RHD)	behind centre of fascia on CD head unit	173
C0092 (8-N) (LHD)	behind radio on CD head unit	56
C0095 (1-B)	behind centre of fascia on clock	109
C0096 (6-W)	behind centre of fascia on hazard switch	91
C0097L (2-) (without memory)	underside of respective front seat to seat height (front) motor	35
C0097L (6-W) (with memory)	underside of respective front seat to seat height (front) motor	35
C0097R (2-) (without memory)	underside of respective front seat to seat height (front) motor	35
C0097R (6-W) (with memory)	underside of respective front seat to seat height (front) motor	35
C0098 (R-S)	behind centre of fascia on CD head unit	56
C0105 (1-B)	beneath centre console on handbrake switch	47
C0119 (1-B)	centre of tailgate on rear load space lamp	7
C0119 (E0119)	centre rear of engine compartment	
C0120 (1-B)	centre of tailgate on rear load space lamp	7
C0121 (4-G)	LH rear of luggage compartment on left rear lamp assembly	18
C0123 (3-B)	behind RH footwell trim panel on inertia fuel shut-off switch	44
C0125 (4-G)	RH rear of vehicle on right rear lamp assembly	3
C0126 (R-W)	front centre of roof on sunroof anti-trap	21
C0127 (1-I)	bottom of engine (RH side) on compressor clutch	143
C0128 (2-W)	LH front of engine to compressor clutch	81
C0132 (3-B)	top of fuel tank on fuel tank pressure sensor	132
C0133 (2-R)	LH rear corner of engine compartment on evaporative emission canister vent seal valve	75
C0138 (2-B)	centre of tailgate to left number plate lamp	8
C0139 (2-B)	centre of tailgate to right number plate lamp	8
C0149 (3-B)	LH side of engine compartment on mass air flow sensor	77
C0152 (2-B)	LH side of engine compartment on evaporative emission canister purge valve	96
C0154L (5-B)	underside of LH front seat on left non-memory seat power relay 1	
C0154R (5-B)	underside of RH front seat on right non-memory seat power relay 1	
C0156 (3-B)	LH rear of engine on ignition coils pack 1	116
C0157L (5-B)	underside of LH front seat on left non-memory seat power relay 2	
C0157R (5-B)	underside of RH front seat on right non-memory seat power relay 2	
C0162 (25-B)	RH rear of engine compartment	75
C0167 (2-B)	LH side of transmission or reverse switch	160
C0168D (2-B)	LH rear of engine to engine speed sensor	138
C0168P (2-W)	LH rear of engine on crankshaft position sensor	115
C0175 (3-B)	LH side of engine to throttle position sensor	76
C0176 (3-B)	lower front of engine to camshaft position sensor	122
C0178 (T0178)	LH rear of engine on starter solenoid	138
C0179 (T0179)	lower RH rear of engine compartment on starter solenoid	100
C0182 (2-U)	driver's side of engine compartment to compressor clutch	146
C0183 (T0183)	LH side of engine on generator	142
C0185 (T0185)	top RH side of engine on generator	97
C0187D (2-B)	LH side of engine compartment on oil pressure switch	142

Connector	Location	View
C0187P (1-B)	lower RH side of engine compartment on oil pressure switch	123
C0192 (T0192)	RH front corner of engine compartment on battery	114
C0195 (2-B)	beneath centre of vehicle on vehicle speed sensor	104
C0196(1) (2-B)	LH side of engine on engine coolant temperature sensor	140
C0196P (2-B)	top of engine on engine coolant temperature sensor	117
C0198 (1-1)	LH side of engine on fuel shut-off solenoid	151
C0203 (25-B)	RH rear of engine compartment beneath coolant expansion tank	135
C0204 (4-B)	top of fuel tank on fuel pump module	132
C0205 (4-B)	top of fuel tank on fuel pump module	132
C0209 (6-B)	LH rear of engine compartment on mass air flow sensor	138
C0215 (12-B)	RH front of engine compartment behind battery on glow plug timer unit	137
C0216 (3-B)	LH rear of engine compartment on boost pressure sensor	139
C0219 (1-B)	beneath centre of vehicle on transfer box oil temperature switch	105
C0223 (2-B)	behind RH footwell trim panel	44
C0226D (T0226D)	LH side of engine on generator	142
C0226P (T0226P)	front centre of engine on generator	97
C0228 (3-S)	LH rear corner of engine compartment on cruise control vacuum pump	84
C0229 (18-W)	behind RH footwell trim panel	44
C0230 (5-LTU)	behind driver's side of fascia on instrument cluster	85
C0231 (4-O)	behind RH footwell trim panel	89
C0232 (2-B) (RHD)	behind centre of fascia on clock	169
C0233 (20-B)	behind driver's side of fascia on instrument cluster	89
C0236 (2-W) (LHD)	behind passenger's side of fascia on glove box lamp	49
C0239 (18-B)	behind driver's side of fascia on cruise control ECU	50
C0240 (2-G)	top centre of fascia to theft alarm LED	69
C0243 (14-B)	beneath centre of vehicle on gearbox case	124
C0244 (6-S)	LH side of transmission on gear box position switch	124
C0246 (1-W)	lower LH side of windscreen to heated front screen	153
C0247 (1-W)	lower RH side of windscreen to heated front screen	152
C0252 (2-Y)	in lower part of LH B-post on LH pretensioner	68
C0254 (2-Y)	in lower part of RH B-post on RH pretensioner	40
C0256 (50-)	beneath centre console on SRS diagnostic control unit	171
C0257 (2-R) (RHD)	behind driver's side of fascia on driver's air bag	172
C0257 (2-R) (LHD)	behind driver's side of fascia on driver's air bag	50
C0262 (2-W)	inside driver's seat belt buckle assembly	67
C0269 (1-B)	beneath centre of vehicle on transfer box rear oil	105
C0272 (2-B)	front LH wing in beneath engine compartment fuse box on EGR control solenoid	141
C0277 (2-U)	front RH side of engine compartment to compressor clutch	146
C0278 (8-B)	right of steering column on wash/wipe switch	61
C0280 (2-B)	behind LH side of front bumper to right condenser fan motor	126
C0302L (6-B)	inside respective rear door on left rear door lock actuator	27
C0302R (6-W)	inside respective rear door on right rear door lock actuator	27
C0304L (6-B)	respective rear door on left rear window motor	27
C0304R (6-W)	respective rear door on right rear window motor	27
C0308 (18-LS)	beneath RH front seat	
C0310 (18-LS)	beneath RH front seat	
C0319L (13-B)	respective front door on left memory mirror	25
C0319R (13-B)	respective front door on right memory mirror	25
C0350 (2-B)	RH rear of vehicle on accessory socket	178
C0355 (4-B)	LH centre of headlining to left interior lights	10
C0356 (4-B)	RH centre of headlining to right interior lights	15

Connector	Location	View
C0357 (4-B)	front centre of roof on front interior roof lamp	21
C0358 (3-W)	RH side of luggage compartment on alarm R.F. antenna module	4
C0359 (4-B)	top of LH B-post on ultrasonic module	20
C0360 (F0360)	beneath centre console	47
C0361 (E0361)	behind centre of fascia	60
C0362 (E0362)	RH rear of engine compartment near engine compartment fuse box	74
C0369L (2-B)	behind front door trim panel on left front midrange speaker	31
C0369R (2-B)	behind front door trim panel on right front midrange speaker	31
C0381 (1-B)	RH side of tailgate on rear screen	11
C0382 (1-B)	LH side of tailgate on rear screen	12
C0388 (3-B)	top centre of rear screen to rear wiper motor	9
C0411 (53-B)	RH front of engine compartment behind battery on engine control module (ECM)	137
C0417 (2-B)	underside of steering column on evaporator temperature sensor	57
C0433 (2-R)	behind glovebox or passenger's air bag	52
C0441L (2-B)	inside respective front door on left front door lock actuator	33
C0441R (2-B)	inside respective front door on right front door lock actuator	33
C0445L (2-B)	respective rear door on left rear midrange speaker	24
C0445R (2-B)	respective rear door on right rear midrange speaker	24
C0448 (25-B)	RH rear of engine compartment	75
C0467 (14-W)	behind LH footwell trim panel	85
C0469 (14-W)	behind LH footwell trim panel	85
C0475L (6-W) (with memory)	underside of respective front seat on seal height (front) motor	35
C0475R (2-W) (without memory)	underside of respective front seat on seal height (front) motor	35
C0475R (2-) (without memory)	underside of respective front seat on seal height (front) motor	35
C0475R (6-W) (with memory)	underside of respective front seat on seal height (front) motor	35
C0476 (T0476)	LH side of engine on glow plugs	143
C0477 (T0477)	LH side of engine on glow plugs	143
C0478 (T0478)	LH side of engine on glow plugs	140
C0479 (T0479)	LH side of engine on glow plugs	140
C0489 (4-G)	RH side of tailgate on right tailgate lights	1
C0490 (4-G)	LH side of tailgate on left tailgate lights	2
C0491 (42-B)	LH side of luggage compartment on DSP amplifier	177
C0492L (10-W)	respective rear door on left rear door speaker amplifier	26
C0492R (10-W)	respective rear door on right rear door speaker amplifier	26
C0494 (4-W)	inside front of RH rear door	14
C0495 (2-W)	inside front of RH rear door	14
C0496 (2-B)	inside front of RH rear door	14
C0499 (7-B)	beneath rear of vehicle on trailer connector	
C0362 (1-W)	rear RH side of engine compartment or ABS booster unit	144
C0501 (13-B)	rear RH side of engine compartment or ABS booster unit	144
C0502 (2-)	beneath LH rear of vehicle to left rear wheel speed sensor	113
C0503 (2-)	beneath RH rear of vehicle to right rear wheel speed sensor	129
C0504 (18-B)	behind glovebox or anti-lock brake system ECU	147
C0505 (9-B)	behind glovebox or anti-lock brake system ECU	147
C0506 (15-B)	behind glovebox or anti-lock brake system ECU	147
C0507 (2-W)	front RH side of engine compartment to ABS hydraulic pump	146
C0513 (2-W)	behind RH side of front bumper on right front fog lamp	109
C0514 (2-W)	behind LH side of front bumper on left front fog lamp	98
C0516 (2-)	LH front of engine compartment to left front wheel speed sensor	77
C0517 (2-)	RH side of engine compartment to right front wheel speed sensor	93

Connector	Location	View
C0518L (6-W)	underside of respective front seat to seat recline motor	37
C0518R (6-W)	underside of respective front seat to seat recline motor	37
C0519L (18-W) (with memory)	underside of respective front seat on left seat outstation	35
C0519L (18-W) (without memory)	underside of respective front seat	35
C0519R (18-W) (with memory)	underside of respective front seat on right seat outstation	35
C0519R (18-W) (without memory)	underside of respective front seat	35
C0520 (2-B) (with battery backed up alarm sounder)	LH side of engine compartment to battery backed up alarm sounder	149
C0520 (2-B) (without battery backed up alarm sounder)	RH side of engine compartment on alarm sounder	71
C0522 (3-B)	top LH side of engine on fuel injector	119
C0523 (2-B)	top RH side of engine on fuel injector	119
C0524 (2-B)	top LH side of engine on fuel injector	119
C0525 (2-B)	top RH side of engine on fuel injector	118
C0526 (2-B)	top LH side of engine on fuel injector	119
C0527 (2-B)	top RH side of engine on fuel injector	119
C0528 (2-B)	top LH side of engine on fuel injector	119
C0529 (2-B)	top RH side of engine on fuel injector	118
C0530L (2-B)	respective front door on left front tweeter	29
C0530R (2-B)	respective front door on right front tweeter	28
C0540 (2-W)	LH side of engine compartment to battery backed up alarm sounder	149
C0556 (E0556)	LH rear of engine compartment near air valve block	110
C0556D (E556D)	beneath engine compartment fuse box	136
C0557 (E0557)	LH front of engine compartment	110
C0558 (E0558)	LH rear of engine compartment near air valve block	110
C0559 (E0559)	RH rear of engine compartment near engine compartment fuse box	74
C0560 (E0560)	RH side of engine compartment	93
C0561 (E0561)	RH side of engine compartment	93
C0562 (E0562)	behind RH footwell trim panel	89
C0564 (E0564)	behind RH footwell trim panel	89
C0565 (E0565)	RH side of luggage compartment	6
C0570 (8-S)	RH front of engine compartment on engine compartment fuse box	73
C0571 (8-N)	RH front of engine compartment on engine compartment fuse box	73
C0572 (8-K)	RH side of engine compartment on engine compartment fuse box	73
C0573 (8-U)	RH front of engine compartment on engine compartment fuse box	72
C0574 (8-Y)	RH front of engine compartment on engine compartment fuse box	72
C0575 (8-P)	RH front of engine compartment on engine compartment fuse box	72
C0576 (8-G)	RH front of engine compartment on engine compartment fuse box	72
C0577 (8-B)	RH side of engine compartment on engine compartment fuse box	136
C0607 (2-W)	centre rear of roof	14
C0608 (4-W)	centre rear of roof	14
C0609 (2-B)	centre rear of roof	14
C0613 (2-W)	centre of tailgate to centre mounted stop lamp	10
C0615 (3-B)	centre of tailgate RH rear of luggage compartment tailgate unlock switch	1
C0616 (2-B)	centre of tailgate on tailgate switch	1
C0617 (2-B)	centre of tailgate on tailgate lock actuator	2
C0620 (2-U)	behind RH side of front bumper near battery to screen wash fluid level switch	127
C0626 (2-S)	lower RH side of engine on right knock sensor	120

Connector	Location	View
C0627 (2-B)	lower LH side of engine on left knock sensor	121
C0631 (T3631)	lower RH rear of engine compartment on starter solenoid	100
C0632 (T3632)	RH front of engine compartment on engine compartment fuse box	
C0634 (9-B)	LH rear corner of engine compartment on engine control module (ECM)	83
C0635 (24-B)	LH rear corner of engine compartment on engine control module (ECM)	83
C0636 (52-B)	LH rear corner of engine compartment on engine control module (ECM)	83
C0637 (40-B)	LH rear corner of engine compartment on engine control module (ECM)	83
C0638 (9-B)	LH rear corner of engine compartment on engine control module (ECM)	83
C0641 (3-S)	LH side of engine on idle air control valve	76
C0642 (4-B)	beneath RH side of vehicle to right heated oxygen sensor (post Catalytic)	103
C0643 (4-B)	beneath LH side of vehicle to left heated oxygen sensor (post Catalytic)	103
C0644 (4-B)	lower LH side of engine to left heated oxygen sensor	103
C0645 (4-B)	lower RH side of engine to right heated oxygen sensor	103
C0646 (3-W)	LH rear corner of engine compartment on fan	95
C0652 (2-B)	rear RH side of engine compartment on brake fluid level switch	144
C0666 (2-W)	LH side of engine compartment to battery backed up alarm sounder	149
C0667 (2-W)	behind driver's side of fascia on clutch pedal position switch	145
C0672 (3-W)	right of steering column to key-in switch	61
C0673 (6-W)	beneath centre console on transfer micro switch/shift lock solenoid	48
C0675 (12-B)	beneath centre console on 'H' gate sensor module	53
C0683 (8-B)	beneath centre of vehicle on transfer box solenoid	103
C0684 (2-B)	LH side of transmission on neutral switch	160
C0685 (6-W)	behind centre of fascia on transfer switch manual	150
C0686 (2-U)	LH front of engine compartment to automatic transmission oil temperature switch	80
C0688L (2-B)	respective front door on left front bass speaker	31
C0688R (2-B)	respective front door on right front bass speaker	31
C0690 (2-W)	RH side of luggage compartment on fuel flap actuator	5
C0697 (12-B)	RH rear of luggage compartment	5
C0698 (5-B) (MY 1999)	top centre of front screen on electrochromatic rear view mirror	21
C0698 (10-B) (MY 2000)	top centre of front screen on electrochromatic rear view mirror	21
C0726L (2-B)	respective rear door on left rear bass speaker	26
C0726R (2-B)	respective rear door on right rear bass speaker	26
C0731 (4-B)	LH side of engine compartment on battery backed up alarm sounder	149
C0732L (4-W)	respective rear door on left rear window door switch	25
C0732R (4-W)	respective rear door on right rear window door switch	25
C0736 (2-B)	RH front of roof to sun-visor lamp 2	22
C0737 (2-B)	LH front of roof to sun-visor lamp 1	23
C0739 (1-)	LH side of luggage compartment on left antenna amplifier	17
C0745 (18-LS)	beneath centre console	47
C0746 (14-LS)	beneath centre console	47
C0748 (5-B)	left of steering column on fuel flap release switch	87
C0749 (6-G) (HHD)	behind centre of fascia on cruise control switch	157
C0749 (6-W) (LHD)	behind centre of fascia on cruise control switch	91
C0754 (8-W)	beneath LH front seat	
C0756L (8-W)	underside of respective front seat	

Connector	Location	View
C0756R (8-W)	underside of respective front seat	
C0772 (8-W)	beneath RH front seat	
C0787R (8-G)	behind driver's side of fascia on throttle position sensor	145
C0787L (8-G)	behind driver's side of fascia on throttle position sensor	145
C0789 (10-B)	RH rear of luggage compartment	5
C0791 (12-B)	behind centre of fascia on heating ventilation and air conditioning control unit (HEVAC)	60
C0792 (8-W)	behind centre of fascia on heating ventilation and air conditioning control unit (HEVAC)	60
C0793 (20-B)	behind centre of fascia on heating ventilation and air conditioning control unit (HEVAC)	60
C0807 (E0807)	RH side of luggage compartment	6
C0808 (E0808)	beneath RH front seat on body electrical control module (BeCM)	45
C0809 (E0809)	LH side of luggage compartment	19
C0810 (E0810)	centre rear of engine compartment	76
C0811 (E0811)	centre rear of engine compartment	76
C0820 (6-B)	behind centre of fascia on display and control unit	178
C0822 (E0822)	RH side of engine on chassis	
C0823 (T0823)	LH rear of engine on starter solenoid	138
C0834 (6-W)	LH side of luggage compartment to subwoofer	13
C0844 (4-B)	behind LH side of front bumper on A/C dual pressure switch	125
C0845 (2-B)	behind LH side of front bumper on pressure switch 2	125
C0853 (4-B)	LH front of vehicle on left headlamp wiper motor	79
C0854 (4-B)	RH front of engine compartment on right headlamp wiper motor	70
C0855 (5-B)	front RH side of engine compartment on ABS pressure switch unit	146
C0861 (3-B)	beneath LH rear of vehicle to left rear height sensor	107
C0865 (3-B)	beneath LH front of vehicle to left front height sensor	101
C0866 (9-B)	beneath LH front seat on air suspension delay turn off timer	64
C0867 (35-B)	beneath LH front seat on air suspension ECU	60
C0868 (6-W)	beneath LH front seat	64
C0870 (3-B)	beneath RH front of vehicle to right front height sensor	102
C0871 (13-B)	LH rear of engine compartment on air valve block	78
C0873 (4-B)	LH rear of engine compartment to air suspension compressor	79
C0874 (2-W)	behind RH side of front bumper on headlamp wash pump	127
C0875 (3-B)	beneath RH rear of vehicle to right rear height sensor	106
C0877 (12-G)	beneath RH front seat on body electrical control module (BeCM)	42
C0879 (2-B)	RH front of engine compartment on secondary air injection pump	173
C0880 (2-S)	LH side of engine on secondary air injection valve	174
C0881 (2-B)	top centre of fascia on sun sensor	69
C0882 (3-W)	behind LH side of fascia on left recirculating motor	36
C0883 (3-W)	passenger's side of bulkhead on right recirculating motor	53
C0884 (2-B)	LH front of vehicle in front of condenser on ambient air sensor	
C0884 (2-B)	behind LH side of front bumper on ambient air sensor	126
C0885 (1-B)	behind driver's side of fascia to left blower motor	50
C0886 (1-B)	passenger's side of bulkhead on right blower motor	53
C0890 (2-U)	behind glovebox on water temperature sensor	52
C0891 (2-B)	right of steering column to key illumination	62
C0893 (8-B)	behind centre of fascia on ride height switch	157
C0894 (6-B)	behind centre of fascia on air suspension inhibit switch	157
C0895D (9-B)	behind driver's side of fascia on cruise control converter/inverter module	156
C0895P (9-B)	behind driver's side of fascia on cruise control converter/inverter module	156

Connector	Location	View
C0903 (6-W)	beneath LH front seat	61
C0910 (E0910)	behind RH footwell trim pane	89
C0921 (6-Y)	behind radio on CD head unit	56
C0922 (12-G)	behind centre of fascia on CD head unit	
C0925 (3-B)	LH rear of engine compartment on fuel heater	139
C0941 (10-B)	LH rear of luggage compartment on CD changer	164
C0948 (2-Y)	beneath LH front seat on LH side air bag	65
C0949 (2-Y)	beneath RH front seat on RH side air bag	92
C0950 (3-Y)	LH front of vehicle on LH air bag front sensor	79
C0951 (3-Y)	RH front of vehicle on RH air bag front sensor	70
C0959 (12-D)	RH side of luggage compartment on GPS receiver	180
C0974L (4-W)	underside of respective front seat to left lumbar pump	37
C0974R (4-W)	underside of respective front seat to right lumbar pump	37
C0977L (4-W) (with memory)	underside of respective front seat to seat base motor	35
C0977L (4-W) (without memory)	underside of respective front seat to seat base motor	35
C0977R (4-W) (with memory)	underside of respective front seat to seat base motor	35
C0977R (4-W) (without memory)	underside of respective front seat to seat base motor	35
C0980L (2-B)	behind rear door trim panel to left rear door puddle lamp	29
C0980R (2-B)	behind rear door trim panel to right rear door puddle lamp	29
C0988 (18-LS)	beneath centre console	47
C0989 (14-LS)	beneath centre console	47
C0992 (2-B)	front centre of roof on home link connector	
C0993 (10-B)	behind centre of fascia on display and control unit	176
C103R (2-W) (with memory)	LH side of engine on injector needle lift sensor	
C1123	centre of tailgate behind trim panel	9
C1124	LH rear of luggage compartment	18
C1136 (1-)	RH rear of roof behind trim panel	180
C1254 (7-P)	top of steering column to steering wheel switches	
C1276 (10-W)	beneath RH front seat on body electrical control module (BeCM)	45
C1277 (8-B)	beneath RH front seat on body electrical control module (BeCM)	43
C1278 (20-Y)	beneath RH front seat on body electrical control module (BeCM)	43
C1279 (20-W)	beneath RH front seat on body electrical control module (BeCM)	43
C1280 (16-W)	beneath RH front seat on body electrical control module (BeCM)	43
C1281 (14-Y)	beneath RH front seat on body electrical control module (BeCM)	38
C1282 (10-Y)	beneath RH front seat on body electrical control module (BeCM)	38
C1283 (18-S)	beneath RH front seat on body electrical control module (BeCM)	38
C1284 (12-S)	beneath RH front seat on body electrical control module (BeCM)	38
C1285 (20-U)	beneath RH front seat on body electrical control module (BeCM)	39
C1286 (16-B)	beneath RH front seat on body electrical control module (BeCM)	39
C1287 (20-B)	beneath RH front seat on body electrical control module (BeCM)	39
C1288 (16-G)	beneath RH front seat on body electrical control module (BeCM)	39
C1289 (20-G)	beneath RH front seat on body electrical control module (BeCM)	39
C1290 (12-W)	beneath RH front seat on body electrical control module (BeCM)	42
C1291 (18-W)	beneath RH front seat on body electrical control module (BeCM)	42
C1292 (4-W)	beneath RH front seat on body electrical control module (BeCM)	33
C1293 (4-W)	beneath RH front seat on body electrical control module (BeCM)	42
C1319 (36-B)	beneath LH front seat on transfer gear box ECU	66
C1320 (68-B)	beneath LH front seat on auto gear box control unit	66
C1321 (55-B)	beneath LH front seat on auto gear box control unit	66
C1322 (4-O)	behind RH footwell trim pane	89
C1333 (T1333)	beneath RH front seat on body electrical control module (BeCM)	94

Connector	Location	View
C1334 (T1334)	beneath RH front seat on body electrical control module (BeCM)	94
C1335 (T1335)	beneath RH front seat on body electrical control module (BeCM)	94
C1336 (T1336)	beneath RH front seat on body electrical control module (BeCM)	41
C1337 (T1337)	beneath RH front seat on body electrical control module (BeCM)	41
C1338 (T1338)	beneath RH front seat on body electrical control module (BeCM)	41
C1343 (3-B)	LH front of vehicle on left front lamp assembly	11
C1345 (3-B)	RH front of vehicle on right front lamp assembly	70
C1346 (2-B)	RH front of vehicle on right front indicator lamp	70
C1347 (E1347)	behind centre of fascia	
C1348 (E1348)	behind RH footwell trim panel	
C1349 (18-B)	RH side of luggage compartment on navigation computer	179
C1350 (18-B)	RH side of luggage compartment on navigation computer	179
C1351 (E1351)	LH side of luggage compartment	
C1354 (20-U)	behind centre of fascia on CD head unit	
C1355 (E1355)	RH side of engine compartment	45
C1356 (T1356)	beneath RH front seat on body electrical control module (BeCM)	41
C1357 (2-W)	RH side of engine compartment	99
C1358 (4-W)	LH rear of luggage compartment	18
C1359 (4-W)	LH rear of luggage compartment	19
C1360 (6-W)	behind rear door trim panel	130
C1361 (6-S)	behind rear door trim panel	130
C1362 (6-Y)	behind rear door trim panel	130
C1363 (8-W)	behind LH footwell trim panel	85
C1364 (12-B)	front of LH front door jamb	131
C1365 (4-W)	front of LH front door jamb	131
C1366 (6-Y)	front of LH front door jamb	131
C1367 (6-S)	front of LH front door jamb	
C1368 (6-W)	front of LH front door jamb	131
C1369 (6-W)	in lower part of RH B-post	30
C1370 (6-S)	in lower part of RH B-post	30
C1371 (6-Y)	in lower part of RH B-post	30
C1372 (4-W)	front of RH front door jamb	34
C1373 (12-B)	front of RH front door jamb	34
C1374 (12-W)	behind LH footwell trim panel	85
C1375 (6-W)	RH rear of vehicle	3
C1376 (8-W)	RH rear of vehicle	3
C1376 (3-W)	LH side of luggage compartment on phone	
C1377 (8-W)	behind LH footwell trim panel	85
C1378 (12-W)	behind LH footwell trim panel	85
C1379L (6-Y)	front of LH front door jamb	131
C1379R (6-Y)	front of RH front door jamb	34
C1380L (6-S)	front of LH front door jamb	
C1380R (6-S)	front of RH front door jamb	
C1381 (3-B)	beneath LH rear of vehicle	
C1382 (7-B)	beneath centre rear of vehicle on trailer auxiliary socket	
C1383L (12-B)	front of LH front door jamb	34
C1383R (12-B)	front of RH front door jamb	34
C1384L (4-W)	front of LH front door jamb	34
C1384R (4-W)	front of RH front door jamb	34
C1385L (6-S)	behind rear door trim panel	130
C1385R (6-S)	in lower part of RH B-post	30
C1386L (6-W)	behind rear door trim panel	130
C1387L (6-Y)	behind rear door trim panel	130

Connector	Location	View
C1386R (6-W)	in lower part of RH B-post	30
C1387R (6-Y)	in lower part of RH B-post	30
C1388 (3-B)	beneath RH rear of vehicle	
C1389 (4-B)	beneath RH rear of vehicle	
C1390 (3-B)	beneath LH rear of vehicle	
C1391 (4-W)	behind centre of fascia to transfer switch manual	166
C1398 (E1398)	RH side of engine compartment	93
C1401 (3-W)	beneath LH front seat to left heated seat	133
C1402 (2-W)	beneath LH front seat to left heated seat	133
C1403 (3-W)	beneath RH front seat to right heated seat	134
C1404 (2-W)	beneath RH front seat to right heated seat	134
C1405L (2-B)	behind front door trim panel on left front door puddle lamp	33
C1405R (2-B)	behind front door trim panel on right front door puddle lamp	33
C1406 (16-B)	inside respective front door on right front door outstation	32
C1407L (12-B)	inside respective front door on left front door outstation	32
C1407R (12-B)	inside respective front door on right front door outstation	32
C1412 (E1412)	beneath RH front seat near body electrical control module (BeCM)	45
C1413 (E1413)	beneath RH front seat near body electrical control module (BeCM)	45
C1415 (4-B)	beneath RH rear of vehicle	
C1416 (3-B)	beneath RH rear of vehicle	
C1418L (1-R)	underside of respective front seat on headrest motor	37
C1418R (1-R)	underside of respective front seat on headrest motor	37
C1419L (1-B)	underside of respective front seat on headrest motor	37
C1419R (1-B)	underside of respective front seat on headrest motor	37
C1421 (6-B)	inside respective front door on left front door lock actuator	
C1422 (0-W)	inside respective front door on right front door lock actuator	33
C1423 (0-W)	behind RH footwell trim panel	44
C1424 (10-W)	behind RH footwell trim panel	44
C1425L (12-G) (with memory)	underside of respective front seat on left seat outstation	36
C1425R (12-G) (with memory)	underside of respective front seat on right seat outstation	36
C1427L (10-W)	respective front door on left front door speaker amplifier	31
C1427R (10-W)	respective front door on right front door speaker amplifier	31
C1429 (12-S)	beneath LH front seat on left seat outstation	133
C1430 (12-S)	beneath RH front seat on right seat outstation	134
C1431 (C1431)	beneath RH front seat	45
C1432 (2-B) (LHD)	beneath LH front seat on left front seat height adjuster	
C1433 (2-B) (RHD)	beneath RH front seat on right front seat height adjuster	
C1442 (2-W)	beneath cubby box liner on rear footwell lamp	51
C1444 (4-W)	behind centre of fascia to transfer switch manual	166
C1445L (4-W)	underside of respective front seat to Fore-Air sensor	35
C1445R (4-W)	underside of respective front seat to Fore-Air sensor	35
C1487L (12-W)	underside of respective front seat	
C1487R (12-W)	underside of respective front seat	
C1488L (12-G)	underside of respective front seat	36
C1488 (12-W)	underside of respective front seat	36
C1489L (4-)	underside of respective front seat to recline motor and potentiometer	37
C1489R (4-)	underside of respective front seat to recline motor and potentiometer	37
C1490L (3-W)	underside of respective front seat to headrest potentiometer	37
C1490R (3-W)	underside of respective front seat to headrest potentiometer	37
C1500 (T1500)	LH side of engine on glow plugs	140
C1501 (T1501)	LH side of engine on glow plugs	140

Connector	Location	View
C1502 (7-B)	LH side of engine on fuel pump assembly	151
C1503 (2-B)	LH front of engine on solenoid valve, injection timing device	142
C1505 (2-R)	LH front corner of engine compartment on cooling fan switch	
C1506 (2-B)	LH front corner of engine compartment on cooling fan motor	
C1547 (E1547)	RH front of engine	
C1548 (4-B)	behind centre of fascia on A/C aspirator	59
C1563L (6-B)	respective front door on left mirror actuator	29
C1563R (6-B)	respective front door on right mirror actuator	28
C1564 (6-W)	on right front window motor	32
C1565 (6-B)	on left front window motor	155
C1565L (6-B)	respective front door on left front window motor	155
C1565R (6-W)	respective front door on right front window motor	155
C1568 (6-Y)	front of RH front door jamb	34
C1569 (6-S)	front of RH front door jamb	
C1570 (10-W)	behind RH footwell trim panel	44
C1571 (6-W)	behind RH footwell trim panel	44
C1576 (12-G)	behind centre of fascia on heating ventilation and air conditioning control unit (HEVAC)	60
C1577L (2-B)	behind front door trim panel on left front midrange speaker	31
C1577R (2-B)	behind front door trim panel on right front midrange speaker	31
C1578L (6-W)	front of LH front door jamb	131
C1578R (6-W)	front of RH front door jamb	34
C1579 (20-B)	inside respective front door on left front door outstation	32
C1580 (16-D)	inside respective front door on left front door outstation	155
C1581 (1-)	RH side of luggage compartment	
C1582 (1-)	lower RH side of windscreen	175
C1583 (6-W)	front of RH front door jamb	34
C1584 (18-B)	behind glovebox on anti-lock brake system ECU	52
C1584 (18-S)	beneath RH front seat on body electrical control module (BeCM)	38
C1585 (15-B)	behind glovebox on anti-lock brake system ECU	52
C1585 (20-U)	beneath RH front seat on body electrical control module (BeCM)	39
C1586 (9-B)	behind glovebox on anti-lock brake system ECU	52
C1586 (12-S)	beneath RH front seat on body electrical control module (BeCM)	38
C1587 (4-S)	beneath RH front seat on body electrical control module (BeCM)	38
C1587R (6-Y)	behind rear door trim panel	30
C1588 (2-B)	driver's side of engine compartment on brake fluid level switch	68
C1588 (1-)	centre rear of roof	
C1590 (5-B)	LH side of engine compartment on ABS pressure switch unit	77
C1591 (13-B)	driver's side of engine compartment on ABS booster unit	128
C1592 (1-W)	driver's side of engine compartment on ABS booster unit	128
C1593 (4-B) (LHD)	lower LH side of windscreen to front wiper motor	154
C1594 (2-B)	beneath centre console on fascia cigar lighter	54
C1595 (1-W)	beneath centre console on fascia cigar lighter	54
C1597	behind centre of fascia	60
C1597	behind centre of fascia on heating ventilation and air conditioning control unit (HEVAC)	60
C1618L	underside of respective front seat on left seat outstation	165
C1618R	underside of respective front seat on right seat outstation	165
C1619 (with memory)	underside of respective front seat on left seat outstation	165
C1619 (without memory)	underside of respective front seat to left seat switch	165
C1620 (with memory)	underside of respective front seat on right seat outstation	167
C1620 (18-W) (without memory)	underside of respective front seat to right seat switch	167

Connector	Location	View
C1621 (10-W)	LH side of luggage compartment on subwoofer amplifier	13
C1622 (6-W)	LH side of luggage compartment to subwoofer	13

Ground	Location	View
E0119	centre rear of engine compartment	
E0360	beneath centre console	47
E0361	behind centre of fascia	60
E0500	RH rear of engine compartment near engine compartment fuse box	74
E0556	LH rear of engine compartment near air valve block	110
E0556D	beneath engine compartment fuse box	136
E0557	LH front of engine compartment	110
E0558	LH rear of engine compartment near air valve block	110
E0559	RH rear of engine compartment near engine compartment fuse box	74
E0560	RH side of engine compartment	93
E0561	RH side of engine compartment	93
E0562	behind RH footwell trim panel	89
E0563	RH rear of engine compartment	
E0564	behind RH footwell trim panel	89
E0565	RH side of luggage compartment	6
E0807	RH side of luggage compartment	6
E0808	beneath RH front seat on body electrical control module (BeCM)	45
E0809	LH side of luggage compartment	19
E0810	centre rear of engine compartment	76
E0811	centre rear of engine compartment	76
E0822	on Chassis	
E0810	behind RH footwell trim panel	89
E1347	behind centre of fascia	
E1348	behind RH footwell trim panel	
E1351	LH side of luggage compartment	
E1355	RH side of engine compartment	45
E1398	RH side of engine compartment	93
E1412	beneath RH front seat	45
E1413	beneath RH front seat	45
E1431	beneath RH front seat	45
E1547	RH front of engine	

CIRCUIT DIAGRAMS

- Circuit diagrams are arranged so that current flow is from the top of the diagram (current source) to the bottom of the diagram (ground).
- Only those components that work together in the circuit are shown. If only part of a component is used in the circuit, then only that part of the component is shown.
- Remember:

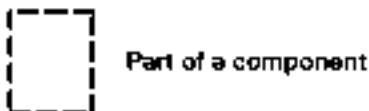

TERMINAL NUMBER	DESIGNATION
50	Battery voltage: Ignition Switch in position III
30	Battery voltage: supplied constantly
15	Battery voltage: Ignition Switch in position II or III
R	Battery voltage: Ignition Switch in positions I, II
31	Ground

See Introduction (I) for additional circuit diagram symbols.

DIAGNOSIS

- If the diagram is accompanied by text:
 - Read the Circuit Operation before proceeding with the electrical diagnosis.
 - Read the Troubleshooting Hints before performing the System Diagnosis.
 - Tests follow the System Diagnosis
 - When performing the System Diagnosis, be certain that all components disconnected in previous steps are reconnected unless otherwise directed.

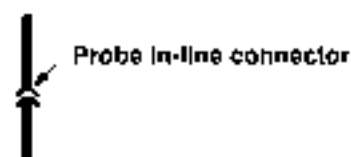
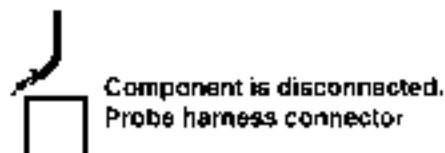
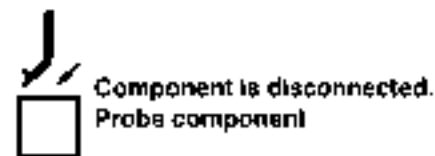
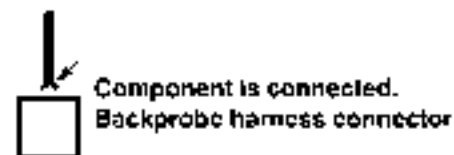
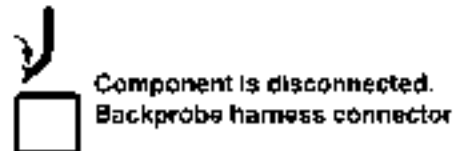

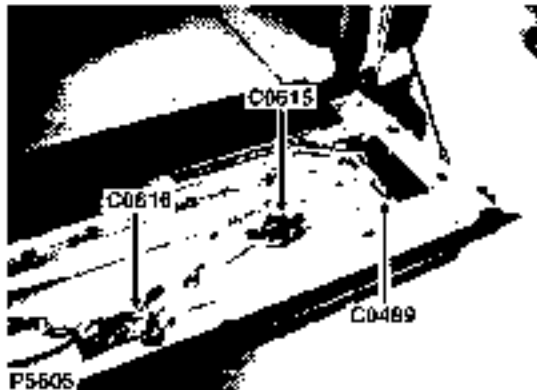

P5605

1 on tailgate behind trim panel behind trim panel

C0489 (4-G)
C0615 (3-B)
C0616 (2-B)

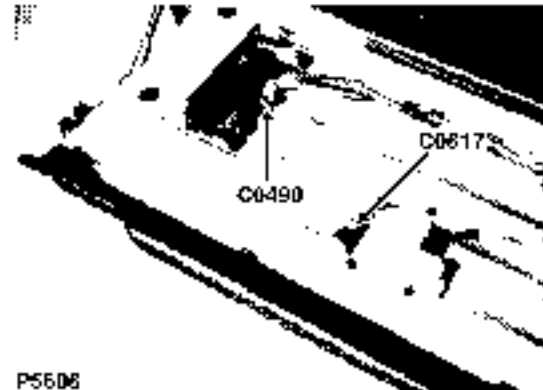

P5606

2 on tailgate behind trim panel behind trim panel

C0490 (4-G)
C0617 (2-B)

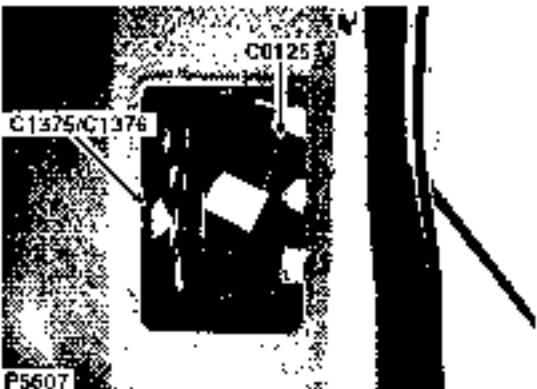

P5607

3 RH rear of vehicle

C0125 (4-G)
C1375 (8-W)
C1376 (8-W)



P5608

4 RH side of luggage compartment

C0022 (1-B)
C0358 (3-W)



P5609

5 RH rear of luggage compartment

C0690 (2-W)
C0697 (12-B)
C0789 (12-B)



P5610

6 RH side of luggage compartment

E0565
E0807

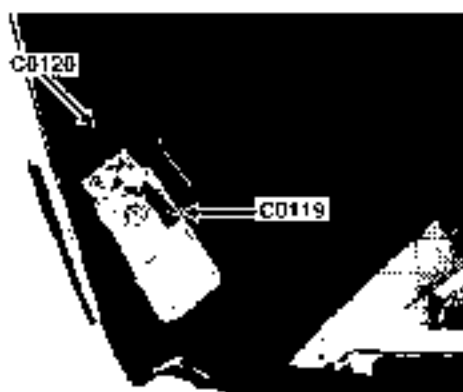

P5611

7 centre of the gate

C0119 (1-B)
C0120 (1-B)



P5612

8 centre of the gate behind trim panel

C0138 (2-B)
C0139 (2-B)

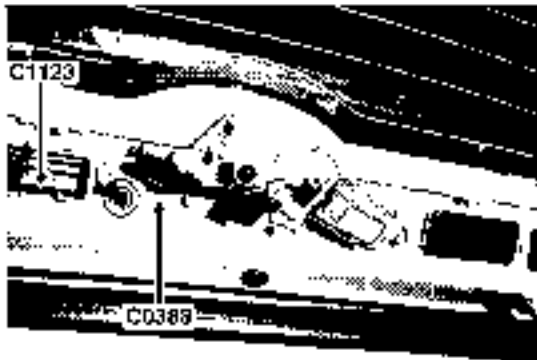

P5613

9 centre of tailgate behind trim panel
C0388 (3-B)
C1123



P5614

10 centre of tailgate behind trim panel
C0613 (2-W)



P5615

11 RH side of tailgate
C0381 (1-B)



P5616

12 LH side of tailgate
C0382 (1-B)

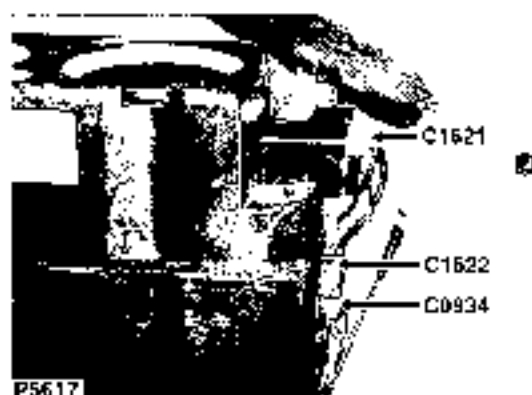

P5617

13 LH side of luggage compartment

C0834 (6-W)

C1621 (10-W)

C1622 (6-W)

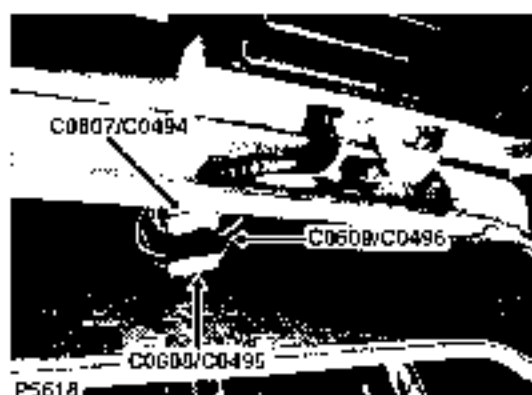

P5618

14 Inside front of RH rear door, (trim removed)

C0494 (4-W)

C0495 (2-W)

C0496 (2-B)

C0607 (4-W)

C0608 (2-W)

C0609 (2-B)



P5619

15 RH centre of headlining

C0356 (4-B)



P5620

16 LH centre of headlining

C0355 (4-B)



P5621

17 LH side of luggage compartment
C0739 (1-B)

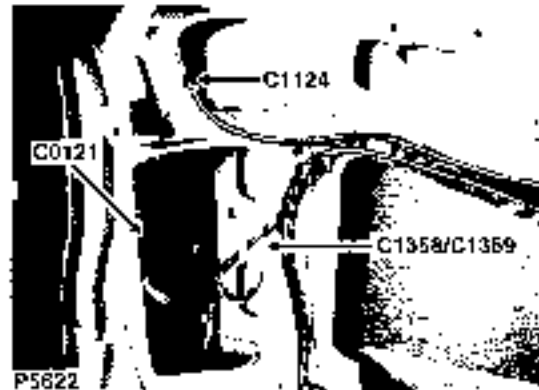

P5622

16 LH rear of luggage compartment
C0121 (4-G)
C1124
C1358 (4-W)
C1359 (4-W)



P5623

19 LH side of luggage compartment
E0809

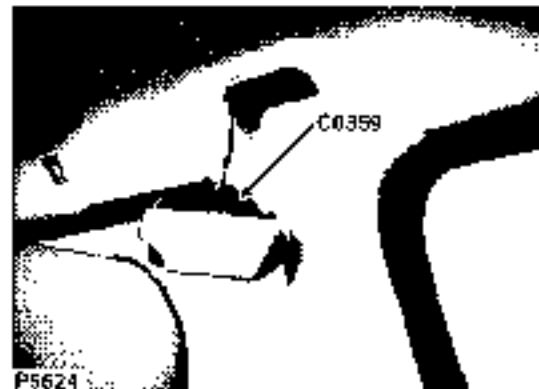

P5624

20 top of LH B-pest
C0359 (4-B)



21. front RH side of engine compartment
 C0126 (8-W)
 C0357 (4-B)
 C0698 (5-B) (MY 1998)
 C0696 (10-B) (MY 2000)

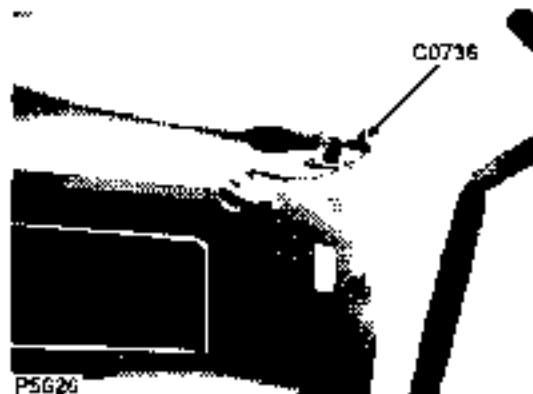

22. RH front of roof
 C0736 (2-B)

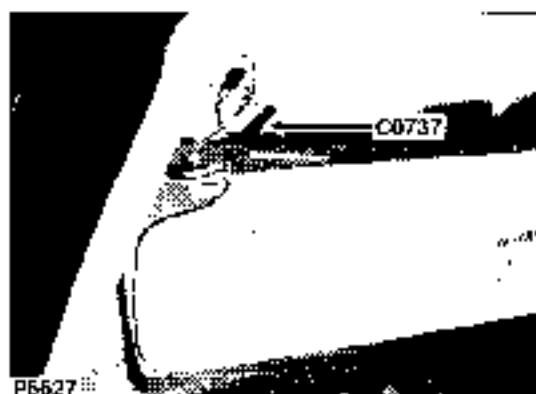

23. LH front of roof
 C0737 (2-B)



24. respective rear door
 C0445 (2-B)

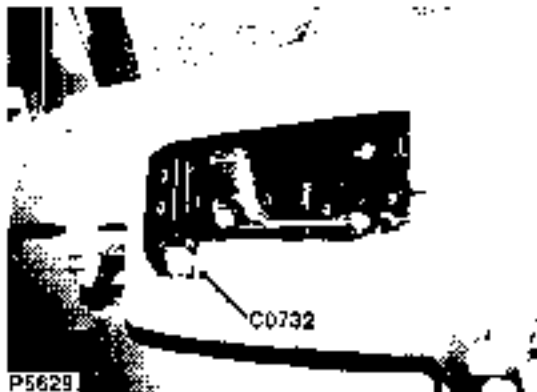

P5629
25 respective rear door
C0732 (4-W)

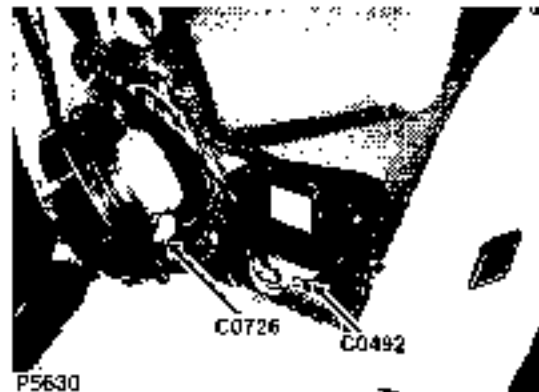

P5630
26 respective rear door
C0492 (10-W)
C0726 (2-0)

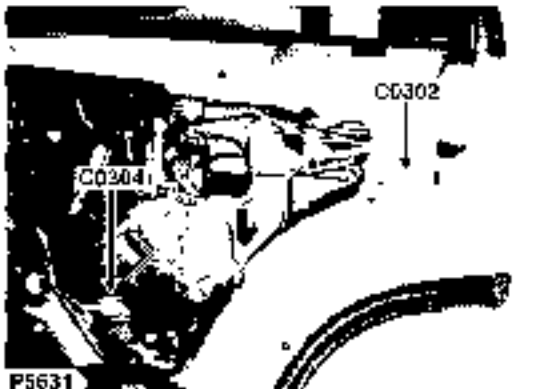

P5631
27 respective rear door
C0302 (6-W)
C0304 (6-W)

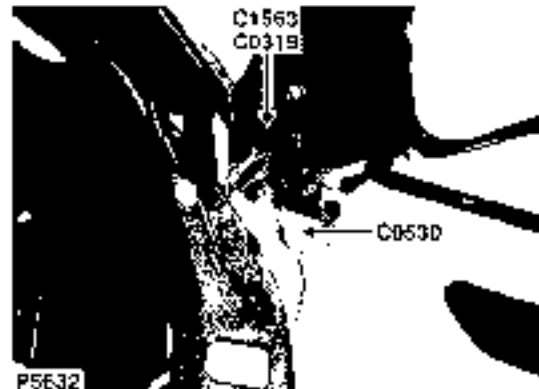

P5632
28 respective front door
C0319 (13-B)
C1563 (6-B)
C1563 (13-B)



P5633

29 behind rear door trim panel
C0980 (2-B)

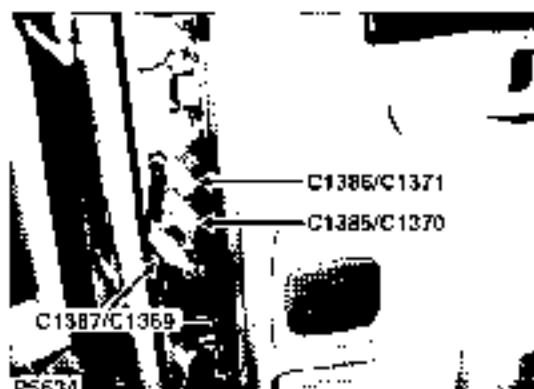

P5634

30 behind rear door trim panel
C1369 (6-W)
C1370 (6-S)
C1371 (6-Y)
C1385 (6-S)
C1386 (6-W)
C1387 (6-Y)



P5635

31 behind front floor trim panel
C0369 (2-B)
C0688 (2-B)
C1427 (10-W)
C1577 (2-B)

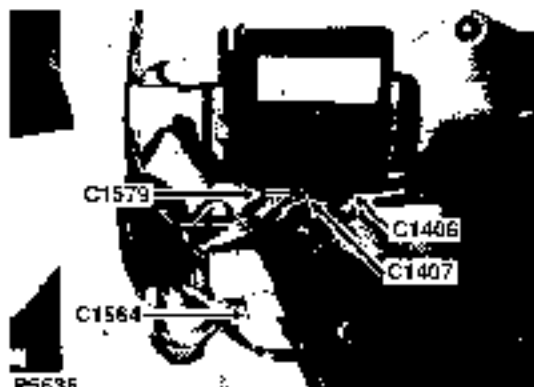

P5636

32 inside respective front door
C1406 (16-B)
C1407 (12-B)
C1564 (6-W)
C1597 (20-B)

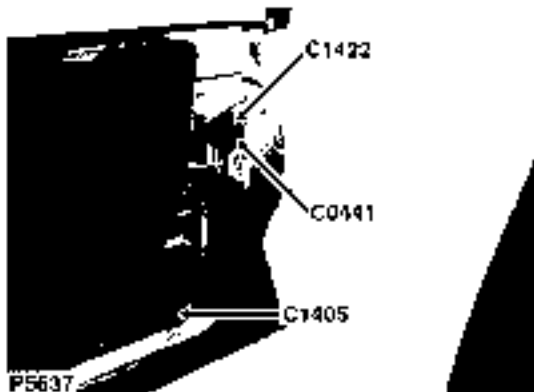

P5637

33. inside respective front door
 C0441 (2-B)
 C1405 (2-B)
 C1422 (6-W)



51178093

34. front of RH front door jamb
 C1372 (12-B) (MY 1999)
 C1373 (4-W) (MY 1999)
 C1379 (6-Y) (MY 2000)
 C1383 (12-B) (MY 1999)
 C1384 (4-W) (MY 1999)
 C1583 (6-W) (MY 2000)
 C1568 (6-Y) (MY 2000)
 C1578 (6-W) (MY 2000)

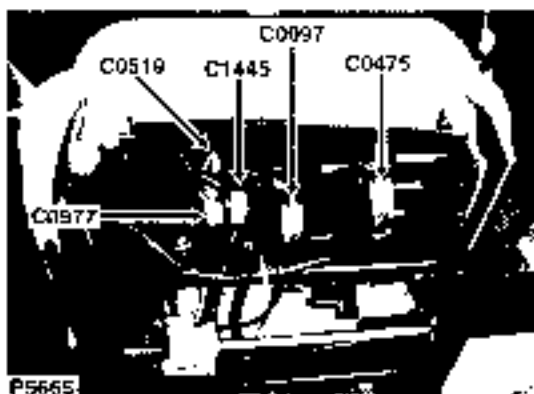

P5665

35. underside of respective front seat
 C0097 (6-W) With Memory Seat
 C0097 (2-) Without Memory Seat
 C0475 (6-W) With Memory Seat
 C0475 (2-) Without Memory Seat
 C0519 (18-W)
 C0977 (4-W)
 C1445 (3-W)



P5666

36. Underside of respective front seat
 C1425 (12-G)
 C1488 (12-G)

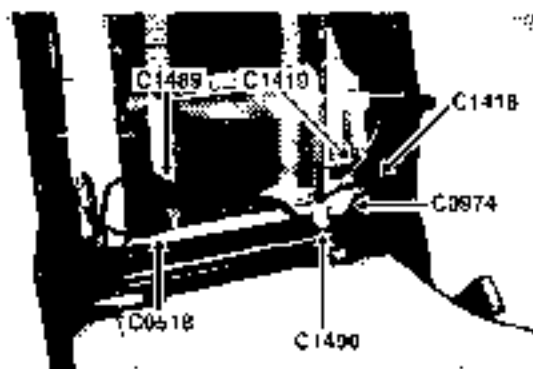

P5667

37. underside of respective front seat.

C0518 (2-)
 C0974 (4-W)
 C1418 (1-B)
 C1419 (1-B)
 C1489 (4)
 C1490 (3-W)

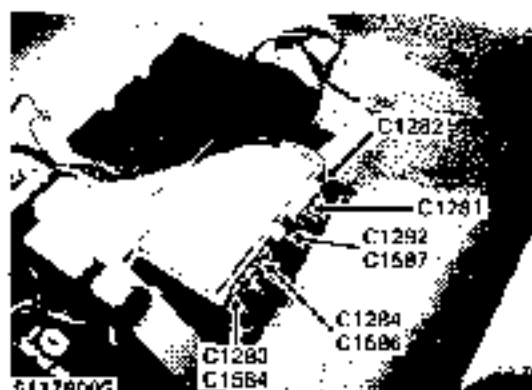

S1178006

38. beneath RH front seat.

C1281 (14-Y)
 C1282 (10-Y)
 C1283 (18-S) (MY 1999)
 C1284 (12-S) (MY 1999)
 C1292 (4 W) (MY 1999)
 C1584 (18-S) (MY 2000)
 C1586 (12-S) (MY 2000)
 C1587 (4-S) (MY 2000)

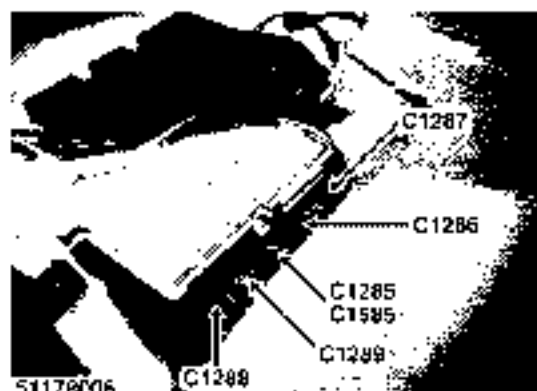

S1178006

39. beneath RH front seat.

C1285 (20-U) (MY 1999)
 C1286 (16-B)
 C1287 (20-B)
 C1288 (16-G)
 C1289 (20-G)
 C1585 (20-U) (MY 2000)



P5870

40. in lower part of RH B-post.
C0254 (2-Y)

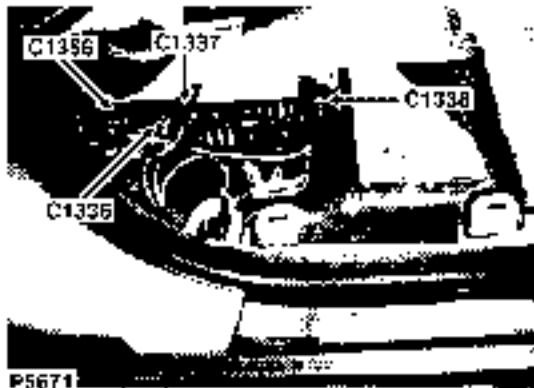

P5671

41 beneath RH front seat

- C1336 (1 -)
- C1337 (1 -)
- C1338 (1 -)
- C1356 (1 -)

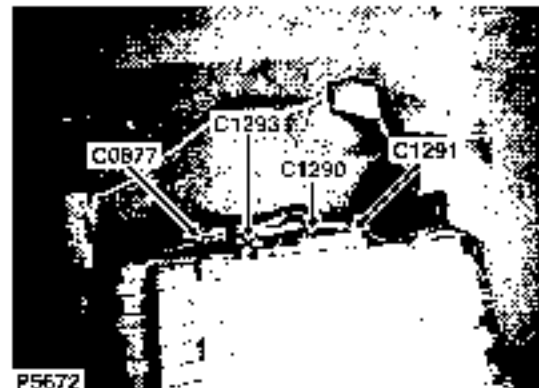

P5672

42 beneath RH front seat

- C0877 (12 - G)
- C1290 (12 - W)
- C1291 (18 - W)
- C1293 (4 - W)

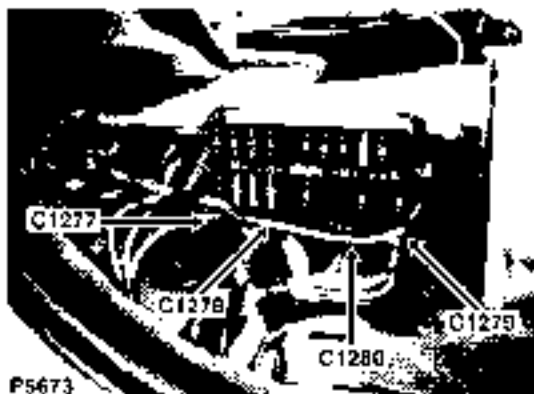

P5673

43 beneath RH front seat

- C1277 (8 - B)
- C1278 (20 - Y)
- C1279 (20 - W)
- C1280 (16 - W)

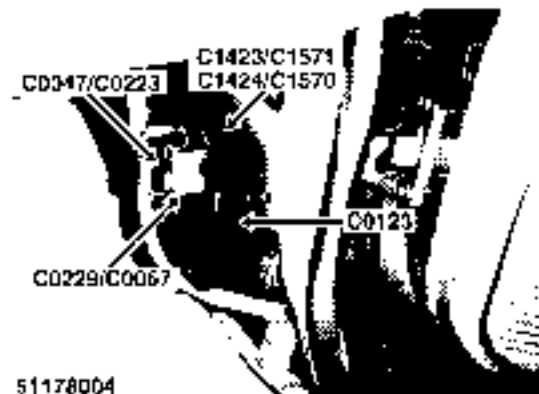

51178004

44 behind RH footwell trim panel

- C0047 (2 - N)
- C0067 (18 - W)
- C0123 (3 - B)
- C0223 (2 - N)
- C0229 (18 - W)
- C1423 (6 - W) (MY 1999)
- C1424 (10 - W) (MY 2000)
- C1570 (10 - W) (MY 2000)
- C1571 (6 - W) (MY 1999)



P5675

45 beneath RH front seat

C1276 (10-W)

E0608

E1355

E1412

E1413

E1431

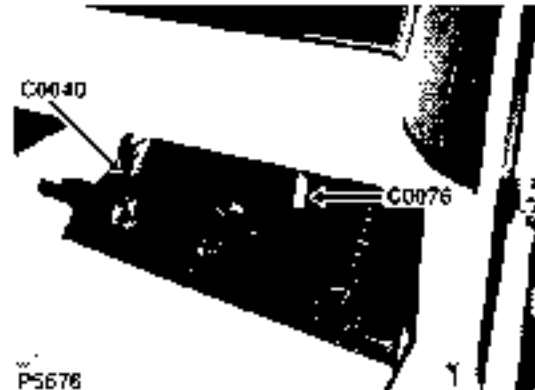

P5676

46 passenger's footwell

C0040 (16-B)

C0076 (2-W)

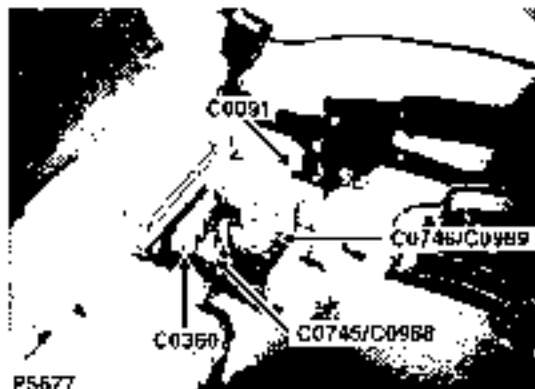

P5677

47 beneath centre console

C0091 (1-B)

C0745 (18-LS)

C0746 (14-LS)

C0988 (18-LS)

C0989 (14-LS)

E0360

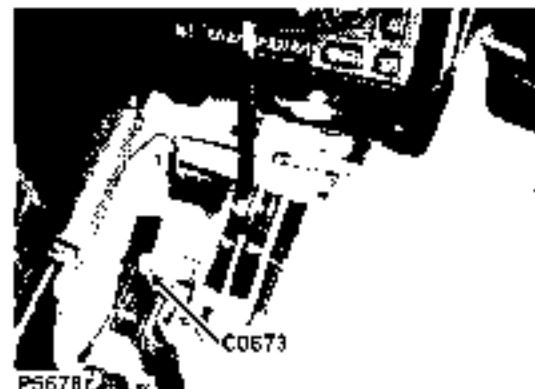

P5678

48 beneath centre console

C0573 (6-W)



P5679

49. behind glovebox
C0238 (2-W)

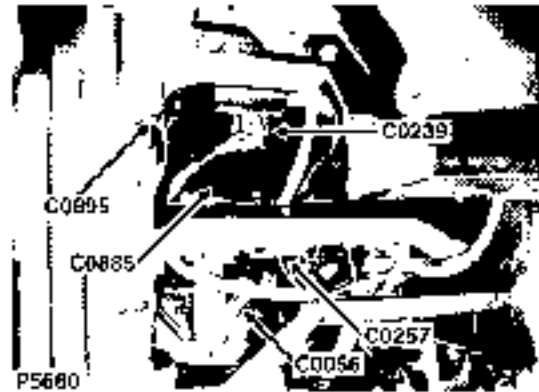

P5680

50. behind driver's side of fascia
C0056 (4-N)
C0239 (18-B)
C0257 (2-R)
C0885 (1-B)
C0895D (9-B)
C0895P (9-B)

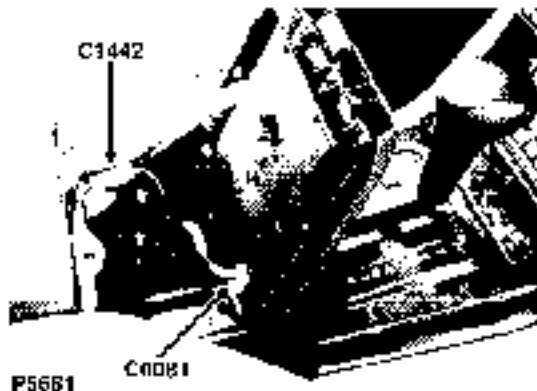

P5681

51. beneath centre console
C0081 (8-U)
C1442 (2-W)

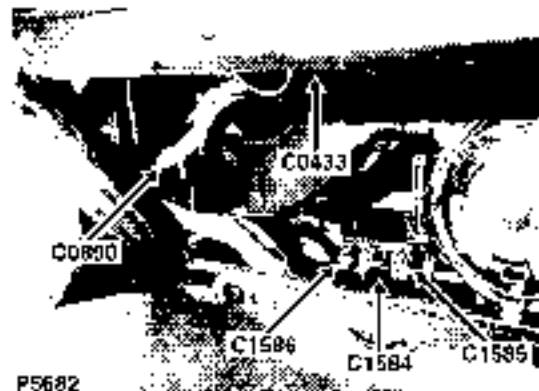

P5682

52. behind glovebox
C0433 (2-R)
C0890 (2-U)
C1584 (18-B)
C1585 (15-B)
C1588 (9-B)



53 passenger's side of bulkhead

C0023 (A-N)
C0883 (B-W)
C0886 (I-B)

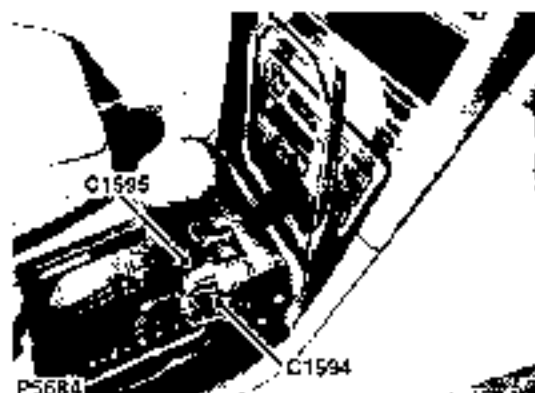

54 beneath centre console

C1594 (Z-B)

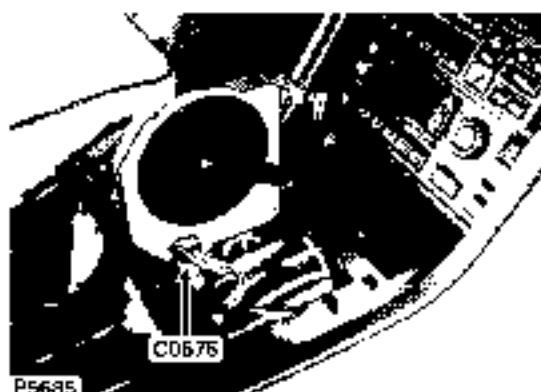

55 beneath centre console

C0675 (I2-B)

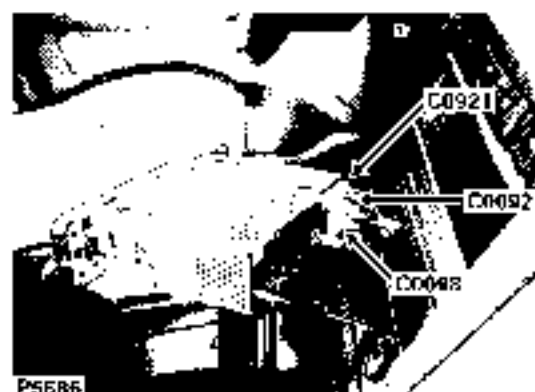

56 behind radio

C0092 (B-N)
C0098 (B-S)
C0921 (B-Y)

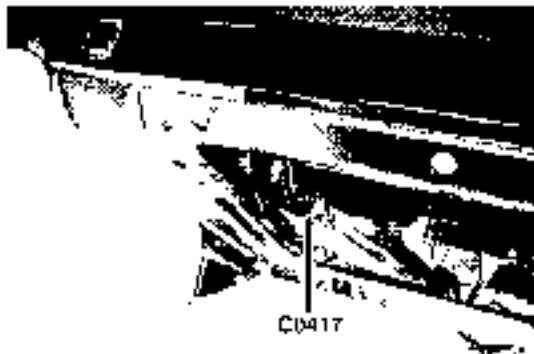

P5687

57. behind driver's side of fascia
C0417 (2-B)



P5688

58. behind centre of fascia
C0041 (4-W)
C0064 (6-Y)
C0065 (6-U)



P5689

59. behind centre of fascia
C0095 (1-B)
C0232 (2-B)
C1548 (4-B)

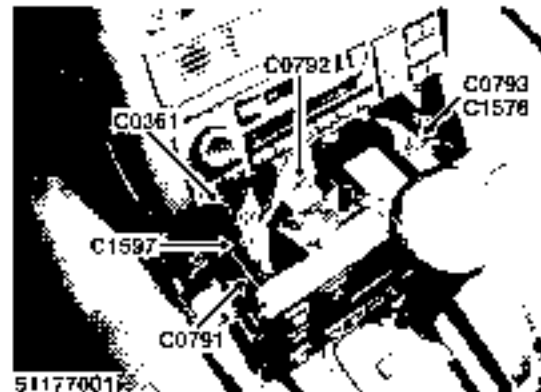

51177001P

60. behind centre of fascia
C0791 (12-B)
C0792 (8-W)
C0793 (20-B)
C1578 (12-G)
C1597
E0361

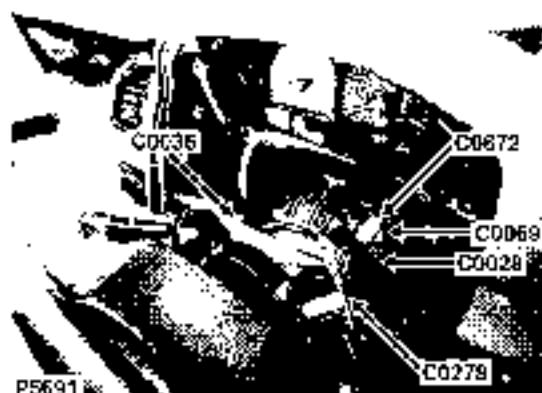

P5691

61 near steering column

C0028 (4-W)

C0036 (12-B)

C0069 (3-W)

C0278 (8-B)

C0672 (4-W)



P5692

62 underside of steering column

C0082 (6-W)

C0891 (2-B)



P5693

63 behind LH side of fascia

C0077



P5694

64 beneath LH front seat

C0866 (9-B)

C0865 (6-W)

C0903 (8-W)



P5695

65 beneath LH front seat
C0948 (2-Y)



P5696

66 beneath LH front seat
C0867 (35-B)
C1319 (30-B)
C1320 (88-W)
C1321 (55-W)



P5697

67 inside driver's seat bell buckle assembly
C0262 (2-W)

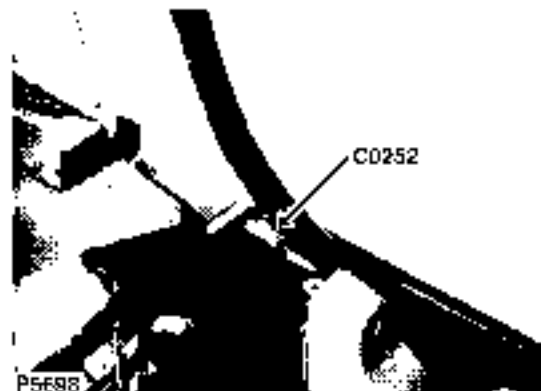

P5698

68 in lower part of LH B-post
C0252 (2-Y)

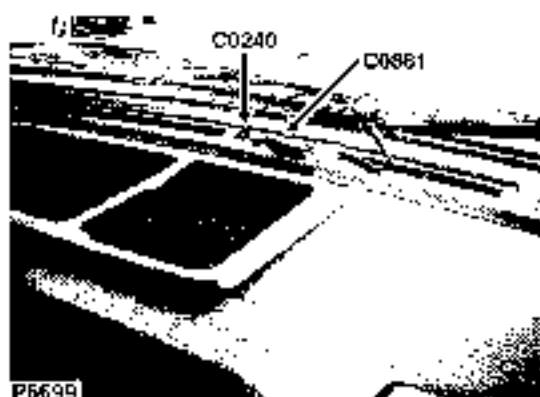

P5699
69 Top centre of fascia
C0240 (2-G)
C0861 (2-D)



P5700
70 RH front of vehicle
C0011 (6-B)
C0854 (4-B)
C1345 (3-B)
C1346 (2-B)

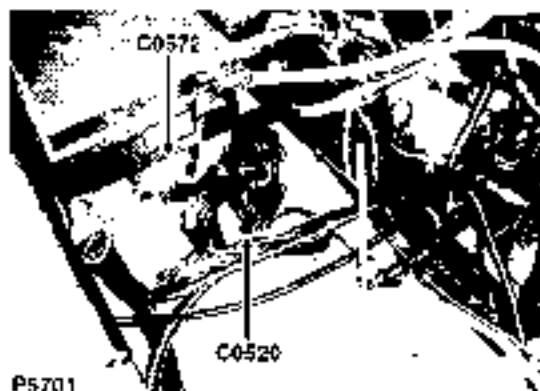

P5701
71 RH side of engine compartment
C0520 (2-B) Without Battery Backed Up
Alarm Sounder
C0572 (8-K)

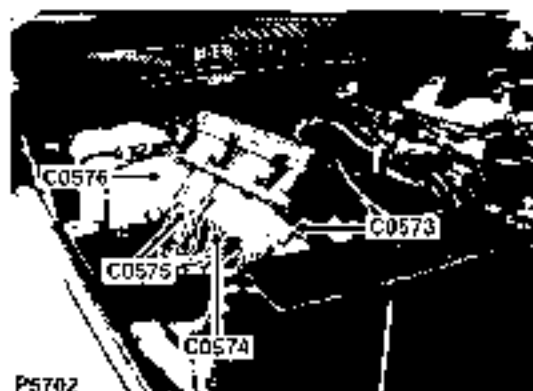

P5702
72 RH side of engine compartment
C0573 (8-U)
C0574 (8-Y)
C0575 (8-P)
C0576 (8-G)



70 RH side of engine compartment
 C0570 (8-S)
 C0571 (8-N)
 C0572 (8-K)



74 RH rear of engine compartment
 E0362
 E0558



75 RH rear of engine compartment
 C0126 (25-B)
 C0133 (2-R)
 C0448 (25-B)

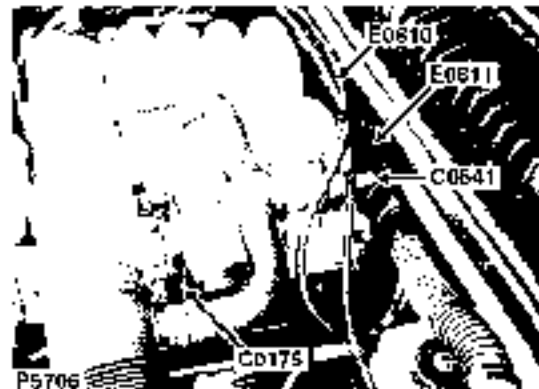

78 RH side of engine compartment
 C0175 (3-B)
 C0641 (3-S)
 E0810
 E0811

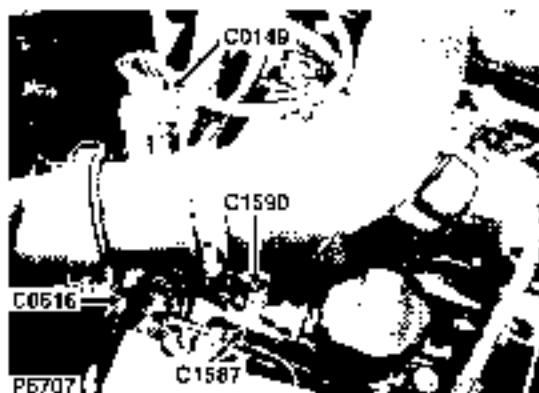

77 LH side of engine compartment
 C0149 (5-B)
 C0516 (2-)
 C1587 (2-W)
 C1590 (5-B)

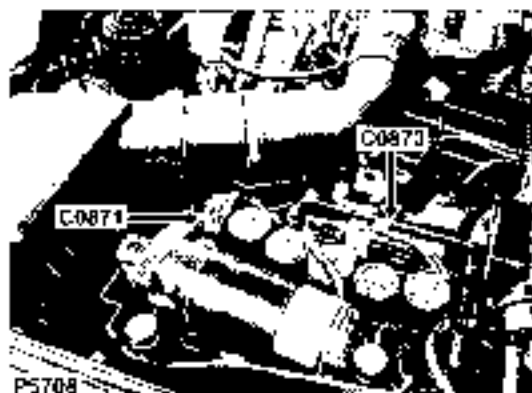

70 LH side of engine compartment
 C0871 (13-B)
 C0873 (4-B)



79 LH front of vehicle
 C0001 (2-B) Except NAS
 C0009 (6-B)
 C0853 (4-B)
 C0950 (3-Y)
 C1343 (3-B) NAS

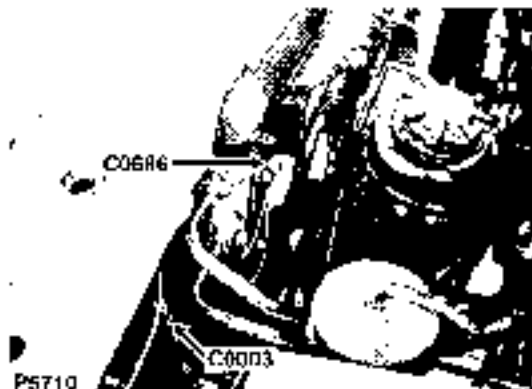

80 LH front of vehicle
 C0003 (2-B)
 C0686 (2-U)



P5711

61 LH front of engine
C0128 (2-S)



P5712

62 RH front of engine compartment
C0004 (2-B)
C0007 (2-B)

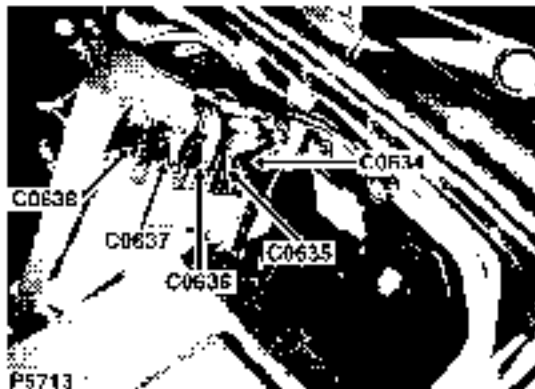

P5713

63 LH rear corner of engine compartment
C0634 (9-B)
C0635 (24-B)
C0636 (52-B)
C0637 (40-B)
C0638 (9-B)

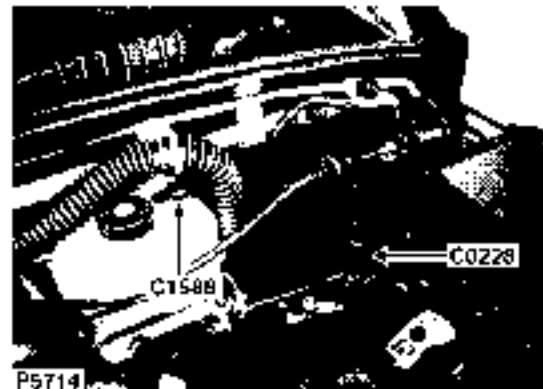

P5714

64 LH rear corner of engine compartment
C0228 (3-S)
C1588 (2-B)



51178002

85. behind LH footwell trim panel

C0467 (14 -W)

C0469 (14 -W)

C1363 (8-W); (MY 1999)

C1374 (12 -W) (MY 2000)

C1377 (8-W); (MY 1999)

C1378 (12 -W) (MY 2000)

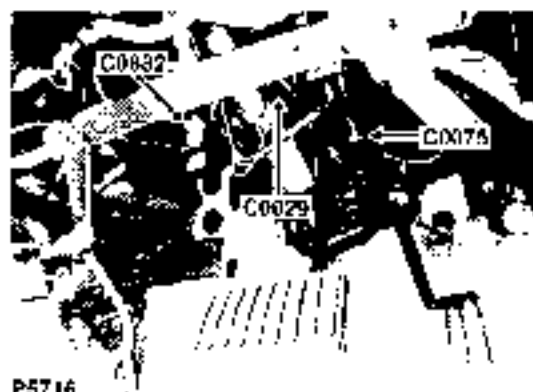

P5716

86. behind driver's side of fascia L/H/D

C0029 (2 -W)

C0075 (3 -Y)

C0882 (3 -W)



P5717

87. left of steering column

C0748 (5 -B)

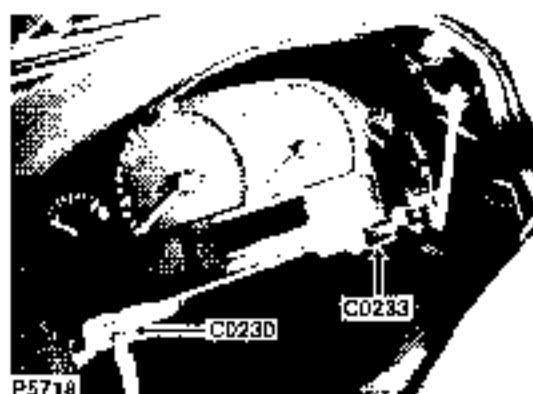

P5719

88. behind driver's side of fascia

C0230 (5 -LU)

C0233 (20 -B)



P5719

89 behind RH footwell trim panel

C0231 (4-O)

C1322 (4-O)

E0562

E0564

E0910

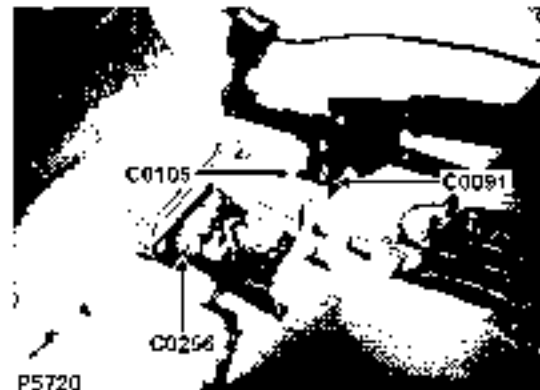

P5720

50 beneath centre console

C0091 (1-B)

C0105 (3-B)

C0256 (50-)

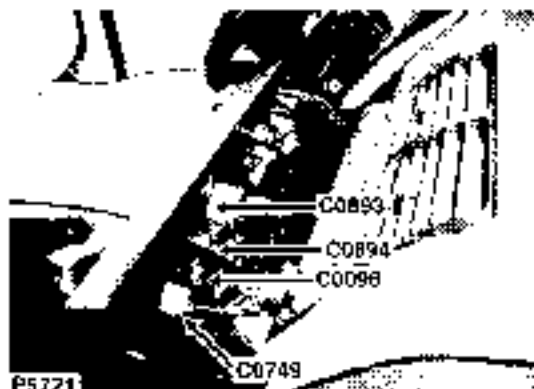

P5721

91 behind centre of fascia

C0098 (8-R)

C0749 (6-G)

C0893 (8-B)

C0894 (6-B)

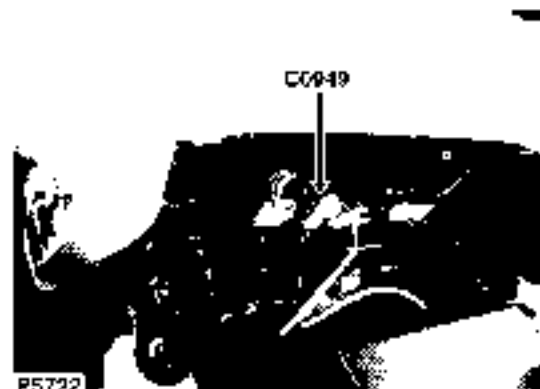

P5722

52 LH side of engine

C0949 (2-Y)

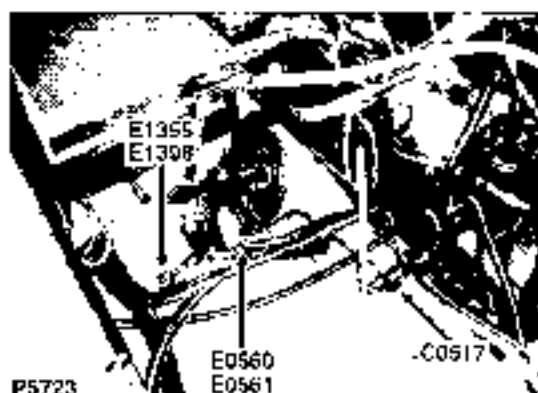

P5723

93 RH side of engine compartment

C0517 (2-)

E0560

E0561

E1355

E1398



P5724

94 beneath engine compartment fuse box

C1333 (1-)

C1334 (1-)

C1335 (1-)



P5725

95 LH rear corner of engine compartment

C0646 (3-W)



P5726

96 LH rear of engine compartment

C0152 (2-E)

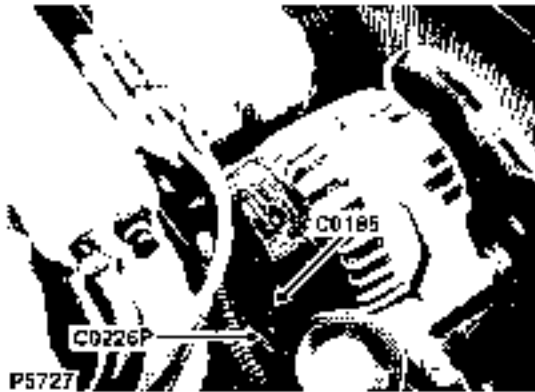

P5727
 97 front centre of engine
 C0185 (1 - 1)
 C0226 (1 - 1)



P5728
 98 behind LH side of front bumper
 C0514 (2 - W)



P5729
 99 beneath engine compartment fuse box
 13E7 (2 - W)



P5730
 100 lower RH rear of engine compartment
 Petrol
 C0179 (1 - 1)
 C0631 (1 - 1)



P5731

101. beneath LH front of vehicle

C0865 (3-W)



P5732

102. beneath RH front of vehicle

C0870 (3-W)



P5733

103. beneath beneath RH side of vehicle

C0642 (4-S)

C0645 (4-O)



P5734

104. beneath centre of vehicle

C0195 (2-E)

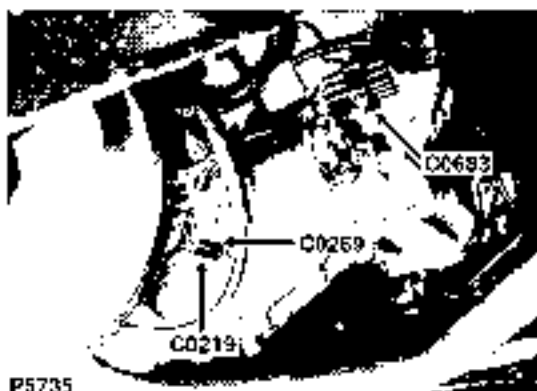

P5735

105 beneath centre of vehicle

C0219 (1-B)

C0269 (1-B)

C0683 (8-B)



P5736

106 beneath RH rear of vehicle

C0875 (3-W)

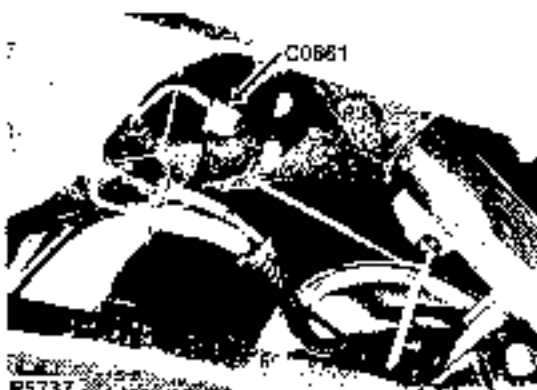

P5737

107 beneath LH rear of vehicle

C0861 (3-W)



P5738

108 lower LH side of engine

C0643 (4-S)

C0644 (4-O)

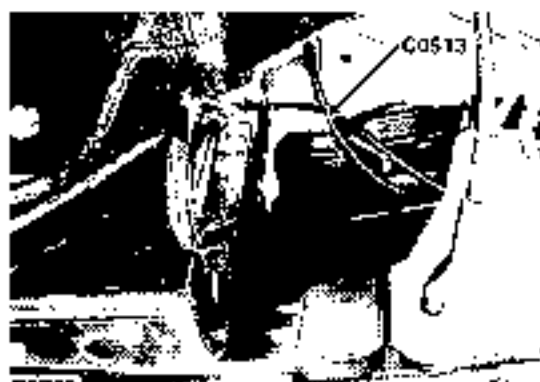

P5739

109. behind RH side of front bumper
C0513 (2-W)



P5740

110. LH side of engine compartment
E0556
E0557
E0558

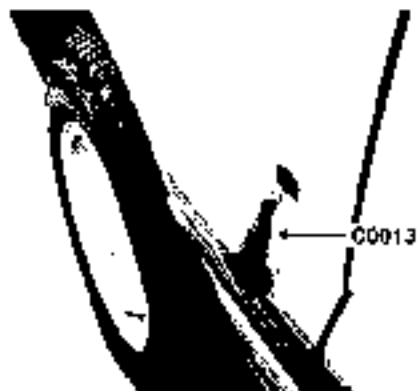

P5741

111. LH front side of vehicle
C0013 (2-B)

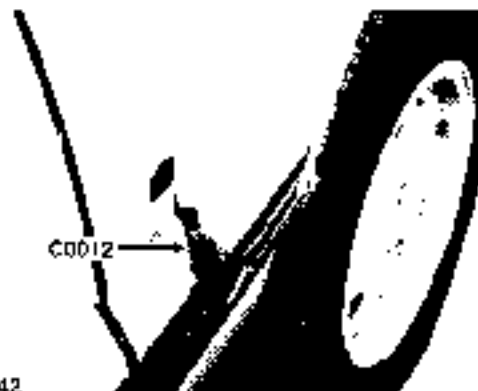

P5742

112. RH front side of vehicle
C0012 (2-B)

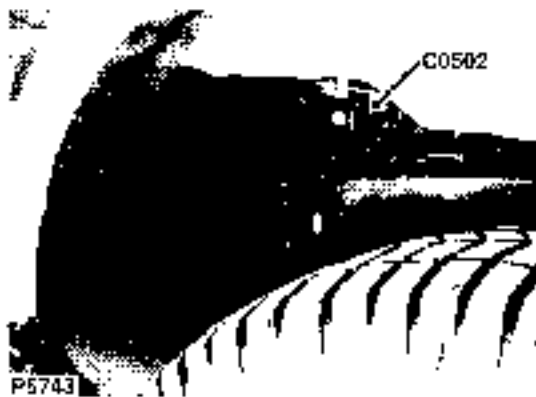

P5743

113 beneath LH rear of vehicle
C0502 (2-1)

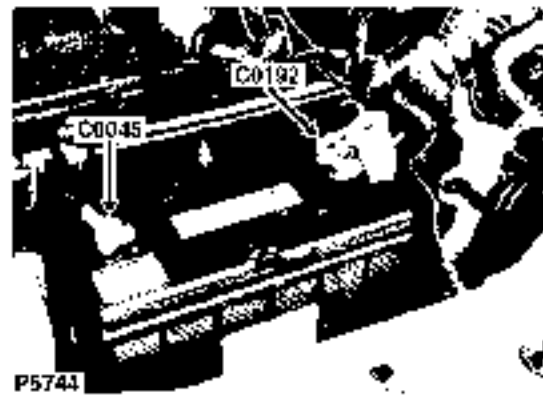

P5744

114 RH front corner of engine compartment
C0045 (1-)
C0192 (1-)



P5745

115 LH rear of engine
C0168P (3-B)

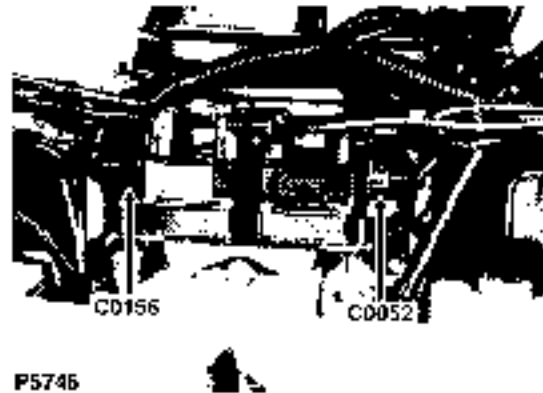

P5746

116 LH rear of engine
C0052 (3-B)
C0156 (3-B)

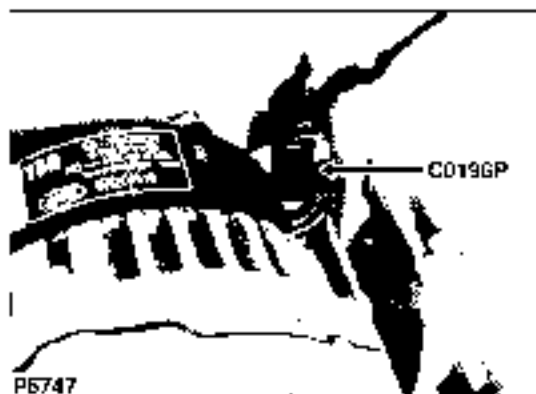

P5747

117. top of engine

C0196P (4-B)



P5748

118. top RH side of engine

C0529 (2-B)

C0525 (2-B)

C0527 (2-B)

C0529 (2-B)

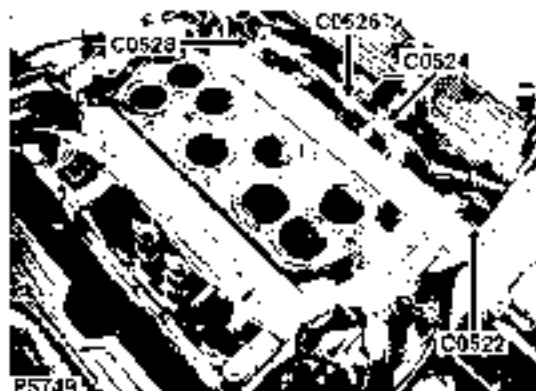

P5749

119. top LH side of engine

C0522 (2-B)

C0524 (2-B)

C0526 (2-B)

C0528 (2-B)

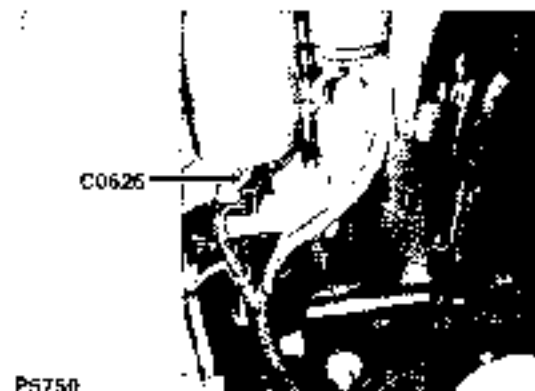

P5750

120. lower RH rear of engine compartment

C0626 (2-B)



P5751
121 lower LH rear of engine
C0627 (2-B)



P5752
122 lower RH front of engine compartment
C0176 (3-B)



P5753
123 lower RH front of engine compartment
C0187P (1-B)



P5754
124 LH side of transmission
C0243 (14-B)
C0244 (6-S)

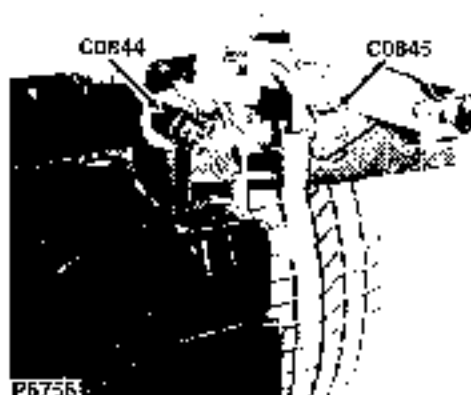

P5756

125. behind LH side of front bumper

C0844 (4-B)

C0845 (2-B)



P5756

126. behind LH side of front bumper

C0025 (2-B)

C0280 (2-B)

C0884 (2-B)

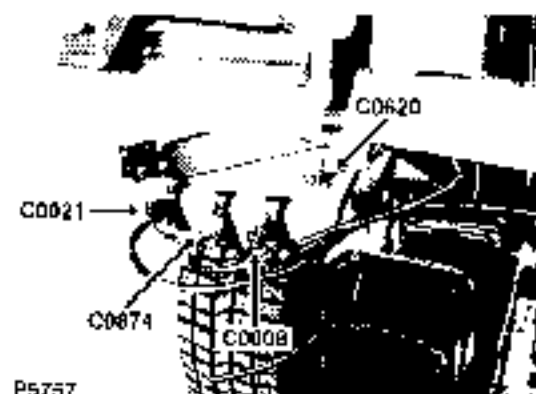

P5757

127. behind RH side of front bumper

C0008 (2-F)

C0021 (2-B)

C0620 (2-U)

C0874 (2-W)

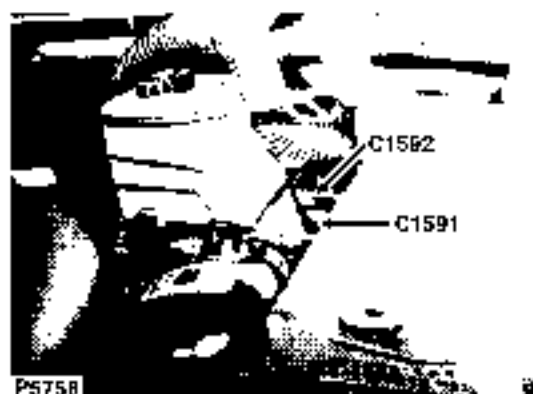

P5758

128. driver's side of engine compartment

C1591 (13-B)

C1592 (1-W)

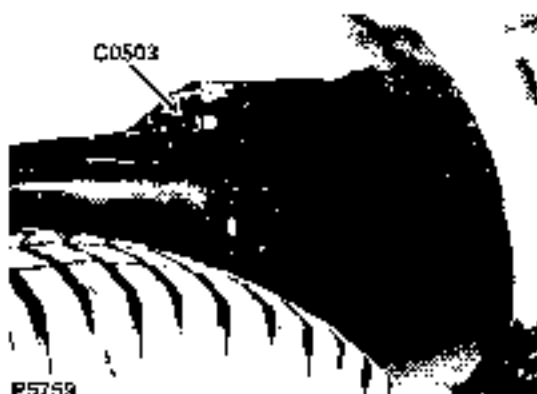

P5759

129. beneath RH rear of vehicle
C0503 (2 - 1)

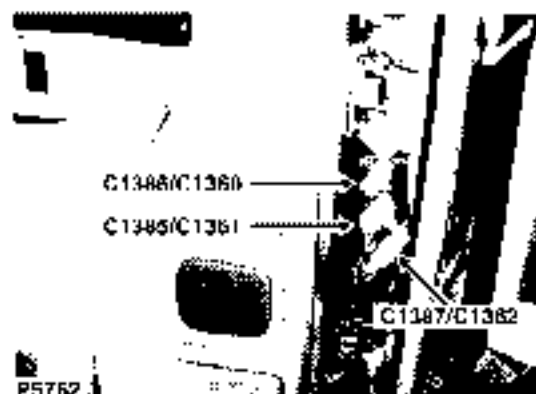

P5762

130. behind rear door trim panel
C1360 (6-W)
C1361 (6-S)
C1362 (6-Y)
C1385 (6-S)
C1386 (6-W)
C1387 (6-Y)

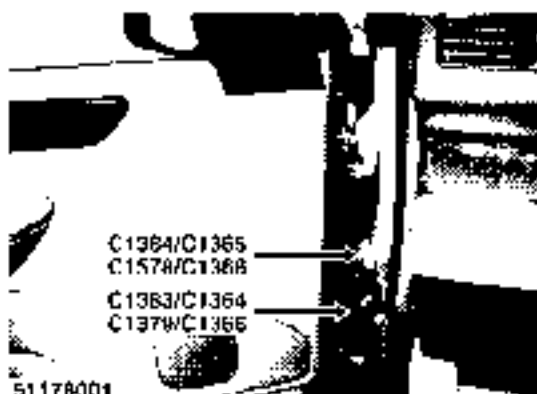

51178001

131. front of LH front door jamba
C1364 (12-R) (MY 1999-
C1365 (4-W) (MY 1999)
C1366 (6-Y) (MY 2000)
C1368 (6-W) (MY 2000)
C1379 (6-Y) (MY 2000)
C1383 (12-B) (MY 1999)
C1384 (4-W) (MY 1999)
C1578 (6-W) (MY 2000)

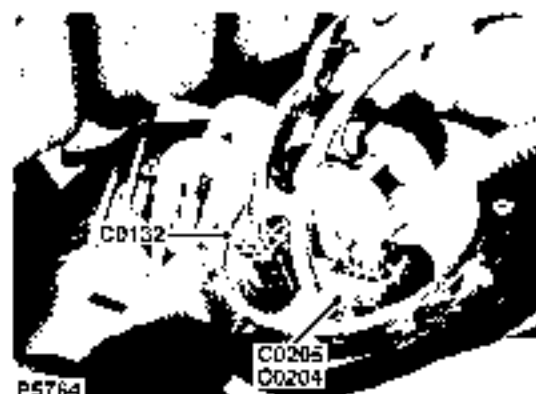

P5764

132. top of fuel tank
C0132 (3-R)
C0204 (4-B)
C0205 (4-B)

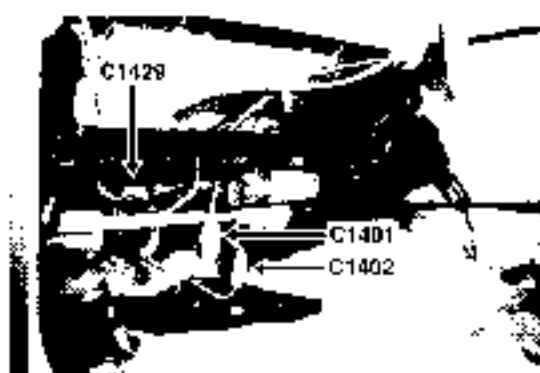

P5772

133. beneath LH front seat

C1401 (3-W)

C1402 (2-W)

C1429 (12-S)

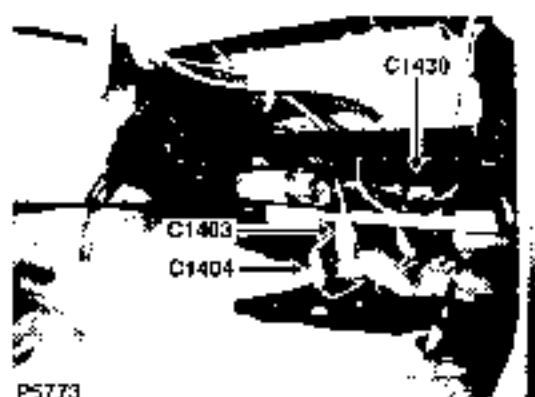

P5773

134. beneath RH front seat

C1403 (3-W)

C1404 (2-W)

C1430 (12-S)



P5784

135. RH rear of engine compartment

C0203 (25-B)

C0448 (25-B)



P5785

136. beneath engine compartment fuse box
Diesel

C0577 (8-B)

E0556D



P5786

107 RH front of engine compartment

C0215 (12-B)

C0411 (55-B)

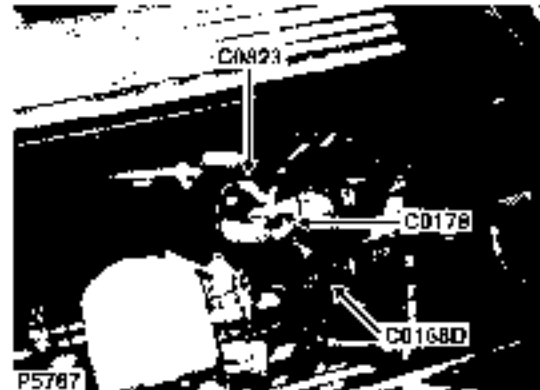

P5787

130 LH rear of engine

C0168D (3-B)

C0178 (-)

C0823 (-)

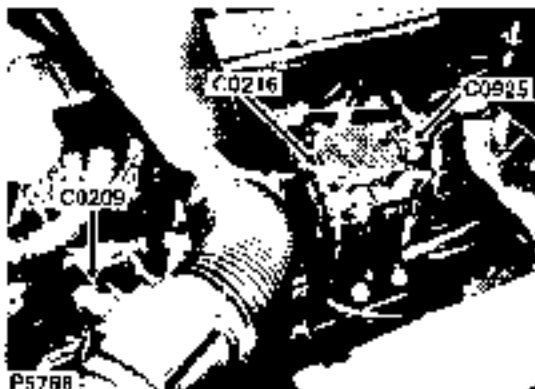

P5788

139 LH rear of engine compartment

C0209 (6-B)

C0216 (3-B)

C0925 (3-B)

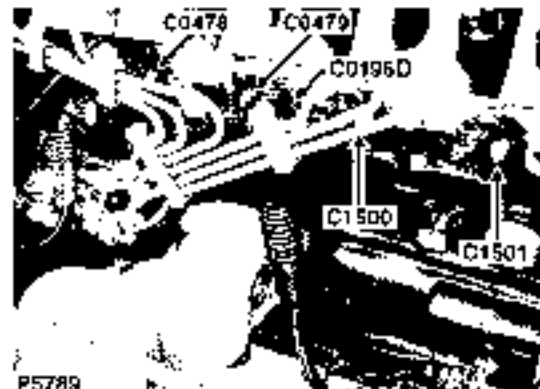

P5789

140 LH side of engine

C0196D (2-B)

C0478 (-)

C0479 (-)

C1500 (-)

C1501 (-)



P5790

141. LH rear of engine compartment
C0272 (2-B)



P5791

142. LH side of engine
C0183 (1-I)
C0187D (2-D);
C0226 (1-I)
C1503 (2-B)



51177002

143. LH side of engine
C0476 (1-I)
C0477 (1-I)



P5793

144. rear RH side of engine compartment
C0500 (1-W)
C0501 (13-B)
C0652 (2-B)

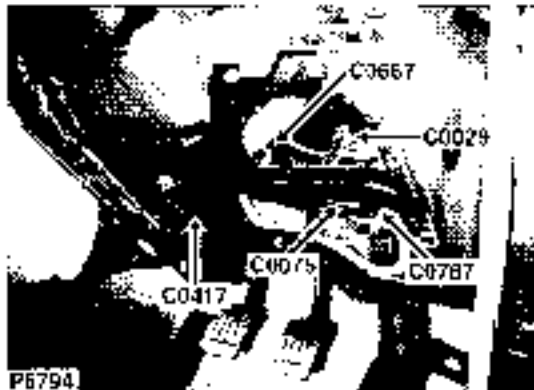

P5794

145 behind driver's side of fascia

C0029 (2-W)
 C0075 (3-W)
 C0417 (2-B)
 C0667 (2-W)
 C0787 (8-S)

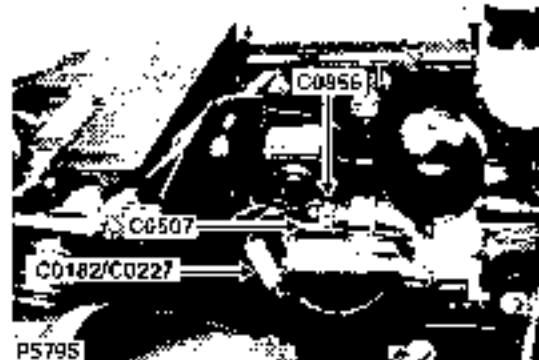

P5795

146 driver's side of engine compartment

C0182 (2-U)
 C0277 (2-U)
 C0507 (2-W)
 C0855 (5-B)

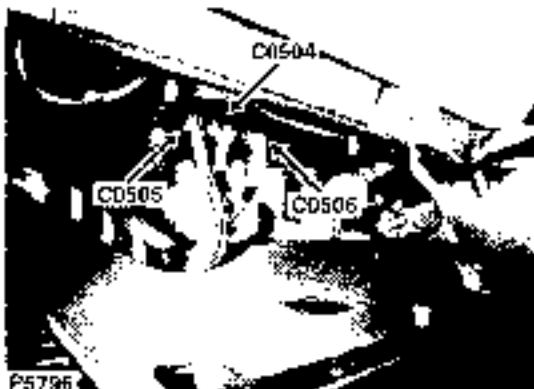

P5796

147 behind glovebox

C0504 (18-B)
 C0505 (9-B)
 C0506 (15-B)



P5797

148 bottom of engine (RH side)

C0127 (3-)

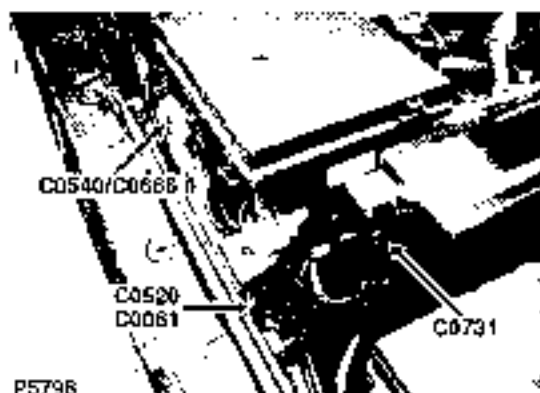

P5796

149. LH side of engine compartment

C0061 (2-B)

C0520 (2-B) With Battery Backup Up Alarm
Sounder

C0540 (2-W)

C0666 (2-W)

C0731 (4-B)



P5799

150. behind centre of fascia

C0685 (6-W)



P5800

151. LH side of engine

C0198 (1-)

C1502 (7-B)



P5812

152. lower RH side of windscreen

C0247 (1-W)

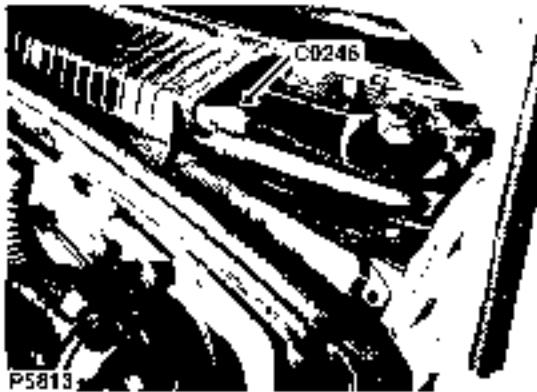

P5813

153 lower LH side of windscreen
C0246 (1-W)



P5814

154 lower LH side of windscreen
C1593 (4-B)

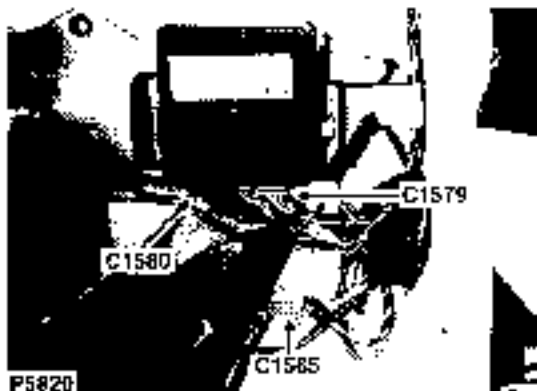

P5820

155 behind LH front door
C1565 (6-B)
C1579 (20-B)
C1580 (16-B)

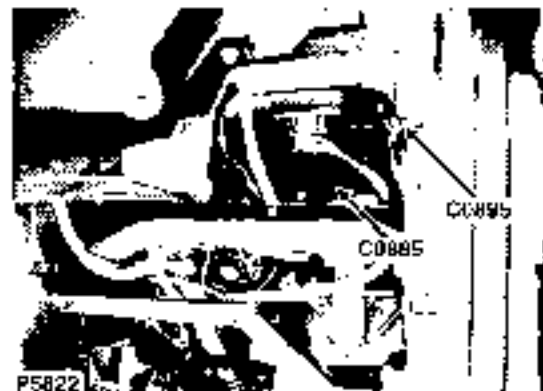

P5822

156 behind driver's side of fascia
C0885 (1-B)
C0895 (8-B)



P5823

157. behind centre of fascia

C0096 (8-R)

C0749 (6-G)

C0893 (8-B)

C0894 (6-B)



P5824

158. behind glovebox

C0883 (3-W)

C0886 (1-B)



P5825

159. behind centre of fascia

C0041 (4-W)

C0064 (6-Y)

C0065 (6-U)



P5826

160. LH side of transmission

C0167 (2-B)

C0684 (2-B)

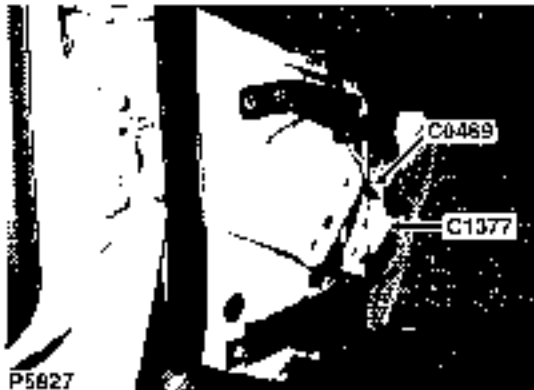

P5827

161 behind LH footwell trim panel
 C0469 (14-W)
 C1377 (8-W)



P5828

162 behind RH footwell trim panel
 C0229 (18-W)
 C1571 (6-W)
 E0562
 E0564

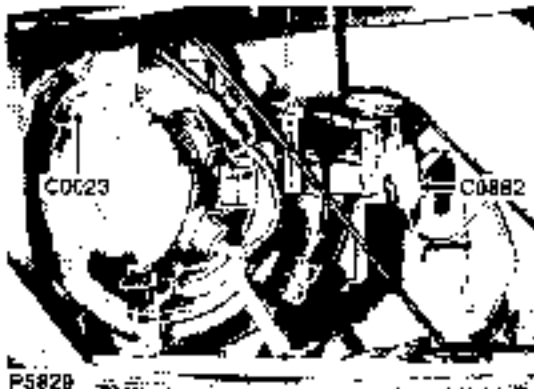

P5829

163 behind glovebox
 C0023 (4-N)
 C0882 (3-W)

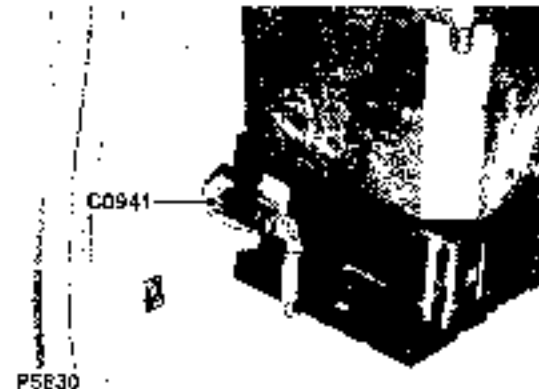

P5830

164 LH rear of luggage compartment
 C0941 (10-B)



165. underside of respective front seat

C1618

C1619

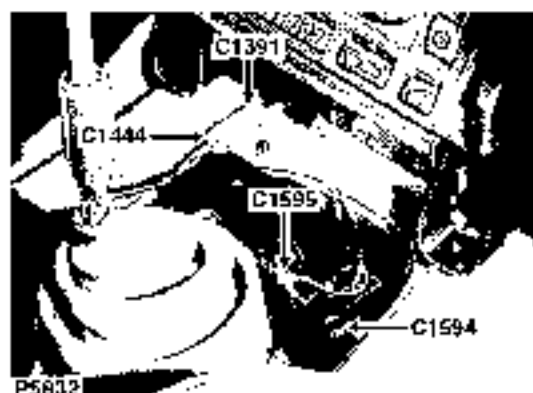

166. beneath centre console

C1391 (4 - W)

C1444 (4 - W)

C1594 (2 - B)

C1595 (1 - W)



167. underside of respective front seat

C1620

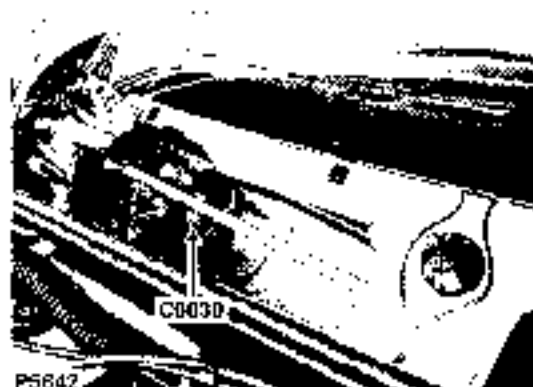

168. lower RH side of windscreen

C0030 (2 - B)



P5836

169 behind centre of fascia

C0095 (1-B)

C0232 (2-B)



P5837

170 behind passenger's side of fascia

C0239 (2-W)

C0433 (2-R)

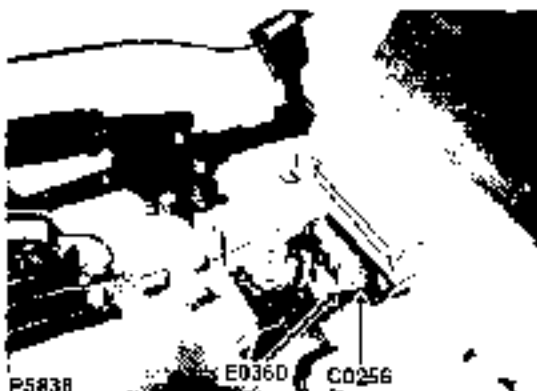

P5838

171 beneath centre console

C0256 (5D-)

E0360



P5839

172 behind driver's side of fascia

C0056 (4-N)

C0239 (1B-B)

C0257 (2-R)



P6188

173. RH front of engine compartment
C0879 (2-B)

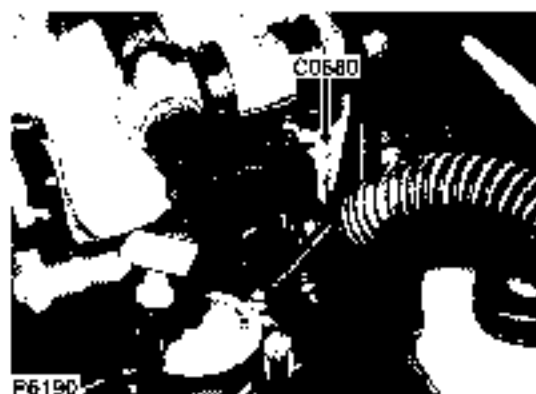

P6190

174. LH side of engine
C0680 (2-S)



P6116

175. lower RH side of windscreen
C1582 (1-)



P6195

176. behind centre of fascia
C0820 (6-R)
C0993 (10-B)



P6184

177. LH side of luggage compartment
C0491 (42-B)



P6191

178. RH rear of vehicle
C0350 (2-B)

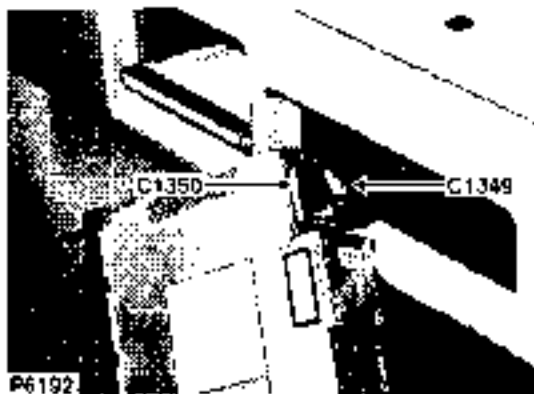

P6192

179. RH side of luggage compartment
C1349 (18-R)
C1350 (18-R)



P6193

180. RH side of luggage compartment
C0959 (8-U)
C1136 (1-)

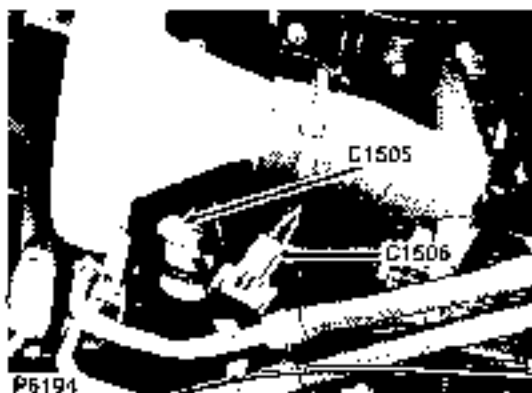

151, LH front corner of engine compartment

C1505 (2-R)

C1506 (2-B)

C0001



(2 - B) 

1	GR
2	B

CA3C0001

C0003



(2 - B) 

1	1S
2	U

CA3C0003

C0004



(2 - B) 

1	PS
2	B

CA3C0004

C0007

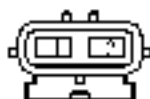

(2 - B) 

1	25V
2	EP

CA3C0007

C0008



(2 - 9) 

1	△ B
2	E

CA3C0008

C0009

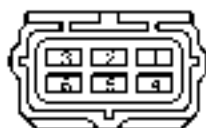

(6 - B) 

1	JSP
2	JSE
3	B	F	B

CA3C0009

C0011

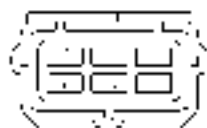

① - B1

1	115	4	11
2	116	5	112
3	5	6	5

CA3C0011

C0012



② - B1

1	11
2	112

CA3C0012

C0013

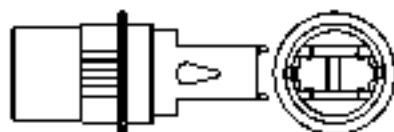

③ - B1

1	11
2	112

AF113598

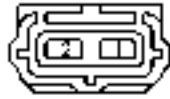
C0021

(2 - B)

1	B1
2	B

CA3C0021

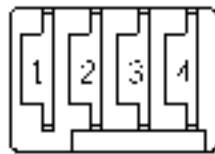
C0023

(4 - V)

1	B1	1	B1
2	B	3	B1

CA3C0023

C0025

(2 - B)

1	B1
2	B1

CA3C0025

C0028

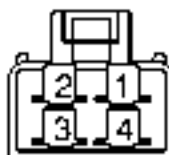

(4 - W)



1	AN	2	WS
3	Z	4	9

CA3C0028

C0029

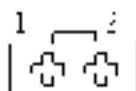

(2 - W)



1	1A
2	1B

CA3C0029

C0030



(4 - B)



1	HLA	3	LTA
2	RLC	4	B

CA3C0030

C0036

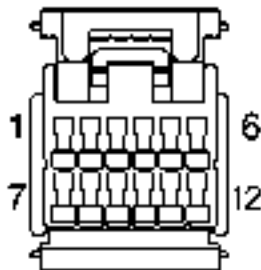

(12 - B)

1	1.5	2	36	4	5
2	1.5	3	36	5	6
3	2P	4	42	11	12
4	2U	5	6	12	UP

CA3C0036

C0040

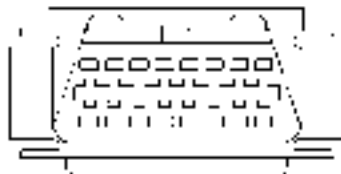

(12 - B)

1	1.5	2	42	11	12
2		3		11	12
3		4		11	12
4	B	5	14	14	15
5	H	6	14	14	15
6	L	7	14	14	15

CA3C0040

C0041

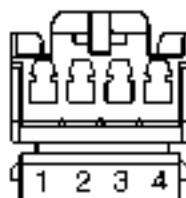

(4 - W)

1	1.5	2	6
3	2P	4	6

CA3C0041

C0052

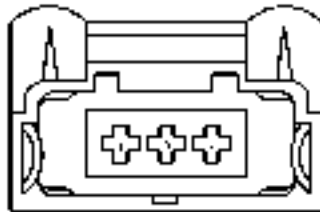

(3 - B)

1	MA
2	MA
3	MA

CA3C0052

C0056

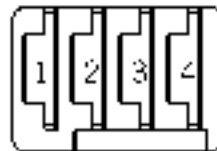

(4 - N)

1	PU	1	P
2	R	2	PF

CA3C0056

C0061

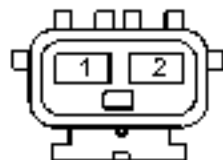



(2 - B)

1	FY
2	E

CA3C0061

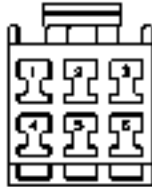
C0064



(6 - W) 

1	B	4	R,G
2	RY	5	BL
3	RV	6	

CA3C0064

C0065



(6 - W) 

1	B	4	R,G
2	RV	5	RY
3	RY	6	R,G

CA3C0065

C0067

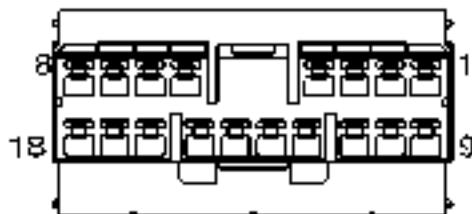

(16 - W) 

1	RY	9	RY	10	RY	11	K
2	RY	10	RY	11	RY	12	11/3
3	RY	11	RY	12	RY	13	G
4	RY	12	RY	13	RY	14	
5	RY	13	RY	14	RY	15	

CA3C0067

C0069



3 00

1	FN
2	
3	FN

CA3C0069

C0075

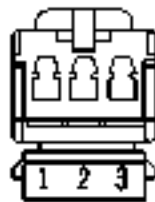

3 00

1	W
2	YP
3	G

CA3C0075

C0076

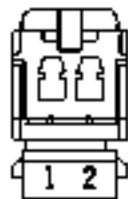



2 00

1	F
2	FP

CA3C0076

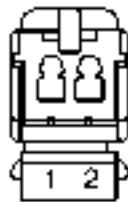
C0077



(2 - W) 

1	1
2	1A

CA3C0077

C0081

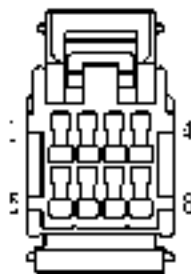



(8 - U) 

1	1L	5	NU
2	2L	5	U
3	3U	7	
4	4	5	

CA3C0081

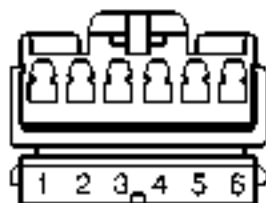
C0082





(6 - W) 

1	Y<	4	MB
2	Z<	5	R
3	Y>	6	

CA3C0082

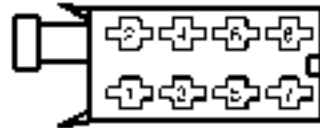

C0092

(8 - N) 

1	J	7	V
2	JB	6	10
3	A	7	3
4	AB	11	105

CA3C0092

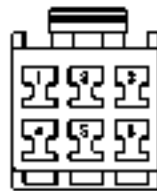

C0096

(6 - W) 

1	S	4	4W
2	PS	5	14/2
3	A.B	6	

CA3C0096

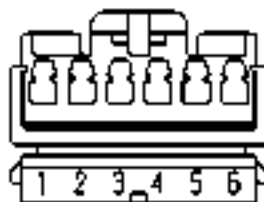
C0097L

(6 - W) 

1	KG	1	17
2	WV	5	115
3		11	111

CA3C0097L

C0097R

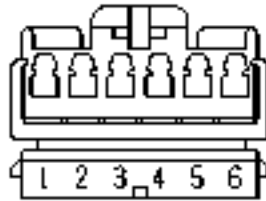

(6 - W)

1	BO	4	LV
2	VA	3	MU
3		2	MB

CA3C0097R

C0098

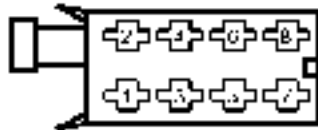

(8 - S)

1		5	SD
2	SC	4	KA
3		7	WE
4	P	6	B

CA3C0098

C0121

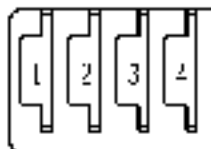

(4 - G)

1	F	3	RG
2	DF	4	GR

CA3C0121

C0123

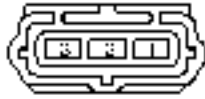

3 - P1 

1	WR
2	WR
3	WR

CA3C0123

C0125

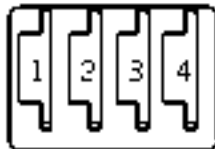

4 - S 

1	B	6W
2	WR	WR

CA3C0125

C0126

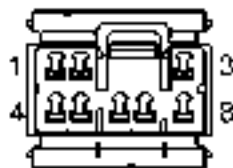

8 - W1 

1	WR	2	WR
2	WR	3	WR
3	WR	4	WR
4	WR	5	WR

CA3C0126

C0127

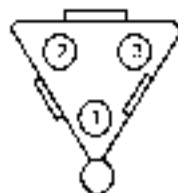

(3 - 1)

1	ALL
2	
3	

CA3C0127

C0128



(2 - 5)

1	ALL
2	6

CA3C0128

C0132



(5 - B)

1	4
2	3B
3	2A

CA3C0132

C0133



12 - P1

1	KJ
2	KA

CA3C0133

C0138

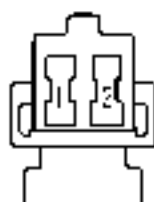

12 - P1

1	n
2	nJ

CA3C0138

C0139

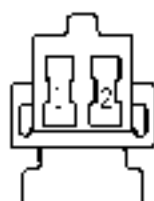

12 - P1

1	U
2	nJ

CA3C0139

C0149





15 - 31 

1	NC
2	NC
3	NC
4	A
5	LG

CA3CU149

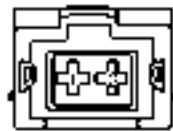
C0152





12 - 61 

1	A
2	B

CA3C00C152

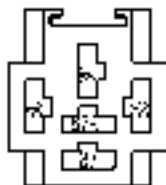
C0154L



10 - 61 

1	NC
2	NC
3	NC
4	A
5	LG

CA3C0154L

C0154R

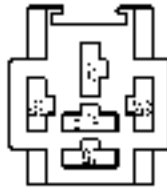

15 - B1



1	W0
2	GY
3	GR
4	W
5	

CA3C0154R

C0156

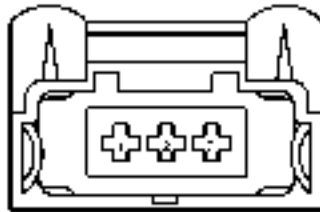

13 - B1



1	B
2	W
3	J

CA3C0156

C0157L



15 - B1



1	W0
2	GY
3	GR
4	W
5	

CA3C0157

C0157R

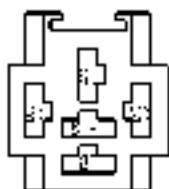

(5 - B)



1	WV, WU
2	W
3	WU
4	W
5	

CA3C0157R

C0162



(25 - B)



1	b	1	2K	11		1d	4K	22	4B
2	WU	1	2C	11	5c	12	K	21	2k
3	U2	6	4	L	2	19	2	24	OU
4	615	K	9B	11	25	10	4B	25	11-
5	12	2	2L	14	Y	20	2		
6	7h	2	72	17	251	11	2k		

CA3C0162

C0167



(2 - B)



1	WV
2	E

CA3C0167

C0168P



(3 - B)

1	Gv
2	HB
3	n

CA3C0168P

C0168D

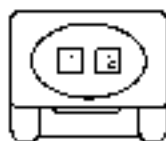

(2 - B)

1	n
2	v

CA3C0168D

C0175



(3 - B)

1	M
2	PE
3	~U2

CA3C0175

C0176

(3 - B) 



1	B
2	Σ ₀
3	Σ ₁

CA3C0176

C0182

(2 - U) 



1	Σ ₀
2	

CA3C0182

C0187D

(2 - S) 



	Σ ₀
2	Σ ₁

CA3C0187

C0187P

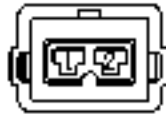

(2 - S)

1	49
2	

CA3C0187

C0195



(2 - B)

1	J
2	47
SCR	

CA3C0195

C0196P



(4 - S)

1	S	3	49
2	G	4	G.J

CA3C0196

C0196D

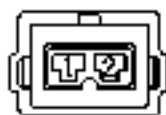

(2 - J)

1	49
2	52

CA3C0196D

C0203

(25 - B)



	C	E	NY	11	NG	16	20	23	25
1	YP	2	b	12	U	17	19	22	YD
3	U *	5	A	15	UP	18	BY	21	WN
4	BU	7	YS	14	Y	19	VL	24	LU
6	SS	10	Sp	13	KL	20	5	25	KV

CA3C0203

C0204

(4 - B)

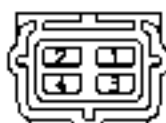

1	UE	3	2
2	BP	4	YU

CA3C0204

C0205

(4 - B)



1	UN	3	AP
2	UE	4	2

CA3C0205

C0209

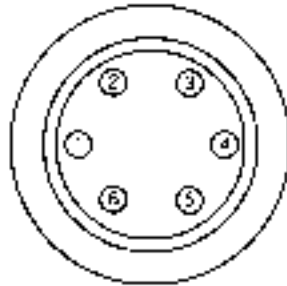

(6 - B)

1	MA	1	
2	KV	2	MA
3	UA	3	b

CA3C0209

C0215



(12 - B)

1	TA	5	B	6	TA
2	BY	6	BM	7	BY
3	AB	7	AV	8	AV
4		8	CP	9	BA

CA3C0215

C0216



(3 - B)

1	TA
2	AV
3	TA

CA3C0216

C0223

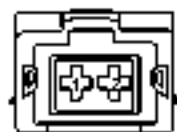

(2 - B)

1	6"
2	1011

CA3C0223

C0228



3 S

1	6"
2	10"
3	11"

CA3C0228

C0229

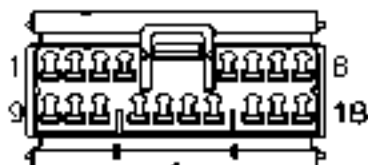

(18 - W)

1	B ₁	2	6"	3	P15	14	10"
1	10"	5	11"	11	15	15	K
2	F ₁	7	G ₁	11	15	16	1053
1	1 B	4	10"	12	22	17	10
2	17"	1	11"	13	2	16	10

CA3C0229

C0230

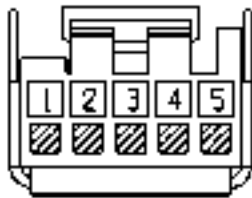
(5 - LTU) 

1	a	2	
2		3	W
3	b		

CA3C0230



C0231

(4 - 0) 

1	36	2	JB
2	76	3	K

CA3C0231

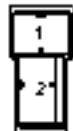
C0232

(2 - B) 

1	a
2	b

CA3C0232

C0233

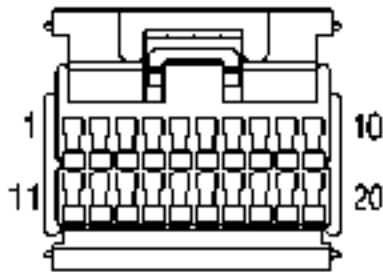

(20 - B)

1	2J	6	RA	10	S1	14	3
2	3J	7	B	11	RV1	15	4
3	CD	8	BD	12	SG	16	DC
4	P	9	V	13	T	17	UJ
5	LU	10	BP	14	LV	18	V

CA3C0233

C0238



(2 - W1)

1	B
2	B

CA3C0238

C0239

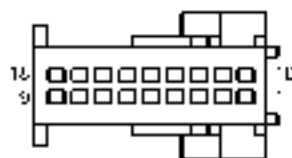

(16 - B)

1	CA	7	CP	13	
2	AY	8	DP	14	
3		9		15	
4	S-	10		16	KA
5	CP	11	DL	17	CP
6		12		18	F

CA3CU239

C0240

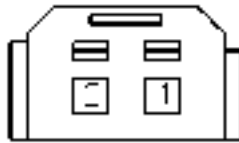

(2 - G)

1	GA
2	R

CA3C0240

C0243



(14 - B)

H	GP	K	LA
I	T	L	LU
F	N	M	PL
F	UC		SDH

CA3C0243

C0244



(6 - I)

1	UB	4	
2	UB	5	
3	UL	6	BC

C0252(2 - P) 

1	G
2	-25

CA3CU252

C0254(2 - P) 

1	V
2	TM

CA3C0254

C0256

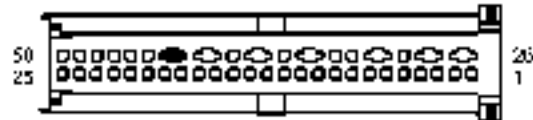

(50 · 1)

1	D	11	20	21		21		21
2	OK	12		22		22		22
3	HK	13	A	23		23	B	23
4	K	14	20	24	LO	24		24
5	Q	15	OK	25	20	25		25
6	F	16	20	26		26		26
7	YU	17	20	27		27	20	27
8		18	20	28		28		28
9	W	19	20	29		29		29
10	K	20		30		30		30

CA3C0256

C0257





(12 · 6)

1	K
2	K

CA3C0257

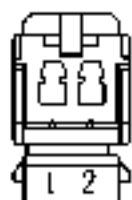
C0262





(2 - R) 

1	R
2	WB

CA3C0262

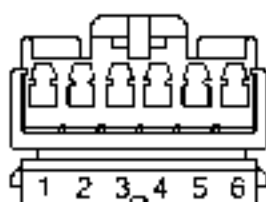
C0272



(6 - W) 

1	U	1	30
2	V	2	14
3	W	3	50

CA3C0272

C0272



(2 - B) 

1	BW
2	B

CA32C0272

C0277

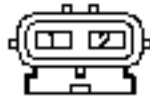

(2 -)

1	WU
2	

CA32C0277

C0278

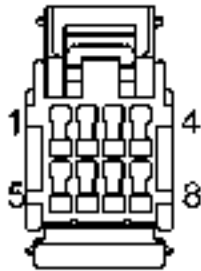

(8 - B)

1	TR	5	LTC
2	SUC	6	S
3	CP	7	WV
4	LD	8	LGZ

CA3C0278

C0280



(2 - B)

1	B+
2	B

CA3C0280

C0302L

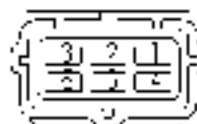

16 W 

1	B	A	PK
1	C	A	A
2		B	JK
2	C	B	K
2	D	C	FK

CA3C0302L

C0302R

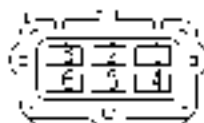



16 B; 

1	B	A	PK
1	D	A	A
2		B	JK
2	D	B	A
2	B	B	PK

CA3C0302R

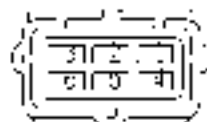
C0304L



16 R; 

1	B	A	JK
1	DK	A	YK
2	DK	C	B

CA3C0304L

C0304R



(6 W)

1	2	3	YS
4	20	5	Y1
3	30	6	3

CA3C0304R

C0308

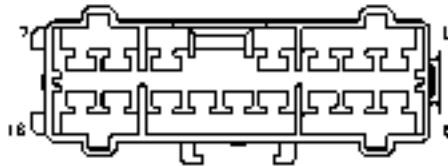

(16 L3)

1	20	6	2W	11	
2	112	7	2W1	12	
3	122	8	2W2	13	2W
4	33	9	F	14	FB
5	25	10	FE	15	7

CA3C0308

C0310

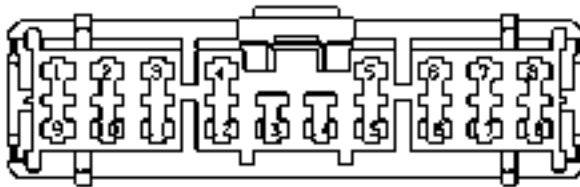

(16 L3)

1	2F	6	FW	11		17
2	12	7	W1	12		17
3	2E	8	13V	13	LN	18
4	12	9	"	14	JE	
5	25	10	FE	15	VF	

CA3C0310

C0319L



(13 B)

1	1	6	b	11	U
2	2	7		12	P
3	3	8	22	13	A
4	4	9	2		
5	Y	10	2F		

CA3C0319L

C0319R



(13 B)

1	2	6	E	11	O
2	3	7		12	C
3	4	8	22	13	W
4	L	9	2E		
5	Y	10	2F		

CA3C0319R

C0350

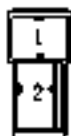

(2 - B)

1	B
2	B

CA3C0350

C0355

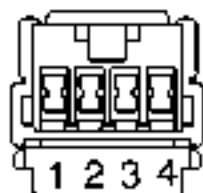

(4 - B)

1	B	2	B
3	B	4	B

CA3C0355

C0356

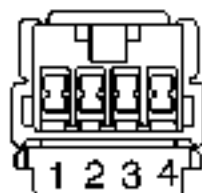

(4 - B)

1	B	3	B
2	B	4	B

CA3C0356

C0357

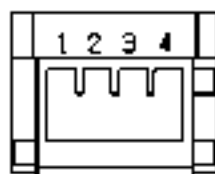

(4 - B)

1	B	3	B
2	B	4	B

CA3C0357

C0358

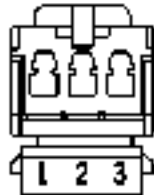

(3 - 71)

1	U1
2	B
3	V

CA3C0358

C0359

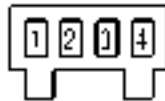

(4 - B)

1	2b	3	4c
2	1	2	

CA3C0359

C0369L



(2 - B)

1	Gr
1	-B
1	V1
2	Ab
2	-
2	Ar

CA3C0369L

C0369R



(2 B) 

1	GW
1	YE
1	RD
2	DB
3	W
4	W

CA3C369R

C0388



(3 B) 

1	n
2	DC
3	CA

CA3C0388

C0411

155 - B)



1	L	2	BY	3		22		24	V	25		27	BR	28	S
4	L	7	BC	10	BA	11		13		17	W	18	BA	19	A
14	D	10	A	12	BA	14	BS	15	YP	16	BR	18	F	20	
11	VJ	11	BY	13	S	15	SW	17		19	F	20		22	DU
1	B	12	V	14	S	15	UP	16	Yb	17	Yc	18	b	19	J
4	MS	11	MS	2	11	12	13	14	BY	15	BR	16		17	
1		12	E	13	P	14	15	16	S	17	BR	18	GR		

CA3C0411

C0417



12 - B1



1	UB
2	FA

CA3C0417

C0433(2 - R) 

1	3
2	4

CA3C0433

C0441L(2 - B) 

1	3
2	4

CA3C0441L

C0441R(2 - B) 

1	3
2	4

CA3C0441R

C0445L



2 E) 

1	972	2	11
1	983	2	115
1	1911	2	115

CA3C0445L

C0445R



2 E) 

1	972	2	6
1	983	2	115
1	1911	2	115

CA3C0445R

C0448

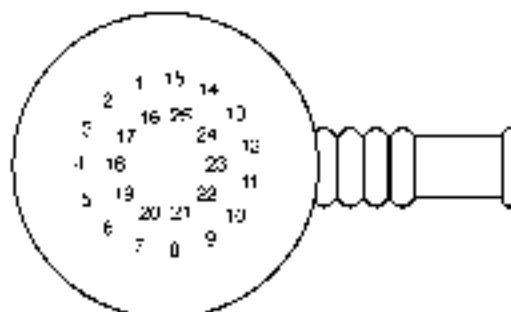

125 - 31

1	16	5	12	4	20	10	18	17	24	13	22	11
2	17	6	13	5	21	11	19	18	25	14	23	12
3	18	7	14	6	22	12	20	19	26	15	24	13
4	19	8	15	7	23	13	21	20	27	16	25	14
5	20	9	16	8	24	14	22	21	28	17	26	15
6	21	10	17	9	25	15	23	22	29	18	27	16
7	22	11	18	10	26	16	24	23	30	19	28	17
8	23	12	19	11	27	17	25	24	31	20	29	18
9	24	13	20	12	28	18	26	25	32	21	30	19
10	25	14	21	13	29	19	27	26	33	22	31	20
11	26	15	22	14	30	20	28	27	34	23	32	21
12	27	16	23	15	31	21	29	28	35	24	33	22
13	28	17	24	16	32	22	30	29	36	25	34	23
14	29	18	25	17	33	23	31	30	37	26	35	24
15	30	19	26	18	34	24	32	31	38	27	36	25
16	31	20	27	19	35	25	33	32	39	28	37	26
17	32	21	28	20	36	26	34	33	40	29	38	27
18	33	22	29	21	37	27	35	34	41	30	39	28
19	34	23	30	22	38	28	36	35	42	31	40	29
20	35	24	31	23	39	29	37	36	43	32	41	30
21	36	25	32	24	40	30	38	37	44	33	42	31
22	37	26	33	25	41	31	39	38	45	34	43	32
23	38	27	34	26	42	32	40	39	46	35	44	33
24	39	28	35	27	43	33	41	40	47	36	45	34
25	40	29	36	28	44	34	42	41	48	37	46	35

CA3C0448

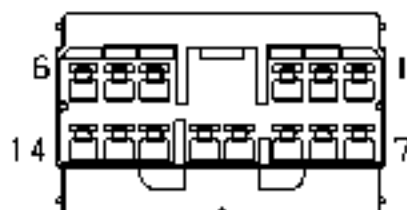

C0467



14 - 14

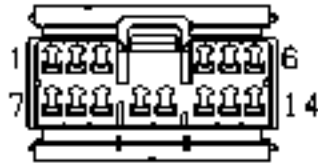

1	10	5	20	15	30
2	11	6	21	16	31
3	12	7	22	17	32
4	13	8	23	18	33
5	14	9	24	19	34

C0469

(14 - W) 

1	11	12	13	14	15
2	16	17	18	19	20
3	21	22	23	24	25
4	26	27	28	29	30
5	31	32	33	34	35

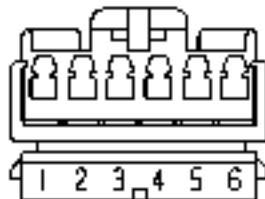
C0475L

(6 - Y) 

1	BY	4	U1
2	AY	5	U2
3		6	U3

CA3C0475L

C0475R

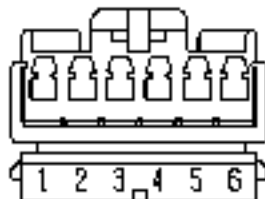
(6 - Y) 

1	BY	4	UR
2	AY	5	UR
3		6	UR

CA3C0475H

C0489

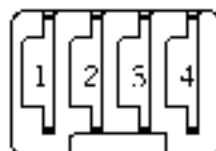

(4 - G)

1	W	Y	
2	W	-	W

CA3C0489

C0490

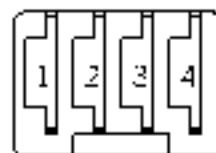

(4 - G)

1	W	Y	
2	W	Y	Y

CA3C0490

C0491

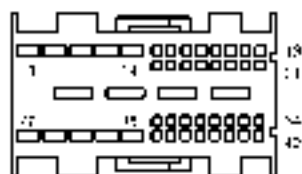

(12 - B)

1	LS	11	AK	27	tb	21	
2	RS	12	AS	28	A	22	V
3	YS	13	N	29	W	23	U
4	RS	14		30	FS	24	OH
5	F	15	WB	31		25	BLG
6	S	16	YS	32	YB	26	LSB
7	S	17	OS	33	UK		
8		18	RF	34	AL		
9	F	19	YS	35	Y		
10	RS	20	UG	36	YS		
11	WS	21	US	37			
12	SW	22	US	38			

CA3C0491

C0492

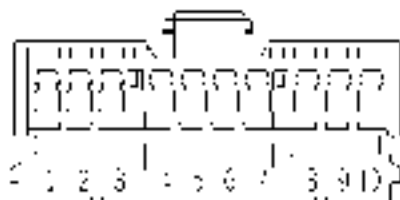

(10 - G)

1	YS	7	S
2	OH	8	
3	SW	9	SB
4	OS	10	YS
5	F	11	RF

CA3C0492

C0496



(2 - B)

1	S
2	PLS

CA3C0496

C0494



(2 - W)

1	CP	2	GN
2	CP	3	GN

CA3C0494

C0495



(2 - W)

1	FP
2	1

CA3C0495

C0496



(2 - E)

1	B
2	FL0

CA3C0496

C0499

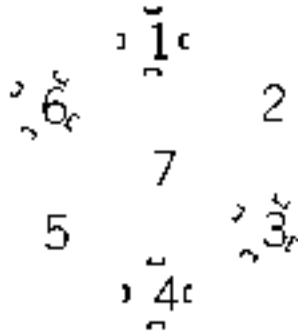

17 - B:

1	v	5	L
2	J	6	R
3	w	7	8
4	r		

CA3C0499

C0501



13 - B:

1	LM	5	SK	11	BJ
2	ab	6	SK	12	LJ
3	R	7	K	13	CS
4	W	8	SK		
5	TK	9	SK		

CA3C0501

C0502

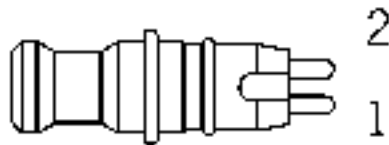

12 - 1:

1	B
2	C

CA3C0502

C0503

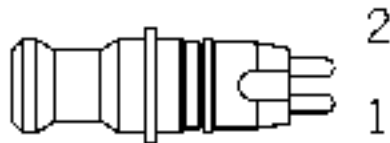

(2 - 1)

1	2
2	1

CA3C0503

C0504

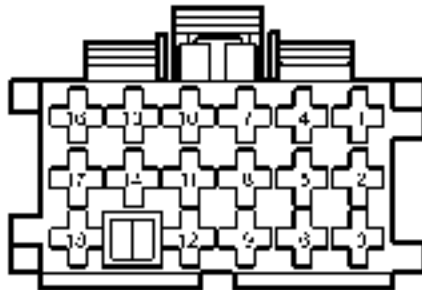

(15 - B)

1	PH	7		11	SC	16	
2	A	2	7F	12	B	17	AK
3	MG	8	MR	13		18	BS
4	RF	3		14	DF		
5	N	15	SR	15			

CA3C0504

C0505

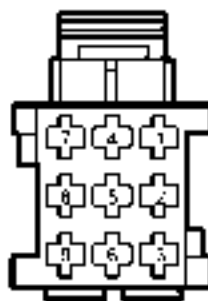

(9 - B)

1	C	d	A	7	K
2	D	G	B	H	L
3	F	E	G	N	

CA3C0505

C0506

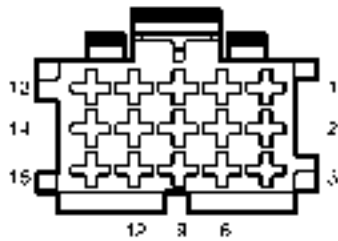

(1) B)

1	SN	F	SR	11		12	SC
2	SN	F		11	21	14	SD
3	B	-	SD	11	22	15	SE
4	SD	F	2	12	21		

CA3C0506

C0507



(1) B)

1	KR
2	B

CA3C0507

C0513



(1) B)

1	Pr
2	B

CA3C0513

C0514



2 W:

1	W
2	b

CA3C0514

C0516

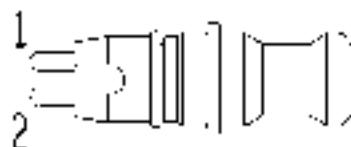

2 W:

1	W
2	b

CA3C0516

C0517

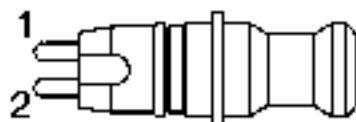

2-1

1	W
2	n

CA3C0517

C0519L With Memory

(18 - W) 

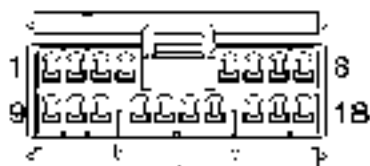

1	VE	7		13	RG
2	FG	8	WG	14	RG
3	UP	9	J	15	FG
4	A	10	SG	16	
5		11	PG	17	A+
6	SV	12	LR	18	BA

CA3C0519L

C0519R With Memory

(18 - W) 

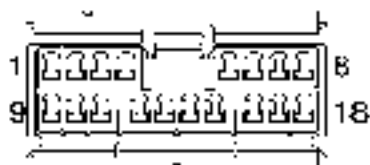

1	VE	7		13	RG
2	FG	8	WG	14	RG
3	UP	9	J	15	FG
4	A	10	SG	16	
5		11	PG	17	A+
6	SV	12	LR	18	BA

CA3C0519
R

C0519L Without Memory

(18 - W) 



1	A	7	V	13	G
2	A	8	W	14	CG
3	G	9	W	15	CG
4	S	10	B+	16	KG
5	U	11		17	YS
6	SR	12	BS	18	EW

CA3C0519L

C0519R Without Memory(18 - W) 



1	F	2	V	12	G
2	A	3	Wb	14	LC
3	B	4	A	15	BU
4	B	5	BP	16	AG
5	U	11		17	Yb
6	CP	12	RC	18	RY

CA3C0519R

C0520(2 - B) 

1	FV
2	B

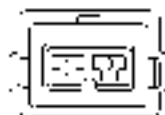
CA3C0520

C0522(4 - B) 

1	YJ
2	YD

CA3C0522

C0523

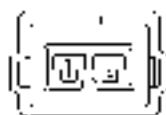

2 - B

1	YN
2	NU

CA3C0523

C0524

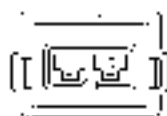

2 - B

1	YN
2	NU

CA3C0524

C0525



2 - B

1	YN
2	NU

CA3C0525

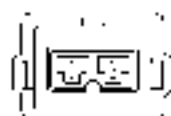
C0526

12 B

1	V2
2	W2

CA3C0526

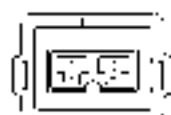
C0527

12 B1

1	V5
2	W5

CA3C0527

C0528

2 B1

1	V3
2	W3

CA3C0528

C0529

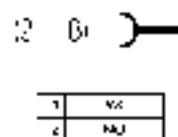
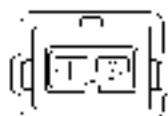

CA3C0529

C0530L

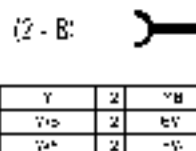

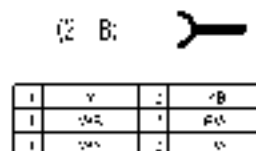

CA3C0530L

C0530R

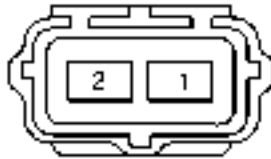

CA3C0530R

C0540

(2-W) 

1	rd
2	rn

CA3C0540

C0570

(8-S) 

1	LN	7	LN
2	rd	8	UN
3	RN	7	RN
4	UN	7	UN

CA3C0570

C0571

(8-M) 

1	G	6	LC-3
2	UN	6	UN
3	UN	7	UN
4	UN	8	UN

CA3C0571

C0572

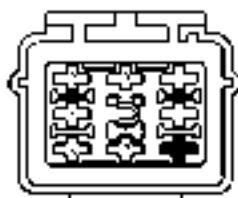

(8 - 4)

1	MP	5	J
2	LP	6	
3	MO	7	PK
4	PO	8	Y

CA3C0572

C0573



(8 - U)

1	MC	5	PN
2	NC	6	PN
3	VC	7	PN
4	WC	8	N

CA3C0573

C0574



(8 - Y)

1	PLG	5	PN
2	P	6	PN
3	PLG	7	PN
4	Y	8	PN

CA3C0574

C0575



(8 - P)

1	YN	r	NY
2	U	r	UR
3	A	r	UA
4	L	r	UL
5	W	r	

CA3C0575

C0576



(8 - G)

1	UJ	r	UJG
2	RG	r	URG
3	G	r	UG
4	U	r	URG

CA3C0576

C0577



(8 - R)

1	NR	n	
2	NR	n	NY
3	RY	r	
4		n	U

CA3C0577

C0607

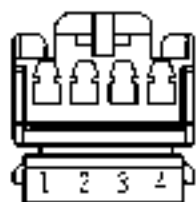

(4 - W) 

1	DN	3	PA
2	DP	4	RA, RA1

CA3C0607

C0608

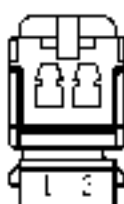

(2 - W) 

1	PA
2	I

CA3C0608

C0609



(2 - B) 

1	E
2	~00

CA3C0609

C0613

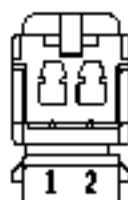

12 - W

1	W
2	W

CA3C0613

C0615



13 - B1

1	W
2	W
3	

CA3C0615

C0616

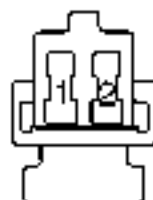

12 - B1

1	W
2	W

CA3C0616

C0617



(2 - B) 

1	a
2	b

CA3C0617

C0620



(2 - U) 

1	a
2	b

CA3C0620

C0626



(3 - B) 

1	a
2	b
3	B

CA3C0626

C0627



(2 · B)

1	a
2	b

CA3C0627

C0634



(9 · B)

1	w	4	e	7	10
2		1	e	4	NO
3		a	b	2	

CA3C0634

C0635

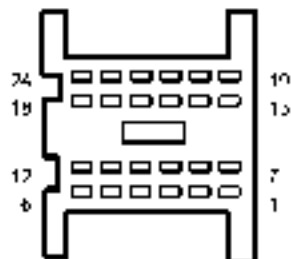

(24 · B)

1	W	7	W	13	W	19	W
2		1	RE	14	U	20	
3		4	KB	15	U	21	
4		11	KE	16	J	22	SR
5		17	KE	17	-	23	SR
6		12		18	VE	24	SR

CA3C0635

C0636

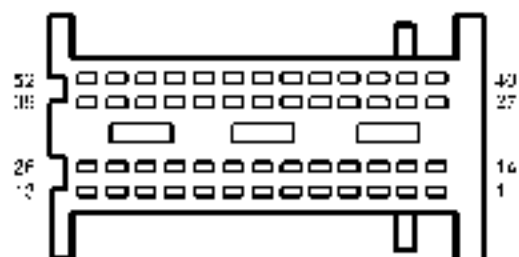

(52 - B) 

1	20	4	46	17	B	25	28	15		41	YJ	31	49
2	32	11	6	14		26		2	3,5	42	LS	23	
3	NR	1		15		27	NR	17		43	RD	27	
4	KJ	L		12	21	28	6	28	NR	11	DL	22	
5		L		21	NR	29		27		45	B		
6	RU	L	YH	22	UL	30	27	28		46	KJ		
7	R	17	25	23	LC	31	24	29		47			
8		16	NR	24	UL	32	D	27	YH	48			

CA3C0636

C0637

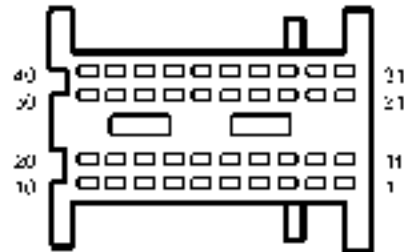

40 - Pin

1		2		3	11	4		5		6		7		8		9		10		11	YK	12	YK
2		4	LN	11	64	2		3	AN	12		4		5	21	24		25		26	24	24	24
3		4	F	11		6		7		13		14		15	22	24		25		26	24	24	24
4		11	64	12	64	12		13	Y	24		25		26	24		25		26	24	24	24	24
5		17		17	2	22		23		23	24		25	24		25		26		26	24	24	24
6		12	US	14		24		24		24		25		26	24		25		26	24	24	24	24

CA3C0637

C0638



9 - Pin

1		2		3	24
2		4	B	24	24
3		6	24	24	24

CA3C0638

C0641

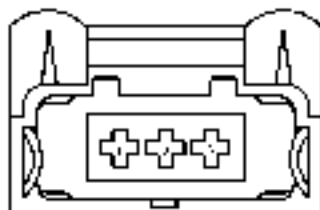

(3 - LS) 

1	RG	2	RG
2	Y	3	Y

CA3C0641

C0642



(4 - S) 

1	RG	2	Y
2	Y	4	RG

CA3C0642

C0643



(4 - S) 

1	RG	2	Y
2	Y	4	RG

CA3C0643

C0644



(4 - 3)



1	NE
2	U
3	W
4	ZK

CA3C0644

C0645



(4 - 5)



1	W	1	WY
2	U	2	NE

CA3C0645

C0646



(3 - 5)



1	BK
2	
3	KK

CA3C0646

C0652



(2 - W) 

1	GC
2	SP

CA3C0652

C0666



(2 - W) 

1	b
2	VS

CA3C0666

C0667

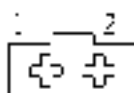

(2 - W) 

1	b
2	VS

CA3C0667

C0672

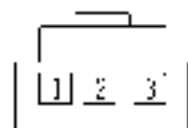

6 - A

1	N/A
2	
3	0

CA3C0233

C0673

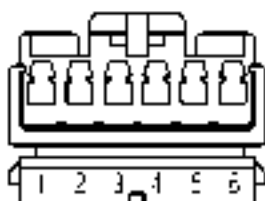

12 - W

	1	2	3
1	10	11	12
2	20	21	22

CA3C0673

C0675



112 - B

1	10	11	12	20	21
2	20	21	22	30	31
3	30	31	32	40	41
4	40	41	42	50	51

CA3C0675

C0683



(8 - B) 

1	K3	1	6A
2	K4	6	
3	K1	7	EP
4	K2	8	EE

CA3C0683

C0684

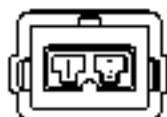



(2 - B) 

1	B
2	B

CA3C0684

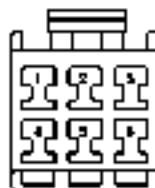
C0685



(6 - N) 

1	B, B	4	
2	B1	5	EP
3	B2	6	G

CA3C0685

C0686



(2 - U)



1		R	
2		BP	

CA3C0686

C0686L



(2 - B)



1	YB	1	1
1	YD	1	6A
1	YD	2	6A

CA3C0686L

C0686R



(2 - B)



1	YB	1	1
1	YD	2	6A
1	YD	2	6A

CA3C0686R

C0690

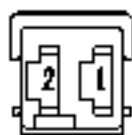

(2 - B)

1	B
2	CR

CA3C0690

C0697



(12 - B)

1	P	2	GA	3	Py
2	B	4	CR	5	GA
3	Py	7		11	z
4	Py	1		12	

CA3C0697

C0698 (MY 1999)

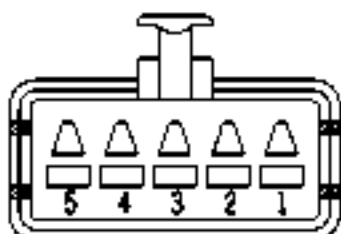

(5 - B)

1	WY	4	
2	z	5	
3			

CA3CU698

C0698 (MY 2000)

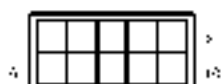

(10 - B)

1	GA	h	
2		7	
3	WY	8	
4	CR	9	
5	z	10	B

C0726L

2 - R1 

1	RD	2	CR
1	GR	2	GP
2	VR	2	GR

CA3C0726L



C0726R

2 - R1 

1	RD	2	CR
1	GR	2	GP
1	VR	2	GR

CA3C0726R

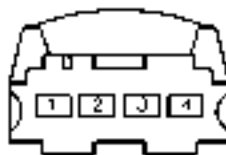
C0731

(4-N) 

1	RR	1	PR
2	VR	4	SR

CA3C0731

C0732L

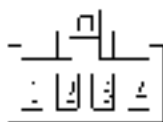

14 W

1	14	1	B
2	30	2	Bh

CA3C0732L

C0732R

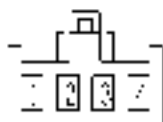

14 W

1	14	1	B
2	30	2	Bh

CA3C0732R

C0736

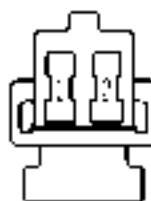

12 - 31

1	G
2	r

CA3C0736

C0737

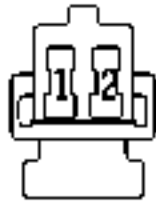

2 (1)

1	V
2	R

CA3C0737

C0745

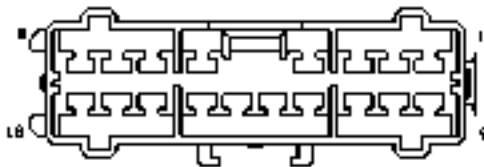

(18 - 18)

1		2	21C	11	22	11	
2	22			12	11	11	
3	12	4		13	11	11	
4	12		12	14	11	11	
5	12	1	12	15	22	11	

CA3C0745

C0746

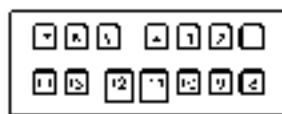

(14 - 14)

1	11	1	11	11	11
2	11	2	11	11	11
3	11	3	11	11	11
4	11	4	11	11	11
5	11	5	11	11	11

CA3C0746

C0748

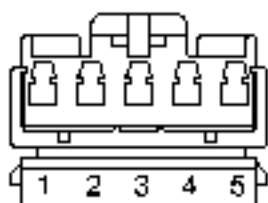

(5 - B)

1	B	4	GG
2		5	
3			

CA3C0748

C0749



(6 - W)

1	B	4	GN
2	HW	5	GY
3	B	6	DD

CA3C0749

C0754

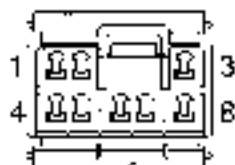

(8 - W)

1	W	5	W*
2	W*	6	R
3	B	7	B*
4	B	8	

CA3C0754

C0756L

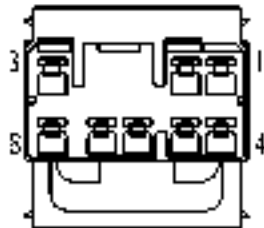

(8 - W)

1	VP2	5	#7J2
2	VP2	6	5
3	5	7	5-6r
4	5	4	

CA3C0756L

C0756R

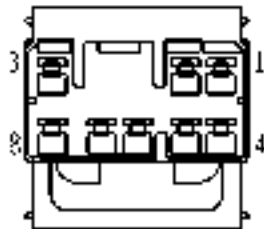

(8 - W)

1	VP2	5	#7J2
2	VP2	6	5
3	5	7	5-6r
4	5	4	

CA3C0756R

C0772

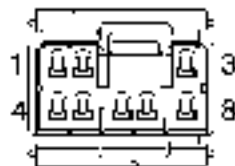

(8 - W)

1	VP2	5	AJ25
2	VP2	6	5
3	5	7	5r
4	5	4	

CA3C0772

C0787L

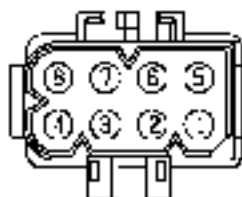

18 · 8



1	47	11	15
2	75	9	
3		7	
4	92	4	8

CA3C0787L

C0787R

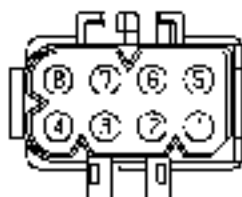

18 · 8



1	47	11	15
2	75	9	
3		7	
4	92	4	8

CA3C0787R

C0789

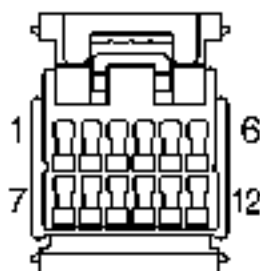

18 · 8



1	21	2	47	11	15
2	21	11	47	11	15
3	21	7		11	15
4	41	7		11	

CA3C0789

C0791

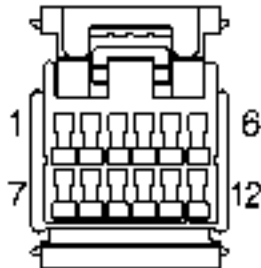

(12 - B)

1	C-	7	NC	6	BD
2	R	7	R	10	AK
3	L	7	NC	11	DF
4	LV	8	W	12	W

CA3C0791

C0792

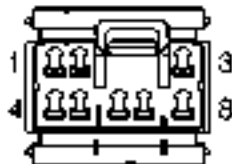

(8 - W)

1	W	7	NC
2	PH	7	FW
3	A	7	DS
4	B	8	FS

CA3C0792

C0793

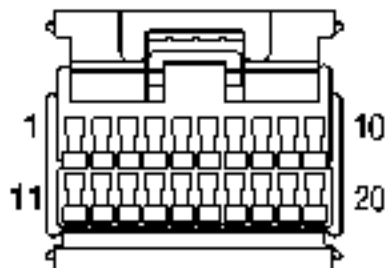

(20 - B)

1	C	ND	11	C	14	CV
2	GO	7	LGP	12	LE	AP
3		8	NY	13	CS	SW
4	CV	8	NJ	14	FG	FS
5	7	10	EW	15	N	DT

CA3C0793

C0797

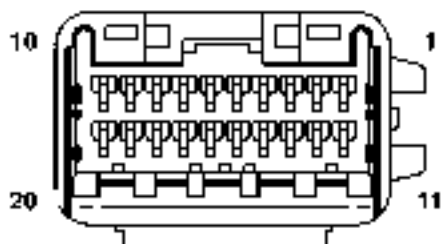

(20 - B)

1	11	12	13	14	15	16
2	2	GF	17		18	19
3	4	147	12		16	18
4	3		13		15	17
5	11		15		14	16

CA3C0797

C0820

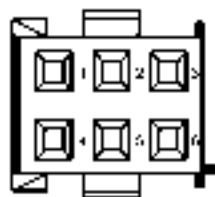

(6 - B)

1	1W	2	1
2	11	3	WK
3	11	4	

CA3C0820

C0834

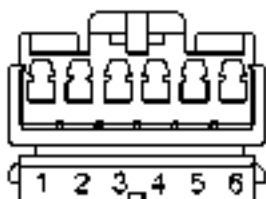

(6 - W)

1	De	1	Se
2	U	2	1
3	C	3	B
4	1	4	1

CA3C0834

C0844



(4 - B)

1	GW	2	14
1	1	4	11
2	11		

CA3C0844

C0845

(2 - 3) 

1	VB
2	GN

CA3C0845

C0853

(4 - 8) 

1	VB	2	
3	GN	4	8

CA3C0853

C0854

(4 - 8) 

1	VB	3	LU
2	GN	4	8

CA3C0854

C0855

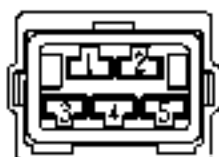

(5 - B) 

5	R
2	bV
1	b+
3	b-
4	L

CA3C0855

C0861



(3 - B) 

3	b+
2	b-
1	Us

CA3C0861

C0865





(3 - B) 

3	b+
2	b-
1	Us

CA3C0865

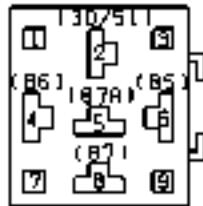

C0866

(9 - 8) 

1		4	4	1	
2	FB	5	BA	2	7G
3	BP	6	7	3	

CA3C0866

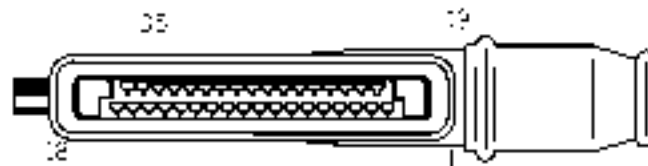
C0867

(35 - 8) 

1	20	4		11	67N	16	6P	27	10P	37	6P3	47	6P
2	25	5	14	12	8	17	26K	22	10A	28	14	12	10
3	16	6	15	13	10A	18	6	23	11P	24	14P	13	15A
4	10K	9	05	14	64	19		24	14	25		24	20
5	02	10	GB	15	15	20	26K	21	15A	22	1	26	14.2

CA3C0867

C0868



(6 - W)

1	4B	1	1M
2	2B	4	2Y
3	3B	3	3A
4	5B	2	

CA3C0868

C0870



(3 - B)

1	GP
2	GP
3	GP

CA3C0870

C0871



(12 - B)

1	15A	2	15B	11	11
2	15C	7	20	12	20
3	15D	4	15G	13	20
4	15E	5	20		
5	15F	6	6		

CA3C0871

C0873

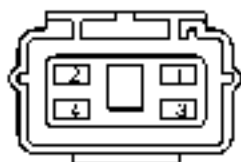

(4 - 2)

1	2	3	4
2	4	3	1, 1

CA3C0873

C0874

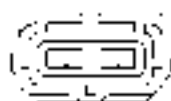

(2 - 2)

1	2
2	1

CA3C0874

C0875



(3 - 3)

1	2	3
2	3	1
3	1	2

CA3C0875

C0877

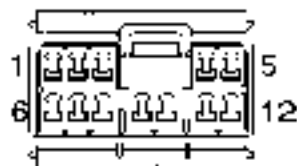

(12 - G)

1	W	7	W
2	WR	8	W
3	RY	9	WR
4	EW	10	WC
5	WL	11	RY
6	WU	12	WU

CA3C0877

C0879



(2 - B)

1	R
2	R

CA3C0879

C0880

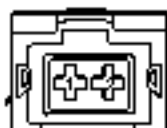

(2 - S)

1	RS
2	RS

CA3C0880

C0881

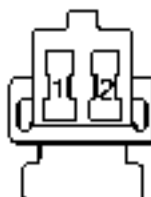

(2 - B)

1	WR
2	RY

CA3C0881

C0882

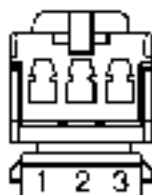

(3 - W)

1	WR
2	
3	WU

CA3C0882

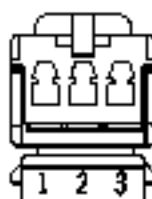
C0883

(3 - W)

1	B2
2	
3	W1

CA3C0883

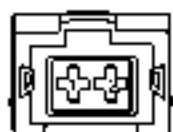
C0884

(2 - D)

1	D3
2	W5

CA3C00C0884

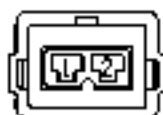
C0890

(2 - J)

1	J4
2	W7

CA3C00C0890

C0891

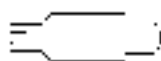

(8 - B)

1	RS		
2	R		

CA3C0891

C0893

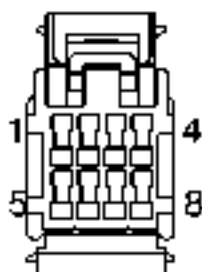

(8 - B)

1	LV	1	RD
2	RV	2	RV
3	W	3	B
4	JA	4	LV

CA3C0893

C0894



(6 - W)

1	R	1	W
2	RV	2	RV
3	YS	3	YS

CA3C0894

C0895P

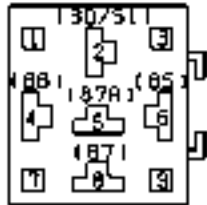

(9 - B)

1		4	GR	Y	
2	PV	7	VC	N	W
3		8	B		

CA3C0894P

C0895D

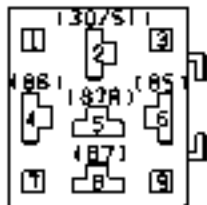

(9 - B)

1		6	YI
2	B	7	
3		8	W
4	CV	9	
5	VC		

CA3C0895D

C0903

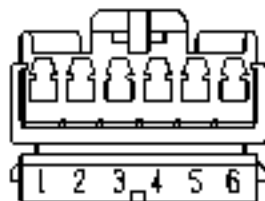

(6 - W)

1	GR	3	U1
2	VF	4	U2
3	CV	5	W
4	W	6	

CA2C0903

C0921

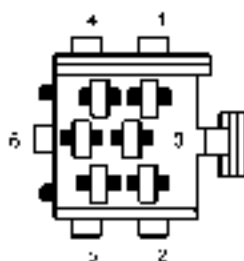

(6 -)

1	C	J	
2	K	J	115
3	P	V	-
		W	

C0922

CA2C0921

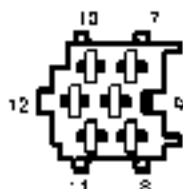

(8 - G)

1		H		S	
2		S		H	15
3		-		H	
4		T		H	

C0923

CA3C0922

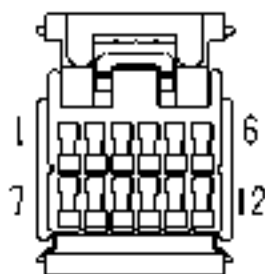

(12 - B)

1	U	S		Q	V10
2	Q	K		III	
3	W	-		II	6
4	W	R		II	6

C0925

CA2C0923

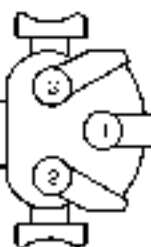

(3 - B)

-	P
V	F
1	4.5

CA2C0925

C0941

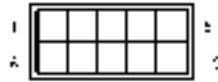

10 R1

1	W	J		E	B	0	h
2	B	S	U	T	U	2	
3	C					11	P

CA3C0941

C0948



12 Y1

1	NC
2	AT

CA3C0948

C0949



12 Y1

1	NC
2	SP

CA3C0949

C0950



13-Y:

1	1
2	2
3	3

CA3C0950

C0951



13-Y:

1	
2	2
3	3

CA3C0951

C0959

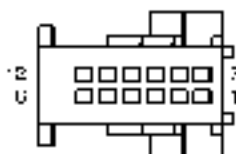

12-B:

1	6	5	13	4
2	8	7	14	15
3	10	9	16	11
4	12	11	12	

CA3C0959

C0974L

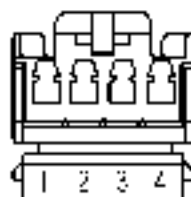

14-W:

1	10	2	11
2	9	3	

CA3C0974L

C0974R

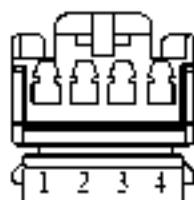

14 - W1



1	0P	1	000
2	05	4	

CA3C0974R

C0977

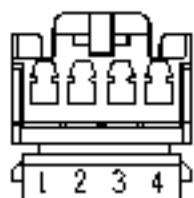

14 - W1



1	03	2	
2	00	2	

CA3C0977L

C0980L

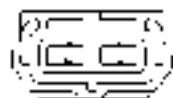

12 - B1



1	0F		
2	n		

CA3C0980L

C0980R

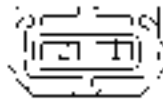

12 01

1	K
2	b

CA3C0980R

C0988

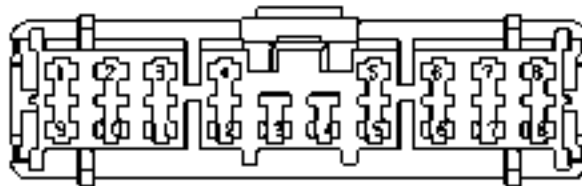

18 151

		1	11	16	
2	FG	2	12	FG	17
3	UE	3	13	N	18
4	DE	4	14	V	
5	LB	5	15	d	

CA3C0988

C0989

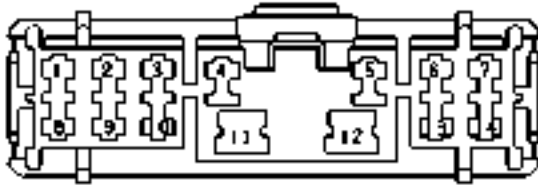

14 - LS:



1	MF	7	GA	11	RF
2	DM	8	I	12	RP
3	KL	9	U	13	GN
4	KP	10	V	14	Y
5	AS	11	2		

CA3C0989

C0993

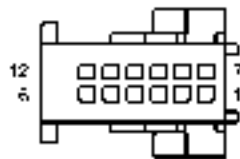

(12 - 8):



1	P	5	J	9	TA
2	AS	6	AS	10	
3	S	7	BA	11	
4	ES	8		12	

CA3C0993

C0992

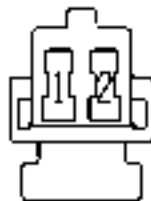

2 - G1:



1	B
2	F

CA3C0992

C1038



2 - W1:



1	B
2	V

CA3C1038

C1254

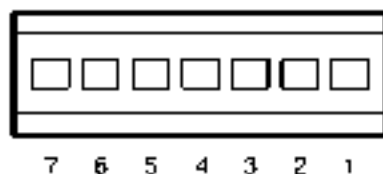

(7 - W) 

1	PE	5	YB
2	LN	4	RG
3	R	1	PE
4	GN		

CA3C1254

C1258



(2 - B) 

1	G
2	B

CA3C1258

C1276



(10 - W) 

1	LN	6	WB
2	PE	7	B
3	PE	8	W
4	GN	9	W
5	L	10	

CA3C1276

C1277

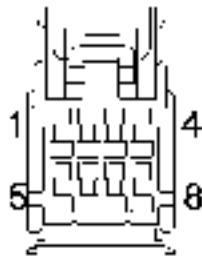

18 - B:

1	P	7	G
2	UV	5	JU
3	HS	3	RY
4	SA	1	K

CA3C1277

C1278

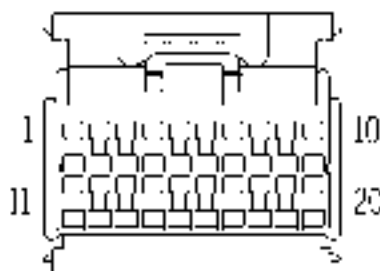

120 - 9:

1	LC	6	VS	17	VF	12	WG
2	DA	7	DP	12	UV	17	WB
3	-	4	LS	11	DB	14	LSB
4	JU	5	DP	14	RY	11	-
5	LG	10	VR	15	LU	21	-

CA3C1278

C1279

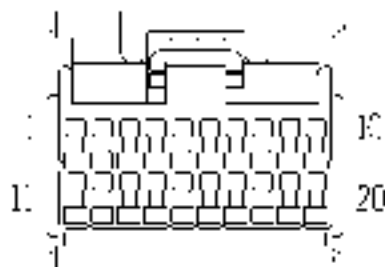

120 - 9:

1	VA	6	VS	17	VF	12	WG
2	-	7	DP	12	UV	17	WB
3	HS	4	LS	11	DB	14	LSB
4	VG	5	DP	14	RY	11	-
5	-	10	VR	15	LU	21	-K

CA3C1279

C1280

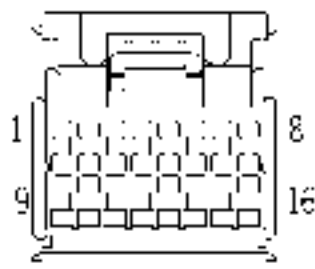

05 - Y

1	LC	2	GC	3	DL	4	WR
5	BA	6	FA	7	KG	8	RG
9	LS	10	DF	11	LC	12	DA
13	WU	14	Y	15	DR	16	Y

CA3C1280

C1281

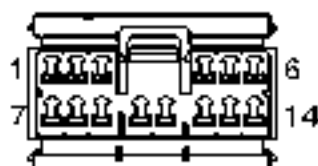

04 - Y

1	W	6	BA	11	WR
2	FA	7	FA	12	LR
3	FR	8	LS	13	LR
4	BU	9	W	14	WR
5	WR	10	Y		

CA3C1281

C1282

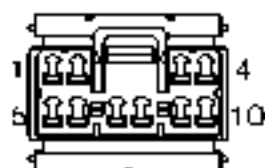

03 - Y

1	LU	6	WR
2	WR	7	WR
3	JS	8	LS
4	BA	9	WR
5	LF	10	Y

CA3C1282

C1283

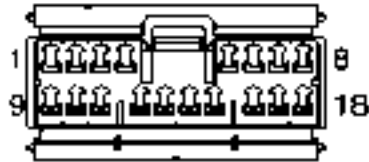

18 - S



1	EV	5	Q4	1	RF	17	RJ
2	10A	2	OC	15	GP-CP	12	7
3	PV, EV	3	3	13	19	18	4
4	EW	4	EN	11	DT		
5	WU	11	HP, HA	14	U		

CA3C1283

C1284

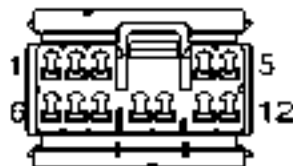

12 - S



1	AK	2	CS	11	WP
2	RF	11	RF	1	3
3	RF	7	CS	11	RM
4	P	1	RB	12	RJ

CA3C1284

C1285

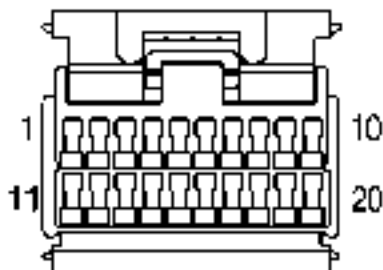

20 - L



1	U1	2	U1	11	UG	16	YJ
2	UP	1	Y	15	U1	17	RS
3	U1	2	DU	15	MS	18	
4	R1	2	R	12	VP	19	UG
5	UG	10	UG	17	UG	20	U1

CA3C1285

C1286

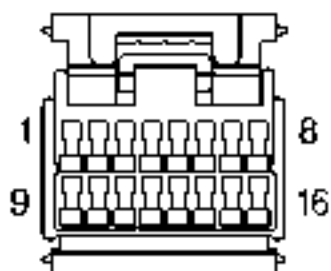

(16 - B)

1	17	2	BD	10	10B	15	
2	Y2	3	-K	11	M	16	2P
3	Y1	4	AO	12	Y	16	3V
4	PW	5	PO	13		17	1P

CA3C1286

C1287

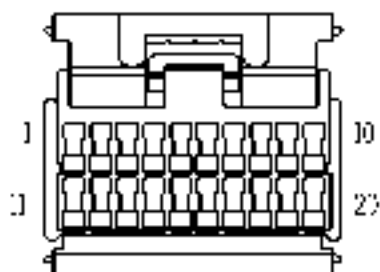

(20 - B)

1	GD	11	C
2	GG	12	K2
3	LY	13	F
4	NW	14	LG
5	Y1	15	17
6	GB	16	YS
7	VA	17	RL
8	LB	18	LG
9	7H	19	N
10	LP	20	WE
11		21	LV

CA3C1287

C1288

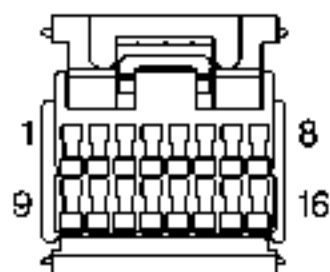

(16 - G)

1		4	3	6	4	15	7
2	3A	5		10	85	12	6V
3	20	7		11	86	15	
4	7	8	40-G	12		16	86

CA3C1288

C1289

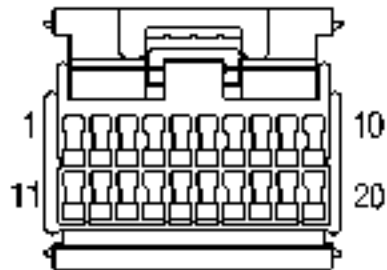

(20 - G)

1	16	K		11	Y2	16	67
2	WP	7	WA	12	AK	17	
3	4,6	8	PA	13		18	13.5
4		9	KA	14	2.9	19	5
5	10	10	CP	15	1.2	20	5

CA3C 1289

C1290

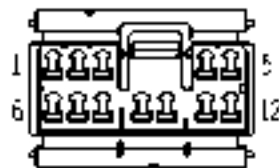

(12 - W)

1		7	6	8	
2	16	1	4K	10	
3		2	2	11	3.1
4	12	3	PL, PL	12	1.6

CA3C 1290

C1291

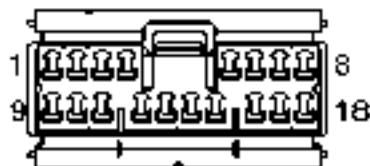

(18 - W)

1	10	6	6	7		14	2.1
2	5	7	PA	12	PA	17	CP
3	PP	8	PA	13	H	18	0
4	12	9	PA	14	1.7		
5	11	10	SD	15	0.5		

CA3C 1291

C1292

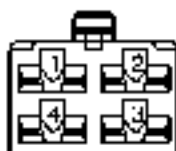

(4 - W)

1	YD	3	L
2	YV	4	-K

CA3C1292

C1293

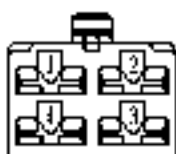

(4 - W)

1		3	
2		4	E, F

CA3C1293

C1319



136 - B)

1	AS	7	4A	14	K	15	31	25	AP	31	111	27	WV
2	AV	F		14	VA	26		27	BP	17	1-N	26	KW
3		D		15	GB	21	W	27		32	PL		
4	H	12		16		25		25	UN	34	J4 LN		
5	D	17		17	K2	21	F	21	B	31	1, K		
6		16		16		24	K	8	U	34	RU		

CA3C1319

C1320

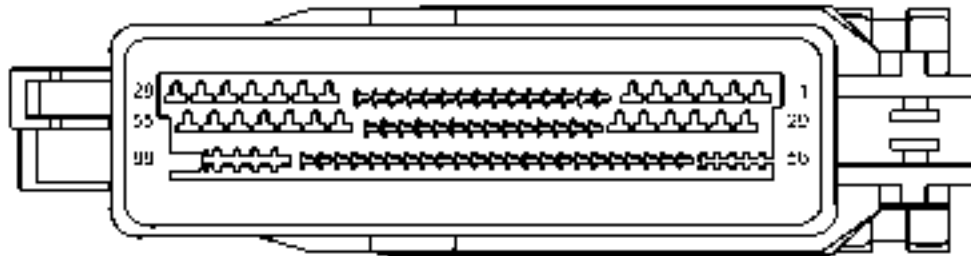

1		1		21		31		41	U	51		61		71
2		2	LV	24		34		44		54		64		74
3		3		25	VB	35	JS	45		55		65		75
4		4	SCM	26	W	36	UC	46		56		66		76
5	CA	5	B	27		37		47		57		67		77
6	A	6		28	S	38		48		58		68		78
7		7		29		39		49	Y	59	R	69		79
8	LF	8		30	CP	40		50		60		70		80
9		9		31	RC	41	E	51	DU	61		71		81
10		10		32	AI	42		52	A	62		72		82
11		11		33	CG	43	Y	53		63		73		83

CA3C1320

C1321

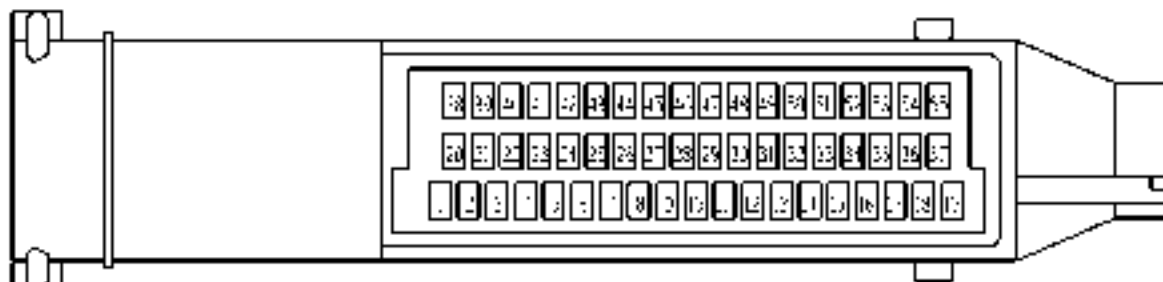

153 - 81 

1	1A	1		15	15A	15		28	28A	28		41		54	54A
2	2A	2		16	16A	16		29	29A	29		42		55	55A
3	3A	3		17		17	20A	30	30A	30		43		56	
4		4		18		18		31	31A	31		44	44A	57	57A
5	5A	5		19	19A	19	21A	32	32A	32		45		58	58A
6	6A	6		20	20A	20		33		33		46		59	59A
7	7A	7	7B	21		21		34		34	37A	47		60	60A

CA3C0193

C1322

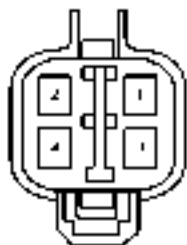

4 - (1)



1	5K	3	1K
2	9K	4	LL

CA3C1322

C1343



3 - (1)



1	n
2	CP
3	PE

CA3C1343

C1345

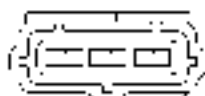

3 - (1)



1	n
2	15A
3	15B

CA3C1345

C1346



(2 - B)

1	GN
2	P

CA3C1346

C1349

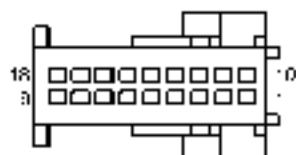

(8 - B)

1	1	2	11	15	
2		3		14	20
3	GN	4		13	26
4	Y	5	9	12	35
5	P	10		17	
6	1	16	7	18	

CA3C1349

C1350

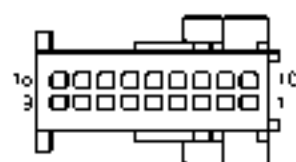

(8 - R)

1	GN	7		15	20
2	Y	8	35	14	
3	W	3	26	13	
4	U	12	Y	12	4Y
5		11		17	11
6		16	7	18	2

CA3C1350

C1354

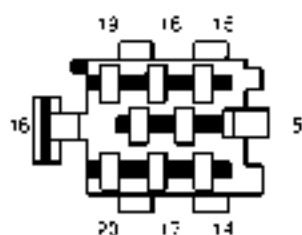

(20 - J)

1			11	16	5
2	1		14	17	8
3	8		12	18	11
4	2		14	15	6
5	10		12	14	11

CA3C1354

C1357

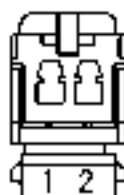

(2 - W)

1	LP
2	W

CA2C1357

C1358

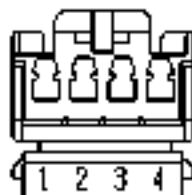

(4 - W)



1	S	3	NC
2	12	4	121

CA3C1358

C1359



(4 - W)



1	U	2	4
2	R	3	

CA3C1359

C1360

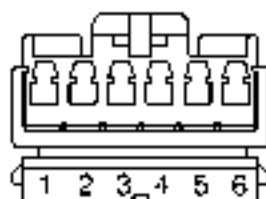

(6 - W)



1	Δ	1	W
2	ΔL	2	BC
3	RF	3	PK
4	RG	4	BC

CA3C1360

C1361

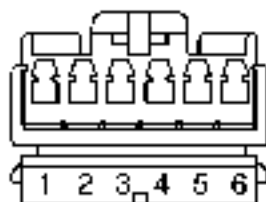

(6 - W)

1	Y4	4	h
2	R4	5	3
3	V5	6	2K

CA3C1361

C1362

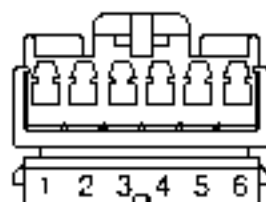

(6 - Y)

1	S	5	SP
2	2D	6	100
3	T	6	P
4	3P	6	W-

CA3C1362

C1363

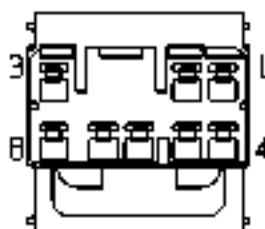

(8 - W)

1	V	6	3
2	V5	6	2C
3	G	7	SE
4	2E	8	V1

CA3C1363

C1364

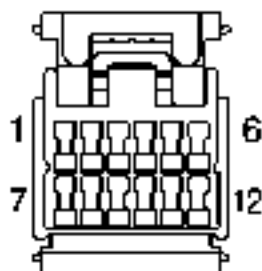

(12 - B)

1	V	3	CG	3	
2	Y5	6	SS	10	-
3	LU	7		11	
4	R	8	25	12	VL

CA3C1364

C1365

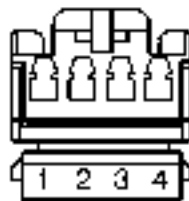

(A - W)

1	B	S	PS
2	W	A	B

CA3C1365

C1366

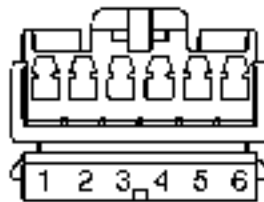

(S - Y)

1	US	4	Y
2	V	5	W
3	FD	6	FK

CA3C1366

C1367

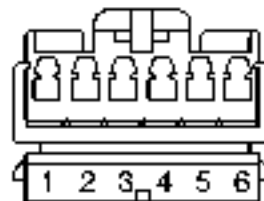

(G - S)

1	-	5	2Y
2	YH	6	1U
3	-E	4	
4	W	7	3Y

CA3C1367

C1368

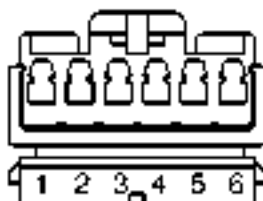

(S - W)

1	T	2	S
2	N	3	LU
3	W	4	UE

CA3C1368

C1369

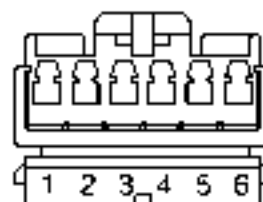



(S - Y)

1	GR	5	FW
2	U	6	YS
3	KG	7	SN
4	JS	8	ML

CA3C1369

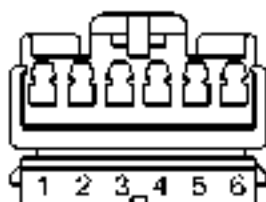
C1370



(6 - S) 

1	NR	4	C
2	PN	5	C
3	PT	6	CK

CA3C1370

C1371

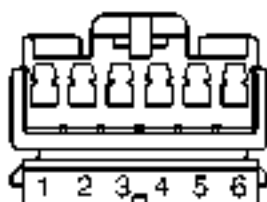

(6 - Y) 

1	S	5	NR
2	CK	6	PT
3	C	4	PN
6	PT	3	Y

CA3C1371

C1372

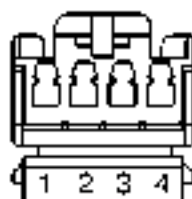

(4 - W) 

1	C	3	PC
2	PC	4	C

CA3C1372

C1373

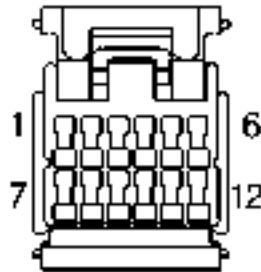

112 - BI

1	B	4	13	1	GB
2	B2	11	38	11	-
3	14	7		12	
4	B	1	13	17	11

CA3C1373

C1374

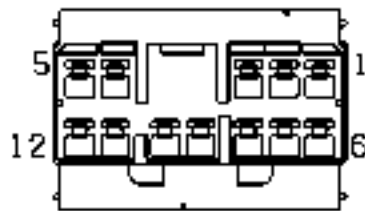

112 - WI

1	W	7	15
2	WB	7	13
3	W	5	50
4	GB	11	7
5	W	11	10
6	WB	11	15
7	W		

CA3C1374

C1375

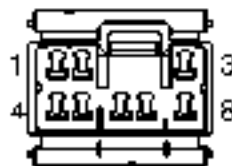

(8 - W)

1	W	7	17
2	WB	7	
3	W	7	21
4	W	7	17

CA3C1375

C1376

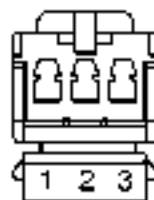

(3 - W)

1	WB
2	B.15
3	W

CA3C1376

C1376

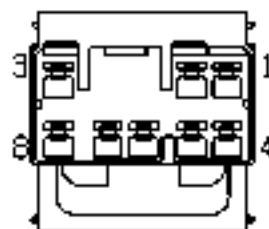

(8 - W)

1	W	5	1
2	WB	5	
3	W	5	4
4	W	5	5

CA3C1376

C1377

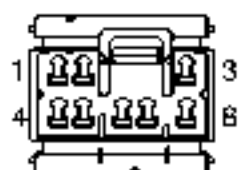

(8 - W)

1	V	5	C
2	VE	6	DE
3	U	7	DU
4	US	8	

CA3C1377

C1378

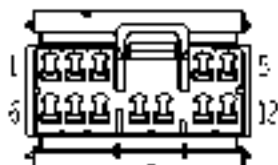

(12 - W)

1	V	7	ED
2	VE	8	EDr
3	U	9	EDC
4	US	10	F
5	U	11	UD
6	US	12	UP
7	-0		

CA3C1378

C1379

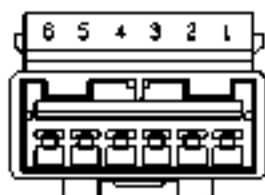

(6 - Y)

1	UG	4	V
2	R	5	UL
3	UC	6	UG

CA3C1379

C1380

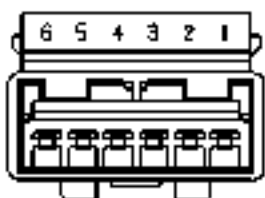

(6 - S)

1	WV	5	UV
2	V	6	US
3	UV	7	USr
4	UV	8	US

CA3C1380

C1381

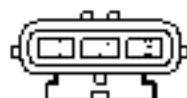

(3 - B)

1	U
2	U
3	H

CA3C1381

C1382

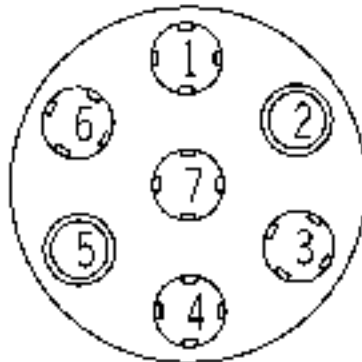

(7 - S)

1	2	3	
4		5	P
6		7	
8			

CA3C1382

C1383L

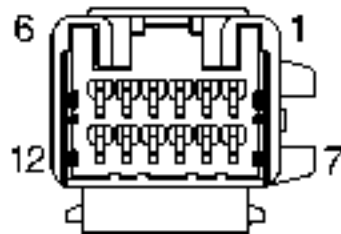

(12 - B)

1	2	3	4	5	6
7	8	9	10	11	12
1	2	3	4	5	6
7	8	9	10	11	12

CA3C1383L

C1383R

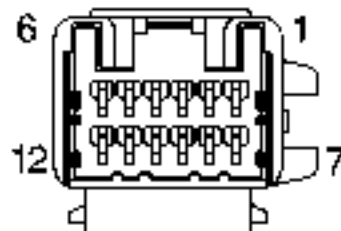

(12 - B)

1	2	3	4	5	6
7	8	9	10	11	12
1	2	3	4	5	6
7	8	9	10	11	12

CA3C1383R

C1384L



(4 - W)

1	2	3	4
1	2	3	4

CA3C1384L

C1384R



(4 • W) 

1	5	3	10
2	PU	2	6, 5

CA3C1384R

C1385L

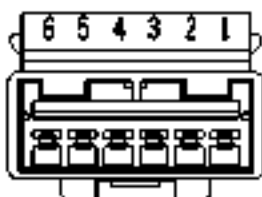

(6 • S) 

1	11	4	K
2	12	5	C
3	12	6	DK

CA3C1385L

C1385R



(6 • S) 

1	12	4	K
2	12	5	C
3	12	6	DK

CA3C1385R

C1386L

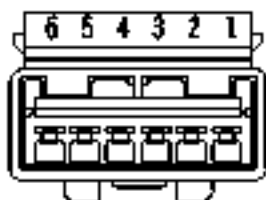

16 W:

1	0	4	Pa
1	12	4	B2
2	16	5	B4
3	UG	6	SC

CA3C1386L

C1386R

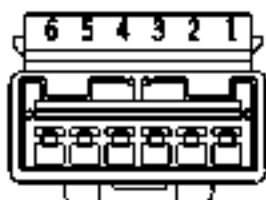

16 W:

1	0	5	Pa
1	12	4	B2
2	UG	5	B4
3	16	6	B2

CA3C1386R

C1387L



16 W:

1	0	7	Pa
2	20	7	UW
3	7	8	P
4	17	8	GU

CA3C1387L

C1387R

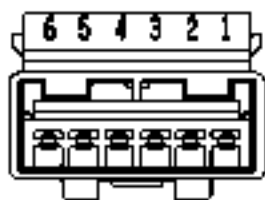

(5 - 4)

1	S	11	SB
2	SB	11	LEA
3	B	11	P
4	SB	11	SB

CA3C1387R

C1388



(3 - 3)

1	E
2	R
3	B

CA3C1388

C1389



(4 - 0)

1	V	1	B
2	L	1	G

CA3C1389

C1390

(3 - B)

1	U
2	U
3	R

CA3C1390

C1391

(3 - W)

1	B
2	SP
3	RJ

CA3C1391

C1401

(3 - W)

1	W
2	W
3	W

CA3C1401

C1402



(2 - W) 

1	W1
2	1

CA3C1402

C1403





(3 - W) 

1	WJ
2	1
3	W3

CA3C1403

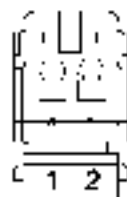
C1404



(2 - W) 

1	W1
2	1

CA3C0248R

C1405L

(2 - B) 

1	FR
2	R

CA3C1405L



C1405R

(2 - B) 

1	FR
2	R

CA3C1405R

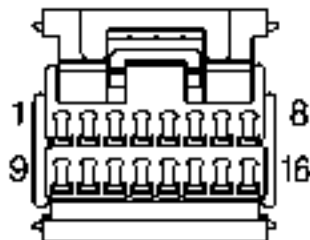
C1406

(16 - B) 

1	BU	1		2	E	1	LC
2	NC	2	BU	3	FB	2	R
3	FU	3	B	4	B	3	CU
4	NR	4	CU	5	F	4	SN

CA3C1406

C1407L

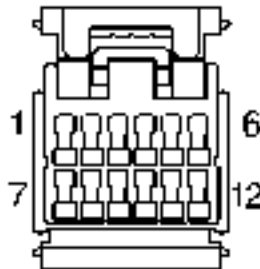



(12 - B) 

1	Y	4	2H	1	
2	H	5	U	10	A
3	..	2	4	11	P
4		4	U	12	B

CA3C1407L

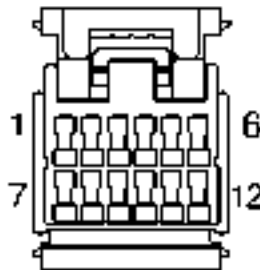
C1407R



(12 - B) 

1	Y	5	2H	1	
2	H	6	U	10	A
3	L	2	2	11	P
4		4	U	12	B

CA3C1407R

C1415

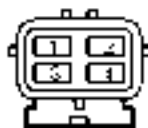

(4 - B) 

1	Y
2	J
3	W
4	V

CA3C1415

C1416



2 - B)

1	b
2	P
3	b

CA3C1416

C1421



6 - B)

1	CS	5	W
2	JR	6	OK
3	CS	K	KB

CA3C1421

C1422



6 - W)

1	GR	4	CS
2	JR	7	OK
3	GR	7	PW

CA3C1422

C1423



6 W

1	R	3	LE
2	RD	5	SD
3	J	6	

CA3C1423

C1424

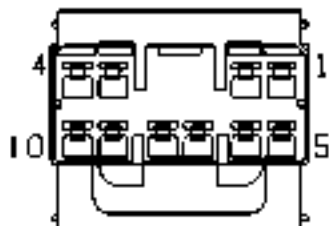

6 W

1	1	6	1A
2	ME	7	Y
3	1	8	
4	UP	9	1B, 2
5	SA	10	1G, 7

CA3C1424

C1425L

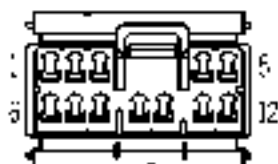

12-6

1	W	7	BT	9	Y
2	G	8	Y	10	
3	RP	9	1a	11	2L
4	J	10	1A, 2	12	2R

CA3C1425L

C1425R

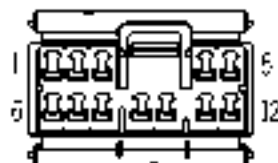

12-6

1	LG	8	1E	9	Y
2	L	9	Y	10	
3	YH	10	1a	11	2L
4	U	11	1A, 2	12	2R

CA3C1425R

C1427L

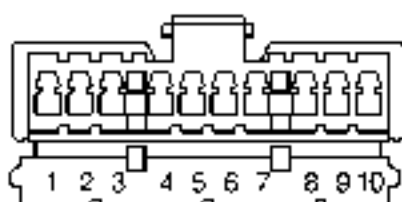

(10 - W)

1	2V	1	3
2	12B	2	4
3	3A, 3A	3	5B
4	12B, 12B	4	Y
5	P	11	Y2

CA3C1427L

C1427R

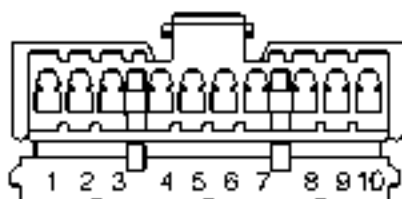

(10 - W)

1	2V	1	3
2	12B	2	4
3	3A, 3A	3	5B
4	12B, 12B	4	Y
5	P	11	Y2

CA3C1427R

C1429

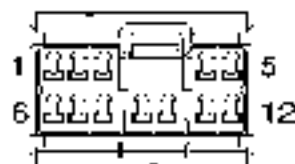



(12 - S)

1	AV	1	3A	1	6
2	AV	6	2A	2	6
3	W	7	11A	3	
4	12B	11		12	11W

CA3C1429

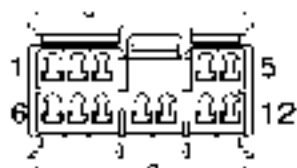
C1430



(12 - S) 

1	F	2	6A	4	3
2	F	3	6A	5	4
3	6A	4	6	6	
4	6A	5		7	6

CA3C1430

C1432



(3 - S) 

1	B
2	W

CA3C1432

C1433



(3 - S) 

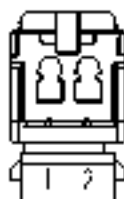

1	B
2	WF

CA3C1433

C144212 - W1 

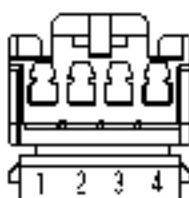

1	RG
2	FG

CA3C1442

C144412 - W1 

1	S	2	2P
2	U	3	4

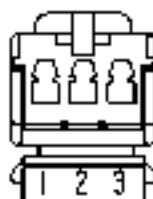
CA3C1444

C1445L13 - W1 

1	RG
2	A
3	U

CA3C1445L

C1445R

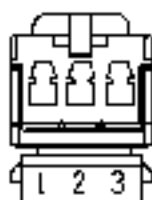

3 - W

1	3
2	4
3	5

CA3C1445R

C1487L

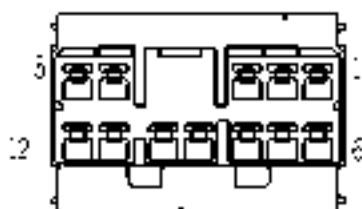

12 - W

1	1A	1	2B	4	
2	U	6	V	10	
3		7		11	ES
4		8	W, T	12	EP

CA3C1487L

C1487R

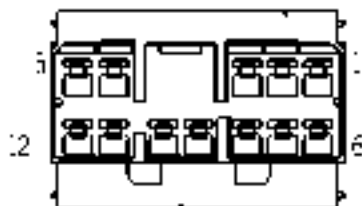

12 - W

1	1A	1	2B	4	
2	U	6	V	10	
3		7		11	ES
4		8	W, T	12	EP

CA3C1487R

C1488L

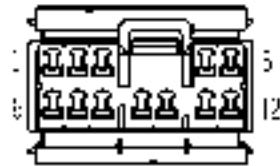

(12 - 6)



1	UG	5	YS	4	
2	G	6	V	13	
3		7		11	BS
4		8	N, K	12	FS

CA3C1488L

C1488R

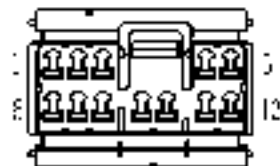

(12 - 6)



1	UG	6	YS	4	
2	G	5	V	13	
3		7		11	BS
4		8	N, K	12	FS

CA3C1488R

C1490

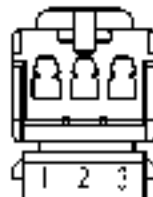

(3 - 3)



1	H
2	FS
3	LY

CA3C1490

C1502

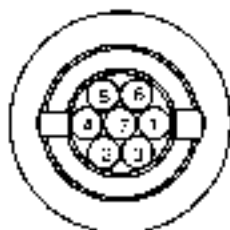

(6 - P)

1	M	5	W
2	S	4	S
3	V	3	W
4	L		

CA3C1502

C1503



(2 - B)

1	W
2	B

CA3C1503

C1505



(2 - R)

1	b
2	Ua

CA3C1505

C1506



(2 - B)

1	F
2	R

CA3C1506

C1548

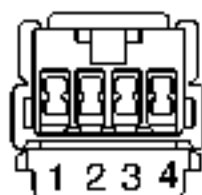

(4 - B)

1	W	3	W
2	W	4	B

CA3C1548

C1563

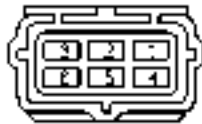

(6 - B)

1	6	4	U
2	5	3	V
3	4	2	W

CA3C1563

C1564



(6 - B)

1	6W	4	-U
2	-	3	-V
3	6S	2	6U

CA3C1564

C1565



(6 - W)

1	2W	4	U
2	V	3	W
3	2S	2	3U

CA3C1565

C1568

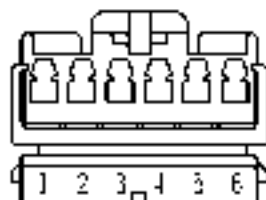

(6 - Y)

1	1G	4	Y
2	1F	3	-U
3	1A	2	1V

CA3C1568

C1569

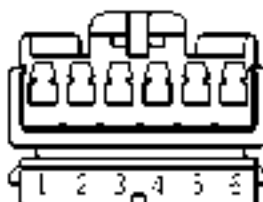

(6 - S)

1	F	3	6S
2	6A	2	6S
3	6B	4	1A
4	6V	1	6B

CA3C1569

C1570

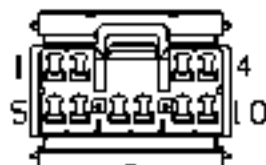

(10 - W) 

1	-	6	CG
2	RB	7	-
3	-	8	-
4	BB	9	LF
5	UB	10	LG

CA3C1570

C1571

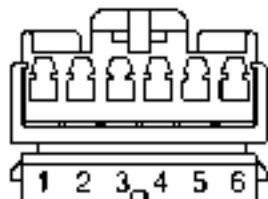



(6 - W) 

1	U	4	JU
2	RB	5	EB
3	U	6	-

CA3C1571

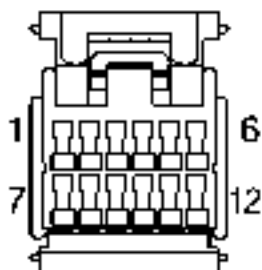
C1576



(12 - G) 

1	U	6	UB
2	RB	7	U
3	UGF	8	UB
4	UR	9	UB

CA3C1576

C1577L



(2 - B) 

1	CG
2	UB

CA3C1577L

C1577R



(2 - B) 

1	CG
2	UB

CA3C1577R

C1578

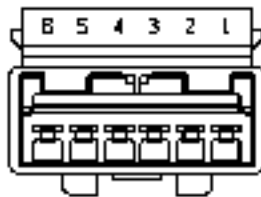

(6 - W)

1	C	2	D
2	E	3	JG
3	2E	4	JB

CA3C1578

C1579

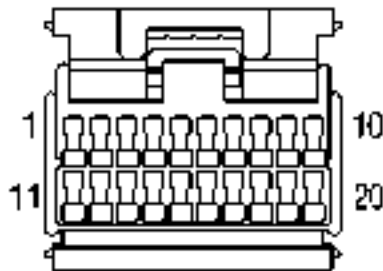

(20 - B)

1	CA	2	AC	11	P	16	
2	4C	3	2A	12		17	
3		4	UB	13		18	
4		5		14		19	
5	GA	6		15		20	

CA3C1579

C1580

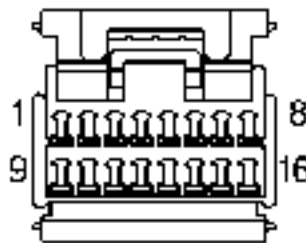

(16 - B)

1	BU	2		11	B	16	UJ
2	BR	3	2A	12	2E	17	F
3	PD	4	B	13	P	18	JG
4	2R	5	2A	14	P	19	2W

CA3C1580

C1583

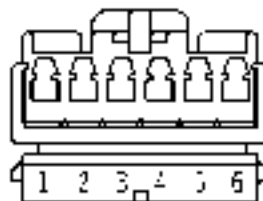

(6 - W)

1	2	3	4
2	2A	3	B
3	2E	4	JG

CA3C1583

C1584

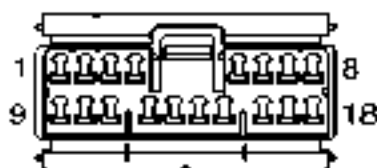

(18 - S)

1	2V	2	US	12	2J
2	JG	3	O	13	2A
3	2V, 2V	4	C1, 2A	14	2V
4	2A	10	2W, 2A	17	2A
5	2	11	2E	18	2
6	2A	12	2V, 2E	19	2

CA3C1584

C01584

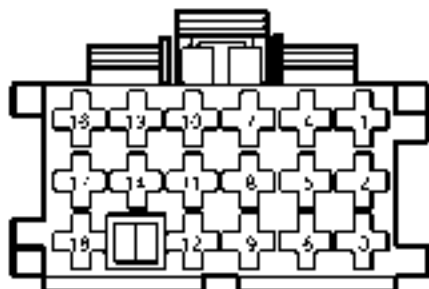

(18 - B)

1	N6	1		11	Y6	17	
2	V6	2	VF	12	Y	17	W6
3	Y2	3	NT	13		17	25
4	Y6	4		14	GP		
5	K	5	3-N	15			

CA3C1584

C1585

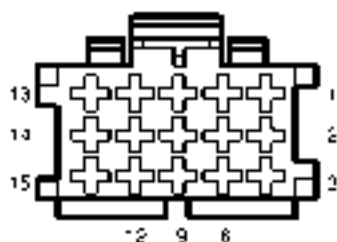

(15 - B)

1	2N	1	2A	11		15	22
2	2A	2		12	2P	16	25
3	1	3	2A	13	1A	17	21
4	2A	4		14	2A		

CA3C1585

C1585

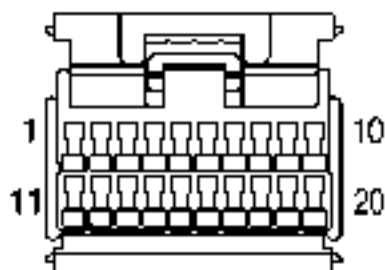

(20 - U)

1	U	1	U-1	11	Y2	16	YL
2	2P	2	Y	12		17	6A
3	2A	3	20	13	2A	18	
4	2A	4	A	14	2P	19	U5
5	2A	5	20	15	2A	20	

CA3C1585

C1586

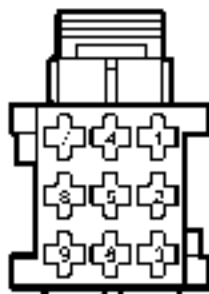

(9 - B)

1	U	4	A	7	Y
2	2	4	A	A	1
3	Y	7	A	2	

CA3C1586

C1586

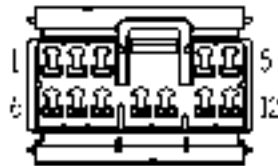

12 - S;

1	W	1	SD	2	AP
2	VS	6	11	12	2
3	HE	7	US	13	M4
4	F	8	VR	14	PJ

CA3C1586

C1587



2 - W;

1	M4
2	

CA3C1587

C1587

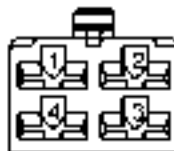

(4 - S);

1	YD	3	G
2	WJ	4	FX

CA3C1587

C1588



(2 - B);

1	M4
2	AP

CA3C1588

C1590

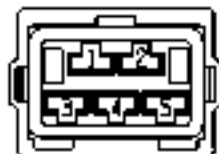

3 - B;

1	2	4	bW
2	2*	5	E
3	bU		

CA3C1590

C1591



(13 - 6)

1	2N	P	5N	11	5U
2	2E	T	5I	12	6U
3	3	S	6	13	7P
4	3V	V	8V		
5	CC	V	10		

CA3C1591

C1593



(4 - 3)

1	NU	J	LU
2	NU	J	P

CA3C1593

C1594





(2 - 6)

1	P
2	P

CA3C1594

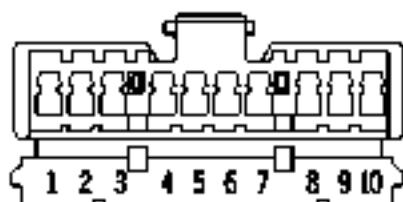
C1621

119 A1 

1	B	C	D
2	BW	F	
3	U	A	G
4	6V	J	BV
5	K	H	G

CA3C1621

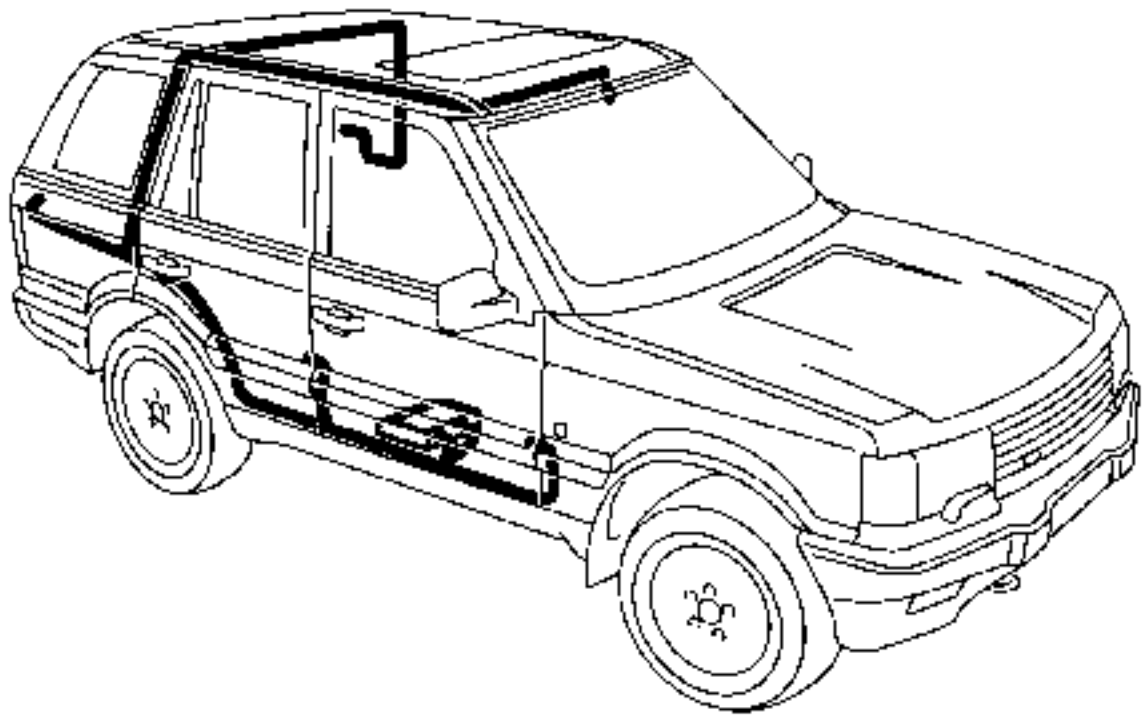

RH Body Wire Harness

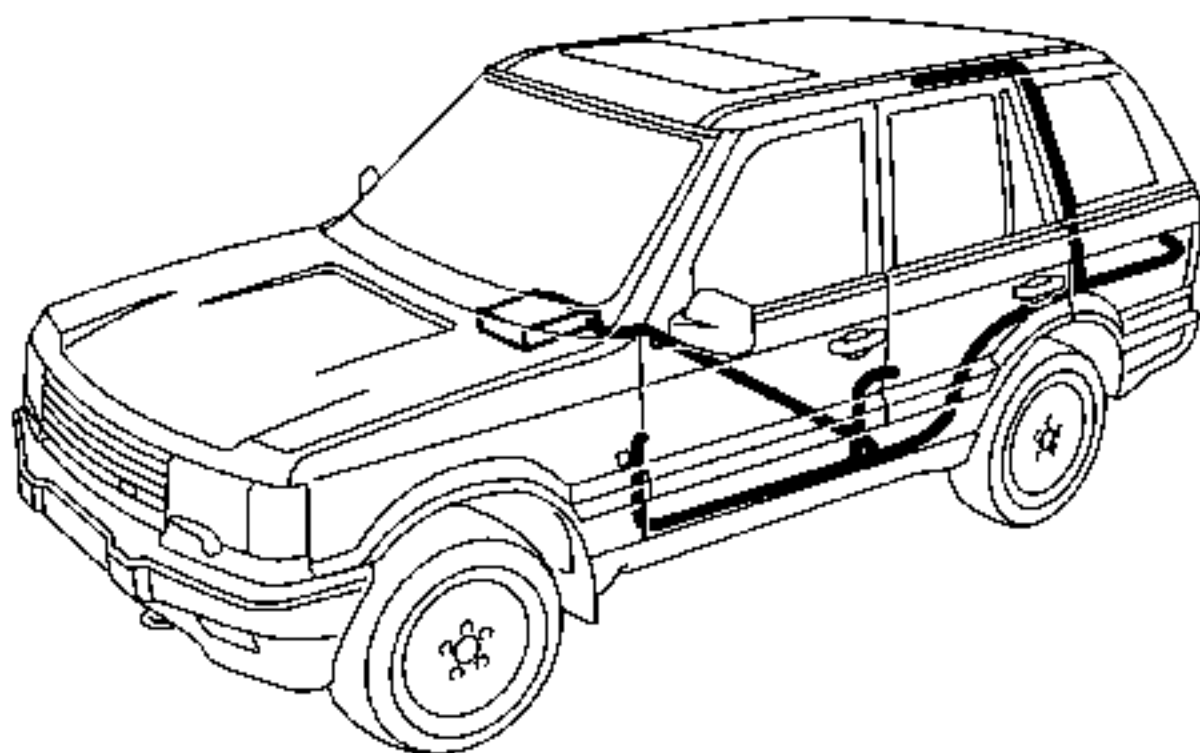

LH Body Wire Harness

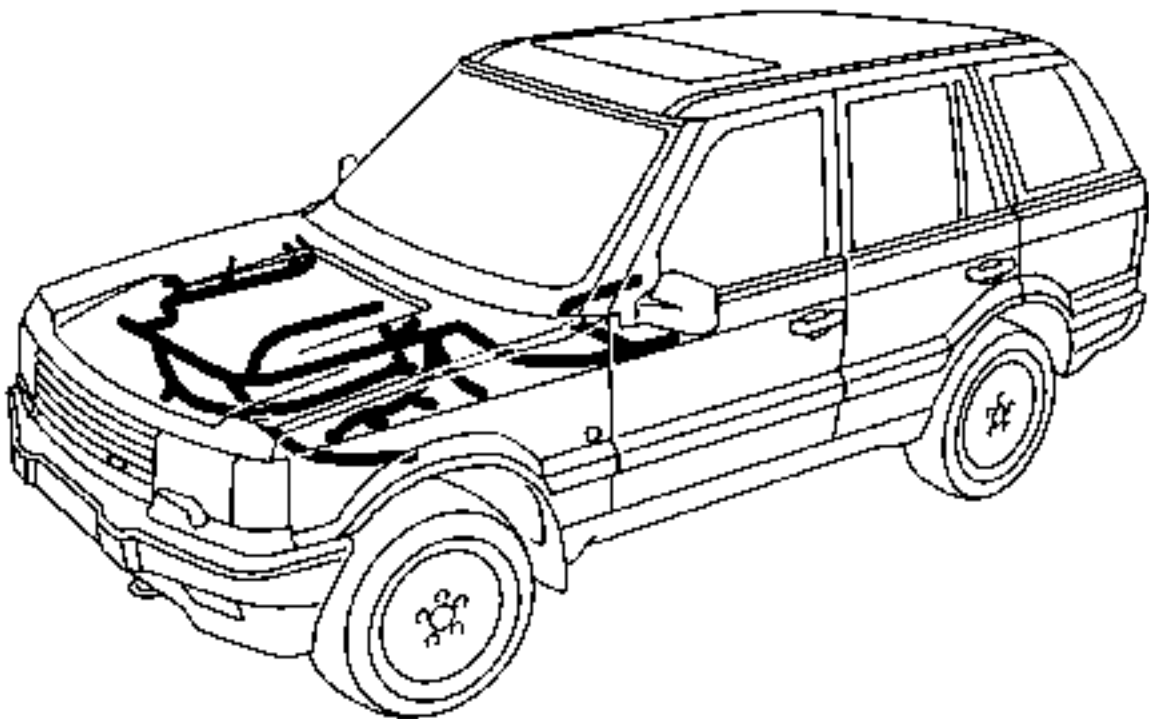

Engine Wire Harness

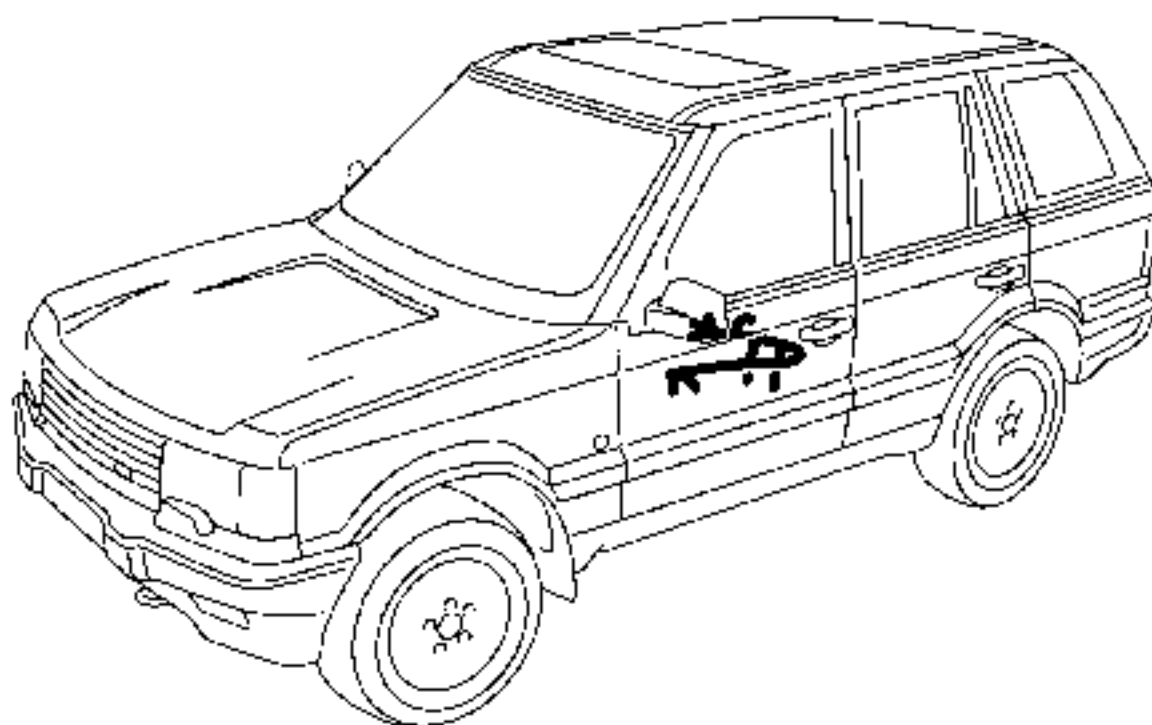

Manual Transmission Harness

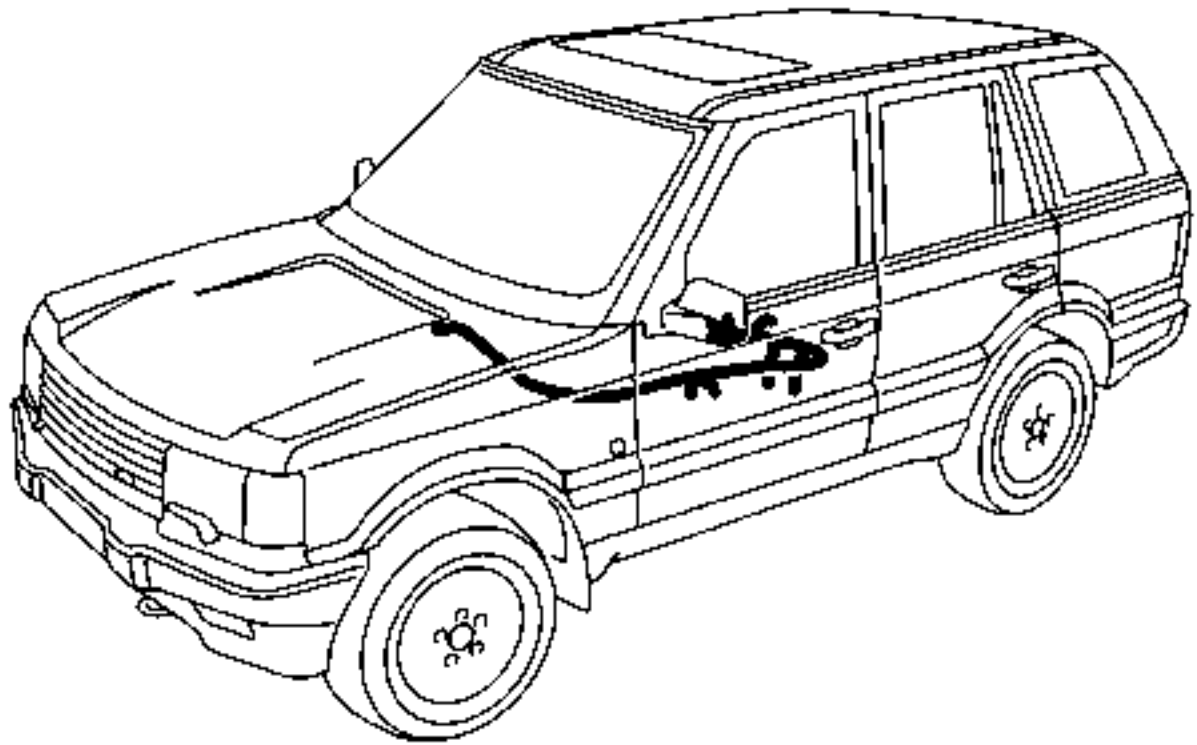

Automatic Transmission Harness

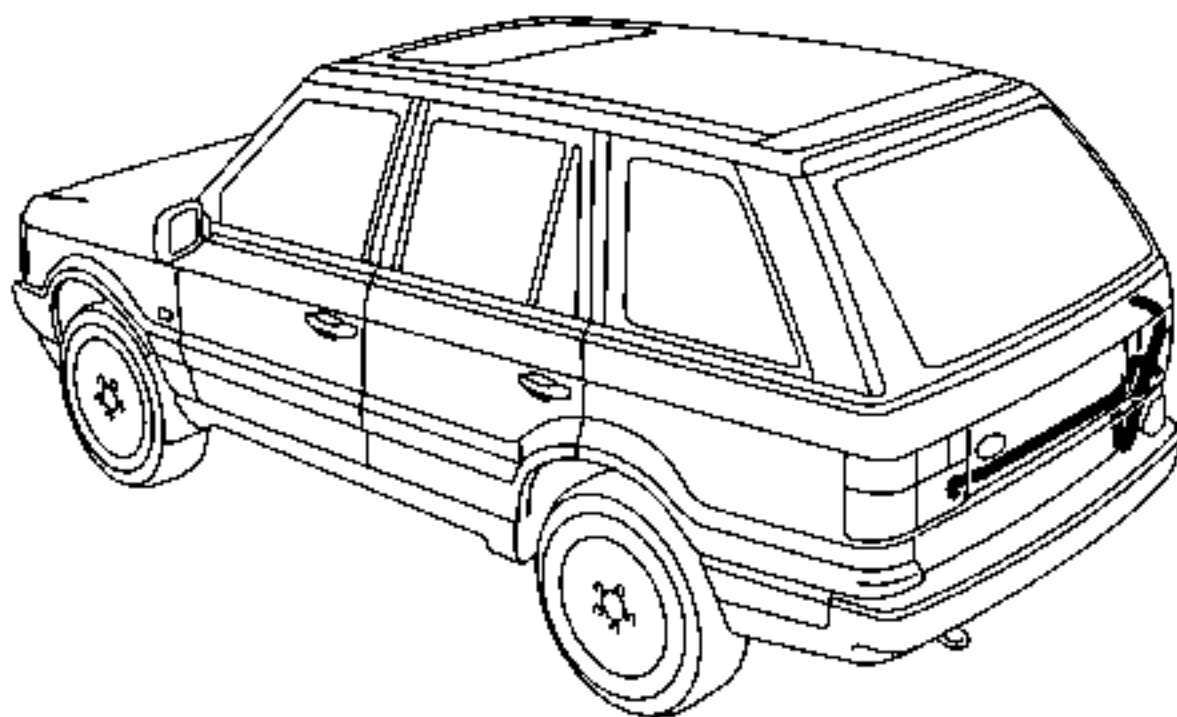

Lower Tailgate Harness

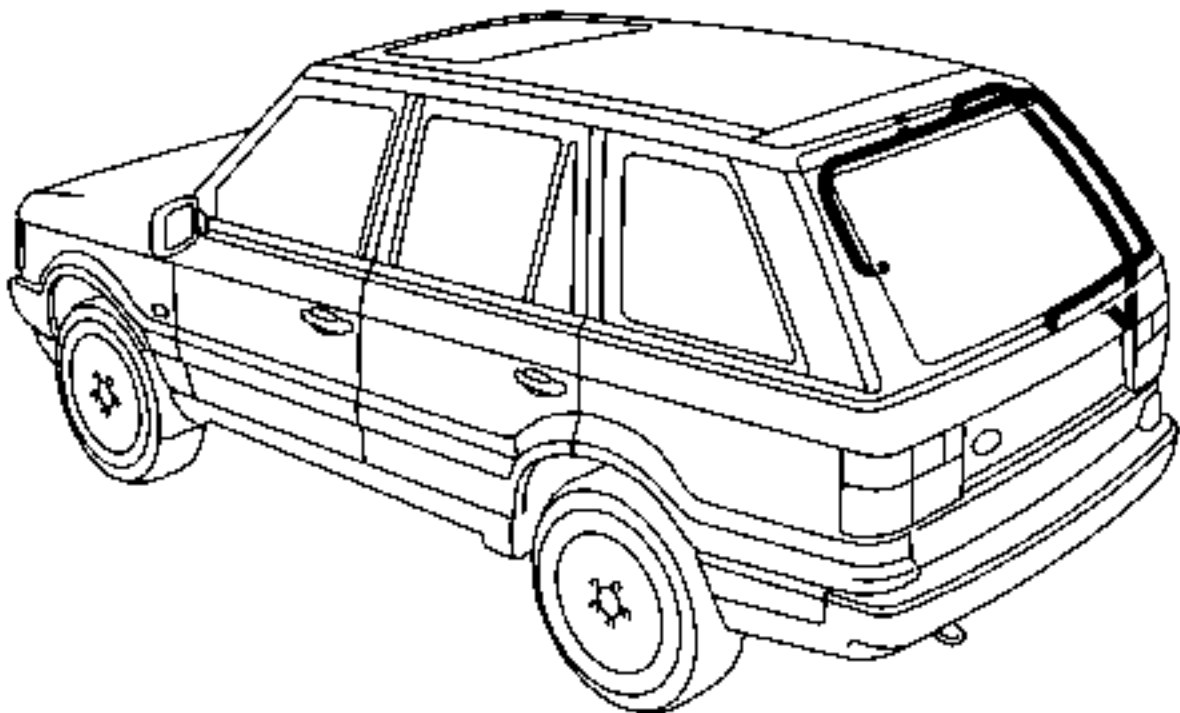

Upper Tailgate Harness

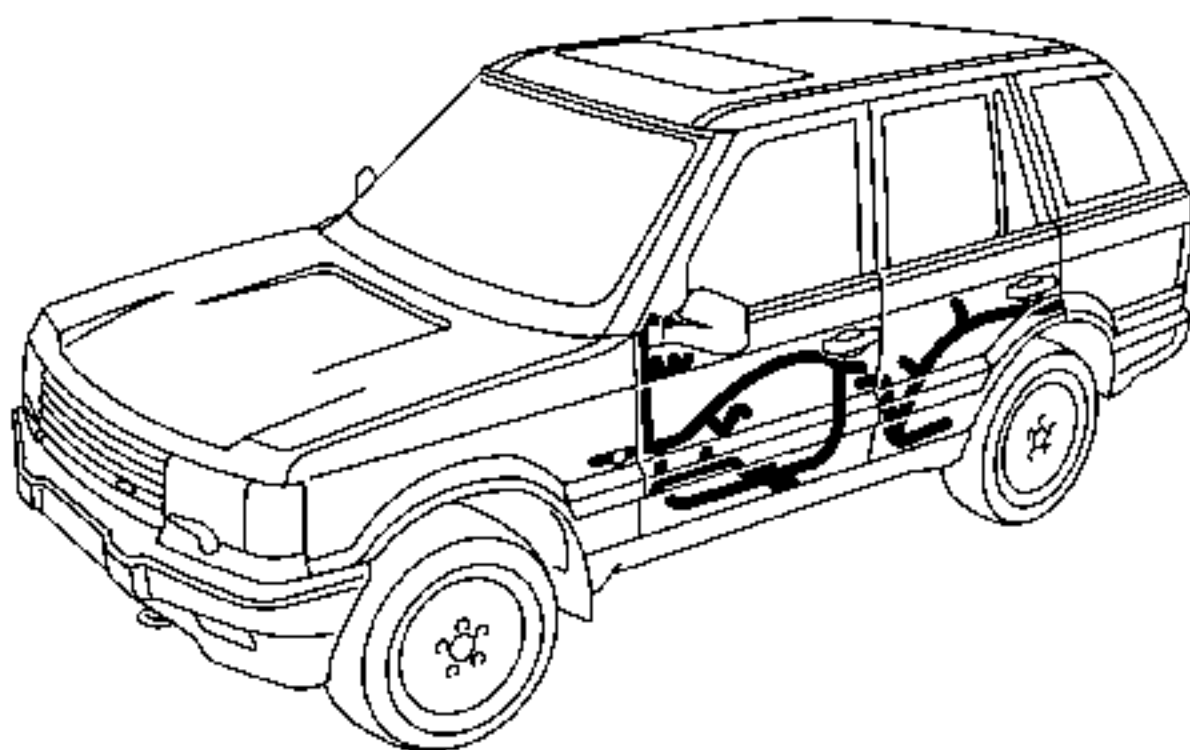

Front and Rear Door Harness

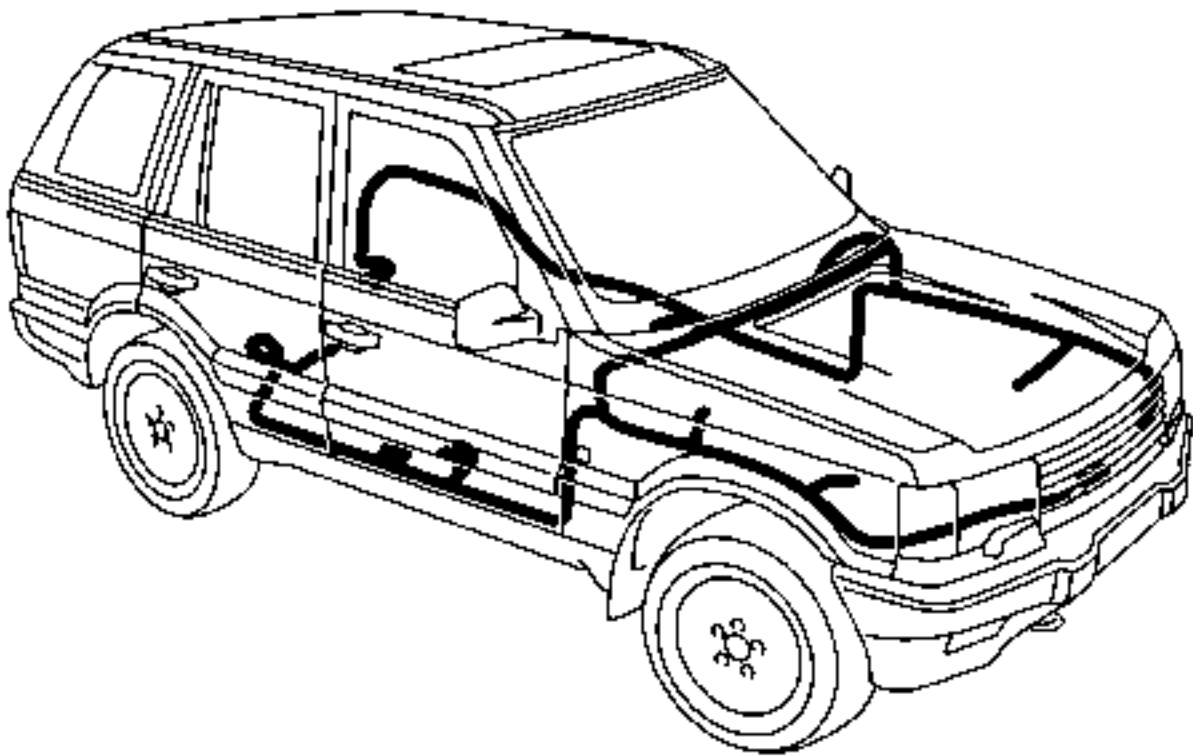

Under-bonnet Harness

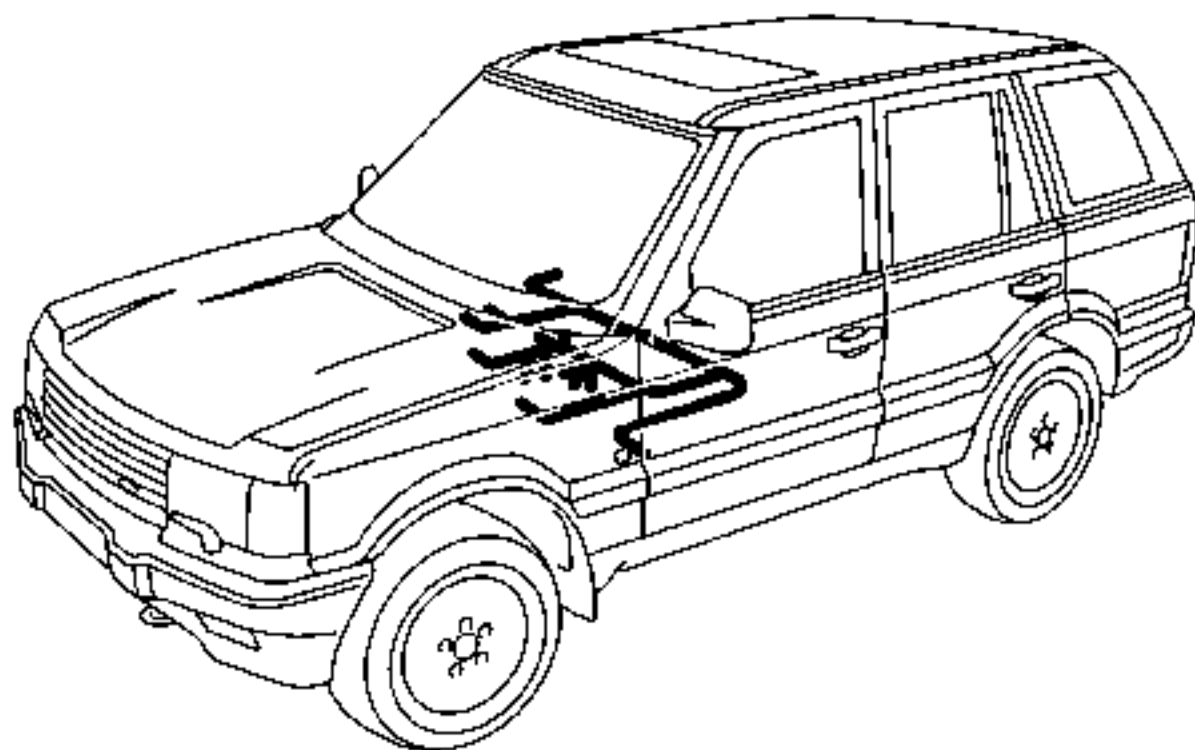

Centre Console Harness

Air Suspension	S1-1
Anti-Lock Brake System	D1-1
Automatic Gearbox	B7-1
Cigar Lighter/Clock	J2-1
Component Location Table	Z4-1
Component Location Views	Z5-1
Connector Views	Z6-1
Cruise Control (Diesel)	B5-1
Cruise Control (Petrol)	B5-1
Data Link Connector	D3-1
Diesel	A0-1
Direction Indicator Lamps	H6-1
Electrochromic Rear View Mirror	G1-1
Fog Guard Lamps	H9-1
Fuse Details	Y2-1
Body Electrical Control Module (BECM) (Z238)	
F1	Y2-1
F2	Y2-2
F3	Y2-2
F4	Y2-2
F5	Y2-2
F6	Y2-3
F7	Y2-3
F8	Y2-4
F9	Y2-4
F10	Y2-5
F11	Y2-5
F12	Y2-6
F13	Y2-6
F14	Y2-6
F15	Y2-7
F16	Y2-8
F17	Y2-8
F18	Y2-8
F19	Y2-8
F20	Y2-9
F21	Y2-9
F22	Y2-10
Engine Compartment Fuse Box (P125a)	
F23	Y2-10
F24	Y2-10

F25	Y2-11
F26	Y2-12
F27	Y2-14
F28	Y2-14
F29	Y2-14
F30	Y2-14
F31	Y2-14
F32	Y2-14
F33	Y2-15
F34	Y2-15
F35	Y2-15
F36	Y2-16
F37	Y2-16
F38	Y2-16
F39	Y2-17
F40	Y2-17
F41	Y2-17
F42	Y2-17
F43	Y2-17
F44	Y2-17
Ground Distribution	YG-1
Harness Routing	ZR-1
Headlamps	H1-1
Heated Front Screen	F6-1
Heated Rear Screen	F9-1
Heated Seats	M6-1
Heating and Ventilation (with A/C)	K4-1
Heating and Ventilation (without A/C)	K3-1
Home Link Connector (X325)	Y2-7, Y5-18
Horns	E5-1
Ignition and Shift Interlock	C1-1
Instruments	C1-1
Interior Lamps	J1-1
Introduction	I-1
Lights	
Centre Mounted Stop Lamp (B103)	H5-3
Footwell Lamp 1 (B158)	J1-11
Footwell Lamp 2 (B169)	J1-11
Front Interior Roof Lamp (B107)	J1-3
Glove Box Lamp (B152)	L1-6
Key Illumination (B170)	J1-11

Left Front Door Puddle Lamp (B114)	J1-12
Left Front Fog Lamp (B184)	H9-2
Left Front Indicator Lamp (B153)	H6-4
Left Front Lamp Assembly (B115)	H4-3
Left Headlamp (B116)	H1-3
Left Interior Lights (B180)	J1-7
Left Number Plate Lamp (R120)	H4-5
Left Rear Door Puddle Lamp (B148)	J1-12
Left Rear Lamp Assembly (B175)	H4-4
Left Repeater Lamp (B122)	H6-5
Left Tailgate Lights (B177)	H9-3
Rear Footwell Lamp (B182)	J1-11
Rear Load Space Lamp (B174)	J1-3
Right Front Door Puddle Lamp (B127)	J1-12
Right Front Fog Lamp (B183)	H9-2
Right Front Indicator Lamp (B154)	H6-4
Right Front Lamp Assembly (B128)	H4-3
Right Headlamp (B130)	H1-3
Right Interior Lights (B179)	J1-3
Right Number Plate Lamp (B134)	H4-5
Right Rear Door Puddle Lamp (B150)	J1-12
Right Rear Lamp Assembly (B176)	H4-4
Right Repeater Lamp (B107)	H6-5
Right Tailgate Lights (B178)	H9-3
Sun-visor Lamp 1 (B172)	J1-7
Sun-visor Lamp 2 (B173)	J1-7
Memory Mirrors	M7-1
Memory Seats	M4-1
Power Distribution	Y1-1
Body Electrical Control Module (BECM) (Z238)	
RL10	Y1-2
Engine Compartment Fuse Box (P125a)	
MF 1	Y1-2
MF 2	Y1-2
MF 3	Y1-2
MF 4	Y1-2
MF 5	Y1-3
RL15	Y1-1
Power Mirrors	M3-1
Power Seats	M1-1
Power Windows	L1-1

Radio	E6-1
Reversing Lamps	H7-1
Security/Central Locking	S3-1
Sequential Multiport Fuel Injection (SF-V8)	A1-1
Side Lamps	H4-1
Starting and Charging (Diesel)	B1-1
Starting and Charging (Petrol)	R1-1
Stop Lamps	H5-1
Sunroof	L4-1
Supplementary Restraint System (SRS)	N1-1
Trailer Auxiliary Socket	P1-1
Transfer Gearbox	B6-1
Warnings and Indicators	E2-1
Wash/Wipe	F5-1