

Advice

This Owner's Manual defines both the establishment and termination of right and liability with respect to product quality guarantee responsibility and after-sales service between Chery Automobile Co., Ltd. and customers. It is necessary for customers to carefully read this manual before using Chery products.

Owner's Manual for Chery Tiggo

Truly congratulate you on having a Chery Tiggo! Also, sincerely thank you for your preference towards Chery and Chery's products!

The advanced technology and the preeminent performance are incorporated into Chery Tiggo with good ratio of performance to price. This owner's manual is intended to introduce technical characteristics, use methods and relevant precautions of Chery Tiggo; you can get the features of Tiggo and be familiar with the properly using & maintenance to ensure your driving safety.

You should carefully read over this owner's manual before your first driving of Tiggo.

This manual is compiled in accordance with the current Tiggo structure and features; Chery may not give the further notification in the case of changing products after the printing of this manual.

All staff of Chery authorized service stations have experienced the good and professional training, and they provide you with the best service heart and soul.

All comments and suggestions are welcomed.

Chery Automobile Co., Ltd.

Special Statements

- ◇ Chery Automobile Co., Ltd. (hereinafter referred to as “the Company” or “Chery”) provides quality guarantee service for you and please use your car in accordance with the requirements of the owner’s manual; especially pay attention to the section “Quality Guarantee Service”, you may lose the right of enjoying the quality guarantee service due to your violation against the use compliance;
- ◇ The unapproved modification or device addition to your car is forbidden, especially the parts related with electric devices, brake, steering and any other safety systems; Chery shall bear no responsibility for such direct or indirect damage caused by unapproved modification or device addition;
- ◇ Please follow the technical maintenance regulations for car of different stages as set by Chery;
- ◇ The new car running-in and regular maintenance effect significantly influences the service life and protect customer lawful rights. In case maintenance is not completed within specified period or mileage, improper car using or not to sign and stamp the maintenance record will be considered as to give up the warranty rights; meanwhile Chery shall not bear the normal warranty responsibility;
- ◇ Please come to Chery authorized service station to purchase the parts supplied by Chery (genuine parts); in case any direct or indirect damage caused by using non-genuine parts, Chery shall bear no responsibility
- ◇ If the any problem is found in Chery product during the course of use, the car shall be checked and repaired by Chery authorized service station. In the process of check and repair, the station, considering the actual conditions, is entitled to decide whether to carry out maintenance by means of repairing or replacing the equivalent.
- ◇ Please send your car to Chery authorized service station for car maintenance; all staff of Chery authorized service stations have experienced the strict and professional training, and they provide you with the best service;
- ◇ Please put this manual in your car, so as to help you whenever need it. If you are going to resell the car, please hand over this manual and the complete set of attached files together with the car to the new owner;
- ◇ If you meet something unclear when reading the Owner’s Manual, you can get further interpretation from Chery authorized service station.

May you enjoy the driving!

The copyright of this manual is reserved by Chery Automobile Co., Ltd.

Contents

Contents

Special Statements.....	1
Chapter 1 Introduction.....	9
Warning Symbols in the Manual.....	10
New Car Inspection.....	10
Running-in of New Car.....	11
“One-to-one” Service.....	12
Delivery Check Certification.....	13
“One-to-one” Consultative Service Sheet.....	14
Explanation for Common Symbols on Car.....	16
Chapter 2 Instrument Panel.....	19
Instrument Panel.....	20
Alarm Device.....	24
Low Fuel Level Alarm Lamp.....	24
ABS Alarm Lamp.....	24
Vacuum Alarm indicator.....	24
Parking Brake Indicator Lamp.....	24
Brake System Alarm Lamp.....	24
Unclosed Door Alarm Lamp.....	25

Position Indicator Lamp (green).....	25
Unfastened Seat Belt Alarm Lamp.....	25
Engine Malfunction Alarm Lamp.....	25
Indicator of High Beam Lamp.....	26
Turn Signal Indicator Lamps.....	26
Airbag Alarm Lamp.....	26
Low Engine Oil Pressure Alarm Lamp.....	26
Indicator of Low Beam Lamp.....	26
Alternator Alarm Lamp.....	26
Coolant Temperature Alarm Lamp.....	27
4WD System Failure Indicator.....	27
Engine Electronic Control Alarm Indicator.....	27
Maintenance Alarm Lamp.....	27
Cruise Indicator.....	27
Automatic Transmission Failure Indicator.....	28
Snow Road Mode Indicator.....	28
Brake Pad Thickness Indicator.....	28
Coolant Temperature Gauge of Engine.....	28
Below C – Low Temperature Range.....	28
Between C and H - Normal Temperature Range.....	28

Over H–Overheating Range	29	Method to operate the CD player.....	35
Fuel Gauge	29	Chapter 4 A/C System	39
Speedometer	29	A/C System.....	40
Odometer, Digital Clock and Instant Fuel Consumption	29	Ventilation	40
Chapter 3 Audio	31	Air Filter	42
Panel Instruction.....	32	Airflow Distribution	42
Method of Operation.....	33	Central and Side Vent.....	42
Adjust the Volume	33	Maximum Airflow.....	42
Adjust the Bass	33	1. Vehicle Internal Circulation Button	42
Adjust the Treble	33	2. Blower Speed Knob	42
Adjust the Balance	33	3. Temperature control switch	43
Adjust the Fade	34	4. Air blow mode knob	43
Loudness Function.....	34	5. A/C Cooling Button	43
Radio Operating Method	34	6. A/C Operating Mode	44
Radio Playing.....	34	General Remark	45
Frequency Scan	34	Troubleshooting.....	46
Station Search sensitivity (for FM band only)	34	Defrosting of Rear Windshield & Rear-view Mirror	46
Manual Tuning.....	34	Chapter 5 Light Control.....	47
Automatic Scanning Tracking (AST).....	35	Light Control	48
Preset and Store	35	Headlamp Switch.....	48

Contents

Headlamp Dimmer Switch.....	49	Low-speed Wiping (LOW).....	57
Flashing of Headlamp	49	High-speed Wiping	57
Front and Rear Fog Lamp Switches.....	49	Water Spray Switch.....	57
Turn Signal Lamp	49	Rear Windshield Wiper and Rear Washing Switch	57
Way Change Signal Lamp.....	50	Vehicle Interior Rear-view Mirror.....	57
Electric Headlamp Regulating Knob.....	50	Sun Visor	57
Instrument Luminous Regulator	50	Sun glasses Box	58
Interior Front Ceiling Lamp.....	50	Control Switch on Doors	58
Luggage Boot Lamp	50	Electric Exterior Rear-view Mirror	58
Sunroof Control Switch.....	51	Manual Foldable Exterior Rear-view Mirror.....	58
Front Doorsill Lamp and Key Hole Luminous Lamp	53	Safety Switch of Rear Window.....	59
Hazard Warning Lamp Switch	53	Driver Seat Heating Switch	59
Daytime Lamp	53	Front Passenger Seat Heating Switch	59
Chapter 6 Operation & Adjustment of Vehicle Devices.....	54	Cigar Lighter	60
Steering Wheel Lock/Ignition Switch	55	Glove Box	60
Adjusting Steering Wheel	55	Left Small Glove Box	60
Steering Wheel Horn	56	Storage Box	60
Windshield Wiper and Washer System	56	Rear Ashtray	60
Single Wiping (MIST)	56	Auto Cruise System Switch.....	61
Intermittent Wiping (INT)	56	Multi-function Display.....	61

Reverse Radar	64	Assembly and Removal Method of Headrest.....	73
Chapter 7 Door Lock & Anti-theft.....	66	Rear Headrest	74
Remote Controller	67	Rear Seat.....	74
Central Control Door Lock System	67	Carrying Luggage	74
Door Lock.....	68	Seat Belt	75
Child Safety Lock of Rear Door	68	Alarm Lamp of Seat Belt Unfastened.....	75
Releasing Rod of Fuel Filler Cap.....	68	Fastening Seat Belt	75
Opening Engine Hood	69	Central Two-point Rear Seat Belt	75
Wireless Remote Control System with Anti-theft Function	69	Airbag Alarm Lamp	78
Locking and Unlocking of the Door.....	70	Safety Seat for Children.....	78
Anti-theft Alarm System	70	Chapter 9 Driving.....	80
Alarm.....	70	Starting.....	81
Replacing the Battery of Remote Controller	70	Preparation Work before Starting.....	81
Chapter 8 Seat & Safety Protection.....	71	Safety Precautions.....	81
Seat.....	72	Start of Engine	82
Correct Sitting Position.....	72	Cautions of Exhaust Gas	82
Adjustment of Front Passenger Seat.....	72	Pay Attention to Ventilation	83
Adjust the Driver Seat	73	Adaptive Function of the Engine Control System.....	83
Headrest.....	73	Limitation of Engine Speed	83
Adjusting Method of Headrest	73	Stop Engine	83

Contents

Brake.....	84	Shift Lock.....	91
Dual-Circuit Brake System	84	Starting up.....	93
Brake Fluid.....	84	Drive Out of Mud & Sand, Snow	93
Brake Booster	85	Forced Downshifting	93
Brake Failure.....	85	Stopping on the Way.....	93
Anti-lock Brake System (ABS).....	86	Driving Precautions of AT Vehicle	94
Actions of ABS.....	86	(Under Different Road Conditions).....	94
Make Use of ABS Brake.....	86	Wading.....	95
ABS Self-check	86	Function Definition of Cruise Buttons.....	95
Hand Brake	87	Three-way Catalytic Converter	96
Steering.....	87	Parking.....	97
MT Operation	88	Key Points of Fuel Saving and Environment Protection.....	98
Gear Shifting	88	Radiator Fan	99
Engine Operation for Vehicle Equipped With AMT	89	Chapter 10 Emergency Procedure	100
Operation of AMT	89	Hazard Warning Lamp	101
Vehicle starting up with AMT Transmission	90	Partial Operation Function	101
Display of Gear Position.....	90	Adding Fuel in Time	101
Manual Mode:	90	Replacing the Bulb.....	101
Auto Mode	90	Headlamp assembly	102
Operation of AT	91	Fuse and Relay.....	104

Engine Compartment Fuse Box	105	Battery	120
Instrument Fuse Box	107	Maintenance of Alternator	120
Replacing Wheel	109	Washer System of Windshield	121
Install Wheel.....	110	Inspection of Wiper Blade	121
Connect Lead.....	112	Replacement of Wiper Blade	121
Start Engine.....	112	Tyre.....	121
Disconnect Lead.....	113	Replacement of Tyre.....	122
Breakdown Trailer	113	Anti-skid Chain for Snowy Ground.....	122
Chapter 11 Maintenance	114	Wheel Train Belt	123
Services Provided by Chery Service Station	115	Car Wash.....	123
Items You Must Implement	115	Cleaning of Headlamp	123
General Maintenance	115	Cleaning of Rear Windshield	124
Maintenance Schedule.....	115	Corrosion Protection for Chassis	124
Maintenance Items of Engine Compartment	117	Cleaning of Wheel	124
Engine Oil Dipstick	118	Cleaning Articles	124
Filling Cap of Engine Oil.....	118	Paint Falling off Treatment	124
Brake Fluid / Clutch Oil.....	118	Protection of Vehicle Paint.....	124
Engine Coolant Tank	119	Maintenance of Leather Veneer.....	124
Engine Coolant.....	119	Regular Maintenance Provisions	125
Check the Power Steering Fluid Level.....	120	Car Data	130

Contents

Car Sale & Delivery Sheet.....	131	Automatic Transmission Oil	145
Maintenance Certification.....	133	Transfer Case Oil.....	145
Safety Protection System	139	Rear Main Reducer Oil	145
Chapter 12 Capacity & Specification Parameters.....	142	Power Steering Oil	145
VIN	143	Brake Fluid & Clutch Oil.....	145
Vehicle Nameplate	143	Coolant	146
Engine Number	143	Windshield Washing Fluid.....	146
ACTECO Engine	143	Vehicle Mass.....	147
Fuel	144	Wheel and Tyre.....	149
Engine Oil.....	144	Engine Specification	150
Filling Engine Oil	145	Vehicle Dimensions	151
Vehicle Oil & Fluid	145	Contact Information of Chery International	153
Manual Transmission Oil	145		

Chapter 1 Introduction

Introduction

What You Should Get to Know before Reading the Owner's Manual

Thank you for purchasing a Chery car. In order to utilize your car and protect your right, you need to spend some time to carefully read this manual.

This manual provides you with some important instructions and prompts with regard to daily driving and routine maintenance, which enable you to manipulate the car. The more you know about your car, the more safety, economy and joy of driving can be ensured.

Any improper operation may both damage your car and deprive your car of the warranty rights.

The periodical maintenance for car helps to retain the performance and second-hand value of car. Chery authorized service stations are star-studded all over country, and numbers of maintenance specialists in these stations can provide the instant service for you.

The professionally trained maintenance personnel are able to properly perform maintenance to your car and the car-mounted equipment. The spare parts used in these stations are the genuine ones supplied by Chery.

Special Instruction

This manual describes the maximum possible equipped scope of Tiggo series till the printing of the manual. It's the introduction of all configurations of Tiggo. Some of these configurations may be provided in the future or merely in partial market, so that some function introductions may inapplicable to your car; so certain device or function may inapplicable to your car and please be subject to car you purchased.

Warning Symbols in the Manual



How to reduce the damage to car or on-vehicle equipment and avoid the injury of personnel in the case of using a car? In this manual, the answer to this question is contained in the note which is marked with a triangular warning symbol. Please carefully read and follow the contents that involved.



If you see this symbol on the car, you must read the related sections of this manual before conducting the corresponding operation.



We must perform the responsibility and obligation we bear for the environmental protection. The proper use of car and the legal disposal of cleaning articles and lubricating materials are significant steps for achieving this goal. The information with respect to such an aspect is highlighted by a tree-shape symbol.

New Car Inspection

Before deliver the car to you, the dealer under Chery has implemented the vehicle check according to Chery's rules. The dealer shall fill in the "delivery check certification" of this manual with the date of delivery, and press the certification with an official seal of sales unit.

The sales unit shall refer to the Chery Car Sale & Delivery Sheet to check the performance of complete car in the presence of customer and introduce the general knowledge of vehicle use and vehicle model configuration scope to the customer. The sheet shall be signed by both the seller and the customer.

Running-in of New Car

Owing to the machining and assembly errors, the frictions between active components of a new car at the beginning of use are always much greater than those under the normal conditions. Since the initial running-in effect significantly influences the service life, working reliability and economy of a car, the running-in rules shall be strictly abided by in the event of using a new car.

Rules for Running-in Within 1,000km

It is absolutely forbidden to drive the car at its full speed;

Generally, it is forbidden to drive the car at a speed over 100km/h;

It is required to avoid driving the car at its top speed at various gear positions.

Rules for Running-in from 1,000km to 1,500km

It is allowable to accelerate till the top speed or drive the car with the maximum tolerable engine speed.

Precautions after Running-in Period:

For a running car equipped with an engine speedometer, the maximum engine speed is 6,000r/min in short-time. In case of manual shift, no later has the speedometer pointed to the red indication area than the gearshift lever shall be pulled to the adjacent higher gear position.

It is required to prevent the engine from running at an unnecessary high speed. Shifting the lever to higher gears as soon as possible is helpful for saving fuel, reducing working noise and lower environmental pollution.

When the car is running, the very low engine speed is also undesired. It is necessary to shift the lever to the proper gear, as the case may be.

In case of a cold car, do not let the engine working at the maximum speed, despite the lever being set in the neutral or a driving gear.

At beginning of use, a new tyre does not get the best adhesive force. Therefore, even a new tyre also needs running-in. Consequently, during the first 100km, the car speed shall be kept low and the driving shall be particularly careful.

A new brake friction needs running-in as well, for the brake plate does not have the ideal friction within the first 200km. If the braking effect during such a period seems poor, it is allowed to properly increase the pressure on the pedal. This method is also applicable every time you henceforth replace the brake lining with new ones.

Once a new car has traveled for 800km in total, it is compulsory to retighten the wheel nuts to the specified torques. See Chapter "Specification Parameters" in this manual for these correct torque values. For the car whose wheels have been replaced or whose wheel nuts have been loosened, it is also required to retighten these wheel nuts to the specified torques as soon as the car has run for 800km.

Introduction

“One-to-one” Service

For the purpose of providing you with the better service and car, the dealer under Chery will assign a service consultant for you when you are buying Chery car. If you have any question during in car using, you can contact with your service consultant and he/she will present the best service to you.

Delivery Check Certification

It is hereby proved that this car has been checked in accordance with rules of CHERY Automobile Co., Ltd. and its quality meets the technical requirements specified by CHERY.

Date of Delivery: _____

Official Seal of Sales Unit:

Name (Company) of This Car' s Owner	Name of Responsible Service Station
_____	_____
_____	_____
Address	Responsibility Undertaker
_____	_____

Tel _____	Tel _____

Introduction

“One-to-one” Consultative Service Sheet

Name of Customer: Date of Purchase:

Service Seller: Model:

Car VIN:

The following items shall be confirmed by the customer.

- I. Confirmation of Items regarding Car Delivery (√ for yes, x for no)
- The basic use method of car has been introduced, the delivery check has been given to the car in the presence of customer and the car has been proved qualified.
 - The quality guarantee policies have been introduced.
 - The precautions of driving have been introduced.
 - The importance of periodic car maintenance and the interval time/mileage of maintenance have been introduced.
 - The importance of maintaining/repairing car in Chery authorized service station has been informed.
 - The *Owner's Manual* has been delivered and I have been reminded of reading.
 - The functions and use methods of Chery customer service hot line have been told.
- II. Introduction to “One-to-one” Consultative Service Model (√ for yes, x for no)
- If you have some questions or requirements, you just need to inquire nobody but your service consultant.
 - The service consultant is the only person that is designated by the service station to communicate with his customer.
 - A service consultant is responsible for only one customer, and that is “one-to-one”.
 - The customer can reselect a service consultant if he/she feels unsatisfactory at the previous consultant.

III. Introduction to Main Tasks of Service Consultant (√ for yes, x for no)

- | | |
|---|---|
| <input type="checkbox"/> Reception for periodic maintenance service | <input type="checkbox"/> Acceptance and treatment for customer's complaint |
| <input type="checkbox"/> Reminding call-back for periodic maintenance | <input type="checkbox"/> Answer to enquiry on repair/maintenance |
| <input type="checkbox"/> Periodic greeting call-back | <input type="checkbox"/> Acceptance and treatment for repair/maintenance bespeaking |
| <input type="checkbox"/> Reminding call-back for service action | <input type="checkbox"/> Reminding/ acceptance and treatment for annual check |
| <input type="checkbox"/> Greetings for important festivals | <input type="checkbox"/> Other affairs required by customer |

IV. Establishment of “One-to-one” Consultative Service Relation



Business Card of Service Consultant

Signature of Customer/ Date:

Signature of Service Consultant/ Date:

“One-to-one” Consultative Service Sheet

Name of Customer: Date of Purchase:

Service Seller: Model:

Car VIN:

The following items shall be confirmed by the customer.

I. Confirmation of Items regarding Car Delivery (√ for yes, x for no)

- The basic use method of car has been introduced, the delivery check has been given to the car in the presence of customer and the car has been proved qualified.
 - The quality guarantee policies have been introduced.
 - The precautions of driving have been introduced.
 - The importance of periodic car maintenance and the interval time/mileage of maintenance have been introduced.
 - The importance of maintaining/repairing car in Chery authorized service station has been informed.
 - The *Owner's Manual* has been delivered and I have been reminded of reading.
 - The functions and use methods of Chery customer service hot line have been told.
- ### II. Introduction to “One-to-one” Consultative Service Model (√ for yes, x for no)
- If you have some questions or requirements, you just need to inquire nobody but your service consultant.
 - The service consultant is the only person that is designated by the service station to communicate with his customer.
 - A service consultant is responsible for only one customer, and that is “one-to-one”.
 - The customer can reselect a service consultant if he/she feels unsatisfactory at the previous consultant.

III. Introduction to Main Tasks of Service Consultant (√ for yes, x for no)

- | | |
|---|---|
| <input type="checkbox"/> Reception for periodic maintenance service | <input type="checkbox"/> Acceptance and treatment for customer's complaint |
| <input type="checkbox"/> Reminding call-back for periodic maintenance | <input type="checkbox"/> Answer to enquiry on repair/maintenance |
| <input type="checkbox"/> Periodic greeting call-back | <input type="checkbox"/> Acceptance and treatment for repair/maintenance bespeaking |
| <input type="checkbox"/> Reminding call-back for service action | <input type="checkbox"/> Reminding/ acceptance and treatment for annual check |
| <input type="checkbox"/> Greetings for important festivals | <input type="checkbox"/> Other affairs required by customer |

Establishment of “One-to-one” Consultative Service Relation

















Business Card of Service Consultant





Signature of Customer/ Date:





Signature of Service Consultant/ Date:





Introduction

Explanation for Common Symbols on Car













Symbol	Definition	Symbol	Definition	Symbol	Definition
	Front & rear power window		Refer to owner's manual		Warning light for parking brake
	Rear window switch disabled		Safety warning		Sound alarm
	Indicator light for rear fog lamp		Electric seat		Fuel
	Indicator light for front fog lamp		Cigar lighter		Engine anti-theft
	Air conditioning system switch		Warning light for brake system malfunction		Central control lock

Symbol	Definition
	Anti-lock brake system malfunction indication
	Diode
	Engine cooling fan
	Headlamp switch
	Battery

Symbol	Definition
	Warning light indicating unfastened seat belt
	Hazard warning indication
	Battery positive pole
	Indicator light for airbag malfunction
	Rear windshield heating

Symbol	Definition
	Interior lamp
	Horn
	No smoking
	Anti-skid indicator light
	Rear-view mirror heating

Introduction

Symbol	Definition	Symbol	Definition	Symbol	Definition
	Jack		Be careful of fan		Windshield defrosting
	High beam lamp indication		Acid material		Non-petroleum base brake fluid
	Low beam lamp indication		Explosive gas		Wiper switch
EPC	Malfunction light for throttle valve		Brake pad warning indication		Vehicle maintenance indication
	Cruise indication		AT transmission malfunction indication	WIN	Snow road mode indication

Chapter 2 Instrument Panel

Instrument Panel

Instrument Panel

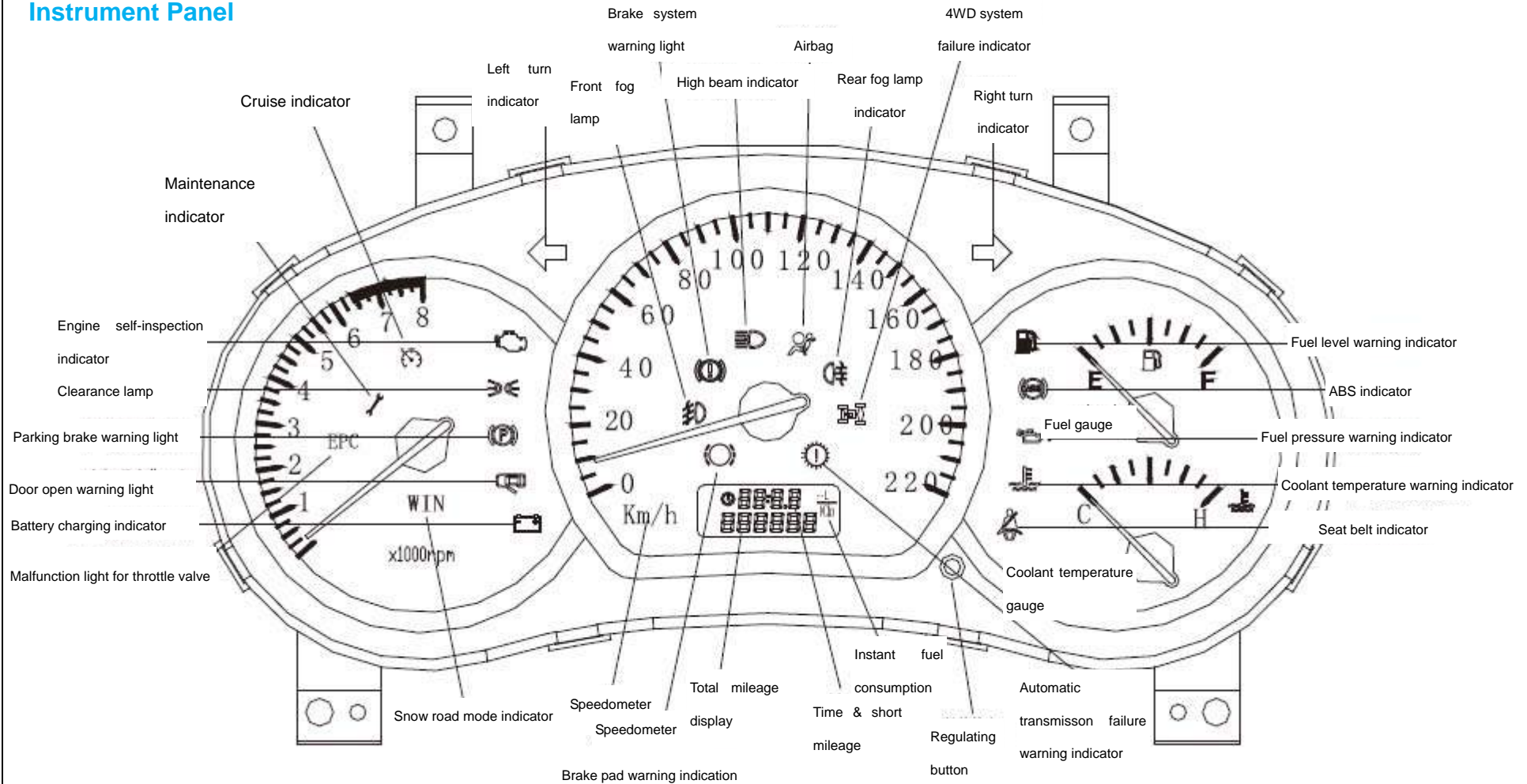

Clock display

Reverse radar, instant fuel consumption, mileage subtotal display

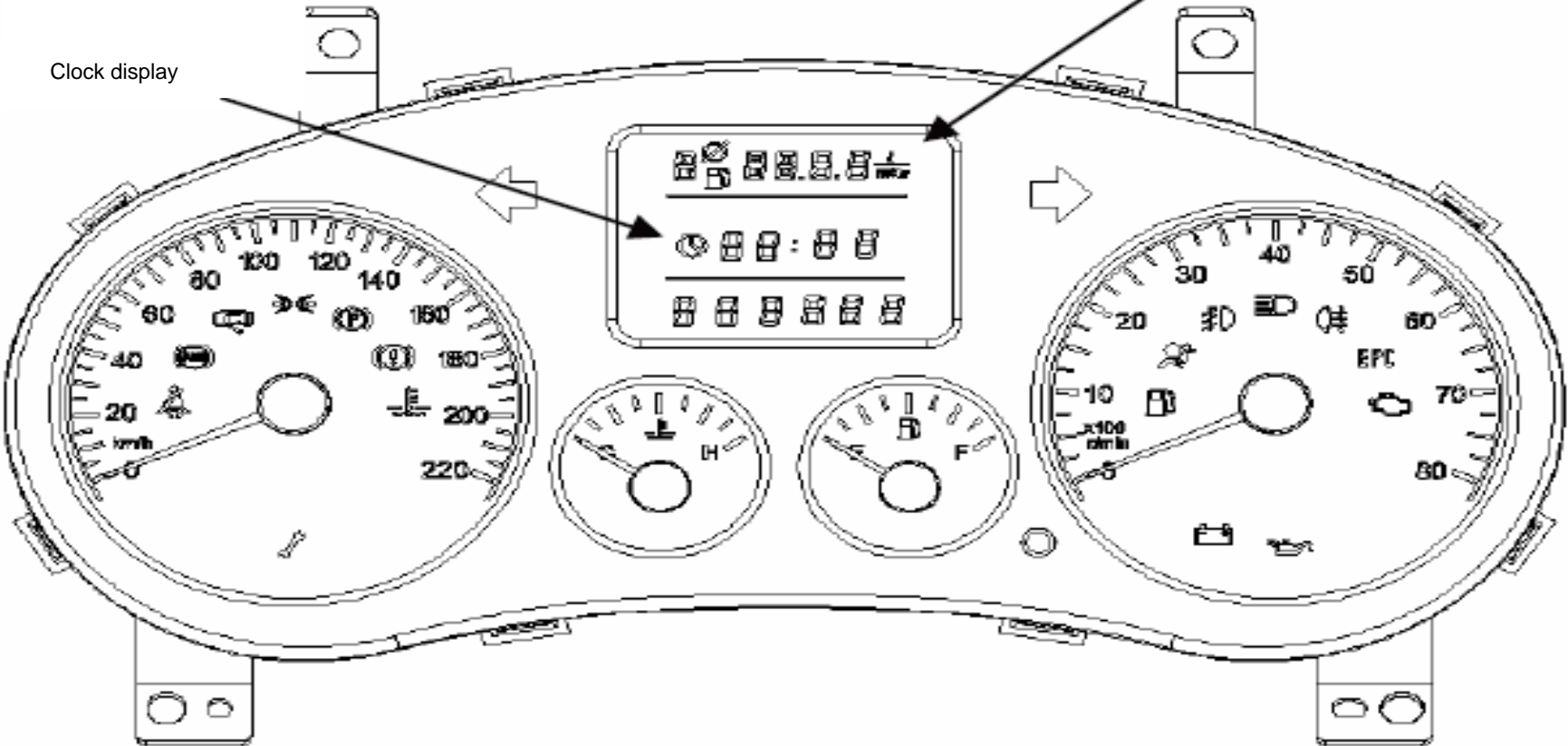

Instrument Panel

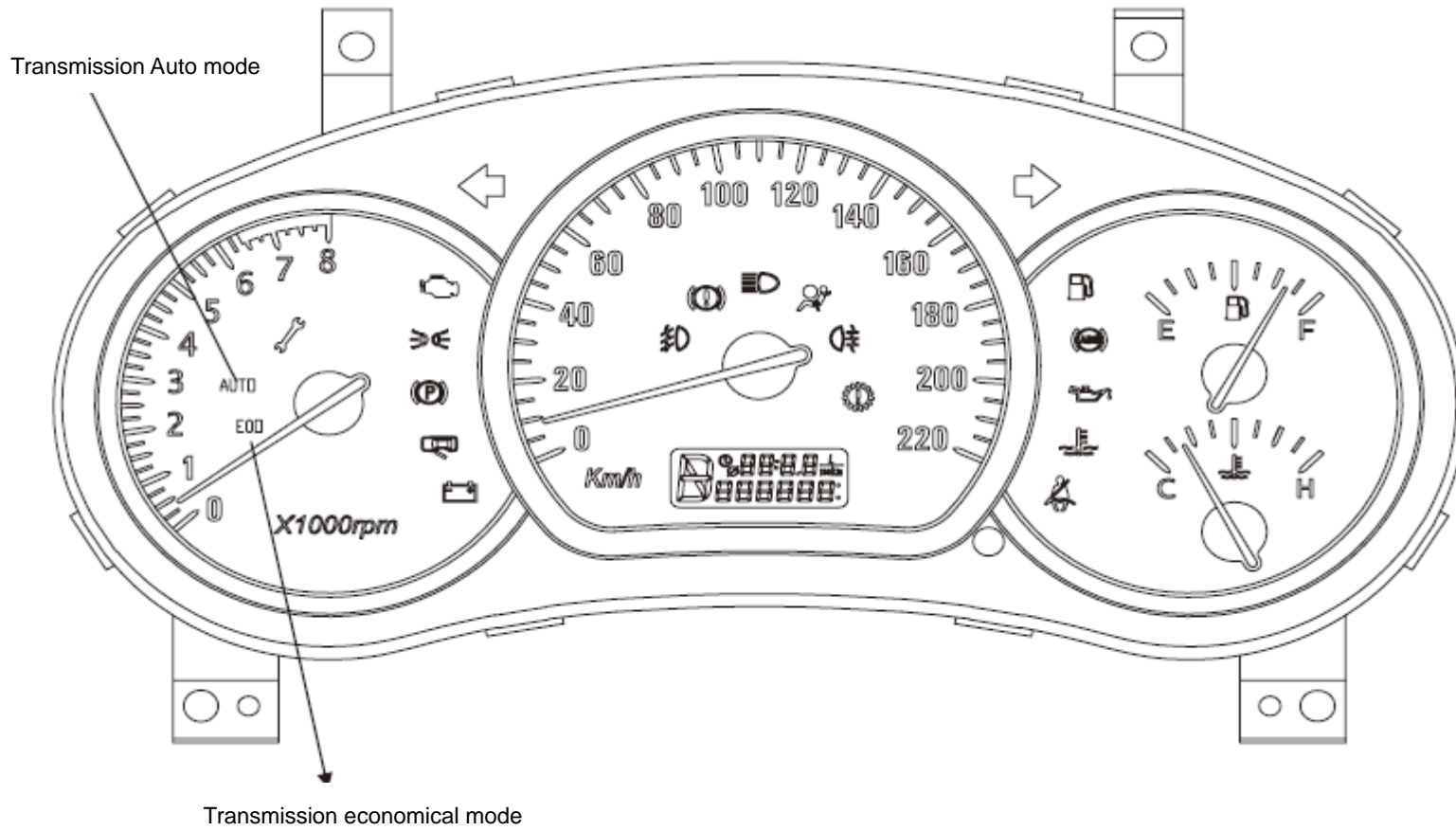

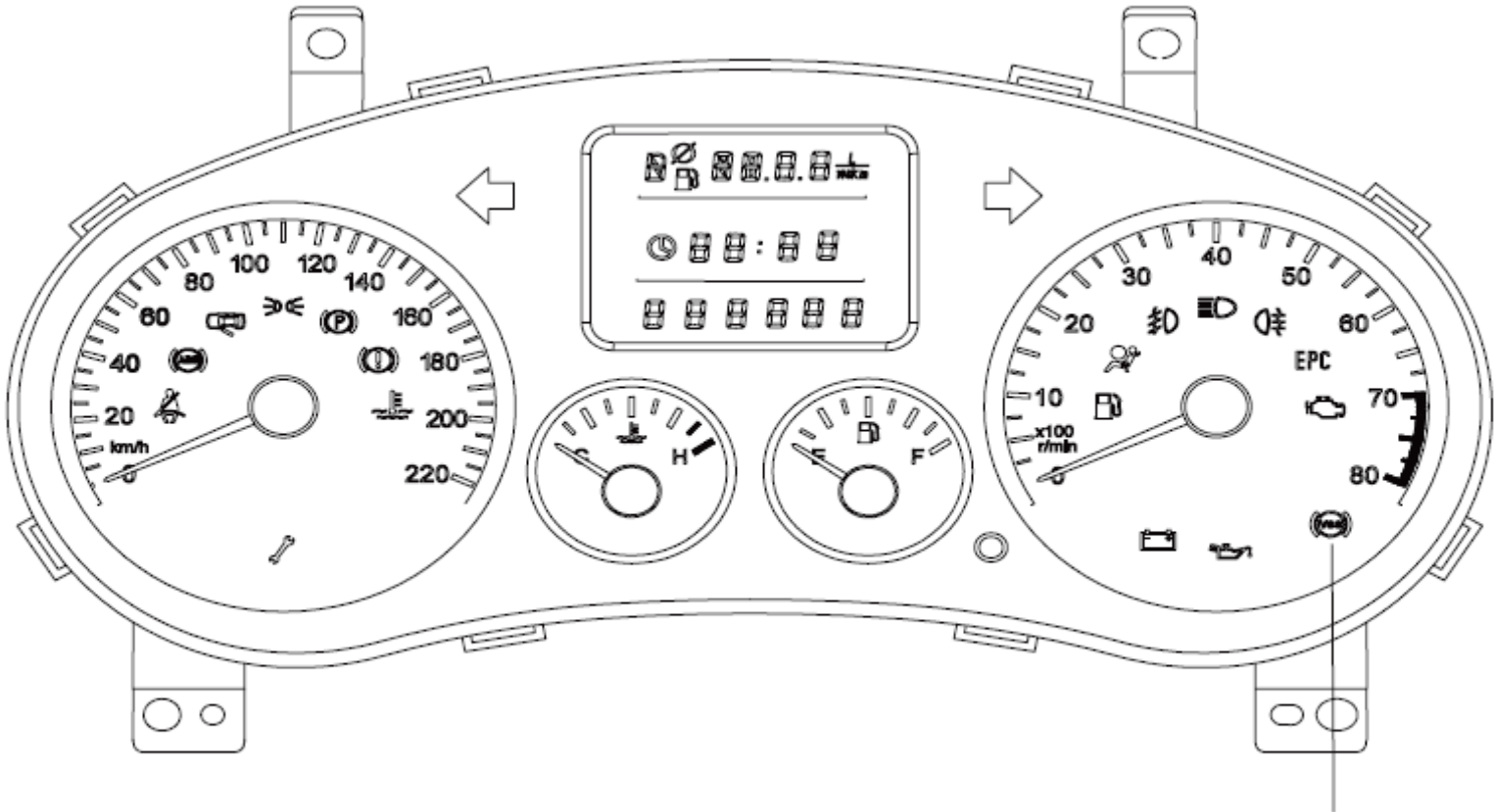

vacuum tank warning indicator

Instrument Panel

Alarm Device

The alarm device is used to inform the driver of operating conditions and whether the car is in troubles which may lead to great damage or hurt. If one system goes faulty, the corresponding alarm lamp will be lit or flash.

Part of the alarm lamps will go on in seconds when the ignition switch is on, and the system will do self check. If some alarm lamps are off or some are always on or flash after engine starting, please send the vehicle to the Chery authorized service station for overhaul.

Low Fuel Level Alarm Lamp



The lamp will be lit for alarm if the fuel capacity is less than 14 liters, and the hand of fuel gauge will point to the red alarm line.

Please refuel as soon as possible if the lamp is lit.

ABS Alarm Lamp



The lamp will be lit seconds when the ignition switch is on, at this time, ABS will do self-check to confirm whether the system can operate properly. If the lamp always goes on or flashes after the ignition switch is on, it means ABS failure. Still the vehicle has the ability of normal brake (without ABS) unless the alarm lamp of brake system also is lit. By now, go to the Chery authorized service station as soon as possible for overhaul. Drive carefully and avoid the over-speed.

Vacuum Alarm indicator



Because of the vacuum consumption, this indicator may light up shortly; it is normal if the light turns off after the engine vacuum pump works for a while and reaches to enough vacuum degree; There is malfunction in case the indicator is lit when engine

is working normally without stepping the brake pedal; please send the vehicle to the Chery authorized service station for overhaul.

Parking Brake Indicator Lamp



Turn on the ignition switch and pull up the hand brake, and the indicator lamp of parking brake is lit.

Brake System Alarm Lamp



Only the ignition switch is turned on, can the lamp work. This lamp is always on after pulling up hand brake. If the lamp is always on after releasing the hand brake, please ask the Chery authorized service station to check the system.



If the alarm lamp of brake system goes on while driving, it means that one of double circuits in brake system is faulty. In this case, drive carefully and go to the nearest Chery authorized service station for a professional overhaul. Taking account of the seriously-reduced brake performance and increased braking distance, keep a wide distance from the front car while driving and step hard on the pedal appropriately.

In the event that both the ABS malfunction alarm lamp and the brake system alarm lamp continue to be on at the same time, stop the car as quickly as safety permits. Go to the Chery authorized service station for brake system check before continuing driving.

Unclosed Door Alarm Lamp



This lamp will indicate any door is open if the vehicle door is not closed properly after switching the ignition switch.

Position Indicator Lamp (green)

When the clearance lamp is switched on, this lamp is lit.

Unfastened Seat Belt Alarm Lamp

As the ignition switch is turned on, if the driver seat belt is not plugged in, this lamp will be lit to warn the driver to fasten the seat belt well.

Engine Malfunction Alarm Lamp



This warning lamp has two function status and below is the introduction:

1. EOBD system failure indicator

The lamp is lit when the ignition switch is on, and the EOBD system is in a self-checking state, if the system is free of failure, then the alarm lamp will go off after engine start; please check the engine if the lamp always is on; if the alarm lamp is on while driving, it means that the car electronic control

system has fault and the emission has exceeded national standard IV, please go to the Chery authorized service station for overhaul.

Application scope:

◇ The vehicle equipped with SQR481, SQR484 engine series is model with EOBD system (higher than national III standard)

2. Engine electric control system failure warning indicator

The lamp is lit when the ignition switch is on, and the engine electric control system is in a self-checking state, if the system is free of failure, then the warning lamp will go off after engine start; please check the engine if the lamp always is on; if the alarm lamp is on while driving, it means that the car electronic control system has fault, please go to the Chery authorized service station for overhaul.

Application scope:

◇ The vehicle model equipped with Mitsubishi engine.

Instrument Panel

Indicator of High Beam Lamp



This lamp is lit while using the high beam lamp or while the headlamp is flashing.

Turn Signal Indicator Lamps



The lamp consists of left turn signal indicator lamp and the right turn indicator lamp. The corresponding indicator lamp will flash (slowly) as the left or right turn lamps are switched on. Both of them will flash simultaneously when the hazard flashing alarm lamp is switched on.

It means that the corresponding turn lamps go wrong if the flashing frequency of the turn signal indicator lamps has doubled, please send the vehicle to the Chery authorized service station for overhaul.

Airbag Alarm Lamp



When the ignition switch is on, the alarm lamps will flash for 6 times and then off; in case of the malfunction, the alarm lamp will be lit up for 6s, which means that some malfunction codes occur but not affecting the airbag normal function.

It means failure if the lamp is lit while driving. Sent the vehicle to the Chery authorized service station for overhaul.

Low Engine Oil Pressure Alarm Lamp



The lamp will be lit once the ignition switch is on, and will go off after engine start. Please stop the car immediately if the lamp is on or flashes while driving over engine RPM 2000, and shut off the engine and check the engine oil level.

Add the oil immediately if the oil level is too low.



If the engine oil consumption is very fast, please go to the Chery authorized service station for check.

Indicator of Low Beam Lamp



This lamp is lit while turning on the low beam lamp and ignition switch.

Alternator Alarm Lamp



The lamp is lit when the ignition switch is turned on; the lamp will go off soon after engine start.

Stop the car immediately if the lamp is lit while driving, and shut down the engine to check the alternator belt and other related components.

If the belt is normal, keep driving to the nearest Chery authorized service station for overhaul; Because the battery continues to discharge, all unnecessary electrical appliances should be turned off, including the air conditioning system.

If the belt is broken, never keep driving and have it maintained by specialists.

Coolant Temperature Alarm Lamp



The lamp will go on for several seconds and then off after the ignition switch is on. Several seconds later, if the lamp is still on, and it flashes or goes on due to over high coolant temperature or too low coolant level while driving and the buzzer makes alarm, if so, it is necessary to stop the car immediately and shut off the engine, and check the coolant level, then add coolant according to the specifications; meanwhile contacting with Chery service station without driving.



Warning of scald! When the engine is hot, the cooling system is in high temperature and high pressure conditions, so it is necessary to open the radiator cover after engine cooling. It is forbidden to touch radiator fan!

4WD System Failure Indicator



Some Tiggo models adopt intelligent 4WD system, the indicator lamp will be on if 4WD system has failure.

Engine Electronic Control Alarm Indicator

EPC

The alarm lamp is lit and the electronic control unit of engine is in self-checking state when the ignition switch is on; if the system is free of failure, the alarm lamp will go off after starting; If it keeps on, it is necessary to check the engine; if the lamp is lit

while driving, it indicates the malfunction occurs on the electronic control unit of engine, please go to the Chery authorized service station for overhaul as soon as possible. Application scope: ◇ The vehicle equipped with SQR481, SQR484 engine series.

Maintenance Alarm Lamp



If the accumulative mileage shown in the odometer reaches the pre-set value (5,000km), the lamp will go on to warn the customer to go to the Chery authorized service station for maintenance. Note: the technicians shall reset the maintenance mileage to zero after maintenance.

Cruise Indicator



When the ignition is turned on and the cruise switch is turned on; the cruise indicator lamp will flash indicating the condition of cruise; in driving, the cruise indicator lamp will be always on in cruise mode.

Instrument Panel

Automatic Transmission Failure Indicator



The indicator will be on after turning on ignition switch and automatic transmission system is on self-checking status; the indicator will go off if the system is free of failure. Please check the automatic transmission system if the indicator is always on.

If the indicator is on during your driving, it means the automatic transmission system has failure and please come to Chery authorized service station for overhaul as soon as possible.

If the indicator blinks during your driving, it means the over high temperature of automatic transmission and please come to Chery authorized service station for overhaul as soon as possible.

Snow Road Mode Indicator



When ignition switch is turned on, pressing the snow road mode button nearby the gearshift lever, the instrument panel snow road indicator will be on; start the engine and shift to gear D to start up and driver the vehicle in 2nd gear (suggest to select this mode when driving on snow road or road of poor coefficient of adhesion); pressing the snow road mode button again; this indicator in instrument panel will go off and system will quit the snow road mode.

Brake Pad Thickness Indicator



The brake pad thickness indicator will be on if the brake pad has severe wearing; please drive the vehicle carefully and replace the brake pad at service station soon.

Coolant Temperature Gauge of Engine



It indicates the coolant temperature.

Below C – Low Temperature Range

During the warming-up process of starting, the engine may operate across this range for a short time. In this temperature range, the engine shall not operate at high speed; moreover, the operating load of engine shall be never excessive.

Please go to the Chery authorized service station for overhaul if the hand remains in this range for a long time.

Between C and H - Normal Temperature Range

The hand lies in the range while driving properly.

The hand may depart off this range when the outside temperature is too high and the engine is heavy loaded. The vehicle may travel as long as the coolant alarm lamp is off, it is necessary to stop the engine immediately and check the cooling system in the event of flashing alarm from coolant alarm lamp.

Over H–Overheating Range

Once the hand reaches the red range, it means engine overheating. Stop the car safely and immediately, and shut down the ignition switch; find out the causes after the engine gets cool.



If the engine is still hot, do not open the water tank cover so as to avoid scald.

Notes:

If the auxiliary headlamp is mounted in front of air inlet port at lower of front bumper, the cooling air flow will be affected and it is not good for engine cooling.

The heavy-duty engine overheats easily in the event of a very high outside temperature!

The front spoiler also has the function of air cooling. The engine may overheat if the spoiler is damaged or even broken due to collision. Please go to the Chery authorized service station for bumper repair timely.

Fuel Gauge



Capacity of fuel tank: 57 liters.

When the hand reaches the red alarm position (the first short bar), about 14 liters of fuel is left in the fuel tank.

After the fuel tank is fully filled and vehicle has run for a while, the needle will point to position “F”.

The added fuel may be less than the rated capacity due residual fuel while refueling.

When the low level alarm lamp goes on, please refuel as soon as possible. Refer to the section of “Low Fuel Level Alarm Lamp”.

Speedometer



It indicates the current speed of the vehicle.

Notice:

The vehicle speed is affected by tyre size. Please select the tyre in size of Chery genuine one, otherwise the vehicle speedometer cannot show the correct speed.

Odometer, Digital Clock and Instant Fuel Consumption



Instrument Panel

The right lower part displays the total mileage; the right upper part displays time or single trip mileage. The time display is in digital way.

Switching between Time and Single Trip Mileage and regulating Method:

By spot pressing the regulating button on odometer, the time and single trip mileage display can be switched.

If the odometer shows single trip mileage, you can reset the mileage to zero by long pressing the regulating button.

If the odometer shows time, you can adjust the clock by long pressing the regulating button.

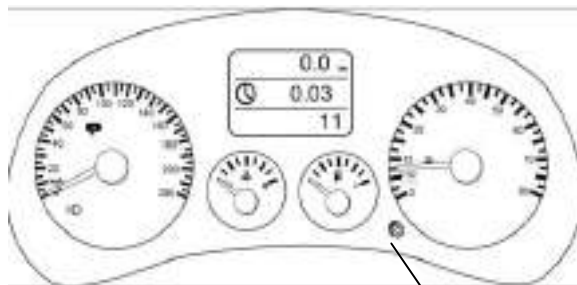

Regulating button

(Combined instrument clock regulating method for 09 model vehicle)

1. Premise of regulating: turn off the ignition switch and clearance lamp is on, then clock can be regulated.

2. Regulating steps:

1. Long press the regulating button until the digital hour starts blinking then releasing the regulating button; now you can change the hour by pressing the regulating knob;

2. Please hold on after regulating the digital hour until the digital minute starts banking; you can change the digital minute by pressing the regulating knob;

3. The clock regulating is finished after the digital minute is completed.

Engine Tachometer

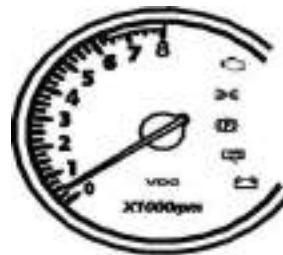

It indicates the engine speed (RPM).

The right red range of dial gauge denotes the maximum allowable speed range of engine in a short time and at operating temperature after running-in. However, it is recommended that the gearshift lever should be shifted to a higher gear when the hand reaches this range at latest or the foot be moved off the pedal.

Notice:

An early shifting to high gear is significant for fuel saving and noise reduction.

Shift to an adjoining gear in case of unstable engine running.

Overspeed alarm

The speed of more than 120 km/h, instrument buzz after three stop,

When the speed under 120 km/h after another, more than 120 km/h, instrument continue to buzz after three stop, so cycle.

Chapter 3 Audio

Note: if the vehicle is not equipped with this audio system, please read the audio owner's manual on vehicle.

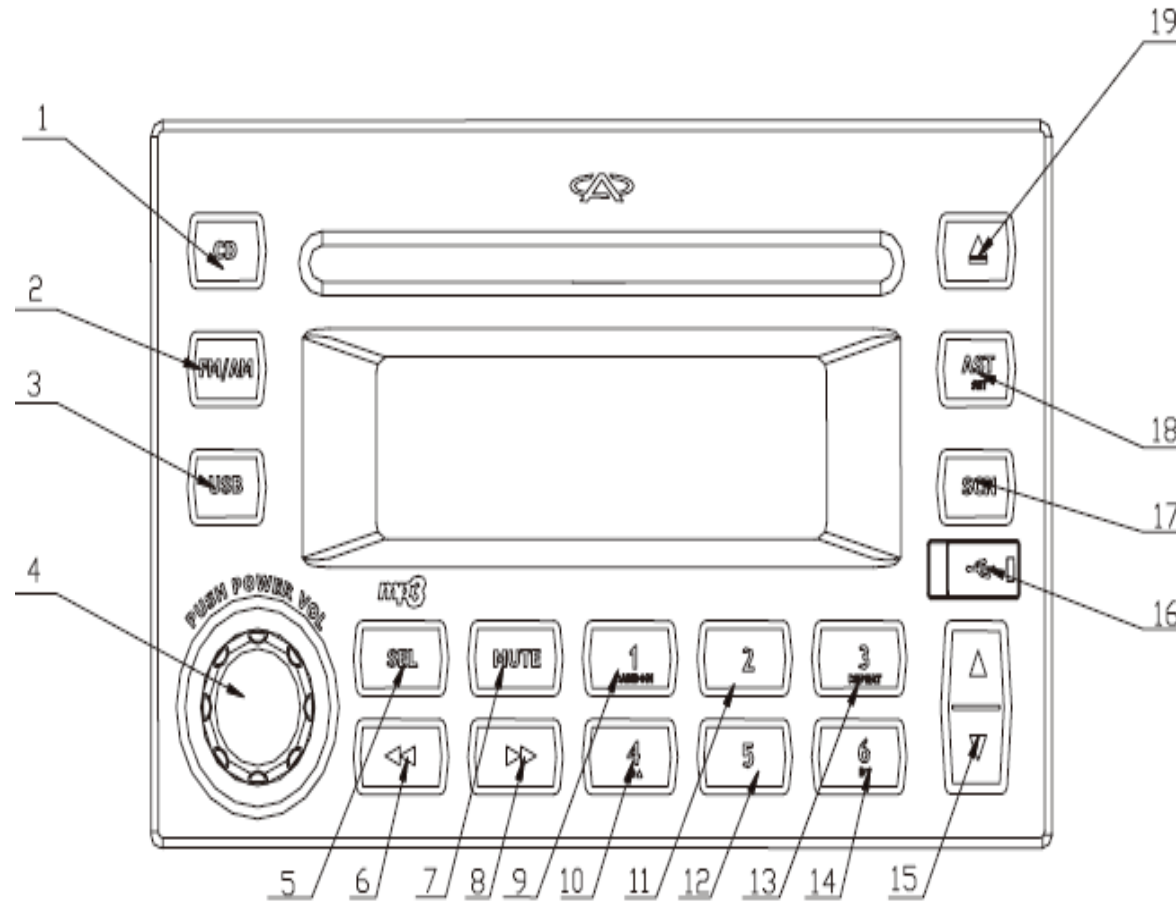

Panel Instruction

1. CD (CD play selection) button
2. BAND selection button (Radio FM/AM band switch) button
3. USB button
4. Power Switch/Volume regulating (Knob) Button
5. SEL (Sound Effect Mode Selection) button
6. Low frequency search (radio)/Fast Backward/Play (CD play)
7. MUTE button
8. High frequency search (radio)/Fast forward/play (CD play)
9. Preset button 1 (Radio) / RANDOM button
10. Preset button 4 (Radio)
11. Preset button 2 (Radio)
12. Preset button 5 (Radio)
13. Preset button 3 (Radio) REPEAT button
14. Preset button 6
15. Search previous or backwards (CD play)
16. USB interface
17. SCN (radio frequency scan/CD play track scan) button
18. AST (Automatic Storage) button
- SET (long press over 2s to enter setting) button
19. Disc eject button

Method of Operation

Operation

Notice:

Please refer to the above figure of front panel “Panel Instruction” to read this chapter.



Please lower the sound volume before turning off the ignition switch or main power.

Device can keep the memory of final setting of volume value before turning off. If the volume is very high before turning off, the sudden high volume may hurt your ear or damage your device when you turn it on in next time.

Power ON or OFF

Notice:

If the engine of the vehicle doesn't start up, you shall be careful of device operation in long time, since the vehicle may not be able to start up if the battery power is low, also the service life of the battery may be reduced.

Press the POWER button to turn on/off the CD player.

Mode Selection

1. Press the BAND (FM/AM) button to select the required band.
2. Press the CD button to select the CD play mode.

Adjust the Volume

Turn the knob in clockwise direction to increase the volume; and turn the knob in anticlockwise direction to decrease the volume.

The Max. volume is 31 and Min. volume is 0.

Please ensure that you can hear the traffic signals (whistle, alarm,).

Adjust the Bass

1. Press the SEL button to select the “BASS”.
2. Turn this button in the clockwise direction to increase the bass; and turn the button in anticlockwise direction to decrease the bass.

*Its value is set as “0” before leaving factory.

The range of adjustment: -7 to +7.

3. After the completion of adjustment, long press the SEL button to finish the setting.

Adjust the Treble

1. Press the SEL button to select the “TREB”.
2. Turn this knob in clockwise direction to increase the treble; and turn the knob in the anticlockwise direction to decrease the treble.

*Its value is set as “0” before leaving factory.

The range of adjustment: -7 to +7.

3. After the completion of adjustment, long press the SEL button to finish the setting.

Adjust the Balance

1. Press the SEL button to select the “BAL”.
2. Turn this button in clockwise direction to increase the volume of right speaker; and turn the button in anticlockwise direction to increase the volume of left speaker.

*Its value is set as “0” before leaving factory.

3. After the completion of adjustment, long press the SEL button to finish the setting.

Audio

Adjust the Fade

1. Press the SEL button to select the "FAD".
2. Turn this button in clockwise direction to increase the volume of front speaker; and turn the button in anticlockwise direction to increase the volume of rear speaker.

*Its value is set as "0" before leaving factory.

3. After the completion of adjustment, long press the SEL button to finish the setting.

Loudness Function

The loudness effect adds the bass & treble to create the natural tone. This function is automatic.

Radio Operating Method

Radio Playing

1. Press the FM/AM button to select the radio mode.
2. Press the FM/AM button to select band, and when you press the FM/AM button, the band will change as following sequence:

FM FM1FM2AMFM....

3. Press the button ◀◀ or ▶▶ to tune the radio to find the radio as required.

Frequency Scan

The frequency scanning function enables you to listen to the first 10 seconds of program of each current band of local radio station.

- Press the SCN button to turn on/off the frequency scanning function.

Automatic Search

- Press the button ◀◀ to tune into the lower-frequency radio station.
- Press the button ▶▶ to tune into the higher-frequency radio station.

--Press the button ◀◀ or ▶▶ again to search another radio station.

Station Search sensitivity (for FM band only)

The local/remote mode switch is available. The specific method of operation is as follows:

1. Press the button SET for at least 2 seconds to enter the SETUP menu.
2. Press the button ◀ or ▶ to select the SRCH option that you want to change.
3. Press the button SET to change the setting LO/DX.
4. Press the button SET for at least 2 seconds to exit the SETUP menu.

Manual Tuning

Please switch to the manual tuning mode, the specific method of operation is as follows:

1. Press the button SET for at least 2 seconds to enter the SETUP menu.
 2. Press the button ◀ or ▶ to select the TUN option that you want to change.
 3. Press the button SET to change the setting AUTO/MAN, and set to MAN.
 4. Press the button SET for at least 2 seconds to exit the SETUP menu.
- Press the button ◀◀ to tune into the lower-frequency radio station.
 - Press the button ▶▶ to tune higher-frequency radio station.

Automatic Scanning Tracking (AST)

You can store 6 strongest FM radio frequencies in the FM AST band or store 6 radio frequencies in the MW (AM) AST band. When you use the automatic storing function, the radio stations that are originally stored in the FM AST or MW (AM) AST band will be overwritten.

Press the button AST to enter the automatic storing mode and then

- the device makes a sound of “Hua”, and then mute, the display starts to flash.
- after finishing the storage, you will hear a sound of “Hua” again, and the display stops flashing.
- The stations are stored in the Preset button 1-6.
- Sometimes, it is possible that the stations available are less than 6 radio stations.

Preset and Store

Use the preset buttons 1 to 6 to store 6 radio stations in each band.

- Tune to the required radio station.
- Press the required preset button for at least 2 seconds and hears a sound of “Hua”; it indicates you can store the current radio station into the preset button.

Method to operate the CD player

CD play

Put disc into the CD entrance and start playing.

Screen display:

- Sound effect mode (if selected)
- CD play symbol
- Current track number, time elapses.



Track Scanning

The track scanning function enables you to listen to the first 10 seconds of contents of each track.

Press the button SCN to enter the track scanning mode

- Press the button SCN again to exit the track scanning mode.

Previous/Next play



Press the button  or  to select the next/previous track.

 = to next track

 = to previous track

- Start to play the track after the completion of selection.

Fast Backward/Forward

Press the button  or  to fast backward or fast forward the selected track.

- Press this button again to make the device return to the normal play mode.

Random Play

Short press the **RANDOM** button can enter the random play mode.

- Press the button again to exit the random play mode.

Repeat Play

Short press the **REPEAT** button can enter the repeat play current track mode.

- Press the button again to exit the repeat play mode.

Eject Disc

Press the EJECT button to exit the disc.

Audio

CD maintenance

- Please don't leave your finger mark on a disc.
- After a disc ejects from the device, please place it into the CD box to prevent from damaging or foreign particles.
- Please avoid CD heating or exposing to direct sunshine.

CD Operation Method

CD Play

- Connect one compatible **VDO CD** with the device.
- Start playing.
- Screen display:
- Sound effect mode (if selected),
- CD** play symbol,
- Current play track No., elapsed time.
- Press the **DISC**△ or **DISC**▽ to select the required disc.

Track scanning

The track scanning function can search and play the first 10 seconds of all music on this disc.

- Press the **SCN** button to enter the track scanning.
- Press the button **SCN** again to stop the track scanning.

Repeat play

- Short press the **REPEAT** button can enter or quit the repeat play current track mode.
- Random play

- Short press the **RANDOM** button can enter or quit the random play mode.

Previous/Next track

- Press the button △ or ▽ to select the previous/next track.

△ = To the next track

▽ = To the previous track

-- It starts to play the track after the completion of selection.

Fast Backward/Forward

- Short press the button ◀◀ or ▶▶ to fast backward or fast forward the selected track.

Release the button can return to the normal play mode.

USB interface

Press the USB button can switch to USB play mode.

Precautions:

Do not use the following discs:

1. Bad quality or deformed disc.
2. The disc with transparent or semitransparent burning part.
3. The disc adhered with adhesive tape or CD-R label, or label off disc.

Please follow the precautions as below, otherwise the disc or player may be damaged seriously.

1. Do not insert disc player with any other object except disc.
2. Do not apply oil on the disc player.
3. Keep out of the direct sun for the disc storage.
4. Do not insert multiple discs at one time

Audio Shortcut Button



Note: please take actual vehicle as reference.

Left Shortcut Button

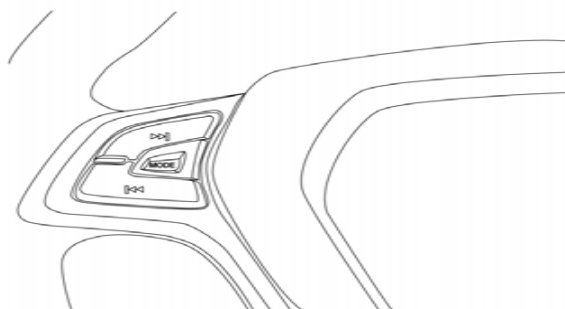

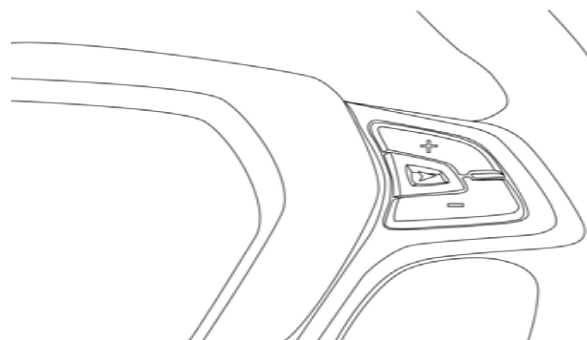

Right Shortcut Button



Note: please take actual vehicle as reference.

Audio

Function and operation method of shortcut button

Button	Operation	Radio	CD player
MODE	Short press	Select other working mode	Select other working mode
	Long press	Mute	Mute
	Short press	+, Volume up; --, volume down	+, Volume up; --, volume down
	Long press		
	Short press	Auto search previous or next track	Previous/next track
	Long press	Manual search previous or next track	Fast forward / backward
	Short press	Next preset radio frequency	Play the 1st track
	Long press	Next band	Track scanning (play for 10s switch to next track)



1. When the vehicle is driving on bumpy roads, it is normal for the player to fail to read the disc or sound an interrupted tone.
2. Please use copyrighted discs, for failure caused by pirated discs does not enjoy quality guarantee.

Chapter 4 A/C System

A/C System

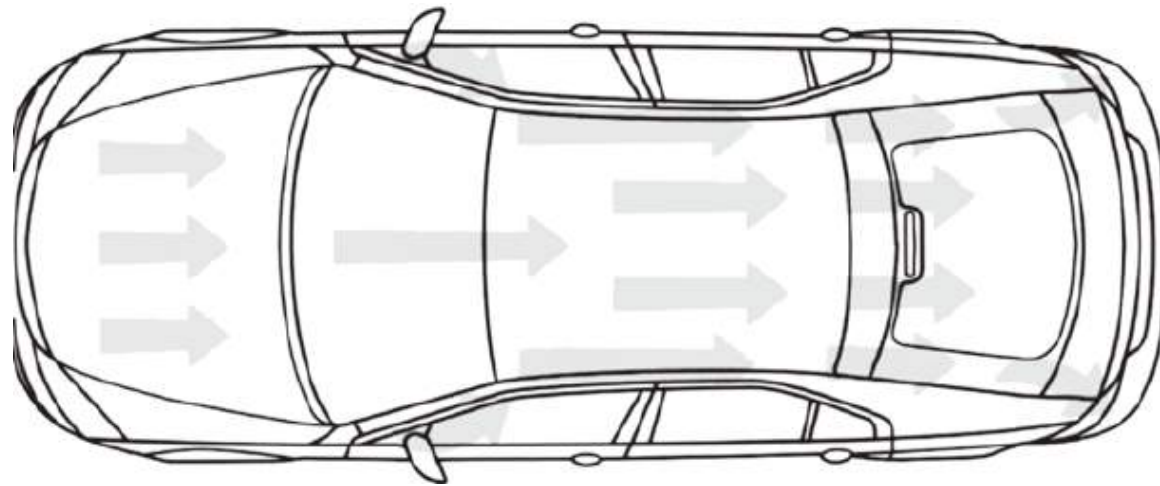

Ventilation

The outside air enters the vehicle through the air inlet at front of windshield. Please keep the air inlet under windshield free of snow and leaves, etc. to the normal and effective working of heating and ventilation.

The indoor contaminated air can be discharged through vent hole of luggage boot side panel.

Notice:

Do not block up the vent hole when loading luggage.

Windshield defrosting vent

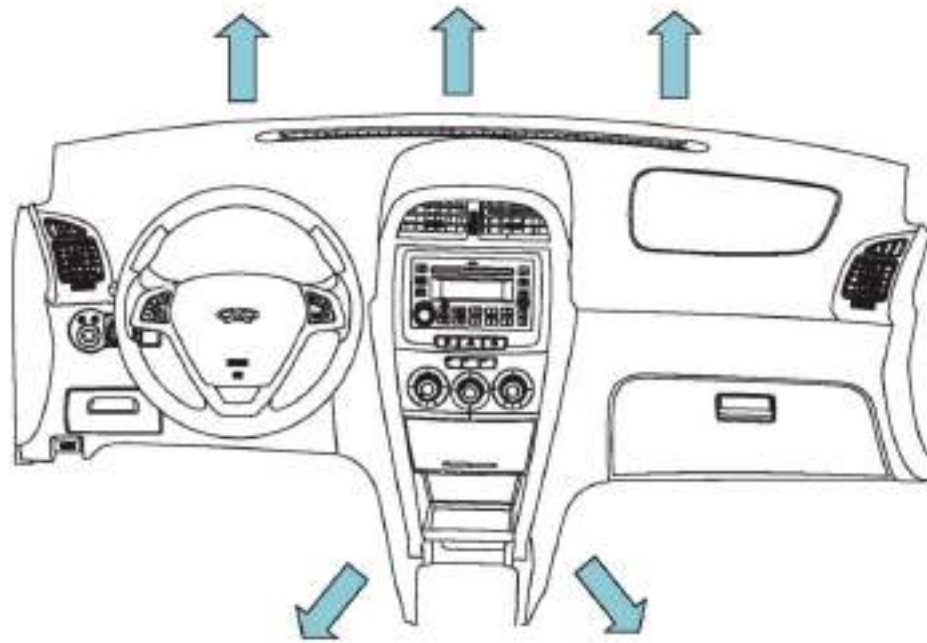

Floor vent

A/C System

Air Filter

The air filter can filter the harmful particles in air such as pollen, industrial dust, road dust and etc before air entering into vehicle.

When passing the automatic car washing machine, we suggest turning off the air blower to avoid excessive wax on air filter.

The air filter shall be changed in accordance with driving environment and customer habits.

Airflow Distribution

The airflow and direction can be adjusted by the button on A/C control panel and control device on central vent.

Central and Side Vent

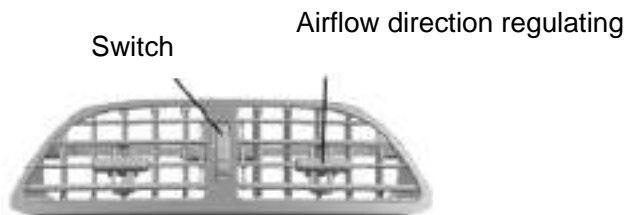

Maximum Airflow

Close the central and side vent can make the maximum airflow flow to the foot area or glass of windshield.

1. Vehicle Internal Circulation Button

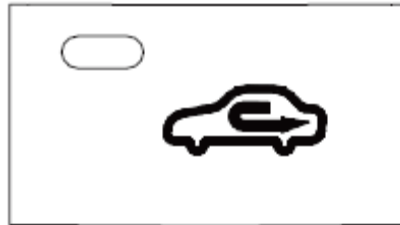

Pressing down or pop up the internal air circulation button can switch between the outside air and internal air circulation. When working in internal circulation mode, the air in vehicle only circulates within vehicle.

In case of hot weather, turning on the A/C and press the internal circulation button can lower the indoor temperature quickly. Also this mode can prevent the outer peculiar smell entering inside.

2. Blower Speed Knob

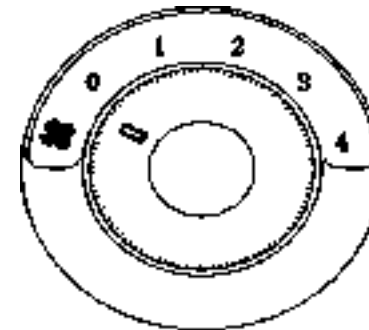

The blower speed knob is used to control speed of the blower. Turn the knob to position 0 can switch off the blower.

3. Temperature control switch

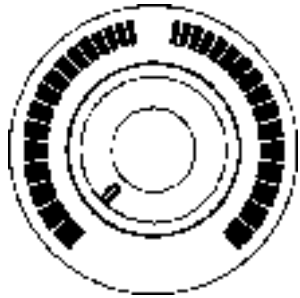



It is used to control temperature of the air flowing out of vent. Turn the knob leftwards (blue area) to get cold air; turn the knob rightwards (red area) to get warm air.

4. Air blow mode knob



The A/C working mode is selected by rotating the air blow mode knob.

Foot blowing:  all output airflow flow across foot area.

Face blowing:  all output airflow flow across face area.

Face and foot blowing:  part of output airflow flow across foot area and others flow across face area.

Defrosting:  The setting is used to let in air and lead them to flow across the floor duct and front defroster;

5. A/C Cooling Button



Pressing the "A/C" button can operate the A/C cooling system.

The cooling system can work only under below conditions:

- Engine is running.
- Environment temperature is over -1°C
- The blower switch is set in position 1-4.

When cooling system is working, it will reduce the inside temperature and lower the inside air humidity, making more comfortable in vehicle and avoid the windows being covered with water vapor.

To achieve the best cooling effect, please close all windows during operating of cooling system.

A/C System

6. A/C Operating Mode

Strongest Cooling

In torrid weather, when the vehicle is exposed under sun for long, open windows for a short time to let hot air inside the vehicle rapidly flow out.

A/C switch: ON

internal/external circulation operating knob: 

Airflow distributing switch: 

Temperature control switch: turn it anti-clockwise to bottom (blue).



Blower switch: maximum speed

Normal Cooling

Normal cooling works in long-distance traveling and quick traveling.

A/C Switch: ON

Internal/external circulation operating knob: 

Airflow distributing switch:  or 

Temperature control switch: blue

Head and foot

This mode is used in transition stage when outside temperature is low without sunlight. When regulating the temperature control switch between cold (blue) and hot (red), the warm airflow will enter vehicle bottom area and cold or normal temperature air will enter the upper room.

A/C switch: ON or OFF

Internal/external circulation operating knob : 

Airflow distributing switch: 

Temperature control switch:



Between blue (Cold) and red (Hot)

Blower switch: random

Ventilation

The air outside the vehicle will flow in through central air vents and side air vents. A/C switch: OFF

Internal/external circulation operating knob: 

Airflow distributing switch:  or 

Temperature control switch: blue

Blower switch: random

Forced Heating

A/C switch: OFF

Internal/external circulation operating knob: 

Airflow distributing switch: 

Temperature control switch: turn it clockwise to bottom.

Blower switch: top speed



Not use "Forced Heating" long so as to avoid inside air becoming foul and generation of fog on windows. In case fog is generated on any window or the window becomes wet, turn off the internal circulation switch. "Forced Heating" only applies to quick heating, and then it should be shifted to "Normal Heating" as soon as possible.

Normal Heating

A/C switch: OFF

Internal/external circulation switch:  Airflow

distributing switch:  or 



Temperature control switch: red

Blower switch: random

Defrosting



A/C switch: OFF or ON

Internal/external circulation switch: 

Airflow distributing switch:  or 

Temperature control switch: red

Blower switch: random

Turning on A/C can improve defrosting performance. When refrigerating, if it is very humid, do not use  or  position, otherwise, temperature difference between outside air and windshield may occur, which will generate fog on inner surface of the windshield to affect vision.

Defogging



A/C switch: ON (pressed on) and working indicator light turns on

Internal/external circulation switch: external circulation 

Airflow distributing knob: 

Temperature control switch: in red zone

Blower switch: appropriate position

1. Using detergent to wash inner surface of glass is an effective method to prevent generation of fog. Use absorbent cotton or soft cloth to dip it and smear at inside of front and rear windshields (including the window glass at rear view mirror); after air dry, use soft dry cloth to wipe away the residual fiber left on the windshield when smearing.
2. When refrigerating, if it is very humid, do not use  or  position, otherwise, temperature difference between outside air and windshield may occur, which will generate fog on inner surface of the windshield to affect vision.

Economical Operation of A/C System



In cooling, the A/C compressor will consume engine power and increase fuel consumption. To save the energy and save fuel, please turn off A/C if unnecessary.

The inside temperature is high if vehicle is parked in sunlight for long time, you can open the window or door for a while to let hot air out. This will help to improve cooling effect and lower fuel consumption.

In driving, please do not turn A/C system on if window is open.

General Remark

The A/C system will absorb the water in cooled air and there is water condensation in evaporator. After stopping vehicle for a while, it is normal if small area of water is found on ground under vehicle.

A/C System

The heating effect depends on engine coolant temperature. After engine is heated, the heating system can work normally.

To avoid the misting on glass, please set the blower at low speed position if driving at low speed.

Please do not blow your body directly by cold wind.

Troubleshooting

Failure of cooling system

- The environment temperature may be lower than -1°C .
- The fuse may burn out.

Check the fuse and replace it if necessary. If the failure is not caused by fuse, please turn off the A/C cooling system (turn off "A/C" button) and send your vehicle to Chery authorized service station for overhaul.

Low cooling efficiency

Once the low cooling efficiency or low airflow is found, please turn off the A/C system and ask technician for overhaul.

Defrosting of Rear Windshield & Rear-view Mirror



The rear windshield and rear-view mirror heating control switch is located on central control panel of instrument panel. Pressing the defrosting heating switch can eliminate the thin ice or mist on glass.

The rear windshield and rear-view mirror heater can work after turning on ignition switch; the heating system is controlled by pressing the electric heating switch. After the heater is working, the working indicator on the switch will be lit to indicate working status.



Once the rear windshield gets clear, please turn off the heater to save the power.

After the defrosting continues for 15 ± 3 minutes or turn off the ignition switch; the rear windshield defrosting will be turned off automatically. If you

stop the rear windshield defrosting manually less than 15 ± 3 minutes, please press the defrosting switch again and the corresponding indicating light will go off.

After the rear windshield defrosting works, the exterior rear-view mirror heater is also working.

If the defrosting switch is pressed before engine starting, the defrosting function works; but the defrosting will stop working after engine starting.

Precautions of A/C System Operation

To extend the service life of A/C system, please pay attention as following:

1. When operating the A/C for cooling, please turn off the compressor 2-3 minutes before vehicle stopping and let the blower continue working (it's better to select the external circulation mode, since outside temperature is higher and the condensed water on surface of condenser core can be dry quickly), to dry up the condensed water on surface of condenser core.
2. When operating the A/C for cooling, in case the outside air is not clean or smells bad, please switch to internal circulation mode timely.

Chapter 5 Light Control

Light Control

Light Control

Please comply with relevant traffic laws when using the lighting devices as follows.

When the vehicle is driven in rainy days, the glass of window will be cooled rapidly and the temperature around the glass inside the vehicle will decrease fast, so the vapor contained in air will be agglomerate to form water. And the water will adhere to the inner side of window glass to form dew. The reason for formation of dew on the inner surface of headlamp glass lens is the same. In other words, the amount of water contained in air will increase with the rising of temperature and if the temperature decreases, the water will be agglomerate to form dew, which is called the fog phenomenon.

If the mirage appears on light fittings of vehicle, within the 30 minutes after the upper beam lamp and lower beam lamp are opened, the mirage appears on headlamp glass lens begins to dissipate and disappears after 1 hour, and this is a normal phenomenon. Or else, there may be water exists. Please contact the designated service stations for authentication and repair.



When replacing the bulb, strictly check the installation of each part of lamp to make sure the correction of installation and good seal! Or else, the serious result that the water and ash enter the light fittings will happen!



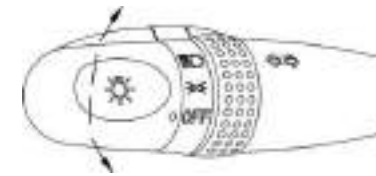

The high-pressure water jet mustn't be used for washing engine compartment, especially the lighting fittings. If it is used, due to the high pressure it gets, the accessory on lighting fittings may loose and fall off, and the air hole, wiring harness and plug-in part will get wet. As a result, the water exists in the lighting fittings or the vapor doesn't dissipate, which will create huge amounts of dew.

Headlamp Switch



OFF turn off exterior lamps

Position 1  the clearance lamp, instrument and switch parts luminous light and license plate lamp is turned on.

Position 2  turn on low beam of headlamp

Note:

The headlamp can work only after turning on ignition switch. When engine is starting up or after turning off the ignition switch, the headlamp will go off automatically.

Headlamp Dimmer Switch

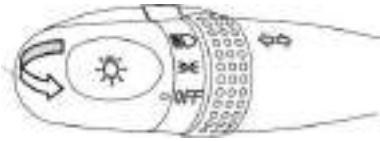

When the headlamp switch is turned on, pull the handle away from the steering wheel to cross the pressure point, and the headlamp will be changed into high beam. And when the high beam is turned on, the indicating lamp of high beam in the instrument will also light. Pull the handle towards the steering wheel to return the former position, and the low beam will be back.

Flashing of Headlamp

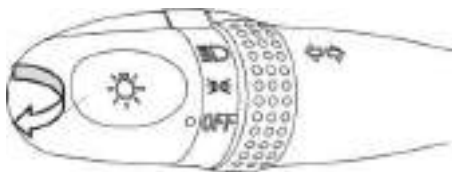

When driving, if you want to flash the headlamp, only pull the handle towards the steering wheel to the pressure point, and then loose the handle and the handle will return automatically. Repeat this action, the headlamp will flash continuously.

Front and Rear Fog Lamp Switches

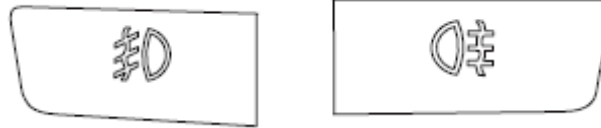

The front and rear fog lamp switches are located on central control panel of instrument panel.

When headlamp switch is in position 1, pressing the front fog lamp switch is to switch on front fog lamp firstly, pressing the rear fog lamp switch is to switch on the rear fog lamp.

Note: the rear fog lamp can be switched on only after switching on the front fog lamp firstly.

When the front fog lamp is switched on, the

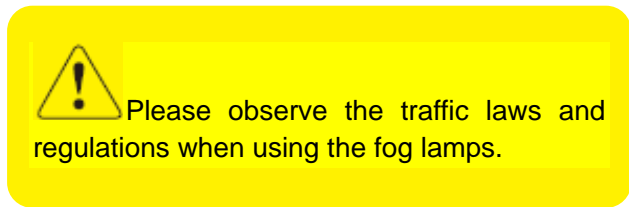

indicator on instrument panel will illuminate. The

front fog lamp is switched on only when it is foggy, snowy and rainy or the visibility is seriously limited.

When the rear fog lamp is switched on, the indicator on the instrument panel will illuminate.

Since the rear fog lamp is highly dazzling, it shall be turned on only when there is a very low visibility.

Turn Signal Lamp

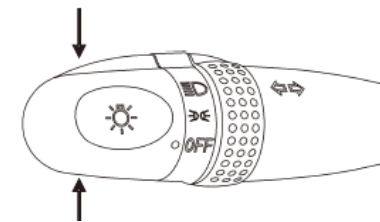

The turn signal lamp can work only after the ignition switch is turned on.

Left turn signal lamp - turn the lever downward

Right turn signal lamp - turn the lever upward

When the turn signal lamp is switched on, the turn signal indicator on the instrument panel flashes at the same time.

Light Control

Way Change Signal Lamp

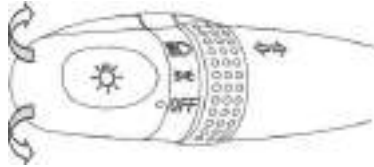

Push the lever upwards or downwards to pressure point and hold on, the corresponding way change lamp will blink, meanwhile the signal indicator on the instrument panel flashes at the same time.

Electric Headlamp Regulating Knob

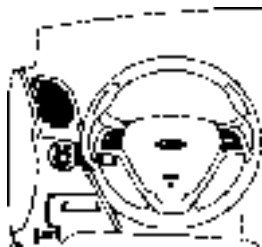

The electric headlamp regulating knob is located at left lower position of instrument panel.

This knob has four positions including 0, 1, 2 and 3. The electric headlamp lights can be controlled by knob 4 positions.

Instrument Luminous Regulator



The luminous regulator is located at left lower of instrument panel and nearby the electric headlamp regulating knob. The instrument panel luminous intensity is controlled by this regulator.

Interior Front Ceiling Lamp

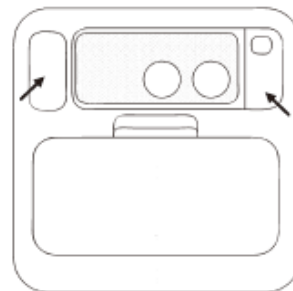

The right one is interior front ceiling lamp switch, the interior front ceiling lamp will light up after pressing down this switch. (the switch shall be pressed in place)

The left one is sunroof control switch and used to control the opening and closing of sunroof.



After leaving the vehicle, please turn off the interior front ceiling lamp if not necessary.

Luggage Boot Lamp



Position OFF: the lamp is off.

Position ON: the lamp is always on.

Position DOOR (door controller position): the luggage boot lamp will be on after opening the rear door or luggage boot cover; the lamp will keep on for 8s then go off automatically after door or luggage boot closing.

Sunroof Control Switch

When vehicle key is turned to position ON, the sunroof can be lifted, opened and closed by operating the sunroof control switch.

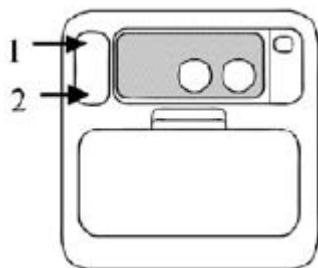

■ Sunroof opening to closing

▶ Press the switch button once, the sunroof will open automatically (One-touch Open):

Keep pressing the button ① for 0.5s, the sunroof will fall down to open automatically; press the switch button again if needs to stop the sunroof during its sliding process.

▶ Press the control switch once; the sunroof will close automatically (One-touch Close):

Keep pressing the button ② for 0.5s and the sunroof will close automatically!

Press the switch button again if needs to stop the sunroof during closing process.

■ Anti-trap System (A.T.S)

In process of sunroof auto closing, it will return to full open condition after meeting certain resistance and the auto-closing function will be disabled in case of continuous three traps. Then keep pressing the close button to close the sunroof. The sunroof auto-open and auto-close function will be recovered after closing it well! The anti-trap function can be started only after meeting certain resistance! It can avoid head, hand, some part of human being or other things passing through the sunroof during its operating. In spite of this, nobody is allowed to stretch the head out of the sunroof during its opening or closing.



In condition of running vehicle and open sunroof, it is not allowed to pass one part of head, hand or body through the sunroof; it will cause accident in case of emergency brake.

■ Sunroof tilting up / down

▶ Sunroof tilting up:

In sunroof full close condition; keep pressing the button ② for 0.5s and the sunroof rear windows will tilt up automatically! Press the switch button again if needs to stop the sunroof during lifting process.

Light Control

► Sunroof falling down:

In sunroof lifting condition, keep pressing the button ① for 0.5s; the sunroof rear window will fall down at closing position automatically. Press the switch button again if needs to stop it during falling down process.



1. The sunroof going down and lifting up can not be enabled at the same time; since the sunroof can not be lift up during going down; also can not going down during lifting up; please close it firstly before starting lifting up or going down;

2. Do not keep pressing the button if the sunroof is fully opened or closed; otherwise it will cause the malfunction of sunroof motor and module.

3. Wash up the dust and other foreign materials in sunroof slide and rubber strip regularly with water.

4. It may cause damage to sunroof glass and motor
If the sunroof is operated in case of being frozen or covered with snow.

Operation of sunroof visor

The position of sunroof visor is shown as Fig.1; the sunroof visor is opened with the sliding of sunroof. If necessary, the sunroof visor can be opened or closed by hand when sunroof is fully closed.

(Note: during the sliding of sunroof glass, do not close the sunroof visor by force)



1. Close the sunroof before leaving the vehicle to avoid water leakage in raining;

2. Wipe off the water on sunroof after car washing or raining; the water onto roof may flow into vehicle when opening the sunroof.

Please contact with Chery authorized service station on following conditions (the fault caused by initial memory lost of sunroof module):

- 1) The sunroof cannot be closed fully or opened, extended. Shacking occurs in process of opening and closing.
- 2) The sunroof cannot reach to original position when opening, extending or closing.
- 3) The sunroof cannot be opened or closed by one short press.
- 4) The sunroof module cannot control the operation of sunroof.



Note: Following operations may cause the initial memory lost of sunroof module

1. During vehicle maintenance, replace the battery or disconnect the power when sunroof is not at initial position.
2. Disconnect module power during sunroof operation.
3. When sunroof controller can not return to normal position.
4. Other causes that leads the lost of module initial memory.

Front Doorsill Lamp and Key Hole Luminous Lamp

When left front door is opened, the key hole luminous lamp will be on.

The front doorsill lamp is installed into two front door inner trim panel; Regardless if ignition switch is turned on, the doorsill lamp will be on if door is

opened. The doorsill lamp will light up foot area to guide driver and will go off automatically after closing the door.

The key hole luminous lamp is installed around the ignition switch. This lamp will be on once opening the left front door to help driver inserting ignition key. The lamp will go off when key is switched to position "ON".

Hazard Warning Lamp Switch



The hazard warning switch is only for use under emergency; it can warn the following vehicles of a failure or a dangerous condition. Pressing this switch down can turn on or turn off the hazard warning system. The hazard warning light can still work even if ignition switch is turned off.

After the warning light is turned on, the indicator light on the switch will flash. At the same time, turn signal indicator lights on the combination instrument will also light.

Daytime Lamp

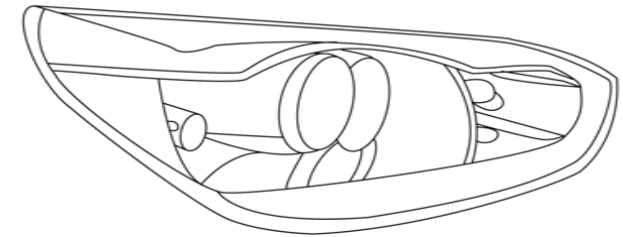

Daytime lamp



When engine is running normally, the high beam and fog lamp is turned off and release the hand brake; then daytime lamp will be on and daytime lamp symbol is lit on instrument panel.

If the high beam and fog lamp is turned on, the daytime lamp will be turned off automatically. But the lamp will not go off if using the turn signal lamp for short time.

Chapter 6 Operation & Adjustment of Vehicle Devices

Steering Wheel Lock/Ignition Switch



The combined steering wheel lock/ignition switch has key positions as follows:

LOCK - the ignition switch is turned off and steering wheel is locked.

In order to make sure that the steering wheel is locked, after the key is pulled out, turn the steering wheel until hearing the lock meshing sound of steering wheel.

ACC - steering system is unlocked. The electric accessory circuit is on and the electric appliances such as audio player, cigar lighter and wiper can be operated, but the ignition switch and main electric circuits are all cut off.

If the key can't or is difficult to be turned to this position from LOCK, the steering wheel may be turned around gently and the lock device of steering wheel will be released.

The ignition key shall not stay in this position too long time to avoid the battery power loss.

ON - the ignition circuit is connected. All the electric appliance loops can work, and the warning lamp and indicating lamp light. This is the normal position of key when the vehicle is being driven and the position which shall be chosen when the vehicle is being trailed.

START - the starting motor is connected to start engine.

When the locking hole is in this position, the wiper and audio player of high power consumption will be cut off to ensure vehicle starting.

If the starting fails, the ignition key shall be turned to the LOCK position before restarting and then turned to this position. After start, the key will automatically go to ON position when releasing the key.



Once the engine is started, the key shall be loosened immediately.

After pulling the key out of ignition switch, the steering wheel lock will be activated to lock up the steering wheel.



When vehicle is moving, do not turn the key to position LOCK.

Adjusting Steering Wheel



Operation & Adjustment of Vehicle Devices

In order to drive safely and comfortably, sometimes the extending length and height of steering wheel is required to be adjusted. Here, pull the adjustable handle under the protective cover of steering column towards steering wheel, and now the steering wheel can be moved up and down to certain position. After the steering wheel is adjusted in position, release the adjustable handle so that the steering wheel can be locked.



It is forbidden to adjust the steering wheel in driving.

Steering Wheel Horn



□ Horn

Press the button with horn marked on the steering wheel, the horn sounds immediately. When the ignition switch is off, the horn still can be operated.

Windshield Wiper and Washer System

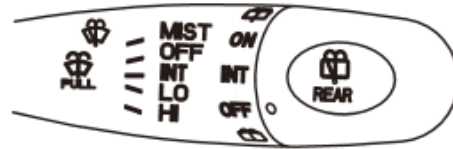

In cold seasons, the wiper blade shall be check whether it is frozen on the windshield before being used. If it is, the wiper blade shall be made melt before being used. Or else, the wiper motor will be damaged.

If there are obstacles on the windshield, for example, snow, the wiper motor will be also damaged when the wiper is operated. If there are obstacles on the windshield, for example, snow, the wiper motor will be also damaged when the wiper is operated.

The below functions are available only when the ignition switch is on.

Single Wiping (MIST)

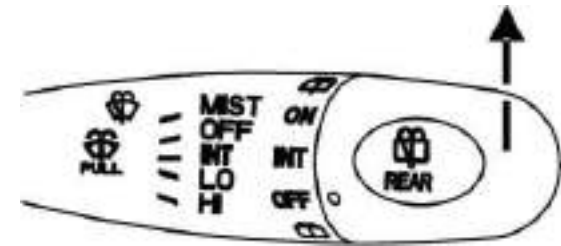

Rotate the control lever upwards.

Intermittent Wiping (INT)

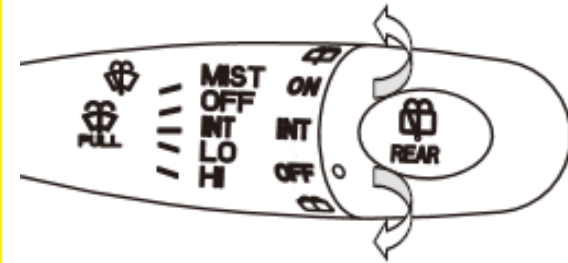

Rotate the control lever downwards by one position.

Operation & Adjustment of Vehicle inside Device

Low-speed Wiping (LOW)

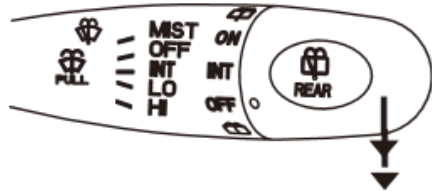

Rotate the control lever downwards by two positions.

High-speed Wiping

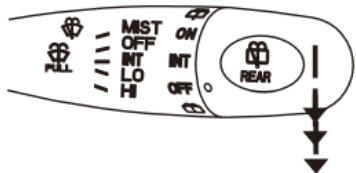

Rotate the control lever upwards by three positions.

Water Spray Switch

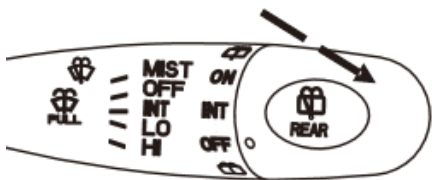

Pull the handle of switch towards the steering wheel and hold the position, the washing liquid will spray through the nozzle before the windshield, and at the same time, the wiper works. The spray immediately stops after the handle is loosened, but the wiper still scrapes for 3 times.

 The time of water spray shall not exceed 10 seconds for every time, and it mustn't be done when there is no washing liquid in the fluid reservoir.

Rear Windshield Wiper and Rear Washing Switch

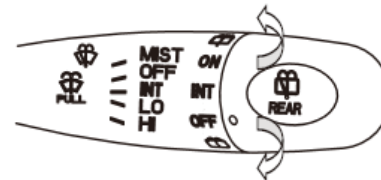

Rotate the switch lever downwards and hold the position; the washing fluid will spray from nozzle behind the windshield; releasing the lever is to stop spraying water. Rotate the lever upwards by one position is intermittent wiping; rotate the lever upwards by two positions is normal wiping; rotate

the lever to the end is rear windshield washing status.

Vehicle Interior Rear-view Mirror

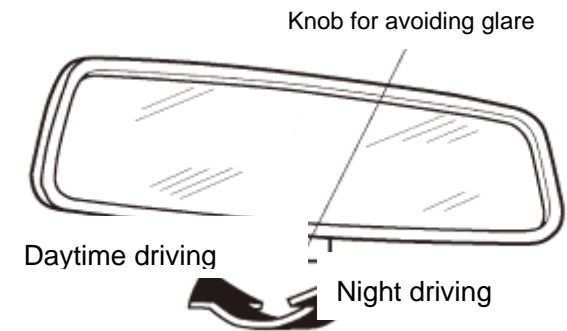

When driving at night, pull the adjustable knob backwards can adjust the angle of rear-view mirror in order to reduce the glare.

Sun Visor

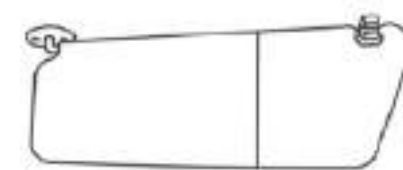

The sun visor can be loosen through the retaining clip and rotated towards side window.

Operation & Adjustment of Vehicle Devices

Sun glasses Box

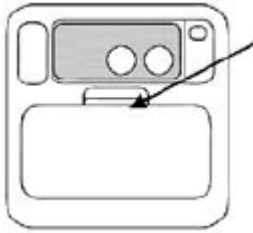

Press it can open the box.

Control Switch on Doors

Switch on left front door



Right front door

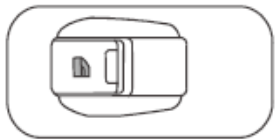

Left and right rear door

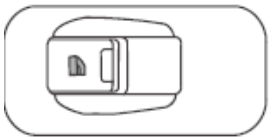

When the ignition switch is in the “ON” position, the power window can be operated; after the ignition switch is turned off for 60s, the window regulating is disabled.

Every window can be operated by the control switch of glass regulating which is on the interior trim panel of each door.

The window can be opened or closed through pressing or lifting the switch. Methods: manual rising up or falling down; automatic falling down.

Except the switch of window of the door which is near the driver, there are still three switches of window on the trim panel of the door which is near the driver.

Electric Exterior Rear-view Mirror



The switch of electric rear-view mirror is in the left lower position of instrument panel. And this switch can work only when the ignition switch is turned on.

When the “L” button of electric rear-view mirror is

pressed, the left exterior rear-view mirror can be adjusted by pressing the direction buttons.

When the “R” button of electric rear-view mirror is pressed, the right exterior rear-view mirror can be adjusted by pressing the direction buttons.

Manual Foldable Exterior Rear-view Mirror



If necessary, for example, in a cabined space, the exterior rear-view mirror can be pulled inwards by hand. If you want it back, the rear-view mirror can be pulled forth with a certain angle and it will return automatically.



The view in the outside rear-view mirror is smaller and farther than it actually is. Do not overestimate the actual distance.

Safety Switch of Rear Window

There is still a safety switch button on the trim panel of left front door. Press the button, the electric window switches of right front door and two rear doors are invalid. Then the regulating of window is only controlled by the switch of left front door. It is suggest operating it if child is sitting on rear seat.



Be careful when closing the window!
Please observe carefully to avoid injury
caused by window crushing.

Driver Seat Heating Switch



This switch is located at right lower of steering wheel.

Pressing the HI button is to heat the seat backrest; and the HI yellow working indicator will be on.

Pressing the LO button is to heat the cushion; and the LO green working indicator will be on.

Front Passenger Seat Heating Switch



This switch is located at right lower of steering wheel.

Pressing the HI button is to heat the seat backrest; and the HI yellow working indicator will be on.

Pressing the LO button is to heat the cushion; and the LO green working indicator will be on.

Front Ashtray

The front ashtray is in the armrest you can open it by opening the cover. If want to empty it, take the ashtray out.

Operation & Adjustment of Vehicle Devices

Cigar Lighter



The cigar lighter shall not be inserted in for a long time to avoid danger. If a child stays in the vehicle alone, it shall be taken away.

If you want to use the cigar lighter, press it and wait it springs out automatically.

Glove Box

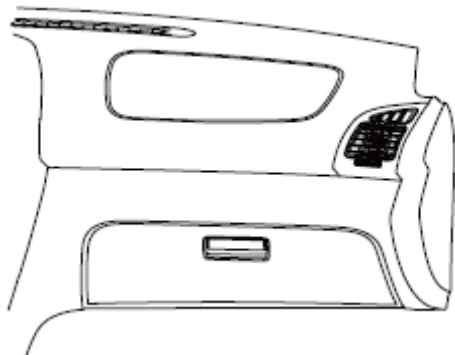

The glove box is located at right lower of instrument panel; press the button of glove box can open it.

Left Small Glove Box



The left small glove box is located at left lower of instrument panel; press the button of left small glove box can open it.

Storage Box

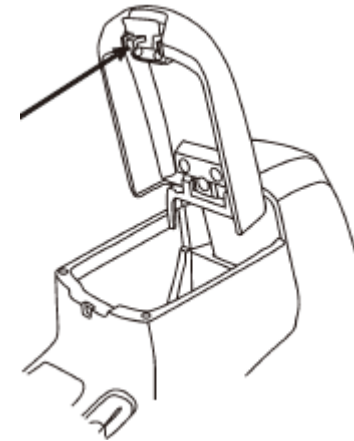

The storage box is located at central armrest; it can be opened by pressing its button.

Rear Ashtray

The rear ashtray is located at armrest back; it can be opened by pulling the ashtray backwards; the central armrest rear part can provide one cup holder for rear passengers.

Auto Cruise System Switch



1. The ignition switch is turned to position ON, press the cruise button ON, then the cruise indicating light will light up on instrument panel and blink, it is pre-cruise condition; When vehicle is driving in cruise mode, the cruise indicating light will light up constantly without blinking to indicate the system is working.

2. When vehicle speed is over 25Km/h, after pressing the cruise button SET, you can increase the speed by pressing button ACC or decrease the speed by pressing button DEC; if keep pressing the button ACC or DEC without releasing, the speed will be increased or decreased constantly by certain speed value. Set the required speed and vehicle will run at the set speed (please refer to the electronic cruise control system of chapter 9)

3. If the vehicle driving condition is changed (such as brake, shift to gear N or set speed is lower than 25Km/h), vehicle will quit the cruise mode automatically; if original cruise status is needed, please press the cruise button RESUM (please refer to the electronic cruise control system of chapter 9).

4. If needs to quit the automatic cruise system, press the button F on automatic cruise switch.

Multi-function Display

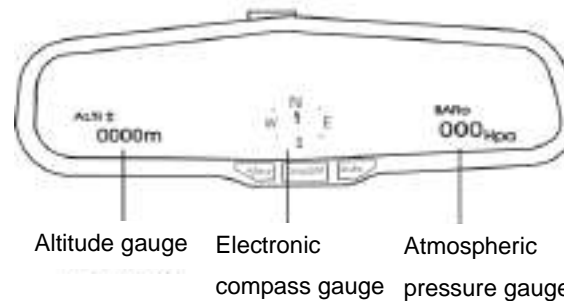

The 09 model multi-function display works on vehicle interior rear-view mirror; the main functions of the multi-function display are as following:

1. Electronic compass;
2. Atmospheric pressure gauge;
3. Altitude gauge.

The electronic compass

The electronic compass indicates in 8 directions to show the real-time display of current vehicle head direction; its layout is designed in the way that north points up and south points down; west points left and east points right. The display effect shows as following:

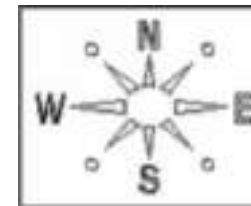

Since the geomagnetic field is relatively weak and can be interfered easily; the electronic compass maybe not able to show the correct direction under following conditions:

- The vehicle stops immediately after running. The direction guide cannot be adjusted when vehicle is stopped.
- When vehicle is running on slope.

Operation & Adjustment of Vehicle Devices

- The vehicle location's geomagnetic field is interfered by artificial magnetic field. (E.g. underground parking, under the tower, between buildings, roof parking, near the crossroads, besides the large vehicles and etc.).
- Be magnetized (the magnet or metal object is placed onto or near the multi-function display instrument).

The calibration of electronic compass gauge (calibration by driving in circle)

Sometimes the direction guide may show no direction change when changing the vehicle's direction. To adjust the deviation, stop the vehicle and carry out following procedures:

1. Long press the ADJ adjustment button ($\geq 5s$) until the 8 red indicators of the Electronic compass gauge blink simultaneously, the blinking frequency is 1HZ;
2. Drive the vehicle slowly in anti-clockwise direction by one cycle and stop the vehicle.

Short press the ADJ adjustment button ($\leq 1s$), the direction display will be recovered in normal mode and the calibration is finished; or after entering the calibration mode and 128s later, the direction will return to normal mode automatically and the calibration is finished.

3. It is suggested to perform magnetic direction calibration once before vehicle's delivery from factory.

Note: do not make calibration by driving in circle in location where the geomagnetic field is interfered by artificial magnetic field. (E.g. underground parking, under the tower, between buildings, roof parking, near the crossroads, besides the large vehicles and etc).

Atmospheric pressure gauge

It shows the atmospheric pressure where the vehicle running. The pressure display unit is hPa and the measuring range is from 540hPa to 1040hPa, the Min. variation range is 5hPa. The display effect is shown as following:



The atmospheric pressure gauge shows the measured value and is not adjustable.

The showing of pressure value may deviate from the actual value since the value depends on the temperature, humidity and driving conditions.

Altitude gauge

The altitude means the vehicle's location level that relative to sea level and the altitude value is adjustable;

The altitude measuring range is -200~5000m; the Min. variation range is 50m. it displays -200m if the altitude is lower than -200m,; it displays 5000m if the altitude is higher than 5000m;

(1) Altitude

Since the altitude value is converted from atmospheric pressure value and can be easily affected by factors of airflow, temperature and etc, the display value may have deviation; you can correct the deviation by adjusting the button.

The display effect is shown as following:

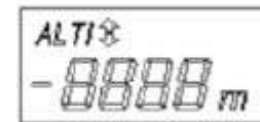

Operation & Adjustment of Vehicle inside Device

(2) Relative altitude

It shows the relative altitude between two locations and cannot be adjusted; by pressing the button “MOD”, it can be switched between altitude and relative altitude;

The relative altitude measuring range is $\pm 5200\text{m}$; the Min. variation range is 50m.

The display effect is shown as following:

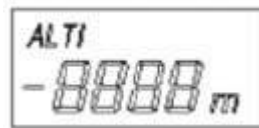

After confirming the current location as the starting point, to know the relative altitude between the destination and current location, you can make adjustment by following method:

1. Long press the button “Mod” (>5s), to enter into relative altitude mode;

Meanwhile press the left button “ ” and right button “ADJ” over 1s; then the relative altitude is set as 0m.

2. After the vehicle reached to destination, the display value shows the relative altitude between two locations.
3. Under the relative altitude mode, long press the button “ MOD” (>5s), the display will return to altitude mode.

Normally the error of basic Atmospheric pressure gauge and altitude gauge shall meet the following specifications:

Altitude check poin (m)	Corresponding atmospheric pressure	Indicating error range (m)
-200	1040	± 100
0	1013	± 100
500	955	± 150
1000	898	± 150
1500	845	± 150
2000	795	± 150
3000	701	± 200
4000	616	± 250
5000	540	± 300

Operation & Adjustment of Vehicle Devices

Button function

Button	Function
Mode (▲MOD)	
▲(Up) ▼(Down)	<p>(1) Altitude adjustment, pressing the button ▲ once is to increase 50m, reversely pressing the button ▼ is to decrease 50m; (2) Pressing the button ▲▼ at the same time is to set relative altitude as "0". Remark: the button "▲▼" is the compound button, the "MOD" and "ADJ" share one button.</p>
Display switch (ON/OFF)	Switch ON/OFF
Adjustment (ADJ▼)	Select the direction indicator and adjust the mode

Reverse Radar

The vehicle reverse radar system is combined by three probes and one control module; they work when vehicle is in reverse gear and show the reversing information on LCD of combined instrument. The detecting system response way includes buzzer and screen response ways. The relationship between displayed frequency, displayed distance and actual obstacle distance is as below:

Actual distance (cm)	<35	35~60	61~90	91~150	>150
Buzzing frequency	Long	4Hz	2HZ	1HZ	No buzzing

In operating, please notice the below points:

1. The detected distance is the shortest distance between obstacle and bumper vertically.
2. The maximum detecting distance: for standard obstacle, the furthest detecting length is 150cm.
3. The displayed minimum precision is 5cm; such as if the actual distance is 34cm which displays as 30cm; if the actual distance is 36cm which displays as 35cm; the default distance unit is m.

Displayed symbol meaning:

1. The nearest obstacle is at left side, displays as L
2. The nearest obstacle is at right side and displays as R.
3. The nearest obstacle is at left central or right central; displays as C.
4. The LCD displays the nearest distance between any probes to obstacle. Note: for safety, the reversing speed shall be less than 5km/h.

Operation & Adjustment of Vehicle inside Device

The parking radar probe detects the nearest object. It may not detect the bumper of a vehicle with a high body.

The content of this manual may be inconsistent with the actual condition of the vehicle due to changes in specifications.

Please wipe with cloth or wash away (low water pressure) snow or mud stuck to the surface of the reversing radar probe.



High pressure water such as water gun or big external forces may cause the radar probe to fail. So do not press or knock the surface of the radar probe.

If approaching the obstacle and finds no warning, during reversing, please check:

- If the surface of the radar probe is stuck with snow or mud.
- If the surface of the radar probe is frozen.
- If the vehicle has been parked for a long time in hot or cold weather.



The radar probe may malfunction if the temperature is below -30°C or above 80°C .

Please note that the radar probe may not give an alarm even if it approaches the following obstacles:

- Wires, ropes, mesh walls and other thin objects
- Low objects such as stones
- Soft snow, cotton, sponge and other objects that absorb ultrasonic wave easily.
- When water drops are splashed and frozen on the surface of the radar probe
- When the reversing radar probe is stuck and covered with snow or mud.



For obstacles outside the detection range, the radar probe does not give an alarm. For several obstacles, the reversing radar probe gives an alarm only for the nearest one. In addition, please note that when the vehicle is moving, the reversing radar probe on the other side of the vehicle may approach other obstacles.

Please note that in the following situations, false detection may occur:

- When the honk of other vehicles, the engine noise of motorcycles and objects that give gas braking sound approach.
- When the vehicle is driving in jellylike snow or rain;
- Based on their shapes, objects that are hard to reflect ultrasonic wave (refer to the following figure).

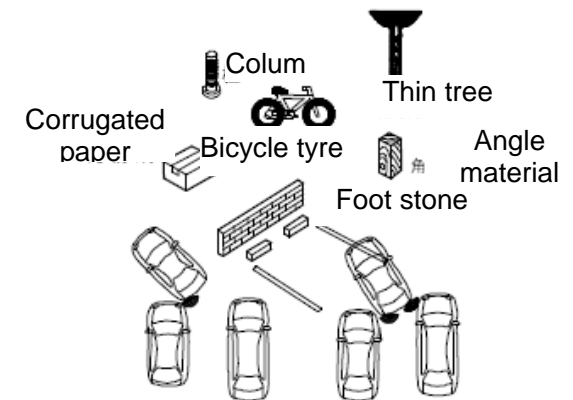

Chapter 7 Door Lock & Anti-theft

Door lock and Normal Anti-theft Remote Controller

The key to this vehicle can operate all the locks of your vehicle. If it is lost, you can ask for a new one from Chery authorized service station. You would better put your second key at a safe place for emergency use.

Remote Controller

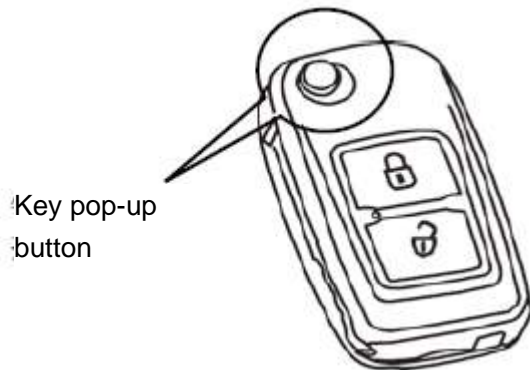

Press down the key pop-up button, and the key will eject out from the remote controller inside. When you use the remote controller to lock the door after all the doors are closed, if the windows do not rise, press the lock button on the remote controller for over 3 seconds so as to not only lock the doors but also raise the windows; the key can be folded after usage for the convenience of carrying.

Central Control Door Lock System

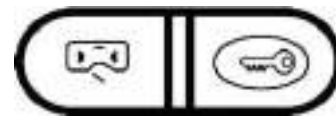

All the doors of this vehicle can be operated by key, remote controller and the control switch on the driver & front passenger side door trim panel.

You can lock or unlock all the doors by key outside the driver-side door.

When all doors are closed, press down the lock button on the driver's door trim panel, and all the doors will be locked simultaneously; press down the unlock button on the driver's door trim panel, and all the doors will be unlocked simultaneously.

During unlocking, the safety pull rod handles of all the doors will move backwards; while during locking, the safety pull rod handles of all the doors will move forwards. You can also lock the door by pressing down the safety switch.



In order to avoid outside force intruding into the vehicle during driving, you should drive the vehicle with all the doors totally locked.

Door Lock & Anti-theft

Door Lock

The front door can be locked or unlocked by key from the outside. In the vehicle, you can unlock the door by door handle.

If you need to lock the rear door, you can press down the safety switch when leaving the vehicle, and then close the door.



If vehicle speed reaches 40Km/h, the door will be locked automatically; in door lock status, the speed sensing lock only can be disabled manually except engine stops and speed sensing lock is not working.

Child Safety Lock of Rear Door

The child safety lock switch of rear door can be enabled by pushing it forwards. At this time, the rear door can be only opened from the outside of the vehicle. The child safety lock function can be cancelled by pushing backwards the child safety lock switch.

The figure shows the position of child safety door enable position. Pulling the child safety door lock forwards is to enable the function of child safety door lock.



If child safety lock is in close position, but the inside opening handle cannot work (feels inside opening handle is clipped, unable to work), please do not operate the inside opening handle by force, otherwise the inside opening system will be damaged.



In hot weather, the temperature inside the vehicle will rise quickly after the engine is shut down. If there is person or animal staying in the high temperature at such time, even for a very short time, they may be hurt or even killed (including brain death) by the high temperature inside the vehicle, which is more dangerous for infants. Therefore, check the inside of vehicle before locking, and do not leave infants or the animal in the vehicle.

Releasing Rod of Fuel Filler Cap

The fuel filler cap releasing rod is located at left of driver seat and besides left front doorsill; the fuel filler cap can be opened by pulling up the releasing rod.

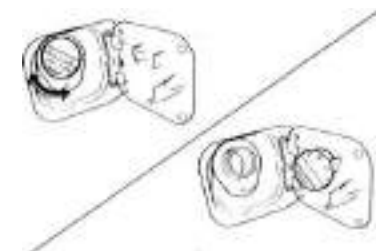

As shown in the figure, the screwed off fuel tank cap can be hanged onto fuel filler cap.

Opening Engine Hood

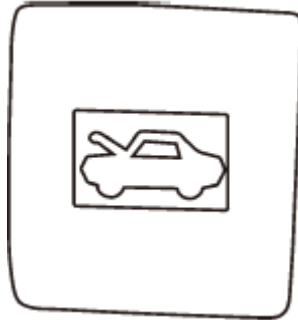

1. The engine hood opening lever is located at the lower left of the instrument panel. If you pull the lever backward and downward, the engine hood lock will be opened.
2. Walk to the vehicle front, reach your hand under the front end of engine hood, and then you can touch the engine hood lever. Push the lever leftward, and pull up the engine hood at the same time.



3. Lift the engine hood and it will be supported by two air shock absorbers.

4. When closing the engine hood, first lower the engine hood to the height of 20-30cm above hood lock, and then let it fall into the pawl.

5. After closing the engine hood, do try to lift the hood to ensure whether the engine hood lock is locked totally or not.



The engine hood must be completely closed during driving. If you find that the engine hood is not closed firmly, you must stop driving at once and close the engine hood.

Wireless Remote Control System with Anti-theft Function

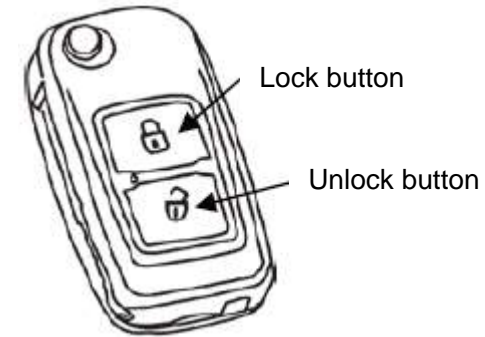

The maximum range of action of the remote controller is about 10m. If the distance between the remote controller and vehicle is over 6m, the remote controller may not work normally.



If the frequency of the remote controller is interfered, it may not unlock the vehicle. Then you can directly lock or unlock it by key. Other wireless short-distance emitters may also use the emissive frequency of remote controller (like amateurish radio, medical device, wireless headset, remote controller, and alarm system) to interfere the remote controller.

Door Lock & Anti-theft

Locking and Unlocking of the Door

Press locking button  on the remote controller once, and all the doors will be locked; at the same time, the safety LED will show the system is in alert condition, which means the anti-theft function is enabled.

Press this unlocking button  once, and all the doors will be unlocked; which means the anti-theft system is disabled.

Anti-theft Alarm System

The system function is to prevent unauthorized person opening door or luggage boot; when anti-theft system is enabled, the door turn signal lamps will blink and alarm will sound up.

Alarm

If the anti-theft system is not disabled, someone try to open the doors, luggage boot or attempt to start engine or remove the radio; the alarm will be enabled again..

Replacing the Battery of Remote Controller

If the range of action of remote controller is gradually decreased, you should replace the battery. (The battery model shall be specified by Chery.)

Follow the following steps:

1. Use plain end tools to open the remote controller unit from the side clip.
2. Carefully pry out the battery and then insert the new battery into the two connection points with the mark (+) facing upwards.
3. Assemble the remote controller unit in reverse order of disassembling.



The used lithium cell cannot be dealt with as general household rubbish. Please send it to the qualified waste disposal station.

Chapter 8 Seat & Safety Protection

Seat & Safety Protection

Seat



Correct Sitting Position

The seat, headrest, seat belt and safety airbag can help to protect passengers. Fully using these articles can help you get more protections. Therefore, please obey the following points:

- Sit upright, try to lean back the lower part of your back as possible as you can. The leaning angle of seat back should not exceed 25 degrees.
- Adjust the headrest properly to make the top of the headrest level with that of your head.

- Don't put the seat too close to the instrument panel. The arms should be slightly bent to control the steering wheel during driving. Feet should also be slightly bent in order to fully step on the pedal to the floor.
- The shoulder seat belt of seat should cling to and diagonally pass against the breast via the centre of the outside shoulder, but never via the neck. The waist seat belt should cling to and pass against the hip but not the stomach.



It is forbidden to adjust seat during driving.

Adjustment of Front Passenger Seat



Adjusting forwards or backward

Adjusting forwards or backward

Adjusting the Seat Forward and Backward

As shown in the figure, by pulling up the adjusting rod on the front outer edge of the seat, you can slide the seat forward and backward. When the seat is adjusted to the right position, release the adjusting rod, and shake the seat forward and backward to ensure whether the seat is locked on the track.



Seat height adjusting

You can adjust the seat height by your body height, body shape and driving habit to get the best driving sight and comfort level.

Adjust the Seat Leaning Angle

Please first lean your back against the seat back, pull the adjusting handle (as shown by upper figure) and then adjust the seat back to the right angle you want by changing the leaning angle of your body; then releasing the adjusting handle, shake the seat back rest forward and backward to confirm if the seat back rest is locked up.

Adjust the Driver Seat

Move the seat forward and backward; the adjusting method of seat back leaning angle is the same as the other seats.



Adjusting the seat during driving may cause the vehicle out of control and result in an accident. For your safety, please adjust the seat after you stop the vehicle.



The driver seat adjusting handle shall not be operated by other passengers during driving; the movement of driver seat may cause vehicle out of control and result in accident.

Headrest

If the vehicle is crashed by the vehicle behind during driving, the headrest can limit the movement of your head and thus protect your cervical vertebra. However only when the headrest is adjusted to the right position, it can perform protection function.

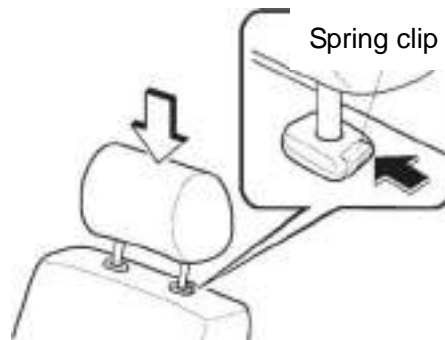

If the vehicle is crashed by the vehicle behind during driving, the headrest can limit the movement of your head and thus protect your cervical vertebra. However only when the headrest is adjusted to the right position, it can perform protection function.

Adjusting Method of Headrest

Hold the both ends of headrest by hands and then pull up or press down the headrest

The best height of headrest is keeping level with the top of your head.

Assembly and Removal Method of Headrest

When removing the headrest, it is needed to press headrest spring clip outer of guide part by hand, then pull the headrest out of the guide part; when mounting the headrest, firstly you should separate the front and rear seat headrest (the front seat headrest is arc-shaped and the rear seat headrest is L-shaped with straight lower feet rod), then push the headrest feet into the guide part until the spring clip on the guide part is meshed correctly.

Seat & Safety Protection

Rear Headrest

The adjusting, removal and assembling method of rear headrest is the same as front headrest.



Headrest adjusting:

The headrest can't be removed or adjusted too low during driving so as to avoid the neck damage during the crash for the head is lack of support. The headrest shall be adjusted to the right position.

Rear Seat

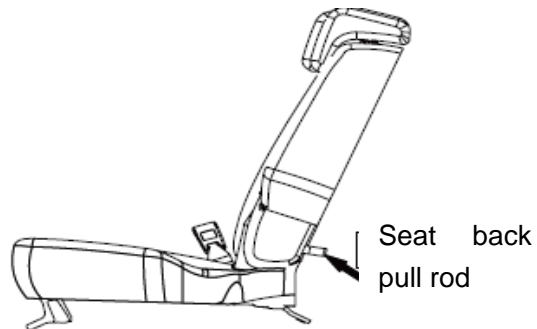

Open the luggage boot, pull up the pull ring of rear seat back; push the seat back by hand to fold the rear seat.

Carrying Luggage

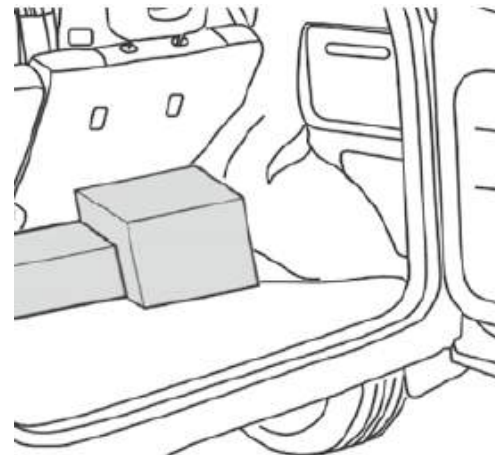

The luggage and other loaded articles should be put in the front part of luggage boot as possible as you can. Driving with the rear doors open is very dangerous, as excessive exhaust gas may go into the vehicle from the open luggage boot.



If your articles need to be placed in the vehicle, please fix them to avoid moving.

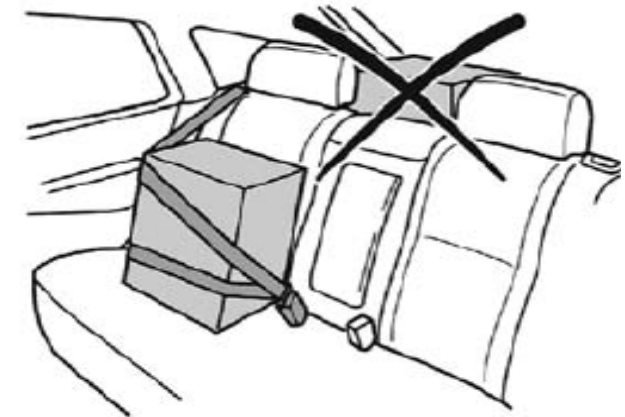

Seat Belt

The seat belt or safety seat for children must be used at any moment. The seat belt should not be shared by multiple persons. Ensure that the seat belt is done up well without looseness, distortion or obstacle.



Both the driver and passenger in the front seats should fasten the seat belt well during the driving.



Don't wear loose and thick clothes. To achieve best protection, the seat belt should cling to the body.

After vehicle is moving, do not let child sit on the knees; the child safety will be in danger in accident.

Alarm Lamp of Seat Belt Unfastened



The alarm lamp should be lighted when the ignition switch is turned on. Keep it on to remind the passengers to fasten the seat belts.

Fastening Seat Belt

Pull out the seat belt smoothly. It may be locked if overexerted or the vehicle is on the slope. The seat belt should be placed at the centre of outer shoulder, and the belt part should cling to the belly but not the stomach.



Insert the clapper into the buckle clamp until a click is heard, or the seat belt is not locked correctly.

To loosen the seat belt, press down the red button on the seat belt buckle and let the seat belt draw back smoothly.

You shall ensure that each seat belt is equipped with correct belt buckle.



If the seat belt still can't be pulled out, please pull and then loose it by force quickly, and the seat belt can be pulled out smoothly.

Central Two-point Rear Seat Belt



The length of this seat belt cannot be adjusted automatically. When using it, insert the clapper into the buckle clamp until hearing a click, and then adjust its length manually so that the seat belt clings to the hip.

Do not over tilt the front seat; the seat belt can provide maximum protection when seat is almost upright.

Seat & Safety Protection

Central Three-point Rear Seat Belt



Firstly fix up the seat belt; then insert the waist belt clapper into the buckle clamp until a click is heard; then adjust the seat belt and waist belt in correct position.

Adjusting of Front Seat Belt Height



It is forbidden to let seat belt go across neck. To adjust the seat belt height, please press the lock-up button on height regulator (as shown by upper figure) and move the belt upwards and downwards to let seat belt go across the shoulder center; then release the lock-up button and shake

the regulator to confirm if it is locked up.

Maintenance of Seat Belt

Check of Seat Belt



Regularly check the seat belt for damage or abrasion. The stretched seat belt (for example, after a traffic accident) should be replaced and the relevant parts should be checked by Chery authorized service station.



Don't try to repair or lubricate the retractor or belt buckle mechanism of safety belt, or change the seat belt in any way, or else Chery Company will not be responsible for the problem caused therebv.

Cleaning Seat Belt

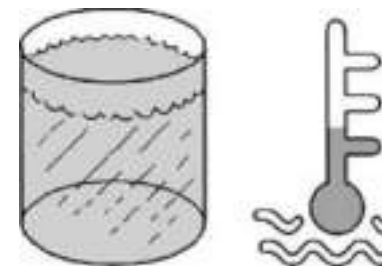

Clean the seat belt with interior detergent or clean warm water and make it dry naturally rather than by any manual heating manner.



It is forbidden to use chemical cleaning agents, boiling water, bleach or dye. It is not allowed to let water leak into seat belt retractor mechanism.

Airbag

Jointly using the airbag and seat belt will help to reduce the danger of severe injury during heavy collision.



The airbag will make a tremendous noise when inflated, and harmless smog-like powder will be left. Those are normal phenomena.

Front Airbag



Very dangerous! It is forbidden to use rear-direction child seat at the seat with front airbag.

This is an ideal driving posture, which helps to reduce the danger of injury to the driver when the airbag is opened.

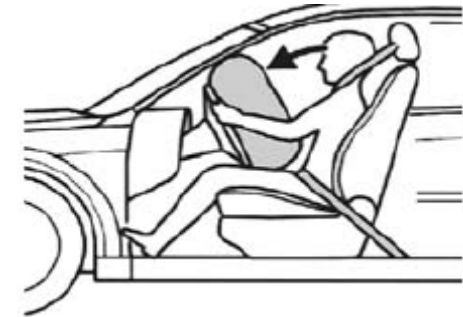

Severe front collision (front collision or collision within left or right 30° range) will lead to the explosion of front airbag. Within one thousandth second after the collision, the airbag will inflate. When touching the body of driver, it will deflate to buffer the forward movement of passengers. Slight collision, rear or side collision will not lead to the explosion of airbag.

Note: the severe vehicle bottom collision may cause the explosion of airbag, such as: knock the edge of road side, pavement or hard obstacles surface, drop or leap the deep hole or wheel falls off.



Front passengers can get the best protection only by sitting uprights as shown in the right figure above.



Please wear the seatbelt any time and keep proper distance with steering wheel. By using seat belt, it can ensure the best protection performance for body.

Both the seat and the backrest should be located correctly so as to assist the airbag in achieving the best protection. Sit straight and try to keep the lower part of back clinging to the backrest. The backrest should not incline backward over 30 degrees. Don't keep the front seat too close to the instrument panel. Hold the steering wheel with arms bent slightly during driving.

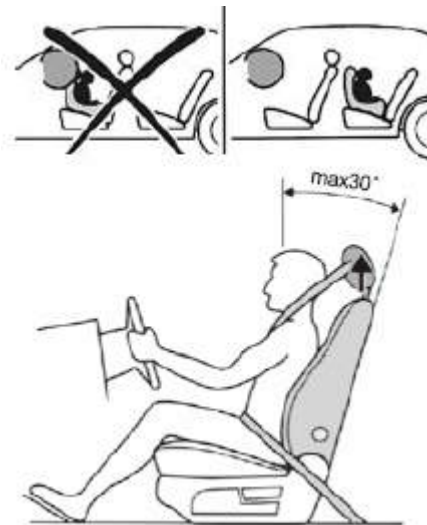

Seat & Safety Protection



Keep the front area of airbag clear at any time, and don't place anything above or in it.



The steering wheel, steering column and airbag system can be repaired only by the trained technician of Chery authorized service station, as the accidental explosion of airbag may lead to injury.

Airbag Alarm Lamp



When the ignition switch is turned to the position of "ON", if the indicator lamp on the instrument panel keeps lighted for about 6 seconds and then goes out, it indicates that the system works.

If the indicator lamp fails to be lighted, or keeps lighted intermittently or continuously, it indicates the system has malfunction. For safety purpose, please send the vehicle to Chery authorized service station for check.

The manufacturer of airbag of this vehicle suggests that the airbag be replaced after 10 years' use as the inflation efficiency and the function of airbag will have been weakened by that time. If you're not clear about the service life of airbag, Chery authorized service station will be willing to search for relevant information for you.

The airbag system can only be disposed by Chery authorized service station

Safety Seat for Children



Very dangerous! It is forbidden to use rear-direction child seat at the seat with front airbag.

Make sure to read this owner's manual carefully and follow the instruction of manufacturer when installing the safety seat for children.



Don't hold children on the knee during traveling.

It is suggested that children who are under the age of 12 or shorter than 150cm use the special safety seat for children (e.g. baby seat, safety seat for children or heightened cushion, etc.) and be fixed firmly. The safety seat for children should be applicable and has the approval of government.

Jointly using this kind of safety seat and seat belt can help to offer the maximum safety.

The baby with a weight less than 10kg or under the age of 1 should be placed on the baby bed of back seat, and kept lying low with proper binding or fixing. The best protection method for the children is using backward baby safety seat at the back seat.



Direction of driving



Direction of driving

- Children under the age of 4 or with a weight between 10 and 18kg must be seated in the safety seat for children at the back seat of vehicle.



Direction of driving

- Children who are 4~12 years old or whose weight is 18~30kg should be seated on the back seat mounted with higher cushion. For the adjustable auxiliary seat belt fixed on the higher cushion seat, make sure the diagonal seat belt passes against the shoulder properly. The heightened seat can assure that the seat belt of adult seat passes against the center of shoulder but not the neck, and the seat belt of waist clings to the hip but not the stomach.

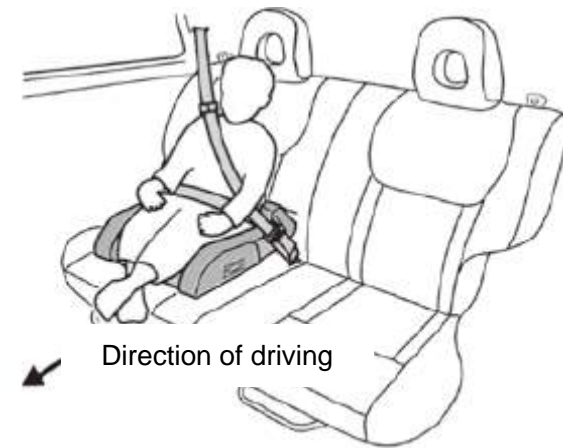

Direction of driving



The riding limit of one safety seat is one child. According to the stipulation of the road traffic safety law, children are prohibited to be seated on the front seat and should use proper safety seat.

Chapter 9 Driving

Starting

Preparation Work before Starting

The engine starting is controlled by the electronic control system of engine.

As starting the electric injection engine, don't step on the accelerator pedal before or during starting. The accelerator pedal can be stepped only when the starting is difficult. Please refer to section "The Start of Engine" for details.



Long-time running of engine at high speed will cause excessively high temperature of the engine and exhaust system, which will possibly result in fire and other damages.



Don't start the vehicle in the enclosed garage or other closed areas, for the exhaust gas is noxious. Do open the garage gate before starting the vehicle, please refer to section "Cautions of Exhaust Gas" in this chapter for details.



Don't park, idle running or driving the vehicle on the ground with dry grass or other dry coverings. The emission system will increase the temperature of engine compartment and exhaust pipe, it may set them fire.



If smelling the smoking in vehicle, please stop driving and ask for inspection by Chery authorized service station.

Safety Precautions

The idle speed of engine is controlled by electronic control system. The high idle speed as the engine starting makes for the temperature rise of engine. After the temperature rise, the idle speed should be reduced automatically. If the idle speed can't be reduced automatically, the vehicle should be sent to Chery authorized service station for overhaul. Don't let the engine operate for more than 10 minutes at the speed higher than the specified idle speed.

Precautions before Starting

1. Make sure the seat belts of all the passengers are fastened. Refer to the chapter "Seat and Safety Protection Device" for the details of the seat belt and its correct usage.
2. Make sure the power supplies of headlamp and other electric accessories are cut off.
3. Make sure the hand brake is applied.
4. As for AT model, the gear shift lever shall be in position of P (parking).

Driving

The engine can be started only when AT gearshift lever is set in position N or P.

Your vehicle is equipped with gearshift lever lock-up device; this device can work effect when gearshift lever is set in position P.

Start the engine, step on foot brake pedal and press the lock-up button; and then gearshift lever can be moved.

5. For MT model vehicle, please confirm if gearshift lever is in neutral gear position.

6. Turn the ignition switch to position ON, not to position START.

If it is hard to turn the key, you can rotate the steering wheel left and right for several times until the key can be turned easily. Reasons causing this situation are listed as follows:

- Deflection of the front wheel.
- The front wheel touches curb.
- The steering wheel has been rotated as getting on or off the vehicle.

While turning on the ignition key, make sure whether the instrument panel alarm lamp is on, if not, it is necessary to deliver the vehicle to Chery authorized service station for overhaul.

If the seat belt of driver has been fastened before turning on the ignition key, the seat belt alarm lamp will not light.

Start of Engine

1. Turn the ignition switch to “START”, don’t step on the accelerator pedal, and release it at once after the engine is started, then the key goes back to the position “ON”.

2. If the engine temperature is higher than 121 °C and the engine can’t be started within 5 seconds, try to start again after turning the key to the position “OFF” and keeping the state for 10 seconds.

3. If it can’t be started for the second time, please step on accelerator pedal to the end and turn the key to position “START”. After the engine is started, release the key, and release the accelerator pedal gradually along with the engine speed increase.

4. For AT model vehicle, after the engine is started, keep it operate at idle speed for several seconds, then step on brake pedal and release the hand brake, shift to the driving gear to complete the preparation for driving.



Before gear shifting, please pull up the hand brake or step on brake pedal; otherwise vehicle may move in gear shifting and cause damage.

5. For MT model vehicle, after the engine is started, keep it operate at idle speed for several seconds, then step on the clutch pedal, shift to the driving gear, and release the hand brake to complete the preparation for driving.

Cautions of Exhaust Gas

Although the vehicle exhaust gas has low toxicity, it contains carbon monoxide which should be beware of.



If there is a peculiar smell of exhaust gas inside the vehicle, please go to Chery authorized service station for overhaul, don't continue driving, because the exhaust gas is noxious and may be life-threatening.

Please check the vehicle exhaust system and the body ventilation system in case of the following conditions.

- When lifting the vehicle for overhaul.
- When the sound of exhaust system changes.
- When the vehicle is damaged in collision.



Some components of the exhaust gas and some chemicals contained in or emitted by certain parts may cause cancer, birth defect or damage of genital system.

Pay Attention to Ventilation

To avoid the CO poisoning caused by increased CO in vehicle, when vehicle is stopped with someone in vehicle, please open the window by over 2.5cm, especially during the vehicle is running in idle speed or the air conditioner is turned on for long time.

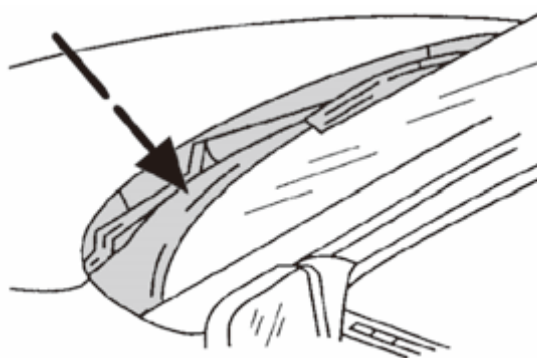

Please often remove the blocks of snow, leaves and other foreign materials at vent, in order to improve the ventilation effect of vehicle.

Adaptive Function of the Engine Control System

If the battery wires were once removed from the battery, there may be some abnormal phenomena at the very beginning of the traveling after reconnection. This is because the engine control system is relearning to adapt to the engine, which is normal.

Limitation of Engine Speed

The engine speed is limited by electronic device (ECU) to protect the engine.

Stop Engine



Release the accelerator pedal. Wait for the engine to reduce to the idle speed, and then turn off the ignition switch.

Driving



Don't step on the accelerator pedal before stopping the engine.

For parking after long-time traveling at high speed, don't stop the engine immediately; let the engine operate for another 2 minutes at the speed higher than idle speed, in order to make the temperature decrease gradually.



After the ignition switch is turned off to stop the engine, if the engine temperature is still high, the electronic cooling fan of radiator will continue to operate about 10 minutes. Even though the cooling fan stops operation, it may operate again because of the high temperature. Therefore, you have to be cautious when working beside the engine.

Brake

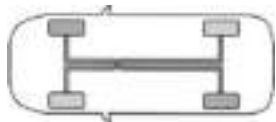

Dual-Circuit Brake System

Your vehicle is equipped with X-type dual-circuit system. If one of the circuits does not work, the other can still operate well.



When one of the circuits does not work, it is necessary to step on the brake pedal with great force, and the stopping distance becomes longer. If this situation occurs, please send the vehicle to Chery authorized service station for overhaul before your travel.

Brake Fluid

If the brake system warning light is not off after releasing the hand brake, it means the brake fluid level is low or other failures.

Please check the level of brake fluid according to requirement and check the failures.



The brake fluid shall be added immediately to the Max level and the vehicle shall be sent to Chery authorized service station to check the brake system.

Introduction to Brake System

It is normal that the brake system makes a noise sometimes. But if it has made noises of metal grinding or screeches for a long time, it indicates the brake lining may be seriously worn and needs to be replaced. Here the vehicle shall be sent to Chery authorized service station for overhaul.

If there is continuous jitter or vibration passing to the steering wheel when braking, the vehicle shall be sent to Chery authorized service station for overhaul.

The new friction lining of brake has to be run in to get the best braking effect. The braking effect may reduce a little in the first 200km, in this situation; only stepping on the pedal with a greater force can retrieve the braking efficiency. This point is also applicable for the newly-replaced brake lining.

The wearing conditions of the brake friction lining mostly depends on the working condition and driving manner. For the vehicles mainly used on the city road, the working conditions of the brake friction lining is very rigorous for frequent starting and shutdown, therefore, please be sure to check the thickness of brake friction lining or change it at Chery authorized service station according to the service mileage specified by maintenance rules.

When driving downhill, it is necessary to shift to lower gear position and take full advantage of the engine braking to avoid operating brake continuously. Otherwise the longer braking distance will occur due to overheating of brake or even cause temporary brake failure.

The moister brake disc will cause vehicle cannot slow down properly or deviation in braking; stepping down the brake pedal slightly can test the influence to brake. After vehicle going through deep water, the brake pedal shall be stepped on lightly to test the if the brake is affected; to dry up the brake, please keep the safe driving speed and step on brake pedal slightly until the brake function is recovered.

Note:

If the front spoiler is mounted optionally on the vehicle, it is necessary to ensure the air to the front brake is unobstructed, or else the brake system may be too hot for poor radiation

Brake Booster

Note:

The brake booster is controlled by engine vacuum. It works only when the engine operates. Therefore, don't stop the engine to let vehicle sliding as going downhill.

If the brake booster cannot work because the vehicle is drawn or it breaks down, it is necessary to step on the brake pedal with great force to restore the assisting efficiency of the booster.

Note:

Each pedal can be stepped to the end and return back to the original position completely, and should move freely.

Therefore, the floor around cannot be covered by foot mat or other coverings. If it surely is necessary, it shall be assured that the foot mat not hamper the movement of pedal and not slide.

Brake Failure

If brake failure occurs in vehicle running, please use parking brake for emergency stop, but the vehicle stop distance will be longer than normal brake.



During vehicle's normal running, the applying of hand brake will cause vehicle's instant out of control; if it is necessary to stop the vehicle by hand brake, please apply the force slowly to avoid rear wheel lock and you shall be on high alert in the process.

Anti-lock Brake System (ABS)

The anti-lock brake system can avoid the wheel lock and even let the vehicle maintain the steering performance in case of emergency braking so as to help you to avoid obstructions.

This ABS of this vehicle is integrated with electric brake force distribution that makes ABS performance more advanced.

Actions of ABS



The anti-lock brake system will not work during normal service braking; it only works when wheels are going to lock. If the brake pedal pulsates with noise during braking, it indicates the ABS is working. The pulsation and noise are normal.

Do not release the brake pedal at the moment.

Notice: the tyre size and tyre pattern are vital to the ABS normal performance, please ensure to change the tyre with the one of the same size, load range and structure. Use the tyre of any different size will affect the operation of ABS seriously.

Make Use of ABS Brake

Step on the brake pedal with all effort continuously in emergency, and the antilock brake system will be started immediately so that you are still able to control the steering. If the space is enough, you can even avoid obstructions.

It is suggested that you should have acquaintance with the brake skills; however, you should avoid any unnecessary risk.



ABS can ensure best braking efficiency, but the parking distance will be greatly different based on the road conditions. ABS can't ensure that the brake distance can be shortened under all road conditions.



For example, in the sand or snow field, the brake distance of the vehicle with ABS is much longer than that of the vehicle without ABS. In the same way, the use of ABS can't avoid the dangers caused by short distance to the front vehicle, traveling in water, too fast steering or poor road condition; it can't avoid the accidents caused by mistake as well as the incorrect driving. Please be cautious of driving and reduce the speed as turning.

ABS Self-check

After the vehicle starting up, the ABS will carry out self-check. In the process, you can hear the noise of machine, it is normal.



During driving, if it is found the ABS warning lamp is on, it indicates there is malfunction in the circuit of ABS system, please stop the vehicle and contact with Chery authorized service station.

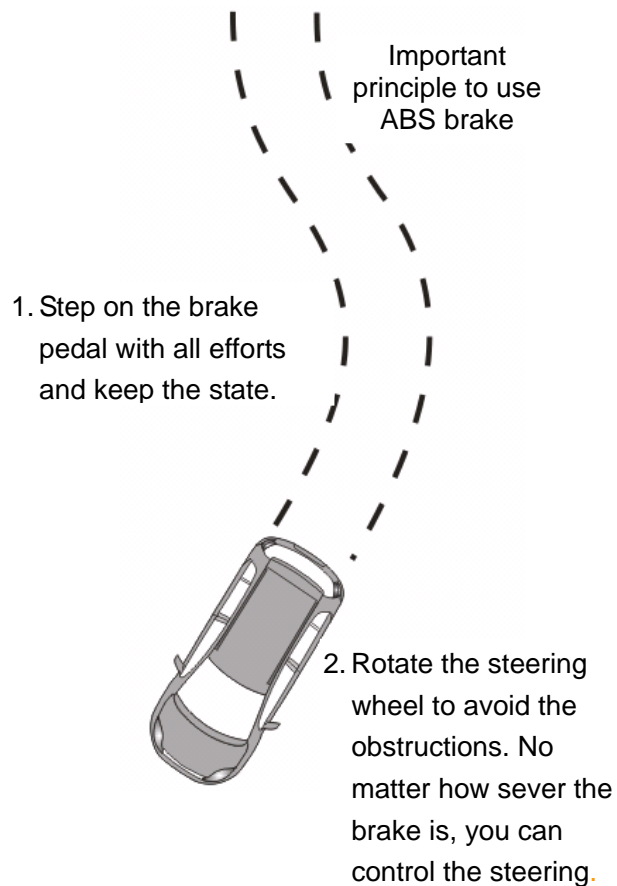

Hand Brake

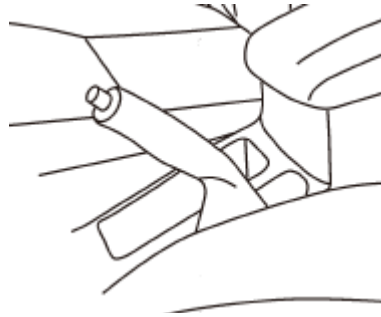

The hand brake handle should be pulled upward tightly to avoid the vehicle sliding.



Please pull up the hand brake handle when stops or leaves the vehicle, do not operate gearshift lever instead of applying hand brake; do not let others impacting the hand brake; if the hand brake is released by accident, the vehicle will slide on the slope and cause serious accident.

In the condition that the ignition switch is on, pull the hand brake handle, and the parking braking indicator lamp will light. If you want to use the hand brake, pull the hand brake handle upward.

If you want to release the hand brake, you can pull the hand brake handle upward a little, press the release button on the top of handle and then push it downwards.

The manual brake works on the rear wheels. Stepping on the brake pedal while pulling the manual brake upwards can make the hand brake pulled easily.

Steering

In order to avoid damaging the power steering system:

- When the engine operating, it is forbidden to let the steering wheel stay at any limit point (turn to the left or right dead center) for over several seconds.
- When the power steering fluid in the power steering fluid reservoir is below the MIN mark, the power steering fluid shall be added immediately. Before filling, driving vehicle is forbidden.

If the power steering system breaks down or the engine is shut off, the vehicle will lose the power-assisted steering. You still can rotate the steering wheel but with more force.

If the vehicle is off tracking or swaying during traveling, please check the following items:

- Whether the pressures of tyres are the same;
- Whether the abrasion of tyres is uniform;
- Whether the suspension components are loosening or wearing;
- Whether the steering components is loosening or wearing;
- Whether the wheel alignment is correct.
- On the steep downhill road, to achieve better brake effects, please select manual gearshift mode and choose lowest gear position before going downhill.

MT Operation

The manual transmission has five forward gears and one reverse gear.

Layout of gear positions:

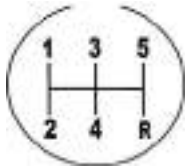

Gear Shifting

Application/operation methods and precautions:

- Step on the clutch pedal completely when shifting, move the gearshift lever to required position with slight force. Make the transmission disconnected with engine torque and then operate the shift lever. To avoid the noise during shifting the reverse gear, wait for 3 seconds after stepping down the clutch pedal completely when vehicle is stopped, meanwhile the operation will make reverse gear shifting smoother.
- The low gear shall be applied as going downhill or turning, and it is forbidden to make the vehicle slide with applying clutch.
- When the transmission is shifting up, don't skip over gears, or else it will affect the service life of the synchronizer.
- In condition of idle gear and engine stopping, it is forbidden to use synchronizer for gearshift and start engine by force, or else it will affect the service life of synchronizer.
- Flapping method (that is the operation method of pushing followed by releasing) is forbidden as shifting. The shift gear shall be pressed with hand all the time, which can reduce the wearing time of the lock ring of synchronizer and reduce the abrasion.
- After gear shifting, don't put your hand on the shift lever, or else it will cause too early abrasion of shift fork.
- If there are abnormal phenomena of transmission in use such as abnormal sound and obviously difficult operation, stop the vehicle at once to check and continue to drive after troubleshooting.
- Don't put your foot on the clutch pedal as traveling, or else it will cause too early abrasion of transmission.
- Only when vehicle is stopped, the reverse gear can be applied. When engine is running, step down the clutch pedal and wait for several seconds before shifting to avoid noise from transmission; once shifting into reverse gear, the back-up light will be on.



When driving forwards, it is forbidden to shift to reverse gear position, otherwise the transmission will be damaged which is not covered by warranty of Chery.

Engine Operation for Vehicle Equipped With AMT

Before starting engine, please shift to gear N, 1st gear or 2nd gear; when shifting to gear position N, you can start engine without stepping brake pedal; when shifting to 1st gear or 2nd gear, you cannot start engine without stepping brake pedal.

Operation of AMT

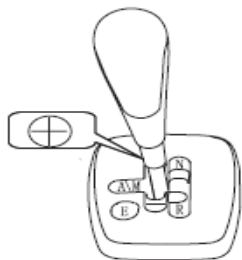

- R = reverse gear
- N = neutral gear
- AM = selection of automatic, manual control
- E = select the economic or normal mode
- + = up-shifting
- = downshifting

1. After starting vehicle, vehicle speed is 0km/h, the transmission is in neutral gear; the gearshift lever is placed in neutral position or TIP position. (As shown in following figure: Fig.1: Neutral gear position; Fig.2: TIP position)



Fig.1

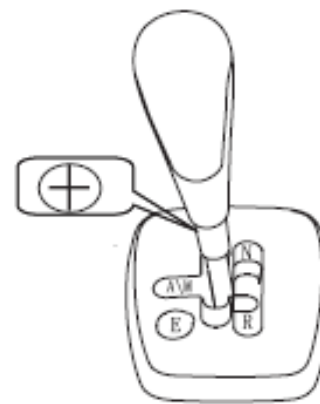

Fig.2

2. The vehicle moving forwards or backwards can be selected by driver; if going to shift 1st or 2nd gear, please step down the brake pedal and shift the gearshift lever to “TIP” position or “+” position, release the brake pedal and step down accelerator pedal, vehicle can move forward.

3. Switch the manual mode to automatic mode: by shifting the gearshift lever to automatic or manual mode direction; the instrument tachometer display will show “AUTO”; repeat the operation will active the manual mode.

4. In manual gear shifting mode: push the gearshift lever towards “+” for up-shifting to higher gear; push the gearshift lever towards “-” for downshifting to lower gear. In manual mode, the up-shifting can be performed at any vehicle speed; but downshifting only can be performed within allowed vehicle speed.

Note: the operation and function of button “E” on gearshift panel:

In automatic mode, the pressing of the button will enable engine running at economic mode and speed odometer will show “ECO”.

Driving

Fuel consumption will be lowered in this mode; pressing the button again will enable engine running at normal mode, the vehicle power performance of this mode will be stronger than economic mode. The 2nd gear is shown as the figure.

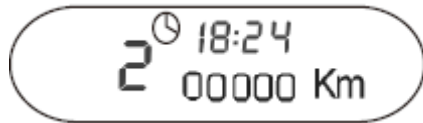

When stepping the brake pedal in emergency, whether in manual or automatic mode, the downshifting can be performed automatically without manual operation.

Vehicle starting up with AMT

Transmission

After starting engine, please step down the brake pedal before shifting gears; on the ground with low adhesion, you can shift to the 2nd gear at most for starting up vehicle; after shifting the gear, please release the brake pedal and step accelerator pedal before starting driving. Without stepping the brake

pedal, vehicle cannot move even if shifted in gear position.

Display of Gear Position

After turning on ignition switch, the gearshift lever position is shown on LCD display in middle of instrument panel.

The gear positions are shown as following figure:

Position R:

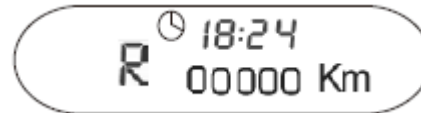

Position N:



Manual Mode:

In manual gearshift mode, the selected gear position will be shown in digital form in display.

The 2nd gear is show as the figure:



Auto Mode

Under the auto gearshift mode, the current gear position will be displayed on the screen in digital form, while the instrument tachometer display shows "AUTO" on the upper left side.

The 2nd gear is show as the figure:



Operation of AT

The automatic transmission of the vehicle is one manual & automatic integrated 4-gear automatic transmission.

1. F4A4 model AT gear select and shift mechanism



2. QR425AHA model AT gear select and shift mechanism:

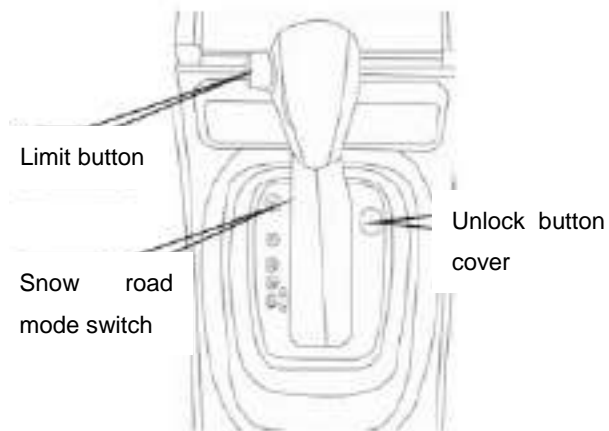

Gearshift Lever Position

P=Park gear

R=Reverse

N=Neutral

D=Driving

MT Mode

+ = Up shifting

— = Downshifting

P=Parking gear

For F4A4 AT model, in this position, the transmission output shaft is locked and the driving wheel cannot move; if the gear position “P” is not selected, you can hear the warning sound when opening the door before your leaving.

For QR425AHA AT model, in this position, the transmission output shaft is locked and the driving wheel cannot move; if the gear position “P” is not selected, the key cannot be pulled out from ignition lock.



This position can be selected only when full stop of vehicle.

Only after ignition key is turned to position ON and stepping brake pedal, the gear shift lever can be moved away from parking gear.

Shift Lock

If needs to move gearshift lever without stepping brake pedal (ignition switch in position ON), please press button of SHIFT LOCK.

Gear P Unlock Button Cover

For AT model QR425AHA, turn off ignition switch and set gearshift lever in position P; then pry out this cover and press the inside gear P unlock button by tool (such as screwdriver), then you can move gearshift lever without stepping brake pedal.

R =reverse gear

Please select this gear position when reversing.



This gear position only can be selected when vehicle is fully stopped and engine runs in idle speed.

N = neutral gear

This gear position only can be selected when starting up engine or at idle speed. Then no power is transferred to driving wheel.

D = driving gear

It is the normal position of gearshift lever in driving.

Manual Gear shifting Mode

Only after gearshift lever is set in position D can switch into manual gear shifting mode.

Push the gearshift lever rightwards in position to switch into manual gear shifting mode.

Under manual gear shifting mode, if push the gearshift lever towards +, transmission will select to higher gear position; if push the gearshift lever towards -, transmission will select to lower gear position.

Under manual gear shifting mode, up shifting can be operated under any vehicle speed; but downshifting only can be operated if vehicle speed permits.

Gear Position Display

After turning on ignition switch, the gearshift lever position is displayed on instrument panel central screen.

Gear Positions:

Position P

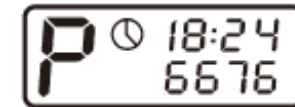

Position R

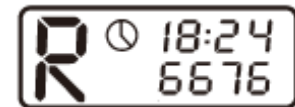

Position N

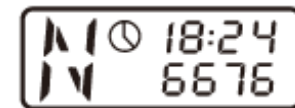

Position D

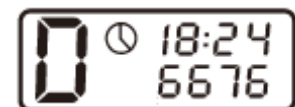

MT Mode

In MT mode, the gear position that selected by driver will be shown in digital form by display screen. E.g. the 2nd gear is shown as the figure.

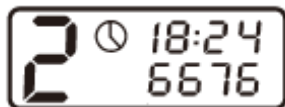

Gearshift Lever Lock

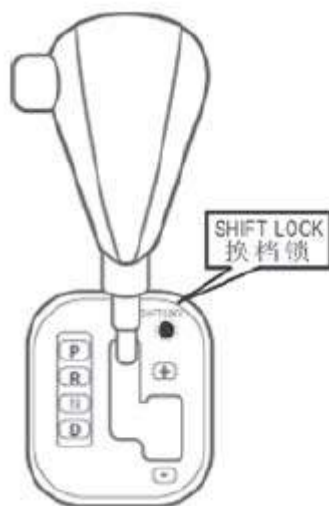

If needs to move gearshift lever from position P to R, from N to R or from R to P, the limit button on gearshift lever shall be pressed down to disable shift lock. It is not need to press the limit button if gearshift lever moves in other gear positions.

Starting up

Keep the engine running at idle speed and step down the brake pedal, shift the gearshift lever to one of driving gear; release the brake pedal and vehicle will move slowly. Stepping down the accelerator pedal will speed up the vehicle.



The AT vehicle can not be started by traction or pushing. Please connect the connecting wire with support battery for jump start.

Under special circumstances, the vehicle can be started in 2nd gear position at MT mode on snow road.

Drive Out of Mud & Sand, Snow

If the driving wheel is bogged into mud & sand or snow, you can try to move the vehicle forwards or backwards repeatedly. Change the gearshift lever between position D and R for several times and step down the accelerator pedal slightly. Avoid

keeping shift the gear in position of forward gear and reverse gear for long time, it will cause the excessive wear of transmission, and the operation time shall be less than 1 minute.

Try to keep the engine running in low speed before the operation.

Forced Downshifting

When vehicle is running on steep slopes or overtaking, the automatic transmission can provide increased torque. To get the effect of forced downshifting, you can step down the accelerator pedal to the end and hold it in gear position D. After engine comes to maximum speed, transmission will get to next gear position.

Stopping on the Way

Release the accelerator pedal and step down the foot brake, keep the gearshift lever in original position. Please release the foot brake before starting up.

Driving

Driving Precautions of AT Vehicle

(Under Different Road Conditions)

- On the small slope and flat road, it is suggested to shift to position D, step down the accelerator pedal quickly to get immediate acceleration.

Quick stepping accelerator pedal: driver steps down the accelerator pedal to the end quickly.

Quick stepping accelerator pedal to downshift the transmission mechanism to lower gear instantly and increase the torque; engine speed is increased to higher level and shift to higher gear to get improved acceleration ability.

Notice: When vehicle will get a shock during downshifting and speeding up, it is caused by operation of forced downshifting but not engine shaking. All these are related with quick stepping accelerator pedal and important precautions for driver. In case of stepping accelerator pedal slowly, it is not easy for downshifting and speed up. Stepping the accelerator pedal by half or 2/3 travel will improve the power output (torque), but it is impossible to get enough accelerating power (torque).

This is the reason for your feeling of low power. Also greater vehicle shaking will occur in case of slow stepping the accelerator pedal, it shall be avoided.

- On the medium slope road, it is suggested to shift to 3rd gear or 2nd gear in manual mode; quick stepping accelerator pedal can get instant acceleration.
- On large slope road, please shift to gear position 1 in manual mode, do not shift to position D, quick stepping accelerator pedal will get instant accelerating; vehicle cannot be shifted to gear position 1 during whole travel; Driver shall notice the slope change and shift to gear position 2 or position D manually for normal driving. Please pay attention that transmission damage may occur if vehicle is running in gear position 1 without shifting to gear position D for long time.
- If vehicle is going downhill and the braking time is too long; the brake performance degradation will occur due to overheating of brake. Please slow down the vehicle with the help of engine brake.

Engine brake is the brake effect that achieved by shifting to lower gear position, releasing the accelerator pedal to slows down the vehicle through engine braking and low transmission ratio.

Lower gear position can get better engine brake performance.



When vehicle runs in high speed, downshifting to lower gear position will cause great impact to engine and transmission which will cause damage to engine and transmission. The downshifting can only be performed by reducing speed until the allowable level.

On the downhill road of large slope, to get better brake effect, please select MT mode and downshift to lowest gear position.

Wading

If the vehicle has to wade during traveling, you must drive carefully and slowly, especially when you don't know the depth of the water.



If the water is deep to submerge the hub, you shall not drive forwards.

When wading, both the traction force and brake performance reduce, and the vehicle has the risk of stop.

If the water goes into the air intake pipe of engine, it will cause serious damage to the engine. If wading deeply, the water entering the transmission through air vent of transmission, it will damage the transmission.

After wading, you must drive the vehicle slowly and step on the brake pedal lightly for several times to remove the water on the brake.

Function Definition of Cruise Buttons



1. The ignition switch is turned to position ON, press the cruise button ON, then the cruise indicating light will light up on instrument panel and blink (it is pre-cruise condition and normal); When vehicle is driving within speed of 25-130km/h, press the cruise button SET/- and vehicle will keep running in constant cruise speed when button SET/- is pressed (do not place foot onto accelerator pedal, the cruise system will adjust the throttle valve opening by road condition); then the cruise indicating light will light up constantly indicating the vehicle is in cruise.

If the cruise indicator lamp still blinks, it means the vehicle is not in cruise mode; please try the cruise function again. (If it still not works, please contact with Chery authorized service station for overhaul)

2. In cruise condition, stepping down the accelerator pedal will increase vehicle speed (the cruise indicating light will light up constantly); after releasing the accelerator pedal, vehicle will resume the speed before stepping the accelerator pedal;

3. In cruise condition, stepping down the accelerator pedal will increase vehicle speed (the cruise indicating light will light up constantly); on releasing the accelerator pedal, pressing the cruise button SET/- will make vehicle runs at new cruise speed;

4. In cruise condition, each short pressing of button **ACC** (less than 0.5s), vehicle cruise speed will be added by 2km/h; in cruise condition, long pressing the button **ACC** (more than 0.5s), vehicle will speed up continuously; on releasing the button **ACC**, vehicle will stop accelerating and continue running at speed when releasing the button **ACC**; the cruise indicating light will light up constantly. (long press the ACC button is not suggested, or else it will increase vehicle constantly and cause dangerous to driving)

Driving

5. In cruise condition, each short pressing of button **DEC** (less than 0.5s), vehicle cruise speed will be decreased by 2km/h; in cruise condition, long pressing the button **DEC** (more than 0.5s), vehicle will slow down continuously; on releasing the button **DEC**, vehicle will stop slowing down and continue running at speed when releasing the button **DEC**; the cruise indicating light will light up constantly.



Long pressing the button **DEC** is just like vehicle slides with released accelerator pedal, it has no brake function. So please step down the brake pedal if needs to brake.

6. In cruise condition, stepping down the brake pedal, the cruise indicating light will light up on instrument panel and blink (it is pre-cruise condition and normal); vehicle will slow down; only if the vehicle speed is not less than 25Km/h, releasing the brake pedal and press the button **RESUM**, vehicle will continue running at the speed before stepping the brake pedal; the cruise indicating light will light up constantly on instrument panel.

7. In cruise condition, stepping down the brake pedal, the cruise indicating light will light up on instrument panel and blink (it is pre-cruise condition and normal); vehicle will slow down; in case vehicle speed is lower than 25Km/h, release the brake pedal and press the button **RESUM**, vehicle cannot resume the cruise condition before stepping the brake pedal; but you can accelerate the vehicle until speed exceeds 25Km/h, release the accelerator pedal and press the button **RESUM**, vehicle will resume the cruise condition before stepping the brake pedal; the cruise indicating light will light up constantly on instrument panel.

8. In case of the complete vehicle fault that may affect the cruise safety, the cruise condition is not available and the cruise indicating light will blink; please send your vehicle to Chery authorized service station for maintenance.

9. In cruise or pre-cruise condition, pressing button **OFF** is to quit the cruise condition; the cruise indicating light will go off on instrument panel.

Three-way Catalytic Converter

The three-way catalytic converter contributes to reducing the waste air pollution.



Be sure to use the unleaded fuel. The leaded fuel will cause permanent damage to the three-way catalytic converter and oxygen sensor. Chery Company shall not bear any responsibility for the damage resulted by using leaded fuel. This kind of damage is out of the warranty scope. If you add the leaded fuel inadvertently, please contact the nearest Chery authorized service station immediately.

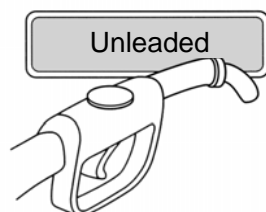

The vehicle with gasoline engine is equipped with narrow fuel filler, which only admits the filling gun nozzle of the unleaded petrol pump.



When the engine is running, it is forbidden to pull out the ignition cable of the ignition coil and check whether the engine works well with individual cylinder cut-off method, or else it will damage the three-way catalytic converter.

Note:

If the engine keeps operating, the three-way catalytic converter will become very hot; wear the protective glove during maintenance to avoid being hurt.

Driving the Vehicle Equipped with Catalytic Converter



During traveling, if the engine ignites badly or the performance reduces, please drive at low speed to the nearest Chery authorized service station.

Driving with wide open throttle is forbidden.

Please avoid all the cases that can cause the unburned or partly burnt fuel to enter the catalytic converter, especially when the engine is of high temperature.

Always avoid the following cases:

- Fuel exhaustion
- Unnecessary long-time of engine starting.

- The engine operates in the condition that more than one spark plug are removed.
- Start the vehicle with the engine at operating temperature through pushing or drawing.
- Turn off the ignition switch during traveling.



Parking

Don't park on the ground with dry leaves or grass. Even if the engine has been stopped, there is a potential fire hazard because the exhaust pipe still emits much heat in short time. When stopping vehicle, do not operate gearshift lever instead of hand brake. Please pull up the hand brake and the gearshift lever shall be placed in position P.

Before leaving the vehicle, the ignition switch must be turned off. Don't let the engine operate when nobody in the vehicle. If this point is neglected, your vehicle is likely to move unexpectedly, resulting in personal injury or property damage.

Chassis Protection

Your vehicle has been equipped with thermal baffle. Don't hold painting work on the thermal baffle, exhaust pipe or the catalytic converter body or beside them. Please don't remove the thermal baffle.

Fuel Consumption

Fuel consumption is influenced by the following factors:

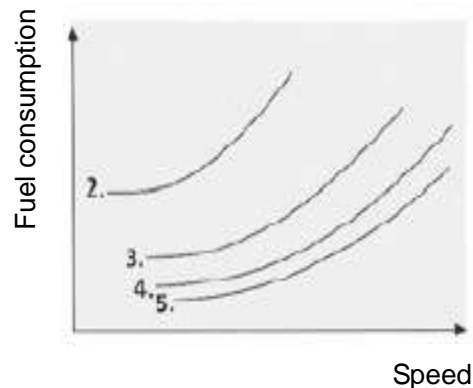

The above figure shows how the fuel consumption is influenced by the selection of speed and gear. Operating at low gear to improve the acceleration performance will result in the obvious higher fuel consumption.

Travel distance/ engine temperature

Often cold-start and short-range travel will result in obvious increase of the fuel consumption.

Traffic and road conditions

Traffic jam, uphill driving, lots of bends and rough road all affect the fuel consumption.

Good driving habit

Foresee the danger and keep safety distance from the front vehicles, which not only can decrease fuel consumption but reduce the braking abrasion and noise. In traffic jam or wait for red light in long time, it is suggested to stop the engine. Since the long engine idle time will increase fuel consumption.

Vehicle load condition

Increase the load of vehicle will cause higher fuel consumption.

Vehicle technical condition

Too low tyre pressure or the improper maintenance of engine & vehicle will result in high fuel consumption.

Key Points of Fuel Saving and Environment Protection

- Travel based on fuel saving and use additional electrical load only as it is necessary.
- The vehicle can be started before warmed.
- Use the accelerator smoothly.
- Shift to next higher gear as soon as possible to get faster speed of engine.
- Foresee the traffic condition.
- Turn off the air conditioner and rear windshield heater if they are unnecessary.
- Check or adjust the tyre pressure regularly.
- Ask the professionals in Chery authorized service station to do maintenance regularly.

Radiator Fan

The radiator fan is an electric fan, and is controlled by the engine ECU. When the temperature of coolant or in the engine compartment reaches a certain extent, the switch will get through the fan circuit automatically.



After stopping the engine, the radiator fan will operate for a while (about 10 minutes) because the engine is still hot. When the engine gets cool to a certain temperature, the fan stops operation. Even so, as long as the temperature of engine compartment increases greatly caused by the ambient temperature (exposure to sunlight or high temperature area), the fan could start abruptly. Therefore, when working in engine compartment, the operator must be cautious to avoid accident!

Note:

If the coolant temperature has reached the fan starting temperature, but the fan does not work, you should check whether the fuse of fan is fusing, and replace the fuse if necessary. Find out other reasons if the replacement of fuse does not work.

The speed of fan is independent of the speed of engine. Downshifting can't improve the cooling effect of the fan; therefore, as long as the engine operates well and the speed of going downhill does not reduce evidently, you don't have to shift to lower gear position.

Chapter 10 Emergency Procedure

Emergency

Hazard Warning Lamp

The hazard warning lamp is used only in case of emergencies to warn vehicles behind and in the opposite direction. If your vehicle breaks down or is in imminent danger, press the hazard warning lamp switch to turn on or off the lamp. When the ignition switch is turned off, the hazard warning lamp can still work.

Partial Operation Function

The control system of the engine of this vehicle has the partial operation function, which enables the system to continue running even if it is faulty. However, the performance of the engine may deteriorate at that time.



In case of system failure, please send the vehicle immediately to Chery authorized service station for inspection.

Adding Fuel in Time



If the fuel gauge indicates low fuel level or the alarm lamp is on, add fuel as soon as possible.

When the fuel has reached a too low level and the low fuel level alarm lamp has been on for some time, the engine will run unsteadily as an extra warning. Please drive the vehicle to the nearest gas station to add fuel.



Failure to add fuel in time will cause the engine to stall on its own, leading to hard start even damage to the engine. You shall contact with Chery authorized service station for help.

Using Fuel Gun Correctly in Filling

- The fuel gun shall be inserted into the fuel tank completely. Do not tilt it against the fuel filler.

- If an automatic fuel gun is used, once the gun closes automatically, it indicates that the fuel tank is filled up. In this case, do not attempt to continue filling, or there will be no expansion space in the fuel tank. Once the temperature rises, the fuel tank will overflow.
- After adding the fuel, make sure to tighten the fuel tank cap.
- If spare canned fuel is carried on the vehicle, make sure to observe relevant local laws and regulations.

For safety reasons, it is advised not to carry spare canned fuel on the vehicle lest the oil can be damaged and the fuel overflows to cause fire.

Replacing the Bulb

Before replacing any lamp bulb, make sure to turn off the lamp and turn off the ignition switch.

Don't hold the lamp bulb glass directly with fingers, otherwise fingerprints left on it will volatilize due to heat from the lighted lamp, deposit on the mirrors and darken the reflector.

Emergency Procedure

To replace a lamp bulb, make sure to use a bulb of same type. Please check the specification of the lamp bulb before installing it.

Headlamp, front fog lamp bulb:

12V 55W

Turn signal lamp, rear fog lamp, reverse lamp, high mounted brake lamp bulb:

12V 21W

License plate lamp, brake, clearance, side turn signal lamp bulb:

12V 5W

Front and rear ceiling lamp bulb:

12V 10W



Once after the headlamp bulb has been replaced, the headlamp shall be adjusted.

Headlamp assembly

(high beam, low beam, clearance and turn signal lamp)

The headlamp assembly shall be removed if any above bulb needs to be replaced.

1. Open the engine hood.
2. Remove the 3 fixing bolts of headlamp assembly (the position is shown as the figure)
3. Pull out of headlamp assembly carefully and disconnect the wire connectors.

High beam, low beam bulb

1. As shown in the figure, press down the protective cover fixing clip. Remove the protective cover of low beam.

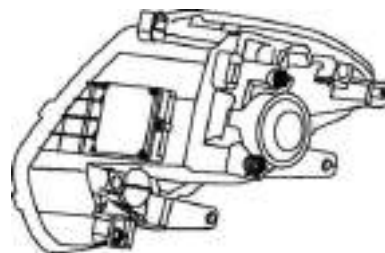

2. Pull off the lamp seat connector, remove the fixing clipping ring to take out the bulb; change the damaged bulb with new one. Clip up the fixing clip and mount the headlamp cover.

3. Correct the headlamp beams by headlamp beam tester.

Note:

The halogen bulb must be fixed well in lamp seat.

Front Turn Signal Lamp Bulb

1. Hold the lamp seat and rotate the bulb anti-clockwise to remove the bulb.
2. Install the new bulb in reverse sequence.

Clearance Lamp Bulb

1. Remove the rear sealing cover, pull off lamp seat connector and remove the damaged bulb.
2. Insert the new bulb seat into mounting hole, connect the lamp seat connector and install the rear cover.

Front Fog Lamp Bulb

Please lift up your vehicle and change the bulb from its back if replacing the front fog lamp bulb. Or remove the fog lamp for replacement. It is better to ask Chery authorized service station to change the fog lamp bulb.

Tail Lamp Bulb



1. Open the luggage boot cover; from the inner side of luggage boot to loosen the clip of tail lamp assembly cover. Pull the lamp assembly out slightly.
2. Unscrew the lamp seat in reverse direction of lock-up direction marked on lamp seat, remove the lamp seat.
3. Slightly press down and rotate the bulb in anti-clockwise direction, the bulb can be took out for replacement.
4. The installation is in reverse order of removal.
5. Check if the lamp works normally after installation.

High-mounted Brake Lamp Bulb

1. Open the luggage boot cover. Remove two cross head screws and cover. Disconnect the wire connector and take out the lamp assembly. Pull out the cover and bulb for replacement.
2. The installation is in reverse order of removal.

License plate lamp bulb

Mounting position: lower the license plate lamp panel

1. Unscrew and remove the tapping screws that fixing the license plate lamp.
2. Pull out the lamp holder and then remove the damaged bulb.
3. Mount the new bulb into the lamp holder and then mount the lamp holder.
4. Fix the license plate with tapping screws.

Vehicle Interior Front Ceil Lamp Bulb

1. Turn off the vehicle interior lamp.
2. Insert the screwdriver between the lamp housing and lamp cover to remove the lamp cover carefully.
3. Replace the bulb and install the reflector.
4. The lamp cover shall be reinstalled into mounting holes of the lamp housing.

Emergency Procedure

Sun Visor Mirror Lamp

The lamp is located behind the sun visor. Pry out of the mirror and replace the bulb.

Luggage Boot Lamp

Mounting position: on left rear speaker cover

1. Press the position A by hand at lamp back side; across the lamp convex par to remove the luggage boot lamp.
2. Replace the bulb.
3. Install it into mounting hole of speaker cover.

Adjusting Headlamp Beam

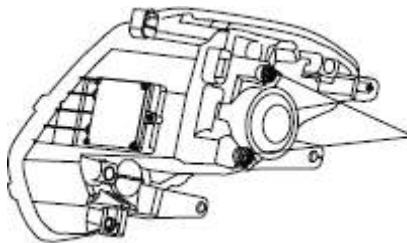

Regulating screw

The proper adjustment of the headlamp beam directly concerns the driving safety. Therefore, only special instruments can be used to adjust the beam. Please observe the law in this regard.

The position of headlamp shall meet vehicle loading condition.

1. The headlamp regulating screw is shown as the figure. The regulating screws of left and right headlamps layout symmetrically of same regulating method.

Fuse and Relay



Before the fuses and the relay are replaced, the ignition switch and all the electrical equipment shall be turned off.

New fuses of the same ratings shall be used to replace the faulty ones. The positions of main fuse and relay fuse are shown as the figure.

To replace the relay, special knowledge is needed.

You can get all types of fuse from Chery authorized service station.

It is advised to carry several spare fuses on the vehicle for emergency use.

A burnt fuse can be identified by the disconnection of the fuse.

All the fuses are of the push-in type.

Fuse

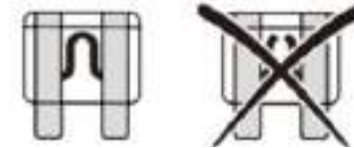

Fuse Tube

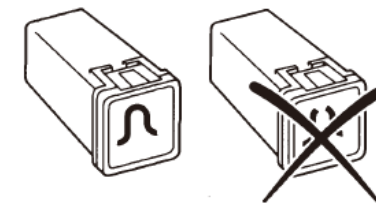

Any unauthorized alteration to the electrical system or fuel system of vehicle can affect the vehicle performance and may cause fire or safety dangers. Therefore, it is advised that any work involving the removal of the fuel system or electrical system, or the replacement of the relay be done by Chery authorized service station.

Engine Compartment Fuse Box

The fuse box is located at right rear part in engine compartment; below the windshield trim panel.

Please follow the below steps to check or replace the fuse or relay:

1. Turn off all electric devices.
2. Disconnect the battery negative wiring harness from the negative pole.
3. Use screwdriver to remove the fixing plastic clip of right front windshield trim plate. (5 units)
4. Remove the upper cover of engine compartment fuse box (both ends have metal clip), and then you can see fuses and relays; check the function layout instruction on cover back for replacement guide.

Remark:

1. To help customer in emergency, the cover of engine compartment fuse box is printed with the fuse and relay function layout. (refer to figure 1)
2. There are 8 spare fuses on the fuse box cover. (2*15A; 2*5A; 3*10A and one 30A)

Emergency Procedure

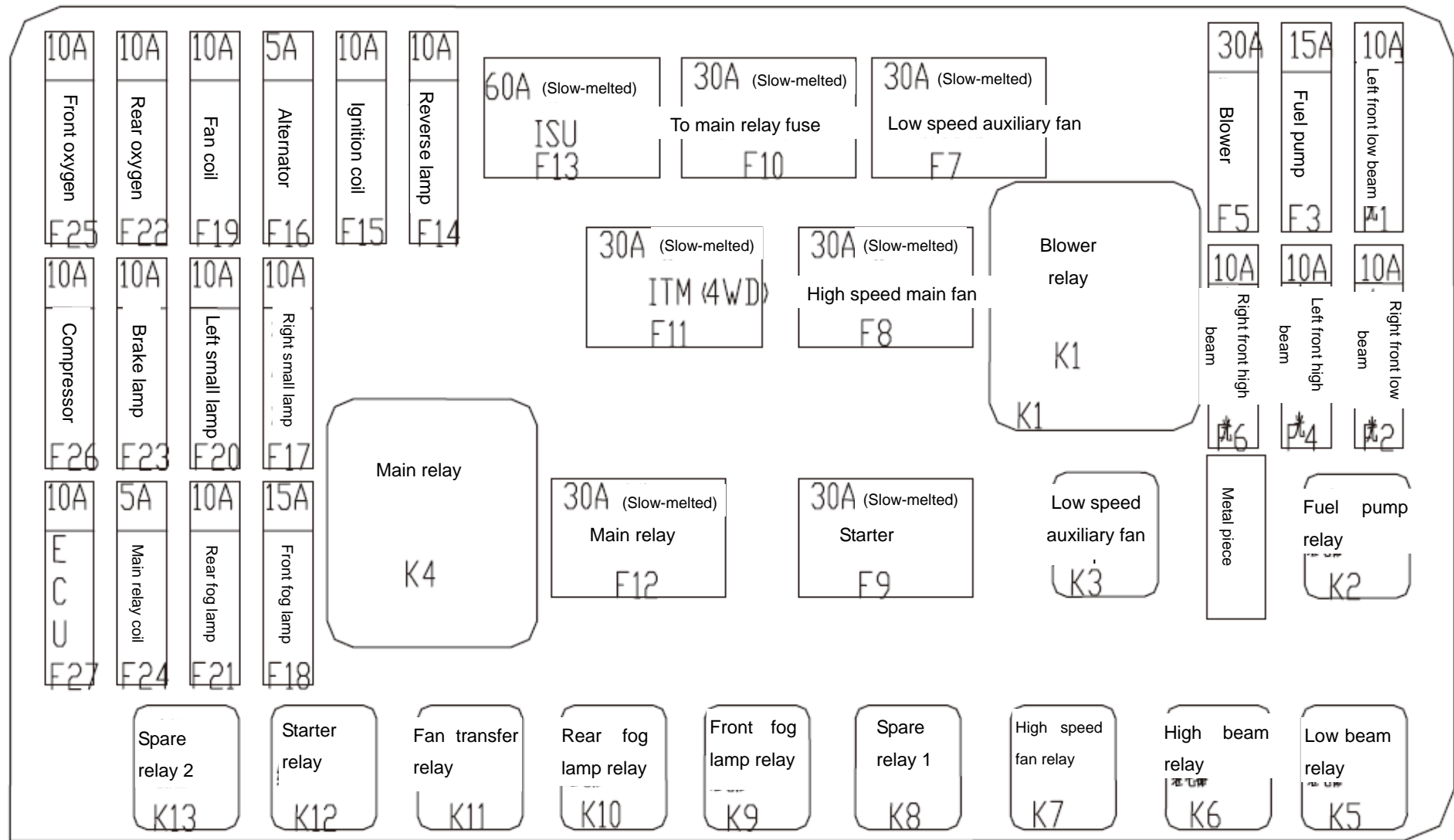

Instrument Fuse Box

The fuse box is located at left front part of driver cab, under the instrument and fixed onto cross beam of instrument panel.

Please follow the below steps to check or replace the fuse or relay:

1. Turn off all electric devices.
2. Disconnect the battery negative wiring harness from the negative pole.
3. Open the instrument panel left lower panel and you can see fuses and relays; check the function layout instruction on cover back for replacement guide.

Remark

1. To help customer in emergency, the cover of engine compartment fuse box is printed with the fuse and relay function layout. (refer to figure 3)
2. The vehicle diagnosis interface is fixed at lower position of instrument fuse box, notice not to damage it.

3. There are 8 spare fuses on the fuse box cover. (2*15A; 2*5A; 3*10A and one 30A)

The layout of fuse and relay in instrument panel fuse box (Fig.3)

Emergency Procedure

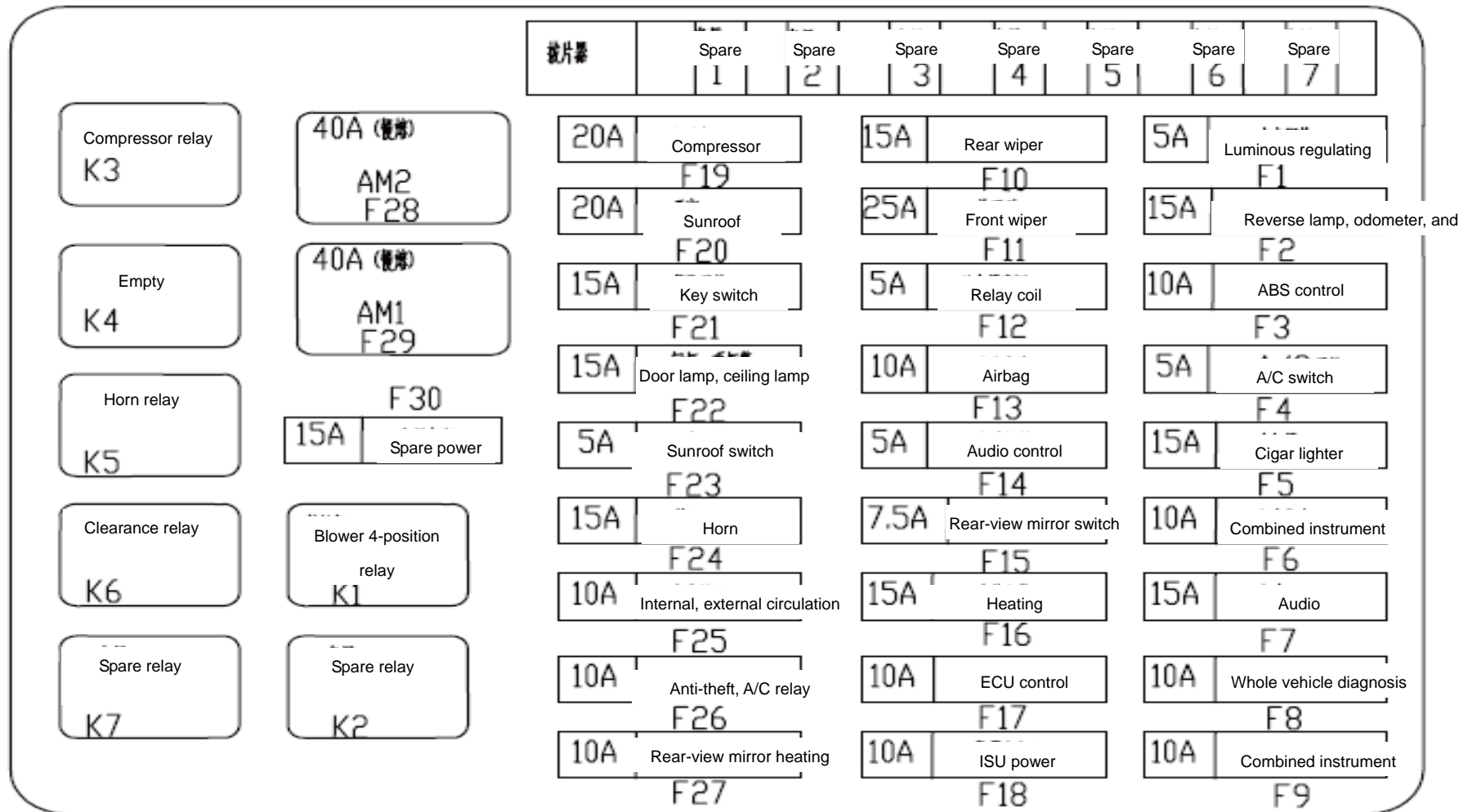

Replacing Wheel



Before jacking up the vehicle, make sure to observe the following precautions.

Park your vehicle in a proper place and make sure that the replacement of tyres will not affect the traffic or endanger yourself.

Make sure that the vehicle is on a firm and even ground. If necessary, use a proper wedge block to stop the wheels and further secure your vehicle.

Make sure that the front wheels point to the front.

If the vehicle is equipped with the automatic transmission, please set it to position P.

Spare Tyre



Please follow below regulations in case certain tyre size (steel rim or tyre) differs with other mounted tyre.

- Whenever, your vehicle shall not be mounted with over 1 spare tyre.
- Do not use skid chain for spare tyre.
- Not to pass the auto car washing machine.

Spare Tyre on Back Door



1. Open the spare tyre cover;
2. Unscrew the bolt fully;
3. Take out the spare tyre.

On-vehicle Jack



Jack up the vehicle with the on-vehicle jack only when a wheel is to be replaced. In this case, operation under the vehicle is prohibited.



The maximum operating load of the jack is 1200 kg.

The jack is located in storage slot below bottom plate of luggage boot.

Rear tyre jack position

One welded supporting block



Front tyre jack position

Outer beam of bottom plate



Emergency Procedure

Removing Wheel

1. Make sure the front wheels point to the front.
2. Turn off the ignition switch.
3. If the vehicle is equipped with the automatic transmission, please set it to position P.
4. Ask the passengers to get off the vehicle.
5. If necessary, use a proper wheel block stop to secure the vehicle and prevent it from rolling or sliding.
6. Insert the slotted screwdriver between wheel rim and wheel hub cover, and then rotate it carefully to remove the wheel hub cover.
7. Use special tools on the vehicle to loosen the wheel bolts as shown in the following figure.



8. Place the jack so that the whole foot seat surface is located on a firm ground.
9. The jack shall be jacked up vertically to the jack-up point.
10. Jack up the vehicle until the wheel is above the ground.

11. Loosen the wheel bolts to remove the wheel.

Install Wheel

1. Push the wheel onto wheel hub bolts. Screw the wheel nuts clockwise and ensure the wheel nuts sharp end shall face towards the wheel.
2. Lower the vehicle to remove the jack.
3. Tighten the wheel nuts in diagonal sequence.
4. Press into the wheel hub cap by hands carefully.
5. Take away the jack and the faulty wheel in reverse order, and tighten them.
6. If possible, deliver the wheel to Chery authorized service station to check the tightening torque of the wheel bolt and the tyre pressure.

Battery

Your vehicle is equipped with the 12V and 60A maintenance-free lead-acid battery.

Safety Advices



While handling the battery, make sure to take the following precaution measures.



The acid liquid of the battery is corrosive. Be sure to wear gloves and goggles. Do not allow your skin or clothing to come in contact with acid or lead. Do not tilt the battery, for the acid liquid may flow from the vent opening. If the acid liquid splashes into your eyes, wash your eyes immediately with clean water for several minutes and then seek doctor's advice. If the acid liquid splashes onto your skin or clothing, neutralize it with alkaline water (soap) and then wash your skin or clothing with clean water. If the acid liquid is swallowed, rush to the hospital immediately.



- Keep children away from the acid liquid of the battery.



- When the battery is being charged, it will release explosive gases.



- While doing wiring and electrical work, please avoid sparks. Do not connect the electrodes, positive pole with body with any metal or wire, the resultant short circuit can cause sparks and thereby lead to injuries.



- The electronic ignition system has high voltage. Please do not touch the components in the system when the engine is running or the ignition switch is on.

Removal and Installation



While removing and installing the battery, make sure to take the following precaution measures:

- To replace the battery, only use a lead-acid battery, and don't use other types of batteries. The current and capacity of the new battery shall be the same as the old battery or the specification of Chery. For the correct battery specification, please consult Chery authorized service station.
- After the ignition switch and all the electrical devices have been turned off, remove the negative (-) cable first.

- Try to prevent the metal tools from contacting the two electrodes of the battery at the same time or accidentally contacting the positive pole and the body.
- When reconnecting the battery, first connect the positive (+) cable and then the negative (-) cable.
- If the battery is re-connected after being removed, the vehicle may initially show slightly abnormal performance. This indicates that the control system of the engine is re-adapting to the engine.



The used battery contains sulphur acid and lead, so it shall not be discarded as normal household rubbish. Please deliver it to qualified local waste disposal stations.



Emergency Procedure

Engine Jump-start Method

If the battery of the vehicle has no power, battery power of other vehicles can be input to help the engine to start.

Only a battery of the same nominal voltage (12V) can be connected. Use jump leads with insulating clips and cables of proper sizes. Please do not disconnect the battery from the electrical system of the vehicle.

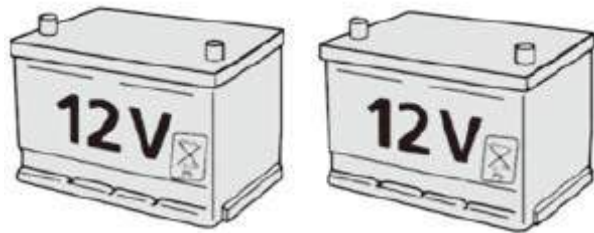

Connect Lead

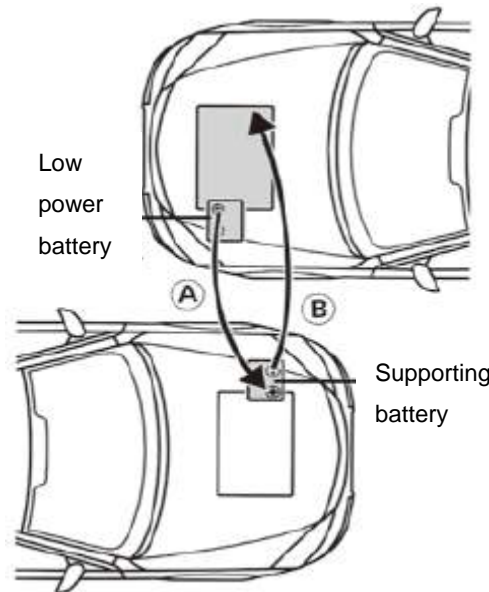

1. Park the vehicles properly so that they do not contact each other.
2. Stop the engine and any other unnecessary electrical devices.
3. Connect the positive (+) terminal of the low battery with the positive (+) terminal of the supporting battery using lead A.

4. Connect one terminal of lead B with the negative (-) terminal of the supporting battery, and then connect the other terminal of lead B with the metal part of the engine to be started. Position the jumper leads to prevent it from contacting the running parts of the engine compartment.

5. Make sure that the jumper cables do not interfere with the running parts of the engine.



The negative (-) terminal of the low battery shall not be connected.

Start Engine

1. The engine of the vehicle with the supporting battery shall run at a properly high speed.
2. Start the engine of vehicle with the low battery.
3. Before disconnecting the leads, run the engines of the two vehicles for three minutes.

Disconnect Lead

First disconnect lead B (-) and then lead A (+).



Please do not turn on the headlamps in stead of the heated rear windshield, for the surge voltage may burn and damage the bulbs.



To reduce the voltage surge during the disconnection, please connect the blower and the electric-heated rear windshield of the vehicle with the low battery.

During the trailing, drive the trailer slowly and smoothly to prevent the trailer and the trailed vehicle from bouncing. If the pulling force of the trailing cable is too big, the vehicle may be damaged.



During the trailing, the ignition switch of the trailed vehicle shall be in the "ON" position so that the steering wheel, the turn lamp and the brake lamp can all work. Since the engine is turned off, there neither is nor is the braking or steering force, so greater operating force needed. Therefore, the braking and steering forces shall be increased accordingly. The 4*4 vehicle wheels shall not be off ground during trailing, or else the driving mechanism will be damaged.

Breakdown Trailer

The vehicle is equipped with threaded holes for trailer rings at both the front and the rear.

Chapter 11 Maintenance

Maintenance

Maintenance is divided into two categories: one is routine maintenance which can be completed by vehicle owners, and the other is regular maintenance, inspection and repair which should be finished by the authorized service station of Chery.

Services Provided by Chery Service Station

To keep the vehicle reliability and driving performance, please obey the regular maintenance plan specified in this manual. The maintenance shall be performed by Chery authorized service station.

Items You Must Implement

Regularly inspect the liquid level and add the oil liquid. Check the tyre pressure, the lamps and the brakes. Check the warning lamps. (See the Regular Maintenance Schedule below for reference).

Containers of brake fluid, coolant and power steering fluid are semitransparent to facilitate the quick visual inspection.



Because of the high voltage inside the electronic ignition system, do not touch these components when the engine is running or the ignition switch is turned on.



The ignition switch should be turned off before the operation of engine compartment. Even if the ignition switch is turned off, the cooling fan may automatically operate all the same. Therefore, please be careful to avoid clothes (tie) being involved in the fan or driving belt.

General Maintenance



Only use the vehicle-washing area which does not harm the ecological drainage system.

Maintenance Schedule

Daily Inspection:

Operating conditions of all exterior and interior lamps. Replace the burned or dim bulbs and ensure the cleanness of all lenses.

Inspection When Adding Fuel:

- Level of engine oil
- Level of brake fluid
- Level of windshield cleaning fluid
- Air pressure and state of tyres (only under cold state)
- Inspect all the pipelines of crankcase ventilation system to ensure there is no abrasion and breakage.

Maintenance

Monthly Inspection:

- Level of coolant level (engine in cold state)
- Leakage of powertrain, pipeline, hose and oil tank
- Level of brake fluid
- Level of power steering oil
- Operating condition of air conditioning
- Operating condition of hand brake
- Operating condition of horn

Notice: keep the A/C running 30 minutes at least per month.



The vehicle's oil, lubricating grease and fluids shall be kept out of the reach of children. Please follow the safety instructions of the container. Avoid the skin touching the used oil.



The used engine oil, brake fluid, anti-freezing fluid, battery and tyre can only be treated by the qualified waste disposal agencies or by consulting the supporting factories, and are not allowed to be dumped along with the family rubbish or drained into the public drainage system. Everyone should be concerned about environmental protection and contribute to it.

Maintenance Items of Engine Compartment

(ACTECO engine model as example)

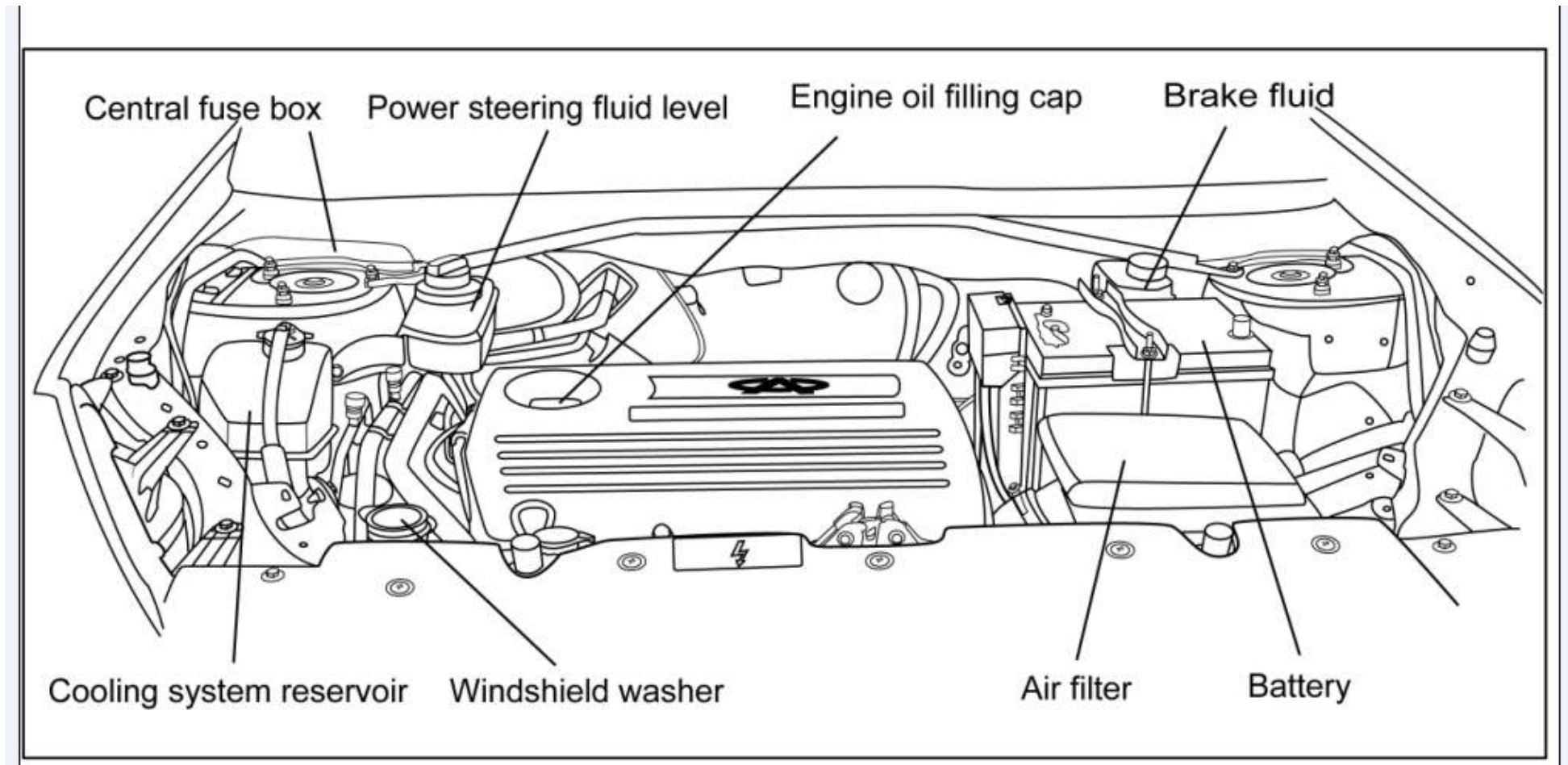

Maintenance

Engine Oil Dipstick

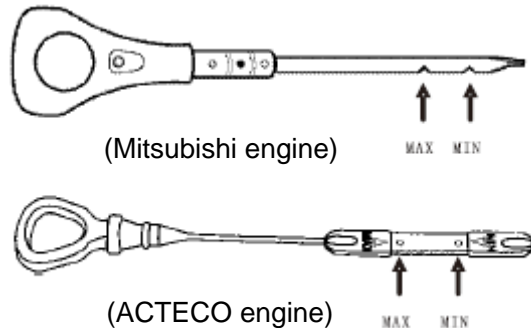

The engine oil consumption is affected by a number of factors. The new engine will reach the normal value of consumption after the vehicle has run for approximately 5,000km. The engine will consume more oil under the high-load operation.

It is necessary to carry out the regular inspection on engine oil, for example, when adding fuel or before starting a long-distance journey.

When inspecting the engine oil, parked the vehicle on the level ground. Turn off the ignition switch and wait a few minutes to allow the engine oil to flow into the oil pan (a longer time may be needed if the exterior temperature is rather low or the engine has not reached the operating temperature). The vehicle engine should not be started before the inspection of engine oil. Pull out the dipstick and wipe it with a piece of clean non-cottony cloth, then fully insert the dipstick and finally pull it out again.

In case the oil level stays between the MIN and the MAX signs at the lower end of dipstick, there is no need to add the oil again. The hot engine oil may surpass the above gap sign for several millimeters due to the thermal expansion.

In case the oil level is flush with or below the MIN sign, only add the engine oil about 1L in line with Chery specifications to make the level stay between the MIN and the MAX signs. See the chapter "Capacity and Specification" for details.

Filling Cap of Engine Oil



(Mitsubishi engine) (ACTECO engine)

Simply rotated anticlockwise and pulled, the filling cover will be open. Do not open the filling cover during the operation of engine.



Do not use the engine oil additives or engine processing agents. They are not only unnecessary but in some cases may also damage the engine, and this kind of damage is not within the scope of warranty.

Close the cover by rotating it clockwise until hearing a click sound.



Empty containers of wasted engine oil can not be thrown away along with the home rubbish. When discarding these items, please ask the qualified waste disposal agency for treatment.

Brake Fluid / Clutch Oil



In the event that the coolant contact your skin or eyes, please clean the affected parts with plenty of water and immediately seek the medical treatment.

The brake fluid and clutch oil is supplied by the same reservoir.

The fluid level should stay between MAX and MIN marks at the side of reservoir. If the fluid level drops to the MIN mark, the low brake fluid level warning light will light up.

Please add Chery special brake fluid. See the chapter “Capacity and Specification” and send your car to Chery authorized service station to check system leakage.

It is important to ensure the absolute cleanness in case of adding the brake fluid.



Change the brake fluid after the driving of each 2 years or 40000KM. Do not let the brake fluid contact paint. If the fluid touches the paint surface, please wipe out the fluid with the wet sponge or rinse the paint surface with plenty of water.

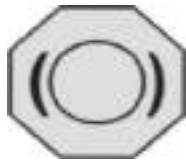

The symbol behind brake fluid reservoir means using non-paraffin brake fluid.

Engine Coolant Tank



Do not open the filling cover in the event of a running engine or the high temperature.

Inspect the coolant level through the translucent reservoir. When the engine is in the cold state, the coolant level should be between MIN and MAX marks. The coolant level may exceed the MAX mark when engine is hot. The coolant can be added when engine is cold; if it is needed to add the coolant when engine is hot, first of all, wait 10 minutes to let the engine cool down. Unscrew the cover of reservoir for a quart of circle to discharge the pressure. Wait for a period of time and then open the cover fully. Add the coolant with mixture of 50% water and 50% coolant.



When adding the coolant, be careful to avoid splash it onto any part of engine.

Engine Coolant



Do not let the brake fluid contact your skin or eyes. Providing such occasion is encountered, please clean the affected parts with plenty of water and immediately seek the medical treatment.

Using the coolant with correct concentration will not only protect the engine from freeze in the winter, but also provide the anticorrosion protection throughout the year. Modern engines operate at the extremely high temperature, so the bad coolant cannot provide the proper anticorrosion protection for the cooling system. So, please add the coolant in line with the specification of Chery. Please refer to the chapter of “Capacity and Specification Parameters” for capacity.



Do not mix the coolants together of different colors and specifications

Maintenance



Please add the coolant when engine is in cold condition.

Transmission Oil Level

Transmission oil level of your vehicle will be inspected when vehicle comes to Chery authorized service station for maintenance.



Change the transmission gear oil after the driving of each 1 year or 30000KM for manual transmission.

Check the Power Steering Fluid Level

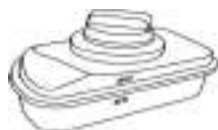

When engine is cold, the fluid level shall reach to position MAX.

Please fill in the specified fluid if the level is under mark MIN.



It is suggested to replace the steering oil for private vehicle after initial 15000km; replace the steering oil for taxi after initial 25000KM. Afterwards, replace the transmission oil after driving of each 40000km.

Battery



The battery maintenance is rare; you can inspect the battery fluid level in regular inspection. Your vehicle is equipped with maintenance-free battery. The current and capacity of new battery should be in line with the old one or the specifications of Chery vehicle.

Consult the authorized service station of Chery for the correct battery specification. It is not recommended to use other types of storage batteries.

Maintenance of Alternator

The vehicle's long time driving may cause the looseness connection of alternator terminal. To ensure the normal working of alternator, after the mileage of 20,000Km, within the warranty your vehicle shall be inspected for terminal tightening by Chery authorized service station by each 10,000Km. Tightening torque list:

	Type of terminal	Thread Spec.	Vehicle type (engine type)	Tightening torque
Alternator	B+ output end	M8	SQR481, SQR484, SQR475, SQR480, SQR477, Mitsubishi series	13±1
		M6	SQR372, SQR472, SQR473 series	8±1

Washer System of Windshield



Please use the specified windshield cleaning fluid.



It is dangerous to drive the vehicle without cleaning fluid, so please check the cleaning fluid level before driving. The anti-freezing fluid will cause damage to the paint; therefore

1. Do not add anti-freezing fluid into windshield washer fluid reservoir.
2. Do not mix water with the cleaning fluid; since water may be frozen and cause damage to washer fluid reservoir and other components of washing system.
3. The using of unqualified cleaning fluid will also cause damage to washing system.

Inspection of Wiper Blade

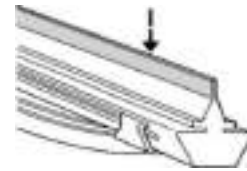

Inspect the roughness of wiper blade by sliding the fingertip on the edge of this blade. Great roughness will affect the wiper cleaning effect. Butter, silicone resin and fuel may disable the wiper blade from normally working. It is recommended to use the glass cleaning fluid to clean the wiper blade.

Replacement of Wiper Blade

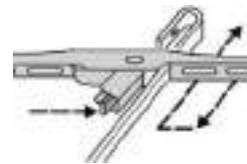

To remove the wiper blade, arise the wiper arm and make it form a right angle with the wiper blade. please press the fixing clip according to the direction shown by arrow, then release the wiper blade, and finally pull out the wiper arm according to the opposite direction.

Tyre

For your safety, please check the tyre pressure after the tyres (including spare tyre) become cold. See the proposed tyre pressure in the chapter “Capacity and Specification”.

The correct tyre pressure should be complied with especially during the high-load and high-speed running. The insufficient tyre pressure will reduce the stability, increase the rolling resistance and advance tyre abrasion and even lead to the accident.

If you need to drive the vehicle on the curb, you have to keep a low running speed, and if possible, make the wheels close to curb at right angle. Avoid the vertical and sharp obstructions. When parking the vehicle, do not have the side wall of tyre scratched.

Regularly inspect tyre surface for cut trace, foreign body and uneven wear. The uneven tread wear may indicate the incorrect alignment of wheel.

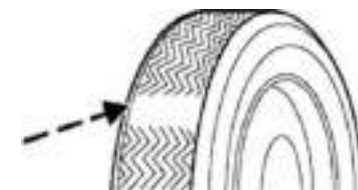

Maintenance

The worn depth of tread is limited in relevant laws and regulations. Notice that: when the worn depth reaches the limiting value of 3mm, the worn areas will appear on the tread, which indicate that the performance and security of tyre has greatly degraded and the tyre must be replaced.



The worn tyres should be treated under local environmental protection provisions. Once the road conditions allow, the winter tyres should be immediately changed with summer ones. This will reduce the fuel consumption and the noise. Regularly interchange the tyres. It is recommended to interchange four wheels for every 10,000 km. (the best tyres interchange mileage is 5000-7000Km) interchange left front tyre with the right rear tyre, and interchange the right front tyre with the left rear tyre.

Replacement of Tyre



The unsuitable tyres and rims may lead to an accident, which are not within the scope of warranty.

The tyres used by your vehicle are specially chosen to provide the best vehicle control, comfort and safety. The above-mentioned combined provisions of tyre and rim are applicable to the steel or aluminum alloy wheel rim. If you want to know whether other types of tyre and rim can be used in the vehicle, please consult the authorized service station of Chery.

It is strongly advised that you use the genuine tyres or refer to the authorized service station of Chery when installing the tyres.



If you want to install the non-standard tyre or rim, (such as the light alloy rim or wheel of winter tyre); surely you should comply with the instructions or consult the authorized service station of Chery.

Note: The speedometer is affected by the size of tyres used for the vehicle. If the tyre size (diameter) is different from the original one, the correct speed will not be shown.



It is suggested to check and adjust the four wheels alignment in vehicle first maintenance and then make inspection and adjustment on every 20,000Km.

Anti-skid Chain for Snowy Ground

The anti-skid chains for snowy ground can be used for summer and winter tyres, but are only applicable to the driving wheels (i.e. front wheels).



1. When using the anti-skid chains, be sure that the vehicle speed shall not exceed 50 km/hour.
2. The anti-skid chains should be removed immediately in the absence of snow on the road.

When the anti-skid chains for snowy ground are in use, the traveling performance of vehicle equipped with the anti-skid control system may have some anomalies which can be eliminate by shutting down this system.

To avoid the damage of wheel cover, please remove the cover firstly before mounting anti-skid chain. And remember to mount it back at once after removing the anti-skid chain.

Wheel Train Belt

The driving belt is one of the parts stressed most seriously in the vehicle, so the quality of belt should be good and reliable to meet the work requirements.

When replacing the driving belt, only choosing the belts of the same size cannot meet the requirements. For the sake of safety, be sure to use the genuine belt of Chery. Authorized service stations of Chery have the genuine driving belts.

Driving Belt Tension Inspection

Note:

The driving belt will elongate after being used for a certain period of time. When the elongation is up to a certain degree, the belt will be so loose that it may cause the damage to the vehicle. Therefore, it is necessary to inspect the tensivity of alternator belt every time the vehicle has covered a 1,000km. Check of Drive Belt Tension

1. Turn off the ignition switch and take off the key.
2. Press the middle part of the belt by thumb (with force about 100N) to check the deflection of the belt: the max permitted deflection: 10mm.
3. Please go to Chery authorized service station for adjustment if the deflection exceed the allowed value.



Change of timing belt: it is suggested to change the timing belt (taxi & private vehicle) on every 40,000km.

Car Wash



The washing material shall not be thrown away into home garbage and shall be processed by local qualified waste disposal facilities. Please use the car washing area that will not destroy the ecological drainage system. The most important factor of protecting paint is to use clean water.

Cold water or slight warm water can be used to wash car.



Automatic Car Washing Machine

The best car washing method is the brushless car wash in good washing area. The washing are that equipped with high pressure water gun will let water be sprayed into water.



Close the heater blower before automatic washing.

Manual Washing

If the vehicle washing agent is used, plenty of water shall be used to wash the vehicle and be dried by dry cloth.



After washing the vehicle, please slightly step on the brake pedal to remove water from brake disc.

Cleaning of Headlamp

In order to avoid the damage to the plastic lens headlamp, the invasive abrasive or chemical solvent should not be used. Do not wipe the lamp or use the sharp objects as the lens cleaner when the mirror is dry.

Maintenance

Cleaning of Rear Windshield



When cleaning the rear windshield, only use the soft cloth in order to avoid the damage to the heating components and the radio antenna. Do not clean the glass by the solvent or sharp objects.

Corrosion Protection for Chassis

The anticorrosive treatment has been exerted on the vehicle chassis. It is necessary to inspect the anticorrosion protection of chassis regularly, and, if necessary, ask the authorized service station of Chery for repair.

Cleaning of Wheel

Depending on the time or mileage distance, clean the wheels by the wheel cleaner or warm water and soft sponge once a week so as to avoid the

dust accumulating in the brake. Do not use the friction materials to avoid the damage to the specially processed surface.

Cleaning Articles

For the best effects, please properly use the care articles of vehicle.

Paint Falling off Treatment

The damage or minor scratch of painted surface caused by road gravels can be treated in the authorized service station of Chery.



In order to ensure the duration of painted surface, it is necessary to remove the harmful objects in time, such as: guano, resin, insect residues, tar stains and etc.

Protection of Vehicle Paint

Applying the wax to the painted surface of your vehicle once or twice a year will help keep the surface smooth.



When polishing the vehicle, be careful to keep the polishing agent away from the plastic surface. Otherwise, it is difficult to remove the agent. Do not polish the vehicle under strong sunshine, either.

Maintenance of Leather Veneer



Only the proper leather cleaning materials and cleanser can be used.

Use the wet cotton cloth and towel to wipe the leather surface, and use the clean soft cloth to dry it. The very dirty surface can be cleaned by neutral cleanser, such as soap bubble agent. During the normal usage period, it is recommended to take the leather maintenance with special leather conservation agent once six months.

Do not make leather too wet. Especially, do not let water into the gap.

Regular Maintenance Provisions

Please go to the authorized service station of Chery for vehicle maintenance according to the specified mileage. The authorized service station of Chery will provide your vehicle with the maintenance items defined by the company.

Process	Process Name	Remarks		
		5,000	15,000	30,000
1	Install three protective covers and one pad	★	★	★
2	Record the fuel volume and the mileage in details	★	★	★
3	Inspect the appearance of vehicle	★	★	★
4	Remind the customer of keeping tips for valuables	★	★	★
5	Issue the work card	★	★	★
6	Customer signs after the confirmation	★	★	★
7	Pass the work card to workshop staff	★	★	★
8	Inspect the front lighting	★	★	★
9	Inspect the low beam lamp	★	★	★
10	Inspect the high beam lamp	★	★	★
11	Inspect the left-front turn lamp	★	★	★
12	Inspect the right-front turn lamp	★	★	★
13	Inspect the front alarm lamp	★	★	★
14	Inspect the front fog lamp	★	★	★
15	Finish the inspection	★	★	★
16	Inspect the high-low horn	★	★	★
17	Inspect the rear lighting	★	★	★

Maintenance

Process	Process Name	Remarks		
		5,000	15,000	30,000
18	Inspect the rear brake lamp	★	★	★
19	Inspect the left-rear turn lamp	★	★	★
20	Inspect the right-rear turn lamp	★	★	★
21	Inspect the rear alarm lamp	★	★	★
22	Inspect the rear reversing lamp	★	★	★
23	Inspect the rear fog lamp	★	★	★
24	Inspect the license lamp	★	★	★
25	Finish the inspection	★	★	★
26	Inspect the steering wheel	★	★	★
27	Inspect all buttons of air conditioner	★	★	★
28	Inspect the air state of air outlet	★	★	★
29	Inspect all indicator lamps of instruments	★	★	★
30	Inspect the control performance of parking handle	★	★	★
31	Inspect the gearlever	★	★	★
32	Inspect the clutch pedal	★	★	★
33	Inspect the brake pedal and the accelerator pedal	★	★	★
34	Inspect the front and rear wiper blades and the nozzle		★	★
35	Inspect all keys of instrument panel	★	★	★
36	Inspect the CD player and the loudspeaker	★	★	★
37	Inspect the front ceiling lamp	★	★	★
38	Inspect the rear-view mirrors on both sides	★	★	★

Process	Process Name	Remarks		
		5,000	15,000	30,000
39	Inspect the central control door lock	★	★	★
40	Inspect the electric glass regulators of all doors	★	★	★
41	Inspect the sun visor, the teacup stand and the ash tray	★	★	★
42	Inspect the cigar lighter, the sundries box and the electronic clock	★	★	★
43	Inspect the driver's seat, the seat belt, the switch of front door and the door lock hinge		★	★
44	Inspect the left-rear door's glass regulator, door switch, door hinge, seat and seat belt		★	★
45	Inspect the right-rear door's glass regulator, door switch, door hinge, seat and seat belt		★	★
46	Inspect the right-front door's glass regulator, door switch, door hinge, seat and seat belt		★	★
47	Open the rear door and inspect the door lock hinge, the accompanying tools and the spare tyre	★	★	★
48	Open the engine hood	★	★	★
49	Install the protective cover of fender	★	★	★
50	Inspect the air cleaner core	★	★	★
51	Inspect the gap and burning state of ignition plug		★	★
52	Inspect the power steering oil	★	★	★
53	Inspect the cleaning fluid of windshield	★	★	★
54	Inspect and measure the engine coolant	★	★	★
55	Inspect the battery		★	★
56	Inspect the volume of transmission oil	★	★	★
57	Inspect the volume of engine oil	★	★	★
58	Inspect the level of brake fluid	★	★	★
59	Inspect the timing belt			★

Maintenance

Process	Process Name	Remarks		
		5,000	15,000	30,000
60	Inspect the generator belt	★	★	★
61	Inspect the pipeline of air conditioner	★	★	★
62	Inspect the cooling pipeline	★	★	★
63	Inspect the oil leakage at upside of engine	★	★	★
64	Inspect the engine harness	★	★	★
65	Inspect the shock absorber	★	★	★
66	Unscrew the tyre bolts	★	★	★
67	Support the vehicle	★	★	★
68	Initially raise the vehicle	★	★	★
69	Remove the tyres			★
70	Inspect the brake pad			★
71	Inspect the wheel hub bearing for abnormal noise		★	★
72	Inspect the pressure and appearance of tyres	★	★	★
73	Change the positions of tyres			★
74	Inspect the pressure and appearance of spare tyre	★	★	★
75	Raise the vehicle again	★	★	★
76	Drain the old engine oil and install back the oil block	★	★	★
77	Replace the engine oil filter with new one and clean the bottom of engine	★	★	★
78	Replace the gear oil of gearbox with new one and clean the gearbox			★
79	Replace the petrol filter with new one			★
80	Inspect the torque of chassis bolt (front and rear auxiliary frame control arm bolt, transmission, engine mount bolt)	★	★	★
81	Inspect the rear axle and the fuel tank	★	★	★
82	Inspect the relevant pipelines of chassis for oil leakage	★	★	★

Process	Process Name	Remarks		
		5,000	15,000	30,000
83	Inspect the transmission shaft and the steering tie rod	★	★	★
84	Inspect the protective sleeve of transmission shaft universal joint for breakage	★	★	★
85	Inspect the protective sleeve of steering cross tie rod universal joint assembly for breakage	★	★	★
86	Inspect the ball-head protective sleeve of knuckle and the clearance	★	★	★
87	Lower the vehicle	★	★	★
88	Fasten the tyre nuts and install back the spare tyre and the accompanying tools			★
89	Add the specified-volume engine oil	★	★	★
90	Start the engine for 3 minutes	★	★	★
91	Test the engine computer and the sensor	★	★	★
92	Shut down the engine, wait for 90 seconds and then confirm the level of engine oil	★	★	★
93	Raise the vehicle again, inspect the engine oil filter, the oil pan, the oil drain bolts and the gearbox for oil leakage, and then lower the vehicle	★	★	★
94	Conduct the trial run to inspect the vehicle, and then fill in the work card with all inspection results	★	★	★
95	Wash the vehicle	★	★	★
96	Accompany the customer to inspect the vehicle and pay the fares	★	★	★
97	Remind the customer of the next maintenance	★	★	★
98	Take off three sleeves and one pad	★	★	★
99	Thanks and look after the customer	★	★	★

Note: For the manual transmission, replace the gear oil of transmission every year or every 30,000km; replace the transfer case gear oil every 50000Km for 4WD vehicle only; replace the rear axle main reducer oil every 50000Km for 4WD vehicle only; replace the brake fluid every 2 years or every 40,000km. Suggest cleaning the throttle valve body every 15,000km.

Car Sale & Delivery Sheet

Classification	No	Item	Is the item proved qualified and well-explained?	
			Yes <input type="checkbox"/>	No <input type="checkbox"/>
Overall Performance	1	Engine	Yes <input type="checkbox"/>	No <input type="checkbox"/>
	2	Engine oil, brake fluid, steering fluid, coolant, battery fluid and windscreen detergent	Yes <input type="checkbox"/>	No <input type="checkbox"/>
	3	Marks such as VIN code, engine No, nameplate and so on	Yes <input type="checkbox"/>	No <input type="checkbox"/>
	4	Locks and car keys of complete car	Yes <input type="checkbox"/>	No <input type="checkbox"/>
	5	Lamps of complete car, including: headlamp, turn lamp, fog lamp, combination lamp, trunk lamp, brake lamp, reversing lamp, tail lamp, reading lamp, instrument lamp and so on	Yes <input type="checkbox"/>	No <input type="checkbox"/>
	6	Windshield glass and painted surface of car body	Yes <input type="checkbox"/>	No <input type="checkbox"/>
	7	Tachometer, engine speedometer, odometer	Yes <input type="checkbox"/>	No <input type="checkbox"/>
	8	Wheelhouse, spare tyre, attached tools and <i>Owner's Manual of Complete Car</i>	Yes <input type="checkbox"/>	No <input type="checkbox"/>
	9	Seat belt, cigarette lighter, air conditioner switch, air outlet, glove box and sun visor	Yes <input type="checkbox"/>	No <input type="checkbox"/>
	10	Glass regulator, rearview mirror, windscreen wiper, scrubber, horn, audio system and antenna	Yes <input type="checkbox"/>	No <input type="checkbox"/>

Maintenance

General Knowledge	1	Using 93# gasoline as fuel	Yes <input type="checkbox"/>	No <input type="checkbox"/>
	2	Normal use during running-in period	Yes <input type="checkbox"/>	No <input type="checkbox"/>
	3	Use of all lights	Yes <input type="checkbox"/>	No <input type="checkbox"/>
	4	Meanings of warning signal lights	Yes <input type="checkbox"/>	No <input type="checkbox"/>
	5	Proper maintenance time and mileage	Yes <input type="checkbox"/>	No <input type="checkbox"/>
	6	Maintenance items of car during summer and winter	Yes <input type="checkbox"/>	No <input type="checkbox"/>
	7	Proper understanding of cooling system and correct use of coolant	Yes <input type="checkbox"/>	No <input type="checkbox"/>
	8	Proper use of air conditioner	Yes <input type="checkbox"/>	No <input type="checkbox"/>
	9	Precautions regarding car startup	Yes <input type="checkbox"/>	No <input type="checkbox"/>
	10	Proper use of audio system	Yes <input type="checkbox"/>	No <input type="checkbox"/>
Signature of Car Seller: _____ Date: _____ Signature of Customer: _____ Date: _____				

The maintenance shall be conducted according to the items specified in Regular Technical Maintenance of Tiggo. (The maintenance is subject to the fore mentioned mileage and time, whichever comes earlier.)

Maintenance Certification

Regular Maintenance

Implement the 5,000km maintenance items when the car has run for 10,000km or it is within 6 months after the latest maintenance.

Date: _____
Mileage: _____

Official Seal of Service Station
Signature of Car Owner
Next Appointed Maintenance Time or Mileage

Date: _____
Mileage: _____

Regular Maintenance

Implement the 15,000km maintenance items when the car has run for 15,000km or it is within 6 months after the latest maintenance.

Date: _____
Mileage: _____

Official Seal of Service Station
Signature of Car Owner
Next Appointed Maintenance Time or Mileage

Date: _____
Mileage: _____

Regular Maintenance

Implement the 5,000km maintenance items when the car has run for 20,000km or it is within 6 months after the latest maintenance.

Date: _____
Mileage: _____

Official Seal of Service Station
Signature of Car Owner
Next Appointed Maintenance Time or Mileage

Date: _____
Mileage: _____

The maintenance shall be conducted according to the items specified in Regular Technical Maintenance of Tiggo. (The maintenance is subject to the fore mentioned mileage and time, whichever comes earlier.)

Maintenance

Regular Maintenance

Implement the 5,000km maintenance items when the car has run for 25,000km or it is within 6 months after the latest maintenance.

Date: _____

Mileage: _____

Official Seal of Service Station

Signature of Car Owner

Next Appointed Maintenance Time or Mileage

Date: _____

Mileage: _____

Regular Maintenance

Implement the 30,000km maintenance items when the car has run for 30,000km or it is within 6 months after the latest maintenance.

Date: _____

Mileage: _____

Official Seal of Service Station

Signature of Car Owner

Next Appointed Maintenance Time or Mileage

Date: _____

Mileage: _____

Regular Maintenance

Implement the 5,000km maintenance items when the car has run for 35,000km or it is within 6 months after the latest maintenance.

Date: _____

Mileage: _____

Official Seal of Service Station

Signature of Car Owner

Next Appointed Maintenance Time or Mileage

Date: _____

Mileage: _____

The maintenance shall be conducted according to the items specified in Regular Technical Maintenance of Tiggo. (The maintenance is subject to the fore mentioned mileage and time, whichever comes earlier.)

Regular Maintenance

Implement the 5,000km maintenance items when the car has run for 40,000km or it is within 6 months after the latest maintenance.

Date: _____

Mileage: _____

Official Seal of Service Station
Signature of Car Owner
Next Appointed Maintenance Time or Mileage

Date: _____

Mileage: _____

Regular Maintenance

Implement the 15,000km maintenance items when the car has run for 45,000km or it is within 6 months after the latest maintenance.

Date: _____

Mileage: _____

Official Seal of Service Station
Signature of Car Owner
Next Appointed Maintenance Time or Mileage

Date: _____

Mileage: _____

Regular Maintenance

Implement the 5,000km maintenance items when the car has run for 50,000km or it is within 6 months after the latest maintenance.

Date: _____

Mileage: _____

Official Seal of Service Station
Signature of Car Owner
Next Appointed Maintenance Time or Mileage

Date: _____

Mileage: _____

The maintenance shall be conducted according to the items specified in Regular Technical Maintenance of Tiggo. (The maintenance is subject to the fore mentioned mileage and time, whichever comes earlier.)

Maintenance

Regular Maintenance

Implement the 5,000km maintenance items when the car has run for 55,000km or it is within 6 months after the latest maintenance.

Date: _____

Mileage: _____

Official Seal of Service Station

Signature of Car Owner

Next Appointed Maintenance Time or Mileage

Date: _____

Mileage: _____

Regular Maintenance

Implement the 30,000km maintenance items when the car has run for 60,000km or it is within 6 months after the latest maintenance.

Date: _____

Mileage: _____

Official Seal of Service Station

Signature of Car Owner

Next Appointed Maintenance Time or Mileage

Date: _____

Mileage: _____

Regular Maintenance

Implement the 5,000km maintenance items when the car has run for 65,000km or it is within 6 months after the latest maintenance.

Date: _____

Mileage: _____

Official Seal of Service Station

Signature of Car Owner

Next Appointed Maintenance Time or Mileage

Date: _____

Mileage: _____

The maintenance shall be conducted according to the items specified in Regular Technical Maintenance of Tiggo. (The maintenance is subject to the fore mentioned mileage and time, whichever comes earlier.)

Regular Maintenance

Implement the 5,000km maintenance items when the car has run for 70,000km or it is within 6 months after the latest maintenance.

Date: _____

Mileage: _____

Official Seal of Service Station
Signature of Car Owner
Next Appointed Maintenance Time or Mileage

Date: _____

Mileage: _____

Regular Maintenance

Implement the 15,000km maintenance items when the car has run for 75,000km or it is within 6 months after the latest maintenance.

Date: _____

Mileage: _____

Official Seal of Service Station
Signature of Car Owner
Next Appointed Maintenance Time or Mileage

Date: _____

Mileage: _____

Regular Maintenance

Implement the 5,000km maintenance items when the car has run for 80,000km or it is within 6 months after the latest maintenance.

Date: _____

Mileage: _____

Official Seal of Service Station
Signature of Car Owner
Next Appointed Maintenance Time or Mileage

Date: _____

Mileage: _____

The maintenance shall be conducted according to the items specified in Regular Technical Maintenance of Tiggo. (The maintenance is subject to the fore mentioned mileage and time, whichever comes earlier.)

Maintenance

Regular Maintenance

Implement the 5,000km maintenance items when the car has run for 85,000km or it is within 6 months after the latest maintenance.

Date: _____

Mileage: _____

Official Seal of Service Station

Signature of Car Owner

Next Appointed Maintenance Time or Mileage

Date: _____

Mileage: _____

Regular Maintenance

Implement the 30,000km maintenance items when the car has run for 90,000km or it is within 6 months after the latest maintenance.

Date: _____

Mileage: _____

Official Seal of Service Station

Signature of Car Owner

Next Appointed Maintenance Time or Mileage

Date: _____

Mileage: _____

Regular Maintenance

Implement the 5,000km maintenance items when the car has run for 95,000km or it is within 6 months after the latest maintenance.

Date: _____

Mileage: _____

Official Seal of Service Station

Signature of Car Owner

Next Appointed Maintenance Time or Mileage

Date: _____

Mileage: _____

The maintenance shall be conducted according to the items specified in Regular Technical Maintenance of Tiggo. (The maintenance is subject to the fore mentioned mileage and time, whichever comes earlier.)

Safety Protection System

If your vehicle is equipped with airbag system, the whole airbag system should be replaced by the authorized service station of Chery at the 10th year since the purchase date.

To ensure the normal operation of airbag system, be sure to replace the airbag system in the authorized service station of Chery according to the specified time.

If the airbag system is replaced before the specified date (for example, after an accident), please fill in the replacing records carefully for the future reference.

Replacing Records of Safety System

- Driver's airbag
- Front passenger airbag
- Control module of airbag
- Airbag wiring harness
- Pre-tightening safety belt
- Other parts

1. -----
 2. -----
 3. -----
 4. -----
 5. -----
 6. -----
 Date: -----

Official Seal of Authorized Service Station:

Replacing Records of Safety System

- Driver's airbag
- Front passenger airbag
- Control module of airbag
- Airbag wiring harness
- Pre-tightening safety belt
- Other parts

1. -----
 2. -----
 3. -----
 4. -----
 5. -----
 6. -----
 Date: -----

Official Seal of Authorized Service Station:

Maintenance

Replacing Records of Safety System

- Driver's airbag
- Front passenger airbag
- Control module of airbag
- Airbag wiring harness
- Pre-tightening safety belt
- Other parts

1. -----

2. -----

3. -----

4. -----

5. -----

6. -----

Date: -----

Official Seal of Authorized Service Station:

Replacing Records of Safety System

- Driver's airbag
- Front passenger airbag
- Control module of airbag
- Airbag wiring harness
- Pre-tightening safety belt
- Other parts

1. -----

2. -----

3. -----

4. -----

5. -----

6. -----

Date: -----

Official Seal of Authorized Service Station:

Replacing Records of Safety System

- Driver's airbag
- Front passenger airbag
- Control module of airbag
- Airbag wiring harness
- Pre-tightening safety belt
- Other parts

1. -----

2. -----

3. -----

4. -----

5. -----

6. -----

Date: -----

Official Seal of Authorized Service Station:

Replacement Record of Instrument

Replacement Date: _____

Replacement Mileage: _____

Official Seal of Authorized Service Station:

Replacement Record of Instrument

Replacement Date: _____

Replacement Mileage: _____

Official Seal of Authorized Service Station:

Replacement Record of Instrument

Replacement Date: _____

Replacement Mileage: _____

Official Seal of Authorized Service Station:

Replacement Date: _____

Replacement Mileage: _____

Official Seal of Authorized Service Station:

Replacement Date: _____

Replacement Mileage: _____

Official Seal of Authorized Service Station:

Replacement Date: _____

Replacement Mileage: _____

Official Seal of Authorized Service Station:

Chapter 12 Capacity & Specification Parameters

VIN

The vehicle VIN is located on right front wheelhouse.



Vehicle Nameplate



The vehicle nameplate is located on left front wheelhouse in engine compartment.

Engine Number

Mitsubishi engine

The Mitsubishi **4G6 series** engine number is located at engine exhaust side cylinder body upper part, as shown in the figure.

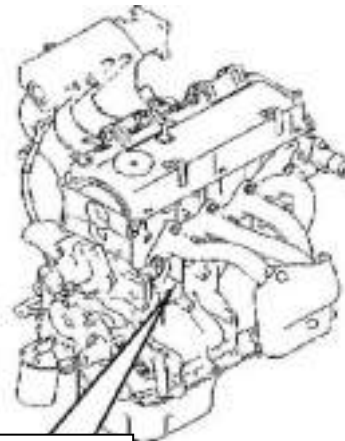

ACTECO Engine

The ACTECO engine number is located on upper position of engine cylinder block as shown in the figure.

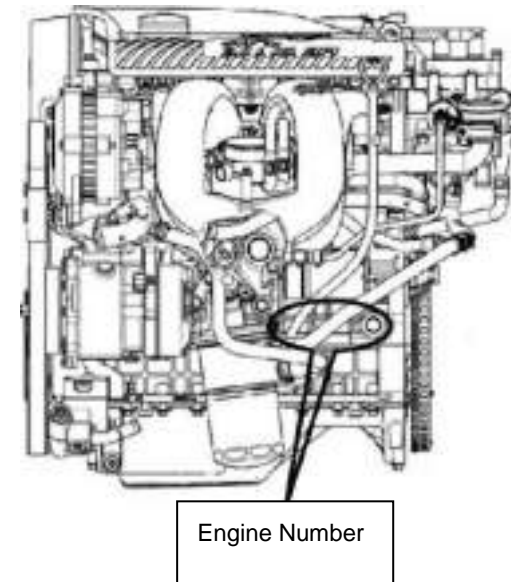

Capacity & Specification Parameters

Fuel

Capacity of Fuel Tank

Metal fuel tank capacity is **57L**;

Plastic fuel tank capacity is **55 L**.

Only choose the following fuel grade and use the high quality fuel with detergent and other additives. The using of low quality fuel may cause damage to the engine.

If the high quality gasoline with additives is unavailable at the very moment, or in case of engine malfunctions, such as difficult starting, rough idle or power dip etc, proper additives may be added when filling fuel. Fuel additives have the functions of preventing the engine from rust and scaling, cleaning the fuel supply system, preventing the throttle valve from icing up within temperature range **0-15°C**.

Chery authorized service station can provide the fuel additives verified by Chery Company. The operators at the station are proficient in the using of such additives and the handling method for the engine scaling, and they are ready to offer you the best service.



Do not use the additives or engine finishing agent that have not been verified by Chery company, as such additives are not necessary, and they may damage the engine under certain conditions and such damage is

It is normal to hear the sound of “hissing” when opening the oil filler cap.

Above 93# Unleaded Gasoline (octane rating is above 93)

It is forbidden to use unleaded gasoline lower than 93#, or the engine will be damaged and such damage is out of the warranty scope of the Chery company.

Vehicle equipped with the catalytic converter can only use unleaded gasoline.

To avoid the possible mistake of wrong fuel filling, the fuel tank is designed with a collaring oil filler cap. Only the oil gun with unleaded gasoline could be put into it.



If you fill the fuel tank with leaded gasoline by accident, don't start the engine (even though only a little is added), as the lead contained in the fuel will permanently damage the catalytic converter. It is recommended to contact the nearest Chery authorized service station immediately.

Engine Oil

Engine Oil Change

Oil specification: SJ or higher grade of SJ (SAE-10W-40)

Your vehicle engine is designed for the use of this special oil. Be sure to use the required oil to achieve the best performance of the vehicle.



In the winter of alpine region, please change the engine oil to the 5W-40 of the same grade. The S means gasoline engine oil, J means the oil quality and SAE means the viscosity grade.

Filling Engine Oil

Chery authorized service station will keep oil change records, and will select the suggested oil.

If you need some advices or information in details, Chery authorized service station is glad to help you.



Don't use the oil that doesn't comply with above specification and requirements, improper oil using may damage the engine, and this kind of damage is excluded from warranty range.



Do not use the additives or engine finishing agent that have not been verified by Chery company, as such additives are not necessary, and they may damage the engine under certain conditions and such damage is out of the warranty scope of the Chery.



Oil filling quantity should not be above the MAX mark on the dipstick.

Vehicle Oil & Fluid

Please change the oil & fluid according to the maintenance intervals indicated in the maintenance content.

Manual Transmission Oil

Please use Chery specified transmission oil provided by Chery authorized service station.

Please inspect the oil level during regular maintenance.

Automatic Transmission Oil

Please use Chery specified transmission oil provided by Chery authorized service station.

Transfer Case Oil

Please use Chery specified transmission oil provided by Chery authorized service station.

Rear Main Reducer Oil

Please use Chery specified transmission oil provided by Chery authorized service station.

Power Steering Oil

Chery specified power steering oil.

Brake Fluid & Clutch Oil

Use Dot4 brake fluid. Fill the fluid to the Max mark as required. Only use the brake fluid without paraffin wax.



Under heavy load conditions (e.g. trailer vehicle, driving in mountain areas for a long time), change the brake pads together with the brake fluid. Make sure the filled brake fluid is clean; no any dirt gets into the brake system, or else braking performance breakdown will occur.

Capacity & Specification Parameters

Coolant

Only use the coolant that complies with Chery specification, and Chery authorized service station has the Chery genuine oil/fluid.

Windshield Washing Fluid

Please use Chery Automobile specified windshield washing fluid.



Notice: the washing system may cause damage to vehicle paint, so please notice:

1. Do not use anti-freezing liquid in windshield washer.
2. Do not mix water with washing agent. Water may cause the freezing of solution and damage the washer reservoir and other parts in system.
3. The non-specified specified washing agent may cause damage to washing system. So please use the washing agent suggested by Chery.

Capacity (L)		
Engine oil (including oil filter)	4.3(4G64S4M/4 G63S4M)	
	4.5 (ACTECO)	
Cooling system	7.5	
Power steering	MAX mark	
Windshield washing system	MAX mark	
Fuel tank	Metal fuel tank	57
	Plastic fuel tank	55
Brake fluid / clutch oil reservoir	MAX mark	
Transfer case (4WD)	0.8	

Rear main reducer (4WD)	0.8
MT (QR523, QR523T, QR523MHC. QR523MHF)	2.2
AT (F4A4BK)	6.5
AT (QR425AHA)	6

Vehicle Mass



Please abide by the requirements about the payload in the manual (if applicable), it's not allowed to be overload, or else it may result in changing of braking and operation performance, and may cause accident.

Payload is the gross mass deducting kerb mass.

Optional parts and equipments installed afterwards will decrease the payload.

Payload: four passengers weight about 300Kg, 75Kg per passenger.

Complete vehicle kerb mass is referred to the vehicle mass in running condition, namely contains coolant, lubrication oil, 90% fuel tank capacity ,tool, spare wheel.



Empty containers of wasted engine oil or filter can not be thrown away along with the home rubbish. Please ask the qualified waste disposal agency for treatment.

Capacity & Specification Parameters

Vehicle Model		SQR72 06	SQR72 47	SQR72 46	SQR716 0T11	SQR724 0T11T	SQR7206 T11T	SQR718 0T11	SQR718 0T116	SQR7200 T11T6	SQR7161 T117
Whole vehicle kerb mass (kg)		1375	1380	1475	1375	1400	1395	1390		1400	1403
Whole vehicle kerb axle laden mass	Front axle (kg)	770	775	825	770	785	780	785		785	803
	Rear axle (kg)	605	605	650	605	615	615	605		615	600
Rated Max. load mass (including the passengers) Kg		375	375	375	375	375	375	375		375	375
Rated Max. mass (kg)		1750	1755	1850	1750	1775	1770	1765		1775	1778
Axle laden mass under rated Max. mass	Front axle (kg)	885	890	910	885	900	895	900		900	918
	Rear axle (kg)	865	865	940	865	875	875	865		875	860
Rated Max. allowable axle laden mass	Front axle (kg)	1000									
	Rear axle (kg)	1200									
Passenger No. (including driver)		5									

Wheel and Tyre

Tyre pressure

Check the tyre pressure in cold condition before your traveling. (including spare tyre pressure)

Tyre pressure (cold tyre) (Kpa)

Item	Front tyre	Rear tyre	Spare tyre
215/65R16 98H	200	200	250
235/60R16 100H	200	200	250
215/60R17 96H	200	200	250

Tyre pressure notices

- ◇ Check the tyre pressure at least once a month, tyre pressure is more important at a high-speed driving.
- ◇ The pressure values in the table are for cold tyre, the pressure will increase slightly after heated, but it is not necessary to decrease the pressure.

- ◇ If winter tyres are used, the pressure values in above table should increase by 20Kpa.
- ◇ To facilitate finding the prescribed pressure value, there is a label attached on the inner side of fuel filler cap.

Wheel

Tyre	Wheel rim
215/65R16 98H	7JX16 (ET+45)
215/60R17 96H	17X7J(ET+45)
235/60R16 100H	7JX16 (ET+33)

The tightening torque of wheel bolt is 110N•m.

Capacity & Specification Parameters

Engine Specification

Engine model	4G63S4M	4G64S4M	SQR481F	SQR484F	SQR481FC	SQR481FG
Engine type	In-line 4-cylinder, 4-stroke, water cooling, SOHC, 16-valve, sequential multi-point fuel injection		Vertical type, in-line 4-cylinder, 4-stroke, 16-valve, forced water cooling, DOHC, multi-point electronic fuel injection			Vertical type, in-line 4-cylinder, water cooling, 4-stroke, DOHC, mechanical supercharger
Cylinder bore (mm)	85	86.5	81	83.5	81	81
Piston stroke (mm)	88	100	77.5	90	89.5	77.5
Displacement (ml)	1997	2350	1597	1971	1845	1597
Output power kW	92(6000r/min)	95(5500r/min)	80 (5800 r/min)	95 (5500 r/min)	97(5750 r/min)	110(5500 r/min)
Output torque N•m	167.7(3000-4500r/min)	195(2500-3000r/min)	144 (4200r/min)	180(4000 r/min)	170(4500 r/min)	205(3500-4000 r/min)
Fuel	93#	93#	93#	93#	93#	93#
Compression ratio	10: 1	9.5:1	10.5: 1	10: 1	10.5: 1	8.8:1
Ignition sequence	1-3-4-2	1-3-4-2	1-3-4-2	1-3-4-2	1-3-4-2	1-3-4-2
Spark plug (NGK)	BKR6E-11/K20P R-U11/K7RF-11	BKR5E-11/K16PR -U11/K6RF-11	FR7DTC	FR7DTC	FR7DTC	FR7DTC

You can start the Inspections and adjustments after at least 5 minutes as of the engine stop.

Vehicle Dimensions

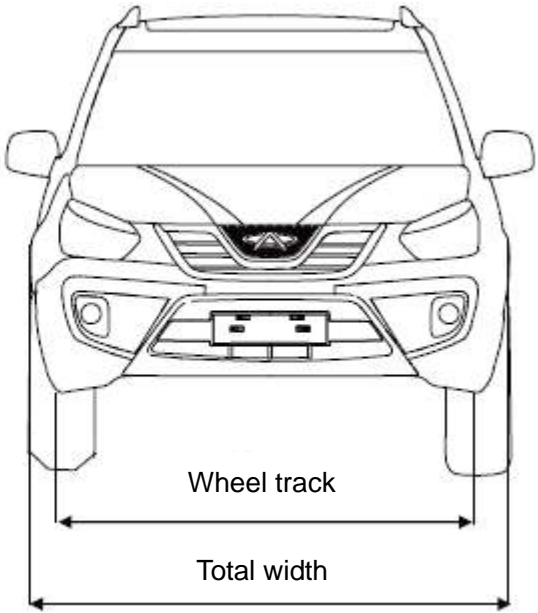
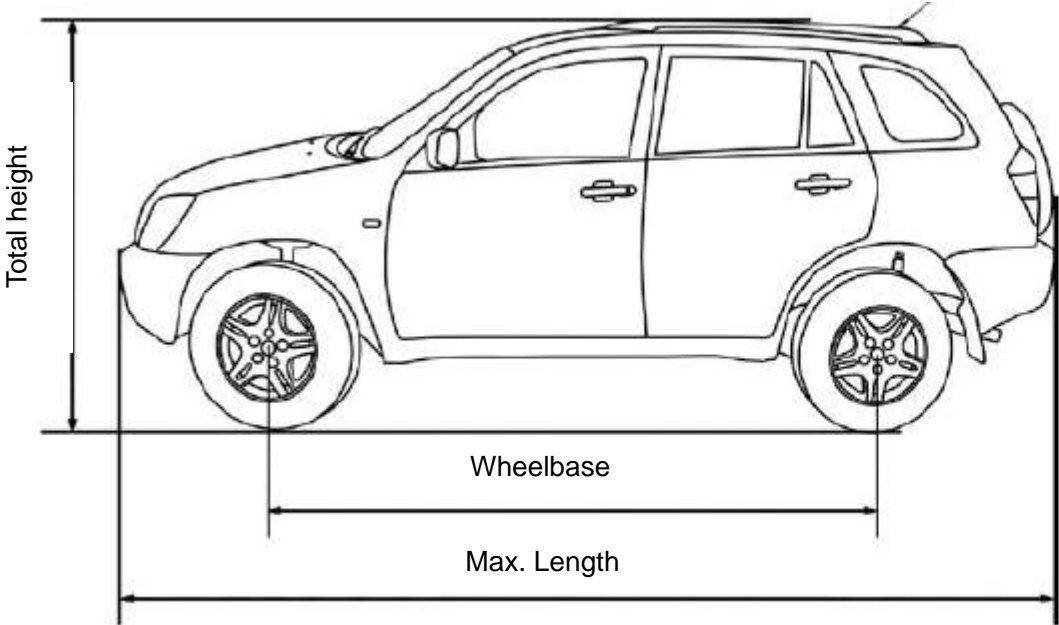

Capacity & Specification Parameters

Note: because of various tyres, the vehicle height differs slightly.

Tyre model		215/65R16	235/60R16	215/60R17
Max. Length		4285		4390
Width		1765		
Height		1705		
Wheelbase		2510		
Wheel track	Front	1500	1524	1500
	Rear	1495	1519	1495
Suspension	Front suspension	750		850
	Rear suspension	1025		1030

Contact Information of Chery International

Address: After-sales Service Dept, Chery International

No.8, Changchun Road, Wuhu Economic & Technology Development Zone Anhui Province, P.R.China

Post: 241009

E-mail: helpdesk@mychery.com

Website: www.cheryinternational.com

Chery Automobile Co., Ltd. reserves the rights of revising this manual and may not give the further notification in the case of changing.