

Foreword

Dear user, we sincerely appreciate your choosing ZOTYE and T300 will bring you to the fan of driving.

All the Zotye Auto models manufactured by the Company have obtained the compulsory product certification of China (namely, 3C certification).

Please read the manual carefully and thoroughly to better enjoy the fun of driving.

ZOTYE T300 is equipped with advanced technologies and various high-end features. The manual is applicable to all existing models of ZOTYE T1300. The features and functions introduced in the manual may be different from those of your vehicle. The manual provides you with operation and caution information. Correct operation and maintenance ensure safe driving and prolong service life.

As ZOTYE vehicles are being improved continuously, ZOTYE INTERNATIONAL AUTOMOBILE TRADING CO., LTD (herein after refer to as “the company”) reserves the right of changing the manual without notice in advance.

The accompanying Three-guarantee Service and Warranty Certificate describe various rights of vehicle warranty and regular maintenance. Please read the manual to understand your rights and responsibilities. Besides, Quick Start Guide, Navigation, Entertainment System and Communication System, Tye-net Operation Guide.

In case of any question during operation of vehicle or when reading the manual or other driver’s manuals, please contact with ZOTYE authorized service station (herein after referred to as “authorized service station”) or dial ZOTYE hotline 400-900-9900.

The manual is an indispensable part of the vehicle. Keep the manual and other driver’s document at hand for reference at any time. In case of transferring the vehicle to another user, do not forget the manual.

Thanks for your support to ZOTYE and wish you pleasant and safe journey.

ZOTYE INTERNATIONAL AUTOMOBILE TRADING CO., LTD

Aug. 17

Safety information

Your and other passengers' safety is the most important. As a driver, you shall always ensure safe driving.

Various safety signs and operation steps in the manual help you to understand safety issues and hidden risks.

The safety notes include:

Safety label adhered to the vehicle;

Safety instruction: warning, caution, note and environment protection note:

Meaning of safety instruction is:



The text with this symbol contains the information about your safety, and reminds you of potential traffic accident and injury.



The texts with this mark aim to warn you of possible vehicle damage.



The text with this symbol contains the additional information.



The text with this symbol contains the environment-friendly notes.

Important information about T300

Safety marking



When you see safety sign as illustrated above, it means XXXX is forbidden; it is not allowed to XXX; XXX shall not happen; it may lead to injury or death in case of operation against the instruction.

The driver shall be able to make correct decision as it is impossible to list all hazard cautions about vehicle operation and maintenance.

T300 parts and accessories

Use authentic parts and accessories of ZOTYE whenever it is required. ZOTYE shall not be responsible for any failure caused by delayed service or maintenance in specified service station or unauthorized service or maintenance.

Warning!

It is forbidden to modify, adjust or disassemble the car. The modification, adjustment or disassembling of vehicle may affect the safety, handling performance and service life of car, and violate the laws and regulations. Additionally, the damage and degradation of vehicle caused by unauthorized modification, adjustment or disassembling are excluded from the warranty scope.

Vehicle scrapping

The air bag of vehicle contains the explosive chemicals. If the vehicle is scrapped before air bag is dismantled, a fire or other incident may be caused. Therefore, before scrapping, air bag shall be dismantled and discarded in the authorized service station of Zotye Auto or other qualified maintenance plant.

Safety precautions

Please read below safety rules and abide by the rules.

◆ Wear seat belt

Seat belt plays a vital role in protecting the driver and passengers in all collision accident. The driver and passengers shall wear the belt correctly even the vehicle is equipped with air bags.

◆ Protect the children

For 12-year-old children or younger, use child restraint system and three-point safety belt on rear row seat.

◆ Be careful with airbag

The air bag safeguards your life, but also causes serious or deadly injury to the one who is close to it or the one who is not properly restrained, extremely baby, kid and short adult. Please follow warnings and cautions specified in chapter Safety of the manual.

◆ Drunk driving is forbidden

A little alcohol reduces your response against emergency and you require longer time to respond to emergency each time when you drink. Never drink before driving, so does your friend.

◆ Abide by traffic rules and act with comity

◆ Ensure safe driving

If you fail to concentrate on driving, it may lead to accident. Always be concentrated when driving.

◆ Control vehicle speed

High speed is one of the main reasons of injury and death caused by collision. Generally, the higher the speed is, the great risk it will be. However, low driving speed may also lead to serious injury and death. Never drive at speed above the limit specified in the traffic rules.

◆ Ensure safe conditions for driving

Flat tire or mechanical failure is dangerous. Always check tire pressure and tire condition and perform regular service in accordance with the Service Manual.

Guide to users

Features and functions described in the manual are not applicable to all vehicle models. * before the item indicates optional feature.

The details shown on the diagram in the Manual may be different from the physical car, but the described principles are the same. The Contents is at the beginning of the Operation Manual. The sequence of contents described in the Manual is the same as shown in the Contents. The index table sequenced as per phonetic alphabet order is at the end of the Operation Manual.

Unless specially instructed, the descriptions about vehicle orientation (front, back, left and right) in the Manual refer to the driving direction of car.

Notes about measuring units

The measuring units used in the manual are described below:

s	Second	kW	Kilowatt
min	Minute	Hz	Hertz
mm	Millimeter	rpm	Revolution/ minute
m	Meter	kPa	Kilopascal
km	Kilometer	g	Gram
km/h	Kilometer/ hour	kg	Kilogram
V	Volt	Nm	Newton. meter
W	Watt	L	Liter

Content

Overview of car	10	* Side air bag.....	35
General view of vehicle front	10	* Side air curtain	35
General view of vehicle back.....	12	Causes that trigger the air bag	36
General view of driver's cab.....	14	Conditions that front frontal air bag extends:	37
Safety		The front frontal air bag may not extend in following conditions:	38
Safe driving	19	* Conditions that side air bag and side air curtain may extend..	41
General description	19	Warning light of air bag failure	41
Correct sitting posture of driver and passenger.....	21	Child safety protection.....	42
Pedal area.....	23	Child notice	42
Seat belt	25	Use notices of child safety seat	43
Why you must wear the safety belt.....	25	Classification of child restraint system (for reference).....	43
Warning light of unfastened belt.....	27	Correct installation of child restraint system.....	47
Three-point seat belt	28	Safety label.....	49
* Pre-tightening seat belt	28	Safety label.....	49
Correct wearing of safety belt.....	29	Handling	
Air bag	33	Combination instrument.....	50
Air bag system	33	* LCD instruments	50
Front frontal air bag	34		

Fuel gauge.....	51	Theme setting.....	73
LCD of instrument.....	52	Navigation.....	74
Engine coolant temperature gauge.....	55	* Tire pressure.....	74
* Common combined instrument.....	56	Driving information.....	75
Speedometer.....	57	Setting.....	78
Tachometer.....	58	Common instruments setting.....	83
Engine coolant temperature gauge.....	58	Lock and unlock.....	87
Fuel gauge.....	59	Remote control key.....	87
Driving information LCD.....	60	Mechanical key.....	94
Adjust rod.....	61	Use mechanical key to lock and unlock doors.....	95
* Indicators of LCD instruments.....	62	* Engine immobilizer system.....	97
* Indicators of common instruments.....	64	Vehicle body immobilizer system.....	97
Indicator lamp.....	66	Central control door lock system.....	99
Hazard warning lamp.....	68	Child safety lock.....	100
Driver information system.....	71	Tail gate.....	101
Introduction.....	71	Power glass.....	104
Button operation.....	71	* Power all-view sunroof.....	107
Door-open warning.....	72	Lighting.....	112
Level 1 menu.....	73	Lighting combination switch.....	112

Manual adjustment of headlamp height	115	* Luggage rack	145
Delayed off of headlamp (home lighting)	116	A/C system	146
Hazard warning light	116	Control panel	146
Exterior lights	117	Wind direction and airflow regulation of vent	152
Interior lights	119	Use skills of A/C system	155
Wiper	123	Dangerous exhaust gas	156
Combine switch of wiper	123	CO	156
Rearview mirror	126	Multimedia system	157
Exterior rearview mirror	126	* Introduction to multimedia control panel	157
Internal rearview mirror	129	* Internet of Vehicles	159
Sun visor	131	Driving instructions	160
Sun visor	131	* Ignition switch	160
Seat	132	* Starter switch	161
Head restraint	132	Starting and shutdown of engine	163
Front seat	134	Gearshift	164
Rear seat	136	Driving operation	168
Storage	137	* Mechanical parking brake	171
Storage	137	* Electronic parking brake (EPB)	172
Trunk	143	* Multi-functional steering wheel	174

* Cruise.....	176	* Traveling data recorder.....	202
Improvement of economy/reduction of environmental pollution	178	Traveling environment.....	203
Driving Guide		Run-in period	203
Intellectual technology.....	179	Notices for running in the run-in period.....	203
ABS+EBD	179	Safety inspection and precautions before driving.....	204
* Electronic Speed Controller ESC.....	181	Three-way catalytic converter	205
* Traction control system (TCS).....	183	Safe driving under various road and weather conditions.....	205
* Braking assist.....	184	Fire prevention	207
* Hill descent control system.....	184	Operating Guide	
Brake override system	185	Cleaning and maintenance of car.....	208
* Launch assist.....	185	General description	208
* Hill-start assist control system	186	Safety precautions	208
* Parking assist control system	186	Exterior maintenance of car	209
* Visual reversing image & tracking function.....	189	Internal maintenance of car	212
* Lane departure warning (LDW).....	190	Internal maintenance of car	213
* Blind spot assist (BSA).....	191	Attachments and refitting.....	214
* 360 Around View Monitor (AVM).....	195	Attachments and refitting	214
* Wireless charging of mobile phone.....	199	Vehicle maintenance.....	215
* Tire pressure monitor	200	Instructions on maintenance.....	215

Maintenance schedule (ordinary conditions or bad conditions)217	Specifications of fuses in front engine compartment.....256
Inspection and filling of oil and liquids 222	Instrument panel fuse specifications.....259
Fuel 222	Towing of vehicle262
Front engine hood 224	Vehicle overheating269
Overview of front engine compartment 226	Jumper type startup270
Engine oil..... 227	Technical Data
Coolant 230	Technical Data271
Brake fluid 232	VIN 271
Washing liquid 233	Engine No.272
Replacement of front windshield wiper blade..... 234	Manufacturer's nameplate273
Battery 235	Vehicle dimensions.....274
DIY	Total weight and other design parameters276
Handling of accidents 238	Engine parameters277
Onboard tools 238	Parameters of transmission and chassis.....279
Warning triangle 238	Wheel alignment data.....281
Replace the bulb 239	Recommended oil and capacity.....282
Inspection of wheels 240	Bulb specifications283
Replacement of wheels and installation of spare wheel 244	Index285
Replace the fuse 254	Index

General view of vehicle front

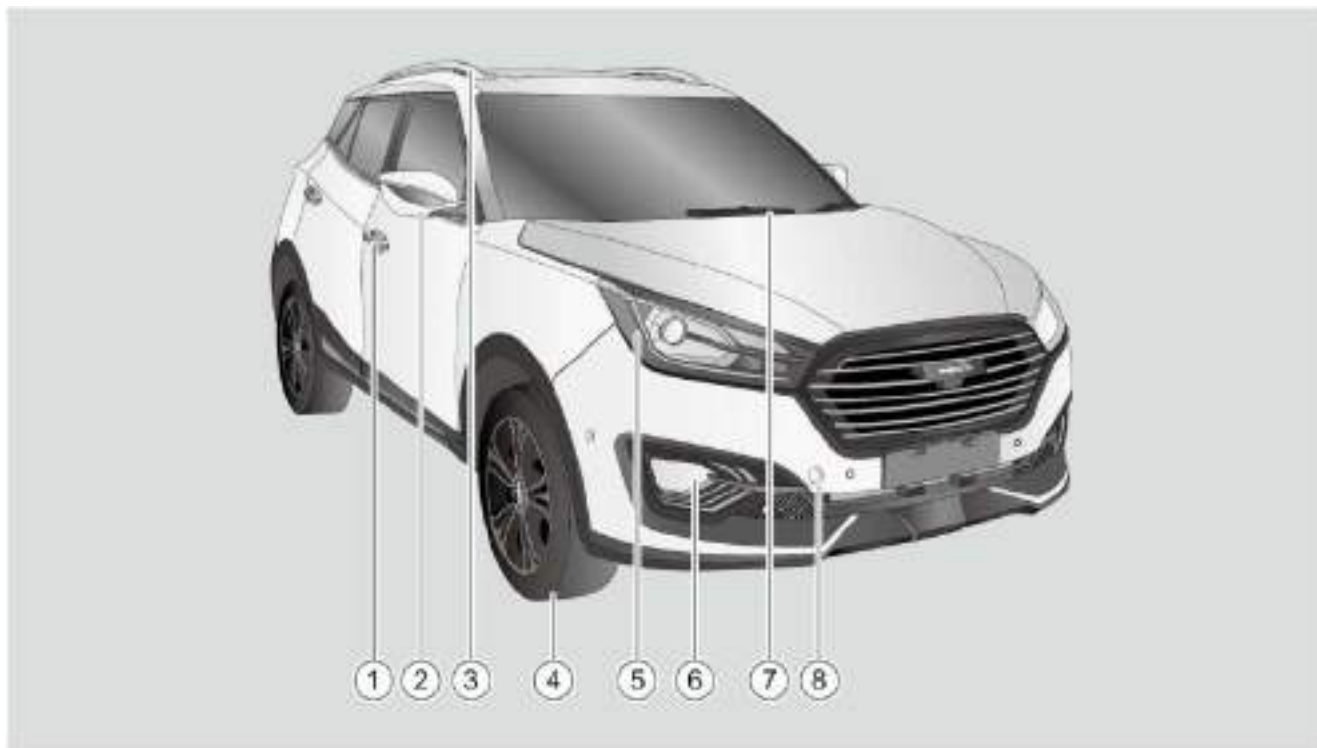

General view of vehicle front

1. * Keyless entry (refer to page 090)
2. Exterior rearview mirrors
 - Turn on turn signal light on outside rearview mirror (refer to page 115)
3. * Luggage rack (refer to page 145)
4. Wheels (refer to page 240)
5. Front combination lamp
 - Turn on low beam (refer to page 113)
 - Low beam bulb specification (refer to page 283)
 - Turn on high beam (refer to page 114)
 - High beam bulb specification (refer to page 283)
 - Turn on front turn light (refer to page 115)
 - Front turn light bulb specification (refer to page 283)
 - Turn on front position light/* daytime driving light (refer to page 112)
 - Front position light bulb/*daytime driving light bulb specification (refer to page 283)
6. * Front fog lamp
 - Turn on front fog lamp (refer to page 113)
 - Front fog lamp bulb specification (refer to page 284)
7. Blade of front windscreen wiper
 - Change the blade (refer to page 234)
8. Front traction (refer to page 265)

General view of vehicle back

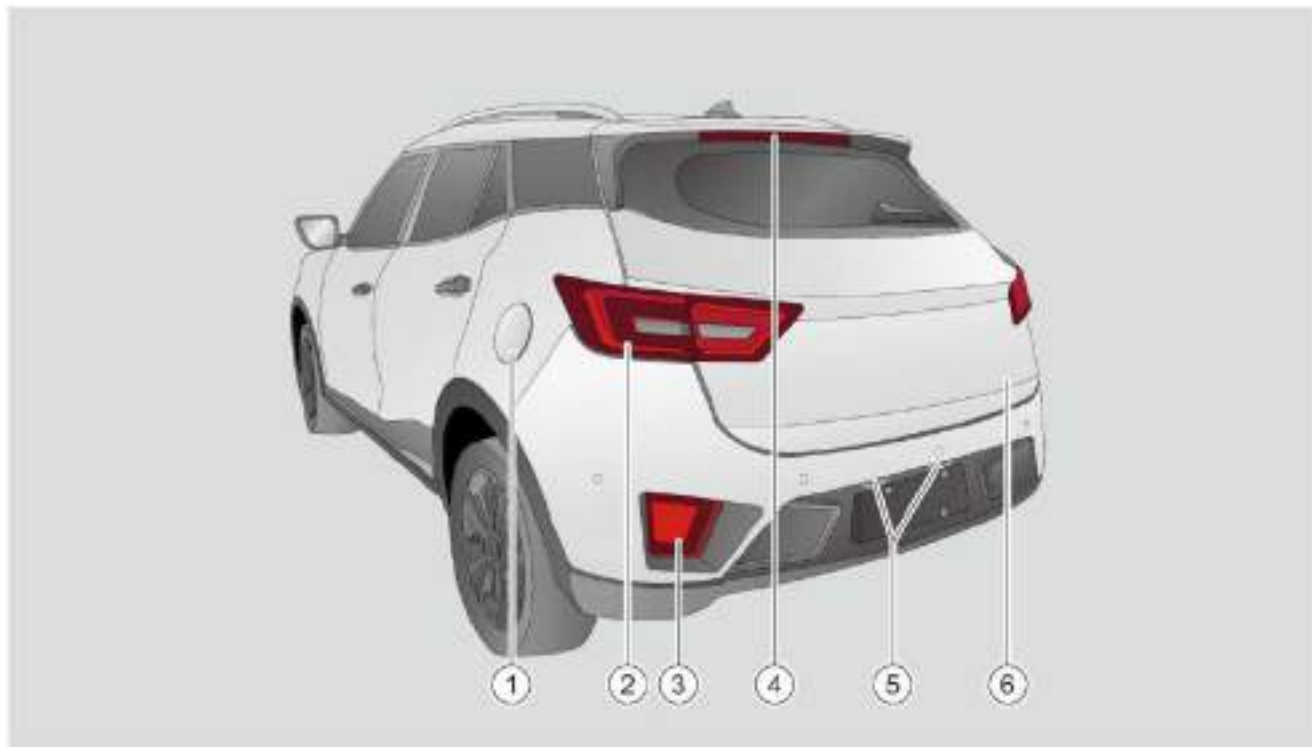

General view of vehicle back

1. Fuel filler cap (refer to page 222)
2. Rear combination lamp:
 - Turn on rear steering light (refer to page 115)
 - Rear turn light bulb specification (refer to page 283)
 - Reverse light bulb specification (refer to page 283)
 - Brake light/rear position light bulb specification (refer to page 283)
3. Rear fog lamp:
 - Turn on rear fog lamp (refer to page 114)
 - Rear fog lamp bulb specification (refer to page 284)
4. High-mount brake lamp:
 - High-mount stop light bulb specification (refer to page 284)
5. License plate lamp
 - License plate bulb specification (refer to page 284)
6. Tail gate (refer to page 101)

General view of driver's cab

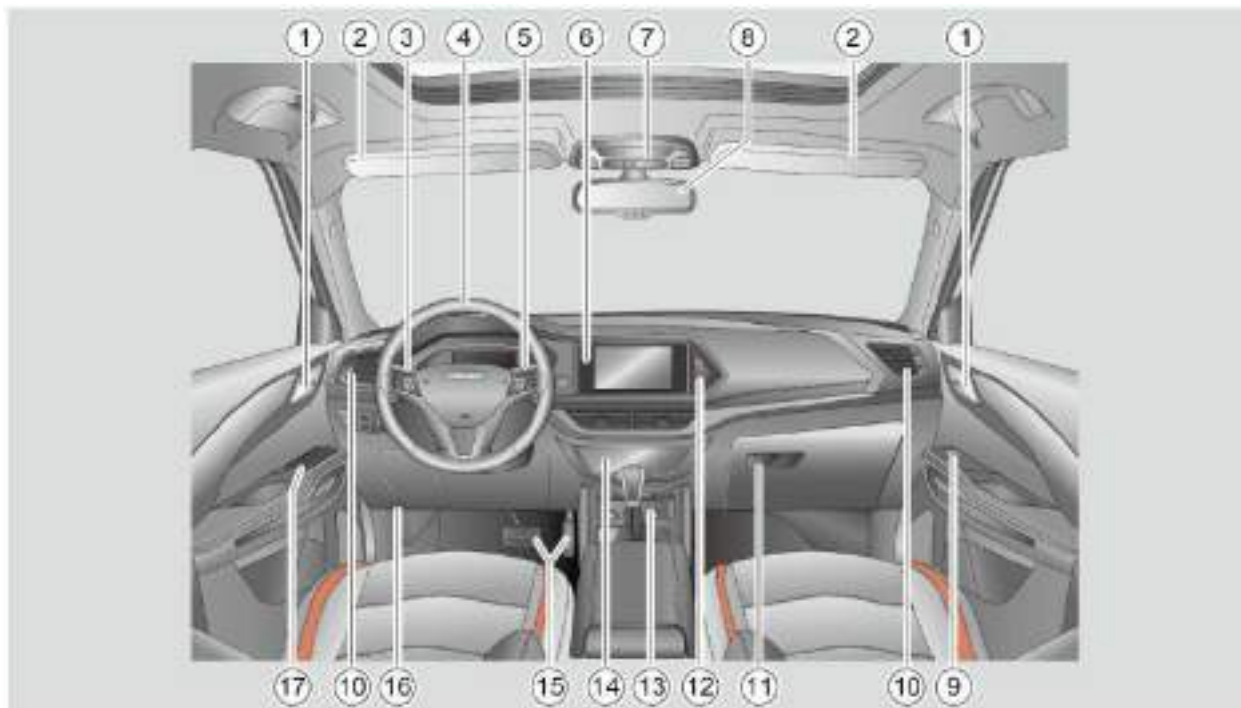

General view of driver's cab

1. Interior door handle (refer to page 100)
2. Sun shield (refer to page 131)
3. Light switch cluster (refer to page 112)
4. * Multi-purpose steering wheel (refer to page 174)
5. Wiper switch cluster (refer to page 123)
6. * Multi-media system control panel (refer to page 157)
7. Switch cluster of front ceiling light:
 - Front ceiling light button (refer to page 119)
 - *power all-view sunroof button (refer to page 108)
 - *power sunblind button (refer to page 108)
8. Interior rearview mirror:
 - *Manual anti-glare interior rearview mirror (refer to page 129)
 - *Power anti-glare interior rearview mirror (refer to page 130)
9. Power glass button at the passenger's side (refer to page 106)
10. A/C air vent (refer to page 152)
11. Glove box (refer to page 137)
12. Central control switch cluster:
 - *Electronic stability program system button (refer to page 181)
 - *Hill descent control button (refer to page 184)
 - Hazard warning light switch button (refer to page 116)
13. Power supply in the cab
 - Cigar lighter (refer to page 138)
 - *12V PS socket (refer to page 138)
 - * Front row USB interface (refer to page 139)
14. A/C system control panel (refer to page 146)
15. Pedal area (refer to page 023)
16. Handle of front engine hood (refer to page 224)
17. Switch cluster at the driver's side:
 - Power glass button (refer to page 104)
 - Central control door lock button (refer to page 099)
 - Outside power mirror button (refer to page 126)

General view of driver's cab

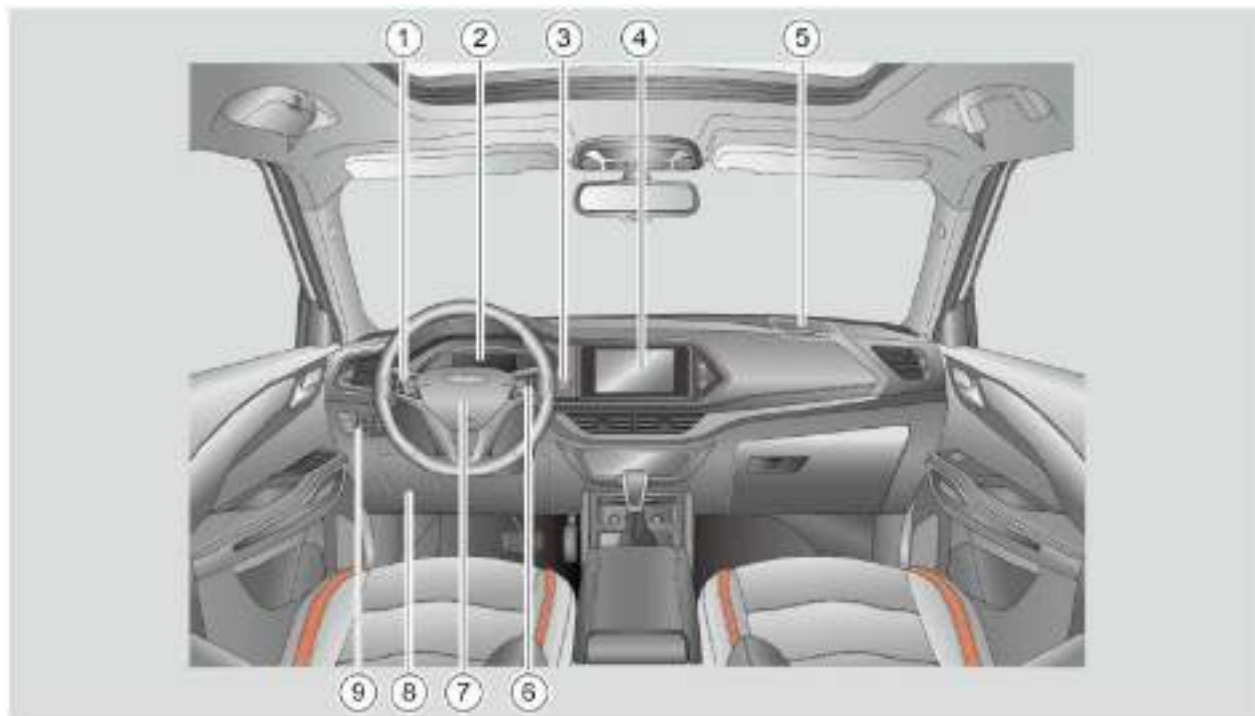

General view of driver's cab

1. * Left button on multi-purpose steering wheel (refer to page 175)
2. * Instrument panel (refer to page 050)
 - Indicators on instrument panel (refer to page 062)
3. * Start switch (refer to page 161)
4. * LCD of multimedia control system (refer to page 157)
5. Air bag of front row passenger (refer to page 034)
6. * Right button on multi-purpose steering wheel (refer to page 175)
7. Driver's air bag (refer to page 034)
 - Horn button on steering wheel (refer to page 176)
8. Instrument fuse (refer to page 255)
9. Switch cluster on left side of instrument panel
 - Open button of tail gate (refer to page 101)
 - Manual height adjust knob of headlamp (refer to page 115)
 - *Driving data recorder camera button (refer to page 202)
 - *Lane deviation early-warning system button (refer to page 190)
 - *Parking assistant system switch button (refer to page 187)
 - *Dead zone detection system button (refer to page 191)

General view of driver's cab

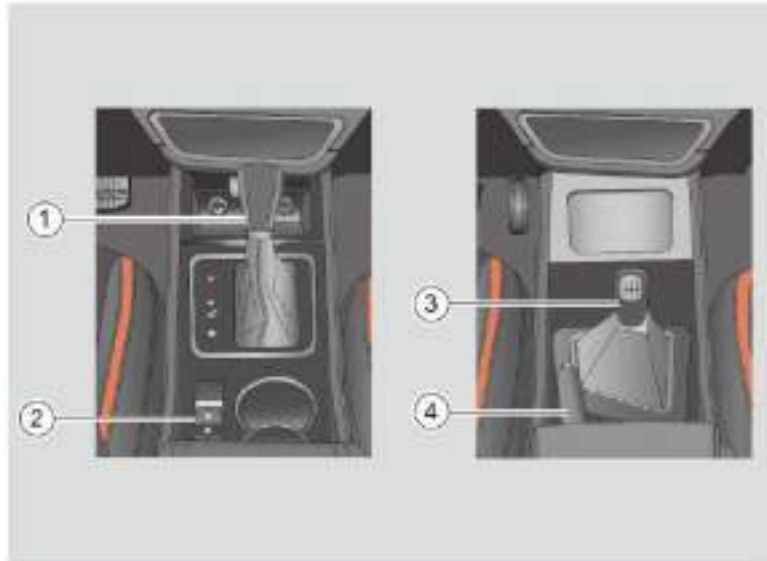

1. * AT lever (refer to page 165)
2. * EPB button (refer to page 172)
3. * MT lever (refer to page 164)
4. * Mechanical parking brake lever (refer to page 171)

General description

The chapter describes important information of safe driving, operation steps, suggestion and safety notes. You can find important safety information of driver and passengers (warning and note), please read and abide by the rules.

Notices before driving

Inspect as listed below for your and passenger's safety:

- Ensure that the lighting and turn signal devices of the vehicle can function normally.
- Ensure acceptable oil level.
- Check tire pressure and ensure acceptable tire pressure.
- Ensure that all window glasses are clear enough to have good visual field.
- Ensure acceptable fuel level.
- Ensure acceptable coolant level.
- Ensure acceptable brake fluid level.
- Ensure acceptable front windscreen washing fluid level.
- Make sure all the belongs on board are secured reliably.

- Ensure no articles obstructing the driver's leg from depressing the pedal;
- Adjust the seat, head rest and rearview mirror according to height and body size of you or passenger.
- Use the appropriate child safety seat and correctly wear the safety belt.
- Please be well seated and wear the seat belt correctly and remind other passengers to be well seated and wear the seat belt correctly.

Caution !

- Be concentrated during driving.
- Never drive when your response is poor, for example when you have taken medicine, alcohol or drug.
- Abide by the traffic rules and drive below limited speed.
- Always pay attention to road and weather conditions and drive at proper speed.
- Never drive when you are tired.

General description

Safety devices on the vehicle

The vehicle is equipped with various safety devices. In case of collision, the safety devices protect you and the passengers. Below are examples of safety devices:

- Three-point seat belt /*pre-tightening seat belt
- Seat headrest
- Driver's air bag and front passenger's air bag
- * Air bag in backrest of front seat
- *Side air curtain
- ISOFIX child restraint system interface
- Crumple energy absorption steering column
- Safety frame

Some safety devices protect you and passengers in case of an accident without any operation, including a strong enough frame, front and rear collision energy absorption buffer, crumple energy absorption steering column and a three-point seat belt/*pre-tightening seat belt that retracts in case of emergency or collision.

The safety devices may fail if you and the passengers are not well seated and fail to wear the seat belt. Instead, the safety device may hurt you and the passengers due to improper operation.

Please read the safe driving suggestion and abide by the suggestion.

Correct sitting posture of driver and passenger



Correct sitting posture of driver

Driver's gesture during driving directly leads driver's fatigue and driving safety.

Driver shall follow below instruction for your safety and reduce the risk of death and injury in case of an accident:

- Adjust up/down inclination of steering wheel and ensure the space between the air bag and driver's chest shall be no less than 25cm.
- Correctly adjust the seat head rest (refer to page 132).

- Adjust the seat forward and backward to ensure effective operation of accelerator pedal, brake pedal and clutch pedal with slightly bending leg.
- Adjust the backrest till you feel comfortable and sit straightly and your back shall completely contact with the backrest.
- Wear the seat belt correctly (refer to page 030).

Warning!

- Adjust the steering wheel to align it with driver's chest in order to reduce injury as possible caused by triggered air bag.
- The air bag may fail to protect the driver if the space between the steering wheel and driver's chest is small, instead, it may even cause serious injury.
- The driver shall always hold the steering wheel with two hands at the position 9 o' clock and 3 o' clock on the outer ring and ensure it is clear to see the LCD and indicators on instrument panel.

Correct sitting posture of driver and passenger

Correct gesture of front passenger

For the safety of front passenger and to reduce risks of death and injury in case of an accident, the front passenger shall do as follows:

- Rest your feet in the space reserved.
- Adjust the seat head rest correctly (refer to page 132).
- Adjust the seat forward and backward to ensure proper space between front passenger and instrument panel to enable the air bag to protect the passenger effectively when it is triggered.
- Adjust the backrest till you feel comfortable and sit straightly and your back shall completely contact with the backrest.
- Wear the seat belt correctly (refer to page 029).

 **Warning!**

- Never rest your feet on instrument panel, extend your feet out of the door glass or cross your legs on the seat during driving. Always rest your legs in the space reserved; otherwise you may be easily injured in case of emergency braking or collision.

Correct sitting posture of rear occupant

For the safety of rear passenger and to reduce risks of death and injury in case of an accident, the rear passenger shall do as follows:

- Rest your feet in the space before the seat.
- Adjust the seat head rest correctly (refer to page 132).
- Be well seated and your back shall completely contact with the backrest.
- Wear the seat belt correctly (refer to page 030).
- In case a child in the vehicle, use proper child restraint system. Refer to page 047 for installation information of child restraint system.

 **Warning!**

- Wrong sitting gesture or leaving the seat during driving may lead to injury in case of emergency braking or collision.
- If the rear passengers fail to wear seat belt or wear the seat belt in wrong ways, it may easily lead to serious injury or even death in case of emergency braking or collision.

Pedal area

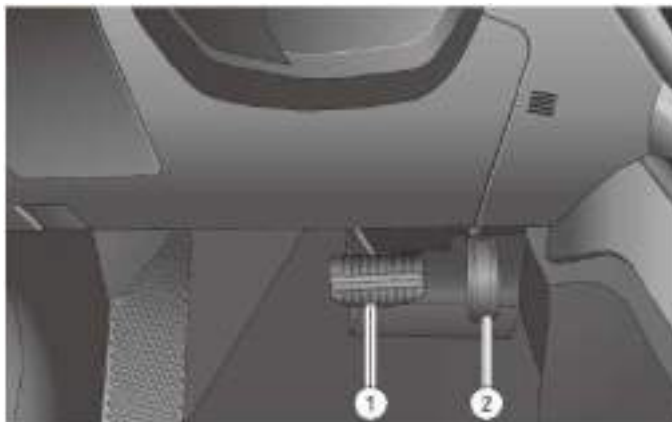

Pedals of vehicle with AT

1. Brake pedal
2. Accelerator pedal

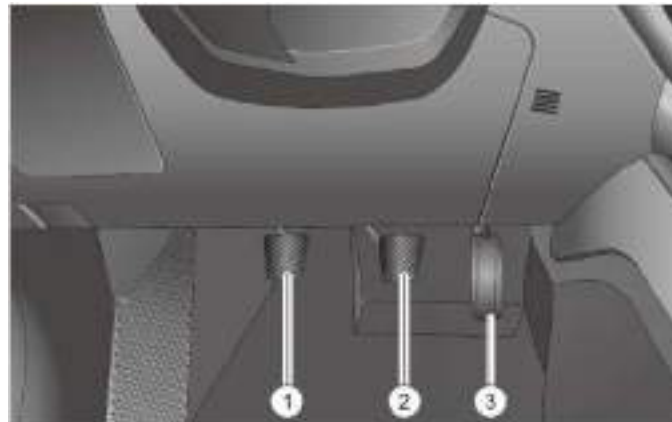

Pedals of vehicle with MT

1. Clutch pedal
2. Brake pedal
3. Accelerator pedal

Pedal area

Before driving, ensure that all pedals can be easily depressed to the end and return.

In case of failure of brake system, it is necessary to depress the brake pedal further in order to brake the vehicle. In such condition, please contact with authorized service station for repairing.

Warning!

- The space reserved for the driver's legs and the space below the seat shall never be occupied with articles; otherwise the article may roll into pedal area, which results in failed depressing of pedal by the driver in case of emergency and leads to accident.

Driver's foot pad

It is allowed to use foot mat that can be firmly fixed in the driver's leg space and does not hinder the driver from depressing the pedal.

Warning!

- Ensure the foot mat is always fixed in the driver's leg space.
- Never lay any other mat on the fixed mat or cover the mat with something else. Such article may roll into pedal area, cutting short pedal travel and hindering the driver from depressing the pedal in case of emergency and leading to accident.
- When the mat is removed from the vehicle for cleaning, it shall be tightened again when installed in the vehicle.

Wear suitable shoes

The driver shall wear such a pair of shoe that fit his feet and ensure the feet to agilely sense to pedal movement.

Why you must wear the safety belt

Seat belt ensures maximum protection to adult and children (for kids of 12 years old or younger, use child restraint system).

If the seat belt is not correctly worn, the driver or the passenger may get injured or even die in case of emergency even the vehicle is equipped with air bag.

It turns out that the belt provides effective protection to passengers.

Wear the belt correctly:

- Tie the driver and passengers to the vehicle as a whole, protecting the driver and passengers with innate device of the vehicle.
- Avoid the driver and passengers from colliding with articles in the vehicle.
- Protect the driver and passengers from being throwing out of the vehicle.
- Help the driver and passengers with good gesture to gain maximum protection from air bag.



Warning!

- The belt shall be worn correctly. It shall cross hip, chest and shoulder. The waist belt shall cross the hip as low as possible, instead of the abdomen.
- The belt shall not be twisted.
- The belt shall not be shared.

Why you must wear the safety belt



When the collision has stopped, the one who does not wear seat belt may still move forward at the speed before collision due to inertia.

Even the vehicle runs at low speed, the force on human caused by the collision is great that the passenger fails to control himself/herself and the passenger who does not wear seat belt will be thrown forward. Once he/she collides with any object in the cab, he/she may be injured seriously.



Rear row passengers shall also wear seat belt correctly, or he/she will be thrown forward in case of an accident. Rear row passenger that does not wear seat belt not only be injured seriously in case of an accident, but also hurts other passengers.

Warning!

- Never control your body with your arms and hands during collision, because it may cause serious injury to yourself.

Warning light of unfastened belt



Driver's safety belt unfastening alarm lamp

When the start switch or ignition switch is turned to ON and when you are not wearing seat belt, the driver seat belt warning light will be illuminated, reminding the driver to wear the belt.

* Front passenger seat belt warning light

When the start switch or ignition switch is turned to ON and when the front passenger is not wearing seat belt, the front passenger seat belt warning light will be illuminated, reminding the front passenger to wear the belt.

When the vehicle speed is above 25km/h, if the driver or front passenger does not wear the belt, the belt warning light will be illuminated and sends out audible warning till the driver or front passenger wears the belt.

Warning!

If the warning light is illuminated when the front seat is not occupied, please drive to authorized service station for troubleshooting.

Three-point seat belt

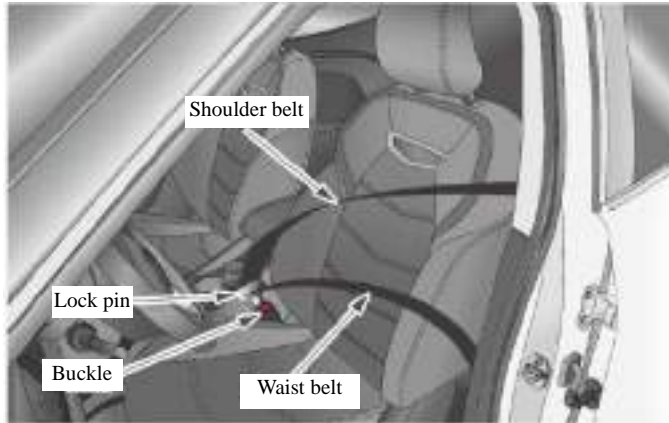

The three-point belt restrains the driver and passengers to reduce harm during collision or emergency braking.

Warning!

- If the seat belt fails, contact with authorized service station for repairing.

* Pre-tightening seat belt



When the collision happens, the driver or passenger moves forward due to inertia and the belt force limiter starts to work to control the restraining force within a certain range to avoid further injury to the driver or passenger due to high restraining force; besides, it cooperates with the air bag for better safety protection.

* Pre-tightening seat belt

! Caution !

- Once the pre-tightening seat belt is activated, it shall not be used for a second time. The pre-tightening seat belt shall be changed by authorized service station.
- You hear noisy sound when the pre-tightening seat belt is activated, then you see huge smoke, which does not mean the vehicle is on fire; however, you shall not breathe in the smoke too much, because it stimulates your respiratory tract and even leads to suffocation. One who is suffering from diseases of respiratory tract or dyspnea, please leave the vehicle when it is safe to where the air is fresh.

Correct wearing of safety belt



Wear front row seat belt correctly

- Ensure the doors are locked when you have seated.
- Adjust front row seat correctly (refer to page 134).
- Adjust head rest correctly (refer to page 132).
- Slowly and evenly pull out the belt to cross your shoulder, chest and hip as possible. Insert the pin into the buckle till you hear clicking sound.
- Pull the belt to check if the belt is fastened.

Correct wearing of safety belt



Wear rear row seat belt correctly

- Ensure the doors are locked when you have seated.
- Adjust head rest correctly (refer to page 132).
- Slowly and evenly pull out the belt to cross your shoulder, chest and hip as possible. Insert the pin into the buckle till you hear clicking sound.
- Pull the belt to check if the belt is fastened.

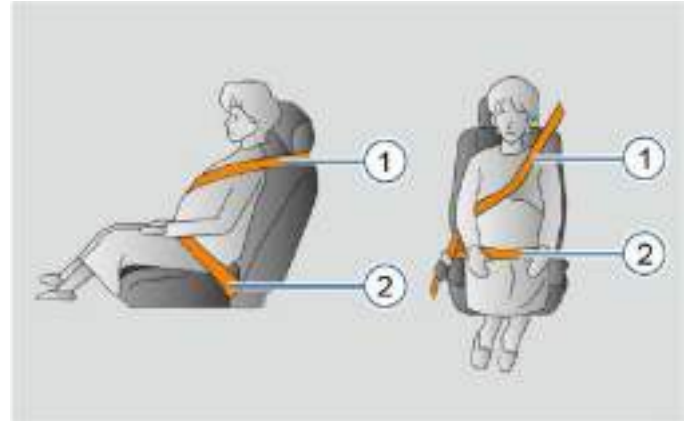

How a pregnant woman wear the belt in a correct way?

- Ensure the doors are locked when you have seated.
- Adjust front row seat correctly (**refer to page 134**).
- Adjust headrest correctly (**refer to page 132**).
- Slowly and evenly pull out the belt to cross your shoulder, chest and hip as possible. Do not cross your abdomen. Insert the pin into the buckle till you hear clicking sound.
- Pull the belt to check if the belt is fastened.

Correct wearing of safety belt

⚠ Caution !

- When pull out the belt and insert into the buckle, check if the belt is twisted. Twisted belt may cause injury during collision.
- Hold the upper end of the belt and pull it out quickly to check if the retractor works well. Normally, it shall lock quickly.
- Do not pull the belt to cross your body too fast, otherwise the belt may be locked. If it is locked, retract it a little to unlock and then pull out the belt evenly and slowly.

⚠ Warning!

- The lock pin of the belt shall be inserted to correspondent buckle.



Unfasten the belt

To unfasten the belt, press red “PRESS” button on the buckle to unlock and hold the belt to retract it slowly.

If the belt fails to retract smoothly, pull out the belt and check if it is twisted. Ensure the belt retracts smoothly.

Correct wearing of safety belt



Adjust the belt height:

- Press the guide component of belt to unlock.
- Hold the guide to move up and down to adjust to proper height.
- After adjustment, ensure the guide component is locked at proper position.



Warning!

- Never unlock the belt during driving to avoid serious injury or death caused by accident.
- When unlocking the belt, do not retract the belt too fast, because the metal lock pin may hurt you.

Air bag system

In case of collision between vehicle and obstacle, the air bag expands rapidly if it is triggered to reduce impact on driver or passengers due to inertia movement and absorbs the impact to reduce injury.

Driver and front passenger shall be correctly seated to keep proper distance to frontal air bag so that the air bag can effectively protect the driver and passenger.



Warning!

Though the air bag helps to protect the life of driver and passengers, if the driver or passenger fails to wear the belt correctly or seated in wrong gesture, the air bag may fail to protect and serious injury or death may still happen.

Air bag system equipped on the vehicle includes:

- The driver air bag and front passenger air bag
- *Side air bag
- *Side air curtain

Front frontal air bag



Driver airbag

The driver air bag is installed in the steering wheel where marked with AIRBAG.

Warning!

Never place hard or sharp object between the driver and the air bag; otherwise it may lead to serious injury when the air bag is expanding.



Front passenger air bag

Front passenger air bag is installed in the instrument panel (dotted line and shadow) where marked with AIRBAG.

Warning!

Never place any object on front passenger air bag, because once the air bag expands, the object may roll in the cab and hurt passengers.

* Side air bag



Front side air bag is installed in the driver seat and inside the backrest of front passenger seat to the door side (dotted line and shadow) where marked with AIRBAG.

Warning!

Never hang hard object on front door or close to the front door, because once the air bag expands, the object may roll in the cab and hurt passengers.

* Side air curtain



The side air curtain is installed inside the left and right sides of ceiling (dotted line and shadow) where marked with AIRBAG.

Warning!

Never hang coat hanger or hard object on the coat and hat hook, because once the air bag expands, the hanger or the hard object may roll in the cab and hurt passengers.

Causes that trigger the air bag



When the vehicle collides with an obstacle, the air bag expands quickly if the trigger condition is met. The condition include collision energy, accident type, collision angle, obstacle and vehicle speed. The air bag may not be triggered even the vehicle is seriously damaged in an accident.



Description!

Smoke is seen when the air bag expands. The smoke is non-poisonous and does not mean the vehicle is on fire; however, you shall not breathe in the smoke too much, because it stimulates your respiratory tract and even leads to suffocation. One who is suffering from diseases of respiratory tract or dyspnea, please leave the vehicle when it is safe to where the air is fresh.

Conditions that front frontal air bag extends:

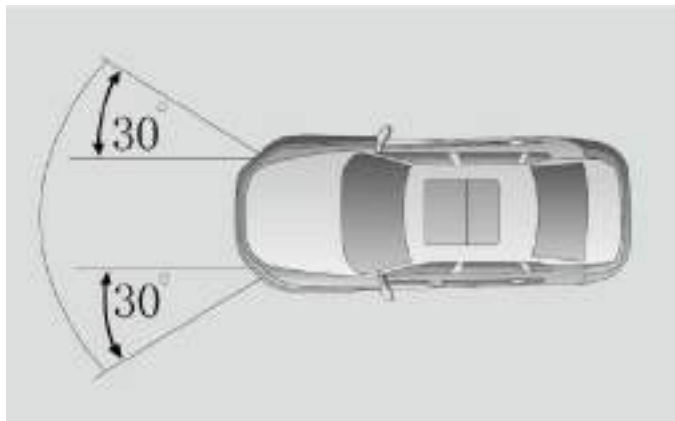

Condition 1:

Collision happens within $\pm 30^\circ$ in front of the vehicle



Condition 2:

Deceleration reaches trigger condition of control unit of air bag at the moment of collision.

The front frontal air bag may not extend in following conditions:**Condition 1:**

The head of vehicle collides with the ground when the vehicle is running downhill.

**Condition 2:**

The vehicle suffers from rear impact or collision.

The front frontal air bag may not extend in following conditions:



Condition 3:
Angular collision

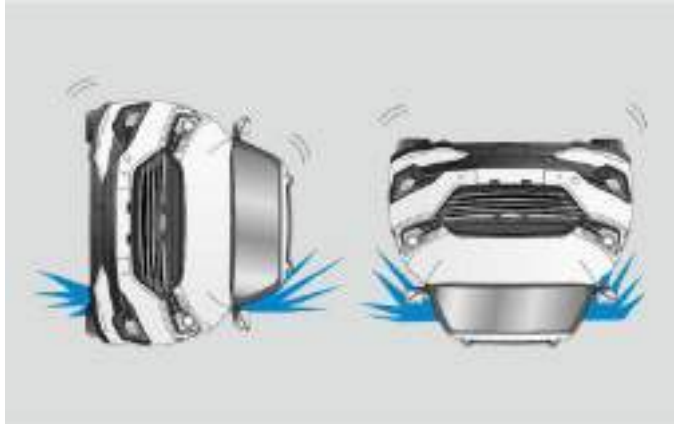

Condition 4:
Collide with the tail of trucks

The front frontal air bag may not extend in following conditions:

Condition 5:

Lateral rolling of vehicle



Condition 6:

Collide with cement, pillar, tree or other thin and tall object

* Conditions that side air bag and side air curtain may extend

* The side air bag and side air curtain do not extend unless the vehicle is suffering from side impact and transverse acceleration has reached the threshold value.

* Extension of side air bag or side air curtain will not trigger the frontal air bag.

Warning light of air bag failure



When the start switch or ignition switch is turned to ON, the warning light is illuminated for 4s and then goes off for self-inspection.

Following conditions of air bag warning light indicate system failure and you shall contact with local authorized service station for inspection:

- Warning light is not illuminated and self-inspect is not started.
- The light fails to go off when the self-inspection has completed.
- Warning light is illuminated or flashes during driving.

Child notice

In case of 12-year-old child or younger, restraint the child on rear row seat with child restraint system and lock.

Please read the operation manual and cautions of child restraint system and abide by the rules.

Before installing the child restraint system on rear row, adjust the front seat to proper position according to size of child restraint system and child's body size so as to ensure the child on rear row will not be injured by hard object in case of collision or emergency braking and the child will not be injured by extension of air bag.



Warning!

- Only child restraint system of proper size protects the child's safety. Child without protection or improperly protected will be injured seriously or even die in an accident.
- Never hold a baby in your arm during driving (including an infant)!
- Child restraint system shall never be shared by two children.
- In case the vehicle is not installed with a child restraint system, child that is below 1.5m shall not wear seat belt, because the belt may hurt abdomen and neck in case of emergency braking or accident.

Use notices of child safety seat



A warning label can be found on the sun shield.

Never install a backward child restraint system on a seat with air bag, otherwise it may lead to death or serious injury---Please read and abide by the note.

Classification of child restraint system (for reference)

Applicable child restraint system to different position:

Weight group	Fixing position		
	Front passenger seat	Two rear row seats	Rear row middle seat
0 group < 10 kg	X	U	X
0 group < 13 kg	X	U	X
I group : 9~18 kg	X	U/UF	X
II group : 15~32 kg	X	UF	X
III group: 22~36 kg	X	UF	X

Note: letters filled in the table mean:

U= Universal child restraint system

UF= Universal forward child restraint system

X= Child restraint system that is not applicable to the weight group



Description!

Some child restraint systems may specify size. Please follow instruction from manufacturer on operation, packing and label of child restraint system to check the size.

For correct installation, please refer to operation manual of child restraint system.

Classification of child restraint system (for reference)

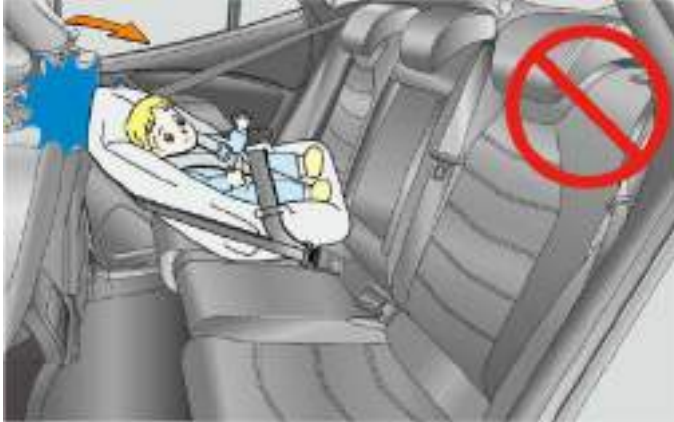

0/0+ Child restraint system

For infant that is less than 13kg, it is better to use child restraint system of type 0/0+ that can be adjusted to enable the baby to lie.



I Child restraint system:

For baby or kid weighting 9kg ~ 18kg, use child restraint system of type I.

Classification of child restraint system (for reference)



II Child restraint system:

For child weight 15 ~ 32kg, Use child restraint system of type II.



III Child restraint system:

For child weighting 22 ~ 36kg and no taller than 1.5m, use child restraint system of type III.

Classification of child restraint system (for reference)

Fixing position of ISOFIX child restraint system

Weight group	Size	Fixing module	Fixing position		
			Front passenger seat	Two rear row seats	Rear row middle seat
Portable baby seat	F	ISO/L1	X	IL	X
	G	ISO/L2	X	IL	X
0 group < 10kg	E	ISO/R1	X	IL	X
0+ group < 13kg	E	ISO/R1	X	IL	X
	D	ISO/R2	X	IL	X
	C	ISO/R3	X	IL	X
I group : 9~18kg	D	ISO/R2	X	IL	X
	C	ISO/R3	X	IL	X
	B	ISO/F2	X	IUF	X
	B1	ISO/F2X	X	IL	X
	A	ISO/F3	X	IUF	X
II group : 15~32kg			X		X
III group : 22~36 kg			X		X

Note: letters filled in the table mean:

IUF—Universal ISOFIX Child restraint system applicable to “Face upward” and secured by upper drawstring of the weight group

IL —Child restraint system applicable to special ISOFIX that has been listed. The system may be for special vehicle, limited or half-universal vehicles.

X—Child restraint system that is not applicable to the weight group

Correct installation of child restraint system

Child restraint system is usually installed in three ways: three-point belt, ISOFIX system and LATCH system. The three-point belt pulls and tightens the child restraint system, as described in “Classification of child restraint system”; ISOFIX system and LATCH system secure the child restraint system via the fastening device and reserved anchor.

ISOFIX system is similar to LATCH system in terms of fastening of child restraint system; however, LATCH has an additional upper anchor and the lower anchors can be shared. The two rear rows are provided with LATCH, so the vehicle can be either equipped with child restraint system of LATCH or child restraint system of ISOFIX.

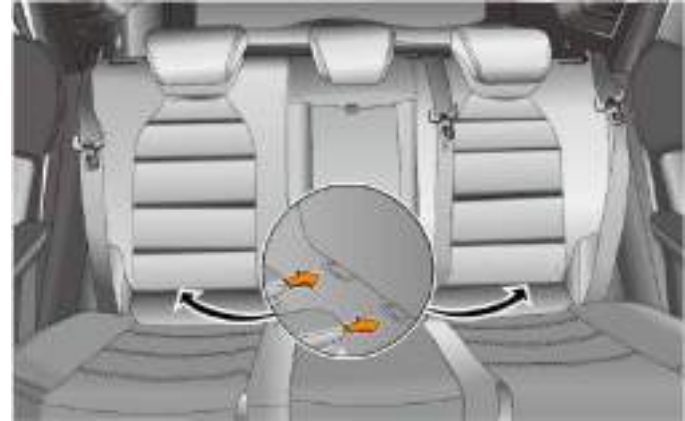

1. Place the child restraint system on rear row seat and insert the guide slot into the lower anchor in the gap between backrest and cushion till you hear clicking sound.
2. Lift the rear row seat headrest to the maximum position, thread the belt through the pillar of headrest and hook to the anchor. Ensure the belt is not twisted.
3. Tighten the fastening belt. Shake the child restraint system forward/backward and to the left and right to ensure it is firmly secured.

Correct installation of child restraint system



Description!

- Lower anchors of the two rear rows are hid in the gap between backrest and cushion. You can find the anchor in the gap.
- Upper anchor is on the back of backrest of seat.

Safety label



1. Curtain warning label
2. Child restraint system / air bag warning label
3. Dangerous expansion tank warning label
4. Engine coolant warning label
5. Front engine chamber safety warning label

The labels are as shown in the picture: they warn of hidden danger that may lead to serious injury or death. Please read the labels carefully.



Description!

The labels may not be applicable to all vehicle models and the picture may not show all positions or quantity of the labels. Please refer to labels on vehicle.

*** LCD instruments**

* LCD instruments

1. Fuel gauge
2. Indicator lamp
3. LCD of instrument cluster
 - Current vehicle speed
 - Engine speed
 - Driving information
 - Setting menu
 - Open door indicator
 - Short mileage
 - Total mileage
 - Gear indication
 - Warning and remind information in text or illustration
4. Engine coolant temperature gauge

Fuel gauge



- Fuel gauge shows remaining fuel in the tank. The 8 scale marks ranging from E-F. E indicates an empty fuel and F indicates a full tank. The scale mark is illuminated according fuel level in the tank.
- When only when first scale mark (red) is illuminated, it indicates fuel in the tank is less than 8L. In such condition, the low fuel level indicator  (yellow) on the instrument panel is illuminated, reminding the driver of inadequate fuel.

Fuel gauge

⚠ Caution !

- Before refueling, turn start switch to OFF.
- The fuel shall be above 1/4 volume as possible.
- When running on a slope or rough road, the warning light illumination may be abnormal.

📖 Description!

The leftward triangle symbol in the icon  on the fuel meter indicates that the fuel filler cap is on the left of vehicle body.

LCD of instrument



Current vehicle speed

It displays current vehicle speed.

LCD of instrument



Engine speed

It shows current engine rpm ($\times 1000$ rpm) from 0 ~ 8,000 rpm.

Caution !

The red area on engine rpm gauge means the engine is running with heavy load, which may cause the engine to cut off fuel supply for safety. Do not run the engine in red area as possible.



Short mileage

It shows mileage from 0 km ~ 999.9 km. When short mileage is above 999.9 km, it is reset to 0.

LCD of instrument



Odometer

It shows total mileage the vehicle has covered at present.



Gear display

It shows current speed gear.

AT: P, R, N or D is shown according to the signal received.

MT: 1, 2, 3, 4, 5 or R is shown according to the signal received.

Gear remind: in case of up or down arrow is shown, it reminds the driver to upshift or downshift to proper speed gear.

Engine coolant temperature gauge



Engine coolant temperature gauge shows current temperature of coolant.

- The gauge is divided into 8 scale marks from C to H, among which, C means low temperature and H means high temperature. Scales marks are shown according to the temperature.
- When the temperature is above 40 °C , one scale mark is illuminated. When the engine has worked for a period, the 4th and the 5th scale marks are illuminated.

- When H is illuminated, it means the coolant is hot and high coolant temperature indicator () (red) is illuminated. The buzzer warns to remind the driver of high coolant temperature. In such condition, you shall reduce engine load (do not run the engine for a long period at high rpm or do not run downhill for a long period) and stop to check coolant level.

Caution !

- If high coolant temperature indicator is illuminated, it means the coolant is hot and you shall stop the vehicle at once and contact with authorized service station for troubleshooting.
- In case of installing accessories on front bumper, it may reduce cooling performance of coolant. High environment and high engine load may easily lead to hot engine.

*** Common combined instrument**

* Common combined instrument

1. Tachometer
2. Indicator lamp
3. Speedometer
4. Engine coolant temperature gauge
5. Right adjust lever
6. LCD of instrument cluster
7. Left adjust lever
8. Fuel gauge

Speedometer



Showing current traveling speed in km/h

Warning!

Control the speed during driving, abide by the traffic rules and overspeed driving is not allowed.

Tachometer



Showing current engine rpm ranging from 0~8000 r/min

! Caution !

When the pointer reaches the red area, it means the engine is running with heavy load and the engine may lose power by cutting off fuel supply for self-protection. Do not run the engine with heavy load as possible.

Engine coolant temperature gauge



Coolant temperature gauge, showing current engine coolant temperature, is divided into 8 scale marks indicating temperature from C to H. C means low temperature while H means high temperature.

- When engine coolant temperature is above 40°C, the gauge shows one scale mark.
- When the engine has worked for a certain period, the gauge shall show 4 ~ 5 scale marks.

Engine coolant temperature gauge

- When the pointer stays at the 8th scale mark, it means the engine coolant is hot and hot coolant indicator is illuminated and the buzzer warns to remind the driver of hot coolant. In such condition, reduce engine load, stop the vehicle and check coolant level.

Fuel gauge



Fuel gauge, showing fuel left in the tank, is divided into 8 scale marks indicating fuel level from E to F. E means an empty fuel tank while F means a full fuel tank. Scale mark is shown according to the fuel level in the tank.

- When the gauge shows one red scale mark, it means fuel volume in the tank is less than 8L. In such condition, the low fuel level indicator is illuminated to remind the driver of refueling.

Driving information LCD



It shows current driving information, door open indication and warning.

Odometer

- Odometer, showing traveled mileage the vehicle has covered, including total mileage and short mileage A and short mileage B.

Short mileage A/B

- Short mileage A/B, showing from 0km ~ 999.9km; when it is above 999.9km, it will be reset.

- Short mileage A/B: long press right adjust rod to reset;

Gear display

- Speed gear display: showing current speed gear

MT: 1, 2, 3, 4, 5 or R is shown according to the signal received.

AT : Showing P, R, N or D according to signal received

Gear remind: in case of up or down arrow is shown, it reminds the driver to upshift or downshift to proper speed gear.

Adjust rod



The adjust rod can either be short pressed (less than 3s) or long pressed (more than 3s) to shift between driving information and interior backlight adjustment.

- When the start switch or ignition switch is turned to ON, turn on position light (clearance light), short press the left adjust rod to change interior backlight.
- When the start switch or ignition switch is turned to ON, short press the right adjust rod to shift to driving information or long press the right adjust rod to reset some driving information.

* Indicators of LCD instruments



* Indicators of LCD instruments

Caution !

When any indicator or warning lamp lights up after vehicle is started up or in traveling, it means the related system or some function is in use or failed. Please carefully learn the meaning of each indicator or warning lamp, and immediately contact the authorized service station in case of any failure for solutions.

* Indicators of common instruments













* Indicators of common instruments

Caution !

When any indicator or warning lamp lights up after vehicle is started up or in traveling, it means the related system or some function is in use or failed. Please carefully learn the meaning of each indicator or warning lamp, and immediately contact the authorized service station in case of any failure for solutions.

Indicator lamp

Indicator lamp		Function description
	Position lamp	It is illuminated when the position light is turned on.
	* Daytime running lamps	It is illuminated when daytime driving light is illuminated.
	High beam	The lamp will go on when the high-beam lamp or overtaking lamp is turned on.
	*Front fog lamp	It is illuminated when front fog lamp is illuminated.
	Rear fog lamp	The indicator lamp will go on when the rear fog lamps are turned on.
	Left turn indicator lamp	It flashes when left turn light is turned on.
	Right turn indicator lamp	It flashes when right turn light is turned on.
	*EPB indicator	It is illuminated when EPB is applied; the buzzer sounds when vehicle speed is above 5km/h and EPB is not released. It goes off and the buzzer stops when EPB is released.
	*AUTO HOLD working indicator	It is illuminated when EPB is activated.
	* Cruise control working indicator lamp	It is permanently illuminated when cruise function is activated and drives at set cruise speed. It goes off when cruise is deactivated.
	*HDC working indicator	It is illuminated when HDC is activated.

Indicator lamp

Indicator lamp		Function description
	* ESC indicator	It flashes when ESC is activated.

If the above mentioned indicator is illuminated or flashes on the instrument panel, it means the correspondent system is working.







 **Description!**

Press the hazard warning light button, the left/right turn light indicator and all turn lights flash at the same time and the instrument panel makes intermittent warning. Press the hazard warning light button again, the left/right turn light indicator and all turn lights go off at the same time and the warning becomes silent.







Indicator lamp		Function description
	* ESC off indicator	It is illuminated when ESC is off.

In any of above indicator is illuminated, it means the corresponding system is deactivated. If the indicator is illuminated, you may hear warning sound or warning information is shown on the instrument.









Hazard warning lamp

Hazard warning lamp		Function description
	Warning light of low oil pressure	When the vehicle is started, the light flashes and makes audible alarm. Please stop the vehicle, shut off the engine and contact with authorized service station for troubleshooting.
	Warning light of brake failure	ABS failure warning light and brake failure warning light are illuminated at the same time in case of brake system failure. The light is also illuminated in case of low brake fluid level. If the light is permanently illuminated, you have to depress the brake pedal heavily and it requires longer braking distance. In such condition, please come to authorized service station for troubleshooting.
	Driver's safety belt unfastening alarm lamp	When the start switch or ignition switch is turn to ON, if the driver fails to wear the belt, the light keeps flashing. When vehicle speed is above 25km/h, the buzzer alarms (100s). The light does not go off till the driver wears the belt.
	* Warning light of front passenger failing to wear the seat belt	When the start switch or ignition switch is turn to ON, if the front seat is occupied and the front passenger does not wear the belt, the light flashes to remind the passenger of wearing the belt. The light goes off when the passenger wears the belt correctly.
	Warning light of engine exhaust system failure	When the start switch or ignition switch is turn to ON, the light is illuminated for 3s and then goes off. If the light is permanently illuminated or illuminated during driving, it indicates failure of engine exhaust. Please contact with authorized service station for troubleshooting.
	Warning light of engine system failure	It is illuminated inn case of engine system failure. Please contact with authorized service station for troubleshooting.
	Warning light of low fuel level	It is illuminated in case of low fuel level. You can drive for a certain distance in such condition and you shall come to the nearest fuel station for refueling.

Hazard warning lamp

Hazard warning lamp		Function description
	Warning light of high coolant temperature	It is illuminated if coolant temperature is above to equal to warning temperature (120°C).
	Warning light of ABS failure	It is illuminated in case of ABS failure. When the start switch or ignition switch is turned to ON, the light is illuminated for 3s for self-inspection and then goes off. If the light does not go off when the self-inspection has completed, please contact with authorized service station for troubleshooting. Please contact with authorized service station for troubleshooting.
	Warning light of battery charging failure	If the light is illuminated when starting the engine, please flame out the engine and power off all electrical appliances and inspect the vehicle for any failure. Please contact with authorized service station for troubleshooting if necessary.
	Warning light of air bag failure	When the start switch or ignition switch is turned to ON, the light is illuminated for 3s for self-inspection and then goes off. If the light does not go off when the self-inspection has completed or it flashes or keeps being illuminated during driving, it indicates failure of warning light or air bag system, please contact with authorized service station for troubleshooting.
	Warning light of transmission failure	It is illuminated in case of transmission failure. It flashes if the transmission oil is hot. If it flashes or keeps being illuminated, please stop the vehicle at a safe place and contact with authorized service station for troubleshooting.
	Warning light of an open door	When any door, front hood or back door of the vehicle is open, the indicator lamp will go on to warn the driver that a door is open or not well closed.
	Tire pressure system failure warning light	The light is illuminated and makes audible alarm in case of abnormal tire pressure or tire temperature. Please stop the vehicle and contact with authorized service station for troubleshooting.

Hazard warning lamp

	Hazard warning lamp	Function description
	HDC failure warning light	It is illuminated in case HDC failure.
	Rainfall sensor failure (flashing) warning light	It flashes in case of rainfall sensor failure.
	Body immobilizer warning light	Close all doors and lock the doors with remote key, the light flashes. If any door is open and unlocked, the light flashes and makes audible alarm.
	PEPS Warning light	It is illuminated in case of PEPS failure or remote key failure. Please change the battery of remote key.
	Warning light of emergent braking	It is illuminated in case of emergent braking.
	Warning light of EPB failure	It is illuminated in case of EPB failure, please contact with authorized service station for troubleshooting.
	Cruise status and failure warning light	It is illuminated permanently when the vehicle fails to drive at set cruise speed or when it has quit the cruise system. It flashes in case of cruise system failure.
	Electronic power steering system (EPS) malfunction indicator lamp	It is illuminated in case EPAS failure. If it is illuminated, please stop the vehicle at a safe place and contact with authorized service station for troubleshooting.
	Warning light of vehicle maintenance	It is illuminated when the new vehicle has covered 3,000km to remind the owner of maintenance for the first time as scheduled. After that, the light is illuminated every 5,000km to remind the owner of scheduled maintenance.

Introduction



* LCD instruments

The driver understands current vehicle information from the LCD in the middle of instrument panel, including open/close condition of doors, front engine chamber and tail gate, total mileage, time, outside temperature.

When the start switch or ignition switch is turned to ON, the driver's information system starts to work.



Description!

It does not show value if it fails to detect valid value.

Button operation



The buttons on the right side of steering wheel are control button of instrument LCD and cruise control button.

Control button of instrument LCD

- "OK" button: select/enter
 - Select current menu
- "BACK": return
 - Return to previous page;

Button operation

- ▲ / ▼: up/down
 - Short press up/down to choose desired item or up/down to change the value.

* Cruise control button

- *Constant cruise speed button (refer to page 177).

Door-open warning



It shows close/open condition of left front door, left rear door, right front door, right rear door, front engine hood and tail gate.

When any door is open, a symbol is shown on the instrument and warning light of an open door is illuminated. When the open door is closed, the warning light goes off.



Warning!

Close and lock the doors, engine hood and tail gate before driving for safety.

Level 1 menu



Short press OK button on multi-purpose steering wheel to enter menu setting page.

Short press ▲ / ▼ buttons on the right side of multi-purpose steering wheel and move the cursor, press OK button to enter sub-level menu.

Theme setting

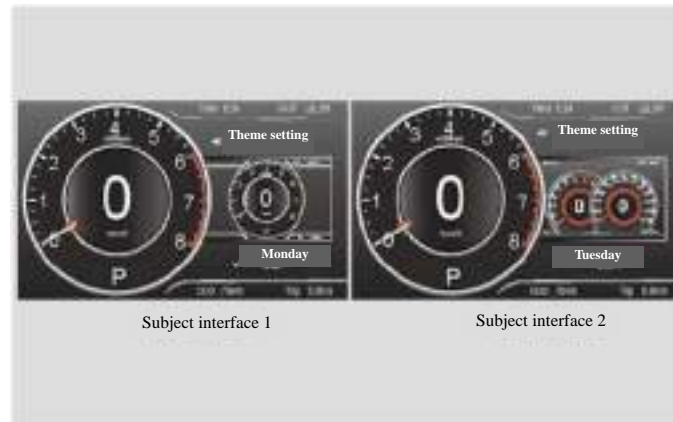

Short press ▲ / ▼ buttons on the right side of multi-purpose steering wheel to choose subject and press OK button to enter.



Description!

There are four subjects provided to shift to anyone.

Navigation



It shows current navigation information.

Short press the BACK button on the right side of the steering wheel to return to previous page.

* Tire pressure



It shows current pressure and temperature of the four tires. It warns in case of abnormal pressure or temperature.



Description!

It does not show value if it fails to detect valid value.

Driving information



Short press ▲ / ▼ button on the right side of the steering wheel to shift between below pages:

- Instant fuel consumption
- Average vehicle speed
- Average fuel consumption
- Driving mileage
- Subtotal mileage



Average fuel consumption reset

Short press OK button on the right side of multi-purpose steering wheel to reset the average fuel consumption.

Short press ▲ / ▼ button on the right side of the steering wheel and move the cursor.

- Click YES and press OK to reset fuel consumption.
- Click NO and press OK to back to previous page.

Driving information



Average vehicle speed reset

Short press OK button on the right side of multi-purpose steering wheel reset the average vehicle speed.

Short press BACK button on the right side of multi-purpose steering wheel to return to previous page.



Short press ▲ / ▼ button on the right side of the steering wheel and move the cursor.

- Click YES and short press OK button on the right side of multi-purpose steering wheel, the average vehicle speed is reset.
- Click NO and short press OK button on the right side of multi-purpose steering wheel to return to previous page.

Driving information



Trip mileage reset

Short press OK button on the right side of multi-purpose steering wheel to reset the subtotal mileage.

Short press BACK button on the right side of multi-purpose steering wheel to return to previous page.



Short press ▲ / ▼ button on the right side of the steering wheel and move the cursor.

- Click YES and short press OK button on the right side of multi-purpose steering wheel, the subtotal mileage is reset.
- Click NO and short press OK button on the right side of multi-purpose steering wheel to return to previous page.

Setting



Short press ▲ / ▼ button on the right side of the steering wheel to shift between below pages:

- Maintenance
- Navigation setting
- Time setting
- Traveling computer display
- Speed limit warning setting
- Backlight adjustment



Short press ▲ / ▼ button on the right side of the steering wheel and move the cursor.

Short press OK button on the right side of multi-purpose steering wheel to enter next page.

Setting



Maintenance setting

Short press OK button on the right side of multi-purpose steering wheel to reset the maintenance schedule.

Short press BACK button on the right side of multi-purpose steering wheel to return to previous page.



Short press ▲ / ▼ button on the right side of the steering wheel and move the cursor.

- Click YES and short press OK button on the right side of multi-purpose steering wheel to reset the maintenance.
- Click NO and short press OK button on the right side of multi-purpose steering wheel to return to previous page and the schedule is not reset.

Setting



Description!

Maintenance information is shortly shown on the instrument to remind you when to perform maintenance.



Caution !

- Maintenance schedule is important to service life and value keep of vehicle, especially the engine. Never exceed the time deadline of next maintenance even the vehicle has travelled short distance.
- When the vehicle is disconnected from the battery, the calculation of time to next oil change is interrupted.
- Pay attention to descriptions in maintenance manual to follow the maintenance interval during long-period shutdown.
- Vehicle maintenance shall be performed in authorized service station as scheduled.



Navigation setting

Either Trigger to display or Select to display according to your operation of navigation system;

- Short press ▲ / ▼ on the right side of multi-purpose steering wheel to move the cursor and press OK to enter.
- Short press BACK button on the right side of multi-purpose steering wheel to return to previous page.

Setting



Time setting

Either “Synchronous with GPS time” or manual setting to update the time.



Driving information display setting

Short press ▲ / ▼ on the right side of multi-purpose steering wheel to shift the information pages:

- Short press OK button on the right side of multi-purpose steering wheel to select one or more than one piece of information shown on the page; information that is not selected will not be shown.
- Short press BACK button on the right side of multi-purpose steering wheel to return to previous page.

Setting



* Speed limit warning setting

Short press ▲ / ▼ on the right side of multi-purpose steering wheel and move the cursor to set warning speed.

Short press OK button on the right side of multi-purpose steering wheel to enter.

Short press the BACK button on the right side of the steering wheel to return to previous page.



Backlight adjustment

Backlight adjustment in the cab:

- The backlight could not be adjusted when the position light is not turned on;
- When the position light is turned on, press ▲ / ▼ to adjust backlight (press ▲ to increase or press ▼ to decrease).
- Short press OK button on the right side of multi-purpose steering wheel and then return to previous page.

Common instruments setting



In the middle area of instrument cluster is a display of driving information, showing information of vehicle during driving.

Turn the start switch or ignition switch to ON, shift the adjust rod of instrument cluster and short press the right adjust rod to show driving information page.



Description!

- It does not show value if it fails to detect valid value.



Exterior temperature

It shows the temperature outside.

Common instruments setting



Driving mileage

It shows maximum mileage that the fuel in the tank could afford. When driving mileage is less than 50km, it shows — KM.



Description!

The data is for reference only and could not be set. It adjusts according to fuel level in the tank.



Instant fuel consumption

It shows current instant fuel consumption and could not be set.

Common instruments setting



Average fuel consumption

It shows average fuel consumption from last resetting. Long press the right adjust rod (longer than 3s) to reset.



Instant speed

It shows current instant speed, which could not be set.

Common instruments setting



Average speed

It shows average driving speed from last resetting. Long press the right adjust rod (longer than 3s) to reset.



Time setting

On time page, long press ($t > 2s$) left adjust rod to enter time adjustment page.

Adjust the hour: the system adjusts hour first. Press the left button to increase by one hour and the digit flashes at frequency of 1Hz; in case of no operation for 5s after the adjustment, the hour setting is completed and the system shifts to minute setting.

Adjust the minute: same with that of adjusting hour; in case of no operation for 5s after the adjustment, the minute setting is completed;

Remote control key



* Intelligent remote key

1. Mechanical key
2. Tail gate unlock button
3. Unlock button
4. Lock button

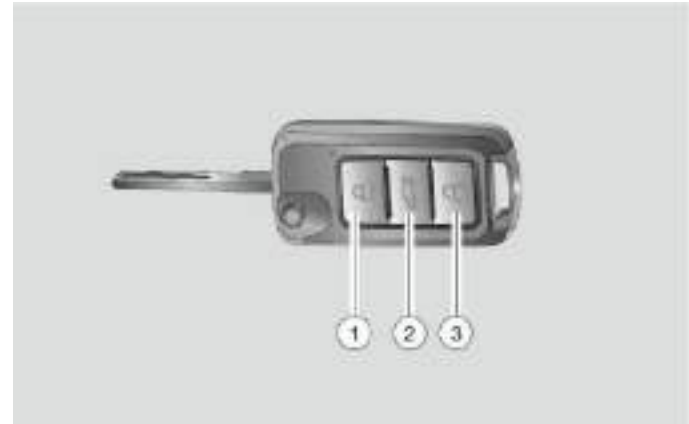

* Remote key

1. Lock button
2. Tail gate unlock button
3. Unlock button



Description!

When start switch or ignition switch is turned to ACC or ON, it is invalid to press buttons on intelligent remote key / remote key.

Remote control key

Operation of lock button

- In effective range, when the start switch or ignition switch is turned to OFF and all doors are closed, short press (less than 2s) lock button on intelligent key/remote key, all doors are locked.
- In effective range, when the start switch or ignition switch is turned to OFF and all doors are closed, long press (longer than 2s) lock button on intelligent key, all doors are locked and * outside rearview mirror is folded. For vehicle with one-button operation glass at the driver' side, when the glass is not closed, it rises to close automatically.
- When the door is locked, press the lock button on intelligent key for 2 times in 2s to search the vehicle. The left and right turn signal lights flash and the horn sound for twice. The turn signal light goes off 25s if no operation happens. If you press unlock button on the intelligent key or any door is open during the period, the right and left turn signal lights flash.

Caution !

In case of any door is not closed, press the lock button, the four doors will be locked and then unlocked.

Operation of unlock button

- In effective range and the doors are locked, short press (less than 2s) unlock button on intelligent key/ remote key, all doors are unlocked, * outside rearview mirror extends
- In effective range and doors are locked, long press (longer than 2s) unlock button on intelligent key, all doors are unlocked, * outside rearview mirror extends and door glass descends to the lowest position. Press unlock button when the door glass is descending, the door glass stops.



Description!

When unlocking the door, the turn signal light flashes once; when locking the door, the turn signal light flashes twice.



Caution !

If the door fails to open in 30s when the unlock button has been pressed, the door will be locked again by the system.

Remote control key

Unlock button operation of tail gate

Within effective range, when the tail gate is locked, long press the unlock button on intelligent key/ remote key for more than 2s to unlock the tail gate.

Caution !

Inside the remote key there is a circuit for activating anti-theft locking system. If the circuit is damaged, it is impossible to start the engine, so:

- Never keep the remote key in sunlight or hot or wet place.
- The remote key shall not fall off or be squeezed by heavy stuff.
- Avoid the remote key from touching liquid. If it is wet, wipe it with soft cloth.

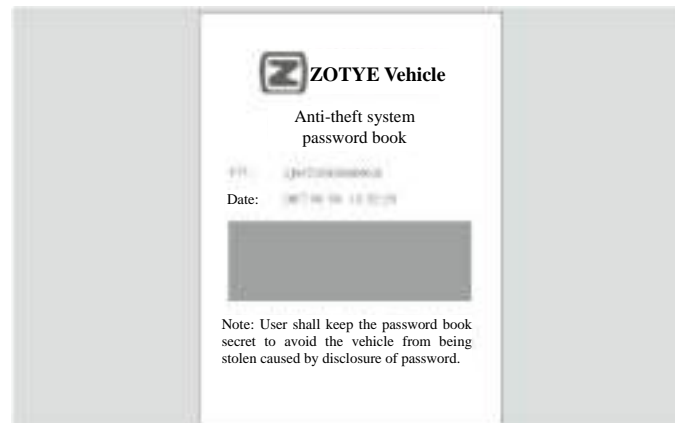

Anti-theft system password book

The password book can be found in the driver's manuals, please keep the password book secret. In case of invalid intelligent key or lost key, please take along the password book to come to authorized service station for a new key.

Remote control key

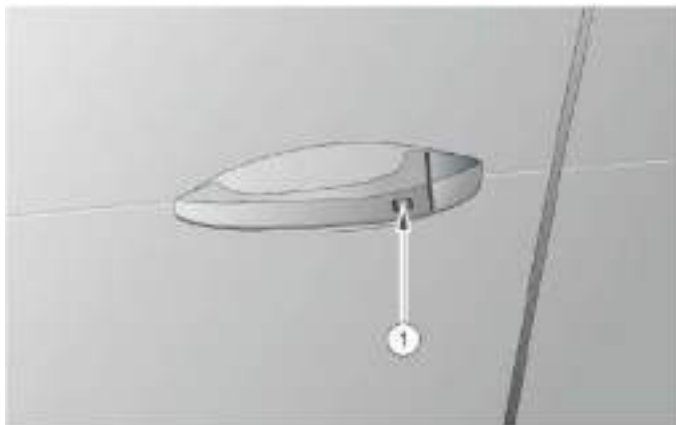

* Keyless access

Unlocking

When the start switch is turned to OFF and the doors are locked, user presses microswitch ① on intelligent key no more than 1m to left and right front doors to unlock the four doors * outside rearview mirror extends and the turn light flashes once.

Lock

When the start switch is turned to OFF and the four doors are closed but unlocked, user presses micro switch ① on intelligent key no more than 1m to left and right front doors to lock the four doors and the turn light flashes twice.

Remote control key

Replacement of battery

Intelligent remote key / remote key contains a wireless emitter and a battery and the wireless receiver is located in the vehicle. If the battery is full, the intelligent remote key / remote key works when it is operated in effective range. In case of any obstacle between intelligent remote key / remote key and the vehicle or low battery or in case of adverse weather, the effective range will be shrunk.



Description!

- In case you have to press the button for several times to lock or unlock the doors, it means the battery is low and it is necessary to change the battery.
- The key may be easily damaged when changing the battery. It is suggested to change the battery in authorized service station.



Steps to change the battery:

1. Take out the mechanical key

- Intelligent remote key: press the lock button to pull out the mechanical key.
- Remote key: press the button, the mechanical key pops up.

Remote control key

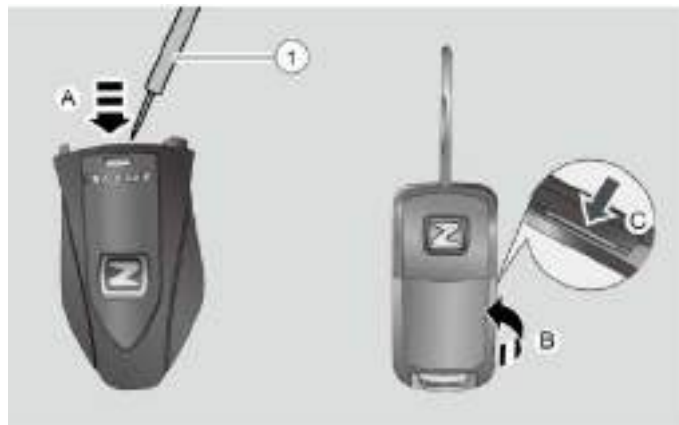

2. Remove key housing

- Intelligent remote key: use a screw driver ① to pry at the gap on the intelligent remote key to remove the housing;
- Remote key: pry at the gap on the bottom to remove the housing of remote key;



3. Change the cell battery

- Intelligent remote key: press the edge of battery to remove it.
- Remote key: push the edge of the battery to remove it;

! Caution !

When removing the cell battery, be careful not to touch the circuit board, for it may produce static electricity and damage the remote key.

Remote control key

4. Recover the installation of remote key

- Check the positive and negative terminals of the battery before installation.
- Ensure the battery cap is correctly engaged to protect the battery against dust.
- Test the remote key when the battery has been changed.



Caution !

When installing a new cell battery, the side with “+” shall face up. The new battery shall be same specification with that of the previous one. Battery model is CR2032. Wrong battery may damage the remote key.



Description on environmental protection!

The disposal of waste battery must abide by the relevant environmental protection laws and regulations.

Mechanical key



1. The mechanical key is contained in remote key
2. Standby mechanical key
3. The mechanical key is contained in intelligent remote key

The mechanical key is contained in remote key and the standby mechanical key shall be used in emergency. If the remote key fails, use mechanical key to unlock the doors.



Take out the mechanical key

- Intelligent remote key: press the lock button to pull out the mechanical key.
- Remote key: press the button, the mechanical key pops up.



Description!

The mechanical key is only used to lock the door or unlock the door at the driver's side, instead of starting the engine.

Use mechanical key to lock and unlock doors

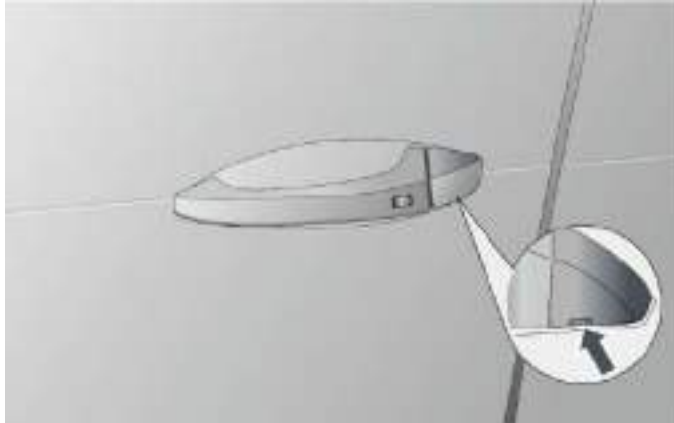

1. Take out the mechanical key
2. Insert the mechanical key into removal hole of trim cap and turn the mechanical key to pry the cap.

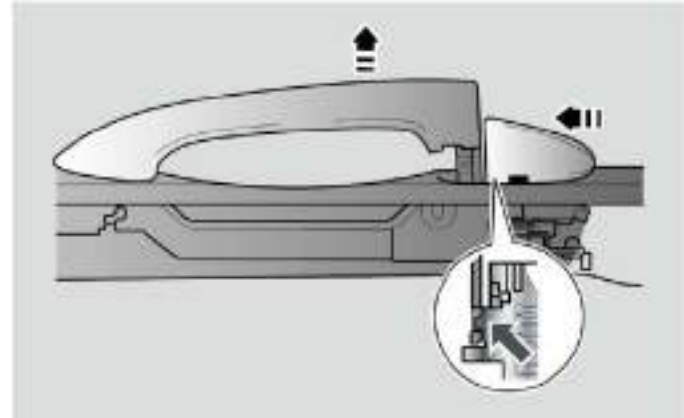

3. Pull the door handle, disengage the trim cap and remove the cap.

Use mechanical key to lock and unlock doors

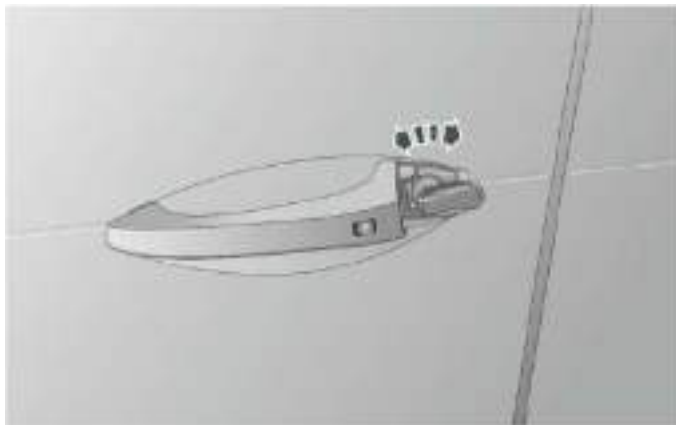

4. Insert the mechanical key into the door lock hole at the driver's side.
5. Turn mechanical key anticlockwise to lock the door.
6. Turn mechanical key clockwise to unlock the left front door.

Caution !

When unlocking the door with invalid remote key, the anti-theft system warns.

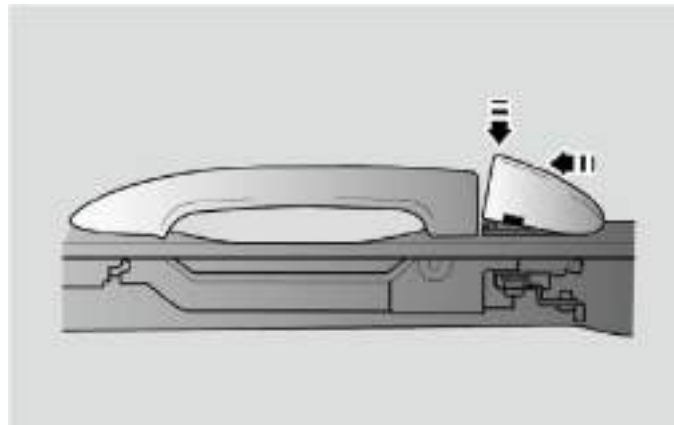

Install door trim cap

1. Keep the sharp end of the trim cap tightly to the door and form an angle between the trim cap and door, push the cap forward to get the sharp end stuck.
2. Press the other end of the trim cap to engage.

* Engine immobilizer system



The vehicle is equipped with engine immobilizer system, which shall not be manually activated or deactivated. When pressing the start button, the valid intelligent remote key is identified in the cab, the engine immobilizer locking system will be deactivated. If the system fails to be deactivated, the immobilizer indicator on instrument panel will be illuminated (remind the driver of failed detection of valid key). In such condition, you can try to start the engine in following two ways: depress clutch pedal of MT vehicle or brake pedal of AT vehicle, place the intelligent remote key at the cup holder marked with a symbol of key at the bottom of auxiliary instrument panel, press start button to try to deactivate the engine immobilizer system or try the standby intelligent remote key. If both ways fail, contact with authorized service station for troubleshooting.

Vehicle body immobilizer system



If the vehicle is equipped with immobilizer system, please read this chapter carefully to understand the features and operation so as to ensure safety.

Vehicle body immobilizer system

Defense status

Turn the start switch or ignition switch to OFF and close all doors, the intelligent remote key is outside the cab, the driver presses lock button on microswitch or intelligent remote key at the front door handle to lock the doors. Meanwhile, the turn indicator on instrument panel and turn light flashes twice, indicating the system has entered immobilizer status and the immobilizer system indicator flashes slowly.

Warning status

Turn the start switch or ignition switch to OFF and the immobilizer system has been activated, unlock any door (left front, right front, left rear and right rear) with illegal key without permission, the system warns.

In case of warning, the turn signal lamp will flicker continuously for 5min with the buzzer beeping for 28s, and the immobilizer indicator lamp will flicker fast; after the 5min audible and visual warning, the warning is deactivated provided there is no new intrusion signal no matter if the intrusion source is closed. In case of new intrusion source, the system will activate the 5min visual warning and 28s buzzer warning for the occurrence of new intrusion source.

Deactivation of warning status

If the unlocking or locking button on the intelligent remote key is pressed during warning, the audible and visual warning can be deactivated; at this moment, the immobilizer indicator lamp still flickers fast and the system is still in the defense status.

If the system continues to receive the intrusion signal, the warning will be activated again. To deactivate the defense completely, it is necessary to deactivate the audible and visual warning for the first time and then press the unlocking button again.

Deactivation of defense

Turn the start switch or ignition switch to OFF when the immobilizer system has been activated, the driver carries intelligent remote key to approach the door and press unlock button on microswitch or intelligent remote key at the front door handle to unlock the door. Meanwhile, the turn indicator on instrument panel and turn light flashes once and the immobilizer system indicator go off, indicating it has quit immobilizer system.

Secondary immobilizer

When the immobilizer system has been deactivated, if the door fails to open or start switch fails to turn to ON in 30s, the immobilizer system recovers and locks the doors.

Central control door lock system

The central control door lock system can be operated in following two ways to lock or unlock all doors:

1. Press lock or unlock button on intelligent remote key / remote key to control the central control door lock system.
2. Press button of central control door lock to operate.

Vehicle speed lock

When vehicle speed is above 20 km/h, the central door lock system locks the doors.

Auto unlock

The door is unlocked when the engine has flamed out.



Central control door lock button

Unlock or lock the door from inside by pressing the central control door lock button at the driver's side.

Unlock: press button ② to unlock the door.

Lock: press button ① to lock the door.

Central control door lock system



Inward opening handle of door

When the system is unlocked:

- Pull the door handle in the cab to open the door.

When the system is locked:

- Pull the door handle at the driver's side for two times continuously to unlock all doors and open the door at driver's side.
- Pull the door handle at the passenger's side for two times continuously to unlock and open the door.

Child safety lock



Child safety lock

The two rear doors are installed with children' lock switches on each.

The children's lock forbids the children from pulling the handle on rear doors, which may lead to accident.

Child safety lock

Activate the children's lock:

1. Open the door, which is necessary to activate the children's lock.
2. Take out the mechanical key (refer to page 094).
3. Turn the switch anticlockwise to the end to activate the lock.

Deactivate the children's lock:

1. Open the door, which is necessary to deactivate the children's lock.
2. Take out the mechanical key (refer to page 094).
3. Turn the switch clockwise to the end to deactivate the lock.



Description!

- Activate the lock when a child is in the cab.
- When the lock has been activated, the rear door can be open from outside only. Do not pull the door handle inside the cab rudely, or it may be damaged.

Tail gate



Open the tail gate

Press the tail gate button of among the switch cluster on the left side of instrument panel to unlock the tail gate and open the tail gate manually to the highest position.

Tail gate



Open the tail gate in emergency

1. In case of emergency, remove the trim cover of emergency button on trim board of tail gate from inside.

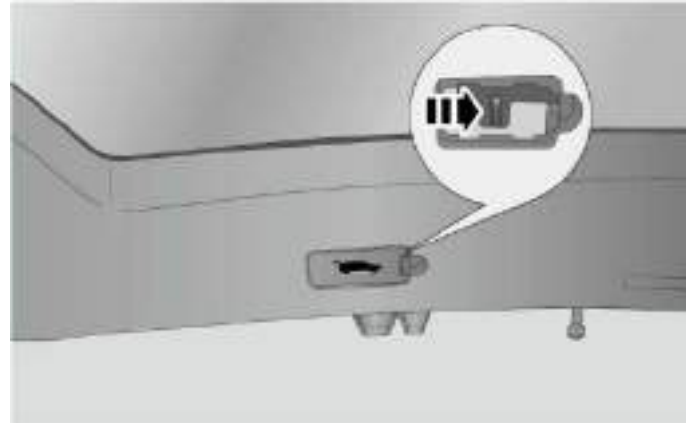

2. Shift the emergency lever on tail gate lock to unlock the gate.

Tail gate



Close the tail gate

Lower the tail gate to close to rear bumper and push down the tail gate with your hands hardly to close it.

Warning!

- When open or close the tail gate, inspect the condition around the tail gate and ensure no body is standing close to the tail gate.
- When close the tail gate, be careful not to get your finger pinched.
- No one is allowed to stay in the trunk, because it may easily cause injury or death in case of emergency or collision.

Power glass

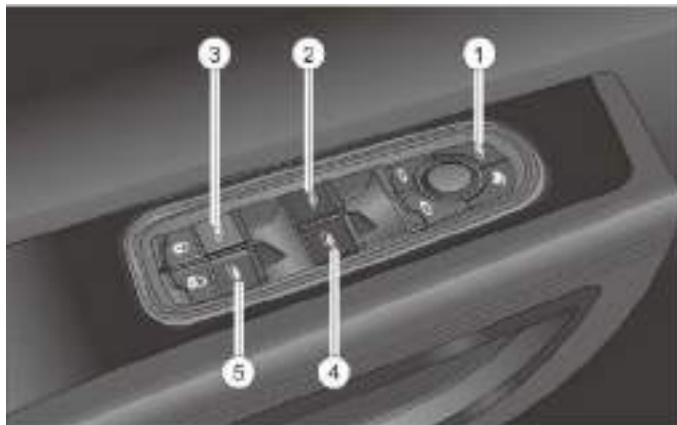

Power glass control switch at the driver' side

1. Power glass lift lock button at the passenger' side
2. Left front power glass lift lock button
3. Left rear power glass lift lock button
4. Right front power glass lift lock button
5. Right rear power glass lift lock button

Window glass opening

- Short press the button ② downward, the power glass descends.
- Long press buttons ②, ③, ④ and ⑤ downward, the power glass descends. The power glass stops descending when the button is released or when it has descended to the end.

Closing of window glass

- Short press the button ② upward, the power glass ascends.
- Lift the button ②, ③, ④ and ⑤ to rise the power glass. The glass stops when the button is released or when the glass has risen to the top.

Locking and unlocking of power glass lift at the passenger's side

Press lock button ① to lock the three power glass, except the driver's. Press the button again, the button bounces to unlock.

Power glass

* Anti-pinch of left front power glass

If the rising glass is obstructed, it stops where it is and descends at once. Such being the case, find out the cause before close the glass.

In case such condition occurs for several times in a short period, the power glass losses initial information of anti-pinch. Please inspect if any obstacle on the way that causes continuous occurrence of the condition. After inspection, initialize to learn to recover the anti-pinch function.



* Initialization of anti-pinch

Long press elevation button ① upward of left front power glass, the glass moves upward. It is necessary to lift the button for several times till the glass is closed. When the glass is closed, lift the button ① of left front glass and holds for 2 ~ 3s for initialization.

Power glass

⚠ Caution !

- Though the glass is provided with anti-pinching function, ensure the smooth movement when closing the glass, otherwise the function may not be triggered in some conditions (thin or flexible obstacle).
- Do not install other accessories within movement range of glass, otherwise anti-pinching function may be affected or triggered by mistake that causes the glass fail to close.
- Though the glass is not provided with anti-pinching function during initialization, do not hinder the glass from closing with your body or any other object; otherwise it may lead to damage and affect the initialization.
- In case of failure of power glass system, please come to authorized service station for troubleshooting.



Elevation button of power glass at the passenger's side

Power glass button of right front and rear row is on the door of each side.

Window glass opening

- Long press buttons ① downward, the power glass descends. The power glass stops descending when the button is released or when it has descended to the end.

Closing of window glass

- Lift the button ① to rise the power glass. The glass stops when the button is released or when the glass has risen to the top.

Power glass

Warning!

- Before closing the power glass, make sure that nothing is above the power glass and ensure heads, hands and bodies of all passengers are inside the vehicle. If passenger's neck, head or hand is pinched by the glass, it will cause serious injury. Ensure it is safe when closing the power glass.
- If a child in car, do not allow him/her to touch the button of power glass. The lock button of glass elevator avoids such unexpected pressing of power glass button.
- Never leave anyone (especially children) in the cab alone, because when the start switch or ignition switch is turned to ON, the one who is left in the cab alone may be get caught by power glass and leads to serious injury.

* Power all-view sunroof

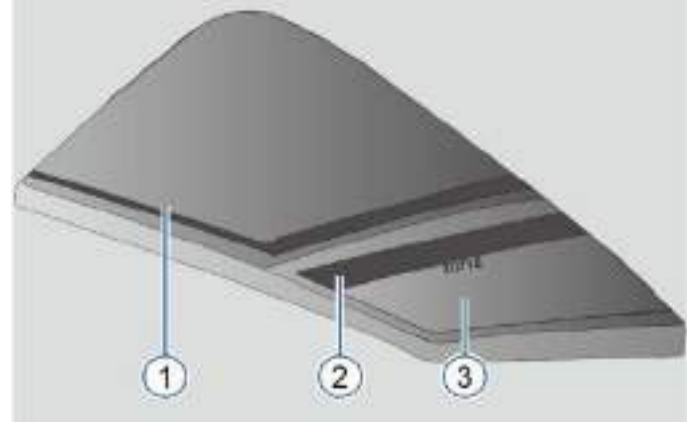

1. *Front glass (movable)
2. Rear glass (fixed on frame, immovable)
3. Power sunblind

* Power all-view sunroof

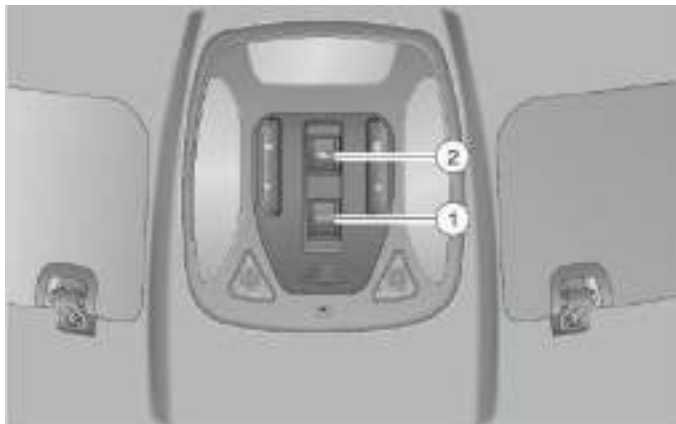

1. * Power all-view sunroof button
2. Power sunblind button

When the start switch is turned to ON, press power sunblind button and power all-view sunroof button to operate the power sunblind and power all-view sunroof.



Extend the power sunblind

Short press B end backward to extend the power sunblind backward. When the sunblind is extending, press power sunblind button to stop it at current position.

Close the power sunblind

Short press A end forward to close the power sunblind forward. When the sunblind is closing, press the power sunblind button to stop it at current position.

* Power all-view sunroof

⚠ Caution !

- Before closing the power sunblind, close the power all-view sunroof.
- If the power sunblind is close but the power all-view sunroof is not closed, rain may get into the cab.



Turn on power all-view sunroof

Short press the button of power all-view sunroof, the sunroof raises and then short press the button backward again, the sunroof moves to the maximum position. Press the button and the sunroof stops at the current position.

* Power all-view sunroof

Close the power all-view sunroof

Short press the button of power all-view sunroof forward, the sunroof raises and stops. Short press the button of power all-view sunroof forward, the sunroof moves and closes. Press the button of sunroof, it stops at current position.

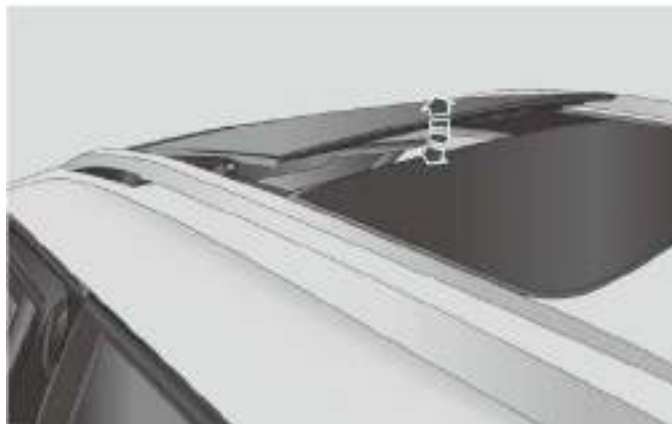

Upward the sunroof for ventilation

When the sunroof is close, short press the button of power all-view sunroof backward, the rear of sun roof upwards. When it is upwarding, press the button of sunroof, it stops at current position.

Close ventilation

Short press the button of power all-view sunroof forward to close sunroof to close ventilation. Press the button and the sunroof stops at current position.

* Power all-view sunroof

Caution !

- Keep the left and right guide rails of sunroof, drain groove and front and rear glass tapes clean without foreign matters.
- Apply a proper amount of grease on the rail and move the glass to fully lubricate it.
- In case of leaving the vehicle for a moment or the vehicle has to stay outdoor, close the sunroof to avoid foreign matter, rain and theft.

Warning!

Before opening/closing the sunroof, make sure that no one stays in the movement range in order to avoid accident.

Lighting combination switch



* Auto illumination of headlamp

When the start switch or ignition switch is turned to ON, turn light cluster switch to **AUTO**. If the exterior light is poor (in night or driving through a tunnel), the position light (clearance light) and low beam will be illuminated automatically.

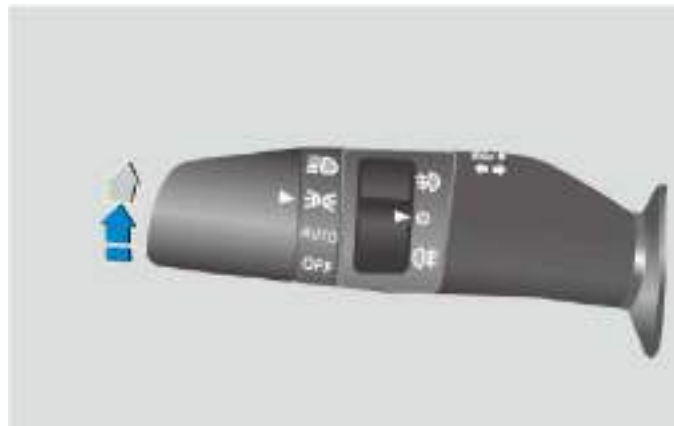

Position light (clearance light)

When the start switch or ignition switch is turned to ON, turn light cluster switch to **POSITION** to turn on front and rear position lights (clearance light), instrument and buttons backlight and front and rear license plates lights **POSITION** on the instrument panel is illuminated.

Lighting combination switch







Low beam

When the start switch or ignition switch is turned to ON, turn the light cluster switch to  to turn on low beam.



* Front fog lamp

When the start switch or ignition switch is turned to ON, turn the light cluster switch to  or .



Up shift the fog lamp switch to  to turn on the front fog lamp and  on the instrument panel is illuminated. Up shift the fog lamp switch to  again to turn off the front fog lamp.



Lighting combination switch

* Fog lamp serves as assistant lighting

- When the low beam or high beam is turned on, upshift or downshift the light cluster switch to turn on turn signal light, or when the steering wheel has turned for a certain angle, the assistant light of fog lamp will be illuminated.

Rear fog lamp



When the start switch or ignition switch is turned to ON, turn the light cluster switch to  or .

Turn fog lamp switch to  to turn on rear fog lamp and  on instrument panel is illuminated. Turn the fog lamp switch clockwise to  again to turn off the rear fog lamp.



High beam

In case of encountering a vehicle coming from opposite direction, pull the light cluster switch backward to turn on the high beam or release the switch to turn off.

When the start switch or ignition switch is turned to ON, turn the light cluster switch to . Push the light cluster switch forward to turn on high beam and  on instrument panel is illuminated. Pull the light cluster switch backward to turn off high beam and the indicator on the instrument panel goes off.

Lighting combination switch



Turn signal lamp

Turn the start switch or ignition switch to ON.

Up shift or down shift the joystick of light switch to turn on right or left turn signal light and ← or → on the instrument flashes.



Description!

With the turn signal lamps on, if the steering wheel is aligned after the vehicle turns around or the lighting switch lever is returned to the middle position, the turn signal lamps will go out.

Manual adjustment of headlamp height



The headlamp height manual adjustment knob is located on the left switch group of dashboard.

Manual adjustment knob of headlamp is located on left switch cluster on the instrument panel. Adjust the headlamp lighting range to 0, 1, 2 and 3 according to passenger and luggage weight.

Delayed off of headlamp (home lighting)

When the lighting condition at parking position is poor, the headlamp prolongs lighting for a certain period to help you with parking.

Turn on home lighting

When the engine is off, turn the light switch to each position one by one to activate the home lighting: light switch OFF → position light → low beam → high beam → low beam → position light → OFF. The low beam keeps being illuminated for 5 minutes.

When home lighting is activated, the headlamp goes off with 3 minutes delay if any door condition is changed. Such function is valid for at most 10 times.



Description!

The home lighting shall not be activated when the start switch or ignition switch has stayed at OFF for over 2 minutes.

Hazard warning light



The hazard warning light switch is on the central control switch cluster. When the hazard warning light is turned on, the turn light flashes and ← and → on instrument panel flash.

When the hazard warning light is turned on, the turn light switch becomes invalid.

Turn on the hazard warning light to attract other drivers' attention in case of following circumstances:

Hazard warning light

- It is impossible to drive further due to any failure.
- The vehicle waits at the end of the steam due to traffic jam.
- The vehicle has to be towed or tow other vehicles due to emergency.

⚠ Caution !

- Not used any longer, the hazard warning lamp should be turned off, as it consumes the battery.
- Abide by related laws and regulations when using the hazard warning light.

Exterior lights



* Daytime running lamp

Daytime driving light acts as a signal light to make the vehicle be easily recognized when it is running in daytime for safety concern.

The position light (clearance light) shares bulbs with the daytime driving light.

Daytime driving light is illuminated when the engine is started and light switch is turned to OFF.

Daytime driving light goes off when the engine is off and light switch is turned to any position other than OFF.

Exterior lights



Brake light and high-mount stop light

When the driver depresses the brake pedal, brake light ② and high-mount stop light ① are illuminated at the same time to remind the driver behind to keep safe distance.

When the driver releases the brake pedal, brake light ② and high-mount stop light ① go off at the same time.



License plate lamp

License plate lamp is on the rear bumper. When the position light is turned on, the license plate lamp is illuminated.

Exterior lights



* Door handle light

Press the remote key to unlock the door and the door handle light is illuminated, telling the driver and passenger of position of door handle.

Turn start switch to ON or press lock button of remote key to lock the door and handle light goes off.

When the vehicle has stopped, the outside door handle light keeps being illuminated when any door is open.

Interior lights

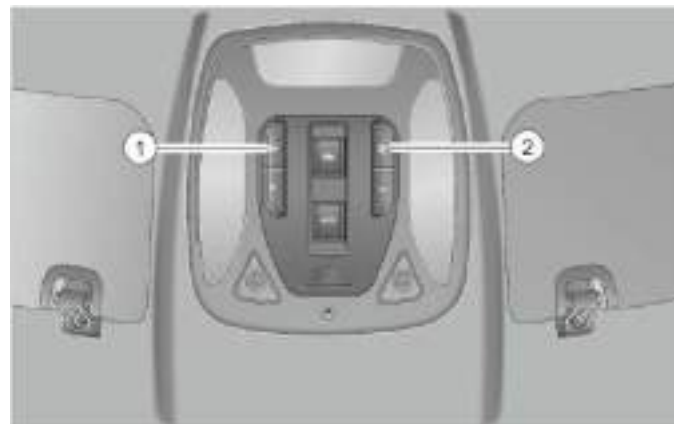

Turn on and turn off front ceiling light

Press button ① to turn on the light or press the button again to turn off.

Press button ② to activate automatic illumination of front ceiling light. The light is illuminated when the door is open or the light goes off when the door is closed. Press the button ② again to deactivate the automatic illumination.

Interior lights

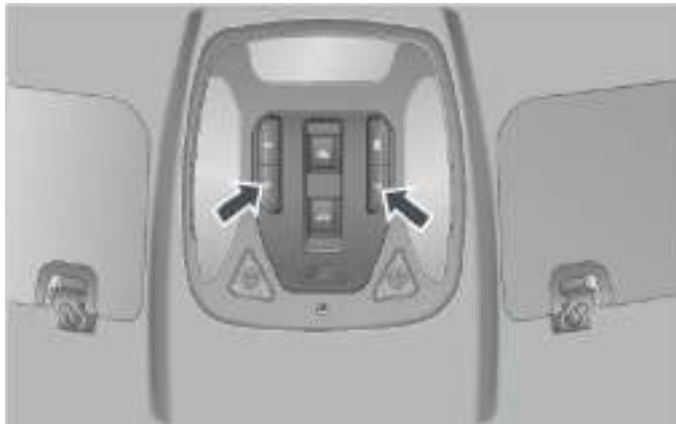

Turn on and turn off reading light at the driver's side and front passenger's side.

Press button ① to turn on the driver's reading light or press it again to turn off.

Press button ② to turn on the front passenger's reading light or press it again to turn off.



*** Rear ceiling light**

Press the button of rear ceiling light to turn on or press the button again to turn off.

Interior lights



Luggage compartment lamp

Trunk light is on the trim board at the left side.

The trunk light is illuminated when the tail gate is open and goes off when the tail gate is closed.



* Interior LED

When the ignition switch is turned to ON and light cluster switch is turned to any gear except OFF, the interior LEDs are illuminated (located on auxiliary instrument panel and four doors).

Interior lights



Warning light of door open (front door)

When the front door is open, the light reflects to warn vehicles and pedestrian behind to be careful.



* Ground projection light of front door (shows the LOGO)

It is located on the bottom of left front door and right front door.

When the door is open, the light is illuminated; when the door is closed, the light goes off.

Combine switch of wiper



Continuous wiping

- Shift the control lever of wiper combine switch to **MIST**, the front wiper wiping one time; release this lever, it returning to “OFF” by itself, stopping the wiping.
- If this lever is kept at **MIST**, the front wiper works continuously.

Wiping stops

- Shift this lever to “OFF”, turning off the front wiper.

* Automatic wiping

- For the vehicle equipped with automatic wiper (there is a rain sensor on the front windshield), this lever is shifted to **AUTO**, activating the sensor. Then, the wiper will be automatically turned on or off, depending on the signals from rain sensor.

* Intermittent wiping

- Shift this lever to **INT**, making the front wiper intermittently work. At this time, the switch for adjusting the cycle of intermittent wiping could be used to set the front wiping period. As this switch’s scale is widening, the wiper works slower and slower.

Slow cleaning

- Shift this lever to **LO**, front wiper working at low speed.

Fast cleaning

- Shift this lever to **HI**, front wiper working at high speed.

Combine switch of wiper



Front windshield washer system turned to ON

Turn on the switch or turn the ignition switch to “ON”, and pull backwards the lever, sprayer nozzle on the wiper cover beginning to spray water onto the front windshield and later the wiper starting to wipe.

Loosen the lever, washer stopping work and wiper keeping the running for one cycle.



Rear windshield washer system turned to ON

Clockwise turn the lever from “OFF” to “ON”, rear wiper starting to wipe.

Keep turn the lever clockwise from “ON” to , the washer spraying water and the wiper starting to work. Loosened, it goes back to “ON” by itself, and the rear wipe keeps working. Turn the lever to “OFF”, stopping rear wiper from working.

Combine switch of wiper

Counterclockwise rotate the lever to , spraying and wiping water; released, it goes back to “OFF” by itself, rear wiper stopping work.



Description!

- Only when the switch is turned on or the ignition switch is at “ON”, can the front/rear wiper and the front/rear windshield washer work.



Caution !

- With the front/rear windshield dry or covered with dust or grit, do not use the wiper, which otherwise may scratch the glass and shorten the service life of wiper blade.

Exterior rearview mirror

The exterior rearview mirror has the functions shown below:

- Electric adjustment
- * Electric folding
- * Automatic folding
- Defogging and defrosting

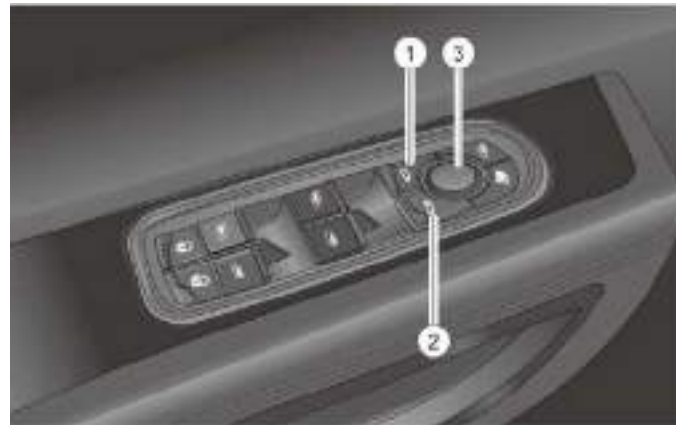

Power adjustment of exterior rearview mirror

With the switch ON or the ignition key turned to ON, press the selector switch of exterior rearview mirror at driver side ① or the one at co-driver side ②, to select the mirror to be adjusted.

Press the button ③, to alter the mirror angle upwards, downwards, leftwards and rightwards. After the adjustment, turn off the selector switch ① or ②.

Exterior rearview mirror

Caution !

- After adjustment of exterior rearview mirror, do not turn off the selector switch ① or ②, so as not to change the position of exterior rearview mirror by accident by touching its button.
- When the rearview mirror is frozen, do not use the switch or wipe the mirror, but use the spray type deicer to clean it.

Warning!

Although convex and spherical rearview mirror could enlarge the field of view, the reflected image is smaller and further than the practical one. Therefore, do not take the reflected image to judge the vehicle distance before change of lanes. Otherwise, accident may happen due to mis-judgement.



* Power folding of exterior rearview mirror

Turn the switch to “ON”, press the folding switch of the exterior rearview mirror, folding it; press switch again, unfolding it.

* Automatic folding of exterior rearview mirror

Press the lock button on smart remote key, automatically folding the exterior rearview mirror. Press the unlock button on smart remote key, automatically unfolding the exterior rearview mirror.

Exterior rearview mirror



* Defogging and defrosting of exterior rearview mirror

While running on rainy, snowy or foggy days, the mirror surface may have the condensed mist, impairing the sight. In such case, press the



on the A/C panel, starting the defogging and thus heating up the heater inside of mirror to clean the mirror surface.



Description!

- Press the defroster button of rear windshield/exterior rearview mirror on the A/C panel, simultaneously turning on the defroster for both rear windshield and exterior rearview mirror.
- In case of no other operations, defrosting of rear windshield / exterior rearview mirror will last for 15min before shutdown. If it is needed to remove the fog and the frost after that, press this button again.
- Do not use the defogging or defrosting for a long time, which otherwise may overheat the heater or even damage it.
- When it is unnecessary to have the defrosting or defogging active before startup, please turn them off, so as to save the battery electricity.

Internal rearview mirror

It is extremely dangerous that the internal rearview mirror cannot clearly show the conditions behind vehicle!

The internal rearview mirror has anti-dazzling function. At night traveling:

- For the vehicle equipped with * manual anti-dazzling rearview mirror, please manually adjust it to weaken the reflections from the behind and thus to best the rear sight.
- For the vehicle equipped with * automatic anti-dazzling rearview mirror, its light sensor could monitor the lights from the front/rear of vehicle, so as to weaken the strong light reflected on mirror from the behind and thus to best the rear sight.



* Manual anti-dazzling internal rearview mirror

Forward move its handle, offsetting the reflect light from the behind and thus eliminating the glare.

Backward move its handle, backing its angle to the normal.



While traveling, it is prohibited to adjust the internal rearview mirror to avoid any risk!

Internal rearview mirror

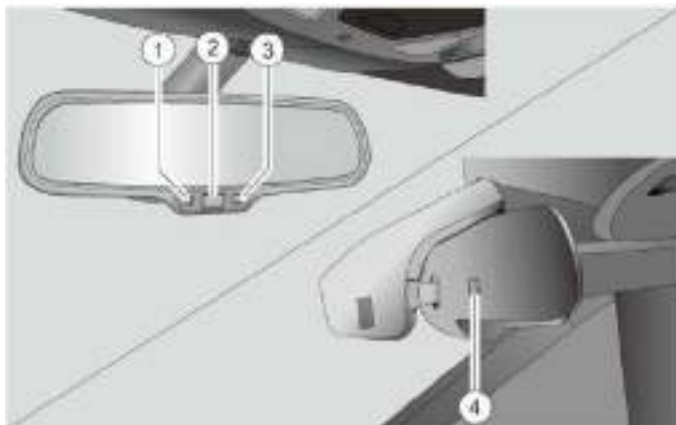

* Automatic anti-dazzling internal rearview mirror

1. Anti-dazzling indicator
2. Anti-dazzling control switch
3. Rear light sensor
4. Front light sensor

⚠ Caution !

In order to make sure the sensor of anti-dazzling internal rearview mirror work normally, do not cover the front/rear light sensor.



With the ignition switch at ON, the anti-dazzling functions will be activated by itself when the sensor senses the rear strong light.

Press this switch, turning off the automatic anti-dazzling function. Press it again, re-activating this function.

Sun visor

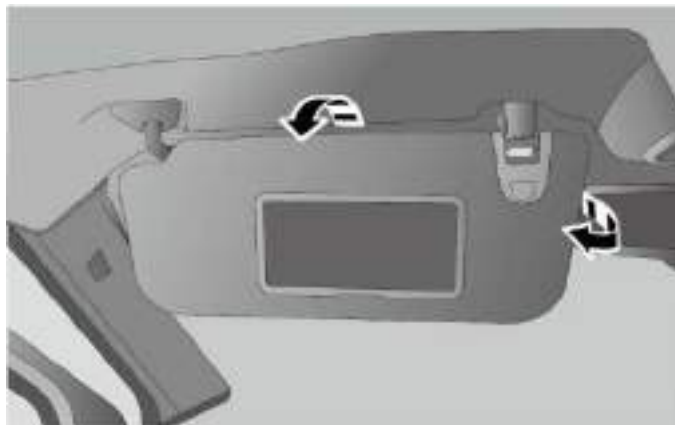

Put down the sun visor at driver / co-driver side, sheltering from the sunshine from the front windshield.

After putting it down, pull it out of the sided movable bracket, sheltering from the sunshine from the side window.



* Makeup mirror with light on sun visor

Open the makeup mirror cover on the side sun visor, the light automatically lighting up. Close the cover, the light going out.

Head restraint



Correct adjustment of headrest is key to drop the accidents and to protect drivers and passengers.

The headrest should be so adjusted that your center of rear head could be at the center of headrest and that the upper edge of headrest could be as high as the head top (or as much as possible).

Otherwise, it is apt to cause personal injury in case of accident.



Adjustment of front seat headrests

While pressing the lock button at the top of seat back, move the headrest longitudinally to the proper height. With the lock button released, make sure the headrest is locked in place.

Head restraint



Adjustment of rear seat headrests

While pressing the lock button at the top of seat back, move the headrest longitudinally to the proper height. With the lock button released, make sure the headrest is locked in place.

Warning!

Strictly observe the following to drop the accidents of personal casualty:

- The headrest should be always at mounting position. While traveling with headrest taken off or with headrest improperly installed, it is liable to cause personal casualty in case of accident.
- Do not adjust the headrest in traveling.

Front seat



* Manual adjustment of seat

1. Control lever for forward and backward adjustment.
2. Handle for backrest inclination
3. * Handle for adjustment of driver seat height

Front and back adjustment of seat

Upward pull the handle ① and hold it, to move the seat forwards and backwards.

After the adjustment to the proper position, release the handle ①, and slightly move the seat to make sure the seat is reliably locked up.

* Adjustment of cushion height

Uplift the handle ③, elevating the cushion.

Downward move the handle ③, dropping the cushion.

Backrest angle adjustment

Uplift the handle ②, adjusting the backrest forwards and backwards.

After the adjustment to the proper angle, release the handle ② and slightly move the backrest to make sure it is locked reliably.

Front seat



* Electrical adjustment of seat

1. Switch for adjustment of seat
2. Switch for adjustment of backrest angle

Front and back adjustment of seat

Forward push the switch ①, to move the seat forwards.

Backward push the switch ①, to move the seat backwards.

Adjustment of cushion height

Upward press the switch ①, lifting the cushion.

Downward press the switch ①, lowering the cushion.

Backrest angle adjustment

Forward push the switch ②, to tilt the backrest forwards.

Backward push the switch ②, to tilt the backrest backwards.

Rear seat

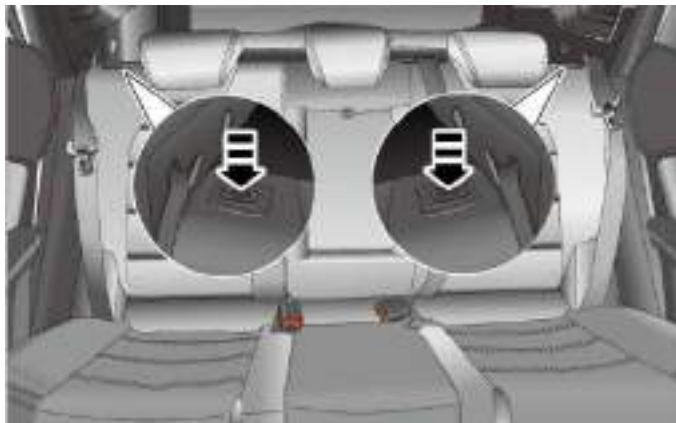

Folding of rear backrests

1. Drop the rear headrests to the lowest.
2. Press the unlock button, to unlock the rear backrests and then to forward push them to the end. In addition, forward tilt the rear backrests, to enlarge the trunk room.
3. If needed, uplift the rear backrests until they are locked, and then pull them to check for reliable lockup.

Warning!

- After uplifting the rear backrests, the seatbelt and the buckles should return to the normal retraction position.
- Rear backrests should be reliably locked up, so that the goods could not slide into the compartment from the trunk in case of emergency brake.

Caution !

Before the rear seat backrest is turned forward, the position of front seat shall be adjusted to prevent the rear seat from damage by the rear seat turned forward.

Storage

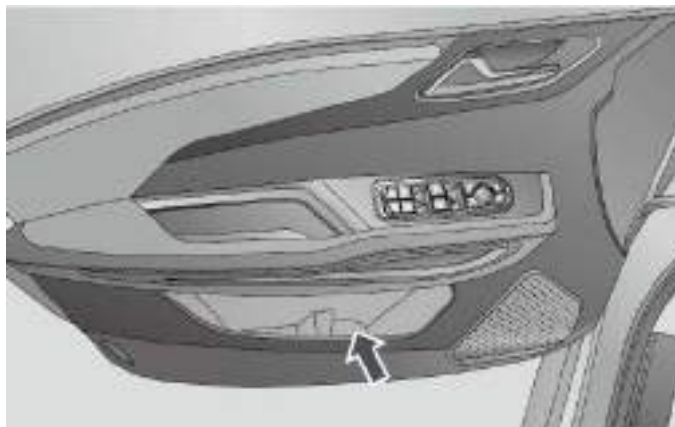

Store inside of internal trim of door

The store is used to contain any item.



Glovebox

Glove box is behind the instrument panel at co-driver's side.

Pull the handle to open the glove box and upward push the cover of glove box, closing it.

Warning!

The glove box should be closed while traveling; otherwise the items may fly out of it in case of emergency brake or accident.

Storage



Cigarette lighter

Cigarette lighter is beneath the A/C control panel.

After pressing the cigarette lighter button, it pops out by itself after being heated. Then, take it out to light cigarette with the hot spiral wire.

Insert the cigarette lighter back into the socket after the use.

Warning!

- Mis-use of cigarette lighter may lead to fire or scald.

12V power supply

The front 12V outlet is beneath the A/C control panel.

Warning!

- Improper use of power supply and electrical equipment may lead to fire.

Caution !

- The on-board power outlet is of 12V and its electrical appliances cannot exceed 120W of load.
- With engine shut down, do not use the power outlet for a long time, which otherwise may lead to excessive discharge of battery and impairing the vehicle startup.
- Please use the plug matching the power outlet, so as not to damage the outlet.

Storage



* Front USB port

Beneath the A/C control panel.



Warning!

- Mis-use of USB port may lead to fire.



* Rear USB port

Beneath the trim behind the central armrest



Warning!

- Mis-use of USB port may lead to fire.

Storage

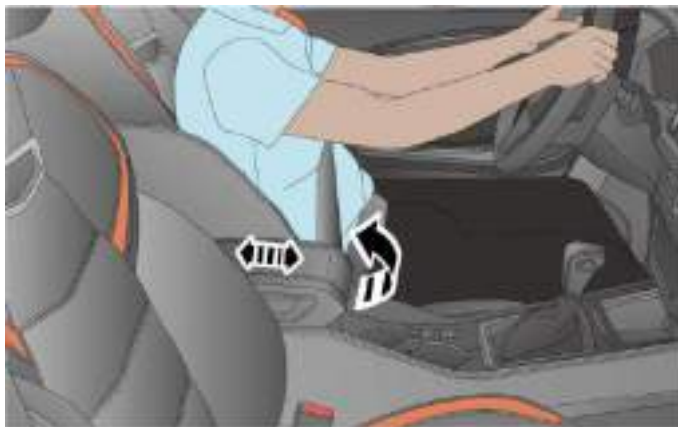

Central armrest box

The front central armrest box is between the front two seats, resting the driver or passenger' arm.

Uplift the cover, opening the armrest box. Press it, closing the armrest box.

* Sliding of front central armrest box

Push or pull the armrest box cover, moving it forward or returning it to original position.

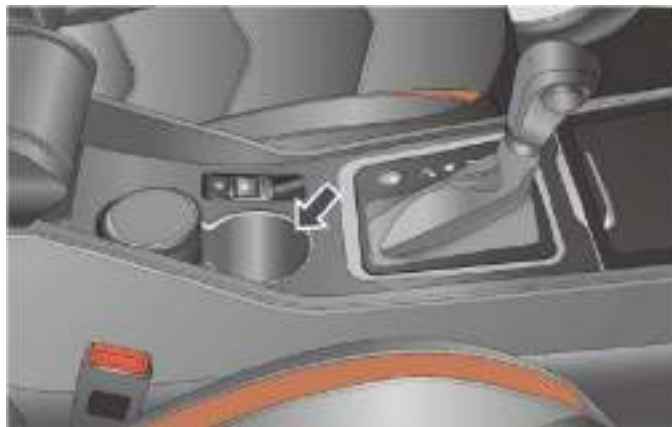

Front cup holder

The front cup holder could hold the container with its cap closely tightened up.

* Movable ashtray

Inside of front cup holder



Warning!

Improper use of ashtray may lead to fire.

Storage

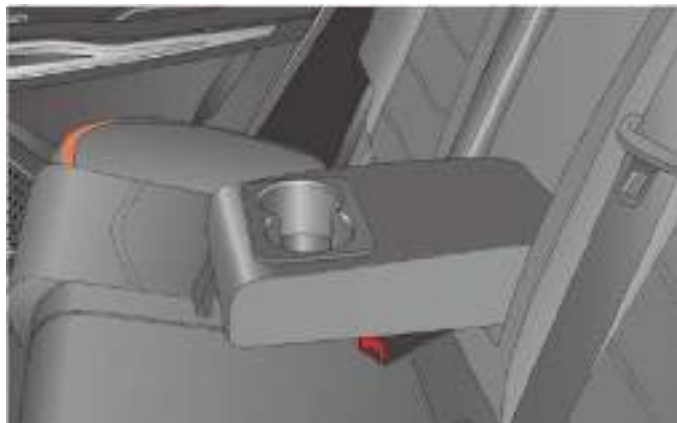

Cup holder on the central armrest of rear seat

Inside of rear central armrest, it could be pulled out for use.



*** Glasses case**

In the ceiling area at driver's side

Storage



Armrests and coat hooks for passengers

The passenger armrests are respectively at the co-driver's side and the ceiling area at both sides of rear doors.

The clothing hooks are located inside the handrails above two rear doors.



Warning!

Only the light cloth is allowed on the clothing hook. Notice that there is no heavy or sharp article in the pocket for fear of personal injury in case of accident or emergency braking.

Trunk



* Trunk curtain

To load up the trunk, pull the curtains out and secure them into the grooves respectively at left and right of trunk.

Caution !

- The curtain could not be retracted by itself, but manually guide it to retract in, which otherwise may damage the trunk curtain.



In addition, there is warning marker attached on curtain to remind you of risk of hanging onto curtain. Please read and observe this marker.

Trunk



Capacity of trunk

- Forward tilt the rear seat to lay it down.
- Hold the both ends of trunk curtain and meanwhile retract it, so as to take down the curtain and to enlarge the trunk space.

Loading notices for trunk

1. All items inside of trunk should be reliably secured.
2. The loads should be evenly distributed inside of trunk.
3. The heavy loads should be put on as close to front part of inside trunk as possible.
4. After placing the load, pull the curtain out.



Warning!

- The unsecured items will move inside of trunk, offsetting the center of vehicle gravity and thus dropping the traveling performance or safety.
- It is a must that all the items should be secured reliably inside of trunk, with the * curtain pulled out. Otherwise, the items in trunk may cause the unnecessary damage to the rear passengers in case of emergency brake.

Trunk

Warning!

- It is risky to transport the heavy load, as the vehicle traveling performance may drop due to the offsetting of center of gravity! Therefore, your driving ways and vehicle speed should be dependent on the current conditions.
- Neither overload it nor exceed the allowable total mass, which otherwise may deteriorate the traveling performance, leading to traffic accident or vehicle damage.
- With the back gate opened, the vehicle should not be left unattended, as children may get in the trunk, locking the back gate from the inside and thus unable to get out, which may endanger their lives! Furthermore, no passenger is allowed to stay in trunk.

* Luggage rack



The luggage rack is regarded as trim.

Warning!

It is prohibited to directly put the load onto the luggage rack!

Control panel

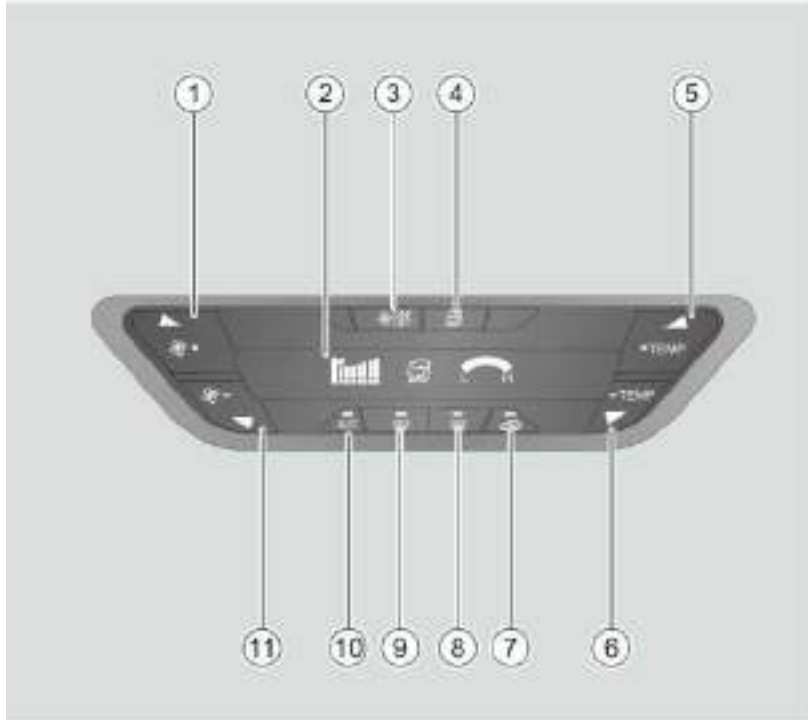

* Electric A/C

1. Volume Up button
2. Display screen
3. Blower switch
4. Blowing mode changeover button
5. Temperature UP button
6. Temperature Down button
7. Internal/external cycle changeover
8. Rear windshield defogging mode
9. Front windshield defogging/defrosting mode
10. A/C refrigerant switch
11. Volume Down button

Control panel

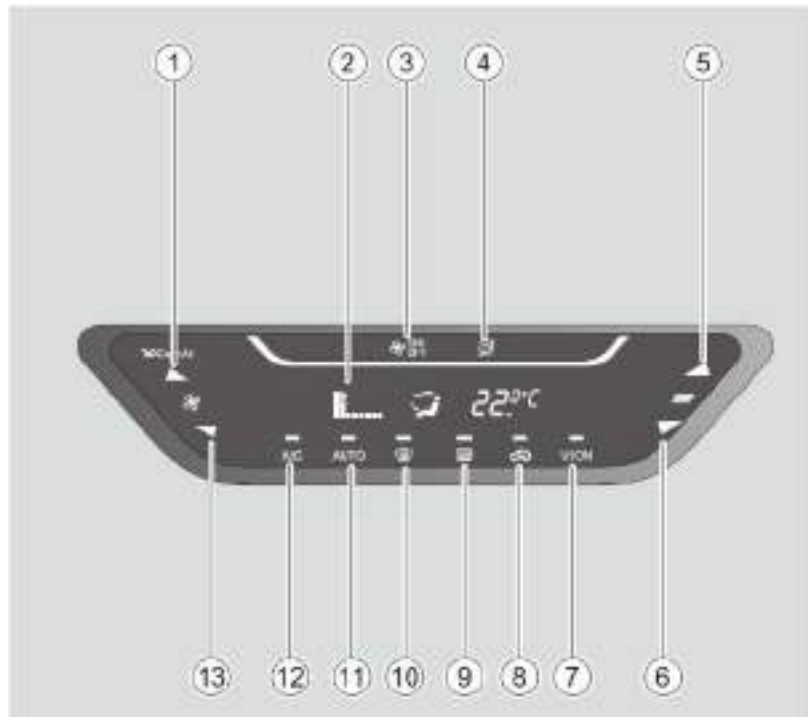





* Automatic A/C

1. Volume Up button
2. Display screen
3. Blower switch
4. Blowing mode changeover button
5. Temperature UP button
6. Temperature Down button
7. * Negative ion air purification (ION) button
8. Internal/external cycle changeover
9. Rear windshield / external rearview mirror defogging / heater mode
10. Front windshield defogging/defrosting mode
11. Automatic A/C button
12. A/C refrigerant switch
13. Volume Down button

Control panel

Setting of wind speed

-  Volume Up button
 - This button is for the speeding up of air volume.
-  Volume Down button
 - This button is for the dropping of air volume.

The wind speed could be controlled manually or automatically. Press  or , manually adjusting the wind at air outlet.

Manual setting:

At manual control mode, the wind at air outlet could be regulated step by step, ranging from levels 1 to 7 and correspondingly displaying the current level.

: Press it once, decreasing the wind speed at vent by one level.

: Press it once, increasing the wind speed at vent by one level.

Auto setting:

At Auto mode, the A/C system could control the wind speed at vent by itself, without any manual operations. Any operation on wind control button could shift the Auto mode to the Manual mode, Auto indicator going out.

Display screen

The display screen shows the set temperature, wind level and blowing mode.





ON/OFF button

With A/C system running, press ON/OFF button, shutting down the A/C system. All the settings before shutdown of A/C system will be recorded. Press the ON/OFF again, resuming the A/C system to the last work conditions.

Control panel

Blowing mode changeover button

Press the blowing mode, cycling the “Face → Face and Foot → Foot → Foot and Defrost → Face”.



-  Face mode: with the A/C screen showing the icon of blowing-face, the air flow of both central and side vents is directed to the driver and the front passenger.
-  Face and Foot mode: with the A/C screen showing the icon of blowing to face and foot, the air flow of both central, side and bottom vents is directed to not only the driver and the front passenger, also to their feet.
-  Foot mode: with the A/C screen showing the icon of blowing to foot, the air flow beneath the instrument panel is guided to the driver and the front passenger's feet.
-  Foot and Defrost mode: with the A/C screen showing the icon of blowing foot and defrosting, the air flow beneath the instrument panel is guided not only to the driver and the front passenger's feet, but also through the defrosting vents to front windshield and glasses of left-front and right-front doors.

Temperature setting

-  Temperature UP button
 - Press this button to increase the set temperature.

-  Temperature Down button
 - Press this button to decrease the set temperature.

To set the internal temperature with the temperature button:

- The set temperature could be shown on display, ranging from 18.5°C to 31.5°C.
- Press  or  to increase / decrease temperature by 0.5°C each time.
- When the set temperature is less than 18.5°C, the display shows LO; when it is higher than 31.5°C, the display shows HI.

In addition, the setting of temperature cannot change the A/C running mode. At Auto mode, system will run at high volume to enter into LO / HI.

In order to obtain the ideal internal temperature at Auto mode, it is recommended to have the set temperature at 25.0°C. However, its temperature could be adjusted if needed.



Description!



The temperature on the display screen is the target value of set temperature, instead of the practical value inside of vehicle.

Control panel

* ION button

Press button , lighting up its indicator and activating the air purifier.

Internal/external cycle changeover

This button  could manually exchange the external and internal cycles. Press this button , lighting up its indicator and entering into the internal cycle mode. At this mode:

- It is compulsory that the external air cannot get in, forming the internal circle.
- It could prevent the external exhaust or other dirty air from getting in.
- At Auto mode in summer, system adopts the internal circle mode to do the compulsory cooling down.

Press again , its indicator going out and entering into the external cycle mode. At this mode:

- The external air could get in, to keep the inside air fresh.



Warning!

- Do not use the internal circle mode for a long time, as the outside of windshield is fogged, dropping the sight.
- Use of internal cycle mode for a long time may make the internal air excessively dirty and drop the oxygen concentration. Therefore it is needed to open the window for fresh air.

* Rear windshield / external rearview mirror defrosting mode

Press this button to have the system enter into , its indicator lighting up; press it again, stopping the heating and its indicator going out. If the rear windshield defrosting is not manually turned off, it will shut down by itself after running for 15min.



Caution !



With the engine not running, use of the rear windshield defrosting for a long time may lead to the battery voltage too low and even to the vehicle unable to start up.



Control panel

Defrosting/ demising mode button of front windshield

Press this button to have system enter into Defrost/Defog mode, its indicator lighting up and A/C screen showing its icon . Press this button again to have the system quit the Defrost/Defog mode, its indicator going out.

* AUTO button

Press , A/C system entering into  and its indicator on  lighting up. At this mode, the wind speed, the volume, the blowing mode and the air inlet mode could be automatically adjusted to the comfortable conditions.

At mode , the internal/external air circle could be exchanged automatically and the air purifier will be turned on by itself. Press any one of manual control buttons at  mode, getting out of the  mode into the manual status.

A/C button

Press A/C button, its compressor being started and its indicator on A/C button lighting up. Press A/C button again, stopping its compressor from running and its indicator on A/C button going out.

Warning!

- Follow the practical conditions to start the internal circle mode and get out of this mode if unneeded.
- Since the blurred window is liable to cause the accidents or even the personal casualty, all the windows should be free of any ice, snow or fog to make sure the clear sight.
- When the internal air gets dirty, driver is easy to get tired and unfocused, causing accidents or personal casualty.

Caution !

- Diagnosis and repair of A/C system should be done with the special tools by the professionals. Therefore, please go to the authorized service station for repair in case of any failure or suspected failures occurring to A/C system.

Control panel



Description!

- When the external temperature and humidity are high, the moisture in air will be condensed on the evaporator of refrigerating system, and the condensed water drops from the evaporator, forming the accumulated water beneath vehicle. Therefore do not get panic in such situation.
- The air inlet in the front of windshield should be unblocked, free of any snow, ice or leaves, so as to make sure the normal heating and cooling down, and to prevent the front windshield from being fogged.
- After the window and the skylight are closed, the A/C system could play the best cooling effect. When the inside is very hot due to direct sunshine, please open the window to dissipate the heat and thus to accelerate the cooling.

Wind direction and airflow regulation of vent



1. Air vents at left and right sides of instrument panel
2. Defroster vents at left and right sides of instrument panel
3. Defroster vents at windshield
4. Air vents at center of instrument panel
5. Front vents for foot

Wind direction and airflow regulation of vent



As shown in the above figure, the rear vents for foot is beneath the front seat.

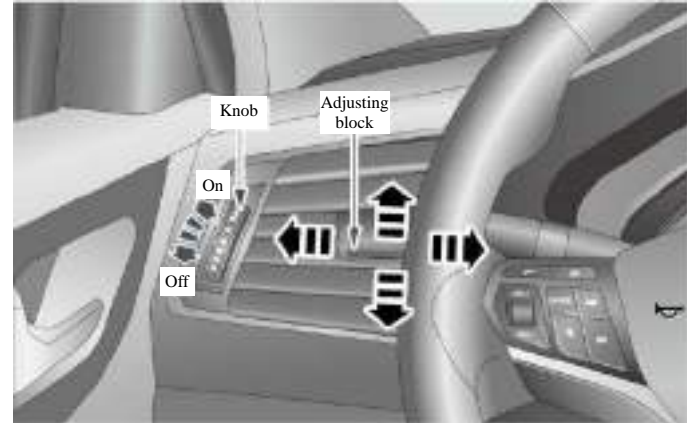

Air vents at driver side.

The air direction could be adjusted in four directions with the adjusting block.

Rotate the knob nearby vent upwards and downwards to regulate the air volume, with OFF at the lowest position

Wind direction and airflow regulation of vent

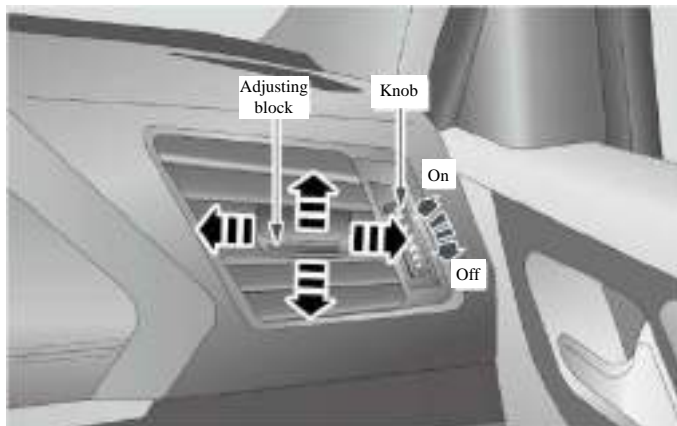

Air vents at co-driver side

The air direction could be adjusted in four directions with the adjusting block.

Rotate the knob nearby vent upwards and downwards to regulate the air volume, with OFF at the lowest position

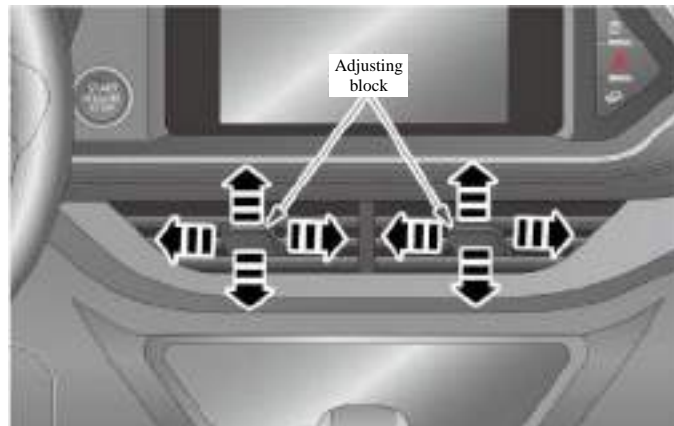

Air vents at center of instrument panel

The air direction could be adjusted in four directions with the adjusting block.

Use skills of A/C system

Daily use

1. When the vehicle is in the hot environment for a long time, the temperature in the air will become very high. It is suggested to open the doors before turning on the A/C, and turn the air regulating knob to the maximum to expel the hot air from the car. The doors and windows shall be closed after the temperature in the vehicle decreases. The temperature in the vehicle shall be adjusted as needed.
2. In the damp weather, the cold air must not be blown directly onto the front windshield for fear of water mist condensing outside the glass because of the difference between temperature inside and outside the glass.
3. In the cold weather, the air flow rate shall be increased and keep on blowing for minutes in order to eliminate the ice or moisture in the intake duct and reduce the mist on the glass.
4. When driving on the dusty road, all the windows shall be closed and the internal recycling mode is suggested.
5. In case of smoking in the vehicle when the A/C system is operating, the external recycling mode shall be activated to expel the smoke.
6. The air inlet grille near the front windshield shall not be covered by leaves or other sundries.

7. The space under the front seat shall be kept smooth to facilitate the air recycling.

Regular maintenance

The A/C filter element could remove the pollen and the dust away from the A/C system.

The A/C filter element should be periodically cleaned and replaced. For more, see the “Maintenance Schedule”.

The interval to replace the A/C filter element should be shortened in case of frequent traveling in smoky environment due to factories and diesel vehicles. When the air cannot smoothly get out of heater or cooling system, timely replace the A/C filter element.

CO

There is CO in exhaust gas (colorless, odorless, extremely toxic).

Part of CO may get inside of vehicle while traveling with the back gate opened, causing the carbon monoxide poisoning.

When it is needed to travel with the back gate opened, open all the windows and start the A/C system:

1. Select the “External Circle” mode;
2. Select  mode;
3. Maximize the wind speed.



Warning!

- Do not idle engine for a long time at unventilated site (such as garage), as the CO content goes up quickly, leading to lose of conscience or even death.

* Introduction to multimedia control panel

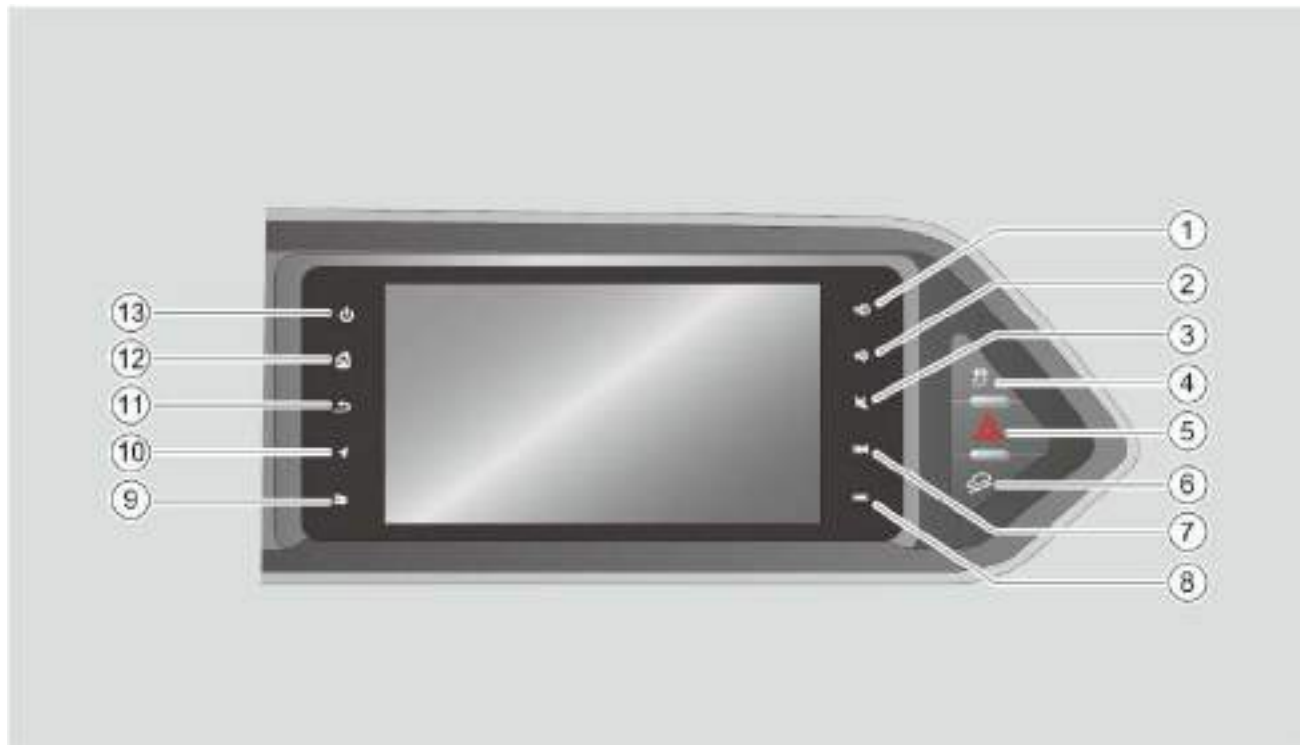

* Introduction to multimedia control panel

S/N	Function description
1	Volume up
2	Volume down
3	Mute
4	Turn on/off the * electronic stability system
5	Turn on/off the hazard warning lamp
6	Start / stop the * Hill Descent Control system.
7	Last channel search on radio interface / selection of last song on video interface
8	Next channel search on radio interface / selection of next song on video interface
9	Radio interface
10	Cruise interface
11	Return to last interface
12	Home page
13	Turn on / off the power supply of multi-media system



Description!

For more operations and illustrations, refer to the on-board Navigation, Audio and Visual and Communication System.

* Internet of Vehicles



The Internet of Vehicles system communicates with the vehicle via the mobile phone APP to exert the relevant functions of the car.

The Internet of Vehicles system has the following main functions:

- 1. Remote instrument panel
- 2. Remote locking/ unlocking
- 3. Remote lighting and beeping
- 4. Remote opening of luggage compartment
- 5. Remotely turn on/off A/C
- 6. Remotely turn on/off engine
- 7. Vehicle immobilizer alarm
- 8. Tracing of stolen car
- 9. Vehicle locating
- 10. One-key navigation
- 11. Traffic violation inquiry
- 12. Maintenance
- 13. Message box

 **Description!**

As for vehicle Network, the practical cell-phone APP prevails.

For more information about operation and instructions of Internet of Vehicles, please visit the official website of TYENET: www.tye-net.com.

* Ignition switch

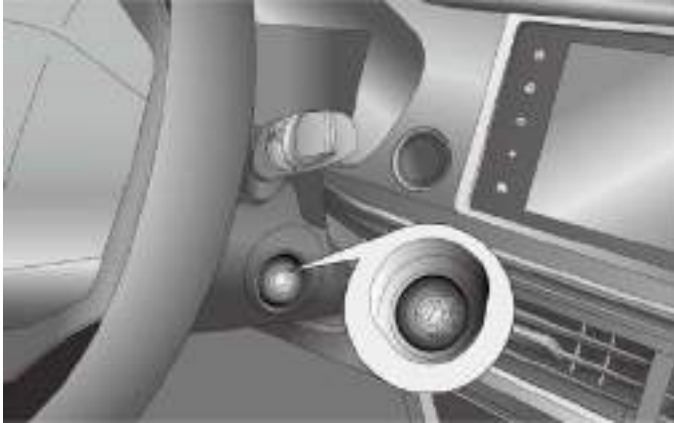

The ignition switch has four gears:

LOCK: at this gear, the electrical appliances are not powered on. Only at this gear, can the ignition key be pulled out.

ACC: the accessories, such as the cigarette lighter, are powered on.

ON: all the electrical appliances are powered on; after the engine is started, the ignition switch goes back to this gear.

START: this gear is merely used to start engine.



Description!

When the ignition key cannot or becomes difficult to go from "LOCK" to "ACC", slightly rotate the steering wheel to unlock it, until the ignition key could be rotated to START.

* Starter switch



To turn on the internal power supplies or to start the engine, the valid remote key has to be inside of vehicle and could be detected. The starter switch has four gears: OFF, ACC, ON and START.

OFF:

The power appliances are not powered on.

ACC:

The accessories, such as the cigarette lighter, are powered on.

When the starter switch is at “OFF”, press the starter switch, and meanwhile do not depress the brake pedal (for the vehicle equipped with automatic transmission) or the clutch pedal (for the vehicle equipped with manual transmission), so that the starter switch could go back to ACC.

Caution !

If the Start switch is kept at ACC all the time, the battery may become dead, resulting in the vehicle start.

* Starter switch

ON

All the electrical appliances are powered on.

When the starter switch is at “ACC”, press the starter switch, and meanwhile do not depress the brake pedal (for the vehicle equipped with automatic transmission) or the clutch pedal (for the vehicle equipped with manual transmission), so that the starter switch could go back to ON. Pressed again after that, the starter switch is shifted to OFF.

START

This gear is merely used to start engine.

To start the engine, shift the gear lever to P and depress the brake pedal (for automatic transmission), or shift the gear lever to neutral gear and depress the clutch pedal (for the manual transmission), and then press the Starter Switch.

Changeover of power supply gears

With the intelligent remote key in the car, the power supply can be switched to other status:

Changeover of power supply gears	Operation
From ON to OFF	Press the start switch
From ON to ACC	Without pressing the brake pedal (for the vehicle with automatic transmission) or clutch pedal (for the vehicle with manual transmission), press the start switch
From ON to OFF	Without pressing the brake pedal (for the vehicle with automatic transmission) or clutch pedal (for the vehicle with manual transmission), press the start switch
From OFF to ON	Without pressing the brake pedal (for the vehicle with automatic transmission) or clutch pedal (for the vehicle with manual transmission), press twice the start switch

Starting and shutdown of engine

Normal start

Vehicle equipped with ignition switch

1. Insert the mechanical key into the ignition switch
2. Vehicle equipped with manual transmission: depress the clutch pedal to the end and hold it.
Vehicle equipped with automatic transmission: depress the brake pedal to the end and hold it.
3. Vehicle equipped with manual transmission: make sure the gear lever is at Neutral.
Vehicle equipped with automatic transmission: make sure the gear lever is at P.
4. Turn the mechanical key to “START”, starting the engine.

Vehicle equipped with starter switch

1. Get in the vehicle, together with the smart remote key.
2. Vehicle equipped with manual transmission: depress the clutch pedal to the end and hold it.
Vehicle equipped with automatic transmission: depress the brake pedal to the end and hold it.
3. Vehicle equipped with manual transmission: make sure the gear lever is at Neutral.
Vehicle equipped with automatic transmission: make sure the gear lever is at P.
4. Press the starter switch, starting engine.



Caution !

- As soon as the engine is started, loosen the mechanical key.
- Starting of engine cannot exceed 15s, and have another try after 30s when engine fails to start up.
- After startup, do not hurry to depress the accelerator pedal, which otherwise lead to engine running at high speed or overloading it, or even damaging it.
- When the battery electricity is insufficient to start engine up, it is possible to jump the cable for emergency startup.
- Do not use the pushing or towing to start up engine.



Description!

When the smart remote key does not work, the PEPS warning indicator  on combine instrument will light up.

Try the following to start up engine: depress the clutch pedal for the vehicle with manual transmission or the brake pedal for the vehicle with automatic transmission, and put the smart remote key (the end with indicator) on the cup holder with a key marker at the bottom of console. Then press the starter switch to start up engine.

Gearshift



* Manual transmission

The manual transmission has five drive gears and one reverse gear as shown on the above diagram.

! Caution !

- Select the correct gear by following the tachometer, so as to prevent the gear from shifting in advance or delayed — lower engine rpm leads to the dragging of low speed gear or over-speeding leads to the dragging of high speed gear.
- Traveling under the condition of dragging of high/low-speed gear may excessively wear the transmission, consume the fuel, lose the power or even cause damage to the vehicle.

Gearshift



* Automatic transmission

1. Unlock button
2. Snow mode button

Gear information

P (Parking gear)

When the shift lever is at Gear P, the drive wheels will be locked mechanically and the engine can start. To shift the gear from P to D or R, the brake pedal must be pressed and the unlocking button on the shift lever shall also be pressed.

D (drive)

When the shift lever is at Gear D, the high or low gear will be selected automatically in accordance with the engine load and vehicle speed. To shift the gear from D or R or P, both the unlocking button and the brake pedal shall be pressed. To shift the gear from D or N, it is only needed to push the shift lever.

R (reverse)

To shift the handle from R to P while vehicle stands still, press the Unlock button on the handle. R could be directly shifted to N, without pressing the Unlock button.

Gearshift

N (neutral)

When the shift lever is turned to Gear N, the transmission will operate idly, the engine power cannot be transmitted to the drive wheels, and the engine brake cannot be used. When the vehicle stops or the engine starts, both the SHIFTLOCK button and the brake pedal shall be pressed to shift the gear from N to P or R; however, Gear N can be shifted to D directly by pushing the shift lever.

Caution !

- The Gear P can be engaged only when the vehicle is static; otherwise, the transmission may be damaged.
- Never slide the vehicle at Gear N when the engine stops; otherwise, the automatic transmission may be damaged due to lack of lubrication.



Description!

The engine can start only when the shift lever is at Gear P or N.

Warning!

When the vehicle is running downhill, the shift lever shall be at Gear N; otherwise, the engine brake cannot be used to assist the service brake.

Mode switching

D (+/-)- Manual mode

First turn the shift lever to Gear D, and then turn the shift lever rightward to enter the D (+/-) mode (manual shift mode).

M (+/-) mode is capable of automatic return. The transmission can be upshifted for one year every time when the shift lever is pushed forward (+), or downshifted for one year every time when the shift lever is pulled backward (-).

Warning!

When running on a long slope or steep slope, it is necessary to use the manual mode, slow down the car, and downshift the transmission to a low gear to apply the engine brake to avoid braking failure because the brake pedal is operated continuously.

Gearshift

❄️ Snow mode:

“❄️” mode is also known as winter-driving mode. At this mode, the vehicle could output the torque more steadily and gently. In addition, the transmission could control the driving-away gear by itself, avoiding any risk of skidding at driving-away on the slippery road.



Description!

The winter mode can limit the engine power output. Therefore, it is not suggested to use the winter mode unless traveling on slippery road, so as not to impair the driving performance or not to drop the fuel economy.



Emergent gear-shifting

Unlock switch for gear-shifting is beneath the gear lever panel.

When the gear lever is so stuck as not to normally shift to a gear, take off the gear-shifting panel cover to press the Unlock button, realizing the emergent gear-shifting.

Gearshift



Description!

The shift lever at Gear P can leave Gear P if the solenoid valve is locked. After the shift lever leaves Gear P, the shift lever can be pushed even if the solenoid valve is locked; the shift lever, if returned to Gear P, will be locked by the mechanical mechanism.



Caution !

This method could be available when the gear lever is locked and thus unable to normally shift out of P gear.

In such case, the transmission is possibly failed and please go to the authorized service station for repair.

Driving operation

Parking

In case of long-period parking, it is necessary to push the shift lever to Gear P and then park the car.

To park the vehicle on a slope, the vehicle shall be operated in the following steps in order to prevent the transmission from damage because the locking mechanism of Gear P bears a high force: To shut down engine, sequentially follow the steps shown below: depress the brake pedal, shift the transmission to N gear, apply the electronic parking brake, shift the transmission to P gear, loosen the brake pedal, switch off engine.



Warning!

- When the vehicle is moving, the transmission must not be shifted to Gear P; otherwise, the transmission may be damaged severely, even resulting in the vehicle out of control.

Driving operation

Uphill start

To prevent the vehicle from sliding during uphill start, the automatic mode of EPB can be used to assist the uphill start.

With the safety belt well fastened, press the brake pedal, shift the transmission to Gear D, then slowly release the brake pedal, and press the accelerator pedal to move the car.

Caution !

The accelerator pedal shall not be operated frequently to prevent the vehicle from sliding; otherwise, the automatic transmission may overheat, and even be damaged.

Forward running

With the shift lever to Gear P or N, start the engine, press the brake pedal when the engine operates stably, push the shift lever to Gear D, release the parking brake, release the brake pedal and press the accelerator pedal gently to move the car.

Warning!

In the course of driving, the shift lever must not be pushed to Gear R or P for fear of accident!

Caution !

- The transmission shall be shifted before the accelerator pedal is pressed. It is forbidden to press the accelerator pedal when or before shifting the transmission.

Driving operation

Reversing

When the engine is operating stably or the vehicle stands still, press the brake pedal, check that the parking brake is released, press the locking button, push the shift lever to Gear R, release the brake pedal, and press the accelerator pedal gently.

Protection mode



In case of frequent start or transmission overload in the hot environment, the automatic transmission may overheat. In order to protect the transmission from damage, the system will activate the thermal protection with the transmission malfunction indicator lamp

 flickering.

In such case, it is necessary to stop the car, maintain the idle running of engine or maintain a gear and drive the vehicle at a constant speed, in order to cool down the automatic transmission. It is forbidden to accelerate the vehicle before the transmission temperature drops and the transmission malfunction indicator lamp goes out.

If the transmission malfunction indicator lamp  does not go out after the long-time cooling (about 20 min), it is necessary to contact the local authorized service station of Zotye Auto for repair as soon as possible; otherwise, the transmission may be damaged severely.

Caution !

- In the thermal protection stage of transmission, the shift impact will increase in order to prevent the transmission from damage; such symptom will disappear after the transmission temperature becomes normal.
- If the vehicle keeps on running with the transmission malfunction indicator lamp  flickering, the transmission overheat will deteriorate further; if both the transmission malfunction indicator lamp  and the emergency brake indicator lamp **EP** go on, it is necessary to stop the vehicle immediately and contact the local authorized service station of Zotye Auto for repair as soon as possible.

Limp mode

The transmission with some faults may enter the limp mode; at this moment, the transmission can operate at some gears, but the vehicle cannot run reversely, and the transmission malfunction indicator lamp  will be on all the time. In such case, it is necessary to contact the local authorized service station of Zotye Auto for repair as soon as possible.

Description!

In the limp mode, the manual shift function will be forbidden.

* Mechanical parking brake

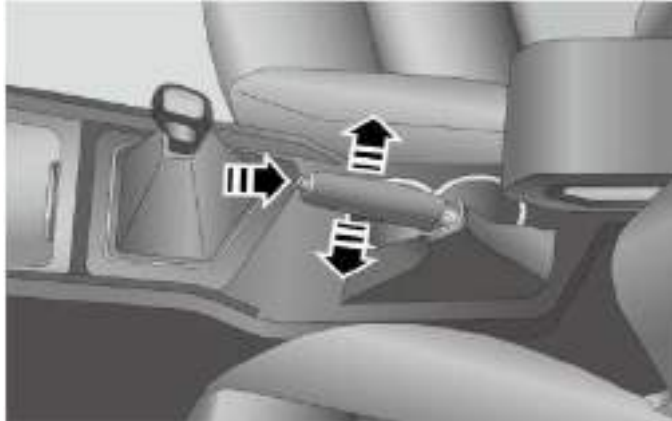

Applying of Mechanical parking brake

Uplift the mechanical parking brake handle to the limit, applying the mechanical parking brake.

Releasing of mechanical parking brake

Slightly uplift the mechanical parking brake handle, then press the Unlock button on its handle, and lastly press the handle to the end, unlocking the mechanical parking brake.

Warning function when mechanical parking brake is not yet released

While the mechanical parking brake is in use, its indicator keeps ON; this brake is not yet released when vehicle speed is more than 5km/h, the beeper sounds out until it is loosened and its indicator goes out.

Warning!

- After stopping of vehicle, it is a must to apply the mechanical parking brake.
- In traveling, do not use the mechanical parking brake to drop the vehicle speed, because this brake merely acts on the rear wheels, prone to cause traffic accidents.
- No traveling with the parking brake not completely released, which otherwise may overheat the rear wheel brake, drop the braking efficiency and early wear the friction lining of rear wheel brake.

* Electronic parking brake (EPB)

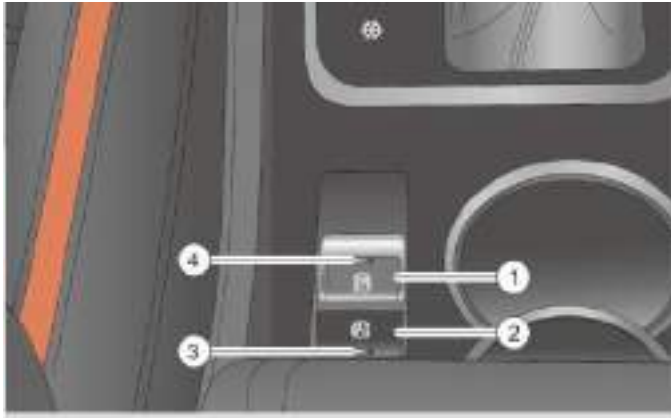

1. Parking button
2. Automatic parking mode button
3. Automatic parking mode indicator
4. Parking indicator lamp

Mode switching

With all the doors closed up and seatbelts buckled up, press the Auto Parking button, its indicator lighting up and activating the electronic parking; press this button again, its indicator going out and electronic parking changing to manual mode.

Manual parking

After vehicle stands still, press the parking button and hold it until its indicator lights up. When the parking indicator lights up, it means the parking is done.

Manual release

With the starter switch at “ON” and the electronic parking activated, depress the brake pedal (for automatic transmission) or the clutch pedal (manual transmission), and press the Parking button, releasing the electronic parking. In such case, the parking indicator goes out.

* Electronic parking brake (EPB)

Automatic parking

In the AUTO mode, after the vehicle stops and the start switch is turned from ON to OFF, EPB will brake and park the vehicle automatically; after successful parking, the parking indicator lamp will go on.

Automatic release

EPB can determine how to perform the automatic release in accordance with the current road conditions:

With the AUTO mode active and the vehicle parked, close the driver's door, wear the safety belt, start the engine, press the clutch pedal (the vehicle equipped with manual transmission) or the brake pedal (the vehicle equipped with automatic transmission), push the shift lever to Gear D or R, release the clutch pedal (the vehicle equipped with manual transmission) or the brake pedal (the vehicle equipped with automatic transmission), and press the accelerator pedal; then EPB releases the braking.

When the forward moving power of the vehicle is over its sliding force, EPB will release the braking. Upon successful release, the parking indicator lamp will go out. This is the normal operating process of hill start.

Emergency brake

In case of malfunction of service brake, the emergency brake can be applied by the dynamic parking function of EPB to brake the vehicle slowly till the vehicle stops.

Fault parking

In case of vehicle speed signal with the start switch at "ON", when the parking button is pulled up for longer than 30s, EPB will brake the vehicle with a low force, and increase the braking force gradually in 30s till the vehicle stops successfully. If the parking button is released before the vehicle stops successfully, the braking will be released.

* Electronic parking brake (EPB)

Warning!

- When there are obstacles in 2m forwards and backwards before vehicle drives away, please cancel the Auto Release function, but use the manual one.
- Under the same speeds, the emergency brake has the longer braking distance than the service brake has the shortest one. Therefore, it is prohibited that the emergency brake is used to take the place of service brake.
- While service brake system is working normally, it is prohibited to simultaneously operate the service brake and the emergency brake. Otherwise, the rear wheels will be locked up, leading to traffic accidents.

Caution !

When the parking brake indicator flashes in traveling and the EPB indicator on combine instrument is kept ON, it means the EPB system is failed. Please go to the special service station for repair.

* Multi-functional steering wheel



Angle adjustment of steering wheel

1. Push the locking detent of the steering wheel to its downmost end.
2. While holding the steering wheel, move the steering column upwards or downwards until the comfortable position where all the instruments and indicators are visible on the instrument panel.
3. Push up the locking detent to lock the steering wheel.
4. Move the steering wheel up and down, and make sure that the steering wheel is locked in place.

* Multi-functional steering wheel





Left buttons

VOL+ : upwards toggle this button, the volume going up step by step; keep this button uplifted, the volume going up continuously; release this button, stopping the volume from going up.

VOL-: downward toggle this button, the volume going down step by step; keep this button pressed, the volume going down continuously; release this button, stopping the volume from going up.

MODE key: Pressing this key can will switch the mode.

 : Mute

 : Answer button of bluetooth telephone

 : Turn on the voice function

 : Last channel search on radio interface / selection of last song on video interface

 : Next channel search on radio interface / selection of next song on video interface

Right buttons

 : Under the constant-speed cruise, the vehicle speed or the deceleration could be set.



 : Under the constant-speed cruise, it is possible to accelerate vehicle; the constant-speed cruise canceled, the original speed is resumed.

 : Turn on/off the constant-speed cruise control.

 : Cancel the constant-speed cruise control.

OK key: By short press, confirm the relevant information setting on the trip computer.

BACK: Click it to return to last page on the trip computer.

 /  : Click it to upwards / downwards select the information on trip computer

* Multi-functional steering wheel



Horn





Horn switch is on the central of steering wheel (its icon ) , and press any central position, vehicle horning; release it, stopping the vehicle horning.

Warning!

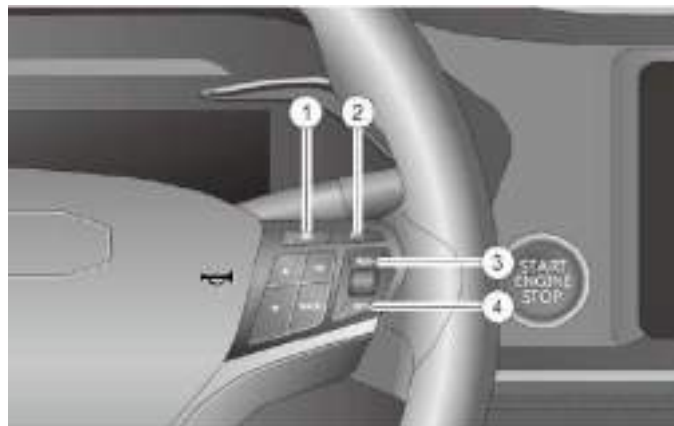
The horn button panel on the steering wheel is also the cover of driver's airbag. To use the horn, it is forbidden to forcefully press or knock the steering wheel panel in order to avoid accident.





* Cruise





1.  : Cancel the constant-speed cruise control.
2.  : Turn on/off the constant-speed cruise control.
3.  : Under the constant-speed cruise, it is possible to accelerate vehicle; the constant-speed cruise cancelled, the original speed is resumed.
4.  : Under the constant-speed cruise, the vehicle speed or the deceleration could be set.

* Cruise



Turning on of constant-speed cruise

1. Click , its indicator  on the combine instrument showing yellow.
2. Speed up to 40 km/h or more.
3. Downwards toggle , and release it, setting and saving the current speed, and meanwhile the yellow indicator  on combine instrument turns to green.
4. Under the constant-speed cruise, loosen the accelerator pedal.

Increase the cruise speed

- Upwards toggle  once, increasing the speed by 2 km/h.
- Keep  uplifted, vehicle speed continuously going up to the setting.

Decrease the cruise speed

- Downwards toggle  once, decreasing the speed by 2 km/h.
- Keep downwards , vehicle speed continuously going down to the setting.





Description!

Vehicle speed drops to 40 km/h, automatically quitting the constant-speed cruise control.

Cancellation/recovery of cruise

Under the constant-speed cruise, click , quitting the cruise and erasing the set cruise speed.

Under the constant-speed cruise, click  or depress the brake pedal, quitting the constant-speed cruise.

After the quitting, toggle  upwards once, resuming the last speed before the cruise control.

Under the constant-speed cruise, it is possible to directly depress the accelerator pedal; accelerator pedal released, vehicle speed resumes to the setting before the cruise control is cancelled.



Warning!

- Do not use the constant-speed cruise control system in case of heavy traffic, slopes, corner-full segment or slippery road, which otherwise may lead to accident.
- The set speed and the distance to the front vehicle should be suitable to the local traffic conditions. Furthermore, as a traveling assist system, the constant-speed cruise control system should be used carefully.
- Finished, the constant-speed cruise control system should be timely turned off.

Improvement of economy/reduction of environmental pollution

Foreseeable driving

At acceleration, vehicle generally consumes more fuel. Predictive traveling could reduce the braking times and thus the acceleration times. For example: when you see that next traffic light is about to turn red, slide the vehicle as much as possible with transmission engaged.

Energy-efficient gearshifting

An effective method to save the fuel is to shift the gear as soon as possible. A high revolution at a low gear may increase the fuel consumption. It is suggested to shift from Gear 1 to 2 properly in advance, and shift to a higher gear when the engine speed is up to 2,000 rpm.

Avoid the full opening of throttle

The running at the highest speed shall be avoided. When the vehicle speed is faster, the fuel consumption, emission of hazardous substances and driving noise will also increase obviously. The running at an intermediate speed can save the fuel.

Avoid the short-distance trips for a long term

Only when both engine and exhaust purification unit reach the best working temperature, can the fuel consumption and the hazard material effectively drop. In addition, the fuel consumes relatively higher before engine warms up. Only after engine reaches the ideal work temperature, could the fuel consumption become normal. Therefore, avoid the short-distance traveling for a long term as much as possible.

Avoid the unnecessary emergency braking

Efforts shall be made to avoid the unnecessary emergency braking, maintain a stable speed and calculate the change time of traffic signal in order to minimize the frequency of stop. A suitable running distance shall be kept with other vehicles to avoid the emergency braking and reduce the wear of parts cause of emergency braking.

Avoid the unnecessary loading

Since 1kg more of load could increase the fuel consumption, check the trunk to take out the unnecessary load.

Pay attention to tire pressure

Pay attention to the tire pressure all the time, so as to save the fuel. Additionally, the very-low tire pressure may also result in the severe wear of tire because of the increase of rolling resistance, and thus worsen the running conditions.

ABS+EBD

ABS (anti-skid brake system)

In case of emergency braking, the vehicle with ABS can adjust the brake pressure by electronic control unit that ABS can prevent wheels from locking when braking on skid road or emergency braking and the wheels can still rotate under braking mode, in order to ensure the stability of braking direction and avoid the side-slipping and deflection. This improves the driving safety.

In addition, ABS is also provided with self-diagnosis function to monitor the system operation. Once any fault which may affect the system operation is found, ABS will be automatically closed and ABS alarm lamp  will be lit to remind the driver. At this time, the brake system of the vehicle can function as normal brake system.

While ABS is working, you may feel that the brake pedal slightly vibrates. When ABS fault indicator  does not light up when engine is being started or does not go out after lighting up or lights up in traveling, it means the some part of ABS system is failed. Please contact the authorized service station as soon as possible for inspection of vehicle.

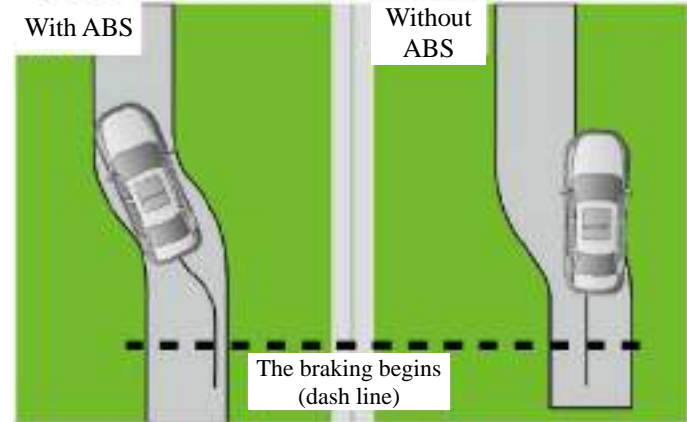

As for the vehicle without ABS, when the front wheels are locked up, the vehicle cannot steer, but slides forwards along the braking direction.

ABS+EBD

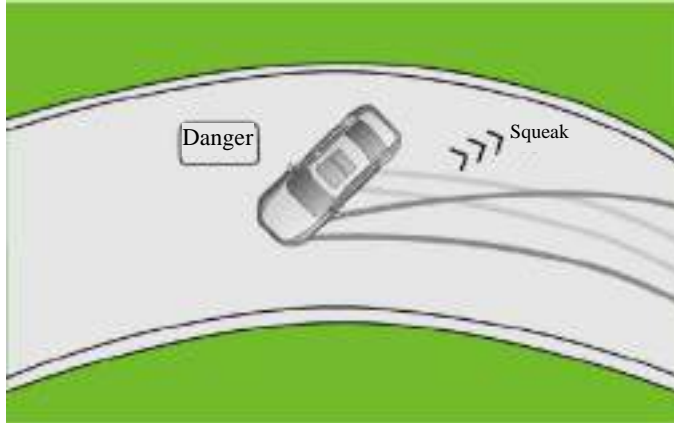

As for the vehicle without ABS, when the rear wheels are locked up, it is liable for vehicle to drift by even 180°.



Description!



With brake pedal depressed, it is normal that you feel that brake pedal vibrates or hear the sound similar to hydraulic control, meaning the ABS is working.

EBD (electronic brake force distribution system)

EBD (electronic brake force distribution system) is complementary to ABS, which can improve the function of ABS when used with ABS. In case of emergency braking, EBD will, based on the vehicle weight and road condition, automatically take the front wheel as reference to compare the sliding ratio of rear wheels before ABS functions. If such difference is deemed necessary to be adjusted, the hydraulic brake system will adjust the oil pressure transmitted to rear wheels so as to obtain the more balanced and idealized brake force distribution. It can avoid the occurrence of drift and sideways.

* Electronic Speed Controller ESC



Electronic Speed Controller (ESC) could keep vehicle under the best driving stability at different conditions. With the starter switch at ON, ESC system is turned on. Press ESC switch (as shown in the above figure), ESC system is turned off, its indicator  on combine instrument lighting up; press the ESC switch again, turning on ESC system and its indicator  on combine instrument going out.

Warning!

To improve the driving safety and comfort, make sure that the ESC system is active when the vehicle is running.

Caution !

- In case of following special situations, ESC shall be deactivated:
 - The vehicle runs with the tire chain;
 - The vehicle runs on the thick snow or loose road;
 - The vehicle is trapped and has to move forward and backward to get rid of trapping.
- The ESC system does not work when the vehicle speed is below 10km/h; in case of ESC braking, the slight vibration or downward moving of brake pedal can be felt.

* Electronic Speed Controller ESC



Electronic Speed Controller (ESC) makes the traveling safer, as it drops the risk of side-sliding and better the traveling stability.

ESC makes analysis according to the running status information received from various sensors. If any steering action bad for the vehicle stability occurs when the vehicle is turning around, the relevant sensor of ESC will detect such action, and send the correcting command to the ESC actuator to help the vehicle to maintain the dynamic balance.



ESC serves to correct the under-steering or the over-steering. For example, take the leftward over-steering on the slippery road as the case: when the vehicle sensor senses the vehicle is slipping, the right-front wheel will be quickly braked to resume the adhesive force, generating a reverse torque to keep the vehicle on the same lane.



Caution !

ESC cannot exceed the physical limit of adhesive force, especially on the slippery road or while towing the vehicle.

* Traction control system (TCS)

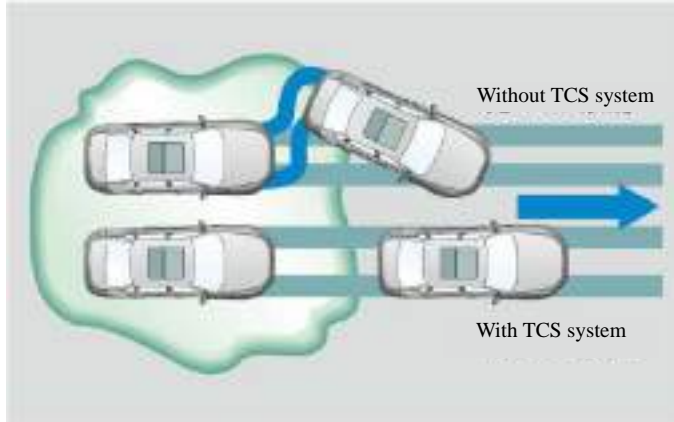

TCS, short for traction control system, is the subsystem of ESC. According to RPM of drive wheels and driven wheels, it determines whether drive wheels is skidding and thereby inhibits RPM of drive wheels when they are faster than driven wheels.

TCS is very helpful for the vehicle stability. When running on the slippery road, the drive wheels of the vehicle without TCS are easy to slip during acceleration. In case of rear wheels, the vehicle is easy to drift; in case of front wheels, the vehicle is easy to lose control, resulting in the vehicle deflecting to one side. The installation of TCS can avoid or relieve such symptom and keep the vehicle running in the correct direction when the vehicle is accelerating.

⚠ Caution !

TCS shares a button with ESC. When TCS is operating, the ESC indicator lamp  on the combination instrument will flicker.

* Braking assist

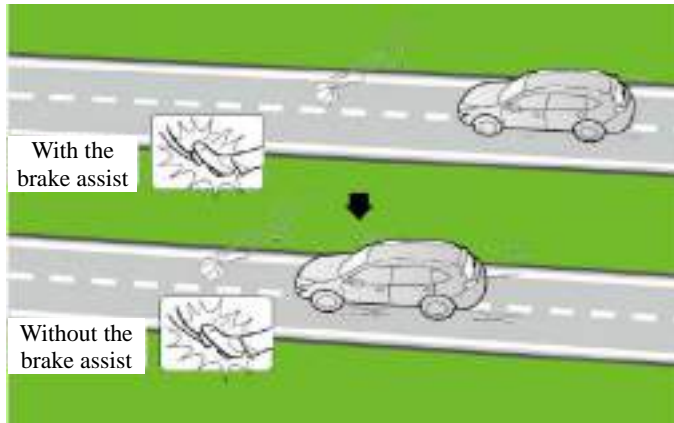

Through identifying the pressing of pedal, the braking assist system identifies and determines if the emergency braking procedure is applied. This system can motivate the maximum braking pressure instantly to achieve the highest braking effect and the ideal braking effect to avoid traffic accident.

* Hill descent control system

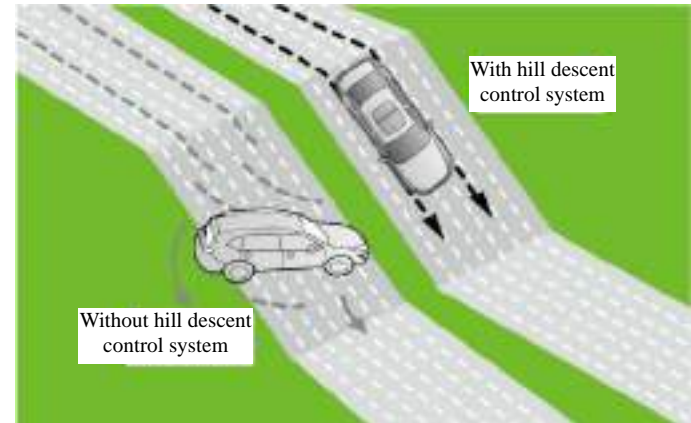

* Hill descent control system

Its switch is integrated into the central control combine switch.

As one part of electronic speed control system (ESC), hill descent control system is an assist related to the driving comfort. When the driver does not depress the brake pedal in downhill traveling, the hill descent control system could make use of ESC to positively apply the brake force, so as to slow down the downhill traveling.

Brake override system

The brake override system is a system to stop the vehicle by using brake pedal when the accelerator pedal is stepped and the throttle is fully opened (the throttle is stepped to its bottom). In other words, the brake override system can automatically change the engine to idle speed when it finds that the driver fails to apply brake successfully. For example, when the accelerator pedal fails to reset because it is caught by carpet, the brake override system will function.

* Launch assist

To drive away the vehicle with the launch assist, engine can slightly speed up.

* Hill-start assist control system

Hill-start assist control system

The hill-start assist control system could enable the vehicle with the electronic parking inactivated to start away on a hill, free of any back sliding. Namely, when driver' right foot leaves the brake pedal, the vehicle could still keep the braking for a few seconds, so that the driver could easily shift his/her foot from brake pedal to accelerator pedal, and thus calmly start away on a hill.

* Parking assist control system



1. Forward radar detector

Being of ultrasonic ranging, the parking assist system could detect the distance from the vehicle to the obstacle, and the beeper gives out warning at different frequencies depending on the detected distance. Therefore, this makes the parking safer, reducing the vehicle damage and the personal injury at parking.

* Parking assist control system



The parking assist control system could be turned on or off with its switch **P** in left switch group on the instrument panel. When this system is turned off, its indicator **P** goes out.

When the parking assist system is turned on, the front radar does not work if transmission is at other gears than R gear and vehicle speed is more than 18km/h; when the vehicle speed is less than 18km/h, the front radar will be turned on by itself.

! Caution !

- Its indicator on switch keeping ON means this system is self-inspected normal; its indicator flashing means this system is self-inspected abnormal.
- The parking assist system cannot take the place of driver, because it cannot detect:
 - Any item beneath the bumper or vehicle body; or any item too far or too close.
 - Very fine items
 - Failure to notice the conditions behind vehicle before and during the parking may lead to vehicle damage or personal casualty. Pay attention to the obstacles through the rearview mirror before parking, even if the parking assist system is equipped.

* Parking assist control system



1. Reversing sensor probe

Turn the starter switch or the ignition switch to “ON”, and shift to the R-gear, activating the parking assist system.

This system could detect the 150cm or less of distance and firstly identifies the closer obstacle when two obstacles are detected at the same time.

Description of detecting distance and warning frequency

1. The buzzer will sound at 1Hz when the distance between object and rear bumper is about 150cm~90cm.
2. The buzzer will sound at 2Hz when the distance between object and rear bumper is about 90cm~60cm.
3. The buzzer will sound at 4Hz when the distance between object and rear bumper is about 60cm~35cm.
4. The buzzer will sound for long when the distance between object and rear bumper is within 35cm. At this time, it is necessary to stop the vehicle immediately to prevent colliding with the rear obstruction.

* Parking assist control system

In any of following situations, the park assist system may give false or no alarm:

1. Iron wire, rope, net wall and other thin objects;
2. Driving or parking on uneven ground or in the grass;
3. When the radio or antenna with high-frequency output is installed and used;
4. A low object, like a rock;
5. Something like snow, cotton and sponge that can absorb ultrasound easily;
6. At the approach of the horn sound from other vehicle, the engine sound of the motorcycle, and the gas braking sound.
7. When the sensor is covered by snow or mud;
8. When sensor surface is freezing with drips;
9. Traveling on rainy/snowy days;
10. Metal knocking interference;
11. Within an environment of same frequency.

* Visual reversing image & tracking function

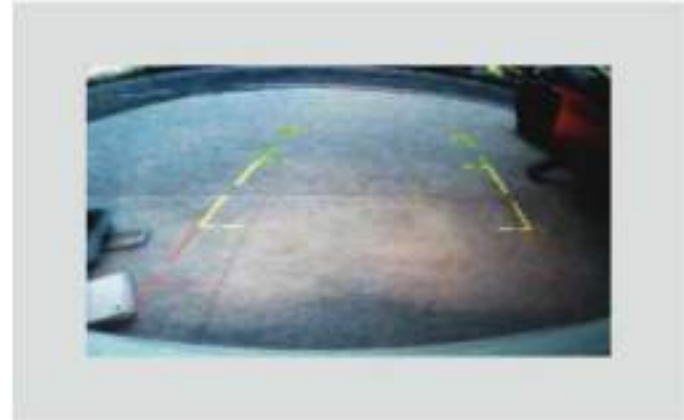

When the start switch is at ON and the reverse gear is engaged, the multimedia screen will show the reversing image automatically. Based on the received angle signal of steering wheel, the reversing image system shows the dynamic reversing assist line in superposition on the multimedia screen. The assist line will vary dynamically and proportionally to the rotation of steering wheel, to indicate the moving trace of current vehicle body.

* Lane departure warning (LDW)



The LDW switch is located in the left instrument panel switch combination, as shown on the above diagram.

When LDW switch is turned on, the LDW will operate with the indicator lamp on the switch lighting.

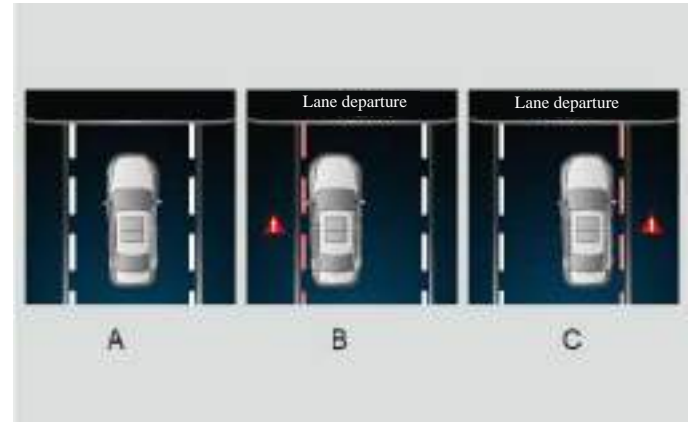

When the lane departure warning system (LDW) is turned on and vehicle speed exceeds 60km/h:

1. With LDW working, vehicle does not run on the lane or normally changes a lane, and combine instrument shows fig. A.
2. When vehicle runs on the left lanes, with steering wheel not turned leftwards, the combine instrument shows the fig. B, red line flashing and beeper sounding.
3. When vehicle runs on the right lanes, with steering wheel not turned leftwards, the combine instrument shows the fig. B, red line flashing and beeper sounding.

* Lane departure warning (LDW)

Some vehicle conditions and ambient environment may affect the performance of LDW, especially:

- The lane line is worn or discolored;
- Yellow lane line under the strong sunshine or on the light-color road surface
- At night, the light of coming vehicle illuminates the camera;
- The road surface is reflective;
- The lane line is blocked because the distance to the front vehicle is too small;
- The vehicle is at the expressway entrance, irregular lane line or construction guide line;
- The lane line is covered (by rain, snow or fog) in the bad weather;
- The lane line is covered by water, snow or dirt;
- The camera is collided strongly.
- There is water mist or rainwater on the camera lens.



Warning!

LDW may be affected by the weather conditions and ambient environment. In any case, it is just an assist, and cannot be used as the driver's judgment. The driver must avoid hazards and drive the vehicle in a civilized way.

* Blind spot assist (BSA)



The BSA switch  is located in the left instrument panel switch combination, as shown on the above diagram, and is used to turn on or off the BSA. When BSA is on, the indicator lamp on the switch will go on.

* Blind spot assist (BSA)



The BSA detectors are located on both sides of front and rear bumpers. When the BSA switch is turned on and the vehicle speed is above 20km/h, BSA will provide assist. The warning on the exterior rearview mirror reminds the driver that the vehicle is detected in the monitoring area. If the driver turns on the appropriate turn signal lamps to change the lane, the driver will be warned by the flickering of warning on the exterior rearview mirror and two beeping of rear buzzer.



Description!

With the blind-zone detection system activated, shift the starter switch to ON, enabling the system to carry out the self-inspection and to show the results to driver.

Normal self inspection: The alarm lamp on the exterior rearview mirror goes on for 3s and then goes out; the indicator lamp on the BSA switch is on all the time.

Abnormal self inspection: The alarm lamp on the exterior rearview mirror is on all the time; the indicator lamp on the BSA switch flickers.

Activating conditions of BSA

1. The starter switch is at "ON".
2. The BSA switch is turned on;
3. Shift gear lever to D (for auto transmission) or non-R (for manual transmission)
4. The vehicle speed is between 20km/h and 140km/h.

* Blind spot assist (BSA)

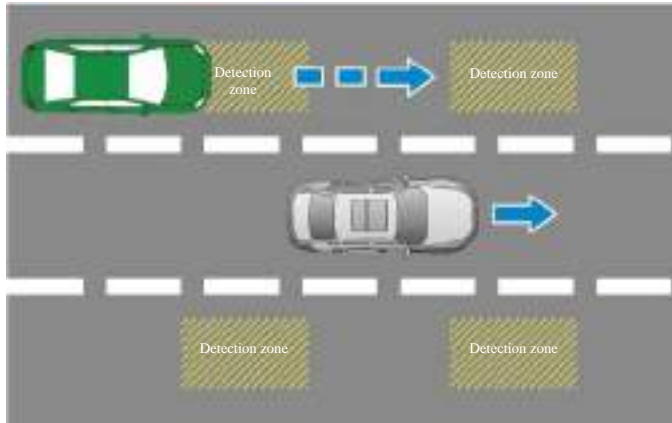

Activation of warning

When any other vehicle enters the blind spot detection area of the car, the warning will be activated, as shown on the above diagram.



Description!

On the diagram in the section of BSA: the gray vehicle indicates the vehicle with BSA; the green vehicle indicates other vehicle on the road; the yellow shadow area indicates the blind spot detection area of gray car.

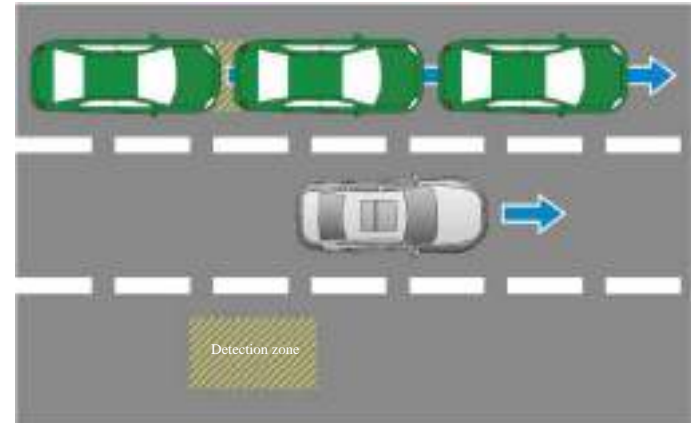

Cases that may result in warning omission or failure

In some cases, there is item not reported or warned (mis-warned target: when the item comes out, the warning indicator does not light up). It is normal that some targets are missed.

1. The warning may be omitted when the cars, as a fleet, pass through the blind spot, as shown on the above diagram.
2. While overtaking (overtaken by) a long vehicle (truck train or bus), this vehicle appears both the rear blind zone and in the field of driver's view, leading to the warning missed.

* Blind spot assist (BSA)

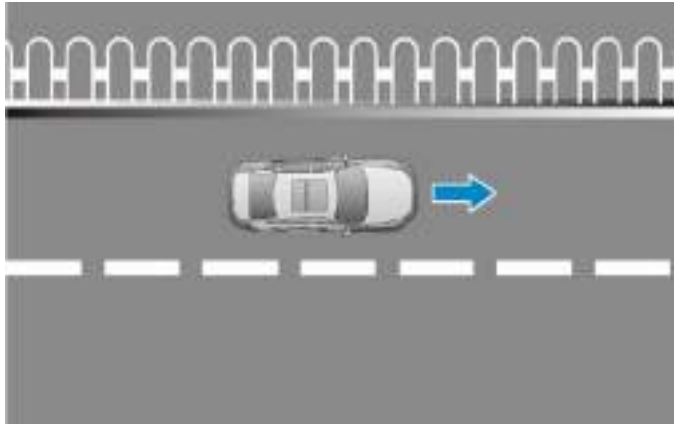

3. The guardrail, wall, sign, static vehicle or similar stationary obstacle may not activate the warning, as shown on the above diagram.
4. The vehicle stopped at the roadside parking space in front may result in warning omission;

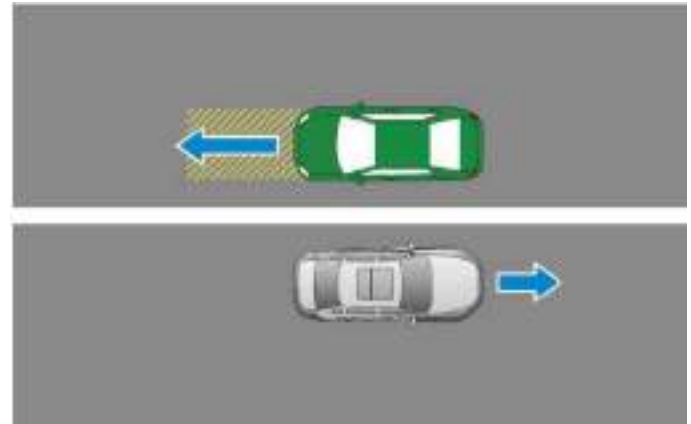

5. The oncoming car, as shown on the above diagram, may not activate the warning.
6. The vehicle running on the same lane and in the same direction may not activate the warning.

* Blind spot assist (BSA)

In case of following conditions, the BSA may produce the wrong warning:

- Highway median;
- Concrete wall;
- Fence or vegetation;
- Sharp turn around a pole or building;
- The vehicle stops suddenly with a vehicle behind it, and a long distance is kept with the vehicle behind;
- Bad weather conditions (heavy rain, snow and hail);
- The vehicle is running uphill or downhill;
- Water spattered by other vehicles in the rainy weather.



Description!

In some case, there may be wrong warning (incorrect warning: there is no target, but the warning indicator lights up). It is normal that there are a few of wrong warnings.



Warning!

BSA may be affected by the weather conditions and ambient environment. In any case, it is just an assist, and cannot take place the driver's judgment.

* 360 Around View Monitor (AVM)



- Front bumper camera
- External rearview mirror camera

*360 Around View Monitor (AVM)



- Rear bumper camera
- External rearview mirror camera



With starter switch at “ON”, press the “360 Around View” icon on the multimedia interface, turning it on; press the Back button, quitting the “360 Around View”, returning to the homepage.

*360 Around View Monitor (AVM)



Front + *360° image

On the front/rear/left/right big screen, while clicking the key "360" at the center of virtual key, the multimedia screen will display the relevant image and 360° image.

When AVM start key is not triggered

Forward function

AVM image will not appear.

Steering functions

- Turn on the steering button: with vehicle speed equal to or less than 50km/h, turn on the left/right turn switch, the multimedia showing "Left - View + Around View" or "Right - View + Around View"; when vehicle speed higher than 50km/h, turn on the steering switch, not activating the side-view function. Namely the multimedia still shows the original functions (radio and navigation).
- Turn off the steering button: AVM system is turned off, and the multimedia still shows the original functions (radio and navigation).



Description!

While the turn switch is turned on, the "left + 360° image" or "right + 360o image" realized by turning will change to "left big screen" or "right big screen" only by pressing the left or right virtual key and other virtual keys will be invalid. At this time, the quit key will also be invalid.

*360 Around View Monitor (AVM)



Description!

With the hazard warning lamp ON, the Around View function still work (exchange the windows by pressing the virtual key).

Reversing function

- Shift lever at Gear R: when the vehicle speed is equal to or below 20Km/h, the multimedia screen will show the "rear + 360° image"; in case of vehicle speed above 20Km/h, AVM system will be deactivated and the multimedia screen will show the original page (radio, navigation, etc.).
- Getting out of R-gear: AVM system is turned off, and the multimedia still shows the original functions (radio and navigation).



Description!

With the shift lever at Gear R, the "rear + 360° image" realized by such Gear R can just be mutually changed to the relevant rear big screen, and other virtual keys are invalid. At this time, the quit key is also invalid.

When AVM start key is triggered

Forward function

- When the vehicle speed is equal to or below 20Km/h, the multimedia screen will show the AVM image.
- When the vehicle speed is above 20Km/h, the multimedia screen will show the original page (the page before AVM is activated, such as radio, navigation, etc.). When the vehicle speed drops from above 20Km/h to 15Km/h or below, the multimedia screen will change to AVM image, showing the "front + 360o image".



Description!

When AVM key is triggered with the Gear R disengaged or the turn switch activated, the multimedia screen will display the "front + 360° image".

Steering functions

- Turn on the steering function: With the vehicle speed equal to or below 50Km/h, the multimedia screen will show the "left/right + 360° image" when the steering signal lamp is operated; with the vehicle speed above 50Km/h, the operating of steering signal lamp will not activate the side view function, i.e. the multimedia screen still shows the original page (radio, navigation, etc.).

*360 Around View Monitor (AVM)

- Turn off the steering function: With the vehicle speed equal to or below 20Km/h, the multimedia screen will display the "front + 360° image"; in case of vehicle speed greater than 20Km/h , AVM system will display the original screen (radio, navigation, etc.). When the vehicle speed reduces from 20Km/h above to 15Km/h or below, the multimedia screen will change to AVM screen to display the "front + 360° image"; in case of vehicle speed greater than 20Km/h, the side image will not function, namely, the multimedia screen will still display the original screen (radio, navigation, etc.).



Description!

With the steering switch at On position, the "left/right + 360° image" which is realized due to operation of virtual key will only change to the relevant left/right big screen and the other virtual keys will be invalid. At this time, the quit key will also be invalid.

* Wireless charging of mobile phone



1. Wireless charger indicator
2. Wireless charger position for cell-phone

With wireless charging function

With the starter switch at ON, put the cell-phone to the charger position, and its indicator shows green and flashes slowly, meaning the cell-phone is in the charging.

* Wireless charging of mobile phone

- After the charging, its indicator is kept on, reminding the user of taking phone away.
- With metallic items close to the charger position, its indicator shows red and after 10s, the beeper keeps the sounding.

⚠ Caution !

- Before charging, the mobile phone to be charged shall be placed in the charging box.
- No metal object or chip card is allowed at the mobile-phone wireless charging position for fear of affecting the service life of mobile phone charging module.
- In the course of mobile phone charging, the key must not be placed on the mobile phone; otherwise, a warning “No intelligent remote key is found” will appear.

📱 Description!

The wireless charger of cell-phone is simply suitable for the cell phone with build-in wireless charging function.

* Tire pressure monitor

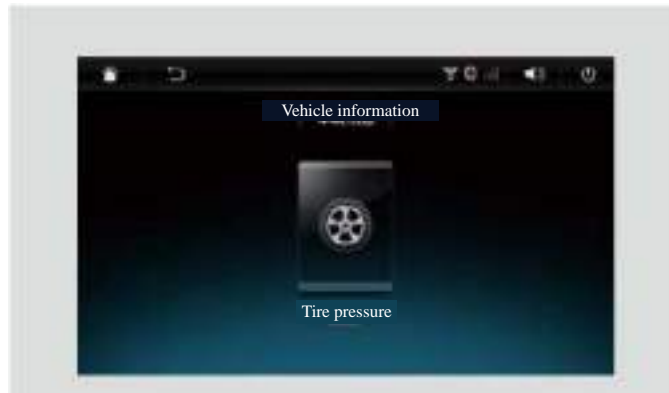

Press the “Vehicle Information” icon on the multimedia interface, entering the interface of vehicle information, as shown in the above figure. Press “Tire Pressure” icon to enter into the interface of tire pressure monitor.

* Tire pressure monitor

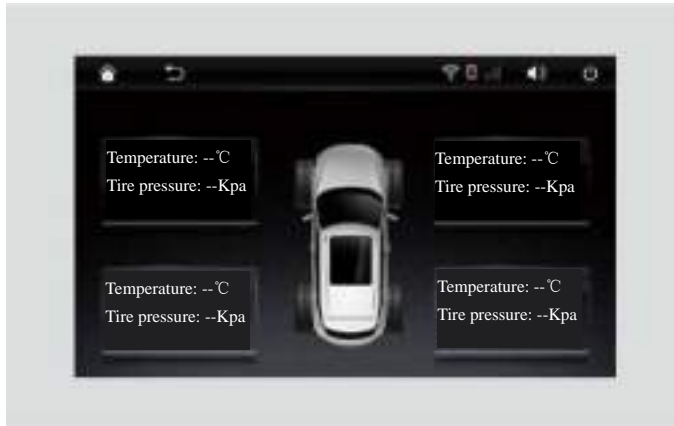

The tire pressure monitor interface shows the temperatures and the pressures of all the wheels.

The tire pressure monitor could detect the tire pressure, temperature and others, and give out the warning in case of any abnormality such as quick leaking of air and other system failures.

Functions of tire pressure monitoring device:

1. Avoid the occurrence of accident;
2. Prolong the service life of tire;
3. Improve the driving safety;
4. Reduce the abrasion of suspension system.

Caution !

When the tire pressure monitoring device on your vehicle is in failure, the tire pressure alarm lamp  on combination instrument will be lit and the buzzer will sound. In order to ensure the real-time monitoring on your car, you are advisable to immediately go to the authorized service station of Zotye Auto for troubleshooting.

Description!

For the detailed information about the monitoring of tire pressure, please refer to the Navigation, Audio & Visual and Communication System supplied with the car.

* Traveling data recorder



Press the “REC” in the switch group at left side of instrument panel, so as to view the film recorded by the recorder.



As a digital electronic recording device, the traveling data recorder could record and store the vehicle speed, the time, the mileage and other status information, and then output the data through its port. In addition, the integrated locating and communication modules could upload the location and the over-speed information.



Description!

For the detailed information about the traveling data recorder, please refer to the Navigation, Audio & Visual and Communication System supplied with the car.

Run-in period

To guarantee the service life of car, the run-in is required in the early period before the vehicle is put into operation; the vehicle can be put into normal operation only after run-in.

Provisions for run-in period

- During the run-in period, the fuel and engine oil consumptions may be higher.
- The engine shall not run at a high speed.
- Select the good road and restrict the load and speed. It is forbidden to open the throttle completely or accelerate the vehicle suddenly.
- The vehicle with manual transmission shall not run at high gear but low speed. It is necessary to shift the gear timely.

Notices for running in the run-in period

The overload is forbidden

Do not load above maximum limit during running-in. Otherwise, it will cause serious damage to parts beyond good running-in condition.

- 0~800 km: not over 50% of maximum load;
- 800~2000km: not over 70% of maximum load;

The long-distance driving is forbidden

Do not drive a long distance during running-in. Parts will be worn if the engine works constantly for a long time.

Avoid the emergency braking

Minimize the number of emergency braking, otherwise the brake system will be subject to impact and the impact load onto the engine is increased by the chassis. Avoid the emergency braking within the first 300km of run-in period whenever possible.

Avoid towing the car

When vehicle cannot travel normally, please use the flatbed type towing vehicle for transportation. Use of rope for towing may damage to the vehicle.

First maintenance

Within the first 3000±500km mileage or three months after purchase of a new vehicle (whichever comes first), the first run-in maintenance is required in order to ensure the good condition of car.

Safety inspection and precautions before driving

Safety inspection before traveling

It is needed to check the vehicle before traveling, which benefits the traveling safety.

1. Appearance inspection

- Check if the tires are damaged, the tire pressure is suitable and if there are sundries embedded on the tire treads; take the corrective measures when necessary.
- Check if tire nuts are loose.
- Make sure all the windows, rearview mirrors and external lamps are clean and uncovered.
- Check if there is fuel, engine oil or other fluid leaking from the vehicle chassis (It is normal to drop water after use of A/C)
- Check if there are sundries hung on the chassis.
- Check if the external lamps work normally.

2. Inspection of inside of front compartment

- Check the levels of brake fluid, coolant, engine oil and windshield washer fluid.
- Check if the battery terminals and the cables are properly connected and if the housing is cracked.

3. Inspection inside the car

- Check if the on-board tools are complete.
- Check instruments and indicators on instrument panel for good condition while checking engine.
- Check if the safety buckles are normal, and ensure that the safety belts are not worn or scratched.

Notices before driving

- Clear the articles scattered on the instrument panel in order to prevent them from blocking the vision and resulting in personal injury or vehicle damage due to collision with the occupant in case of emergency braking or collision.
- Adjust the seats, steering wheel and interior/ exterior rearview mirrors, etc.
- Close and lock all the doors and compartment doors.
- All the goods inside of trunk should be put evenly.
- Do not put the inflammable inside of vehicle.

Three-way catalytic converter

The three-way catalytic converter is an emission controller installed in exhaust system. It is used to reduce the pollutant in waste gas.

Caution !

A large amount of unburned gas will enter into three-way catalytic converter to overheat the three-way catalytic converter and cause a fire. In order to avoid the occurrence of this condition or other damage damages, the following requirements must be met:

- Timely refuel vehicle (merely use of lead-less gasoline) when the fuel level is extremely low, because engine will shut down when fuel uses up, overloading the three-way catalytic converter.
- Avoid the engine idling or running at high speed for a long time.
- Maintain the engine in good condition. The abnormal electrical system, electronic ignition system or fuel system of engine may result in too high temperature of three-way catalytic converter. The three-way catalytic converter may be invalid in case of abnormal high temperature for long.
- In order to ensure the normal operation of three-way catalytic converter and whole emission control system, the vehicle must be subject to regular inspection according to the Zotye vehicle maintenance schedule.

Safe driving under various road and weather conditions

Traveling on the poor roads

It is necessary to driver your vehicle at low speed in case of cross wind. This is convenient to control the car.

Avoid traveling on the high or sharp-edged roads, curb or other obstacles, which otherwise may lead to tire blow-out.

Please slow down firstly before traveling on bumpy roads, which otherwise may damage the tire or the wheel hub.

The brake may wet when washing your vehicle or driving into deep water area. To check whether it is wet, it is necessary to first check whether the vicinity is safe and then lightly step the brake pedal. If the normal braking force is not felt, this shows that the brake may be wet. In order to dry it, it is allowed to drive the vehicle at low speed and lightly step the brake pedal till that it recovers function. If it still fails to operate safely, it is allowed to park your vehicle at a safe place and seek for helps from the authorized service station of Zotye Auto.

Warning!

- You need to be careful when driving on bad road or off-road. Too high speed and incorrect driving may result in vehicle damage and personal injury.
- Slow down and shift the transmission to the low-speed gear before driving on long and steep slope. In addition, use the engine brake, rather than the sliding with transmission shifted to neutral, because excessive use of brake may overheat or even fail the engine.

Safe driving under various road and weather conditions

Driving in the rain

In the rain, you are required to decelerate and drive carefully because of reduced visibility, foggy window and smooth road. Do not drive your vehicle at high speed on expressway in the rain. This is because that the water film between tire and road will hinder the normal steering and braking operation.



Warning!

- When driving on smooth road, any emergency braking, acceleration or steering may cause the wheel slipping and reduce the vehicle maneuverability to result in the occurrence of accident.
- After passing through any puddle, please slightly depress the brake pedal to dry it, so as to make sure the brake works normally.



Caution !

- Care must be taken before passing through the water-accumulated road, and do not take any risk before learning of the depth of accumulated water, which otherwise may lead to engine shutdown or other severe failures.
- When engine is shut down during wading, do not try to restart engine! That may severely damage to the engine.

When driving in winter

1. Use of proper coolant

Coolant should satisfy the requirements of original manufacturer.

2. Inspection of the battery

As low temperature may drop the battery performance, battery should keep the sufficient electricity for startup in winter.

3. Engine oil viscosity suitable for winter driving.

In winter, engine oil with poor fluidity at low temperature may lead to the difficult to start up. Therefore, use of the engine oil should be in line with the original manufacturer.

4. Avoiding of door lock from being frozen

Spray the deicer or the glycerin into the door lock cylinder, so as to prevent it from being frozen.

5. Avoid accumulating the ice and snow below mud guard.

Any accumulated ice and snow below mud guard may result in steering difficulty. When driving in cold weather, it is necessary to frequently check whether there is accumulated ice and snow below mud guard. Please clean the vehicle of any accumulated ice and snow and then use the car.

It is advisable to carry some emergency supplies upon the different driving destination. The possible objects include tire chain, window scraper, sand bag or salt bag, flashing device, scoop, jumper cable, etc.

Safe driving under various road and weather conditions

Caution !

- Do not use the tap water or the purified water to take place of coolant!
- When the door locker cylinder is frozen, do not engine coolant or other items, which otherwise may damage to the painting.

Fire prevention

Pay attention to the following in order to prevent against fire:

1. It is prohibited to put the inflammable inside of vehicle;
 - As the inside temperature of vehicle exposed to sunshine in hot summer could reach as high as 70 °C or more, the inflammable such as lighter or perfume inside of vehicle may lead to fire or even explosion.
2. It is suggested to go to the authorized service station for inspection;
 - All entire circuits should be periodically checked, such as electrical appliances, connectors, insulation layer and its securing position, and timely shoot the found problems.
3. It is prohibited to refit the vehicle circuits or add any electrical appliances.
 - Adding of other electrical appliances (such as high-power audio and xenon headlamp) can overload the circuits, overheating or even firing them.
 - It is prohibited to use the fuse out of the rated specifications or other metal wires to take place of fuse.
4. The portable fire extinguisher should be put on vehicle and be learned of how to use it.
 - For sake of traveling safety, the fire extinguisher should be put on vehicle, and then periodically checked and replaced. In addition, it is necessary to be familiar with how to use it.

General description

The periodical and special maintenance can maintain the value of your car. In addition, the special and periodical maintenance is one of preconditions to obtain the warranty right for body rust and paint damage defects.

The necessary maintenance supplies can be purchased from the authorized service station of Zotye Auto. Pay attention to the use regulations of maintenance supplies.



Warning!

- Safe storage of maintenance materials: do not put them into the food cans or bottles, away from children. Otherwise there is risk of children swallowing them.
- The products for vehicle maintenance may contain the toxic and hazardous substances; the improper use may result in personal poisoning or vehicle damage.
- Before using the materials for vehicle maintenance, carefully read and abide by the use instructions and safety notices.



Description on environmental protection!

The environment-friendly materials for vehicle maintenance shall be selected. The residual materials for maintenance shall not be treated as domestic wastes, and must be disposed in accordance with the relevant instructions.

Safety precautions

In order to avoid the potential risk, please read this chapter before work, so as to make sure you are equipped with the needed tools and technologies.

- Make sure the vehicle parks on flat ground, engine is shut down and parking brake is tensioned up.
- Cleaner of parts should be of the marketable de-greasant or special detergent, rather than gasoline.
- The smoking cigarette, spark or open flame should be kept away from the battery or all other fuel systems.
- Please wear the goggles and the protective suits before working on battery or compressed air related components.



Warning!

Driving of vehicle with incorrect maintenance or before the safety failures being solved may lead to traffic accidents or even personal casualty.

Exterior maintenance of car

Cleaning of car

Use the normal cleaning method to clean the car. Any of following situations may corrode the paint surface or body and component, so you must clean your vehicle immediately:

- When you drive your vehicle in coastal area;
- When you drive your vehicle on the road with anti-freezing agent;
- When your vehicle is polluted with coal tar, resin, guano and dead insect;
- When you drive your vehicle in the area where is a large amount of smoke dust, coal ash, scrap iron or chemical substance;
- When your vehicle is obviously polluted with dust and mud.

Manual cleaning of Zotye car

1. Do not clean vehicle until it cools down in the shade.
2. Wash away the loose dirt by water pipe. Thoroughly wash away all muds or road salts from the vehicle bottom and fender.
3. Use the neutral detergent to clean vehicle, with the mixture of detergent in line with the manufacturer's requirements.
4. Do not forcefully wipe it. After the wiping, thoroughly clean the vehicle with clean water.
5. After the washing, use a clean and soft cotton towel to dry the residual water spots.



Warning!

While cleaning, pay special attention to the vehicle bottom and the inside of wheel cover, and care must be taken not to get hands and arms hurt.



Caution !

While cleaning vehicle with high-pressure cleaner, pay attention to the work pressure and the spraying distance and do follow the operational illustration of high-pressure cleaner.



Description!

The special detergent should be used to remove the pitch or other away. After that, clean it again with water, so as not to impair the vehicle body smoothness.

Exterior maintenance of car

Waxing

In order to maintain the vehicle body clean as new, it is advisable to polish and wax the vehicle body regularly.

1. Before waxing, it is necessary to clean and dry the vehicle body.
2. Use the quality polishing agent and wax
 - When the vehicle body painting is severely weathered, please clean and polish it.
 - After the polishing, use the quality wax to protect the painting.

Caution !

When the wax nozzle is blocked unintentionally, do not use the pins or other tools to clean it. It is suggested to contact the authorized service station for cleaning.



Cleaning of wiper blade

1. The starter switch or the ignition switch is turned to ON and then to “OFF/LOCK”.
2. 10s after last step, shift the combine switch of wiper to **MIST**. At this time, the wiper arm runs for half a cycle.
3. Uplift the wiper arm and use a soft cloth to carefully wipe away the dust and dirt away from the wiper blade.
4. After the cleaning, put the wiper arm back to the windshield.
5. With starter switch or the ignition switch turned to ON, the wiper arm returns by itself.

Exterior maintenance of car

Caution !

- The new wiper blade is coated with a layer of graphite, smoothing the wiping and muting the wiping noise. For the hard foam or the sharp may damage to the graphite layer, the wiping noise gets louder and louder. Therefore, the damaged wiper blade should be replaced timely.
- Before use of wiper blade in winter, please check if the wiper blade and the windshield are frozen together. If so, please deice them firstly, which otherwise may damage to wiper blade and wiper motor.

Cleaning of window and rearview mirror

The good visual field can improve the traffic safety.

Window and rearview mirror should be cleaned with the glass detergent and then dried with clean and lint-free cloth.

Cleaning of trims and decoration strips

Dirt and the attachment should be removed from the decoration strips with neutral detergent.

The polishing agent of painting cannot be used for maintenance of decorating parts and trims.

Repair of damaged paintings

The small piece of damaged painting (such as scratch or impact with stones) should be repaired before rusted.

In case of being rusted, please go to the authorized service station to thoroughly remove the rust and repair the painting.

Maintenance of weather strips

The rubber curing agent should be timely sprayed onto the rubber strips of doors, front compartment cover, back door, sliding skylight and window (such as silicon sprayer), so as to keep their flexibility unchanged and to prolong its service life. In addition, that could also prevent the weather strips from being worn prematurely and from being leaked, making the door easier to open.

Cleaning of wheels

Periodically remove the non-slip salt and the braking debris from the wheels, so as to keep the wheel surface smooth and beautiful, and to prolong its service life.

Internal maintenance of car

Plastic trims

The plastic trims should be easily cleaned with the neutral detergent or the water.

Before cleaning, vacuum the trim and then spray the neutral detergent with foam or soft cloth onto the trim surface for soaking a few minutes. After that, use clean and wet cloth to wipe away the dirt and the residual detergent.

Carpet

Use the high quality of foam-type cleaner to clean the carpet.

Before cleaning, use a vacuum cleaner to remove the dust. Then, use a foam or brush together with the foam detergent to clean the carpet.

Please read and observe the operational illustration of foam detergent.

Caution !

Do not rinse the carpet, which otherwise may cause the electrical appliances near carpet to be failed.

Seatbelt

Please periodically check if the seatbelt is clean and clean the dirty one with neutral detergent.

After cleaned, the seatbelt cannot be used until it is thoroughly dried.

Warning!

- It is prohibited to take off the seatbelt for cleaning.
- Do not use any corrosive detergent to clean the seatbelt.
- Please go to the authorized service station for replacement of the damaged seatbelt strap, connectors, automatic retractor or buckles.

Instrument panel

A piece of clean soft cloth is soaked wet, then twisted, and used to wipe dust away from the A/C control panel, the instrument panel, the central console and switches.

Leather interior trims

Leather trims could be cleaned with neutral detergent.

Before cleaning, vacuum the leather trims and then spray the neutral detergent onto the soft cloth to wipe dirt away.

Internal maintenance of car

After cleaning, use clean wet cloth to clean the dirt and the residual detergent. Ventilate the leather to dry it.



Warning!

It is prohibited to splash any fluid onto the internal electrical appliances, which otherwise may lead to electrical appliance failures or catch fire.



Caution !

- Do not use the corrosive detergent to clean leather, which otherwise may discolor or stain the leather.
- The leather may be aged under the direct sunshine. Therefore, it is suggested to park vehicle in the shade.

Attachments and refitting

Mounting of attachments

Before ex-factory, the vehicle components, such as the engine hood locker frame, are attached with data labels and markers, showing the key data and information on vehicle operations. Do not remove or damage the labels and markers, but keep their data and information clean and readable.

In order to keep vehicle performance unchanged, please go to the authorized service station for mounting of attachments and for replacement of parts.

It is suggested to use the attachments and parts approved by our company. Use of the attachments and parts not produced by our company will waive your rights to quality guarantee.

Before installation of any parts, please pay attention to that:

1. Make sure the attachments do neither dim the vehicle lamps, nor impair the normal operations or performance
2. For the vehicle equipped with a sided airbag, do not mount a cover onto a seat, which otherwise may impair the airbag's normal work.

 **Warning!**

Mounting of improper attachment or refitting of vehicle may impair the vehicle stability and other performance or even lead to personal casualty.

Refitting of vehicle

Removing of parts or replacing the original parts with the one rather than ZOTYE can severely impair the vehicle stability and reliability. For example:

- Larger or smaller wheels and tires may impair the ABS and other systems from normally working.
- Refitting of steering wheel or other safety devices may lead to system failures.

 **Warning!**

- Improper refitting of this vehicle (especially the brake system, the steering system and other components related to wheels and tires) can drop the airbag performance, leading to system failures or even personal casualty.
- It is prohibited to mount the wheels and tires not approved by our company.
- Refitting of the front part of vehicle and front engine compartment may weaken the protection of pedestrian, violating the road regulations.

Instructions on maintenance

We suggest referring to the maintenance schedule for periodic maintenance of ZOTYE T300. Periodic maintenance is beneficial to:

- Fuel economy;
- Increase of longevity of the vehicle;
- Enjoyment of driving;
- Safe driving;
- Stable driving;
- Compliance with the scope of warranty;
- Compliance with applicable regulations.

ZOTYE T300 is so designed to take the economy of both driving and maintenance into consideration. In order to make sure vehicle runs at best conditions, observe the maintenance schedule for maintenance.

However, this maintenance schedule does not cover all the requirements of vehicle, and therefore, the daily maintenance is needed after the initial running-in maintenance and between the two times of maintenance. For example: routine inspection, replenishment of fluid and tire pressure inspection.

Where can your vehicle be serviced?

The best place for you to service your vehicle is the authorized service station. The technical personnel of authorized service stations have been well trained. They have been provided with the latest maintenance information through the specialized technical data, technical circulars, maintenance prompts and internal training programs.

The authorized service stations have spent much money to acquire various special tools and repair equipment, so as to provide you the better service at a lower price.

How about do-it-yourself maintenance?

If you have certain knowledge on machines and some basic vehicle tools, you can complete a great many of maintenance items by yourself and easily. For details, please refer to the Chapter “DIY”.

It should be noted that some of maintenance work requires the use of special tools and expertise. Such maintenance work should be done by the competent technical personnel. They will record the maintenance work performed on the vehicle, and such record is very important for the claiming of warranty service.

Instructions on maintenance

Zotye's maintenance schedule

The interval of the maintenance schedule can be determined by the reading on the odometer or the time interval ,whichever comes first (as shown in the schedule)

The maintenance item of which the interval time is expired shall be performed in the next interval.

The maintenance interval each item should be listed in the maintenance schedule. It is suggested to follow the maintenance schedule for maintenance at the authorized service station.



Description!

In accordance with the ZOTYE's maintenance schedule, the rubber hoses should be inspected by the qualified technicians (the rubber hoses for cooling and heating systems, brake and fuel systems. since the rubber hoses are aging over time, leading to expansion, abrasion or damage).

Daily traveling on sandy, muddy or puddle roads, it is needed to check the following items and do the repair or maintenance if needed:

- Brake friction pad and brake disc
- Brake pipeline and hose
- Transmission oil
- Steering linkage and dustproof boot
- A/C filter element
- Air filter element

Maintenance schedule (ordinary conditions or bad conditions)

Maintenance interval Maintenance item	Subject to the reading on the odometer or the number of months, whichever comes first.																					
	×1000km	3	8	13	18	23	28	33	38	43	48	53	58	63	68	73	78	83	88	93	98	103
	Numbers of months	3	9	15	21	27	33	39	45	51	57	63	69	75	81	87	93	99	105	111	117	123
Engine																						
Poly V - Belt	J		J		J		J		G		J		J		J		G		J		J	
Timing chain	Inspect every 50,000km and replace every 100,000km, or earlier under rigorous operating conditions																					
Ignition cable	J		J		J		J		J		J		J		J		J		J		J	
Spark plug	General operating conditions	Common spark plug: change it every 20,000 km or 12 months; platinum spark plug: change it every 50,000 km or 2 years.																				
	Rigorous operating conditions	Earlier inspection and replacement																				
Crankshaft ventilation system (PVC valve and vent hose)	J		J		J		J		J		J		J		J		J		J		J	
Cooling water pipe and connection	J	J	J	J	J	J	J	J	J	J	J	J	J	J	J	J	J	J	J	J	J	J
Engine coolant level	J	J	J	J	J	J	J	J	J	J	J	J	J	J	J	J	J	J	J	J	J	J
Engine coolant	Change it every 2 years or 40,000km.																					
Air filter element	General operating conditions	Q	Q: Every 5,000km or 6 months; G: Every 10,000km or 12 months																			
	Rigorous operating conditions	Q: Every 2,000km or 3 months; G: Every 5,000km or 6 months																				
Engine oil	General operating conditions	G	G: Every 5,000km or 6 months																			
	Rigorous operating conditions	G: Every 3,000km or 3 months																				

Maintenance schedule (ordinary conditions or bad conditions)

Maintenance interval Maintenance item	Subject to the reading on the odometer or the number of months, whichever comes first.																					
	×1000km	3	8	13	18	23	28	33	38	43	48	53	58	63	68	73	78	83	88	93	98	103
	Numbers of months	3	9	15	21	27	33	39	45	51	57	63	69	75	81	87	93	99	105	111	117	123
Cigarette lighter and horn	J		J		J		J		J		J		J		J		J		J		J	
Windshield wiper and washer	J	J	J	J	J	J	J	J	J	J	J	J	J	J	J	J	J	J	J	J	J	J
Windshield cleaning liquid	B	B	B	B	B	B	B	B	B	B	B	B	B	B	B	B	B	B	B	B	B	B
Windshield wiper blade	J	Replace if necessary																				
Electric window lifter and electric rearview mirror	J		J		J		J		J		J		J		J		J		J		J	
Sunroof and multi-function steering wheel	J		J		J		J		J		J		J		J		J		J		J	
Audio navigation system and reversing radar	J		J		J		J		J		J		J		J		J		J		J	
Seat, air bag and safety belt	J	J	J	J	J	J	J	J	J	J	J	J	J	J	J	J	J	J	J	J	J	J
A/C and control button	J		J		J		J		J		J		J		J		J		J		J	
A/C filter element / pollen filter	Q	Q: every 6 months; G: every 20,000km or 2 years																				
Chassis and body																						
Tighten the chassis fixing bolts and nuts	J		J		J		J		J		J		J		J		J		J		J	
Brake fluid	J	Change every 2 years or 40,000km																				
Brake pedal and parking brake	J	J	J	J	J	J	J	J	J	J	J	J	J	J	J	J	J	J	J	J	J	J
Brake disc and friction lining	J		J		J		J		J		J		J		J		J		J		J	
Braking system pipeline and hose	J	J	J	J	J	J	J	J	J	J	J	J	J	J	J	J	J	J	J	J	J	J

Maintenance schedule (ordinary conditions or bad conditions)

Maintenance interval Maintenance item	Subject to the reading on the odometer or the number of months, whichever comes first.																					
	× 1000km	3	8	13	18	23	28	33	38	43	48	53	58	63	68	73	78	83	88	93	98	103
	Numbers of months	3	9	15	21	27	33	39	45	51	57	63	69	75	81	87	93	99	105	111	117	123
Steering system pipeline and hose	J	J	J	J	J	J	J	J	J	J	J	J	J	J	J	J	J	J	J	J	J	J
Steering wheel and linkage	J		J		J		J		J		J		J		J		J		J		J	
Ball stud and dust cover	J		J		J		J		J		J		J		J		J		J		J	
Drive shaft and dust cover	J		J		J		J		J		J		J		J		J		J		J	
Front & rear suspension	J		J		J		J		J		J		J		J		J		J		J	
Exhaust pipe and installation accessories	J		J		J		J		J		J		J		J		J		J		J	
Tire and inflation pressure	J	J	J	J	J	J	J	J	J	J	J	J	J	J	J	J	J	J	J	J	J	J
Tightening of wheel nuts and wheel bearing	J		J		J		J		J		J		J		J		J		J		J	
Wheel alignment and tire rotation	Four-wheel alignment or rotation should be done every 10,000km or 6 months.																					
Door limiter and buckles of doors, engine hood and trunk lid	J	J	J	J	J	J	J	J	J	J	J	J	J	J	J	J	J	J	J	J	J	J
Body damages	J	Inspect every year																				

Maintenance schedule (ordinary conditions or bad conditions)

Note:

1. Meanings of symbols in the schedule:

J means inspection, and if necessary, adjustment or replacement; G means replacement; Q means clearing or cleaning; B means make-up.

2. “Rigorous operating conditions” include the following cases:

- Run in the dusty area, or frequently exposed to salt-containing air or salt water.
- Run on uneven road, the road with stagnant water, or the mountainous road.
- Run in the cold areas.
- The engine will run at idle speed for long time or often travel by a short distance in the cold season.
- It is required to frequently apply the brake or often apply the emergency brake.
- Tow a vehicle.
- Used as the taxi or the rented vehicle for self-driving.
- Run slowly in the crowded urban area at a temperature higher than 32°C for more than 50% of the total driving time.
- Run at a speed higher than 120km/h and at a temperature higher than 30°C for more than 50% of the total driving time.
- Overloading

Fuel

Fuel type

In order to keep vehicle performance unchanged, use the gasoline with qualified grade.

This vehicle must use the 92# or higher high-quality lead-free gasoline.

Capacity of fuel tank

48±2 (L)

Caution !

- Use of low-grade or inferior gasoline may shorten the engine service life.



Refuel.

The fuel tank cap opening lever is located under and on the left of driver's seat.

1. Engine needs to be shut down before refueling.
2. Uplift the opening lever, fuel tank cap popping up by itself.

Fuel

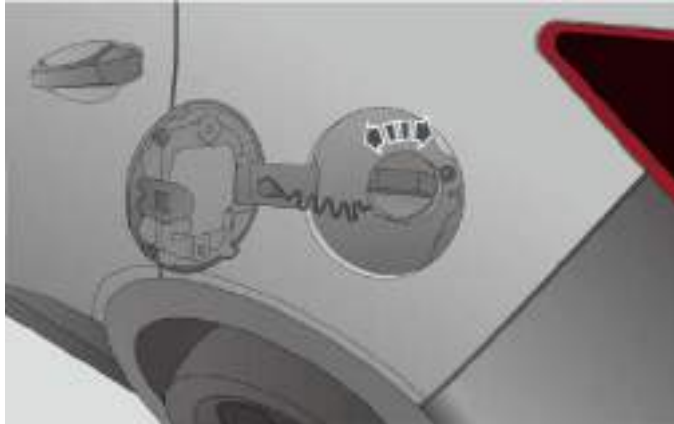

3. Counterclockwise rotate the cap, opening it. Wait a moment before taking off the fuel cap.
4. Take off the fuel cap and refuel the tank with the filler gun.
5. After the refueling, put the cap back on and clockwise rotate it until “Snap” is heard, meaning the cap is tightened up.

! Caution !

When refueling in the gasoline station, the followings must be noticed:

- No smoking or open flame;
- Never use the mobile phone;
- The fuel shall not be filled too much for fear of fuel spillage.

! Warning!

The gasoline is flammable, and easy to explode in the airless space.

- After the refueling, make sure the cap is tightened up to prevent the fuel from overflowing in case of accidents.
- Only the fuel cap of genuine ZOTYE should be used, because it could regulate the fuel pressure.
- Dry weather is apt to generate the static electricity. Therefore, before taking off the fuel cap, please release the static electricity, so as to prevent the static electricity from creating the spark and thus igniting the fuel vapor.
- Do not have the fuel contact skin or clothes, as fuel is harmful to your health whether you touch or inhale it. If your skin is touched with fuel accidentally, immediately clean it with water.

Front engine hood



Opening of front engine hood

1. Park the vehicle, apply the parking brake and pull the front hood lever beneath the left of instrument panel, the hood unlocked and slightly popping up.



2. Gently uplift the hood, finger to press the opening handle leftwards, and completely raise the hood.

Front engine hood



3. Raise the hood to the proper position and then support it in place with a bar.

Closing of front engine hood

1. To close the hood, lower it close to the wing and then forcefully press it with both hands.
2. After the hood is closed, check if the buckle is locked reliably.



Description!

- The movable parts of hood locker should be lubricated, helpful to open or close the front engine hood.
- When the hood is not closed in place, the combine instrument shows the notice, and the beeper sounds out when vehicle speed exceeds 5 km/h.



Warning!

Front engine compartment dangerous! Mis-operation is liable to cause the accidents.

- When the visible steam or coolant comes out of front engine compartment, do not open the hood, which otherwise may cause the scalding.
- Do not touch the hot parts, which otherwise may cause the scalding!
- With each system heated up, the cooling system is at high temperature and pressure, so do not open the cap of coolant surge tank.
- As the engine is started or running, do not touch the rotary parts, such as drive belt, the generator, the radiator fan, high-pressure ignition system and high-temperature exhaust system.

Overview of front engine compartment

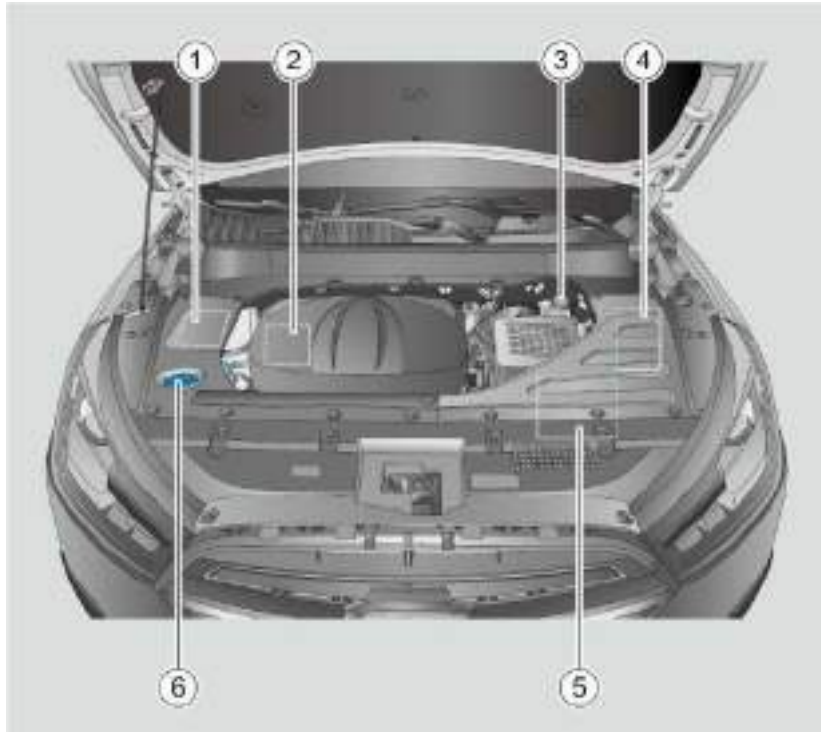

1. Coolant surge tank
2. Decoration cover of engine
 - Oil dipstick
 - Oil filler
3. Brake fluid reservoir
4. Electrical box of front compartment
5. Battery
6. Washer fluid reservoir



Description!

For details, the physical vehicle prevails.

Engine oil

After engine is started, if the engine oil pressure warning indicator flashes, and system gives out three sounds of warning, and the instrument screen shows the related texts, hints and warning, you need to shut down engine immediately to cool it down, and then check the engine oil level and add it if needed.

When the engine oil level is normal but the its warning indicator keeps flashing, do not travel any longer, nor idle the engine, but contact the authorized service station as soon as possible for solution.

Warning!

Neglecting of engine oil pressure warning indicators or related warnings may damage to engine or cause more loss.

Description!

Since the engine oil pressure warning indicator cannot show the engine oil level, it is suggested to check the engine oil level before traveling and periodically.

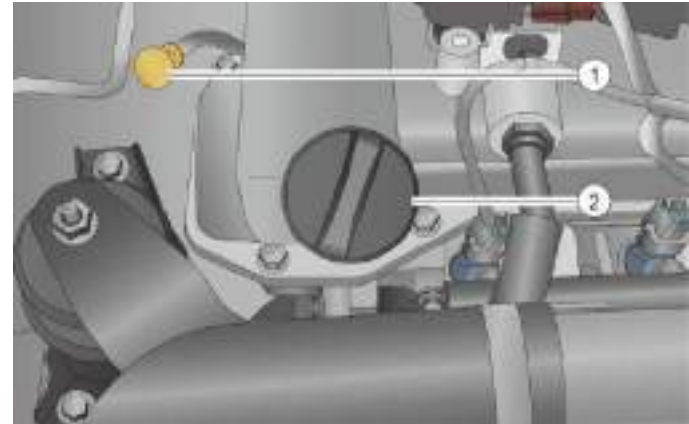

1. Oil dipstick
2. Engine oil filler cap

Engine oil has five functions: cooling, lubrication, cleaning, sealing and anti-rust, playing a key role to make sure engine runs normally. Therefore, periodically check the engine oil status, add and change the engine oil if needed.

Engine oil

⚠ Caution !

- The engine oil shall be changed pursuant to requirements on the running-in and routine maintenance. Only the scheduled maintenance and oil change will ensure the normal service life of the engine.
- Engine oil products of different grades shall not be mixed.



Description on environmental protection!

The waste engine oil should be disposed according to the related environmental protection regulations.



Description!

It is needed to remove the decoration cover of engine before inspection or adding of engine oil.

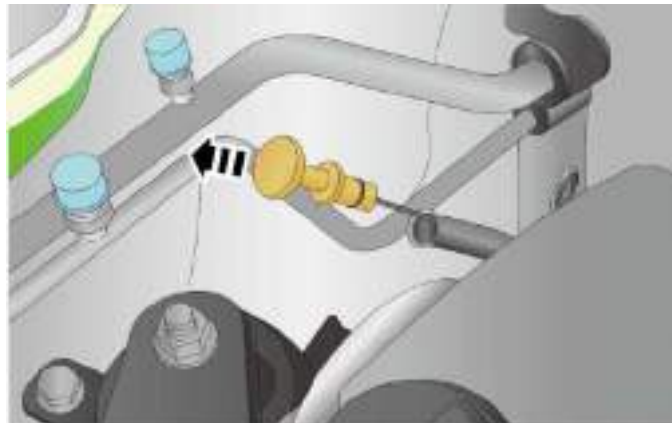

Check the engine oil level

With engine switched off and cooling down, open the front compartment to take off its decoration cover, so as to pull out the oil dipstick and to check the oil level.

1. To obtain the accurate reading, it is needed to park vehicle on flat road, shut down engine and to wait a moment for engine oil to flow back to oil sump.
2. Pull out the dipstick, wipe it with tissue or cloth and then insert it back to the end.
3. Pull out the dipstick again to check if the level is between “MIN” and “MAX” (notch).

Engine oil

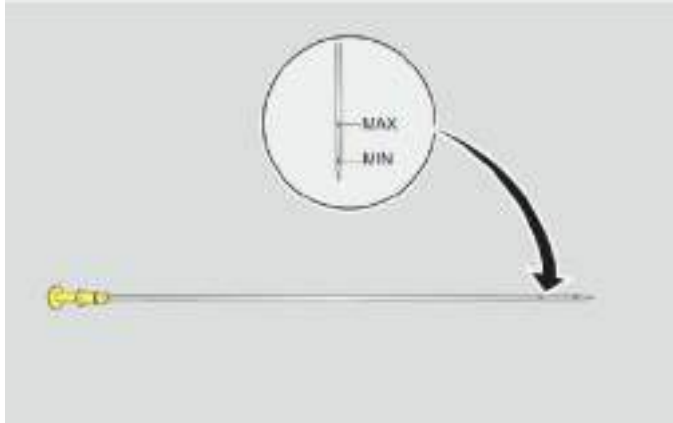

“MAX” refers to the upper limit of engine oil level.

“MIN” refers to the lower limit of engine oil level.

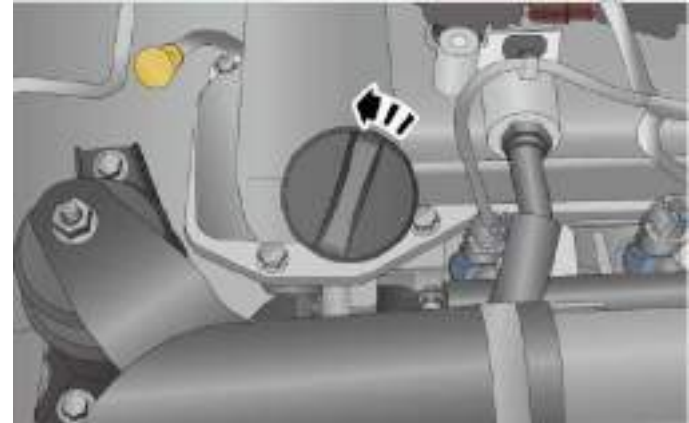

Filling of engine oil

1. If the engine oil level is below “MIN”, counterclockwise screw off the engine oil filler cap, to add the engine oil until between “MIN” and “MAX”.
2. After waiting for a few minutes, check the engine oil level again and add the proper engine oil if needed.
3. After inspection of fluid, make sure the dipstick is put back in place and the engine filler cap is tightened up.

Engine oil

Warning!

- Care must be taken to work on the front engine compartment.
- As the front engine compartment is dangerous, please carefully read and observe the related warnings before opening the compartment.
- Care must be taken to fill the engine oil, and do not sprinkle the engine oil onto the hot engine parts or exhaust pipeline.
- When the engine oil is added excessively, do not start engine, and contact the authorized service station for solution, which otherwise may damage to three-way catalytic converter.
- After the engine oil is added, the filler cap should be kept tightened, so as to prevent the engine oil from sprinkling out in traveling, which otherwise may lead to fire.

Caution !

The consumption of engine oil varies with the driving types and the service conditions. Therefore, it is needed to periodically check the engine oil level, best before the long-distance traveling.

Coolant



With engine cooling down, check if the coolant level in surge tank is between “FULL” and “LOW”. When the coolant level is below “LOW”, add the coolant.

In addition, the coolant level in surge tank varies with the engine temperature. However, the coolant level should be kept between “FULL” and “LOW”.

Coolant

Adding of coolant

Only after the cooling system (including the surge tank cap and the hose at top of radiator) completely cools down, can the cap of surge tank be opened.

Suggestion: the change should be done by the authorized service station.

1. Open and take off the front engine hood.
2. In order to prevent any risk of scalding, cover the cap with wet towel, and slowly counterclockwise screw it off.
3. Add the proper coolant into the surge tank until between “FULL” and “LOW”.
4. With its cap removed, start engine to have it run until the hose at top of radiator becomes heated up.
5. If coolant level drops in surge tank, add the proper coolant until between “FULL” and “LOW”
7. Put the cap back on and tighten it up.



Warning!

- When engine and coolant are hot, do not take down the pressure cap for fear of scalding.
- Make sure that the pressure cap is fixed correctly after the coolant is filled. The pressure cap, if not tightened, may cause the missing of coolant, and even damage the engine.
- When the coolant level drops obviously in short time, it means the cooling system is leaking. Therefore, please go to the authorized service station as soon as possible.



Description on environmental protection!

The waste coolant should be disposed according to the related environmental protection regulations.

Brake fluid

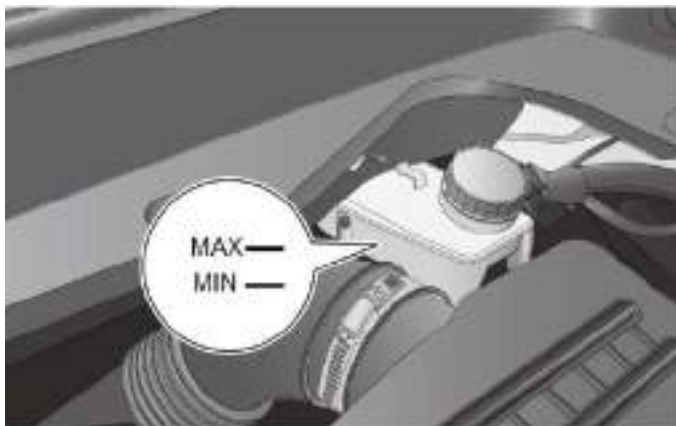

Check the level on the brake liquid tank. This level must be always maintained between MIN and MAX. During the vehicle operation, due to the wear-out and automatic regulation of the brake lining, the brake liquid level may be slightly lower. This is normal.

However, if the liquid level drops significantly or becomes lower than the “MIN” mark in short period of time, there may be leakage in the braking system. If the brake liquid level is too low, the brake indicator lamp will be also illuminated. In such a case, you should immediately drive your vehicle to service station.

As the braking system is critical for safety, you need to check various components of the brake frequently to ensure that they work normally. The brake liquid shall be changed by a professional.

The brake liquid is hygroscopic; therefore, it may absorb the moisture in the ambient air during operation. However, a too high moisture content in the brake liquid may result in the constant corrosion inside the braking system. In addition, the boiling point of the brake liquid may be also reduced largely. Under certain conditions, this may influence the braking efficiency. Therefore, the brake liquid must be changed.

Change of the brake fluid should observe Three-Guarantee Certificate and Maintenance Manual, which is suggested to be performed by the authorized service station.

Warning!

- The old brake liquid shall be properly stored in the sealed original vessel which shall be kept out of reach by the children to avoid any poisoning risk !
- If the brake liquid is too old, it may produce air bubbles in the brake device in the case of abrupt braking operation. These bubbles may influence the braking efficiency, thus to impair the driving safety and result in risks of traffic accident!

Washing liquid



! Caution !

Do not use the engine anti-freezing liquid or other substitutes, for this may cause damages of the vehicle paint surface.

🌿 Description on environmental protection!

The waste washer fluid should be disposed according to the related environmental protection regulations.

The washer fluid is used to clean the front and rear windshields.

When any one of washer does not work, it is possible that the washer fluid reservoir becomes empty. Therefore, check the washer fluid level.

Fill the dedicated washing liquid into the tank. However, in the cold areas, if the air temperature is lower than 0°C, the washing liquid containing the anti-freezing liquid shall be used. You can decide the ratio of mixture with water according to the manufacturer's instructions.

Replacement of front windshield wiper blade

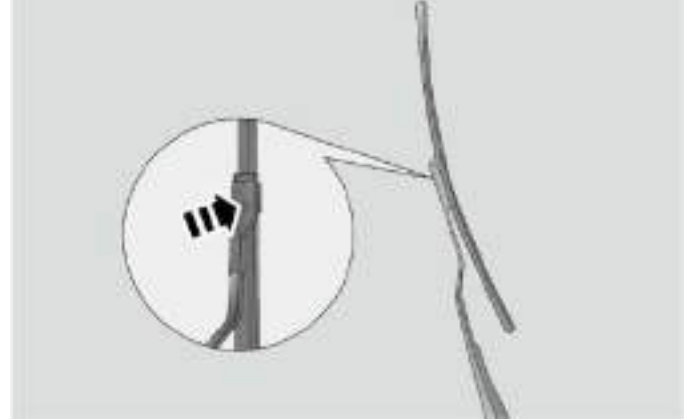

1. The starter switch or the ignition switch is turned to ON and then to “OFF/LOCK”.
2. 10s after last step, shift the combine switch of wiper to **MIST**, enabling wiper arm to run for half a cycle.
3. Uplift the wiper arm, and press the Lock button to take the wiper blade away.
4. Slowly put down the wiper arm.
5. Put the new wiper blade back into the wiper arm in the reverse order until “Click” is heard.
6. Gently put the wiper arm back onto the windshield.
7. The starter switch or the ignition switch turned to ON, the wiper arm returns by itself.

Replacement of front windshield wiper blade

Caution !

- The wiper arm, rather than the wiper blade, should be held for the uplifting.
- The new wiper blade should have the same length and specifications as the old one.
- Care must be taken to put down the wiper arm, so as to prevent it from dropping down and from thus impacting the windshield.
- The wiper blade should be periodically checked and replaced if damaged.
- Excessively worn or dirty wiper blade is easy to scratch the windshield, impairing the field of view and dropping the traveling safety.

Battery

Warning on operations of battery

1. Since the battery electrolyte is strongly corrosive, the gloves and the goggles have to be put on before operation!
2. The smoking and the cover-less lamps are prohibited at work site!
3. Being charged, the battery is easy to generate the explosive gas mixture!
4. Children have to keep away from electrolyte and battery!

Unfamiliar with the operational procedures or without the special tools, do not do any operation on electrical system. If you do not have confidence, please go to the authorized service station for solution.

Charging system indicator

This warning lamp is used to show if the generator is failed.

Shift the starter switch or the ignition switch to “ON”, the charging system warning indicator lighting up. Then, this indicator goes out when engine starts to run.

When this indicator lights up in traveling, it means the generator does not charge the battery any more. Therefore, it is suggested to contact the authorized service station.

Battery



Description!

Blocked with other parts in engine compartment, battery is difficult to be checked up directly. In such case, it is suggested to go to the authorized service station for inspection.

Driving in winter

In cold seasons, the battery bears higher load. Furthermore, battery's starting power drops when the external temperature is low. It is suggested to park the vehicle indoors.

Precautions for battery

Being charged, the battery can generate hydrogen, and therefore pay attention to the following before the charging:

1. Do not disconnect the negative terminal if the battery is charged onboard.
2. Ensure that the charger power switch is turned off when connecting or disconnecting the battery charging cable.

Replacement of battery

Please go to the authorized service station for replacement of battery.

Battery



Description on environmental protection!

Since the battery contains the sulfuric acid, the lead and others, it is needed to be properly treated.



Warning!

- The battery to be replaced with should have the satisfied specifications, which otherwise may impair the system from working normally.
- In order to protect the electrical system, do not directly connect the electricity generator, such as the solar panel or the battery charger, to the 12V of power outlet or cigar lighter.

Onboard tools



1. Uplift the cover of spare tire.
2. Take off the spare tire cover, exposing the warning board, the on-board tools and the spare tire.

The on-board tools include the warning triangle, jack, jack crank, wheel nut spanner and towing eye.

Warning triangle



If the vehicle cannot move due to any fault in the course of running, it is necessary to unfold the warning triangle support, place it upright or horizontally behind the vehicle at a suitable position (dependent on the road condition) in order to warn other vehicles running in the same direction behind to pay attention and make avoidance.



Description!

The warning triangle shall be placed 50m behind the vehicle on the ordinary road, or 150m behind the vehicle on the expressway when the vehicle has to emergency stop.

Replace the bulb

Replacement of bulbs

As for the bulbs enable to be replaced until other parts are removed, please ask for the professional for replacement. Therefore, it is suggested to go to the authorized service station for replacement.

Caution !

Unfamiliar with the operational procedures, the safe regulations and how to use tools, do not replace any bulbs by themselves.

Before the replacement, turn off the combine switch of lamp and wait until the bulb cools down.

Before the replacement, pay attention to the sharp parts on the headlamp housing and on the tail lamp housing. During the replacement, care must be taken to protect both hands from being scratched.

Inspection of wheels

Precautions for use of tire

- Take special care for the initial 500km when driving with a new tire.
- When passing the road edge or similar sections, the car can only pass it vertical to the road edge as long as possible at a low speed.
- Frequently check whether the bus tire is damaged (puncture, cracks, or bulging). Remove foreign matters from the tire tread.
- The damaged wheel or tire shall be replaced as soon as possible.
- Keep the tire from engine oil, and grease and fuel.
- Lost, a valve cap should be re-installed timely.



Warning!

- Tire flatted or leaked in traveling is apt to cause severe accidents.
- Do not use the damaged wheels or tires, or the one worn to the pattern mark. Otherwise, this is liable to lead to accidents since this kind of tires may get flatted in traveling. Therefore, they should be timely replaced.
- Tire pressure should be in line with regulations, which otherwise may lead to accidents. Insufficient tire pressure could lead to tires bent or overheated after traveling at high speed, or even make tire come out of housing or flatted.
- Pay attention to those tires cannot touch the chemicals, the engine oil, the grease, the fuel and the brake fluid.
- Avoid the use of tires more than 6 year old as much as possible. If you have to, excessive care must be taken to drive at low speed.
- In any case, do not use the unknown old tires and wheels, because those tires may be invisibly damaged, leading to vehicle out of control and thus causing traffic accidents.

Inspection of wheels

New tires

For a new tire, its best adhesion force is still not formed when used for the first time. Therefore, in the first 500km, the vehicle shall be driven at an intermediate speed and using the prudent driving method for running-in operation. This can also help to increase the service life of the tire.

Pattern depths of new tires vary with the structural features and the tread designs.



Caution !

- Non-running-in or excessively worn, the tires may have insufficient road adhesive, directly impairing the braking effect.
- When vehicle vibrates or offsets abnormally in traveling, please immediately stop to check if the tires are damaged.
- When the tires are excessively worn, please go to the authorized service station for inspection as soon as possible.

Hidden damages

The damage to wheel rims and tires are frequently invisible. In case of abnormal vibration or offset in traveling, it means the tires are damaged. When you doubt tire is damaged, please immediately drop the vehicle speed and then stop for inspection. When the tire damage cannot be seen outside, please go to the authorized service station for inspection.

Inspection of wheels



Inspection of tires

In each groove on the tire, certain projections are distributed at a certain spacing, and they are the tire wear marks.

If the tire wear mark appears on the tire surface due to the wear-out of the tire, the tire shall be replaced.

The tires used for 6 years or more have to be replaced, even though there is no obvious damage.

Even an unused or rarely used tire will be naturally aged as the time goes. This is also applicable to the spare wheel and the tires stored for future use. If there is any heave (bulging) inside the tire, the tire must be replaced.

If the tire can't be correctly recovered due to the frequent leakage or due to the size and location of other damages, the tire shall be replaced. If you can't find out the reason, please contact the authorized service store.

If the air leakage occurs during the driving operation, no further driving is allowed. Even a further driving by a small distance will cause unrecoverable damages of the tire.

Inspection of wheels



Tire pressure

The tire pressure label is located under the driver's door frame lock, and shows the size and recommended pressure of wheel and spare wheel. It is suggested to check all the tires often and ensure that the tire pressure maintained at the recommended pressure.

Inspection of the tire pressure

Tire specification	Tire pressure	
	No load	Full load
205/65 R16 215/55 R17	230kPa	250kPa
205/65 R16 (spare tires)	220kPa	
T135/90R17 (spare tires)	420kPa	

The tire pressure, as well as the pressure of spare wheel, shall be measured every two weeks or at least, every month.

The inappropriate tire pressure may cause additional consumption of fuel, and the impairment of the driving comfort, tire longevity and driving safety.

During inspection of the tire pressure, the following requirements must be abided by:

The cold tire pressure reading can be only obtained when the tire is cold. The tire pressure gauge shall be used. An error may be caused if the tire pressure is judged only based on the tire surface conditions.

It is normal that the tire pressure goes relatively high after traveling, because of heating up.

Make sure the tire valve cap is installed.

Inspection of wheels

Caution !

A too low tire pressure may result in:

- Excessive wear-out
- Uneven wear-out
- Difficult control of the vehicle
- Too hot tires to result in air leakage
- Improper sealing of tire bead
- Wheel deformation or even separation of tire
- Increase of possibility of tire damages where the road conditions are unfavorable

A too high tire pressure may result in:

- Difficult control of the vehicle
- Excessive wear-out
- Uneven wear-out

Replacement of wheels and installation of spare wheel

Replacement of the tire

At replacement of the tire, the tire having the same size and structure with the original one and having a loading capacity equal to or greater than the original one shall be used. Furthermore, all tires shall have the same brand and tread pattern.

The use of tires of other sizes or types may seriously influence the driving and operating performance, the calibration of the speedometer/odometer, and the ground clearance and the clearance between the body and the tire or the snow chain.

It is suggested to replace four tires at one time, or at least two front or rear tires at a time.

After tires are placed, wheels must be balanced. Any imbalance of the wheel will impair the vehicle operation and the tire longevity. Even in the normal operation, wheels may become unbalanced; therefore, it is required to provide inspections from time to time. At replacement of the tubeless wheel, the inflating valve shall be also replaced.

Replacement of wheels and installation of spare wheel

Warning!

Please observe following requirements, failing which may result in serious injuries.

- The mixed use of radial tire, bias belted tire and diagonal-ply tire in the vehicle is not allowed; otherwise this may result in the dangerous operation to cause loss of control.
- Do not use any tire of a size other than those recommended by the manufacturer; otherwise it may result in the dangerous operation to cause loss of control.
- The use of tires with different models and tread patterns and the treads which are worn out at different degrees, is not allowed; otherwise it may result in the loss of control of the vehicle.

Caution !

- As for the vehicle provided with any tire pressure monitoring device, the tire pressure monitoring device shall be re-matched after the wheel replacement.
- Production date of tires is marked in the oval nearby “DOT”.

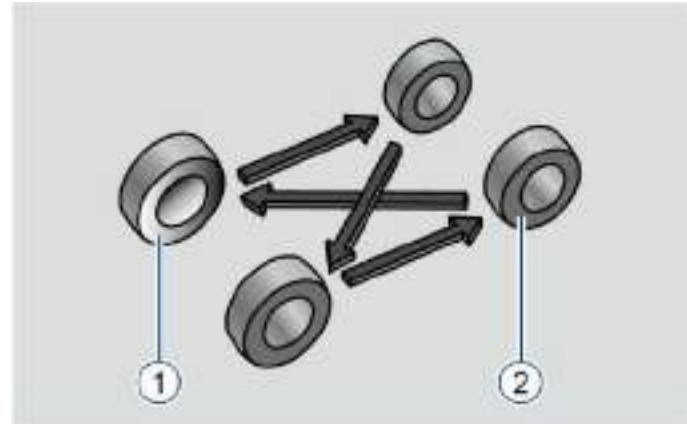

Tire rotation

1. Front tire
2. Rear tire

To maintain the even wear of the tires and prolong their service life, our company recommends you to carry out the tire rotation every 10,000km . After tires are rotated as required, the front and rear tire pressures shall be readjusted.

Replacement of wheels and installation of spare wheel

However, the most appropriate time for the tire rotation shall depend on the driving habits of the driver and the road conditions.

During tire rotation, it is necessary to check tires for uneven wear and damages. Wrong tire pressure, improper wheel orientation, unbalanced wheel or abrupt braking operation may result in abnormal wear-out of tires.

Summer tires

Tread depth cannot be less than 3mm.

There is highly risk of water skiing when the tread depth is less than 3mm.

Installation of snow tire and snow chain

When to use the snow tire and snow chain

It is recommended to use the snow tire or snow chain when the vehicle moves on the snow or icy road surface. On the wet or dry road surface, the towing force generated by an ordinary tire is greater than that of a snow tire.

Selection of snow tire

If it is necessary to use the snow tire, the tire of the same size, structure and bearing capacity with the original one shall be used. Furthermore, for the 4WD vehicles, all tires shall have the same brand and tread pattern.

It is not allowed to use tires other than those specified above. Before installation of any tire provided with spikes, you are required to get clear whether any restriction of such spikes is specified in the local regulations.

Installation of snow tire

All wheels must be fitted with snow tires. If the snow tire is only fitted to the front wheels, this may result in a significant difference in the adherence between front and rear tires, which may cause the loss of control of the vehicle. The removed tires must be stored on a cool and dry place.

Selection of tire chain

The tire chain of the correct size shall be used. The regulations regarding the use of tire chains will vary with the region or road type; therefore, the reference shall be made to the local regulations before installation of the tire chain.

Installation of tire chain

The tire chain shall be fitted onto the front tire as tightly as possible. Do not install any tire chain onto the rear wheel.

After driving for 0.5-1.0km, retighten the tire chain again. When installing the tire chain onto the tire, do observe the instructions given by the tire chain manufacturer.

If the wheel casing is used, the tire chain may scratch the wheel casing; therefore, before installation of the tire chain, the wheel casing shall be removed.

Replacement of wheels and installation of spare wheel

Warning!

- It is suggested to use the winter tires in winter. At low temperature, the summer tires get obviously worse in adaptive capacity, losing the adhesive force and the braking capacity.
- The vehicle shall not be operated with incorrect pressure of the snow tire. It is required to observe the requirements on the maximum permissible speed and the legal extreme speed of the snow tire.
- The traveling speed shall not exceed 50km/h or the speed limit specified by the tire chain manufacturer, whichever is lower.
- The vehicle must be operated with much care to keep away from any obstacle or pit and avoid any abrupt turning, for these may cause jolts of the vehicle.
- With the tire chain in use, the deceleration should be carried out before cornering. In addition, avoid the sharp turn or the wheels locked, leading to vehicle out of control or even accidents.

Caution !

If the tire chain doesn't match with the tire, the chain may cause damages of the vehicle body.

In the case of tire leakage:

1. Gradually reduce the vehicle speed, and keep straight-line driving. Carefully drive the vehicle off the road, and park it on a safe place far away from the traffic. Do not park the vehicle at the road center.
2. Park the vehicle on a flat and hard ground surface.
3. Stop the engine and turn on the hazard warning lamp.
4. Apply the EPB.
5. Have all occupants leave the vehicle, and pull over the vehicle to keep away from the traffic.
6. Replace the leaking tire by carefully observing following instructions.

Caution !

Do not continue to drive the vehicle with a leaking tire, for even the driving by a small distance may result in the unrecoverable damages of the tire and wheel.

Replacement of wheels and installation of spare wheel

Wheel balance

The new tires are balanced, but may get imbalanced for some reasons, which is reflected by the joggling of steering mechanism.

The imbalanced wheels may lead to the steering system, the suspension mechanism and the tires worn excessively. Therefore, it is necessary to rebalance the tires.

In addition, the new or repaired tires need to be rebalanced.

Necessary tools

The necessary tools and spare wheel are accommodated in the trunk. When the user has to change the tire himself in emergency, the user must be familiar with the operation methods and storage positions of jack and various tools.

Warning!

- Only one spare wheel can be used each time, and the maximum speed shall not exceed 80km/h.
- The spare wheel can be used only in an emergency. After the emergency, the normal wheel shall be used.

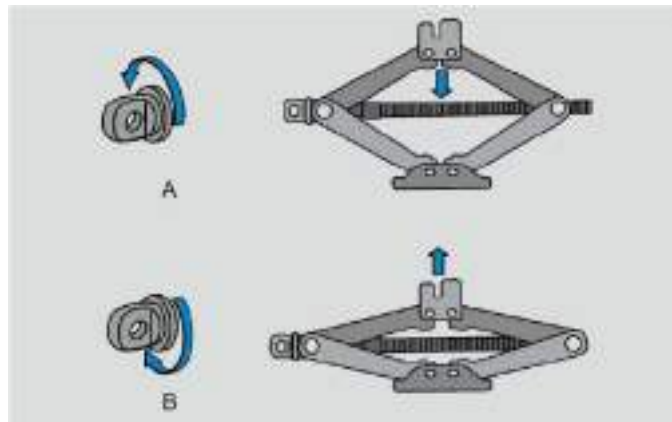

Jack

Take it off: rotate the joint until the jack is loosened.

Storage: rotate the joint until the jack is secured reliably, so as to prevent against being drifted to the front in case of impact or emergency braking.

Replacement of wheels and installation of spare wheel

Warning!

- Abide by the use instructions of the jack.
- When the vehicle is being supported by a jack, no body part is allowed under the car; otherwise this may cause serious injuries.
- When the vehicle is being supported by a jack, never start or run the engine.
- Park the vehicle on a flat and solid ground surface, pull up the parking brake handle, and set the transmission at the reverse gear (manual). If necessary, provide a blocks at the wheel in the diagonal direction of the wheel being replaced.
- Ensure that the jack is located at the correct jacking point. Jacking the vehicle with the jack at an incorrect position may damage the vehicle or cause the vehicle from dropping from the jack, resulting in serious injuries.
- The vehicle can be supported with a jack just for wheel replacement.
- If anybody is in the car, never jack the car.
- When the vehicle is being supported, never place any object on or beneath the jack.
- The vehicle shall be jacked to a height at which the tire can be removed and replaced.

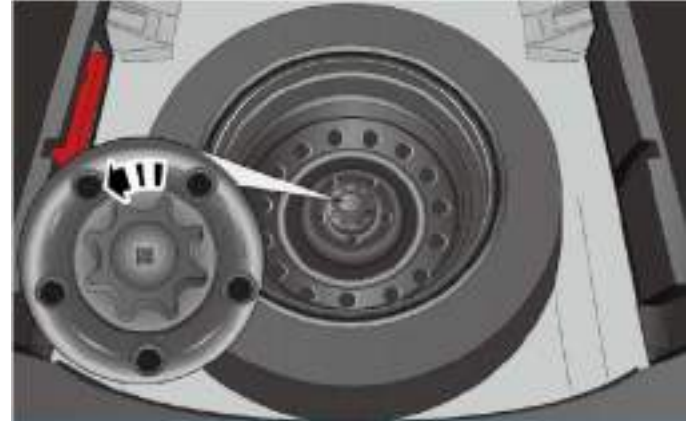

Removal of spare wheel

1. Open the back gate, and uplift the spare tire cover to get out of the tool box.
2. Counterclockwise rotate the compression screw to take down the bolts, getting out of spare tires.
3. The spare tire should be saved back in place and then the screw should be tightened up, so as to prevent against being drifted to the front in case of impact or emergency braking.
4. Put the tool box and the spare tire cover back in place.
5. Close the back gate.

Replacement of wheels and installation of spare wheel



Replacement of leaking tire

1. When the vehicle is being supported with a jack, a block must be provided at the wheel in the diagonal direction of the leaking wheel to prevent the wheels from rolling.



Warning!

- When tires leaks due to the pricking, stop for inspection and replace the tires. Vehicle should be parked away from the main lane, with the hazard warning lamp lighting up and the triangle warning board put in place.
- All the passengers should get off to wait at the safe site.



2. Take off the cover of wheel nuts.

Replacement of wheels and installation of spare wheel



3. Before jacking up the vehicle, it is a must that all the wheel nuts should be loosened counterclockwise by approximately one and half cycles with the special wrench, instead of taking them off.

Warning!

The wrench for removing of wheel nuts should be installed in place, so as to prevent the nuts from being damaged or from personal injuries.



4. Put the jack at the correct supporting position.

Caution !

Ensure that the jack is placed on a flat and firm ground.

Replacement of wheels and installation of spare wheel



5. Assemble with the jack crank, as shown in the above figure. Clockwise rotate the crank to slowly raise up jack. Make sure the jack slot reliably clamps the edge behind the vehicle body. Jack up vehicle to have the tires slightly leave from the ground.
6. Take off all the wheel nuts to remove the flatted tires.

Warning!

The rust or dirt on the wheel or wheel coupler may make the wheel nut become loose after a period. The wheel may fall, resulting in accident.

To replace the wheel, the rust or dirt on the connection between the wheel and the vehicle shall be removed. In emergency, the rust or dirt shall be wiped off with fabric or paper. When necessary, the rust or dirt must be removed with scraper or wire brush later.

Replacement of wheels and installation of spare wheel



- Before installation of spare tire, install the wheel nuts and pre-tighten them with a wheel wrench until the wheel is reliably secured.
- Rotate the jack crank counterclockwise to lower the car.
- Use the wheel wrench to screw down the wheel nuts crosswise as per the sequence indicated by the number shown on the above diagram.
- Lower the jack to the bottom, and take out the jack under the car.

Warning!

Oil or grease must not be used on the bolt or nut; otherwise, the nut may fall, resulting in traffic accident because of falling of wheel.

Inspection after tire replacement

- Check the tire pressure after replacement.
- Adjust the tire pressure to the stipulated value. If the actual pressure is below the stipulated value, drive the vehicle slowly to the service station nearby for air filling, and increase the pressure to the correct value.
- Install the valve cap to prevent the dust and moisture from entering the valve; the entering of dust may cause air leaking, and thus result in accident. The valve cap that is missing shall be refitted as soon as possible.
- All the tools, warning triangle and flat tire shall be arranged properly.

Warning!

- Before driving, make sure that all the tools, warning triangle and flat tire are fastened at the storage position for fear of personal injury in case of emergency braking or collision.
- The spare tire can only be used for a short time, and is unsuitable for expressway.

Replace the fuse



Replacement of fuse in the front compartment electrical box

1. Turn off the starter switch or the ignition switch and electrical appliances, to open the front engine compartment;
2. Take off the trim of front engine compartment by using a cross screwdriver.
3. Press the release button to loosen the fuse box cover and take it down.
4. Use the small end of fuse clamp to hold and pull out the relevant fuse. The melt fuse (whose metal plate is melt) shall be replaced with the fuse with same size (same color and identification).
5. Refit the fuse box cover onto the fuse box till the locking sound is heard.

Caution !

- Finishing the check, put the fuse box cover back on.
- Any electrical component in the vehicle may be damaged by the splashed fluid so the cover of every electrical component shall be refitted well.

Replace the fuse



Warning!

After the inspection of instrument fuse, please put back the cover at left-lower side of instrument panel, so as to avoid the cover from coming off and thus impairing the operations on brake pedal or even causing accidents.

Replacement of instrument fuse

1. Turn off the starter switch or the ignition switch.
2. Take off the cover at left-lower side of instrument panel, to see the electrical box of instrument.
3. Pull out the related fuse with a fuse calipers. The blown fuse (melted metal sheet) should be replaced with a new one with same size (same color and identification)
4. After the replacement of fuse, put back the cover at the left-lower side of instrument panel.

Specifications of fuses in front engine compartment



Specifications of fuses in front engine compartment

No.	Name	Rated value
FB01	Left high beam	10A
FB02	Right high beam	10A
FB03	Left low beam	10A
FB04	Right low beam	10A
FB05	Main relay/ ECU module	5A
FB06	Oil pump	15A
FB07	Compressor	10A
FB08	Brake lamp switch	10A
FB09	—	
FB10	ABS/ESC module	20A
FB11	Front fog lamp	15A
FB12	Daytime travel lamp	7.5A
FB13	Trunk locker	10A
FB14	ESC module	5A
FB15	—	
FB16	TCU module (UPS)	5A
FB17	—	—
FB18	—	—
FB19	Generator excitation	5A
FB20	ECU module /TCU module	5A
FB21	ABS/ESC module	5A

No.	Name	Rated value
FB22	Electric power steering module /A/C high/low-voltage switch	5A
FB23	Oil pump relay / compressor relay/ high-speed fan relay / low-speed fan relay / electronic vacuum pump relay	5A
FB24	Ignition coil	15A
FB25	Injector	15A
FB26	Variable cam timing solenoid valve / carbon tank solenoid valve	10A
FB27	Oxygen sensor	10A
FB28	N-gear switch	5A
FB29	PEPS startup feedback	5A
FB30	R-lamp switch / R- gear relay	10A
FB31	Power-saving fuse	30A
MF01	Instrument	60A
MF02	Electric power steering module	60A
MF03	Alternator	125A
SB01	Radiator fan	40A
SB02	Starter motor	30A
SB03	ABS/ESC module	40A
SB04	—	—

Specifications of fuses in front engine compartment

No.	Name	Rated value
SB05	Ignition switch	30A
SB06	EPB left-side motor	30A
SB07	EPB right-side motor	30A
SB08	—	—
SB09	Electric vacuum pump	20A
SB10	—	—
RLY1	—	—
RLY2	High-beam relay	—
RLY3	—	—
RLY4	Compressor relay	—
RLY5	—	—
RLY6	Low beam relay	—
RLY7	Fuel pump relay	—
RLY8	Low-speed fan relay	—
RLY9	Starter motor relay	—
RLY10	Electronic vacuum pump relay	—
RLY11	—	—
RLY12	High-speed fan relay	—
RLY13	Trunk locker relay	—
RLY14	TCU brake signal relay	—
RLY15	R-gear relay	—

No.	Name	Rated value
RLY16	Daytime running lamp relay	—
RLY17	—	—
RLY18	—	—
RLY19	Front fog lamp relay	—
RLY20	ECU main relay	—
RLY20	Main relay	—

Instrument panel fuse specifications

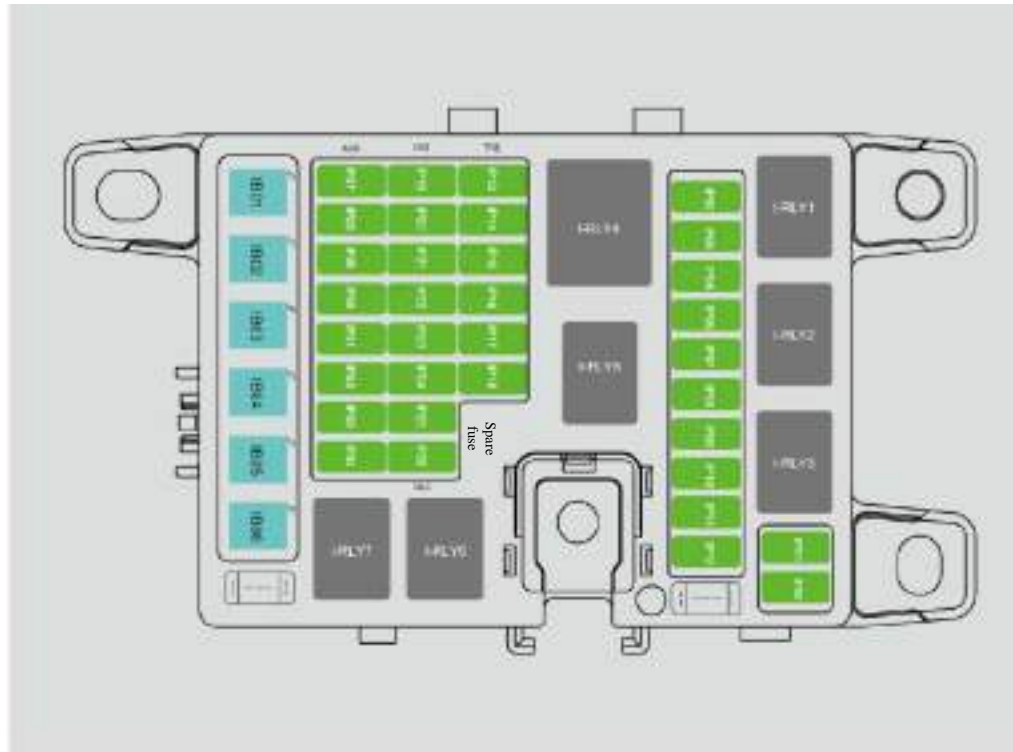

Instrument panel fuse specifications

No.	Name	Rated value
IP01	—	—
IP02	—	—
IP03	Horn / front wiper	30A
IP04	Steering column lock	7.5A
IP05	Steering lamp / fog lamp / small lamp	30A
IP06	Battery electricity – saving	15A
IP07	EPB memory power supply	10A
IP08	Rear defroster	25A
IP09	Keyless entry module	10A
IP10	ESCL/IMMO anti-theft coil / diagnostic port / gear-shifting mechanism / unplugged key switch	10A
IP11	Rear wiper	15A
IP12	Rearview mirror un-folder relay / rearview mirror folding relay	10A
IP13	Audio	15A
IP14	Combination instrument	5A
IP15	A/C control module / wireless cell-phone charger module / interior PM 2.5 sensor	10A
IP16	T-BOX module	5A
IP17	Seat heating	10A
IP18	Traveling data recorder	5A

No.	Name	Rated value
IP19	BCM/ keyless entry module	5A
IP20	Electrical box IG in front engine compartment	15A
IP21	Electronic parking module / cornering sensor /ESC switch	7.5A
IP22	Skylight / rain sensor	5A
IP23	Instrument	5A
IP24	A/C control module / Reversing radar module / 360 around view / negative ion generator	5A
IP25	Safety bag control module	7.5A
IP26	—	—
IP27	Cigar lighter / spare power supply in the front row	20A
IP28	Spare power supply in the back / spare power supply for trunk	5A
IP29	Audio /T-BOX module / A/C control module	5A
IP30	Blower relay coil / rear defroster relay coil / power rearview mirror adjuster switch / traveling data recorder / cell-phone wireless charger module / anti-dazzling internal rearview mirror	7.5A

Instrument panel fuse specifications

No.	Name	Rated value
IP31	BCM/ keyless entry module	5A
IP32	—	—
IP33	—	—
IP34	Rearview mirror heating	7.5A
IB01	Fan	25A
IB02	Right window / door lock motor	30A
IB03	Left window / front and rear washers	20A
IB04	Sunroof	20A
IB05	Seat adjuster	30A
IB06	—	—
I-RLY1	Rear wiper relay	—
I-RLY2	Rearview mirror unfolding relay	—
I-RLY3	Rearview mirror folding relay	—
I-RLY4	Fan relay	—
I-RLY5	Rear defroster relay	—
I-RLY6	ON relay	—
I-RLY7	ACC relay	—



Description!

The pictures are not suitable to all the models of vehicles. Fuses vary with different models of vehicles. For example, some electrical appliance is equipped with multiple fuses, and multiple electrical appliances share one fuse.



Warning!

Improper or repaired fuse may lead to fire.

Towing of vehicle

General description

If the vehicle cannot continue running due to the following fault and needs towing, it is suggested to entrust the authorized service station or the professional rescue company for solution. Only when no authorized service station or professional rescue company can be found, the vehicle can be towed by the user in accordance with the section “Towing” in the Manual. To tow the car, the suitable towing equipment shall be used to prevent the vehicle from damage. The wrong towing method may damage the car. In order to avoid vehicle damage, the following notices shall be followed. When necessary, the trailer driver shall read this page.

- The vehicle cannot start.
- The engine operates normally, but the vehicle cannot move.
- The steering system fails.
- The vehicle has abnormal noise.
- The vehicle is damaged seriously.

Caution !

Any towing work shall abide by the national/ provisional and local regulations. The wheels and shafts in contact with ground must maintain a good condition. In case of damage, the traction trolley shall be used.

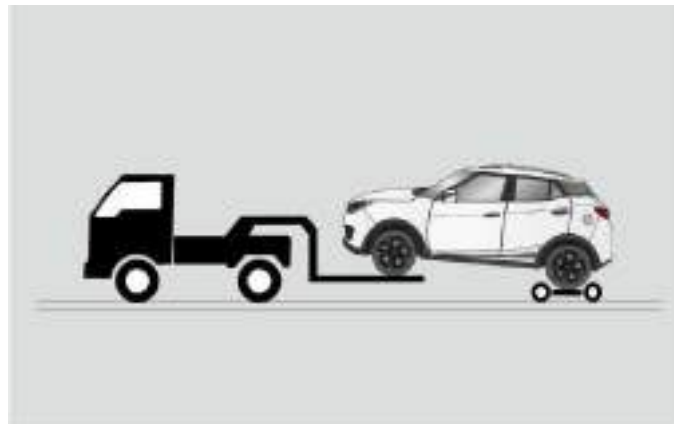

Towing method

Use of wheel lifting trailer

When the wheel lifting trailer is used to tow the front part of the car, it is suggested to use the traction trolley under the rear wheels. If the traction trolley is not used, the parking brake shall be released.

Towing of vehicle

⚠ Caution !

- For the vehicle equipped with electronic parking brake (EPB), the towing trolley should be used, which otherwise may damage to the brake and the tires.
- While uplifting the front part of vehicle, pay attention to the proper clearance from the rear part of vehicle to the ground, which otherwise may damage to the rear bumper cover or the vehicle body baseplate.



To tow the vehicle from the back with the wheels uplifted, it is suggested to use the towing trolley beneath the front wheels. When the towing trolley is not available, it is needed to turn the starter switch or the ignition switch to “ON” gear, and then shift the gear lever to neutral.

⚠ Caution !

To lift the car, it is necessary to ensure that there is a sufficient ground clearance at the ground touching end of the car; otherwise, the vehicle may be damaged in the course of towing.

Towing of vehicle



Use of flat-bed truck

This towing is suitable for the failed vehicles or the one with all configurations, and therefore is suggested to use.

Warning!

- After the vehicle is towed to the platform-type trailer, the vehicle must be firmly fastened on the trailer.
- With the starter switch or the ignition switch at “OFF”, please tow the vehicle from the back; otherwise, the steering locker cannot keep the front wheels straightforward, leading to the towing out of control.
- In the course of towing, it is necessary to start the vehicle at a low speed, operate the shift lever stably, run the vehicle slowly, turn around properly and avoid emergency braking.
- It is needed to turn on the hazard warning lamps of both towing and towed vehicles

Towing of vehicle

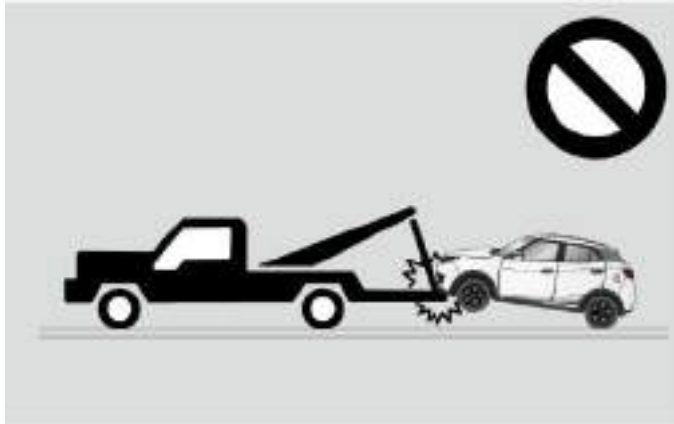

It is prohibited to use the hoist-type truck.

Do not use the hoist-type truck for towing from the front or the back, which otherwise may damage to vehicle body.



Mounting of front towing hook

- Take the towing hook and the wrench of wheel nuts out of the on-board tool box in trunk.
- Use a slotted screwdriver with its front end wrapped with cloth to take down the front towing hole cover from the front bumper.

Towing of vehicle

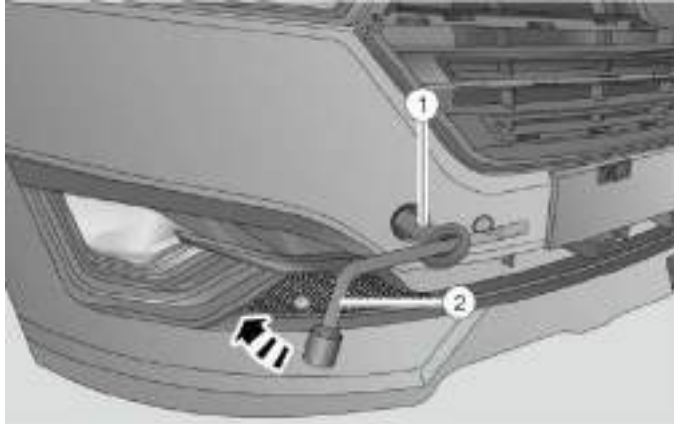

- Clockwise screw the towing hook ① into the thread hole.
- Insert the wrench ② of wheel nuts into the round hole of towing hook, clockwise rotate the wrench of wheel bolts to screw the hook into the thread hole.

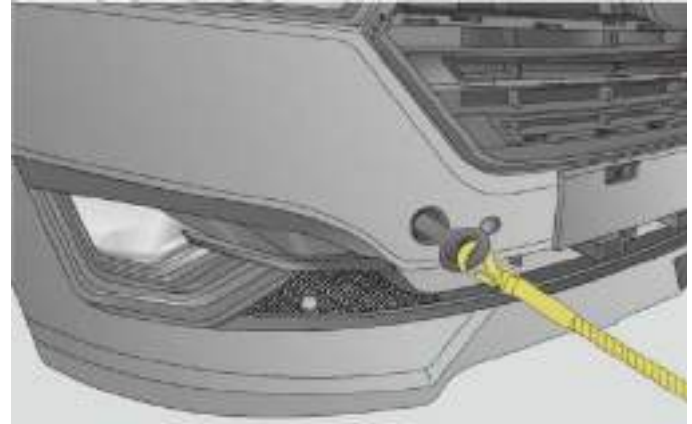

Emergent towing

When the uplift-type or platform-type towing vehicle cannot be available in emergency, it is possible to tie the towing rope into the towing ring in the front or at the back, for makeshift towing. This is merely suitable for low-speed and short-distance towing.

Warning!

Since the emergent towing is relatively dangerous, the inexperienced driver does not attempt to tow other vehicles, so as to avoid any risk of accident.

Towing of vehicle



Mounting of rear towing hook

- Use a slotted screwdriver with its front end wrapped with cloth to pry off the towing ring cover from the rear bumper.



- Insert the towing ring into the towing hole, and clockwise rotate it, tightening it.
- Tighten the towing ring by using the wrench of wheel nuts.

Towing of vehicle



Rear towing ring



Warning!

Only when the wheels, the drive system, the axles, the steering wheel and the brake are at good conditions, can the emergent towing type be used to tow the vehicle.

Precautions for use of towing ring

- Before the towing, pay attention to whether if the towing ring is damaged or broken.
- No towing from side or vertically, so as to protect the towing ring. In addition, the straight-line towing should be kept always
- Do not forcefully drag the towing ring, but exert the steady and evenly force on it.
- Turn on the hazard warning lamps from both the towing and the towed vehicles, and observe the local traffic regulations.
- As for the towed vehicle, the gear lever has to be shifted to “N”.
- As for the towed vehicle, it is needed to turn the starter switch to “ON”, and repeatedly rotate the steering wheel to make sure the steering wheel is not locked out.
- It is a must to travel steadily, neither sudden acceleration/deceleration nor sharp turning.
- Remember that the towed vehicle’s brake assist and the steering assist cannot work, and therefore braking should be earlier than the normal.
- The towing rope should be kept tensioned.

Vehicle overheating

Vehicle overheating refers to the engine coolant temperature is too high. When the coolant temperature warning indicator  lights up on the combine instrument, it means the engine is overheated, and follow the following steps for troubleshooting:

1. Park the vehicle at safe site away from the road and turn on the hazard warning indicators. Furthermore, shift the gear lever of transmission to the neutral, tension up the electronic parking switch and shut down engine.
2. If the coolant or its vapor sprays out of the radiator or surge tank, engine may be shut down, and do not open the hood until the little vapor comes out. If there is no coolant or vapor coming out, keep the engine running and make sure the cooling fan is working. When the cooling fan does not work, shut down engine.
3. Visually check if the engine drive belt (coolant pump belt) is broken or loosened, and if there is coolant obviously leaking out of radiator, hose and bottom of vehicle. It is normal that the water drops from the activated A/C.
4. When the engine drive belt is broken or the coolant is leaking, please immediately shut down engine and contact the authorized service station.
5. When the engine drive belt has no problem and there is no obvious leakage of coolant, check if the surge tank is empty, and if so, with engine running, and add the proper coolant into the surge tank.

6. When engine coolant cools down to the normal temperature, check the coolant level in surge tank again. If there is considerable coolant going away, it means system leaks, and then please contact the authorized service station for inspection.



Warning!

- In order to protect against the personal injury, keep the engine hood closed until no vapor comes out, as vapor or coolant flowing out means system pressure is very high.
- With engine and radiator hot, do not take off the pressure cap, for the out-sprayed hot vapor and fluid may lead to personal injury.
- With engine running, keep your hands and clothes away from the running fan and the engine drive belts.

Jumper type startup

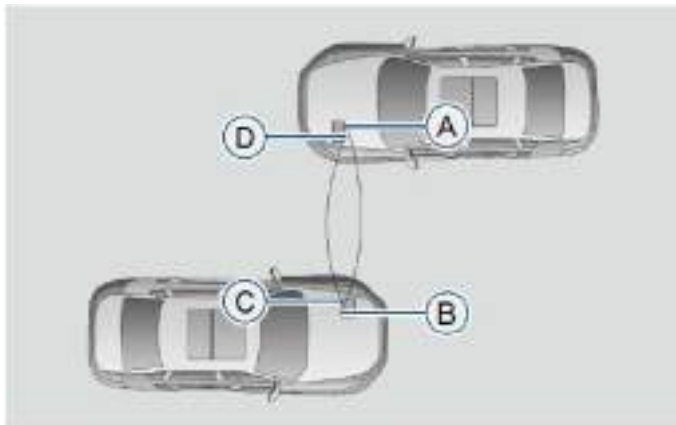

When the battery is dead or cannot start vehicle, it is possible to connect a cable from another vehicle to your vehicle for startup. It is a must to follow the steps shown below to make sure the safe operations.

1. Turn the starter switch or the ignition switch to "OFF", and turn off all the lamps and electrical appliances from both vehicles, except for the hazard warning indicators (if needed).
2. Connect the cable with red positive pole to the positive (+) pole (A) of vehicle to be started.
3. Do not have the other end of cable with red positive pole (+) contact any metal, but connect it to positive pole (+) of live battery (B).
4. Connect the black negative pole (-) of cable to the negative pole (-) of live battery (C). Remember that, the other end of this cable cannot touch anything before the next step. In addition, do not connect the other end of negative-pole (-) cable to the dead battery, but to unpainted metal part of engine of vehicle to be started up.
5. Connect the other end of cable with black negative pole (-) to the unpainted metal part (D) of engine with dead battery, away from the engine running parts and battery.
6. Start the engine of another vehicle. Then slightly raise the engine rpm and hold it for 5min, so as to charge your vehicle.
7. While keeping another engine running, start your vehicle.
8. After startup of engine, remove the jumper cable in the reverse order and go to the authorized service station for inspection.



Description!

Please go to the authorized service station for help, when the battery in the engine compartment is blocked with other parts and thus enable to directly do the jumper startup due to difficult removal and re-installation.

VIN

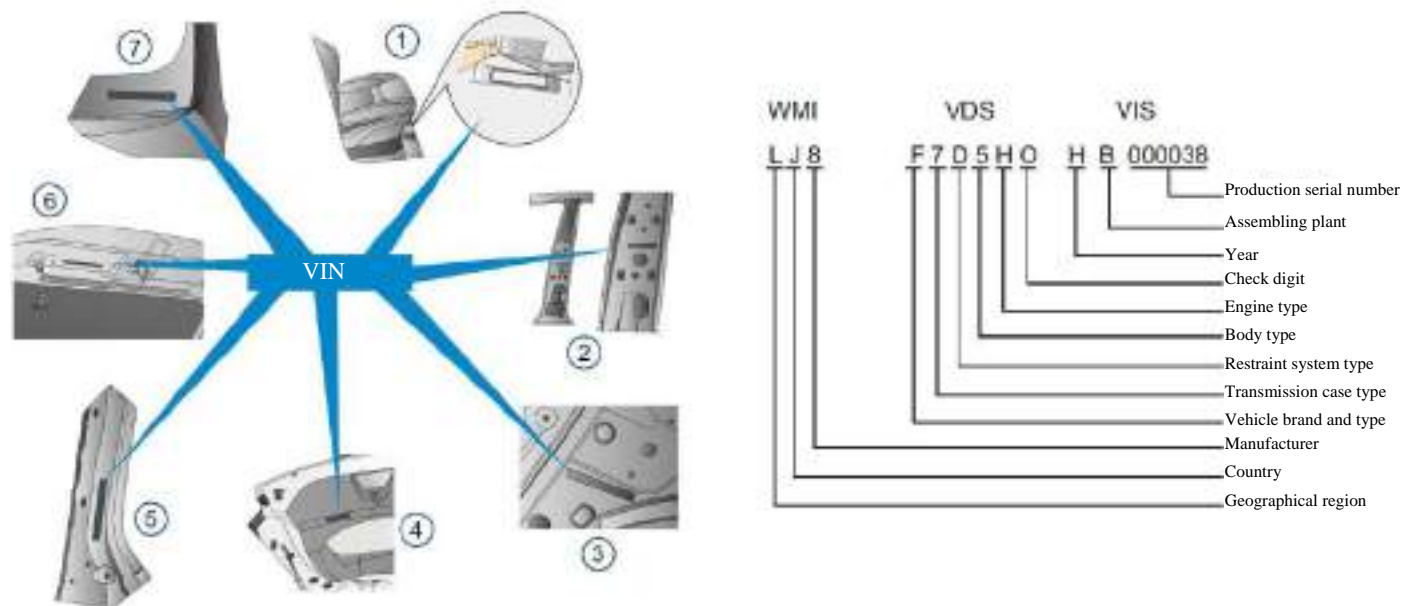

The vehicle identification number (VIN) is the legal identification mark of the car.

VIN positions (as shown in the above figure): 1. Front floor beam; 2. Inner plate of B pillar (right); 3. Inner plate of C pillar (right); 4. Left-lower part of tail gate cover; 5. Inner plate of pillar A (right); 6. Inner plate of front engine compartment 7. Front windshield.

Engine No.

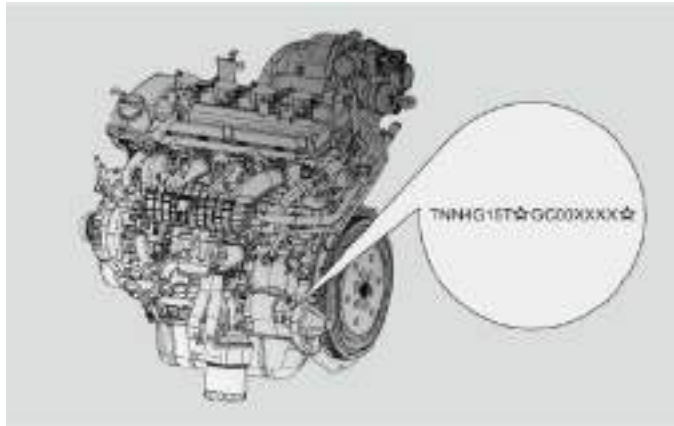

* TNN4G15T Engine No.

TNN4G15T Engine No. is inscribed onto the engine block.

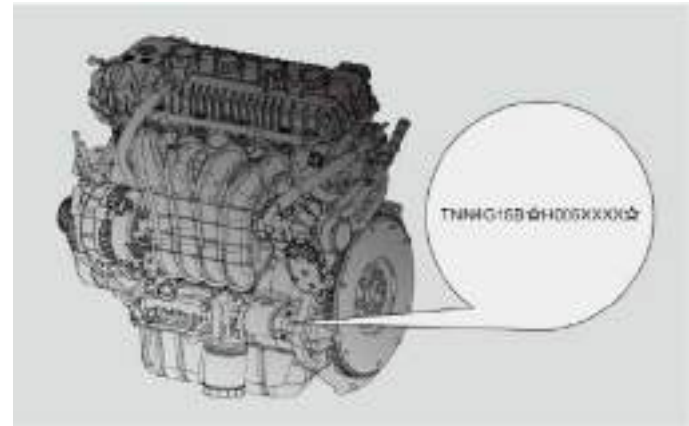

* TNN4G15B Engine No.

TNN4G15B Engine No. is inscribed onto the engine block.

Manufacturer's nameplate



The vehicle nameplate is located under the right pillar A, and contains the following information:

- Name of company
- VIN
- Brand
- Vehicle model
- Engine model
- Max. net power of engine
- Engine capacity
- Persons
- Max. permissible gross mass
- Date of production

Vehicle dimensions

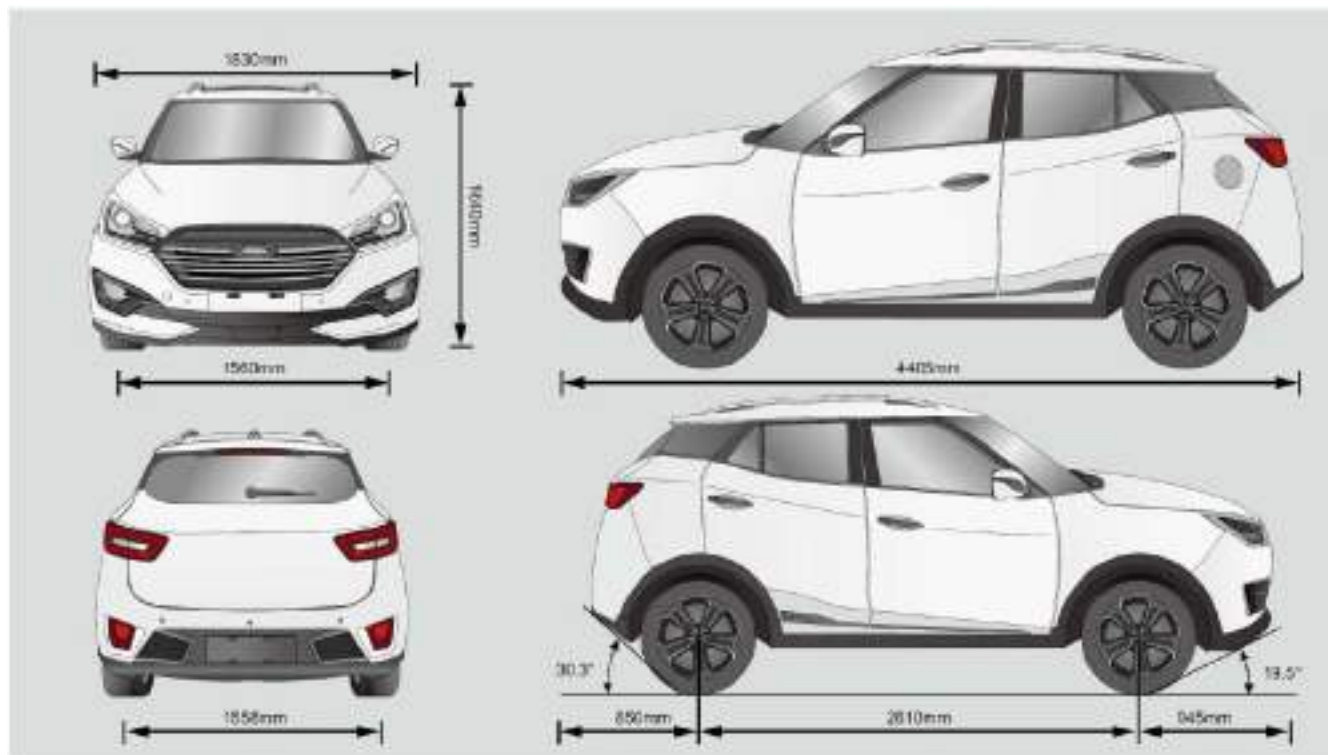

Vehicle dimensions

Item \ Model	JNJ7155	JNJ7155T	JNJ7155QT	JNJ7155Q
Length (mm)	4405			
Width (mm)	1830			
Height (mm)	1640			
Wheelbase (mm)	2610			
Front wheel track (mm)	1565(205/65 R16),1560(215/55 R17)		1560	
Rear wheel track (mm)	1563(205/65 R16),1558(215/55 R17)		1558	
Front suspension (mm)	945			
Rear suspension (mm)	850			

Total weight and other design parameters

Item		Model	JNJ7155	JNJ7155T	JNJ7155QT	JNJ7155Q
Maximum gross mass (kg)			1720	1745	1795	1770
Curb mass (kg)			1345	1370	1420	1395
Axle load (kg)	Front axle load		893	925	962	940
	Rear axle load		827	820	833	830
Rated number of passengers (people)			5			
Maximum gradeability %			42	35	42	42
Minimum turning diameter (m)			10.3			
Minimum ground clearance (mm)			180 (curb) /161 (full loaded)			
Approach angle (°)			19.5 (curb) /18.9 (full loaded)			
Departure angle (°)			30.3 (curb) /23.7 (full loaded)			
Capacity of fuel tank (L)			48±2			
Comprehensive fuel consumption (L/100km)			6.7	6.7	7.2	7.1



Description!

Meaning of vehicle model code in parameter sheet of technical performance: JNJ7155 (1.5L 5MT)/JNJ7155Q (1.5L CVT)/JNJ7155QT(1.5T CVT)/JNJ7155T(1.5T5MT).

Engine parameters

Item \ Model	JNJ7155	JNJ7155T	JNJ7155QT	JNJ7155Q
Engine model	TNN4G15B		TNN4G15T	
Transmission model	LD516A	VT2i	VT3	LD525
Engine type	Four strokes, four cylinders, water cooling, in line, DOHC, i-vvt		Four strokes, four cylinders, water cooling, in line, DOHC, turbocharger gasoline.	
Displacement (ml)	1499			
Idling Speed (rpm)	700±50	750±50		
Rated power / rpm (kW//rpm)	82/6000		106/5600	115/5600
Max. torque / rpm (N.m/rpm)	143/4000		215/2500-4500	215/2000-4000
Max. net power / rpm (kW//rpm)	77/6000		102/5600	
Intake mode	Naturally aspirated		Turbocharged and inter-cooled	
Bore × travel (mm)	75×84.8		75×84.8	
Compression ratio	10.5: 1		9.3: 1	
Valve mechanism	DOHC, i-vvt		DOHC	

Engine parameters

Item \ Model	JNJ7155	JNJ7155T	JNJ7155QT	JNJ7155Q
Lubricating system	Pressure and Splash Composite Type			
Oil pump type	Rotor type			
Cooling mode	Water Cooling			
Coolant	Glycol			
Emission standard	China Stage V			
Fuel grade	No. 92 or more lead-less high-cleanliness gasoline			

Parameters of transmission and chassis

Model		JNJ7155	JNJ7155T	JNJ7155QT	JNJ7155Q
Item					
Drive method		Front engine and front wheel drive			
Type of transmission		5MT	CVT	CVT	5MT
Type of steering gear		Power steering			
Shock absorber (front/rear)		Telescopic			
Type of service brake		Ventilated disc (front wheel) and solid disc (rear wheel)			
Body	Structural form	Load-bearing type			
	Number of doors	5			
	Trunk volume (L)	400			
Maximum speed (km / h)		170	165	180	
Number of wheels and number of driving wheels		4×2			
Type of parking brake		Mechanical parking / electronic parking, mechanical integrated calipers (rear wheels)		Electronic parking, mechanical integrated calipers (rear wheels)	
Suspension	Type of front suspension	Macpherson independent suspension with stabilizer bar			
	Type of rear suspension	Torsional beam type semi-independent suspension.			
Brake pedal travel	Travel	130			
	Free travel	5.6			

Parameters of transmission and chassis

Item		Model	JNJ7155	JNJ7155T	JNJ7155QT	JNJ7155Q
Rotational angle	Max. rotational angle of inside wheels		39.69°			
	Max. rotational angle of outside wheels		33.97°			
Brake lining	Abrasion limit of front wheel brake lining (excluding the back plate of friction lining)		Thickness of friction lining (excluding the back plate): 10mm; wear limit: 2mm			
	Abrasion limit of rear wheel brake lining (excluding the back plate of friction lining)		Thickness of friction lining (excluding the back plate): 9mm; wear limit: 2mm			

Wheel alignment data

Item		Model	JNJ7155	JNJ7155T	JNJ7155QT	JNJ7155Q
		Tire size and pressure (zero load) (kPa)		205/65 R16、 215/55 R17(zero load: 230KPa/220KPa, full loaded: 250kPa)		
Air pressure of spare tire (no loaded) (kPa)		Full dimension: 240KPa and non-full dimension: 420KPa				
Wheel alignment data	Front wheel	Front wheel toe-in (°)	6 ' ±6 '			
		Front wheel camber angle (°)	- 4 ' ±45 '			
		Kingpin caster angle (°)	5° 36 ' ±45 '			
		Kingpin inclination angle (°)	11° 43 ' ±1°			
	Rear wheel	Rear wheel toe-in (°)	6 ' ±15 '			
		Rear wheel camber angle(°)	- 1° 23 ' ±45 '			
Wheel dynamic balance	Front wheel	Negative camber (residual dynamic unbalance)	≤ 5g			
		Camber (residual dynamic unbalance)	≤ 5g			
	Rear wheel	Negative camber (residual dynamic unbalance)	≤ 5g			
		Camber (residual dynamic unbalance)	≤ 5g			

Recommended oil and capacity

Model		JNJ7155	JNJ7155T	JNJ7155QT	JNJ7155Q
Engine oil	Model	Meets the SG or higher lubricant according to API	Meets the SJ or higher lubricant according to API	CNPC "Kunlun" ACEA A1/B1 5W-30	
	Capacity (L)	3.5±0.5	4	3.5±0.5	
Transmission oil	Model	75W-90(GL-4)	CVTF-EX1	CVTF-EX1	75W-90(GL-4)
	Capacity (L)	1.8-2.0	4.1±0.05	4.1±0.05	1.8-2.0
Engine coolant	Model	Sinopec Great Wall FD-2			
	Capacity (L)	6.5±0.3			
Brake fluid	Model	DOT-4			
	Capacity (L)	0.84			
Refrigerant oil	Model	PAG56			
	Capacity (g)	120			
A/C refrigerant	Model	R134a			
	Capacity (g)	520			

Bulb specifications

Lamp		Model	Power (W)
Front combination lamp (halogen)	High/low beam	HB3	60
	Steering lamp	LED	1
	Position lamp	LED	0.5
Front combination lamp (halogen with daylight traveling lamp)	High/low beam	HB3	60
	Steering lamp	LED	1
	Position /daytime traveling lamp	LED	0.5
Front combination lamp (LED)	Low beam	LED	15
	High beam	LED	9
	Steering lamp	LED	1
	Position /daytime traveling lamp	LED	0.5
Rear combination lamp (secured part)	Brake lamp	LED	0.2
	Position lamp	LED	0.2
	Steering lamp	PY21W	21
Rear combination lamp (movable part)	Brake lamp	LED	0.2
	Position lamp	LED	0.2
	Reversing lamp	W16W	16

Bulb specifications

Lamp		Model	Power (W)
Front fog lamp		H7	55
Rear fog lamp		P21W	21
High-position brake lamp		LED	0.2
License light		W5W	5
Front roof lamp		LED	0.2
Rear roof lamp		LED	0.2
Trunk lamp		W3W	3
Mood lamp	Mood lamp on door (four doors)	LED	0.2
	Mood lamp on console		0.2
LOGO projection lamp		LED	1

Index

Roman capitals

A

A/C system	146
ABS+EBD	179
Adjust rod	61
Air bag system	33
Around View Monitor (AVM)	195
Air bag	33
Attachments and refitting.....	214
Attachments and refitting.....	214

B

Battery	235
Blind spot assist (BSA).....	191
Brake fluid	232
Brake override system	185
Braking assist.....	184
Bulb specifications	283
Button operation	71

C

Causes that trigger the air bag.....	36
Central control door lock system	99
Child notice	42
Child safety lock	100
Child safety protection.....	42
Classification of child restraint system (for reference)	43
Cleaning and maintenance of car	208

CO	156
Combination instrument	50
Combine switch of wiper.....	123
Common combined instrument.....	56
Common instruments setting	83
Conditions that front frontal air bag extends:	37
Conditions that side air bag and side air curtain may extend.....	41
Control panel	146
Coolant	230
Correct installation of child restraint system	47
Correct sitting posture of driver and passenger.....	21
Correct wearing of safety belt.....	29
Cruise.....	176

D

Dangerous exhaust gas	156
Delayed off of headlamp (home lighting)	116
Door-open warning	72
Driver information system	71
Driving information LCD	60
Driving information	75
Driving instructions	160
Driving operation.....	168

E

Electronic parking brake (EPB).....	172
Electronic Speed Controller ESC.....	181
Engine coolant temperature gauge.....	55

Index

Engine coolant temperature gauge.....	58
Engine immobilizer system	97
Engine No.....	272
Engine oil.....	227
Engine parameters	277
Exterior lights	117
Exterior maintenance of car	209
Exterior rearview mirror	126
F	
Fire prevention.....	207
Front engine hood.....	224
Front frontal air bag.....	34
Front seat	134
Fuel gauge	51
Fuel gauge	59
Fuel.....	222
G	
Gearshift	164
General description.....	19
General description.....	208
General view of driver's cab.....	14
General view of vehicle back.....	12
General view of vehicle front	10

H

Handling of accidents	238
Hazard warning lamp.....	68
Hazard warning light	116
Head restraint.....	132
Hill descent control system.....	184
Hill-start assist control system	186

I

Ignition switch	160
Improvement of economy/reduction of environmental pollution.....	178
Indicator lamp.....	66
Indicators of common instruments.....	64
Indicators of LCD instruments	62
Inspection and filling of oil and liquids	222
Inspection of wheels	240
Instructions on maintenance	215
Instrument panel fuse specifications	259
Intellectual technology.....	179
Interior lights	119
Internal maintenance of car.....	212
Internal maintenance of car.....	213
Internal rearview mirror.....	129
Internet of Vehicles	159
Introduction to multimedia control panel.....	157

Index

Introduction	71
J	
Jumper type startup	270
L	
Lane departure warning (LDW).....	190
Launch assist	185
LCD instruments.....	50
LCD of instrument.....	52
Level 1 menu	73
Lighting combination switch	112
Lighting	112
Lock and unlock	87
Luggage rack	145
M	
Maintenance schedule (ordinary conditions or bad conditions).....	217
Manual adjustment of headlamp height.....	115
Manufacturer's nameplate	273
Mechanical key.....	94
Mechanical parking brake.....	171
Multi-functional steering wheel.....	174
Multimedia system	157
N	
Navigation	74
Notices for running in the run-in period	203
O	
Onboard tools	238
Overview of car	10
Overview of front engine compartment	226
P	
Parameters of transmission and chassis	279
Parking assist control system.....	186
Pedal area.....	23
Power all-view sunroof.....	107
Power glass.....	104
Pre-tightening seat belt	28
R	
Rear seat	136
Rearview mirror.....	126
Recommended oil and capacity	282
Remote control key.....	87
Replace the bulb	239
Replace the fuse.....	254
Replacement of front windshield wiper blade	234
Replacement of wheels and installation of spare wheel.....	244
Run-in period.....	203
S	
Safe driving under various road and weather conditions	205
Safe driving	19

Index

Safety inspection and precautions before driving	204	Towing of vehicle	262
Safety label	49	Traction control system (TCS).....	183
Safety label	49	Traveling data recorder	202
Safety precautions.....	208	Traveling environment.....	203
Seat belt	25	Trunk	143
Seat	132	U	
Setting.....	78	Use mechanical key to lock and unlock doors	95
Side air bag	35	Use notices of child safety seat	43
Side air curtain.....	35	Use skills of A/C system.....	155
Specifications of fuses in front engine compartment	256	V	
Speedometer	57	Vehicle body immobilizer system.....	97
Starter switch	161	Vehicle dimensions	274
Starting and shutdown of engine.....	163	Vehicle maintenance	215
Storage.....	137	Vehicle overheating	269
Storage.....	137	VIN	271
Sun visor.....	131	Visual reversing image & tracking function	189
Sun visor.....	131	W	
T		Warning light of air bag failure.....	41
Tachometer	58	Warning light of unfastened belt.....	27
Tail gate	101	Warning triangle	238
Technical Data	271	Washing liquid.....	233
The front frontal air bag may not extend in following conditions: ...	38	Wheel alignment data	281
Theme setting	73	Why you must wear the safety belt.....	25
Three-point seat belt	28	Wind direction and airflow regulation of vent	152
Tire pressure	74	Wiper	123
Total weight and other design parameters.....	276	Wireless charging of mobile phone.....	199