

# 发动机

GREATWALL ENGINE PARTS CATALOGUE

# 零部件手册



**ENGINE 491QE**

长城·发动机



## 前 言

《发动机零部件手册》是供广大用户了解长城系列发动机各种零部件的装配关系和整机结构，并为用户选购零部件提供指导。

本手册根据保定长城内燃机制造有限公司提供的技术资料编制而成。

使用本图册时，请注意以下几点：

(1) 用户选购长城系列发动机部件时，请说明发动机机型，对照本图册查找零件名称和对应的零件编码，以避免与其它零件混淆。

(2) 本图册以 491QE 发动机为基础编绘。

虽然我们尽力认真编绘本图册，但不能保证图册中所有内容完全正确无误。我们必须保留供货范围、装备和技术方面的修改权。因此，用户不得以本图册中的零件明细表和图解为根据提出任何要求。对于使用本图册而造成的损失，我们皆不负直接和间接责任。

未经长城汽车股份有限公司同意，不得将本图册翻版、出版。

长城汽车股份有限公司明确保留法律规定的有关版权的一切权力，保留更改权和解释权。

长城汽车股份有限公司

二〇〇三年三月

## Foreword

“Engine Parts Catalogue” is to provide the users with information on the parts assembly and complete engine structure, and guide them to specify and order parts accordingly.

This Parts Catalogue is compiled on the basis of the technical documents supplied by Dingxing Interior Combustion Engine Plant.

The following points should be noted when using this manual:

1. When you are going to purchase engine parts, please kindly specify the engine type, parts name and parts number so as not to make any confusion or ambiguity.
2. This Parts Catalogue is fulfilled on the basis of the engine 491QE.

We've made our best to compile the Parts Catalogue. However, it may happen that some items in this Catalogue are not completely satisfactory. In the case, we reserve the right to make any modification on parts supplying and relevant technology without prior notice, and no claim shall be made according to the Parts List and the Parts Illustrations in this Parts Catalogue. We are not responsible for any direct or

indirect loss arising from the application of this Parts Catalogue.

All rights reserved. Without the permission or consent of Great Wall Automobile Holding Company Limited the book can not be reproduced or copied, in whole or in part. The rights of interpretation and modification on the book are reserved.

Great Wall Automobile Holding Company Limited

March , 2003

## 使用方法

《发动机零部件手册》供广大用户了解长城系列发动机零部件结构、装配关系及供选购配件时查阅参考。

用户在使用时，请按照以下说明对所选用的零部件所适用车型进行查找。

1、本图册在编制时，由于车型较多配置了不同型号发动机，基于车型配置特点采用了特征编码。其编码的对应关系如下表所示。用户在使用时，请按发动机型号选择正确的零部件。

本图册包括迪尔系列汽车各车型，其简明技术特点和在本图册中编码如下：

车型简明分类特点

表1

车型	系列	系列	发动机	备注
CC10C5PR	SP	H	491E	491QE
CC10D4R	A	H	491E	491QE
CC10D5SR	1S	1S	491E	491QE
CC10D6R	I	1S	491E	491QE
CC10D9R	D	1S	491E	491QE
CC10D9TR	C	1b	491E	491QE
CC10Q15V	15V	11V	491E	491QE, 1W11
CC10Q16V	16V	12V	491E	491QE, 1W11

车型说明分类特点

表 2

车型	前轴	后轴	轴数/轴距	驱动
CC100LSY	LSY	LY	2/2.4	4WD
CC100LSD	SD	LY	2/2.4	4WD
CC100LSDY	SDY	LYY	2/2.4	4WD, 4WD + 4WD
CC100AD	AD	LD	2/2.4	4WD
CC100ADY	ADY	LDY	2/2.4	4WD, 4WD + 4WD
CC100LSD	LSD	LD	4/2.4	4WD
CC100LSDY	LSDY	LDY	4/2.4	4WD, 4WD + 4WD
CC100SC	SC	LC	2/2.4	4B
CC100AC	AC	LC	2/2.4	4B
CC100LSC	LSC	LC	4/2.4	4B
CC100LC	LC	LC	2/2	4B
CC100DC	DC	LC	2/2.4	4B
CC100CC	CC	LC	2/2.4	4B
CC100A	A	LD	2/2.4	4B, Q
CC100B	B	LD	2/2.4	4B, Q
CC100E	E	LD	2/2	4B, Q
CC100D	D	LD	2/2.4	4B, Q
CC100K	K	LD	2/2.4	4B, Q



本图册中各车型相应编码说明：编码共有四位，前两位表示车型类别代码；后两位表示特征代码。在车型类别代码中，第一位用1表示迪尔轻型客货系列，后一位在现有车型驾驶室与货箱形式加以区分，无形式区分的用“0”表示。用“1”表示小双排系列；用“2”表示大双排系列；用“3”表示中双排系列；用“4”表示一排半系列；用“5”表示小单排系列；用“6”表示大单排系列。在特征代码中用字母C表示柴油发动机（4JB1）系列；用字母H表示化油器型发动机（491Q）系列。

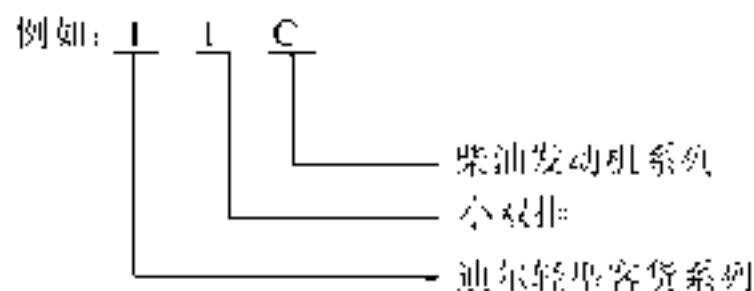

用户可根据目录查找零件总成图解和零件明细表，可参照零件明细表查出与其相应的部件图解（零件的形状和安装位置）、零件编码和所属用量。

## How to use the Parts Catalogue

“Engine Parts Catalogue” aims to help the users learn information on the engine parts, assembly, and find the engine parts ordered.

When using this Parts Catalogue please find the applicable vehicle model in relation to the parts according to the following instruction:

1. While compiling we've used special vehicle codes (V-code). When the users use this Parts Catalogue, please find the correct parts according to the applicable engine type.

This Parts Catalogue includes various types of Great Wall Deer Pickups, and the corresponding special vehicle codes show as follows:

Vehicle Model Classification Chart

Vehicle Model	Code	Number Code	Cabin Model	Supplement
CC1021SER	SF	11	Regular Double Cabin	42 Qb
CC1020AR	A	12	Extra-long Double Cabin	42 Qb
CC1020SR	SN	13	Mid Double Cabin	42 Qb
CC1020LR	L	14	One and a half Cabin	42 Qb
CC1020DR	D	15	Regular Single Cabin	42 Qb
CC1020CR	C	16	Extra-long Single Cabin	42 Qb
CC1021SY	SY	11A	Regular Double Cabin	42 Qb +W 1

### Vehicle Model Classification Chart

Model	Code	Number Code	Cabin Model	Specifications
CC1020SY	AY	12Y	Extra Long Double Cabin	491QE, 4WD
CC1020SY	1SY	13Y	Mid Double Cabin	491QE, 4WD
CC1021SD	AF	12D	Regular Double Cabin	491QE, Big Monitor
CC1021SDY	SDY	12D	Regular Double Cabin	491QE, 4WD, Big Monitor, 4WD
CC1020AD	AD	12D	Extra Long Double Cabin	491QE, Big Monitor
CC1020ADY	ADY	12DY	Extra Long Double Cabin	491QE, 4WD, Big Monitor, 4WD
CC1020SD	1SD	13D	Mid Double Cabin	491QE, Big Monitor
CC1020SDY	1SDY	13DY	Mid Double Cabin	491QE, 4WD, Big Monitor, 4WD
CC1021SC	SC	1D	Regular Double Cabin	4JH1
CC1020AM	AM	12C	Extra Long Double Cabin	4JH1
CC1020LSC	1SC	12C	Mid Double Cabin	4JH1
CC1020LC	LC	13C	One and a half Cabin	4JH1
CC1020XC	XC	15C	Regular Single Cabin	4JH1
CC1020CC	CC	16C	Extra Long Single Cabin	4JH1
CC1021S	S	13B	Regular Double Cabin	491Q
CC1020A	A	12D	Extra Long Double Cabin	491Q
CC1020L	L	14D	One and a half Cabin	491Q
CC1020D	D	15D	Regular Single Cabin	491Q
CC1020C	C	16D	Extra Long Single Cabin	491Q

There are four codes to describe vehicle. The first two codes represent vehicle model, and the latter two codes represent vehicle feature. In the first vehicle model code, "1" represents Deer series light-duty pick up, "0" indicates that the vehicle is without distinction of cabin and cargo body, "1" represents regular double cabin, "2" represents extra-long double cabin, "3" represents medium double cabin, "4" represents one and a half cabin, "5" represents regular single cabin, "6" represents extra-long single cabin.

In vehicle feature codes, "C" represents diesel engine (4JB1) series, "H" represents carburetor engine (491Q) series.

For example:

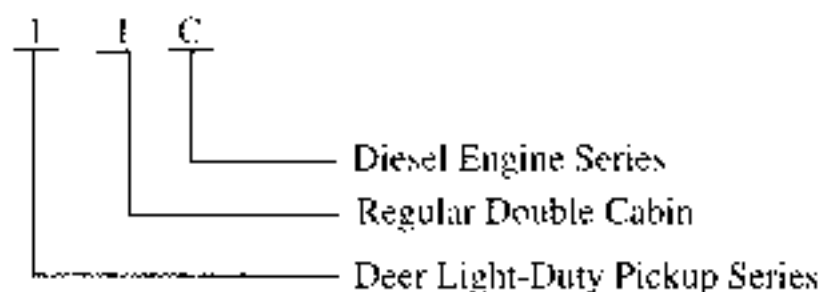

2. Look up the table of contents, and find parts assembly illustration and parts list, then you'll get the parts figure, parts number and the relevant quantity.

## 目 录 CONTENTS

1	缸体左侧面 CYLINDER BLOCK LEFT PROFILE	1
2	缸体右侧面 CYLINDER BLOCK RIGHT PROFILE	4
3	油堵 OIL PLUG	7
4	旁路暖风水管的安装 HEATING WATER BYPASS PIPE	9
5	气门室罩及摇臂轴等的装配 VALVE CHAMBER COVER & ROCKER ARM SHAFT	11
6	气门及火花塞的装配 VALVE & SPARK PLUG	14
7	化油器型分电器拆解图 DISTRIBUTOR (CARBURETOR TYPE)	16
8	化油器的拆解 CARBURETOR	19
9	化油器型燃油系 FUEL SYSTEM (CARBURETOR TYPE)	23
10	化油器型进排气及化油器 CARBURETOR, AIR INTAKE & EXHAUST (CARBURETOR TYPE)	25
11	活塞连杆的装配 PISTON CONNECTING ROD	27
12	曲轴飞轮的装配 CRANKSHAFT FLYWHEEL	29
13	凸轮轴及正时链轮 CAMSHAFT & TIMING SPROCKET	31
14	电喷型进排气系统组件 AIR INTAKE & EXHAUST (ELECTRIC FUEL INJECTION)	34
15	机油泵+集滤器组件 OIL PUMP+STRAINER	36
16	燃油系( )-DELPHI FUEL SYSTEM(I)	38

## 目 录 CONTENTS

17	燃油系 (1) -UAES FUEL SYSTEM(1)	41
18	风扇皮带轮 FAN PULLEY	43
19	水泵风扇组装 WATER PUMP FAN	45
20	怠速控制阀的安装-UAES IDLE AIR CONTROL VALVE	47
21	节气门体的装配 THROTTLE VALVE BODY	49
22	进气压力传感器 (1) AIR INTAKE PRESSURE SENSOR(1)	51
23	进气压力传感器 (2) AIR INTAKE PRESSURE SENSOR(2)	53
24	进气温度传感器 AIR INTAKE TEMPERATURE SENSOR	55
25	曲轴位置传感器 CRANKSHAFT POSITION SENSOR	57
26	冷却液温度传感器的安装 COOLANT TEMPERATURE SENSOR	61
27	冷却液温度传感器的安装 COOLANT TEMPERATURE SENSOR	62
28	分电器及阻尼线的装配-化油器型 DISTRIBUTOR & DAMPING CABLE (CARBURETOR TYPE)	63
29	点火线圈及高压阻尼线-DELPHI IGNITION COIL & HIGH VOLTAGE DAMPING WIRE	65
30	相位传感器-LAES PHASE SENSOR	69
31	线束组件-DELPHI WIRING HARNESS SET	71
32	线束组件-UAES WIRING HARNESS SET	74

## 目 录 CONTENTS

33	爆震传感器-LAES KNOCK SENSOR	76
34	随机附件 ACCESSORIES	78
35	65A 外调发电机 OUTSIDE ADJUSTING ALTERNATOR (65A)	80
36	90A 内调交流发电机 INTERIOR ADJUSTING ALTERNATOR(90A)	82
37	起动机 STARTER	84
38	活塞连杆组件 PISTON CONNECTING ROD	86
39	左右支架及左右加强板 LEFT/RIGHT BRACKET & REINFORCEMENT	88
40	主轴承与曲轴的安装 MAIN BEARING & CRANKSHAFT	90
41	机油盘的装配 OIL PAN	92
42	飞轮、离合器、前后油封及减震皮带轮 FLYWHEEL, CLUTCH, FRONT/REAR OIL SEAL & DAMPING PULLEY	94
43	齿轮室体的安装 GEAR CHAMBER BODY	96
44	齿轮、齿轮室盖、齿轮室体的安装 GEAR, GEAR CHAMBER COVER, GEAR CHAMBER BODY	98
45	凸轮轴的安装 CAMSHAFT	101
46	进气歧管和排气歧管的安装 INTAKE & EXHAUST MANIFOLD	103
47	右隔音盖板及线束夹 RIGHT SOUND Baffle & WIRING HARNESS CLIP	105
48	压缩机支架 COMPRESSOR BRACKET	107



## 目 录 CONTENTS

49	水泵的安装 WATER PUMP	109
50	冷却水管焊合件的安装 COOLANT PIPE WELDMENT	111
51	机油滤清器的安装 OIL FILTER	113
52	喷油泵的安装 INJECTION PUMP	117
53	发电机的安装 GENERATOR	119
54	高压油管及机油尺的安装 HIGH PRESSURE FUEL PIPE& OIL DIP ROD	122
55	风扇、风扇皮带轮及皮带的安装 FAN、FAN PULLEY & BELT	124
56	进气管、机油滤清器冷却进水管的安装 BREATHER HOSE、OIL FILTER COOLANT INLET& OUCTLET PIPE	127
57	隔热板的安装 HEAT INSULATING PANEL	128
58	导水管、油压感应塞及油压感应塞座 WATER GUIDE PIPE、OIL PRESSURE SENSING PLUG & SENSING PLU SEAT	130
59	缸盖在缸体上的安装 CYLINDER HEAD	132
60	进排气门的组装 INTAKE/EXHAUST VALVE	134
61	气门室罩盖的组装 VALVE CHAMBER COVER	136
62	摇臂轴总成的组装 ROCKER ARM SHAFT ASSY	138
63	喷油器、回油软管、电热塞及电热塞连接板 INJECTOR、RETURN HOSE、GLOW PLUG& GLOW PLUG CONNECTING PLATE	140
64	节温器及节温器壳的安装 THERMOSTAT & THERMOSTAT HOUSING	142



缸体左侧面 CYLINDER BLOCK LEFT PROFILE

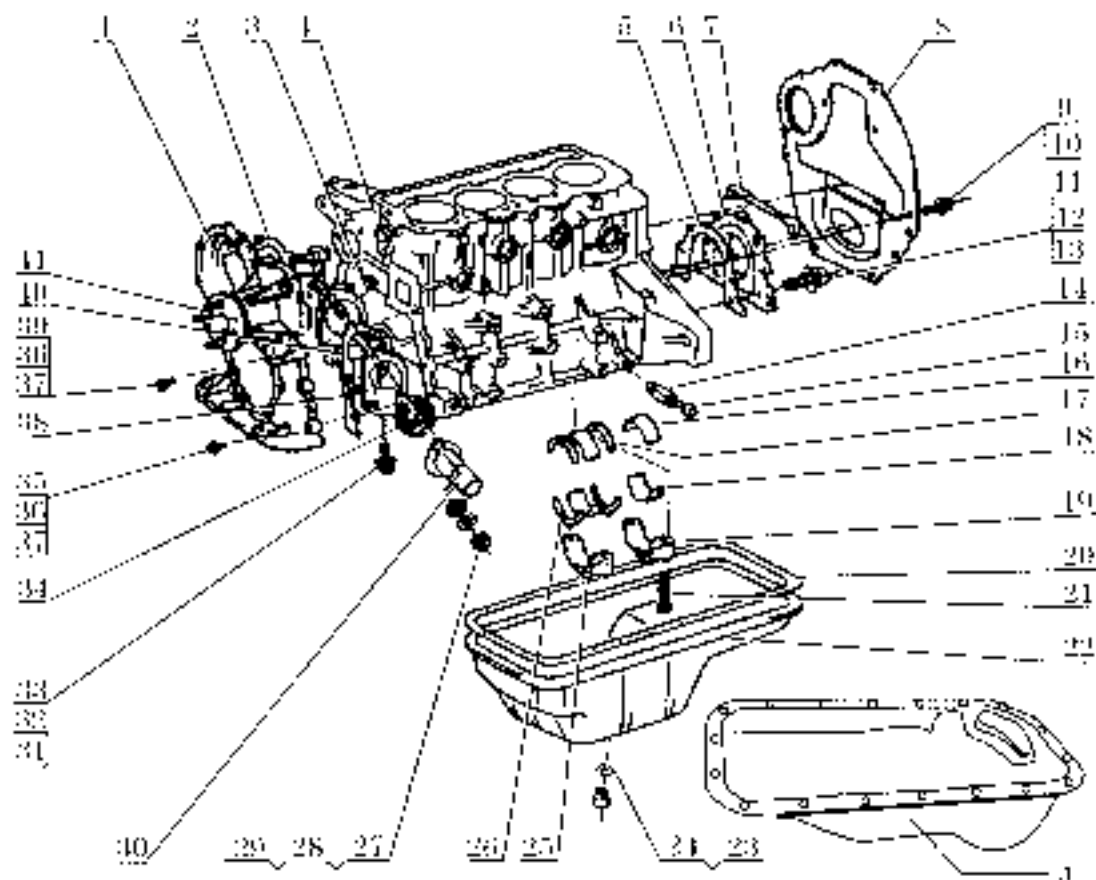

## 缸体左側面 CYLINDER BLOCK LEFT PROFILE

序号 SN	部件代码 PART CODE	部件名称 DESCRIPTION	部件规格 SPECIFICATION	用量 QTY.	适用车型 VEHICLE MODEL	备注 REMARK
1	DH-1002051	箱体	SPROCKET CHAMBER	1		
2	EH-1002012	箱体垫	SPROCKET CHAMBER GASKET	1		
3	Q1200K50	双头螺栓	STD BOLT	2		替代零件 - 可拆替换
4	EH-1002031	缸体	CYLINDER BLOCK	1		
5	11E-1002016	后油封油垫	GASKET	1		
6	11E-1002001	后油封座	RETAINER, ENGINE REAR OIL SEAL	1		
7	11E-1002014	后油封密封胶条	SEAL STRIP, REAR OIL SEAL	1		
8	11E-1002015	后油封	REAR END PLATE	1		
9	Q15010014	垫片	BOLT	2		后油封 - 副件
10	Q40308	弹簧垫圈	SPRING WASHER	2		
11	Q15010022	垫片	BOLT	5		后油封座 - 副件
12	Q40108	平垫圈	PLAIN WASHER	5		
13	Q40308	弹簧垫圈	SPRING WASHER	5		
14	1E3-1205031	放水开关	WATER DRAIN COCK	1		
15	1E3-1305012	放水开关螺塞	WATER DRAIN COCK PLUG	1		
16	1E3-1002038	上轴衬瓦	UPPER MAIN BEARING	5		
17	1E3-1002019	上轴衬瓦	UPPER THRUST PLATE	2		
18	1E3-1002017	下轴衬瓦	LOWER MAIN BEARING	5		
19	1E3-1002034	主轴承盖	MAIN BEARING CAP	2		
20	1E3-1002011	机油泵衬垫	OIL PAN GASKET	1		
21	1E3-1002035	主轴承盖螺栓	MAIN BEARING CAP BOLT	10		

## 缸体左侧面 CYLINDER BLOCK LEFT PROFILE

序号	部件代码	部件名称	部件规格	用量	适用车型	备注
S/N	PART CODE	DESCRIPTION	SPECIFICATION	QTY	VEHICLE MODEL	REMARK
22	1111-1009020	机油盘焊接组件	OIL PAN WELDMENT ASSY	1		
23	1111-1009012	机油放油塞垫圈	OIL DRAIN PLUG WASHER	1		
24	1111-1009012	机油放油塞	OIL DRAIN PLUG	1		
25	1111-1002025	中间轴衬套	INTERMEDIATE MAIN BEARING CAP	1		
26	1111-1002021	下轴衬套	LOWER THROST PLATE	2		
27	Q40208	平垫圈	PLAIN WASHER	2		进水管接头-喷油嘴体
28	Q40109	平垫圈	PLAIN WASHER	2		进水管接头-喷油嘴体
29	Q340108	螺母	NUT	2		进水管接头-喷油嘴体
30	1111-1300014	进水管接头	WATER INTAKE PIPE CONNECTOR	1		
31	Q150B0520	螺栓	BOLT	1		正副滤芯-喷油嘴体
32	Q40208	平垫圈	PLAIN WASHER	1		正副滤芯-喷油嘴体
33	Q40208	平垫圈	PLAIN WASHER	1		正副滤芯-喷油嘴体
34	1111-1300010	温度器	TEMPERATURE ADJUSTER	1		
35	Q150B0036	螺栓	BOLT	3		喷油嘴体-缸体
36	Q40108	平垫圈	PLAIN WASHER	7		喷油嘴体-缸体
37	Q40208	平垫圈	PLAIN WASHER	7		喷油嘴体-缸体
38	1111-1300019	温度器座	TEMPERATURE ADJUSTER SEAT	1		
39	Q150B0050	螺栓	BOLT	4		喷油嘴体-缸体
40	1111-1300018	温度器座垫圈	TEMPERATURE REGULATOR SEAT GASKET	1		
41	1111-1307020	水泵组件	WATER PUMP SET	1		
42	1111-1009021	机油盘	OIL PAN	1		ASD

缸体右側面 CYLINDER BLOCK RIGHT PROFILE

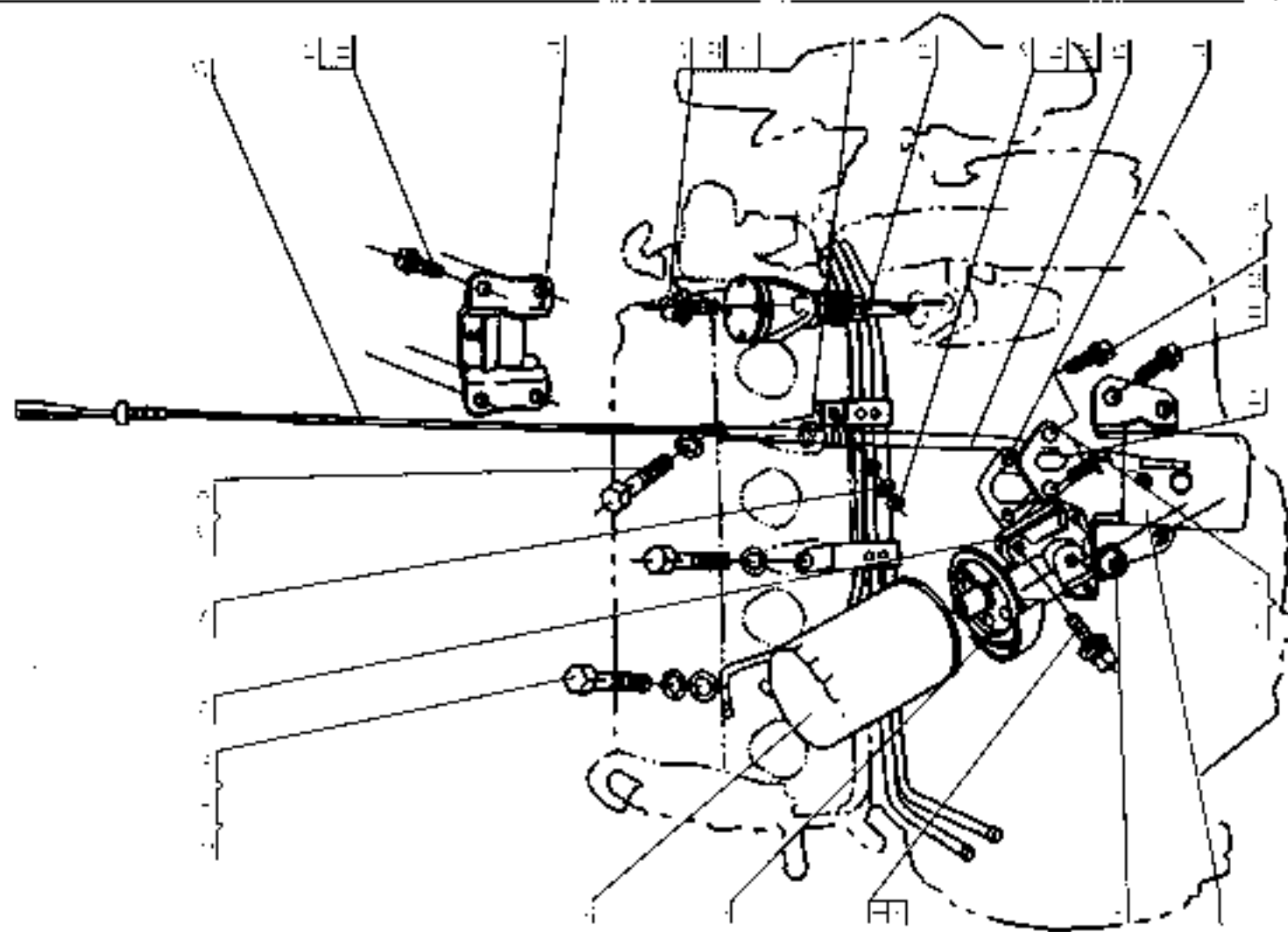

## 缸体右侧面 CYLINDER BLOCK RIGHT PROFILE

序号	部件代码	部件名称	部件规格	用量	适用车型	备注
SN	PART CODE	DESCRIPTION	SPECIFICATION	QTY.	VEHICLE MODEL	REMARK
1	1111-0012020	机油滤网	OIL FILTER	1		
2	1111-0012001	机油滤网滤芯	OIL FILTER SEAT	1		
3	Q15010035	螺栓	BOLT	3		
4	1040108	平垫圈	PLAIN WASHER	3		
5	Q40308	弹簧垫圈	SPRING WASHER	3		
6	11-2011020	机油报警灯	OIL ALARM	1		
7	491Q-1001030	右托架	HOLDER,ROD	1		
8	Q15010016	螺栓(后盖)	BOLT(REAR)	1		
9	Q40308	弹簧垫圈	SPRING WASHER	2		
10	11-1002202	汽油泵孔盖板	GASOLINE PUMP HOLE COVER	1		
11	Q15110020	螺栓	BOLT	5		
12	Q40310	弹簧垫圈	SPRING WASHER	8		
13	Q15010020	螺栓(前盖)	BOLT(FRONT END)	1		
14	11-1002206	汽油泵孔盖板垫	FUEL PUMP HOLE COVER GASKET	1		
15	1111-1002070	机油尺管	OIL DRAIN TUBE	1		
16	Q340806	螺母	NUT	1		
17	Q40106	平垫圈	PLAIN WASHER	1		
18	Q40406	弹簧垫圈	SPRING WASHER	1		
19	11-3000200	机油泵传动轴	OIL PUMP DRIVE SHAFT	1		DELIVER
20	1111-1104053	汽油泵孔固定片	GASOLINE PUMP SET PLATE	1		
21	Q15010025	螺栓	BOLT	1		

## 缸体右侧面 CYLINDER BLOCK RIGHT PROFILE

序号	部件代码	部件名称	部件规格	用量	适用车型	备注
S/N	PART CODE	DESCRIPTION	SPECIFICATION	QTY.	VEHICLE MODEL	REMARK
22	Q40108	平垫圈	PLAIN WASHER	8		
23	Q40108	弹簧垫圈	SPRING WASHER	8		
24	111-1001109	气门挺	VALVE TAPPET	1		
25	111-1002089	机油杆	OIL DIP ROD	1		
26	Q15080943	螺母	NUT	3		
27	Q40108	弹簧垫圈	SPRING WASHER	3		
28	111-1004020	汽油进回油管总成	FUEL INTAKE & RETURN PIPE WELDMENT ASSY	1		
29	111-1002014	机油滤清器座垫	OIL FILTER SEAT GASKET	1		
30	Q40108	平垫圈	PLAIN WASHER	1		



油堵 OIL PLUG

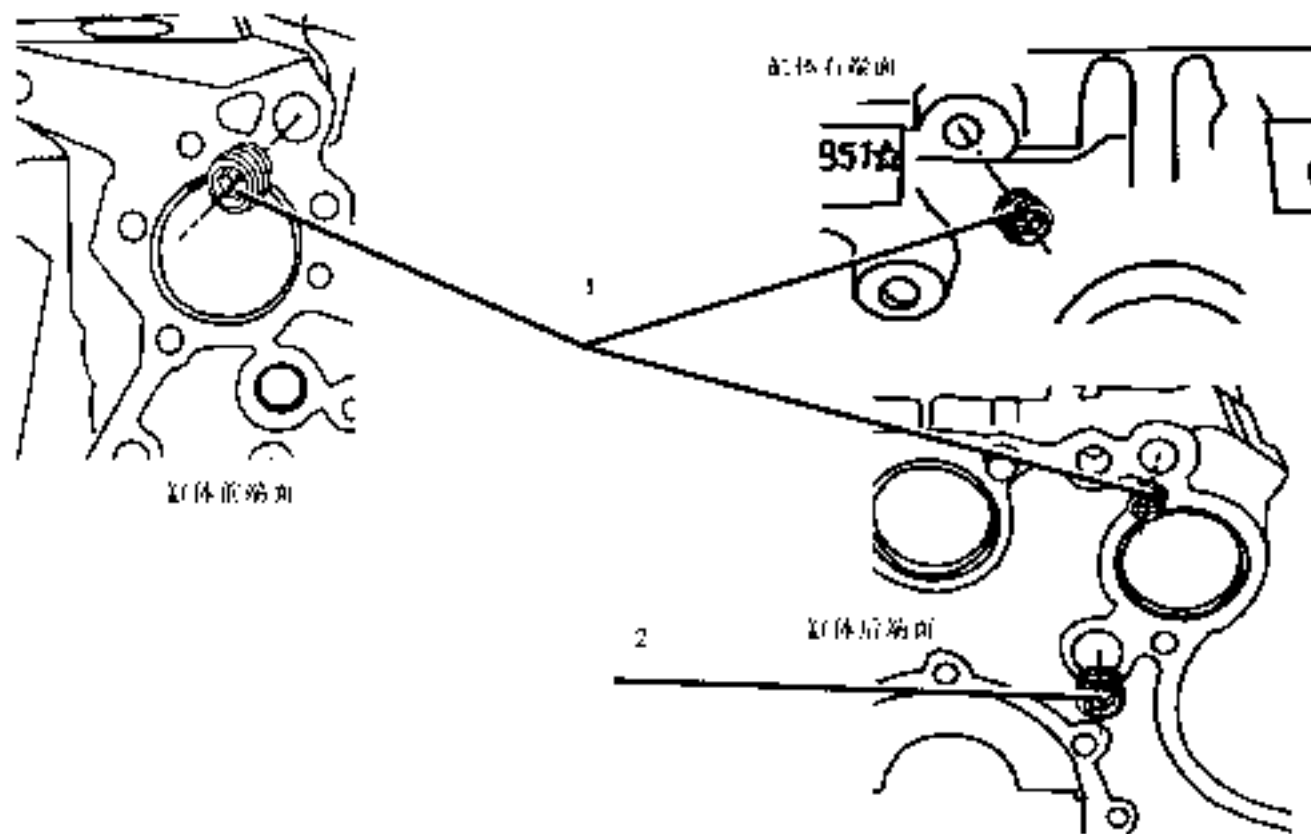

## 油堵 OIL PLUG

序号 SN	部件代码 PART CODE	部件名称 DESCRIPTION	部件规格 SPECIFICATION	用量 QTY	适用车型 VEHICLE MODEL	备注 REMARK
1	10H-1002047	后油道螺塞 SECONDARY OIL PASSAGE SCREW PLUG		3		
2	10H-1002048	主油道螺塞 MAIN OIL PASSAGE SCREW PLUG		1		

旁路暖风水管的安装 HEATING WATER BYPASS PIPE

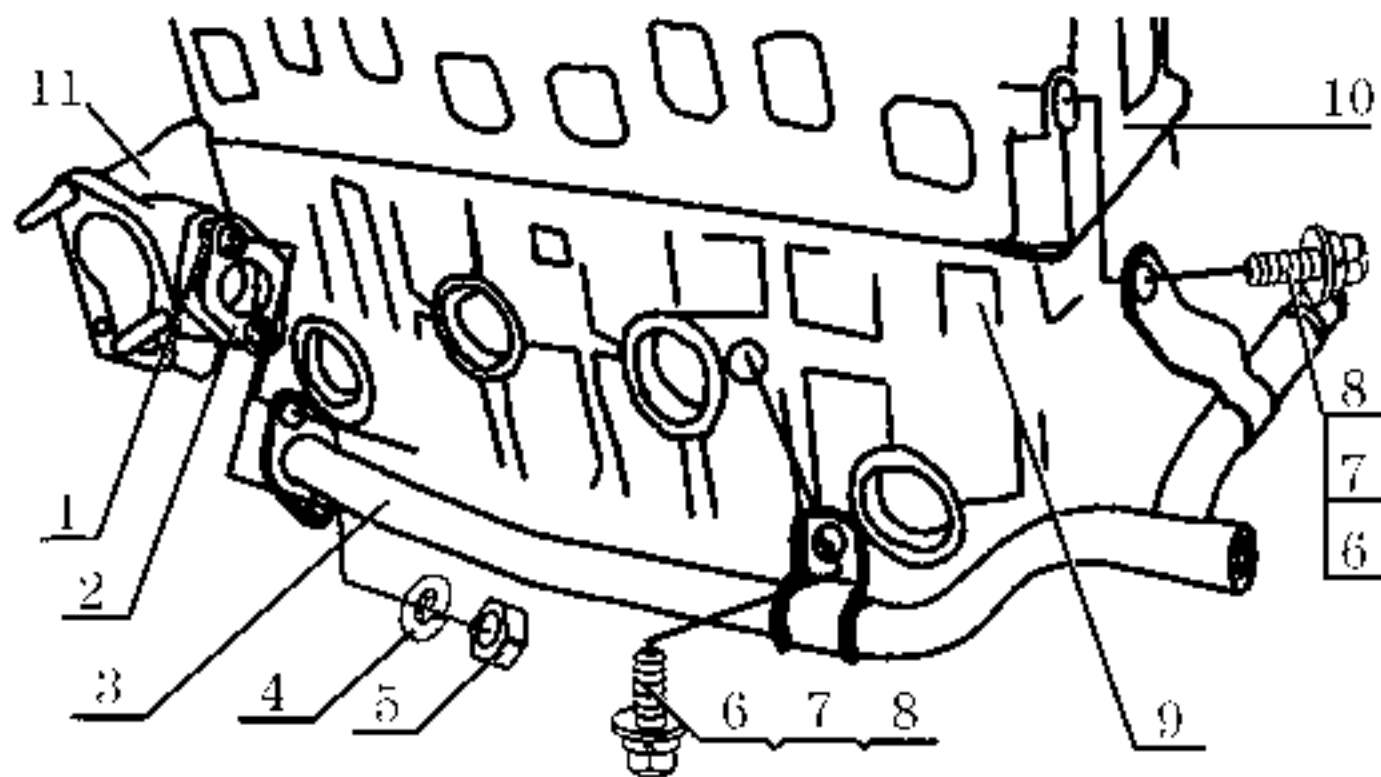

## 旁路暖风水管的安装 HEATING WATER BYPASS PIPE

序号	部件代码	部件名称	部件规格	用量	适用车型	备注
S/N	PART CODE	DESCRIPTION	SPECIFICATION	QTY.	VEHICLE MODEL	REMARK
1	GB899-88	双头螺柱	STUD BOLT	2		
2	11H-1400016	旁路管垫片	WATER BYPASS PIPE GASKET	1		
3	11H-1400060	旁路暖风水管	HEATING WATER BYPASS PIPE	1		
4	Q40308	弹簧垫圈	SPRING WASHER	2		
5	340R08	螺母	NUT	2		
6	Q150B0812	螺栓	BOLT	2		
7	Q40306	弹簧垫圈	SPRING WASHER	2		
8	Q40108	平垫圈	PLAIN WASHER	2		
9	11H-1002031	缸体	CYLINDER BLOCK	1		
	11H-1002030	缸体	CYLINDER BLOCK	1		03 1 1 1
10	11H-1003670	缸盖	CYLINDER HEAD	1		
11	11H-1002051	前盖	SPROCKET CHAMBER	1		

气门室罩及摇臂轴等的装配 VALVE CHAMBER COVER & ROCKER ARM SHAFT

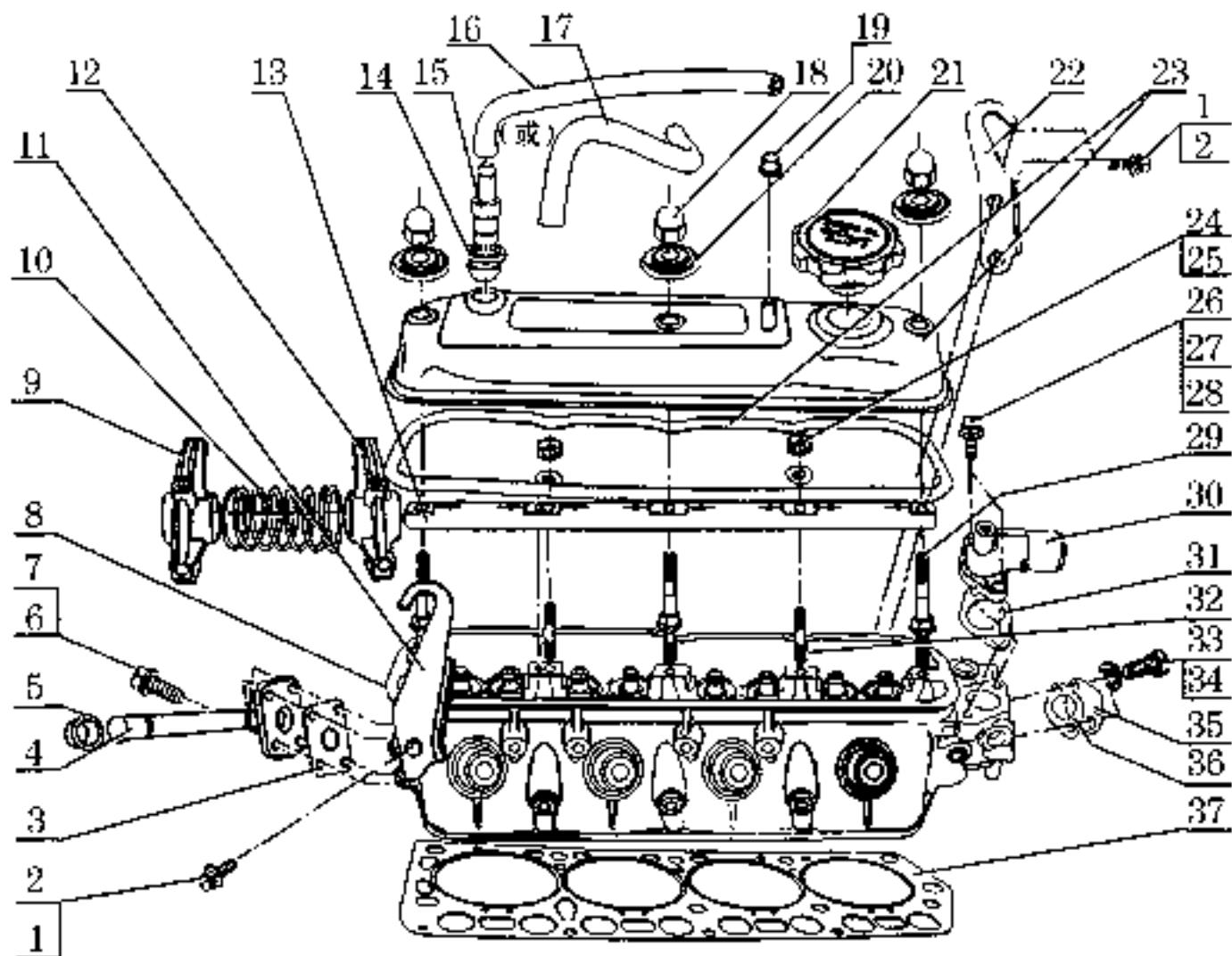

气门室罩及摇臂轴等的装配 VALVE CHAMBER COVER & ROCKER ARM SHAFT

序号	部件代码	部件名称	部件规格	用量	适用车型	备注
S/N	PART CODE	DESCRIPTION	SPECIFICATION	QTY	VEHICLE MODEL	REMARK
1	Q15101030	螺栓	BOLT	2		
2	Q44008	扁平弹簧垫圈	SPRING WASHER	3		
3	1111-1005125	后加热器水管垫	REAR HEATER WATER PIPE GASKET	1		
4	11-1003150	后加热器水管	REAR HEATER WATER PIPE	1		
5	11-1005126	后加热器水管胶罩	REAR WATER PIPE RUBBER COVER	1		
6	Q1500014	螺栓	BOLT	4		
7	Q40008	平垫圈	PLAIN WASHER	4		
8	1111-1003070	缸盖衬垫	CYLINDER HEAD	1		
9	1111-1007012	右摇臂	ROCKER ARM, RH	4		
10	1111-1007013	摇臂弹簧	ROCKER ARM SPRING	4		
11	1111-1003013	右摇臂	ROCKER ARM, RH	1		
12	1111-1007014	左摇臂	ROCKER ARM, LH	4		
13	1111-1007050	摇臂轴	ROCKER ARM SHAFT	1		
14	1111-1014013	PCV 橡胶垫	PCV VALVE RUBBER SEAT	1		
15	1111-1014010	PCV 阀	PCV VALVE	1		
16	1111-1014011	PCV 阀进气软管	PCV VALVE BREATHER HOSE	1		长款本型
17	11-1004011	PCV 阀进气软管	PCV VALVE BREATHER HOSE	1		长款本型
18	GH925-88	六角螺母	NUT	3		
19		防尘罩	DEST COVER	1		
20	1111-1003050	六角螺母垫圈	NUT GASKET	3		
21	1111-1003085	油封衬套	PISTON PILLER WASHER	1		

气门室罩及摇臂轴等的装配 VALVE CHAMBER COVER & ROCKER ARM SHAFT

序号	部件代码	部件名称	部件规格	用量	适用车型	备注
S/N	PART CODE	DESCRIPTION	SPECIFICATION	QTY	VEHICLE MODEL	REMARK
22	11H-1009018	前挂钩	FRONT HOOK	1		
23	11H-1003000	气门室罩盖	VALVE CHAMBER COVER	1		
24	Q130008	螺母	NUT	2		
25	Q40108	平垫圈	PLAIN WASHER	2		
26	Q1500025	螺栓	BOLE	2		
27	Q40108	平垫圈	PLAIN WASHER	2		
28	Q40308	弹簧垫圈	SPRING WASHER	2		
29	11H-1007011	摇臂轴螺栓	ROCKER ARM SHAFT BOLT	3		
30	11H-1300014	出水管接头	WATER OUTLET PIPE CONNECTOR	1		
31	11H-1300015	出水管接头	WATER OUTLET PIPE CONNECTOR	1		
		衬垫	GASKET			
32	Q120025	双头螺栓	SHU BOLT	2		
33	Q1500020	螺栓	BOLE	2		
34	Q40308	弹簧垫圈	SPRING WASHER	2		
35	11H-1009010	前放水盖板	FRONT WATER SEAL COVER	1		
36	11H-1009012	前放水盖板	FRONT WATER SEAL COVER	1		
		垫圈	WASHER			
37	11H-1009001	汽缸垫	CYLINDER GASKET	1		

气门及火花塞的装配 VALVE & SPARK PLUG

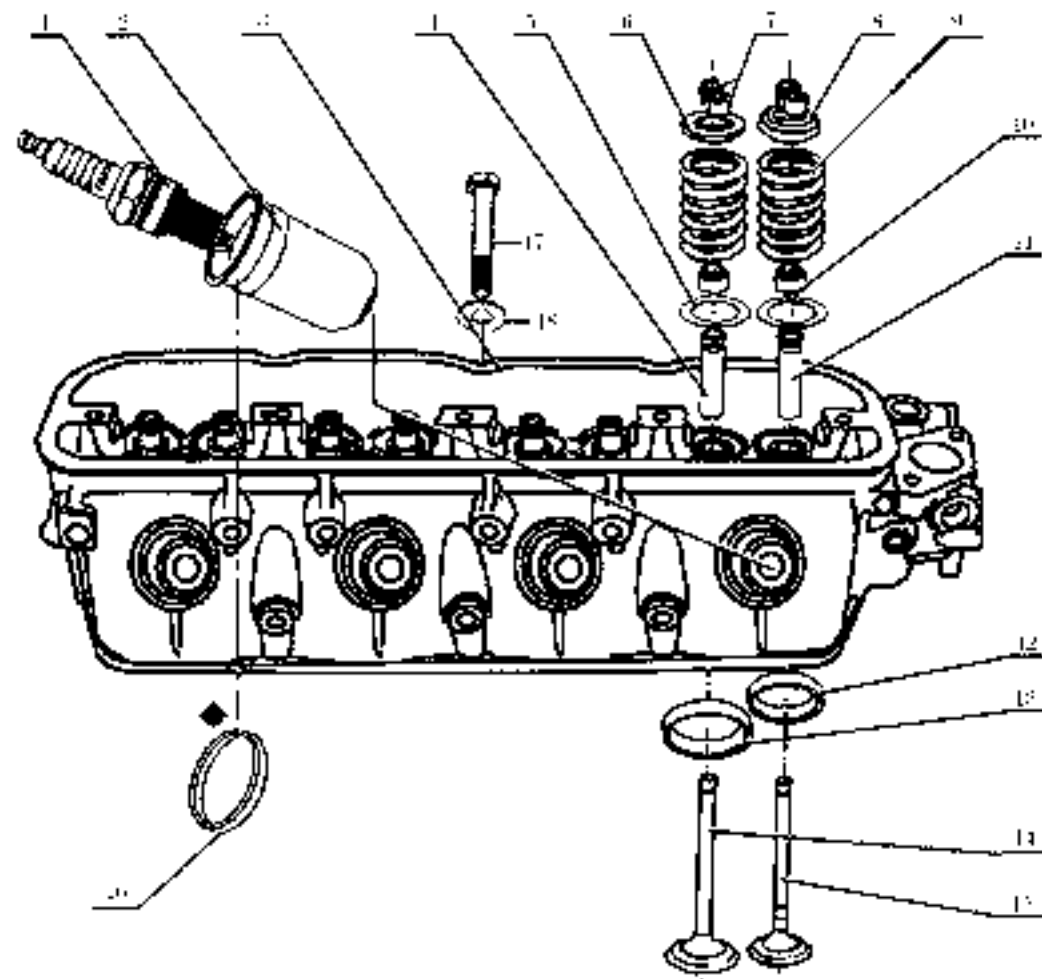



## 气门及火花塞的装配 VALVE & SPARK PLUG

序号	部件代码	部件名称	部件规格	用量	适用车型	备注
SN	PART CODE	DESCRIPTION	SPECIFICATION	QTY.	VEHICLE MODEL	REMARK
1	100-3707010	火花塞(化油器型)	SPARK PLUG(CARBURETOR)	4		
4	10-3707010	火花塞(电喷型)	SPARK PLUG(ELECTRIC INJECTION)	4		电喷型
2	100-1003001	火花塞套	SPARK PLUG BUSHING	4		
3	100-1003079	缸盖衬垫	CYLINDER HEAD	1		
4	100-1003101	进气门导管	INTAKE VALVE GUIDE	4		
5	100-1007015	气门弹簧座垫	VALVE SPRING RETAINER GASKET	8		
6	100-1007021	进气门弹簧上座	INTAKE VALVE SPRING UPPER RETAINER	4		
7	100-1007019	气门弹簧	VALVE SPRING	16		
8	100-1007030	排气门弹簧上座衬套	EXHAUST VALVE SPRING UPPER RETAINER	4		
9	100-1007017	气门弹簧	VALVE SPRING	8		
10	100-1007040	气门油封	VALVE OIL SEAL	8		
11	100-1003102	排气门导管	EXHAUST VALVE GUIDE	4		
12	100-1003103	排气门衬圈	EXHAUST VALVE SEAL (INSERT)	4		
13	100-1003014	进气门衬圈	INTAKE VALVE SEAL INSERT	4		
14	100-1007018	排气门	EXHAUST VALVE	4		
15	100-1007016	进气门	INTAKE VALVE	4		
16	100-1002012	火花塞套衬圈	SPARK PLUG BUSHING SEAL	4		
17	100-1003016	缸盖螺栓	CYLINDER HEAD BOLT	10		
18	100-1003017	缸盖螺栓衬圈	CYLINDER HEAD BOLT WASHER	10		

# 化油器型分电器拆解图 DISTRIBUTOR (CARBURETOR TYPE)

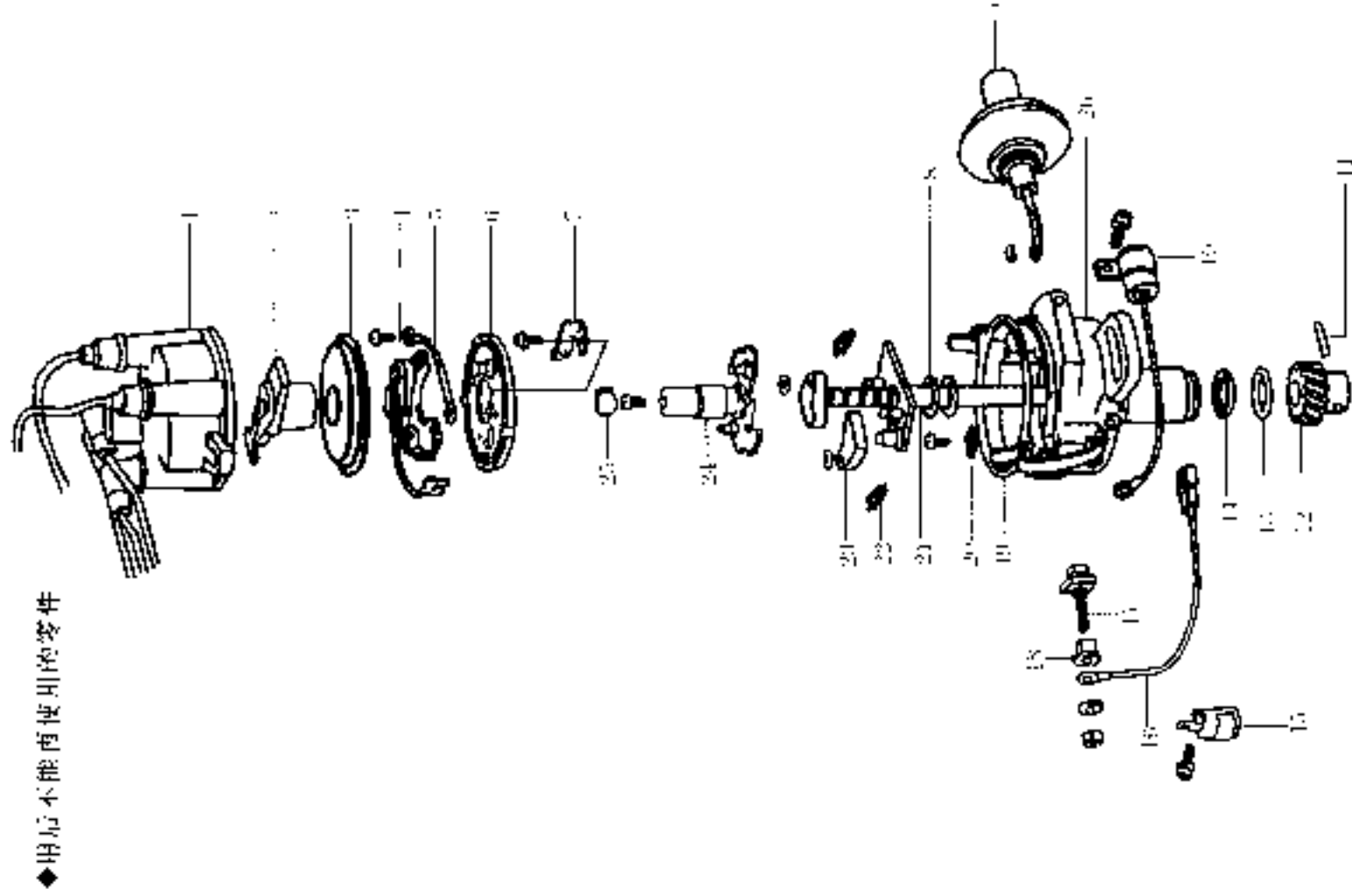

## 化油器型分电器拆解图 DISTRIBUTOR (CARBURETOR TYPE)

序号	部件代码	部件名称	部件规格	用量	适用车型	备注
NO.	PART CODE	DESCRIPTION	SPECIFICATION	QTY.	VEHICLE MODEL	REMARK
	11H-3706020	分电器	DISTRIBUTOR	1		
1	11H-3706021	分电器高压点火线	DISTRIBUTOR HEAD WITH HIGH VOLTAGE WIRE	1		
2	11H-3706023	分电器	DISTRIBUTOR ROTOR	1		
3	11H-3706024	防尘罩	DUST HOOD	1		
4	11H-3706025	断电器触点	BREAKER CONTACT POINT	1		
5	11H-3706026	导线	WIRE	1		
6	11H-3706027	断电器底座	BREAKER BASE PLATE	1		
7	11H-3706028	减振器	SHOCK ABSORBER	1		
8	11H-3706034	止回垫圈	THRUST WASHER	2		
9	11H-3706037	真空点火提前装置	VACUUM IGNITION ADVANCE UNIT	1		
10	11H-3706038B	电容器 (B 型)	CAPACITOR (B)	1		
11	11H-3706044	直钉	STRAIGHT PIN	1		
12	11H-3706045	驱动齿轮	DRIVEN GEAR	1		
13	11H-3706043	O 形环	O-RING	1		
14	11H-3706042	平垫圈	PLAIN WASHER	1		
15	11H-3706038	电容器 (A 型)	CAPACITOR (A)	1		
16	11H-3706041	分电器壳体	DISTRIBUTOR CASE	1		
17	11H-3706039	端子	TERMINAL	1		
18	11H-3706040	绝缘体	INSULATOR	1		
19	11H-3706036	密封垫圈	GASKET	1		
20	11H-3706035	平垫圈	PLAIN WASHER	1		

## 化油器型分电器拆解图 DISTRIBUTOR (CARBURETOR TYPE)

序号	部件代码	部件名称	部件规格	用量	适用车型	备注
SN	PART CODE	DESCRIPTION	SPECIFICATION	QTY.	VEHICLE MODEL	REMARK
21	11E-370603	调速轴	SPEED REGULATOR SHAFT	1		
22	11E-370602	调速器弹簧	SPEED REGULATOR SPRING	2		
23	11E-370601	调速器凸轮	SPEED REGULATOR CAM	1		
24	11E-370600	凸轮	CAM	1		
25	11E-370609	油脂杯盖	GREASE PLUG	1		
26	11E-370604	分电器外壳	DISTRIBUTOR HOUSING	1		

# 化油器的拆解 CARBURETOR

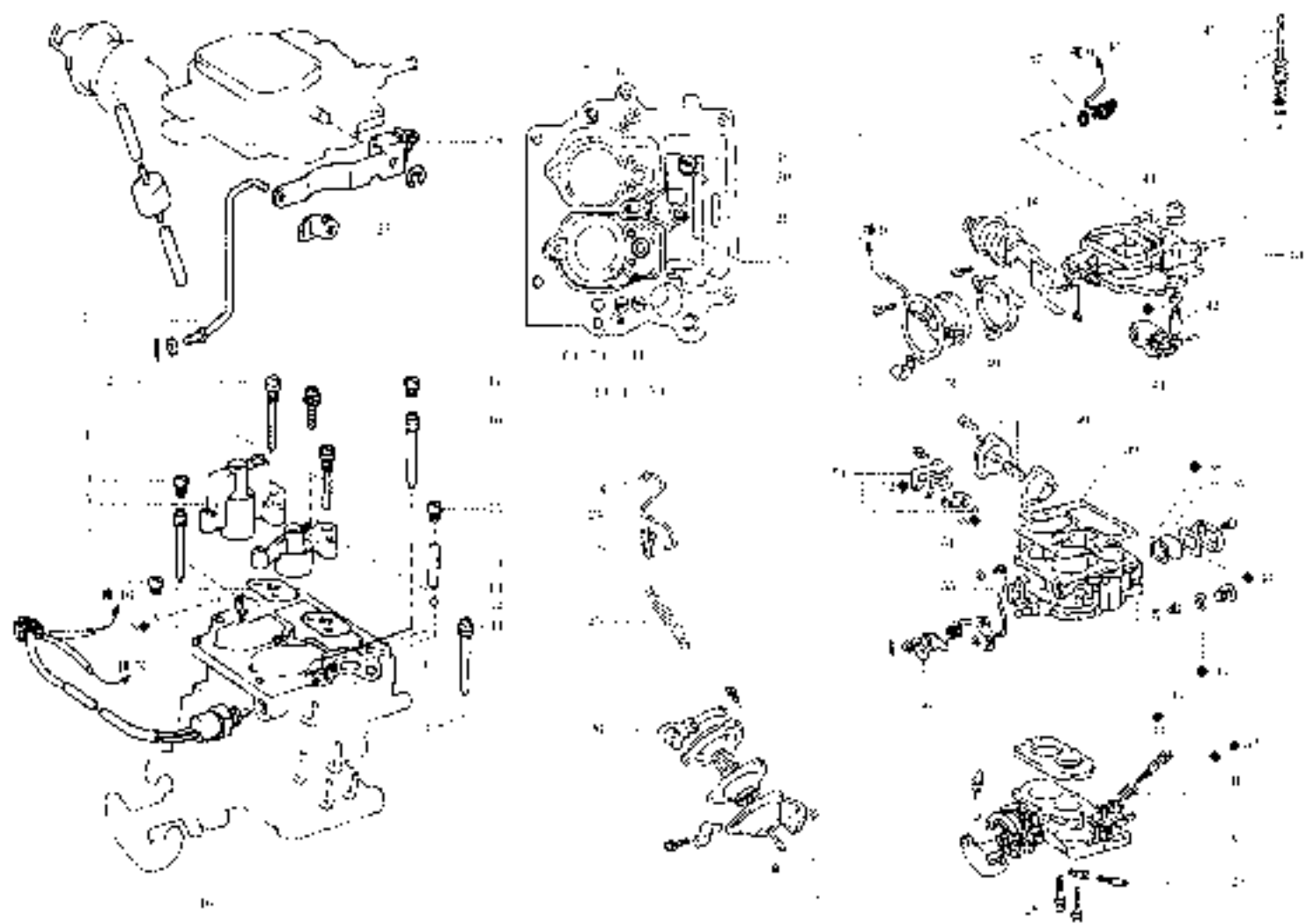

## 化油器的拆解 CARBURETOR

序号 SN	部件代码 PART CODE	部件名称 DESCRIPTION	部件规格 SPECIFICATION	用量 QTY	适用车型 VEHICLE MODEL	备注 REMARK
	11H-1107010	化油器总成	CARBURETOR ASSY	1		
1	11H-1107002	柱塞连杆	PLUNGER CONNECTING ROD	1		
2	11H-1107114	第二道气阀	2ND MAIN AIR BLEEDER	1		
3	11H-1107113	第一道气阀	1ST MAIN AIR BLEEDER	1		
4	11H-1107099	塞	PUMP JET PLUG	1		
5	11H-1107112	第二喷嘴	2ND NOZZLE	1		
6	11E-1107114	加速泵孔	STEP JET	1		
7	11E-1107100	孔塞	SLOW PASSAGE PLUG	1		
8	11H-1107115	密封垫圈	GASKET	2		
9	11H-1107051	电接插头	POWER PLUG	1		
10	11G-1107052	燃油器电磁阀	THROTTLE VALVE SOLENOID	1		
11	11B-1107093	低速空气孔	SLOW JET	1		
12	11H-1107101	止回球	STOP BALL	1		
13	11H-1107111	第一喷嘴	1ST INJECTING PIPE	1		
14	11H-1107102	泵喷射器	PUMP INJECTING PIPE BLOCK	1		
15	11H-1107091	塞	PLUG	1		
16	11E-1107109	低速孔	SLOW JET	1		
17	11H-1107092	塞	PLUG	1		
18	11E-1107103	柱塞臂	PLUNGER ARM	1		
19	11E-1107095	加速孔	ACCELERATING JET	1		
20	11H-1107097	第二道孔	SECONDARY MAIN JET	1		

## 化油器的拆解 CARBURETOR

序号	部件代码	部件名称	部件规格	用量	适用车型	备注
SN	PART CODE	DESCRIPTION	SPECIFICATION	QTY	VEHICLE MODEL	RE-MARK
21	11H-1107086	主量孔	PRIMARY MAIN JET	1		
22	11H-1107085	功率量孔	POWER JET	1		
23	11H-1107084	固定夹子	CLIP	1		
24	11H-1107088	连杆	CONNECTING ROD	1		
25	11H-1107087	加速踏板回位弹簧	ACCELERATOR RETURN SPRING	1		
26	11H-1107076	第二气室隔膜片	2ND DIAPHRAGM GASKET	1		
27	11H-1107071	衬垫	DIAPHRAGM GASKET	1		
28	11H-1107067	快怠速混合器螺钉	FAST IDLE ADJUSTING SCREW	1		
29	11H-1107064	怠速混合器螺钉	IDLE ADJUSTING SCREW	1		
30	11H-1107062	化油器下体	CARBURETOR LOWER BODY	1		
31	11H-1107063	怠速混合器螺钉	IDLE MIXTURE ADJUSTING SCREW	1		
32	11H-1107061	橡胶垫	INSULATOR	1		
33	11H-1107038	衬垫	GASKET	1		
34	11H-1107037	第二量孔	2ND MAIN JET	1		
35	11H-1107036	主通气塞	MAIN PASSAGE PLUG GASKET	1		
36	11H-1107035	主通气垫	MAIN GATE GASKET	1		
37	11H-1107034	观察窗玻璃	SIGHT GLASS	1		
38	11H-1107033	O形圈	O-RING	1		
39	11H-1107032	空气滤网	AIR HOEN GASKET	1		
40	11H-1107030	真空膜片泵	VACUUM ACCELERATING PUMP	1		
41	11H-1107023	浮子	FLOATER	1		
42	11H-1107022	针阀	NEEDLE VALVE	1		

## 化油器的拆解 CARBURETOR

序号	部件代码	部件名称	部件规格	用量	适用车型	备注
S/N	PART CODE	DESCRIPTION	SPECIFICATION	QTY	VEHICLE MODEL	REMARK
43	1103-1107020	进气喇叭总成	AIR HORNS ASSY	1		
44	1103-1107021	进气喇叭罩	AIR HORN	1		
45	1103-1107024	泵柱塞	PUMP PLUGGER	1		
46	1103-1107052	外部空气控制阀	OUTSIDE AIR CONTROL VALVE	1		
47	1103-1107054	衬垫	GASKET	1		
48	1103-1107057	阻风门控制总成	CHOKER BREAKER	1		
49	1103-1107056	恒温器壳	TEMPERATURE HOUSING	1		
50	1103-1107055	阻风门控制器	CHOKER HEATER	1		
51	1103-1107060	高温补偿空气补偿	HOT HOT F COMPENSATION	1		
52	1103-1107041	密封垫圈	GASKET	1		
53	1103-1107042	O形环	O-RING	1		
54	1103-1107031	化油器本体	CARBURETOR BODY	1		
55	1103-1107085	连杆	CONNECTING ROD	1		
56	1103-1107084	快速怠速凸轮	FAST IDLE CAM	1		



化油器型燃油系 FUEL SYSTEM (CARBURETOR TYPE)

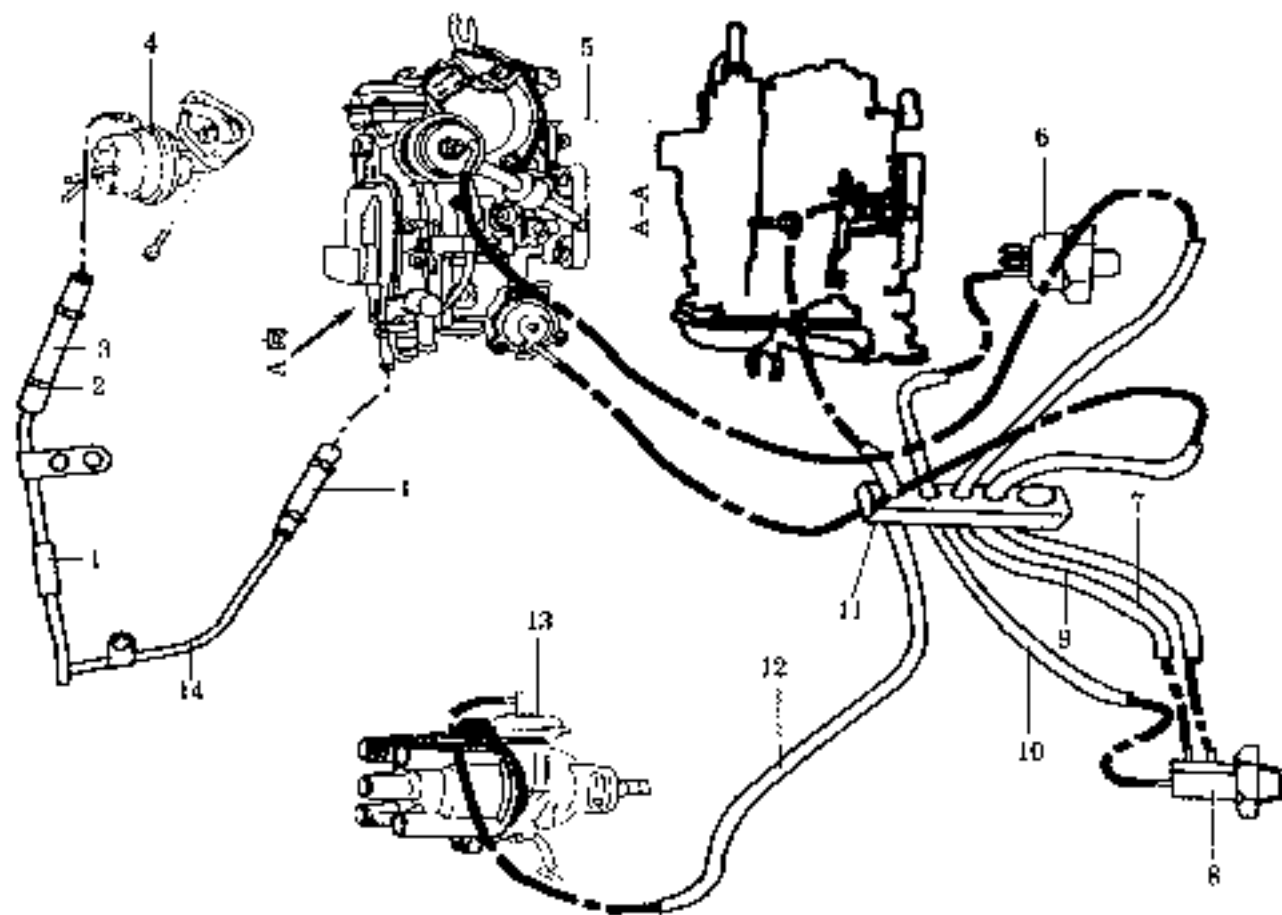

## 化油器型燃油系 FUEL SYSTEM (CARBURETOR TYPE)

序号	部件代码	部件名称	部件规格	用量	适用车型	备注
S/N	PART CODE	DESCRIPTION	SPECIFICATION	QTY	VEHICLE MODEL	REMARK
1	111F-1104112	右外弯管接头	FULL BEND PIPE SLEEVE	1		
2	111F-1104111	半型卡箍 12	RING CLIP	4		
3	111F-1104111	右外弯管接头	FULL BEND PIPE SLEEVE	1		
4	111F-1106020	汽油泵	GASOLINE PUMP	1		
5	111F-1107010	化油器	CARBURETOR	1		
6	111F-1105020	真空分配器	VACUUM DISTRIBUTOR	1		
7	111F-1106014	TYSV 433 APP 软管	HOSE FROM TVSV VALVE TO APP	1		
8	111F-1105020	限制真空开关(TYSV 88)	LIMIT RATE RETURN CONTROL VACUUM SWITCH VALVE	1		
9	111F-1106015	TYSV 433 软管接头	HOSE FROM TVSV VALVE TO CH VALVE	1		
10	111F-1106012	TYSV 433 软管接头	HOSE FROM TVSV VALVE TO VACUUM DISTRIBUTOR	1		
11	111F-1106015	真空管接头	CLIP FOR VACUUM PIPE & FITTING PIPE	1		
		真空软管及化油器接头	HOSE TO CARBURETOR VACUUM			
12	111F-1106013	软管接头	CONNECTOR	1		
13	111F-1106010	分配器	DISTRIBUTOR	1		
14	111F-1104120	右内弯管	GASOLINE BEND PIPE	1		
15	111F-1104115	化油器进气管	CARBURETOR INTAKE HOSE	1		

化油器型进排气及化油器 CARBURETOR, AIR INTAKE & EXHAUST (CARBURETOR TYPE)

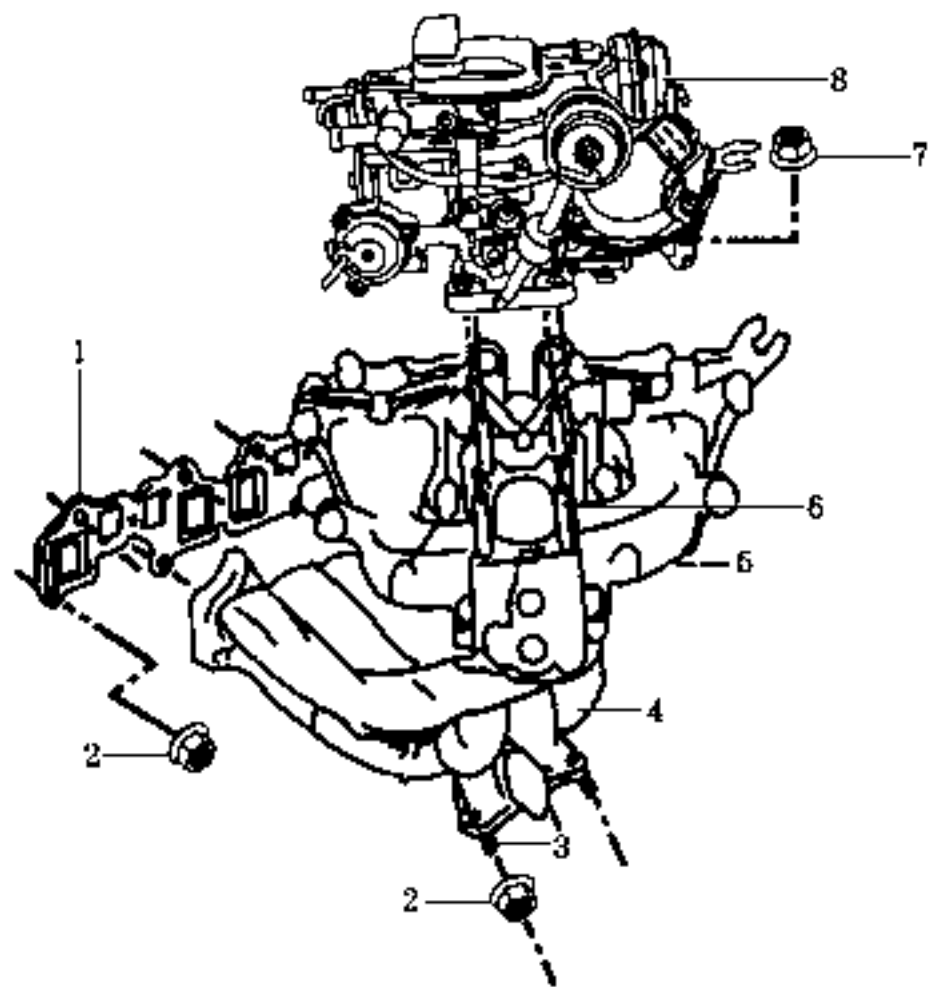

化油器型进排气及化油器 CARBURETOR, AIR INTAKE & EXHAUST (CARBURETOR TYPE)

序号	部件代码	部件名称	部件规格	用量	适用车型	备注
S/N	PART CODE	DESCRIPTION	SPECIFICATION	QTY	VEHICLE MODEL	REMARK
1	L1H-100020	进排气管垫圈	INTAKE & EXHAUST PIPE GASKET <b>KIT</b>	1		
2	L1H-100015	进排气管自锁螺母	SELF LOCK NUT			
3	L1H-100014	进排气管六角螺母	STUD BOLT			
4	J1H-100002	排气歧管	EXHAUST MANIFOLD	1		
5	J1H-100001	进气歧管	INTAKE MANIFOLD	1		
6	Q1200835	双头螺母	STUD BOLT	4		
7	Q1200808	螺母	NUT	4		
8	L1H-100000	化油器	CARBURETOR	1		

活塞连杆的装配 PISTON CONNECTING ROD

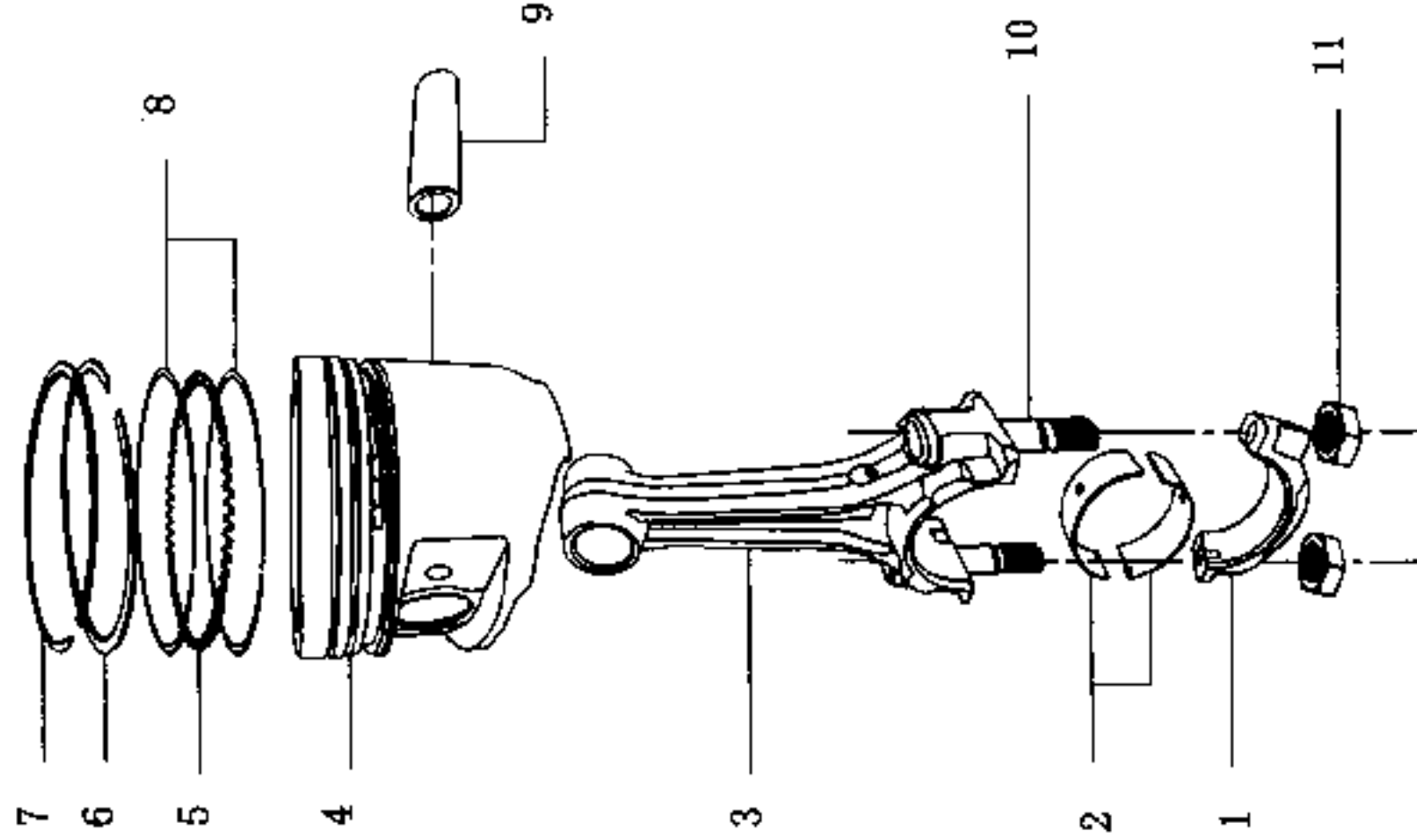

## 活塞连杆的装配 PISTON CONNECTING ROD

序号	部件代码	部件名称	部件规格	用量	适用车型	备注
SN	PART CODE	DESCRIPTION	SPECIFICATION	QTY	VEHICLE MODEL	REMARK
	31EE-10H4020	活塞组套	PISTON CONNECTING ROD KIT	4		
	31EE-10H4030	气环衬套	OIL RING SET	4		
1	31EE-10H4021	连杆盖	CONNECTING ROD CAP	4		
2	31EE-10H4023	连杆瓦	CONNECTING ROD BEARING	X		
3	31EE-10H4024	连杆体	CONNECTING ROD	4		
4	31EE-10H4015	活塞	PISTON	4		
5	31EE-10H4021	连杆衬套	OIL RING SPRING	4		
6	31EE-10H4012	第一道气环	NO.1 COMPRESSION RING	4		
7	31EE-10H4011	第二道气环	TOP COMPRESSION RING	4		
8	31EE-10H4012	气环簧	OIL RING VANE	8		
9	31EE-10H4016	活塞销	PISTON PIN	4		
10	31EE-10H4025	连杆螺栓	CONNECTING ROD BOLT	8		
11	31EE-10H4022	连杆螺母	CONNECTING ROD NUT	8		

曲轴飞轮的装配 CRANKSHAFT FLYWHEEL

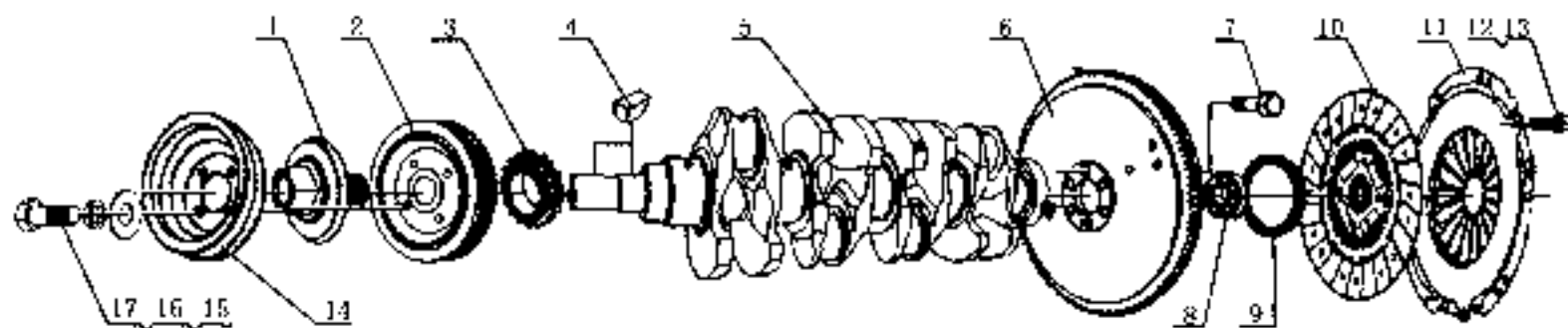

## 曲轴飞轮的装配 CRANKSHAFT FLYWHEEL

序号 NO.	部件代码 PART CODE	部件名称 DESCRIPTION	部件规格 SPECIFICATION	用量 QTY	通用车型 VEHICLE MODEL	备注 REMARK
1	1111-1005001	减振皮带张紧螺栓	DAMPING BELT TIGHTENING BOLT	1		
2	1111-1005002	减振皮带轮	DAMPING BELT PULLEY	1		比油冷型
	11-1005002	减振飞轮张	DAMPING BELT PULLEY	1		电冷型
3	1111-1005002	曲轴正时链轮	CRANKSHAFT TIMING SPROCKET	1		
4	Q3590019	圆键	ROUND KEY	1	5x7,5x19	
5	1111-1005015	曲轴	CRANKSHAFT	1		
6	1111-1005009	飞轮及齿圈总成	FLYWHEEL & RING GEAR	1		
7	1111-1005016	飞轮螺栓	FLYWHEEL BOLT	1		
8	6201	轴承	BEARING	1	6201	
9	1111-1002120	后油封	REAR OIL SEAL	1		
10	11-1600035	离合器从动片	CLUTCH DRIVEN DISC	1		
11	11-1600020	离合器压盘	CLUTCH PRESSURE DISC	1		
12	Q15000015	压盘螺栓	PRESSURE DISC BOLT	1	M8x15	
13	Q340308	弹簧垫圈	SPRING WASHER	1	8	
14	11Y-100504A	飞轮轴	DRIVE SHAFT PULLEY	1		电冷、油冷均用
15	Q15000014	螺栓	BOLT	2	M8x14	
16	Q300308	平垫圈	PLAIN WASHER	2	8	
17	Q340308	弹簧垫圈	SPRING WASHER	2	8	



# 凸轮轴及正时链轮 CAMSHAFT & TIMING SPROCKET

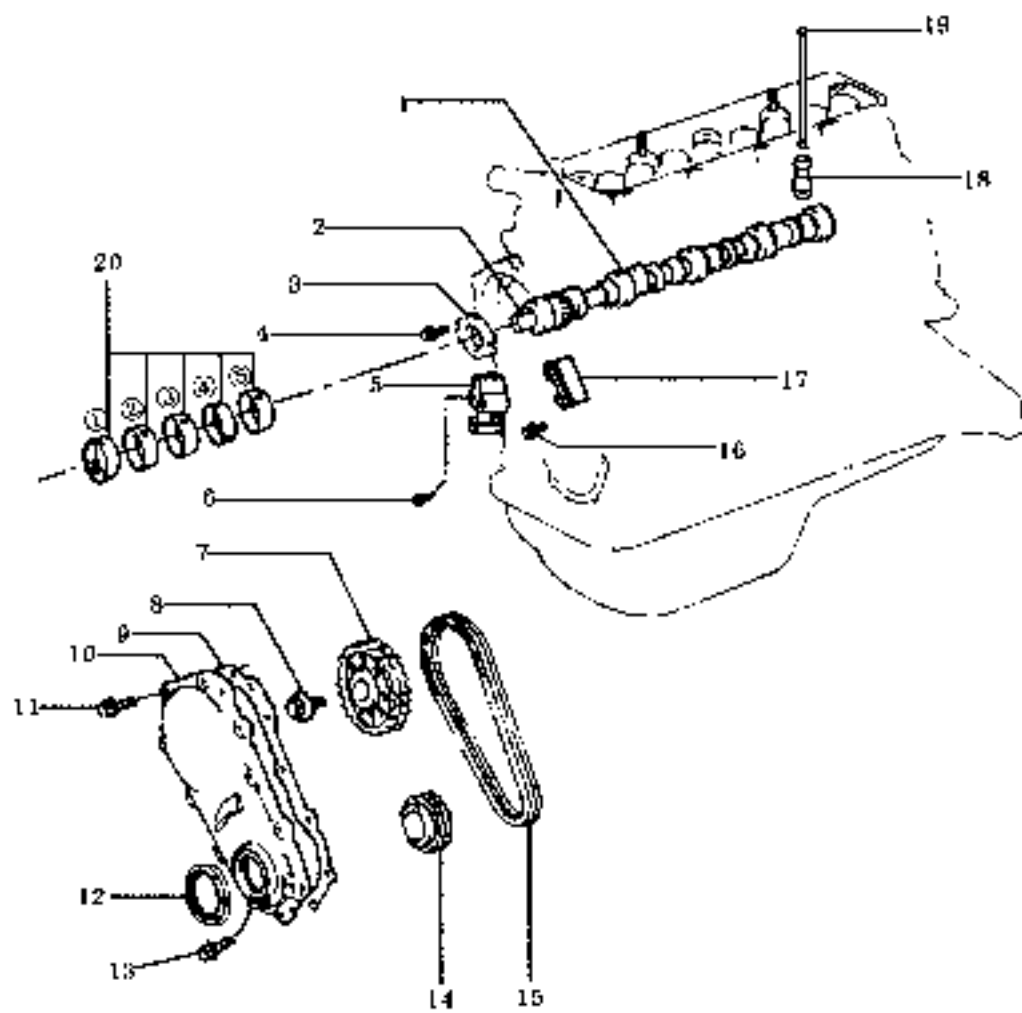

## 凸轮轴及正时链轮 CAMSHAFT & TIMING SPROCKET

序号	部件代码	部件名称	部件规格	用量	适用车型	备注
SN	PART CODE	DESCRIPTION	SPECIFICATION	QTY	VEHICLE MODEL	REMARK
1	11H-100605	凸轮轴	CAMSHAFT	1		
2	Q1500519	凸轮键	ROW NUT KEY	1		
3	11H-100601	衬套	THRUST PLATE	1		
4	Q1500016	螺栓	BOLT	2		
	Q40008	平垫圈	PLAIN WASHER	2		
	Q40008	弹簧垫圈	SPRING WASHER	2		
5	11H-100600	衬套	THROTTLE	1		
6	Q1500040	螺栓	BOLT	2		
	Q40008	弹簧垫圈	SPRING WASHER	2		
7	11H-100602	凸轮轴正时链轮	CAMSHAFT TIMING SPROCKET	1		
8	11H-100604	凸轮轴螺栓	CAMSHAFT BOLT	1		
	11H-100603	凸轮轴衬套	CAMSHAFT WASHER	1		
9	11H-100202	链轮室盖	SPROCKET CHAMBER COVER GASKET	1		
10	11H-100203	链轮室盖	SPROCKET CHAMBER COVER	1		
11	Q15000620	螺栓	BOLT	9		
	Q40008	平垫圈	PLAIN WASHER	9		
	Q40008	弹簧垫圈	SPRING WASHER	9		
12	11H-1002100	正时油封	FRONT OIL SEAL	1		
13	Q15000625	螺栓	BOLT	2		
	Q40006	平垫圈	WASHER	2		
	Q40006	弹簧垫圈	SPRING WASHER	2		
14	11H-1005012	曲轴正时链轮	CRANKSHAFT TIMING SPROCKET	1		

## 凸轮轴及正时链轮 CAMSHAFT & TIMING SPROCKET

序号	部件代码	部件名称	部件规格	用量	适用车型	备注
SN	PART CODE	DESCRIPTION	SPECIFICATION	QTY	VEHICLE MODEL	REMARK
15	11H-1000000	正时链条	TIMING CHAIN	1		
16	Q150B0016	垫片	BOET	2		
	Q40006	弹簧垫圈	SPRING WASHER	2		
17	11H-1009020	阻尼器	DAMPER	1		
18	11H-1007070	液压衬套	HYDRAULIC LIFTER	8		
19	11H-1002080	垫块	THRUST ROD	8		
20	11H-1002042	凸轮轴上轴衬套	CAMSHAFT BEARING SET A	1		
	11H-1002043	凸轮轴下轴衬套	CAMSHAFT BEARING SET B	1		
	11H-1002044	凸轮轴上轴衬套	CAMSHAFT BEARING SET C	1		
	11H-1002046	凸轮轴下轴衬套	CAMSHAFT BEARING SET D	1		
	11H-1002045	凸轮轴下轴衬套	CAMSHAFT BEARING SET A	1		

电喷型进排气系统组件 AIR INTAKE & EXHAUST(ELE FUEL INJECTION )

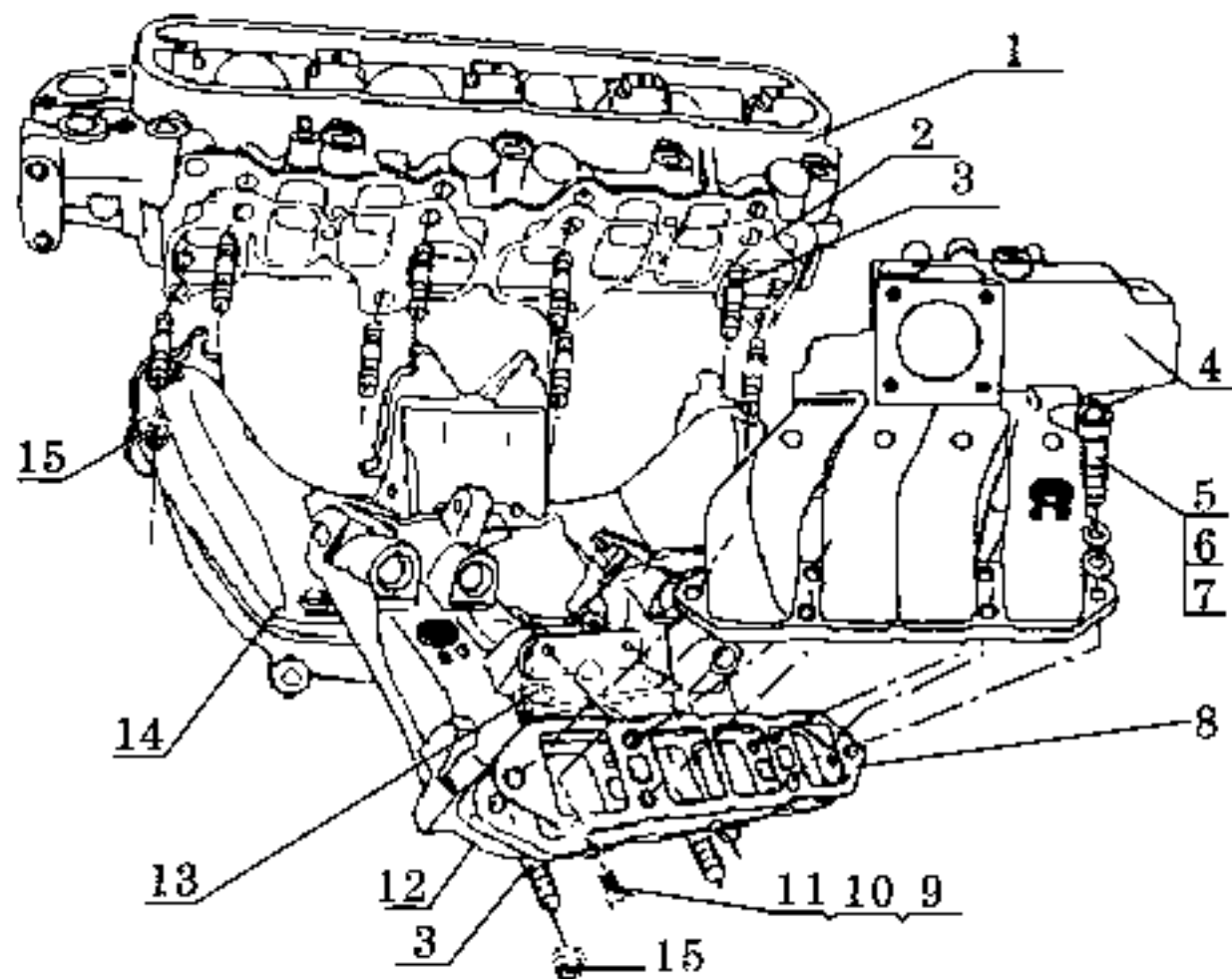

电喷型进排气系统组件 AIR INTAKE & EXHAUST(ELE FUEL INJECTION)

序号 SN	部件代码 PART CODE	部件名称 DESCRIPTION	部件规格 SPECIFICATION	用量 QTY.	适用车型 VEHICLE MODEL	备注 REMARK
1	11H-1000070	汽缸盖	CYLINDER HEAD	1		
2	11H-1000020	进气歧管垫总成	MANIFOLD GASKET KIT	1		
3	11H-1000014	进气歧管双头螺柱	MANIFOLD STUD BOLT	11		
4	11-1000042	进气歧管上体	INTAKE MANIFOLD UPPER BODY	1		
5	Q2100030	内六角螺柱	ALLEN SCREW	M8*30	6	
6	Q00308	弹簧垫圈	SPRING WASHER	3	6	
7	Q00108	平垫圈	PLAIN WASHER	3	6	
8	11-1000040	进气歧管下体总成零件	GASKET	1		
9	Q1500018	螺柱	BOLT	M6*18	2	
10	Q00406	弹簧垫圈	SPRING WASHER	4	2	
11	Q00106	平垫圈	PLAIN WASHER	6	2	
12	11-1000041	进气歧管下体	INTAKE MANIFOLD LOWER BODY	1		
13	11-1000043	线束护套	WIRE HARNESS INSULATOR	1		
14	11-1000051	排气歧管	EXHAUST MANIFOLD	1		
15	11H-1000015	进气歧管自锁螺母	MANIFOLD SELF LOCK NUT	M10*1.25	11	

机油泵 - 集滤器组件 OIL PUMP-STRAINER

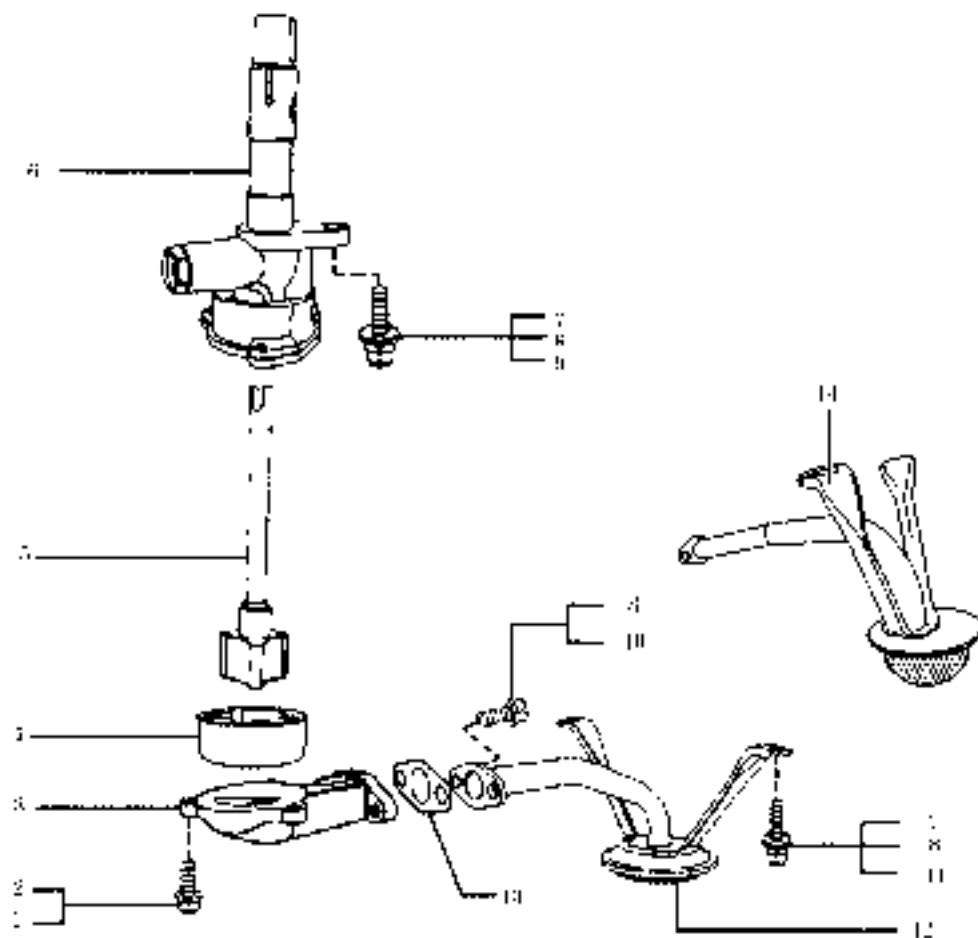

## 机油泵 - 集滤器组件 OIL PUMP-STRAINER

序号 S/N	部件代码 PART CODE	部件名称 DESCRIPTION	部件规格 SPECIFICATION	用量 QTY	适用车型 VEHICLE MODEL	备注 REMARK
	10H-1001020	机油泵总成	OIL PUMP	1		
1	Q150150618	螺栓	BOLT	3		
2	Q201006	弹簧垫圈	SPRING WASHER	5		
3	10H-1001026	机油泵盖	OIL PUMP COVER	1		
4	10H-1001025	机油泵外转子	OIL PUMP OUTER ROTOR	1		
5	10H-1001030	内转子与心轴轴套	INNER ROTOR & SHAFT	1		
6	10H-1001021	机油泵壳体	OIL PUMP HOUSING	1		
7	10H-1001010	平垫圈	PLAIN WASHER	5		
8	10H-1001010	弹簧垫圈	SPRING WASHER	5		
9	10H-1001010	螺母	NUT	1		机油泵 壳体
10	10H-1001010	螺栓	BOLT	2		集滤器 - 机油泵
11	10H-1001010	螺栓	BOLT	2		集滤器 - 壳体
12	10H-1001011	机油集滤器	OIL STRAINER	1		
13	10H-1001012	集滤器垫圈	STRAINER GASKET	1		
14	10V-1001020	机油集滤器(总成)	OIL STRAINER (4WD)	1		4WD

燃油系 ( - ) -DELPHI FUEL SYSTEM(1)

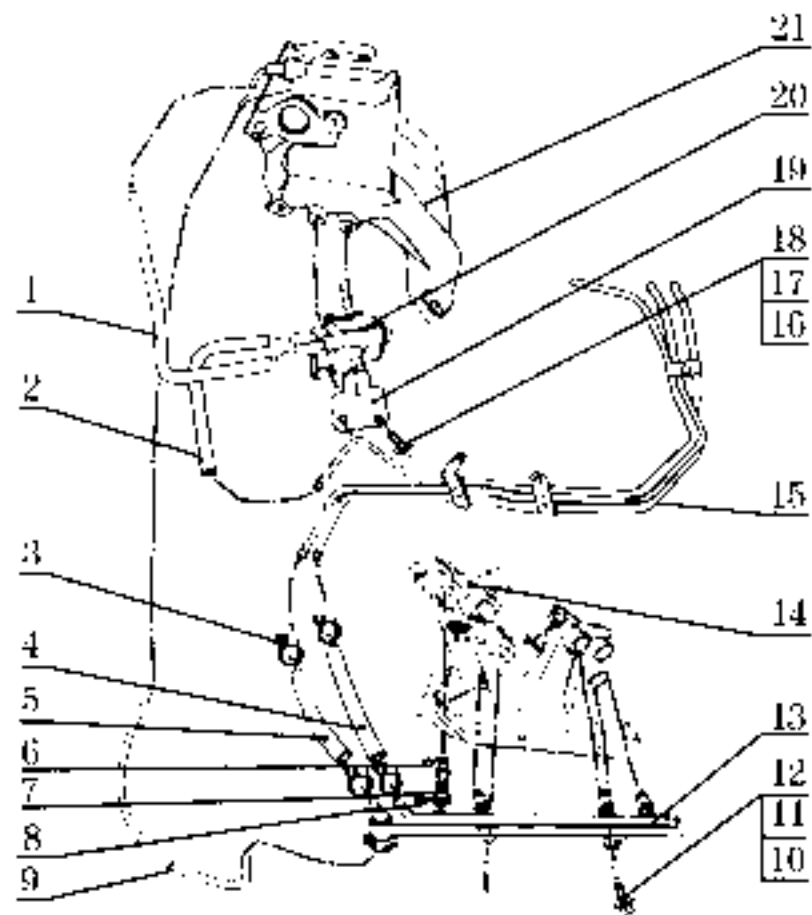



燃油系 (一) -DELPHI FUEL SYSTEM(1)

序号	部件代码	部件名称	部件规格	用量	适用车型	备注
S/N	PART CODE	DESCRIPTION	SPECIFICATION	QTY	VEHICLE MODEL	REMARK
1	11-3510012	炭罐总成(左侧)	CHARCOAL CANISTER FUEL FROM MAGNETIC VALVE HOSE II	1		
2	11-3510011	炭罐总成(右侧)	CHARCOAL CANISTER FUEL FROM MAGNETIC VALVE HOSE I	1		
3	Q07E09-1999	螺栓	CLIP	4		
4	11-1104101	进气管	INTAKE PIPE	1		
5	11-1104102	回油管	RETURN HOSE	1		
6	11-1112121	喷油嘴密封环	INJECTOR SEALING RING	4		
7	11-1112120	喷油器	INJECTOR	4		
8	11-1112122	喷油器-密封环(左侧)	SEALING RING	4		
9	11-1104104	压力调节器软管	PRESSURE REGULATOR HOSE	1		
10	Q150E0815	螺栓	BOLT	2	M6x25	
11	Q40108	平垫圈	PLAIN WASHER	2	6	
12	Q40308	弹簧垫圈	SPRING WASHER	2	6	
	11-1112100	燃油分配器总成	FUEL DISTRIBUTOR ASSY	1		
13	11-1112110	燃油分配器	FUEL DISTRIBUTOR	1		
14	11-1104001	进气总管	AIR INTAKE LOWER BODY	1		
15	11-1104130	汽油管焊接接头	GASOLINE PIPE WELDMENT	1		
16	Q150E0612	螺栓	BOLT	2	M6x12	
17	Q40106	平垫圈	PLAIN WASHER	2	6	
18	Q40306	弹簧垫圈	SPRING WASHER	2	6	

燃油系 (一) -DELPHI FUEL SYSTEM(1)

序号 S/N	部件代码 PART CODE	部件名称 DESCRIPTION	部件规格 SPECIFICATION	用量 QTY.	适用车型 VEHICLE MODEL	备注 REMARK
19	11-350013	碳罐电磁铁支架	CHARCOAL CANISTER ELECTROMAGNETIC VALVE BRACKET	1		
20	11-350014	碳罐电磁阀	CHARCOAL CANISTER ELECTROMAGNETIC VALVE	1		
21	11-1009042	进气歧管上体	AIR INTAKE UPPER BODY	1		

燃油系 (二) -UAES FUEL SYSTEM(2)

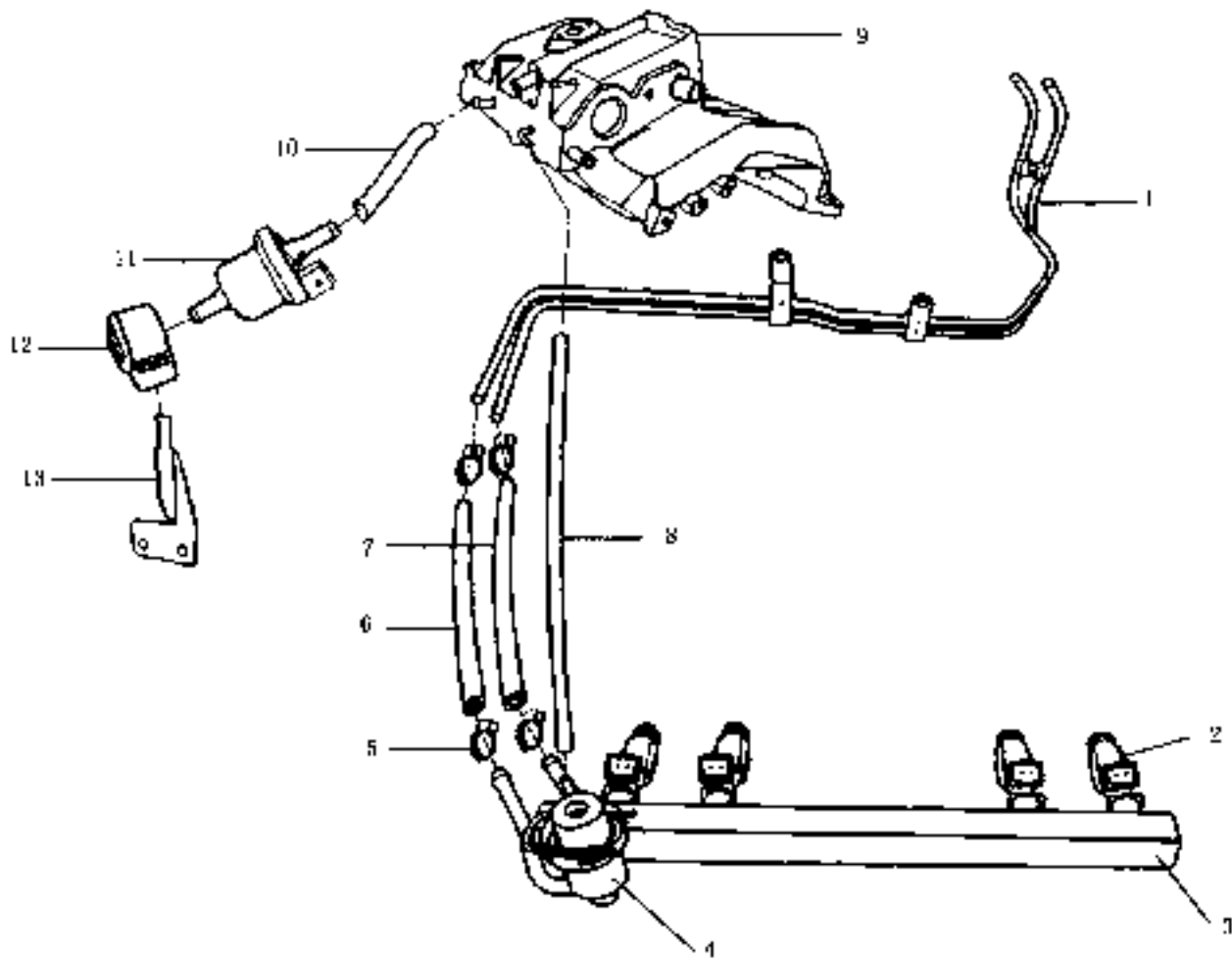

**燃油系 (二) -UAES FUEL SYSTEM(2)**

序号	部件代码	部件名称	部件规格	用量	适用车型	备注
SN	PART CODE	DESCRIPTION	SPECIFICATION	QTY.	VEHICLE MODEL	REMARK
1	H-11040206	汽油进回油管总成	FUEL INTAKE & RETURN PIPE WELDMENT ASSY	1		UAES
2	H-11121206	多油泵	INJECTOR	4		UAES
3	H-11121106	燃油分配器	FUEL DISTRIBUTOR	1		UAES
4	H-11121306	燃油压力调节阀	FUEL PRESSURE REGULATOR	1		UAES
5	QC71619-1999	密封垫圈	BOSE RING CLIP	4		
6	H-11040206	汽油回油软管	FUEL RETURN HOSE	1		UAES
7	H-11040101	汽油进油管	FUEL INTAKE HOSE	1		
8	H-11040301	燃油压力调节阀软管	FUEL PRESSURE REGULATOR HOSE	1		UAES
9	H-10080421	进油管上体	INTAKE MANIFOLD UPPER BODY	1		UAES
10	H-36041031	炭罐电磁阀	CHARCOAL CANISTER ELECTROMAGNETIC VALVE HOSE	1		UAES
11	H-36041001	炭罐电磁阀	CHARCOAL CANISTER ELECTROMAGNETIC VALVE	1		UAES
12	H-36041041	炭罐电磁阀软管	CHARCOAL CANISTER ELECTROMAGNETIC VALVE SLEEVE	1		UAES
13	H-36041031	炭罐电磁阀支架	CHARCOAL CANISTER ELECTROMAGNETIC VALVE BRACKET	1		UAES

风扇皮带轮 FAN PULLEY

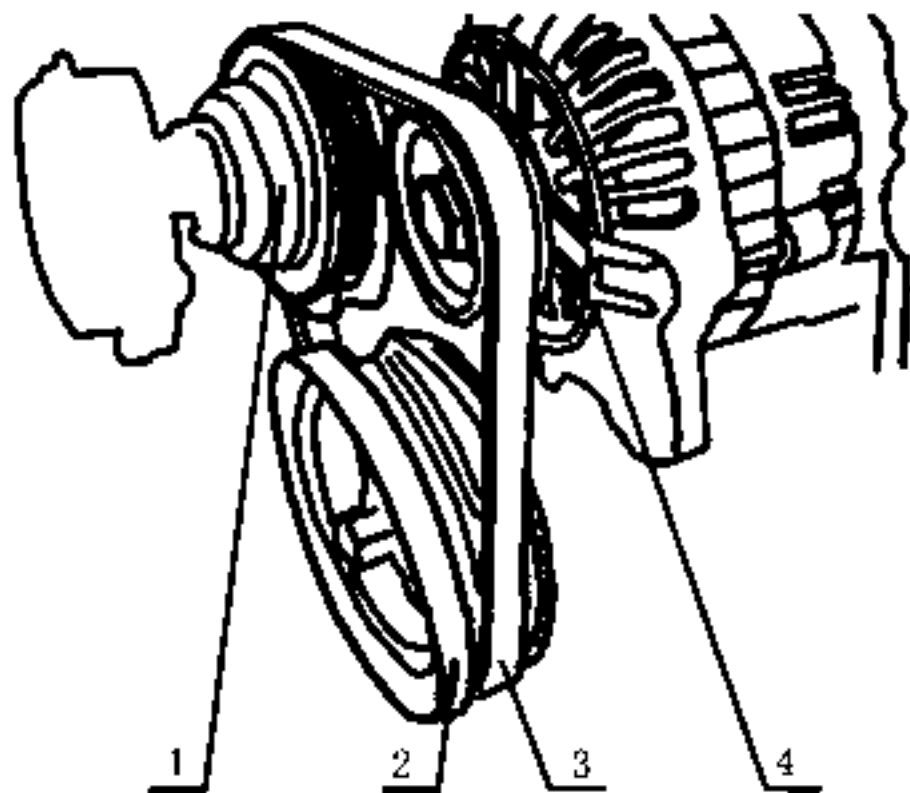

## 风扇皮带轮 FAN PULLEY

序号	部件代码	部件名称	部件规格	用量	适用车型	备注
S/N	PART CODE	DESCRIPTION	SPECIFICATION	QTY.	VEHICLE MODEL	REMARK
1	11H-1300041	风扇皮带轮	FAN PULLEY	1		
2	11H-1005022	减震皮带轮	DAMPING PULLEY	1		
3	11H-1300011	减震皮带	DAMPING BELT	1		
4	11H-3701020	发电机	GENERATOR	1		

水泵风扇组装 WATER PUMP FAN

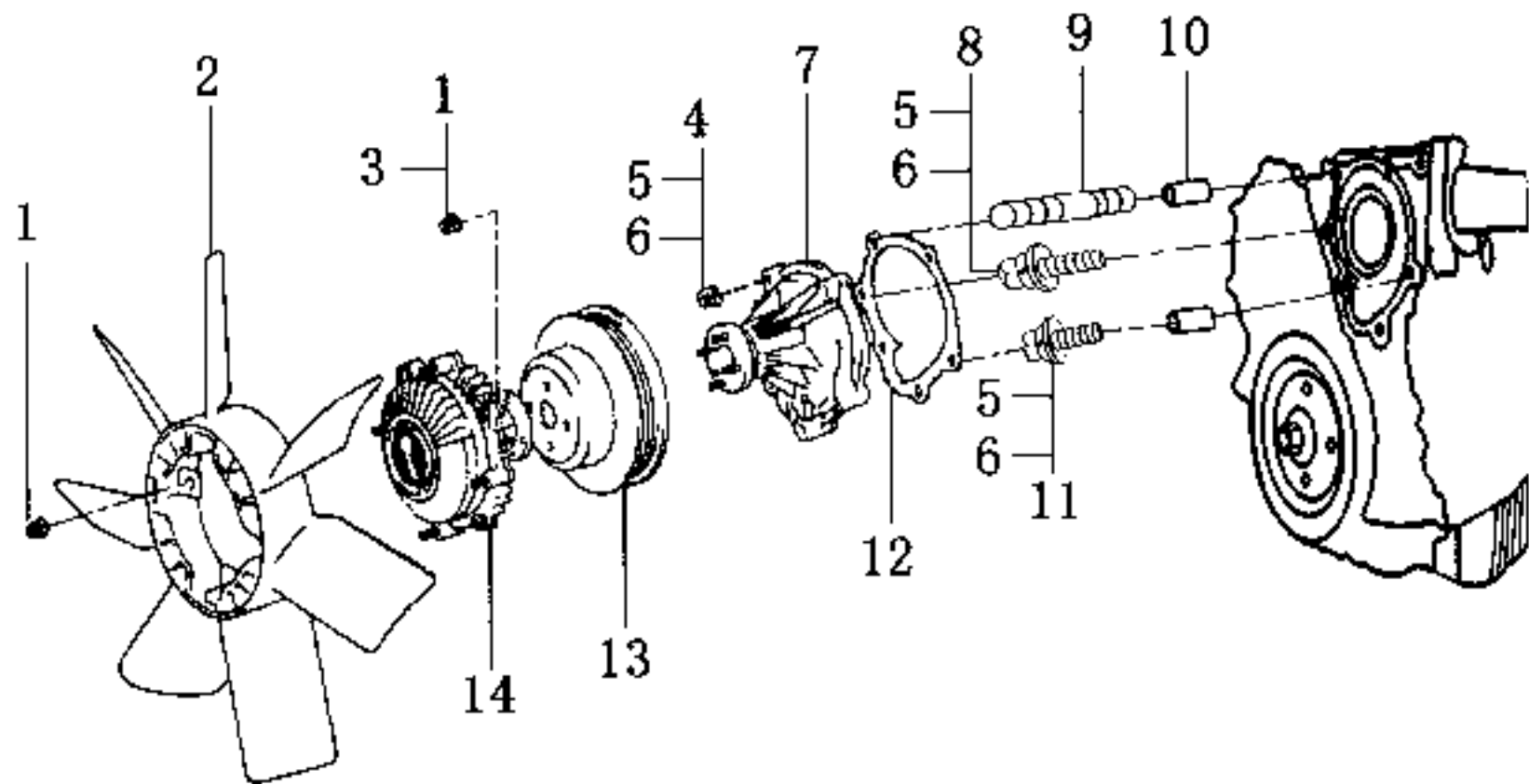

## 水泵风扇组装 WATER PUMP FAN

序号	部件代码	部件名称	部件规格	用量	适用车型	备注
S/N	PART CODE	DESCRIPTION	SPECIFICATION	QTY.	VEHICLE MODEL	REMARK
1	QJ400006	螺母	M6	8		
2	11-1300010	上叶片架组件	FAN KIT	1		
3	QJ40406	弹簧垫圈	SPRING WASHER	4		
4	QJ40008	螺母	M8	1		
5	QJ40008	弹簧垫圈	SPRING WASHER	4		
6	QJ40108	平垫圈	PLAIN WASHER	5		
7	11-1300020	水泵组件	WATER PUMP KIT	1		
8	QJ1500065	螺栓	BOLT	2		
9	QJ200060	六角螺母	STD BOLT	1		
10	11-1000052	水泵盖衬套	WATER PUMP COVER PIN BUSHING	2		
11	QJ1500060	螺栓	BOLT	2		
12	11-1300017	水泵密封垫	WATER PUMP GASKET	1		
13	11-1300041	水泵皮带轮	FAN PULLEY	1		
14	11-1300010	水泵皮带固定板	SEALING BELT CLIP BRASS	4		



怠速控制阀的安装 -UAES IDLE AIR CONTROL VALVE

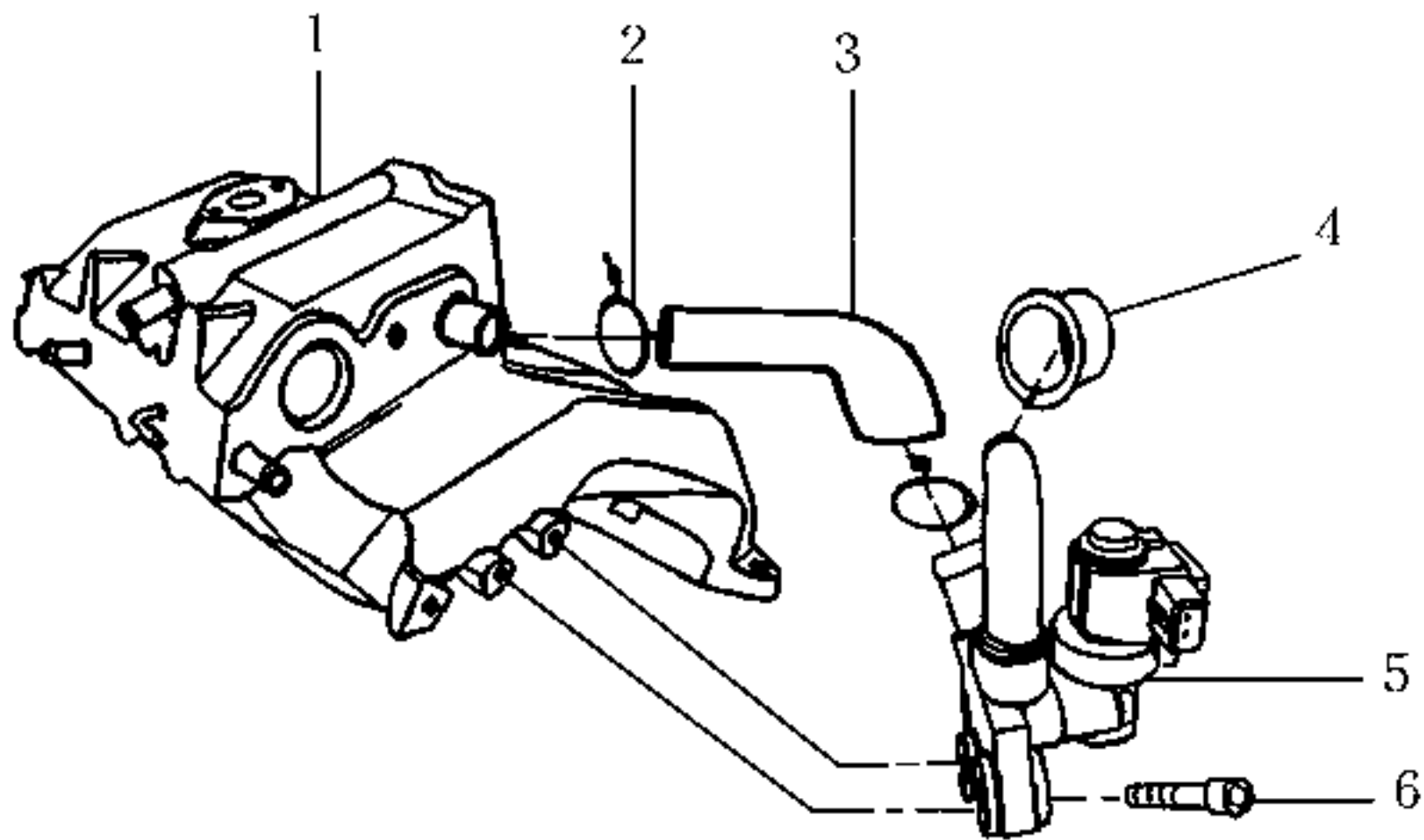

## 怠速控制阀的安装 -UAES IDLE AIR CONTROL VALVE

序号	部件代码	部件名称	部件规格	用量	适用车型	备注
S/N	PART CODE	DESCRIPTION	SPECIFICATION	QTY	VEHICLE MODEL	REMARK
1	11-10060420	进气歧管上体	INTAKE MANIFOLD UPPER BODY	1		UAES
2	067612	卡箍	CLIP	3		
3	11-30060018	怠速控制阀-进气-橡胶管	IAC VALVE INTAKE HOSE	1		UAES
4	11-30040050	怠速进气孔橡胶帽	IDLE INTAKE PORT RUBBER CAP	1		UAES
5	11-30060008	怠速控制阀安装支架	IAC VALVE BRACKET ASSY	1		UAES
6	0917400690	六角螺栓 M5*20	HEX SCREW	2		

节气门体的装配 THROTTLE VALVE BODY

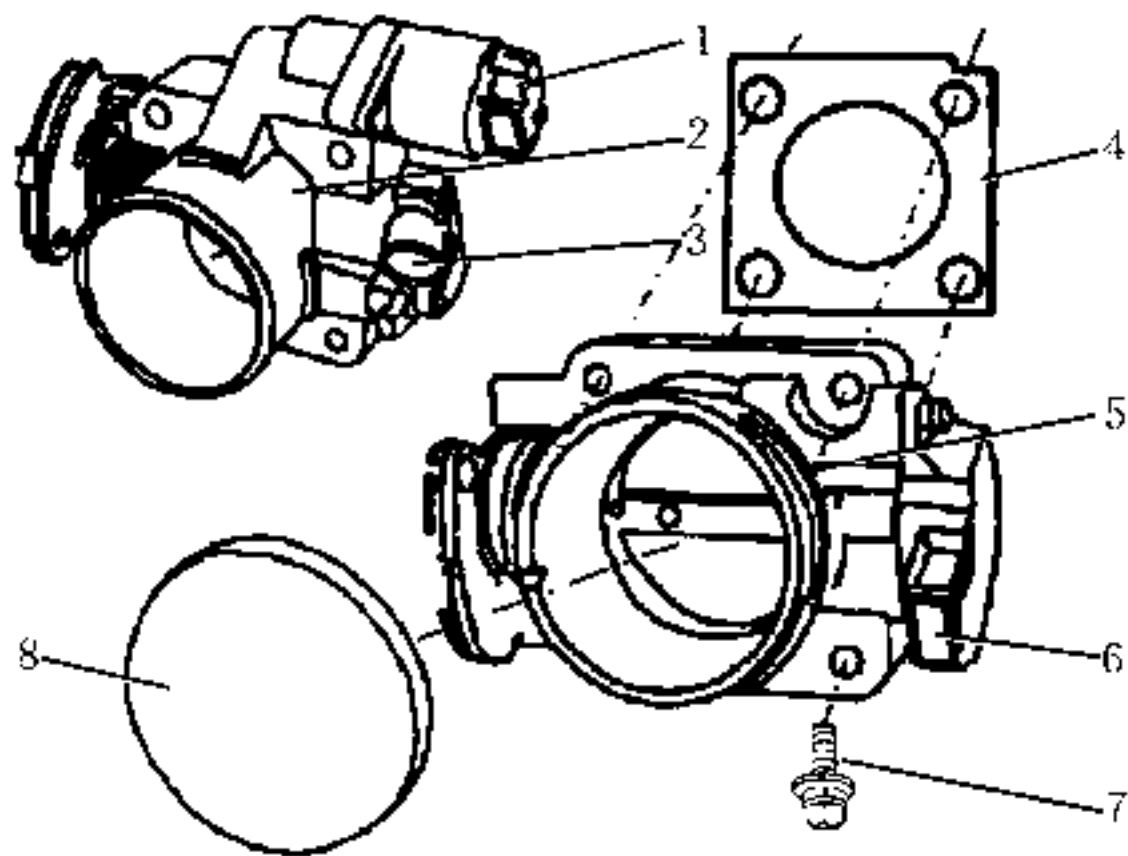

## 节气门体的装配 THROTTLE VALVE BODY

序号 S/N	部件代码 PART CODE	部件名称 DESCRIPTION	部件规格 SPECIFICATIONS	用量 QTY	适用车型 VEHICLE MODEL	备注 REMARK
1	11-3728010	怠速步进电机	STEPPER MOTOR FOR IDLE-SPEED CONTROL	1		
2	11-1008110	节气门体	THROTTLE BODY	1		
3	11-3600030	节气门位置传感器	THROTTLE POSITION SENSOR	1		
4	11-1008101	节气门垫圈	THROTTLE GASKET	1		
5	11-1008100B	节气门体	THROTTLE BODY	1		
6	11-3600030B	节气门位置传感器	THROTTLE POSITION SENSOR	1		IAPN
7	Q150H0640	螺栓	BOLT	M6x40	4	
	Q4040	锥形弹簧垫圈	SPRING WASHER	h	4	
	Q4010	平垫圈	PLAIN WASHER	h	4	
8	11-1008101	节气门体总成	THROTTLE BODY	1		

进气压力传感器 (一) AIR INTAKE PRESSURE SENSOR(1)

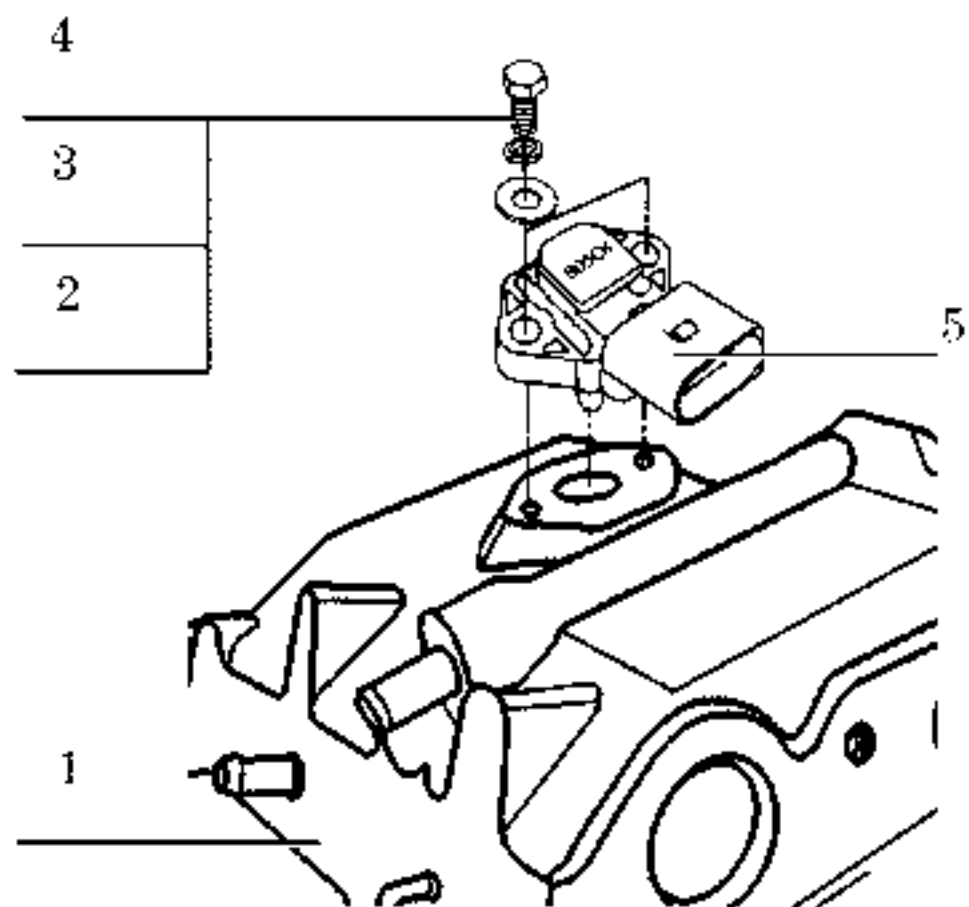

进气压力传感器 ( - ) AIR INTAKE PRESSURE SENSOR(1)

序号 SN	部件代码 PART CODE	部件名称 DESCRIPTION	部件规格 SPECIFICATION	用量 QTY	适用车型 VEHICLE MODEL	备注 REMARK
1	13-1106042B	进气歧管上体	INTAKE MANIFOLD UPPER BODY	1		TAFS
2	Q15050612	螺母	NUT	2		
3	QJ0106	弹簧垫圈	SPRING WASHER	2		
4	QJ0106	平垫圈	PLAIN WASHER	2		
5	11-3610040H	进气压力感应电桥传感器	AIR INTAKE PRESSURE & TEMPERATURE SENSOR	1		TAFS

进气压力传感器 (二) AIR INTAKE PRESSURE SENSOR(2)

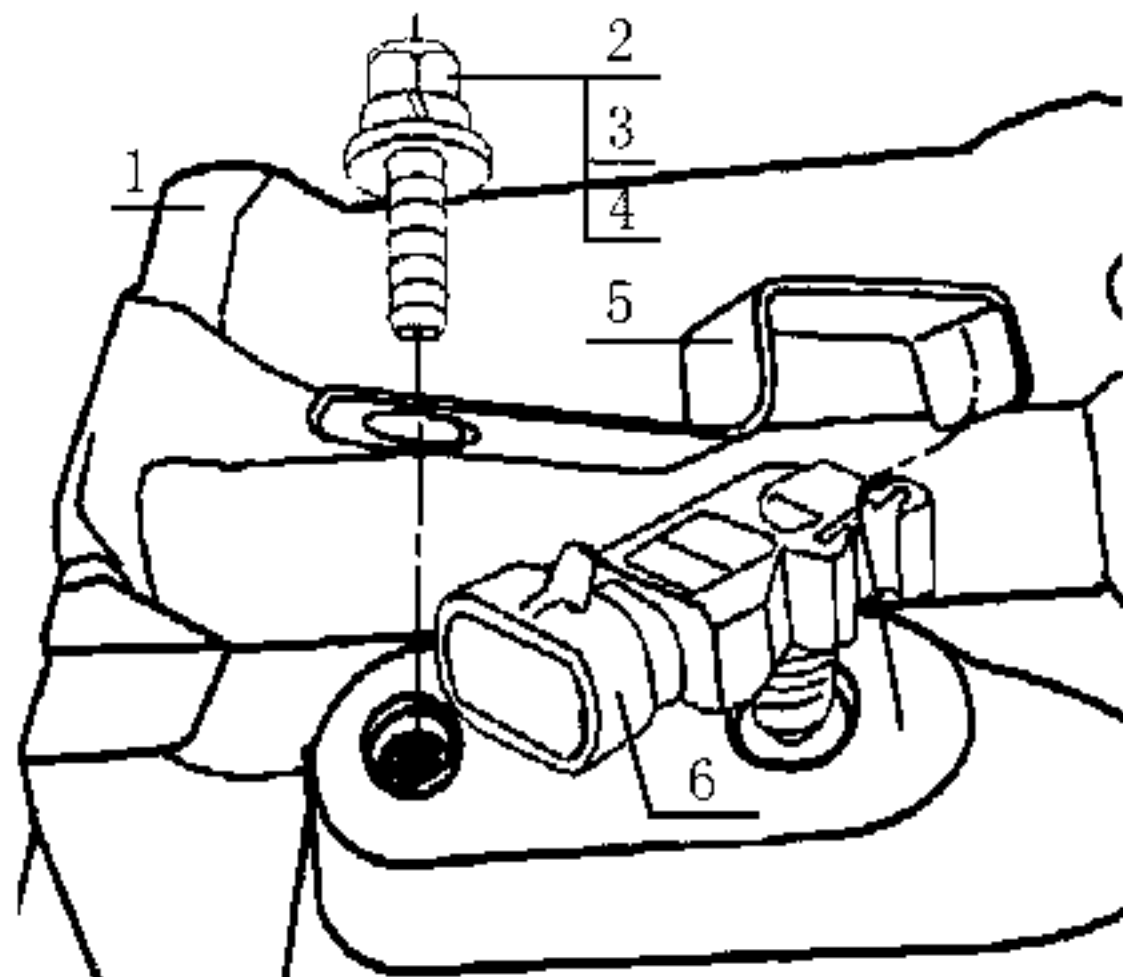

## 进气压力传感器 (二) AIR INTAKE PRESSURE SENSOR(2)

序号	部件代码	部件名称	部件规格	用量	适用车型	备注
SN	PART CODE	DESCRIPTION	SPECIFICATION	QTY	VEHICLE MODEL	REMARK
1	12-1000142	进气歧管上体	INTAKE MANIFOLD UPPER BODY	1		
2	6102783-06	螺栓	BOLT	1		
3	620059-07	弹簧垫圈	SPRING WASHER	1		
4	610971-05	平垫圈	PLAIN WASHER	1		
5	11-3609301	进气压力传感器支架	ABSOLUTE PRESSURE SENSOR BRACKET	1		
6	11-3609300	进气压力传感器	ABSOLUTE PRESSURE SENSOR	1		



进气温度传感器 AIR INTAKE TEMPERATURE SENSOR

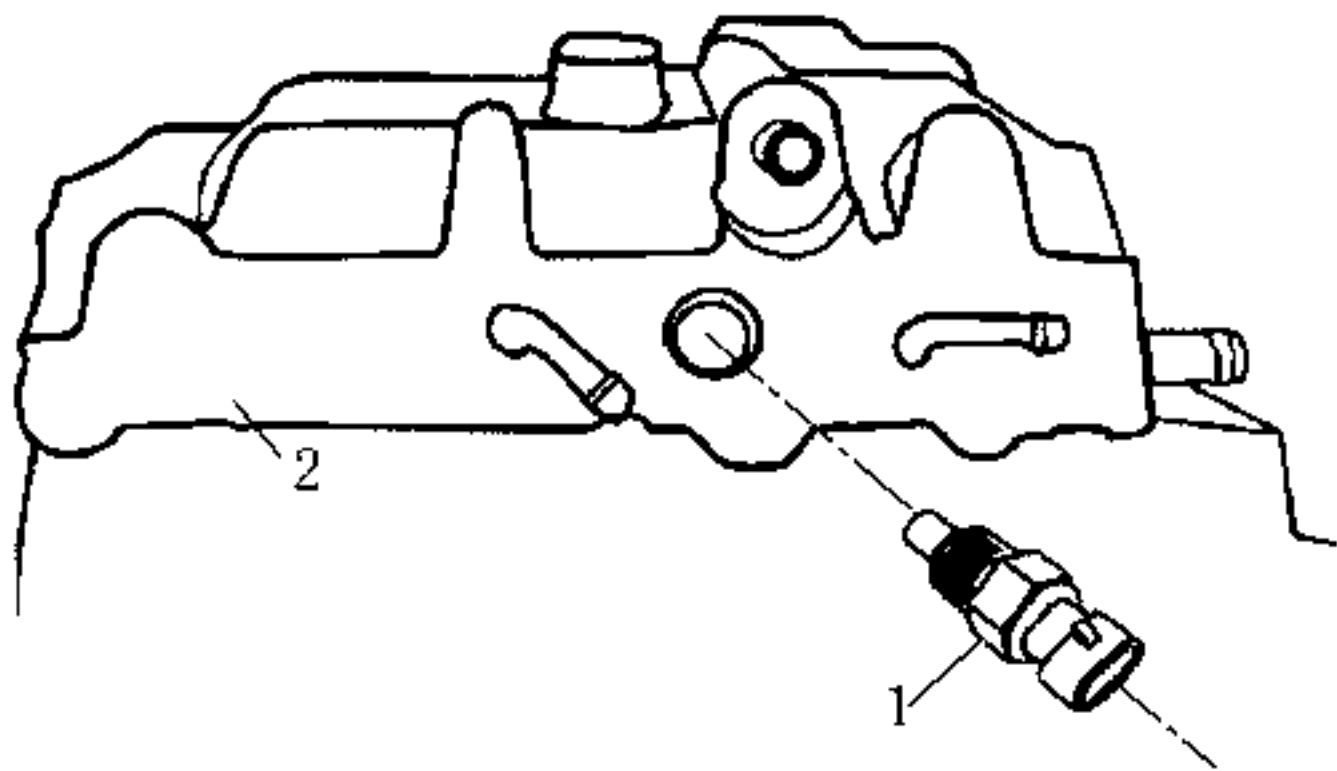

## 进气温度传感器 AIR INTAKE TEMPERATURE SENSOR

序号	部件代码	部件名称	部件规格	用量	适用车型	备注
SN	PART CODE	DESCRIPTION	SPECIFICATION	QTY	VEHICLE MODEL	REMARK
1	11-J609310	进气温度传感器	AIR INTAKE TEMPERATURE SENSOR	1		
2	11-1000642	进气歧管垫板	AIR INTAKE MANIFOLD	1		

曲轴位置传感器 CRANKSHAFT POSITION SENSOR

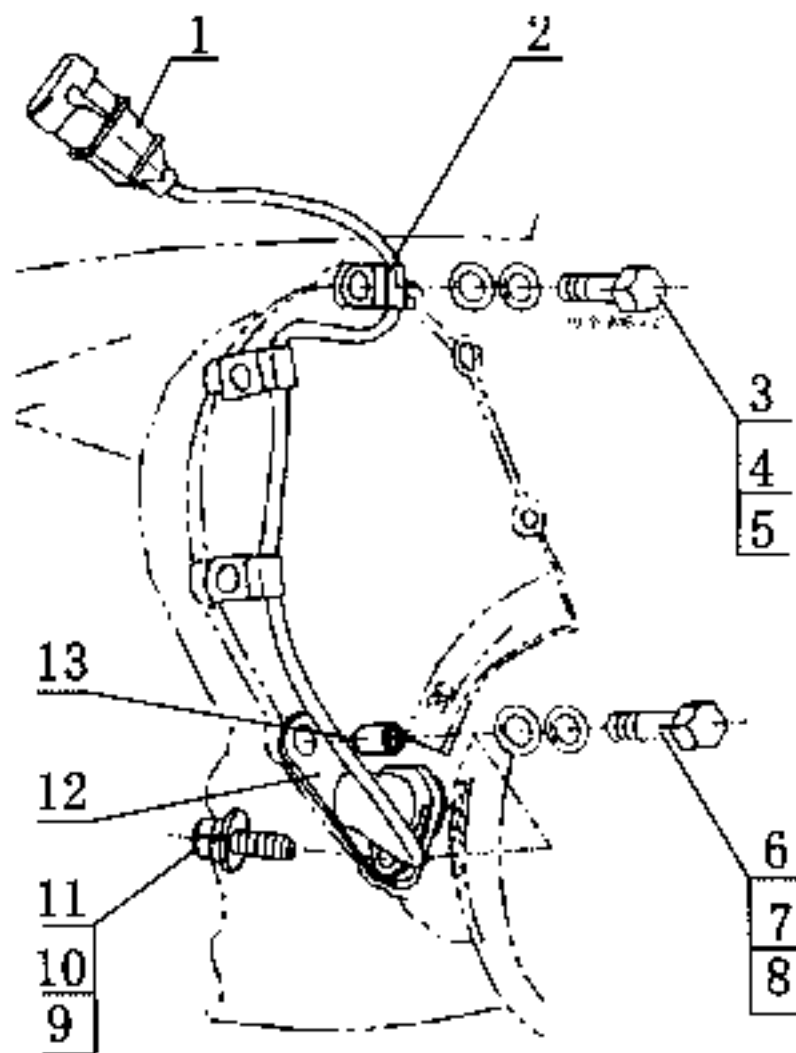

## 曲轴位置传感器 CRANKSHAFT POSITION SENSOR

序号	部件代码	部件名称	部件规格	用量	适用车型	备注
NO.	PART CODE	DESCRIPTION	SPECIFICATION	QTY.	VEHICLE MODEL	REMARK
1	11-3619400	曲轴位置传感器	CRANKSHAFT POSITION SENSOR	1		
2	11-3619400	曲轴位置传感器线束	CRANKSHAFT POSITION SENSOR WIRE CLIP	1		
3	Q15010820	螺母	BOLT	M8x20	4	
4	Q40108	弹簧垫圈	SPRING WASHER	4		
5	Q40108	平垫圈	PLAIN WASHER	4		
6	Q15010625	螺母	BOLT	M6x25	2	
7	Q40106	弹簧垫圈	SPRING WASHER	4		
8	Q40106	平垫圈	PLAIN WASHER	4		
9	15010612	螺母	BOLT	M6x12	1	
10	Q40106	弹簧垫圈	SPRING WASHER	6		
11	Q40106	平垫圈	PLAIN WASHER	6		
12	11-3619400	曲轴位置传感器支架	CRANKSHAFT POSITION SENSOR ENSURE BRACKET	1		
13	11-3619400	曲轴位置传感器支架固定件	CRANKSHAFT POSITION SENSOR BRACKET BOWEL PIN	1		

曲轴位置传感器 CRANKSHAFT POSITION SENSOR

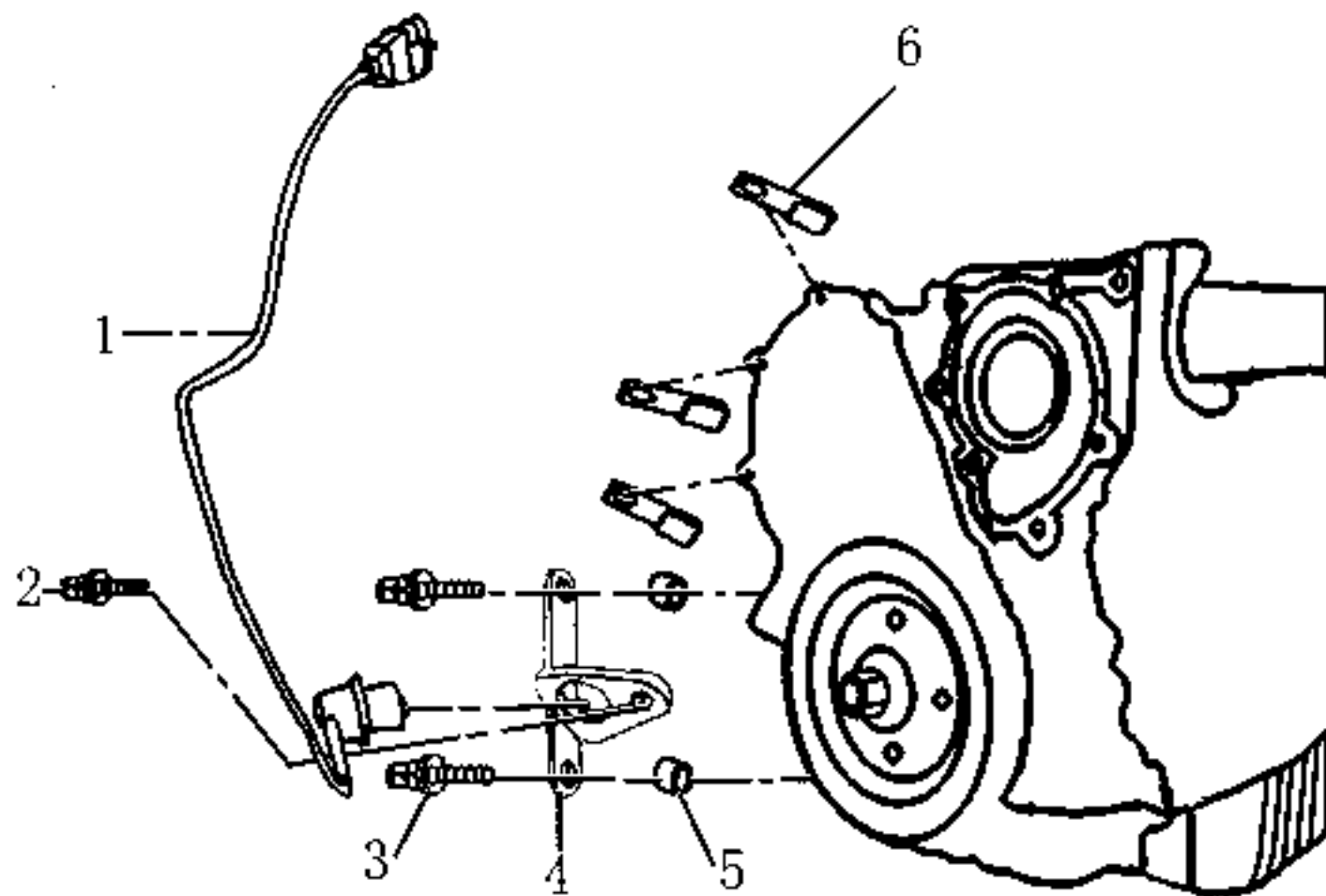

## 曲轴位置传感器 CRANKSHAFT POSITION SENSOR

序号	部件代码	部件名称	部件规格	用量	适用车型	备注
S.N.	PART CODE	DESCRIPTION	SPECIFICATION	QTY	VEHICLE MODEL	REMARK
1	11-26094000	曲轴位置传感器	CRANKSHAFT POSITION SENSOR	1	CAFS	CAFS
2	Q15000612	螺栓	BOLT	4		
	Q40406	弹簧垫圈	SPRING WASHER	4		
	Q40106	平垫圈	PLAIN WASHER	4		
3	Q15000625	螺栓	BOLT	2		
	Q40406	弹簧垫圈	SPRING WASHER	2		
	Q40106	平垫圈	PLAIN WASHER	2		
4	11-26094000	曲轴位置传感器支架	CRANKSHAFT POSITION SENSOR BRACKET	1	CAFS	CAFS
5	11-26094020	定位销套	DRIVE PIN BUSHING	2	CAFS	CAFS
6	11-26094030	曲轴位置传感器线卡	CRANKSHAFT SENSOR WIRE CLIP	3	CAFS	CAFS

# 冷却液温度传感器的安装 COOLANT TEMPERATURE SENSOR

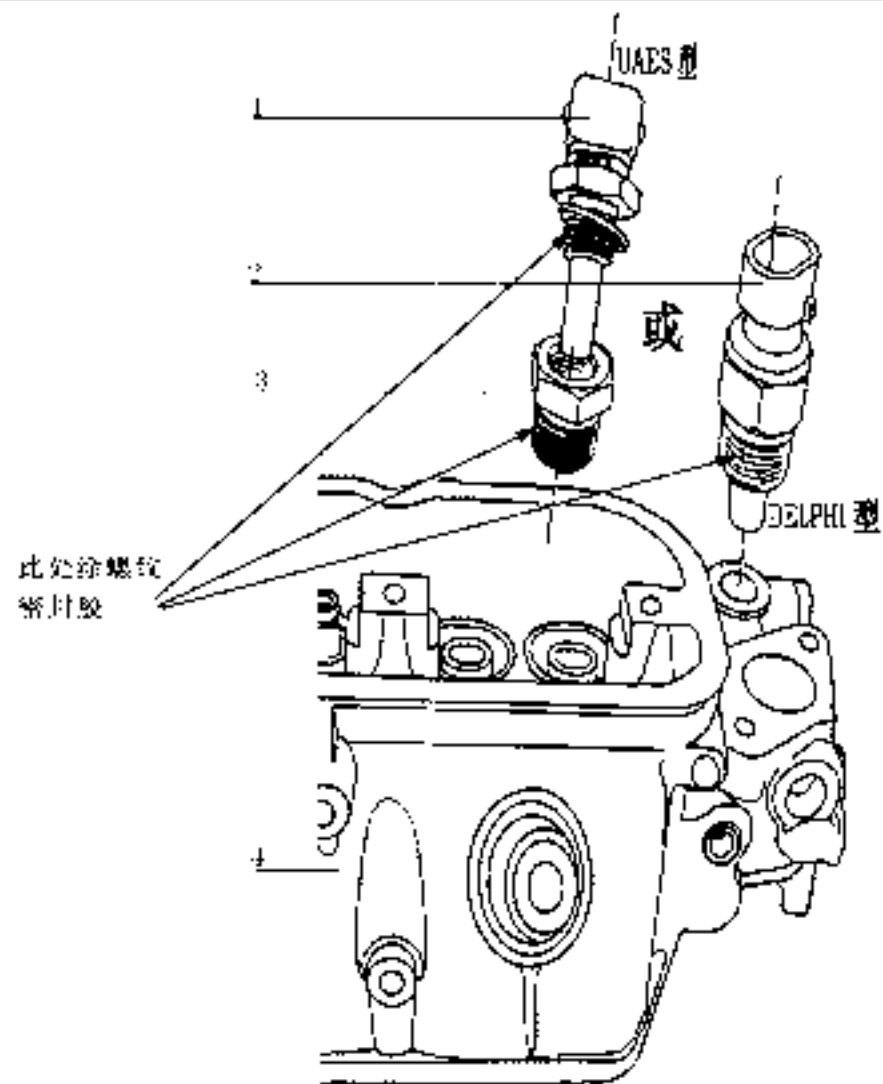

## 冷却液温度传感器的安装 COOLANT TEMPERATURE SENSOR

序号	部件代码	部件名称	部件规格	用量	适用车型	备注
SN	PART CODE	DESCRIPTION	SPECIFICATION	QTY	VEHICLE MODEL	REMARK
1	11-3609500B	冷 液 温 度 传 感 器	COOLANT TEMPERATURE SENSOR	1	CAES	CAES
2	11-3609500	冷 液 温 度 传 感 器	COOLANT TEMPERATURE SENSOR	1		备件型号
3	11-3609501B	冷 液 温 度 传 感 器 插 头	COOLANT TEMPERATURE SENSOR PLUG	1	CAES	CAES
4	11-1180970	缸 盖	CYLINDER HEAD	1		



分电器及阻尼线的装配 - 化油器型 DISTRIBUTOR & DAMPING CABLE (CARBURETOR TYPE)

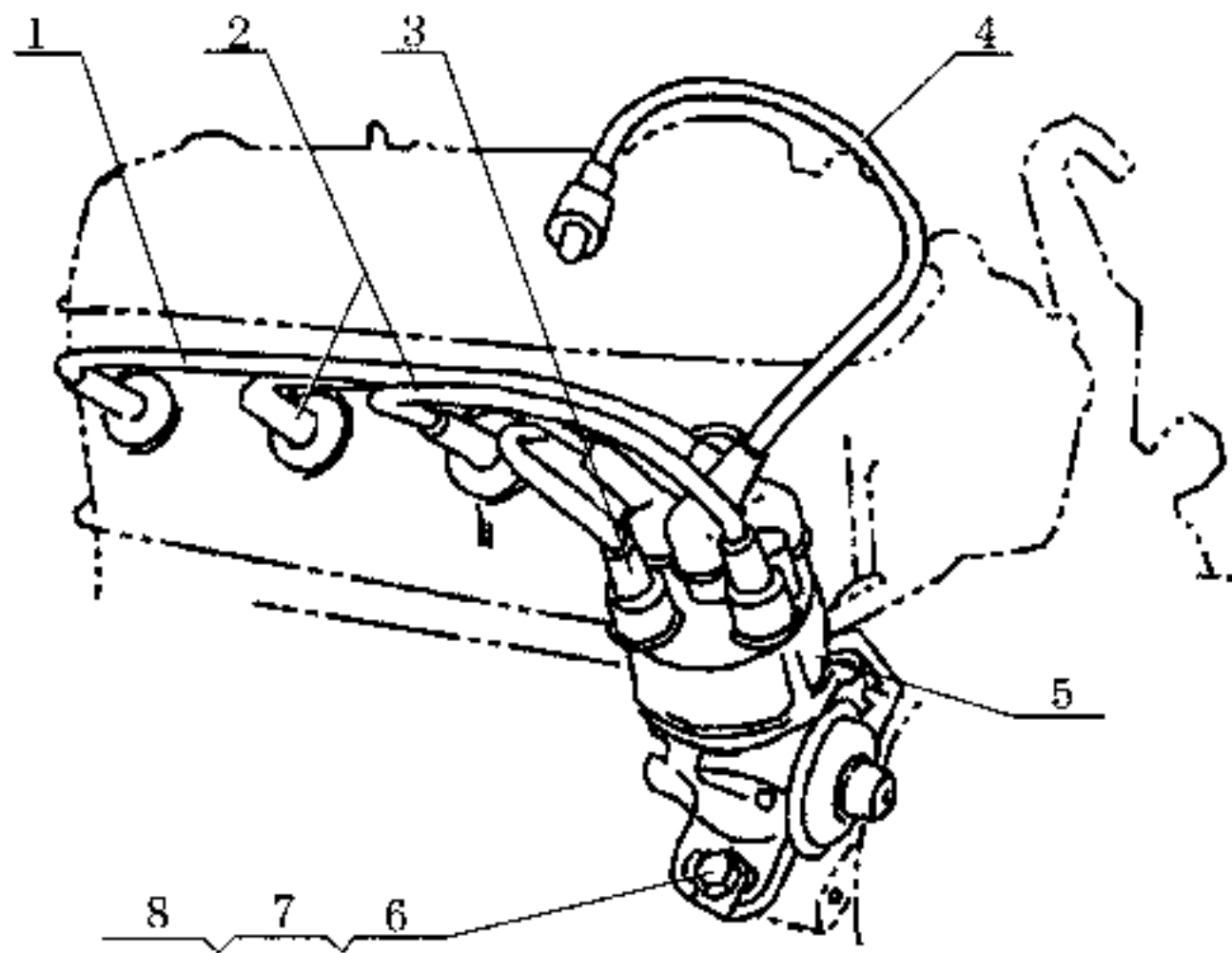

分电器及阻尼线的装配 - 化油器型 DISTRIBUTOR & DAMPING CABLE (CARBURETOR TYPE)

序号	部件代码	部件名称	部件规格	用量	适用车型	备注
SN	PART CODE	DESCRIPTION	SPECIFICATION	QTY	VEHICLE MODEL	RE-MARK
	111-3700120	高压线总成	HIGH VOLTAGE WIRE SET			
1	111-3700124	4缸汽缸线	4TH CYLINDER HIGH VOLTAGE WIRE	1		
2	111-3700127	2缸汽缸线	2ND & 3RD CYLINDER HIGH VOLTAGE WIRE	2		
3	111-3700120	1缸汽缸线	1ST CYLINDER HIGH VOLTAGE WIRE	1		
4	111-3700125	点火线圈至分电器总成	HIGH VOLTAGE WIRE FROM IGNITION COIL TO DISTRIBUTOR	1		
5	111-3706021	分电器壳	DISTRIBUTOR HOUSING	1		
6	Q12000025	螺栓	BOLT	1	M8x25	
7	Q30408	弹簧垫圈	SPRING WASHER	1	8	
8	111-3706011	分电器垫圈	DISTRIBUTOR WASHER	1		

点火线圈及高压阻尼线 - DELPHI IGNITION CIL & HIGH VOLTAGE DAMPING WIRE

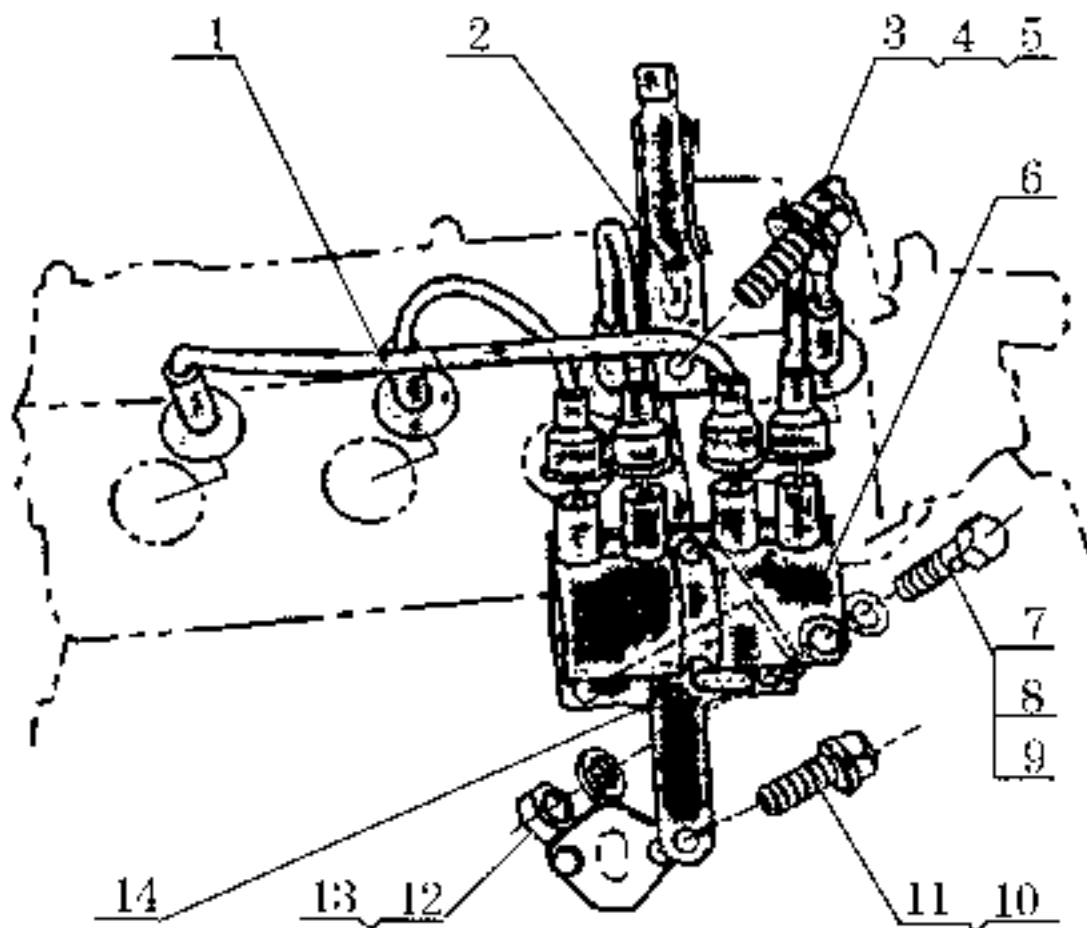

点火线圈及高压阻尼线 -DELPHI IGNITION COIL & HIGH VOLTAGE DAMPING WIRE

序号	零件代码	零件名称	零件规格	用量	适用车型	备注
SN	PART CODE	DESCRIPTION	SPECIFICATION	QTY.	VEHICLE MODEL	REMARK
1	IL-5705100	高压阻尼线	HIGH VOLTAGE DAMPING WIRE	1 套		分孔位安装
2	IL-1106201	加速踏板架 II	ACCELERATOR CABLE BRACKET II	1		不装
3	Q15040920	螺母	BOLT	M8x20	1	
4	Q40306	平垫圈	PLAIN WASHER	8	1	
5	Q40308	弹簧垫圈	SPRING WASHER	8	1	
6	IL-5705100	点火线圈	IGNITION COIL	1		
7	Q15040635	螺母	BOLT	M6x35	2	
8	Q40406	弹簧垫圈	SPRING WASHER	6	2	
9	Q40106	平垫圈	PLAIN WASHER	6	2	
10	Q15040820	螺母	BOLT	M8x20	1	
11	Q40308	弹簧垫圈	SPRING WASHER	8	1	
12	Q40406	螺母	NUT	M6	3	
13	Q40406	平垫圈	PLAIN WASHER	6	3	
14	IL-5705101	点火线圈 2 支	IGNITION COIL BRACKET	1		

点火线圈及高压阻尼线 -UAES IGNITION COIL & HIGH VOLTAGE DAMPING WIRE

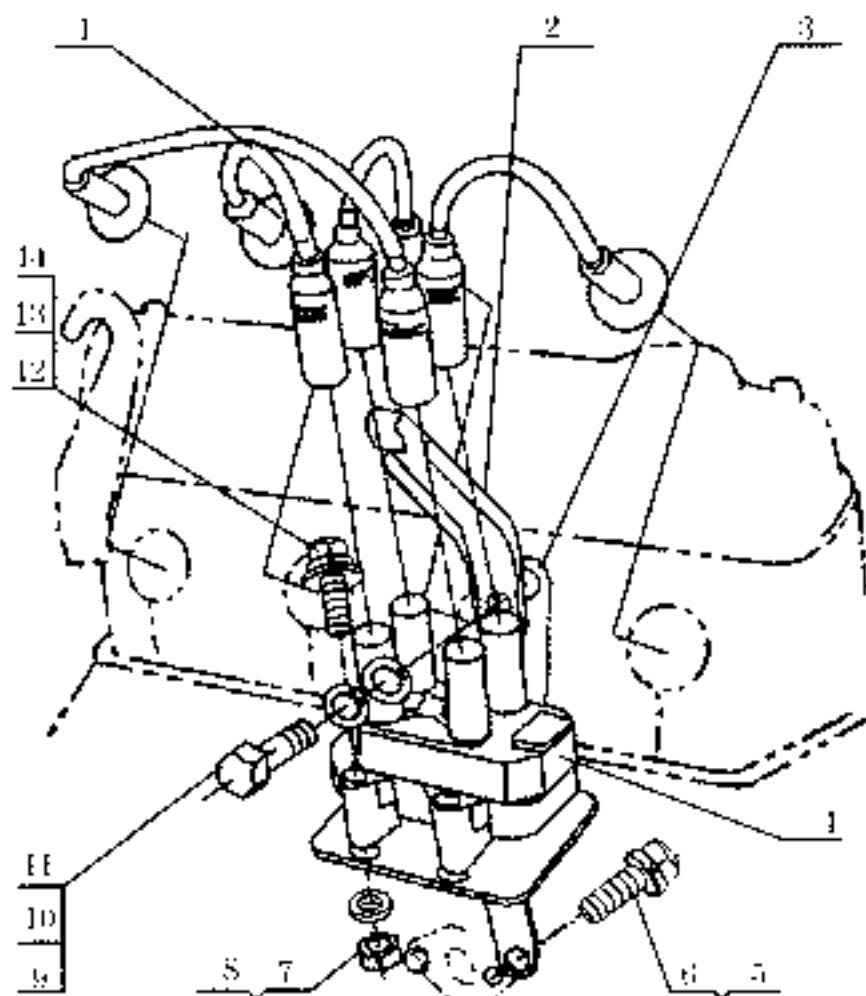

点火线圈及高压阻尼线 -UAES IGNITION COIL & HIGH VOLTAGE DAMPING WIRE

序号 S/N	部件代码 PART CODE	部件名称 DESCRIPTION	部件规格 SPECIFICATION	用量 QTY.	适用车型 VEHICLE MODEL	备注 REMARK
1	11-27071000	高压阻尼线	HIGH VOLTAGE DAMPING WIRE	4 只		UAFS
2	11-1108101	加速线圈支架	ACCELERATOR COIL BRACKET	1		
3	11-37051000	点火线圈支架	IGNITION COIL BRACKET	1		UAFS
4	11-37051000	点火线圈	IGNITION COIL	1		UAFS
5	Q15010020	螺母	BOLT	1	M8*20	
6	Q40308	弹簧垫圈	SPRING WASHER	1	8	
7	Q301006	螺母	NUT	4	M6	
8	Q40106	平垫圈	PLAIN WASHER	4	6	
9	Q15010020	螺母	BOLT	1	M8*20	
10	Q40108	平垫圈	PLAIN WASHER	1	8	
11	Q40308	弹簧垫圈	SPRING WASHER	1	8	
12	Q15010020	螺母	BOLT	4	M8*20	
13	Q40406	弹簧垫圈	SPRING WASHER	4	6	
14	Q40106	平垫圈	PLAIN WASHER	4	6	

相位传感器 -UAES PHASE SENSOR

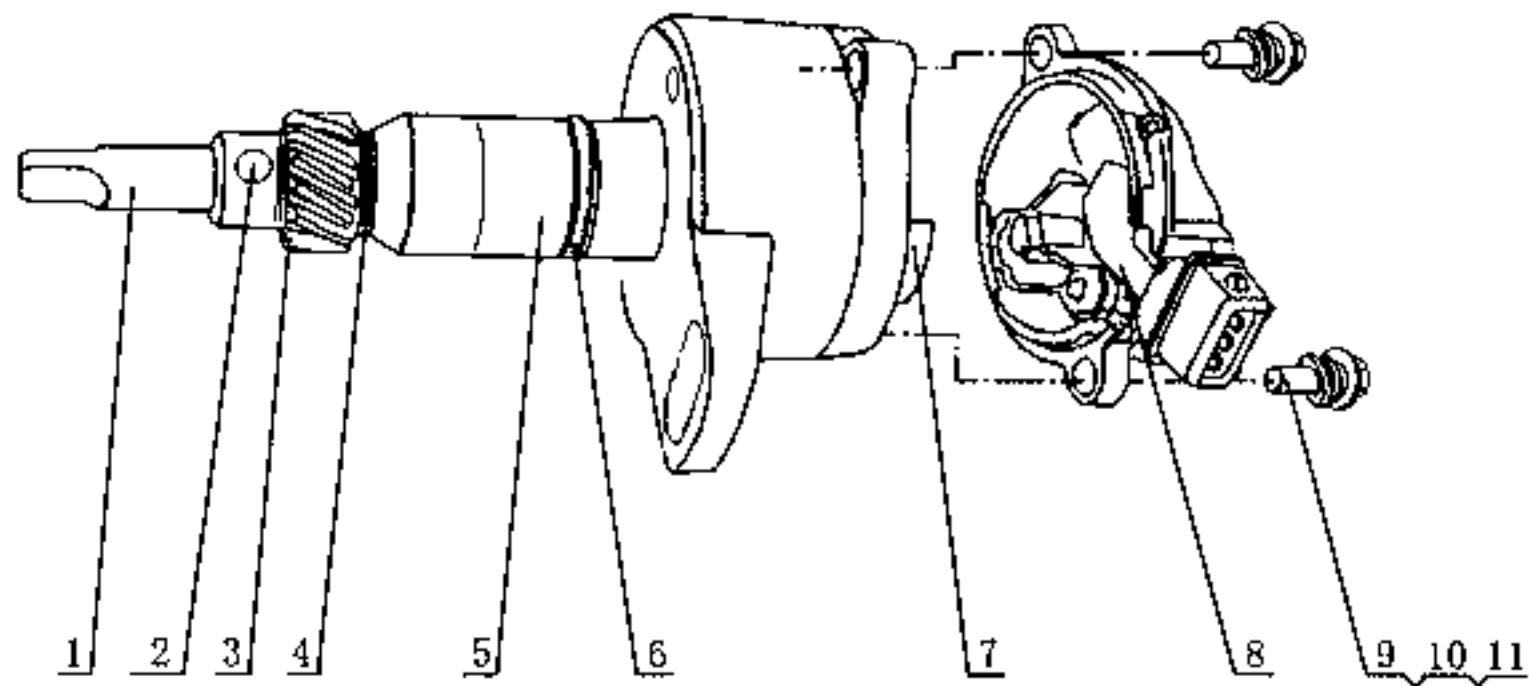

## 相位传感器 -UAES PHASE SENSOR

序号	部件代码	部件名称	部件规格	用量	适用车型	备注
SN	PART CODE	DESCRIPTION	SPECIFICATION	QTY	VEHICLE MODEL	REMARK
	11-36002000	相位传感器及机油泵总成	PHASE SENSOR & OIL PUMP PROPELLER SHAFT	1		UAES
	11-3600050	相位传感器总成	PHASE SENSOR BRACKET ASSY	1		UAES
1	11-3600051	传动轴	PROPELLER SHAFT	1		UAES
2	11-3600052	驱动齿轮销	DRIVE GEAR PIN	1		UAES
3	11-3600053	驱动齿轮	DRIVE GEAR	1		UAES
4	11-3600054	铜垫圈	BRONZE WASHER	1		UAES
5	11-3600055	传动轴外壳	PROPELLER SHAFT HOUSING	1		UAES
6	11-3600056	垫片垫圈	WASHER	1		UAES
7	11-3600057	相位信号轮	PHASE SIGNAL PULLEY	1		UAES
8	11-36002100	相位传感器	PHASE SENSOR	1		UAES
9	Q1300600	法兰螺栓	FLANGE BOLT	2		
10	Q40006	弹簧垫圈	SPRING WASHER	6		
11	Q10006	平垫圈	PLAIN WASHER	6		



线束组件 -DELPHI WIRING HARNESS SET

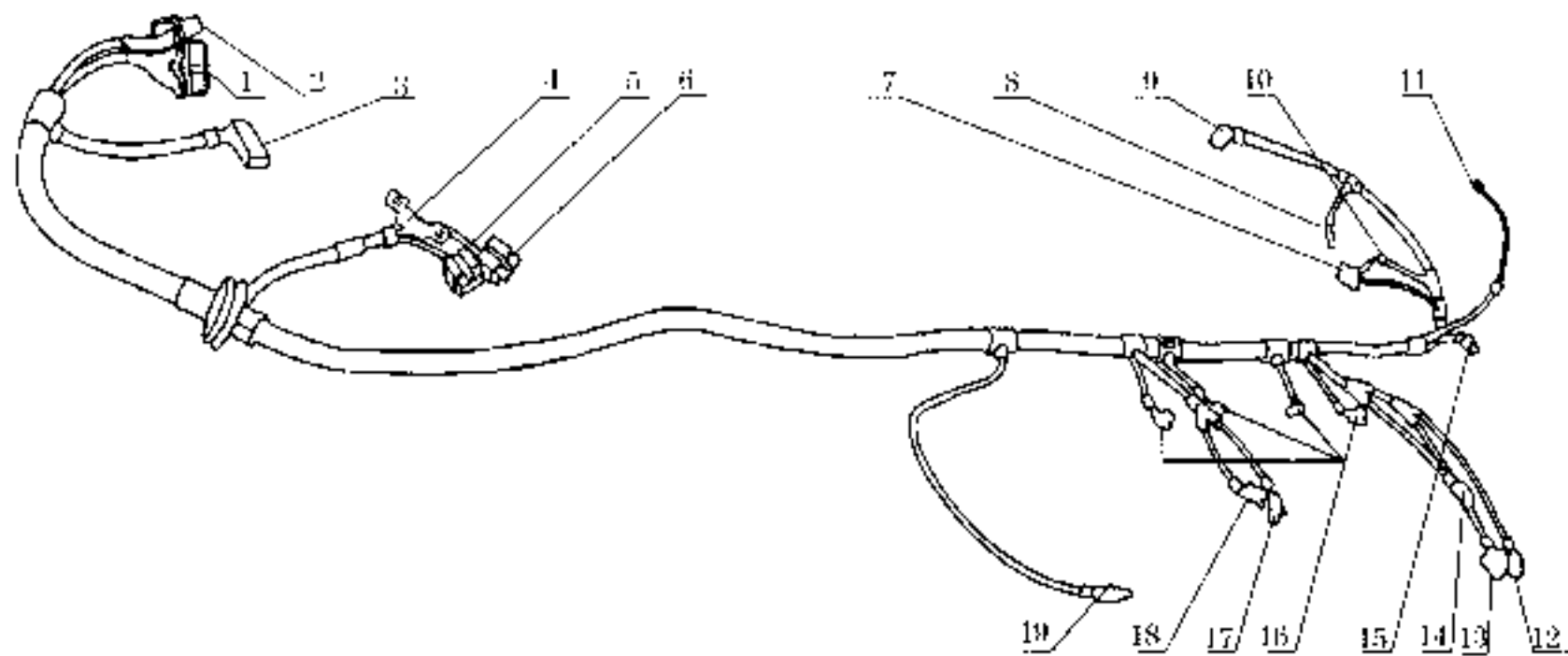

## 线束组件 -DELPHI WIRING HARNESS SET

序号	部件代码	部件名称	部件规格	用量	适用车型	备注
S/N	PART CODE	DESCRIPTION	SPECIFICATION	QTY	VEHICLE MODEL	REMARK
	11-3724190	线束组件	WIRE HARNESS SET	1	SERLAR	
	20-3324190	线束组件	WIRE HARNESS SET		CU6450	
	31-3324190	线束组件	WIRE HARNESS SET		CU1025S	
1		ECM 线插头	NO.1 ECM TERMINAL	1		
2		ECM 线插头	NO.2 ECM TERMINAL	1		
3		蓄电池插头	POWER PLUG	1		
4		故障诊断插头	TROUBLE SHOOTING PLUG	1		
5		燃油继电器	FUEL PUMP RELAY	1		
6		空调继电器	A/C RELAY	1		
7		曲轴位置传感器插头	CRANKSHAFT POSITION SENSOR PLUG	1		
8		水温表插头	WATER TEMPERATURE GAUGE PLUG	1		
9		点火线圈插头	IGNITION COIL PLUG	1		
10		空调表插头	A/C PLUG	1		
11		搭铁	GROUND CONNECTION	1		
12		进气温度传感器插头	INTAKE AIR TEMPERATURE SENSOR PLUG	1		
13		绝对压力传感器插头	ABSOLUTE PRESSURE SENSOR PLUG	1		
14		电磁线圈插头	ELECTROMAGNETIC VALVE PLUG	1		
15		冷却液温度传感器插头	COOLANT TEMPERATURE SENSOR PLUG	1		
16		喷油嘴插头	INJECTOR PLUG	1		



线束组件-UAES WIRING HARNESS SET

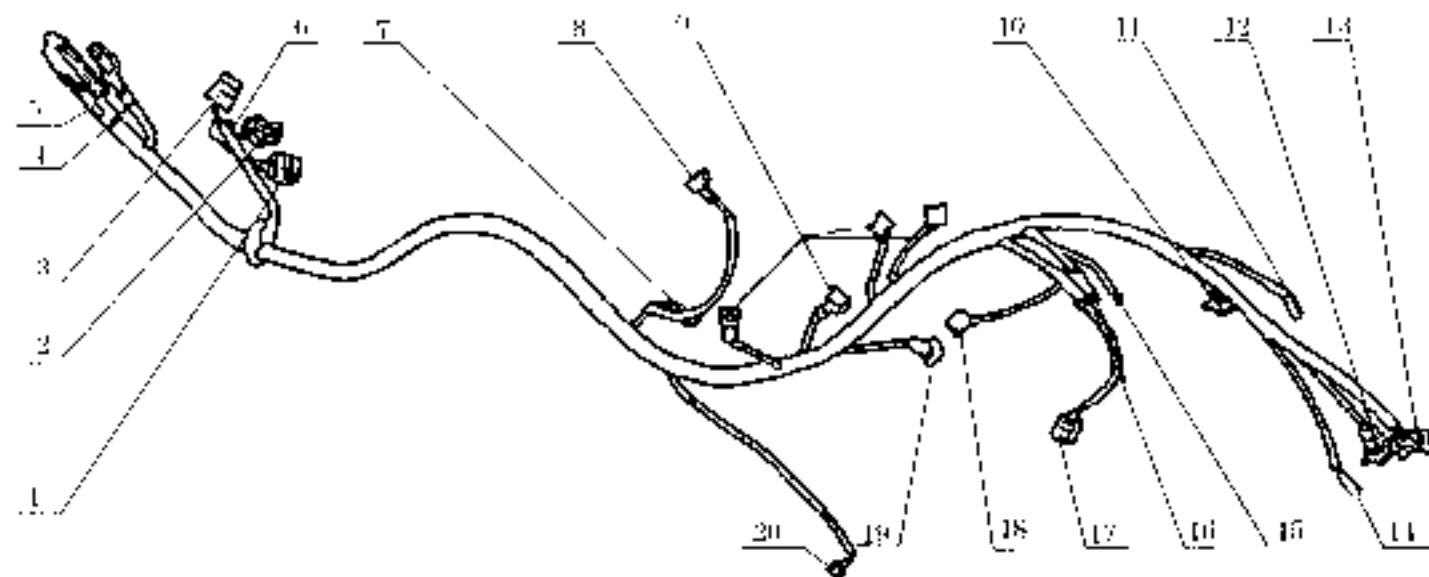

## 线束组件-UAES WIRING HARNESS SET

序号 S/N	部件代码 PART CODE	部件名称 DESCRIPTION	部件规格 SPECIFICATION	用量 QTY	适用车型 VEHICLE MODEL	备注 REMARK
	11-27240900	线束组件	WIRING HARNESS SET	1		UAES
1		ECM继电器	ECM RELAY	1		
2		油泵继电器	OIL PUMP RELAY	1		
3		空调继电器	AIR CONDITIONER RELAY	1		
4		电源插头	POWER PLUG	1		
5		ECM插头	ECM PLUG	1		
6		故障诊断插头	TROUBLE SHOOTING PLUG	1		
7		爆震传感器插头	KNOCK SENSOR PLUG	1		
8		怠速控制阀插头	IDLE AIR CONTROL VALVE PLUG	1		
9		喷嘴插头	INJECTOR PLUG	1		
10		转速传感器插头	ENGINE SPEED SENSOR PLUG	1		
11		水温表插头	WATER TEMPERATURE GAUGE PLUG	1		
12		相位传感器插头	PHASE SENSOR PLUG	1		
13		点火线圈插头	IGNITION COIL PLUG	1		
14		空调请求插头	A/C PLUG	1		
15		接地	GROUND CONNECTION	1		
16		冷却液温度传感器	COOLANT TEMPERATURE SENSOR	1		
17		进气歧管压力传感器插头	MANIFOLD AIR TEMPERATURE SENSOR PLUG	1		
18		活性炭罐电磁阀	CHARCOAL CANISTER ELECTROMAGNETIC VALVE PLUG	1		
19		节气门位置传感器插头	THROTTLE POSITION SENSOR PLUG	1		
20		氧传感器插头	OXYGEN SENSOR PLUG	1		

爆震传感器 -UAES KNOCK SENSOR

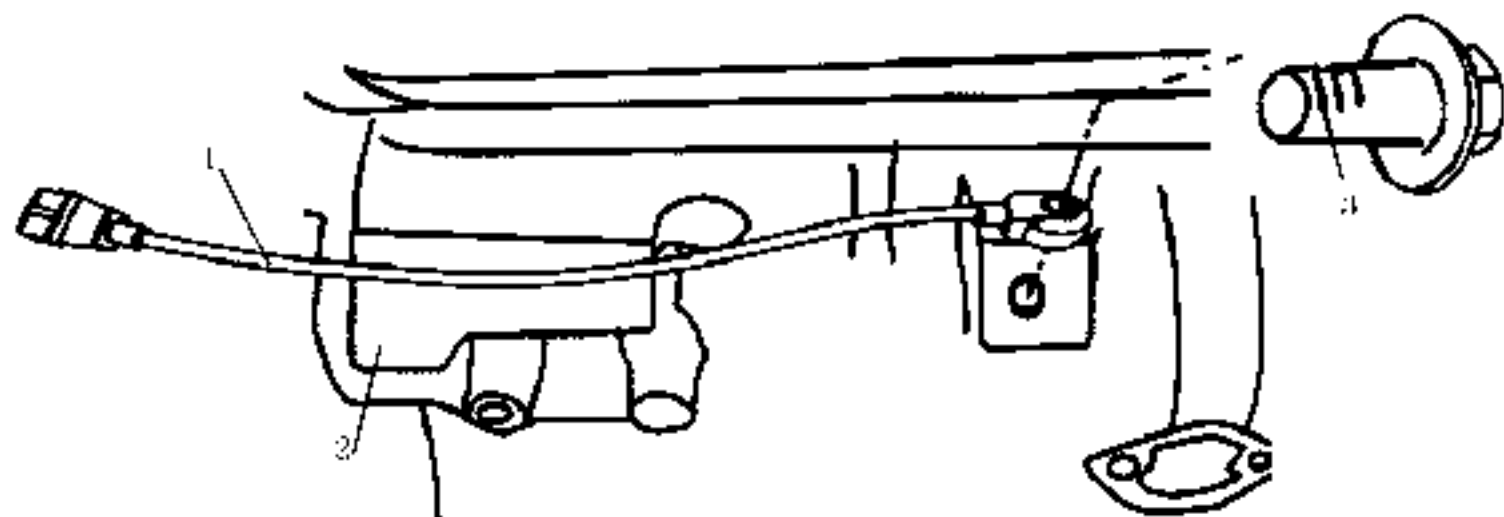

## 爆震传感器 - UAES KNOCK SENSOR

序号	部件代码	部件名称	部件规格	用量	适用车型	备注
S/N	PART CODE	DESCRIPTION	SPECIFICATION	QTY.	VEHICLE MODEL	REMARK
1	11-3705101B	爆震传感器	KNOCK SENSOR	1		UAES
2	11-1002031B	缸盖	CYLINDER BLOCK	1		UAES
3	Q18106	缸盖螺栓	FLANGE BOLT	1		

随机附件 ACCESSORIES

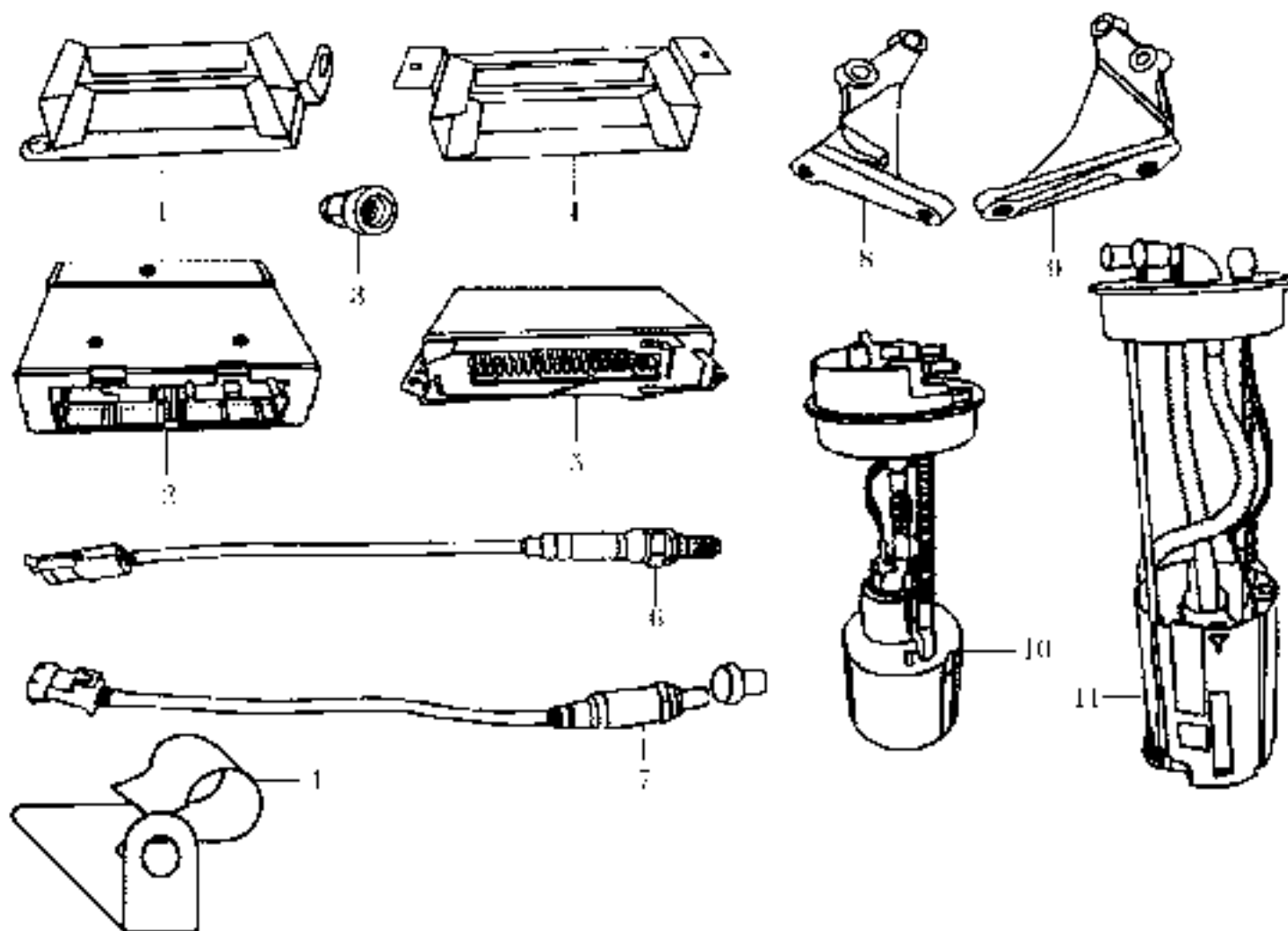



## 随机附件 ACCESSORIES

序号	部件代码	部件名称	部件规格	用量	适用车型	备注
NO.	PART CODE	DESCRIPTION	SPECIFICATION	QTY.	VEHICLE MODEL	RE-MARK
1	11-060001	ECU 支架总成	ECU BRACKET ASSY	1		
2	11-060001	ECU	ECU	1		
3	11-1000005	排气管出口 螺母	EXHAUST PIPE OUTLET NUT	5		
4	11-060001B	ECU 支架总成	ECU BRACKET ASSY	1		U15
5	11-060001H	ECU	ECU	1		U15
6	11-1205020	氧传感器	OXYGEN SENSOR	1		
7	11-1205020H	氧传感器	OXYGEN SENSOR	1		U15
8	11-0002023	混合器壳体右支架	ELC FUEL HOUSING BRACKET, R.H.	1		
9	11-0002024	混合器壳体左支架	ELC FUEL HOUSING BRACKET, L.H.	1		
10	11-1106000	汽油泵及支架组件	GASOLINE PUMP & BRACKET	1		
11	11-1106000B	汽油泵及支架组件	GASOLINE PUMP & BRACKET	1		
12	11-1205021	氧传感器支架	OXYGEN SENSOR BRACKET	1		
	11-1205021B	氧传感器支架	OXYGEN SENSOR BRACKET	1		U15

65A 外调发电机 OUTSIDE ADJUSTING ALTERNATOR (65A)

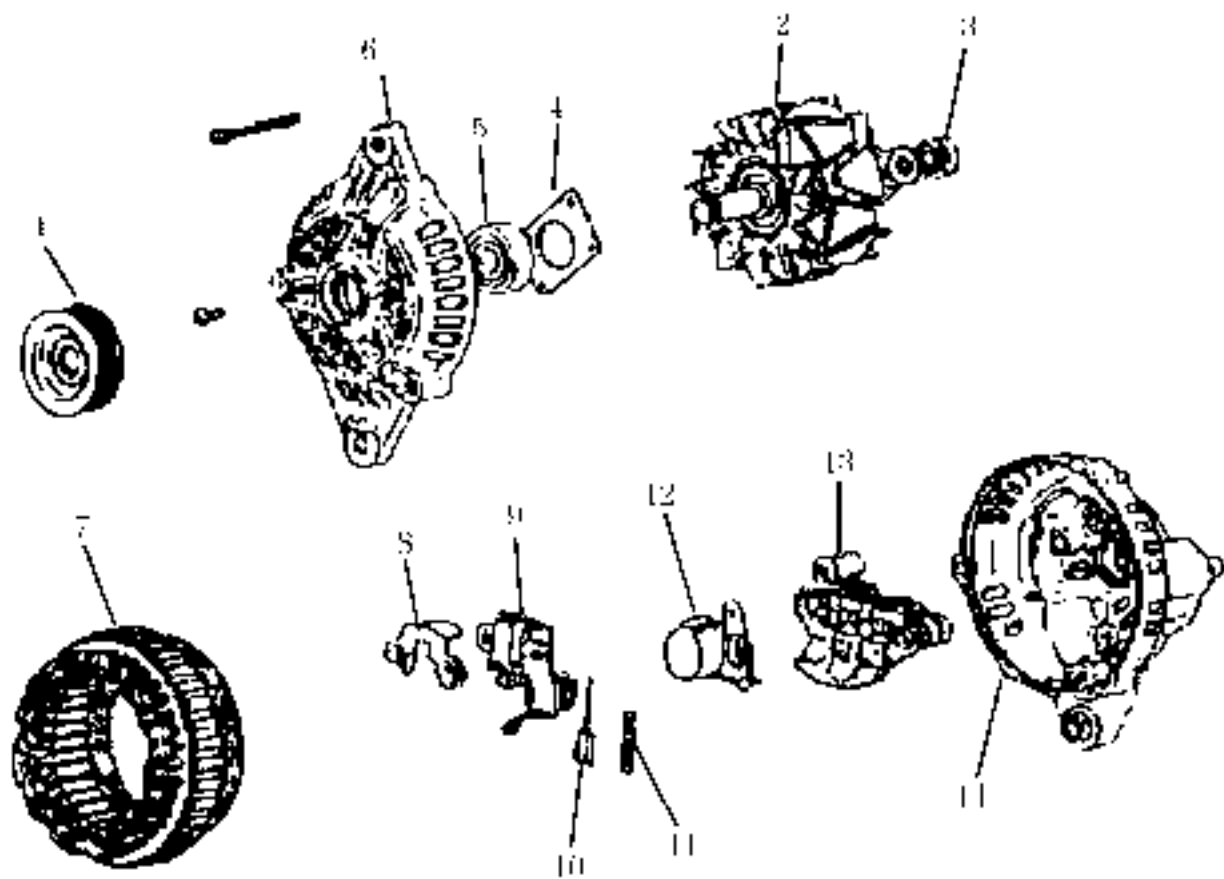

## 65A 外调发电机 OUTSIDE ADJUSTING ALTERNATOR (65A)

序号	部件代码	部件名称	部件规格	用量	适用车型	备注
SN	PART CODE	DESCRIPTION	SPECIFICATION	QTY.	VEHICLE MODEL	REMARK
1	E1-370001	交流发电机皮带轮	ALTERNATOR BELT PULLEY	1		
2	E1-370002	转子总成	ROTOR ASSY	1		
3	E1-370003	后轴承	REAR BEARING	1		
4	E1-370004	后承盖板	RETAINER PLATE	1		
5	E1-370005	前轴承	FRONT BEARING	1		
6	E1-370006	前盖壳	FRONT END COVER	1		
7	E1-370007	定子总成	STATOR ASSY	1		
8	E1-370008	定转子架	REFLECTOR PLATE	1		
9	E1-370009	换向器架	ALTERNATOR BRUSH HOLDER	1		
10	E1-370020	碳刷	ALTERNATOR BRUSH	1		
11	E1-370021	碳刷弹簧	ALTERNATOR BRUSH SPRING	1		
12	E1-370022	卡簧	CLIP RING	1		
13	E1-370023	整流桥	RECTIFIER	1		
14	E1-370024	后盖壳	REAR END COVER	1		
15	E1-370010	交流发电机总成	ALTERNATOR ASSY	1		

90A 内调交流发电机 INTERIOR ADJUSTING ALTERNATOR(90A)

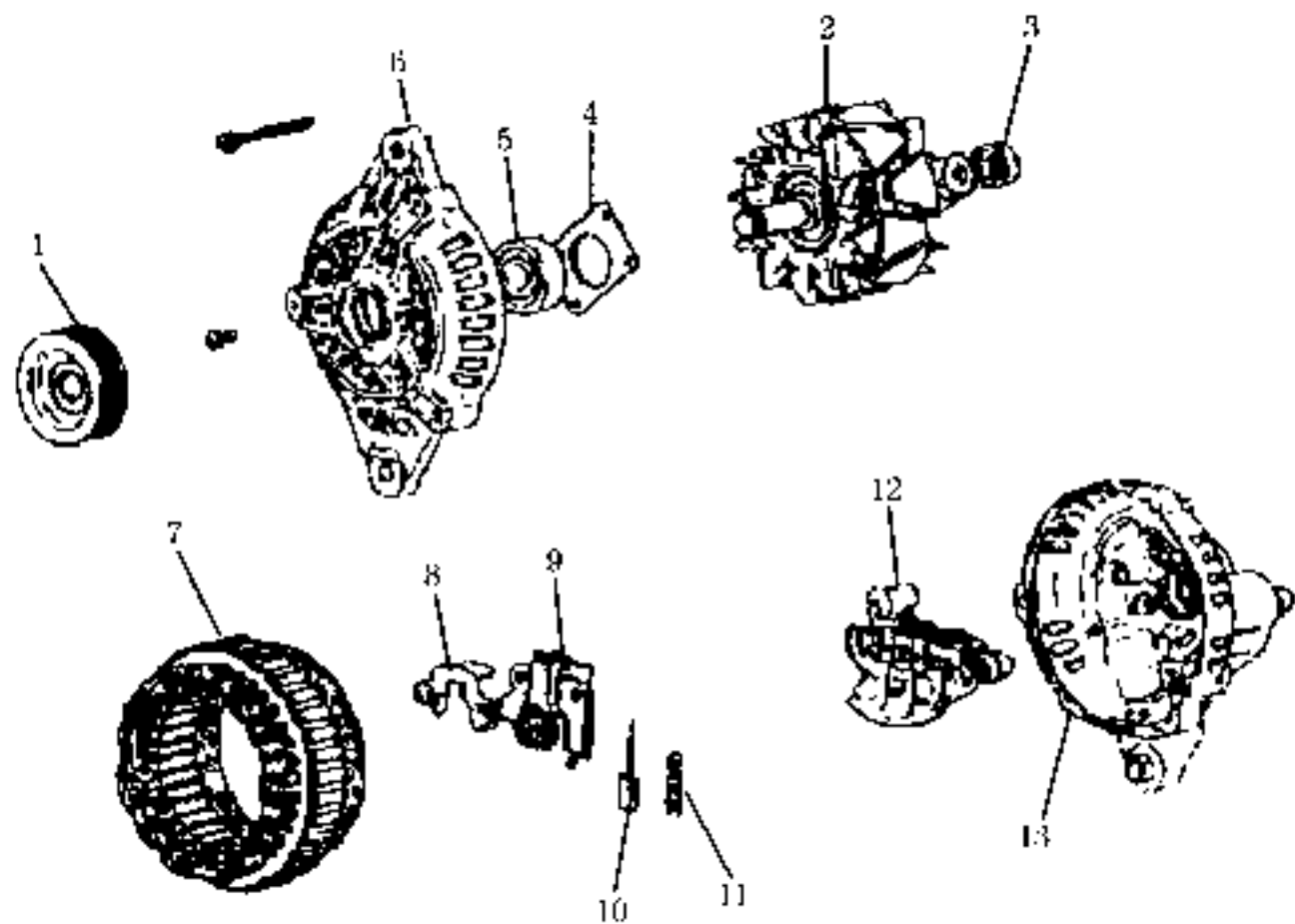

## 90A 内调交流发电机 INTERIOR ADJUSTING ALTERNATOR(90A)

序号 SN	部件代码 PART CODE	部件名称 DESCRIPTION	部件规格 SPECIFICATION	用量 QTY	适用车型 VEHICLE MODEL	备注 REMARK
1	11-37010016	交流发电机总成	ALTERNATOR REPT PULLEY	1		
2	11-37010020	转子总成	ROTOR ASSY	1		
3	11-37010020	后轴承	REAR BEARING	1		
4	11-37010040	后轴承盖	RE-TAINER PLATE	1		
5	11-37010050	前轴承	FRONT BEARING	1		
6	11-37010060	前盖	FRONT END COVER	1		
7	11-37010070	定子总成	STATOR ASSY	1		
8	11-37010080	定位板	RESTRICT PLATE	1		
9	11-37010090	调压器和电刷支架	REGULATOR & BRUSH HOLDER	1		
10	11-37010200	磁串	ALTERNATOR SH	1		
11	11-37010210	磁串弹簧	ALTERNATOR BRUSH SPRING	1		
12	11-37010220	整流桥	RECTIFIER	1		
13	11-37010230	后盖	REAR END COVER	1		
14	11-37010000	交流发电机总成	ALTERNATOR ASSY	1		

# 起动机 STARTER

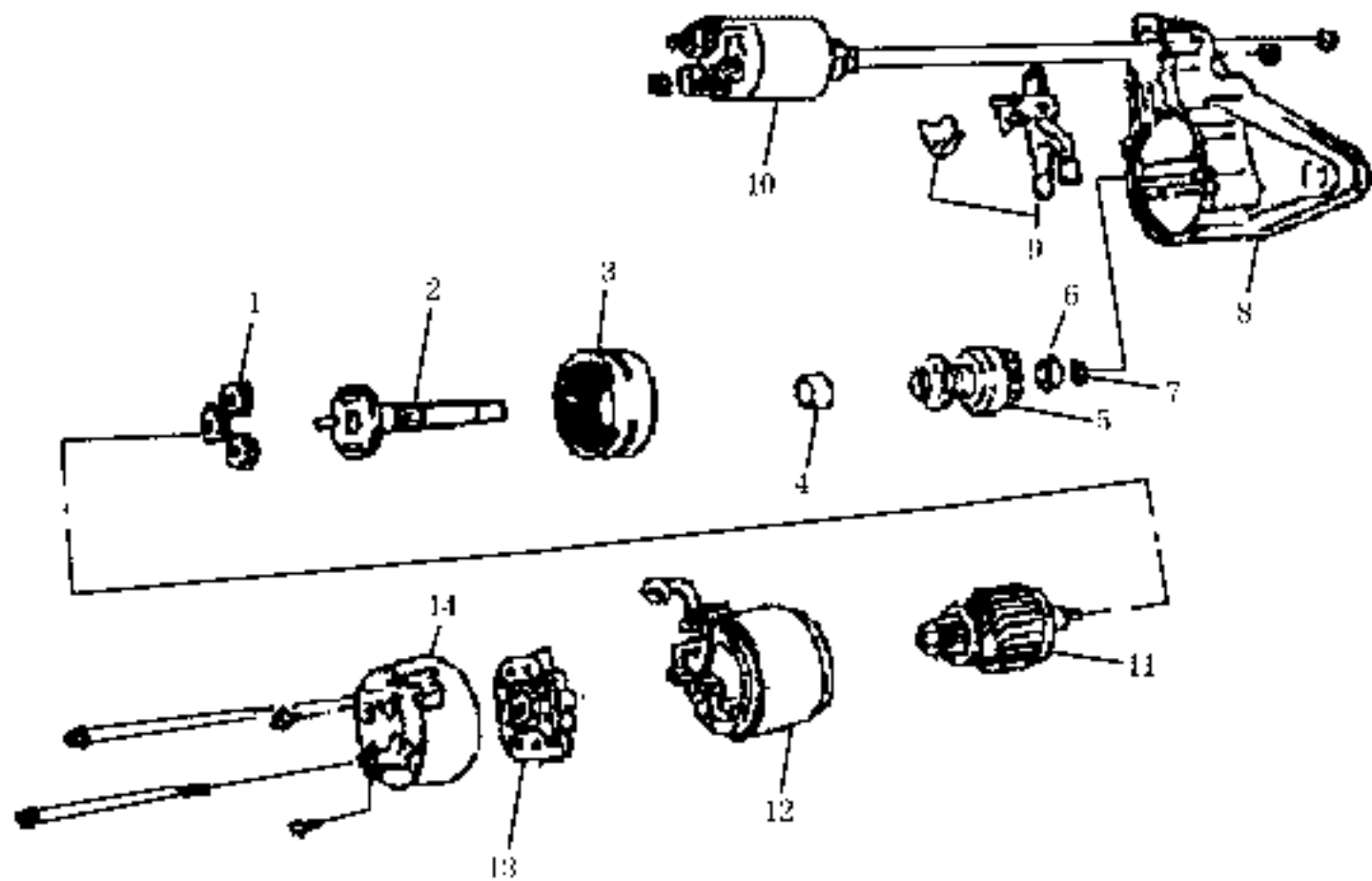

## 起动机 STARTER

序号	部件代码	部件名称	部件规格	用量	适用车型	备注
S/N	PART CODE	DESCRIPTION	SPECIFICATION	QTY.	VEHICLE MODEL	REMARK
1	11-3700001	行星齿轮	PLANETARY GEAR	1		
2	11-3700002	行星齿轮轴	PLANETARY GEAR SHAFT	1		
3	11-3700003	定轮	RESTRICT WHEEL	1		
4	11-3700004	中心轴承	CENTRE BEARING	1		
5	11-3700005	起动机离合叉	STARTER CLUTCH	1		
6	11-3700006	销钉	SNAP PIN	1		
7	11-3700007	销轴	SNAP RING	1		
8	11-3700008	驱动端盖	DRIVE END HOUSING	1		
9	11-3700009	拨叉	FORK	1		
10	11-3700010	发电机碳刷架	ALTERNATOR BRUSH SET END SWITCH	1		
11	11-3700011	电枢	ARMATURE	1		
12	11-3700012	外壳	HOUSING	1		
13	11-3700013	电刷架	ALTERNATOR BRUSH BRACKET	1		
14	11-3700014	后盖	REAR END COVER	1		

# 活塞连杆组件 PISTON CONNECTING ROD

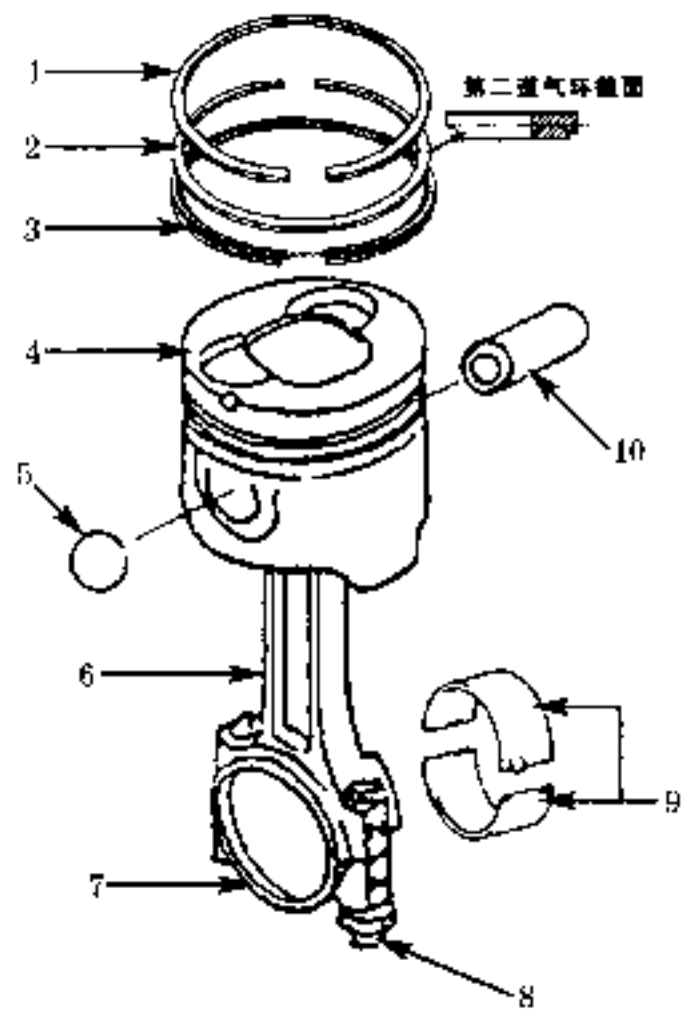



## 活塞连杆组件 PISTON CONNECTING ROD

序号 S/N	部件代码 PART CODE	部件名称 DESCRIPTION	部件规格 SPECIFICATION	用量 QTY	适用车型 VEHICLE MODEL	备注 REMARK
1	HC-106401	顶 盖 气 环	TOP COMPRESSION RING	4		
2	HC-106402	第 二 道 气 环	2ND COMPRESSION RING	4		
3	HC-106403	螺 丝 帽 高 压 垫	OIL RING	4		
4	HC-106405	活 塞	PISTON	4		
5	HC-106405	活 塞 销 卡 簧	PISTON PIN SNAP RING	8		
6	HC-1064024	连 杆 体	CONNECTING ROD	4		
7	HC-1064021	连 杆 盖	CONNECTING ROD CAP	4		
8	HC-1064025	连 杆 螺 丝	CONNECTING ROD BOLT	8		
9	HC-1064023	连 杆 轴 承	CONNECTING ROD BEARING	8		
10	HC-1064016	活 塞 销	PISTON PIN	4		

左右支架及左右加强板 LEFT/RIGHT BRACKET & REINFORCEMENT

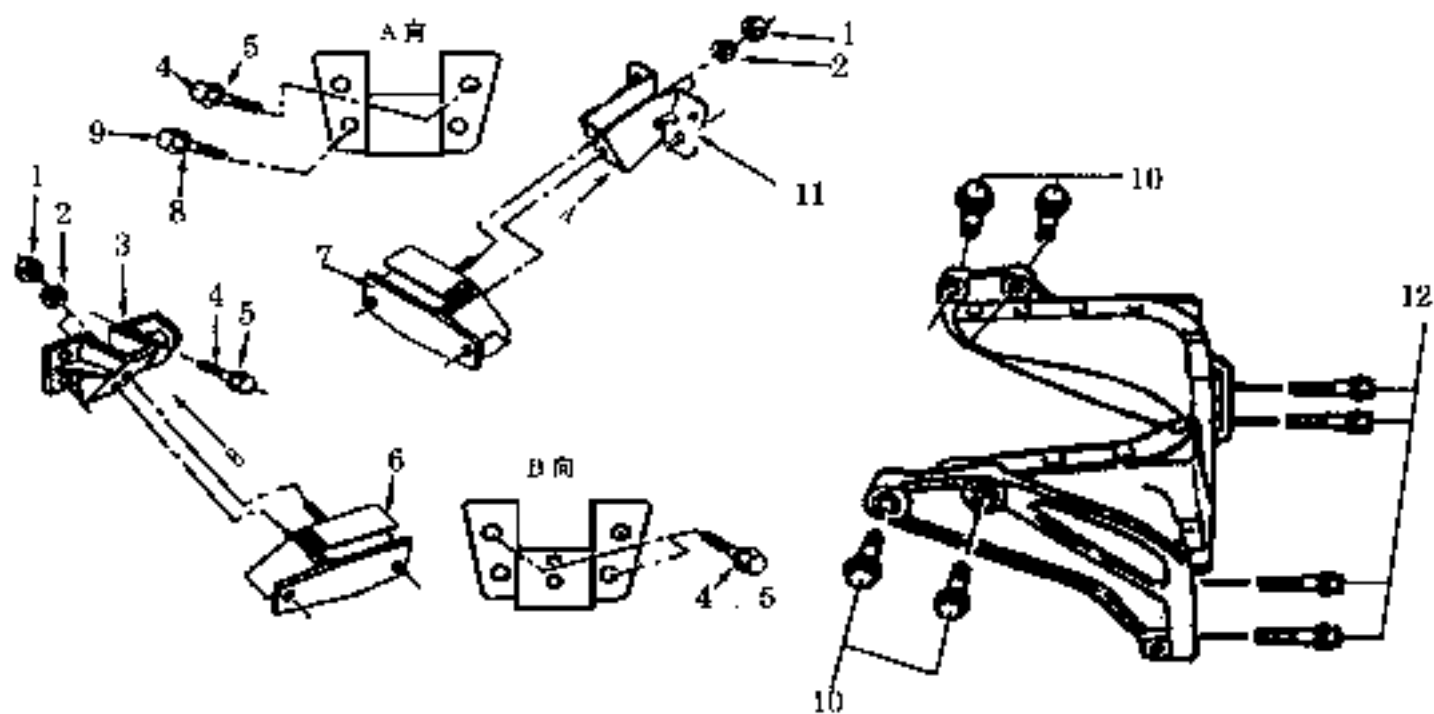

## 左右支架及左右加强板 LEFT/RIGHT BRACKET & REINFORCEMENT

序号	部件代码	部件名称	部件规格	用量	适用车型	备注
S/N	BART CODE	DESCRIPTION	SPECIFICATION	QTY	VEHICLE MODEL	REMARK
1	Q39H00	螺母	HEX NUT	4		
2	Q40H0	弹簧垫圈	SPRING WASHER	4		
3	HC-1001022	右支架	BRACKET, RH	1		
4	Q40J0	弹簧垫圈	SPRING WASHER	5		
5	Q15H1022	螺栓	BOLT	5		
6	HC-1001011	右加强板冲板	BRACKET CUSHION BLANK, RH	1		左右相同
7	HC-1001011	左加强板冲板	BRACKET CUSHION BLANK, LH	1		
8	Q40AL4	弹簧垫圈	SPRING WASHER	1		
9	Q15H10425	螺栓	BOLT	1		
10	Q15HC1040	螺栓	BOLT	4		
11	HC-1001021	左支架冲板	BRACKET WELDMENT, LH	1		
12	Q15HC1225	螺栓	BOLT	4		

# 主轴承与曲轴的安装 MAIN BEARING & CRANKSHAFT

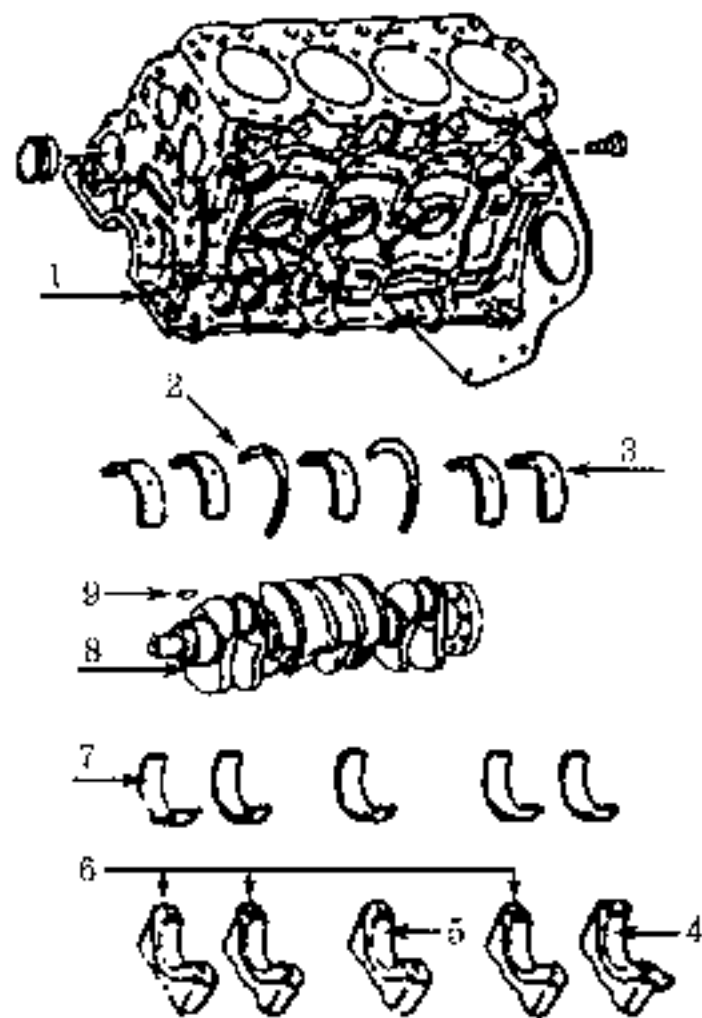

## 主轴承与曲轴的安装 MAIN BEARING & CRANKSHAFT

序号	部件代码	部件名称	部件规格	用量	适用车型	备注
S/N	PART CODE	DESCRIPTION	SPECIFICATION	QTY.	VEHICLE MODEL	REMARK
1	LIC-1002031	汽缸盖衬套	CYLINDER BUSH	1		
2	LIC-1002019	止推瓦	THRUST PLATE	2		
3	LIC-1002018	主轴承上瓦	MAIN BEARING UPPER SHEET	5		
4	LIC-1002005	第五主轴承盖	5TH MAIN BEARING CAP	1		
5	LIC-1002006	第三主轴承盖	3RD MAIN BEARING CAP	1		
6	LIC-1002004	第一、二主轴承盖	1ST, 2ND, 4TH MAIN BEARING CAP	3		
7	LIC-1002017	主轴承下瓦	MAIN BEARING LOWER SHEET	5		
8	LIC-1005015	曲轴	CRANK SHAFT	1		
9	LIC-1005017	曲轴键	CRANKSHAFT KEY	1		

机油盘的装配 OIL PAN

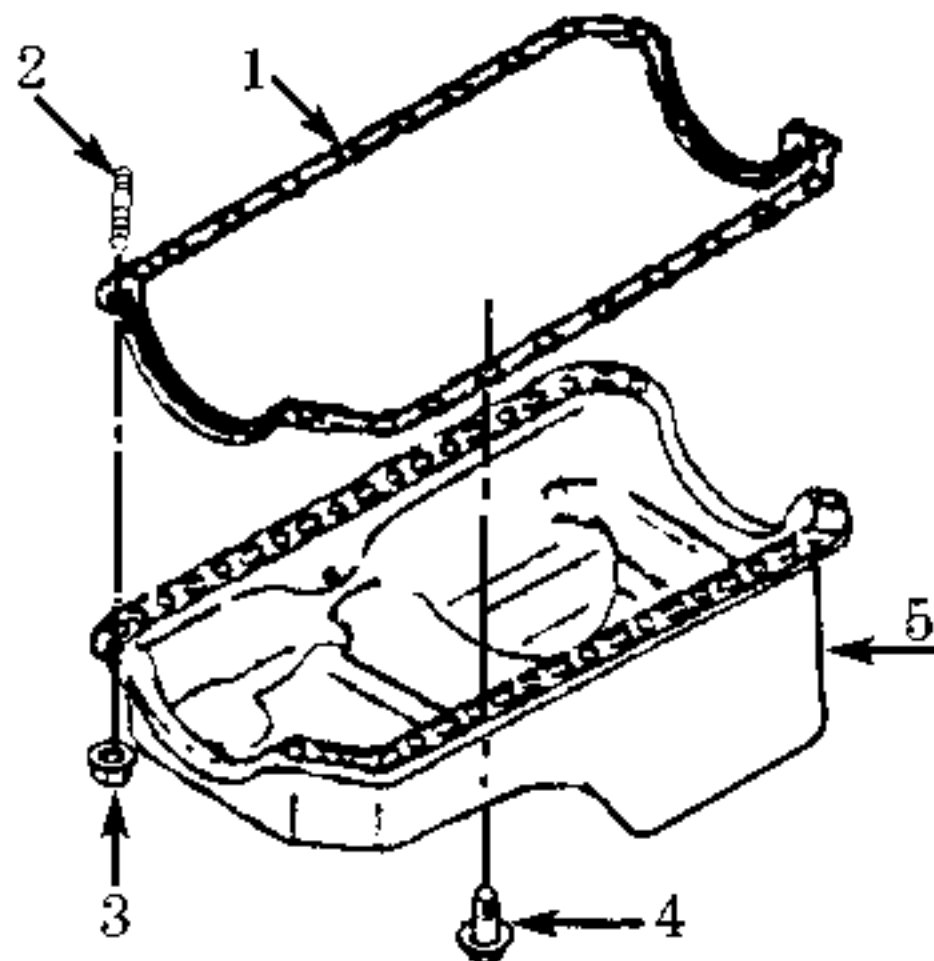

- 双头螺柱孔
- 螺栓孔

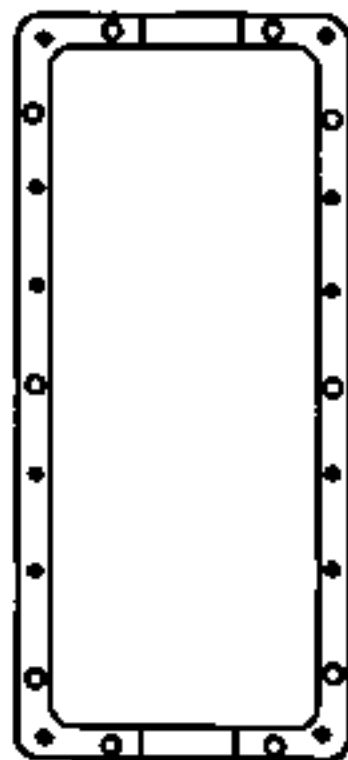

## 机油盘的装配 OIL PAN

序号	部件代码	部件名称	部件规格	用量	适用车型	备注
S/N	PART CODE	DESCRIPTION	SPECIFICATION	QTY	VEHICLE MODEL	REMARK
1	HC11009011	油盘密封垫	OIL PAN GASKET	1		
2	HC11009014	双头螺栓	SHUO BOLT	10		
3	HC11009015	六角法兰面螺母	HEX FLANGED NUT	10		
4	HC11009016	锁紧定位螺栓	TIGHTENING STOP BOLT	10		
5	HC11009020	油底壳总成	OIL PAN KIT	1		

飞轮、离合器、前后油封及减震皮带轮  
FLYWHEEL, CLUTCH, FRONT/REAR OIL SEAL & DAMPING PULLEY

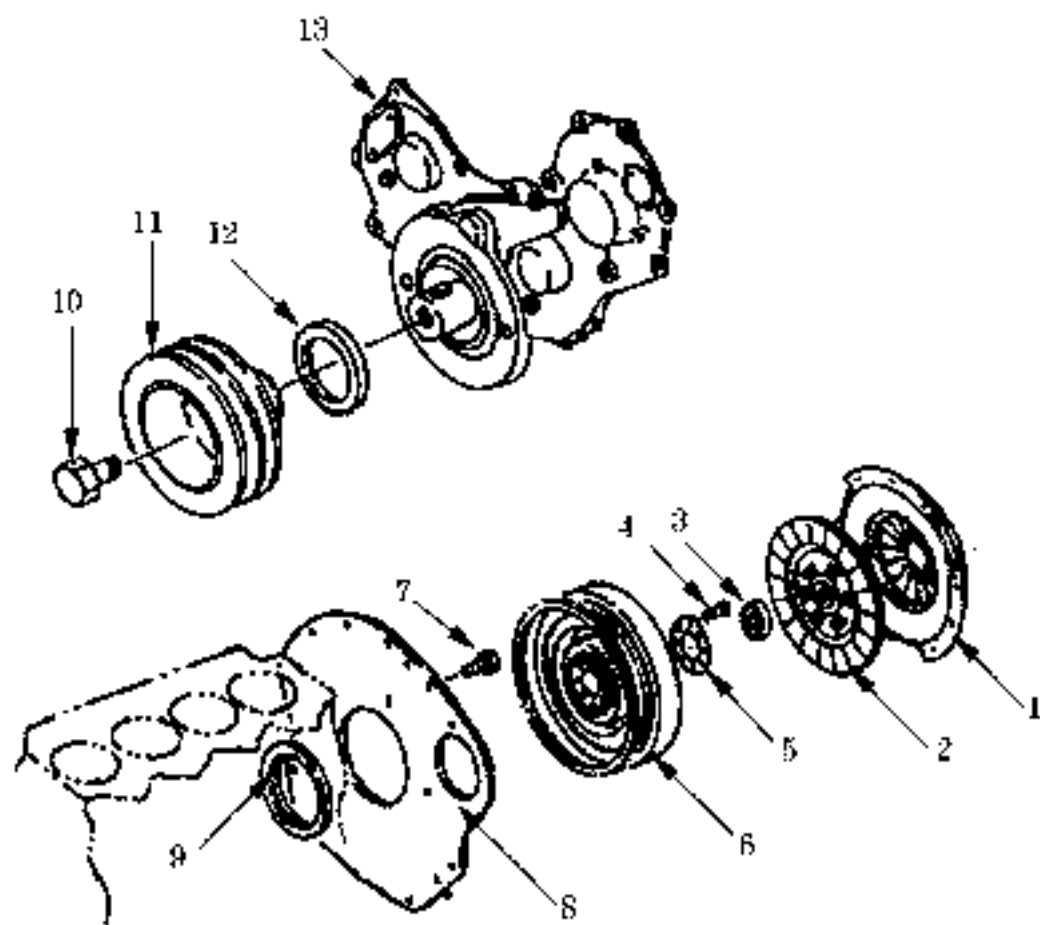



**飞轮、离合器、前后油封及减震皮带轮**  
**FLYWHEEL, CLUTCH, FRONT/REAR OIL SEAL & DAMPING PULLEY**

序号 S/N	部件代码 PART CODE	部件名称 DESCRIPTION	部件规格 SPECIFICATION	用量 QTY.	适用车型 VEHICLE MODEL	备注 REMARK
1	21-1401109	离合器罩壳	CLUTCH COVER ASSY	1		
2	21-1401109	离合器总成	CLUTCH DISC ASSY	1		
3	89203	曲轴衬套	CRANKSHAFT BEARING	1		
4	HC-1005016	飞轮螺栓	FLYWHEEL BOLT	8		
5	HC-1005031	飞轮螺栓垫圈	FLYWHEEL BOLT WASHER	1		
6	HC-1005030	飞轮螺母	FLYWHEEL NUT	1		
7	HC-1002022	后连接板螺栓	REAR CONNECTING PLATE BOLT	3		
8	HC-1002023	后连接板	REAR CONNECTING PLATE	1		
9	HC-1002020	后油封	REAR OIL SEAL	1		
10	HC-1005032	曲轴皮带轮螺栓	CRANKSHAFT PULLEY BOLT	1		
11	HC-1005033	减震皮带轮	DAMPING PULLEY	1		
12	HC-1002140	曲轴前油封	CRANKSHAFT FRONT OIL SEAL	1		
13	HC-1002051	汽缸罩罩壳	GEN. CHAMBER COVER ASSY	1		

# 齿轮室体的安装 GEAR CHAMBER BODY

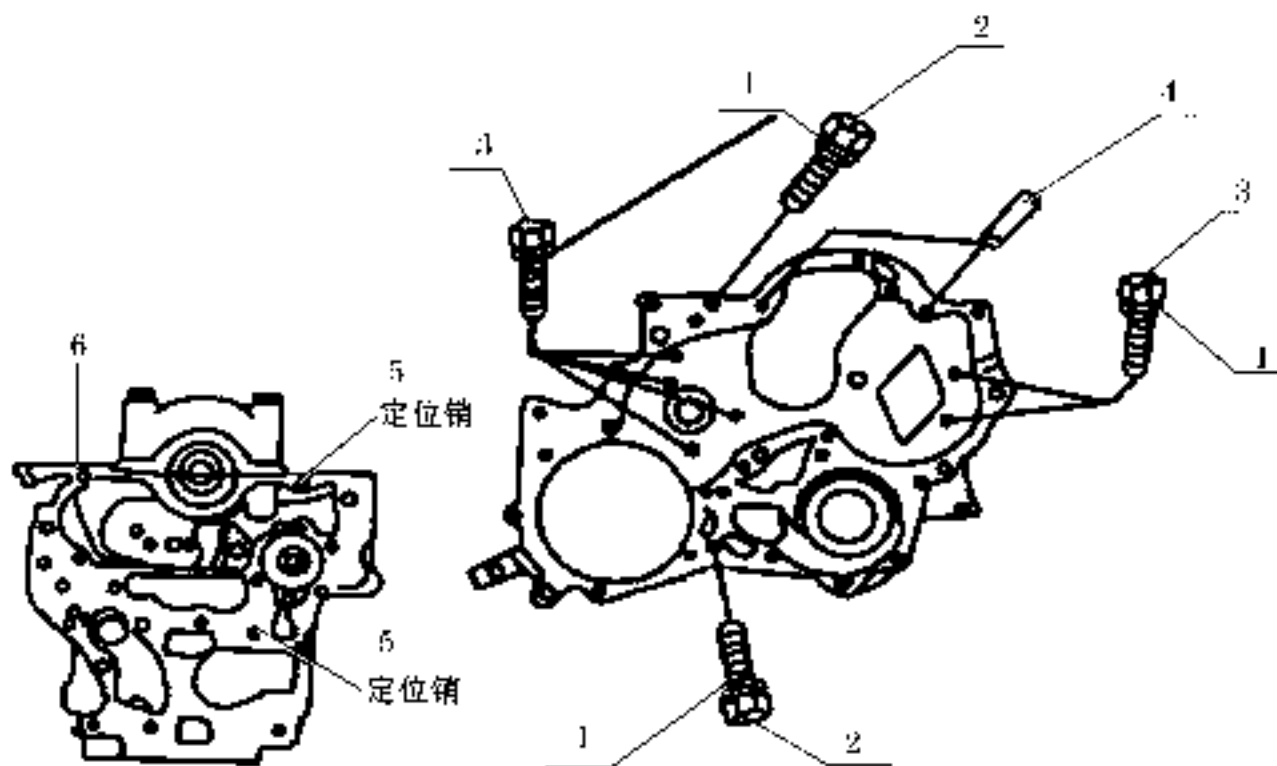

## 齿轮室体的安装 GEAR CHAMBER BODY

序号 S/N	部件代码 PART CODE	部件名称 DESCRIPTION	部件规格 SPECIFICATION	用量 QTY.	适用车型 VEHICLE MODEL	备注 REMARK
1	Q40108	平垫	PLAIN WASHER	16		
2	Q1420845	螺栓组套	BOLT SET	2		
3	Q1420820	螺栓组套	BOLT SET	6		
4	Q5321020	定位销	DOWEL PIN	2		
5	Q5321020	定位销	DOWEL PIN	2		
6	011-1002012	齿轮室垫	GEAR CHAMBER GASKET	1		

齿轮、齿轮室盖、齿轮室体的安装  
 GEAR, GEAR CHAMBER COVER, GEAR CHAMBER BODY

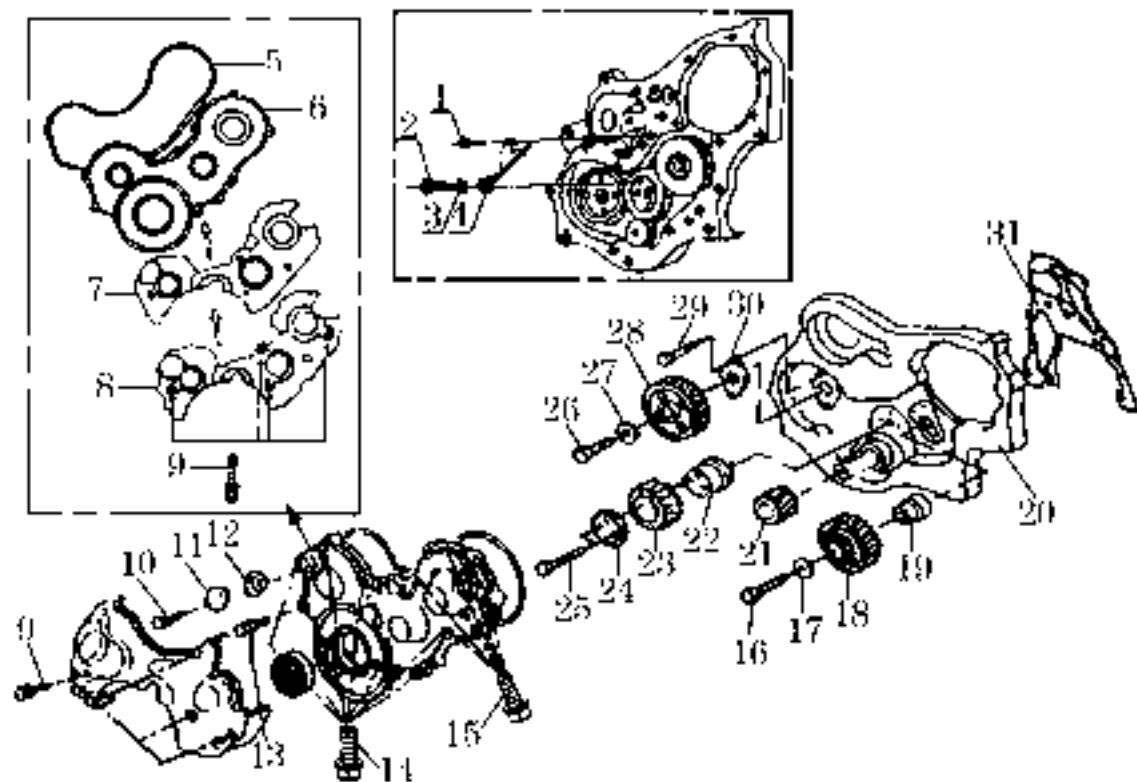

**齿轮、齿轮室盖、齿轮室体的安装**  
**GEAR, GEAR CHAMBER COVER, GEAR CHAMBER BODY**

序号 SN	部件代码 PART CODE	部件名称 DESCRIPTION	部件规格 SPECIFICATION	用量 QTY.	适用车型 VEHICLE MODEL	备注 REMARK
1	Q1420820	螺栓组合件	BOLT SET	5x20		
2	HC-1002801	三联头螺栓	UNION JOINT BOLT			
3	HC-1002802	铜垫圈	BRONZE WASHER			
4	HC-1002850	润滑脂注射器组合件	LUBRICANT INJECTION PUMP SET			
5	HA-1002305	盖衬垫圈	GASKET			
6	HC-1002051	齿轮室盖	GEAR CHAMBER COVER			
7	HC-1002035	隔音泡沫橡胶条	SILENCING FOAM RUBBER			
8	HC-1002500	隔音盖板组合件	SILENCING COVER PLATE			
9	Q1420618	螺栓组合件	BOLT SET	6x18		
10	Q1420612	螺栓组合件	BOLT SET	6x12		
11	HC-1002403	防尘罩盖帽	SHIELD HOPE COVER			
12	HC-1002404	防尘罩	COVER PLATE GASKET			
13	HC-1002406	内六角螺栓	ALLEN BOLT			
14	Q1420635	螺栓组合件	BOLT SET	8x35		
15	Q1420643	螺栓组合件	BOLT SET	8x43		
16	HA-1002305	螺母	BOLT			
17	HC-1006004	高压齿轮泵壳体	HIGH GEAR-B P RESSURE PLATE			
18	HC-1002500	高压齿轮轴	HIGH GEAR-B			
19	HC-1002502	高压齿轮轴	HIGH GEAR-B SHAFT			

**齿轮、齿轮室盖、齿轮室体的安装**  
**GEAR, GEAR CHAMBER COVER, GEAR CHAMBER BODY**

序号 S/N	部件代码 PART CODE	部件名称 DESCRIPTION	部件规格 SPECIFICATION	用量 QTY.	适用车型 VEHICLE MODEL	备注 REMARK
20	11C-1002011	齿轮室	GEAR CHAMBER			
21	11C-1005012	曲轴齿轮	CRANKSHAFT GEAR			
22	11C-1002201	惰齿轮 A 轴	IDLE GEAR-A SHAFT			
23	11C-1002250	惰齿轮 A 齿	IDLE GEAR-A			
24	11C-1002202	惰齿轮 A 压板	IDLE GEAR-A PRESSURE PLATE			
25	Q4420855	螺栓	BOLT			
26	11C-1006014	凸轮轴齿轮螺栓	CAMSHAFT GEAR BOLT			
27	11C-1006016	压板	PRESSURE PLATE			
28	11C-1006012	凸轮轴齿轮	CAMSHAFT GEAR			
29	Q2420816	螺母组套	NUT SET			
30	11C-1006013	凸轮轴止推板	CAMSHAFT THRUST PLATE			
31	11C-1002012	齿轮室垫	GEAR CHAMBER GASKET			

## 凸轮轴的安装 CAMSHAFT

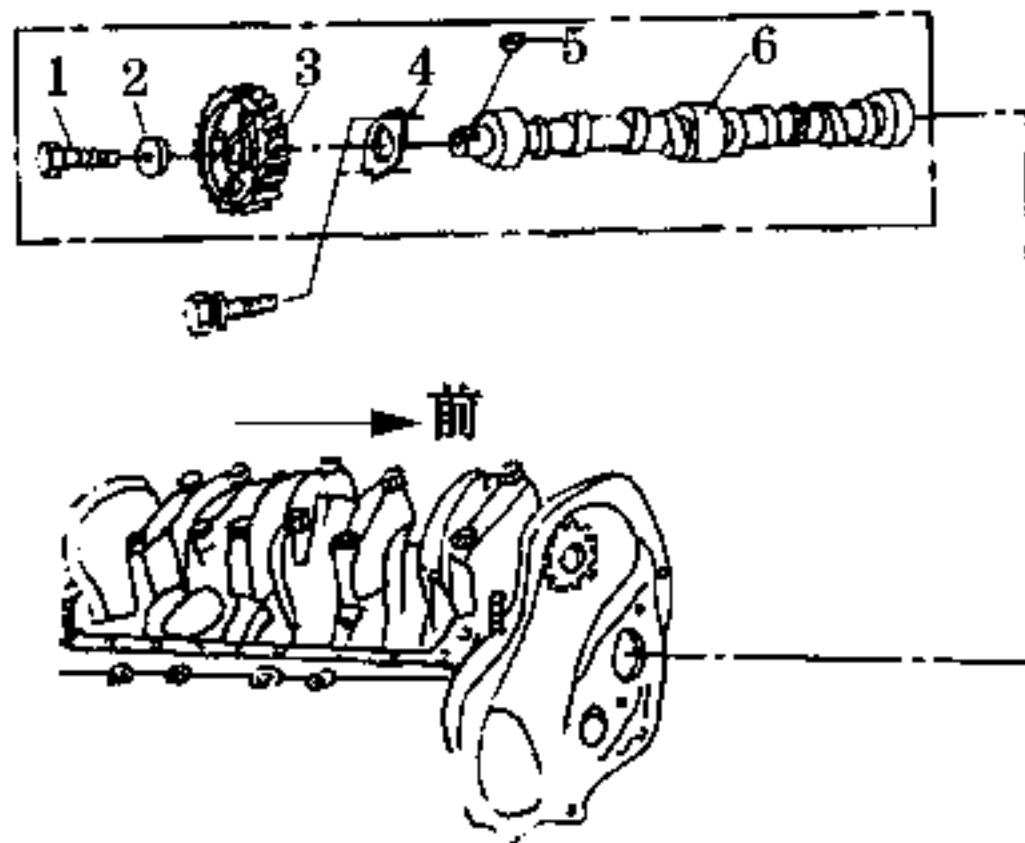

## 凸轮轴的安装 CAMSHAFT

序号	部件代码	部件名称	部件规格	用量	适用车型	备注
S/N	PART CODE	DESCRIPTION	SPECIFICATION	QTY	VEHICLE MODEL	REMARK
1	1H1-1006014	凸轮轴齿轮螺栓	CAMSHAFT GEAR BOLT	1		
2	1H1-1006013	平垫	PLATE WASHER	1		
3	1H1-1006012	凸轮轴齿轮	CAMSHAFT GEAR	1		
4	1H1-1006011	凸轮轴正时板	CAMSHAFT THROST PLATE	1		
5	1H1-1006016	凸轮轴下键	CAMSHAFT KEY	1		
6	1H1-1006015	凸轮轴	CAMSHAFT	1		



进气歧管和排气歧管的安装 INTAKE & EXHAUST MANIFOLD

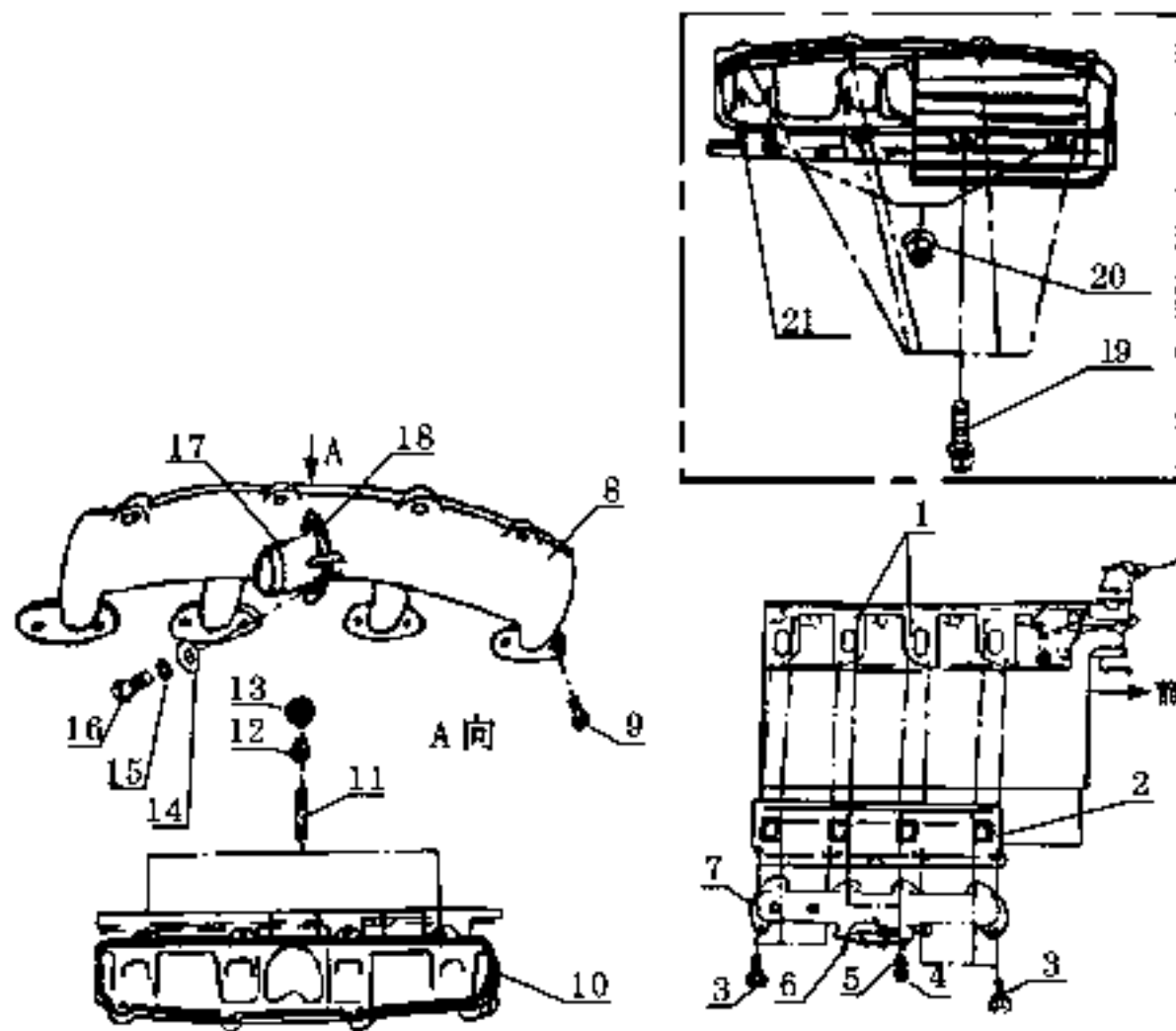

## 进气歧管和排气歧管的安装 INTAKE&EXHAUST MANIFOLD

序号 S/N	零件代码 PART CODE	零件名称 DESCRIPTION	零件规格 SPECIFICATION	用量 QTY.	适用车型 VEHICLE MODEL	备注 RE-MARK
1	Q1200835	双头螺栓	STUD BOLT	2		
2	11C-1008020	排气歧管垫圈	EXHAUST MANIFOLD GASKET	1		
3	Q1400835	螺栓组合件	BOLT SET	6		
4	Q300006	六角螺母	HEX NUT	2		
5	Q40308	弹簧	SPRING WASHER	2		
6	11C-1203033	双头螺栓	STUD BOLT	4		
7	11C-1008051	排气歧管	EXHAUST MANIFOLD	1		
8	11C-1008042	进气歧管	INTAKE MANIFOLD	1		
9	Q1400625	螺栓组合件	BOLT SET	6		
10	11C-1008046	进气歧管垫圈	INTAKE MANIFOLD GASKET	1		
11	Q1200825	双头螺栓	STUD BOLT	2		
12	Q40308	弹簧	SPRING WASHER	2		
13	Q1009013	螺母	NUT	2		
14	Q40110	平垫	PLAIN WASHER	2		
15	Q40310	弹簧	SPRING WASHER	2		
16	Q151C1028	螺栓	BOLT	2		
17	11C-1008050	弯管套件	BEND SET	1		
18	11C-1008052	进气弯管垫圈	INTAKE BEND PIPE GASKET	1		
19	Q1400625	螺栓组合件	BOLT SET	6		
20	Q32006	螺母	NUT	2		
21	11C-1008060	进气管罩套件	INTAKE PIPE COVER SET	1		

右隔音盖板及线束夹 RIGHT SOUND Baffle & WIRING HARNESS CLIP

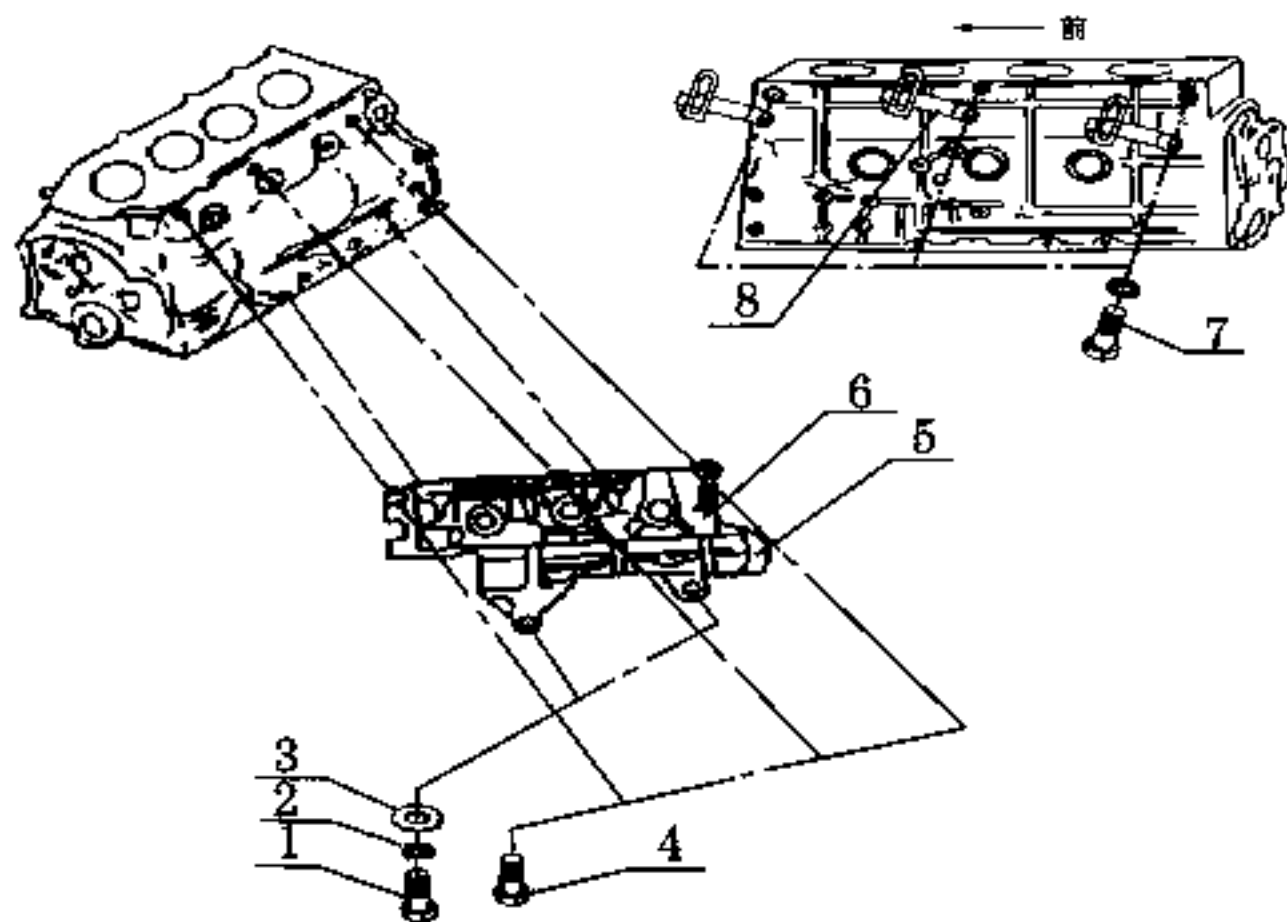

## 右隔音盖板及线束夹 RIGHT SOUND BAFLE & WIRING HARNESS CLIP

序号 S/N	部件代码 PART CODE	部件名称 DESCRIPTION	部件规格 SPECIFICATION	用量 QTY	适用车型 VEHICLE MODEL	备注 REMARK
1	Q153C1009	螺栓	BOLT	2		
2	Q405D9	垫片	PLAIN WASHER	2		
3	Q40110	弹簧	SPRING WASHER	2		
4	Q1468E25	螺栓垫片	BOLT W/SLT	3		
5	1EC1002151	右侧隔音海绵	SHIELDING SPONGE,RH	1		
6	1EC1002150	右侧隔音盖板总成	SOUND BAFLE,RH	1		
7	Q1420E12	螺栓垫片	BOLT W/SLT	3		
8	1EC1002152	线束夹	WIRING HARNESS CLIP	3		

压缩机支架 COMPRESSOR BRACKET

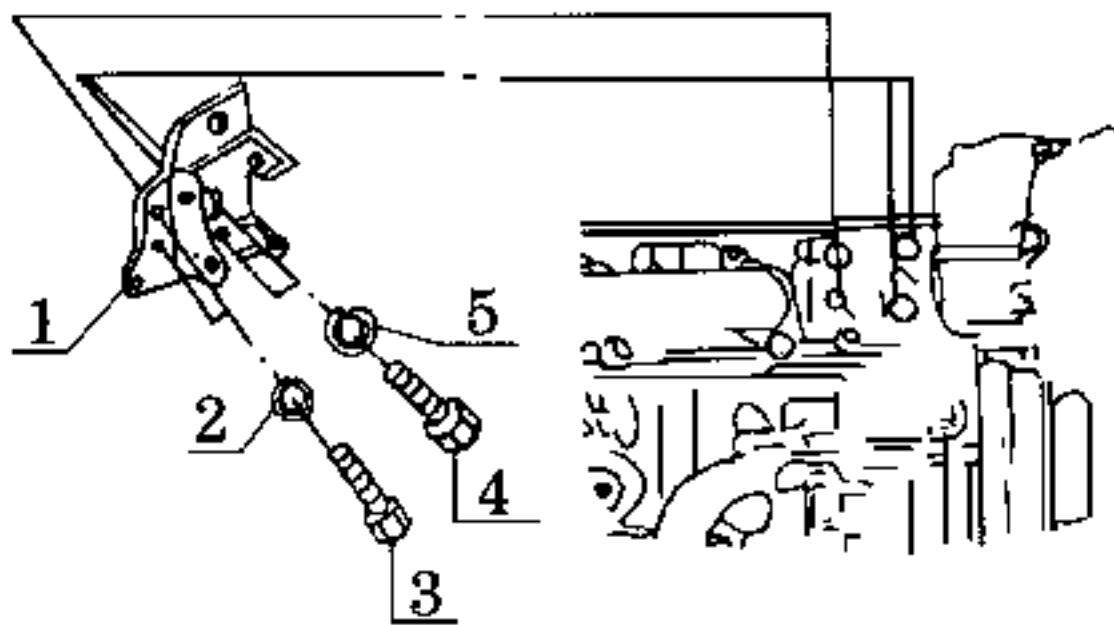

## 压缩机支架 COMPRESSOR BRACKET

序号	部件代码	部件名称	部件规格	用量	适用车型	备注
S/N	PART CODE	DESCRIPTION	SPECIFICATION	QTY.	VEHICLE MODEL	REMARK
1	ZIC-821030	压缩机支架	COMPRESSOR BRACKET	1		
2	Q40J08	垫片	SPRING WASHER	2		
3	Q150R0855	螺栓	BOLT	2		
4	Q151C 1055	螺栓	BOLT	2		
5	Q40J10	垫片	SPRING WASHER	2		

## 水泵的安装 MATER PUMP

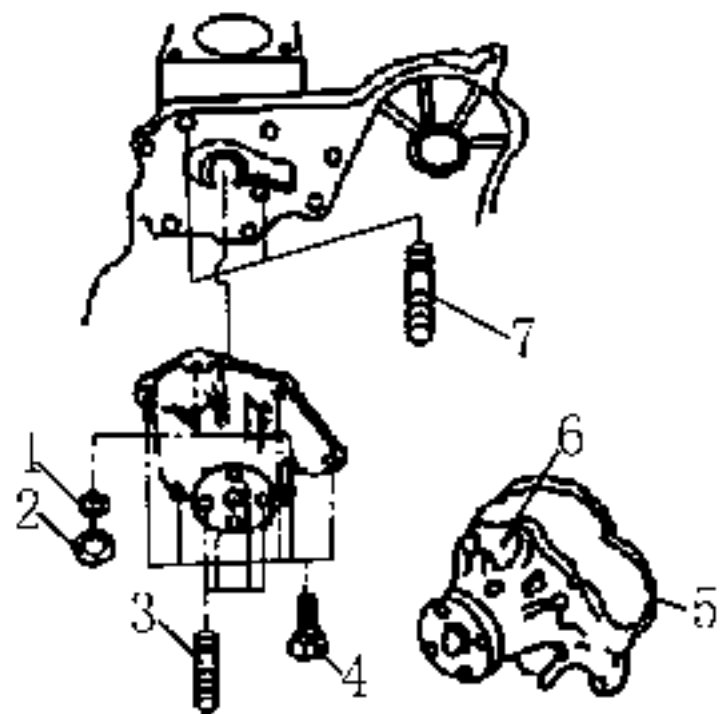

## 水泵的安装 WATER PUMP

序号	部件代码	部件名称	部件规格	用量	适用车型	备注
S/N	PART CODE	DESCRIPTION	SPECIFICATION	QTY	VEHICLE MODEL	REMARK
1	Q30108	平垫	PLAIN WASHER	8		
2	Q340408	六角螺母	HEX NUT	2		
3	HC1307021	六角螺母	HEX NUT	4		
4	Q1420825	螺栓带垫圈	BOLT SET	5		
5	HC1300007	水泵密封环	WATER PUMP SEALING RING	1		
6	HC1307020	水泵总成	WATER PUMP ASSY	1		
7	Q1200825	六角螺母	HEX NUT	2		



## 冷却水管焊合件的安装 COOLANT PIPE WELDMENT

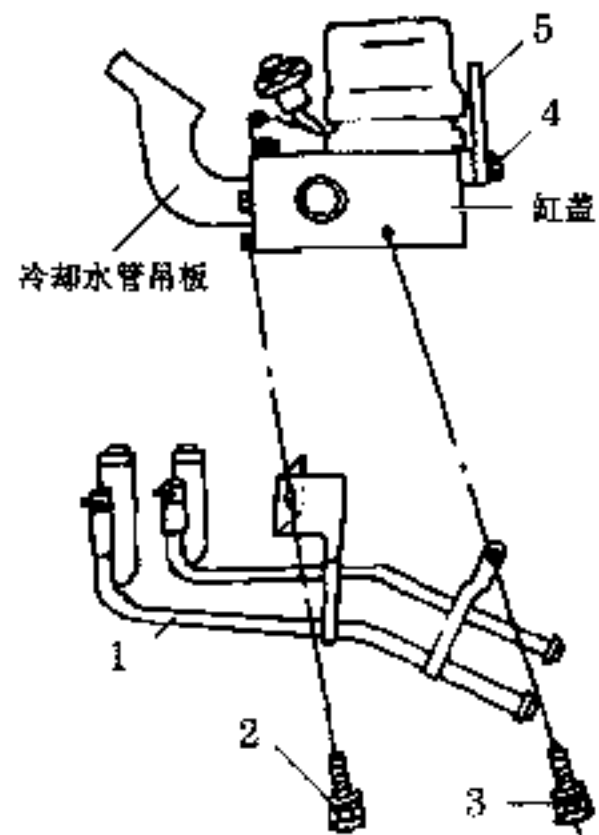

## 冷却水管焊合件的安装 COOLANT PIPE WELDMENT

序号	部件代码	部件名称	部件规格	用量	适用车型	备注
SN	PART CODE	DESCRIPTION	SPECIFICATION	QTY.	VEHICLE MODEL	REMARK
1	DC-L00060	冷却水管焊合件	COOLANT PIPE WELDMENT	1		
2	Q1420625	螺母垫合件	BOLT SET	1		
3	Q1840612	螺母垫合件	BOLT SET	1		
4	Q1420025	螺母垫合件	BOLT SET	1		
5	DC-L007013	吊钩	REAR HANGER	1		
:			:			
:			:			
:			:			

机油滤清器的安装 OIL FILTER

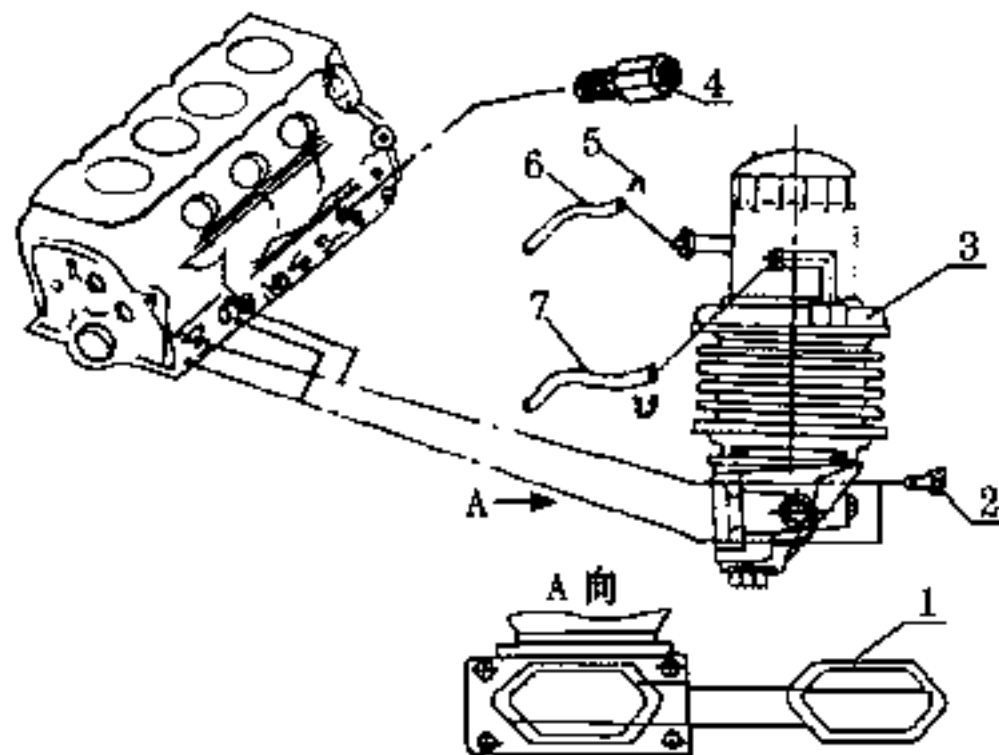

## 机油滤清器的安装 OIL FILTER

序号 S/N	部件代码 PART CODE	部件名称 DESCRIPTION	部件规格 SPECIFICATION	用量 QTY.	适用车型 VEHICLE MODEL	备注 REMARK
1	11C-1017011	橡胶密封圈	RUBBER SEAL RING	1		
2	Q1420870	螺栓组合件	BOLT SET	4		
3	11C-1017010	机油滤清器总成	OIL FILTER ASSY	1		
4	11C-1017021	润滑油回油管接头	LUBRICANT RETURN PIPE CONNECTOR	1		
5	11C-1017012	卡箍	RING CLIP	2		
6	11C-1017014	滤清器冷油出水管	COOLANT OUTLET PIPE	1		
7	11C-1017013	滤清器冷油进水管	COOLANT INLET PIPE	1		

# 机油泵的安装 OIL PUMP

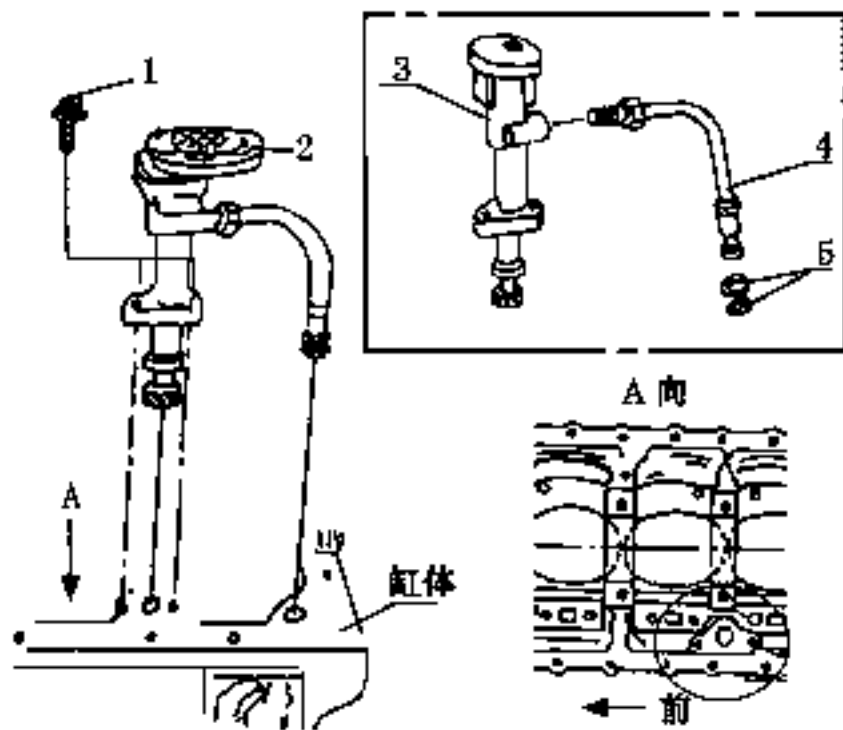

## 机油泵的安装 OIL PUMP

序号	部件代码	部件名称	部件规格	用量	适用车型	备注
S/N	PART CODE	DESCRIPTION	SPECIFICATION	QTY.	VEHICLE MODEL	REMARK
1	Q1468830	螺栓组合	BOLT SET	2		
2	DC-1011020	机油泵安装总成	OIL PUMP MOUNTING ASSY	1		
3	DC-1011010	机油泵总成	OIL PUMP ASSY	1		
4	DC-1011040	机油管合件	OIL PIPE SET	2		
5	DC-1011011	O 型密封圈	O-RING	1		

# 喷油泵的安装 INJECTION PUMP

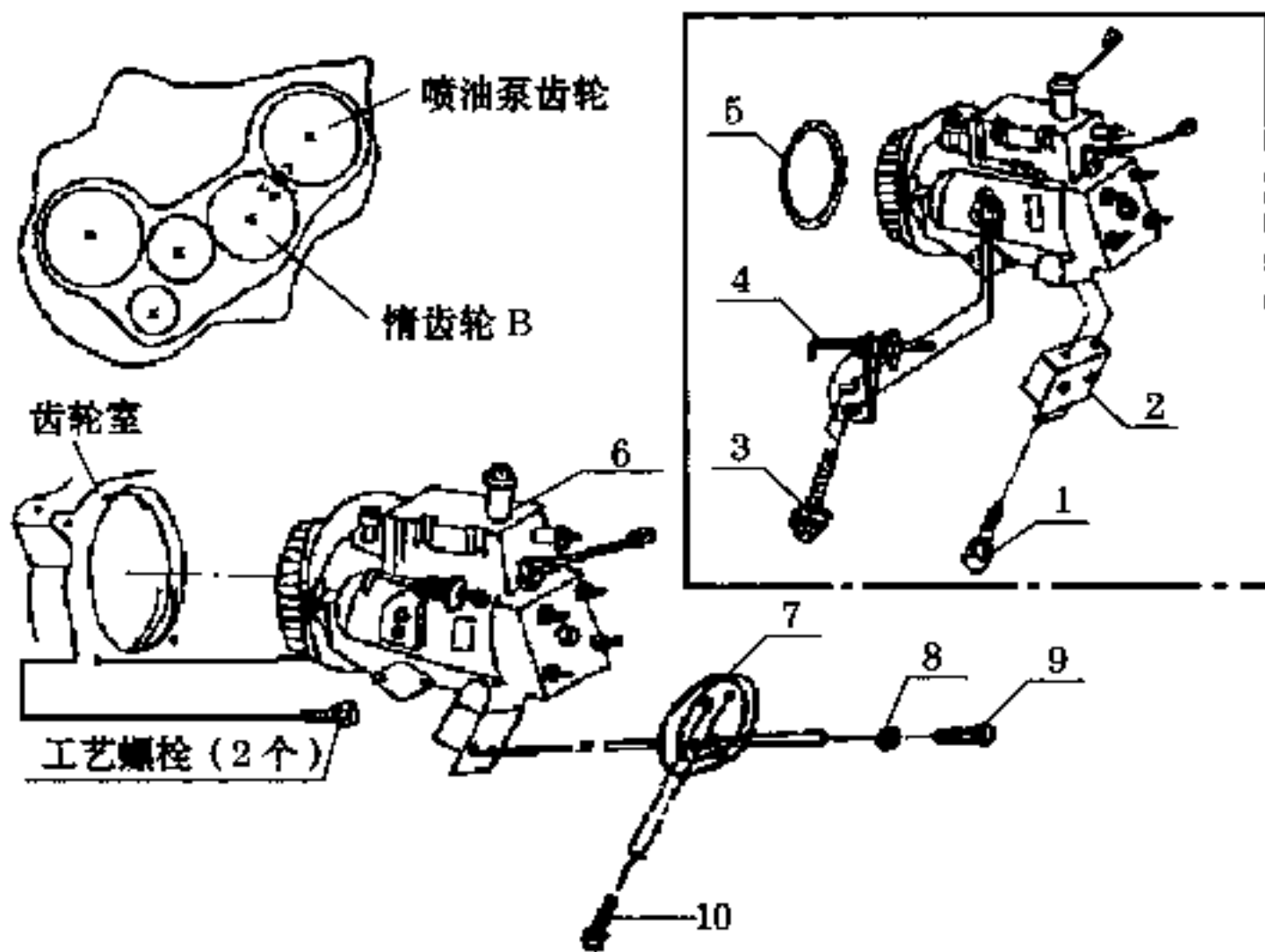

## 喷油泵的安装 INJECTION PUMP

序号	部件代码	部件名称	部件规格	用量	适用车型	备注
S/N	PART CODE	DESCRIPTION	SPECIFICATION	QTY	VEHICLE MODEL	REMARK
1	Q1420020	螺栓组合件	BOLT SET	2		
2	DC-1010012	后支架组合件	REAR BRACKET-REAR MOUNT	1		
3	Q1460012	螺栓组合件	BOLT SET	2		
4	DC-1010020	转速提升装置	SOLE SPEED LIFTING DEVICE	1		
5	O 型密封圈	O-RING	1			
6	DC-1010010	喷油泵组合件	INJECTION PUMP	1		
7	DC-1010011	后支架 A	REAR BRACKET-A	1		
8	DC-1010014	平垫圈	PLAIN WASHER	2		
9	Q1420025	螺栓组合件	BOLT SET	2		
10	Q1460020	螺栓组合件	BOLT SET	2		



# 发电机的安装 GENERATOR

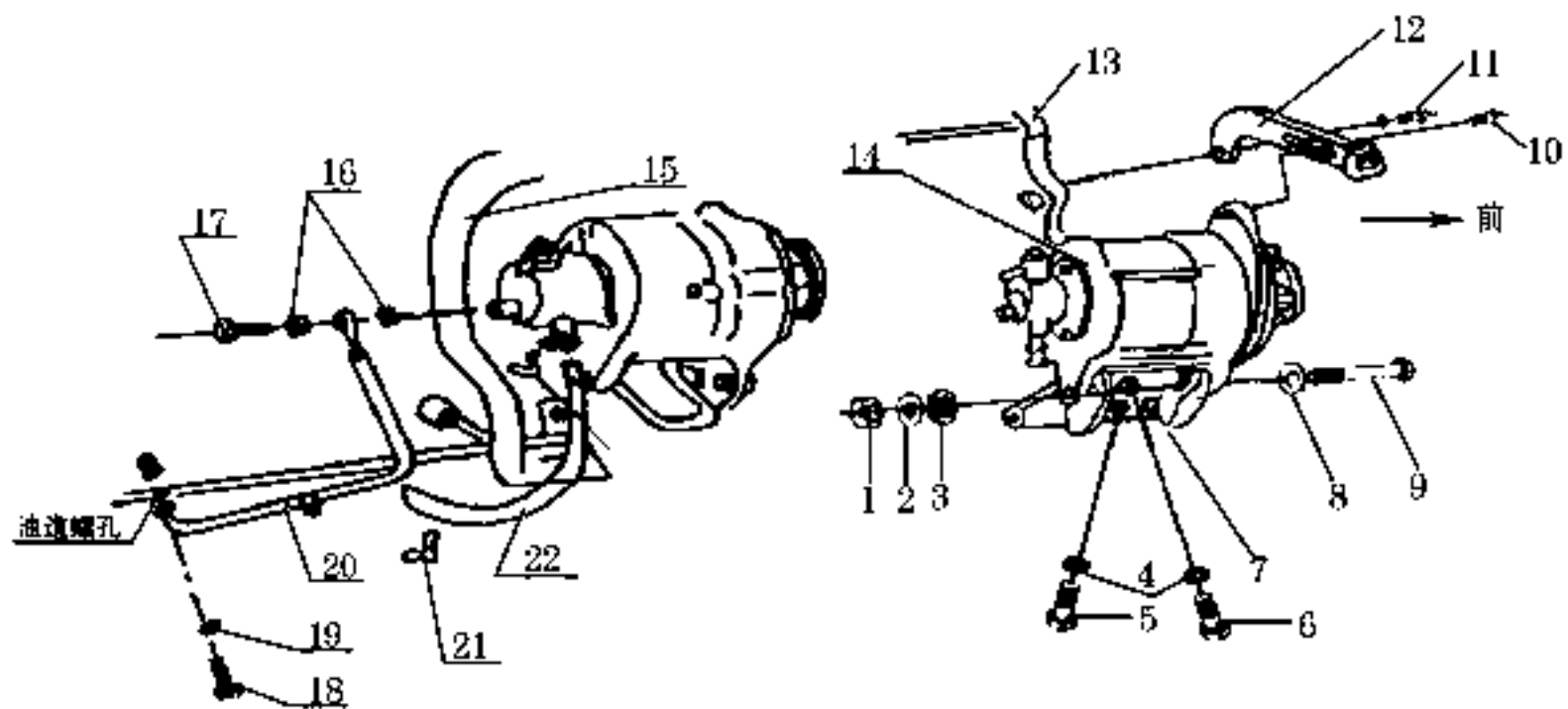

## 发电机的安装 GENERATOR

序号 SN	部件代码 PART CODE	部件名称 DESCRIPTION	部件规格 SPECIFICATION	用量 QTY	适用车型 VEHICLE MODEL	备注 REMARK
1	11C-370104	螺母	NUT	1		
2	Q40310	弹簧垫圈	SPRING WASHER	1		
3	Q40110	平垫圈	PLAIN WASHER	2		
4	Q40310	弹簧垫圈	SPRING WASHER	2		
5	Q4510-0035	螺栓	BOLT	1		
6	Q4510-0070	螺栓	BOLT	2		
7	11C-370103	发电机支架	GENERATOR BRACKET	1		
8	Q40110	平垫圈	PLAIN WASHER	2		
9	11C-370103	发电机螺栓	GENERATOR BOLT	1		
10	Q4420R25	螺栓	BOLT SET	1		
11	Q4420R25	螺栓	BOLT SET	1		
12	11C-3701032	发电机副支架	GENERATOR ADJUSTOR BRACKET	1		
13	11C-1002051	齿轮室	GEAR CHAMBER	1		
14	11C-3701010	发电机总成	GENERATOR ASSY	1		1618型 枪头
15	11C-3701041	进水管	WATER INLET PIPE	1		
16	11C-3701045	铜垫圈	BRONZE WASHER	2		
17	11C-3701046	管接头螺栓	UNION JOINT BOLT	1		
18	11C-3701048	管接头螺栓	UNION JOINT BOLT	1		
19	11C-3701047	铜垫圈	BRONZE WASHER	2		
20	11C-3701042	润滑进油管接头	LUBRICANT INLET PIPE	1		

## 发电机的安装 GENERATOR

序号 NO.	部件代码 PART CODE	部件名称 DESCRIPTION	部件规格 SPECIFICATION	用量 QTY.	适用车型 VEHICLE MODEL	备注 REMARK
21	HC-3701044	空滤固定卡箍	RING CLIP	2		
22	HC-3701043	机油回油管	LUBRICANT RETURN PIPE	1		



## 高压油管及机油尺的安装 HIGH PRESSURE FUEL PIPE& OIL DIP ROD

序号	部件代码	部件名称	部件规格	用量	适用车型	备注
S/N	PART CODE	DESCRIPTION	SPECIFICATION	QTY	VEHICLE MODEL	REMARK
1	HC-141021	第一缸高压油管	NO.1 CYLINDER HIGH PRESSURE FUEL PIPE	1		
2	HC-141022	第二缸高压油管	NO.2 CYLINDER HIGH PRESSURE FUEL PIPE	1		
3	HC-141023	第三缸高压油管	NO.3 CYLINDER HIGH PRESSURE FUEL PIPE	1		
4	HC-141024	第四缸高压油管	NO.4 CYLINDER HIGH PRESSURE FUEL PIPE	1		
5	HC-141025	高压油管快速接头	HIGH PRESSURE FUEL PIPE FASTENING DEVICE	2		
6	HC-1002070	机油尺总成	OIL DIP ROD	1		
7	HC-1002060	机油尺总成安装螺母	OIL DIP ROD GLIDE WELD NUT	1		

风扇、风扇皮带轮及皮带的安装 FAN, FAN PULLEY & BELT

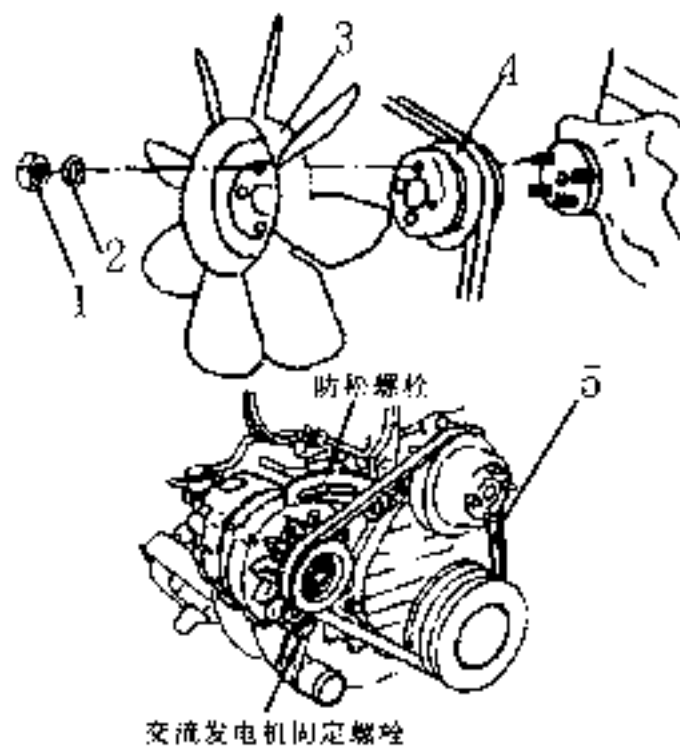

## 风扇、风扇皮带轮及皮带的安装 FAN、FAN PULLEY & BELT

序号	部件代码	部件名称	部件规格	用量	适用车型	备注
S/N	PART CODE	DESCRIPTION	SPECIFICATION	QTY	VEHICLE MODEL	REMARK
1	Q340806	六角螺母	HRX NUT	4		
2	Q40306	弹簧垫圈	SPRING WASHER	4		
3	HC-4308010	风扇离合器	FAN CLUTCH	1		
4	HC-4308044	水泵皮带轮	WATER PUMP PULLEY	1		
5	HC-4308011	皮带	BELT	1		

通气软管、机油滤清器冷却进出水管的安装  
 BREATHER HOSE, OIL FILTER COOLANT INLET & OUTLET PIPE

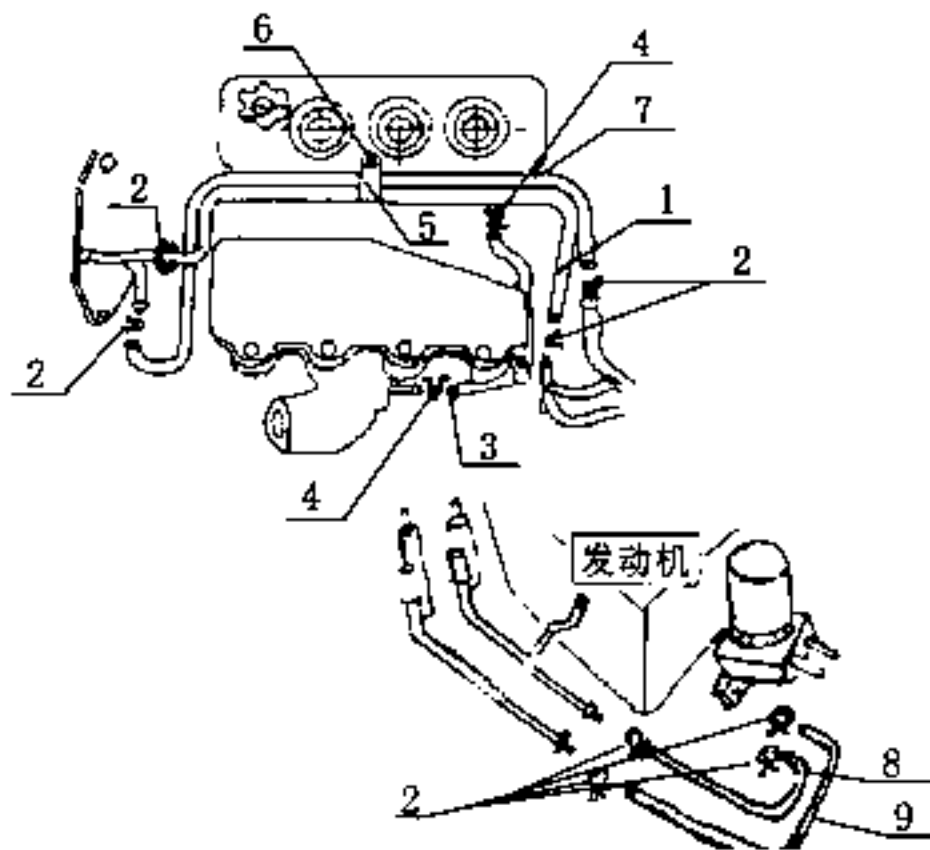



**通气软管、机油滤清器冷却进出水管的安装**  
**BREATHER HOSE, OIL FILTER COOLANT INLET&OUTLET PIPE**

序号 S/N	部件代码 PART CODE	部件名称 DESCRIPTION	部件规格 SPECIFICATION	用量 QTY.	适用车型 VEHICLE MODEL	备注 REMARK
1	LIC-130301	冷却出水软管	COOLANT OUTLET HOSE	1		
2	LIC-130302	环箍	RING CLIP	4		
3	LIC-1013021	通气软管	BREATHER HOSE	1		
4	LIC-1013022	环箍	RING CLIP	2		
5	LIC-1013023	软管夹	HOSE CLIP	1		
6	Q1040812	螺栓组合件	BOLT SET	1		
7	LIC-1303013	冷却进水软管	COOLANT INLET HOSE	1		
8	LIC-1017013	油水分离器进水管	OIL WATER SEPARATOR INLET PIPE	1		
9	LIC-1017014	油水分离器出水管	OIL WATER SEPARATOR OUTLET PIPE	1		

隔热板的安装 HEAT INSULATING PANEL

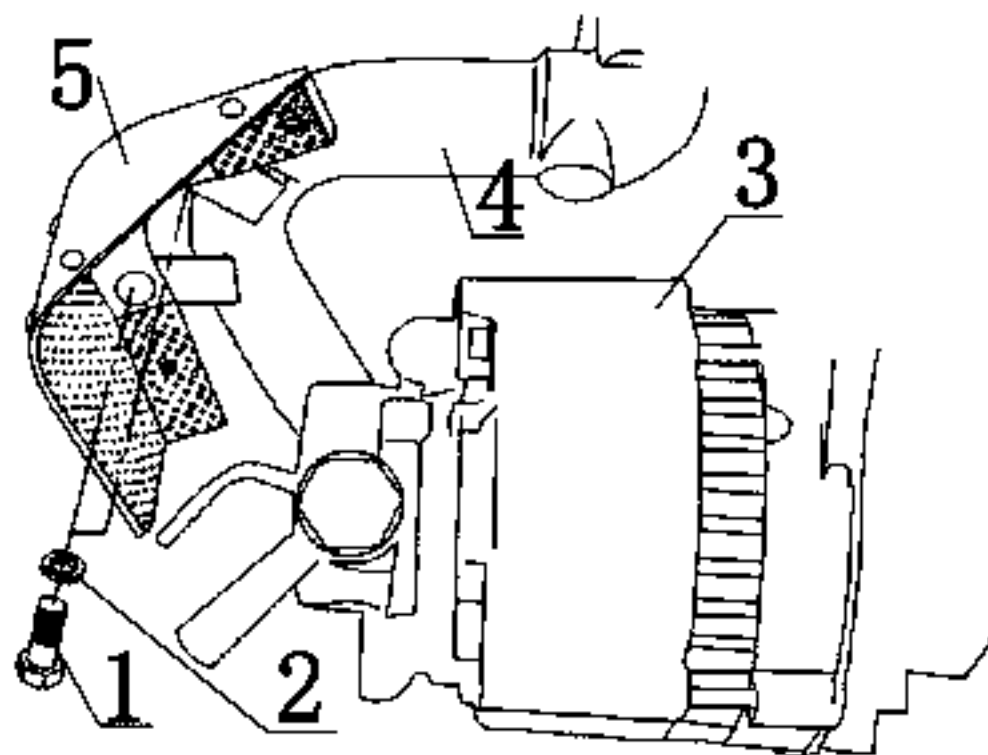

## 隔热板的安装 HEAT INSULATING PANEL

序号	部件代码	部件名称	部件规格	用量	适用车型	备注
SN	PART CODE	DESCRIPTION	SPECIFICATION	QTY.	VEHICLE MODEL	RE-MARK
1	Q420816	螺栓组合件	BOLT SET	2		
2	Q40108	垫圈	FLAT WASHER	2		
3	11U-3701030	发电机总成	GENERATOR ASSY	1		
4	11U-130004	进水管总成	WATER INLET PIPE	1		
5	11U-1303020	隔热板总成	HEAT INSULATING PANEL REVET	1		

导水管、油压感应塞及油压感应塞座  
WATER GUIDE PIPE, OIL PRESSURE SENSING PLUG & OIL PRESSURE SENSING PLUG SEAT

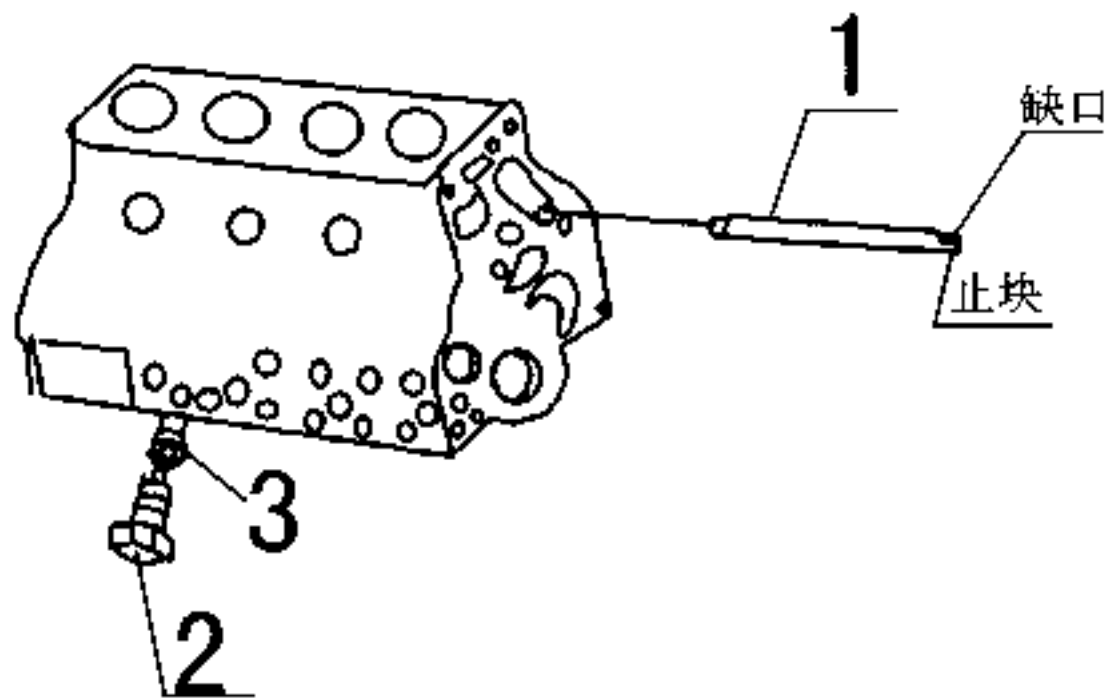



缸盖在缸体上的安装 CYLINDER HEAD

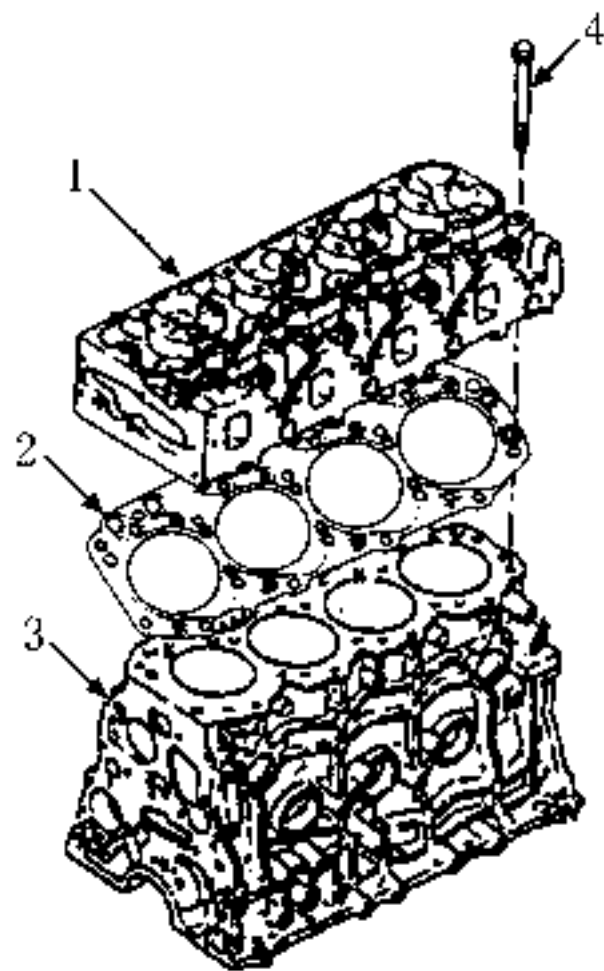

## 缸盖在缸体上的安装 CYLINDER HEAD

序号 SN	部件代码 PART CODE	部件名称 DESCRIPTION	部件规格 SPECIFICATION	用量 QTY.	适用车型 VEHICLE MODEL	备注 RE-MARK
1	HC-1003070	缸盖安装总成	CYLINDER HEAD MOUNTING ASSY	1		
2	HC-1003090	缸盖垫圈套	CYLINDER GASKET KIT	1		
3	HC-1002054	缸体机械总成	CYLINDER BLOCK	1		
4	HC-1003016	缸盖螺栓	CYLINDER HEAD BOLT	18		





## 进排气门的组装 INTAKE/EXHAUST VALVE

序号	部件代码	部件名称	部件规格	用量	运用车型	备注
S/N	PART CODE	DESCRIPTION	SPECIFICATION	QTY	VEHICLE MODEL	REMARK
1	11C-1007010	摇臂轴总成	ROCKER ARM & SHAFT ASSY	1		
2	11C-1007019	气门挺杆	VALVE KEEPER	16		
3	11C-1007021	气门弹簧上座	VALVE UPPER SPRING RETAINER	8		
4	11C-1007017	气门弹簧	VALVE SPRING	8		
5	11C-1007040	气门油封	VALVE OIL SEAL	8		
6	11C-1007015	气门弹簧垫圈	VALVE SPRING WASHER	8		
7	11C-1007011	气门导管	VALVE GUIDE	8		
8	11C-1007014	排气门座	EXHAUST VALVE SEAT	4		
9	11C-1007018	进气门座	INTAKE VALVE SEAT	4		
10	13C-1017016	排气门	EXHAUST VALVE	4		
11	13C-1017020	进气门	INTAKE VALVE	4		
12	13C-1017021	摇杆	TAPPET	8		
13	13C-1017060	推杆	PUSHER ROD	8		
14	11C-1003029	气缸盖	CYLINDER HEAD	1		

气门室罩盖的组装 VALVE CHAMBER COVER

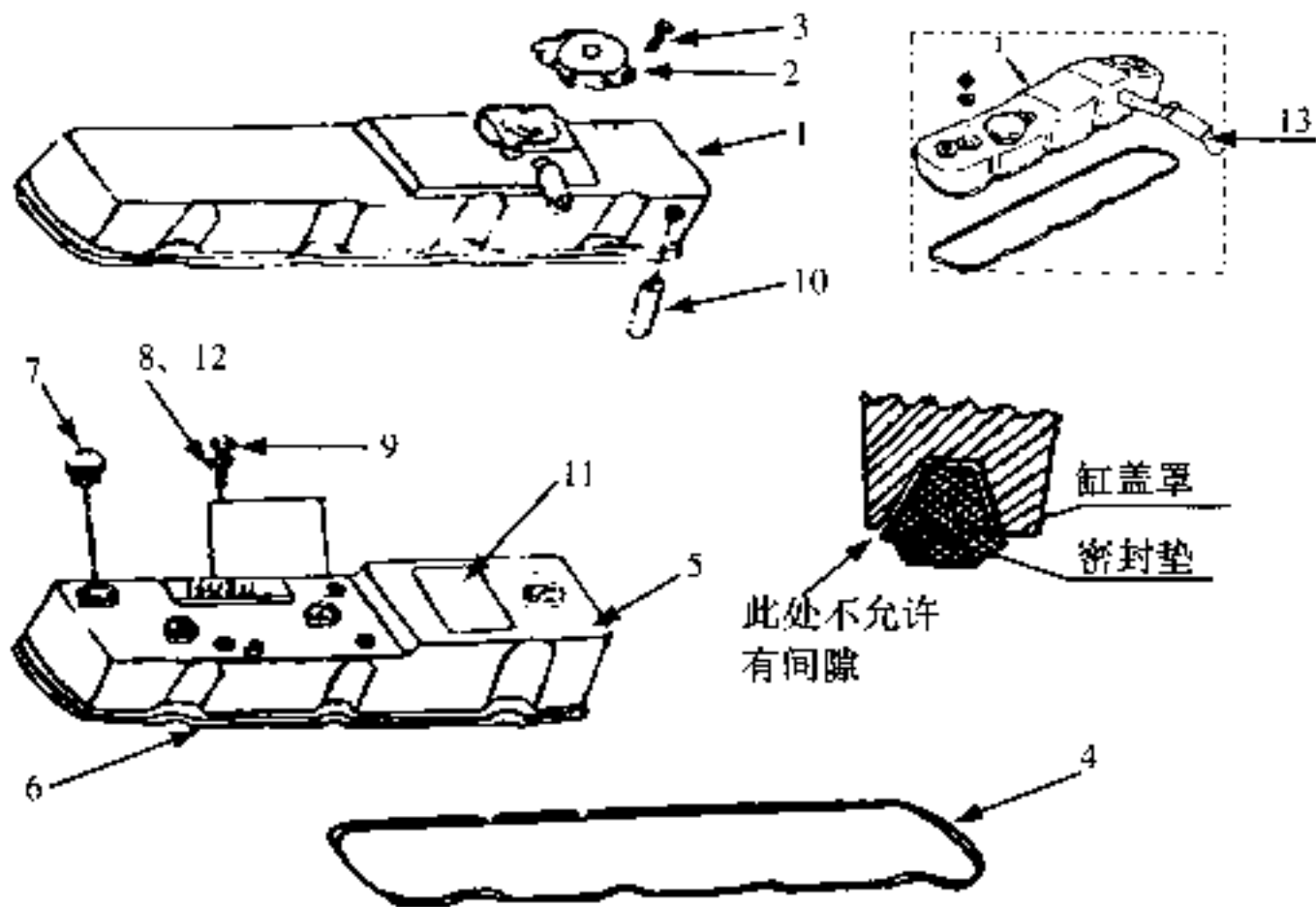

## 气门室罩盖的组装 VALVE CHAMBER COVER

序号	部件代码	部件名称	部件规格	用量	适用车型	备注
S/N	PART CODE	DESCRIPTION	SPECIFICATION	QTY	VEHICLE MODEL	REMARK
1	JIC-1003080	气缸罩	CYLINDER HEAD COVER	1		
2	JIC-1003060	膜片组合件	DIAPHRAGM VALVE SET	1		
3	Q2320408	十字槽内六角	CROSS SLOT SCREW	4		
4	JIC-1003082	气缸罩密封垫	CYLINDER HEAD COVER GASKET	1		
5	JIC-1003084	罩壳密封垫	SHIELD GASKET	1		
6	JIC-1003085	气缸罩密封海绵	CYLINDER HEAD SEALING SPONGE	1		
7	JIC-1003083	机油油盖	OIL FILLER CAP	1		
8	Q40200	平垫	PLAIN WASHER	2		
9	Q154000512	螺帽	BOLT	2		
10	JIC-10140010	进气口接头	BREATHER HOLE UNION	1		
11	JIC-1003086	铭牌	NAME PLATE	1		
12	Q40200	垫圈	SPRING WASHER	2		
13	JIC-10140011	曲轴箱通风软管	CRANKCASE BREATHER PIPE	1		

摇臂轴总成的组装 ROCKER ARM SHAFT ASSY

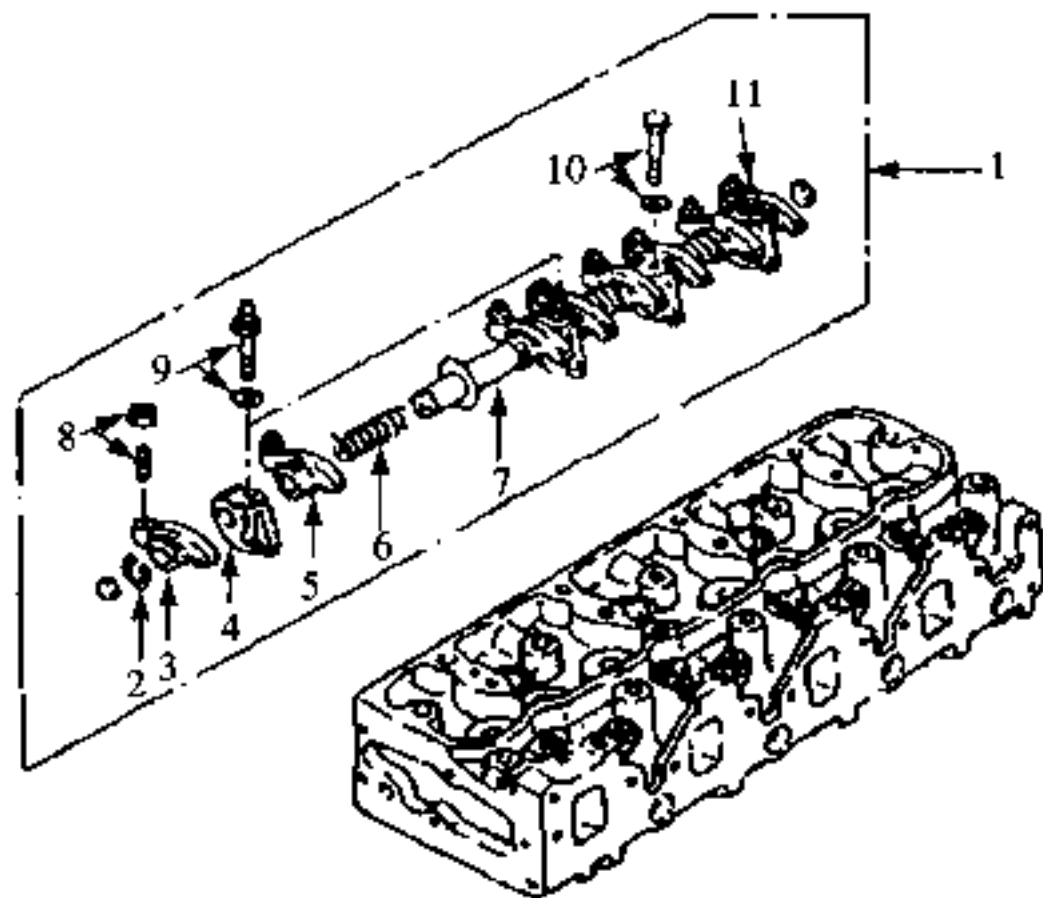

## 摇臂轴总成的组装 ROCKER ARM SHAFT ASSY

序号	部件代码	部件名称	部件规格	用量	适用车型	备注
S/N	PART CODE	DESCRIPTION	SPECIFICATION	QTY	VEHICLE MODEL	REMARK
1	1101-L107010	摇臂及摇臂轴总成	ROCKER ARM & SHAFT ASSY	1		
2	Q45119	摇臂轴衬套衬套圈	ROCKER ARM SHAFT SLEAVE RING	2		
3-5	1101-L107012	摇臂	ROCKER ARM	8		
4	1101-L107022	摇臂轴衬套	ROCKER ARM SHAFT SLEAVE	4		
6	1101-L107013	摇臂轴衬套圈	ROCKER ARM SHAFT SLEAVE RING	3		
7	1101-L107050	摇臂轴	ROCKER ARM SHAFT	1		
8	1101-L107023	六角螺母	HEX NUT	8		
	1101-L107024	调整螺钉	ADJUSTING SCREW	8		
9	1101-L107025	螺母	NUT	2		
	Q40110	平垫圈	PLAIN WASHER	4		
10	Q45119-L107012	衬套	BUSH	1		
11	1101-L107026	螺母	NUT	1		

喷油器、回油软管、电热塞及电热塞连接板  
INJECTOR, RETURN HOSE, GLOW PLUG & GLOW PLUG CONNECTING PLATE

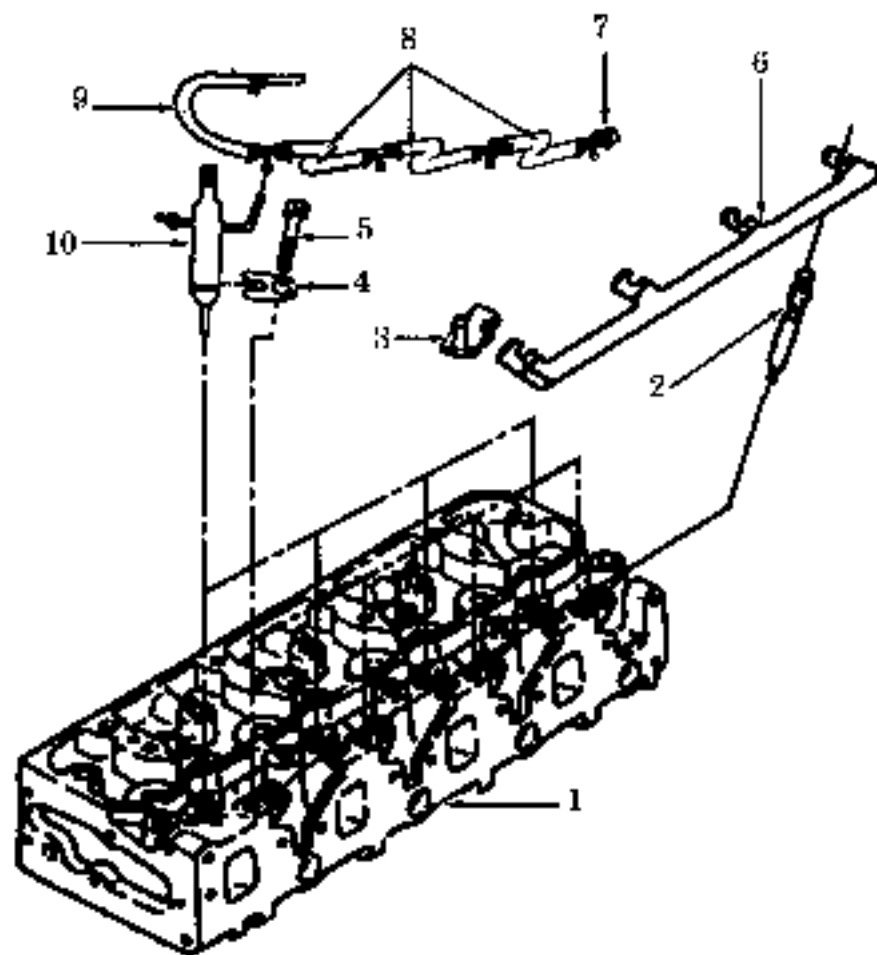

**喷油器、回油软管、电热塞及电热塞连接板**  
**INJECTOR, RETURN HOSE, GLOW PLUG & GLOW PLUG CONNECTING PLATE**

序号 SN	部件代码 PART CODE	部件名称 DESCRIPTION	部件规格 SPECIFICATION	用量 QTY	适用车型 VEHICLE MODEL	备注 REMARK
1	11C-000300	缸盖	CYLINDER HEAD	1		
2	11C-377000	电热塞	GLOW PLUG	4		
3	11C-377002	线束	WIRE BUNDLE	1		
4	11C-011201	喷油器连接板	INJECTOR PRESSURE PLATE	4		
5	11C-011202	喷油器紧固螺栓	INJECTOR TIGHTENING BOLT	4		
6	11C-377001	电热塞连接板	GLOW PLUG CONNECTING PLATE	1		
7	11C-011203	回油软管端盖	RETURN HOSE END COVER	1		
8	11C-011204	回油软管	RETURN HOSE	3		
9	11C-011205	回油软管接口	RETURN HOSE	1		
10	11C-011206	喷油器总成	INJECTOR ASSY	4		

节温器及节温器壳的安装 THERMOSTAT & THERMOSTAT HOUSING

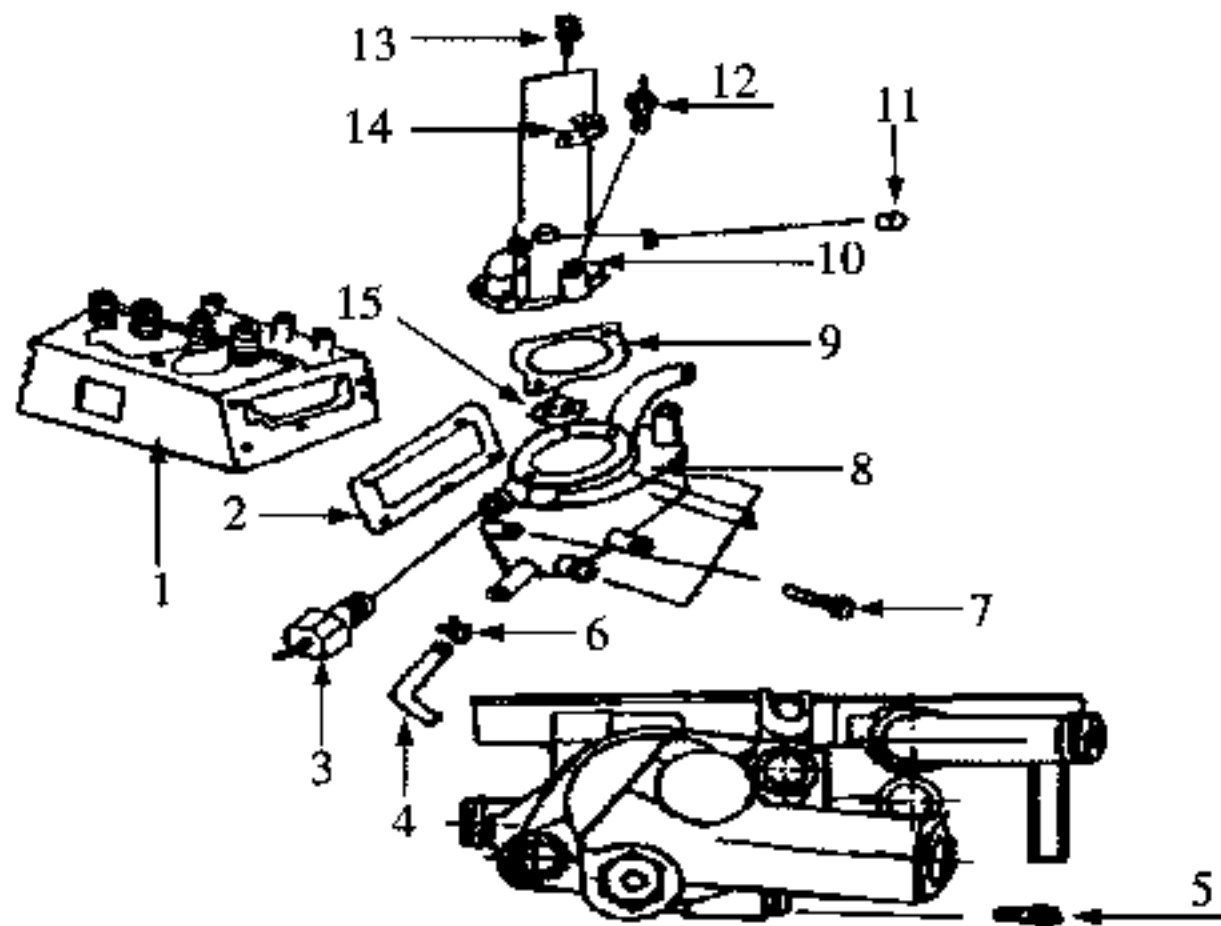



## 节温器及节温器壳的安装 THERMOSTAT & THERMOSTAT HOUSING

序号	部件代码	部件名称	部件规格	用量	适用车型	备注
S/N	PART CODE	DESCRIPTION	SPECIFICATION	QTY.	VEHICLE MODEL	REMARK
1	HC-100070	缸盖	CYLINDER HEAD	1		
2	HC-130011	垫圈-下壳	GASKET - LOWER HOUSING	1		
3	HC-360950	水温传感器	WATER TEMPERATURE SENSOR	1		
4	HC-130015	小循环水管	WATER PIPE FOR SMALL CIRCULATION	1		
5	HC-130013	锥管螺塞	TAPER PIPE SCREW PLUG	1	R3N	
6	Q67612	分型面密封环	RING CLIP	1		
7	Q1420830	螺栓组合件	BOLT SET	5	M8*30	
8	HC-130014	节温器下壳总成	THERMOSTAT LOWER HOUSING ASSY	1		
9	HC-130012	垫圈-上壳	GASKET - UPPER HOUSING	1		
10	HC-130020	节温器-总成	THERMOSTAT UPPER HOUSING ASSY	1		
11	HC-430021	加水管-总成	WATER INLET PIPE ASSEMBLY	1		
12	HC-430040	冷启动传感器	COLD START SENSOR	1		
13	Q1400830	螺栓组合件	BOLT SET	2	M8*30	
14	HC-130022	线束夹	WIRING HARNESS CLIP	1		
15	HC-130010	节温器	THERMOSTAT	1		







每天进步一点点  
*improving little by little everyday*

## 吉利汽车股份有限公司

地址: 浙江省杭州市钱江世纪城 邮编: 311003  
ADD: No. 1, Qianjiang South Road, Hangzhou, P.R. China, 311003  
销售热线: 0571 2182988 传真: 0571 2182984  
Sales Dept. Tel: 0571 2182988 Fax: 0571 2182984  
售后服务: 0571 2182445 2182447  
After sales Dept. Tel: 0571 2182445 2182447  
网址: <http://www.geely.com.cn>