

**>> OWNER'S MANUAL
QUICK REFERENCE GUIDE**

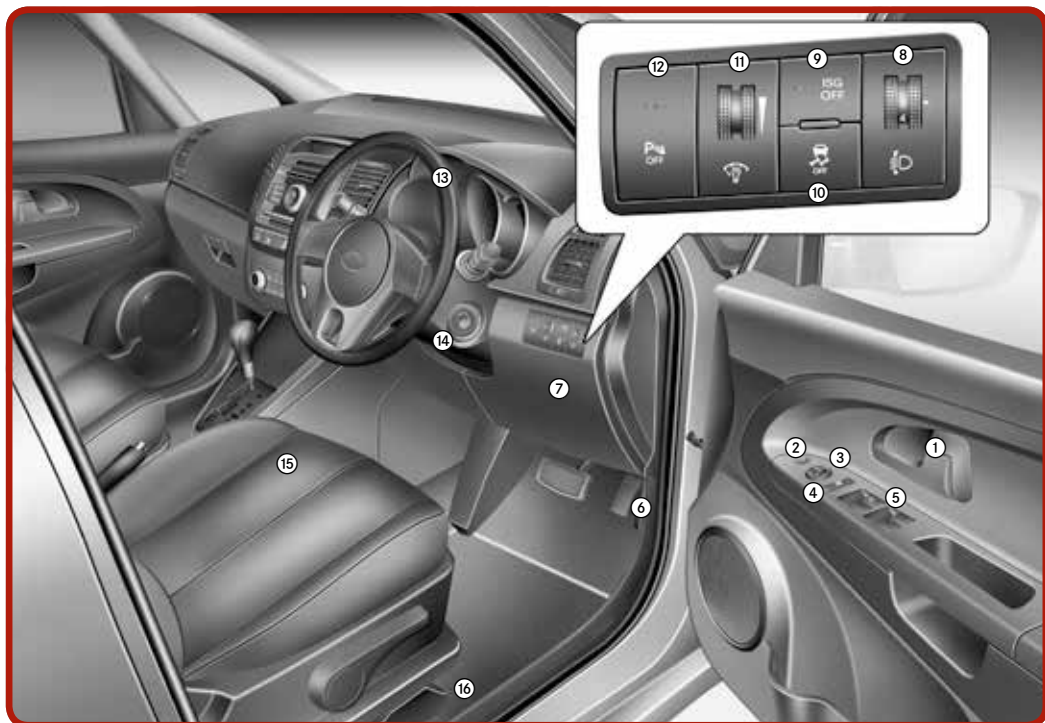

The Power to Surprise

Interior Overview



- ① Inside door handle [4]
- ② Outside rearview mirror folding button* [4]
- ③ Outside rearview mirror control switch [4]
- ④ Power window lock switch* [4]
- ⑤ Power window switches* [4]
- ⑥ Bonnet release lever [4]
- ⑦ Interior fuse box [7]
- ⑧ Headlight levelling control* [4]
- ⑨ Idle Stop and Go (ISG) OFF button* [5]
- ⑩ ESC OFF button* [5]
- ⑪ Instrument panel illumination control* [4]
- ⑫ Parking assist system ON/OFF button* [5]
- ⑬ Steering wheel [4]
- ⑭ Tilt and telescopic steering column control lever [4]
- ⑮ Seat [3]
- ⑯ Fuel filler lid open lever [4]

* if equipped

[#] Number in brackets indicates chapter in Owner's Manual

The illustrations in this guide may vary from the actual vehicle.

Instrument Panel Overview / Engine Compartment



- | | | |
|--|----------------------------------|---------------------------------------|
| ① Driver's front air bag [3] | ⑦ LCD display/Trip computer* [4] | ⑭ Glove box [4] |
| ② Light/Turn signal control lever [4] | ⑧ Audio system [4] | ⑮ Power outlet/Cigarette lighter* [4] |
| ③ Instrument cluster [4] | ⑨ Hazard warning light [4] | ⑯ Gear lever [5] |
| ④ Wiper and washer control lever [4] | ⑩ Central door lock switch [4] | ⑰ Parking brake [5] |
| ⑤ Audio remote control buttons* [4] | ⑪ Front seat warmer* [3] | ⑱ Brake pedal [5] |
| ⑥ Cruise control/Speed limiter switches* [5] | ⑫ Climate control system [4] | ⑲ Accelerator pedal [5] |
| | ⑬ Passenger's front air bag [3] | ⑳ Air vents [4] |
| | | ㉑ Steering wheel warmer* [4] |

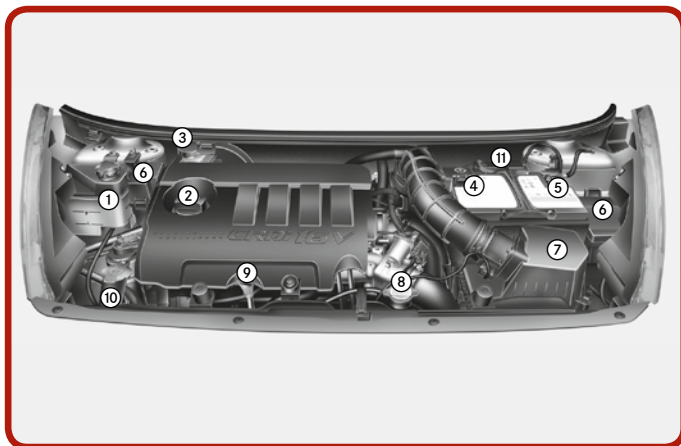

- | |
|---|
| ① Engine coolant reservoir [7] |
| ② Engine oil filler cap [7] |
| ③ Brake/clutch* fluid reservoir [7] |
| ④ Positive battery terminal [7] |
| ⑤ Negative battery terminal [7] |
| ⑥ Engine room fuse box [7] |
| ⑦ Air cleaner [7] |
| ⑧ Radiator cap [7] |
| ⑨ Engine oil dipstick [7] |
| ⑩ Windshield washer fluid reservoir [7] |
| ⑪ Fuel filter [7] |

Door Locks / Tailgate / Bonnet / Fuel Filler Lid

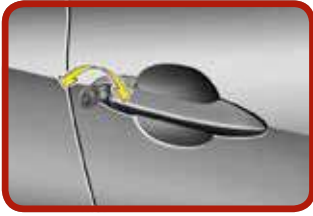

Operating door locks manually [4]



Operating door locks from inside the vehicle with central door lock switch [4]



Emergency door locking [4]

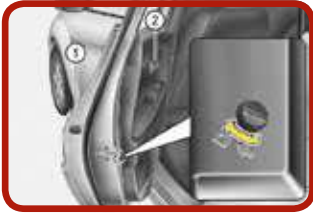

Child-protector rear door lock [4]



Opening the tailgate [4]



Emergency tailgate release [4]



Opening the bonnet [4]
Pull the release lever to unlatch the bonnet.

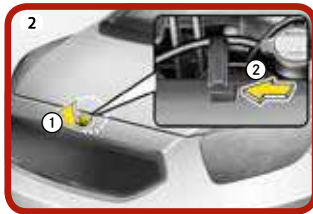

① Lift the bonnet slightly.
② Push the secondary latch inside and open the bonnet.



Release the support rod and insert it into the position shown.



Opening the fuel filler [4]
Pull up the fuel-filler lid release lever.

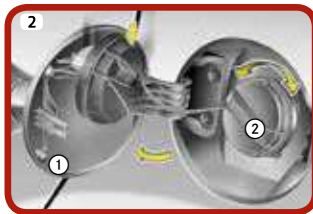

① Fully open the lid.
② Turn cap counterclockwise to open.

Closing the fuel filler

1. Turn cap clockwise until it "clicks" to ensure it is securely closed.
2. Close the lid and press the edge until it is securely locked.

Windows / Wipers and Washers

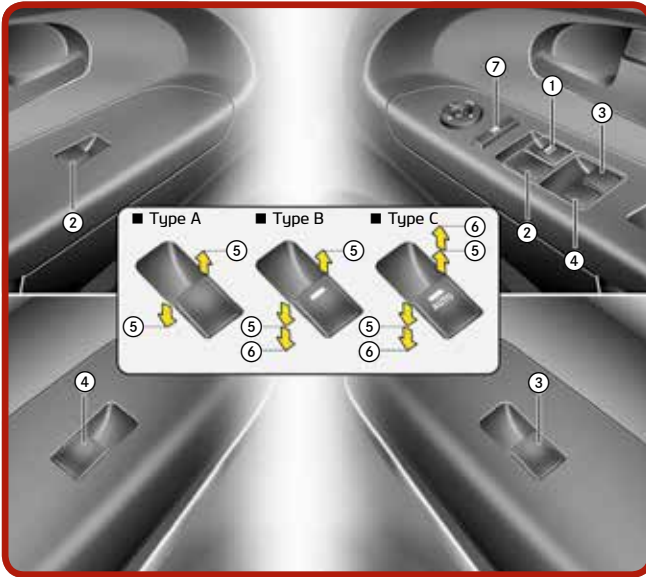

- ① Driver's door power window switch
- ② Front passenger's door power window switch
- ③ Rear door (right) power window switch*
- ④ Rear door (left) power window switch*
- ⑤ Window opening and closing
- ⑥ Automatic power window up*/down*
- ⑦ Power window lock switch*

NOTICE

In cold and wet climates, power windows may not work properly due to freezing conditions.

Windows [4]

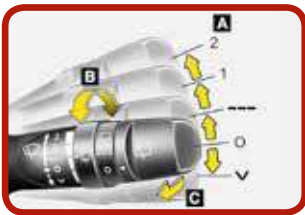

A: Wiper speed control (front)

- 2 High wiper speed
- 1 Low wiper speed
- Intermittent wipe
- 0 OFF
- ✓ Single wipe

B: Intermittent control wipe time adjustment

C: Wash with brief wipers (front)

Front [4]

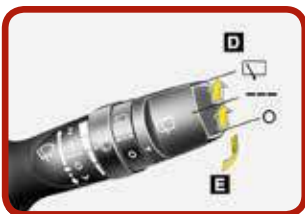

D: Rear wiper/washer control

- High wiper speed
- Low wiper speed
- 0 OFF

E: Wash with brief wipers (rear)

Rear* [4]

Seat / Air Bag / Child Restraint System

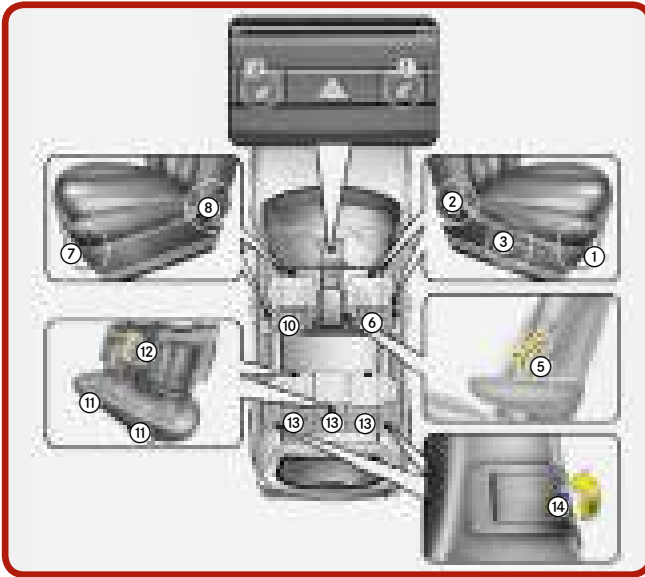

Driver's seat

- ① Forward and backward
- ② Seatback angle
- ③ Seat cushion height*
- ④ Seat warmer*
- ⑤ Armrest*
- ⑥ Headrest

Front passenger seat

- ⑦ Forward and backward
- ⑧ Seatback angle
- ⑨ Seat warmer*
- ⑩ Headrest

Rear seat

- ⑪ Forward and backward
- ⑫ Armrest*
- ⑬ Headrest
- ⑭ Split folding rear seat

Seat [3]



Passenger's front air bag ON/OFF switch [3]

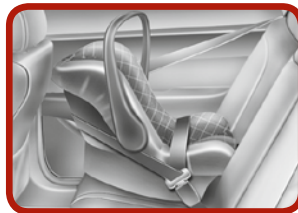

Rearward-facing child restraint system [3]

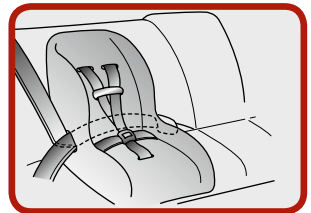

Installing a child restraint system by lap/shoulder belt [3]

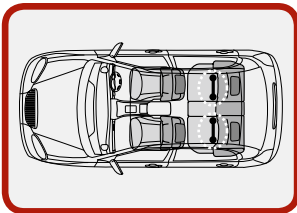

Securing with "ISOFIX" system and "Tether Anchorage" system* [3]

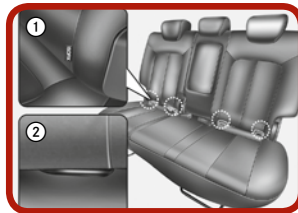

- ① ISOFIX Anchor Position Indicator
- ② ISOFIX Anchor



Securing with "Tether Anchor" system* [3]

Climate Control System



Manual climate control system* [4]

- ① Fan speed control
- ② Mode selection
- ③ Temperature control
- ④ Front windshield defroster
- ⑤ Rear window defroster
- ⑥ Air intake control
- ⑦ Air conditioning



Automatic climate control system* [4]

- ① AUTO (automatic control)
- ② Temperature control
- ③ Blower OFF
- ④ Mode selection
- ⑤ Fan speed control
- ⑥ Air conditioning
- ⑦ Front windscreen defroster
- ⑧ Rear window defroster
- ⑨ Air intake control
- ⑩ A/C display

Lighting Control / Steering Wheel / Cruise Control System



Lighting control [4]

- ① OFF
- ② Position light
- ③ Headlight
- ④ Auto light*

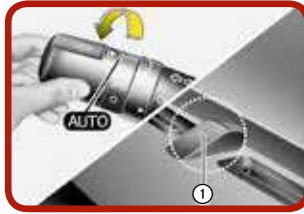

Auto light function* [4]

If the light switch is in AUTO position, the headlights will be turned ON or OFF automatically, depending on the amount of light detected by the sensor below the windshield.

- ① Sensor

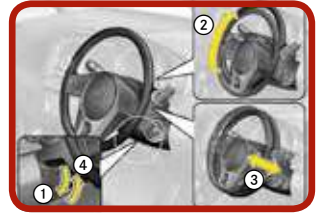

Tilt & telescopic steering [4]

Steering wheel adjustment:

- ① Pull down lock release lever.
- ② Adjust the steering wheel to the desired angle.
- ③ Height adjustment.
- ④ Pull up lock release lever to lock the steering wheel.



Cruise control system* [5]

Activate Cruise Control System by pressing the shown button.



Set cruise control speed by moving the lever down to SET -.



To increase cruise control set speed.



To decrease cruise control set speed.



Cancel cruise control set speed by pressing the Cancel button.



Resume cruising speed by moving the lever up to RES +.

Towing / Spare Tyre / Tyre Mobility Kit

Towing [6]

When towing your vehicle in an emergency without wheel dollies:

1. Set the ignition switch in the ACC position.
2. Place the transaxle shift lever in N (Neutral).
3. Release the parking brake.

Emergency towing

If towing is necessary, we recommend you to have it done by an authorised Kia dealer or a commercial tow truck service.

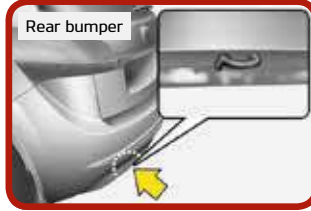
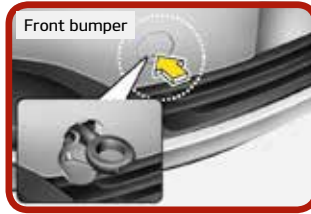

Removable towing hook

1. Open the tailgate and remove the towing hook from the tool case.
2. Remove the hole cover pressing the lower part of the cover on the bumper.
3. Install the towing hook by turning it clockwise until it is fully secured.
4. Remove the towing hook and install the cover after use.

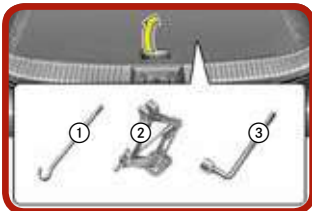

Spare tyre, jack and tools* [6]

Pull up the luggage box cover to access the equipment.

- ① Jack handle
- ② Jack
- ③ Wheel lug nut wrench

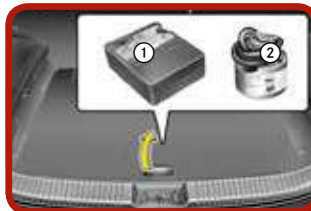

Tyre Mobility Kit* [6]

Please read the instructions before using the Tyre Mobility Kit.

- ① Compressor
- ② Sealant bottle



With the Tyre Mobility Kit it is possible to stay mobile even after experiencing a tyre puncture.

Once the punctured tyre is properly sealed, cautiously drive (up to max. 200 km (120 miles)) at a max. speed of 80 km/h (50 mph) to the nearest vehicle or tyre service point, in order to have the tyre repaired or replaced.

Engine Oil / Washer Fluid / Additional Info

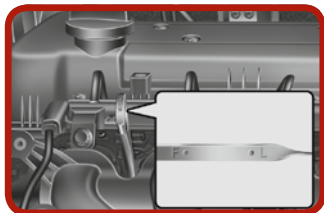

Checking the engine oil level [7]

Warm up the engine to operating temperature and switch off. On level ground pull the dipstick out and wipe clean before re inserting it fully. Pull the dipstick out again and check the level. It should be between F and L.



Refilling engine oil [7]

Only refill with the specified engine oil [8], using a funnel to avoid spillage on engine components.



Checking the washer fluid level [7]

Check the fluid level and add fluid if necessary.

Additional Information*

Idle Stop & Go (ISG)

When enabled, ISG automatically stops the car's engine to reduce fuel consumption and emissions. The ISG function may not work if the car's battery charge status, ambient temperature and/or engine temperature is too low. Air conditioning/heater control settings may also affect ISG function.

Starting your vehicle with the parking brake applied:

- For Manual Transaxle vehicles: Make sure the transaxle is in Neutral and the clutch pedal is fully depressed before starting the vehicle.
- For Automatic Transaxle vehicles: Make sure the transaxle is in the P (Park) position and the brake pedal fully depressed before starting the vehicle.

Bluetooth®

Many of our cars have Bluetooth® connectivity to enable the driver to safely enjoy the convenience of the mobile phone. For Bluetooth® compatibility please visit the owners section on our website www.kia.co.uk.

For full details and instructions on any item contained in this quick reference guide, please read the owner's manual.

Hill-Start Assist Control (HAC)

This is designed to assist with hill starts by preventing the car rolling backwards when driving off. The system maintains the braking pressure in certain circumstances for 2 seconds enabling to pull away when you are ready.

Parking brake (handbrake)

When engaging the parking brake, apply the footbrake first and keep it depressed. Then ensure the parking brake is properly applied according to the type. Hand type: pull the parking brake lever up as far as possible. Foot type: depress the parking brake pedal down as far as possible. Electric (EPB) type: pull up the EPB switch and make sure the warning light comes on.

We strongly recommend to leave the car in first or reverse gear or in the 'P' (Park) position on automatics when leaving the car.

The Kia Service App – now available for free on iPhone/iPad and Android

With the Kia Service, you have (almost) all Kia dealers in Europe within reach*. Looking for a showroom or just a service, the app displays all dealers around your current location on the map. With one click you can call a dealer, visit their website or get directions to the showroom. Great for travel at home or abroad.

(* In selected markets only)

The Kia Service App

