



KIA MOTORS

SPECTRA

2002 Owner's Manual

Now that you are the owner of a Kia Vehicle, you'll probably be asked a lot of questions about your vehicle and the company like "What is a Kia?", "Who is Kia?", "What does 'Kia' mean?".

Here are some answers. First, Kia is the oldest car company in Korea. It's a company that has thousands of employees focused on building high-quality vehicles at affordable prices.

The first syllable, *Ki*, in the word "Kia" means "to arise from to the world" or "to come up out of to the world." The second syllable, *a*, means "Asia." So, the word *Kia*, means "to arise from" or "to come up out of Asia to the world."

Enjoy your Vehicle!

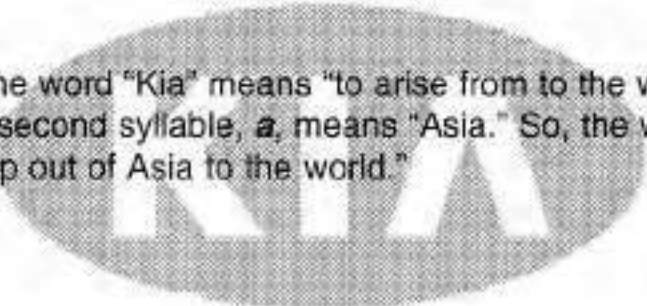
The Kia logo, consisting of the word "KIA" in a bold, sans-serif font, is centered within a dark, horizontally-oriented oval. The oval has a textured, stippled appearance. The letters are white and stand out against the dark background of the oval.

FOREWORD

Thank you for choosing a Kia vehicle.

When you require service, remember that your authorized Kia dealer knows your vehicle best. Your dealer has factory-trained technicians, recommended special tools, genuine Kia replacement parts, and is dedicated to your complete satisfaction.

Because subsequent owners require this important information as well, this publication should remain with the vehicle if it is sold. This manual covers all 2002 Spectra models and will familiarize you with operational, maintenance and safety information about your new vehicle. It is supplemented by a Warranty and Consumer Information Manual that provides important information on all warranties regarding your vehicle: New Vehicle Limited Warranty, Powertrain Limited Warranty, Limited Warranty Covering Perforation from Corrosion, and Emission Control System Warranty. If your vehicle is equipped with an audio system, you will also have a Kia Integrated Audio Systems manual explaining its operation. We urge you to read these publications carefully and follow the recommendations to help assure enjoyable and safe operation of your new vehicle.

Kia offers a great variety of options, components and features for its various models.

Therefore, the equipment described in this manual, along with the various illustrations, may not all be applicable to your particular vehicle. The information and specifications included in this manual were accurate at the time of printing. Kia Motors reserves the right to discontinue or change specifications or design at any time without notice and without incurring any obligation. If you have questions, always check with your Kia Dealer.

We assure you of our continuing interest in your motoring pleasure and satisfaction in your Kia vehicle.

© 2001 Kia Canada, Inc.

All rights reserved. May not be reproduced or translated in whole or in part without the written consent of Kia Motors Corp.

Printed in Korea

TABLE OF CONTENTS

INTRODUCTION	1
YOUR VEHICLE AT A GLANCE	2
KNOWING YOUR VEHICLE	3
DRIVING YOUR VEHICLE	4
DRIVING TIPS	5
IN CASE OF AN EMERGENCY	6
MAINTENANCE	7
SPECIFICATIONS	8
INDEX	9

How To Use This Manual	1-2
Vehicle Break-In Process	1-3

INTRODUCTION

HOW TO USE THIS MANUAL

We want to help you get the greatest possible driving pleasure from your vehicle. Your Owner's Manual can assist you in many ways. We strongly urge you to review the entire manual. However, in order to prevent death or injuries, at the very least, you must review the **WARNING** and **CAUTION** sections spread throughout the manual, which are easily recognized by their special markings indicated below.

Illustrations complement the words in this manual to help explain the best way to enjoy your vehicle. By reading your manual, you can find out about features, important safety information, and driving under various road conditions.

Layout of the manual is provided in the Table of Contents.

Index: A good place to start is the index; it has an alphabetical listing of all information in your manual.

Sections: This manual has nine sections plus an index. Each begins with a brief list of contents so you can tell at a glance if that section has the information you want.

You'll find various **WARNINGS**, **CAUTIONS**, and **NOTICES** in this manual. These **WARNINGS**, **CAUTIONS** and **NOTICES** were prepared to enhance your personal safety and continued satisfaction with your Kia vehicle. You should carefully read and follow ALL procedures and recommendations provided in these **WARNINGS**, **CAUTIONS** and **NOTICES**.

WARNING

A WARNING indicates a situation in which serious bodily injury or death could result if the warning is ignored.

CAUTION

A CAUTION indicates a situation in which personal injury, perhaps severe, could result if the caution is ignored.

NOTICE

A NOTICE indicates a situation in which damage to your vehicle could result if the notice is ignored.

VEHICLE BREAK-IN PROCESS

No special break-in period is needed. By following a few simple precautions for the first 1000 km (600 miles) you may add to the performance, economy and life of your vehicle.

- Do not race the engine.
- Do not maintain a single speed for long periods of time, either fast or slow. Varying engine speeds are beneficial for proper engine break-in.
- Avoid hard stops, except in emergencies, to allow the brakes to seat properly.
- Avoid full-throttle starts.

Interior and Exterior Overview	2-2
Instrument Panel Overview	2-3

YOUR VEHICLE AT A GLANCE

INTERIOR AND EXTERIOR OVERVIEW

4 Door Coupe

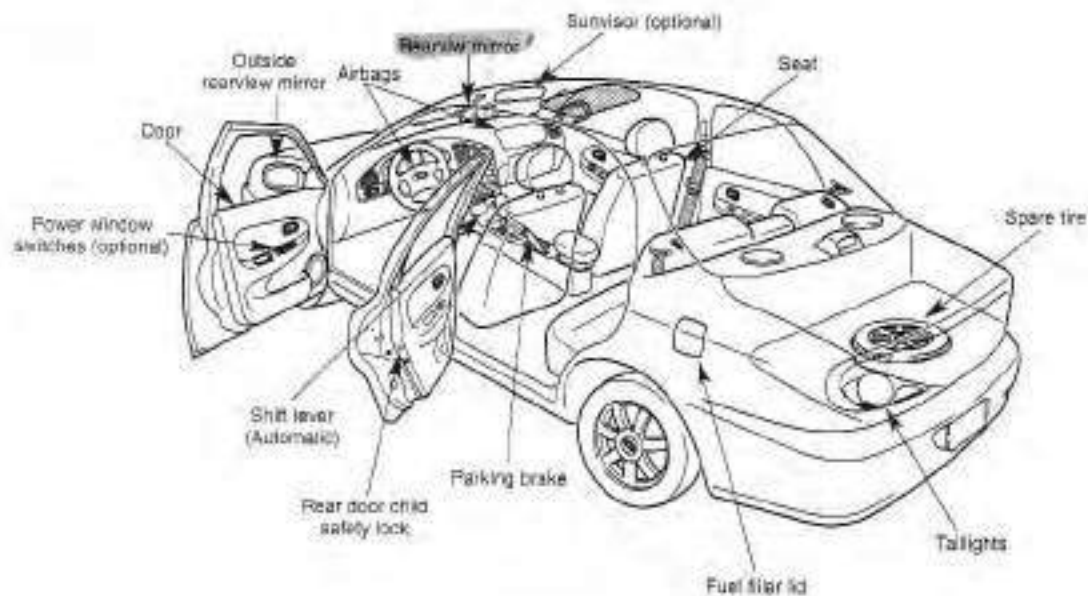

BS402001

YOUR VEHICLE AT A GLANCE

INSTRUMENT PANEL OVERVIEW

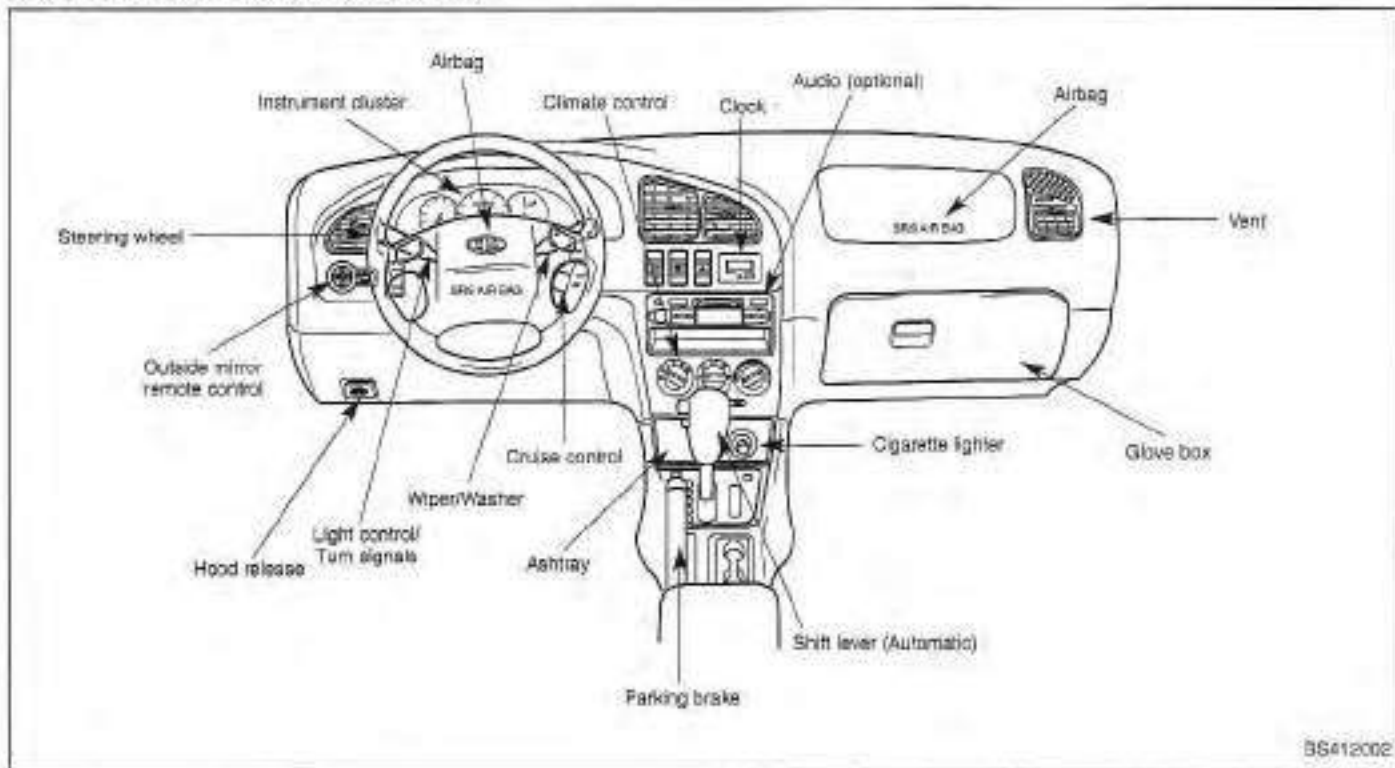

B6412002

Keys	3-2
Door Locks	3-3
Windows	3-5
Seats	3-8
Safety Belts	3-12
Airbags	3-31
Trunk Lid	3-38
Hood	3-40
Fuel Filler Door	3-42
Steering Wheel	3-43
Mirrors	3-44
Interior Lights	3-46
Cup Holders and Console Storage Compartment	3-47

KEYS

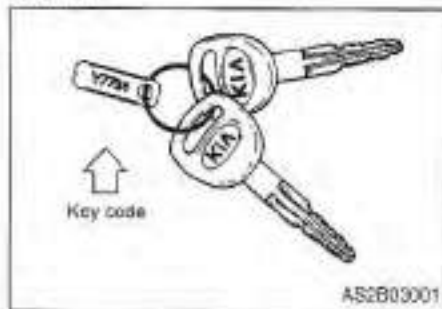

The key code number is stamped into the plate attached to the key set. If you should lose your keys, this number will enable an Authorized Kia Dealer to duplicate the keys easily. Remove the plate and store it in a safe place. Also, record the code number and keep it in a safe and handy place, but not in the vehicle.

⚠ WARNING - Ignition Key

Leaving children unattended in a vehicle with the ignition key is dangerous even if the key is not in the ignition. Children copy adults and they could place the key in the ignition. The ignition key would enable children to operate power windows or other controls, or even make the vehicle move which could result in serious bodily injury or even death. Never leave the keys in your vehicle with unsupervised children.

DOOR LOCKS

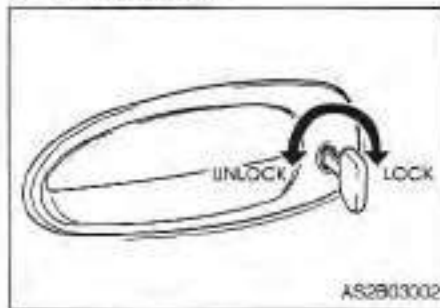

Manual Door Locks

Operating door locks - with key

- Both front doors can be locked and unlocked with the key.
- Turn the key to the left to unlock and to the right to lock the door.
- Once a door is unlocked, it may be opened by lifting the door handle.

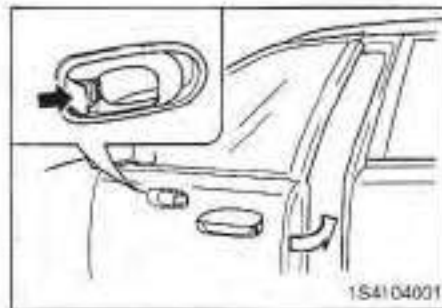

Operating door locks - without key

To lock a door without the key, push the inside door lock button to the "LOCK" position and close the door.

*** NOTICE**

Always remove the ignition key, engage the parking brake, close all windows and lock all doors when leaving your vehicle unattended.

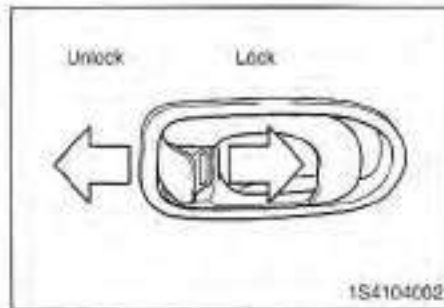

Operating door locks from inside the vehicle

- To lock a door, push the door lock button to the "LOCK" position.
 - To unlock a door, push the door lock button to the "UNLOCK" position.
 - To open a door, pull the door handle towards the middle of your vehicle.
- The door ajar warning light will illuminate if a door is not fully closed. Close the door completely and the light will go out.*

▲ WARNING

Never leave children or animals unattended in the vehicle. An enclosed vehicle can become extremely hot, causing death or severe injury to children or to animals who cannot escape the vehicle.

▲ CAUTION

The doors should always be fully closed and locked while the vehicle is in motion to prevent accidental opening of the doors. Locked doors will also discourage potential intruders when the vehicle stops or slows.

Central Door Locks (optional)

When the driver's door is locked or unlocked with a key or with the door lock button, all the other doors will lock or unlock automatically.

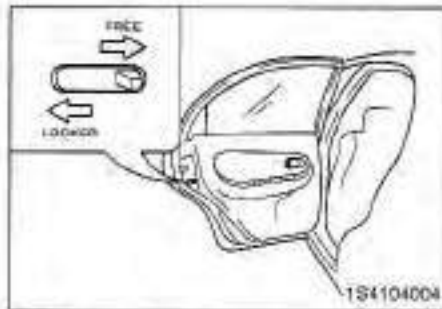

Rear Door Child Safety Lock

The child safety lock is provided to help prevent children from accidentally opening the rear doors from inside the vehicle.

- To lock a rear door so that it cannot be opened from the inside, push the child safety lock located on the rear edge of the door to the "LOCKED" position (toward front of vehicle) before closing the door.

- To open a rear door while the child safety lock is engaged, push the door lock knob to the "FREE" position (toward rear of vehicle) then lift the outside door handle.

▲ WARNING - Rear Door Locks

If children accidentally open the rear doors while the vehicle is in motion, they could fall out and be seriously or fatally injured. To prevent children from opening the rear doors from the inside, the rear door safety locks should be used whenever children are in the vehicle.

WINDOWS

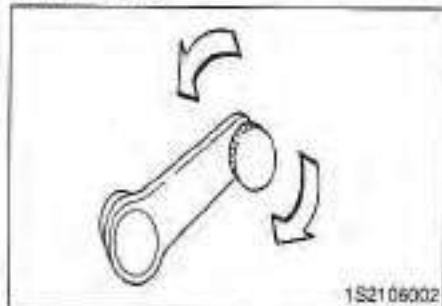

Manual Windows

Use the window crank to open and close each window.

Power Windows (If Equipped)

The ignition switch must be in the ON position for power windows to operate. Each door has a power window switch that controls that door's window.

However, the driver has a power window lock switch which can cancel the operation of the three passenger window switches.

*** NOTICE**

To prevent the power window fuse from malfunctioning and the power window system from being damaged, do not open or close more than two windows at the same time.

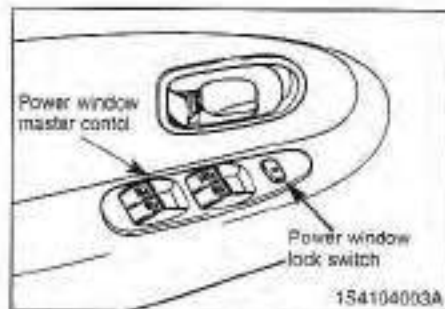

Driver's door power window controls

All windows can be opened or closed using the power window master control on the driver's door. To open a window, press down on the corresponding power window switch. To close a window, pull up on the corresponding power window switch.

Driver's window automatic-down window switch

The driver's window has an "Automatic-Down" feature. To activate the express-down feature, momentarily depress the front of the switch to the second detent position. To cancel this feature, pull up on the front of the switch and then release it.

Driver's power window switch

The driver's power window switch provides two (2) separate window-down functions.

- Depressing the driver's power window switch completely, automatically lowers (Automatic-Down) the driver's window. To cancel this function, pull up on the front of the switch and release it.
 - Depressing the driver's power window switch partially (to the first detent) provides precise control of the window-down position.
- To raise/close the driver's window, pull up on the power window switch.

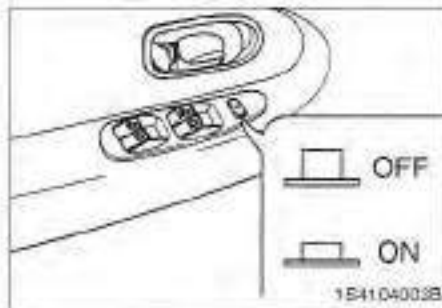

Power window lock switch feature

The driver can disable the power window switches on all passenger doors by depressing the power window lock switch located on the driver's door to ON. When the power window lock switch is ON, only the driver's master control can operate the windows.

Power window timer (If Equipped)

The power windows can be operated for approximately 30 seconds after the ignition key is turned to the ACC or LOCK position.

⚠ WARNING - Passengers

- Keep the power window lock switch on the driver's door in the ON (depressed) position except when someone is operating a passenger door window. Serious injury can result from unintentional window operation, especially to children.
- Always double check to make sure all arms, hands, and other obstructions are safely out of the way before closing a window.

*** NOTICE**

If you experience buffeting and pulsation (wind shock) with either side window open, you should open the opposite window slightly to reduce the condition.

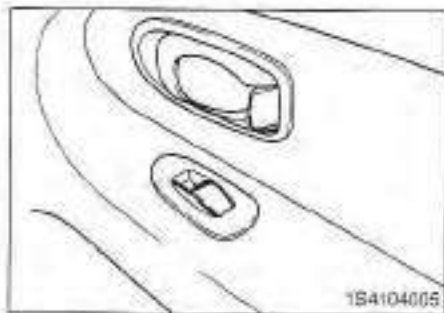

Passenger door power window controls

To open a window, press the front portion of the switch down. To close a window, pull the front portion of the switch up.

▲ WARNING - Passengers

Do not allow children to play with the power windows. They may seriously injure themselves or others.

SEATS

⚠ WARNING - Drivers

- Never adjust the driver's seat or seatback when the vehicle is moving. Doing so could cause loss of control, and serious personal injury or death.
- Do not allow packages or other objects to interfere with the normal position of a seat-back. These objects may prevent the seat-back from locking, which could result in serious injury or death in the event of a sudden stop or collision.
- Always drive and ride with your seatback upright and the lap portion of the safety belt snug and low across the hips.
- If a child is riding in the front passenger seat, they should always ride with the seatback in the fully upright position.

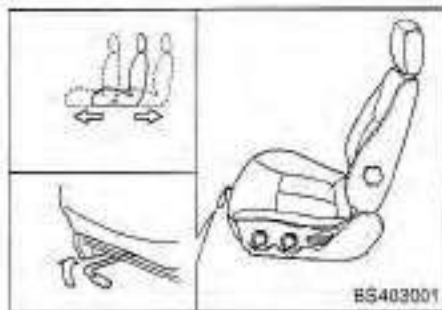

Front Seat Adjustment

Moving the front seat forward and backward

To move the seat forward or backward:

1. Pull the seat slide adjustment lever under the front edge of the seat cushion up and hold it.
2. Slide the seat to the position you desire.
3. Release the lever and make sure the seat is locked in place.

⚠ CAUTION

Do not place anything under the front seats. Loose objects might interfere with the seat slide mechanism or possibly roll out from under the seat and interfere with the operation of the brake, clutch or accelerator foot pedals.

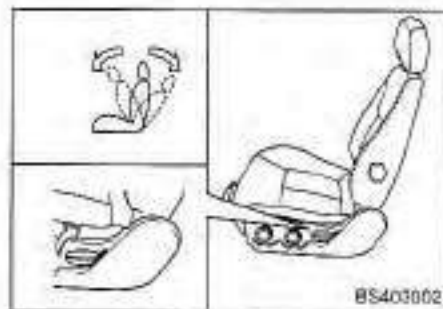

BS403002

Adjusting the front seatback recliner

To recline the seatback:

1. Lean forward slightly and lift up on the seatback recline lever located on the outside of the seat, toward the rear.
2. Lean back on the seat and adjust the back of the seat to the position you desire.

3. Release the lever and make sure the seatback is located in place. (The lever **MUST** return to its original position for the seatback to lock.)

⚠ WARNING - Passengers

To reduce the risk of sliding under the lap portion of the lap/shoulder belt, and potentially suffering serious personal injury or death in the event of a collision, do not use the front seatback in a reclined position while the vehicle is in motion. If a seat is reclined, the occupant's hip could slide under or out of the lap portion of the lap/shoulder belt during a collision. If that occurs, the occupant may no longer be properly restrained, and the safety belt could apply restraint forces to the unprotected abdomen resulting in serious personal injury or death. Therefore, keep the seatbacks in a comfortably upright position whenever the vehicle is in motion.

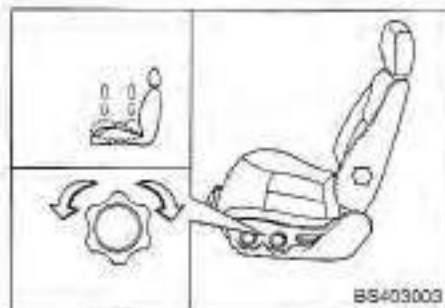

BS403003

Adjusting the height of driver's seat cushion

To change the height of the seat cushion, rotate the knob located on the outside of the seat cushion.

- To lower the seat cushion, rotate the knob toward the front of the vehicle.
- To raise the seat cushion, rotate the knob toward the rear of the vehicle.

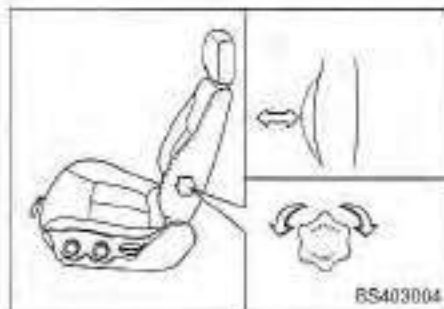

BS403004

Lumbar support (driver's side)

You can adjust the lumbar support by moving the lever on the side of the driver's seatback. Pivoting the lever toward the front of the vehicle increases the lumbar support. Pivoting the lever toward the rear of the vehicle decreases the lumbar support.

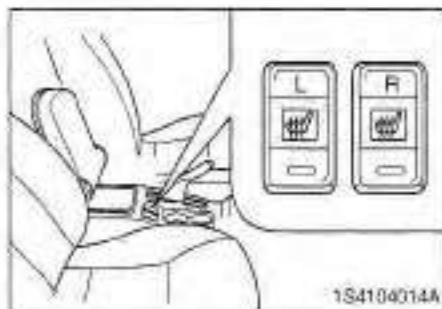

1S4104014A

Heating the Front Seats (If Equipped)

The front seats are electrically heated individually when the applicable switches are depressed and the ignition is ON. A thermostat regulates seat temperature when the corresponding switch (shown above) is depressed. To deactivate the front seat heating system, depress the corresponding switch once again.

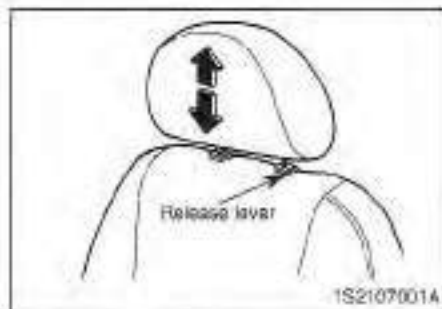

1S2107001A

Adjustable headrest

To raise the headrest, simply pull it up to the desired position. To lower the headrest, press the release lever on the left side grommet, while pushing the headrest down to the desired position. To remove the headrest, raise it as far as it can go then press the release lever while pulling upward.

⚠ WARNING - Headrests

- To reduce the risk of head and neck injuries, do not operate the vehicle with the headrest removed or improperly positioned.
- Do not attempt to adjust the driver's headrest while driving.
- Adjust the top of the headrest so that it is even with the top of your ears in order to reduce the chance of injury in the event of a collision.

⚠ WARNING

Before starting the vehicle, adjust the driver's seat and headrest to the proper position. After doing so, you should adjust the day/night rearview mirror and the outside rearview mirror.



Split Folding Rear Seat (If Equipped)

The rear seatbacks fold forward to provide additional cargo space and to provide an access to the trunk area.

- To fold the rear seatback(s) down, press the unlock button located in the top of the seatbacks, then fold the seatback forward and down.
- To raise the seatback, lift and push it firmly until it clicks into place.
- When you return the seatback to its upright position, reposition the rear safety belts so that they can be used by rear seat passengers.

⚠ WARNING - Cargo

Cargo should always be secured to prevent it from shifting and causing injury to the vehicle occupants.

⚡ CAUTION

Do not remove the floor carpet in your vehicle, emission control system components cause high exhaust temperatures under the floor.

*** NOTICE**

When returning the rear seatbacks to the upright position, remember to return the rear shoulder belts to their proper position. Routing the safety belt webbing through the rear safety belt guides will help keep the belts from being trapped behind or under the seats.

SAFETY BELTS



Pre-tensioner Seat Belt

Your vehicle is equipped with driver's and front passenger's pre-tensioner seat belts. The purpose of the pre-tensioner is to make sure that the seat belts fit tightly against the occupant's body in certain frontal collisions.

The pre-tensioner seat belts can be activated where the frontal collision is severe enough, together with the airbags.



The pre-tensioner seat belt operates in the same way as an Emergency Locking Retractor (ELR) type of seat belt. When the vehicle stops suddenly, or if the occupant tries to lean forward too quickly, the seat belt retractor will lock into position. However, in certain frontal collisions, the pre-tensioner will activate and pull the seat belt into tighter contact against the occupant's body.

The seat belt pre-tensioner system consists mainly of the following components.

Their locations are shown in the illustration.

1. SRS airbag warning light
2. Seat belt pre-tensioner assembly
3. SRS control module

⚠ WARNING

To obtain maximum benefit from a pre-tensioner seat belt:

1. The seat belt must be worn correctly.
2. The seat belt must be adjusted to the correct position.

* NOTICE

- Both the driver's and front passenger's pre-tensioner seat belt will be activated in certain frontal collisions. When the frontal collision is severe enough, the pre-tensioners will be activated together with the airbags. The pre-tensioners will be activated under these conditions even if the seat belts are not being worn at the time of the collision.
- When the pre-tensioner seat belts are activated, a loud noise may be heard and fine dust that may appear to be smoke, may be visible in the passenger compartment. These are normal operating conditions and are not hazardous.
- Although it is harmless, the fine dust may cause skin irritation and should not be breathed for prolonged periods. Wash your hands and face thoroughly after an accident in which the pre-tensioner seat belts were activated.

CAUTION

- *Because the sensor that activates the SRS airbag is connected with pre-tensioner seat belt, the SRS airbag warning light  on the instrument panel will illuminate for approximately 6 seconds after the ignition key has been turned to the "ON" position, and then it should turn off.*
- *If the pre-tensioner seat belt is not working properly, this warning light will illuminate even if there is no malfunction of SRS airbag system. If the SRS airbag warning light does not illuminate when the ignition key is turned to "ON" or if it remains illuminated after illuminating for approximately 6 seconds, or if it illuminates while the vehicle is being driven, please have an authorized Kia dealer inspect the pre-tensioner seat belt or SRS airbag system as soon as possible.*

WARNING

- Pre-tensioners are designed to operate only one time. After activation, pre-tensioner seat belts must be replaced. All seat belts, of any type, should always be replaced after they have been worn during a collision.
- The pre-tensioner seat belt assembly mechanisms become hot during activation. Do not touch the pre-tensioner seat belt assemblies for several minutes after they have been activated.
- Do not attempt to inspect or replace the pre-tensioner seat belts yourself. This must be done by an authorized Kia dealer.
- Do not strike the pre-tensioner seat belt assemblies.
- Do not attempt to service or repair the pre-tensioner seat belt system in any manner.

(Continued)

(Continued)

- Improper handling of the pretensioner seat belt assemblies, and failure to heed the warnings to not strike, modify, inspect, replace, service or repair the pretensioner seat belt assemblies may lead to improper operation or inadvertent activation and serious injury.
- Always wear the seat belts when driving or riding in a motor vehicle.

Safety Belt Restraint System

WARNING

The driver and all passengers should always use the safety belts provided in order to minimize the risk of severe bodily injury.

We strongly recommend that the driver and all passengers be properly restrained at all times by using the safety belts provided with the vehicle. Proper use of the safety belts decreases the risk of severe injury or death in accidents or sudden stops. In most states and in Canada, the law requires their use.

Safety belts provide the best restraint when:

- the seatback is upright
- the occupant is sitting upright (not slouched)
- the lap belt portion of the safety belt is snug and low on the hips
- the shoulder belt portion of the safety belt is snug against the chest
- the knees are straight forward

To help you remember to fasten your safety belt, a warning light may come on and a chime may sound.

All seats, except the center rear seat, have lap/shoulder belts. The center rear seat has a lap belt.

Inertial locks in the safety belt retractors allow all of the lap/shoulder safety belts to remain unlocked during normal vehicle operation. This allows the occupants some freedom of movement and increased comfort while using the safety belts. If a force is applied to the vehicle, such as a strong stop, a sharp turn, or a collision, the safety belt retractors will automatically lock the safety belts.

Since the inertial locks do not require a collision in order to lock-up, you may become aware of the safety belts locking while braking or going around sharp corners.

The center rear seat safety belt does not have an inertial lock so it is always in a locked condition. Whenever possible, use the center rear seat position to install your child restraint.

The center rear seat is the best position to install your child restraint. However, if the center seat is unavailable, a child restraint may be installed in the rear outboard seats.

The rear outboard safety belts have been designed to allow a child restraint to be used in these positions without an added locking clip.

 **WARNING - Twisted Safety Belts**

Never drive or ride with a twisted or jammed safety belt. If you cannot untwist or unjam the safety belt, see your Kia dealer immediately.

 **WARNING - Safety Belt Usage**

Each seating position in your vehicle has a specific safety belt assembly which includes a buckle and tongue that are designed to be used together. 1) Use the shoulder belt on the outside shoulder only. Never wear the shoulder belt under the arm. 2) Never swing the safety belt around your neck to fit over the inside shoulder. 3) Never use a single belt for more than one person.

 **WARNING - After a Collision**
Lap/shoulder belt assemblies may be stretched or damaged when subjected to the stress and forces of a collision. The entire restraint system should be inspected following any collision. All belts, retractors, anchors and hardware damaged by a collision should be replaced before the vehicle is operated again.

▲ WARNING - Safety Belt Care
Safety belts should be inspected periodically for excessive wear or damage. Pull out each belt fully and look for excessive fraying, cuts, burns or other damage. Make sure that the lap/shoulder belts return smoothly and easily into the retractor. Check the latches to make sure they latch and release without interference or delay. Any belt not in good condition or in good working order should be promptly replaced.

⚡ CAUTION - Damage to Safety Belts

Never close the doors on any part of the lap or shoulder belt. It can damage the safety belt or buckle which could increase the risk of injury in case of an accident.

Restraint of Pregnant Women

Pregnant women should wear lap/shoulder belt assemblies whenever possible according to specific recommendations by their doctors. The lap portion of the belt should be worn **AS SNUGLY AND AS LOW AS POSSIBLE.**

▲ WARNING - Pregnant Women

Pregnant women must never place the lap portion of the safety belt over the area of the abdomen where the fetus is located or above the abdomen.

Restraint of Infants and Small Children

Small children and infants should be restrained by an approved child restraint system to help protect them while riding in a vehicle.

Never allow a child to stand or kneel on the seat of a moving vehicle. Never allow a safety belt to be placed around both a child and an adult or around two children at the same time.

▲ WARNING - Children on Laps

Never hold a child on your lap or in your arms in a moving vehicle. Even a very strong person cannot hold onto a child in the event of even a minor collision.

Many companies manufacture child restraint systems (often called child seats) for infants and small children. An acceptable child restraint system must always satisfy Canadian Motor Vehicle Safety Standards. Make sure that any child restraint system you use in your vehicle is labeled as complying with those safety standards.

The child restraint system should be chosen to fit both the size of the child and the size of the vehicle seat. Be sure to follow any instructions provided by the child restraint system manufacturer when installing the child restraint system.

CAUTION - Hot Metal Parts

Safety belts and seats can become hot in a vehicle that has been closed during warm/hot weather; they could burn a child. Check seat covers and buckles before you place a child anywhere near them.

Restraint of Large Children

As children grow, they may need to use new child restraint systems, including larger child seats or booster seats, which are appropriate for their increased size.

A child who has outgrown available child restraint systems should use the belts provided in the vehicle. When seated in the rear outboard seats, the child should be restrained by the lap/shoulder belt.

If the shoulder belt portion touches the child's neck or face, you can use some after-market devices made by independent manufacturers which help pull the shoulder belt down and away from the child's face or neck.

WARNING - Shoulder belts on Small Children

- Never allow a shoulder belt to be in contact with a child's neck or face while the vehicle is in motion.
- If safety belts are not properly worn and adjusted, the risk of death or serious injury to such a child is high.

▲ WARNING - Child Restraints

- All child restraint systems are designed to be secured in vehicle seats by lap belts or the lap-belt portion of a lap/shoulder belt. Children will be endangered in a crash if their child restraint systems are not properly secured by the safety belts in the vehicle.
- According to accident statistics, children are safer when properly restrained in the rear seating positions rather than the front seating positions.
- When a child restraint system is not secured by a safety belt, store it in the trunk so that it will not be thrown forward in the event of a sudden stop or accident.

Placement of a Child Restraint System

We recommend that, whenever possible, you put the child restraint system in the center position of the rear seat and secure it to the vehicle with the lap belt.

If the center rear seat is not available, or you are using more than one child restraint system in the vehicle at the same time, rear outboard safety belts have been designed to allow a child restraint system to be used in these positions.

▲ WARNING - Restraint Instructions

Failure to observe this manual's instructions regarding child restraint systems and the instructions provided with the child restraint system itself could increase the chance and/or severity of injury in an accident.



Installing a child restraint in the rear center seat

Use the following procedure to install a child restraint in the rear center seat:

1. Place the child restraint in the desired position. Route the lap belt through the restraint according to the seat manufacturer's instructions.
2. Insert the tongue plate into the buckle.
3. Adjust the lap safety belt for a snug hold on the child restraint by pulling on the loose end of the belt.

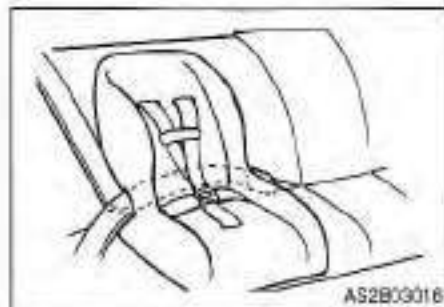

Installing a child restraint system in rear outboard seats

⚠ WARNING

Children can be killed or injured by the passenger airbag. The rear seats are the safest place for children 12 and under. Make sure all children use seat belts, or the applicable child restraint system.

⚠ WARNING - Child Restraint Placement

NEVER use a child restraint in the front passenger seat. A child in a child restraint installed in the front passenger seat can be severely or fatally injured by an airbag which could impact the child restraint with great force when the airbag inflates.

Placing a passenger safety belt into the "Auto Lock" mode (if equipped)

The use of the auto lock mode will ensure that the normal movement of the child in the vehicle does not cause the safety belt to be pulled out and loosen the firmness of its hold on the child restraint.

To secure a child restraint in the front passenger seat or rear outboard seats, follow the procedure below.

1. Place the child restraint system in the seat and route the lap/shoulder belt around or through the restraint, following the restraint manufacturer's instructions. Be sure the belt webbing is not twisted.



2. Insert the lap/shoulder belt latch into the buckle. Listen for the distinct "click" sound.

Position the release button so that it is easy to access in case of an emergency.



3. Grasp the shoulder portion of the belt and pull downward until the entire belt is extracted. When the belt is fully extracted, the retractor changes to the automatic locking mode (child restraint mode).



4. Slowly allow the belt to retract. Pull up on the shoulder webbing. A "clicking" or "ratcheting" sound will be heard as the belt retracts. This indicates the retractor is now in the automatic locking mode. Push down on the child restraint while you pull up on the belt in order to remove any slack in the belt.



5. Before placing the child in the child restraint, forcibly try to push the seat from side to side and forward to make sure that the seat is securely held in place.
6. Double check that the retractor is in the automatic locking mode by trying to pull the shoulder portion of the safety belt out of the retractor. If you cannot pull the belt out of the retractor, it is in the automatic locking mode. If you can, repeat step 4.

To remove the child restraint, press the release button on the buckle and then pull the lap/shoulder belt out of the restraint and allow the safety belt to retract fully.

▲ WARNING - Auto Lock Mode

The lap/shoulder belt automatically returns to the "emergency lock mode" whenever the belt is allowed to retract fully. Therefore, the preceding six steps must be followed each time a child restraint is installed. If the safety belt is not placed in the "auto lock" mode, severe injury or death could occur to the child and/or other occupants in the vehicle in a collision, since the child seat will not be effectively held in place.

To return the safety belt retractor to the emergency lock mode, allow the seat belt to retract fully to its stowed position and the retractor will automatically switch back to the emergency lock mode for normal adult usage.

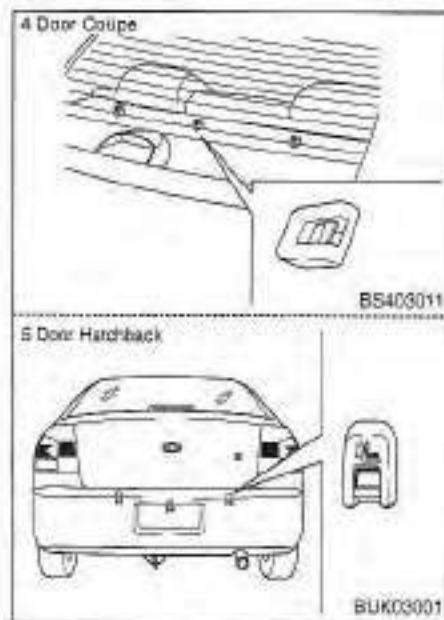

Child Restraint Anchorage

The child restraint anchor fittings are installed on the shelf behind the rear seat or in the trunk on the inboard side of the rear bumper in the 5-door hatchback.

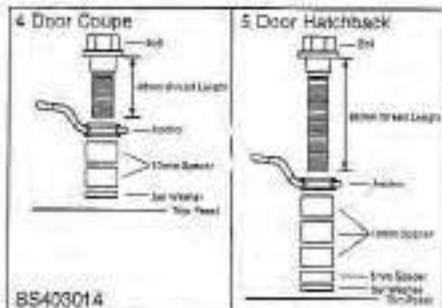

Child restraint anchorage fitting

Your vehicle is equipped with an anchor for securing the tether strap of a child restraint system (child seat).

The anchor fitting package consists of:

- Bolt : 5/16 inch-18 unc,
45 mm thread length (4 doors),
60 mm thread length (5 doors).
- Spacer : 10 mm thickness X 2EA
(4 doors),
10 mm thickness X 3EA,
5 mm thickness (5 doors).
- Set washer : 0.7 mm thickness.
- Anchor fitting : three is installed on
the vehicle.

⚠ WARNING - Child Restraint Anchor Fitting

- Infants and small children should be restrained at all times in an approved child restraint designed for your vehicle.
- Child restraint anchorage is designed to withstand only those loads imposed by correctly fitted child restraints. Under no circumstances are they to be used for adult seat belts or harnesses or for attaching other items or equipment to the vehicle.
- The standard 30 mm bolt and spacers provided with the child restraint **MUST NOT** be used. Additional non-standard bolt and spacers may be obtained from an Authorized Kia Dealer.

- Check that the child restraint system is secured by pushing and pulling it in different directions. Incorrectly fitted child restraint may swing, twist, tip or come away causing death or injury.

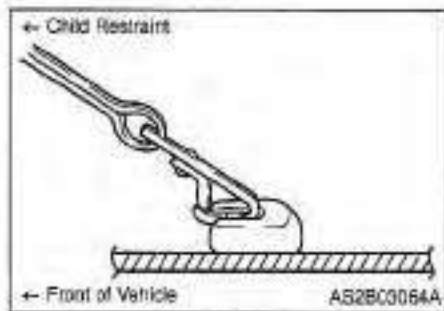

Placement of a child restraint system

To install the child restraint on the rear seat, use the anchorage fitting located on the shelf behind the rear seat or in the trunk on the inboard side of the rear bumper in the 5-door hatchback.

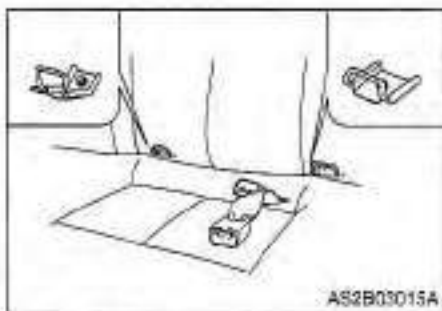

Child restraint lower anchor striker position

The child lower anchor striker is located between rear seat and seatback.

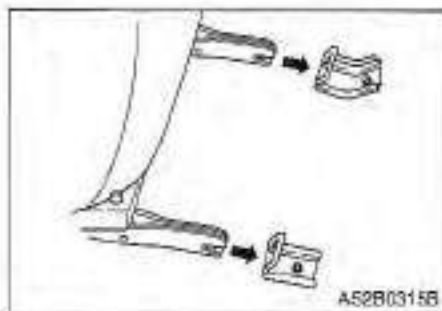

To install the child restraint to the child lower anchor striker, insert the child restraint latch into the child lower anchor striker. Listen for the audible "Click" sound.

Safety belt warning light



AS2B03022

Safety Belt Warning Light and Chime

If the driver's lap/shoulder belt is not fastened when the key is turned ON, the safety belt warning chime sounds for approximately six seconds and the safety belt warning light illuminates for approximately six seconds.



AS2B03023

Front lap/shoulder belt

To fasten the front lap/shoulder belt:

1. Grasp the buckle and tongue plate.
2. Slowly pull the lap/shoulder belt out from the retractor.



AS2B03024

3. Insert the tongue plate into the open end of the buckle until an audible "click" is heard, indicating the belt is locked in the buckle.



4. Position the lap portion of the belt across your lap as **LOW ON THE HIPS** as possible to reduce the risk of sliding under it during an accident. Adjust the belt to a **SNUG FIT** by pulling up on the shoulder portion of the safety belt. The belt retractor applies tension to the belt in order to take up excess webbing automatically and to maintain tension on the belt. For maximum safety, do not put any excess slack into the safety belt.



5. Adjust the shoulder anchor position to your size. To raise the anchor position, pull the knob and push the anchor up. To lower the anchor position, pull the knob and slide the anchor down. After adjustment, make sure the anchor is locked in position.

⚠ WARNING - Front Safety Belts

- The front seatbacks should always remain in a comfortable, upright position while the vehicle is in motion. The safety belt system will provide the most protection with the seatbacks in an upright position.
- Never wear the shoulder portion of the safety belt under the outside arm or behind the back.
- Never wear the shoulder portion of the safety belt across the neck or face.
- Wear the lap portion of the safety belt as low on the hips as possible. Be sure the lap belt fits snugly around the hips. Never wear the lap belt over your waist.
- Never drive or ride with a twisted or jammed safety belt. If you cannot untwist or unjam the safety belt, see the nearest Kia dealer immediately.

- Never use a single belt to restrain more than one person at a time. Failure to follow these warnings will increase the risk and severity of injury in an accident.



To unfasten the front lap/shoulder belt:
Press the release button on the buckle.

Rear Safety Belts

Two kinds of safety belts are provided:

- Lap/shoulder belts for people who sit on the outboard sides of the vehicle.
- A lap belt for people who sit in the center of the rear seat.



Rear lap/shoulder belt

To fasten:

1. Grasp the buckle with one hand and the tongue plate with the other.
2. Slowly pull the lap/shoulder belt out.
3. Insert the tongue plate into the open end of the buckle until an audible "click" is heard, indicating the belt is locked.



4. Position the lap portion of the belt across your lap as **LOW ON THE HIPS** as possible to reduce the risk of sliding under it during an accident.

Adjust the belt to a **SNUG FIT** by pulling up on the shoulder portion of the safety belt. The belt retractor is designed to take up excess webbing automatically and to maintain tension on the belt. This is for your safety. Do not put excess slack into the safety belt.

To unfasten:

Press the release button on the buckle.

⚠ WARNING - Rear

Lap/Shoulder Safety Belts

- **Never wear the shoulder portion of the safety belt under the outside arm or behind the back.**
- **Never wear the shoulder portion of the safety belt across the neck or face.**
- **Wear the lap belt or the lap portion of the belt as low as possible. Be sure the lap belt fits snugly around the hips. Never wear the lap belt over your waist.**
- **Never ride or drive with a twisted or jammed safety belt. If you cannot untwist or unjam the safety belt, see the nearest Kia dealer immediately.**
- **Never use a single belt to restrain more than one person at a time.**

Failure to follow these warnings could increase the chance and severity of injury in an accident.

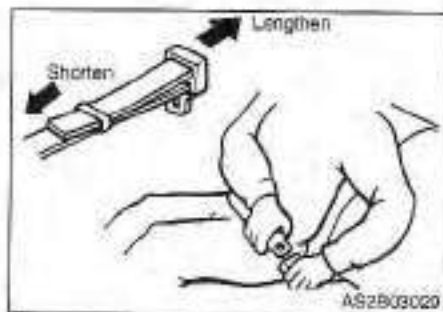

Lap belt (rear center seat)

To fasten the rear lap belt:

1. Grasp the buckle end and pull it low over the abdomen.
2. Insert the tongue plate into the open end of the buckle until an audible "click" is heard, indicating the latch is locked. Make sure the belt is not twisted.
3. To lengthen the belt, hold the latch plate tongue at a right angle to the safety belt webbing and pull.



4. To shorten the belt, hold the latch plate tongue at a right angle to the safety belt webbing and pull on the loose end of the belt until the desired belt length is reached.
5. Grasp the free portion of the belt webbing and pull until the belt is snug over the hips and as low on the abdomen as possible.
6. Make sure that the belt is placed as **LOW ON THE HIPS** as possible.



To unfasten the rear lap belt:
Press the release button on buckle.

▲ WARNING - Center Rear Lap Belt

Be sure the center rear lap belt is positioned snugly around the hips, and not on the waist. Failure to position the center rear lap belt snugly around the hips and not on the waist will increase the chance and severity of injury in the event of a collision.

Proper Use and Care of the Safety Belt System

To ensure that the safety belts provide the maximum protection, please follow these instructions:

- Use the belts at all times - even on short trips.
- If the safety belt is twisted, straighten it prior to use.
- Keep sharp edges and damaging objects away from the belts.
- Periodically inspect belt webbing, anchors, buckles, and all other parts for signs of wear and damage.

- Replace damaged, excessively worn or questionable parts immediately.
- To clean the belt webbing, use any mild soap solution recommended for cleaning upholstery or carpets. Follow the instructions provided with the soap. Do not bleach or dye the webbing because this may weaken the webbing fibers and allow them to fail when loaded in a collision.
- Do not make modifications or additions to the safety belt.
- After wearing a safety belt, make sure it fully retracts to the stowed position. Do not allow the belt to get caught in the door when you close it.

AIRBAG - SUPPLEMENTAL RESTRAINT SYSTEM

What your airbag system does

Your vehicle is equipped with a dual Supplemental Restraint System (SRS), which includes an airbag for the driver and another airbag for the front passenger.

What your airbag system does not do

The airbag system is designed to supplement or add to the protection provided to properly belted occupants in moderate to severe frontal collisions. It is not a substitute for the driver's or front passenger's safety belt and it does not provide restraint to the lower body.

Why didn't my airbag go deploy in a collision?

There are many types of accidents in which the airbag would not be expected to provide additional protection. These include side or rear impacts, rollovers, and second or third impacts in multiple-impact accidents as well as low speed impacts.

Remember, airbags are only designed to inflate when the impact would throw the occupant into the airbags - generally from a little to the left to a little to the right of straight ahead.

In other words, just because your vehicle is damaged and even if it is totally unusable, don't be surprised that the airbag(s) did not inflate.

The importance of using safety belts

There are four very important reasons to use safety belts even with an airbag system, they:

- help keep you in the proper position (away from the airbag) when it inflates
- reduce the risk of harm in rollover, side or rear impact collisions, because an airbag is not designed to inflate in such situations.
- reduce the risk of harm in frontal collisions that are not severe enough to activate the supplemental restraint system.
- reduce the risk of being thrown from your vehicle.

▲ WARNING - Airbags & Safety Belts

Even in vehicles with airbags, you and your passengers must always wear the safety belts provided in order to minimize the risk and severity of injury in the event of a collision or rollover.

- Always wear your safety belt. It can help keep you away from the airbags during heavy braking just before a collision.
- Airbags are designed to inflate only in severe frontal collisions and will generally not provide protection in side or rear impacts, rollovers or less severe frontal collisions. They will also not provide protection from later impacts in a multi-impact collision.

- If your vehicle has been subjected to flood conditions (e.g. soaked carpeting/standing water on the floor of the vehicle, etc.) or if your vehicle has become flood damaged in any way, do not attempt to start the vehicle or put the key in the ignition before disconnecting the battery. This may cause airbag deployment, which could result in serious personal injury or death. Have the vehicle towed to an authorized Kia dealer for inspection and necessary repairs.

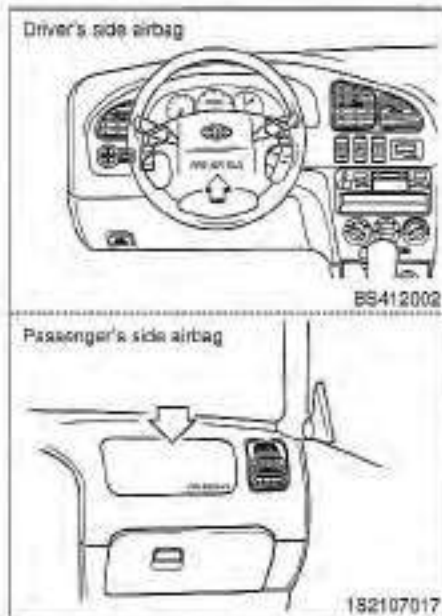

Airbag System Components

The main components of your vehicle's SRS are:

- One airbag in the steering wheel for the driver, and another in the dashboard for the front passenger.
- A diagnostic system that continually monitors system operation.
- An indicator light to warn you of a possible problem with the system.
- Emergency power backup in case your car's electrical system is disconnected in a crash.

To indicate that your vehicle is equipped with airbags, the airbag covers on the steering wheel and on the dashboard are marked with "SRS AIRBAG."

How the Airbag System Works

The driver's airbag is stored in the center of the steering wheel. The passenger side airbag is stored in the front instrument panel above the glove box.

If you ever have a severe frontal collision, your airbags will instantly inflate to help protect you from serious physical injury.

There is no single vehicle speed at which the airbags will inflate. Generally, airbags are designed to inflate in severe frontal collisions. The airbag Supplemental Restraint System (SRS) reacts to the severity of a collision and its direction. These two factors determine whether the sensors send out an electronic deployment or inflation signal. Whether the airbags will inflate depends on a number of factors including vehicle speed, angle of impact and the density and stiffness of the vehicles or objects that your vehicle hits in the collision.

The airbags will completely inflate and deflate in less than 1/10 of one second. The speed of inflation and deflation protects the driver's ability to operate the vehicle. This is important in crashes where a vehicle continues to move after an impact and the driver still has some control of the vehicle's steering, braking, throttle and/or transmission systems.

It is virtually impossible for you to see the airbags inflate during an accident. It is much more likely that you will simply see the deflated airbags hanging out of their storage compartments after the collision.

In order to help provide protection in a severe collision, the airbags must inflate rapidly. However, that speed also causes the airbags to expand with a great deal of force. The speed of this inflation has been determined by the Canadian Motor Vehicle Safety Standards (CMVSS) to reduce the likelihood of serious or life-threatening injuries and is thus a mandatory part of airbag design.



Thus, airbag inflation could also cause injuries which normally can include facial abrasions, bruises and broken bones. However, there are even circumstances under which contact with the steering wheel airbag can cause fatal injuries, especially if the occupant is positioned excessively close to the steering wheel.

YOU MUST ALWAYS SIT AS FAR BACK FROM THE STEERING WHEEL AIRBAG AS POSSIBLE, WHILE STILL MAINTAINING A COMFORTABLE SEATING POSITION FOR GOOD VEHICLE CONTROL, IN ORDER TO REDUCE THE RISK OF INJURY OR DEATH IN A COLLISION.

▲ WARNING - Airbag Injuries

- Sit as far back from the steering wheel as possible without interfering with your control of the vehicle. Positioning yourself too close to the steering wheel can result in serious or even fatal injuries if the airbag deploys.
- Never place objects over the airbag storage compartments or between the airbags and yourself. Due to the speed and force of the airbag inflation, such objects could hit your body at high speed and cause severe bodily injury and even death.

Noise and Smoke

When the airbags inflate, they make a loud noise and they leave smoke and powder in the air inside of the vehicle. This is normal and is a result of the ignition of the airbag inflator.

After the airbags inflate, you may feel substantial discomfort in breathing due both to the contact by your chest with both the safety belt and the airbag, as well as from breathing the smoke and powder.

We strongly urge you to open your doors and/or windows as promptly as possible after impact in order to reduce discomfort and prevent prolonged exposure to the smoke and powder.

▲ WARNING - Hot Metal Parts

When the airbags deploy, the airbag inflators in the steering wheel and/or in the dashboard are very hot. To prevent injury, do not touch the airbag storage area's internal components immediately after an airbag has inflated.



The Importance of The Passenger Being Properly Seated

The front seat passenger's airbag is much larger than the driver's airbag and inflates with considerably more force. It can seriously hurt or kill a passenger who is not in the proper position and wearing the safety belt properly. The front passenger should always move their seat as far back as practical and sit well back in the seat.

It is essential that the front passenger always wear their safety belt, even when mounting in a parking lot or up a drive way into a garage.

The reason for this is that in most frontal impacts there is substantial pre-impact braking which tends to throw the occupants forward. If the right front passenger is not using their safety belt, they will be directly in front of or even touching the airbag storage compartment when inflation occurs. In that situation, death or severe injury is possible.

⚠ WARNING - Right Front Seat
Pre-impact braking could throw an unbelted passenger toward or onto the airbag storage compartment. Upon impact in a collision, the airbag would rapidly inflate and possibly severely injure or kill that occupant who failed to wear their safety belt.

Because of the airbag, you must **NEVER INSTALL A REAR-FACING CHILD RESTRAINT SYSTEM IN THE FRONT PASSENGER SEAT.** There is a very significant risk of serious or fatal injuries to a child in a rear-facing child restraint if the right front passenger airbag inflates. We also strongly recommend that you do not put a front-facing child restraint system in the front passenger seat. If a front-facing child restraint system must be used in the front passenger seat, the vehicle seat should be moved as far back as possible. If the passenger's airbag inflates, it could seriously or fatally hurt a child who is not in the proper position or properly restrained.

⚠ WARNING - Front

Passengers

- **NEVER** use a child restraint in the front seat. In the front seat, a child restraint would be positioned too close to where the airbags are stored and in the event an airbag deploys, the airbag would impact the rear-facing child restraint and cause serious injuries or death.
- **Failure to observe the instructions provided with the child restraint system could increase the risk and/or severity of injury in an accident.**

Airbag Warning Light

The purpose of the airbag warning light in your instrument panel is to alert you of a potential problem with your Airbag - Supplemental Restraint System (SRS).



Have the system checked if:

- The light does not illuminate when you turn the ignition ON.
- The light stays on after the engine starts.
- The light comes on or flashes while you are driving.

Supplemental Restraint System Service

Your Supplemental Restraint System is virtually maintenance-free. There are no parts which you can service.

You must have the system serviced under the following circumstances:

- If an airbag ever inflates, the airbag must be replaced. Do not try to remove or discard the airbag by yourself. This must be done by an authorized Kia dealer.
- If the airbag warning indicator light alerts you of a problem, have the airbag system checked as soon as possible. Otherwise, your airbag might not inflate when you need it.

⚠ WARNING - Airbag (SRS) Malfunctions

- Do not modify your steering wheel or any other part of the Supplemental Restraint System. Modification could make the system ineffective.
- Do not work on the system's components or wiring. This could cause the airbags to inflate inadvertently, possibly seriously injuring someone. Working on the system could also disable the system so that the airbags did not deploy in a collision.



**Airbag warning label
(sunvisor - front side)**

To remind you of the dangers of the airbag, airbag warning labels which are now required by the Canadian Motor Vehicle Safety Standards (CMVSS) are adhered to the driver's and passenger's sunvisors and attached to the glove box.

Note that these government warnings focus on the risk to children. Kia also wants you to be aware of the risks which adults are exposed to. Those have been described in previous pages.

TRUNK LID

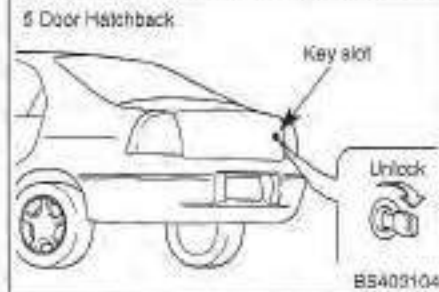
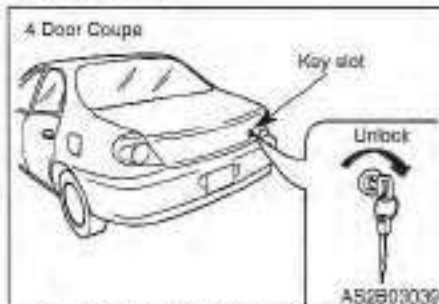

- To open the trunk, insert the key into the lock and turn it clockwise until an audible "click" is heard.
- To close the trunk, use both hands to push the trunk lid down until the lock "snaps" shut.
- Do not slam the trunk lid.
- Pull up on the trunk lid to make sure it is securely latched.

To prevent premature wear or damage to the trunk lid lift cylinders and attaching hardware, the trunk lid must be fully closed before you drive your vehicle.

⚠ WARNING - Exhaust Fumes
 If you drive with the trunk lid open, you will draw dangerous exhaust fumes into your vehicle.

If you must drive with the trunk lid open, keep the air vents open so that additional outside air comes into the vehicle.

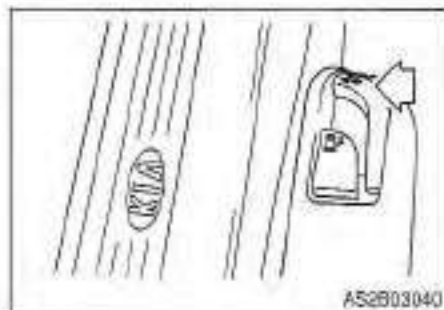

Remote Trunk Lid Release

The release is located at the left front corner of the driver's seat on the floor. To open the trunk, pull up on the lever.

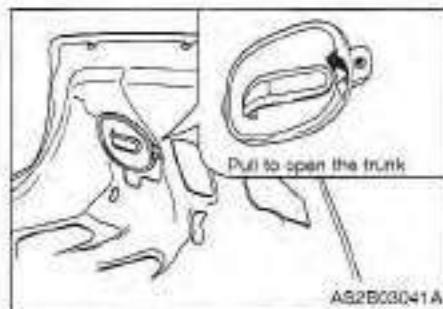

Emergency Trunk Safety Release

You vehicle is equipped with an emergency trunk release cable located inside the trunk. When pulled, this cable will release the trunk latch mechanism and open the trunk.

⚠ WARNING

No one should be allowed to occupy the trunk of the vehicle at any time. If the trunk is partially or totally closed and the person is unable to get out, severe injury or death could occur due to lack of ventilation, fumes and rapid heat build-up, or because of exposure due to cold weather conditions. The trunk is also a highly dangerous location in the event of a crash because it is not a protected occupant space and is instead part of the vehicle's crush zone.

HOOD

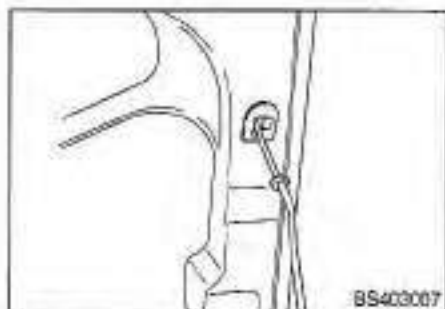
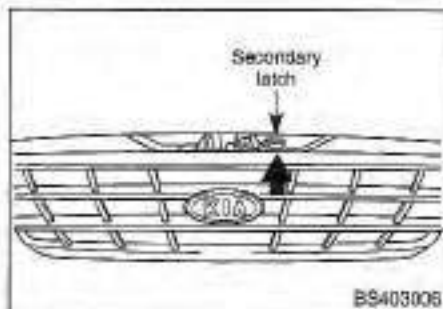

Opening the Hood

1. Inside the vehicle, pull the hood release handle located at the bottom left corner of the instrument panel.
2. Go to the front of the vehicle, raise the hood until the secondary latch catches then pull the secondary latch up (located under the hood at the center of the vehicle).
3. Lift the hood and hold it open with the prop rod by inserting the free end of the rod into the slot.

CAUTION

Before closing the hood, make sure that all parts and tools have been removed from the engine area and that everyone is clear of the hood opening.

Closing the Hood

- Before closing the hood, secure the prop rod in its retainer to prevent it from rattling.
- Check the underhood area to make certain all filler caps are in place and that all loose items have been removed.
- Close the hood firmly so that it latches securely. Do not slam it shut.

FUEL FILLER DOOR

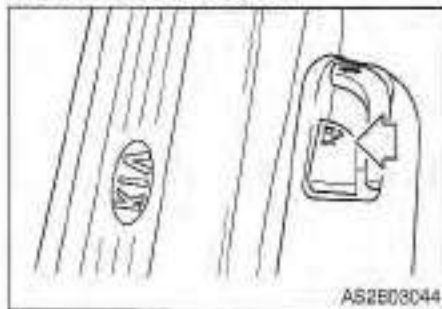

Remote Fuel Filler Door Release

Pull up on the release lever (located on the floor) at the left front corner of the driver's seat to open the filler door.

⚠ WARNING - Fuel Filling

- Fuel may be under pressure. Always remove the fuel cap carefully and slowly. If the cap is venting fuel or if a hissing sound is heard, wait until the condition stops before completely removing the cap. If these precautions are not followed, fuel may spray out and cause serious personal injury.
- Fuel vapor is extremely hazardous and can explode. When refueling, always stop the engine and never allow sparks or open flames near the filler neck. Always extinguish cigarettes and other smoking materials before refueling.

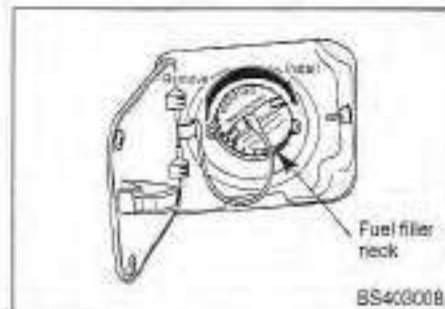

- To remove the cap, turn it counterclockwise.
- To install the cap, turn it clockwise until it "clicks." This indicates that the cap is securely tightened.

*** NOTICE**

A loose fuel filler cap may cause the OBD-II Malfunction Indicator Light () light in the instrument panel to illuminate unnecessarily. Always ensure that the fuel filler cap is tight.

The fuel filler neck is designed to prevent filling the fuel tank with anything but unleaded fuel.

* NOTICE

If the fuel filler cap requires replacement, use only a genuine Kia cap for your vehicle. An incorrect fuel filler cap can result in a serious malfunction of the fuel system or emission control system. Correct replacement caps are available at Authorized Kia Dealers.

If the fuel filler lid will not open in cold weather because the area around it is frozen, push or lightly tap the lid.

* NOTICE

Do not spill fuel on the exterior surfaces of the vehicle. Any type of fuel on painted surfaces may damage the paint.

STEERING WHEEL

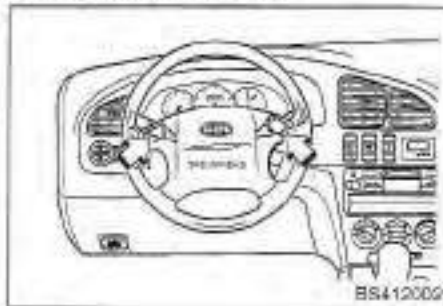

Horn

To sound the horn, push the horn button on either side of the steering wheel. Check the horn regularly to be sure it operates properly.

MIRRORS

Outside Rearview Mirror

Your vehicle is equipped with both left-hand and right-hand outside review mirrors. The mirrors can either be adjusted remotely with the control levers or remote switch, depending on the type your vehicle has. The mirror heads can be folded rearward to prevent damage when using an automatic car wash.

CAUTION

- *The right outside rearview mirror is convex. Objects seen in the mirror are closer than they appear.*
- *When changing lanes, use your interior rearview mirror or direct observation to determine the actual distance of following vehicles behind you.*

*** NOTICE**

Do not scrape ice off the mirror face; this may damage the surface of the glass. If ice should restrict movement of the mirror, do not force the mirror to adjust it.

To remove ice, use a de-icer spray, or a sponge or soft cloth with very warm water.

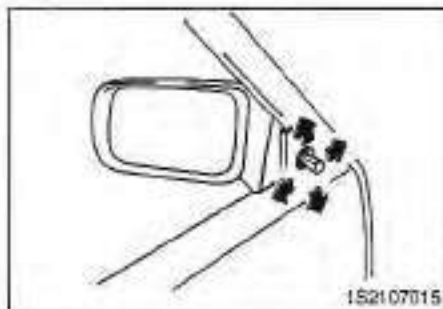

Manual control

To adjust an outside mirror, move the control lever which is located at the forward inside area of the window frame.



Electric remote control (If Equipped)

This switch, located on the left side of the instrument panel, controls the adjustments for both right and left outside mirrors. To adjust the position of either mirror:

1. Move the selector switch to the right or left to activate the adjusting mechanism for the corresponding mirror.
2. Adjust the mirror angle by depressing the mirror adjustment control switch in the desired direction.

*** NOTICE**

The mirrors stop moving when they reach the maximum adjusting angles, but the motor continues to operate while the switch is depressed. Do not depress the switch longer than necessary or the motor may be damaged.

Outside rearview mirror heater (If Equipped)

The outside rearview mirror heater is actuated in conjunction with the rear window defroster. To heat the outside rearview mirror glass, push in the switch for the rear window defroster. The rearview mirror glass will be heated for defrosting or defogging and will provide improved rear visibility during inclement weather. Push the switch again to turn the heater off. The outside rearview mirror heater automatically turns itself off after 15 minutes.

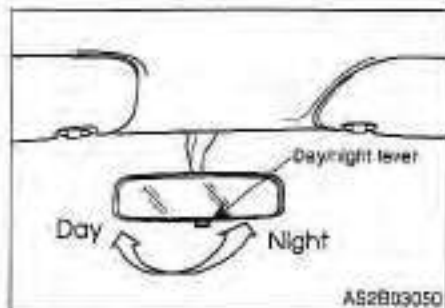

Day/Night Rearview Mirror

Adjust the rearview mirror to center on the view through the rear window. Make this adjustment before you start driving and while the day/night lever is in the day position.

Pull the day/night lever toward you to reduce glare from the headlights of vehicles behind you during night driving.

Remember that you lose some rearview clarity in the night position.

CAUTION

Do not allow objects in the rear seat to interfere with your line of vision through the rear window.

INTERIOR LIGHTS

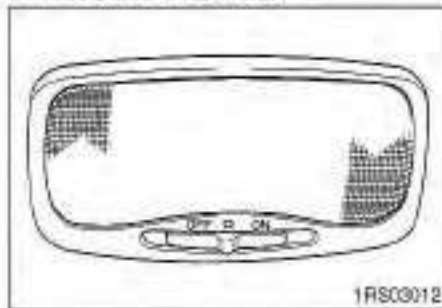

Dome Light

The dome light switch, located in the light assembly, has three positions:

- OFF - The light stays off even when a door is open.
- - The light turns on or off when a door is opened or closed. After a door is closed the light remains ON for approximately 5 seconds and goes OFF slowly.
- ON - The light turns on and stays on even when the doors are all closed.

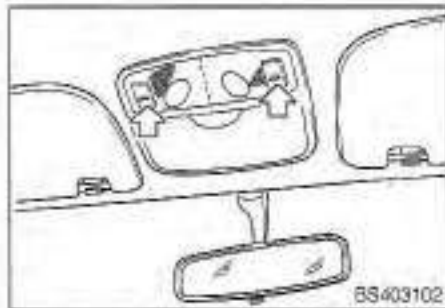

Map Lights

The map lights are switched ON or OFF by pressing the corresponding switches.

CUP HOLDERS AND CONSOLE STORAGE COMPARTMENT

The cup holders and console storage compartment are located in the center console.

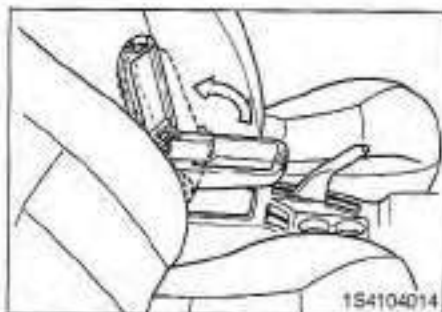

Console Storage Compartment

To use the console storage compartment, depress the release button located on the cover and pull the cover up.



Cup Holders

▲ WARNING

- Do not place uncovered cups of hot liquid in the cup holder while the vehicle is in motion. If the hot liquid spills, you could be burned and lose control of the vehicle. Moreover, the spilled liquid could cause the failure of the transaxle change lever.
- To reduce the risk of personal injury in the event of a sudden stop or collision, do not place bottles, drinking glasses, cans, etc., in the cup holder while the vehicle is in motion.

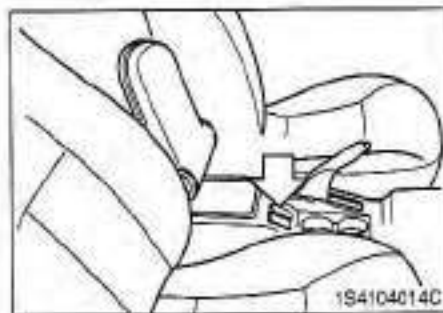

Coin Holder

Coin holder slots are located in the center console compartment. Do not use this as ashtray.



Sunglass Holder

A compartment is provided on the overhead console for the storage of sunglasses. To open the sunglass holder, press the cover and the cover will slowly open. Place your sunglasses in the compartment door with the lenses facing out.

Ignition Switch	4-2
Starting the Engine	4-4
Manual Transaxle	4-5
Automatic Transaxle	4-7
Brake System	4-12
Power Steering	4-16
Tilt Steering (If Equipped)	4-17
Cruise Control (If Equipped)	4-18
Instrument Cluster	4-21
Gauges	4-23
Warnings and Indicators	4-25
Lighting	4-31
Wipers and Washers	4-33
Front Fog Lights (If Equipped)	4-35
Rear Window Defroster	4-36
Interior Features	4-37
Climate Control System	4-39
Windshield Defrosting and Defogging	4-44

IGNITION SWITCH

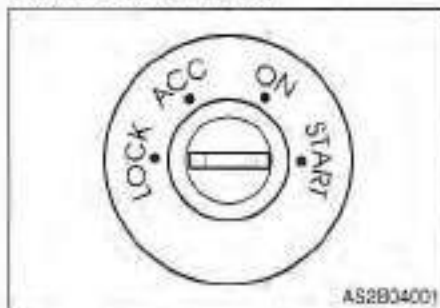

Ignition Switch and Anti-Theft Steering Column Lock

Ignition switch position

LOCK

The steering wheel is locked to protect against theft. The ignition key can be removed only in the LOCK position. For vehicle equipped with an automatic transaxle, it also locks the gear shift lever in the P (Park) position.

ACC (Accessory)

Turning the ignition switch to this position unlocks the steering wheel and will allow some of your vehicle's electrical accessories such as the radio and the windshield wipers to operate when the engine is OFF.

ON

Turning the ignition switch to this position allows you to test your vehicle's warning lights (except the brake system warning light) to make sure they work before you start the engine. The ignition key returns to the ON position once the engine is started and remains in this position while the engine is running.

Do not leave the ignition switch in the ON position for extended periods with the engine OFF because the battery will discharge.

START

Turn the ignition key to the START position to start the engine. The engine will crank until you release the key, then it returns to the ON position. Also, the brake warning indicator illuminates to check the bulb in this position.

Difficulty in turning the ignition key to the START position can be caused by pressure on the switch from the steering column. To allow the ignition key to turn, move the steering wheel right or left to release the tension and then turn the key.

WARNING

- Never turn the ignition switch to LOCK or ACC while the vehicle is moving. This could result in loss of directional control and braking function, which could cause an immediate accident.
- Never reach for the ignition switch, or any other controls, through the steering wheel while the vehicle is in motion. Failure to observe this warning can result in loss of vehicle steering and braking control, which may result in an accident.

Automatic transaxle

When turning the ignition switch to the LOCK position, the shift lever must be in the P (Park) position.

Manual transaxle

When turning the ignition switch to the LOCK position, push the key inward at the ACC position and turn the key toward the LOCK position.

STARTING THE ENGINE

1. Make sure the parking brake is applied.
2. **Manual Transaxle** - Depress the clutch pedal fully and shift the transaxle into NEUTRAL. Keep the clutch pedal depressed while cranking the engine. The starter will not operate if the clutch pedal is not fully depressed.
Automatic Transaxle - Place the transaxle shift lever in P (Park). Depress the brake pedal fully.
You can also start the engine if the shift lever is in the N (Neutral) position.

3. Turn the ignition switch to START and hold it there until the engine starts (a maximum of 10 seconds), then release the key.

In extremely cold weather, below 0°F (minus 18°C), or after the vehicle has not been operated for several days, let it warm up without depressing the accelerator.

Whether the engine is cold or warm, it should be started without depressing the accelerator.

CAUTION

If the engine stalls while you are in motion, do not attempt to move the shift lever to P (Park).

If it is safe to do so considering traffic and road conditions, you may put the shift lever in the N (Neutral) position while still moving and turn the ignition switch to the START position in an attempt to restart the engine.

If the engine fails to start using this procedure, attempt the following.

The engine fails to start when the engine is cold (engine coolant temperature is below 32°F/0°C):

A no start condition may be caused by an engine that has become flooded (has excessive fuel in the cylinders). If this is the case, follow the starting procedure below.

1. Make sure the parking brake is applied.
2. **Manual Transaxle** - Depress the clutch pedal fully and shift the transaxle into N (Neutral). Keep the clutch pedal depressed while cranking the engine. The starter will not operate if the clutch pedal is not fully depressed.
Automatic Transaxle - Place the transaxle shift lever in P (Park) or N (Neutral). Depress the brake pedal fully.
3. Depress the accelerator fully and hold it.
4. While holding the accelerator fully depressed, turn the ignition switch to the START position and hold it (a maximum of 10 seconds) to discharge the excess fuel. If the engine starts, the engine speed will increase suddenly; immediately release the ignition key and the accelerator. If the engine has not yet started, release the accelerator after cranking the engine.
5. Without depressing the accelerator, crank the engine until it starts (a maximum of 10 seconds).

If the engine fails to start when the engine is warm:

If the engine is unusually difficult to restart when it is warm (fails to start after repeated attempts without depressing the accelerator):

1. Make sure the parking brake is applied.
2. **Manual Transaxle** - Depress the clutch pedal fully and shift the transaxle into N (Neutral). Keep the clutch pedal depressed while cranking the engine. The starter will not operate if the clutch pedal is not fully depressed.
Automatic Transaxle - Place the transaxle shift lever in P (Park) or N (Neutral). Depress the brake pedal fully.
3. While depressing the accelerator pedal about halfway down, turn the ignition switch to the START position and hold it (a maximum of 10 seconds).
4. After the engine has started, let it idle for about 10 seconds before driving.

* NOTICE

Do not engage the starter for more than 10 seconds. If the engine stalls or fails to start, wait 5 to 10 seconds before re-engaging the starter. Excessive or improper use of the starter may damage it.

The starter will not operate if:

- In an automatic transaxle, the shift lever is NOT in P (Park) or N (Neutral).
- In a manual transaxle, the clutch pedal is not fully depressed.

Excessive engine noise (from valve tappets) may occur if the engine has not been operated for an extended period.

The noise should stop after the engine has reached normal operating temperature.

If the noise does not stop, have the vehicle inspected by an Authorized Kia Dealer.

* NOTICE

This spark ignition system complies with Canadian ECES-002

KNOWING YOUR VEHICLE

MANUAL TRANSAXLE

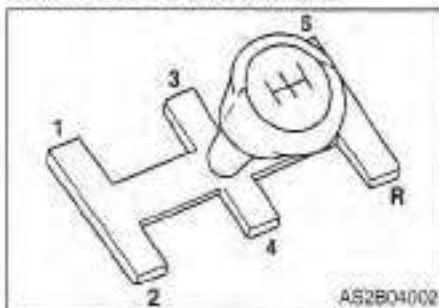

Manual Transaxle Operation

The shift pattern is conventional for five forward gears, as shown below.

Press the clutch pedal down fully while shifting, then release it slowly.

A special safety feature prevents inadvertent shifting from 5 (Fifth) to R (Reverse). The gearshift lever must be returned to the Neutral position before shifting into R (Reverse).

* NOTICE

Make sure the vehicle is completely stopped before shifting into R (Reverse).

* NOTICE

To avoid premature clutch wear and damage, do not drive with your foot resting on the clutch pedal. Also, don't use the clutch to hold the vehicle stopped on an upgrade (while waiting for a traffic light, etc).

▲ WARNING - Manual Transaxle

Before leaving the driver's seat, always set the parking brake fully and shut the engine off, then make sure the transaxle is shifted into 1st gear. Unexpected and sudden vehicle movement can occur if these precautions are not followed in the order identified.

Downshifting

When you must slow down in heavy traffic or while driving up steep hills, downshift before the engine starts to "labor". Downshifting reduces the chance of stalling and gives better acceleration when you again need to increase your speed. When the vehicle is traveling down steep hills, downshifting one gear level helps maintain safe speed and prolongs brake life.

AUTOMATIC TRANSAXLE

O/D (Overdrive) System

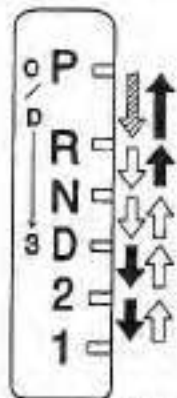

Normal transaxle gear ranges are provided on the right side of the indicator.



To move the shift lever from the P position, the ignition switch must be in the ON position, the brake pedal must be depressed and the lock release button must be depressed.



The lock release button must be depressed while moving the shift lever.

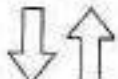

The shift lever can be moved without depressing the lock release button.

Lock release button prevents shift lever movement without first depressing the button.

O/D System
Pressing the button de-activates the O/D mode. Pressing again re-activates the O/D mode.

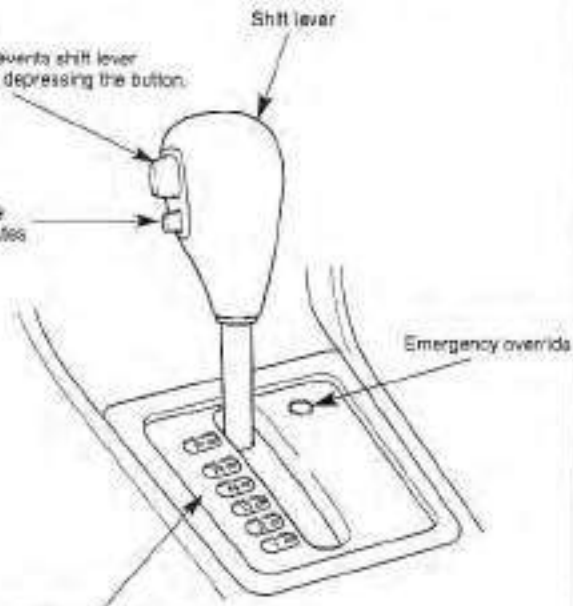

Shift pattern indicator shows shift lever position and gear range of the transaxle.

AS2B04100

Automatic Transaxle Operation

All normal forward driving is done with the shift lever in the D (Drive) position.

To move the shift lever from the P (Park) position, the ignition switch must be in the ON position, the brake pedal must be depressed, and the lock release button must be depressed.

For smooth operation, depress the brake pedal when shifting from N (Neutral) to a forward or Reverse gear.

CAUTION

- **Do not accelerate the engine in R (Reverse) or any of the forward positions with the brakes on.**
- **When stopped on an upgrade, do not hold the vehicle stationary with engine power. Use the service brake or the parking brake.**
- **Do not shift from N (Neutral) or P (Park) into 1 (1st), 2 (2nd), D (Drive) or R (Reverse) when the engine is above idle speed.**

WARNING - Automatic Transaxle

Before leaving the driver's seat, always make sure the shift lever is in the P (PARK) position; then set the parking brake fully and shut the engine off. Unexpected and sudden vehicle movement can occur if these precautions are not followed in the order identified.

Transaxle Ranges

O/D (overdrive) system

Pressing the O/D system button cancels and engages the overdrive system. When the O/D system is cancelled (button is depressed), the O/D off indicator illuminates and the transaxle gear range is limited to 1st through 3rd. The transaxle will not shift to 4th gear until the O/D system button is again depressed.

When the ignition is switched OFF, the O/D OFF mode is automatically cancelled.

O/D OFF indicator

This indicator light illuminates in the instrument panel when the O/D mode is cancelled.

* NOTICE

If the Malfunction Indicator Light flashes, it indicates an electrical problem with the transaxle. Should this occur, have the vehicle checked by an Authorized Kia Dealer as soon as possible.

Normal operation

P (Park)

This position locks the transaxle and prevents the front wheels from rotating. Always come to a complete stop before shifting into this position.

WARNING

Shifting into P (Park) while the vehicle is in motion will cause the front wheels to lock and you will lose driving control of the vehicle.

* NOTICE

The transaxle may be damaged if you shift into P (Park) while the vehicle is in motion.

⚠ WARNING

- Do not use the P (Park) position in place of the parking brake when leaving the vehicle. Always make sure the shift lever is latched in the P (Park) position so that it cannot be moved unless the lock release button is pushed in AND the parking brake is fully set.
- Turn the ignition switch off whenever you leave the vehicle unattended. Never leave the vehicle unattended while the engine is running. Unexpected and sudden vehicle movement may occur if these precautions are not taken.
- Never leave a child unattended in a vehicle.

R (Reverse)

Use this position to drive the vehicle backward.

⚡ CAUTION

Always come to a complete stop before shifting into or out of R (Reverse). You may damage the transaxle if you shift into R while the vehicle is in motion, except as explained in "Rocking the Vehicle."

N (Neutral)

In this position, the wheels and transaxle are not locked. The vehicle will roll freely even on the slightest incline unless the parking brake or service brakes are applied.

D (Drive)

This is the normal forward driving position. The transaxle will automatically shift through a four-gear sequence, providing the best fuel economy and power.

For extra power when passing another vehicle or climbing steep grades, depress the accelerator fully, at which time the transaxle will automatically downshift into the next lower gear.

2 (2nd)

Move shift lever to this position for driving in heavy, slow-moving traffic or when climbing hills. This position also provides engine braking when going down hills and helps reduce wheel spin on slippery surfaces.

1 (1st)

Move the shift lever to this position in hard pulling situations and for climbing or descending steep grades.

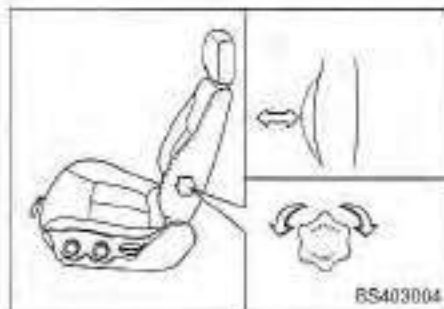

BS403004

Lumbar support (driver's side)

You can adjust the lumbar support by moving the lever on the side of the driver's seatback. Pivoting the lever toward the front of the vehicle increases the lumbar support. Pivoting the lever toward the rear of the vehicle decreases the lumbar support.

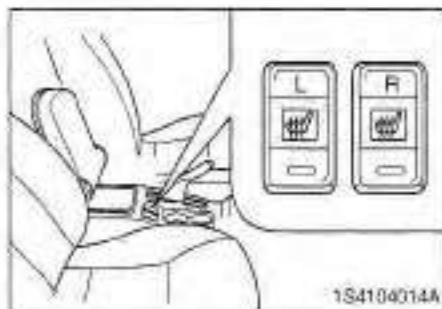

1S4104014A

Heating the Front Seats (If Equipped)

The front seats are electrically heated individually when the applicable switches are depressed and the ignition is ON. A thermostat regulates seat temperature when the corresponding switch (shown above) is depressed. To deactivate the front seat heating system, depress the corresponding switch once again.

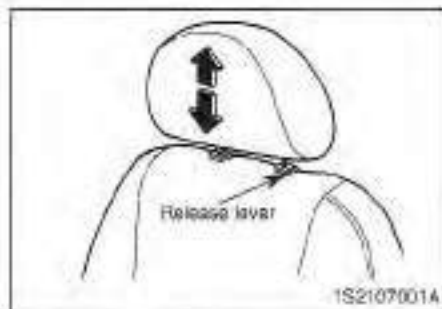

1S2107001A

Adjustable headrest

To raise the headrest, simply pull it up to the desired position. To lower the headrest, press the release lever on the left side grommet, while pushing the headrest down to the desired position. To remove the headrest, raise it as far as it can go then press the release lever while pulling upward.

⚠ WARNING - Headrests

- To reduce the risk of head and neck injuries, do not operate the vehicle with the headrest removed or improperly positioned.
- Do not attempt to adjust the driver's headrest while driving.
- Adjust the top of the headrest so that it is even with the top of your ears in order to reduce the chance of injury in the event of a collision.

⚠ WARNING

Before starting the vehicle, adjust the driver's seat and headrest to the proper position. After doing so, you should adjust the day/night rearview mirror and the outside rearview mirror.



Split Folding Rear Seat (If Equipped)

The rear seatbacks fold forward to provide additional cargo space and to provide an access to the trunk area.

- To fold the rear seatback(s) down, press the unlock button located in the top of the seatbacks, then fold the seatback forward and down.
- To raise the seatback, lift and push it firmly until it clicks into place.
- When you return the seatback to its upright position, reposition the rear safety belts so that they can be used by rear seat passengers.

⚠ WARNING - Cargo

Cargo should always be secured to prevent it from shifting and causing injury to the vehicle occupants.

⚠ CAUTION

Do not remove the floor carpet in your vehicle, emission control system components cause high exhaust temperatures under the floor.

*** NOTICE**

When returning the rear seatbacks to the upright position, remember to return the rear shoulder belts to their proper position. Routing the safety belt webbing through the rear safety belt guides will help keep the belts from being trapped behind or under the seats.

SAFETY BELTS



Pre-tensioner Seat Belt

Your vehicle is equipped with driver's and front passenger's pre-tensioner seat belts. The purpose of the pre-tensioner is to make sure that the seat belts fit tightly against the occupant's body in certain frontal collisions.

The pre-tensioner seat belts can be activated where the frontal collision is severe enough, together with the airbags.



The pre-tensioner seat belt operates in the same way as an Emergency Locking Retractor (ELR) type of seat belt. When the vehicle stops suddenly, or if the occupant tries to lean forward too quickly, the seat belt retractor will lock into position. However, in certain frontal collisions, the pre-tensioner will activate and pull the seat belt into tighter contact against the occupant's body.

The seat belt pre-tensioner system consists mainly of the following components.

Their locations are shown in the illustration.

1. SRS airbag warning light
2. Seat belt pre-tensioner assembly
3. SRS control module

⚠ WARNING

To obtain maximum benefit from a pre-tensioner seat belt:

1. The seat belt must be worn correctly.
2. The seat belt must be adjusted to the correct position.

* NOTICE

- Both the driver's and front passenger's pre-tensioner seat belt will be activated in certain frontal collisions. When the frontal collision is severe enough, the pre-tensioners will be activated together with the airbags. The pre-tensioners will be activated under these conditions even if the seat belts are not being worn at the time of the collision.
- When the pre-tensioner seat belts are activated, a loud noise may be heard and fine dust that may appear to be smoke, may be visible in the passenger compartment. These are normal operating conditions and are not hazardous.
- Although it is harmless, the fine dust may cause skin irritation and should not be breathed for prolonged periods. Wash your hands and face thoroughly after an accident in which the pre-tensioner seat belts were activated.

CAUTION

- *Because the sensor that activates the SRS airbag is connected with pre-tensioner seat belt, the SRS airbag warning light  on the instrument panel will illuminate for approximately 6 seconds after the ignition key has been turned to the "ON" position, and then it should turn off.*
- *If the pre-tensioner seat belt is not working properly, this warning light will illuminate even if there is no malfunction of SRS airbag system. If the SRS airbag warning light does not illuminate when the ignition key is turned to "ON" or if it remains illuminated after illuminating for approximately 6 seconds, or if it illuminates while the vehicle is being driven, please have an authorized Kia dealer inspect the pre-tensioner seat belt or SRS airbag system as soon as possible.*

WARNING

- Pre-tensioners are designed to operate only one time. After activation, pre-tensioner seat belts must be replaced. All seat belts, of any type, should always be replaced after they have been worn during a collision.
- The pre-tensioner seat belt assembly mechanisms become hot during activation. Do not touch the pre-tensioner seat belt assemblies for several minutes after they have been activated.
- Do not attempt to inspect or replace the pre-tensioner seat belts yourself. This must be done by an authorized Kia dealer.
- Do not strike the pre-tensioner seat belt assemblies.
- Do not attempt to service or repair the pre-tensioner seat belt system in any manner.

(Continued)

(Continued)

- Improper handling of the pretensioner seat belt assemblies, and failure to heed the warnings to not strike, modify, inspect, replace, service or repair the pretensioner seat belt assemblies may lead to improper operation or inadvertent activation and serious injury.
- Always wear the seat belts when driving or riding in a motor vehicle.

Safety Belt Restraint System

WARNING

The driver and all passengers should always use the safety belts provided in order to minimize the risk of severe bodily injury.

We strongly recommend that the driver and all passengers be properly restrained at all times by using the safety belts provided with the vehicle. Proper use of the safety belts decreases the risk of severe injury or death in accidents or sudden stops. In most states and in Canada, the law requires their use.

Safety belts provide the best restraint when:

- the seatback is upright
- the occupant is sitting upright (not slouched)
- the lap belt portion of the safety belt is snug and low on the hips
- the shoulder belt portion of the safety belt is snug against the chest
- the knees are straight forward

To help you remember to fasten your safety belt, a warning light may come on and a chime may sound.

All seats, except the center rear seat, have lap/shoulder belts. The center rear seat has a lap belt.

Inertial locks in the safety belt retractors allow all of the lap/shoulder safety belts to remain unlocked during normal vehicle operation. This allows the occupants some freedom of movement and increased comfort while using the safety belts. If a force is applied to the vehicle, such as a strong stop, a sharp turn, or a collision, the safety belt retractors will automatically lock the safety belts.

Since the inertial locks do not require a collision in order to lock-up, you may become aware of the safety belts locking while braking or going around sharp corners.

The center rear seat safety belt does not have an inertial lock so it is always in a locked condition. Whenever possible, use the center rear seat position to install your child restraint.

The center rear seat is the best position to install your child restraint. However, if the center seat is unavailable, a child restraint may be installed in the rear outboard seats.

The rear outboard safety belts have been designed to allow a child restraint to be used in these positions without an added locking clip.

WARNING - Twisted Safety Belts

Never drive or ride with a twisted or jammed safety belt. If you cannot untwist or unjam the safety belt, see your Kia dealer immediately.

WARNING - Safety Belt Usage

Each seating position in your vehicle has a specific safety belt assembly which includes a buckle and tongue that are designed to be used together. 1) Use the shoulder belt on the outside shoulder only. Never wear the shoulder belt under the arm. 2) Never swing the safety belt around your neck to fit over the inside shoulder. 3) Never use a single belt for more than one person.

 **WARNING - After a Collision**
Lap/shoulder belt assemblies may be stretched or damaged when subjected to the stress and forces of a collision. The entire restraint system should be inspected following any collision. All belts, retractors, anchors and hardware damaged by a collision should be replaced before the vehicle is operated again.

▲ WARNING - Safety Belt Care
Safety belts should be inspected periodically for excessive wear or damage. Pull out each belt fully and look for excessive fraying, cuts, burns or other damage. Make sure that the lap/shoulder belts return smoothly and easily into the retractor. Check the latches to make sure they latch and release without interference or delay. Any belt not in good condition or in good working order should be promptly replaced.

⚡ CAUTION - Damage to Safety Belts

Never close the doors on any part of the lap or shoulder belt. It can damage the safety belt or buckle which could increase the risk of injury in case of an accident.

Restraint of Pregnant Women

Pregnant women should wear lap/shoulder belt assemblies whenever possible according to specific recommendations by their doctors. The lap portion of the belt should be worn **AS SNUGLY AND AS LOW AS POSSIBLE.**

▲ WARNING - Pregnant Women

Pregnant women must never place the lap portion of the safety belt over the area of the abdomen where the fetus is located or above the abdomen.

Restraint of Infants and Small Children

Small children and infants should be restrained by an approved child restraint system to help protect them while riding in a vehicle.

Never allow a child to stand or kneel on the seat of a moving vehicle. Never allow a safety belt to be placed around both a child and an adult or around two children at the same time.

▲ WARNING - Children on Laps

Never hold a child on your lap or in your arms in a moving vehicle. Even a very strong person cannot hold onto a child in the event of even a minor collision.

Many companies manufacture child restraint systems (often called child seats) for infants and small children. An acceptable child restraint system must always satisfy Canadian Motor Vehicle Safety Standards. Make sure that any child restraint system you use in your vehicle is labeled as complying with those safety standards.

The child restraint system should be chosen to fit both the size of the child and the size of the vehicle seat. Be sure to follow any instructions provided by the child restraint system manufacturer when installing the child restraint system.

CAUTION - Hot Metal Parts

Safety belts and seats can become hot in a vehicle that has been closed during warm/hot weather; they could burn a child. Check seat covers and buckles before you place a child anywhere near them.

Restraint of Large Children

As children grow, they may need to use new child restraint systems, including larger child seats or booster seats, which are appropriate for their increased size.

A child who has outgrown available child restraint systems should use the belts provided in the vehicle. When seated in the rear outboard seats, the child should be restrained by the lap/shoulder belt.

If the shoulder belt portion touches the child's neck or face, you can use some after-market devices made by independent manufacturers which help pull the shoulder belt down and away from the child's face or neck.

WARNING - Shoulder belts on Small Children

- Never allow a shoulder belt to be in contact with a child's neck or face while the vehicle is in motion.
- If safety belts are not properly worn and adjusted, the risk of death or serious injury to such a child is high.

▲ WARNING - Child Restraints

- All child restraint systems are designed to be secured in vehicle seats by lap belts or the lap-belt portion of a lap/shoulder belt. Children will be endangered in a crash if their child restraint systems are not properly secured by the safety belts in the vehicle.
- According to accident statistics, children are safer when properly restrained in the rear seating positions rather than the front seating positions.
- When a child restraint system is not secured by a safety belt, store it in the trunk so that it will not be thrown forward in the event of a sudden stop or accident.

Placement of a Child Restraint System

We recommend that, whenever possible, you put the child restraint system in the center position of the rear seat and secure it to the vehicle with the lap belt.

If the center rear seat is not available, or you are using more than one child restraint system in the vehicle at the same time, rear outboard safety belts have been designed to allow a child restraint system to be used in these positions.

▲ WARNING - Restraint Instructions

Failure to observe this manual's instructions regarding child restraint systems and the instructions provided with the child restraint system itself could increase the chance and/or severity of injury in an accident.



Installing a child restraint in the rear center seat

Use the following procedure to install a child restraint in the rear center seat:

1. Place the child restraint in the desired position. Route the lap belt through the restraint according to the seat manufacturer's instructions.
2. Insert the tongue plate into the buckle.
3. Adjust the lap safety belt for a snug hold on the child restraint by pulling on the loose end of the belt.

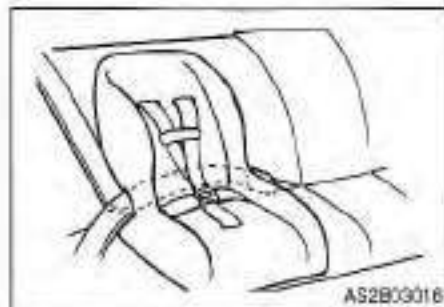

Installing a child restraint system in rear outboard seats

⚠ WARNING

Children can be killed or injured by the passenger airbag. The rear seats are the safest place for children 12 and under. Make sure all children use seat belts, or the applicable child restraint system.

⚠ WARNING - Child Restraint Placement

NEVER use a child restraint in the front passenger seat. A child in a child restraint installed in the front passenger seat can be severely or fatally injured by an airbag which could impact the child restraint with great force when the airbag inflates.

Placing a passenger safety belt into the "Auto Lock" mode (if equipped)

The use of the auto lock mode will ensure that the normal movement of the child in the vehicle does not cause the safety belt to be pulled out and loosen the firmness of its hold on the child restraint.

KNOWING YOUR VEHICLE

To secure a child restraint in the front passenger seat or rear outboard seats, follow the procedure below.

1. Place the child restraint system in the seat and route the lap/shoulder belt around or through the restraint, following the restraint manufacturer's instructions. Be sure the belt webbing is not twisted.



2. Insert the lap/shoulder belt latch into the buckle. Listen for the distinct "click" sound.

Position the release button so that it is easy to access in case of an emergency.



3. Grasp the shoulder portion of the belt and pull downward until the entire belt is extracted. When the belt is fully extracted, the retractor changes to the automatic locking mode (child restraint mode).



4. Slowly allow the belt to retract. Pull up on the shoulder webbing. A "clicking" or "ratcheting" sound will be heard as the belt retracts. This indicates the retractor is now in the automatic locking mode. Push down on the child restraint while you pull up on the belt in order to remove any slack in the belt.



5. Before placing the child in the child restraint, forcibly try to push the seat from side to side and forward to make sure that the seat is securely held in place.
6. Double check that the retractor is in the automatic locking mode by trying to pull the shoulder portion of the safety belt out of the retractor. If you cannot pull the belt out of the retractor, it is in the automatic locking mode. If you can, repeat step 4.

To remove the child restraint, press the release button on the buckle and then pull the lap/shoulder belt out of the restraint and allow the safety belt to retract fully.

⚠ WARNING - Auto Lock Mode

The lap/shoulder belt automatically returns to the "emergency lock mode" whenever the belt is allowed to retract fully. Therefore, the preceding six steps must be followed each time a child restraint is installed. If the safety belt is not placed in the "auto lock" mode, severe injury or death could occur to the child and/or other occupants in the vehicle in a collision, since the child seat will not be effectively held in place.

To return the safety belt retractor to the emergency lock mode, allow the seat belt to retract fully to its stowed position and the retractor will automatically switch back to the emergency lock mode for normal adult usage.

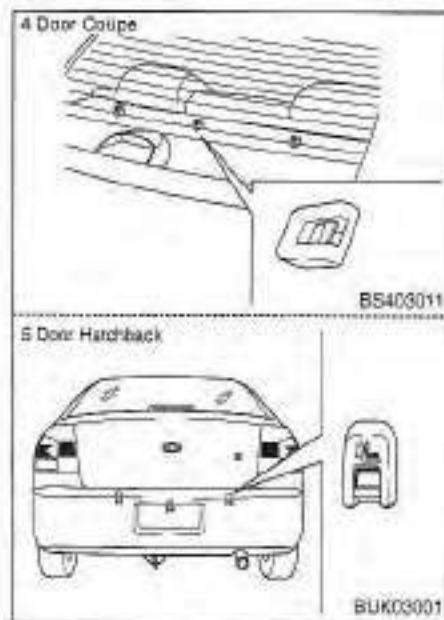

Child Restraint Anchorage

The child restraint anchor fittings are installed on the shelf behind the rear seat or in the trunk on the inboard side of the rear bumper in the 5-door hatchback.

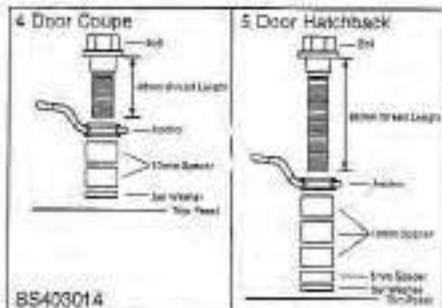

Child restraint anchorage fitting

Your vehicle is equipped with an anchor for securing the tether strap of a child restraint system (child seat).

The anchor fitting package consists of:

- Bolt : 5/16 inch-18 unc,
45 mm thread length (4 doors),
60 mm thread length (5 doors).
- Spacer : 10 mm thickness X 2EA
(4 doors),
10 mm thickness X 3EA,
5 mm thickness (5 doors).
- Set washer : 0.7 mm thickness.
- Anchor fitting : three is installed on the vehicle.

⚠ WARNING - Child Restraint Anchor Fitting

- Infants and small children should be restrained at all times in an approved child restraint designed for your vehicle.
- Child restraint anchorage is designed to withstand only those loads imposed by correctly fitted child restraints. Under no circumstances are they to be used for adult seat belts or harnesses or for attaching other items or equipment to the vehicle.
- The standard 30 mm bolt and spacers provided with the child restraint **MUST NOT** be used. Additional non-standard bolt and spacers may be obtained from an Authorized Kia Dealer.

- Check that the child restraint system is secured by pushing and pulling it in different directions. Incorrectly fitted child restraint may swing, twist, tip or come away causing death or injury.

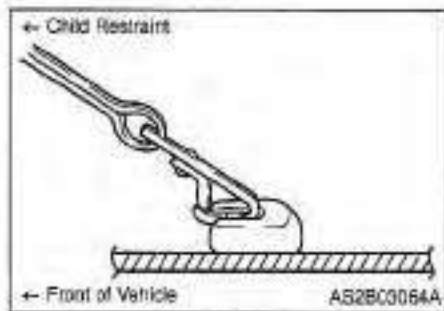

Placement of a child restraint system

To install the child restraint on the rear seat, use the anchorage fitting located on the shelf behind the rear seat or in the trunk on the inboard side of the rear bumper in the 5-door hatchback.

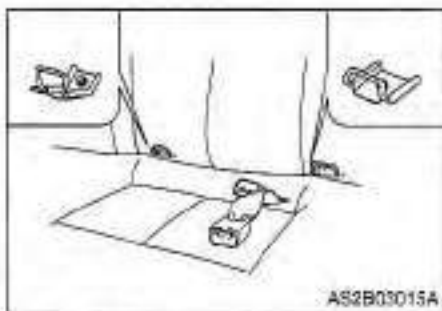

Child restraint lower anchor striker position

The child lower anchor striker is located between rear seat and seatback.

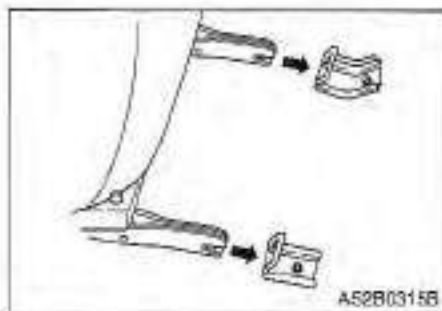

To install the child restraint to the child lower anchor striker, insert the child restraint latch into the child lower anchor striker. Listen for the audible "Click" sound.

Safety belt warning light



AS2B03022

Safety Belt Warning Light and Chime

If the driver's lap/shoulder belt is not fastened when the key is turned ON, the safety belt warning chime sounds for approximately six seconds and the safety belt warning light illuminates for approximately six seconds.



AS2B03023

Front lap/shoulder belt

To fasten the front lap/shoulder belt:

1. Grasp the buckle and tongue plate.
2. Slowly pull the lap/shoulder belt out from the retractor.



AS2B03024

3. Insert the tongue plate into the open end of the buckle until an audible "click" is heard, indicating the belt is locked in the buckle.



4. Position the lap portion of the belt across your lap as **LOW ON THE HIPS** as possible to reduce the risk of sliding under it during an accident. Adjust the belt to a **SNUG FIT** by pulling up on the shoulder portion of the safety belt. The belt retractor applies tension to the belt in order to take up excess webbing automatically and to maintain tension on the belt. For maximum safety, do not put any excess slack into the safety belt.



5. Adjust the shoulder anchor position to your size. To raise the anchor position, pull the knob and push the anchor up. To lower the anchor position, pull the knob and slide the anchor down. After adjustment, make sure the anchor is locked in position.

⚠ WARNING - Front Safety Belts

- The front seatbacks should always remain in a comfortable, upright position while the vehicle is in motion. The safety belt system will provide the most protection with the seatbacks in an upright position.
- Never wear the shoulder portion of the safety belt under the outside arm or behind the back.
- Never wear the shoulder portion of the safety belt across the neck or face.
- Wear the lap portion of the safety belt as low on the hips as possible. Be sure the lap belt fits snugly around the hips. Never wear the lap belt over your waist.
- Never drive or ride with a twisted or jammed safety belt. If you cannot untwist or unjam the safety belt, see the nearest Kia dealer immediately.

- Never use a single belt to restrain more than one person at a time. Failure to follow these warnings will increase the risk and severity of injury in an accident.



To unfasten the front lap/shoulder belt:
Press the release button on the buckle.

Rear Safety Belts

Two kinds of safety belts are provided:

- Lap/shoulder belts for people who sit on the outboard sides of the vehicle.
- A lap belt for people who sit in the center of the rear seat.



Rear lap/shoulder belt

To fasten:

1. Grasp the buckle with one hand and the tongue plate with the other.
2. Slowly pull the lap/shoulder belt out.
3. Insert the tongue plate into the open end of the buckle until an audible "click" is heard, indicating the belt is locked.



4. Position the lap portion of the belt across your lap as **LOW ON THE HIPS** as possible to reduce the risk of sliding under it during an accident.

Adjust the belt to a **SNUG FIT** by pulling up on the shoulder portion of the safety belt. The belt retractor is designed to take up excess webbing automatically and to maintain tension on the belt. This is for your safety. Do not put excess slack into the safety belt.

To unfasten:

Press the release button on the buckle.

⚠ WARNING - Rear

Lap/Shoulder Safety Belts

- **Never wear the shoulder portion of the safety belt under the outside arm or behind the back.**
- **Never wear the shoulder portion of the safety belt across the neck or face.**
- **Wear the lap belt or the lap portion of the belt as low as possible. Be sure the lap belt fits snugly around the hips. Never wear the lap belt over your waist.**
- **Never ride or drive with a twisted or jammed safety belt. If you cannot untwist or unjam the safety belt, see the nearest Kia dealer immediately.**
- **Never use a single belt to restrain more than one person at a time.**

Failure to follow these warnings could increase the chance and severity of injury in an accident.

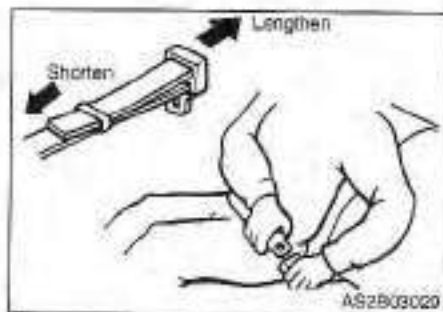

Lap belt (rear center seat)

To fasten the rear lap belt:

1. Grasp the buckle end and pull it low over the abdomen.
2. Insert the tongue plate into the open end of the buckle until an audible "click" is heard, indicating the latch is locked. Make sure the belt is not twisted.
3. To lengthen the belt, hold the latch plate tongue at a right angle to the safety belt webbing and pull.



4. To shorten the belt, hold the latch plate tongue at a right angle to the safety belt webbing and pull on the loose end of the belt until the desired belt length is reached.
5. Grasp the free portion of the belt webbing and pull until the belt is snug over the hips and as low on the abdomen as possible.
6. Make sure that the belt is placed as **LOW ON THE HIPS** as possible.



To unfasten the rear lap belt:
Press the release button on buckle.

▲ WARNING - Center Rear Lap Belt

Be sure the center rear lap belt is positioned snugly around the hips, and not on the waist. Failure to position the center rear lap belt snugly around the hips and not on the waist will increase the chance and severity of injury in the event of a collision.

Proper Use and Care of the Safety Belt System

To ensure that the safety belts provide the maximum protection, please follow these instructions:

- Use the belts at all times - even on short trips.
- If the safety belt is twisted, straighten it prior to use.
- Keep sharp edges and damaging objects away from the belts.
- Periodically inspect belt webbing, anchors, buckles, and all other parts for signs of wear and damage.

- Replace damaged, excessively worn or questionable parts immediately.
- To clean the belt webbing, use any mild soap solution recommended for cleaning upholstery or carpets. Follow the instructions provided with the soap. Do not bleach or dye the webbing because this may weaken the webbing fibers and allow them to fail when loaded in a collision.
- Do not make modifications or additions to the safety belt.
- After wearing a safety belt, make sure it fully retracts to the stowed position. Do not allow the belt to get caught in the door when you close it.

AIRBAG - SUPPLEMENTAL RESTRAINT SYSTEM

What your airbag system does

Your vehicle is equipped with a dual Supplemental Restraint System (SRS), which includes an airbag for the driver and another airbag for the front passenger.

What your airbag system does not do

The airbag system is designed to supplement or add to the protection provided to properly belted occupants in moderate to severe frontal collisions. It is not a substitute for the driver's or front passenger's safety belt and it does not provide restraint to the lower body.

Why didn't my airbag go deploy in a collision?

There are many types of accidents in which the airbag would not be expected to provide additional protection. These include side or rear impacts, rollovers, and second or third impacts in multiple-impact accidents as well as low speed impacts.

Remember, airbags are only designed to inflate when the impact would throw the occupant into the airbags - generally from a little to the left to a little to the right of straight ahead.

In other words, just because your vehicle is damaged and even if it is totally unusable, don't be surprised that the airbag(s) did not inflate.

The importance of using safety belts

There are four very important reasons to use safety belts even with an airbag system, they:

- help keep you in the proper position (away from the airbag) when it inflates
- reduce the risk of harm in rollover, side or rear impact collisions, because an airbag is not designed to inflate in such situations.
- reduce the risk of harm in frontal collisions that are not severe enough to activate the supplemental restraint system.
- reduce the risk of being thrown from your vehicle.

▲ WARNING - Airbags & Safety Belts

Even in vehicles with airbags, you and your passengers must always wear the safety belts provided in order to minimize the risk and severity of injury in the event of a collision or rollover.

- Always wear your safety belt. It can help keep you away from the airbags during heavy braking just before a collision.
- Airbags are designed to inflate only in severe frontal collisions and will generally not provide protection in side or rear impacts, rollovers or less severe frontal collisions. They will also not provide protection from later impacts in a multi-impact collision.

- If your vehicle has been subjected to flood conditions (e.g. soaked carpeting/standing water on the floor of the vehicle, etc.) or if your vehicle has become flood damaged in any way, do not attempt to start the vehicle or put the key in the ignition before disconnecting the battery. This may cause airbag deployment, which could result in serious personal injury or death. Have the vehicle towed to an authorized Kia dealer for inspection and necessary repairs.

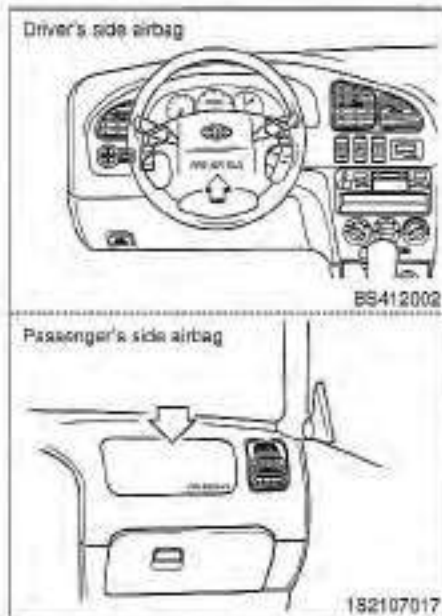

Airbag System Components

The main components of your vehicle's SRS are:

- One airbag in the steering wheel for the driver, and another in the dashboard for the front passenger.
- A diagnostic system that continually monitors system operation.
- An indicator light to warn you of a possible problem with the system.
- Emergency power backup in case your car's electrical system is disconnected in a crash.

To indicate that your vehicle is equipped with airbags, the airbag covers on the steering wheel and on the dashboard are marked with "SRS AIRBAG."

How the Airbag System Works

The driver's airbag is stored in the center of the steering wheel. The passenger side airbag is stored in the front instrument panel above the glove box.

If you ever have a severe frontal collision, your airbags will instantly inflate to help protect you from serious physical injury.

There is no single vehicle speed at which the airbags will inflate. Generally, airbags are designed to inflate in severe frontal collisions. The airbag Supplemental Restraint System (SRS) reacts to the severity of a collision and its direction. These two factors determine whether the sensors send out an electronic deployment or inflation signal. Whether the airbags will inflate depends on a number of factors including vehicle speed, angle of impact and the density and stiffness of the vehicles or objects that your vehicle hits in the collision.

The airbags will completely inflate and deflate in less than 1/10 of one second. The speed of inflation and deflation protects the driver's ability to operate the vehicle. This is important in crashes where a vehicle continues to move after an impact and the driver still has some control of the vehicle's steering, braking, throttle and/or transmission systems.

It is virtually impossible for you to see the airbags inflate during an accident. It is much more likely that you will simply see the deflated airbags hanging out of their storage compartments after the collision.

In order to help provide protection in a severe collision, the airbags must inflate rapidly. However, that speed also causes the airbags to expand with a great deal of force. The speed of this inflation has been determined by the Canadian Motor Vehicle Safety Standards (CMVSS) to reduce the likelihood of serious or life-threatening injuries and is thus a mandatory part of airbag design.



Thus, airbag inflation could also cause injuries which normally can include facial abrasions, bruises and broken bones. However, there are even circumstances under which contact with the steering wheel airbag can cause fatal injuries, especially if the occupant is positioned excessively close to the steering wheel.

YOU MUST ALWAYS SIT AS FAR BACK FROM THE STEERING WHEEL AIRBAG AS POSSIBLE, WHILE STILL MAINTAINING A COMFORTABLE SEATING POSITION FOR GOOD VEHICLE CONTROL, IN ORDER TO REDUCE THE RISK OF INJURY OR DEATH IN A COLLISION.

▲ WARNING - Airbag Injuries

- Sit as far back from the steering wheel as possible without interfering with your control of the vehicle. Positioning yourself too close to the steering wheel can result in serious or even fatal injuries if the airbag deploys.
- Never place objects over the airbag storage compartments or between the airbags and yourself. Due to the speed and force of the airbag inflation, such objects could hit your body at high speed and cause severe bodily injury and even death.

Noise and Smoke

When the airbags inflate, they make a loud noise and they leave smoke and powder in the air inside of the vehicle. This is normal and is a result of the ignition of the airbag inflator.

After the airbags inflate, you may feel substantial discomfort in breathing due both to the contact by your chest with both the safety belt and the airbag, as well as from breathing the smoke and powder.

We strongly urge you to open your doors and/or windows as promptly as possible after impact in order to reduce discomfort and prevent prolonged exposure to the smoke and powder.

▲ WARNING - Hot Metal Parts

When the airbags deploy, the airbag inflators in the steering wheel and/or in the dashboard are very hot. To prevent injury, do not touch the airbag storage area's internal components immediately after an airbag has inflated.



The Importance of The Passenger Being Properly Seated

The front seat passenger's airbag is much larger than the driver's airbag and inflates with considerably more force. It can seriously hurt or kill a passenger who is not in the proper position and wearing the safety belt properly. The front passenger should always move their seat as far back as practical and sit well back in the seat.

It is essential that the front passenger always wear their safety belt, even when mounting in a parking lot or up a drive way into a garage.

The reason for this is that in most frontal impacts there is substantial pre-impact braking which tends to throw the occupants forward. If the right front passenger is not using their safety belt, they will be directly in front of or even touching the airbag storage compartment when inflation occurs. In that situation, death or severe injury is possible.

⚠ WARNING - Right Front Seat
Pre-impact braking could throw an unbelted passenger toward or onto the airbag storage compartment. Upon impact in a collision, the airbag would rapidly inflate and possibly severely injure or kill that occupant who failed to wear their safety belt.

Because of the airbag, you must **NEVER INSTALL A REAR-FACING CHILD RESTRAINT SYSTEM IN THE FRONT PASSENGER SEAT.** There is a very significant risk of serious or fatal injuries to a child in a rear-facing child restraint if the right front passenger airbag inflates. We also strongly recommend that you do not put a front-facing child restraint system in the front passenger seat. If a front-facing child restraint system must be used in the front passenger seat, the vehicle seat should be moved as far back as possible. If the passenger's airbag inflates, it could seriously or fatally hurt a child who is not in the proper position or properly restrained.

⚠ WARNING - Front

Passengers

- **NEVER** use a child restraint in the front seat. In the front seat, a child restraint would be positioned too close to where the airbags are stored and in the event an airbag deploys, the airbag would impact the rear-facing child restraint and cause serious injuries or death.
- **Failure to observe the instructions provided with the child restraint system could increase the risk and/or severity of injury in an accident.**

Airbag Warning Light

The purpose of the airbag warning light in your instrument panel is to alert you of a potential problem with your Airbag - Supplemental Restraint System (SRS).



Have the system checked if:

- The light does not illuminate when you turn the ignition ON.
- The light stays on after the engine starts.
- The light comes on or flashes while you are driving.

Supplemental Restraint System Service

Your Supplemental Restraint System is virtually maintenance-free. There are no parts which you can service.

You must have the system serviced under the following circumstances:

- If an airbag ever inflates, the airbag must be replaced. Do not try to remove or discard the airbag by yourself. This must be done by an authorized Kia dealer.
- If the airbag warning indicator light alerts you of a problem, have the airbag system checked as soon as possible. Otherwise, your airbag might not inflate when you need it.

⚠ WARNING - Airbag (SRS) Malfunctions

- Do not modify your steering wheel or any other part of the Supplemental Restraint System. Modification could make the system ineffective.
- Do not work on the system's components or wiring. This could cause the airbags to inflate inadvertently, possibly seriously injuring someone. Working on the system could also disable the system so that the airbags did not deploy in a collision.



**Airbag warning label
(sunvisor - front side)**

To remind you of the dangers of the airbag, airbag warning labels which are now required by the Canadian Motor Vehicle Safety Standards (CMVSS) are adhered to the driver's and passenger's sunvisors and attached to the glove box.

Note that these government warnings focus on the risk to children. Kia also wants you to be aware of the risks which adults are exposed to. Those have been described in previous pages.

TRUNK LID

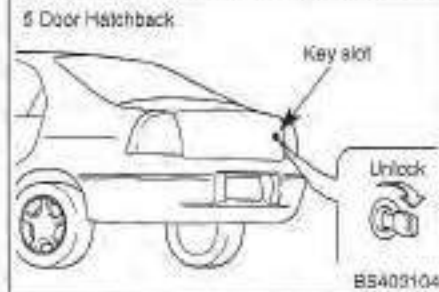
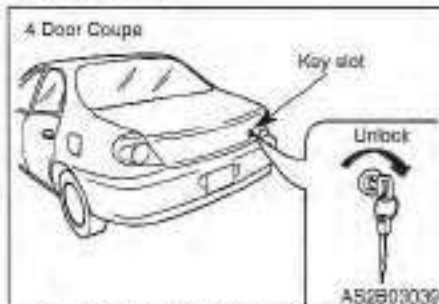

- To open the trunk, insert the key into the lock and turn it clockwise until an audible "click" is heard.
- To close the trunk, use both hands to push the trunk lid down until the lock "snaps" shut.
- Do not slam the trunk lid.
- Pull up on the trunk lid to make sure it is securely latched.

To prevent premature wear or damage to the trunk lid lift cylinders and attaching hardware, the trunk lid must be fully closed before you drive your vehicle.

⚠ WARNING - Exhaust Fumes
 If you drive with the trunk lid open, you will draw dangerous exhaust fumes into your vehicle.

If you must drive with the trunk lid open, keep the air vents open so that additional outside air comes into the vehicle.

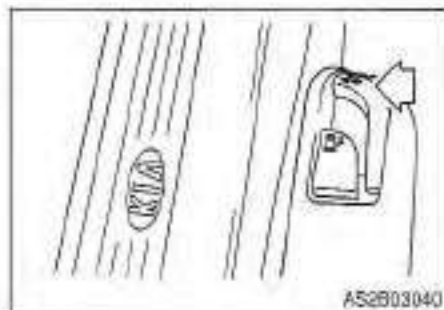

Remote Trunk Lid Release

The release is located at the left front corner of the driver's seat on the floor. To open the trunk, pull up on the lever.

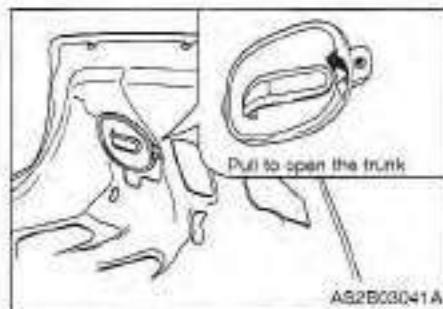

Emergency Trunk Safety Release

Your vehicle is equipped with an emergency trunk release cable located inside the trunk. When pulled, this cable will release the trunk latch mechanism and open the trunk.

⚠ WARNING

No one should be allowed to occupy the trunk of the vehicle at any time. If the trunk is partially or totally closed and the person is unable to get out, severe injury or death could occur due to lack of ventilation, fumes and rapid heat build-up, or because of exposure due to cold weather conditions. The trunk is also a highly dangerous location in the event of a crash because it is not a protected occupant space and is instead part of the vehicle's crush zone.

HOOD

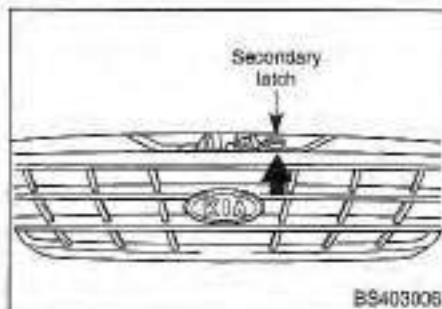

Opening the Hood

1. Inside the vehicle, pull the hood release handle located at the bottom left corner of the instrument panel.
2. Go to the front of the vehicle, raise the hood until the secondary latch catches then pull the secondary latch up (located under the hood at the center of the vehicle).
3. Lift the hood and hold it open with the prop rod by inserting the free end of the rod into the slot.

CAUTION

Before closing the hood, make sure that all parts and tools have been removed from the engine area and that everyone is clear of the hood opening.

Closing the Hood

- Before closing the hood, secure the prop rod in its retainer to prevent it from rattling.
- Check the underhood area to make certain all filler caps are in place and that all loose items have been removed.
- Close the hood firmly so that it latches securely. Do not slam it shut.

FUEL FILLER DOOR

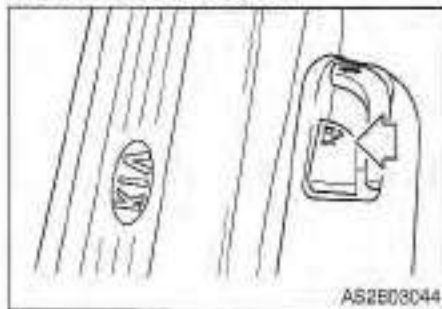

Remote Fuel Filler Door Release

Pull up on the release lever (located on the floor) at the left front corner of the driver's seat to open the filler door.

⚠ WARNING - Fuel Filling

- Fuel may be under pressure. Always remove the fuel cap carefully and slowly. If the cap is venting fuel or if a hissing sound is heard, wait until the condition stops before completely removing the cap. If these precautions are not followed, fuel may spray out and cause serious personal injury.
- Fuel vapor is extremely hazardous and can explode. When refueling, always stop the engine and never allow sparks or open flames near the filler neck. Always extinguish cigarettes and other smoking materials before refueling.

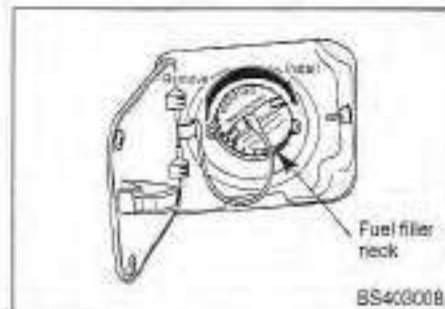

- To remove the cap, turn it counterclockwise.
- To install the cap, turn it clockwise until it "clicks." This indicates that the cap is securely tightened.

*** NOTICE**

A loose fuel filler cap may cause the OBD-II Malfunction Indicator Light () light in the instrument panel to illuminate unnecessarily. Always ensure that the fuel filler cap is tight.

The fuel filler neck is designed to prevent filling the fuel tank with anything but unleaded fuel.

* NOTICE

If the fuel filler cap requires replacement, use only a genuine Kia cap for your vehicle. An incorrect fuel filler cap can result in a serious malfunction of the fuel system or emission control system. Correct replacement caps are available at Authorized Kia Dealers.

If the fuel filler lid will not open in cold weather because the area around it is frozen, push or lightly tap the lid.

* NOTICE

Do not spill fuel on the exterior surfaces of the vehicle. Any type of fuel on painted surfaces may damage the paint.

STEERING WHEEL

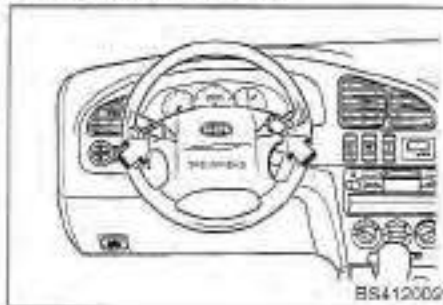

Horn

To sound the horn, push the horn button on either side of the steering wheel. Check the horn regularly to be sure it operates properly.

MIRRORS

Outside Rearview Mirror

Your vehicle is equipped with both left-hand and right-hand outside review mirrors. The mirrors can either be adjusted remotely with the control levers or remote switch, depending on the type your vehicle has. The mirror heads can be folded rearward to prevent damage when using an automatic car wash.

CAUTION

- *The right outside rearview mirror is convex. Objects seen in the mirror are closer than they appear.*
- *When changing lanes, use your interior rearview mirror or direct observation to determine the actual distance of following vehicles behind you.*

*** NOTICE**

Do not scrape ice off the mirror face; this may damage the surface of the glass. If ice should restrict movement of the mirror, do not force the mirror to adjust it.

To remove ice, use a de-icer spray, or a sponge or soft cloth with very warm water.

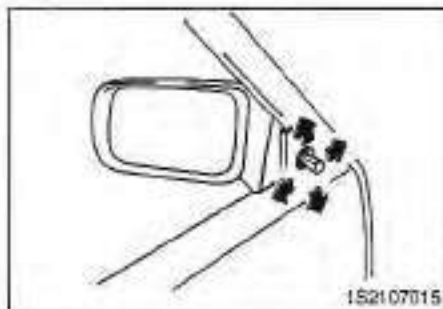

Manual control

To adjust an outside mirror, move the control lever which is located at the forward inside area of the window frame.



Electric remote control (If Equipped)

This switch, located on the left side of the instrument panel, controls the adjustments for both right and left outside mirrors. To adjust the position of either mirror:

1. Move the selector switch to the right or left to activate the adjusting mechanism for the corresponding mirror.
2. Adjust the mirror angle by depressing the mirror adjustment control switch in the desired direction.

*** NOTICE**

The mirrors stop moving when they reach the maximum adjusting angles, but the motor continues to operate while the switch is depressed. Do not depress the switch longer than necessary or the motor may be damaged.

Outside rearview mirror heater (If Equipped)

The outside rearview mirror heater is actuated in conjunction with the rear window defroster. To heat the outside rearview mirror glass, push in the switch for the rear window defroster. The rearview mirror glass will be heated for defrosting or defogging and will provide improved rear visibility during inclement weather. Push the switch again to turn the heater off. The outside rearview mirror heater automatically turns itself off after 15 minutes.

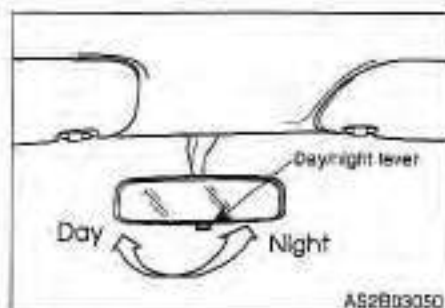

Day/Night Rearview Mirror

Adjust the rearview mirror to center on the view through the rear window. Make this adjustment before you start driving and while the day/night lever is in the day position.

Pull the day/night lever toward you to reduce glare from the headlights of vehicles behind you during night driving.

Remember that you lose some rearview clarity in the night position.

CAUTION

Do not allow objects in the rear seat to interfere with your line of vision through the rear window.

INTERIOR LIGHTS

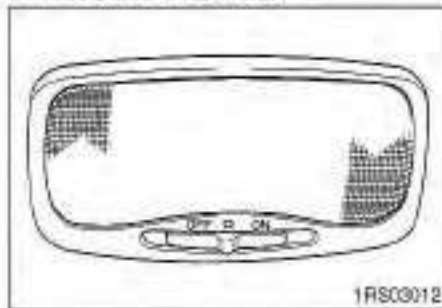

Dome Light

The dome light switch, located in the light assembly, has three positions:

- OFF** - The light stays off even when a door is open.
- - The light turns on or off when a door is opened or closed. After a door is closed the light remains **ON** for approximately 5 seconds and goes **OFF** slowly.
- ON** - The light turns on and stays on even when the doors are all closed.

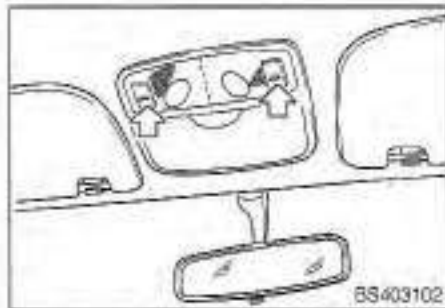

Map Lights

The map lights are switched **ON** or **OFF** by pressing the corresponding switches.

CUP HOLDERS AND CONSOLE STORAGE COMPARTMENT

The cup holders and console storage compartment are located in the center console.

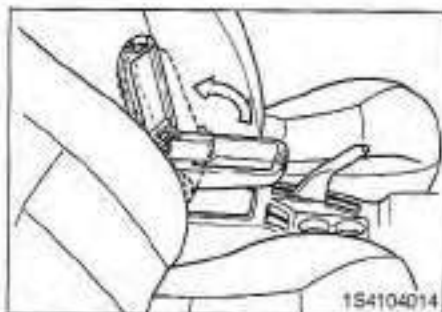

Console Storage Compartment

To use the console storage compartment, depress the release button located on the cover and pull the cover up.



Cup Holders

▲ WARNING

- Do not place uncovered cups of hot liquid in the cup holder while the vehicle is in motion. If the hot liquid spills, you could be burned and lose control of the vehicle. Moreover, the spilled liquid could cause the failure of the transaxle change lever.
- To reduce the risk of personal injury in the event of a sudden stop or collision, do not place bottles, drinking glasses, cans, etc., in the cup holder while the vehicle is in motion.

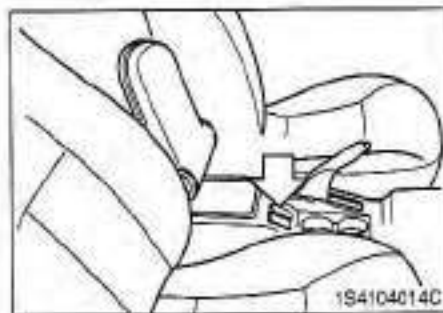

Coin Holder

Coin holder slots are located in the center console compartment. Do not use this as ashtray.



Sunglass Holder

A compartment is provided on the overhead console for the storage of sunglasses. To open the sunglass holder, press the cover and the cover will slowly open. Place your sunglasses in the compartment door with the lenses facing out.

DRIVING TIPS

5

Fuel Requirements	5-2
Emission Control System	5-3
Before Driving	5-5
Suggestions for Economical Operation	5-6
Special Driving Conditions	5-7
Trailer Towing	5-10
Overloading	5-10
Label Information	5-11

FUEL REQUIREMENTS

Your new Kia Vehicle must use only unleaded fuel having an octane rating of 87 or higher. Your new Kia is designed to obtain maximum performance with unleaded fuel. Unleaded fuel will minimize exhaust emissions and spark plug fouling.

* NOTICE

NEVER USE LEADED FUEL. The use of leaded fuel is detrimental to the catalytic converter. Never add any fuel system cleaning agents to the fuel tank other than what Kia has specified or the equivalent. (Consult an Authorized Kia Dealer for details.)

Leaded fuel will damage the engine control system's oxygen sensor and affect the emission control system.

Gasoline containing alcohol and methanol

Ethanol (also known as grain alcohol) is a mixture of ethanol and gasoline marketed as gasohol. Do not use gasohol containing more than 10% ethanol.

Methanol (also known as wood alcohol) is a mixture of gasoline and methanol marketed as gasohol. Do not use gasoline or gasohol containing methanol.

Either of these fuels may cause driveability problems and damage to the fuel system.

Discontinue using gasohol of any kind if driveability problems occur.

Vehicle damage or driveability problems may not be covered by the manufacturer's warranty if they result from the use of:

- Gasohol containing more than 10% ethanol,
- Gasoline or gasohol containing methanol, or
- Leaded fuel or leaded gasohol

* NOTICE

Never use gasohol which contains methanol. Discontinue use of any gasohol product which impairs driveability.

EMISSION CONTROL SYSTEM

The vehicle emission control system is covered by a written limited warranty. Please see the warranty information contained in the Warranty and Consumer Information Manual in your vehicle.

Vehicle Modifications

This vehicle should not be modified. Modification of your Kia could affect its performance, safety or durability and may even violate governmental safety and emissions regulations.

In addition, damage or performance problems resulting from any modification may not be covered under warranty.

Engine Exhaust Gas Precautions (carbon monoxide)

Engine exhaust gases contain carbon monoxide. Though colorless and odorless, it is dangerous and could be lethal, if inhaled.

- Carbon monoxide can be present with other exhaust fumes. Therefore, if you smell exhaust fumes of any kind inside your vehicle, have it inspected and repaired immediately by an Authorized Kia Dealer. If at all possible, do not drive with exhaust fumes present. If you must, do so only with all windows fully open. Have your vehicle checked and repaired immediately.
- Do not operate the engine in confined or closed areas (such as garages) any more than what is necessary to move the vehicle in or out of the area.

- When the vehicle is stopped in an open area for more than a short time with the engine running, adjust the ventilation system to draw outside air into the vehicle. Turn the engine off if you smell any exhaust fumes.
- Never sit in a parked or stopped vehicle for an extended time with the engine running.

Operating Precautions for Catalytic Converters

Your vehicle is equipped with a catalytic converter emission control device.

Therefore, the following precautions must be observed:

- Use only UNLEADED FUEL.
- Do not park the vehicle over or near flammable objects, such as dry grass, paper, leaves, etc. Under certain conditions, they could be ignited by a hot exhaust system.
- Do not operate the vehicle when there are signs of engine malfunction, such as misfire or a noticeable loss of performance.
- Do not misuse or abuse the engine. Examples of misuse are coasting with the ignition off and descending steep grades in gear with the ignition off.
- Do not operate the engine at high idle speed for extended periods (5 minutes or more).

- Do not modify or tamper with any part of the engine or emission control system. All inspections and adjustments must be made by a qualified technician.

Failure to observe the above precautions could result in damage to the catalytic converter and to your vehicle and could void your warranties.

BEFORE DRIVING

Before entering vehicle:

- Be sure that all windows, outside mirror(s), and outside lights are clean.
- Check the condition of the tires.
- Check under the vehicle for any sign of leaks.
- Be sure there are no obstacles behind you if you intend to back up.

Necessary Inspections

Fluid levels, such as engine oil, engine coolant, brake/clutch fluid, and washer fluid should be checked on a regular basis, with the exact interval depending on the fluid. Further details are provided in Maintenance, Section 7.

Before Starting

- Close and lock all doors.
- Position the seat so that all controls are easily reached.
- Adjust the inside and outside rearview mirrors.
- Be sure that all lights work.
- Check all gauges.

- Check the operation of warning lights when the ignition switch is turned to the ON position.
- Release the parking brake and make sure the brake warning light goes out.

For safe operation, be sure you are familiar with your vehicle and its equipment.

Drunk Driving

Drinking and driving is dangerous. Drunk driving is the number one contributor to the highway death toll each year. Alcohol impairs a driver's judgment, vision and muscular coordination. Even a small amount of alcohol will affect a driver's reflexes, perceptions and judgment.

Please don't drink and drive, or ride with a driver who has been drinking. Choose a designated driver if you're with a group, or if you're alone, call a cab.

Drugs and Driving

Driving while under the influence of drugs is as dangerous or more dangerous than driving under the influence of alcohol, depending on the drug(s) used and the quantity consumed. Don't take drugs and drive.

If you are taking a prescription medicine, check with your doctor or pharmacist regarding whether you may operate a motor vehicle.

Suggestions for Economical Operation

Your vehicle's fuel economy is mainly dependent on your style of driving, how you drive, where you drive and when you drive.

Each of these factors has an effect on how many miles (kilometers) you can get from a gallon (liter) of fuel. To operate your vehicle as economically as possible, use the following driving suggestions to help save money in both fuel and repairs:

- Avoid lengthy warm-up idling. Once the engine is running smoothly, begin driving. Remember, though, that on cold days, engine warm-up may take a little longer.
- Save fuel by accelerating slowly after stopping.
- Keep the engine in tune and follow the recommended periodic maintenance schedule. This will increase the life of all parts and lower your operating costs.
- Do not use the air conditioner unnecessarily.
- Slow down when driving on rough roads.

- For longer tire life and better fuel economy, always keep the tires inflated to the recommended pressures.
- Maintain a safe distance from other vehicles to avoid sudden stops. This will reduce wear on brake linings and pads and save fuel because extra fuel is required to accelerate back to driving speed.
- Do not carry unnecessary weight in the vehicle.
- Do not rest your foot on the brake pedal while driving. This can cause needless wear, possible damage to the brakes, and poor fuel economy.
- Improper wheel alignment causes the tires to roll at excessive angles, which results in faster tire wear. It takes more power to overcome this improper alignment, which wastes fuel.
- Open windows at high speeds can reduce fuel economy.
- Crosswinds and headwinds reduce fuel economy. To help offset some of this loss, slow down when driving in these conditions.

Keeping a vehicle in good operating condition is important both for economy and safety. Therefore, have an Authorized Kia Dealer perform scheduled inspections and maintenance.

WARNING - Engine OFF Motion

Never turn the engine off to coast down hills or anytime the vehicle is in motion. The power steering and power brakes will not function without the engine running. Instead, downshift to any appropriate gear for engine braking effect.

SPECIAL DRIVING CONDITIONS

Hazardous Driving

When hazardous driving is encountered because of water, snow, ice, mud, sand, or similar hazard, follow these suggestions:

- Drive cautiously and allow extra distance for braking.
- Avoid sudden movements in braking or steering.
- When braking in vehicles without anti-lock brakes, depress the brake pedal with a controlled up-and-down motion until the vehicle is stopped.
- When starting from a stop in snow, mud, or sand, use second gear and accelerate slowly to avoid spinning the front wheels. Low gear may be used, if necessary.
- Use sand, rock salt, tire chains, or other non-slip material under the front wheels to provide traction when stalled on ice, snow, or mud.

WARNING - Downshifting

Downshifting into first gear with a manual transaxle or into low with an automatic transaxle while driving on slippery surfaces can cause an accident. The sudden change in tire speed could cause the tires to skid. Be careful when downshifting on slippery surfaces.

Rocking the Vehicle

If it is necessary to rock the vehicle to free it from snow, sand, or mud, move the shift lever of an automatic transaxle from D (Drive) to R (Reverse) in a repeat pattern while depressing the accelerator gently. With a manual transaxle, move the shift lever back and forth from 1 (First) to R (Reverse).

Do not race the engine. If you are still stuck after a couple minutes of rocking, have the vehicle pulled out by a tow vehicle to avoid engine overheating and possible damage to the transaxle.

* NOTICE

Prolonged rocking may cause engine overheating, transaxle damage or failure, and tire damage.

WARNING - Spinning Tires

Do not spin the wheels especially at speeds more than 35 mph (56 km/h). Spinning the wheels at high speeds when the vehicle is stationary could cause a tire to overheat, explode and injure bystanders.

Driving at Night

Because night driving presents many more hazards than driving in the daylight, here are some important tips to remember:

- Slow down and keep more distance between you and other vehicles as it may be more difficult to see at night, especially in rural areas where there may not be any street lights.
- Adjust your mirrors to reduce the glare from other driver's headlights.
- Keep your headlights clean and properly aimed. Dirty or misaimed headlights will make it much more difficult to see at night.
- Avoid staring directly at the headlights of oncoming vehicles. You could be temporarily blinded and it will take several seconds for your eyes to readjust to the darkness.

Driving in the Rain

Rain and wet roads can make driving dangerous, especially if you're not prepared for the slick pavement. Here are a few things to consider when driving in the rain:

- Be sure your windshield wipers are in good condition.
- A heavy rainfall will make it harder to see and will increase the distance needed to stop your vehicle, so slow down.
- If your tires aren't in good condition, making a quick stop on wet pavement can cause a skid and possibly lead to an accident. Be sure your tires and windshield wipers are in good shape.
- Turn on your headlights to make it easier for others to see you.
- Driving too fast through large puddles can affect your brakes. If you must go through puddles, try to drive through them slowly.
- If you believe you may have gotten your brakes wet, apply them lightly while driving until normal braking operation returns.

Winter Driving

- We recommend that you carry emergency equipment. Some things you might include are tire chains, a window scraper, windshield de-icer, a bag of sand or salt, flares, a small shovel and jumper cables.
- Make sure you have sufficient ethylene glycol coolant in the radiator.
- Check the battery condition and cables. Cold temperatures reduce the capacity of any battery, so it must be in top shape to provide enough winter starting power.
- Make sure the engine oil viscosity is suitable for cold weather.
- Check the ignition system for loose connections and damage.
- Use antifreeze-formulated windshield washer fluid and make sure you have sufficient fluid for your trip. (Do not use engine coolant antifreeze.)

- Do not use the parking brake if it might freeze. This is most likely to happen after driving in slushy or wet conditions and temperatures drop into the freezing range. When parking, shift to P (Park) with automatic transaxle, or to 1 (First) or R (Reverse) with a manual transaxle and block the rear wheels.

Snow tires

When snow tires are used, select the size and construction specified on the Tire Pressure Label. It is strongly recommended that snow tires be used on all four wheels, or poor handling may result. Snow tires should not be operated at speeds exceeding 75 mph (120 km/h).

These tires should be inflated 4 psi (28 kPa,

0.3 kg/cm²) above the recommended pressures shown on the Tire Specification/Pressure Label, but inflation should never exceed the maximum cold-tire pressure shown on the tire sidewalls.

⚠ WARNING - Snow Tire Size
Snow tires should be equivalent in size and type to the vehicle's standard tires. Otherwise, the safety and handling of your vehicle may be adversely affected.

Do not install studded tires without first checking local, state and municipal regulations for possible restrictions against their use.

Tire chains

Tire chain selection

Regulations regarding the use of tire chains vary according to location or type of road, so always check them before installing chains.

Use only SAE Class "S" tire chains. Chains must be the proper size for the vehicle, as recommended by the chain manufacturer.

Chain installation

When installing chains on your tires, carefully follow the instructions of the chain manufacturer.

The chain bands will scratch the wheel covers. Remove the covers before installing the chains.

⚠ WARNING - Tire Chains

- The use of chains may adversely affect vehicle handling.
- Do not exceed 30 mph (50 km/h) or the chain manufacturer's recommended speed limit, whichever is lower.
- Drive carefully and avoid bumps, holes, sharp turns and other road hazards, which may cause the vehicle to bounce.
- Avoid sharp turns or locked-wheel braking.
- Do not attempt to use a tire chain on the temporary spare tire because it may impair vehicle handling and result in damage to the vehicle and the tire.

Install the chains on the front tires as tightly as possible. The use of chains on the rear tires is not recommended. Retighten the chains after driving 1/4-1/2 mile (0.5-1.0 km).

Driving in Flooded Areas

Avoid driving through flooded areas unless you are sure the water is no higher than the bottom of the wheel rims. Drive through any water slowly. Allow adequate stopping distance because brake performance may be affected.

After driving through water, dry the brakes by gently applying them several times while the vehicle is moving slowly.

Trailer Towing

We do not recommend using this vehicle for trailer towing.

Overloading

CAUTION

The gross axle weight rating (GAWR) and the gross vehicle weight rating (GVWR) for your vehicle are on the manufacturer's label attached to the driver's door or are listed in the "Specifications" section of this Owner's Manual. Exceeding these ratings can cause an accident or vehicle damage. You can calculate the weight of your load by weighing the items (or people) before putting them in the vehicle. Be careful not to overload your vehicle.

Label Information

There are several important labels and identification numbers located on your vehicle. The label locations are identified in the illustrations on the following pages.

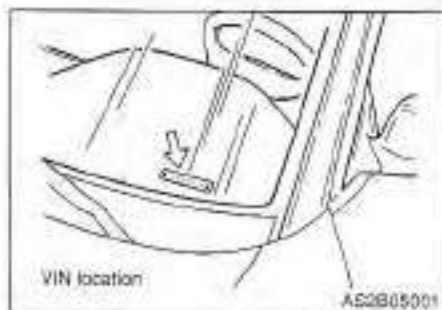

Vehicle Identification Number (VIN)

This is the legal identifier for your vehicle. It appears on a plate attached to the left side of the forward portion of the instrument panel. The VIN plate can easily be seen from the outside of the vehicle through the windshield on the driver's side.

The VIN also appears on the vehicle's certification label which is attached to the driver's door jamb and is stamped into the center of the engine compartment bulkhead, the engine cylinder block and the cover of transaxle.

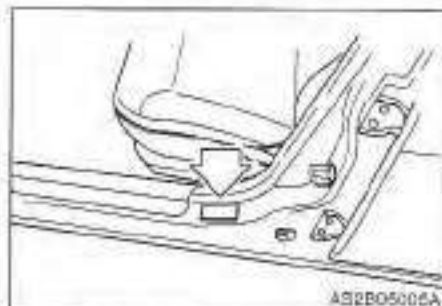

Vehicle Certification Label

DRIVING TIPS

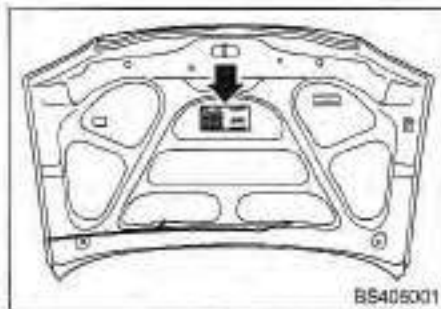

Vehicle Emission Control
Information and Vacuum Hose
Routing Diagram

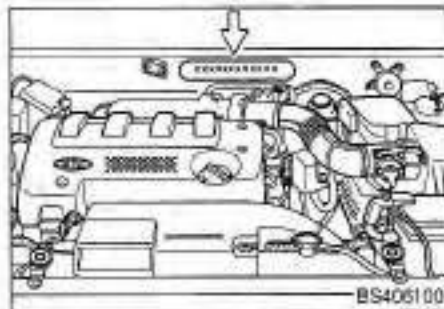

Chassis number

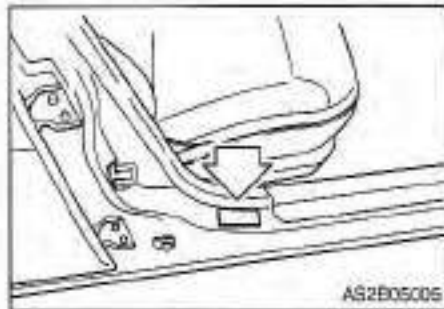

Tire specification/pressure label

IN CASE OF AN EMERGENCY

6

Road Warning	6-2
Overheating	6-3
Emergency Starting	6-4
Electrical Circuit Protection	6-7
Towing	6-12
If You Have a Flat Tire	6-14

ROAD WARNING

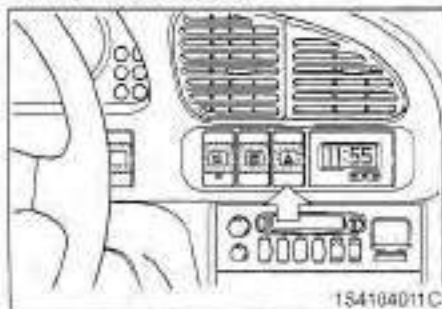

Hazard Warning Flasher

The hazard warning flasher serves as a warning to other drivers to exercise extreme caution when approaching, overtaking, or passing your vehicle. It should be used whenever emergency repairs are being made or when the vehicle is stopped near the edge of a roadway.

Depress the flasher switch with the ignition switch in any position. The flasher switch is located in the center console just below the center vents. All turn signal lights will flash simultaneously.

- *The hazard warning flasher will operate whether your vehicle is running or not.*
- *The turn signals do not operate when the hazard flasher is on.*
- *Care must be taken when using the hazard warning flasher while the vehicle is being towed. Local regulations may prohibit using it in this manner.*

Overheating

If your temperature gauge indicates overheating, if you experience a loss of power, or if you hear a loud knocking or pinging noise, the engine has probably overheated. You should follow these procedures if you experience any of these symptoms.

1. Turn the hazard warning flasher on, then drive to the nearest safe location and stop your vehicle; set the automatic transaxle in P (Park), or shift the manual transaxle to neutral and apply the parking brake.
2. Make sure the air conditioner is off.
3. If coolant or steam is boiling out of the radiator, stop the engine, then turn the ignition switch to the ON position. Do not restart the engine. The radiator cooling fan will automatically operate with the ignition switch in the ON position. If the cooling fan does not operate, call an Authorized Kia Dealer for assistance.

If coolant is not boiling out, allow the engine to idle and open the hood to permit the engine to cool gradually.

If the temperature does not go down with the engine idling, stop the engine and allow sufficient time for it to cool.

4. The coolant level should then be checked. If the level in the reservoir is low, look for leaks at the radiator hoses and connections, heater hoses and connections, radiator, and water pump. If you find a major leak or another problem that may have caused the engine to overheat, do not operate the engine until the problem has been corrected. Call an Authorized Kia Dealer for assistance. If you do not find a leak or other problem, carefully add coolant to the reservoir.

WARNING - Removing Radiator Cap

Do not remove the radiator cap when the engine and radiator are hot. Scalding hot coolant and steam may blow out under pressure. This could cause serious injury.

If the engine frequently overheats, have the cooling system checked and repaired.

EMERGENCY STARTING

Jump Starting

Jump starting can be dangerous if done incorrectly. Therefore, to avoid harm to yourself or damage to your vehicle or battery, follow the jump starting procedures on the next page. If in doubt, we strongly recommend that you have a competent technician or towing service jump start your vehicle.

* NOTICE

Use only a 12-volt jumper system. You can damage a 12-volt starting motor, ignition system, and other electrical parts by using a 24-volt power supply (two 12-volt batteries in series or a 24-volt motor generator set).

WARNING - Battery

- Keep all flames or sparks away from the battery. The battery produces hydrogen gas which may explode if exposed to flame or sparks.
- Do not attempt to jump start vehicle if the discharged battery is frozen or if the electrolyte level is low; the battery may rupture or explode.

Jump starting procedure

1. Make sure the booster battery is 12 volts and that its negative terminal is grounded.
2. Check the electrolyte level of each of the battery cells.
3. If the booster battery is in another vehicle, do not allow the vehicles to touch.

IN CASE OF AN EMERGENCY

CONNECTING JUMPER CABLES

Connect cables in numerical order and disconnect in reverse order.

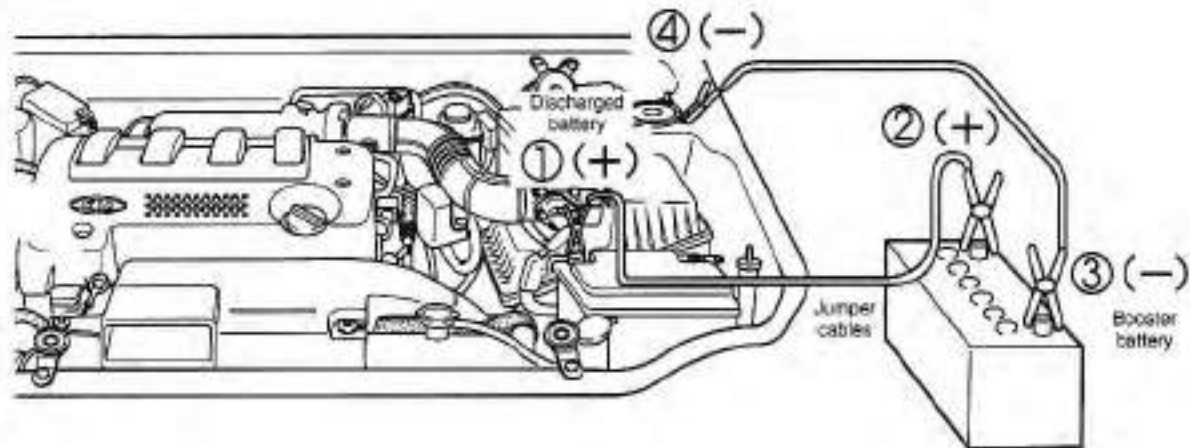

ES4060C2

4. Turn off all unnecessary electrical loads.
5. Connect the jumper cables in the exact sequence shown in the illustration on the previous page. First, connect one end of a jumper cable to the positive terminal (+) of the discharged battery ①, then the other end of the same cable to the positive terminal (+) on the booster battery ②. Next, connect one end of the other jumper cable to the negative terminal (-) of the booster battery ③, then the other end to a solid, stationary, metallic point (for example, the engine lifting bracket) ④ away from the battery. Do not connect the jumper cable to or near any part that moves when the engine is cranked. Do not connect the jumper cable from the negative terminal (-) of the booster battery to the negative terminal (-) of the discharged battery. Do not allow the jumper cables to contact anything except the correct battery terminals or the correct ground. Do not lean over the battery when making connections.

6. Start the engine of the vehicle with the booster battery and run it at 2,000 rpm. Then, start the engine of the vehicle with the discharged battery.

If the cause of your battery discharging is not apparent (for example, having left the lights on accidentally), you should have your vehicle checked by an Authorized Kia Dealer.

Push-Starting

A vehicle equipped with an automatic transaxle cannot be started by pushing. A vehicle equipped with a manual transaxle should not be push-started because it could damage the emission control system. Follow the directions for jump starting.

CAUTION

Never tow a vehicle to start it. A sudden surge forward when the engine starts could cause a collision with the tow vehicle.

ELECTRICAL CIRCUIT PROTECTION.

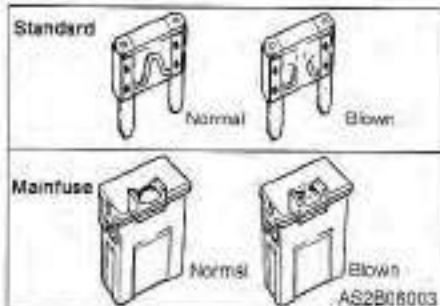

Fuses

A vehicle's electrical system is protected from electrical overload damage by fuses.

This vehicle has two fuse panels, one located in the driver's side kick panel, the other in the engine compartment near the battery. A fuse panel chart is provided later in this section.

If any of your vehicle's lights, accessories, or controls do not work, check the appropriate circuit fuse. If a fuse has blown, the element inside the fuse will be melted.

Always replace a blown fuse with one of the same rating.

If the replacement fuse blows out, this indicates an electrical problem. Avoid using the system involved and immediately consult an Authorized Kia Dealer.

Two kinds of fuses are used: standard for lower amperage rating, and main for higher amperage ratings.

IN CASE OF AN EMERGENCY

Fuse Panel Description

Driver-side kick panel

	TURN LAMP 10A	METER 10A	TCU (IG 1) 10A
	(ABS) 10A	(AIR BAG) 10A	FRONT WIPER 20A
	AUDIO 10A	CIGAR LIGHTER 15A	(SEAT WARM) 15A
	ECU B+ 10A	STOP LAMP 15A	

• USE THE DESIGNATED FUSE SIZE ONLY.
 • REFER TO OWNER'S MANUAL FOR FUSE SERVICE
 • () : OPTION

DESCRIPTION	FUSE RATING	PROTECTED COMPONENT
ECU B+	10 A	ECU, ECAT, Shift lock, Data link connector, Check connector
AUDIO	10 A	Audio, Auto clock, ETWIS
ABS	10 A	ABS
TURN LAMP	10 A	Turn lamp
STOP LAMP	10 A	Stop light
CIGAR LIGHTER	15 A	Cigar lighter
A/R BAG	10 A	Airbag
METER	10 A	Meter, Inhibitor S/W, Speed sensor, Back-up light, ETWIS
SEAT WARM	15 A	Seat warmer
FRONT WIPER	20 A	Front wiper & Washer
TCU IG 1	10 A	ECAT, DRL

IN CASE OF AN EMERGENCY

Engine compartment

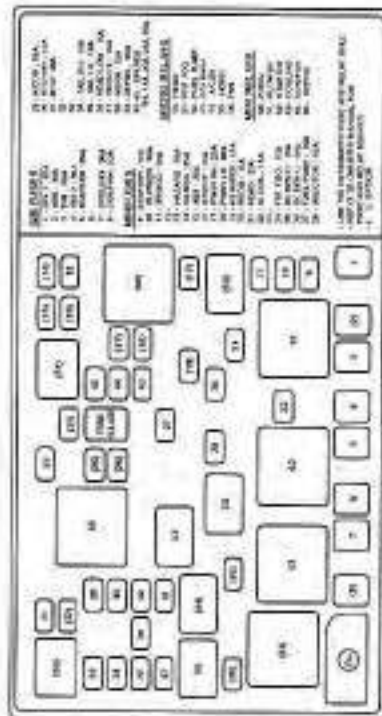

1. IGN 1	30 A	Ignition S/W (IG1, ACC)
2. ABS	30 A	ABS
3. TNS	30 A	TNS relay
4. IGN 2	30 A	Ignition S/W (IG2, ST)
5. STARTER	20 A	Starter
6.	-	-
7. COOLING	30 A	Cooling fan
8. CONDAN	20 A	Condenser fan
9. STARTER	10 A	Starter, ECU, ECAT, Cruise control
10. BLOWER	30 A	Blower relay
11. SPVACC	15 A	Smoke SW, ACS, DRL, Cruise control
12.	-	-
13. HAZARD	15 A	Hazard switch
14. CLOCK	25 A	Door lock, Power window
15. ABS	30 A	ABS
16. S'ROOF	15 A	Sunroof
17. PWIN RH	25 A	Power window RH
18. PWIN LH	30 A	Power window LH
19. RR WIPER	15 A	Rear wiper & Washer
20. ROOM	10 A	Room lamp, ETMS, Audio, Auto dock
21. HEAD	25 A	Headlight, Generator
22. IG COIL	15 A	IG1, IG coil, Data link connector, Check connector
23.	-	-
24. FRT FOG	15 A	Front fog lamp
25. CX SEN D	10 A	O2 Sensor down
26. CX SEN U	10 A	O2 Sensor up
27. FUEL PUMP	10 A	Fuel pump
28. INJECTOR	10 A	Injector, ECU, Fuel pump relay
29. ACCN	10 A	ACCN relay (magnet clutch)
30. HTO MIR	10 A	Outside rearview mirror heater
31. BTN	30 A	Stop, ECU B+ Fuse
32.	-	-
33.	-	-
34. TAIL RH	10 A	ECU, Position lamp RH, Tail lamp RH, License light
35. TAIL LH	10 A	Position lamp LH, Tail lamp LH, Illumination lamp
36. HEAD LOW	15 A	Headlight low
37. HEAD HI	15 A	Headlight HI
38. HORN	15 A	Horn
39. DEFOG	30 A	Rear defroster

IN CASE OF AN EMERGENCY

TOWING

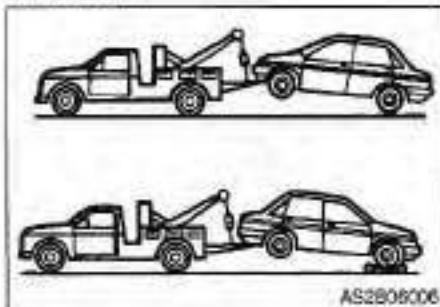

If emergency towing is necessary, we recommend having it done by an Authorized Kia Dealer or a competent tow-truck service. Proper lifting and towing procedures are necessary to prevent damage to the vehicle. State and local laws applicable to towing vehicles must be followed.

As a general rule, towed vehicles should be pulled with the driving wheels off the ground. If excessive damage or other conditions prevent towing the vehicle with the driving wheels off the ground, use wheel dollies.

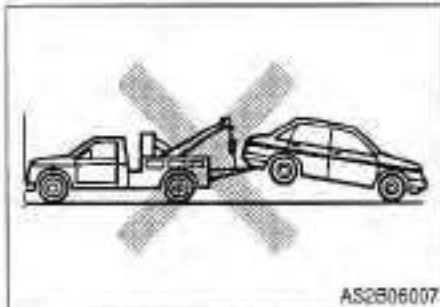

With either an automatic or manual transaxle:

1. Set the ignition switch in the ACC position;
2. Place the shift lever in N (Neutral);
3. Release the parking brake.

* NOTICE

Do not tow the vehicle backward with the front wheels on the ground. This may cause internal damage to the transaxle.

* NOTICE

Do not tow with sling-type equipment. Use wheel lift or flatbed equipment.

⚠ CAUTION

Do not use the hooks under the front or rear of the vehicle for towing purposes. These hooks are designed ONLY for transport tie-down. If the tie-down hooks are used for towing, the front/rear bumper will be damaged and the vehicle may break free from the tow vehicle.

4 Door Coupe



BS406004



BLK06001

Tie-Down hooks (for flatbed towing)

IF YOU HAVE A FLAT TIRE

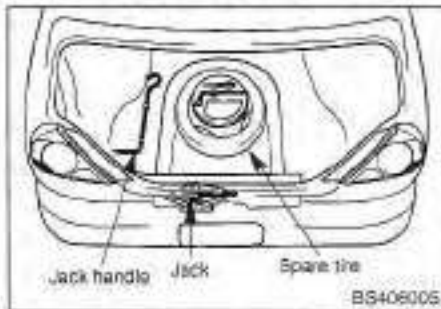

Storing the Spare Tire, Jack and Tools

The spare tire, tool bag, jack and jack handle are stored in the trunk compartment. Move the carpeting out of the way to reach this equipment.

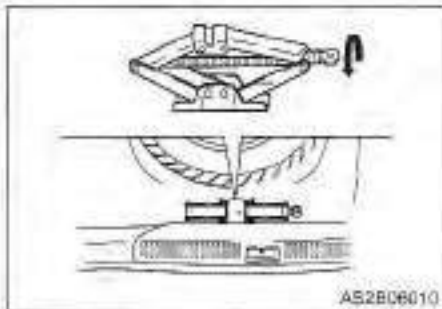

To Remove The Jack:

Turn the jack socket counterclockwise.



To Remove Spare Tire:

Remove the cover from the spare tire. Turn the tire hold-down wing bolt counterclockwise.

Store the jack and tire in the reverse order of removal.

To prevent the jack, jack handle, and tool bag from "rattling" while the vehicle is in motion, store them properly.

Important - Use of compact spare tire

your vehicle is equipped with a compact spare tire, this compact spare tire takes up less space than a regular-size tire. This tire is smaller than a conventional tire and is designed for temporary use only.

CAUTION

- *You should drive carefully when the compact spare is in use. The compact spare should be replaced by the proper conventional tire and rim at the first opportunity.*
- *The operation of this vehicle is not recommended with more than one compact spare tire in use at the same time.*

CAUTION

This spare tire should be used only for VERY short distances. Compact spares should NEVER be used for long drives or extended distances.

* NOTICE

Check the inflation pressure after installing the spare tire. Adjust it to the specified pressure, as necessary.

When using a compact spare tire, observe the following precautions:

- Under no circumstances should you exceed 50 mph (80 km/h); a higher speed could damage the tire.
- Ensure that you drive slowly enough for the road conditions to avoid all hazards. Any road hazard, such as a pothole or debris, could seriously damage the compact spare.
- Any continuous road use of this tire could result in tire failure, loss of vehicle control, and possible personal injury.
- Do not exceed the vehicle's maximum load rating or the load-carrying capacity shown on the sidewall of the compact spare tire.
- Avoid driving over obstacles. The compact spare tire diameter is smaller than the diameter of a conventional tire and reduces the ground clearance approximately 1 in. (25 mm), which could result in damage to the vehicle.
- Do not take this vehicle through an automatic car wash.
- Do not use tire chains on this tire. Because of the smaller size, a tire chain will not fit properly. This could damage the vehicle and result in loss of the chain.
- This tire should not be installed on the front axle if the vehicle must be driven in snow or on ice.
- Do not use the compact spare tire on any other vehicle because this tire has been designed especially for your vehicle.
- The compact spare's tread life is shorter than a regular tire. Inspect your compact spare tire regularly and replace worn compact spare tires with the same size and design, mounted on the same wheel.

Changing Tires

Jacking Instructions

The jack is provided for emergency tire changing only.

Follow jacking instructions to reduce the possibility of personal injury.

⚠ WARNING - Changing Tires

- Never attempt vehicle repairs or a tire change in the traffic lanes of a public road or highway. Always move the vehicle completely off the road and onto the shoulder before trying to change a tire. If you cannot find a firm, level place off the road, call a towing service company for assistance.
- Do not exceed the maximum permissible load of the jack: 1,320 lbs. (600 kg).
- Be sure to use the correct front or rear jacking positions on the vehicle; never use the bumpers or any other part of the vehicle for jack support.

- Never allow any portion of your body to get beneath the vehicle while using the jack.
- Do not start or run the engine while the vehicle is supported by the jack.

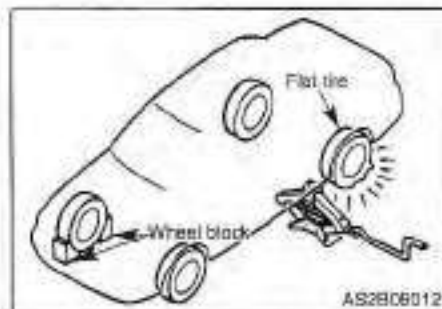

Tire replacement

1. Park on a level surface and set the parking brake firmly.
2. Set the automatic transaxle in P (Park), or shift the manual transaxle into R (Reverse).
3. Activate the hazard warning flasher.
4. Remove the wheel lug nut wrench, jack, jack handle, and spare tire from the vehicle.
5. Block both the front and rear of the wheel that is diagonally opposite the jack position.

⚠ WARNING - Changing a Front Tire

When one front wheel is lifted off the ground, neither the automatic transaxle P (Park) position nor the manual transaxle R (Reverse) position will prevent the vehicle from moving and possibly slipping off the jack, even if these positions are properly engaged. To prevent vehicle movements while changing a tire, always set the parking brake fully, and always block the wheel diagonally opposite the wheel being changed.

- For models with alloy wheels, remove the center cap.
- Loosen the four lug nuts counterclockwise one turn each, but do not remove any nut until the tire has been raised off the ground.

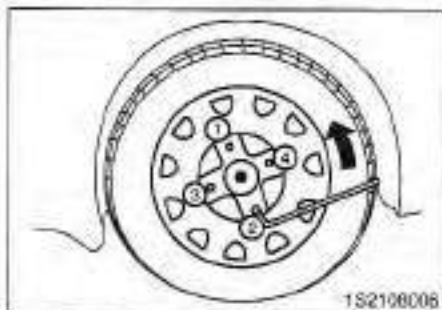

- Place the jack at the front or rear jacking position closest to the tire you are changing. Place the jack under the side sill at the designated location.

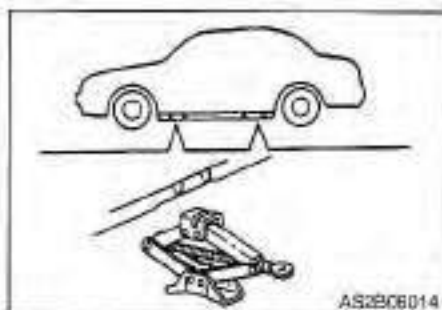

⚠ WARNING - Jack Location
To reduce the possibility of injury, be sure to use only the jack provided with the vehicle and in the correct jack position; never use any other part of the vehicle for jack support.

IN CASE OF AN EMERGENCY

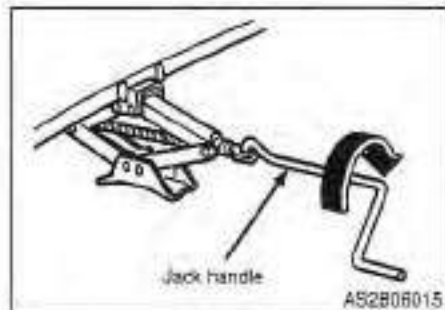

9. Insert the jack handle into the jack and turn it clockwise, raising the vehicle until the tire just clears the ground, approximately 1.2 in. (30 mm). Before removing the lug nuts, make sure the vehicle is stable and that there is no chance for it to slip or move.

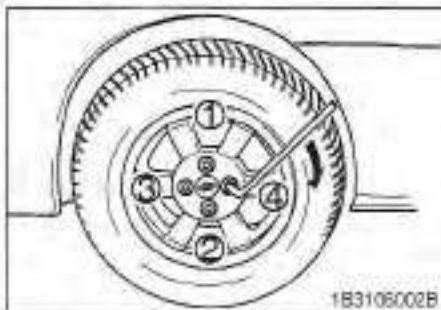

10. Remove the lug nuts by turning them counterclockwise, then remove the wheel.
11. Mount the spare tire into position and tighten the nuts by hand. Install the lug nuts with the beveled edge inward.
12. Turn the jack handle counterclockwise and lower the vehicle until it touches the ground. Tighten the lug nuts firmly in an "X" pattern.

Once the lug nuts have been tightened, lower the vehicle fully to the ground and continue to tighten the lug nuts until they are completely secured.

If you are unsure of the tightness of the wheel lug nuts, have them checked at the nearest service station. The specified tightening torque is 103 N.m. (76 ft. lb).

CAUTION

Your vehicle has metric threads on the wheel studs and nuts. During wheel removal, make certain that the same nuts removed are reinstalled - or, if replaced, that nuts with metric threads and the same configuration are used. Installation of a non-metric thread nut on a metric stud or vice-versa will not secure the wheel to the hub properly and will damage the stud so that it must be replaced. Note that most U.S. lug nuts do not have metric threads. Be sure to use extreme care in checking for thread style before installing aftermarket lug nuts or wheels. If in doubt, consult an Authorized Kia Dealer. Damaged studs may result in wheel loss and personal injury.

WARNING - Wheel Studs

If the studs are damaged, they may lose their ability to retain the wheel. This could lead to the loss of the wheel and a collision.

*** NOTICE**

Check the inflation pressures as soon as possible after installing the spare tire. Adjust it to the specified pressure, if necessary.

To prevent the jack, jack handle, wheel lug nut, wrench and spare tire from rattling while the vehicle is in motion, store them properly.

Maintenance Services.....	7-2
Maintenance Schedule.....	7-4
Owner Maintenance.....	7-8
Engine Compartment.....	7-10
Engine Oil and Oil Filter.....	7-11
Engine Cooling System.....	7-13
Brakes and Clutch.....	7-16
Parking Brake.....	7-17
Power Steering.....	7-18
Automatic Transaxle.....	7-19
Lubricants and Fluids.....	7-21
Air Cleaner.....	7-22
Wiper Blades.....	7-23
Battery.....	7-25
Tires and Wheels.....	7-27
Bulb Replacement.....	7-33
Lubricant Specifications.....	7-45
Exterior Care.....	7-47
Interior Care.....	7-50

MAINTENANCE SERVICES

You should exercise the utmost care to prevent damage to your vehicle and/or injury to yourself whenever performing any maintenance or inspection procedures.

Should you have any doubts concerning the inspection or servicing of your vehicle, we strongly recommend that you have an Authorized Kia Dealer perform this work.

An Authorized Kia Dealer has factory-trained technicians and genuine Kia parts to service your vehicle properly. For expert advice and quality service, see an Authorized Kia Dealer.

Inadequate, incomplete or insufficient servicing may result in operational problems with your vehicle that could lead to vehicle damage, an accident or personal injury.

Owner's Responsibility

Maintenance service and record retention are the owner's responsibility.

You should retain documents to show that proper maintenance has been performed on your vehicle in accordance with the scheduled maintenance service charts shown on the following pages. You need this information to be able to establish your compliance with the servicing and maintenance requirements of your Kia warranties.

Detailed warranty information is provided in your Warranty and Consumer Information Manual. Repairs and adjustments required as a result of improper maintenance or a lack of required maintenance are not covered.

We recommend that such maintenance be performed by an Authorized Kia Dealer using genuine Kia parts. However, such maintenance may be performed by any competent automotive repair establishment using automotive parts equivalent to those with which your vehicle or engine was originally equipped.

Whenever we recommend that you have service or maintenance performed by an Authorized Kia Dealer, you may have a competent automotive repair establishment using proper parts perform that work as well.

Scheduled Maintenance Service

*After 60 months or 96,000 miles
(60,000 km) continue to follow the
prescribed maintenance intervals.*

MAINTENANCE

MAINTENANCE SCHEDULE

Engine Control system

MAINTENANCE INTERVALS MAINTENANCE ITEM	Kilometers or Time in Months, Whichever Comes First																	
	Months	6	12	18	24	30	36	42	48	54	60	66	72	78	84	90	96	
	km x 1,000	12	24	36	48	60	72	84	96	108	120	132	144	156	168	180	192	
Engine oil & Engine oil filter (1)	change every 6,000 km or 3 months, whichever comes first																	
Drive belt (tension)																		
Cooling system hoses & connections																		
Engine coolant (1)				R				R				R				R		
Fuel filter							R						R					
Fuel tank cap, lines and hoses																		
Air cleaner element (2)				R				R				R				R		
Ignition wires																		
Spark plugs				R				R				R					R	

I : Inspect these items and their related parts. If necessary, correct, clean, refill, adjust or replace.

R : Replace or change.

NOTE

Check the engine oil and coolant levels every week.

MAINTENANCE

MAINTENANCE SCHEDULE

Engine Control system (cont.)

MAINTENANCE INTERVALS MAINTENANCE ITEM	Kilometers or Time in Months, Whichever Comes First																	
	Months	6	12	18	24	30	36	42	48	54	60	66	72	78	84	90	96	
	km x 1,000	12	24	36	48	60	72	84	96	108	120	132	144	156	168	180	192	
Idle speed		I		I		I		I		I		I		I		I		I
Evaporative emission canister & vapour lines						I					I						I	
PCV valve							I					I						
Engine timing belt	Replace every 102,000 km																	

I : Inspect these items and their related parts. If necessary, correct, clean, refill, adjust or replace.

R : Replace or charge.

(1) Refer to the lubricant and coolant specifications in the Owner's Manual.

(2) More frequent maintenance is required if driving under dusty conditions.

OWNER MAINTENANCE

Owner Maintenance Schedule

A qualified service technician should perform these vehicle inspections at the indicated intervals to ensure safe and dependable operation.

Bring any problem to the attention of an Authorized Kia Dealer as soon as possible.

When refueling, check:

- Engine oil level
- Engine coolant level

CAUTION

Be careful when checking your engine coolant level. The engine compartment will be hot and you could be burned.

- Brake and clutch fluid level
- Washer fluid level

At least monthly

- Tire inflation pressures

Every 6 months, check:

- Power steering fluid level
 - Automatic transaxle fluid level
- You can do the following scheduled maintenance items if you have some mechanical ability, a few basic tools and if you closely follow the directions in this manual.

Owner Maintenance Precautions

Improper or incomplete service may result in problems. This section gives instructions only for the maintenance items that are easy to perform.

WARNING - Maintenance Work

Performing maintenance work on a vehicle can be dangerous. You can be seriously injured while performing some maintenance procedures. If you lack sufficient knowledge, experience or the proper tools and equipment to do the work, have it done by a qualified technician.

As explained earlier in this section, several procedures can be done only by a qualified service technician with special tools.

Improper owner maintenance during the warranty period may affect warranty coverage. For details, read the separate Kia Warranty and Consumer Information Manual provided with the vehicle. If you're unsure about any servicing or maintenance procedure, have it done by an Authorized Kia Dealer.

⚠ WARNING - Loose Clothing/Jewelry

Working under the hood with the engine running is dangerous. It is even more dangerous when you wear jewelry, long hair or loose clothing. These can become entangled in moving parts and result in injury. Therefore, if you must run the engine while working under the hood, make certain that you pull hair back, remove all jewelry (especially rings, bracelets, watches, and necklaces) and all neckties, scarves, and similar loose clothing before getting near the engine or cooling fans.

⚠ WARNING - Engine Cooling Fans

Because your engine cooling fans are electrically controlled, they will run if the ignition switch is on, even if the engine is not running. This could cause serious injury. To prevent this, be sure the ignition is off, unless you must run the engine while performing maintenance or an inspection.

ENGINE COMPARTMENT

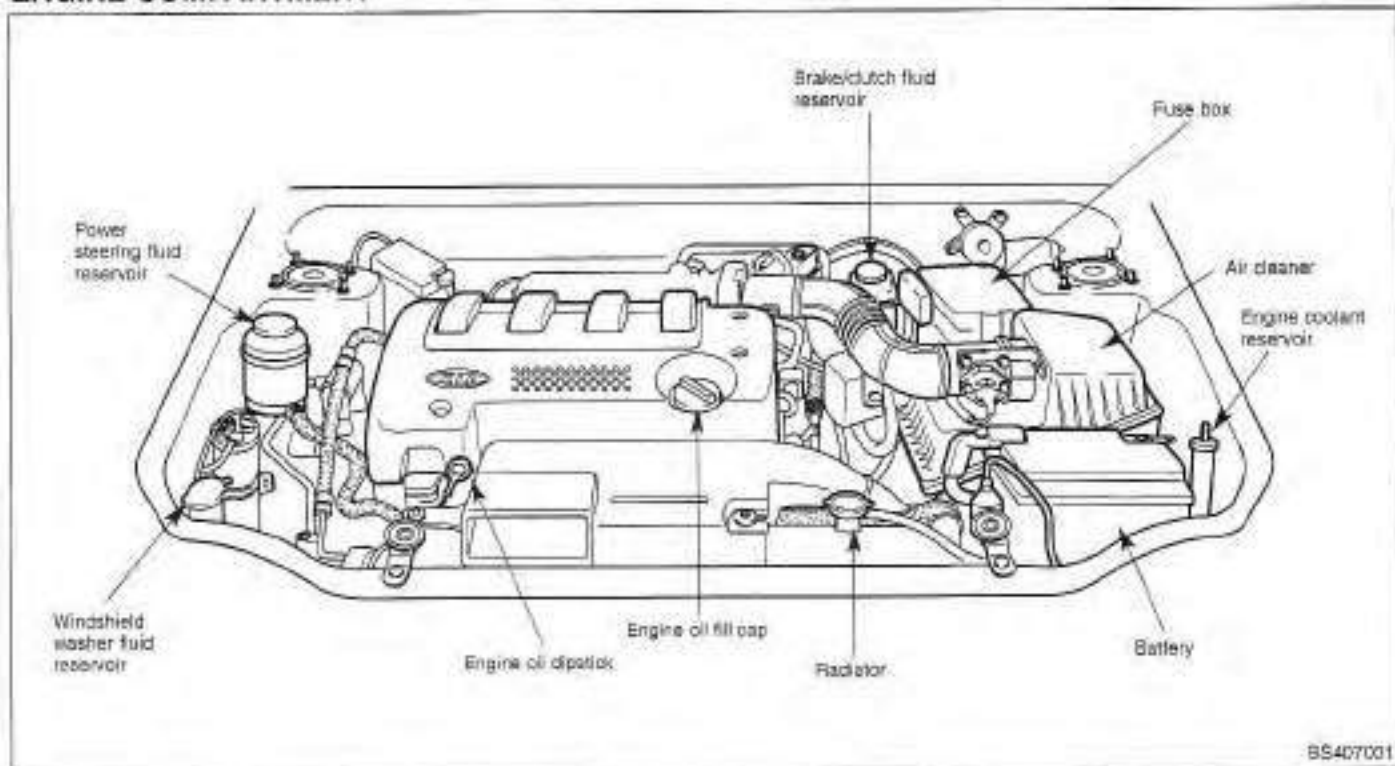

ENGINE OIL AND OIL FILTER

Checking the Engine Oil Level

1. Be sure the vehicle is on level ground.
2. Start the engine and allow it to reach normal operating temperature.
3. Turn the engine off and wait a few minutes for the oil to return to the oil pan.
4. Pull out the dipstick, wipe it clean, and re-insert it fully.
5. Pull the dipstick out again and check the level. The level should be between F and L.

If it is near or at L, add enough oil to bring the level to F. **Do not overfill.**

The distance between L and F on the dipstick represents 0.7 liter (0.85 US qt.).

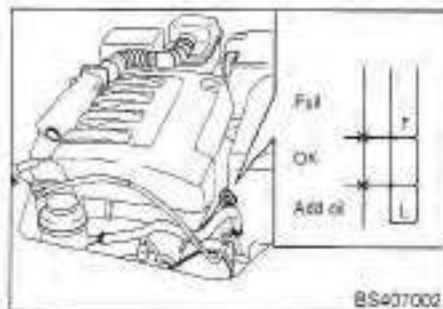

Use only the specified engine oil. (Refer to "Recommended Lubricants" in the index.)

Changing the Engine Oil and Filter

Change engine oil and filter according to the Scheduled Maintenance earlier in this section.

⚠ WARNING - Engine Oil

- Continuous contact with **USED** engine oil has caused skin cancer in laboratory mice. Protect your skin by washing with soap and water.
- Keep all engine oil out of the reach of children.

1. Warm the engine up for a few minutes and then turn it off. Remove the oil filler cap.
2. Drain the oil into a suitable container after removing the oil filler cap and drain plug.

⚠ CAUTION

Both the oil and engine are hot. Do not burn yourself.

3. Remove the engine oil filter with an oil filter wrench.

* NOTICE

When installing the replacement oil filter, do not allow the oil filter gasket to remain on the oil filter mounting surface. This will cause oil leakage and engine damage. Remove the old gasket completely so that a new gasket will properly seat and seal.

4. Use a clean rag to clean the oil filter mounting surface on the engine.
5. Apply a small amount of engine oil to the new oil filter O-ring seal.
6. Install the oil filter and tighten it. (Refer to the oil filter caution label for tightening instructions.)
7. Replace the drain plug tightly after the oil has thoroughly drained.
8. Refill the engine with new oil to the F mark on the dipstick. **Do not overfill.**
9. Re-install the oil filler cap securely.

10. Start the engine and inspect around the oil filter seal for leaks. Stop the engine. Check the oil level and fill to the F mark, if necessary.

Oil capacity

Use only the specified engine oil. (Refer to "Recommended Lubricants" in the Index.)

* NOTICE

- Follow these instructions carefully. An improper oil filter installation can cause oil leakage and engine damage.
- Although oil filters may have the same external appearance, their internal designs differ significantly. These filters are not interchangeable. To avoid potential engine damage, use only the specified filter. Consult an Authorized Kia Dealer.

ENGINE COOLING SYSTEM

The cooling system is a high-pressure type with a reservoir and is filled with year-round antifreeze coolant at the factory.

Check the antifreeze protection and coolant level at least once a year, at the beginning of the winter season, and before traveling to a colder climate.

Checking the Coolant Level

WARNING - Removing Radiator Cap

- Never attempt to remove the radiator cap while the engine is operating. Doing so might lead to cooling system and/or engine damage and could result in serious personal injury from escaping hot coolant or steam.

Turn the engine off and wait until it has cooled. Even then, use extreme care when removing the radiator cap. Wrap a thick towel around it, and turn it counterclockwise slowly to the first stop. Step back while the pressure is released from the cooling system. When you are sure all the pressure has been released, press down on the cap, using a thick towel, and continue turning counterclockwise to remove it.

- Even if the engine is not operating, do not remove the radiator cap or the drain plug while the engine and radiator are hot. Hot coolant and steam may still blow out under pressure, causing serious injury.

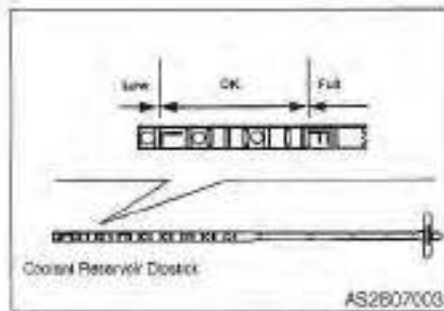

Check the condition and connections of all cooling system hoses and heater hoses. Replace any swollen or deteriorated hoses.

The coolant level should be full in the radiator

and between F (Full) and L (Low) on the coolant reservoir dipstick when the engine is cool.

Check the coolant level using the dipstick attached to the reservoir cap.

If the coolant level is low, add enough specified coolant to provide protection against freezing and corrosion and to bring the level to F in the coolant reservoir. Do not overfill. If frequent additions are required, see an Authorized Kia Dealer for a cooling system inspection.

Changing Coolant

Change coolant according to the Scheduled Maintenance.

- Use only soft (de-mineralized) water in the coolant mixture.
- The engine in your vehicle has aluminum engine parts and must be protected by an ethylene glycol-based coolant to prevent corrosion and freezing.
- DO NOT USE alcohol or methanol coolant and do not mix them with the specified coolant.
- Do not use a solution that contains more than 60 percent coolant, which would reduce the effectiveness of the solution.

For mixture percentages, refer to the following table:

PROTECTION	Mixture Percentage (volume)	
	Coolant Solution	Water
Above 3°F (-16°C)	35	65
Above -15°F (-26°C)	45	55
Above -40°F (-40°C)	55	45

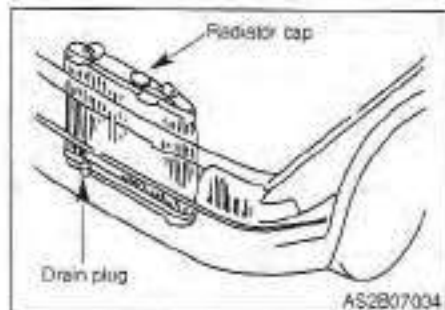

1. Turn the radiator cap counterclockwise and remove it.
2. Loosen the radiator drain plug and drain the coolant into a suitable container.
3. With the drain plug loose, flush the system with running water.
4. Drain the system completely and retighten the drain plug. Add the necessary amount of ethylene glycol-based coolant and water to provide the required protection against freezing and corrosion. In extremely cold climates, add the necessary amount of ethylene glycol-based coolant in accordance with the instructions of the coolant manufacturer.
5. Run the engine at idle with the radiator cap off. Slowly add additional coolant if necessary.
6. At this point, wait until the engine reaches normal operating temperature. Depress the accelerator two or three times; then add coolant if required. **Be careful not to burn yourself.**
7. Install the radiator cap. Inspect all connections for leaks and recheck the coolant level in the reservoir. Recheck again after a few days of driving and add coolant as necessary.

BRAKES AND CLUTCH

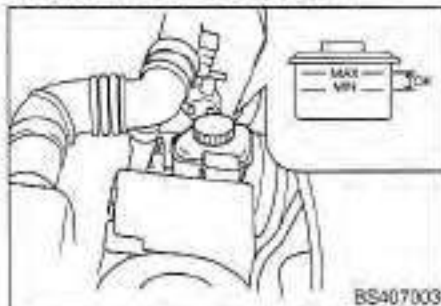

Checking Brake/Clutch Fluid Level

Brake fluid reservoir

Before adding fluid, thoroughly clean the area around the reservoir cap to prevent brake fluid contamination.

If you add brake/clutch fluid, fill the brake/clutch fluid reservoir to the MAX line. The brake/clutch fluid level will drop with accumulated mileage. This is a normal condition associated with brake/clutch lining wear.

Check the fluid level in the reservoir periodically; it should be between MAX and MIN on the side of the reservoir.

If the fluid level is excessively low, have the brake/clutch system checked by an Authorized Kia Dealer.

Use only the specified brake/clutch fluid. (Refer to "Recommended Lubricants" later in this section.)

Do not mix different types of fluid.

* NOTICE

In the event the brake/clutch system requires frequent additions of fluid, the vehicle should be inspected by an Authorized Kia Dealer.

PARKING BRAKE

Checking the Parking Brake

Check the stroke of the parking brake by counting the number of "clicks" heard while fully applying it from the released position. Also, the parking brake alone should securely hold the vehicle on a fairly steep grade.

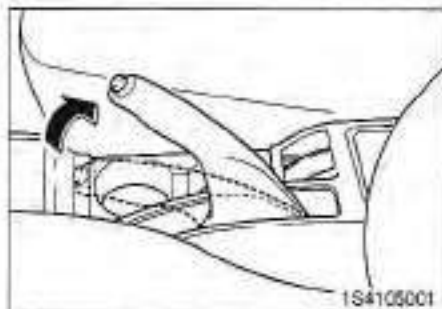

If the number of "clicks" is more or less than specified, have the parking brake adjusted by an Authorized Kia Dealer.

Stroke:

5-9 "clicks" at a force of 98N (22 lbs.).

POWER STEERING

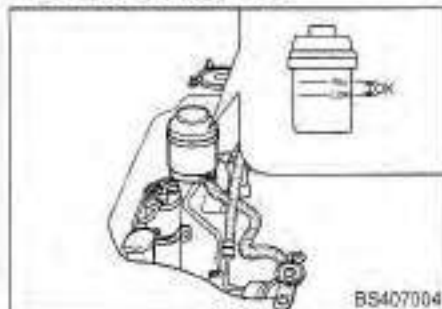

Checking the Power Steering Fluid Level

The power steering fluid level should be checked periodically.

With the engine off and the vehicle on level ground, check the fluid level in the power steering reservoir; it should be between the FULL and LOW reservoir indicators.

Before adding power steering fluid, thoroughly clean the area around the reservoir cap to prevent power steering fluid contamination.

If the level is low, add fluid to the FULL level.

In the event the power steering system requires frequent addition of fluid, the vehicle should be inspected by an Authorized Kia Dealer.

* NOTICE

To avoid damage to the power steering pump, do not operate the vehicle for prolonged periods with a low power steering fluid level.

Use only the specified power steering fluid. (Refer to "Recommended Lubricants" later in this section.)

MANUAL TRANSAXLE



Checking the Manual Transaxle Oil Level

1. Raise and suitably support the vehicle.
2. Remove the fill/check plug on the side of the transaxle.

⚠ WARNING - Raising Vehicle
 To help avoid personal injury when a vehicle is on a hoist, provide additional support for the vehicle at the opposite end from where you are working. The additional support will reduce the possibility of the vehicle falling off the hoist. Failure to follow these precautionary measures could result in vehicle damage and/or fatal injuries.

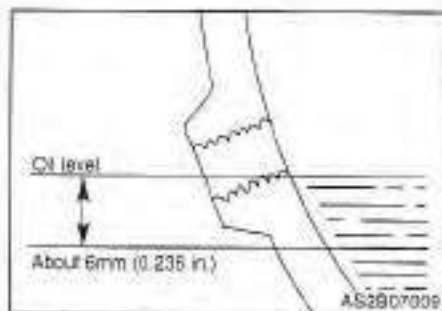

3. Verify that the oil level reaches the bottom of the fill/check hole.
4. Fill as necessary.
5. If the oil level is low, check for leaks before adding oil. Do not overfill. Use only the specified manual transaxle oil (Refer to 'Recommended Lubricants' later in this section).
6. Install a new washer on the fill/check plug and tighten the plug to 22 lb-ft. (30N•m).

AUTOMATIC TRANSAXLE

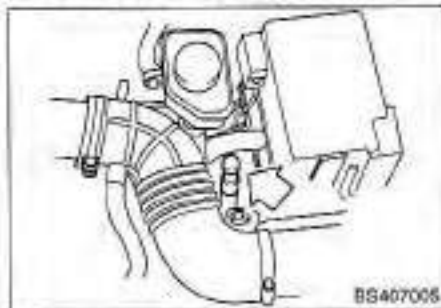

Checking the Automatic Transaxle Fluid Level

The automatic transaxle fluid level should be checked regularly. Take the following precautions to measure the fluid level properly.

The volume of the transaxle fluid changes with temperature. For that reason, it is best to check the level after having driven the vehicle for 30 minutes. If necessary, however, the fluid can also be checked when the vehicle has not been driven.

CAUTION

- *Low fluid level causes transaxle slippage. Overfilling can cause foaming, loss of fluid, and transaxle malfunction.*
- *Use only SK ATF SP-III or Diamond ATF SP-III in the automatic transaxle. The use of a non-specified fluid could result in transaxle malfunction and failure.*

WARNING - Parking Brake
To avoid sudden movement of the vehicle, set the parking brake and depress the brake pedal while shifting the shift lever.

1. Park the vehicle on level ground and set the parking brake firmly.
2. Allow the engine to idle for about 2 minutes, then depress the brake pedal. Move the shift lever slowly through all ranges then set it in the P (Park) position.

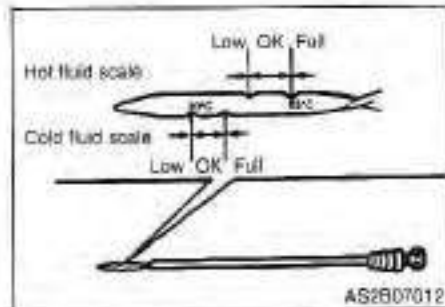

3. With the engine still idling, pull the dipstick out, wipe it clean, and reinsert it fully.
4. Pull the dipstick out again.
The fluid level is checked as follows:

Using the hot fluid scale:

If the vehicle has been driven and the fluid is warmed to the normal operating temperature of approximately 65°F (149°C), the fluid level should be between Full and Low.

LUBRICANTS AND FLUIDS



Checking the Washer Fluid Level

Check the fluid level in the washer fluid reservoir and add fluid if necessary. The washer fluid is checked using the dipstick attached to the reservoir cap.

Plain water may be used if washer fluid is not available. However, use windshield washer solvent with antifreeze characteristics in cold climates to prevent freezing.

Using the cold fluid scale:

If the engine has not been running and the outside temperature is approximately 20°F (68°C), the fluid level should be between Full and Low.

- Use the cold scale as a rough reference only.
- If the outside temperature is lower than 20°F (68°C), start the engine and measure the fluid level after letting the engine reach operating temperature.
- If the vehicle has been driven for an extended period at high speeds or in city traffic in hot weather, it is usually best to measure the fluid level after stopping the engine and allowing the fluid to cool for 30 minutes.

When inserting the dipstick, be sure to insert it completely. When adding fluid, measure frequently with the dipstick to make sure the fluid level does not go above the Full mark. Do not overfill.

Use only the specified automatic transaxle fluid SK ATF SP-III or Diamond ATF SP-III. (Refer to "Recommended Lubricants" in the Index.)

CAUTION

- *Do not use radiator coolant or antifreeze in the washer fluid reservoir.*
- *Radiator coolant can severely obscure visibility when sprayed on the windshield and may cause loss of vehicle control or damage to paint and body trim.*

Body Lubrication

All moving points of the body, such as doors, hood hinges and locks, should be lubricated each time the engine oil is changed.

Use a non-freezing lubricant on locks during cold weather.

Make sure the engine hood secondary latch keeps the hood from opening when the primary latch is released.

AIR CLEANER

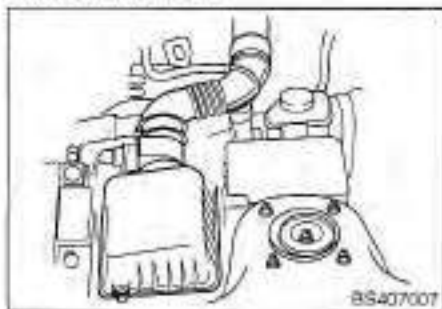

Element Replacement

A paper air cleaner filter is used. It must be replaced when necessary, and should not be cleaned and reused.

1. Loosen the hose clamp and remove the intake air hose.
2. Remove the four (4) air cleaner cover attaching bolts and a clip.
3. Wipe the inside of the air cleaner housing with a clean, damp cloth.

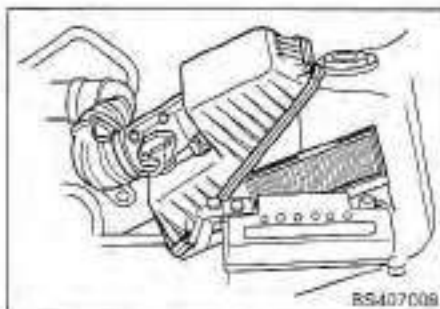

4. Replace the air cleaner element.

5. Re-install in the reverse order of removal.

Replace the element according to the Scheduled Maintenance.

CAUTION

- *Do not drive with the air cleaner removed; this will result in excessive engine wear.*
- *Driving without an air cleaner encourages backfiring, which could cause a fire in the engine compartment.*

WIPER BLADES

Wiper Blade Maintenance

* NOTICE

Commercial hot waxes applied by automatic car washes have been known to make the windshield difficult to clean.

Contamination of either the windshield or the wiper blades with foreign matter can reduce the effectiveness of the windshield wipers. Common sources of contamination are insects, tree sap, and hot wax treatments used by some commercial car washes. If the blades are not wiping properly, clean both the window and the blades with a good cleaner or mild detergent, and thoroughly rinse with clear water.

* NOTICE

To prevent damage to the wiper blades, do not use gasoline, kerosene, paint thinner, or other solvents on or near them.

Windshield Wiper Blade Replacement

When the wipers no longer clean adequately, the wiper blades may be worn or cracked, requiring replacement.

* NOTICE

To prevent damage to the wiper arms or other components, do not attempt to move the wipers manually.

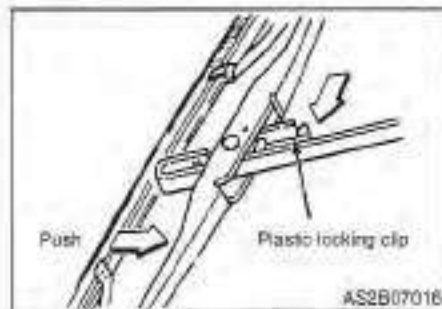

1. Raise the wiper arm and turn the wiper blade assembly to expose the plastic locking clip. Compress the clip and slide the blade assembly toward the windshield, then slide it off the arm.

* NOTICE

Do not allow the wiper arm to fall against the windshield.

MAINTENANCE

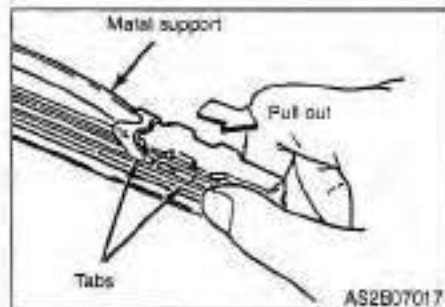

2. Firmly grasp the end of the rubber blade and pull until the tabs are free of the metal support.

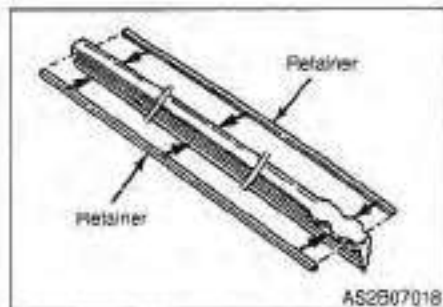

3. Remove the metal retainers from the rubber blade and install them in the new rubber blade.

* NOTICE

Do not bend the metal retainers.



4. Carefully insert a new rubber blade and re-install the blade assembly in the reverse order of removal.

Install the blade with the tabs facing towards the bottom of the wiper arm.

BATTERY

⚠ WARNING - Battery Dangers

- Keep lighted cigarettes and all other flames or sparks away from the battery. Hydrogen, which is a highly combustible gas, is always present in battery cells and may explode if ignited.
- Keep batteries out of the reach of children; batteries contain highly corrosive **SULFURIC ACID**. Do not allow battery acid to contact your skin, eyes, clothing or paint finish.
- If any electrolyte gets into your eyes, flush your eyes with clean water for at least 15 minutes and get immediate medical attention. If possible, continue to apply water with a sponge or cloth until medical attention is received.
- If electrolyte gets on your skin, thoroughly wash the contacted area. If you feel a pain or a burning sensation, get medical attention immediately.
- When charging a battery or working near a battery, wear eye protection.
- Always provide ventilation when working in an enclosed space.
- When lifting a plastic-cased battery, excessive pressure on the case may cause battery acid to spew through the vent caps, resulting in personal injury. Lift with a battery carrier or with your hands on opposite corners. Never attempt to charge a battery when the battery cables are connected.

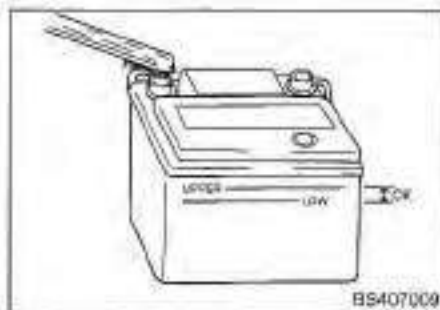

Battery Maintenance

For best battery service:

- Keep the battery securely mounted.
- Keep the battery top clean and dry.
- Keep the terminals and connections clean, tight, and coated with petroleum jelly or terminal grease.
- Immediately rinse any spilled electrolyte from the battery with a solution of water and baking soda.
- If the vehicle is not going to be used for an extended period of time, disconnect the battery cables.

Battery Recharging

Your vehicle has a maintenance-free, calcium-based battery and normally does not require additional water during its service life.

- If the battery becomes discharged in a short time (headlights or interior lights were left on while the vehicle was not in use), recharge it by slow (trickle) charging for 10 hours.
- If the battery gradually discharges because of high electric load while the vehicle is being used, recharge it at 20-30A for two hours.

WARNING - Recharging Battery

When recharging the battery, observe the following precautions:

- Check the battery electrolyte level before charging.
- The battery must be removed from the vehicle and placed in an area with good ventilation.

- Do not allow cigarettes, sparks, or flame near the battery.
- Watch the battery during charging, and stop or reduce the charging rate if the battery cells begin gassing (boiling) violently or if the temperature of the electrolyte of any cell exceeds 49°F (120°C).
- Wear eye protection when checking the battery during charging.
- Disconnect the battery charger in the following order.
 1. Turn off the battery charger main switch.
 2. Unhook the negative clamp from the negative battery terminal.
 3. Unhook the positive clamp from the positive battery terminal.

* NOTICE

- Before performing battery maintenance or recharging, turn OFF all accessories and stop the engine.
- When removing battery, disconnect the negative (-) battery cable first. When re-installing the battery, reconnect the negative (-) battery cable last.

TIRES AND WHEELS

Tire Care

For proper maintenance, safety, and maximum fuel economy, you must always maintain recommended tire inflation pressures and stay within the load limits and weight distribution recommended for your vehicle.

Inflation Pressures

Check all tire pressures (including the spare) monthly when the tires are cold. "Cold tires" means the car has not been driven for at least three hours or driven less than one mile (1.6 km). Recommended pressures must be maintained to ensure ride quality, vehicle handling, and minimum tire wear.

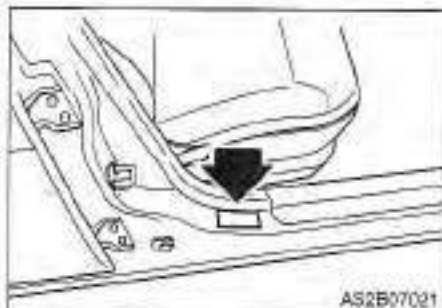

All specifications (sizes and pressures) can be found on a label attached to the front passenger door sill.

The correct tire pressure is 200kPa (29psi). The compact spare should be at 420 kPa (60psi).

* NOTICE

- Warm tires normally exceed recommended cold tire pressures by 28 to 41 kPa (4 to 6 psi). Do not release air from warm tires to adjust the pressure. The tires will become underinflated when cold.
- Underinflation results in excessive wear, poor handling, reduced fuel economy, and the possibility of blowouts from overheated tires. Also, low tire pressure can cause poor sealing of the tire bead. If the tire pressure is excessively low, wheel deformation and/or tire separation are possible. Keep tire pressures at the proper levels. If a tire frequently needs refilling, have it checked by an authorized Kia dealer or a tire shop.
- Overinflation produces a harsh ride, handling problems, excessive wear at the center of the tire tread, and a greater possibility of damage from road hazards.

⚠ WARNING - Tire Inflation

Overinflation or underinflation can reduce tire life, adversely affect vehicle handling, and lead to sudden tire failure. This could result in loss of vehicle control.

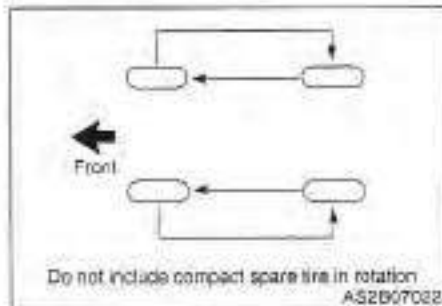

Tire rotation

To equalize tread wear, it is recommended that the tires be rotated every 12,000km (7,500 miles), or sooner if irregular wear develops.

During tire rotation, check the tires for correct balance.

Check for uneven wear and damage. Abnormal wear is usually caused by incorrect tire pressure, improper wheel alignment, an out-of-balance condition, severe braking or severe cornering. Look for bumps or bulges in the tread or side of tire. Replace the tire if you find either of these conditions. Also, replace the tire if you can see fabric or cord. After rotation, be sure to bring the front and rear tire pressures to specification and check lug nut tightness.

Disc brake pads should be inspected for wear whenever tires are rotated.

*** NOTICE**

Rotate radial tires that have an asymmetric tread pattern from front to rear only and not from right to left.

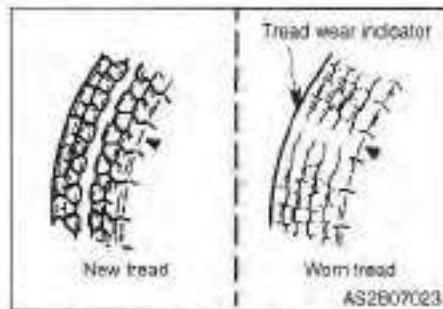

Tire replacement

If the tire is worn evenly, a tread wear indicator will appear as a solid band, 1/2 inch wide (12.7 mm) across the tread. This shows there is less than 1/16 inch (1.6mm) of tread remaining on the tire. Replace the tire when this happens.

Do not wait for this band to appear across the entire tread before replacing the tire.

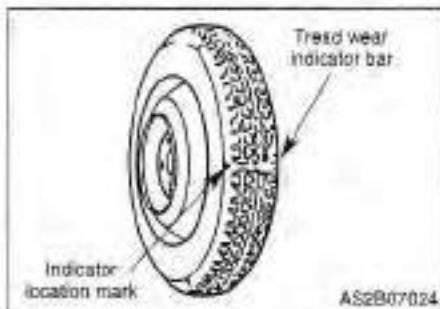

Compact spare tire replacement

A compact spare tire has a shorter tread life than a regular size tire. Replace it when you can see the tread wear indicator bars on the tire. The replacement compact spare tire should be the same size and design tire as the one provided with your new Kia and should be mounted on the same compact spare tire wheel. The compact spare tire is not designed to be mounted on

a regular size wheel, and the compact spare tire wheel is not designed for mounting a regular size tire.

Wheel Alignment and Tire Balance

In addition to proper tire inflation, correct wheel alignment helps to minimize tire wear. Your vehicle's alignment should be checked every 12 months or 24,000km (15,000 miles).

Your tires were properly balanced at the factory, but they may need to be rebalanced before they wear out. If you notice a consistent vibration when driving, have your Kia Dealer inspect your tires. A tire should always be rebalanced if it has been removed from the wheel.

*** NOTICE**

Improper wheel weights can damage your vehicle's aluminum wheels. Use only approved wheel weights.

* NOTICE

- When replacing tires, never mix radial, bias-belted, and bias-type tires. All four tires should be of the same size, design and construction. Use only the tire sizes listed on the Tire Label attached to the passenger's door. Make sure that all tires and wheels are the same size and have the same load-carrying capacity. Use only tire and wheel combinations recommended on the Tire Label or by an Authorized Kia Dealer. Failure to follow these precautions can adversely affect the safety and handling of your vehicle.
- The use of any other tire size or type may seriously affect ride, handling, ground clearance, tire clearance, and speedometer calibration.

- Driving on worn-out tires is very hazardous and will reduce braking effectiveness, steering accuracy, and traction.
- It is best to replace all four tires on your vehicle at the same time. If that is not possible, then replace the two front or two rear tires as a pair. Replacing just one tire can seriously affect vehicle handling.

Wheel Replacement

When replacing the metal wheels for any reason, make sure the new wheels are equivalent to the original factory units in diameter, rim width and offset.

CAUTION

A wheel that is not the correct size may adversely affect wheel and bearing life, braking and stopping abilities, handling characteristics, ground clearance, body-to-tire clearance, snow chain clearance, speedometer calibration, headlight aim and bumper height.

Tire Size Designation

A tire's sidewall is marked with a tire size designation. You will need this information when selecting replacement tires for your car. The following explains what the letters and numbers in the tire size designation mean.

Example tire size designation:
P185/65R14 85H

P - Applicable vehicle type (tires marked with the prefix "P" are intended for use on passenger cars; however, not all tires have this marking).

185 - Tire width in millimeters.

- 65** - Aspect Ratio. The tire's section height as a percentage of tire width.
- R** - Tire construction code (radial).
- 14** - Rim diameter in inches.
- 85** - Load Index; A numerical code associated with the maximum load the tire can carry.
- H** - Speed Rating Symbol. See the speed rating chart in this section for additional information.

Wheel Size Designation

Wheels are also marked with important information that you need if you ever need to replace one. The following explains what the letters and numbers in the wheel size designation mean.

Example wheel size designation: 14 x 5J

- 14** - Rim diameter in inches.
- 5** - Rim width in inches.
- J** - Rim contour designation.

Tire Speed Ratings

The following chart below shows many of the different speed ratings currently used for passenger car tires. The speed rating symbol is part of the tire size designation on the sidewall of the tire. This symbol corresponds to that tire's designed maximum safe operating speed.

Speed Rating Symbol	Maximum Speed
S	180 km/h (112 mph)
T	190 km/h (118 mph)
H	210 km/h (130 mph)
V	240 km/h (149 mph)
Z	Above 240 km/h (149 mph)

Uniform Tire Quality Grading

The following information relates to the tire grading system developed by the Canadian Motor Vehicle Safety Standard (CMVSS) for grading tires by tread wear, traction and temperature performance.

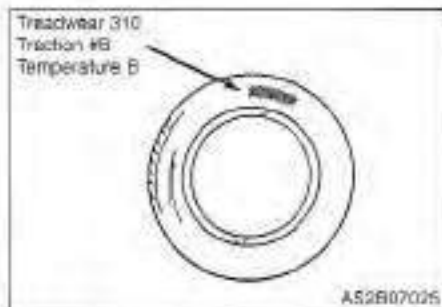

These temperature grades are molded on the sidewalls of passenger vehicle tires. Tires available as standard or optional equipment on Kia vehicles may vary with respect to grade.

Tread wear

The tread wear grade is a comparative rating based on the wear rate of the tire when tested under controlled conditions on a specified government test course. For example, a tire graded 150 would wear one-and-a-half times as well on the government course as a tire graded 100.

The relative performance of tires depends upon the actual conditions of their use. Variations in driving habits, service practices and differences in road characteristics and climate may significantly affect performance.

Traction - A, B and C

The traction grades, from highest to lowest, are A, B and C, and they represent the tire's ability to stop on wet pavement as measured under controlled conditions on specified government test surfaces of asphalt and concrete. A tire marked C may have poor traction performance.

Temperature - A, B and C

The temperature grades are A (the highest), B and C, representing the tire's resistance to generate heat and to dissipate heat when tested under controlled conditions on a specified indoor laboratory test wheel. Sustained high temperatures can cause the material of the tire to degenerate and reduce tire life, and excessive temperature can lead to sudden tire failure. Grade C corresponds to a level of performance that all passenger vehicle tires must meet under the Canadian Motor Vehicle Safety Standard No. 109. Grades A and B represent higher levels of performance on the laboratory test wheel than the maximum required by law.

WARNING - Tire Temperature

The temperature grade for a tire is established for a tire that is properly inflated and not overloaded. Excessive speed, underinflation, or excessive loading, either separately or in combination, can cause heat build-up and possible sudden tire failure. This can cause loss of vehicle control and death or personal injury.

BULB REPLACEMENT

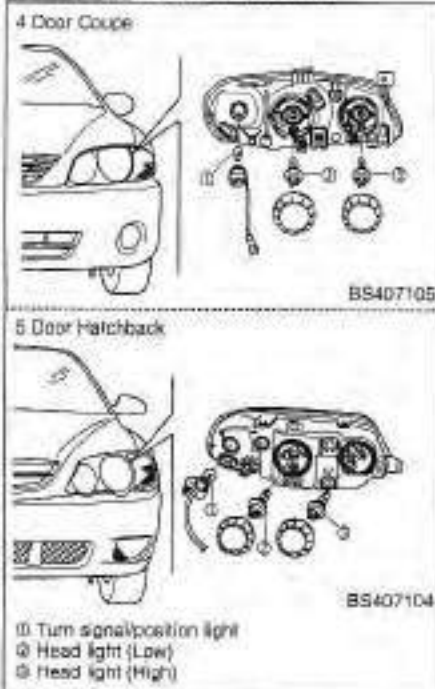

Headlight Bulb Replacement

⚠ WARNING - Halogen Bulbs

- Wear eye protection when changing a bulb. Allow the bulb to cool before handling it.
- Halogen bulbs contain pressurized gas. If broken, a halogen bulb will explode and will produce flying pieces of glass.
- Always handle halogen bulbs carefully to avoid scratches and abrasion. If the bulbs are lit, avoid contact with liquids. Never touch the glass with bare hands. Residual oil may cause the bulb to overheat and burst when lit. A bulb should be operated only when installed in the headlight assembly.
- If a bulb becomes damaged or cracked, replace it immediately and carefully dispose of it.

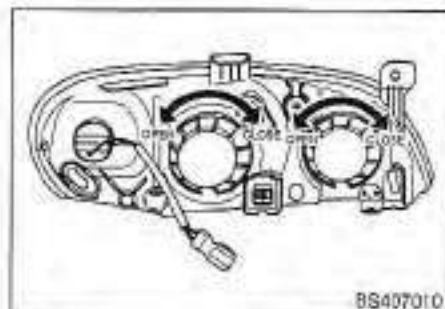

1. Remove the headlight bulb cover by turning it counterclockwise.

MAINTENANCE

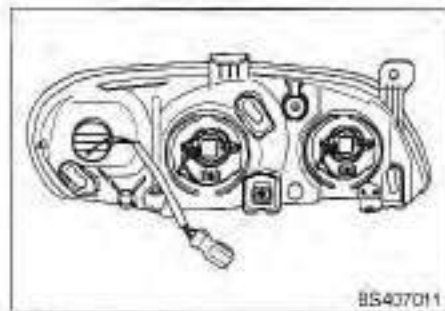

2. Disconnect the headlight bulb electrical connector.

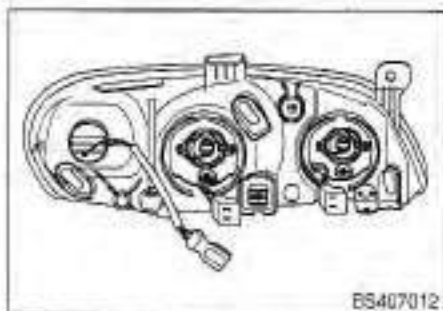

3. Unsnap the headlight bulb retaining wire.

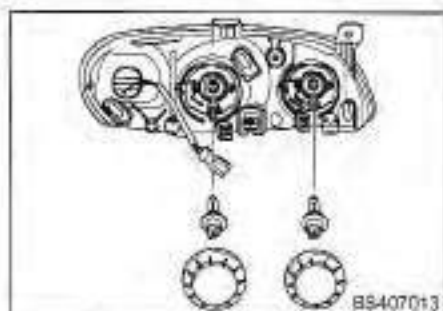

4. Remove the bulb from the three (3) slots on the headlight assembly.
5. Install a new headlight bulb in the three (3) slots on the headlight assembly and snap the headlight bulb retaining wire into position.
6. Connect the headlight bulb electrical connector.
7. Install the headlight bulb cover by turning it clockwise.

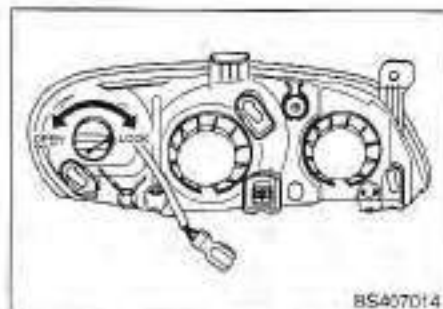

Front Turn Signal Light Bulb Replacement

1. Turn the front turn signal bulb-socket counterclockwise.

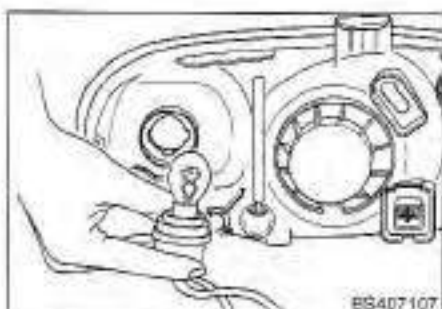

2. Remove the bulb-socket from the headlight assembly.

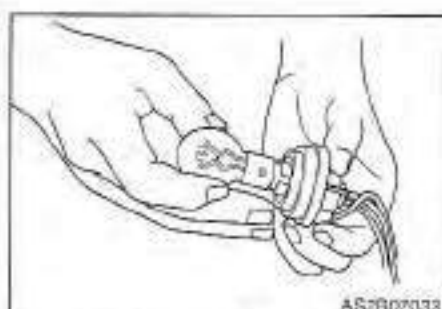

3. Push the bulb in, rotate it one-quarter turn counterclockwise and remove the bulb from the socket.
4. Insert a new bulb in the socket, then push the bulb in and rotate it one-quarter turn clockwise to lock the bulb in place.

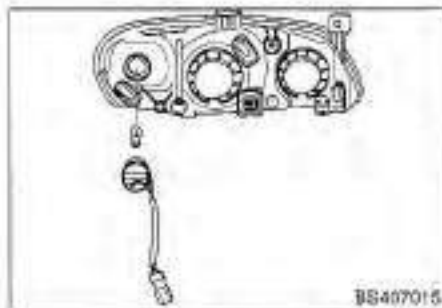

5. Re-install the turn signal bulb socket into the headlight housing and rotate it one-quarter turn clockwise to lock the socket in place.

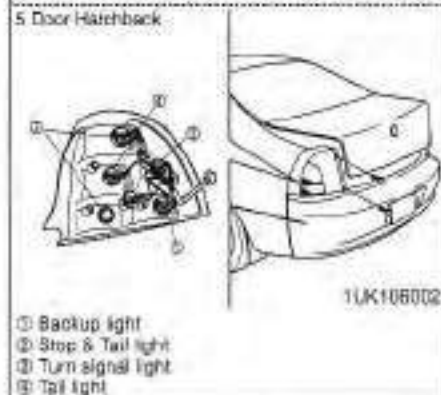
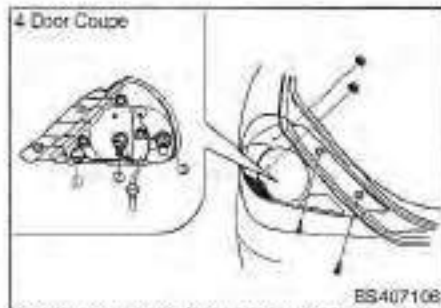

Rear Backup Light Bulb Replacement

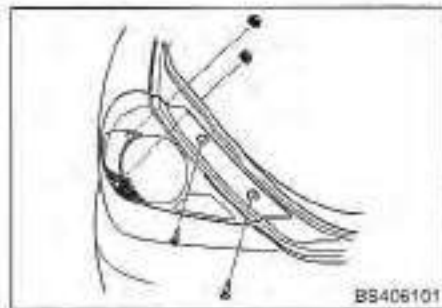

1. Using a Phillips screwdriver, remove the two (2) Phillips screws attaching the rear combination light assembly to the body. Open the service cover in a trunk and remove the two (2) nuts.

MAINTENANCE

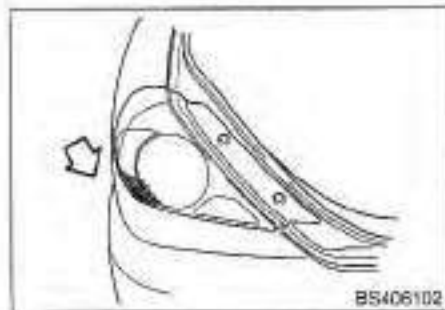

2. Carefully pull the rear combination light assembly out of the vehicle.

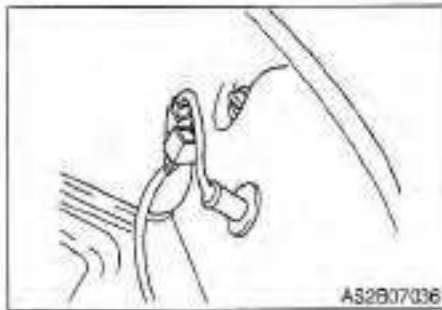

3. From inside the trunk, disconnect the rear combination light assembly electrical connector.

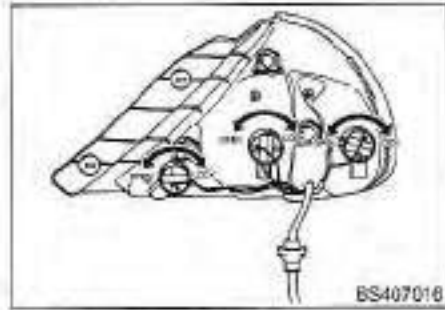

4. Carefully remove the rear combination light assembly from the vehicle.

MAINTENANCE

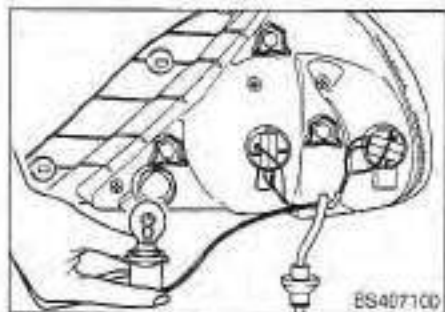

5. Turn the backup light bulb socket counterclockwise and remove it from the housing.
6. Push the bulb in, then rotate it one quarter turn counterclockwise and remove the bulb from the socket.

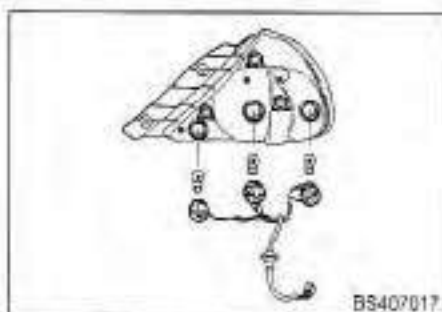

7. Insert a new bulb in the socket, then push the bulb in and rotate it one-quarter turn clockwise to lock the bulb in place.
8. Re-install the bulb socket into the tail light assembly and rotate it one-quarter turn clockwise to lock the socket in place.
9. Carefully re-install the tail light assembly in the vehicle.
10. Reconnect the tail light assembly electrical connector.

Rear Turn Signal and Rear Stop & Tail Light Bulbs Replacement

To replace the rear turn signal light and rear stop & tail light bulbs, use the procedures for "Rear Backup Light Bulb Replacement".

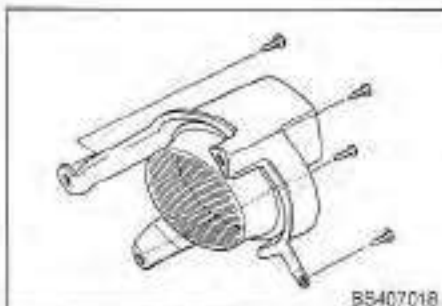
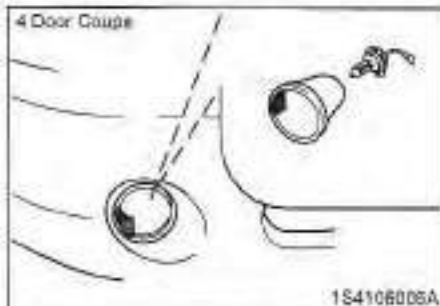

1. Remove the front fog light assembly from the front bumper by removing the four (4) bolts.

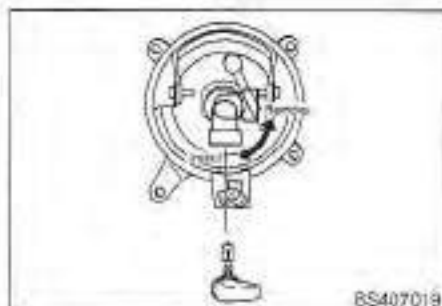

2. Rotate the socket one-quarter turn counter clockwise and remove the front fog light bulb-socket from the assembly.
3. Insert a new bulb-socket into the assembly, then rotate it one-quarter turn clockwise to lock the bulb in place.
4. Re-install the assembly into the front bumper.

Front Fog Light Bulb Replacement

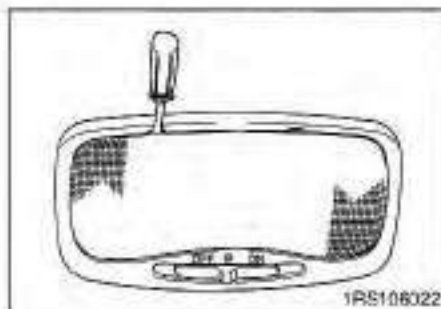

Dome Light Bulb Replacement

1. Using a flat-blade screwdriver, gently pry the lens from the dome light housing.

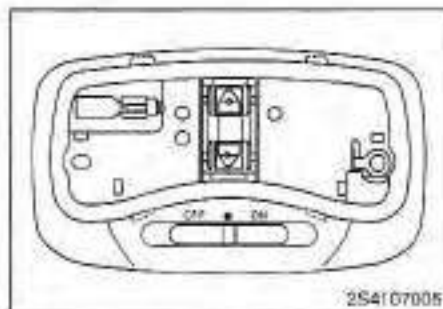

2. Remove the bulb from the socket.
3. Insert a new bulb in the socket.
4. Align the four (4) lens tabs with the dome light housing notches and snap the lens into place.



License Plate Light Bulb Replacement

1. Using a Phillips screwdriver, remove the two (2) lens mounting screws and the lens.

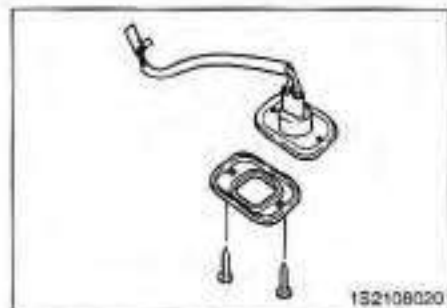

2. Carefully pull the bulb out of the socket.
3. Insert a new bulb in the socket.
4. Re-install the lens and the two (2) mounting screws.

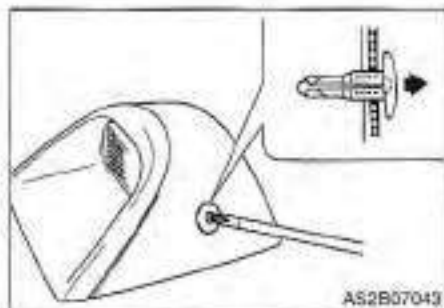

Center High-Mounted Stoplight Bulb Replacement (4 door notchback)

1. Using a small Phillips screwdriver, gently depress the center of the retaining clips on each side of the cover.

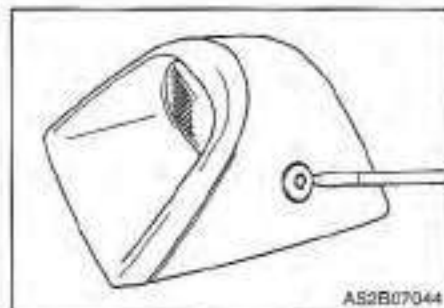

2. Using a flat-blade screwdriver, carefully pry the retaining clips from the cover and remove the cover.

MAINTENANCE

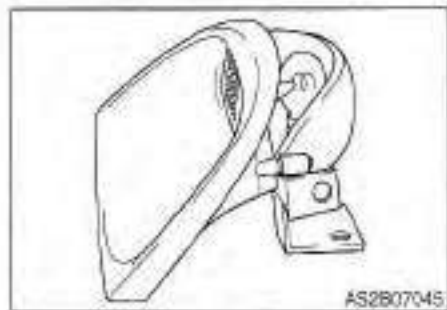

3. Push the bulb in, then rotate it one-quarter turn counterclockwise and remove the bulb from the socket.
4. Insert a new bulb in the socket, then push the bulb in and rotate it one-quarter turn clockwise to lock the bulb in place.

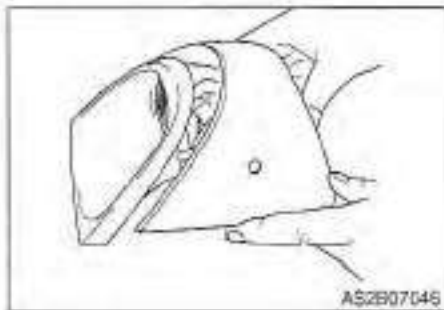

5. Re-install the cover.

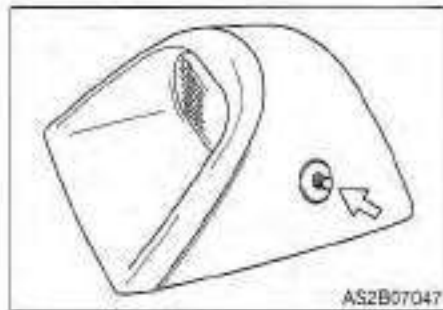

6. Pull the center pins out of the retaining clips until the end of the clips are closed.
7. Re-install the retaining clips into the cover.
8. Press firmly on the center pin to lock the retaining clips in place.



Center High-Mounted Stoplight Replacement (5 door hatchback)

1. Open the rear hatch.

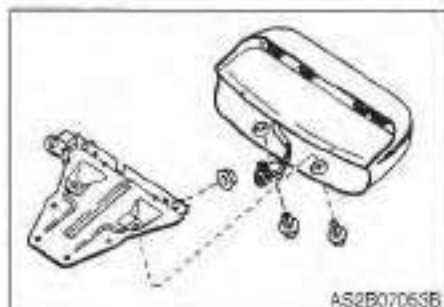

2. Using a flat-blade screwdriver, remove the two rivets and nut attached to the high-mounted stop light assembly.
3. Disconnect the electrical connector.

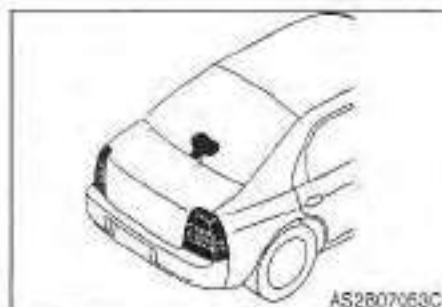

4. Replace the high-mounted stoplight assembly.

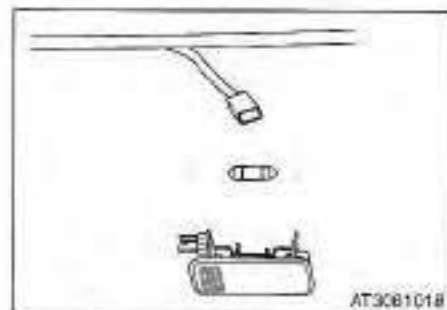

Trunk Room Lamp Bulb Replacement (If Equipped)

1. Remove the trunk room lamp cover using a flat blade screwdriver.
2. Replace the bulb and install the cover.

LUBRICANT SPECIFICATIONS

Recommended Lubricants

To help achieve proper engine and powertrain performance and durability, use only lubricants of the proper quality. The correct lubricants also help promote engine efficiency which results in improved fuel economy.

Engine oils labeled Energy Conserving Oil are now available. Along with other additional benefits, they contribute to fuel economy by reducing the amount of fuel necessary to overcome engine friction. Often, these improvements are difficult to measure in everyday driving, but in a year's time they can offer significant cost and energy savings.

These lubricants and fluids are recommended for use in your vehicle.

Lubricant	Classification
Engine oil ¹	API SG, SH or SAE 5W-30
Manual transaxle oil ²	API Service GL-4 or GL-5 (SAE 75W-90)
Automatic transaxle fluid	SK ATF SP-III or Diamond ATF SP-III
Power steering fluid	PSF-III
Brake/clutch fluid	SAEJ1703 or FMVSS116 DOT-3 or DOT-4

¹Refer to the recommended SAE viscosity numbers on the next page.

²Only SP-III classification automatic transaxle fluid should be used.

Do not use Dexron[®]III, Mercon[®]III, Mercon[®]V ATF or Type 7176 fluids.

The use of non specified fluid could result in transaxle malfunction and failure.

See your Kia dealer for the correct SP-III automatic transaxle fluid.

* NOTICE

To ensure optimum vehicle performance in the Canadian climate, high performance synthetic oils are the recommended lubricants for the engine and manual transmission (If Equipped). The operating ranges for both regular and synthetic engine oil are shown on the next page.

Recommended SAE Viscosity Number

* NOTICE

Always be sure to clean the area around any filler plug, drain plug, or dipstick before checking or draining any lubricant. This is especially important in dusty or sandy areas and when the vehicle is used on unpaved roads. Cleaning the plug and dipstick areas will prevent dirt and grit from entering the engine and other mechanisms that could be damaged.

Engine oil viscosity (thickness) has an effect on fuel economy and cold weather operation (starting and oil flow). Lower viscosity engine oils can provide better fuel economy and cold weather performance, however, higher viscosity engine oils are required for satisfactory lubrication in hot weather. Using oils of any viscosity other than those recommended could result in engine damage.

When choosing an oil, consider the range of temperature your vehicle will be operated in before the next oil change. Then select the recommended oil viscosity from the chart.

Temperature Range for SAE Viscosity Numbers										
Temperature	°C	-30	-20	-10	0	10	20	30	40	50
	(°F)	-20	0	20	40	60	80	100	120	
Engine Oil	5W-30		30							
	5W-20		20W-20			40				
			10W-30							
			10W-40			10W-50				
			20W-40			20W-50				

EXTERIOR CARE

Exterior General Caution

It is very important to follow the manufacturer's directions when using any chemical cleaner or polish. Read all warning and caution statements that appear on the label.

Finish Maintenance

Washing

To help protect your vehicle's finish from rust and deterioration, wash it thoroughly and frequently at least once a month with lukewarm or cold water. Pay special attention to the removal of any accumulation of salt, dirt, mud, or other foreign materials. Make sure the drain holes in the lower edges of the doors and rocker panels are kept clear and clean.

Insects, tar, tree sap, bird droppings, industrial fallout and similar deposits can damage your vehicle's finish if not removed immediately.

Even prompt washing with plain water may not completely remove all these deposits. A mild soap, safe for use on painted surfaces, can be used.

* NOTICE

Do not use strong soap, chemical detergents or hot water, and do not wash the vehicle in direct sunlight or when the body of the vehicle is warm.

After washing, rinse the vehicle thoroughly with lukewarm or cold water. Do not allow soap to dry on the finish.

CAUTION

After washing the vehicle, test the brakes while driving slowly to see if they have been affected by water. If braking performance is impaired, dry the brakes by applying them lightly while maintaining a slow forward speed.

CAUTION

- ***Water washing in the engine compartment may cause the failure of electrical circuits located in the engine compartment.***
- ***Pay extreme attention to wash the engine compartment by using water.***

Waxing

Wax the vehicle when water will no longer bead on the paint.

Always wash and dry the vehicle before waxing. Use a good quality liquid or paste wax, and follow the manufacturer's instructions. Wax all metal trim as well, to protect it and to maintain its luster.

Removing oil, tar, and similar materials with a spot remover will usually strip the wax from the finish. Be sure to re-wax these areas even if the rest of the vehicle does not yet need waxing.

* NOTICE

- Wiping dust or dirt off the body with a dry cloth will scratch the finish.
- Do not use steel wool, abrasive cleaners, or strong detergents containing highly alkaline or caustic agents on chrome-plated or anodized aluminum parts. This may result in damage to the protective coating and cause discoloration or paint deterioration.

Finish Damage Repair

Deep scratches or stone chips in the painted surface must be repaired promptly. Exposed metal will quickly rust and may develop into a major repair expense.

* NOTICE

If your vehicle is damaged and requires any metal repair or replacement, be sure the body shop applies anti-corrosion materials to the parts repaired or replaced.

Bright-Metal Maintenance

- To remove road tar and insects, use a tar remover, not a scraper or other sharp object.
- To protect the surfaces of bright-metal parts from corrosion, apply a coating of wax or chrome preservative and rub to a high luster.
- During winter weather or in coastal areas, cover the bright metal parts with a heavier coating of wax or preservative. If necessary, coat the parts with non-corrosive petroleum jelly or other protective compound.

Underbody Maintenance

Corrosive materials used for ice and snow removal or dust control may collect on the underbody. If these materials are not removed, accelerated rusting can occur on underbody parts, such as the fuel lines, frame, floor pan and exhaust system, even though they have been treated with rust protection.

Thoroughly flush the vehicle underbody and wheel openings with lukewarm or cold water once a month and especially at the end of each winter. Pay special attention to these areas because it is difficult to see all the mud and dirt. The lower edges of doors, rocker panels, and frame members have drain holes that should not be allowed to clog with dirt; trapped water in these areas can cause rusting. It will do more harm than good to wet down the road grime without removing it.

CAUTION

After washing the vehicle, test the brakes while driving slowly to see if they have been affected by water.

Aluminum Wheel Maintenance

The aluminum wheels are coated with a clear protective finish.

- *Do not use any abrasive cleaner, polishing compound, solvent, or wire brushes on aluminum wheels. These items may scratch or damage the finish.*
- *Use only a mild soap or neutral detergent, and rinse thoroughly with water. Be sure to clean the wheels after driving on salted roads to help prevent corrosion.*
- *Avoid washing the wheels with high-speed car wash brushes.*

INTERIOR CARE

Interior General Precautions

Prevent caustic solutions such as perfume and cosmetic oil from contacting the dashboard; they may cause damage or discoloration. If they do contact the dashboard, wipe them off immediately.

Upholstery and interior trim cleaning

Vinyl

First, remove dust and loose dirt from vinyl with a whisk broom or vacuum cleaner. Then, clean vinyl surfaces with a vinyl cleaner.

Fabric

First, remove dust and loose dirt from fabric with a whisk broom or vacuum cleaner. Then, clean with a mild soap solution recommended for upholstery or carpets. Remove fresh spots immediately with a fabric spot cleaner. If fresh spot do not receive immediate attention, the fabric may be stained and its color can be affected. Also, its fire-resistant properties may be reduced if the material is not properly maintained.

CAUTION

Using anything but recommended cleaners and procedures may affect the fabric's appearance and fire-resistant properties.

Lap/Shoulder belt webbing cleaning

Clean the belt webbing with any mild soap solution recommended for cleaning upholstery or carpet. Follow the instructions provided with the soap. Do not bleach or re-dye the webbing because this may weaken it.

Interior window glass cleaning

If the interior glass surfaces of the vehicle become fogged (that is, covered with an oily, greasy or waxy film), they should be cleaned with glass cleaner. Follow the directions on the glass cleaner container.

* NOTICE

Do not scrape or scratch the inside of the rear window. This could damage the rear window defroster grid.

Lap/Shoulder belt webbing cleaning

Clean the belt webbing with any mild soap solution recommended for cleaning upholstery or carpet. Follow the instructions provided with the soap. Do not bleach or re-dye the webbing because this may weaken it.

Interior window glass cleaning

If the interior glass surfaces of the vehicle become fogged (that is, covered with an oily, greasy or waxy film), they should be cleaned with glass cleaner.

Follow the directions on the glass cleaner container.

*** NOTICE**

Do not scrape or scratch the inside of the rear window. This could damage the rear window defroster grid.

SPECIFICATIONS

8

Specifications 8-2

SPECIFICATIONS

SPECIFICATIONS

The specifications given here are for general information only. Please check with an authorized Kia dealer for more precise and more up-to-date information.

Dimensions

Unit : mm

Item	4 Door ¹⁾	5 Door ²⁾
Overall length	4510	4525
Overall width	1725	1725
Overall height	1425	1425
Front tread	1475	1475
Rear tread	1455	1455
Wheelbase	2560	2560

¹⁾ 4 Door : 4door coupe

²⁾ 5 Door : 5door hatchback

Air Conditioner

Refrigerant complies with SAE J639	R134A
Maximum operating charge	25 oz. [700 g]

Weights

Unit : kg

Item	4 Door		5 Door	
	1.8DOHC		1.8DOHC	
Axle	MT	AT	MT	AT
GVWR	1660	1660	1670	1670
Curb Weight	1207-1242	1232-1237	1218-1223	1243-1248

SPECIFICATIONS

Light Bulbs

Light Bulb		4 Door	5 Door
Front	Headlights	55W	55W
	Turn signal/Position lights	28/8W	28/8W
	Fog lights (if equipped)	27W	27W
	Side marker lights	—	8W
Rear	Stop and tail lights	27/8W	27/8W
	Turn signal lights/side marker	28/8W	27/5W
	Backup lights	27W	27W
	High mounted stop lights	27W	4W
	License plate lights	5W	5W
Interior	Interior light	10W	10W
	Map light	10W	10W
	Trunk room lamp	5W	5W

Tires

	4 Door	5 Door
Size	P185/65R 14 85H	P185/65R 85H
Inflation pressure (psi)	29 (front and rear)	29 (front and rear)
Spare tire (temporary spare)	Size : T115/70D 15 T115/70R 15 Inflation pressure : 60	Size : T115/70D 15 T115/70R 15 Inflation pressure : 60

Gear ratio

Gear	Type	1.8DOHC	
		M/T ¹⁾	A/T ²⁾
1st		3.307	2.80
2nd		1.833	1.54
3rd		1.310	1.00
4th		1.030	0.700
5th		0.795	-
Reverse		3.166	2.333

¹⁾ MT : Manual Transaxle

²⁾ AT : Automatic Transaxle

SPECIFICATIONS

Engine

Item	1.8 DOHC
Bore*Stroke (mm)	81 X 87
Displacement (cc)	1,793
Compression Ratio	9.5:1
Firing order	1-3-4-2
Idle speed	800 ± 50

Electrical System

Item	1.8 DOHC	
Battery	MF 60 AH	
Alternator	12V-80A, 12V-90A	
Starter	M/T	12V-0.9 kw
	A/T	12V-1.2 kw
Spark plugs	Gap(mm)	0.7-0.8
	Type	BKR6E

Capacities

Item	liter/US qt.	
Engine Oil	Without filter change	3.8/4.0
	With filter change	4.0/4.2
Coolant	6.0/6.3	
Transaxle Oil	M/T	2.7/2.8
	A/T	5.4/5.7
	liter/US gal.	
Fuel Tank	50/13.2	

M/T : Manual Transaxle

A/T : Automatic Transaxle

DOHC : Dual Over Head Cam

INDEX

- Air Bag - Supplemental Restraint System**3-31
- Air Bag Warning Indicator Light**3-36
- Air Cleaner**7-22
- Air Conditioning Switch**4-41
- Alignment and Tire Balance, Wheel**7-29
- Aluminum Wheel Maintenance**7-49
- Anchor, Child Restraint**3-20
- Anti-Lock Brakes (ABS)**4-12
- Anti-Lock Brakes (ABS) Warning Light**4-28
- Anti-Theft Steering Column Lock,**
Ignition Switch and4-2
- Ashtrays, front**4-37
- Assistance, Consumer**9-1
- Audible Indicators/Warning Lights**4-25
- Automatic Transaxle**4-7, 7-19
- Backup Light Bulb Replacement**7-36
- Battery**7-25
- Belts, Safety**3-12
- Brake**
Fluid Warning Light, Parking Brake and4-25
Light, Rear7-47
Parking4-13, 7-17
- System4-12
- Wear Indicators, Disc4-14
- Brakes and Clutch**7-16
- Brakes**
Power4-12
Rear Drum4-14
- Break-In Process, Vehicle**1-3
- Bulb Replacement**7-33
- Catalytic Converts, Operating**
Precautions for5-4
- Center High-Mounted Stoplight**
Bulb Replacement7-41
- Chains, Tire**5-9
- Changing Tires**6-16
- Charging System Warning Light**4-26
- Chassis Number**5-12
- Child Restraint Anchorage**3-20
- Child Restraint Lower Anchor Striker Position**3-21
- Child-Restraint System, Placement of a**3-18
- Child Safety Lock, Rear Door**3-4
- Children, Restraint of Infants and Small**3-16
- Cigarette Lighter**4-37

INDEX

Circuit Protection, Electrical.....	6-7	Conditions, Special.....	5-7
Climate Control System.....	4-39	Hazardous.....	5-7
Cluster, Instrument.....	4-21	In Flooded Areas.....	6-10
Clutch, Brakes and.....	7-16	In the Rain.....	5-8
Compact Spare Tire.....	6-15	Tips.....	5-1
Consumer Assistance.....	9-1	Your Vehicle.....	4-1
Cooling System, Engine.....	7-13	Winter.....	5-8
Cruise Control.....	4-18	Drugs and Driving.....	5-5
Day/Night Rearview Mirror.....	3-45	Drunken Driving.....	5-5
Defects, Reporting Safety.....	9-5	Economical Operation, Suggestions for.....	5-6
Defroster, Rear Window.....	4-36	Electric Remote Control Mirror.....	3-45
Dimensions.....	8-2	Electrical Circuit Protection.....	6-7
Disc Brake Wear Indicators.....	4-14	Electrical Equipment.....	9-4
Dome Light Bulb Replacement.....	7-40	Emergency, In Case of an.....	6-1
Door Ajar Warning Light.....	4-28	Emergency Roadside Assistance.....	9-2
Door Child Safety Lock, Rear.....	3-4	Emergency Starting.....	6-4
Door Locks		Emergency Trunk Safety Release.....	3-39
Central.....	3-4	Emission Control System.....	5-3
Manual.....	3-3	Engine	
Driving		Compartment.....	7-10
At Night.....	5-8	Cooling System.....	7-13
Before.....	5-5	Exhaust Gas Precautions.....	5-3

INDEX

- Oil and Oil Filter.....7-11
- Oil Pressure Warning Light.....4-27
- Starting the.....4-4
- Temperature Gauge.....4-24
- Exhaust Gas Precautions, Engine.....5-3
- Exterior Care.....7-47
- Exterior Overview, Interior and.....2-2
-
- Finish Maintenance.....7-47
- Flashing Headlights.....4-32
- Flat Tire, If You Have a.....6-14
- Flooded Areas, Driving in.....5-10
- Fluids, Lubricants and.....7-21
- Folding Rear Seat, Split.....3-11
- Foreign Country, Registering Your Vehicle in a.....9-3
- Front
- Ashtay.....4-37
 - Fog Light Bulb Replacement.....7-39
 - Seat Adjustment.....3-8
 - Safety Belts.....3-22
 - Turn Signal Light Bulb Replacement.....7-35
- Fuel Filler Door.....3-42
- Fuel Filler Door Release
- Remote.....3-42
 - Fuel Gauge.....4-23
 - Fuel Level Warning Light, Low.....4-27
 - Fuel Requirements.....5-2
 - Fuse Panel Description.....6-9
 - Fuse Replacement.....6-7
 - Fuses.....6-7
-
- Gauges.....4-23
- Glass Cleaning, Interior Window.....7-50
- Glove Box.....4-34
-
- Hazard Warning Flasher.....6-2
- Hazardous Driving.....5-7
- Headlight High Beam Indicator.....4-27
- Headlight Bulb Replacement.....7-33
- Headlights, Flashing.....4-32
- Headrest, Adjustable.....3-10
- High Beam Indicator, Headlight.....4-27
- Hood.....3-40
- Horn.....3-43
-
- Ignition Switch.....4-2

INDEX

- Ignition Switch and Anti-Theft Steering
 - Column Lock.....4-2
- Ignition Switch Illumination.....4-2
- Indicators, Warnings and.....4-25
- Infants and Small Children, Restraint of.....3-19
- Inflation Pressures.....7-27
- Inspections, Necessary.....5-5
- Installation of a Mobile Two-Way Radio System.....9-4
- Instrument
 - Cluster.....4-21
 - Panel Illumination.....4-24
 - Panel Overview.....2-3
- Interior
 - And Exterior Overview.....2-2
 - Care.....7-50
 - Features.....4-37
 - Lights.....3-46
 - Trim Cleaning, Upholstery and.....7-50
 - Window Glass Cleaning.....7-50
- Intermittent Wipers, Variable-Speed.....4-33
- Jacks and Tools, Storing the Spare Tire.....6-14**
- Jacking Instructions.....6-16
- Jump Starting.....6-4
- Key Reminder Warning Chime.....4-27**
- Keys.....3-2
- Knowing Your Vehicle.....3-1
- Label Information.....5-11**
- Lane Change Signals.....4-32
- Lap Belt, Rear.....3-25
- Lap/Shoulder Belt, Rear.....3-25
- Lap/Shoulder Belt Webbing/Cleaning.....7-50
- License Plate Light Bulb Replacement.....7-40
- Lighter, Cigarette.....4-37
- Lighting.....4-31
- Lighting Control.....4-31
- Lights-On Warning Chime.....4-27
- Lights, interior.....3-46
- Lock, Rear Door Child Safety.....3-4
- Locks
 - Central Door.....3-4
 - Door.....3-3
 - Manual Door.....3-3
- Low Brake Fluid Level Warning Light.....4-25

INDEX

Low Fuel Level Warning Light.....	4-27	Night, Driving at.....	5-8
Lubricant Specifications.....	7-45	Odometer.....	4-23
Lubricants and Fluids.....	7-21	O/D Off Indicator.....	4-28
Lubricants, Recommended.....	7-45	O/D System.....	4-8
Maintenance	7-1	Oil.....	
Owner.....	7-8	Filter, Engine Oil and.....	7-11
Service, Scheduled.....	7-3	Pressure Warning Light, Engine.....	4-27
Services.....	7-2	One-Touch Wipers.....	4-33
Malfunction Indicator.....	4-29	Outside Rearview Mirror.....	3-44
Manual.....		Overheating.....	6-3
Control Mirror.....	3-44	Overloading.....	5-10
Door Locks.....	3-3	Owner Maintenance.....	7-8
Transexle.....	4-6	Parking Brake	4-15, 7-17
Windows.....	3-5	Parking Brake and Brake Fluid Warning	
Mirror.....		Lights.....	4-25
Day/Night Rearview.....	3-45	Placement of a Child-Restraint System.....	3-18
Electric Remote Control.....	3-45	Power.....	
Manual Remote Control.....	3-44	Brakes.....	4-12
Outside Rearview.....	3-44	Steering.....	4-16, 7-18
Vanity.....	4-36	Windows.....	3-5
Mirrors.....	3-44	Pregnant Women, Restraint of.....	3-16
Modifications, Vehicle.....	5-3		

INDEX

- Proper Use and Care of the Safety Belt System3-27
- Rain, Driving in the**..... 5-8
- Rear**
- Ashtray.....4-37
 - Backup Light Bulb Replacement.....7-36
 - Door Child Safety Lock.....3-4
 - Drum Brakes.....4-14
 - Lap Belt.....3-25
 - Lap/Shoulder Belt.....3-25
 - Safety Belts.....3-25
 - Seat.....3-11
 - Stop & Tail Light Bulb Replacement.....7-38
 - Turn Signal Light Bulb Replacement.....7-38
 - Window Defroster.....4-36
 - Window Defroster Indicator.....4-27
- Rearview Mirror**
- Day/Night.....3-45
 - Outside.....3-44
- Recommended Lubricants**.....7-45
- Registering Your Vehicle in a Foreign Country**.....9-3
- Remote**
- Fuel Filler Door Release.....3-42
 - Trunk Lid Release.....3-38
- Reporting Safety Defects**.....9-5
- Restraint**
- Of Infants and Small Children.....3-16
 - Of Pregnant Women.....3-16
 - System, Safety Belt.....3-14
 - System, Child Anchor.....3-21
- Roadside Assistance**.....9-2
- Road Warning**.....6-2
- Rocking the Vehicle**.....5-7
- Rotation, Tire**.....7-28
- Safety Defects, Reporting**.....9-5
- Scheduled Maintenance Service**.....7-3
- Seat Adjustment, Front**.....3-8
- Safety Belts**
- Pre-tensioner seat belt.....3-12
 - Rear.....3-25
 - Restraint System.....3-14
 - System, Proper Use and Care of the.....3-27
 - Warning Light.....4-25
 - Warning Light and Chime.....3-22

INDEX

- Seats
 - Front.....3-8
 - Rear.....3-11
 - Recliner.....3-9
 - Split Folding.....3-11
- Shift Lock Override.....4-10
- Shift Lock System.....4-10
- Snow Tires.....5-9
- Spare Tire
 - Compact.....6-15
 - Jack and Tools, Storing the.....6-14
- Special Driving Conditions.....5-7
- Specifications.....8-1
- Speedometer.....4-23
- Starting the Engine.....4-4
- Steering Column Lock, Ignition Switch and
 - Anti-Theft.....4-2
- Steering
 - Power.....4-21, 7-18
 - Wheel.....3-54
- Suggestions for Economical Operation.....5-6
- Sunvisors.....4-38
- Supplemental Restraint System Service.....3-46
- Switch, Ignition.....4-2
- Tachometer.....4-23
- Temperature Gauge, Engine.....4-24
- Tire
 - Balance, Wheel Alignment and.....7-29
 - Chains.....5-9
 - Label.....5-11
 - Replacement.....7-29
 - Rotation.....7-28
 - Size Designation.....7-30
 - Speed Ratings.....7-31
- Tires and Wheels.....7-27
- Tires
 - Changing.....6-16
 - Snow.....5-9
- Towing.....6-12
- Trailer Towing.....5-10
- Transaxle, Automatic.....4-7, 7-19
- Transaxle, Manual.....4-6
- Trip Meter.....4-23
- Trunk Lid.....3-38
- Trunk Lid Release, Remote.....3-38

INDEX

- Turn Signals.....4-32
- Two-Way Radio System, Installation
Of a Mobile9-4
- Underbody Maintenance**.....7-49
- Uniform Tire Quality Grading.....7-31
- Upholstery and Interior Trim Cleaning.....7-50
- Vacuum Hose Routing Diagram, Vehicle**
Emission Control Information and.....5-12
- Vanity Mirror.....4-38
- Variable-Speed Intermittent Wipers.....4-33
- Vehicle**
Break-In Process.....1-3
Certification Label.....5-12
Driving Your.....4-1
- Vehicle**
Emission Control Information and Vacuum
Hose Routing Diagram.....5-12
Identification Number.....5-11
Knowing Your.....3-1
Modifications.....5-3
Rocking the.....5-7
- Warning Flasher, Hazard**.....6-2
- Warning Lights/Audible Indicators.....4-25
- Warnings and Indicators.....4-25
- Warranty Coverage at a Glance.....9-5
- Washer, Wipers and.....4-33
- Washers, Windshield.....4-34
- Washing.....7-60
- Wheel**
Alignment and Tire Balance.....7-29
Maintenance, Aluminum.....7-62
Replacement.....7-30
Size Designation.....7-31
- Wheels, Tires and.....7-27
- Window Glass Cleaning, Interior.....7-50
- Windows**
Manual.....3-5
Power.....3-5
- Windshield**
Washers.....4-34
Wipers.....4-33
- Winter Driving.....5-8
- Wiper Blades.....7-23

Wipers

And Washer	4-33
One-Touch	4-33
Variable-Speed Intermittent	4-33
Windshield	4-33