

GAS STATION INFORMATION

Gasoline

UNLEADED gasoline
AKI (Anti-Knock Index) 87 or higher

Fuel Tank Capacity

18.5 gal. (70 liters)

Recommended Engine Oil

API Service SL or above,
ILSAC GF-3 or above

Engine Oil Capacity with Filter

5.49 qts. (5.2 liters)

Engine Coolant

9.2 qts. (8.7 liters)

Tire Pressure (measured cold)

P225/60R16 : 30 psi

P235/55R17 : 30 psi

Compact Spare Tire Pressure

T125/80D16 : 60 psi

Automatic Transaxle Fluid

DIAMOND ATF SP-III or SK ATF SP-III
or other brands meeting the SP-III specification approved by Kia Motors Corp.
Capacity : 11.5 qts. (10.9 liters)

Brake Fluid

FMVSS116 DOT-3 or DOT-4

Power Steering Fluid

PSF-IV

KIA, THE COMPANY



Congratulations! Your selection of a Kia was a wise investment. It will give you years of driving pleasure. Now that you are the owner of a Kia vehicle, you'll probably be asked a lot of questions about your vehicle and the company like "What is a Kia?", "Who is Kia?", "What does 'Kia' mean?".

Here are some answers. First, Kia is the oldest car company in Korea. It is a company that has thousands of employees focused on building high-quality vehicles at affordable prices.

The first syllable, ***Ki***, in the word "Kia" means "to arise from to the world" or "to come up out of to the world." The second syllable, ***a***, means "Asia." So, the word ***Kia***, means "to arise from" or "to come up out of Asia to the world."

Drive safely and enjoy your Kia!

Thank you for choosing a Kia vehicle.

When you require service, remember that your dealer knows your vehicle best. Your dealer has factory-trained technicians, recommended special tools, genuine Kia replacement parts and is dedicated to your complete satisfaction.

Because subsequent owners require this important information as well, this publication should remain with the vehicle if it is sold.

This manual will familiarize you with operational, maintenance and safety information about your new vehicle. It is supplemented by a Warranty and Consumer Information manual that provides important information on all warranties regarding your vehicle. If your vehicle is equipped with an audio system, you will also have a Kia Integrated Audio System manual explaining its operation. We urge you to read these publications carefully and follow the recommendations to help assure enjoyable and safe operation of your new vehicle.

Kia offers a great variety of options, components and features for its various models.

Therefore, the equipment described in this manual, along with the various illustrations, may not all be applicable to your particular vehicle.

The information and specifications provided in this manual were accurate at the time of printing. Kia reserves the right to discontinue or change specifications or design at any time without notice and without incurring any obligation. If you have questions, always check with your Kia Dealer.

We assure you of our continuing interest in your motoring pleasure and satisfaction in your Kia vehicle.

© 2008 Kia Motors Corp.

All rights reserved. May not be reproduced or translated in whole or in part without the written consent of Kia Motors America, Inc.

Printed in Korea

TABLE OF CONTENTS ■

Introduction	1
Your vehicle at a glance	2
Knowing your vehicle	3
Driving your vehicle	4
Driving tips	5
In case of an emergency	6
Maintenance	7
Specifications	8
Consumer assistance, Reporting safety defects	9
Index	10

Introduction

1

How to use this manual / 1-2

Vehicle break-in process / 1-3

Vehicle data collection and event data recorders / 1-4

HOW TO USE THIS MANUAL

We want to help you get the greatest possible driving pleasure from your vehicle. Your Owner's Manual can assist you in many ways. We strongly recommend that you read the entire manual. Especially, in order to prevent death or injury, at the very least, you must read the **WARNING** and **CAUTION** sections spread throughout the manual, which are easily recognized by their special markings listed.

Illustrations complement the words in this manual to best explain how to enjoy your vehicle. By reading your manual, you learn about features, important safety information, and driving tips under various road conditions.

The general layout of the manual is provided in the Table of Contents. A good place to start is the index; it has an alphabetical listing of all information in your manual.

Sections: This manual has eight sections plus an index. Each section begins with a brief list of contents so you can tell at a glance if that section has the information you want.

You'll find various **WARNING's**, **CAUTION's**, and **NOTICE's** in this manual. These **WARNING's**, **CAUTION's** and **NOTICE's** were prepared to enhance your personal safety and continued satisfaction with Kia vehicle. You should carefully read and follow ALL procedures and recommendations provided in these **WARNING's**, **CAUTION's** and **NOTICE's**.

WARNING

A WARNING indicates a situation in which harm, serious bodily injury or death could result if the warning is ignored.

CAUTION

A CAUTION indicates a situation in which damage to your vehicle could result if the caution is ignored.

*** NOTICE**

A NOTICE indicates interesting or helpful information is being provided.

VEHICLE BREAK-IN PROCESS

No special break-in period is needed. By following a few simple precautions for the first 600 miles (1,000 km) you may add to the performance, economy and life of your vehicle.

- Do not race the engine.
- Do not maintain a single speed for long periods of time, either fast or slow. Varying engine speed is needed to properly break-in the engine.
- Avoid hard stops, except in emergencies, to allow the brakes to seat properly.
- Avoid full-throttle starts.

PROPOSITION 65 WARNING

Engine exhaust and a wide variety of automobile components and parts, including components found in the interior furnishings in a vehicle, contain or emit chemicals known to the State of California to cause cancer and birth defects and reproductive harm. In addition, certain fluids contained in vehicles and certain products of component wear contain or emit chemicals known to the State of California to cause cancer and birth defects or other reproductive harm.

VEHICLE DATA COLLECTION AND EVENT DATA RECORDERS

Your Kia vehicle is equipped with many high technology, electronically controlled systems that help to ensure your vehicle operates properly and provides the performance that you expect. These systems utilize computers to monitor the operation of various systems and components and help to control their operation. These computerized system operations are wide-ranging and involve components to reduce emissions, to continuously evaluate the readiness of the airbag and seatbelt pretensioner systems, to determine when the airbag and seatbelt pretensioner systems should be deployed and then to activate the deployment, and if equipped, to operate anti-lock braking, traction control and electrical stability control to assist the driver to control the vehicle in difficult driving situations. These systems electronically store information that is useful to service technicians when they need to diagnose and repair these systems.

Additional information is stored only when a crash occurs that results in the deployment of the airbags or seatbelt pretensioners. This type of data storage is done by devices called event data recorders (EDR).

After a crash event, the airbag and seatbelt pretensioner computer system, known as the Supplemental Restraint System Control Module (SRSCM) or Airbag Control Unit (ACU), may record some information about the condition of the vehicle and how it was being operated. This information consists of data related to seatbelt usage and if there was diagnostic information in the airbag or seatbelt systems at the time that a crash occurred, and if the ACU sensed that a crash of sufficient severity occurred to require seat belt pretensioner or airbag deployment.

To retrieve this information, special equipment is needed and access to the vehicle or the device that stores the data is required. Kia will not access information about a crash event or share it with others except:

- in response to an official request of police or similar government office, or
- with the consent of the vehicle owner or, if the vehicle is leased, with the consent of the lessee, or
- as part Kia's defense of litigation through the discovery process, or
- as required by law.

Your rights with respect to the information discussed above may vary from state to state. In some states, such information is considered private, is exclusively owned by the owner of the motor vehicle, and is not retrievable or usable by another person or entity.

Your vehicle at a glance

2

Interior overview / 2-2

Instrument panel overview / 2-3

Engine compartment / 2-4

INTERIOR OVERVIEW

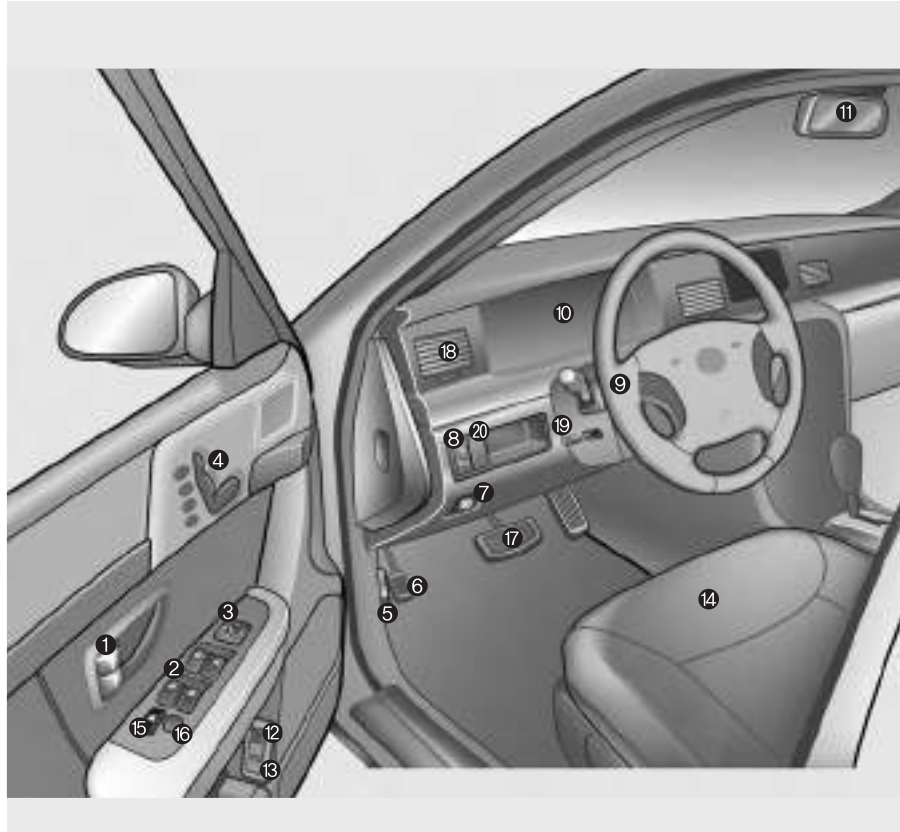

1. Door lock/unlock button.....3-9
 2. Power window switches.....3-14
 3. Outside rearview mirror control switch3-84
 4. Seat adjust knob3-19
 5. Hood release lever3-80
 6. Parking brake pedal4-13
 7. Parking brake release lever.....4-13
 8. Instrument panel illumination4-27
 9. Steering wheel4-17
 10. Instrument cluster.....4-25
 11. Inside rearview mirror3-86
 12. Trunk release lever3-76
 13. Fuel filler lid release button3-81
 14. Seat.....3-17
 15. Master power door lock control.....3-10
 16. Master power window control lock ..3-15
 17. Brake pedal4-10
 18. Vent controls.....4-53
 19. Steering wheel tilt.....4-18
 20. Power adjustable pedal switch*4-12
- *: if equipped

OGH006002N

INSTRUMENT PANEL OVERVIEW



- 1. Driver's Air Bag3-57
 - 2. Light control / Turn signals.....4-38/4-40
 - 3. Instrument cluster4-25
 - 4. Wiper/Washer4-42
 - 5. Ignition switch4-2
 - 6. Seat warmer3-23
 - 7. Front passenger's air bag off indicator ..3-59
 - 8. Hazard4-45, 6-2
 - 9. Rear climate control selection button ..4-55
 - 10. Climate control system4-46
 - 11. Shift lever4-5
 - 12. Passenger's airbag3-58
 - 13. Glove box3-90
 - 14. Trunk lid control button.....3-77
 - 15. Audio controls*3-99
 - 16. Auto cruise controls*4-19
 - 17. Electronic stability control*4-22
- *: if equipped

OGH009001N

ENGINE COMPARTMENT

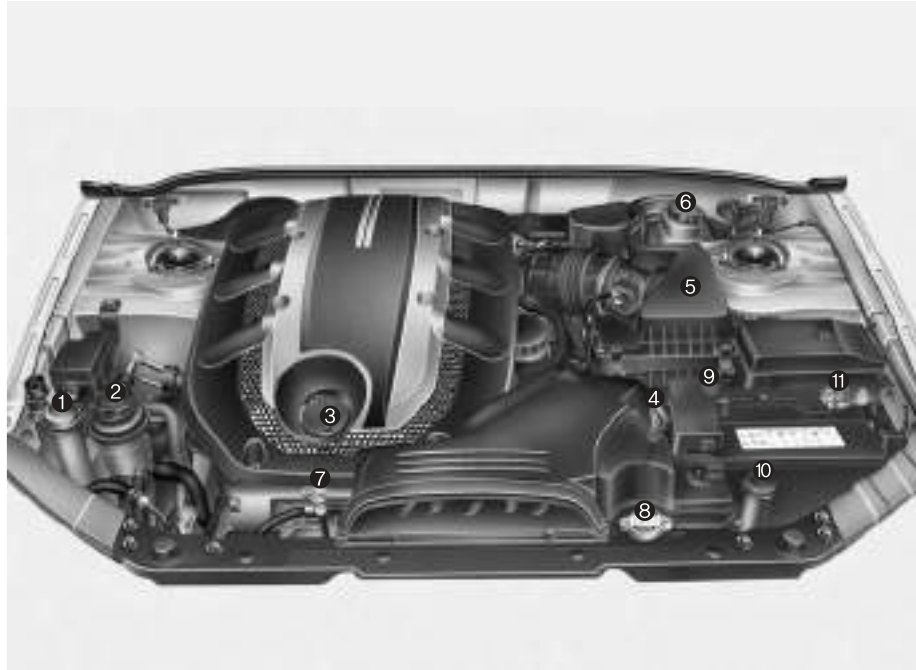

1. Windshield washer fluid reservoir7-20
2. Power steering fluid reservoir7-17
3. Engine oil filler cap7-13
4. Auto transaxle oil dipstick7-18
5. Air cleaner.....7-21
6. Brake fluid reservoir.....7-16
7. Engine oil dipstick7-13
8. Radiator cap7-15
9. Positive battery terminal6-5, 7-26
10. Engine coolant reservoir.....7-14
11. Negative battery terminal6-5, 7-26

OGH057001N

Keys / 3-2
Remote keyless entry / 3-4
Immobilizer system / 3-7
Door locks / 3-9
Windows / 3-13
Seats / 3-17

Knowing your vehicle

3

Driver position memory system / 3-28
Safety belts / 3-30
Air bags-advanced supplemental restraint system / 3-52
Trunk / 3-76
Hood / 3-80
Fuel filler lid / 3-81
Mirrors / 3-84
Interior lights / 3-88
Storage compartments / 3-89
Interior features / 3-91
Sunroof / 3-96
Antenna / 3-98
Audio remote control / 3-99
Audio systems / 3-100

KEYS



OGH039001N

The key code number is stamped on the plate attached to the key set. Should you lose your keys, this number will enable an authorized Kia Dealer to duplicate the keys easily. Remove the plate and store it in a safe place. Also, record the code number and keep it in a safe and handy place, but not in the vehicle.

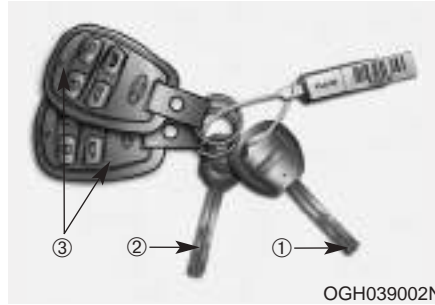

OGH039002N

Key operations

- ① Master key
Used to start the engine, lock and unlock the doors, lock and unlock the glove box, and open the trunk.
- ② Sub key
Used only to start the engine and lock and unlock the door.
- ③ Transmitter
Used to lock and unlock the doors and trunk (trunk can only be opened with the transmitter when the trunk lid control button located in the glove compartment is turned on. See page 3-3).

⚠ WARNING - Ignition key
Leaving children unattended in a vehicle with the ignition key is dangerous even if the key is not in the ignition. Children copy adults and they could place the key in the ignition. The ignition key would enable children to operate power windows or other controls, or even make the vehicle move, which could result in serious bodily injury or even death. Never leave the keys in your vehicle with unsupervised children.

⚠ WARNING

Use only Kia original parts for the ignition key in your vehicle. If an aftermarket key is used, the ignition switch may not return to ON after START. If this happens, the starter will continue to operate causing damage to the starter motor and possible fire due to excessive current in the wiring.

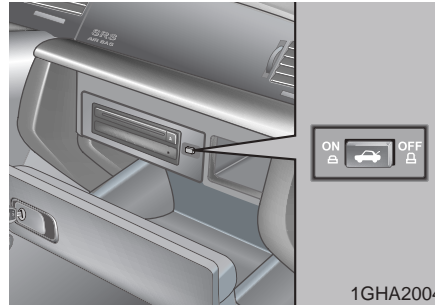
**Restrictions in handling keys**

When leaving keys with parking lot and valet attendants, the following procedures will ensure that your vehicle's trunk and glove box compartment cannot be opened in your absence.

1. Unlock the glove box with the master key and open it.
2. Set the trunk lid control button in the glove box compartment to OFF (not depressed). In the OFF position, the trunk cannot be unlocked with either the trunk release lever inside the car or trunk open button of transmitter.
3. Close the glove box, and lock the glove box using the master key.
4. Leave the sub key with the attendant. The trunk and glove box are secured because the sub key only allows the engine to start and locks and unlocks the door.

REMOTE KEYLESS ENTRY (IF EQUIPPED)

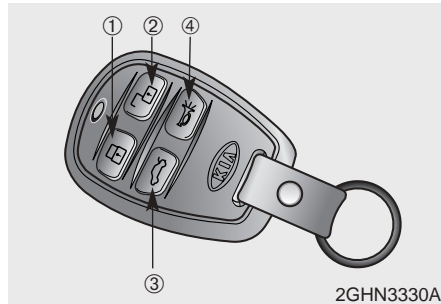

- ① Lock button
- ② Unlock button
- ③ Trunk lid open button
- ④ Alarm button

① Lock (🔒)

All doors are locked and the hazard lamp will flash once if the lock button is pressed. Also, the trunk is locked and cannot be opened with the outside handle.

② Unlock (🔓)

Driver's door is unlocked and the hazard lamp will flash twice if the unlock button is pressed once. Also, the trunk is unlocked and can be opened with the outside handle. All doors are unlocked if the unlock button is pressed twice within 3 seconds.

After depressing this button, the doors will be locked automatically unless you open them within 30 seconds.

③ Trunk lid open (🚗)

The trunk lid opens if this button is pressed. If this button is pressed while all the doors are locked, the trunk will open, however it will remain locked when closed.

If any door is unlocked, the trunk will remain unlocked when closed.

When the trunk lid control button in the glove box is OFF, the trunk will not open or unlock even when the button on the transmitter is pressed.

④ Alarm (🚨)

The horn sounds and hazard lamp will flash for about 27 seconds if this button is pressed.

*** NOTICE**

The transmitter will not work if any of the following occur:

- The ignition key is in the ignition switch.
- You exceed the operating distance limit (393.7 inches [10 m]).
- The battery in the transmitter is weak.
- Other vehicles or objects may be blocking the signal.
- The weather is extremely cold.
- The transmitter is close to a radio transmitter such as a radio station or an airport which can interfere with normal operation of the transmitter.

When the transmitter does not work correctly, open and close the door with the ignition key. If you have a problem with the transmitter, contact an authorized Kia Dealer.

*** NOTICE**

Keep the transmitter away from water or any liquid. If the keyless entry system is inoperative due to exposure to water or liquids, it will not be covered by your manufacturer vehicle warranty.

Operational distance may vary depending upon the area the transmitter is used in. For example, if the vehicle is parked near police stations, government and public offices, broadcasting stations, military installations, airports, or transmitting towers, etc., operational distance may be lessened.

This device complies with Part 15 of the FCC rules.

Operation is subject to the following two conditions:

1. This device may not cause harmful interference, and
2. This device must accept any interference received, including interference that may cause undesired operation.

 **WARNING**

Changes or modifications not expressly approved by the party responsible for compliance could void the user's authority to operate the equipment.



Battery replacement

Transmitter uses a 3 volt lithium battery which will normally last for several years. When replacement is necessary, use the following procedure.

1. Insert a slim tool into the slot and gently pry open the transmitter's center cover (1).
2. Replace the battery with a new one. When replacing the battery, make sure the battery's positive "+" symbol faces up as indicated in the illustration.
3. Install the battery in the reverse order of removal.

* NOTICE

The keyless entry system transmitter is designed to give you years of troublefree use, however it can malfunction if exposed to moisture or static electricity. If you are unsure how to use your transmitter or replace the battery, contact an authorized Kia dealer.

For replacement of transmitters, see an Authorized Kia Dealer for reprogramming.

CAUTION

- *Using the wrong battery can cause the transmitter to malfunction. Be sure to use the correct battery.*
- *To avoid damaging the transmitter, don't drop it, get it wet, or expose it to heat or sunlight.*

IMMOBILIZER SYSTEM (IF EQUIPPED)

Your vehicle is equipped with an electronic engine immobilizer system to reduce the risk of unauthorized vehicle use.

The immobilizer system is comprised of a small transponder in the ignition key and electronic devices inside the vehicle. With the immobilizer system, whenever you insert your ignition key into the ignition switch and turn it to ON, it checks and determines whether the ignition key is valid or not.

If the key is determined to be valid, the engine will start.

If the key is determined to be invalid, the engine will not start.

To deactivate the immobilizer system:

Insert the ignition key into the key cylinder and turn it to the ON position.

To activate the immobilizer system:

Turn the ignition key to the OFF position. The immobilizer system activates automatically. Without a valid ignition key for your vehicle, the engine will not start.

WARNING

In order to prevent theft of your vehicle, do not leave spare keys anywhere in your vehicle. Your Immobilizer password is a customer unique password and should be kept confidential. Do not leave this number anywhere in your vehicle.

CAUTION

Do not put metal accessories near the key or ignition key. The engine may not start for the metal accessories may interrupt the transponder signal from normally transmitting

CAUTION

The transponder in your ignition key is an important part of the immobilizer system. It is designed to give years of trouble free service, however you should avoid exposure to moisture, static electricity and rough handling. Immobilizer system malfunction could occur.

CAUTION

Do not change, alter or adjust the immobilizer system because it could cause the immobilizer system to malfunction and should only be serviced by an authorized Kia dealer.

Malfunctions caused by improper alterations, adjustments or modifications to the immobilizer system are not covered by your vehicle manufacturer warranty.

*** NOTICE**

When starting the engine, do not use the key with other immobilizer keys near it. Otherwise the engine may not start or may stop soon after it starts. Keep each keys separate.

This device complies with Part 15 of the FCC rules.

Operation is subject to the following two conditions:

1. This device may not cause harmful interference, and
2. This device must accept any interference received, including interference that may cause undesired operation.

WARNING

Changes or modifications not expressly approved by the party responsible for compliance could void the user's authority to operate the equipment.

DOOR LOCKS

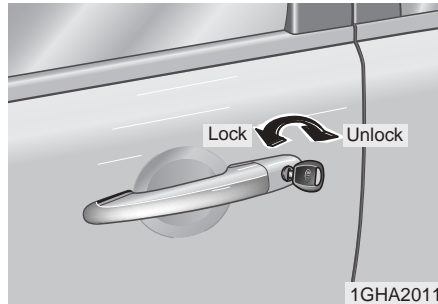

Operating door locks from outside the vehicle

- Driver's door can be locked and unlocked with the key.
- Turn the key to the left to lock all doors.
- Turn the key to the right once to unlock the driver's door and to the right twice within 3 seconds to unlock all doors.
- Doors can also be locked and unlocked with the transmitter key.
- Once the doors are unlocked, it may be opened by pulling the door handle.
- When closing the door, push the door with your hand. Make sure that doors are closed securely.

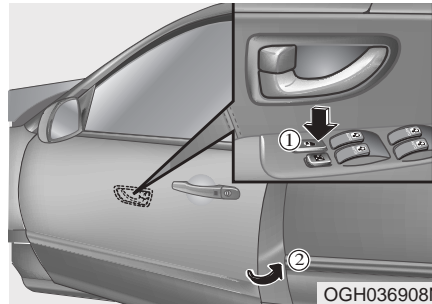

To lock a door without the key, push the door lock switch (①) to the "LOCK" position and close the door (②).

* NOTICE

Always remove the ignition key, engage the parking brake, close all windows and lock all doors when leaving your vehicle unattended.

* NOTICE

If the door is locked/unlocked multiple times in rapid succession with either the vehicle key or door lock switch, the system may stop operating temporarily in order to protect the circuit and prevent damage to system components.

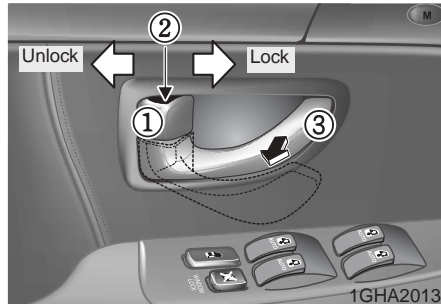

Operating door locks from inside the vehicle

With the door lock button

- To unlock a door, pull the door lock button out to the "UNLOCK" position (the red part (2) of the button becomes visible).
- To lock a door, push the door lock button (1) to the "LOCK" position (red part (2) of the knob is not visible).
- To open a door, pull the door handle (3) outward.

- If the inner door handle of the front door is pulled when the door lock button is in lock position, the button is unlocked and the door opens (if equipped).
- Front doors cannot be locked if the ignition key is in the ignition switch and when the front door is opened.

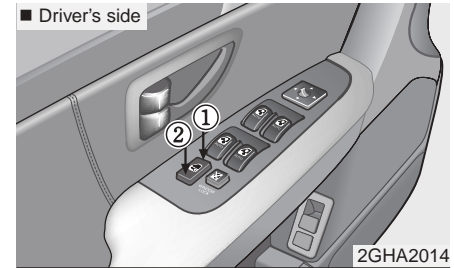

With central door lock switch

The central door locking switch is located on the front door's rest. It is operated by depressing the door lock switch. If any door is open when the switch is depressed, the door will remain locked when closed.

- When pushing down on the front portion (①) of the door lock switch, all vehicle doors will lock.
- When pushing down on the rear portion (②) of the switch, all vehicle doors will unlock.
- However, if the key is in the ignition switch and any front door is open, the doors will not lock by pressing the door lock switch.

 CAUTION

- *The doors should always be fully closed and locked while the vehicle is in motion to prevent accidental opening of the door. Locked doors will also discourage potential intruders when the vehicle stops or slows.*
- *Be careful when opening doors and watch for vehicles, motorcycles, bicycles or pedestrians approaching the vehicle in the path of the door. Opening a door when something is approaching can cause damage or injury.*

 WARNING

Leaving your vehicle unlocked can invite theft or possible harm to you or others from someone hiding in your vehicle while you are gone. Always remove the ignition key, engage the parking brake, close all windows and lock all doors when leaving your vehicle unattended.

 WARNING - Unattended children

An enclosed vehicle can become extremely hot, causing death or severe injury to unattended children or animals who cannot escape the vehicle. Furthermore, children might operate features of the vehicle that could injure them, or they could encounter other harm, possibly from someone gaining entry to the vehicle. Never leave children or animals unattended in your vehicle.

Impact sensing door unlock system (if equipped)

All doors will automatically unlock if a collision that warrants SRS air bag deployment is detected when the ignition switch is in the ON position.

However, if the impact causes damage to the vehicle electrical system or the mechanical door lock mechanisms, the impact sensing door unlock system may not operate.

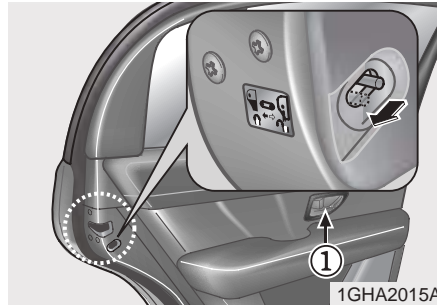

Rear door child safety lock

The child safety lock is provided to help prevent children from accidentally opening the rear doors from inside the vehicle. The rear door safety locks should be used whenever children are in the vehicle.

1. Open the rear door.
2. Push the child safety lock located on the rear edge of the door to the “lock” position. When the child safety lock is in the “lock (⊕)” position, rear door will not open when the inner door handle is pulled from inside the vehicle.
3. Close the rear door.
4. To open the rear door, pull the outside door handle.

Even though the doors may be unlocked, the rear door will not open by pulling the inner door handle (①) until rear door child safety lock is unlocked (⊖).

⚠ WARNING - Rear door locks

If children accidentally open the rear doors while the vehicle is in motion, they could fall out and be severely injured or killed. To prevent children from opening the rear doors from inside, the rear door safety locks should be used whenever children are in the vehicle.

WINDOWS

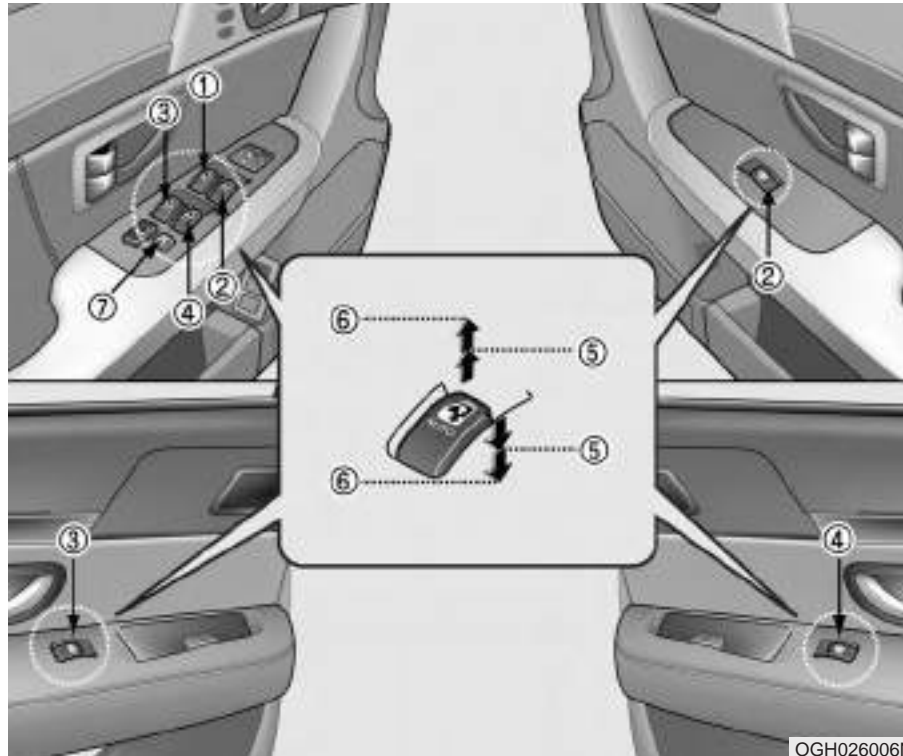

- ① Driver's door power window switch
- ② Front passenger's door power window switch
- ③ Rear door (left) power window switch
- ④ Rear door (right) power window switch
- ⑤ Window opening and closing
- ⑥ Automatic power window
- ⑦ Power window lock switch

OGH026006N

Power windows

The ignition switch must be in the ON position for power windows to operate. Each door has a power window switch that controls that door's window. However, the driver has a power window lock switch which can block the operation of the passenger windows.

If you notice buffeting and pulsation (wind shock) with either side windows opened, you should open the opposite window slightly to reduce the condition.

CAUTION

- *To prevent the power window system from the possibility of damage, do not open or close two windows at the same time. This will also ensure the longevity of the fuse.*
- *Never try to operate the main switch on the driver's door and the individual door window switch in opposing directions at the same time. If this is done, the window will stop and cannot be opened or closed.*

WARNING

- Make sure hands and face are safely out of the way before closing a window.
- Do not allow children to play with the power windows. Keep the driver's door power window lock switch in the LOCK position (depressed). Serious injury can result from unintentional window operation by the child.
- Do not extend face or arms outside through the window opening while driving.
- Always double check to make sure all arms, hands and other obstructions are safely out of the way before closing a window

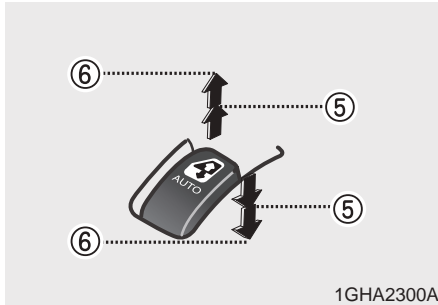

Window opening and closing

The driver's door has a master power window switch that controls all the windows in the vehicle. To open or close a window, press down or pull up the front portion of the corresponding switch.

Automatic power window

Depressing or pulling up the power window switch momentarily to the second detent position (⑥) completely lowers or lifts the window even when the switch is released. To stop the window at the desired position while the window is in operation, pull up or depress the switch momentarily to the opposite direction of the window movement.

If the battery has been discharged or disconnected, the automatic power window system must be reset as follows:

1. Turn the ignition key to ON position.
2. Close each window and continue pulling up on each power window switch for at least 0.5 second after the window is completely closed.

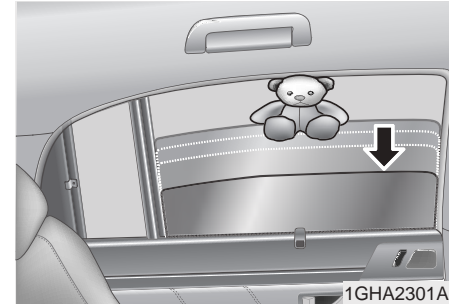

Automatic window reversal (When window is closed by the automatic power window)

If the upward movement of the window is blocked by an object or part of the body, the window will detect the resistance and will stop upward movement. The window will then lower approximately 5.9 inches (150 mm) to allow the object to be cleared.

WARNING

- The automatic window reversal feature (window lowers 5.9 inches [150 mm] when a resistance is detected) will only operate when the automatic power window up operation feature is used. Automatic window reversal will not operate if the window is raised using the first detent position (Ⓢ) on the power window switch. Always double check to make sure all faces, arms, hands and other obstructions are safely out of the way before operating the power window.
- If an object less than 0.16 inch (4 mm) in diameter is caught between the window glass and the upper window channel, the automatic reversal may not detect the resistance and will not operate. Therefore, always check for any obstructions before raising any window.

Power window lock switch

- The driver can disable the power window switches on a passenger door by depressing the power window lock switch located on the driver's door to LOCK (pressed).
- When the power window lock switch is ON, the driver's master control cannot operate the passenger door power windows either.

Power window timer (if equipped)

The power windows can be operated for approximately 30 seconds after the ignition key is removed or turned to the ACC or LOCK position. However, if the front doors are opened, the power windows cannot be operated even within 30 seconds after the ignition key is removed.

SEATS

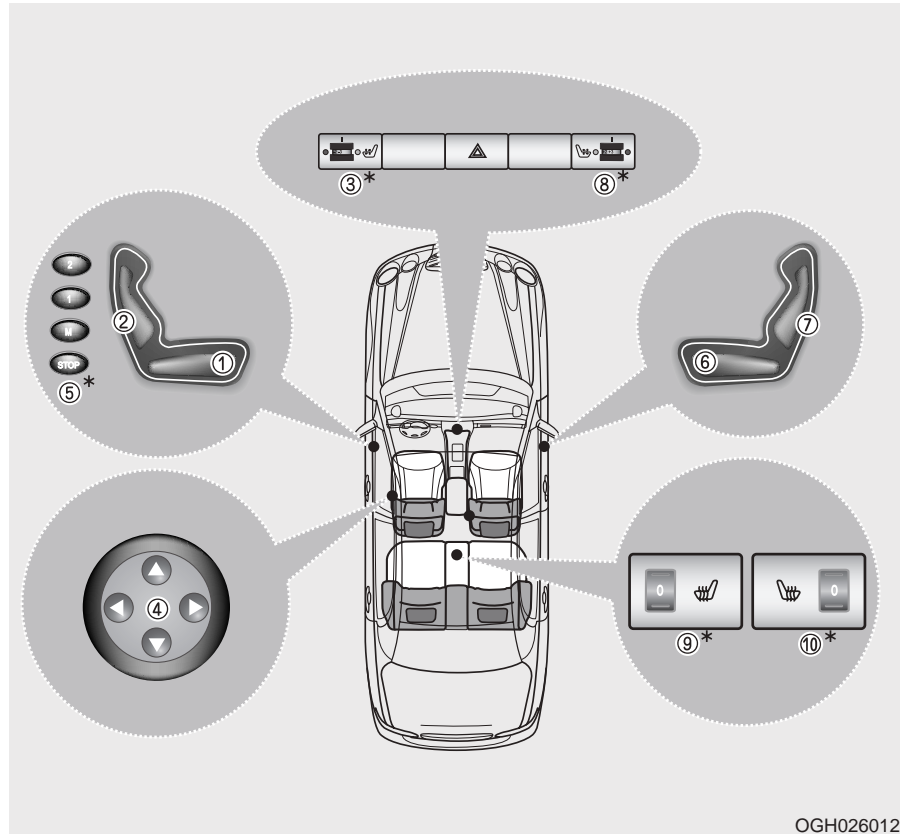

Driver's seat

- ① Seat adjustment, forward / backward/height
- ② Seatback recliner
- ③ Seat heater / ventilator switch*
- ④ Lumbar support
- ⑤ Driver position memory system*
- Headrest adjustment (headrest cannot be adjusted by a switch)

Front passenger seat

- ⑥ Seat adjustment, forward / backward
- ⑦ Seatback recliner
- ⑧ Seat heater / ventilator switch*
- Headrest adjustment (headrest cannot be adjusted by a switch)

Rear seat

- ⑨ Seat heater switch (left)*
- ⑩ Seat heater switch (right)*

* : if equipped

For a seating position more comfortable to the driver and front passenger, adjust the seat forward, backward, up and down.

CAUTION

- *Power seats are driven by electric motor. Stop operating when the adjustment is completed. Excessive operation may damage the electrical equipment.*
- *When in operation, the power seats consume large amounts of electrical power. To prevent unnecessary charging system drain, don't adjust the power seats longer than necessary while the engine is not running.*
- *Do not operate two or more power seat control buttons at the same time. Doing so may result in power seat motor or electrical component malfunction.*

WARNING

- Loose objects in the driver's foot area could interfere with the operation of the foot pedals, possibly causing an accident. Loose objects might interfere with the seat slide mechanism. Do not place anything under the front seats.
- The power seats are operable with the ignition OFF. Therefore, children should never be left unattended in the car.

WARNING - Driver's seat

- Never attempt to adjust the seat while the vehicle is moving. This could result in loss of control, and an accident causing death, serious injury, or property damage.
- Do not allow anything to interfere with the normal position of the seatback. Storing items against a seatback or in any other way interfering with proper locking of a seatback could result in serious or fatal injury in a sudden stop or collision.
- Always drive and ride with your seatback upright and the lap portion of the safety belt, or lap belt, snug and low across the hips. This position puts your safety belts in the best position to protect you in case of an accident.
- In order to avoid unnecessary air bag injuries including the possibility of severe injury or death, always sit as far back as possible from the steering wheel so that your chest is away at least 10 inches (250 mm) away from the steering wheel.

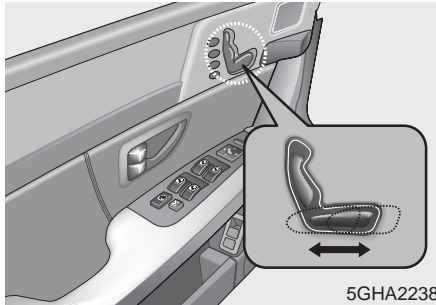

Driver's seat adjustment

Forward/backward position and height adjustment

Adjusting the seat forward and backward

Push the control button forward or backward to move the seat to the desired position. Release the knob and the seat will lock in the selected position.

Adjust the seat before driving, and make sure the seat is locked securely by trying to move forward and backward without using the control knob. If the seat moves, it is not locked properly.

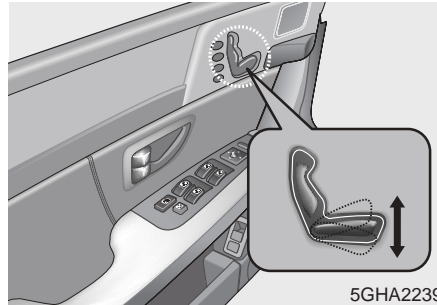

Adjusting front height of seat cushion

Move the front portion of the control knob up to raise or down to lower the front part of the seat cushion.

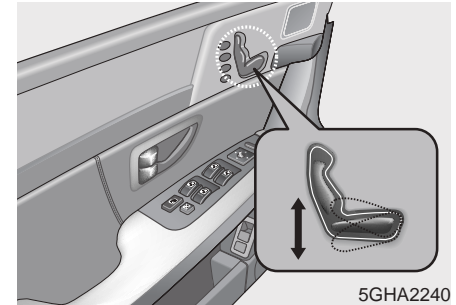

Adjusting rear height of seat cushion

Move the rear portion of the control knob up to raise or down to lower the rear part of the seat cushion.

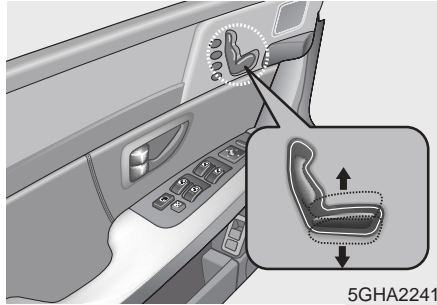

Adjusting the height of seat cushion

To raise or lower the seat cushion, pull up or push down on the center of the corresponding switch. Release the knob once the seat reaches the desired position.

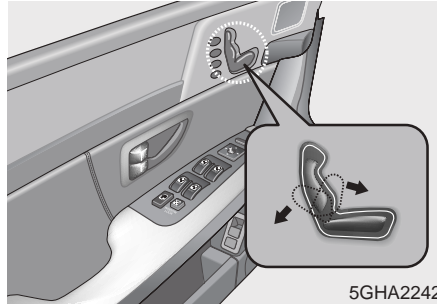

Adjusting the driver's seatback recliner

Move the lever forward or backward to the desired angle and release the lever. If the lever is released, seatback will lock in place. After adjustment, make sure that the lever has returned to its original locked position.

⚠ WARNING

Driving or riding in a vehicle with a front seatback reclined could lead to serious or fatal injury in an accident. If a front seat is reclined during an accident, the occupant's hips may slide under the lap portion of the safety belt applying great force to the unprotected abdomen or neck or a passenger may be ejected in a rollover. Serious or fatal internal injuries could result. Keep the seatbacks in a comfortably upright position whenever the vehicle is in motion.

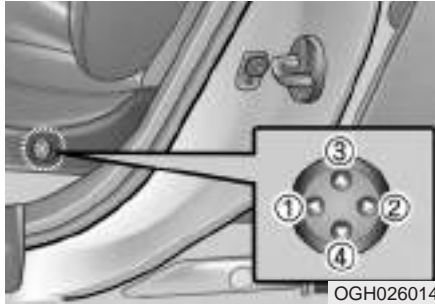

OGH026014

Lumbar support

The lumbar support can be adjusted by pressing the lumbar support switch on the side of the driver's seat. Press the front portion of the switch (①) to increase support, or the rear portion of the switch (②), to decrease support.

Move the support position up and down by pressing the switch (③) or (④).



OGH039901N

Driver position memory system (if equipped)

A driver position memory system is provided to store and recall the seat and outside mirror positions with a simple button operation. By saving the desired positions into the system memory, different drivers can reposition the seat and outside mirror based upon their driving preference.

See page 3-28 for detail information.

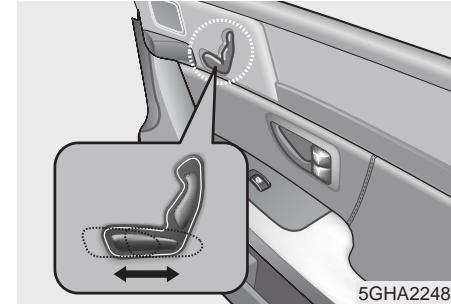

5GHA2248

Adjusting the front passenger seat

Forward/backward position adjustment

Push the control knob forward or backward to move the seat to the desired position. Release the knob and the seat will lock in the selected position.

Adjust the seat before driving, and make sure the seat is locked securely by trying to move forward and backward without using the control knob. If the seat moves, it is not locked properly.

⚠ WARNING

In order to avoid unnecessary air bag injuries including the possibility of severe injury or death, always sit as far back as possible by moving the seat far back, while still maintaining good vehicle control. Serious injury or death may be caused due to the deployment of the passenger's air bag.

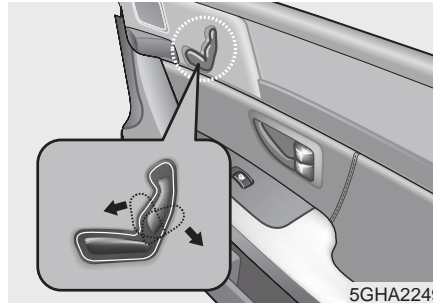

Adjusting seatback recliner

Move the lever forward or backward to the desired angle and release the lever. If the lever is released, seatback will lock in place. After adjustment, make sure that the lever has returned to its original locked position.

⚠ WARNING

Riding in a vehicle with a front seatback reclined could lead to serious or fatal injury in an accident. If a front seat is reclined, the occupant's hips may slide under the lap portion of the safety belt applying great force to the unprotected abdomen or neck or a passenger may be ejected in a rollover. Serious or fatal internal injuries could result. Keep the seatbacks in a comfortably upright position whenever the vehicle is in motion.

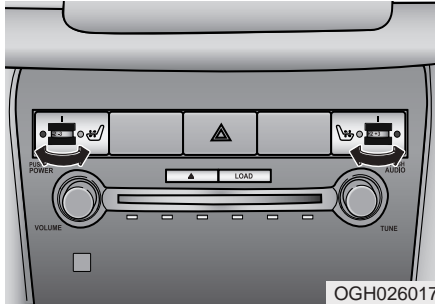

Warming and ventilating the front seats (if equipped)

Warming the seats

The front seats can be electrically heated individually when the ignition switch is ON. When the switch is ON, a number ranging from 1 to 5 is displayed on the switch (5 = warmest setting).

To turn off the seat warmer, set the switch to 0.

The seat warmer turns off automatically when the seat temperature reaches the selected range and will turn on again if the temperature drops below the selected range.

Ventilating the seats

The front seats are ventilated by the small vent hole on the surface of the seats and seatbacks, when the ignition switch is ON and the control switch is displayed in the range of -1 to -3.

Do not spill liquid such as water or beverages on the surface of the front seats and seatbacks. For the air vent holes may be blocked and prevent them from working properly.

Do not place materials such as plastic bags or newspapers under the seats. The air vent may not work properly as the air intake can be blocked.

When the air vent does not operate, restart the vehicle. If there is no change, have your vehicle inspected by an authorized KIA dealer.

As you operate the control switch, you will be able to notice the temperature change after 3 to 5 minutes. For the temperature is adjusted by the small air vent. For more effective use, you may use it with the air conditioner and heater.

CAUTION

- **When cleaning the seats, do not use an organic solvent such as thinner, benzene, alcohol and gasoline. Doing so may damage the surface of the heater or seats.**
- **To prevent overheating the seat warmer, do not place blankets, cushions or seat covers on the seats while the seat warmer is in operation.**
- **Do not place heavy or sharp objects on seats equipped with seat warmers. Damage to the seat warming components could occur.**

⚠ WARNING

Passengers should use extreme caution when using seat warmers due to the possibility of excess heating or burns. In particular, the following types of passengers should exercise extreme care:

1. Infants, children, elderly or disabled persons, or hospital outpatients
2. Persons with sensitive skin or those that burn easily
3. Fatigued individuals
4. Intoxicated individuals
5. Individuals taking medication that can cause drowsiness or sleepiness (sleeping pills, cold tablets, etc.)

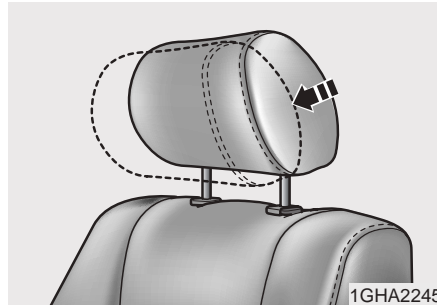

Headrest adjustment

Adjusting forward and backward

The headrest may be adjusted forward to three different positions by pulling the headrest forward. To adjust the headrest backward, pull it fully forward to the farthest position and release it. Adjust the headrest so that it properly supports the head and neck.

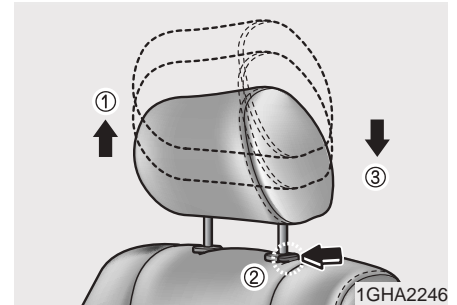

Adjusting the height up and down

The headrest not only provides comfort for the driver and passengers, but also helps protect the head and neck in the event of a collision.

To raise the headrest, pull it up to the desired position (①). To lower the headrest, push and hold the release button (②) on the headrest support and lower the headrest to the desired position (③). For best protection, adjust the headrest so its center is as high as your ears. Also adjust the headrest so its distance from the head is as wide as your fist.

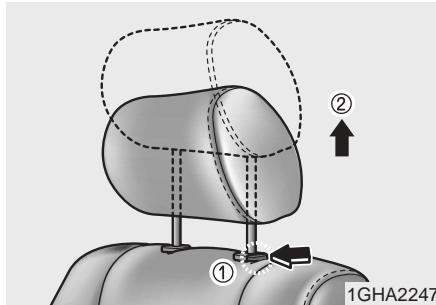

1GHA2247

Removal

To remove the headrest, raise it as far as it can go then press the release button (1) while pulling upward (2).

⚠ WARNING

To reduce the risk of head and neck injuries, do not drive the vehicle with the headrest removed or improperly positioned.

Do not adjust the driver's headrest while driving.



OGH026090N

Rear seat

Armrest

The armrest is located in the center of the rear seat. Pull the armrest down from the seatback.

You will find a storage cover and cup holders (if equipped).

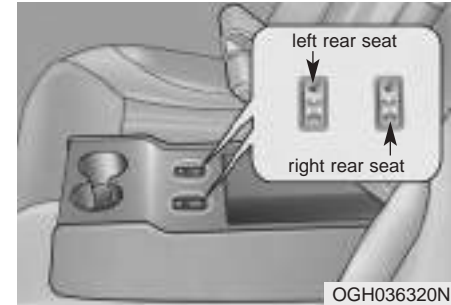

OGH036320N

Warming the rear passenger seats (if equipped)

Rear seats can be electrically heated when the ignition switch is ON.

1. Pull the armrest down using the strap provided on the armrest.
2. When the switch is ON, a number ranging from 1 to 5 is displayed on the switch (5 = warmest setting).

To turn off the seat warmer, set the switch to 0.

The seat warmer turns off automatically when the seat temperature reaches the selected range and will turn on again if the temperature drops below the selected range.

CAUTION

- *When cleaning the seats, do not use an organic solvent such as thinner, benzene, alcohol and gasoline. Doing so may damage the surface of the heater or seats.*
- *To prevent overheating the seat warmer, do not place blankets, cushions or seat covers on the seats while the seat warmer is in operation.*
- *Do not place heavy or sharp objects on seats equipped with seat warmers. Damage to the seat warming components could occur.*

WARNING

Passengers should use extreme caution when using seat warmers due to the possibility of excess heating or burns. In particular, the following types of passengers should exercise extreme care:

1. Infants, children, elderly or disabled persons, or hospital outpatients
2. Persons with sensitive skin or those that burn easily
3. Fatigued individuals
4. Intoxicated individuals
5. Individuals taking medication that can cause drowsiness or sleepiness (sleeping pills, cold tablets, etc.)

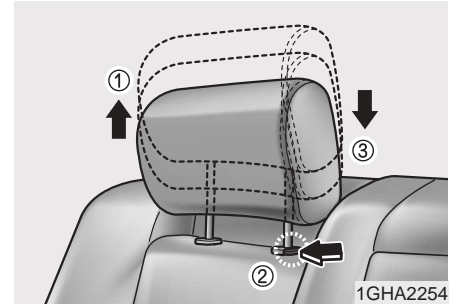

Headrest adjustment

Adjusting the height up and down

The headrest not only provides comfort for the rear passengers, but also helps protect the head and neck in the event of a collision.

For best protection, adjust the headrest so its center is as high as your ears. Also adjust the headrest so its distance from the head is as wide as your fist.

To raise the headrest, pull it up to the desired position (①). To lower the headrest, push and hold the release button (②) on the headrest support and lower the headrest to the desired position (③).

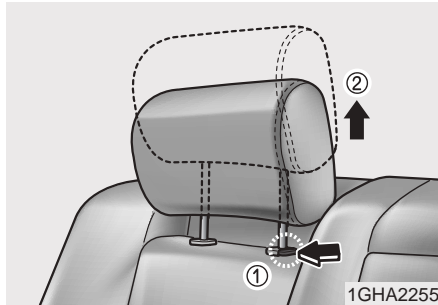

Removal

To remove the headrest, raise it as far as it can go then press the release button (1) while pulling upward (2).

⚠ WARNING

To reduce the risk of head and neck injuries, do not drive the vehicle with the headrest removed or improperly positioned.

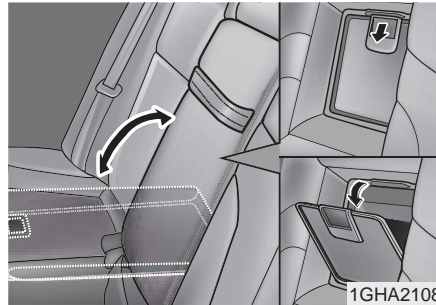

Storing long/narrow cargo with trunk closed (if equipped)

Pull the armrest down using the strap provided on the armrest. Pull the cover down while pushing the release lever down. Additional cargo space is provided to accommodate long/narrow cargo (skis, poles, lumber, etc.) not able to fit properly in the trunk when closed.

⚠ WARNING

- Make sure the engine is off, the transaxle is in P and the parking brake is applied whenever loading or unloading cargo. Vehicle may move if shift lever is inadvertently moved to another position.
- When cargo is loaded through the rear passenger seats, ensure the cargo is properly secured to prevent it from moving while driving. Unsecured cargo in the passenger compartment can cause damage to the vehicle or injury to its occupants.

⚠ CAUTION

Be careful when loading cargo through the rear passenger seats to prevent damage to the vehicle interior.

DRIVER POSITION MEMORY SYSTEM (IF EQUIPPED)



A driver position memory system is provided to store and recall the seat and outside mirror positions with a simple button operation. By saving the desired positions into the system memory, different drivers can reposition the seat and outside mirror based upon their driving preference.

If battery is disconnected, the position memory will be lost and the driving positions should be restored in the system.

Storing positions into memory using the buttons on the door

Storing driver's seat positions

1. Shift the transaxle lever into P while the ignition switch is ON.
2. Adjust the seat and outside rearview mirror to positions comfortable for the driver.
3. Press the SET button on the control panel.
4. Press one of the memory buttons (1 or 2) within 5 seconds after pressing the SET button. The system will beep twice when memory has been successfully stored.

The particular driver positions are memorized in the button (1 or 2) selected.

Recalling positions from memory

1. Shift the transaxle lever into P while the ignition switch is ON.
2. To recall the position in memory, press the desired memory button (1 or 2) the system will beep once, then the seat and outside rearview mirror will automatically adjust to the stored positions.

Adjusting one of the control knobs for the seat or outside rearview mirror while the system is recalling the stored positions will cause the movement for that component to stop and move in the direction that the control knob is moved. Other components will continue position recalling.

To stop the position recall at any point in the recall process, press the STOP button once. Seat and outside rearview mirror position recalling will stop.

CAUTION

Use with caution when recalling adjustment memory while sitting in the vehicle. Press the STOP button immediately if the seat moves too far in any direction.

Storing and recalling with transmitter

Storing with the transmitter

Turn the ignition switch to LOCK from ON and lock all the doors using the transmitter. The seat and outside rearview mirror positions will be stored in the system memory.

Driver's position recalling with transmitter

Unlock the door with the transmitter, positions stored in the system memory will be recalled automatically.

If using two transmitters, recalling times may vary because stored positions in each transmitter may be different.

Example) If doors are locked with transmitter A and unlocked with transmitter B, the positions memorized when unlocked with transmitter B will be recalled and may take slightly longer than if unlocked with transmitter A.

SAFETY BELTS



Pre-tensioner seat belt

Your vehicle is equipped with driver's and front passenger's pre-tensioner seat belts. The purpose of the pre-tensioner is to make sure that the seat belts fit tightly against the occupant's body in certain frontal collisions. The pre-tensioner seat belts can be activated alone or, together with the air bags, where the frontal collision is severe enough.

* NOTICE

The pre-tensioner seat belt is installed at the front seats, and the sensor is equipped inside the buckle, where presence of passenger is sensed by the fastening of the seat belts. Therefore, pre-tensioner will not activate if the passenger is not fastened with the seat belts. Likewise, it will activate if buckled even without a passenger in the seat. Pre-tensioner seat belt is designed to activate when the seatbelt is in use. To ensure the pretensioner seatbelts activate in event of a possible seatbelt buckle switch malfunction, the system is designed to activate regardless of whether a seat belt is in use or if no seat belt use is detected within 6 seconds of turning the ignition switch ON.

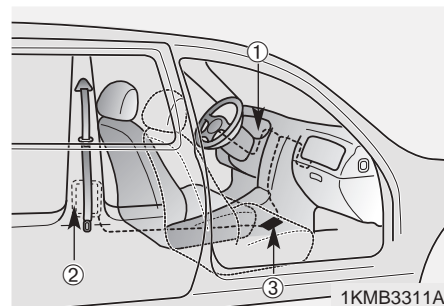

The seat belt pre-tensioner system consists mainly of the following components. Their locations are shown in the illustration.

- ① SRS air bag warning light
- ② Seatbelt pre-tensioner assembly
- ③ SRS air bag control module

⚠ WARNING

To obtain maximum benefit from a pre-tensioner seat belt:

- The seat belt must be worn correctly.
- The seat belt must be adjusted to the correct position.

Load limiter

When the pre-tensioner activates, if the system senses excessive seat belt tension on the driver or passenger's seat belt, the load limiter inside the pre-tensioner will release some of the pressure on the affected seat belt.

⚠ WARNING

When the pre-tensioner seat belts are activated and the air bag is deployed, a loud noise may be heard and fine dust, which may appear to be smoke, may be visible in the passenger compartment and are not toxic.

Although, it is harmless, the fine dust may cause skin irritation and should not be breathed for prolonged periods. Wash your hands and face thoroughly after an accident in which the air bags and/or pre-tensioner seat belts were activated.

⚠ WARNING

- Because the sensor that activates the SRS air bag is connected with pre-tensioner seat belt, the SRS air bag warning light on the instrument panel will blink or illuminate for approximately 6 seconds after the ignition key has been turned to the "ON" position, then the light should go off.
- If the pre-tensioner seat belt is not working properly, this warning light will illuminate even if there is no malfunction of SRS air bag system. If the SRS air bag warning light does not illuminate when the ignition key is turned to "ON", or if it remains illuminated after blinking or illuminating for approximately 6 seconds, or if it illuminates while the vehicle is being driven, please have an authorized Kia dealer inspect the pre-tensioner seat belt or SRS air bag system as soon as possible.

⚠ WARNING

The pre-tensioner seat belt assembly mechanisms become hot during activation. Do not touch the pre-tensioner seat belt assembly for several minutes after they have been activated.

⚠ WARNING

- Pre-tensioners are designed to operate once. After activation, pre-tensioner seat belts must be replaced. All seat belts, of any type, should always be replaced after they have been worn during a collision.
- Do not attempt to inspect or replace the pre-tensioner seat belts yourself. This must be done by an authorized Kia dealer.

WARNING

- Do not strike the pre-tensioner seat belt assemblies.
 - Do not attempt to service or repair the pre-tensioner seat belt system in any manner.
 - Improper handling of the pre-tensioner seat belt assemblies, and failure to heed the warnings not to strike, modify, inspect, place, service or repair the pre-tensioner seat belt assemblies may lead to improper operation or inadvertent activation causing serious injury.
- Always wear the seat belts when driving or riding in a motor vehicle.

Safety belt restraint system

WARNING - Safety belts

To minimize the risk of serious or fatal injury in an accident, the driver and all passengers should use the appropriate safety restraints for their age and size. The presence of air bags does not change the need to be properly restrained by a safety belt or size-appropriate child restraint. In fact, air bags are designed to work the best when passengers are correctly restrained in the vehicle. Be sure you are familiar with the information in this section, including the information on infant and child restraints. Read the safety warnings on the sun visors of your vehicle also.

We strongly recommend that the driver and all passengers be properly restrained at all times by using the safety belts provided with the vehicle. Proper use of the safety belts decreases the risk of severe injury or death in accidents or sudden stops. In most states, and in Canada, the law requires their use.

All seats have lap/shoulder belts. Inertial locks in the safety belt retractors allow all of the lap/shoulder safety belts to remain unlocked during normal vehicle operation. This allows the occupants some freedom of movement and increased comfort while using the safety belts. If a force is applied to the vehicle, such as a strong stop, a sharp turn, or a collision, the safety belt retractors will automatically lock the safety belts.

Since the inertial locks do not require a collision in order to lock up, you may become aware of the safety belts locking while braking or going around sharp corners.

⚠ WARNING

Always use the rear seat position(s) to install your child restraint(s).

Never install a child restraint system in the front passenger position, as an inflating air bag could cause serious or fatal injury to a child in that position.

The rear safety belts use a special auto-lock feature designed to allow a child restraint to be used without an added locking clip. These safety belt positions normally lock only under extreme or emergency conditions (emergency lock mode). However, they can be adjusted so that they remain in fixed and locked when a child restraint system is in place. (Use this auto-lock mode only to secure a child restraint, never for passengers restrained by the safety belts.) Page 3-46 gives instructions on placing the safety belt in the auto lock mode.

The driver's safety belt can only operate in the emergency lock mode.

Safety belts provide the best restraint when:

- The seatback is upright.
- The occupant is sitting upright (not slouched).
- The lap belt is snug across the hips.
- The shoulder belt is snug across the chest.
- The knees are straight forward.

To help you remember to fasten your safety belt, a warning light will come on and a chime will sound. See Safety Belt Warning Light and Chime on page 3-35.

⚠ WARNING - After a collision

- **Lap/shoulder belt assemblies may be stretched or damaged when subjected to the stress and forces of a collision.**
- **The entire restraint system should be inspected following any collision. All belts, retractors, anchors and hardware damaged by a collision should be replaced before the vehicle is operated again.**

**⚠ WARNING - Cargo area
(if equipped)**

Passengers should never be allowed to ride in the cargo area of a vehicle. No safety belts are provided for the cargo area. Persons riding in the vehicle without a fastened safety belt are much more likely to suffer serious bodily injury or death during an accident.

⚠ WARNING - Twisted belts

A twisted or jammed safety belt cannot restrain you properly. If you cannot untwist or unjam the safety belt, have an authorized Kia dealer repair or replace it immediately. Never drive or ride with a twisted or jammed safety belt.

⚠ WARNING - Belt use

Safety belts must be used correctly to work properly in an accident. Each seating position in your vehicle has a specific safety belt assembly that includes a buckle and tongue designed to be used together.

For greatest effectiveness, follow these guidelines in using safety belts:

- Use the shoulder portion of the safety belt on the outside shoulder only. Never wear the shoulder portion under the arm.
- Never swing the safety belt around your neck to fit over the inside shoulder.
- Never wear the shoulder portion of the safety belt across the neck or face.

(Continued)

(Continued)

- Wear the lap portion as low as possible. Be sure that the lap belt fits snugly around the hips. Never wear a lap portion of a lap/shoulder belt over your waist; it should always go over the stronger area of your hips.
- Never use a single safety belt for more than one person.
- The front seatbacks should always remain in a comfortable, upright position when the vehicle is moving.

⚠ WARNING - Safety belt care

- A damaged belt may not give you the protection you need in an accident.
- Inspect your safety belts periodically for excessive wear or damage. Pull out each belt fully and look for fraying, cuts, burns or other damage. Pull the safety belt out and let it retract a number of times. Make sure that the lap/shoulder belts return smoothly and easily into the retractor.
- Check the latches to make sure they latch and release without interference or delay.
- Never close the doors on any part of the lap or shoulder belt.
- Any belt not in good condition or in good working order should be promptly replaced.

⚠ CAUTION

Never close the doors on any part of the lap or shoulder belt. It can damage the safety belt or buckle which could increase the risk of injury in case of an accident.

**Safety belt warning light and chime**

If the driver's lap/shoulder belt is not fastened when the key is turned ON or if it is unfastened after the key is turned ON, safety belt warning light blinks until the belt is fastened.

If the driver's lap/shoulder belt is not fastened when the key is turned ON or if it is unfastened after the key is turned ON, safety belt warning chime sounds for approximately 6 seconds.



Lap/shoulder belt

To fasten the front lap/shoulder belt:

1. Grasp the buckle and tongue plate.
2. Slowly pull the lap/shoulder belt out from the retractor.



3. Insert the tongue plate (①) into the open end of the buckle (②) until an audible “click” is heard, indicating the belt is locked in the buckle.

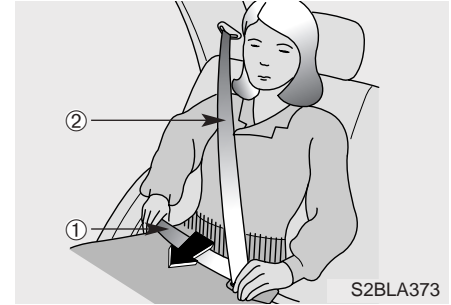

4. Position the lap portion (①) of the belt across your lap as **LOW ON THE HIPS** as possible to reduce the risk of sliding under it during an accident. Adjust the belt to a **SNUG FIT** by pulling up on the shoulder portion (②) of the safety belt. The belt retractor is designed to take up excess webbing automatically and to maintain tension on the belt. For your safety, do not put any excess slack into the safety belt at any location.

*** NOTICE**

If you are not able to pull out the safety belt from the retractor, firmly pull the belt out and release it. Then you will be able to pull the belt out smoothly.

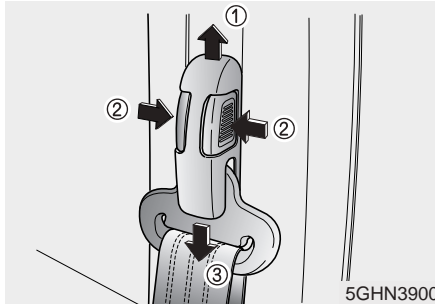

5. Adjust the shoulder anchor position to your size. To raise the anchor position, push the anchor up (①). To lower the anchor position, press the button (②) and slide the anchor down (③). After adjustment, make sure the anchor is locked in position.

⚠ WARNING

- The height adjuster must be in the locked position when the vehicle is moving.
- The misadjustment of height of the shoulder belt could reduce the effectiveness of the seat belt in a crash.

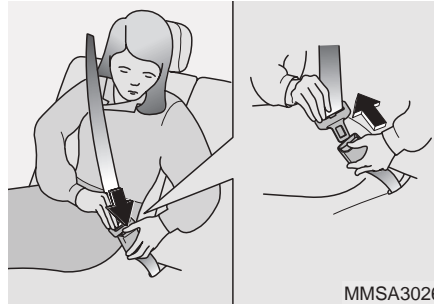

To unfasten the front lap/shoulder belt:

Press the release button on the buckle and allow the belt to slowly retract.

⚠ WARNING

- The seatbacks should always remain in a comfortable, upright position while the vehicle is in motion. The safety belt system will provide the most protection with the seatbacks in an upright position.
- Never wear the shoulder portion of the safety belt under the outside arm or behind the back.
- Never wear the shoulder portion of the safety belt across the neck or face.
- Wear the lap portion of the safety belt as low on the hips as possible. Be sure the lap belt fits snugly around the hips. Never wear the lap belt over your waist.

(Continued)

(Continued)

- Never drive or ride with a twisted or jammed safety belt. If you cannot untwist or unjam the safety belt, see the nearest Kia dealer immediately.
 - Never use a single belt to restrain more than one person at a time.
- Failure to follow these warnings may increase the risk and severity of injury in an accident.



Rear lap/shoulder belt

To fasten the rear lap/shoulder belt:

1. Grasp the buckle and tongue plate.
2. Slowly pull the lap/shoulder belt out.
3. Insert the tongue plate (①) into the open end of the buckle (②) until an audible “click” is heard, indicating the belt is locked in the buckle.

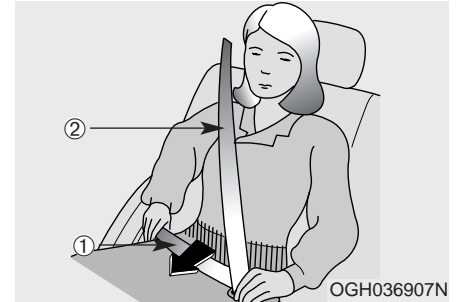

4. Position the lap portion (①) of the belt across your lap as **LOW ON THE HIPS** as possible to reduce the risk of sliding under it during an accident. Adjust the belt to a **SNUG FIT** by pulling up on the belt to a **SNUG FIT** by pulling up on the shoulder portion (②) of the safety belt. The belt retractor is designed to take up excess webbing automatically and to maintain tension on the belt. For your safety do not put any excess slack into the safety belt.

To unfasten:

Press the release button on the buckle and allow the belt to slowly retract.

⚠ WARNING

- Never wear the shoulder portion of the safety belt under the outside arm or behind the back.
- Never wear the shoulder portion of the safety belt across the neck or face.
- Wear the lap portion of the safety belt as low as possible. Be sure the lap belt fits snugly around the hips. Never wear the lap belt over your waist.

(Continued)

(Continued)

- Never drive or ride with a twisted or jammed safety belt. If you cannot untwist or unjam the safety belt, see the nearest Kia dealer immediately.
- Never use a single belt to restrain more than one person at a time.

Failure to follow these warnings may increase the risk and severity of injury in an accident.

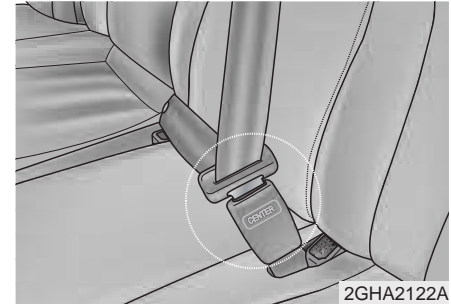

2GHA2122A

When using the rear center seat belt, the buckle with the "CENTER" mark must be used.

Proper use and care of the safety belt system

To ensure that the safety belts provide the maximum protection, please follow these instructions:

- Use the belts at all times - even on short trips.
 - If the safety belt is twisted, straighten it prior to use.
 - Keep sharp edges and damaging objects away from the belts.
 - Periodically inspect belt webbing, anchors, buckles and all other parts for signs of wear and damage. Replace damaged, excessively worn or questionable parts immediately.
- To clean the belt webbing, use a mild soap solution recommended for cleaning upholstery or carpets. Follow the instructions provided with the soap. Do not bleach or dye the webbing because this may weaken the webbing fibers and allow them to fail when loaded in a collision.
 - Do not make modifications or additions to the safety belt.
 - After wearing a safety belt, make sure it fully retracts to the stowed position. Do not allow the belt to get caught in the door when you close it.

Restraint of pregnant women

Pregnant women should wear lap/shoulder belt assemblies whenever possible according to specific recommendations by their doctors. The lap portion of the belt should be worn AS SNUGLY AND LOW AS POSSIBLE.

 **WARNING - Pregnant women**

Pregnant women must never place the lap portion of the safety belt over the area of the abdomen where the fetus is located or above the abdomen where the belt could crush the fetus during an impact.

Restraint of infants and small children

To increase their safety, infants and young children should always be restrained by a restraint system approved for their age and size.

Never allow a child to stand or kneel on the seat of a moving vehicle. Never allow a safety belt to be placed around both a child and an adult or around two children at the same time.

It is best for children to be seated in the rear seats.

WARNING - Children on laps

Never hold a child on your lap or in your arms in a moving vehicle.

Even a very strong person cannot hold onto a child in the event of even a minor collision.

Many companies manufacture child restraint systems (often called child seats) for infants and small children. An acceptable child restraint system must always satisfy U.S. Federal Motor Vehicle Safety Standards. Make sure that any child-restraint system you use in your vehicle is labelled as complying with those safety standards.

The child-restraint system should be chosen to fit both the size of the child and the size of the vehicle seat. Be sure to follow any instructions provided by the child-restraint system manufacturer when installing the child-restraint system.

WARNING - Infants and young children

- **Infants and young children are at much greater risk of serious injury or death in an accident or sudden stop if they are unrestrained or restrained improperly. Follow all instructions in this section of your Kia manual and the instructions that came on and with an improved child safety restraint system. The child restraint must be correctly installed in the vehicle, and the child must be correctly installed in the child restraint.**
- **All children under 12 are safest in the back seat.**
- **Never install a child or infant seat in the front passenger position. The baby could be injured or killed by the air bag if it deploys in an accident.**
- **Never allow a child to stand or kneel on the seat of a moving vehicle. Insist the child sit down in an approved restraint system.**

⚠ WARNING - Hot metal parts

Safety belts and seats can become hot in a vehicle that has been closed during warm/hot weather; they could burn a child. Check seat covers and buckles before you place a child anywhere near them.

Restraint of larger children

As children grow, they may need to use new child-restraint systems, including larger child seats or booster seats, which are appropriate for their increased size.

A child who has outgrown available child-restraint systems should use the belts provided in the vehicle. When seated in the rear outboard seats, the child should be restrained by the lap/shoulder belt.

If the shoulder belt portion slightly touches the child's neck or face, try placing the child closer to the center of the vehicle. If the shoulder belt still touches their face or neck they may need to be returned to a child restraint system. In addition, after-market devices are available from independent manufacturers which help pull the shoulder belt down and away from the child's face or neck.

Larger children should use one of the seat belts provided.

⚠ WARNING - Shoulder belts on small children

- **Never allow a shoulder belt to be in contact with a child's neck or face while the vehicle is in motion.**
- **If safety belts are not properly worn and adjusted, there is a risk of death or serious injury to a child.**

Child restraint system (if equipped)

For small children and babies, the use of a child seat or infant seat is required by law. This child seat or infant seat should be of appropriate size for the child and should be installed in accordance with the manufacturer's instructions. It is strongly recommended that the seat be placed in the vehicle's rear seat since this can make an important contribution to safety.

Children riding in the car should sit on the rear seat and must always be properly restrained to minimize the risk of injury in an accident, sudden stop or sudden maneuver. According to accident statistics, children are safer when properly restrained in the rear seats than in the front seat.

You are required by law to use safety restraints for children. If small children ride in your vehicle you must put them in a child restraint system (safety seat).

Child restraint systems are designed to be secured in vehicle seats by lap belts or the lap belt portion of a lap/shoulder belt, or by a LATCH system (if equipped). Children could be injured or killed in a crash if their restraints are not properly secured. For small children and babies, a child seat or infant seat must be used. Before buying a particular child restraint system, make sure it fits your car and seat belts, and fits your child. Follow all the instructions provided by the manufacturer when installing the child restraint system.



ADAIRBAG

⚠ WARNING

- **A child restraint system must be placed in the rear seat. Never install a child or infant seat on the front passenger's seat.**

Should an accident occur and cause the passenger air bag to deploy, it could severely injure or kill an infant or child seated in an infant or child seat. Thus, only use a child restraint in the rear seat of your vehicle.

(Continued)

(Continued)

- Since a safety belt or child restraint system can become very hot if it is left in a closed vehicle, be sure to check the seat cover and buckles before placing a child there.
- When the child restraint system is not in use, store it in the trunk or fasten it with a safety belt or LATCH system so that it will not be thrown forward in the case of a sudden stop or an accident.
- Children who are too large to be in a child restraint should sit in the rear seat and be restrained with the available lap/shoulder belts. Never allow children to ride in the front passenger seat.

(Continued)

(Continued)

- Always make sure that the shoulder belt portion of the lap/shoulder belt is positioned midway over the shoulder, never across the neck or behind the back. The lap belt portion of the lap/shoulder belt must always be positioned as low as possible on the child's hips and as snug as possible.
- If the seat belt will not properly fit the child, an approved booster seat in the rear seat must be used in order to raise the child's seating height so that the seat belt will properly fit the child.

(Continued)

(Continued)

- Never allow a child to stand up or kneel on the seat.
- Never use an infant carrier or child safety seat that "hooks" over a seatback; it may not provide adequate security in an accident.
- Never allow a child to be held in a person's arms while they are in a moving vehicle, as this could result in serious injury to the child in the event of an accident or a sudden stop. Holding a child in a moving vehicle does not provide the child with any means of protection during an accident, even if the person holding the child is wearing a seat belt.

Installing a child restraint system

For safety reasons, we recommend that the child restraint system be used in the rear seats. **Never place a rear-facing child restraint in the front passenger seat, because of the danger that an inflating passenger side air bag could impact the rear-facing child restraint and kill the child.**

Since all passenger's (except driver's) safety belts move freely under normal conditions and only lock under extreme or emergency conditions (emergency lock mode), you must manually change these safety belts to the auto lock mode to secure a child restraint.

*** NOTICE**

The driver's safety belt incorporates the emergency lock mode only.

⚠ WARNING

- Before installing the child restraint system, read the instructions supplied by the child restraint system manufacturer.
- If the seat belt does not operate as described, have the system checked immediately by your authorized Kia dealer.
- Failure to observe this manual instructions regarding child restraint system and the instructions provided with the child restraint system could increase the chance and/or severity of injury in an accident.

⚠ WARNING

- Do not install any child restraint system in the front passenger seat. Should an accident occur and cause the passenger air bag to deploy, it could severely injure or kill an infant or child seated in an infant or child seat. Therefore, only use a child restraint system in the rear seat of your vehicle.
- If the child restraint seat is not anchored properly, the risk of a child being seriously injured or killed in a collision greatly increases.

Placing a passenger safety belt into the auto lock mode

The use of the auto lock mode will ensure that the normal movement of the child in the vehicle does not cause the safety belt to be pulled out and loosen the firmness of its hold on the child restraint system. To secure a child restraint system, use the following procedure.

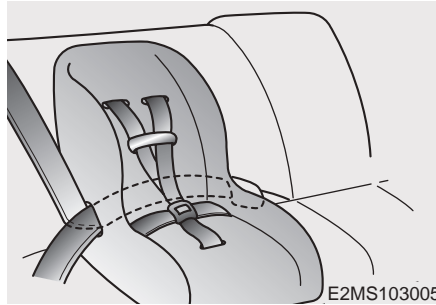

Installing a child restraint system by lap/shoulder belt

To install a child restraint system on the outboard or center rear seats, do the following:

1. Place the child restraint system in the seat and route the lap/shoulder belt around or through the restraint, following the restraint manufacturer's instructions. Be sure the safety belt webbing is not twisted.

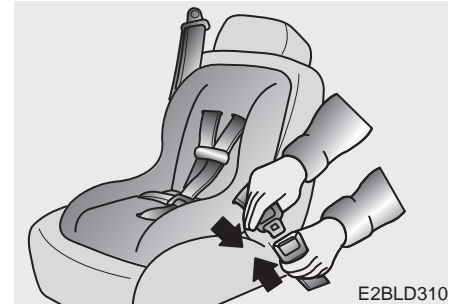

2. Fasten the lap/shoulder belt latch into the buckle. Listen for the distinct "click" sound.

Position the release button so that it is easy to access in case of an emergency.

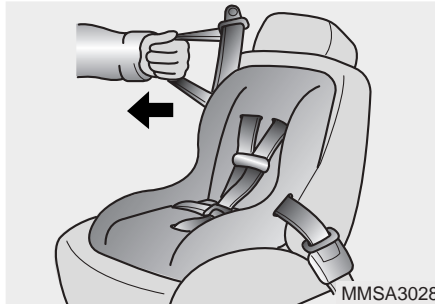

MMSA3028

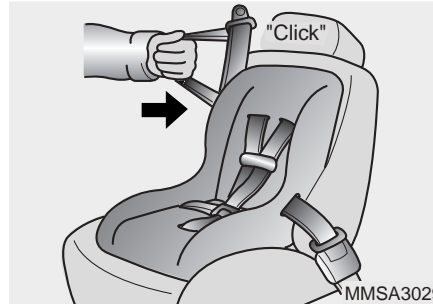

MMSA3029



MMSA3030

3. Pull the shoulder portion of the safety belt all the way out. When the shoulder portion of the safety belt is fully extended, it will shift the retractor to the "Auto Lock" (child restraint) mode.
4. Slowly allow the shoulder portion of the safety belt to retract and listen for an audible "clicking" or "ratcheting" sound. This indicates that the retractor is in the "Auto Lock" mode. If no distinct sound is heard, repeat steps 3 and 4.
5. Remove as much slack from the belt as possible by pushing down on the child restraint system while feeding the shoulder belt back into the retractor.
6. Push and pull on the child restraint system to confirm that the safety belt is holding it firmly in place. If it is not, release the safety belt and repeat steps 2 through 6.
7. Double check that the retractor is in the "Auto Lock" mode by attempting to pull more of the safety belt out of the retractor. If you cannot, the retractor is in the "Auto Lock" mode.

To remove the child restraint, press the release button on the buckle and then pull the lap/shoulder belt out of the restraint and allow the safety belt to retract fully.

⚠ WARNING - Auto lock mode

The lap/shoulder belt automatically returns to the “emergency lock mode” whenever the belt is allowed to retract fully. Therefore, the preceding seven steps must be followed each time a child restraint is installed.

If the safety belt is not placed in the “auto lock” mode, severe injury or death could occur to the child and/or other occupants in the vehicle in a collision, since the child restraint will not be effectively held in place.

*** NOTICE**

When the safety belt is allowed to retract to its fully stowed position, the retractor will automatically switch from the “Auto Lock” mode to the emergency lock mode for normal adult usage.

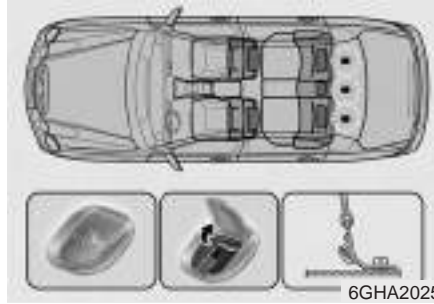

Securing a child restraint seat with “Tether Anchor” system

Child restraint hook holders are located on the shelf behind the rear seats.

1. Open the tether anchor cover on the shelf behind the rear seats.



2. Route the child restraint seat strap over the seatback.

For vehicles with adjustable headrest, route the tether strap under the headrest and between the headrest posts, otherwise route the tether strap over the top of the seatback.

3. Connect the tether strap hook to the correct child restraint hook holder and tighten to secure the seat.

⚠ WARNING - Tether strap

If the tether strap is secured incorrectly, the child restraint seat may not be restrained properly in the event of a collision. Do not mount more than one child restraint seat to a tether anchorage, since the anchorage can then fail in a collision.

⚠ WARNING - Child restraint

Check that the child restraint system is secure by pushing and pulling it in different directions. Incorrectly fitted child restraints may swing, twist, tip or come away causing death or injury.

⚠ WARNING - Child restraint anchorage

- Child restraint anchorages are designed to withstand only those loads imposed by correctly fitted child restraints. Under no circumstances are they to be used for adult seat belts or harnesses or for attaching other items or equipment to the vehicle.
- The tether strap may not work properly if attached somewhere other than the correct tether anchor.

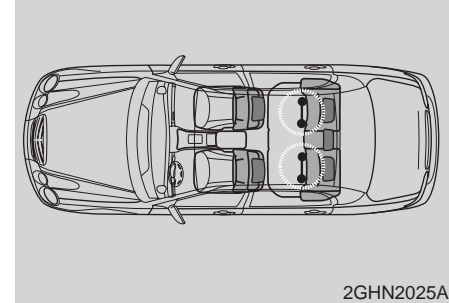
***Child seat lower anchors***

Some child seat manufacturers make child restraint seats that are labeled as LATCH or LATCH compatible. LATCH stands for “Lower Anchors and Tethers for Children”. These seats include two rigid or webbing mounted attachments that connect to two lower anchors and a tether anchors at specific seating positions in your vehicle. This type of child restraint seat eliminates the need to use seat belts to attach the child seat in the rear seats.



There is a child restraint symbol located on the lower portion of each side of the rear seatbacks. These symbols indicate the position of the lower anchors for child restraints so equipped.

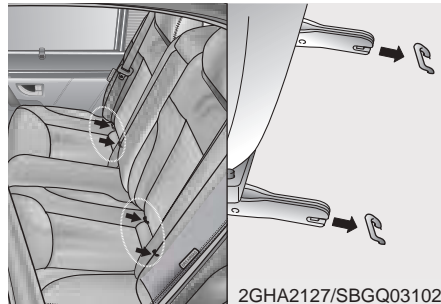

LATCH anchors have been provided in your vehicle. The LATCH anchors are located in the left and right outboard rear seating positions. Their locations are shown in the illustration. There is no LATCH anchor provided for the center rear seating position.

The LATCH anchors are located between the seatback and the seat cushion of the rear seat left and right outboard seating positions.

Follow the child seat manufacturer's instructions to properly install child restraint seats with LATCH or LATCH-compatible attachments.

Once you have installed the LATCH child restraint, assure that the seat is properly attached to the LATCH and tether anchors. Also, test the child restraint seat before you place the child in it. Tilt the seat from side to side. Also try to tug the seat forward. Check to see if the anchors hold the seat in place.

CAUTION

Do not allow the rear seat belt webbing to get scratched or pinched by the child-seat latch and LATCH anchor during the installation.

⚠ WARNING

When using the vehicle's "LATCH" system to install a child restraint system in the rear seat, all unused vehicle rear seat belt metal latch plates or tabs must be latched securely in their seat belt buckles and the seat belt webbing must be retracted behind the child restraint to prevent the child from reaching and taking hold of unretracted seat belts. Unlatched metal latch plates or tabs may allow the child to reach the unretracted seat belts which may result in strangulation and a serious injury or death to the child in the child restraint.

⚠ WARNING

If the child restraint is not anchored properly, the risk of a child being seriously injured or killed in a collision greatly increases.

⚠ WARNING

- Do not mount more than one child restraint to a single tether or to a child restraint lower anchorage point. The improper increased load may cause the anchorage points or tether anchor to break, causing serious injury or death.
- Do not install a child restraint seat at the rear center seating position using the vehicle's LATCH anchors. The LATCH anchors are only provided for the left and right outboard rear seating positions. Do not misuse the LATCH anchors by attempting to attach a child restraint seat in the middle rear seating position to the LATCH anchors.

In a crash, the child restraint seat LATCH attachments may not be strong enough to secure the child restraint seat improperly in the rear center seating position and may break, causing serious injury or death.

(Continued)

(Continued)

- Attach the LATCH or LATCH-compatible child restraint seat only to the appropriate locations shown in the illustration.
- Always follow the installation and use instructions provided by the manufacturer of the child restraint.

AIR BAG - ADVANCED SUPPLEMENTAL RESTRAINT SYSTEM

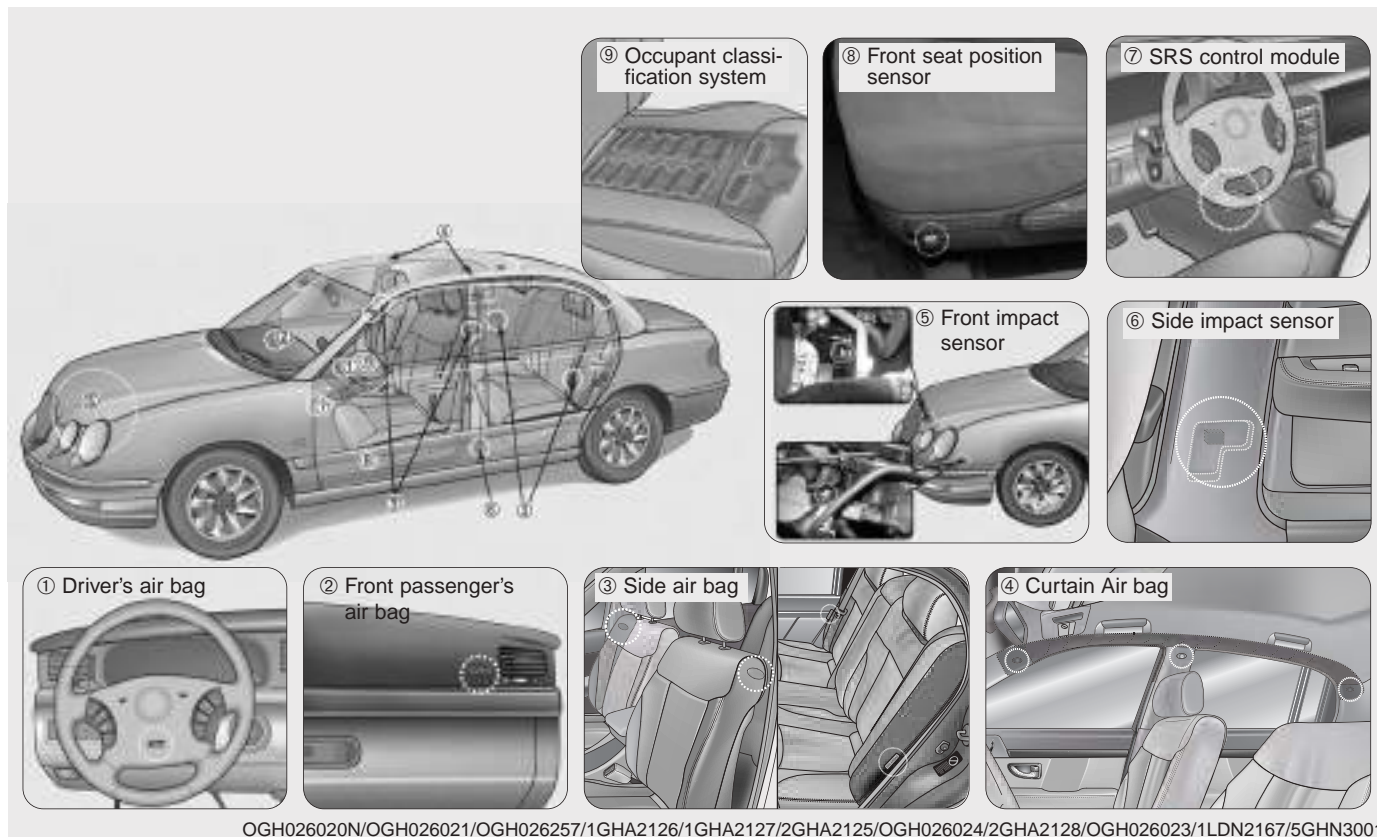

What your air bag system does

Driver's air bag and front passenger's air bag are designed to supplement the protection offered by the safety belt in certain frontal collisions. Likewise, side air bag and curtain air bags are designed to supplement the protection offered by the safety belt in side collisions. Safety belts are designed to reduce the injury of the driver or passengers in case of impact or collision. No safety belt or air bag system can completely eliminate injuries that may be caused in collisions or impacts. To help reduce impact on driver or passengers in any collision, safety belts must be correctly worn.

What your air bag system does not do

The air bag system is designed to supplement the protection offered by the safety belt system. **IT IS NOT A SUBSTITUTE FOR THE SAFETY BELT.**

The importance of using safety belts

There are four very important reasons to use safety belts even with an air bag supplemental restraint system. They:

- help keep you in the proper position (away from the air bag) when it inflates.
- reduce the risk of harm in rollover, side impact (vehicles not equipped with side and curtain air bags) or rear impact collisions, because an air bag is not designed to inflate in such situations and even a side curtain air bag is designed to inflate only in certain side impact collisions.
- reduce the risk of harm in frontal or side collisions which are not severe enough to actuate the air bag supplemental restraint system.
- reduce the risk of being ejected from your vehicle.

*** NOTICE**

Your vehicle's Supplemental Restraint System Control Module is equipped with a recording device that may record the use or status of the safety belt restraint system by the driver and front passenger in certain collisions.

⚠ WARNING - Air bags & safety belts

- Even in vehicles with air bags, you and your passengers must always wear the safety belts provided in order to minimize the risk and severity of injury in the event of a collision or rollover.
- Always wear your safety belt. It can help keep you away from the air bags during heavy braking just before a collision.
- If occupants are not wearing safety belts or correctly seated, they cannot be protected, and thus face serious injury or death.

(Continued)

(Continued)

- Driver's and front passenger's air bags are designed to inflate only in certain frontal collision, and side and curtain air bags are designed to inflate in certain side impacts. Frontal air bags will generally not provide protection in side impacts (vehicles not equipped with side and curtain air bags) or rear impacts, rollovers, less severe frontal collisions. They will not provide protection from later impacts in a multi-impact collision.

(Continued)

(Continued)

- If your vehicle has been subjected to flood conditions (e.g. soaked carpeting/standing water on the floor of the vehicle, etc.) or if your vehicle has become flood damaged in any way, do not attempt to start the vehicle or put the key in the ignition before disconnecting the battery.

Disregarding this precaution may cause air bag deployment, which could result in serious personal injury or death. If your vehicle is subjected to flooded conditions, before starting the vehicle, have the vehicle towed to an authorized Kia dealer for inspection and necessary repairs.

Air bag system components

- The SRS air bag consists of the following components;
 1. Driver's air bag module
 2. Passenger's air bag module
 3. Side air bag module
 4. Curtain air bag module
 5. Front impact sensors
 6. Side impact sensors
 7. SRS air bag control module
 8. Driver's seat position sensor
 9. Occupant Classification System (Front passenger's seat only)
 10. "PASSENGER AIR BAG OFF" indicator (Front passenger's seat only)
 11. Driver's and front passenger's safety belt buckle sensors
 12. Retractor Pre-tensioner Assemblies
 13. SRS "AIR BAG" warning light
- A diagnostic system that continually monitors the system operation.
- An indicator light to warn you of a possible problem with the system.
- Emergency power backup in case your car's electrical system is disconnected in a crash.

The SRS uses a collection of sensors to gather information about the driver's seat position, the driver's and front passenger's safety belt usage and impact severity.

The driver's seat position sensor, which is installed on the seat track, determines if the seat is fore or aft of a reference position. Similarly, the safety belt usage sensors determine if the driver and front passenger's safety belts are fastened. These sensors provide the ability to control the SRS deployment based on how close the driver's seat is to the steering wheel, how close the passenger's seat is to the instrument panel, whether or not the safety belts are fastened, and the severity of the impact.

The advanced SRS offers the ability to control the air bag inflation with two levels. A first stage level is provided for moderate-severity impacts. A second stage level is provided for more severe impacts.

According to the impact severity, seating position (only driver) and safety belt usage, the SRSCM (SRS Control Module) controls the air bag inflation. **Failure to properly wear safety belts can increase the risk or severity of injury in an accident.**

Additionally, your SRS is equipped with an occupant classification system in the front passenger's seat. The occupant classification system detects the presence of a passenger in the front passenger's seat and will turn off the front passenger's air bag under certain conditions. For more detail, see "Occupant Classification System" later in this section.

CAUTION

If the seat position sensor is not working properly, the SRS air bag warning light (^{AIR}_{BAG}) on the instrument panel will illuminate even if there is no malfunction of the SRS air bag system, because the SRS air bag warning light is connected with the seat position sensor. If the SRS air bag warning light does not illuminate when the ignition key is turned to the "ON" position, if it remains illuminated after blinking for approximately 6 seconds, or if it illuminates while the vehicle is being driven, have an authorized Kia dealer inspect the seat position sensor and the advanced SRS air bag system as soon as possible.

WARNING

- Modification to the seat structure can adversely affect the seat position sensor and cause the air bag to deploy at a different level than should be provided.
- Failure to properly wear safety belts can increase the risk or severity of injury by causing the air bags to deploy at a different level than should be provided.
- Do not place any objects underneath the driver's seats which could damage the seat position sensor.
- Do not place any objects that may cause magnetic fields near the front seat. These may cause a malfunction of the seat position sensor.

⚠ WARNING

- Ignoring the SRS indicator light (air bag indicator and passenger air bag off indicator) can result in serious or fatal injury if the air bags occupant classification system or pretensioners do not work properly. Have your car checked by a dealer as soon as possible if the SRS warning light alerts you to a potential problem.
- Sitting improperly or out of position can result in serious or fatal injury in a crash. All occupants should sit upright in their seats with their feet on the floor until the vehicle is parked and the ignition key is removed.

**Driver's air bag**

The driver's air bag is stored in the center of the steering wheel.

⚠ WARNING

- You must always sit as far back from the steering wheel air bag as possible (chest at least 10 inches (250 mm) away from the steering wheel), while still maintaining a comfortable seating position for good vehicle control, in order to reduce the risk of injury or death in a collision.
- Never place objects over the air bag storage compartments or between the air bags and yourself. Due to the speed and force of the air bag inflation, such objects could hit your body at high speed and cause severe bodily injury and even death.
- Do not put stickers or ornaments on the steering wheel cover. These may interfere with the deployment of the air bag.



Front passenger's air bag

Front passenger's air bag is stored in the instrument panel on the glove box.

Since you cannot know which air bags will deploy or from what direction, never put any objects or ornaments on the instrument panel.

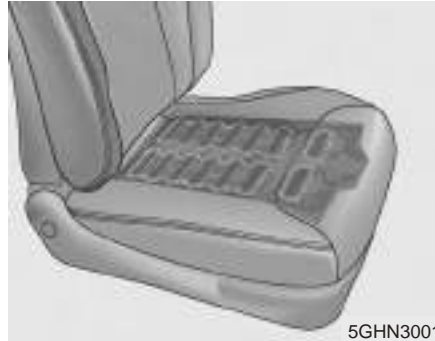

Occupant classification system

The occupant classification system detects the presence of a passenger in the front passenger's seat and will turn off the front passenger's air bag under certain conditions.

The occupant classification system is designed to detect the presence of a properly-seated occupant and determine if the front passenger's air bag should be enabled (may inflate) or not.

Main components of occupant classification system

- A detection device located within the front passenger seat cushion.
- Electronic system to determine whether passenger air bag systems (both front passenger's front and side air bag only) should be activated or deactivated.
- A warning light located on the instrument panel which illuminates the words "PASSENGER AIR BAG OFF" passenger air bag system is deactivated.
- The instrument panel air bag warning light is interconnected with the occupant classification system.

The location of OCS warning indicator



OGH036367N

If there is no passenger in the front passenger seat or if the passenger in the front passenger's seat is very small, (such as a child), the front PASSENGER AIR BAG OFF indicator may go ON.

When this indicator is ON, the front passenger's air bag will not deploy.

The front passenger's side air bag will not deploy if the front seat is unoccupied.

The front passenger's side air bag may deploy if the front seat is occupied by a small occupant.

Always be sure that you and all vehicle occupants are seated and restrained properly (sitting upright with the seat in an upright position, centered on the seat cushion, with the person's legs comfortably extended, feet on the floor, and wearing the safety belt properly) for the most effective protection by the air bag and the safety belt.

- The OCS may not function properly if the passenger takes actions which can defeat the detection system. These include:

- (1) Failing to sit in an upright position.
- (2) Leaning against the door or center console.
- (3) Sitting towards the sides or the front of the seat.
- (4) Putting legs on the dashboard or resting them on other locations which reduce the passenger weight on the front seat.
- (5) Improperly wearing the safety belt.
- (6) Reclining the seat back.

- The "PASSENGER AIR BAG OFF" indicator illuminates after the ignition key is turned to the "ON" position or after the engine is started. If the front passenger seat is unoccupied or is occupied by very small person, or is occupied by someone who is improperly seated, the "PASSENGER AIR BAG OFF" indicator will remain illuminated. If the front passenger seat is occupied by someone of adult size and body shape, the "PASSENGER AIR BAG OFF" indicator will turn off after 6 seconds.
- If the "PASSENGER AIR BAG OFF" indicator illuminates, the front passenger's air bag will not deploy. The front passenger's side air bag will not deploy if the front seat is unoccupied. The front passenger's side air bag may deploy if the front seat is occupied by a small occupant.
- If the "PASSENGER AIR BAG OFF" indicator is not illuminated, the front passenger front air bag and front passenger side air bag may deploy in either a side or frontal collision.

Condition and operation in the front passenger occupant classification system

Condition detected by the occupant classification system	Indicator/Warning light		Device
	"PASSENGER AIR BAG OFF" indicator light	AIR BAG warning light	Front passenger front air bag
1. Adult *1	Off	Off	Activated
2. Child*2 or child restraint system	On	Off	Deactivated
3. Unoccupied	On	Off	Deactivated

*1 The system detects a person who is generally adult size as an adult, thus allowing the passenger air bag to deploy. When a smaller adult sits in the front passenger seat, the system may detect their body shape as that of a child, thus preventing air bag deployment.

*2 When a larger child who has outgrown a child restraint system sits in the front passenger seat, the system may recognize him/her as an adult depending on his/her body shape or seating position, thus permitting air bag deployment.

CAUTION

If the "PASSENGER AIR BAG OFF" indicator illuminates or blinks continuously when a person of adult size sits in the front passenger's seat, it could be because that person isn't sitting properly in the seat. If this happens, turn the vehicle off, make sure the seat back is not reclined, have the passenger center on the seat cushion, with legs comfortably extended, and the safety belt properly positioned. Restart the vehicle and have the person remain in this position long enough to allow the system to detect the person and activate the passenger air bag.

CAUTION

If the occupant classification system is not working properly, the air bag warning light (^{AIR}_{BAG}) on the instrument panel will illuminate because the passenger's air bag is connected with the occupant classification system. If there is a malfunction of the occupant classification system, the "Passenger Air bag Off" indicator will not illuminate and the front passenger's air bag will deploy in frontal crashes even if there is child or no occupant in the front passenger's seat.

Have an authorized Kia dealer inspect the occupant classification system with the SRS air bag system as soon as possible if any of following occur;

- *The SRS air bag warning light does not illuminate when the ignition key is turned to "ON" position.*

(Continued)

(Continued)

- *The SRS air bag warning light remains illuminated after illuminating or blinking for approximately 6 seconds.*
- *The SRS air bag warning light illuminates while the vehicle is being driven.*

WARNING

- Even though your vehicle is equipped with the occupant classification system, do not install a child restraint system in the front passenger seat. The child could be severely injured or killed if the air bag deploys. Children are afforded the most protection in the event of an accident when they are restrained by the proper restraint system in the rear seat.

(Continued)

(Continued)

- If the "PASSENGER AIR BAG OFF" indicator is illuminated when the front passenger's seat is occupied by a person of adult size who is seated properly, or if the "PASSENGER AIR BAG OFF" indicator is not illuminated when the front passenger's seat is unoccupied or occupied by a very small person, the occupant classification system is not working properly. Have your vehicle immediately inspected by your Kia dealer if the occupant classification system is not working properly.

(Continued)

(Continued)

- If a low weight adult is seated in the front passenger seat, the occupant classification system may or may not turn off the right front passenger air bag, depending upon the person's seating position and body type. Everyone in your vehicle should wear a safety belt properly -- whether or not there is an air bag for that person.
- If the front seat passenger changes their seating position (for example, by not sitting upright, by sitting on the edge of the seat, or by otherwise being out of position), the "PASSENGER AIR BAG OFF" indicator may be turned on, and the passenger air bag may not deploy in a collision. Always be sure to sit properly in the front passenger seat and wear the safety belt properly and do not do any of the following.

(Continued)

(Continued)



1KMN3661

- Never put a heavy load in the front passenger seat.



1KMN3663

- Never sit with hips shifted towards the front of the seat.



1KMN3665

- Never place feet on the dashboard.



1KMN3662

- Never excessively recline the front passenger seatback.



1KMN3664

- Never lean on the center console.
- Never sit on one side of the front passenger seat.



1KMN3666

- Always sit in a proper seating position.

(Continued)

(Continued)

- Manufacturers are required by government regulations to provide a contact point concerning modifications to the vehicle for persons with disabilities, which modifications may affect the vehicle's advanced air bag system. That contact is Kia's toll-free Consumer Assistance center at 1-800-333-4KIA. However, Kia does not endorse nor will it support any changes to any part or structure of the vehicle that could affect the advanced air bag system, including the occupant classification system. Specifically, the front passenger seat, dashboard or door should not be replaced except by an authorized Kia dealer using original Kia parts designed for this vehicle and model. Any other such replacement or modification could adversely affect the operation of the occupant classification system and your advanced air bags.

(Continued)**(Continued)**

- For the same reason, do not attach anything to the seat, dashboard or door, even temporarily. If the system is adversely affected, it could cause severe personal injuries or death in a collision.
- Do not place sharp objects on the front passenger seat. These can damage the occupant classification system, if they puncture the seat cushion.
 - Do not install accessory seat covers on the front seats, since these will interfere with proper sensor operation.

*** NOTICE**

- If luggage or other objects are placed on the front passenger's seat or if the temperature of the seat changes while the seat is unoccupied, the "PASSENGER AIR BAG OFF" indicator may blink. These conditions do not indicate a problem.
- Do not put heavy objects on the front passenger's seat. This may cause front passenger air bag deployment in the event of an accident, thus increasing your repair costs.

⚠ WARNING

- The front seat passenger air bag is much larger than the steering wheel air bag and inflates with considerably more force. It can seriously hurt or kill a passenger who is not in the proper position and wearing the safety belt properly. The front passengers should always move their seats as far back as practical and sit back in their seats.
- It is essential that the front passenger always wears their safety belts, even when the vehicle is moving in a parking lot or up a driveway into garage.
- If the driver brakes the vehicle heavily prior to an impact, unbelted occupants will be thrown forward. If the front passenger is not wearing a safety belt, he/she will be directly in front of the storage compartment when deployment occurs. In that situation, serious injury or death is possible.

(Continued)

(Continued)

- Never allow front passenger to put their hands, feet or face on or close to the instrument panel. In the event of air bag deployment, such a mispositioned occupant would be likely to suffer severe injury or death.
- Never allow children, pregnant women or frail persons to sit in the front passenger seat. Do not put child restraint system on the front passenger's seat either. They may be seriously injured by the air bag inflation when air bag deploys.
- Do not put objects or stickers on the instrument panel. Do not apply any accessory to the front windshield. Do not install after-market mirrors or accessories on the factory-installed rearview mirror. Any of these could interfere with the deployment of the air bag or could hit your body at high speed and cause severe bodily injury and even death.

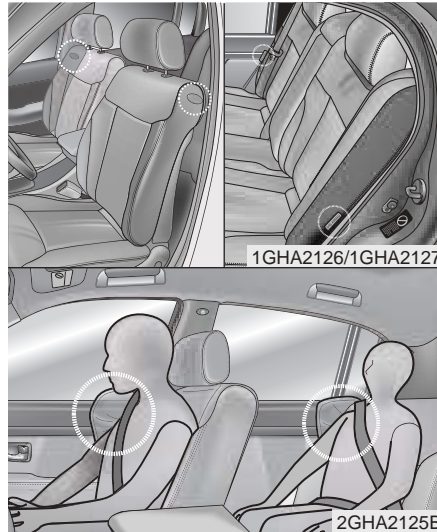

Side air bag (if equipped)

Side air bags are stored in the left side of the driver's seat, right side of the front passenger's seat and left and right sides of the rear seats.

Side air bags are designed to deploy only during certain side impact collisions depending on the crash severity, angle, speed and impact. The side air bags are not designed to deploy in all side impact situations.

⚠ WARNING

- Do not use any accessory seat covers for the vehicle equipped with side air bags. Use of seat covers could interfere with side air bag deployment. If seat or seat cover is damaged, have the vehicle checked and repaired by an authorized Kia dealer. Inform them that your vehicle is equipped with side air bags and an occupant detection system.
- Do not make modifications or additions to the seats. If inappropriate seats are used, unexpected injury may result in due to the malfunction of the air bag system.

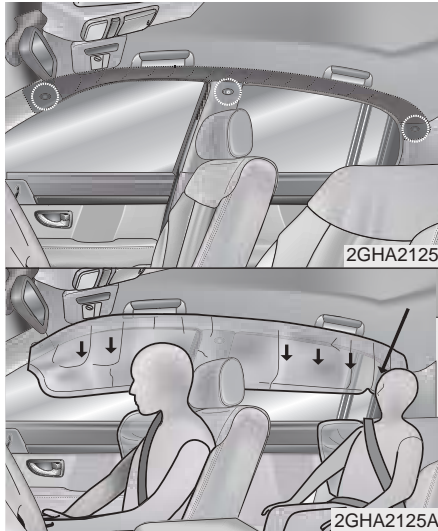

Curtain air bag

Curtain air bags are located along both sides of the roof rails above the front and rear doors.

It is designed to help protect the heads of the front seat occupants and the rear outboard seat occupants in certain side impact collisions.

- The curtain air bag deployment occurs only on the side of the vehicle affected by the impact.
- The side air bags (side and curtain air bags) are not designed to deploy during collisions from the front or rear of the vehicle or in most rollover situations.
- The curtain air bags are designed to deploy only during certain side-impact collisions, depending on the crash severity, angle, speed and impact. The curtain air bags are not designed to deploy in all side impact situations.

⚠ WARNING

- In order for side air bags (side and curtain air bags) to provide best protection, both front seat occupants and both outboard rear occupants should sit in an upright position with the seat belts properly fastened. Importantly, children should sit in a proper child restraint system in the rear seat.

(Continued)

(Continued)

- When children are seated in the rear outboard seats, they must be seated in the proper child restraint system. Make sure to put the child restraint system as far away from the door side as possible, and securely lock the child restraint system in position.
- Do not allow the passengers to lean their heads or bodies onto doors, put their arms on the doors, stretch their arms out of the window, or place objects between the doors and passengers when they are seated on seats equipped with side air bags.
- Never try to open or repair any components of the side curtain air bag system. This should only be done by an authorized Kia dealer.

Failure to follow the above mentioned instructions can result in injury or death to the vehicle occupants in an accident.

Why didn't my air bag go off in a collision?

(Inflation and non-inflation conditions of the air bag)

There are many types of accidents in which the air bag would not be expected to provide additional protection.

These include rear impacts, second or third collisions in multiple impact accidents, as well as low speed impacts. In other words, just because your vehicle is damaged and even if it is totally unusable, don't be surprised that the air bags did not inflate.



Air bag collision sensors

- ① SRS control module
- ② Front impact sensor

- ③ Side impact sensor

⚠ WARNING

- Do not hit or allow any objects to impact the locations where air bag or sensors are installed.

This may cause unexpected air bag deployment, which could result in serious personal injury or death.

- If the installation location or angle of the sensors is altered in any way, the air bags may deploy when they should not or they may not deploy when they should, causing severe injury or death. Therefore, do not try to perform maintenance on or around the air bag sensors. Have the vehicle checked and repaired by an authorized Kia dealer.

(Continued)

(Continued)

- Problems may arise if the sensor installation angles are changed due to the deformation of front bumper, body or B pillar where side collision sensors are installed. Have the vehicle checked and repaired by an authorized Kia dealer.
- Your vehicle has been designed to absorb impact and deploy the air bag(s) in certain collisions. Installing aftermarket bumper guards or replacing a bumper with non-genuine parts may adversely affect your vehicles collision and air bag deployment performance.



Air bag inflation condition

Front air bag

Front air bags (driver's and front passenger's air bags) are designed to inflate when the impact is delivered to front collision sensors depending on the intensity, speed or angles of impact of the front collision.

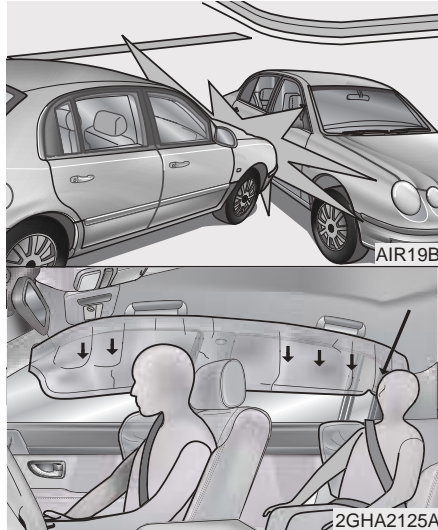

Side air bag (if equipped)

Side air bags (side and/or curtain air bags) are designed to inflate when an impact is detected by side collision sensors depending on the strength, speed or angles of impact, collision or rollover.

Although the front air bags (driver's and front passenger's air bags) are designed to inflate only in frontal collision, it may inflate in any collision if front impact sensors detect a sufficient impact. Side air bags (side and/or curtain air bags) are designed to inflate only in side impact collision, it may inflate in any collision if side impact sensors detect a sufficient impact.

If the vehicle chassis is impacted by bumps or objects on unimproved roads or sidewalks, air bags may deploy. Drive carefully on unimproved roads or on surfaces not designed for vehicle traffic to prevent unintended air bag deployment. To protect occupants, front air bags or pre-tensioner seat belts may deploy in certain side impact collisions.



Air bag non-inflation conditions

- In certain low-speed collisions the air bags may not deploy. The air bags are designed not to deploy in such cases because the risk of injuries which can be caused by the air bags exceeds the benefits they provide in protecting occupants.

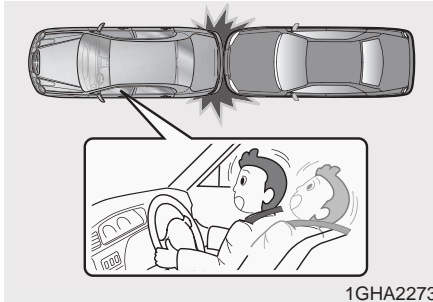

1GHA2273

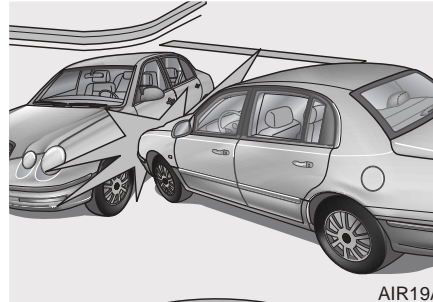

AIR19A

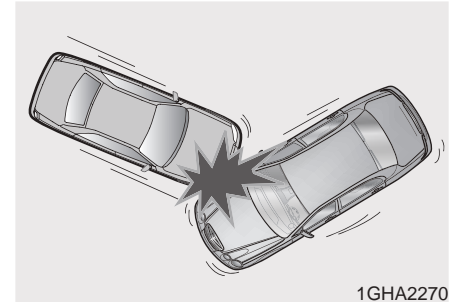

1GHA2270

- Frontal air bags are not designed to inflate in rear collisions, because occupants are moved backward by the force of the impact. In this case, the air bags do not provide proper protection.
- Front air bags may not inflate in side impact collision, because occupants move to the direction of the collision, and thus in side impacts, frontal air bag deployment does not provide occupant protection.
However, side or curtain air bags may inflate depending on the intensity, vehicle speed and angles of impact.
- In a slant or angled collision, the force of impact may direct the occupants in a direction between the front and side air bags, and thus the sensors may not deploy any air bags.

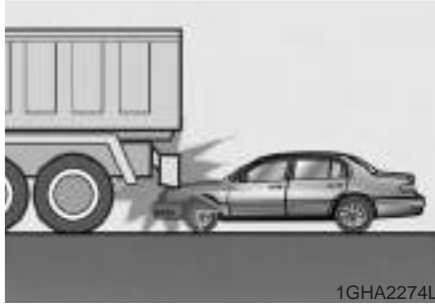

- Just before impact, drivers often brake heavily. Such heavy braking lowers the front portion of the vehicle causing it to "ride" under a vehicle with a higher ground clearance. Air bags may not inflate in this "under-ride" situation because deceleration forces that are detected by sensors may be significantly altered by such "under-ride" collisions.

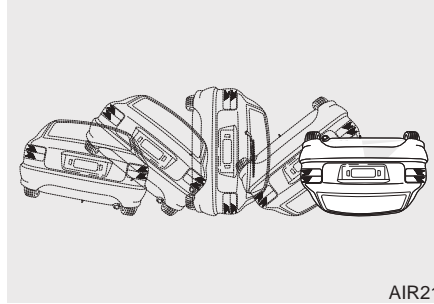

- Air bags may not inflate in rollover accidents because air bag deployment would not provide proper protection to the occupants. However, side air bags may inflate when the vehicle is rolled over by a side impact collision, if the vehicle is equipped with side air bags and curtain air bags.

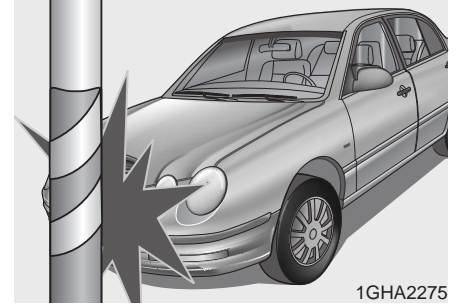

- Air bags may not inflate if the vehicle collides with objects such as utility poles or trees, where the point of impact is concentrated to one area and the full force of the impact is not adequately delivered to the sensors.

How does the air bag system operate

- Air bag only operates when the ignition switch is turned to the ON or START positions.
- Air bags inflate instantly in the event of serious frontal or side collision (if equipped with side air bag or curtain air bag) in order to help protect the occupants from serious physical injury.
- There is no single speed at which the air bags will inflate.

Generally, air bags are designed to inflate by the severity of a collision and its direction. These two factors determine whether the sensors send out an electronic deployment/inflation signal.

- Air bag deployment depends on a number of factors including vehicle speed, angles of impact and the density and stiffness of the vehicles or objects which your vehicle hits in the collision. However, factors are not limited to those mentioned above.
- The front air bags will completely inflate and deflate in an instant.

It is virtually impossible for you to see the air bags inflate during an accident. It is much more likely that you will simply see the deflated air bags hanging out of their storage compartments after the collision.

- In order to help provide protection in a severe collision, the air bags must inflate rapidly. The speed of air bag inflation is a consequence of the extremely short time in which a collision occurs and the need to get the air bag between the occupant and the vehicle structures before the occupant impacts those structures. This speed of inflation reduces the risk of serious or life-threatening injuries in a severe collision and is thus a necessary part of air bag design.

However, air bag inflation can also cause injuries which normally can include facial abrasions, bruises and broken bones, and sometimes more serious injuries because that inflation speed also causes the air bags to expand with a great deal of force.

- **There are even circumstances under which contact with the steering wheel air bag can cause fatal injuries, especially if the occupant is positioned excessively close to the steering wheel.**

⚠ WARNING - Seated positioning

- Driver should sit as far back (at least 10 inches (250 mm) away from the steering wheel air bag as possible to reduce the risk of injury or death in a collision. The front passenger should always move their seat as far back as possible and sit back in their seat.
- In the event of a collision the air bags inflate instantly. Passengers may be injured by the air bag expansion force if they are not in proper position.
- Air bag inflation may cause injuries which normally include facial or bodily abrasions, injuries by the broken glasses or burns by the explosives.

Noise and smoke

When the air bags inflate, they make a loud noise and they leave smoke and powder in the air inside of the vehicle. This is normal and is a result of the ignition of the air bag inflator. After the air bag inflates, you may feel substantial discomfort in breathing due to the contact of your chest to both the safety belt and the air bag, as well as from breathing the smoke and powder. **We strongly urge you to open your doors and/or windows as soon as possible after impact in order to reduce discomfort and prevent prolonged exposure to the smoke and powder.**

Though smoke and powder are non-toxic, it may cause irritation to the skin (eyes, nose and throat, etc). If this is the case, wash and rinse with the cold water immediately and consult the doctor if the symptom persists.

⚠ WARNING

When the air bags deploy, the air bag related parts in steering wheel and/or instrument panel and/or in both sides of the roof rails above the front and rear doors are very hot. To prevent injury, do not touch the air bag storage areas internal components immediately after an air bag has inflated.



Installing a child restraint on a front passenger's seat is forbidden.

Never place a rear-facing child restraint in the front passenger's seat. If the air bag deploys, it would impact the rear-facing child restraint, causing serious or fatal injury.

In addition, do not place front-facing child restraint in the front passenger's seat either. If the front passenger air bag inflates, it would cause serious or fatal injuries to the improperly positioned or improperly restrained child.

⚠ WARNING

- Never put child restraint in the front passenger's seat. If the front passenger air bag inflates, it would cause serious or fatal injuries.
- When children are seated in the rear outboard seats in which side air bags are equipped, be sure to put the child restraint system as far away from the door side as possible, and securely lock the child restraint system in position. **Inflation of side or curtain air bag could cause serious injury or death due to the expansion impact.**

AIR BAG

Air bag warning light

The purpose of the air bag warning light in your instrument panel is to alert you of a potential problem with your air bag - Supplemental Restraint System (SRS).

When the ignition switch is turned ON, the indicator light should blink or illuminate for approximately 6 seconds, then go off.

Have the system checked if:

- The light does not turn on briefly when you turn the ignition ON.
- The light stays on after the engine starts.
- The light comes on while the vehicle is in motion.

Air bag (Supplemental Restraint System) service

Your Supplemental Restraint System is virtually maintenance-free. There are no parts which you can service.

You must have the system serviced under the following circumstances:

- If an air bag ever inflates, the air bag must be replaced. Do not try to remove or discard the air bag by yourself. This must be done by an authorized Kia dealer.
- If the air bag warning indicator light alerts you to a problem, have the air bag system checked as soon as possible. Otherwise, your air bag system may be ineffective.

CAUTION - No modification

Do not modify any part of the air bag system. Modification could make the air bag system ineffective or could cause unnecessary deployment.

WARNING - No maintenance or repair

- **Do not modify your steering wheel, seat or any other part of the Supplemental Restraint System. Modification could make the system inoperable.**
- **Do not work on the system's components or wiring. This could cause the air bags to inflate inadvertently, possibly seriously injuring someone. Working on the system could also disable the system so that the air bags would not deploy in a collision.**
- **Any work on the SRS system, such as removing, installing, repairing, or any work on the steering wheel must be performed by a qualified Kia technician. Improper handling of the air bag system may result in serious personal injury or death.**

When repairing or scrapping the vehicles

- Repairing steering wheel, instrument panel, center console or roofs, or installing car audio around center console or painting front metal sheet could disable the air bag system. Have them checked by an authorized Kia dealer.
- When leaving the vehicle at an authorized Kia dealer, inform the facility that the vehicle is equipped with an air bag system, and leave the owner's manual in the vehicle.
- Since the air bag system contains explosive chemical substances, contact an authorized Kia dealer when scrapping the vehicle.

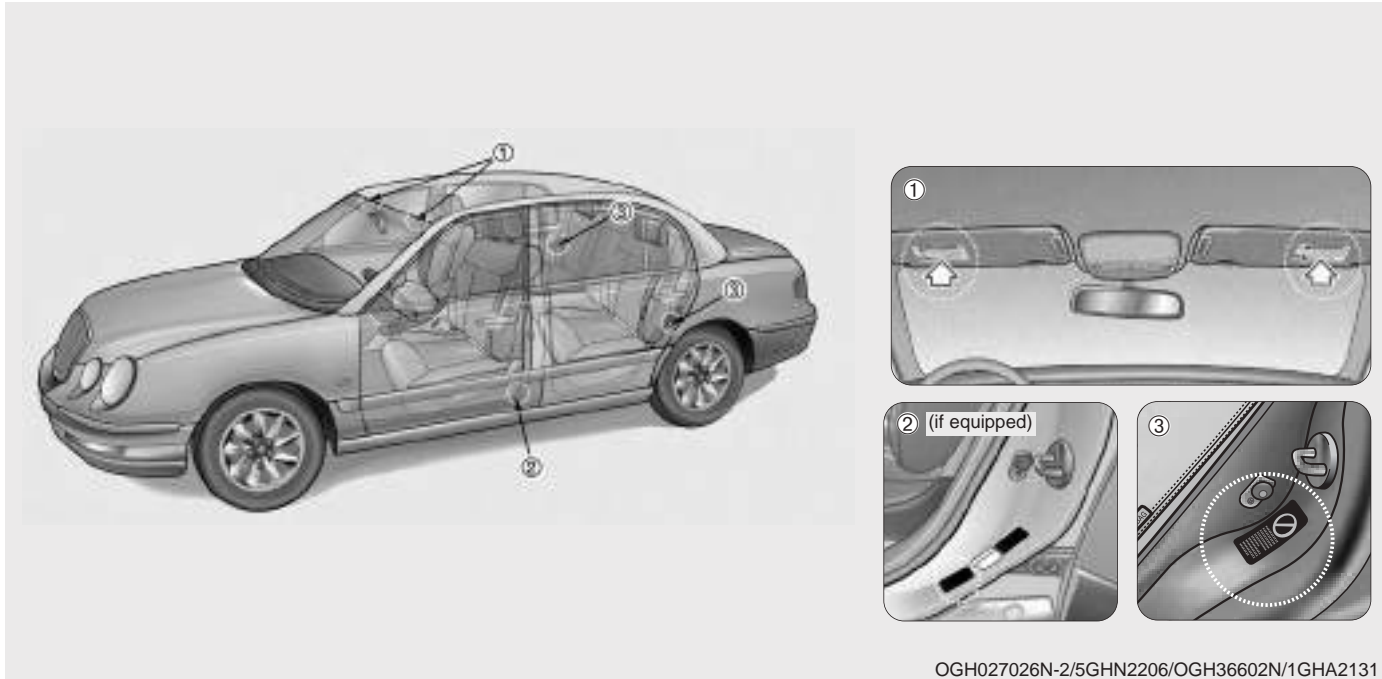

Air bag warning label

Air bag warning labels which are required by the U.S. National Highway Traffic Safety Administration (NHTSA) are attached to alert driver and passengers of potential risk of air bag system.

Note that these government warnings focus on the risk to children, Kia also wants you to be aware of the risks which adults are exposed to. Those have been described in previous pages.

TRUNK

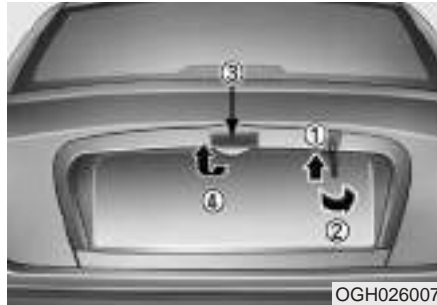

Outside the vehicle

- To open the trunk, insert the key into the lock (①) and turn it clockwise (②). If the trunk is opened with the key while all the doors are locked, trunk will be locked if closed.
- To open the trunk, pull up (④) the trunk lid by pressing the button (③) of the trunk handle when the trunk is unlocked. Trunk can be opened by pressing the button (③) of the handle and pulling up the lid while any door is unlocked.
- To close the trunk, use both hands to push the trunk lid down. Check to see if the trunk is completely shut. If all the doors are locked then the trunk will be locked too.
- If the trunk lid control button in the glove box is in the ON position (depressed), the trunk can be opened with a transmitter.
- If the trunk is opened with the transmitter while all the doors are locked, the trunk will be locked when closed.
- Trunk cannot be opened with the sub key.

CAUTION

Do not try to open the trunk with the sub key. It may damage the key set.

PROPOSITION 65 WARNING

Engine exhaust and a wide variety of automobile components and parts, including components found in the interior furnishings in a vehicle, contain or emit chemicals known to the State of California to cause cancer and birth defects and reproductive harm. In addition, certain fluids contained in vehicles and certain products of component wear contain or emit chemicals known to the State of California to cause cancer and birth defects or other reproductive harm.

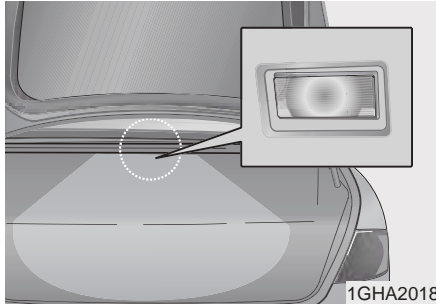

Trunk room lamp

Trunk room lamp turns on when the trunk is opened. It remains on until the trunk is securely closed.

CAUTION

Make sure to close the trunk securely. If it remains open while the engine is not running, it may cause battery discharge because the trunk room lamp remains on.

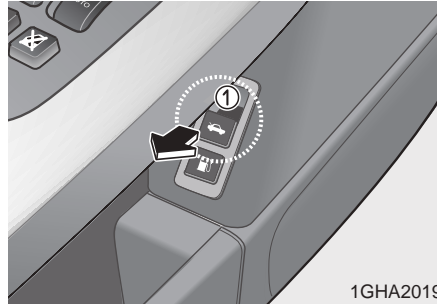

Inside the vehicle

To open the trunk from inside the vehicle, make sure the trunk lid control button in the glove box is ON, then pull the trunk lid release switch (①) on the driver's door panel.

If the trunk lid control button in the glove box is OFF, the trunk can only be opened with the vehicle master key.

WARNING - Exhaust fumes

If you drive with the trunk lid open, you will draw dangerous exhaust fumes into your vehicle causing serious injury or death to vehicle occupants. Open trunk lids can also dangerously obscure rear view vision.

If you must drive with the trunk lid open, keep the air vents open so that additional outside air comes into the vehicle.

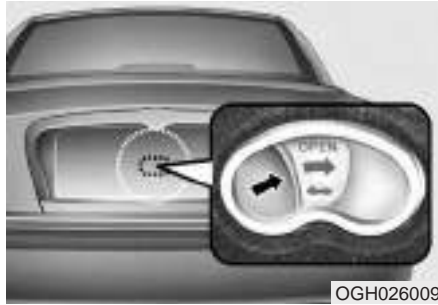

Emergency trunk safety release

Your vehicle is equipped with an emergency trunk release cable located inside the trunk. The lever glows in the dark when the trunk lid is closed. If someone is inadvertently locked in the trunk, moving the handle in the direction of the arrow will release the trunk latch mechanism and open the trunk.

⚠ WARNING

No one should be allowed to occupy the trunk of the vehicle at any time. If the trunk is partially or totally latched and the person is unable to get out, severe injury or death could occur due to lack of ventilation, exhaust fumes and rapid heat build-up, or because of exposure to cold weather conditions. The trunk is also a highly dangerous location in the event of a crash because it is not a protected occupant space but merely a part of the vehicle's crush zone.

⚠ WARNING

- If a person is locked in the trunk, they can pull the emergency release to open the trunk lid.
- We recommend that cars be kept locked and keys be kept out of the reach of children, and that parents teach their children about the dangers of playing in trunks.

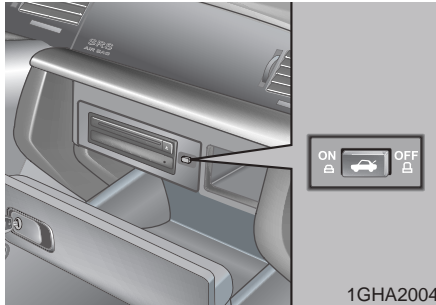

Trunk lock system

The trunk lid control button located in the vehicle glove box is used to prevent unauthorized access to the trunk.

Trunk locking

To activate the trunk lock system so that the trunk can only be opened with the master key, perform the following:

1. Open the glove box.
2. Set the trunk lid control button to OFF position (not depressed).
3. Close the glove box and lock the glove box with the master key.

When leaving the key with a parking lot attendant or valet, perform steps 1 to 3 above and leave the sub key with the attendant. Sub key can start the engine and operate door locks only.

Lock release

To release the trunk lock feature, open the glove box with the master key and set the trunk lid control button to ON position (depressed). In this position the trunk will open with the trunk lid release switch or transmitter. The trunk can never be opened with the sub key.

HOOD

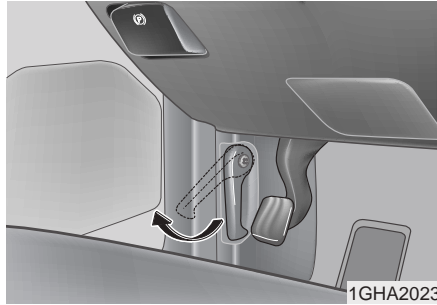

Opening the hood:

1. Pull the release lever on the lower left side of the instrument panel to unlatch the hood. The hood should pop open slightly.



2. Go to the front of the vehicle, slightly raise the hood, pull (2) the secondary latch (1) inside of the hood center and lift the hood.
3. Raise the hood. It will raise completely by itself after it has been raised about halfway.

Closing the hood

1. Before closing the hood, check the following:
 - All filler caps in engine compartment must be correctly installed.
 - Gloves, rags or any other combustible material must be removed from the engine compartment.
2. Lower the hood halfway and push down to securely lock in place. Make sure the hood is properly locked before driving.

⚠ WARNING

- Before closing the hood, make sure that all engine parts and tools have been removed from the engine area and that no one's hands are near the hood opening.
- Do not leave gloves, rags or any other combustible material in the engine compartment. Doing so may cause a heat-induced fire.

FUEL FILLER LID

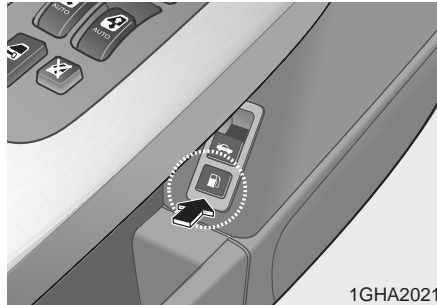

1. Stop the engine.
2. To open the fuel filler lid, push the release button located on the driver's lower door.

⚠ WARNING

To avoid injury from sharp objects, wear protective gloves when opening the fuel filler door manually.



3. Pull the fuel filler lid out to open.
4. To remove the cap, turn the fuel tank cap counter-clockwise.
5. Refuel as needed.
6. To install the cap, turn it clockwise until it "clicks". This indicates that the cap is securely tightened.
7. Close the fuel filler lid and push it lightly and make sure that it is securely closed.

⚠ WARNING - Refueling

If pressurized fuel sprays out, it can cause serious injuries. Always remove the fuel cap carefully and slowly. If the cap is venting fuel or if you hear a hissing sound, wait until the condition stops before completely removing the cap.

⚠ WARNING

Automotive fuels are flammable/explosive materials. When refueling, please note the following guidelines carefully. Failure to follow these guidelines may result in severe personal injury, severe burns or death by fire or explosion.

- Before refueling always note the location of the Emergency Gasoline Shut-Off, if available, at the gas station facility.

Note and follow all safety precautions and warning posted at the facility.

- Before touching the fuel nozzle or fuel filler cap, you should eliminate potentially dangerous static electricity discharge by touching another metal part of the front of the vehicle, a safe distance away from the fuel filler neck, nozzle, or other gas source.

(Continued)

(Continued)

- Do not get back into a vehicle once you have begun refueling. Do not touch, rub or slide against any item or fabric (polyester, satin, nylon, etc.) capable of producing static electricity. Static electricity discharge can ignite fuel vapors resulting in explosion. If you must re-enter the vehicle, you should once again eliminate potentially dangerous static electricity discharge by touching a metal part of the vehicle, away from the fuel filler neck, nozzle or other gasoline source.
- When using a portable fuel container be sure to place the container on the ground prior to refueling. Static electricity discharge from the container can ignite fuel vapors causing a fire. Once refueling has begun, contact with the vehicle should be maintained until the filling is complete. Use only portable fuel containers designed to carry and store gasoline.

(Continued)

(Continued)

- Do not use cellular phones around a gas station or while refueling any vehicle. Electric current and/or electronic interference from cellular phones can potentially ignite fuel vapors causing a fire. If you must use your cellular phone use it in a place away from the gas station.
- When refueling always shut the engine off. Sparks produced by electrical components related to the engine can ignite fuel vapors causing a fire. Always insure that the engine is OFF before and during refueling. Once refueling is complete, check to make sure the fuel filler cap and door are securely closed, before starting the engine.

(Continued)

(Continued)

- Do not light any fire around a gas station. DO NOT use matches or a lighter and DO NOT SMOKE or leave a lit cigarette in your vehicle while at a gas station especially during refueling. Automotive fuel is highly flammable and can, when ignited, result in explosion by flames.
- If a fire breaks out during refueling, leave the vicinity of the vehicle, and immediately contact the manager of the gas station or contact the police and local fire department. Follow any safety instructions they provide.

CAUTION

- *Make sure to refuel with gasoline (unleaded fuel) only for the gasoline engine vehicles.*
- *Check to make sure the fuel filler cap is securely closed after refueling.*
- *If the fuel filler cap requires replacement, use only a genuine Kia cap or the equivalent specified for your vehicle. An incorrect fuel filler cap can result in a serious malfunction of the fuel system or emission control system. Correct replacement caps are available at authorized Kia dealers.*
- *Do not spill fuel on the exterior surfaces of the vehicle. Any type of fuel spilled on painted surfaces may damage the paint.*
- *A loose fuel filler cap may cause the “Check Engine” (Malfunction Indicator) light in the instrument panel to illuminate unnecessarily.*
- *If the fuel filler lid will not open in cold weather because the area around it is frozen, push or lightly tap the lid.*

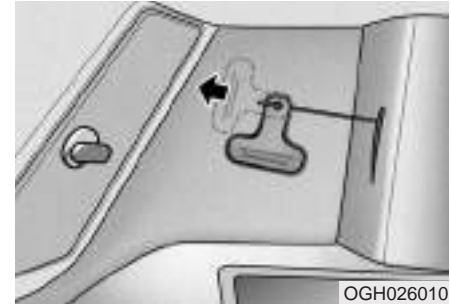

When fuel filler lid does not open with the release button

1. Open the trunk.
2. Pull the emergency hook for fuel filler lid inside the trunk.

MIRRORS

Outside rearview mirror

Be sure to adjust mirror angles before driving.

⚠ WARNING

- The right outside rearview mirror is convex. Objects seen in the mirror are closer than they appear.
- Use your interior rearview mirror or direct observation to determine the actual distance of following vehicles when changing lanes.

⚡ CAUTION

Do not scrape ice off the mirror face; this may damage the surface of the glass. If ice should restrict movement of the mirror, do not force the mirror for adjustment. To remove ice, use a deicer spray, or a sponge or soft cloth with very warm water.

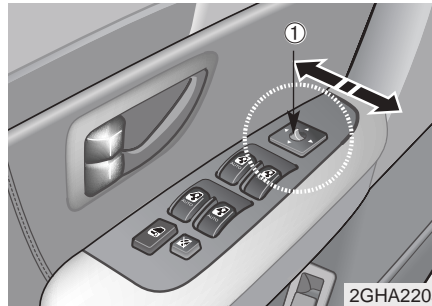

The electric remote control mirror switch allows you to adjust the position of the left and right outside rearview mirrors. To adjust the position of either mirror, move the lever (①) to R or L to select the right side mirror or the left side mirror, then press a corresponding point (▲) on the mirror adjustment control to position the selected mirror up, down, left or right.

After adjustment, put the lever into neutral position to prevent inadvertent adjustment.

⚡ CAUTION

- *The mirrors stop moving when they reach the maximum adjusting angles, but the motor continues to operate while the switch is depressed. Do not depress the switch longer than necessary, the motor may be damaged.*
- *Do not attempt to adjust the outside rearview mirror by hands. Doing so may damage the parts.*

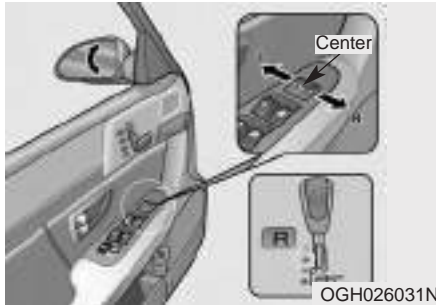

Automatic mirror adjustment in reverse maneuvers (if equipped)

When the transaxle gear is shifted into reverse (R), the outside rearview mirror(s) will automatically be turned downward about 5 degrees to improve driver visibility. It will stay in that position until the transaxle shift lever is shifted out of reverse (R).

- L : Both the left and right outside rearview mirrors will be turned downward about 5 degrees.
- R : Only the right outside rearview mirror will be turned downward about 5 degrees.
- Center : Automatic mirror adjustment function is disabled, no mirror will be turned downward.

The outside rearview mirror(s) will return to its previous position automatically if outside rearview mirror selection switch is changed to another position, or transaxle shift lever is shifted out of reverse (R).

(Examples)

If the shift lever is shifted into reverse (R) when the outside rearview mirror selection switch is in L, both the right and left outside rearview mirrors will automatically be turned down 5 degrees

If the outside rearview mirror selection switch is set to R while shift lever is in reverse (R), the left outside rearview mirror will return to its previous position. The right outside rearview mirror will not return to its previous position.

If the shift lever is shifted into any other range OR the outside rearview mirror selection switch is set to the center, the right outside rearview mirror will automatically return to its original position.

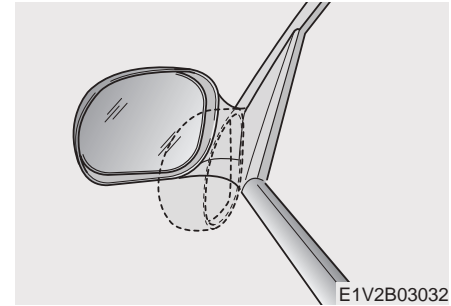

Folding the outside rearview mirror

Manual type

To fold the outside rearview mirror, grasp the housing of the mirror and then fold it toward the rear of the vehicle.

Outside rearview mirror heater (if equipped)

The outside rearview mirror heater is actuated in connection with the rear window defroster. To heat the outside rearview mirror glass, push the button for the rear window defroster.

The outside rearview mirror glass will be heated for defrosting or defogging and will give you improved rear vision in inclement weather conditions. Push the button again to turn the heater off. The outside rearview mirror heater automatically turns off after 20 minutes.

Day/night rearview mirror

Adjust the rearview mirror to the center on the view through the rear window. Make this adjustment before you start driving.

⚠ WARNING

Do not place objects in the rear seat or cargo area which would interfere with your vision out the rear window.

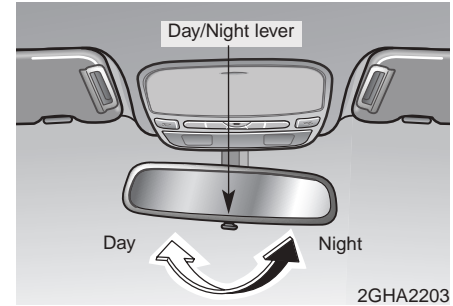

Manual type

Make this adjustment before you start driving and while the day/night lever is in the day position.

Pull the day/night lever toward you to reduce glare from the headlights of vehicles behind you during night driving.

Remember that you lose some rearview clarity in the night position.

Electric type (if equipped)

The electric rearview mirror automatically controls the glare from the headlights of the car behind you in nighttime or low light driving conditions. The sensor mounted in the mirror senses the light level around the vehicle, and through a chemical reaction, automatically controls the headlight glare from vehicles behind you.

When the engine is running, the glare is automatically controlled by the sensor mounted in the rearview mirror.

Whenever the shift lever is shifted into reverse (R), the mirror will automatically go to the brightest setting in order to improve the drivers view behind the vehicle.

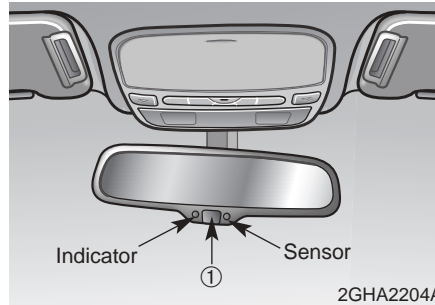

• Type A (if equipped)

Press the button (1) to turn the automatic-dimming function on, the mirror indicator light will illuminate.

Press the button (1) once again to turn the automatic-dimming function off. The mirror indicator light will turn off.

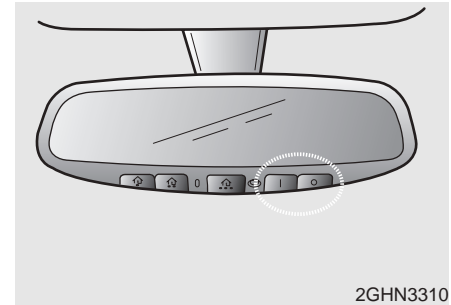

• Type B (if equipped)

Press the “O” button to turn the automatic-dimming function off. The mirror indicator light will turn off.

Press the “I” button to turn the automatic-dimming function on, the mirror indicator light will illuminate.

*** NOTICE**

When cleaning the mirror, use a paper towel or similar material dampened with glass cleaner. Do not spray glass cleaner directly on the mirror as that may cause the liquid cleaner to enter the mirror housing.

INTERIOR LIGHTS

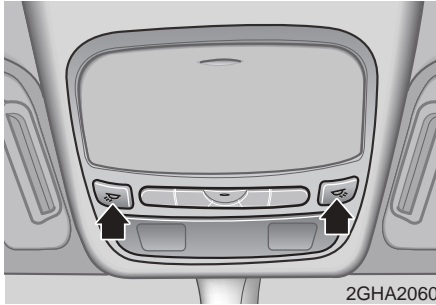

Map light

Front (if equipped)

The lights are turned ON or OFF by pressing the corresponding switch.

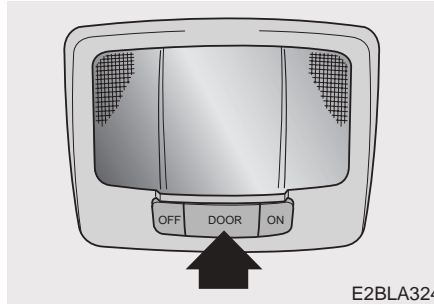

Dome light (if equipped)

- ① OFF - The light stays off even when a door is open.
- ② DOOR - The light turns on when a door is opened or when a door is unlocked by the transmitter (if equipped). Interior light goes out slowly after 30 seconds if the door is closed. However if the ignition switch is ON or all vehicle doors are locked when the door is closed, interior light will turn off even within 30 seconds.
- ③ ON - The light turns on and stays on even when the doors are all closed.

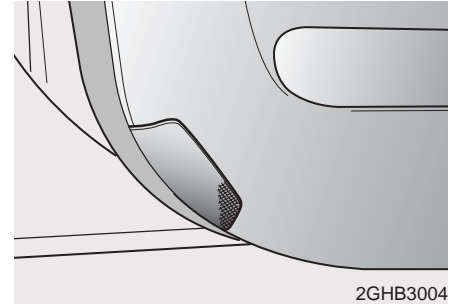

Door courtesy lamp

The door courtesy lamp comes ON when the door is opened to assist entering or exiting the vehicle. It also serves as a warning to passing vehicles that the vehicle door is open.

STORAGE COMPARTMENTS

* NOTICE

- To avoid possible theft, do not leave valuables in the storage compartment.
- Since stored items may move while driving, be sure to position them in the storage compartment so that they do not make noise or cause a potential safety hazard when the vehicle is moving.
- Always keep the storage compartment covers closed while driving. Do not attempt to place many items in the storage compartment that the storage compartment cover cannot close securely.

⚠ WARNING

Do not store cigarette lighters, propane cylinders, or other flammable/explosive materials in the vehicle. These items may catch fire and/or explode if the vehicle is exposed to hot temperatures for extended periods.



OGH039376N

Center console storage

To open either of the console storage compartments, press button ① or ②. These compartments can be used to store small items required by the driver or front passenger.

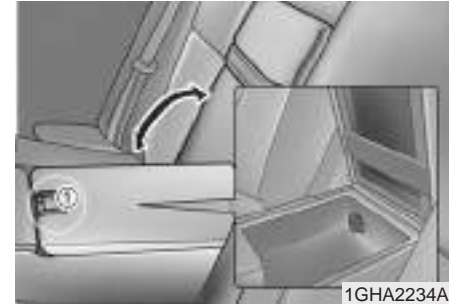

1GHA2234A

Multi box

Rear (if equipped)

To open the storage compartment, pull the armrest down and pull up on the locking tab (①). It can be used for storing small items.

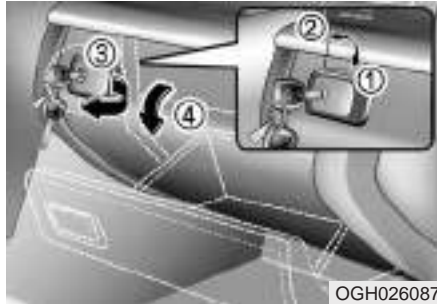

OGH026087

Glove box

The glove box can be locked (①) and unlocked (②) with a master key. It cannot be locked/unlocked with the sub key.

To open the glove box, make sure it is unlocked, then pull the handle (③) and the glove box will automatically open (④). Close the glove box after use.

* NOTICE

Since key is not fully inserted into the glove box key set, do not apply excessive force. Doing so may damage the parts.

⚠ WARNING

To reduce the risk of injury in case of an accident or sudden stop, always keep the glove box door closed while driving.

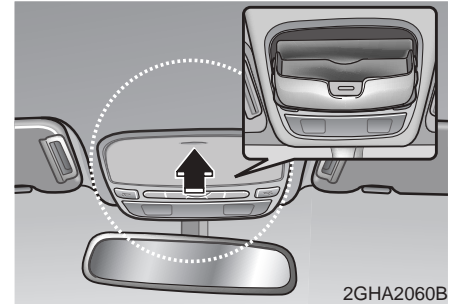

2GHA2060B

Sunglass holder

A sunglass storage compartment is provided on the overhead console. To open the sunglass holder, press the cover and the holder will slowly open. Place your sunglasses in the compartment door with the lenses facing out. Push to close.

* NOTICE

Make sure the sunglass holder is closed while driving.

INTERIOR FEATURES



Cigarette lighter

Front

To use the cigarette lighter, press the front face then release it to allow the cigarette lighter and ashtray to slowly extend from the center panel.

To operate the cigarette lighter, press it in and release it. When it is heated, it automatically pops out ready for use.

If the engine is not running, the ignition switch must be in the ACC position for the lighter to operate.

CAUTION

- *Do not hold the lighter in after it is already heated because it will overheat.*
- *Only a genuine Kia lighter should be used in the cigarette lighter socket. The use of plug-in accessories (shavers, hand-held vacuums, and coffee pots, for example) may damage the socket or cause electrical failure.*
- *If the lighter does not pop out within 30 seconds, remove it to prevent overheating.*

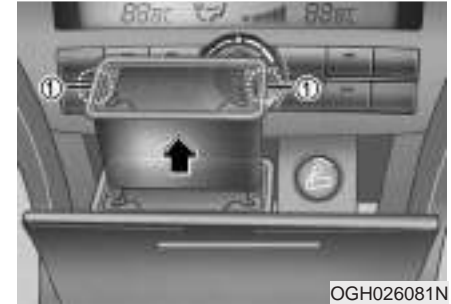

Ashtrays

Front

To use the ashtray, press the front face and release it to allow the cigarette lighter and ashtray to slowly extend from the center panel.

To remove the ashtray, grasp the ashtray bucket (①) and carefully pull it out.

⚠ WARNING - Ashtray use

- Do not use the vehicle's ashtrays as waste receptacles.
- Putting lit cigarettes or matches in an ashtray with other combustible materials may cause a fire.

Cup holder

Cups or small beverage cans may be placed in the cup holders.

⚠ WARNING - Hot liquids

- Do not place uncovered cups of hot liquid in the cup holder while the vehicle is in motion. If the hot liquid spills, you could be burned. Such a burn to the driver could cause a loss of control of the vehicle.
- To reduce the risk of personal injury in the event of sudden stop or collision, do not place uncovered or insecure bottles, glasses, cans, etc., in the cup holder while the vehicle is in motion.

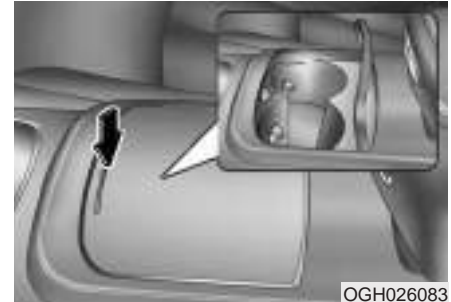

Front

To open the cup holder cover, press the cover and it will automatically open. Push the cover to close after use.



OGH026090

Rear

To use cup holders in rear seat, pull down the rear seat armrest.

CAUTION

Do not place heavy cups or cans in cup holders. Cup holders could be damaged.

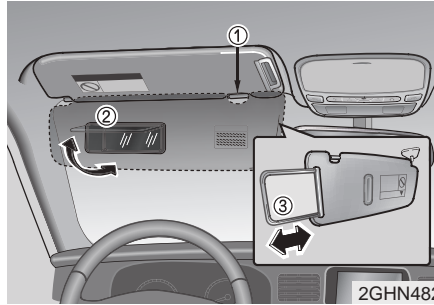

2GHN482

Sunvisor

Use the sunvisor to shield direct light through the front or side windows.

To use a sunvisor, pull it downward.

To use a sunvisor for a side window, pull it downward, unsnap it from the bracket (①) and swing it to the side.

To use the vanity mirror, pull down the visor and pull up the mirror cover (②).

Pull the extension panel (③) of the sunvisor to lengthen the sunvisor.

CAUTION

Close the vanity mirror cover securely and return the sunvisor to its original position after use. If the vanity mirror is not closed securely, the lamp will stay on and could result in battery discharge and possible sunvisor damage.



Power outlet (if equipped)

The power outlets are designed to provide power for mobile telephones or other devices designed to operate with vehicle electrical systems. The devices should draw less than 10 amps with the engine running.

* NOTICE

- Use when the engine is running and remove a plug from the power outlet after using the electric appliance. Using when the engine stops or remaining the electric appliance plugged in for many hours may cause the battery to discharge.
- Only use the electric appliances which are less than 12V and 10A in electric capacity.
- Adjust the air-conditioner or heater to the lowest operation level when you have to use the power outlet while using the air-conditioner or heater.
- Close the cover when not in use.
- Some electronic devices can cause electronic interference and when plugged into a vehicle's power outlet. These devices may cause excessive audio static and malfunctions in other electronic systems or devices used in your vehicle.



Aux, USB and iPod port (if equipped)

If your vehicle has an aux and/or USB(universal serial bus) port or iPod port, you can use an aux port to connect audio devices and an USB port to plug in an USB and also an iPod port to plug in an iPod.

* NOTICE

When using a portable audio device connected to the power outlet, noise may occur during playback. If this happens, use the power source of the portable audio device.

* iPod® is a trademark of Apple Inc.

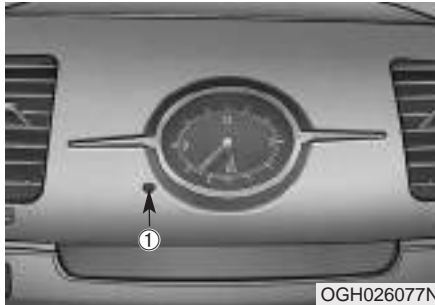

Clock

Analog (if equipped)

Whenever the battery terminals, A/V CLOCK fuse, or Power Connect are disconnected, you must reset the time.

When the ignition switch is in the ACC or ON position, the clock buttons operate as follows:

- ① : time increases one minute each time the button is pressed. It increases continuously if pressed longer than 3 seconds.



Digital (if equipped)

Whenever the battery terminals, A/V CLOCK fuse, or Power Connect are disconnected, you must reset the time.

For details, see end of chapter 3.

SUNROOF (IF EQUIPPED)

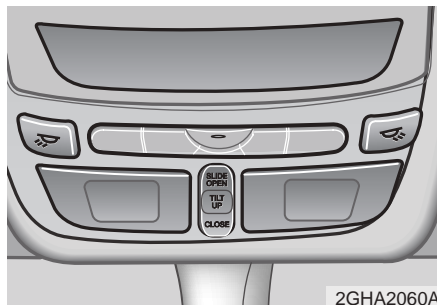

If your vehicle is equipped with this feature, you can slide or tilt your sunroof with the sunroof control buttons located on the overhead console.

The sunroof can only be opened, closed, or tilted when the ignition switch is in the "ON" position.

CAUTION

- *Do not continue to press the sunroof control button(s) after the sunroof is fully opened, closed, or tilted. Damage to the motor or system components could occur.*
- *The sunroof cannot slide when it is in the tilt position nor can it be tilted while in an open or slide position.*

Sliding the sunroof

Autoslide open

To use the autoslide feature, momentarily (more than 0.5 second) press the SLIDE OPEN button on the overhead console. The sunroof will slide all the way open. To stop the sunroof sliding at any point, press any sunroof control button.

Manual slide open

Press the SLIDE OPEN button on the overhead console for less than 0.5 second.

Close

To close the sunroof, press the CLOSE button on the overhead console and hold it until the sunroof is closed.

Tilting the sunroof

Autotilt open

To use the autotilt feature, momentarily (more than 0.5 second) press the TILT UP button on the overhead console. The sunroof will tilt all the way open. To stop the sunroof tilting at any point, press any sunroof control button.

Manual tilt open

Press the TILT UP button on the overhead console for less than 0.5 second.

Close

To close the sunroof, press the CLOSE button on the overhead console and hold it until the sunroof is closed.

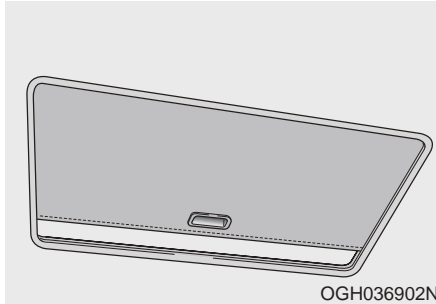

Sunshade

The sunshade will be opened with the glass panel automatically when the glass panel is slid. After closing the glass panel the sunshade will only close manually.

CAUTION

- *Do not press any sunroof control button longer than necessary. Damage to the motor or system components could occur.*
- *Periodically remove any dirt that may accumulate on the guide rail.*
- *If you try to open the sunroof when the temperature is below freezing or when the sunroof is covered with snow or ice, the glass or the motor could be damaged.*
- *The sunroof is made to slide together with sunshade. Do not leave the sunshade closed while the sunroof is open.*

WARNING

- **Do not extend face or arms outside through the sunroof opening while driving.**
- **Make sure hand and face are safely out of the way before closing a sunroof.**



In case of an emergency

If the sunroof does not open electrically:

1. Remove the lens.
2. Open the sunglasses holder.
3. Remove the four (4) screws, and then remove the overhead console.
4. Insert the emergency handle (provided with the vehicle) and turn the handle clockwise to open or counterclockwise to close.

Resetting the sunroof

Whenever the vehicle battery is disconnected or discharged, or you use the emergency handle to operate the sunroof, you have to reset your sunroof system as follows:

1. Turn the ignition key to the ON position.
2. According to the position of the sunroof, do as follows.
 - 1) in case that the sunroof has closed completely or been tilted
: Press the TILT UP button for 1 second.
 - 2) in case that the sunroof has slide-opened
: Press and hold the CLOSE button for more than 5 seconds until the sunroof has closed completely. And then press the TILT UP button for 1 second
3. Then, release it.
4. Press and hold the TILT UP button once again until the sunroof has returned to the original position of TILT UP after it is raised a little higher than the maximum TILT UP position.

When this is complete, the sunroof system is reset.

ANTENNA

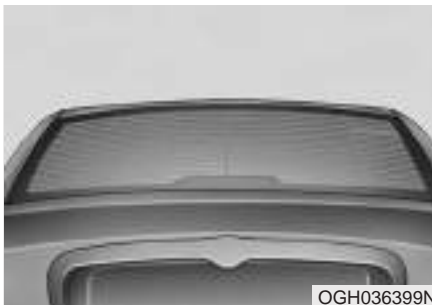

Glass antenna (if equipped)

When the radio power switch is turned on while the ignition key is in either the “ON” or “ACC” position, your car will receive both AM and FM broadcast signals through the antenna in the rear window glass.

CAUTION

- *Do not clean the inside of the rear window glass with a cleaner or scraper to remove the foreign deposits as this may cause damage to the antenna elements.*
- *Avoid adding metallic coating such as Ni, Cd, and so on. These can disturb receiving AM and FM broadcast signals.*

AUDIO REMOTE CONTROL (IF EQUIPPED)



The steering wheel audio remote control button is installed to promote safe driving.

* NOTICE

Do not operate audio remote control buttons simultaneously.

MODE

Press the MODE button to select Radio, CD (Compact Disc) or CDC* (Compact Disc Changer).*

Each press of the button changes the display as follows:

RADIO (FM1 → FM2 → AM) → CD → CDC*



* : if equipped

VOLUME (▲/▼)

- Press the VOLUME (▲) button to increase volume.
- Press the VOLUME (▼) button to decrease volume.

PRESET

If the PRESET button is pressed for 0.8 second or more, it will work as follows in each mode.

RADIO mode

It will function as the SEEK UP select button.

CD mode

It will function as the FF button.

CDC mode

It will function as the DISC UP button.

If the PRESET button is pressed for less than 0.8 second, it will work as follows in each mode. (if equipped)

RADIO mode

It will function as the PRESET UP select button.

CD mode

It will function as the TRACK UP button.

CDC mode

It will function as the TRACK UP button.

Detailed information for audio control buttons is described in the following pages in this section.

AUDIO SYSTEM (IF EQUIPPED)

FM reception

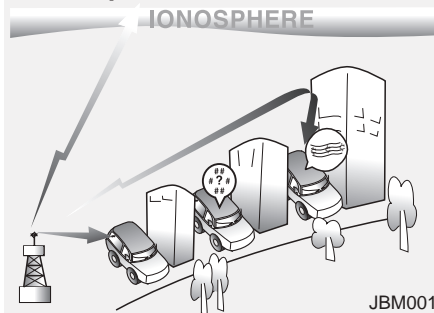

How car audio works

AM and FM radio signals are broadcast from transmitter towers located around your city. They are intercepted by the radio antenna on your car. This signal is then received by the radio and sent to your car speakers.

When a strong radio signal has reached your vehicle, the precise engineering of your audio system ensures the best possible quality reproduction. However, in some cases the signal coming to your vehicle may not be strong and clear. This can be due to factors such as the distance from the radio station, closeness of other strong radio stations or the presence of buildings, bridges or other large obstructions in the area.

AM reception

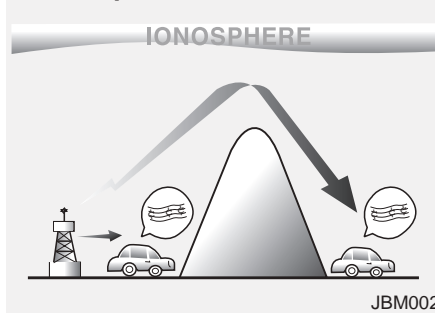

AM broadcasts can be received at greater distances than FM broadcasts. This is because AM radio waves are transmitted at low frequencies. These long, low frequency radio waves can follow the curvature of the earth rather than travelling straight out into the atmosphere. In addition, they curve around obstructions so that they can provide better signal coverage.

FM radio station

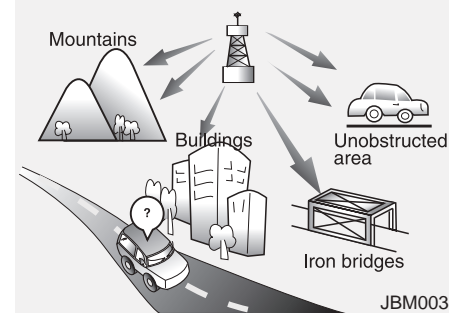

FM broadcasts are transmitted at high frequencies and do not bend to follow the earth's surface. Because of this, FM broadcasts generally begin to fade at short distances from the station. Also, FM signals are easily affected by buildings, mountains, or other obstructions. These can result in certain listening conditions which might lead you to believe a problem exists with your radio. The following conditions are normal and do not indicate radio trouble:

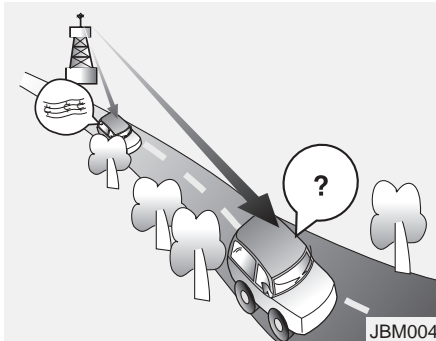

JBM004

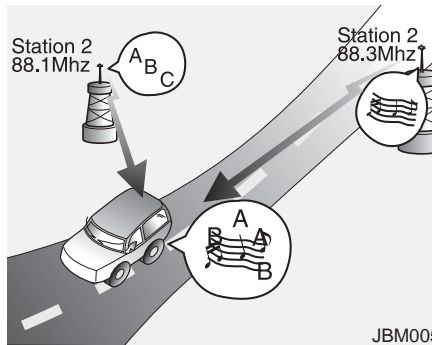

JBM005

- **Fading** - As your car moves away from the radio station, the signal will weaken and sound will begin to fade. When this occurs, we suggest that you select another stronger station.
- **Flutter/Static** - Weak FM signals or large obstructions between the transmitter and your radio can disturb the signal causing static or fluttering noises to occur. Reducing the treble level may lessen this effect until the disturbance clears.
- **Station Swapping** - As a FM signal weakens, another more powerful signal near the same frequency may begin to play. This is because your radio is designed to lock onto the clearest signal. If this occurs, select another station with a stronger signal.

- **Multi-Path Cancellation** - Radio signals being received from several directions can cause distortion or fluttering. This can be caused by a direct and reflected signal from the same station, or by signals from two stations with close frequencies. If this occurs, select another station until the condition has passed.

Using a cellular phone or a two-way radio

When a cellular phone is used inside the vehicle, noise may be produced from the audio equipment. This does not mean that something is wrong with the audio equipment. In such a case, use the cellular phone at a place as far as possible from the audio equipment.

CAUTION

When using a communication system such as a cellular phone or a radio set inside the vehicle, a separate external antenna must be fitted. When a cellular phone or a radio set is used with an internal antenna alone, it may interfere with the vehicle's electrical system and adversely affect safe operation of the vehicle.

WARNING

Don't use a cellular phone when you are driving. The driver should stop at a safe place to use a cellular phone.

Care of disc (if equipped)

- If the temperature inside the car is too high, open the car windows for ventilation before using your car audio.
- Do not apply volatile agents such as benzene and thinner, normal cleaners and magnetic sprays made for analogue disc onto CDs.
- To prevent the disc surface from getting damaged. Hold and carry CDs by the edges or the edges of the center hole only.
- Clean the disc surface with a piece of soft cloth before playback (wipe it from the center to the outside edge.)
- Do not damage the disc surface or attach pieces of sticky tape or paper onto it.
- Make sure on undesirable matter other than CDs are inserted into the CD player (Do not insert more than one CD at a time).
- Keep CDs in their cases after use to protect them from scratches or dirt.

- Depending on the type of CD-R/CD-RW CDs, certain CDs may not operate normally according to manufacturing companies or making and recording methods. In such circumstances, if you still continue to use those CDs, they may cause the malfunction of your car audio system.

*** NOTICE - Playing an Incompatible Copy-Protected Audio CD**

Some copy-protected CDs, which do not comply with the international audio CD standards (Red Book), may not play on your car audio. Please note that if you try to play copy protected CDs and the CD player of your car audio is not performing to your expectation, this may be caused by those CDs and not a defect in the device itself. Please replace those CDs.

RADIO, SET UP, VOLUME CONTROL(CDP MODEL)



1. FM/AM Selection Button
2. Automatic Channel Selection Button
3. SCAN Button
4. MUTE Button
5. Pre-set Button
6. SET UP Button
7. TUNE/ENTER Button
8. Power ON/OFF/Volume Control Button

A-200GHU

RADIO, SET UP, VOLUME CONTROL(6CDC MODEL)

MONITOR

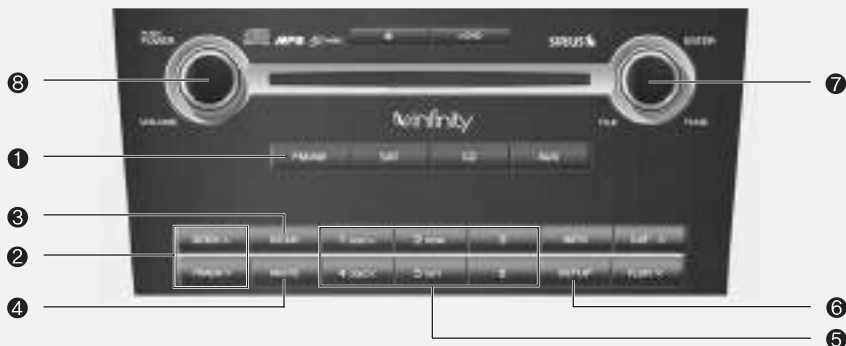

1. FM/AM Selection Button
2. Automatic Channel Selection Button
3. SCAN Button
4. MUTE Button
5. Pre-set Button
6. SET UP Button
7. TUNE/ENTER Button
8. Power ON/OFF/Volume Control Button

A-300GHU

1. FM/AM Selection Button

Turns to FM or AM mode and toggles FM1→FM2→AM→...→FM1→... when the button is pressed each time.

2. Automatic Channel Selection Button

- When the [TRACK √] is pressed, it will automatically tune to the previous lower station.
- When the [SEEK ^] is pressed, it will automatically tune to the next higher station.

3. SCAN Selection Button

When the button is pressed, it automatically only [SCAN] up. The sound hearing for 5 seconds per all searched station preset.

4. MUTE Selection Button

Push button to stop sound and [MUTE] is displayed.

5. Pre-set Selection Button

- Push [1]–[6] buttons less than 0.8 seconds to play the channel saved in each button.
- Push pre-set button for 0.8 seconds or longer to save current channel to the respective button with a beep.

6. SET UP Button

- The SET UP Mode is displayed if the [SET UP] Button is pressed. While in SET UP Mode, use the [TUNE/ENTER] Button to set the SOUND(BASS, MIDDLE, TREBLE, FADER, BALANCE), SAT(CHANNEL/TITLE, CATEGORY/CHANNEL), CLOCK(12, 24), TEMP (°C, °F) and SCROLL(ON, OFF).
- To exit from SET UP Mode, press "RETURN" or wait 10 seconds.
- Method of adjusting the SET UP is the same for CDP, AUX, USB, and iPod Mode.

■ Setting the SET UP Mode

Press the [TUNE/ENTER] Button to select and make adjustments to the desired mode within SET UP Mode.

- While in SOUND Mode, press the [TUNE/ENTER] Button to change in the order of BASS→MIDDLE→TREBLE→FADER→BALANCE→SET UP Mode. Turn the [TUNE/ENTER] Button in clockwise or counterclockwise direction to make adjustments for each SUB Mode.
- While in SAT Mode, press the [TUNE/ENTER] Button to display the "CHANNEL/TITLE, CATEGORY/CHANNEL". Rotate the [TUNE/ENTER] Button to select the SUB Mode and press the [TUNE/ENTER] Button to set.
- While in CLOCK Mode, press the [TUNE/ENTER] Button to display the "ON, OFF". Rotate the [TUNE/ENTER] Button to select the SUB Mode and press the [TUNE/ENTER] Button to set. (CLOCK Mode CDC Only)

- While in TEMP Mode, press the [TUNE/ENTER] Button to display the "°C, °F". Rotate the [TUNE/ENTER] Button to select the SUB Mode and press the [TUNE/ENTER] Button to set. (TEMP Mode CDC Only)
- While in SCROLL Mode, press the [TUNE/ENTER] Button to display the "ON, OFF". Rotate the [TUNE/ENTER] Button to select the SUB Mode and press the [TUNE/ENTER] Button to set.

7. TUNE/ENTER Button

- Turn this button clockwise by one notch to increase frequency by 200KHz(AM: 10KHz) from current frequency.
- Turn this button counterclockwise by one notch to decrease frequency by 200KHz(AM:10KHz)from current frequency.
- Press this button while holding SET UP button to activate/inactivate the item to select SET UP item using left and right function of the Tune button.

8. Power ON/OFF & Volume Control Button

Turns on/off the set when the IGNITION SWITCH is on ACC or ON. If the button is turned to the right, it increases the volume and left, decreases the volume. channel is found.

CDP(CDP MODEL)



- 1. CD Loading Slot
- 2. CD Indicator
- 3. Automatic Track Selection Button
- 4. SCAN Play Button
- 5. MUTE Button
- 6. RANDOM Play Button
- 7. REPEAT Play Button
- 8. INFO Selection Button
- 9. FOLDER Search Button
- 10. CD Selection Button
- 11. File(Track) Search/ENTER Button
- 12. CD Eject Button

A-200GHU

CD(6CDC MODEL)

MONITOR

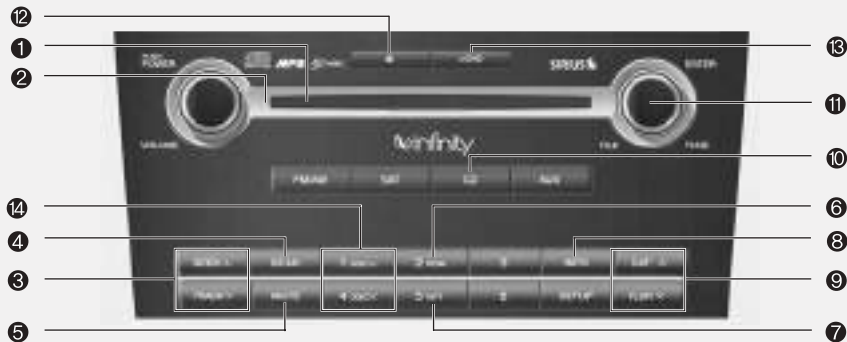

- 1. CD Loading Slot
- 2. CD Indicator
- 3. Automatic Track Selection Button
- 4. SCAN Play Button
- 5. MUTE Button
- 6. RANDOM Play Button
- 7. REPEAT Play Button
- 8. INFO Selection Button
- 9. Folder Search Button
- 10. CD Selection Button
- 11. File(Track) Search/ENTER Button
- 12. CD Eject Button
- 13. CD LOAD Button
- 14. DISC UP/DOWN Button

A-300GHU

1. CD Loading Slot

Please face printed side upward and gently push in. When the ignition switch is on ACC or ON and power is off, power is automatically turned on if the CD is loaded. This CDP supports only 12cm CD. If VCD, Data CD are loaded, Reading "Error message" will appear and CD will be ejected.

2. CD Indicator

- When car ignition switch is ACC or ON and if the CD is loaded, this indicator is lighted. If the CD is ejected the light is turned off(CDP Only).
- If the LOAD button is pressed, this indicator will begin to blink(CDC Only).

3. Automatic Track Selection Button

- Push [TRACK √] button for less than 0.8 seconds to play from the beginning of current song.
- Push [TRACK √] button for less than 0.8 seconds and press again within 1 seconds to play the previous song.
- Push [TRACK √] button for 0.8 or longer to initiate reverse direction high speed sound search of current song.

- Push [SEEK ^] button for less than 0.8 seconds to play the next song.
- Push [SEEK ^] button for 0.8 or longer to initiate high speed sound search of current song.

4. SCAN Play Button

Plays first 10 seconds of each song in the CD. To cancel the mode, press the key once again.

5. MUTE Button

Press this button to temporarily cut off the Sound. "Mute" is displayed on the LCD. Press the button once again to cancel MUTE mode.

6. RANDOM Play Button

Press this button for less than 0.8 seconds to activate 'RDM' mode and more than 0.8 seconds to activate 'ALL RDM' mode.

- RDM : Only files/tracks in a folder/disc are played back in a random sequence.
- ALL RDM(MP3/WMA Only) : All files in a disc are played back in the random sequence.

7. REPEAT Play Button

Press this button for less than 0.8 seconds to activate 'RPT' mode and more than 0.8 seconds to activate 'FLD RPT' mode.

- RPT : Only a track(file) is repeatedly played back.
- FLD RPT(MP3/WMA Only) : Only files in a folder are repeatedly played back.

8. INFORMATION Selection Button

Displays the information of the current CD TRACK(FILE) as below when the button is pressed each time.

- CDDA : DISC TITLE→DISC ARTIST→TRACK TITLE→TRACK ARTIST→TOTAL TRACK→...
- MP3/WMA : FILE NAME→TITLE→ARTIST→ALBUM→FOLDER NAME→TOTAL FILE→...

9. Folder Search Button

- Folder name/File name(the first song in the folder) is moved up or down from currently playing folder.
- To select to the displayed folder, press ENTER(NO.11) button.

10. CD Selection Button

- If there is a cd in the CDP DECK it turns to CD mode when the button is pressed each time.
- If no Disc, it displays "NO DISC" and returns to th previous mode.

11. File(Track) Search/ENTER Button

- Turn this button clockwise to display Track NO(File name) after current song.
- Turn this button counterclockwise to display Track NO(File Name) before current song.
- To select to the displayed song, press the button.

12. CD Eject Button

- Press this button to eject the CD during CD playback.
- If no CD is in the deck, "NO DISC" will be displayed and returns to the previous mode.

* ALL EJECT(CDC ONLY)

Press this button for more than 0.8 seconds to eject all discs inside the decks in respective order.

13. CD LOAD Button(CDC Only)

- Press this button for less than 0.8 seconds to load CD into deck.
- Press this button for more than 0.8 seconds to load CDs into all available deck(from 1~6).
- The last CD will play. 10 seconds idle status will disable loading process.

14. DISC UP/DOWN Button(CDC Only)

Disc is moved up or down from currently playing disc.

CAUTION - Using USB device

- To use the external USB device, make sure the device is not mounted when starting up the vehicle and mount the device after starting up.
- If you start the vehicle when the USB device is mounted, it may damage the USB device. (USB is not ESA)
- If the vehicle is started up or turned off while the external USB device is connected, the external USB device may not work.
- It may not play inauthentic MP3 or WMA files.
 - 1) It can only play MP3 files with the compression rate between 8Kbps~320Kbps.
 - 2) It can only play WMA music files with the compression rate between 8Kbps~320Kbps.
- Take cautions for static electricity when mounting or dismounting the external USB device.
- Encoded MP3 PLAYER is not recognizable.

(Continued)

(Continued)

- Depending on the condition of the external USB device, the connected external USB device can be unrecognizable.
- When the formatted byte/sector setting of External USB devices is not either 512BYTE or 2048BYTE, then the device will not be recognized.
- Only the USB device formatted to FAT 12/16/32.
- USB device without USB IF authentication may not be recognizable.
- Make sure the USB connection terminal does not come in contact with human body or any object.
- If you repeat mounting or dismounting USB device in a short period of time, it may break the device.
- You might hear strange noise when mounting or dismounting a USB device.

(Continued)

(Continued)

- If you dismount the external USB device during playback in USB mode, the external USB device can be damaged or malfunction. Therefore, mount the external USB device when the engine is turned off or in another mode.
- Depending on the type and capacity of the external USB device or the type of the files stored in the device, there is a difference in the time taken for recognition of the device, but this is not a trouble. Please wait for a moment.
- Do not use the USB device for other purposes than playing music files.
- Use of USB accessories such as the recharger or heater using USB I/F may lower the performance or cause trouble.
- If you use devices such as the USB hub you purchased separately, the vehicle's audio system may not recognize the USB device. Connect the USB device directly to the multimedia terminal of the vehicle.

USING USB(CDP MODEL)



1. AUX(USB) Selection Button
2. Automatic Track Selection Button
3. SCAN Play Button
4. RANDOM Play Button
5. REPEAT Play Button
6. INFO Selection Button
7. Folder Search Button
8. File Search/ENTER Button

A-200GHU

USING USB(CDC MODEL)

MONITOR



1. AUX(USB) Selection Button
2. Automatic Track Selection Button
3. SCAN Play Button
4. RANDOM Play Button
5. REPEAT Play Button
6. INFO Selection Button
7. Folder Search Button
8. File Search/ENTER Button

A-300GHU

1. AUX/USB Selection Button

- If auxiliary device/USB/ is connected, it turns to AUX/USB mode and toggles as below when the button is pressed each time.
- If no auxiliary device and USB is connected, it displays "No Media" and returns to the previous mode.

2. Automatic Track Selection Button

- Press [TRACK ∨] to return to the beginning of current file and Press again within 1 seconds to return the previous track file.
- Press and hold [TRACK ∨] to initiate fast backward search.
- Press [SEEK ^] for less than 0.8 seconds to advance the next file.
- Press and hold [SEEK ^] to initiate fast forward search.

3. SCAN Play Button

Plays 10 seconds of each song in the USB device. Press the button once again to cancel scanning.

4. RANDOM Play Button

Press this button for less than 0.8 seconds to activate 'RDM' mode and more than 0.8 seconds to activate 'ALL RDM' mode.

- RDM : Only files in a folder are played back in a random sequence.
- ALL RDM : All files in a USB memory are played back in the random sequence.

5. REPEAT Play Button

Press this button for less than 0.8 seconds to activate 'RPT' mode and more than 0.8 seconds to activate 'FLD RPT' mode.

- RPT : Only a file is repeatedly played back.
- FLD RPT : Only files in a folder are repeatedly played back.

6. INFORMATION Button

Displays the information of the file currently played in the order of FILE NAME → TITLE → ARTIST → ALBUM → FOLDER → TOTAL FILE → NORMAL DISPLAY → FILE NAME → ... (Displays no information if the file has no song information.)

Press the button again to cancel the mode.

7. Folder Search Button

- Folder name/File name(the first song in the folder) is moved up or down from currently playing folder.
- To select to the displayed folder, press ENTER(NO.8) button.

8. File Search/ENTER Button

- Turn this button clockwise to display File name after current song.
- Turn this button counterclockwise to display File Name before current song.
- To select to the displayed song, press the button.

RUNNING iPod®(CDP MODEL)



1. iPod Selection Button
2. Automatic Track Selection Button
3. RANDOM Play Button
4. REPEAT Play Button
5. INFO Selection Button
6. Category Search Button
7. File Search/ENTER Button

A-200GHU

iPod® is a trademark of Apple Inc.

RUNNING iPod(CDP MODEL)

MONITOR

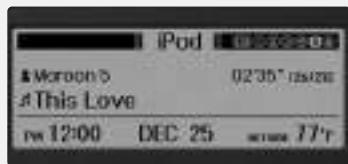

1. iPod Selection Button
2. Automatic Track Selection Button
3. RANDOM Play Button
4. REPEAT Play Button
5. INFO Selection Button
6. Category Search Button
7. File Search/ENTER Button

A-300GHU

1. iPod Selection Button

If iPod is connected, it turns to iPod mode.

2. Automatic Track Selection Button

- Press the [TRACK ∨] button for less than 0.8 seconds to play from the beginning of the song currently played. Press the button for less than 0.8 seconds and press it again within 1 seconds to move and play the previous track. Press the button for 0.8 seconds or longer to play the song in reverse direction in fast speed.
- Press the [SEEK ∧] button for less than 0.8 seconds to move to the next track. Press the button for 0.8 seconds or longer to play the song in forward direction in fast speed.

3. RANDOM Play Button

Press this button for less than 0.8 seconds to activate 'RDM ' mode and more than 0.8 seconds to activate 'ALBUM RDM 'mode.

- RDM : All songs in the current category are played back at random.
- ALBUM RDM: An album in the iPod is selected at random and is played back in the album song order.

4. REPEAT Play Button

A single song is repeatedly played back.

5. INFORMATION Button

Displays the information of the file currently played back as below when the button is pressed each time.
TITLE→ARTIST→ALBUM→...

6. Category Search Button

Moves to the upper category from currently played category of the iPod. To move to the category displayed, press [File Search /ENTER] Button. You will be able to search through the lower category of the selected category. The order of iPod's category is PLAYLISTS, COMPOSERS, SONGS, ALBUMS, ARTISTS, GENRES.

7. File Search/ENTER Button

- When you turn the button clockwise, it will display the songs(category) next to the song currently played(category in the same level). Also, when you turn the button counterclockwise, it will display the songs(category) before the song currently played(category in the same level).

If you want to listen to the song displayed in the song category, press the button, then it will skip to the selected song and play.

- When you turn the button, it will display the categories next to the categories currently displayed. you can narrow down your search as shown in the table below.

1 STEP	2 STEP	3 STEP	4 STEP	5 STEP
Playlist	Playlists	Songs	-	-
Artist	Artists	Albums	Songs	-
Album	Albums	Songs	-	-
Song	Songs	-	-	-
Genre	Genres	Artists	Albums	Songs
Composer	Composers	Albums	Songs	-

*** NOTICE - Using iPod device**

- Some iPod models might not support the communication protocol and the files will not be played. (iPod models supported: Mini, 4G, Photo, Nano, 5G)
- The order of search or playback of songs in the iPod can be different from the order searched in the audio system.
- If the iPod crashes due to its own trouble, reset iPod. (Reset: Refer to iPod manual)
- iPod may not operate normally on low battery.

CAUTION - Using iPod device

- *You need the power cable exclusive for iPod in order to operate iPod with the buttons on the audio system. The PC cable provided by Apple may cause malfunction and do not use it for vehicle use.*
- *When connecting the device with iPod cable, push in the jack fully not to interfere with communication.*
- *When adjusting the sound effects of iPod and the audio system, the sound effects of both devices will overlap each and might cause reduce or distort the quality of the sound.*
- *Deactivate (turn off) the equalizer function of iPod when adjusting the audio system's volume, and turn off the equalizer of the audio system when using the equalizer of iPod.*

(Continued)

(Continued)

- *When the iPod cable is connected, the system can be switched to the AUX mode even without the iPod device and can cause noise. Disconnect iPod cable when you are not using the iPod device.*

SIRIUS SATELLITE RADIO(CDP MODEL)



1. SATELLITE RADIO Selection Button
2. Channel Selection Button
3. SCAN Selection Button
4. MUTE Selection Button
5. Preset Selection Button
6. INFO Selection Button
7. CAT/FOLDER Button
8. Tune Knob and Enter Button

A-200GHU

SIRIUS SATELLITE RADIO(6CDC MODEL)

MONITOR

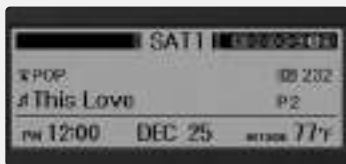

- 1. SATELLITE RADIO Selection Button
- 2. Channel Selection Button
- 3. SCAN Selection Button
- 4. MUTE Selection Button
- 5. Preset Selection Button
- 6. INFO Selection Button
- 7. CAT/FOLDER Button
- 8. Tune Knob and Enter Button



A-300GHU

How to Use SIRIUS Satellite Radio

Your new Kia vehicle is equipped with 3 months complimentary period of SIRIUS Satellite Radio so you have access to over 130 channels of music, information and entertainment programming.

Activation

In order to extend or reactivate your subscription to SIRIUS Satellite Radio, you will need to contact SIRIUS Customer Care at 888-539-7474. Have your 12 digit SID(Sirius Identification Number)/ESN (Electronic Serial Number) ready. To retrieve the SID/ESN, turn on the radio, press the [SAT] button and tune to channel zero. please note that the vehicle will need to be turned on, in Sirius mode, and have an unobstructed view of the sky in order for the radio to receive the activation signal.

1. SATELLITE RADIO Selection Button(SIRIUS Satellite Radio)

Press the [SAT] button to switch to SIRIUS Satellite Radio. It cycles through the different bands as noted below.

SAT1 → SAT2 → SAT3 → SAT1 → ...

2. Channel Selection Button

- Press [TRACK √] or [SEEK ^] button for less than 0.8 seconds to select previous or next channel.
- Press [TRACK √] or [SEEK ^] button for 0.8 or longer to continuously move to previous or next channel.
- if "CATEGORY" Icon is displayed at the top of the screen, channel up/down is done through the channels within current category.

3. SCAN Selection Button

- When the button is pressed, it automatically scans the radio stations upwards.
- The SCAN feature steps through each channel, starting from the initial channel, for ten seconds. Press the [SCAN] button again to stop the scan feature and to listen to the currently selected channel.

4. MUTE Selection Button

Press this button to temporarily cut off the Sound. "MUTE" is displayed on the LCD. Press the button once again to cancel MUTE mode.

5. Preset Selection Button

- Press [1]–[6] buttons less than 0.8 seconds to play the Channel saved in each button.
- Press [1]–[6] button for 0.8 seconds or longer to save current Channel to the respective button with a beep.

6. INFO Selection Button

Displays the information of the channel currently played by in the order of CATEGORY NAME → ARTIST NAME → COMPOSER NAME → ... (CH/TITLE Selection)
Displays the information of the channel currently played in the order of SONG TITLE → ARTIST NAME → COMPOSER NAME → ... (CAT/CH Selection) (If there is no information of COMPOSER NAME, it returns to main display.)

7. CAT/FOLDER Button

- Press [CAT ^] or [FLDR v] button to enter the Category list Mode, it displays category items and highlights the category that currently tuned channel belongs to.
- On Category List Mode, press these buttons to navigate category list.
- Press [ENTER] Button to select the lowest channel in highlighted category.
- If channel is selected by selecting category CATEGORY Icon is displayed at the top of the screen.

8. Tune Knob and Enter Button

- Rotate clockwise to increase the channel number or to down the category in the category list.
- Rotate counterclockwise to decrease the channel number or to up the category in the category list.
- Press this button to make selection of channels or items.

* Troubleshooting

1. Antenna Error

If this message is displayed, the antenna or antenna cable is broken or unplugged. Please consult with your Kia dealership.

2. Acquiring Signal

If this message is displayed, it means that the antenna is covered and that the SIRIUS Satellite Radio signal is not available. Ensure the antenna is uncovered and has a clear view of the sky.

KEY BOARD



1. DISPLAY ON/OFF
2. CLOCK Function
3. Time/Date Increase/Reduce Function
4. RESET Function
5. DATE Function

A-300GHU

1. DISPLAY ON/OFF

- This is the display window ON/OFF function.
- Each time the [DISP] button is pressed, the display window will be turned ON/OFF.

2. CLOCK Function

- This is the clock adjustment function.
- Each time [CLOCK] is pressed, the second→minute will blink once every 0.5 seconds and switch modes.
- Pressing the [CLOCK] again while the "minute" mode is blinking or waiting 10 seconds will turn off time adjustment mode and save the set time.
- The clock can be set in 12 hour or 24 hour modes. The 12 hour system is the default and can be changed to 24 hour system within the SET-UP menu.

3. Time/Date Increase/Decrease Function

- While in Time/Date mode, pressing the [∧], [∨] buttons will increase/decrease the time/date.
- This function will operate only after pressing the time/date button and the hour/minute/month/day is blinking.

4. RESET Function

- The RESET function can be used when adjusting the time.
- If the [RESET] is pressed while adjusting the "hour", the hour will display "AM12" when using 12 hour clock mode and "00" when using 24 hour clock mode.
- If the RESET is pressed while adjusting the "min", the minute display will be changed to "00".
- The RESET function can be used while adjusting the date.
- If the [RESET] is pressed while adjusting the "month/day", the corresponding display will be changed to "01month/01day".

5. DATE Function

- This is used to adjust the date.
- Each time [DATE] is pressed, the month→day will blink once every 0.5 seconds and switch modes.
- Pressing the [DATE] again while the "day" is blinking or waiting 10 seconds will turn off date adjustment mode and save the set date.
- ※ Slight differences with actual time may occur. Please readjust the time upon the occurrence of such differences.

Ignition switch / 4-2
Starting the engine / 4-4
Automatic transaxle / 4-5
Brake system / 4-10
Steering wheel / 4-17
Cruise control system / 4-19
Electronic stability control / 4-22
Instrument cluster / 4-25

Driving your vehicle

4

Warnings and indicators / 4-31
Lighting / 4-38
Wipers and washers / 4-42
Defroster / 4-44
Hazard warning flasher / 4-45
Automatic climate control system / 4-46
Windshield defrosting and defogging / 4-56

IGNITION SWITCH

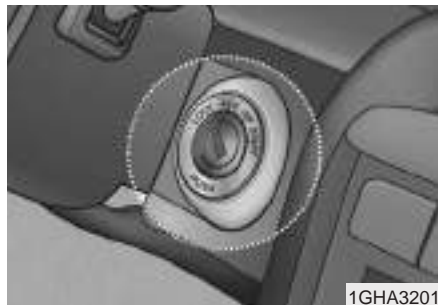

Illuminated ignition switch

Whenever a door is opened, the ignition switch will be illuminated for your convenience, provided the ignition switch is not in the ON position. The light will go off approximately 10 seconds after closing the door or when the ignition switch is turned on.



Ignition switch and anti-theft steering column lock

Ignition switch position

LOCK

The steering wheel locks to protect against theft. The ignition key can be removed only in the LOCK position. When turning the ignition switch to the LOCK position, push the key inward at the ACC position and turn the key toward the LOCK position.

ACC (Accessory)

The steering wheel is unlocked and electrical accessories are operative.

*** NOTICE**

If difficulty is experienced turning the ignition switch to the ACC position, turn the key while turning the steering wheel right and left to release the tension.

ON

The warning lights can be checked before the engine is started. This is the normal running position after the engine is started.

Do not leave the ignition switch ON if the engine is not running to prevent battery discharge.

START

Turn the ignition key to the START position to start the engine. The engine will crank until you release the key; then it returns to the ON position. The brake warning lamp can be checked in this position.

⚠ WARNING

When you intend to park or stop the vehicle with the engine on, be careful not to depress the accelerator pedal for a long period of time. It may overheat the engine or exhaust system and cause fire.

⚠ WARNING - Ignition switch

- Never turn the ignition switch to LOCK or ACC while the vehicle is moving. This would result in loss of directional control and braking function, which could cause an immediate accident.
- The anti-theft steering column lock is not a substitute for the parking brake. Before leaving the driver's seat, always make sure the shift lever is engaged in P (Park), set the parking brake fully and shut the engine off. Unexpected and sudden vehicle movement may occur if these precautions are not taken.
- Never reach for the ignition switch, or any other controls through the steering wheel while the vehicle is in motion. The presence of your hand or arm in this area could cause a loss of vehicle control, an accident and serious bodily injury or death.
- Do not put any movable things around the driver's seat as they can disturb your driving and may cause accidents.

Automatic transaxle

When turning the ignition switch to the LOCK position, the shift lever must be in the P (Park) position.

STARTING THE ENGINE

WARNING

Always wear appropriate shoes when operating your vehicle. Unsuitable shoes (high heels, ski boots, etc.) may interfere with your ability to use the brake and accelerator pedal.

1. Make sure the parking brake is applied.
2. Place the transaxle shift lever in P (Park). Depress the brake pedal fully. You can also start the engine when the shift lever is in the N (Neutral) position.
3. Turn the ignition switch to START and hold it there until the engine starts (a maximum of 10 seconds), then release the key.
4. In extremely cold weather (below -18°C / 0°F) or after the vehicle has not been operated for several days, let the engine warm up without depressing the accelerator.

*Whether the engine is cold or warm, it should be started **without depressing the accelerator.***

CAUTION

If the engine stalls while you are in motion, do not attempt to move the shift lever to the P (Park) position. If traffic and road conditions permit, you may put the shift lever in the N (Neutral) position while the vehicle is still moving and turn the ignition switch to the START position in an attempt to restart the engine.

AUTOMATIC TRANSAXLE

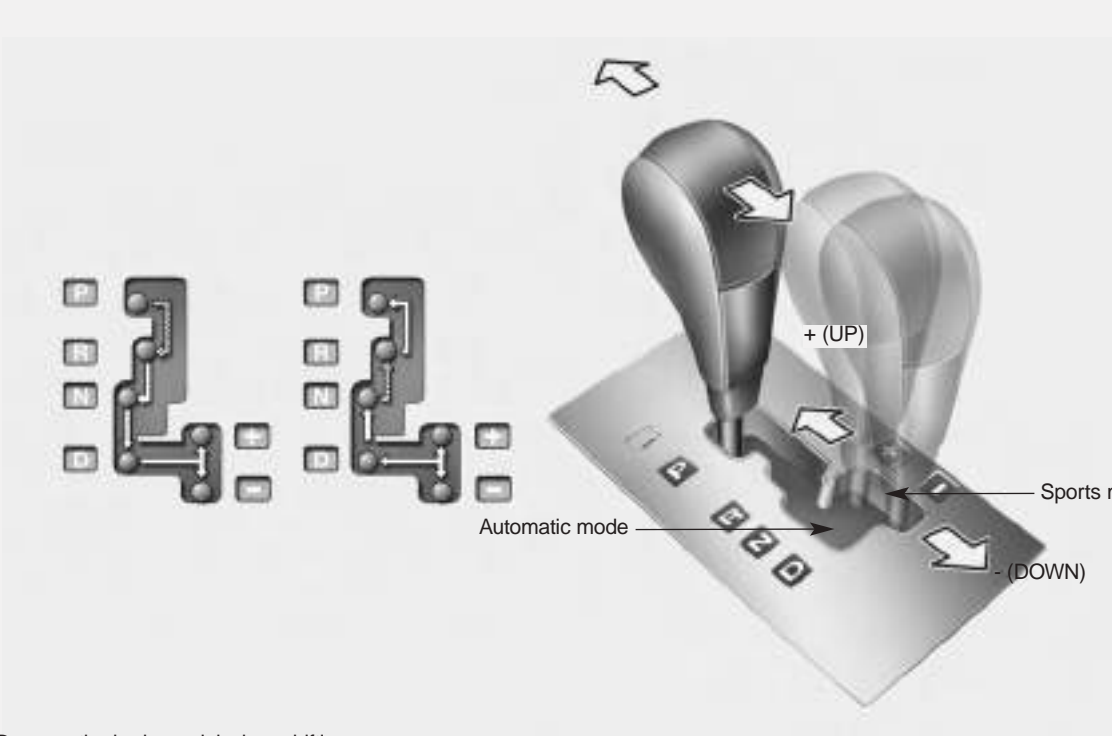

 Depress the brake pedal when shifting.

 The shift lever can be moved freely.

Automatic transaxle operation

All normal forward driving is done with the shift lever in the D (Drive) position. To move the shift lever from the P (Park) position, the brake pedal must be depressed and the lock release button must be depressed.

For smooth operation, depress the brake pedal when shifting from N (Neutral) to a forward or reverse gear.

WARNING - Automatic transaxle

Before leaving the driver's seat, always make sure the shift lever is in the P (PARK) position; then set the parking brake fully and shut the engine off. Unexpected and sudden vehicle movement can occur if these precautions are not followed in the order identified.

* NOTICE

- To avoid damage to your transaxle, do not accelerate the engine in R (Reverse) or any forward gear position with the brakes on.
- When stopped on an upgrade, do not hold the vehicle stationary with engine power. Use the service brake or the parking brake.
- Do not shift from N (Neutral) or P (Park) into D (Drive), or R (Reverse) when the engine is above idle speed.

Transaxle ranges

P (park)

This position locks the transaxle and prevents the front wheels from rotating. Always come to a complete stop before shifting into this position.

WARNING

- Shifting into P (Park) while the vehicle is in motion will cause the drive wheels to lock which will cause you to lose control of the vehicle.
- Do not use the P (Park) position in place of the parking brake. Always make sure the shift lever is latched in the P (Park) position so that it cannot be moved unless the lock release button is pushed in, AND set the parking brake fully.

(Continued)

(Continued)

- Before leaving the driver's seat, always make sure the shift lever is in the P (PARK) position. Set the parking brake fully, shut the engine off and take the key with you. Unexpected and sudden vehicle movement can occur if you do not follow these precautions in the order specified.
- Never leave a child unattended in a vehicle.

 CAUTION

The transaxle may be damaged if you shift into P (Park) while the vehicle is in motion.

R (reverse)

Use this position to drive the vehicle backward.

 WARNING

Always apply the brake pedal when you stop the vehicle on an inclined road with the shift lever in the D (Drive) position. Do NOT rely on the engine and transaxle to prevent the vehicle from rolling down the hill.

Before attempting to backup on an inclined road, always apply the brake pedal before moving the shift lever to the R (Reverse) position.

*** NOTICE**

Always come to a complete stop before shifting into or out of R (Reverse); you may damage the transaxle if you shift into R while the vehicle is in motion, except as explained in "Rocking the Vehicle", in this manual.

N (neutral)

With the gearshift in the N position, the wheels and transaxle are not locked. The vehicle will roll freely even on the slightest incline unless the parking brake or service brakes are applied.

D (drive)

This is the normal forward driving position. The transaxle will automatically shift through a 5-gear sequence, providing the best fuel economy and power.

For extra power when passing another vehicle or climbing grades, depress the accelerator fully, at which time the transaxle will automatically downshift to the next lower gear.

*** NOTICE**

Always come to a complete stop before shifting into D (Drive).

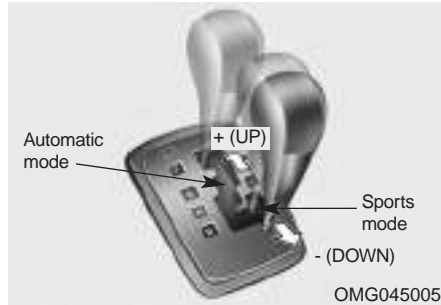

Sports mode

Whether the vehicle is stationary or in motion, sports mode is selected by pushing the shift lever from the “D” position into the sports mode. To return to “D” range operation, push the shift lever back into the automatic mode.

In sports mode, moving the shift lever backwards and forwards will allow you to make gearshifts rapidly. In contrast to a manual transaxle, the sports mode allows gearshifts with the accelerator pedal depressed.

Up (+) : Push the lever forward once to shift up one gear.

Down (-) : Pull the lever backwards once to shift down one gear.

Snow mode

When driving on a slippery road, push the shift lever forward into the +(up) position. This causes the transaxle to shift into the 2nd gear which is better for smooth driving on a slippery road. Push the shift lever to the -(down) side to shift back to the 1st gear.

* NOTICE

- Upshifts do not take place automatically in sports mode. The driver must execute upshifts in accordance with road conditions, taking care to keep the engine speed below the red zone.
- In sports mode, only the five forward gears can be selected. To reverse or park the vehicle, move the shift lever to the “R” or “P” position as required.
- In sports mode, downshifts are made automatically when the vehicle slows down. When the vehicle stops, 1st gear is automatically selected.
- In sports mode, when the engine rpm approaches the red zone shift points are varied to upshift automatically.
- To maintain the required levels of vehicle performance and safety, the system may not execute certain gearshifts when the shift lever is operated.

Moving up a steep grade from a standing start

To move up a steep grade from a standing start, depress the brake pedal, shift the shift lever to D (Drive). Select the appropriate gear depending on load weight and steepness of the grade, and release the parking brake. Depress the accelerator gradually while releasing the service brakes.

When accelerating from a stop on a steep hill, the vehicle may have a tendency to roll backwards. Shifting the shift lever into 2 (Second Gear) while in Sport mode will help prevent the vehicle from rolling backwards.

Ignition key inter lock system

The ignition key cannot be removed unless the shift lever is in the P (Park) position. If the ignition switch is in any other position, the key cannot be removed.

Shift lock system

For your safety, the Automatic Transaxle has a shift lock system which prevents shifting the transaxle out of P (Park) unless the brake pedal is depressed.

To shift the transaxle out of P (Park):

1. Depress and hold the brake pedal.
2. Start the engine or turn the ignition to the ON position.
3. Move the shift lever.

If the brake pedal is repeatedly depressed and released with the shift lever in the P (Park) position, a chattering sound near the shift lever may be heard. This is a normal condition.



Shift-lock override

If the shift lever should fail to move from the P (Park) position with the brake pedal depressed, continue depressing the brake, then do the following:

1. Carefully remove the cap covering the S/Lock override access hole which is located on the right side of the shift lever.
2. Insert the screwdriver or key into the access hole and press down on the key.
3. Depress the lock release button and move the shift lever.
4. Have your vehicle inspected by an authorized Kia dealership immediately.

BRAKE SYSTEM

Power brakes

Your vehicle has power-assisted brakes that adjust automatically through normal usage.

In the event that the power-assisted brakes lose power because of a stalled engine or some other reason, you can still stop your vehicle by applying greater force to the brake pedal than you normally would. The stopping distance, however, will be longer.

When the engine is not running, the reserve brake power is partially depleted each time the brake pedal is applied. Do not pump the brake pedal when the power assist has been interrupted.

In the event of brake failure

If service brakes fail to operate while the vehicle is in motion, you can make an emergency stop with the parking brake. The stopping distance, however, will be much greater than normal.

WARNING - Parking brake

Depressing the parking brake while the vehicle is moving at normal speeds can cause a sudden loss of control of the vehicle. If you must use the parking brake to stop the vehicle, use great caution in applying the brake.

WARNING - Brakes

- **Do not drive with your foot resting on the brake pedal. This will create abnormal high brake temperatures, excessive brake lining and pad wear, and increased stopping distances.**
- **When descending a long or steep hill, shift to a lower gear and avoid continuous application of the brakes. Continuous brake application will cause the brakes to overheat and could result in a temporary loss of braking performance.**

(Continued)

(Continued)

- **Wet brakes may result in the vehicle not to slow down at the usual rate and make it pull to one side when the brakes are applied. Applying the brakes lightly will indicate whether they have been affected in this way. Always test your brakes in this fashion after driving through deep water. To dry the brakes, apply them lightly while maintaining a safe forward speed until brake performance returns to normal.**

Disc brakes wear indicator

Your vehicle has disc brakes.

When your brake pads are worn and it's time for new pads, you will hear a high-pitched warning sound from your front brakes or rear brakes. You may hear this sound come and go or it may occur whenever you depress the brake pedal.

Please remember that some driving conditions or climates may cause a brake squeal when you first apply (or lightly apply) the brakes. This is normal and does not indicate a problem with your brakes.

*** NOTICE**

To avoid costly brake repairs, do not continue to drive with worn brake pads.



WARNING - Brake wear

This brake wear warning sound means your vehicle needs service. If you ignore this audible warning, you will eventually lose braking performance, which could lead to a serious accident.

CAUTION

Always replace brake pads as complete front or rear axle sets.



Power adjustable pedals (if equipped)

To adjust the position of the accelerator and brake pedals, turn the ignition key to the "ON" position with the selector lever in the "P" position and push the switch.

If you push the "▲" portion of the switch, the pedals move rearward.

If you push the "▼" portion of the switch, the pedals move forward.

Setting the driver's position

1. Be sure the parking brake is engaged.
2. Move the accelerator and brake pedals to the front most position by pushing the "▼" portion of the switch.
3. Adjust the seat position and the steering wheel angle properly.
4. Move the pedals toward you until you can fully depress the brake pedal by pushing the "▲" portion of the switch.
5. Depress the pedals a few times to get used to the feel after adjusting.

⚠ WARNING - Pedal adjustment

- Adjust the pedals after parking the vehicle on level ground. Never attempt to adjust the pedals while the vehicle is moving.
- Never adjust the pedals with your foot on the accelerator pedal as this may result in increasing the engine speed and acceleration.
- Make sure that you can fully depress the brake pedal before driving. Otherwise, you may not be able to hold down the brake pedal firmly in an emergency stop.

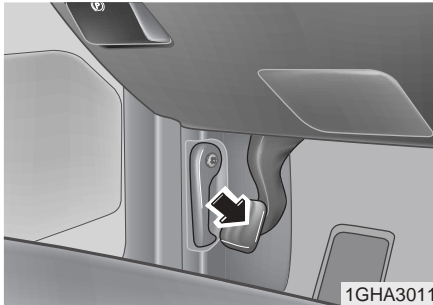

Parking brake

To set the parking brake, depress the parking brake pedal fully and firmly downward while applying the service brake.

CAUTION

Driving with the parking brake applied will cause excessive brake pad and brake rotor wear.

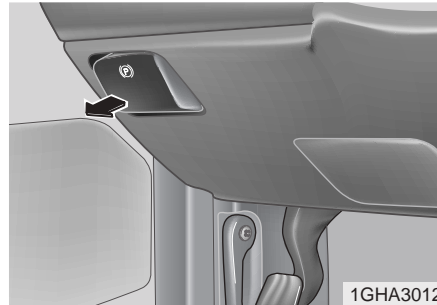

Manual release

To release the parking brake, pull the parking brake release lever while applying the service brake. The pedal will automatically extend to the fully released position. If the parking brake pedal does not release or does not release all the way, have the system checked by an authorized Kia dealer.

WARNING - Parking brake

- To prevent unintentional movement when stopped and leaving the vehicle, do not use the gearshift lever in place of the parking brake. Set the parking brake AND make sure the gearshift lever is securely positioned in P (Park).
- Never allow a person who is unfamiliar with the vehicle or children to touch the parking brake. If the parking brake is released unintentionally, serious injury may occur.



Check the brake warning light by turning the ignition switch ON (do not start the engine). This light will be illuminated when the parking brake is applied with the ignition switch in the START or ON position.

Before driving, be sure the parking brake is fully released and the brake warning light is off.

If the brake warning light remains on after the parking brake is released, there may be a malfunction in the brake system. Immediate attention is necessary.

If at all possible, cease driving the vehicle immediately. If that is not possible, use extreme caution while operating the vehicle and only continue to drive the vehicle until you can reach a safe location or repair shop.

Parking on curbed streets

- When parking your vehicle on an uphill grade, park as close to the curb as possible and turn the front wheels away from the curb so that the front wheels will contact the curb if the vehicle moves backward.
- When parking your vehicle on a downhill grade, park as close to the curb as possible and turn the front wheels toward the curb so that the front wheels will contact the curb if the vehicle moves forward.

Anti-lock brake system (ABS)

WARNING - ABS Brakes

Your ABS is not a substitute for good driving judgement. You can still have an accident. In fact, your ABS system will probably not be able to prevent an accident in the following driving conditions:

- Dangerous driving, such as neglecting safety precautions, speeding, or driving too close to the vehicle in front of you.
- Driving at high speed in situations providing considerably less traction, such as wet conditions where hydroplaning could occur.
- Driving too fast on poor road surfaces. The ABS is designed to improve maximum braking effectiveness on typical highways and roads in good condition. On poor road surfaces in poor condition, the ABS may actually reduce braking effectiveness.

The ABS system continuously senses the speed of the wheels. If the wheels are going to lock, the ABS system repeatedly modulates the hydraulic brake pressure to the wheels.

When you apply your brakes under conditions which may lock the wheels, you may hear a “tik-tik” sound from the brakes, or feel a corresponding sensation in the brake pedal. This is normal and it means your ABS system is active.

In order to obtain the maximum benefit from your ABS system in an emergency situation, do not attempt to modulate your brake pressure and do not try to pump your brakes. Press your brake pedal as hard as possible or as hard as the situation warrants and allow the ABS system to control the force being delivered to the brakes.

- Even with the anti-lock brake system, your vehicle still requires sufficient stopping distance. Always maintain a safe distance from the vehicle in front of you.
- Always slow down when cornering. The anti-lock brake system cannot prevent accidents resulting from excessive speeds.
- On loose or uneven road surfaces, operation of the anti-lock brake system may result in a longer stopping distance than for vehicles equipped with a conventional brake system.



*** NOTICE**

- If the ABS warning light is on and stays on, you may have a problem with the ABS system. In this case, however, your regular brakes will work normally.
- The ABS warning light will stay on for approximately 3 seconds after the ignition switch is ON. During that time, the ABS will go through self-diagnosis and the light will go off if everything is normal. If the light stays on, you may have a problem with your ABS system. Contact an authorized Kia dealer as soon as possible.

*** NOTICE**

- When you drive on a road having poor traction, such as an icy road, and operate your brakes continuously, the ABS will be active continuously and the ABS warning light may illuminate. Pull your car over to a safe place and stop the engine.
- Restart the engine. If the ABS warning light is off, then your ABS system is normal. Otherwise, you may have a problem with the ABS. Contact an authorized Kia dealer as soon as possible.

*** NOTICE**

When you jump start your vehicle because of a drained battery, the engine may not run as smoothly and the ABS warning light may turn on at the same time. This happens because of the low battery voltage. It does not mean your ABS is malfunctioning.

- Do not pump your brakes!
- Have the battery recharged before driving the vehicle.

STEERING WHEEL

Power steering

Power Steering uses energy from the engine to assist you in steering the vehicle. If the engine is off or if the power steering system becomes inoperative, the vehicle may still be steered, but it will require increased steering effort.

Should you notice any change in the effort required to steer during normal vehicle operation, have the power steering checked by an Authorized Kia Dealer.

* NOTICE

- Never hold the steering wheel against a stop (extreme right or left turn) for more than 5 seconds with the engine running. Holding the steering wheel for more than 5 seconds in either position may cause damage to the power steering pump.
- If the power steering drive belt breaks or if the power steering pump malfunctions, the steering effort will greatly increase.

* NOTICE

If the vehicle is parked for extended periods outside in cold weather (below -10 °C/14 °F), the power steering may require increased effort when the engine is first started. This is caused by increased fluid viscosity due to the cold weather and does not indicate a malfunction.

When this happens, increase the engine RPM by depressing the accelerator until the RPM reaches 1,500 rpm then release or let the engine idle for two or three minutes to warm up the fluid.

Tilt steering (if equipped)

A tilt steering wheel allows you to adjust the steering wheel before you drive. You can also raise it to the highest level to give your legs more room when you exit and enter the vehicle.

The steering wheel should be positioned so that it is comfortable for you to drive, while permitting you to see the instrument panel warning lights and gauges.



To change the steering wheel angle, pull up the lock release lever (①), adjust the steering wheel to the desired angle (②), then release the lock-release lever to lock the steering wheel in place. Be sure to adjust the steering wheel to the desired position before driving.



Horn

To sound the horn, press the horn symbol on your steering wheel. Check the horn regularly to be sure it operates properly.

⚠ WARNING

- **Never adjust the angle of steering wheel while driving. You may lose your steering control and cause severe personal injury or accidents.**
- **After adjusting, push the steering wheel both up and down to be certain it is locked in position.**

⚠ CAUTION

- **To sound the horn, press the area indicated by the horn symbol on your steering wheel (see illustration). The horn will operate only when this area is pressed.**
- **Do not strike the horn severely to operate it, or hit it with your fist. Do not press on the horn with a sharp-pointed object.**

CRUISE CONTROL (IF EQUIPPED)

The cruise control system allows you to program the vehicle to maintain a constant speed without resting your foot on the accelerator pedal.

With cruise control, you can set and automatically maintain any speed of between 24 mph (40 km/h) and 125 mph (200 km/h).

⚠ WARNING - Cruise control

Do not use the cruise control feature under the following conditions:

- Heavy or unsteady traffic
- Slippery or winding roads
- Situations that involve varying speeds



OGH046335N

To set cruise control speed:

1. Push the CRUISE ON/OFF button on the steering wheel, to turn the system on. The CRUISE indicator light in the instrument cluster will illuminate.
2. Accelerate to the desired speed, which must be more than 24 mph (40 km/h) and less than 125 mph (200 km/h).

⚠ WARNING

If the cruise control is left on, (CRUISE indicator light in the instrument cluster illuminated) the cruise control can be switched on accidentally. Keep the cruise control system off (CRUISE indicator light OFF) when cruise control is not in use.



OGH046336N

3. Depress the COAST/SET switch, located on the steering wheel, and release it at the speed you want. The "SET" indicator light in the instrument cluster will illuminate. Release the accelerator at the same time. The desired speed will automatically be maintained.

The SET function cannot be activated until approximately 2 seconds after the CRUISE ON/OFF button has been engaged.

On a steep grade, the vehicle may momentarily slow down while going downhill.

To cancel cruise control, do one of the following:

- Depress the brake pedal.
- Shift into N (Neutral).
- Depress the CANCEL switch located on the steering wheel.
- Depress the COAST/SET and RES/ACCEL switches at the same time.

Each of these actions will cancel cruise control operation (the "SET" indicator light in the instrument cluster will go OFF), but it will not turn the system off. If you wish to resume cruise control operation, depress the RES/ACCEL switch located on your steering wheel. You will return to your previously preset speed.

To turn cruise control off, do one of the following:

- Push the CRUISE ON/OFF button on the steering wheel (the CRUISE indicator light in the instrument cluster will go OFF).
- Turn the ignition off.

Both of these actions cancel cruise control operation. If you want to resume cruise control operation, repeat the steps provided in "To Set Cruise Control Speed" on the previous page.



To increase cruise control set speed:

Follow either of these procedures:

- Depress the RES/ACCEL switch and hold it. Your vehicle will accelerate. Release the switch at the speed you want.
- Depress the RES/ACCEL switch and release it immediately. The cruising speed will increase 1 mph (1.6 km/h) by one touch and will be memorized to the reset speed.

To temporarily accelerate with the cruise control on

If you want to speed up temporarily when the cruise control is on, depress the accelerator pedal. Increased speed will not interfere with cruise control operation or change the set speed.

To return to the set speed, take your foot off the accelerator.



OGH046336N

To decrease the cruising speed:

Follow either of these procedures:

- Depress the COAST/SET switch and hold it. Your vehicle will gradually slow down. Release the switch at the speed you want to maintain.
- Depress the COAST/SET switch and release it immediately. The cruising speed will decrease 1 mph (1.6 km/h) by one touch and will be memorized to the reset speed.



OGH046337N

To resume cruising speed at more than 24 mph (40 km/h):

If any method other than the CRUISE ON/OFF switch was used to cancel cruising speed and the system is still activated, the most recent set speed will automatically resume when the RES/ACCEL switch is depressed.

It will not resume, however, if the vehicle speed has dropped below 24 mph (40km/h).

ELECTRONIC STABILITY CONTROL (IF EQUIPPED)

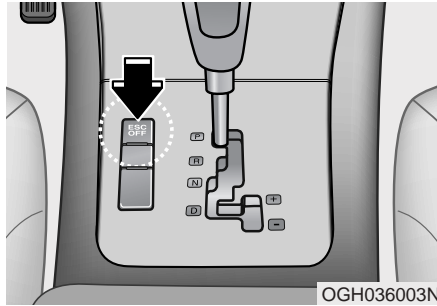

The Electronic Stability Control (ESC) monitors information from various vehicle sensors and then compares the driver's commands with the actual behavior of the vehicle. If an unstable condition is created by the driver - a sudden evasive movement for example - ESC intervenes within fractions of a second via the engine computer and brake system and attempts to stabilize the vehicle.

ESC operation

ESC ON condition



- When the ignition is turned ON, ESC and ESC OFF indicator lights illuminate for approximately 3 seconds, then ESC is turned on.
- Press the ESC OFF button to turn ESC off. (ESC OFF indicator will illuminate). To turn the ESC on, press the ESC OFF button (ESC OFF indicator light will go off).
- When starting the engine, you may hear a slight ticking sound. This is the ESC performing an automatic system self-check and does not indicate a problem.

When operating



- When the ESC is in operation, ESC indicator light blinks.
- When the Electronic Stability Control is operating properly, you can feel a slight pulsation in the vehicle. This is only the effect of brake control and indicates nothing unusual.
 - When moving out of the mud or slippery road, pressing the accelerator pedal may not cause the engine rpm (revolutions per minute) to increase.

ESC operation off**ESC OFF state**

 A rectangular button with the text "ESC OFF" inside.

- To cancel ESC operation, press the ESC OFF button (ESC OFF indicator light illuminates).
- If the ignition switch is turned to LOCK position when ESC is off, ESC remains off. Upon restarting the engine, the ESC will automatically turn on again.

- ESC indicator light (blinks)

 The text "ESC" in a bold, sans-serif font.

- ESC OFF indicator light (comes on)

 The text "ESC OFF" in a bold, sans-serif font.
Indicator light

When ignition switch is turned to ON, the indicator light illuminates, then goes off if ESC system is operating normally.

The ESC indicator light blinks whenever ESC is operating.

ESC OFF indicator light comes on when either the ESC is turned off with the button, or ESC fails to operate when turned on.

⚠ WARNING

The Electronic Stability Control system is only a driving aid; use precautions for safe driving by slowing down on curved, snowy, or icy roads. Drive slowly and don't attempt to accelerate whenever the ESC indicator light is blinking, or when the road surface is slippery.

ESC OFF usage

When driving

- It's a good idea to keep the ESC turned on for daily driving whenever possible.
- To turn ESC off while driving, press the ESC OFF button while driving on a flat road surface.

Never press ESC OFF button while ESC is operating (ESC indicator light blinks). If ESC is turned off while ESC is operating, the vehicle may slip out of control.

* NOTICE

- When measuring the vehicle speed with a Chassis dynamo-meter, make sure the ESC is turned off (ESC OFF light illuminated). If the ESC is left on, it may prevent the vehicle speed from increasing, and cause a false diagnosis of a faulty speedometer.
- Turning the ESC off does not affect ABS or brake system operation.

WARNING

Never press the ESC OFF button while ESC is operating.

If the ESC is turned off while ESC is operating, the vehicle may slip out of control.

To turn ESC off while driving, press the ESC OFF button while driving on a flat road surface.

INSTRUMENT CLUSTER

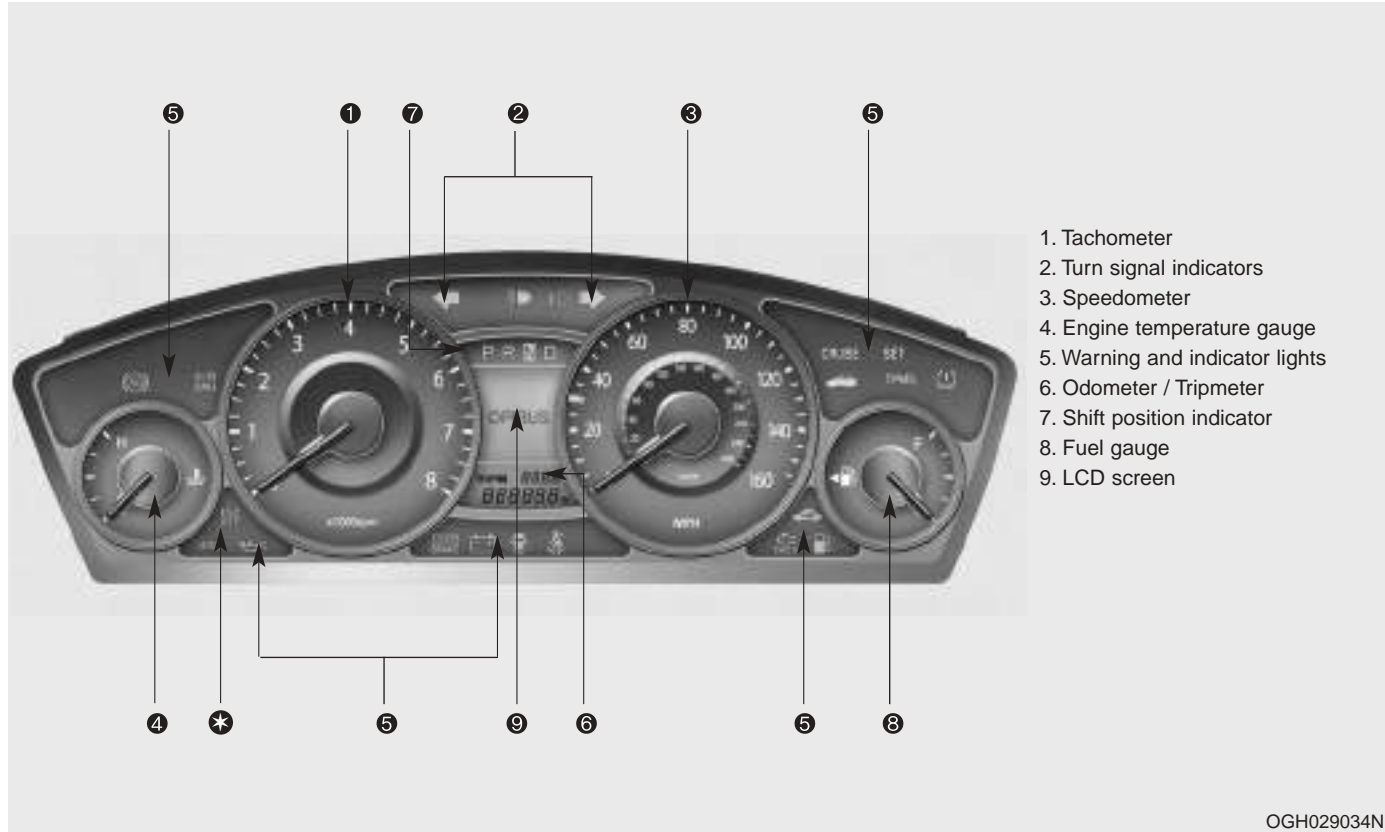

OGH029034N

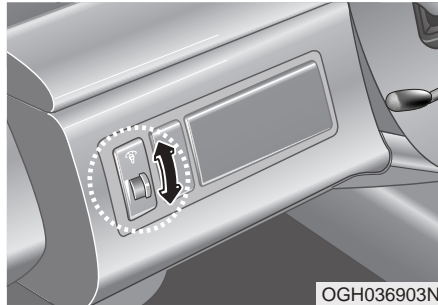

OGH036903N

Instrument panel illumination

When the vehicle's parking lights or headlights are on, rotate the illumination control knob to adjust the instrument panel illumination intensity.

Gauges

Speedometer

The speedometer indicates the forward speed of the vehicle.

⚠ WARNING

Speedometer and Odometer is calculated according to the tire size. Therefore, if you do not use the tire recommended for the vehicle, the calculation of the Speedometer and Odometer may be incorrect.

Tachometer

The tachometer indicates the approximate number of engine revolutions per minute (rpm).

Use the tachometer to select the correct shift points and to prevent lugging and/or over-revving the engine.

The tachometer pointer may move slightly when the ignition switch is in ACC or ON position with the engine OFF. This movement is normal and will not affect the accuracy of the tachometer once the engine is running.

⚡ CAUTION

Do not operate the engine within the tachometer's RED ZONE. This may cause severe engine damage.

Engine temperature gauge

This gauge shows the temperature of the engine coolant when the ignition switch is ON.

Do not continue driving with an overheated engine. If your vehicle overheats, refer to "Overheating" in the Index.

⚡ CAUTION

If the gauge pointer moves beyond the normal range area toward the "H" position, it indicates overheating that may damage the engine.

Fuel gauge

The fuel gauge indicates the approximate amount of fuel remaining in the fuel tank.

Fuel tank capacity - 18.49 US gal. (70 liters).

The fuel gauge is supplemented by a low fuel warning light, which will illuminate when the fuel tank is nearly empty.

⚠ WARNING - Fuel gauge

Running out of fuel can expose vehicle occupants to danger.

You must obtain additional fuel as soon as possible after the warning light comes on or when the gauge indicator comes close to the E level.

Trip computer

The trip computer is a microcomputer-controlled driver information system that displays information related to driving, including odometer, tripmeter, driving time, average speed, average fuel consumption, instant fuel consumption and distance to empty on the display when the ignition switch is in the ON position. All stored driving information (except odometer) is reset if the battery is disconnected.



TRIP Button

Push the TRIP button for less than 1 second to select tripmeter function as follows:





Odometer (mi.)

The odometer indicates the total distance the vehicle has been driven.



Tripmeter (mi.)

TRIP A : Tripmeter A

TRIP B : Tripmeter B

This mode indicates the distance of individual trips selected since the last tripmeter reset.

The meter's working range is from 0.0 to 999.9 miles.

Pressing the TRIP button for more than 1 second, when the tripmeter (TRIP A or TRIP B) is being displayed, clears the tripmeter to zero (0.0).

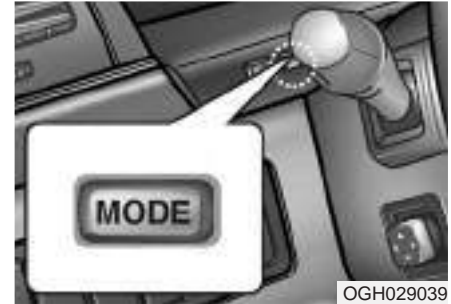

MODE Button

Push the MODE Button for less than 1 second to select distance to empty, average fuel consumption, instant fuel consumption, average speed, elapsed time function as follows:

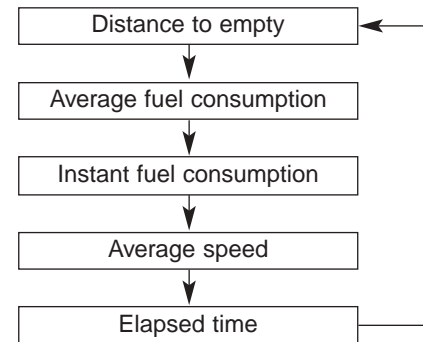



Distance to empty (mi.)

This mode indicates the estimated distance to empty based on the current fuel in the fuel tank and the amount of fuel delivered to the engine. When the remaining distance is below 30 miles, "--" will be displayed and the distance to empty indicator will blink.

The meter's working range is from 30 to 999 miles.

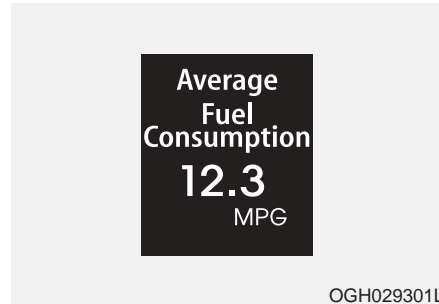

Average fuel consumption (MPG)

This mode calculates the average fuel consumption from the total fuel used and the distance since the last average consumption reset. The total fuel used is calculated from the fuel consumption input. For an accurate calculation, drive more than 0.03 miles.

Pressing the MODE button for more than 1 second, when the average fuel consumption is being displayed, clears the average fuel consumption to zero (---).

If the vehicle speed exceeds 0.6mph after refueled than 1.6 gallons(6L), the average fuel consumption will be cleared to zero(---).



Instant fuel consumption (MPG)

This mode calculates the instant fuel consumption every 2 second from the driving distance and quantity of fuel injection.



Average speed (MPH)

This mode calculates the average speed of the vehicle since the last average speed reset.

Even if the vehicle is not in motion, the average speed keeps going while the engine is running.

Pressing the MODE button for more than 1 second, when the average speed is being displayed, clears the average speed to zero (---).

If 2 hours have passed after the ignition switch is OFF, the average speed will be cleared to zero(---).

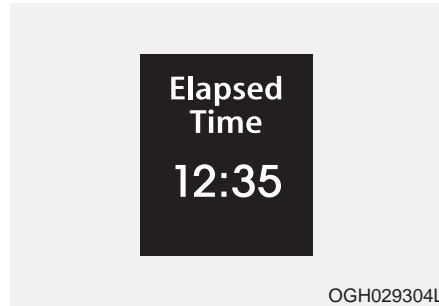

Elapsed time

This mode indicates the total time traveled since the last driving time reset.

Even if the vehicle is not in motion, the driving time keeps going while the engine is running.

The meter's working range is from 00:00~99:59.

Pressing the MODE button for more than 1 second, when the driving time is being displayed, clears the driving time to zero (00:00).

If 2 hours have passed after the ignition switch is OFF, the elapsed time will be cleared to zero(---).

* NOTICE

- If the vehicle is not on level ground or the battery power has been interrupted, the “Distance to empty” function may not operate correctly. The trip computer may not register additional fuel if less than 6 liters (1.6 gallons) of fuel are added to the vehicle.
- The fuel consumption and distance to empty values may vary significantly based on driving conditions, driving habits, and condition of the vehicle.
- The distance to empty value is an estimate of the available driving distance. This value may differ from the actual driving distance available.

WARNINGS AND INDICATORS

Warning lights / audible indicators

Checking operation

All warning lights are checked by turning the ignition switch ON (do not start the engine). Any light that does not illuminate should be checked by an Authorized Kia Dealer.

After starting the engine, check to make sure that all warning lights are off. If any are still on, this indicates a situation that needs attention. When releasing the parking brake, the brake system warning light should go off. The fuel warning light will stay on if the fuel level is low.

Anti-lock brake system (ABS) warning light (if equipped)



This light illuminates if the key is turned to ON and goes off approximately 3 seconds if the system is operating normally. If the light stays on, you may have a problem with your ABS system. Contact an authorized Kia dealer as soon as possible.

Electronic brake force distribution (EBD) system warning light (if equipped)



If two warning lights illuminate at the same time while driving, your vehicle has a problem with ABS and EBD system.

In this case, your ABS system and regular brake system may not work normally. Have the vehicle checked by an Authorized Kia Dealer as soon as possible.

⚠ WARNING

If both ABS and Brake warning lights are ON and stay ON, your vehicle's brake system will not work normally. In such a case, you may experience an unexpected and dangerous situation when braking abruptly. When both ABS and brake lights are on, avoid high speed driving and abrupt braking. Have your vehicle checked by an Authorized Kia Dealer as soon as possible.

Engine oil pressure warning



This warning light indicates the engine oil pressure is low.

If the warning light illuminates while driving:

1. Drive safely to the side of the road and stop.
2. With the engine off, check the engine oil level. If the level is low, add oil as required.

If the warning light remains on after adding oil or if oil is not available, call an Authorized Kia Dealer.

CAUTION

If the engine is not stopped immediately, severe damage could result.

Charging system warning

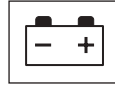

This warning light indicates a malfunction of either the generator or electrical charging system.

If the warning light comes on while the vehicle is in motion:

1. Drive to the nearest safe location.
2. With the engine off, check the generator drive belt for looseness or breakage.
3. If the belt is adjusted properly, a problem exists somewhere in the electrical charging system. Have an Authorized Kia Dealer correct the problem as soon as possible.

Safety belt warning



If the driver's lap/shoulder belt is not fastened when the key is turned ON or if it is unfastened after the key is ON, the safety belt warning light blinks until the belt is fastened.

If the system does not operate as described, see an Authorized Kia Dealer for assistance.

**Front fog light indicator
(if equipped)**

This light comes on when the front fog lights are ON.

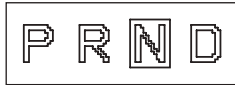
**Shift pattern
indicators**

The individual indicators illuminate to show the shift lever selection.

**Parking brake & brake
fluid warning*****Parking brake warning***

This light is illuminated when the parking brake is applied with the ignition switch in the START or ON position. The warning light should go off when the parking brake is released.

Low brake fluid level warning

If the warning light remains on, it may indicate that the brake fluid level in the reservoir is low.

If the warning light remains on:

1. Drive carefully to the nearest safe location and stop your vehicle.
2. With the engine stopped, check the brake fluid level immediately and add fluid as required. Then check all brake components for fluid leaks.
3. Do not drive the vehicle if leaks are found, the warning light remains on or the brakes do not operate properly. Have it towed to any Authorized Kia Dealer for a brake system inspection and necessary repairs.

To check bulb operation, check whether the parking brake and brake fluid warning light illuminates when the ignition switch is in the ON position.

⚠ WARNING

Driving the vehicle with a warning light on is dangerous. If the brake warning light remains on, have the brakes checked and repaired immediately by an Authorized Kia Dealer.

Trunk lid open warning



This warning light activates when the trunk is not closed securely.

Low fuel level warning



This warning light indicates the fuel tank is nearly empty. The warning light will come on when the fuel level has dropped to about 2.38 US gal. (9 liters). Refuel as soon as possible.

Door open display



This warning light illuminates when a door is not closed securely with the ignition in any position. And the door open display will illuminate the corresponding position light which door is not closed securely.

Immobilizer indicator (if equipped)



This light illuminates when the immobilizer key is inserted and turned to the ON position to start the engine. If this light turns off or blinks when the ignition switch is in the ON position before starting the engine, have the system checked by an authorized Kia Dealer.

Headlight high beam indicator



This indicator illuminates when the headlights are on and in the high beam position or when the turn signal lever is pulled into the Flash-to-Pass position.

Malfunction indicator (if equipped)

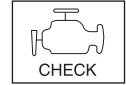



This indicator light is part of the Engine Control System which monitors various emission control system components. If this light illuminates while driving, it indicates that a potential problem has been detected somewhere in the emission control system.

Generally, your vehicle will continue to be drivable and will not need towing, but have the system checked by an Authorized Kia Dealer as soon as possible.

* NOTICE

A loose fuel filler cap may cause the On Board Diagnostic System Malfunction Indicator Light () in the instrument panel to illuminate unnecessarily. Always make sure that the fuel filler cap is tight.

CAUTION

- *Prolonged driving with the Emission Control System Malfunction Indicator Light () illuminated may cause damage to the emission control systems which could effect drivability and/or fuel economy.*
- *If the Emission Control System Malfunction Indicator Light () begins to flash ON and OFF, potential catalytic converter damage is possible which could result in loss of engine power. Have the Engine Control System inspected as soon as possible by an Authorized Kia Dealer.*

Air bag warning (if equipped)**AIR
BAG**

This warning light will blink or illuminate for approximately 6 seconds each time you turn the ignition switch to the ON position.

If this indicator does not go out, or if it illuminates while the vehicle is being driven, see an Authorized Kia Dealer for immediate service.

Low washer fluid level warning indicator (if equipped)**LOW WASHER
LIQUID!**

This warning light indicates the washer fluid reservoir is nearly empty. Refill the washer fluid as soon as possible.

Auto cruise indicator (if equipped)**CRUISE** indicator**CRUISE**

The indicator light illuminates when the cruise control system is enabled.

SET indicator**SET**

The indicator light illuminates when the cruise function switch (COAST/ SET or RES/ACCEL) is ON.

ESC indicator (Electronic Stability Control) (if equipped)



ESC

The ESC indicator will illuminate when the ignition switch is turned ON, but should go off after approximately 3 seconds. When the ESC is on, it monitors the driving conditions and under normal driving conditions, the ESC light will remain off. When a slippery or low traction condition is encountered, the ESC will operate, and the ESC indicator will blink to indicate the ESC is operating.

ESC OFF indicator (if equipped)



ESC
OFF

The ESC OFF indicator will illuminate when the ignition switch is turned ON, but should go off after approximately 3 seconds. To switch to ESC OFF mode, press the ESC OFF button. The ESC OFF indicator will illuminate indicating the ESC is deactivated. If this indicator stays on in the ESC ON mode, the ESC may have a malfunction. Take your car to an authorized Kia dealer and have the system checked.

Safety belt warning chime

If the driver's seat belt is not fastened when the ignition key is turned "ON" or if it is disconnected after the key is ON, the safety belt warning chime will sound for approximately 6 seconds.

Key reminder warning chime

If the driver's door is opened and the ignition key is left in the ignition switch in the LOCK or ACC position, the key reminder warning chime will sound. This is to prevent you from locking your keys in the vehicle.

Low tire pressure telltale



The low tire pressure telltale comes on for 3 seconds after the ignition key is turned to the "ON" position.

If the warning light does not come on, the Tire Pressure Monitoring System is not working properly. If this occurs, have your vehicle checked by an authorized Kia dealer as soon as possible.

This warning light will also illuminate if one or more of your tires are significantly under-inflated.

You should stop and check your tires as soon as possible. If the warning lights illuminate while driving, reduce vehicle speed immediately and stop the vehicle. Avoid hard braking and overcorrecting at the steering wheel. Inflate the tires to the proper pressure as indicated on the vehicle's tire information placard.

⚠ WARNING

Significantly low tire pressure makes the vehicle unstable and can contribute to loss of vehicle control and increased braking distances.

Continued driving on low pressure tires will cause the tires to overheat and fail.

TPMS (Tire pressure monitoring system) malfunction indicator

TPMS malfunction indicator illuminates for 3 seconds after the ignition key is turned to the "ON" position. If the warning light does not come on, or continuously remains on after the 3-second bulb check when you turned the ignition key to the "ON" position, the Tire Pressure Monitoring System is not working properly. If this occurs, have your vehicle checked by an authorized Kia dealer as soon as possible.

The warning light also comes on and stays on when there is a problem with the Tire Pressure Monitoring System.

If this happens, the system may not monitor the tire pressure. Have the system checked by an authorized Kia dealer as soon as possible.

⚠ WARNING

- The TPMS cannot alert you to severe and sudden tire damage caused by external factors.
- If you feel any vehicle instability, immediately take your foot off the accelerator and slowly move to a safe position off the road.

LIGHTING

Battery saver function

- The purpose of this feature is to prevent the battery from being discharged. The system automatically turns off the exterior light when the driver removes the ignition key and opens the driver-side door.
- With this feature, the parklight will be turned off automatically if the driver parks on the side of road at night.

If necessary, to keep the lights on when the ignition key is removed, perform the following :

- 1) Open the driver-side door.
- 2) Turn the parklights OFF and ON again using the light switch on the steering column.

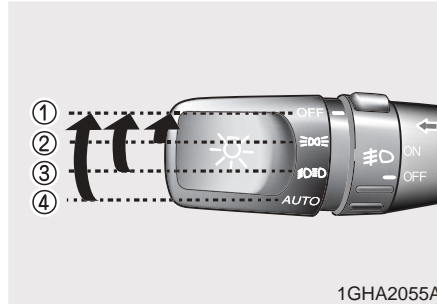

Lighting control

The light switch has a Headlight and a Parklight position.

To operate the lights, turn the knob at the end of the control lever to one of the following positions:

- ① OFF position
- ② Parklight position
- ③ Headlight position
- ④ Auto light position

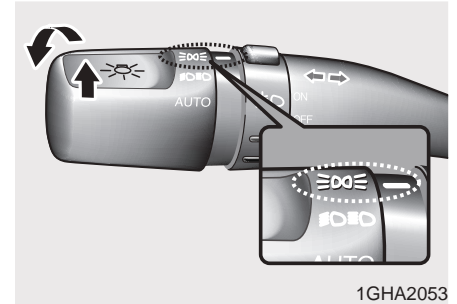

Parklight position (①)

When the light switch is in the parklight position (1st position), the tail, position, license and instrument panel lights are ON.

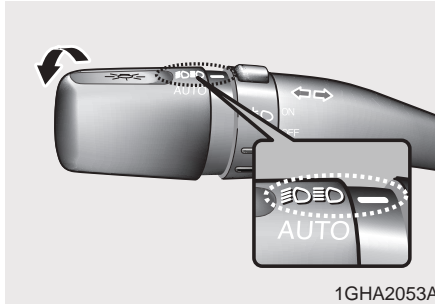

Headlight position (headlights)

When the light switch is in the headlight position (2nd position) the head, tail, position, license and instrument panel lights are ON.

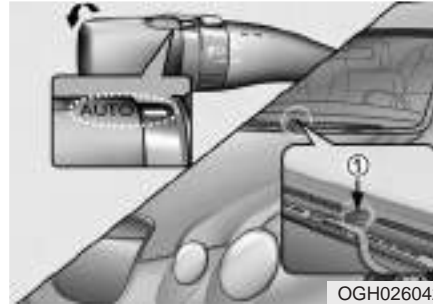

Auto light position (if equipped)

When the light switch is in the AUTO light position, the taillights and headlights will be turned ON or OFF automatically depending on the amount of light outside the vehicle.

*** NOTICE**

- Never place anything over sensor (①) located on the instrument panel, this will ensure better auto-light system control.
- If your vehicle has window tint or other types of coating on the front windshield, the Auto light system may not work properly.

CAUTION

Don't clean the sensor using a window cleaner, the cleanser may leave a light film which could interfere with sensor operation.

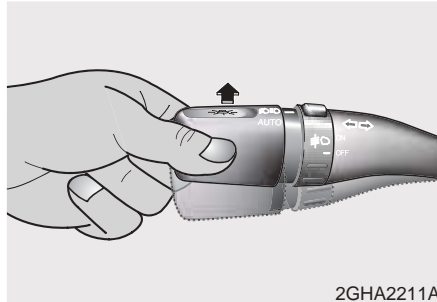

High - beam operation

To turn on the high beam headlights, push the lever away from you. Pull it back for low beams.

The high-beam indicator will light when the headlight high beams are switched on.

To prevent the battery from being discharged, do not leave the lights on for a prolonged time while the engine is not running.

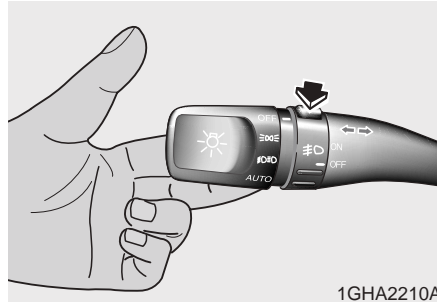

Flashing headlights

To flash the headlights, pull the lever towards you. It will return to the normal (low-beam) position when released. The headlight switch does not need to be on to use this flashing feature.

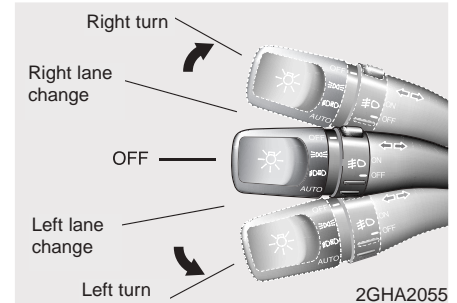

Turn signals

The ignition switch must be on for the turn signals to function. To turn on the turn signals, move the lever up or down. Green arrow indicators on the instrument panel indicate which turn signal is operating. They will self-cancel after a turn is completed. If the indicator continues to flash after a turn, manually return the lever to the OFF position.

Lane change signals

To signal a lane change, move the turn signal lever slightly and hold it in position. The lever will return to the OFF position when released.

If an indicator stays on and does not flash or if it flashes abnormally, one of the turn signal bulbs may be burned out and will require replacement.

* NOTICE

If an indicator flash is abnormally quick or slow, bulb may be burned out or have a poor electrical connection in the circuit.

Automatic headlight aiming (if equipped)

To provide better driver visibility and reduce eye fatigue, the headlight aiming (direction) is automatically controlled depending on vehicle load and vehicle angle (when vehicle is loaded with passengers, cargo or used for towing, the additional load can alter the headlight aiming point on the road surface). This system provides constant automatic headlight aiming under various vehicle conditions and angles to ensure the headlights are always pointed in the right direction.

CAUTION

If the automatic headlight aiming system does not operate when the vehicle is loaded with passengers and the front portion of the vehicle is at an elevated angle, or it is not adjusting correctly, have the vehicle checked and repaired by an authorized Kia dealer. Do not attempt to adjust the headlights manually, damage to the automatic headlight aiming system could occur.

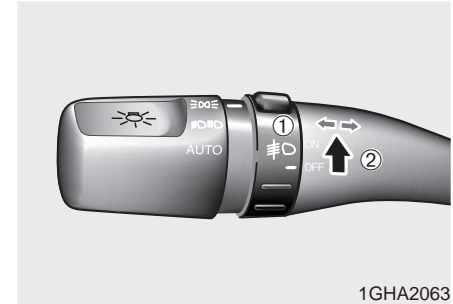

1GHA2063

Front fog light (if equipped)

Fog lights are used to provide improved visibility and avoid accidents when visibility is poor due to fog, rain or snow etc. The fog lights will turn on when fog light switch (1) is turned to ON (2) after the headlight switch is turned on.

To turn off the fog lights, turn the switch to OFF.

* NOTICE

When in operation, the fog lights consume large amounts of vehicle electrical power. Only use the fog lights when visibility is poor or unnecessary battery and generator drain could occur.

WIPERS AND WASHERS



Windshield wipers

Operates as follows when the ignition switch is turned ON.

MIST : For a single wiping cycle, push the lever forward and release it with the lever in the OFF position. The wipers will operate continuously if the lever is pushed upward and held.

OFF : Wiper is not in operation

INT : Wiper operates intermittently at the same wiping intervals. Use this mode in a light rain or mist. To vary the speed setting, turn the speed control knob(①).

LO : Normal wiper speed

HI : Fast wiper speed

* NOTICE

If there is heavy accumulation of snow or ice on the windshield, defrost the windshield for about 10 minutes, or until the snow and/or ice is removed before using the windshield wipers to ensure proper operation.



Variable intermittent wipers

Set the lever to the INT position and choose the desired wiper interval by turning the ring (①).



One - touch wiper

For a single wiping cycle, push the lever upward and release it with the lever in the OFF position.

The wipers will operate continuously if the lever is pushed upward and held.

CAUTION

- *To prevent possible damage to the wipers or windshield, do not operate the wipers when the windshield is dry.*
- *To prevent damage to the wiper blades, do not use gasoline, kerosene, paint thinner, or other solvents on or near them.*
- *To prevent damage to the wiper arms and other components, do not attempt to move the wipers manually.*



Windshield washers

In the OFF position, pull the lever gently toward you to spray washer fluid on the windshield and to run the wipers 2-3 cycles.

Use this function when the windshield is dirty.

The spray and wiper operation will continue until you release the lever.

If the washer does not work, check the washer fluid level. If the fluid level is not sufficient, you will need to add appropriate non-abrasive windshield washer fluid to the washer reservoir.

The reservoir filler neck is located in the front of the engine compartment on the passenger side.

CAUTION

To prevent possible damage to the washer pump, do not operate the washer when the fluid reservoir is empty.

WARNING

Do not use the washer in freezing temperatures without first warming the windshield with the defrosters; the washer solution could freeze on contact with the windshield and obscure your vision.

DEFROSTER



The defroster heats the window to remove frost, fog and thin ice from the interior and exterior of the rear window, while the engine is running.

To activate the rear window defroster, press the rear window defroster button located in the heater control panel. The indicator on the rear window defroster button illuminates when the defroster is ON.

If your vehicle is equipped with the front windshield deicer, it will be operating at the same time when you operate the rear window defroster.

If there is heavy accumulation of snow on the rear window, brush it off before operating the rear defroster.

The rear window defroster automatically turns off after 20 minutes or when the ignition switch is turned off. To turn off the defroster, press the rear window defroster button again.

HAZARD WARNING FLASHER

* NOTICE

- To prevent damage to the conductors bonded to the inside surface of the front windshield and the rear window, never use sharp instruments or window cleaners containing abrasives to clean the window.
- To prevent the battery from being discharged, operate the defroster only while the engine is running.
- The front windshield defroster is designed to defrost wiper blades. If you want to defrost and defog the front windshield, refer to “Windshield Defrosting and Defogging” in this section.

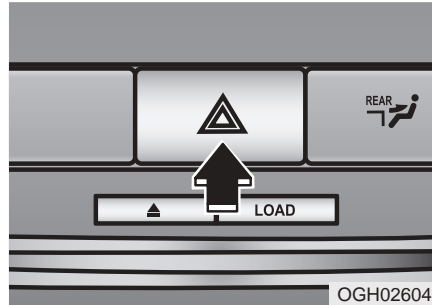

The hazard warning flasher causes the rear tail lights and front turn signal lights to flash on and off, which serves as a warning to other drivers to exercise caution when approaching or passing your vehicle.

To activate the flasher, depress the hazard warning flasher switch. This switch operates in any ignition switch position. To turn the flashers off, depress the switch again.

AUTOMATIC CLIMATE CONTROL SYSTEM



1. A/C display
2. Driver's temperature control button
3. AUTO (automatic control) button
4. Air conditioning button
5. Fan speed control button
6. Mode selection button
7. Dual temperature control selection button

8. Front windshield defrost button
9. Rear window defrost button
10. OFF button
11. Recirculated air position button
12. Outside (fresh) air position button
13. Passenger's temperature control button
14. Rear climate control selection button

OGH026051N/OGH026052



Automatic operation

The automatic climate control system is controlled by simply setting the desired temperature.

The Full Automatic Temperature Control (FATC) system automatically controls the heating and cooling system as follows;

1. Push the AUTO button. The indicator light will come on and the modes, fan speeds, air intake and air-conditioning will be controlled automatically by temperature setting.

2. Push the TEMP button to set the desired temperature.

If the temperature is set to the lowest setting 62°F/17°C (Lo), the air conditioning system will operate continuously.

3. To turn the automatic operation off, press any button except temperature control button. If you press the mode selection button, air-conditioning button, defrost button, recirculated air position button, outside (fresh) air position button or fan speed button, the selected function will be controlled manually while other functions operate automatically.

Regardless of the temperature setting, when using automatic operation, the air conditioning system will automatically turn on to decrease the humidity inside the vehicle, even if the temperature is set to warm.

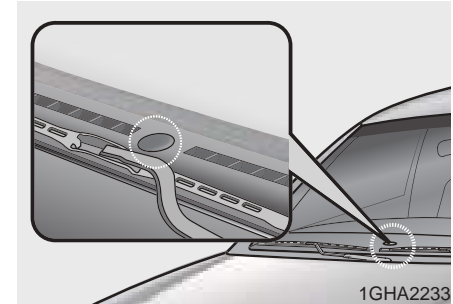

* NOTICE

Never place anything over the sensor located on the instrument panel to ensure better control of the heating and cooling system.

Manual operation

The heating and cooling system can be controlled manually as well by pushing buttons other than the AUTO button. In this case, the system works sequentially according to the order of buttons selected.

When pressing any button except AUTO, the functions of the buttons not selected will be controlled automatically.

Press the AUTO button in order to convert to full automatic control of the system.

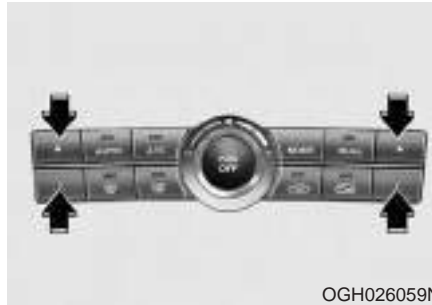

Temperature control button

The temperature will increase to the maximum 90°F/32°C (HI) by pushing the up button. Each push of the button will cause the temperature to increase by 1°F/0.5 °C.

The temperature will decrease to the minimum 62°F/17°C (Lo) by pushing the down button. Each push of the button will cause the temperature to decrease by 1°F/0.5°C. When set to the lowest temperature setting, the air conditioning will operate continuously.

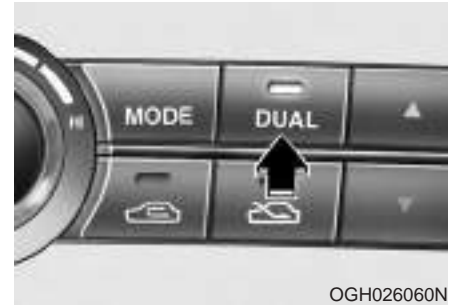

Dual temperature control selection button

Adjusting the driver and passenger side temperature individually

1. Press the DUAL button to operate the driver and passenger side temperature individually (the indicator light in the button illuminates). Pressing the right temperature control button will automatically switch to the DUAL mode as well.
2. Press the left temperature control to adjust the driver side temperature. Press the right temperature control to adjust the passenger side temperature.

Adjusting the driver and passenger side temperature equally

1. Press the DUAL button again or if you select the highest (HI) or lowest (LO) temperature, the DUAL mode deactivates (the indicator light in the button turns off). The passenger side temperature will be set to the same temperature as the driver side.
2. Press the left temperature control button. The driver and passenger side temperature will be adjusted equally.

Temperature conversion

If the battery has been discharged or disconnected, the temperature mode will reset as Centigrade degrees.

This is normal condition and you can switch the temperature mode between Centigrade to Fahrenheit as follows;

While depressing the MODE button, depress the DUAL button for 3 seconds or more. The display will change from Centigrade to Fahrenheit, or from Fahrenheit to Centigrade.



Fan speed control button

The fan speed can be set to the desired speed by turning the appropriate fan speed control knob.

The higher the fan speed is, the more air is delivered.

Pressing the "OFF" button turns off the fan.

Air intake control button

This is used to select outside (fresh) air position or recirculated air position.

To change the air intake control position, push the control button.



Recirculated air position

The indicator light on the button is illuminated when the recirculated air position button is depressed.

With the recirculated air position selected, air from the passenger compartment will be drawn through the heating system and heated or cooled according to the function selected.



Outside (fresh) air position

The indicator light on the button is illuminated when the outside (fresh) air position button is depressed.

With the outside (fresh) air position selected, air enters the vehicle from outside and is heated or cooled according to the function selected.

When starting the vehicle, the system is automatically set to the outside (fresh) air position. Press the button once to select the recirculated air position.

*** NOTICE**

Prolonged operation of the heating in recirculated air position will cause fogging of the windshield and side windows and the air within the passenger compartment will become stale.

In addition, prolonged use of the air conditioning with the “recirculated air position” selected, will result in excessively dry air in the passenger compartment.

⚠ WARNING

- **Continued climate control system operation in the recirculated air position may allow humidity to increase inside vehicle which may fog the glass and obscure visibility.**
- **Do not sleep in a vehicle with air conditioning or heating system on. It may cause serious harm or death due to a drop in the oxygen level and/or body temperature.**
- **Continued climate control system operation in the recirculated air position can cause drowsiness or sleepiness, and loss of vehicle control. Set the air intake control to the outside (fresh) air position as much as possible while driving.**

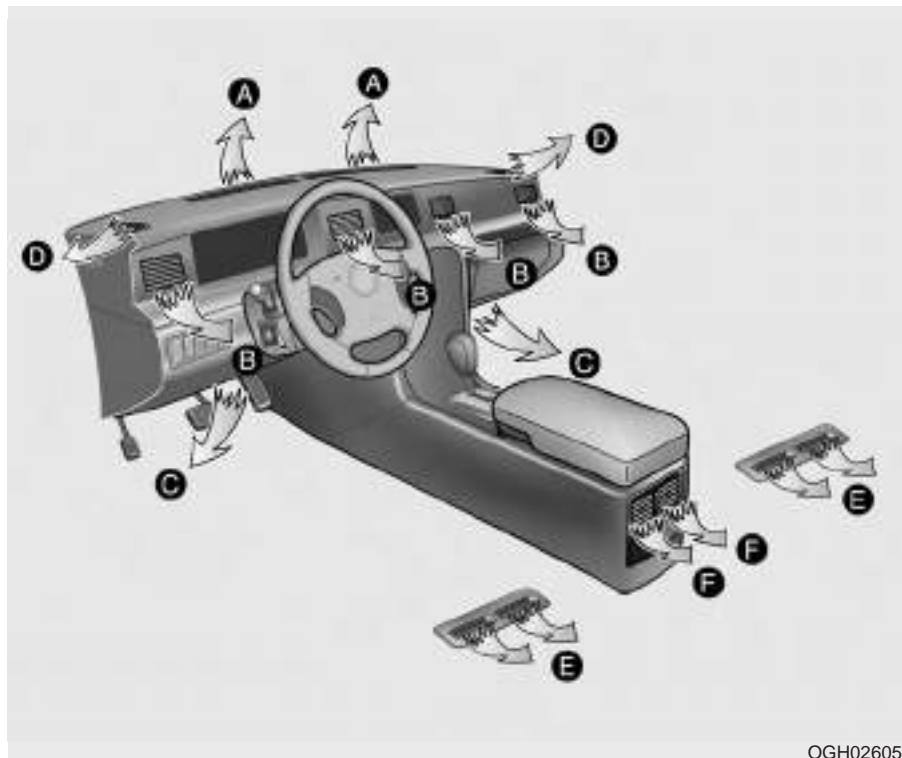

Mode selection button

The mode selection button controls the direction of the air flow through the ventilation system.

The air flow outlet port is converted as follows:



Face position



Air flow is directed toward the upper body and face. Additionally, each outlet can be controlled to direct the air discharged from the outlet. (outlet port: **B**)

Face - floor position



Air flow is directed towards the face and the floor. The air to the floor is warmer than the air to the face (except when the temperature control is set to the extreme cold position). (outlet port: **B**, **C**, **E**)

Floor position



Most of the air flow is directed to the floor, with a small amount of the air being directed to the windshield and side window defroster. (outlet port: **A**, **C**, **D**, **E**)

Floor - defrost position



Most of the air flow is directed to the floor and the windshield with a small amount directed to the side window defrosters. (outlet port: **A**, **C**, **D**, **E**)



Defrost button

Most of the air flow is directed to the windshield with a small amount of air directed to the side window defrosters. (outlet port: **A**, **D**)

When the defrost button is pressed, the outside (fresh) air position will automatically be selected and air will be discharged through the windshield defrost vents. The air conditioning will automatically operate based on ambient temperature.



Instrument panel vents

If air flow control is not satisfactory, check the instrument panel vents. The outlet port (B) can be opened or closed separately using the thumbwheel.

Also, you can adjust the direction of air delivery from these vents using vertical or horizontal thumbwheels as shown.



Air conditioning button

Push the A/C button to turn the air conditioning system on (indicator light will illuminate).

Push the button again to turn the air conditioning system off.



OFF button

Push the OFF button to turn off the air climate control system. However you can still operate the mode and air intake buttons as long as the ignition switch is ON.

Air conditioning system operation tips

- If the vehicle has been parked in direct sunlight during hot weather, open the windows for a short time to let the hot air inside the vehicle escape.
- To help reduce moisture inside of the windows on rainy humid days, decrease the humidity inside the vehicle by operating the air conditioning system.
- During air conditioning system operation, you may occasionally notice a slight change in the engine speed as the air conditioning compressor cycles on. This is a normal system operation characteristics.
- Use the air conditioning system every month only for a few minutes to ensure maximum system performance.
- When using the air conditioning system, you may notice clear water dripping (or even puddling) on the ground under the passenger side of the vehicle. This is a normal system operation characteristics.

- Operating the air conditioning system in the recirculated air position does provide maximum cooling, however, continual operation in this mode may cause the air inside the vehicle to become stale.

CAUTION

When using the air conditioning system, monitor the temperature gauge closely while driving up hills or in heavy traffic when outside temperatures are high. Air conditioning system operation may cause engine overheating. Continue to use the blower fan but turn the air conditioning system off if the temperature gauge indicates engine overheating.

Checking the amount of air conditioner refrigerant and compressor lubricant

When the amount of refrigerant is low, the performance of the air conditioning is reduced. Overfilling also has a bad influence on the air conditioning system.

Therefore, if abnormal operation is found, have the system inspected by an authorized Kia dealer.

WARNING

The air conditioning system should be serviced by an authorized Kia dealer. Improper service may cause serious injury to the person performing the service.

CAUTION

When the performance of the air conditioning system is reduced it is important that the correct type and amount of oil and refrigerant is used. Otherwise, damage to the compressor and abnormal system operation may occur.

Rear climate control

The rear climate control system allows the rear passengers to adjust the temperature and airflow distribution using the control panel located on the back of the center console, facing the rear passenger compartment. The rear climate control system only operates when the front climate control system is on and, supplements the functions of the front climate control system for increased rear passenger comfort.



OGH026068

Operating the rear climate control system

To operate the rear climate control system, perform the following:

1. Press the rear climate control selection button in the front control panel () (the indicator light in the button illuminates).



OGH026070



OGH026071

2. Turn the temperature control knob located between the vents on the rear control panel to adjust the temperature. Turn the knob up (RED mark) when warm air is desired, or down (BLUE mark) when cool air is desired.
3. Adjust the direction of the airflow using the vent control lever.

WINDSHIELD DEFROSTING AND DEFOGGING





To defog inside windshield

1. Select desired fan speed
2. Select desired temperature.
3. Press the defrost button ().
4. The air-conditioning will be turned on according to the detected ambient temperature and outside (fresh) air position will be selected automatically.



To defrost outside windshield

1. Set fan speed to the  or  position.
2. Set temperature to the extreme hot (77~90°F / 25~32°C) position.
3. Press the defrost button ().
4. The air-conditioning will be turned on according to the detected ambient temperature and outside (fresh) air position will be selected automatically.

⚠ WARNING

Do not use defrost position during cooling operation in extremely humid weather. The difference between the temperature of the outside air and that of the windshield could cause the outer surface of the windshield to fog up, causing loss of visibility.

- For maximum defrosting, set the temperature control button to the hot position and the fan speed control button to the highest speed.
- If warm air to the floor is desired while defrosting or defogging, set the mode selection button to the floor-defrost position.
- Before driving, clear all snow and ice from the windshield, rear window, outside rear view mirrors, and all side windows.
- Clear all snow and ice from the hood and air inlet in the cowl grill to improve heater and defroster efficiency and to reduce the probability of fogging up inside of the windshield.

Fuel requirements / 5-2
Emission control system / 5-3
Before driving / 5-5
Suggestions for economical operation / 5-6
Special driving conditions / 5-7
Vehicle load limit / 5-13
Weight of the vehicle / 5-17
Trailer towing / 5-18
Label information / 5-25
Homelink® wireless control system / 5-27

Driving tips

FUEL REQUIREMENTS

Gasoline engine (unleaded)

Your new Kia vehicle is designed to use only unleaded fuel with a minimum Octane Rating of 87 Anti-Knock Index (AKI).

CAUTION

NEVER USE LEADED FUEL. *The use of leaded fuel is detrimental to the catalytic converter and will damage the engine control system's oxygen sensor and affect emission control.*

Never add any fuel system cleaning agents to the fuel tank other than what Kia has specified. (Consult an Authorized Kia Dealer for details.)

Gasoline containing alcohol and methanol

Gasohol, a mixture of gasoline and ethanol (also known as grain alcohol), and gasoline or gasohol containing methanol (also known as wood alcohol) are being marketed along with or instead of leaded or unleaded gasoline.

Do not use gasohol containing more than 10% ethanol, and do not use gasoline or gasohol containing any methanol. Either of these fuels may cause drivability problems and damage to the fuel system.

Discontinue using gasohol of any kind if drivability problems occur.

Vehicle damage or driveability problems may not be covered by the manufacturer's warranty if they result from the use of:

1. Gasohol containing more than 10% ethanol.
2. Gasoline or gasohol containing methanol.
3. Leaded fuel or leaded gasohol.

* NOTICE

Never use gasohol which contains methanol. Discontinue use of any gasohol product which impairs drivability.

EMISSION CONTROL SYSTEM

The emission control system of your vehicle is covered by a written limited warranty. Please see the warranty information contained in the Warranty & Consumer Information Manual in your vehicle.

Vehicle modifications

This vehicle should not be modified. Modification of your Kia could affect its performance, safety or durability and may even violate governmental safety and emissions regulations.

In addition, damage or performance problems resulting from any modification may not be covered under warranty.

Engine exhaust gas precautions (carbon monoxide)

WARNING

Engine exhaust gases contain carbon monoxide (CO). Though colorless and odorless, it is dangerous and could be lethal if inhaled. Follow the instructions following to avoid CO poisoning.

- Carbon monoxide can be present with other exhaust fumes. Therefore, if you smell exhaust fumes of any kind inside your vehicle, have it inspected and repaired immediately by an authorized Kia dealer or other competent repair shop. If you ever suspect exhaust fumes are coming into your vehicle, drive it only with all the windows fully open. Have your vehicle checked and repaired immediately.

- Do not operate the engine in confined or closed areas (such as garages) any more than what is necessary to move the vehicle in or out of the area.
- When the vehicle is stopped in an open area for more than a short time with the engine running, adjust the ventilation system (as needed) to draw outside air into the vehicle.
- Never sit in a parked or stopped vehicle for any extended time with the engine running.
- When the engine stalls or fails to start, excessive attempts to re-start the engine may cause damage to the emission control system.

Operating precautions for catalytic converters

WARNING - Fire

A hot exhaust system can ignite flammable items under your vehicle. Do not park the vehicle over or near flammable objects, such as dry grass, paper, leaves, etc.

Your vehicle is equipped with a catalytic converter emission control device.

Therefore, the following precautions must be observed:

- Use only UNLEADED FUEL for gasoline engine (unleaded).
- Do not operate the vehicle when there are signs of engine malfunction, such as misfire or a noticeable loss of performance.
- Do not misuse or abuse the engine. Examples of misuse are coasting with the ignition off and descending steep grades in gear with the ignition off.

- Avoid driving with a very low fuel level. If you run out of gasoline, it could cause the engine to misfire and result in excessive loading of the catalytic converter.
- Do not operate the engine at high idle speed for extended periods (5 minutes or more).
- Do not modify or tamper with any part of the engine or emission control system. All inspections and adjustments must be made by a qualified technician.

Failure to observe these precautions could result in damage to the catalytic converter and to your vehicle. Additionally, such actions could void your warranties.

BEFORE DRIVING

Before entering vehicle:

- Be sure that all windows, outside mirror(s), and outside lights are clean.
- Check the condition of the tires.
- Check under the vehicle for any sign of leaks.
- Be sure there are no obstacles behind you if you intend to back up.

Necessary inspections

Fluid levels, such as engine oil, engine coolant, brake fluid, and washer fluid should be checked on a regular basis, with the exact interval depending on the fluid. Further details are provided in Section 7, Maintenance.

Before starting

- Close and lock all doors.
 - Position the seat so that all controls are easily reached.
 - Adjust the inside and outside rearview mirrors.
 - Be sure that all lights work.
 - Check all gauges.
 - Check the operation of warning lights when the ignition switch is turned to the ON position.
 - Release the parking brake and make sure the brake warning light goes out.
- For safe operation, be sure you are familiar with your vehicle and its equipment.

 **WARNING - Driving under the influence of alcohol or drugs**

Drinking and driving is dangerous. Drunk driving is the number one contributor to the highway death toll each year. Even a small amount of alcohol will affect your reflexes, perceptions and judgement.

You are much more likely to have a serious accident if you drink and drive.

If you are drinking or taking drugs, don't drive. Do not ride with a driver who has been drinking or taking drugs. Choose a designated driver or call a cab.

Driving while under the influence of drugs is as dangerous or more dangerous than driving drunk.

SUGGESTIONS FOR ECONOMICAL OPERATION

Your vehicle's fuel economy depends mainly on your style of driving, where you drive and when you drive.

Each of these factors affects how many kilometers (miles) you can get from a liter (gallon) of fuel. To operate your vehicle as economically as possible, use the following driving suggestions to help save money in both fuel and repairs:

- Avoid lengthy warm-up idling. Once the engine is running smoothly, begin driving. Remember, engine warm-up may take a little longer on cold days.
- Save fuel by accelerating slowly after stopping.
- Keep the engine in tune and follow the recommended periodic maintenance schedule. This will increase the life of all parts and lower your operating costs.
- Do not use the air conditioner unnecessarily.
- Slow down when driving on rough roads.
- For longer tire life and better fuel economy, always keep the tires inflated to the recommended pressures.
- Maintain a safe distance from other vehicles to avoid sudden stops. This will reduce wear on brake linings and pads. Driving in such a way will also save fuel because extra fuel is required to accelerate back to driving speed.
- Do not carry unnecessary weight in the vehicle.
- Do not rest your foot on the brake pedal while driving. This can cause needless wear, possible damage to the brakes, and poor fuel economy.
- Improper wheel alignment results in faster tire wear and lower fuel economy.

- Open windows at high speeds can reduce fuel economy.
- Fuel economy is less in crosswinds and headwinds. To help offset some of this loss, slow down when driving in these conditions.

Keeping a vehicle in good operating condition is important both for economy and safety. Therefore, have an authorized Kia dealer perform scheduled inspections and maintenance.

 **WARNING - Engine off during motion**

Never turn the engine off to coast down hills or anytime the vehicle is in motion. The power steering and power brakes will not function without the engine running. Instead, downshift to an appropriate gear for engine braking effect.

SPECIAL DRIVING CONDITIONS

Hazardous driving conditions

When hazardous driving conditions are encountered such as water, snow, ice, mud, sand, or similar hazards, follow these suggestions:

- Drive cautiously and allow extra distance for braking.
- Avoid sudden movements in braking or steering.
- When braking, pump the brake pedal with a light up-and-down motion until the vehicle is stopped.

* NOTICE

Do not pump the brake pedal on a vehicle equipped with ABS.

- If stalled in snow, mud, or sand, use second gear. Accelerate slowly to avoid spinning the drive wheels.
- Use sand, rock salt, tire chains, or other non-slip material under the drive wheels to provide traction when stalled in ice, snow, or mud.

 **WARNING - Downshifting**
Downshifting with an automatic transaxle, while driving on slippery surfaces can cause an accident. The sudden change in tire speed could cause the tires to skid. Be careful when downshifting on slippery surfaces.

Rocking the vehicle

If it is necessary to rock the vehicle to free it from snow, sand, or mud, first turn the steering wheel right and left to clear the area around your front wheels. Then, shift back and forth between R (Reverse) and any forward gear in vehicles equipped with an automatic transaxle. Do not race the engine, and spin the wheels as little as possible. If you are still stuck after a few tries, have the vehicle pulled out by a tow vehicle to avoid engine overheating and possible damage to the transaxle.

* NOTICE

Prolonged rocking may cause engine over-heating, transaxle damage or failure, and tire damage.

WARNING - Spinning tires

Do not spin the wheels, especially at speeds more than 35 mph (56 km/h). Spinning the wheels at high speeds when the vehicle is stationary could cause a tire to overheat, explode and injure bystanders.

Driving at night

Because night driving presents more hazards than driving in the daylight, here are some important tips to remember:

- Slow down and keep more distance between you and other vehicles, as it may be more difficult to see at night, especially in areas where there may not be any street lights.
- Adjust your mirrors to reduce the glare from other driver's headlights.
- Keep your headlights clean and properly aimed on vehicles not equipped with the automatic headlight aiming feature. Dirty or improperly aimed headlights will make it much more difficult to see at night.
- Avoid staring directly at the headlights of oncoming vehicles. You could be temporarily blinded, and it will take several seconds for your eyes to readjust to the darkness.

Driving in the rain

Rain and wet roads can make driving dangerous, especially if you're not prepared for the slick pavement. Here are a few things to consider when driving in the rain:

- A heavy rainfall will make it harder to see and will increase the distance needed to stop your vehicle, so slow down.
- Keep your windshield wiping equipment in good shape. Replace your windshield wiper blades when they show signs of streaking or missing areas on the windshield.
- If your tires are not in good condition, making a quick stop on wet pavement can cause a skid and possibly lead to an accident. Be sure your tires are in good shape.
- Turn on your headlights to make it easier for others to see you.

- Driving too fast through large puddles can affect your brakes. If you must go through puddles, try to drive through them slowly.
- If you believe you may have gotten your brakes wet, apply them lightly while driving until normal braking operation returns.

Winter driving

- We recommend that you carry emergency equipment, including tire chains, a window scraper, windshield de-icer, a bag of sand or salt, flares, a small shovel and jumper cables.
- Make sure you have sufficient ethylene-glycol coolant in the radiator.
- Check the battery condition and cables. Cold temperatures reduce the capacity of any battery, so it must be in excellent condition to provide enough winter starting power.
- Make sure the engine oil viscosity is suitable for cold weather.
- Check the ignition system for loose connections and damage.

- Use antifreeze-formulated windshield washer fluid. (Do not use engine coolant antifreeze.)
- Do not use the parking brake if it might freeze. When parking, shift to P (Park) with an automatic transaxle and block the rear wheels.

Snow tires

If you mount snow tires on your Kia, make sure they are radial tires of the same size and load range as the original tires. Mount snow tires on all four wheels to balance your vehicle's handling in all weather conditions. Keep in mind that the traction provided by snow tires on dry roads may not be as high as your vehicle's original equipment tires. You should drive cautiously even when the roads are clear. Check with the tire dealer for maximum speed recommendations.

Do not install studded tires without first checking local, state and municipal regulations for possible restrictions against their use.

⚠ WARNING - Snow tire size
Snow tires should be equivalent in size and type to the vehicle's standard tires. Otherwise, the safety and handling of your vehicle may be adversely affected.

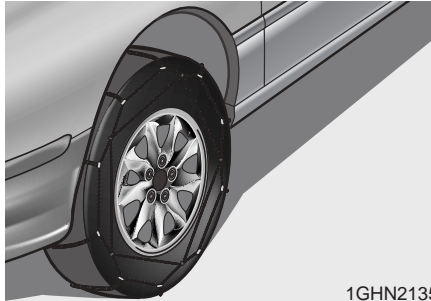

Tire chains

Since the sidewalls of radial tires are thinner, they can be damaged by mounting some types of snow chains on them. Therefore, the use of snow tires is recommended instead of snow chains. Do not mount tire chains on vehicles equipped with aluminum wheels, snow chains may cause damage to the wheels. If snow chains must be used, use wire-type chains with a thickness of less than 0.47 (12 mm) for tire treads and sidewall. Do not fully turn the steering wheel (turning the steering wheel one way to the end) with your snow chains installed. In case, you fully turn your steering wheel, you must drive at the speed less than 10km/h.

Damage to your vehicle caused by improper snow chain use is not covered by your vehicle manufacturers warranty. Install them only on the front tires.

CAUTION

- *Make sure the snow chains are the correct size and type for your tires. Incorrect snow chains can cause damage to the vehicle body and suspension and may not be covered by your vehicle manufacturer warranty. Also, the snow chain connecting hooks may be damaged from contacting vehicle components causing the snow chains to come loose from the tire. Make sure the snow chains are SAE class "S" certified. Cable-type, or plastic-type snow chain can also be used.*
- *Always check chain installation for proper mounting after driving approximately 0.5 to 1 km to ensure safe mounting. Retighten or remount the chains if they are loose.*

Chain installation

When installing chains, follow the manufacturer's instructions and mount them as tightly as you can. Drive slowly with chains installed. If you hear the chains contacting the body or chassis, stop and tighten them. If they still make contact, slow down until it stops. Remove the chains as soon as you begin driving on cleared roads.

WARNING

When mounting snow chains, park the vehicle on level ground away from traffic. Turn on the vehicle Hazard Warning flashers and place a triangular emergency warning device behind the vehicle if available. Always place the vehicle in park (P), apply the parking brake and turn off the engine before installing snow chains.

WARNING - Tire chains

- The use of chains may adversely affect vehicle handling.
- Do not exceed 20 mph (30 km/h) or the chain manufacturer's recommended speed limit, whichever is lower.
- Drive carefully and avoid bumps, holes, sharp turns, and other road hazards, which may cause the vehicle to bounce.
- Avoid sharp turns or locked-wheel braking.
- Chains that are the wrong size or improperly installed can damage your vehicle's brake lines, suspension, body and wheels.
- Stop driving and retighten the chains any time you hear them hitting the vehicle.

Driving in flooded areas

Avoid driving through flooded areas unless you are sure the water is no higher than the bottom of the wheel hub. Drive through any water slowly. Allow adequate stopping distance because brake performance may be affected.

After driving through water, dry the brakes by gently applying them several times while the vehicle is moving slowly.

HLA (Hydraulic Lash Adjuster) noise

The engine HLA's keep the gap between the valve and cam at zero regardless of the valve expansion.

Occasionally, you may hear a temporary or continuous sound (clatter) from the engine when starting or idling. This noise will usually go away by following a few simple steps:

CAUTION

Do not run the engine at more than 3000 rpm until the noise goes away. Damage to the HLA's could occur.

If the temporary sound occurs when starting a cold engine:

This is a normal condition. This sound will disappear after the engine oil has reached normal operating pressure.

If the sound occurs when starting the engine after the engine has not been operated for more than 48 hours; or engine has been cranked excessively:

This condition may be caused by oil draining from the HLA's. This allows air to enter the HLA causing insufficient lubricating oil in the HLA. This will usually disappear within 15 minutes with the engine running at 2000~3000 rpm. If the sound does not disappear, have the engine oil pressure, engine lubrication system and HLA's inspected by an Authorized Kia Dealer.

VEHICLE LOAD LIMIT

Type A

TIRE AND LOADING INFORMATION PNEUS ET CHARGE-INFORMATION					
SEATING CAPACITY		TOTAL 5	FRONT 2	REAR 3	
NOMBRE DE SIEGES		TOTAL 5	AVANT 2	ARRIERE 3	
The combined weight of occupants and cargo should never exceed 390 kg or 860 lbs. Le poids combiné des occupants et du chargement ne doit jamais excéder 390 kg ou 860 lbs.					
TIRE / PNEU	SIZE / DIMENSION	COLD TIRE PRESSURE / PRESSION A FROID	SEE OWNER'S MANUAL FOR ADDITIONAL INFORMATION / CONSULTER LE GUIDE DU PROPRIETAIRE POUR OBTENIR LES RENSEIGNEMENTS ADDITIONNELS		
FRONT / AVANT	P235/55R17	210kPa, 30psi			
REAR / ARRIERE	P235/55R17	210kPa, 30psi			
SPARE / SECOURS	P235/55R17	210kPa, 30psi			

OGH056900N

Type C

TIRE AND LOADING INFORMATION PNEUS ET CHARGE-INFORMATION					
SEATING CAPACITY		TOTAL 5	FRONT 2	REAR 3	
NOMBRE DE SIEGES		TOTAL 5	AVANT 2	ARRIERE 3	
The combined weight of occupants and cargo should never exceed 390 kg or 860 lbs. Le poids combiné des occupants et du chargement ne doit jamais excéder 390 kg ou 860 lbs.					
TIRE / PNEU	SIZE / DIMENSION	COLD TIRE PRESSURE / PRESSION A FROID	SEE OWNER'S MANUAL FOR ADDITIONAL INFORMATION / CONSULTER LE GUIDE DU PROPRIETAIRE POUR OBTENIR LES RENSEIGNEMENTS ADDITIONNELS		
FRONT / AVANT	P225/60R16	210kPa, 30psi			
REAR / ARRIERE	P225/60R16	210kPa, 30psi			
SPARE / SECOURS	P235/55R17	210kPa, 30psi			

OGH056912N

Type B

TIRE AND LOADING INFORMATION PNEUS ET CHARGE-INFORMATION					
SEATING CAPACITY		TOTAL 5	FRONT 2	REAR 3	
NOMBRE DE SIEGES		TOTAL 5	AVANT 2	ARRIERE 3	
The combined weight of occupants and cargo should never exceed 390 kg or 860 lbs. Le poids combiné des occupants et du chargement ne doit jamais excéder 390 kg ou 860 lbs.					
TIRE / PNEU	SIZE / DIMENSION	COLD TIRE PRESSURE / PRESSION A FROID	SEE OWNER'S MANUAL FOR ADDITIONAL INFORMATION / CONSULTER LE GUIDE DU PROPRIETAIRE POUR OBTENIR LES RENSEIGNEMENTS ADDITIONNELS		
FRONT / AVANT	P235/55R17	210kPa, 30psi			
REAR / ARRIERE	P235/55R17	210kPa, 30psi			
SPARE / SECOURS	T125/80D16	420kPa, 60psi			

OGH056910N

Type D

TIRE AND LOADING INFORMATION PNEUS ET CHARGE-INFORMATION					
SEATING CAPACITY		TOTAL 5	FRONT 2	REAR 3	
NOMBRE DE SIEGES		TOTAL 5	AVANT 2	ARRIERE 3	
The combined weight of occupants and cargo should never exceed 390 kg or 860 lbs. Le poids combiné des occupants et du chargement ne doit jamais excéder 390 kg ou 860 lbs.					
TIRE / PNEU	SIZE / DIMENSION	COLD TIRE PRESSURE / PRESSION A FROID	SEE OWNER'S MANUAL FOR ADDITIONAL INFORMATION / CONSULTER LE GUIDE DU PROPRIETAIRE POUR OBTENIR LES RENSEIGNEMENTS ADDITIONNELS		
FRONT / AVANT	P225/60R16	210kPa, 30psi			
REAR / ARRIERE	P225/60R16	210kPa, 30psi			
SPARE / SECOURS	T125/80D16	420kPa, 60psi			

OGH056913N

Vehicle capacity weight:

860 lbs (390 kg)

Vehicle capacity weight is the maximum combined weight of occupants and cargo. If your vehicle is equipped with a trailer, the combined weight includes the tongue load.

Seating capacity:

Total : 5 persons

(Front seat : 2 persons,
Rear seat : 3 persons)

Seating capacity is the maximum number of occupants including a driver, your vehicle may carry. However the seating capacity may be reduced based upon the weight of all of the occupants, and the weight of the cargo being carried or towed.

Do not overload the vehicle as there is a limit to the total weight, or load limit including occupants and cargo, the vehicle can carry.

Tire and loading information label

The label located on the driver's door sill gives the original tire size, cold tire pressures recommended for your vehicle, the number of people that can be in your vehicle and vehicle capacity weight.

Towing capacity:

Without trailer brakes:

1000 lbs (454 kg)

With trailer brakes:

2000 lbs (908 kg)

Towing capacity is the maximum trailer weight including its cargo weight, your vehicle can tow.

Cargo capacity:

The cargo capacity of your vehicle will increase or decrease depending on the weight and the number of occupants and the tongue load, if your vehicle is equipped with a trailer.

Steps for determining correct load limit

1. Locate the statement "The combined weight of occupants and cargo should never exceed XXX kg or XXX lbs." on your vehicle's placard.
2. Determine the combined weight of the driver and passengers that will be riding in your vehicle.
3. Subtract the combined weight of the driver and passengers from XXX kg or XXX lbs.
4. The resulting figure equals the available amount of cargo and luggage load capacity. For example, if the "XXX" amount equals 1400 lbs. (635 kg), and there will be five 150 lbs. (68 kg) passengers in your vehicle, the amount of available cargo and luggage load capacity is 650 lbs. (295 kg).
 $(1400 - 750 (5 \times 150) = 650 \text{ lbs. or } 635 - 340 (5 \times 68) = 295 \text{ kg})$

5. Determine the combined weight of luggage and cargo being loaded on the vehicle. That weight may not safely exceed the available cargo and luggage load capacity calculated in Step 4.
6. If your vehicle will be towing a trailer, load from your trailer will be transferred to your vehicle. Consult this manual to determine how this reduces the available cargo and luggage load capacity of your vehicle.

Example 1

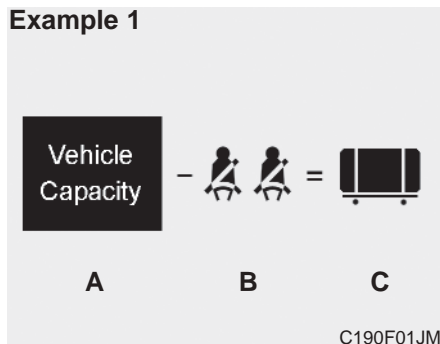

Example 2

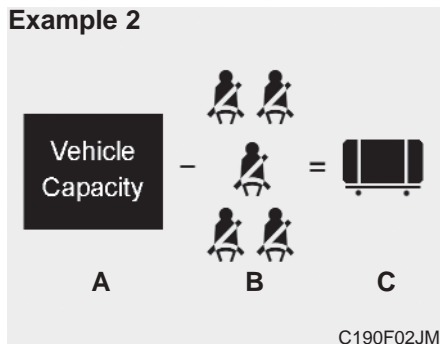

Example 3

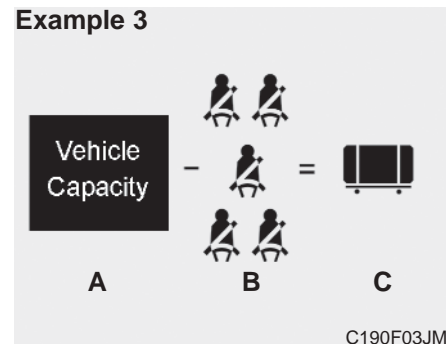

Item	Description	Total
A	Vehicle Capacity Weight	1400 lbs (635 kg)
B	Subtract Occupant Weight 150 lbs (68 kg) × 2	300 lbs (136 kg)
C	Available Cargo and Luggage weight	1100 lbs (499 kg)

Item	Description	Total
A	Vehicle Capacity Weight	1400 lbs (635 kg)
B	Subtract Occupant Weight 150 lbs (68 kg) × 5	750 lbs (340 kg)
C	Available Cargo and Luggage weight	650 lbs (295 kg)

Item	Description	Total
A	Vehicle Capacity Weight	1400 lbs (635 kg)
B	Subtract Occupant Weight 172 lbs (78 kg) × 5	860 lbs (390 kg)
C	Available Cargo and Luggage weight	540 lbs (245 kg)

Refer to your vehicle's tire and loading information label for specific information about your vehicle's capacity weight and seating positions. The combined weight of the driver, passengers and cargo should never exceed your vehicle's capacity weight.



Compliance label

The compliance label is located on the driver's door sill.

This label shows the maximum allowable weight of the fully loaded vehicle. This is called the GVWR (Gross Vehicle Weight Rating). The GVWR includes the weight of the vehicle, all occupants, fuel and cargo.

This label also tells you the maximum weight that can be supported by the front and rear axles, called Gross Axle Weight Rating (GAWR).

To find out the actual loads on your front and rear axles, you need to go to a weigh station and weigh your vehicle. Your dealer can help you with this. Be sure to spread out your load equally on both sides of the centerline.

⚠ WARNING - Over loading

- **Never exceed the GVWR for your vehicle, the GAWR for either the front or rear axle and vehicle capacity weight. Exceeding these ratings can cause an accident or vehicle damage. You can calculate the weight of your load by weighing the items (or people) before putting them in the vehicle. Be careful not to overload your vehicle.**
- **Do not load your vehicle any heavier than the GVWR, either the maximum front or rear GAWR and vehicle capacity weight.**

(Continued)

(Continued)

If you do, parts, including tires on your vehicle can break, and it can change the way your vehicle handles and braking ability. This could cause you to lose control and crash. Also, overloading can shorten the life of your vehicle.

*** NOTICE**

- **Overloading your vehicle may cause damage. Repairs would not be covered by your warranty. Do not overload your vehicle.**
- **Using heavier suspension components to get added durability might not change your weight ratings. Ask your dealer to help you load your vehicle the right way.**

The label will help you decide how much cargo and installed equipment your vehicle can carry.

WEIGHT OF THE VEHICLE

If you carry items inside your vehicle - like suitcases, tools, packages, or anything else - they are moving as fast as the vehicle. If you have to stop or turn quickly, or if there is a crash, the items will keep going and can cause an injury if they strike the driver or a passenger.

⚠ WARNING - Loose cargo
Items you carry inside your vehicle can strike and injure occupants in a sudden stop or turn, or in a crash.

- Put items in the cargo area of your vehicle. Try to spread the weight evenly.
- Never stack items, like suitcases, inside the vehicle above the tops of the seats.
- Do not leave an unsecured child restraint in your vehicle.
- When you carry something inside the vehicle, secure it.
- Do not drive with a seat folded down unless necessary.

This section will guide you in the proper loading of your vehicle and/or trailer, to keep your loaded vehicle weight within its design rating capability, with or without a trailer. Properly loading your vehicle will provide maximum return of the vehicle design performance. Before loading your vehicle, familiarize yourself with the following terms for determining your vehicle's weight ratings, with or without a trailer, from the vehicle's specifications and the compliance label:

Base curb weight

This is the weight of the vehicle including a full tank of fuel and all standard equipment. It does not include passengers, cargo, or optional equipment.

Vehicle curb weight

This is the weight of your new vehicle when you picked it up from your dealer plus any aftermarket equipment.

Cargo weight

This figure includes all weight added to the Base Curb Weight, including cargo and optional equipment.

GAW (Gross axle weight)

This is the total weight placed on each axle (front and rear) - including vehicle curb weight and all payload.

GAWR (Gross axle weight rating)

This is the maximum allowable weight that can be carried by a single axle (front or rear). These numbers are shown on the compliance label. The total load on each axle must never exceed its GAWR.

GVW (Gross vehicle weight)

This is the Base Curb Weight plus actual Cargo Weight plus passengers.

GVWR (Gross vehicle weight rating)

This is the maximum allowable weight of the fully loaded vehicle (including all options, equipment, passengers and cargo). The GVWR is shown on the compliance label located on the driver's door sill.

TRAILER TOWING

⚠ WARNING - Towing a trailer

If you don't use the correct equipment and drive properly, you can lose control when you pull a trailer. For example, if the trailer is too heavy, the brakes may not work well - or even at all. You and your passengers could be seriously or fatally injured. Pull a trailer only if you have followed all the steps in this section.

Item		Specification
Maximum trailer weight	lbs. (kg)	Without trailer brakes 1000 (454)
		With trailer brakes 2000 (908)

*** NOTICE**

Pulling a trailer improperly can damage your vehicle and result in costly repairs not covered by your warranty. To pull a trailer correctly, follow the advice in this section.

Your vehicle can tow a trailer. To identify what the vehicle trailering capacity is for your vehicle, you should read the information in “Weight of the Trailer” that appears later in this section. Remember that trailering is different than just driving your vehicle by itself. Trailering means changes in handling, durability, and fuel economy. Successful, safe trailering requires correct equipment, and it has to be used properly.

This section contains many time-tested, important trailering tips and safety rules. Many of these are important for your safety and that of your passengers. Please read this section carefully before you pull a trailer.

Load-pulling components such as the engine, transaxle, wheel assemblies, and tires are forced to work harder against the load of the added weight. The engine is required to operate at relatively higher speeds and under greater loads. This additional burden generates extra heat. The trailer also adds considerably to wind resistance, increasing the pulling requirements.

If you do decide to pull a trailer

Here are some important points if you decide to pull a trailer:

- Consider using a sway control. You can ask a hitch dealer about sway control.
- After your odometer indicates 500 miles (800 km) or more, you can tow a trailer. For the first 500 miles (800 km) that you tow a trailer, don't drive over 50 mph (80 km/h) and don't make starts at full throttle. This helps your engine and other parts of your vehicle "wear" in at the heavier loads.
- Always drive your vehicle at a moderate speed (Less than 100 km/h).
- The important considerations have to do with weight:

Weight of the trailer

How heavy can a trailer safely be? It should never weigh more than 2000 lbs. (908 kg) with trailer brakes. But even that can be too heavy.

It depends on how you plan to use your trailer. For example, speed, altitude, road grades, outside temperature and how much your vehicle is used to pull a trailer are all important. The ideal trailer weight can also depend on any special equipment that you have on your vehicle.

Weight of the trailer tongue

The tongue load of any trailer is an important weight to measure because it affects the total gross vehicle weight (GVW) of your vehicle. This weight includes the curb weight of the vehicle, any cargo you may carry in it, and the people who will be riding in the vehicle. And if you will tow a trailer, you must add the tongue load to the GVW because your vehicle will also be carrying that weight.

After you've loaded your trailer, weigh the trailer and then the tongue, separately, to see if the weights are proper. If they aren't, you may be able to correct them simply by moving some items around in the trailer.

WARNING

- **Never load a trailer with more weight in the rear than in the front. The front should be loaded with approximately 60% of the total trailer load; the rear should be loaded with approximately 40% of the total trailer load.**
- **Never exceed the maximum weight limits of the trailer or trailer towing equipment. Improper loading can result in damage to your vehicle and/or personal injury. Check weights and loading at a commercial scale or highway patrol office equipped with scales.**
- **An improperly loaded trailer can cause loss of vehicle control.**

Hitches

It's important to have the correct hitch equipment. Crosswinds, large trucks going by, and rough roads are a few reasons why you'll need the right hitch. Here are some rules to follow:

- Will you have to make any holes in the body of your vehicle when you install a trailer hitch? If you do, then be sure to seal the holes later when you remove the hitch.
If you don't seal them, deadly carbon monoxide (CO) from your exhaust can get into your vehicle, as well as dirt and water.
- The bumpers on your vehicle are not intended for hitches. Do not attach rental hitches or other bumper-type hitches to them. Use only a frame-mounted hitch that does not attach to the bumper.

Safety chains

You should always attach chains between your vehicle and your trailer. Cross the safety chains under the tongue of the trailer so that the tongue will not drop to the road if it becomes separated from the hitch.

Instructions about safety chains may be provided by the hitch manufacturer or by the trailer manufacturer. Follow the manufacturer's recommendation for attaching safety chains. Always leave just enough slack so you can turn with your trailer. And, never allow safety chains to drag on the ground.

Trailer brakes

If your trailer weighs more than 1000 lbs. (454 kg) loaded, then it needs its own brakes and they must be adequate. Be sure to read and follow the instructions for the trailer brakes so you'll be able to install, adjust and maintain them properly.

- Don't tap into your vehicle's brake system.

WARNING

Do not use a trailer with its own brakes unless you are absolutely certain that you have properly set up the brake system. This is not a task for amateurs. Use an experienced, competent trailer shop for this work.

Driving with a trailer

Towing a trailer requires a certain amount of experience. Before setting out for the open road, you must get to know your trailer. Acquaint yourself with the feel of handling and braking with the added weight of the trailer. And always keep in mind that the vehicle you are driving is now a good deal longer and not nearly so responsive as your vehicle is by itself.

Before you start, check the trailer hitch and platform, safety chains, electrical connector(s), lights, tires and mirror adjustment. If the trailer has electric brakes, start your vehicle and trailer moving and then apply the trailer brake controller by hand to be sure the brakes are working. This lets you check your electrical connection at the same time.

During your trip, check occasionally to be sure that the load is secure, and that the lights and any trailer brakes are still working.

Following distance

Stay at least twice as far behind the vehicle ahead as you would when driving your vehicle without a trailer. This can help you avoid situations that require heavy braking and sudden turns.

Passing

You'll need more passing distance up ahead when you're towing a trailer. And, because you're a good deal longer, you'll need to go much farther beyond the passed vehicle before you can return to your lane.

Backing up

Hold the bottom of the steering wheel with one hand. Then, to move the trailer to the left, just move your hand to the left. To move the trailer to the right, move your hand to the right. Always back up slowly and, if possible, have someone guide you.

Making turns

When you're turning with a trailer, make wider turns than normal. Do this so your trailer won't strike soft shoulders, curbs, road signs, trees, or other objects. Avoid jerky or sudden maneuvers. Signal well in advance.

Turn signals when towing a trailer

When you tow a trailer, your vehicle has to have a different turn signal flasher and extra wiring. The green arrows on your instrument panel will flash whenever you signal a turn or lane change. Properly connected, the trailer lights will also flash to alert other drivers you're about to turn, change lanes, or stop.

When towing a trailer, the green arrows on your instrument panel will flash for turns even if the bulbs on the trailer are burned out. Thus, you may think drivers behind you are seeing your signals when, in fact, they are not. It's important to check occasionally to be sure the trailer bulbs are still working. You must also check the lights every time you disconnect and then reconnect the wires.

Do not connect a trailer lighting system directly to your vehicle's lighting system. Use only an approved trailer wiring harness.

Your Authorized Kia Dealer can assist you in installing the wiring harness.

WARNING

Failure to use an approved trailer wiring harness could result in damage to the vehicle electrical system and/or personal injury.

Driving on grades

Reduce speed and shift to a lower gear before you start down a long or steep downgrade. If you don't shift down, you might have to use your brakes so much that they would get hot and no longer operate efficiently.

On a long uphill grade, shift down and reduce your speed to around 45 mph (70 km/h) to reduce the possibility of engine and transaxle overheating.

If your trailer weighs more than 1000 lbs. (454 kg) and you have an automatic transaxle, you should drive in D (Drive) when towing a trailer.

Operating your vehicle in D (Drive) when towing a trailer will minimize heat buildup and extend the life of your transaxle.

CAUTION

- ***When towing a trailer on steep grades (in excess of 6%) pay close attention to the engine coolant temperature gauge to ensure the engine does not overheat. If the needle of the coolant temperature gauge moves across the dial towards "H" (HOT), pull over and stop as soon as it is safe to do so, and allow the engine to idle until it cools down. You may proceed once the engine has cooled sufficiently.***
- ***You must decide driving speed depending on trailer weight and uphill grade to reduce the possibility of engine and transaxle overheating.***

Parking on hills

Generally, you should not park your vehicle, with a trailer attached, on a hill. People can be seriously or fatally injured, and both your vehicle and the trailer can be damaged if they begin a downhill trajectory.

WARNING - Parking on a hill

Parking your vehicle on a hill with a trailer attached could cause serious injury or death, should a downhill trajectory happen.

However, if you ever have to park your trailer on a hill, here's how to do it:

1. Apply your brakes, but don't shift into gear.
2. Have someone place chocks under the trailer wheels.
3. When the wheel chocks are in place, release the brakes until the chocks absorb the load.
4. Reapply the brakes. Apply your parking brake, and then shift to P (Park) for an automatic transaxle.
5. Release the brakes.

WARNING - Parking brake

It can be dangerous to get out of your vehicle if the parking brake is not firmly set.

If you have left the engine running, the vehicle can move suddenly. You or others could be seriously or fatally injured.

When you are ready to leave after parking on a hill

1. With the automatic transaxle in P (Park), apply your brakes and hold the brake pedal down while you:
 - Start your engine;
 - Shift into gear; and
 - Release the parking brake.
2. Slowly remove your foot from the brake pedal.
3. Drive slowly until the trailer is clear of the chocks.
4. Stop and have someone pick up and store the chocks.

Maintenance when trailer towing

Your vehicle will need service more often when you regularly pull a trailer. Important items to pay particular attention include engine oil, automatic transaxle fluid, axle lubricant and cooling system fluid. Brake condition is another important item to frequently check. Each item is covered in this manual, and the Index will help you find them quickly. If you're trailering, it's a good idea to review these sections before you start your trip. Don't forget to also maintain your trailer and hitch. Follow the maintenance schedule that accompanied your trailer and check it periodically. Preferably, conduct the check at the start of each day's driving. Most importantly, all hitch nuts and bolts should be tight.

CAUTION

Due to higher load during trailer usage, overheating might occur in hot days or during uphill driving. If the coolant gauge indicates overheating, switch off the A/C and stop the vehicle in a safe area to cool down the engine.

LABEL INFORMATION

There are several important labels and identification numbers located on your vehicle. The label locations are identified in the illustrations follows:

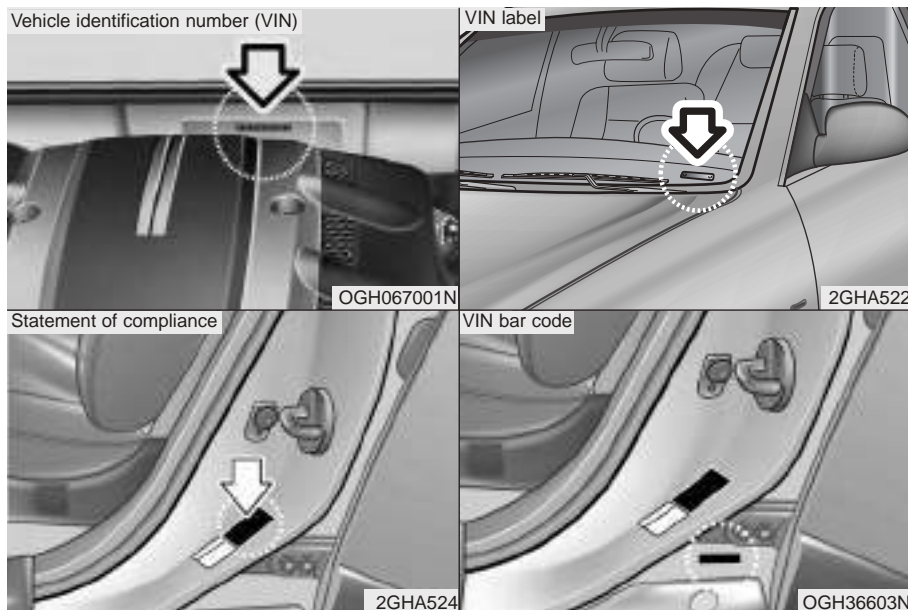

Vehicle identification number (VIN)



3GHA523

Tire specification / pressure label

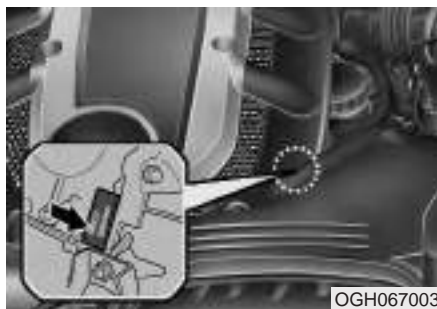

OGH067003

Engine number

HOMELINK® WIRELESS CONTROL SYSTEM (IF EQUIPPED)

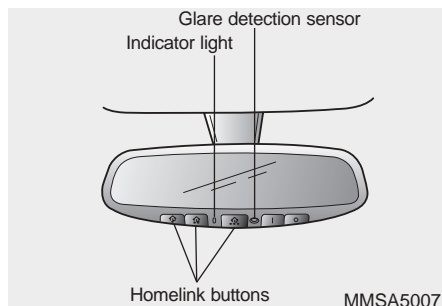

Your new mirror comes with an integrated HomeLink Universal Transceiver, which allows you to program the mirror to activate your garage door(s), estate gate, home lighting, etc. The mirror actually learns the codes from your various existing transmitters.

⚠ WARNING

- When programming the HomeLink® Wireless Control System, you may be operating a garage door or gate operator. Make sure that people and objects are out of the way of the moving door or gate to prevent potential harm or damage.
- Do not use HomeLink with any garage door opener that lacks the safety stop and reverse feature as required by federal safety standards. (This includes any garage door opener model manufactured before April 1, 1982.) A garage door opener which cannot detect an object, signaling the door to stop and reverse, does not meet current federal safety standards. Using a garage door opener without these features increases risk of serious injury or death. For more information, call 1-800-355-3515 or on the internet at www.homelink.com.

(Continued)

(Continued)



- Retain the original transmitter for future programming procedures (i.e., new vehicle purchase). It is also suggested that upon the sale of the vehicle, the programmed HomeLink buttons be erased for security purposes (follow step 1 in the “Programming” portion of this text).

Programming

Your vehicle may require the ignition switch to be turned to the ACC position for programming and/or operation of HomeLink. It is also recommended that a new battery be replaced in the hand-held transmitter of the device being programmed to HomeLink for quicker training and accurate transmission of the radio-frequency.

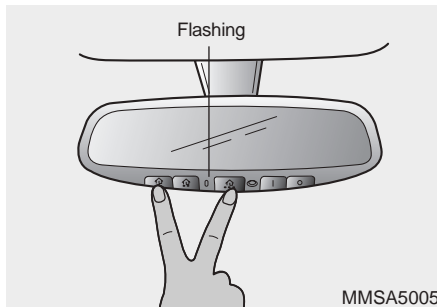
Follow these steps to train your HomeLink mirror:



1. When programming the buttons for the first time, press and hold the left and center buttons ( , ) simultaneously until the indicator light begins to flash after approximately 20 seconds. (This procedure erases the factory-set default codes. Do Not perform this step to program additional hand-held transmitters.)

* NOTICE

For non rolling code garage door openers, follow steps 2 - 3.

For rolling code garage door openers, follow steps 2 - 6.

For Canadian Programming, please follow the Canadian Programming section. For help with determining whether your garage is non-rolling code or rolling code, please refer to the garage door openers owner's manual or contact HomeLink customer service at 1-800-355-3515.

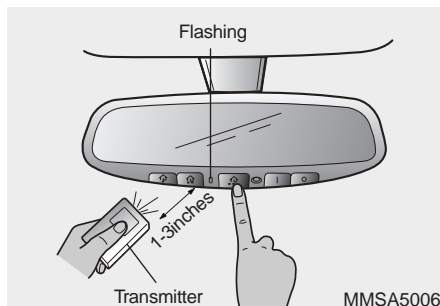

2. Press and hold the button on the HomeLink system you wish to train and the button on the transmitter while the transmitter is approximately 1 to 3 inches away from the mirror. Do not release the buttons until step 3 has been completed.

3. The HomeLink indicator light will flash, first slowly and then rapidly. When the indicator light flashes rapidly, both buttons may be released. (The rapid flashing light indicates successful programming of the new frequency signal.)

* NOTICE

Some gate operators and garage door openers may require you to replace step #3 with the “cycling” procedure noted in the “Canadian Programming” section of this document.

Rolling code programming

To train a garage door opener (or other rolling code equipped devices) with the rolling code feature, follow these instructions after completing the “Programming” portion of this text. (A second person may make the following training procedures quicker & easier.)

4. Locate the “learn” or “smart” button on the device’s motor head unit. Exact location and color of the button may vary by product brand. If there is difficulty locating the “learn” or “smart” button, reference the device’s owner’s manual or contact HomeLink at 1-800-355-3515 or on the internet at www.homelink.com.
5. Press and release the “learn” or “smart” button on the device’s motor head unit. You have 30 seconds to complete step number 6.

- Return to the vehicle and firmly press and release the programmed HomeLink button up to three times. The rolling code equipped device should now recognize the HomeLink signal and activate when the HomeLink button is pressed. The remaining two buttons may now be programmed if this has not previously been done. Refer to the "Programming" portion of this text.

Operating HomeLink

To operate, simply press the programmed HomeLink button. Activation will now occur for the trained product (garage door, security system, entry door lock, estate gate, or home or office lighting). For convenience, the hand-held transmitter of the device may also be used at any time. The HomeLink Wireless Controls System (once programmed) or the original hand-held transmitter may be used to activate the device (e.g. garage door, entry door lock, etc.). In the event that there are still programming difficulties, contact HomeLink at 1-800-355-3515 or on the internet at www.homelink.com.

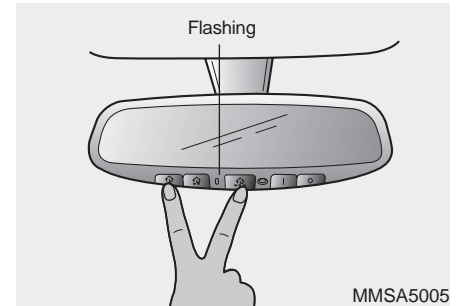

Erasing programmed HomeLink buttons

To erase the three programmed buttons (individual buttons cannot be erased):

- Press and hold the left and center buttons simultaneously, until the indicator light begins to flash (approximately 20 seconds). Release both buttons. Do not hold for longer than 30 seconds.

HomeLink is now in the train (or learning) mode and can be programmed at any time.

Reprogramming a single HomeLink button

To program a device to HomeLink using a HomeLink button previously trained, follow these steps:

1. Press and hold the desired HomeLink button. Do NOT release until step 4 has been completed.
2. When the indicator light begins to flash slowly (after 20 seconds), position the hand-held transmitter 1 to 3 inches away from the HomeLink surface.
3. Press and hold the hand-held transmitter button (or press and “cycle” - as described in “Canadian Programming” above).
4. The HomeLink indicator light will flash, first slowly and then rapidly. When the indicator light begins to flash rapidly, release both buttons.

The previous device has now been erased and the new device can be activated by pushing the HomeLink button that has just been programmed. This procedure will not affect any other programmed HomeLink buttons.

Gate operator programming & canadian programming

During programming, your hand-held transmitter may automatically stop transmitting. Continue to press and hold the HomeLink button (note steps 2 through 4 in the “Programming” portion of this text) while you press and re-press (“cycle”) your handheld transmitter every two seconds until the frequency signal has been learned. The indicator light will flash slowly and then rapidly after several seconds upon successful training.

* NOTICE

If programming a garage door opener or gate, it is advised to unplug the device during the “cycling” process to prevent possible motor burn-up.

Accessories

If you would like additional information on the HomeLink Wireless Control System, HomeLink compatible products, or to purchase other accessories such as the HomeLink® Lighting Package, please contact HomeLink at 1-800-355-3515 or on the internet at www.homelink.com. This device complies with FCC rules part 15. Operation is subject to the following two conditions:

- (1) This device may not cause harmful interference.
- (2) This device must accept any interference that may be received including interference that may cause undesired operation.

CAUTION

The transmitter has been tested and complies with FCC and DOC/MDC rules. Changes or modifications not expressly approved by the party responsible for compliance could void the user's authority to operate the device.

**IC: 4112104541A Gentex
MODEL/FCC ID: NZLSTDHL3**

Road warning / 6-2

In case of an emergency while driving / 6-2

Overheating / 6-3

Emergency starting / 6-4

Electrical circuit protection / 6-6

Towing / 6-13

Tires pressure monitoring system (TPMS) / 6-17

If you have a flat tire / 6-22

In case of an emergency

6

ROAD WARNING

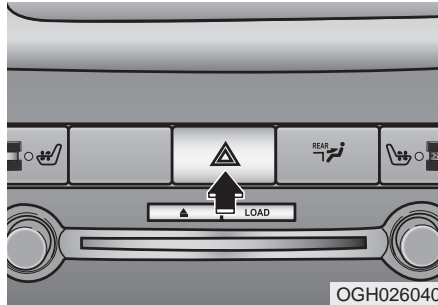

Hazard warning flasher

The hazard warning flasher serves as a warning to other drivers to exercise extreme caution when approaching, overtaking, or passing your vehicle. It should be used whenever emergency repairs are being made or when the vehicle is stopped near the edge of a roadway.

Depress the flasher switch with the ignition switch in any position. The flasher switch is located in the center console switch panel. All turn signal lights will flash simultaneously.

- The hazard warning flasher operates whether your vehicle is running or not.
- The turn signals do not work when the hazard flasher is on.
- Care must be taken when using the hazard warning flasher while the vehicle is being towed.

IN CASE OF AN EMERGENCY WHILE DRIVING

If the engine stalls at a crossroad or crossing

If the engine stalls at a crossroad or crossing, set the shift lever in the N (Neutral) position and then push the vehicle to a safe place.

If you have a flat tire while driving

If a tire goes flat while you are driving:

1. Take your foot off the accelerator pedal and let the car slow down while driving straight ahead. Do not apply the brakes immediately or attempt to pull off the road as this may cause a loss of control. When the car has slowed to such a speed that it is safe to do so, brake carefully and pull off the road. Drive off the road as far as possible and park on firm, level ground. If you are on a divided highway, do not park in the median area between the two traffic lanes.
2. When the car is stopped, turn on your emergency hazard flashers, set the parking brake and put the transaxle in P.

3. Have all passengers get out of the car. Be sure they all get out on the side of the car that is away from traffic.
4. When changing a flat tire, follow the instruction provided later in this section.

If engine stalls while driving

1. Reduce your speed gradually, keeping a straight line. Move cautiously off the road to a safe place.
2. Turn on your emergency flashers.
3. Try to start the engine again. If your vehicle will not start, contact an authorized KIA dealer or seek other qualified assistance.

OVERHEATING

If your temperature gauge indicates overheating, if you experience a loss of power, or if you hear a loud knocking or pinging noise, the engine has probably overheated. Should any of these symptoms occur, use the following procedure:

1. Turn on the hazard warning flasher, then drive to the nearest safe location and stop your vehicle; set the automatic transaxle in P (Park) and apply the parking brake.
2. Make sure the air conditioner is off.
3. If coolant or steam is boiling out of the radiator, stop the engine and call an Authorized Kia Dealer for assistance. If coolant is not boiling out, allow the engine to idle and open the hood to permit the engine to cool gradually. If the temperature does not go down with the engine idling, stop the engine and allow sufficient time for it to cool.

4. The coolant level should then be checked. If the level in the reservoir is low, look for leaks at the radiator hoses and connections, heater hoses and connections, radiator, and water pump. If you find a major leak or another problem that may have caused the engine to overheat, do not operate the engine until it has been corrected. Call an Authorized Kia Dealer for assistance. If you do not find a leak or other problem, carefully add coolant to the reservoir.

WARNING - Removing radiator cap

Do not remove the radiator cap when the engine and radiator are hot. Scalding hot coolant and steam may blow out under pressure. This could cause serious injury.

If the engine frequently overheats, have the cooling system checked and repaired by an Authorized Kia Dealer.

EMERGENCY STARTING

Jump starting

Jump starting can be dangerous if done incorrectly. Therefore, to avoid harm to yourself or damage to your vehicle or battery, follow the jump starting procedures listed on page 6-5. If in doubt, we strongly recommend that you have a competent technician or towing service jump start your vehicle.

* NOTICE

Use only a 12-volt jumper system. You can damage a 12-volt starting motor, ignition system, and other electrical parts beyond repair by use of a 24-volt power supply (either two 12-volt batteries in series or a 24-volt motor generator set).

WARNING - Battery

Never attempt to check the electrolyte level of the battery as this may cause the battery to rupture or explode causing serious injury.

WARNING - Battery

- Keep all flames or sparks away from the battery. The battery produces hydrogen gas which may explode if exposed to flame or sparks.
- Do not attempt to jump start the vehicle if the discharged battery is frozen or if the electrolyte level is low; the battery may rupture or explode.

Connecting jumper cables

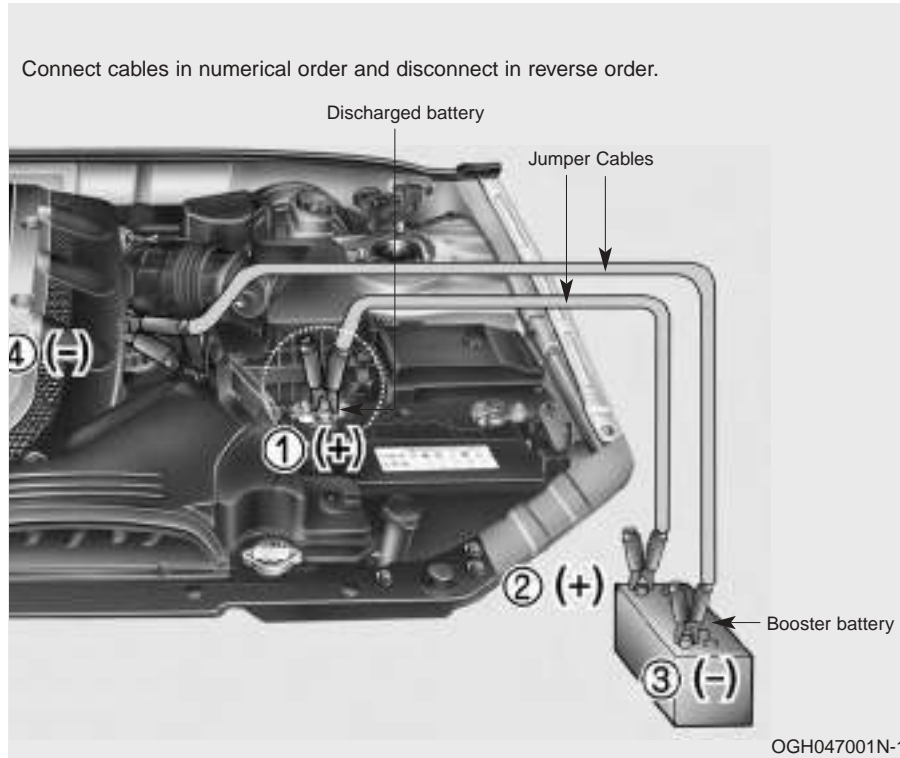

Jump starting procedure

1. Make sure the booster battery is 12-volt and that its negative terminal is grounded.
2. If the booster battery is in another vehicle, do not allow the vehicles to touch.
3. Turn off all unnecessary electrical loads.
4. Connect the jumper cables in the exact sequence shown in the previous illustration. First connect one end of a jumper cable to the positive terminal of the discharged battery (①), then connect the other end to the positive terminal on the booster battery (②).

Proceed to connect one end of the other jumper cable to the negative terminal of the booster battery (③), then the other end to a solid, stationary, metallic point (for example, the engine lifting bracket) away from the battery (④). Do not connect it to or near any part that moves when the engine is cranked. Do not connect the jumper cable from the negative terminal of the booster battery to the negative terminal of the discharged battery.

Do not allow the jumper cables to contact anything except the correct battery terminals or the correct ground. Do not lean over the battery when making connections.

5. Start the engine of the vehicle with the booster battery and let it run at 2,000 rpm, then start the engine of the vehicle with the discharged battery.

If the cause of your battery discharging is not apparent, you should have your vehicle checked by an Authorized Kia Dealer.

Refer to illustration on page 6-5.

Push-starting

Vehicles equipped with automatic transaxle cannot be push-started. Follow the directions in this section for jump-starting.

WARNING

Never tow a vehicle to start it because the sudden surge forward when the engine starts could cause a collision with the tow vehicle.

ELECTRICAL CIRCUIT PROTECTION



Normal



Blown



Normal



Blown



Normal



Blown

1VQA4037

Fuses

A vehicle's electrical system is protected from electrical overload damage by fuses.

This vehicle has two fuse panels, one located in the driver's side knee bolster, the other in the engine compartment near the battery.

If any of your vehicle's lights, accessories, or controls do not work, check the appropriate circuit fuse. If a fuse has blown, the element inside the fuse will be melted.

If the electrical system does not work, first check the driver's side fuse panel.

Always replace a blown fuse with one of the same rating.

If the replacement fuse blows, this indicates an electrical problem. Avoid using the system involved and immediately consult an Authorized Kia Dealer.

Fuse replacement

⚠ WARNING - Fuse replacement

- **Never replace a fuse with anything but another fuse of the same rating.**
- **A higher capacity fuse could cause damage and possibly a fire.**
- **Never install a wire instead of the proper fuse - even as a temporary repair. It may cause extensive wiring damage and possibly a fire.**
- **Do not use a screwdriver or any other metal object to remove fuses because it may cause a short circuit and damage the system.**

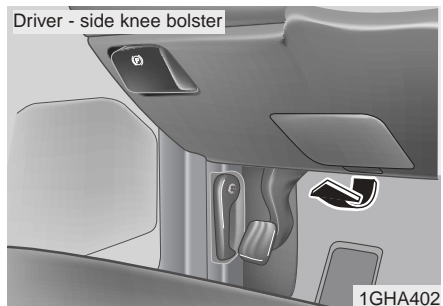

1. Turn the ignition switch and all other switches off.
 2. Pull the suspected fuse straight out. Use the removal tool provided on the main fuse box in the engine compartment.
 3. Check the removed fuse; replace it if it is blown.
Spare fuses are provided in the fuse panel.
 4. Push in a new fuse of the same rating, and make sure it fits tightly in the clips.
- If it fits loosely, consult an Authorized Kia Dealer.

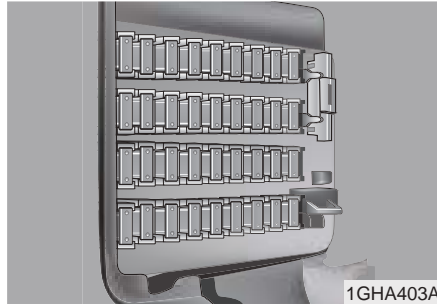

If you do not have a spare, use a fuse of the same rating from a circuit you may not need for operating the vehicle, such as the radio or room lamp fuse.

If the headlights or other electrical components do not work and the fuses are OK, check the fuse block in the engine compartment. If a fuse is blown, it must be replaced.

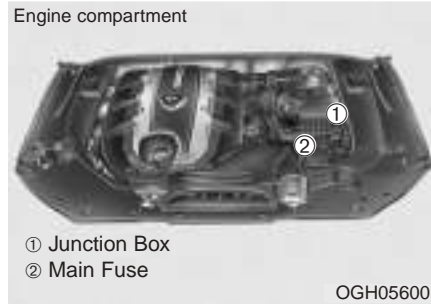

To check the fuse or relay in the engine compartment, remove the engine compartment shroud.

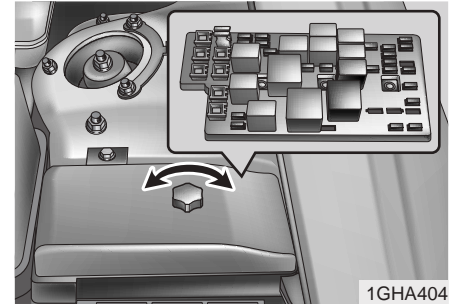

1. Turn the ignition switch and all other switches off.
2. Remove the fuse box cover by removing the bolt on the cover and unhooking the tab on one end and tilting the cover back toward the other end.
3. Check the fuses. If one is blown, replace it with a new one of the same rating.

* NOTICE

After checking the fuse box in the engine compartment, securely install the fuse box cover. If not, electrical failures may occur from water leaking in.



Main fuse

If the BATT (60A) or ALT (150A) fuse are blown, it must be removed as follows:

1. Disconnect the negative battery cable.
2. Remove the nuts shown in the picture above.
3. Replace the fuse with a new one of the same rating.
4. Reinstall in the reverse order of removal.

Fuse/Relay panel description

Inside the fuse/relay box covers, you can find the fuse/relay label describing fuse/relay name and capacity.

Engine compartment

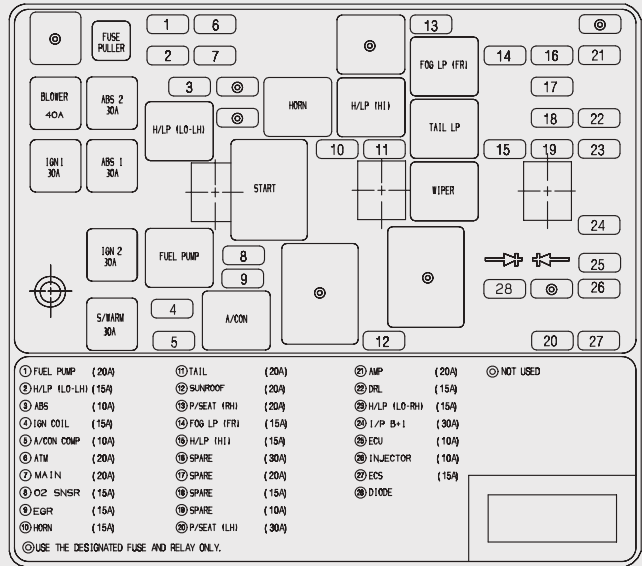

91950-3F100

Engine compartment

	Description	Fuse rating	Protected component
1	FUEL PUMP	20A	Fuel pump
2	H/LP (LO-LH)	15A	Headlight (low-left)
3	ABS	10A	Anti-lock brake system
4	IGN COIL	15A	Ignition coil
5	A/CON COMP	10A	Air-conditioner compressor
6	ATM	20A	Automatic transaxle control relay
7	MAIN	20A	Engine control unit relay
8	O2 SNSR	15A	Oxygen sensor
9	EGR	15A	Power train control system sensors
10	HORN	15A	Horn
11	TAIL	20A	Tail light
12	SUNROOF	20A	Sun roof
13	P/SEAT (RH)	20A	Power seat (right)
14	FOG LP (FR)	15A	Fog light (front)
15	H/LP (HI)	15A	Headlight (high)
16	SPARE	30A	spare fuse
17	SPARE	20A	spare fuse
18	SPARE	15A	spare fuse
19	SPARE	10A	spare fuse
20	P/SEAT (LH)	30A	Power seat (left)
21	AMP	20A	Radio amplifier
22	DRL*	15A	Daytime running light

* : if equipped

	Description	Fuse rating	Protected component
23	H/LP (LO-RH)	15A	Headlight (low beam-right)
24	I/P B+	30A	All electrical system
25	ECU	10A	Engine control unit
26	INJECTOR	10A	Injector
27	ECS *	15A	Electronic control suspension
	BLOWER	40A	Blower motor
	IGN 1	30A	Ignition switch
	ABS 2	30A	Anti-lock brake system
	ABS 1	30A	Anti-lock brake system
	IGN 2	30A	Ignition switch
	S/WARM	30A	Seat warmer
	H/LP (LO-LH)	-	Headlight relay (low beam-left)
	FUEL PUMP	-	Fuel pump relay
	HORN	-	Horn relay
	START	-	Start motor relay
	A/CON	-	Air conditioner relay
	H/LP (HI)	-	Headlight relay (high beam)
	FOG LP (FR)	-	Fog light relay (front)
	TAIL LP	-	Taillight relay
	WIPER	-	Wiper relay
	BATT	60A	Alternator, Battery
	ALT	150A	Alternator
	COOLING	60A	Cooling fan

Driver-side knee bolster

POWER/CONN		SHUNT CONN	
B/ALARM 10A	AV. CLOCK 15A	LAN UNIT 10A	ROOM LP 10A
P/HANDLE 15A	P/WDW(RH) 20A	BACK WARN'G 10A	DR LP 10A
MIRROR HTD 15A	TRUNK OPEN 15A	CURTAIN(RR) 15A	HTD GLASS 30A
F/LID OPEN 15A	B/ALARM 10A	FOG LP(RR), PIC 15A	TPMS 15A
STOP LP 15A	T/SIG LP 15A	P/WDW(LH) 20A	S/WARMER 10A
P/SEAT (RR) 30A	A/CON 10A	EPS 10A	H/LP WASHER 20A
P/OUTLET 25A	H/LP 10A	LAN UNIT 10A	WIPER(FR) 25A
CLOCK 10A	T/REDUCER 10A	AV 10A	C/LIGHTER 20A
TAIL LP (RH) 10A	B/UP LP 10A	A/BAG IND 10A	A/BAG 15A
TAIL LP (LH) 10A	ENG SNSR 10A	TRIP COMPUTER 10A	CLUSTER 10A

USE ONLY DESIGNATED FUSE ONLY

91117-3F060

Driver-side knee bolster

Description	Fuse rating	Protected component
B/ALARM	10A	Burglar alarm
A/BAG	15A	Air bag
C/LIGHTER	20A	Cigar lighter
S/WARMER	10A	Seat warmer
P/WDW(RH)	20A	Power window (right)
P/HANDLE	15A	Power steering wheel
T/SIG LP	15A	Turn signal light
HTD GLASS	30A	Defroster
TRUNK OPEN	15A	Trunk lid opener
CLUSTER	10A	Cluster
A/BAG IND	10A	Air bag indicator
P/OUTLET	25A	Electrical power socket
LAN UNIT	10A	Lan unit
CURTAIN(RR)	15A	Electric curtain (rear)
FOG LP(RR), PIC	15A	Fog light (rear), Personal identification card
F/LID OPEN	15A	Fuel filler lid opener
P/SEAT(RR)	30A	Power seat (rear)
B/ALARM	10A	Burglar alarm
STOP LP	15A	Stop light
TRIP COMPUTER	10A	Trip computer
B/UP LP	10A	Back-up light
AV	10A	Audio
H/LP	10A	Headlight

Description	Fuse rating	Protected component
A/CON	10A	Air-conditioning system
P/PDW(LH)	20A	Power window (left)
TAIL LP(RH)	10A	Taillight (right)
BACK WARN'G	10A	Back warning
DR LP	10A	Door courtesy lamp
MIRROR HTD	15A	Outside review mirror defroster
ENG SNSR	10A	Power train control system sensors
T/REDUCER	10A	Seat belt tension reducer
CLOCK	10A	Clock
WIPER(FR)	25A	Wiper (front)
EPS	10A	Electronic power steering
TAIL LP(LH)	10A	Tail light (left)
ROOM LP	10A	Room lamp
AV, CLOCK	15A	Audio, Clock
LAN UNIT	10A	Lan unit
TPMS	15A	Tire pressure monitoring system
H/LP WASHER	20A	Headlight washer
SHUNT CONN	-	Switch illumination
POWER/CONN	-	Power connector

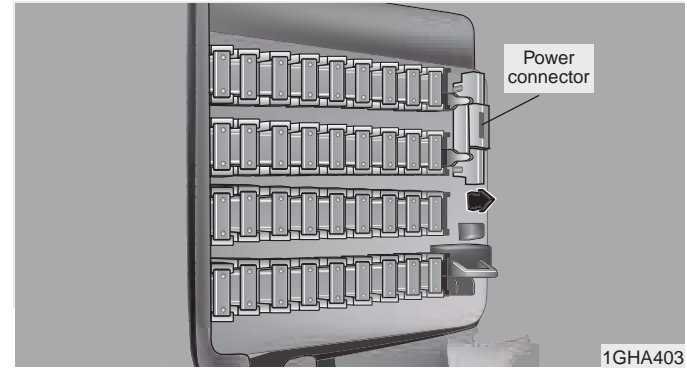

Power connector

Your vehicle is equipped with a power connector to prevent battery discharge if your vehicle is parked without being operated for prolonged periods. Use the following procedures before parking the vehicle for prolonged period.

1. Turn off the engine.
2. Turn off the headlights and tail lights.
3. Open the driver-side knee bolster cover and pull up the "POWER/CONN".

* NOTICE

- If the power connector is pulled up from the fuse panel, the warning chime, AV system, clock and interior lamps, etc., will not operate. Some items must be reset after replacement.
- Even though the power connector is pulled up, the battery can still be discharged by operation of the headlights or other electrical devices.

TOWING

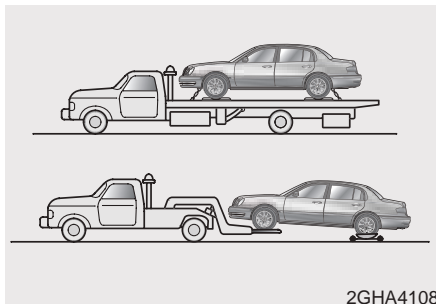

If emergency towing is necessary, we recommend having it done by an authorized Kia dealer or a commercial tow-truck service. Proper lifting and towing procedures are necessary to prevent damage to the vehicle. The use of wheel dollies or flatbed is recommended.

For trailer towing guidelines information, refer to section 5 "Driving Tips".

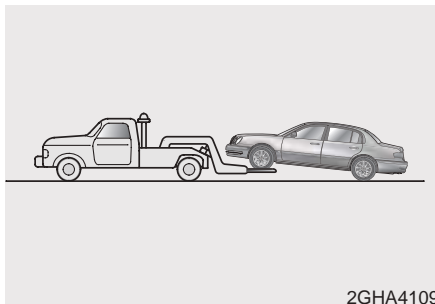

It is acceptable to tow the vehicle with the rear wheels on the ground (without dollies) and the front wheels off the ground. When being towed by a commercial tow truck and wheel dollies are not used, the front of the vehicle should always be lifted, not the rear.

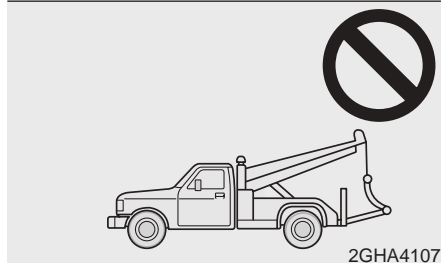
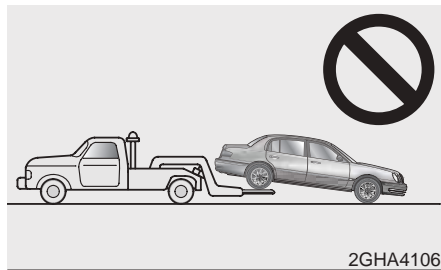

CAUTION

- **Do not tow the vehicle backwards with the front wheels on the ground as this may cause damage to the vehicle.**
- **Do not tow with sling-type equipment. Use wheel lift or flatbed equipment.**

In case of an emergency

When towing your vehicle in an emergency without wheel dollies :

1. Set the ignition switch in the ACC position.
2. Place the transaxle shift lever in N (Neutral).
3. Release the parking brake.

CAUTION

Failure to place the transaxle shift lever in N (Neutral) may cause internal damage to the transaxle.



**Tie-down hook
(for flatbed towing)**

WARNING

Do not use the hooks under the front of the vehicle for towing purposes. These hooks are designed **ONLY** for transport tie-down. If the tie-down hooks are used for towing, the tie-down hooks will be damaged and this could lead to serious injury.



Towing with a vehicle other than a tow truck

If towing is necessary, we recommend you to have it done by an Authorized Kia dealer or a commercial tow truck service.

If towing service is not available in an emergency, your vehicle may be temporarily towed using a cable or chain secured to the emergency towing hook under the front or rear of the vehicle. Use extreme caution when towing the vehicle. A driver must be in the vehicle to steer it and operate the brakes.

Towing in this manner may be done only on hard-surfaced roads for a short distance and at low speeds. Also, the wheels, axles, power train, steering and brakes must all be in good condition.

- Do not use the tow hooks to pull a vehicle out of mud, sand or other conditions from which the vehicle cannot be driven out under its own power.
- Avoid towing a vehicle heavier than the vehicle doing the towing.
- The drivers of both vehicles should communicate with each other frequently.

CAUTION

- **Attach a towing strap to the tow hook.**
- **Using a portion of the vehicle other than the tow hooks for towing may damage the body of your vehicle.**
- **Use only a cable or chain specifically intended for use in towing vehicles. Securely fasten the cable or chain to the towing hook provided.**
- Before emergency towing, check that the hook is not broken or damaged.
- Fasten the towing cable or chain securely to the hook.
- Do not jerk the hook. Apply steady and even force.
- To avoid damaging the hook, do not pull from the side or at a vertical angle. Always pull straight ahead.

WARNING

Use extreme caution when towing the vehicle.

- Avoid sudden starts or erratic driving maneuvers which would place excessive stress on the emergency towing hook and towing cable or chain. The hook and towing cable or chain may break and cause serious injury or damage.
- If the towing vehicle can hardly move, do not forcibly continue the towing. Contact an Authorized Kia dealer or a commercial tow truck service for assistance.
- Tow the vehicle as straight ahead as possible.
- Keep away from the vehicle during towing.

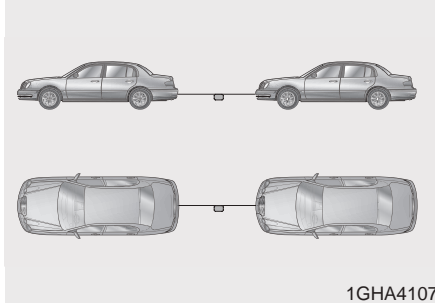

- Use a towing strap less than 16 feet (5 m) long. Attach a white or red cloth (about 12 inches (30 cm) wide) in the middle of the strap for easy visibility.
- Drive carefully so that the towing strap is not loosened during towing.

When your vehicle is being towed by another vehicle other than a tow truck (In case of an emergency)

- Turn the ignition switch to ACC so the steering wheel isn't locked.
- Place the transaxle shift lever in N (Neutral).
- Release the parking brake.
- Vehicle equipped with automatic transaxles should not exceed 28 mph (45 km/h) and should not be towed more than 50 miles (80 km).
- Press the brake pedal with more force than normal since you will have reduced brake performance.
- More steering effort will be required because the power steering system will be disabled.
- If you are driving down a long hill, the brakes may overheat and brake performance will be reduced. Stop often and let the brakes cool off.

CAUTION

To prevent internal damage to the transaxle, never tow your vehicle from the rear (backwards) with all four tires in contact with the surface.

Tips for towing a stuck vehicle

The following methods are effective when your vehicle is stuck in mud, sand or similar substances that prevent the vehicle from being driven out under its own power.

- Remove the soil and sand, etc. from the front and the back of the tires.
- Place a stone or wood under the tires.

TIRES PRESSURE MONITORING SYSTEM (TPMS) (IF EQUIPPED)



- ① Low Tire Pressure Telltale
- ② TPMS Malfunction Indicator

Each tire, including the spare (if provided), should be checked monthly when cold and inflated to the inflation pressure recommended by the vehicle manufacturer on the vehicle placard or tire inflation pressure label. (If your vehicle has tires of a different size than the size indicated on the vehicle placard or tire inflation pressure label, you should determine the proper tire inflation pressure for those tires.)

As an added safety feature, your vehicle has been equipped with a tire pressure monitoring system (TPMS) that illuminates a low tire pressure telltale when one or more of your tires is significantly under-inflated. Accordingly, when the low tire pressure telltale illuminates, you should stop and check your tires as soon as possible, and inflate them to the proper pressure. Driving on a significantly under-inflated tire causes the tire to overheat and can lead to tire failure. Under-inflation also reduces fuel efficiency and tire tread life, and may affect the vehicle's handling and stopping ability.

Please note that the TPMS is not a substitute for proper tire maintenance, and it is the driver's responsibility to maintain correct tire pressure, even if under-inflation has not reached the level to trigger illumination of the TPMS low tire pressure telltale.

Your vehicle has also been equipped with a TPMS malfunction indicator to indicate when the system is not operating properly. The TPMS malfunction indicator is provided by a separate telltale, which displays the symbol "TPMS" when illuminated. When the malfunction indicator is illuminated, the system may not be able to detect or signal low tire pressure as intended. TPMS malfunctions may occur for a variety of reasons, including the installation of replacement or alternate tires or wheels on the vehicle that prevent the TPMS from functioning properly. Always check the TPMS malfunction telltale after replacing one or more tires or wheels on your vehicle to ensure that the replacement or alternate tires and wheels allow the TPMS to continue to function properly.

Low tire pressure telltale



When the tire pressure monitoring system warning telltale is illuminated, one or more of your tires is significantly under-inflated.

Immediately reduce your speed, avoid hard cornering and anticipate increased stopping distances. You should stop and check your tires as soon as possible when the tires are cool. And inflate the tires to the proper pressure as indicated on the vehicle's placard or tire inflation pressure label located on the driver's side center pillar outer panel. If you cannot reach a service station or if the tire cannot hold the newly added air, replace the low pressure tire with the temporary spare tire.

Then the TPMS malfunction indicator or the Low Tire Pressure telltale may turn on after restarting and about 20 minutes of continuous driving before you have the low-pressure tire repaired and reinstalled on the vehicle.

CAUTION

In winter or cold weather, the low tire pressure telltale may be illuminated if the tire pressure was adjusted to the recommended tire inflation pressure in warm weather. It does not mean your TPMS is malfunctioning because the decreased temperature leads to a proportional lowering of tire pressure.

When you drive your vehicle from a warm area to a cold area or from a cold area to a warm area, or the outside temperature significantly increases or decreases, you should check the tire inflation pressure and adjust the tires to the recommended tire inflation pressure.

WARNING - Low tire pressure

Significantly low tire pressure makes the vehicle unstable and can contribute to loss of vehicle control and increased braking distances.

Continued driving on low pressure tires will cause the tires to overheat and fail.

TPMS (Tire Pressure Monitoring System) malfunction indicator

TPMS

The TPMS malfunction indicator turns on and stays on when there is a problem with the Tire Pressure Monitoring System. If the system is able to correctly detect an under-inflation warning at the same time as system failure then it will illuminate both the TPMS malfunction and the low tire pressure telltale e.g. if Front Left sensor fails, the TPMS malfunction indicator turns, but if Front Right, Rear Left, or Rear Right tire is under-inflated, the low tire pressure telltale may turn on at the same time as the TPMS malfunction indicator.

Have the system checked by an authorized KIA dealer as soon as possible to determine the cause of the problem.

* NOTICE

- The TPMS malfunction indicator may be illuminated if the vehicle is moving around electric power supply cable or radio transmitter such as police stations, government and public offices, broadcasting stations, military installations, airports, or transmitting tower, etc. this can interfere with normal operation of the Tire Pressure Monitoring System (TPMS).
- The TPMS malfunction indicator may be illuminated if snow chains or some electronic devices, such as notebook computers, are used in the vehicle. This can interfere with normal operation of the Tire Pressure Monitoring System (TPMS).

(Continued)

(Continued)

- If there is a failed tire sensor, it is possible for the TPMS to temporarily learn a replacement sensor if closely driven to another vehicle that is also equipped with TPMS. In rare cases, this may temporarily delay the TPMS malfunction indicator from turning on.

Changing a tire with TPMS

If you have a flat tire, the Low Tire Pressure telltale will turn on. Have the flat tire repaired by an authorized KIA dealer as soon as possible or replace the flat tire with the spare tire.

NEVER use a puncture-repairing agent to repair and/or inflate a low pressure tire. If used, you will have to replace the tire pressure sensor.

Each wheel is equipped with a tire pressure sensor mounted inside the tire behind the valve stem. You must use TPMS specific wheels. It is recommended that you always have your tires serviced by an authorized KIA dealer as soon as possible.

After you replace the low pressure tire with the spare tire, the TPMS malfunction indicator or the Low Tire Pressure telltale may illuminate after restarting and driving about 20 minutes of continuous driving.

Once the low pressure tire is re-inflated to the recommended pressure and installed on the vehicle, the TPMS malfunction indicator and the low tire pressure telltale will extinguish.

If the low pressure and TPMS malfunction indicators are not extinguished after about 20 minutes of continuous driving, please visit an authorized Kia dealer.

You may not be able to identify a low tire by simply looking at it. Always use a good quality tire pressure gauge to measure the tire's inflation pressure. Please note that a tire that is hot (from being driven) will have a higher pressure measurement than a tire that is cold (from sitting stationary for at least 3 hours and driven less than 1 mile (1.6km) during that 3 hour period). Allow the tire to cool before measuring the inflation pressure.

Always be sure the tire is cold before inflating to the recommended pressure.

A cold tire means the vehicle has been sitting for 3 hours and driven for less than 1 mile (1.6km) in that 3 hour period.

CAUTION

- *Do not use any tire sealant if your vehicle is equipped with a Tire Pressure Monitoring System. The liquid sealant can damage the tire pressure sensors.*
- *In order for the system to correctly monitor tires for under-inflation, there should be a total of exactly 4 sensors fitted to each of the four driven wheel positions. There should be no other sensors in the vehicle include spare tire position since this could cause the system to monitor the wrong sensors.*

WARNING - TPMS

- The TPMS cannot alert you to severe and sudden tire damage caused by external factors.
- If you feel any vehicle instability, immediately take your foot off the accelerator and slowly move to a safe position off the road.

WARNING

Tampering with, modifying, or disabling the Tire Pressure Monitoring System (TPMS) components may interfere with the system's ability to warn the driver of low tire pressure conditions and/or TPMS malfunctions. Tampering with, modifying, or disabling the Tire Pressure Monitoring System (TPMS) components may void the warranty for that portion of the vehicle.

This device complies with Part 15 of the FCC rules. Operation is subject to the following two conditions:

1. This device may not cause harmful interference, and
2. This device must accept any interference received, including interference that may cause undesired operation.

WARNING

Changes or modifications not expressly approved by the party responsible for compliance could void the user's authority to operate the equipment.

IF YOU HAVE A FLAT TIRE



The spare tire, jack, jack handle, and wheel lug nut wrench are stored in the trunk compartment. Move the carpeting out of the way to reach this equipment.

The jack assembly is located in the trunk, under the carpeting, on the spare tire.

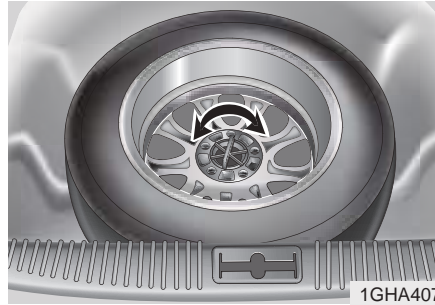

Removing the spare tire

Turn the tire hold-down wing bolt counterclockwise.

Store the tire in the reverse order of removal.

To prevent the spare tire and tools from “rattling” while the vehicle is in motion, store them properly.

Important - use of compact spare tire (if equipped)

Your vehicle is equipped with a compact spare tire. This compact spare tire takes up less space than a regular-size tire. This tire is smaller than a conventional tire and is designed for temporary use only.

CAUTION - Compact spare

- *You should drive carefully when the compact spare is in use. The compact spare should be replaced by the proper conventional tire and rim at the first opportunity.*
- *The operation of this vehicle is not recommended with more than one compact spare tire in use at the same time.*

⚠ WARNING - Compact spare
This spare tire should be used only for VERY short distances. Compact spares should NEVER be used for long drives or extended distances.

The compact spare should be inflated to 60 psi (420 kPa).

*** NOTICE**

Check the inflation pressure after installing the spare tire. Adjust it to the specified pressure, as necessary.

When using a compact spare tire, observe the following precautions:

- Under no circumstances should you exceed 50 mph (80 km/h); a higher speed could damage the tire.
- Ensure that you drive slowly enough for the road conditions to avoid all hazards. Any road hazard, such as a pothole or debris, could seriously damage the compact spare.
- Any continuous road use of this tire could result in tire failure, loss of vehicle control, and possible personal injury.
- Do not exceed the vehicle's maximum load rating or the load-carrying capacity shown on the sidewall of the compact spare tire.
- Avoid driving over obstacles. The compact spare tire diameter is smaller than the diameter of a conventional tire and reduces the ground clearance approximately 1 inch (25 mm), which could result in damage to the vehicle.
- Do not take the vehicle through an automatic car wash with a compact spare.
- Do not use tire chains on this tire. Because of the smaller size, a tire chain will not fit properly. This could damage the vehicle and result in loss of the chain.
- This tire should not be installed on the front axle if the vehicle must be driven in snow or on ice.
- Do not use the compact spare tire on any other vehicle because this tire has been designed especially for your vehicle.
- The compact spare tire's tread life is shorter than a regular tire. Inspect your compact spare tire regularly and replace worn compact spare tires with the same size and design, mounted on the same wheel.

Changing tires

Jacking instructions

The jack is provided for emergency tire changing only.

Follow jacking instructions to reduce the possibility of personal injury.

⚠ WARNING - Changing tires

- Never attempt vehicle repairs in the traffic lanes of a public road or highway.
- Always move the vehicle completely off the road and onto the shoulder before trying to change a tire. The jack should be used on level firm ground whenever possible. If you cannot find a firm, level place off the road, call a towing service company for assistance.
- Be sure to use the correct front and rear jacking positions on the vehicle; never use the bumpers or any other part of the vehicle for jack support.

(Continued)

(Continued)

- The vehicle can easily roll off the jack causing serious injury or death. No person should place any portion of their body under a vehicle that is supported only by a jack ; use vehicle support stands.
- Do not start or run the engine while the vehicle is on the jack.
- Do not allow anyone to remain in the vehicle while it is on the jack.
- Make sure any children present are in a secure place away from the road and from the vehicle to be raised with the jack.



Tire replacement

1. Park on a level surface and apply the parking brake firmly.
2. Shift the shift lever into P (Park).
3. Activate the hazard warning flasher.



4. Remove the wheel lug nut wrench, jack, jack handle, and spare tire from the vehicle.
5. Block both the front and rear of the wheel that is diagonally opposite the jack position.

- ⚠ WARNING - Changing a tire**
- To prevent vehicle movement while changing a tire, always set the parking brake fully, and always block the wheel diagonally opposite the wheel being changed.
 - It is recommended that the wheels of the vehicle be chocked, and that no person should remain in a vehicle that is being jacked.

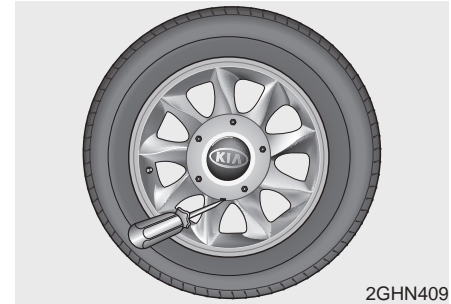

6. Wrap a piece of cloth around the tip of the screwdriver to avoid scratching.
7. Insert a screwdriver into the notch of the wheel cover and pry gently to remove the wheel cover (if equipped).

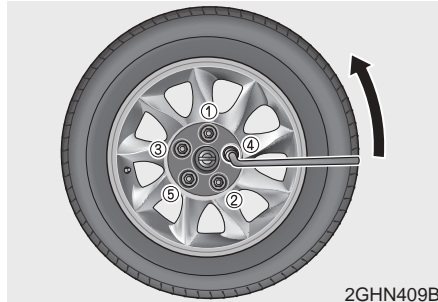

8. Loosen the wheel lug nuts counterclockwise one turn each, but do not remove any nut until the tire has been raised off the ground.

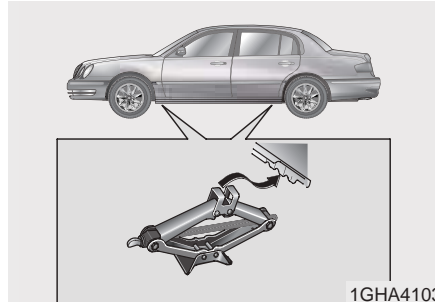

9. Place the jack at the front or rear jacking position closest to the tire you are changing. Place the jack at the designated locations under the frame. The jacking positions are plates welded to the frame with two tabs and a raised dot to index with the jack.

⚠ WARNING - Jack location
To reduce the possibility of injury, be sure to use only the jack provided with the vehicle and in the correct jack position; never use any other part of the vehicle for jack support.

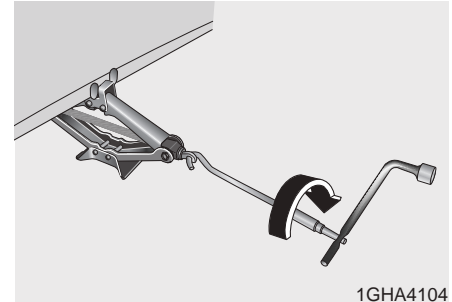

10. Insert the jack handle into the jack and turn it clockwise, raising the vehicle until the tire just clears the ground. This measurement is approximately 1.2 in (30 mm). Before removing the wheel lug nuts, make sure the vehicle is stable and that there is no chance for movement or slippage.

11. Remove the wheel lug nuts by turning them counterclockwise, then remove the wheel.

12. Mount the spare tire into position and install the wheel lug nuts with the beveled edge inward.

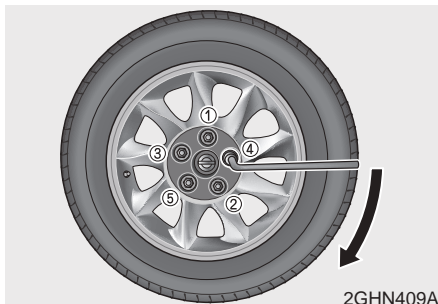

13. Once the wheel lug nuts have been tightened, lower the vehicle fully to the ground and continue to tighten the lug nuts until they are fully secured. Tighten the wheel lug nuts firmly in a “star” pattern.

If you are unsure of the tightness of the wheel lug nuts, have them checked at the nearest service station. The specified tightening torque is 65-79 lb•ft (9~11 kg•m, 88-107 N•m). Improperly tightened wheel lug nuts could cause brake pedal vibration while braking.

14. Reinstall the wheel cover by fitting the boss of the wheel cover in the groove of the wheel.

CAUTION

Your vehicle has metric threads on the wheel studs and nuts. Make certain during wheel removal that the same nuts removed are reinstalled - or, if replaced, that nuts with metric threads and the same chamfer configuration are used. Installation of a non-metric thread nut on a metric stud or vice-versa will not secure the wheel to the hub properly and will damage the stud so that it must be replaced.

Note that most lug nuts do not have metric threads. Be sure to use extreme care in checking for thread style before installing aftermarket lug nuts or wheels. If in doubt, consult an Authorized Kia Dealer.

WARNING - Wheel studs
If the studs are damaged, they may lose their ability to retain the wheel. This could lead to the loss of the wheel and a collision.

To prevent the jack, jack handle, wheel lug nut, wrench and spare tire from rattling while the vehicle is in motion, store them properly.

WARNING
Check the inflation pressures as soon as possible after installing the spare tire. Adjust it to the specified pressure, if necessary. Refer to Section 8, Specifications.

Maintenance services / 7-2
Normal maintenance schedule / 7-3
Severe maintenance schedule / 7-6
Owner maintenance / 7-9
Engine compartment / 7-12
Engine oil and oil filter / 7-13
Engine cooling system / 7-14
Brakes / 7-16
Power steering / 7-17
Automatic transaxle / 7-18
Lubricants and fluids / 7-20
Air cleaner / 7-21
Climate control air filter / 7-22
Wiper blades / 7-24
Battery / 7-26
Tires and wheels / 7-29

Maintenance

7

Bulb replacement / 7-41
Lubricant specifications / 7-46
Exterior care / 7-48
Interior care / 7-51
California perchlorate notice / 7-52

MAINTENANCE SERVICES

You should exercise the utmost care to prevent damage to your vehicle and injury to yourself whenever performing any maintenance or inspection procedures.

Should you have any doubts concerning the inspection or servicing of your vehicle, we strongly recommend that you have an Authorized Kia Dealer perform this work.

An Authorized Kia Dealer has factory-trained technicians and genuine Kia parts to service your vehicle properly. For expert advice and quality service, see an Authorized Kia Dealer.

Inadequate, incomplete or insufficient servicing may result in operational problems with your vehicle that could lead to vehicle damage, an accident, or personal injury.

Owner's responsibility

* NOTICE

Maintenance Service and Record Retention are the owner's responsibility.

You should retain documents that show proper maintenance has been performed on your vehicle in accordance with the scheduled maintenance service charts shown on the following pages. You need this information to establish your compliance with the servicing and maintenance requirements of your Kia warranties.

Detailed warranty information is provided in your Warranty & Consumer Information manual.

Repairs and adjustments required as a result of improper maintenance or a lack of required maintenance are not covered.

We recommend you have your vehicle maintained and repaired by an Authorized Kia Dealer. An Authorized Kia Dealer meets Kia's high service quality standards and receives technical support from Kia in order to provide you with a high level of service satisfaction.

Scheduled maintenance service

If none of the following conditions are applicable, then use Schedule 1 – Normal Maintenance.

- Repeated short distance driving.
- Driving in dusty conditions or sandy areas.
- Extensive use of brakes.
- Driving in areas where salt or other corrosive materials are being used.
- Driving on rough or muddy roads.
- Driving in mountainous areas.
- Extended periods of idling or low speed operation.
- Driving for a prolonged period in cold temperatures and/or extremely humid climates.
- More than 50% driving in heavy city traffic during hot weather above 90°F (32°C)

If any of the preceding conditions apply, follow Schedule 2 – Severe Maintenance.

After 105 months or 105,000 miles (168,000 km) continue to follow the prescribed maintenance intervals.

SCHEDULE 1 - NORMAL MAINTENANCE

MAINTENANCE INTERVALS MAINTENANCE ITEM	Number of Months or Miles (kilometers), whichever comes first														
	Months	6	12	18	24	30	36	42	48	54	60	66	72	78	84
	Miles x 1,000	7.5	15	22.5	30	37.5	45	52.5	60	67.5	75	82.5	90	97.5	105
	(km x 1,000)	(12)	(24)	(36)	(48)	(60)	(72)	(84)	(96)	(108)	(120)	(132)	(144)	(156)	(168)
Drive belts (1)				I					I				I		
Engine oil and engine oil filter	Replace every 7,500 miles or 12 months														
Auto transaxle fluid		I		I		I		I		I		I		I	R
Air cleaner element	I	I	I	R	I	I	I	R	I	I	I	R	I	I	
Spark plugs	Replace every 100,000 miles or 10 years														
Valve clearance (2)								I							
Engine coolant (3) (4)	At first, replace at 60,000 miles or 60 months ; after that, replace every 30,000 miles or 24 months														

I: Inspect and, if necessary, adjust, correct, clean or replace.

R: Replace or change.

- (1) The drive belt should be replaced when cracks occur or tension is reduced excessively.
- (2) Inspect for excessive valve noise and/or engine vibration and adjust if necessary. A qualified technician should perform the operation.
- (3) Coolant level adjustment and leak : Inspect regularly.
- (4) When adding coolant, use only a qualified coolant additive for your vehicle and never mix hard water in the coolant filled at the factory. An improper coolant mixture can result in serious malfunction or engine damage.

SCHEDULE 1 - NORMAL MAINTENANCE (CONTINUED)

MAINTENANCE INTERVALS MAINTENANCE ITEM	Number of Months or Miles (kilometers), whichever comes first														
	Months	6	12	18	24	30	36	42	48	54	60	66	72	78	84
	Miles x 1,000	7.5	15	22.5	30	37.5	45	52.5	60	67.5	75	82.5	90	97.5	105
	(km x 1,000)	(12)	(24)	(36)	(48)	(60)	(72)	(84)	(96)	(108)	(120)	(132)	(144)	(156)	(168)
Fuel filter						R					R				
Fuel tank, cap, lines and hoses															
Vaccum and crankcase ventilation hoses															
Fuel tank air filter					R				R				R		
Battery condition															
Brake lines, hoses and connections															
Brake pedal	Inspect frequently depending on the condition														
Parking brake															
Disc brakes															
Brake fluid															

I: Inspect and, if necessary, adjust, correct, clean or replace.

R: Replace or change.

SCHEDULE 1 - NORMAL MAINTENANCE (CONTINUED)

MAINTENANCE INTERVALS MAINTENANCE ITEM	Number of Months or Miles (kilometers), whichever comes first														
	Months	6	12	18	24	30	36	42	48	54	60	66	72	78	84
	Miles x 1,000	7.5	15	22.5	30	37.5	45	52.5	60	67.5	75	82.5	90	97.5	105
	(km x 1,000)	(12)	(24)	(36)	(48)	(60)	(72)	(84)	(96)	(108)	(120)	(132)	(144)	(156)	(168)
Power steering fluid	I	I	I	I	I	I	I	I	I	I	I	I	I	I	I
Steering operation, linkage and hoses	I	I	I	I	I	I	I	I	I	I	I	I	I	I	I
Front suspension ball joints				L				L				L			
Drive shaft and boots	Inspect every 12 months or 15,000 miles														
Tire	Pressure	Please refer to section "Tires and wheels" on Chapter 7													
	Tread wear	I	I	I	I	I	I	I	I	I	I	I	I	I	I
Chassis/body nuts and bolts				I				I				I			
All locks and hinges	L	L	L	L	L	L	L	L	L	L	L	L	L	L	
Air conditioner refrigerant	Inspect refrigerant amount annually														
Air conditioner compressor	Inspect operation annually														
Climate control air filter	Replace every 10,000 miles														

I: Inspect and, if necessary, adjust, correct, clean or replace.

R: Replace or change.

L: Lubricate

SCHEDULE 2 - SEVERE MAINTENANCE

MAINTENANCE INTERVALS MAINTENANCE ITEM	Number of Months or Miles (kilometers), whichever comes first														
	Months	3	6	9	12	15	18	21	24	27	30	33	36	39	42
	Miles x 1,000	3	6	9	12	15	18	21	24	27	30	33	36	39	42
	(km x 1,000)	(5)	(10)	(15)	(20)	(25)	(30)	(35)	(40)	(45)	(50)	(55)	(60)	(65)	(70)
Drive belts (1)		I	I	I	I	I	I	I	I	I	I	I	I	I	I
Engine oil and engine oil filter		R	R	R	R	R	R	R	R	R	R	R	R	R	R
Auto transaxle fluid						I					R				
Air cleaner element		Inspect more frequently depending on the condition and if necessary, replace													
Spark plugs		Inspect more frequently depending on the condition and if necessary, replace													
Valve clearance (2)		Inspect every 60,000 miles or 48 months													
Engine coolant (3) (4)		At first, replace at 60,000 miles or 60 months ; after that, replace every 30,000 miles or 24 months													

I: Inspect and, if necessary, adjust, correct, clean or replace.

R: Replace or change.

- (1) The drive belt should be replaced when cracks occur or tension is reduced excessively.
- (2) Inspect for excessive valve noise and/or engine vibration and adjust if necessary. A qualified technician should perform the operation.
- (3) Coolant level adjustment and leak : Inspect regularly.
- (4) When adding coolant, use only a qualified coolant additive for your vehicle and never mix hard water in the coolant filled at the factory. An improper coolant mixture can result in serious malfunction or engine damage.

SCHEDULE 2 - SEVERE MAINTENANCE (CONTINUED)

MAINTENANCE INTERVALS MAINTENANCE ITEM	Number of Months or Miles (kilometers), whichever comes first														
	Months	3	6	9	12	15	18	21	24	27	30	33	36	39	42
	Miles x 1,000	3	6	9	12	15	18	21	24	27	30	33	36	39	42
(km x 1,000)	(5)	(10)	(15)	(20)	(25)	(30)	(35)	(40)	(45)	(50)	(55)	(60)	(65)	(70)	
Fuel filter	Replace every 37,500 miles														
Fuel tank, cap, lines and hoses															
Vaccum and crankcase ventilation hoses															
Fuel tank air filter							R					R			
Battery condition															
Brake lines, hoses and connections															
Brake pedal	Inspect frequently depending on the condition														
Parking brake															
Disc brakes															
Brake fluid															

I: Inspect and, if necessary, adjust, correct, clean or replace.
 R: Replace or change.

SCHEDULE 2 - SEVERE MAINTENANCE (CONTINUED)

MAINTENANCE INTERVALS MAINTENANCE ITEM	Number of Months or Miles (kilometers), whichever comes first															
	Months	3	6	9	12	15	18	21	24	27	30	33	36	39	42	
	Miles x 1,000	3	6	9	12	15	18	21	24	27	30	33	36	39	42	
	(km x 1,000)	(5)	(10)	(15)	(20)	(25)	(30)	(35)	(40)	(45)	(50)	(55)	(60)	(65)	(70)	
Power steering fluid	I	I	I	I	I	I	I	I	I	I	I	I	I	I	I	
Steering operation, linkage and hoses	I	I	I	I	I	I	I	I	I	I	I	I	I	I	I	
Front suspension ball joints				L				L				L				
Drive shaft and boots	Inspect every 6 months or 7,500 miles															
Tire	Pressure	Please refer to section "Tires and wheels" on Chapter 7														
	Tread wear	I	I	I	I	I	I	I	I	I	I	I	I	I	I	
Chassis/body nuts and bolts				I				I				I				
All locks and hinges	L	L	L	L	L	L	L	L	L	L	L	L	L	L		
Air conditioner refrigerant	Inspect refrigerant amount annually															
Air conditioner compressor	Inspect operation annually															
Climate control air filter	Replace every 10,000 miles															

I: Inspect and, if necessary, adjust, correct, clean or replace.

R: Replace or change.

OWNER MAINTENANCE

Owner maintenance schedule

The following lists are vehicle checks and inspections that should be performed by the owner or qualified service technician at the frequencies indicated to help ensure safe, dependable operation of your vehicle.

Any adverse conditions should be brought to the attention of your dealer or qualified service technician or service advisor as soon as possible.

These Owner Maintenance Checks are generally not covered by warranties and you may be charged for labor, parts and lubricants used.

When you stop for fuel:

- Check the engine oil level.
- Check coolant level in coolant reservoir.

WARNING

Be careful when checking your engine coolant level when the engine is hot. Scalding hot coolant and steam may blow out under pressure. This could cause serious injury.

- Check the windshield washer fluid level.
- Look for low or under-inflated tires.

While operating your vehicle:

- Note any changes in the sound of the exhaust or any smell of exhaust fumes in the vehicle.
- Check for vibrations in the steering wheel. Notice any increased steering effort or looseness in the steering wheel, or change in its straight-ahead position.
- Notice if your vehicle constantly turns slightly or “pulls” to one side when traveling on smooth, level road.
- When stopping, listen and check for strange sounds, pulling to one side, increased brake pedal travel or “hard-to-push” brake pedal.
- If any slipping or changes in the operation of your transaxle occurs, check the transaxle fluid level.
- Check automatic transaxle P (Park) function.
- Check parking brake.
- Check for fluid leaks under your vehicle (water dripping from the air conditioning system after use is normal).

At least monthly:

- Check coolant level in the coolant recovery reservoir.
- Check the operation of all exterior lights, including the stoplights, turn signals and hazard warning flashers.
- Check the inflation pressures of all tires including the spare.

At least twice a year (i.e., every Spring and Fall) :

- Check radiator, heater and air conditioning hoses for leaks or damage.
- Check windshield washer spray and wiper operation. Clean wiper blades with clean cloth dampened with washer fluid.
- Check headlight alignment.
- Check muffler, exhaust pipes, shields and clamps.
- Check the lap/shoulder belts for wear and function.
- Check for worn tires and loose wheel lug nuts.

At least once a year :

- Clean body and door drain holes.
- Lubricate door hinges and checks, and hood hinges.
- Lubricate door and hood locks and latches.
- Lubricate door rubber weatherstrips.
- Check the air conditioning system before the warm weather season.
- Check the power steering fluid level.
- Inspect and lubricate automatic transaxle linkage and controls.
- Clean battery and terminals.
- Check the brake fluid level.

Owner maintenance precautions

Improper or incomplete service may result in problems. This section gives instructions only for the maintenance items that are easy to perform.

As explained earlier in this section, several procedures can be done only by a qualified service technician with special tools.

* NOTICE

Improper owner maintenance during the warranty period may affect warranty coverage. For details, read the separate Kia Warranty & Consumer Information Manual provided with the vehicle. If you're unsure about any servicing or maintenance procedure, have it done by an Authorized Kia Dealer.

WARNING - Maintenance work

- Performing maintenance work on a vehicle can be dangerous. You can be seriously injured while performing some maintenance procedures. If you lack sufficient knowledge and experience or the proper tools and equipment to do the work, have it done by a qualified technician.
- Working under the hood with the engine running is dangerous. It becomes even more dangerous when you wear jewelry or loose clothing. These can become entangled in moving parts and result in injury. Therefore, if you must run the engine while working under the hood, make certain that you remove all jewelry (especially rings, bracelets, watches, and necklaces) and all neckties, scarves, and similar loose clothing before getting near the engine or cooling fans.

ENGINE COMPARTMENT

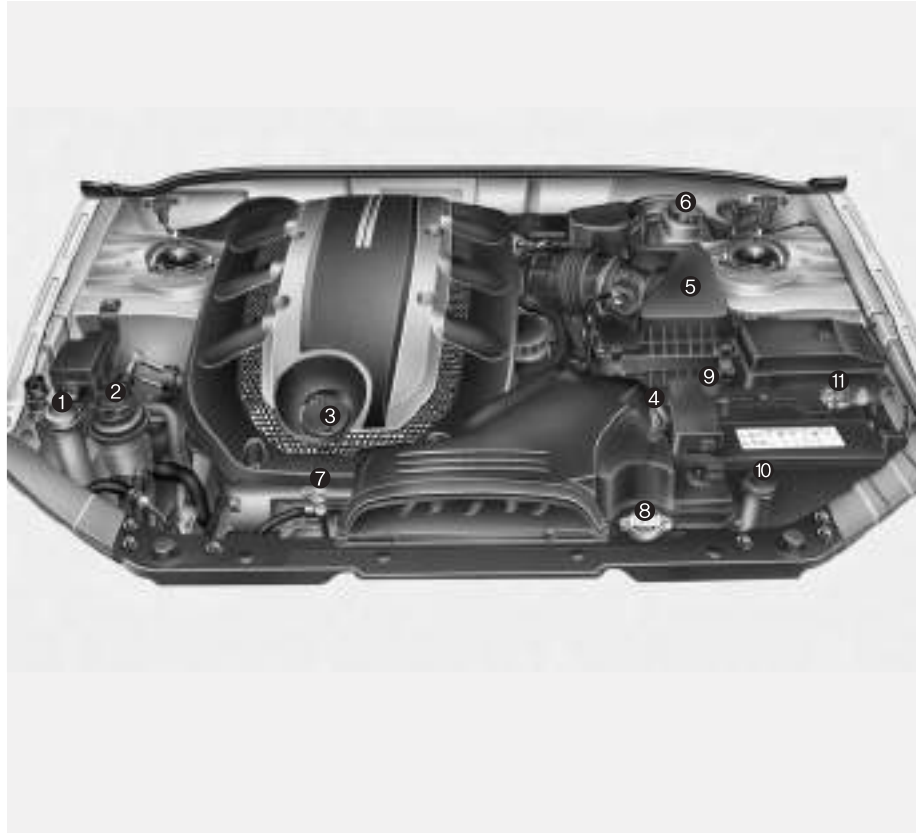

1. Windshield washer fluid reservoir
2. Power steering fluid reservoir
3. Engine oil filler cap
4. Auto transaxle oil dipstick
5. Air cleaner
6. Brake fluid reservoir
7. Engine oil dipstick
8. Radiator cap
9. Positive battery terminal
10. Engine coolant reservoir
11. Negative battery terminal

OGH057001N

ENGINE OIL AND OIL FILTER

Checking the engine oil level

1. Be sure the vehicle is on level ground.
2. Start the engine and allow it to reach normal operating temperature.
3. Turn the engine off and wait for a few minutes (about 5 minutes) for the oil to return to the oil pan.
4. Pull the dipstick out, wipe it clean, and re-insert it fully.
5. Pull the dipstick out again and check the level. The level should be between F and L.

If it is near or at L, add enough oil to bring the level to F. **Do not overfill.**

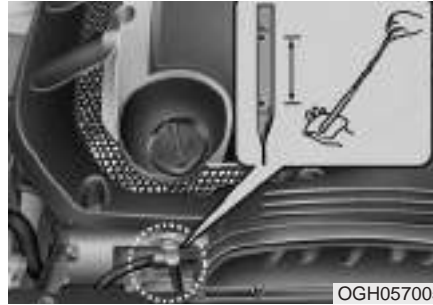

Use only the specified engine oil. (Refer to "Recommended Lubricants" later in this section.)



Changing the engine oil and filter

Change engine oil and filter according to the Scheduled Maintenance at the beginning of this section.

ENGINE COOLING SYSTEM

The high-pressure cooling system has a reservoir filled with year-round antifreeze coolant. The reservoir is filled at the factory.

Check the antifreeze protection and coolant level at least once a year, at the beginning of the winter season, and before traveling to a colder climate.

Checking the coolant level

⚠ WARNING - Removing radiator cap

- Never attempt to remove the radiator cap while the engine is operating or hot. Doing so might lead to cooling system and engine damage and could result in serious personal injury from escaping hot coolant or steam.

(Continued)

(Continued)

- Turn the engine off and wait until it cools down. Even then, use extreme care when removing the radiator cap. Wrap a thick towel around it, and turn it counterclockwise slowly to the first stop. Step back while the pressure is released from the cooling system. When you are sure all the pressure has been released, press down on the cap, using a thick towel, and continue turning counterclockwise to remove it.
- Even if the engine is not operating, do not remove the radiator cap or the drain plug while the engine and radiator are hot. Hot coolant and steam may still blow out under pressure, causing serious injury.



Check the condition and connections of all cooling system hoses and heater hoses. Replace any swollen or deteriorated hoses.

The coolant level should be filled between F and L marks on the level gauge attached to the coolant reservoir cap when the engine is cool.

If the coolant level is low, add enough specified coolant to provide protection against freezing and corrosion. Bring the level to F, but do not overfill. If frequent additions are required, see an Authorized Kia Dealer for a cooling system inspection.

Engine coolant

- Use only soft (de-mineralized) water in the coolant mixture.
- The engine in your vehicle has aluminum engine parts and must be protected by an ethylene-glycol-based coolant to prevent corrosion and freezing.
- DO NOT USE alcohol or methanol coolant or mix them with the specified coolant.
- Do not use a solution that contains more than 60% antifreeze or less than 35% antifreeze, which would reduce the effectiveness of the solution.

For mixture percentage, refer to the following table.

Ambient Temperature	Mixture Percentage (volume)	
	Coolant Solution	Water
5°F (-15°C)	35	65
-13°F (-25°C)	40	60
-31°F (-35°C)	50	50
-49°F (-45°C)	60	40



⚠ WARNING

Do not remove the radiator cap when the engine and radiator are hot. Scalding hot coolant and steam may blow out under pressure. This could cause serious injury.

BRAKES

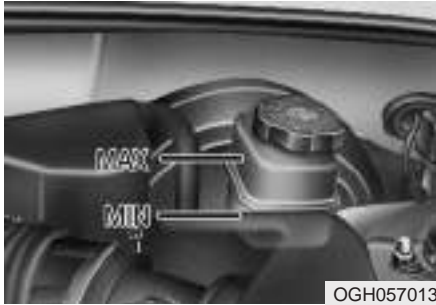

Checking brake fluid level

Check the fluid level in the reservoir periodically. The fluid level should be between MAX and MIN marks on the side of the reservoir.

Before removing the reservoir cap and adding brake fluid, clean the area around the reservoir cap thoroughly to prevent brake fluid contamination.

If the level is low, add fluid to the MAX level. The level will fall with accumulated mileage. This is a normal condition associated with the wear of the brake pads. If the fluid level is excessively low, have the brake system checked by an Authorized Kia Dealer.

Use only the specified brake fluid. (Refer to "Recommended Lubricants" later in this section.)

Never mix different types of fluid.

⚠ WARNING

In the event the brake system requires frequent additions of fluid, the vehicle should be inspected by an Authorized Kia Dealer.

⚠ WARNING

When changing and adding brake fluid, handle it carefully. Do not let it come in contact with your eyes. If brake fluid should come in contact with your eyes, immediately flush them with a large quantity of fresh tap water. Have your eyes examined by a doctor as soon as possible.

⚠ CAUTION

Do not allow brake fluid to contact the vehicle's body paint, as paint damage will result. Brake fluid, which has been exposed to open air for an extended time should never be used as its quality cannot be guaranteed. It should be thrown out. Don't put in the wrong kind of fluid. For example, just a few drops of mineral-based oil, such as engine oil, in your brake system can damage brake system parts.

POWER STEERING



Checking the power steering fluid level

With the vehicle on level ground, check the fluid level in the power steering reservoir periodically. The fluid should be between MAX and MIN marks on the level gauge attached to the cap.

Before adding power steering fluid, thoroughly clean the area around the reservoir cap to prevent power steering fluid contamination.

If the level is low, add fluid to the MAX level.

In the event the power steering system requires frequent addition of fluid, the vehicle should be inspected by an Authorized Kia Dealer.

* NOTICE

- To avoid damage to the power steering pump, do not operate the vehicle for prolonged periods with a low power steering fluid level.
- Never start the engine when the reservoir tank is empty.
- When adding fluid, be careful that dirt does not get into the tank.
- Too little fluid can make the steering wheel heavier or strange noise can be generated.
- The use of the non-specified fluid could reduce the effectiveness of the power steering wheel and cause damage to it.

Use only the specified power steering fluid. (Refer to "Recommended Lubricants" later in this section.)

Power steering hose

Check the connections for oil leaks, severe damage and the twists in the power steering hose before driving.

AUTOMATIC TRANSAXLE

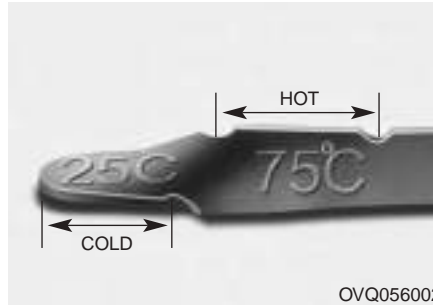

Checking the automatic transaxle fluid level

The automatic transaxle fluid level should be checked regularly.

Keep the vehicle on the level ground with the parking brake applied and check the fluid level according to the following procedure.

1. Place the selector lever in N (Neutral) position and confirm the engine is running at normal idle speed.
2. After the transaxle is warmed up sufficiently (fluid temperature 158~176°F (70~80°C)), for example by 10 minutes usual driving, shift the selector lever through all positions then place the selector lever in N (Neutral) or P (Park) position.

3. Confirm that the fluid level is in "HOT" range on the level gauge. If the fluid level is lower, add the specified fluid from the fill hole. If the fluid level is higher, drain the fluid from the drain hole.
4. If the fluid level is checked in cold condition (fluid temperature 68~86°F (20~30°C)) add the fluid to "COLD" line and then recheck the fluid level according to the above step 2.

⚠ WARNING - Transaxle fluid
The transaxle fluid level should be checked when the engine is at normal operating temperature. This means that the engine, radiator, radiator hose and exhaust system etc., are very hot. Exercise great care not to burn yourself during this procedure.

⚠ CAUTION

- *Low fluid level causes transaxle slippage. Overfilling can cause foaming, loss of fluid and transaxle malfunction.*
- *The use of a non-specified fluid could result in transaxle malfunction and failure.*

⚠ WARNING - Parking brake
To avoid sudden movement of the vehicle, apply parking brake and depress the brake pedal before moving the shift lever.

*** NOTICE**

“COLD” scale is for reference only and should **NOT** be used to determine transaxle fluid level.

New automatic transaxle fluid should be red. The red dye is added so the assembly plant can identify it as automatic transaxle fluid and distinguish it from engine oil or antifreeze. The red dye, which is not an indicator of fluid quality, is not permanent. As the vehicle is driven, the automatic transaxle fluid will begin to look darker. The color may eventually appear light brown.

*** NOTICE**

Have an Authorized Kia dealer inspect or change the automatic transaxle fluid according to the Scheduled Maintenance at the beginning of this section.

LUBRICANTS AND FLUIDS



OGH057500

Checking the washer fluid level

The reservoir is translucent so that you can check the level with a quick visual inspection.

Check the fluid level in the washer fluid reservoir and add fluid if necessary. Plain water may be used if washer fluid is not available. However, use washer solvent with antifreeze characteristics in cold climates to prevent freezing.

⚠ WARNING

- **Do not use radiator coolant or antifreeze in the washer fluid reservoir.**
- **Radiator coolant can severely obscure visibility when sprayed on the windshield and may cause loss of vehicle control or damage to paint and body trim.**
- **Windshield Washer fluid agents contain some amounts of alcohol and can be flammable under certain circumstances. Do not allow sparks or flame to contact the washer fluid or the washer fluid reservoir. Damage to the vehicle or it's occupants could occur.**
- **Windshield washer fluid is poisonous to humans and animals. Do not drink and avoid contacting windshield washer fluid. Serious injury or death could occur.**

Body lubrication

All moving points of the body, such as door hinges, hood hinges, and locks, should be lubricated each time the engine oil is changed. Use a non-freezing lubricant on locks during cold weather.

Make sure the engine hood secondary latch keeps the hood from opening when the primary latch is released.

AIR CLEANER



Element replacement

It must be replaced when necessary, and should be inspected according to the maintenance schedule.

1. Remove the engine compartment shroud on the air cleaner.



2. Loosen the air cleaner cover attaching clips and open the cover.
3. Wipe the inside of the air cleaner housing with a clean, damp cloth.

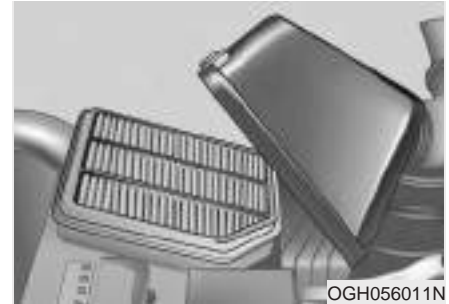

4. Replace the air cleaner element. We recommend that the air cleaner element be replaced with genuine Kia parts.
5. Lock the cover with the cover attaching clips.

Replace the element according to the Scheduled Maintenance Section.

If the vehicle is operated in extremely dusty or sandy areas, replace the element more often than the usual recommended intervals. (Refer to Severe Maintenance Schedule in this section.)

CAUTION

- **Do not drive with the air cleaner removed; this will result in excessive engine wear.**
- **Driving without an air cleaner encourages backfiring, which could cause a fire in the engine compartment.**
- **When removing the air cleaner element, be careful that dust or dirt does not enter the air intake, or damage may result.**

CLIMATE CONTROL AIR FILTER (IF EQUIPPED)

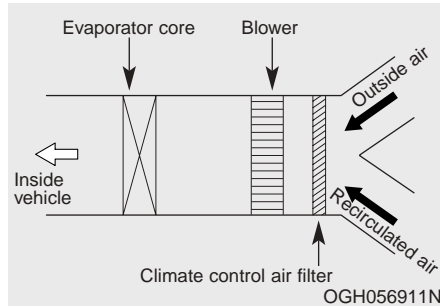

The climate control air filter located between the evaporator core and blower filters the air coming into the vehicle.

If dust or other pollutants accumulate in the filter for a period of time, the air flow from the air vents may be decreased and the dust intake may increase. Therefore the air filter should be replaced at the intervals shown in the maintenance schedule. If the vehicle is operated in dusty or sandy areas, replace the filter more often than the recommended intervals.



Filter replacement

1. Open the glove box part way, reach inside and pull out the elastic line and push the retaining clip through the hole in the rear of the glove box. Allow the glove box to open.

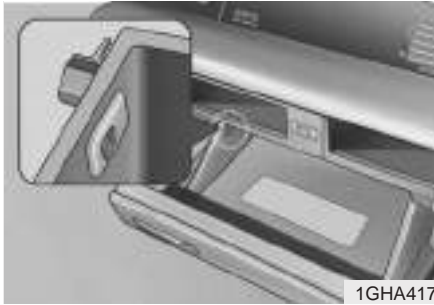

2. With the glove box open, grasp both sides of the glove box, push inward on the stoppers and pull them over the trim panel to allow the glove box hang freely on the hinges.

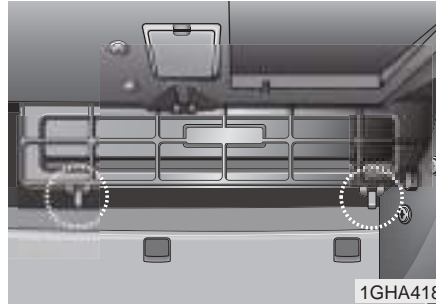

3. Pull the hooks under the climate control air filter cover upwards and remove the cover.



4. Replace the climate control air filter.
5. Reassemble in the reverse order of disassembly.

* NOTICE

When replacing the climate control air filter install it according to the “UP” and “DOWN” identification marks. Otherwise, the system may produce noise and the effectiveness of the filter may be reduced.

WIPER BLADES

Wiper blade maintenance

* NOTICE

Commercial hot waxes applied by automatic car washes have been known to make the windshield difficult to clean.

Contamination of either the windshield or the wiper blades with foreign matter can reduce the effectiveness of the windshield wipers. Common sources of contamination are insects, tree sap, and hot wax treatments used by some commercial car washes. If the blades are not wiping properly, clean both the window and the blades with a good cleaner or mild detergent, and rinse thoroughly with clean water.

CAUTION

To prevent damage to the wiper blades, do not use gasoline, kerosene, paint thinner, or other solvents on or near them.

Windshield wiper blade replacement

When the wipers no longer clean adequately, the blades may be worn or cracked, and require replacement.

CAUTION

To prevent damage to the wiper arms or other components, do not attempt to move the wipers manually.

* NOTICE

The use of a non-specified wiper blade could result in wiper malfunction and failure.

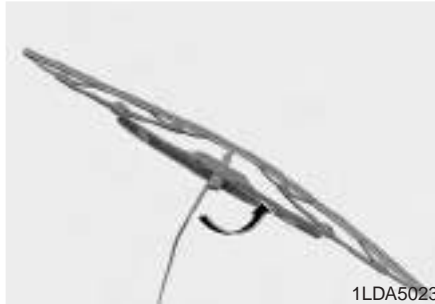

1. Raise the wiper arm and turn the wiper blade assembly to expose the plastic locking clip.

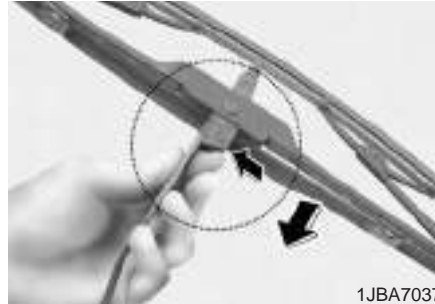

2. Compress the clip and slide the blade assembly downward.



3. Lift it off the arm.
4. Install the blade assembly in the reverse order of removal.

* NOTICE

Do not allow the wiper arm to fall against the windshield, since it may chip or crack the windshield.

BATTERY

WARNING - Battery dangers



Always read the following instructions carefully when handling a battery.



Keep lighted cigarettes and all other flames or sparks away from the battery.



Hydrogen, which is a highly combustible gas, is always present in battery cells and may explode if ignited.



Keep batteries out of the reach of children because batteries contain highly corrosive **SULFURIC ACID**. Do not allow battery acid to contact your skin, eyes, clothing or paint finish.

(Continued)

(Continued)



If any electrolyte gets into your eyes, flush your eyes with clean water for at least 15 minutes and get immediate medical attention. If possible, continue to apply water with a sponge or cloth until medical attention is received.

If electrolyte gets on your skin, thoroughly wash the contacted area. If you feel a pain or a burning sensation, get medical attention immediately.



Wear eye protection when charging or working near a battery. Always provide ventilation when working in an enclosed space.

(Continued)

(Continued)

- When lifting a plastic-cased battery, excessive pressure on the case may cause battery acid to leak, resulting in personal injury. Lift with a battery carrier or with your hands on opposite corners.
- Never attempt to charge the battery when the battery cables are connected.
- The electrical ignition system works with high voltage. Never touch these components with the engine running or the ignition switched on.

PROPOSITION 65 WARNING

Battery posts, terminals, and related accessories contain lead and lead compounds, chemicals known to the State of California to cause cancer and reproductive harm. Batteries also contain other chemicals known to the State of California to cause cancer. Wash hands after handling.

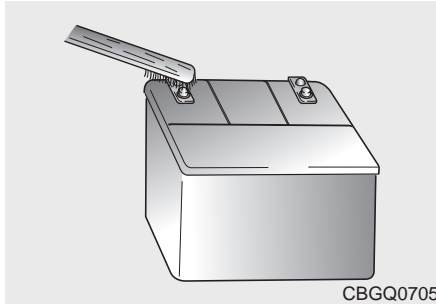

For best battery service :

- Keep the battery securely mounted.
- Keep the battery top clean and dry.
- Keep the terminals and connections clean, tight, and coated with petroleum jelly or terminal grease.
- Rinse any spilled electrolyte from the battery immediately with a solution of water and baking soda.
- If the vehicle is not going to be used for an extended time, disconnect the battery cables.

Battery recharging

Your vehicle has a maintenance-free, calcium-based battery.

- If the battery becomes discharged in a short time (because, for example, the headlights or interior lights were left on while the vehicle was not in use), recharge it by slow charging (trickle) for 10 hours.
- If the battery gradually discharges because of high electric load while the vehicle is being used, recharge it at 20-30A for two hours.

Items to be reset after the battery has been discharged or the battery has been disconnected.

- Driver seat position memory system (See Chapter 3)
- Power window (See Chapter 3)
- Clock (See Chapter 3)
- Climate control system (See Chapter 4)
- Audio (See Chapter 3)
- Sunroof (See Chapter 3)

* NOTICE

- Before performing maintenance or recharging the battery, turn off all accessories and stop the engine.
- The negative battery cable must be removed first and installed last when the battery is disconnected.

WARNING - Recharging battery

When recharging the battery, observe the following precautions:

- The battery must be removed from the vehicle and placed in an area with good ventilation.
- Do not allow cigarettes, sparks, or flame near the battery.
- Watch the battery during charging, and stop or reduce the charging rate if the battery cells begin gassing (boiling) violently or if the temperature of the electrolyte of any cell exceeds 120°F (49°C).
- Wear eye protection when checking the battery during charging.

(Continued)

(Continued)

- Disconnect the battery charger in the following order.
 1. Turn off the battery charger main switch.
 2. Unhook the negative clamp from the negative battery terminal.
 3. Unhook the positive clamp from the positive battery terminal.

TIRES AND WHEELS

⚠ WARNING

Speedometer and Odometer is calculated according to the tire size. Therefore, if you do not use the tire recommended for the vehicle, the calculation of the Speedometer and Odometer may be incorrect.



3GHA523

All specifications (sizes and pressures) can be found on a label attached to the vehicle.

TIRE AND LOADING INFORMATION		PNEUS ET CHARGE-INFORMATION	
SEATING CAPACITY		TOTAL X	FRONT X REAR X
NOMBRE DE SIÈGES		TOTAL X	AVANT X ARRIÈRE X
The combined weight of occupants and cargo should never exceed 300 kg or 660 lbs. Le poids combiné des occupants et du chargement ne doit jamais excéder 300 kg ou 660 lbs.			
TIRE / PNEU	SIZE / DIMENSION	COLD TIRE PRESSURE / PRESSION À FROID	SEE OWNER'S MANUAL FOR ADDITIONAL INFORMATION
FRONT / AVANT	PXXXXXXRXX	XXXkPa, XXpsi	CONSULTER LE GUIDE DU PROPRIÉTAIRE POUR OBTENIR DES RENSEIGNEMENTS ADDITIONNELS
REAR / ARRIÈRE	PXXXXXXRXX	XXXkPa, XXpsi	
SPARE / SECOURS	PXXXXXXRXX	XXXkPa, XXpsi	

OGH036905N

⚠ WARNING - Tire underinflation

Severe underinflation (10 psi (70 kPa) or more) can lead to severe heat build-up, causing blowouts, tread separation and other tire failures that can result in the loss of vehicle control leading to severe injury or death. This risk is much higher on hot days and when driving for protracted periods at high speeds.

Tire care

For proper maintenance, safety, and maximum fuel economy, you must always maintain recommended tire inflation pressures and stay within the load limits and weight distribution recommended for your vehicle.

Recommended cold tire inflation pressures

All tire pressures (including the spare) should be checked every day when the tires are cold. "Cold Tires" means the vehicle has not been driven for at least three hours or driven less than one mile (1.6 km).

Recommended pressures must be maintained for the best ride, top vehicle handling, and minimum tire wear.

*** NOTICE**

- Underinflation also results in excessive wear, poor handling and reduced fuel economy. Wheel deformation also is possible. Keep your tire pressures at the proper levels. If a tire frequently needs refilling, have it checked by an Authorized Kia Dealer.
- Overinflation produces a harsh ride, excessive wear at the center of the tire tread, and a greater possibility of damage from road hazards.

*** NOTICE**

- Warm tires normally exceed recommended cold tire pressures by 4 to 6 psi (28 to 41 kPa). Do not release air from warm tires to adjust the pressure or the tires will be underinflated.
- Be sure to reinstall the tire inflation valve caps. Without the valve cap, dirt or moisture could get into the valve core and cause air leakage. If a valve cap is missing, install a new one as soon as possible.

⚠ WARNING - Tire Inflation
Overinflation or underinflation can reduce tire life, adversely affect vehicle handling, and lead to sudden tire failure. This could result in loss of vehicle control and potential injury.

⚠ WARNING - Tire pressure
Always observe the following:

- Check tire pressure when the tires are cold. (After vehicle has been parked for at least three hours or hasn't been driven more than one mile (1.6 km) since startup.)
- Check the pressure of your spare tire each time you check the pressure of other tires.
- Never overload your vehicle. Be careful not to overload a vehicle luggage rack if your vehicle is equipped with one.
- Worn, old tires can cause accidents. If your tread is badly worn, or if your tires have been damaged, replace them.

Checking tire inflation pressure

Check your tires once a month or more.

Also, check the tire pressure of the spare tire.

How to check

Use a good quality gauge to check tire pressure. You can not tell if your tires are properly inflated simply by looking at them. Radial tires may look properly inflated even when they're underinflated.

Check the tire's inflation pressure when the tires are cold. - "Cold" means your vehicle has been sitting for at least three hours or driven no more than 1 mile (1.6 km).

Remove the valve cap from the tire valve stem. Press the tire gauge firmly onto the valve to get a pressure measurement. If the cold tire inflation pressure matches the recommended pressure on the tire and loading information label, no further adjustment is necessary. If the pressure is low, add air until you reach the recommended amount.

If you overfill the tire, release air by pushing on the metal stem in the center of the tire valve. Recheck the tire pressure with the tire gauge. Be sure to put the valve caps back on the valve stems. They help prevent leaks by keeping out dirt and moisture.

Tire rotation

To equalize tread wear, it is recommended that the tires be rotated every 7,500 miles (12,000 km) or sooner if irregular wear develops.

During rotation, check the tires for correct balance.

When rotating tires, check for uneven wear and damage. Abnormal wear is usually caused by incorrect tire pressure, improper wheel alignment, out-of-balance wheels, severe braking or severe cornering. Look for bumps or bulges in the tread or side of tire. Replace the tire if you find either of these conditions. Replace the tire if fabric or cord is visible. After rotation, be sure to bring the front and rear tire pressures to specification and check lug nut tightness.

Refer to Section 8, Specifications.

With a full-size spare tire

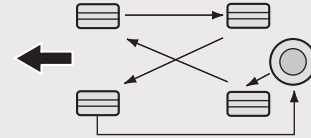

CBGQ0706

Without a spare tire

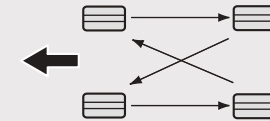

CBGQ0707

Directional tires (if equipped)

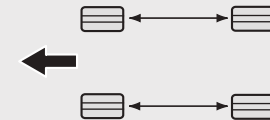

CBGQ0707A

Disc brake pads should be inspected for wear whenever tires are rotated.

Rotate radial tires that have an asymmetric tread pattern only from front to rear and not from right to left.

⚠ WARNING

- Do not use the temporary spare tire for tire rotation
- Do not mix bias ply and radial ply tires under any circumstances. This may cause unusual handling characteristics that could result in death, severe injury, or property damage.

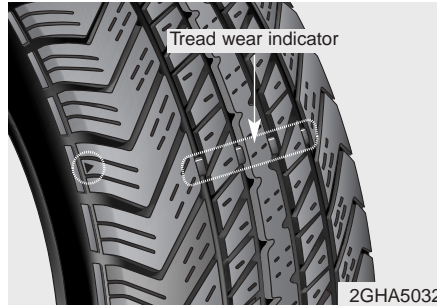

Tire replacement

If the tire is worn evenly, a tread wear indicator will appear as a solid band across the tread. This shows there is less than 1/16 inch (1.6 mm) of tread left on the tire. Replace the tire when this happens.

Do not wait for the band to appear across the entire tread before replacing the tire.

Wheel alignment and tire balance

The wheels on your vehicle were aligned and balanced carefully at the factory to give you the longest tire life and best overall performance.

In most cases, you will not need to have your wheels aligned again. However, if you notice unusual tire wear or your vehicle pulling one way or the other, the alignment may need to be reset.

If you notice your vehicle vibrating when driving on a smooth road, your wheels may need to be rebalanced.

*** NOTICE**

Improper wheel weights can damage your vehicle's aluminum wheels. Use only approved wheel weights.

⚠ WARNING - Replacing tires

- Driving on worn-out tires is very hazardous and will reduce braking effectiveness, steering accuracy, and traction.
- Your vehicle is equipped with tires designed to provide for safe ride and handling capability. Do not use a size and type of tire and wheel that is different from the one that is originally installed on your vehicle. It can affect the safety and performance of your vehicle, which could lead to handling failure or rollover and serious injury. When replacing the tires, be sure to equip all four tires with the tire and wheel of the same size, type, tread, brand and load-carrying capacity. If you nevertheless decide to equip your vehicle with any tire/wheel combination not recommended by Kia for off road driving, you should not use these tires for highway driving.

(Continued)

(Continued)

- The use of any other tire size or type may seriously affect ride, handling, ground clearance, stopping distance, body to tire clearance, snow tire clearance, and speedometer reliability.
- It is best to replace all four tires at the same time. If that is not possible, or necessary, then replace the two front or two rear tires as a pair. Replacing just one tire can seriously affect your vehicle's handling.
- The ABS works by comparing the speed of the wheels. Tire size can affect wheel speed. When replacing tires, all 4 tires must use the same size originally supplied with the vehicle. Using tires of a different size can cause the ABS (Antilock Brake System) and ESC (Electronic Stability Control) (If equipped) to work irregularly.

Wheel replacement

When replacing the metal wheels for any reason, make sure the new wheels are equivalent to the original factory units in diameter, rim width and offset.

⚠ WARNING

A wheel that is not the correct size may adversely affect wheel and bearing life, braking and stopping abilities, handling characteristics, ground clearance, body-to-tire clearance, snow chain clearance, speedometer calibration, headlight aim and bumper height.

Tire maintenance

In addition to proper inflation, correct wheel alignment helps to decrease tire wear. If you find a tire is worn unevenly, have your dealer check the wheel alignment.

When you have new tires installed, make sure they are balanced. This will increase vehicle ride comfort and tire life. Additionally, a tire should always be rebalanced if it is removed from the wheel.

Tire traction

Tire traction can be reduced if you drive on worn tires, tires that are improperly inflated or on slippery road surfaces. Tires should be replaced when tread wear indicators appear. To reduce the possibility of losing control, slow down whenever there is rain, snow or ice on the road.



Tire sidewall labeling

Federal law requires tire manufacturers to place standardized information on the sidewall of all tires. This information identifies and describes the fundamental characteristics of the tire and also provides the tire identification number (TIN) for safety standard certification. The TIN can be used to identify the tire in case of a recall.

1. *Manufacturer or brand name*

Manufacturer or Brand name is shown.

2. *Tire size designation*

A tire's sidewall is marked with a tire size designation. You will need this information when selecting replacement tires for your car. The following explains what the letters and numbers in the tire size designation mean.

Example tire size designation:

(These numbers are provided as an example only; your tire size designator could vary depending on your vehicle.)

P185/65R14 86H

P - Applicable vehicle type (tires marked with the prefix "P" are intended for use on passenger cars or light trucks; however, not all tires have this marking).

185 - Tire width in millimeters.

65 - Aspect ratio. The tire's section height as a percentage of its width.

R - Tire construction code (Radial).

14 - Rim diameter in inches.

86 - Load Index, a numerical code associated with the maximum load the tire can carry.

H - Speed Rating Symbol. See the speed rating chart in this section for additional information.

Wheel size designation

Wheels are also marked with important information that you need if you ever have to replace one. The following explains what the letters and numbers in the wheel size designation mean.

Example wheel size designation:

5.5JX14

5.5 - Rim width in inches.

J - Rim contour designation.

14 - Rim diameter in inches.

Tire speed ratings

The chart below lists many of the different speed ratings currently being used for passenger cars. The speed rating is part of the tire size designation on the sidewall of the tire. This symbol corresponds to that tire's designed maximum safe operating speed.

Speed Rating Symbol	Maximum Speed
S	112 mph (180 km/h)
T	118 mph (190 km/h)
H	130 mph (210 km/h)
V	149 mph (240 km/h)
Z	Above 149 mph (240 km/h)

3. Checking tire life (TIN : Tire Identification Number)

Any tires that are over 6 years, based on the manufacturing date, tire strength and performance, decline with age naturally (even unused spare tires). Therefore, the tires (including the spare tire) should be replaced by new ones. You can find the manufacturing date on the tire sidewall (possibly on the inside of the wheel), displaying the DOT Code. The DOT Code is a series of numbers on a tire consisting of numbers and English letters. The manufacturing date is designated by the last four digits (characters) of the DOT code.

DOT : XXXX XXXX OOOO

The front part of the DOT means a plant code number, tire size and tread pattern and the last four numbers indicate week and year manufactured.

For example:

DOT XXXX XXXX 1606 represents that the tire was produced in the 16th week of 2006.

⚠ WARNING

Tires degrade over time, even when they are not being used. Regardless of the remaining tread, it is recommended that tires generally be replaced after six (6) years of normal service. Heat caused by hot climates or frequent high loading conditions can accelerate the aging process. Failure to follow this warning can result in sudden tire failure, which could lead to a loss of control and an accident involving serious injury or death.

4. Tire ply composition and material

The number of layers or plies of rubber-coated fabric in the tire. Tire manufacturers also must indicate the materials in the tire, which include steel, nylon, polyester, and others. The letter "R" means radial ply construction; the letter "D" means diagonal or bias ply construction; and the letter "B" means belted-bias ply construction.

5. Maximum permissible inflation pressure

This number is the greatest amount of air pressure that should be put in the tire. Do not exceed the maximum permissible inflation pressure. Refer to the Tire and Loading Information label for recommended inflation pressure.

6. Maximum load rating

This number indicates the maximum load in kilograms and pounds that can be carried by the tire. When replacing the tires on the vehicle, always use a tire that has the same load rating as the factory installed tire.

7. Uniform tire quality grading

The following information relates to the tire grading system developed by the National Highway Traffic Safety Administration (NHTSA) for grading tires by tread wear, traction and temperature performance.

Tread wear

The tread wear grade is a comparative rating based on the wear rate of the tire when tested under controlled conditions on a specified government test course. For example, a tire graded 150 would wear one-and-a-half times as well on the government course as a tire graded 100.

The relative performance of tires depends upon the actual conditions of their use. However, performance may differ from the norm because of variations in driving habits, service practices and differences in road characteristics and climate.

These grades are molded on the side-walls of passenger vehicle tires. The tires available as standard or optional equipment on Kia vehicles may vary with respect to grade.

Traction - AA, A, B & C

The traction grades, from highest to lowest, are AA, A, B and C. The grades represent the tires ability to stop on wet pavement as measured under controlled conditions on specified government test surfaces of asphalt and concrete. A tire marked C may have poor traction performance.

Temperature -A, B & C

The temperature grades are A (the highest), B and C. The grades represent the tire's resistance to the generation of heat and its ability to dissipate heat when tested under controlled conditions on a specified indoor laboratory test wheel.

Sustained high temperature can cause the material of the tires to degenerate and reduce tires life, and excessive temperature can lead to sudden tires failure. Grade C corresponds to a level of performance which all passenger vehicle tires must meet under the Federal Motor Vehicle Safety Standard No. 109. Grades A and B represent higher levels of performance on the laboratory test wheel than the minimum required by the law.

WARNING - Tire temperature

The temperature grade for this tire is established for a tire that is properly inflated and not overloaded. Excessive speed, underinflation, or excessive loading, either separately or in combination, can cause heat build-up and possible sudden tire failure. This can cause loss of vehicle control and serious injury or death.

Tire terminology and definitions

Air Pressure: The amount of air inside the tire pressing outward on the tire. Air pressure is expressed in pounds per square inch (psi) or kilopascal (kPa).

Accessory Weight: This means the combined weight of optional accessories. Some examples of optional accessories are, automatic transmission, power seats, and air conditioning.

Aspect Ratio: The relationship of a tire's height to its width.

Belt: A rubber coated layer of cords that is located between the plies and the tread. Cords may be made from steel or other reinforcing materials.

Bead: The tire bead contains steel wires wrapped by steel cords that hold the tire onto the rim.

Bias Ply Tire: A pneumatic tire in which the plies are laid at alternate angles less than 90 degrees to the centerline of the tread.

Cold Tire Pressure: The amount of air pressure in a tire, measured in pounds per square inch (psi) or kilopascals (kPa) before a tire has built up heat from driving.

Curb Weight: This means the weight of a motor vehicle with standard and optional equipment including the maximum capacity of fuel, oil and coolant, but without passengers and cargo.

DOT Markings: A code molded into the sidewall of a tire signifying that the tire is in compliance with the U.S. Department of Transportation motor vehicle safety standards. The DOT code includes the Tire Identification Number (TIN), an alphanumeric designator which can also identify the tire manufacturer, production plant, brand and date of production.

GVWR: Gross Vehicle Weight Rating

GAWR FRT: Gross Axle Weight Rating for the front Axle.

GAWR RR: Gross Axle Weight Rating for the rear axle.

Intended Outboard Sidewall: The side of an asymmetrical tire, that must always face outward when mounted on a vehicle.

Kilopascal (kPa): The metric unit for air pressure.

Load Index: An assigned number ranging from 1 to 279 that corresponds to the load carrying capacity of a tire.

Maximum Inflation Pressure: The maximum air pressure to which a cold tire may be inflated. The maximum air pressure is molded onto the sidewall.

Maximum Load Rating: The load rating for a tire at the maximum permissible inflation pressure for that tire.

Maximum Loaded Vehicle Weight: The sum of curb weight; accessory weight; vehicle capacity weight; and production options weight.

Normal Occupant Weight: The number of occupants a vehicle is designed to seat multiplied by 150 pounds (68 kg).

Occupant Distribution: Designated seating positions.

Outward Facing Sidewall: The side of a asymmetrical tire that has a particular side that faces outward when mounted on a vehicle. The outward facing sidewall bears white lettering or bears manufacturer, brand, and/or model name molding that is higher or deeper than the same moldings on the inner facing sidewall.

Passenger (P-Metric) Tire: A tire used on passenger cars and some light duty trucks and multipurpose vehicles.

Recommended Inflation Pressure: Vehicle manufacturer's recommended tire inflation pressure and shown on the tire placard.

Radial Ply tire: A pneumatic tire in which the ply cords that extend to the beads are laid at 90 degrees to the centerline of the tread.

Rim: A metal support for a tire and upon which the tire beads are seated.

Sidewall: The portion of a tire between the tread and the bead.

Speed Rating: An alphanumeric code assigned to a tire indicating the maximum speed at which a tire can operate.

Traction: The friction between the tire and the road surface. The amount of grip provided.

Tread: The portion of a tire that comes into contact with the road.

Treadwear Indicators: Narrow bands, sometimes called "wear bars," that show across the tread of a tire when only 2/32 inch of tread remains.

UTQGS: Uniform Tire Quality Grading Standards, a tire information system that provides consumers with ratings for a tire's traction, temperature and treadwear. Ratings are determined by tire manufacturers using government testing procedures. The ratings are molded into the sidewall of the tire.

Vehicle Capacity Weight: The number of designated seating positions multiplied by 150 lbs. (68 kg) plus the rated cargo and luggage load.

Vehicle Maximum Load on the Tire: Load on an individual tire due to curb and accessory weight plus maximum occupant and cargo weight.

Vehicle Normal Load on the Tire: That load on an individual tire that is determined by distributing to each axle its share of the curb weight, accessory weight, and normal occupant weight and driving by 2.

Vehicle Placard: A label permanently attached to a vehicle showing the original equipment tire size and recommended inflation pressure.

All season tires

Kia specifies all season tires on some models to provide good performance for use all year round, including snowy and icy road conditions. All season tires are identified by ALL SEASON and/or M+S (Mud and Snow) on the tire sidewall. Snow tires have better snow traction than all season tires and may be more appropriate in some areas.

Summer tires

Kia specifies summer tires on some models to provide superior performance on dry roads. Summer tire performance is substantially reduced in snow and ice. Summer tires do not have the tire traction rating M+S (Mud and Snow) on the tire side wall. If you plan to operate your vehicle in snowy or icy conditions, Kia recommends the use of snow tires or all season tires on all four wheels.

Snow tires

If you equip your car with snow tires, they should be the same size and have the same load capacity as the original tires. Snow tires should be installed on all four wheels; otherwise, poor handling may result.

Snow tires should carry 4 psi (28 kPa) more air pressure than the pressure recommended for the standard tires on the tire label on the driver's side of the center pillar, or up to the maximum pressure shown on the tire sidewall, whichever is less.

Do not drive faster than 75 mph (120 km/h) when your car is equipped with snow tires.

Tire chains

Tire chains, if necessary, should be installed on the drive wheels (front wheel).

Be sure that the chains are installed in accordance with the manufacturer's instructions.

To minimize tire and chain wear, do not continue to use tire chains when they are no longer needed.

WARNING - Snow or ice

- **When driving on roads covered with snow or ice, drive at less than 20 mph (30 km/h).**
- **Use the SAE "S" class or wire chains.**
- **Do not use tire chains on vehicles equipped with aluminum wheels. In unavoidable circumstance, use a wire type chain.**
- **Use wire chains less than 15mm to prevent damage to the chain's connection.**

*** NOTICE**

- **If you hear noise caused by chains contacting the body, retighten the chain to avoid contact with the vehicle body.**
- **To prevent body damage, retighten the chains after driving 0.3 ~ 0.6 miles (0.5 ~ 1.0 km).**

BULB REPLACEMENT

⚠ WARNING - Working on the lights

Prior to working on the light, firmly apply the parking brake and ensure that the ignition switch is turned to the "LOCK" position to avoid sudden movement of the vehicle and burning your fingers or receiving an electric shock.

Use only the bulbs of the specified wattage.

⚠ CAUTION

If you don't have necessary tools, the correct bulbs and the expertise, consult an Authorized Kia Dealer. In many cases, it is difficult to replace vehicle light bulbs because other parts of the vehicle must be removed before you can get the bulb. Especially if you must remove the front bumper to replace the light bulbs in the front of the vehicle. This may result in damage to the vehicle.

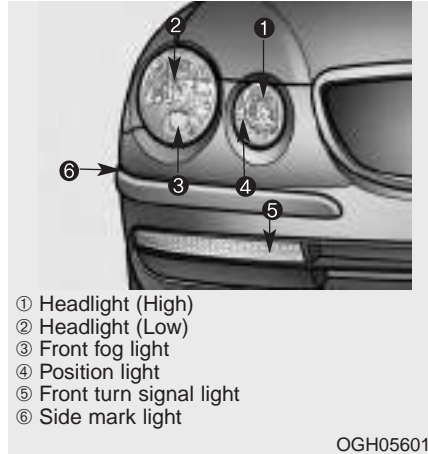

Headlight bulb replacement

* NOTICE

After heavy, driving rain or washing, headlight and taillight lenses could appear frosty. This condition is caused by the temperature difference between the lamp inside and outside. This is similar to the condensation on your windows inside your vehicle during the rain and doesn't indicate a problem with your vehicle. If the water leaks into the lamp bulb circuitry, have the vehicle checked by an Authorized Kia Dealer.



⚠ WARNING - Halogen bulbs

- Halogen bulbs contain pressurized gas that will produce flying pieces of glass if broken.
- Always handle them carefully, and avoid scratches and abrasions. If the bulbs are lit, avoid contact with liquids. Never touch the glass with bare hands. Residual oil may cause the bulb to overheat and burst when lit. A bulb should be operated only when installed in a headlight.

(Continued)

(Continued)

- If a bulb becomes damaged or cracked, replace it immediately and carefully dispose of it.
- Wear eye protection when changing a bulb. Allow the bulb to cool down before handling it.

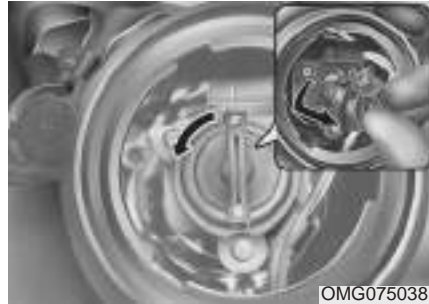

1. Open the hood.
2. Remove the engine compartment shroud.
3. Remove the headlight bulb cover by turning it counterclockwise.
4. Disconnect the headlight bulb assembly by turning it counterclockwise.
5. Install a new headlight bulb assembly.
6. Install the headlight bulb cover by turning it clockwise.

Headlight (HID type), position and front fog light, turn signal light and side mark light bulb replacement

If the light bulb is not operating, have the vehicle checked by an authorized Kia Dealer.

⚠ WARNING - HID Headlight low beam (if equipped)

Do not attempt to replace or inspect the low beam (XENON bulb) due to electric shock danger. If the low beam (XENON bulb) is not working, have your vehicle checked by an Authorized Kia Dealer.

* HID : High Intensity Discharge

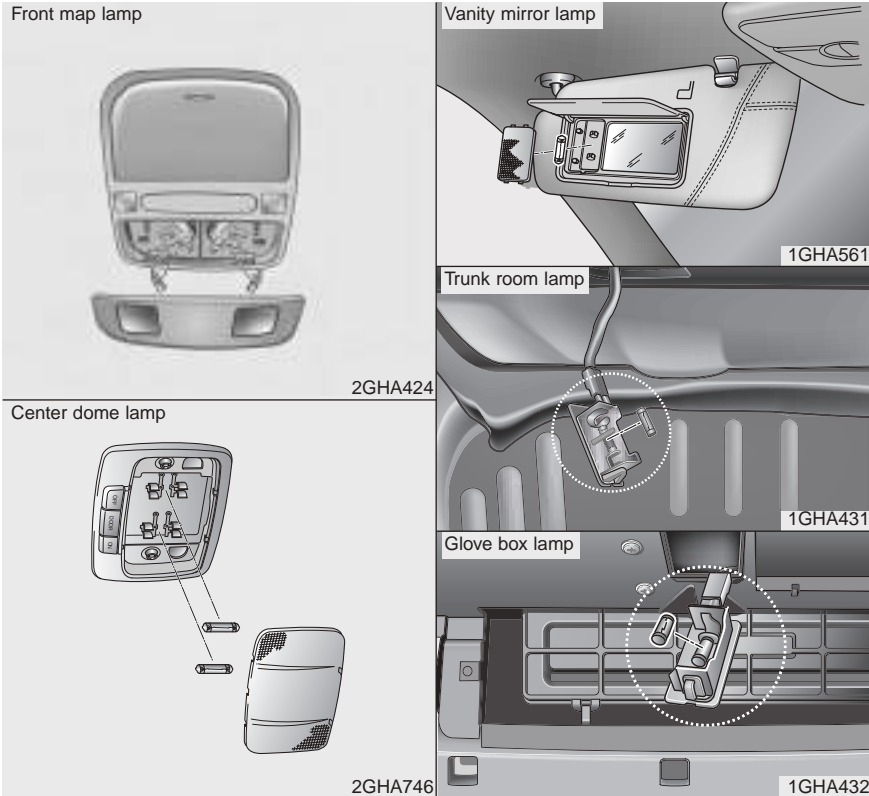

Interior light bulb replacement

1. Using a flat-blade screwdriver, gently pry the lens from the interior light housing.

⚠ WARNING - HID Headlight low beam (if equipped)

Prior to working on the Interior Lights, ensure that the "OFF" button is depressed to avoid burning your fingers or receiving an electric shock.

2. Remove the bulb by pulling it straight out.
3. Install a new bulb.
4. Align the lens tabs with the interior light housing notches and snap the lens into place.

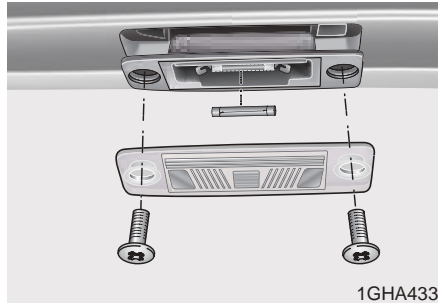

License plate light bulb replacement

1. Loosen the lens retaining screws with a cross-tip screwdriver.
2. Remove the lens.
3. Remove the bulb by pulling it straight out.
4. Install a new bulb.
5. Reinstall the lens securely with the lens retaining screws.

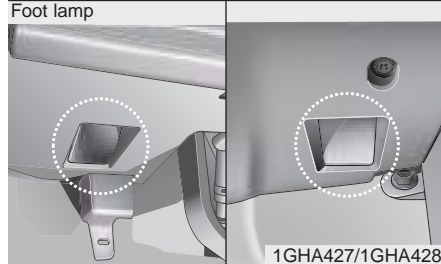
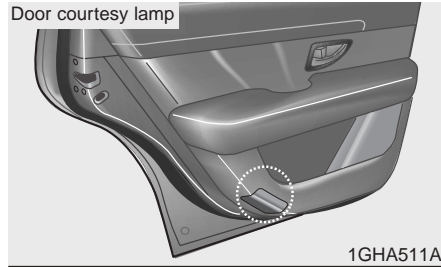

Door courtesy and foot lamp bulb replacement

If the light bulb is not operating, have the vehicle checked by an authorized Kia Dealer.

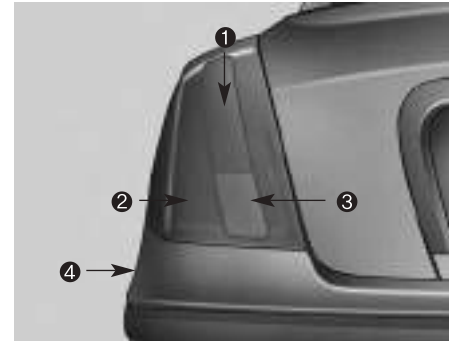

- ① Rear turn signal light
- ② Stop and tail light
- ③ Back-up light
- ④ Side marker

OGH056017

Rear combination light bulb replacement

1. Open the trunk lid.



OGH056018

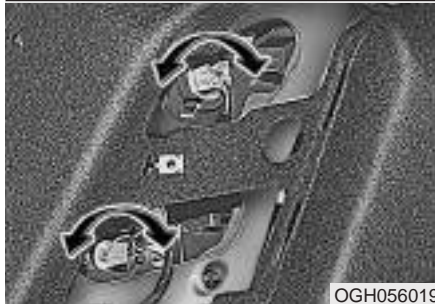

OGH056019

2. Remove the service cover by turning the plastic screw counterclockwise and removing the cover.
3. Remove the socket from the assembly by turning the socket counterclockwise until the tabs on the socket align with the slots on the assembly.



OGH056020

4. Remove the bulb from the socket by pressing it in and rotating it until the tabs on the bulb align with the slots in the socket. Pull the bulb out of the socket.
5. Insert a new bulb by inserting it into the socket and rotating it until it locks into place.
6. Install the socket in the assembly by aligning the tabs on the socket with the slots in the assembly. Push the socket into the assembly and turn the socket clockwise.
7. Replace the service cover and tighten the screw.

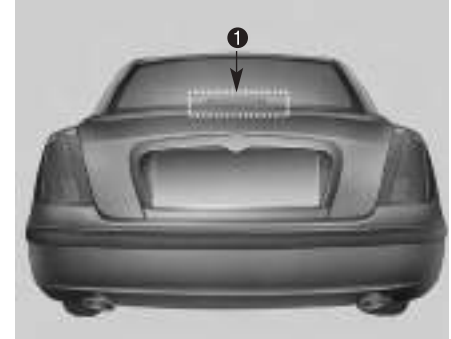

① High mounted stop light

OGH056021

High mounted stop light bulb replacement

If the light bulb is not operating, have the vehicle checked by an authorized Kia Dealer.

LUBRICANT SPECIFICATIONS

Recommended lubricants

To help achieve proper engine and powertrain performance and durability, use only lubricants of the proper quality. The correct lubricants also help promote engine efficiency that results in improved fuel economy.

Engine oils labeled Energy Conserving Oil are now available. Along with other additional benefits, they contribute to fuel economy by reducing the amount of fuel necessary to overcome engine friction. Often, these improvements are difficult to measure in everyday driving, but in a year's time, they can offer significant cost and energy savings.

These lubricants and fluids are recommended for use in your vehicle.

Lubricant	Classification
Engine oil *1	API Service SL or above, ILSAC GF-3 or above
Automatic transaxle fluid	DIAMOND ATF SP-III or SK ATF SP-III or other brands meeting the SP-III specification approved by Kia Motors Corp.
Power steering fluid	PSF-IV
Brake fluid	FMVSS116 DOT-3 or DOT-4

*1 Refer to the recommended SAE viscosity numbers on the next page.

Recommended SAE viscosity number

CAUTION

Always be sure to clean the area around any filler plug, drain plug, or dipstick before checking or draining any lubricant. This is especially important in dusty or sandy areas and when the vehicle is used on unpaved roads. Cleaning the plug and dipstick areas will prevent dirt and grit from entering the engine and other mechanisms that could be damaged.

Engine oil viscosity (thickness) has an effect on fuel economy and cold weather operating (starting and oil flow). Lower viscosity engine oils can provide better fuel economy and cold weather performance, however, higher viscosity engine oils are required for satisfactory lubrication in hot weather. Using oils of any viscosity other than those recommended could result in engine damage.

When choosing an oil, consider the range of temperature your vehicle will be operated in before the next oil change. Proceed to select the recommended oil viscosity from the chart.

		Temperature Range for SAE Viscosity Numbers									
Temperature	°C	-30	-20	-10	0	10	20	30	40	50	
	(°F)	-10	0	20	40	60	80	100	120		
Gasoline Engine Oil *1		10W-30									
		5W-20, 5W-30									

1. For better fuel economy, it is recommended to use the engine oil of a viscosity grade SAE 5W-20,5W-30 (API SL / ILSAC GF-3). However, the engine oil is not available in your country, select the proper engine oil using the engine oil viscosity chart.

EXTERIOR CARE

Exterior general caution

It is very important to follow the label directions when using any chemical cleaner or polish. Read all warning and caution statements that appear on the label.

Finish maintenance

Washing

To help protect your vehicle's finish from rust and deterioration, wash it thoroughly and frequently at least once a month with lukewarm or cold water.

If you use your vehicle for off-road driving, you should wash it after each off-road trip. Pay special attention to the removal of any accumulation of salt, dirt, mud, and other foreign materials. Make sure the drain holes in the lower edges of the doors and rocker panels are kept clear and clean.

Insects, tar, tree sap, bird droppings, industrial pollution and similar deposits can damage your vehicle's finish if not removed immediately.

Even prompt washing with plain water may not completely remove all these deposits. A mild soap, safe for use on painted surfaces, may be used.

After washing, rinse the vehicle thoroughly with lukewarm or cold water. Do not allow soap to dry on the finish.

CAUTION

Do not use strong soap, chemical detergents or hot water, and do not wash the vehicle in direct sunlight or when the body of the vehicle is warm.

WARNING

After washing the vehicle, test the brakes while driving slowly to see if they have been affected by water. If braking performance is impaired, dry the brakes by applying them lightly while maintaining a slow forward speed.



CAUTION

- *Water washing in the engine compartment including high pressure water washing may cause the failure of electrical circuits located in the engine compartment.*
- *Never allow water or other liquids come in contact with electrical/electronic components inside the vehicle as this may damage them.*

Waxing

Wax the vehicle when water will no longer bead on the paint.

Always wash and dry the vehicle before waxing. Use a good quality liquid or paste wax, and follow the manufacturer's instructions. Wax all metal trim to protect it and to maintain its luster.

Removing oil, tar, and similar materials with a spot remover will usually strip the wax from the finish. Be sure to re-wax these areas even if the rest of the vehicle does not yet need waxing.

*** NOTICE**

- Wiping dust or dirt off the body with a dry cloth will scratch the finish.
- Do not use steel wool, abrasive cleaners, or strong detergents containing highly alkaline or caustic agents on chrome-plated or anodized aluminum parts. This may result in damage to the protective coating and cause discoloration or paint deterioration.

Finish damage repair

Deep scratches or stone chips in the painted surface must be repaired promptly. Exposed metal will quickly rust and may develop into a major repair expense.

*** NOTICE**

If your vehicle is damaged and requires any metal repair or replacement, be sure the body shop applies anti-corrosion materials to the parts repaired or replaced.

Bright-metal maintenance

- To remove road tar and insects, use a tar remover, not a scraper or other sharp object.
- To protect the surfaces of bright-metal parts from corrosion, apply a coating of wax or chrome preservative and rub to a high luster.
- During winter weather or in coastal areas, cover the bright metal parts with a heavier coating of wax or preservative. If necessary, coat the parts with non-corrosive petroleum jelly or other protective compound.

Underbody maintenance

Corrosive materials used for ice and snow removal and dust control may collect on the underbody. If these materials are not removed, accelerated rusting can occur on underbody parts such as the fuel lines, frame, floor pan and exhaust system, even though they have been treated with rust protection.

Thoroughly flush the vehicle underbody and wheel openings with lukewarm or cold water once a month, after off-road driving and at the end of each winter. Pay special attention to these areas because it is difficult to see all the mud and dirt. It will do more harm than good to wet down the road grime without removing it. The lower edges of doors, rocker panels, and frame members have drain holes that should not be allowed to clog with dirt; trapped water in these areas can cause rusting.

WARNING

After washing the vehicle, test the brakes while driving slowly to see if they have been affected by water. If braking performance is impaired, dry the brakes by applying them lightly while maintaining a slow forward speed.

Aluminum wheel maintenance

The aluminum wheels are coated with a clear protective finish.

- Do not use any abrasive cleaner, polishing compound, solvent, or wire brushes on aluminum wheels. They may scratch or damage the finish.
- Use only a mild soap or neutral detergent, and rinse thoroughly with water. Also, be sure to clean the wheels after driving on salted roads. This helps prevent corrosion.
- Avoid washing the wheels with high-speed car wash brushes.
- Do not use any acid detergent. It may damage and corrode the aluminum wheels coated with a clear protective finish.

INTERIOR CARE

Interior general precautions

Prevent caustic solutions such as perfume and cosmetic oil from contacting the dashboard because they may cause damage or discoloration. If they do contact the dashboard, wipe them off immediately. See the instructions that follow for the proper way to clean vinyl.

Cleaning the upholstery and interior trim

Vinyl

Remove dust and loose dirt from vinyl with a whisk broom or vacuum cleaner. Clean vinyl surfaces with a vinyl cleaner.

Fabric

Remove dust and loose dirt from fabric with a whisk broom or vacuum cleaner. Clean with a mild soap solution recommended for upholstery or carpets. Remove fresh spots immediately with a fabric spot cleaner. If fresh spots do not receive immediate attention, the fabric can be stained and its color can be affected. Also, its fire-resistant properties can be reduced if the material is not properly maintained.

CAUTION

Using anything but recommended cleaners and procedures may affect the fabric's appearance and fire-resistant properties.

Cleaning the lap/shoulder belt webbing

Clean the belt webbing with any mild soap solution recommended for cleaning upholstery or carpet. Follow the instructions provided with the soap. Do not bleach or re-dye the webbing because this may weaken it.

Cleaning the interior window glass

If the interior glass surfaces of the vehicle become fogged (that is, covered with an oily, greasy or waxy film), they should be cleaned with glass cleaner. Follow the directions on the glass cleaner container.

*** NOTICE**

Do not scrape or scratch the inside of the rear window. This may result in damage to the rear window defroster grid.

CALIFORNIA PERCHLORATE NOTICE

Perchlorate Material-special handling may apply, See www.dtsc.ca.gov/hazardouswaste/perchlorate.

Notice to California Vehicle Dismantlers:
Perchlorate containing materials, such as airbag inflators, seatbelt pretensioners and keyless remote entry batteries, must be disposed of according to Title 22 California Code of Regulations Section 67384.10 (a).

Specifications / 8-2

Specifications

8

SPECIFICATIONS

The specifications given here are for general information only. Although this information was accurate at the time of printing, Kia reserves the right to change its vehicles or their specifications without notice. Please check with an authorized Kia dealer for more precise and more up-to-date information.

Dimensions

Item	in (mm)
Overall length	196.9 (5,000)
Overall width	72.8 (1,850)
Overall height	58.5 (1,485)
Front tread	62.4 (1,585)
Rear tread	62.6 (1,590)
Wheelbase	110.2 (2,800)

Light Bulbs

Light Bulb	Wattage
Headlight (High)	55
Headlight (Low)	55 or 35 ¹⁾
Front turn signal lights (LED type)	14.5
Position lights	5
Side mark lights	5
Front fog lights (if equipped)	55
Stop and tail lights	27/8
Rear turn signal lights	28
Back-up lights	18
High mounted stop light (LED type)	2.5
License plate lights	5
Front map lamp	8 or 10 ²⁾
Center dome lamp	10
Door courtesy lamps	5
Vanity mirror lamps	1.5
Trunk room lamp	5
Foot lamp	5
Glove box lamp	5

¹⁾ HID(High Intensity Discharge) type

²⁾ Sunroof type

Tires

Item		Recommended Cold Tire Inflation Pressure psi (kPa)	Wheel lug nut torque lb-ft (kg-m, N-m)
Tire	Wheel		
Full size tire			
P235/55 R 17	6.5Jx17	30 (210)	65~79 (9~11, 88~107)
P225/60 R 16	6.5Jx16	30 (210)	65~79 (9~11, 88~107)
Compact spare tire			
T125/80D16		60 (420)	65~79 (9~11, 88~107)

Capacities

Lubricant	Volume	Classification
Engine oil ^{*1} (with filter change)	5.49 US qt. (5.2 l)	API Service SL or above, ILSAC GF-3 or above
Transaxle fluid	11.5 US qt. (10.9 l)	DIAMOND ATF SP-III or SK ATF SP-III or other brands meeting the SP-III specification approved by Kia Motors Corp.
Power steering	1.1 US qt. (1.0 l)	PSF-IV
Coolant	9.2 US qt. (8.7 l)	Ethylene glycol base for aluminum radiator
Brake fluid	0.7~0.8 US qt. (0.7~0.8 l)	FMVSS116 DOT-3 or DOT-4
Fuel	18.5 US gal (70 l)	Unleaded gasoline with AKI 87 or higher

*1 Refer to the recommended SAE viscosity numbers on the page 7-47.

Toll free assistance / 9-2

Emergency roadside assistance / 9-2

Trip interruption / 9-3

Registering your vehicle in a foreign country / 9-3

Electrical equipment / 9-4

Reporting safety defects / 9-5

Purchasing factory authorized manuals / 9-6

CONSUMER ASSISTANCE (U.S. ONLY)

Roadside Assistance is provided on all new current model year Kia Vehicles from the date the vehicle is delivered to the first retail buyer or otherwise put into use (in-service date), whichever is earlier, for a period of 60 months or 60,000 miles, whichever is earlier, subject to the terms, conditions and exclusions set forth in the Kia Warranty and Consumer Information Guide applicable to your model year vehicle.

KMA reserves the right to limit or deny services or other benefits to any owner or driver when, in KMA's judgment, the claims and/or service requests are excessive in frequency or type of occurrence.

Toll Free Consumer Assistance

Kia's toll-free Consumer Assistance hot line is staffed from 5:00 AM to 6:00 PM PST, Monday through Friday and is accessible by dialing 1-800-333-4Kia (4542).

For more information regarding assistance available, please refer to your Kia Warranty & Consumer Information Manual.

Emergency Roadside Assistance

Kia's toll free Roadside Assistance hot line is staffed 24 hours a day, 365 days a year and is accessible by dialing 1-800-333-4Kia (4542).

Please note that you must provide your Vehicle Identification Number (VIN) to verify coverage at the time of your call. The VIN can be found on the dash of your vehicle on the driver's side, on the door jamb of the driver's door, your vehicle's registration or proof of insurance card.

Kia utilizes a network of over 17,000 roadside assistance providers. Should you accidentally run out of fuel, require a battery jump, or need help changing a tire, a Kia Roadside Assistance Representative will dispatch someone to deliver a small quantity of gas, change a flat tire with your inflated spare, or arrange a battery jump to allow you to proceed to your destination. We have access to a network of over 10,000 locksmiths to help you should you become locked out of your Kia, also at no charge.

In the event that mechanical difficulty renders your vehicle undriveable due to a warranty-related concern, Kia's Roadside Assistance Representative will arrange to transport your vehicle to the nearest Kia dealer or to an alternative service location.

Your vehicle must be accessible to our dispatch transport vehicle, as determined by our driver, to receive this service. In the event that Kia does not have a dealer or an alternative service location available in a particular location, Kia will work with a reputable local service facility to ensure that you receive prompt service. Warranty repairs are performed.

*** NOTICE**

Roadside Assistance benefits are not available for any Kia vehicle that has ever been or should be issued a "salvage" title or similar "branded" title under any state's law or has been declared a "total loss" or equivalent by a financial institution or insurance company.

Trip Interruption

Trip interruption expense benefits are provided in the event that a warranty-related disablement occurs more than 150 miles from your home, and the repairs require more than 24 hours to complete. Reasonable reimbursement is included for meals, lodging, or rental car expenses. Trip interruption coverage is limited to \$100 per day subject to a three day maximum limit per incident. You must contact the Kia Roadside Assistance Center to obtain pre-authorization of expenses. Once the Kia Roadside Assistance Center gives authorization for trip interruption benefits, they will assist you in making the necessary arrangements. Insurance deductibles, expenses, and claims paid by your insurance company or other providers are not eligible for reimbursement.

Fleet vehicles are excluded from reimbursement under Kia's Trip Interruption Policy.

Registering Your Vehicle in a Foreign Country

If you plan to register your vehicle in a foreign country, you should confirm that it conforms to the regulations in that country. Even if you successfully register the vehicle in a foreign country, you may experience the following problems and should therefore consider the possibility of having to deal with them:

1. The fuel specified for your vehicle may be unavailable. If other than the specified fuel is used, it could cause damage to the engine, the fuel injection system, and other fuel-related parts which may not be covered under your New Vehicle Emissions Limited Warranty.
2. We must, therefore, clearly state that when you leave the country in which you purchased your Kia as a new and register it in another country, problems arising from the use of fuel other than the specified fuel are not subject to manufacturer's warranty. Because vehicles like yours may not be marketed in the new country of registration, parts, servicing techniques and tools necessary to maintain and repair your vehicle may be unavailable.
Even if vehicles like yours are sold there, mechanical specifications required by the government may vary enough from the country of purchase to cause additional problems.
3. There may not be an Authorized Kia Dealer in the area in which you plan to register your vehicle. You may additionally experience difficulty in obtaining services in a foreign country for any number of reasons.

Further, we cannot assume any responsibility for problems that result from unsatisfactory service or lack of service outside of the United States.

ELECTRICAL EQUIPMENT (U.S. ONLY)

The electrical system of your vehicle is designed to perform under all reasonably expected operating conditions. However, before any additional electrical equipment is installed in your vehicle, consult an Authorized Kia Dealer, in order to ensure that you do not void your warranty.

Certain electrical equipment, or the way in which it is installed, may adversely affect the operation of your vehicle, including such systems as the engine control system, the audio system and the electrical charging system and thus potentially void all or part of your warranty.

We assume no responsibility for any expense you may incur or for any malfunction of your vehicle or any of its components or systems that may result from the installation of additional electrical equipment that is not supplied, or recommended for installation by, Kia.

Installation of a Mobile Two-Way Radio System

If a mobile two-way radio system is installed improperly, or if an excessively powerful type of system is used, other electronic systems may be adversely affected. To avoid damage to your vehicle, consult an Authorized Kia Dealer concerning the proper equipment and installation.

Kia motor vehicles are designed and manufactured to meet or exceed all applicable safety standards.

For your safety, however, we strongly urge you to read and follow all directions in this Owner's Manual, particularly the information under the headings "NOTICE", "CAUTION" and "WARNING".

If, after reading this manual, you have any questions regarding the operation of your vehicle, safety issues and defects please contact Kia's toll-free Consumer Assistance hot line as below:

National Consumer Affairs Manager
Kia Motors America, Inc.
P.O. Box 52410
Irvine, CA 92619-2410
1-800-333-4Kia (4542)

REPORTING SAFETY DEFECTS (U.S. ONLY)

If you believe that your vehicle has a defect which could cause a crash or could cause injury or death, you should immediately inform the National Highway Traffic Safety Administration (NHTSA) in addition to notifying Kia Motors America, Inc.

If NHTSA receives similar complaints, it may open an investigation, and if it finds that a safety defect exists in a group of vehicles, it may order a recall and remedy campaign. However, NHTSA cannot become involved in individual problems between you, your dealer, or Kia Motors America, Inc.

To contact NHTSA, you may call the Vehicle Safety Hotline toll-free at 1-888-327-4236 (TTY: 1-800-424-9153); go to <http://www.safercar.gov>; or write to: Administrator, NHTSA, 400 Seventh Street, SW., Washington, DC 20590. You can also obtain other information about motor vehicle safety from <http://www.safercar.gov>.

PURCHASING FACTORY AUTHORIZED MANUALS (U.S. ONLY)

The following publications can be ordered by calling the toll-free phone number 1-866-542-6268. Publications for the previous years may also be obtained by calling the same number.

Publication Part Number	Form Description
UH090 PS 010	2009 Kia Amanti Service Repair Manual
UH090 PS 011	2009 Kia Amanti Electrical Troubleshooting Manual
UH090 PS 013	2009 Kia Amanti Owner's Manual

Valid only for sales within the U.S.. Canadian owners should contact their Authorized Kia Dealer.

ORDER TOLL FREE: 1-866-542-6268
(NOTE: For Credit Card Holder Orders Only)
Monday-Friday 8:00 A.M. - 6:00 P.M. EST
MINIMUM CREDIT CARD PURCHASE \$10.00

Service manual:

This manual covers maintenance and recommended procedures for repair to engine and chassis components. It is written for the Journeyman mechanic, but is simple enough for most mechanically-inclined owners to understand.

Electrical troubleshooting manual:

This manual complements the Service Manual by providing in-depth troubleshooting information for each electrical circuit in your vehicle.

Owner's manual:

This manual describes the overall features and operating procedures for the vehicle.

A

Air Bags - Advanced Supplemental Restraint System ···3-52

Air Bag

- Curtain ·········3-65
- Driver's ·········3-57
- Front Passenger's ·········3-58
- Side ·········3-64
- Warning Light ·········3-73, 4-35

Air Cleaner ·········7-21

Air Conditioning

- Button ·········4-53
- System Operation Tips ·········4-54

Air Intake Control Button ·········4-49

Alignment, Tire Balance and Wheel ·········7-32

Aluminum Wheel Maintenance ·········7-50

Antenna ·········3-98

Anti-Lock Brake System ·········4-15

- Warning Light ·········4-31

Anti-Theft Steering Column Lock,

- Ignition Switch and ·········4-2

Ashtray ·········3-91

Audio

- Remote Control ·········3-99
- Systems ·········3-100

Automatic

- Climate Control System ·········4-46
- Transaxle ·········4-5, 7-18
- Transaxle Fluid Level, Checking the ·········7-18

B

Balance, Wheel Alignment and Tire ·········7-32

Battery ·········7-26

- Recharging ·········7-27
- Service, For Best ·········7-27

Before Driving ·········5-5

Belts,

- Safety ·········3-30
- Pre-tensioner, seat ·········3-30

Blade Replacement, Windshield Wiper ·········7-24

Blades, Wiper ·········7-24

Body Lubrication ·········7-20

Brake

- Fluid Level, Checking ·········7-16
- Parking ·········4-13
- System ·········4-10
- System, Anti-Lock ·········4-15
- Wear Indicators, Disc ·········4-11

Brakes ·········7-16

- Power ·········4-10
- Trailer ·········5-21

Break-In Process, Vehicle ·········1-3

Bulb Replacement ·········7-41

Bulbs, Light ·········8-2

C

- California Perchlorate Notice 7-52
- Capacities8-3
- Care
 - of the Safety Belt System, Proper Use and3-40
 - Exterior7-48
 - Interior7-51
- Catalytic Converters, Operating Precautions for5-4
- Chain
 - Installation5-11
 - Safety5-21
 - Tire5-10
- Charging System Warning4-32
- Child
 - Restraint System3-43
 - Safety Lock, Rear Door3-12
- Children
 - Restraint of Infants and Small3-41
 - Restraint of Larger3-42
- Cigarette Lighter3-91
- Cleaner, Air7-21
- Cleaning
 - Interior Window Glass7-51
 - Lap/Shoulder Belt Webbing7-51
 - Upholstery and Interior Trim7-51
- Climate Control System, Automatic4-46
 - Air Filter7-22
- Clock3-95

- Cluster, Instrument4-25
- Compartment, Engine2-4, 7-12
- Consumer Assistance9-2
- Coolant Level, Checking the7-14
- Cooling System, Engine7-14
- Cruise Control System4-19
- Cup Holder3-92

D

- Day/Night Rearview Mirror3-86
- Defroster4-44
 - Rear Window4-44
- Dimensions8-2
- Disc Brake Wear Indicators4-11
- Dome Light3-88
- Door
 - Child Safety Lock, Rear3-12
 - Courtesy Lamp3-88
 - Locks3-9
 - Open Display4-34
- Driver Position Memory System3-28
- Driving
 - at Night5-8
 - Conditions, Special5-7
 - Conditions, Hazardous5-7
 - in Flooded Areas5-12
 - in the Rain5-8
 - Tips5-1

your Vehicle	4-1
Winter	5-9
with a Trailer	5-21
Economical Operation, Suggestions for	5-6

E

Electrical	
Circuit Protection	6-6
Equipment	9-4
Electronic Stability Control	4-22
Emergency	
In Case of an	6-1
Roadside Assistance	9-2
Starting	6-4
Emission Control System	5-3
Engine	
Compartment	2-4, 7-12
Cooling System	7-14
Exhaust Gas Precautions	5-3
Oil and Oil Filter	7-13
Oil Level, Checking the	7-13
Oil Pressure Warning	4-32
Starting the	4-4
Exhaust Gas Precautions, Engine	5-3
Exterior Care	7-48

F

Fan Speed Control Knob	4-49
Filler Lid, Fuel	3-81
Finish	
Damage Repair	7-49
Maintenance	7-48
Flasher, Hazard Warning	4-45
Flat Tire, If You Have a	6-22
Flooded Areas, Driving in	5-12
Fluids, Lubricants and	7-20
Fuel	
Filler Lid	3-81
Gauge	4-27
Level Warning, Low	4-34
Requirements	5-2
Fuse/Relay Panel Description	6-9
Fuses	6-7
Driver-side Knee Bolster	6-11
Engine Compartment	6-10
Replacement	6-7

G

Gasoline	
Engine (unleaded)	5-2
Containing Alcohol and Methanol	5-2

Glove Box3-90

H

Hazard Warning Flasher4-45, 6-2

Hazardous Driving conditions5-7

Headlight

 High Beam Indicator4-34

 Bulb Replacement7-41

Headrest Adjustment3-24, 3-26

Hitches5-20

Homelink Wireless Control System5-27

Hood3-80

Horn4-18

How To Use This Manual1-2

I

If You Have a Flat Tire6-22

Ignition Switch4-2

 and Anti-Theft Steering Column Lock4-2

Illumination, Instrument Panel4-27

Immobilizer System3-7

In case of an emergency while driving6-2

Indicators, Warnings and4-32

Infants and Small Children, Restraint of3-41

Inspections, Necessary5-5

Instrument

 Cluster4-25

 Panel Illumination4-27

 Panel Overview2-3

Interior

 Care7-51

 Features3-91

 Lights3-88

 Overview2-2

 Trim, Cleaning the Upholstery and7-51

 Window Glass, Cleaning the7-51

Intermittent Wipers, Variable4-42

J

Jacking Instructions6-24

Jump Starting6-4

K

Keyless Entry, Remote3-4

Key Reminder Warning Chime4-36

Keys3-2

Knowing Your Vehicle3-1

L

Label
 Information5-25
 Tire Specification/Pressure.....5-26
 Lamp, Door Courtesy3-88
 Lap/Shoulder Belt.....3-36
 Rear.....3-38
 Webbing, Cleaning the7-51
 Light
 Bulbs (Specifications)8-2
 Bulb Replacement, Headlight.....7-41
 Bulb Replacement, Interior7-43
 Bulb Replacement, License Plate.....7-44
 Bulb Replacement, Rear Combination.....7-44
 Dome3-88
 Interior3-88
 Map.....3-88
 Lighter, Cigarette3-91
 Lighting Control4-41
 Locks, Door3-9
 Low Fuel Level Warning4-34
 Low Washer Fluid Level Warning Indicator4-35
 Lubricant Specifications7-46
 Lubricants and Fluids7-20
 Lumbar Support3-21

M

Main Fuse6-9
 Maintenance.....7-1
 Normal - Schedule.....7-3
 Owner7-9
 Severe - Schedule7-6
 Services.....7-2
 Malfunction Indicator4-34
 Mirror.....3-84
 Day/Night Rearview.....3-86
 Outside Rearview3-84
 Modifications, Vehicle.....5-3

O

Odometer4-26
 Oil
 Level, Checking the Engine7-13
 Pressure Warning, Engine4-32
 One-Touch Wiper.....4-43
 Outside Rearview Mirror.....3-84
 Overheating.....6-3
 Owner Maintenance.....7-9
 Precautions.....7-11

P

- Parking
 - Brake.....4-13
 - Brake and Brake Fluid Warning.....4-33
- Power
 - Brakes.....4-10
 - Outlet.....3-94
 - Steering.....4-17, 7-17
 - Steering Fluid Level, Checking the.....7-17
 - Windows.....3-14
- Pregnant Women, Restraint of.....3-40
- Pre-tensioner Seat Belt.....3-30
- Proper Use and Care of the Safety Belt System.....3-40
- Purchasing Factory Authorized Manuals.....9-6

R

- Rain, Driving in the.....5-8
- Rear
 - Lap/Shoulder Belt.....3-38
 - Seat.....3-25
 - Window Defroster.....4-44
- Rearview Mirror
 - Day/Night.....3-86
 - Outside.....3-84
- Recharging, Battery.....7-27
- Registering Your Vehicle in a Foreign Country.....9-3

- Reminder Warning Chime, Key.....4-36
- Remote Keyless Entry.....3-4
- Reporting Safety Defects.....9-5
- Restraint
 - of Infants and Small Children.....3-41
 - of Larger Children.....3-42
 - of Pregnant Women.....3-40
 - System, Child.....3-43
 - System, Safety Belt.....3-32
- Roadside Assistance, Emergency.....9-2
- Road Warning.....6-2
- Rocking the Vehicle.....5-7
- Rotation, Tire.....7-31

S

- Safety Belt.....3-30
 - Restraint System.....3-32
 - System, Proper Use and Care of.....3-40
 - Warning Light.....4-32
 - Warning Chime.....4-36
 - Warning Light and Chime.....3-35
- Safety Chains.....5-21
- Safety Lock, Rear Door Child.....3-12
- Scheduled
 - Maintenance Service.....7-2
 - 1 - Normal Maintenance.....7-3
 - 2 - Severe Maintenance.....7-6

Seat.....3-17
 Adjustment3-19
 Warming and Ventilating the Front3-23
 Snow Tires.....5-10, 7-40
 Spare Tire, Removing the.....6-22
 Special Driving Conditions5-7
 Specifications.....8-2
 Lubricant.....7-46
 Speedometer.....4-26
 Starting
 Emergency, Jump6-4
 the Engine.....4-4
 Steering
 Column Lock, Ignition Switch and Anti-Theft4-2
 Power4-17, 7-17
 Wheel.....4-17
 Tilt.....4-18
 Storage Compartments.....3-89
 Suggestions for Economical Operation5-6
 Storing the Jack and Tools.....6-22
 Storing the Spare Tire.....6-22
 Sunglass Holder.....3-90
 Sunroof.....3-96
 Sunvisor3-93
 Switch, Ignition.....4-2

T

Tachometer.....4-26
 Temperature
 Control Knob4-48
 Gauge, Engine4-26
 Tilt Steering4-18
 Tips for Towing a Stuck Vehicle6-17
 Tire
 and Wheels7-29
 Balance, Wheel Alignment and7-32
 Care.....7-29
 Chains.....5-10, 7-40
 Changing.....6-24
 Pressure Monitoring System (TPMS).....4-37, 6-17
 Quality Grading, Uniform7-36
 Replacement.....6-24, 7-32
 Rotation7-31
 Size Designation.....7-34
 Snow.....5-10, 7-40
 Speed Ratings7-35
 Specifications8-3
 Toll-Free Consumer Assistance9-2
 Towing6-13
 With a Vehicle Other Than a Tow Truck.....6-15
 Trailer
 Brakes5-21
 Driving with a.....5-21

Towing	5-18
Weight of the	5-19
Transaxle, Automatic	4-5, 7-18
Trip	
Interruption	9-3
Meter	4-26
Trunk	3-76
Turn Signals	4-40
Two-Way Radio System, Installation of a Mobile	9-4

U

Underbody Maintenance	7-50
Uniform Tire Quality Grading	7-36
Upholstery and Interior Trim, Cleaning the	7-51

V

Vehicle	
at a Glance, Your	2-1
Break-In Process	1-3
Data Collection and Event Data Recorders	1-4
Driving Your	4-1
Identification Number	5-25
Knowing Your	3-1
Load Limit	5-13
Modifications	5-3
Rocking the	5-7

Ventilating the Front Seats	3-23
-----------------------------------	------

W

Warming the Front Seats	3-23
Warning	
and Indicators	4-31
Road	6-2
Washer	
Fluid Level, Checking the	7-20
Wipers and	4-42
Washing	7-48
Waxing	7-49
Weight	
of the Vehicle	5-17
of the Trailer Tongue	5-20
Wheel	
Alignment and Tire Balance	7-32
Aluminum, Maintenance	7-50
Replacement	7-33
Size Designation	7-35
Steering	4-17
Wheels, Tires and	7-29
Window	3-13
Glass, Cleaning the Interior	7-51
Windows, Power	3-14
Windshield	
Defrosting and Defogging	4-56

Index

Washers	4-43
Wiper Blade Replacement	7-24
Winter Driving	5-9
Wiper Blades	7-24
Wipers	
and Washers	4-42
Variable Intermittent	4-42
One-Touch	4-43

Y

Your Vehicle At A Glance	2-1
--------------------------------	-----