

OPERATION  
MANUAL  
FOR THE  
MORRIS EIGHT

(SERIES II)

IN WHICH IS INCLUDED—

RUNNING  
MAINTENANCE AND  
ADJUSTMENT  
INSTRUCTIONS

PUBLISHED BY  
MORRIS MOTORS LIMITED  
COWLEY · OXFORD · ENGLAND

**ALL CAR OWNERS**

*should read*

***Motoring***

First-class technical and sports sections are regular features of this very popular monthly which carries articles by leading correspondents on a wide range of subjects of interest to all car-owning families.

Owners of Morris, Wolseley, Riley and M.G. cars are specially catered for.

9d. per copy from all newsagents.

Postal subscription 11/- per annum.

**MOTORING**

The Nuffield Organization

Cowley, Oxford, England

OPERATION MANUAL  
FOR THE  
**MORRIS EIGHT**  
CAR  
(SERIES II)

A copy of this book is sent out with every Morris Eight car. Additional copies can be obtained from Service Department, Morris Motors, Cowley, Oxford, England.

**ENGINE AND CHASSIS NUMBERS**

The engine and chassis numbers of the Morris Eight car are located on a brass plate on the dash, under the bonnet.

Please remember this in case you:

- (a) Write to our Service Department, or
- (b) Want to take your car abroad.

Published by  
**MORRIS MOTORS LIMITED**  
Chateaux - VISCOUNT NUFFIELD, G.B.E.  
Pine-Chalmers - - - R. F. HANES



THE MORRIS EIGHT CHASSIS (Series II)



---

## FOREWORD

---

IN the compilation of this book an attempt has been made to give in a concise form all the information normally required for the efficient management and upkeep of Morris Eight cars, and to give instruction on how to effect those minor but all-important operations that mean so very much to the operation of the car and to the satisfaction of the owner. It must be remembered, however, that in a book of this nature it is impossible to deal in full with every aspect of car maintenance and that this publication is confined to essentials.

We know that every Morris Eight car that leaves our Works can give absolute satisfaction. In case of trouble, first study this *Operation Manual*; then, if still puzzled, write to your Dealer or the Works. We are yours to command, and have a well-organized Information Bureau at your complete disposal.



## General Data

Bore	...	...	...	57 mm.	2.24 in.
Stroke	...	...	...	90 mm.	3.54 in.
Cubic capacity	...	...	...	918 c.c.	56.02 cu. in.
Wheelbase	...	...	...	2.286 metres	90 in.
Track	...	...	...	1.143 metres	45 in.
Tyre size	...	...	...	4.5-17	
Wheel size	...	...	...	2.25 x 17	
Gear ratios—1st	...	...	...	16.846 to 1	
2nd	...	...	...	9.568 to 1	
3rd	...	...	...	5.286 to 1	
Reverse	...	...	...	22.466 to 1	
Sparking plugs	...	...	...	14 mm. Champion L.10	
Petrol tank capacity	...	...	...	5½ gallons	
Engine oil capacity	...	...	...	5 pints	
Gearbox oil capacity	...	...	...	½ pint	
Rear axle oil capacity	...	...	...	1½ pints	
Total water capacity	...	...	...	15½ pints	

THE OPERATION MANUAL FOR THE

# Morris Eight Car

(SERIES II)

## General Hints on Driving

### FILLING UP

#### (1) PETROL

Before starting out for a run always make a point of seeing that the tank contains sufficient petrol. The quantity of petrol in the tank can very easily be seen on the dial gauge on the instrument panel when the ignition is switched on. The tank capacity of the Morris Eight is approximately five and a half gallons.

Any good quality petrol as sold to-day will give satisfactory running.

#### (2) OIL

Before starting out see that there is a plentiful supply of oil in the engine sump. To check this remove the dipper rod with hooked end, which will be found projecting on the left-hand side of the engine between the carburetter and the dash. Carefully wipe the lower portion of the rod, reinsert it and withdraw. Oil will cling to the rod, thus showing the actual quantity present in the sump.



The oil filler and graduated dipper rod on the Morris Eight.



The normal oil level is indicated by a deep depression on the rod marked "full," and the engine should not be run for long periods when the oil has dropped below the "low" mark.

The filling orifice is at the forward end of the engine, and is provided with a quick-action cap.

*Clean fresh oil is essential.* Use one of the oils recommended on page 49.

### (3) WATER

To ensure proper functioning of the cooling system the radiator when cold should be filled with clean water to a point just below the top of the filler-cap. When possible, rain water should be used for filling the radiator.

### WHEN IN COMMUNICATION WITH THE WORKS

The Address is: *Morris Motors Ltd.*  
*Cowley, Oxford*  
*England*

The Telegraphic Address is:  
*"Voiturette," Telex, Oxford*  
*England*

The Telephone Number is:  
*77777 Oxford, England*

The Telex Number is:  
*Oxford Telex 7194*

When writing *ALWAYS* quote model, engine  
and chassis numbers, and sign your name legibly

### CONTROLS

On the Morris Eight car every necessary control is provided. In the centre of the car will be found two levers, one plain and ending in a round black knob, which is the gear lever, and a little farther to the rear a lever with a ratchet handle—the hand brake lever. The hand brake lever pulls upwards to apply the brake and will stay on until released, which is achieved by pulling on the lever to take the load and pressing the ratchet release. Projecting through the floorboards on the right of the car will be found

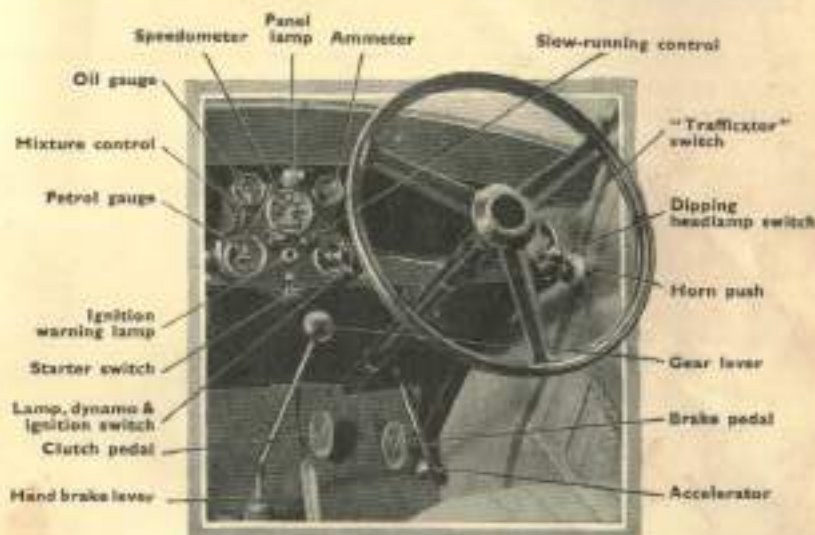

The controls of the Morris Eight.

three pedals, two with oval heads of similar size, and to the right of these a smaller one with a roller head. These from right to left are the accelerator pedal, foot brake and the clutch.

#### Mixture Control

On the left of the instrument panel, just below the central speedometer, will be found a projecting knob. This controls the strength of the mixture (that is, the amount of petrol in proportion to the amount of air) that is fed by the carburettor to the engine. When starting and getting away from cold, this knob should be pulled out as far as it will come, *but on no account should the engine be run for any length of time with the knob in this position.* If this is done neat petrol may be drawn into the cylinders, which will wash the oil away from the working parts and may cause considerable damage. As soon as the engine is under way this knob should be pushed inwards as far as it is possible without causing the engine to splutter or run with hesitation. The control is spring-loaded to



ensure its return to the "weak" position. A very little practice will soon familiarise the driver with the correct use of this control. If the engine fails to run evenly with the mixture control knob pushed right in, it is probable that the engine is not warm enough.

### The Slow-running Control

In order to prevent the engine from stopping when the foot is taken off the accelerator *while the engine is cold* the slow-running control should be made use of. This is situated on the right centre of the instrument panel. Turning it anti-clockwise increases the engine speed and turning it clockwise reduces the engine speed. Remember that it is unnecessary to set this control so that the engine races. All that is required is that the engine should just continue running with the foot removed from the accelerator. When the engine has attained its normal temperature this control should be completely released.

The slow running when the engine is warm should be controlled entirely by the carburetter setting (see page 38).



The "Trafficator" control on the steering column, and the combined horn button and dimming switch for the headlamps, which are conveniently situated close to the driver's right hand.

### Switches

At the right-hand bottom corner of the instrument board is a large black switch set in a circular dial. This controls the electrical circuits, serving the dual purpose of controlling the dynamo output and the lights. The switch has four positions. When in the position that the pointer head coincides with the word "Low," it indicates that the dynamo is on half charge and only giving

half its normal output. When the pointer head coincides with the word "High," the dynamo is delivering its full output.

The rest of the switch scarcely needs explanation. When the pointer coincides with the word "Side" it means that the sidelamps and tail-lamp are alight. When it coincides with the word "Head," it means that the headlamps, sidelamps and tail-lamp are alight.

Generally speaking, the switch should be kept on the "Low" mark during the Summer months and on the "High" mark during the Winter months, when greater use is made of the lamps.

In the centre of the switch is a removable key. This serves to switch the ignition—and therefore the engine—on and off. Turning the key clockwise switches on the ignition. Care should be taken not to lose the key.

Switching on the ignition also switches on the electric petrol pressure pump, and the electric petrol gauge will now register the tank contents.

In the centre of the panel is a red indicator light. When the dynamo output is insufficient to supply the needs of the ignition system, the red light appears, indicating that current is being drawn for ignition purposes from the battery. *Under no circumstances should the engine be left idling or stationary for anything but a few moments with this red light showing, or you may find that your battery has been drained. Never leave the car with the ignition switch on and the engine stationary.*

### Ignition Control

The distributor is fitted with fully automatic ignition control and no manual control is therefore fitted.

### Instruments

The instruments normally provided on the standard Morris Eight indicate to the driver everything he really needs to know. In the centre of the instrument panel is the speedometer, which gives the speed of the car in miles per hour, and also gives indication of the mileage it has run. To the right of this at the top is a smaller instrument, which is the ammeter. Its vertical finger swings both to the right and to the left, showing that the battery is being charged or discharged. When no lights are on and the dynamo and ignition switch is turned to the "High" position the ammeter needle should swing over to the right-hand side until it reads about 8 amperes when the car is running between 20 and 25 miles per hour. If the ammeter does not register when the dynamo and ignition switch is on and the car is travelling at this speed it means either that the fuse has blown or attention is necessary to the electrical system (see section on electrical equipment). To the left of the panel at the top is the oil gauge which gives indication of the pressure of the oil being fed to the engine. It should indicate a pressure of approximately 60 lb. when the engine is warm (see page 50).



The remaining instrument is the electric petrol gauge, which gives indication of the petrol tank contents. It should be noted that it only registers when the ignition is switched on.

## STARTING UP

### Starting Switch

The small central black knob situated at the bottom of the instrument panel is the starting switch. Pulling this knob outwards switches on the starter motor. It should always be pulled out and returned to the "off" position smartly.

Before starting up the engine make sure that the gear lever is in the central or neutral position—that is to say, it is free to move sideways. Turn the key in the switch on the switchboard clockwise. Turn the throttle control knob one or two turns-anti-clockwise. Pull the mixture control knob, at the left of the instrument panel, right out.

Pull the engine starting switch in the centre of the instrument panel smartly outwards. The engine will start revolving, and after a second or two should fire; the starter switch knob should then immediately be returned to the "off" position. *With a new car in cold weather it is helpful to swing the starting handle with the ignition switch off before using the electric starter.* It is bad practice to keep the starter switch pulled out if the starter is not turning the engine round, as may happen if the battery becomes run down, or with a new stiff engine, or in very cold weather. The method adopted of starting new stiff engines in cold weather at the Works is to get an assistant to pull the starter switch while the engine is hand-swung by the starting handle. Using the starter intelligently on the lines indicated will greatly prolong the life of the battery.

**NOTE :—**It is extremely bad practice to allow the engine to warm up from cold by letting it idle slowly. The correct procedure is to let the engine turn over fairly fast (approximately 1000 r.p.m., corresponding to a speed of 15 m.p.h. in top gear) so that it attains its correct working temperature as **QUICKLY AS POSSIBLE**. Allowing the engine to work in a cold state, however slowly, leads to excessive cylinder wear, and far less damage is done by driving the car on the road straight from cold than by letting it idle slowly in the garage.

### Gear Changing

After getting into the car, press the left (or clutch) pedal down and keep it there for a few seconds, with the engine running slowly. The clutch is thereby released and the gear lever may then be swung to the left and back, which will engage the first or low-speed gear.

The gears should engage easily. Do not use force. Should the gears not engage readily, repeat the instructions in the previous paragraph.

The hand brake should now be released, and the clutch pedal gradually let up; at the same time the engine should be accelerated by gentle pressure of the foot on the accelerator pedal. The car will move off.

When it has gained some headway change into second speed. To do this again depress the clutch pedal, bring the gear lever into the neutral position, then swing it to the right and push it gently forward, when the second-speed gear will be engaged. The clutch pedal should now be gradually released. Second and top gears are provided with synchromesh mechanism to enable a quiet change to be made without the necessity for double declutching. It must, however, be realised that the gear wheels must be given time to attain their correct speeds and that the gear lever movement must not be too hurried.

To change into third or top speed repeat the operation, but bring the gear lever straight back on the right-hand side.

The reverse position is forward on the left side. Care should be exercised when changing from low speed into second to avoid pushing the gear lever beyond the neutral position into the reverse, as this would result in setting up a tremendous strain on the gear wheels and might cause a serious breakdown. This can always be guarded against by maintaining a light pressure to the right on the gear lever while effecting this change.

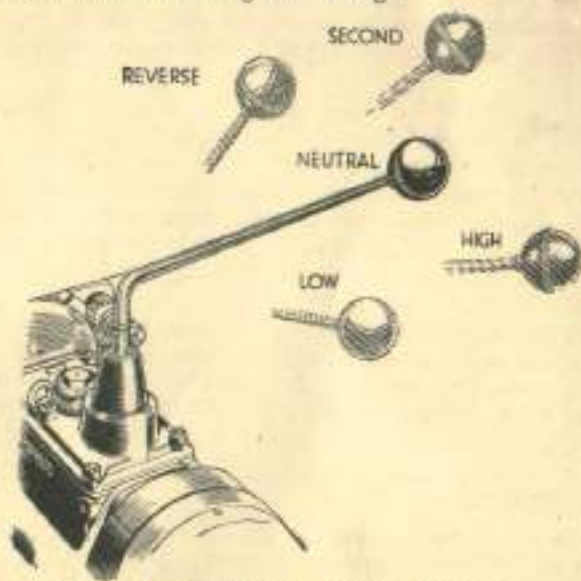

The gear positions of the 3-speed synchromesh gearbox.

### General Advice on Gear Changing

If you have made a bad change, with the result that you cannot move the lever into the desired position, and cause considerable



noise when you attempt to do so, do not endeavour to force the lever into position, but stop the car and start again from neutral. In this way you will avoid damaging the gears and incidentally gain additional practice. *When undue resistance is felt on engaging the synchromesh gears (second and third), don't force the lever. Push it back into neutral and try again.*

*Never engage a "forward" speed while the car is still running backwards, even though the clutch is kept disengaged. If this is done considerable damage to the gearbox may ensue. Always wait until the car is at rest before engaging a gear which will reverse the direction of travel.*

The diagrams herewith clearly illustrate the positions of the gear lever for the different speeds.

Study the illustrations carefully before attempting the operation on the car.

When changing gear upwards from first to second, the clutch pedal should be pressed down and the foot momentarily taken off the accelerator whilst the change is being made. A slight pause beyond the neutral position is advisable.

Second and top gears, being fitted with synchromesh control, go into engagement without special care on the part of the driver in the matter of relative engine speed, and the engagement of these gears is therefore a simple matter, providing the change is not hurried. The same remarks apply to changing down from top to second.

When changing down from second to low, the clutch pedal should only be lightly depressed, and after waiting for half a second *with the throttle remaining open for the engine to gain speed*, the change can be made noiselessly. The expert driver will have recourse to double declutching in such cases, but this requires a little tuition and practice, and is dealt with in the pages of *Motoring* from time to time. *Learn to change properly from the beginning.*

*It must always be remembered that the engine should have the opportunity of increasing its speed when changing to a lower gear, but must lose speed when changing to a higher. The engine speed is controlled by the small accelerator pedal with roller head, situated on the right-hand side.*

### Stopping the Car

To stop, take the foot off the accelerator and apply the foot brake gently. When the speed of the car has fallen to approximately five miles an hour, declutch and place the gear lever in the neutral position—that is, in the centre. Always endeavour to pull up as though the car has no brakes, when opportunity allows. This saves tyre wear and transmission stress and generally helps to prolong the life of the car.

Do not "coast" downhill with the clutch out. There is no advantage gained in this, and it is bad practice, causing unnecessary wear on the clutch withdrawal mechanism.

### Brakes

The foot brake operates hydraulically on drums fitted to the front and back wheels. This foot brake is the service brake and should be employed for general use on the road. For emergency and parking an additional hand-operated brake is provided which operates on the rear wheels by cables.

### Descending Steep Hills

On approaching a hill which is known to be steep, slow down the car and engage second or low gear before the descent is begun. The foot can then be removed from the accelerator and the clutch left in engagement. This will enable the engine to function as a brake, leaving the foot brake for additional braking and emergency. When using the engine as a brake it is inadvisable to switch off the ignition, as this is liable to cause the plugs to become oiled up.

**DON'T** :—Attempt to force the gears into mesh. If they do not engage easily, start again from neutral position.

**DON'T** :—Imagine that the synchromesh is provided to enable you to make ultra rapid changes. It must be operated reasonably slowly to give it time to level up the gear wheel speeds, and is mainly designed to give *quiet* changes.

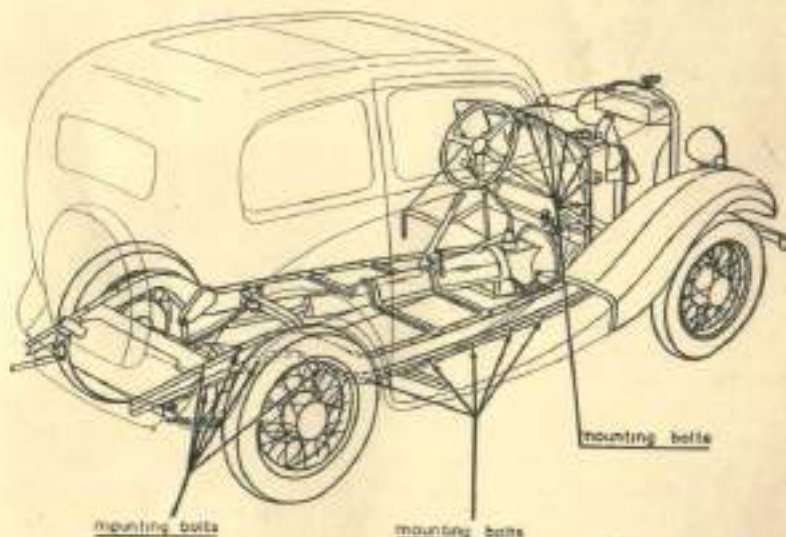

The position of the body bolts is clearly indicated in this illustration. There are a similar number on the other side of the car, of course.



## GENERAL CARE OF THE CAR

### New Engines

When the car is given its first run it will be noticed that power is lacking. This will continue for the first 150 to 200 miles. The reason for this is that the engine is stiff on account of the bearings being a very accurate fit. As the car is further used, however, this lack of power will gradually disappear as the bearings are being run in. There will be a progressive improvement in the engine and the car generally for the first 1000 miles if proper care is exercised. It is a great mistake to drive a new car fast. Hard pulling on full throttle, such as when going uphill, is bad for a new engine. Liberal use of the gearbox should be made. A new engine should not be fully extended, although so long as reasonable care is exercised no harm need be anticipated.

**For the first 200 miles 30 m.p.h. must not be exceeded in top gear, 16 m.p.h. in second gear or 10 m.p.h. in bottom gear. In addition, the engine should never be raced when cold.**

New engines should be given attention during the first 500 miles if they are to be ensured a long and satisfactory life. The cylinder head stud nuts should also be tightened after the first 250 miles. The oil should be drained and the engine refilled with clean oil at the end of the first 500 miles.

### Wings

Wings are stove enamelled and should not be dusted with a dry duster, but always washed down with plenty of water. No attempt should be made to remove tar spots by the use of benzole or a similar medium, but use may be made of eucalyptus oil applied on a piece of rag. After they have been well washed down with hose and sponge, all beads of water remaining should carefully be cleaned off with a chamois leather, and a final polish should be given with one of the special preparations obtainable for the purpose.

### Chromium Finish

The introduction of chromium finish has greatly reduced the labour previously entailed in cleaning the bright portions of the car. The chromium-finished parts of the Morris Eight should on no account be cleaned by the use of metal polishes (all of which contain a certain amount of abrasive matter), but by the simple expedient of washing the parts with plenty of water and, when the dirt has been removed, polishing the surface with a clean dry cloth or with chamois leather, until bright. In short, chromium finish should be treated in precisely the same way as coachwork and no special polish of any description is necessary.

When the chromium finish has become badly tarnished it should be cleaned only with soap and a flannel.

### Coachwork

**Door Hinges:** Inspect screws holding hinges to body pillars and the door pillars after 1000 miles and give each screw half a turn with a screwdriver if necessary. Inspect these occasionally during the life of the car.

**Body Bolts:** Tighten bolts holding the body to the chassis frame after the body has settled, say after 500 miles. (See illustration, page 13.)

**Cleaning:** The cellulose finish of the body should be washed and cleaned in the same way as wings, but for polishing, "Apollo" Car Polish is recommended.

### Radiator and Cooling System

It is of some importance that the radiator be filled only with clean rain water. The use of hard water for this purpose results in the deposit of the impurities which it contains on the surface of the water passages of the cooling system, reducing its efficiency. It is therefore advisable to flush out the cooling system approximately every six months.

### Frosty Weather

If the car is not stored in a warmed building, steps must be taken to prevent the cooling water from freezing during frosty weather. Water upon freezing expands, with the result that there is a very considerable risk of bursting either the radiator or the cylinder block by the pressure generated. As a precautionary measure when frost is anticipated, the water should be drawn from the radiator before the car is stored for the night. When refilling in the morning it is of advantage to use warm water, firstly because it facilitates starting, and, secondly, it is more free from those impurities which form deposits in the cooling system.

Anti-freezing solutions may be used in the radiator to overcome severe climatic conditions.

We recommend owners to use Smith's "Bluecol" non-corrosive anti-freeze in order to protect the cooling system during frosty weather and reduce corrosion to a minimum.

The recommended "Bluecol" size for Morris Eight cars is No. 2 size.

With this anti-freeze in the cooling water it is unnecessary to drain the system, even in the coldest weather, and one filling lasts the whole Winter.

"Bluecol" does not evaporate—therefore it is only necessary to top-up in the usual manner.

Before introducing the above anti-freeze mixture to the radiator it is advisable to clean out the cooling system thoroughly by draining out the water and swilling out the water passages with a hose inserted in the water filler cap opening, keeping the drain tap open.



## THE MORRIS EIGHT ENGINE

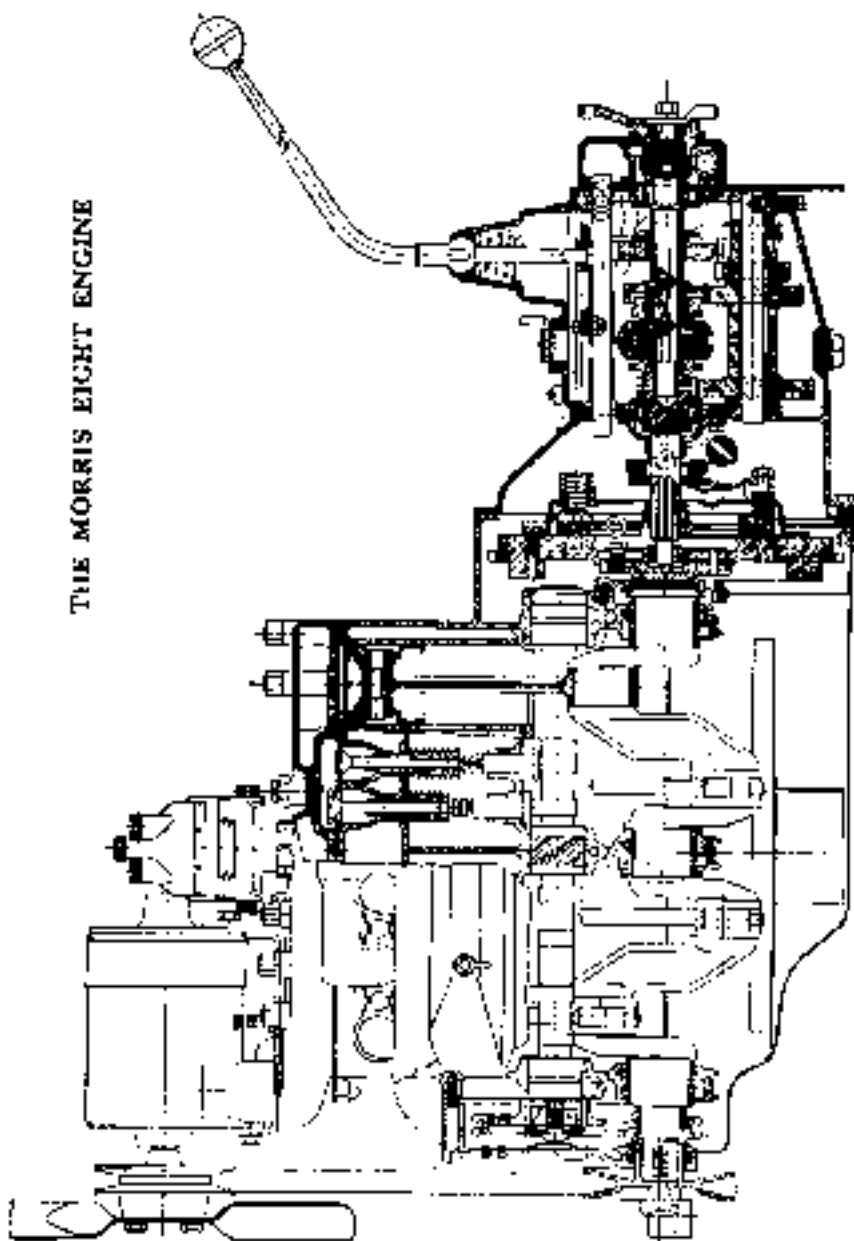

This sectional illustration of the Morris Eight engine clearly shows all its essential features and indicates the simplicity and thoroughness of the design.

## Adjustments

### Windscreen

THE single-panel windscreen fitted to the Morris Eight saloon models is provided on either side with adjustable guides. The guides have a thumb lever with a slot so that when the lever is pushed into a vertical position the windscreen is firmly

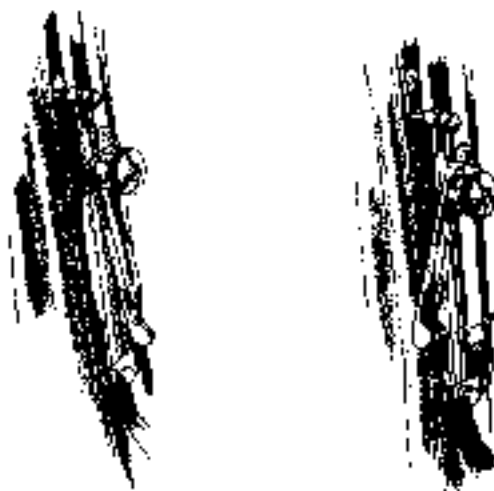

The windscreen cannot be opened until the thumb levers have been pulled down, in the direction of the arrow, into the position shown.

locked in the closed position. It is therefore impossible to open the windscreen, even though the lock nuts have been slackened off, until these quadrant levers have been pulled rearwards by hand into their free position, which will release the windscreen.

### The Springs

The spring clips which secure the front and rear springs to the axles should be examined periodically, to see that they are bolted up tight. It is essential, particularly when the car is new, to test the nuts on these clips to ensure that no slackness has taken place. The majority of spring failures are traceable to the fact that slackness has occurred at these points and has not been attended to.

Brakes (see page 29.)



## THE MORRIS EIGHT REAR AXLE

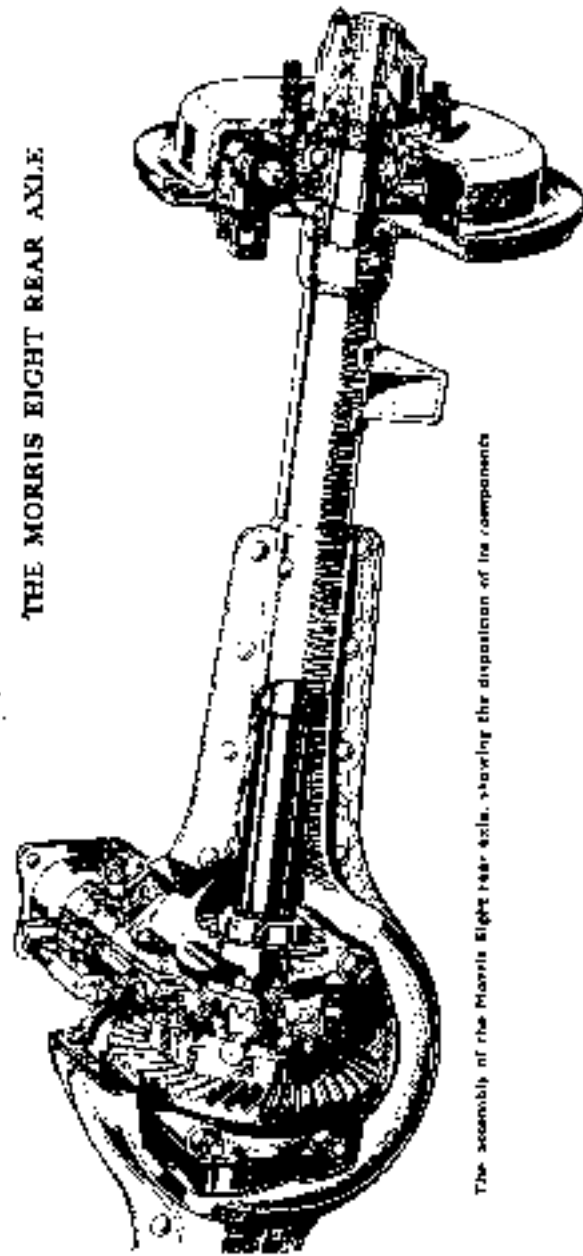

The assembly of the Morris Eight rear axle, showing the disposition of its components

**Rear Axle**

The Morris Eight rear axle is of the three quarter floating type where the driving shafts only transmit the driving torque and do not carry any of the load. The bearings are therefore not mounted on the driving shaft itself, but on the axle casing, and the wheel hub with driving shaft attached can be withdrawn without interfering with any other part, after the wheels and brake-drums have been removed. If the brake linings require attention, access to them is attained in the way detailed on page 14.

If any adjustments to the differential bearings are required, this work should be entrusted to your nearest authorised Morris Dealer, who is equipped with the necessary facilities and has the experience to carry out this work effectively.

When the differential has been remounted, adjustment to the drive pinion may be required, and such corrections entail considerable experience if satisfactory results are to be obtained. The owner is therefore advised not to tamper with this portion of the car.

**Top Dead Centre**

For checking the top dead centre position a small hole is provided in the crankshaft pulley flange which registers with an arrow on the cylinder block when the crankshaft is in the top dead centre position for Nos. 1 and 4 cylinders.

**Wheel Hub Discs**

The plated discs protecting the wheel stud nuts and hubs are easily removed by inserting the screwdriver end of the wheel brace in the slot of the disc retaining screw and unscrewing it. When replacing the disc see that the retaining screw is done up tight or you may lose your hub disc.

**The Ignition**

The distributor is mounted on the cylinder head, to which it is located by a quadrant plate and fixing bolt. The quadrant plate is marked with graduations and the cylinder head has an indicating arrow marked on it. Slackening the fixing bolt enables the ignition timing to be varied within certain limits to suit different operating conditions. Moving the distributor clockwise advances the ignition. Moving the distributor anti-clockwise retards the ignition. The distributor should not be moved more than half a division at a time.

**The Dynamo and Fan Driving Belt**

The dynamo and fan belt should be kept fairly taut and adjusted from time to time by moving the dynamo in its cradle so as to take up the slack. To do this loosen the three clamping screws, when the dynamo will be released and can be reset by pulling it



upwards, against the tension of the belt, and locking it in the new position. Care should be taken not to over-tighten the belt, or undue strain will be thrown on the dynamo bearings. Only a light pull with the hand on the dynamo is needed, and it should be possible to move the belt from side to side to the extent of one inch at the centre of the run.

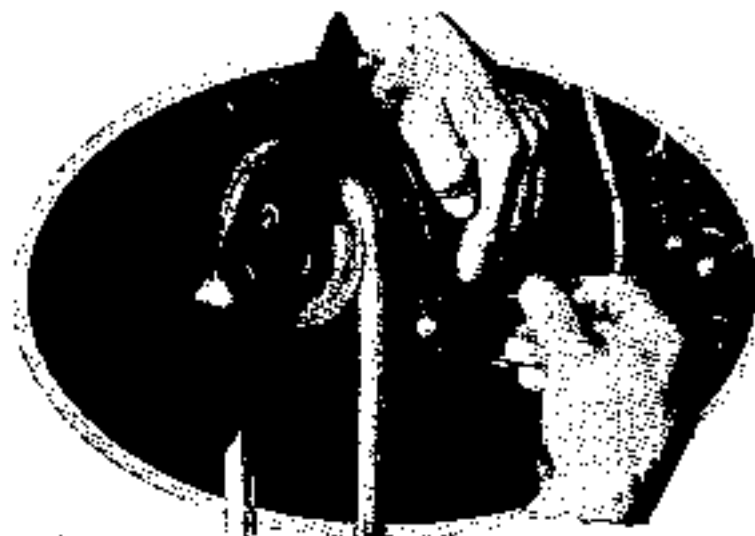

The belt tension is adjusted by slackening the dynamo fixing nuts while supporting the dynamo with the other hand.

### Valve Tappets

The tappet clearance should be set to .019 in. when the engine is hot, or .020 in. when the engine is cold.

The correct clearance is clearly indicated on the plate on the valve chamber cover.

When the valves are ground the tappet clearances must be reset.

The good tune of engines is frequently spoilt through the owner seeking silence by cutting down the tappet clearance. In order to maintain good tune over long periods it is imperative to set the tappet clearance after a valve-grinding operation to the amount indicated above carefully.

Adjustment of the valve clearance is easily and quickly effected by holding the flat on the head of the tappet by the thin spanner provided, and slackening off the steel lock nut bearing on it with the  $\frac{1}{4}$  in. spanner. Rotation of the hexagonal tappet screw in one direction or the other, by means of the other special tappet spanner, will

then enable the operator accurately to set the clearance. When the correct clearance has been obtained the tappet screw must be relocked to the tappet by tightening up the steel lock nut. While tightening up this nut it is of course essential not to disturb the position of the tappet screw which has just been reset, and it should be held in position, by the spanner provided, together with the tappet itself, during the relocking operation.

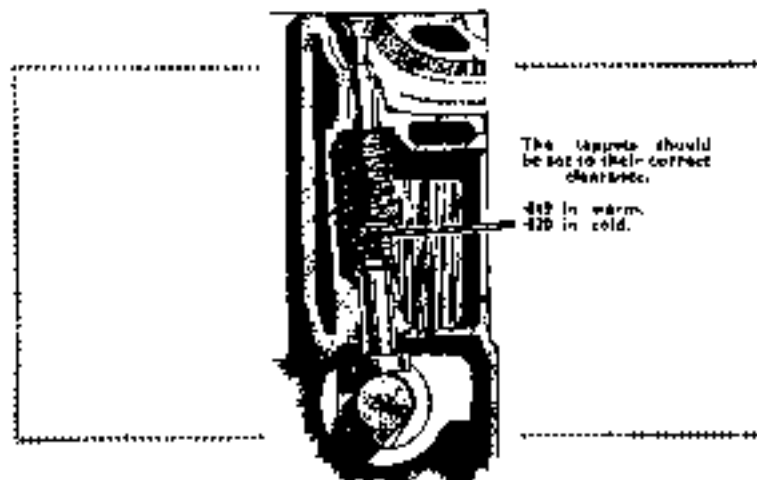

The tappets should be set to their correct clearance.

.019 in. warm.  
.020 in. cold.

It is of importance to note while the clearance is being set that the tappet of the valve being operated on is bearing on that portion of the cam which is concentric with the camshaft.

Once it is realized that the pistons of Nos. 1 and 4 cylinders and Nos. 2 and 3 cylinders move in unison and that while the valve of one is fully open the corresponding valve of the other is fully closed, no difficulty will be experienced in ensuring this, since it is only necessary to rotate the engine by the starting handle until the corresponding valve belonging to the other cylinder paired with it is fully open. To assist the owner, the correct sequence of adjustment to ensure the minimum rotation of the engine is here tabulated:—

Set No.	1 tappet with	No. 8 valve fully open.
" " 3	" " "	" " "
" " 5	" " "	" " "
" " 2	" " "	" " "
" " 8	" " "	" " "
" " 6	" " "	" " "
" " 4	" " "	" " "
" " 7	" " "	" " "

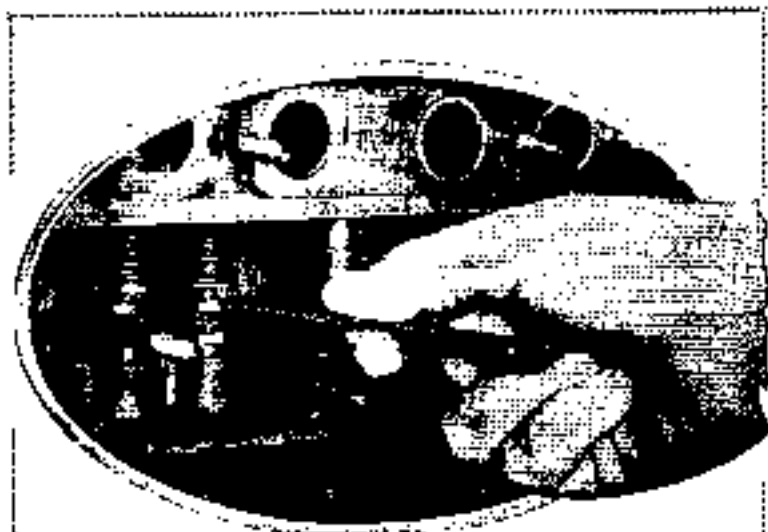

Testing the valve clearance with a feeler gauge.



Tightening up the tappets after setting. The tappet stem and tracer screw should be held in position by the special tappet spanner while the tappet locknut is firmly tightened with the appropriate double-ended spanner from the tool kit.

## Piston and Piston Rings

To remove a piston it is first of all necessary to remove the engine oil sump, and then the connecting rod assembly, and this is work which is outside the scope of the average owner. You are therefore advised to entrust any attention these parts may require to your nearest authorised Morris Dealer, who is not only competent to deal with this work but has all the necessary facilities for carrying it out speedily and satisfactorily.

## Connecting Rods

It should distinctly be understood by the owner that the white-metalled bearings in the Morris Light engine are of the full-ring butted type—that is to say, the two halves of the white-metalled bearing completely encircle the connecting rod and make contact with each other at their joint without leaving a gap and without the use of packing shims.



*On no account whatever must these bearings be closed together for any reason by the process of filing the caps, as this will immediately render the whole bearing non-standard and render the connecting rod valueless for future bearing replacement. The bearings are made on a system which ensures a sufficient degree of accuracy to make it totally unnecessary for the caps or rods to be touched by a file or scraper, and, in fact, renders any hand fitting superfluous. The bearings are of a heavy type in which the white metal is run direct on to the connecting rod, and if this white metal should run in use or become worn, the connecting rods should be replaced by new ones. Under no circumstances can Morris Motors Ltd. recognise any trouble consequent on interference with these bearings by owners. Any attention required to connecting rods should be entrusted to a competent Morris Dealer.*

The correct working clearance between the big-end bearing and the crankshaft journal is rather larger than was accepted practice a few years back, and is such that an appreciable rocking is present in the bearing when it is in an unlubricated state. The correct clearance is automatically allowed for in the machining process.



and no hand work whatever is necessary or advisable. This relatively large clearance permits a substantial protective film of oil to exist between the bearing surfaces, and the connecting rod under these circumstances should fall quite freely in its journal when the big-end bearing is bolted up quite tight.

It is important to note that when a connecting rod has been removed for any purpose it should be reassembled with the little end clamp bolt on the *opposite* side of the oil filler orifice.

Every facility is given the owner for obtaining replacement rods at the bare cost of reconditioning his old ones under the Morris Service Scheme by every Morris Dealer.

### Clutch

The clutch is intended to run dry, and persistent slipping of the clutch is usually an indication that oil has found its way into the clutch compartment, in which case it will be necessary to ascertain the cause. Since this entails the removal of the gearbox and export diagnosis you are advised to entrust this work to your nearest authorised Morris Dealer.

If the clutch is allowed to slip continuously the centre driven plate very quickly becomes excessively hot, and the heat and friction will very soon destroy the surface of the fabric linings.

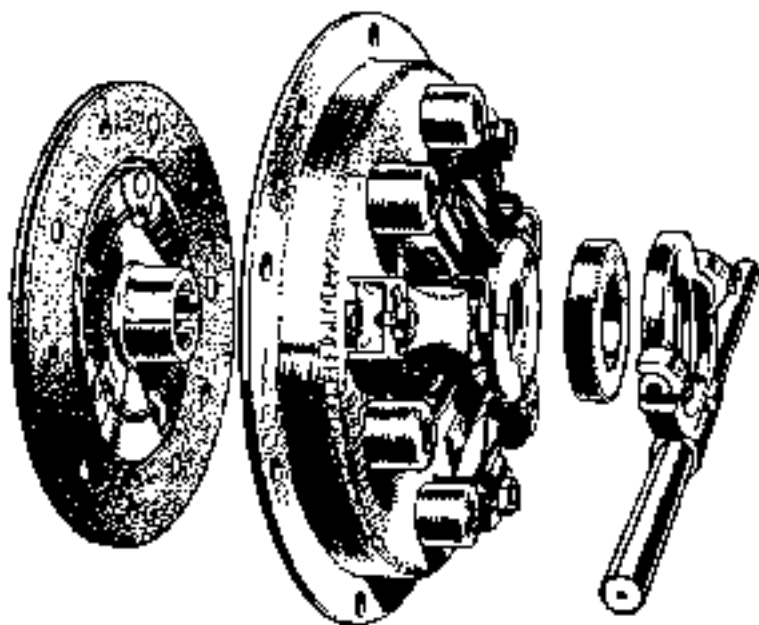

The component parts of the Morris Eight clutch separated to show their construction.

Morris Eight clutches are correctly adjusted at the Works before the car is delivered. In the early life of the car, however, a certain amount of bedding down of the friction surfaces takes place, which will permit the pressure plate to take up a position nearer the withdrawal mechanism, and thus reduce the necessary clearance between the withdrawal lever plate and the thrust bearing. If this clearance is completely taken up, the clutch cannot be fully engaged and clutch slip is produced, which rapidly wears the friction lining and further aggravates the trouble.

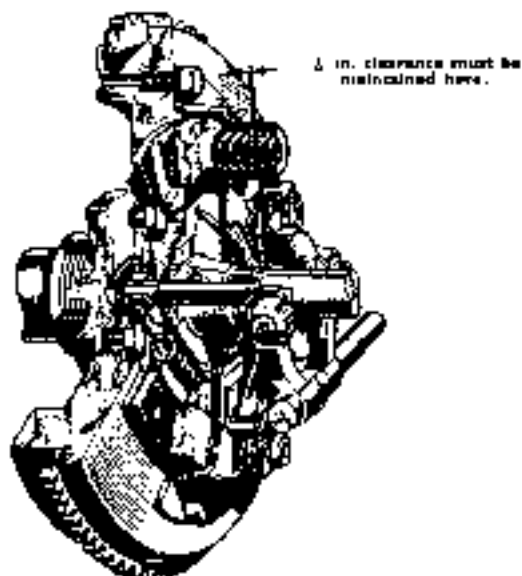

This sectional illustration of the Morris Eight clutch clearly indicates the correct adjustment.

The maintenance of an adequate clearance between the thrust bearing and the release lever plate is an absolute necessity and is the only service attention required by this type of clutch.

The minimum clearance between the withdrawal lever plate and the face of the thrust bearing is  $\frac{1}{8}$  in., which gives a free movement of  $\frac{1}{2}$  in. at the clutch pedal.

When the clutch pedal movement approaches this figure, it is essential to make use of the adjustment provided at the base of the clutch pedal, so that it has ample clearance.

The adjustment consists of a slotted quadrant lever with serrated face, to which the clutch pedal arm is held by a bolt. Slackening the locking nut enables the clutch pedal to be moved into the desired position, and it is to be noted that the serrated washer between the pedal and the quadrant lever has its serrations offset, so that adjustment to the extent of half a serration can be obtained by rotating this washer through half a revolution.

Take care to tighten up the locking nut carefully after an adjustment has been carried out.

In addition, care must be taken to see that there is not excessive pedal travel, as this will throw unnecessary strain on the carbon thrust block, leading to its early failure. There should not be more than  $1\frac{1}{2}$  in. clearance between the pedal arm and its stop on the clutch housing when the pedal is lightly held with the carbon block in contact with the thrust ring. Need for this adjustment will be indicated when there is a tendency for the engine to stop when the clutch pedal is fully depressed.

There should be approx.  $\frac{1}{2}$ " backlash here before resistance is felt.



Adjusting nut

The clutch pedal adjustment on the Morris Eight consists of a slotted lever with serrated face and locating washer.

The thrust bearing consists of a solid graphite block and therefore requires no lubrication, but may be damaged if there is too much clutch pedal travel.

### Steering Gear

The presence of stiffness in the steering gear can be ascertained by jacking the front axle, so that both the front wheels are clear of the ground, and rotating the steering wheel.

If stiffness exists, disconnect the rear end of the draglink from the steering drop arm. It will then be an easy matter to locate

When the pedal is depressed so that resistance is felt there should be at least  $\frac{1}{2}$ " between the pedal arm and its stop, but not more than  $1\frac{1}{2}$ "

if the stiffness is due to the wheel mounting and steering connections, or whether it is due to stiffness in the steering column and steering gearbox assembly.

Slackness in the steering column assembly is due either to excessive clearance between the cam and the hardened end of the rocker-shaft, or end play in the steering column mounting.

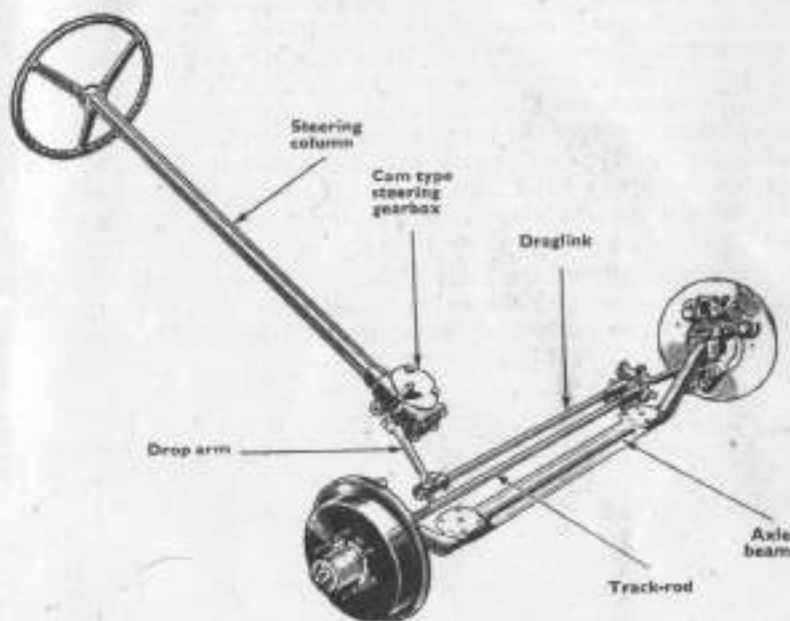

The Bishop cam steering gear fitted to the Morris Eight.

The presence of end play on the steering column is easily felt by lifting the steering wheel in line with the column itself. Any appreciable motion in this direction needs rectification inside the steering gearbox—a procedure which should be entrusted to a competent Morris Dealer.

If slackness is due to lost motion between the cam and the end of the rocker-shaft, this may be rectified by removing the top cover-plate and removing one or more of the thin brass shims to be found between this cover-plate and the main casing. The cam gear is made so that there is no appreciable backlash at the bottom of the drop arm when the gear is in the mid position.

When reconnecting the drop arm to the gearbox spindle, care should be taken to see that the drop arm is in its correct position, permitting full lock in both directions, the wheel stub axles coming into contact with the stops provided on the axle beams in either



direction. The drop arm and the marker-shaft are marked to facilitate their correct replacement.

### Heavy Steering

Heavy steering and excessive front tyre wear are frequently caused by faulty wheel tracking. The length of the track rod should be such that the distance between the forward inside edges of the wheel rims measures  $\frac{1}{8}$  inch less than does the distance between the rear inside edges. Care must be used in measuring to ensure that the measurements are taken at axle level above the ground and that the rims run true. These measurements might with advantage be tried if at any time the car has a tendency to steer badly. The track rod is provided with a right-hand thread at one end and a left-hand thread at the other, so that tracking adjustments can be carried out by simple rotation of the track rod after the pinch bolts have been slackened off.

Correct setting of the front wheels entails the use of a wheel alignment gauge, and the owner is therefore advised to entrust this work to an authorised Morris Dealer, who has the necessary equipment to carry it out properly.

## The Hydraulic Brakes

### THEIR FUNCTIONING AND MAINTENANCE

THE foot brakes fitted to Morris Eight cars are of the self-equalising hydraulic type. They have no cross shafts, operating rods or hinged joints to rattle or need lubrication. They are actuated by a master cylinder operated from the brake pedal. Pressure on the brake pedal is conveyed to fluid contained within the master cylinder and equally distributed by special pipe lines to each individual wheel brake.

### The Master Cylinder and Supply Tank

These are of the automatically compensating type and maintain a constant volume of fluid in the braking system. Special expanders are fitted to all the cup joints, ensuring that the system is completely sealed and leak-proof.

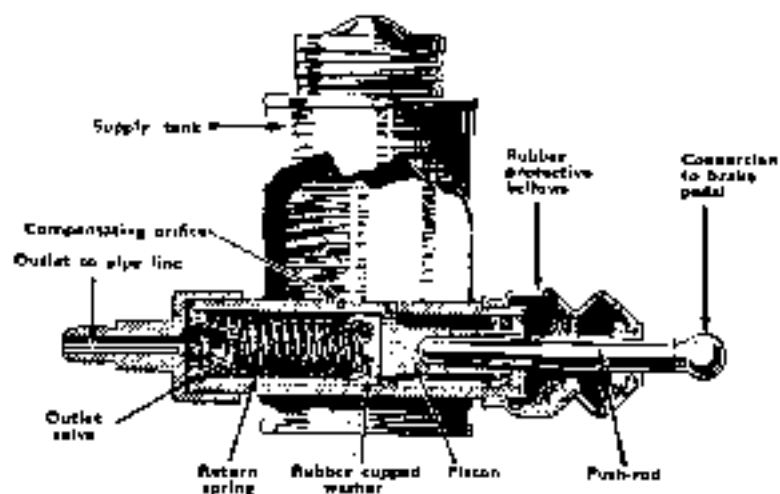

The combined master cylinder and supply tank of the Morris Eight.

Provision is made automatically to compensate for expansion and contraction of the fluid in the system due to temperature changes.

The fluid supply tank is mounted on the master cylinder beneath the floorboard.

The supply tank is merely a simple reservoir containing a sufficient quantity of fluid to feed the braking system under all conditions.

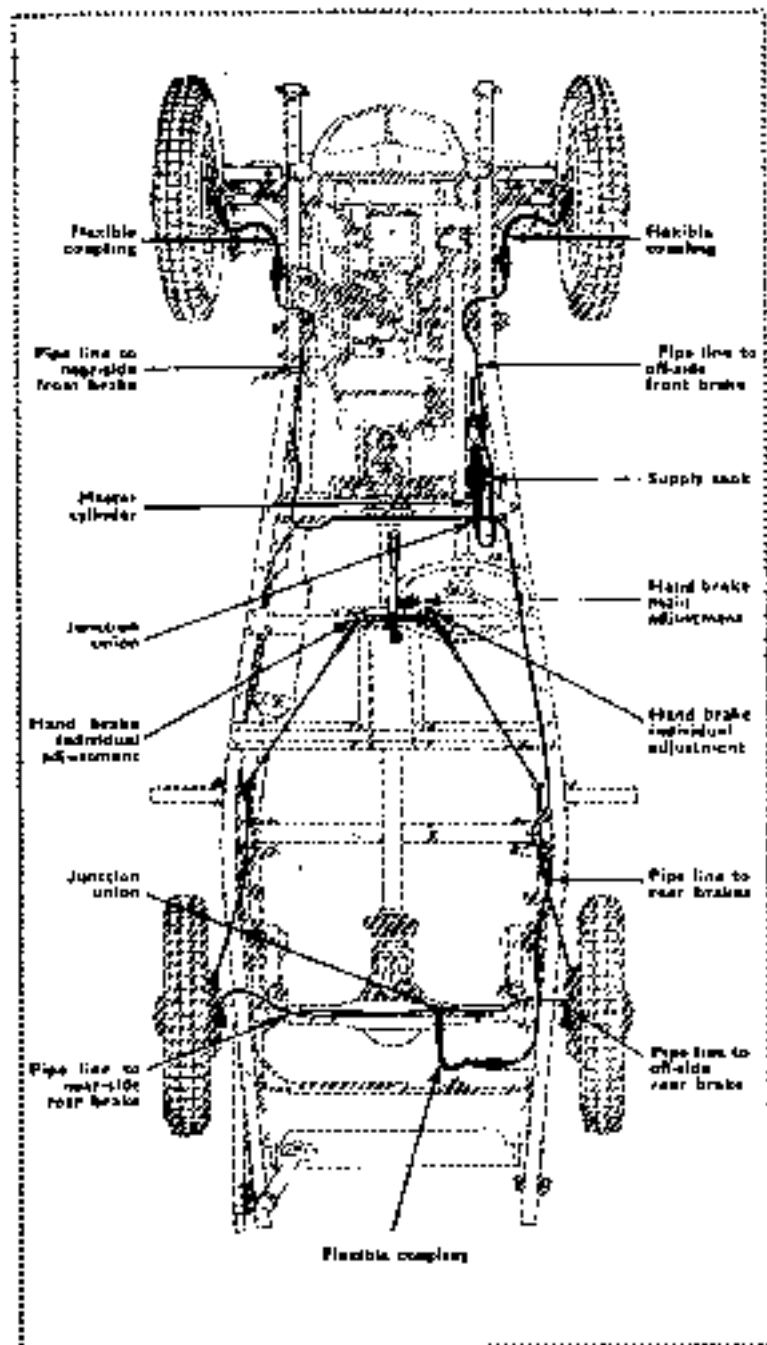

**The Wheel Cylinders**

The wheel brake-shoe cylinders are open at both ends, rigidly attached to the brake dust covers, and are each equipped with two opposed pistons with cup washers and push-rods for connection to the brake-shoe ends. The open mouths of these cylinders are covered with rubber boots to prevent the entry of dirt.

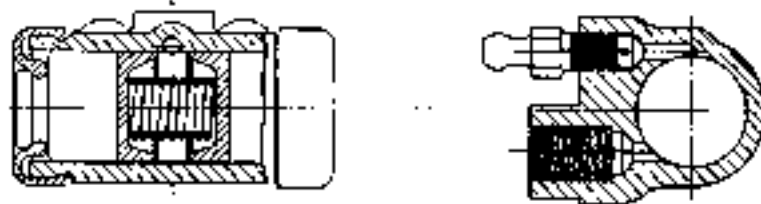

Wheel cylinder detail

Depression of the brake pedal introduces fluid to the centre of the cylinder between the opposed pistons, and they are as a result forced apart, thus applying the brakes.

Since it is imperative that all air should be withdrawn from the braking system, provision is made at each wheel brake cylinder to expel any air which may be present in the pipe line. This consists of a "bleeder valve" situated at the top of each cylinder immediately above the pipe line union.

**The Pipe Line**

The pipe line is of stout gauge copper tubing, specially prepared and cleaned, and should not be replaced by piping of an inferior quality. Where spring deflection and steering movement must be provided for, special patent flexible hose connections are fitted. These, though flexible, are non-expansible, and are capable of withstanding a pressure of 6000 lb. per square inch.

**Adjustments and Replenishments**

The brakes on all Morris cars are carefully adjusted before leaving the Works, and all Morris Dealers have instructions to check the brake adjustments before handing the car to you. The brake mechanism should therefore require but little attention for a lengthy mileage. The supply tank filler cap should, however, be removed every 1,000 miles, and the level of the fluid checked. If it is found to be particularly low it is an indication that a leak has developed somewhere in the system, and it should be traced and rectified without delay. The supply tank should be about three-quarters full of fluid, and never less than half full. Always use Lockheed Orange brake fluid.



No equalisation adjustment is required, since the pressure applied to the shoes will always be precisely equal. It must be remembered, however, that the presence of oil, grease, or similar foreign matter on the braking surfaces will seriously affect the coefficient of friction, and in consequence the retarding effect on that particular brake, in spite of the fact that it is being applied with the same force as the others. In such cases it is necessary thoroughly to clean the brake lining with petrol, and slightly roughen its surface with a file.

The only adjustment required is that needed to compensate for the wear of the brake-shoe linings, and the frequency for such adjustment is, of course, dependant upon the character of the service to which the brakes have been submitted. During the first 500 miles, however, the maximum braking power may not be available, and adjustments may have to be carried out by the owner in order to take up the natural surface wear inevitable with new brake linings.

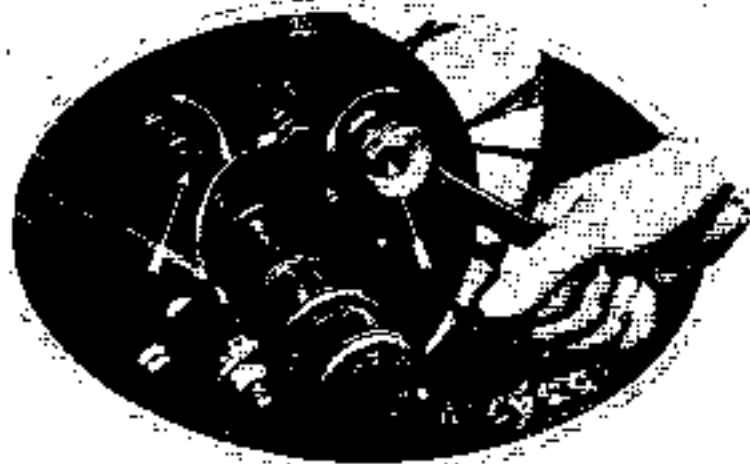

Here are shown the brake adjusting bolts, which when rotated away from the centre of the wheel, as indicated by the arrows, bring the shoes closer to the drum, and when rotated in the opposite direction bring the shoes farther from the drum.

When the linings have worn so far that the brake pedal is in danger of coming into contact with the floorboards, it is necessary to bring the brake-shoes in closer relation to the brake-drums. It is advisable to have at least  $1\frac{1}{2}$  in. clearance between the head of the pedal and the floorboard when the brake is fully applied. Adjustment is effected by jacking each wheel in turn, spinning the wheel and partly rotating the hexagon adjustment bolts which are to be found on either side of the wheel cylinder until the brake-shoes just come into contact with the drums, then slackening back this adjustment until the wheel just rotates freely and without drag.

The adjustment bolts operate snap-type cams bearing against the shoes. They are frictionally held, and require no locking device; they can easily be rotated with a spanner into the desired position. To bring the shoes closer to the drums the adjustment bolts should be rotated away from the centre of the wheel, and to bring the shoes further away from the drums they should be rotated towards the centre of the wheel, with the spanner above the nut. When these operations have been carried out on all four wheels, all brakes should be in correct adjustment.

### Brake Linings

It is of importance that the brake linings of all brakes be of the same kind, or equalisation of the braking will not be achieved. Service replacement shoes relieved with the correct material can be supplied by your Morris Dealer.

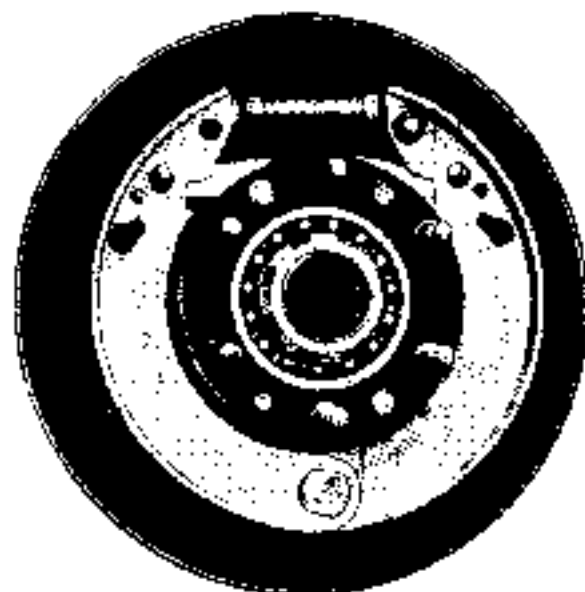

The brake-drum removed, showing the rear brake-shoe assembly. The assembly for the front shoes is identical with the exception of the hand operating mechanism.

All brake re-lining should preferably be entrusted to a competent Morris Dealer who is also a Lockheed service agent. During the first 500 miles after re-lining the maximum braking effect may not be available, and adjustments may have to be carried out, at fairly frequent intervals, by the owner in order to take up the natural surface wear inevitable with the new brake linings. (See Adjustments on page 31.)



### Access to Brake-shoes

Access to the brake-shoes for attention is achieved by jacking the wheel and removing it from the hub. This will reveal two large countersunk screws spaced between the six wheel studs. With removal of these two screws will permit the brake-drum to be drawn off quite easily. Removal of the brake-drum reveals the entire brake-shoe assembly, and the brake-shoes can now be detached for cleaning in the following way—

In the case of the front shoes unhook the brake return springs from their anchorage to the brake-shoes. A piece of stout string or wire passed through the spring eye will greatly facilitate this. Remove also the split pins and washers from the guide pins passing through the brake-shoe webs. The shoes are released from the pivot pin by removing the circlip retaining the shoes on the pivot pin. This will allow the shoes to come away.

In the case of the rear shoes the brake return spring remains in position, and the shoes are released by removing the split pins and washers from the guide pins and releasing the pivot pin circlip. It is then a fairly simple matter to withdraw the shoes and then unhook the operating cable from the expanding lever.

*Do not interfere with the wheel brake cylinders unless they are found to be leaking, and obviously need attention, and do not operate the brake pedal while the drums are removed, or the wheel cylinder pistons may be forced out of their cylinders.*

### Bleeding the System

The process of bleeding is necessary only when a portion of the system has been disconnected, or when the level in the supply tank has been allowed to fall below the half mark, thus permitting air to enter the fluid circuit. It consists of removing any air which may have found its way into the system. While this is not a difficult matter, it entails the use of special equipment to obtain the best results, and is at the best not a pleasant operation. Owners are therefore advised to entrust this work to an authorised Morris Dealer, who is also a Lockheed service agent.

### The Brake Fluid

The Lockheed fluid used in the Morris Eight braking system is specially prepared for the purpose and it is important that no other fluid be introduced into the system for replenishment or serious trouble will ensue. This special fluid is unaffected by high temperatures, and is immune from freezing. Oil, petrol, paraffin and similar mediums are definitely injurious to some parts of the system, and should on no account be introduced to the system or used for cleaning purposes. If it is required to clean any parts of the braking system, they should be washed either in this special brake fluid supplied or alcohol. If alcohol is used, the parts should be well dried and treated with brake fluid before being replaced.

Lockheed Orange fluid is stocked by all Morris Dealers.

### Leakage of Brake Fluid

Excessive consumption of brake fluid is an indication of a leak somewhere in the system. A leak may be traced by applying very heavy pressure to the brake pedal with the car stationary and checking over the various connections until the point of leakage is found. *Note*—The pistons of the wheel or master cylinders should never be removed. Special tools are required correctly to assemble these components and there is nothing in them to give trouble.

### In Conclusion

Don't use any substitute for the special brake fluid, or you will have trouble.

Don't permit grease, paint, oil or brake fluid to get into contact with the brake linings.

Don't use packing compounds for the joints; only straight metal-to-metal joints should be made.

Don't use paraffin or petrol for cleaning purposes. Nothing but alcohol or brake fluid should be used.

Don't re-line one wheel with a different make of lining from that used on the others. Always use genuine Morris linings.

Don't allow the supply tank to become less than half full of brake fluid.

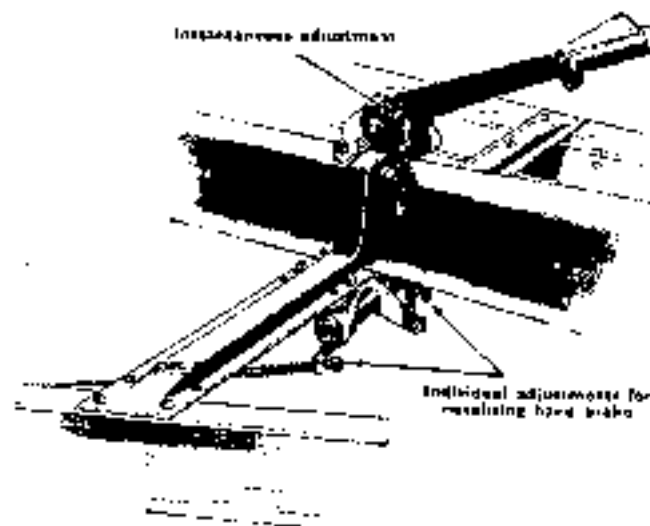

### The Hand Brake

The hand brake on the Morris Eight is centrally situated next to the gear lever and operates the shoes in the rear brake-drum by cable mechanism. Ample and simple equalisation adjustment for the cables is provided at their junction to the brake cross-shaft.

levers below the floorboards, and care must be taken to see that both brakes are applied with equal force in order to obtain maximum braking efficiency.

A service adjustment whereby both the hand brake-shoe controls are adjusted in unison, is provided at the junction of the brake lever pull-rod with the hand lever, and it takes the form of a spring-loaded self-locking wing nut.

This instantaneous adjustment is easily operated from the driving seat.

Great care must be taken not to take up the hand brake adjustment too tightly, or a tendency may exist for the brake to come on of its own accord when additional passengers are carried.

Other than a free use of the oil can on all joints, the hand brake mechanism requires little attention.

**A** N INDEX AND OILING CHART are provided for your convenience at the end of this book.

## The Carburetter and its Adjustments

### The S.U. Carburetter with Controllable Jet

**T**HE function of the carburetter is to supply to the engine a correctly proportioned mixture of petrol and air under all conditions of engine speed and load. Since these conditions are constantly varying within very considerable limits, means must be taken automatically to adjust the mixture proportions as the demands upon the engine change.

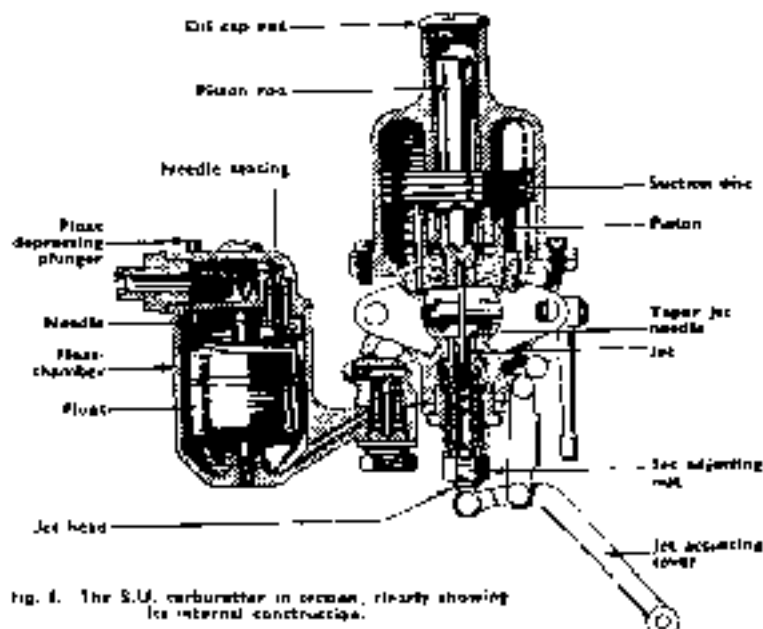

Fig. 1. The S.U. carburetter in section, clearly showing its internal construction.

The S.U. carburetter fitted to Morris Eight cars achieves this through the medium of a suction-operated piston which varies the size of the choke area, and in addition, controls the delivery from the jet by means of a tapered needle.

The functioning of the carburetter can be followed in detail by reference to Fig. 1. The petrol flow to the jet is governed by a float mechanism of the "top feed" type, where the rising petrol lifts the float, forcing it against a pivoted lever engaging with the lower end of a needle. The upper end of the needle terminates in a cone that engages in the vertical orifice of the petrol feed, upon which it is forced by the action of the lever, thereby shutting



### ADJUSTING

Run the engine until it attains its normal running temperature. Set the slow-running control on the right center of the instrument panel so that the engine idles fairly fast. Disconnect the mixture control wire from the end of the brass lever actuating the jet, and screw the jet adjusting nut well downwards. Note that the jet actuating lever is kept in contact with the jet head by its return spring and must be kept in contact during the whole of the adjusting process. The jet adjusting nut should now be screwed upwards slowly (thus gradually weakening the mixture) until the engine idles evenly, firing on all four cylinders regularly, and running at its best speed. This will be the normal running position when the engine is hot, and as the jet needle is of the correct size the general performance of the carburetter on the road should be entirely satisfactory. The mixture control wire may now be reconnected to the jet actuating lever, care being taken to see that the control knob has ample clearance when the jet is in contact with the adjusting nut.

Final adjustment for slow-running is then carried out by completely slackening off the dash throttle control so that it is quite clear of the accelerator control, and adjusting the carburetter throttle lever stop screw, which is spring-loaded for screwdriver operation, until gentle slow-running is attained.



Adjusting the carburetter throttle stop screw to obtain the correct slow-running position after setting the jet.

off the petrol supply when the petrol level in the float-chamber has reached a predetermined level. The lever and needle mechanism is attached to the lid of the float-chamber and the whole can readily be detached after unscrewing the retaining nut in the centre of the float-chamber lid.

Petrol from the float chamber is led to a jet, the size of whose orifice—and consequent delivery—is regulated by means of a tapered needle attached to the lower end of a piston controlled

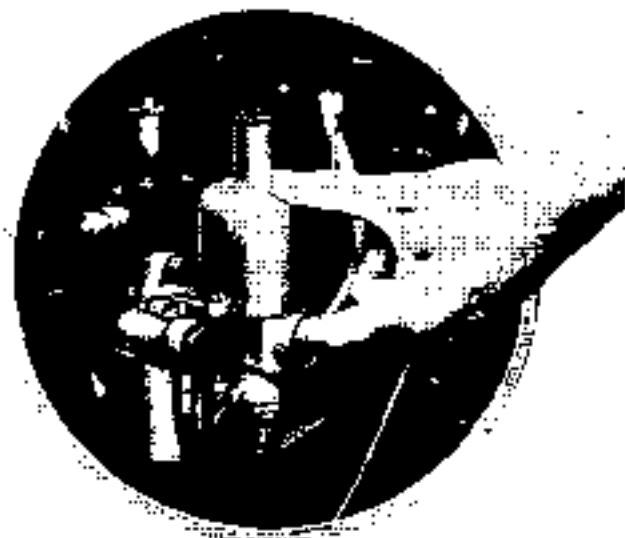

By inserting a finger in the air intake the piston may be raised or lowered to free its orifice.

by the suction from the engine. As this suction increases the needle is gradually withdrawn from the jet, enlarging its effective opening and permitting it to pass more petrol.

The lower end of the suction-operated piston also functions as a variable choke, regulating the size of the passage in the region of the jet as it rises and falls, thereby maintaining a practically constant depression—or suction on the jet—notwithstanding the varying requirements of the engine.

The jet is so mounted that it may readily be moved up or down relative to the tapered needle, in order to weaken or strengthen the mixture over the whole working range, by a lever operated from the mixture control situated on the instrument panel. This control provides an enriched mixture to ensure easy starting and even running when the engine is cold. The minimum jet opening can accurately be set by means of the adjusting nut, which forms an adjustment for the enlarged head of the jet.

The carburetter is extremely simple, and its adjustment is equally simple if it is remembered that the jet is of a fixed standard size and cannot be altered. The only possible adjustment, other than the slow-running adjustment, is the fitting of a new needle of a different size. Since a needle of the correct size is fitted at the Works before the car is dispatched, this adjustment should not be required, and the suction chamber is therefore sealed.

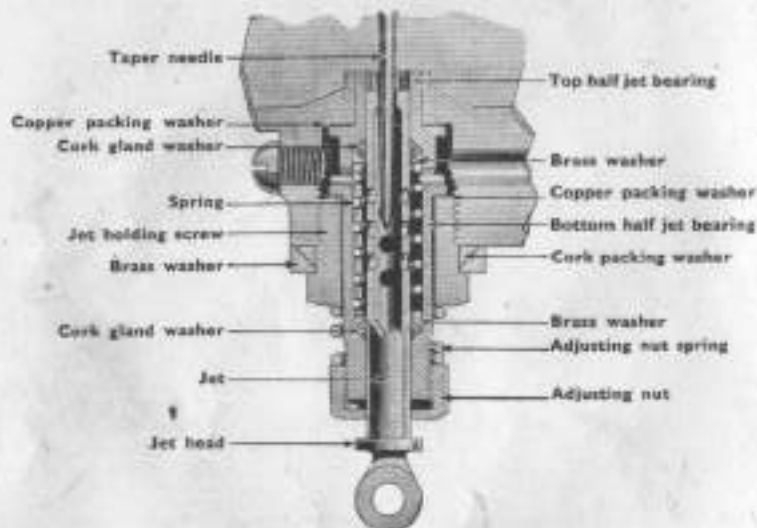

Fig. 2.

An enlarged section of the jet assembly. It will be noticed that the junction between the jet and the casing is rendered perfectly petrol-tight by means of two cork washers which are forced against the sides of the jet by a coil spring and conical washers. If the jet is dismantled great care must be taken not to lose these washers.

### Sources of Trouble

There are only three troubles which may affect the functioning of the S.U. carburetter.

1. The piston may be sticking and not functioning properly.
2. There may be dirt or water in the carburetter.
3. The float mechanism may have become deranged, and the carburetter is in consequence flooding.

### Piston Sticking

The suction piston consists of the piston proper forming the choke; the suction disc, into which is inserted the hardened and ground piston rod working in a bearing in the suction chamber; and a tapered needle regulating the jet opening. If the piston is sticking this can easily be ascertained by inserting a finger in the air intake and raising the piston. The piston should come up quite freely and return to its seat with a click as soon as it is released.

If the piston does not return readily to its seat it is probable that the piston rod has become dry or sticky.

To free this, remove the oil cap nut to be found at the top of the suction chamber, pour in a few drops of good quality thin oil—such as sewing machine oil—and replace the cap. In particularly obstinate cases a little paraffin may be introduced into the oil

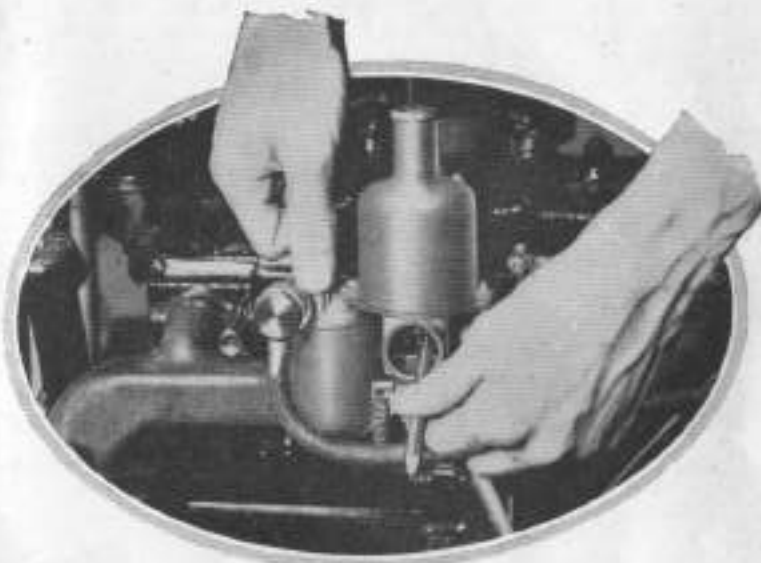

To observe the petrol flow from the jet, the piston should be raised with a small implement and the float-chamber flooded by raising the protruding needle.

cap opening and the piston worked up and down until it is free by inserting a finger in the air inlet. *Under no circumstances should a heavy-bodied lubricant such as engine oil be used, and no oil must be introduced on any other part of the suction chamber.*

### Water or Dirt

If this is suspected, with a small article—such as a pencil—raise the piston so that the jet can be seen. Flood the carburetter by switching on the ignition and depressing the plunger on float-chamber cover, observing if the petrol issues freely from the jet. If it does not do so there is foreign matter of some sort blocking the passage to the jet. To rectify this, start the engine, and open the throttle, then momentarily block the air inlet by placing the hand over it, keeping the throttle open until the engine commences to race.

This trouble is not a frequent one with the S.U. carburetter owing to the size of the jet and petrol passages.



### Float-chamber Flooding

This is usually obvious from the quantity of petrol flowing over the float-chamber and dripping from the air inlet. Flooding is generally caused by foreign matter finding its way on to the seating of the float-chamber needle. This should seldom occur, as the incoming petrol stream washes away the particles of grit. It may be rectified by removing the float-chamber cover and then twisting the needle on its seating a few times with the fingers; the seating

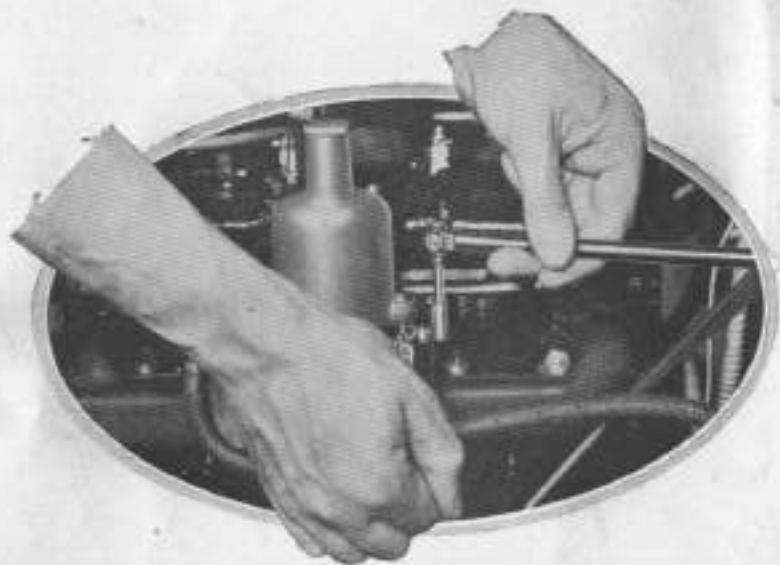

An obstructed jet should be cleared by opening the throttle by means of the accelerator rod while the engine is running and momentarily closing the air intake with the other hand.

should on no account be ground in. It is advisable in all cases of flooding to clean out thoroughly the filter and filter housing.

### Float-chamber Empty

First disconnect the petrol feed pipe from the float-chamber and make sure that the petrol delivery is in order. If the petrol feed is satisfactory, the trouble is probably due to the float needle sticking on to its seating. It may be freed by rotating it on its seating with the fingers. On no account should grinding paste be used or considerable damage will be done.

### The Jet

Whenever the jet assembly or the automatic piston assembly is disturbed it is imperative to correctly re-centre the jet. This requires experience and should be entrusted to a competent Morris Dealer.

### The Filter

To ensure a free flow of petrol to the float-chamber the filter should occasionally be dismantled (every 5,000 miles) and thoroughly cleaned. The filter is situated behind the large hexagon nut at the junction of the petrol pipe to the float-chamber cover, and is released by uncoupling the petrol pipe union by unscrewing this large hexagon nut. The filter should never be cleaned with rag; always employ a stiff brush and petrol. When replacing the filter remember that the coil spring is first introduced into the filter housing and that the open end of the filter bears against the large hexagon nut.

*NOTE.—We strongly advocate that owners should not interfere with their carburettors. The jet and needle fitted as standard have been proved by extended tests to be the correct ones for best results, and nothing is to be gained by individual experiment.*



The filter is released by unscrewing the hollow hexagon screw attaching the petrol pipe to the float-chamber lid. Note that the open mouth of the filter faces outwards.

### The Air Intake Silencer

An air intake silencer is fitted to the carburettor, which serves to eliminate the roar produced by the ingoing air. It is extremely simple in construction and needs no maintenance attention whatever.

## The Automatic Petrol Feed

### THE S.U. ELECTRICAL PETROL PRESSURE PUMP

**T**HIS petrol pump is of the diaphragm type and its construction is such that it will give prolonged service with the minimum attention.

The only actual maintenance attention called for is the occasional removal and cleaning of the filter. The filter is inserted into the bottom of the pump body and can easily be withdrawn by unscrewing its hexagon attachment screw. When removed it should be thoroughly cleaned in petrol with a stiff brush, *never use rag.*

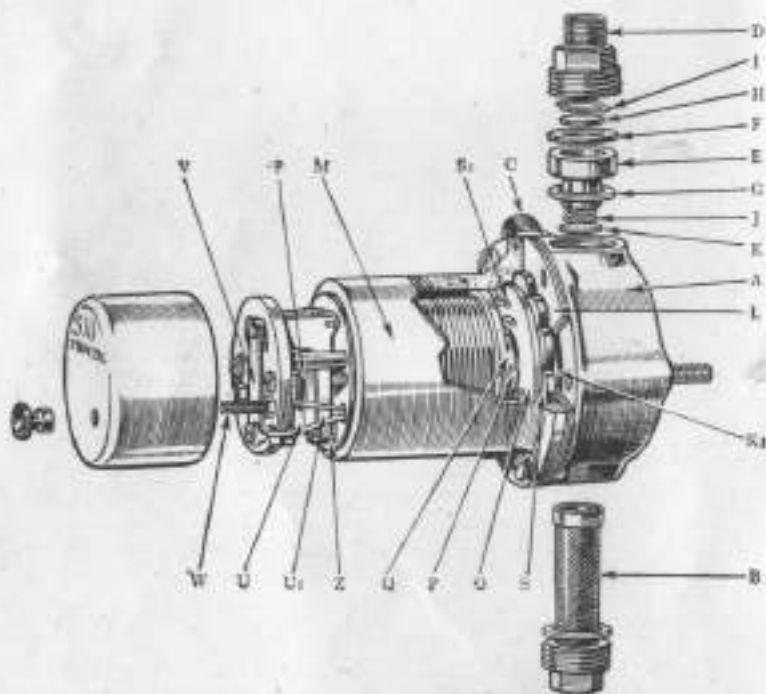

The S.U. electrical petrol pump in part section, showing salient features.

#### Tracing Troubles

Should pump trouble be suspected, first disconnect the pump union of the pipe from the pump to the carburettor and switch on the engine. If the pump functions the shortage is due either to blockage of the petrol pipe to the carburettor, or possibly to the carburettor float needle sticking up. If the pump will not function after this has been done, first remove the filter, which is

held in position by the brass hexagon nut at the base of the pump, and see if this is clear. Then disconnect the petrol pipe leading to the tank and blow down this with a tyre pump to ensure the pipe being absolutely clear, and reconnect the petrol pipe.

If the pump still does not function or only works slowly, the stoppage may be due to a bad earth return. To test for this, make definite metallic contact between the brass body of the pump and the car chassis with the length of copper wire fitted. To ensure a good earth it may be necessary to scrape off a small portion of the black enamel with which the chassis is coated. If the pump then functions normally, the copper earth wire connections should be cleaned and remade.

A bad connection in the pump itself may sometimes be traced to the nut on the terminal inside the cover not being screwed down firmly.

Should these points be found in order but the pump still does not work, the trouble is in the pump itself and the cause will be too much tension on the diaphragm or blackened contact points, the cause of which is the tensioning of the diaphragm. The remedy is to remove the cover from the contact points and pass a piece of thin card between the points when pressed together, so as to effect the necessary cleaning.

To release the tension on the diaphragm, remove the body from the base of the pump by undoing the small screws which hold these two parts together. The diaphragm itself will then be found to be adhered to the body of the pump, from which it will have to be separated. A knife will help in this operation, care being taken to prevent the rollers which support the diaphragm and act as a bearing from falling out. The body should then be replaced on to the base, and the screws put in loosely, but before finally tightening up it is advisable to stretch the diaphragm to its highest possible position. This is effected by switching on the pump and holding the contact points together while tightening the screws well up. This will effect a permanent cure.

Should a pump work intermittently or not start clicking when switched on in the morning, it is an indication that this trouble is occurring and it should be given immediate attention to obviate final stoppage on the road.

#### The Filter

The filter is situated at the bottom of the pump body and is easily removed for cleaning purposes by unscrewing the hexagon plug holding it in position. It should be removed and cleaned in petrol with a stiff brush every 1,000 miles.

#### A Noisy Pump

If the pump becomes noisy it is usually an indication that an air leak is taking place on the suction side of the pump. Check the level of the petrol in the tank and see that it is not too low;



also check all the unions and joints, making sure that the filter union and inlet unions are quite airtight.

If the connections to the pump are in order and the trouble persists, then it is probable that an air leak has developed somewhere in the petrol feed pipe between the tank and the pump. The best way to test whether this is so is to replace the feed pipe by a short length of temporary piping, the mouth of which can be inserted in a can of petrol. If the pump then functions properly it is obvious that a leak has developed somewhere in the feed pipe.

#### Failure to Deliver Petrol

Should the pump continue beating without delivering petrol it is very probable that some dirt has become lodged under one of the valves, in which case they should be dismantled by unscrewing the top or delivery union and lifting out the valve cage, when they can be cleaned and reassembled.

If, however, the pump struggles to pump and becomes very hot, it is probable that the pipe line has become obstructed or that the filter has become clogged.

**A**N INDEX AND OILING CHART are provided for your convenience at the end of this book.

## Care of the Shock Absorbers

**T**HE Armstrong hydraulic shock absorbers fitted to the Morris Eight are of the double-acting type, controlling spring action on both deflection and rebound. They are self-regulating in the sense that their shock-absorbing properties are automatically and progressively regulated to meet the road conditions prevailing. For instance, on a good road the shock absorber provides a normal resistance just sufficient to damp the spring action and avoid all trace of harshness, but when bad roads are encountered and the amplitude of the spring motion is thus increased, the shock absorber automatically builds up an additional resistance which effectively damps out excessive spring motion and enables the car to traverse bad ground exceptionally comfortably.

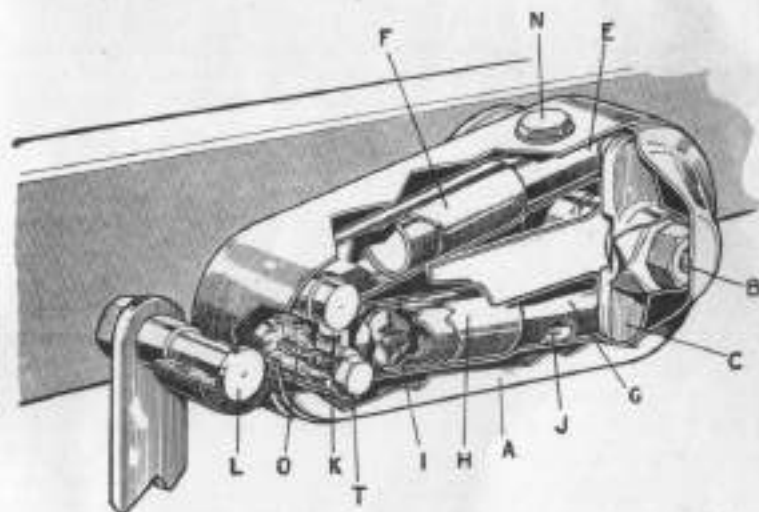

This sectional illustration of the Armstrong hydraulic shock absorber clearly shows main features.

The Armstrong shock absorbers fitted to Morris Eight cars are provided with an improved regulating valve which automatically compensates for differences in the viscosity of the fluid due to changes in temperature. These shock absorbers therefore give the maximum riding comfort under all conditions.

#### Adjustment

The regulating valve of this type of Armstrong shock absorber is controlled by springs. It is correctly set by the manufacturers and cannot be altered. No adjustments are therefore possible.

### Maintenance

Under normal conditions the shock absorber should need no attention whatever, except replenishment of the casing with oil at lengthy intervals. Providing leakage does not take place there is sufficient oil in the casing to last 10,000 miles, or approximately one year's normal mileage. It is, however, advisable to inspect the quantity of oil in the casing at least once a year and replenish the supply, if necessary, through the filler and seal plug "N", taking care to tighten it up firmly again. Ordinary oil must not be used, and it is essential only to use the special oil prepared by Armstrong Patents Ltd for this purpose. This is obtainable in quart tins either from Messrs. Armstrong Patents or from the Service Department at Cowley.

To prevent oil leakage past the shock absorber spindle a special packing gland is provided where it emerges from the casing. Any leakage taking place at this point should immediately be rectified by tightening up the gland nut with a suitable "C" spanner.

Care must, however, be taken not to overtighten the gland nut, or undue strain will be placed on the shock absorber spindle. It is only necessary to tighten up the nut sufficiently to effect an oil seal.

### Repairs

The working parts of the shock absorber are sealed within the casing and cannot be interfered with.

In case of trouble the defective shock absorber should be sent for servicing to Armstrong Patents Co. Ltd., Eastgate, Beverley, E. Yorks, who make a point of rapid servicing in connection with both repairs and spares.

## Lubrication

**C**ORRECT lubrication of any piece of mechanism is of paramount importance, and in no instance is it of greater importance than in the correct choice of lubricant for a motorcar engine. Automobile engines have different characteristics, such as operating temperatures, oiling systems, size of oilways, clearances and similar technicalities.

*Note. The high pressure oils recommended, produced by different makers, differ considerably in their composition, and it is dangerous to replenish the sash with a different make of oil from that in use. If a new make of oil is introduced the sash should first be drained.*

### RECOMMENDED LUBRICANTS

Component	A		B		C	D	E	F
	Lights and Air Leaker	Carbox Sealing Gaskets and Heat-Kills	Wheel Hubs and Fan Bearings	Chain Gears, Pignions and Springs				
Engine Conditions	Tropical and extreme temperature down to 32° F. (-10° C.)	Cold and extreme cold down to 10° F. (-10° C.)	Tropical and extreme temperature down to 32° F. (-10° C.)	Arctic below 32° F. (-10° C.)	Arctic below 32° F. (-10° C.)	Arctic below 32° F. (-10° C.)	Arctic below 32° F. (-10° C.)	Arctic below 32° F. (-10° C.)
"DUCHEMAN'S" (Armstrong-Durston & Co. Ltd)	Durston's N.O.L. "Terny"	Durston's N.O.L. "Terny"	Durston's N.O.L. "Terny"	Durston's N.O.L. "Terny"	Durston's N.O.L. "Terny"	Durston's N.O.L. "Terny"	Durston's N.O.L. "Terny"	Durston's N.O.L. "Terny"
"CASTROL" (C. C. Petroleum & Co. Ltd)	"Castrol" X 1	"Castrol" X 1	"Castrol" X 1	"Castrol" X 1	"Castrol" X 1	"Castrol" X 1	"Castrol" X 1	"Castrol" X 1
"ESOLUBE" (Anglo-American Oil Co. Ltd)	"Esolube" N	"Esolube" N	"Esolube" N	"Esolube" N	"Esolube" N	"Esolube" N	"Esolube" N	"Esolube" N
"MORRISON" (Preston Oil Co. Ltd)	Mobil "A" & "B"	Mobil "A" & "B"	Mobil "A" & "B"	Mobil "A" & "B"	Mobil "A" & "B"	Mobil "A" & "B"	Mobil "A" & "B"	Mobil "A" & "B"
"ENERGOL" (Preston's Lubricants Ltd)	"Energol" S.A.E. 20	"Energol" S.A.E. 20	"Energol" S.A.E. 20	"Energol" S.A.E. 20	"Energol" S.A.E. 20	"Energol" S.A.E. 20	"Energol" S.A.E. 20	"Energol" S.A.E. 20
"SHELL" (Shell Petroleum & B.P. Ltd)	"Shell" "Shell"	"Shell" "Shell"	"Shell" "Shell"	"Shell" "Shell"	"Shell" "Shell"	"Shell" "Shell"	"Shell" "Shell"	"Shell" "Shell"
"FILTRATE" (Edward & Sons Ltd)	"Filtrate" "Filtrate"	"Filtrate" "Filtrate"	"Filtrate" "Filtrate"	"Filtrate" "Filtrate"	"Filtrate" "Filtrate"	"Filtrate" "Filtrate"	"Filtrate" "Filtrate"	"Filtrate" "Filtrate"
"STERNOL" (Starratt Ltd)	"Sternol" "Sternol"	"Sternol" "Sternol"	"Sternol" "Sternol"	"Sternol" "Sternol"	"Sternol" "Sternol"	"Sternol" "Sternol"	"Sternol" "Sternol"	"Sternol" "Sternol"



### Engine

The oil supply is carried in the pressed-steel sump below the cylinder block. On the left-hand side of the cylinder block an oil filler and an oil indicator rod are fitted. The indicator rod has two marks on its lower extremity, indicating the maximum and minimum levels for the oil. By drawing the indicator rod out, the quantity of oil in the sump can be read off from where the oil adheres to the rod. When the oil level reaches the upper or "full" mark on the indicator rod the sump contains approximately half a gallon of oil. The oil level should never be allowed to fall below the lower mark. Inspect at intervals of 250 miles.

In checking the quantity of oil in the sump the rod should be withdrawn, wiped clean, and reinserted before taking the reading. Owing to the surging and splashing of the oil when the engine and car are in motion, an accurate reading is not otherwise possible.

A gear-type pump is carried in the sump of the engine and driven from a vertical shaft. The oil is filtered by a large filter before passing to the pump, thus ensuring the circulation of clean oil. An oil pressure gauge is provided on the instrument panel to indicate the proper functioning of the pump. The actual reading on the gauge may be found to vary considerably on the same car under varying conditions. It will be found on first starting up the engine from cold that a high reading will be obtained. As the engine warms up, and the oil consequently becomes more fluid, this pressure will steadily drop until a reading of some 30 to 60 pounds only is registered. It must be understood that so long as a pressure somewhere in the neighbourhood of this figure is registered on the dial it is an indication that the pump is functioning correctly.

The lubricating pump draws its supply of oil from the bottom of the sump direct and delivers the oil into the pump shaft tunnel, which communicates at its upper end with an oil duct running horizontally from the front to the rear of the engine. Drilled passages deliver oil to the main camshaft bearings, which are in consequence fed with oil under high pressure.

Drilled passages in the crankshaft webs provide lubrication for the big-end bearings, the surplus oil from which splashes on to the camshaft and tappet gear and also serves to lubricate the cylinder walls.

A special oil duct and jet discharges surplus oil from the front camshaft bearing on to the camshaft drive chain, which is consequently well lubricated.

An observant driver will pay as much attention to his supply of lubricating oil as to his petrol supply. Neglect of this results in harsh running and an overheated engine, loss of power, and finally "seizing-up" of pistons or bearings.

### The Dynamo

Every 10,000 miles remove the lubricator cap at the commutator end of the dynamo, refill it with grease to Ref. D (page 49), and replace.

### The Ignition Distributor

Every 1,000 miles add two drops of thin oil to the oiler.

Every 3,000 miles withdraw the rotating arm from the top of the distributor spindle and add a few drops of thin machine oil. Do *not* remove the screw which is exposed. An oil passage is provided leading to the spindle bearing. Take care to refit the arm correctly and push it right home.

Every 3,000 miles the cam should be given the slightest smear of grease to Ref. D (page 49), and every 5,000 miles a single drop of oil should be added to the contact breaker pivot.

Every 10,000 miles the contact breaker base moulding should be removed after releasing its two retaining screws and withdrawing the rotating arm. The automatic advance mechanism which is now exposed should be lubricated with engine oil.

### Gearbox

It is of the utmost importance to keep this filled to the correct level. If the level is too low harsh running of the gears results. If it is too high oil may get into the clutchcase and cause clutch slip.

To fill the gearbox, remove the rubber dust excluder covering the gearbox. This will reveal the oil level dipstick and the filler plug.

When the gearbox has been drained empty, approximately  $\frac{3}{4}$  pint of oil is required.



The rear end of the gearbox, showing the oil filler and some adjacent components.

Oil should be poured in through the filler plug until the oil reaches the "full" mark on the dipstick. The gearbox should be drained and filled with fresh oil after the first 1,000 miles and subsequently every 5,000 miles.

### Draining the Sump

We recommend that when the car has completed the first 500 miles the oil in the sump and the gearbox should be drained to free them from any impurities that may have accumulated during the initial running-in process. Also by reason of the fact that all oil loses some of its lubricating properties after it has been in use for a length of time, we recommend that the sump should be drained every 1,000 miles after the first 500 miles.

On the near-side of the engine below the oil pump will be found a hexagon-headed drain plug. Removal of this plug will release the contents of the sump. When the sump has been drained, approximately 5 pints of oil are required to fill it.

### Chassis Lubrication

At all points of the chassis of the Morris Eight car that require lubrication the new type Enots nipples are fitted, and in the tool kit will be found an Enots "Autolub" oilgun. This gun should be filled with the appropriate brand of Transmission Oil by unscrewing the large cap on the end of the container and removing the automatic feed plunger by pulling on the chain attached to it. When the gun is sufficiently full of oil, the plunger and end cap should be replaced. Removal of the cover on the other end of the gun displays an extension piece with a strong recoil spring surrounding it. This extension is really a type of high-pressure pump, and it has at its end a recess with a hole in the centre. By applying this recess to the projection presented by a nipple and pushing the whole of the pump inwards, oil will be forced under pressure into the nipple, and as soon as pressure is removed from the oilgun the extension will be forced out again by its return spring, and the vacuum created will cause the automatic plunger to take up a new position ready for delivery of the next charge. After using the gun replace the cap over the extension, screwing it up reasonably tightly. This will prevent leakage of the oil from the gun while it is not in use.

### Propeller Shaft

The Spicer propeller shaft sliding joint fitted to the Morris Eight requires regular application of the oilgun every 500 miles to the nipple provided adjacent to the front universal joint. The needle-type universal joints are packed with grease and effectively sealed so that they do not require lubrication attention during the normal life of the car.

### Steering Gear (Bishop Cam)

An Enots nipple is provided on the steering gearbox to which the oilgun should be applied every 500 miles until the gearbox is filled. Use Transmission Oil to Ref. B (page 49) in the oilgun.

### Hand Brake Lubrication

The hand brake gear of the Morris Eight is equipped with special expanding mechanism which requires no lubrication attention.

The oilcan should be applied freely to the brake control lever joints and adjustment screws every 500 miles.

### Front Wheels

These run on journal type ball bearings, and are protected from dirt by a special dust excluder and oil retainer. The bearings are filled with grease before leaving the Works and should only require attention once every 1,000 miles, when the wheel covers should be removed and the oilgun applied to the nipple found on the edge of the large circular washer on the axle end and given two strokes.

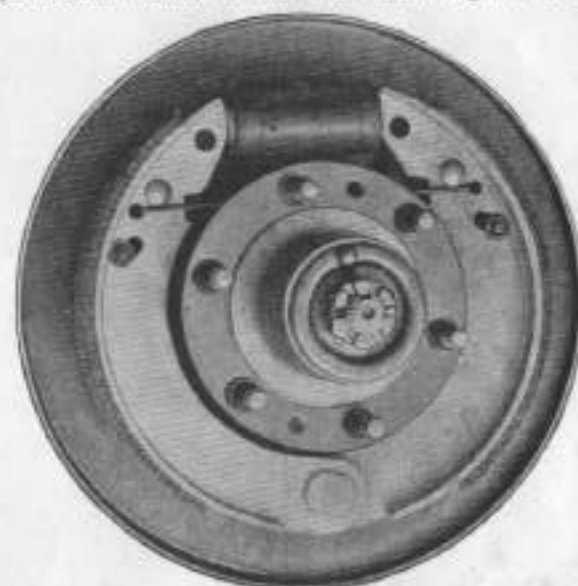

The front hub oil nipple can clearly be seen just above the hub nut.

### Rear Wheels

Once a month, or every 1,000 miles, the wheel covers should be removed, the Enots oilgun applied to the nipple on the end of the axle and given two strokes. It is advisable, whenever screwing on the wheel stud nuts, to place a little oil on the wheel stud threads and smear the outside of the hubs with grease when the wheel is removed.

### Rear Axle

This should be filled to the level of the mark on the dipstick level indicator. When empty the rear axle requires approximately 1½ pints of oil to fill it. The use of Transmission Oil to Ref. B (page 49) is advised. While the car is new the rear axle and gearbox should receive special attention, and it is advisable after the first 1,000 miles to drain the oil out by removing the drain plug at the bottom of the axle case. Then wash out with paraffin, and after



replacing the plug fill up with fresh oil. The rear axle should subsequently be drained every 5,000 miles and refilled with fresh oil.

Always use the same make of oil. If oil of a different make is introduced, it is essential to drain off the old oil and flush out the axle, as extreme pressure oils of different makes do not mix.



The oil filling plug of the Morris Eight rear axle, which also serves to indicate the oil level by means of a dipstick.

### Springs

The springs should be sprayed with one of the special penetrating oils now marketed for the purpose and the spring bolts should be given a liberal supply of oil with the oilgun every 500 miles, as indicated in the oiling chart at the end of this *Manual*. It is to be noted that the rear spring front anchorage is provided with a Silentbloc bush and therefore requires no lubrication.

### Bodywork

Door lock bolts: Oil occasionally in oil hole.  
 Door hinges: Oil occasionally with oilcan.  
 Seat slide runners: Grease lightly occasionally and oil rollers.  
 Sliding roof: Apply a small quantity of thin oil with an oily rag to the inside of the guide channels on which the roof slides.

## Periodical Inspection

As it is of great importance to have all small adjustments attended to, and to make sure that the lubrication of all wearing parts is not neglected, the owner of a car should make a point of periodical inspection. A résumé of items to be looked after will be found useful.

## Items Requiring Attention

### After First 500 miles

Tighten cylinder head stud nuts.  
 Drain old oil from engine; *do not wash this with paraffin* but merely fill with fresh oil. (Page 52). Tighten body holding-down bolts. (Pages 13 and 15.)  
 Tighten spring clip nuts.  
 Adjust four-wheel brakes evenly.

### Every 250 Miles

Inspect oil level in engine. Refill if necessary. (Page 50.)

### Every 500 Miles

See that wheel nuts are tight.  
 Oil up the steering gear, attach oilgun to Enots fittings, and give pump three or four strokes. (Page 52.) These Enots are situated as under:—

10 on shackle bolts; 4 on front axle knuckles; 2 on steering track link; 2 on steering draglink; 1 on brake pedal; 1 on steering gearbox; 1 on propeller shaft sliding joint, making 21 in all.

See that **radiator** is full of water. The water level should never be allowed to sink so low that the opening for cylinder outlet-pipe is not fully covered.

Test tyre pressures. (See page 57.)

### Every 1,000 Miles

Drain engine and refill with *fresh* oil. (Page 52.) Inspect oil level in gearbox and rear axle. Refill if necessary. (Pages 51 and 53.)

Examine level in Lockheed brake supply tank and replenish with Lockheed Orange fluid if necessary.

Add two drops of thin oil to distributor oiler.

Remove wheel covers and give one stroke of oilgun to nipple.  
 Top up battery. (See page 81.)

### Every 3,000 Miles

Withdraw rotating arm from distributor and add two drops of thin machine oil in the aperture.

Remove also contact breaker base moulding and lubricate the automatic advance mechanism with engine oil.

### Every 5,000 Miles

Remove filters from carburetter and petrol pump, clean and replace. (Pages 43 and 45.)

Drain gearbox and rear axle. Refill with fresh oil. Tighten door hinge fixing screws.

Examine the gaps of the sparking plugs and make sure that they are not too wide; they should be .022 to .025 inch. (Page 61.)  
Add a smear of grease to Ref. D (page 49) to the distributor cam.

#### Every 10,000 Miles

Remove sump, clean and refill with fresh oil.

Examine fluid level in shock absorbers and replenish with Armstrong fluid if necessary.

Remove dynamo lubricator cap and refill with grease to Ref. D (page 49).

## Care of the Tyres

**A**LL Morris Eight cars are fitted as standard with Dunlop cord tyres of the wired type for well-base rims.

#### Tyre Pressure

The pressure at which tyres are run is most important, as the modern large-section tyre is sensitive to its degree of inflation. The table given herewith should be adhered to rigidly, for which purpose we recommend that the owner should purchase a pressure gauge.

Do not neglect the pressure until the tyres look as though they wanted more air, because by that time irreparable damage may have been done.

Test the pressure frequently in the spare as well as the running tyres, and restore any loss, even if only a matter of two or three pounds per square inch.

Once a tyre is punctured do not leave it on the spare wheel but have it repaired as soon as possible, or the advantage of the fifth wheel is lost. The spare wheel tyre should always be in repair and fully inflated.

#### RECOMMENDED TYRE PRESSURES FOR MORRIS EIGHT CARS

Type	Tyre Size	Front	Rear
Two-seater ... ..	4.50-17	26 lb. per sq. in.	26 lb. per sq. in.
Tourer ... ..	4.50-17	26 lb. "	26 lb. "
Saloon ... ..	4.50-17	26 lb. "	26 lb. "
Four-door Saloon ...	4.50-17	26 lb. "	26 lb. "

Gauges for testing tyre pressures can be bought from all reputable motor dealers.

## TYRE FITTING AND REMOVAL INSTRUCTIONS

**Special Note**

*Inextensible* wires are incorporated in the edges of wired-type tyres. Therefore do not attempt to stretch the wire edges of the tyre cover over the rim edge.

Force is entirely unnecessary and may be dangerous, as it merely tends to damage the cover edges and serves no helpful purpose.

Fitting or removing will be quite easy if the wire edges are carefully adjusted into the rim base; if it is not found to be easy, the operation is not being correctly performed.

**To Remove Tyre**

Remove all valve parts and push both cover edges into the base of the rim at the part diametrically opposite the valve, then lever the cover edges near the valve over the rim edge (see above illustration).

**To Fit Tyre**

Push one edge of the cover over the edge of the rim. It will go quite easily if the part first put on is pushed right down into the rim base.

Very slightly inflate the inner tube—do not distend it—place it in the cover, with the valve through the hole in the rim. (Take care that the valve, which is fitted in the side of the tube, is on the correct side of the rim.)

Fit the second edge of the cover, commencing at a point diametrically opposite the valve, and pushing the edge down into the base of the rim.

Small levers may be gently used to ease the last few inches over the rim edge.

Whilst inflating, see that the edges of the cover are seated evenly round the rim.

## TYRE VALVES

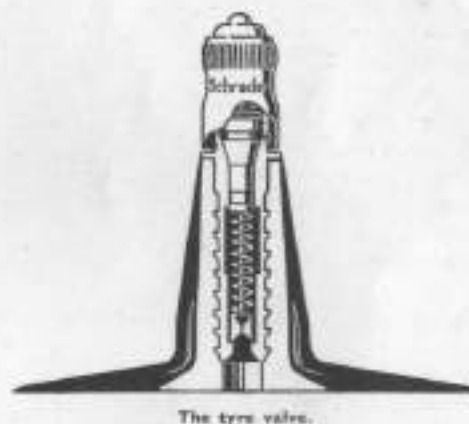
**Valve Interior**

The air-tightness of the valve depends upon the proper functioning of its "interior." It may be tested for air-tightness by rotating the wheel until the valve is at the top and inserting its end in an eggcupful of water. If bubbles appear the seating is faulty. It should be removed and replaced by a new interior. It is advisable always to have spare interiors handy, and these are procurable suitably packed in small metal containers. A small extracting and fitting tool is supplied in the tool kit.



## ACCESSORIES and EQUIPMENT

### SPECIAL PROPRIETARY FITTINGS

The following proprietary equipment and parts therefor can either be obtained direct from the manufacturers, or will be supplied by any authorised Morris Dealer or by the Service Department of Morris Motors Ltd. at current list prices.

All correspondence for replacement parts must be referred direct to the respective manufacturers.

<i>Name of Part.</i>	<i>Name and Address of Manufacturer.</i>
Dynamo ... ..	Joseph Lucas Ltd.
Starter ... ..	Ditto
Ignition Coil ... ..	Ditto
Distributor... ..	Ditto
Direction Indicators ... ..	Ditto
Switchbox ... ..	Ditto
Cut-out ... ..	Ditto
Fusebox ... ..	Ditto
Junction Box ... ..	Ditto
Battery ... ..	Ditto
Ammeter ... ..	Ditto
Lamps ... ..	Ditto
Horn (Electric) ... ..	Ditto
Starter Switch ... ..	Ditto
Windscreen Wiper ... ..	Ditto
Observation Mirror ... ..	Ditto
Instrument Panel Assembly	Ditto
Electric Bulbs ... ..	Ditto
Petrol Gauge and Attach. (Elec.)	S. Smith & Sons (Motor Accessories) Ltd.
Speedometer and Cable ... ..	Ditto
Oilgun ... ..	Benton & Stone Ltd.
Carburetter ... ..	The S.U. Carburetter Co. Ltd.
Petrol Pump ... ..	Ditto
Tyres ... ..	Dunlop Rubber Co. Ltd.
Shock Absorbers ... ..	Armstrong Patents Co. Ltd.
Radiators ... ..	To:—Authorised Morris Radiator Repair Stations.
Lifting Jack and Tools ... ..	R. T. Shelley Ltd.
Sparkling Plugs ... ..	Champion Sparking Plug Co. Ltd.

## Care of the Sparking Plug

ALL Morris Eight cars are fitted with Champion No. L.10 extra range sparking plugs, a view of which is shown herewith. This particular plug has a 14 mm. thread.

The gap between the sparking plug points should be set between .022 and .025 inches. Too wide a gap will cause misfiring, especially at high speeds and under heavy pulling at low speed with an open throttle, while too small a gap causes poor idling. When adjusting gap move the side wire—never bend the centre wire!



The Champion sparking plug.

After the first several hundred miles of operation, it will be necessary to clean the sparking plugs, for during the "wearing-in" process which is taking place in the car's early life, an excess amount of oil is generally used, and the slow-speed carburetter adjustment is a little rich, with the result that carbon may deposit on the sparking plug insulator, causing a fouling condition. This soon disappears, however, when the motor has been well run-in and fresh oil introduced.

It must not be forgotten that the best of sparking plugs do not wear for ever. The intense stresses and strains imposed, especially in modern high-compression engines—often under conditions which are not of the best—are so terrific that naturally there is a gradual

deterioration of the sparking plug. Inefficient functioning of the plugs means incomplete combustion in the engine cylinder, and incomplete combustion means unburnt gas going out of the exhaust. In this case the full heat value of the fuel is not used, and as a result power is lost and fuel is wasted. In this connection, therefore, it is recommended that sparking plugs should be replaced at intervals of 10,000 miles of service. By so doing you will restore power, speed, and save their cost many times over. Moreover, during the life of the plugs every considerate attention thereto will be repaid by unflinching service.



Adjustments should be made only by the side wire, and the combined setting tool and gap gauge illustrated can be obtained from the Champion Sparking Plug Co. or your Morris Dealer.

## Decarbonising and Valve Grinding

THE formation of carbon is unfortunately one of the troubles every internal combustion engine is heir to. It occurs on every car and is mainly due to the necessary use of oil for lubrication purposes. The existence of an excessive deposit of carbon in the cylinder head is usually indicated by a falling off in power and a metallic noise from the engine when it is pulling hard uphill or picking up on top gear, which is commonly known as "pinking." The noise is similar to that produced when the ignition is too far advanced, but it should not be confused with that noise.

Decarbonising and grinding-in the valves of the Morris Eight engine is really a very simple operation, well within the capacity of the average "handy-man." The materials required, in addition to the standard tool kit, are a plentiful supply of clean rags, some valve-grinding paste, a flat tin (a deep baking tin is particularly suitable), some paraffin to make a washing bath, a special suction valve-grinding tool and a special locating tool for the cylinder head. Both the latter tools can be obtained from the Service Department of Morris Motors Ltd. or your nearest Morris Dealer. A valve spring compressing tool will greatly facilitate removal of the valves. This also can be obtained from any Morris Dealer.

Having collected the required equipment, start up the engine and let it run until it is nicely warm. It is far more comfortable to work on a warm engine. Then manoeuvre the car so that the radiator is near a drain or other suitable place where the cooling water can be run off. Whilst the radiator is draining you may with advantage proceed to remove the bonnet by unscrewing the two bolts which attach the radiator stays at the rear end to the dash. This will enable you to tilt the radiator forward slightly and release the bonnet rod from its sockets.

### Removing the Cylinder Head

For safety disconnect the positive battery lead from the battery. Remove the air intake silencer.

Release the water outlet hose from the cylinder head outlet.

The tension of the fan belt should then be released by slacking the dynamo cradle clamping bolts and the water outlet hose released from the cylinder head and radiator.

Release the air silencer from the carburettor and cylinder head stud.

Uncouple the leads to the horn and dynamo, making careful note from which terminal they are removed.

The bolts attaching the adjustable portion of the dynamo cradle to the bracket portion attached to the cylinder head should now be removed completely, thus releasing the dynamo, which should be placed in a safe place.

Uncouple the high-tension wires from the sparking plugs and the high-tension lead and low-tension lead from distributor to coil at their attachment to the coil.

Release the distributor by removing the set screw near the centre of the head which locks the timing lever to the head, first making a note of the position of the graduated quadrant in relation to the arrow mark on the cylinder head. *On no account disturb the pinch bolt attaching the distributor quadrant to the distributor or the timing will be lost.* Withdraw the distributor.

The cylinder head is held on to the cylinder block by thirteen nuts screwed on to the long studs passing through the cylinder head, and these also hold the dynamo cradle, air silencer and horn bracket in position. Slacken off these nuts in rotation, half a turn at a time, until they are quite loose, then finally remove them. It is unwise to unscrew any one of these nuts completely before slackening off the remainder, as this will impose uneven stress upon the cylinder head, leading to its distortion.

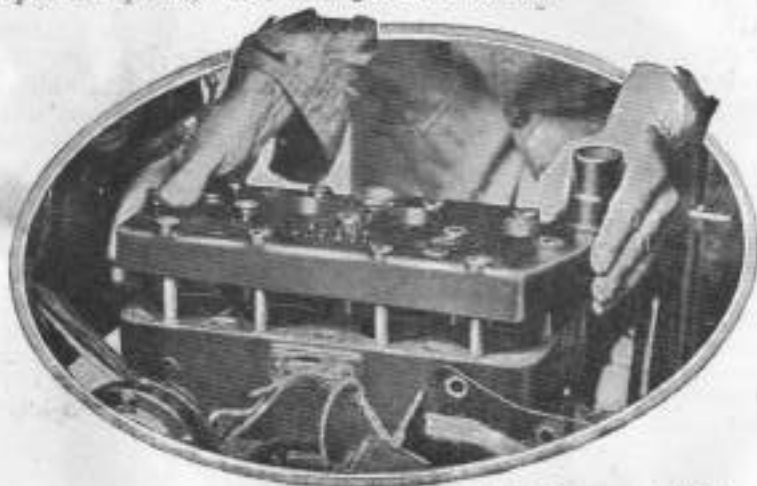

The cylinder head can easily be lifted from the studs in the manner indicated.

The cylinder head is now ready to be lifted from the cylinder block. The breaking of the joint between the two will be facilitated by smartly turning the engine by the starting handle. Do not insert a screwdriver or similar tool against the gasket, which would become damaged as a result. When the joint is broken no difficulty should be experienced in lifting the head clear of the studs providing it is withdrawn squarely. Place the head on a bench out of harm's way, and carefully lift the copper-asbestos gasket straight off the cylinder head studs, keeping it parallel with the upper face of the cylinder block and taking particular care that it is not bent or otherwise damaged in the process.

#### Decarbonising

Turn the engine by the starting handle until any two pistons are at the top of their travel. Stuff the open ends of the other cylinders with clean rag, and with an old screwdriver, or some other blunt

tool, scrape the black deposit off the top of the pistons and the face of the cylinder block adjacent to the cylinder bores. With a clean rag dampened with paraffin clean off every trace of foreign matter remaining, but do not attempt to polish things up with emery cloth or other abrasive, or you will do far more harm than good. Take particular care to go round each valve with a small screwdriver in order to remove all trace of carbon. When these two pistons have been properly cleaned give the starting handle half a turn and clean the other two in the same way.

Attention should now be given to the cylinder head. Remove the sparking plugs and turn the head upside down, thus exposing the combustion chambers.

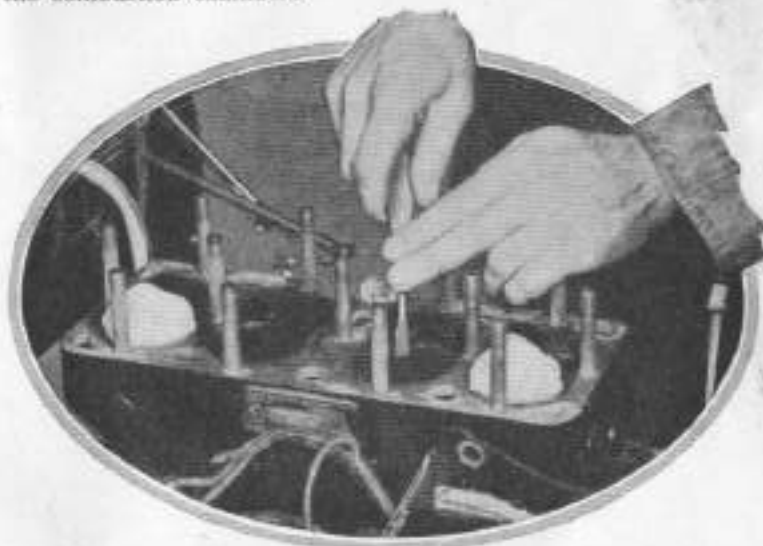

Removing the carbon from the piston crowns.

With a blunt screwdriver carefully scrape away the carbon deposit adhering to the surface of the combustion spaces and carefully clean with rag moistened with paraffin.

#### Removing the Valves

Having thoroughly cleaned the combustion spaces, pistons and valve heads, you may remove the valves. To obtain access to the valve springs, it is necessary to remove the inlet and exhaust manifold and the valve chamber cover-plate on the near-side of the engine below the manifold by unscrewing the two knurled nuts holding the cover in position.

When removing the cover care should be taken not to damage the composition gasket beneath it or difficulty will be experienced in making an oiltight joint later.

The valve spring can now be compressed with the special valve tool previously mentioned, after removing the inlet and exhaust



manifold. Compression of the springs will expose two small conical cotters engaging in a groove in the pencil-like end of the valve stem. Removal of the cotters will release the valve spring cap from the valve stem, permitting its removal and releasing the valve spring. When the spring cotters have been removed, the valve may be withdrawn from its guide. Repeat this operation on the remaining valves until they are all removed. It is not essential completely to remove the valve springs; they may be left resting in the tappet heads until the valve is replaced, providing care is



Decarbonising the cylinder head.

taken to see that the valve stem passes through the spring cap during the grinding process, and the tappet screws are slackened back.

#### Grinding-in the Valves

When grinding-in the valves the utmost care should be taken to see that they are inserted into the correct port. Each valve is clearly numbered on its head, No. 1 being at the forward end of the cylinder block.

The grinding-in process consists in coating the bevelled face of the valve with a small quantity of valve-grinding paste—applied on the end of a match-stick—reinserting the valve in its guide and partially rotating it backwards and forwards on its seating by means of the special suction tool previously mentioned. Here we come to the secret of good valve grinding. The valve should be raised from its seating every few reciprocations and given a half turn in order that the grinding compound may spread itself evenly over the whole of the surface. Probably the most convenient way of carrying out

this periodical lifting is to obtain a light coil spring (similar to the valve spring but much lighter), and insert it into the valve port beneath the valve head. When pressure is released on the valve-grinding tool the valve will pop up, when it can easily be rotated into a fresh position.

It is not necessary to continue grinding the valves once the faces of both valve and seating have assumed a clean, even, matt-surfaced appearance. A polished surface must not be expected and

The special suction type valve-grinding tool in use. The use of a light spring under the valve head greatly facilitates the grinding-in process.



is quite unnecessary. If the engine has been run for a long period without being decarbonised, the valve face may be badly "pitted"—that is to say, it will have a number of small black spots or depressions on its face. Should these depressions be at all excessive or deep, it is best to have the valve face trued up on a special machine at a garage. This will prevent needless grinding away of the valve seating in the cylinder block—a matter of importance, as it cannot easily be renewed. Any valves which are distorted should immediately be replaced by new ones. To attempt to grind them in will only produce extensive damage to the seating.

After each valve is ground in it should be withdrawn and carefully washed in paraffin, and, what is equally important, the valve seating and the surrounding valve port should also thoroughly be cleaned with a rag moistened with paraffin. Do not wash out the valve ports with petrol or paraffin or some of the grinding compound will find its way into the valve guides or other working parts, where extensive damage may be done.

### Reassembling the Valves

The valves may now be reassembled. Care should again be taken to see that they are in their correct ports. Reassembly of the valves is not a difficult matter with the aid of the valve tool described. After inserting the valve in its guide, the valve spring may be placed in position, followed by the valve spring cap. Engage the valve tool on the cap and compress the spring so as to expose very nearly the whole of the groove in the lower end of the valve stem, on which you should place a little thick grease to hold the cotters. Insert the two conical cotters into the groove in the valve stem (small ends upwards, of course) and gradually release the spring. Make sure that the cotters are properly engaging in their grooves before dealing with the next valve.

The component parts of the valve, consisting of the valve, valve cotters, valve spring and valve spring cap.

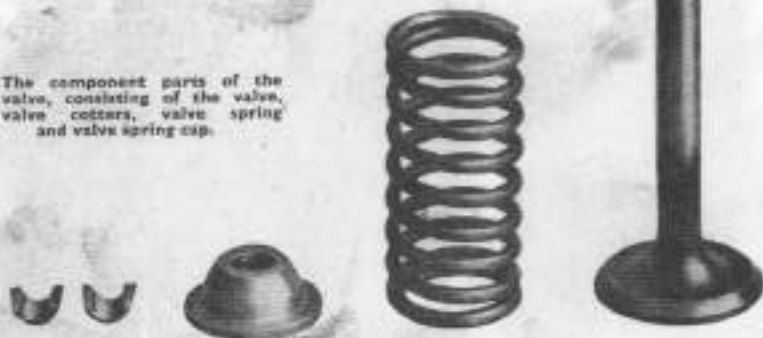

### Adjusting the Tappets

In the process of grinding-in the valves a certain amount of metal is always removed. This tends to reduce the clearance existing between the stem of the valve and the head of the tappet. It is essential for the proper functioning of the engine that this clearance should not be less than .010 in. when the engine is hot, and it is therefore necessary to check the clearance of each valve with the feeler gauge attached to one of the special tappet adjusting spanners in the manner outlined on page 20.

### Replacing the Cylinder Head

When all the valve clearances have been correctly adjusted, the cylinder head is ready for replacement. It is first of all necessary thoroughly to clean the gasket and remove any carbon deposit adhering to its edges, and to coat both sides of it with an even film of gold size or similar jointing compound. If the gasket has been in any way damaged during the removal of the cylinder head, do not attempt to use it again, but immediately procure a new one. See that any new gasket does not burr up around the stud

holes and that the cylinder bore openings are clear of the cylinder bores themselves. The gasket can then be located over the studs in the cylinder block and gently pushed into position on to the upper face of the cylinder block. It will be found convenient to use a short length of tubing (a box spanner does quite well) over the studs to push the gasket in position. This should be done very gently, taking care to keep the gasket parallel with the cylinder head and not to force one end or one side down before the other.

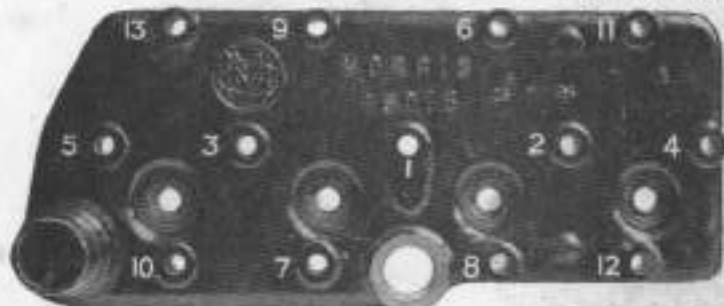

Indicating the sequence in which the cylinder head stud nuts should gradually be tightened.

Having located the gasket in position, the head may be lowered on to the cylinder block. Insert the special cylinder head locating tool right home into the distributor spindle tunnel. Replace the horn, air silencer and dynamo brackets and then the thirteen cylinder head nuts, tightening them up in the rotation indicated in the illustration, and giving each a quarter of a turn at a time until all are up tight.

The special locating tool may now be withdrawn.

The distributor should now be replaced and the distributor rotating arm carefully rotated until the tongue of the lower end of the spindle engages with the slot on the upper end of the drive shaft. The tongue and slot are offset to ensure their correct replacement. Set the distributor timing arm to the correct mark and tighten up the locking set screw.

The sparking plugs should now be replaced, as should the high-tension leads, low-tension leads, horn leads, dynamo, dynamo leads, and dynamo belt.

Adjust the dynamo belt tension, fill the radiator with water, start up the engine and let it idle quietly until it is thoroughly warm. Then, switching off again, go over each of the cylinder head nuts in turn, giving each a final tightening up. It will be found that now the engine is warm an extra half turn or so can be given to each nut. Do not attempt to speed up the engine until this final tightening has been effected.

You may now replace the bonnet. After 250 miles the cylinder head nuts should again be tightened up, the valve cover removed and the valve clearances checked.

# Tracing Troubles

## Motor will not Start

**I**F for any reason the motor fails to start readily when the starter button is pulled, do not keep it revolving for a long period, but return the starting switch to the "off" position at once. One of the following things may be the cause of the trouble:—

- The ignition switch may not have been turned on.
- Your petrol supply may be exhausted.
- The carburetter mixture control may be wrongly set, causing the mixture to be either too rich or too weak.
- Carburetter piston stuck.
- The sparking plugs may be fouled with oil or carbon.
- The high-tension lead from ignition coil to distributor may be loose, broken or damaged so as to leak.
- The petrol filters of the petrol pump and carburetter may be choked.
- The automatic petrol pump may not be functioning properly.
- The petrol pipe may be clogged or may have an air lock.
- The battery may be run down (lamps light when switched on, but gradually fade out).
- The ignition coil may be defective.
- The distributor contacts may be faulty and require resetting and cleaning.
- The low-tension wire from coil to distributor and coil to ignition switch may be broken or faulty.
- There may be water in the petrol feed.

## Motor Misses at High Speeds only

- This may be occasioned by:—
- Faulty sparking plugs which may be fouled or gaps not properly set.
- Shortage of fuel due to dirt or obstructions in the petrol pipe, accumulation of dirt at filters, or petrol feed not working properly.
- Improper functioning of inlet or exhaust valves (inlet valve indicated when spitting in carburetter takes place, exhaust valve when "banging" in silencer takes place).
- Valve clearance may be badly set.
- One of the electrical connections may be loose, particularly in the high-tension lead between the coil and distributor.
- Distributor contact breaker badly set or dirty.

## Motor Misses at All Speeds

- This may be due to:—
- Faulty sparking plugs with an internal fault, such as oil on plug points, carbon deposit, or too wide a setting.
- Faulty valve action due to incorrect setting of valve tappet clearance or valve sticking in guide.

Warped or badly pitted valves also arising from faulty setting of the tappet clearance.

- Broken valve spring.
- Insufficient fuel due to petrol filters being clogged. (See pages 43 and 45.)
- One of the ignition wires may be loose and making intermittent connection, particularly that between coil and distributor.
- Distributor contacts may not be functioning with regularity and in need of attention. (See page 76.)
- The carburetter may be flooding, due to dirt on the needle valve seating causing mixture to be too rich. (See page 42.)

## Motor Misses at Low Speeds only

- This may be due to:—
- Valves not seating properly, due to faulty tappet setting or distortion. (See page 20.)
- Air leaks in induction system, due to faulty joints between carburetter and induction pipe or induction pipe and cylinder block. Check joint gaskets for soundness and tighten up all nuts.
- Carburetter setting faulty (refer to carburetter section, page 38).
- Spark may be too far advanced when motor is running very slowly. Check functioning of automatic advance and retard in distributor.
- Battery run down and thus unable to supply sufficient current for ignition purposes.

## Engine Stops Suddenly

- If the engine stops suddenly without making any further attempts to run:—
- Examine carburetter and ascertain that float-chamber is receiving sufficient petrol supply. (Shortage of fuel is usually indicated by one or two restarts before the engine finally stops, or by spitting through the carburetter.)
- Test flow from carburetter jet. (See page 41.)
- Test spark at plug points by removing plug, resting on engine, and observing spark when starter motor switch is pressed.
- If spark is weak or non-existent, check distributor lead connections to coil and distributor, check distributor contact breaker points, clean and reset, if necessary.
- If the spark is still weak, test all electrical connections.
- If spark still remains weak, check coil as indicated in paragraph on checking ignition faults.

## Engine Spits through Carburetter

- This is usually an indication of a weak mixture.
- Check fuel supply to carburetter float-chamber. Remove carburetter and automatic petrol pump filters, clean and replace.
- Carburetter piston may be sticking.



It may be caused by air leaks in the induction system. Check over all joints in the induction manifold, and tighten up nuts.

Faulty setting of the inlet valve tappet clearance, preventing valves from closing properly, also causes this trouble.

One or other of the inlet valves may be sticking in its guide.

#### "Banging in Silencer"

This is usually an indication of a faulty exhaust valve which is not closing properly, due to a warped seating or faulty valve tappet clearance. It may also be due to the exhaust valve sticking in its guide. It may also be produced by faulty mixture supply, which is either much too rich or too weak.

If "banging" takes place in the silencer when proceeding downhill with the throttle closed, it is usually an indication that the throttle does not fully close when the foot is taken off the accelerator pedal. The slow-running position of the throttle should be checked over and the carburettor setting checked.

#### Checking Ignition Faults

The first step is to ascertain whether the fault lies in the sparking plugs, the wiring, or the coil and distributor. If the engine does not fire on one particular cylinder, the fault usually lies in the sparking plug for that cylinder or the high-tension lead to it. The faulty cylinder can be determined by short-circuiting each sparking plug in turn with a screwdriver *having a wooden or insulated handle*, the blade making connection between the sparking plug terminal and an adjacent portion of the engine. If shorting of the plug makes no difference to the engine beat, then it is this cylinder which is definitely at fault. If, on the other hand, shorting the plug alters the beat of the engine, it is an indication that this cylinder is functioning correctly and that the trouble lies with one of the others. Try each cylinder until the faulty one is definitely located. Remove the plug of the faulty cylinder and examine points for gap and the plug for condition generally. If it is very oily or shows signs of heavy carbon deposit in its interior, the plug should be cleaned with petrol and the points reset. Before replacing the plug check the spark by connecting the high-tension lead to its terminal and resting it on some part of the engine, taking care that the terminal is not making contact. Get someone to turn the engine with the starting handle and observe whether a spark is taking place at the plug points. If no spark is taking place, try a fresh plug. If a spark still does not appear, switch on the ignition, turn the engine and observe the ammeter reading. (The engine should be turned by hand if it is known that the battery is in a low state of charge.)

If the ammeter reading rises and falls with the closing and opening of the contacts, then the low-tension wiring is in order. If, however, the reading does not fluctuate in this way, a short

in the low-tension wiring is indicated or the contacts are remaining closed. When no reading at all is given, a broken or loose connection in the low-tension wiring is indicated or the battery may be exhausted. Check the high-tension lead from coil to distributor, making sure it is in proper contact with its terminal sockets. Remove distributor cover and check contact breaker points, clean and reset if necessary. If you still fail to obtain a spark at the plug points, check over all battery connections and connections between coil and ignition switch, and coil and distributor.

Examine the high-tension cables, i.e. cables from the coil to the distributor and from the distributor to the plugs.

If the rubber shows signs of deterioration or cracking, the cable should be renewed. Remove the distributor moulding and examine the contacts; clean them if necessary as described on page 76. Turn the engine over by hand and see that the contacts come together smartly.

If no reading is given on the ammeter examine the low tension wiring, i.e. the cables from switchbox to the coil, from the coil to the distributor, and from the distributor to the chassis. Also see that the battery terminals are tight and that the cables from the battery to the switchbox are secure. The battery may be dismissed as the cause of the trouble if the lamps will light.

Test the coil independently of the distributor by removing the cable from the centre distributor terminal and holding it about  $\frac{1}{4}$  in. from some metal part of the chassis. Turning the engine should produce a strong and regular spark if the coil is functioning correctly.

#### Starter Motor does not Operate

This may be caused by an exhausted battery, due to excessive use of the starter motor or the lights, and is the direct result of failure on the part of the owner to observe the recommendations made in the electrical section of this *Manual*. It may also be caused by broken or loose wires, either in the battery, the starting switch, or the starter motor. Therefore examine all terminals and wires carefully for looseness or damage. Corroded terminals sometimes produce poor contact and thus interfere with the functioning of the motor. Disconnect all corroded terminals, thoroughly clean and finally coat them liberally with vaseline.

The starting switch may be defective, in which case it should be replaced.

#### Engine Lacks Power and is Sluggish

This in a new car may be caused by general tightness of the engine and will wear off after the car has been used for approximately 1,000 miles.

It may also be due to faulty setting of the ignition control.

Faulty setting of the carburettor mixture control is also a source of trouble of this nature.

In an engine which has seen some use, sluggishness is an indication of excessive carbon deposit, particularly if accompanied by "pinking" when the engine is pulling hard. It may also be occasioned by faulty valves or faulty valve clearances.

#### Motor Runs Hot

Water supply in radiator too low. It is necessary always to have the water well covering the base of the upper tank.

Running with the spark too far retarded, due to faulty setting. This is accompanied by a marked loss in power and sluggishness.

Carburettor mixture control maintained at "rich" position for too long a period. The carburettor mixture control should be returned to the "weak" position as quickly as possible after starting, without causing the motor to sputter and run unevenly.

Hand brake has been left partly on or foot brake adjusted too closely.

Fan belt broken, indicated by no change reading on the ammeter.

#### Engine Knocks when Pulling Hard

When an unusual sound emanates from the engine, investigate its cause immediately and do not continue running the engine in the hope that matters will right themselves. First of all ascertain that the oil gauge is registering the right pressure and that there is plenty of oil in the sump. Make sure that the noise is not due to shortage of lubricant.

The more general causes of engine knocks are:—

1. *An excessive accumulation of carbon deposit on the piston heads, valves and combustion chamber.* This state of affairs is indicated by a high-pitched metallic ring or "pinking" whenever the engine is made to pull hard. This develops gradually as the engine is further used and must not be confused with a similar noise produced by too far advancing the ignition. When an engine is suffering from excessive carbon deposits, it will have a tendency to be sluggish, run rather hot, and labour heavily on gradients.

2. *Loose or worn bearings.*

*Loose big-end bearings:* These produce a rattle usually heard at speeds of between 25 and 35 m.p.h., when the accelerator is only partly depressed and the engine is running light. If the engine is speeded up with the throttle a quarter open and the car at rest, the noise will usually develop and can then be cut out by shorting the sparking plug of the cylinder concerned. When the sparking plug is released a heavier knock will be produced.

It should be noted, however, that with modern high-pressure lubrication these noises are of very little magnitude, even when the big-end bearing has actually run.

*Loose little end bearing:* This is heard more readily at low speeds and is a somewhat hollow sound which is not completely cut out by shorting the sparking plug, although reduced somewhat.

The accurate diagnosis of knocks is a matter for an expert accustomed to the particular engine, and you are advised to consult your nearest Morris Dealer as soon as any unusual noise occurs.

*Remember it is bad policy to continue running a car if it is in any way faulty.* If the trouble is attended to early, no damage need be done and the matter may be comparatively easily remedied; but if allowed to continue extensive damage may ensue.

For dynamo, starter motor, and lamp troubles see pages 90-92.

**A**N INDEX AND OILING CHART  
are provided for your convenience  
at the end of this book.

## Maintenance of the Lucas Coil Ignition System

VERY little attention is needed to keep the ignition equipment in proper condition. Occasional inspection of the system is advised, however, when any parts needing adjustment or cleaning can be attended to.

### Distributor Unit

Occasionally remove the distributor moulding (Fig. 1) by pushing aside its two securing springs. See that the electrodes are clean and free from deposit. If necessary wipe out the distributor with a dry duster, and clean the electrodes with a cloth moistened with petrol. Also see that the carbon brush slides freely in its holder.



Fig. 1. Distributor UNIT.

Next examine the contact breaker. It is important that the contacts are kept free from any grease or oil. If they are burnt or blackened they may be cleaned with very fine carborundum stone or emery cloth and afterwards with a cloth moistened with petrol. Care must be taken that all particles of dirt and metal dust are wiped away. Misfiring may be caused if the contacts are not kept clean. The correct contact breaker gap is  $\frac{1}{16}$ " maximum.

A gauge of the correct thickness is provided on the ignition screwdriver. Provided that the can is kept clean and that the instructions on can lubrication given on this page are carried out, the wear on the feel will be negligible and the contact breaker gap will then only need adjustment at very long intervals. If the can is dirty it may be cleaned with a cloth moistened with petrol, and afterwards given a smear of vaseline. It is not advisable to alter the setting unless the gap varies considerably from the gauge. If adjustment is necessary, proceed as follows: Turn the engine round slowly by hand until the contacts are seen to be fully opened, then using the ignition screwdriver, slacken the two screws in the contact breaker plate and move the plate until the gap is set to the thickness of the gauge. After making the adjustment care must be taken to tighten the locking screws.

### Lubrication of Distributor Unit

The distributor main bearing is lubricated from an oiler through which one or two drops of thin machine oil should be added every 1,000 miles.

The can should be given a smear of grease to (Ref. B (page 49) about every 5,000 miles. Every 5,000 miles plus a single drop of oil on the point on which the contact breaker works.

Every 3,000 miles withdraw the rotating arm from the top of the spindle and add a few drops of thin machine oil. Do not remove the screw which is now exposed to view; there is a clearance between the screw and the inner face of the spindle through which the oil passes to lubricate the can bearing.

Take care to refit the arm correctly and to push it on to the shaft as far as possible.

About every 3,000 miles the moving parts of the automatic timing control must be lubricated with a good grade engine oil. To render the control accessible remove the distributor moulding and lift off the rotating distributor arm, then remove the contact breaker base moulding by withdrawing its two securing screws.

Take care to refit contact breaker base moulding in original position.

### Adjustment of Ignition Timing

The distributor attachment quadrant is graduated, and an indicating arrow is provided on the cylinder head to facilitate its accurate location. The ignition timing can be adjusted within certain limits, by slackening the quadrant set screw and rotating the distributor body in the desired direction. Moving the distributor clockwise advances the ignition. Moving the distributor anti-clockwise retards the ignition. The quadrant should only be moved through half a division at a time.



### Coil

The coil unit is not adjustable in any way and requires no attention beyond seeing that the terminal connections are kept tight and the moulded coil top is kept clean.

### Renewing High-Tension Cables

When the high-tension cables show signs of perishing or cracking, they should be replaced. Use only 7 mm. rubber-covered ignition cable for all high-tension leads.

The method of connecting the cables is to thread the moulded moulded nut over the lead, bare the end of the cable for about  $\frac{1}{4}$  in., thread the wire through the brass washer provided, and bend back the strands. Finally screw the nut into its respective terminal.



### Ignition Switch and Warning Lamp

The ignition switch is incorporated in the lighting and charging switch on the instrument panel. In addition to merely stopping the engine, the switch serves the purpose of preventing the battery being discharged by current flowing through the coil windings when the engine is stopped. To give indication to the driver when current for the coil is being drawn from the battery, a warning lamp is provided in the instrument panel, which gives a red light when the ignition is "on" and the car is stationary. The warning lamp will also light when the engine is running very slowly, as the dynamo under these conditions is not running at a high enough speed to generate sufficient voltage to actuate the cut out.

If the warning light remains "on" continuously when the car is running at speeds above 20 m.p.h., it is an indication that the dynamo is not charging, and it should be given immediate attention or the battery will quickly become drained.

After long service the warning lamp bulb may burn out. However, this will not affect the ignition, but it should be replaced as soon as possible so as to act as a safeguard to the battery. To replace the bulb, unscrew the lamp front, when the bulb can be removed. The bulb is a 2.5 volt, 2 amp., screw cap type (Lucas No. C252A).

### The Detection and Remedy of Ignition Faults

If failure of the ignition or misfiring occurs and the cause is not obvious, the owner is strongly recommended to proceed in accordance with the routine outlined on page 72, which should enable him to locate the trouble without difficulty.

If, after carrying out the examinations suggested, the trouble cannot be found, we strongly advise that the equipment should be examined by the nearest Lucas Service Depot.

## Maintenance of the Lucas Starting and Lighting System

### Dynamo

THE dynamo is mounted on a platform at the front end of the engine, and is driven by a belt. It is arranged to give half its normal output whenever the charging switch is in the "Low Charge" position, an increased output when the switch is in the "High Charge" position, and its maximum output when the headlights are switched on.

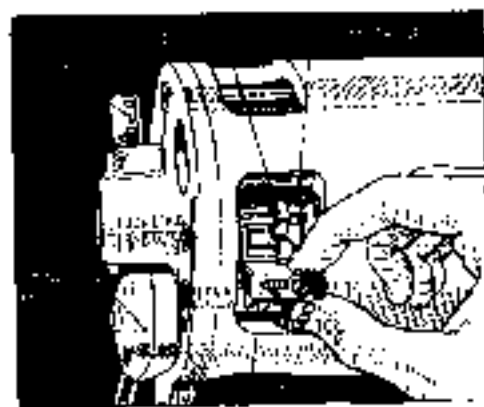

The dynamo requires but little attention; there are a few components, however, which should be inspected about once a year to ensure satisfactory results. These parts are readily accessible by removing the cover fixing screw.

### Brushes

It is essential that the brushes make good, firm contact with the commutator. The brushes are held in boxes by means of springs. Hold back the spring and move the brush to see that it is free to slide in its holder. If there are any signs of sticking, remove the brush from its box and clean both the brush and its box with a cloth moistened with petrol.

After removing brushes for cleaning or any other purpose, care must be taken to replace them in their original positions, otherwise they will not "bed" properly on the commutator.

If, after long service, the brushes have become worn to such an extent that they will not bear properly on the commutator, they should be replaced. Always fit genuine Lucas brushes, as these are made specifically for work on our machines and will give by far the best results and the longest life. We advise you to have the

brushes fitted at a Lucas Service Depot, so that they can be properly "bedded" to the commutator.

When ordering brush replacements, state whether they are main or control brushes, and for what type of machine they are required.

#### Commutator

The surface of the commutator should be kept clean and free from oil and brush dust, etc.; neglect of this precaution will result in the commutator becoming blackened, causing sparking to occur at the brushes, and consequent shortening of the life of the machine. The best way to clean the commutator is to insert a fine duster, held by means of a suitably shaped piece of wood, against the commutator surface, slowly rotating the armature at the same time.

If the commutator has been neglected for long periods, it may need cleaning with fine glass paper, but this is more difficult to do and should not be necessary if it has received regular attention.

#### Lubrication

As the bearings are packed with lubricant before leaving the Works, very little attention is needed. Once every 10,000 miles unscrew the cap of the lubricator at the commutator end. If the lubricating wick is dry, the cap must be refilled with grease to Ref. D (page 49).

After the car has run several thousand miles the dynamo should be cleaned, adjusted and the bearings re-packed with lubricant. This should be entrusted to the nearest Lucas Service Depot.

#### Dynamo Output

The dynamo output is accurately set before leaving the Works to suit the requirements of the equipment fitted on your car, and in normal service the battery will be kept in good condition. If, due to very special running conditions, however, you should find that the battery is not kept in a charged condition, or is being excessively overcharged, we advise you to consult your nearest Lucas Service Depot, where any necessary adjustments can be made. We do not recommend owners to attempt the adjustment themselves.

#### Field Fuse

A fuse is provided in the dynamo field circuit to protect the machine in the event of anything being wrong in the charging circuit, e.g. a loose or broken battery connection. The fuse is of the cartridge type and is housed in the cut-out and fusebox on the engine side of the dash (see page 84).

#### Starting Switch

The switch is extremely simple in construction, and as there are no working parts liable to get out of order, the contacts are permanently enclosed. Operate the switch firmly and quickly, both in switching on and releasing.

#### Starter Motor

The armature spindles of these machines are fitted with a pinion which, on rotation, runs into engagement with the geared ring on the flywheel. Immediately the engine begins to fire, the pinion is automatically thrown out of mesh.

If, for any reason, the pinion wheel on the motor does not engage with the flywheel teeth, examine the screwed sleeve on the armature spindle to see that it is free from dust; if necessary, wash over with paraffin. Occasionally give it a few drops of thin machine oil.

In the unlikely event of the starter motor pinion becoming jammed in mesh with the flywheel, it can be freed by turning the squared end of the starter shaft with a spanner. Access is obtained to this squared end by withdrawing the two screws securing the small metal cap.

As in the case of the dynamo, the surface of the commutator must be kept clean and free from oil, brush dust, etc.

In the event of the engine refusing to fire after being turned by the starter, make sure that the ignition switch is "on."

#### Battery Important Points

1. Keep the acid level with the top of the separators.
2. Add only distilled water; never tap water.
3. Take frequent readings of the specific gravity by means of the hydrometer.
4. Do not allow the battery to remain discharged; if run down, through whatever cause, recharge at once.
5. Keep the terminals spanner-tight and smeared with vaseline.

It is of the utmost importance that the battery should receive regular attention, as upon its good condition depends the satisfactory functioning of the ignition, starting motor and the lamps.

At least once a month the vent plugs in the top of the battery should be removed, and the level of the acid solution examined. If necessary, distilled water (which can be obtained at all chemists and most garages) should be added to bring the acid level with the top of the separators. If, however, acid solution has been spilled from any of the cells, it should be replaced by a diluted sulphuric acid solution of the same specific gravity as the acid in the cells. *It is important, when examining the cells, that naked lights should not be held near the vents, on account of the possible danger of igniting the gas which is generated by the plates.* It is advisable to complete the inspection by measuring the specific gravity of the acid, as this gives a very good indication of the state of charge of the battery. An instrument known as a hydrometer is employed for this purpose; these can be bought from your Dealer or from any of the Lucas Service Depots.

Finally, see that the tops of the cells are clean and dry, and that the terminals are tight and smeared with vaseline.

If the equipment is laid by for several months, the battery must be given a small charge from a separate source of electrical energy about once a fortnight, in order to obviate any permanent injury to the plates.

Under no circumstances must the acid be removed from the battery and the plates allowed to dry, as certain changes take place which result in loss of efficiency.

#### Instructions for using the Lucas Syphon Hydrometer

Before measuring the specific gravity of the acid solution by means of the hydrometer, see that the arm is at its correct level. Readings should be taken after a run on the car, when the acid is thoroughly mixed. To assemble the hydrometer, insert the float, this end first, into the barrel, then wet the plug carrying the rubber tube and push it into position, and the instrument is ready for use. Hold the instrument vertically, compress the bulb and insert the red rubber tube as far as possible into the acid, then gradually lessen the pressure on the bulb until the acid solution rises in the barrel and lifts the hydrometer float about 1 in. Without removing the hydrometer from the cell, note the scale reading at the surface of the acid; this gives the density or specific gravity. Care must be taken that the stem of the float does not touch any part of the barrel or bulb while the reading is actually being taken.

Having taken the reading, return the acid solution to the cell and proceed to take readings for the other cells. All the readings should be approximately the same. If one cell gives a reading very different from the rest it may be that the acid has been spilled or has been leaking away from this particular cell, or there may be a short between the plates, in which case we advise the owner to have his battery examined by a Service Depot to trace the cause and prevent the trouble from developing.

In a fully charged Lucas battery as fitted to the Morris Eight car, the specific gravity of the acid solution should be from 1.285 to 1.300. When half-discharged it will be about 1.215 and about 1.150 when fully discharged. These figures are given assuming the temperature of the solution to be about 60° F.

For fuller particulars regarding temperature corrections see the Lucas "First Charge" instructions, a copy of which can be obtained on application.

The battery must never be left in a fully discharged condition, and, unless some long runs are to be taken, it is advisable to have the battery removed from the car periodically and charged up from an independent electrical supply.



Syphon  
Hydrometer.

#### Lighting, Charging and Ignition Switch

This switch, which is incorporated in the instrument panel, controls the ignition, the lamps, and the charging of the battery.

The ignition switch takes the form of a small key which fits in a slot in the centre of the lighting and charging switch. When the ignition is switched off the key can be withdrawn, thus ensuring the safety of the car in the absence of the owner.

The switch positions are:

"Low Charge"—Dynamo giving about half its normal output.

"High Charge"—Dynamo giving full daytime output.

"Side"—Side and tail-lamps on.

"Head"—Head, side and tail-lamps on.

The dynamo automatically gives its maximum output when the headlamps are switched on.

To switch on the ignition, depress the key and turn to the right, to switch off, turn to the left.

#### Use of the Charging Switch

The dynamo is arranged to give alternative outputs according to the position of the charging switch. In Summer, when the lamps are little used, the dynamo is arranged to give about half its normal output during daytime running. During the Winter, when the lighting and starting loads are heavier, it is intended that the charging switch should be kept in the "High" position, which allows the dynamo to give its full daytime output. When the headlamps are switched on the dynamo automatically gives its maximum output. For the majority of cars this arrangement ensures that the battery is kept in a fully charged state without the possibility of excessive overcharging, always providing the charging switch is kept in the "Low" position during Summer and "High" during Winter.

In exceptional cases, however, it may be advisable to modify the use of the switches. For instance, if in Winter the car is run regularly during the day with practically no night running, thus causing the battery always to be in a fully charged condition (hydrometer readings of 1.285 or over, see page 82), the charging switch should then be kept in the "Low" charge position. On the other hand, if exceptional use is made of the lamps and starter in the Summer, thus causing the battery continually to be in a low state of charge (hydrometer readings of 1.200 or under) then the car should be run with the charging switch in the "High" charge position.

On a new car, during the running-in period, it is advisable to keep the switch in the "High" charge position all the time in order to compensate for the heavy starter motor load due to the initial stiffness of the engine.



Intelligent use of the switch on the lines indicated will greatly prolong the life of the battery.

### Ammeter

The centre-zero ammeter which is incorporated in the instrument panel indicates the actual current flowing into or out of the battery. For instance, suppose two amperes are consumed when the side and tail-lamps are switched on, and the ignition coil takes one ampere, then if the dynamo is generating at seven amperes the meter will show four amperes on the charge side of the scale. This is the current in excess of the lamp and ignition load which is available for battery charging purposes.

### Cut-out and Fusebox Type CFR2

The cut-out is mounted together with two fuses as one unit, which also forms a junction box and incorporates the reduced charge resistances for the dynamo. The moulded cover, which can be withdrawn by springing aside the retaining clip, protects the cut-out and fuses. When the engine is running the cut-out automatically closes the charging circuit as the increasing engine speed causes the dynamo voltage to rise above that of the battery.

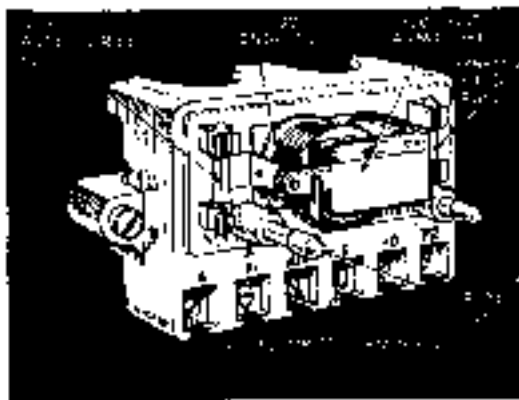

Cut-out and Fusebox.

When the engine slows down and the dynamo voltage falls below that of the battery the reverse action takes place, i.e. the cut out opens and thereby prevents the battery from discharging itself through the dynamo. The cut-out does not switch off the dynamo when the battery is fully charged, and no such automatic device is provided with the equipment. The cut-out is accurately set before leaving the Works and must not be tampered with. Take care not to close the cut-out contacts when removing or replacing the cover as this may cause damage to the equipment.

The two fuses are of the cartridge type. The one marked 25 amps. is the fuse connected in the accessories circuits, and will blow in the event of a short circuit in the wiring of the electric horn, windscreen wiper, and other units connected to the "Aux" terminal, the indication that the fuse has blown being the failure of these units. The other fuse marked 6 amps. is connected in the dynamo field circuit, and it will blow in the event of anything being wrong in the charging circuit (e.g. loose or broken battery connections), thus preventing damage to the dynamo. The indication of a blown dynamo fuse is that the dynamo will fail to charge, a discharge reading being given on the ammeter under normal daytime running conditions. Spare fuses are provided in case of emergency. Before fitting a replacement fuse, the cause of the trouble must be rectified. If the new fuse blows and the cause cannot be found, we advise the owner to have his equipment examined at a Lucas Service Depot.

Never fit any fuse other than the standard Lucas fuse as originally fitted. The size of the fuse is marked on a coloured paper slip inside the fuse.

### Headlamps

The headlamps are provided with an electrically operated "dip and-switch" device. With this arrangement the near-side reflector is arranged to dip to the left and at the same time the off-side lamp is switched off. The dipping mechanism calls for no attention whatsoever. There is nothing to adjust and no lubrication is required.

### Removing the Lamp Front and Reflector

To remove the lamp front, slacken the fixing screw at the bottom of the lamp and swing it aside from the slot. The front can then be withdrawn. When replacing, press the front on to the lamp body, locating the top of the rim first. Finally, swing the screw into the slot and tighten it to lock the front in position.

To remove the near-side reflector, withdraw the fixing screw at the back of the lamp. The reflector can then be withdrawn by dislocating the tongues of the two fixing brackets, riveted to the reflector rim, from the slots in the lamp body.

To remove the off-side reflector turn back the ends of the cork washer and remove the screw opposite the modulation in the top of the lamp. Turn the reflector until the markings "O" stamped on the reflector rim and lamp body coincide. The reflector can then be withdrawn.

### Aligning and Focussing Lamps

To obtain the best results from the lamps, it is essential that they are in good alignment and that the bulbs are focused correctly.

The lamps should be aligned so that the normal driving beam-

are projected straight ahead; that is to say, parallel with the road surface and with each other.

The alignment of the lamps is very easily carried out, as they are fixed on a universal mounting, which is locked by a single nut.

Alternative positions are provided for the headlamp bulb in its holder. Each position should be tried for the best projection of light.

### Cleaning Lamps

The efficiency of the headlamps depends not only upon the shape of the reflector but the quality of its surface. The reflectors are protected by a transparent and colourless coating, which enables any accidental finger marks to be readily removed with a chamois leather or soft cloth without affecting the surfaces of the reflectors. On no account should any metal polish be used on Lucas reflectors. If the ebony black finish of the lamp body becomes dull the original finish can be restored by cleaning with a good car polish.

### Dashlamp

The knurled head of the cover of this lamp operates as a switch; to switch on, turn it to the right.

The cover may be withdrawn from the body of the lamp for a bulb replacement. In refitting the cover, care should be taken that the small stud is placed opposite the slot in the base, so that on pressing the cover it will be secured in position.

### Replacement of Bulbs

Lucas genuine spare bulbs are sold by any reputable garage and are specially tested to check that the filament is in the correct position to give the best results with the lamps. To assist in the identification, Lucas bulbs are marked on the metal cap with a number. When fitting a replacement, see that it is the same number as the original bulb.

We advise you to replace bulbs after long service, before they actually burn out, as very often the filaments sag, making it impossible for them to be focused correctly.

Particulars of bulbs fitted in the lamps of the Morris Eight are given below:—

Lamp	Bulb	Volts	Watts
Headlamps ... ..	Lucas No. 100	6	24
Side and tail-lamps ...	Lucas No. 200	6	3
Dashlamp ... ..	Lucas No. 200	6	3
Ignition warning lamp ...	Lucas No. C252A	2.5	5
"Trafficator" ... ..	Lucas No. 255	6	3

### Electric Windscreen Wiper

To start the wiper, pull out the curved handle and move it aside so as to bring the cleaning arm into position on the screen. Then move the switch in a clockwise direction. To stop the wiper, move the switch in an anti-clockwise direction. Then pull out the curved handle to disengage the wiper blade from its drive, and insert the end of the handle in the top of the switch. This locks the cleaning arm out of the line of vision of the driver and ensures that the wiper is switched off.

The wiper requires no adjustment. All moving parts are packed with grease during assembly, and no lubrication is necessary.

When cleaning the windscreen, the wiper arm can be easily lifted from the glass, but care must be taken that it is not moved from side to side.

### Electric Horn ("Altette" Type)

These horns, before being passed out of the Works, are adjusted to give their best performance, and will give a long period of service without any attention; *no subsequent adjustment is required.*

If the horn becomes uncertain in its action, giving only a clucking sound, or does not vibrate, it does not follow that the horn has broken down. First ascertain that the trouble is not due to some outside source, e.g. a discharged battery, a loose connection or short circuit in the wiring of the horn, or in some cases a blown fuse.

It is also possible that the performance of a horn may be upset by the horn becoming loose on its mounting.

If the note is still unsatisfactory, *do not attempt to dismantle the horn, but return it to a Lucas Service Depot for examination.*

### "Trafficators"

Every two or three months raise the "Trafficator" arm and, by means of a brush or other suitable article, apply a drop or thin machine oil, such as sewing machine or typewriter oil, to the hinge between the arm and the operating mechanism.

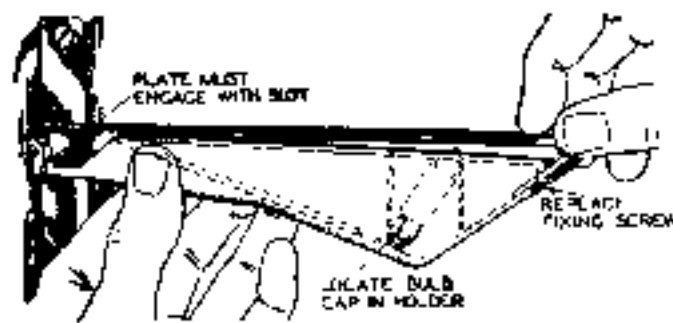

Method of replacing "Trafficator" bulbs.

To replace a bulb, switch the "Trafficator" on and then, supporting the arm, move the switch to the off position.

Withdraw the screw on the underside of the arm and slide off the metal plate, the burnt-out bulb can then be replaced. To replace the metal plate, slide it on in an upwards direction, so that the side plates engage with the slots on the underside of the spindle bearing. Finally, secure the plate by means of its fixing screw.

*Note.*—On some models the "Trafficators" and electric petrol gauge are wired through a separate fuse unit mounted close to the cut-out and fusebox.

### Service

Do not dismantle apparatus needlessly. In the event of any difficulty Messrs. Lucas will be only too pleased to give every assistance possible. The best course to adopt is to call at the nearest Lucas Service Depot, when the equipment can be examined as a whole. The depots are not only at your disposal for repairs, overhauls and adjustments, but to give free advice. If it is necessary to communicate, however, or when ordering spare parts, always give the type and number of the unit in question, the make and, if possible, the date of the car on which it is fitted.

### Location of Faults in the Starting and Lighting Set

Although every precaution is taken to eliminate all possible causes of trouble, failure may occasionally develop through lack of attention to the equipment or damage to the wiring. The most probable faults are tabulated according to the symptoms which are displayed in the fault finding tables on pages 90-92.

We give a few hints on the best way to make use of these tables, since the source of many of the troubles is by no means obvious. In some cases a considerable amount of deduction from the symptoms is needed before the real cause of the trouble is disclosed. For instance, the engine might not respond to the starter switch; a hasty inference would be that the starter motor is at fault. However, as the motor is dependent on the battery, it may be that the battery is exhausted. This in turn may be due to the dynamo failing to charge, and the final cause of the trouble may be perhaps a loose terminal nut either at the battery or elsewhere in the charging circuit.

Much evidence can be gained from the ammeter. If, for instance, no charge reading is indicated when the car is running at, say, twenty miles per hour, with the charging switch in the "full" or "high" charge position and the lights "off," the dynamo is failing to charge. To ensure that the ammeter is not at fault, the lights should be switched on while the car is stationary, when a reading on the discharge side of the scale should be observed. Again, if the maximum ammeter reading is much below normal when the dynamo is charging, or if the needle fluctuates when the car is running steadily, a low or intermittent dynamo output can be

suspected. The dynamo may have been neglected, and the trouble may be caused by, say, worn brushes or a dirty commutator.

Should the intensity of the lights vary, or should they fail entirely, it is probably due to the terminals being allowed to corrode and the consequent breaking of a connection. If the cause of the trouble is not located at the battery, the junction box should next be examined: particularly see that the terminals are quite tight. If one particular lamp does not light, look for a broken filament, a loose adaptor or a broken cable from the lamp to the switchbox. When the car is stationary and the lamps light when switched on but gradually go out, the battery is probably exhausted, due to excessive use of the starter motor or lights, or to the dynamo failing to charge. If it is found that the battery is the cause of the trouble, have it removed from the car, examined, and charged up from an independent electrical supply.

**A**N INDEX AND WIRING CHART  
are provided for your convenience  
at the end of this book.



## HOW TO LOCATE AND REMEDY DYNAMO TROUBLE

Symptoms	Probable Fault	Remedy
Ammeter fails to indicate charge when running with no lights in use, or gives heavy discharge with lights on.	Dynamo not charging, due to: Broken or loose connections in charging circuit causing field loss to blow.	Examine charging circuit wiring. Tighten loose connections or replace broken lead. Particularly examine battery connections. Fit replacement fuse (See page 84.)
	Commutator greasy or dirty.	Clean with soft rag moistened in petrol (See page 86.)
Ammeter gives low or intermittent charge reading.	Dynamo giving low or intermittent output, due to:-	
	Loose or broken connections in dynamo circuit.	Examine charging circuit wiring. Tighten loose connections or replace broken lead. Particularly examine battery connections.
	Commutator or brushes greasy.	Clean. (See page 86.)
Ammeter gives low or intermittent charge reading.	Brushes worn, not fitted correctly.	Replace worn brushes. See that brushes "bed" correctly. (See page 79.)
	Dynamo giving high output due to:-	
	Loose connections in dynamo charging circuit.	Examine charging circuit wiring, particularly battery connections. Tighten loose connections.
	Battery acid level low.	"Top-up" cells with distilled water. (See page 81.)
	Brushes not fitted correctly.	See that brushes "bed" correctly. (See page 79.)
Ammeter gives high charge reading.	Control brush position altered.	Have control brush adjustment re-set at nearest Lucas Service Depot.

## HOW TO LOCATE AND REMEDY STARTER MOTOR TROUBLE

Condition	Probable Fault	Remedy
Motor sluggish or fails to start engine.	If engine cannot be turned by hand, then fault is due to a stiff engine.	Locate and remedy cause of stiffness.
	If engine can be turned by hand, then trouble may be due to:-	
	Battery discharged.	Start by hand. Charge battery either by a long period of daytime running or from independent electrical supply.
Starter operates but does not crank engine.	Broken or loose connections in starter circuit.	See that connections to battery, starter and starter switch are tight, and that cables connecting these units are in order.
	Starter commutator or brushes dirty.	Clean.
	Brushes worn, not fitted correctly.	Replace worn brushes. See that brushes "bed" correctly.
	Starter pinion jammed in mesh with flywheel.	Rotate squared end of starter shaft with spanner. (See page 81.)
	Pinion of starter drive does not engage with flywheel, due to dirt on screwed sleeve.	Clean sleeve with paraffin and add a few drops of machine oil. (See page 81.)
Starter pinion will not disengage from flywheel when engine is running.	Starter pinion jammed in mesh with flywheel.	Rotate squared end of starter shaft with spanner. (See page 81.)

## HOW TO LOCATE AND REMEDY LIGHTING TROUBLE

SYMPTOMS	PROBABLE FAULT	REMEDY
Lamps give insufficient illumination	Battery discharged	Charge battery either by a long period of daytime running or from independent electrical supply.
	Lamps out of alignment, or bulbs out of focus	Align lamps and focus bulbs. (See page 85.)
	Bulbs discoloured through use, or reflectors dirty.	Fit new bulbs (see page 86) or clean reflectors. (See page 86.)
Lamps light when switched on, but gradually fade out.	Battery discharged.	Charge battery either by a long period of daytime running or from independent electrical supply.
Brilliance varies with speed of car.	Battery discharged.	As above.
	Battery connections loose or broken.	Tighten connections, or replace faulty cables.
Lights flicker.	Loose connection.	Locate loose connection and tighten.
Fluctuation of lights	Bulbs burnt out due to battery becoming disconnected from dynamo charging circuit.	Check wiring for faulty cables or connections.
	Battery discharged.	Charge battery either by a long period of daytime running or from independent electrical supply.
	Faulty wiring in lighting circuit	Check wiring for defective cables or connections.

## LUCAS SERVICE DEPOTS

<b>BELFAST</b> 51/53 Upper Library Street.	Telegrams: "Sevedep, Belfast" Telephone: Belfast 25617
<b>BIRMINGHAM, 18</b> Great Hampton Street.	Telegrams: "Lucas, Telex, Birmingham" Telephone: Central 5232
<b>BRIGHTON, 4</b> 85 Old Shoreham Road, Hove.	Telegrams: "Lucas, Brighton" Telephone: Hove 8043
<b>BRISTOL, 4</b> 345 Mack Road.	Telegrams: "Kingly, Bristol" Telephone: Bristol 76001
<b>CARDIFF</b> 54a Penarth Road.	Telegrams: "Lucas, Cardiff" Telephone: Cardiff 4603
<b>DUBLIN</b> Portland Street North, North Circular Road	Telegrams: "Lucas, Dublin" Telephone: Dublin 76795
<b>EDINBURGH, 11</b> 60 Stevenson Road, Gorgie.	Telegrams: "Lucas, Edinburgh" Telephone: Edinburgh 6092
<b>GLASGOW, C.3</b> 4/24 Grant Street (St. George's Road)	Telegrams: "Lucas, Glasgow" Telephone: Douglas 6591
<b>LEEDS, 8</b> 84 Roseville Road.	Telegrams: "Lucasdep, Leeds, 8" Telephone: Leeds 28591
<b>LIVERPOOL, 13</b> 450-470 Edge Lane	Telegrams: "Lucas, Liverpool" Telephone: Stoneycroft 4721
<b>LONDON</b> Dordrecht Road, Acton Vale, W.3.	Telegrams: "Dynamagae, Essex, London" Telephone: Shepherd's Bush 5160
<b>LONDON</b> 757/758 High Road, Leyton, E.10.	Telegrams: "Lucasdep, Leystone, London" Telephone: Leytonstone 1351
<b>MANCHESTER</b> Talbot Road, Strretford.	Telegrams: "Lucas, Salford" Telephone: Longford 1102
<b>NEWCASTLE-ON-TYNE, 1</b> 64-65 St. Mary's Place.	Telegrams: "Motoite, Newcastle-on- Tyne" Telephone: Newcastle 25521

In addition there are Service Agents in most centres.

**Wiring Diagram of the Lucas 6-volt Electric Lighting, Starting and Coil Ignition Equipment on the Morris Eight.**

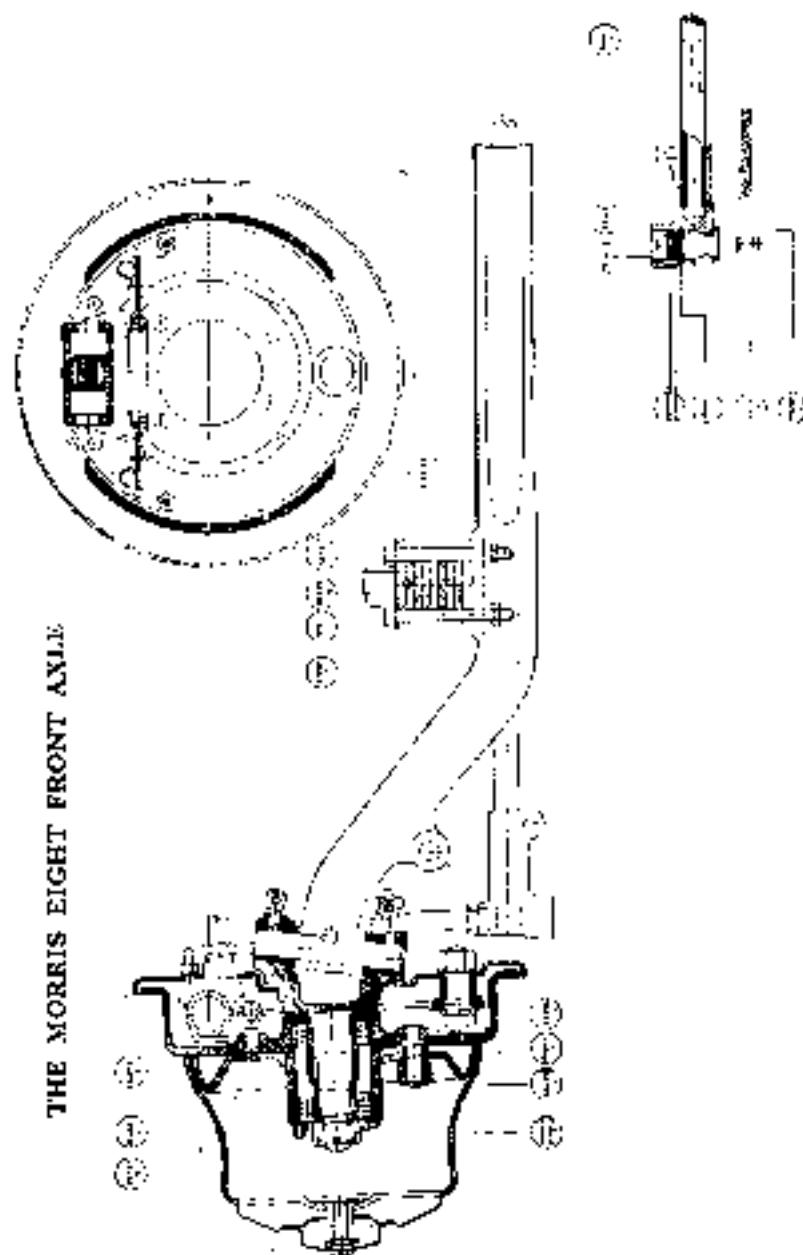
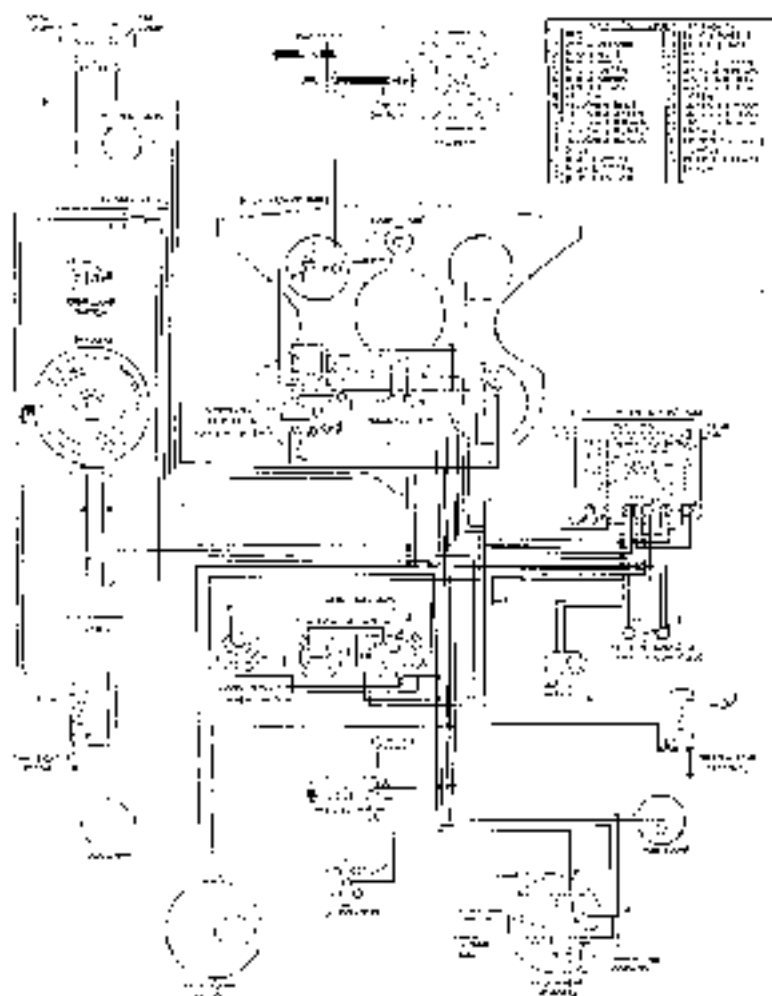



# Morris Universal Service



Whenever you see this hanging sign you know that in dozens of establishments where Morris Service can be obtained.

**T**HE pages of this *Manual* afford the opportunity of making contact with owners of Morris cars who have not been in direct communication with the Works, and a few simple points suggest themselves, by attention to which owners of Morris cars can receive prompt satisfaction on all Service matters.

The existence of the very comprehensive Morris Service Organization is evidence of the Company's desire to ensure that its products give satisfaction. The present-day motorist, in addition to consideration of the actual specification of the car he purchases in relation to the price paid, expects and rightly so, that the manufacturer's interest shall not cease on the completion of its purchase.

## Definition of "Service"

The word "Service" is one which is nowadays interpreted widely. Perhaps it will be as well to explain, therefore, that Service is not necessarily gratuitous. Rather is it a measure of the ability of the organization behind the car to foresee and meet all the normal requirements of Morris owners who require prompt and effective repairs, and the stocking of adequate supplies of genuine Morris parts for replacement purposes.

## Morris Service in Every Centre

Whilst the Service Department at Cowley is the Headquarters of the Morris Service Organization, it must be pointed out that our aim and object is to arrange that reliable service is available in every town of importance throughout the British Isles. For this reason, our energies are concentrated primarily upon close liaison with the Service Staffs of our 1,750 Authorised Morris Distributors and Dealers. Morris Service is therefore not confined to a few large centres which may be miles away when most urgently needed, but is available throughout the length and breadth of the country.

## Technical Instruction for Dealers' Staffs

For the purpose of assisting this work, Classes of Instruction for the foremen and leading mechanics of Morris Dealers are held every week throughout the year, in which all the latest details of the cars, and the best and quickest methods of effecting repairs, are demonstrated and explained. This work is amplified by an Outside Organization comprising a number of technically trained Morris men, who visit our Authorised Distributors and Dealers at regular intervals and keep in close touch with them, notifying all latest developments and assisting generally in diagnosing of complaints, the use of special tools, and advising as to the stocking of suitable replacement parts.

## Morris Authorised Distributors and Dealers as Specialists

Morris Authorised Distributors and Dealers are specialists in servicing Morris cars, and a specialist is primarily an individual who, by observing symptoms, can form a correct diagnosis. Each different make of car has its own peculiarities, and it would be unreasonable to expect the same correctness of opinion from an engineer dealing with many different makes.

Whenever possible, give the local Authorised Morris Distributor or Dealer the opportunity of seeing the car before writing to the Works, and if an owner is non-technical on motoring matters, he will be well advised to arrange for an Authorised Distributor or Dealer to write to the Works on his behalf in the event of Works assistance being necessary.

## Service at Cowley

In the event of an Authorised Morris Distributor or Dealer being unsuccessful in remedying a trouble, or where, possibly, a spare part is not available, the Works should be advised. To ensure that every Morris owner receives advice promptly and efficiently, we have at Cowley a Service Department of considerable magnitude, the function of which is confined entirely to supplementing Dealer Service in the "after-care" of cars produced by this Company.

All letters on the subject of Car Service are dealt with by our Service Department, and correspondence is welcomed from any Morris owner who is in any way interested in writing for advice on Service matters.

For convenience of description, the work of our Service Department may be subdivided under the following headings:-

1. The operation of the Guarantee as given with all Morris cars.
2. The prompt supply of genuine Morris replacement parts for all types of cars produced.
3. The giving of advice on any subject relative to Morris cars and motoring in general.
4. Repair Shop facilities.

#### Correspondence with the Works

At the head of every letter written to the Works on Service matters the model and the chassis and engine numbers of the car referred to should be quoted. The latter will be found stamped on the car identification plate which is under the bonnet.

These numbers enable the individual car to be identified, and a single reference to records will show exactly what fittings were incorporated, and, indeed, the whole record of that car right from the time of its construction.

Place registration numbers are of no help, since these are invariably allocated after delivery of the car from the Works.

In all communications to the Works on Service a really legible signature and the full address, not omitting the name of the country, is necessary and important. If communication with the Works has already been established, mention this fact, quoting the Works' letter reference. This reference is typed in the letter heading on the right-hand side, and a gummed detachable slip, which should be torn off and affixed to a letter addressed to the Works, is also sent out, enabling ready identification of the Department concerned to be made.

#### Taking a Car to the Works

If it is desired to bring the car to the Works for attention, it is absolutely essential that a definite appointment be arranged, in writing, with the Service Department.

Testing and external examination can be done at almost any time and at very short notice; but if, subsequently, it is found necessary to carry out work, the car must take its turn with work already in progress at the time, unless some definite arrangement to the contrary has been agreed to by this Company.

#### Support the Morris Service Organization

In a general way it is very desirable that Morris owners shall take their repair work to an Authorised Morris Distributor or

Dealer, and not, as is sometimes done, to other repairers, because a great deal of trouble is taken to keep in close touch with our Authorised Distributors and Dealers on all matters appertaining to Morris cars, and obviously these facilities, which are ultimately for the benefit of Morris owners, are not available elsewhere. It is realised that the small trader, often right outside the Morris Organization, professes sometimes to undertake Morris repair work at prices which are considerably below the Morris schedule. There is an element of risk here, however, and, bearing in mind that the Authorised Morris Distributor and Dealer has specialised knowledge and a considerable amount of capital locked up in genuine Morris replacement parts, special Morris tools, etc., it is the obvious duty of a Morris owner, in his own interests, to support our Authorised Dealers. Remember there is an Authorised Morris Distributor or Dealer in every town of importance in the British Isles, and a moment's reference to the Car Manual—which should always be carried on the car—will give the name and address of the nearest Morris Service Station.

#### Morris Rapid Repair Facilities

There are in operation a series of quick repair schemes which enable Morris cars to be kept on the road for practically every day of the year without the loss of time which is necessarily incurred by extensive overhaul work in other circumstances. Thus, upon application to any Authorised Morris Distributor or Dealer, re-conditioned replacement engines, rebored cylinder blocks, gear-boxes, front axle beams, back axle casings, radiators and chassis frames can be supplied, and the charges made, unless irreparable damage to the original part has been done, are confined to a standardised charge.

#### Repairs at Cowley

The repair shop at Cowley is intended primarily for complete overhauls and for the rectification of troubles which, for some reason, are not amenable to Authorised Distributor or Dealer treatment.

#### Definition of Works Overhaul

In this connection it may be as well to point out here what is understood at the Works by a complete overhaul, as the term is one which is not always understood.

A complete overhaul at the Works means the dismantling of every component part of the engine and chassis for thorough cleaning and examination and the replacing of any worn component by a new part. Thus it will be seen that the labour involved is practically the same whether a car has been in use for a short or long period.

### Works Visits

If you are anywhere in the neighbourhood of the Works and would like to look round to see exactly how Morris cars are made, do not hesitate to call. Visitors will be received, however, by appointment only, and in view of the vast area covered it has become necessary to organise visitors into parties of not more than twenty. The tours start every weekday (but not on Saturdays or during certain times of the year when the plant is closed down for overhauls and refitting) at 10.30 a.m. and 2.15 p.m. and owners contemplating a visit are requested to state with which of these parties they would prefer to go round, and are urged to arrive punctually at the Sales Office at the time chosen.

# INDEX

<p>Accessories and Equipment .. .. . 81</p> <p>Adjusting the Tappets .. .. . 90</p> <p>Adjustments .. .. . 17</p> <p>Adjustments, Carburettor .. .. . 28</p> <p>Adjustments, Control .. .. . 25</p> <p>Adjustments, Head .. .. . 84</p> <p>Adjustments, Hydraulic .. .. . 81</p> <p>Adjustments, Shock Absorber .. .. . 41</p> <p>Adjustments, Windscreen .. .. . 17</p> <p>Air Intake System .. .. . 43</p> <p>Alloys .. .. . 85</p> <p>Amplifier .. .. . 64</p> <p>Appraising Motors .. .. . 15</p> <p>Arm .. .. . 19</p> <p>Bearing in Illusion .. .. . 71</p> <p>Bearing, Improving .. .. . 81</p> <p>Belts, Drives and Fan Driving .. .. . 10</p> <p>Binding the Hydraulic Brakes, daywork Lubrication .. .. . 50</p> <p>Brake Adjusting, Hydraulic .. .. . 31</p> <p>Brake, Working the Hydraulic .. .. . 24</p> <p>Brake Leaks, Hydraulic .. .. . 24</p> <p>Brake Light, Leakage of .. .. . 25</p> <p>Brake, Hydraulic .. .. . 24</p> <p>Brake Lever .. .. . 29</p> <p>Brake Lenses .. .. . 23</p> <p>Brake Water Cylinder .. .. . 23</p> <p>Brake Light .. .. . 21</p> <p>Brake Repairs .. .. . 21</p> <p>Brake Shoes, Worn .. .. . 24</p> <p>Brake Supply Tank, The .. .. . 23</p> <p>Brake Water Cylinders .. .. . 21</p> <p>Bumper .. .. . 29</p> <p>Bump, Replacement of .. .. . 21</p> <p>Cables, Knowing High-tension .. .. . 78</p> <p>Car, Stopping the .. .. . 82</p> <p>Carburator .. .. . 18</p> <p>Carburator Adjustment .. .. . 28</p> <p>Carburator Filter .. .. . 49</p> <p>Carburator Jet .. .. . 42</p> <p>Carburator Purge Solving .. .. . 47</p> <p>Carburator Troubles, Sources .. .. . 47</p> <p>Carburator, Water or Fuel in .. .. . 47</p> <p>Case of the Car, General .. .. . 14</p> <p>Case of Dashboard .. .. . 15</p> <p>Case of Cooling System .. .. . 26</p> <p>Case of New Engines .. .. . 14</p> <p>Case of Radiator .. .. . 15</p> <p>Case of Shock Absorbers .. .. . 41</p> <p>Case of Spraying Arms .. .. . 6</p> <p>Case of Springs .. .. . 17</p> <p>Case of Tyres .. .. . 57</p> <p>Case of Wipers .. .. . 31</p> <p>Changing Gear .. .. . 17</p> <p>Changing Gear, Control, Advice .. .. . 11</p> <p>Chimes, Lighting and Ignition Switch .. .. . 25</p> <p>Clutch Cable .. .. . 64</p> <p>Clutch Light Cable .. .. . 62</p> <p>Checking Ignition Points .. .. . 82</p> <p>Cleaning Lamps .. .. . 85</p> <p>Clutch .. .. . 24</p>	<p>Clutch Adjustment .. .. . 64</p> <p>Covering, Case of .. .. . 15</p> <p>Coil Ignition .. .. . 74</p> <p>Coil Leads, Troubles .. .. . 64</p> <p>Coupling, Hot .. .. . 21</p> <p>Coupling .. .. . 7</p> <p>Cracking Ignition .. .. . 8</p> <p>Crack, Sealing .. .. . 7</p> <p>Cylinder, Blewing .. .. . 8</p> <p>Cylinder, Case of .. .. . 15</p> <p>Correspondence with the Works .. .. . 80</p> <p>Costly, Repair at .. .. . 80</p> <p>Cowley, Service at .. .. . 37</p> <p>Critical and a Lubric .. .. . 34</p> <p>Cylinder Head, Dressing .. .. . 43</p> <p>Cylinder Head, Dressing .. .. . 43</p> <p>Dash Lamp .. .. . 76</p> <p>Data, General .. .. . 4</p> <p>Decoupling .. .. . 44</p> <p>Decorating and Varnish Finishing .. .. . 81</p> <p>Definition of Morris Motors .. .. . 88</p> <p>Definition of Works Conditions .. .. . 99</p> <p>Developing Steep Hills .. .. . 13</p> <p>Diagnosing .. .. . 13</p> <p>Dial on Water in Carburettor .. .. . 24</p> <p>Disturbances .. .. . 41</p> <p>Distributor, Lubrication .. .. . 29</p> <p>Disturbances for Engine Swap .. .. . 52</p> <p>Driver, Control, Hub or .. .. . 5</p> <p>Disturbances .. .. . 75</p> <p>Disturbances .. .. . 61</p> <p>Disturbances and Fan Driving Belt .. .. . 10</p> <p>Disturbances .. .. . 80</p> <p>Disturbances .. .. . 56</p> <p>Disturbances .. .. . 99</p> <p>Dusts, Road .. .. . 37</p> <p>Dusts, Wind-torn Water .. .. . 47</p> <p>Engine, Case of New .. .. . 14</p> <p>Engine to Switch .. .. . 6</p> <p>Engine, Knocking, Piston Pinning Head .. .. . 74</p> <p>Engine Packs, Power .. .. . 74</p> <p>Engine, Work .. .. . 30</p> <p>Engine, Spark Plugs, Connections .. .. . 71</p> <p>Engine, Work, 1941-46 .. .. . 71</p> <p>Engine, Work, Troubles .. .. . 52</p> <p>Equipment and Accessories .. .. . 81</p> <p>Fan and Engine, Driving Fan .. .. . 10</p> <p>Fault Free, Ignition .. .. . 81</p> <p>Faulty, Up with Oil .. .. . 5</p> <p>Fitting Up with Parts .. .. . 6</p> <p>Fitting Up with Water .. .. . 4</p> <p>Fuel, Carburettor .. .. . 48</p> <p>Fuel, Relief Valve .. .. . 45</p> <p>Fitting, Special, Preparatory .. .. . 61</p> <p>Fuel, Carburettor .. .. . 42</p> <p>Fuel, Carburettor, Troubles .. .. . 42</p> <p>Fitting, Special, Preparatory .. .. . 61</p> <p>Fuel, Carburettor .. .. . 42</p> <p>Fuel, Carburettor, Troubles .. .. . 42</p> <p>Fuel, Carburettor, Troubles .. .. . 42</p> <p>Fuel, Carburettor, Troubles .. .. . 42</p> <p>Fuel, Carburettor, Troubles .. .. . 42</p> <p>Fuel, Carburettor, Troubles .. .. . 42</p> <p>Fuel, Carburettor, Troubles .. .. . 42</p> <p>Fuel, Carburettor, Troubles .. .. . 42</p>
---	---





# IMPORTANT

## MORRIS

### SPARE PARTS

When purchasing replacement parts or having repairs done, owners of Morris cars are requested to see that a label similar to the one illustrated here is attached to the invoice rendered. These labels are issued by Morris Motors Limited and constitute a guarantee that genuine Morris parts are supplied.



No better car maintenance service exists in the world than that provided by Morris Motors Limited, and no car demands less attention; but it is unfair to the makers to expect the continuance of their support if the structure of the car has been disturbed by the use of replacement parts that are not genuine Morris parts.

Replacement parts that are not of genuine Morris manufacture cannot be relied upon to be of Morris specification, material or workmanship, and, therefore, the Company cannot be expected to extend their Guarantee to cars which have been fitted with parts not of their manufacture.

All authorised Morris Distributors and Dealers are under contract to supply only genuine Morris parts.

### KEY TO RECOMMENDED LUBRICANTS

Company	A	B	C	D	E	F
Camelite Condensate	Engine Oil, All Classes Tropical and Arctic temperatures cold down to 40° F. (-40° C.) Duckham's N.O.L. "Twinny" "General" S.L.	Gasoline, Steering Gears and Rear Axle Screwdowns cold below 32° F. (-12° C.) Duckham's N.O.L. E.P. Transmission Oil "General" A. Press	Wheel Hub and Fly Bearings All conditions Duckham's H.M.P. Grease	Grease Greasing Piston and Sprocket All conditions Duckham's H.P.C. Grease	Cabin and Control Tents All conditions Duckham's "Regol" K.P. 14 Grease	Oiler and Carburettor All conditions Duckham's "Regol" K.P. 14 "Twinny" "General" S.L.C. 30
"DUCKHAM'S" (In center Duckham & Co. Ltd.)	"General" S.L. "Eucube" 50 "Mobil" "A" "Energy" S.E.L. 50 "Shell" "Shell" "Medium" "Filtrol" "Super" W.W. 50	"General" S.L. "Eucube" 50 "Mobil" "A" "Energy" S.E.L. 50 "Shell" "Shell" "Medium" "Filtrol" "Super" W.W. 50	"General" S.L. "Eucube" 50 "Mobil" "A" "Energy" S.E.L. 50 "Shell" "Shell" "Medium" "Filtrol" "Super" W.W. 50	"General" S.L. "Eucube" 50 "Mobil" "A" "Energy" S.E.L. 50 "Shell" "Shell" "Medium" "Filtrol" "Super" W.W. 50	"General" S.L. "Eucube" 50 "Mobil" "A" "Energy" S.E.L. 50 "Shell" "Shell" "Medium" "Filtrol" "Super" W.W. 50	"General" S.L. "Eucube" 50 "Mobil" "A" "Energy" S.E.L. 50 "Shell" "Shell" "Medium" "Filtrol" "Super" W.W. 50
"MOBIL-OIL" (In center Mobil Oil Co. Ltd.)	"General" S.L. "Eucube" 50 "Mobil" "A" "Energy" S.E.L. 50 "Shell" "Shell" "Medium" "Filtrol" "Super" W.W. 50	"General" S.L. "Eucube" 50 "Mobil" "A" "Energy" S.E.L. 50 "Shell" "Shell" "Medium" "Filtrol" "Super" W.W. 50	"General" S.L. "Eucube" 50 "Mobil" "A" "Energy" S.E.L. 50 "Shell" "Shell" "Medium" "Filtrol" "Super" W.W. 50	"General" S.L. "Eucube" 50 "Mobil" "A" "Energy" S.E.L. 50 "Shell" "Shell" "Medium" "Filtrol" "Super" W.W. 50	"General" S.L. "Eucube" 50 "Mobil" "A" "Energy" S.E.L. 50 "Shell" "Shell" "Medium" "Filtrol" "Super" W.W. 50	"General" S.L. "Eucube" 50 "Mobil" "A" "Energy" S.E.L. 50 "Shell" "Shell" "Medium" "Filtrol" "Super" W.W. 50
"ENERGOL" (Price's Lubricants Ltd.)	"General" S.L. "Eucube" 50 "Mobil" "A" "Energy" S.E.L. 50 "Shell" "Shell" "Medium" "Filtrol" "Super" W.W. 50	"General" S.L. "Eucube" 50 "Mobil" "A" "Energy" S.E.L. 50 "Shell" "Shell" "Medium" "Filtrol" "Super" W.W. 50	"General" S.L. "Eucube" 50 "Mobil" "A" "Energy" S.E.L. 50 "Shell" "Shell" "Medium" "Filtrol" "Super" W.W. 50	"General" S.L. "Eucube" 50 "Mobil" "A" "Energy" S.E.L. 50 "Shell" "Shell" "Medium" "Filtrol" "Super" W.W. 50	"General" S.L. "Eucube" 50 "Mobil" "A" "Energy" S.E.L. 50 "Shell" "Shell" "Medium" "Filtrol" "Super" W.W. 50	"General" S.L. "Eucube" 50 "Mobil" "A" "Energy" S.E.L. 50 "Shell" "Shell" "Medium" "Filtrol" "Super" W.W. 50
"SHELL" (Shell Mfg. & B. Co. Ltd.)	"General" S.L. "Eucube" 50 "Mobil" "A" "Energy" S.E.L. 50 "Shell" "Shell" "Medium" "Filtrol" "Super" W.W. 50	"General" S.L. "Eucube" 50 "Mobil" "A" "Energy" S.E.L. 50 "Shell" "Shell" "Medium" "Filtrol" "Super" W.W. 50	"General" S.L. "Eucube" 50 "Mobil" "A" "Energy" S.E.L. 50 "Shell" "Shell" "Medium" "Filtrol" "Super" W.W. 50	"General" S.L. "Eucube" 50 "Mobil" "A" "Energy" S.E.L. 50 "Shell" "Shell" "Medium" "Filtrol" "Super" W.W. 50	"General" S.L. "Eucube" 50 "Mobil" "A" "Energy" S.E.L. 50 "Shell" "Shell" "Medium" "Filtrol" "Super" W.W. 50	"General" S.L. "Eucube" 50 "Mobil" "A" "Energy" S.E.L. 50 "Shell" "Shell" "Medium" "Filtrol" "Super" W.W. 50
"FILTROL" (Edward Jay & Sons Ltd.)	"General" S.L. "Eucube" 50 "Mobil" "A" "Energy" S.E.L. 50 "Shell" "Shell" "Medium" "Filtrol" "Super" W.W. 50	"General" S.L. "Eucube" 50 "Mobil" "A" "Energy" S.E.L. 50 "Shell" "Shell" "Medium" "Filtrol" "Super" W.W. 50	"General" S.L. "Eucube" 50 "Mobil" "A" "Energy" S.E.L. 50 "Shell" "Shell" "Medium" "Filtrol" "Super" W.W. 50	"General" S.L. "Eucube" 50 "Mobil" "A" "Energy" S.E.L. 50 "Shell" "Shell" "Medium" "Filtrol" "Super" W.W. 50	"General" S.L. "Eucube" 50 "Mobil" "A" "Energy" S.E.L. 50 "Shell" "Shell" "Medium" "Filtrol" "Super" W.W. 50	"General" S.L. "Eucube" 50 "Mobil" "A" "Energy" S.E.L. 50 "Shell" "Shell" "Medium" "Filtrol" "Super" W.W. 50
"STERNOL" (Sternol Ltd.)	"General" S.L. "Eucube" 50 "Mobil" "A" "Energy" S.E.L. 50 "Shell" "Shell" "Medium" "Filtrol" "Super" W.W. 50	"General" S.L. "Eucube" 50 "Mobil" "A" "Energy" S.E.L. 50 "Shell" "Shell" "Medium" "Filtrol" "Super" W.W. 50	"General" S.L. "Eucube" 50 "Mobil" "A" "Energy" S.E.L. 50 "Shell" "Shell" "Medium" "Filtrol" "Super" W.W. 50	"General" S.L. "Eucube" 50 "Mobil" "A" "Energy" S.E.L. 50 "Shell" "Shell" "Medium" "Filtrol" "Super" W.W. 50	"General" S.L. "Eucube" 50 "Mobil" "A" "Energy" S.E.L. 50 "Shell" "Shell" "Medium" "Filtrol" "Super" W.W. 50	"General" S.L. "Eucube" 50 "Mobil" "A" "Energy" S.E.L. 50 "Shell" "Shell" "Medium" "Filtrol" "Super" W.W. 50

# THE MORRIS EIGHT LUBRICATION CHART

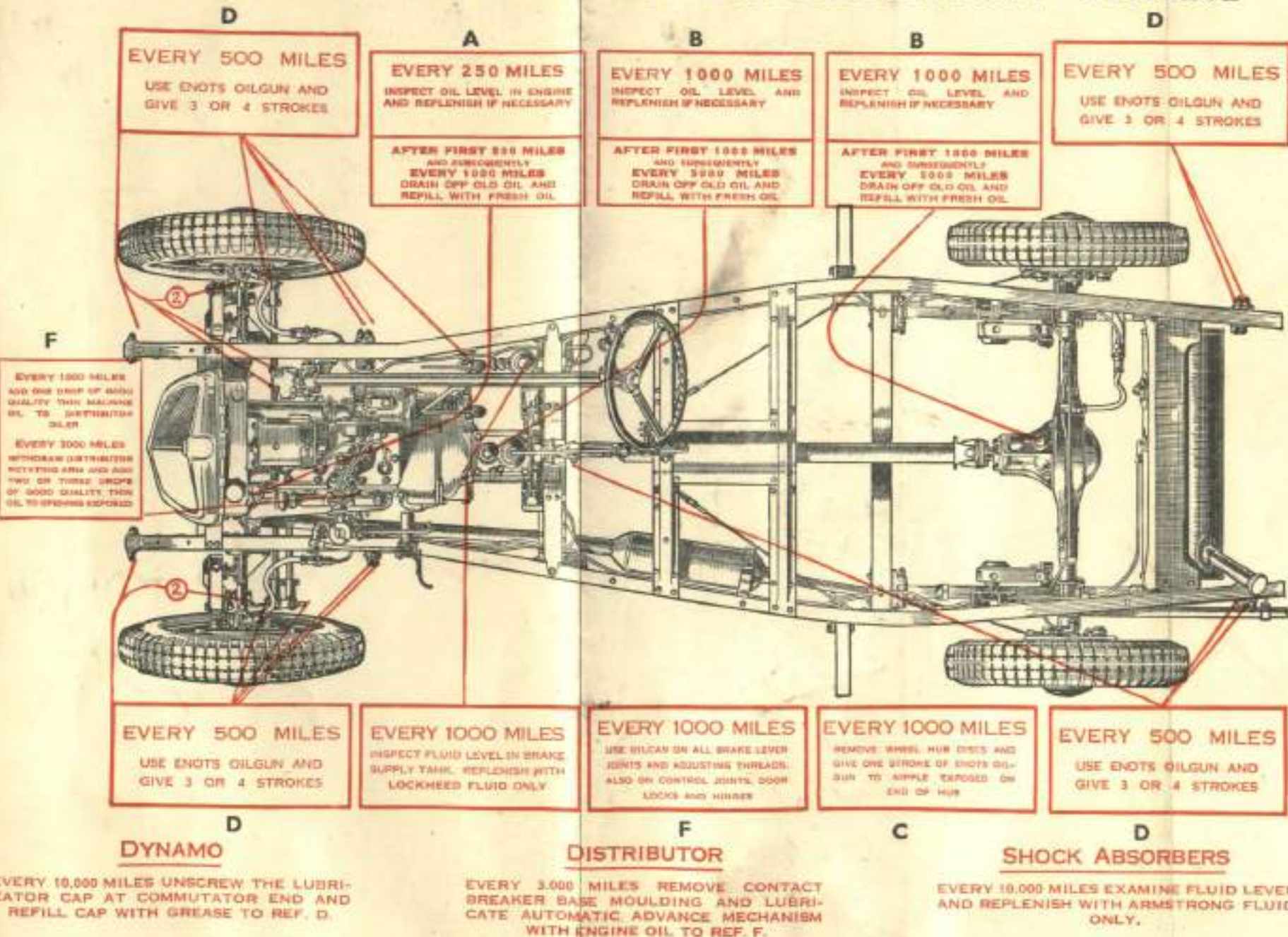

THE REFERENCE LETTERS AGAINST EACH OILING POINT INDICATE THE CORRECT LUBRICANT IN ACCORDANCE WITH THE TABLE OF RECOMMENDED LUBRICANTS.

PUBLISHED OFFICIALLY BY MORRIS MOTORS LTD.

PRINTED BY THE HUFFIELD PRESS LTD.



PRINTED IN GREAT BRITAIN BY  
THE UNIVERSITY PRESS, LONDON  
WALTER DORLAND & COMPANY