

WIRING DIAGRAMS

Article Text

1993 Honda Prelude

For Cadi Centre Nsk CA 95051

Copyright © 1998 Mitchell Repair Information Company, LLC

Sunday, July 08, 2001 11:42AM

ARTICLE BEGINNING

1993 WIRING DIAGRAMS
Honda Wiring Diagrams

Honda; Prelude

IDENTIFICATION

COMPONENT LOCATION MENU

COMPONENT LOCATIONS TABLE

AA

Component	Figure No. (Location)
ABS CONTROL UNIT (W/2WS)	9 (A-B 32)
ABS CONTROL UNIT (W/4WS)	10 (A-C 36)
ABS MOTOR	2 (A 7)
ALTERNATOR	1 (C 3)
ANTENNA MOTOR	16 (A 60)
AUTOMATIC TRANSMISSION CONTROL UNIT	8 (A-C 28)
BACK-UP LIGHT SWITCH (MANUAL TRANSMISSION)	16 (B 61)
BATTERY	1 (A 2)
BLOWER MOTOR	12 (A 47)
BRAKE FLUID LEVEL SWITCH	15 (D 58)
BRAKE SWITCH	10 (D 38)
CHIME	7 (E 24)
CIGARETTE LIGHTER & RELAY	15 (B 59)
CLUTCH INTERLOCK SWITCH (MANUAL TRANSMISSION)	1 (C 3)
COMBINATION SWITCH	13 (A-C 48)
COMPRESSOR CLUTCH RELAY	12 (E 47)
CONDENSER FAN RELAY	12 (B 47)
CRUISE CONTROL SYSTEM	10 (D-E 36-39)
DASH FUSE BLOCK (DASH F/B)	5,6 (A-E 17-22)
DASHLIGHT BRIGHTNESS CONTROLLER	13 (E 51)
DATA LINK CONN	4 (A 15)
DISTRIBUTOR ASSEMBLY	4 (D-E 15)
DOME LIGHT	13 (B 51)
DUAL PRESSURE SWITCH	12 (B 45)
EGR CONTROL SOLENOID	4 (C 15)
EGR VALVE LIFT SENSOR	3 (A 9)
ENGINE CONTROL MODULE (ECM)	3 (A-E 8)
FAIL SAFE RELAY (W/ 2WS)	9 (B 35)
FAIL SAFE RELAY (W/ 4WS)	10 (B 39)
FAN TIMER UNIT	12 (C 47)
FOG LIGHT RELAY	1 (D 3)
FOG LIGHT SWITCH	13 (D 48)

FRONT MAIN STEERING ANGLE SENSOR	11	(A 43)
FUEL PUMP	3	(E 11)
FUEL TANK UNIT	14	(C 55)
FUNCTION CONTROL MOTOR	12	(D 47)
GEAR SELECT SWITCH (AUTOMATIC TRANSMISSION)	8	(A-C 31)
HAZARD SWITCH	13	(C 48)
HEATER CONTROL PANEL	12	(A-E 44)
HORN RELAY	9	(E 35)
IGNITION COIL	4	(E 15)
IGNITION KEY LIGHT	7	(E 27)
IGNITION KEY SWITCH	7	(E 27)
IGNITION SWITCH	6	(D-E 23)
INTEGRATED CONTROL UNIT	7	(A-C 24-27)
INTERMITTENT WIPER RELAY	11	(E 43)
JUNCTION CONNECTOR C131	3	(D 11)
JUNCTION CONNECTOR C326	11	(D-E 40)
JUNCTION CONNECTOR C419	8	(C-E 31)
JUNCTION CONNECTOR C447	15	(C 59)
JUNCTION CONNECTOR C460	10	(E 39)
JUNCTION CONNECTOR C507 (W/ 2WS)	9	(C 35)
JUNCTION CONNECTOR C507 (W/ 4WS)	10	(C 39)
JUNCTION CONNECTOR C534	13	(A 51)
JUNCTION CONNECTOR C609	13	(D-E 48)
JUNCTION CONNECTOR C619	13	(C 51)
KEY INTERLOCK SWITCH	8	(E 28)
LEFT BRAKE LIGHT SENSOR	16	(E 63)
LEFT SEAT BELT SWITCH	7	(E 27)
MAIN INSTRUMENT CLUSTER	14	(A-B 52)
PGM-FI MAIN RELAY	3	(E 11)
POWER DOOR LOCKS	15	(D-E 56-59)
POWER MIRROR SWITCH	16	(D 60)
POWER WINDOWS	15	(A-C 56-59)
RADIATOR FAN MOTOR	2	(E 7)
REAR MAIN STEERING ANGLE SENSOR	11	(A 43)
RECIRC CONTROL MOTOR	12	(E 47)
RIGHT BRAKE LIGHT SENSOR	16	(A 63)
SERVICE CHECK CONNECTOR	4	(A 15)
SRS CONTROL UNIT	9	(D 32)
SRS FUSE BLOCK	6	(D 22)
STARTER	1	(A 3)
STARTER CUT RELAY (MANUAL TRANSMISSION)	1	(B 3)
STEERING WHEEL	9	(D-E 35)
SUB INSTRUMENT CLUSTER	14	(C-E 52)
SUNROOF SWITCH	13	(D 51)
TEMPERATURE SWITCHES	12	(C 47)
THROTTLE ANGLE SENSOR	3	(A 10)
TRUNK LATCH SWITCH	13	(B 51)
UNDERHOOD FUSE BLOCK (U/H F/B)	2	(B-D 4-7)

VEHICLE SPEED SENSOR	3 (A 8)
VTEC PRESSURE SWITCH	3 (D 8)
WASHER MOTOR	11 (E 40)
WIPER/WASHER SWITCH	11 (C-D 43)
4WS CONTROL UNIT	11 (A-C 40)
AA	

GROUND LOCATION MENU

GROUND LOCATIONS TABLE

AA

Component	Figure No. (Location)
GROUND A: (RIGHT FRONT OF ENGINE COMPARTMENT)	1 (A 2)
GROUND B: (ON TRANSMISSION CASE)	1 (B 2)
GROUND C: (LEFT SIDE OF ENGINE COMPARTMENT)	1 (B 2)
GROUND D: (ENGINE MOUNT BRACKET)	1 (C 2)
GROUND E: (VALVE COVER)	1 (C 2)
GROUND F: (RIGHT FRONT CORNER OF ENGINE COMPARTMENT) ..	1 (D 3)
GROUND G: (LEFT FRONT CORNER OF ENGINE COMPARTMENT) ...	1 (E 3)
GROUND H: (BELOW CENTER OF DASH)	2 (A 7)
GROUND I: (RIGHT SIDE OF ENGINE)	4 (E 13)
GROUND J: (RIGHT REAR CORNER OF CEILING)	6 (B 23)
GROUND K: (BEHIND FRONT CONSOLE)	8 (E 30)
GROUND L: (BEHIND RIGHT SIDE OF DASH)	8 (E 31)
GROUND M: (BELOW CENTER OF DASH)	9 (E 32)
GROUND N: (RIGHT KICK PANEL)	11 (C 41)
GROUND O: (BEHIND LEFT REAR SEAT)	11 (C 41)
GROUND P: (RIGHT QUARTER PANEL AREA)	11 (C 41)
GROUND Q: (BEHIND LEFT REAR SEAT)	11 (C 41)
GROUND R: (CENTER OF REAR STEERING ACTUATOR)	11 (D 41)
GROUND S: (BEHIND LEFT SIDE OF FRONT CONSOLE)	12 (A 45)
GROUND T: (LEFT FRONT OF ENGINE COMPARTMENT)	12 (B 47)
GROUND U: (LEFT SIDE OF FLOOR)	13 (A 49)
GROUND V: (LEFT QUARTER PANEL AREA)	13 (B 49)
GROUND W: (CENTER REAR OF TRUNK)	16 (C 62)
AA	

WIRING DIAGRAMS

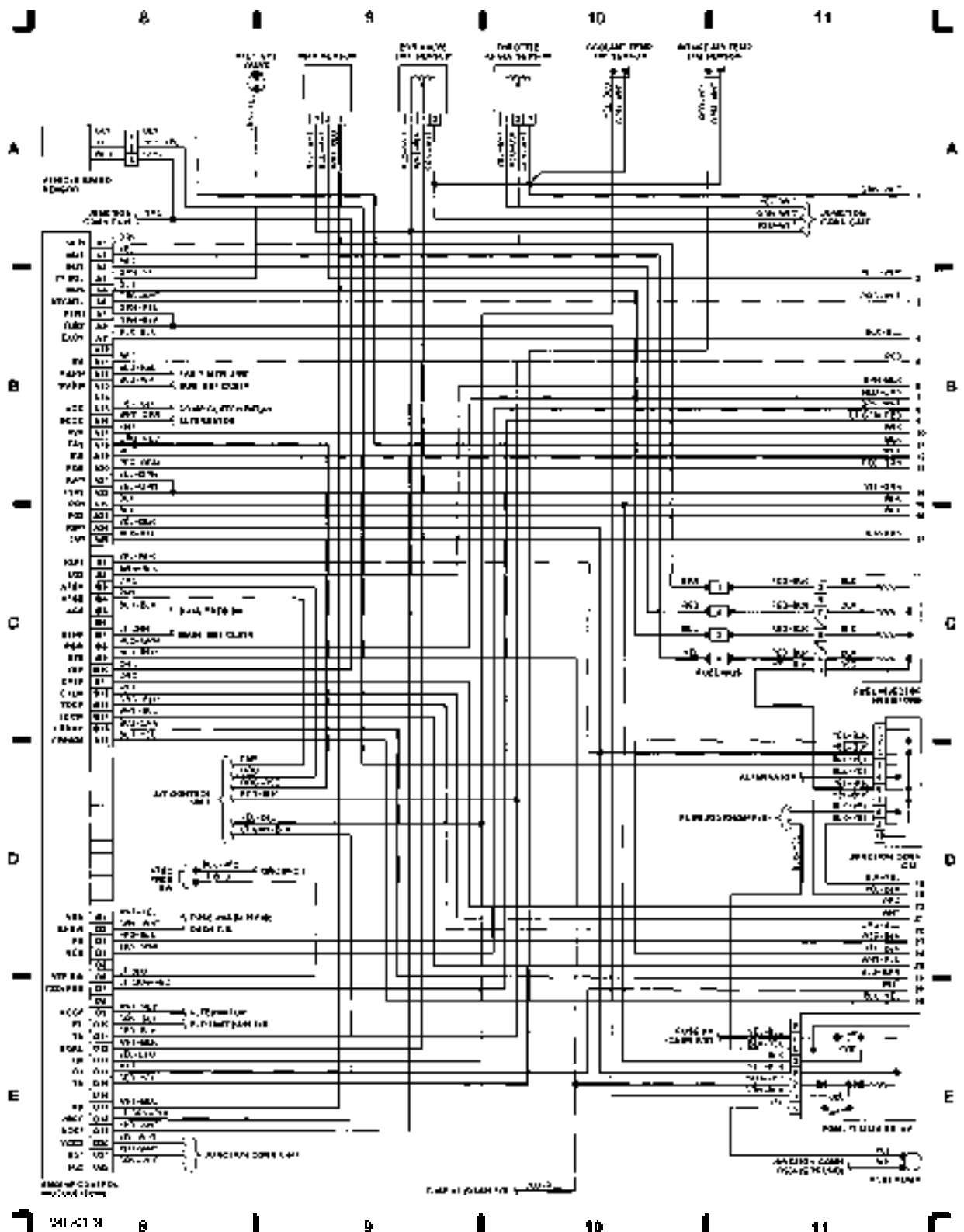

Fig. 3: Engine Control Module, Map Sensor (Grid 8-11)
WIRING DIAGRAMS Article Text (p. 6) 993 Honda Prelude For Cadi Centre Nsk CA 9505 Copyright © 1998 Mitchel

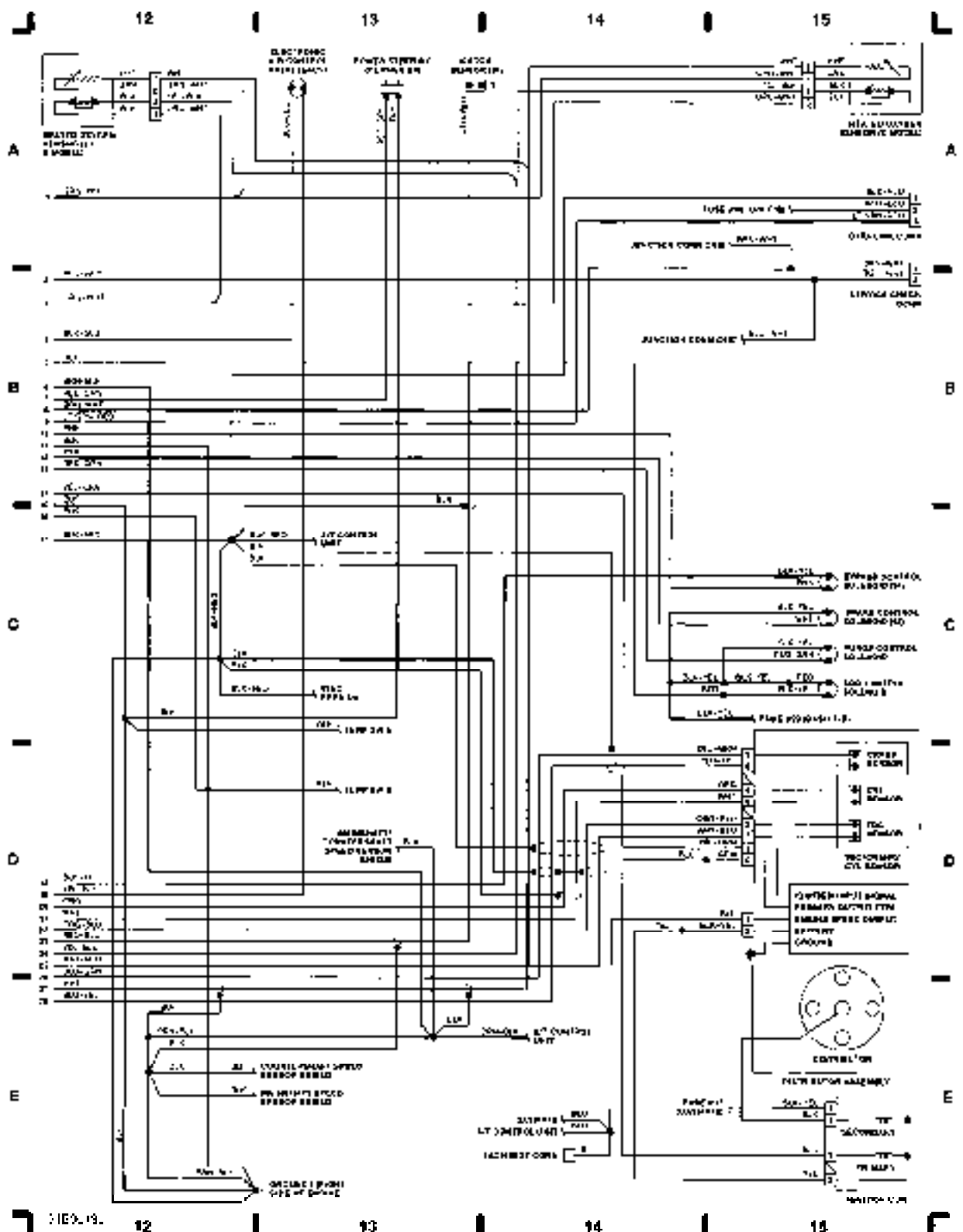

Fig. 4: Distributor Assembly, Ignition Coil (Grid 12-15)

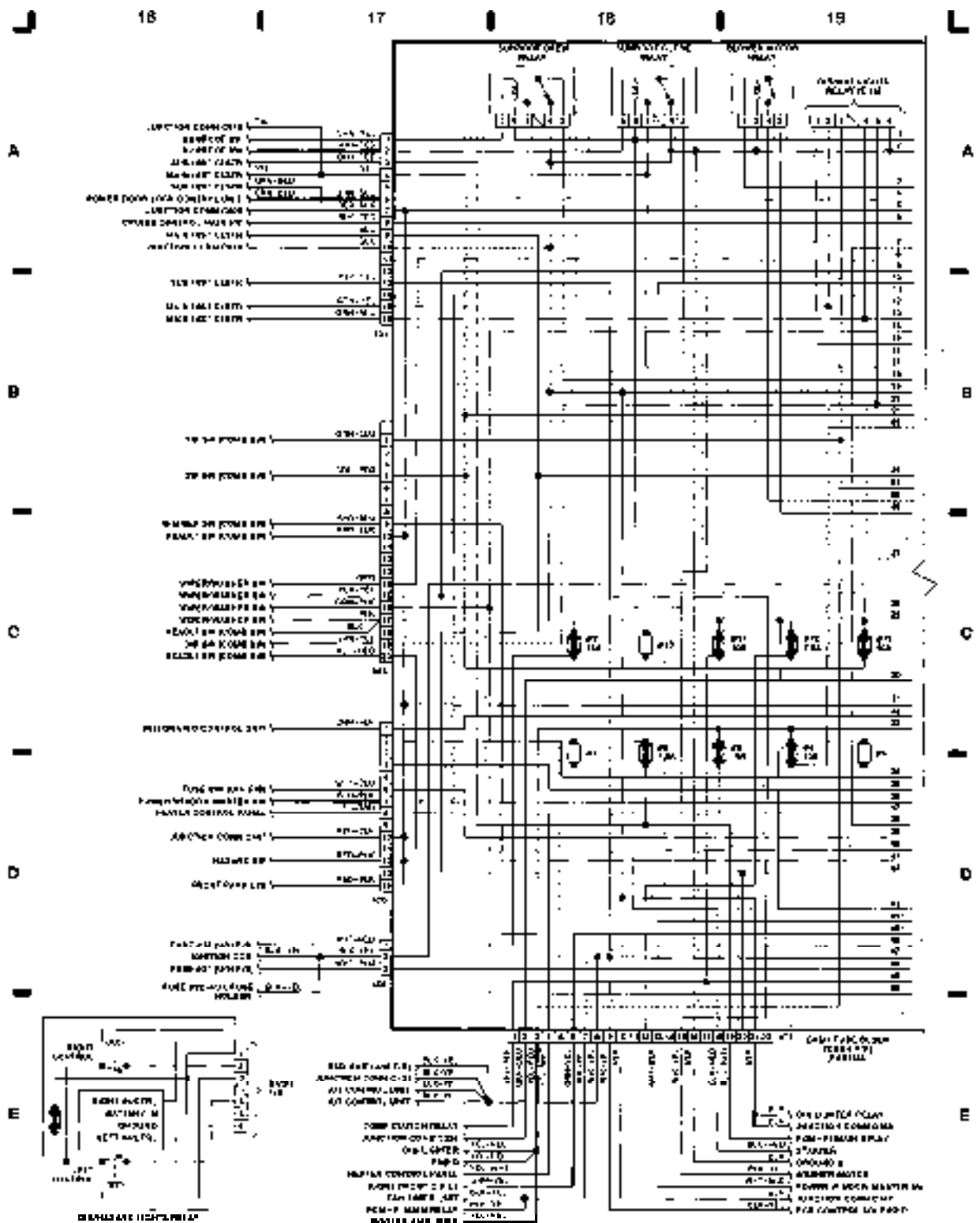

Fig. 5: Dash F/B (Partial), Dir/Hazard Lights Relay (Grid 16-19)
 WIRING DIAGRAMS Article Text (p. 8) 993 Honda Prelude For Cadi Centre Nsk CA 9505 Copyright © 1998 Mitchel

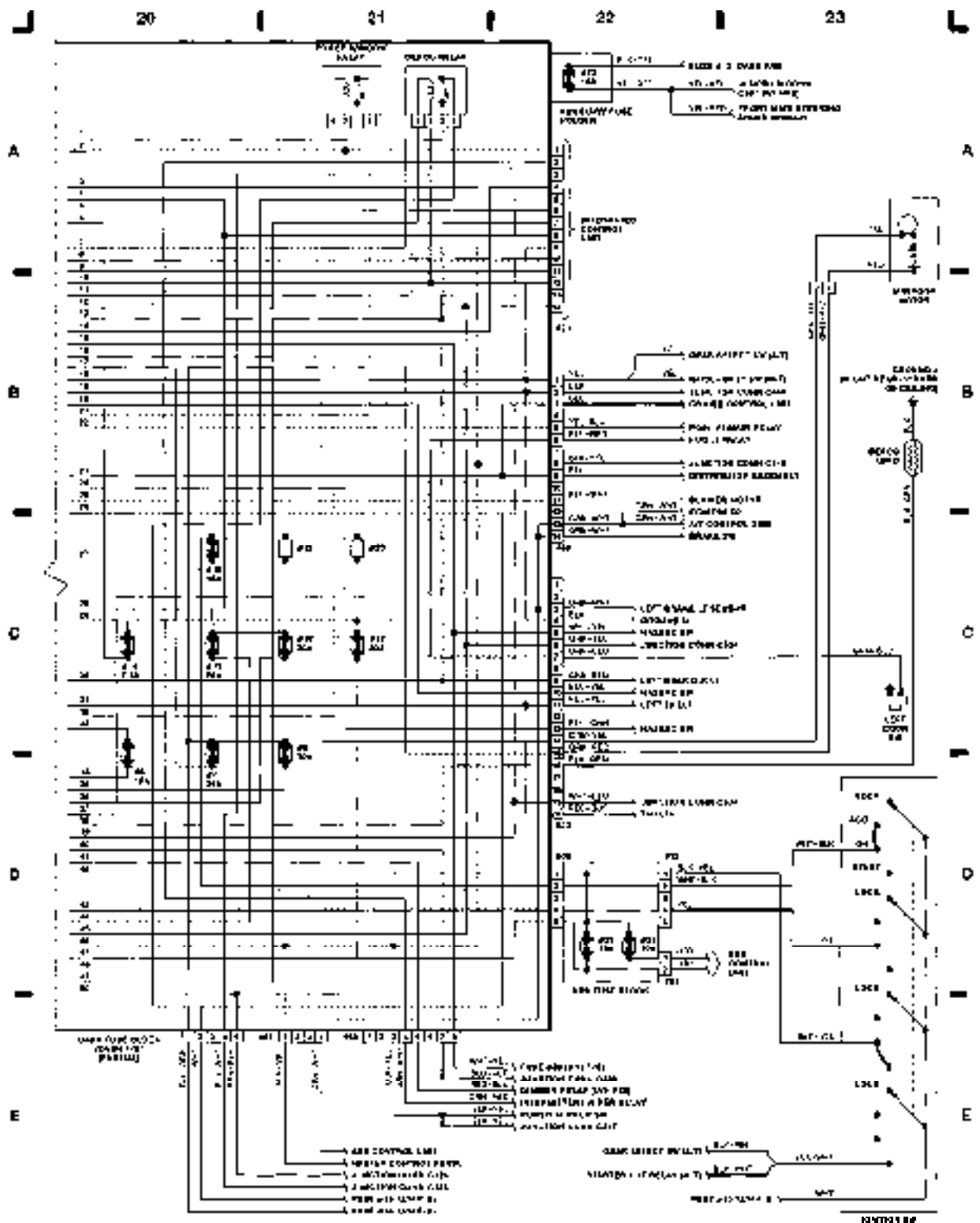

Fig. 6: Dash F/B (Partial), Ignition SW, Sunroof Motor (Grid 20-23)
 WIRING DIAGRAMS Article Text (p. 9) 993 Honda Prelude For Cadi Centre Nsk CA 9505 Copyright © 1998 Mitchel

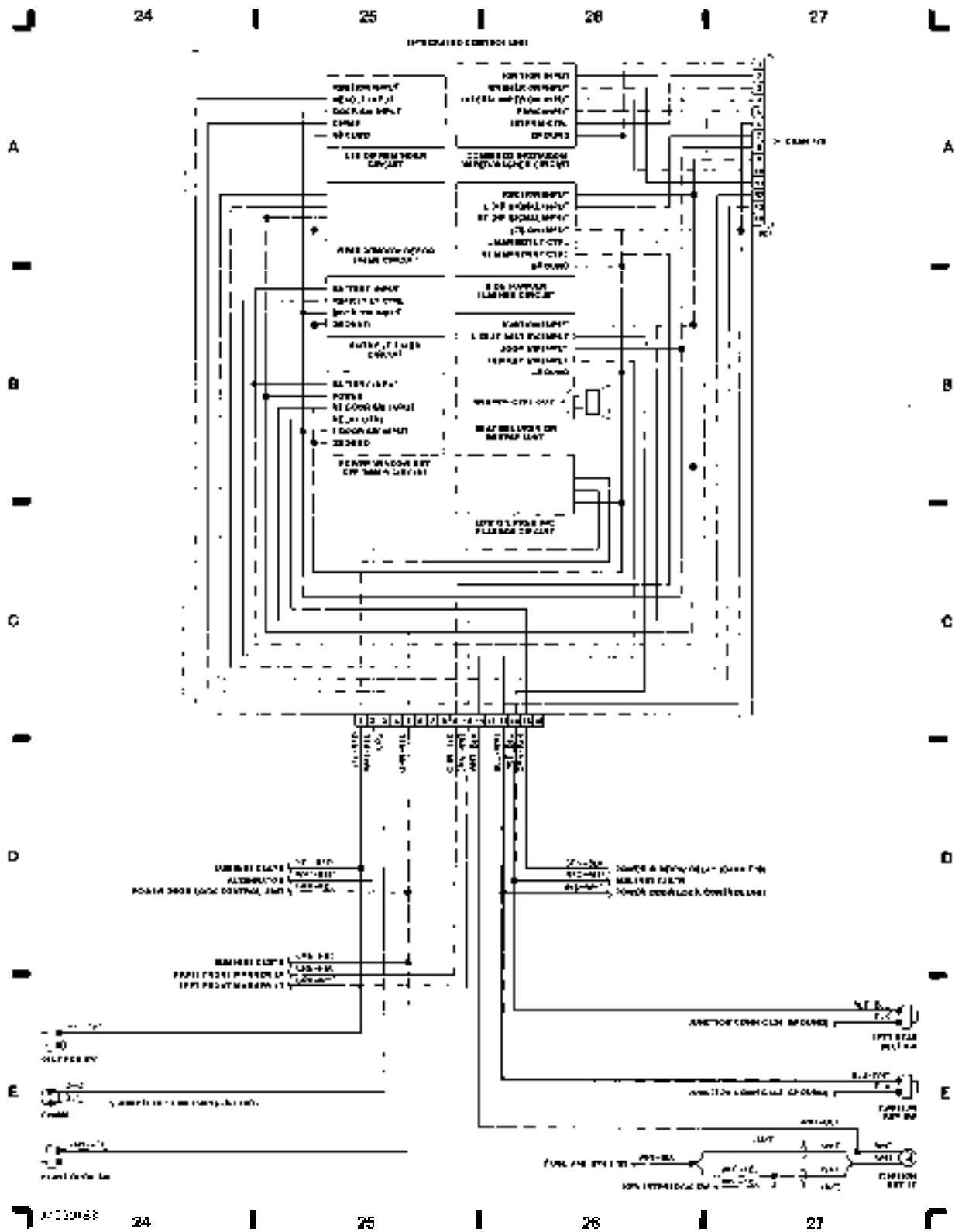

Fig. 7: Integrated Control Unit (Grid 24-27)
WIRING DIAGRAMS Article Text (p. 10) 1993 Honda Prelude For Cadi Centre Nsk CA 9505 Copyright © 1998 Mitch

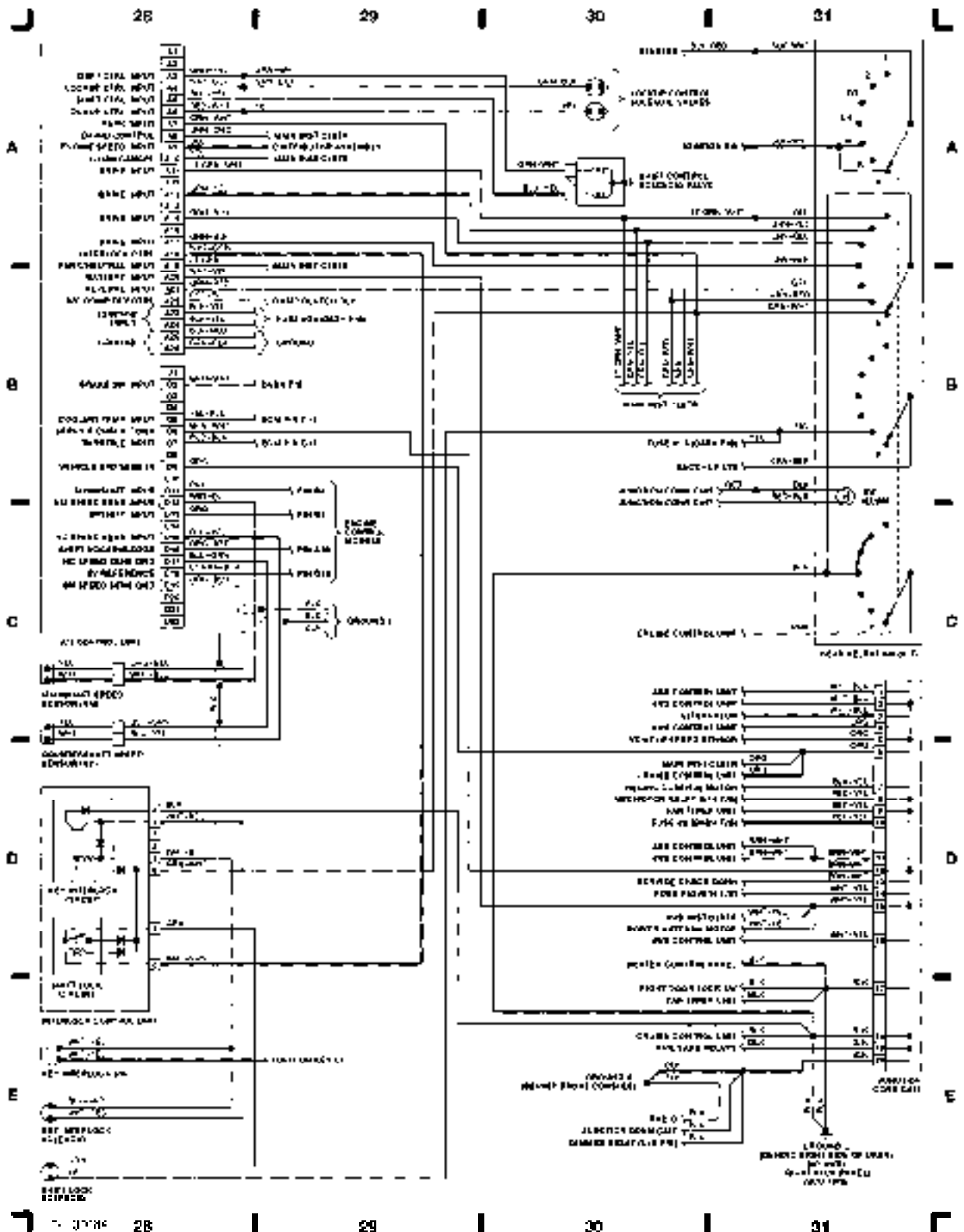

Fig. 8: A/T Control Unit, Gear Select SW (A/T) (Grid 28-31)
 WIRING DIAGRAMS Article Text (p. 11) 1993 Honda Prelude For Cadi Centre Nsk CA 9505 Copyright © 1998 Mitch

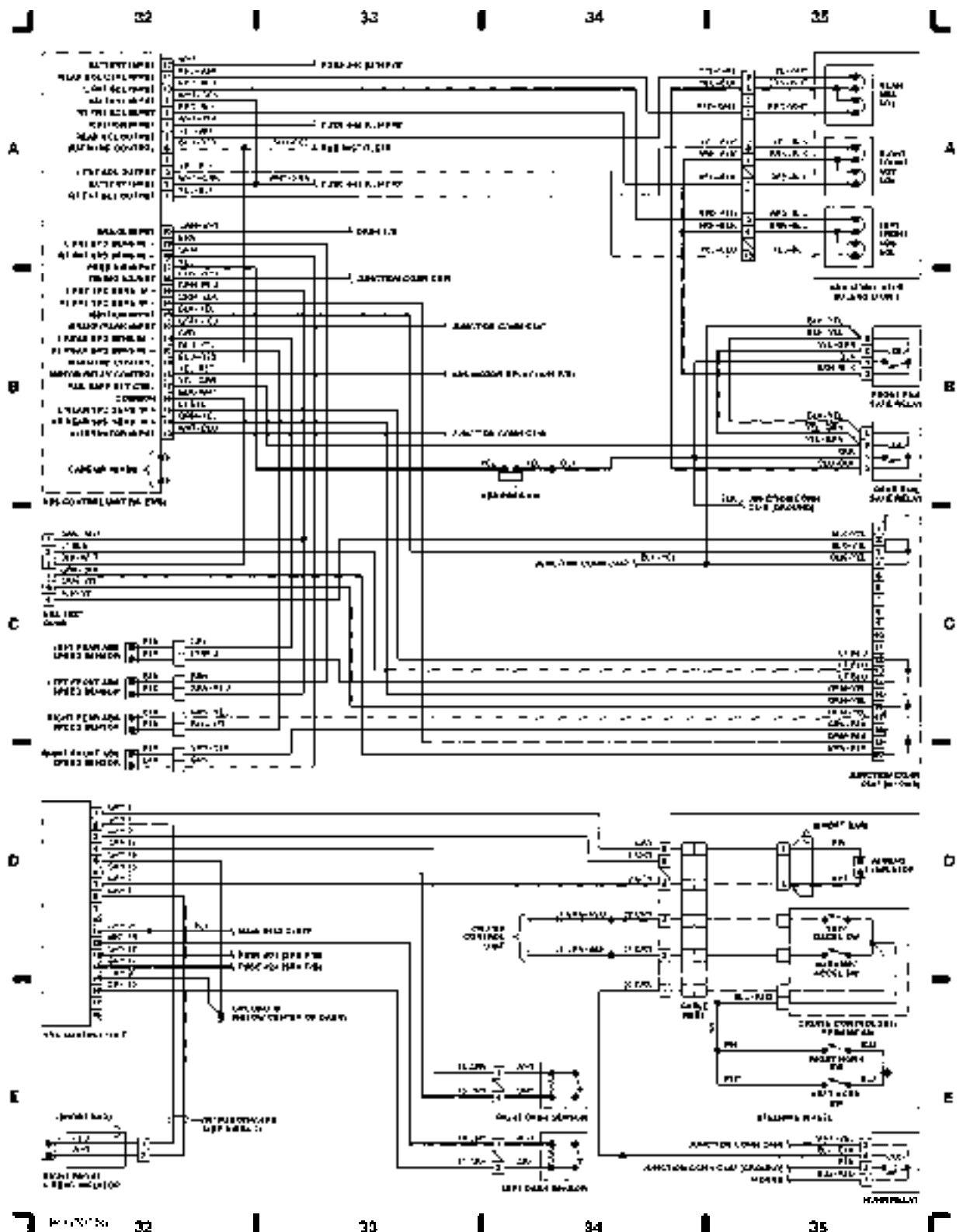

Fig. 9: ABS Control Unit (W/ 2WS), SRS Control Unit (Grid 32-35)
 WIRING DIAGRAMS Article Text (p. 12) 1993 Honda Prelude For Cadi Centre Nsk CA 9505 Copyright © 1998 Mitch

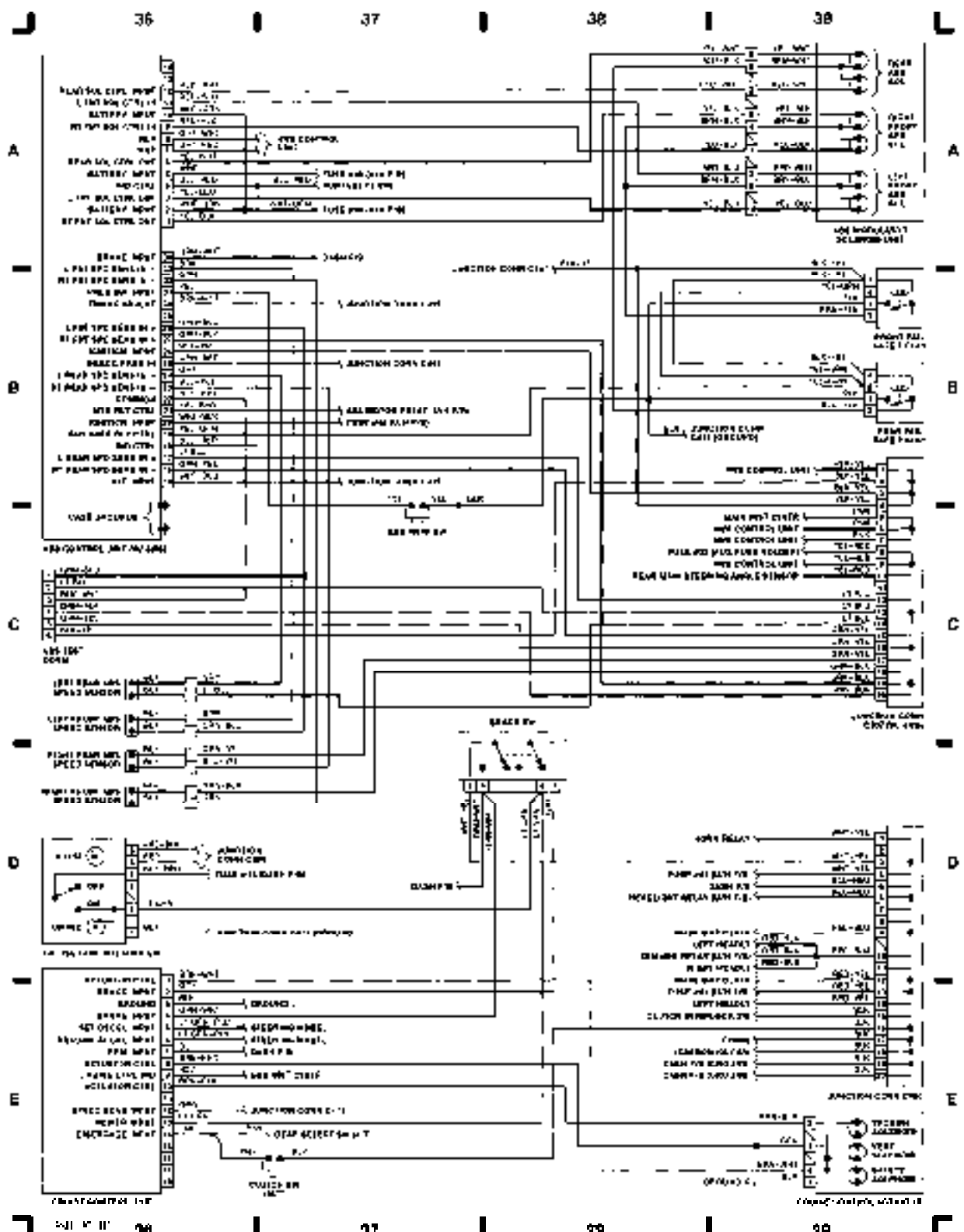

Fig. 10: ABS Control Unit (W/ 4WS), Cruise Control Unit (Grid 36-39)
 WIRING DIAGRAM Article Text (p. 13) 1993 Honda Prelude For Cadi Centre Nsk CA 9505 Copyright © 1998 Mitch

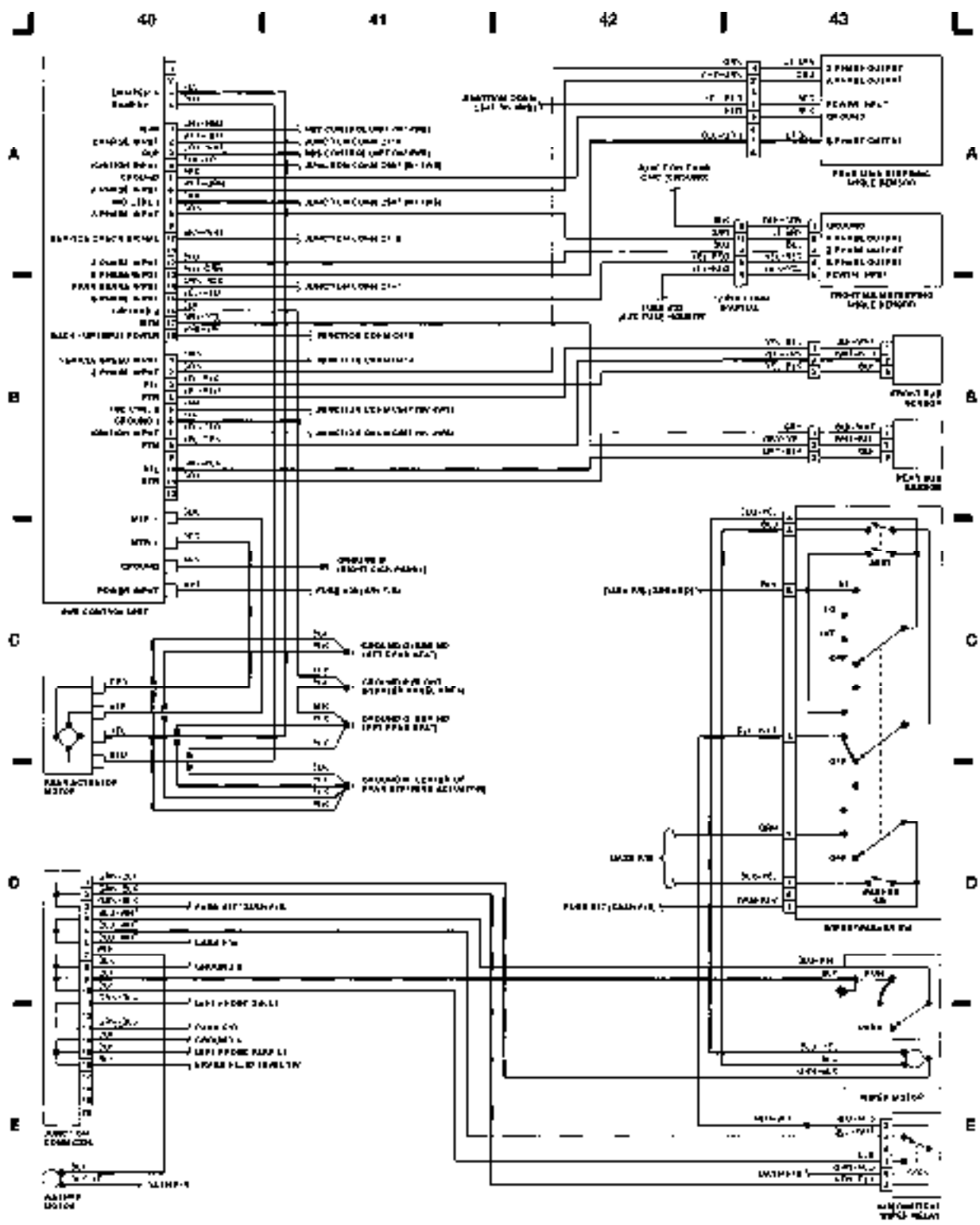
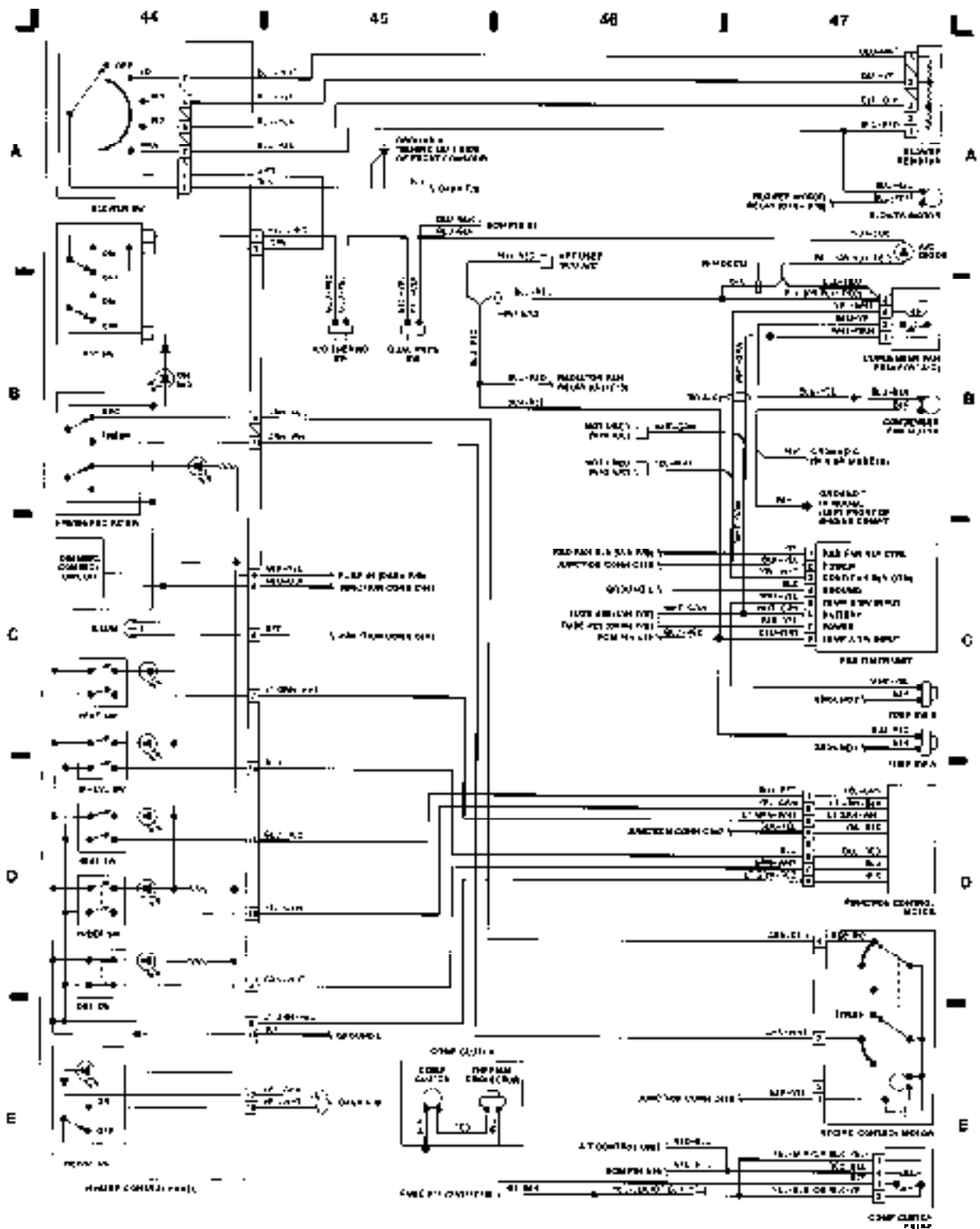

Fig. 11: 4WS Control Unit, Wiper/Washer Motor (Grid 40-43)
 WIRING DIAGRAMS Article Text (p. 14) 993 Honda Prelude For Cadi Centre Nsk CA 9505 Copyright © 1998 Mitch



WIRING DIAGRAMS Article Text (p. 15) 993 Honda Prelude For Cadi Centre Nsk CA 9505 Copyright © 1998 Mitch

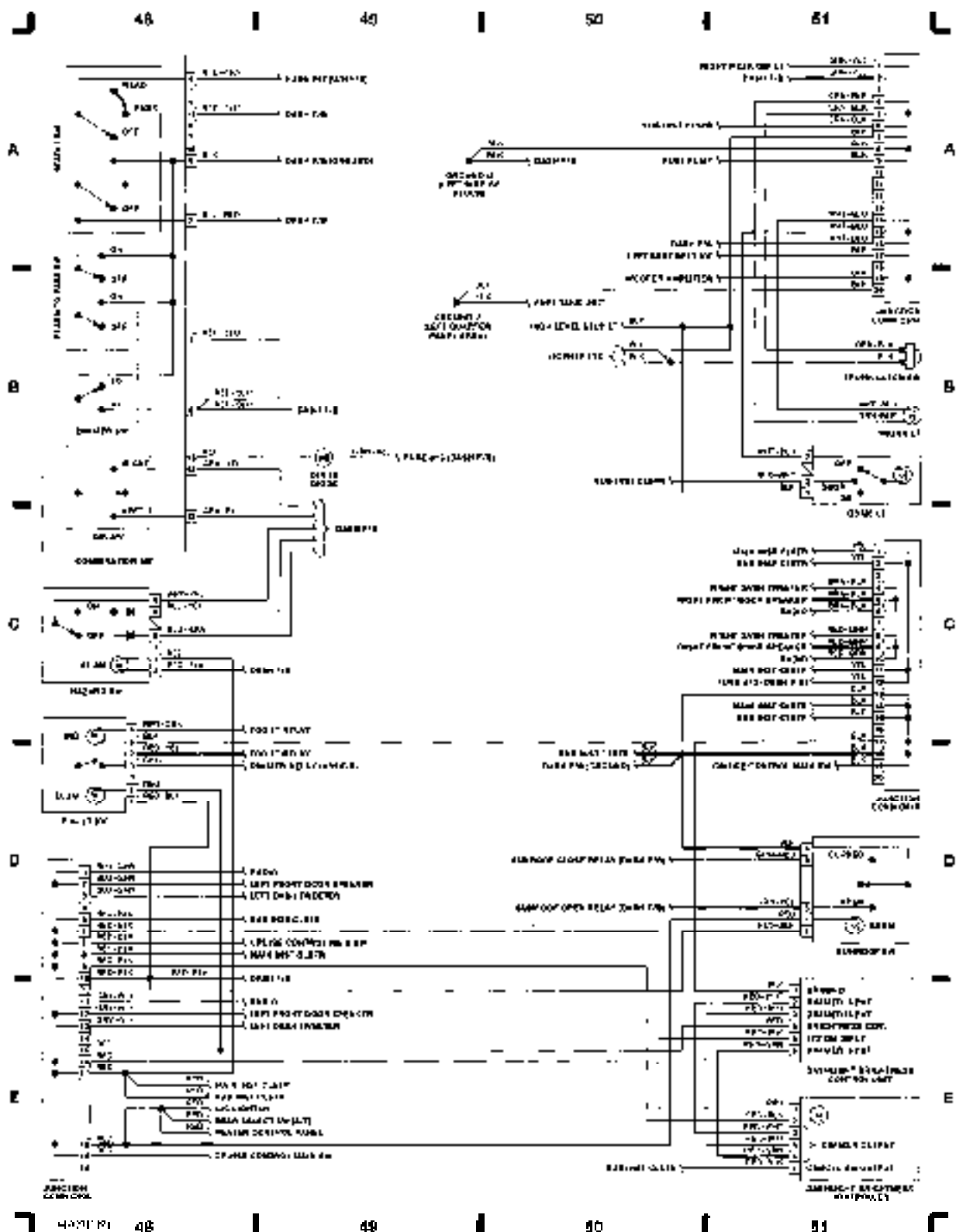

Fig. 13: Combination Sw, Sunroof Sw, Dashlights (Grid 48-51)
 WIRING DIAGRAMS Article Text (p. 16) 993 Honda Prelude For Cadi Centre Nsk CA 9505 Copyright © 1998 Mitch

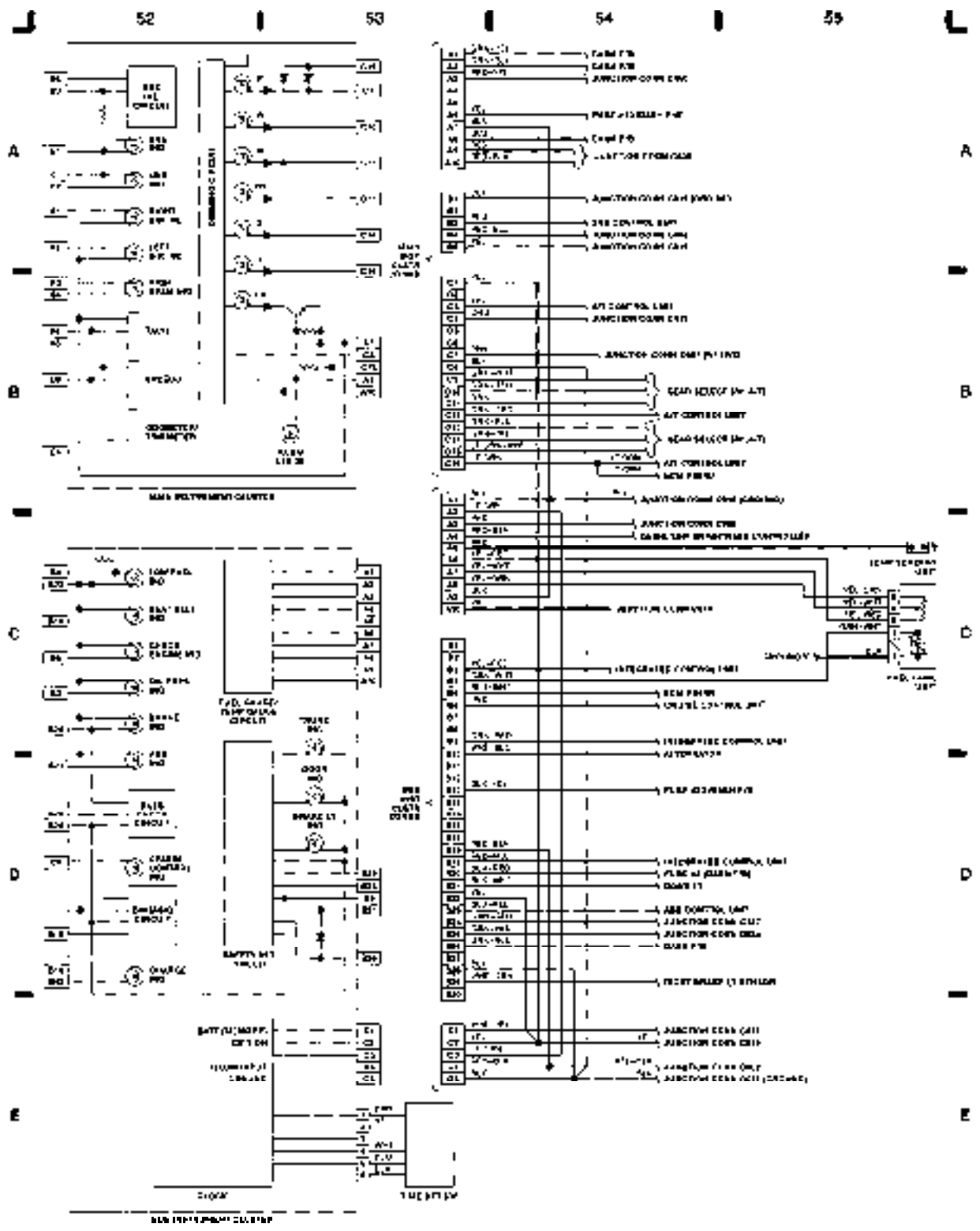

Fig. 14: Sub Instrument Cluster, Main Instrument Cluster (Grid 52-55)
 WIRING DIAGRAMS Article Text (p. 17) 1993 Honda Prelude For Cadi Centre Nsk CA 9505 Copyright © 1998 Mitch

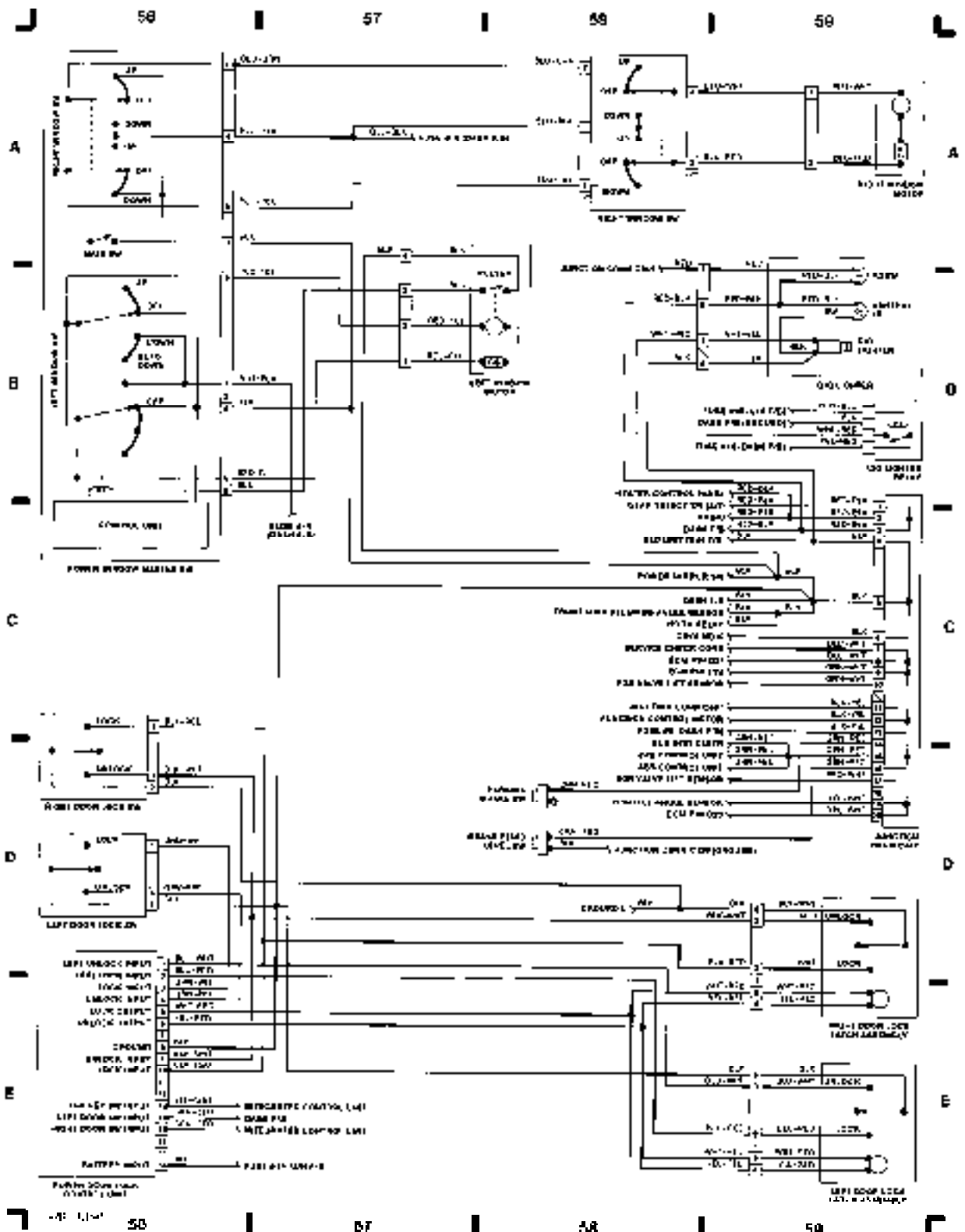

Fig. 15: Power Windows, Power Doors, Cigarette Lighter (Grid 56-59)
WIRING DIAGRAMS Article Text (p. 18) 1993 Honda Prelude For Cadi Centre Nsk CA 9505 Copyright © 1998 Mitch

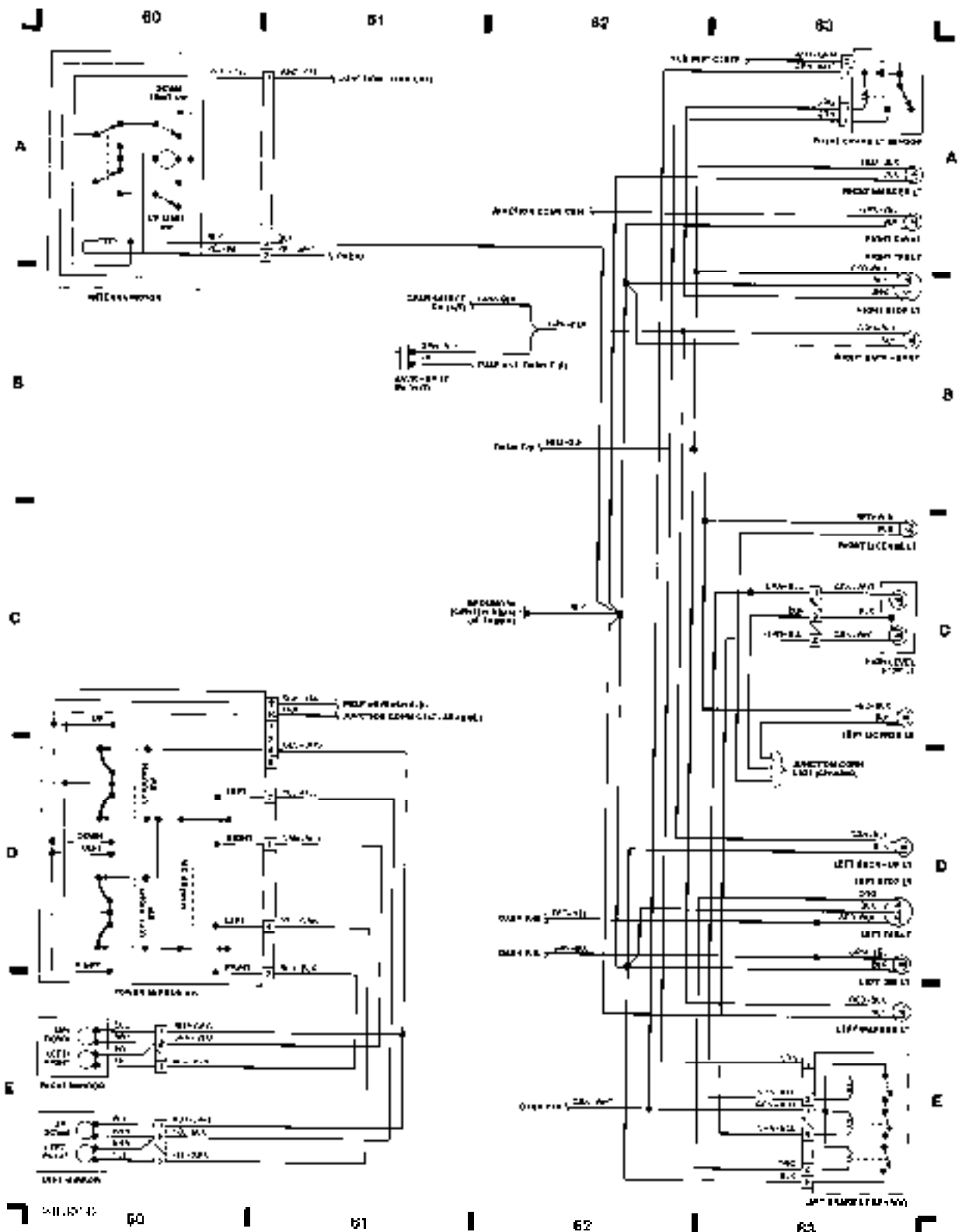

Fig. 16: Power Mirror SW, Antenna Motor (Grid 60-63)
WIRING DIAGRAMS Article Text (p. 19) 1993 Honda Prelude For Cadi Centre Nsk CA 9505 Copyright © 1998 Mitch
 END OF ARTICLE