

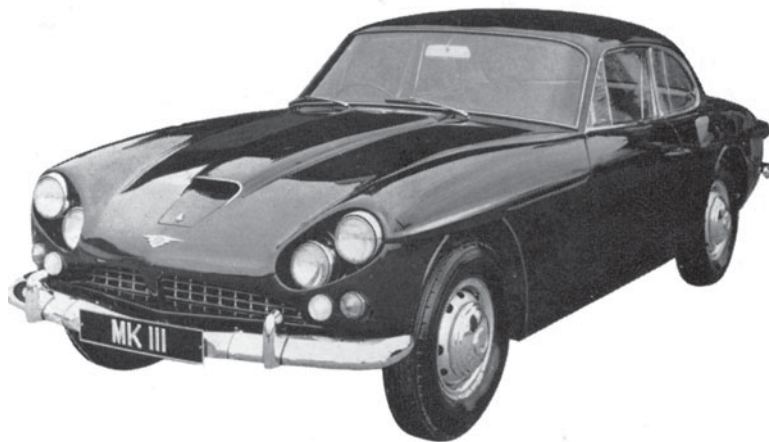

**JENSEN**  
**INSTRUCTION MANUAL**

HANDBOOK OF INSTRUCTIONS  
FOR THE  
**JENSEN C-V8**



This handbook is published for the use and assistance of owners of JENSEN CARS. It embodies in a concise form the advice and suggestions of the Company's Technical Staff in regard to lubrication, general care and maintenance, together with supplementary information regarding the necessary adjustments which may be required from time to time.

COMPILED AND PUBLISHED BY

**JENSEN MOTORS LIMITED**  
**WEST BROMWICH, ENGLAND**

Telephone: West Bromwich 2041 (10 lines)

Telegrams: Expert Telex: 33526

The Chassis Serial Number will be found on the identification plate fixed to the front of the scuttle, and also on the underside of the companion box lid.

**N.B. The full Chassis Serial Number must be quoted in all correspondence.**

**VEHICLE PARTICULARS**

CHASSIS NO .....

ENGINE No .....

KEY Nos.:

Ignition, Shroud and Door .....

Boot and Cubby Locker .....

REGISTRATION No. ....

ORIGINAL DATE OF  
DELIVERY FROM WORKS .....

# Foreword

The Jensen C-V8 is designed and built to high standards of precision and quality. Every car when it leaves the works has been thoroughly tested and adjusted by experts.

However, in order that the car may give the utmost satisfaction, it should receive adequate care and attention, and for this reason the instructions given in this handbook should be observed.

In compiling this handbook some knowledge of the operation and care of a motor car have been pre-supposed. All descriptions of position are relative to the driver's seat.

It is the aim and ambition of Jensen Motors Limited that every owner shall be completely satisfied. For this reason, Jensen dealers are chosen with particular care, and can be relied upon to carry out any servicing or repairs.

Alternatively, the Jensen Service Department at West Bromwich is always at the disposal of any owner, and all communications in connection with service matters should be addressed to the Service Manager.

JENSEN MOTORS LIMITED

# Contents

<b>VEHICLE PARTICULARS</b>	<b>3</b>
Foreword	4
Contents	5
General Dimensions and Data	6
Instuments & Controls	7
Controls and Instruments	8
Start Up and Running Hints	10
Engine Lubrication System	12
Lubrication & Maintenance	14
Fuel System & Carburettor	17
Ignition	20
Distributor	20
Cooling System	21
Transmission	22
Steering & Suspension	24
Brakes	25
Wheels & Tyres	27
Wheel Changing & Jacking System	27
Bodywork	28
Cabin Heating & Ventilation Systems	30
Electrical System	31
Lights	33
Tool Kit	35
Equipment	36
Service Lubrication	37
Rec. Lubricants For Jensen C-V8	40
Index	41

## General Dimensions and Data

The chassis number will be found stamped on a plate secured to the underside of companion box lid and on a plate secured to the front of the scuttle. This number is also stamped on the front of the chassis frame front cross member. The engine number is stamped on the L.H. bank of the cylinder block immediately forward of No. 1 Cylinder.

Cylinders are numbered as follows :—

R.H. Bank Front to Rear 2-4-6-8 L.H. Bank Front to  
Rear 1-3-5-7

Bore	108 mm. (4.25 ins.)
Stroke	86 mm. (3.375 ins.)
Cubic Capacity	6,276 cc. (383 cu. ins.)
B.H.P.	330 at 4,600 r.p.m.
Compression Ratio	10.1
Firing Order	1-8-4-3-6-5-7-2
Coolant Capacity	
including Heater	32 pints (Imp.), 38 pints (U.S.), 18.2 litres
Oil Sump Capacity	8 pints (Imp.), 10 pints (U.S.), 4.7 litres including Filter. (Dipstick top level must <b>not</b> be exceeded).
	Engine Oil Pressure at 40/50 m.p.h. 45/65 p.s.i Gearbox Capacity :
Automatic	17 pints (Imp.), 20 pints (U.S.), 9.5 litres
Manual	6 pints (Imp.), 7 pints (U.S.), 3.3 litres
Rear Axle Capacity	3 pints (Imp.), 3.6 pints (U.S.), 1.705 litres
Fuel Tank Capacity	16 galls. (Imp.), 19 galls. (U.S.), 72 litres

### OVERALL GEAR RATIOS:

Automatic	1st	7.5 : 1
	2nd	4.44 : 1
	3rd	3.07 : 1
	Reverse	6.74 : 1
Manual	1st	8.16 : 1
	2nd	5.86 : 1
	3rd	4.26 : 1
	Top	3.07 : 1
	Reverse	7.92 : 1
Tyres	Dunlop 6.70 x 15 Road Speed	
Tyre Pressure	24 p.s.i. (1.68 kg./sq. cm.) all round (see Notes on Wheels and Tyres)	
Wheelbase	8 ft. 9 ins. (2.667 metres)	
Track (Static laden weight) :	Front : 4 ft. 7-13/16 ins. (1.417 metres) Rear: 4 ft. 8-7/8 ins. (1.445 metres)	
Toe-in (Static laden weight) :	1/16 ins. (1.5875 mm.)	
Camber (Static laden weight) :	1° pos.	
Castor Angle (Static laden weight) :	2° pos.	
King Pin Inclination	6° 30'	
Centre of Gravity	49 ins. (124.46 cm.) aft of front axle	
Overall Width	5 ft. 7 ins. (1.714 metres)	
Overall Height	4 ft. 7 ins. (1.397 metres)	
Overall Length	15 ft. 3-1/2 ins. (4.686 metres)	
Ground Clearance	5-3/8 ins. (14.6 cm.)	
Turning Circle	38 ft. (11.592 metres)	
Weight (dry)	29 cwt. (1473.2 kilogrammes)	
Steering Ratio	17.2:1 (3.3 turns, lock to lock)	
IGNITION TIMING	10° before T.D.C. at 500 r.p.m.	
CONTACT BREAKER	.014 ins. to .019 ins. (.35 mm. to .48 mm ) GAP	
SPARK PLUGS	Champion J10Y. Gap .035 ins. (.89 mm.)	
VALVE CLEARANCES	Zerolash. No adjustment required	
OIL SUMP CAPACITY	It is important that sump should not be filled above the high level mark on the dipstick, other-wise functioning of zerolash tappets may be impaired	

## INSTRUMENTS AND CONTROLS

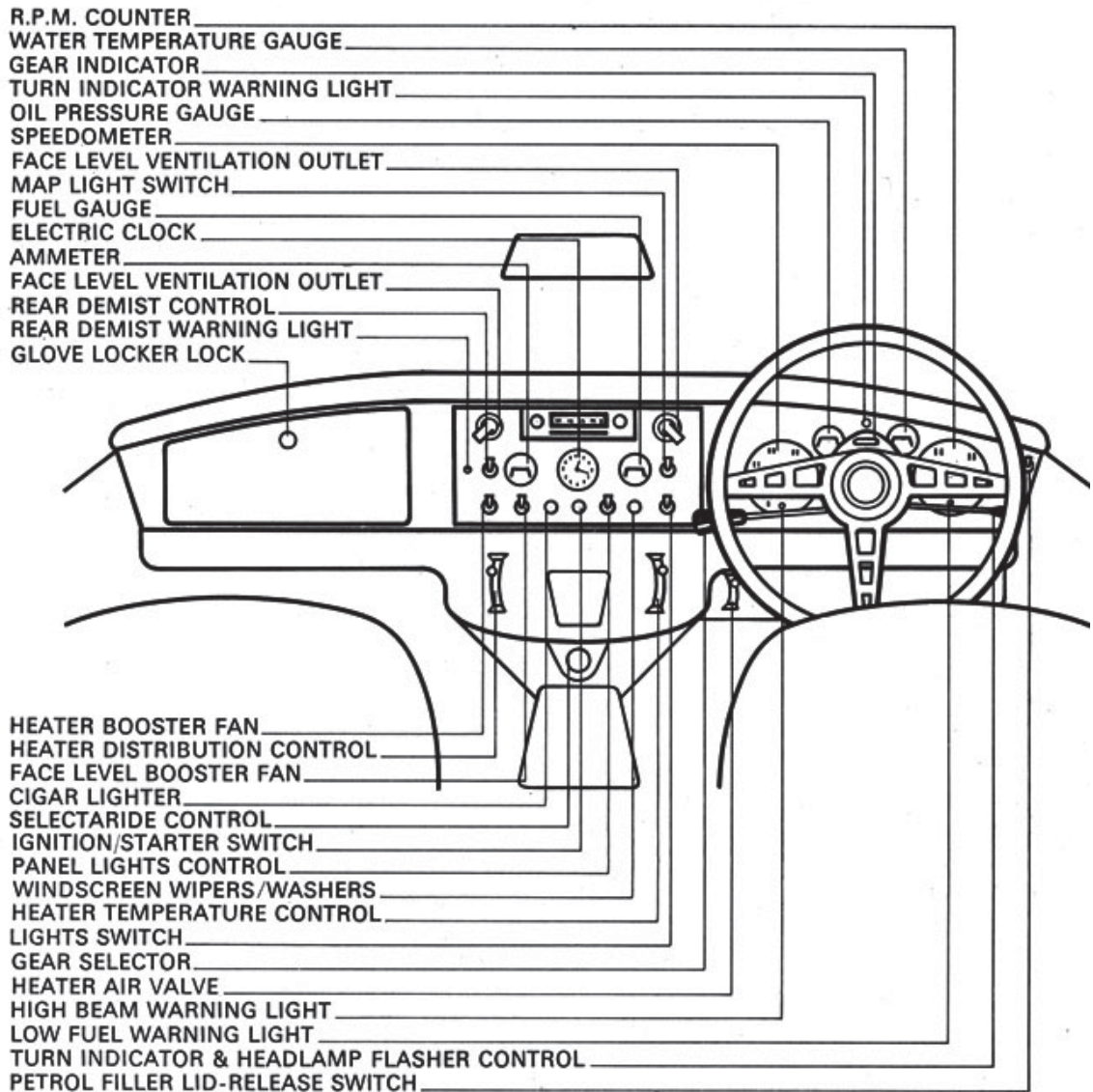

Fig 1

## Controls and Instruments

### **Pedals**

On cars fitted with automatic transmission, only two pedals are used in driving the car. The right-hand pedal controls the accelerator, and the centre, broad pedal, the brake. The left hand pedal operates the dipswitch and provides a footrest. With the manual gearbox the pedal controls follow the conventional arrangement.

### **Handbrake**

The handbrake is centrally located and operates self adjusting mechanical brakes on the rear discs only. A thumb-operated ratchet release is incorporated in the handle.

### **Steering Wheel**

The 17" steering wheel is adjustable on its shaft, to suit individual requirements. Adjustment is effected by the black sleeve immediately below the wheel. The sleeve is loosened by turning it in a clockwise direction. When loose, the steering wheel can be moved up or down to the desired position, and re-locked by turning the sleeve anti-clockwise. (There are four holes toward the lower end of the sleeve, and 3/16" Tommy bar may be used in these if necessary).

### **Ignition and Starter Switch**

The ignition and starter are both controlled by a single switch with a removable key.

Turning the key clockwise switches on the ignition circuit and the ammeter, fuel gauge, and water temperature indicator. Turning the key further clockwise against spring pressure will operate the starter motor. As soon as the engine starts the key should be released.

### **Choke**

The carburettor incorporates an automatic choke (See Starting-up section on page ).

### **Cigar Lighter**

The cigar lighter is operated by pushing it in as far as it will go. After approximately 10 seconds it will pop out, and is then hot enough for use.

### **Fan Switch**

The three-position fan switch controls the two speed heater fan (See Heating Section page ).

### **Panel Light Switch**

The three-position panel light switch controls the panel lights giving two levels of illumination. The panel lights are in circuit with the main lighting switch, and will not work until the sidelights are on.

### **Main Light Switch**

The sidelights and headlights are controlled by a three-position switch on the facia. In the half-way position it will bring on the sidelights, and in the fully down position the headlights. Once the headlights are on, high or low beam should be selected by the foot dipper switch.

The headlights may be flashed by pulling backwards on the direction indicator lever.

### **The Direction Indicators**

The direction indicators are operated by a lever on the right of the steering wheel. To indicate a turn, the lever should be moved the same way as the steering wheel. The direction indicators are self-cancelling after the turn has been completed. A visual indication is given to the driver by the green light on the facia. Pulling backwards on the lever flashes the headlights.

### **Windscreen Wipers and Washer**

A dual purpose switch on the facia controls the windscreen wipers and washer. If the switch is turned clockwise to the first position, the wipers will operate at normal speed : turning it further increases the speed of the wipers. The higher speed should not be used on a drying screen, as this will overload the motor. The wipers are self-parking when switched off. The windscreen washer, which is of the electric type, is operated by pressing the knob of the wiper switch.

**Gear Selector and Indicator** (*Automatic transmission only*) The gear selector and indicator are mounted on the steering column. Five positions are marked on the indicator R N D 2 1. The engine can only be started when the lever is the "N" position (See Starting and Driving Section pages ).



**Clock**

The electric clock is set by the knurled knob on the bezel, which should be pushed in to engage the hands. If necessary, the clock may be regulated by turning the small screw head in the bezel, clockwise to retard, and anti-clockwise to advance.

**Map Light Switch**

A Map light is fitted in the upper facia roll above the left hand face-level ventilator and is controlled by a switch on the facia marked "map".

**Face-level Air Booster Switch**

The switch marked "Air" on the facia operates a fan which increases the fresh air output at face level.

**Rear Demist Switch and Warning Light**

This switch controls the electrically heated back light. (The current to the rear light is cut off when the engine cooling fans come into operation, so the demist warning light goes out, and comes on again when the fans cut out).

**Re-fuel switch**

The re-fuel switch automatically unlocks the fuel filler flap on the left hand rear wing. Should the solenoid fail, the flap can be opened manually from inside the luggage boot. (See Fuel System section page ).

**Horn Push**

The twin horns are operated by the push button in the centre of the steering wheel.

**Selectaride Switch**

The Selectaride switch on the transmission tunnel controls the settings of the rear dampers. Four settings are available, from SOFT up to 4. The harder settings should be used for high speeds, or when the car is fully laden. The switch works in a CLOCKWISE direction only, and should not be used unless the ignition is switched on.

**Revolution Counter**

The revolution counter has a red sector from 5100 RPM to 6000 RPM and engine speeds in this sector should not be sustained. Maximum engine power is developed at 4600 RPM, so no advantage will be gained by over-revving the engine. There is a low-fuel warning light in the rev-counter face. This glows continually when 3 gallons only remain in the tank.

**Speedometer**

The speedometer incorporates trip recorder and odometer. To set the trip, the knob to the right of the steering column and below the facia should be pressed upwards and turned anti-clockwise. In the speedometer face is a high-beam warning light which glows when the headlamps are in the raised position.

**Ammeter**

The ammeter indicates the charging or discharging rate of the battery. Under normal running conditions a small charging rate is indicated. On starting the engine, the ammeter will indicate a high charge rate for a short time, and then fall to suit the battery condition.

**Oil Pressure Gauge**

The oil pressure gauge operates only when the engine is running, and should indicate a pressure of 45-65 p.s.i. under normal conditions.

**Coolant Temperature Indicator**

The coolant temperature indicator operates only when the ignition is on. Under normal running conditions, the instrument pointer should be within the white band on the scale. If the pointer enters the red band—H—the cause should be investigated. **DO NOT** remove the radiator cap when the engine is hot. (See Cooling section on page ).

**Fuel Gauge**

The fuel gauge indicates the petrol level in the tank shortly after the ignition is switched on.

## Starting Up and General Running Hints

### ENGINE RUNNING-IN PERIOD

It is not necessary to drive the new car at consistently low speeds during the first few hundred miles of operation. Precision manufacturing methods and improved design make it possible to begin driving in a normal manner.

While speeds in excess of 50 miles an hour should be avoided for the first 300 miles, occasional spurts up to this speed (after the engine is warmed) will materially assist the "running-in" process. After 300 miles of driving, occasional bursts of higher speed are not only permissible but desirable. The new car should not, however, be operated at top speed until it has been driven at least 500 miles. High speed should always be avoided until the engine is warmed up to operating temperature. During the "running-in" period it is extremely important to keep close watch on the engine oil level and the panel instruments—especially the temperature and oil pressure gauges. Sustained high engine speed should be avoided during early life of the new car so that all parts will become adjusted to their position without excess friction and heat.

The observance of these precautions will be reflected later on in the prolonged life of the car. Under this heading, lubrication is by far the most important item. Many troubles are directly traceable to lack of proper lubrication and owners will be well repaid by giving careful attention to the lubrication diagram. The engine attains maximum power at 4,600 r.p.m., and 5,200 r.p.m. should not be exceeded. The illustration on page 6 shows the general arrangement of controls. The following points should be observed in starting the engine.

### STARTING THE ENGINE

**It is essential to ensure that the handbrake is applied before starting the engine**, as the automatic carburettor system will cause the engine to run at a fairly fast idle speed on initial starting from cold.

On cars with automatic transmission, move the gear range selector lever to neutral, quadrant position "N". The engine cannot be started unless the selector lever is in this position.

### FOR STARTING FROM COLD

**Depress the accelerator pedal slowly to one third of its travel and allow it to return to closed position before starting the engine.**

Turn ignition key to extreme right to operate starter. When engine fires, release key. The engine should start immediately.

**NOTE—Do not pump accelerator pedal. If engine does not start because of excess fuel in cylinders, push accelerator pedal slowly to full open and operate starter while keeping pedal depressed.**

The fuel mixture is automatically adjusted to provide for easy engine starting and for the warming up and operating periods.

### GEARBOX OPERATION

The automatic gearbox is more than just a mechanism which automatically adjusts the gear ratios according to conditions of speed and load. An overriding control is provided which enables the driver to exercise his own judgement and desire in regard to the gear ratios to be selected and an understanding of what is possible greatly enhances the pleasure to be derived from driving the car. The gearbox provides three forward speeds, Neutral and Reverse. The control quadrant is marked as follows :—

RND 2 1

The following indicates the gears obtained in each range :

"1" 1st only (Maximum permissible 48 m.p.h.)

1st and 2nd (Maximum permissible 82 m.p.h.) "D" 1st, 2nd and top

"N" Neutral

"R" Reverse

There is one 'gate' position for reverse only.

To change into reverse press the button in the end of the gear lever.

### TO DRIVE AWAY

If the driver so desires, he can leave everything to the automatic gearbox and gear changes will occur at the theoretically correct moment in terms of speed and load. Obviously, however, road or traffic conditions may be such that the automatic gear change may be undesirable, and it is for this reason that the overriding controls are provided to enable the driver to enforce a gear change as and when

desired.

The driver should, therefore, first familiarise himself with the approximate speeds at which the automatic changes occur. These are as follows :

	D Range	
	Up-changes (m.p.h.)	
	1-2	2-top
Light Throttle	11	15
Full Throttle	40	76

The owner-driver who wishes occasionally to indulge in a very fast get-away will obtain maximum acceleration by allowing the automatic gearbox to make full throttle changes throughout the speed range.

The automatic down-change at light throttle will normally occur at the following speed :

Top to 1st direct 8 m.p.h.

Under "Kick-down" conditions down changes occur at speeds below the following limits :

Top to 1st 37 m.p.h.

Top to 2nd 68 m.p.h.

**Caution must be observed when making a "Kick-down" change at speeds below 32 m.p.h. in view of the sudden surge of power engendered.**

### **MANOEUVRING**

When manoeuvring, "D" should be selected for forward movement. Reverse gear can be selected whilst vehicle is in forward motion but only below 17 m.p.h.

### **MOUNTAIN DRIVING**

When driving in mountainous country or with heavy loads, the 2 or 1 position should be selected on upgrades which require heavy throttle for half a mile or more. Lower ratios reduce the possibility of overheating the transmission and converter under these conditions. The 1 position is for severe operation or to obtain better control or for operation in descending a steep hill.

### **IDLING**

Neutral ("N") should be selected when it is necessary to idle the engine for an extended period.

### **COASTING**

Coasting must be avoided at all times, otherwise the gearbox may suffer serious damage due to lack of lubrication.

### **TOWING**

**Transmission Inoperative.** The vehicle should be towed with a rear end pick-up or remove the propeller shaft.

**Transmission Operating Properly.** The vehicle may be towed safely in "N" (neutral) at moderate speeds. For long distance towing (over 100 miles) the propeller shaft should be removed.

### **PUSH STARTING**

If the engine fails to start in the normal manner, it may be started by pushing the car. Towing is not recommended due to the sudden surge of power when the engine starts. Turn the ignition on, then engage 1 (low) position and depress the accelerator pedal slightly; after the vehicle has been pushed to a speed of 15 to 25 m.p.h. (approximately), the transmission will drive the engine.

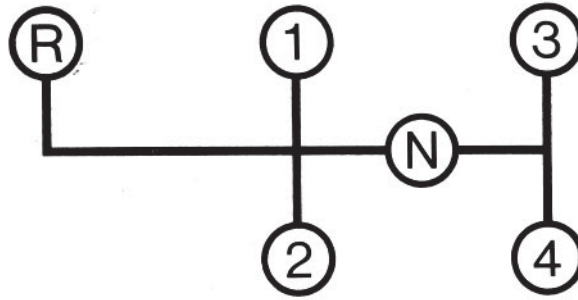

Fig 2

## Optional Manual Transmission

The change speed arrangement being conventional, it is not proposed to describe the method of engaging and changing gear, but a plan showing the gear lever positions is shown above.

## Clutch

The clutch is hydraulically operated and normally requires no adjustment. If attention is required the work should be carried out by an officially appointed Jensen Distributor or Dealer.

## Engine Lubrication System

The engine lubrication system comprises an externally mounted rotor-type pump, a full flow oil filter connected to the pump by flexible pipes, engine sump, and various lubrication passages.

Oil is drawn from the sump through a fine mesh gauze strainer, and delivered to the bearings, via the oil filter, under pressure from the pump. Uniform pressure is maintained by a relief valve in the pump. The valve gear is lubricated by oilways through the cam-shaft, while the gudgeon-pins are splash lubricated.

The oil level should be checked daily by means of the dipstick, which is on the left hand side of the engine. Oil should be added via the filler cap on the left hand bank of cylinders.

### Draining the Sump

The engine oil should be changed every 4,000 miles (or 3 months) (Every 2,000 miles if a great deal of driving is done in heavy traffic or in very cold conditions).

The oil should be drained when the engine is warm. The drain plug is in the bottom of the sump.

### Changing the Filter

The engine oil filter element should be changed with the engine oil with every **second** change. The filter is mounted high up on the left hand side of the engine, and is connected to the pump by two flexible pipes.

The element is changed by undoing the hexagonal nut on top of the filter housing. This will allow the top of the housing to be removed, and the filter element withdrawn.

Before the new element is inserted, the housing, especially the top rim, should be wiped clean. A new gasket should be used every time the element is changed.

After the fitting of a new filter element, the car should be run for a few miles and then the top joint of the filter inspected for leaks. If necessary the hexagonal nut should be retightened.

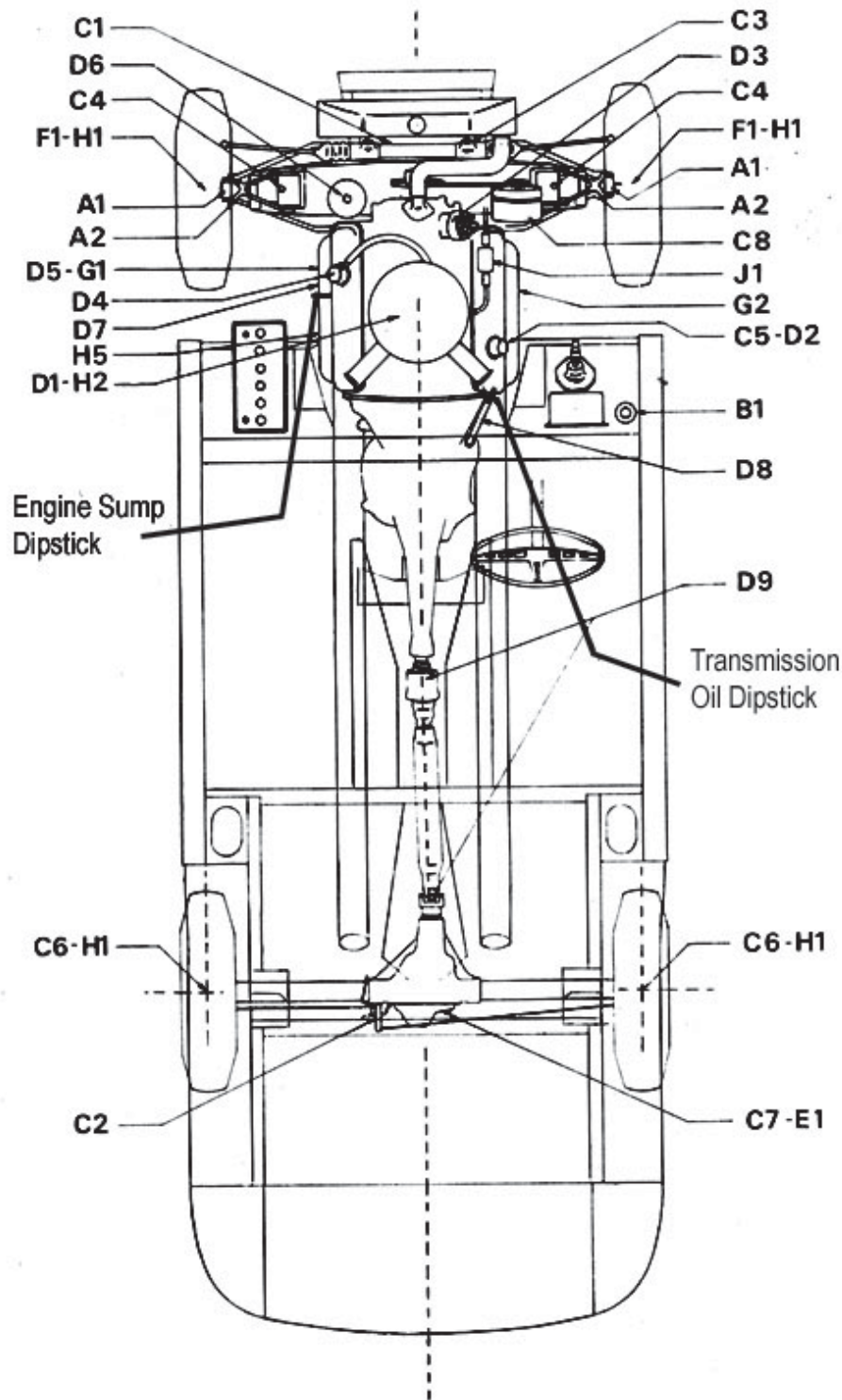

Fig 3

## LUBRICATION AND MAINTENANCE

## LUBRICATION AND MAINTENANCE

### FIRST 1,000 MILES SERVICE

- The following special service is necessary after the car has covered the first 1,000 miles.
- Drain and refill axle.
- Tighten driving belt if necessary.
- Check contact breakers, and adjust if necessary.
- Check electrical system.
- Check steering and front end geometry.
- Check tyre pressures.
- Check hydraulic reservoirs for fluid.
- Check lights.
- Check braking system.
- Check water level and connections and tighten if necessary.

### A-1,000 MILES (second and subsequent)

- A1 — King Pin Bearings Upper and Lower—Grease Gun (4 nipples).
- A2 — Front Suspension Lower—Grease Gun (2 nipples).

### B-2,000 MILES or Monthly

- B1 — Brake and Clutch Master Cylinder Reservoirs—check and top up.

### C-4,000 MILES

- C1 — Steering Rack—Grease Gun (1 nipple).
- C2 — Brake Balance Lever—Grease Gun (1 nipple).
- C3 — Steering Dampers—Check and Top Up.
- C4 — Front Shock Absorbers—Inspect and Top Up.
- C5 — Sump—Drain and Refill.
- C6 — Rear Wheel Hubs—Grease Gun (2 nipples).
- C7 — Rear Axle—Check and Top Up.
- C8 — Alternator—Clean and Check.

### Manual Transmission

- C9 — Clutch Bell Crank Lever—Grease Gun (1 nipple).
- C10 — Clutch Bell Crank and Fork Linkages—Lubricate.

### D-8,000 MILES

- D1 — Air Cleaner Element—Clean and Check.
- D2 — Oil Filler Air Cleaner—Clean and Re-oil.
- D3 — Distributor—Clean, Check Points.
- D4 — Crankcase Ventilator Valve—Check.
- D5 — Sparking Plugs—Clean and Check.
- D6 — Oil Filter Element—Replace.
- D7 — Manifold Heat Control Valve—Lubricate.
- D8 — Automatic Transmission—Check and Top Up.
- D9 — Propshaft U/J's—Inspect for leakage.

### Manual Transmission

- D10 — Gearbox—Check and Top Up.

### E-12,000 MILES

- E1 — Rear Axle—Drain and Refill.

**F-16,000 MILES**

F1 — Front Wheel Hubs—Check and Repack if necessary.

**G-20,000 MILES**

G1 — Sparking Plugs—Replace.

G2 — Fuel Pump Inlet Filter—Replace.

**H-32,000 MILES**

H1 — Wheel Hubs—Clean and Repack.

\*H2 — Air Cleaner Element—Replace.

\*H3 — Automatic Transmission—Drain, Refill and Adjust.

\*H4 — Automatic Transmission Oil Filter—Replace.

\*H5 — Propeller Shaft Joints—Clean and Repack.

\* *Heavy operating conditions only; normally no attention required.*

**Manual Transmission**

\*H6 — Gearbox—Drain and Refill.

**J-80,000 MILES**

J1 — Carburettor Inlet Pipe Fuel Filter—Replace.

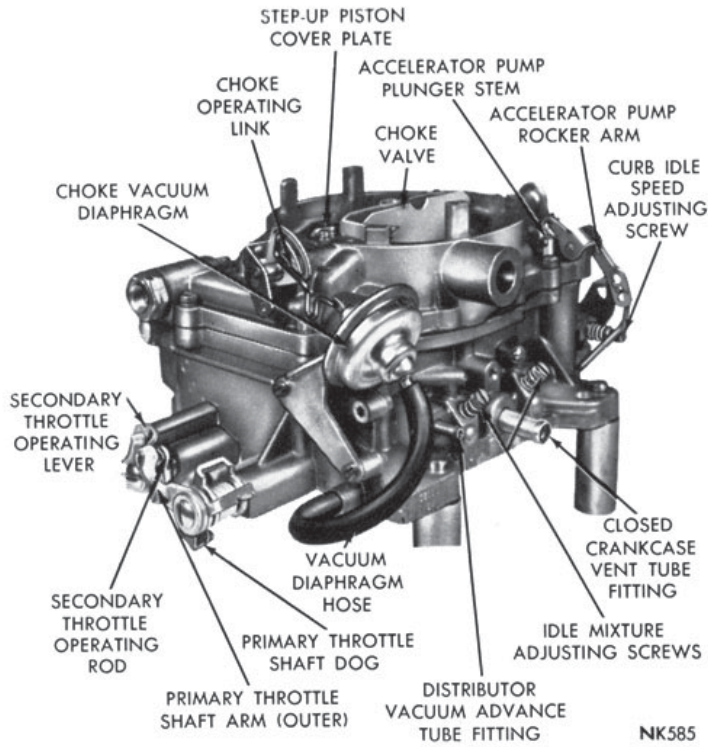

Fig 4

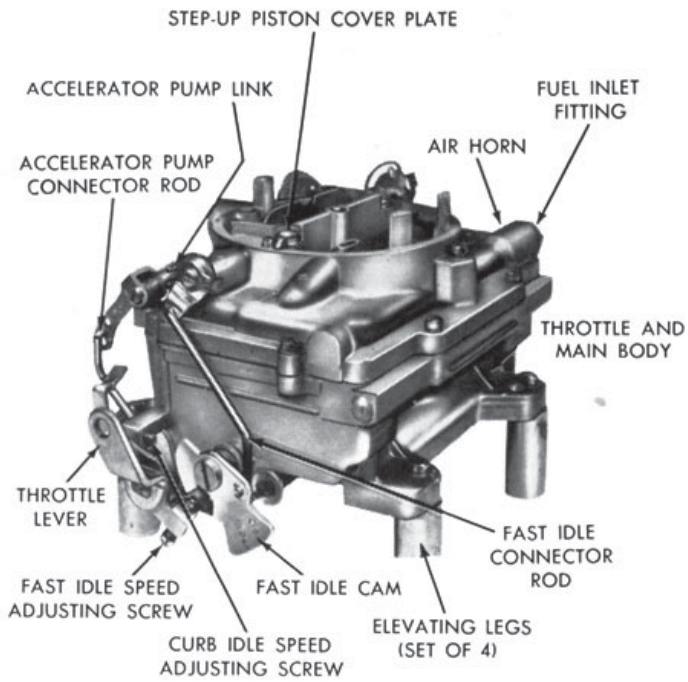

Fig 5



## Fuel System and Carburettor

### Fuel System

The fuel system consists of the fuel tank, line and filters, mechanical pump, carburettor and air cleaner.

### Fuel Tank

The fuel tank is located below the floor of the boot and has a capacity of 16 gallons Imp., 19 gallons (U.S.) or 72 litres. The low fuel warning light in the face of the rev counter burns continuously when 3 gallons or less remain in the tank.

The fuel tank filler pipe is covered by a flap on the left hand rear wing, which can be opened automatically from the driver's seat. The 'Re-fuel' switch on the fascia controls a solenoid which, when energised, allows the flap to fly open. Alternatively the flap can be opened manually by depressing the small plated lever in the top left hand corner of the boot. There is a drain plug in the bottom of the tank.

### Fuel Line and Filters

The fuel line incorporates two filters, one before and one after the fuel pump. These are of the paper cartridge type and cannot be cleaned. The filter between the tank and pump should be replaced every 20,000 miles and the filter after the pump every 80,000 miles. *Note:* Where dirty petrol has been used, more frequent filter changes will be necessary.

### Fuel Pump

The mechanical fuel pump is located on the right hand side of the engine. It is driven from the camshaft and delivers fuel to the carburettor at 3-1/2 p.s.i.

### Carburettor

The Carter AFB (Aluminium Four Barrel) carburettor is a complicated and sensitive instrument, for it combines the best features of both single and multi-choke designs in one unit.

All jets etc. are correctly set before installation, so the only adjustment normally necessary will be to the idling speed settings.

### Idle Speed Adjustment—(Curb Idle)

To make the idle speed adjustment, the engine must be thoroughly warmed up. A much more reliable idle adjustment can be obtained if the car has been driven a minimum of five miles. For the best results, it is recommended that the tachometer be used in this adjustment.

Before making the idle speed adjustment observe the following precautions :

- (1) On cars equipped with the automatic transmission, disconnect the carburettor to bellcrank rod so that the stop in the transmission will not interfere with the free movement of the carburettor throttle lever.
- (2) To make the idle speed adjustment proceed as follows :—
  - (i) Turn the idle speed screw **in** or **out** to obtain 500 r.p.m. Be sure the choke valve is fully open and that the fast idle adjustment screw is not contacting the fast idle cam.
  - (ii) Turn each idle mixture screw to obtain the highest r.p.m. While making the adjustment, carefully watch the tachometer and notice that the speed can be decreased by turning the screws in either direction from the setting that gave the highest r.p.m. reading.
  - (iii) Readjust to 500 r.p.m. with the idle speed screw.
  - (iv) Turn each idle mixture adjusting screw in the clock-wise direction (leaner) until there is a slight drop in r.p.m. Now, turn each screw out, counter-clockwise (richer), just enough to regain the lost r.p.m.  
This procedure will assure that the idle has been set to the leanest possible mixture for smooth idle. **This setting is very important!**  
Since the correct speed was originally set using the speed screw, the speed obtained after finding the leanest smooth idle setting will probably be too fast.
  - (v) Readjust the speed screw to obtain correct idle speed. Repeat steps 2 and 4 above if necessary.

After the proper idle speed has been obtained, check transmission setting as described under throttle linkage.

Fig. 7.

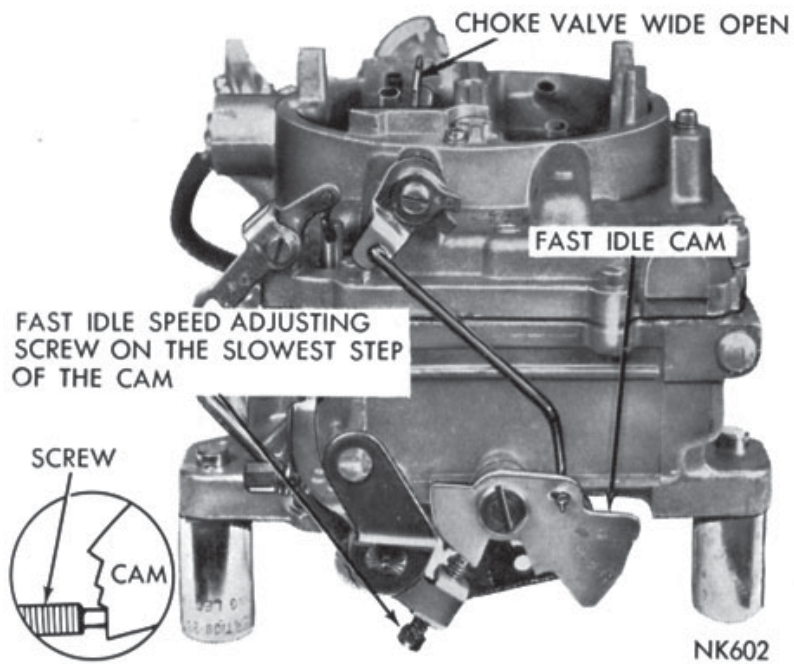

Fig 6

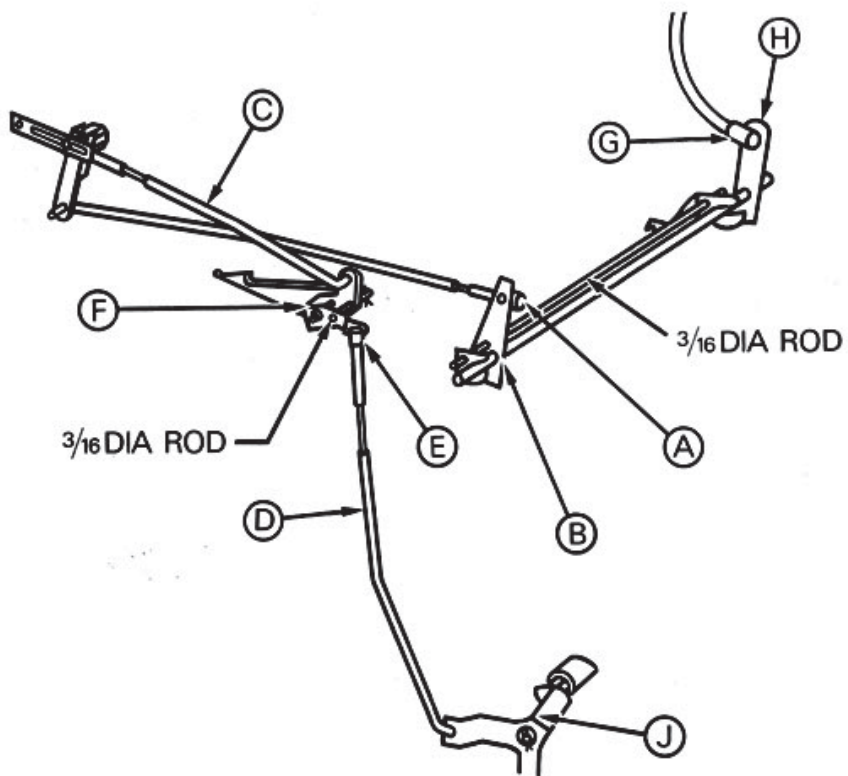

Fig 7

### **Throttle Linkage**

The correct setting of the throttle linkage cannot be over-empha-sized. The throttle and automatic gearbox controls being inter-connected, various conditions affecting car performance can be encountered if the throttle is not set correctly. As well as poor general performance, there may be delays in automatic gear-changes, both up and down, and total failure of the "kick-down". If the linkage has been disturbed for any reason, it must be reset in the following manner, with reference to fig. 7.

- (1) Block choke valve in fully open position and ensure release of fast idle cam. (These precautions are not necessary on a fully warmed-up engine).
- (2) Disconnect :
  - (a) Carb rod (A) at crossshaft lever (B)
  - (b) Carb-bellcrank rod (C) at carburettor
  - (c) Rod (D) at upper end
  - (d) Cable (G) from lever (H)
- (3) Insert 3/16 dia. rods in the two positions indicated.
- (4) Using rod (D) to hold throttle valve lever (J) against forward stop, adjust rod end until it clips onto ball end stud (E).
- (5) Remove 3/16 dia. rod from bellcrank (F) and, still loading system against throttle valve lever stop, adjust rod (C) till slotted hole just slips over carburettor lever stud. Then adjust rod end out three (3) full turns and replace washer and spring pin in position.
- (6) Adjust carburettor rod (A) until ball joint stud locates in lever (B) on crossshaft and fix with nut and spring washer.  
Adjust cable end ball joint, while applying a light load against cable stop, until it locates in hole in accelerator crossshaft lever (H) and fix with nut and spring washer.
- (7) Remove A dia. rod from crossshaft, and blocks from carburettor choke valve, and test that full throttle opening is being obtained in carburettor when the pedal is depressed fully against floor stop. If necessary adjust floor stop.

### **Air Cleaner**

The air cleaner is held on top of the carburettor by one wing nut. Every 8,000 miles the air cleaner element should be cleaned. Every 32,000 miles, or more often under dusty conditions, a new element should be fitted. At any time if there should be an oil mark on 2/3 of the circumference a new element should be fitted.

### **Closed Crankcase Vent System**

The crankcase ventilator valve is located on the right hand rocker cover and is connected to the carburettor body by a rubber tube. The valve serves as a vent for the crankcase, and also provides upper cylinder lubrication by introducing oily vapour into the inlet manifold.

Every 8,000 miles the valve should be checked for correct operation.

The left hand rocker cover is vented via the carburettor air cleaner.

## **Ignition**

The ignition is of basically standard design, but incorporates two features which may be strange to some owners. These are, a ballast resistor mounted in series with the coil, and twin contact breakers fitted to the distributor.

The ballast resistor is a variable resistance in the ignition primary circuit. During low speed operation, when the current flow through the primary circuit is high, the temperature of the ballast resistor rises, increasing its resistance. This reduces the current flow, thus prolonging the life of the contact breakers. At high engine speeds, when the current flow in the primary circuit drops off, the ballast resistor cools down, thus allowing more current to flow, and more efficient high speed operation. As an aid to easier starting, the ballast resistor is bypassed when the starter is in operation, thus allowing full battery voltage to the ignition primary circuit.

The twin contact breakers are fitted to reduce spark erosion at high speeds (on an 8 cylinder engine). The gaps should be set as if for a single unit, in fact the engine will run with only one set. When setting the gap on one, the other should be blocked with a thin strip of insulating material, such as mica.

## **Distributor**

Every 8,000 miles 5-10 drops of oil should be added to the oil cup and 2-3 drops of oil to the rotor wick. The cam and bumper block should also be thinly coated with grease. At the same time the points should be cleaned and checked.

## Cooling System

Capacity 32 pints (Imp.) 38 pints (U.S.) 18.2 litres.

The coolant is circulated by a centrifugal pump driven off the engine, by the same belt as the alternator. A thermostat is fitted, immediately above the water pump, to assist in rapid warming up of the engine.

**WARNING** The cooling system is pressurised to 14 p.s.i. and therefore operates at a higher temperature than normal. Scalding could result if radiator filler cap is removed when the engine is hot. All checks should therefore be made when the engine is cool or cold.

### Topping up

Coolant level should be checked daily. When necessary clean water should be added to bring the level in the radiator up to the indicator bar in the header tank. The radiator should not be over-filled, as the pressurised system requires room for expansion.

Cold water **MUST NOT** be added when the engine is hot, other-wise serious damage may be caused to the engine. It must either be allowed to cool down, or hot water added to the radiator.

### Draining Cooling System

There are 3 draining points; one at the bottom of the radiator, and one at each side of the crankcase, at the base of each cylinder block. It is essential that all three be opened when draining the engine. The radiator drain tap may become clogged with sediment, and should therefore be cleaned occasionally with a piece of stiff wire.

### Frost Precautions

In cold weather there is a risk of the water freezing and cracking the cylinder block or radiator. Therefore, an anti-freeze solution should be used under these conditions. It is essential that only an Ethylene Glycol-based product be used. For the correct quantities to add, for full protection under different weather conditions, reference should be made to the anti-freeze makers' charts.

### Flushing

To reduce the formation of deposits, which impair efficiency, the cooling system should be flushed out with clean water every 5,000 miles. This is particularly important before adding anti-freeze.

### Thermostat

The thermostat restricts flow between the cylinder block and radiator to assist rapid warming up. It is of the copper-impregnated wax type, and should start to open at approximately 57°C. It should be fully open at approximately 75°C. Failure of the thermostat is indicated by slow warming up, and poor heater performance.

### Electric Fans

There is no engine driven cooling fan, but in its place two electric fans which operate only when required to maintain optimum engine operating temperature. These fans are mounted on the cross tube behind the radiator and are controlled by a thermostatic switch in the bottom of the radiator.

They are not wired through the ignition circuit and will therefore continue running, if necessary, even after the engine has been switched off. (This is because the water temperature actually rises during the last few seconds of a journey, owing to the car being stopped and there being no air flow through the radiator. The fans will only run for a very short time, and then switch themselves off).

The fans are protected by a fuse in the Relay Box at the rear of the engine compartment.

# Transmission

## Automatic Gearbox

The Chrysler Torqueflite 8 Automatic Gearbox combines a torque-converter with a fully automatic 3 speed planetary gear system. For correct operation of the gearbox, it is **essential** that only the recommended fluids are used, and that the fluid level is checked and replenished as necessary. To prevent overheating of the transmission, the fluid is circulated through an oil cooler in the bottom tank of the main cooling radiator.

## In an emergency

If the fluid level is low, and none of the recommended fluids are available, SAE 10 engine oil may be added. However, the gearbox should be drained and re-filled with the correct fluid as soon as possible.

## Checking and Topping Up

The fluid level should be checked every 8,000 miles. When checking, the engine and transmission should be idling and at normal operating temperature. To circulate the transmission fluid the handbrake should be firmly applied, and, with the engine idling, each gear position selected in turn, Neutral (N) being finally held.

The dipstick and oil filler pipe are located behind the right hand bank of cylinders. The fluid level should be between the 'FULL' and 'ADD ONE PINT' marks, but never above the 'FULL' mark, when checked in this way. If necessary, fluid should be added via the oil filler pipe. If it is necessary to check the level when cold the level should be at, or just below, the 'ADD ONE PINT' mark.

## Changing Transmission Fluid and Filter

Under normal driving conditions it should not be necessary to change fluid or filter but if a great deal of towing, (or traffic work in hot weather), is done, this operation should be carried out every 32,000 miles. The following procedure should be adopted :

- 1) As no direct drain plug is fitted, a large container should be placed under the gearbox sump and the sump bolts removed.
- 2) With the sump dropped, the access plate in front of the convertor housing should be removed, revealing the drain plug for the torque convertor. This should be removed, allowing the oil to drain out.
- 3) The convertor plug should then be replaced (14 in. lbs. torque) and the access plate bolted back.
- 4) The oil filter should be removed by undoing the three screws which hold it in position.
- 5) The filter should be replaced with a new one. A new gasket should be used, and the screws tightened (28 in. lbs. torque.)
- 6) Clean and replace the gearbox sump using a new gasket (150 in. lbs. torque).
- 7) Fifteen pints of clean transmission fluid should be added.

The procedure for checking the level should then be followed, and any fluid necessary added to bring the level to the full mark (approx. 2 pints).

## Propeller Shaft

The one piece propeller shaft has a constant velocity joint at the forward end and a universal joint at the rear end. The sliding spline at the forward end allows the axle some fore and aft move-ment. The rear joint is of the normal cross and roller type.

Both joints are packed with lubricant and sealed. They should be inspected every 8,000 miles (or 6 months) for external leakage otherwise it is not necessary to relubricate at all. If the car has been used under severe conditions (see Auto-transmission) then it should be cleaned and repacked at 32,000 miles.

If it should be necessary to remove the propeller shaft, the following procedure should be adopted :

- 1) The clamps holding the universal joint to the yoke on the pinion nose should be undone.
- 2) The shaft should be supported, and not allowed to hang loose.
- 3) The sliding spline on the front of the forward universal joint should be disengaged from the transmission unit.

When re-assembling, which should be done in the reverse order the following torque rating should be used : Clamp bolts on rear universal joint 170 in. lbs.

### Rear Axle

The rear axle is of the semi-floating type, and incorporates a limited slip differential 'Powr Lok', which spreads the driving torque to both wheels, even when one is slipping.

The 'Powr Lok' is extremely sensitive to lubrication, and only the oils listed on page should be used, *i.e.* SHELL EP90 SCL

### In an Emergency

If this oil is not available, any 90 E.P. oil may be used for a short period. However, the axle should be drained and refilled with the correct oil as soon as possible.

The rear axle should be drained and refilled at the first 1,000 mile service. Thereafter it should be checked every 4,000 miles, and replenished as necessary. After 12,000 miles it should be drained and re-filled.

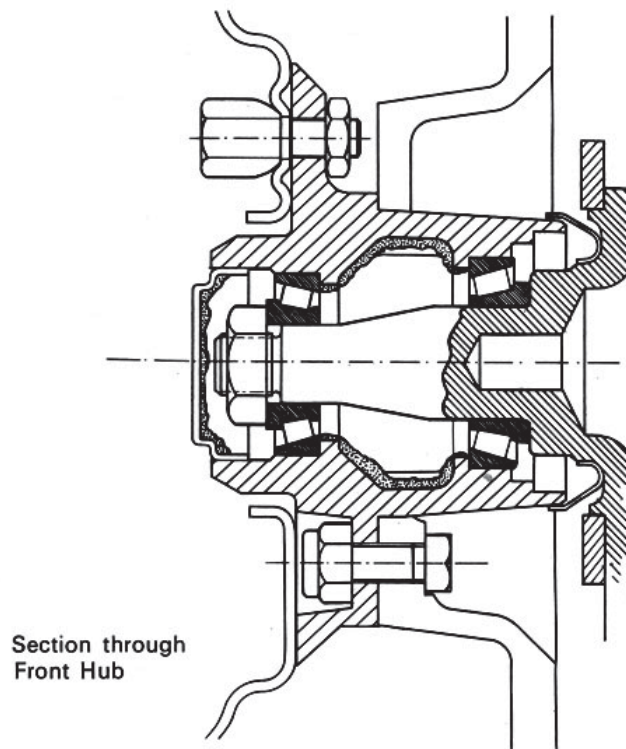

**Refer to : Steering and Suspension, over**

## Steering and Suspension

### Steering

The steering is of the rack and pinion type which provides light and sensitive steering at the cost of some kick-back on poor roads. Dampers are incorporated in the rack housing to control this. There is one grease nipple on the rack which requires attention every 4,000 miles with a general purpose grease. The dampers should be inspected and topped up with Shell Tellus 15 at the same time. The ball joints are sealed and require no attention.

### Front Suspension

The independent front suspension is of the wishbone type, the coil springs being held in compression between the chassis frame and the lower wishbone, while the upper wishbone operates the piston type dampers. An anti-roll bar connects the two lower wishbones. Suspension lubrication points are shown in the lubrication chart. The hydraulic dampers should be topped up with Armstrong Fluid every 4,000 miles. (See front dampers).

### Front Wheel Alignment

Alignment of the front wheels is an important factor in tyre economy and ease of steering. The front wheels should have 'toe in' of 1/16". If adjustment is necessary it is made at the tie-rods.

### Front Hubs - see previous page

The front hub bearings may need periodical adjustment. The following procedure should be adopted.

- 1) The car should be jacked up and the nave plate removed.
- 2) The hub cap should be removed by turning it anti-clockwise.
- 3) The cotter pin should be removed.
- 4) The wheel bearing nuts should be tightened with a Torque Wrench to 90 ft. lbs. while the wheel is rotated.
- 5) The nut should be backed off until a slot in the nut coincides with the cotter pin hole, and a new cotter pin fitted.

### Front Hub Lubrication

Wheel bearings should be inspected every 16,000 miles, under normal conditions. If the grease has emulsified, the hub bearings should be stripped down and thoroughly cleaned before re-greasing. The bearings should be repacked with grease but the hub should not be completely filled with grease, but only lightly applied around its inner perimeter. At 32,000 miles hub and bearing should be cleaned and repacked with grease as above.

### Front Dampers

The front dampers should be checked for level every 4,000 miles and if necessary topped up with Armstrong Damper fluid.

### Rear Suspension

The rear axle is carried on semi-elliptic springs, and is located laterally by a Panhard rod. The telescopic dampers are adjustable from the driver's seat (see Controls page ). No attention to the dampers is required.

### Rear Hubs

One grease nipple on each rear hub requires attention every 4,000 miles. At 32,000 miles the hubs should be stripped, cleaned, greased and re-assembled.



## Brakes

### Brakes

A Dunlop hydraulic disc braking split system is used on all four wheels, operated by the foot pedal in conjunction with a Vacuum Servo unit. The tandem master cylinder ensures that, should a failure occur in any part of the system, braking would still be available on two wheels.

The handbrake is separate from the foot braking system, and operates through a mechanical linkage to the self adjusting parking brake on the rear discs.

The brakes normally require no attention, as both foot and hand-brake are self compensating for wear. When pads have to be changed, reference should be made to the Dunlop booklet supplied with the car.

### Topping Up

The reservoirs for the brake master cylinders are located above the Servo unit in the engine compartment and require checking monthly, or every 2,000 miles, whichever is the shorter period. If required, Dunlop Disc Brake Fluid should be added to a level half an inch below the top of the reservoir. The reservoirs contain a rubber dust seal which should be removed before topping up.

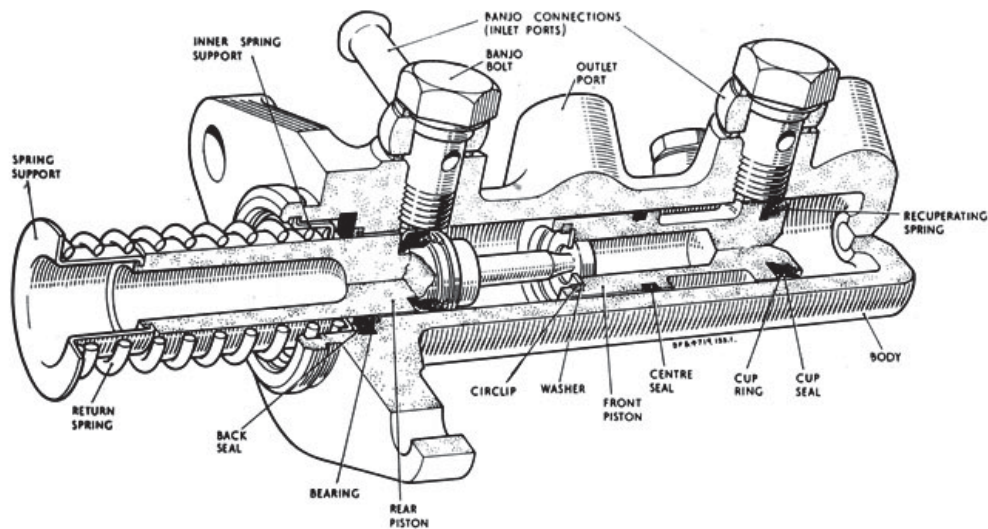

Tandem Master Cylinder

Fig 10

### Lubrication

There is one grease nipple on the handbrake compensating linkage which requires attention every 4,000 miles. A multi purpose grease should be used.

### Bleeding the Braking System

If any item of the hydraulic system has been replaced or if air has entered the system, it must be bled to restore proper working. This operation is fully described in the Dunlop booklet and the instructions given should be carefully followed. It should be noted that Dunlop Disc Brake Fluid was formerly known as Wakefield Crimson.

### Servo

**Note:** The tremendous braking power of the C-V8 stems partly from the fact that one of the chassis tubes is used as a vacuum reservoir. It is therefore **imperative** that these are not drilled, otherwise serious loss of braking power would result.

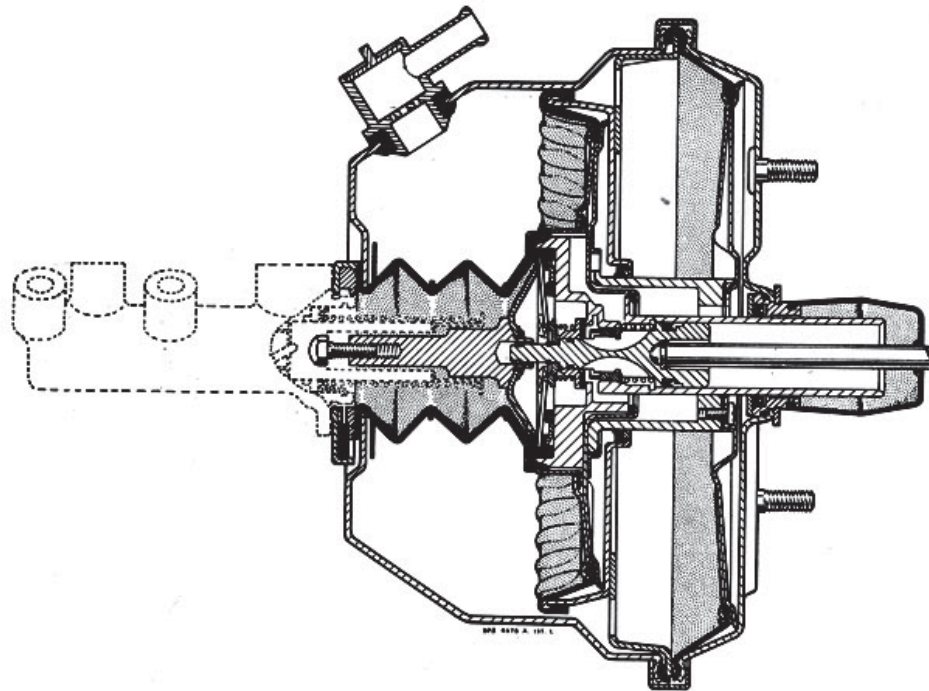

Brake Servo Unit

Fig 11

## **Wheels and Tyres**

### **Wheels**

The ventilated steel disc wheels are secured by five nuts. All nuts have right hand threads.

### **Tyres**

The tyres fitted are 6.70 x 15 Dunlop Road Speed (RS5). These are tubed tyres having a nylon carcass, and suitable for sustained speeds of up to 110 m.p.h. at standard pressures. Development work on tyres is always proceeding, and Jensen Motors Limited will be pleased to give their latest recommendations when new tyres are required.

### **Tyre Pressures**

The recommended tyre pressures are :

Front 24 p.s.i. (1.7 Kg/cm<sup>2</sup>)

Rear 24 p.s.i. (22 p.s.i. for town use only)

For sustained speeds in excess of 110 m.p.h., the tyre pressures, front and rear, should be increased to 30 p.s.i. (2.1 Kg/cm<sup>2</sup>)

### **Tyre and Wheel Balance**

Tyre and wheel assemblies are balanced both statically and dynamically before they are fitted to the car. In view of the high speeds attainable it is recommended that wheel balance is checked every 5,000 miles. Most large garages and service stations have balancing equipment.

### **Tyre Life**

It is not recommended that the tyres be interchanged between front and back. (A tyre weakened by excessive wheelspin could prove dangerous were it to fail when fitted to the front). However, changing tyres from left to right and vice versa will help to prolong tyre life. If desired, the spare can be alternated between the rear wheels.

The following factors have an adverse effect on tyre life :

- 1) Incorrect tyre pressures.
- 2) Misalignment of wheels.
- 3) Harsh acceleration. Wheel spin should be avoided.
- 4) Fierce braking.

## **Wheel Changing and Jacking System**

The jacking system allows the car to be raised with the minimum of effort. The jack is of the Bevelift type and is carried in the tool compartment, in the left hand side of the boot.

Four jacking holes are provided. These are in the chassis side members close to the wheel arches and are protected by rubber plugs. These plugs have retaining wires to prevent them being lost. When it is necessary to change a wheel the following procedure should be adopted.

- 1) The car should be on a hard level surface.
- 2) The handbrake should be applied.
- 3) The nave plates should be removed using the screwdriver in the tool kit. To avoid the possibility of damage to the nave plate, it should be levered off as close as possible to one of the retaining studs. These are located at 3 o/c, 7 o/c and 11 o/c relative to the tyre valve.
- 4) The wheel nuts should be slightly loosened, but not removed, using the wheelbrace provided.
- 5) The spare wheel should be removed from its bracket (see Spare Wheel stowage page ).
- 6) The rubber plug should be removed from the nearest jacking point, and the jack spigot inserted. The handle should be turned clockwise to raise the car.
- 7) When the wheel is well clear of the ground the wheel nuts should be removed, and the wheels changed over.

The procedure should then be reversed.

# Bodywork

## Doors.

The door catches are controlled from the outside of the car by press-buttons in the exterior door handles. They may be locked by either the remote control handles on the inside, or the locks in the handles on the outside. In order to make it impossible to lock the doors with their keys inside the car, the locks are self cancelling, and slamming the door automatically unlocks it.

When leaving the car from the right, the left hand door should be closed from inside by means of the remote control handle, and then the right hand door locked from outside. When leaving from the left, the procedure is reversed.

Roomy map pockets are located in the doors behind the combined arm rest/door pulls.

## Front Shroud

The front shroud is hinged at the back, and has a locking mechanism designed to make it impossible for it to fly open accidentally.

There are three separate operations required to open the shroud. The small square panel at the front of the shroud must be unlocked using the ignition key. When this panel is raised, the shroud release lever will be seen in the recess. This must be turned up-wards to a vertical position to release the main shroud securing pins.

A safety catch is to be found in the air intake, immediately to the right of the car centre-line (to the left when facing the car.) This should be pulled forward, and the shroud lifted with both hands. It will stay open automatically when in its fully open position.

There is a small light mounted on the underside of the shroud. This is illuminated automatically when the shroud is opened, provided that the sidelights are on.

## Boot

The bootlid is spring loaded to the open position. Whenever it is opened a light in the forward left hand corner is switched on.

## Keys

Two keys are provided with each car. One will switch on the ignition, and lock or open the doors and front shroud. The other will lock or open the boot and glove locker. Therefore, if desired, these may be locked and the ignition key left with the car.

A second set of keys will be sent direct to the owner when the Application for Guarantee is made.

It is advisable to record the numbers of the keys, and a page in this book is provided for the purpose.

## Seats

Both front seats are fully adjustable for both fore and aft movement and rake.

The seat adjustment is made by a lever at the front of each outer seat runner. This lever should be moved outwards, and the seat moved forwards or backwards as required.

Rake adjustment of the backs is effected by turning a knob on the front of each seat.

For entry into the rear of the car, a pedal release is mounted at rear outer side of seat. When this is depressed the squab is released and can be pushed forward.

## Lockers

There are four lockers provided in the car. One is in the facia opposite the passenger, one between the front seats, and one alongside each rear seat.

The glove locker in the facia has a pull-down lid which lies horizontal when open, so may be used as a small table. It is locked by the same key as the luggage boot.

The companion box between the front seats has a padded lid which is hinged at one side.

The rear lockers also have padded tops and open upwards, the hinges being on the inside edges.

### **Safety Belts**

Safety belts of the single diagonal type are fitted as standard to the C-V8, Jensen Motors Limited, believing that safety belts can make a significant contribution to road safety.

The belts are fastened at their lower ends to substantial eyebolts on the car chassis, and at their upper ends to the reinforced grab handles.

The belts have snap-action buckles, which can be both fastened and released quickly and with little effort. The buckle is fastened by pushing the tongue into the buckle until a definite 'click' is heard. To release the buckle, the buckle flap should be lifted through approx. 90° when the tongue will be automatically released.

All adjustment for length is made at the fastening end. The belt is tightened by pulling the loose end further through the buckle, and sliding the cursor down the belt to take up the slack. To loosen the belt the buckle should be held by the two black catches and pulled upwards.

### **Spare Wheel**

The spare wheel is carried on a special bracket below the luggage boot.

The bracket is lowered by means of a slotted tube in the right hand rear corner of the boot. To reach this nut it will be necessary to fold back the carpet, and the cut out piece of underfelt. A special adaptor is provided in the toolkit, and this should be used in conjunction with the wheelbrace. The nut should be turned anti-clockwise until the bracket has dropped far enough for the spare wheel to be withdrawn. The spare wheel should be replaced by reversing this sequence of operations.

### **Paint Work**

The car should always be cleaned using a liberal supply of clean water. It is essential not to 'dry clean' the car, as this will produce scratches on the smooth surface of the cellulose. Grease and tar splashes are best removed using a soft rag dipped in petrol.

An occasional application of a good class wax polish will help to preserve the smooth finish.

### **Leather Upholstery**

The leather upholstery should require no attention save an occasional wipe down with a little soapy water. Harsh detergents should not be used. If subjected to heavy wear, or harsh weather conditions, the upholstery will benefit from an occasional application of Connolly Hide Food.

### **Floor Carpets**

When they become soiled, the floor carpets should be taken out and cleaned with a vacuum cleaner. They are held in by press-studs.

### **Ashtrays**

Two ashtrays are provided, one for front seat passengers, and one for those in the rear. Both ashtrays are mounted in the central companion box. The forward one is covered by a chromed snap action lid, while the rear one pulls out rearwards from the companion box. Both are removable for cleaning.

### **Lubrication of Body Parts**

See "Service Lubrication", page .

### **First Aid Kit**

A compact but comprehensive First Aid Kit is supplied with the car. It is mounted under the lid of the left hand rear locker.

## Cabin Heating and Ventilation Systems

### Heating System

A powerful and comprehensive heating system of 4-1/2 Kw output is fitted, and this allows any combination of temperature and air flow to be selected and maintained.

The car interior is heated by fresh air drawn from outside the car and passed over a radiator matrix supplied with hot water from the engine. Therefore the heater will not be fully effective until the engine has reached its normal operating temperature.

### Controls

There are three main heater controls :—

- 1) **Air cut-off control.** This is mounted on the scuttle below the steering wheel and controls the air passing into the heater. This valve is opened by moving the knob down.
- 2) **Distribution control.** This is on the left hand side of the central facia lower, flanking the grille. Its position determines whether air from the heater is directed towards the windscreen, or into the car interior. With the control at 'INT', air flow is directed into the front and rear footwells and also through the grille in the facia lower. If the control is set to 'DEMIST', flow is directed to the windscreen.
- 3) **Temperature control.** This is on the right hand side of the facia lower, opposite the Distribution control. Once the desired temperature is set, it is maintained by a thermostatic valve in the water system, regardless of the engine coolant temperature, or the car speed.
- 4) **Fan.** The flow of air from the heater can be supplemented by a two speed fan, controlled by a switch on the facia. With the switch half way down, slow speed is selected ; moving it fully down increases the fan speed.

### Ventilation Systems

Two completely independent ventilation systems are built into the car.

- 1) **Footwell Ventilation.** Small sliding panels on the outside of each footwell are connected to intakes below the headlights. Opening these panels provides a flow of air dependent on the speed of the car.
- 2) **Face level Ventilation.** Two spherical air vents are mounted in the facia, which provide fresh air from the scuttle intake. These are opened by pulling out the nozzles. A booster fan is fitted to supplement fresh air output and is controlled by the switch marked "Air" on the facia.

## Electrical System

All electrical equipment is of Lucas manufacture with the exception of the Ignition, Starting and Charging Systems, which are of Chrysler origin. The Electrical system is of the 12 volt NEGATIVE earth type. Most British and Continental cars employ a Positive earth system, and the difference must be observed—as INCORRECT POLARITY will cause serious damage to the rectifiers in the alternator.

### Alternator

The alternator takes the place of the usual dynamo. It is an alternating current generator, with six built-in silicone rectifiers which convert the alternating current into direct current. The alternator provides a high charging rate at low engine speed, and this means that the battery can be kept fully charged all the time.

### Belt Tension

The belt which drives the alternator and water pump has to be correctly tensioned. If it is too tight it will load the alternator bearings excessively, causing their early failure ; if too loose, the belt will slip, causing poor water pump and alternator performance. The belt tension can be checked by pressing down on it, midway between the water pump and alternator. The deflection should be 1/4" except where a new belt has just been fitted, when it should be 1/8".

### Battery

The battery is mounted in the engine compartment. The following Lucas battery is fitted and recommended as a replacement :

Type	BTZ11A
Voltage	12
Capacity	72 Ampere hours

The level of the electrolyte should be checked weekly, or more often in hot weather. If it has fallen below the top of the separators, sufficient distilled water should be added to bring it to approx. 1/8" above the separators. It is important not to overfill the battery. The battery is held in its box by two clamps and four wingnuts. It must always be firmly secured. The terminals should be kept clean and tight, and well covered in petroleum jelly.

### Fuses

Six fuses are used to protect the electrical equipment. The radio, the Selectaride rear dampers, and the electric cooling fans are individually fused ; the interior light and the bootlight share a low independent rating fuse, while all other circuits are carried by the two main fuses.

The main fuse box is under a black cover, mounted beneath the facia near to the steering column. The top fuse is of 50 amp rating, and protects all circuits which operate independent of the ignition. The lower one, of 35 amp rating, protects all circuits controlled by the ignition. Two spare fuses, one 50 amp and one 35 amp, are provided.

The fuse protecting the interior light and the bootlight is housed in a white nylon in-line fuse holder adjacent to the main fuse box. This is a 10 amp fuse.

A black nylon in-line fuse holder will be found above the white one. This holds the 15 amp fuse which protects the Selectaride Rear Dampers.

The 5 amp fuse for the radio is mounted below the radio itself. Access to it is gained by removing the central instrument panel. The engine cooling fans are protected by a fuse in the relay box on the bulkhead in the engine compartment. This is mounted in a white nylon in-line fuse holder.

### Blown Fuses

A blown fuse is indicated by failure of all the items protected by it. These will be shown in the wiring diagram. Before a fuse is changed, the cause of the trouble should be remedied, or it will blow again. Fuses should always be replaced by ones of the same rating.

**Voltage Control Box**

The voltage control box is mounted beside the rear demist relay on the left hand side of the bulkhead in the engine compartment. It is a delicate mechanism, and must only be disturbed by a qualified electrician.

**Direction Indicator Flasher Unit**

This is located adjacent to the main fusebox beneath the fascia. It is a sealed unit and requires no attention whatever. It is a plug-in fitment, and must be changed complete if defective.

**Electric Horns**

Twin wind-tone horns, one high note and one low, are fitted in front of the radiator. They are operated by a horn-push in the centre of the steering wheel and are supplied through a relay. This is fitted in the relay box on the bulkhead in the engine compartment, and must be changed complete if defective.



## Lights

### Bulbs

All 12v.			<i>Lucas No.</i>
Headlamps 1A Unit	37.5 w.	S.B.	54521805
2A Unit	37.5/50w	S.B.	54521806
Side Lamps	6 w.	S.B.C.	209
Flasher	21 w.	S.C.C.	382
Stop/Tail	6/21 w.	S.B.C.	Index 380
No. Plate	6 w.	M.C.C.	989
Reversing	21 w.	S.C.C.	382
Boot	6 w.	S.B.C.	209
Bonnet	6 w.	M.C.C.	989
Interior and Map Lights	6 w.	Festoon	254
Warning Lights Et- Clock	2 w.	Peanut	281
Instrument 8- Gear			
Quadrant Illumination	2.2 w.	M.E.S.	987

### Headlamp Setting

Where possible, headlamps should be set by a professional using specially developed equipment. Mechanical Aimers for use on sealed beam units, or Lucas 'Beamsetter' equipment will enable the lights to be set quickly and accurately.

However, where such items are not available, the beams may be set, keeping the following points in mind.

- a) The beams should be set with the car in its normally loaded condition (i.e. 1 or 2 passengers, tank z full).

Setting is most easily done with the car on a flat, level surface.

Centre of maximum light intensity on high beam should be 2" below horizontal in 25 ft.

Adjustment is made by turning the screws on the light unit retaining plate, exposed by removing the rim. There is one screw for vertical adjustment, one for horizontal, except on the European-type unit, where there are two for horizontal adjustment.

### Sidelights and Rear Lights

The lenses on all side and rear lights are secured by two Phillips screws. If these are removed, the lens may be taken off and the bulb changed. Bulbs in the stop/tail lamps have twin filaments, but the offset peg bayonet fixing ensures correct positioning.

Those in the side lamps and front and rear flashers have single filaments only, and may be replaced either way round.

### Reversing Number Plate Light

The combined reversing and number plate lamp is mounted directly beneath the rear number plate. The two bulbs illuminating the number plate come on with the sidelights, while the reversing light is operated whenever Reverse is selected on the gear change quadrant.

Access to all bulbs is gained by removing the two chromed countersunk screws in the cover of the lamp, thus allowing the cover and lens to be withdrawn.

### Map Light

The bulb can be replaced through the light vent.

### **Gear Change Quadrant Light**

To gain access to this light it is necessary to move the selector cover up the steering column towards the wheel. The cover is secured by three wing nuts which can be loosened from behind the fascia. When the cover is withdrawn, the lamp holder can be pulled to the left, out of its housing, and the bulb changed.

### **Interior (Roof) Light**

The interior lamp is mounted in the centre of the roof, and is operated by the opening of either door. It can also be switched on at the light itself. The plastic cover is held in place by four tongues, and can be removed by squeezing it in the middle. The festoon type bulb can then be changed.

### **Boot Light**

To replace bulb, turn plastic cover through 90 and withdraw.

### **Warning Lights**

The location of the four warning lights are shown on Fig. 1. To replace bulbs the following procedure should be adopted :

- 1) **Rear Demist**  
Remove centre panel by removing the two P.K. screws and withdraw bulb holders.
- 2) **Flasher**  
Remove fascia crash pad and withdraw bulb holder.
- 3) **Main Beam and Low Fuel**  
Withdraw bulb holders from rear of appropriate instrument.

### **RADIO**

A Motorola fully-transistorised push-button radio operating through twin rear speakers is fitted as standard equipment. Full operating instructions are given in the separate manual accompanying the car.

N.B. It should be emphasised that the small grille beneath the fascia is **not** a loud-speaker, but is part of the vehicle's heating system.

## Tool Kit

An adequate set of tools is supplied with the car.

The tools are stowed in a compartment on the left hand side of the boot.

The tool kit comprises the following :

- 1—Phillips Head Screwdriver.
- 1—Standard Screwdriver.
- 1—Electricians' Screwdriver.
- 1—Plug Spanner.
- 1—Open Ended Spanner, 7/16" x 1/2" A/F.
- 1—Open Ended Spanner, 9/16" x 5/8" A/F.
- 1—Open Ended Spanner, 11/16" x 3/4" A/F.
- 1—Adjustable Spanner, 3"
- 1—Pair Pliers.
- 1—Tyre Pressure Gauge.
- 1—Lifting Jack.
- 1—Wheelbrace, 3/4" A/F.
- 1—Adaptor for Spare Wheel bracket operation.

## Equipment

JENSEN MOTORS LTD. accept no liability for tyres, batteries or radios not manufactured by the Company although supplied by the Company. All claims in respect of such should be addressed to their respective manufacturers at their addresses quoted below.

### **Important**

When claims are being made *under guarantee* it is essential to quote the chassis number, which is stamped on a plate located under the companion box lid, and the date on which the car was commissioned.

### **Battery**

Joseph Lucas (Electrical) Ltd., Gt. Hampton Street, Birmingham 18, or Dordrecht Road, Acton Vale, London, W.3.

### **Tyres**

Dunlop Rubber Co. Ltd., Fort Dunlop, Birmingham, or 1, Albany Street, London, N.W.1.

### **Radio**

World Radio Ltd., Edgware Road, Cricklewood, London, N.W.2.

*As our policy is one of continual improvement, we reserve the right to alter the specification and maintenance instructions without notice.*

## SERVICE LUBRICATION

ENGINE UNIT	GRADE AND CAPACITIES	ATTENTION PERIODS	DETAILS
Above + 32°F.	SAE 20W-40 or SAE 40	4,000 m. (6,500 k.) or	Change oil.
As low as +10°F.	SAE 10W-30 or SAE 10W	3 Months	Check oil and top up if necessary at more frequent intervals when new.
Sump	As low as -10°F.		Change filter.
	Below -10°F.		
Sump Filter	8-1/2 pints (Brit. Imp.) 10 pints (U.S.) 4.7 litres		If changed separately.
Oil Filler	SAE 30	Normal 8,000 m. (13,000 k.)	Clean with paraffin or petrol and re-oil.
Air Cleaner		Dusty 500 m. (800 k.)	
	Element 2402677	Clean 8,000 m. (13,000 k.)	Clean housing and cover. Remove wrap from filter and wash in paraffin to remove or 6 Months dirt and oil. Shake or blot dry. Clean filter with air nozzle (min. 2" away) from inside. Discard element if damaged. Discard element and wrap if oil shows on 2/3 of circumference.
Carburettor and Air Cleaner	Wrap 2463982	Renew 32,000 m. (51,000 k.) or 2 Years	
	SAE 10W-30 SAE 10W-30	8,000 m. or 6 Months	5-10 drops in oil cup. (13,000 k.) Lubricate felt rotor wick with 2-3 drops.
Distributor	M.P. Chassis Grease		Wipe cam and bumper block clean and apply thin coat of grease.
Manifold Heat Control Valve	Heat Control Valve Solvent P/N. 1879318 Shell Donax P.	8,000 m. (13,000 k.) or 6 Months	Lubricate each end of the valve shaft when manifold is cool and move control back and forth.
Crankcase Ventilator Valve		8,000 m. (13,000 k.) or	Check valve. With engine idling remove valve. Inlet should hiss and vacuum should be felt. Remove oil filler cap. A piece of stiff paper should be sucked against filler tube. With engine off valve should click when shaken. Replace valve if none of these occur.
		20,000 m. (32,000 k.) 80,000 m. (130,000 k.)	Replace filter No. 1. Replace filter No. 2. Earlier replacement may be necessary under some operating conditions.
Fuel Filter	Filter 2120024		
Carburettor Choke	Mopar Carburettor Cleaner 1643273 (Denatured alcohol)	8,000 m. (13,000 k.) or 6 Months	Apply cleaner to ends of choke shaft where it rotates in air horn while moving choke shaft backwards and forwards.

ENGINE UNIT	GRADE AND CAPACITIES	ATTENTION PERIODS	DETAILS
Alternator	2098840	4,000 m. 40 Amp.(6,500 k.) Or 3 Months	Wipe clean and inspect ventilation holes for dirt accumulation.
Engine Tune Up		10,000 m. (16,000 k.) or 1 Year	<b>Spark Plugs.</b> Clean and adjust, if necessary replace.
			<b>Distributor.</b> Remove cap and rotor, clean and inspect. Check breaker points for pitting blueing and misalignment and clean and adjust. Lub-ricate cam and wick. Check all wires and caps for seating and clean and set for ignition timing.
			<b>Carburettor.</b> Clean air filter. Check fast idle cam. Adjust idle speed and mixture to correct sett-ing. Tighten carburettor to manifold nuts. Check oper-ation of choke piston and manifold heat control and crankcase ventilator valve. Use appropriate solvents if necessary.
			<b>Electrical.</b> Check battery S.G. Clean and tighten battery terminals and connections. Test bat-tery line voltage at starter. Test starter cranking ability.
Automatic Transmission	Automatic Transmission Fluid Type 'A' Suffix 'A'.	8,000 m. (13,000 k.) or 6 Months	With engine and trans mission at normal operating temperatures and engine idling, and hand brake on, momentarily engage each gear ending in neutral.
	Note 1.	Use Tundish for ease of filling.	Check fluid level which should be at or below 'F' mark but never above
	Note 2	For normal use no oil change is nec-essary.	when in its warmed up condition. Add or drain off oil. If absolutely necessary to check cold, fluid should be at slightly below the add one pint mark. If below add one pint.
	17 pints (Brit. Imp.) 20 pints (U.S.) 9.5 litres	32,000 m. (51,000 k.) or 2 Years	Only for cars operating under abnormal conditions. Adjust auto transmission and replace oil and filter. Abnormal conditions are as follows: (a) Frequent trailer towing. (b) Operating in dense traffic in hot weather. (c) Operate frequently with abnormal loads.
Manual Transmission	SAE 140 M multi-purpose Gear Lubricant Capacity	8,000 m. (13,000 k.) or 6 Months 6 pints (Brit. Imp.) 7 pints (U.S.) 3.3 litres	Check fluid level by removing filler plug. Replenish to filler hole.  For normal service no change is required. If shift becomes excessively heavy in winter a change may be made to SAE-80 or 90, or even auto trans type A Suffix 'A'. Drain and refill.

UNIT	GRADE AND CAPACITY	ATTENTION PERIOD	DETAILS
Prop. Shaft Universal Joints	<b>Cross and Roller</b> Multi-purpose Grease N LG I Grade '0' (U.S )	8,000 m. (13,000 k.) or 6 Months	Inspect for external leakage or damage.
(a) Front-C.V. Roller with Sliding Yoke	<b>Sliding Yoke</b> Double Cross and Multi-Mileage Roller with lubricant Sliding Yoke. P/N. 2525035		Do not dis-assemble unless external leakage or damage is noted.
(b) Rear Cross and Roller			
Rear Axle	Use only Shell 90 EP. S.C.L. (S1747 A)	4,000 m. (6,500 k.) 12,000 m.	Check and top up.
	3 Pints (Brit. Imp.)	(19,500 k.)	Drain and refill. (N.B.-Drain and refill at 1st 1,000 m.)
Wheel Hub-Front	Multi-Purpose Grease	16,000 m. (26,000 k.) 32,000 m. (51,000 k.)	Inspect and repack if grease is emulsified. Clean and repack.
Wheel Hub-Rear	Multi-Purpose Grease	4,000 m. (6,500 k.) 32,000 m. (51,000 k.)	Grease-gun. Clean and repack.
Steering Rack	Multi-Purpose Grease	4,000 m. (6,500 k.)	Grease-gun.
Front Suspension 3 Points/Side	Multi-Purpose Grease	1,000 m. (1,625 k.)	Grease-gun.
Brake Balance Lever	Multi-Purpose Grease	4,000 m. (6,500 k.)	Grease-gun.
Shock Absorbers	Armstrong Hydraulic Fluid	4,000 m. (6,500 k.)	Inspect and top up.
Steering Rack Dampers	Shell Tellus 15	4,000 m. (6,500 k.)	Inspect and top up.
Clutch Bellcrank Lever	Light Oil	4,000 m. (6,500 k.)	Oil-gun.
Clutch Bellcrank and Fork Linkages	Light Oil	4,000 m. (6,500 k.)	Oil-can.
Brake and Clutch Master Cylinders	Hydraulic Brake Fluid. Dunlop Disc Brake Fluid	Monthly or 2,000 m. (3,250 k.)	Check and top up.
Oil Filter	Mopar Pt. No. 2129109	8,000 m. (13,000 k.)	Replace oil filter element.
Spark Plug	Champion J-10Y	8,000 m. (13,000 k.) 20,000 m. (32,000 k.)	Check, clean, regap. Replace.
Body Maintenance	Light Oil	4,000 m. (6,500 k.) or 6 Months	Door hinges: Door locks and handle push button : Window vent pivot: Rear Qtr. light hinge. Shroud telescopic support hinge pin : Boot lid hinge pin: Fuel filler lid hinge: Boot lock push button.
	Grease M.P.		Shroud lock: Shroud safety catch : Shroud telescopic shaft: Boot lid hinge torsion bar roller: Boot lock: Seat slides.
	Grease M.P.	32,000 m. Or	Window wind mechanism. Door lock mechanism. 2 Years

## RECOMMENDED LUBRICANTS FOR JENSEN C-V8

	SHELL	B.P.	ESSO	CASTROL	MOBIL
<b>ENGINE</b> Above — 32°F.	Shell X-100 30 or Shell Super Motor Oil	Energol SAE 30 or Visco-Static	Esso Extra Motor Oil 10W/30	Castrolite	Mobile Special or Mobiloil A
As Low as + 10°F.	Shell X-100 20W or Shell Super Motor Oil	Energol SAE 20W or Visco Static	Esso Extra Motor Oil 10W/30	Castrolite	Mobile Special or Mobiloil Arctic
As Low as — 10°F.	Shell X-100 10W Or Shell Super Motor Oil	Energol SAE 10W or Visco Static	Esso Extra Motor Oil 10W/30	Castrolite	Mobiloil Special or Mobiloil 10W
Below — 10°F.	Shell X-100 Multigrade 5W/20	Energol SAE 5W	Esso Extra Motor Oil 5W/20	Castrol ZZ	Mobiloil Special or Mobiloil 5W
<b>Oil Filler Air Cleaner</b>	Shell X-100 30	Energol SAE 30	Esso Extra Motor Oil	Castrol XL	Mobiloil A 10W/30
<b>Distributor</b>	Shell Super Motor Oil	Energol Visco Static	Esso Extra Motor Oil	Castrolite	Mobiloil Special 10W/30
<b>Automatic Transmission</b>	Donax T6	BP—AFT—Type A	Esso Auto Trans	Castrol TQ	Mobilfluid 200 Fluid
<b>Manual Transmission</b>	Spirax 140 EP or 90 EP	BP Gear Oil SAE 140 EP or SAE 90 EP	Esso Gear Oil GP 90/140	Castrol Hipress or Castrol Hypoid	Mobilube GX 140 or Mobilube GX 90
<b>Rear Axle</b>	Transmission Oil	None	None	None	None 90 EP SCL
<b>All Grease Points</b>	Retinax A	Energrease L2	Esso Multi-Purpose Grease	Castrol LM	Mobilgrease Special

**Accelerator, Clutch and Fork Linkages:**

AS FOR ENGINE \_\_\_\_\_

N.B.—Additives to any of the above lubricants are not recommended.



## Index (Search)

- A  
Air Cleaner  
Alternator  
Ammeter  
Antifreeze  
Ash Trays  
Axle—Rear  
B  
Battery  
Bearings—Front  
Blubs  
Bodywork  
Boot  
Brakes  
Bulbs  
C  
Carburettor  
Carpets  
Choke  
Cigar Lighter  
Clock  
Clutch  
Contact Breaker Gap  
Controls  
Cooling System  
Crankcase Ventilation  
D  
Dampers—front  
Dampers—rear  
Data general  
Demister rear  
Dimensions  
Direction Indicators  
Distributor  
Doors  
E  
Engine data  
Engine lubrication  
Engine starting  
Electrical Equipment  
Fans—Cooling  
F  
Filter—air  
Filter—fuel  
Filter—oil  
First Aid Kit  
Flushing  
Front Suspension  
Fuel System  
Fuses  
G  
Gearbox—lubrication  
Gearbox—(automatic)  
    operation  
Gearbox—(manual) operation  
Gauges  
H  
Handbrake  
Headlamp adjustment  
Heating and ventilation  
    systems  
Horns  
Hubs—front  
Hubs—rear  
Idling  
Ignition—switch  
Ignition—system  
Ignition—timing  
Instruments  
J  
Jacking system  
K  
Keys  
Kick-down  
L  
Lights  
Linkage—throttle  
Lockers  
Lubrication—axle  
Lubrication—chart  
Lubrication—engine  
Lubrication—gearbox  
M  
Map light.  
N  
Numbers—identification  
O  
Oil Filter  
Oil Pressure  
Panel lights  
Pedals  
Propeller shaft  
Push-starting  
R  
Radiator  
Radio  
Rear Axle  
Recommended Lubricants  
Re-fuel.  
Replacement Bulbs  
Reversing light  
Revolution Counter  
Running Instructions  
Safety Belts  
S  
Seat Adjustment  
Selectaride  
Service Lubrication  
Servo  
Shroud  
Slow running  
Spare wheel  
Sparking plugs  
Speedometer  
Starting  
Steering  
Sump  
Suspension—front  
Suspension—rear  
T  
Tappets  
Temperature Gauge  
Thermostat  
Throttle Linkage  
Tool Kit  
Towing  
Transmission—lubrication  
Transmission—operation  
Tyres  
U  
Upholstery  
V  
Valve Tappets  
Ventilation systems  
Voltage control box  
Warning lights  
Wheels—alignment  
Wheels—balance  
Windscreen washers  
Windscreen wipers  
Wiring Diagram