

WORKSHOP MANUAL

DAIHATSU **CHARADE** Chassis

FOREWORD

This workshop manual contains essential information regarding the construction, disassembly/reassembly procedures and servicing methods of the power train, suspension, brake system, steering system, body and electrical system of the DAIHATSU CHARADE.

We hope that this workshop manual is consulted to the fullest extent, in combination with the workshop manual of the Type CB Engine, Type CL Engine, and Trouble shooting for Engine control system of Type CB-80 Engine so that quality servicing may be assured at all times.

Furthermore, due to continuing improvements in the design, contents and specifications in this workshop manual may be partly revised without advance notice and without incurring any obligation to us.

Published In April, 1987

DAIHATSU MOTOR CO., LTD.

WR-0000

SECTION INDEX

NAME	SECTION
GENERAL INFORMATION	1
CLUTCH	2
MANUAL TRANSMISSION	3
AUTOMATIC TRANSMISSION	4
FRONT AXLE & SUSPENSION	5
REAR AXLE & SUSPENSION	6
STEERING	7
BRAKES	8
BODY	9
BODY ELECTRICAL	10
APPENDIX	11

DAIHATSU

CHARADE

Chassis

SECTION 1

GENERAL INFORMATION

HOW TO READ THIS BOOK	1-2
CONTENTS OF EXPLANATION	1-2
1. Schematic Diagram of Components	1-2
2. Servicing Procedure	1-2
3. Trouble Shooting	1-3
4. Table of SSTs Used	1-3
5. Table of Service Specifications	1-3
6. Table of Tightening Torque	1-3
7. Wiring Diagrams	1-3
DEFINITIONS OF TERMS	1-3
ABBREVIATION CODES	1-4
SERVICING OPERATIONS	1-5
JACKING POINTS AND SUPPORTING	
POINTS OF SAFETY STANDS	1-6
SUPPORTING POINTS OF TWO-POST LIFT	1-6

WR-01001

GENERAL INFORMATION

HOW TO READ THIS BOOK

CONTENTS OF EXPLANATION

1. Schematic Diagram of Components

- (1) The schematic diagram of components that appears at the beginning of each section describes the nomenclature and installed conditions of each component. Furthermore, the tightening torque is posted in the figure.
- (2) Those parts whose reuse is not permitted bear a "*" mark for an identification purpose. Be certain to replace these parts with new ones during the assembly.

(Example)

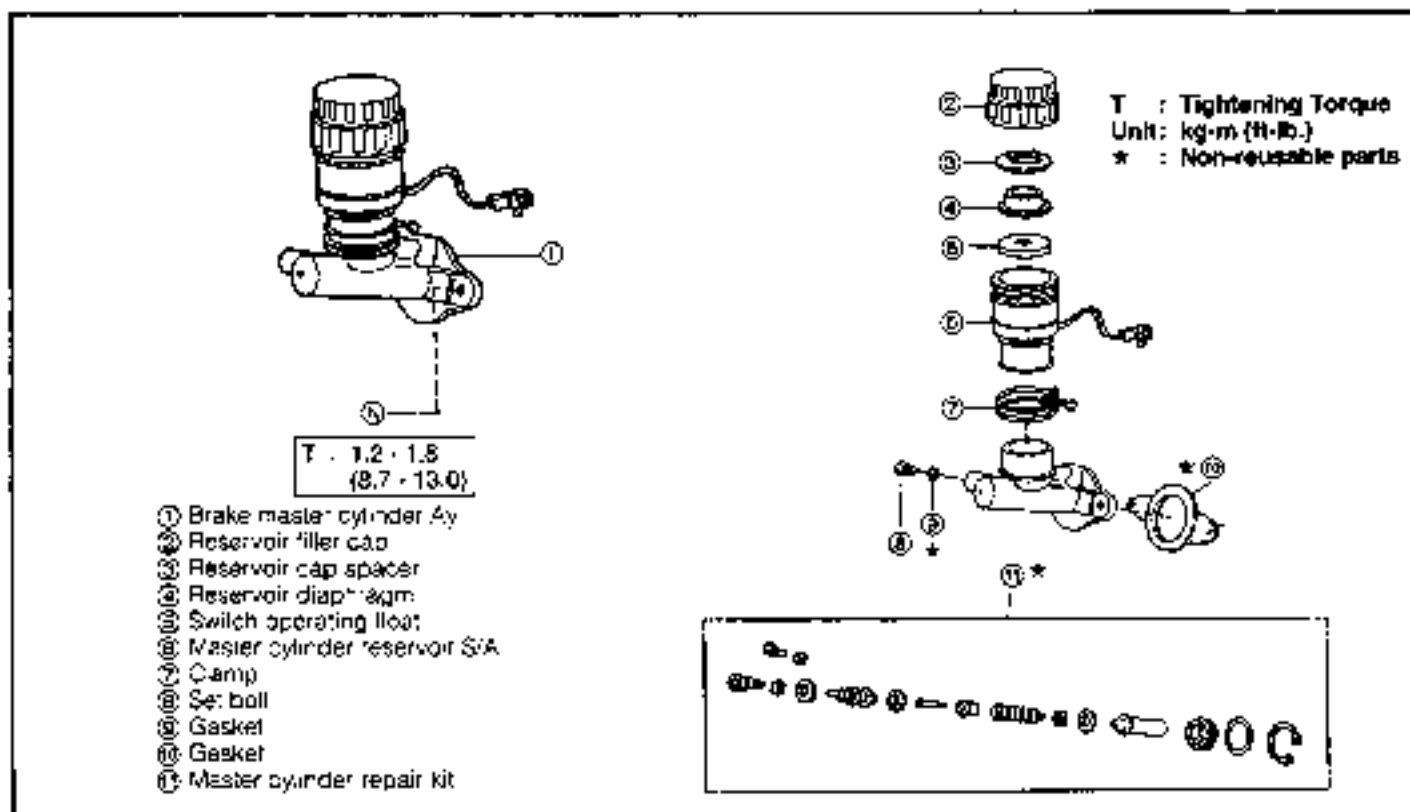

WP-01002

2. Servicing Procedure

- (1) In principle, the servicing procedure is described in the following sequence given below: Removal → Inspection → Installation and Disassembly → Inspection → Assembly.
- (2) The explanation covers detailed servicing methods, specifications and notes.
- (3) The main point of each item explains the servicing section and servicing procedure, using illustrations.

(Example)

What to do	How to do it	What to do and where
3. Brake tube installation	(1) Install the brake tube to the wheel cylinder temporarily by hands. (2) Tighten the brake tube to the wheel cylinder using the following SST. SST: 09751-36011-000	 09751-36011-000

WP-C1003

(4) The inspection section in this manual describes only checking operation. Therefore, if you find any malfunction, replace any defective parts with new ones.

3. Trouble Shooting

(1) As for the three-speed automatic transmission, the trouble shooting table is provided in this book so that you may readily locate causes of troubles.

4. Table of SSTs Used

(1) The SSTs appearing in this book are listed in the appendix of the book.

5. Table of Service Specifications

(1) The service specifications necessary for the service are summarized in the appendix of this book.

6. Table of Tightening Torque

(1) As for those sections where their tightening torque must be controlled during the service, the tightening torque is specified in the appendix of this book.

7. Wiring Diagrams

(1) The vehicle wiring diagrams are posted in the appendix of this book separately for Type CB and Type CL engines.

DEFINITIONS OF TERMS

Specified Value A value which represents the allowable range during the inspection and adjustment.
Limit A maximum or a minimum limit which the value should not exceed or fall below.
Note An item which requires special attention or an item which is prohibited during the service.

WR-01004

GENERAL INFORMATION

ABBREVIATION CODES

The abbreviation codes that appear in this workshop manual stand for the following, respectively.

Abbreviation code	Original word	Meaning
RH	Right Hand	Refers to right side
R.H.D.	Right-Hand Drive	Right hand drive vehicle.
LH	Left Hand	Refers to left side.
L.H.D.	Left-Hand Drive	Left-hand drive vehicle
STD	Standard	When referring to automotive parts "standard" represents those parts which have been installed originally by the manufacturer and which have standard dimensions
O/S	Over Size	In instances where fitting becomes too loose due to wear resulting from use for a long period of time or due to frequent removal/installation operations, if fitting part (e.g. piston) is replaced with a part having larger dimensions, the other mating part may be put into use again. "Over sized" parts denote those parts having larger dimensions compared standard parts.
U/S	Under Size	In the same manner as with the "oversized" parts if fitting part (e.g. bush and bearing) is replaced with a part having smaller bore dimensions, the other mating part may be put into use again. "Under sized" parts denote those parts having smaller dimensions compared with standard parts.
PR	Ply Rating	Represents strength of tires The larger the ply rating number, the stronger the tire strength
SAE	Society of Automotive Engineers	For example, automotive oils are designated as SAE 30 and 50 number. These designation numbers have been set forth by the Society of Automotive Engineers in the United States of America (SAE). The larger the SAE number, the higher the oil viscosity. Conversely the smaller the SAE number, the lower the oil viscosity.
API	American Petroleum Institute	The standards set forth by the American Petroleum Institute (abbreviated as API Classification) have been employed to evaluate and classify properties of various oils. Engine oils for gasoline engines are classified as SD, SE, SF and so on, whereas engine oils for diesel engines are classified as CC, CD and so on.
SST	Special Service Tool	Refers to a tool designed for a specific purpose.
T	Torque	Refers to tightening torque
S/A	Sub-Assembly	Refers to a component comprising more than two single parts which are welded, staked, or studded to each other to form a single component.
Ay	Assembly	Refers to an assembled component comprising more than two single parts or sub-assembly parts.
w/	With	Denotes that the following part is attached
L/	Less	Denotes that the following part is not attached
M/T	Manual Transmission	Refers to manual transmission
A/T	Automatic Transmission	Refers to automatic transmission
ISO	International Organization for Standardization	The standards set forth by the international Organization for Standardization (abbreviated as ISO classification) have been employed to evaluate and classify properties of various component parts and oils etc.

The abbreviation codes that appear in the figure stand for the following, respectively.

⊕	Bolt	⊕	Screw
⊗	Nut	⊗	Washer

WA-0-036



SERVICING OPERATIONS

1. Jacking up

- (1) When only the front section or rear section of the vehicle is jacked up, be sure to place chocks at the wheels so as to insure safe operations.
- (2) When the vehicle has been jacked up, be sure to support the vehicle at the specified sections using safety stands.

2. **In the case of repairs on the electrical system or the removal/installation of the engine, first disconnect the negative \ominus terminal of the battery. Then, proceed to the operations. (On clock-equipped vehicles, set the time of the clock after the negative \ominus terminal of the battery is connected.)**

3. Repairing fuel system of Type CB-80 engine

- Type CB-80 engine employs a high fuel pressure. Therefore, the following notes should be observed
- (1) When the union bolt is removed, take a measure to prevent the fuel from splashing with a cloth or the like. Sacken the union bolt gradually.
 - (2) Tighten each connecting section to the specified torque.
 - (3) Attach the specified clip to each connecting section.

4. **For increased work efficiency and improved accuracy, be sure to utilize the SSTs (Special Service Tools) effectively.**

5. Removal and disassembly

- (1) When disassembling complicated components, put stamped marks or mating marks on those sections where such marks do not affect their functions so that the assembling operation may be performed easily.
- (2) Each time a part is removed, check the part for the assembled condition, deformation, breakage, roughness and scratches.
- (3) Arrange the disassembled parts in the disassembling order. In addition, separate and arrange those parts to be replaced and those parts to be reused
- (4) Thoroughly clean and wash those parts to be reused.
- (5) Inspection and measurement of part
Perform thorough inspection and measurement on those parts to be reused, as required.

6. Installation and assembly

- (1) Assemble those satisfactory parts, following the proper procedure and specified standards (adjusting values and tightening torque etc.).
- (2) Ensure that seal packings and grease are applied to those sections where such application is needed.
- (3) Be sure to use new packings, gaskets, cotter pins and so forth.
- (4) Ensure that the specified bolts and nuts only be used. Moreover, where specified, make sure to employ a torque wrench to tighten bolts and nuts to the specified torque.
Make sure to use only genuine parts for every replacement.

7. Adjustment and operation check

Adjust the reassembled or replaced components to the servicing specifications, using gauges and testers, as required.

8. Handling of hose, etc.

- (1) Connect fuel hoses and water hoses, etc. securely so that they exhibit no leakage
- (2) When disconnecting fuel hoses, make sure that no fuel is splashed around the hose. (Special care must be exercised as to the engine mount rubber, etc., for there is a possibility that the rubber is deteriorated by the petrol-based liquid.)

GENERAL INFORMATION

9. Touch-up painting

If paint finish surfaces of the body and bolts should be scratched when bolts, etc. are removed during the body alignment, etc. touch up the scratch with a paint having the same color as that of the body.

WR-01006

JACKING POINTS AND SUPPORTING POINTS OF SAFETY STANDS

• Jacking point

Front side Engine mounting center member (Place the jack below the member, exercising care of the exhaust pipe.)

Rear side ... Center of rear floor cross member

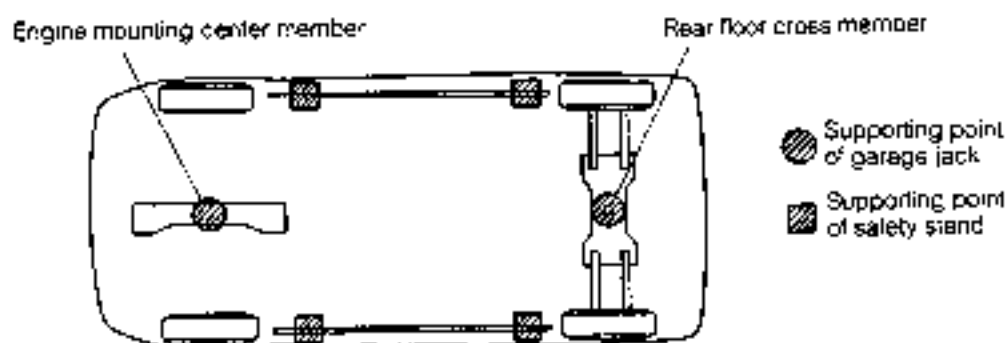

• Supporting points of safety stands

Four supporting points are located at the right and left sides (The supporting points have been strengthened by spot-welding reinforcements. Never support the vehicle at points other than the specified points.)

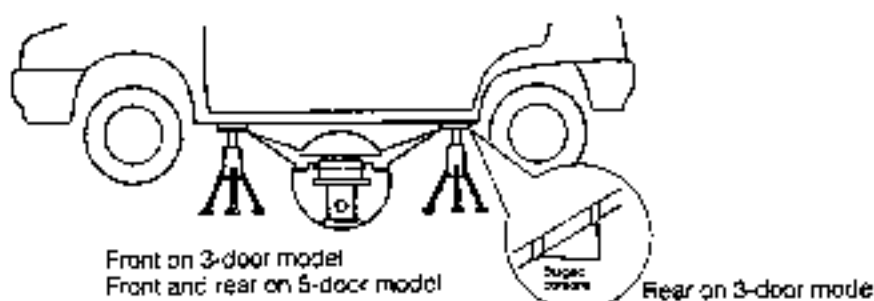

Fig. 1-1

WR-01007

SUPPORTING POINTS OF TWO-POST LIFT

Align the supporting pads of a two-post lift with the supporting points of safety stands, as indicated in the figure above.

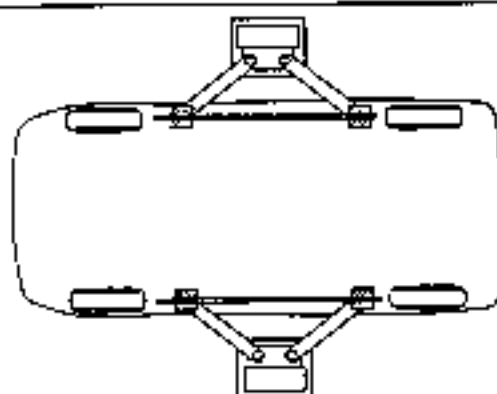

Fig. 1-2

WR-01008

DAIHATSU

CHARADE

Chassis

2

SECTION 2

CLUTCH

DESCRIPTION	2- 2
TROUBLE SHOOTING	2- 2
CLUTCH PEDAL ADJUSTMENT	2- 2
CLUTCH PEDAL AND	
CLUTCH RELEASE CABLE	2- 4
COMPONENTS	2- 4
REMOVAL	2- 4
INSPECTION	2- 5
INSTALLATION	2- 6
CLUTCH UNIT	2- 7
COMPONENTS	2- 7
REMOVAL	2- 7
INSPECTION	2- 8
INSTALLATION	2-10

WF-02001

CLUTCH

DESCRIPTION

TROUBLE SHOOTING

Symptom	Possible causes	Remedies	Page
Gear shifting is hard or impossible.	• Excessive clutch pedal free travel.	• Adjust clutch pedal free travel.	2-3
	• Excessive clutch disc runout, or damaged lining.	• Check clutch disc.	
	• Input shaft or disc splined section contaminated or sticking.	• Repair, as required.	2-8
	• Faulty clutch pressure plate.	• Replace clutch cover.	2-8
Slipping clutch	• Improper clutch pedal free travel.	• Adjust clutch pedal free travel.	2-3
	• Worn or oily clutch disc linings.	• Replace clutch disc.	2-7
	• Faulty pressure plate.	• Replace clutch cover.	2-7
	• Flattened diaphragm spring.	• Replace clutch cover.	2-7
Grabbing and chattering clutch	• Worn or oily clutch disc linings.	• Check clutch disc and replace, as required.	2-8
	• Faulty pressure plate.	• Replace clutch cover.	2-7
	• Flattened disc torsion spring.	• Replace clutch disc.	2-7
	• Bent diaphragm spring.	• Replace clutch cover.	2-7
Clutch noises	• Parts in housing loose.	• Repair, as required.	2-7
	• Worn or contaminated release bearing.	• Replace release bearing.	
	• Release fork and linkage seized.	• Repair, as required.	
Dragging clutch (Poor clutch disengagement)	• Clutch pedal free travel improperly adjusted.	• Adjust clutch pedal free travel.	2-3
	• Flattened diaphragm spring, or worn tip end of spring.	• Replace clutch cover.	2-7

WR-02002

CLUTCH PEDAL ADJUSTMENT

1. Check the clutch pedal for the installation height.
Pedal installation height
(Distance between pedal pad upper surface's center and dash panel)
R.H.D. vehicle 189.5 - 194.5 mm (7.46 - 7.66 inch)
L.H.D. vehicle 181.5 - 186.5 mm (7.15 - 7.34 inch)
2. Adjust the pedal installation height, as required.
 - (1) Slacken the lock nut. Turn the stopper bolt until the installation height conforms to the specification.
 - (2) Tighten the lock nut.

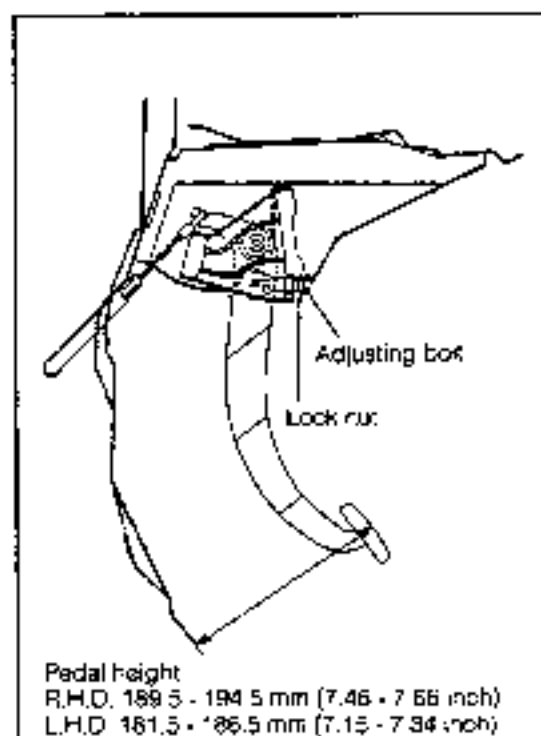

Fig. 2-1

WR-02002

3. Clutch cable adjustment

- (1) Pull the outer cable lightly with a force of 2 - 5 kg (4.4 - 11.0 lb). Check the clearance.
- (2) Ensure that the stopper (protruding portion) is fitted securely in the adjusting groove.
- (3) Adjusting position of clutch outer cable
3 - 6 mm (0.12 - 0.24 inch)

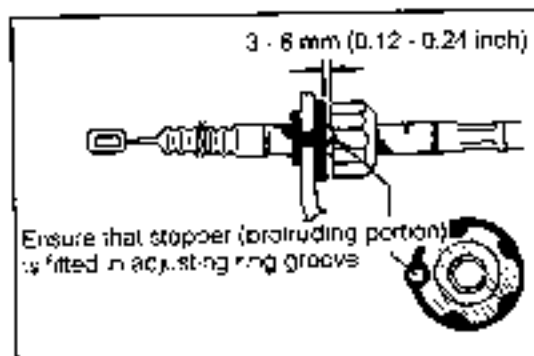

Fig. 2-2

WA-02014

4. Adjust the clutch pedal free travel

- (1) Depress the clutch pedal gradually until you feel a resistance from the clutch. Measure the depressing distance up to this point.

Pedal Free Travel: 15 - 30 mm (0.59 - 1.18 inch)

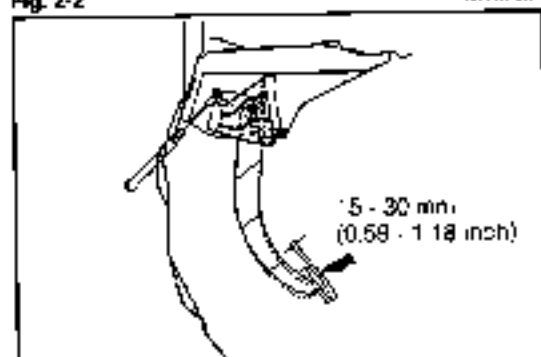

Fig. 2-3

WR-02005

5. Adjust the clearance between the clutch pedal and the floor with the pedal fully depressed. (Minimum clearance between the dash panel and the pedal arm)

Vehicles mounted with Type CB-80 engine:

not less than 20 mm (0.79 inch)

Vehicle other than those mounted with Type CB-80 engine:

not less than 25 mm (0.98 inch)

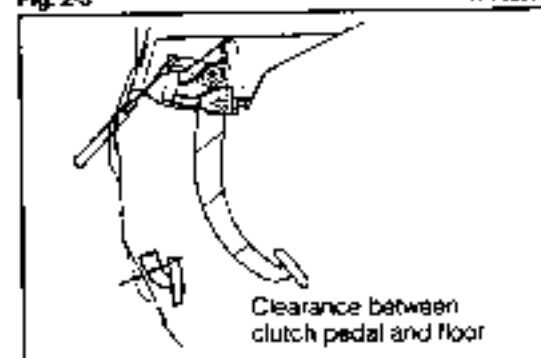

Fig. 2-4

WR-02006

CLUTCH

CLUTCH PEDAL AND CLUTCH RELEASE CABLE COMPONENTS

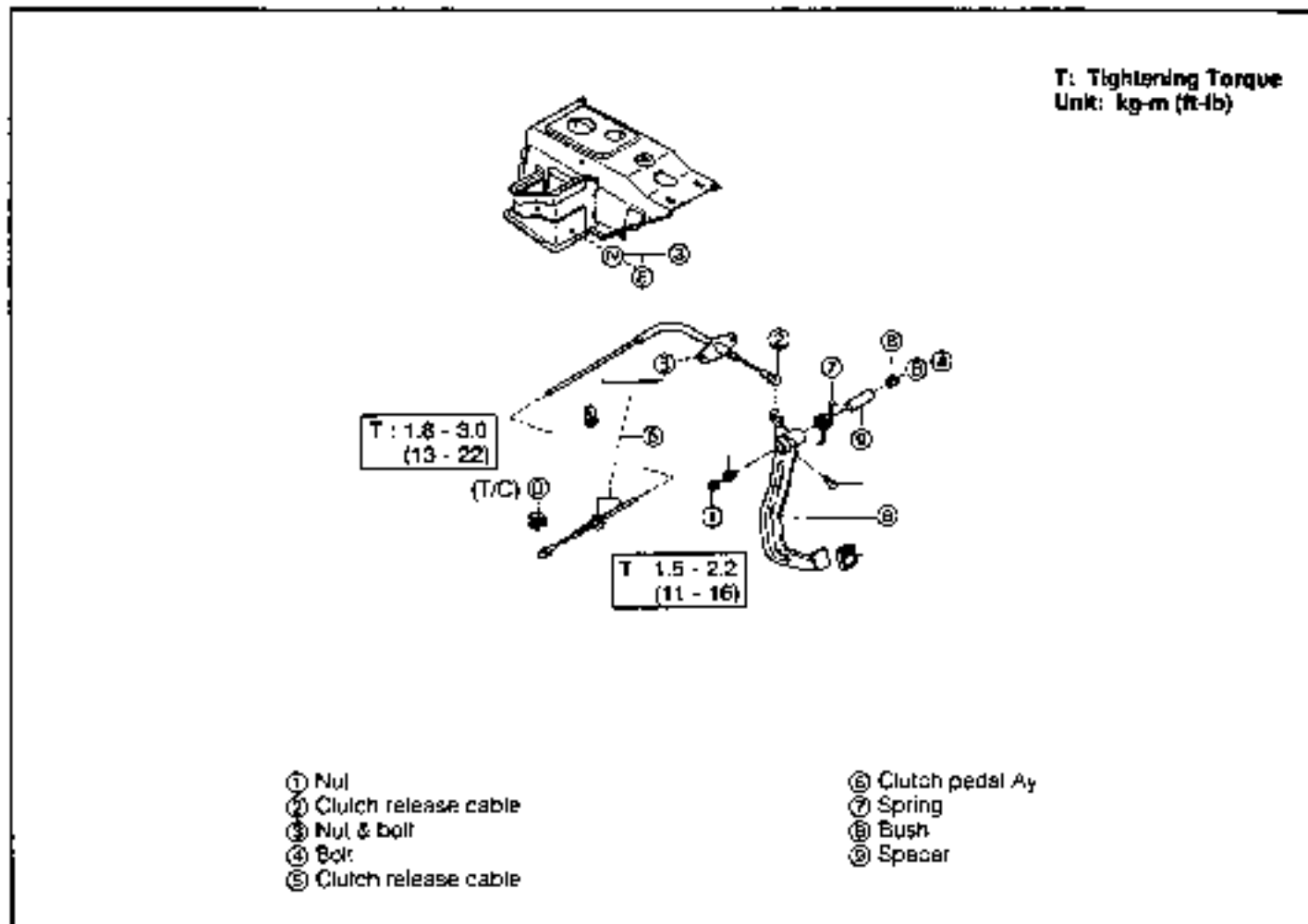

Fig. 2-5

WR-5407

REMOVAL

1. Remove the brake pedal Ay. (Only for L.H.D. vehicles. See page 6-7)
2. Remove the nut located at the clutch pedal installation section. Separate the end section of the clutch release cable.
3. Remove the adjusting bolt.

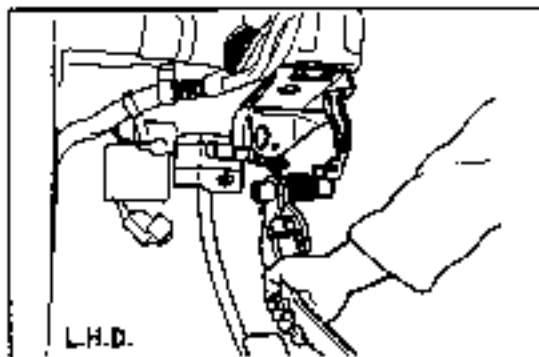

Fig. 2-6

WR-02009

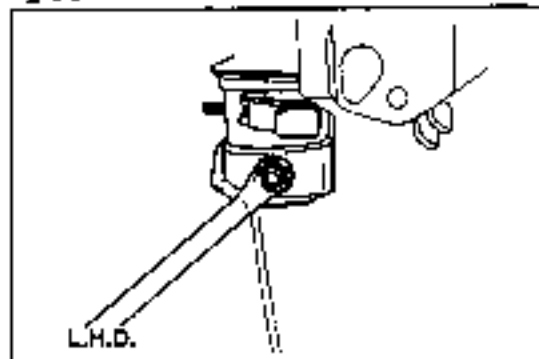

Fig. 2-7

WR-02009

4. Remove the bolt with washer

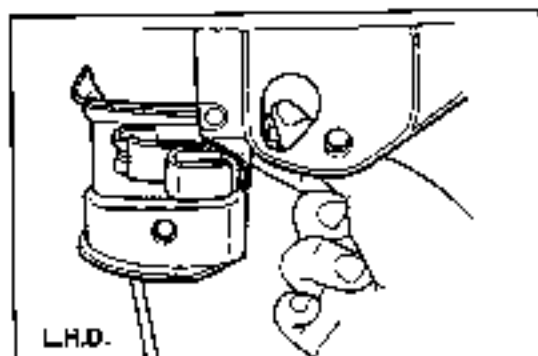

Fig. 2-8 WR-02010

5. Remove the cable bracket attaching bolt. Remove the clutch cable.

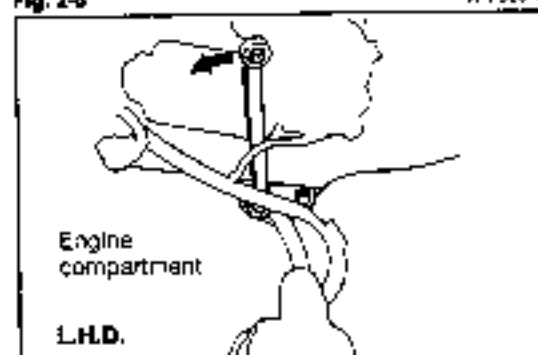

Fig. 2-9 WR-02011

6. Remove the clutch pedal assembly. Remove the spring, bush and spacer.

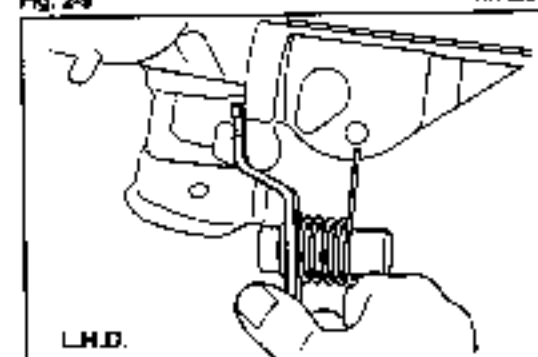

Fig. 2-10 WR-02012

INSPECTION

Inspect the following parts.

1. Bush for wear or damage.
2. Pedal spacer for wear or damage.
3. Pedal for damage or deformation.
4. Pedal pad for wear or damage.
5. Spring for flattened condition.

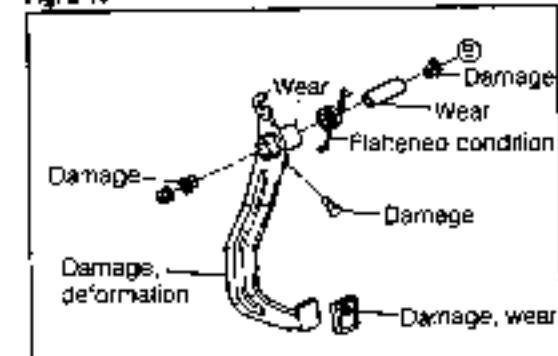

Fig. 2-11 WR-02013

6. Each section of clutch cable

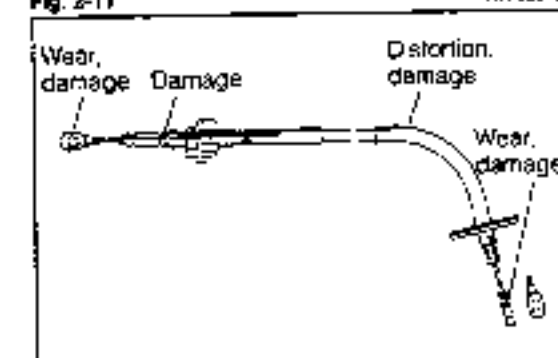

Fig. 2-12 WR-02014

CLUTCH

INSTALLATION

1. Apply MP grease to the following points.
 - (1) Inside of bush and spacer
 - (2) Connecting section of clutch pedal and release cable
2. Install the spring, bush and spacer to the clutch pedal assembly. Then, install the assembly to the pedal bracket.
3. Install the bolt with washer in position.
4. Install both ends of the clutch cable. Tighten the bracket with the bolts.
Tightening Torque: 0.4 - 0.7 kg-m (2.9 - 5.1 lb)
5. Install the adjusting bolt.
6. Tighten the nut.
Tightening Torque: 1.5 - 2.2 kg-m (11 - 16 lb)
7. Depress the clutch pedal two or three times. Proceed to adjust the clutch pedal, following the procedure at page 2-2.
8. Install the brake pedal Ay. (Only for L.H.D. vehicles. See page 8-8)

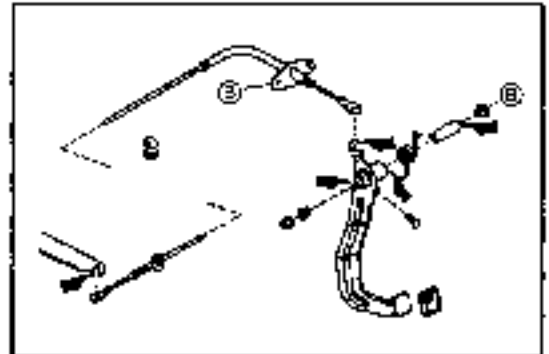

Fig. 2-13

WA-02015

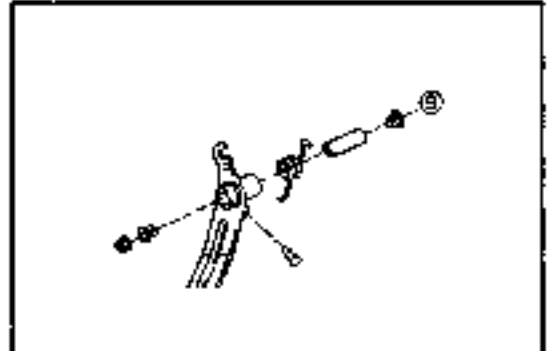

Fig. 2-14

WP-02016

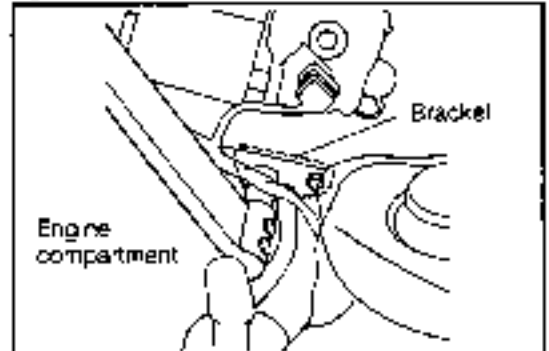

Fig. 2-15

WA-02017

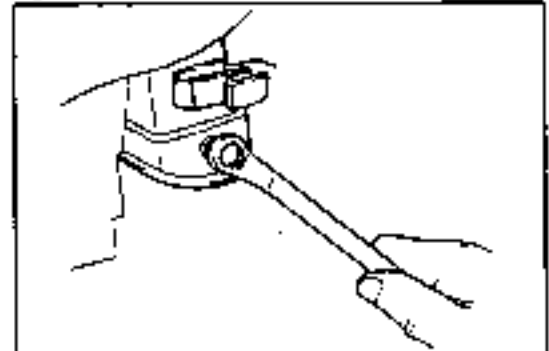

Fig. 2-16

WP-02018

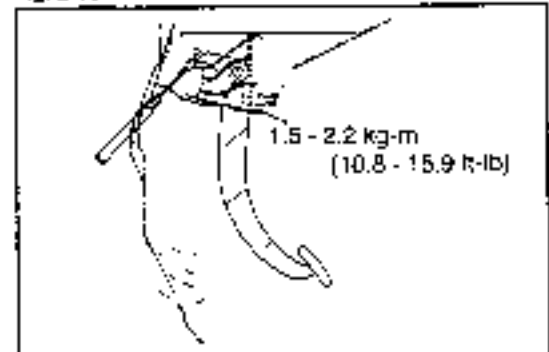
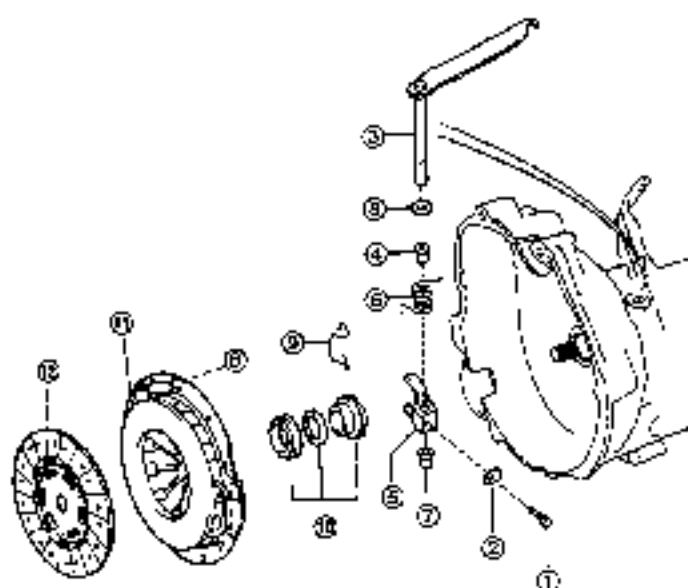

Fig. 2-17

WA-02019



CLUTCH UNIT COMPONENTS



- | | |
|-----------------------------|------------------------------|
| ① Washer bolt | ⑦ Bush No 1 |
| ② Lock plate | ⑧ Dust seal |
| ③ Clutch release fork lever | ⑨ Release bearing clip |
| ④ Bush No. 2 | ⑩ Clutch release bearing hub |
| ⑤ Clutch release lever yoke | ⑪ Clutch cover |
| ⑥ Torsion spring | ⑫ Clutch disc |

Fig. 2-15

WR-02020

REMOVAL

1. Remove the transmission assembly from the vehicle. (See page 3-3)

**SEE
TRANSMISSION
REMOVAL SECTION
Page 3-3 to 3-7.**

WR-02021

2. Release the lock plate. Proceed to remove the lock plate along with the bolt.

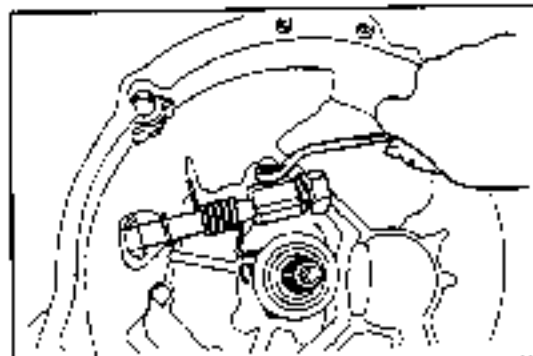

Fig. 2-19

WR-02022

CLUTCH

3. Pull out the clutch release fork lever. Remove the bush, release lever yoke, spring, release bearing clip and release bearing hub.

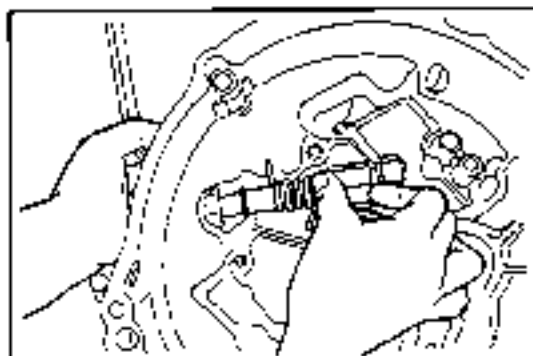

Fig. 2-20

WP-02023

4. Remove the clutch cover from the flywheel. Take out the clutch disc.

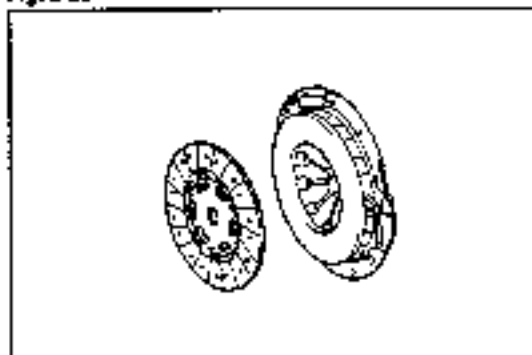

Fig. 2-21

WP-02024

INSPECTION

1. Check the pressure plate and flywheel surface for scores, cracks and discoloration.

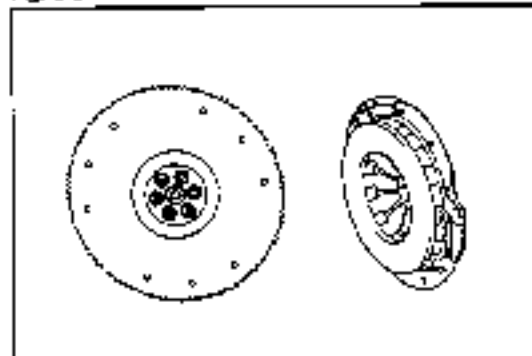

Fig. 2-22

WP-02025

2. Check the diaphragm spring tips for wear, rust and breakage.



Fig. 2-23

WP-02026

3. Check the clutch disc for wear and runout.
Allowable Wear Limit (Rivet Depth):
0.3 mm (0.012 inch)

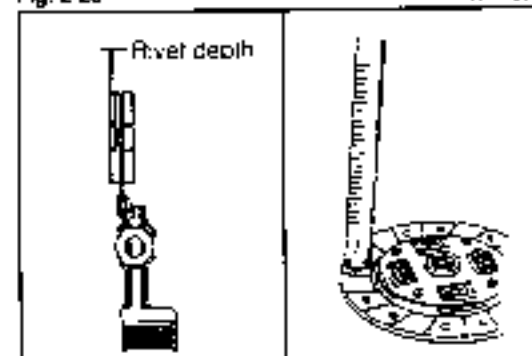

Fig. 2-24

WP-02027



Allowable Limit of Lateral Runout:
1.34 mm (0.0528 inch)

NOTE:

Measure the lateral runout with the clutch disc assembled onto a new input shaft.

- 4 Check to see if the release bearing rotates smoothly. Rotate the release bearing by your hand while applying a pressure to the bearing in a thrust direction. Check to see if the bearing rotates without any abnormal feeling or binding.
- 5 Check the release bearing hub, clip-contacting surface and hub-to-housing sliding section for damage and wear.
- 6 Check to see if the clip has the configuration as shown in the figure in its horizontal plane

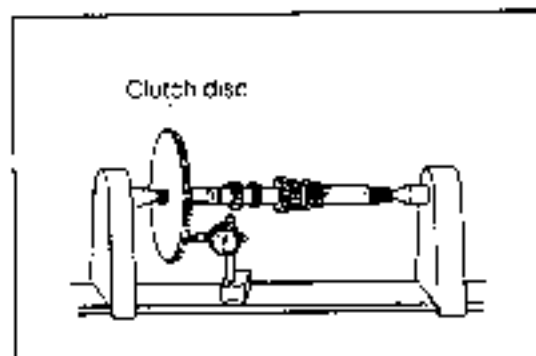

Fig. 2-25

WP-01028

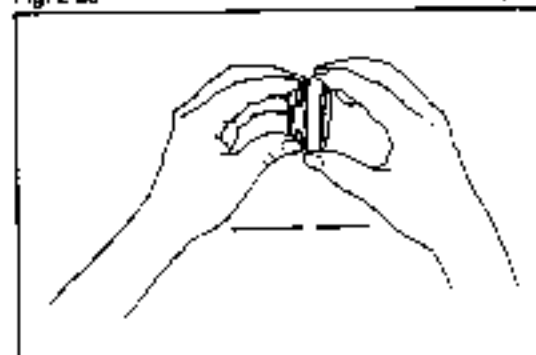

Fig. 2-26

WP-02029

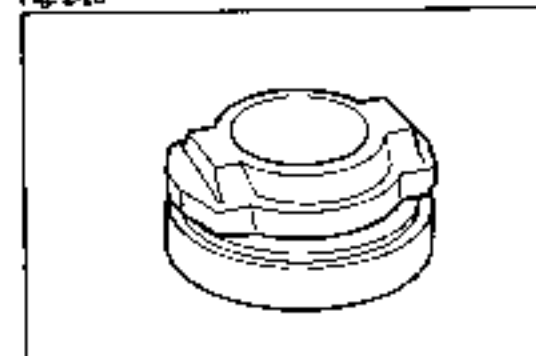

Fig. 2-27

WP-02110

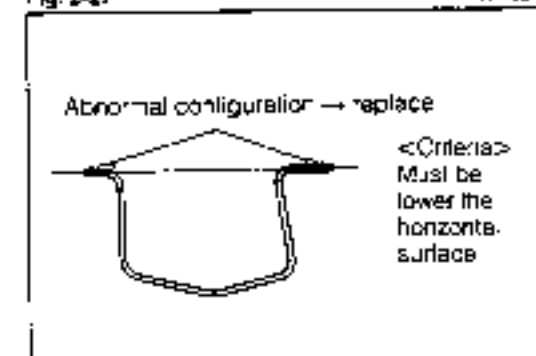

Fig. 2-28

WP-02031

CLUTCH

INSTALLATION

1. Install the clutch disc and clutch cover, using the following SST

SST: 09301-87202-000

Bolt Tightening Torque: 1.5 - 2.2 kg-m (11 - 16 ft-lb)

NOTE:

- (1) Assemble the clutch disc in the direction as shown in the figure.
 - (2) Tighten the bolts evenly, starting with those bolts provided near the locating pin.
 - (3) Apply long-life chassis grease to the clutch disc splined section.
2. Check the clutch cover diaphragm spring tips for variation in height. Adjust the diaphragm spring tips, as required.

Check

Allowable Limit of Variation in Height:

0.7 mm (0.028 inch)

SST: 09302-87701-000

87702

Adjustment

Align the diaphragm spring tips at such a height that makes the number of tips to be adjusted at a minimum number.

SST: 09333-00011-000

3. Assemble the clutch release bearing hub and release bearing clip to the clutch release lever yoke.
 - (1) Bring the cut-out section of the release lever yoke in contact with the clip.
 - (2) Under the condition described in (1), assemble the lever yoke by turning it 180 degrees.

NOTE:

Apply long-life chassis grease to the yoke-to-hub sliding section and bearing-to-housing case sliding section.

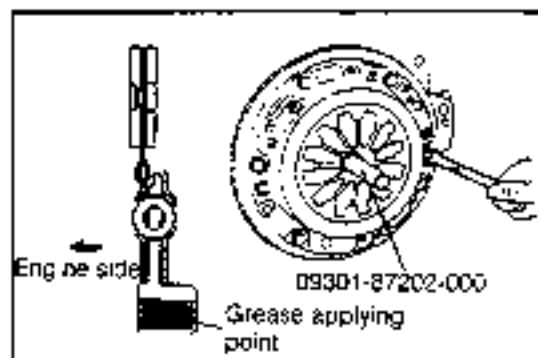

Fig. 2-29

WR-02032

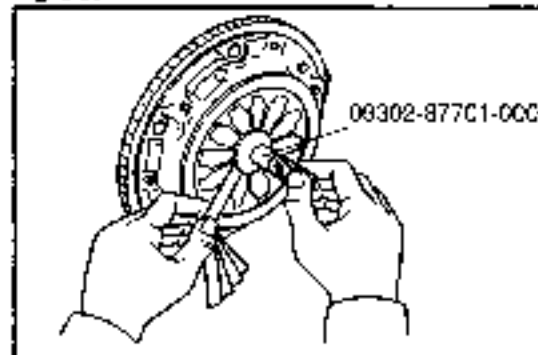

Fig. 2-30

WR-02034

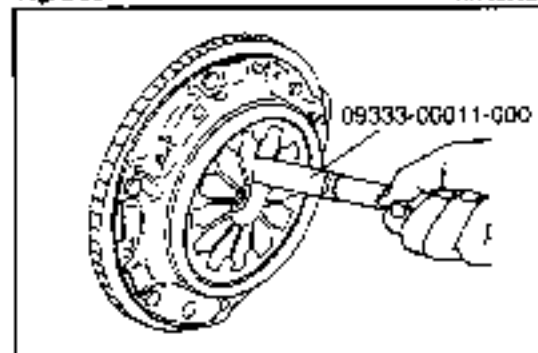

Fig. 2-31

WR-02033

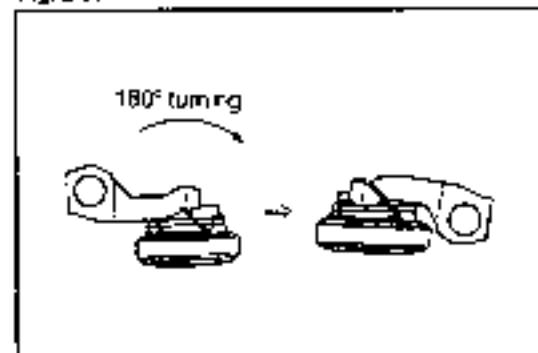

Fig. 2-32

WR-02034



Fig. 2-33

WR-02035



- 4 Assemble the bush, dust seal, torsion spring and clutch release lever in position.

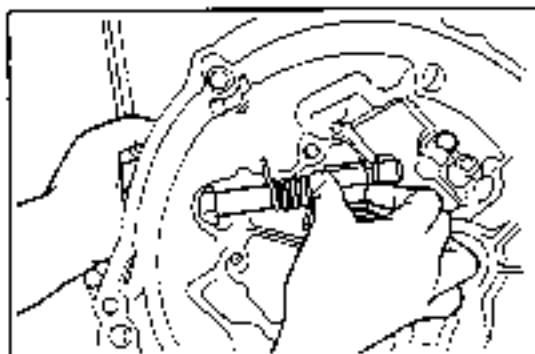

Fig. 2-34

WR-0205

5. Assemble the bolt with washer, with the lock plate interposed.

Tightening Torque: 3.0 - 4.0 kg-m (22 - 29 ft-lb)

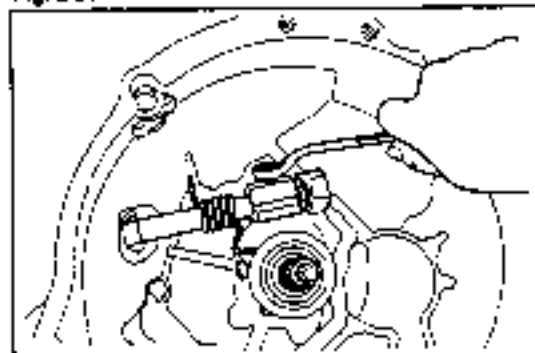

Fig. 2-35

WR-0207

- 6 Check the release hub and yoke for proper operation. Operate the clutch release lever about 50 times. Check the section A of the clip. If the clip exhibits excessive spread and there is a likelihood that the clip may be detached, replace it with a new clip.
7. Install the transmission assembly to the vehicle.
(See page 3-7.)

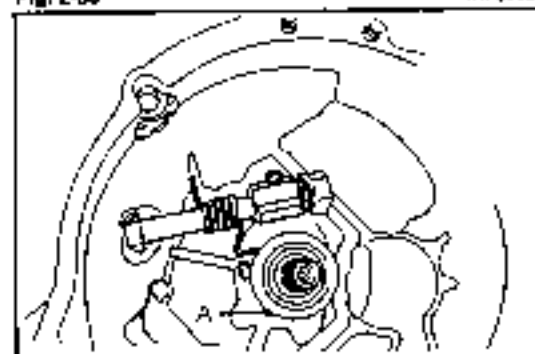

Fig. 2-36

WR-0208

DAIHATSU

CHARADE

Chassis

3

SECTION 3 MANUAL TRANSMISSION

SECTIONAL VIEW	3- 2
MANUAL TRANSMISSION ASSEMBLY	3- 3
REMOVAL	3- 3
INSTALLATION	3- 7
DISASSEMBLY, INSPECTION AND ASSEMBLY OF TRANSMISSION HOUSING, CASE S/A AND CASE COVER	3-12
COMPONENTS	3-12
DISASSEMBLY	3-14
REPLACEMENT	3-16
INSPECTION	3-17
ASSEMBLY	3-18
APPLICATION POINTS OF GREASE & BOND AND APPLICATION PROCEDURE	3-22
DISASSEMBLY, INSPECTION AND ASSEMBLY OF INPUT SHAFT	3-24
COMPONENTS	3-24
DISASSEMBLY	3-25
INSPECTION	3-28
ASSEMBLY	3-28
DISASSEMBLY, INSPECTION AND ASSEMBLY OF OUTPUT SHAFT	3-31
COMPONENTS	3-31
DISASSEMBLY	3-32
INSPECTION	3-34
ASSEMBLY	3-36
DISASSEMBLY, INSPECTION AND ASSEMBLY OF 5TH GEAR	3-38
COMPONENTS	3-38
DISASSEMBLY	3-38
INSPECTION	3-40
ASSEMBLY	3-42
DISASSEMBLY, INSPECTION AND ASSEMBLY OF DIFFERENTIAL CASE	3-44
COMPONENTS	3-44
DISASSEMBLY	3-45
INSPECTION	3-46
ASSEMBLY	3-47
DISASSEMBLY, INSPECTION AND ASSEMBLY OF CONTROL LINKAGE-RELATED PARTS	3-50
COMPONENTS	3-50
DISASSEMBLY	3-52
INSPECTION	3-54
ASSEMBLY	3-55
SHIFT LEVER & SELECTING ROD	3-59
COMPONENTS	3-59
REMOVAL	3-60
INSPECTION	3-61
DISASSEMBLY	3-61
INSPECTION	3-63
ASSEMBLY	3-64
INSTALLATION	3-65

WR-33301

SECTIONAL VIEW

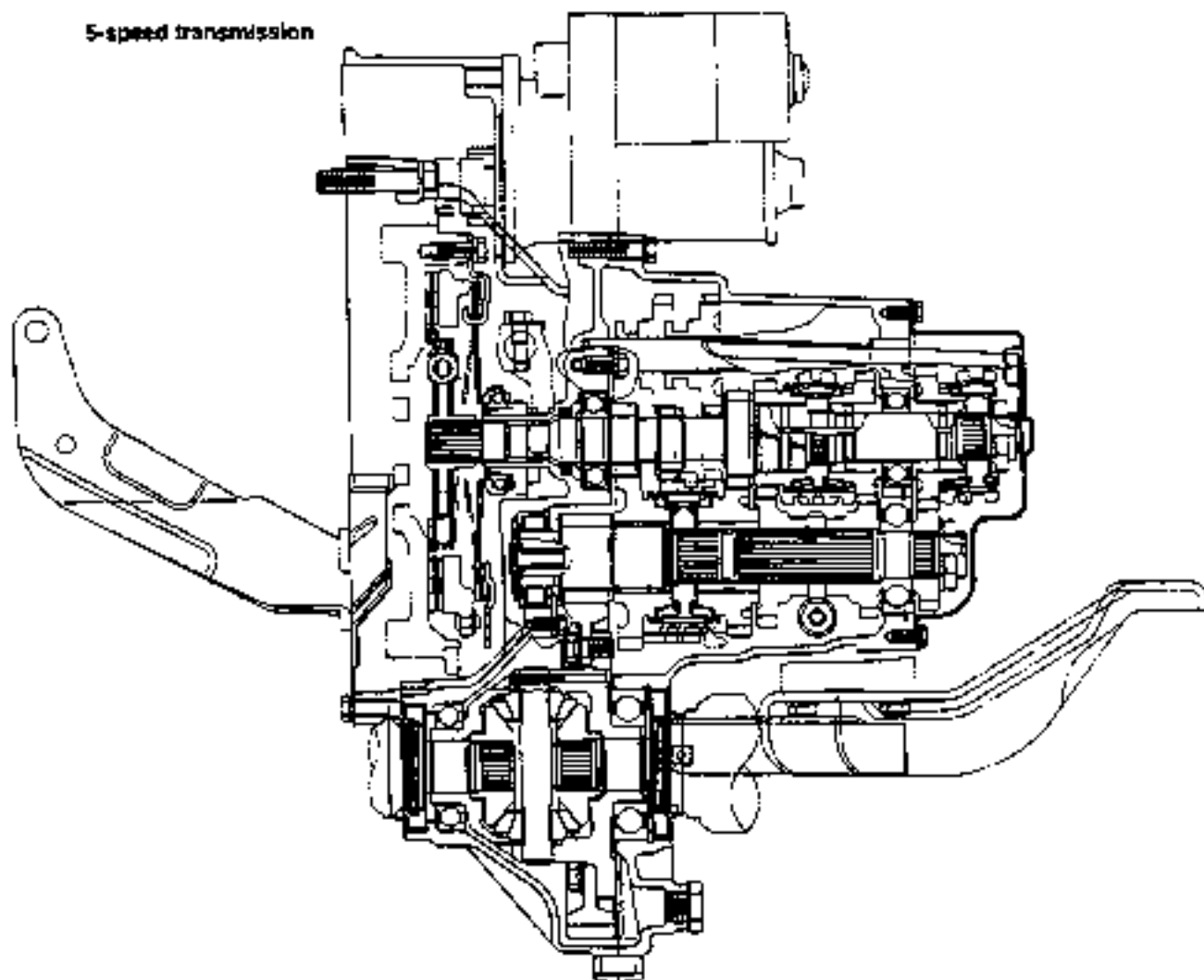

5-speed transmission

Part of 4-speed transmission



Fig. 3-1

WR-0000

Item	Kind	4-speed		5-speed		
		CS-23	CB-23	CL-1	CB-61 CL-61	CB-80
Engine type		CS-23	CB-23	CL-1	CB-61 CL-61	CB-80
Transmission type		Forward gears. Constant mesh. Reverse gear. Selective sliding				
Gear ratio (Tooth number)	1st gear	3.090 (34/11)	3.090 (34/11)	3.090 (34/11)	3.090 (34/11)	3.090 (34/11)
	2nd gear	1.842 (35/19)	1.842 (35/19)	1.842 (35/19)	1.842 (35/19)	1.750 (35/20)
	3rd gear	1.230 (32/26)	1.230 (32/26)	1.230 (32/26)	1.230 (32/26)	1.230 (32/26)
	4th gear	0.864 (32/37)	0.864 (32/37)	0.864 (32/37)	0.864 (32/37)	0.916 (33/36)
	5th gear	—	0.707 (29/41)	0.707 (29/41)	0.707 (29/41)	0.750 (30/40)
	Reverse gear	3.142 (44/30/14)	3.142 (44/30/14)	3.142 (44/30/14)	3.142 (44/30/14)	3.142 (44/30/14)
Final reductor gear ratio (Tooth number)		¹ 4.500 (72/16)	³ 4.500 (72/16)	4.933 (74/15)	4.642 (65/14)	4.642 (65/14)
Number of speedometer gear teeth (driver/drive)		² 16/4	⁴ 16/4	⁵ 18/4	21/5	21/5
Trans- mission oil	Kind	SAE 80. GL-3	SAE 80. GL-3	SAE 80. GL-3	SAE 80. GL-3	SAE 80. GL-3
	Capacity & (Imp. qts U.S. qts)	1.9 - 2.0 (1.67 - 1.76, 2.0 - 2.1)	2.1 - 2.2 (1.85 - 1.94, 2.2 - 2.3)	2.1 - 2.2 (1.85 - 1.94, 2.2 - 2.3)	2.1 - 2.2 (1.85 - 1.94, 2.2 - 2.3)	2.1 - 2.2 (1.85 - 1.94, 2.2 - 2.3)

¹4.933 (74/15). ²18/4 for Swedish specifications

³4.933 (74/15). ⁴18/4 for Swiss & Swedish specifications

⁵17/4 When 155/80 R13 tires are used.

WA-03000

MANUAL TRANSMISSION ASSEMBLY REMOVAL

1. Remove the engine hood assembly.
2. Remove the hold-down clamp and battery.
3. Remove the battery carrier stay.

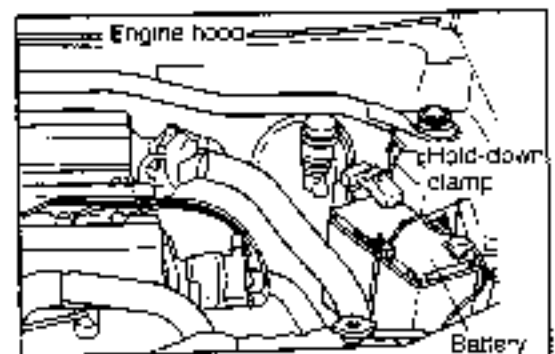

Fig. 3-2

WA-C3004

4. Disconnect the following harnesses:
 - (1) Harness to starter ①
 - (2) Transmission earth
 - (3) Backup lamp harness ②



Fig. 3-3

WA-03005

MANUAL TRANSMISSION

5. Remove the intercooler assembly.
(Vehicles mounted with Type CB-80 engine only)

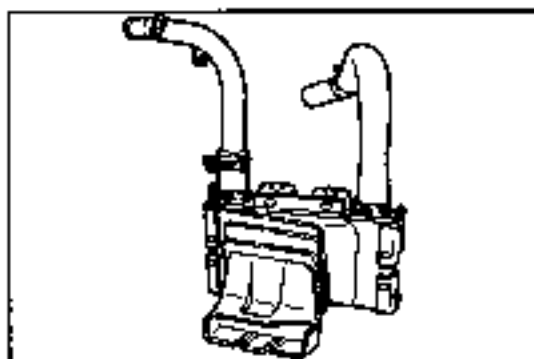

Fig. 3-4

WR-03005

6. Remove the starter assembly.

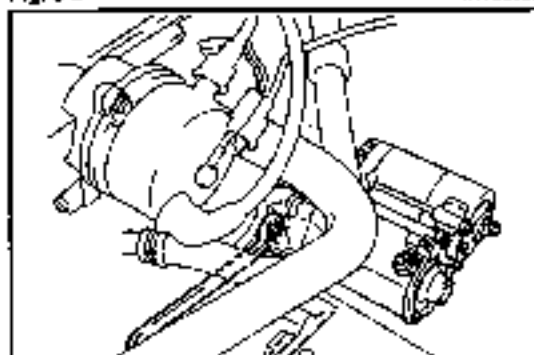

Fig. 3-5

WR-03007

7. Disconnect the speedometer cable

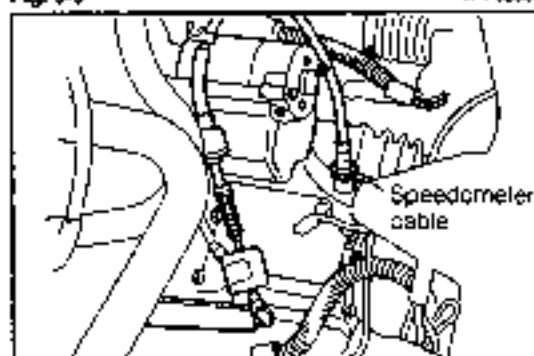

Fig. 3-6

WR-03008

8. Detach the three harness clamps.

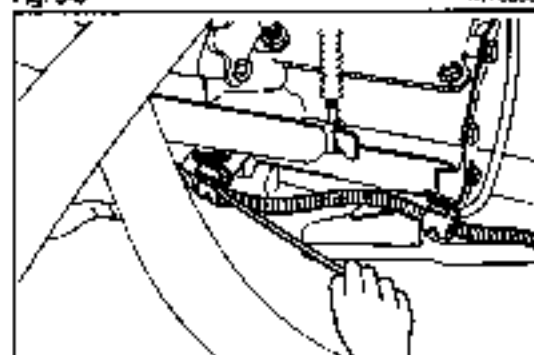

Fig. 3-7

WR-03009

9. Disconnect the clutch cable



Fig. 3-8

WR-03010

10. Remove the two bolts that directly attach the transmission assembly to the engine.

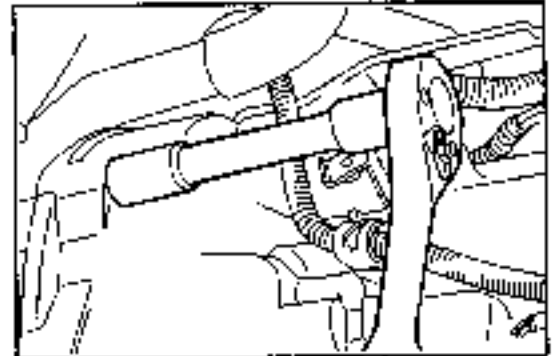

Fig. 3-9

WP-03011

11. Jack up the vehicle. Remove the front tires at the right and left sides of the vehicle.

NOTE:

Be sure to support the vehicle securely by means of safety stands.

12. Drain the transmission oil.

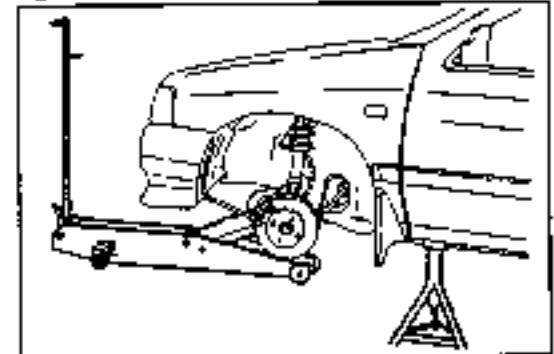

Fig. 3-10

WR-03012

13. Detach the engine undercover (Type CL engine only)
 14. Remove the lower suspension brace. (Types CB-61 and CB-80 engines only)

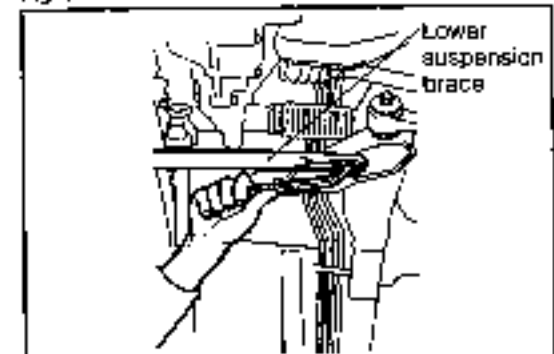

Fig. 3-11

WR-03013

15. Disconnect the front exhaust pipe at the bracket support No.1 and manifold sides.

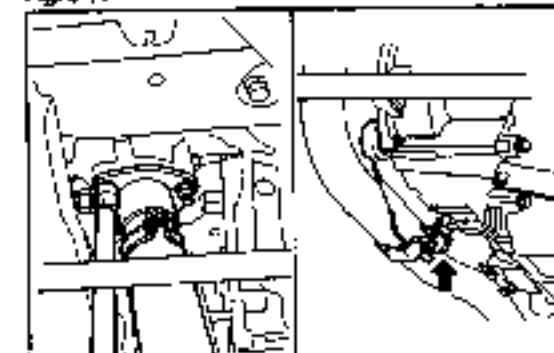

Fig. 3-12

WR-03014

16. Disconnect the following control linkage-related parts from the transmission housing
 (1) Shift & select shaft S/A
 (2) Extension rod S/A

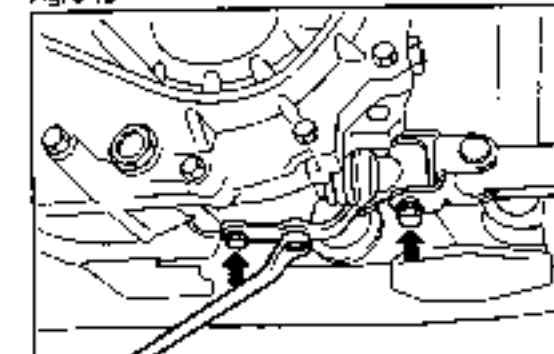

Fig. 3-13

WR-03015

MANUAL TRANSMISSION

17. Remove the stabilizer bar

- (1) Remove the stabilizer bar end nut and retainer.
- (2) Remove the stabilizer bar installing nuts.

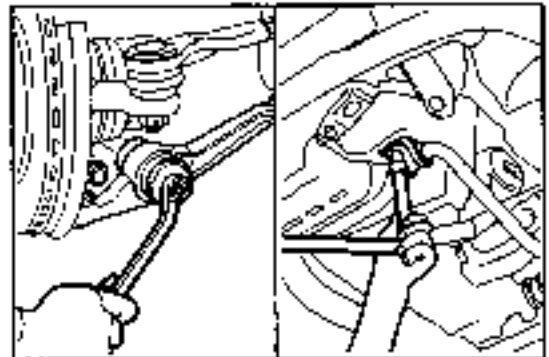

Fig. 3-14

WF 03015

18. Disconnect the lower arm at the bracket side.

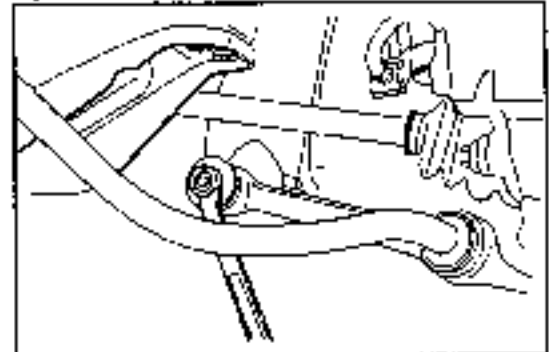

Fig. 3-15

WF 03017

19. Remove the drive shafts at the right and left sides, using the following SST.

SST: 09648-87201-000

NOTE:

1. No stopper is provided at the inboard side of the drive shaft. Hence, be sure to support the inboard joint section during the removal.
2. Be very careful not to damage the lip section of the oil seal during the removal.

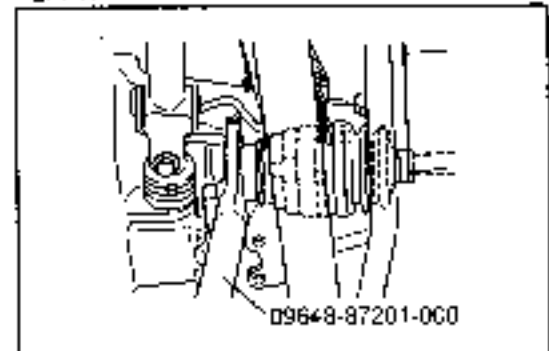

Fig. 3-16

WR 03019

3. As for the right side of vehicles mounted with Type CB-80 engine, insert a crowbar into between the protruding section of the bearing shaft and the drive shaft. Then take out the front drive shaft, being very careful not to deform the dust cover of the drive shaft.

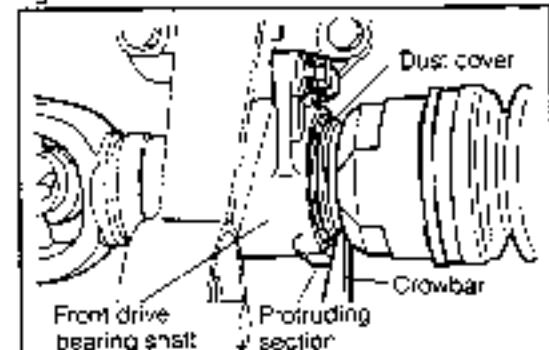

Fig. 3-17

WR 03020

20. Remove the front drive bearing shaft assembly.

(Vehicles mounted with Type CB-80 engine only)

- (1) Remove the two bolts and pull out the front driveshaft bearing shaft from the transmission assembly

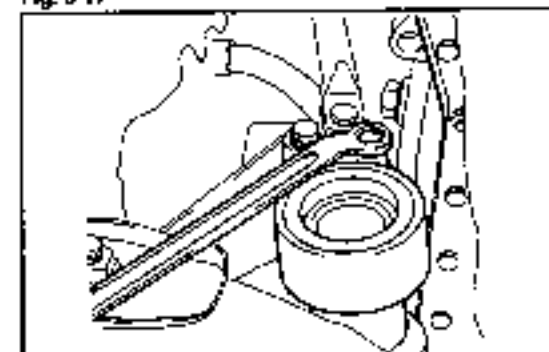

Fig. 3-18

WR 03022

21. Remove the transmission assembly attaching bolts.

NOTE:

Be sure to leave the one bolt located at the front central part.

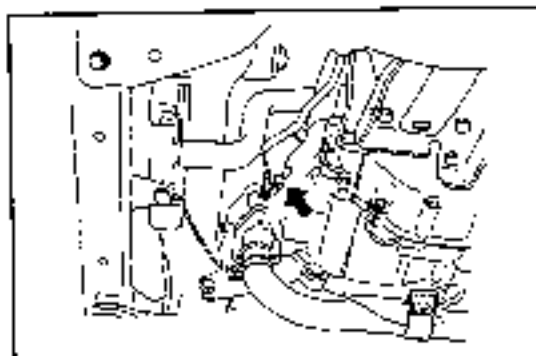

Fig. 3-19

WF-03021

22. Lightly support the lower part of the transmission, using a jack. Then, remove the engine mounting lower/left bracket attaching bolts.

Turn the engine mounting lower/left insulator 90 degrees so that it may point upward.

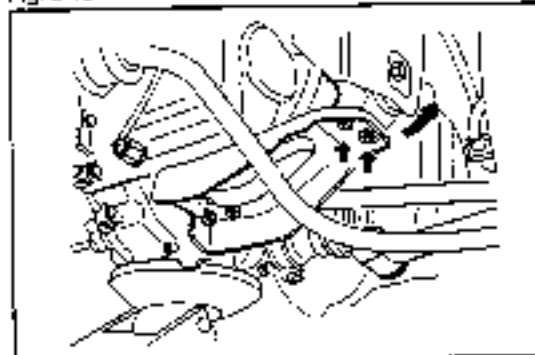

Fig. 3-20

WF-03022

23. Remove the one bolt located at the front central part of the transmission assembly. Slowly jack down the transmission assembly and take it out from below the vehicle.

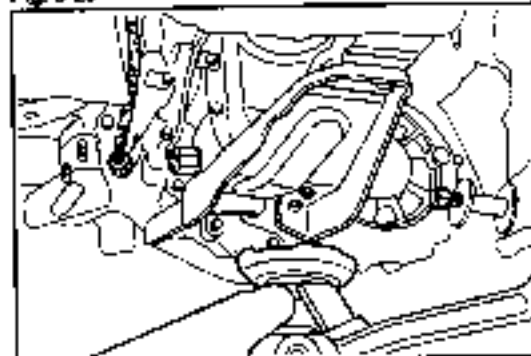

Fig. 3-21

WF-03023

INSTALLATION

1. Install the transmission assembly to the engine assembly as follows:
 - (1) Ensure that the clutch disc is centered in position, using the SST given below.
SST: 09301-87702-000
 - (2) Install the transmission, making sure that the clutch disc may not be dried. Temporarily tighten the attaching bolts.

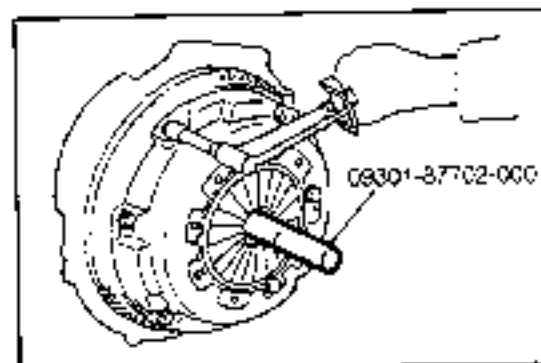

Fig. 3-22

WF-03024

MANUAL TRANSMISSION

2. Tighten the transmission assembly attaching bolts securely.

Tightening Torque: 5.0 - 7.0 kg-m (36 - 51 ft-lb)

3. Install the engine mounting lower/left insulator and engine mounting lower/left bracket.

Bracket Tightening Torque:

3.0 - 4.5 kg-m (22 - 33 ft-lb)

Insulator Tightening Torque:

7.5 - 10.5 kg-m (54 - 76 ft-lb)

4. Install the front drive bearing shaft assembly as follows.
(Vehicles mounted with Type CB-80 engine only)

(1) Slowly install the bearing shaft assembly to the differential case, making sure that no damage is made to the lip section of the oil seal.

(2) Tighten the two attaching bolts.

Tightening Torque: 3.0 - 4.5 kg-m (22 - 33 ft-lb)

5. Install the drive shafts at the right and left sides

NOTE:

Slowly install the drive shaft to the differential case, making sure that no damage is made to the lip section of the oil seal.

6. Install the lower arm (at the bracket side). Temporarily tighten the attaching bolts

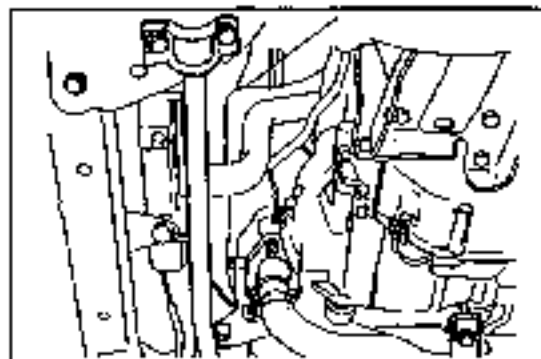

Fig. 3-23

WF-09095

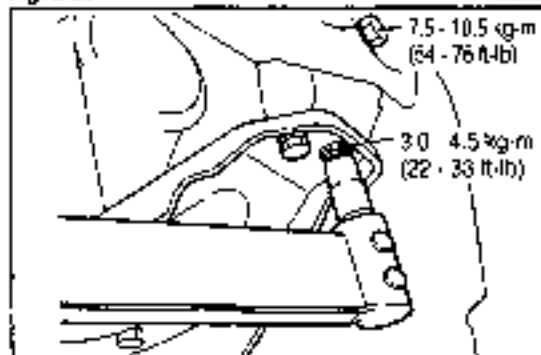

Fig. 3-24

WF-09095

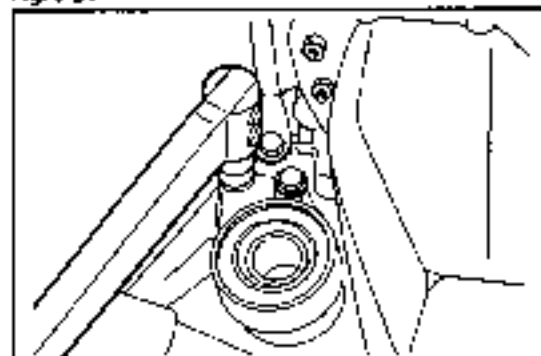

Fig. 3-25

WF-33027

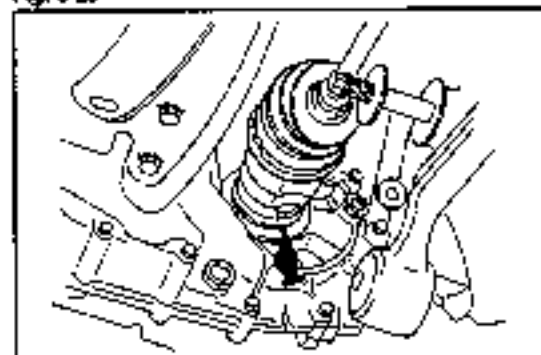

Fig. 3-26

WF-09128

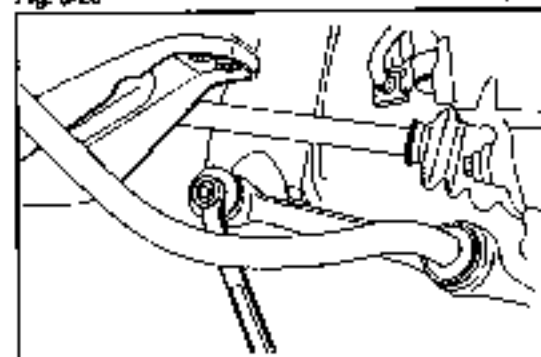

Fig. 3-27

WF-09095

- 7 Install the stabilizer bar.
- (1) Temporarily tighten the stabilizer bar end nut
 - (2) Tighten the cushion and stabilizer bar bracket
- Tightening Torque: 4.0 - 6.0 kg-m (29 - 43 ft-lb)**

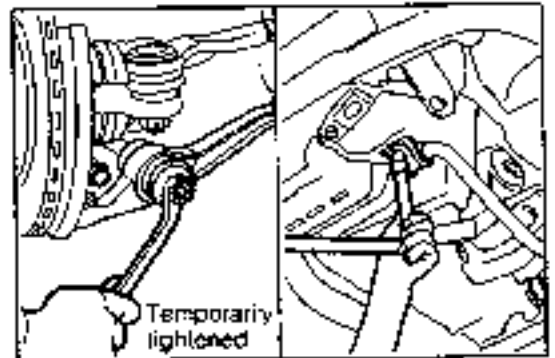

Fig. 3-28

WF-03000

8. Install the following control linkage-related parts
- (1) Shift & select shaft S/A
Tightening Torque: 1.0 - 1.6 kg-m (7.2 - 11.6 ft-lb)
 - (2) Extension rod S/A
Tightening Torque: 1.0 - 1.6 kg-m (7.2 - 11.6 ft-lb)

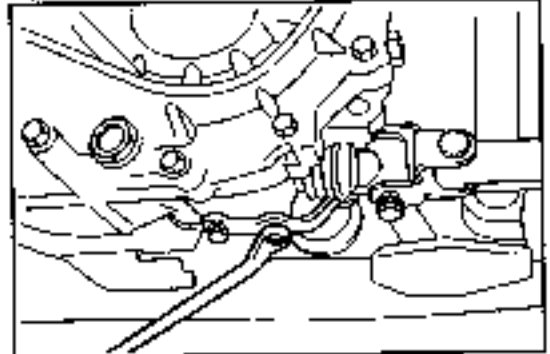

Fig. 3-29

WF-03001

9. Install the manifold side of the front exhaust pipe. Install the bracket support No.1.
- (1) Manifold side
Tightening Torque: 3.0 - 5.0 kg-m (22 - 36 ft-lb)
 - (2) Bracket support No.1
Tightening Torque: 2.0 - 3.0 kg-m (14.5 - 22 ft-lb)

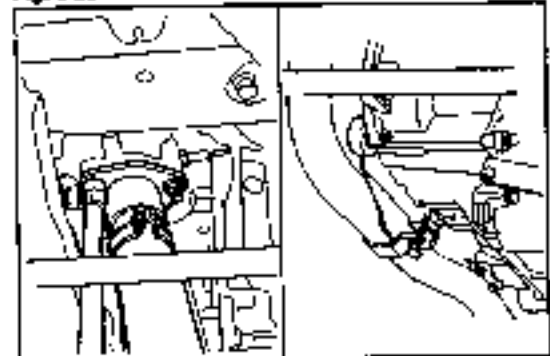

Fig. 3-30

WF-03002

- 10 Install the lower suspension brace.
(Vehicles mounted with Type CB-61 and CB-80 engines only)
- Tightening Torque: 4.0 - 5.5 kg-m (29 - 40 ft-lb)**

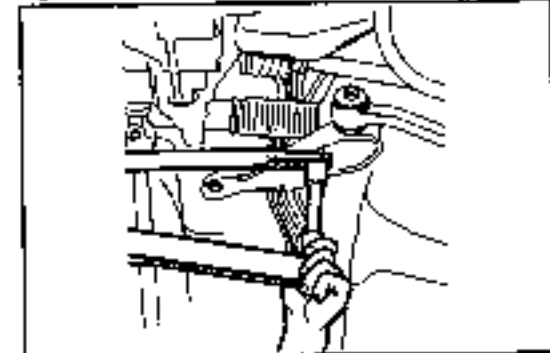

Fig. 3-31

WF-03003

- 11 Install the engine undercover.
(Vehicles mounted with Type CL engine only)
- 12 Install the front wheels at the right and left wheels. Jack down the vehicle.
- 13 Rock the vehicle in a up-and-down direction a few times so as to settle the suspension.
With the vehicle in an unloaded, tighten the nuts.
- (1) Stabilizer bar installing nuts
Tightening Torque: 7.5 - 11.0 kg-m (54 - 80 ft-lb)
 - (2) Lower arm (bracket side)
Tightening Torque: 7.0 - 10.0 kg-m (51 - 72 ft-lb)

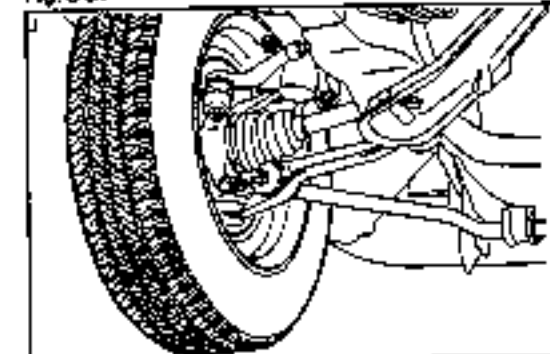

Fig. 3-32

WF-03004

MANUAL TRANSMISSION

13. Fill the transmission oil.

Oil capacity:

4-speed transmission: 1.9 - 2.0 ℓ
(1.7 - 1.8 Imp qts, 2.0 - 2.1 U.S. qts.)

5-speed transmission: 2.1 - 2.2 ℓ
(1.8 - 1.9 Imp qts, 2.2 - 2.3 U.S. qts.)

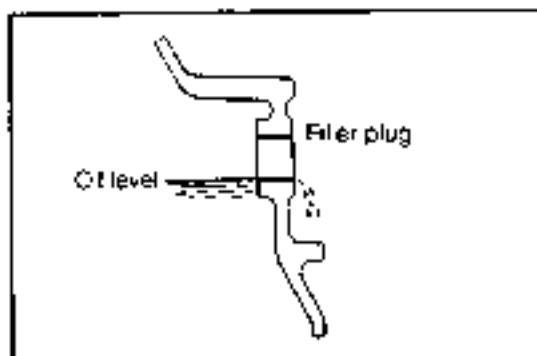

Fig. 3-33

WP-03085

14. Install the clutch cable

(See page 2-3.)

15. Attach the three harness clamps.

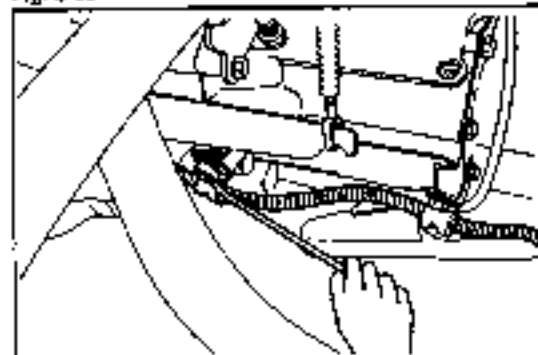

Fig. 3-34

WP-03095

16. Install the speedometer cable.

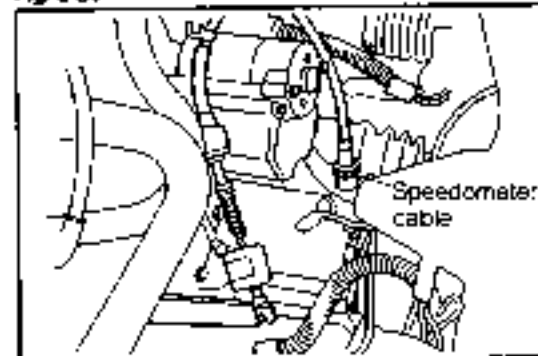

Fig. 3-35

WP-03137

17. Install the starter assembly.

Tightening Torque: 5.0 - 7.0 kg-m (36 - 51 ft-lb)

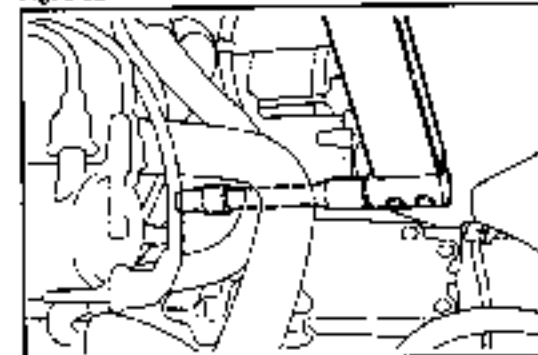

Fig. 3-36

WP-03035

18. Install the intercooler assembly.

(Vehicles mounted with Type CB-80 engine only)

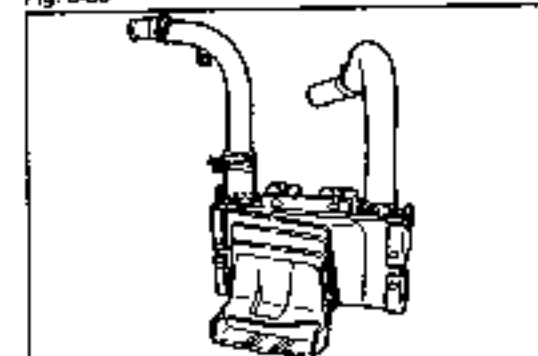

Fig. 3-37

WP-03025

19. Install the following harnesses:
- (1) Harness to starter ①
 - (2) Transmission earth ②
 - (3) Backup lamp harness ③

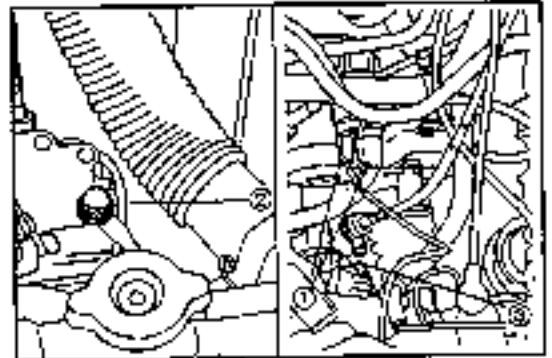

Fig. 3-38

WP-03040

20. Install the battery carrier stay, battery, hold-down clamp and engine hood assembly.

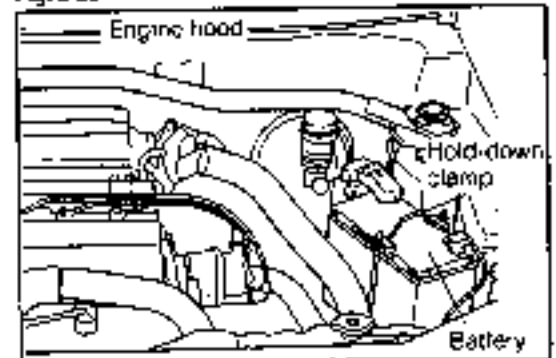
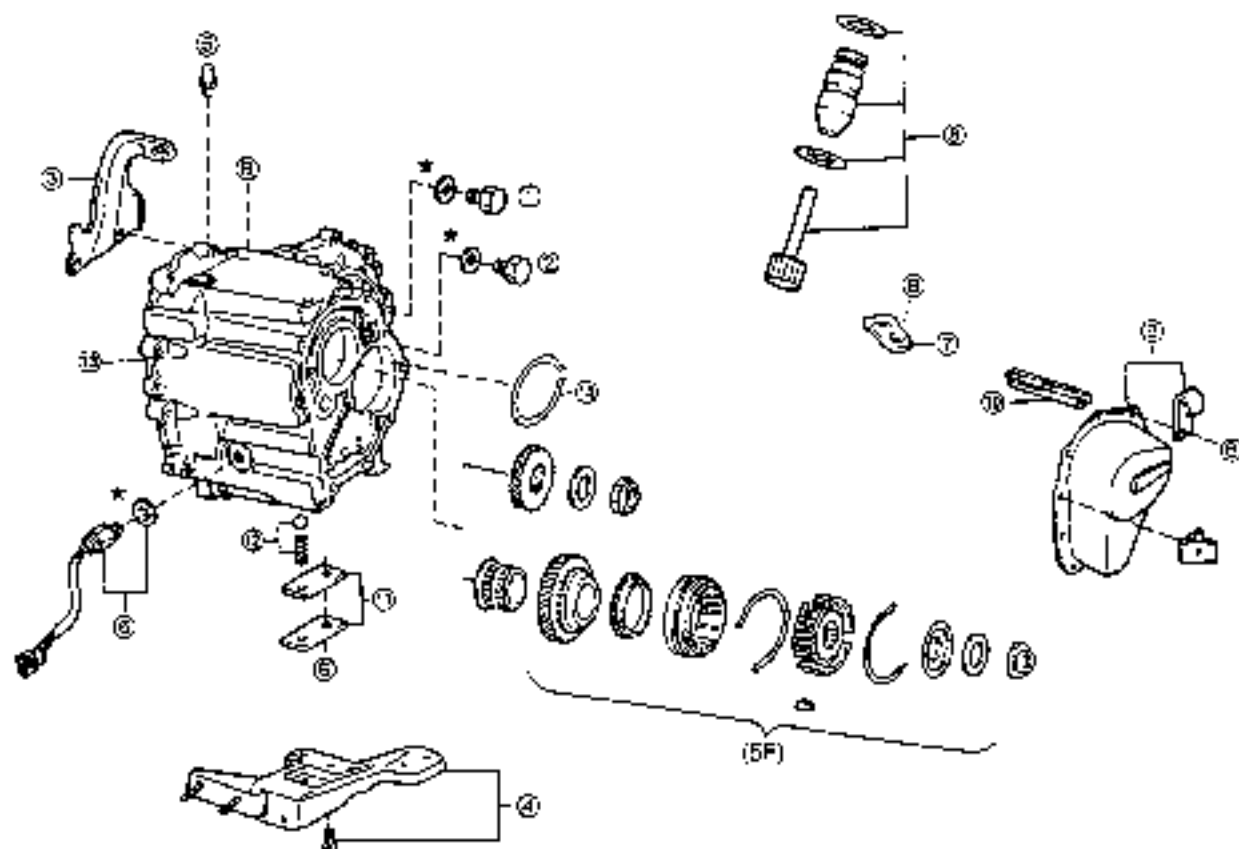

Fig. 3-39

WP-03041

DISASSEMBLY, INSPECTION AND ASSEMBLY OF TRANSMISSION HOUSING, CASE S/A AND CASE COVER COMPONENTS (PART 1)



★ : Non-reusable parts.

- | | |
|--|--------------------------------|
| ① Wheel straight screw plug (if left side) | ⑧ Speedometer shaft sleeve S-A |
| ② Wheel straight screw plug (drain side) | ⑨ Transmission case cover S-A |
| ③ Clutch cable bracket | ⑩ Case cover oil pipe |
| ④ Engine mounting bracket | ⑪ Gasket & lock ball plate |
| ⑤ Breather plug | ⑫ Ball & compression spring |
| ⑥ Backup lamp switch A ₁ & gasket | ⑬ Transmission case |
| ⑦ Lock plate | ⑭ Hoop snapping |

Fig. 3-40

WPC3041A

COMPONENTS (PART 2)

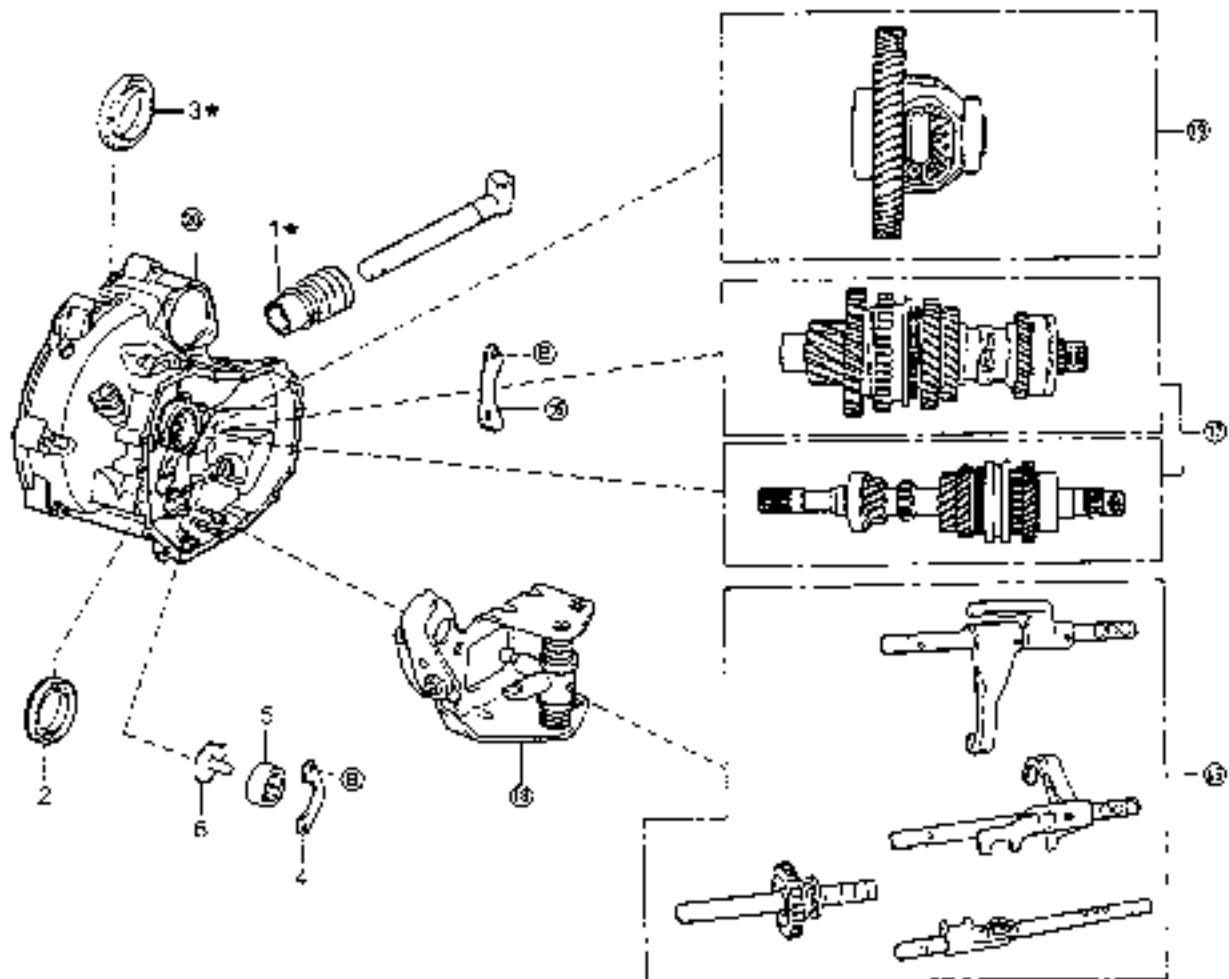

* : Non-reusable parts.

- ① Control related parts
- ② Input shaft bearing lock plate
- ③ Input shaft Ay & output shaft Ay
- ④ Selector support Ay & shifting bell crank
- ⑤ Different of case Ay

- ⑥ Transaxle case
- 1, 2, 3 Oil seal
- 4 Output shaft bearing lock plate
- 5 Needle roller bearing
- 6 Output shaft cover

Fig. 3-41

MF-0201-5

MANUAL TRANSMISSION

DISASSEMBLY

1. Remove the screw plugs (at the drain and filler sides).
2. Remove the clutch cable bracket and engine mounting bracket.
3. Remove backup lamp switch assembly and breather plug.
4. Remove the lock plate and speedometer shaft sleeve subassembly.
5. Remove the oil seal, using the SST given below
SST: 09921-00010-000
6. Remove the transmission case cover subassembly as follows:
 - (1) To drive out the case cover subassembly, tap the flange section lightly in the axial direction, using a plastic hammer.

NOTE:

Never tap the case cover at its side.

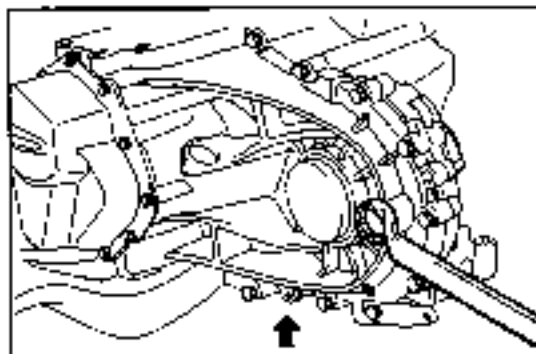

Fig. 3-42

WR-03042

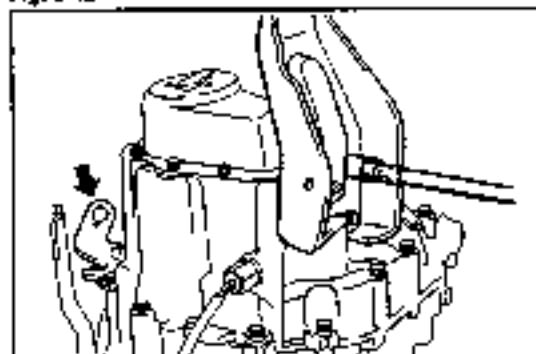

Fig. 3-43

WR-03043

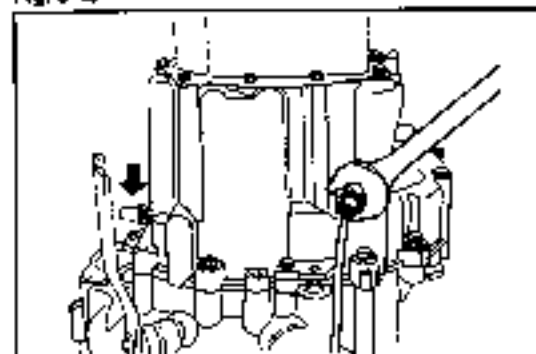

Fig. 3-44

WR-03044

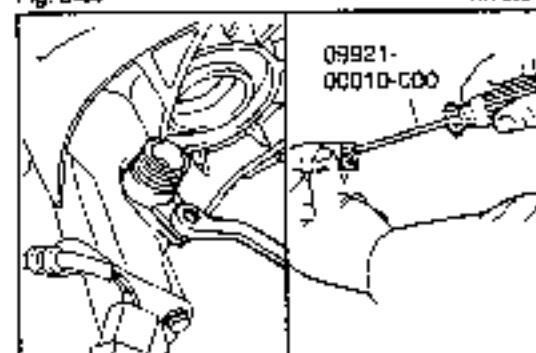

Fig. 3-45

WR-03045

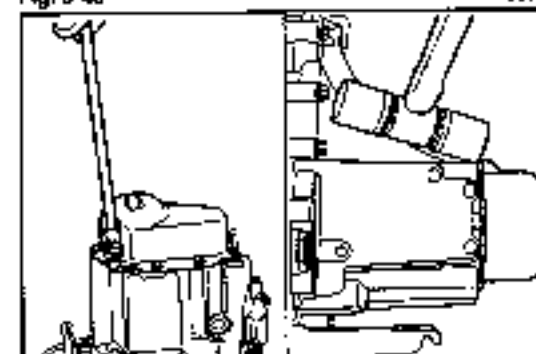

Fig. 3-46

WR-03046

7. Remove the case cover oil pipe.

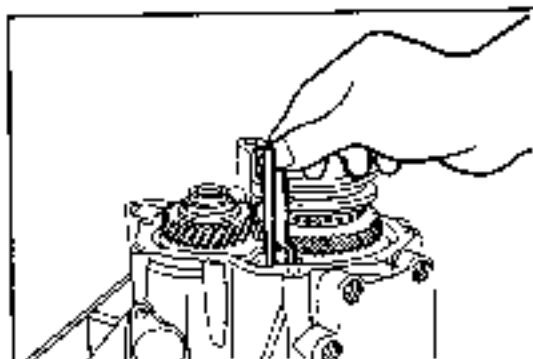

Fig. 3-47

WP-02047

8. Remove the lock bail plate and gasket. Take out the compression spring and bail.
(In the case of the 5-speed transmission, proceed to this operation after the 5th gear has been disassembled.)

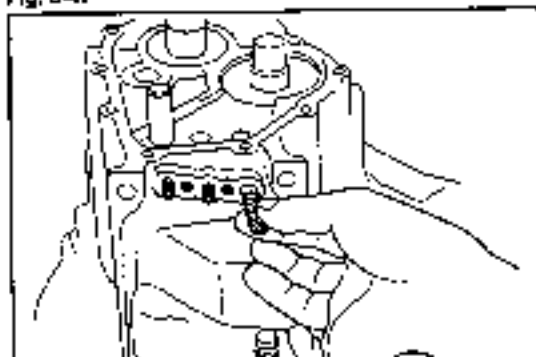

Fig. 3-48

WP-02048

9. Remove the transmission case as follows:

(1) With the hole snap ring for output shaft bearing use held in an expanded state by means of the SST, drop the shaft.

SST: 09905-00012-000

(2) To drive out the transmission case, tap the case hub with a plastic hammer.

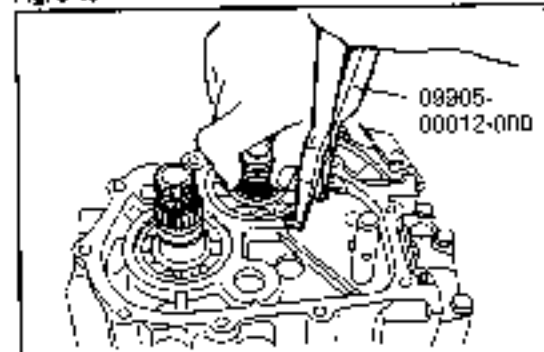

09905-00012-000

Fig. 3-49

WP-03049

10. Detach the hole snap ring

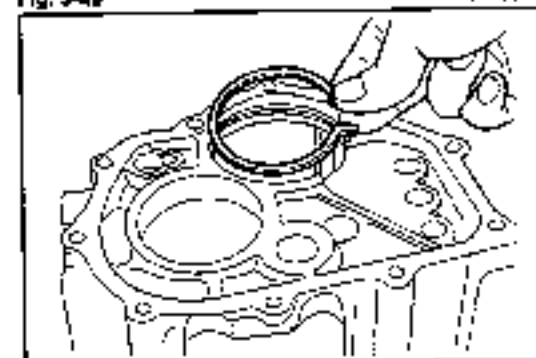

Fig. 3-50

WP-03050

11. Remove the control linkage-related parts

(For the disassembly procedure for each part, see page 3-50.)

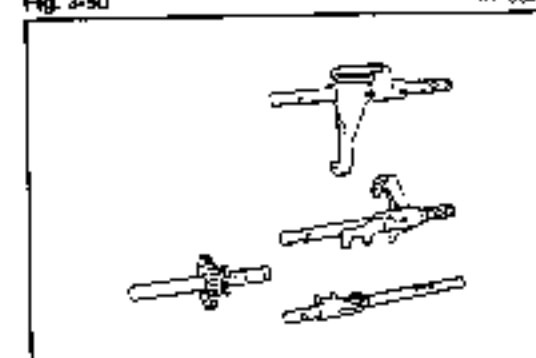

Fig. 3-51

WP-03051

MANUAL TRANSMISSION

12. Remove the input shaft bearing lock plate.

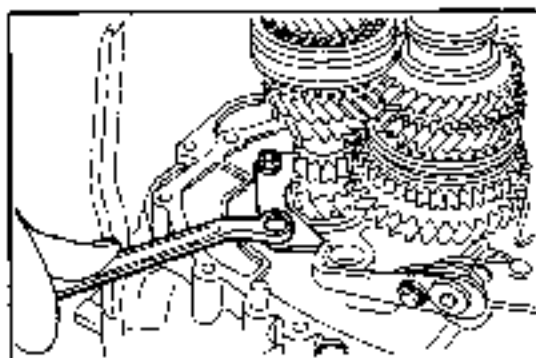

Fig. 3-52

WR-03052

13. Remove the input shaft assembly and output shaft assembly at the same time.

(1) Alternately pull out both shafts a little at a time.

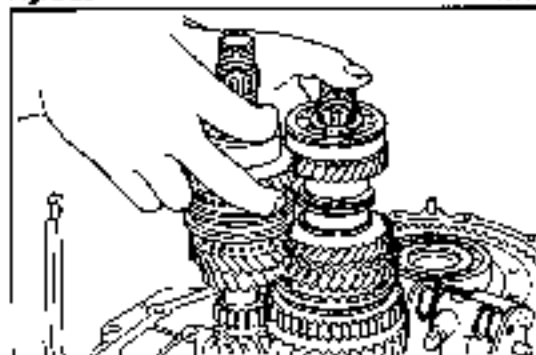

Fig. 3-53

WR-03053

14. Remove the selector support assembly, shifting bell crank and magnet.

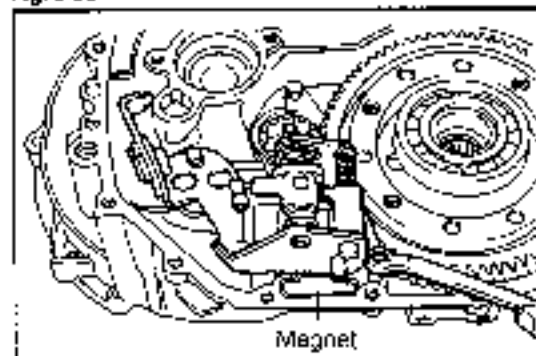

Fig. 3-54

WR-03054

15. Remove the differential case as follows.

(1) With a brass bar placed on the inner race of the side bearing, lightly tap the bar so that the differential case may be driven out from the transaxle case.

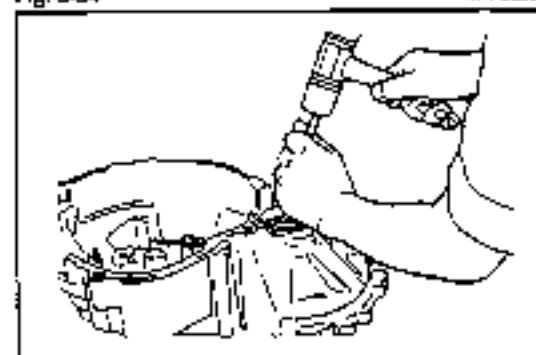

Fig. 3-55

WR-03055

REPLACEMENT

Inspect the following parts (See page 3-18.) Replace any parts that exhibit defects, following the procedure given below.

1. Oil seal for control shaft use

Disassembly: Remove the oil seal by pinching its flange section with pliers.

Assembly: Drive the oil seal into position, until it comes into contact with the axle case.

SST: 09515-87201-000

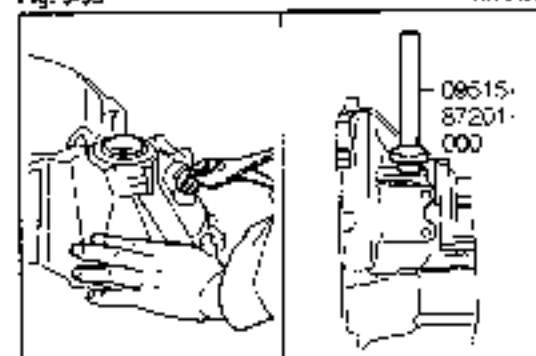

Fig. 3-56

WR-03056

2 Oil seal for input shaft use

Disassembly: Remove the oil seal with a common screwdriver.

Assembly: Drive the oil seal into position, until it becomes flush with the edge surface of the transaxle case.

SST: 09606-87201-000

3 Needle Roller Bearing

Disassembly: After the output shaft bearing lock plate has been removed, remove the roller bearing, using the SST given below:

SST: 09308-00010-000

Assembly:

(1) Assemble the roller bearing, using the SST given below.

SST: 09309-87201-000

NOTE:

Visually check to see if the output shaft cover exhibits severe distortion or clogging.

(2) Install the bearing lock plate.

Tightening Torque: 0.7 - 1.0 kg-m (5.1 - 7.2 ft-lb)

4 Oil seal for differential use

Disassembly: Remove the oil seal with a common screwdriver.

Assembly: Drive the oil seal into position, until it comes into contact with the rib of the axle case.

SST: 09517-87701-000 (Case side)

09517-87702-000 (Housing side)

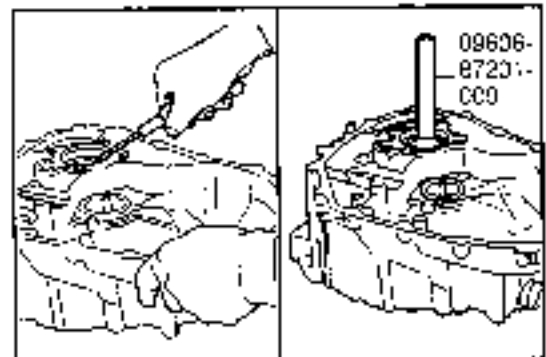

Fig. 3-57

WP-0325*

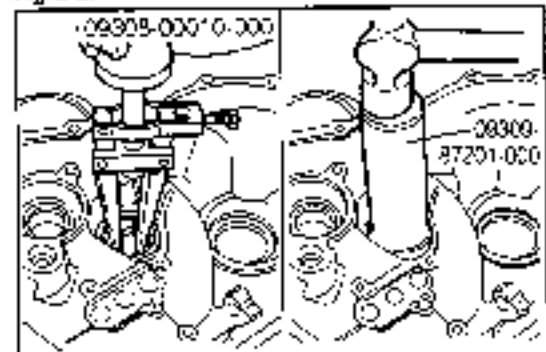

Fig. 3-58

WP-0329

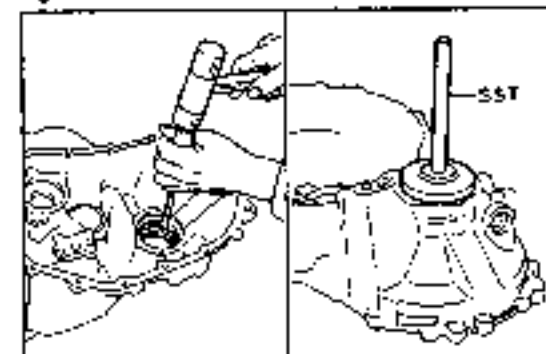

Fig. 3-59

WP-0332

INSPECTION

1. Check each bearing for wear or damage

Part	Inspection criteria
Bearing	When the inner race is rotated by your fingers, it should rotate smoothly without any binding.

2. Check each oil seal for wear or damage

Part	Inspection criteria
Lip section of oil seal	Visually inspect to see if the lip section exhibits excessive damage or wear.

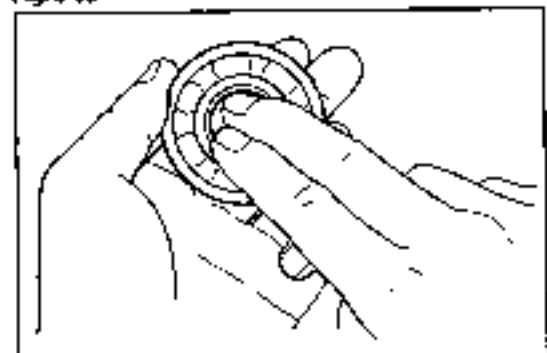

Fig. 3-60

WP-0363

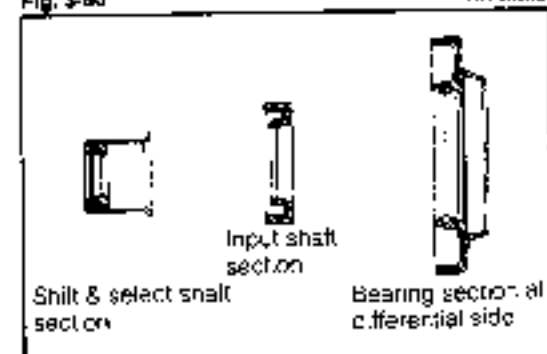

Fig. 3-61

WP-0368

MANUAL TRANSMISSION

3. Check the speedometer shaft sleeve subassembly for wear or damage.

Part	Spec'ed value mm (inch)	Limit mm (inch)
Driven gear shaft diameter ①	$6 \begin{smallmatrix} -0.02 \\ -0.002 \end{smallmatrix}$ (0.2150 $\begin{smallmatrix} -0.0008 \\ -0.0008 \end{smallmatrix}$)	7.96 (0.313)
Shaft sleeve bore ②	$8 \begin{smallmatrix} +0.002 \\ +0.002 \end{smallmatrix}$ (0.3150 $\begin{smallmatrix} +0.0008 \\ +0.0008 \end{smallmatrix}$)	8.10 (0.319)
Oil seal lip section ③	Visually inspect the section for excessive wear or damage	
"O" ring ④		
Driven gear tooth surface ⑤		

ASSEMBLY

1. Assemble the differential case.
(For the assembly procedure for each part, see page 3-47.)

2. Assemble the magnet and selecting & shifting bell crank support assembly.
(For the assembly procedure for each part, see page 3-57.)

Tightening Torque: 0.7 - 1.0 kg-m (5.1 - 7.2 ft-lb)

3. Assemble the input shaft assembly and output shaft assembly at the same time.

4. Assemble the input shaft bearing lock plate
Tightening Torque: 1.5 - 2.2 kg-m (11 - 16 ft-lb)

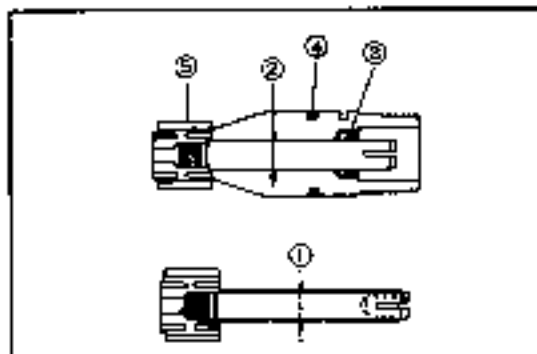

Fig. 3-62

WR-03165

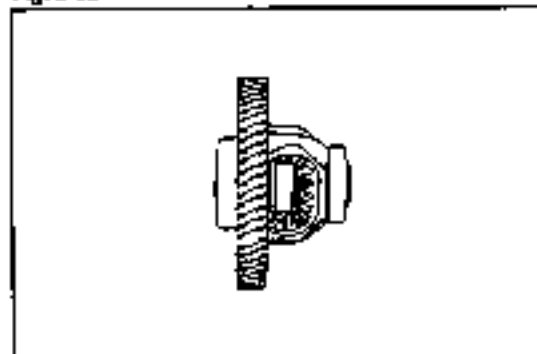

Fig. 3-63

WR-08052

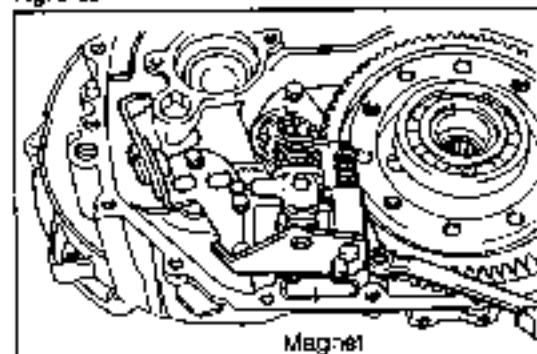

Fig. 3-64

WR-03063



Fig. 3-65

WR-03064

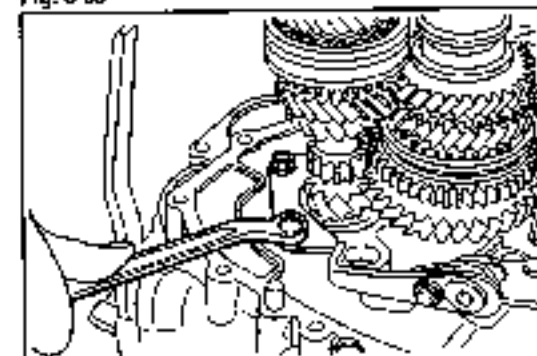

Fig. 3-66

WR-03065

5. Assemble the control linkage-related parts.
(For the assembly procedure for each part, see page 3-57.)

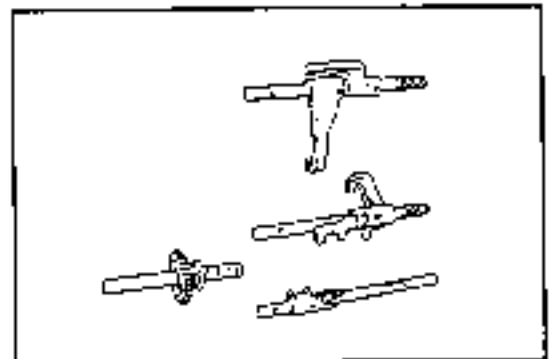

Fig. 3-67

WP-C3065

6. Install the hole snap ring in the transmission case.

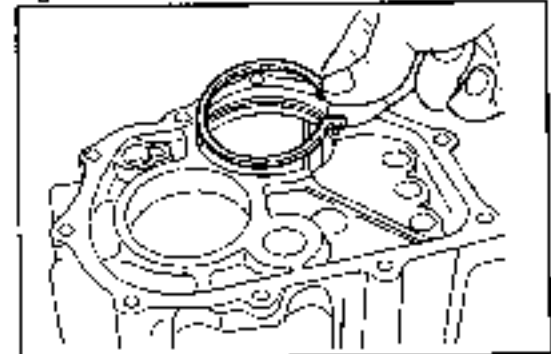

Fig. 3-68

WP-03067

7. Assemble the transmission case as follows:
(1) Apply the Three Bond sealer 1216 to the mating surface of the housing. While the hole snap ring of the bearing is held in an expanded state, assemble the transmission case in the axle case.
SST: 09905-00012-000

NOTE:

Make sure that the snap ring is fitted positively in the bearing, by raising the output shaft by your hand.

- (2) Tighten the housing attaching bolts.
Tightening Torque: 1.5 - 2.2 kg-m (11 - 16 ft-lb)

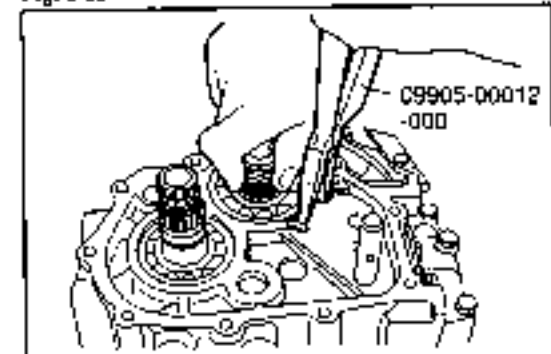

Fig. 3-69

WP-03068

8. Assemble the ball and compression spring.



Fig. 3-70

WP-03069

9. Assemble the lock ball plate and gasket as follows:
(1) Perform the assembling, using the bolts.

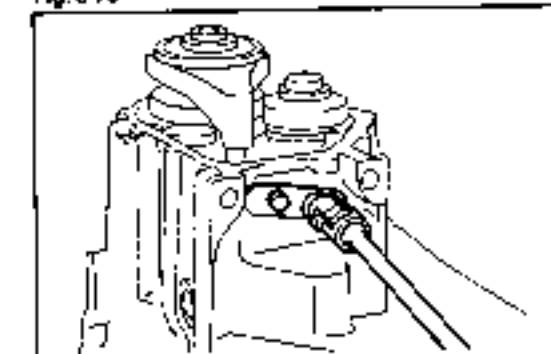

Fig. 3-71

WP-C3070

MANUAL TRANSMISSION

10. Install the case cover oil pipe as follows:

- (1) Insert the oil pipe, until its rib section comes into contact with the case.

NOTE:

The oil pipe for the 4-speed transmission differs from that for the 5-speed transmission in its overall length and tip-end shape.

Overall length:

Oil pipe for 4-speed transmission

126 mm (5.0 inch)

Oil pipe for 5-speed transmission

167 mm (6.6 inch)

11. Assemble the transmission case cover as follows:

- (1) Apply the liquid gasket sealer (Three Bond 1216) to the mating surfaces of the case, except for those hole areas. (See page 3-19.)

Tightening Torque: 0.7 - 1.0 kg-m (5.1 - 7.2 ft-lb)

12. Assemble the oil seal for speedometer shaft sleeve. Using the SST given below

SST: 09201-60011-000

13. Assemble the speedometer shaft sleeve subassembly and lock plate.

Tightening Torque: 0.7 - 1.0 kg-m (5.1 - 7.2 ft-lb)

14. Install the backup lamp switch and breather plug.

Tightening Torque

Backup Lamp Switch: 3.0 - 5.0 kg-m (22 - 36 ft-lb)

Breather Plug: 1.0 - 1.3 kg-m (7.2 - 9.4 ft-lb)

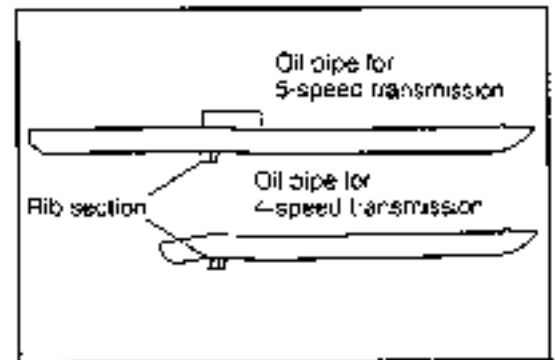

Fig. 3-72

WR-08071

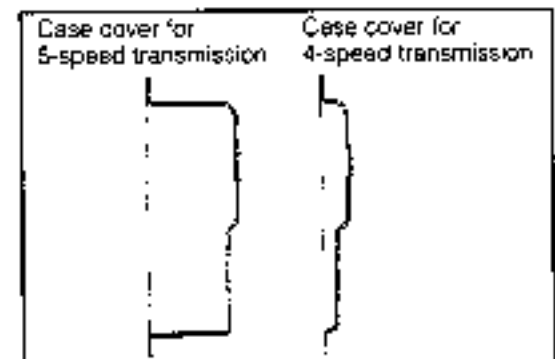

Fig. 3-73

WR-08072

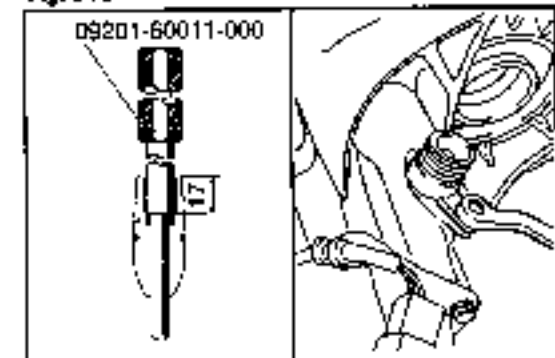

Fig. 3-74

WR-08073

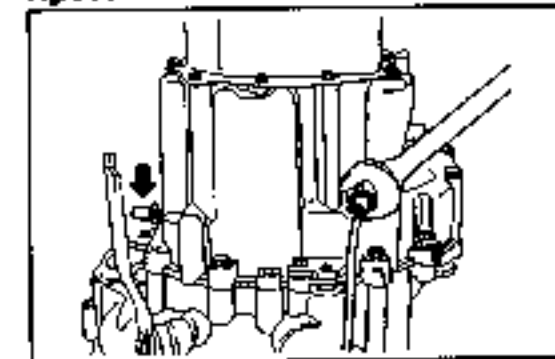

Fig. 3-75

WR-09074

15. Install the clutch cable bracket and engine mounting bracket

Tightening Torques

Clutch Cable Bracket: 1.5 - 2.2 kg-m (11 - 16 ft-lb)

Engine Mounting Bracket: 3.0 - 4.5 kg-m (22 - 33 ft-lb)

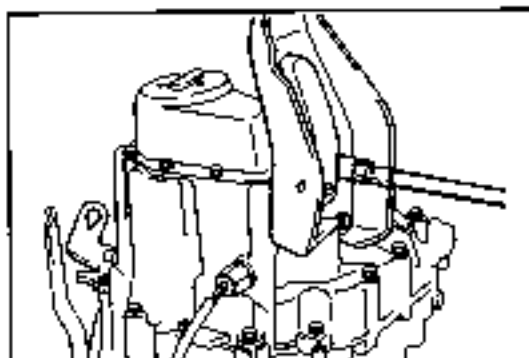

Fig. 3-76

WR 03075

16. Install the screw plugs (at the drain and filler sides).

Tightening Torque: 3.0 - 5.0 kg-m (22 - 36 ft-lb)

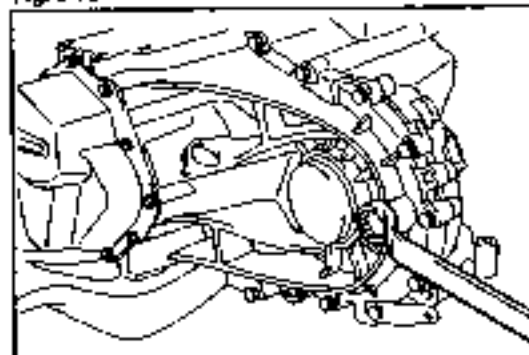
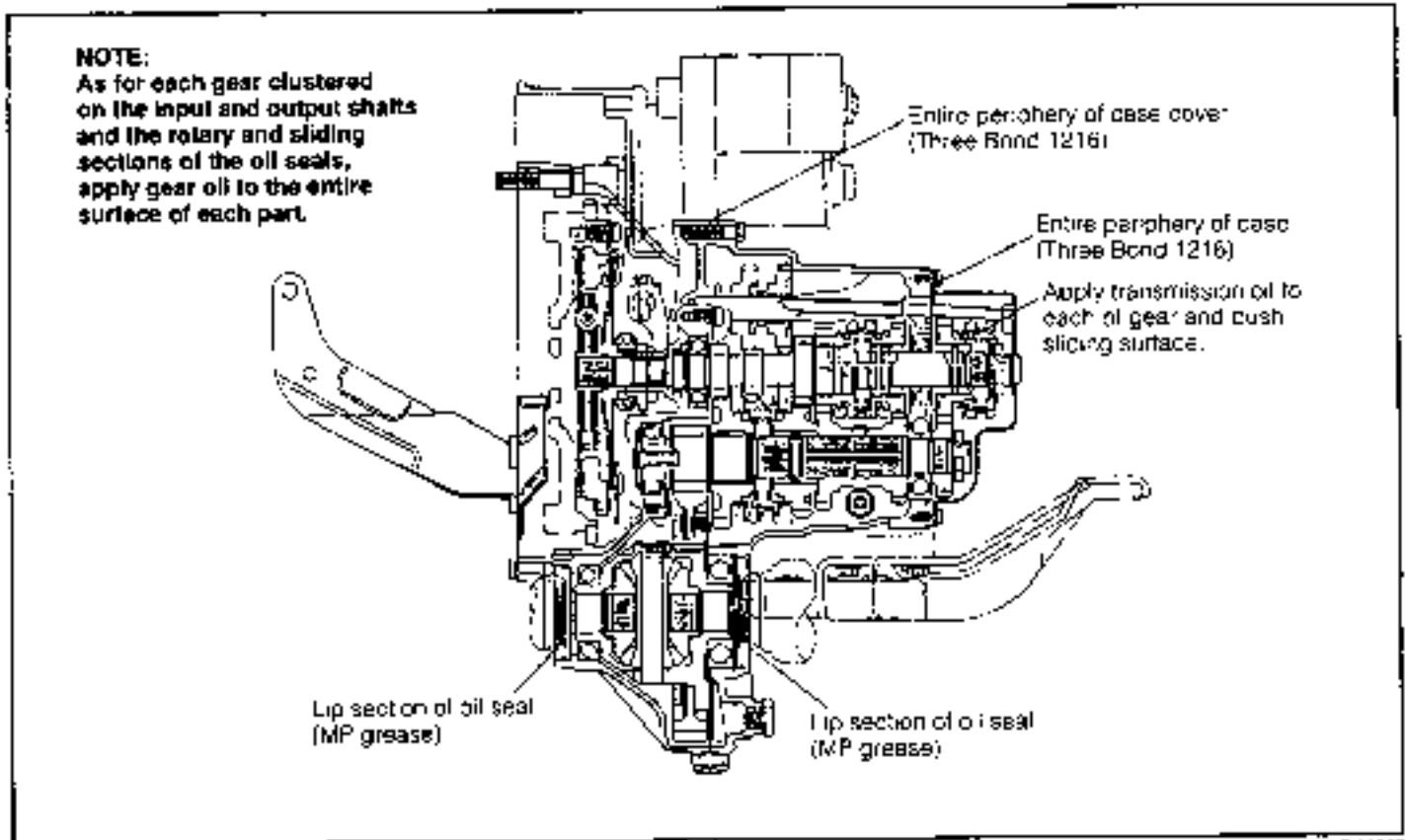

Fig. 3-77

WR 03076

MANUAL TRANSMISSION

APPLICATION POINTS OF GREASE & BOND AND APPLICATION PROCEDURE



Application Procedure for Liquid Gasket Sealer (Three Bond 1216 ... Part No. 999-0480-8U90-00)

1. Cut the first stage of the nozzle of the Daihatsu genuine sealer (Three Bond 1216) that is furnished in accessories.

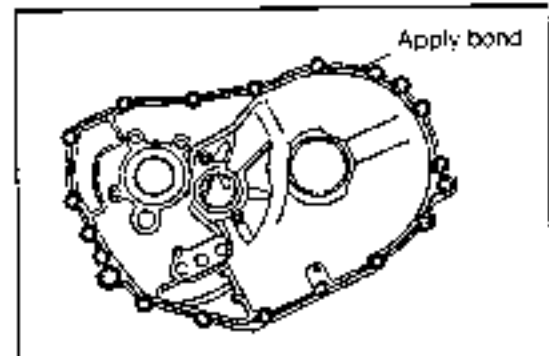
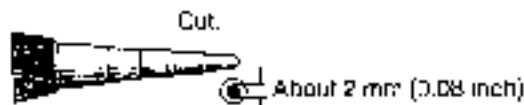

2. Remove any remaining trace of the liquid gasket that may be found on the housing or the case with thinner or a scraper. Care must be exercised not to scratch the surfaces during the cleaning.

3. Apply the liquid sealer to the entire periphery of the housing and case without any unapplied spot, as indicated in the illustration at the right.

NOTE:

1. Apply the liquid sealer to the inside of each hole, excluding those bolts holes.
2. Be sure to perform the assembling within five minutes after the application of the liquid sealer.
3. Make sure to dry the thinner completely.

NOTE:

<Handling Instructions on Liquid gasket>

1. The liquid gasket starts to cure when it reacts with the moisture in the atmosphere. Hence, upon completion of the work, be sure to expel any air trapped in the tube and tighten the tube cap securely.
2. As regards the storage place for this liquid gasket, avoid such places where high temperature or high humidity prevails or those exposed to direct sunrays. Make sure to store it in a dry, cold and dark place.
(The allowable limit for use is approximately six months.)

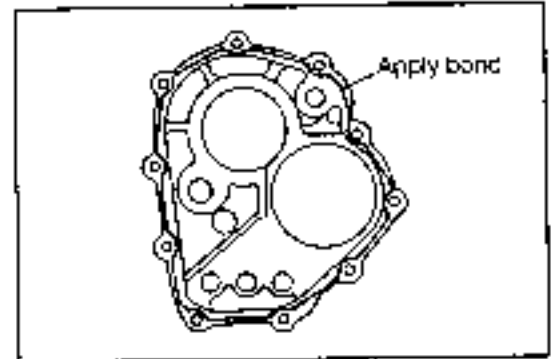

Fig. 3-80

NR-03272

DISASSEMBLY, INSPECTION AND ASSEMBLY OF INPUT SHAFT COMPONENTS

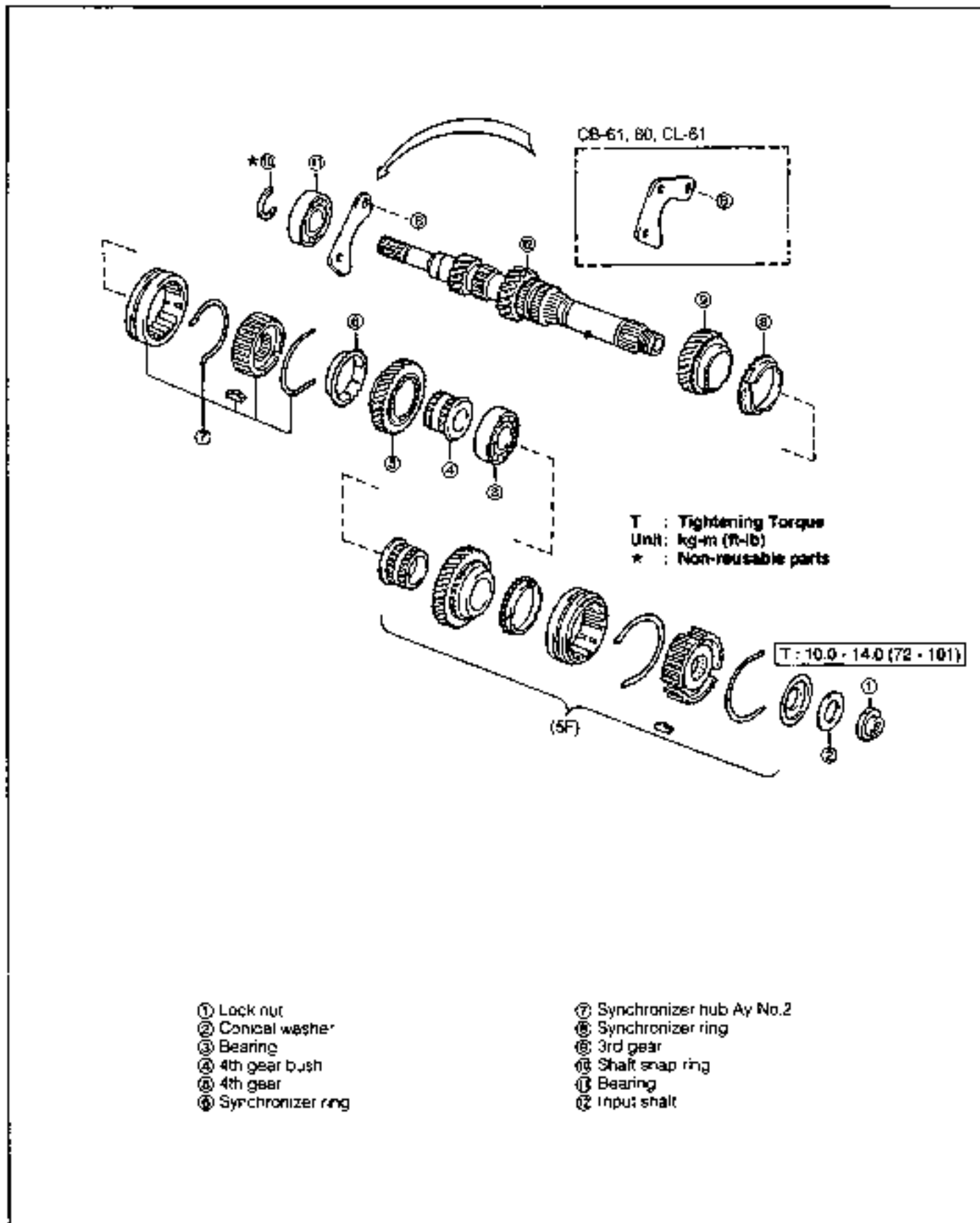

Fig. 3-61

WF-090794

Operation Prior to Disassembly

Pull out the input shaft and the output shaft at the same time from the transmission case. Proceed to the next disassembly operation (See page 3-16.)

DISASSEMBLY

1. Remove the lock nut (4-speed transmission only)
 - (1) Clamp the 1st gear section of the input shaft in a vise, making sure that no scratch is made to the clamped section.
 - (2) Release the staked section of the lock nut, using a chisel.
 - (3) Remove the lock nut.

NOTE:

For the 5-speed transmission, see page 3-39.

2. Remove the conical spring washer. Then, remove the bearing, using the SST given below.
SST: 09602-87301-000

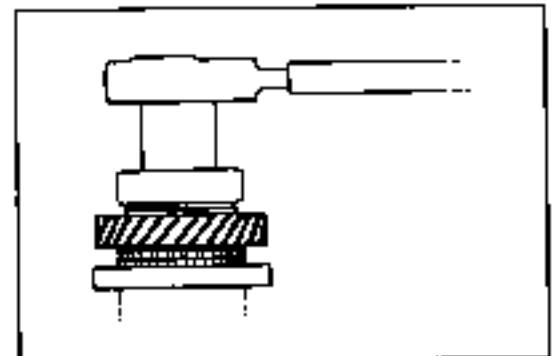

Fig. 3-82

WR-03060

3. Remove the 4th gear and 4th gear bush.

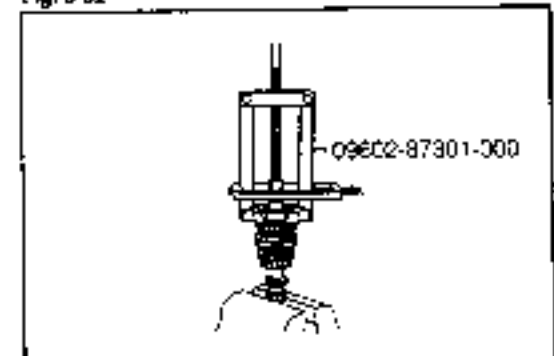

Fig. 3-83

WR-03061

4. Remove the synchronizer ring. Then, remove the synchronizer hub assembly No.2.
 - (1) Detach the two synchroneshifting springs and three synchroneshifting keys.

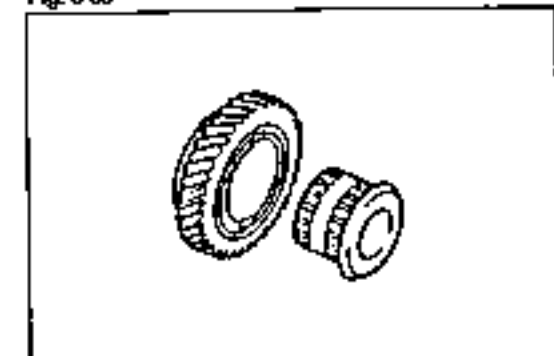

Fig. 3-84

WR-03062



Fig. 3-85

WR-03063

MANUAL TRANSMISSION

5. Remove the synchronizer ring and 3rd gear.

6. Detach the shaft snap ring, using two common screwdrivers.

NOTE:

1. Special care must be exercised as to the snap ring which may jump out during the disassembly.
2. Particular attention should be paid to avoid scratching the shaft.

7. Remove the bearing, using the SST given below.
SST: 09602-87301-000

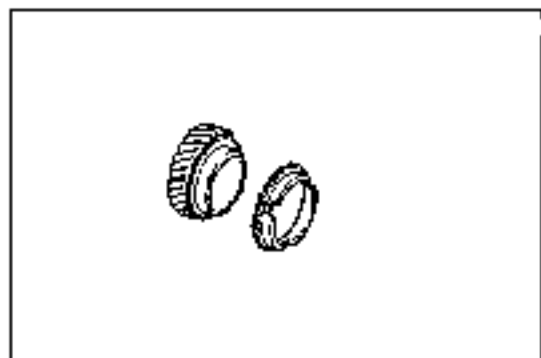

Fig. 3-86

WR-3334

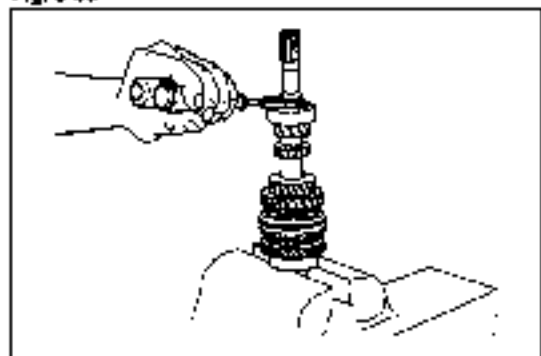

Fig. 3-87

WR-3336

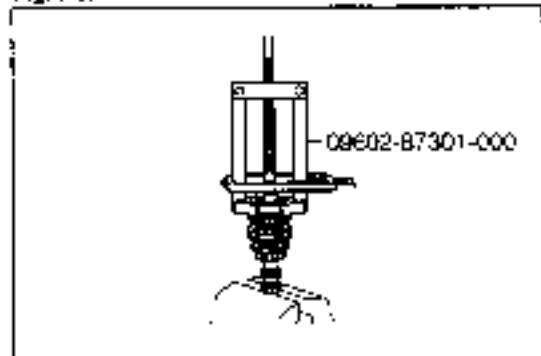

Fig. 3-88

WR-0306

INSPECTION

1. Check the 4th gear bush for wear or damage

Part	Specified value mm (inch)	Limit mm (inch)
Bore ①	25 $\begin{matrix} -0.042 \\ +0.027 \end{matrix}$ (0.9843 $\begin{matrix} +0.0017 \\ -0.0011 \end{matrix}$)	25.02 (0.985)
Outer diameter ②	37 $\begin{matrix} -0.040 \\ +0.060 \end{matrix}$ (1.4567 $\begin{matrix} -0.0016 \\ +0.0024 \end{matrix}$)	36.89 (1.452)
Overall length ③	29 ± 0.03 (1.1417 ± 0.0012)	28.97 (1.141)
Thickness of flange section ④	3 ± 0.06 (0.1181 ± 0.0024)	2.94 (0.116)

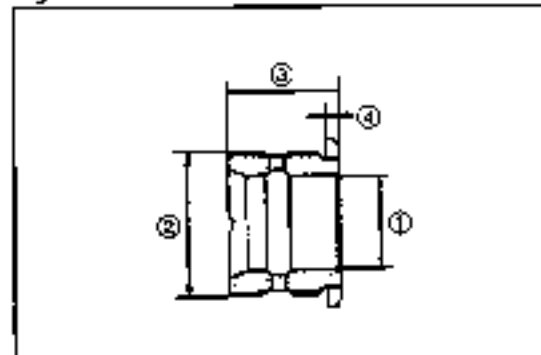

Fig. 3-89

WR-0365

2. Check each gear for wear or damage

Part	Specified value mm (inch)		Limit mm (inch)	
	Bore ①	Width ②	Bore ①	Width ②
3rd gear (input)	$37 \begin{smallmatrix} +0.025 \\ -0.030 \end{smallmatrix}$ (1.4567 $\begin{smallmatrix} +0.0010 \\ -0.0012 \end{smallmatrix}$)	$27.5 \begin{smallmatrix} +0.020 \\ -0.025 \end{smallmatrix}$ (1.0827 $\begin{smallmatrix} +0.0008 \\ -0.0010 \end{smallmatrix}$)	37.05 (1.459)	27.2 (1.071)
4th gear (input)	$37 \begin{smallmatrix} +0.025 \\ -0.030 \end{smallmatrix}$ (1.4567 $\begin{smallmatrix} +0.0010 \\ -0.0012 \end{smallmatrix}$)	$26 \begin{smallmatrix} +0.020 \\ -0.025 \end{smallmatrix}$ (1.0236 $\begin{smallmatrix} +0.0008 \\ -0.0010 \end{smallmatrix}$)	37.05 (1.459)	25.7 (1.012)
Splined section	Visually inspect the section for excessive damage or wear			
Gear section ③				
Tapered section ④				
Both edge surfaces of gear ⑤				
Fitting section with nut sleeve ⑥	Inspect the section for excessive play, nick or rounded edge			

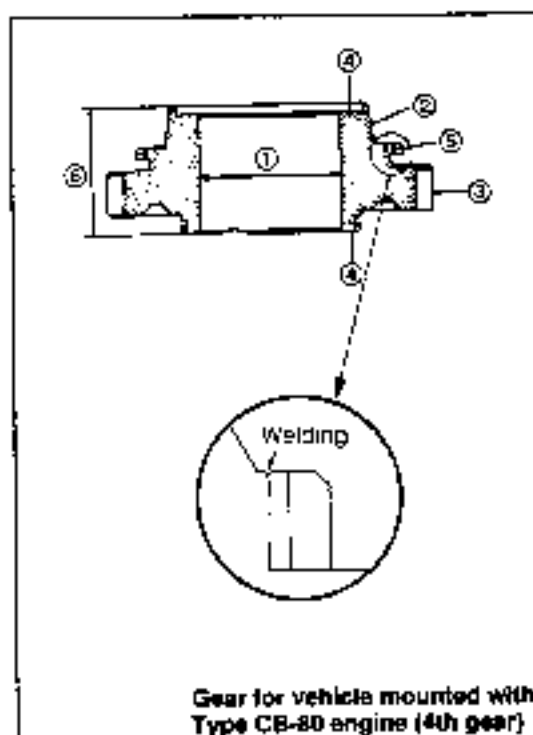

Fig. 3-90

WR-03028

3. Check the clutch hub and sleeve for the 3rd & 4th gear use for wear or damage.

Clutch Hub

Part	Limit
Splined section ①	Visually inspect the section for excessive damage or wear
Synchroneshifting key fitting groove ②	
With the hub fitted into the sleeve, check for excessive looseness in up-&-down direction and slant of the hub and sleeve.	

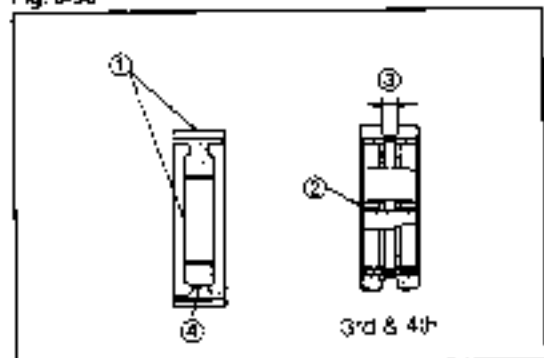

Fig. 3-81

WR-03028

Sleeve

Part	Specified value mm (inch)	Limit mm (inch)
Shift fork groove width ③	$7.0 \begin{smallmatrix} +0.12 \\ -0.05 \end{smallmatrix}$ (0.276 $\begin{smallmatrix} +0.005 \\ -0.002 \end{smallmatrix}$)	7.3 (0.287)
Fitting section with gear ④	Visually inspect the section for excessive damage, wear, nick or rounded edge.	

4. Check the input shaft for wear or damage.

Part	Specified value mm (inch)	Limit mm (inch)
Outer diameter of bush bore-contact-section ①	$25 \begin{smallmatrix} +0.015 \\ +0.002 \end{smallmatrix}$ (0.9843 $\begin{smallmatrix} +0.0006 \\ +0.0001 \end{smallmatrix}$)	24.99 (0.984)
Tooth surfaces of gear and spline	Visually inspect the surface for excessive damage, wear, nick or rounded edge	

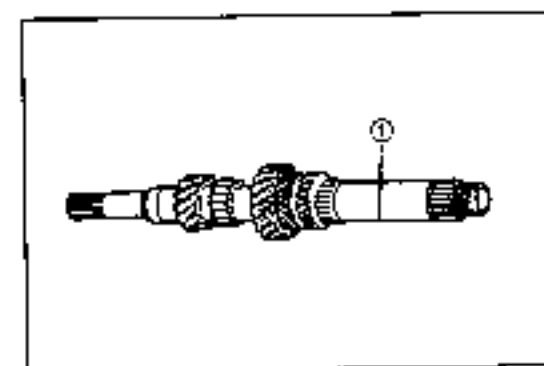

Fig. 3-92

WR-03028

MANUAL TRANSMISSION

5. Check the synchromesh shifting key and key spring for wear or damage.

Part	Specified value mm (inch)	Limit mm (inch)
Key for 3rd & 4th gear (dimension H)	5.0 ± 0.04 (0.197 ± 0.0016)	4.3 (0.169)
Spring	① Visually inspect the spring for damage or distortion.	

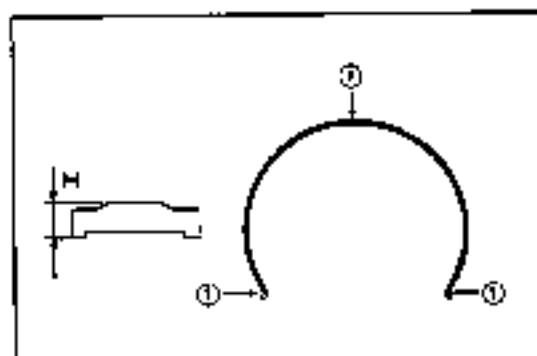

Fig. 3-93

WR-0309

6. Check the synchronizer ring for wear or damage.

Part	Specified value mm (inch)	Limit mm (inch)
Gap when synchronizer ring is pressed to gear	3rd and 4th gears 0.85 - 1.45 (0.034 - 0.06)	0.5 (0.020)
Damage at inner tapered section	Visually inspect the section for excessive damage.	
Damage at spline		

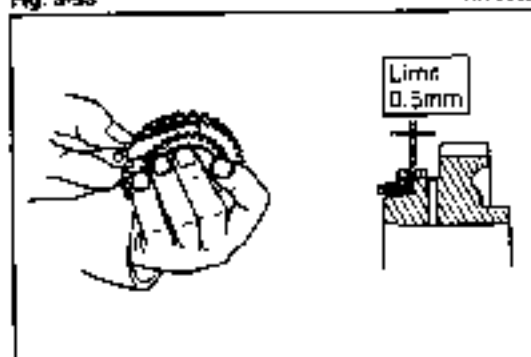

Fig. 3-94

WR-0309

7. Check the bearing for wear or damage.

Part	Inspection criteria
Bearing	When the inner race is rotated by your fingers, it should rotate smoothly without any binding.

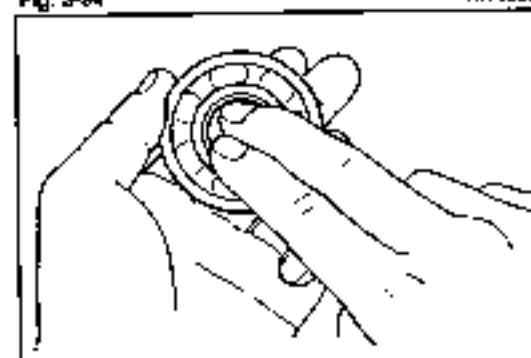

Fig. 3-95

WR-0309

ASSEMBLY

1. Apply gear oil to the entire surface of the rotary or sliding section of each gear of the input shaft.

NOTE:

The overall length of the input shaft differs depending upon the transmission type. Hence, special care must be exercised as to its overall length.

Transmission type	Overall length mm (inch)	Presence of splines at section A
4-Speed	269 (10.59)	No
5-Speed	311 (12.24)	Yes

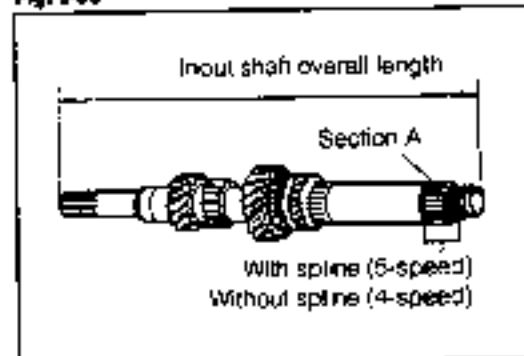

Fig. 3-96

WR-0309

2. Assemble the bearing, using the SST given below
 SST: 09309-87201-000

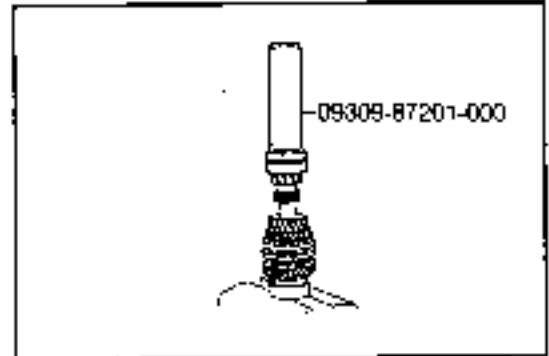

Fig. 3-97

WR-03035

3. Drive a new snap ring into position, using a common screwdriver.
 For easier installation, hold the snap ring with the SST given below.

SST: 09309-87201-000

NOTE:

Be very careful not to scratch the shaft.

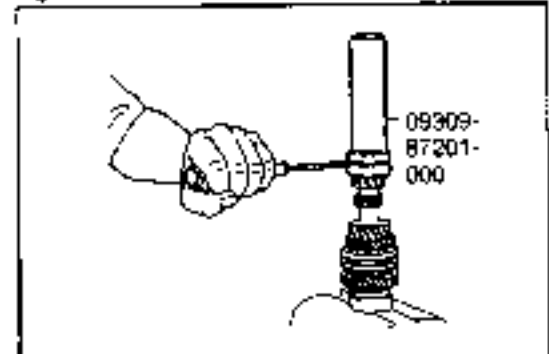

Fig. 3-98

WR-03035

4. Assemble the 3rd gear.



Fig. 3-99

WR-03037

5. Assemble the synchronizer ring and synchronizer hub assembly No.2.

- (1) Assemble the clutch and sleeve. Ensure that both parts can slide smoothly.
 (2) Assemble the shifting keys and springs.

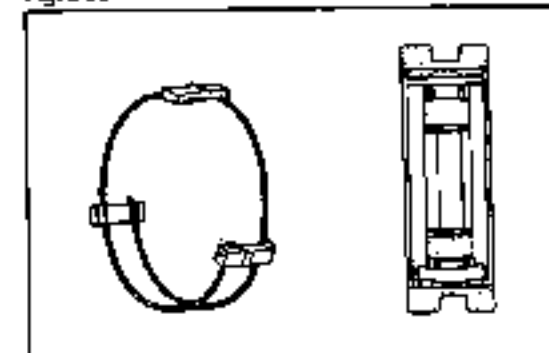

Fig. 3-100

WR-03038

6. Assemble the synchronizer ring and 4th gear.

7. Assemble the 4th gear bush

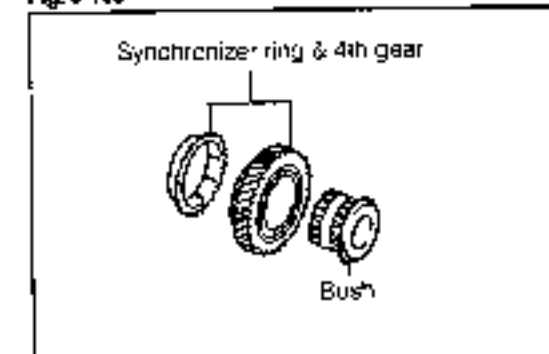

Fig. 3-101

WR-03039

MANUAL TRANSMISSION

8. Assemble the bearing using the SST given below.
SST: 09309-87201-000

NOTE:

On the 5-speed transmission, measure the end play of each gear after the bearing has been assembled.
(See page 3-43.)

9. Assemble the conical spring washer and lock nut.
(4-speed transmission)

- (1) Install the conical spring in such a way that its expanded side may face toward the shaft side.
- (2) Clamp the reduction gear section in a vise, making sure that no scratch may be made to the section.
- (3) Tighten the lock nut.
Tightening Torque: 10.0 - 14.0 kg-m (72 - 101 ft-lb)

10. Upon completion of the assembly, measure the end play of each part of the input shaft.

Part	Specified value mm(inch)	Limit mm (inch)
2nd gear ①	0.1 - 0.23 (0.0039 - 0.0091)	0.4 (0.016)
4th gear ②		

NOTE:

If the end play does not comply with the specification, check the gear, bush and clutch hub sliding section. Replace any parts which exhibit defects.

11. Stake the lock nut, using a chisel.

NOTE:

Be sure to stake the central part of the lock nut so as to avoid dislocation or cracks.

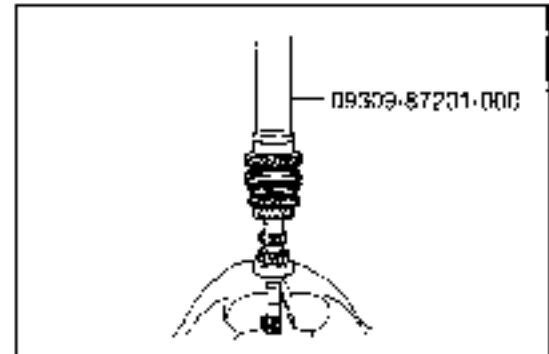

Fig. 3-102

WR-03100

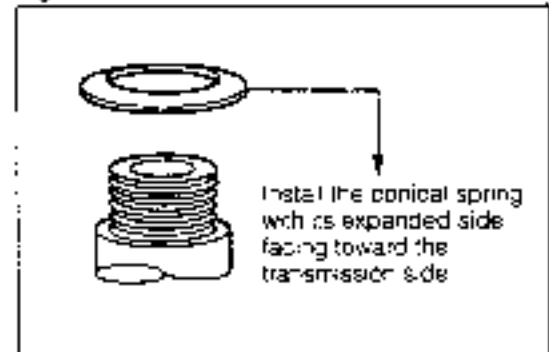

Fig. 3-103

WR-03100

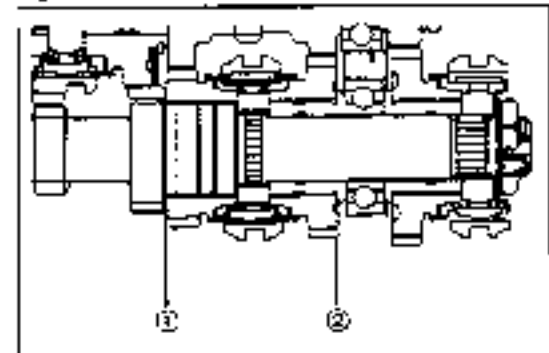

Fig. 3-104

WR-03100

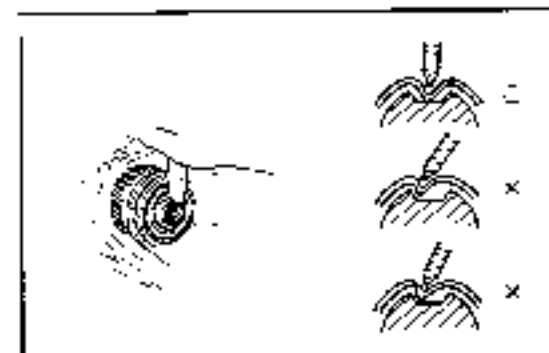
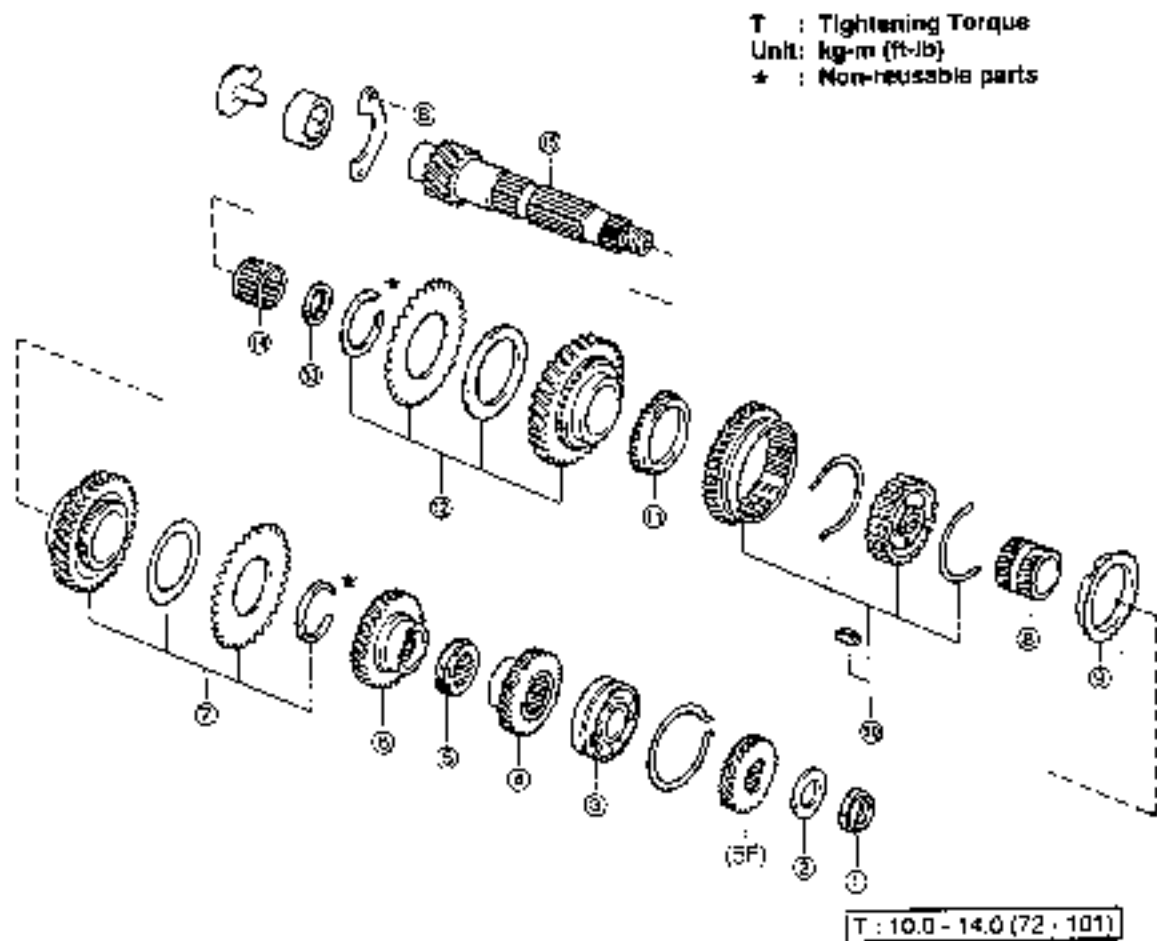

Fig. 3-105

WR-03100

DISASSEMBLY, INSPECTION AND ASSEMBLY OF OUTPUT SHAFT COMPONENTS



- ① Lock nut
- ② Conical spring washer
- ③ Bearing
- ④ Output 4th gear
- ⑤ Speedometer drive gear
- ⑥ Output 3rd gear
- ⑦ 2nd gear Ay
- ⑧ Bush

- ⑨ Synchronizer ring No.3
- ⑩ Synchronizer hub Ay
- ⑪ Synchronizer ring No.3
- ⑫ 1st gear Ay
- ⑬ Washer
- ⑭ Needle roller bearing
- ⑮ Output shaft

Fig. 3-106

WR 307034

MANUAL TRANSMISSION

Operation Prior to Disassembly

Pull out the output shaft and the input shaft at the same time from the transmission case. Proceed to the next disassembly operation. (See page 3-53.)

DISASSEMBLY

1. Remove the lock nut. (4-speed transmission only)
 - (1) Clamp the reduction gear section of the output shaft in a vise, making sure that no scratch is made to the clamped section.
 - (2) Release the staked section of the lock nut, using a chisel.
 - (3) Remove the lock nut.

NOTE:

For the 5-speed transmission, see page 3-39.

2. Remove the conical spring washer. Then remove the bearing, using the SST given below.

SST: 09602-87301-000

3. Remove the output 4th gear, speedometer drive gear and output 3rd gear.

4. Remove the 2nd gear assembly
 - (1) Detach the shaft snap ring, using the SST given below.
SST: 09905-00012-000
 - (2) Remove the 2nd subgear.
 - (3) Remove the conical spring washer.

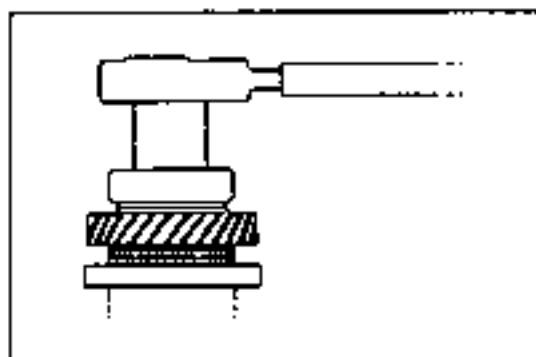

Fig. 3-107

WR-03104

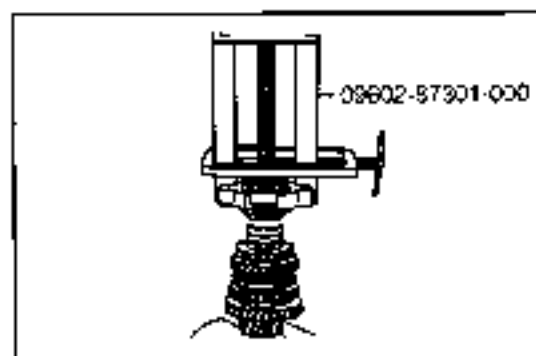

Fig. 3-108

WR-03105

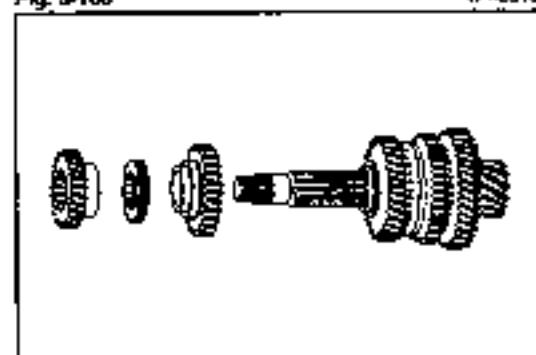

Fig. 3-109

WR-03106

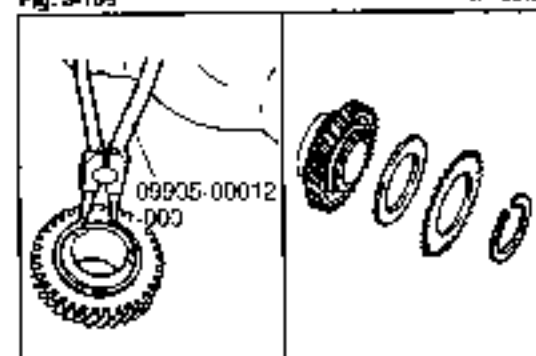

Fig. 3-110

WR-03107

5. Remove the 2nd gear bush and synchronizer ring No.3.

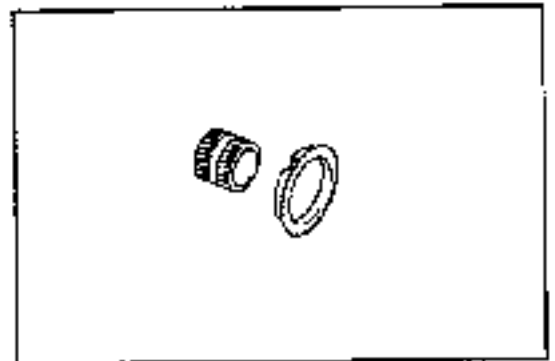

Fig. 3-111

WF-03-08

6. Remove the synchronizer hub assembly No.2
 (1) Remove the two synchromesh shifting key springs and three synchromesh shifting keys.
 7. Remove the synchronizer ring No.3



Fig. 3-112

WF-03108

8. Remove the 1st gear assembly.
 (1) Detach the shaft snap ring, using the SST given below.
 SST: 09905-00012-000
 (2) Remove the 1st subgear.
 (3) Remove the conical spring washer.

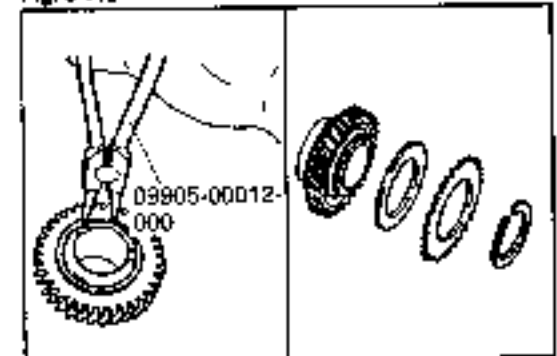

Fig. 3-113

WF-03110

9. Remove the spacer and needle roller bearing.

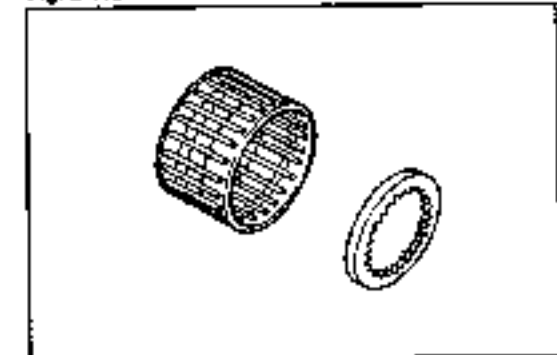

Fig. 3-114

WF-03111

MANUAL TRANSMISSION

INSPECTION

- 1 Check the 2nd gear bush for wear or damage.

Part	Specified value mm (inch)	Limit mm (inch)
Bore ①	$29 \begin{smallmatrix} -0.115 \\ -0.135 \end{smallmatrix}$ (1.1417 $\begin{smallmatrix} -0.0045 \\ -0.0053 \end{smallmatrix}$)	28.84 (1.135)
Outer diameter ②	$37 \begin{smallmatrix} -0.040 \\ -0.060 \end{smallmatrix}$ (1.4567 $\begin{smallmatrix} -0.0016 \\ -0.0024 \end{smallmatrix}$)	36.69 (1.4524)
Overall length ③	32.5 ± 0.03 (1.2795 ± 0.0012)	32.47 (1.2783)

2. Check each gear for wear or damage

Part	Specified value mm (inch)		Limit mm (inch)	
	Bore ①	Width ②	④ Bore	⑤ Width
1st gear (output)	$37 \begin{smallmatrix} -0.040 \\ -0.060 \end{smallmatrix}$ (1.4567 $\begin{smallmatrix} -0.0016 \\ -0.0024 \end{smallmatrix}$)	$52.5 \begin{smallmatrix} -0.20 \\ -0.27 \end{smallmatrix}$ (1.2795 $\begin{smallmatrix} -0.0079 \\ -0.0106 \end{smallmatrix}$)	37.05 (1.459)	32.2 (1.268)
2nd gear (output)	$37 \begin{smallmatrix} -0.040 \\ -0.060 \end{smallmatrix}$ (1.4567 $\begin{smallmatrix} -0.0016 \\ -0.0024 \end{smallmatrix}$)	$32.5 \begin{smallmatrix} -0.13 \\ -0.20 \end{smallmatrix}$ (1.2795 $\begin{smallmatrix} -0.0051 \\ -0.0079 \end{smallmatrix}$)	37.05 (1.459)	32.2 (1.268)
Splined section Tapered section ③	Visually inspect the section for excessive damage or wear			
Gear sector ④	Visually inspect the section for excessive damage or wear			
Both edge surfaces of gear ⑤	Visually inspect the section for excessive damage or wear			
Fitting section with hub sleeve ⑥	Inspect the section for excessive play, nick or rounded edge.			

*30.5 $\begin{smallmatrix} -0.20 \\ -0.27 \end{smallmatrix}$ for GTII mode
(* 200 $\begin{smallmatrix} -0.0079 \\ -0.0106 \end{smallmatrix}$)

- 3 Check the clutch hub for the 1st & 2nd gears and reverse gear for wear or damage.

Clutch Hub

Part	Limit
Splined section ①	visually inspect the section for excessive damage or wear.
Synchronesh shifting key fitting groove ②	
With the hub fitted into the sleeve, check for excessive looseness in up- & down direction and slant of the hub and sleeve	

Reverse Gear

Part	Specified value mm (inch)	Limit mm (inch)
Shift fork groove width ③	$7.0 \begin{smallmatrix} \pm 0.12 \\ \pm 0.05 \end{smallmatrix}$ (3.276 $\begin{smallmatrix} \pm 0.0047 \\ \pm 0.0020 \end{smallmatrix}$)	7.3 (0.287)
Fitting section with gear ④	Visually inspect the section for excessive damage, wear, nick or rounded edge	
Reverse gear tooth surface ⑤	Visually inspect the section for excessive damage, wear, nick or rounded edge	

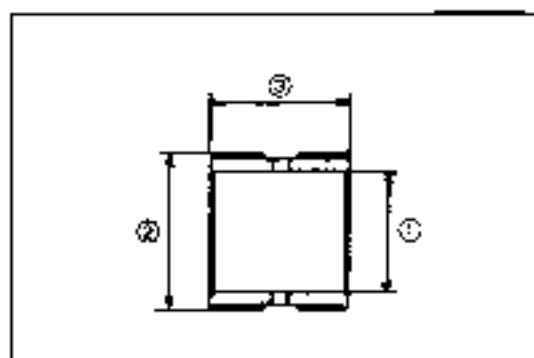

Fig. 3-115

WP-03-12

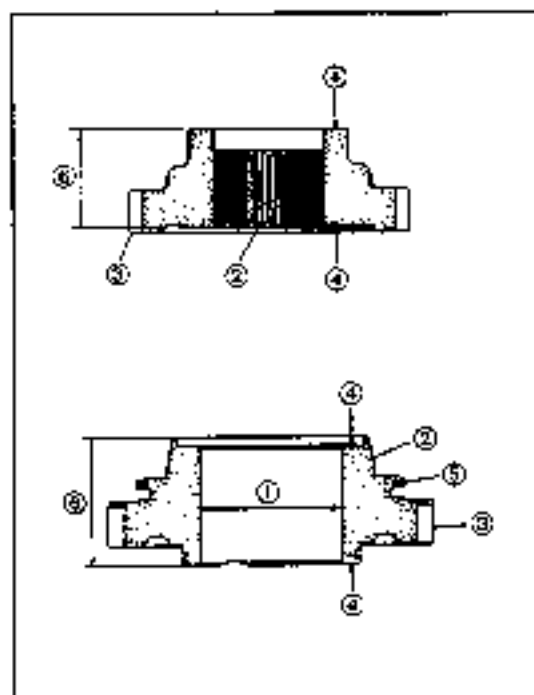

Fig. 3-116

WP-03-13

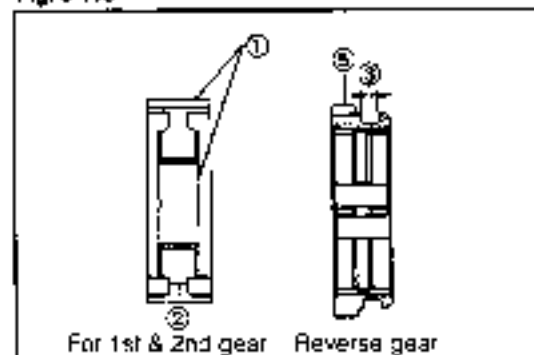

Fig. 3-117

WP-03-14

4. Check the output shaft for wear or damage.

Part	Specified value mm (inch)	Limit mm (inch)
Outer diameter of the needle roller bearing-contact-section	① 30 ± 0.02 (1.1811 ± 0.0008)	29.96 (1.1795)
	② 32 ± 0.03 (1.2598 ± 0.0012)	31.96 (1.2583)
Tooth surfaces of gear and spline	Visually inspect the surface for excessive damage, wear, nick or rounded edge.	

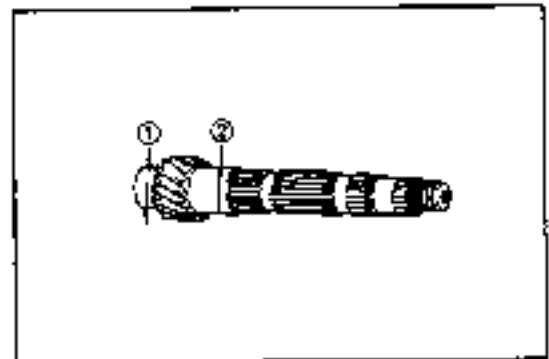

Fig. 3-118

WR-09-118

5. Check the synchromesh shifting key and key spring for wear or damage

Part	Specified value mm (inch)	Limit mm (inch)
Shifting key for 1st & 2nd gears (dimension F)	5.1 ± 0.1 (0.2008 ± 0.0039)	4.7 (0.185)
Spring	①	Visually inspect the spring for damage or distortion

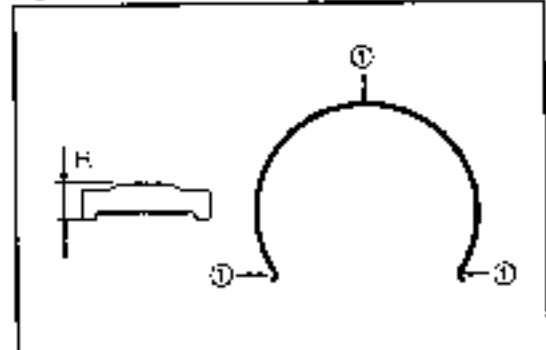

Fig. 3-119

WR-09-119

6. Check the 1st and 2nd subgears and conical spring washer for damage or wear. (Except for vehicles mounted with Type CB-80 engine)

Part	Specified value mm (inch)	Limit mm (inch)
Bore of subgear	① 47 ± 0.2 (1.8504 ± 0.0079)	47.5 (1.870)
Subgear-to-conical spring washer sliding surface	②	Visually inspect the surface for damage or distortion.

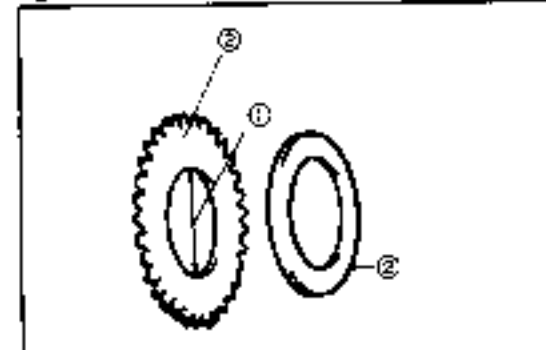

Fig. 3-120

WR-09-120

7. Check the synchronizer ring for wear or damage

Part	Specified value mm (inch)	Limit mm (inch)
Gap when synchronizer ring is pressed to gear	1st and 2nd gears $0.85 - 1.45$ (0.0335 - 0.0571)	0.5 (0.020)
Damage at inner tapered section	Visually inspect the section for excessive damage	
Damage at spline		

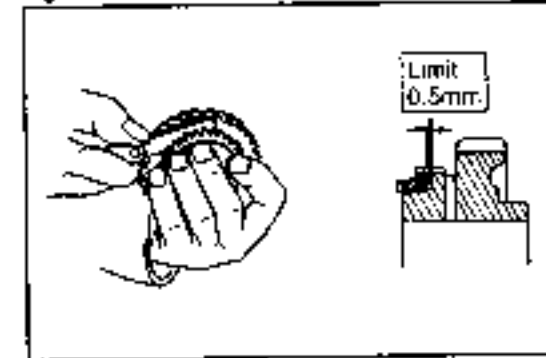

Fig. 3-121

WR-09-121

8. Check the bearing for wear or damage.

Part	Inspection criteria
Bearing	When the inner race is rotated by your fingers, it should rotate smoothly without any binding.

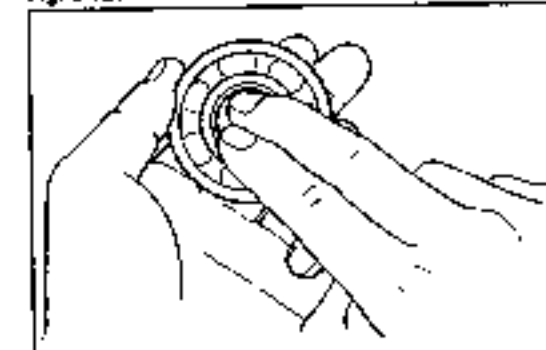

Fig. 3-122

WR-09-122

MANUAL TRANSMISSION

ASSEMBLY

NOTE:

Apply gear oil to the entire surface of the rotary or sliding section of each gear of the output shaft.

1. Assemble the needle roller bearing and spacer.
2. Assemble the 1st gear assembly.
 - (1) Install the conical spring in such a way that its expanded side may face toward the subgear side.
 - (2) Assemble the 1st subgear
 - (3) Assemble a new snap ring, using the SST given below
SST: 09905-00012-000
3. Assemble the synchronizer ring No.3.
4. Assemble the synchronizer hub assembly.
 - (1) Assemble the hub clutch and reverse gear. Ensure that both parts can slide smoothly.
 - (2) Assemble the shifting keys and springs.
5. Assemble the synchronizer ring No.3 and 2nd gear bush.
6. Assemble the 2nd gear assembly.
 - (1) Install the conical spring in such a way that its expanded side may face toward the subgear side.
 - (2) Assemble the 2nd subgear.
 - (3) Assemble a new snap ring, using the SST given below
SST: 09905-00012-000

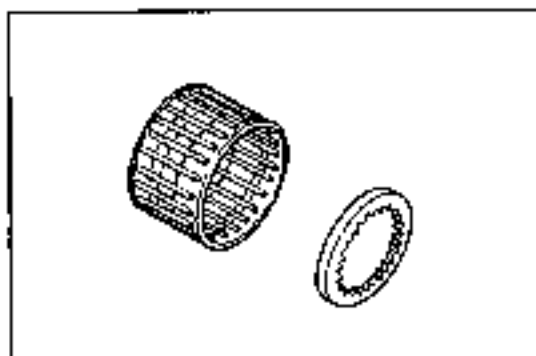

Fig. 3-123

WR-03120

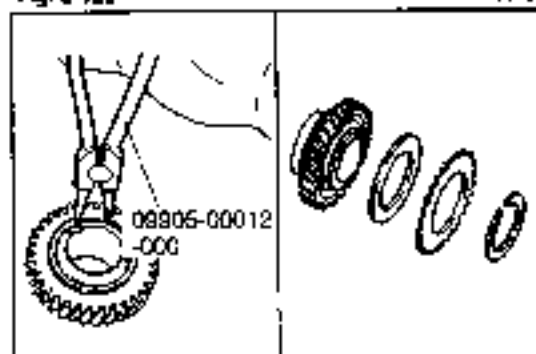

Fig. 3-124

WR-03121

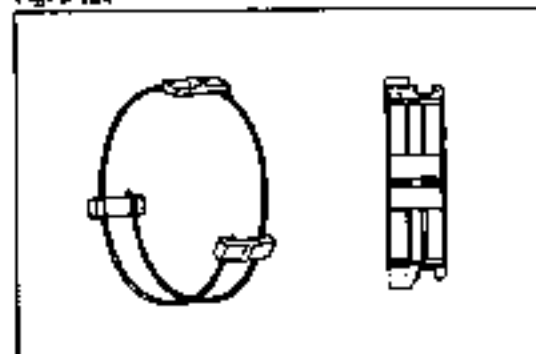

Fig. 3-125

WR-03122

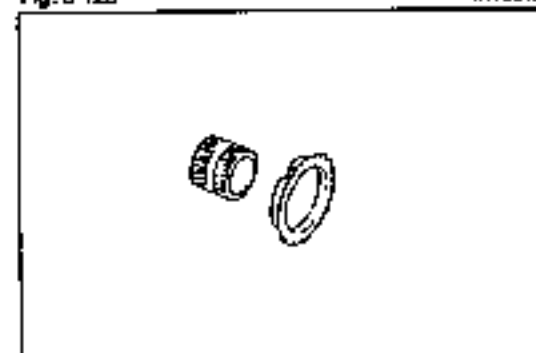

Fig. 3-126

WR-03123

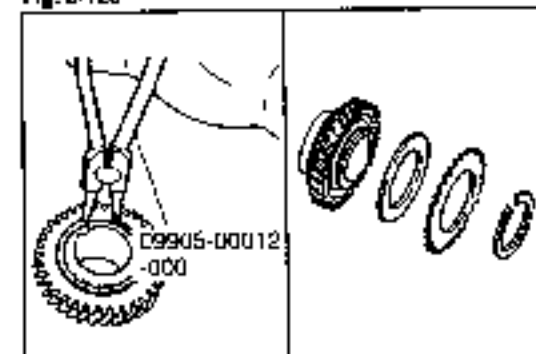

Fig. 3-127

WR-03124

7. Assemble the output 3rd gear, speedometer drive gear and output 4th gear.

NOTE:

The number of the speedometer drive gear teeth differs depending upon the gear reduction ratio. Hence, care must be exercised as to the number of gear teeth during the assembly. (See page 3-3.)

Apply gear oil to the entire surface of the rotary or sliding section of each gear.

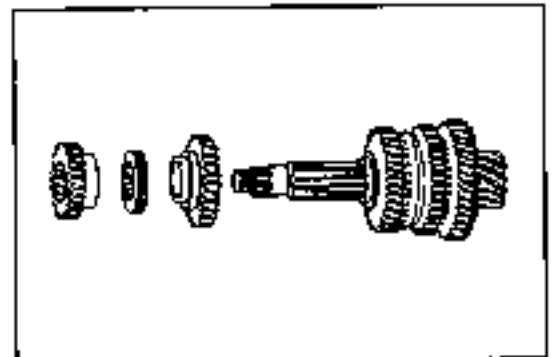

Fig. 3-128

WP-03128

8. Assemble the bearing, using the SST given below.
SST: 09309-87201-000

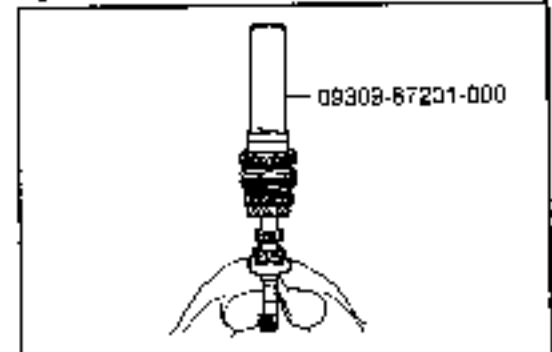

Fig. 3-129

WR-03129

9. Assemble the conical spring washer and lock nut.
(4-speed transmission)

- (1) Install the conical spring in such a way that its expanded side may face toward the gear side.
- (2) Clamp the reduction gear section in a vise, making sure that no scratch may be made to the section.
- (3) Tighten the lock nut

Tightening Torque: 10.0 - 14.0 kg-m (72 - 101 ft-lb)

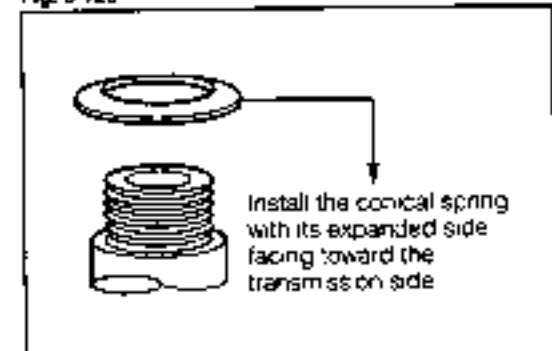

Fig. 3-130

WR-03127

10. Upon completion of the assembly, measure the end play of each part of the output shaft.

Part	Specified value mm(inch)	Limit mm (inch)
1st gear ①	0.1 - 0.37 (0.0039 - 0.0146)	0.5 (0.020)
3rd gear ②		

NOTE:

If the end play does not comply with the specification, check the gear, bush and clutch hub sliding section. Replace any parts which exhibit defects.

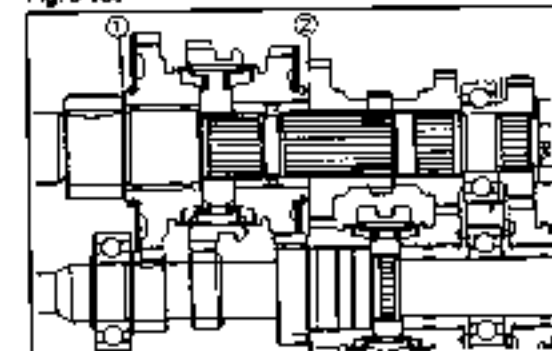

Fig. 3-131

WR-09128

11. Stake the lock nut, using a chisel.

NOTE:

Be sure to stake the central part of the lock nut so as to avoid dislocation or cracks.

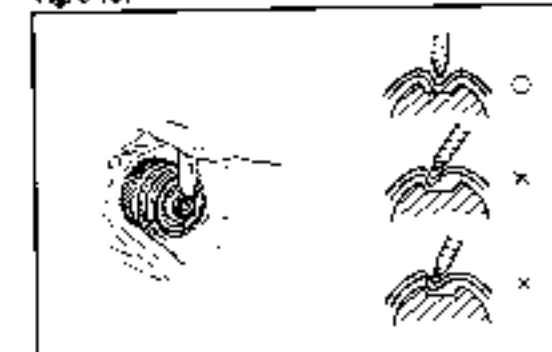
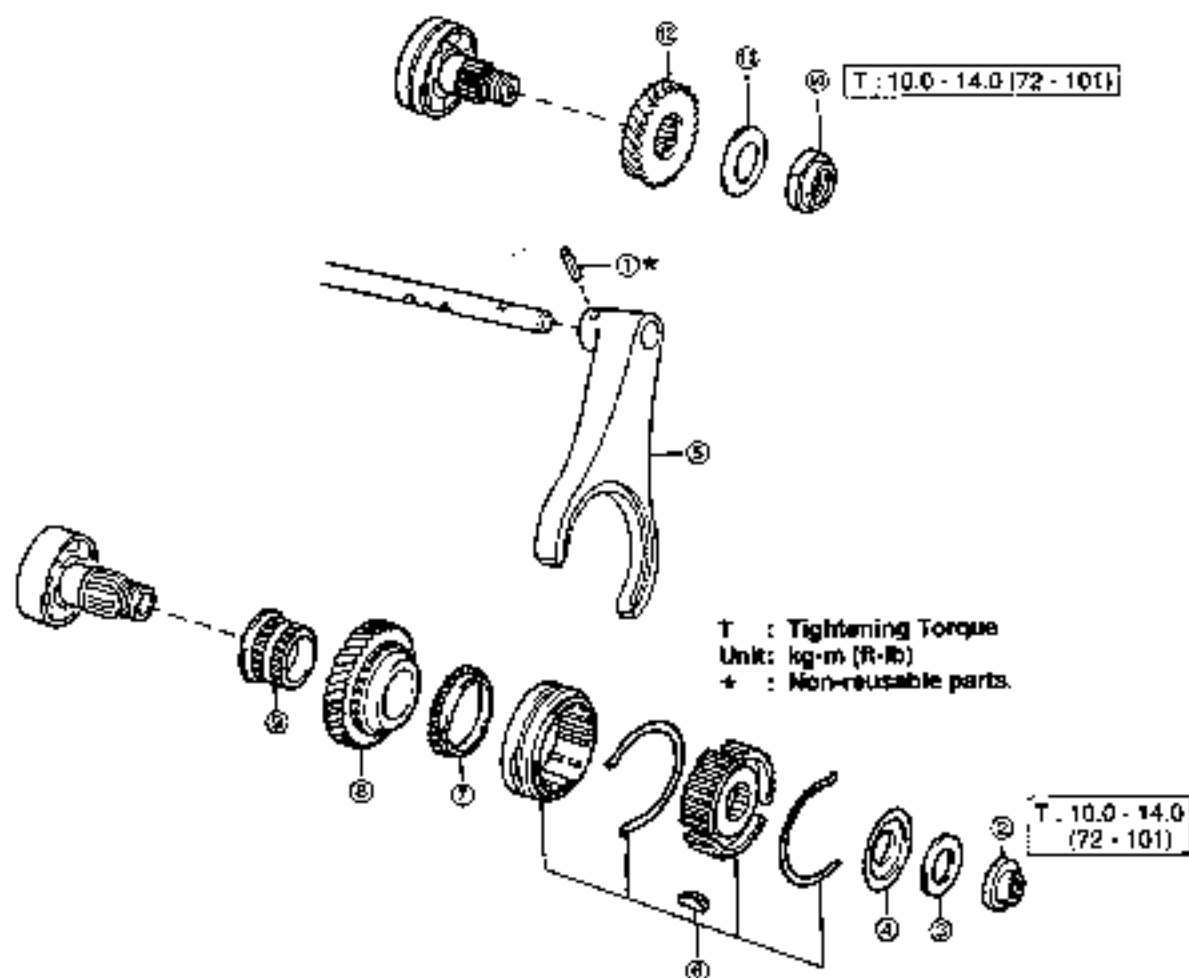

Fig. 3-132

WR-08129

DISASSEMBLY, INSPECTION AND ASSEMBLY OF 5TH GEAR COMPONENTS



- ① Splined spring pin
- ② Lock nut
- ③ Conical spring washer
- ④ Transmission hub sleeve stopper
- ⑤ 5th shift fork
- ⑥ Transmission clutch No 3 hub Ay

- ⑦ Synchronizer ring
- ⑧ 5th gear
- ⑨ 5th gear bush
- ⑩ Lock nut
- ⑪ Conical spring washer
- ⑫ Output 5th gear

Fig. 3-133

vfr-01294

DISASSEMBLY

1. Remove the slotted spring pin.

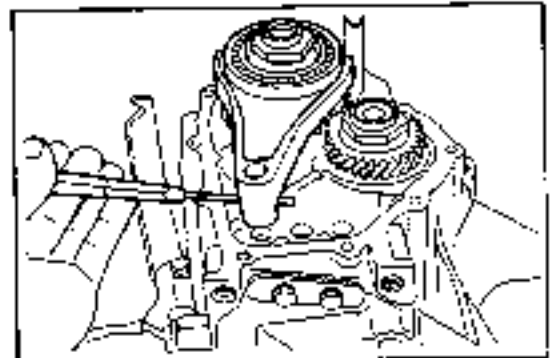

Fig. 3-134

WR-09120

2. Remove the lock nut

- (1) Lock the input shaft, using the recommended tool for this application. (See page 3-66)
- (2) Release the staked lock nut, using a chisel

NOTE:

Be very careful not to damage the threaded portion of the input shaft.

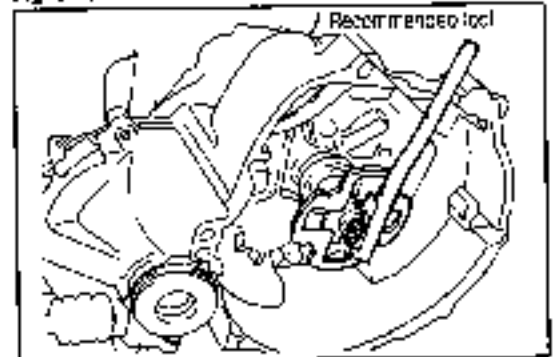

Fig. 3-135

WR 0313

- (3) Remove the lock nut at the input shaft, using a socket whose width across flats is 32 mm.
- (4) Set the sleeve for 5th gear to the 5th gear position.
- (5) Remove the lock nut at the output shaft side.

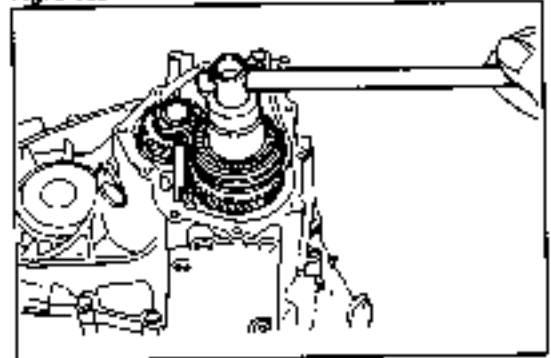

Fig. 3-136

WR-06132

3. Remove the conical spring washer at the input shaft side and transmission hub sleeve stopper

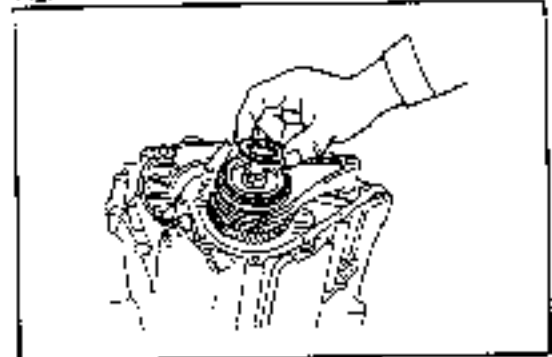

Fig. 3-137

WR-00133

4. Remove the 5th shift fork and transmission clutch hub assembly No.3.

- (1) Remove the 5th shift fork and transmission clutch hub assembly No.3 at the same time

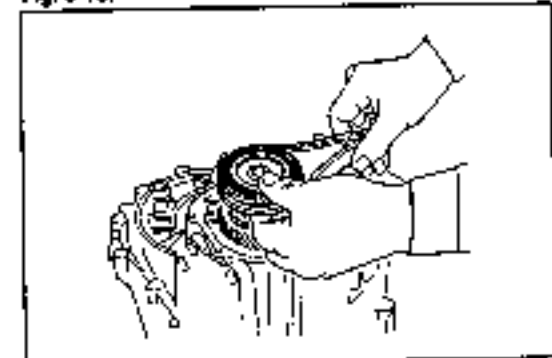

Fig. 3-138

WR-06134

MANUAL TRANSMISSION

5. Remove the synchronizer ring and 5th gear.
 6. Remove the 5th gear bush.
7. Remove the conical spring washer at the output shaft side. Remove the output 5th gear.

INSPECTION

1. Check the bush wear or damage.

Part	Specified value mm (inch)	Limit mm (inch)
Bush bore ①	25 ± 0.015 (0.9843 ± 0.0017)	25.02 (0.985)
Bush outer diameter ②	37 ± 0.040 (1.4567 ± 0.0016)	36.89 (1.452)
Overall length ③	29 ± 0.03 (1.1417 ± 0.0012)	29.87 (1.141)
Thickness of flange section ④	3 ± 0.06 (0.1181 ± 0.0024)	2.94 (0.116)

2. Check the 5th gear for wear or damage.

Part	Specified value mm (inch)		Limit mm (inch)	
	Bore ①	Width ②	Bore ①	Width ②
5th gear (input)	37 ± 0.025 (1.4567 ± 0.001)	26 ± 0.13 (1.0236 ± 0.005)	37.05 (1.459)	25.7 (1.012)
Spined section Tapered sector ③	Visually inspect the section for excessive damage or wear.			
Gear section ④				
Both edge surfaces of gear ⑤				
Fitting sector with rub teeth ⑥	Inspect the section for excessive play, nick or rounded edge			

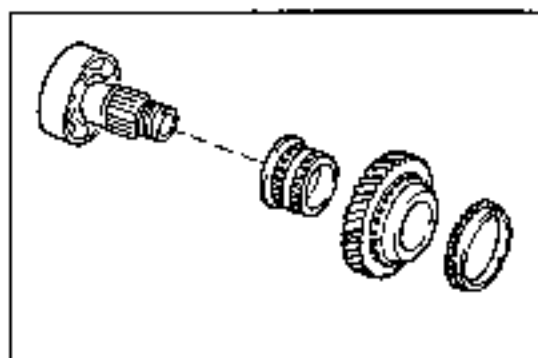

Fig. 3-139

WR-03139

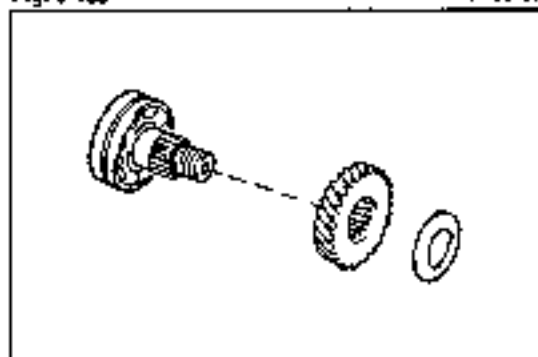

Fig. 3-140

WR-03139

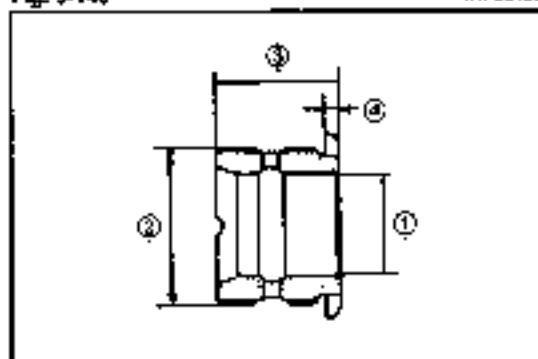

Fig. 3-141

WR-03137

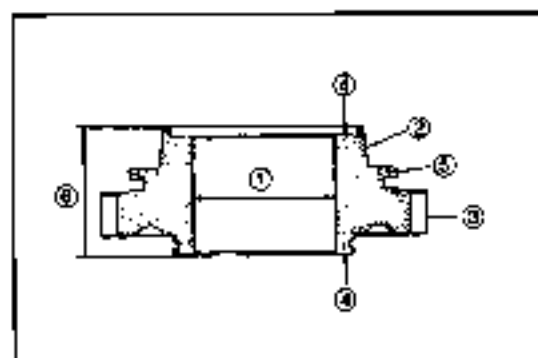

Fig. 3-142

WR-03138

3. Check the clutch hub and sleeve for the 5th gear for wear or damage.

Clutch Hub

Part	Limit
Splined section ①	Visually inspect the section for excessive damage or wear.
Synchronmesh shifting key fitting groove ②	
With the hub fitted into the sleeve, check for excessive looseness in up-&-down direction and slant of the hub and sleeve.	

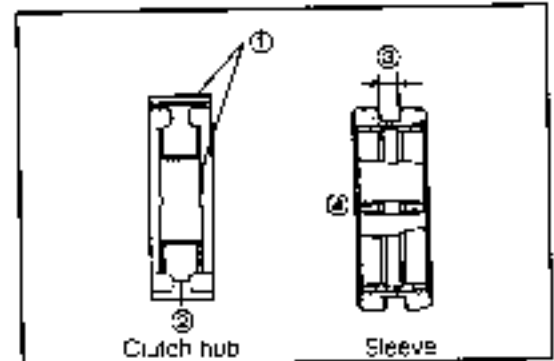

Fig. 3-143

WF-03'25

Sleeve

Part	Specified value mm (inch)	Limit mm (inch)
Shift fork groove width ③	70 $\begin{matrix} \pm 0.12 \\ +0.05 \\ -0.02 \end{matrix}$ (0.276 $\begin{matrix} \pm 0.004 \\ +0.002 \\ -0.002 \end{matrix}$)	7.3 (0.287)
Fitting section with gear ④	Visually inspect the section for excessive damage, wear, nick or rounded edge	

WR-0133

4. Check the synchronmesh shifting key and key spring for wear or damage.

Part	Specified value mm (inch)	Limit mm (inch)
Key for 5th gear (Dimension H)	5.0 $\begin{matrix} \pm 0.04 \\ -0.007 \\ -0.005 \end{matrix}$ (0.1969 $\begin{matrix} \pm 0.0028 \\ -0.0003 \\ -0.002 \end{matrix}$)	4.3 (0.169)
Spring ①	Visually inspect the spring for damage or distortion.	

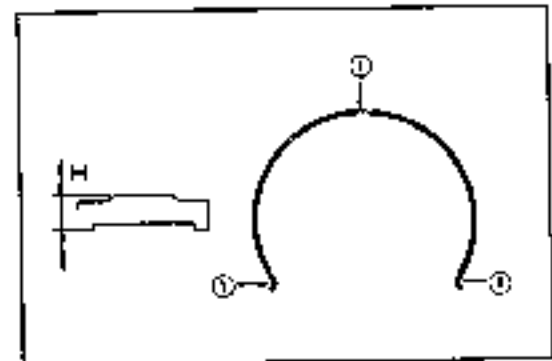

Fig. 3-144

WR-03142

5. Check the synchronizer ring for wear or damage.

Part	Specified value mm (inch)	Limit mm (inch)
Gap when synchronizer ring is pressed to gear	0.85 - 1.45 (0.033 - 0.057)	0.5 (0.020)
Damage at inner tapered section	Visually inspect the section for excessive damage.	
Damage at spline		

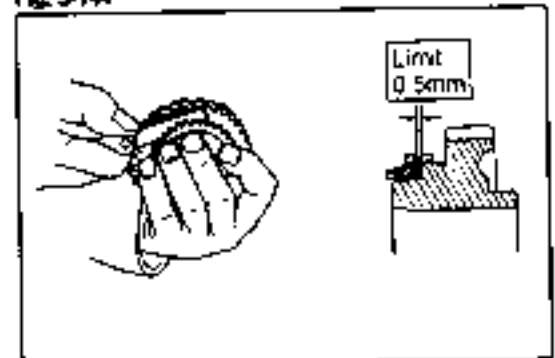

Fig. 3-145

WF-03141

6. Check the shift fork for the 5th gear for damage or wear.

Part	Specified value mm (inch)	Limit mm (inch)
Thickness at tip-section of fork	7.0 (0.28)	6.3 (0.25)

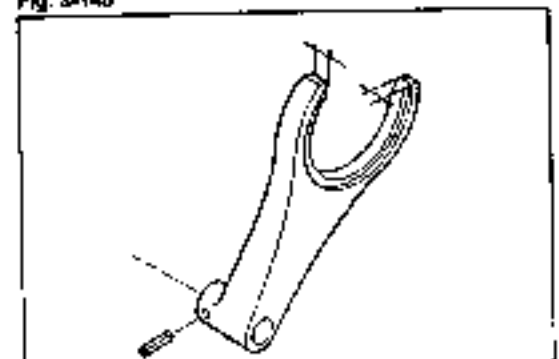

Fig. 3-146

WR-03142

MANUAL TRANSMISSION

ASSEMBLY

NOTE:

Apply gear oil to the entire surface of the rotary or sliding section of each gear of the output shaft.

1. Assemble the output 5th gear and the conical spring washer for the output shaft.

NOTE:

Tighten a new lock nut temporarily.

2. Assemble the 5th gear bush
3. Assemble the 5th gear and synchronizer ring.

4. Assemble the transmission clutch hub assembly.

- (1) Assemble the clutch and sleeve. Ensure that both parts can slide smoothly
- (2) Assemble the shifting keys and springs.

NOTE:

1. The hub assembly for the 3rd and 4th gear use differs from the hub assembly for the 5th gear use only in the inner diameter of the clutch hub. Other parts are shared in common.
 2. The sleeve and clutch do not have any installing direction to be observed during their assembly.
5. Assemble the transmission clutch hub assembly and the 5th gear shift fork at the same time.

6. Assemble the transmission hub sleeve stopper.
7. Assemble the conical spring washer.
 - (1) Install the conical spring in such a way that its expanded side may face toward the transmission side.

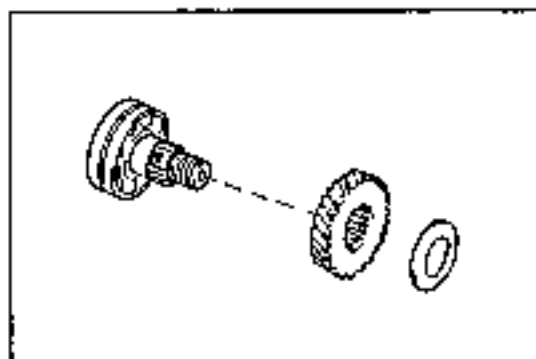

Fig. 3-147

WP-03147

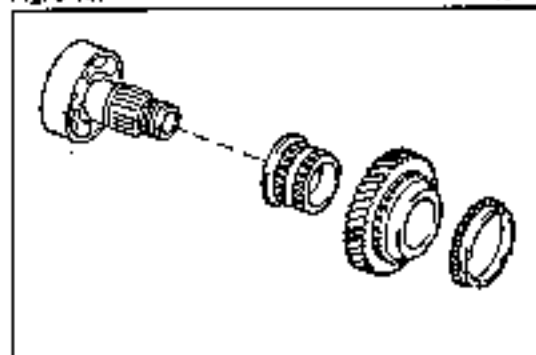

Fig. 3-148

WP-03148

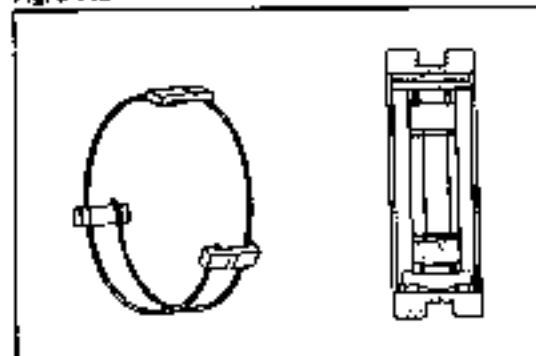

Fig. 3-149

WP-03149

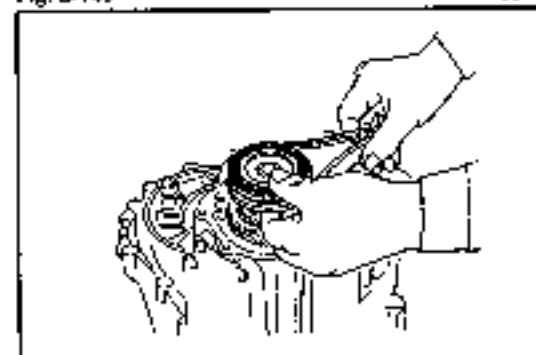

Fig. 3-150

WP-03150

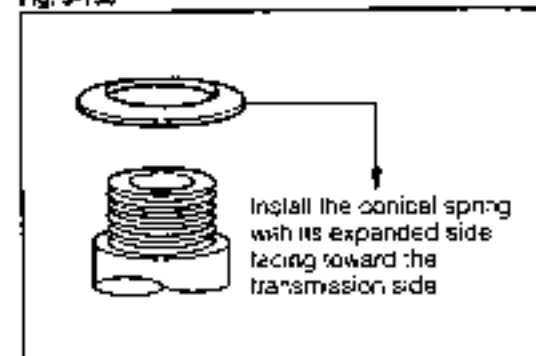

Fig. 3-151

WP-03151

8. Install a new lock nut.
 - (1) Lock the input shaft, using the recommended tool for this application. (See page 3-66.)
 - (2) Tighten the lock nut at the input shaft to the specified torque. Using a socket whose width across flats is 32 mm.
Tightening Torque: 10.0 - 14.0 kg-m (72 - 101 ft-lb)

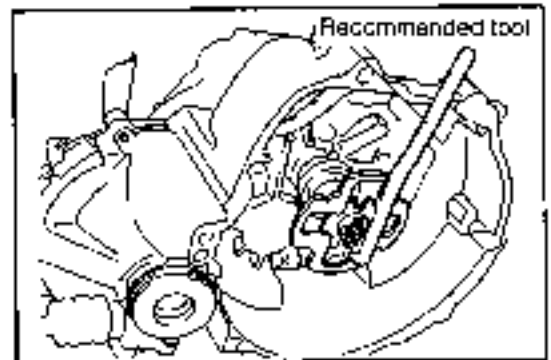

Fig. 3-152

WR-09152

- (3) Set the transmission to the 5th gear position.
- (4) Tighten the lock nut at the output shaft to the specified torque.
Tightening Torque: 10.0 - 14.0 kg-m (72 - 101 ft-lb)

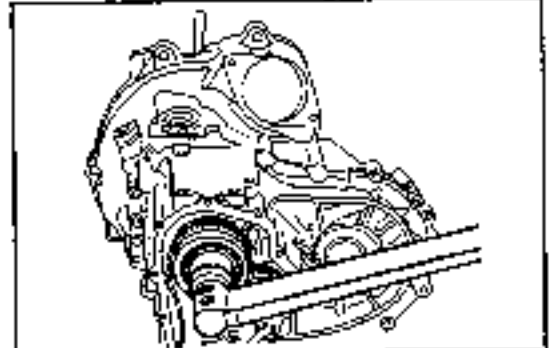

Fig. 3-153

WR-09153

- (5) Before the lock nut is staked, measure the end play of the 5th gear.
 - Specified Value: 0.1 - 0.23 mm (0.004 - 0.009 inch)
 - Limit: 0.4 mm (0.016 inch)

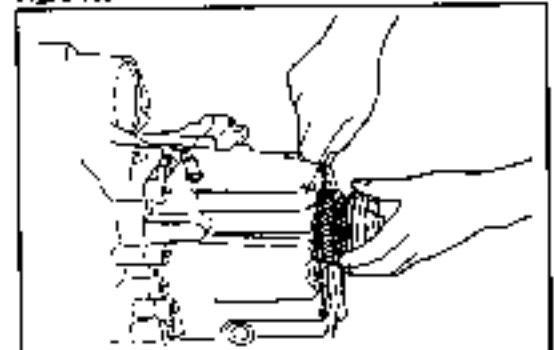

Fig. 3-154

WR-09154

- (6) Stake the lock nut, using a chisel.

NOTE:

Be sure to stake the central part of the lock nut so as to avoid dislocation or cracks.

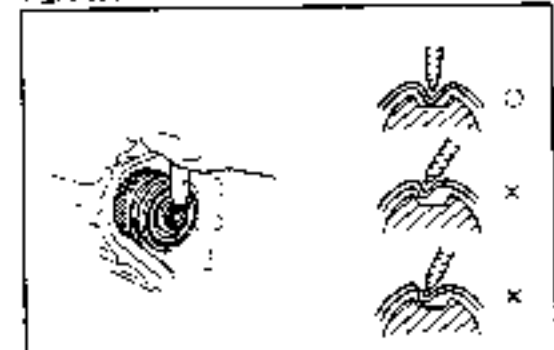

Fig. 3-155

WR-09155

9. Drive the slotted spring pin into position, until it becomes flush with the edge surface of the shift fork.

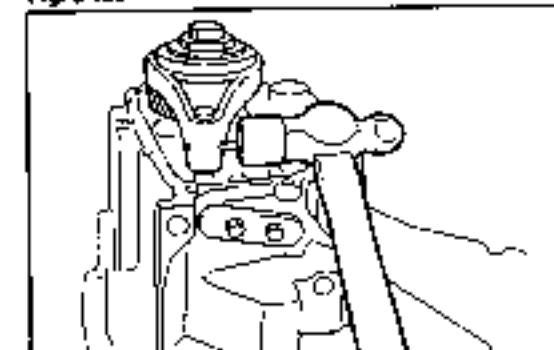
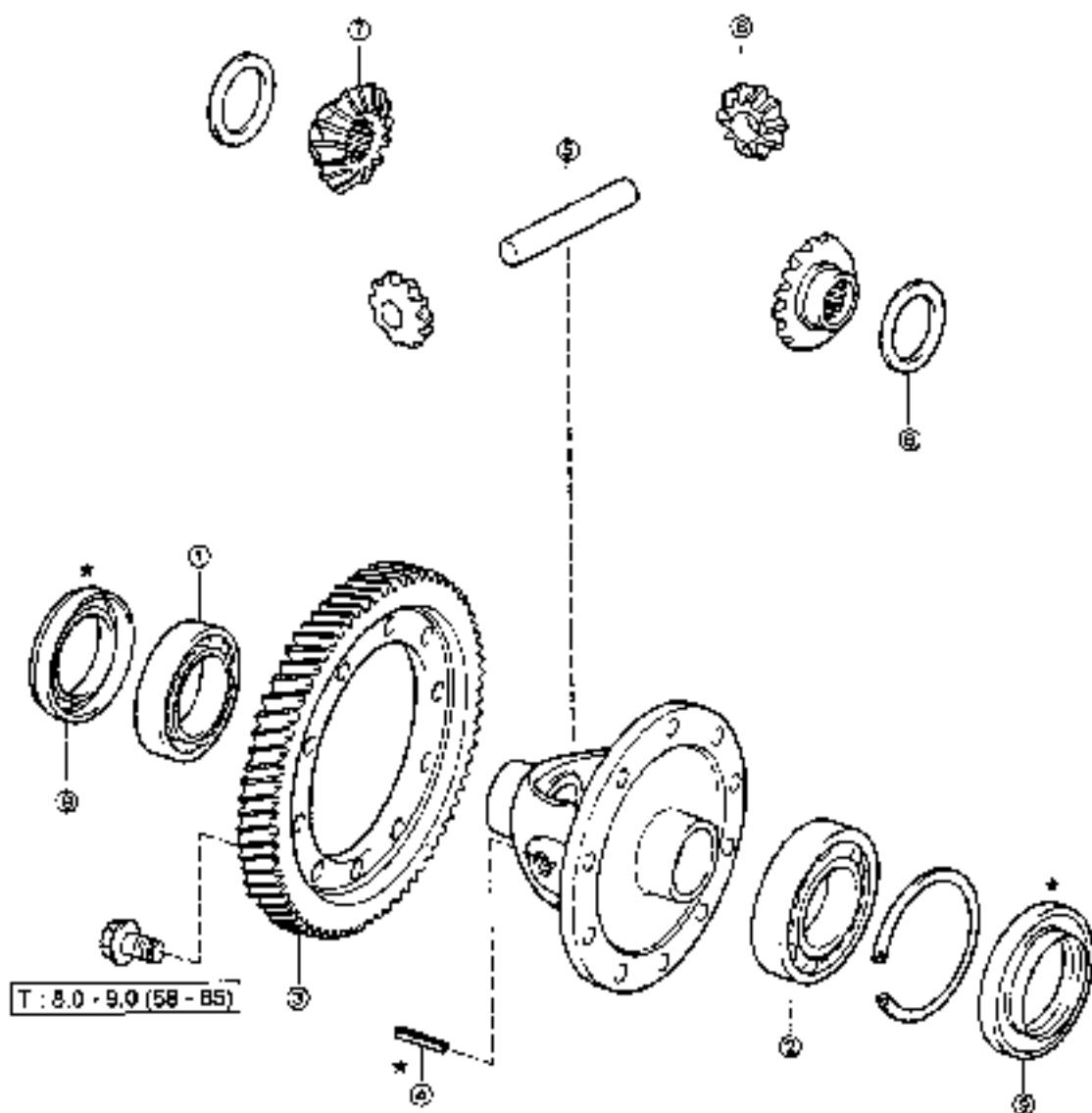

Fig. 3-156

WR-09156

DISASSEMBLY, INSPECTION AND ASSEMBLY OF DIFFERENTIAL CASE COMPONENTS



T : 8.0 - 9.0 (58 - 65)

T : Tightening Torque
Unit: kg-m (ft-lb)
* : Non-reusable parts

- ① Radial ball bearing
- ② Radial ball bearing
- ③ Differential gear
- ④ Shimmed spring pin
- ⑤ Differential pin on shaft
- ⑥ Differential pinion
- ⑦ Differential side gear
- ⑧ Differential washer
- ⑨ Oil seal

Fig. 3-157

WR 02156P

DISASSEMBLY

1. Remove the radial ball bearing.

(1) Remove the bearing at the engine side, using the SST given below.

SST: 09602-87301-000

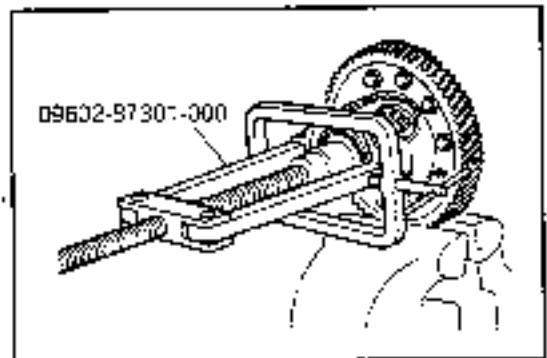

Fig. 3-158

WR-00158

(2) Remove the bearing at the transmission side, using the SST given below.

SST: 09306-87302-000

NOTE:

Grinding off the interfering section of the SST will make the operation easier.

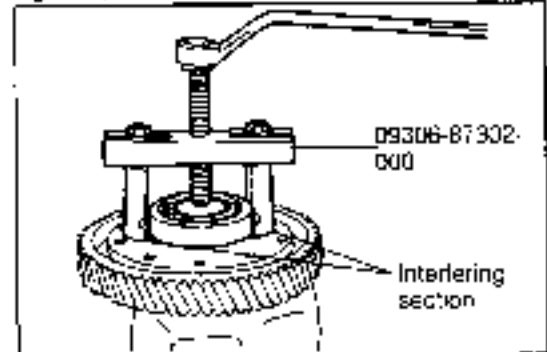

Fig. 3-159

WR-00159

2. Remove the differential ring gear.

(1) Clamp the differential case in a vise. Remove the attaching bolts.

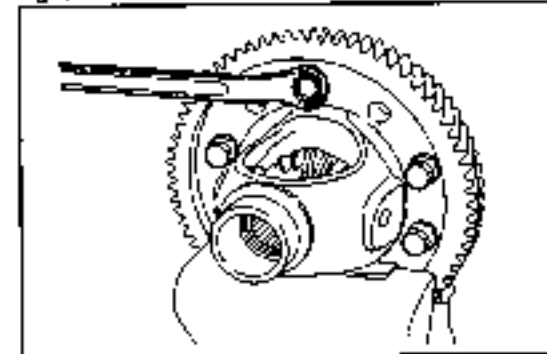

Fig. 3-160

WR-00160

(2) Remove the differential ring gear.

If any difficulty in removing the ring gear is encountered, evenly tap the peripheral section of the ring gear, using a plastic hammer.

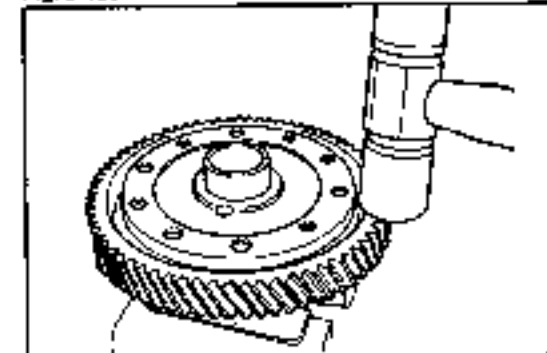

Fig. 3-161

WR-00161

3. Drive out the slotted spring pin, using a punch pin.

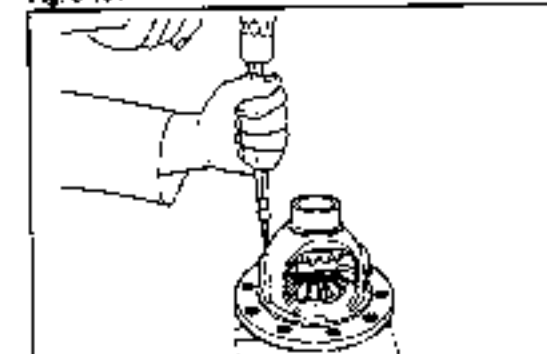

Fig. 3-162

WR-00162

MANUAL TRANSMISSION

4. Pull out the differential pinion shaft.

5. Remove the differential pinion, differential side gear and differential pinion washer.

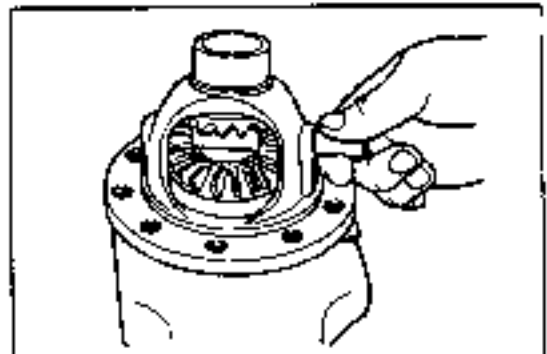

Fig. 3-163

WF-C318C

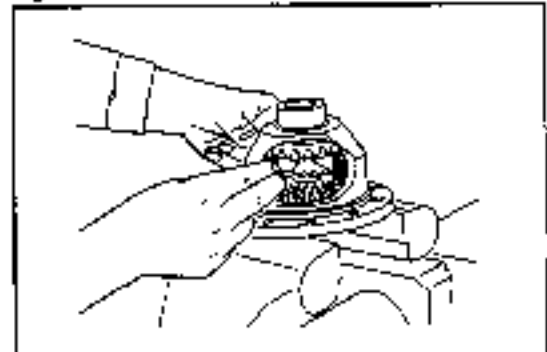

Fig. 3-164

WF-C2161

INSPECTION

1. Check the differential ring gear for wear or damage.

Part	Inspection criteria
Gear tooth surface	Visually inspect the surface for wear, damage, nick or rounded edge

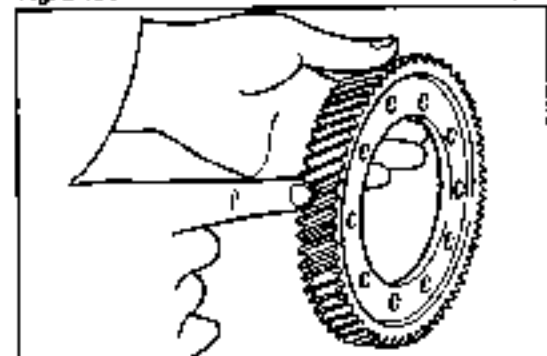

Fig. 3-165

WF-C0162

2. Check the side gear, pinion and pinion shaft for wear or damage.

Part	Specified value mm (inch)	Limit mm (inch)
Outer diameter of side gear boss section ①	Except vehicles mounted with Type CB-80 engine (1.2588 ±0.002)	31.97 (1.259)
	Vehicles mounted with Type CS-80 engine (1.3763 ±0.002)	34.87 (1.377)
Pinion shaft fitting hole of pinion ②	Except vehicles mounted with Type CB-80 engine (0.5906 ±0.002)	15.03 (0.592)
	Vehicles mounted with Type CB-80 engine (0.6299 ±0.002)	16.03 (0.631)
Outer diameter of pinion shaft ③	Except vehicles mounted with Type CB-80 engine (0.5906 ±0.002)	14.97 (0.589)
	Vehicles mounted with Type CB-80 engine (0.6299 ±0.002)	15.97 (0.629)

Check the gear tooth surface and the splined section of the side gear for wear or damage.

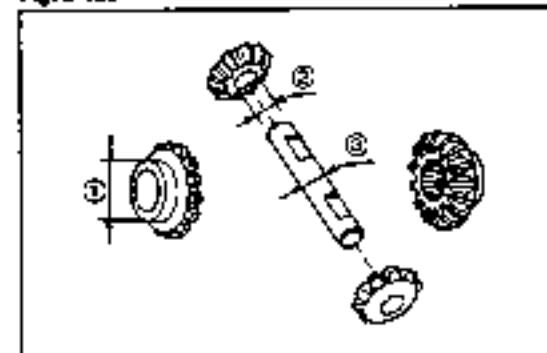

Fig. 3-166

WF-C3163

3. Check the differential case and thrust washer for wear or damage.

Part	Specified value mm (inch)	Limit mm (inch)
Thickness of thrust washer		
Except vehicles mounted with Type CB-80 engine	0.6 ± 0.05 (0.0235 ± 0.0020)	0.7 (0.028)
Vehicles mounted with Type CS-80 engine	1.1 ± 0.05 (0.043 ± 0.0020)	1.0 (0.039)
Side gear boss fitting hole (Except vehicles mounted with Type CG-80 engine)	$32 \begin{smallmatrix} +0.025 \\ -0.025 \end{smallmatrix}$ (1.2599 ± 0.0025)	32.08 (1.263)
Drive shaft fitting hole (Vehicles mounted with Type CB-80 engine)	$28 \begin{smallmatrix} +0.025 \\ -0.025 \end{smallmatrix}$ (1.1024 ± 0.0025)	28.08 (1.106)
Pinion gear-contact-section	②	Visually inspect the section for excessive wear or damage
Side gear thrust washer-contact-section	③	

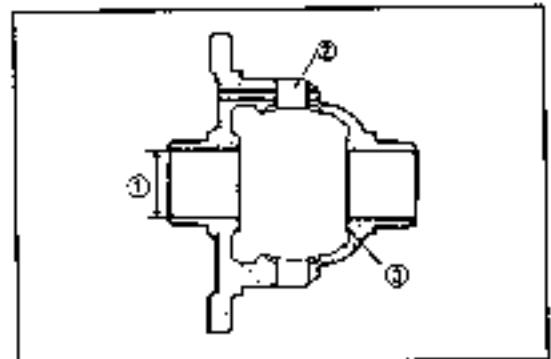

Fig. 3-167

WR-03167

ASSEMBLY

1. Assemble the differential pinion washers and differential side gears.

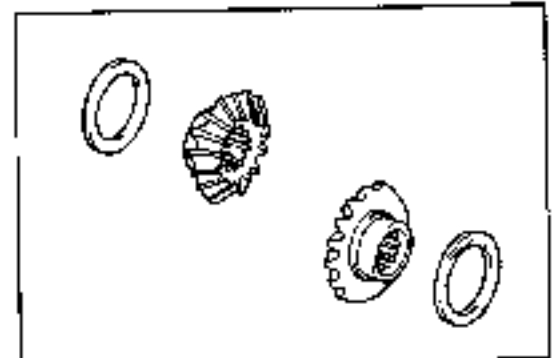

Fig. 3-168

WR-03168

2. Assemble the differential pinions.

- (1) Make the two pinions mesh with the side gears, working from the case side. Rotate the side gear so that the pinion's hole may align with the pinion shaft hole provided in the case.

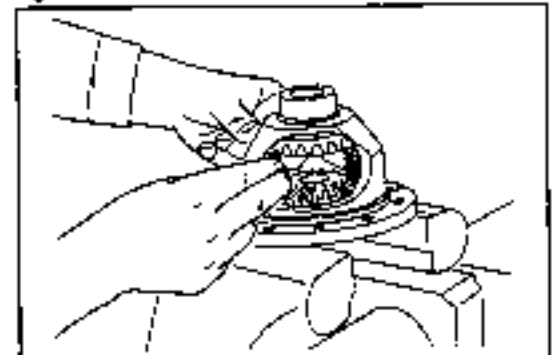

Fig. 3-169

WR-03169

3. Assemble the differential pinion shaft.

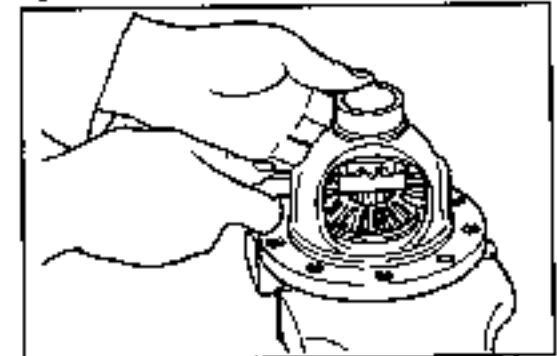

Fig. 3-170

WR-03168

MANUAL TRANSMISSION

Measurement of Side Gear Backlash

- (1) Fix the side gear at one side.
- (2) Measure the backlash of each side gear at the right and left sides at several points, using a dial gauge
Specified Backlash: 0.02 - 0.20 mm (0.001 - 0.008 inch)

4. Drive a new slotted spring pin into position
 - (1) Align the pin hole of the pinion shaft with the corresponding pin hole in the case
 - (2) Working from the backside of the case (ring gear side), drive a new slotted spring pin into position, until it becomes flush with the case edge surface.

5. Assemble the differential ring gear.
 - (1) Install the ring gear in such a way that the side having large chamfer at its inner diameter comes at the case side.

NOTE:

1. The number of gear teeth varies depending upon each reduction ratio. Hence, it is necessary to identify the ring gear by checking the identification groove.
2. Care must be exercised to ensure that no foreign matter gets into the mating surface.

Identification of Ring Gear

Number of gear teeth	Identification groove	Final reduction gear ratio
72	One	4.500
74	None	4.933
65	Two	4.642
* 65	Three	4.642

* For Type CB-80 engine

- (2) Tighten the ring gear attaching bolts.
Tightening Torque: 8.0 - 9.0 kg-m (58 - 65 ft-lb)

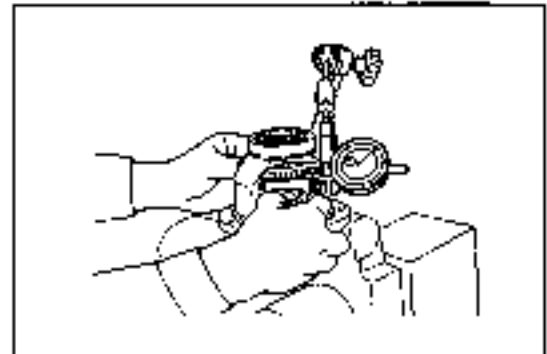

Fig. 3-171

WR-03169

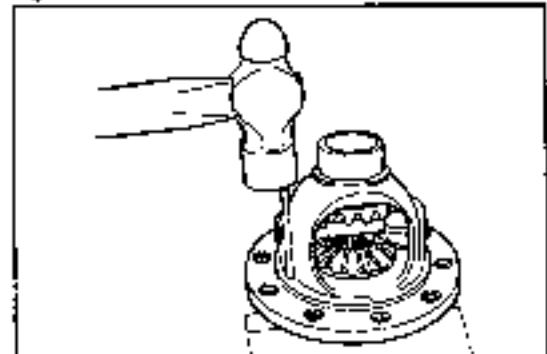

Fig. 3-172

WR-03170

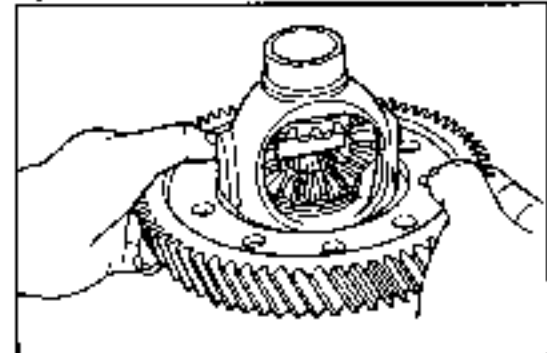

Fig. 3-173

WR-03171

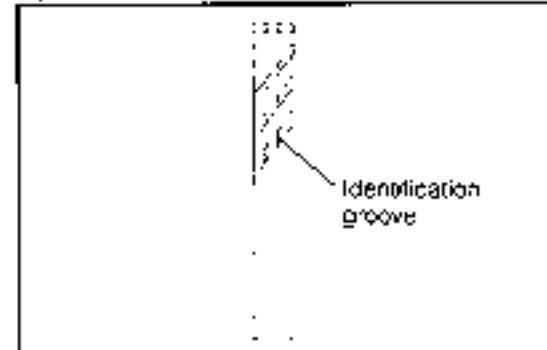

Fig. 174

WR-03172

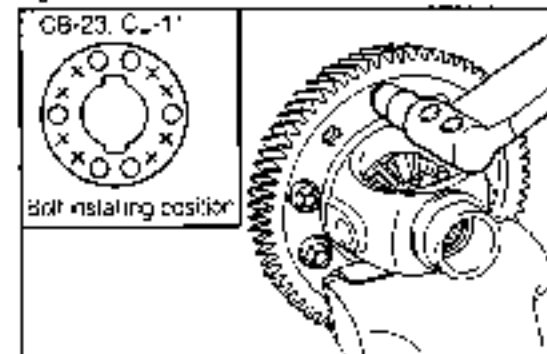

Fig. 3-175

WR-03173

6. Assemble the radial ball bearings, using the SST given below

SST: 09516-87301-000

NOTE:

Install the radial ball bearings with the bearing having a smaller outer diameter assembled at the ring gear side.

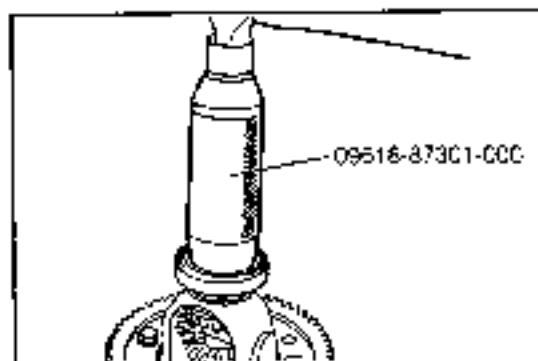
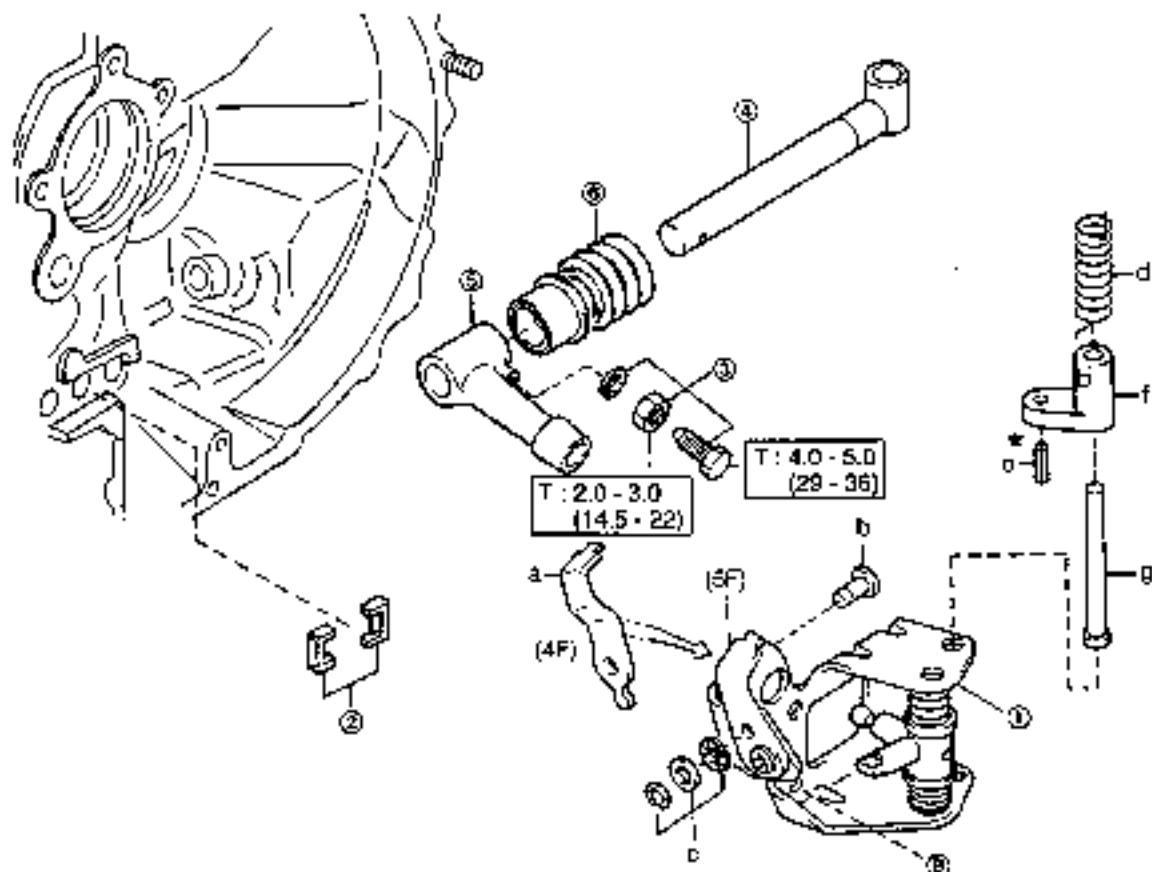

Fig. 3-176

W09-03174

**DISASSEMBLY, INSPECTION AND ASSEMBLY OF CONTROL LINKAGE-RELATED PARTS
COMPONENTS (PART 1)**



T : Tightening Torque
Unit: kg-m (ft-lb)
*** : Non-reusable parts**

- ① Select support Ay & shifting bell crank
- a. Reverse shift arm (4 M-T)
- b. Shift arm pin & washer
- c. E ring & washer
- d. Compressor spring
- e. Slotted spring pin
- f. Reverse restrict cam
- g. Reverse restrict shaft

- ② Shift inter lock plate
- ③ Wave washer, bolt and nut set
- ④ Shift & select shaft
- ⑤ Shift inner lever
- ⑥ Control shaft boot

Fig. 3-177

WR 031720

COMPONENTS (PART 2)

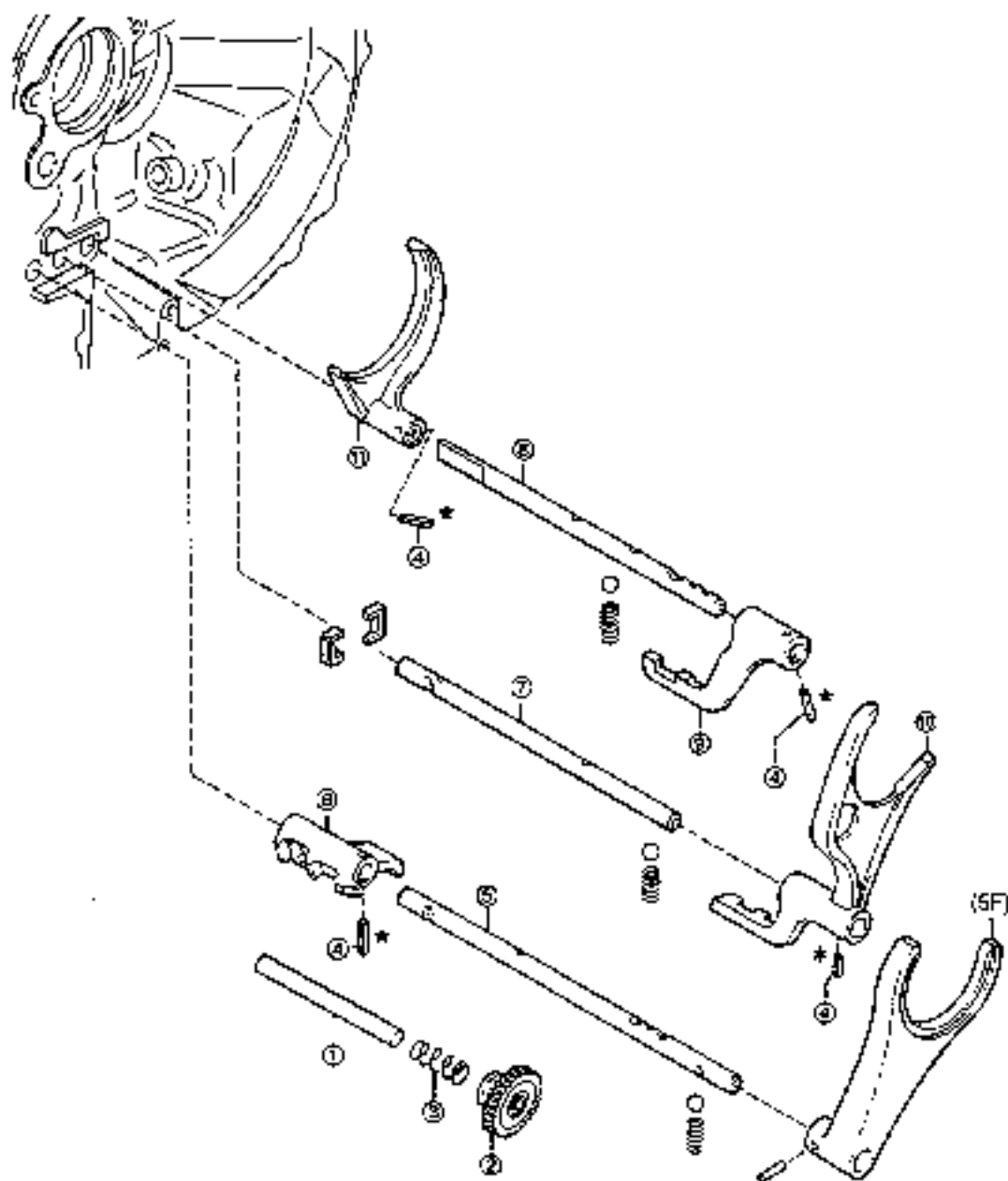

* : Non-reusable parts

- ① Reverse idler shaft
- ② Reverse idler gear
- ③ Compression spring
- ④ Slotted spring pin × 4
- ⑤ 5th & reverse shift lock shaft
- ⑥ Reverse shift arm head

- ⑦ 3rd & 4th shift fork shaft
- ⑧ 1st & 2nd shift fork head
- ⑨ 1st & 2nd shift fork
- ⑩ 3rd & 4th shift fork
- ⑪ 1st & 2nd shift fork

Fig. 3-178

WR-C01742

MANUAL TRANSMISSION

DISASSEMBLY

1. Pull out the reverse idler gear shaft. Remove the reverse idler gear together with the compression spring

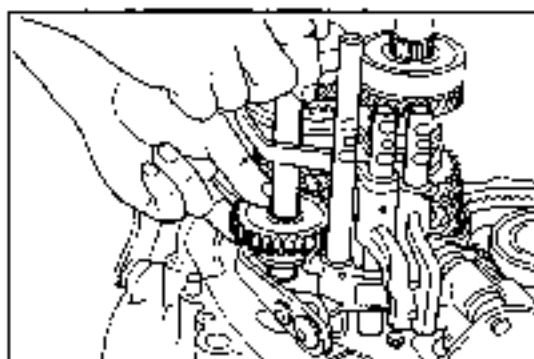

2. Pull out the slotted spring pin.
(1) Working from the arrow-headed direction in the figure drive out the slotted spring pin by means of a punch pin. (Four points)

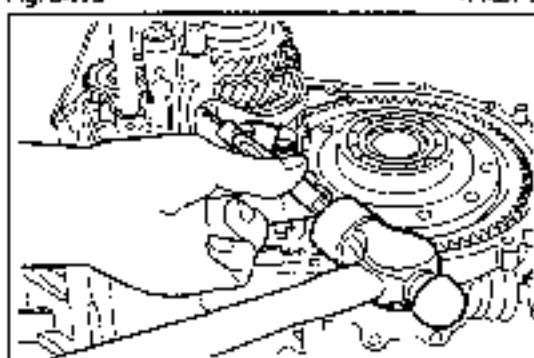

3. Pull out the 5th & reverse shift fork shaft. Remove the reverse shift arm head.

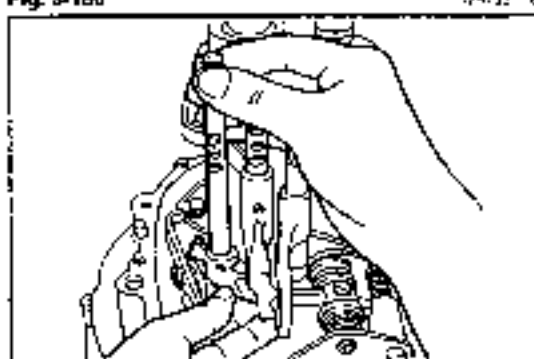

4. Remove the 3rd & 4th shift fork shaft and the 3rd & 4th shift fork.

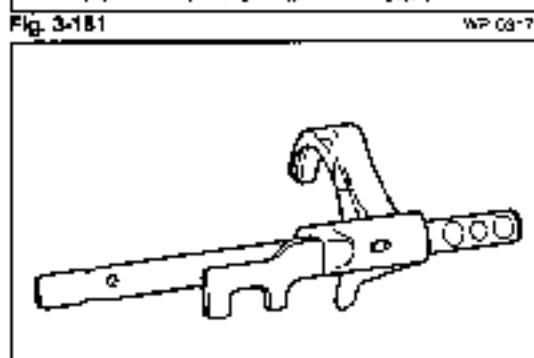

5. Pull out the 1st & 2nd shift fork shaft. Remove the 1st & 2nd shift fork and the 1st & 2nd shift head.

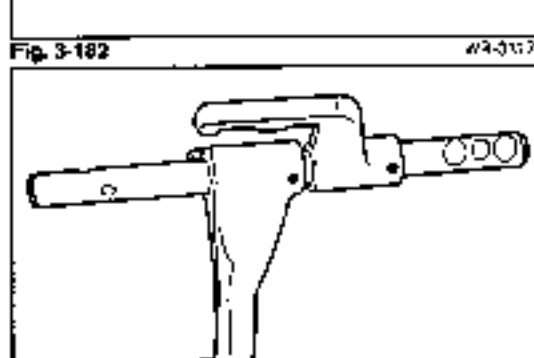

6. Remove the input shaft and output shaft at the same time

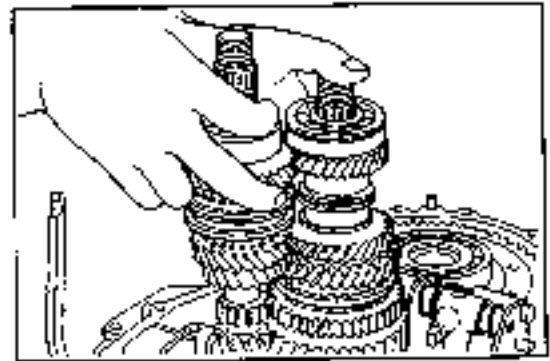

Fig. 3-184

WR-03'80

7. Remove the selecting & shifting bell crank support assembly and magnet

NOTE:

1. Be sure not to release the staked section of the bell crank.
2. On both the 4-speed and 5-speed transmissions, replacement parts are supplied only as those with the bell crank support assembly. (In the case of the replacement parts for the 5-speed transmission, the reverse restricting cam is excluded.)
Furthermore, it should be noted that the reverse restricting cam can not be disassembled.

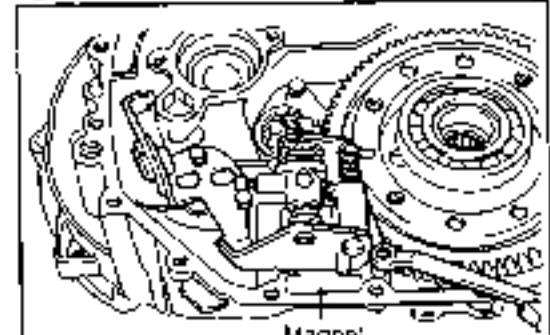

Fig. 3-185

WF-03'81

8. Remove the shift interlock plate.

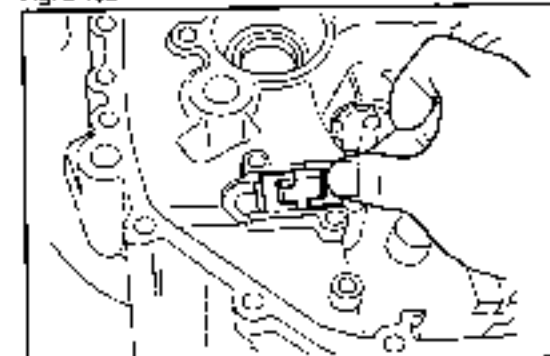

Fig. 3-186

WF-03'82

9. Remove the wave washer, nut and set bolt
(*) After the nut has been slackened, proceed to slacken the set bolt.

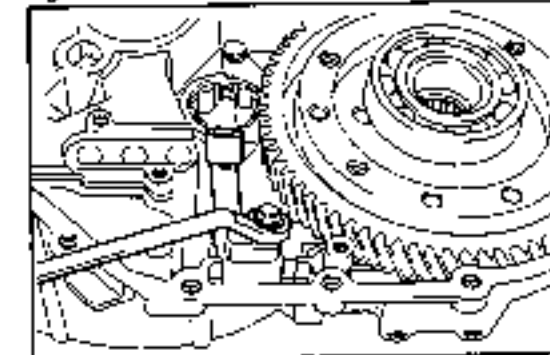

Fig. 3-187

WF-03'83

10. After the differential case assembly has been removed (see page 3-16), remove the shift & select shaft.

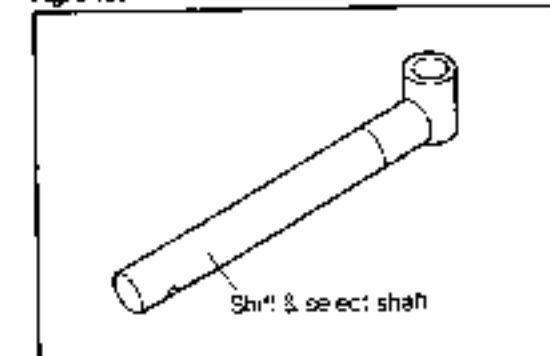

Fig. 3-188

WF-03'84

MANUAL TRANSMISSION

11. Remove the shift inner lever and control shaft boot.

INSPECTION

1. Check the shift fork shafts, balls and springs for damage or wear.

Part	Inspection criteria
Ball lock section and interlock section of fork shaft ①	Visually inspect the section for excessive damage or wear.

2. Check the 1st shift fork, the 2nd shift fork and the reverse shift head for damage or wear.

Part	Specified value mm (inch)	Limit mm (inch)
Thickness at tip-section of fork ①	7.0 (0.276)	6.3 (0.248)
Groove width of shift inner lever-contact-section ②	$12.1 \begin{smallmatrix} +0.1 \\ 0 \\ -0.004 \end{smallmatrix}$ (0.476 $\begin{smallmatrix} +0.004 \\ 0 \\ -0.001 \end{smallmatrix}$)	12.7 (0.500)
Groove width of reverse shift arm pin-contact-section ③	$15.0 \begin{smallmatrix} +0.043 \\ 0 \\ -0.0017 \end{smallmatrix}$ (0.5906 $\begin{smallmatrix} +0.0017 \\ 0 \\ -0.0001 \end{smallmatrix}$)	15.1 (0.595)

3. Check the interlock plate for damage or wear.

Part	Specified value mm (inch)	Limit mm (inch)
*Length of lock plate	16.3 ± 0.15 (0.642 ± 0.006)	16.0 (0.630)
Roller section	Check the section for excessive damage or wear.	

*Two lock plates must be replaced at the same time.

4. Check the control shaft and inner lever for damage or wear.

Part	Inspection criteria
Control shaft ①	Visually inspect the following items given below.
Inner lever recessed section and shaft inserting section ②	
Sliding section of dust boot and breakage ③	
Tip-end of lock bolt ④	

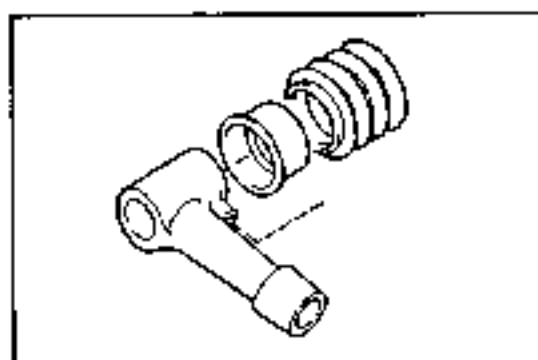

Fig. 3-180

WP-03-85

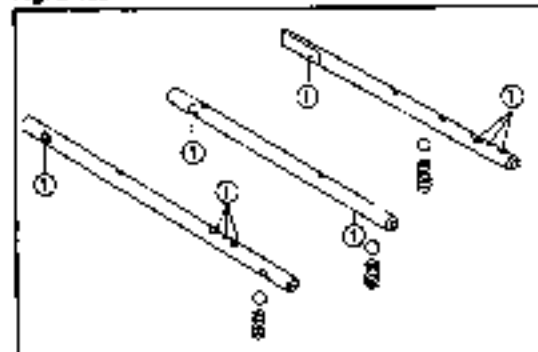

Fig. 3-180

WP-03-85

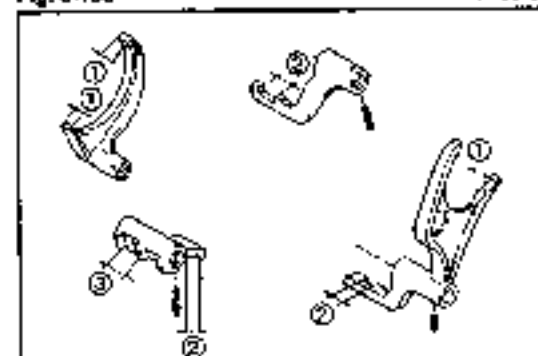

Fig. 3-181

WP-03-87

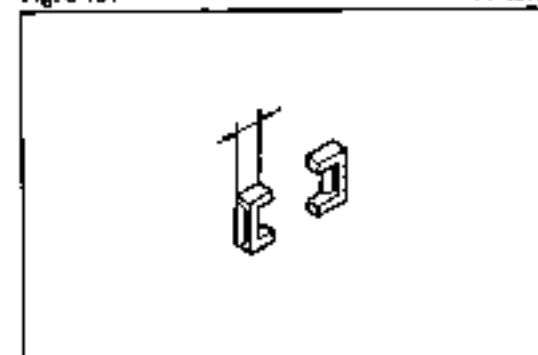

Fig. 3-182

WP-03-84

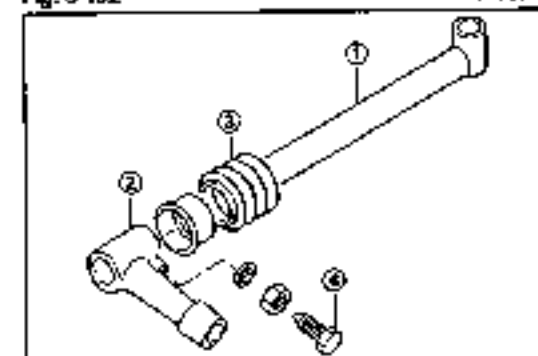

Fig. 3-183

WP-03-80

5. Check the selecting & shifting bell crank and the reverse shift arm for damage or wear.

Part	Specified value mm (inch)	Limit mm (inch)
Reverse shift arm pin diameter ①	15.0 ± 0.050 (0.5906 ± 0.0020)	14.85 (0.5885)
Tip-end width of reverse shift arm ②	8.0 ± 0.092 (0.3150 ± 0.0036)	7.8 (0.307)
Operation of selecting & shifting bell crank	Check to see if the bell crank can move in up-and-down direction with detent falling	

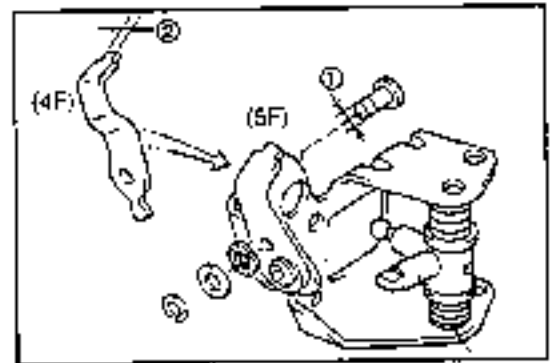

Fig. 3-154

WR-03190

6. Check the reverse restricting cam and shaft for damage or wear. (5-speed transmission only)

Part	Inspection criteria
Operation of restricting cam	<ul style="list-style-type: none"> Ensure that the mis-operation preventing mechanism functions at the support assembly ① The cam should be raised at the same time when the section ② is lifted. ② When turned to the left, ensure that the cam drops and the section ② is locked.
Each part of reverse restricting cam and shaft ③	Visually inspect each part for damage or wear

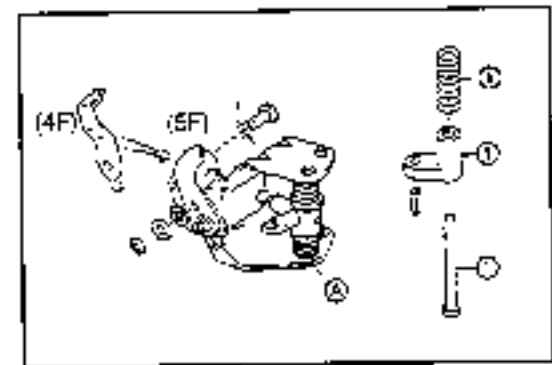

Fig. 3-155

WR-03191

7. Check the reverse idler gear and shaft for wear or damage.

Part	Specified value mm (inch)	Limit mm (inch)
Bush inner diameter ①	17 ± 0.027 (0.6693 ± 0.0011)	17.05 (0.671)
Shaft outer diameter ②	17 ± 0.032 (0.6693 ± 0.0013)	16.9 (0.665)
Groove width ③	8 ± 0.056 (0.3150 ± 0.0023)	8.2 (0.323)
Wear or damage of spring ④	Visually inspect the spring for flattened condition and the washer for wear or damage.	

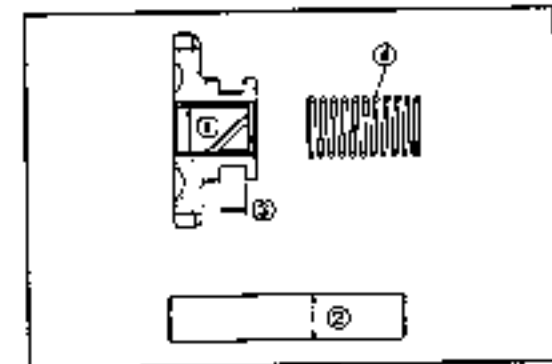

Fig. 3-156

WR-03192

ASSEMBLY

1. Assemble the boot and shift inner lever on the control shaft.

NOTE:

Be very careful not to scratch the boot.

2. Assemble the shift & select shaft in the case.

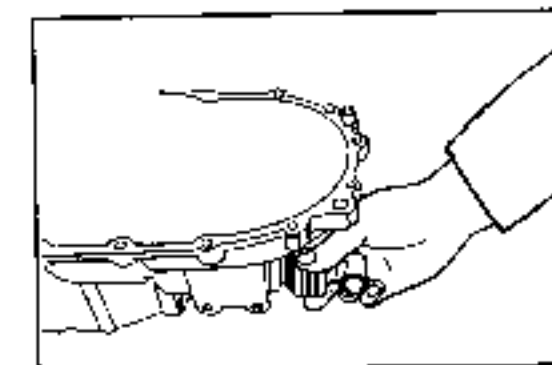

Fig. 3-157

WR-03193

MANUAL TRANSMISSION

- 3 After the differential case assembly has been installed assemble the wave washer, nut and setting bolt.

(1) Align the hole of the shift inner lever with the cut-out section of the shift & select shaft. Proceed to tighten the set bolt to the specified torque.

Tightening Torque: 4.0 - 5.0 kg-m (29 - 36 ft-lb)

(2) Tighten the nut to the specified torque

Tightening Torque: 2.0 - 3.0 kg-m (16 - 22 ft-lb)

- 4 Assemble the shift interlock plate.

(1) Assemble the plate in the Neutral position.

5. Install the magnet into position.

6. Assemble the input shaft and output shaft at the same time.

- 7 Install the input shaft bearing lock plate. Tighten the nuts

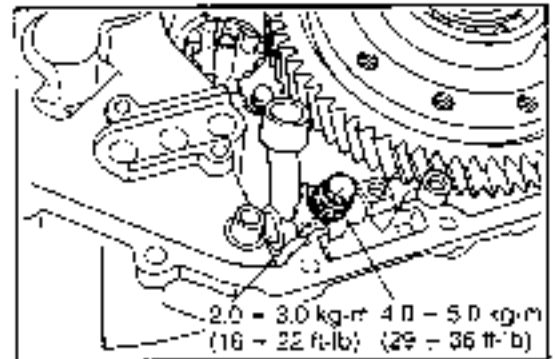

Fig. 3-198

WR-03198

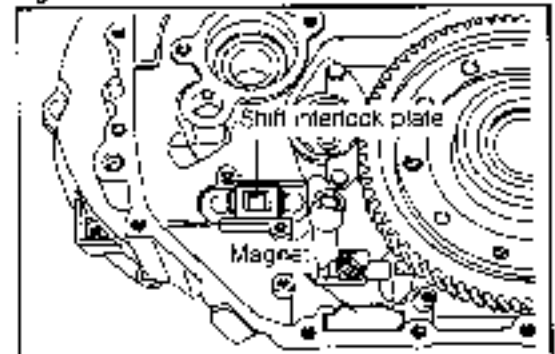

Fig. 3-199

WR-03199

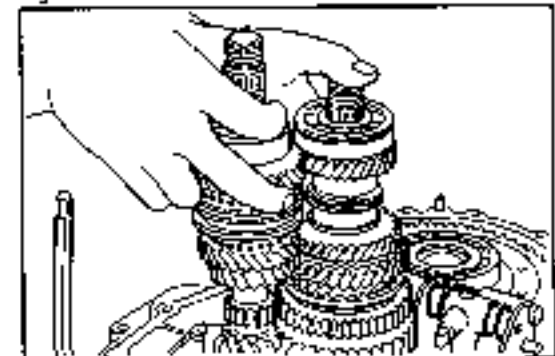

Fig. 3-200

WR-031954

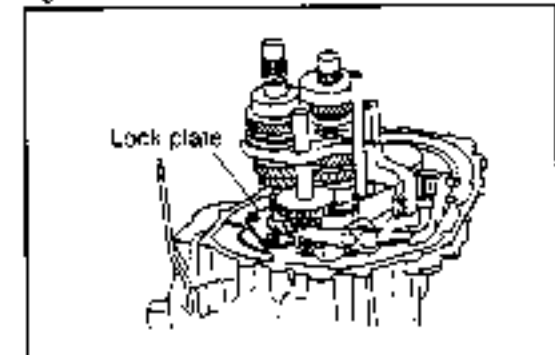

Fig. 3-201

WR-031955

8. Assemble the selecting & shifting bell crank support assembly.

- (1) Working from the inside of the case, install the shift arm pin. Assemble the washer.
- (2) Drive the slotted spring pin into position, until it becomes flush with the edge surface (A) of the restricting cam.
- (3) Assemble the restricting cam.
 - ① Assemble the restricting cam in such a way that the slotted spring pin may be inserted into the hole (B).

NOTE:

Be sure not to forget to attach the spring in place.

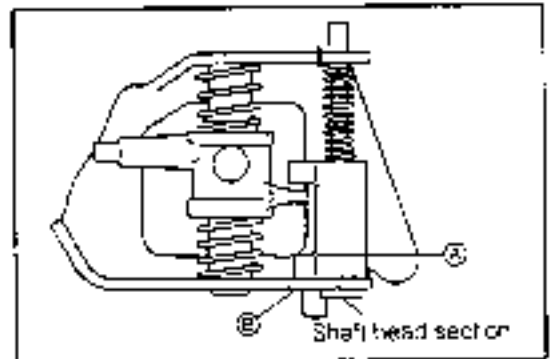

Fig. 3-202

WR-01154

9. Assemble the 1st & 2nd shift fork and the 3rd & 4th shift fork.

NOTE:

Prior to the assembling, apply gear oil to the sliding section of each shift fork.

- (1) Assemble the 1st & 2nd shift fork onto the synchronizer hub for the 1st & 2nd gear use provided at the output shaft side.
- (2) Assemble the 3rd & 4th shift fork onto the synchronizer hub for the 3rd & 4th gear use provided at the input shaft side.

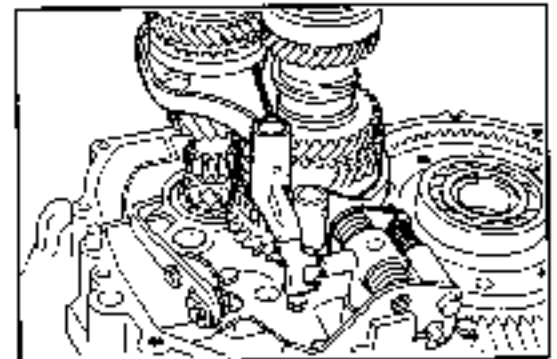

Fig. 3-203

WR-01151

10. Assemble the 1st & 2nd shift head, the 1st & 2nd shift fork shaft and the 3rd & 4th shift fork shaft.

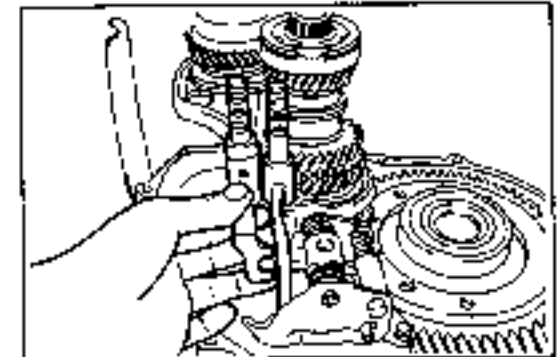

Fig. 3-204

WR-01152

11. Assemble the reverse shift arm head.

- (1) Assemble the arm head in the direction as indicated in the right figure.

NOTE:

It should be noted that the arm head for the 4-speed transmission differs from that for the 5-speed transmission in its shape.

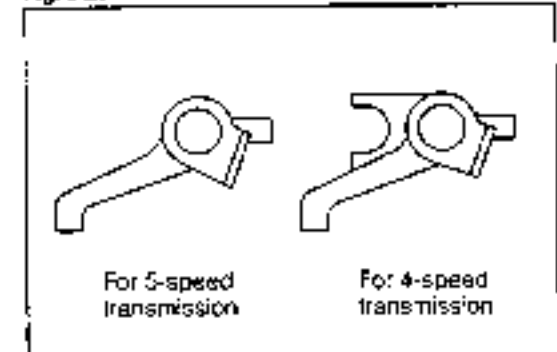

Fig. 3-205

WR-01153

MANUAL TRANSMISSION

12. Assemble the 5th & reverse shift fork shaft.

NOTE:

It should be noted that the fork shaft for the 4-speed transmission differs from that for the 5-speed transmission in its length.

Shaft Length

For 4-speed transmission: 175 mm (6.89 inch)

For 5-speed transmission: 223 mm (8.79 inch)

13. Working from the direction as indicated in the figure, drive the sotted spring pin into position, until it becomes flush with the edge surface of the shift fork.

14. Assemble the compression spring, reverse idler gear and reverse idler gear shaft

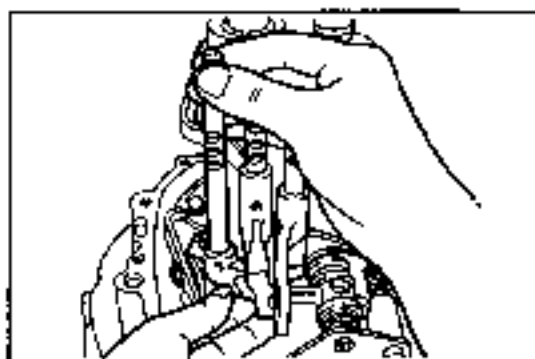

Fig. 3-206

WR-03200

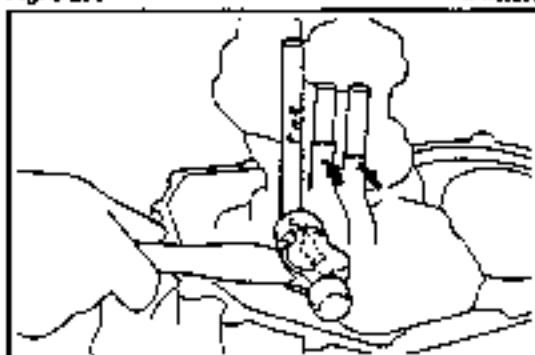

Fig. 3-207

WR-03201

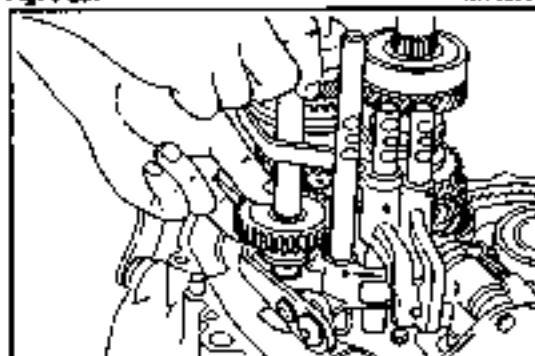
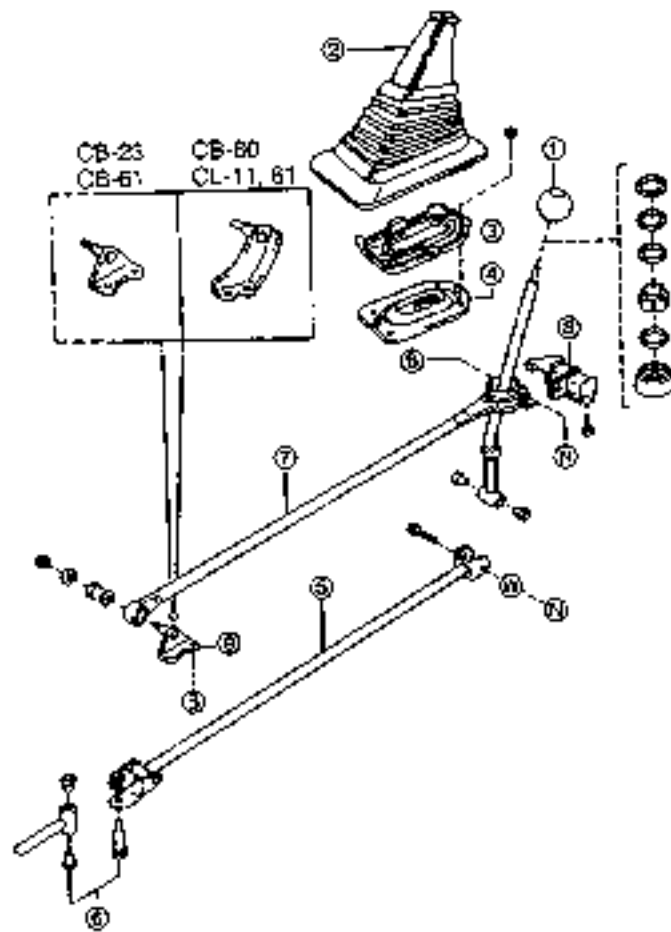

Fig. 3-208

WR-03202

SHIFT LEVER & SHIFTING SELECTING ROD COMPONENTS



- | | |
|--|-----------------------------|
| ① Shift lever knob | ⑦ Extension rod S/A |
| ② Shift & select lever boot | ⑧ Floor shift: support No.2 |
| ③ Dust seal retainer | ⑨ Floor shift: support No.1 |
| ④ Dust boot | |
| ⑤ Shift & select shaft S/A (transmission side) | |
| ⑥ Bush | |

Fig. 3-208

#R-03203

MANUAL TRANSMISSION

REMOVAL

1. Detach the shift lever knob and the shift & select lever boot
2. Detach the dust seal retainer and dust boot
3. Disconnect the shift & select shaft subassembly at the transmission side.
4. Remove the bush
5. Remove the extension rod subassembly and floor shift support No.2.

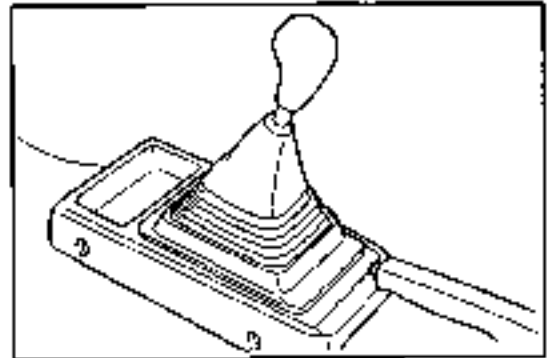

Fig. 3-210

WR-03204

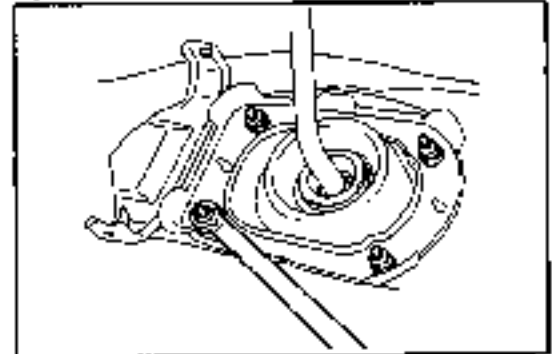

Fig. 3-211

WR-03206

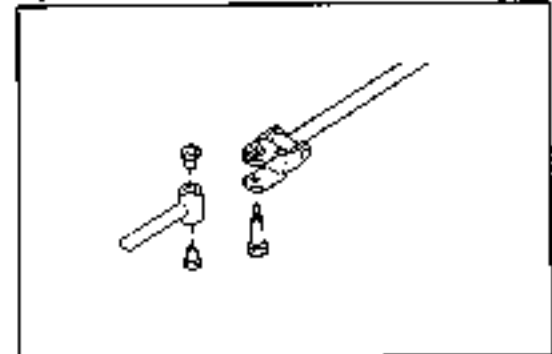

Fig. 3-212

WR-03208

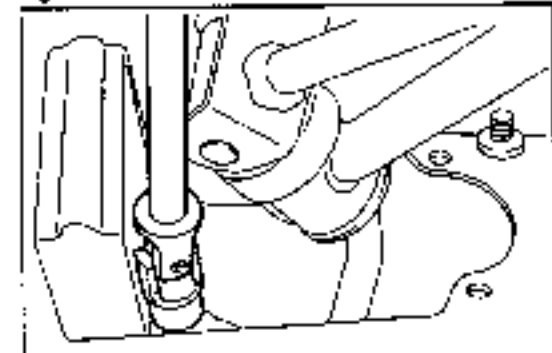

Fig. 3-213

WR-03207

INSPECTION

Check to see if each joint section under an assembled condition rotates smoothly without any binding.

(See the figure below.)

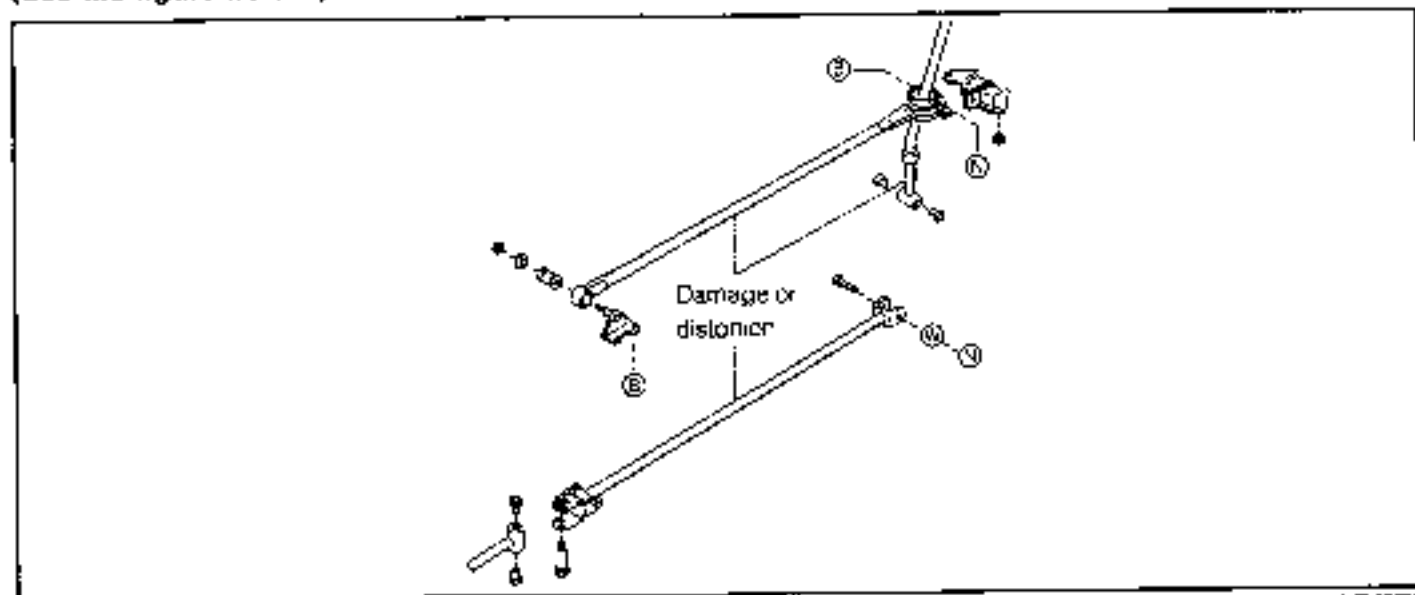

Fig. 3-214

WR-03208

DISASSEMBLY

1. Working from the case side pull out the hole snap ring by means of the SST

SST: 09905-B7001-000

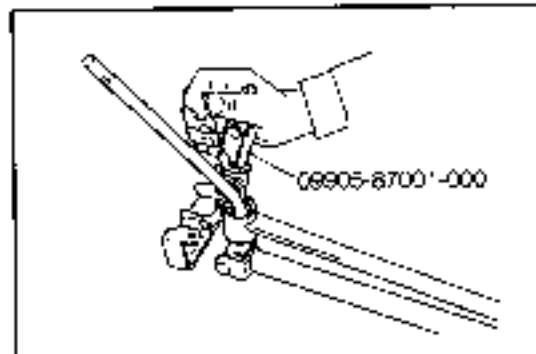

Fig. 3-215

WR-03209

2. Disassemble the plate washer, bush and shift lever seat.

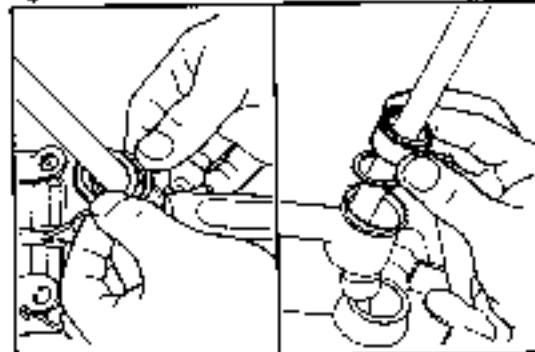

Fig. 3-216

WR-03210

3. Remove the extension rod subassembly from the shift lever subassembly.

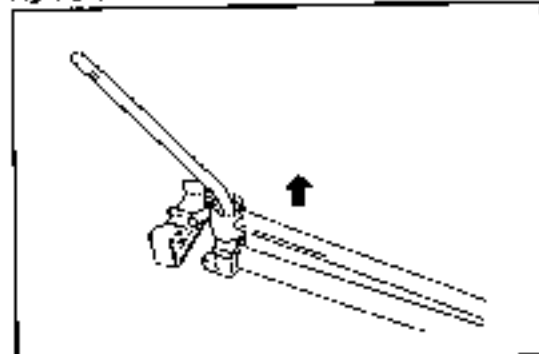

Fig. 3-217

WR-03211

MANUAL TRANSMISSION

4. Disassemble the plate washer and shift lever retainer dust boot.

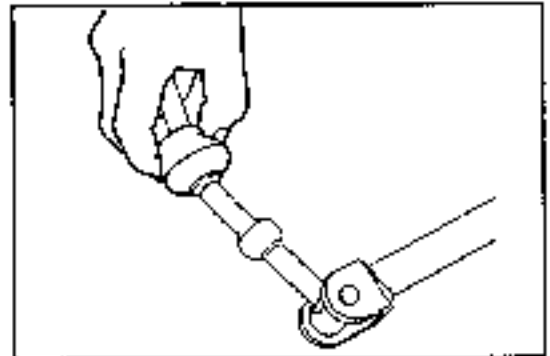

Fig. 3-218

WA-00212

5. Disassemble the bush, nut, plate washer and floor shift support No.1.

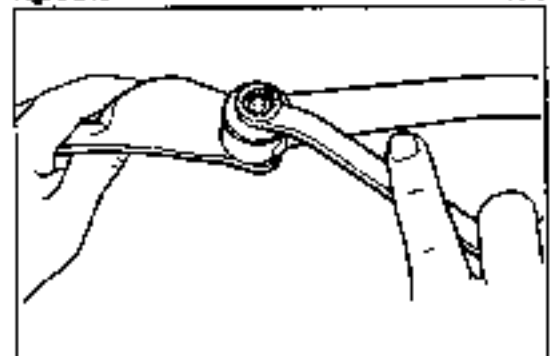

Fig. 3-219

WA-00214

6. Grind off the staked section of the extension rod sub-assembly. Using a grinder.
7. Grind off the staked section of the shift & select sub-assembly. using a grinder.

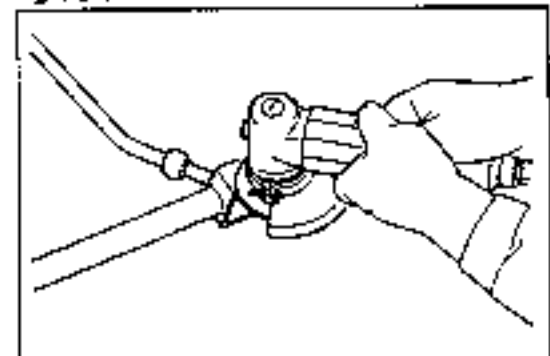

Fig. 3-220

WA-03215

INSPECTION

Inspect the following parts. Replace any parts which exhibit defects.

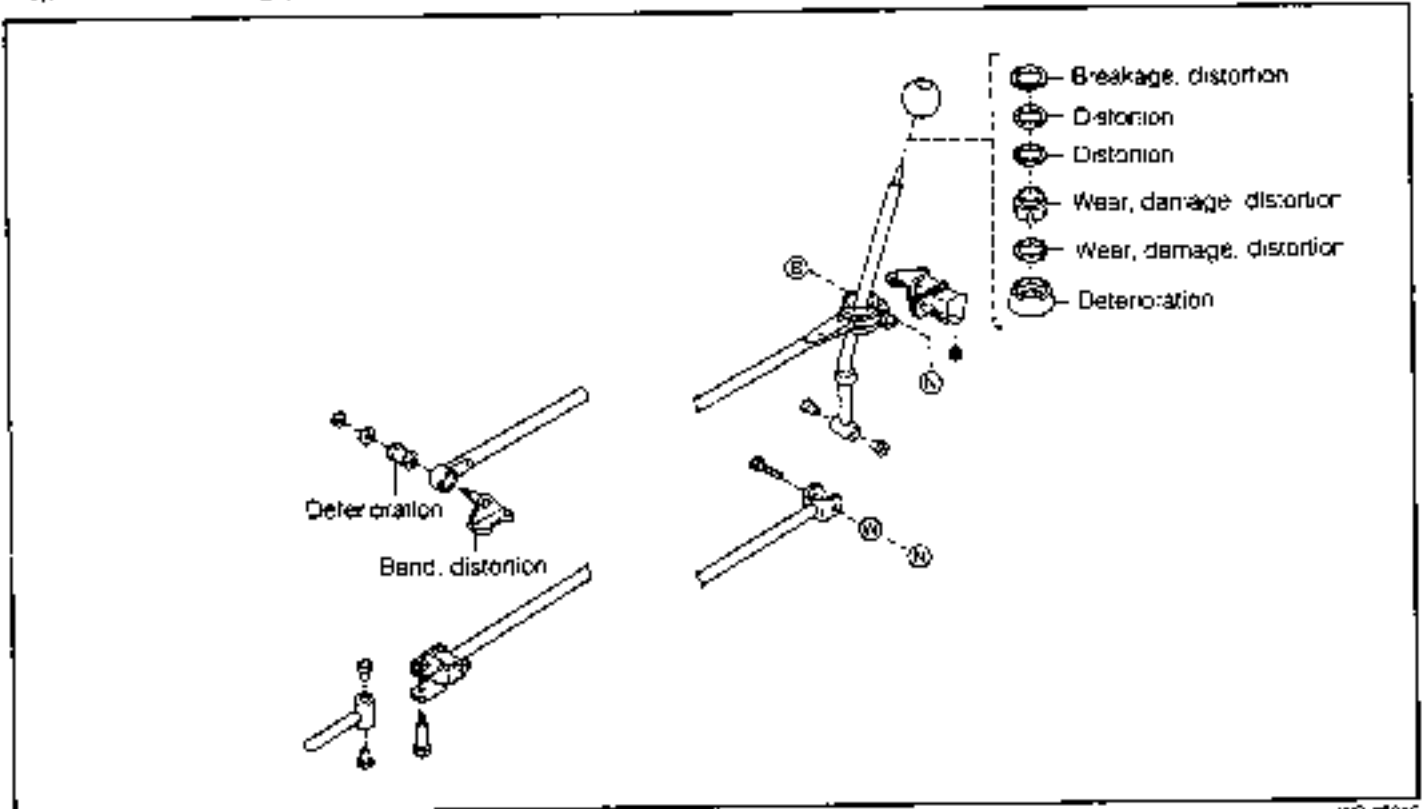

Fig. 3-221

WR-05216

Grease Application Points

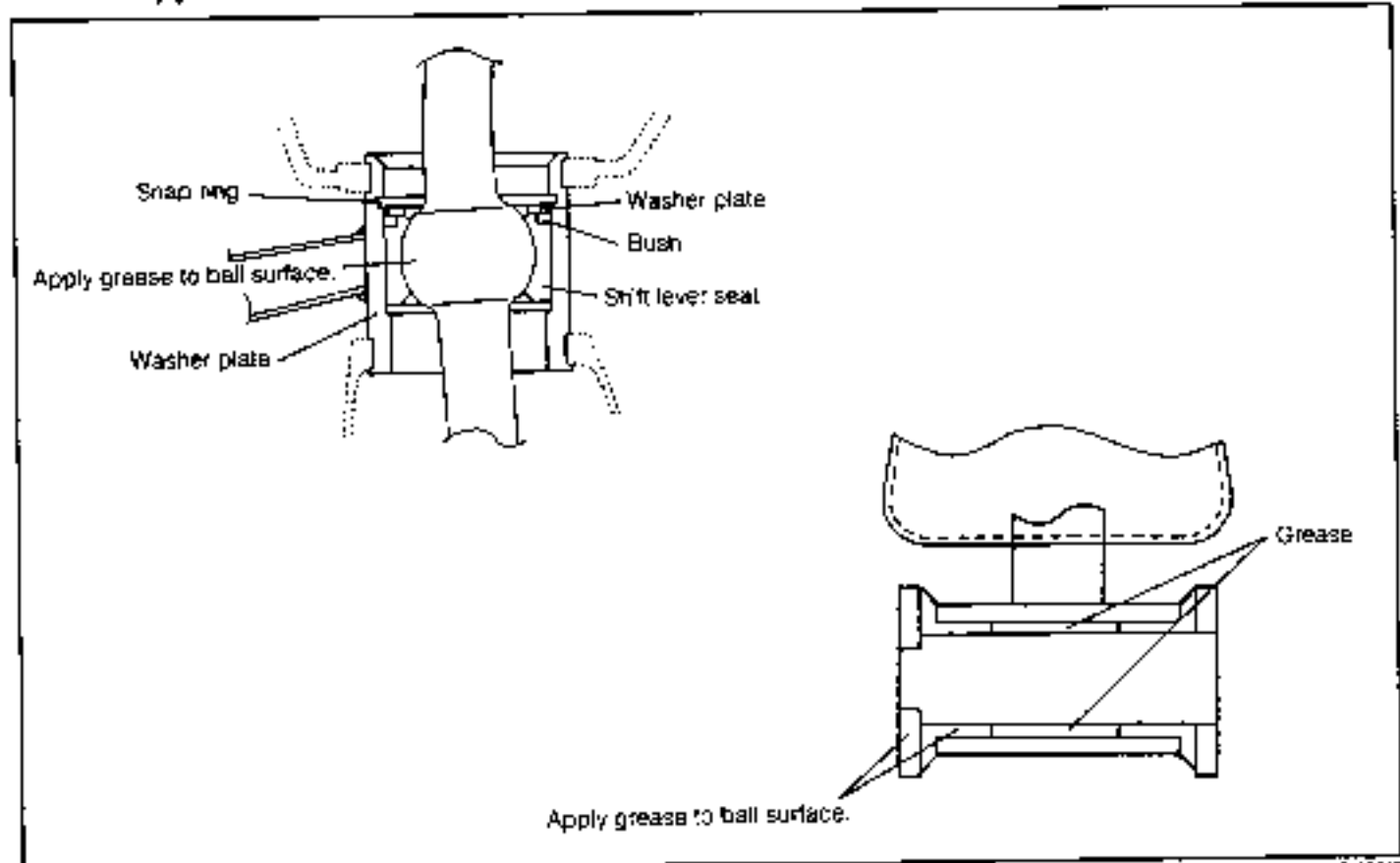

Fig. 3-222

WR-05217

MANUAL TRANSMISSION

ASSEMBLY

1. Assemble the extension rod.

NOTE:

On replacement parts, the connecting method with the support employs a bolt. Hence, care must be exercised to ensure that the assembling is carried out in the correct direction.

2. Insert the bush into position.

NOTE:

If any difficulty is encountered in inserting the bush, apply soap water to the case side for easier installation.

3. Assemble the floor shift support No.1. Install the nut and washer.

4. Assemble the bush in the shift lever subassembly.

1. Assemble the shift & select shaft.

NOTE:

On replacement parts, the connecting method with the shift lever employs a bolt. Hence, care must be exercised to ensure that the assembling is carried out in the correct direction.

Tightening Torque: 1.0 - 1.6 kg-m (7.2 - 11.6 ft-lb)

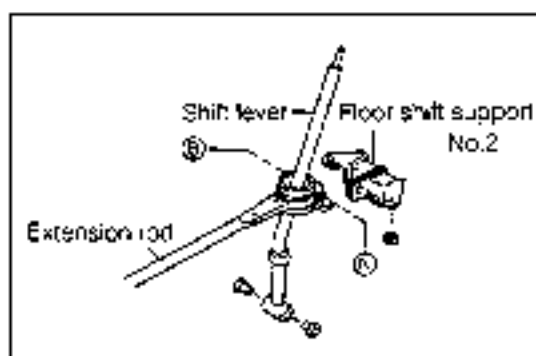

Fig. 3-223

WP-03E15

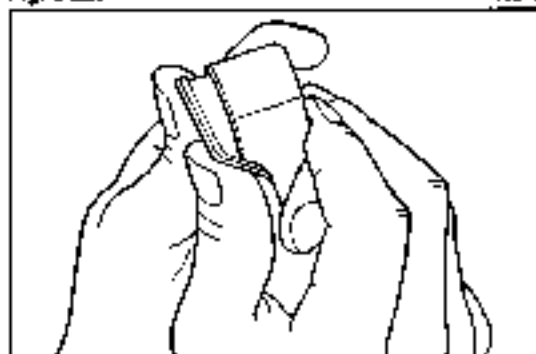

Fig. 3-224

WP-03E19

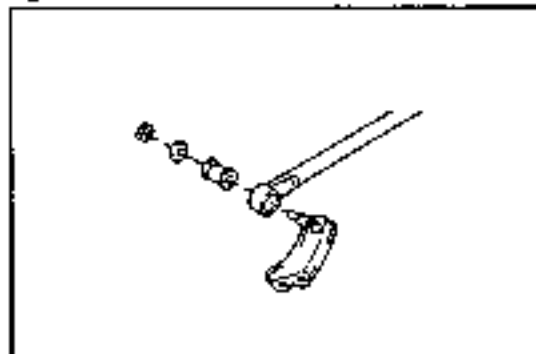

Fig. 3-225

WP-03E20

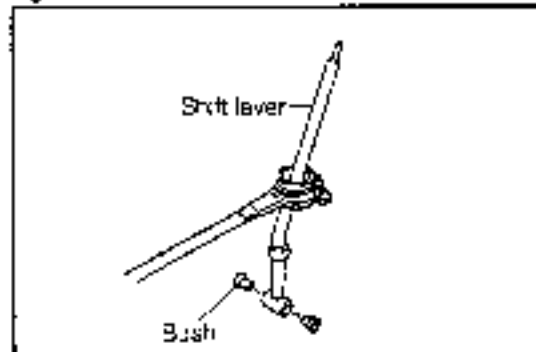

Fig. 3-226

WP-03E21

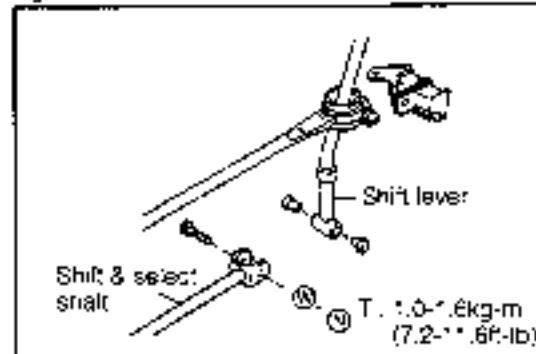

Fig. 3-227

WP-03E22

6. Assemble the shift lever retainer dust boot and plate washer onto the extension rod.

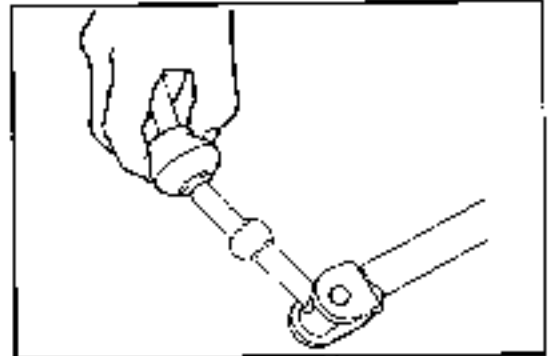

Fig. 3-228

WR-03228

7. After the shift lever subassembly has been installed, assemble the shift lever seat, bush and plate washer.

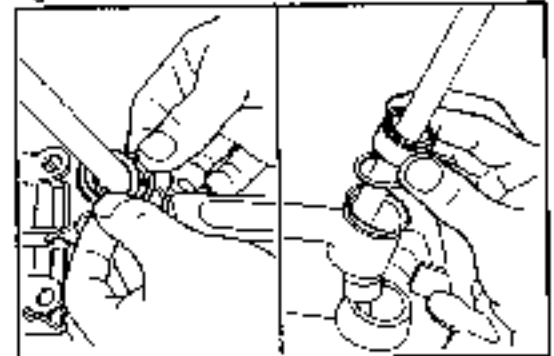

Fig. 3-229

WR-03229

8. Assemble the hole snap ring, using the SST given below.
SST: 09905-87001-000



Fig. 3-230

WR-03230

INSTALLATION

1. Install the floor shift support No.2, shift lever and extension rod as a set on the vehicle.

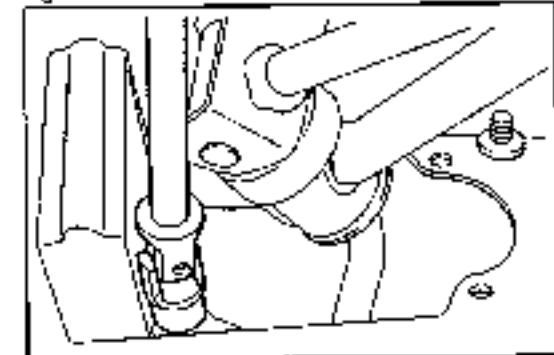

Fig. 3-231

WR-03231

2. Install the extension rod subassembly, onto the transmission.
Tightening Torque: 1.0 - 1.6 kg-m (7.2 - 11.6 ft-lb)

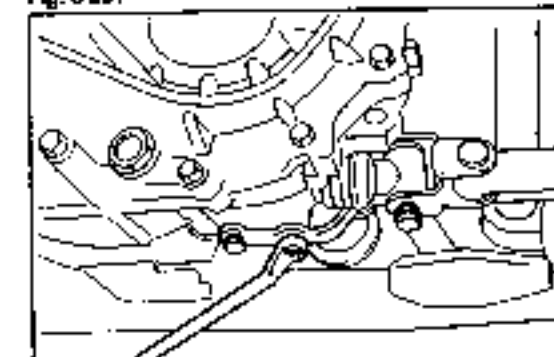

Fig. 3-232

WR-03232

MANUAL TRANSMISSION

3. Assemble the bush in the shift & select shaft. Install the transmission side of the shift & select shaft subassembly.

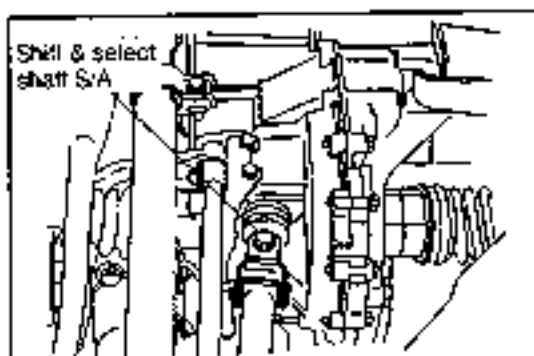

Fig. 3-233

WR-0228

4. Install the dust boot and dust seal retainer.

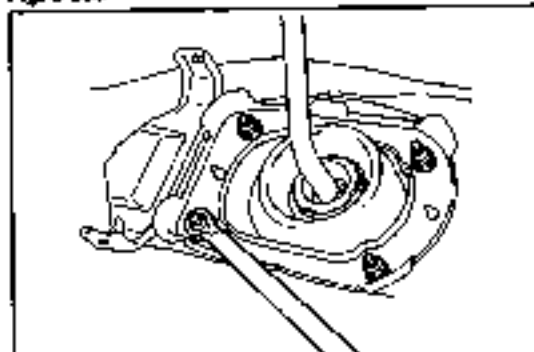

Fig. 3-234

WR-0229

5. Install the shift & select lever boot and the shift lever knob.

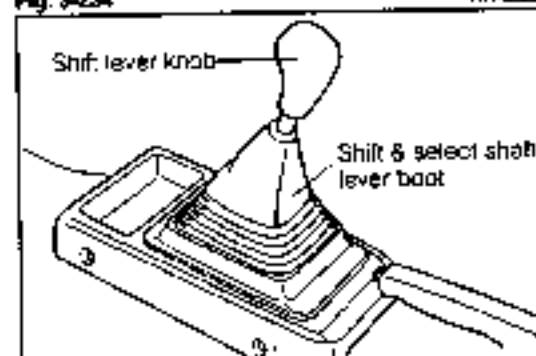

Fig. 3-235

WR-03230

Input Shaft Locking Tool

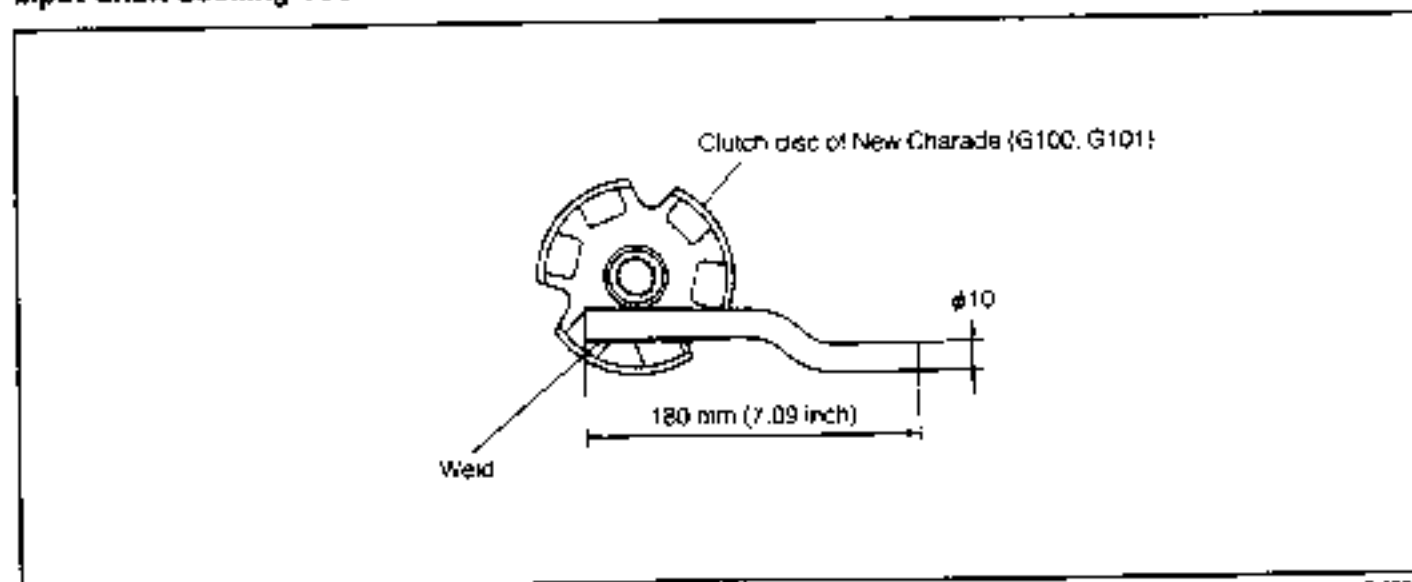

Fig. 3-236

WR-08231

Make the input shaft locking tool with clutch disc of new Charade (G100, G101) as shown in the above illustration.

DAIHATSU

CHARADE

Chassis

4

SECTION 4

AUTOMATIC TRANSMISSION

GENERAL INFORMATION	4- 2	ASSEMBLY OF TRANSMISSION	4-50
SECTIONAL VIEW	4- 2	APPENDIX	4-70
SPECIFICATIONS	4- 3	SHIFT LEVER CONSTRUCTION	4-70
BASIC CHECKS	4- 5	CONTROL CABLE CONSTRUCTION	4-71
ADJUSTMENTS	4- 6	ASSEMBLING POSITION AND DIRECTION	
TESTS	4- 7	OF THRUST BEARING	4-72
UNIT INSPECTION	4-15	LIST OF SPRINGS	4-73
TROUBLE SHOOTING	4-19	LIST OF "O" RINGS	4-73
FLUID CHANGE	4-23	LIST OF BOLTS USED	4-74
TRANSMISSION REMOVAL AND			
INSTALLATION	4-24		
DISASSEMBLY OF TRANSMISSION	4-26		
INSPECTION AND REPAIRS OF			
EACH PART	4-35		
OIL PUMP	4-35		
FORWARD CLUTCH	4-37		
DIRECT CLUTCH	4-40		
VALVE BODY	4-43		

4/9-0400*

AUTOMATIC TRANSMISSION

GENERAL INFORMATION

SECTIONAL VIEW

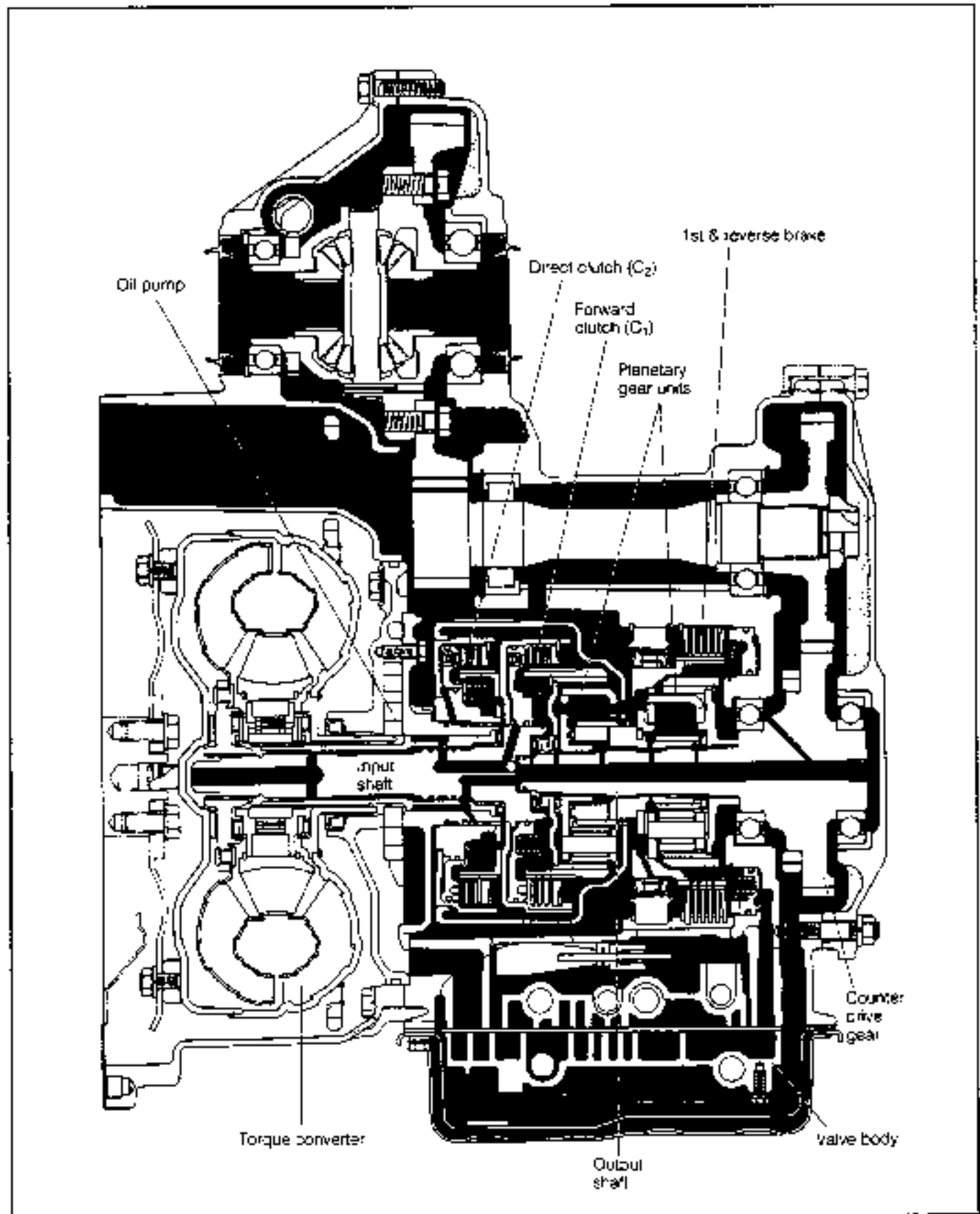

Fig. 4-1

WH 04002

SPECIFICATIONS

Item		Engine type	CB-23
Torque converter	Type	Three-element, one-stage, two-phase type	
	Stall torque ratio	2.26	
	One-way clutch type	Sprag type	
Transmission type	Type	Spiral gear type planetary gear (two-row)	
	Control element:	Wet type multiple clutch	2 sets
		Band type brake	1 set
		Wet type multiple brake	1 set
		One-way clutch	1 piece
	Gear ratio	1st gear: 2.810, 2nd gear: 1.549, 3rd gear: 1.000 reverse gear: 2.296	
	Reduction gear ratio	Reduction gear ratio: 0.980; final gear ratio: 3.872	
	Speedometer	Number of drive gear teeth: 27, Number of driven gear teeth: 24	
	Oil pump	Internal gear type	
	Fluid to be used	Automatic fluid Dexron-II	
	Fluid capacity liter (Imp. qts, US qts)	Approx. 5 (1.4, 5.3)	
Cooling method	Water-cooled (radiator built-in type)		
Control system	Gear shift control method	Electronic hydraulic pressure control method	
	Automatic gear shift	Three forward speeds, full automatic shift	
	Manual control pattern	P-R-N-D-2-L	

WR 04003

AUTOMATIC TRANSMISSION

OPERATING INSTRUCTIONS ON VEHICLE EQUIPPED WITH 3-SPEED AUTOMATIC TRANSMISSION

1. When the transmission is downshifted from the **D** or **2** range to the **L** range during running, as a precautionary measure perform the downshift at a vehicle speed below 50 km/h. The transmission has such function that, even if the transmission is downshifted to the **L** range, no downshift to the first gear will take place at a vehicle speed above 56 km/h.
2. When the automatic transmission-equipped vehicle is towed, set the change lever to the **N** position and tow the vehicle at a speed below 30 km/h. Towing distance is to be limited to 80 km. If troubles seem to exist inside the transmission, move the vehicle with front wheels raised by a wrecker. If the engine is not running, no oil circulates in the transmission. Hence, there is a possibility that the gear, clutch and so forth may get seized.
3. If the electronic control system, such as the computer should be encountered with abnormality, resulting in malfunctioning gear shift, and yet you must perform emergency running you may operate the vehicle, following the procedure given below.
 - 1) Disconnect the 2-pole connector (elliptical and white) leading to the solenoid of the transmission. Secure the disconnected harness leading to the solenoid so that it may not be caught by the drive shaft.
 - 2) When the shift lever is selected to the **L**, **2** and **D** ranges progressively in this order, upshift occurs as follows: the 1st gear in the **L** range, the 2nd gear in the **2** range and the 3rd gear in the **D** range.

WR 04004

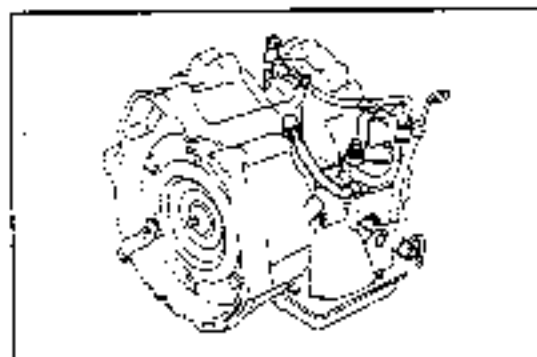
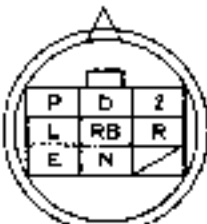
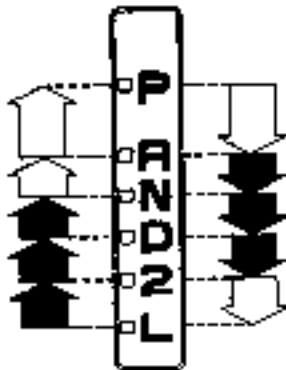
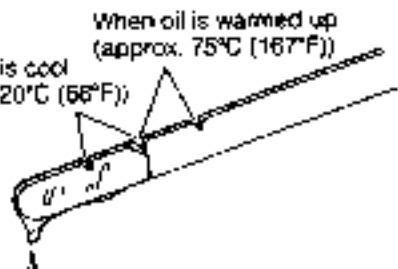

Fig. 4-2

WR 04005

BASIC CHECKS

Item	Procedure																
Preparation of check	<ol style="list-style-type: none"> 1. Park the vehicle on a flat road. 2. Ensure the safety at the forward and rear areas of the vehicle. Perform the following checks. 																
Neutral Start Switch Check 	<ol style="list-style-type: none"> 1. Apply the parking brake. 2. Ensure that the engine can start when the shift lever is set to the [N] or [P] range. Also ensure that the engine will not start when other ranges are selected. 3. Check each continuity specified in the connection table, using a circuit tester. Connection Table <table border="1" style="margin-left: auto; margin-right: auto;"> <thead> <tr> <th>Trans/Range</th> <th>E (to starter)</th> <th>N (to starter)</th> <th>2 (to starter)</th> </tr> </thead> <tbody> <tr> <td>H</td> <td style="text-align: center;">○</td> <td style="text-align: center;">○</td> <td></td> </tr> <tr> <td>P</td> <td style="text-align: center;">○</td> <td></td> <td style="text-align: center;">○</td> </tr> <tr> <td>Over</td> <td style="text-align: center;">○</td> <td style="text-align: center;">○</td> <td style="text-align: center;">○</td> </tr> </tbody> </table>	Trans/Range	E (to starter)	N (to starter)	2 (to starter)	H	○	○		P	○		○	Over	○	○	○
Trans/Range	E (to starter)	N (to starter)	2 (to starter)														
H	○	○															
P	○		○														
Over	○	○	○														
Shift Lever Position Check  <p style="margin-left: 200px;"> → means "Move shift lever without pushing shift lever button." ⇔ means "Move shift lever with shift lever button pushed." </p>	<ol style="list-style-type: none"> 1. Start the engine. Release the parking brake. Ensure that the vehicle moves forward when the shift lever is shifted from the [N] range to the [D], [2] or [L] ranges. Also, ensure that the vehicle moves backward when the shift lever is shifted to the [R] range. 2. Stop the engine, and apply the parking brake. 3. Set the shift lever from the [N] range to each of the [D], [2] and [L] ranges. Make sure that the shift lever can be operated smoothly and shifted to each range with a good detent feeling. Also ensure that the position indicator functions properly. Moreover set the engine key switch to the [ON] position. Ensure that the position indicator in the combination meter functions properly. 4. Set the engine key switch to the [ON] position. Switch the shift lever from the [P] or [N] range to the [R] range. Ensure that the backup lamp goes on. 																
Engine Idling Speed Check Specified Value: 800 - 850 rpm	<ol style="list-style-type: none"> 1. Apply the parking brake. 2. Attach an engine tachometer. 3. With the [N] range selected, warm up the engine. 4. Ensure that the engine idling speed complies with the specification. 																
Automatic Transmission Fluid Level Check  <p style="margin-left: 20px;"> When oil is warmed up (approx. 75°C (167°F)) When oil is cool (approx. 20°C (68°F)) </p> <p style="margin-left: 20px;">Total fluid capacity: Approx. 5.0ℓ (including torque converter)</p>	<ol style="list-style-type: none"> 1. Apply the parking brake. 2. With the brake pedal depressed and the engine running at the idling speed, select the shift lever all through the ranges from the [P] to [L]. Finally, return the shift lever to the [P] range. 3. Take out the level gauge and wipe off the fluid with a cloth. Insert the level gauge and take it out again. Check to see if the fluid level is between the upper and lower limits. <p>NOTE:</p> <ol style="list-style-type: none"> 1. Perform the check when the fluid temperature is 70 - 80°C (158 - 176°F), which is the normal operating temperature. 2. If the fluid level is low, check for fluid leakage. 3. Care must be exercised as to a too-low fluid level, for it will cause various troubles. 																
Solenoid Valve Connector Check Computer Connector Check	<ol style="list-style-type: none"> 1. Check to see if any connector is disconnected. 																
Speedometer Check	<ol style="list-style-type: none"> 1. Check to see if the speedometer pointer is moving. 2. Check to see if the vehicle speed indicator is normal. 3. Check to see if the vehicle speed sensor is producing an output. (See page 4-15.) 																

AUTOMATIC TRANSMISSION

ADJUSTMENTS

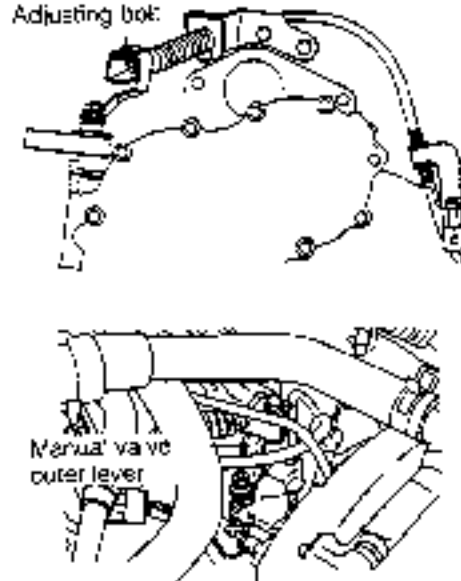
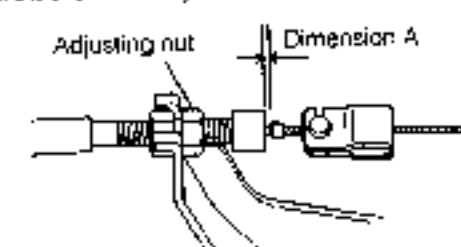
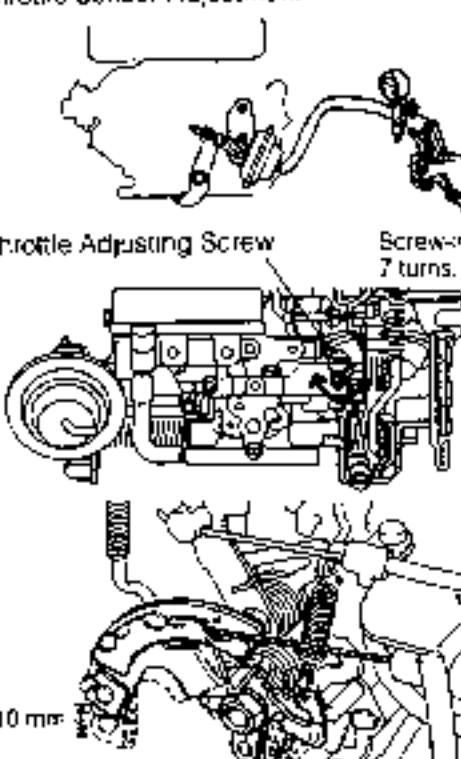
Item	Procedure
<p>Shift Lever Adjustment</p> <p>Adjusting bolt:</p>  <p>Manual valve outer lever</p>	<ol style="list-style-type: none"> 1. Check the joint section between the control rod and the manual valve outer lever for wear. Check other joint sections for wear and deformation. 2. Turn the manual valve outer lever to the left as far as it goes (P range). Then, back off two stages (N range). 3. Slacken the swivel bracket attaching bolt (adjusting bolt) located at the end section of the control cable. 4. Set the shift lever to the N range. With the shift lever lightly pushed to the R range side, tighten the attaching bolt in Step 3 (While drawing the control cable to the transmission side, securely tighten the control cable.) 5. After completion of the adjustment, check the shift lever operation. Ensure that the shift lever is operated with a good detent feeling and that the position indicator functions properly for each range. Also, make sure that the vehicle moves forward in the D, 2 and L ranges, whereas the vehicle backs up in the R range.
<p>Throttle Cable Adjustment</p>  <p>Adjusting nut</p> <p>Dimension A</p>	<p>Adjust the adjusting nut in such a way that the dimension A complies with the specified value when the throttle is fully closed.</p> <p>Specified Value: 0 - 0.5 mm (0 - 0.02 inch)</p> <p>Tightening Torque: 0.85 - 1.55 kg-m (6.15 - 11.2 ft-lb)</p>
<p>Throttle Sensor Adjustment</p>  <p>Throttle Adjusting Screw</p> <p>Screw-in 7 turns.</p> <p>10 mm</p>	<ol style="list-style-type: none"> 1. Using a MityVac (a hand vacuum pump), keep the dashpot in a contracted state. 2. Slacken the throttle adjusting screw so that it may be once cleared from the throttle shaft arm. 3. Screw-in the throttle adjusting screw until it comes in contact with the throttle shaft arm. Further screw-in the throttle adjusting screw 7 turns. (At this point, the periphery of the throttle lever travels 10 mm (0.39 inch).) 4. Adjust the throttle sensor so that the switch "S₂" - to - "earth" continuity of the throttle sensor may be changed from [OFF] to [ON] at this opening degree of the throttle valve. Perform this adjustment by turning the adjusting screw located at the back of the throttle sensor, using the SST. (See page 4-14.) 5. Remove the MityVac. Back off the throttle adjusting screw so that the idling speed may be adjusted to 800 - 850 rpm.

TESTS

Prior to the following tests, be sure to perform basic checks and adjustments.

1. STALL TEST

This test checks the total performance of the transaxle and engine, by measuring the maximum engine revolution speed at each range.

NOTE:

1. Perform this test when the fluid temperature is 70 - 80°C (158 - 176°F), which is the normal operating temperature.
2. Never perform this test continuously for more than six seconds.

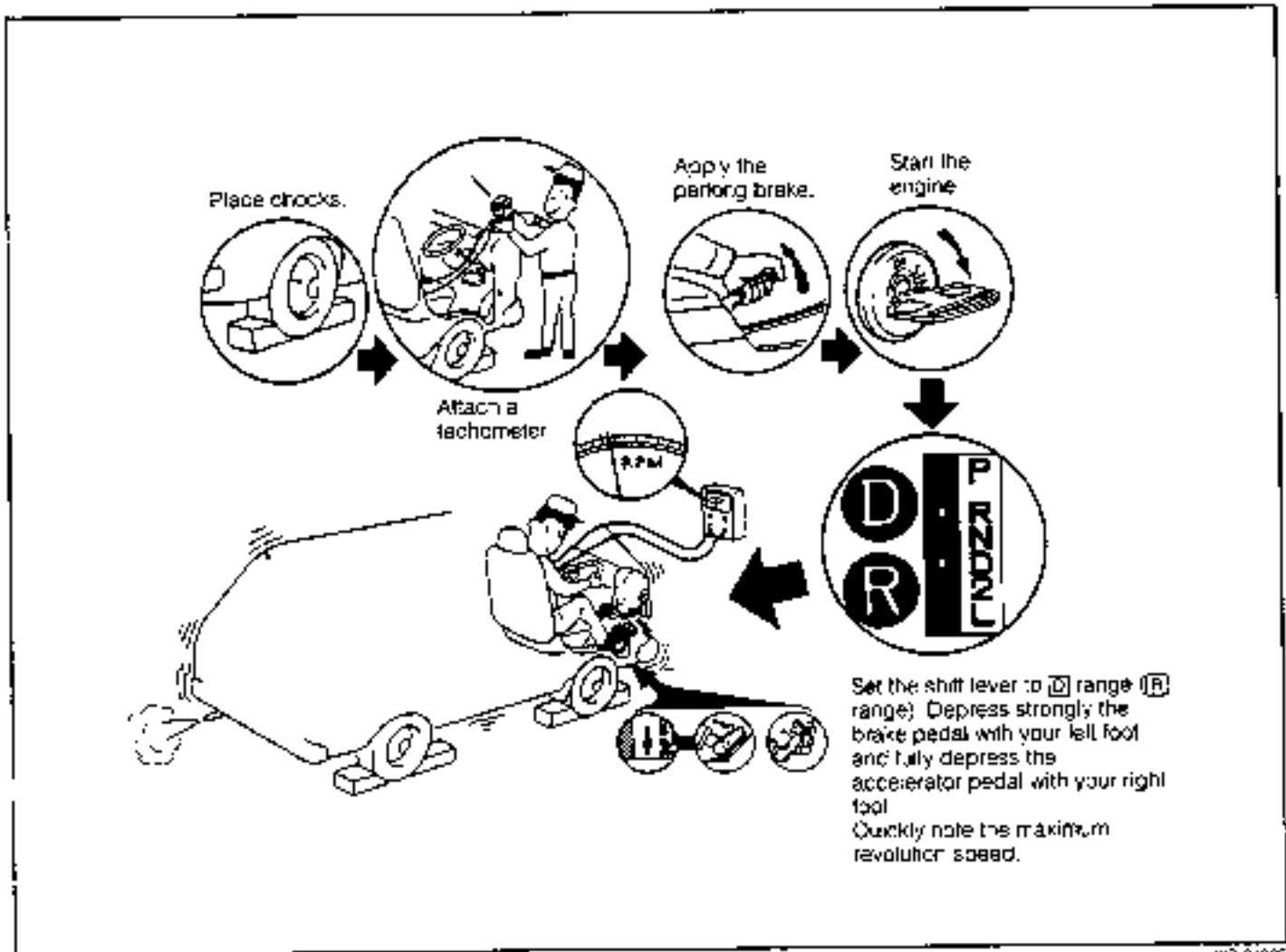

Fig. 4-3

WA-34008

Specified stall revolution speed:

2100 - 2300 rpm

Reference: If the measured value does not conform to the specification, the following are possible causes.

Case where stall revolution speeds for both ranges are the same, but lower than the specified value	<ol style="list-style-type: none"> 1. Lack of engine output 2. Torque converter malfunctioning
Case where stall revolution speed for D range is greater than the specified value	<ol style="list-style-type: none"> 1. Forward clutch slipping 2. One-way clutch of torque converter malfunctioning 3. Line pressure too low
Case where stall revolution speed for R range is greater than the specified value	<ol style="list-style-type: none"> 1. Direct clutch slipping 2. 1st & reverse brake slipping 3. Line pressure too low

WA-34008

AUTOMATIC TRANSMISSION

2. TIME LAG TEST

When the shift lever is shifted while the engine is idling, a certain time elapses before a shock is felt. This time is called the time lag. This time lag test evaluates the conditions of the clutch, brake and line pressure.

NOTE:

1. Perform this test when the fluid temperature is 70 - 80°C (158 - 176°F), which is the normal operating temperature.
2. If the time lag is to be measured consecutively, be sure to put an one-minute interval between the tests.

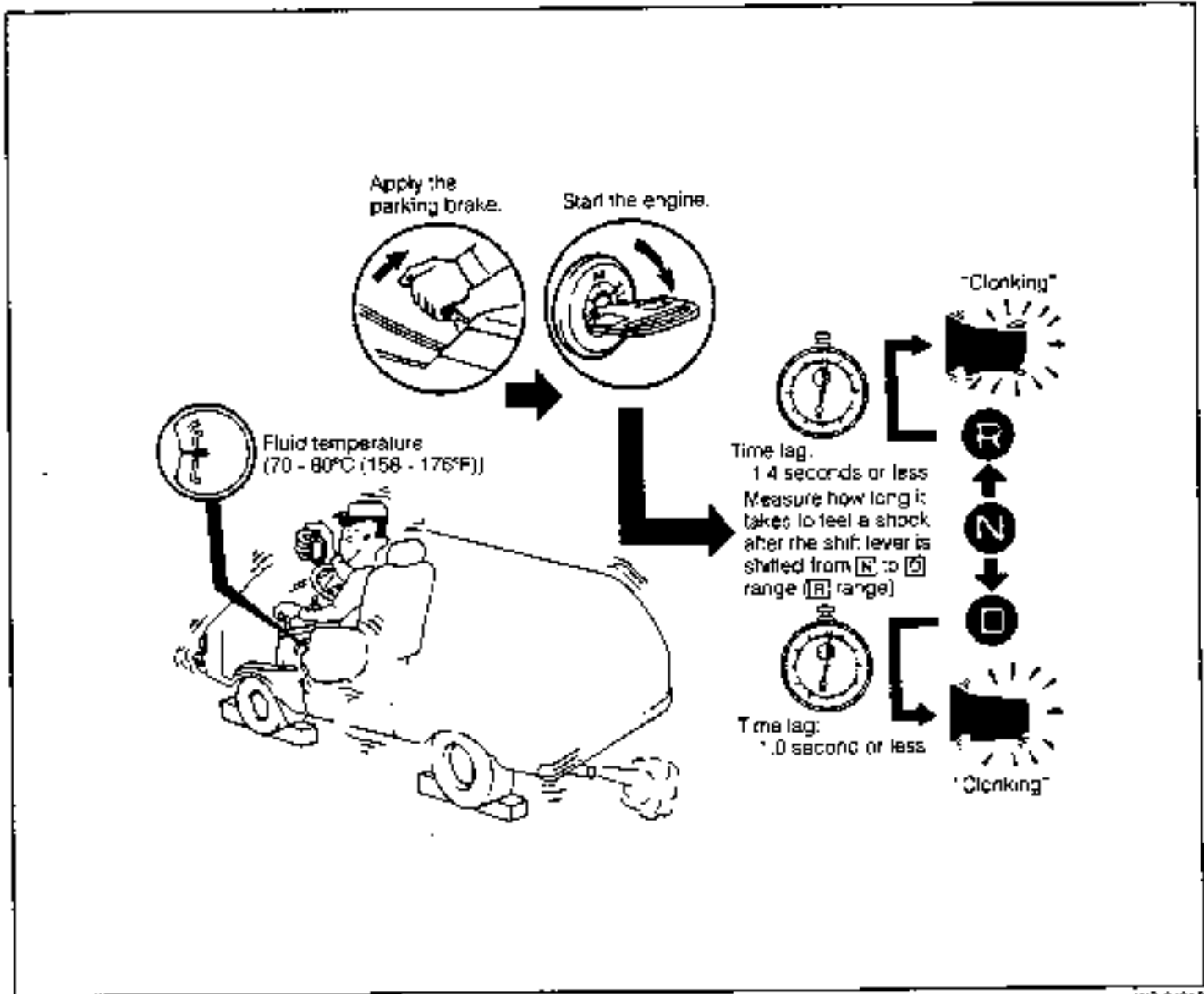

Fig. 4-4

WP-04010

Specified time lag

N → D Range: 1.0 Second or Less

N → R Range: 1.4 Seconds or Less

Reference: If the measured value does not conform to the specification, the following are possible causes.

Case where time lag for N to D shift is greater than the specified value	<ol style="list-style-type: none"> 1. Forward clutch worn 2. Line pressure too low
Case where time lag for N to R shift is greater than the specified value	<ol style="list-style-type: none"> 1. Direct clutch worn 2. First & reverse brake worn 3. Line pressure too low

WP-04011



3. HYDRAULIC PRESSURE TEST

This test checks operating condition of each section by measuring the fluid line pressure.

NOTE:

1. Perform this test when the fluid temperature is 70 - 80°C (158 - 176°F), which is the normal operating temperature.
2. Be sure to replace the test plug with a new one.

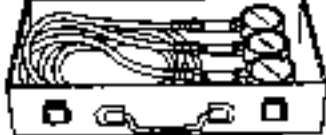
Articles to be prepared

Instruments		<p>09992-00092-000</p> <p>Oil pressure gauge for automatic transmission</p> <p>Tool handled by Banzai, Ltd. Type: DPG-100</p>
		<p>Oil pressure gauge adaptor (For A35 and A55)</p> <p>Tool handled by Banzai, Ltd. Type: OPG-41</p>

Test plug position

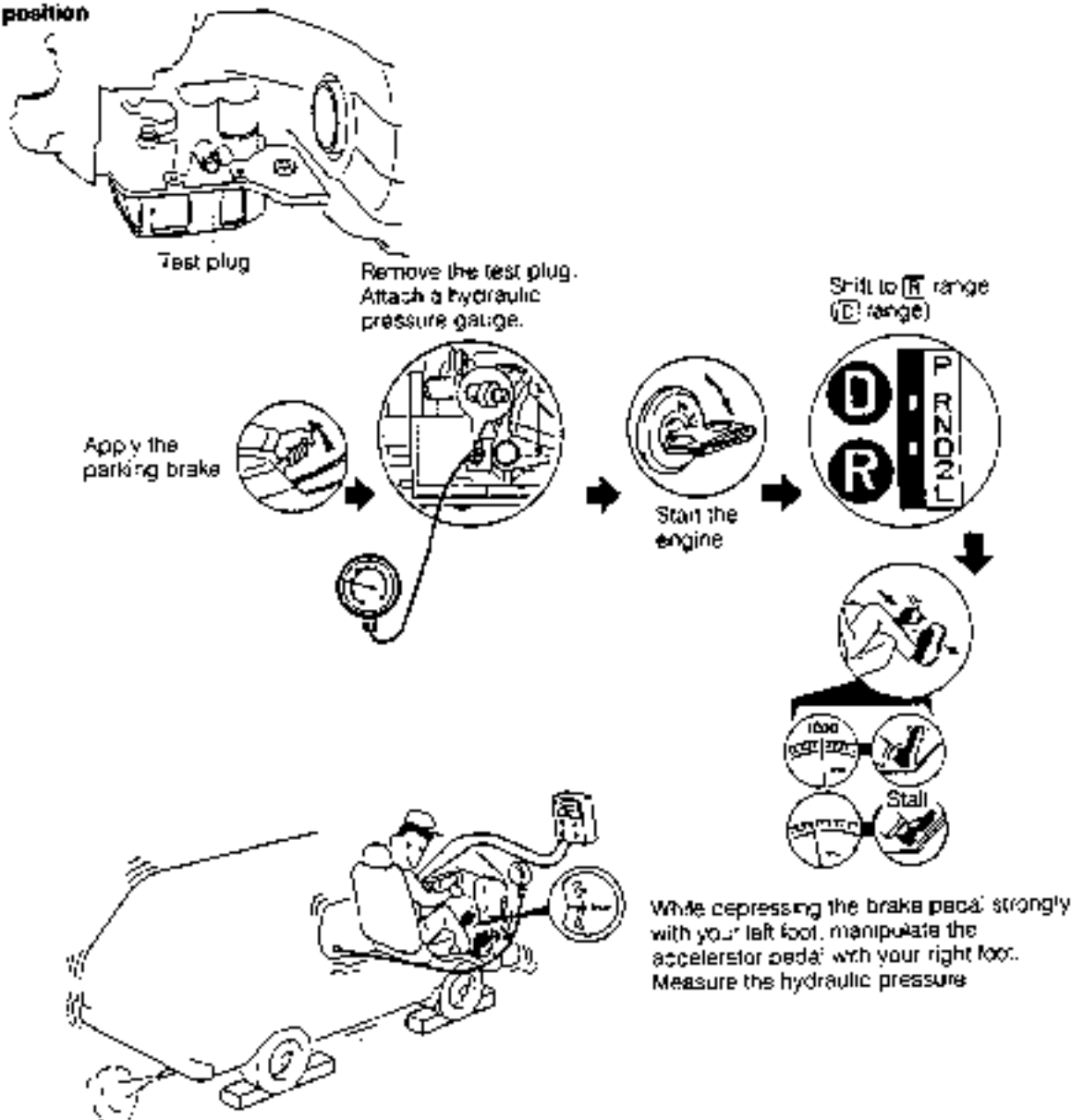

Fig. 4-5

WR-04012

AUTOMATIC TRANSMISSION

Specified hydraulic pressure

Engine running condition	Hydraulic pressure kg/cm ² (psi)	
	D range	R range
Idling revolution	2 - 4 (28 - 57)	5 - 8 (71 - 114)
Stall revolution	4 - 6 (57 - 85)	8 - 12 (114 - 171)

Reference: If the measured value does not conform to the specification, the following are possible causes.

Case where hydraulic pressure for each range is greater than the specified value	<ol style="list-style-type: none"> 1. Regulator valve malfunctioning 2. Throttle valve malfunctioning 3. Throttle cable improperly adjusted
Case where hydraulic pressure for each range is lower than the specified value	<ol style="list-style-type: none"> 1. Oil pump faulty 2. Regulator valve malfunctioning 3. Throttle valve malfunctioning 4. Throttle cable improperly adjusted
Case where hydraulic pressure for D range is lower than the specified value	<ol style="list-style-type: none"> 1. Forward clutch malfunctioning 2. Oil leakage at D range circuit
Case where hydraulic pressure for R range is lower than the specified value	<ol style="list-style-type: none"> 1. Direct clutch malfunctioning 2. First & reverse brake malfunctioning 3. Oil leakage at R range circuit

WA-040-3

4. SYSTEM CHECKS ON TEST VEHICLE

(1) Running test

Check the gear shift at each shift point in accordance with the shift point characteristics diagram. Determine whether or not the gear shift occurs by your body feeling.

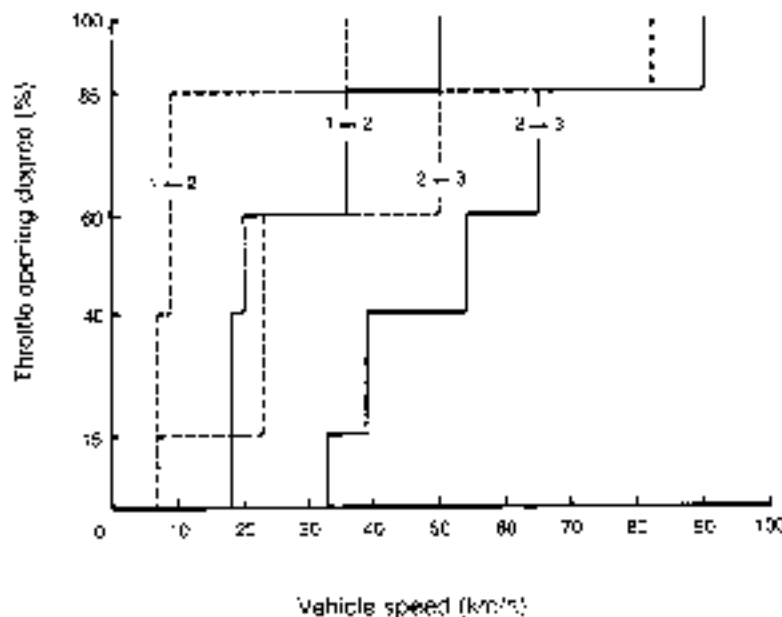

Fig. 4-6

WR-04314

□ range test

1. From the standstill state, start the vehicle by fully depressing the accelerator pedal (in □ range). Ensure that the upshift from 1st gear to 2nd gear occurs at a vehicle speed of approx. 50 km/h.
2. From the standstill state, start the vehicle by depressing the accelerator pedal about halfway. Ensure that the upshift from the 2nd gear to the 3rd gear occurs at a vehicle speed of approx. 54 km/h.

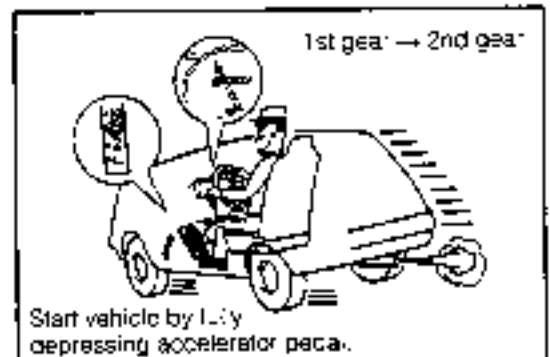

Fig. 4-7

WR-04315

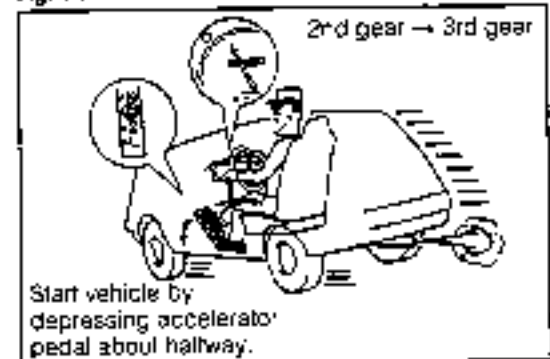

Fig. 4-8

WR-04316

AUTOMATIC TRANSMISSION

3. While running in the 3rd gear of the **D** range at a vehicle speed of 80 km/h or less, depress the accelerator pedal fully. Ensure that the downshift from the 3rd gear to the 2nd gear occurs.

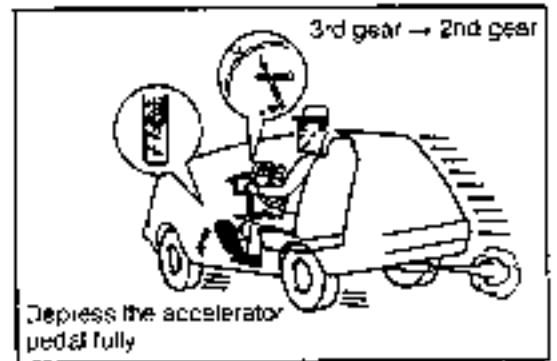

Fig. 4-9

WR-04017

4. While running in the 2nd gear of the **D** range at a vehicle speed of 36 km/h or less, depress the accelerator pedal fully. Ensure that the downshift from the 2nd gear to the 1st gear occurs.

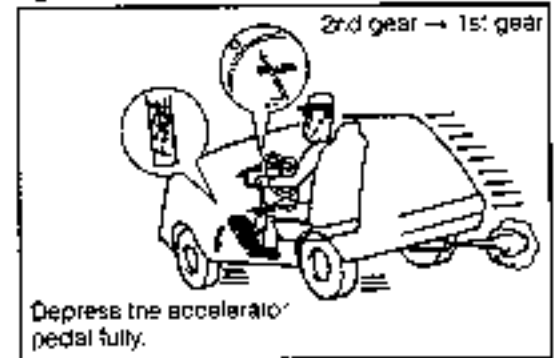

Fig. 4-10

WR-04015

Trouble symptom	Possible causes
No upshift from 1st gear to 2nd gear takes place.	<ol style="list-style-type: none"> 1 - 2 shift valve malfunctioning Solenoid valve No. 2 malfunctioning Shift control system malfunctioning
No upshift from 2nd gear to 3rd gear takes place.	<ol style="list-style-type: none"> 2 - 3 shift valve malfunctioning Solenoid valve No. 1 malfunctioning Shift control system malfunctioning
Incorrect shift points	<ol style="list-style-type: none"> 1 - 2 and 2 - 3 shift valves malfunctioning Shift control system malfunctioning
Excessive shocks	<ol style="list-style-type: none"> Idling speed too high Line pressure too high Accumulator malfunctioning

WR-04015

(2) Engine brake test

While running in the 3rd gear of the **[D]** range, shift to the **[2]** or **[L]** range. Check the engine brake operation in each range.

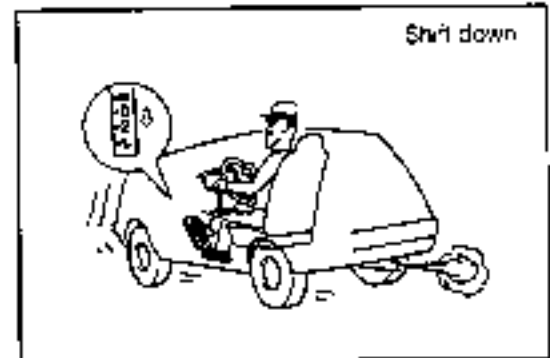

Fig. 4-11

WP-C4023

Reference: If the engine brake does not work effectively, the following are possible causes.

Case where engine brake will not work in [2] range	2nd brake malfunctioning
Case where engine brake will not work in [L] range	First & reverse brake malfunctioning

(3) Manual running test

Remove the harness of the solenoid valves No. 1 and No. 2 at its connector section (white, 2-pole). Run the vehicle by manually shifting the shift lever to each range. Check to see if the gear shifts occur in accordance with each range.

NOTE:

Secure the disconnected harness, using vinyl tape or the like, so that it may not be caught by the rotating sections.

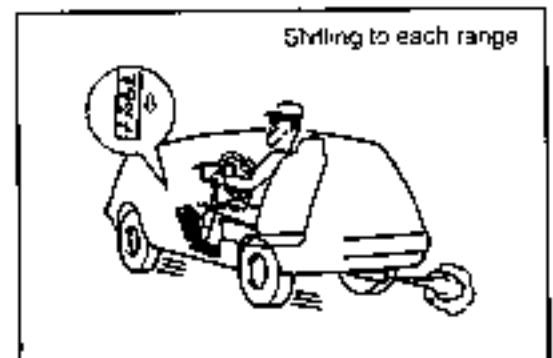

Fig. 4-12

WP-C4021

Specifications

Shift lever position	D	2	L
Gear position	3rd	2nd	1st

(4) **[P]** range test



- Place the vehicle on a grade (about 5 degrees or more) with the vehicle in an upright state. Set the lever to the **[P]** range and release the parking brake lever. Ensure that the vehicle will not move by the operation of the parking lock mechanism.
- Repeat this test in the same procedure for the vehicle facing downhill.
- Check to see if the vehicle moves when the shift lever is changed from the **[P]** range to other ranges.

WP-C4022

AUTOMATIC TRANSMISSION

5. ELECTRICAL SYSTEM CHECK

Articles to be prepared

	Shape	Number and nomenclature of parts	Use
SST		09842-87702-000 Transmission control computer check subharness	For checking computer input/output voltages
		09843-87702-000 A* X computer check lamp	Diagnosis display
Instrument	Digital laser		

WF-6423

How to use SST

Connect the transmission control computer check subharness between the computer and the connector of the harness at the vehicle side. This subharness is used for checking input/output voltages of each terminal:

When measuring the connector terminal voltage, use a circuit tester with adequate internal resistance of more than 40 kΩ. If a circuit tester with small internal resistance is used, no correct voltage is indicated. After completion of the connection, confirm the following items and perform the check.

1. Continuity exists between the body earth and each of the earth terminals ⑩ and ⑪.
2. Regardless of the key switch position, the battery voltage is applied across ⑫ and ⑬ (earth).
3. When the key switch is set to the [LOCK] and [ACC] position, no voltage is applied across ⑫ and ⑬ (earth); when set to the [ON] position, the battery voltage is applied.

Computer terminals

⑫	⑬	⑭	⑮	⑯	⑰	⑱	⑲	⑳	㉑	㉒	㉓
IG	L1	L2	E01	S3	T	SFD	P	D	Z	L	BR
S	FP	-B	E1	S4	S	he	S2	SPC2	Tv	N	R
㉔	㉕	㉖	㉗	㉘	㉙	㉚	㉛	㉜	㉝	㉞	㉟

WF-6423

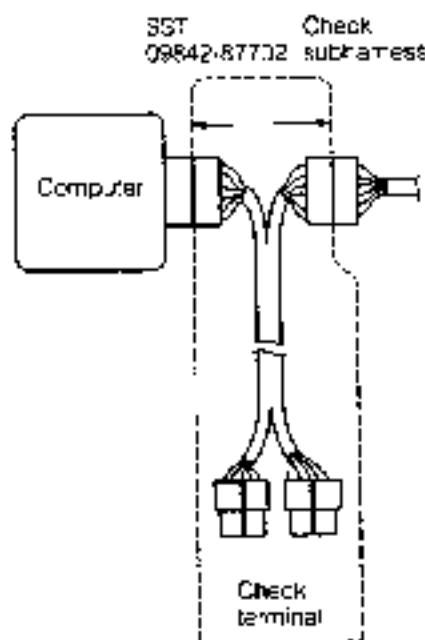
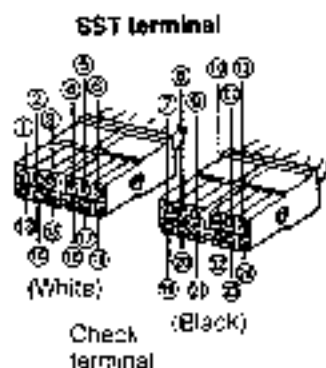

Fig. 4-13

Diagnosis display

This system is provided with a diagnosis function. Therefore, if the vehicle is encountered with any abnormality, first check to see if any abnormality code indication is present. If any abnormality code is displayed, check the corresponding item according to the table below. (For display method, see page 3-50 of the Technical Information No. 9331-GE.)

Code No.	Lamp flashing number	Diagnosis item	Page to be referred to
1	1	Normal	—
2	2	Abnormality in pulse signal of vehicle speed sensor No. 1	P 4-15
3	3	Open wire or short in solenoid valve No. 1	P 4-17
4	4	Open wire or short in solenoid valve No. 2	P 4-17
5	5	Abnormality in signal input of throttle sensor	P 4-17
6	6	Abnormality in shift position signal	P 4-16
7	7	Abnormality in pulse signal of vehicle speed sensor No. 2	P 4-15

WR-04025

UNIT INSPECTION

1. VEHICLE SPEED SENSOR CHECK (Refer to page 3-47 of the Technical Information No. 9331-GE)

Perform this check with the key switch set to the [ON] position, but without starting the engine.

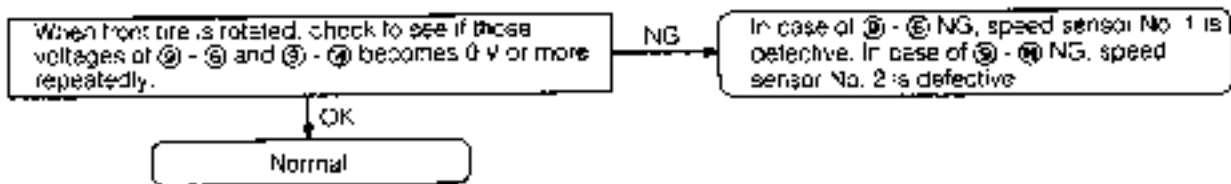

WR-04026

2. IG PULSE CHECK

Perform this check after starting the engine.

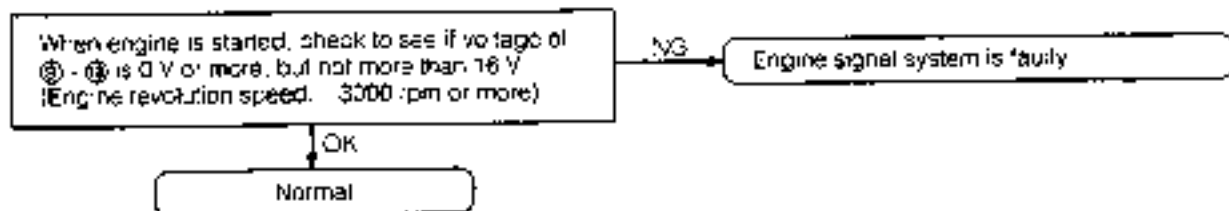

WR-04027

AUTOMATIC TRANSMISSION

3. NEUTRAL START SW CHECK (Refer to page 3-47 of the Technical Information No. 9331-GE)

Perform this check with the key switch set to the [ON] position, but without starting the engine.

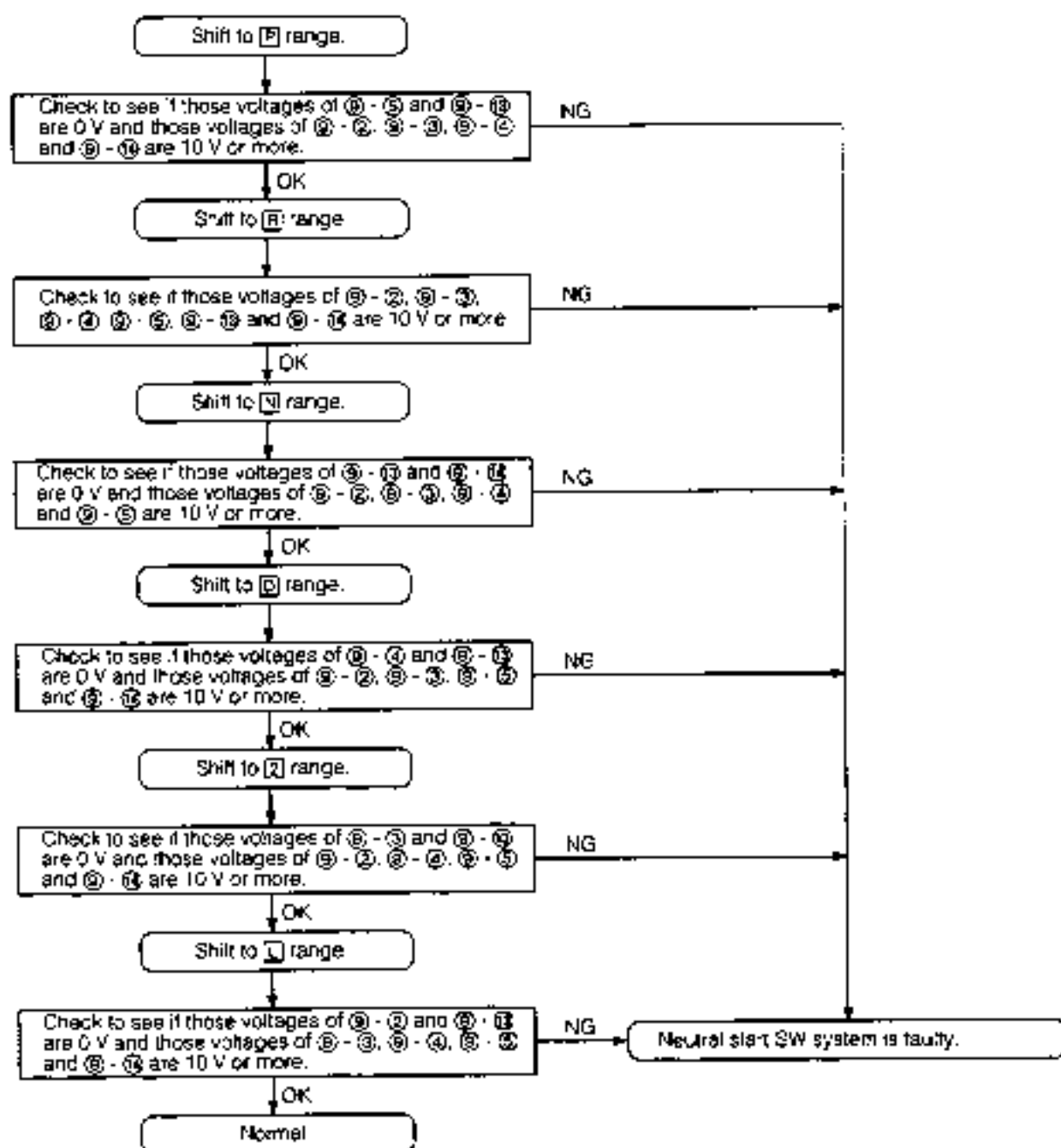

Voltage between ① (E01) and each terminal

Shift position	Terminal No.					
	⑤P	③A	④N	④D	③2	②L
P	L	L	H	H	H	H
R	H	H	H	H	H	H
N	H	L	L	H	H	H
D	H	L	H	L	H	H
2	H	L	H	H	L	H
L	H	L	H	H	H	L

L: 0V H: 10V or more

WA-01024

WA-01025

4. THROTTLE SENSOR CHECK (Refer to page 3-46 of the Technical Information No. 9331-GE)
 Perform this check with the key switch set to the [ON] position, but without starting the engine.

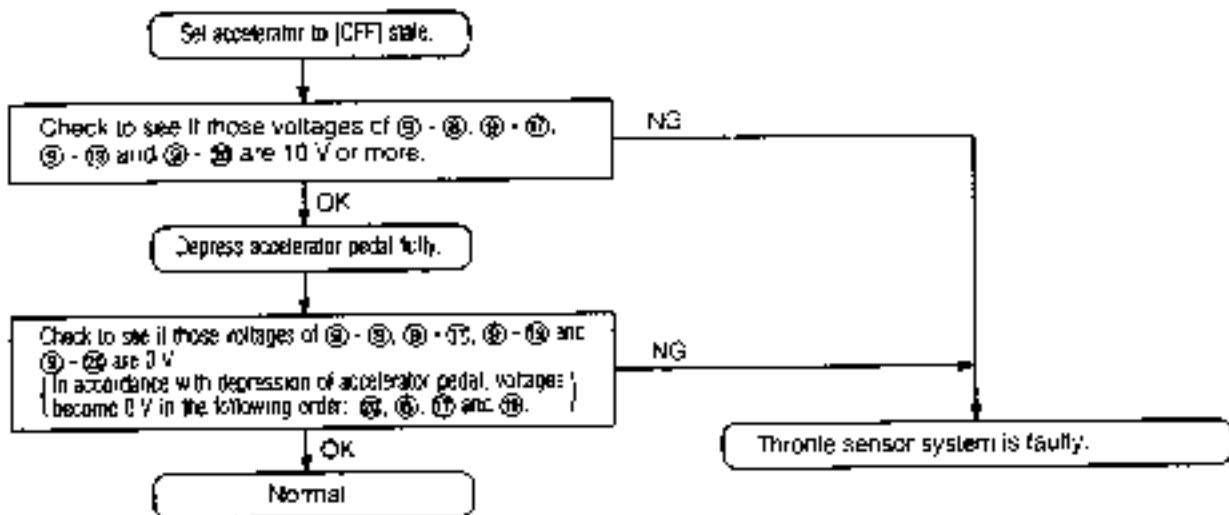

WR-04095

5. SOLENOID VALVE CHECK (2 POINTS) (Refer to page 3-48 of the Technical Information No. 9331-GE)

With the connector of the solenoid harness disconnected, apply the battery voltage to the connector at the transaxle side. Check to see if any operating sound occurs.

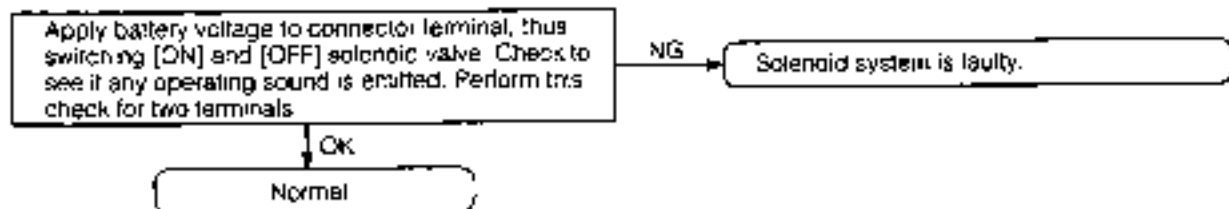

WR-04071

AUTOMATIC TRANSMISSION

6. TRANSMISSION CONTROL COMPUTER

The computer itself can not be checked

- (1) Be very careful not to apply impacts (e.g. drooping) to the transmission control computer
- (2) The connector should be connected, while paying attention to the locking direction. Furthermore, the connector should be disconnected with the lock button being depressed, making sure that the connector is not twisted.
- (3) Be certain to turn OFF the engine switch before the connector is connected or disconnected.
- (4) When the computer is mounted onto the body, be sure to tighten the two attaching bolts evenly and alternately in order that the bracket may not be distorted
- (5) Never open the sealing of the computer proper. Also, be sure not to modify the computer.
- (6) Prior to the removal/installation of the battery terminals, make sure to turn OFF the engine switch.
- (7) Under no circumstances should the battery be connected reversely.
- (8) Care must be exercised to ensure that no water or dust gets to the computer proper. If the computer proper should be soaked by water or the like, do not reuse the computer proper.

NOTE:

The computer is installed on the upper side of the glove compartment box.

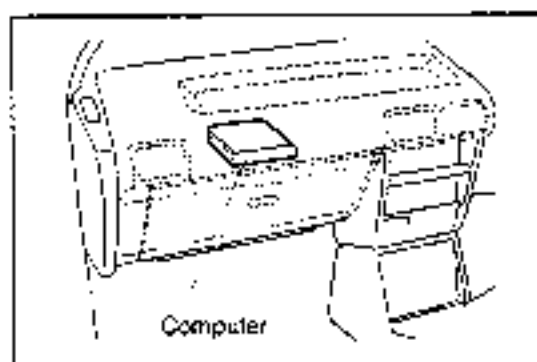
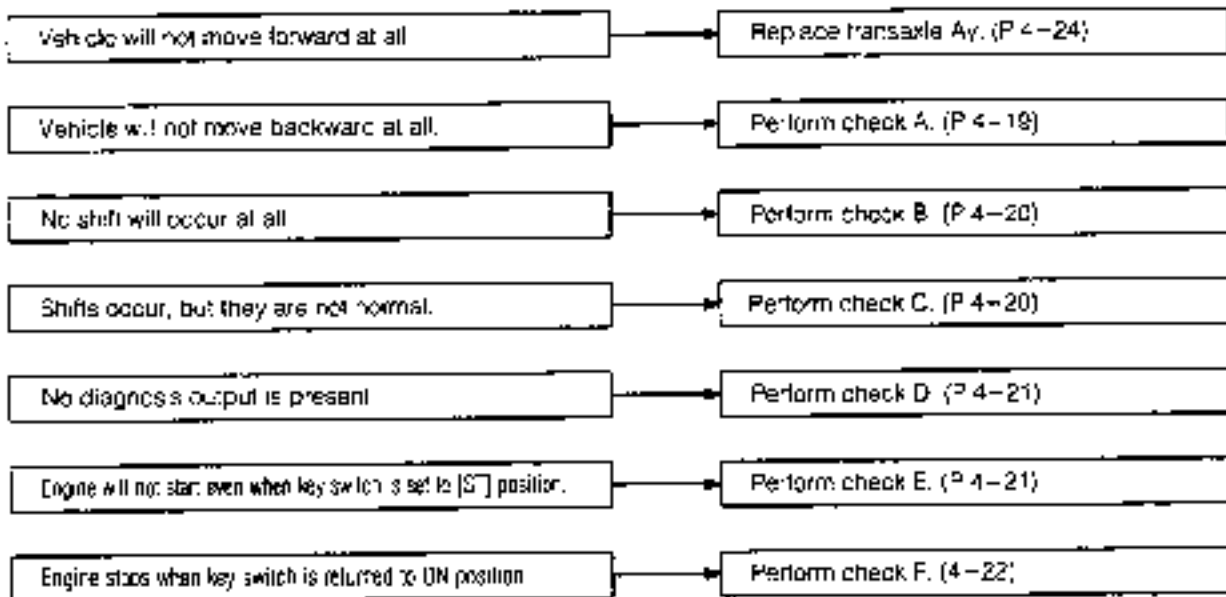

Fig. 4-14

WR-04332

TROUBLE SHOOTING

When checks and repairs have been made on abnormal codes, set the key switch to the [OFF] position. Remove the fuse (tail) or battery negative (-) terminal, thus canceling the memory.



WP-04032

1. CHECK A

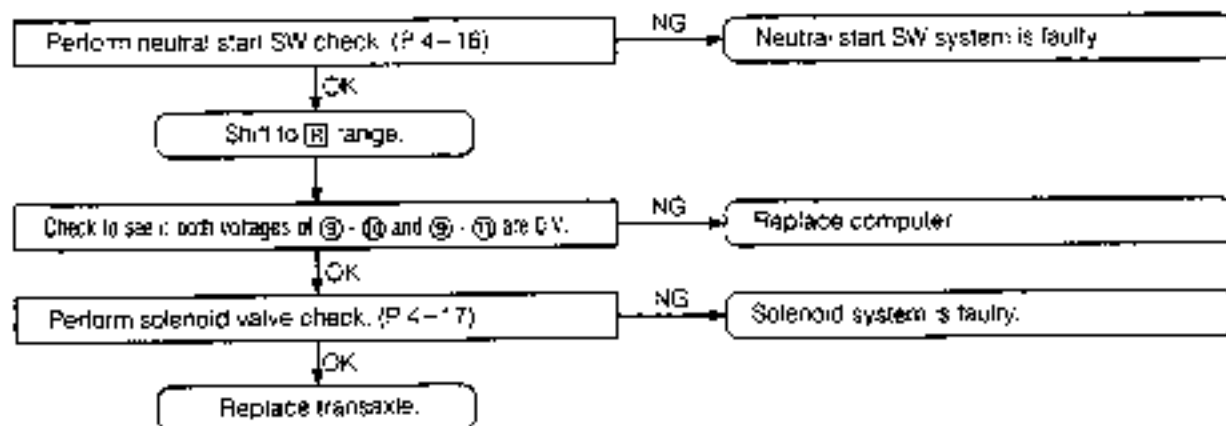

NOTE:

Here, "So-and-so system is faulty" means not only that sensors are faulty but also that there are disconnected connector, open wire, short and so forth at the vehicle side, as viewed from the computer side.

AUTOMATIC TRANSMISSION

2. CHECK B

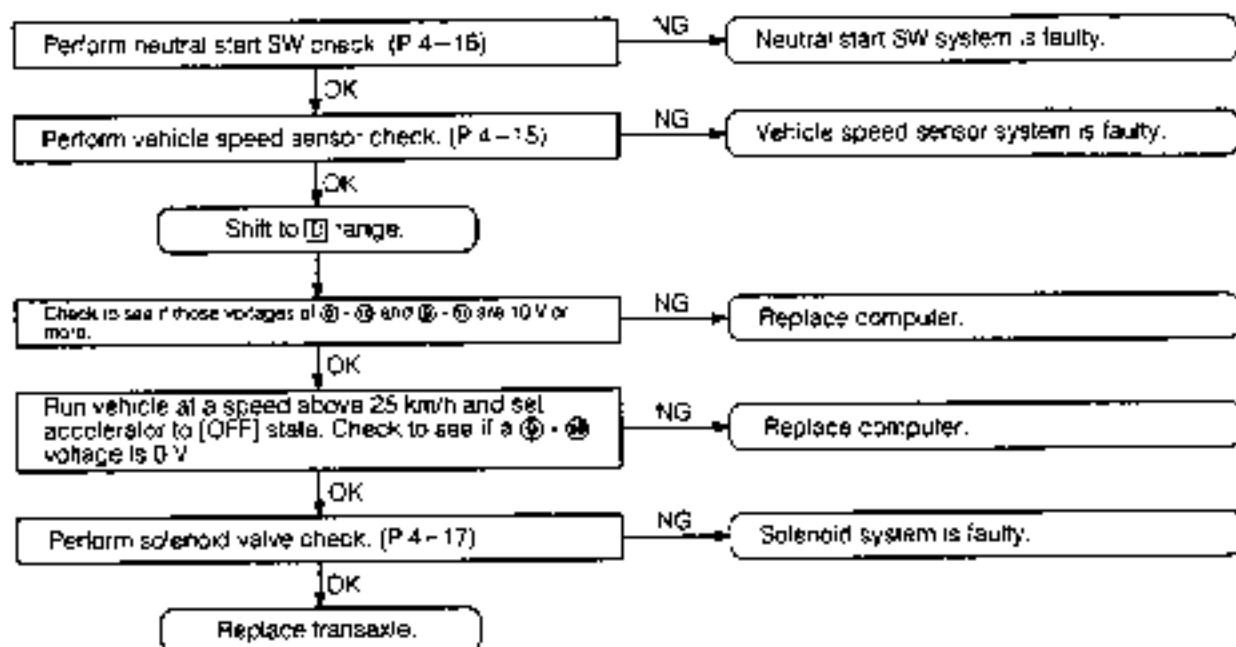

WR-0435

3. CHECK C

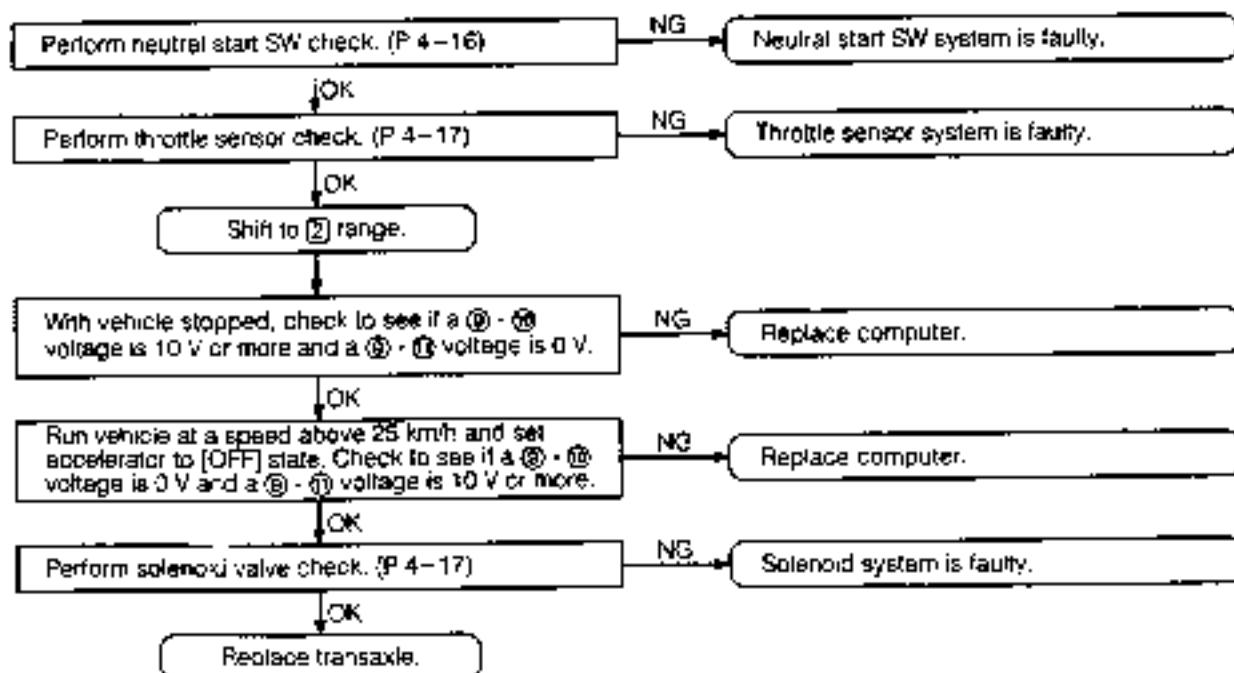

WR-34036

4. CHECK D

Prior to this check, ensure that the battery voltage is applied to the terminal shown in the figure.

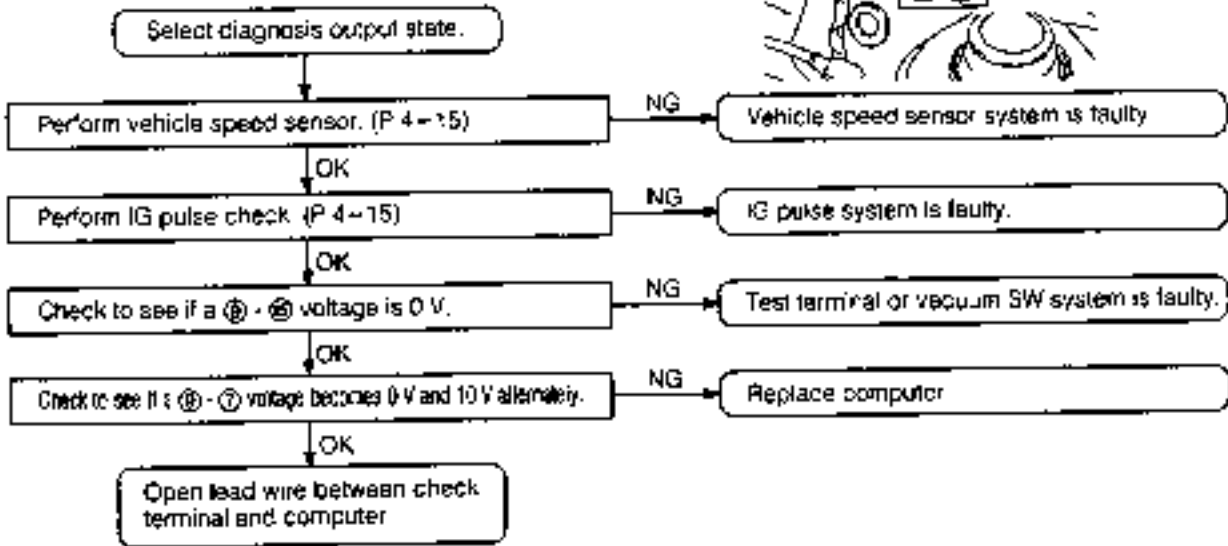
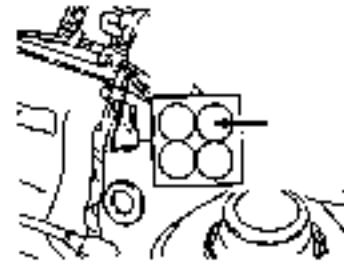

WR-04037

5. CHECK E

Perform this check with the key switch set to the [ON] position, but without starting the engine.

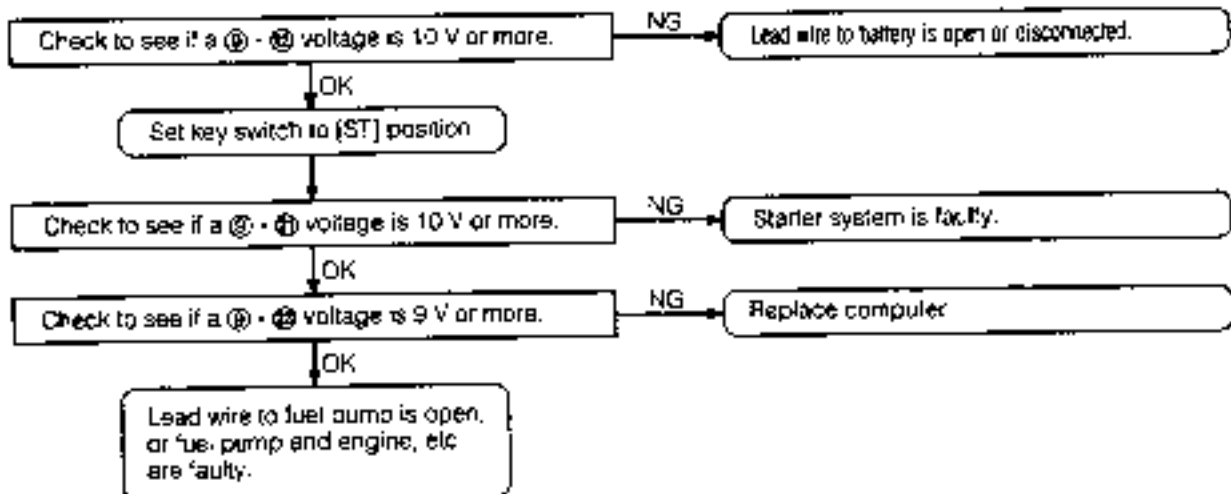

WR-04038

AUTOMATIC TRANSMISSION

6. CHECK F

Perform this check with the key switch set to the [ON] position, but without starting the engine

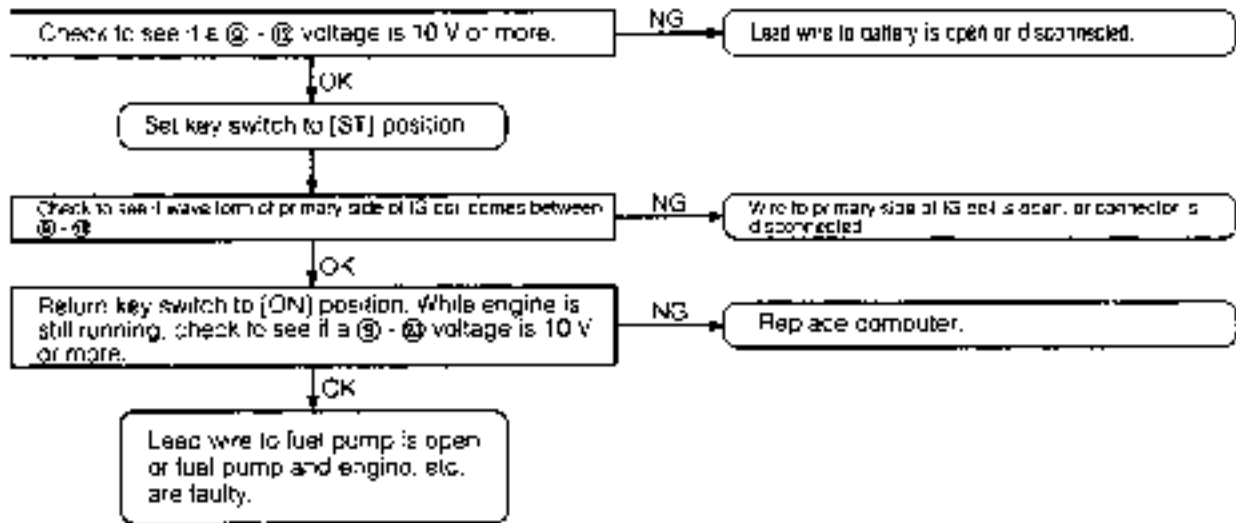

WF-24038

7. MEMORY ELIMINATION OF DIAGNOSIS CODE

After repairing abnormal part., remove the fuse (tail) or battery negative \ominus terminal for more than 10 seconds in order to cancel the memory

FLUID CHANGE

1. Jack up the vehicle
2. Allow the transmission to cool. Remove the drain plug and drain out the automatic fluid

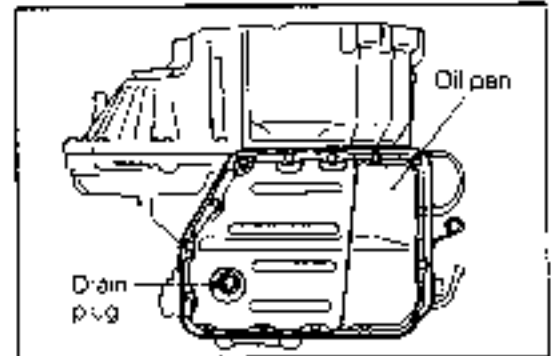

Fig. 4-15

WA-34041

3. Install the drain plug gasket and drain plug. Tighten the plug to the specified torque
Tightening Torque: 1.8 - 2.3 kg-m (13 - 17 ft-lb)
4. While the vehicle is still in a raised state, check the transmission and adjacent areas (including oil hose and oil cooler) for oil leakage, loose connecting sections or damage.
5. Pull out the oil level gauge from the oil filler tube. Add 1.5 ℓ (2.64 Imp.pt) of new fluid through the oil filler tube.

NOTE 1:

When the automatic transmission has been overhauled and the torque converter is to be reused, add 3.5 ℓ (6.2 Imp.pt) of new automatic fluid.

NOTE 2:

As for the torque converter and automatic transmission which contain no fluid at all, add 5 ℓ (6.8 Imp.pt) of new automatic fluid.

6. Check the fluid level only after the vehicle has reached the running state (70 - 80°C, 158 - 176°F).

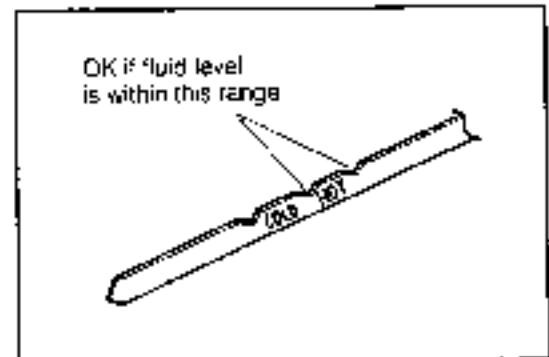

Fig. 4-16

WA-34043

TRANSMISSION REMOVAL AND INSTALLATION

REMOVAL

1. Remove the air suction guide from the air cleaner.
2. Disconnect the negative \ominus terminal of the battery.
3. Disconnect the positive \oplus terminal of the battery.
4. Remove the battery and battery tray.
5. Disconnect the earth terminal from the transmission.
6. Disconnect the solenoid wire coupler and neutral start switch wire coupler.
7. Disconnect the wire harness from the transmission.
8. Disconnect the speedometer cable from the transmission.
9. Disconnect the oil pressure control cable from the accelerator cable. Remove the accelerator cable from the transmission.
10. Remove the control cable from the transmission. (See APPENDIX.)
11. Remove the starter motor.
12. Drain out the automatic fluid from the transmission.
13. Disconnect the fluid inlet/outlet pipes. Then, hang them by means of wire so that no fluid may flow out from the oil cooler and hose.
14. Jack up or lift up the vehicle.
15. Remove the exhaust front pipe.
16. Remove the clutch housing Undercover.
17. Remove the six bolts at the drive plate.

NOTE:

It is advisable to lock the drive plate by inserting a common screwdriver to the drive plate gear through the clutch housing cut-out section.

18. Remove the right and left drive shafts in accordance with the "DRIVE SHAFT DISASSEMBLY" of the SECTION 5 (FRONT AXLE).
19. In order to remove the transmission, securely support the engine and transmission separately, using jacks or the like.
20. Remove the engine lower/left mounting.
21. Remove the bolt connecting the engine and transmission.
22. Remove the transmission from the engine. Carefully lower the transmission.

NOTE 1:

When removing the transmission from the engine, be very careful not to apply excessive forces to the drive plate or the torque converter.

NOTE 2:

After the transmission has been removed, keep the transmission in such a way that the oil pan may come at the bottom so that no fluid may flow out.

INSTALLATION

Reverse the removal procedure to install the transmission, following the operating instructions given below.

NOTE 1:

Prior to the installation, apply grease around the cup located at the center of the torque converter.

NOTE 2:

Prior to the installation, measure the dimension A indicated in the right figure.

Specified Value: 27.2 mm (1.07 inch) or more

If the measured value does not conform to the specifications, rework the installation.

NOTE 3:

Tighten the six bolts on the drive plate and the torque converter to the following torque.

Tightening Torque: 1.5 - 2.2 kg-m (11 - 16 ft-lb)

NOTE 4:

Tighten the bolts attaching the transmission to the engine to the following torque.

Tightening Torque: 5.0 - 7.0 kg-m (36 - 51 ft-lb)

NOTE 5:

Tighten the lower/left mounting bracket to the following torque.

Tightening Torque: 3.0 - 4.5 kg-m (22 - 33 ft-lb)

NOTE 6:

Install the right and left drive shafts in accordance with the "ASSEMBLY OF DRIVE SHAFT" of the SECTION 5 (FRONT AXLE).

NOTE 7:

After completion of the installation, check the automatic fluid level with the vehicle placed on a level place.

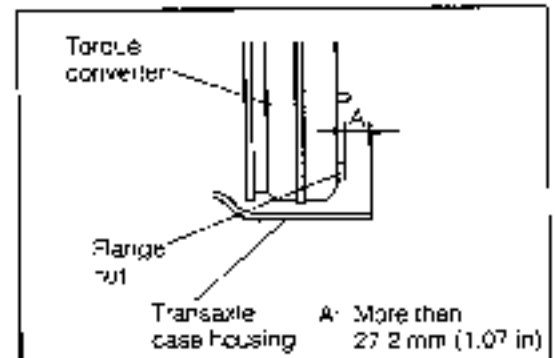

Fig. 4-1B

KR 04017

AUTOMATIC TRANSMISSION

DISASSEMBLY OF TRANSMISSION

INSTRUCTIONS ON DISASSEMBLY

1. In order to prevent dirt or dust from getting into the transmission case, observe the following instructions.
 - (1) Prior to the disassembly thoroughly wash off any sand or mud adhering to the outside of the transmission case.
 - (2) Perform the disassembly at a clean place.
 - (3) Do not wear gloves or use cloth.
2. Prior to the disassembly, check to see if any fluid leakage exists.
3. To prevent the removed parts from being lost or mixed with each other, place those parts removed from the transmission case in order.
4. Perform the disassembly while paying attention to the trouble shooting, too.
5. Do not remove any parts unnecessarily.
6. Completely peel off any trace of the gaskets from the parts making sure that no damage is made to the gasket mate surfaces.
7. When removing the snap rings, care must be exercised not to damage other parts.
8. When removing the bearings, be very careful not to apply forces to the balls and rollers.
9. When disassembling the transmission case, rear cover, oil pump, housing, valve body and so forth, never pry them off by a common screwdriver. Instead, disassemble them by lightly tapping them using a plastic hammer.

1. Remove the torque converter.

NOTE:

Be sure to receive fluid which may leak with a pan or the like.

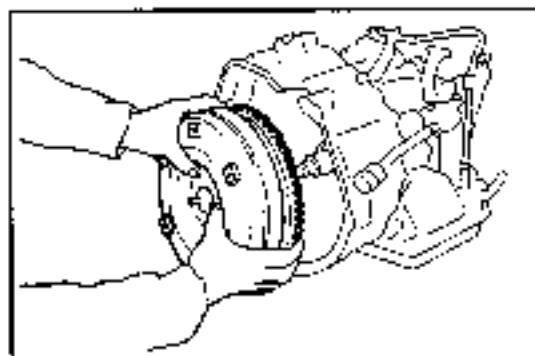

Fig. 4-19

WF-04043

2. Remove the oil filter tube and oil level gauge.

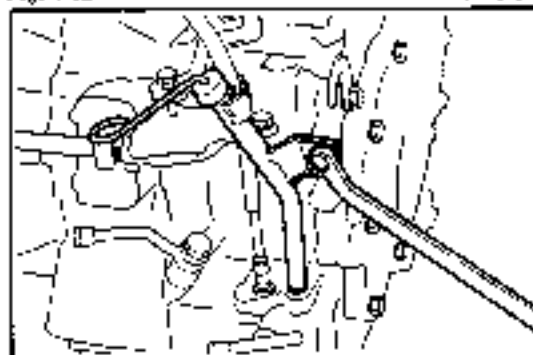

Fig. 4-20

WF-04050

3. Remove the drain plug and drain out the transmission fluid.

NOTE:

Completely drain out the fluid remaining inside the differential case by tilting it in various directions.

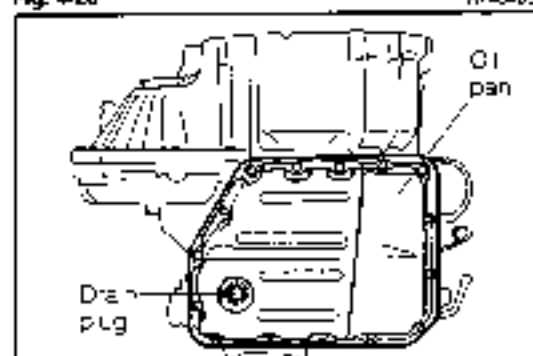

Fig. 4-21

WF-04051

4. Remove the oil pan and oil pan gasket.

NOTE:

- (1) Do not raise the oil pan side higher than the transmission case during the removal. Failure to observe this note will cause foreign matters at the bottom of the oil pan to contaminate the valve body.
- (2) Remove the oil pan by lightly tapping the entire periphery of the oil pan using a plastic hammer. Never pry off the oil pan, using a common screwdriver.

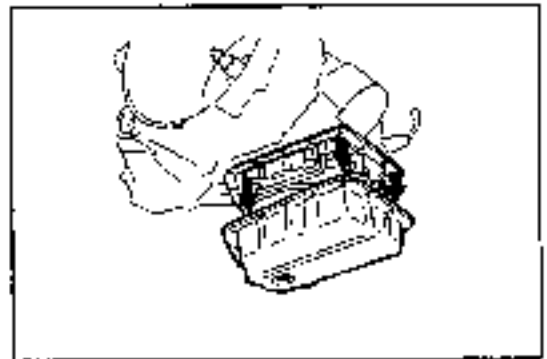

Fig. 4-22

WR-04052

5. Disconnect the solenoid connector (Two points)

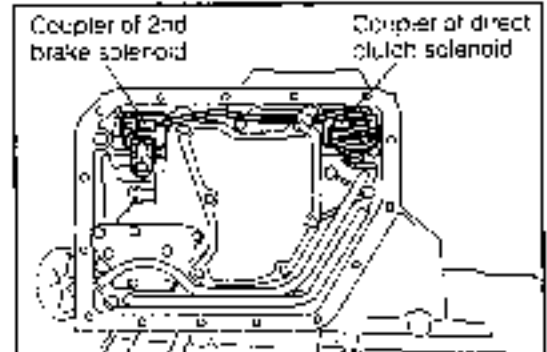

Fig. 4-23

WR-04053

6. Remove the oil tube.

NOTE:

Raise the end of the tube, using a common screwdriver.



Fig. 4-24

WR-04054

7. Remove the throttle cable from the throttle valve cam.

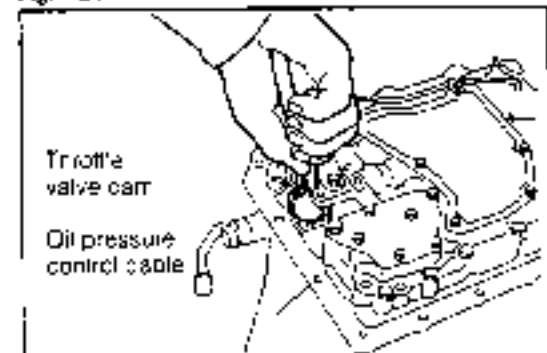

Fig. 4-25

WR-04055

8. Remove the valve body and oil strainer

NOTE:

Remove the 11 bolts indicated in the figure.

9. Remove the throttle cable from the transmission case

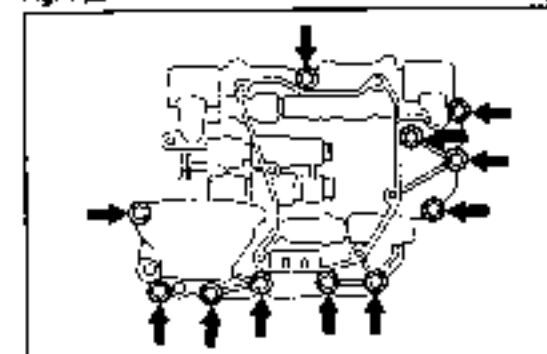

Fig. 4-26

WR-04056

AUTOMATIC TRANSMISSION

9. Removal of the accumulator piston

- (1) Cover with a cloth so as to prevent the piston from jumping out or the fluid from splashing.
- (2) To remove the piston, gently applying compressed air with a low pressure (1 kg/cm^2 , 15 psi at the maximum) into the oil hole indicated in the figure.

NOTE:

Care must be exercised as to jumping out of the piston or fluid splashing.

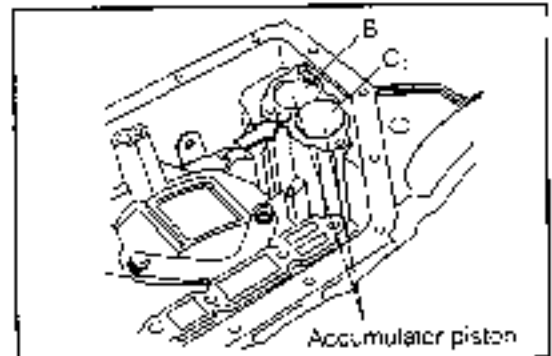

Fig. 4-27

WR-04267

10. Removal of the neutral start switch and the case side cover

- (1) Prior to the removal, shift to **N** range and scribe marks between the manual valve control lever and the neutral start switch and between the switch and the switch attaching position of the case in order to be easy to install.
- (2) Remove the manual valve control lever and the neutral start switch.
- (3) Remove the case side cover and the gasket.

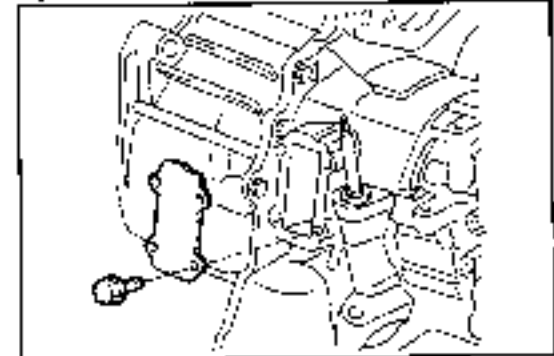

Fig. 4-28

WR-04268

11. Check of the 2nd brake piston rod stroke

- (1) Scribe a mark on the piston rod.
- (2) Apply compressed air into the oil hole indicated in the right figure and measure the rod stroke.
Specified Value: 1.5 - 3.0 mm (0.059 - 0.118 inch)
(The length of difference (A) represents the rod stroke.)
- (3) If the measured value does not comply with the specification, select a rod from the table below and replace it. Or replace the brake band.

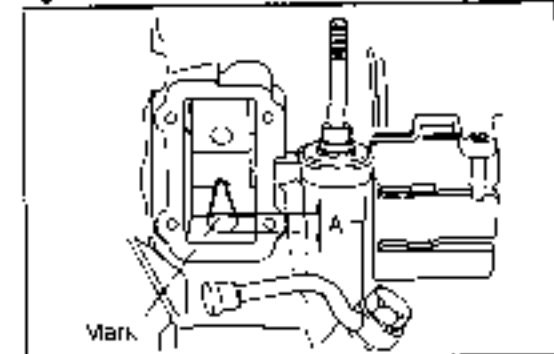

Fig. 4-29

WR-04269

Evaluation	Piston rod length	Identification mark
Too short	21.3 mm (4/77 inches)	Not provided
Too long	22.7 mm (4/83 inches)	Provided (See figure below.)

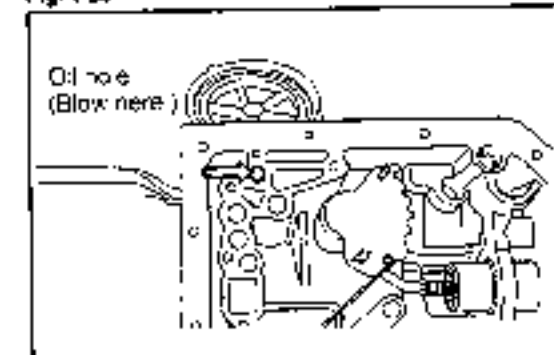

Fig. 4-30

WR-04260

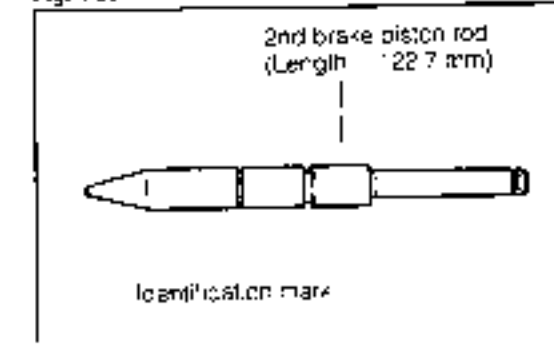

Fig. 4-31

WR-04261

12. Removal of the 2nd brake piston
 (1) Detach the snap ring. Using a common screwdriver or the like. Remove the cover and piston.

NOTE 1:

If the 2nd brake piston and rod are encountered with no trouble, this removal is not required.

NOTE 2:

When removing the 2nd brake piston by applying compressed air, care must be exercised as to jumping out of the piston or fluid splashing.

13. Removal of the solenoid wire harness
 (1) Remove the nut retaining the lock plate. Remove the wire.
 (2) Remove the wire clamps (2 points) of the rear cover.

14. Removal of the oil pump
 (1) Remove the oil pump attaching bolts (5 pieces).
 (2) Remove the oil pump, using the following SST.
 SST: 09350-87702-000

09350-87702-000

15. Removal of the torque converter housing
 (1) Remove the bolts at both inside and outside of the housing.
 (2) Remove the housing by lightly tapping the periphery of the housing, using a plastic hammer.

NOTE:

Before removing the housing, detach the speedometer driven gear.

16. Draw out the straight pin, using pliers.

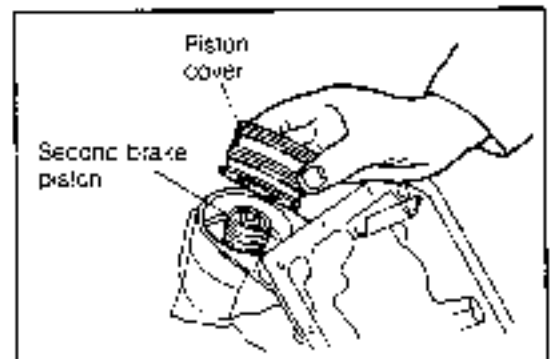

Fig. 4-32

WP-CA62

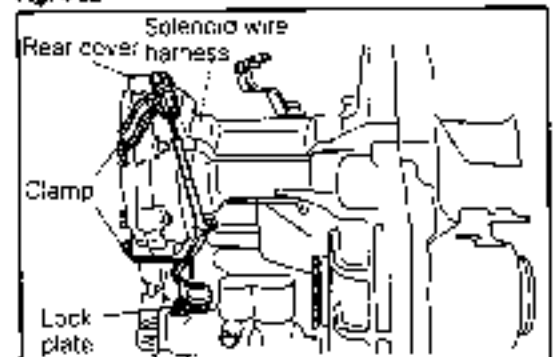

Fig. 4-33

WP-DA53

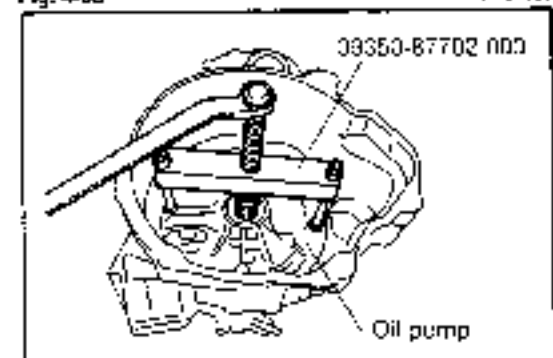

Fig. 4-34

WP-DA64

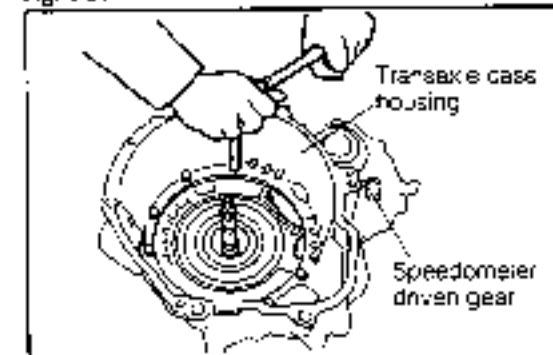

Fig. 4-35

WP-DA66

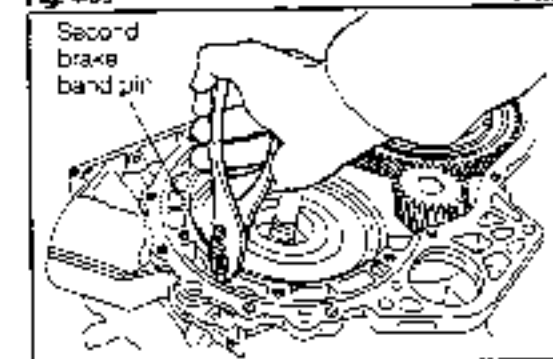

Fig. 4-36

WP-DA67

AUTOMATIC TRANSMISSION

17. Removal of the direct clutch and forward clutch
(1) While holding the input shaft, remove the direct clutch and forward clutch at the same time

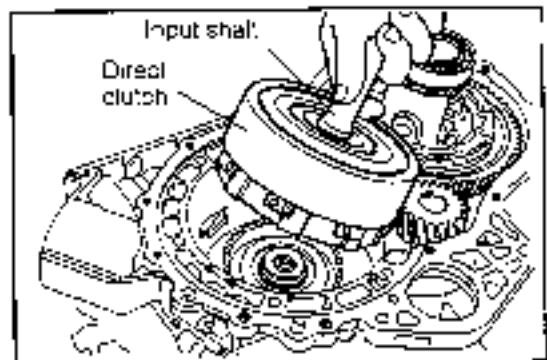

Fig. 4-37

WR-04057

- (2) Remove the direct clutch from the input shaft:

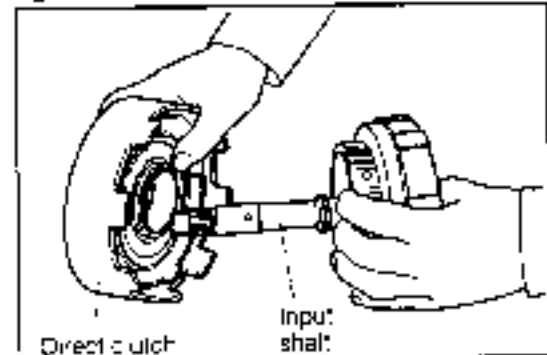

Fig. 4-38

WR-04059

18. Remove the 2nd brake band.

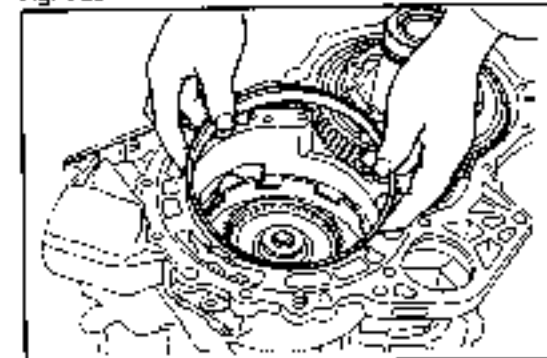

Fig. 4-39

WR-04059

19. Remove the front planetary ring gear
NOTE:
Check the thrust needle roller bearing.

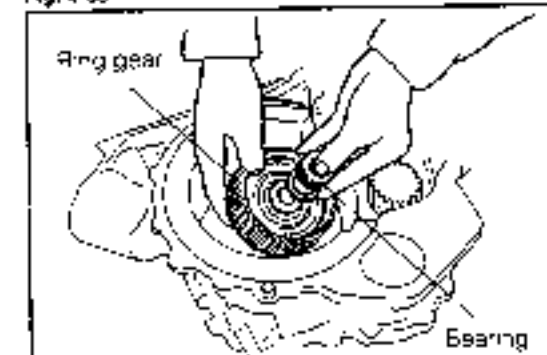

Fig. 4-40

WR-04070

20. Remove the front planetary ring gear assembly.
NOTE:
Check the thrust needle roller bearing.

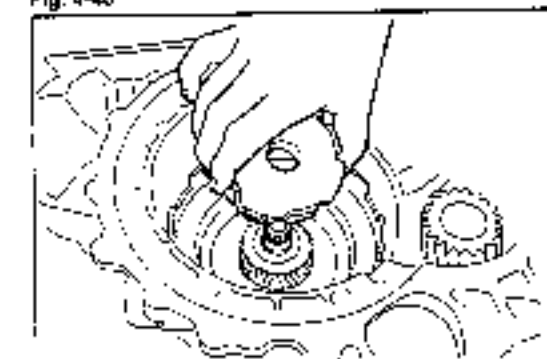

Fig. 4-41

WR-04071

21. Remove the thrust needle bearing from the planetary sun gear.

NOTE:

Check the thrust needle roller bearing.

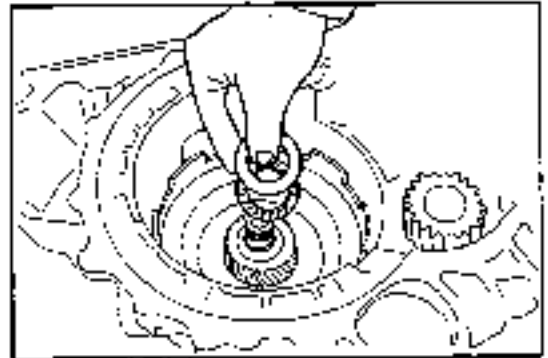

Fig. 4-42

WA-04072

22. Remove the planetary sun gear assembly

NOTE:

Check the thrust washer.

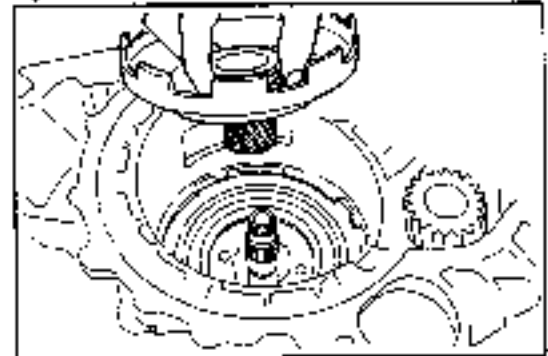

Fig. 4-43

WA-04073

23. Detach the one-way clutch snap ring.

NOTE:

Be very careful not to scratch other parts.

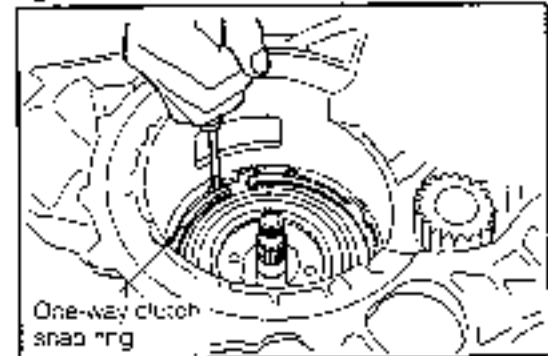

One-way clutch
snap ring

Fig. 4-44

WA-04074

24. Remove the one-way clutch and rear planetary gear

NOTE:

Check the thrust washer.

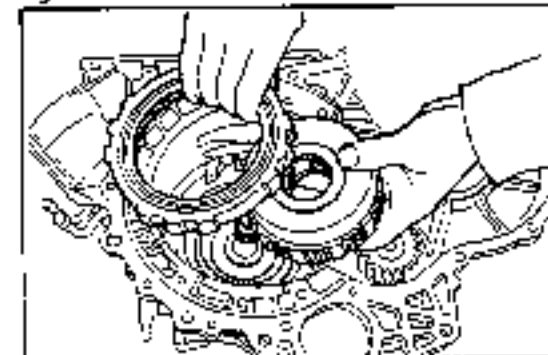

Fig. 4-45

WA-04075

25. Remove the rear planetary ring gear and thrust bearing

NOTE:

Check the thrust needle roller bearing.

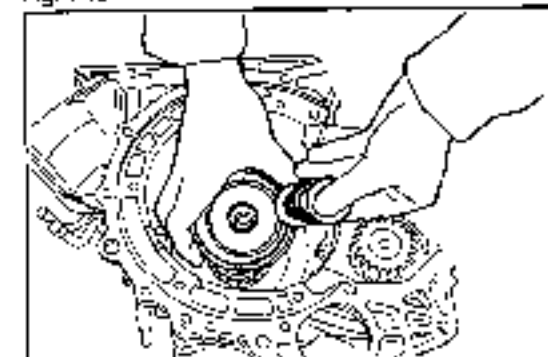

Fig. 4-46

WA-04076

AUTOMATIC TRANSMISSION

- 26 Check of the 1st & reverse brake clearance
(1) Measure the clearance indicated in the right figure, using a thickness gauge.
Specified Value: 0.58 - 1.92 mm (0.023 - 0.075 inch)

(2) If the measure value does not comply with the specification, replace the clutch disc or the plate.

27. Detach the snap rings (2 pieces), using a common screwdriver

NOTE:

Be very careful not to scratch other parts.

- 28 Remove the 1st & reverse brake flange, disc, plate and damper plate.

- 29 Remove the differential gear assembly.

- 30 Removal of the rear cover
(1) Remove the bolts (7 pieces) and nuts (2 pieces).
(2) Remove the rear cover by lightly tapping the position indicated in the figure, using a plastic hammer.

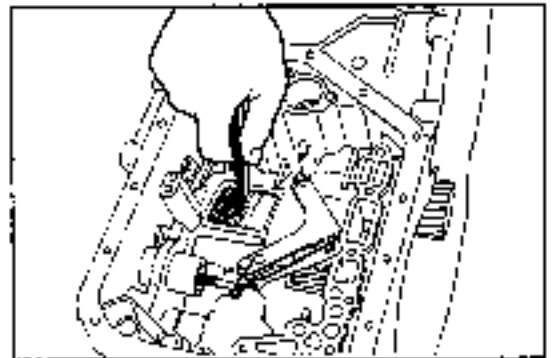

Fig. 4-47

WR 06077

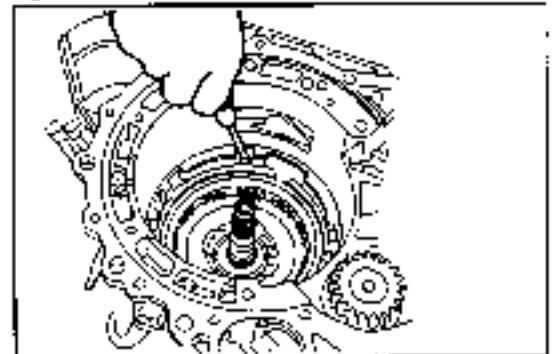

Fig. 4-48

WR 06076

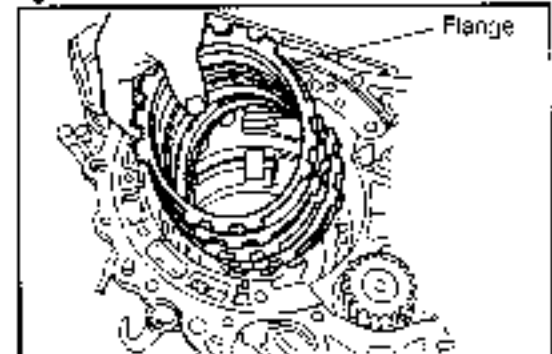

Fig. 4-49

WR 06075

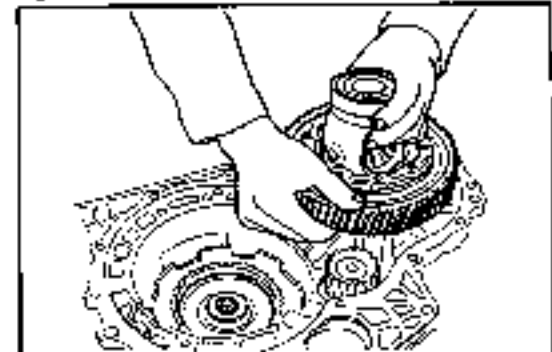

Fig. 4-50

WR 06074

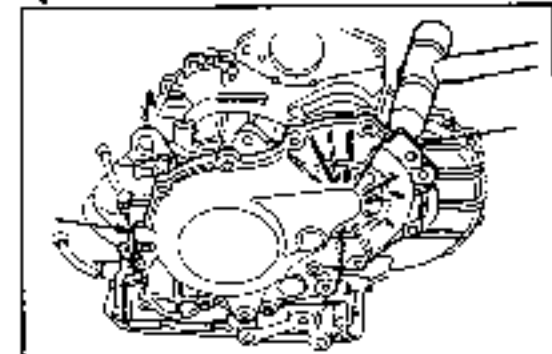

Fig. 4-51

WR 06073

1. Removal of the counter shaft lock nut
 - (1) Release the staked state of the lock nut by means of a chisel.
 - (2) Shift to the P range so that the gear may not turn
 - (3) Loosen the lock nut.

NOTE:

Carefully loosen the lock nut so that no shocks may be given to the parking lock pawl and output shaft.

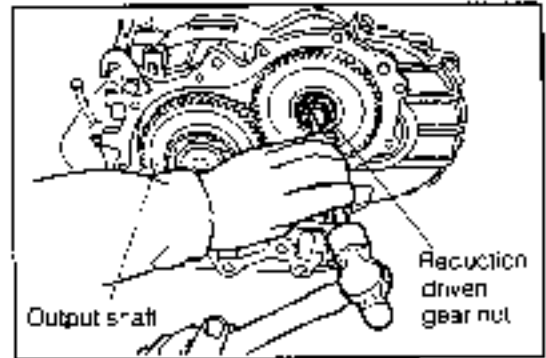

Fig. 4-52

WF-04082

32. Draw out the reduction driven gear.

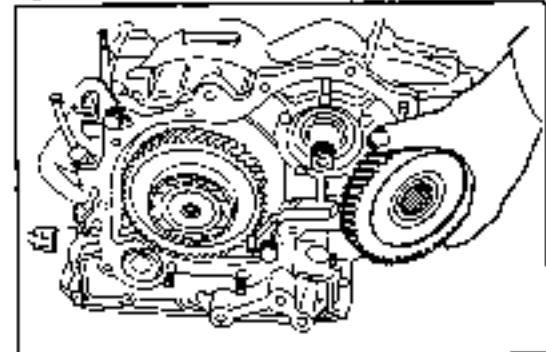

Fig. 4-53

WF-04083

33. Remove the drive counter shaft by lightly tapping it, using a plastic hammer

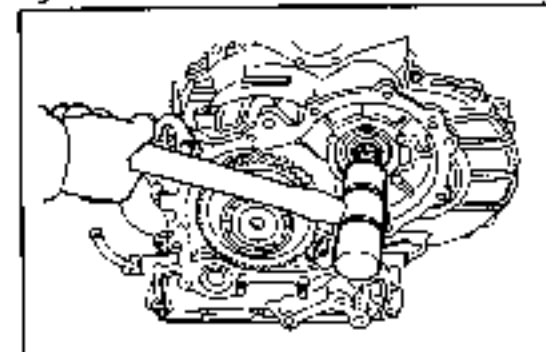

Fig. 4-54

WF-04084

34. Removal of the counter drive gear:
 - (1) Remove the output shaft by pushing the bearing outer race of the inner output shaft. During this operation, use the following SST as shown in the figure.

NOTE:

Never tap the output shaft.

SST: 09350-87702-000

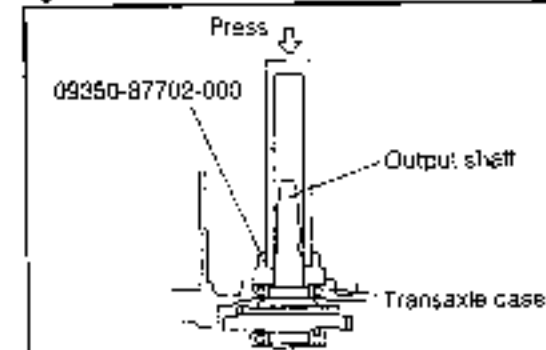

Fig. 4-55

WF-04085

35. Removal of the parking lock pawl
 - (1) Draw out the parking lock pawl shaft and spring.
 - (2) Remove the parking lock pawl.

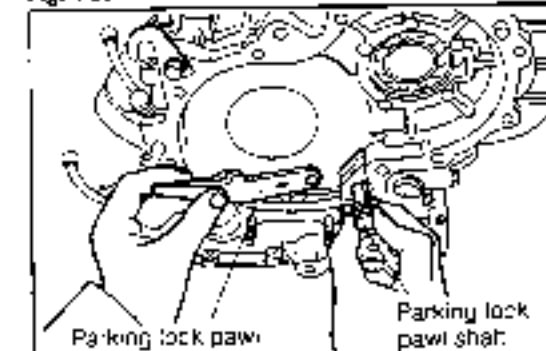

Fig. 4-56

WF-04086

AUTOMATIC TRANSMISSION

(3) Remove the parking lock pawl sleeve

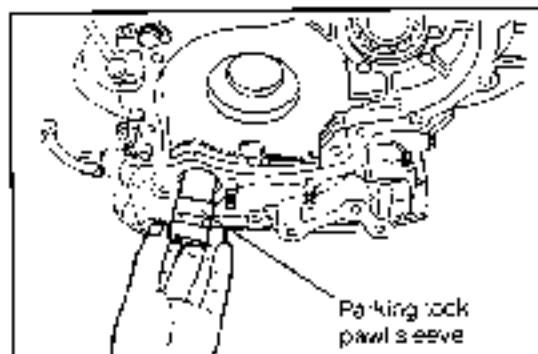

Fig. 4-57

WP-04787

36 Removal of the 1st & reverse brake piston

(1) Compress the return spring, using the SST indicated in the figure

SST: 09350-87702-000

NOTE:

Do not compress the return spring beyond its compression allowance (deflection allowance).

(2) Detach the snap ring.

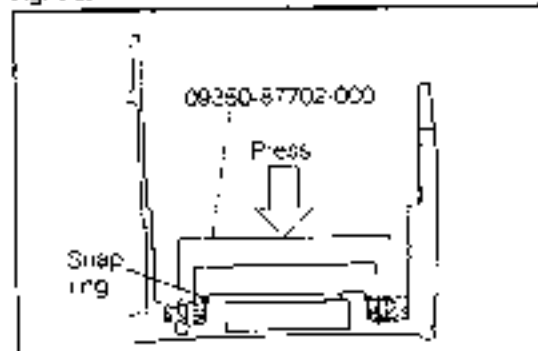

Fig. 4-58

WP-04788

(3) Remove the return spring subassembly.

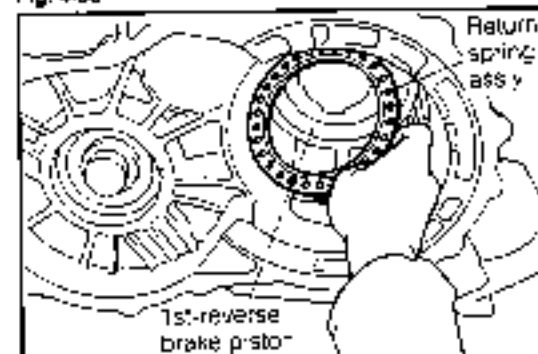

Fig. 4-59

WP-04789

(4) Remove the piston by applying compressed air into the oil hole indicated in the figure.

NOTE:

Slowly apply compressed air with a low pressure (1 kg/cm², 15 psi) so that the piston may not tilt.

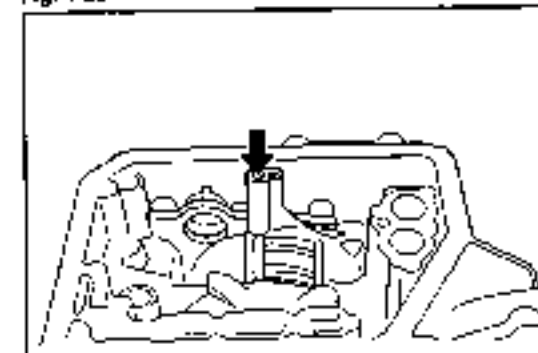

Fig. 4-60

WP-04790

(5) Remove the "O" ring from the piston.

WP-04791

INSPECTION AND REPAIRS OF EACH PART

OIL PUMP COMPONENTS

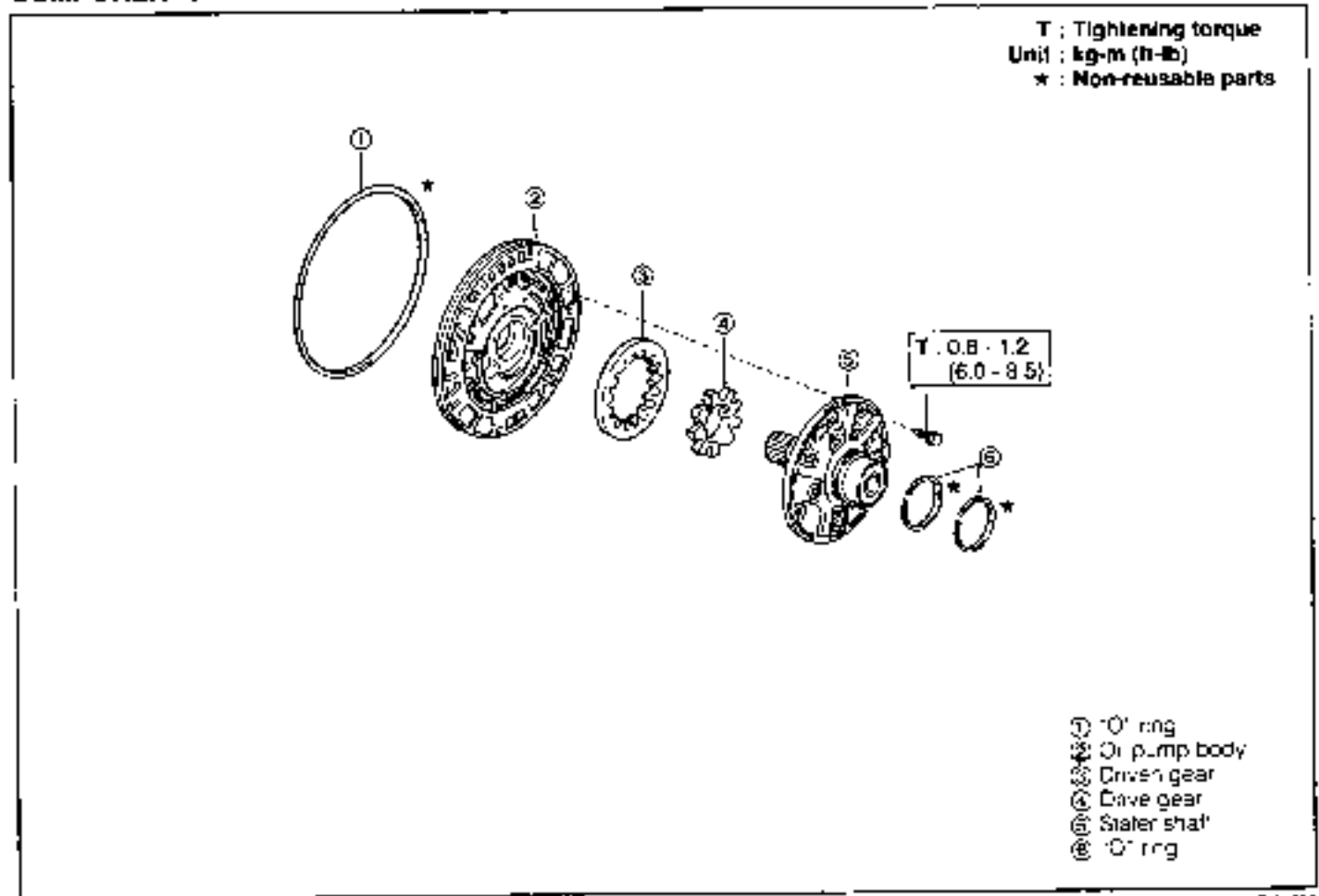

Fig. 4-61

WFL4002

DISASSEMBLY

1. Remove the following parts from the oil pump body.
 - (1) "O" ring
 - (2) Bolts (11 pieces)
 - (3) Stator shaft

WR-04238

INSPECTION

1. Check the pump body oil seal for wear damage and cracks.

NOTE:

Replace any parts that exhibit defects.

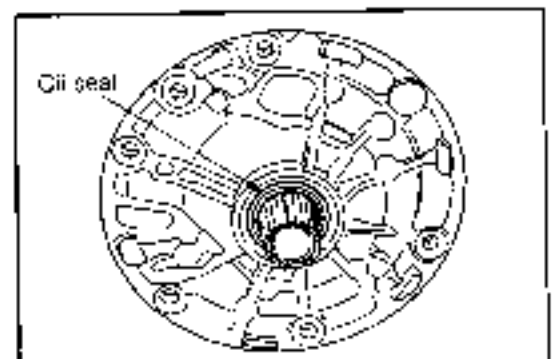

Fig. 4-62

WR-04238

AUTOMATIC TRANSMISSION

2. Body clearance check

- (*) Push the driven gear against the one side of the body.
- (2) Measure the clearance between the driven gear and the body, using a thickness gauge.

Specified Value: 0.07 - 0.15 mm
(0.0028 - 0.0059 inch)

Allowable Limit: 0.30 mm (0.011 inch)

NOTE:

If the clearance exceeds the allowable limit, replace the driven gear.

3. Tip clearance check

- (1) Measure the clearance between the driven gear tooth and the crescent, using a thickness gauge

Specified Value: 0.11 - 0.14 mm
(0.0043 - 0.0055 inch)

Allowable Limit: 0.30 mm (0.011 inch)

NOTE:

If the clearance exceeds the allowable limit, replace the driven gear.

4. Side clearance check

- (1) Measure the side clearance between the gear and the installation surface of the stator shaft over the entire periphery, using a straight edge (square) in combination with a thickness gauge.

Specified Value: 0.02 - 0.05 mm
(0.0008 - 0.0019 inch)

Allowable Limit: 0.1 mm (0.0039 inch)

NOTE:

If the side clearance exceeds the allowable limit, replace the part.

ASSEMBLY

NOTE:

Be sure to replace the "O" rings with new ones.

1. Install the driven gear and drive gear into the pump body.
NOTE:
Prior to the installation, apply the automatic fluid to the parts.
2. Install the stator shaft to the pump body. Tighten the bolts (11 pieces)
Tightening Torque: 0.8 - 1.2 kg-m (6.0 - 8.5 ft-lb)
3. Install the cover seal rings (2 pieces)
4. Apply the automatic fluid to the oil pump bush and "O" ring.
5. Install the "O" ring.
NOTE:
Ensure that the seal is not corrugated and that it is fitted properly in the groove.
6. Ensure that the drive gear rotates smoothly

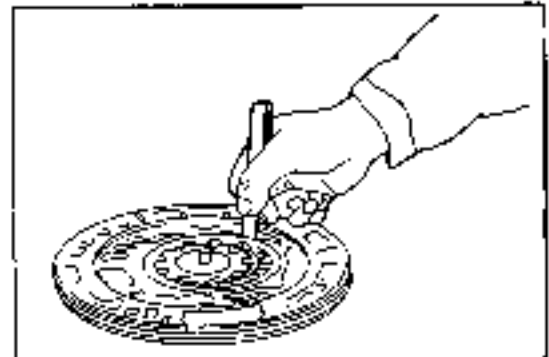

Fig. 4-63

WP-0-025

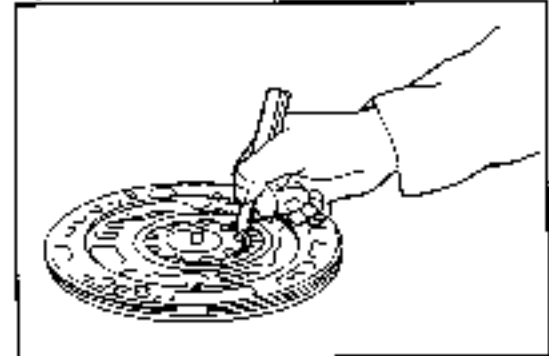

Fig. 4-64

WP-0-025

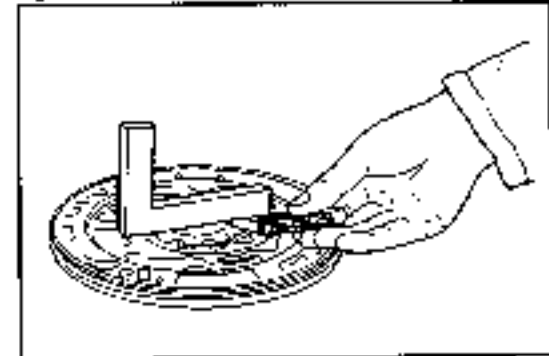

Fig. 4-65

WP-6193

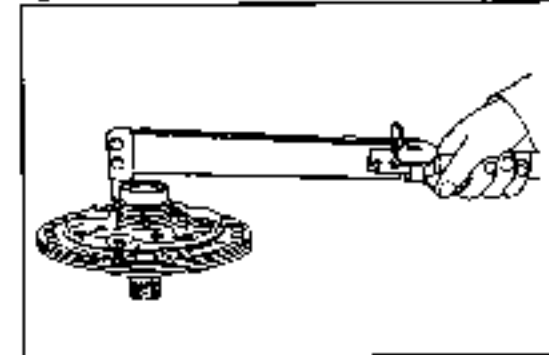

Fig. 4-66

WP-04092

FORWARD CLUTCH COMPONENTS

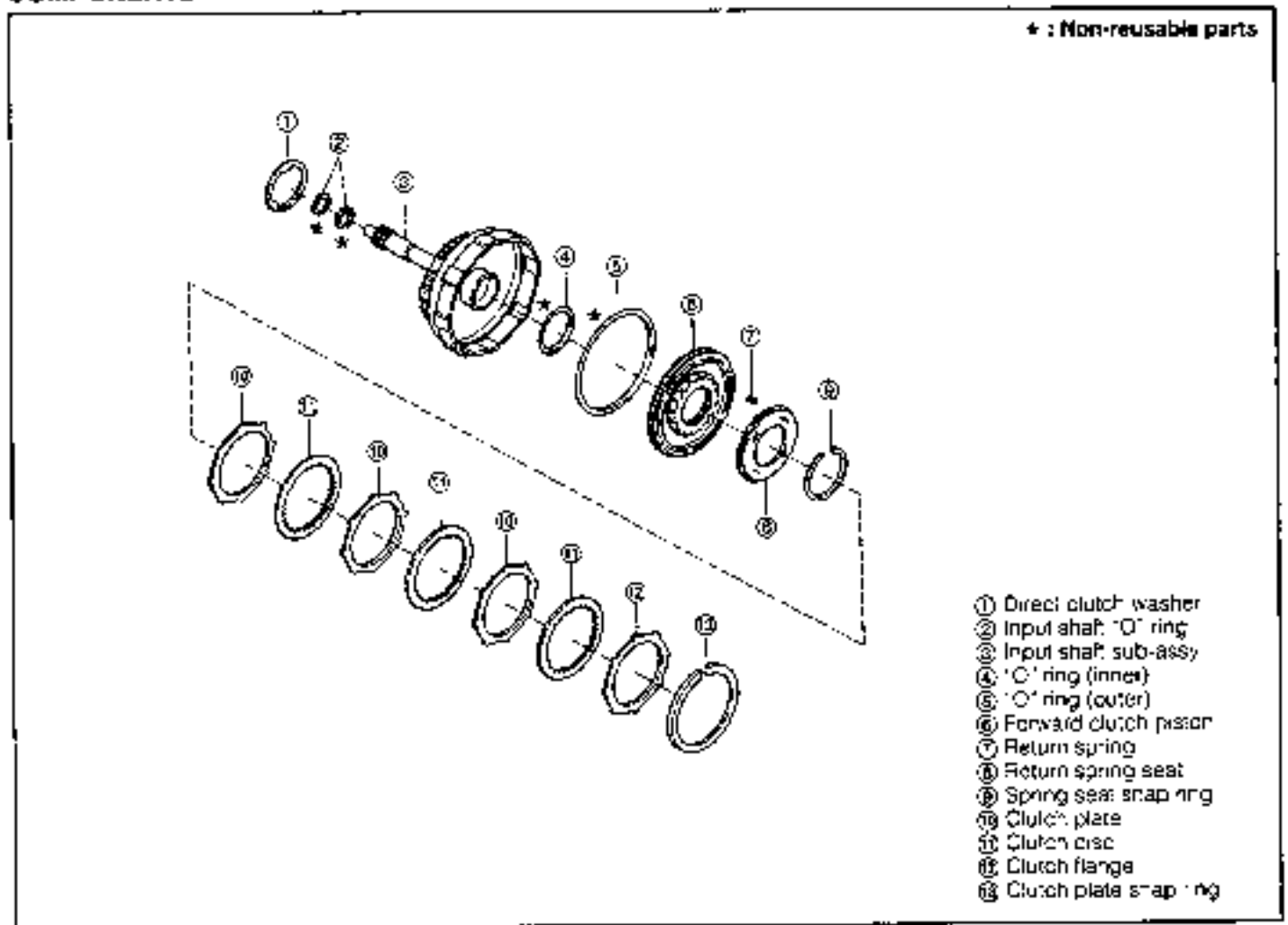

Fig. 4-67

WA-34039

DISASSEMBLY

1. Compress the return spring using the following SST. Remove the spring seat snap ring.

SST: 09350-87702-000

NOTE:

Do not compress the return spring beyond its compression allowance (deflection allowance).

2. Remove the spring seal and return spring.
3. Detach the clutch plate snap ring. Remove the flange disc and plate.

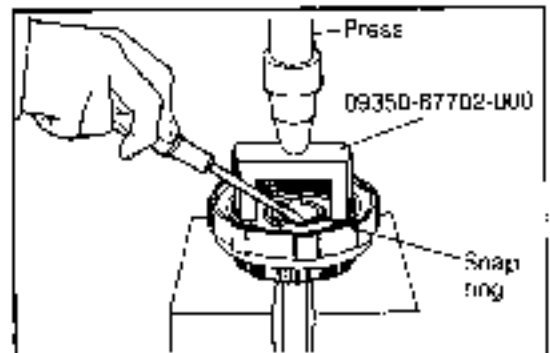

Fig. 4-68

WA-34130

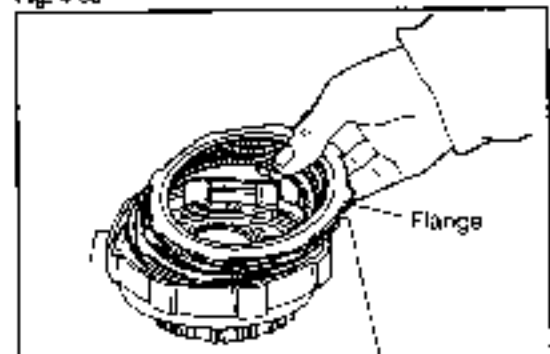

Fig. 4-69

WA-0113

AUTOMATIC TRANSMISSION

4. Remove the forward clutch piston by applying compressed air into the in input shaft oilhole indicated in the figure.
5. Remove the outer and inner 'O' rings from the forward clutch piston.

INSPECTION

1. Ensure that the valve (ball) moves freely in the clutch piston.
2. Check the valve for leakage by applying compressed air with a low pressure.

NOTE:

If any valve seizure or air leakage exists, replace the forward clutch piston.

ASSEMBLY

NOTE:

Be sure to replace the "O" rings and the seal rings with new ones.

1. Apply the automatic fluid to "O" rings (both inner and outer). Proceed to install the "O" rings to the forward clutch piston.
2. Insert the forward clutch piston to the input shaft crum

NOTE:

Be careful not to twist the "O" rings or not to have them caught by other parts.

3. Install the return springs (18 pieces) and spring seats.

4. Compress the return spring and attach the spring seat snap ring, using the following SST.

SST: 09350-87702-000

NOTE 1:

Check to see if the spring seat snap ring is fitted properly on the spring seat.

NOTE 2:

Do not compress the return spring beyond its compression allowance (deflection allowance).

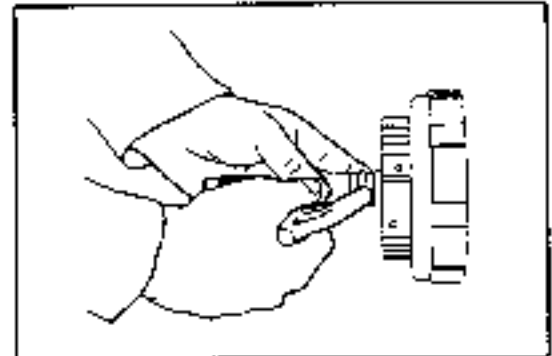

Fig. 4-70

WP-04-02

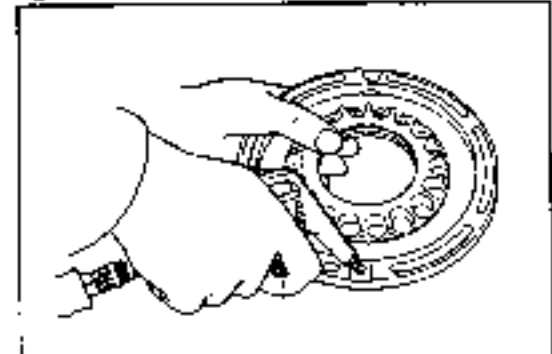

Fig. 4-71

WP-04-03

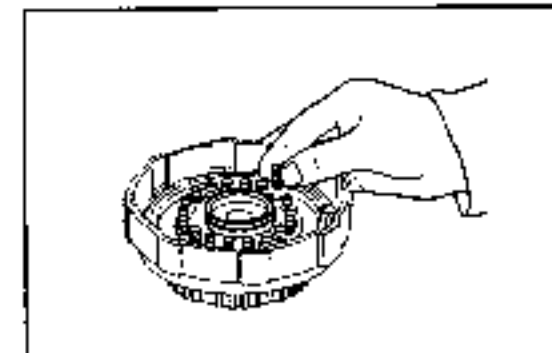

Fig. 4-72

WR-011-5

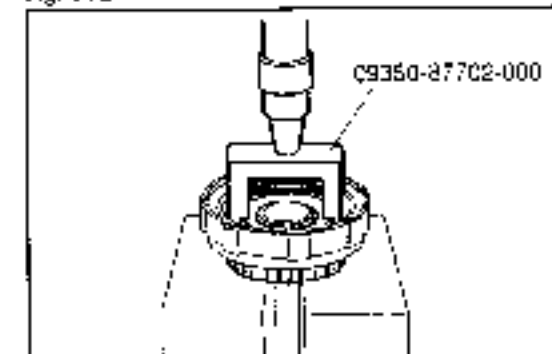

Fig. 4-73

WP-04-05

5. Install the following parts in this order
 - (1) Plate
 - (2) Clutch disc
 - (3) Plate
 - (4) Clutch disc
 - (5) Plate
 - (6) Clutch disc
 - (7) Flange
6. Attach the clutch plate snap ring

WA 04107

7. Clutch clearance measurement

- (1) Measure the clearance indicated in the figure, using a thickness gauge.

Specified Value: 0.41 - 1.08 mm (0.016 - 0.043 inch)

NOTE 1:

If the measured clearance does not comply with the specification, replace the clutch disc or plate.

NOTE 2:

If the measured clearance does not comply with the specification although a new clutch disc or plate has been used, select a proper one from the following two flanges having different thicknesses.

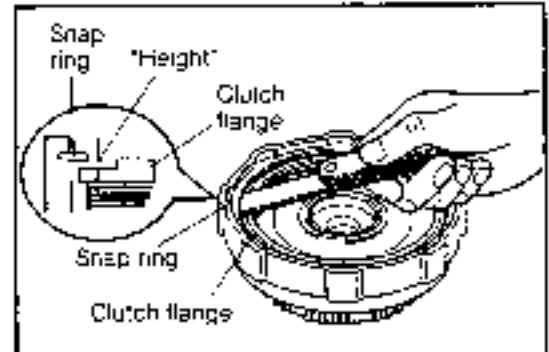

Fig. 4-74

WA 04108

Evaluation	Flange thickness
Too small	3.00 mm (0.118 inch)
Too large	3.37 mm (0.132 inch)

8. Apply compressed air into the oil hole of the input shaft indicated in the figure and check to see if the clutch piston moves freely.

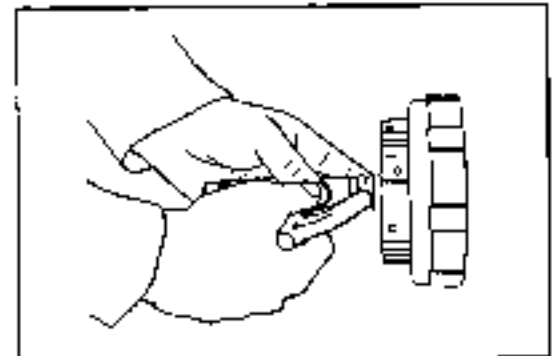

Fig. 4-75

WA 04109

AUTOMATIC TRANSMISSION

DIRECT CLUTCH COMPONENTS

* : Non-reusable parts

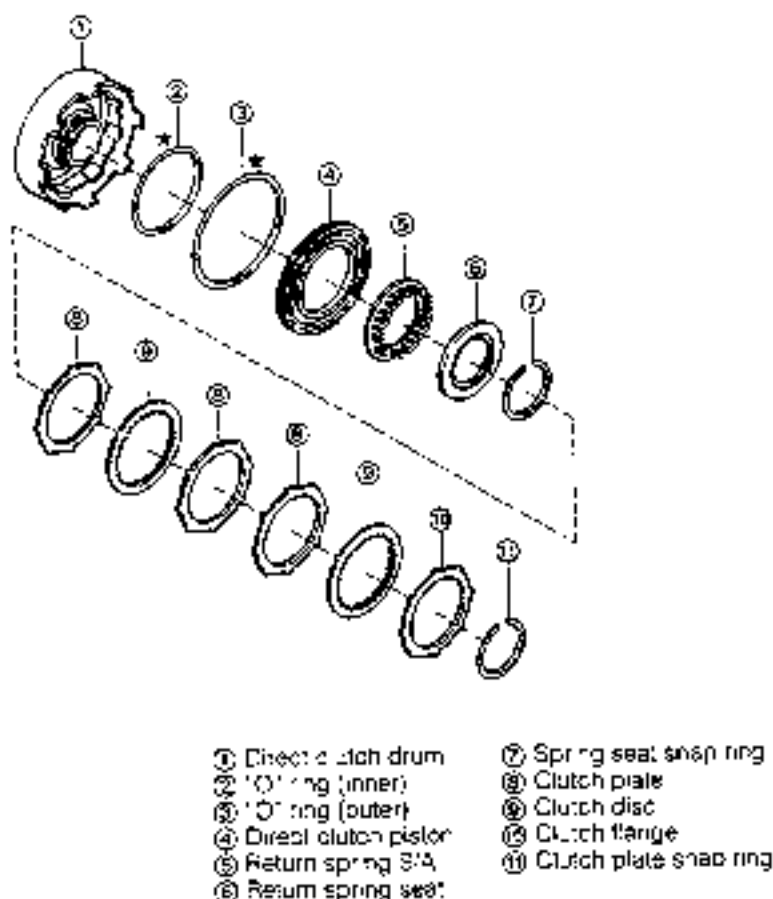

Fig. 4-76

WA-0411C

DISASSEMBLY

- 1 Compress the return spring and detach the spring seat snap ring, using the following SST.

SST: 09350-87702-000

NOTE

Do not compress the return spring beyond its compression allowance (deflection allowance).

- 2 Remove the return spring seat and return spring sub-assembly.
- 3 Detach the clutch plate snap ring. Remove the flange, disc and plate.

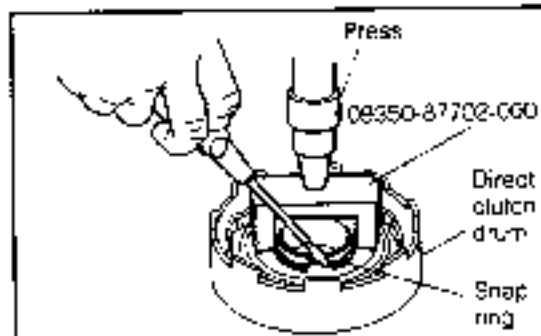

Fig. 4-77

WF-02-11

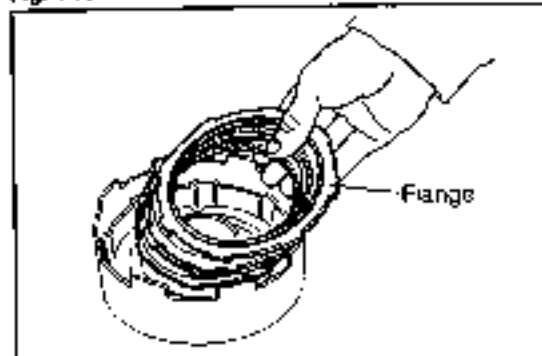

Fig. 4-78

WA-0411C

- Remove the direct clutch piston by applying compressed air into the oil hole indicated in the figure.

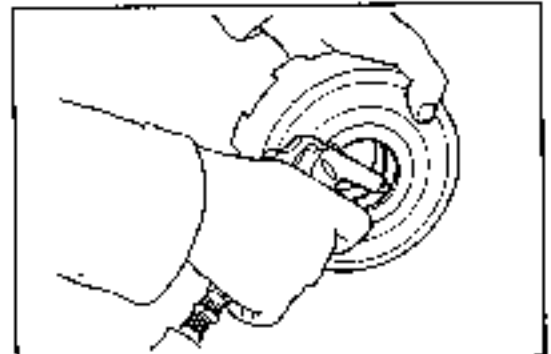

Fig. 4-79

WP-04113

- Remove the "O" ring from the direct clutch drum.
- Remove the "O" ring from the direct clutch piston.

INSPECTION

- Check to see if the check valve (ball) moves freely in the clutch piston.
- Check the valve for leakage by applying compressed air with a low pressure.

NOTE:

If any valve seizure or air leakage exists, replace the direct clutch piston.

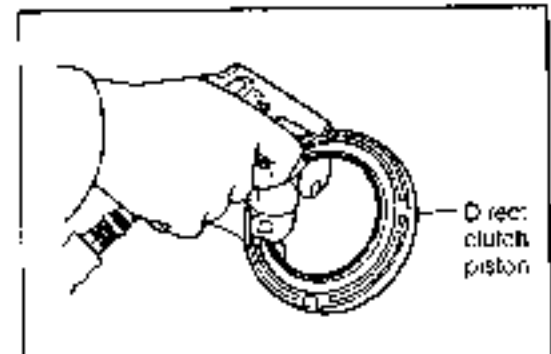

Fig. 4-80

WP-04115

ASSEMBLY

NOTE:

Be sure to replace the "O" rings with new ones.

- Apply the automatic fluid to the "O" ring. Proceed to install the "O" ring to the direct clutch drum.
- Apply the automatic fluid to the "O" ring. Proceed to install the "O" ring to the direct clutch piston.
- Insert the direct clutch piston to the direct clutch drum.

NOTE:

Be careful not to twist the "O" ring or not to have it caught by other parts.

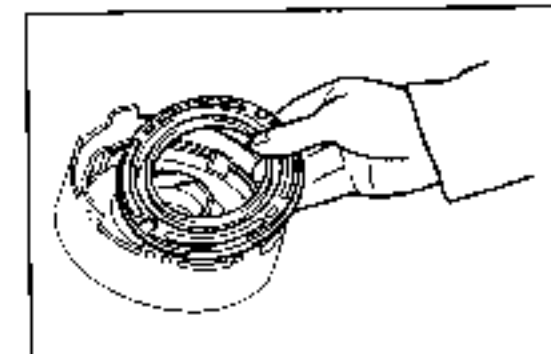

Fig. 4-81

WP-04116

- Install the spring seal subassembly.
- Install the spring seal.

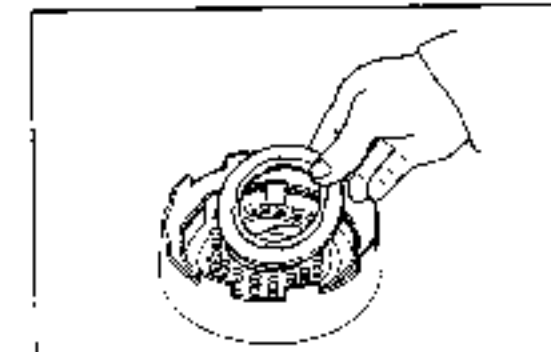

Fig. 4-82

WP-04117

AUTOMATIC TRANSMISSION

- 6 Compress the return spring and attach the spring seat snap ring, using the following SST.

SST: 09350-87702-000

NOTE 1:

Check to see if the spring seat snap ring is fitted properly on the spring seat.

NOTE 2:

Do not compress the return spring beyond the compression allowance (deflection allowance).

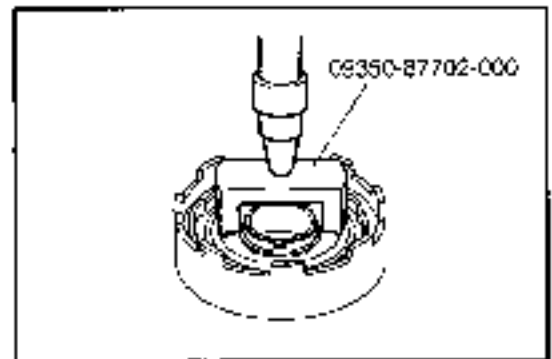

Fig. 4-83

WR-02-12

- 7 Install the following parts in this order

- (1) Plate
- (2) Clutch disc
- (3) Plate
- (4) Plate
- (5) Clutch disc
- (6) Flange

NOTE:

Prior to the installation, immerse the clutch discs in the automatic fluid for at least two hours.

WR-02-15

8. Attach the clutch plate snap ring

9. Measurement of the clutch (C₂) clearance

- (1) Measure the clearance indicated in the figure using a thickness gauge.

Specified Value: 0.89 - 1.46 mm (0.035 - 0.057 inch)

NOTE 1:

If the measured clearance does not comply with the specification, replace the clutch disc or plate.

NOTE 2:

If the measured clearance does not comply with the specification although a new clutch disc or plate has been used, select a proper one from the following two flanges having different thicknesses.

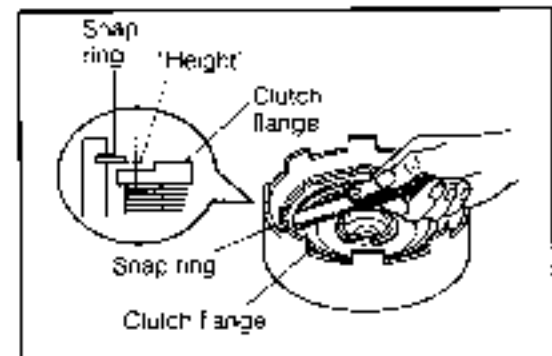

Fig. 4-84

WR-04-10

Evaluation	Flange thickness
Too large	3.37 mm (0.132 inch)
Too small	3.00 mm (0.118 inch)

10. Apply compressed air into the oil hole indicated in the figure and check to see if the direct clutch moves.



Fig. 4-85

WR-06-12

VALVE BODY

COMPONENTS

Upper valve body

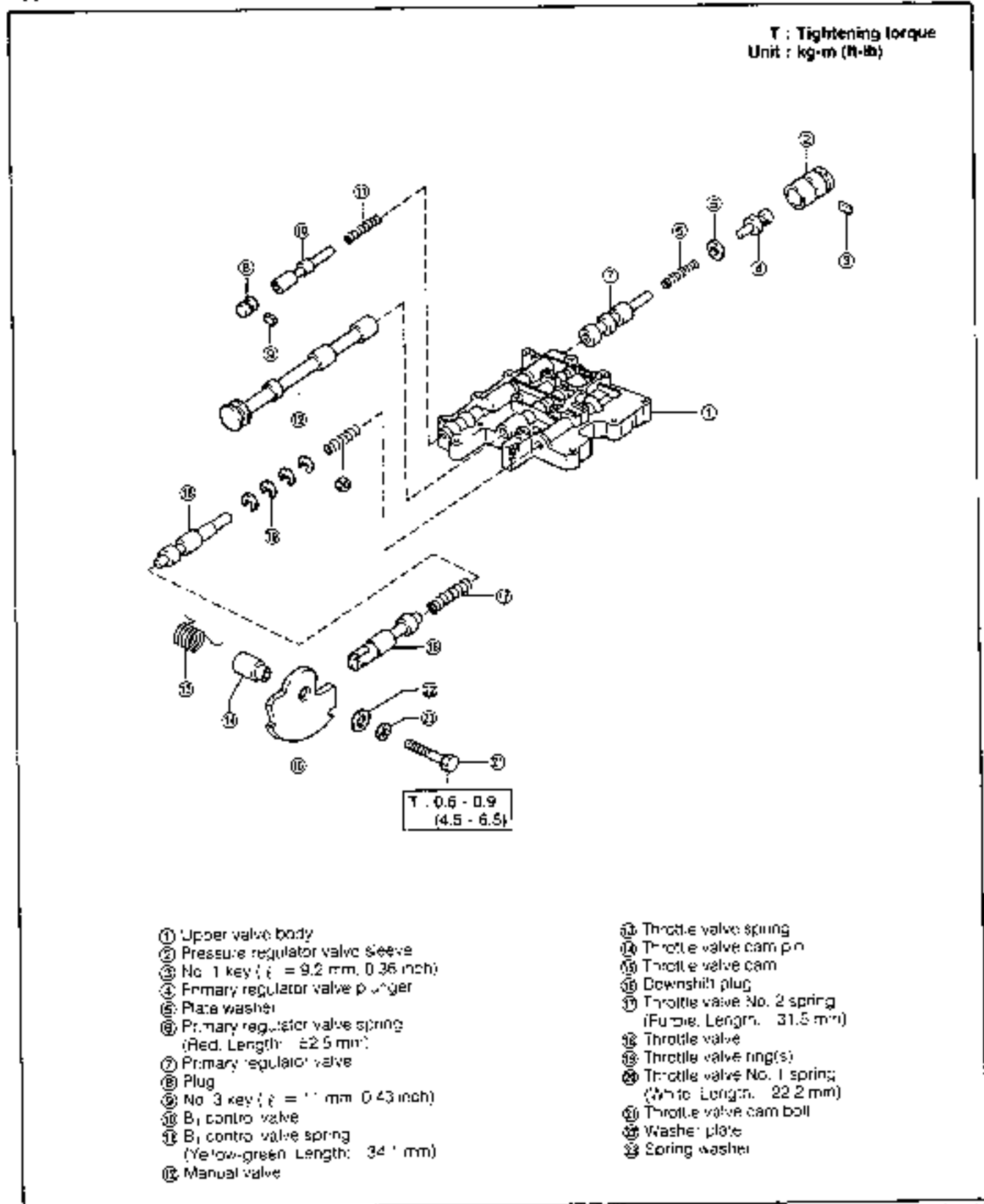

- | | |
|--|--|
| <ul style="list-style-type: none"> ① Upper valve body ② Pressure regulator valve sleeve ③ No. 1 key ($\phi = 9.2$ mm, 0.36 inch) ④ Primary regulator valve plunger ⑤ Plate washer ⑥ Primary regulator valve spring (Red, Length: ± 2.5 mm) ⑦ Primary regulator valve ⑧ Plug ⑨ No. 3 key ($\phi = 11$ mm, 0.43 inch) ⑩ B₁ control valve ⑪ B₁ control valve spring (Yellow-green, Length: 34.1 mm) ⑫ Manual valve | <ul style="list-style-type: none"> ⑬ Throttle valve spring ⑭ Throttle valve cam pin ⑮ Throttle valve cam ⑯ Downshift plug ⑰ Throttle valve No. 2 spring (Purple, Length: 31.5 mm) ⑱ Throttle valve ⑲ Throttle valve rings ⑳ Throttle valve No. 1 spring (White, Length: 22.2 mm) ㉑ Throttle valve cam ball ㉒ Washer plate ㉓ Spring washer |
|--|--|

Fig. 4-86

MF-NC29

AUTOMATIC TRANSMISSION

Lower valve body

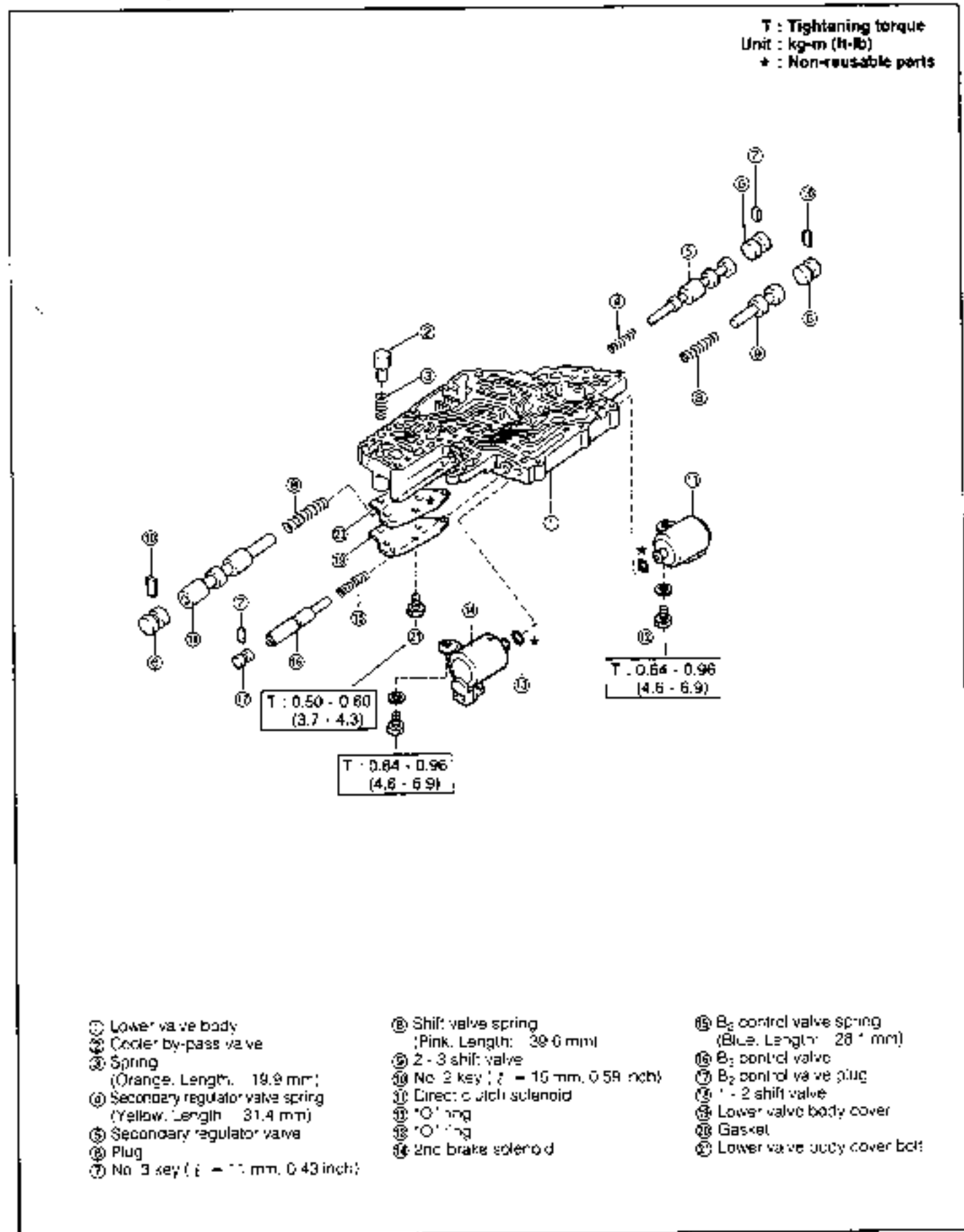

Fig. 4-87

09-00123

DISASSEMBLY

Instructions on disassembly

- (1) The automatic transmission employs many valves, springs, plugs and so forth which are similar in their shapes. It is therefore, advisable to arrange disassembled parts by putting a mark showing the item No. on each part.
- (2) The "E" rings on the throttle valve are used to adjust the hydraulic pressure. Hence, when disassembling the "E" rings, record the number of the "E" rings.
- (3) Thoroughly wash the valve body and components.
- (4) Store the gasket in a vinyl bag. Do not leave the gasket in the atmosphere for more than three hours.
- (5) Before disassembling, draw out the manual valve for fear of fall itself.

1. Separation of the upper valve body and lower valve body
 - (1) Remove the bolts (16 pieces) indicated in the figure.

(Upper valve body side)

NOTE:

Prior to the disassembly, take out the manual valve, for it drops by its own weight.

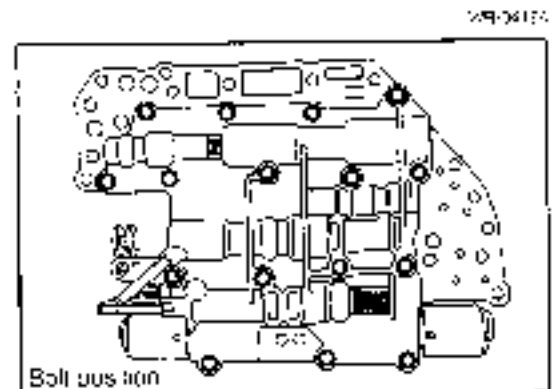

Fig. 4-88

- (2) With the upper valve body held at the lower side, separate the lower valve body.

NOTE 1:

If this separation is made with the upper valve body held at the upper side, there is a possibility that the steel balls drop and will be lost.

NOTE 2:

After completion of the separation, remove the steel balls from the upper valve body.

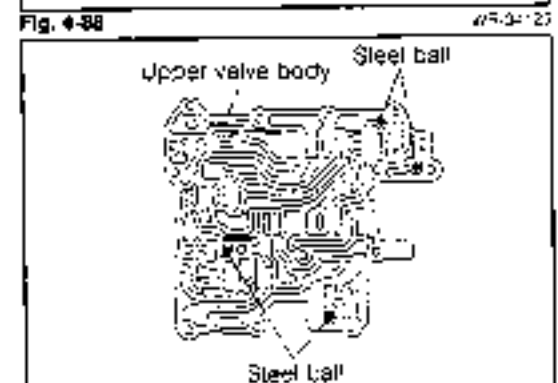

Fig. 4-89

2. Disassembly of the upper valve body assembly
 - (1) Remove the throttle valve cam attaching bolt. Remove the cam, spring and pin.
 - (2) Remove the downshift plug and spring

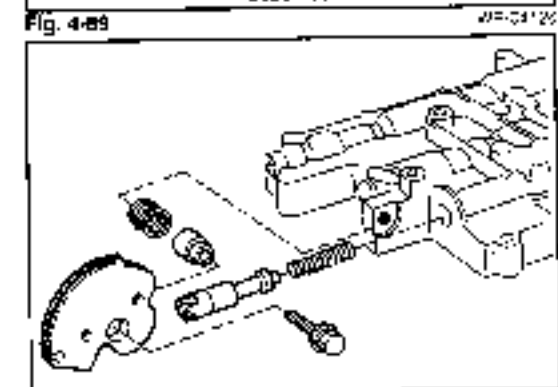

Fig. 4-90

- (3) Remove the throttle valve after the "E" rings have been removed from the outside of the valve body.

NOTE:

Record the number of the "E" rings used.

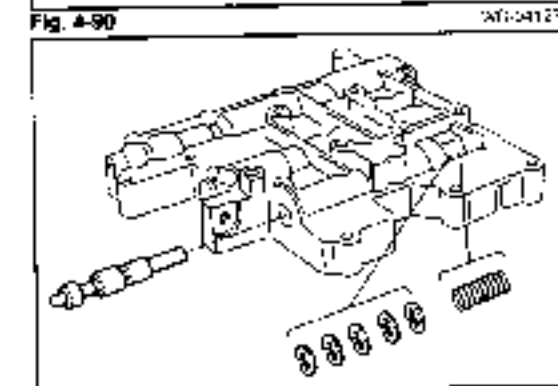

Fig. 4-91

AUTOMATIC TRANSMISSION

- (4) While lightly pushing the plug at the valve inserting hole, remove the straight key. Remove the plug, B- control valve and spring.

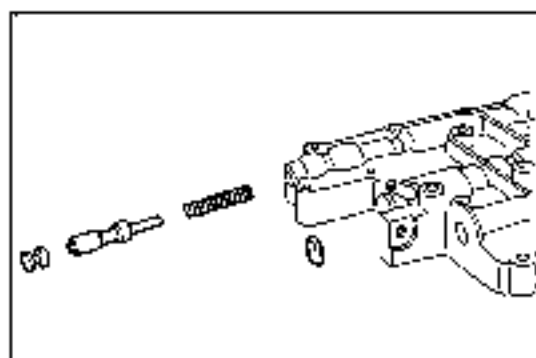

Fig. 4-92

WF-02-29

- (5) While lightly pushing the sleeve at the valve inserting hole, remove the straight key. Remove the sleeve, plunger, washer, spring and primary regulator valve.

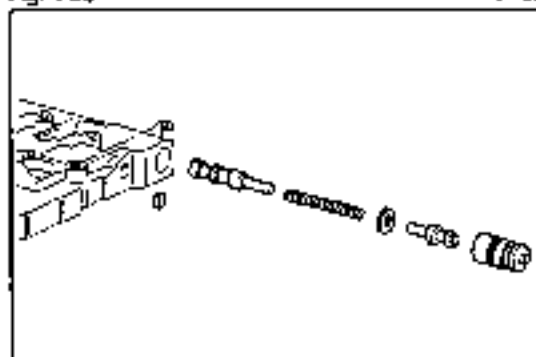

Fig. 4-93

WF-04-31

3. Disassembly of the lower valve body assembly

- (1) Remove the direct clutch solenoid assembly and second brake solenoid assembly.

- (2) Remove the gasket and lower valve body cover.

NOTE:

Care must be exercised as to the jumping out of the cooler bypass valve during this operation.

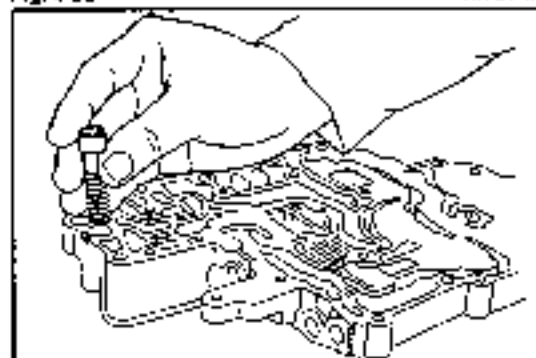

Fig. 4-94

WF-04-31

- (3) Remove the straight key. Remove the plug, secondary regulator valve and spring.

- (4) Remove the straight key. Remove the plug, 2 - 3 shift valve and spring.

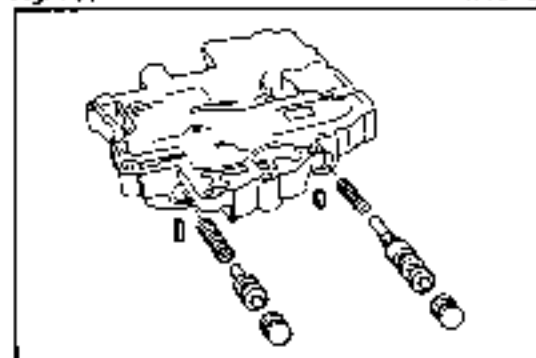

Fig. 4-95

WF-04-32

- (5) Remove the straight key. Remove the plug, B₂ control valve and spring.

- (6) Remove the straight key. Remove the plug, 1 - 2 shift valve and spring.

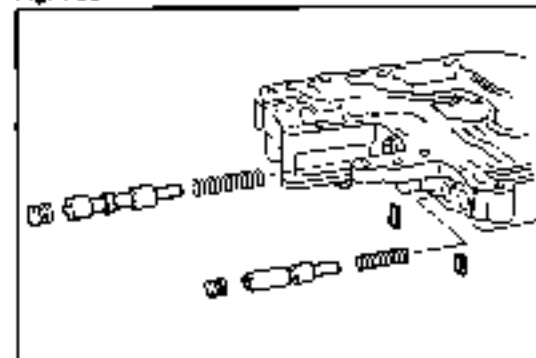

Fig. 4-96

WF-04-33

INSPECTION

1. Check the oil passage of the valve body for restriction.
2. Check to see if scratches are present at the valve body hole and valve sliding surface
3. Check the spring for a flattened condition
(See "LIST OF SPRINGS" of the APPENDIX at page 4-73 ;

ASSEMBLY

NOTE:

Be sure to replace the "O" rings and gaskets with new ones.

Instructions on assembly

- (1) Prior to the installation, apply the automatic fluid to the valve, spring, plug, straight key and so forth.
- (2) Correctly insert the valve to the spring.
- (3) Be very careful to insert the components, such as the valves and springs, to their correct positions

NOTE 1:

Install these parts in accordance with the marks showing the item numbers which were put during the disassembly.

NOTE 2:

See "LIST OF SPRINGS" at page 4-73 during the assembly.

- (4) Care must be exercised to ensure that the valves are inserted in their correct directions.
- (5) When inserting the valve, spring, plug and straight key, be careful not to damage the valve body.
- (6) Check to see if the valve moves smoothly.

NOTE 1:

Make sure that each part (particularly plunger and sleeve) goes in by its own weight during the insertion.

W-04-73

1. Assembly of the upper valve body

(1) Installation of primary regulator valve

- ① Hold the valve body horizontally. Insert the primary regulator valve approx. 80 % of its overall length. Then, push the spring (red) so as to insert the primary regulator valve
- ② Put the plunger into the sleeve. Install the washer plate. Then, insert it into position
- ③ Insert the straight key ($\ell = 9.2 \text{ mm}$, 0.36 inch) so as to secure the sleeve.

(2) Installation of B₁ control valve

- ① Install the spring to the valve. Insert them together into position
- ② Insert the plug. Secure it by means of the straight key ($\ell = 11 \text{ mm}$, 0.43 inch).

(3) Installation of throttle valve and downshift plug

- ① Push the spring (purple) so as to insert the throttle valve
- ② Working from the outside of the valve body, install the "E" rings to the throttle valve.

NOTE:

Install the "E" rings in the same number as that prior to the disassembly.

③ Install the spring (white).

④ Install the downshift plug.

(4) Installation of throttle valve cam

- ① Install the pin and spring to the cam.

NOTE:

Attach the hook of the spring to the cam hole.

AUTOMATIC TRANSMISSION

② Tighten the throttle valve cam, together with the spring washer and washer plate, to the valve body.

M6 bolt Nominal length: 28 mm (1.1 inch)

Tightening Torque: 0.6 - 0.9 kg-m (4.3 - 6.5 ft-lb)

NOTE 1:

Attach the other end of the spring to the outside of the valve body.

NOTE 2:

While pushing the cam against the roller section of the downshift plug, screw-in the cam.

NOTE 3:

Make sure that the roller of the downshift plug is located at the center of the throttle valve cam.

NOTE 4:

Insert the manual valve after the upper body and lower body have been assembled.

WR-0135

2. Assembly of the lower valve body

(1) Installation of secondary regulator valve

① Insert the spring (yellow) secondary regulator valve and plug.

② Insert the straight key ($\phi = 11$ mm, 0.43 inch). Secure it by means of the plug

(2) Installation of 1 - 2 shift valve

① Insert the spring (pink), 1 - 2 shift valve and plug.

② Insert the straight key ($\phi = 11$ mm, 0.43 inch). Secure it by means of the plug

(3) Installation of B_2 control valve

① Insert the spring (blue), B_2 control valve and plug.

② Insert the straight key ($\phi = 15$ mm, 0.59 inch). Secure it by means of the plug.

(4) Installation of 2 - 3 shift valve

① Insert the spring (pink), 2 - 3 shift valve and plug.

② Insert the straight key ($\phi = 15$ mm, 0.59 inch). Secure it by means of the plug

(5) Installation of direct clutch solenoid assembly and second brake solenoid assembly

① Prior to the insertion, apply the automatic fluid to the new 'O' ring

② Care must be exercised as to the tightening bolt holes. When tightening the bolts, be sure not to mistake the right and left holes.

M6 bolt Nominal length: 10 mm (0.39 inch) \times 2 pieces

Tightening Torque: 0.64 - 0.96 kg-m (4.6 - 6.9 lb-ft)

WR-0417

(6) Installation of lower valve body cover

① Install the cover, using a new gasket.

M5 bolt Nominal length:

14 mm (0.55 inch) \times 10 pieces

Tightening Torque: 0.50 - 0.60 kg-m (3.6 - 4.3 ft-lb)

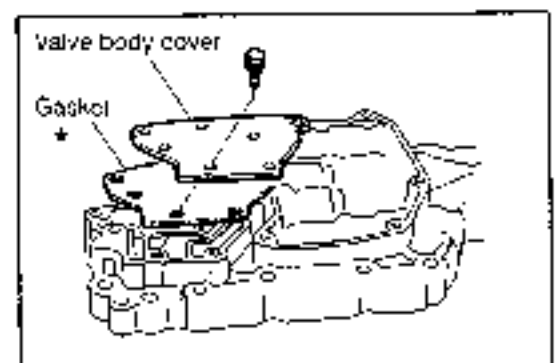

Fig. 4-97

WF-C0143

- 3 Assembly of the valve body assembly
 - (1) Insert the spring (orange) and cooler bypass valve to the lower valve body.
 - (2) Install the steel balls (4 pieces) to the upper valve body.

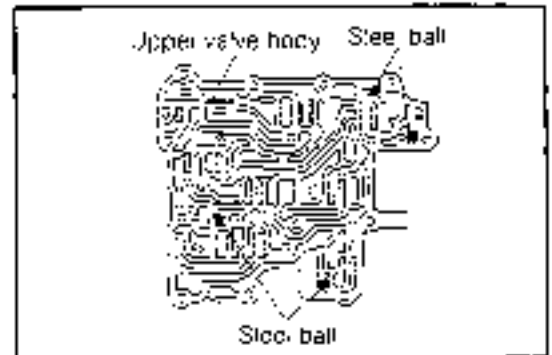

Fig. 4-98

WR-04143

- (3) Install new gaskets on both surfaces of the valve body plate. Place the valve body plate on the upper valve body.
- (4) Turn over the upper valve body, while making sure that the plate may not separate from the upper valve body. Then, place the upper valve body on the lower valve body.

NOTE 1:

When the upper valve body is being turned over, be very careful not to allow the steel balls to drop.

NOTE 2:

Do not pry the cooler bypass valve.

NOTE 3:

Ensure that the plate or gasket may not be displaced from its installation position.

WR-04143

4. Installation of the bolts
 - (1) List of bolts used:

Standard	Nominal length	Shape of head	Number	Installation position
M5	29.5 mm (1.16 inch) Length of threaded portion: 22.0 mm	Deep recess	6	A
M5	38.0 mm (1.50 inch)	Deep recess	6	B
M5	44.0 mm (1.73 inch)	Deep recess	2	C
M5	29.5 mm (1.16 inch) Length of threaded portion: 19.5 mm	Normal recess	2	D

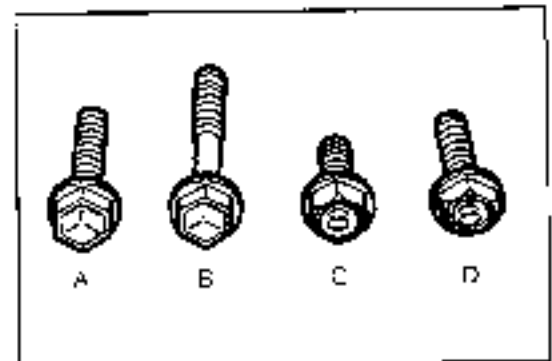

Fig. 4-99

WR-04144

AUTOMATIC TRANSMISSION

(2) Tightening sequence of bolts

- Lightly tighten two bolts marked with ①.
- Securely tighten four bolts marked with ②.
- Securely tighten eight bolts marked with ③.
- Securely tighten four bolts marked with ④.

NOTE:

At the same time, securely tighten the bolts which were temporarily tightened in step ①.

Tightening Torque: 0.5 - 0.8 kg·m (3.6 - 4.9 ft-lb)

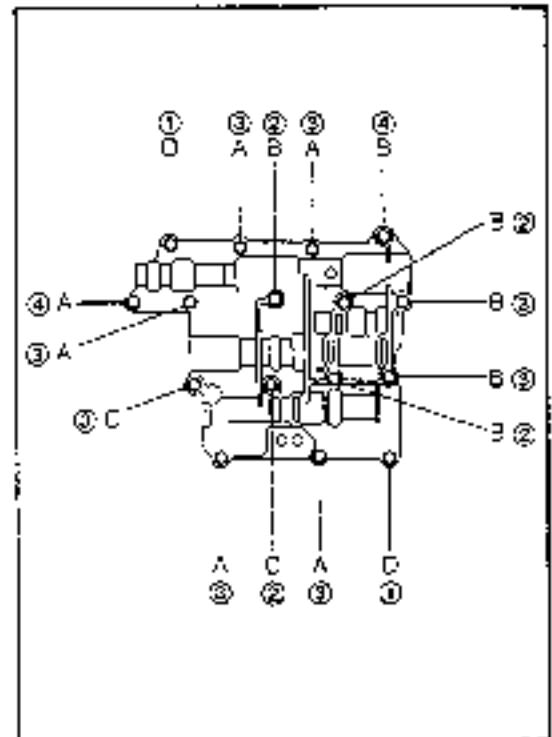

Fig. 4-100

WR-04145

5. Insert the manual valve into the upper valve body.

WR-04146

ASSEMBLY OF TRANSMISSION

INSTRUCTIONS ON ASSEMBLY

1. Be sure to replace the following parts with new ones: gaskets, lock nut, "O" rings, oil seals, seal rings of each piston, seal washers of the oil pump set bolts, oil deflector and test plug.
2. When replacing the low brake band and clutch disc with new ones, immerse the new parts in the automatic fluid for at least two hours preceding the assembly.
3. Be sure to apply the automatic fluid to the sliding sections of the parts.
4. Thoroughly clean the bolts or threaded holes, to which a sealing agent has been applied.
5. Prior to the assembly, ensure that air continuity exists in each oil passage by applying compressed air into each oil passage.
6. Be careful not to damage each gasket surface of the transmission case, rear cover, oil pump, valve body and housing.
7. Tighten the bolts and nuts to the specified torque.
8. Install the bearing and race in their correct positions and directions.
9. In order to prevent foreign matters, such as dust or dirt, from getting into the transmission case, clean each part by applying compressed air prior to the installation.
10. When applying grease, use the specified MP (multipurpose) type.

WR-04147

11. Installation of the manual shift shaft and parking lock pawl
 - (1) Install the lower washer and parking rod to the manual shift shaft.
 - (2) Insert the manual shift shaft into the transmission case.

NOTE:

When the manual shift shaft passes through the oil seal, be careful not to damage the lip section of the oil seal.

- (3) Lock the shift shaft by the washer and the "E" ring.

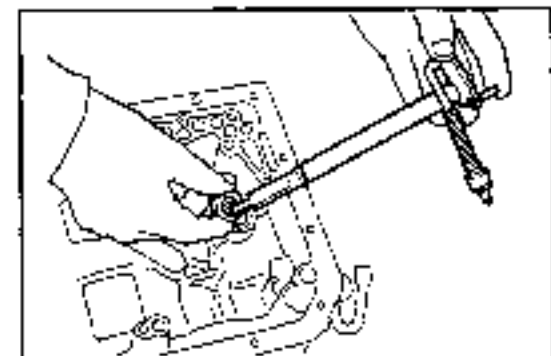

Fig. 4-101

WR-04148

(3) Install the manual detent spring subassembly.

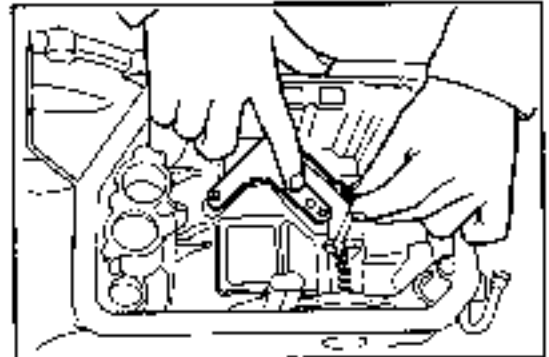

Fig. 4-102

WR-04148-2

(4) Install the pin and snap ring to the parking lock pawl sleeve. Install the sleeve in the transmission case in such a way that the rod may get into the sleeve.

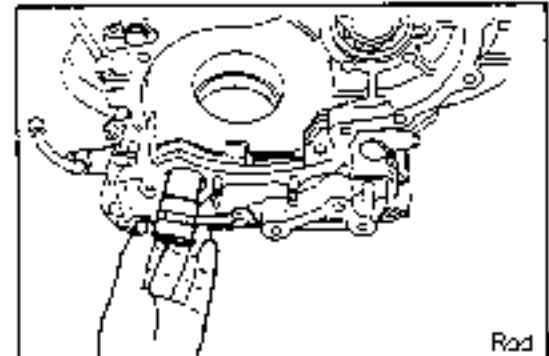

Fig. 4-103

WR-04150

(5) Install the parking lock pawl and parking lock pawl shaft.

- ① Install the pawl in the correct position.
- ② Pass the shaft through the spring. Install them to the pawl, as shown in the right figure.
- ③ Shift the manual shift lever to the **P** range. Ensure that the parking lock pawl moves smoothly.

WR-04151

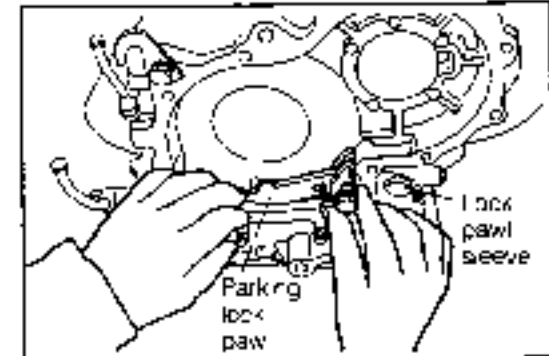

Fig. 4-104

WR-04152

2. Installation of the 1st & reverse brake piston

- (1) Apply the automatic fluid to the "O" rings (both inner and outer). Then, install them to the piston.
- (2) Insert the piston into the transmission case in the direction indicated in the right figure.

NOTE:

Be careful not to twist the "O" rings or not to have them caught by other parts.

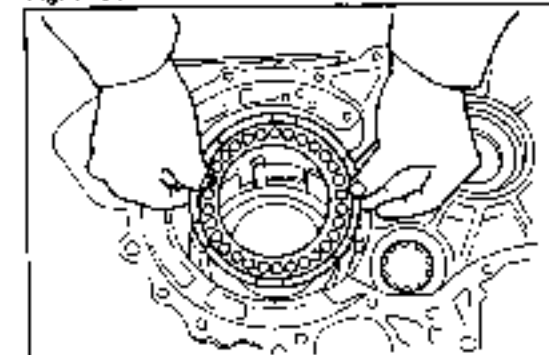

Fig. 4-105

WR-04153

AUTOMATIC TRANSMISSION

- (3) Install the return spring subassembly in such a way that it is fitted into the round groove of the piston. Compress the spring as shown in the right figure, using the following SST. Then, attach the return spring snap ring.

SST: 09350-87702-000

NOTE 1:

Ensure that the snap ring is attached to four grooves of the spring seat.

NOTE 2:

Do not compress the return spring beyond its compression allowance (deflection allowance).

- (4) Install the following parts in this order.

- ① Cushion plate
- ② Plate
- ③ Disc
- ④ Plate Total number of plates: 4
- ⑤ Disc Total number of discs: 4
- ⑥ Plate
- ⑦ Disc
- ⑧ Plate
- ⑨ Disc
- ⑩ Flange

NOTE 1:

Make sure that the cushion plate is installed in the correct installing direction.

(Install it in such a way that, as viewed from above, the floated side may come to the center, whereas the recessed side may come to the outside.)

NOTE 2:

Immerse the discs in the automatic fluid for at least two hours preceding the installation.

NOTE 3:

Care must be exercised as to the assembling sequence and the number of the discs and plates.

- (5) Install the snap ring.

- (6) Measure the clearance indicated in the right figure, using a thickness gauge.

Specified Value: 0.58 - 1.92 mm (0.023 - 0.075 inch)

NOTE:

If the measure value does not comply with the specification, check the installing condition of the clutch discs and the plates.

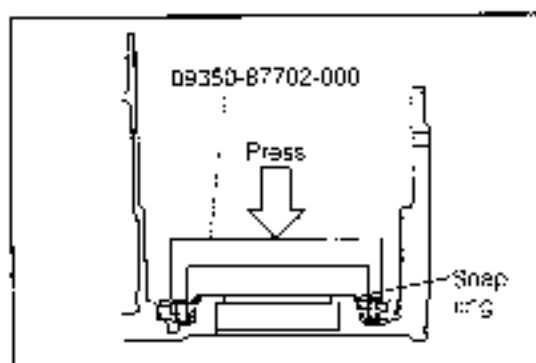

Fig. 4-106

WF-04-55

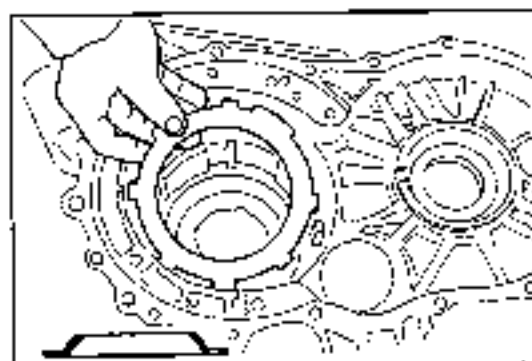

Fig. 4-107

WF-04-55

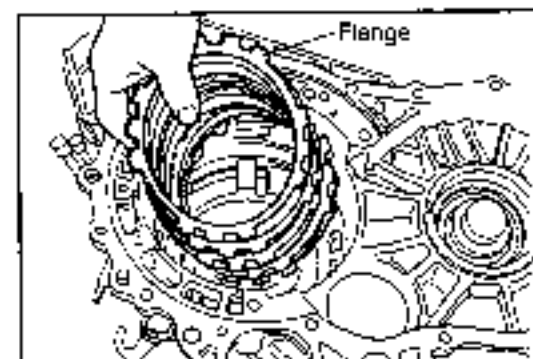

Fig. 4-108

WF-04-55

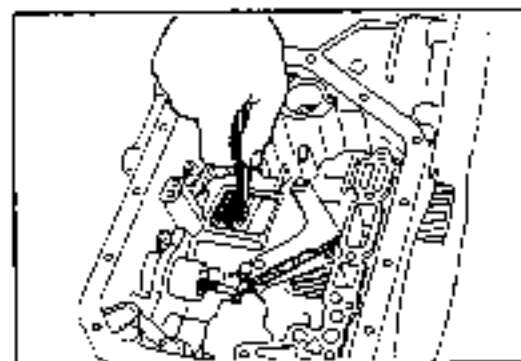

Fig. 4-109

WF-04-55

(7) Apply compressed air into the oil hole indicated in the right figure and check to see if the piston moves freely

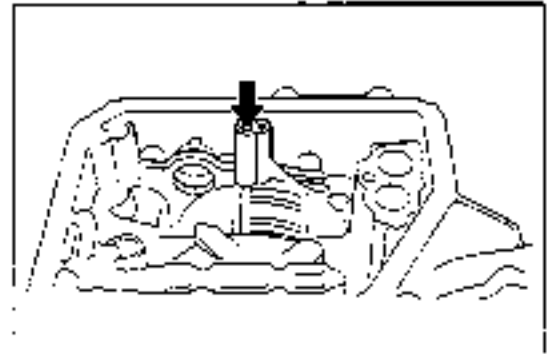

Fig. 4-110

WP-04-53

3 Installation of the counter shaft, reduction gear and rear cover

(1) Press the ball bearing into the output shaft using the following SST.

SST: 09350-87702-000

NOTE:

Prior to the press-fitting, apply the automatic fluid to the inner race and outer race.

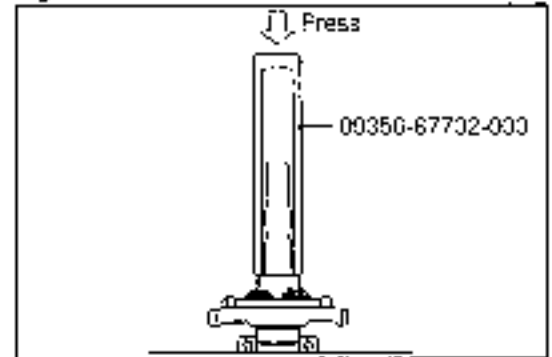

Fig. 4-111

WP-04-53

(2) Drive the ball bearing into the transmission case, using a hammer in combination with the following SST

SST: 09608-30011-000

NOTE:

Prior to the press-fitting, apply the automatic fluid to the inner race and outer race.

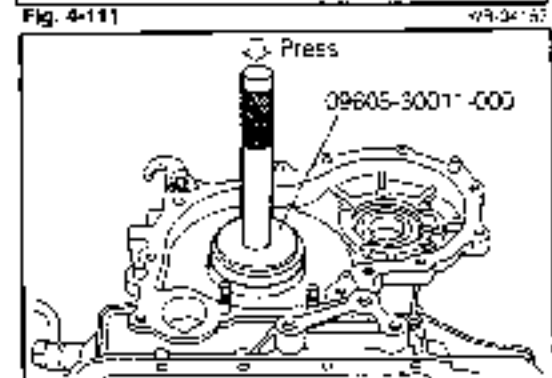

Fig. 4-112

WP-04-53

(3) Press the output shaft into the transmission case using the following SST, as indicated in the figure

SST: 09350-87702-000

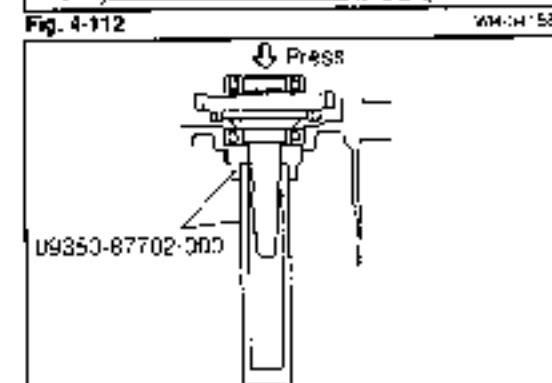

Fig. 4-113

WP-04-53

(4) Press the roller bearing from the differential gear side of the counter shaft case, using the following SST. Then, attach the snap ring.

SST: 09608-30011-000

NOTE:

Prior to the press-fitting of the bearing, apply the automatic fluid to the inner race and outer race.

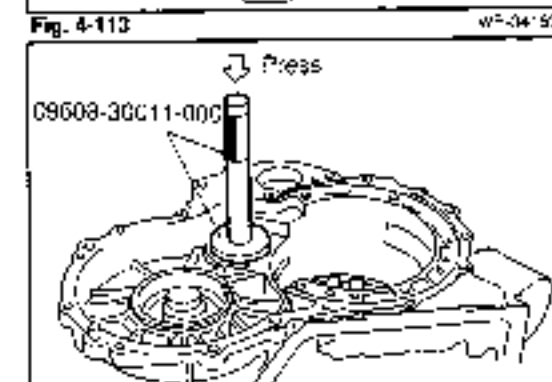

Fig. 4-114

WP-04-53

AUTOMATIC TRANSMISSION

- (5) In advance, put the spacer on the counter shaft case.
(6) Press the ball bearing from the reduction gear side of the counter shaft case using the following SST
SST: 09608-30011-000

NOTE:

Prior to the press-fitting of the bearing, apply the automatic fluid to the inner race and outer race.

- (7) Install the bearing packing plate along the groove.
Attach the snap ring.

- (8) While the inner race of the ball bearing is being sustained, pass the spacer through the counter shaft and press the counter shaft into position.
SST: 09350-87702-000

- (9) Install the reducer driven gear to the counter shaft.
Tighten the lock nut.
Tightening Torque: 11 - 15 kg-m (80 - 106 ft-lb)

- (10) Stake the lock nut using a chisel.

NOTE:

Be careful not to apply excessive forces to the counter shaft.

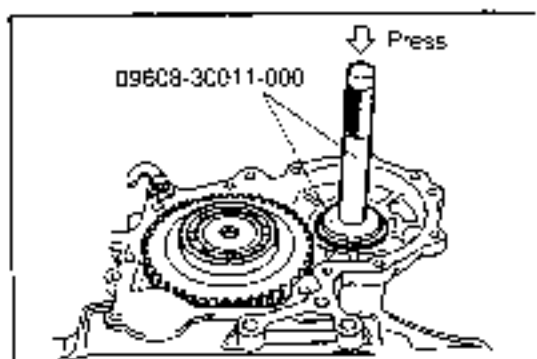

Fig. 4-115

WR-0412

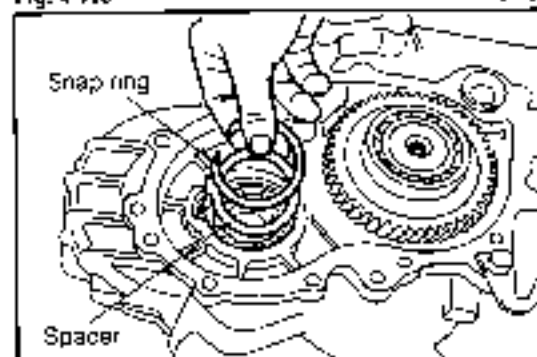

Fig. 4-116

WR-0412

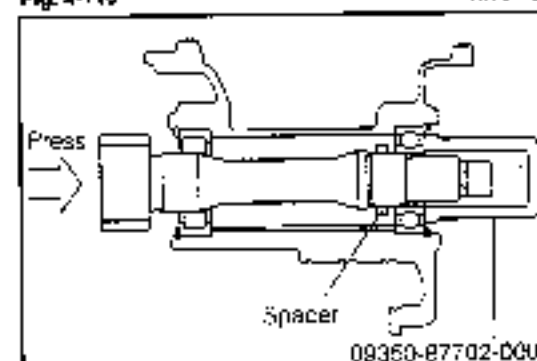

Fig. 4-117

WR-0412

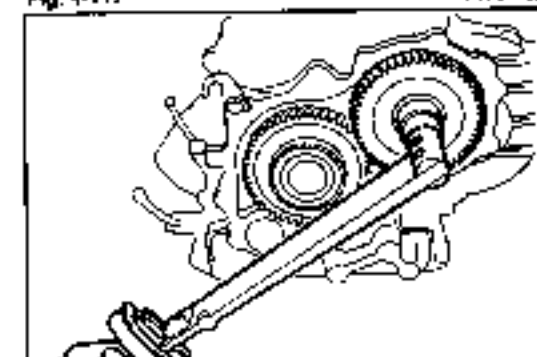

Fig. 4-118

WR-0412

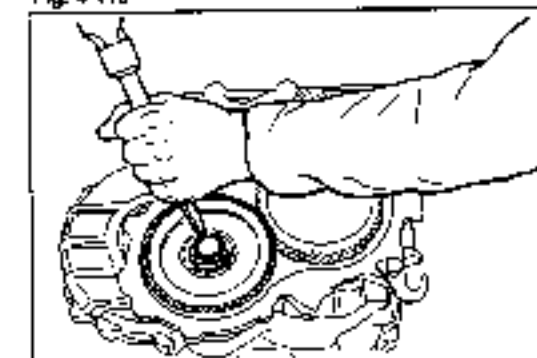

Fig. 4-119

WR-0412

- (11) Install the gasket, making sure that it is aligned with the straight pin of the case. Install the rear cover.

NOTE 1:

Be sure that the bearing smoothly gets into the bearing hole of the rear cover.

NOTE 2:

Check to see if the shaft emits any abnormal gear sound, while rotating the shaft.

4-5-0118*

- (12) Secure the rear cover by tightening the ten bolts and two nuts.

Tightening Torque: Bolt 1.6 - 2.3 kg-m (12 - 16 ft-lb)
Nut 1.1 - 1.5 kg-m (8.0 - 10 ft-lb)

NOTE:

As for the arrow-headed bolt in the right figure, use this bolt to secure the solenoid wire harness in common.

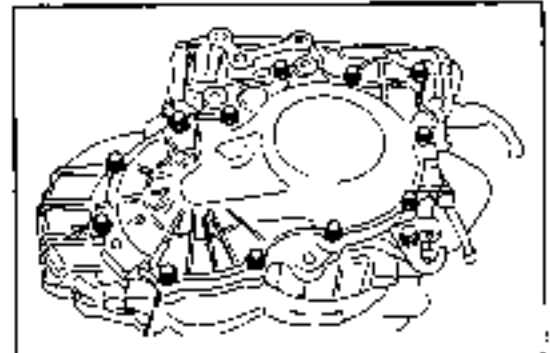

Fig. 4-120

WR-041166

- (13) Working from the inside of the case, push the bearing outer race against the rear cover side, using the following SST.

SST: 09350-87702-000

NOTE 1:

For this operation, use the four cut-out sections of the transmission case.

Pushing Force: 500 kg (1100 lb)

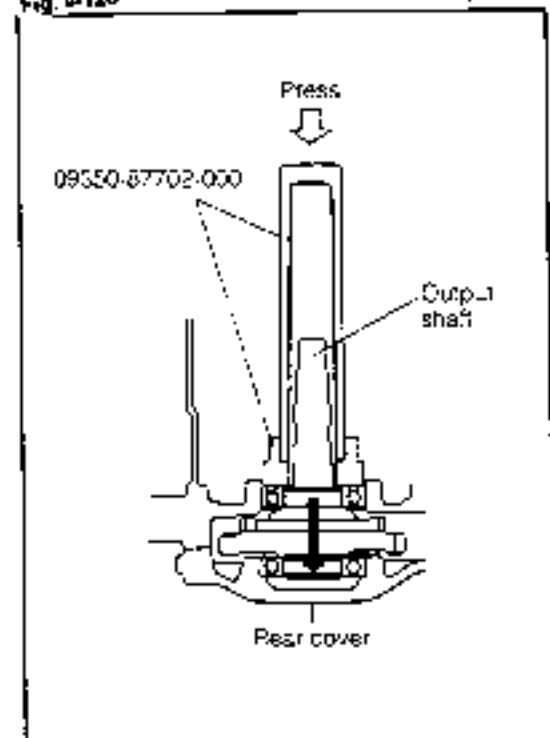

Fig. 4-121

WR-041167

4. Installation of the rear planetary gear and one-way clutch

- (1) Install the rear planetary ring gear, making sure that it is aligned with the spline of the output shaft.

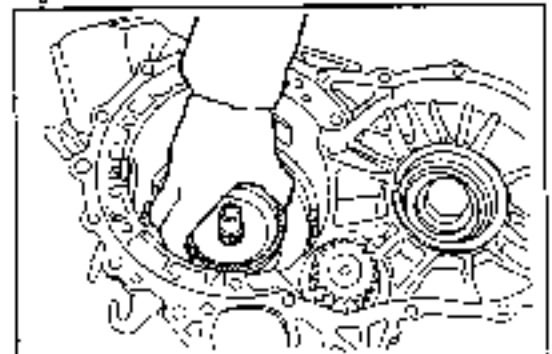

Fig. 4-122

WR-041168

AUTOMATIC TRANSMISSION

(2) Install the bearing races (both sides) and thrust needle roller bearing.

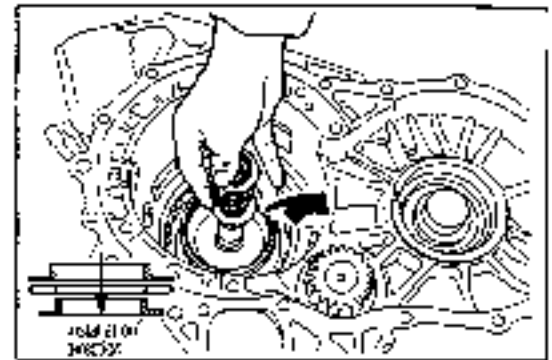

Fig. 4-123

WF-C4-08

(3) Fit the one-way clutch race snap ring to the groove at the 1st reverse brake side of the transmission case.

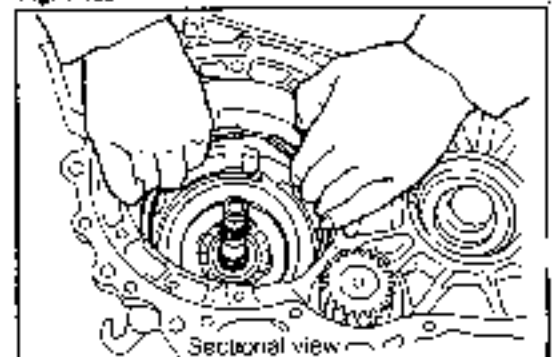

Fig. 4-124

WR-D4-70

(4) Install the thrust washers on each of the front and rear sections of the planetary gear assembly.

NOTE 1:

Apply grease to the washers.

NOTE 2:

Fit the recessed sections of the gear assembly with the two protruding sections correctly.

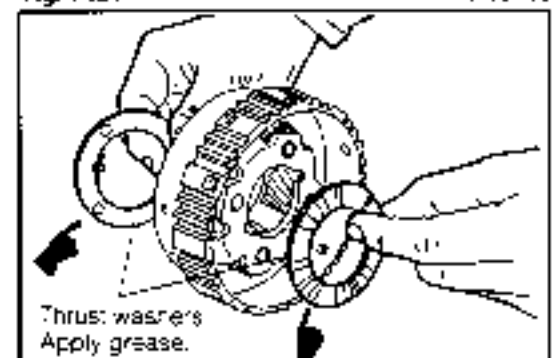

Fig. 4-125

WR-D4-71

(5) While turning the one-way clutch assembly counter clockwise, install it to the planetary gear assembly.

NOTE:

After completion of the installation, be sure that the planetary gear assembly freely rotates clockwise when the one-way clutch outer race is secured.



Fig. 4-126

WR-D4-72

(6) Insert the planetary gear assembly fitted with the one-way clutch assembly into the transmission case while rotating the planetary gear assembly.

NOTE 1:

For easier insertion, align the pawls of the brake disc in advance.

NOTE 2:

If the shift lever is shifted to the **P** range, the shaft is locked, thus making it easier to align the cut-out sections with each other.

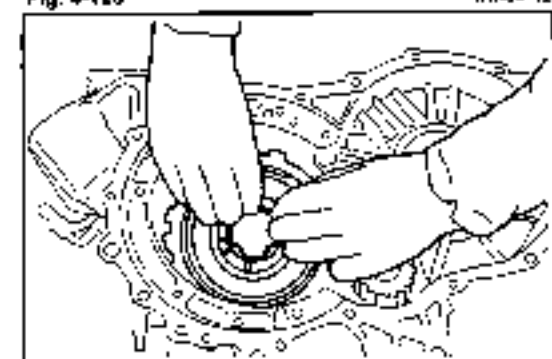

Fig. 4-127

WR-D4-73

NOTE 3:
After completion of the insertion, check the one-way clutch operation.

- Clockwise rotation: Free
- Counterclockwise rotation: Locked

(7) Attach the one-way clutch race snap ring to secure the one-way clutch assembly.

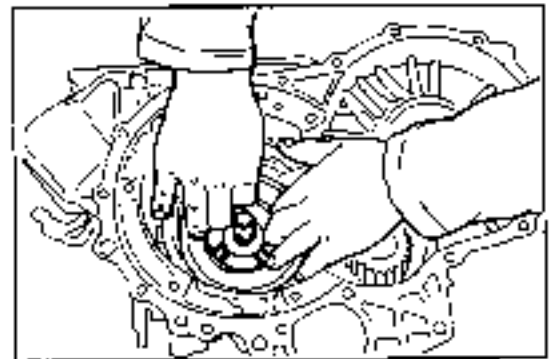

Fig. 4-128 VR-04174

5 Installation of the planetary sun gear assembly
(1) Install the cushion plate and the snap ring (sheet type) to the sun gear

NOTE:
Be sure to install the cushion plate in the correct direction.

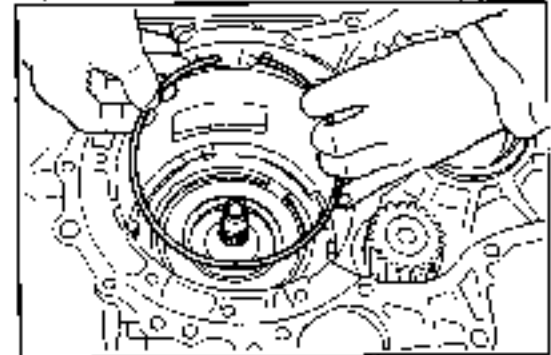

Fig. 4-129 VR-04175

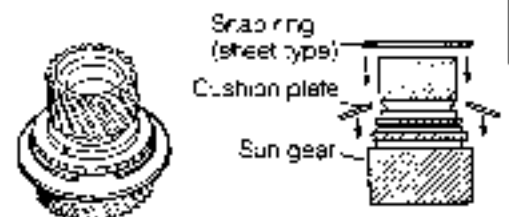

Fig. 4-130 VR-04176

(2) Insert the sun gear into the sun gear input drum.

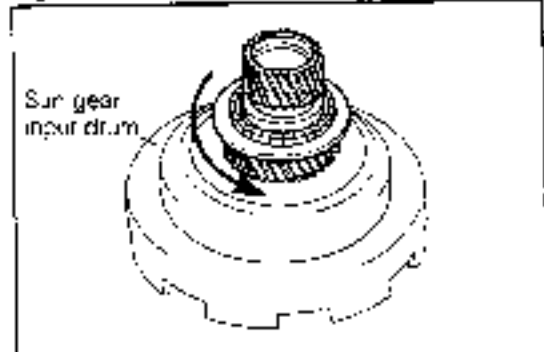

Fig. 4-131 VR-04176A

(3) Temporarily lock the sun gear input drum with another snap ring (wire type)

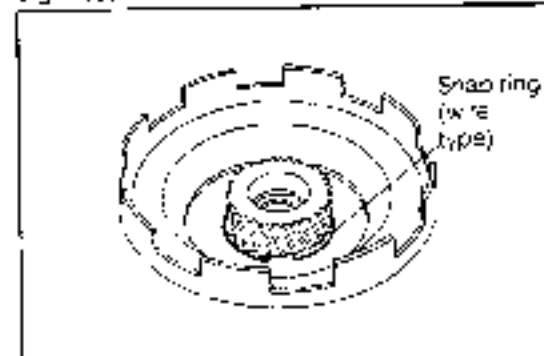

Fig. 4-132 VR-04176B

AUTOMATIC TRANSMISSION

- (4) install the snap ring (wire type) in the correct position by pressing the cushion plate.

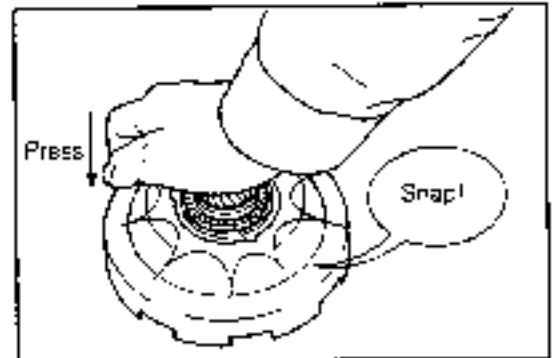

Fig. 4-133

WP-04-76C

- (5) Insert the straight pin into the sun gear
(6) Install the washer in such a way that the straight pin gets into the cut-out section of the planetary thrust washer.

NOTE:

Prior to the installation, apply grease to the washer to prevent it from dropping.

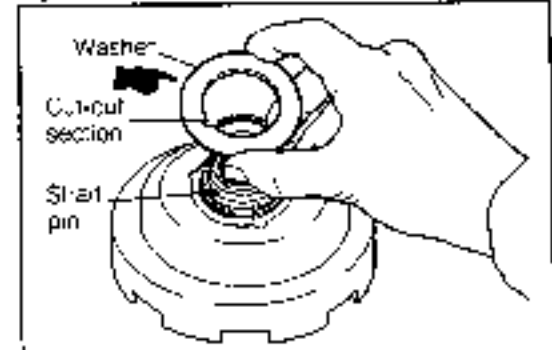

Fig. 4-134

WP-04-77

- (7) While meshing the sun gear assembly with the rear planetary gear, insert the sun gear assembly into the transmission case.

NOTE 1:

Be careful not to damage the bush provided inside of the sun gear.

NOTE 2:

Be certain that the flange section of the thrust bearing race, which was installed in the previous step, has been installed positively into the sun gear bore.

6. Installation of the front planetary gear
(1) Place the thrust needle roller bearing and bearing race on the sun gear.

NOTE:

Be sure to place the bearing race in the correct direction on the sun gear.

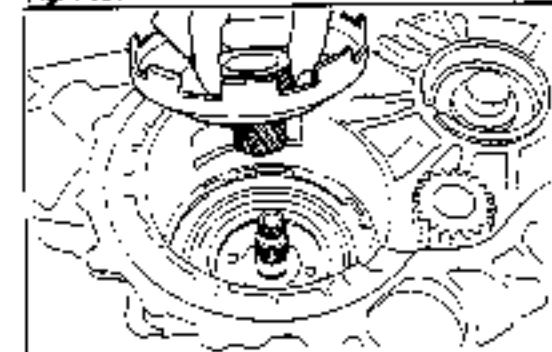

Fig. 4-135

WP-04-77C

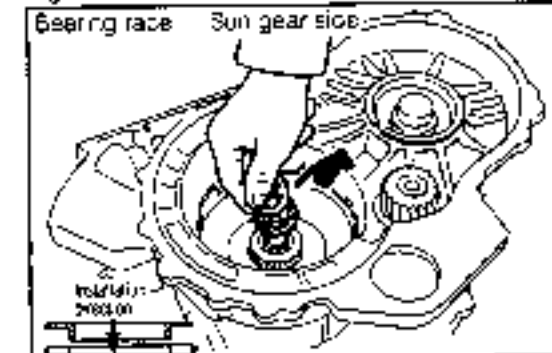

Fig. 4-136

WP-04-79

- (2) While rotating the front planetary gear assembly, fit the pinion gear in the sun gear.

NOTE:

Care must be exercised to ensure that the thrust bearing or the race may not be displaced from the correct position.

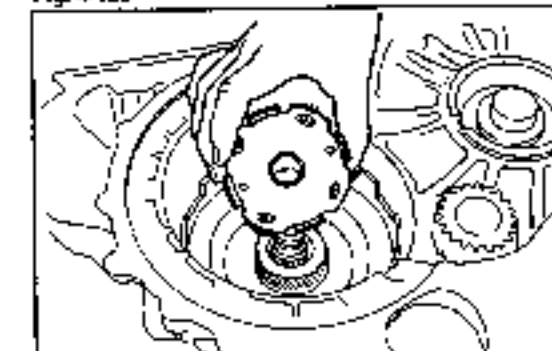

Fig. 4-137

WP-04-100

(3) Place the following parts on the front planetary gear assembly in this order:

- ① Bearing race
- ② Thrust needle roller bearing
- ③ Bearing race

NOTE:

Be sure to place the bearing races in the correct direction on the front planetary gear assembly.

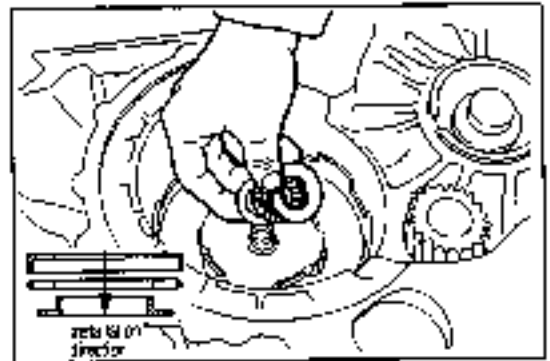

Fig. 4-138

WF-04181

(4) Install the front planetary ring gear to the thrust bearing which was installed in the preceding step.

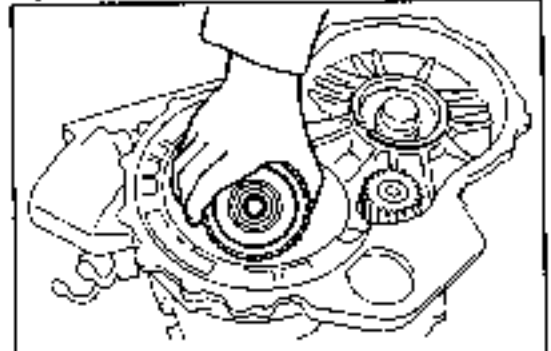

Fig. 4-139

WF-04182

(5) Install the "O" ring at the forward end of the output shaft.

NOTE:

Do not expand the "O" ring excessively during the installation.

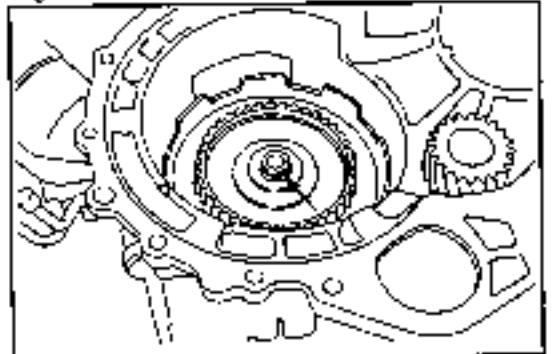

Fig. 4-140

WF-04183

7. Installation of the 2nd brake band

(1) Install the brake 2nd band in the transmission case.

NOTE:

Be sure to install the brake band in the correct direction.



Fig. 4-141

WF-04184

8. Installation of the forward clutch and direct clutch

(1) When the "O" ring of the input shaft is replaced, apply grease to the input shaft side before installing the new "O" ring.

NOTE 1:

Be sure to install the "O" ring to the correct groove.

NOTE 2:

Do not expand the "O" ring excessively during the installation.

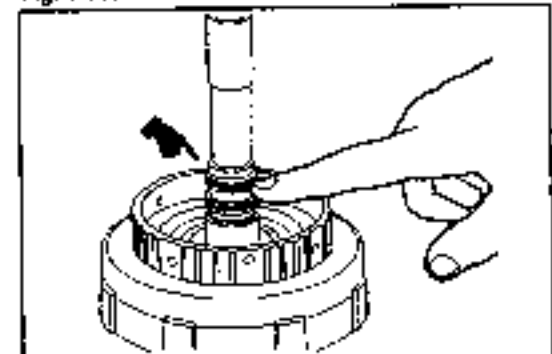

Fig. 4-142

WF-04185

AUTOMATIC TRANSMISSION

- (2) Apply grease to the thrust bearing race and thrust needle roller bearing as well as to their installing sections at the forward clutch. Then, install these parts into positions.

NOTE:

Be certain to install the bearing race in the correct direction.

- (3) Install the thrust washer with the side having no groove facing toward the direct clutch. For easier installation, apply grease to the side of the direct clutch.

NOTE:

Be sure to install the thrust washer in the correct direction.

- (4) Install the direct clutch to the forward clutch.

NOTE 1:

For easier insertion, align the pawls of the clutch disc prior to the installation.

NOTE 2:

Be careful not to drop the thrust washer which was installed in the preceding step.

- (5) Apply grease on the front planetary ring gear in the transmission case. Install the thrust bearing race and thrust needle roller bearing in position.

NOTE:

Care must be exercised as to the installing direction and sequence.

- (6) While holding the input shaft of the forward clutch, install the forward clutch fitted with the direct clutch to the transmission.

NOTE 1:

For easier insertion, align the pawls of the forward clutch disc prior to the installation.

NOTE 2:

Be careful not to drop the thrust bearing which was installed in the preceding step.

NOTE 3:

Be very careful not to damage the oil seal of the output shaft.

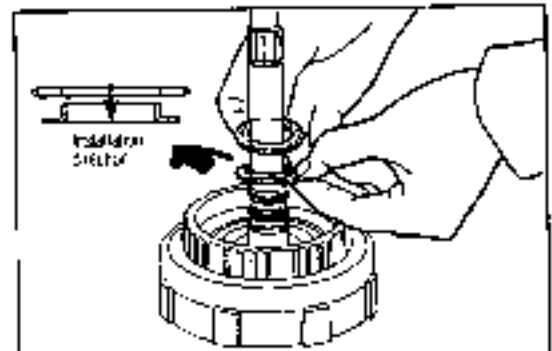

Fig. 4-143

WP-04136

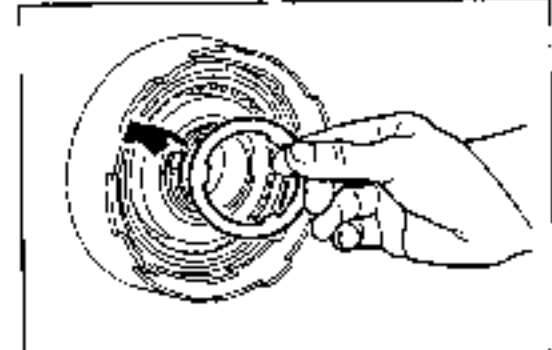

Fig. 4-144

WP-04137

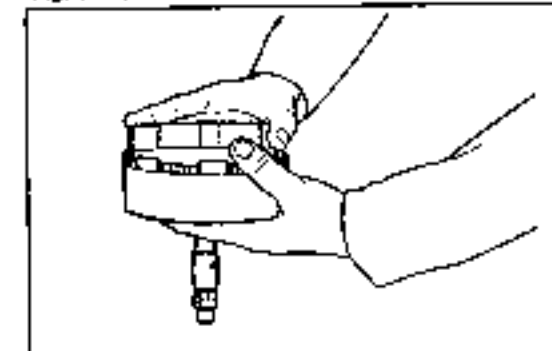

Fig. 4-145

WP-04138

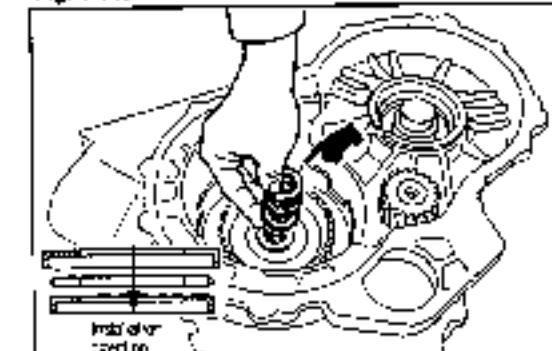

Fig. 4-146

WP-04139

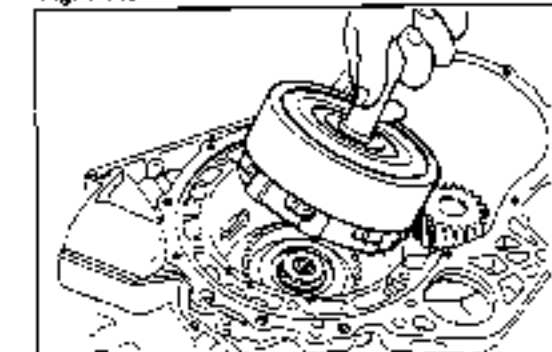

Fig. 4-147

WP-04140

- (7) Secure the 2nd brake band by passing the straight pin through the transmission case and the hole of the 2nd brake band.

NOTE:

Prior to the installation, apply the automatic fluid to the pin.

9. Installation of the differential assembly

- (1) Place the transmission case, with its rear cover side facing downward. While meshing the pinion gear of the counter shaft with the teeth of the differential ring gear, install the differential assembly.

NOTE 1:

Be careful not to damage the teeth of the gear during the installation.

NOTE 2:

The counter shaft pinion gear and the differential ring gear have been set as a pair. Hence, be careful not to mix these parts with other parts.

10. Installation of the torque converter housing

- (1) Install the gasket

NOTE:

Make sure that the gasket is not protruding to the inside.

- (2) While aligning the center of the differential gear bearing and the locating pin position, install the housing in the transmission case.

- (3) Tighten the housing attaching bolts indicated in the right figure.

Tightening Torque: 1.6 - 2.3 kg-m (12 - 16 ft-lb)

NOTE:

Apply the sealant to the entire threaded portion of each bolt which bears a star mark (indicated by an arrow mark in the figure).

11. Installation of the oil pump assembly

- (1) Apply grease to the thrust bearing race and thrust needle roller bearing, install them to the input shaft

NOTE 1:

Be sure to install the bearing race in the correct direction.

NOTE 2:

Make sure that the bearing race and bearing are fitted positively.

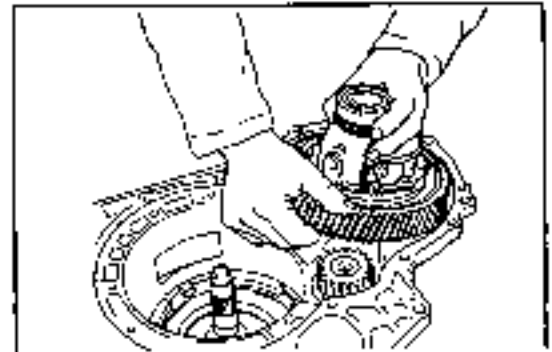

Fig. 4-148

WP-CG-51

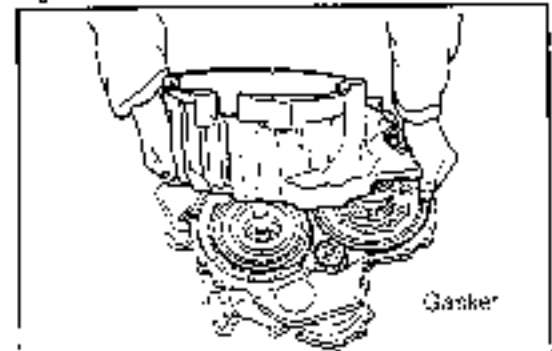
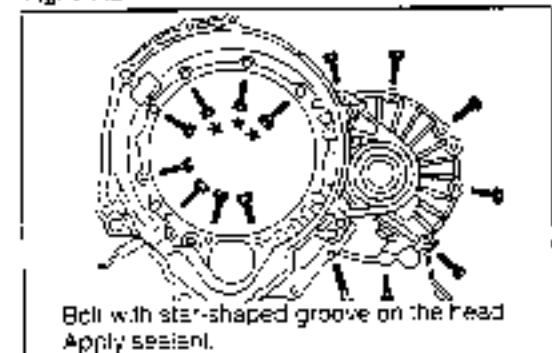

Fig. 4-149

WP-CG-192



Bolt with star-shaped groove on the head
Apply sealant.

Fig. 4-150

WP-AT-16

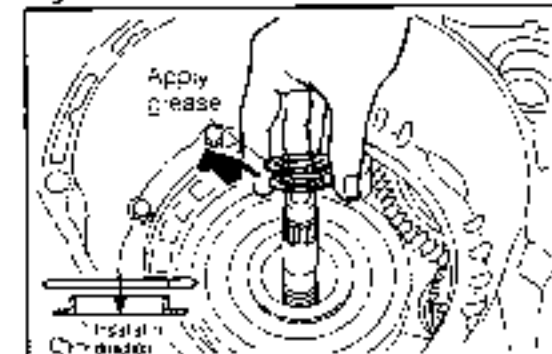

Fig. 4-151

WP-AT-32

AUTOMATIC TRANSMISSION

- (2) Install the thrust bearing race, after coating the oil pump side with grease.

- (3) Attach the clutch drum thrust washer to the oil pump.

NOTE 1:

Align the flange of the washer with the cut-out section of the pump.

NOTE 2:

Prior to the installation, apply grease to retain the thrust washer.

- (4) When the oil seal is replaced, apply grease to the oil seal prior to the installation.

NOTE 1:

Do not expand the oil seal excessively during the installation.

NOTE 2:

Be certain to install the oil seal to the correct groove.

- (5) Install the "O" ring to the periphery of the oil pump.

NOTE 1:

Prior to the installation, apply grease to the "O" ring.

NOTE 2:

Use a new "O" ring.

NOTE 3:

Make sure that the "O" ring is not twisted or displaced from the groove on the periphery of the oil pump.

- (6) Install the oil pump assembly in the transmission case.

NOTE:

Care must be exercised to ensure that the "O" ring of the input shaft and the "O" rings provided inside or outside of the pump may not be pinched or damaged.

WR-04-19E

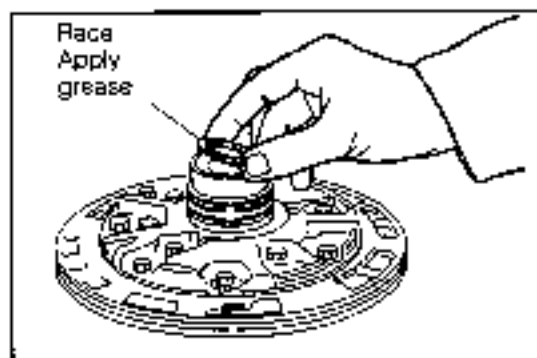

Fig. 4-152

WR-04-19E

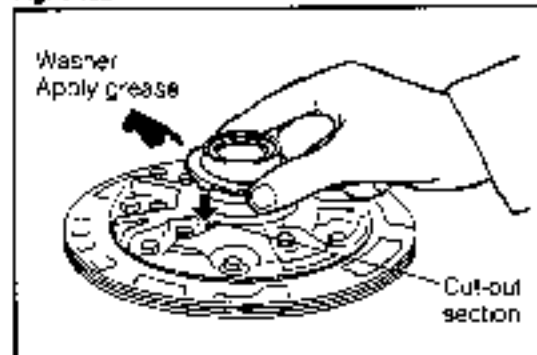
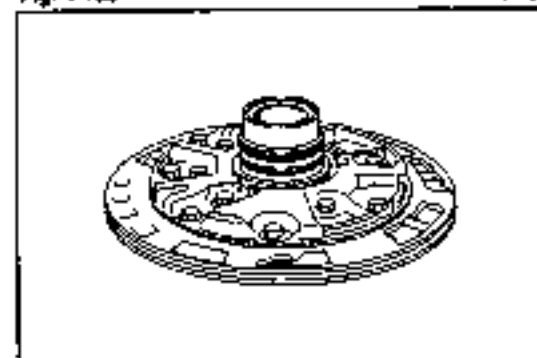

Fig. 4-153

WR-04-19E



WR-04-19E

(7) Tighten the six flange bolts.

Tightening Torque: 1.8 - 2.7 kg-m (14 - 19 ft-lb)

NOTE:

Note that only the bolt indicated by the ↴ mark in the figure is a M10 bolt.

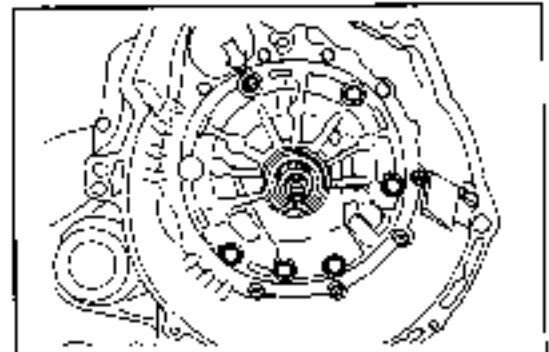

Fig. 4-155

WR 04195

12. Check of the input shaft end play

(1) Measure the play in the axial direction by applying the plunger of a dial gauge to the end surface of the input shaft.

Specified Value: 0.3 - 0.9 mm (0.012 - 0.035 inch)

(2) If the measured value does not comply with the specification, select a proper one from the following two thrust bearing races having different thicknesses. Then, replace the race which was installed in Step 12-(3) at page 00 with the newly-selected bearing race.

Thrust bearing race thickness

Too large end play → 1.4 mm (0.055 inch)

Too small end play → 0.8 mm (0.031 inch)

(3) After the reinstallation, ensure that the input shaft rotates smoothly.

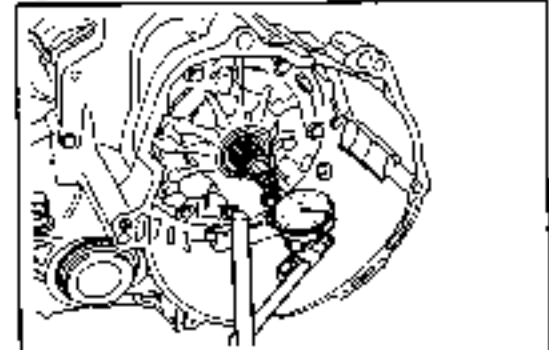

Fig. 4-156

WR 04200

13. Installation of the solenoid wire harness

(1) Fit the lock plate into the groove of the solenoid wire grommet. Install the solenoid wire to the stud bolt of the transmission case.

(2) Attach the washer to the stud bolt and tighten it with the nut.

(3) Clamp the wire harness at two points of the rear cover.

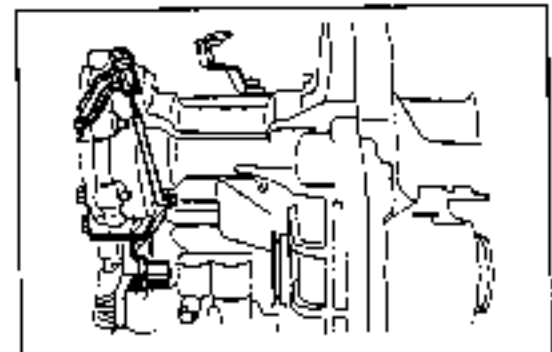

Fig. 4-157

WR 04201

14. Installation of the throttle cable

(1) Insert the throttle cable into the hole of the transmission case.

NOTE 1:

Apply the automatic fluid to the "O" ring.

NOTE 2:

Care must be exercised to ensure that the "O" ring may not be damaged or pinched.



Fig. 4-158

WR 04202

AUTOMATIC TRANSMISSION

15. Installation of the 2nd brake piston

(1) Install the "O" ring and washer to the piston rod.

NOTE:

Prior to the installation, apply grease to the "O" ring.

(2) Insert the spring and rod to the piston. Secure it with the "E" ring.

NOTE:

Prior to the installation, apply the automatic fluid to the inserting section of the rod

(3) Install the two "O" rings to the piston

NOTE 1:

Be careful not to damage the "O" rings.

NOTE 2:

Do not expand the "O" rings excessively.

(4) Put the spring in the transmission case. Insert the piston assembly into the case.

NOTE 1:

Apply the automatic fluid to the inserting section of the piston rod.

NOTE 2:

Care must be exercised to ensure that the "O" ring may not be damaged or pinched.

NOTE 3:

Make sure that the forward end of the rod is aligned with the metal fitting of the brake band.

(5) Install two "O" rings to the piston cover

NOTE:

Prior to the installation, apply the automatic fluid to the "O" rings.

(6) Insert the piston cover into the transmission case.

NOTE:

Care must be exercised to ensure that the "O" ring may not be damaged or pinched.

(7) With the piston cover pushed to the inside, attach the snap ring in position.

(8) Through the side cover hole, check to see if the forward end of the rod is in contact with the metal fitting of the brake band at its specified position.

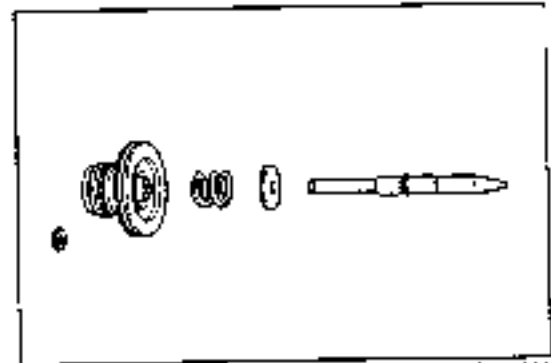

Fig. 4-159

WF-041-204

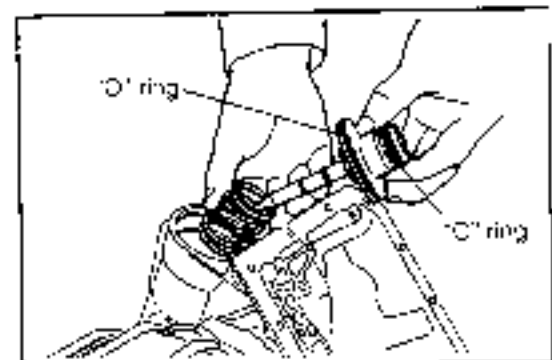

Fig. 4-160

WF-042-05

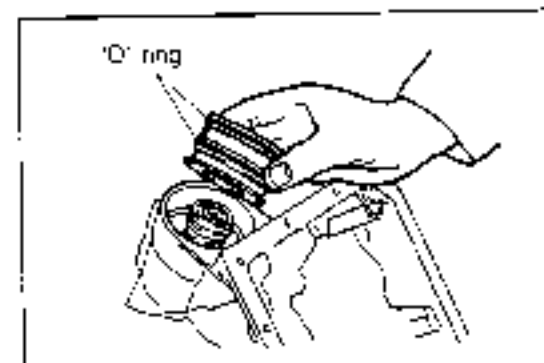

Fig. 4-161

WF-042-04

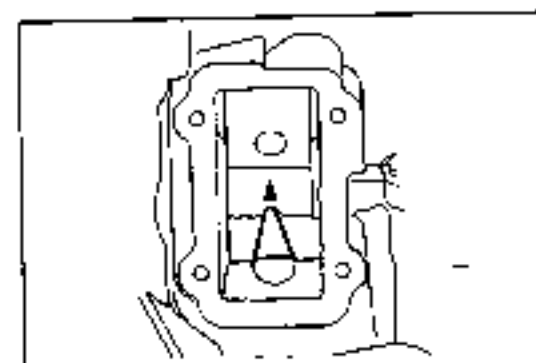

Fig. 4-162

WF-042-03

- (9) Perform the 2nd brake piston stroke check in the same way as with the disassembly. WA-04206
- (10) Install the transmission case side cover and its gasket. Tighten them by means of the four bolts.
Tightening Torque: 0.7 - 0.9 kg-m (5.5 - 6.5 ft-lb)

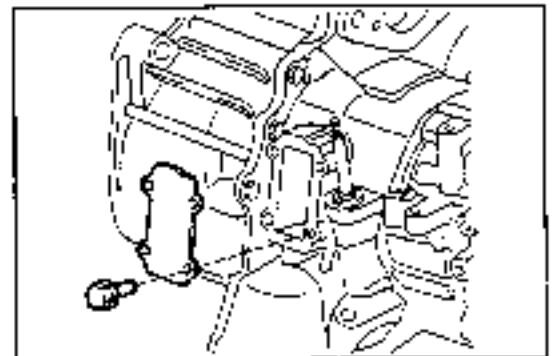

Fig. 4-163

WA-01207

16 Installation of the neutral start switch and the manual valve outer lever

- (1) Install the neutral start switch.
- ① Set the manual shaft to the 'N' position.
 - ② Insert the switch into the control shaft.
 - ③ Temporarily secure the switch bolt (nominal length: 35 mm).
 - ④ Align the scribe lines on the control rod and switch with each other.
 - ⑤ Securely tighten the bolt which has been secured temporarily in the step ③ above.
- Tightening Torque: 1.6 - 2.3 kg-m (12 - 17 ft-lb)**
- ⑥ Ensure that the switch is functioning properly.

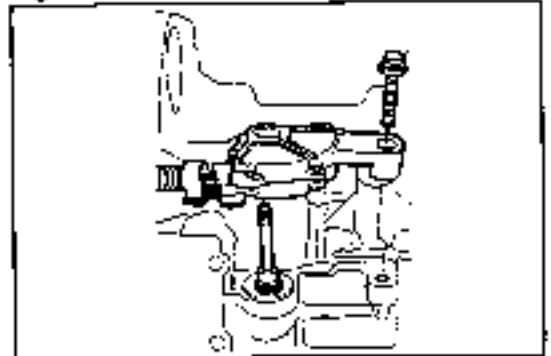

Fig. 4-164

WA-04149

- (2) Pass the upper washer and then the shift lever through the manual shift shaft which protrudes above the transmission upper section. Then secure them by means of double nuts.

NOTE:

The following shows the tightening sequence of double nuts.

- ① Tighten the lower nut.
Tightening Torque: 0.9 - 1.7 kg-m (6.5 - 12 ft-lb)
- ② Tighten the upper nut.
Tightening Torque: 0.9 - 1.7 kg-m (6.5 - 12 ft-lb)
- ③ With the upper nut locked, tighten the lower nut in the reverse direction.
Tightening Torque: 0.9 - 1.7 kg-m (6.5 - 12 ft-lb)



Fig. 4-185

WA-041406

- (3) Check to see if the shaft rotates smoothly.

AUTOMATIC TRANSMISSION

17. Installation of the accumulator piston
(1) Install the "O" ring on the piston.

NOTE:

Prior to the installation, apply the automatic fluid to the piston and "O" ring.

- (2) Insert the spring into the piston.
(3) Insert the piston into the transmission case.

NOTE 1:

	Number of "O" ring	Spring length mm (inch)	Spring outer diameter mm (inch)
B ₁	2	52 (2.05)	10.0 (0.394)
C-	1	64.1 (2.52)	15.0 (0.591)

NOTE 2:

Care must be exercised to ensure that the "O" ring may not be damaged or pinched.

18. Installation of the valve body assembly
(1) Place the valve body assembly on the transmission case
(2) Install the pin of the manual lever in the manual valve
(3) Temporarily tighten the two bolts indicated in the figure.

- (4) Install the throttle cable to the throttle cam.

NOTE:

Do not pull the cable more than 40 mm (1.57 inches).

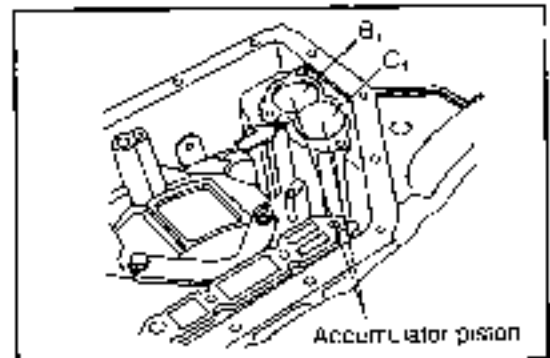

Fig. 4-156

WP-C4206

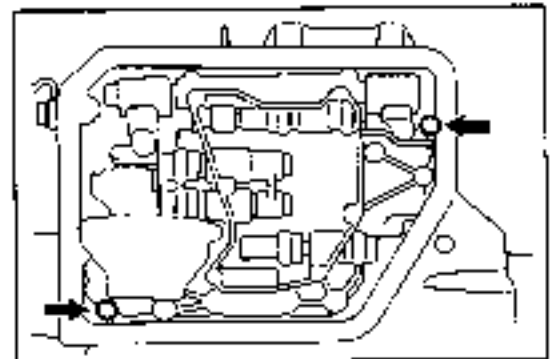

Fig. 4-157

WP-C4202

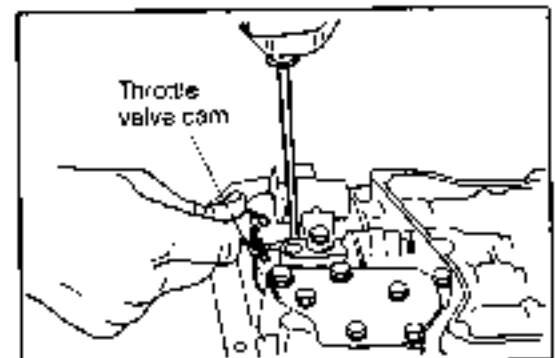

Fig. 4-158

WP-C4210

(5) Tighten all bolts

No	Standard	Normal depth mm (inch)	Tightening torque kg-m (ft.-lb)	Number	Shape of head
①	M6	36 (1.417)	0.80 - 1.20 (6.0 - 8.5)	7	Deep recess
②	M6	47 (1.850)	0.80 - 1.20 (6.0 - 8.5)	1	Deep recess
③	M6	25 (0.984)	0.80 - 1.20 (6.0 - 8.5)	2	Normal recess
④	M6	32 (1.260)	0.80 - 1.20 (6.0 - 8.5)	1	Normal recess

(6) Install the oil tubes.

NOTE 1:

First insert the oil tube's end having no stopper (1 in the right figure) about 2 mm (0.079 inch). Then, insert the end having a stopper (2 in the right figure).

NOTE 2:

To prevent the tube from being deformed, lightly tap the tube using a plastic hammer.

NOTE 3:

Positively insert the tube, until the stopper of the tube comes into contact with the case.

NOTE 4:

Install the tubes in parallel with the valve body.

(7) Connect the solenoid connector.

NOTE:

The wire harness differs in length to prevent wrong connections. Therefore, do not pull it forcibly.

(8) Install the oil strainer. At the same time, clamp the two solenoid connectors. Tighten them all together.

Tightening Torque: 0.4 - 0.6 kg-m (3.0 - 4.0 ft.-lb)

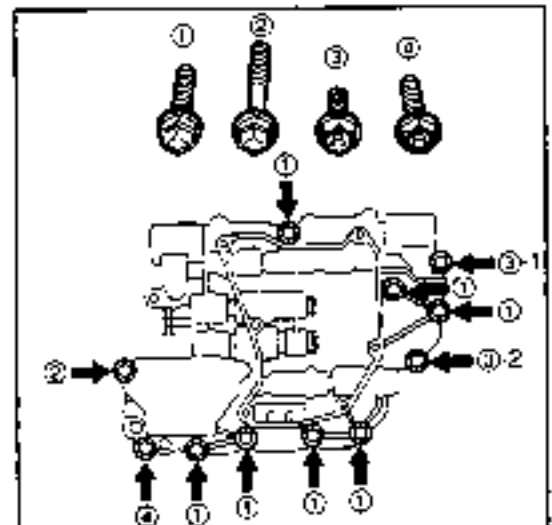

Fig. 4-169

WF-04211

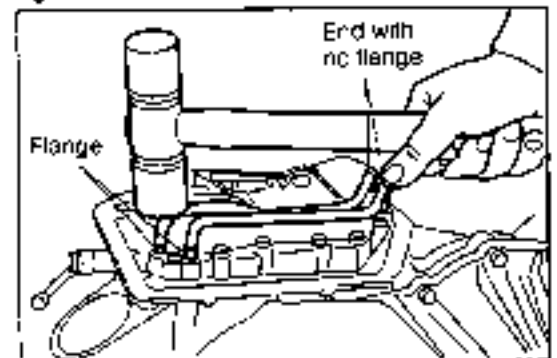

Fig. 4-170

WF-04212

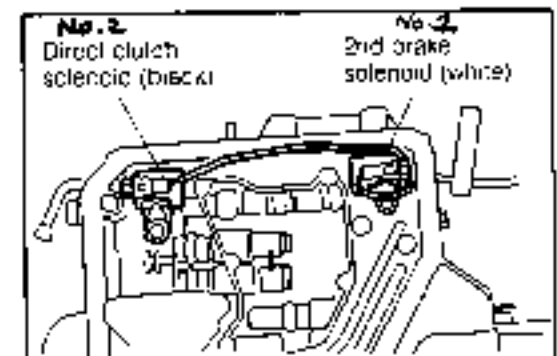

Fig. 4-171

WF-04213

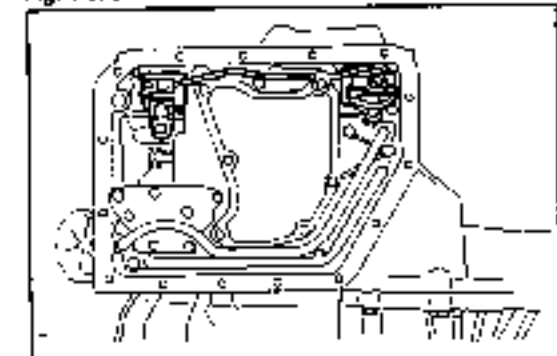

Fig. 4-172

WF-04214

AUTOMATIC TRANSMISSION

19 Installation of the oil pan

- (1) Set the gasket on the transmission case.

NOTE:

Make sure that the bolt holes of the gasket are aligned with those in the transmission case.

- (2) Place the magnet on the oil pan.

NOTE:

It is advisable to place the magnet at the position indicated in the figure.

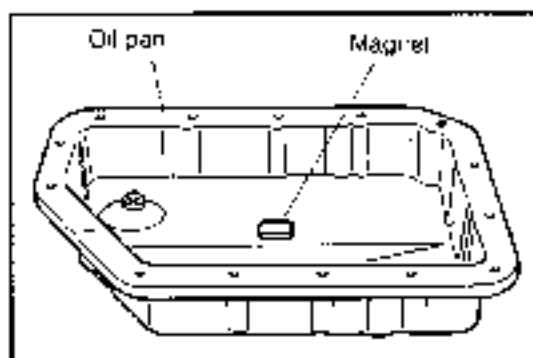

Fig. 4-173

WP-04215

- (3) Tighten the oil pan by means of the bolts (13 pieces) and screws (two pieces).

Tightening Torque: 0.4 - 0.6 kg-m (3.0 - 4.0 ft-lb)

NOTE 1:

Apply the sealant to the two screws indicated in the figure.

NOTE 2:

Make sure that the tube and oil pan do not interfere with each other.

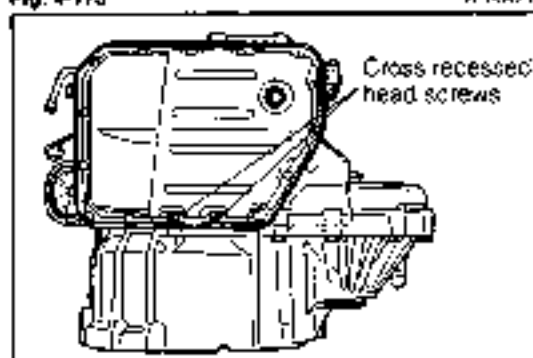

Fig. 4-174

WP-04216

- (4) Tighten the drain plug.

Tightening Torque: 1.8 - 2.3 kg-m (13.5 - 16.5 ft-lb)

WP-04217

20 Installation of the oil filler tube

- (1) Install the "O" ring to the oil filler tube. Insert the oil filler tube into the transmission case.

NOTE 1:

Apply the automatic fluid to the "O" ring.

NOTE 2:

Insert the oil filler tube up to the flange position.

- (2) Secure the oil filler tube by means of the bolt.

Tightening Torque: 0.3 - 0.7 kg-m (2.4 - 5.6 ft-lb)

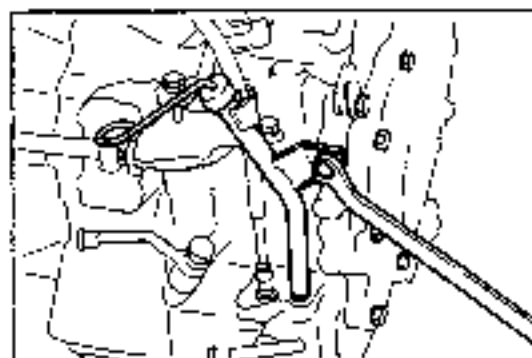

Fig. 4-175

WP-04218

21 Installation of the test plug at the detecting hole

- (1) Install the "O" ring and tighten the plug.

Tightening Torque: 0.6 - 0.9 kg-m (4.3 - 6.5 ft-lb)

NOTE:

Apply the automatic fluid to the "O" ring.

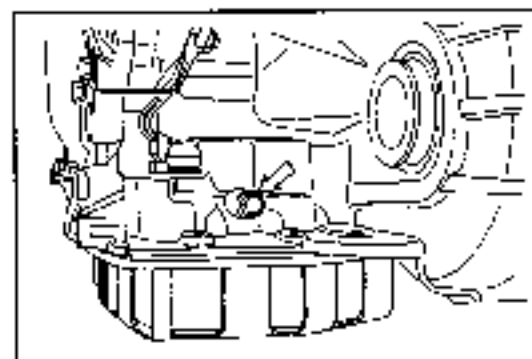

Fig. 4-176

WP-04219

- 72 Installation of the torque converter
 (1) Install the torque converter. Check to see if the attaching dimension indicated in the right figure complies with the specification.

NOTE 1:

Be careful not to damage the oil seal.

NOTE 2:

Make sure that the torque converter rotates lightly.

NOTE 3:

Apply grease to the point indicated in the figure.

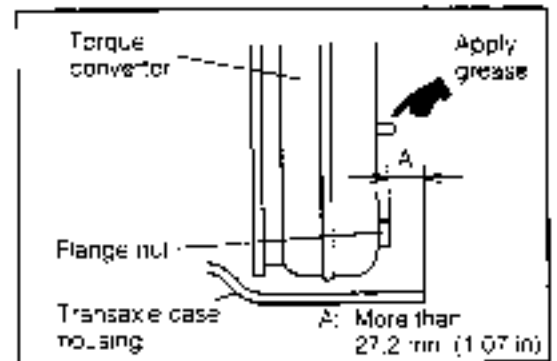

Fig. 4-177

NR-04221

APPENDIX

SHIFT LEVER CONSTRUCTION

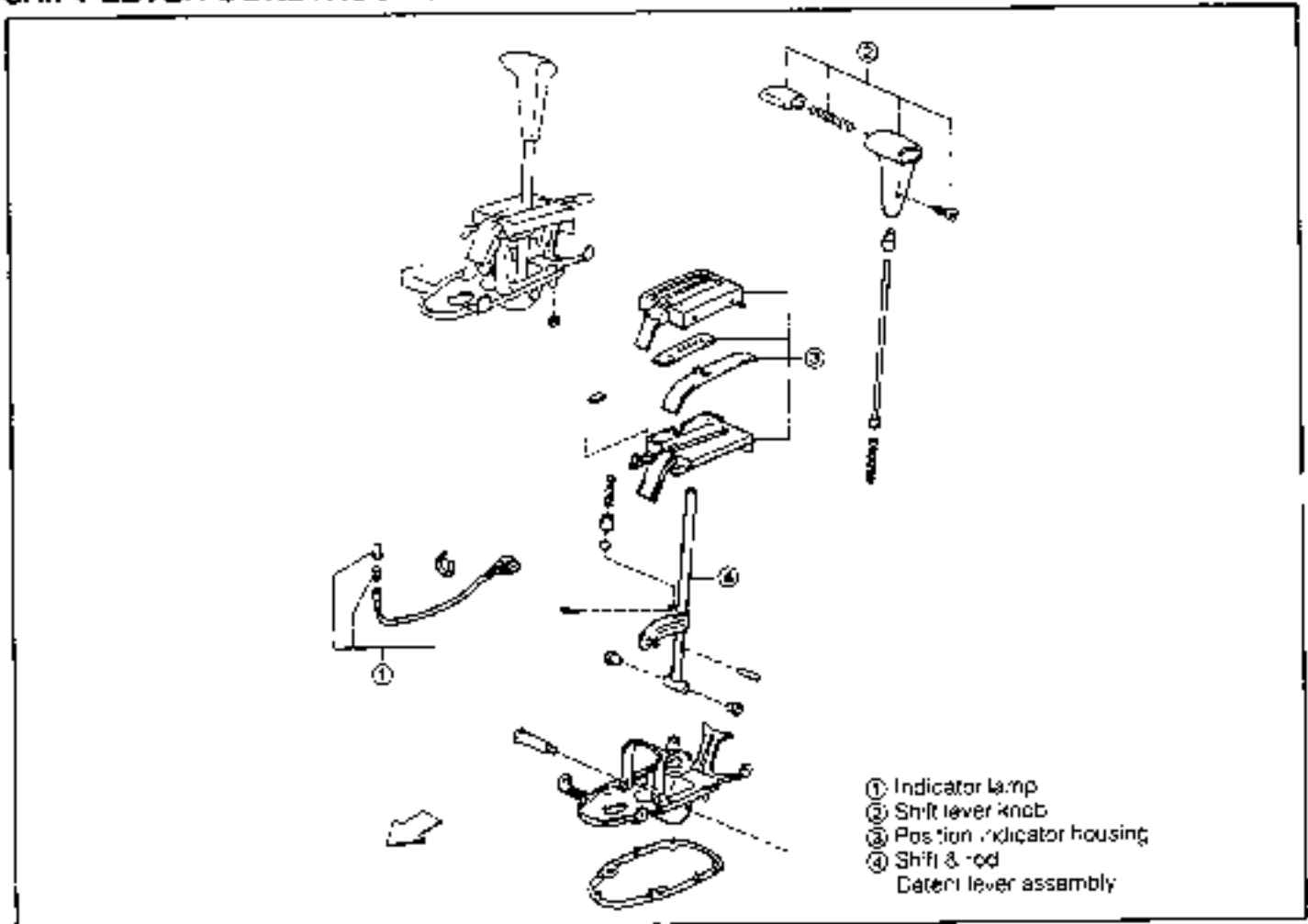

Fig. 4-178

WR-04222

Shift lever components

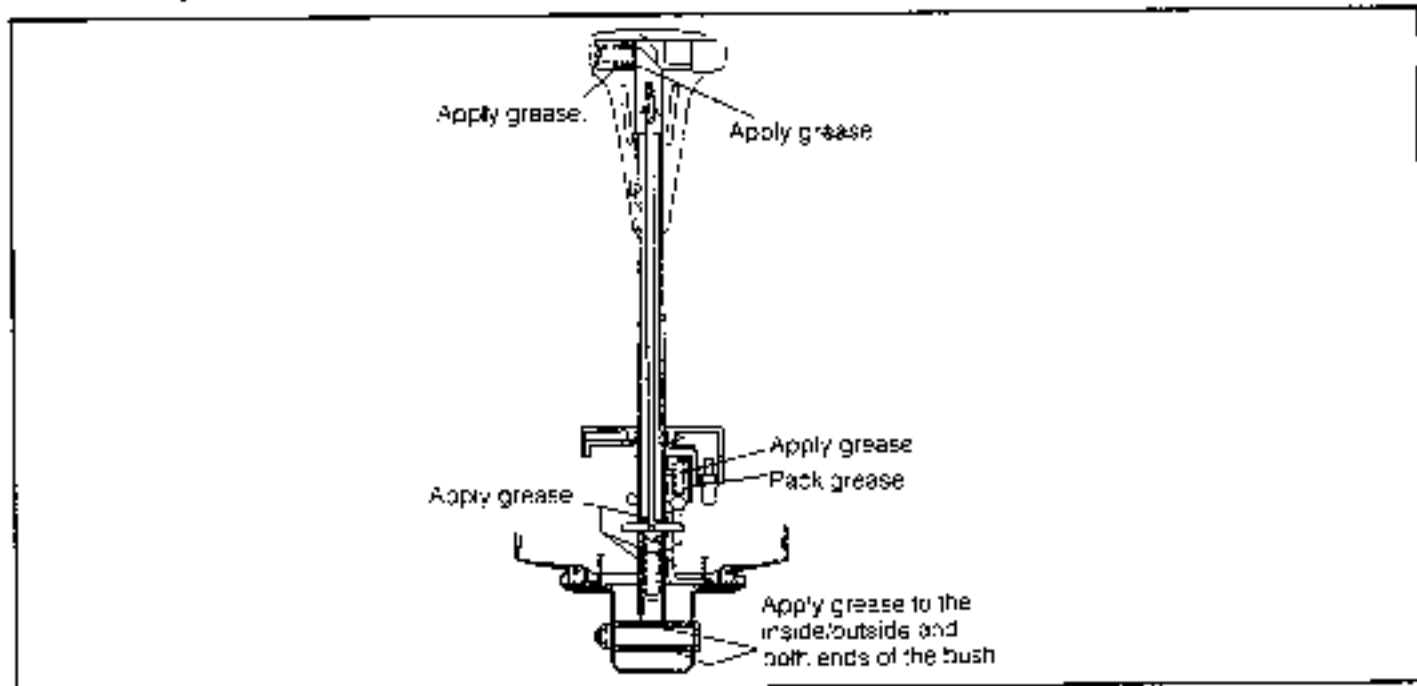

Fig. 4-179

WR-04222A

CONTROL CABLE CONSTRUCTION

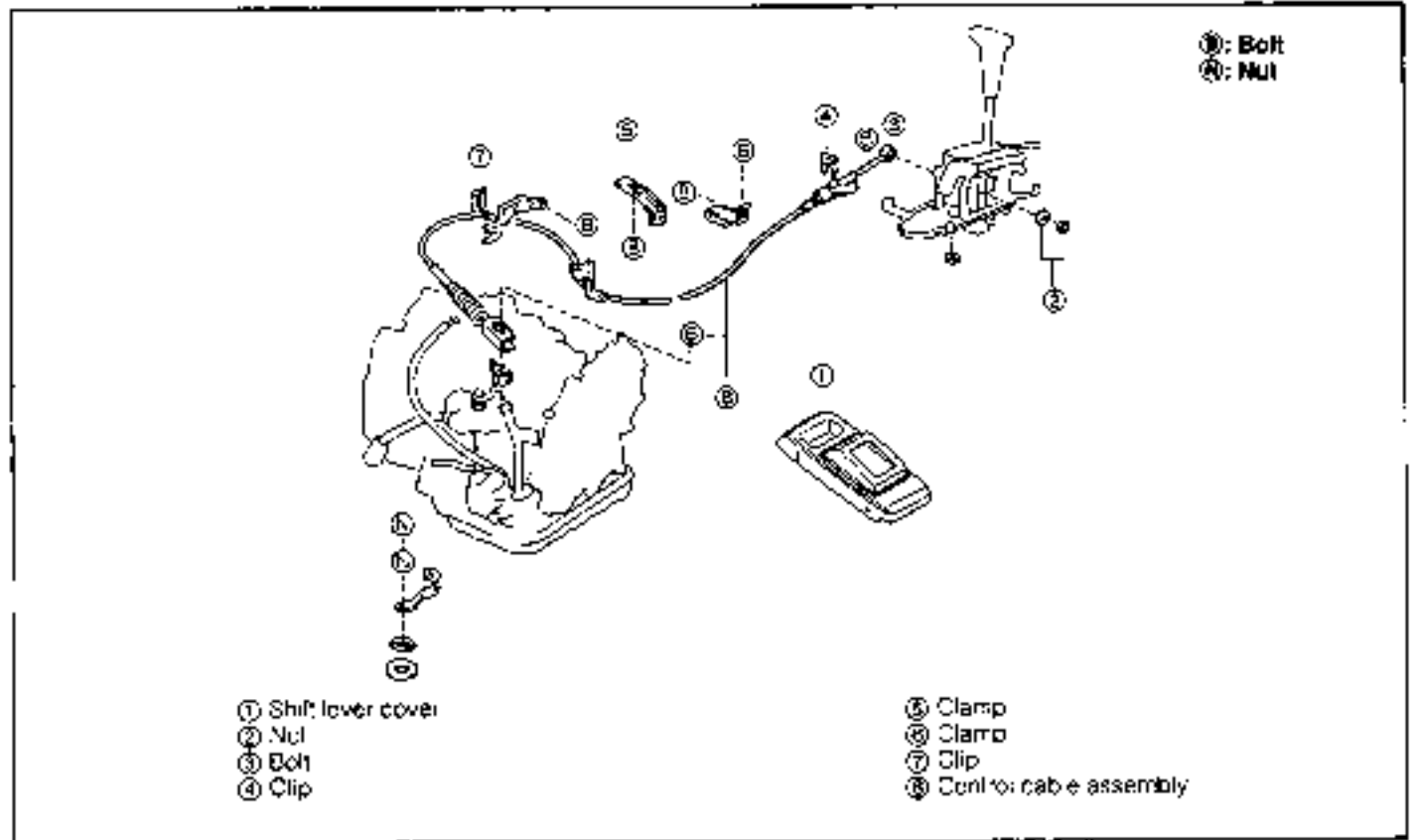

Fig. 4-180

W6-C-223

Control cable components

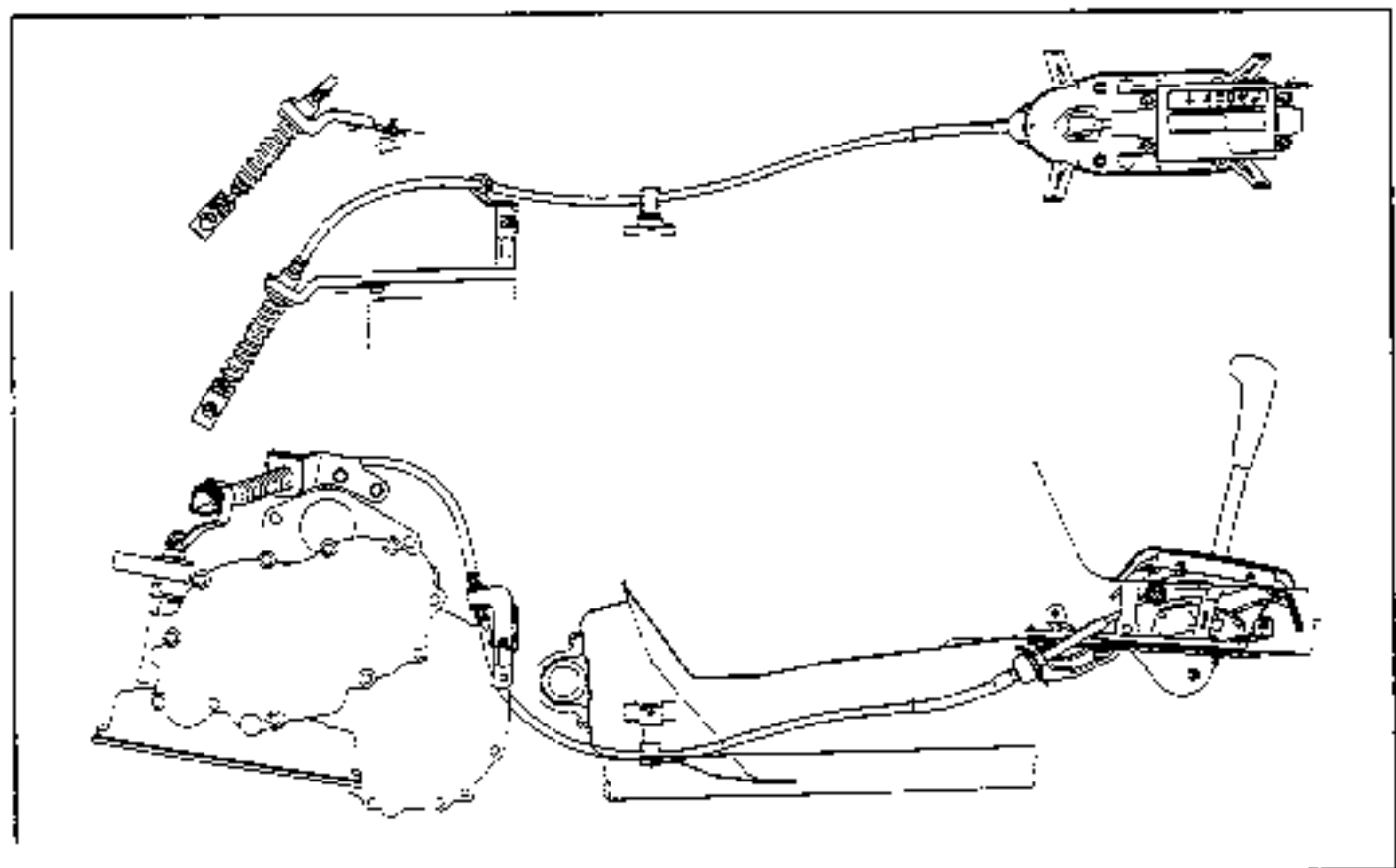
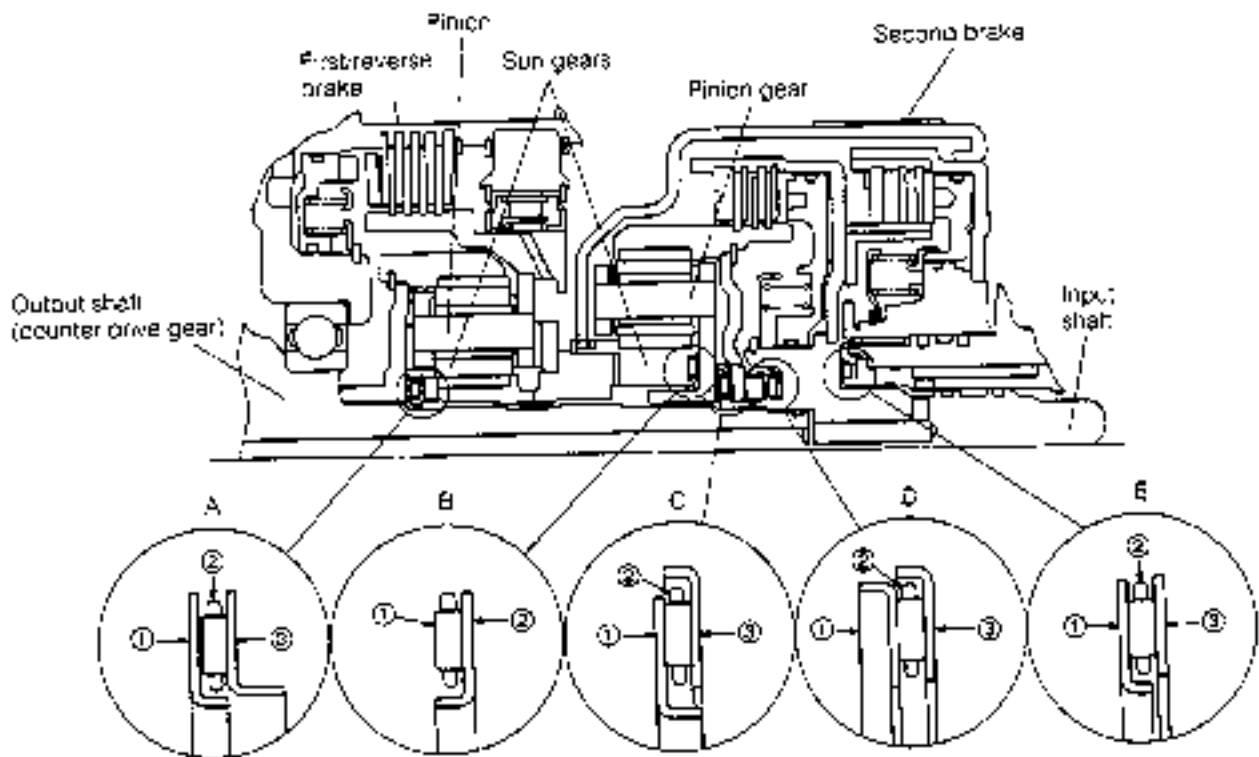

Fig. 4-181

W6-C-223A

AUTOMATIC TRANSMISSION

ASSEMBLING POSITION AND DIRECTION OF THRUST BEARING



Position	Part	Inner diameter mm (inch)	Outer diameter mm (inch)	Flange	Thick- ness	Remarks
A	① Race	22.15 (0.872)	37.5 (1.47)	inner diameter flange		
	② Bearing	24 (0.94)	37.5 (1.47)	—		
	③ Race	24 (0.94)	37.5 (1.47)	inner diameter flange		
B	① Bearing	30 (1.18)	45 (1.77)	—		
	② Race	28 (1.10)	45 (1.77)	inner diameter flange		
C	① Race	19 (0.75)	35 (1.38)	inner diameter flange		
	② Bearing	22.3 (0.88)	36 (1.42)	—		
	③ Race	22 (0.87)	37.9 (1.49)	outer diameter flange		
D	① Race	23 (0.91)	35.6 (1.41)	outer diameter flange		Shared in common with C ② Shared in common with C ③
	② Bearing	22.3 (0.88)	36 (1.42)	—		
	③ Race	22 (0.87)	37.9 (1.49)	outer diameter flange		
E	① Race	27.1 (1.07)	42 (1.65)	inner diameter flange		
	② Bearing	30 (1.18)	42 (1.65)	—	0.8	Option
	③ Race	30.5 (1.20)	43 (1.69)	Not provided	1.4	Option
	④ Race	30.5 (1.20)	43 (1.69)	Not provided		

Fig. 4-182

4-7211

LIST OF SPRINGS

Installing position		Color	Free length (Reference) value mm (inch)	Coil outer diameter mm (inch)
Upper valve	Primary regulator valve	Red	52.5 (2.06)	10 (0.39)
	Orifice control valve	Yellow/green	34.1 (1.34)	6.5 (0.33)
	Throttle valve	White	22.25 (0.8760)	9.2 (0.36)
	Throttle valve (Gasoline turbo,) diesel turbo	Purple	31.81 (1.252)	Inner diameter 6.0 (0.24)
	Throttle valve cam	Light blue	31.04 (1.252)	Inner diameter 6.0 (0.24)
		—	—	Inner diameter 14 (0.55)
Lower valve	Secondary regulator valve (Same as above)	Yellow	31.4 (1.24)	7.4 (0.29)
		Brown	30.17 (1.188)	7.4 (0.29)
	2 - 3 shift valve	Pink	39.6 (1.56)	10.5 (0.413)
	1 - 2 shift valve	Pink	39.6 (1.56)	10.5 (0.413)
	B ₂ control valve	Blue	28.1 (1.11)	7.9 (0.31)
	Cooler bypass	Orange	19.9 (0.783)	11.0 (0.433)
Case	B ₁ accumulator	—	52.0 (2.05)	10.0 (0.394)
	C ₁ accumulator	—	64.1 (2.52)	15.0 (0.591)
C ₁ servo	Inner	—	19 (0.75)	23 (0.91)
	Outer	—	45.9 (1.81)	39 (1.5)
C ₂	For forward clutch (18 pieces)	—	4.90 (0.5868)	7.7 (0.30)
	Shaft parking pawl	—	—	Inner diameter 10.25 (0.4035)

(NOTE)

1. Figures in () in the column of "Coil outer diameter" represent the inner diameter.
2. Figures in () in the column of "Installing point" represent the number of the part.
3. This list does not post those springs which are incorporated in assemblies.

WR-04225

LIST OF "O" RINGS

Installing point	Inner diameter mm (inch)	Installing point	Inner diameter mm (inch)
Oil pump body	200 (7.87)	B ₂ brake	135 (5.31)
Direct clutch drum inner	75.9 (3.00)	B ₁ servo rod	8.8 (0.35)
C ₂ piston, outer	117 (4.61)	C ₁ , B ₁ accumulators	23.47 (0.9240)
B ₁ servo cover	59.6 (2.35)	B ₁ accumulator	15.4 (0.606)
C ₁ piston, inner	46.52 (1.831)	Filter tube	9.6 (0.38)
C ₁ piston, outer	117 (4.61)	Speedometer	19.7 (0.776)
B ₂ brake	94.1 (3.70)		

- C₁: Forward clutch
- C₂: Direct clutch
- B₁: 2nd brake
- B₂: 1st & reverse brake

WR-04225

AUTOMATIC TRANSMISSION

LIST OF BOLTS USED (I)

Installing point	Number	Standard	Tightening torque kg-m (ft-lb)	Nominal length (mm)	Shape
Housing × case	11	M8	1.6 - 2.3 (12 - 16)	35	B, W/W
Rear cover × case	10	M8	1.6 - 2.3 (12 - 16)	35	B, W/W
Rear cover × case	2	M8	0.5 (3.6)	9/16	B, S
Rear cover × case	2	M8	1.1 - 1.5 (8.0 - 10)	—	N
Rear cover × case	2	φ 8	—	—	W
Oil pump assembly × case	5	M8	1.8 - 2.7 (14 - 19)	28	B, F
Stator shaft × Oil pump body	11	M6	0.8 - 1.2 (6.0 - 8.5)	17	B, W/W
Case side cover × case	4	M6	0.7 - 0.9 (5.5 - 6.5)	18	B, W/W
Counter shaft × counter driver gear	1	M22	1 - 15 (80 - 108)	—	N
Differential gear × differential ring gear	10	M10	8.0 - 1.0 (58 - 72)	—	B, F
Manual shift shaft × Manual valve outer lever	2	M8	0.9 - 1.7 (6.5 - 12)	—	N
Detent × case	1	M6	0.8 - 1.2 (6.0 - 8.5)	16.5	B, W/W
Detent × case	1	M6	0.2 (1.4)	1 3/8	B, S
Detent × case	1	M6	0.8 - 1.2 (6.0 - 8.5)	—	N
Detent × case	1	φ 6	—	—	W
Valve body assembly × case	7	M6	0.8 - 1.2 (6.0 - 8.5)	36	B, F
Valve body assembly × case	1	M6	0.8 - 1.2 (6.0 - 8.5)	47	B, F
Valve body assembly × case	2	M6	0.9 - 1.2 (6.0 - 8.5)	25	B, F
Valve body assembly × case	1	M6	0.8 - 1.2 (6.0 - 8.5)	32	B, F
Upper valve body × lower valve body	6	M5	0.5 - 0.6 (3.6 - 4.3)	29.5	B, F
Upper valve body × lower valve body	6	M5	0.5 - 0.6 (3.6 - 4.3)	38	B, F
Upper valve body × lower valve body	2	M5	0.5 - 0.6 (3.6 - 4.3)	44	B, F
Upper valve body × lower valve body	2	M5	0.5 - 0.6 (3.6 - 4.3)	29.5	B, F
Lower cover × lower valve body	6	M5	0.5 - 0.6 (3.6 - 4.3)	14	B, F
Strainer × lower valve body	6	M5	0.5 - 0.6 (3.6 - 4.3)	14	B, F
Solenoid × lower valve body	2	M6	0.64 - 0.95 (4.6 - 6.9)	10	B, W/W
Throttle cam × lower valve body	1	M6	0.6 - 0.9 (4.3 - 6.5)	28	B, F
Oil pan × case	12	M6	0.4 - 0.6 (3.0 - 4.3)	16	B, W/W
Drain plug × oil pan	1	M10	1.8 - 2.3 (13 - 17)	8.3	P
Wire-to-solenoid × case	1	M6	0.2 (1.4)	1 3/8	B, S
Wire-to-solenoid × case	1	M6	0.5 - 0.6 (3.6 - 4.3)	—	N
Wire-to-solenoid × case	1	φ 6	—	—	W

WF-01207

LIST OF BOLTS USED (II)

Installing point	Number	Standard	Tightening torque kg-m (ft-lb)	Nominal length (mm)	Shape
Speedometer × housing	1	M6	0.7 - 1.0 (5.1 - 7.2)	12	B, W/W
Filler tube × case	1	M8	0.3 - 0.7 (2.4 - 5.6)	20	B, W/W
Test plug × case	1	5/16 SAUNF	0.6 - 0.9 (4.3 - 6.5)	9.5	P
* Oil pan × case	2	M6	0.4 - 0.6 (3.0 - 4.3)	16	S, W/W
* Housing × case	3	M8	1.6 - 2.3 (12 - 16)	35	B, W/W
Housing × case	1	M8	1.6 - 2.3 (12 - 16)	50	B, W/W
Speedometer sleeve plate lock × case	1	M6	0.6 - 0.9 (4.3 - 6.5)	12	B, W/W
Throttle cable clamp × case	1	M6	0.6 - 0.9 (4.3 - 6.5)	12	B, W/W
O/P assembly × case	1	M10	1.8 - 2.7 (14 - 19)	28	B, F
Neutral start switch × case	1	M8	1.6 - 2.3 (12 - 16)	35	B, W/W
Clamp × case	1	M8	0.9 - 1.7 (6.5 - 12)	20	B, W/W
Mount bracket × case	3 (5)	M10	3.0 - 4.5 (22 - 33)	25	B, W/W

: Apply sealant to the bolt bearing the "" mark. case Transmission case

WP-04285

Explanation of shape

B, W/W	: Bolt with washer
B, S	: Stud bolt
N	: Nut
W	: Washer
B, F	: Bolt flange
P	: Plug
S, W/W	: Screw with washer

WP-04229

DAIHATSU

CHARADE

Chassis

SECTION 5

FRONT AXLE & SUSPENSION

5

FRONT AXLE	5- 2	DRIVE SHAFT	5-22
SECTIONAL VIEW	5- 2	DRIVE SHAFT-RELATED PARTS	5-22
COMPONENTS	5- 2	OPERATION PRIOR TO REMOVAL	5-23
REMOVAL	5- 3	REMOVAL	5-23
INSPECTION	6- 5	INSPECTION	5-25
INSTALLATION	5- 6	COMPONENTS	5-26
FRONT SUSPENSION	5- 9	DISASSEMBLY	5-27
SECTIONAL VIEW	5- 9	INSPECTION	5-28
FRONT SHOCK ABSORBER	5-10	ASSEMBLY	5-28
COMPONENTS	5-10	INSTALLATION	5-29
REMOVAL	5-10	FRONT DRIVE BEARING SHAFT	5-32
DISASSEMBLY	5-11	COMPONENTS	5-32
INSPECTION	5-12	INSPECTION	5-32
ASSEMBLY	5-13	DISASSEMBLY	5-33
INSTALLATION	5-14	INSPECTION	5-35
FRONT STABILIZER BAR	5-15	ASSEMBLY	5-35
COMPONENTS	5-15	WHEEL ALIGNMENT (FRONT AND REAR) ..	5-38
REMOVAL	5-15	CHECKS PRIOR TO WHEEL ALIGNMENT	
INSPECTION	5-16	MEASUREMENT	5-38
INSTALLATION	5-16	CHECKS AND ADJUSTMENT OF FRONT	
LOWER ARM	5-17	WHEEL ALIGNMENT	5-39
COMPONENTS	5-17	CHECK AND ADJUSTMENT OF REAR	
REMOVAL	5-18	TOE-IN	5-44
INSPECTION	5-19		
INSTALLATION	5-20		

WR 02001

FRONT AXLE & SUSPENSION

FRONT AXLE SECTIONAL VIEW

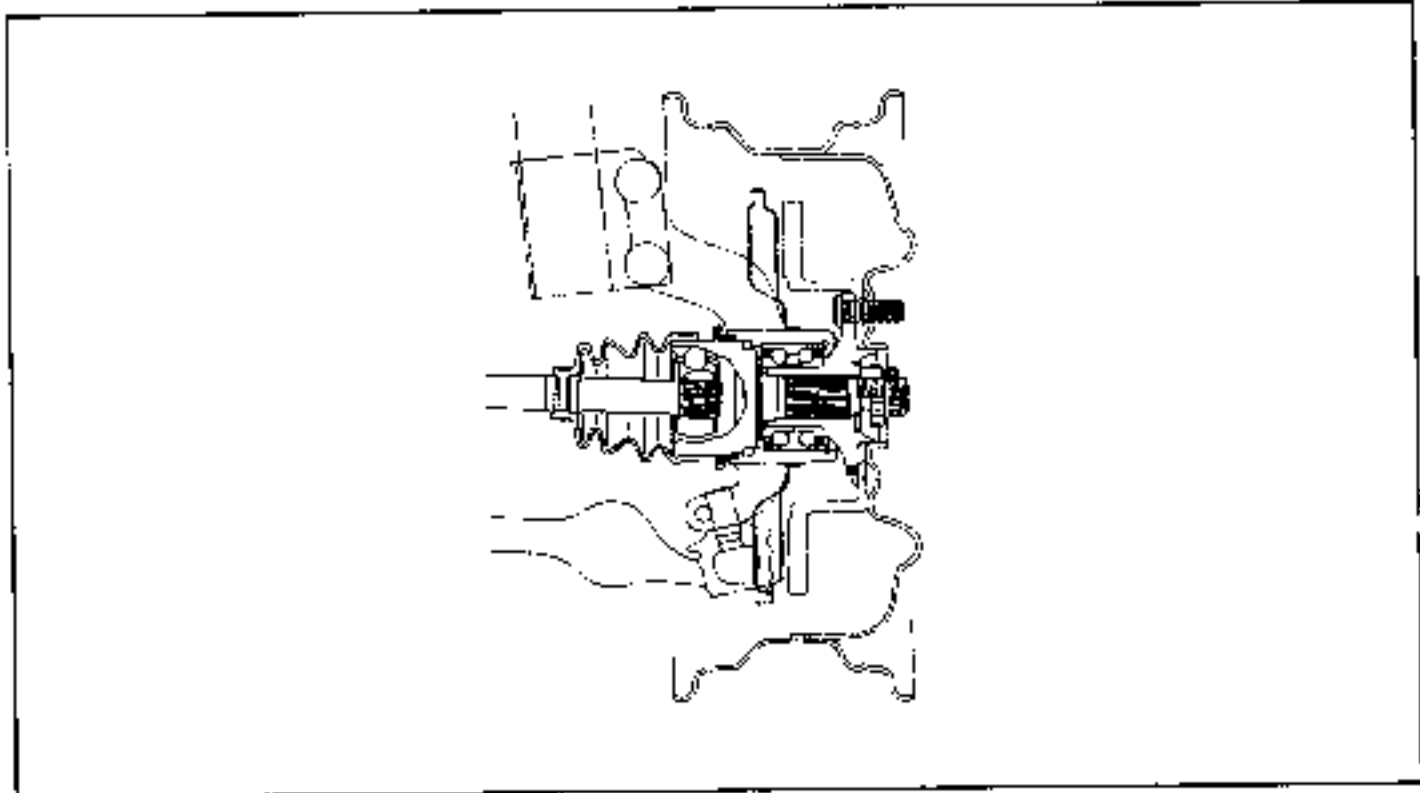

Fig. 5-1

47A-0500E

COMPONENTS

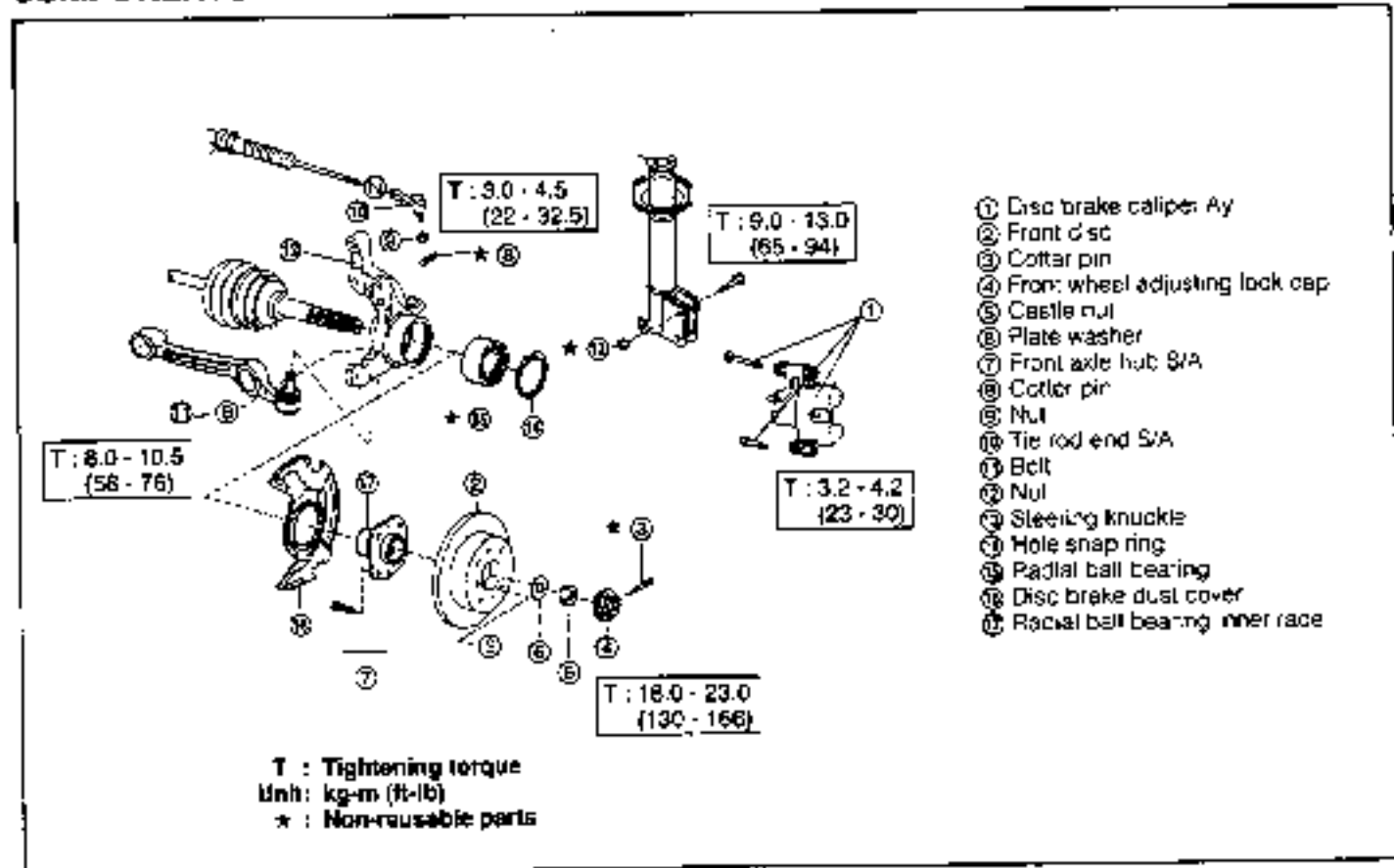

Fig. 5-2

47A-0500E

REMOVAL

1. Jack up the vehicle at the front side. Support the body with safety stands.
2. Remove the front wheel.

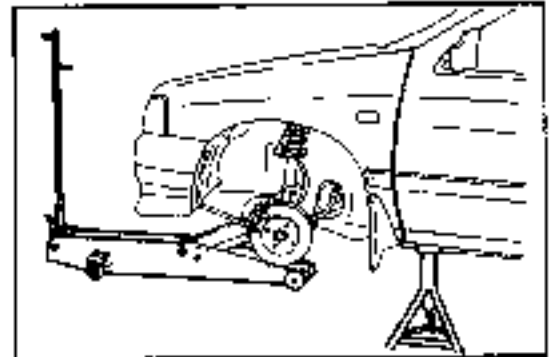

Fig. 5-2

WR-05004

3. Disc brake caliper removal
 - (1) Remove the attaching bolts of the disc brake caliper.
 - (2) Suspend the caliper.

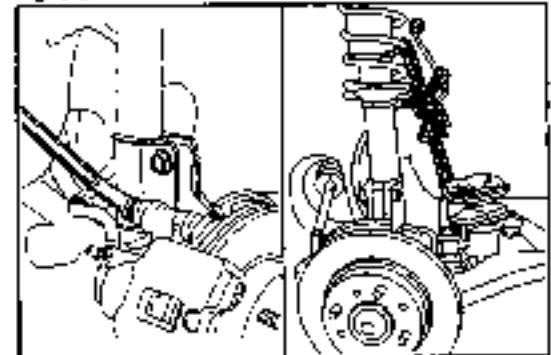

Fig. 5-3

WR-05005

4. Remove the disc rotor.

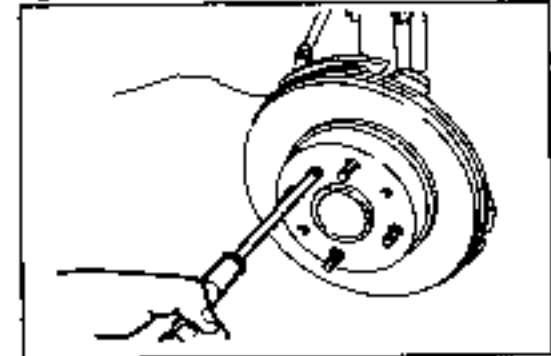

Fig. 5-5

WR-05006

5. Front axle hub removal
 - (1) Remove the cotter pin and front wheel adjusting lock cap.
 - (2) Remove the castle nut, using the following SST.

SST: 09511-87202-000

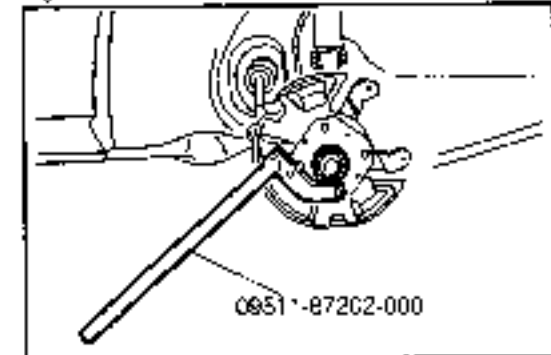

Fig. 5-6

WR-05007

- (3) Draw out the axle hub, using the following SST.

NOTE:

Do not separate the axle hub from the steering knuckle unless such separation is necessary.

SST: 09520-00031-000

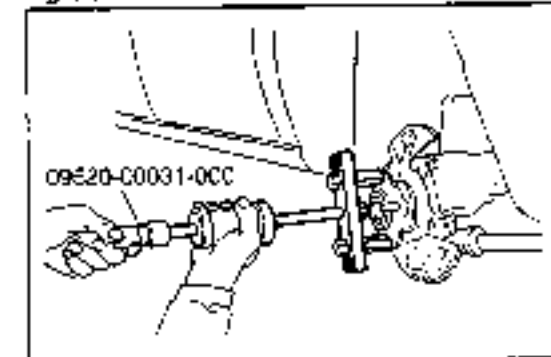

Fig. 5-7

WR-05008

FRONT AXLE & SUSPENSION

6. Tie rod end separation

- (1) Remove the cotter pin castle nut from the tie rod end
- (2) Separate the tie rod end from the steering knuckle, using the following SST.

SST: 09611-87701-000

NOTE:

While using the SST, be very careful not to damage the boot and threaded portion.

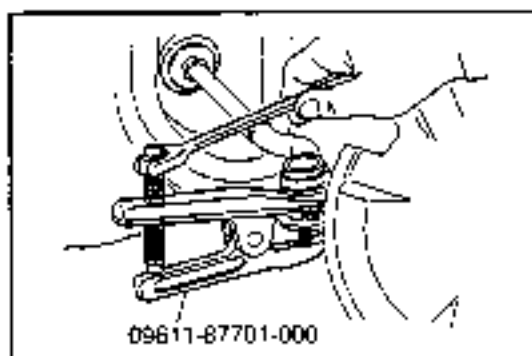

Fig. 5-8

WR-05004

7. Remove the lower ball joint attaching bolt and nut.

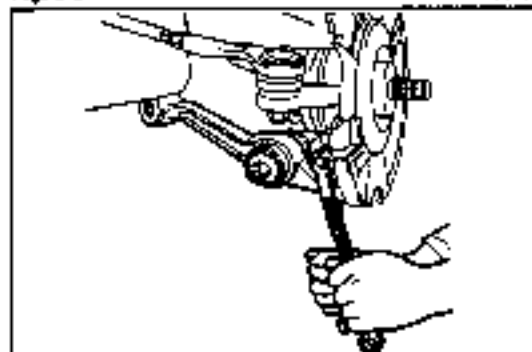

Fig. 5-9

WR-05010

8. Steering knuckle separation

Remove the attaching nuts. Leave the bolts in their inserted conditions.

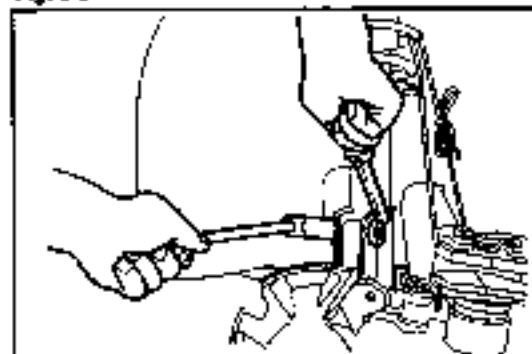

Fig. 5-10

WR-05011

9. Steering knuckle removal

- (1) While supporting the steering knuckle, draw out the attaching bolts of the shock absorber lower bracket.
- (2) Disengage the axle hub from the drive shaft. Remove the steering knuckle.

NOTE:

- Protect the drive shaft boot with cloth or the like so that it may not be damaged during the operation.
- Wind a tape or the like on the drive shaft threaded portion so that the oil seal may not be damaged.

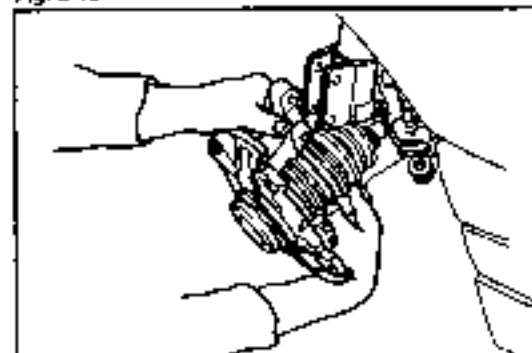

Fig. 5-11

WR-05012

10. Front axle bearing removal

- (1) Remove the dust seal from the axle hub, using a common screwdriver.
- (2) Remove the bearing inner race (outer side) from the axle hub, using the following SST.

SST: 09950-20014-000

09720-00010-000 (Use the item No.3 that is part of the set.)

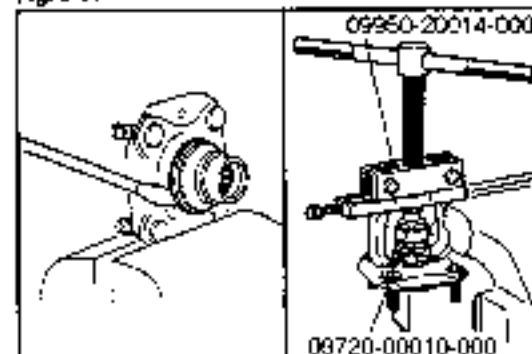

Fig. 5-12

WR-05013

(3) Detach the snap ring, using snap ring pliers.

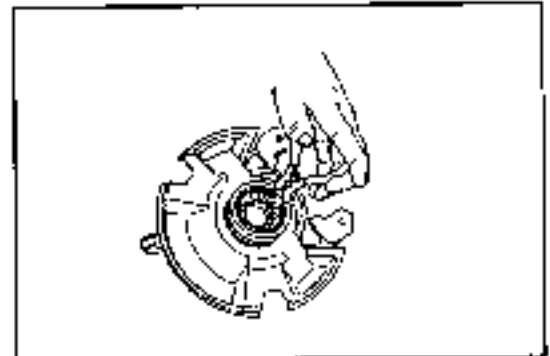

Fig. 5-13

475-05014

(4) Remove the bearing from the steering knuckle. Using a press in combination with the following SSTs.

SST: 09527-87301-000

09550-10012-000 (09554-10010-000, part of the preceding tool)

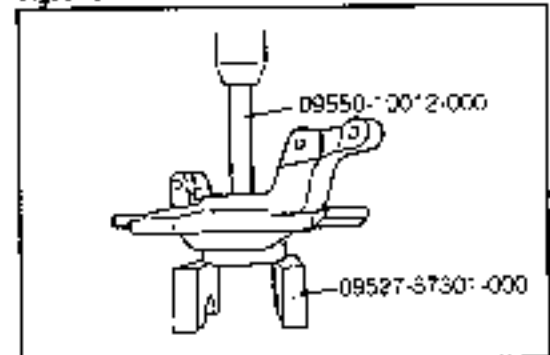

Fig. 5-14

474-35015

INSPECTION

Inspect the following parts

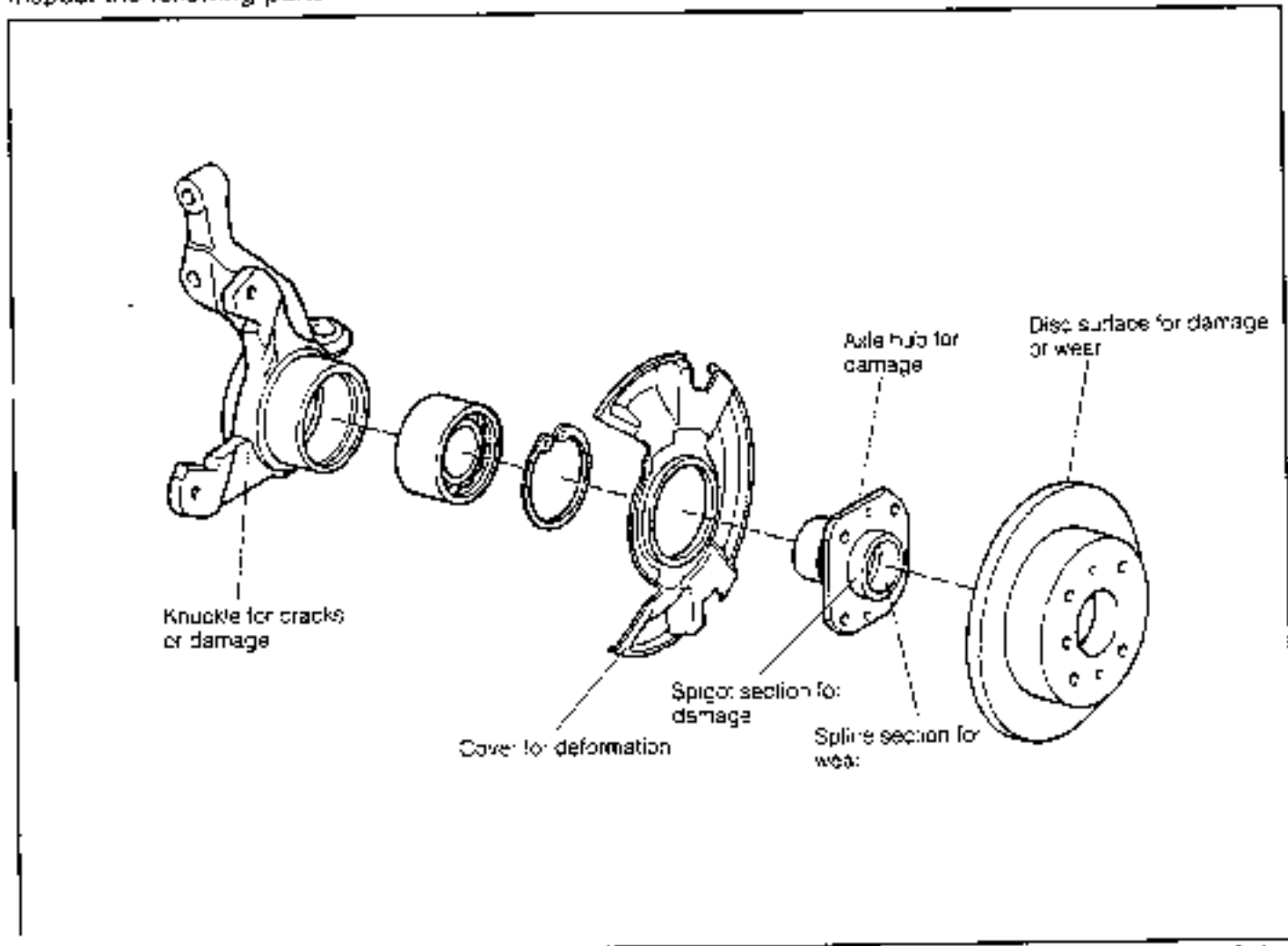

Fig. 5-15

WFA6016

FRONT AXLE & SUSPENSION

1. Disc brake cover replacement
 - (1) Separate the disc brake cover from the knuckle using a common screwdriver or the like.

NOTE:

Do not remove the disc brake cover unless its replacement is required.

- (2) Press the disc brake cover until it comes into close contact with the knuckle using the following SSTs.

SST: 09506-87302-000

09718-87701-000

INSTALLATION

1. Front axle bearing installation

- (1) Press the bearing into position, using the following SSTs.

SST: 09506-87302-000

09550-10012-000 (09554-10010-000, part of the preceding tool)

- (2) Install a new snap ring, using snap ring pliers.
- (3) Press the front axle hub into position, using the following SST

SST: 09550-10012-000 (09554-10010-000, part of the preceding tool)

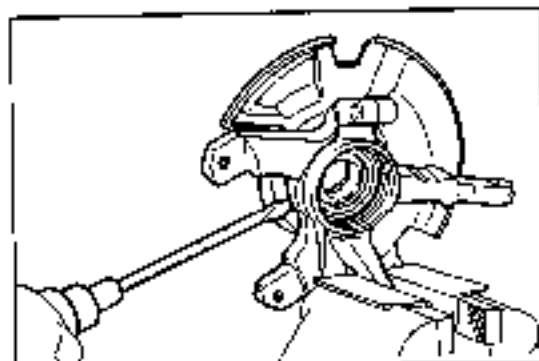

Fig. 5-16

WM-10077

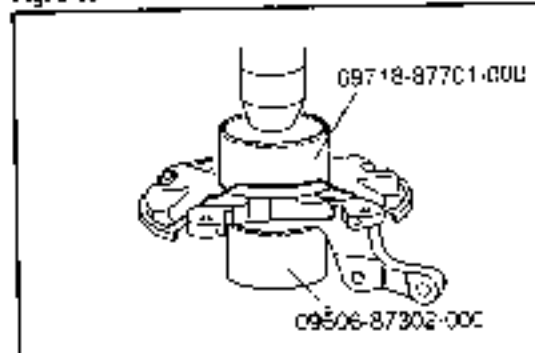

Fig. 5-17

WM-10078

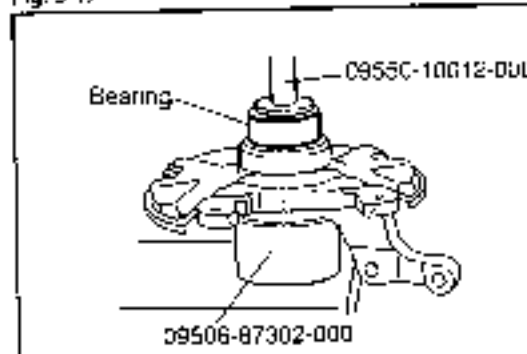

Fig. 5-18

WM-10079

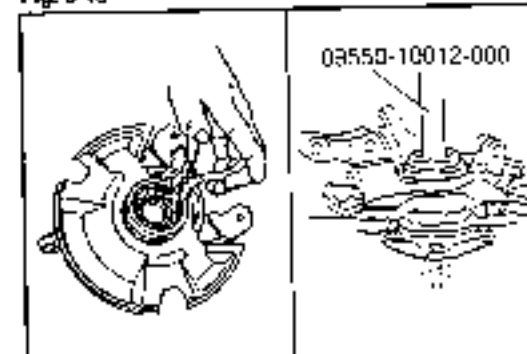

Fig. 5-19

WM-10080

2. Steering knuckle installation

- (1) Insert the steering knuckle into the drive shaft.

NOTE:

- Be careful not to allow the drive shaft to come into contact with the oil seal at the knuckle side.
- Pay utmost attention not to damage the ball joint dust cover.

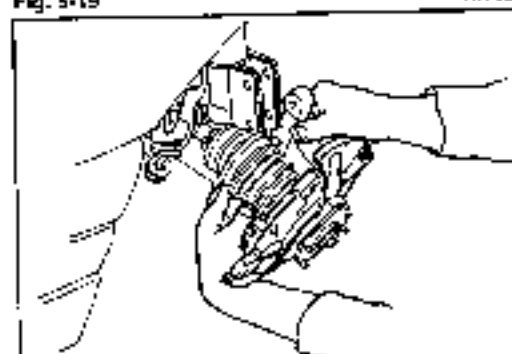

Fig. 5-20

WM-10081

- (2) Mount the steering knuckle on the lower ball joint.
- (3) Mount the steering knuckle on the shock absorber lower bracket. Tighten the bolts and nuts.
Tightening Torque: 9.0 - 13.0 kg-m (65 - 94 ft-lb)

NOTE:

With the knuckle pushed against the lower side, tighten the bolts and nuts.

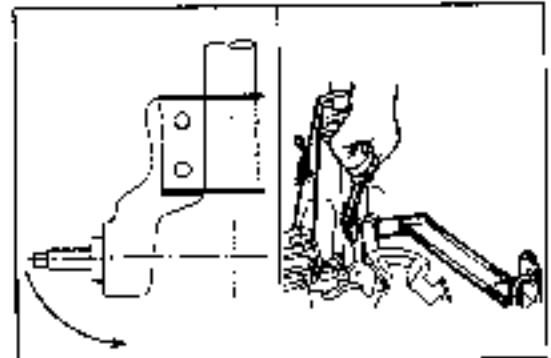

Fig. 5-21

MF-26142

- (4) Install the lower ball joint. Tighten the bolt and nut.
Tightening Torque: 8.0 - 10.5 kg-m (58 - 76 ft-lb)

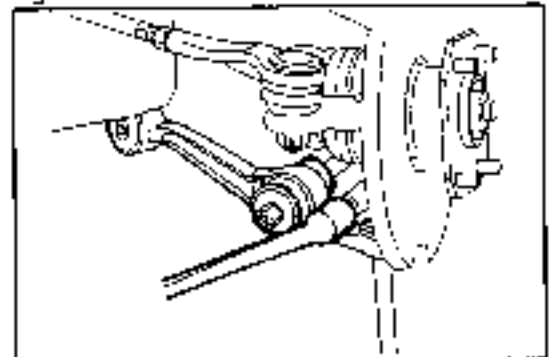

Fig. 5-22

MF-15023

- (5) Install the washer. Install the nut temporarily.

NOTE:

Be sure to install the washer in the correct direction.

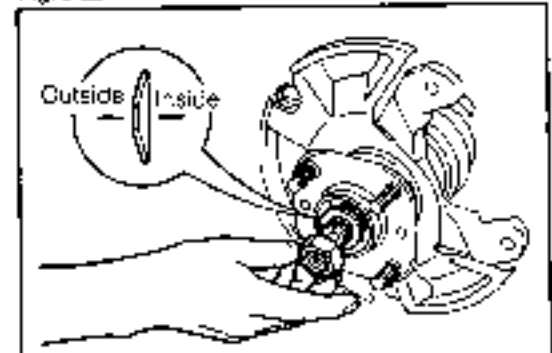

Fig. 5-23

MF-05024

3. Install the disc rotor.

NOTE:

Care must be exercised to ensure that no foreign matter lodge between the hub and the disc rotor.

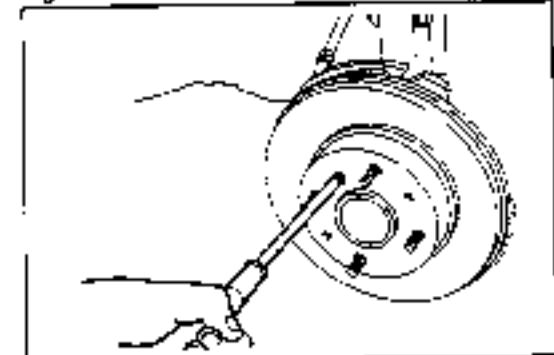

Fig. 5-24

MF-25325

4. Disc brake caliper installation

- (1) Install the pad guide plate to the steering knuckle.
- (2) Tighten the attaching bolts of the disc brake caliper.
Tightening Torque: 3.2 - 4.2 kg-m (23 - 30 ft-lb)

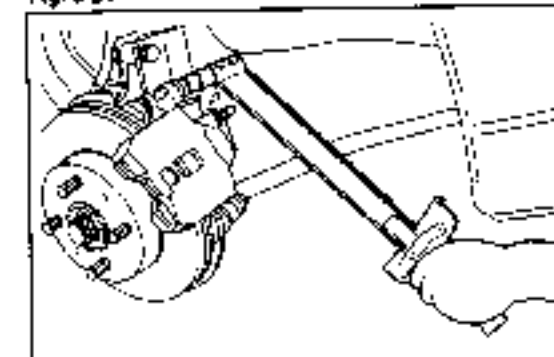

Fig. 5-25

MF-15026

FRONT AXLE & SUSPENSION

5. Tightening of castle nut using the following SST.
 - (1) Tighten the castle nut
SST: 09511-87202-000
Tightening Torque: 18.0 - 23.0 kg-m (130 - 160 ft-lb)
 - (2) Install the front wheel adjusting lock cap and a new cotter pin

6. Tie rod end installation
 - (1) Attach the tie rod end to the steering knuckle and tighten the castle nut
Tightening Torque: 3.0 - 4.5 kg-m (22 - 32.5 ft-lb)
 - (2) Install a new cotter pin.

7. Install the wheel
8. Front wheel alignment inspection and adjustment
(See page 5-38.)

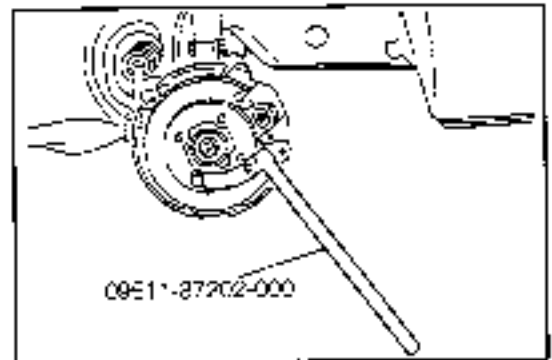

Fig. 5-26

WP-05027

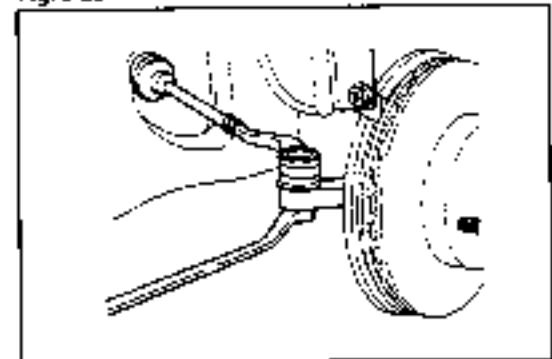

Fig. 5-27

WP-05028

WP-05029

FRONT SUSPENSION

SECTIONAL VIEW

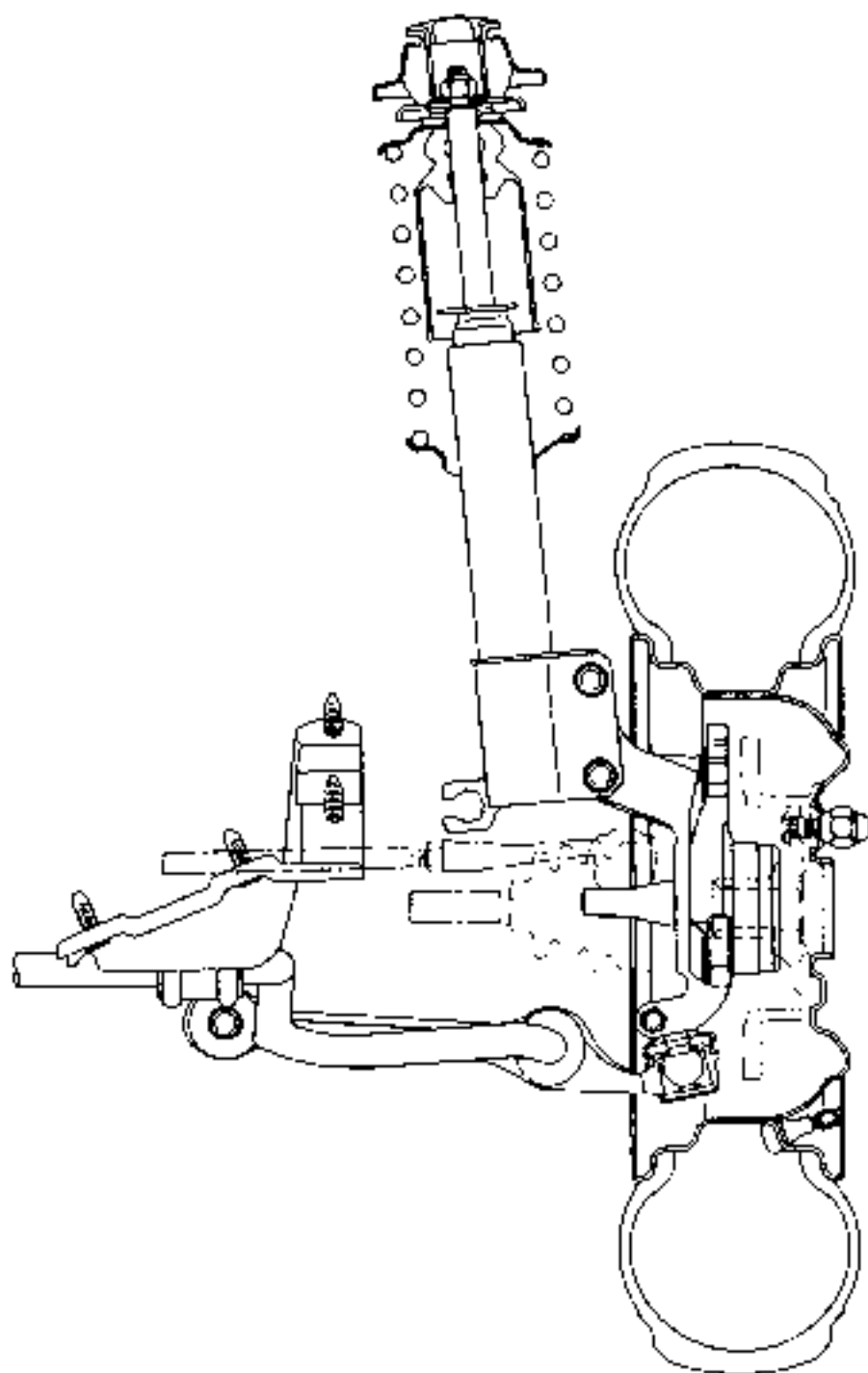

Fig. 5-28

WR-3507

FRONT AXLE & SUSPENSION

FRONT SHOCK ABSORBER

COMPONENTS

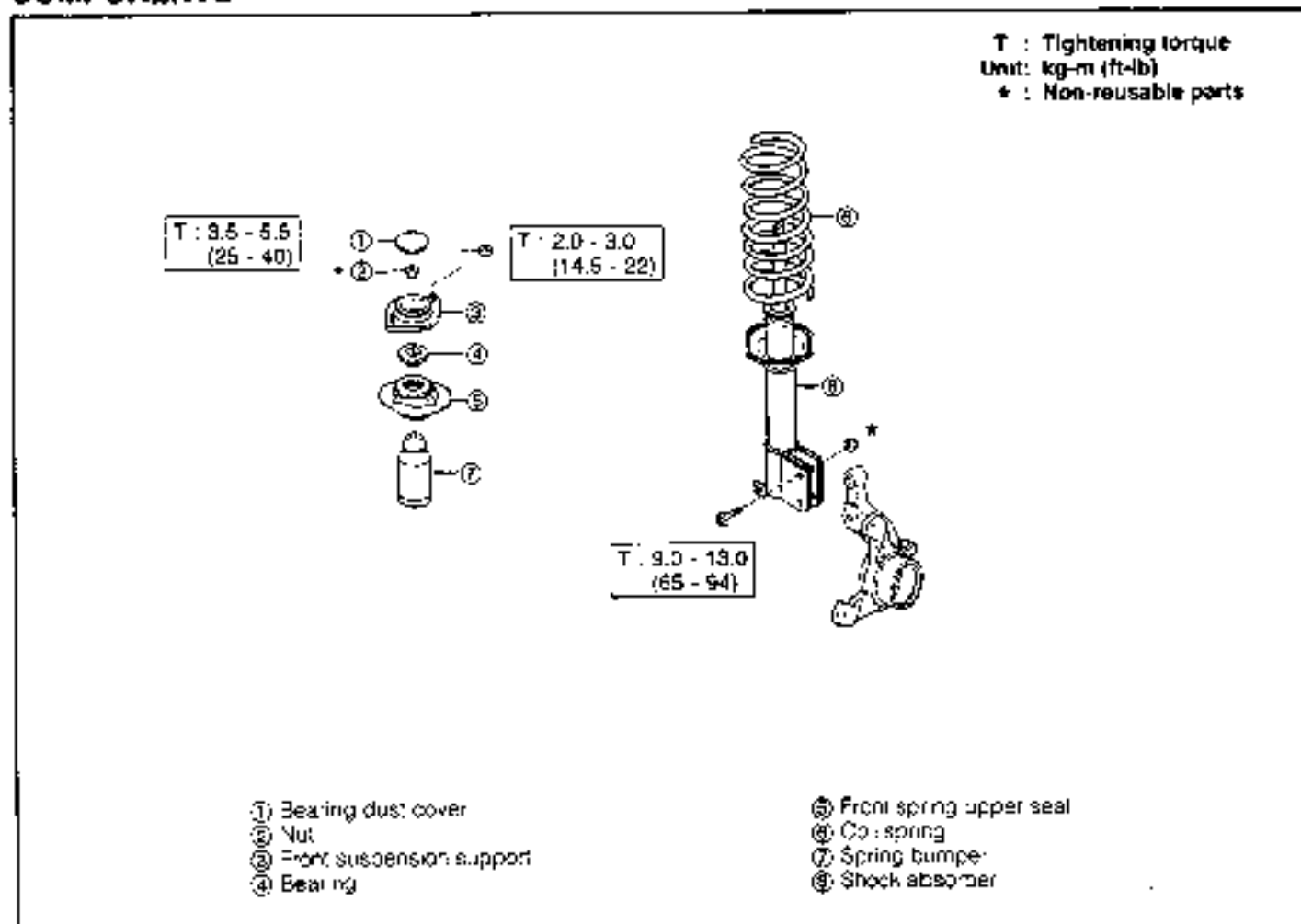
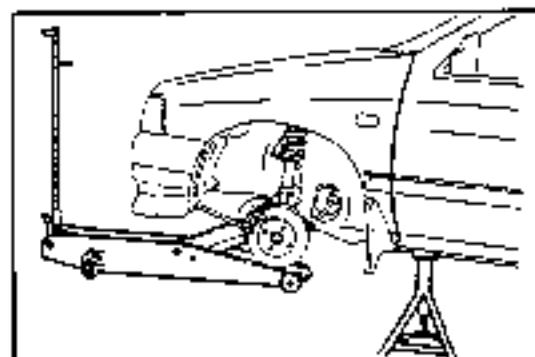

Fig. 5-29

WP-0303

REMOVAL

1. Jack up the vehicle at the front side. Support the body with safety stands.
2. Remove the front wheel.



WP-0303

3. Flexible hose removal
(1) Remove the clip at the shock absorber side.
(2) Disconnect the flexible hose at the shock absorber bracket:

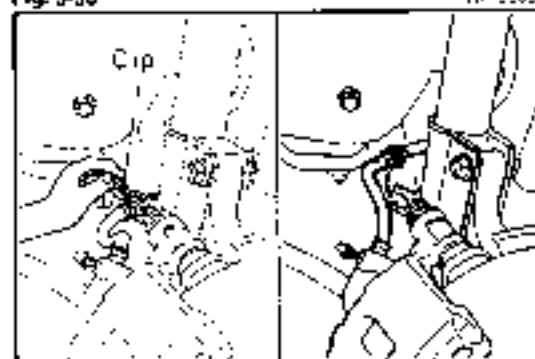

WP-0303

4. Shock absorber removal

- (1) Remove the attaching bolts and nuts of the steering knuckle. Separate the shock absorber from the steering knuckle.

NOTE:

Before removing the left shock absorber, remove the disc brake caliper attaching bolt (upper side).

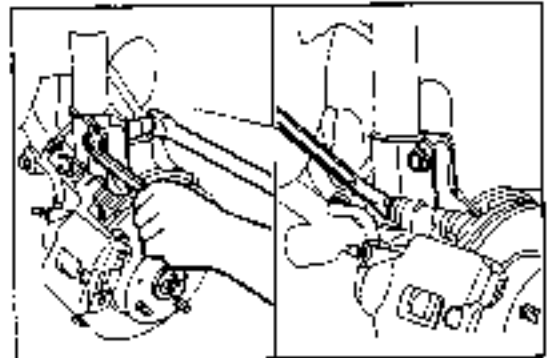

Fig. 5-32

WF-C5094

- (2) Remove the two attaching nuts of the suspension support located at the fender upper section. Remove the shock absorber from the body.

NOTE:

Be sure to protect the drive shaft boot with cloth or the like so that it may not be damaged.

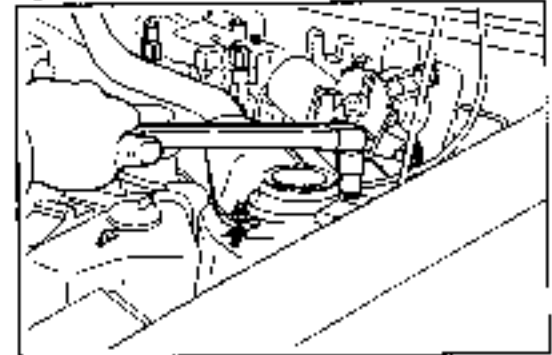

Fig. 5-33

WF-B5C3-

DISASSEMBLY

1. Compress the coil spring using the following SST
SST. 09727-87701-000

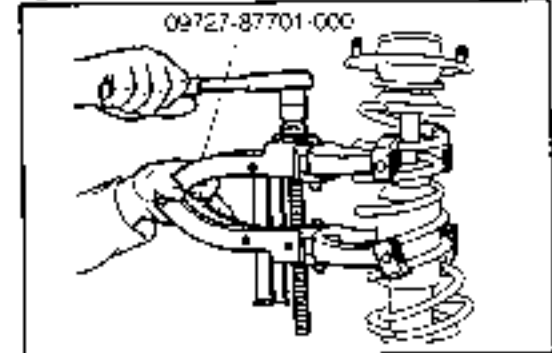

Fig. 5-34

WF-C5095

2. Coil spring disassembly

- (1) Clamp the front suspension support in a vice
- (2) Remove the bearing dust cover and loosen the nut.

NOTE:

Never remove the nut by applying impacts on it, using an impact wrench or the like.

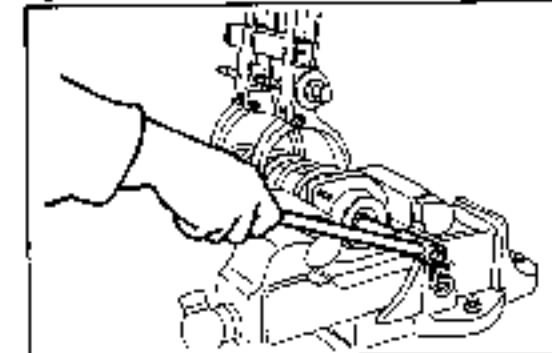

Fig. 5-35

WF-25C07

FRONT AXLE & SUSPENSION

- (3) Remove the following parts; the front suspension support, bearing, front spring upper seat, coil spring and spring bumper.

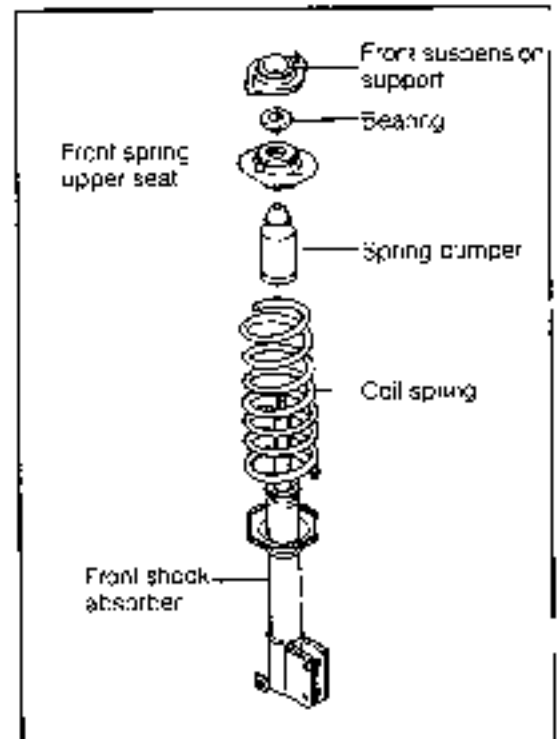

Fig. 5-36

WR-05038

INSPECTION

1. Inspect the following parts.

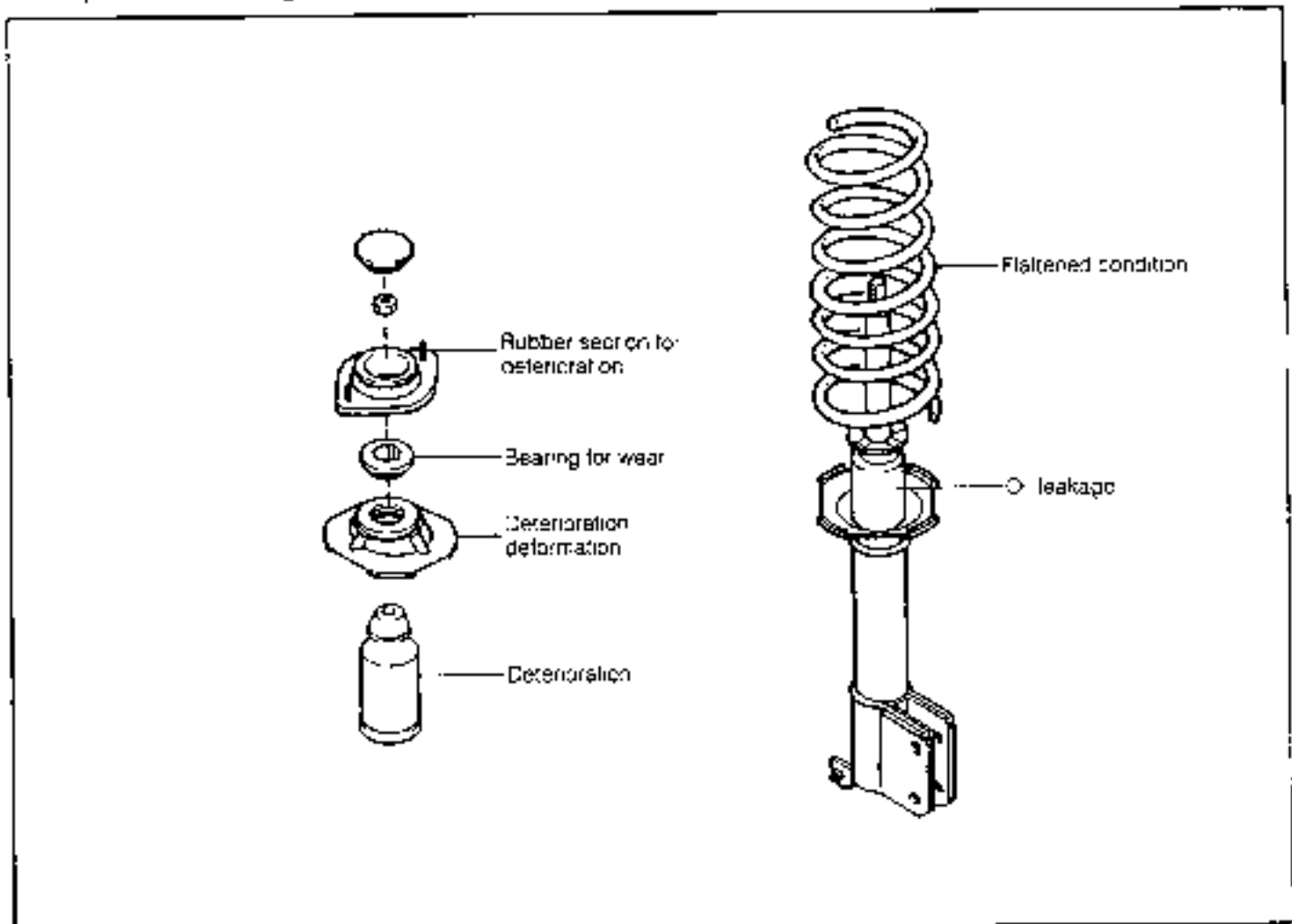

Fig. 5-37

WR-05039

2. Shock absorber operation inspection

- (1) Push or pull the piston rod of the shock absorber at a constant speed. Ensure that the force required to move the rod is uniform over the entire stroke. However, when the piston rod is pulled strongly, the pulling force may become slightly greater over the stroke 30 mm (1.2 inches) toward the end of the pulling stroke. It should be noted that this phenomenon is not abnormal.
- (2) Move the piston rod quickly in a up-and-down direction with a stroke of 5 - 10 mm (0.2 - 0.4 inch). Ensure that the force required to move the rod will not change.
- (3) If any abnormal feeling or noise is encountered during the inspection above, replace the shock absorber.

NOTE:

- Perform this inspection after the piston rod has been moved in a up-and-down direction three or four times.
- When the gas filling type shock absorber is replaced, previous to the disposal, be sure to release the gas from the shock absorber.

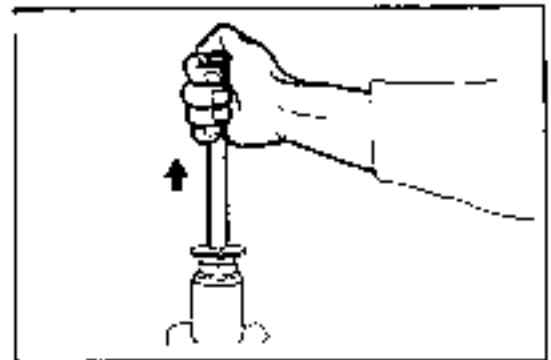

Fig. 5-38

WP-05042

ASSEMBLY

1. Assembly of coil spring

- (1) Insert the spring bumper at a point below the cut-out section of the piston rod.
- (2) Compress the coil spring using the following SST. Install it to the shock absorber.
SST: 09727-87701-000

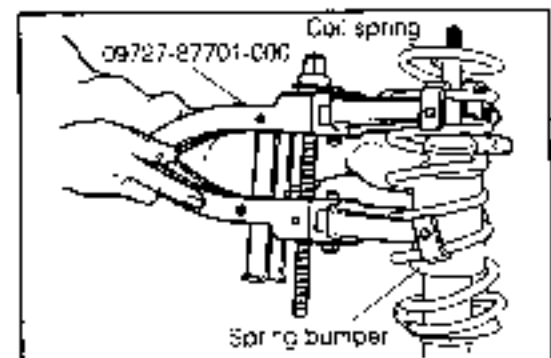

Fig. 5-39

WP-05042

- (3) Install the front spring upper seat and bearing.

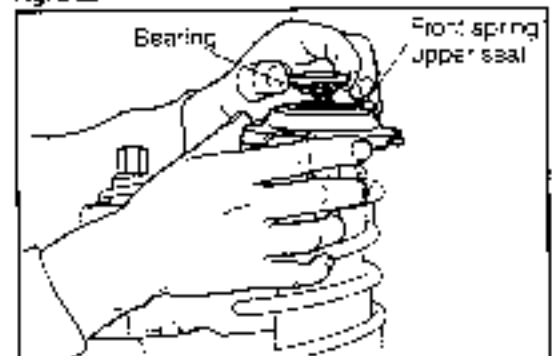

Fig. 5-40

WP-05042

- (4) Install the front suspension support.

NOTE:

Be sure to align the cut-out section of the front suspension support with that of the piston rod during the assembly.

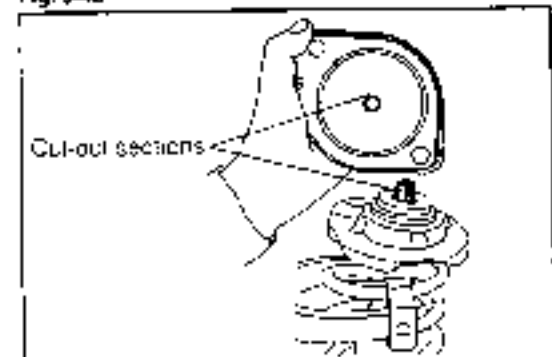

Fig. 5-41

WP-05042

FRONT AXLE & SUSPENSION

- (5) Clamp the front suspension support in a vice. Tighten the suspension support, using a new nut.
Tightening Torque: 3.5 - 5.5 kg-m (25 - 40 ft-lb)

- (6) Install the bearing dust cover
(7) Align the coil spring end with the recessed sections of the upper and lower seats. Proceed to remove the SST.

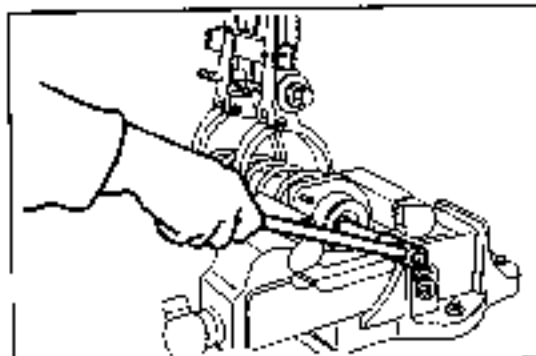

Fig. 5-42

WR-05044

INSTALLATION

1. Installation of shock absorber upper section
(1) Install the suspension support on the fender apron (Use a new nut)
Tightening Torque: 2.0 - 3.0 kg-m (14.5 - 22 ft-lb)

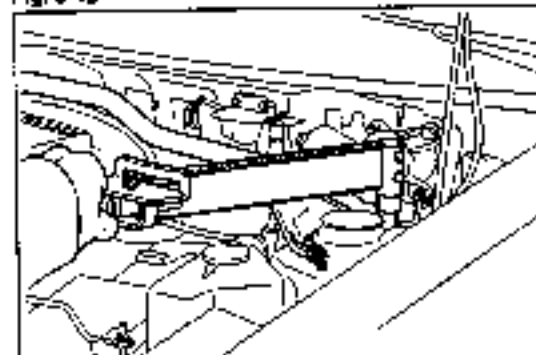

Fig. 5-43

475-05045

2. Installation of steering knuckle section
(1) Mount the steering knuckle on the shock absorber lower bracket.
(2) Install the bolt and nut in position and tighten them.
Tightening Torque: 9.0 - 13.0 kg-m (65 - 94 ft-lb)

NOTE:

With the knuckle pushed against the lower side, tighten the bolt and nut.

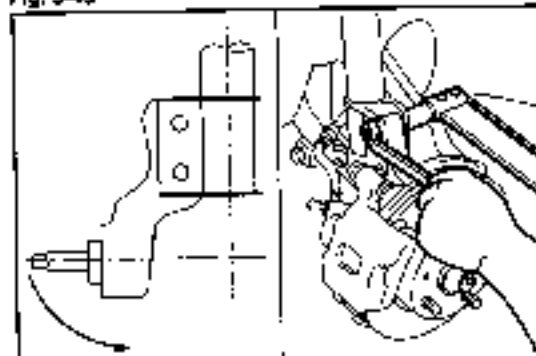

Fig. 5-44

WR-05046

NOTE:

In the case of the removal/installation of the left shock absorber, install the attaching bolt (upper side) of the disc brake caliper after the steering knuckle section has been installed.

Tightening Torque: 3.2 - 4.2 kg-m (23 - 30 ft-lb)

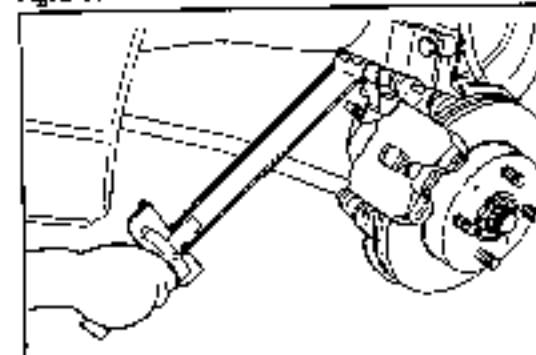

Fig. 5-45

WR-05047

3. Install the flexible hose, as follows:
(1) Install the flexible hose to the shock absorber bracket.
(2) Install the flexible hose clip.
4. Install the wheels. Jack down the vehicle.
5. Front wheel alignment inspection (See page 5-38.)

WR-05048

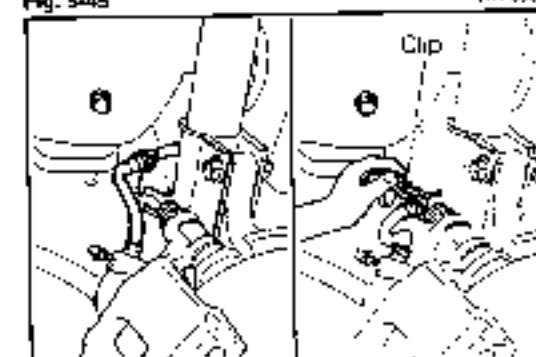

Fig. 5-46

WR-05048

FRONT STABILIZER BAR COMPONENTS

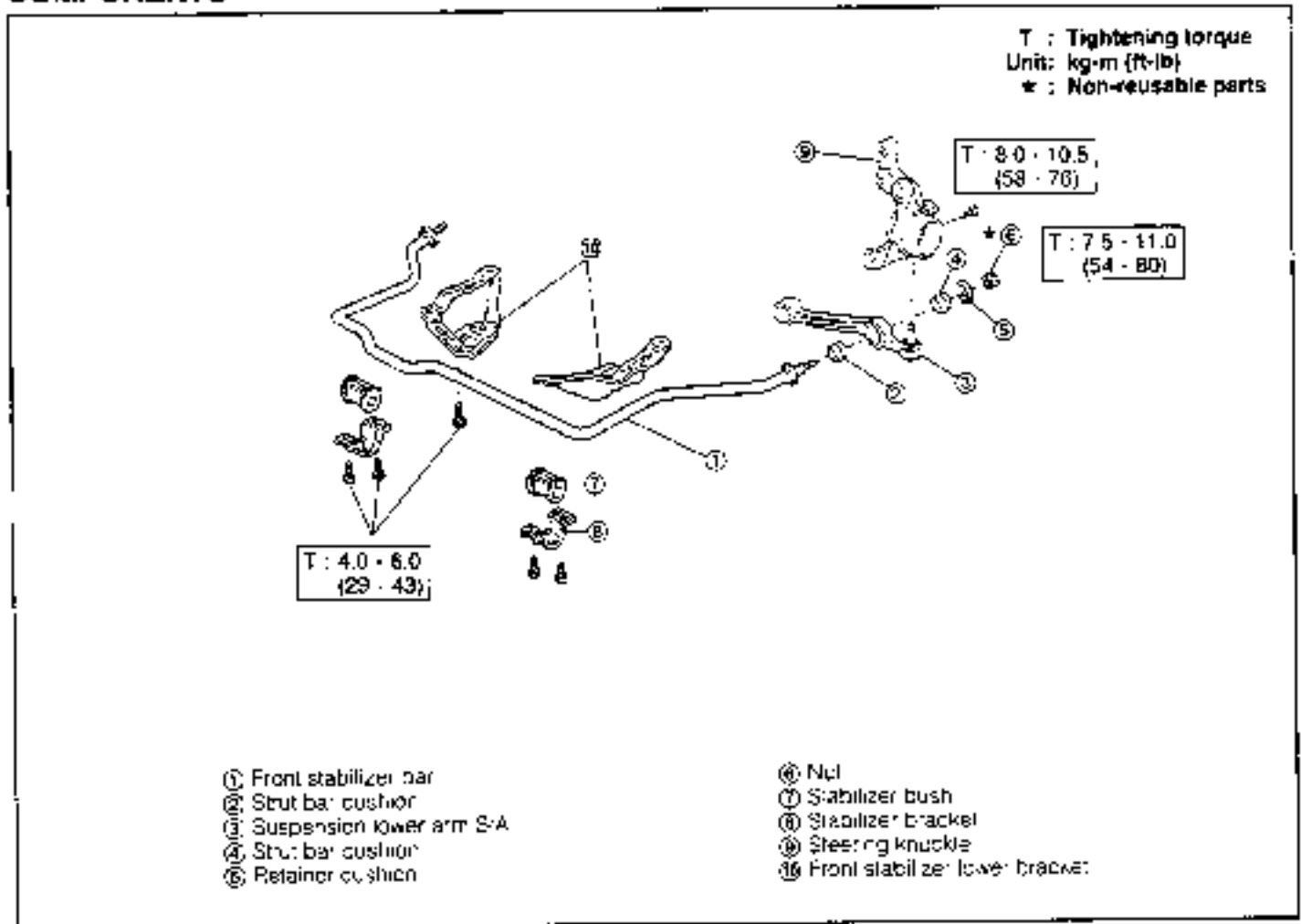

Fig. 5-47

WP-65343

REMOVAL

1. Jack up the vehicle at the front side. Support the body with safety stands.
2. Remove the engine under-cover (Vehicles mounted with Type CL-11 and CL-6* engines only).
3. Remove the stabilizer bar as follows.
 - (1) Remove the stabilizer bar end nuts and retainer.

- (2) Remove the attaching bolts of the stabilizer bar brackets.

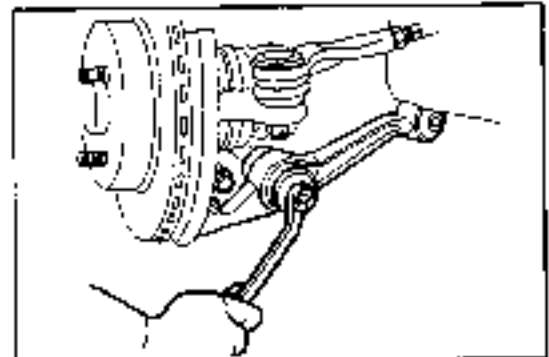

Fig. 5-48

WP-25050

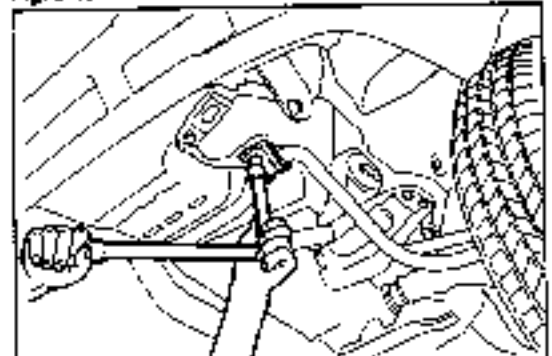

Fig. 5-49

WP-25050

FRONT AXLE & SUSPENSION

(3) Remove the stabilizer bar from the vehicle.

NOTE:

If any difficulty in removing the stabilizer bar is encountered, remove the stabilizer bar by using a jack on the tire.

(4) Remove the bush from the stabilizer bar.

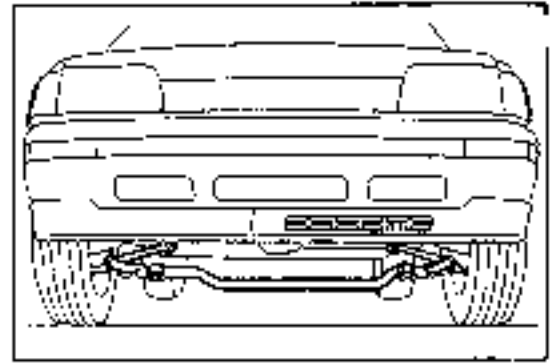

Fig. 5-50

WP-05054

INSPECTION

Inspect the following parts:

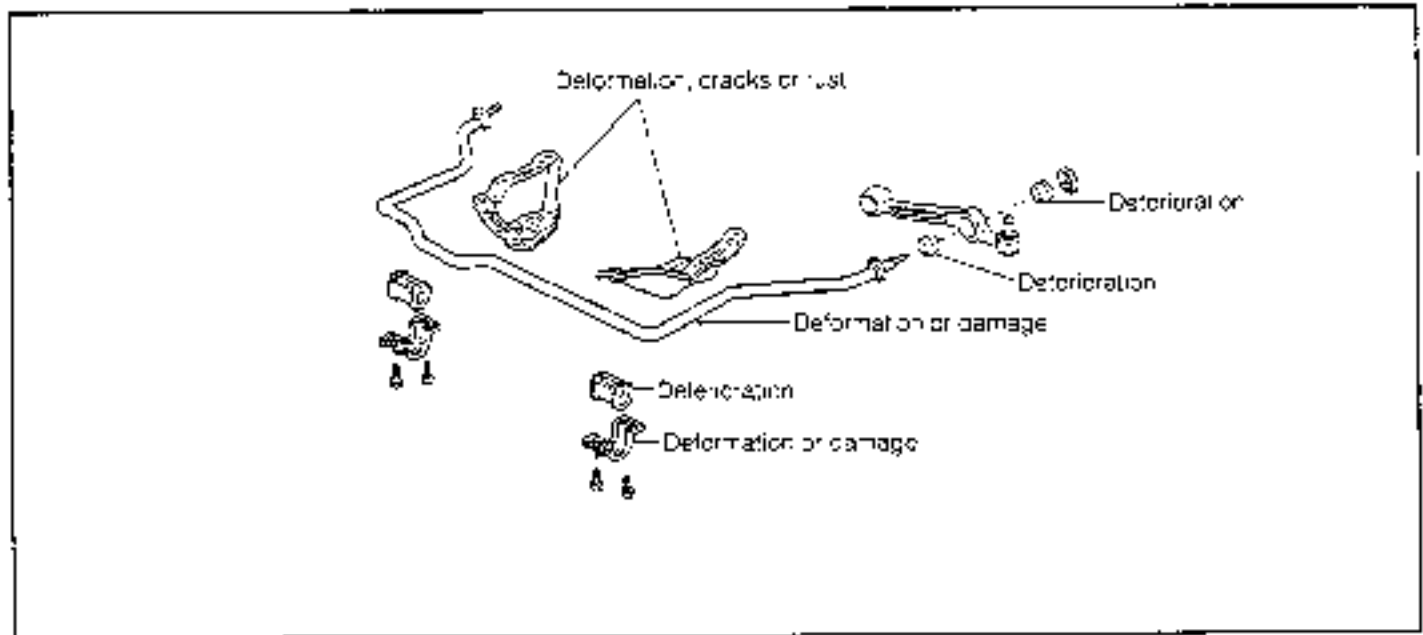

Fig. 5-51

WP-05053

INSTALLATION

1. Stabilizer bar installation.

(1) Install the cushions to the stabilizer bar.

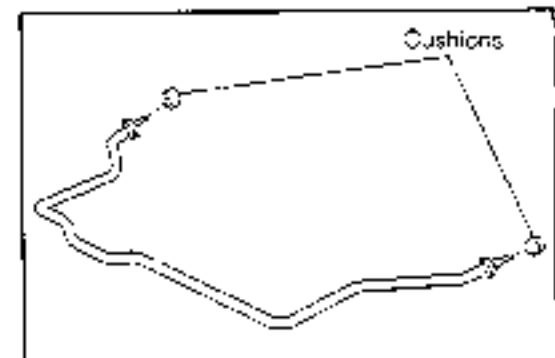

Fig. 5-52

WP-05054

(2) Install the stabilizer bar to the lower arm.

NOTE:

If the stabilizer bar end is not aligned with the lower arm attaching hole, use a jack on the tire so as to align the holes with each other.

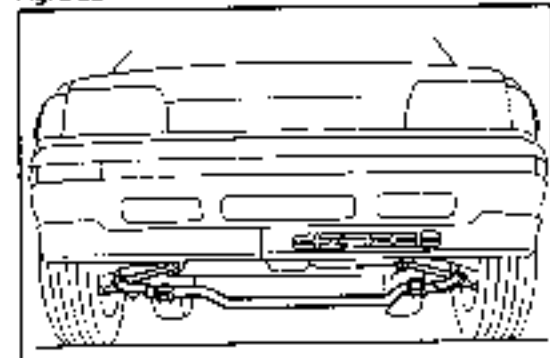

Fig. 5-53

WP-05053

- (3) Install the cushion and stabilizer bar brackets.
Tightening Torque: 4.0 - 6.0 kg-m (29 - 43 ft-lb)

- (4) Install the cushions and retainers while paying attention to the direction of the retainer. Tighten them temporarily, using a new nuts.
(5) Rock the front section of the vehicle in an up-and-down direction two or three times so as to settle the suspension.
(6) With the vehicle in an unloaded state (the lower arm is horizontal), tighten the nuts.

Tightening Torque: 7.5 - 11 kg-m (54 - 80 ft-lb)

NOTE:

If the nut is tightened at the rebound side, the cushion twisting angle will become large, resulting in reduced riding comfort.

2. Install the engine under-cover. (Engines mounted with Type CL-11 and CL-61 engines only)
3. Front wheel alignment inspection (See page 5-38)

LOWER ARM COMPONENTS

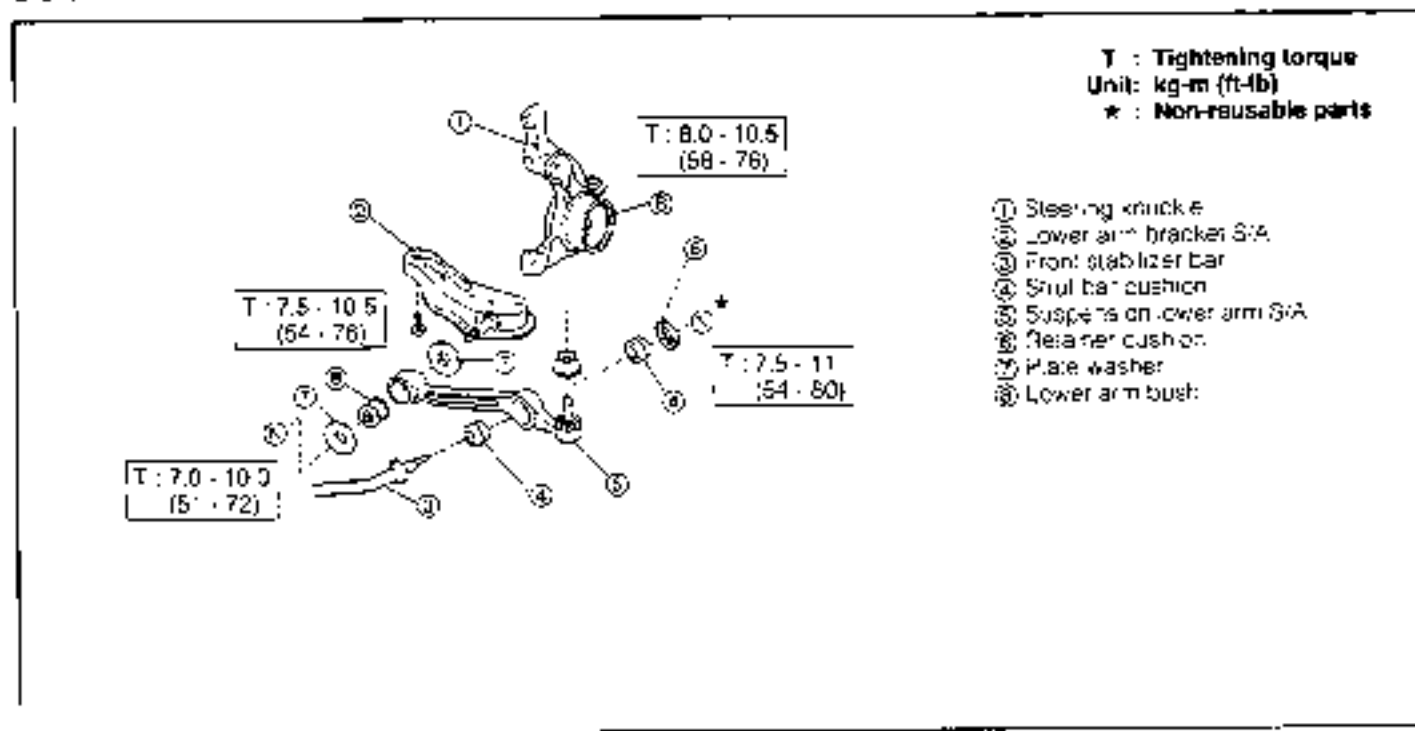

Fig. 5-55

WR05001

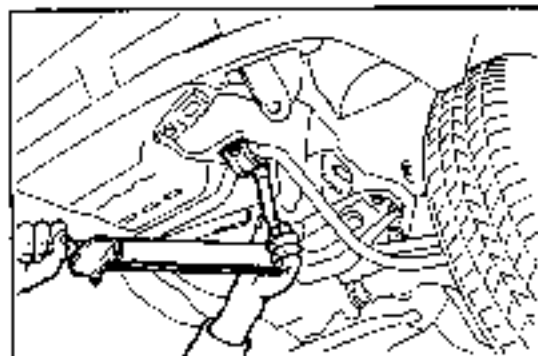

Fig. 5-54

WR05002

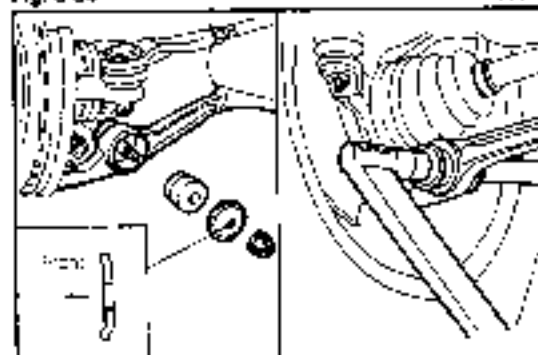

Fig. 5-55

WR05003

FRONT AXLE & SUSPENSION

REMOVAL

1. Jack up the vehicle at the front side. Support the body with safety stands.
2. Remove the front wheel.
3. Lower arm removal.
 - (1) Remove the stabilizer bar end nut.
 - (2) Remove the attaching bolt and nut of the ball joint.

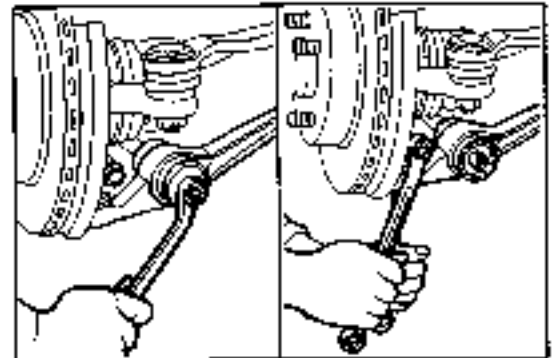

Fig. 5-57

WA-05459

- (3) Remove the attaching nut of the lower arm at the body side.

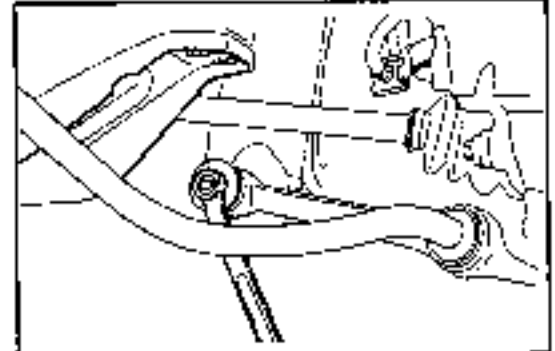

Fig. 5-58

WA-05050

- (4) Remove the attaching bolts of lower suspension brace.
(TURBO and GT grades only)
- (5) Remove the lower arm bracket.
- (6) Remove the lower arm.

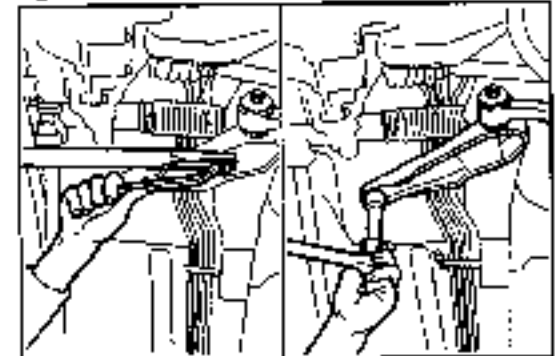

Fig. 5-59

WA-05061

INSPECTION

Inspect the following parts.

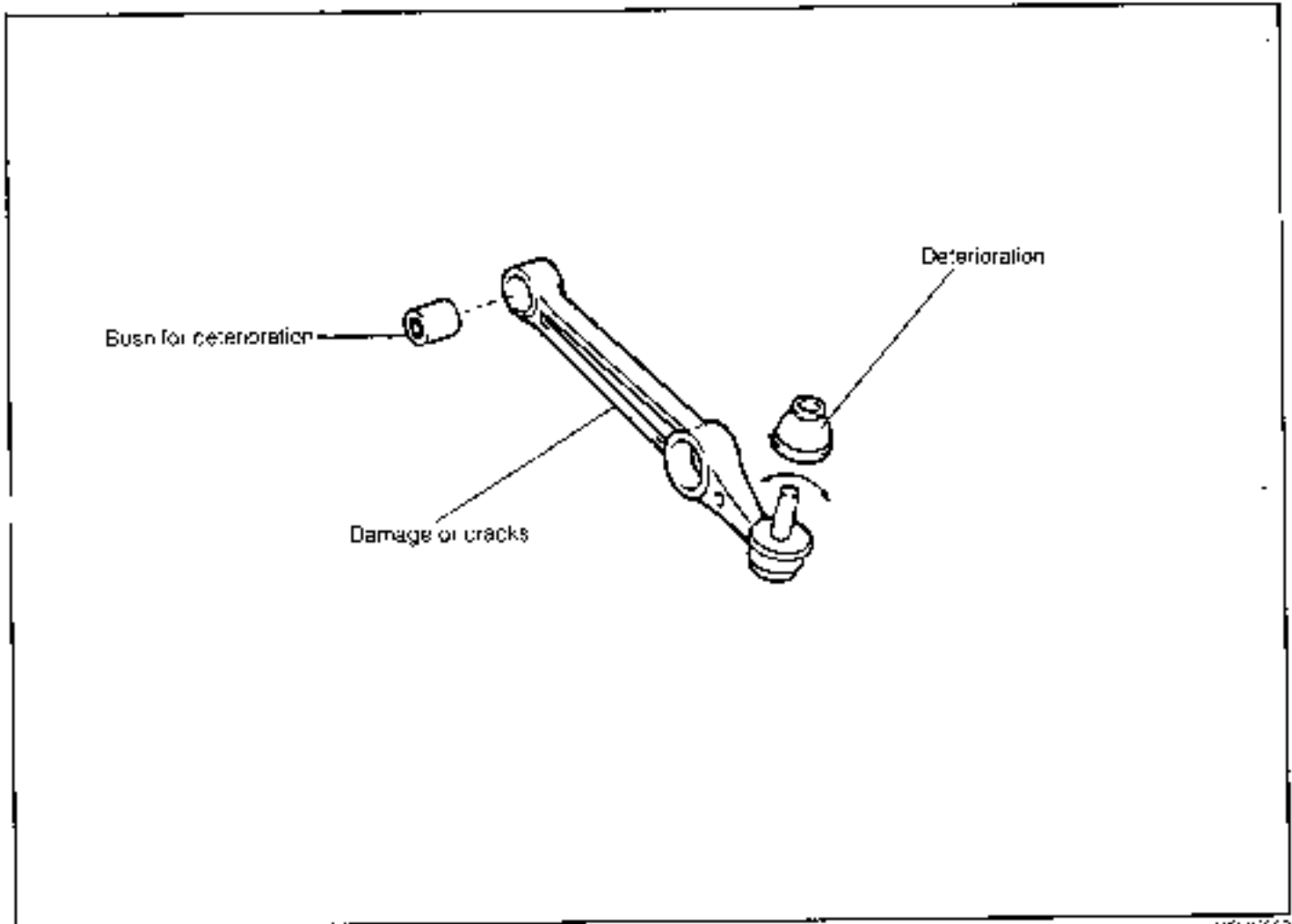

Fig. 5-50

WP-01-62

1. Lower ball joint dust cover replacement
 - (1) Remove the dust cover, using a common screwdriver.

NOTE:
Be very careful not to damage the socket section

 - (2) When assembling the lower ball joint dust cover, apply grease to the following sections.

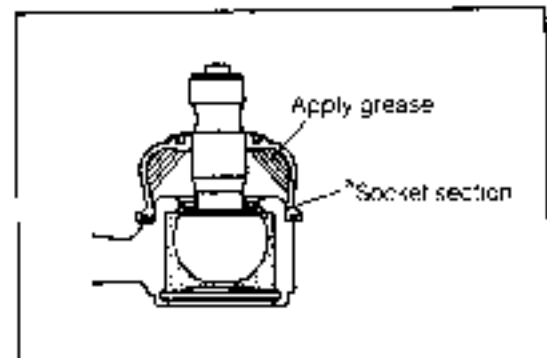

Fig. 5-51

WP-05953

- (3) Press the dust cover into position, using a press in combination with the following SST.

SST: 09618-87301-000

NOTE:
Make sure that no grease or oil gets to the socket section (indicated by a "*" mark) during the press operation.

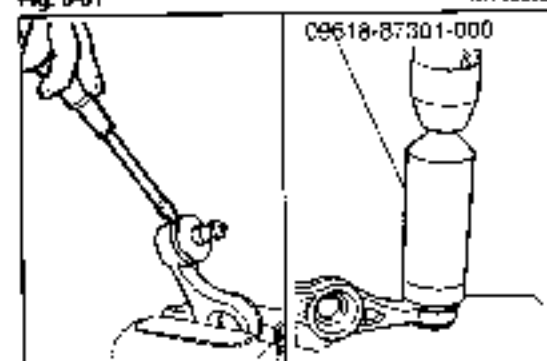

Fig. 5-52

WP-01064

FRONT AXLE & SUSPENSION

2. Lower arm bush replacement

- (1) Remove the bush, using the following SSTs.

SST: 09301-87701
09636-20010

- (2) Press the bush into position, using a press in conjunction with the following SSTs

SST: 09301-87701
09636-20010

INSTALLATION

1. Lower arm installation

- (1) Temporarily tighten the lower arm ball joint section and stabilizer bar end nut section.

- (2) Tighten the bolt and nut of the ball joint section.
Tightening Torque: 8.0 - 10.5 kg-m (58 - 76 ft-lb)

- (3) Install the lower arm bracket.
Tightening Torque: 7.5 - 10.5 kg-m (54 - 76 ft-lb)

- (4) Tighten the lower arm attaching nut temporarily.

- (5) Installation of lower suspension brace.
(TURBO and GT) grades only
Tightening Torque: 4.0 - 5.5 kg-m (29 - 40 ft-lb)

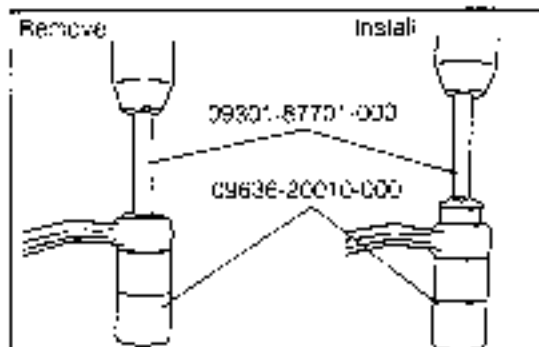

Fig. 5-63

WR-06080

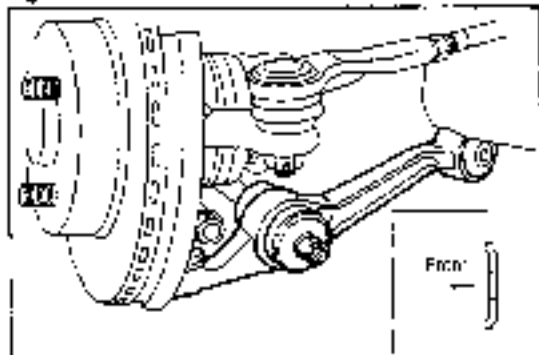

Fig. 5-64

WR-05096

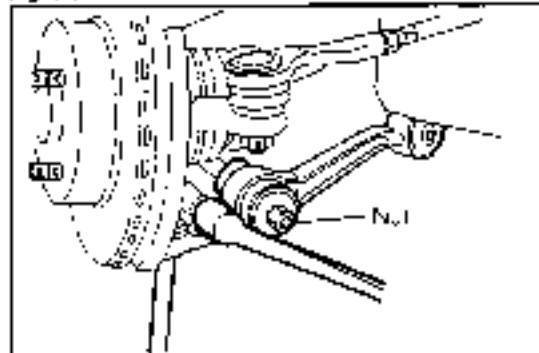

Fig. 5-65

WR-05097

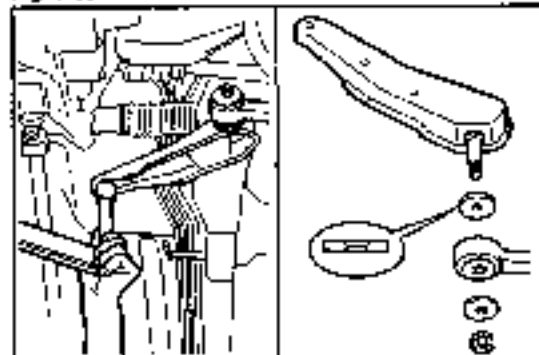

Fig. 5-66

WR-05104

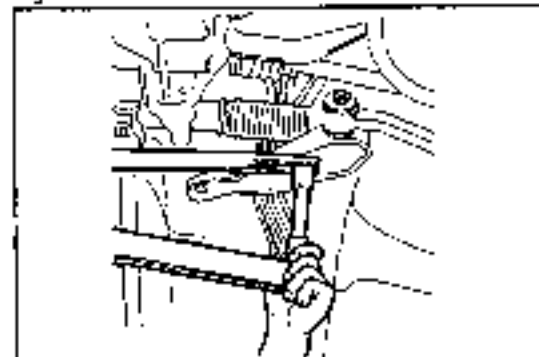

Fig. 5-67

WR-05105

- (6) Install the front wheel.
- (7) Jack down the vehicle. Rock the front section of the vehicle in an up-and-down direction two or three times so as to settle the suspension.
- (8) With the vehicle in an unloaded state (lower arm is horizontal), tighten the nut (Stabilizer bar).

Tightening Torque:
7.5 - 11.0 kg-m (54 - 80 ft-lb)

(Lower arm)
Tightening Torque:
7.0 - 10.0 kg-m (51 - 72 ft-lb)

2. Front wheel alignment inspection (See page 5-38.)

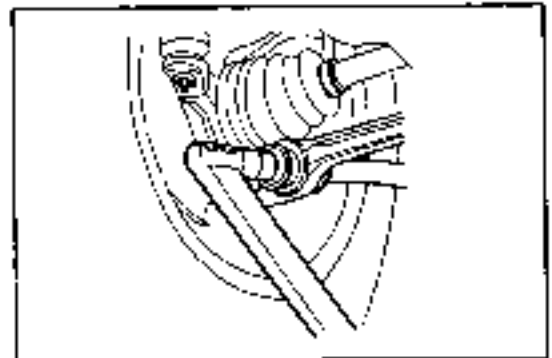

Fig. 5-68

WR-05010

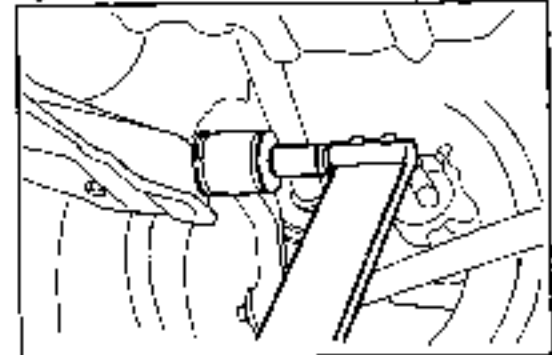

Fig. 5-69

WR-05011

FRONT AXLE & SUSPENSION

DRIVE SHAFT

DRIVE SHAFT-RELATED PARTS

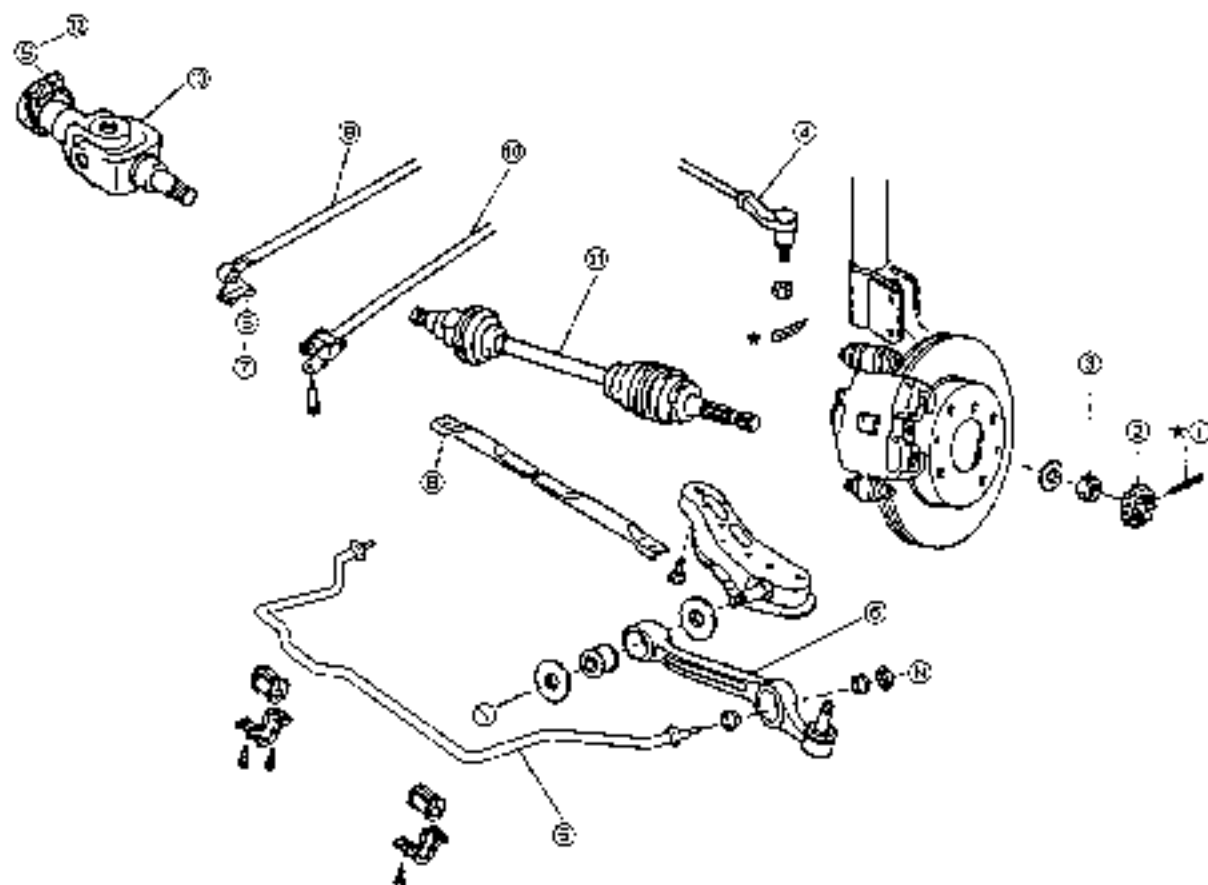

*: Non-reusable parts

- ① Cotter pin
- ② Front wheel adjusting lock cap
- ③ Nut
- ④ Tie rod Ay
- ⑤ Stabilizer bar
- ⑥ Lower arm Ay
- ⑦ Bolt

- ⑧ Extension rod S/A
- ⑨ Lower suspension brace
(Vehicles mounted with Type CB-80 engine only)
- ⑩ Shift & select shaft S/A
- ⑪ Front drive shaft Ay
- ⑫ Bolt
- ⑬ Front drive bearing shaft Ay
(Vehicles mounted with Type CB-80 engine only)

Fig. 5-70

478-5607

OPERATION PRIOR TO REMOVAL

1. Jack up the vehicle.
2. Drain the transmission fluid.
3. Remove the front wheels.

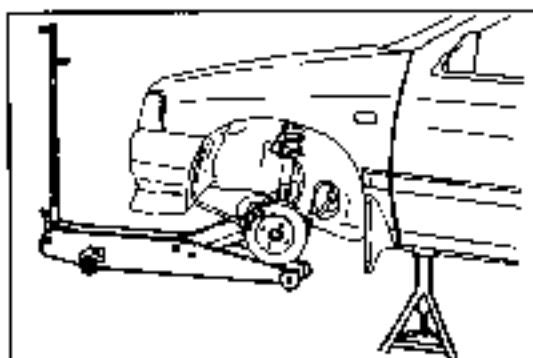

Fig. 5-71

WR-05671

REMOVAL

1. Pull out the cotter pin. Remove the front wheel adjusting lock cap.

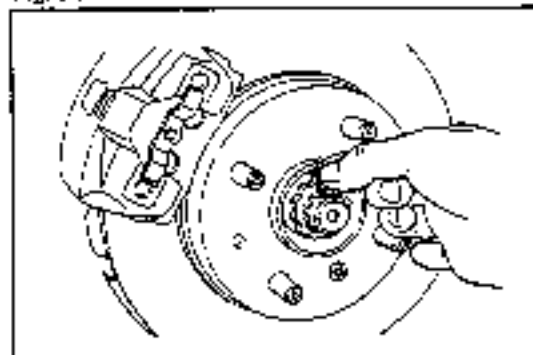

Fig. 5-72

WR-05724

2. Remove the nut, using the following SST.
 - SST: 09511-87202-000

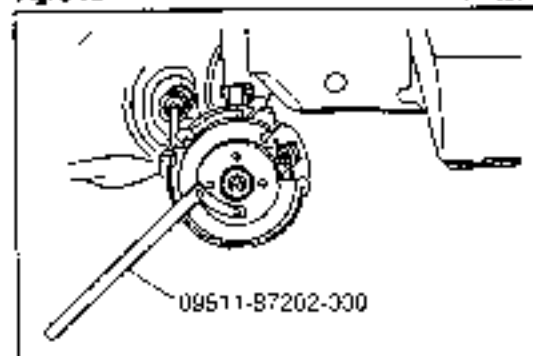

Fig. 5-73

WR-05735

3. Disconnect the tie rod, using the following SST.
 - SST: 09611-87701-000

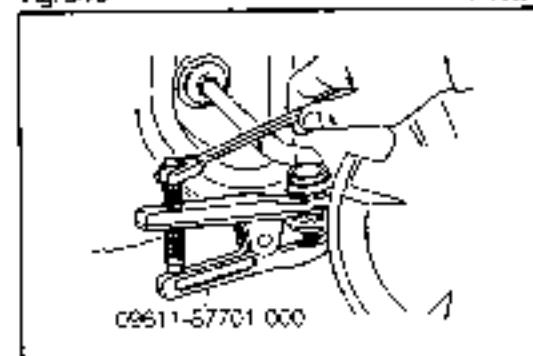

Fig. 5-74

WR-05776

4. Remove the stabilizer bar.

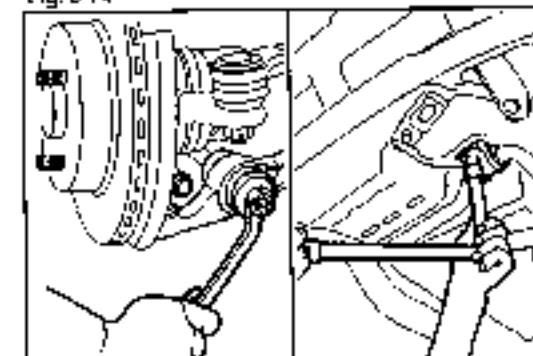

Fig. 5-75

WR-05777

FRONT AXLE & SUSPENSION

5. Remove the lower arm. (Bracket side only)

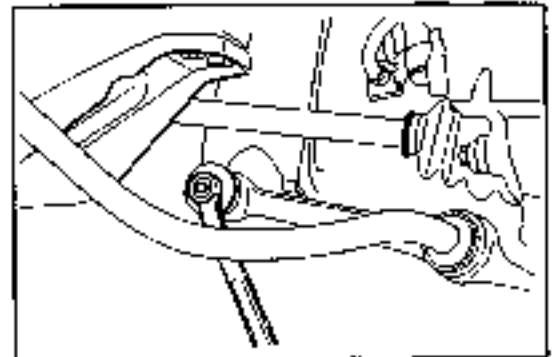

Fig. 5-76

WF-09078

6. Remove the bolts. Separate the extension rod subassembly and shift & select shaft subassembly from the transmission.

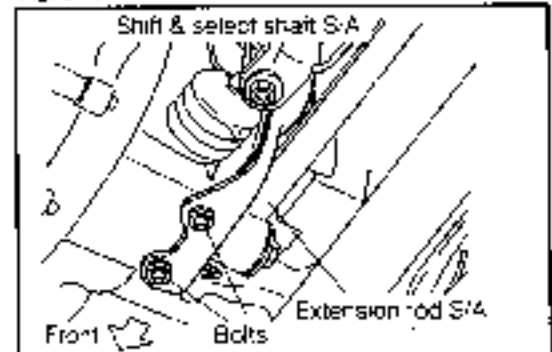

Fig. 5-77

WF-09079

7. Pull out the front drive shaft, using the following SST.
SST: 09648-87201-000

NOTE:

1. As for the inboard side of the drive shaft, no stopper is provided at the inside. Therefore, be sure to support the inboard joint section by your hand during the removal.

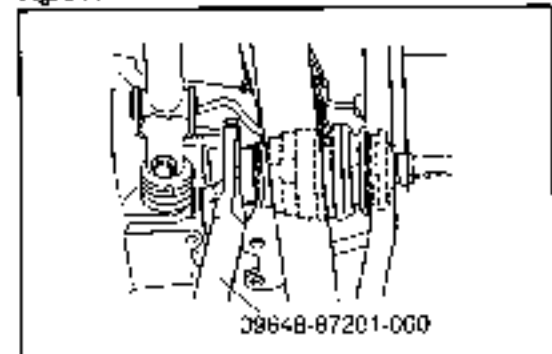

Fig. 5-78

WF-09080

2. As for the right side of vehicles mounted with Type CB-80 engine, insert a crowbar into between the protruding section of the bearing shaft and the drive shaft. Then, take out the front drive shaft, being very careful not to deform the dust cover of the drive shaft.

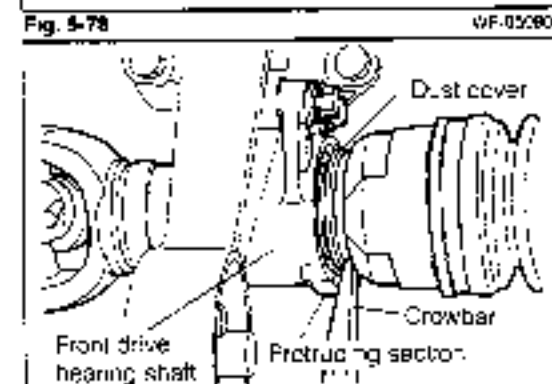

Fig. 5-79

WF-09081

9. Remove the two bolts. Remove the front drive shaft bearing shaft assembly. (Vehicles mounted with Type CB-80 engine only)

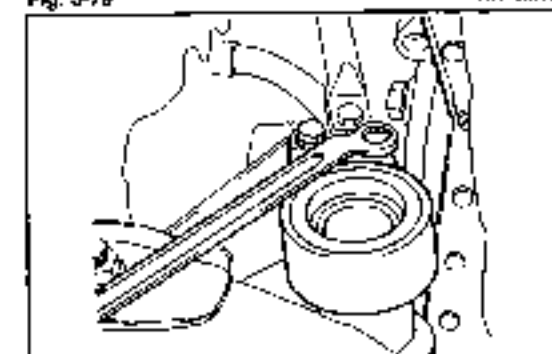

Fig. 5-80

WF-09082

INSPECTION

inspect the following sections.

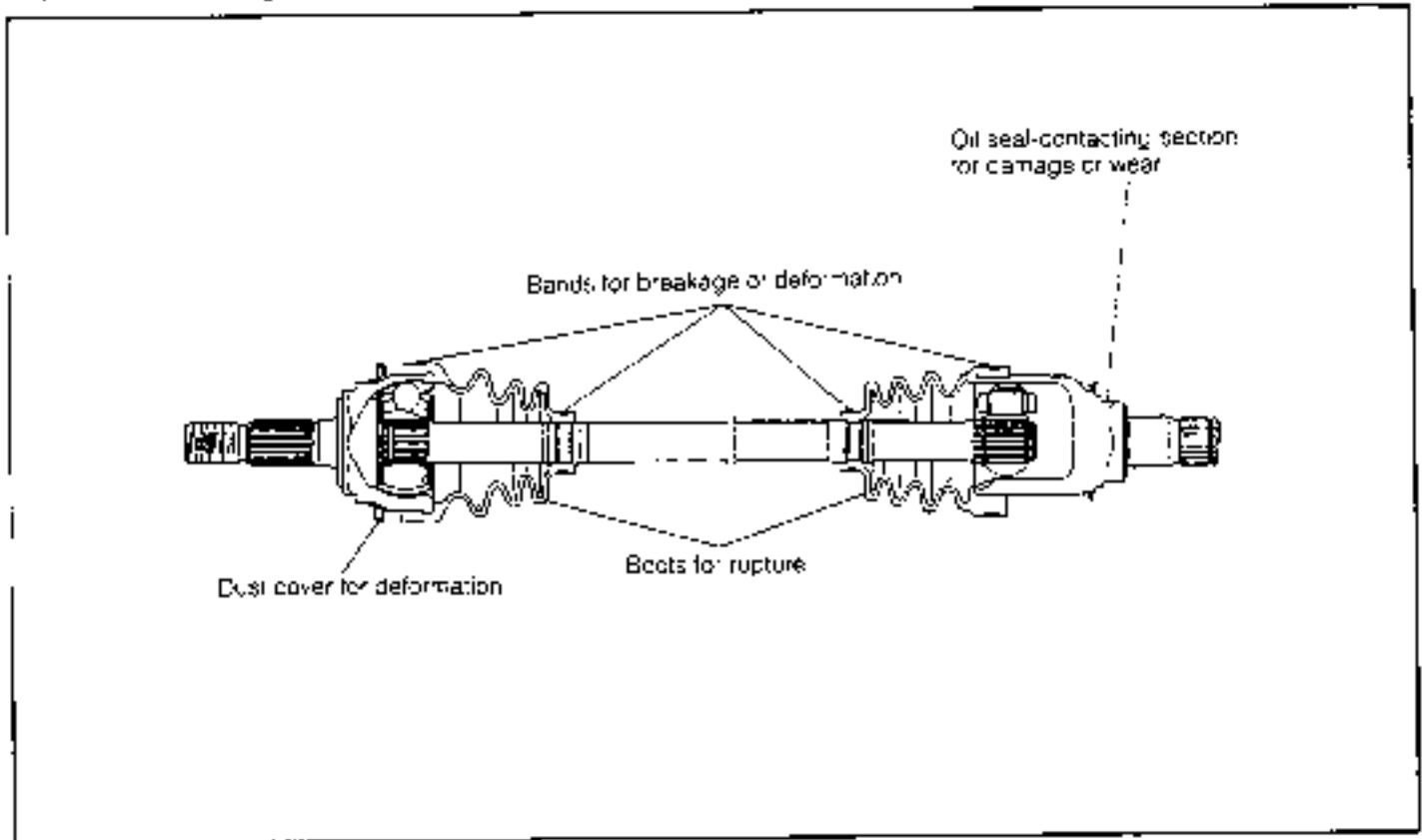

Fig. 5-81

WF C5083

FRONT AXLE & SUSPENSION

COMPONENTS

NOTE:

When replacing the parts of the drive shaft, each of the boot, the inboard joint and the outboard joint (with the front axle shaft) should be replaced only as a complete unit.

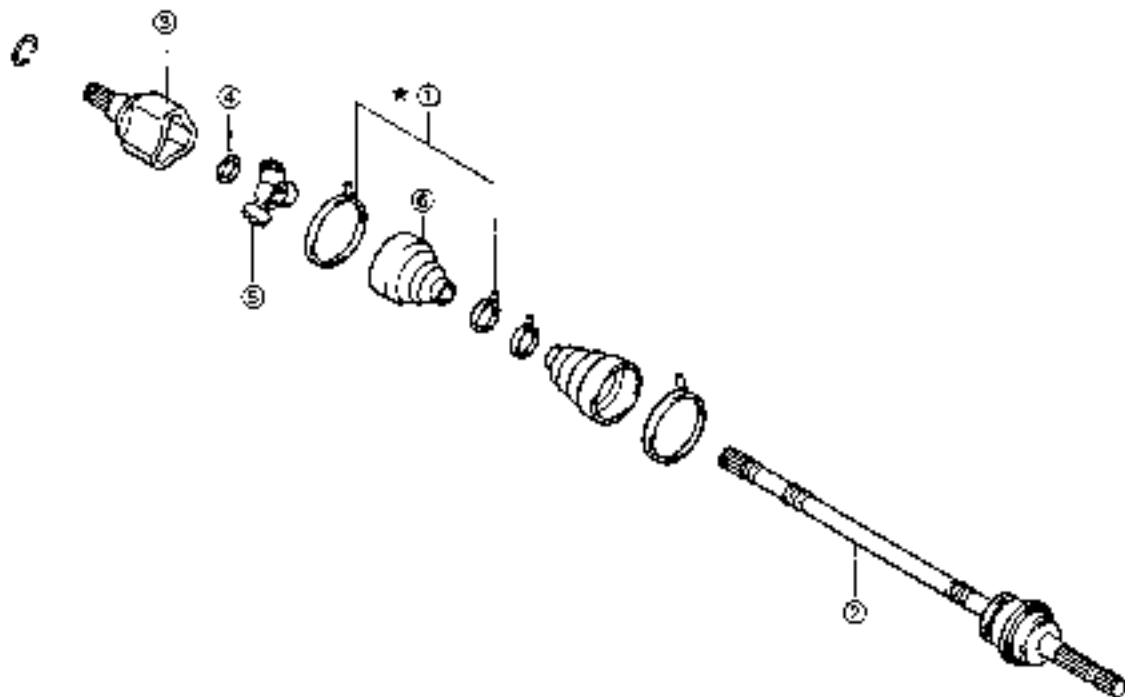

*: Non-reusable parts

- ① Boot band
- ② Outboard joint S/A
- ③ Front axle inboard joint S/A
- ④ Shaft snap ring
- ⑤ Inboard joint S/A
- ⑥ Front axle joint boot

Fig. 5-82

WF-Cat. 8-

DISASSEMBLY

1. Pry up the boot band clip with a common screwdriver.
Detach the boot.

NOTE:

Be very careful not to damage the boot.

2. Put a mating mark on the inboard joint and shaft as shown in the figure. Remove the front axle inboard joint subassembly.

NOTE:

Put mating marks by painting. (Never use a punch to put mating marks.)

3. Detach the shaft snap ring, using a snap ring expander.

4. Remove the inboard joint tripod assembly, as follows:
 - (1) Put a mating mark at the tip end of the tripod and shaft, using a punch.

(2) Pull out the tripod from the shaft, using a brass bar.

NOTE:

Be sure to apply the brass bar to the tripod boss section, not to the roller section.

5. Remove the front axle joint boot.

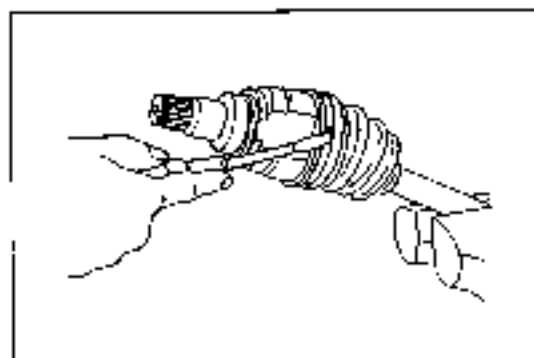

Fig. 5-83

WH-07026

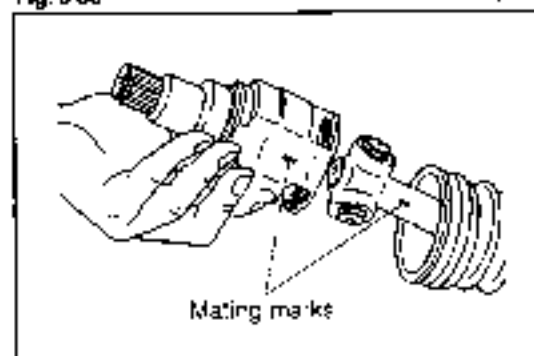

Fig. 5-84

AFR-03026

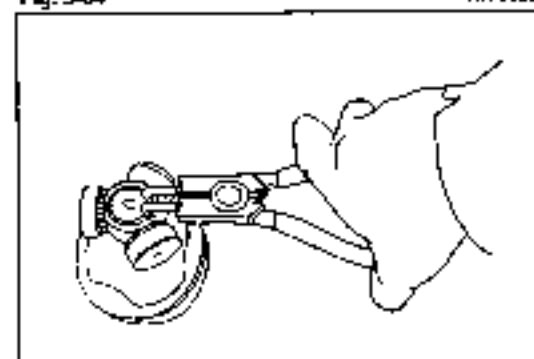

Fig. 5-85

WF-05067

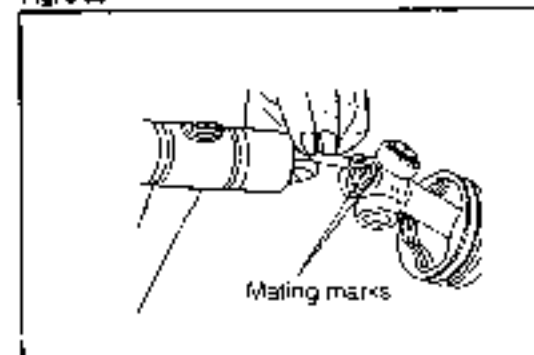

Fig. 5-86

WF-05092

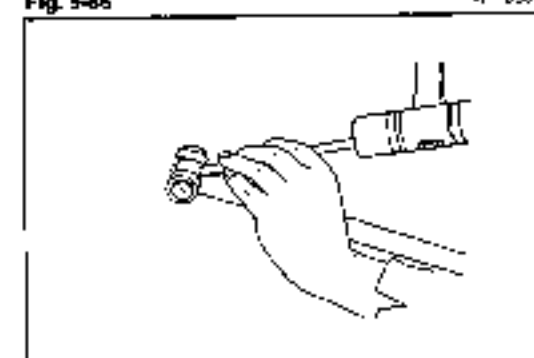

Fig. 5-87

WF-05079

FRONT AXLE & SUSPENSION

INSPECTION

Inspect the following sections.

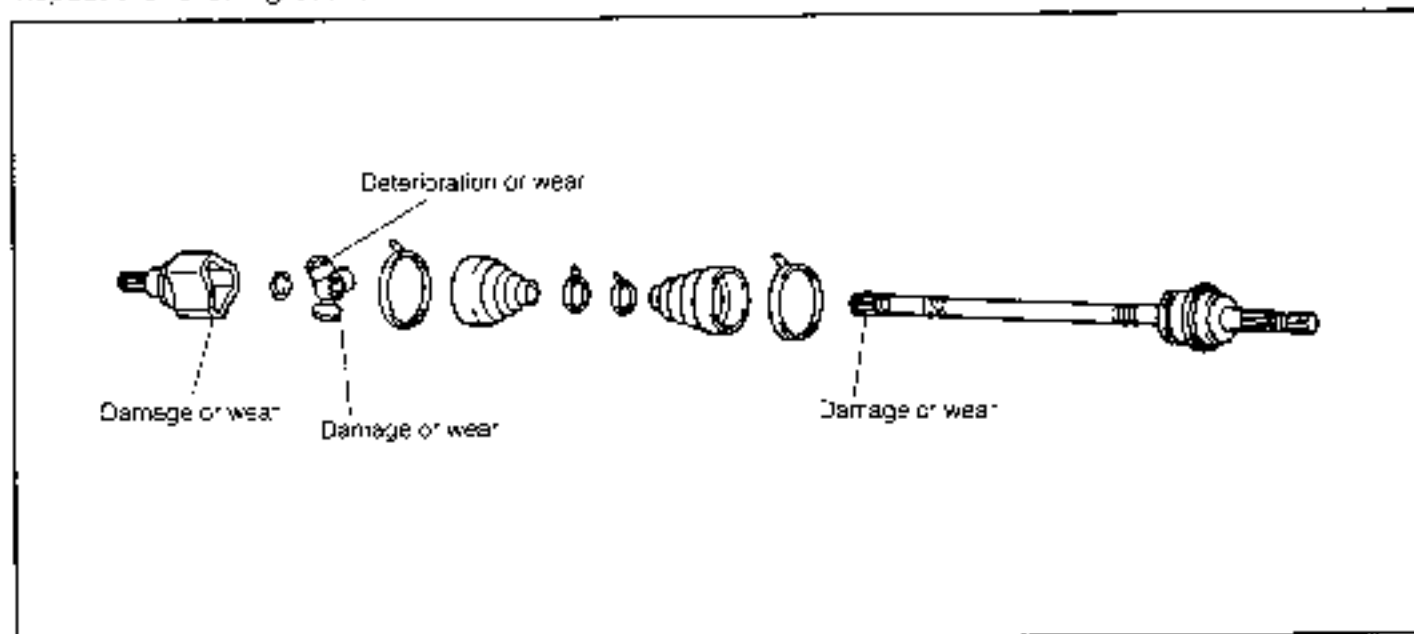

Fig. 5-88

WP-05060

ASSEMBLY

- 1 Assemble the front axle joint boot in position.
- 2 Assemble the inboard joint tripod assembly, as follows:
 - (1) Face the non-splined side of the tripod toward the outboard joint.
 - (2) Align the mating marks which were put during the disassembly.

- (3) Drive the tripod assembly into the shaft lightly, using a brass bar.

NOTE:

Be sure to apply the brass bar to the boss section of the tripod, not to the roller section.

3. Attach the shaft snap ring in position, using a snap ring expander.

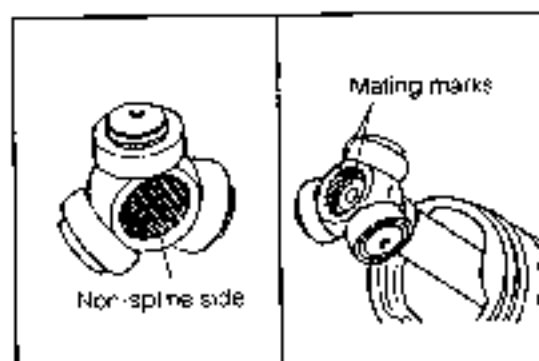

Fig. 5-89

WP-05061

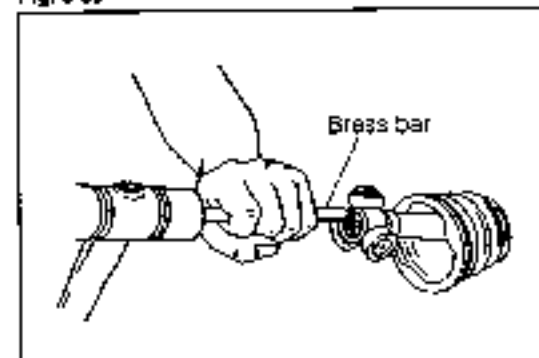

Fig. 5-90

WP-05062

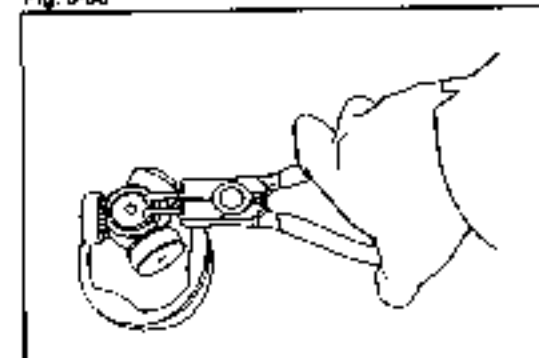

Fig. 5-91

WP-05063

- 4 Assemble the front axle inboard joint, as follows.
 (1) Pack the inboard joint with joint grease.

NOTE:

Use the grease which has been provided in the boot kit of the replacement parts.

- (2) Install the inboard joint, aligning the mating marks which were put during the disassembly.

5. Prior to assembling the boot of the front axle outboard joint, pack the outboard joint with joint grease.

NOTE:

1. Use the grease which has been provided in the boot kit of the replacement parts.
2. On vehicles other than those mounted with Type CB-80 engine, it should be noted that the grease to be used for the inboard joint differs from that to be used for the outboard joint.

Grease for inboard joint ... Yellow

Grease for outboard joint ... Black

- 6 Assemble a new boot band, as shown in the figure

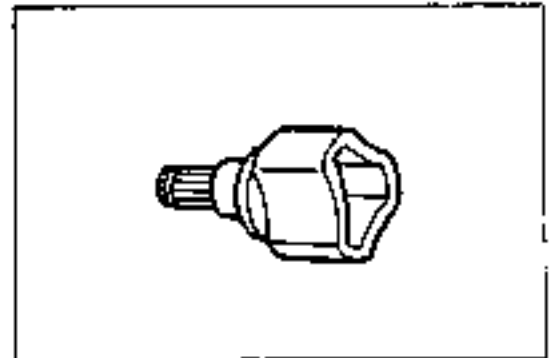

Fig. 5-92

WF-02294

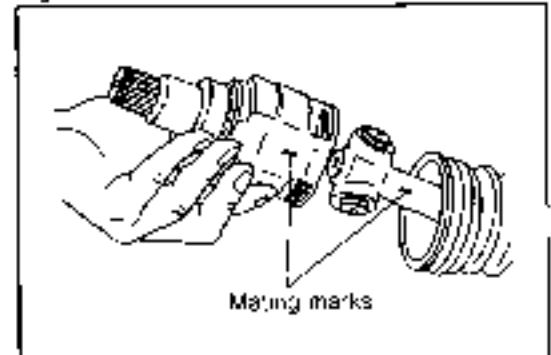

Fig. 5-93

WF-03295

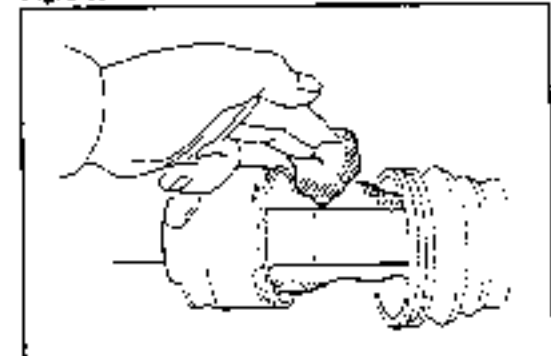

Fig. 5-94

WF-03295

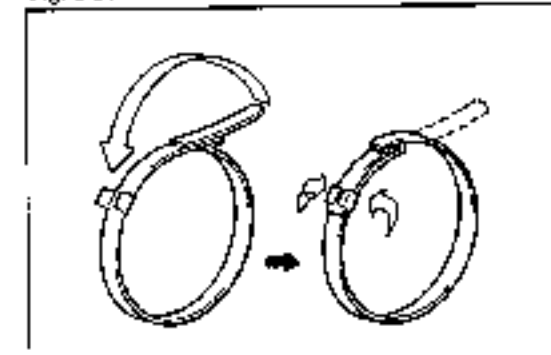

Fig. 5-95

WF-03297

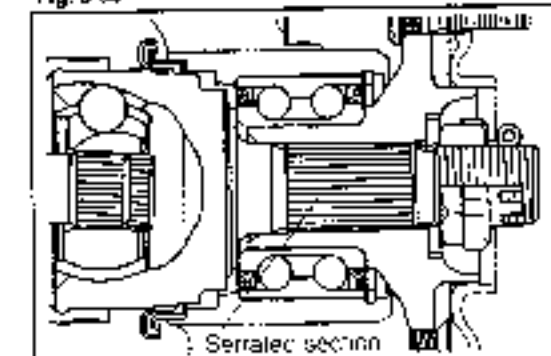

Fig. 5-96

WF-03298

INSTALLATION

Grease applying points

1. Apply chassis grease to the whole serrated section of the front axle hub installation section.

FRONT AXLE & SUSPENSION

2. Install the front drive bearing shaft in position.
(Vehicles mounted with Type CB-80 engine only)
Tightening Torque: 3.0 - 4.5 kg-m (22 - 33 ft-lb)

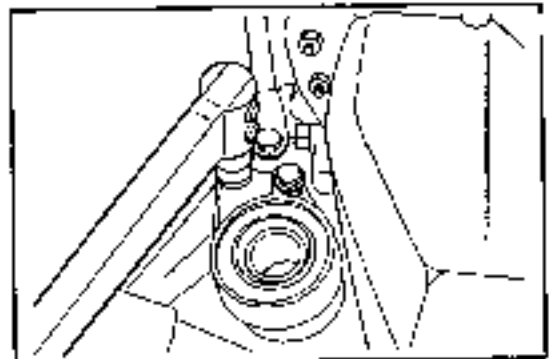

Fig. 5-97

W1-C5678

3. Install the front drive bearing shaft in position.
NOTE:
Be very careful not to damage the oil seal during the installation.

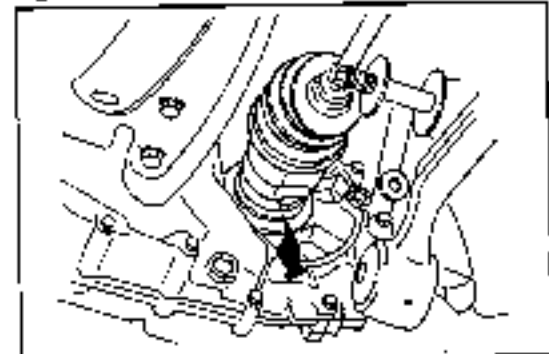

Fig. 5-98

W4-C5712

4. Install the shift & select shaft subassembly and extension rod subassembly in position.
Tightening Torque: 1.0 - 1.6 kg-m (7.2 - 11.6 ft-lb)

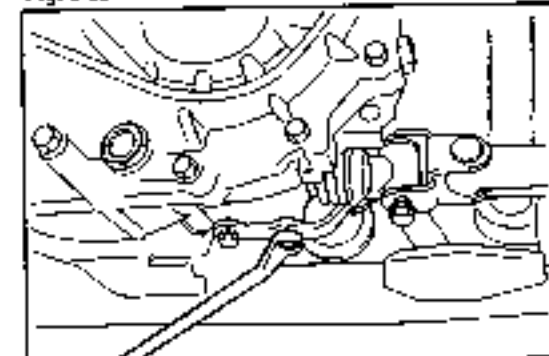

Fig. 5-99

W4-05717

5. Install the bracket side of the lower arm assembly in position.
Tightening Torque: 7.0 - 10.0 kg-m (51 - 72 ft-lb)

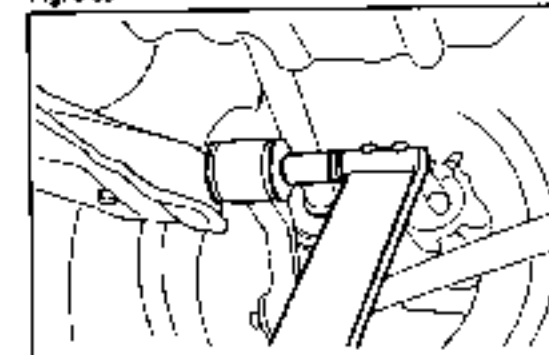

Fig. 5-100

W4-05102

6. Install the stabilizer bar to the lower arm assembly
Tightening Torque: 7.5 - 11.0 kg-m (54 - 80 ft-lb)
7. Install the stabilizer lower bracket to the body.
Tightening Torque: 4.0 - 6.0 kg-m (29 - 43 ft-lb)

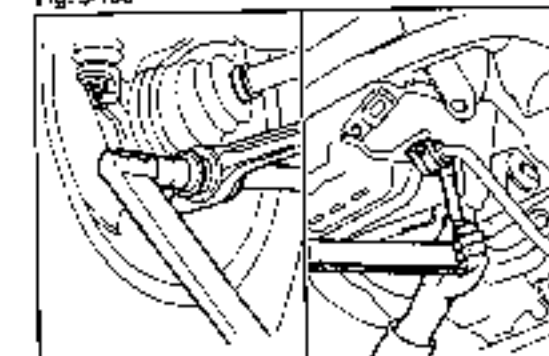

Fig. 5-101

W4-05103

FRONT AXLE & SUSPENSION

5. Install the tie rod assembly to the steering knuckle.
Tightening Torque: 3.0 - 4.5 kg-m (22 - 33 ft-lb)

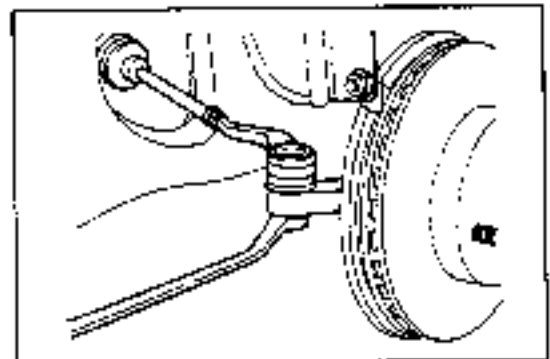

Fig. 5-102

WR-25124

9. Install the drive shaft to the front axle hub. Secure the axle hub, using the following SST.
SST: 09511-87202-000

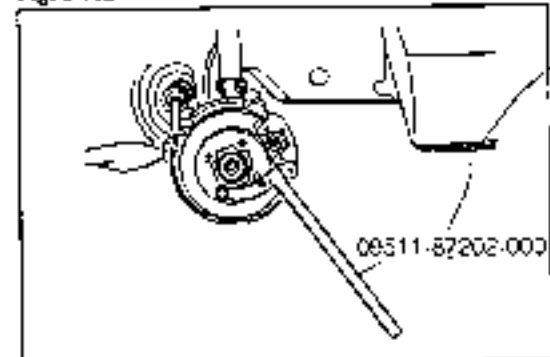

Fig. 5-103

WR-25105

10. Tighten the nut.
Tightening Torque:
18.0 - 23.0 kg-m (130 - 166 ft-lb)

NOTE:

1. When this nut is tightened to the specified torque, the specified preload of the front wheel is attained.
2. Assemble the spring washer in such a way that its recessed side comes to the hub side.

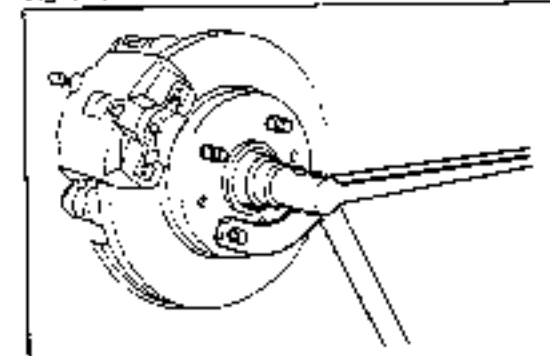

Fig. 5-104

WR-25106

11. Install the front wheel adjusting lock cap to the nut.
12. Install the cotter pin as shown in the right figure.

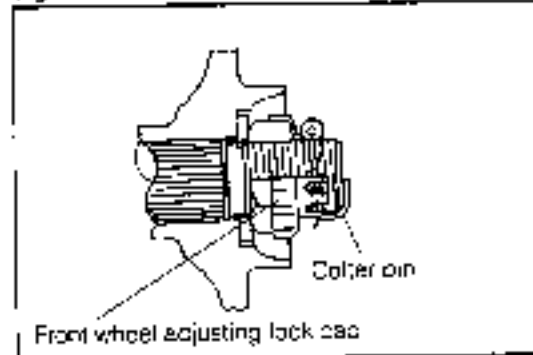

Fig. 5-105

WR-25107

FRONT AXLE & SUSPENSION

FRONT DRIVE BEARING SHAFT

(Vehicles Mounted with Type CB-80 Engine Only)

COMPONENTS

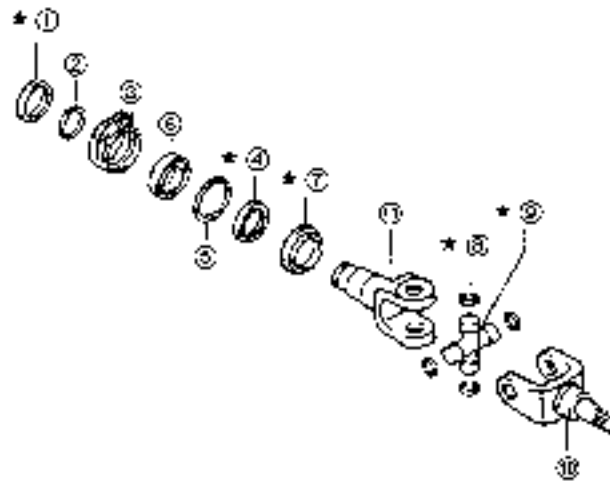

*: Non-reusable parts

- ① Oil seal
- ② Shaft snap ring
- ③ Drive shaft bearing bracket
- ④ Oil seal
- ⑤ Hoop snap ring
- ⑥ Radia ball bearing

- ⑦ Dust deflector
- ⑧ Hoop snap ring
- ⑨ Universal joint spider S02
- ⑩ Universal joint No 2 yoke
- ⑪ Universal joint yoke S1A

Fig. 5-106

6A 05 01

INSPECTION

Inspect the following parts.

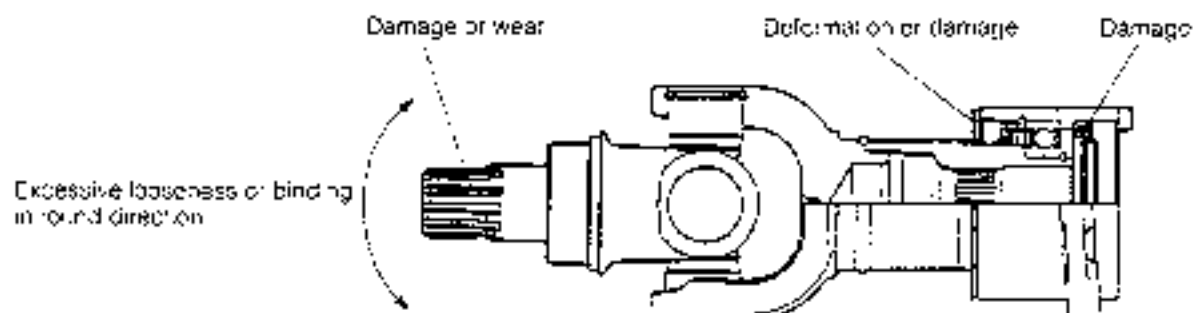

Fig. 5-107

6A 05 01

DISASSEMBLY

1. Remove the oil seal, using a common screwdriver.
2. Detach the shaft snap ring using a snap ring expander.

3. Remove the drive shaft bearing bracket, using the following SSTs.
 SST: 09334-87201-000
 SST: 09608-87501-000

4. Remove the another oil seal, using a common screwdriver.
5. Detach the hole snap ring using a snap ring expander.

6. Remove the radial ball bearing, using the following SSTs.
 SST: 09547-87301-000
 SST: 09608-87501-000

7. Remove the dust deflector, using a brass bar and a hammer. Be careful not to damage the dust deflector during the removal.

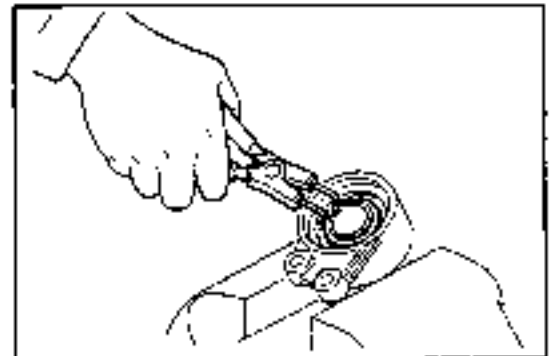

Fig. 5-108 09-05'10

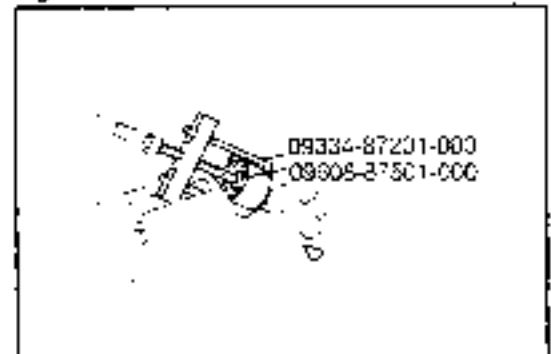

Fig. 5-109 09-05'11

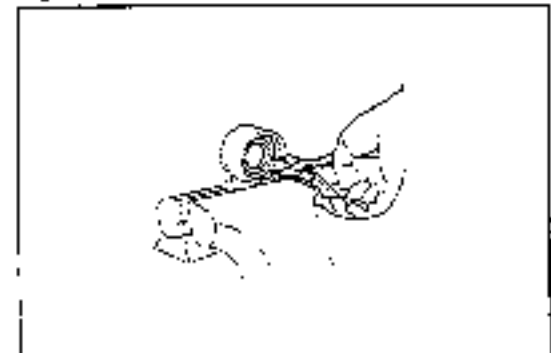

Fig. 5-110 09-05'12

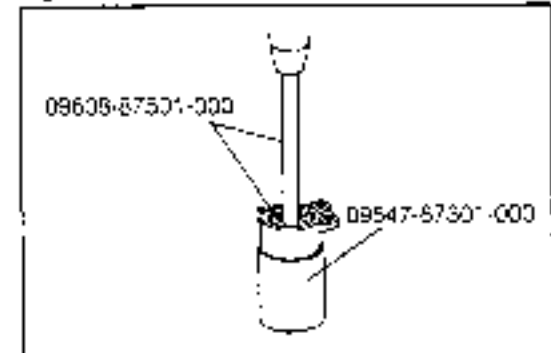

Fig. 5-111 09-05'13

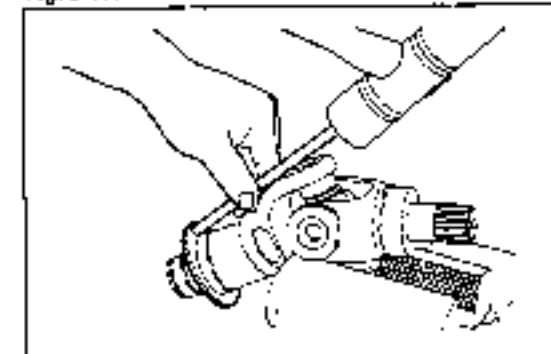

Fig. 5-112 09-05'14

FRONT AXLE & SUSPENSION

- 8 Put a mating mark on the yoke and universal yoke
- 9 Detach the hole snap ring, using a snap ring expander.

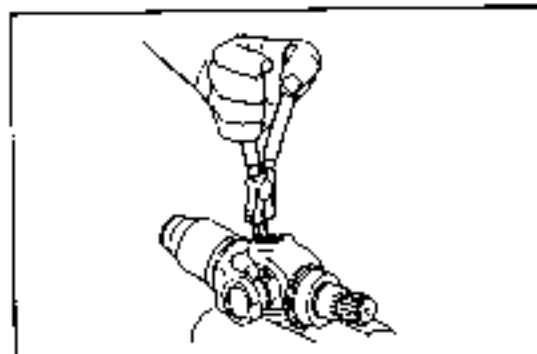

Fig. 5-113

AR-05113

10. Remove the universal joint spider subassembly, following the procedure given below:

- (1) Push off the spider bearing cap, using a vice in combination with a 19 mm socket and the following SST.

SST: 09628-10020-000

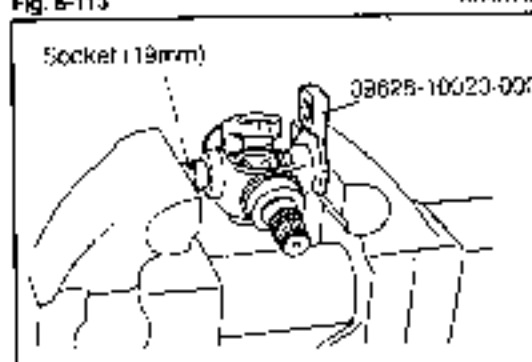

Fig. 5-114

WR-05114

- (2) Clamp the pushed-out cap in a vice. Remove the bearing cap from the yoke No.2 by tapping the yoke No.2 lightly.
- (3) Tap the spider from the side of the cap removed, thus pushing out the another cap.

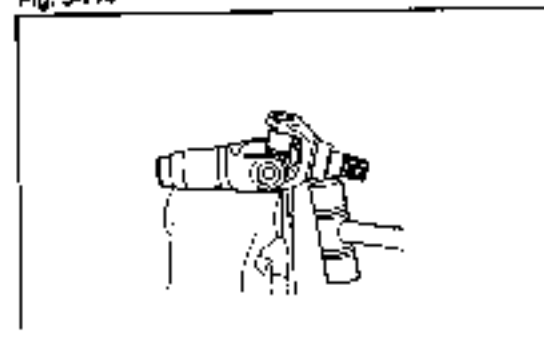

Fig. 5-115

WR-05115

- (4) Clamp the cap in a vice. Remove the cap by tapping the yoke No.2 lightly. Separate the yoke No.2 from the universal joint yoke subassembly.
- (5) Remove the remaining caps, following the same procedure.

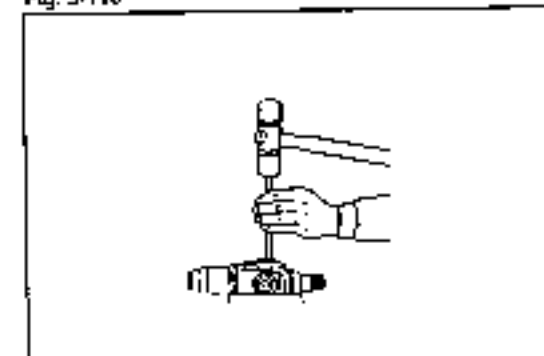

Fig. 5-116

WR-05116

- 11 Disconnect the universal joint No.2 yoke from the universal joint yoke subassembly.

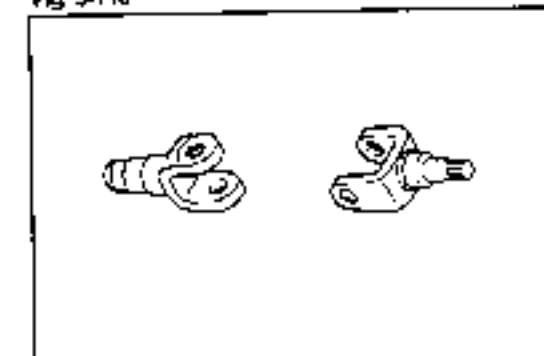

Fig. 5-117

WR-05117

INSPECTION

inspect the following sections

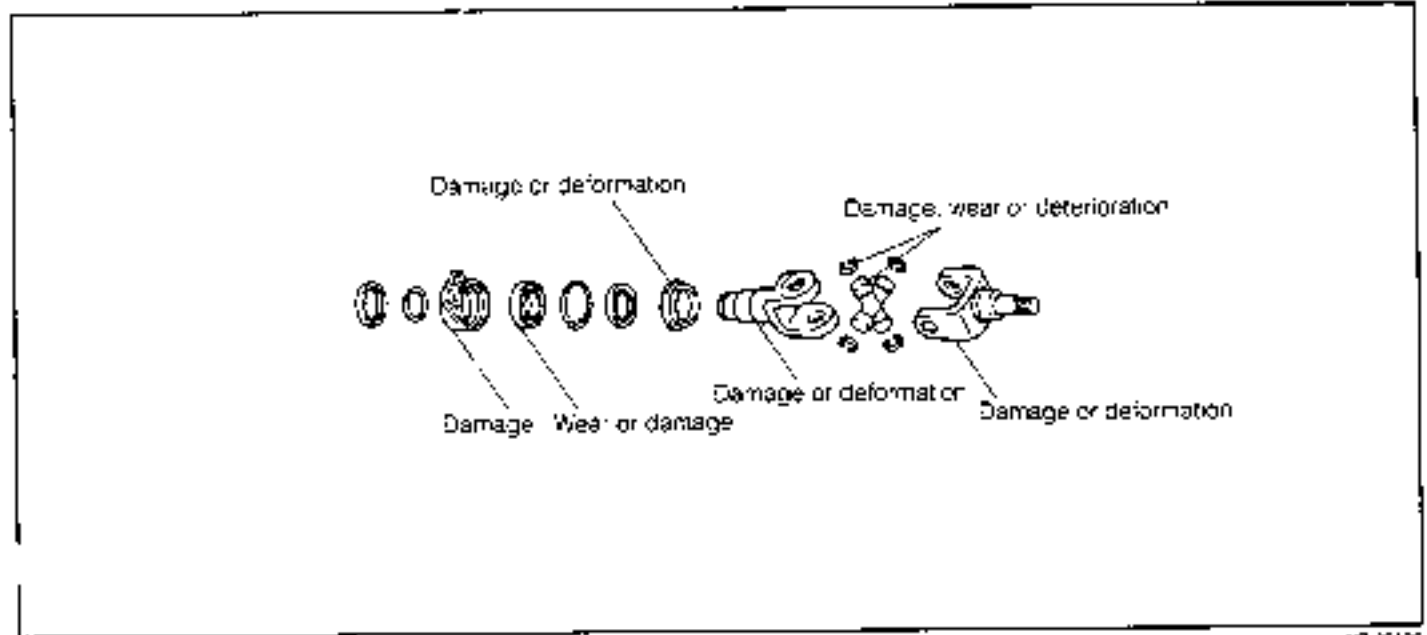

Fig. 5-116

WR-05120

ASSEMBLY

Grease applying points

Apply MP grease to the points shown in the right figure.

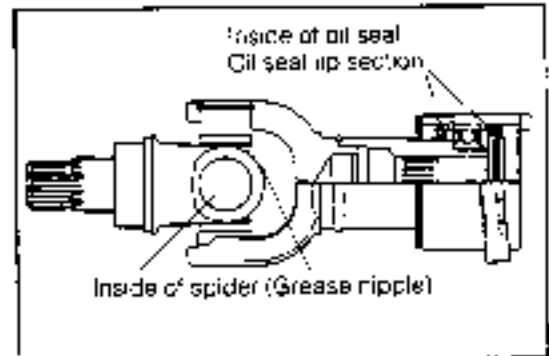

Fig. 6-119

WR-05120

1. Assemble the universal joint yoke spider subassembly, following the procedure given below.
 - (1) Assemble the spider to the universal joint yoke sub-assembly. Push them in a vice from both sides until the bearing cap becomes flush with the end surface of the yoke subassembly.

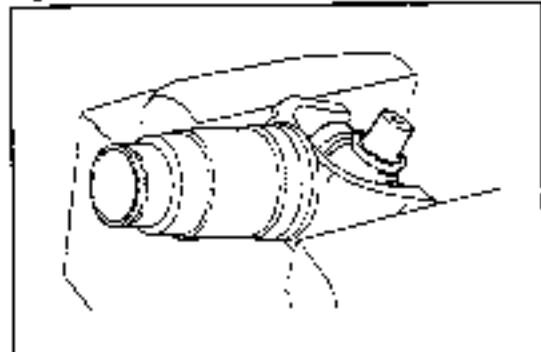

Fig. 5-120

WR-05122

- (2) Using a 19 mm socket push the spider cap in a vice until the snap ring can be inserted in position.
 - (3) Install the universal joint yoke No.2 to the spider. Assemble it in the sequence (1) and (2) described above.

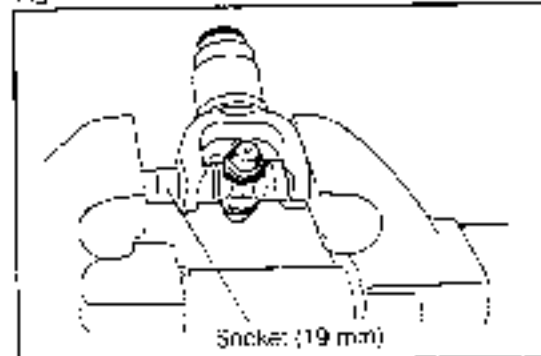

Fig. 5-121

WR-05123

FRONT AXLE & SUSPENSION

2 Assemble the hole snap ring using a snap ring expander, in accordance with the procedure given below.

- (1) Select a proper snap ring so that the play of the spider in the axial direction will not exceed 0.05 mm (0.002 inch) and the thickness of the snap ring becomes the same at both sides.

Reference: Snap Ring Availability

Part number	Thickness
90045-21046-000	1.45 mm (0.057 inch)
90045-21047-000	1.50 mm (0.059 inch)
90045-21048-000	1.55 mm (0.061 inch)

- (2) Assemble the selected snap ring.
- (3) Check the spider bearing for excessive looseness

3 Install the dust deflector, using the following SST.

SST: 09547-87501-000

4 Assemble the radial ball bearing, using the following SSTs.

SST: 09547-87301-000

SST: 09608-87501-000

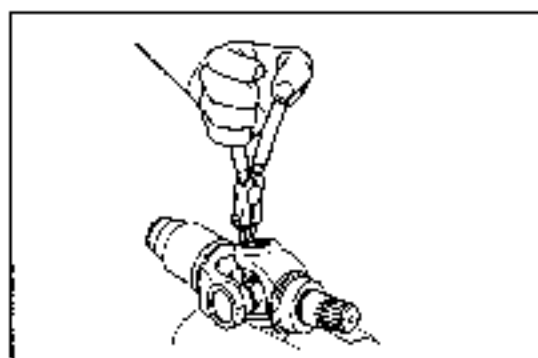

Fig. 5-122

WF-01124

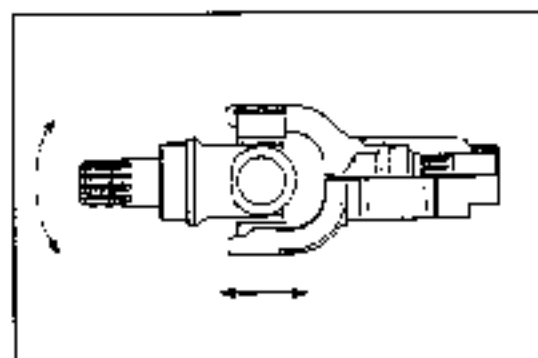

Fig. 5-123

WF-01126

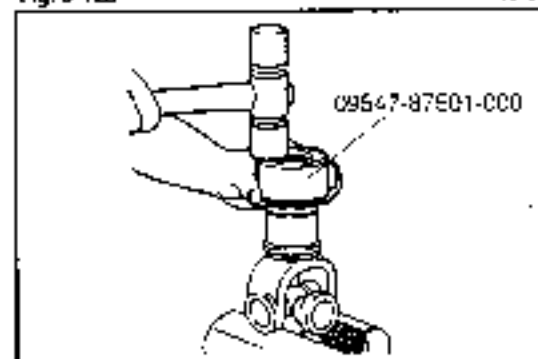

Fig. 5-124

WF-05128

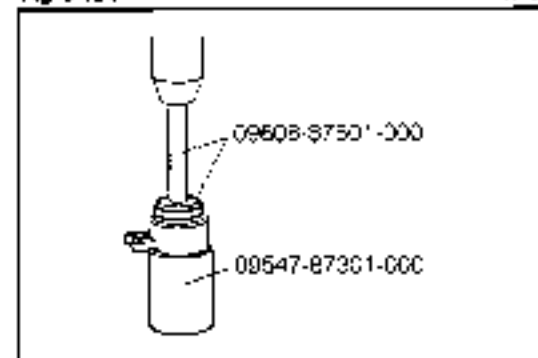

Fig. 5-125

WF-05128

5. Attach the hole snap ring, using a snap ring expander.

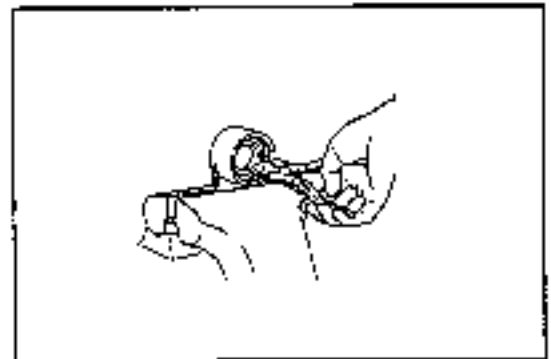

Fig. 5-126

WR-05126

6. Install the oil seal, using the following SST.
SST: 09608-87501-000

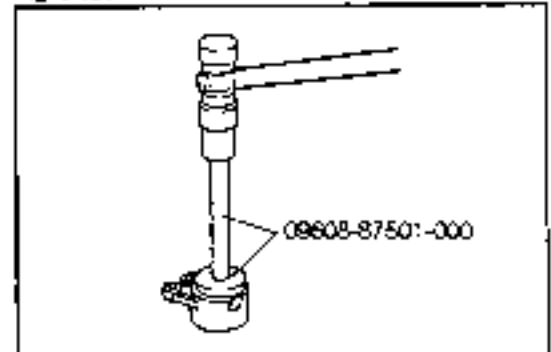

Fig. 5-127

WR-05127

7. Install the drive shaft bearing bracket, using the following SSTs.
SST: 09506-30011-000
SST: 09608-87501-000

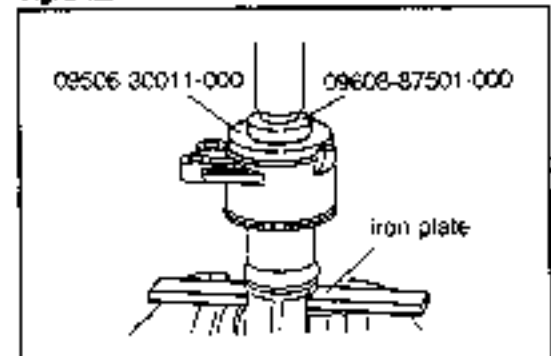

Fig. 5-128

WR-05128

8. Attach the shaft snap ring, using a snap ring expander.
9. Assemble the oil seal, using the following SST.
SST: 09608-87501-000

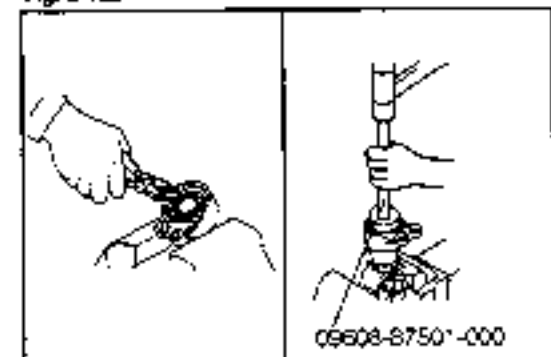



Fig. 5-129

WR-05129

FRONT AXLE & SUSPENSION

WHEEL ALIGNMENT (FRONT AND REAR)

TOOLS AND INSTRUMENTS

	Shape	Nomenclature	Use
Tools		CCK gauge compensator CCK-IN Supplied by Banzai Ltd.	Attachment for camber, caster and kingpin gauge
	Brake pusher, hexagon wrench key (width across flats: 8 mm)		
Instruments	Turning radius gauge, tire pressure gauge, camber, caster, kingpin gauge and dia. gauge		

WF-05-32

CHECKS PRIOR TO WHEEL ALIGNMENT MEASUREMENT

1. Checking Tires for Wear
2. Checking Tires for Air Pressure

Tire	Air inflation pressure (kg/cm ² (psi))	
	G-100	G-101
6.00.12.4PR	1.9 (27)	1.9 (27)
145/80R13 74S, 145SR13	1.8 (26)	2.0 (29)
155/80R13 76S, 155SR13	1.8 (26)	2.0 (29)
165/70R13 79S, 165/70SR13	1.8 (26)	2.0 (29)
175/60R14 78H	1.8 (26)	
185/60R14 82H (Pirelli)	1.8 (26)	

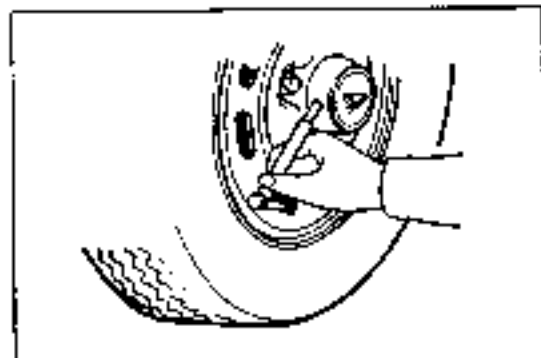

Fig. 5-130

WR-06123

3. Checking Tires for Runout
(Up-and-down and right-and-left directions)
Maximum Limit: 3.0 mm (0.12 inch)
2. mm
4. Checking Bolts of Related Sections for Tightened Condition

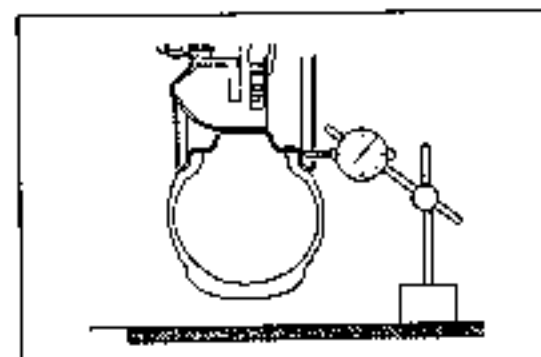

Fig. 5-131

WR-06134

5. Checking Related Sections for Excessive Play
 - (1) Jack up the vehicle. Alternately push and pull the upper and lower parts of each tire. Ensure that the tire exhibits no excessive play.
 - (2) If the tire exhibits an excessive play, perform the following check while the brake pedal is being depressed.
 - The excessive play disappears:
This indicates that the front wheel bearing is loose
 - The excessive play still persists:
This indicates that the knuckle section, axle carrier section or suspension is loose.

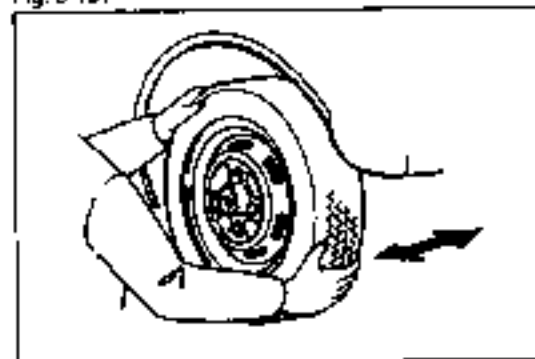

Fig. 5-132

WR-05135

- (3) If the wheel bearing is judged as being loose, proceed to check the play in the axial direction, using the following SST.

SST: 09510-87301-000

(Front and rear wheel bearings)

Specified Value: Not to exceed 0.2 mm (0.008 inch)

Maximum Limit: 0.05 mm (0.002 inch)

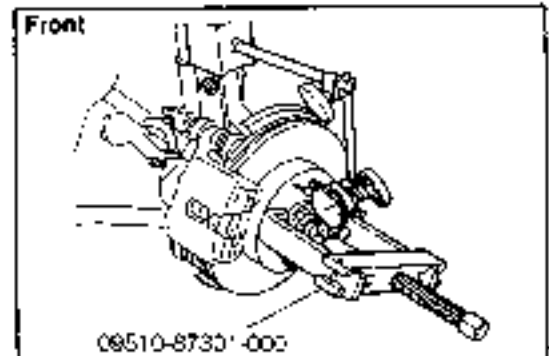

Fig. 5-133

WF-05133

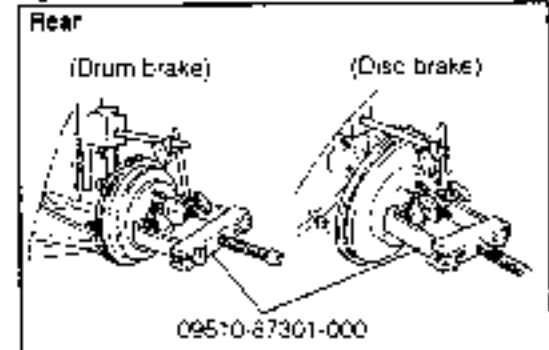

Fig. 5-134

WF-05134

CHECKS AND ADJUSTMENT OF FRONT WHEEL ALIGNMENT

1. Turning Radius Gauge Set

- (1) Set the turning radius gauge to the zero point. Proceed to lock the gauge.
- (2) Place the vehicle on the gauge in such a way that the center of the tire-to-floor contact surface may be aligned with the center of the turning radius gauge.

NOTE:

- Perform the check on a level floor.
- When a portable type turning radius gauge is employed, a plate having the same thickness as that of the gauge should be placed under the rear wheel so that the vehicle levelness may be maintained.
- Make sure that the wheels are in their straightahead conditions.
- Keep the vehicle in an unloaded state. In order to prevent the vehicle from moving during the check, be sure to apply the foot brake, using a brake pedal pusher or the like.
- Remove the stop lamp fuse so as to prevent the stop lamp from glowing.

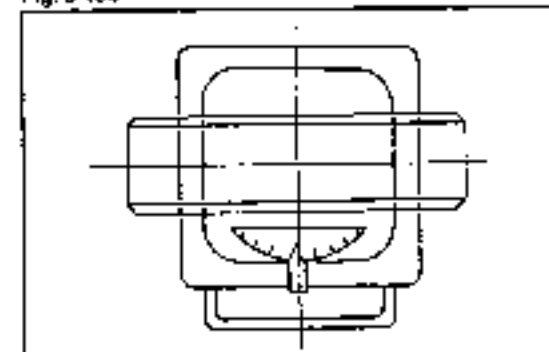

Fig. 5-135

WF-05135

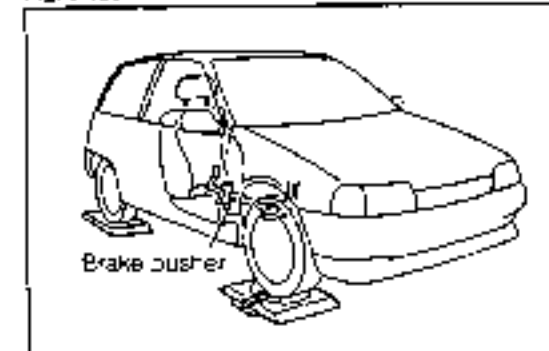

Fig. 5-136

WF-05136

FRONT AXLE & SUSPENSION

2. Checking Wheel Turning Angle

- (1) Measure the wheel turning angle, using a turning radius gauge.

Specified Value:

Inner side	$39^{\circ}55' \pm 2^{\circ}$
Outer side	$35^{\circ}28' 0'' \pm 2^{\circ}$

- (2) If the wheel turning angle differs between the right and left sides, correct the turning angle.

3. Correction Wheel Turning Angle

- (1) Slacken the lock nuts of the tie rod ends.
 (2) Make the length indicated in the right figure equal between the right and left sides

NOTE:

- Make sure that the boot is not twisted during the correction.
- Make sure that the tie rods at the right and left sides are turned by the same amount.

4. Checking Camber, Caster and Kingpin Angles

- (1) In the case of steel wheels, perform the measurement, using the following SST (attachment).
 SST: 09722-87702-000

- (2) In the case of aluminum wheels, perform the measurement, using the CCK (Camber, Caster, Kingpin) gauge compensator (available in the market).

NOTE:

The CCK gauge compensator can be used for the measurement on steel wheels, too.

- (3) Installation procedure for the CCK gauge compensator, and the camber, caster and kingpin gauge.

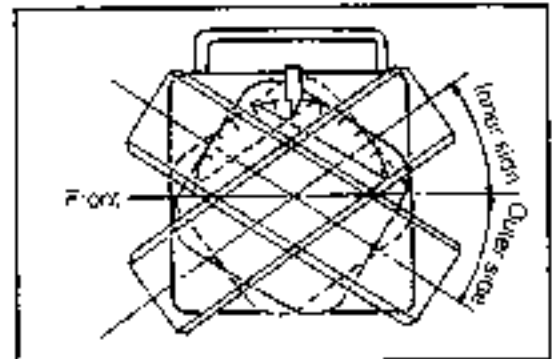

Fig. 5-137

WP-0514C

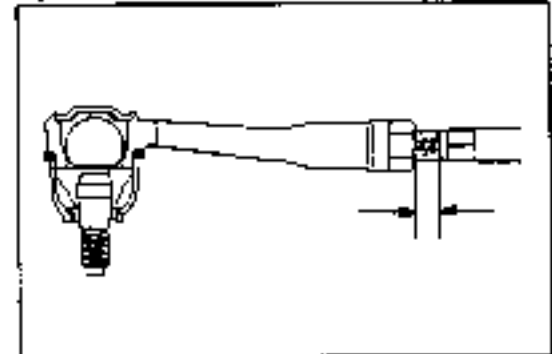

Fig. 5-138

WP-05141

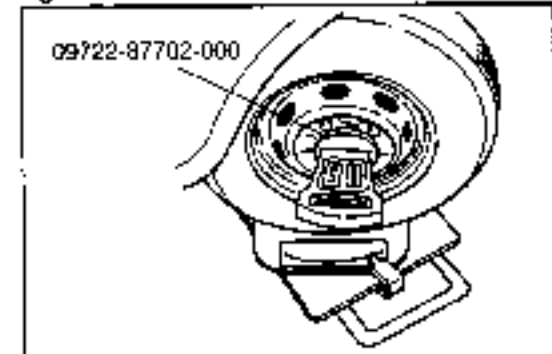

Fig. 5-139

WP-05142

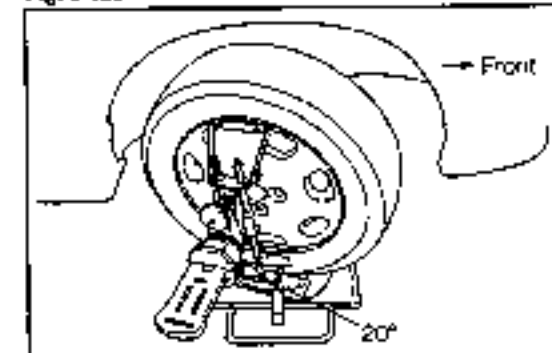

Fig. 5-140

WP-05143

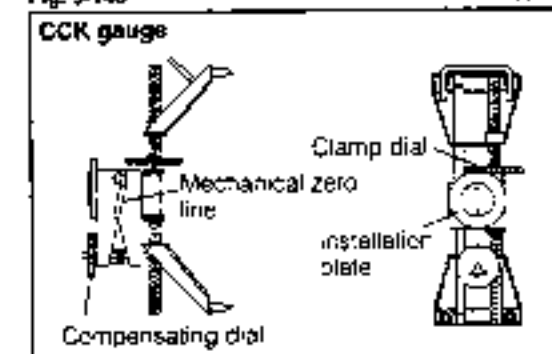

Fig. 5-141

WP-05144

- Jack up the vehicle.
- Before installing the CCK gauge to the wheel, set the CCK gauge compensator to the mechanical zero line by turning the compensating dial of the compensator.

- While turning the clamp dial of the CCK gauge compensator, hook the four pawls to the wheel edges securely. While pushing the compensator, lock the compensator positively by turning the clamp dial.

NOTE:

In order to prevent the wheel edges from being scratched, affix tapes or the like on the wheel edge sections to which the four pawls of the compensator are hooked.

- Set the camber caster and kingpin gauge to the installation plate of the CCK gauge compensator. At this point, align the set lines on the gauge and compensator with each other.

- Turn the wheel so that the level air bubble in the gauge may come to the central position. At this position, turn the caster adjusting screw of the gauge so that the caster air bubble may be aligned with the graduation zero position.

- Turn the wheel 180 degrees so that the gauge may be turned over. Proceed to align the set lines on the gauge and compensator with each other. Next, turn the wheel so that the level air bubble in the gauge may come to the central position.

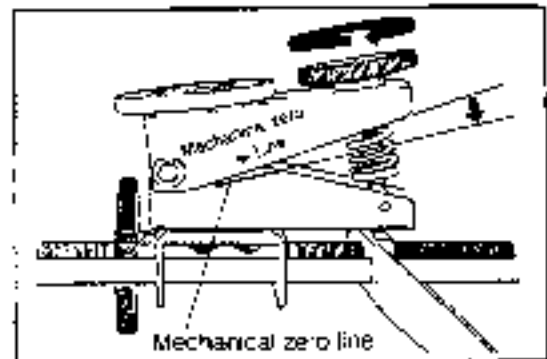

Fig. 5-142

WR-05145

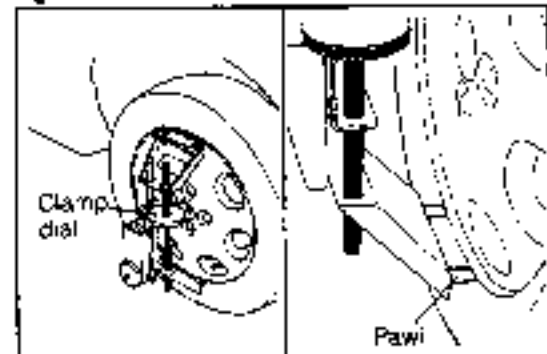

Fig. 5-143

WR-05146

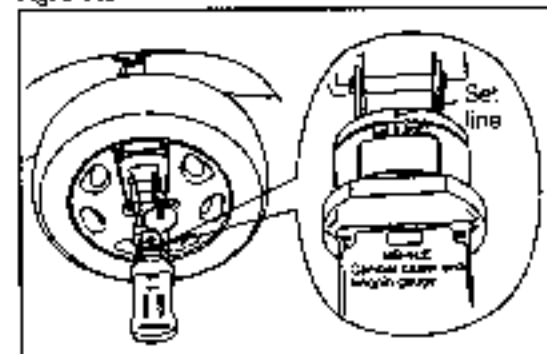

Fig. 5-144

WR-05147

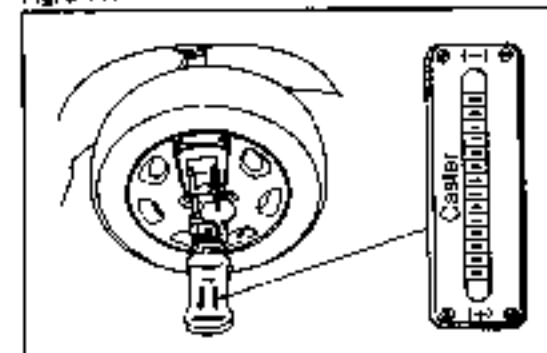

Fig. 5-145

WR-05148

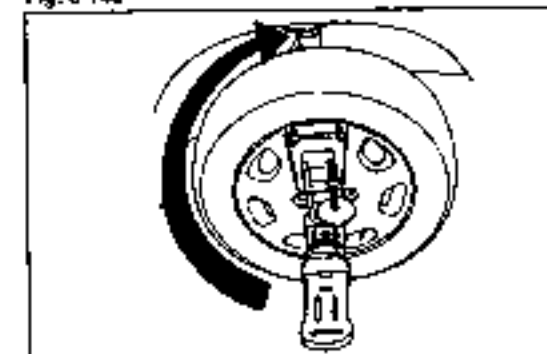

Fig. 5-146

WR-05149

FRONT AXLE & SUSPENSION

- Record the caster reading of the gauge. Turn the compensating dial of the compensator so that it may be aligned with the 1/2 of the recorded caster reading.

NOTE:

Be sure not to tamper the caster adjusting screw of the gauge.

- Repeat the steps described in Fig 5-86 and Fig. 5-87. Ensure that the air bubble of the caster gauge registers the same reading when the wheel is turned 180 degrees in a normal direction and in a reversed direction.
- Jack down the wheel on the turning radius gauge. Rock the vehicle in an up-and-down direction so as to settle the suspension.

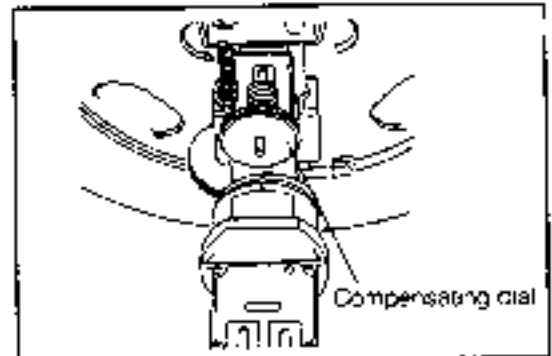

Fig. 5-147

4/9-05-53

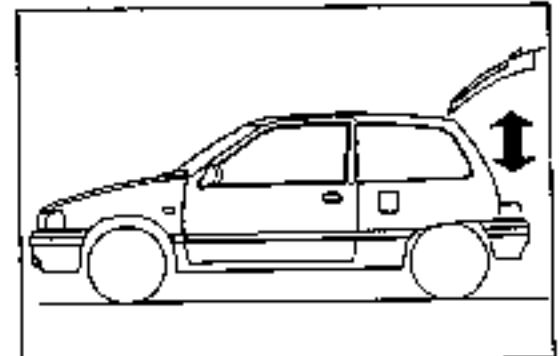

Fig. 5-148

4/9-05-51

(4) Camber check

- Ensure that the wheels are in their straight-ahead conditions.
- Align the level air bubble with the central position.
- Take the camber reading of the gauge.

Specified Value: $0^{\circ}20' \pm 1^{\circ}$

$$0^{\circ}20' \pm 40'$$

$$-20'$$

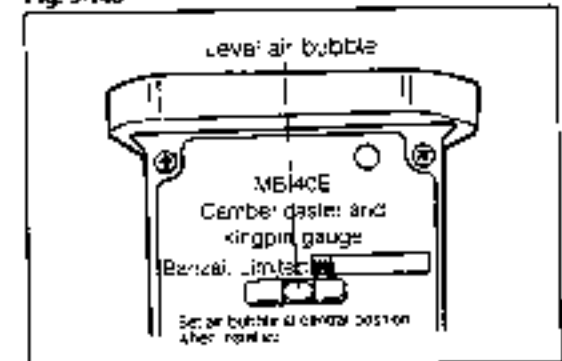

Fig. 5-149

4/9-05-52

(5) Checking caster and kingpin angles
(Right wheel)

- Turn the steering wheel to the right side, until the right front tire comes at a point where the turning radius gauge registers 20 degrees.
- Turn each of the caster and kingpin adjusting screws so that the respective air bubble may be aligned with the zero point
- Turn the steering wheel to the left side, until the right front tire comes at a point where the turning radius gauge registers 20 degrees.
- Take the gauge readings of the caster and kingpin angles

Specified Value: Caster $2^{\circ}55' \pm 1^{\circ}$
Kingpin angle $12^{\circ} \pm 30'$

(Left wheel)

- Perform the check, following the same procedure as with the right wheel. However, the turning direction of the steering wheel must be reversed.

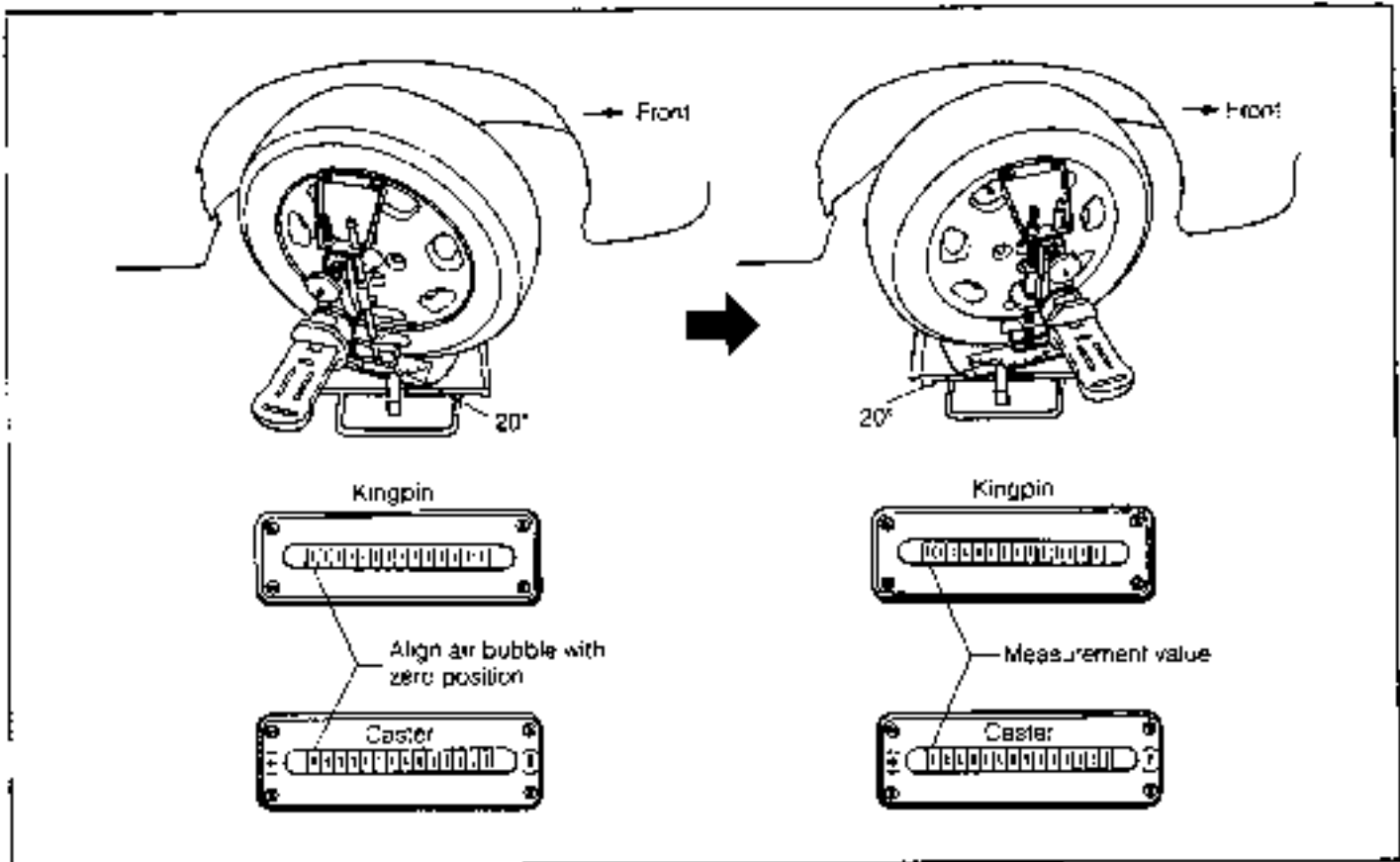

Fig. 5-150

WP-05'53

5. Toe-In Measurement

- (1) Rock the vehicle so that the vehicle height may stabilize.
- (2) Move the vehicle forward about five meters so that the front wheels may become in their straight-ahead conditions

NOTE:

Do not move the vehicle backward during the measurement.

- (3) Align the height of the toe-in gauge pointers with the center height of the front wheels.
- (4) Put a mark on the tread center of each front wheel tire at the rear side. Measure the distance between the two marks (Dimension A) in the figure

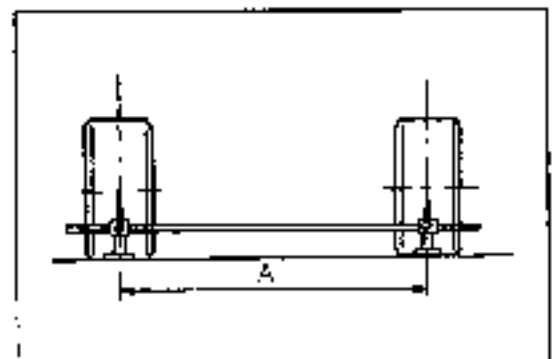

Fig. 5-151

WP-05'54

FRONT AXLE & SUSPENSION

- (5) Slowly move the vehicle forward by pushing the vehicle until the wheels turn 180 degrees

- (6) Measure the distance (Dimension B) between the two marks which were put in the preceding step. This measurement is performed at the front side of the vehicle.

Calculate the amount of toe-in, i.e. (Dimension A - Dimension B).

Specified Value: $-1 - +3 \text{ mm } (-0.04 - +0.12 \text{ inch})$

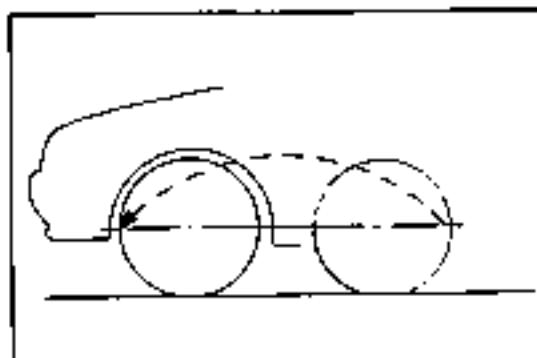

Fig. 5-152

WP-05155

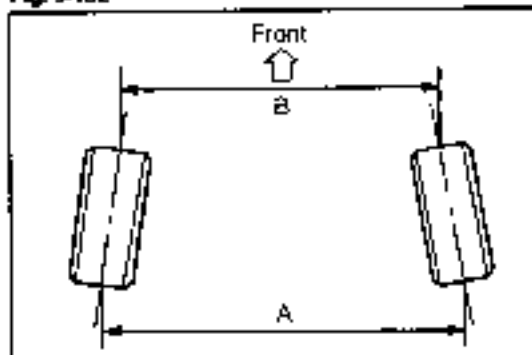

Fig. 5-153

WP-05156

6. Toe-In Adjustment

- (1) Slacken the lock nuts of the tie rod ends.
(2) Perform the toe-in adjustment by turning the tie rod ends.

NOTE:

- Care must be exercised to ensure that the boot is not twisted during the adjustment.
- When adjusting the toe-in, the tie rods at the right and left sides should be turned by the same amount.
- The length indicated in the right figure must be the same amount.

(If the length differs between the right and left sides, a difference occurs in the wheel turning angle between the right and left sides.)

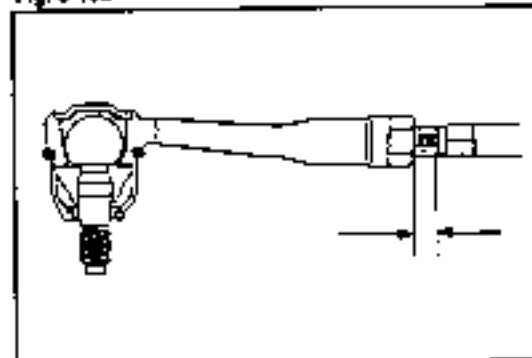

Fig. 5-154

WP-05157

7. Sideslip Check

Check the sideslip, using a sideslip tester.

Specified Value: $-3 - +3 \text{ mm } (-0.12 - +0.12 \text{ inch})$

Per 1 meter (3.28 ft)

$-4 \sim +4$

WP-05158

CHECK AND ADJUSTMENT OF REAR TOE-IN

1. Toe-In Check

- (1) Rock the vehicle so that the vehicle height may stabilize.
(2) Move the vehicle forward about five meters so that the front wheels may become in their straight-ahead conditions.
(3) Align the height of the toe-in gauge pointers with the center height of the rear wheels.
(4) Put a mark on the tread center of each rear wheel tire at the rear side. Measure the distance between the two marks (Dimension A) in the figure

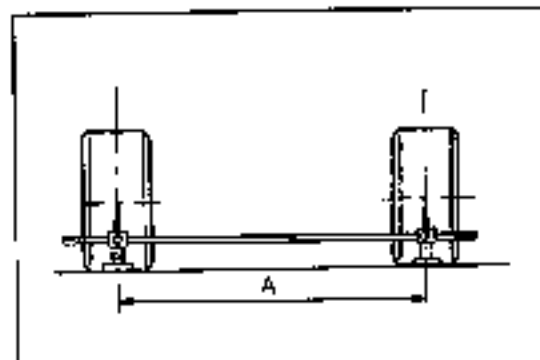

Fig. 5-155

WP-05159

(5) Slowly move the vehicle forward by pushing the vehicle, until the wheels turn 180 degrees.

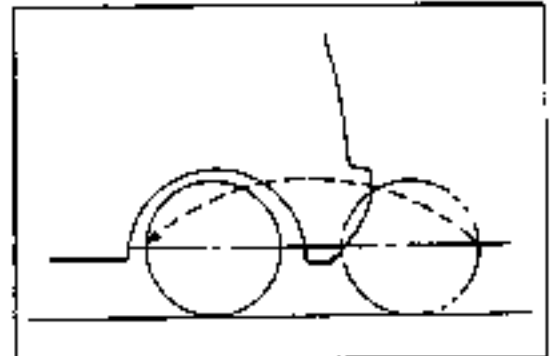

Fig. 5-156 WR-0518C

(6) Measure the distance (Dimension B) between the two marks which were put in the preceding step. This measurement is performed at the front side of the rear wheels.

(7) Calculate the amount of toe-in, i.e. (Dimension A - Dimension B).

Specified Value: +4 - +8 mm (+0.16 - +0.31)

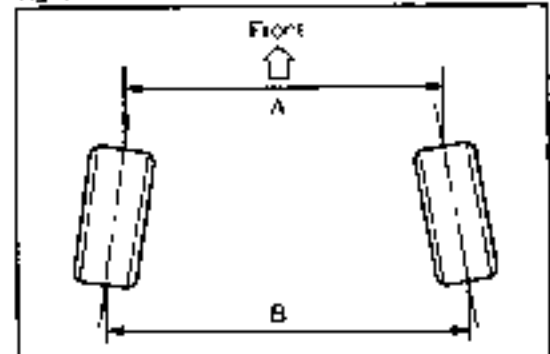

Fig. 5-157 WR-0516

2. Toe-In Adjustment

(1) Slacken the set bolt of the toe adjusting cam.

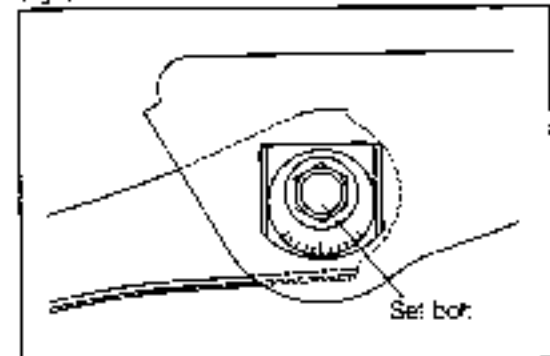

Fig. 5-158 WR-0516Z

(2) Insert a hexagon wrench key into the hexagonal hole provided at the back side of the toe adjusting cam. Turn the hexagon wrench key. (Inside: IN, Outside: OUT)

(Reference)

When each of the adjusting cams provided at both sides is turned by one graduation, the toe-in will change approximately 5 mm (0.20 inch).

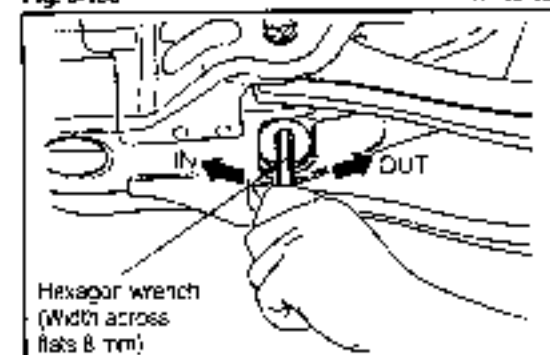

Fig. 5-159 WR-0516Z

3. Sideslip Check

Check the sideslip, using a sideslip tester.

Specified Value: 1 - 7 mm (-0.04 - 0.28 inch)
Per 1 meter (3.28 ft)

DAIHATSU

CHARADE

Chassis

SECTION 6

REAR AXLE & SUSPENSION

6

REAR AXLE	6- 2	SUSPENSION ARM	6-18
SECTIONAL VIEW	6- 2	COMPONENTS	6-18
COMPONENTS	6- 3	REMOVAL	6-18
REMOVAL	6- 4	INSPECTION	6-20
INSPECTION	6- 7	INSTALLATION	6-20
INSTALLATION	6- 8	STRUT ROD	6-22
REAR SUSPENSION	6-11	REMOVAL	6-22
SECTIONAL VIEW	6-11	INSPECTION	6-22
REAR SHOCK ABSORBER	6-11	INSTALLATION	6-22
COMPONENTS	6-11	STABILIZER BAR	6-23
REMOVAL	6-12	COMPONENTS	6-23
DISASSEMBLY	6-13	REMOVAL	6-23
INSPECTION	6-14	INSPECTION	6-24
ASSEMBLY	6-15	INSTALLATION	6-25
INSTALLATION	6-16		

WF-06001

REAR AXLE & SUSPENSION

REAR AXLE SECTIONAL VIEW

Drum Brake

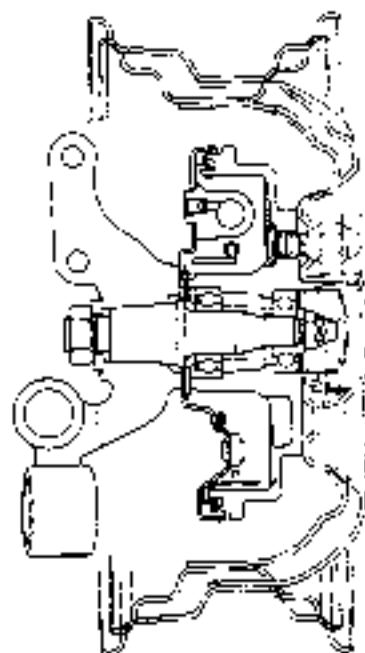

Disc Brake

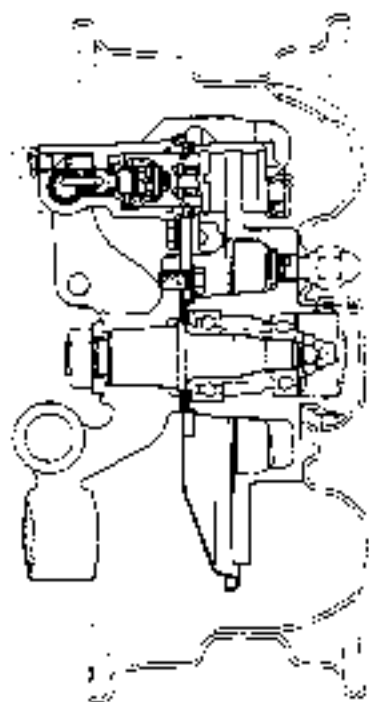
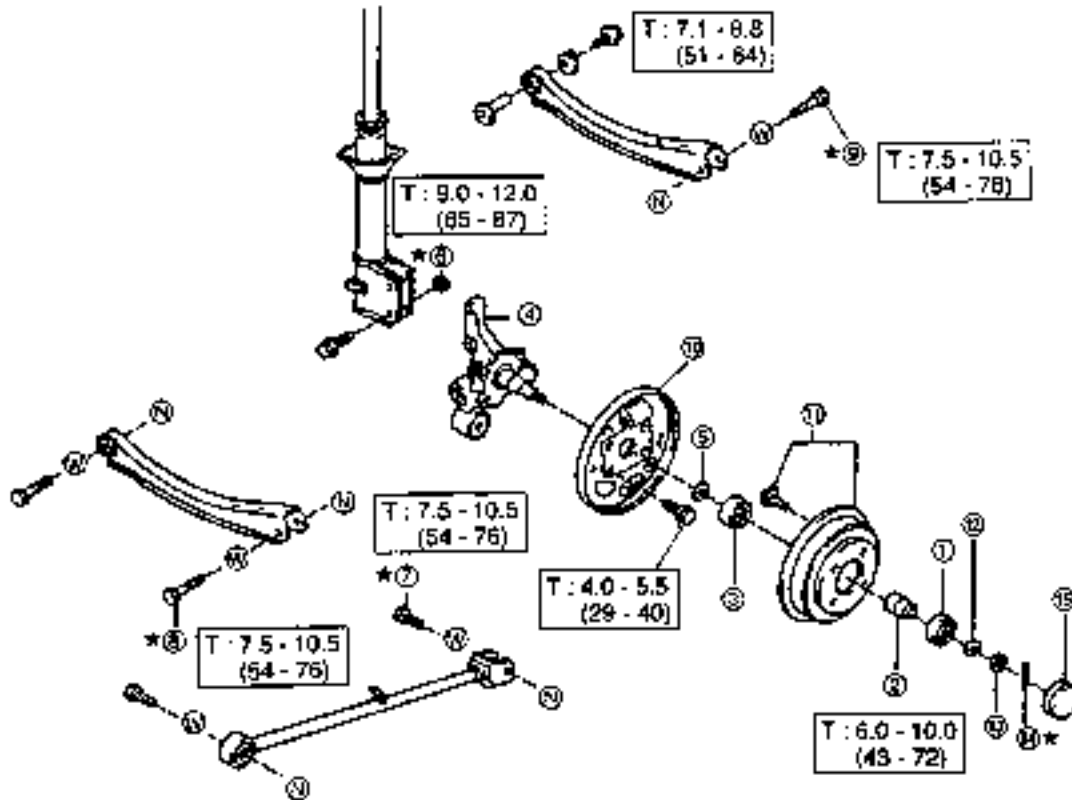

Fig. 6-1

v/9-05002

COMPONENTS



T : Tightening torque
 Unit: kg-m (ft-lb)
 * : Non-reusable parts

- ① Radial ball bearing
- ② Rear axle bearing outer retainer
- ③ Radial ball bearing
- ④ Rear axle carrier S/A
- ⑤ Rear axle bearing inner retainer
- ⑥ Nut
- ⑦ Bolt
- ⑧ Bolt

- ⑨ Bolt
- ⑩ Rear brake Ay
- ⑪ Rear brake drum
- ⑫ Plate washer
- ⑬ Castle nut
- ⑭ Cotter pin
- ⑮ Grease retainer cap

Fig. 6-2

WA-06003

REAR AXLE & SUSPENSION

REMOVAL

1. Jack up the vehicle at the rear side. Support the body with safety stands.
2. Remove the rear wheel.

3. Backing plate removal
(Drum brake equipped vehicle)
(1) Remove the grease retainer cap.
(2) Remove the cotter pin, castle nut, and plate washer.

- (2) Remove the brake drum, using the following SST.
Remove the bearing inner retainer.
SST: 09510-87301-000

- (4) Disconnect the brake tubes from the wheel cylinder, using the following SST.
SST: 09751-36011-000

- (5) Remove the backing plate with the brake shoe installed.

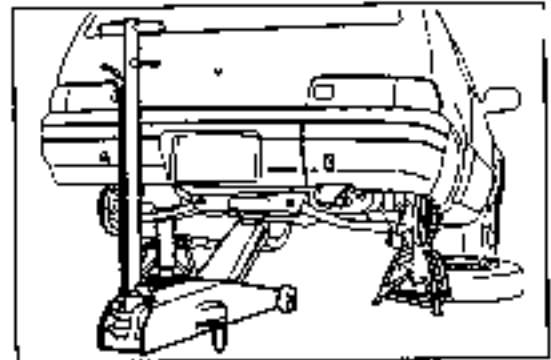

Fig. 6-3

WF 05004

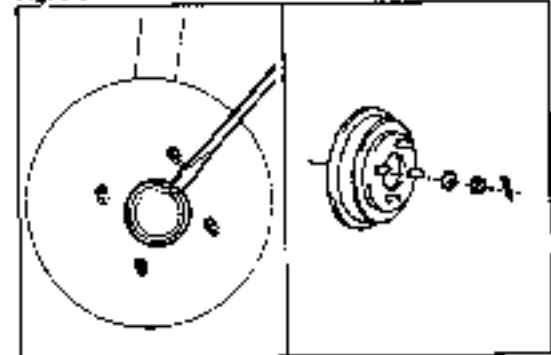

Fig. 6-4

WF 05005

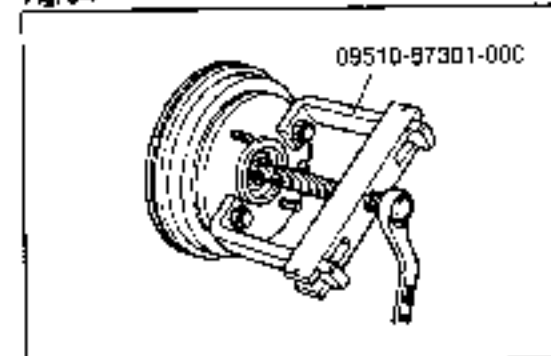

Fig. 6-5

WF 06006

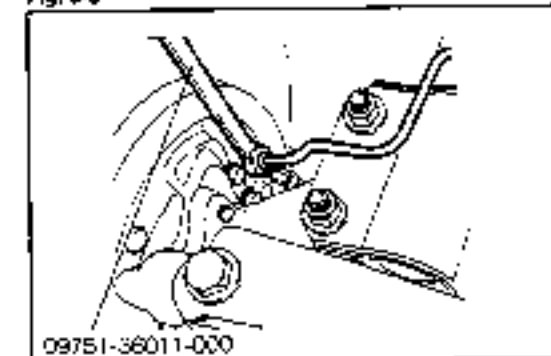

Fig. 6-6

WF 06007

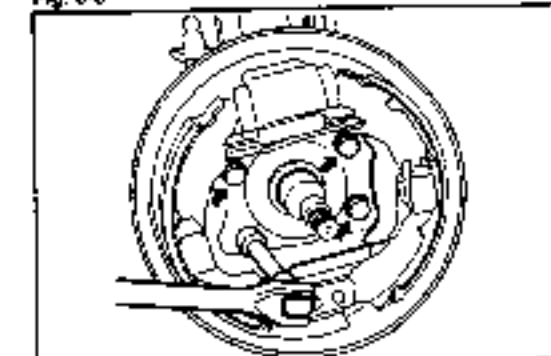

Fig. 6-7

WF 05008

(Disc brake equipped vehicle)

- (1) Remove the parking cable guide.
- (2) Remove the anti-rattle spring.

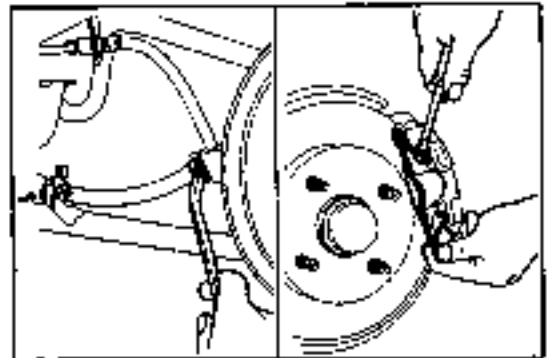

Fig. 6-8

WR-05069

- (3) Remove the caliper.

NOTE:

Suspend the caliper as shown in the right figure.

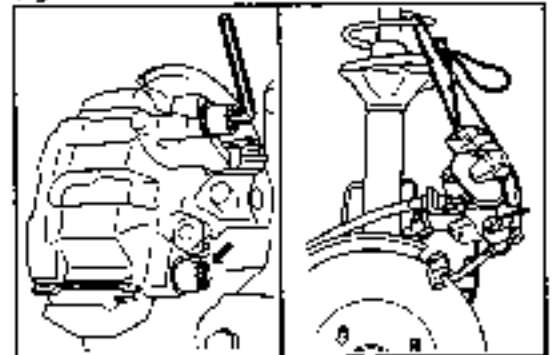

Fig. 6-9

WR-05010

- (4) Remove the caliper support.

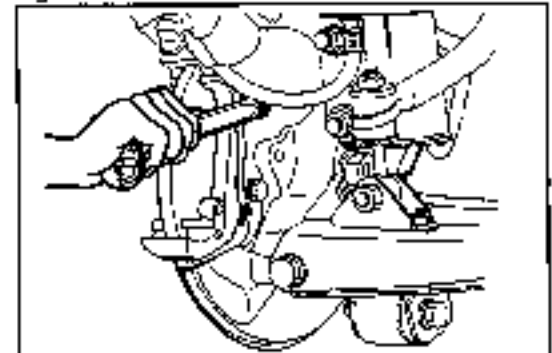

Fig. 6-10

WR-06011

- (5) Remove the grease retainer cap.

- (6) Remove the cotter pin, castle nut and plate washer.

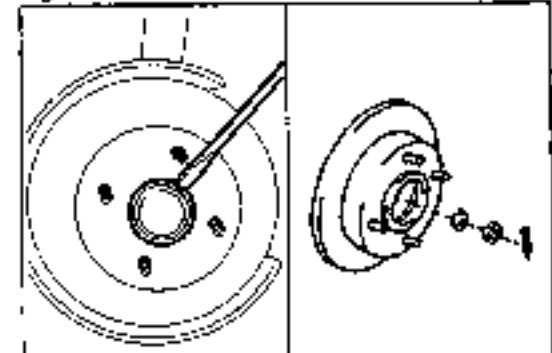

Fig. 6-11

WR-06012

- (7) Remove the disc rotor and bearing inner retainer.

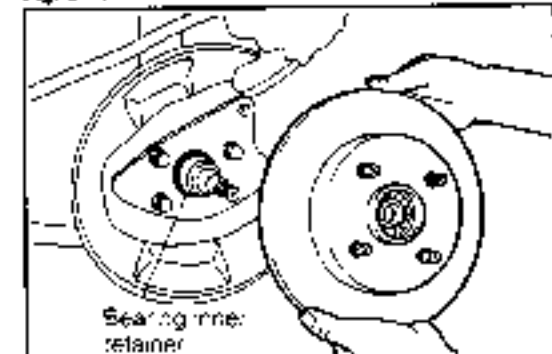

Fig. 6-12

WR-06013

REAR AXLE & SUSPENSION

(8) Remove the backing plate.

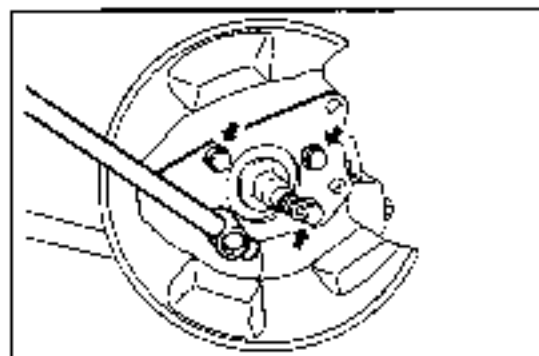

Fig. 6-13

WH-06014

4 Axle carrier removal

(1) Remove the attaching bolt and nut of the axle carrier from the strut rod.

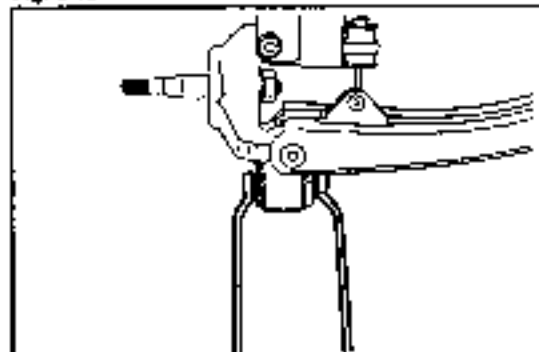

Fig. 6-14

WH-06015

(2) Remove the attaching bolt and nut of the axle carrier from the suspension arm No.1.

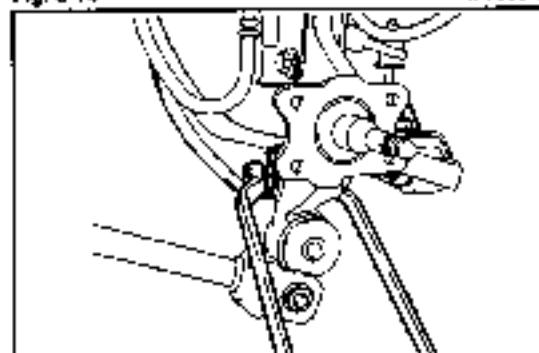

Fig. 6-15

WH-06016

(3) Remove the attaching bolt and nut of the axle carrier from the suspension arm No.2

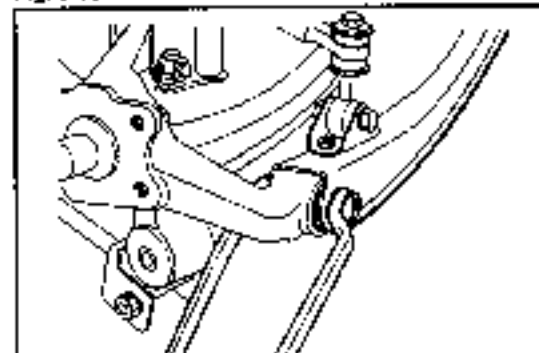

Fig. 6-16

WH-06017

(4) Remove the attaching bolts and nuts of the axle carrier from the shock absorber. Remove the axle carrier.

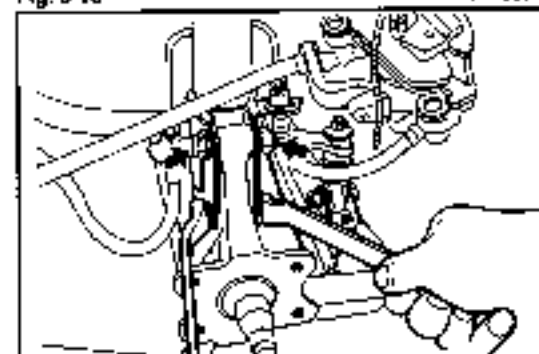

Fig. 6-17

WH-06018

5. Hub bearing removal
- (1) Drive out the inner bearing, using a brass bar. At the same time drive out the bearing outer retainer, too.
 - (2) Drive out the outer bearing, using a brass bar.

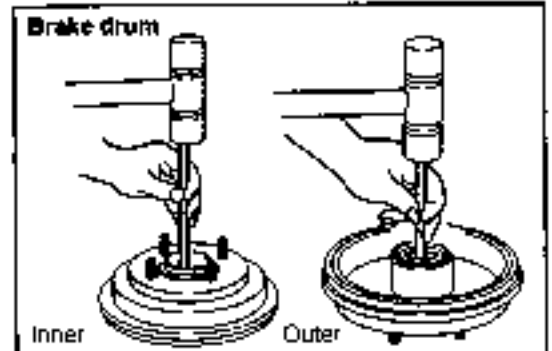

Fig. 6-18

WR-76018

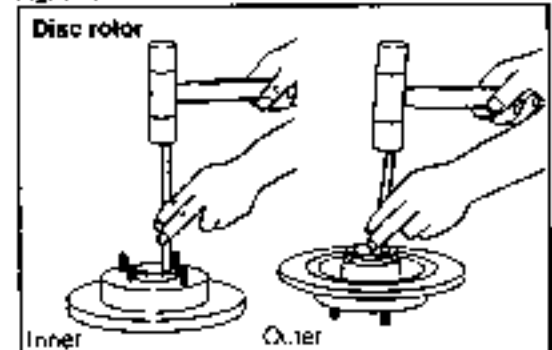

Fig. 6-19

WR-05280

INSPECTION

Inspect the following parts.

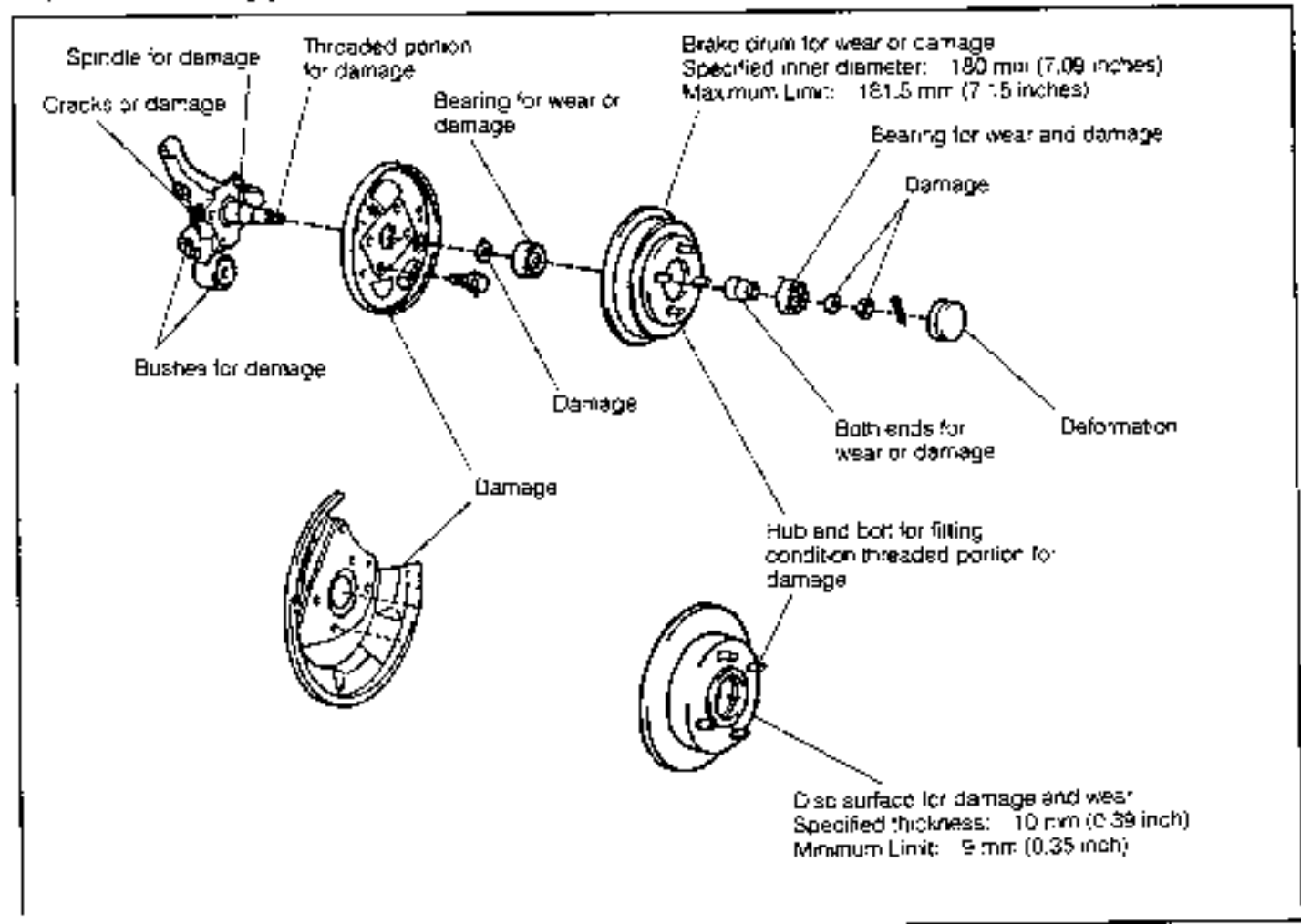

Fig. 6-20

WR-06221

REAR AXLE & SUSPENSION

INSTALLATION

1. Hub bearing installation

Pack the hub and bearing with grease. Then, press the outer bearing, outer retainer and inner bearing, in this order, using a press in conjunction with the following SST.

SST: 09608-12010-000

(For the outer bearing, use No. 13 of the SST set.)

(For the inner bearing, use No. 5 of the SST set.)

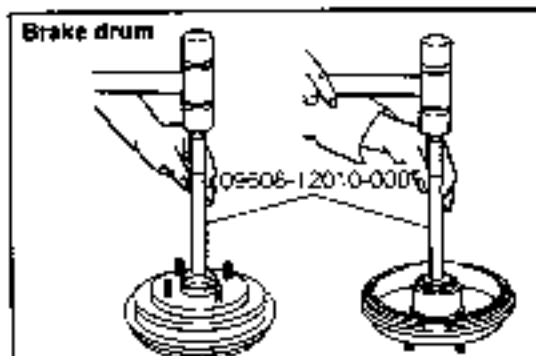

Fig. 6-21

WP-06022

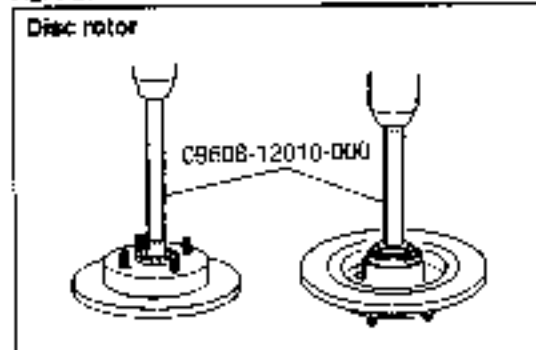

Fig. 6-22

WP-06023

2. Axle carrier installation

NOTE:

As for those suspension-related bolts and nuts on which a friction stabilizing agent has been coated, be certain not to reuse them if they have been once removed.

(1) Mount the axle carrier to the shock absorber.

(2) Install the attaching bolts and new nuts of the axle carrier. Proceed to tighten them.

Tightening Torque: 9.0 - 12.0 kg-m (65 - 87 ft-lb)

NOTE:

Tighten the bolts and nuts while pushing the axle carrier to the lower side (positive side).

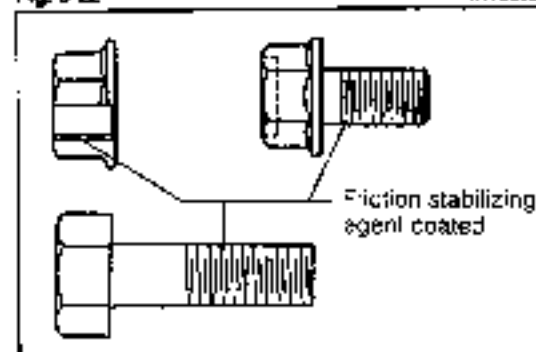

Fig. 6-23

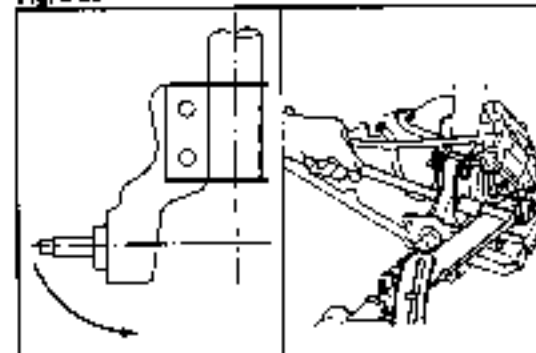

Fig. 6-24

WP-06024

(3) Mount the axle carrier on the suspension arm No. 1. Tighten the new bolt and nut temporarily.

(4) Mount the axle carrier on the suspension arm No. 2. Temporarily tighten the new bolt and nut.

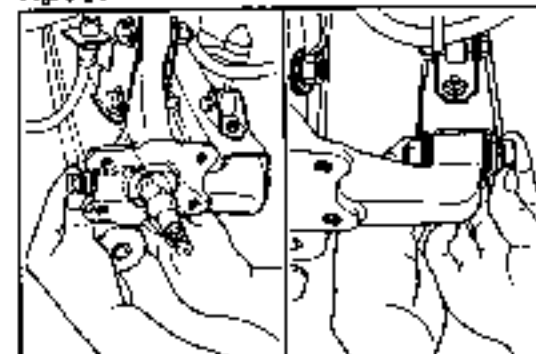

Fig. 6-25

WP-06025

5. Hub bearing removal

- (1) Drive out the inner bearing, using a brass bar. At the same time, drive out the bearing outer retainer, too
- (2) Drive out the outer bearing, using a brass bar.

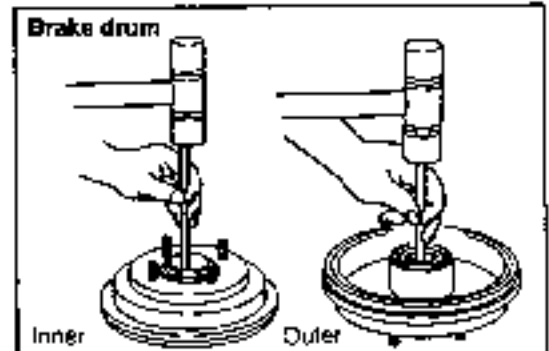

Fig. 6-18

WR-0018

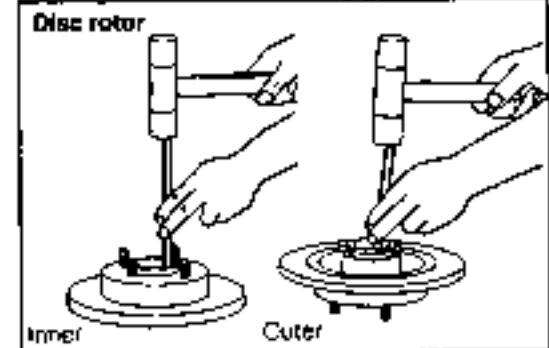

Fig. 6-19

WR-0602

INSPECTION

Inspect the following parts.

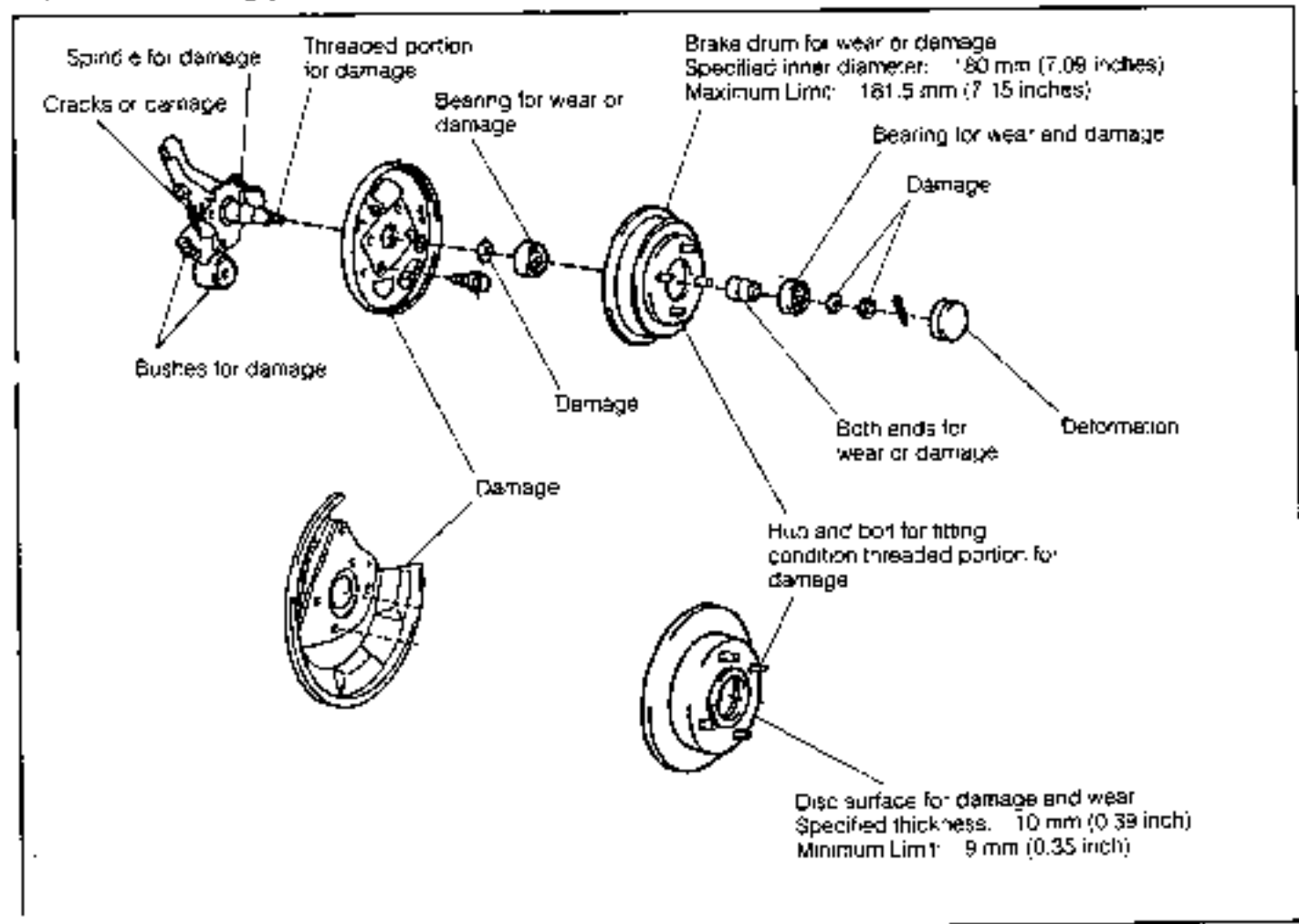

Fig. 6-20

WR-0602

REAR AXLE & SUSPENSION

INSTALLATION

1. Hub bearing installation

Pack the hub and bearing with grease. Then, press the outer bearing, outer retainer and inner bearing, in this order, using a press in conjunction with the following SST

SST: 09608-12010-000

(For the outer bearing, use No. 13 of the SST set.)

(For the inner bearing, use No. 5 of the SST set.)

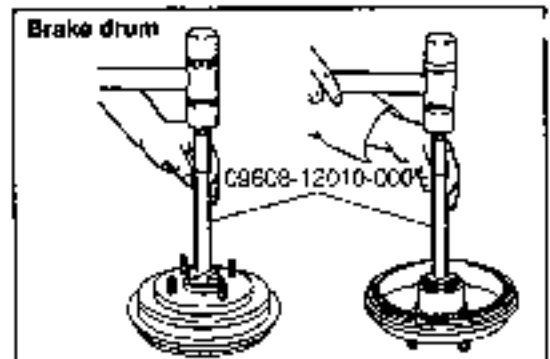

Fig. 6-21

WR-06022

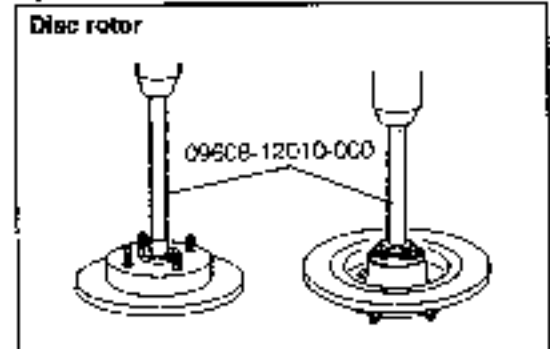

Fig. 6-22

WR-06023

2. Axle carrier installation

NOTE:

As for those suspension-related bolts and nuts on which a friction stabilizing agent has been coated, be certain not to reuse them if they have been once removed

- (1) Mount the axle carrier to the shock absorber
- (2) Install the attaching bolts and new nuts of the axle carrier. Proceed to tighten them.

Tightening Torque: 9.0 - 12.0 kg-m (65 - 87 ft-lb)

NOTE:

Tighten the bolts and nuts while pushing the axle carrier to the lower side (positive side).

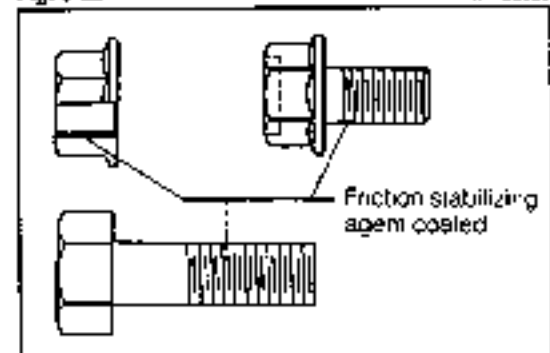

Fig. 6-23

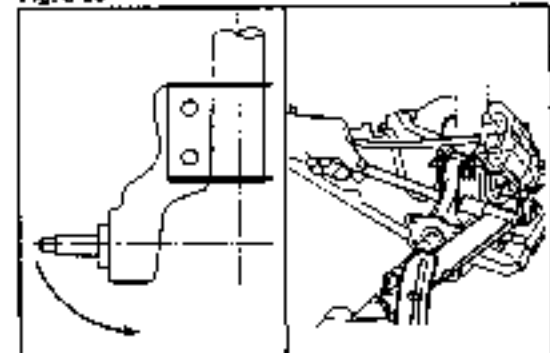

Fig. 6-24

WR-06024

- (3) Mount the axle carrier on the suspension arm No.1. Tighten the new bolt and nut temporarily.
- (4) Mount the axle carrier on the suspension arm No.2. Temporarily tighten the new bolt and nut.

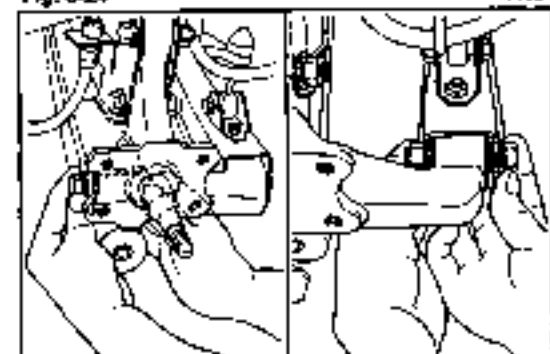

Fig. 6-25

WR-06025

- (5) Mount the axle carrier or the strut rod. Tighten the new bolt and nut temporarily.

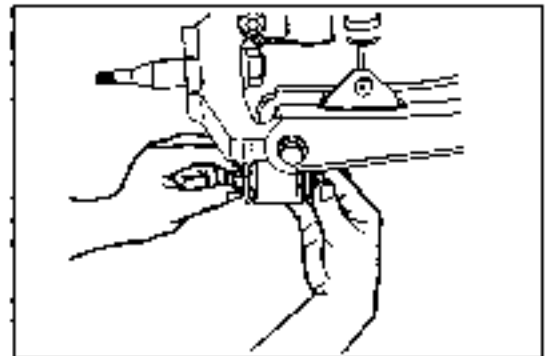

Fig. 6-26

WR-06026

3. Installation of brake drum or disc rotor:
(Drum brake equipped vehicle)

- (1) Install the backing plate.

Tightening Torque: 4.0 - 5.5 kg-m (29 - 40 ft-lb)

NOTE:

Be sure to apply DAIHATSU Bond No.4 (999-6304-6323-00) to the mating surface between the rear brake and the axle carrier. During this sealer application, be very careful not to restrict the 5 mm (0.20 inch) dia. grease releasing hole.

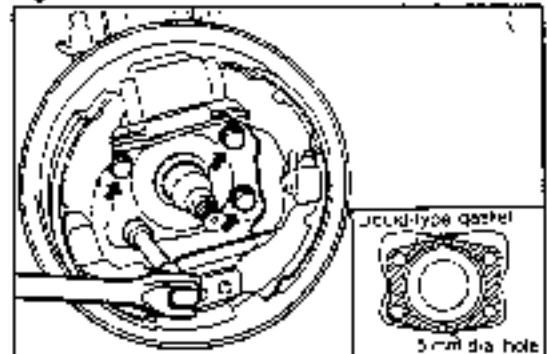

Fig. 6-27

WR-06027

- (2) Install the brake tube to the backing plate.
Tightening Torque: 1.3 - 1.8 kg-m (9.4 - 13.0 ft-lb)
- (3) Install the bearing inner retainer, brake drum plate washer and castle nut.
- (4) Tighten the castle nut.
Tightening Torque: 6.0 - 10.0 kg-m (43 - 72 ft-lb)
- (5) Install a new cotter pin. Install the grease retainer cap.
- (6) Perform air bleeding for the brake system. (See page 8-5.)

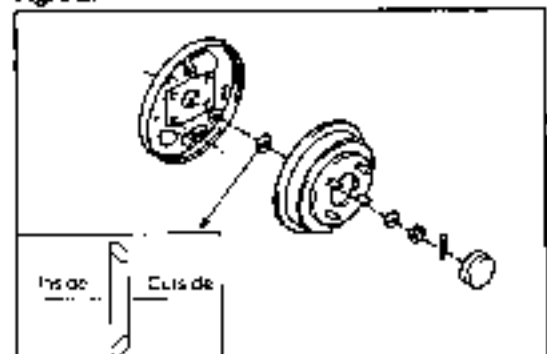

Fig. 6-28

WR-06028

(Disc brake equipped vehicle)

- (1) Install the backing plate.

Tightening Torque: 4.0 - 5.5 kg-m (29 - 40 ft-lb)

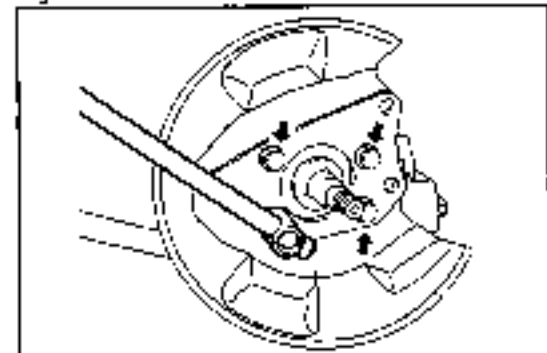

Fig. 6-29

WR-06029

- (2) Install the bearing inner retainer, disc rotor, plate washer and castle nut.
- (3) Tighten the castle nut.
Tightening Torque: 6.0 - 10.0 kg-m (43 - 72 ft-lb)
- (4) Install a new cotter pin. Install the grease retainer cap.

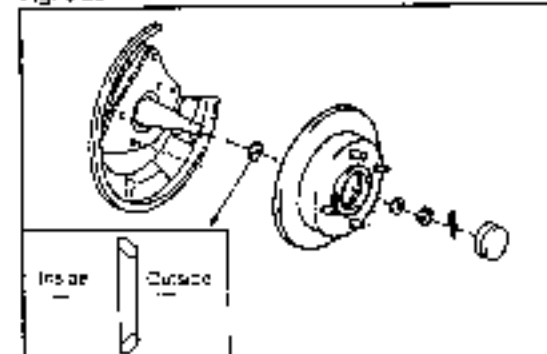

Fig. 6-30

WR-06030

REAR AXLE & SUSPENSION

- (5) Install the caliper support.
Tightening Torque: 4.0 - 5.5 kg-m (29 - 40 ft-lb)
- (6) Install the caliper.

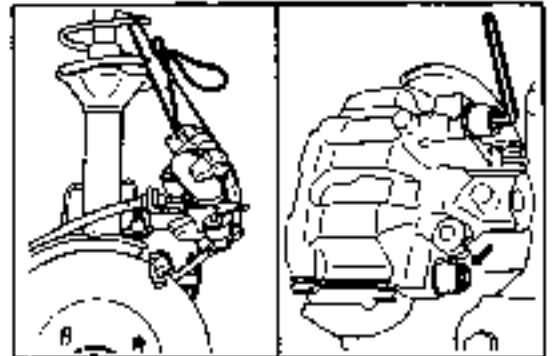

Fig. 6-31

WR-06031

- (7) Install the anti-rattle spring.
(8) Install the parking cable guide.

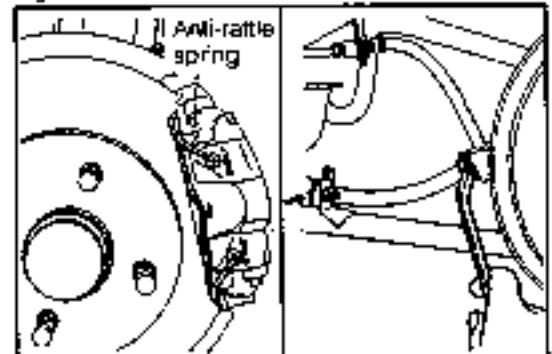

Fig. 6-32

WR-06032

4. Tightening of axle carrier attaching bolts
(1) Install the tires.
(2) With the vehicle in an unloaded state, jack down the vehicle. Rock the vehicle in an up-and-down direction several times to settle the suspensions.

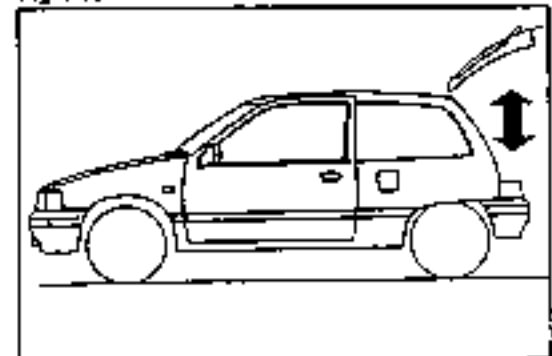

Fig. 6-33

WR-06033

- (3) With the vehicle weight being applied to the suspensions, tighten the bolt and nut of each section.
Tightening Torque: 7.5 - 10.5 kg-m (54 - 76 ft-lb)

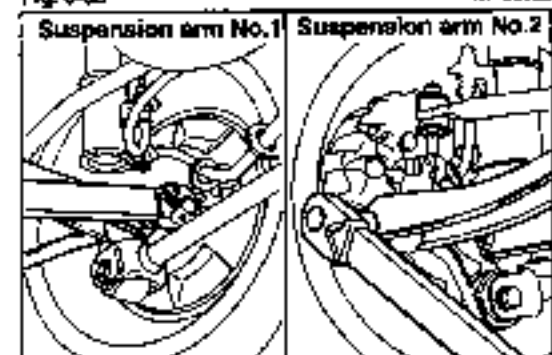

Fig. 6-34

WR-06034

5. Rear wheel alignment inspection
(See Fig. 5-38)

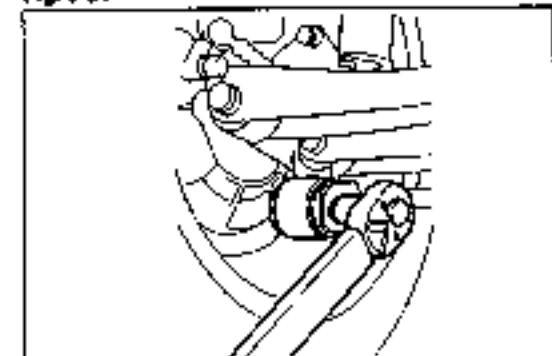

Fig. 6-35

WR-06035

REAR SUSPENSION

SECTIONAL VIEW

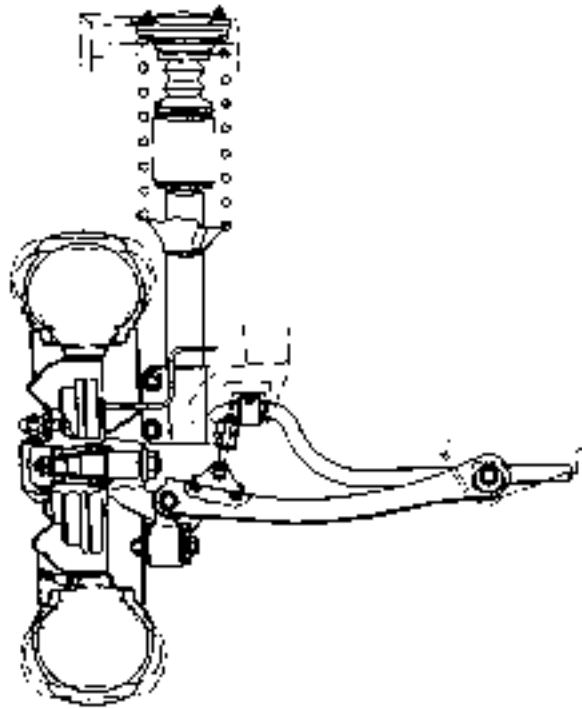

Fig. 6-36

NR-06036

REAR SHOCK ABSORBER

COMPONENTS

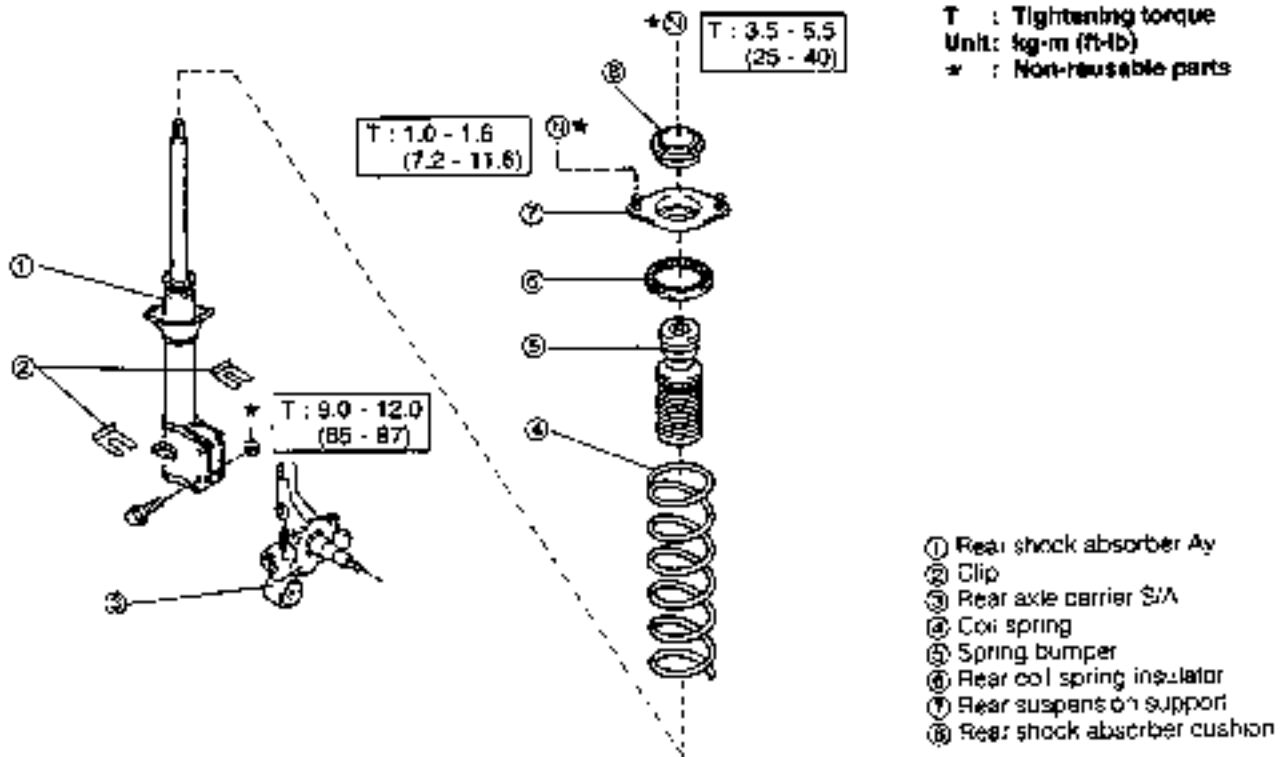

Fig. 6-37

NR-06037

REAR AXLE & SUSPENSION

REMOVAL

1. Jack up the vehicle at the rear section. Support the body with safety stands.
2. Remove the wheel.

3. Removal of brake tube and flexible hose

- (1) Disconnect the brake tube from the flexible hose.
SST: 09751-36011-000

- (2) Detach the clip. Disconnect the flexible hose from the shock absorber.

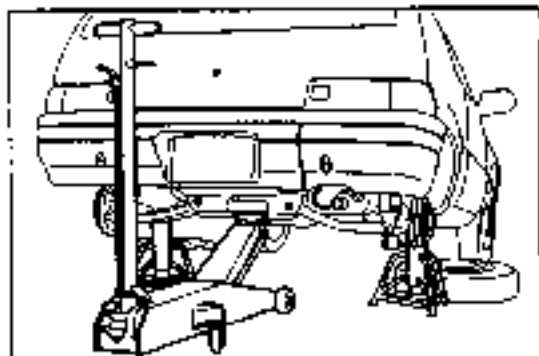

Fig. 5-38

WA-0503B

Drum brake equipped vehicle

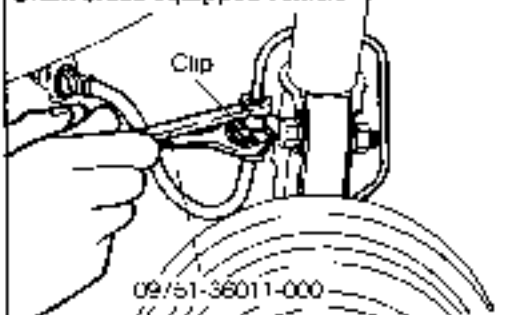

Fig. 5-39

WA-0503B

Disc brake equipped vehicle

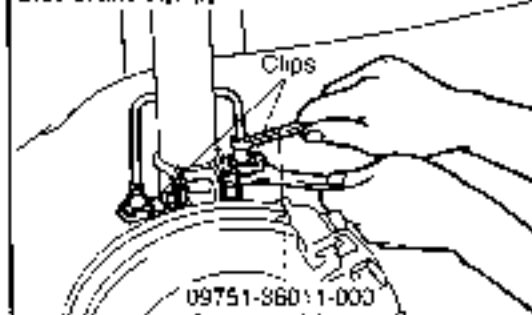

Fig. 5-40

WA-0504C

4. Remove the nuts attaching the shock absorber to the axle carrier. Leave the bolts in an inserted condition.

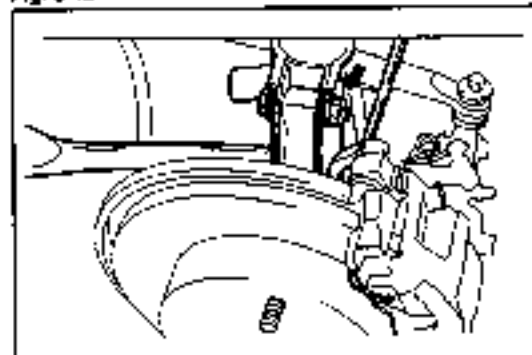

Fig. 5-41

WA-0504C

5. Trim removal

- (1) Remove the package tray.
- (2) Remove the package tray side trim.

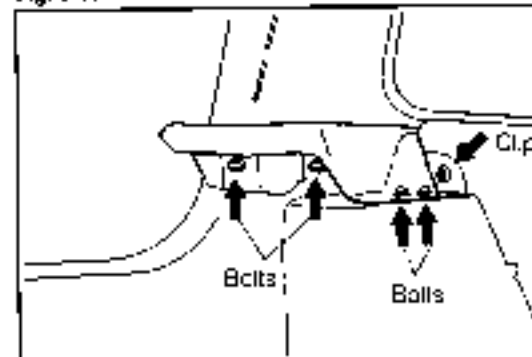

Fig. 5-42

WA-0504D

6. Slacken the nut attaching the shock absorber to the suspension support.

NOTE:

Do not remove the nut.

7. Remove the nuts attaching the suspension support to the body.
8. Remove the attaching bolts of the axle carrier and shock absorber. Remove the shock absorber from the body.

DISASSEMBLY

1. Coil spring removal
 - (1) Compress the coil spring, using the following SST
SST: 09727-87701-000

- (2) Remove the nut.

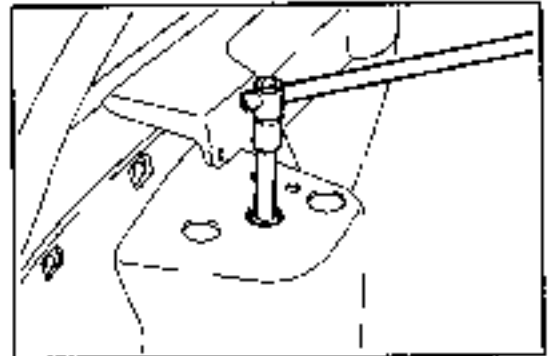
**Fig. 6-43**

WP-08043

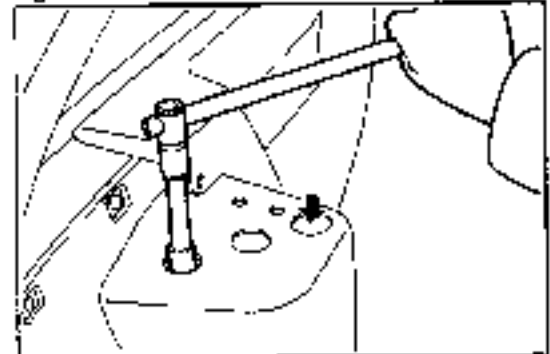
**Fig. 6-44**

WP-08044

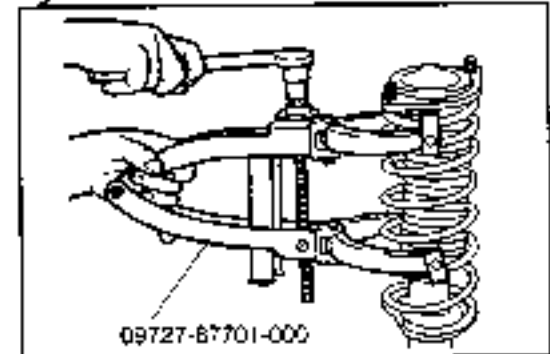
**Fig. 6-45**

WP-08045

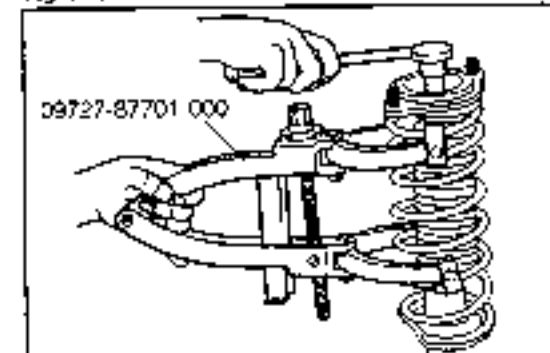
**Fig. 6-46**

WP-08046

REAR AXLE & SUSPENSION

- (3) Remove the rear shock absorber cushion, rear suspension support, rear coil spring insulator, spring bumper and coil spring.

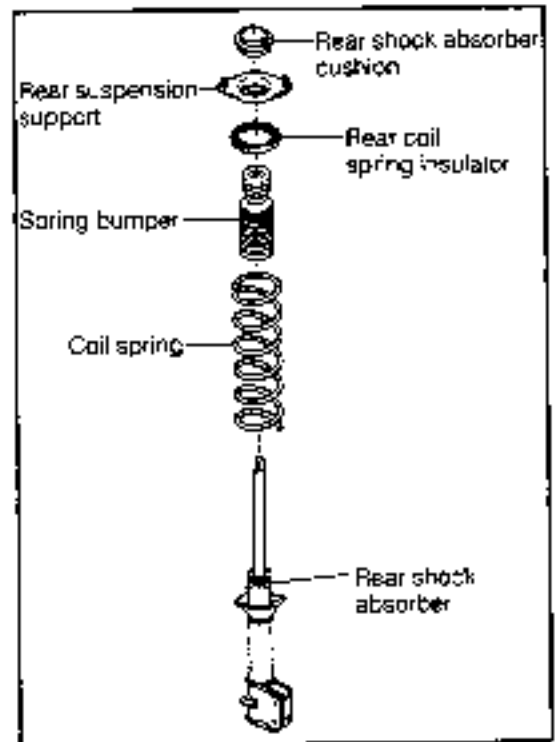

Fig. 6-47

WA-06047

INSPECTION

1. Inspect the following parts.

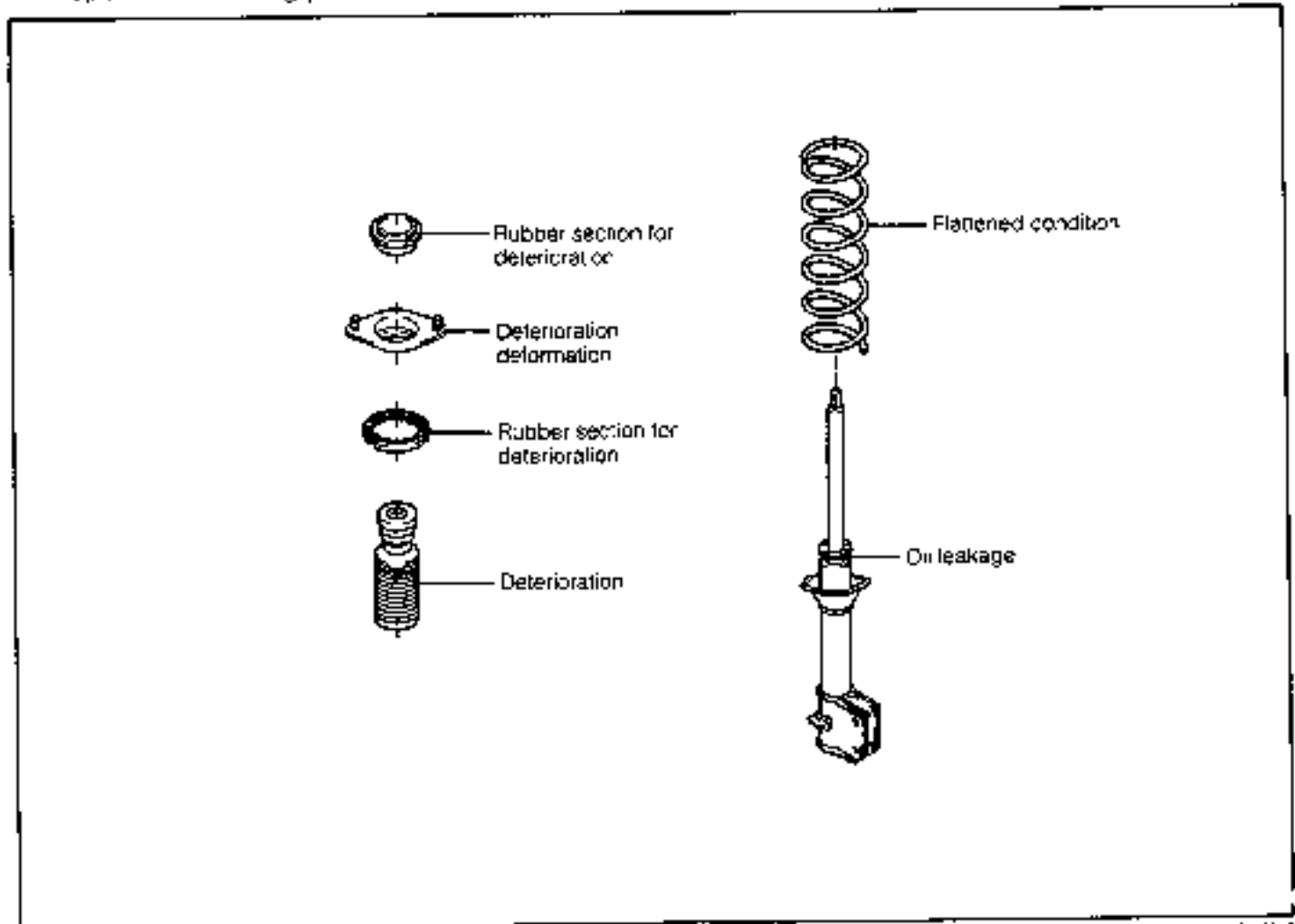

Fig. 6-48

WA-06048

2. Shock absorber operation inspection

- (1) Push or pull the piston rod of the shock absorber at a constant speed. Ensure that the force required to move the rod is uniform over the entire stroke. However, when the piston rod is pulled strongly, the pulling force may become slightly greater over the stroke 30 mm (1.2 inches) toward the end of the pulling stroke. It should be noted that this phenomenon is not abnormal.
- (2) Move the piston rod quickly in a up-and-down direction with a stroke of 5 - 10 mm (0.2 - 0.4 inch). Ensure that the force required to move the rod will not change.
- (3) If any abnormal feeling or noise is encountered during the inspection above, replace the shock absorber.

NOTE:

- Perform this inspection after the piston rod has been moved in a up-and-down direction three or four times.
- When the gas filling type shock absorber is replaced, previous to the disposal, be sure to release the gas from the shock absorber.

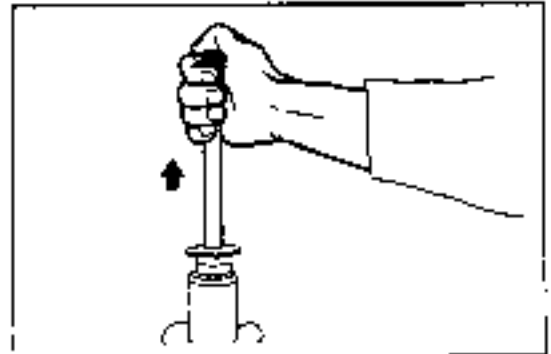

Fig. 6-49

WR-0649

ASSEMBLY

1. Assembly of coil spring

- (1) Install the spring bumper at a point below the cut-out section of the piston rod.
- (2) Compress the coil spring, using the following SST. Install it to the shock absorber.
SST: 09727-87701-000

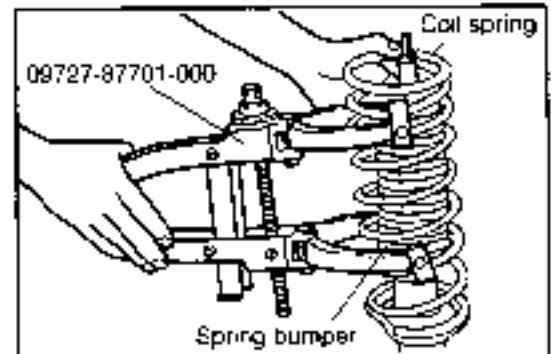

Fig. 6-50

WR-0650

- (3) Install the rear shock absorber cushion to the rear suspension support.
- (4) Install the rear coil spring insulator to the rear suspension support.

NOTE:

Be sure to align the cut-out section of the rear coil spring insulator with the stud bolt section of the rear suspension support during the assembly.

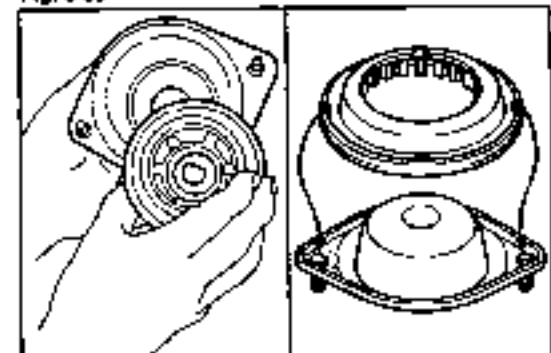

Fig. 6-51

WR-0651

- (5) Install the rear suspension support.

NOTE:

- Be sure to align the cut-out section of the rear suspension support with that of the piston rod during the assembly.
- Align the rear suspension support on the shock absorber lower bracket, as shown in Fig. 6-53.

- (6) Fit the suspension support. Tighten it temporarily, using a new nut.

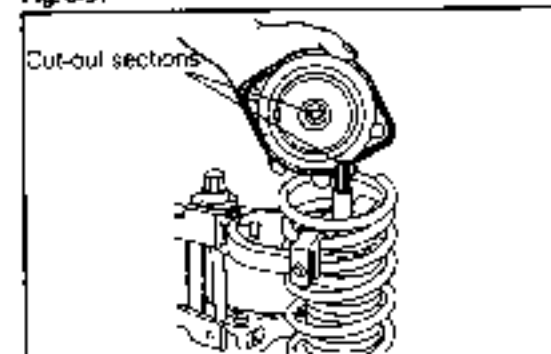

Fig. 6-52

WR-0652

REAR AXLE & SUSPENSION

- (7) Align the coil spring end with the recessed sections of the upper and lower seats. Proceed to remove the SST.

INSTALLATION

1. Install the suspension support to the body, using a new nut.

Tightening Torque: 1.0 - 1.6 kg-m (7.2 - 11.6 ft-lb)

2. Mount the axle carrier on the shock absorber. Fit the bolts and new nuts in position and tighten them.

Tightening Torque: 9.0 - 12.0 kg-m (65 - 87 ft-lb)

NOTE:

- The steering carrier attaching nuts are special nuts on which a friction stabilizing agent has been coated. Hence, be certain not to reuse them.
- Tighten the bolts and nuts while pushing the axle carrier to the lower side (positive side).

3. Install the flexible hose and brake tube, as follows:
- (1) Install the flexible hose to the shock absorber. Secure it with the clip.
 - (2) Install the brake tube to the flexible hose.
- SST: 09751-36011-000

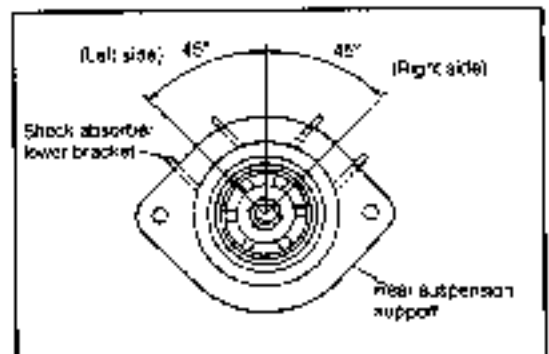

Fig. 6-53

WF-06053

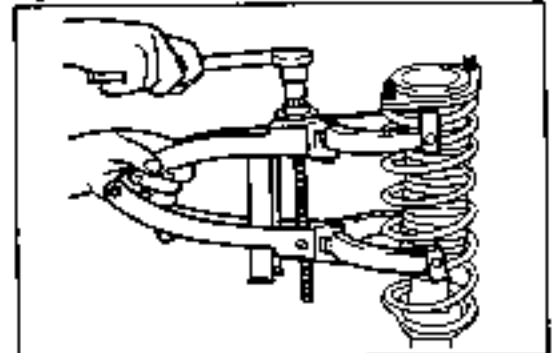

Fig. 6-54

WF-06054

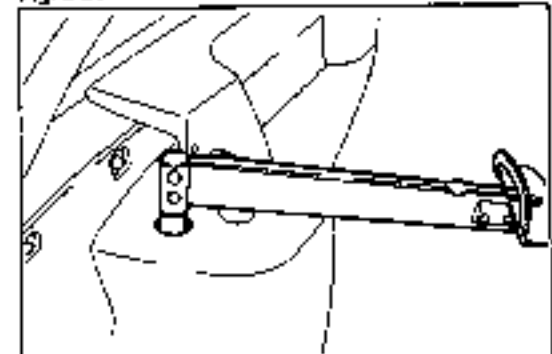

Fig. 6-55

WF-06055

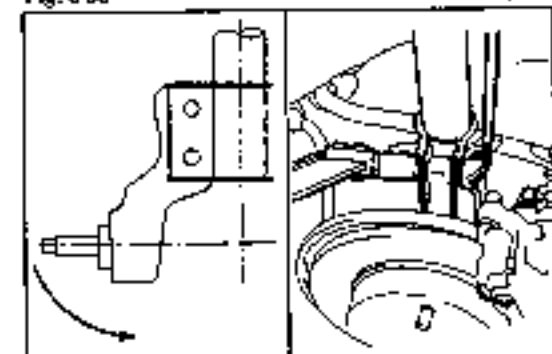

Fig. 6-56

WF-06056

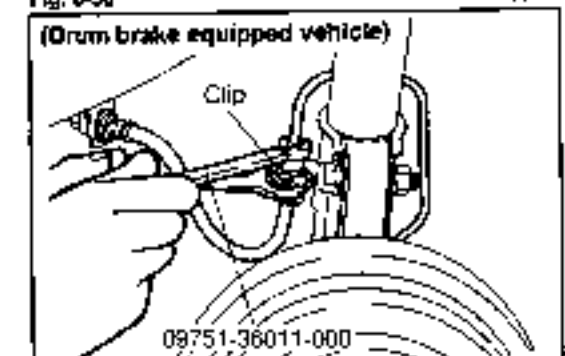

Fig. 6-57

WF-06057

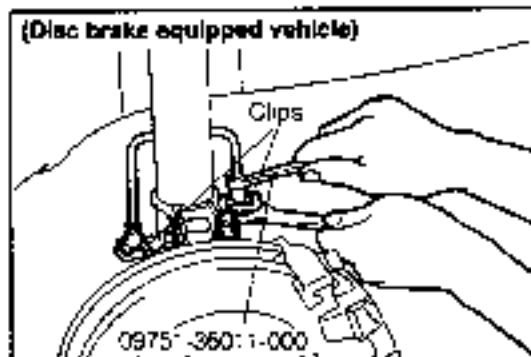

Fig. 6-58

WR-06055

4. Tighten the suspension support attaching nut.
Tightening Torque: 3.5 - 5.5 kg-m (25 - 40 ft-lb)

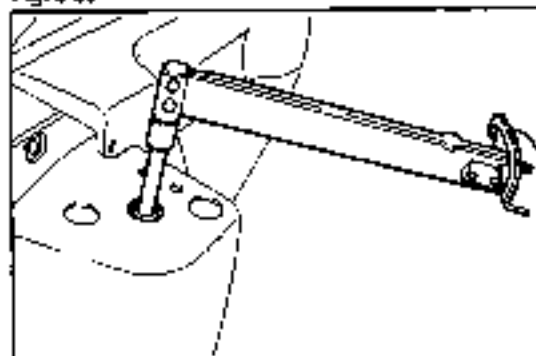

Fig. 6-59

WR-06059

5. Trim installation
 (1) Install the package tray side trim.
 (2) Install the package tray.

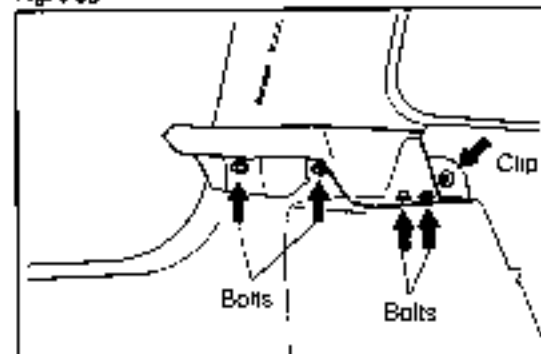

Fig. 6-60

WR-06060

6. Perform air bleeding for the brake system. (See page 8-5)
 7. Install the wheels. Jack down the vehicle.
 8. Check the rear wheel alignment. (See page 5-38.)

WR-06061

REAR AXLE & SUSPENSION

SUSPENSION ARM COMPONENTS

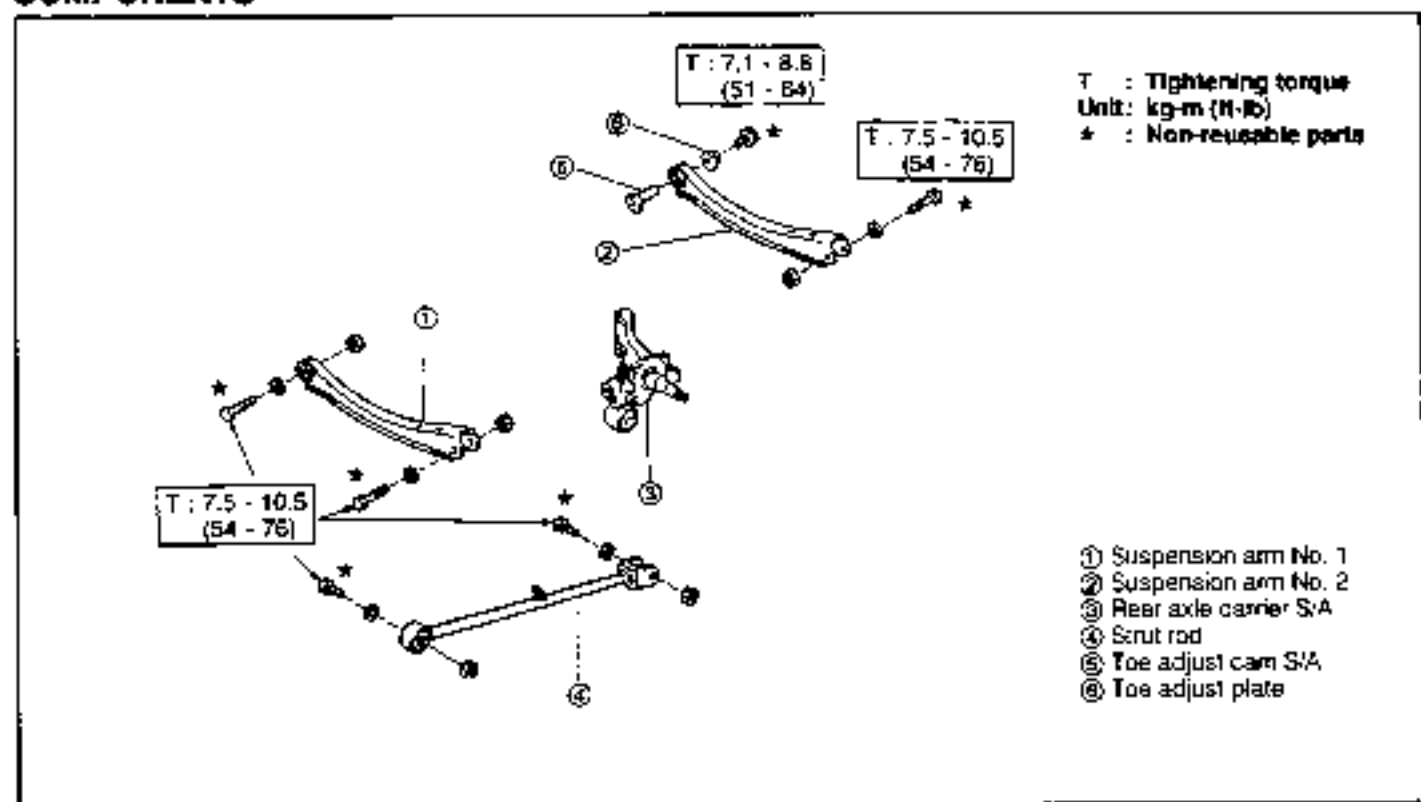

Fig. 6-61

WR-06052

REMOVAL

1. Jack up the vehicle.
 - (1) Jack up the vehicle and support the body with safety stands.
 - (2) Remove the wheel.
2. Removal of suspension arm No.2
 - (1) Remove the attaching bolt and nut of the stabilizer link
 - (2) Remove the attaching bolt and nut of the suspension arm at the axle carrier side

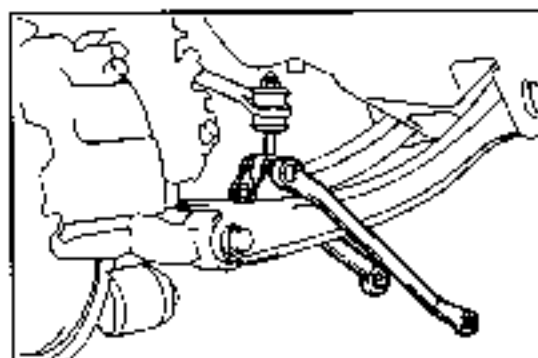

Fig. 6-62

WR-06053

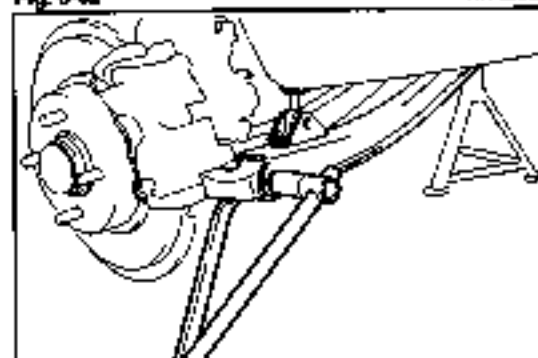

Fig. 6-63

WR-06054

REAR AXLE & SUSPENSION

- (3) Remove the attaching bolt of the suspension arm and cam at the body side. Then, remove the suspension arm.

NOTE:

Put a mate mark on the body bracket and the toe adjusting cam so that the mark may be used as guide during the installation.

- (4) Remove the rear stabilizer bar bracket from the suspension arm.

3. Removal of suspension arm No.1

- (1) Remove the attaching bolt and nut of the suspension arm at the axle carrier side.

- (2) Remove the attaching bolt and nut of the suspension arm at the body side. Then, remove the suspension arm.

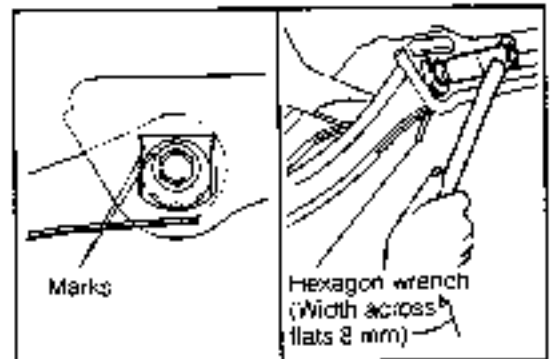

Fig. 8-64

WR-0606

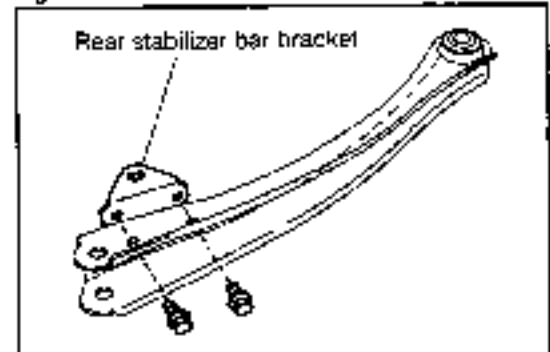

Fig. 8-85

WR-0606

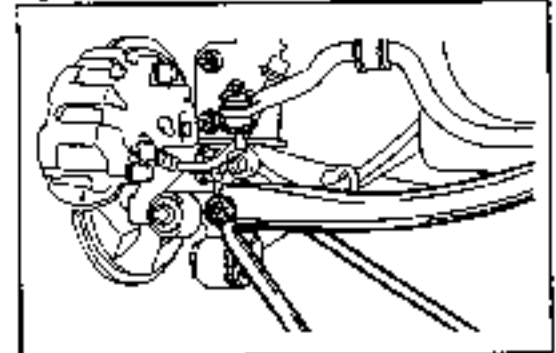

Fig. 8-68

WR-0607

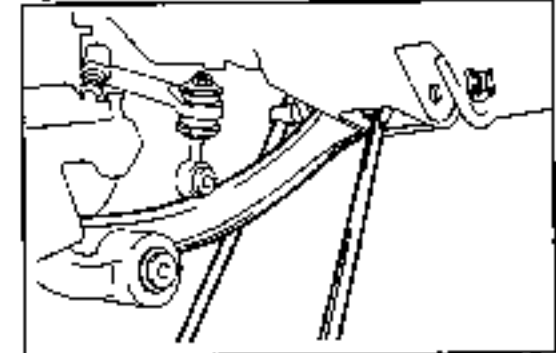

Fig. 8-67

WR-0608

REAR AXLE & SUSPENSION

INSPECTION

Inspect the parts as right figure.

INSTALLATION

NOTE:

The suspension arm attaching bolts are special bolts on which a friction stabilizing agent has been coated. Hence, be certain not to reuse them.

1. Installation of suspension arm No.1
 - (1) Tighten the suspension arm to the body temporarily with the new bolt and nut.
 - (2) Tighten the suspension arm to the axle carrier temporarily with the new bolt and nut.
2. Installation of suspension arm No.2
 - (1) Install the rear stabilizer bar bracket to the suspension arm.
Tightening Torque: 1.0 - 1.6 kg-m (7.2 - 11.6 ft-lb)

- (2) Mount the suspension arm on the body.
- (3) Tighten the suspension arm to the body temporarily with the new bolt and cam.
- (4) Prior to secure tightening, align the mate marks on the toe adjuster cam and body with each other.

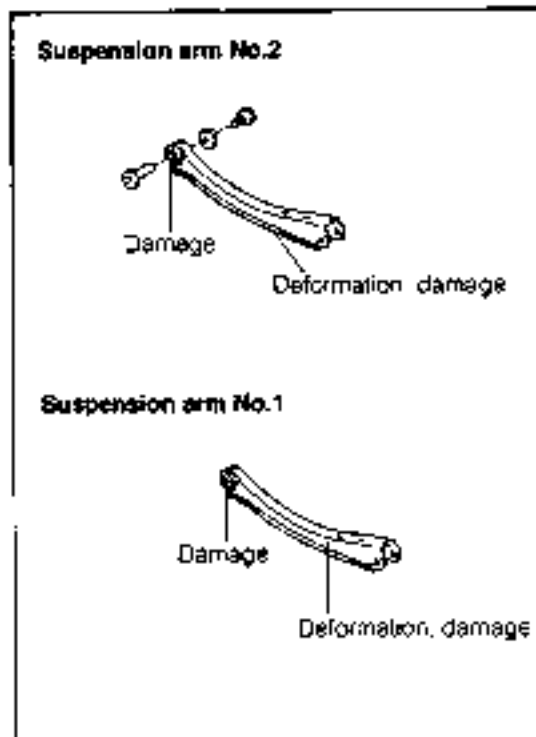

Fig. 6-68

WR-06059

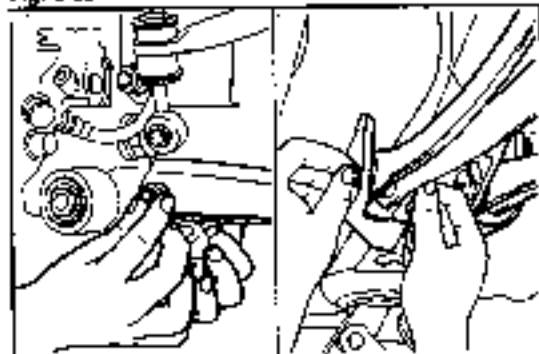

Fig. 8-59

WR-06070

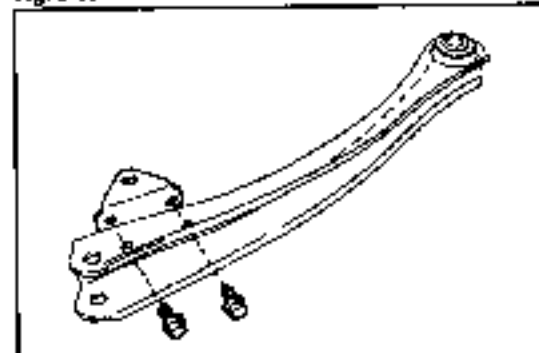

Fig. 8-70

WR-06071

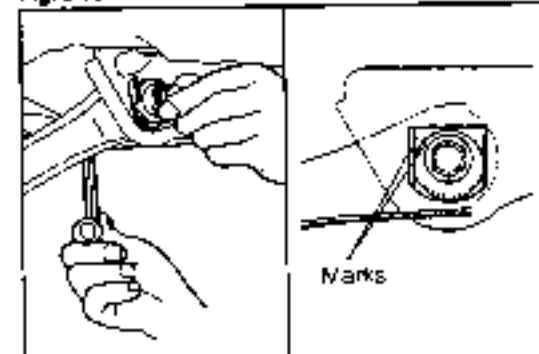

Fig. 8-71

WR-06072

- (5) Tighten the suspensor arm to the axle carrier temporarily with the new bolt and nut.

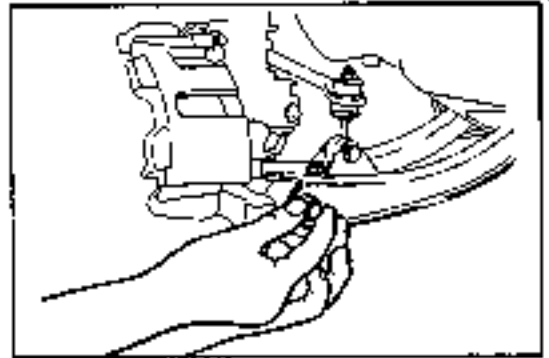

Fig. 6-72

WR-06072

- (6) Tighten the attaching bolt and nut of the stabilizer link to the specified torque

Tightening Torque: 1.9 - 3.1 kg-m (14 - 22 ft-lb)

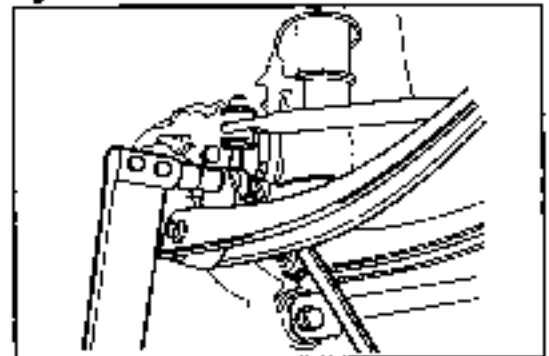

Fig. 6-73

WR-06073

3. Tightening of suspension arm attaching bolt

- (1) Install the wheel.
 (2) With the vehicle in an unloaded state, jack down the vehicle. Rock the vehicle in an up-and-down direction a few times so as to settle the suspension.

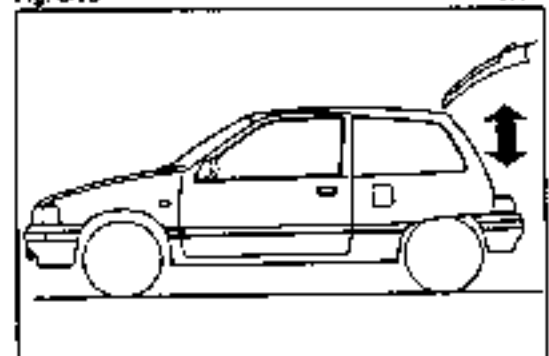

Fig. 6-74

WR-06074

- (3) With the vehicle weight applied to the suspension, tighten the bolts and nuts.

[Suspension arm No.1]

(Axle carrier side)

Tightening Torque: 7.5 - 10.5 kg-m (54 - 76 ft-lb)

(Body side)

Tightening Torque: 7.5 - 10.5 kg-m (54 - 76 ft-lb)

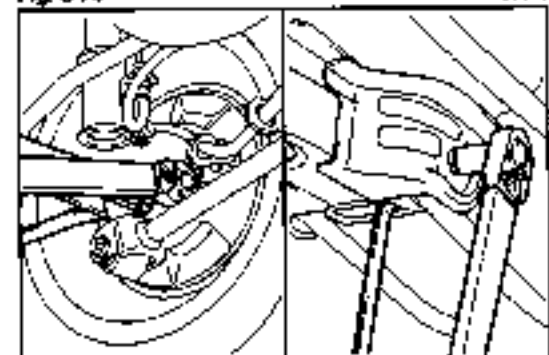

Fig. 6-75

WR-06075

[Suspension arm No.2]

(Axle carrier side)

Tightening Torque: 7.5 - 10.5 kg-m (54 - 76 ft-lb)

(Body side)

Tightening Torque: 7.1 - 8.8 kg-m (51 - 64 ft-lb)

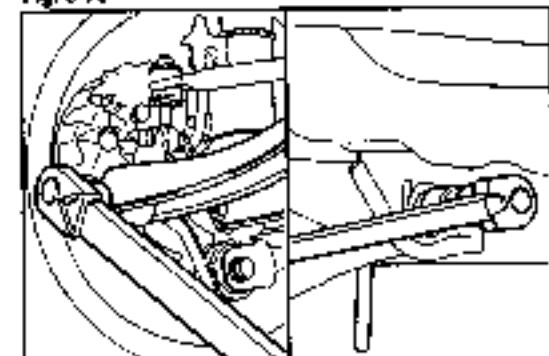

Fig. 6-76

WR-06076

- 4 Check the rear wheel alignment.
 (See page 5-38.)

REAR AXLE & SUSPENSION

STRUT ROD

REMOVAL

1. Jack up the vehicle.
 - (1) Jack up the vehicle. Support the body with safety stands.
 - (2) Remove the wheel.
2. Strut rod removal
 - (1) Remove the attaching bolt and nut of the strut rod at the axle carrier side.
 - (2) Remove the attaching bolt and nut of the strut rod at the body side. Then, remove the strut rod.

WR-0607E

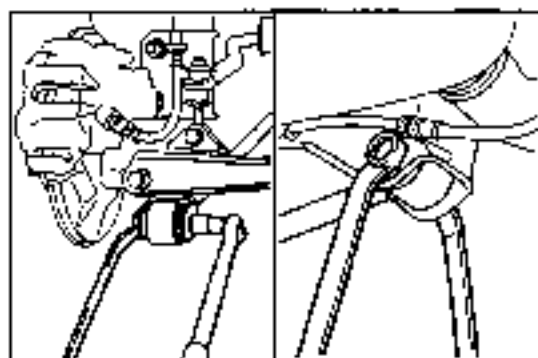

Fig. 6-77

WR-C007E

INSPECTION

Inspect the parts as right figure.

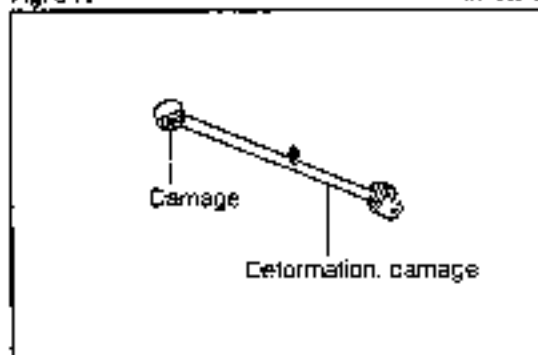

Fig. 6-78

WR-0608E

INSTALLATION

1. Strut rod installation
 - (1) Tighten the strut rod to the body temporarily with the new bolt and nut.
 - (2) Tighten the strut rod to the axle carrier temporarily with the new bolt and nut.

NOTE:

The strut rod attaching bolts are special bolts on which a friction stabilizing agent has been coated. Hence, be certain not to reuse them.

2. Tightening of strut rod attaching bolt
 - (1) Install the wheel.
 - (2) With the vehicle in an unloaded state, jack down the vehicle. Rock the vehicle in an up-and-down direction a few times so as to settle the suspension.

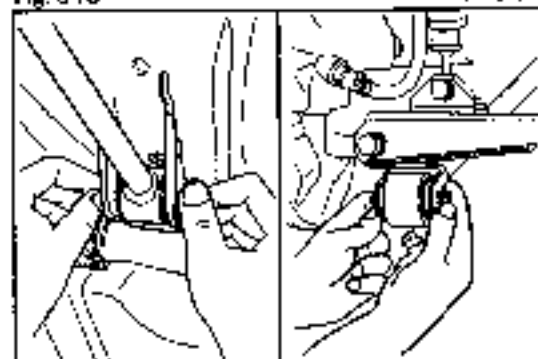

Fig. 6-79

WR-0609E

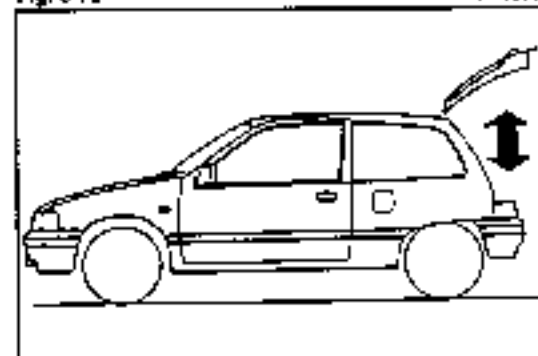

Fig. 6-80

WR-0608E

- (3) With the vehicle weight applied to the suspension, tighten the bolt and nut.
Tightening Torque: 7.5 - 10.5 kg-m (54 - 76 ft-lb)

3. Check the rear wheel alignment. (See page 5-38)

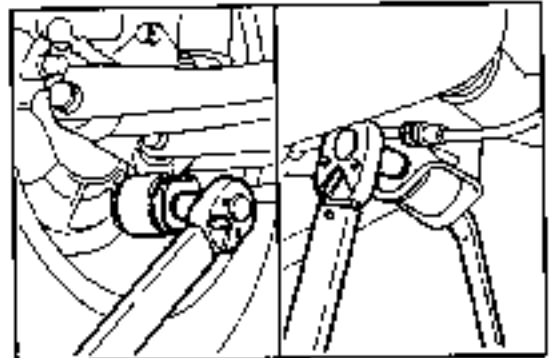
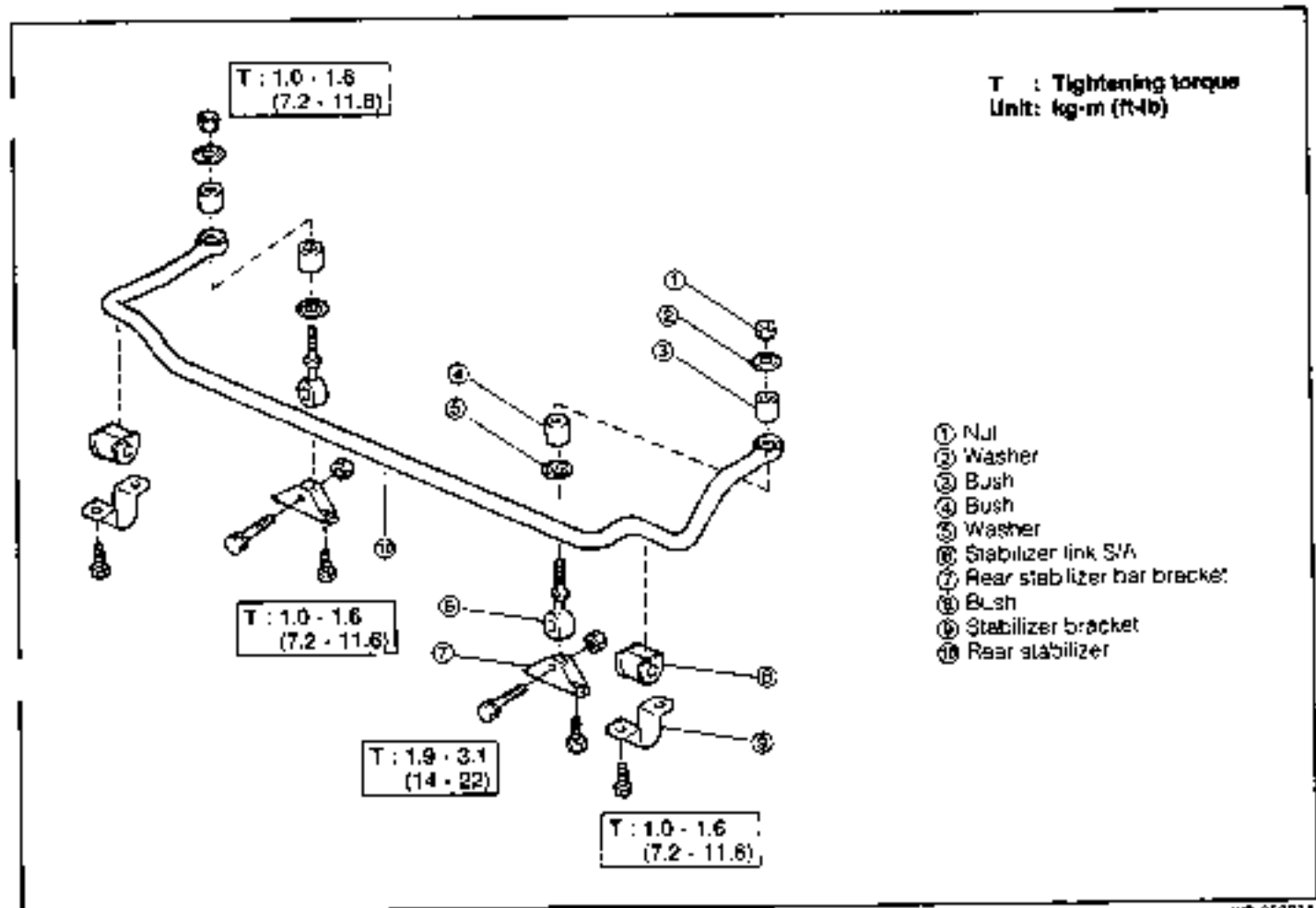

Fig. 6-81

WF-06082

STABILIZER BAR COMPONENTS



WF-06083A

REMOVAL

1. Jack up the vehicle. Support the body with safety stands.
2. Stabilizer bar removal
 - (1) Remove the stabilizer bar attaching nuts from the stabilizer link

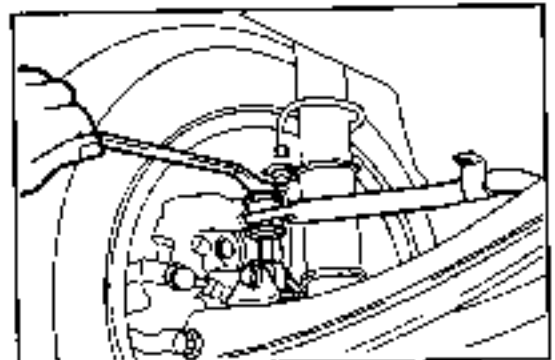

Fig. 6-83

WF-06084

REAR AXLE & SUSPENSION

- (2) Remove the stabilizer bar attaching bolts at the body side. Remove the stabilizer bar.

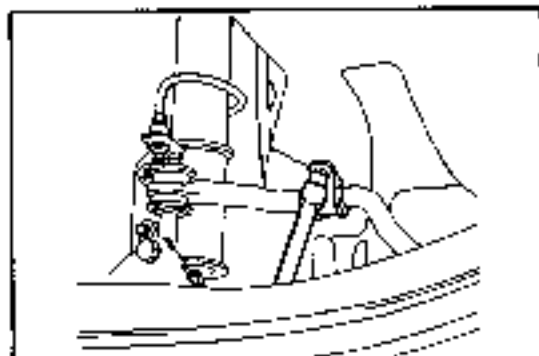

Fig. 6-84

WP-06065

- (3) Remove the attaching bolts and nuts of the stabilizer link. Remove the stabilizer link.

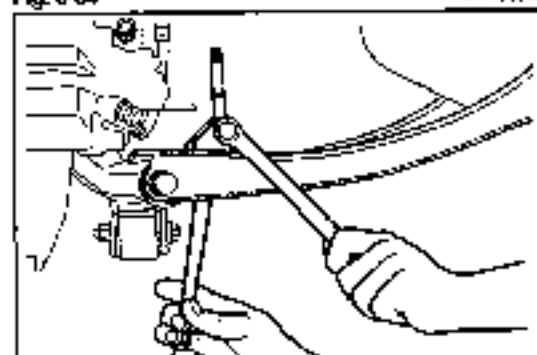

Fig. 6-85

WP-06065

- (4) Remove the rear stabilizer bar bracket attaching bolts. Proceed to remove the stabilizer bar bracket.

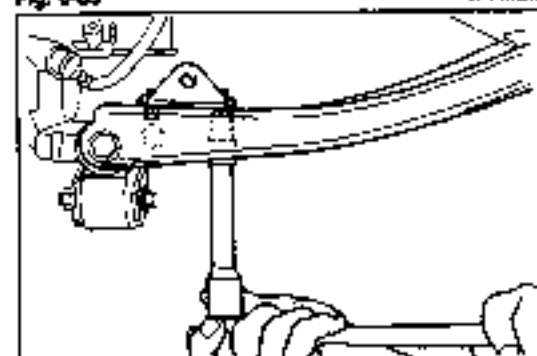

Fig. 6-86

WP-06067

INSPECTION

Inspect the following parts.

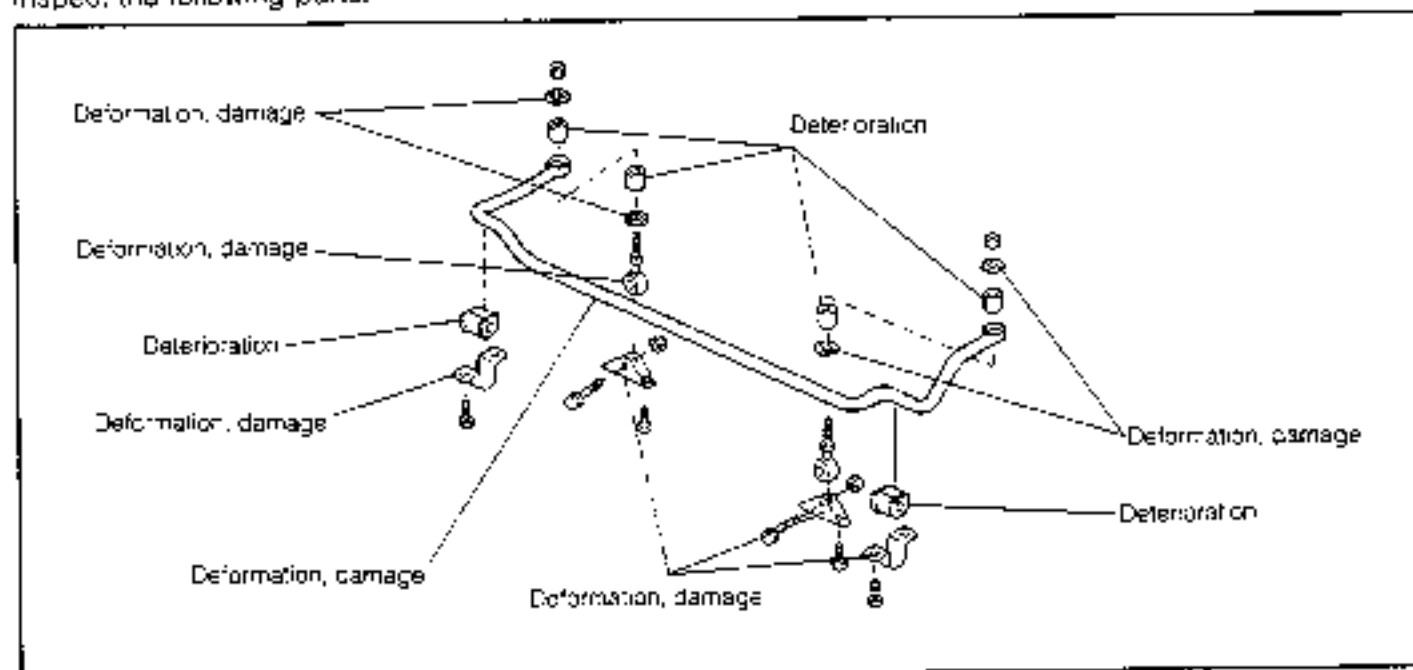

Fig. 6-87

WP-06065

INSTALLATION

1. Stabilizer bar installation

- (1) Install the rear stabilizer bar bracket to the suspension arm No.2.

Tightening Torque: 1.0 - 1.6 kg-m (7.2 - 11.6 ft-lb)

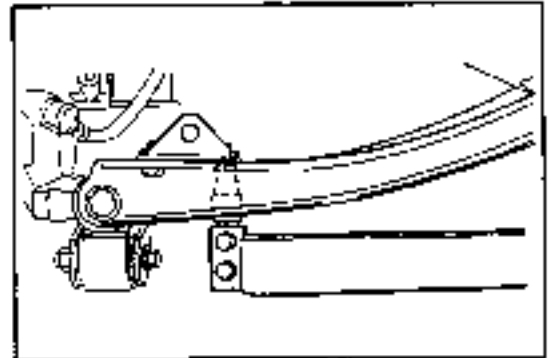

Fig. 6-88

WR 06080

- (2) Tighten the stabilizer link to the rear stabilizer bar bracket temporarily with the bolts and nuts

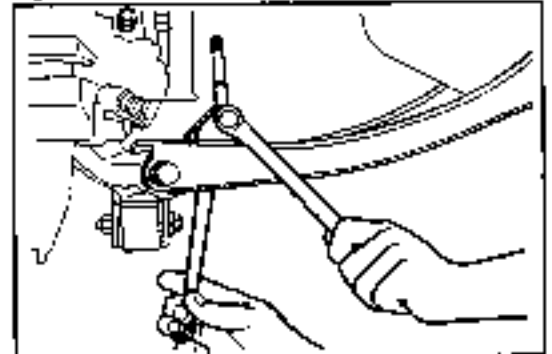

Fig. 6-89

WR 06080

- (3) Fit temporarily the bush, bracket and stabilizer bar to the body

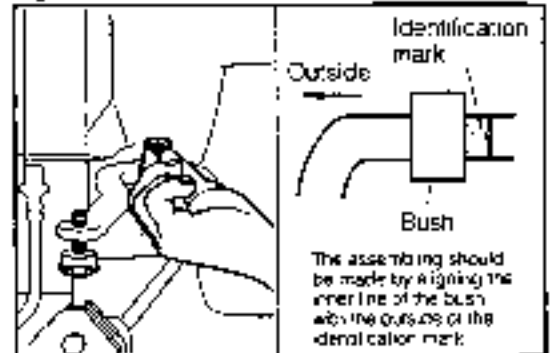

Fig. 6-90

WF 06081

- (4) Fit the stabilizer bar to the stabilizer link. Tighten the nuts temporarily

NOTE:

Assemble the bush and bracket, as shown in the right figure.

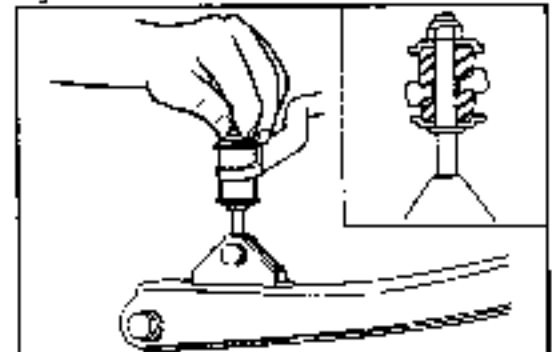

Fig. 6-91

WR 06082

2. Tightening of bolts and nuts

- (1) Tighten the nuts attaching the stabilizer bar to the stabilizer link.

Tightening Torque: 1.0 - 1.6 kg-m (7.2 - 11.6 ft-lb)

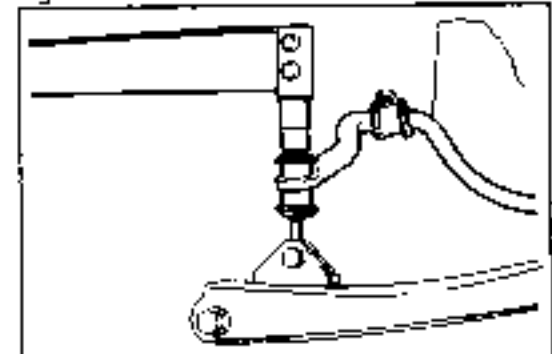

Fig. 6-92

WF 06094

REAR AXLE & SUSPENSION

- (2) Tighten the stabilizer bar attaching bolts at the body side.

Tightening Torque: 1.0 - 1.6 kg-m (7.2 - 11.6 ft-lb)

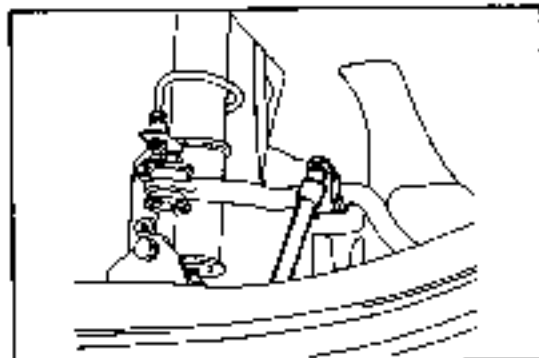

Fig. 5-93

WF 05084

- (3) Tighten the attaching bolts and nuts of the stabilizer link.

Tightening Torque: 1.9 - 3.1 kg-m (14 - 22 ft-lb)

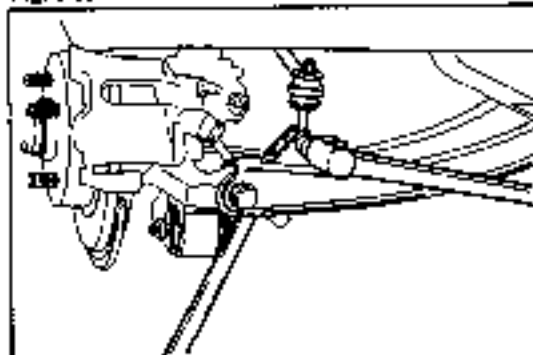

Fig. 5-94

WA-05090

DAIHATSU

CHARADE

Chassis

SECTION 7

STEERING

STEERING	7- 2
SCHEMATIC VIEW	7- 2
STEERING WHEEL	7- 3
COMPONENTS	7- 3
REMOVAL	7- 3
INSTALLATION	7- 4
ENGINE KEY CYLINDER	7- 5
REMOVAL	7- 5
INSTALLATION	7- 5
STEERING COLUMN	7- 6
COMPONENTS	7- 6
REMOVAL	7- 6
DISASSEMBLY	7- 7
INSPECTION	7- 9
ASSEMBLY	7- 9
INSTALLATION	7-10
STEERING GEAR ASSEMBLY	7-12
COMPONENTS	7-12
REMOVAL	7-12
STEERING GEAR HOUSING	7-14
SECTIONAL VIEW	7-14
COMPONENTS	7-15
DISASSEMBLY	7-16
INSPECTION	7-16
ASSEMBLY	7-16
INSTALLATION	7-21

W9-C7001

STEERING

STEERING

SCHEMATIC VIEW

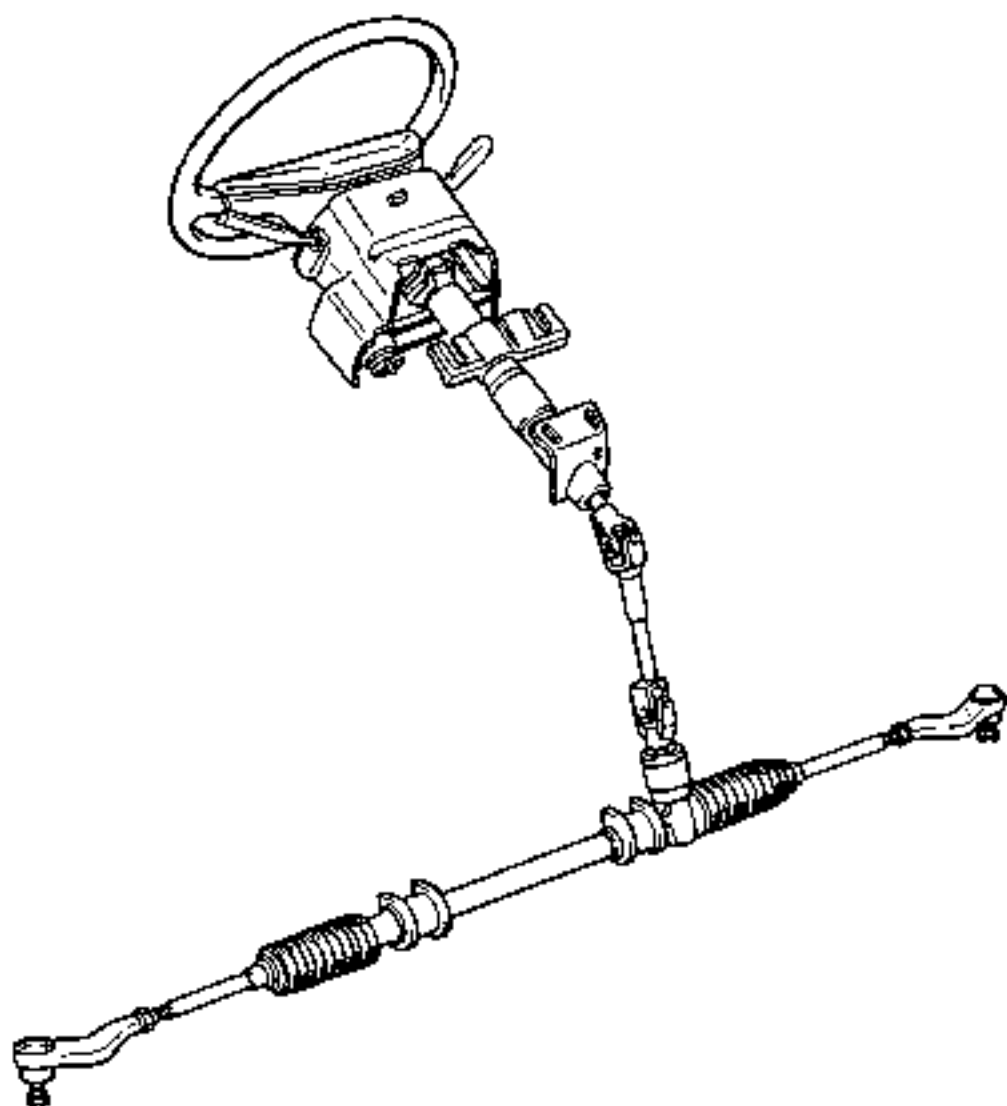
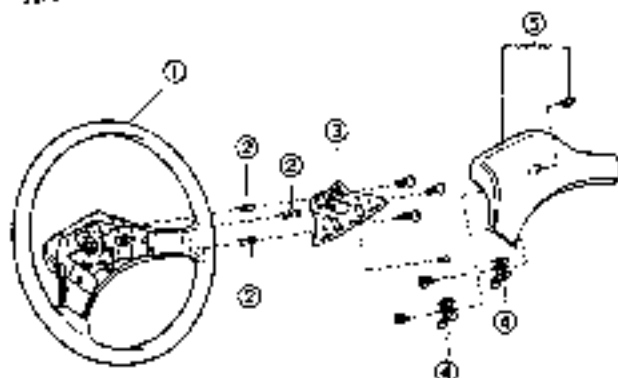

Fig. 7-1

69-0702

STEERING WHEEL COMPONENTS

Resin type



- ① Steering wheel
- ② Horn contact spring
- ③ Horn button contact ring or plate
- ④ Steering wheel pad set spring
- ⑤ Steering wheel pad S/A

Urethane type

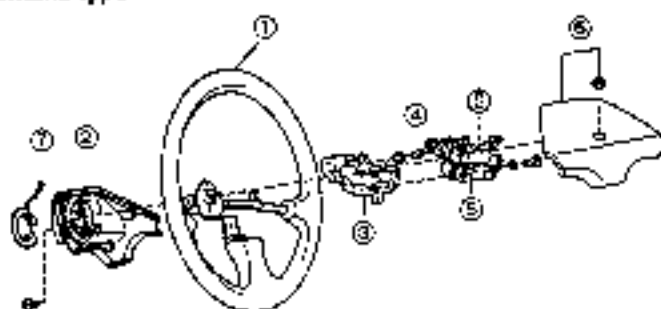

- ① Steering wheel
- ② Steering wheel boss lower cover
- ③ Horn button contact plate
- ④ Horn contact spring
- ⑤ Horn contact spring set plate
- ⑥ Steering wheel cover S/A
- ⑦ Horn contact ring

Fig. 7-2

WR-0703

REMOVAL

1. Disconnect the battery negative (-) terminal.
2. Hold the steering wheel pad at its lower end by your fingers. Then, detach the steering wheel pad by pulling it toward your side.
3. Remove the steering wheel lock nut.

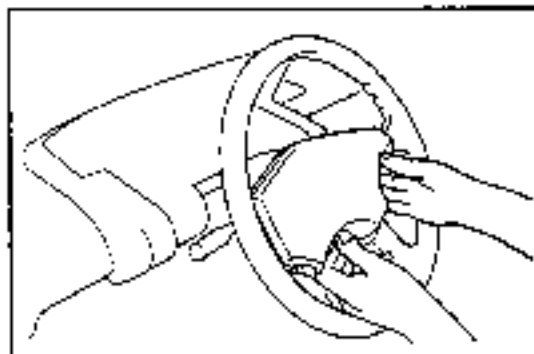

Fig. 7-3

WR-0703

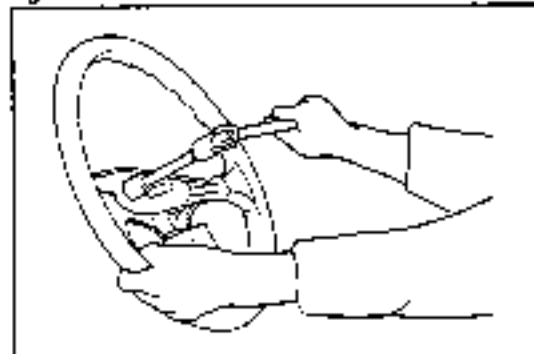

Fig. 7-4

WR-0703

STEERING

4. Remove the steering wheel, using the following SST.
SST: 09609-20011-000

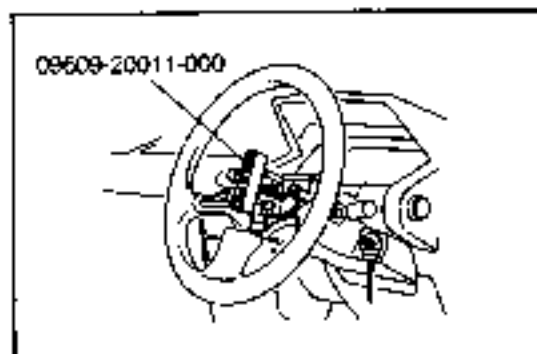

Fig. 7-5

WR-0700E

INSTALLATION

1. Fit the steering wheel and tighten the lock nut.
Tightening Torque: 3.5 - 5.5 kg-m (25 - 40 ft-lb)
2. Install the steering wheel pad.
3. Connect the battery negative (-) terminal.

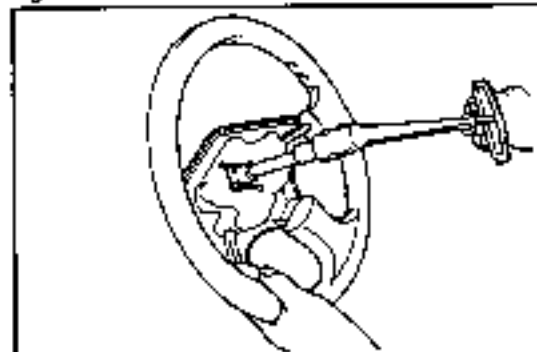

Fig. 7-6

WR-0700F

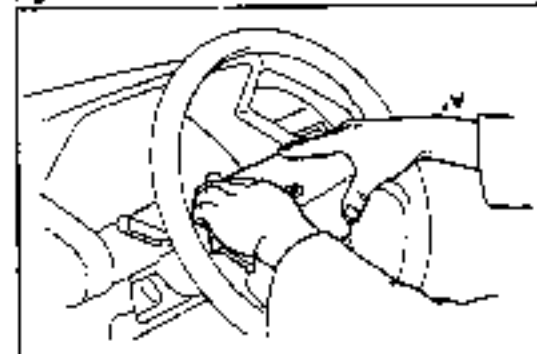

Fig. 7-7

WR-0700G

ENGINE KEY CYLINDER

REMOVAL

1. Loosen six screws and remove the steering column lower cover.

2. Engine key cylinder removal
 - (1) Fabricate a rod as shown in the right figure, by bending an approx. 2 mm (0.08 inch) diameter rod.
 - (2) Set the engine key to the [ACC] position.

 - (3) While pushing the stop pin by means of the rod, draw out the cylinder.

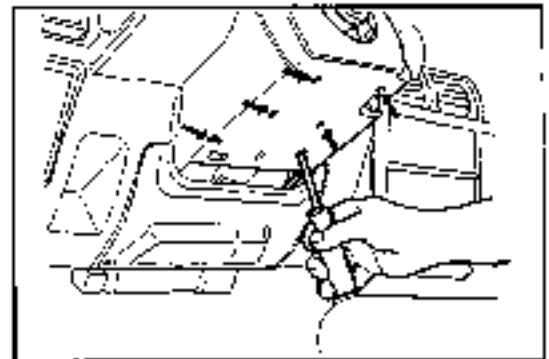

Fig. 7-8 WR-07008

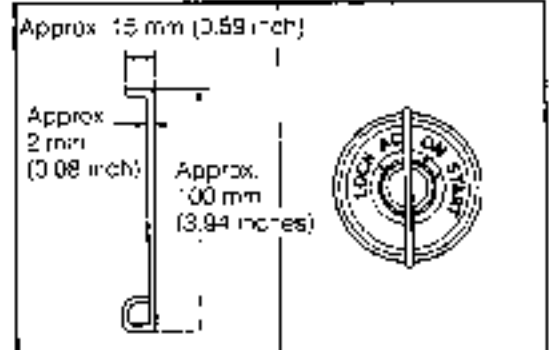

Fig. 7-9 WR-07010

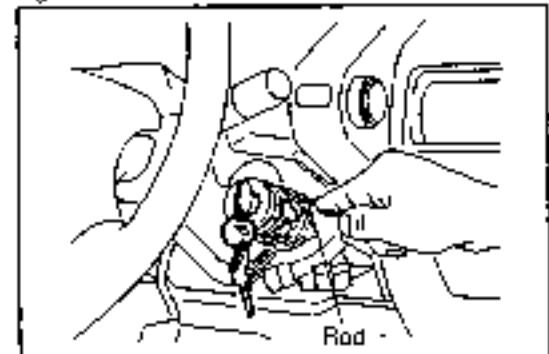

Fig. 7-10 WR-07011

INSTALLATION

1. Engine key cylinder installation
 - (1) Insert a common screwdriver into the pawl groove of the lock cylinder. Set the pawl groove to the [ACC] position.
 - (2) Set the engine key to the [ACC] position. Insert the key cylinder. Ensure that the stop pin is locked to the lock cylinder.

2. Install the steering column lower cover.

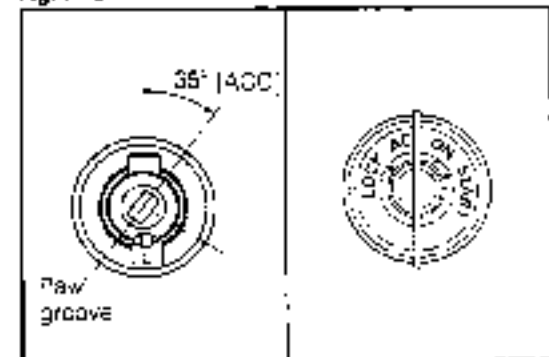

Fig. 7-11 WR-07012

STEERING

STEERING COLUMN COMPONENTS

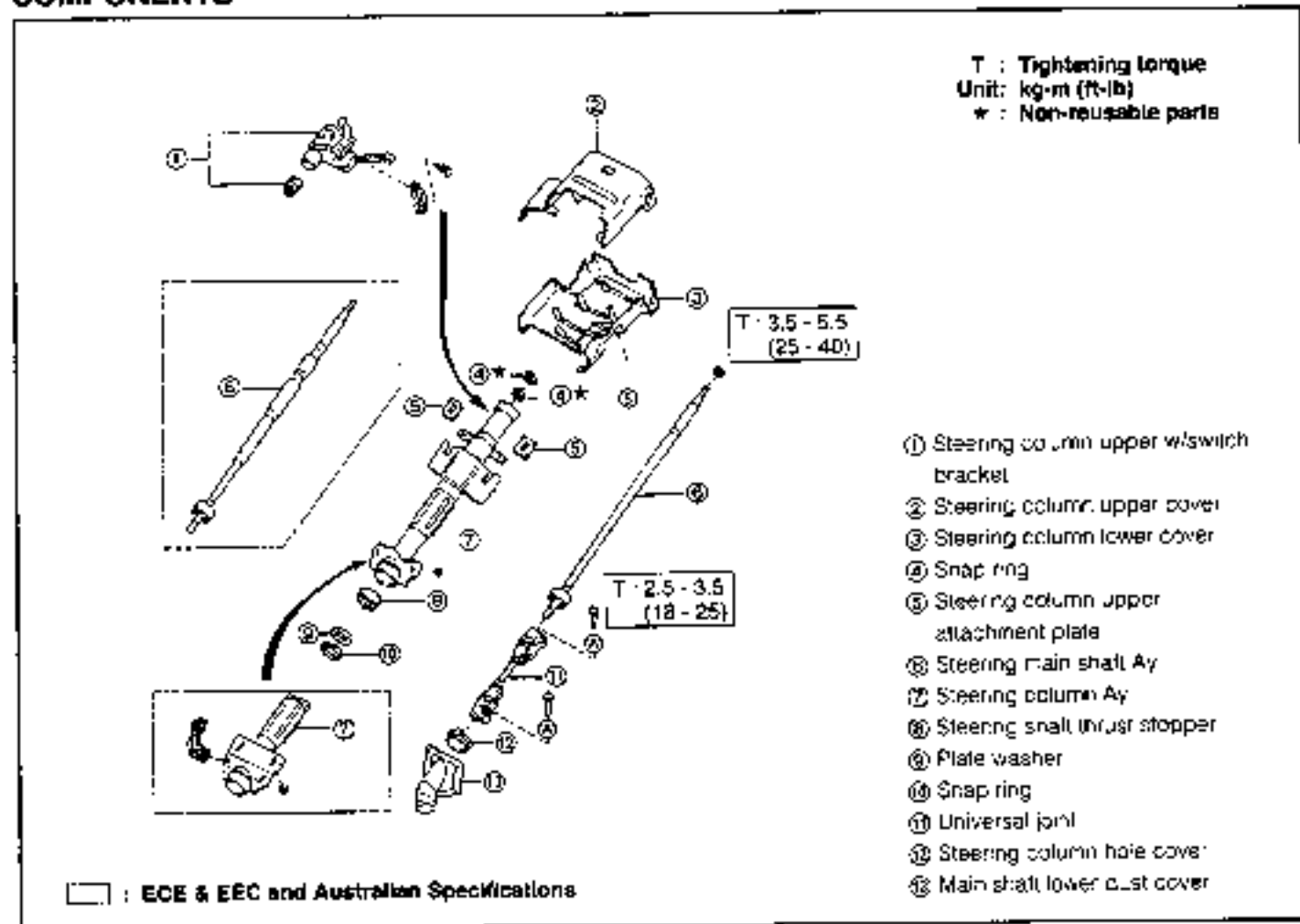

Fig. 7-12

WR-070-3

REMOVAL

1. Disconnect the battery negative (-) terminal
2. Remove the steering wheel. (See page 7-3.)
3. Detach the instrument lower finish panel and steering column lower cover.

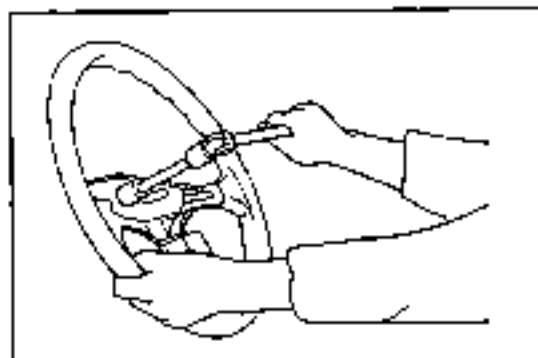

Fig. 7-13

WR-070-3

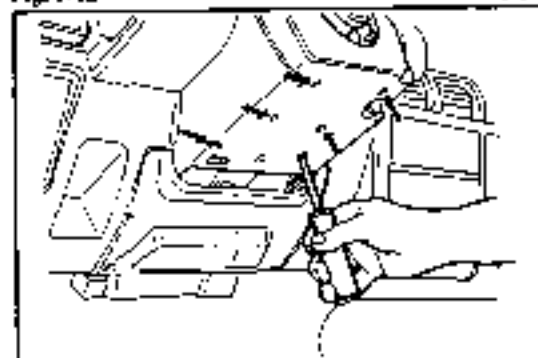

Fig. 7-14

WR-070-5

4. Remove the instrument panel lower reinforcement
5. Remove the connectors for the multi-use lever switch and engine key switch.

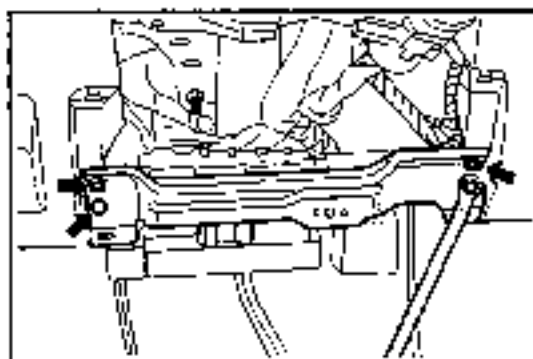

Fig. 7-15 WR 07016

6. Remove the bolt of the universal joint.

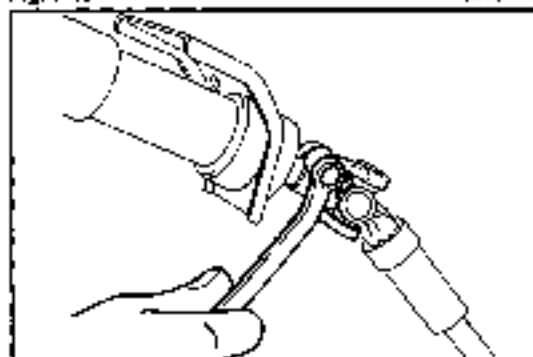

Fig. 7-16 WR 07017

7. Steering column assembly removal
 - (1) Remove three bolts and two nuts
 - (2) Remove the steering column assembly from the body.

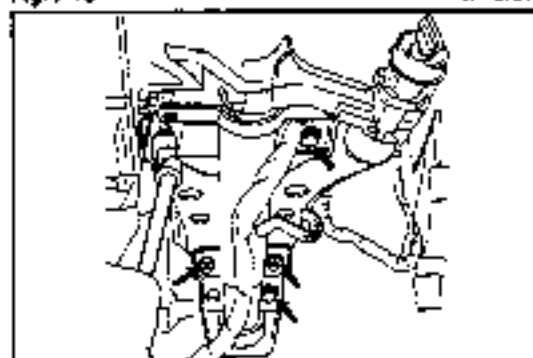

Fig. 7-17 WR 07018

8. Remove the steering column upper cover and multi-use lever switch from the steering column assembly

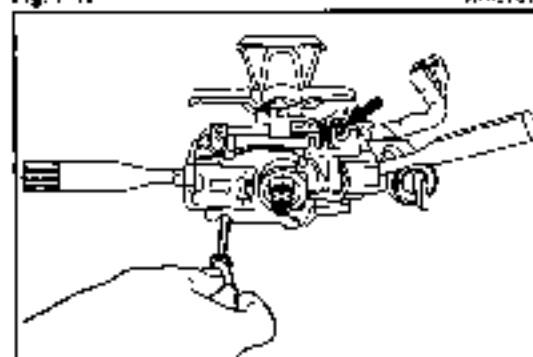

Fig. 7-18 WR 07019

DISASSEMBLY

1. Detach the snap ring and plate washer located at the lower side of the steering main shaft.

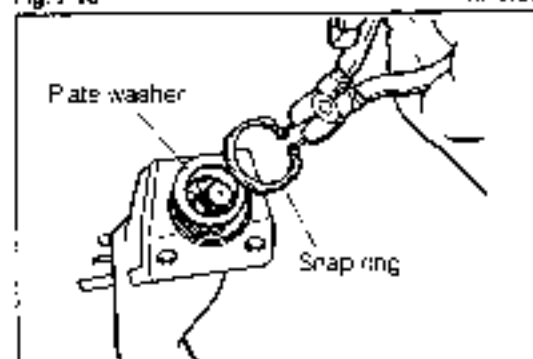

Fig. 7-19 WR 07020

STEERING

2. Detach the snap ring located at the upper side of the steering main shaft.

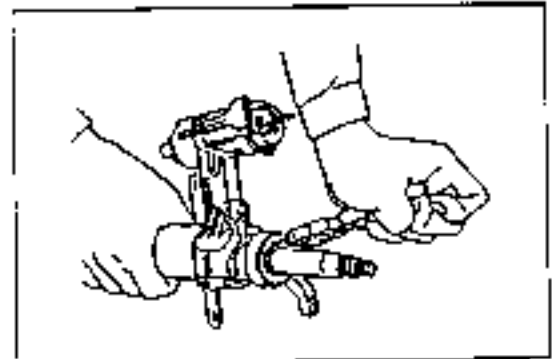

Fig. 7-20

WF 0702

3. Steering main shaft subassembly removal
 - (1) Remove the steering main shaft subassembly by tapping the main shaft lightly with a plastic hammer.

NOTE:
Never tap the main shaft strongly. If the main shaft should be tapped strongly, the resin pin of the steering main shaft may be damaged. (ECE & EEC and Australian specifications)

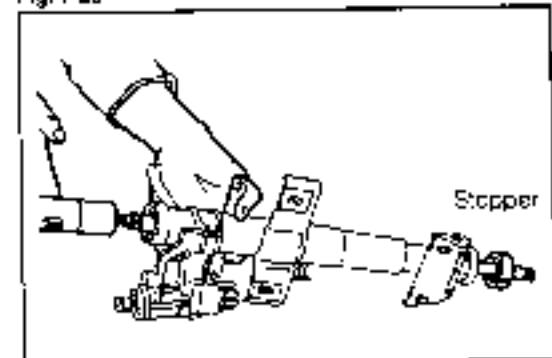

Fig. 7-21

WF 0702

- (2) Remove the stopper from the steering main shaft.
- (3) Detach the snap ring from the steering main shaft.

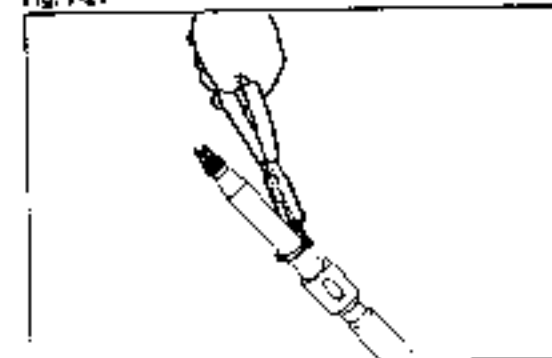

Fig. 7-22

WF 0702

INSPECTION

inspect the following parts.

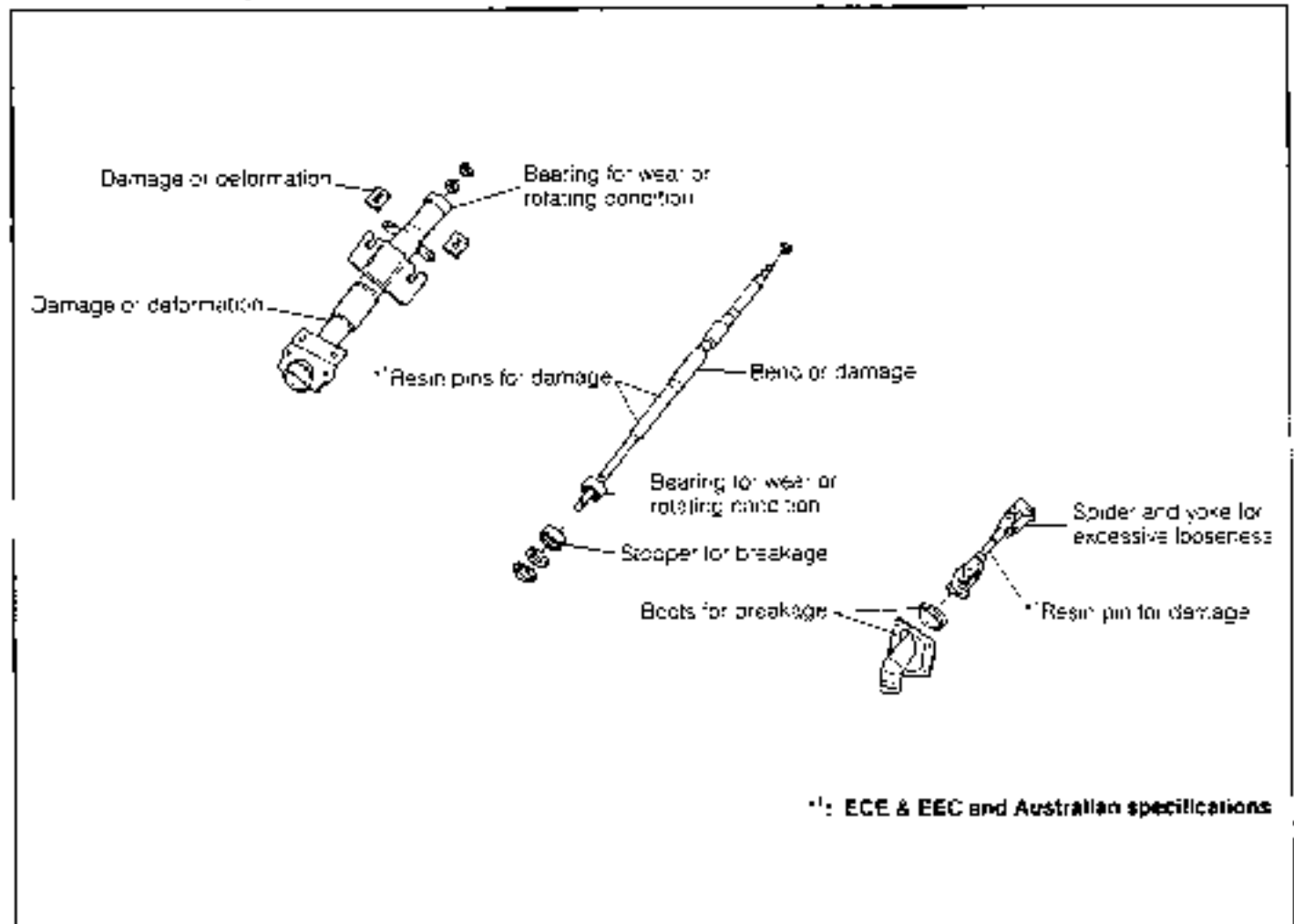

Fig. 7-23

WR-07C06

ASSEMBLY

1. Assembly of steering main shaft
 - (1) Fit a new snap ring to the steering main shaft.
 - (2) Place the stopper on the bearing
2. Insert the main shaft (with the bearing) into the steering column, using a plug wrench

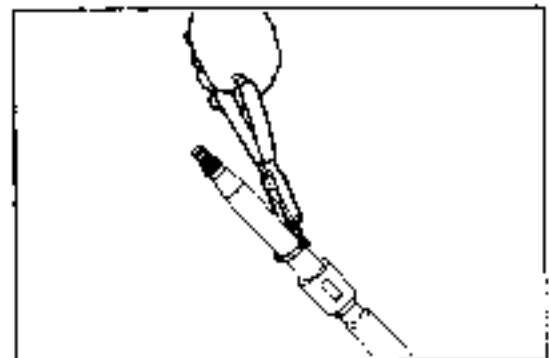

Fig. 7-24

WR-07C06

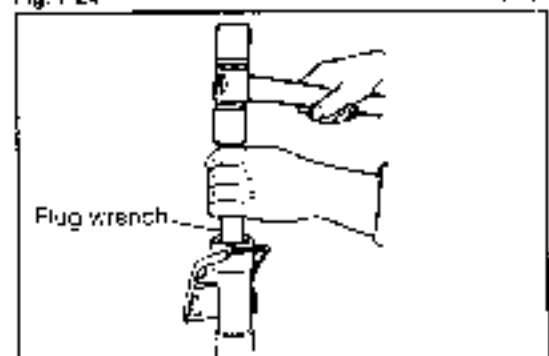

Fig. 7-25

WR-07C06

STEERING

- Fit the new snap ring to the upper side of the steering main shaft.

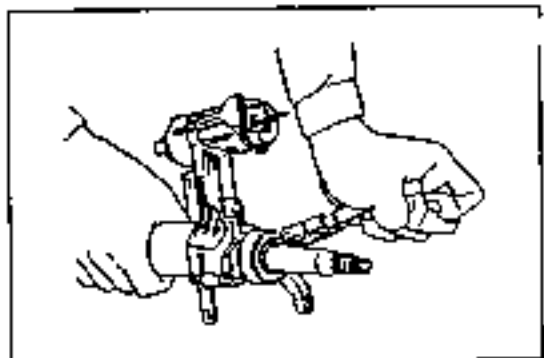

Fig. 7-26

WA-07027

- Install the plate washer and snap ring.

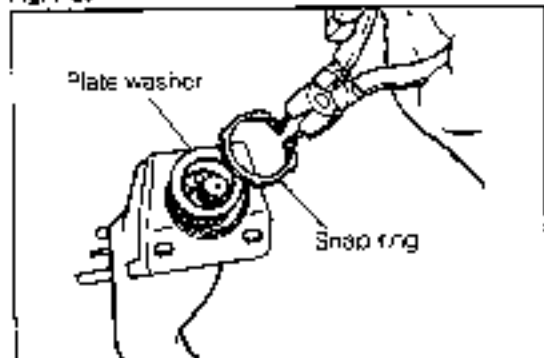

Fig. 7-27

WA-01025

- Install the multi-use lever switch to the steering column.

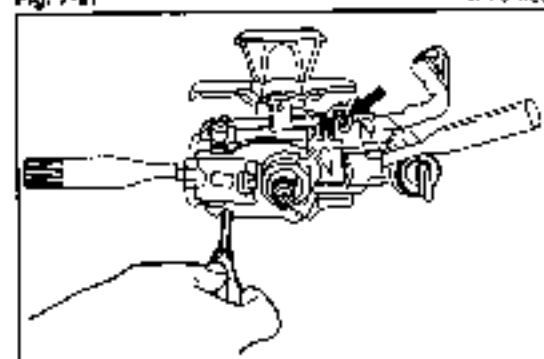

Fig. 7-28

WA-01024

INSTALLATION

- Steering column assembly installation
 - Install the steering column upper cover to the steering column.
 - Tighten the attaching bolt of the universal joint;
Tightening Torque: 2.5 - 3.5 kg-m (18 - 25 ft-lb)
 - Install the steering column with the three bolts and two nuts.
Tightening Torque:
Bolt 1.5 - 2.2 kg-m (11 - 16 ft-lb)
Nut 2.5 - 3.5 kg-m (18 - 25 ft-lb)

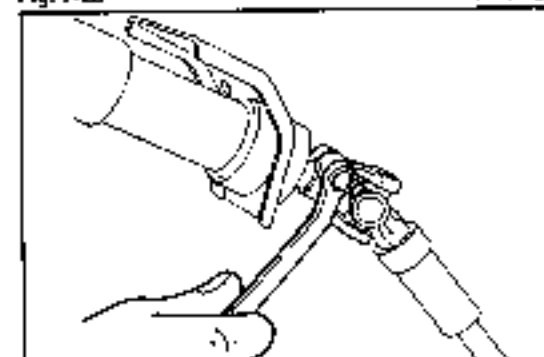

Fig. 7-29

WA-07029

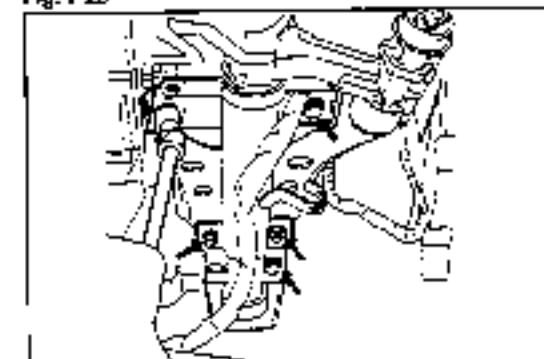
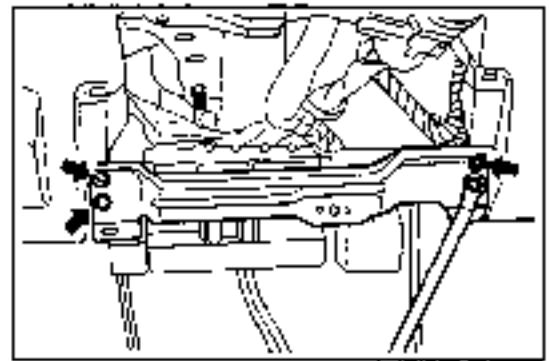

Fig. 7-30

WA-01021

2. Install the connector for the multi-use lever and engine key switch.
3. Install the instrument panel lower reinforcement.
4. Install the instrument lower finish panel and steering column lower cover.
5. Install the steering wheel.
(See page 7-4.)
6. Install the battery negative (-) terminal.

**Fig. 7-31**

WA-C-1002

STEERING

STEERING GEAR ASSEMBLY COMPONENTS

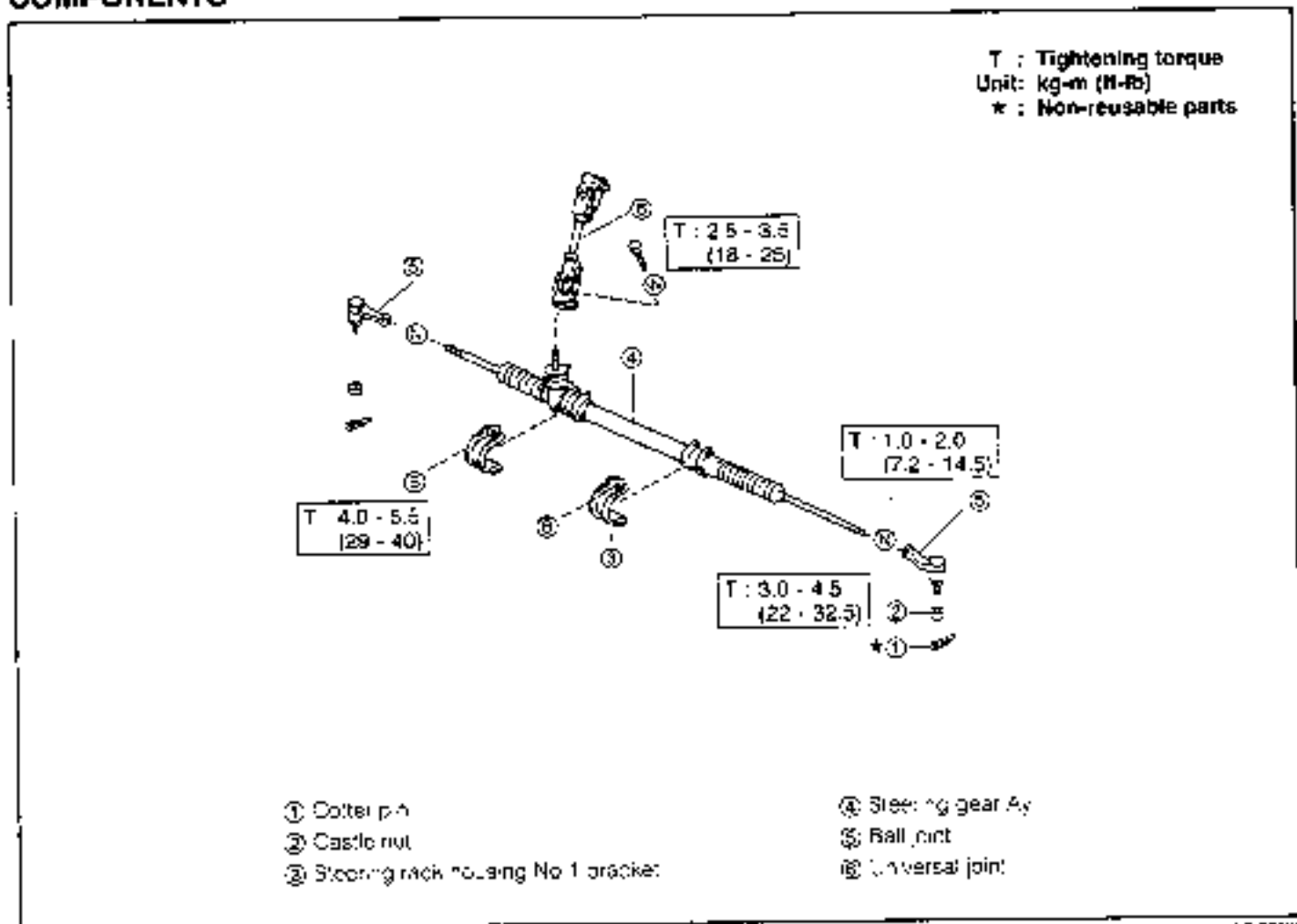

Fig. 7-32

WP-C703G

REMOVAL

1. Jack up the vehicle at the front side. Support the body with safety stands.
2. Remove the wheel.

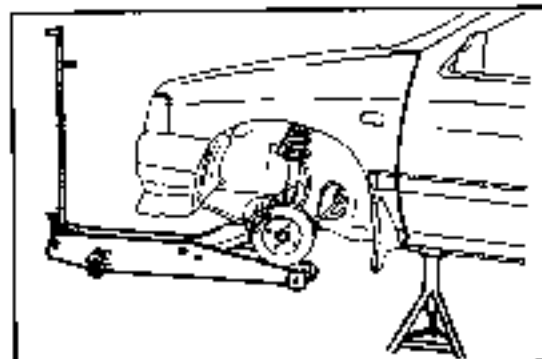

Fig. 7-33

WP-C703H

3. Steering universal joint removal:
 - (1) Remove the bolt.
 - (2) Remove the universal joint.

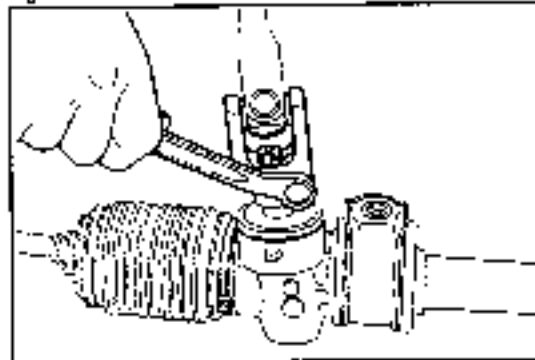

Fig. 7-34

WP-C703B

4. Tie rod end removal

- (1) Remove the collar pins and castle nuts
 - (2) Remove the tie rod end from the knuckle arm, using the following SST.
- SST: 09611-87701-000

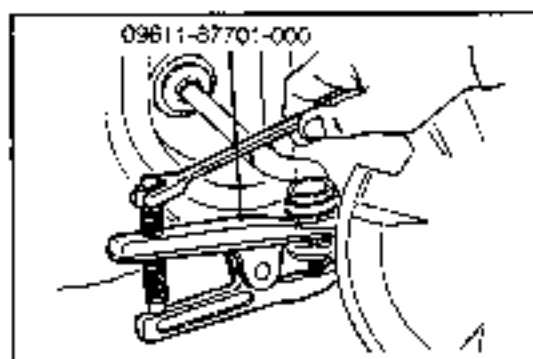

Fig. 7-35

WR-07006

5. Steering gear assembly removal

- (1) Remove the four pieces of steering rack housing bracket set bolts.

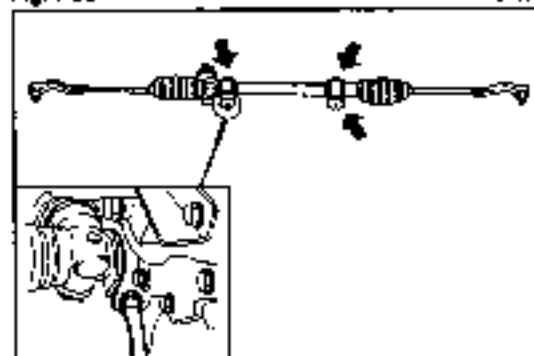

Fig. 7-36

WR-07037

- (2) Remove the steering gear assembly from the vehicle

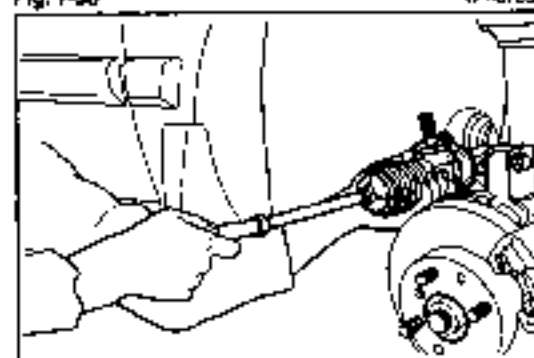

Fig. 7-37

WR-07038

STEERING

STEERING GEAR HOUSING

SECTIONAL VIEW

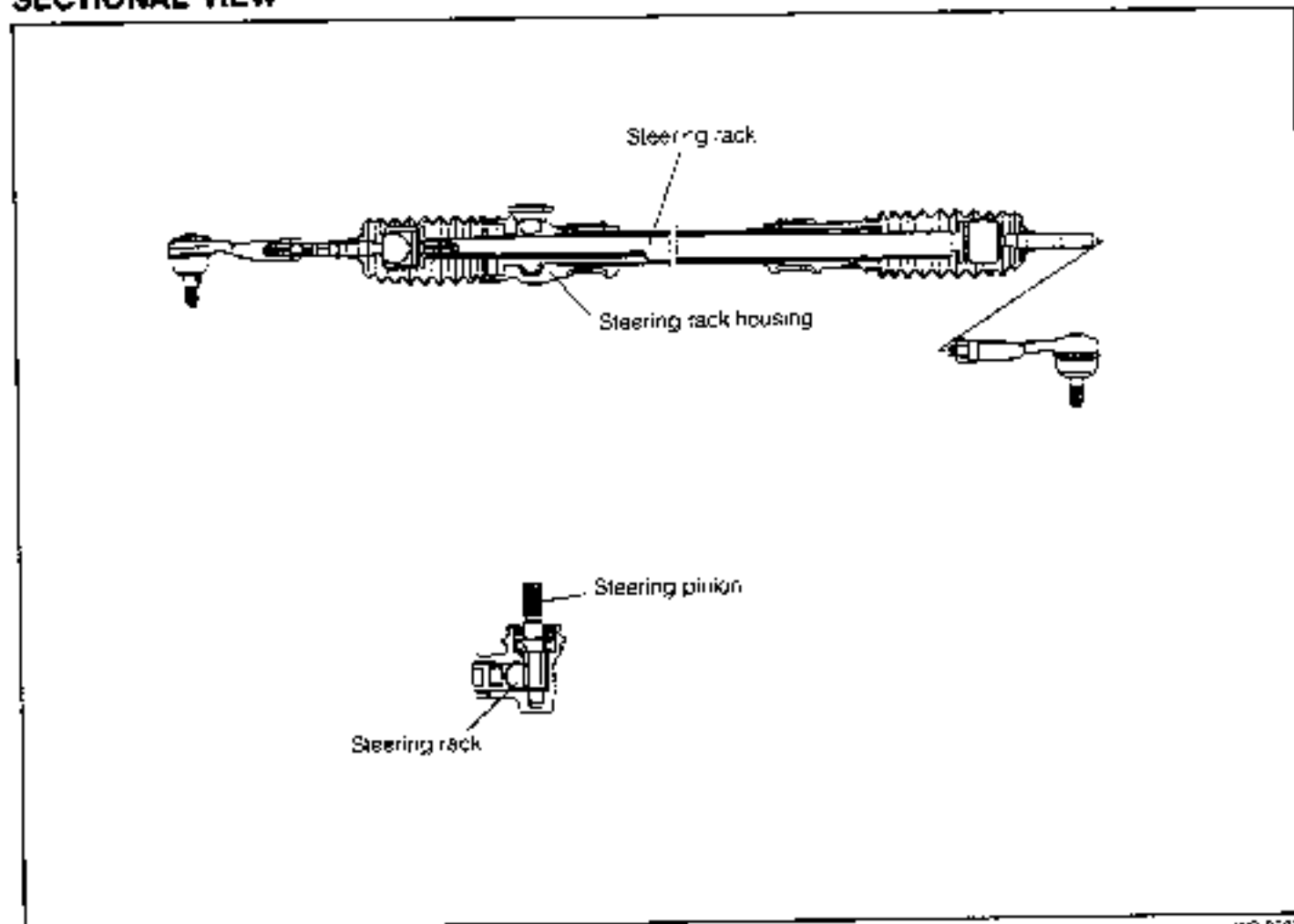

Fig. 7-38

7A-0703E

Specifications

Maximum turns from lock to lock		3.82
Rack stroke	mm. (inch)	141.5 (5.571)
Steering pinion tooth number		6
Rack tooth number		26

7A-0704C

COMPONENTS

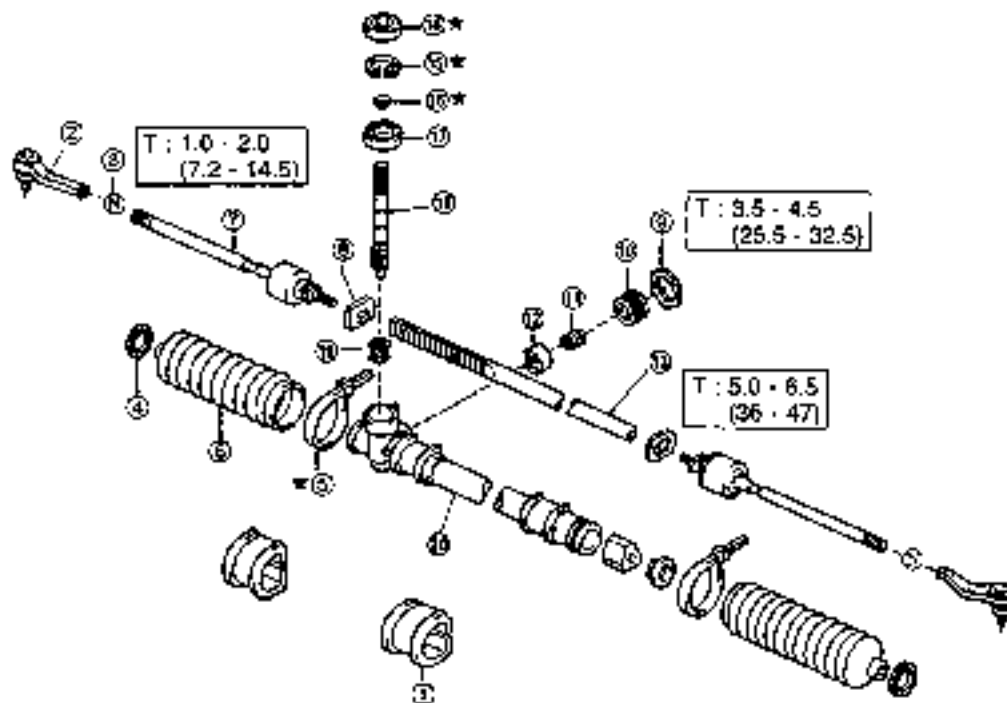

T : Tightening torque
 Unit: kg-m (ft-lb)
 * : Non-reusable parts

- | | |
|---------------------------------|-----------------------------|
| ① Steering rack housing grommet | ⑬ Compression spring |
| ② Tie rod end S/A | ⑭ Rack guide |
| ③ Nut | ⑮ Steering rack |
| ④ Steering boot band No.2 | ⑯ Oil seal |
| ⑤ Steering rack heat band | ⑰ Snap ring |
| ⑥ Steering rack boot | ⑱ Shaft snap ring |
| ⑦ Steering rack end | ⑲ Radial ball bearing |
| ⑧ Rack end plug | ⑳ Steering pinion |
| ⑨ Hexagon nut | ㉑ Needle roller bearing |
| ⑩ Rack guide spring cap | ㉒ Steering rack housing S/A |

Fig. 7-39

47-3754

STEERING

DISASSEMBLY

1. Clamp the mounting section of the steering rack housing in a vice with copper sheets or aluminum sheets interposed.
2. Tie rod end removal
 - (1) Before the steering tie rod end is removed, put a mark on the rack end section in order that this mark may be used as guide to ensure easier toe-in adjustment during the reassembly.
 - (2) Slacken the lock nut. Remove the tie rod end from the rack end.
3. Remove the boot band No.2 and rack boot band. Remove the rack boot.
4. Steering rack end removal
 - (1) Slacken the rack end plug, using the flat sections of the steering rack (width across flats: 19 mm) and the flat sections of the rack end plug (width across flats: 26 mm).
 - (2) Remove the steering rack end from the steering rack.
 - (3) Remove the rack end plug from the steering rack end.
5. Remove the lock nut (hexagon nut), using the following SST.
SST: 09617-22030-000
6. Rack guide spring cap removal
 - (1) Remove the rack guide spring cap, using a simple spinner.
Simple Spinner (Width across flats: 17 mm)
 - (2) Remove the compression spring and rack guide from the steering rack housing.

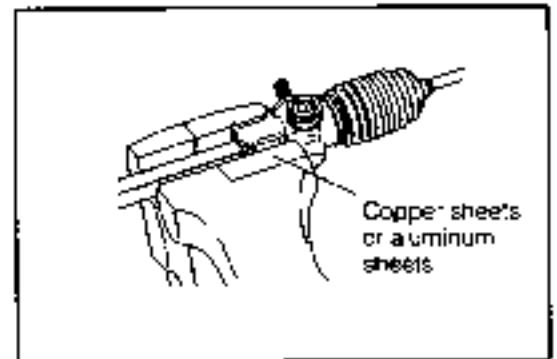

Fig. 7-40

WR-07042

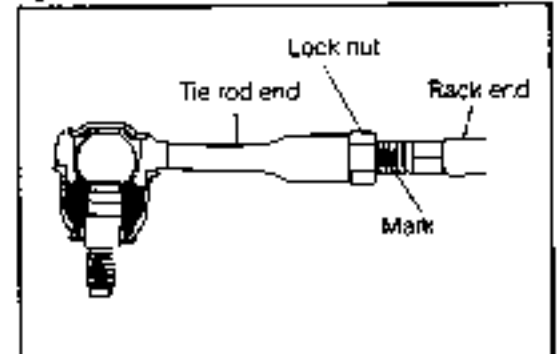

Fig. 7-41

WR-07043

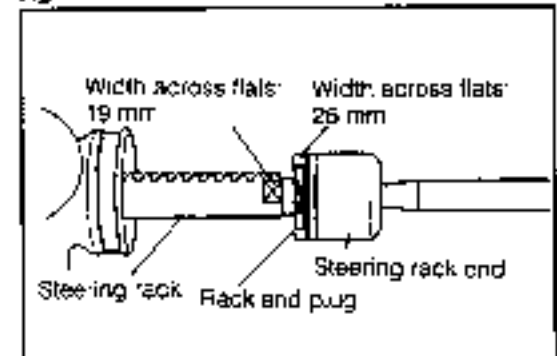

Fig. 7-42

WR-07044

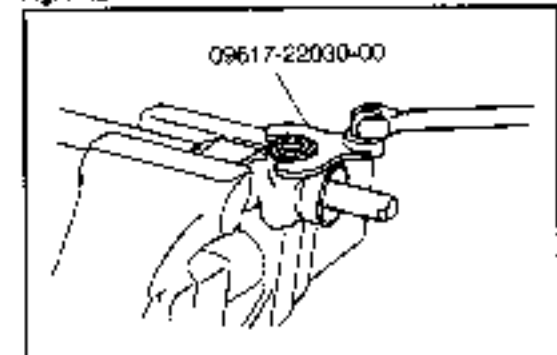

Fig. 7-43

WR-07045

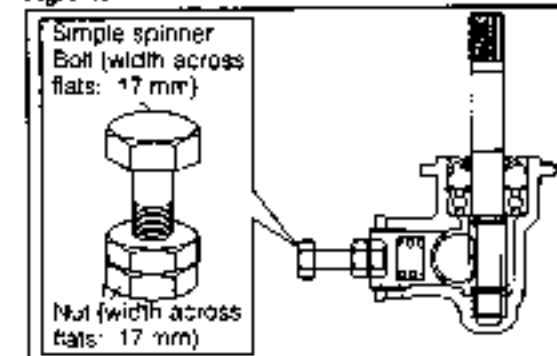

Fig. 7-44

WR-07046

7. Remove the steering rack.

NOTE:

- Be sure to draw out the rack toward the housing side so that the rack bush may not be damaged by the rack tooth surface.
- Draw out the rack straight, not allowing the rack to rotate.

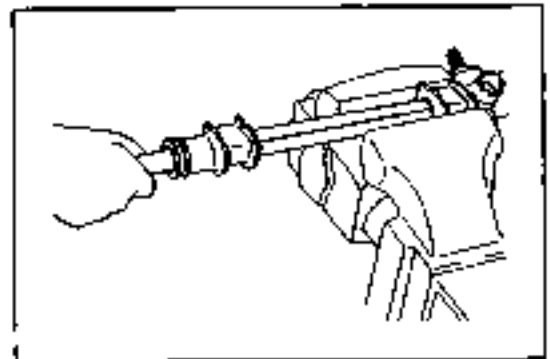

Fig. 7-45

WR-070-7

8. Remove the oil seal, using a common screwdriver or the like. Be careful not to damage the housing during the removal.

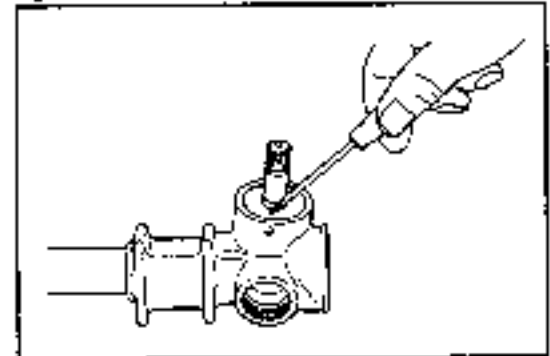

Fig. 7-46

WR-070-8

9. Detach the snap ring, using a snap ring expander

10. Remove the steering pinion, together with the bearing, from the steering rack housing.

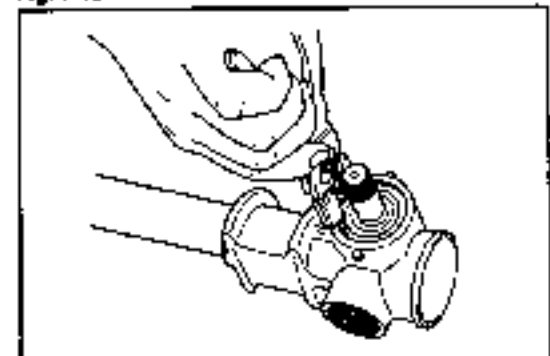

Fig. 7-47

WR-070-9

11. Radial ball bearing removal

- (1) Detach the shaft snap ring, using a snap ring expander
- (2) Remove the bearing, using the following SST.
SST: 09950-20014-000

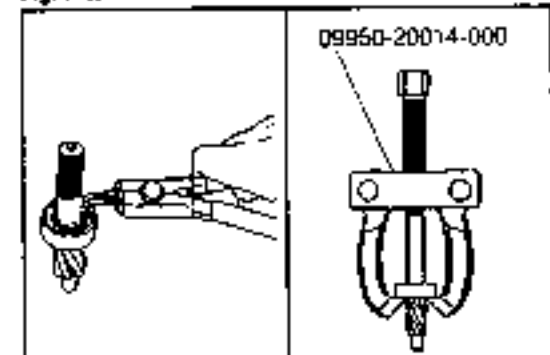

Fig. 7-48

WR-070-10

STEERING

INSPECTION

Inspect the following parts.

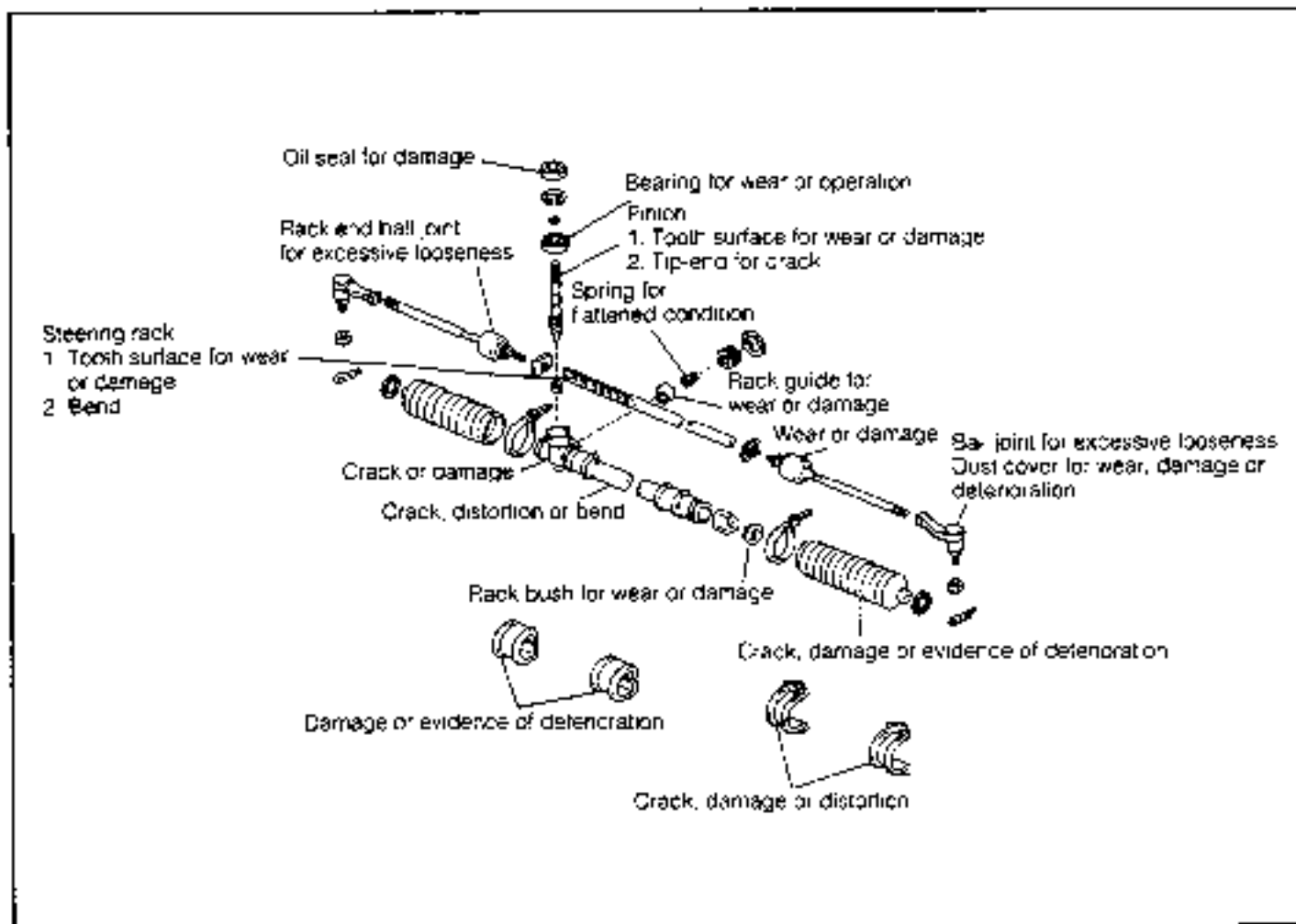

Fig. 7-49

WP-07951

ASSEMBLY

1. Apply grease to the following sections

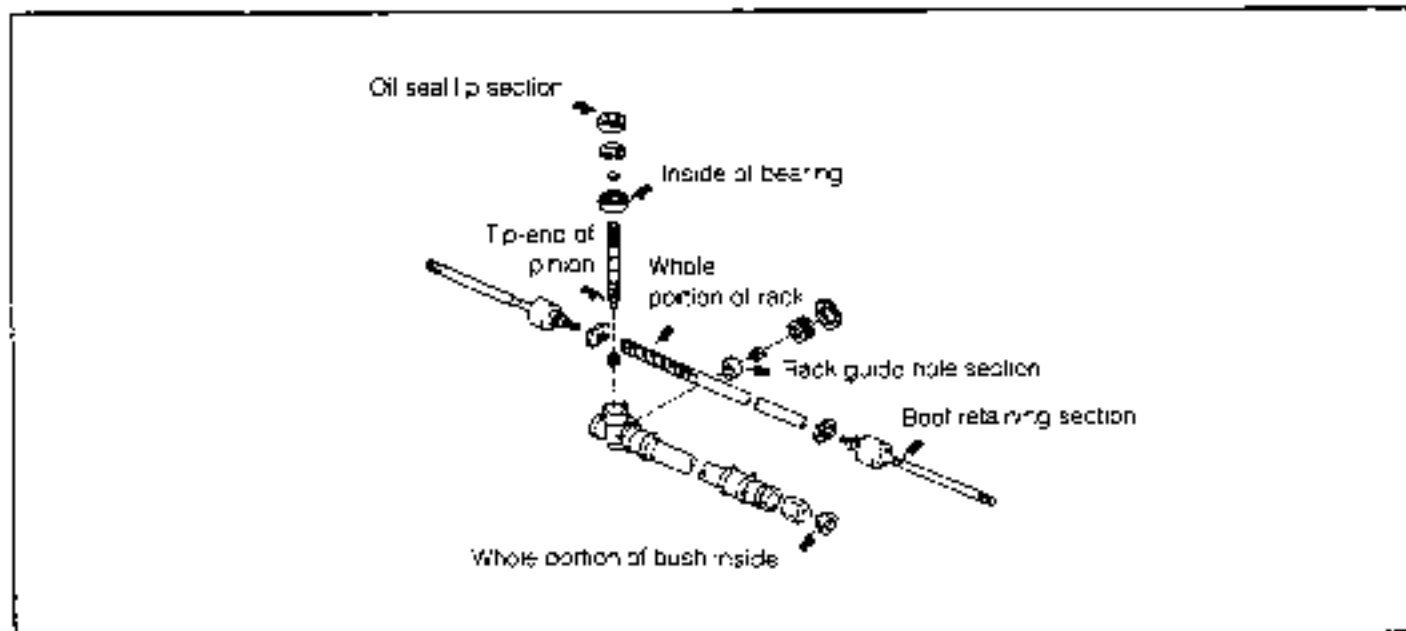

Fig. 7-50

WP-07052

2. Radial ball bearing installation
 (1) Install the bearing to the steering pinion, using the following SST.
 SST: 09612-10061-000

- (2) Attach the shaft snap ring, using a snap ring expander

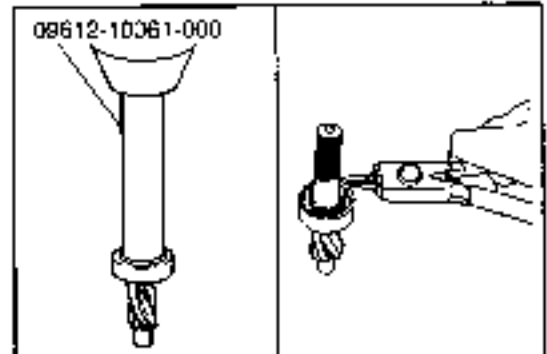

Fig. 7-51

W/P-07353

3. Steering pinion installation
 (1) Install the steering pinion to the steering rack housing, using the following SST.
 SST: 09309-87102-000

- (2) Attach the snap ring using a snap ring expander.

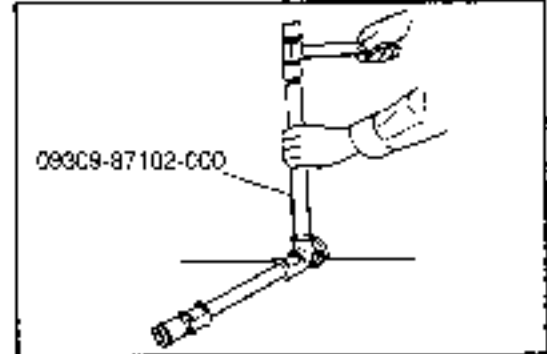

Fig. 7-52

W/P-07054

3. Install the oil seal to the steering rack housing, using the following SST.
 SST: 09309-87201-000

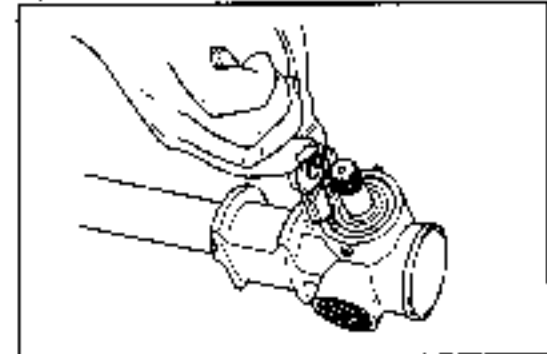

Fig. 7-53

W/P-07055

4. Assembly of steering rack
 (1) Apply EP grease to the tooth surface and whole peripheral portion of the steering rack.
 (2) Assemble the steering rack, paying attention not to damage the rack bush

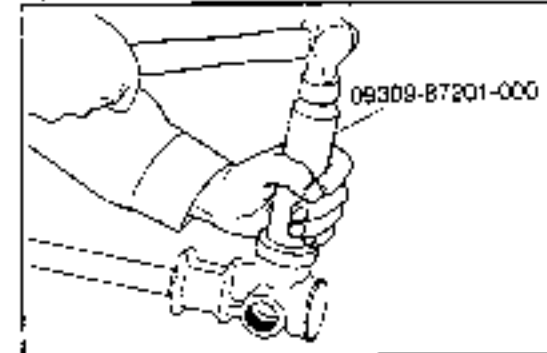

Fig. 7-54

W/P-07356

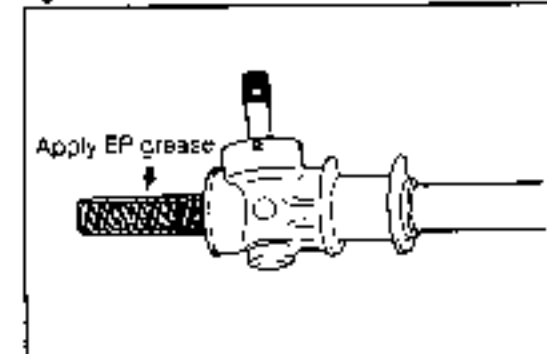

Fig. 7-55

W/P-07057

STEERING

5. Assemble the rack guide, compression spring and rack guide spring cap to the steering rack housing.

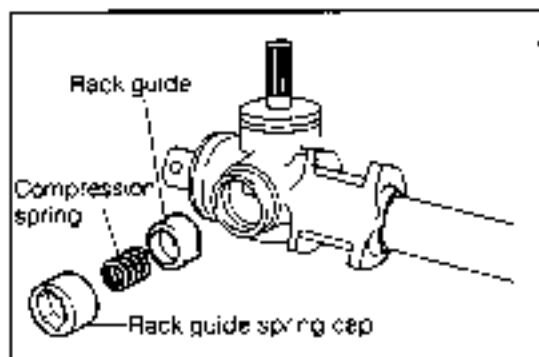

Fig. 7-66

WP-07068

6. Rack preload adjustment

- (1) Tighten the rack guide spring cap, using a simple spinner.

Tightening Torque: 0.7 kg-m (5.1 ft-lb)

- (2) Move the steering rack back and forth about 15 times so as to settle the steering rack. Then, proceed to tighten the rack guide spring cap again.

Tightening Torque: 1.25 kg-m (0.9 ft-lb)

- (3) Back off the rack guide spring cap $45^{\circ} \pm 1^{\circ}$, using a simple spinner.

- (4) Measure the rack preload, using the following SST.

SST: 09616-87701-000

Specified Value (Starting Torque):

3 - 6 kg-cm (2.6 - 5.2 inch-lb)

- (5) If the preload does not comply with the specification, repeat the operations (1) through (4)

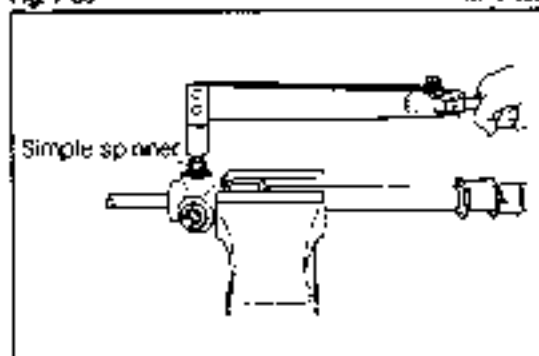

Fig. 7-67

WP-07069

7. Hexagon nut (lock nut) installation

- (1) Tighten the lock nut using the SST, while holding the rack guide spring cap with a simple spinner so as to prevent the rack guide spring cap from turning during the tightening.

SST: 09617-22030-000

Tightening Torque: 3.5 - 4.5 kg-m (25.5 - 32.5 ft-lb)

NOTE:

The actual reading of the torque wrench will be a product that is obtained by multiplying the figure above by the following figure given below:

$$\frac{\text{Length of torque wrench}}{\text{Length of torque wrench} + 6 \text{ cm}}$$

- (2) Check the pinion starting torque again.

SST: 09616-87701-000

Specified Value (Starting Torque):

3 - 6 kg-cm (2.6 - 5.2 inch-lb)

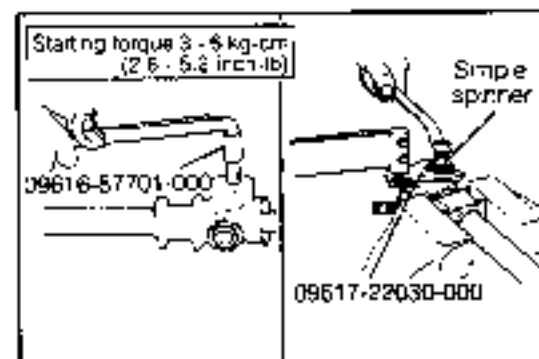

Fig. 7-58

WP-07067

9. Steering rack end installation

- (1) Screw in the rack end plug into the rack end
(Set the rack end plug in such a way that the side having a larger flange comes to the rack end side.)
- (2) Under the condition described in (1), tighten the rack end to the steering rack.
- (3) Secure the steering rack. Tighten the rack end plug
Tightening Torque: 5.0 - 6.5 kg-m (36 - 47 ft-lb)

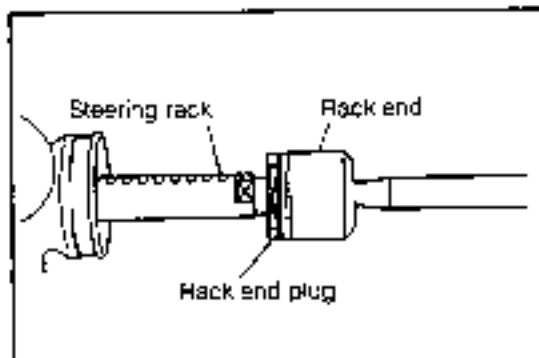

Fig. 7-60 WR-07061

9. Install the steering rack boot. Install the boot band No.2 and rack boot band.

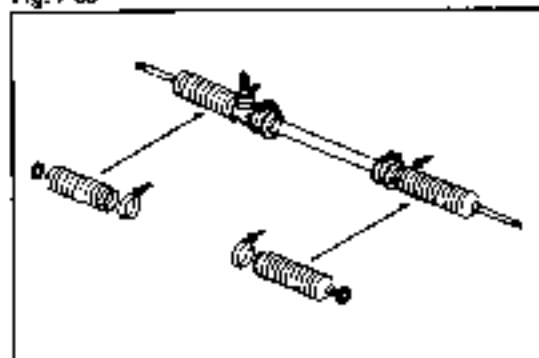

Fig. 7-60 WR-07062

10. Tie rod end installation

- (1) Screw in the lock nut and tie rod end into the rack end up to the mating mark. Tighten the lock nut temporarily.
- (2) Tighten the lock nut securely after the toe-in check and adjustment have been carried out.

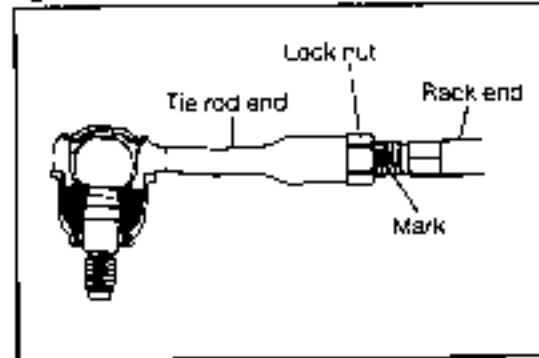

Fig. 7-61 WR-07063

INSTALLATION

1. Steering rack assembly installation

- (1) Install the grommet to the steering rack assembly
Then, insert it to the vehicle

NOTE:

Be very careful not to damage the steering rack boot during the insertion.

- (2) Install the steering universal joint to the steering pinion.
Tighten the bolt temporarily.

- (3) Install the steering rack assembly to the body.
Tightening Torque: 4.0 - 5.5 kg-m (29 - 40 ft-lb)

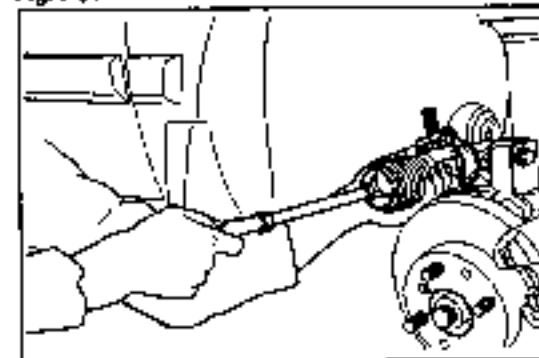

Fig. 7-62 WR-07064

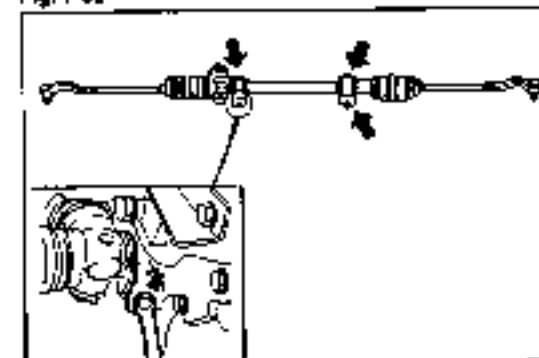

Fig. 7-63 WR-07065

STEERING

2. Tighten the attaching bolt of the steering Universal joint.

Tightening Torque: 2.5 - 3.5 kg-m (18 - 25 ft-lb)

NOTE:

When tightening the bolt, be sure to limit the protruding length of the serration sections of the universal joint and pinion to 5 mm (0.20 inch).

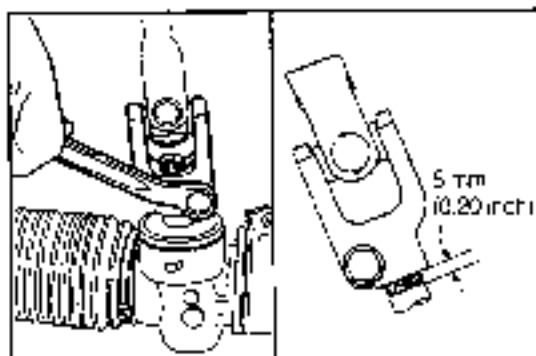

Fig. 7-84

WR-07066

3. Tie rod end installation

(1) Install the tie rod end to the knuckle. Tighten the castle nuts.

Tightening Torque: 3.0 - 4.5 kg-m (22 - 32.5 ft-lb)

(2) Install a new cotter pins.

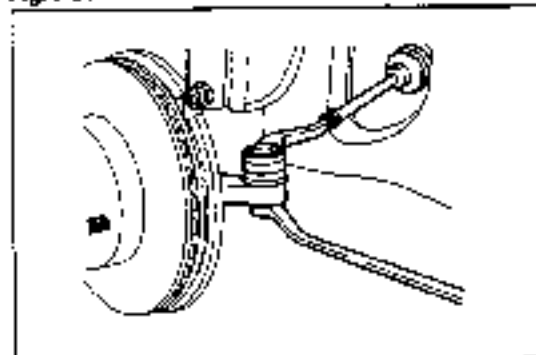

Fig. 7-85

WR-07067

4. Install the wheel. Jack down the vehicle.
5. Check the steering wheel play.
6. Perform the toe-in adjustment. (See page 5-44.)
7. Confirm the straight-ahead position of steering wheel.

WR-07068

DAIHATSU

CHARADE

Chassis

SECTION 8 BRAKES

BRAKE PEDAL CHECKS AND			
ADJUSTMENT	8- 2		
BRAKE BOOSTER OPERATION CHECK	8- 3		
AIR BLEEDING OF BRAKE SYSTEM	8- 5		
SCHEMATIC VIEW	8- 6		
BRAKE PEDAL	8- 7		
COMPONENTS	8- 7		
REMOVAL	8- 7		
INSPECTION	8- 8		
INSTALLATION	8- 8		
BRAKE MASTER CYLINDER AND			
BRAKE BOOSTER	8-10		
SECTIONAL VIEW	8-10		
MASTER CYLINDER	8-11		
COMPONENTS	8-11		
REMOVAL	8-12		
DISASSEMBLY	8-12		
INSPECTION	8-13		
ASSEMBLY	8-13		
INSTALLATION	8-14		
BRAKE BOOSTER	8-15		
(6-inch Booster)			
COMPONENTS	8-15		
REMOVAL	8-16		
DISASSEMBLY	8-16		
INSPECTION	8-17		
ASSEMBLY	8-18		
(7-inch Booster)			
COMPONENTS	8-21		
DISASSEMBLY	8-22		
INSPECTION	8-23		
ASSEMBLY	8-23		
INSTALLATION	8-26		
FRONT BRAKE	8-28		
SECTIONAL VIEW	8-28		
COMPONENTS	8-29		
DISC BRAKE PAD	8-30		
DISC BRAKE FRONT CALIPER	8-31		
REAR DRUM BRAKE	8-37		
SECTIONAL VIEW	8-37		
COMPONENTS	8-37		
REMOVAL	8-38		
INSPECTION	8-40		
INSTALLATION	8-41		
REAR DISC BRAKE	8-45		
SECTIONAL VIEW	8-45		
COMPONENTS	8-46		
DISC BRAKE PAD	8-47		
DISC BRAKE REAR CYLINDER	8-49		
PARKING BRAKE	8-56		
PARKING BRAKE LEVER	8-56		
PARKING BRAKE CABLE	8-58		

BRAKES

BRAKE PEDAL CHECKS AND ADJUSTMENTS

1. Pedal height check

Measure the brake pedal height (the dimension from the center of the pedal applying surface to the dash panel).

Specified Value: 176 - 181 mm (6.93 - 7.13 inch)

2. Pedal height adjustment

- (1) Disconnect the connector from the stop lamp switch. Slacken the nut ① and turn the switch until the pedal has a free travel.
- (2) Slacken the nut ②. Turn the push rod ③ so as to adjust the pedal height. Lock the nut ②.
- (3) Turn the switch, until the pedal cushion comes in contact with the edge of the threaded portion of the stop lamp switch. Lock the nut ①.
- (4) Connect the connector of the stop lamp switch.
- (5) Upon completion of the pedal height adjustment, ensure that the pedal free travel is proper and the stop lamp functions properly.

3. Pedal free travel check

After stopping the engine, depress the brake pedal strongly several times so that no vacuum may remain the brake booster. Measure the brake pedal free travel by pushing the brake pedal lightly by fingers. Here, the pedal free travel means the distance from a point where the brake pedal is free to a point where you begin to feel a resistance.

Specified Value:

6-inch Booster 3 - 7 mm (0.12 - 0.28 inch)

7-inch Booster 0.5 - 2 mm (0.02 - 0.08 inch)

4. Pedal free travel adjustment

- (1) Slacken the nut ②. Turn the push rod ③ so as to adjust the pedal free travel.
- (2) Upon completion of the adjustment, ensure that the pedal height is proper and the stop lamp functions properly.

5. Pedal reserve travel check

With the engine running at the idling speed and with the parking brake lever in its returned state, depress the brake pedal with a pedal applying force of 30 kg (66 lb). Measure the gap between the position where the depressed pedal stops and the floor panel.

Specified Value: 102 mm (4.0 inches) or more

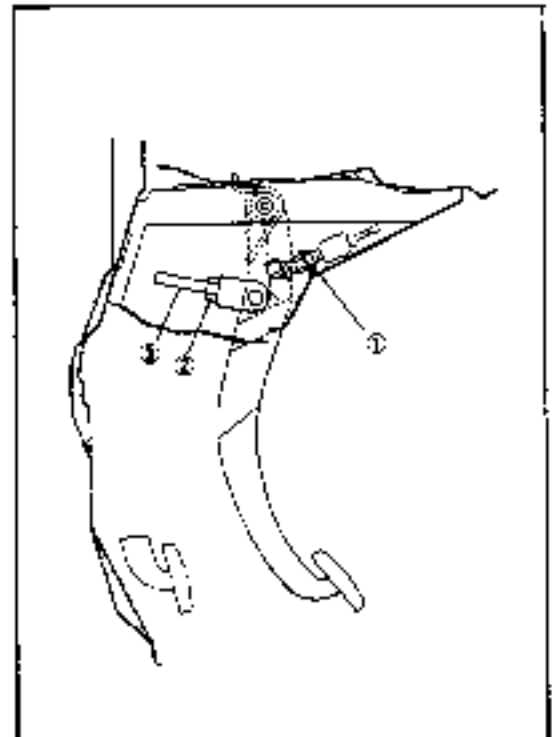

Fig. 8-1

WR-08002

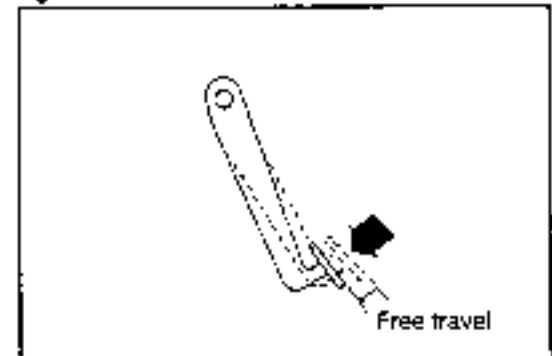

Fig. 8-2

WR-08002

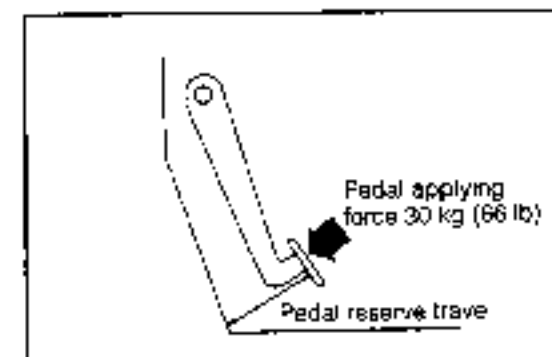

Fig. 8-3

WR-08002

BRAKE BOOSTER OPERATION CHECK

1. SIMPLE CHECK

(1) Booster air-tight performance check

Start the engine. After running the engine for one to two minutes, stop the engine. Depress the brake pedal several times, applying a force which will be used during normal brake applications. If the position of the brake pedal rises progressively at the second and third applications and so on, it indicates the brake booster is functioning properly.

NOTE:

Intervals between the first and second applications as well as between the second and third applications should be at least five seconds.

(2) Booster air-tight performance check under loaded condition

With the engine running, depress the brake pedal. While maintaining this condition, stop the engine. If the brake pedal height remains at the same level at least 30 seconds, it indicates that the booster is functioning properly.

(3) Booster operation check

With the engine stopped, depress the brake pedal several times, applying the same force at each brake application. Ensure that the brake pedal height will not vary at each brake application. Then, start the engine while depressing the brake pedal. If the brake pedal moves in slightly, it indicates that the booster is functioning properly.

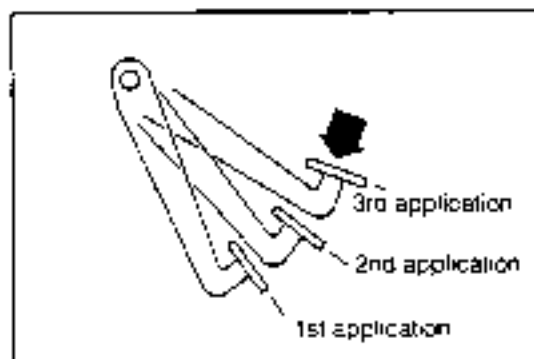

Fig. 8-4

WR-08005

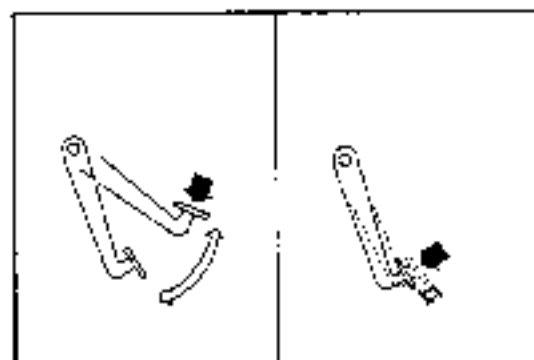

Fig. 8-5

WR-08006

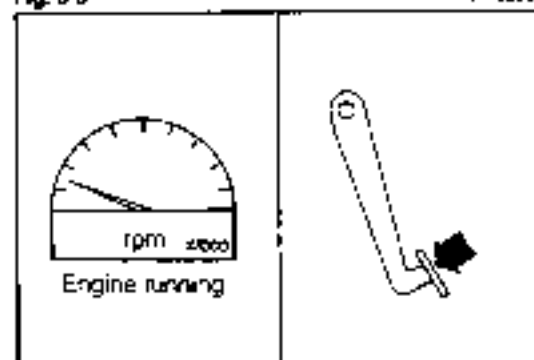

Fig. 8-6

WR-08007

2. CHECK EMPLOYING PORTABLE BRAKE BOOSTER TESTER

(1) Connection of portable brake booster tester

Connect the portable booster tester. Carry out air bleeding for the booster tester.

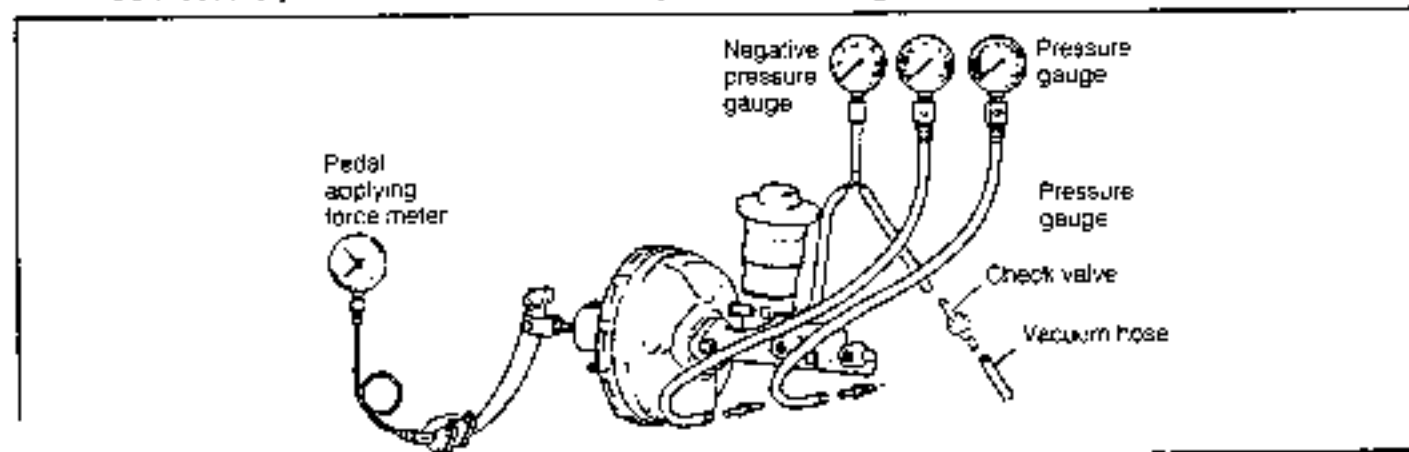

Fig. 8-7

WR-08008

BRAKES

(2) Booster air-tight performance check

Start the engine. When the negative pressure exceeds 500 mmHg stop the engine. Proceed to measure the negative pressure. Ensure that the negative pressure will not drop for a period of 15 seconds following the stoppage of the engine.

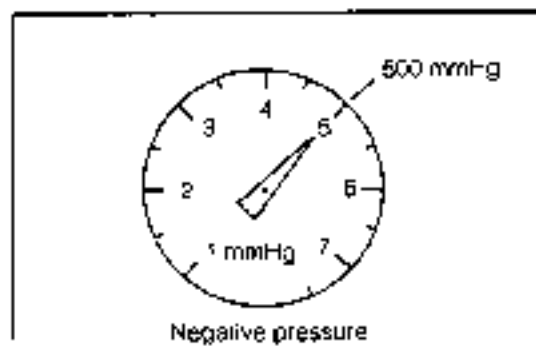

Fig. 8-8

WA-02008

(3) Booster air-tight performance check under loaded condition

With the engine running depress the brake pedal with a pedal applying force of 20 kg (44 lb). Stop the engine when the negative pressure exceeds 500 mm Hg, stop the engine. Proceed to measure the negative pressure. Ensure that the negative pressure will not drop more than 25 mmHg for a period of 15 seconds following the stoppage of the engine.

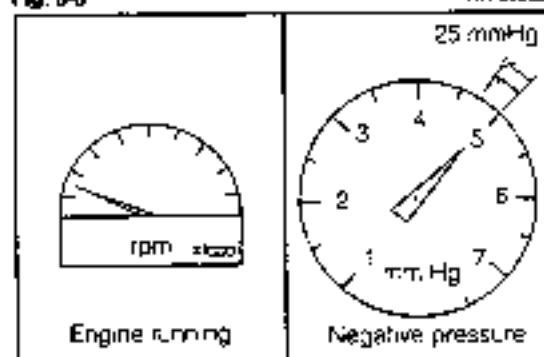

Fig. 8-9

WA00010

(4) No-boosting operation check

With the engine stopped, set the reading of the negative pressure gauge to zero. Under this condition, check the relationship between the pedal applying force and the hydraulic pressure.

Specified Value:

Pedal applying force kg (lb)	Hydraulic pressure	
	6-inch	7-inch
10 (22)	6.5 (92)	5.6 (80)
30 (66)	37.8 (538)	32.4 (461)

WA-00011

(5) Boosting operation check

With the engine running, set the reading of the negative pressure gauge to 500 mmHg. After stopping the engine depress the brake pedal. Check the relationship between the pedal applying force and the hydraulic pressure.

Specified Value:

Pedal applying force kg (lb)	Hydraulic pressure	
	6-inch	7-inch
5 (11)	18.4 (262)	13.6 (193)
10 (22)	46.4 (660)	34.2 (487)
15 (33)	56.0 (797)	54.8 (779)
20 (44)	63.9 (909)	67.2 (955)

WA-00012

AIR BLEEDING OF BRAKE SYSTEM

1. Filling brake fluid

Fill the brake master cylinder reservoir with the brake fluid.

NOTE:

If the brake fluid is spilled inadvertently over the paint-finish surface of the vehicle, quickly wipe off the brake fluid.

2. Connection of vinyl hose to bleeder plug of wheel cylinder

- (1) Submerge one end of a vinyl hose in a container filled with the brake fluid. Connect the other end of the vinyl hose to the wheel cylinder bleeder plug of the vehicle.
- (2) Start this air bleeding operation at the wheel cylinder which is located at the farthest point from the master cylinder.

3. Air bleeding

- (1) Perform the operation by two persons. One person should depress the brake pedal slowly and hold it in a depressed state.
- (2) The other person slackens the bleeder plug $1/3$ through $1/2$ turn at a time. Be sure to tighten the bleeder plug before the hydraulic pressure ceases to exist in the cylinder.
- (3) Repeat the steps (1) and (2) above, until you no longer observe bubbles in the fluid.

4. Checking of brake fluid leakage

Depress the brake pedal and ensure that each section of the pipe line exhibits no fluid leakage.

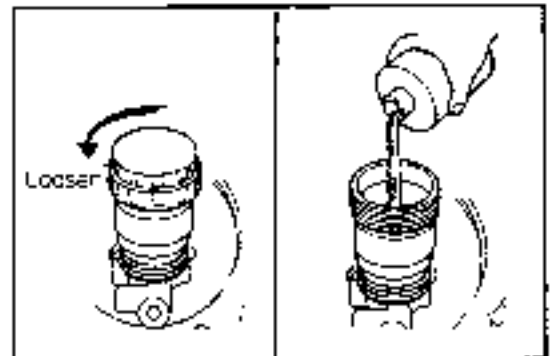

Fig. 8-10

WR-08013

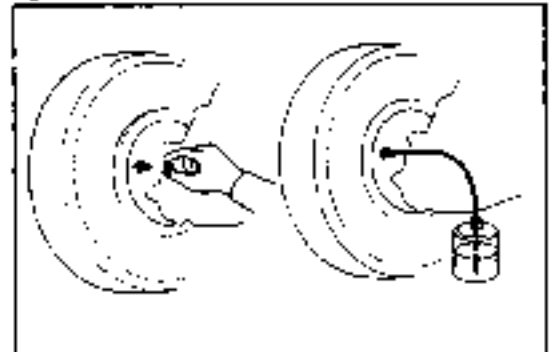

Fig. 8-11

WR-08014

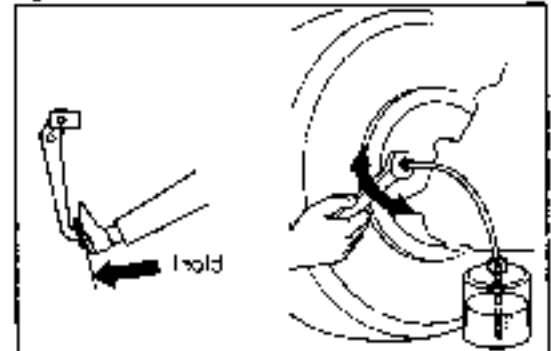

Fig. 8-12

WR-08015

WR-08016

SCHEMATIC VIEW

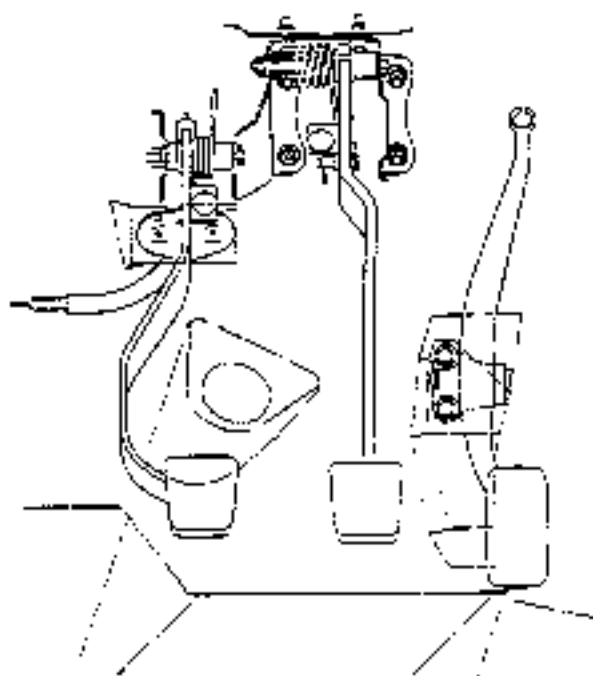
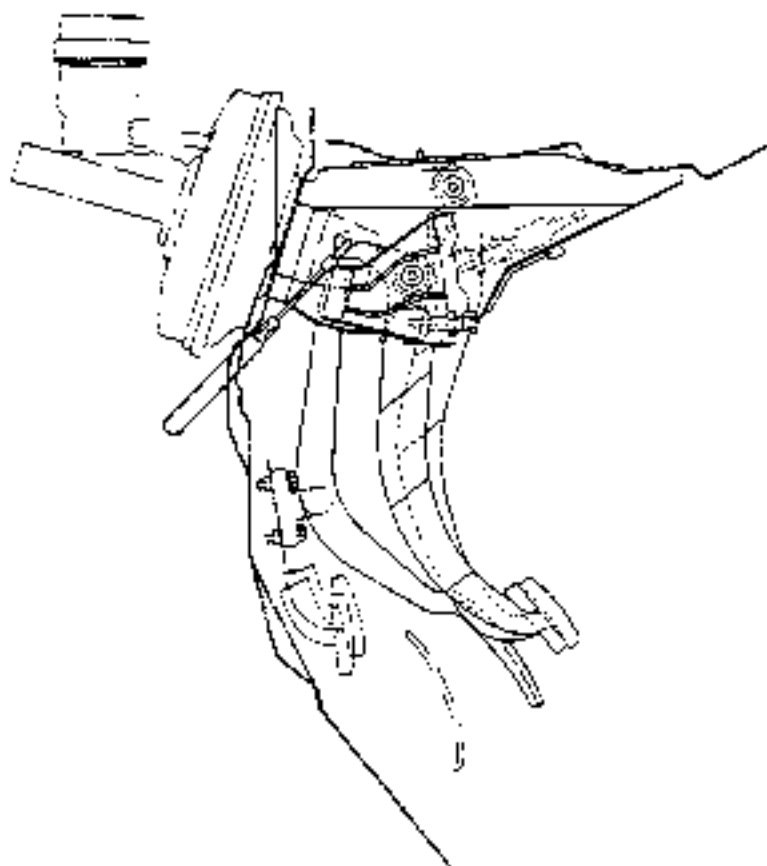
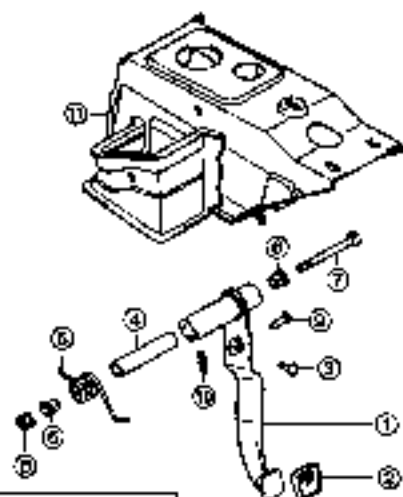

Fig. 8-13

WFL-08017

BRAKE PEDAL COMPONENTS

Manual Transmission



RHD: T : 1.5 - 2.2 (11 - 16)
LHD: T : 1.5 - 2.0 (11 - 15)

Automatic Transmission

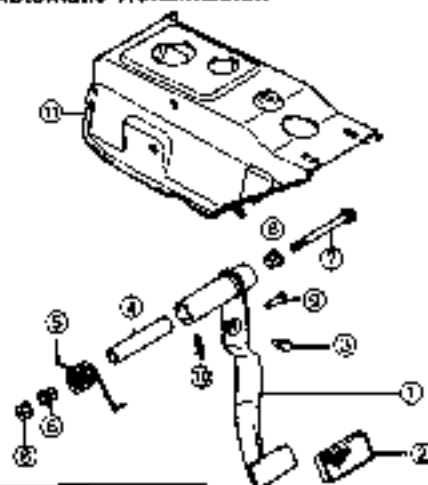

RHD: T : 1.5 - 2.2 (11 - 16)
LHD: T : 1.5 - 2.0 (11 - 15)

T : Tightening torque
Unit: kg-m (ft-lb)

- ① Brake pedal
- ② Brake pedal pad
- ③ Cushion
- ④ Spacer
- ⑤ Spring
- ⑥ Bush

- ⑦ Bolt
- ⑧ Nut
- ⑨ With-hole pin
- ⑩ Clip
- ⑪ Brake pedal bracket

Fig. 8-14

WR-02018

REMOVAL

1. Detach the clamp of the stop lamp switch wiring.
2. Remove the clip and the with-hole pin from the connecting section of the master cylinder push rod with the brake pedal

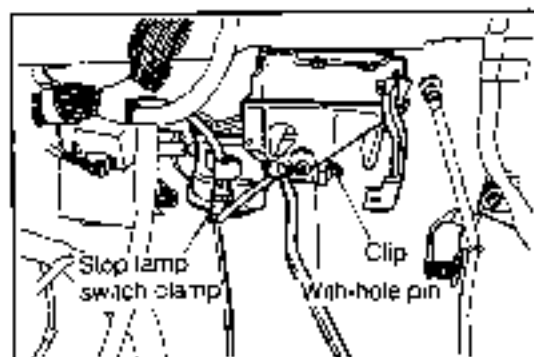

Fig. 8-15

WR-03219

BRAKES

3. Remove the brake pedal attaching bolt and nut.
4. Remove the brake pedal from the brake pedal bracket.

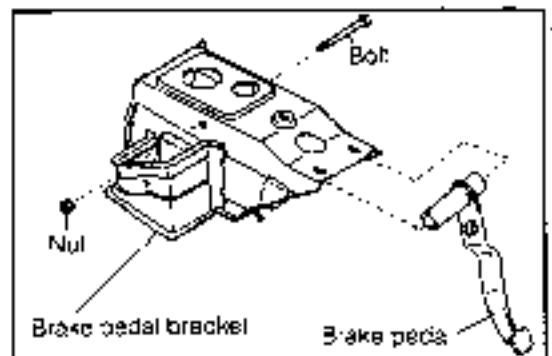

Fig. 8-16

WR-08021

5. Remove the spring, bush, spacer, brake pedal pad and cushion from the brake pedal.

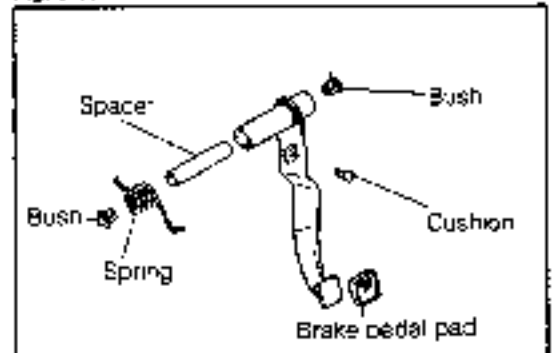

Fig. 8-17

WR-08022

INSPECTION

Inspect the following parts.

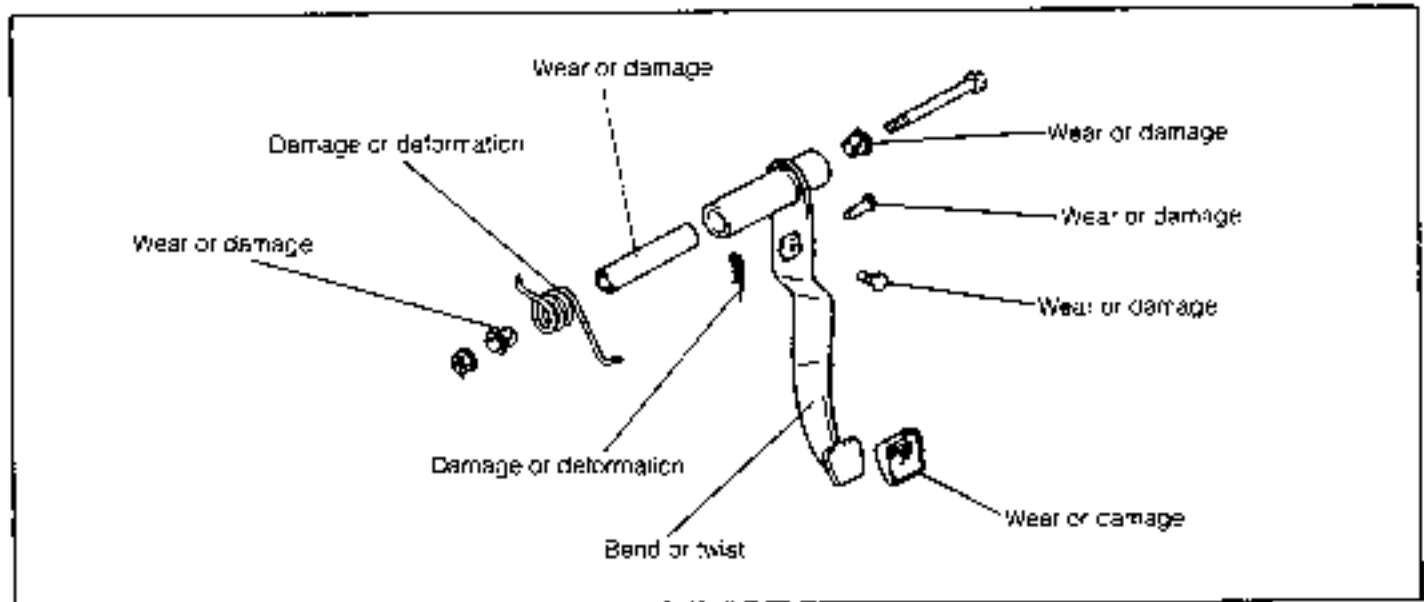

Fig. 8-18

WR-08022

INSTALLATION

1. Install the cushion, brake pedal pad, spacer, bush and spring on the brake pedal.

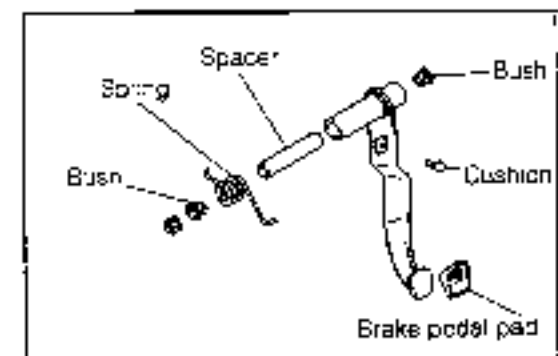

Fig. 8-19

WR-08022

2. Install the brake pedal on the brake pad brake.
3. Install the brake pedal attaching bolt and nut.

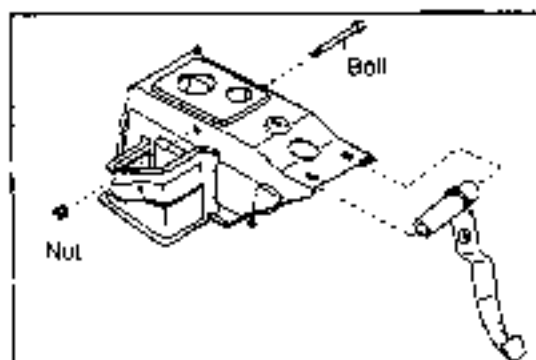

Fig. 8-20

WH-28124

4. Install the with-hole pin and the clip on the connecting section of the master cylinder push rod with the brake pedal.
5. Attach the clamp of the stop lamp switch wiring.
6. Perform the check and adjustment of the brake pedal.
(See page 8-2.)

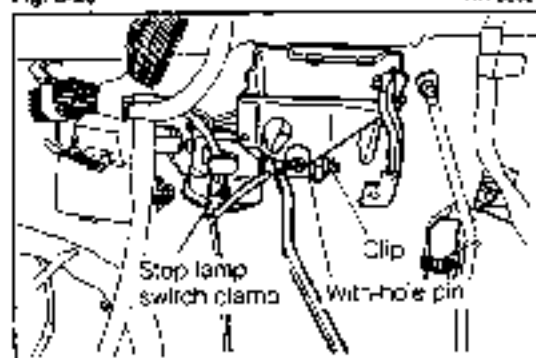

Fig. 8-21

WF-28085

BRAKES

BRAKE MASTER CYLINDER AND BRAKE BOOSTER SECTIONAL VIEW

6-inch

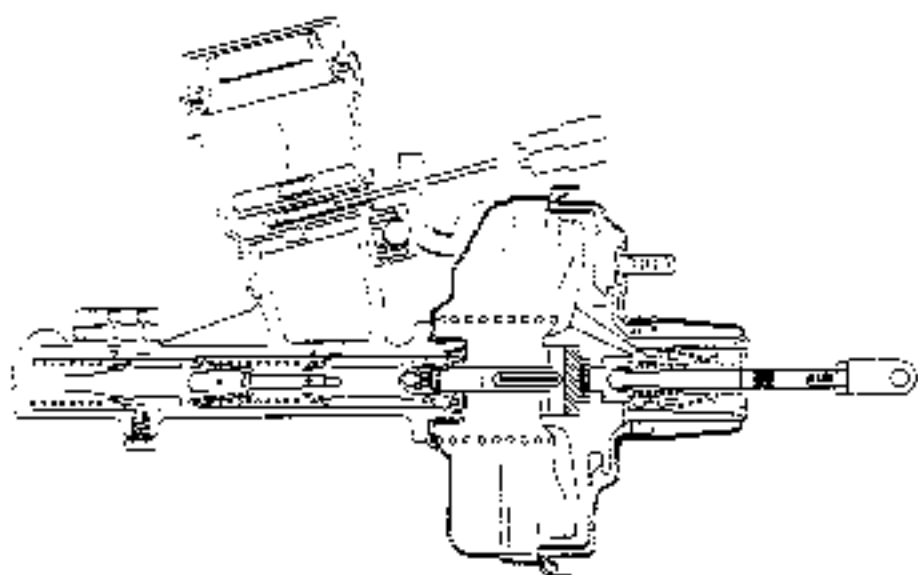

7-inch

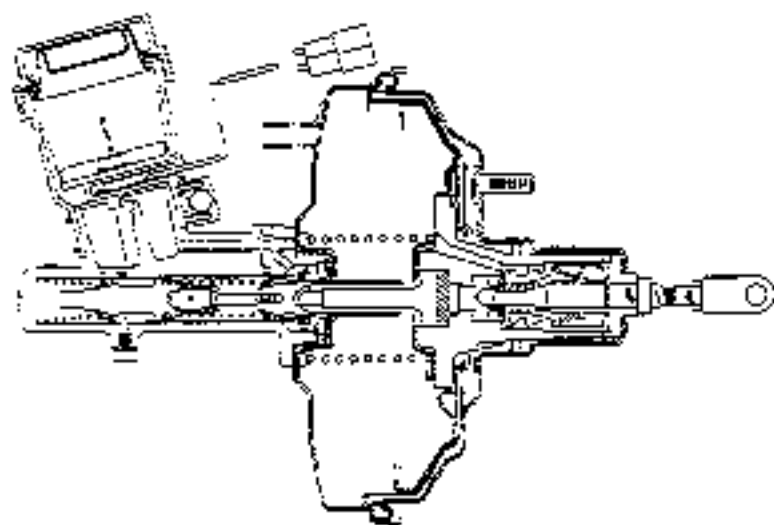
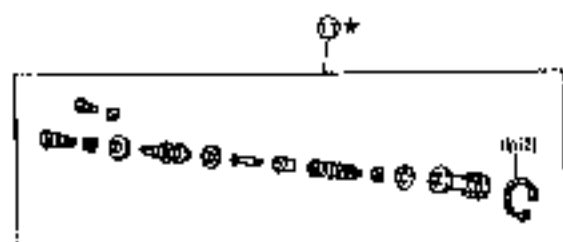
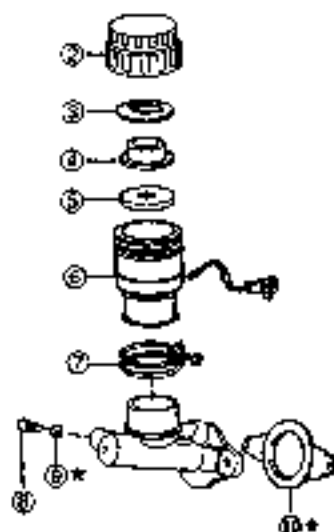
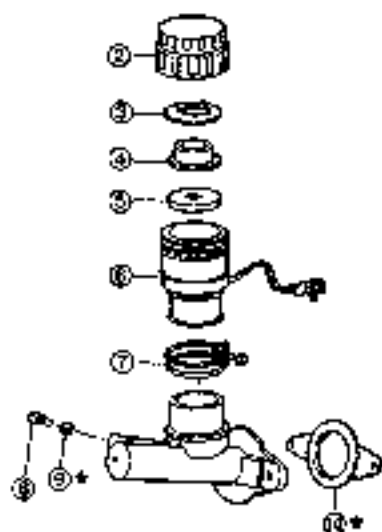
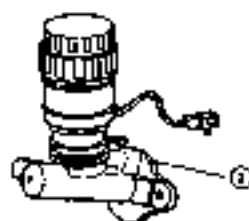
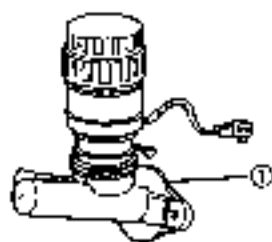

Fig. 8-22

419-08026

MASTER CYLINDER COMPONENTS

6 inch



T : Tightening torque
Unit: kg-m (ft-lb)
* : Non-reusable parts

- ① Brake master cylinder *Ay*
- ② Reservoir filler cap
- ③ Reservoir cap spacer
- ④ Reservoir diaphragm
- ⑤ Master cylinder reservoir float

- ⑥ Master cylinder reservoir *Ay*
- ⑦ Clamp
- ⑧ Set ball
- ⑨ Gasket
- ⑩ Gasket
- ⑪ Tandem master cylinder repair kit

Fig. 8-23

WF-CAC07

BRAKES

REMOVAL

1. Remove the level switch connector.
2. Drain the brake fluid.
3. Disconnect the three brake tubes, using the following SST.
SST: 09751-36011-000

NOTE:

If the brake fluid is spilled inadvertently over the paint-finish surface of the vehicle, quickly wipe off the brake fluid.

4. Remove the two attaching nuts of the master cylinder. Remove the master cylinder and gasket from the brake booster.

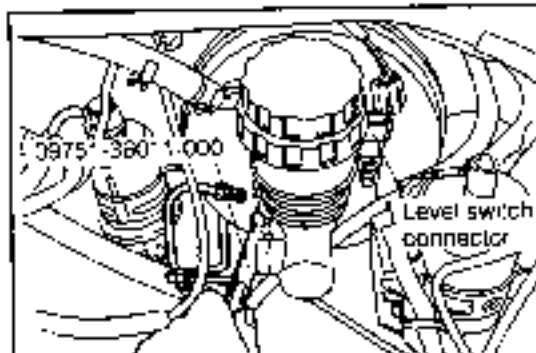

Fig. 8-24

WP-08029

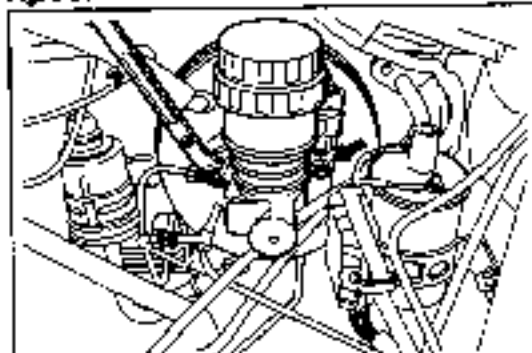

Fig. 8-25

WP-08029

DISASSEMBLY

1. Clamp the flange section of the master cylinder in a vise, with jaw plates or the like interposed.

NOTE:

Be sure not to clamp the cylinder portion of the master cylinder in a vise. Failure to observe this caution will cause cylinder distortion.

2. Remove the reservoir filler cap, reservoir diaphragm, reservoir cap spacer, master cylinder reservoir float, clamp and master cylinder reservoir assembly from the master cylinder.

3. Remove the set bolt and gasket while the pistons are being pushed fully by means of a cross point screwdriver.

NOTE:

During the removal, be sure to push the piston slowly so as to prevent the brake fluid from splashing.

4. Detach the snap ring.
Using a snap ring, detach the snap ring while the pistons are being pushed by means of a screwdriver.
5. Remove the pistons No. 1 and No. 2 from the master cylinder.

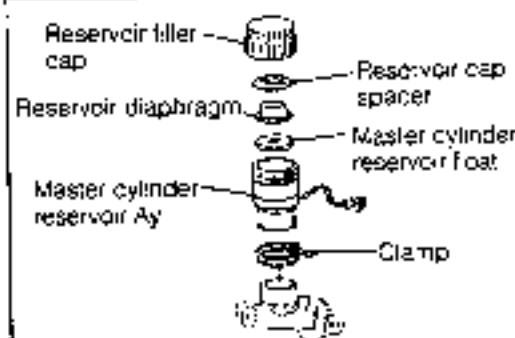

Fig. 8-26

WP-08030

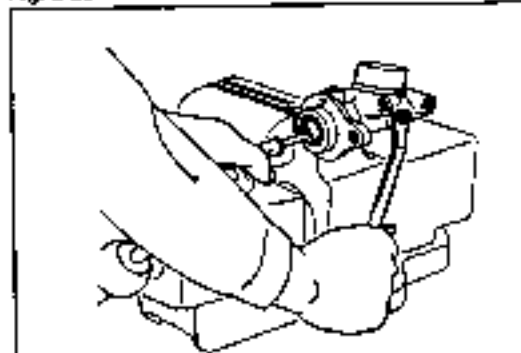

Fig. 8-27

WP-08031

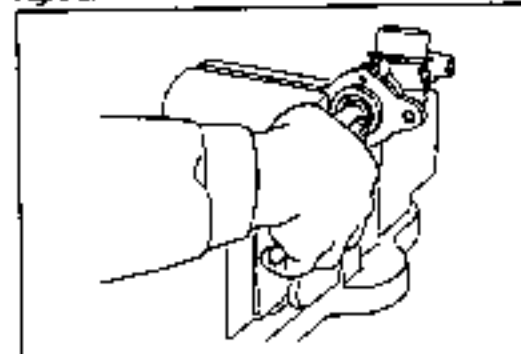

Fig. 8-28

WP-08032

INSPECTION

Inspect the following parts.

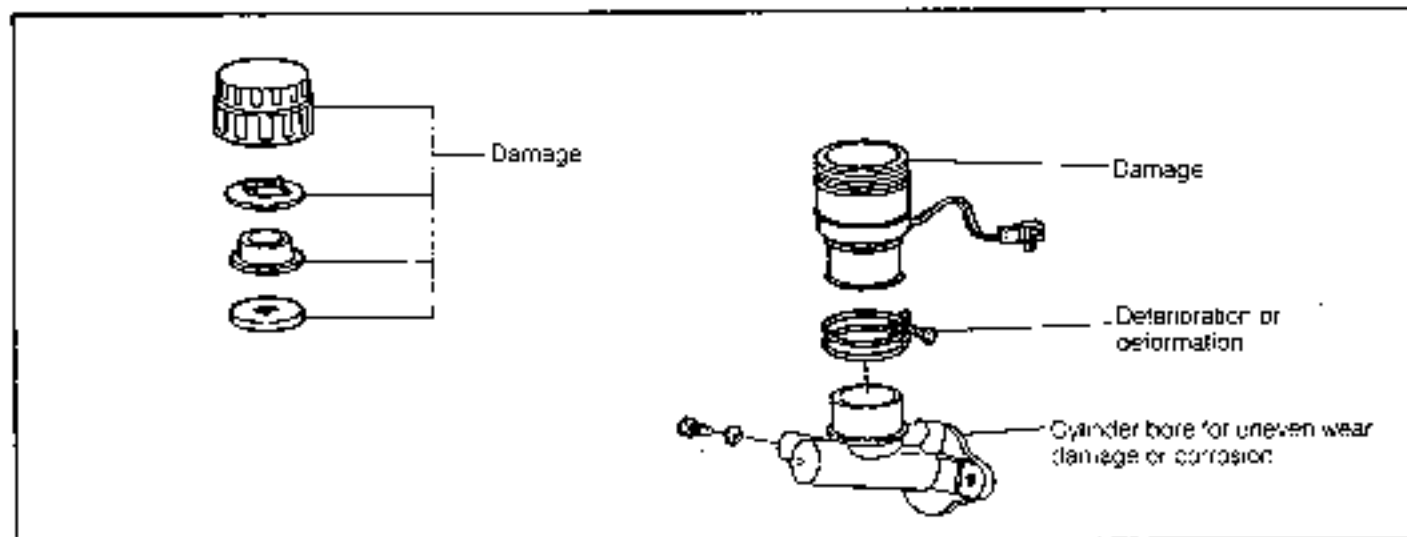

Fig. 8-29

WA-26732

ASSEMBLY

1. Assemble a new tandem master cylinder repair kit (comprising the pistons No.1 and No.2) in the master cylinder.

NOTE:

Apply rubber grease to those points indicated by arrow heads in the figure below.

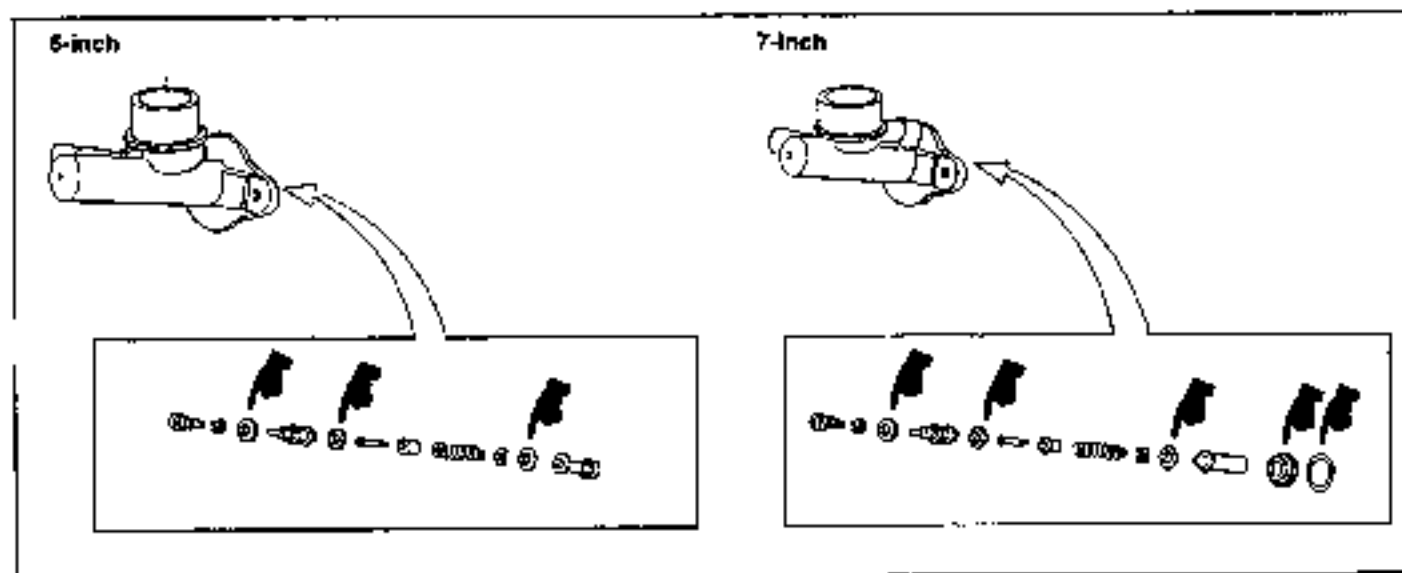

Fig. 8-30

WA-08354

2. Install the snap ring.
With the pistons in their fully pushed-in state, install a new snap ring.

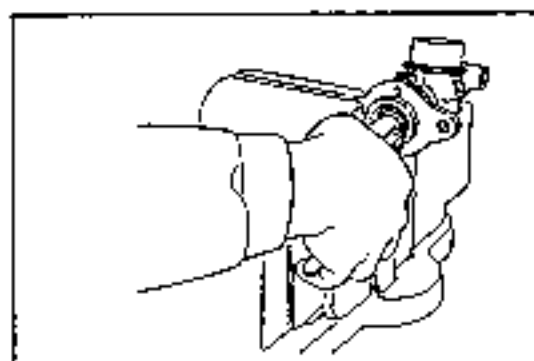

Fig. 8-31

WA-08355

BRAKES

3. While pushing the pistons fully by means of a cross point screwdriver, assemble the set bolt with a new gasket interposed.

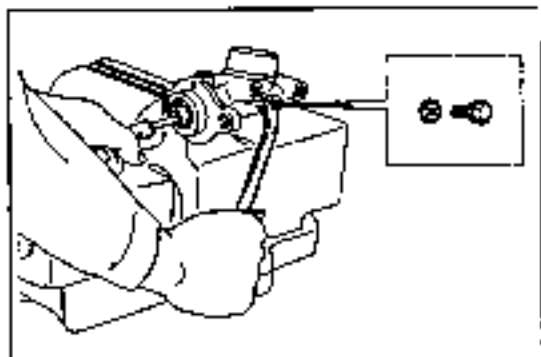

Fig. 8-32

WF-08098

4. Install the clamp, master cylinder reservoir assembly, master cylinder reservoir float, reservoir cap spacer, reservoir diaphragm and reservoir filler cap.

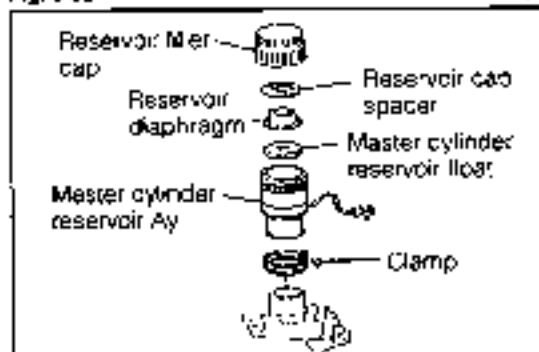

Fig. 8-33

WF-08097

INSTALLATION

1. Adjust the clearance of the brake booster push rod.
6-inch Booster: See page 8-20.
7-inch Booster: See page 8-26.
2. With a new gasket interposed, install the master cylinder using the two nuts.

NOTE:

The master cylinder's attaching nut at the right side, as viewed toward the vehicle, should be used to tighten the bracket, too.

3. Connect the brake tubes
 - (1) Temporarily connect the three brake tubes to the master cylinder by hands.
 - (2) Tighten the brake tube, using the following SST
SST: 09751-36011-000

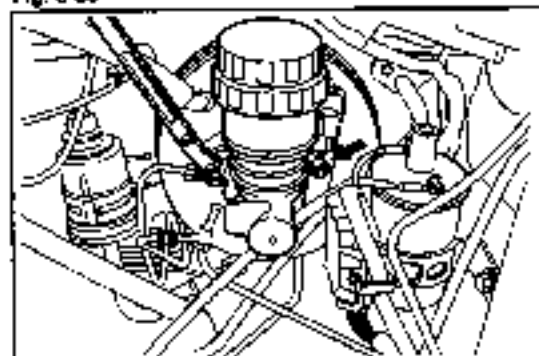

Fig. 8-34

WF-08096

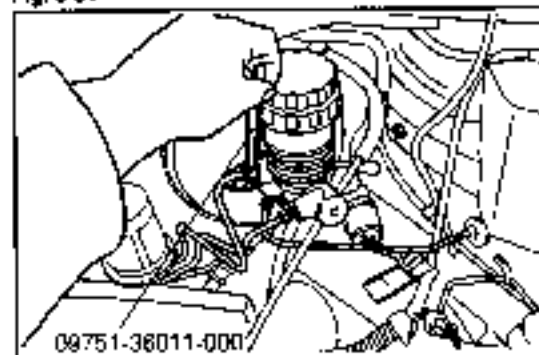

Fig. 8-35

WF-08095

4. Connect the level switch connector
5. Fill the brake fluid.
6. Perform air bleeding for the brake system.
(See page 8-5.)
7. Check the brake system for brake fluid leakage
8. Perform the checks and adjustments for the brake pedal.
(See page 8-2.)

BRAKE BOOSTER

COMPONENTS

(6-inch Booster)

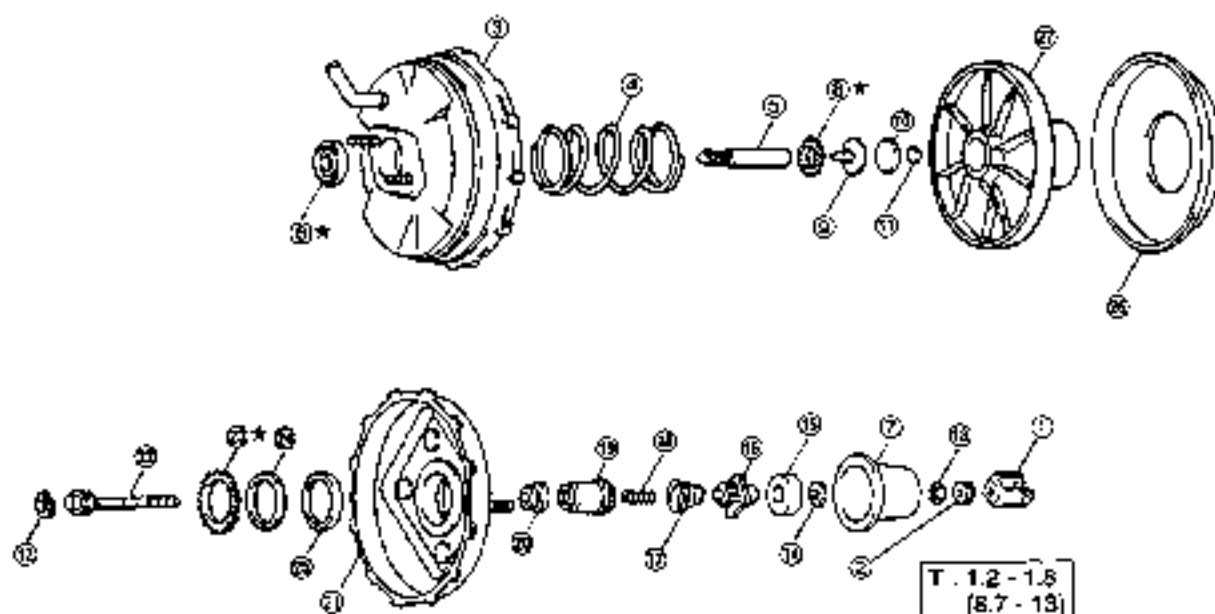

T : Tightening torque
 Unit: kg-m (ft-lb)
 * : Non-reusable parts

- ① Master cylinder push rod clevis
- ② Nut
- ③ Booster body
- ④ Booster spring
- ⑤ Output rod
- ⑥ Rod seal
- ⑦ Boot
- ⑧ Rod stopper
- ⑨ Reaction ring
- ⑩ Reaction rubber
- ⑪ Reaction plate
- ⑫ Snap ring
- ⑬ "E" ring
- ⑭ Plate washer

- ⑮ Element
- ⑯ Spring seal
- ⑰ Valve spring
- ⑱ Poppet spring
- ⑲ Valve stopper
- ⑳ Poppet valve
- ㉑ Booster housing
- ㉒ Push rod W/valve
- ㉓ Bush stopper
- ㉔ Bush
- ㉕ Piston seal
- ㉖ Diaphragm
- ㉗ Booster piston

Fig. 8-36

AS-08311

BRAKES

REMOVAL

1. Remove the master cylinder. (See page 8-12.)
2. Disconnect the vacuum hose.
3. Remove the front suspension upper brace subassembly. (RHD TURBO and GT_i grades only)
4. Remove the clutch cable and ignition coil (LHD TURBO and GT_i grades only)
5. Working from the passenger room side, remove the clip and the with-hole pin. Separate the master cylinder push rod clevis end from the brake pedal. (See Fig. 8-15.)
6. Remove the brake booster assembly.
 - (1) Remove the four attaching nuts of the brake booster, using a long socket wrench (having a width across flats of 12 mm), as indicated in Fig. 8-38
 - (2) Remove the brake booster assembly and gasket from the vehicle.

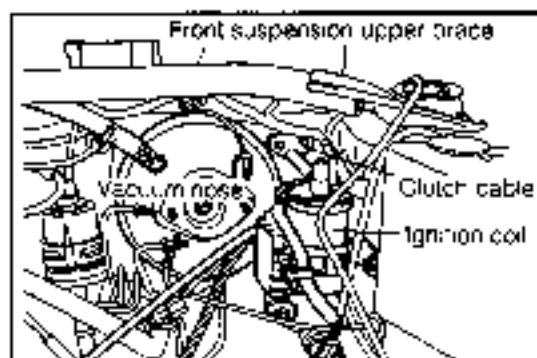

Fig. 8-37

7/9-08042

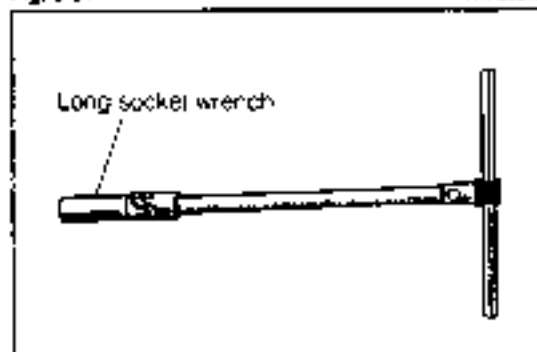

Fig. 8-38

WR-08243

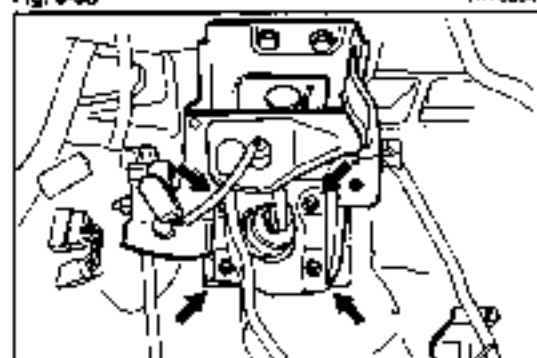

Fig. 8-39

WR-08044

(6-Inch Booster) DISASSEMBLY

1. Remove the master cylinder push rod clevis and lock nut.
2. Separate the booster housing from the booster body as follows.
 - (1) Put mate marks on the booster body and booster housing.

- (2) Secure the brake booster on the following SST.
SST: 09753-87701-000

NOTE:

Be certain to evenly tighten the SST nuts at the right and left sides. Also, be very careful not to tighten the SST nuts excessively.

- (3) Turn the SST screw clockwise so as to disengage the booster housing from the booster body.
- (4) Detach the brake booster from the SST.

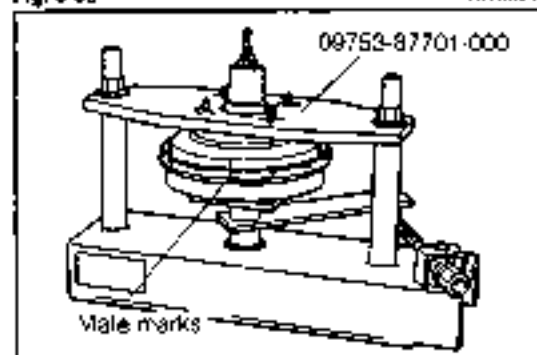

Fig. 8-40

7/9-08043

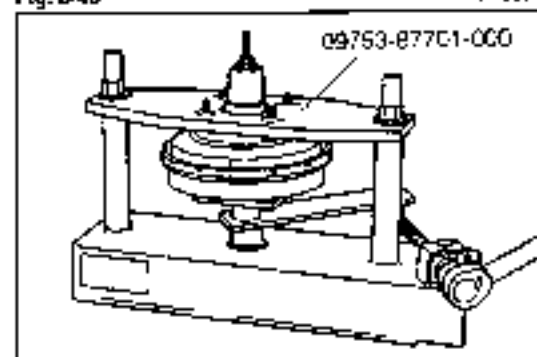

Fig. 8-41

7/9-08043

(5) Disassemble the brake booster

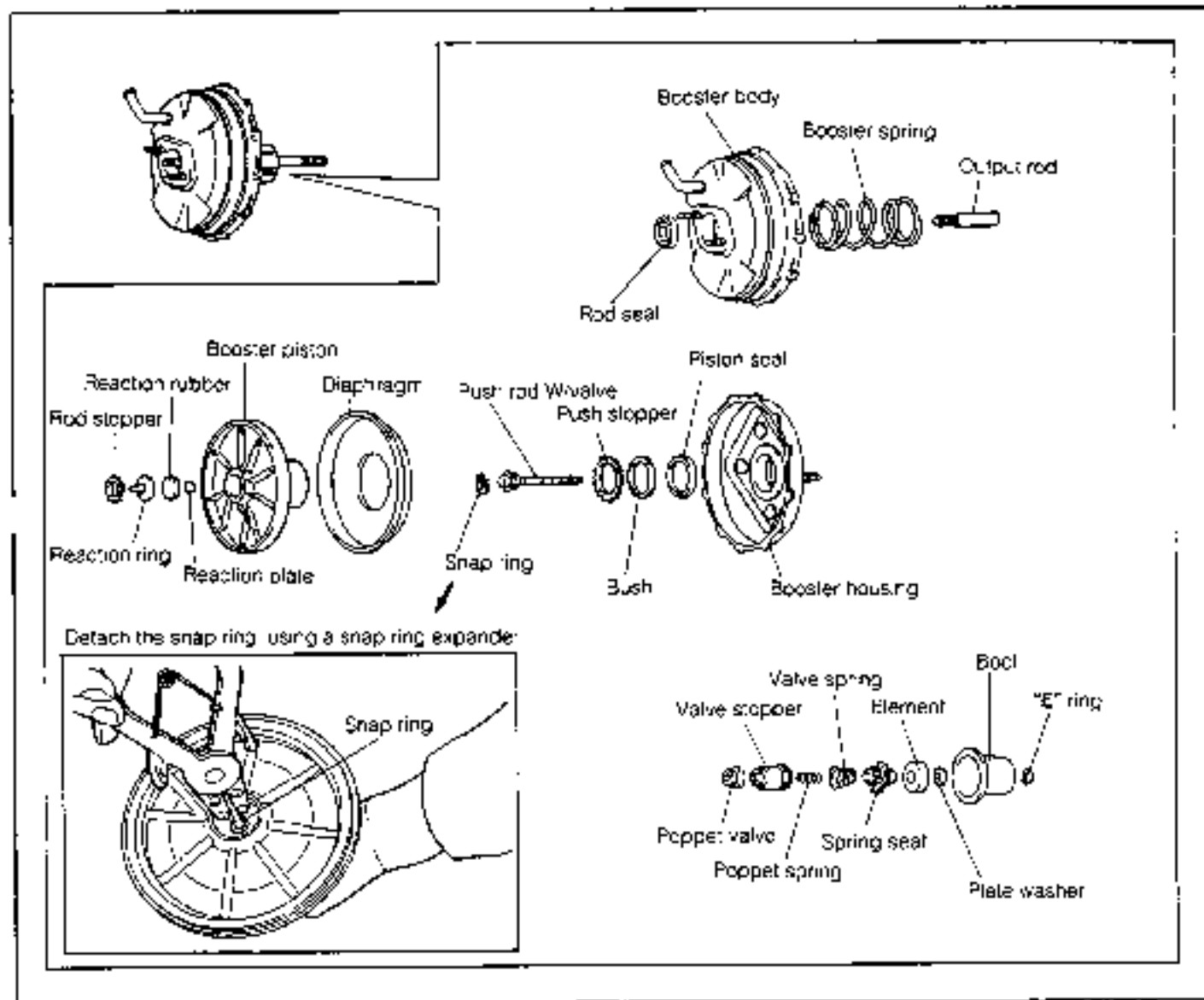

Fig. 8-42

NR-08317

INSPECTION

Inspect the following parts.

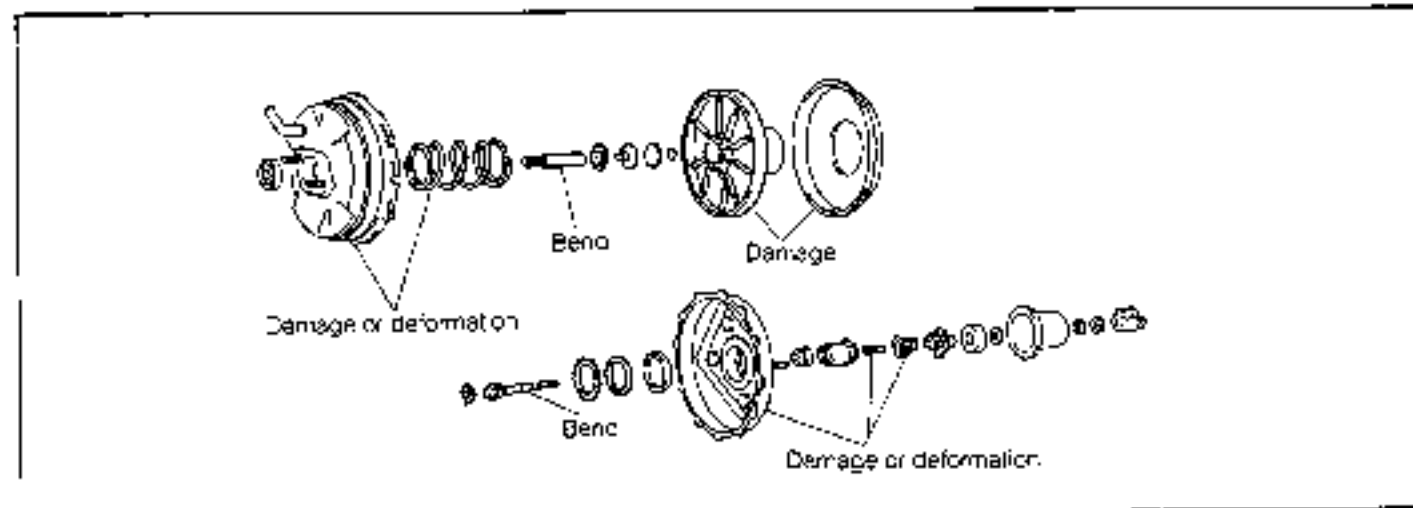

Fig. 8-43

WR-CB048

BRAKES

ASSEMBLY

1. Application of silicon grease
Apply silicon grease to those points indicated by arrow heads in the figure below:

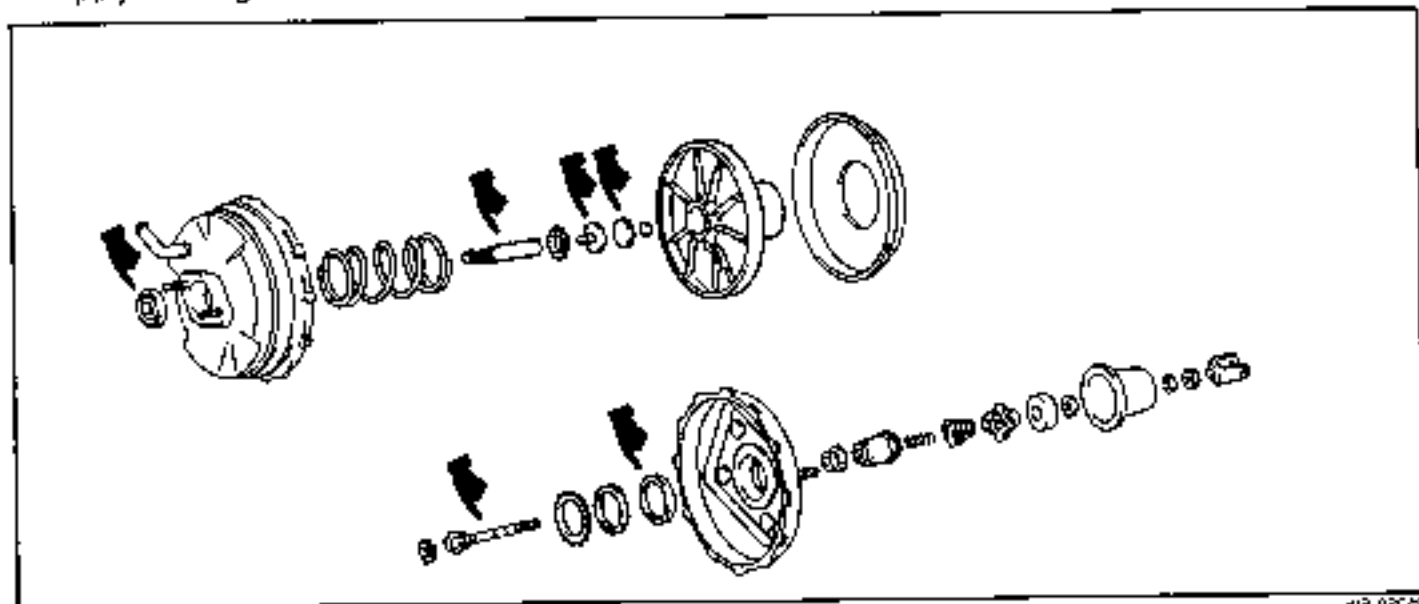

Fig. 8-44

WP-08249

2. Assemble the following parts in the booster piston.
 - (1) Install the diaphragm in position.
 - (2) Assemble the push rod with valve. Retain it with the snap ring.

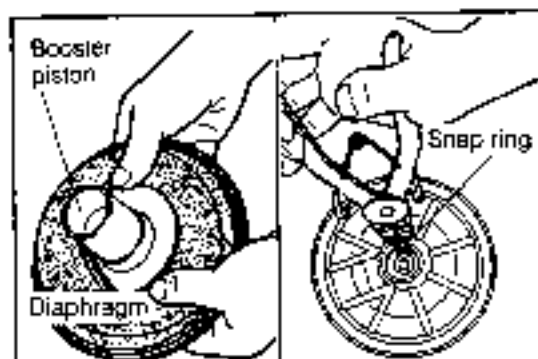

Fig. 8-45

WP-08050

- (3) Install the reaction plate, reaction rubber and reaction ring.
- (4) Install the rod stopper.

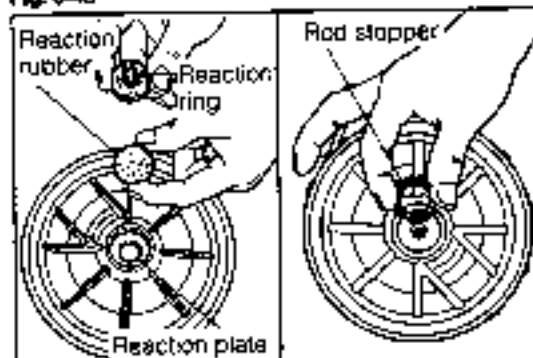

Fig. 8-46

WP-08051

3. Assemble the following parts in the booster housing.
 - (1) Install the piston seal, bush and bush stopper.
 - (2) Install the booster piston.

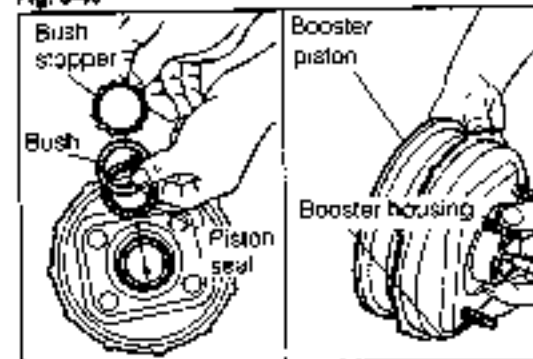

Fig. 8-47

WP-08352

- (3) Assemble the poppet valve to the valve stopper. Then, install them in the booster housing.
- (4) Install the poppet spring, valve spring and spring seat in place.

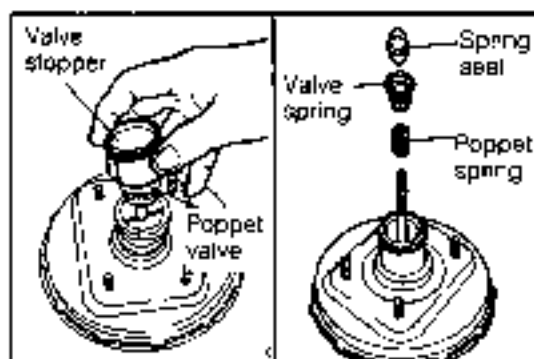

Fig. 8-48

WP-09053

- (5) Install the element, plate washer and 'E' ring.
- (6) Install the boot.

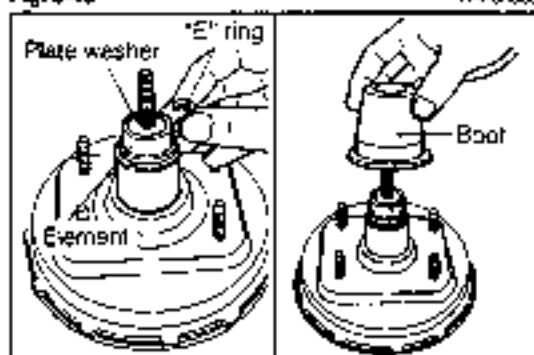

Fig. 8-49

WP-09054

4. Assemble the booster body and booster housing as follows:

- (1) Place the booster body and booster spring in the following SST.

SST: 09753-87701-000

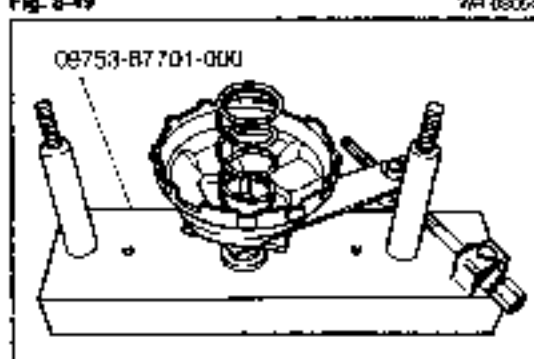

Fig. 8-50

WP-09055

- (2) Place the booster housing in the following SST
- SST: 09753-87701-000

NOTE:

Be certain to evenly tighten the SST nuts at the right and left sides. Also, be very careful not to tighten the SST nuts excessively.

Furthermore, care must be exercised to ensure that the diaphragm will not be pinched.

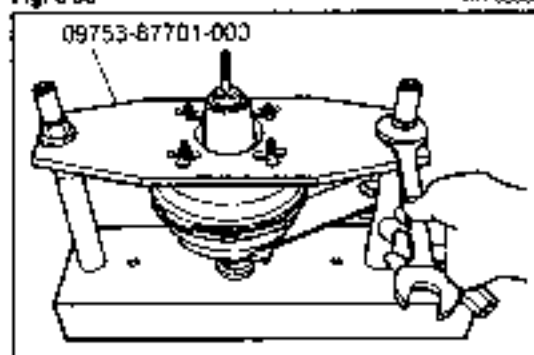

Fig. 8-51

WP-09056

- (3) Turn the SST screw counterclockwise so that the mating marks may be lined up.

If the force required for turning is great, apply a small amount of silicon grease to the portion where the booster body is making contact with the booster housing.

- (4) Remove the brake booster from the SST.

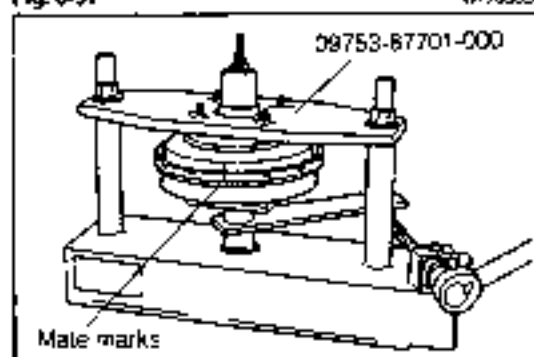

Fig. 8-52

WP-09057

BRAKES

5. Install the output rod and rod seal in the brake booster.
6. Temporarily install the master cylinder push rod clevis and nut.

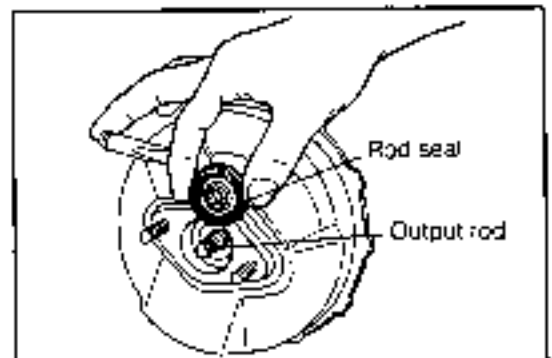

Fig. 8-53

WP-08058

7. Adjust the brake booster push rod clearance as follows:
 - (1) Set the SST in such a way that the SST rod makes a light contact with the piston of the master cylinder, as indicated in Fig. 8-54.

SST: 09737-22011-000

NOTE:

Be sure to carry out this adjustment with the gasket attached in position.

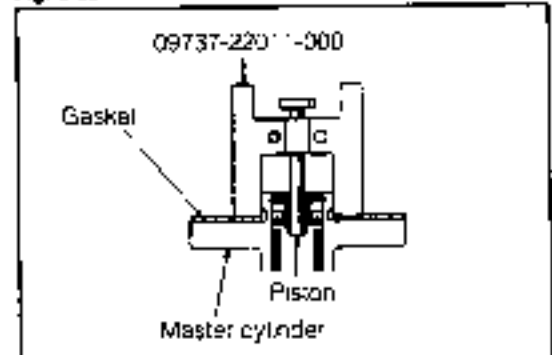

Fig. 8-54

WP-08059

- (2) Connect a MityVac to the union of the brake booster. Apply a negative pressure of 500 mmHg.
 - (3) Set the SST as indicated in Fig. 8-55. Adjust the push rod so that the push rod clearance may become zero.

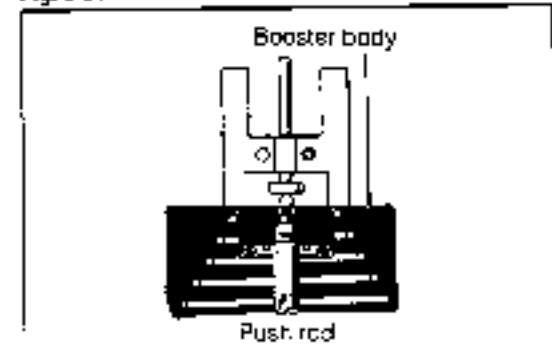

Fig. 8-55

WP-08060

- (4) Perform the adjustment of the push rod clearance by turning the nut provided at the tip end of the push rod.

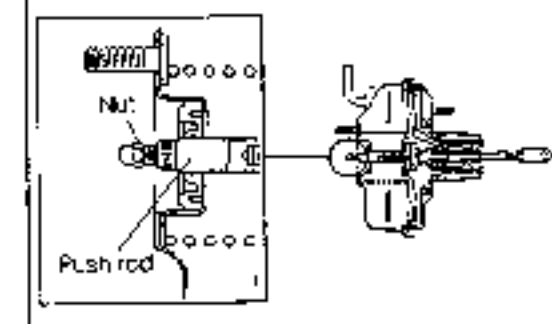
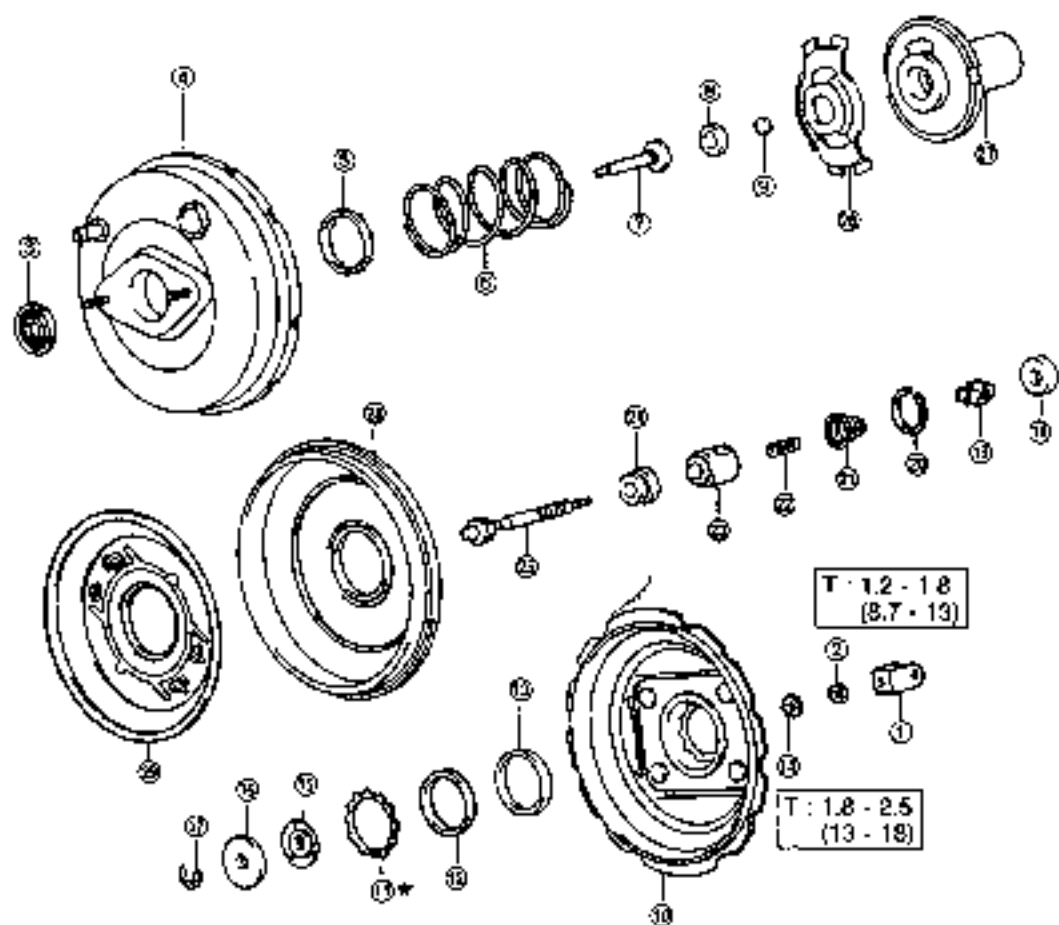

Fig. 8-56

WP-08061

COMPONENTS

(7-Inch Booster)



T : Tightening torque
Unit: kg-m (ft-lb)
* : Non-reusable parts

- ① Master cylinder push rod clevis
- ② Nut
- ③ Rod seal
- ④ Booster body
- ⑤ Retainer spring
- ⑥ Booster spring
- ⑦ Booster piston rod
- ⑧ Reaction disc
- ⑨ Reaction plate
- ⑩ Booster housing
- ⑪ Booster push rod seal retainer
- ⑫ Valve ring
- ⑬ Piston seal
- ⑭ Nut

- ⑮ Adjuster nut
- ⑯ Element B
- ⑰ E ring
- ⑱ Element A
- ⑳ Control valve spring retainer
- ㉑ Piston return spring retainer
- ㉒ Valve spring
- ㉓ Control valve spring
- ㉔ Air valve spring retainer
- ㉕ Poppet valve
- ㉖ Booster with rod, valve S/A
- ㉗ Seal cover
- ㉘ Valve body
- ㉙ Diaphragm
- ㉚ Booster plate

Fig. 8-57

W9C8053

BRAKES

(7-inch Booster) DISASSEMBLY

1. Remove the master cylinder push rod clevis and lock nut.
2. Remove the rod seal.
3. Separate the booster housing from the booster body as follows.

(1) Put mate marks on the booster body and booster housing.

(2) Secure the brake booster on the following SST.

SST: 09753-87701-000

NOTE:

Be certain to evenly tighten the SST nuts at the right and left sides. Also, be very careful not to tighten the SST nuts excessively.

(3) Turn the SST screw clockwise so as to disengage the booster housing from the booster body.

(4) Remove the brake booster from the SST.

4. Disassemble the brake booster.

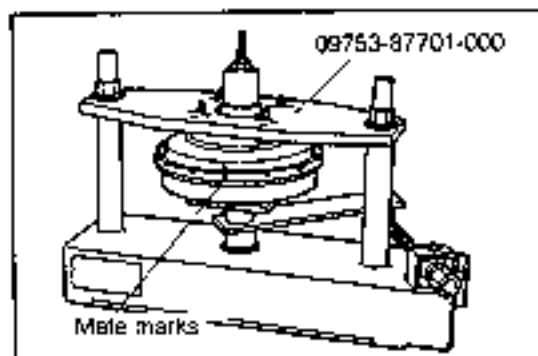

Fig. 8-58

WR 08063

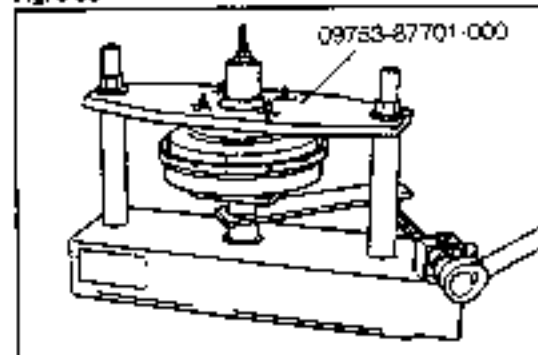

Fig. 8-59

WR 08064

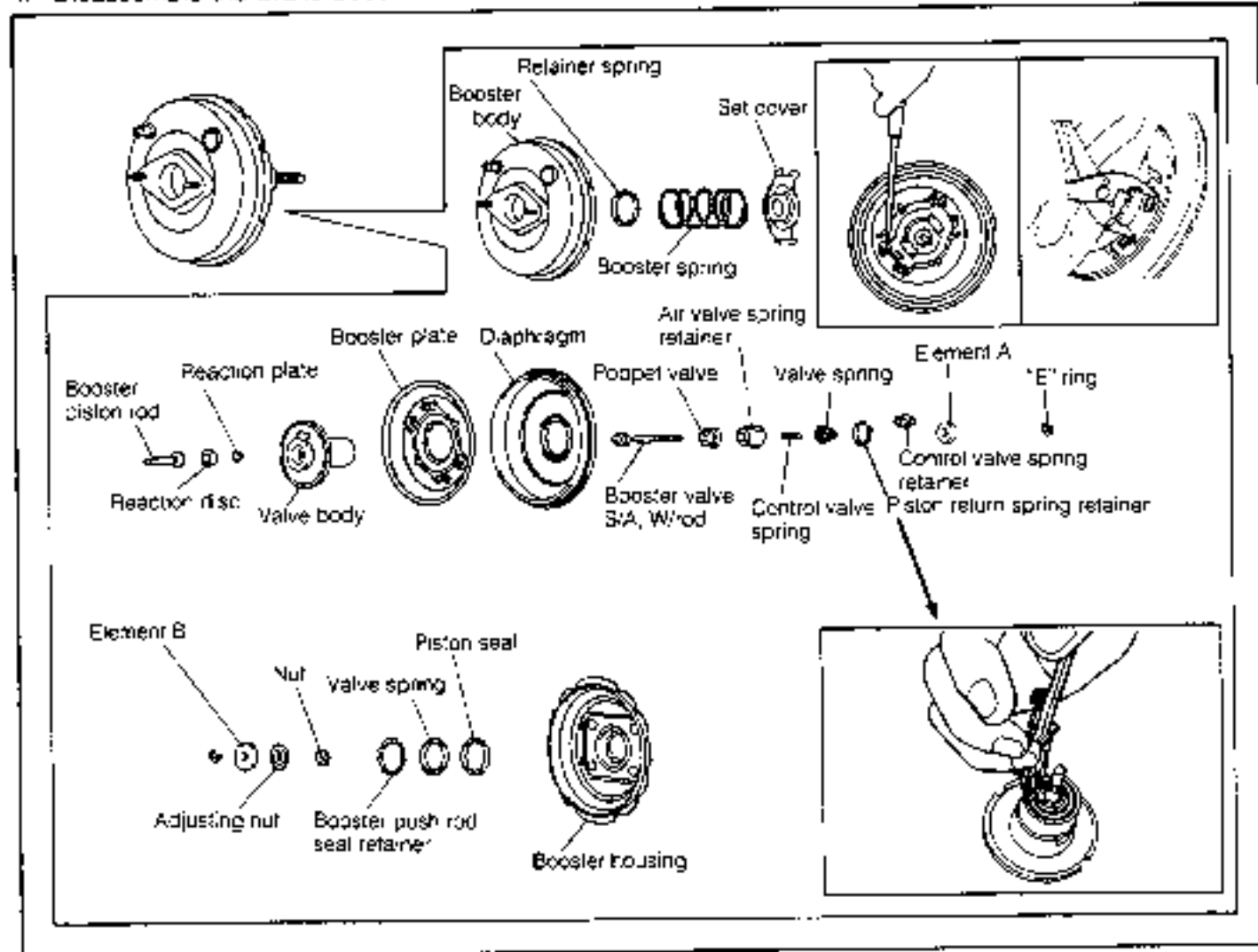

Fig. 8-60

WR 08065

INSPECTION

Inspect the following parts.

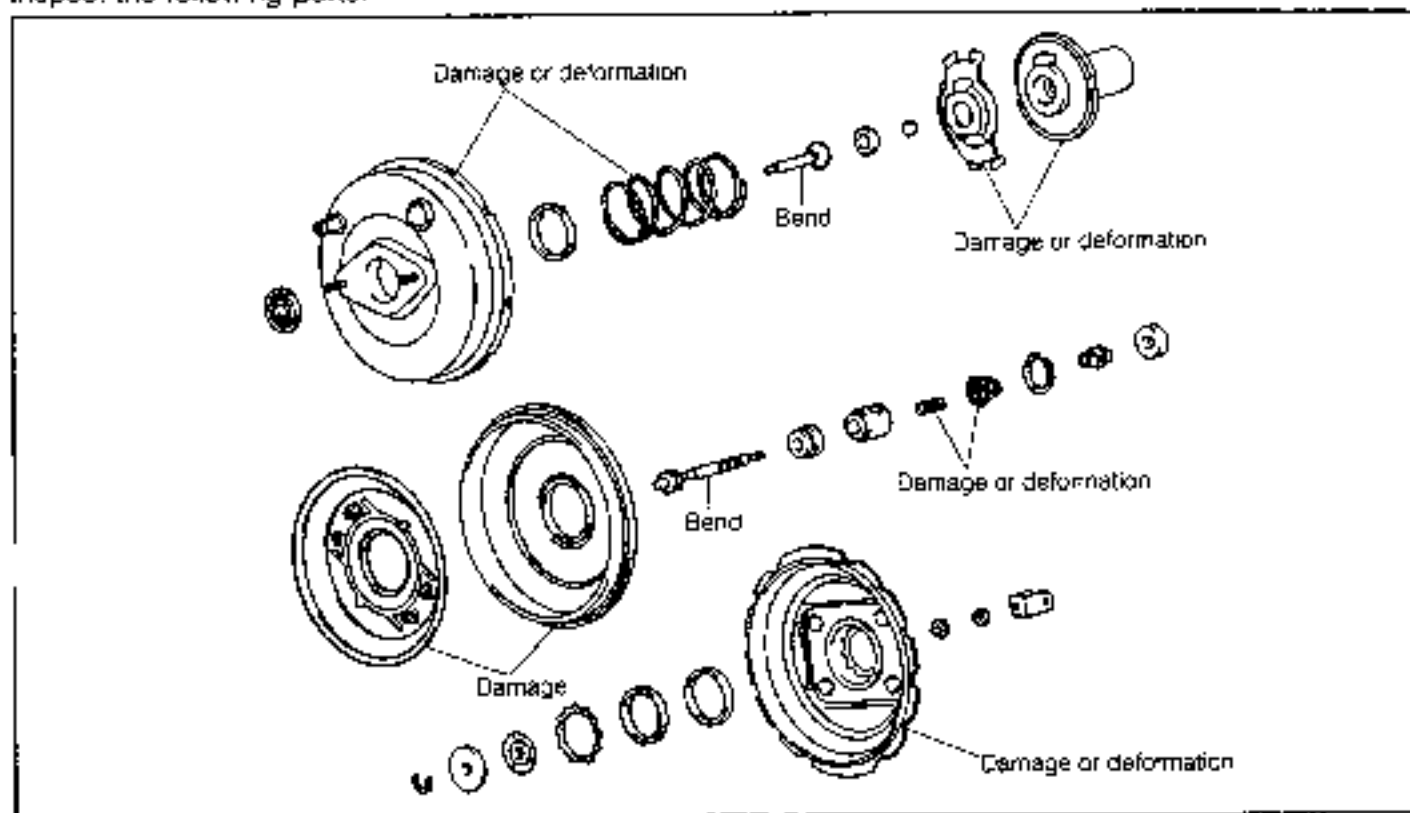

Fig. 8-51

W0-00066

ASSEMBLY

- Application of silicon grease
Apply silicon grease to those points indicated by arrow heads in the figure below.

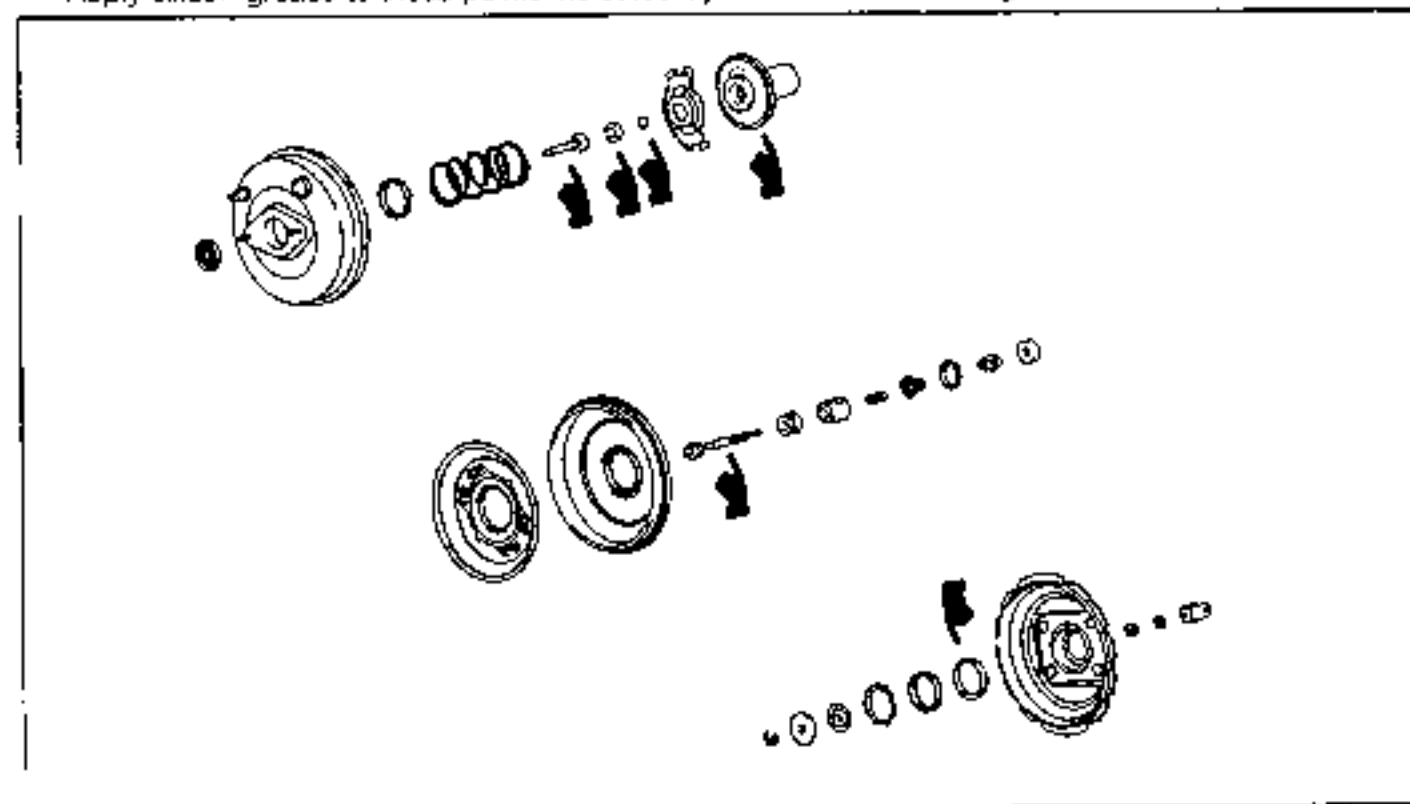

Fig. 8-52

W0-00067

BRAKES

2. Assemble the following parts in the booster valve sub-assembly with rod.

- (1) Install the poppet valve in the air valve spring retainer. Install them in the booster valve subassembly with rod.
- (2) Install the control valve spring, valve spring, control valve spring retainer, element and "E" ring.

3. Install the booster valve subassembly with rod and the piston return spring retainer in the valve body.

4. Install the element, adjusting nut and nut in place.

5. Assemble the following parts in the booster plate.

- (1) Install the diaphragm.
- (2) Install the valve body, reaction plate, reaction disc and booster piston rod.

(3) Install the set cover as follows:

- Temporarily install the set cover on the booster plate.
- Assemble the set cover by pinching the joint section of the booster plate with the claw section of the set cover, using pliers.
- Slide the claw section of the set cover using a common screwdriver, until it is no longer possible to move the claw section.

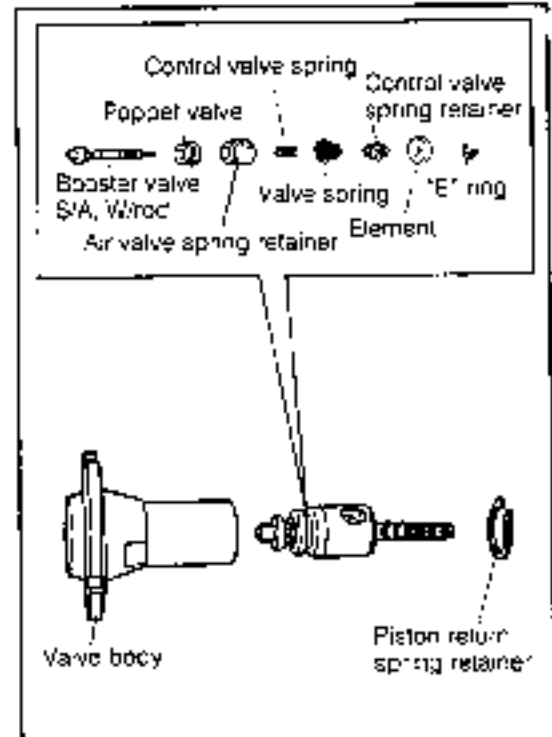

Fig. 8-63

WA-03056

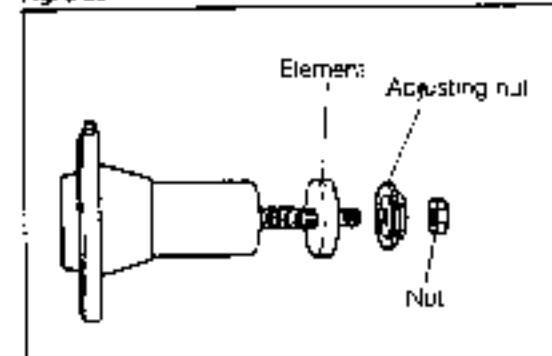

Fig. 8-64

WA-03060

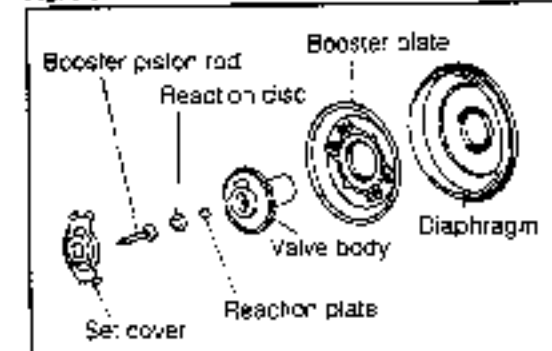

Fig. 8-65

WA-03070

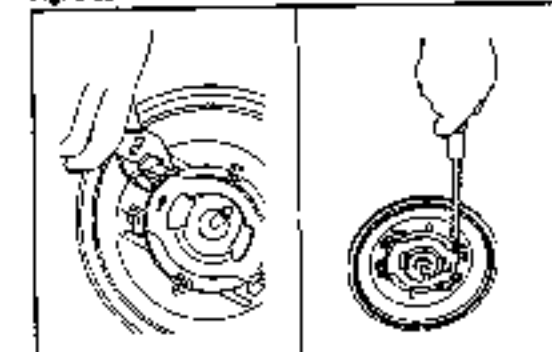

Fig. 8-66

WA-03071

5. Install the piston seal, valve ring and booster push rod seal retainer in the booster housing.

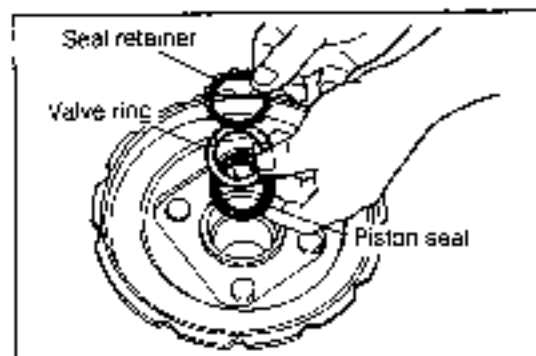

Fig. 8-67 WPC8073

7. Assemble the booster housing and booster plate.

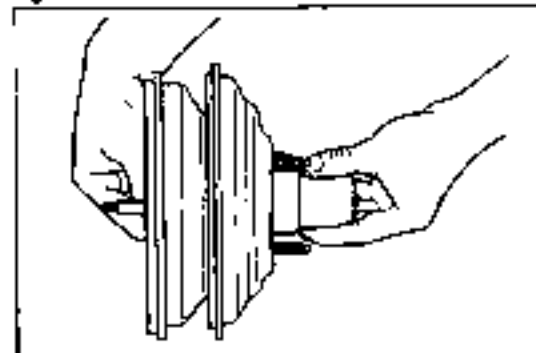

Fig. 8-68 WPC8073

8. Assemble the booster body and booster housing as follows.

- (1) Place the booster body, spring retainer and booster spring in the following SST.
SST: 09753-87701-000

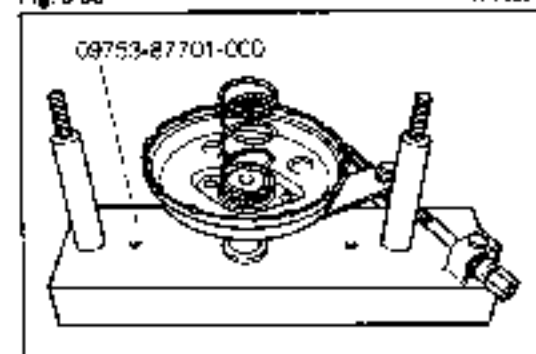

Fig. 8-69 WPC8073

- (2) Place the booster housing in the following SST
SST: 09753-87701-000

NOTE:

Be certain to evenly tighten the SST nuts at the right and left sides. Also, be very careful not to tighten the SST nuts excessively.

Furthermore, care must be exercised to ensure that the diaphragm will not be pinched.

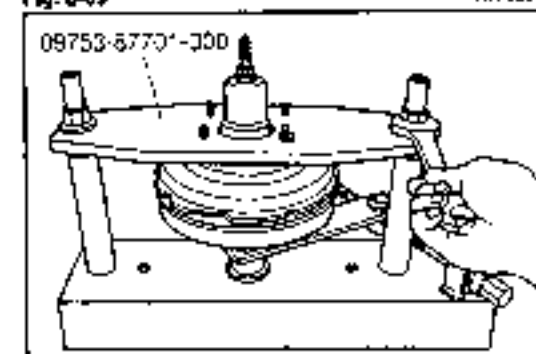

Fig. 8-70 WPC8073

- (3) Turn the SST screw counterclockwise so that the mating marks may be lined up.
If the force required for turning is great, apply a small amount of silicon grease to the portion where the booster body is making contact with the booster housing.

- (4) Remove the brake booster from the SST.

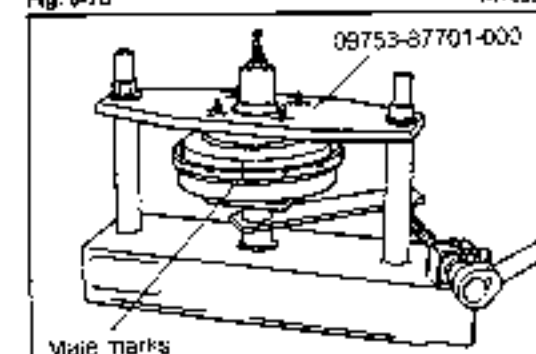

Fig. 8-71 WPC8073

BRAKES

9. Install the rod seal in the brake booster.
10. Temporarily install the master cylinder push rod clevis and nut.

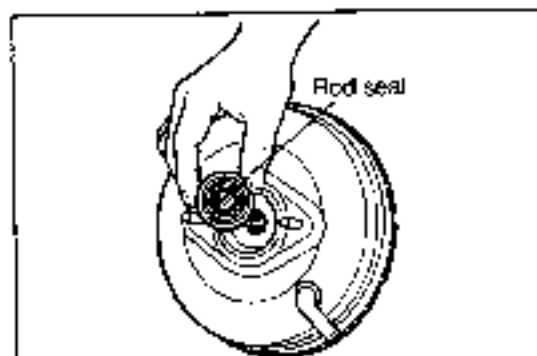

Fig. 8-72

WR-08077

11. Adjust the brake booster push rod clearance as follows:
 - (1) Set the SST in such a way that the SST rod makes a light contact with the piston of the master cylinder as indicated in Fig. 8-73.

SST: 09737-87001-000

NOTE:

Be sure to carry out this adjustment with the gasket attached in position.

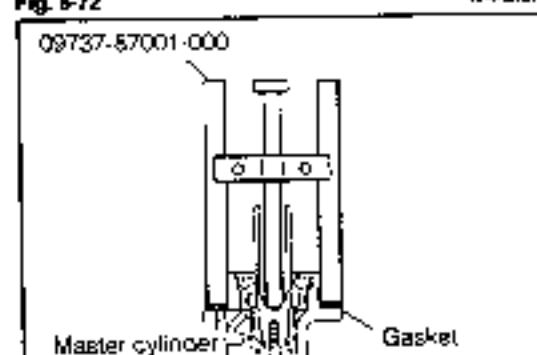

Fig. 8-73

WR-08078

- (2) Set the SST as indicated in Fig. 8-74. Adjust the push rod so that the push rod clearance may become zero.

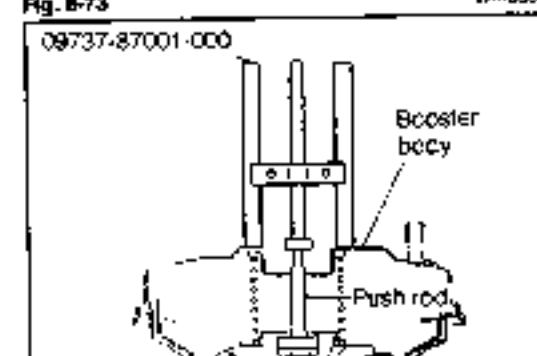

Fig. 8-74

WR-08079

- (3) Perform the adjustment of the push rod clearance by turning the nut provided at the tip end of the push rod.

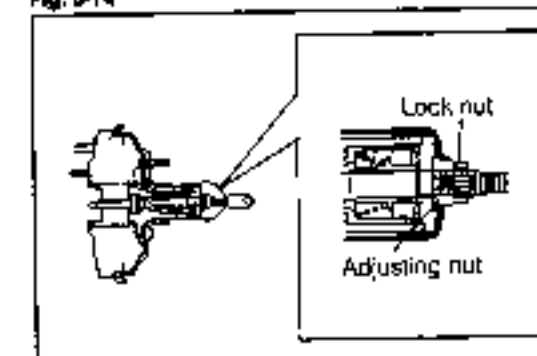

Fig. 8-75

WR-08080

INSTALLATION

1. Install the brake booster on the body with a new gasket interposed, using the four nuts.
2. Attach the master cylinder push rod clevis to the brake pedal by means of the with-hole pin and clip.

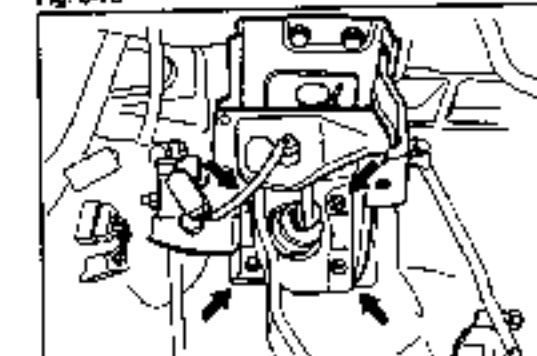

Fig. 8-76

WR-08081

3. Attach the vacuum hose.
4. Install the front suspension upper brace subassembly. (RHD TURBO and GT_{II} grades only)
5. Install the clutch cable and ignition coil. (LHD TURBO and GT_{II} grades only)
6. Install the master cylinder. (See page 8-14)

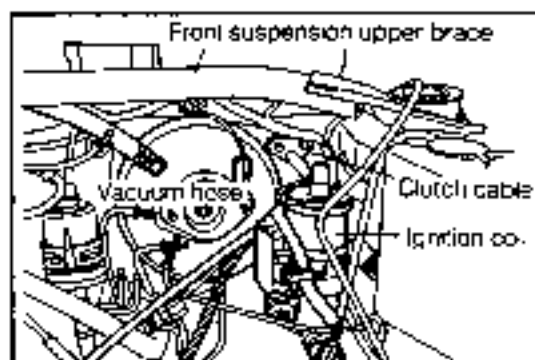

Fig. 8-77

WR C9082

BRAKES

FRONT BRAKE SECTIONAL VIEW

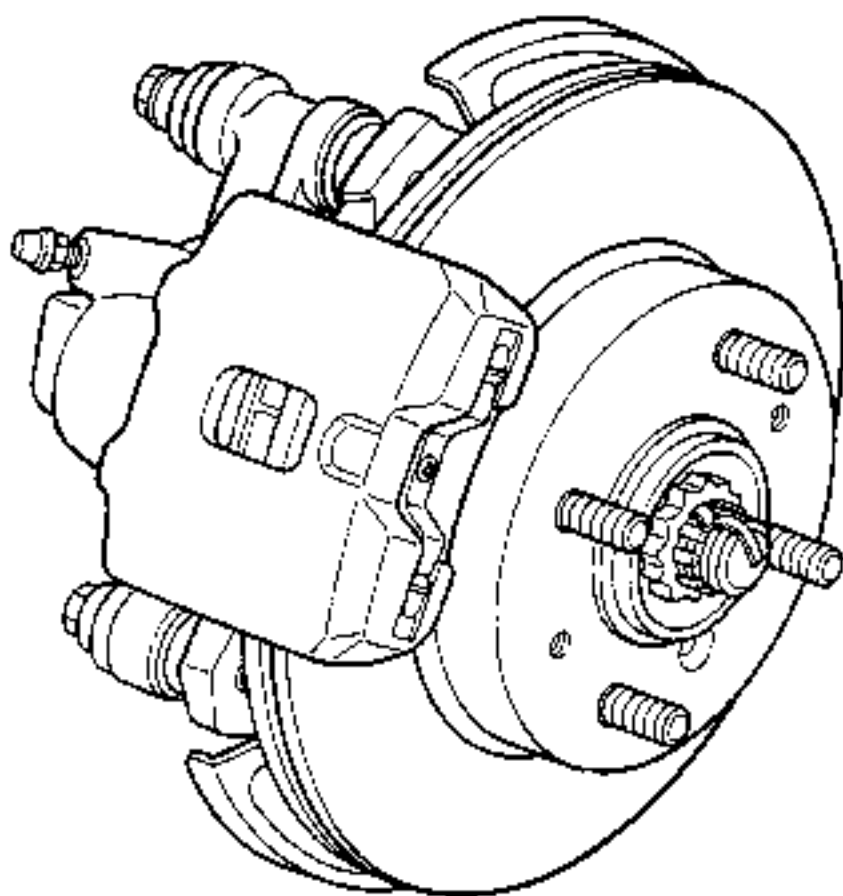

Fig. 6-78

WPI 06C83

COMPONENTS

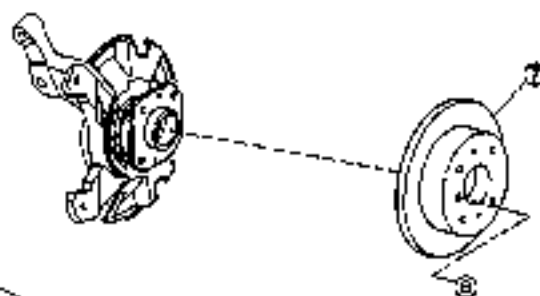
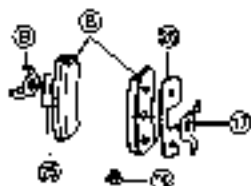

T : Tightening torque
Unit: kg-m (ft-lb)
* : Non-reusable parts

General specifications except for TURBO, GT₁₁ grade

Others

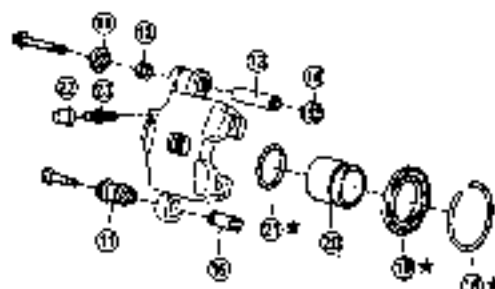
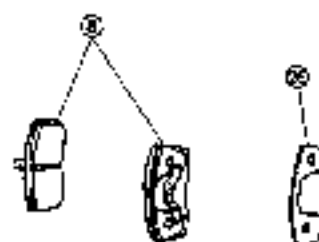

- ① Disc brake front caliper Ay
- ② Bolt
- ③ "E" ring
- ④ Tube clamp
- ⑤ Flexible hose
- ⑥ Screw
- ⑦ Front disc
- ⑧ Disc brake pad
- ⑨ Anti-rattle spring No. 1
- ⑩ Pad wear indicator plate
- ⑪ Bush dust boot
- ⑫ Bush retainer
- ⑬ Cylinder slide bush

- ⑭ Piston boot
- ⑮ Bush retainer
- ⑯ Cylinder slide bush
- ⑰ Anti rattle spring No. 2
- ⑱ Seal ring
- ⑲ Cylinder boot
- ⑳ Front disc brake piston
- ㉑ Piston seal
- ㉒ Bleeder plug cap
- ㉓ Bleeder plug
- ㉔ Disc brake pad guide plate
- ㉕ Anti-squeal shim No. 1
- ㉖ Anti-squeal shim No. 2

Fig. 9-79

WH-C8034

BRAKES

DISC BRAKE PAD REMOVAL

1. Jack up the front end of the vehicle. Support the body with safety stands. Remove the front wheel.
2. Inspect the brake pad thickness through the inspection hole provided in the disc brake front caliper.

	General specifications except for TURBO, GT ₁ , grade	Others
Specified Thickness	10 mm (0.39 inch)	9 mm (0.35 inch)
Minimum Limit	1 mm (0.04 inch)	1 mm (0.04 inch)

3. Remove the two attaching bolts of the disc brake front cylinder assembly.

4. Remove the disc brake pad and anti-squeal shim.
5. Detach the disc brake pad guide plate.
6. Check the front disc thickness. (See Fig. 8-98.)

	General specifications except for TURBO, GT ₁ , grade	Others
Specified Thickness	17 mm (0.67 inch)	18 mm (0.71 inch)
Minimum Limit	10 mm (0.39 inch)	17 mm (0.67 inch)

7. Drain a small amount of brake fluid from the master cylinder reservoir. Push in the piston with the handle of a hammer or the like.

NOTE:

Be sure to carry out the pad replacement operation for one wheel at a time, for there is a possibility that the piston at the opposite side may be jumped out.

INSTALLATION

1. Install a new disc brake pad guide plate on the knuckle.

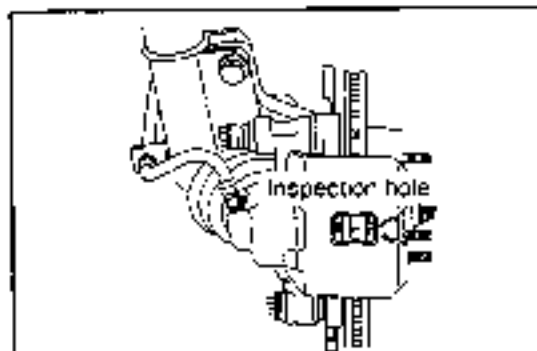

Fig. 8-80

WR-08025

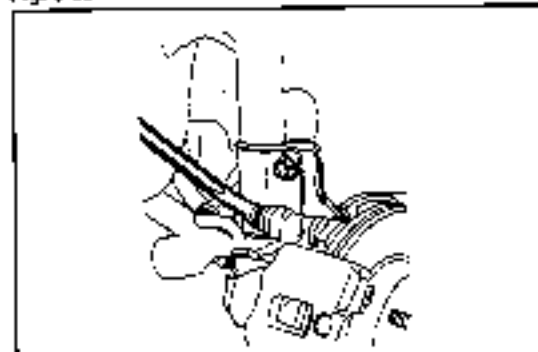

Fig. 8-81

WR-08026

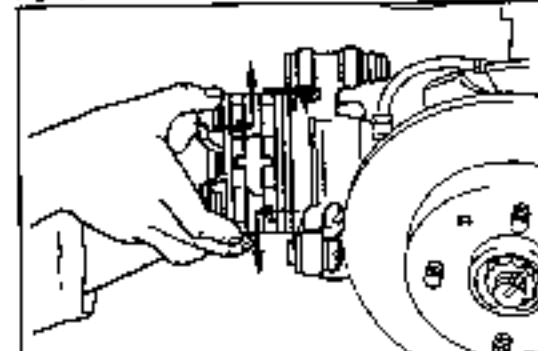

Fig. 8-82

WR-08027

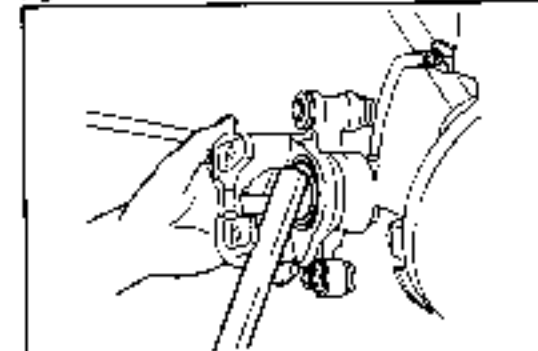

Fig. 8-83

WR-08028

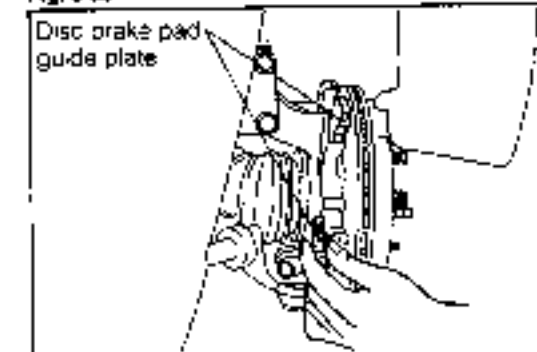

Fig. 8-84

WR-08029

- Assemble a new anti-squeal shim at a new disc brake pad (outboard side). Then, install them on the disc brake front caliper.

- Install the disc brake front caliper assembly on the knuckle.

Tightening Torque: 3.2 - 4.2 kg-m (23 - 30 ft-lb)

NOTE:

Care must be exercised so that the caliper boot may not be pinched during the installation.

- Install the front wheel.
- Fill the brake fluid up to the "MAX" reference line of the master cylinder reservoir.

DISC BRAKE FRONT CALIPER REMOVAL

- Jack up the front end of the vehicle. Support the body with safety stands. Remove the front wheel.
- Disconnect the flexible hose as follows:

(Body side)

- Separate the flexible hose from the brake tube, using the following SST
SST: 09751-36011-000
- Detach the clip.

(Shock absorber side)

- Detach the clip.
- Disconnect the flexible hose from the shock absorber bracket.

- Disconnect the flexible hose from the disc brake front caliper, using the following SST.
SST: 09751-36011-000

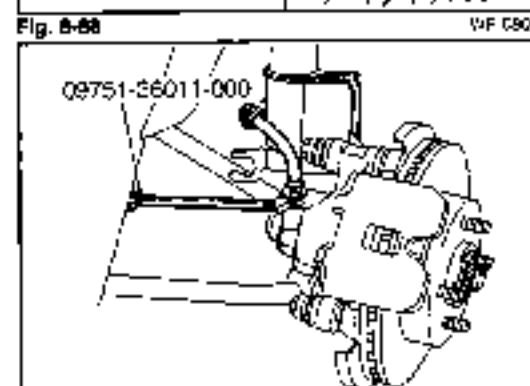
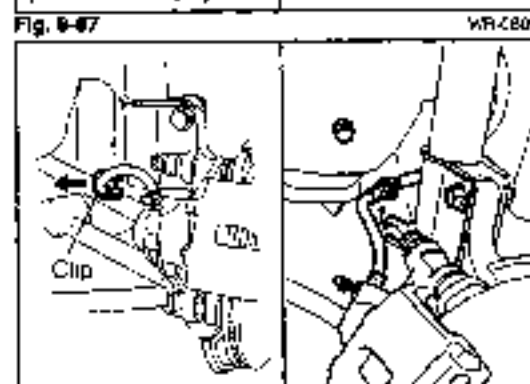
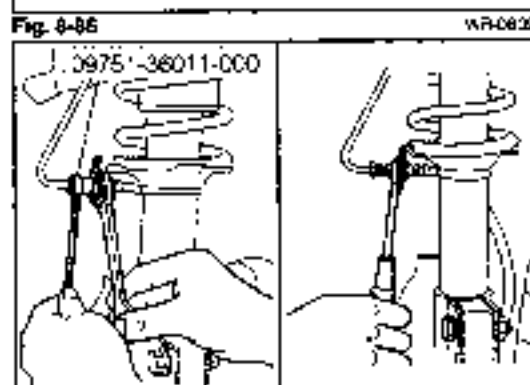
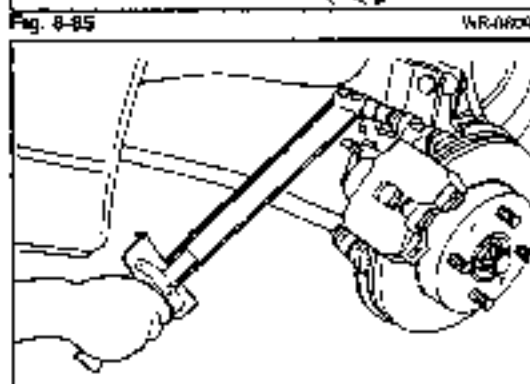
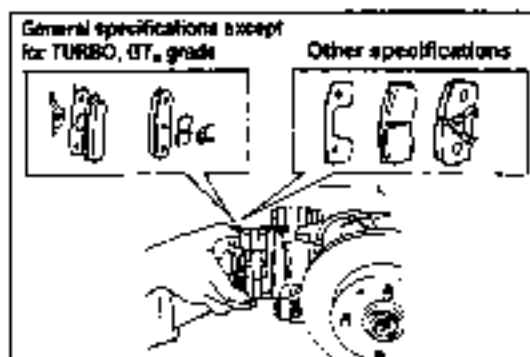

BRAKES

3. Remove the caliper from the vehicle by removing the two attaching bolts of the disc brake front caliper.
4. Detach the disc brake pad from the disc brake front caliper.

DISASSEMBLY

1. Remove the following parts from the disc brake front caliper.

(1) General specifications except for TURBO, GT₁ grade
(Bush dust boot, bush retainer, cylinder slide bush, bleeder plug and plug cap)

(2) Other specifications
(Piston boot, bush dust boot, bush retainer, cylinder slide bush, bleeder plug and plug cap)

2. Detach the cylinder boot set ring and cylinder boot, using a common screwdriver.

3. With a wooden piece or a cloth placed at the end of the disc cylinder, as indicated in the right figure, drive out the piston by applying compressed air.

NOTE:

Special caution must be exercised so that no brake fluid may be splashed. Also, be very careful not to allow your finger be pinched.

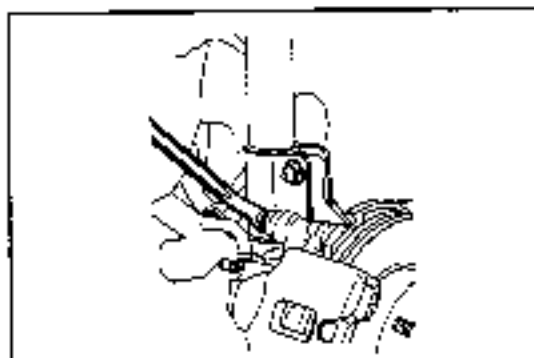

Fig. 8-90

WR-0609C

General specifications except for TURBO, GT₁ grade

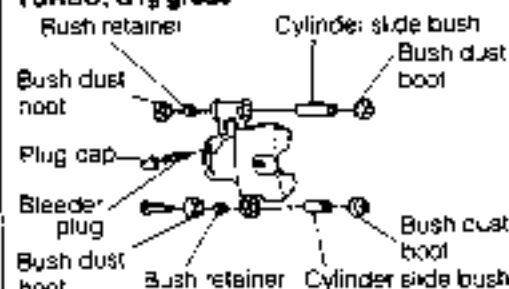

Fig. 8-91

WR-0609C

Other specifications

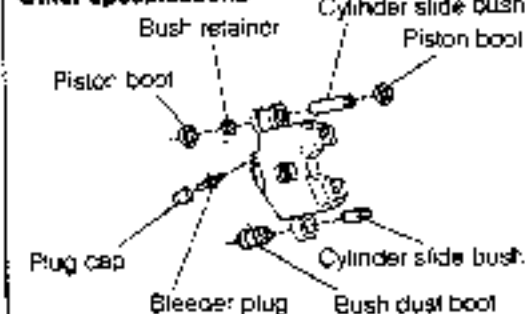

Fig. 8-92

WR-0609C

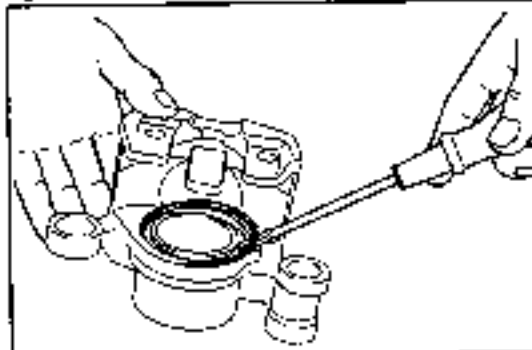

Fig. 8-93

WR-0609C

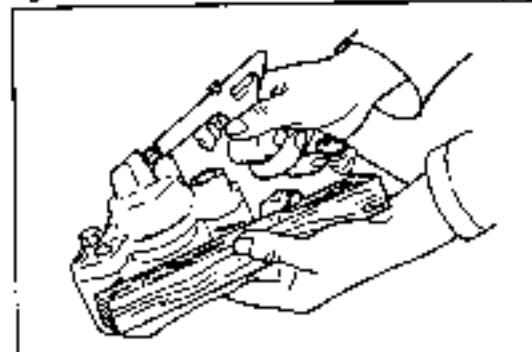

Fig. 8-94

WR-0609C

4. Detach the piston seal, using a common screwdriver

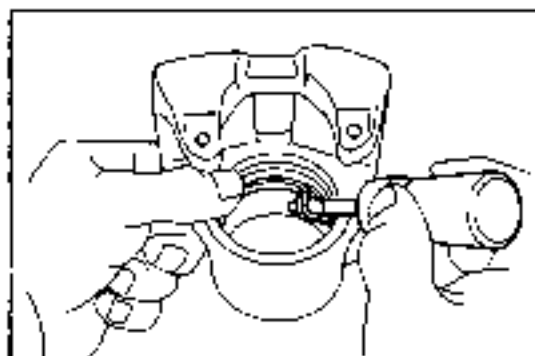

Fig. 8-95 WF-08100

INSPECTION

1. Inspect each part of the disc brake front caliper assembly.

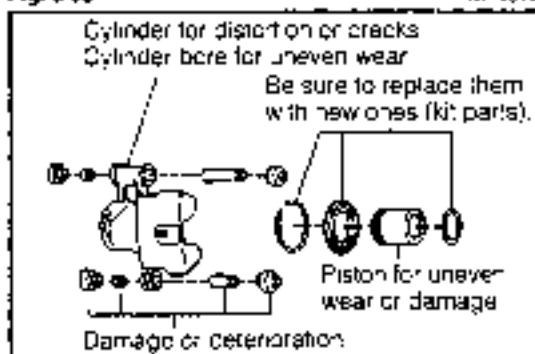

Fig. 8-96 WF-06101

2. Measurement of pad thickness

	General specifications except for TURBO, GT _{ii} grade	Others
Specified Thickness	10 mm (0.39 inch)	9 mm (0.35 inch)
Minimum Limit	1 mm (0.04 inch)	1 mm (0.04 inch)

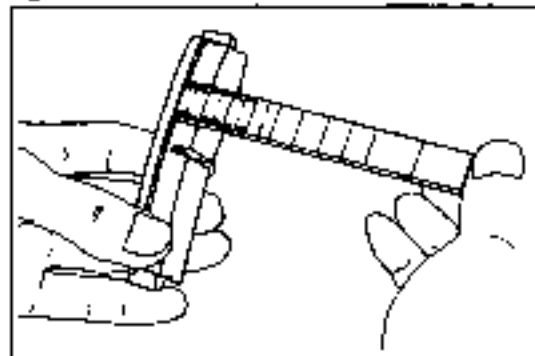

Fig. 8-97 WF-CB102

3. Checking of disc thickness

	Specifications other than GT _{ii}	GT _{ii} grade
Specified Thickness	11 mm (0.43 inch)	18 mm (0.71 inch)
Minimum Limit	10 mm (0.39 inch)	17 mm (0.67 inch)

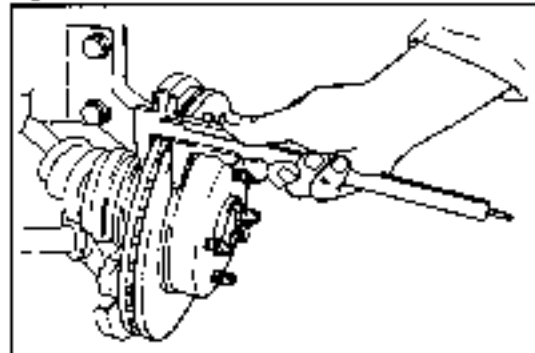

Fig. 8-98 WF-CB103

4. Replace the front disc.

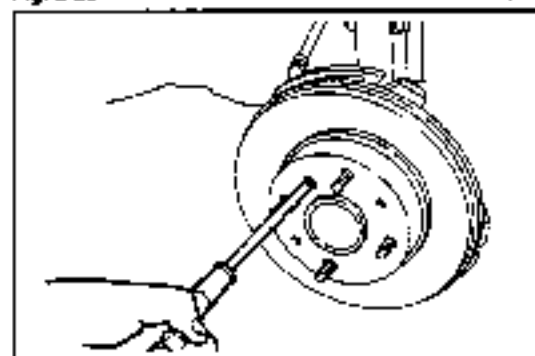

Fig. 8-99 WF-CB105

BRAKES

ASSEMBLY

1. Apply rubber grease to those points indicated by arrow heads in the figure below.

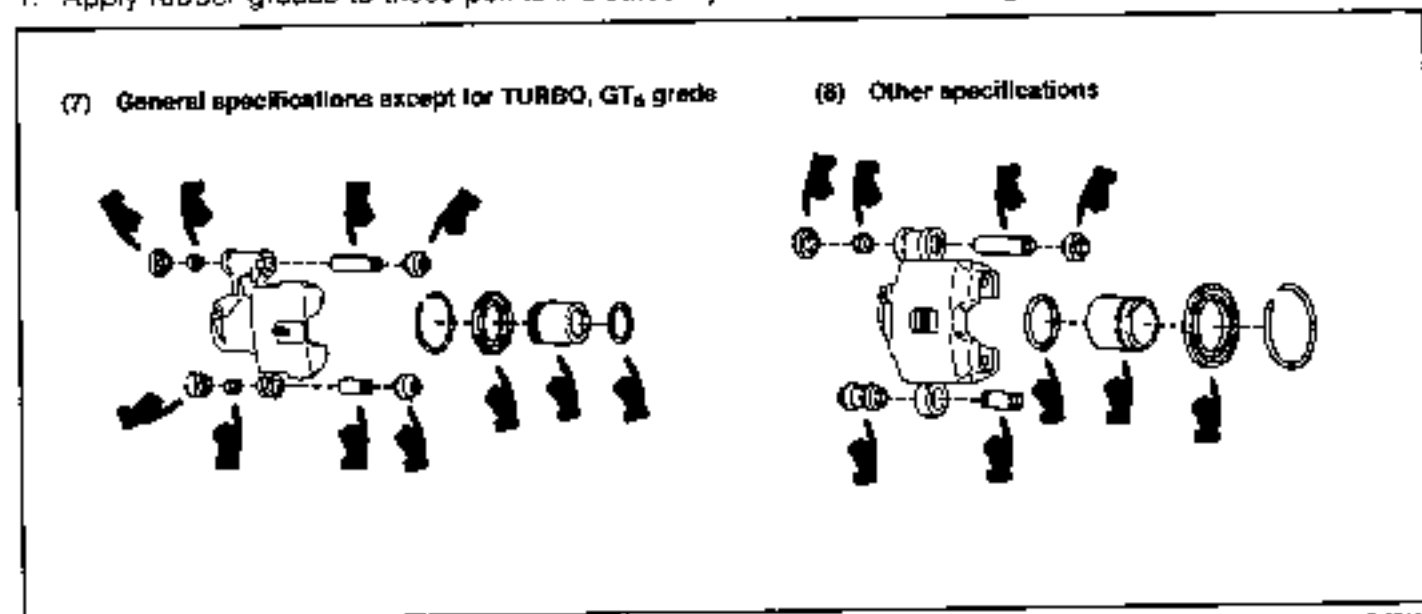
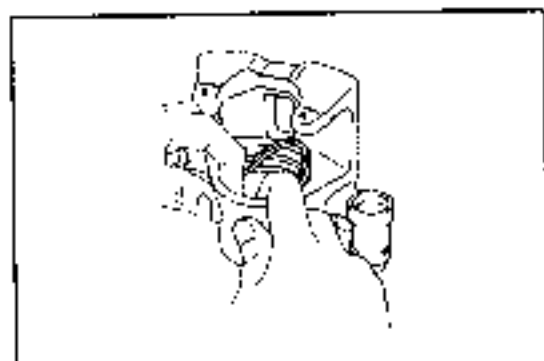

Fig. 8-100

WR-08106

2. Assemble the piston seal and piston.
 - (1) Assemble the piston seal in the disc brake front caliper



WR-08107

- (2) Insert the piston into the disc brake front caliper, making sure that the piston is not tilted during the installation

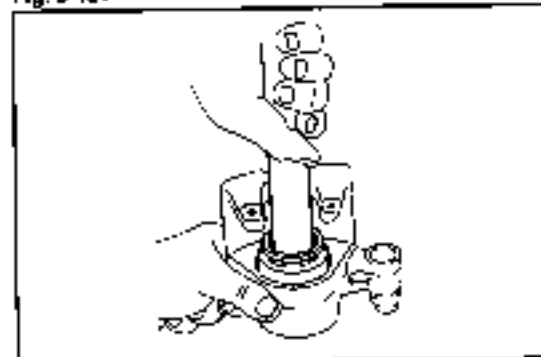

WR-08107A

3. Assemble the cylinder boot in the disc brake front caliper.
NOTE:
Make sure that the boot is fitted securely in the groove.
4. Assemble the cylinder boot set ring, making sure that no scratch is made to the boot

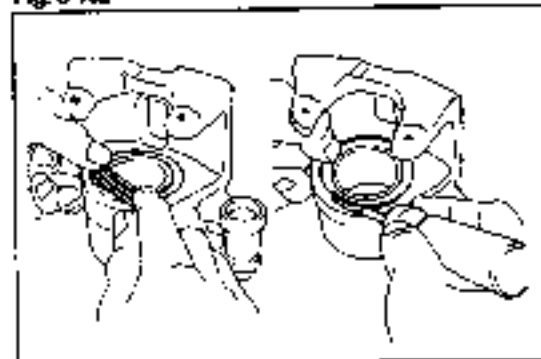

WR-08108

5. Assemble those parts indicated in the figure below in the disc brake front caliper.

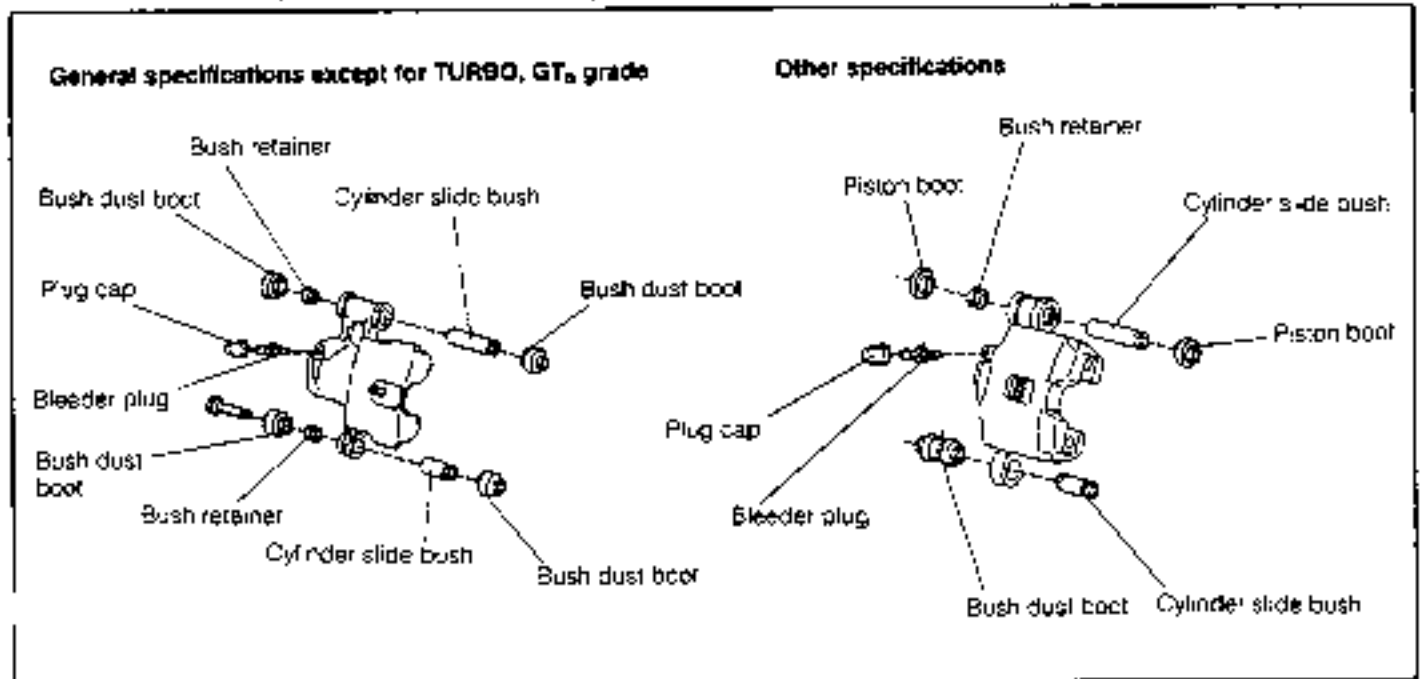

Fig. 8-104

WR-08109

INSTALLATION

1. Install the disc brake pad guide plate on the knuckle. (See Fig. 8-84.)
2. Install the anti-squeal shim at the disc brake pad (out-board side). Then, install them on the disc brake front caliper.

3. Install the disc brake front caliper assembly on the knuckle.

Tightening Torque: 3.2 - 4.2 kg-m (23 - 30 ft-lb)

NOTE:

Care must be exercised so that the caliper boot may not be pinched during the installation.

4. Install the flexible hose.
 - (1) Attach the flexible hose to the disc brake front caliper, using the following SST
SST: 09751-36011-000
 - (2) Attach the flexible hose to the bracket section at the shock absorber side, using the clip.

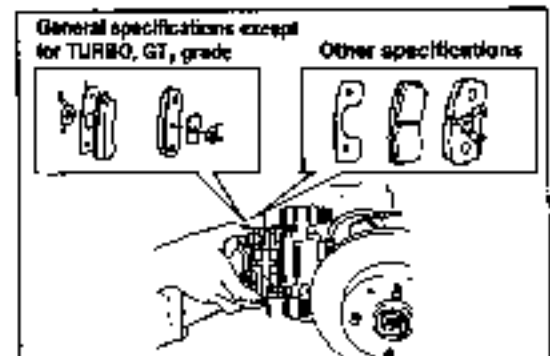

Fig. 8-105

WR-08110

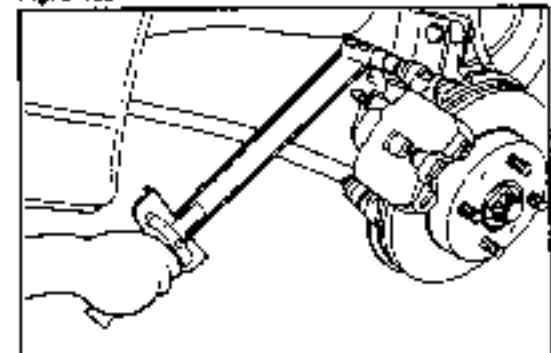

Fig. 8-106

WR-08111

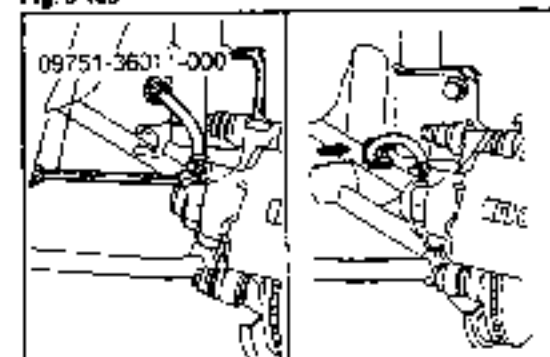

Fig. 8-107

WR-08112

BRAKES

(3) Temporarily install the flexible hose and brake tube by hands.

(4) Tighten the flexible hose and brake tube.

NOTE:

Make sure that the flexible hose is not twisted or stretched excessively.

(5) Attach the clip at the bracket section at the body side

NOTE:

After completion of the installation, turn the steering wheel from lock to lock position. Make sure that the flexible hose is not interfering with any part of the body.

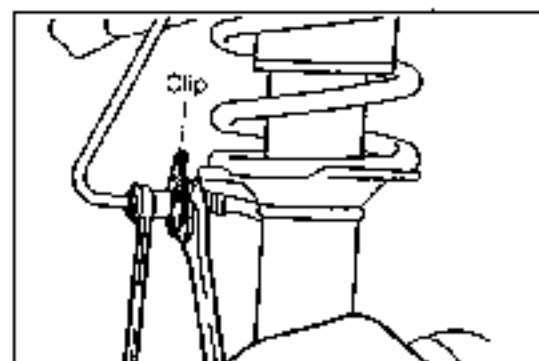

Fig. 8-108

WP-08114

5. Perform air bleeding for the brake system.
(See page 8-5.)
6. Check the brake system for brake fluid leakage.
(See page 8-5.)

WP-08114

REAR DRUM BRAKE

SECTIONAL VIEW

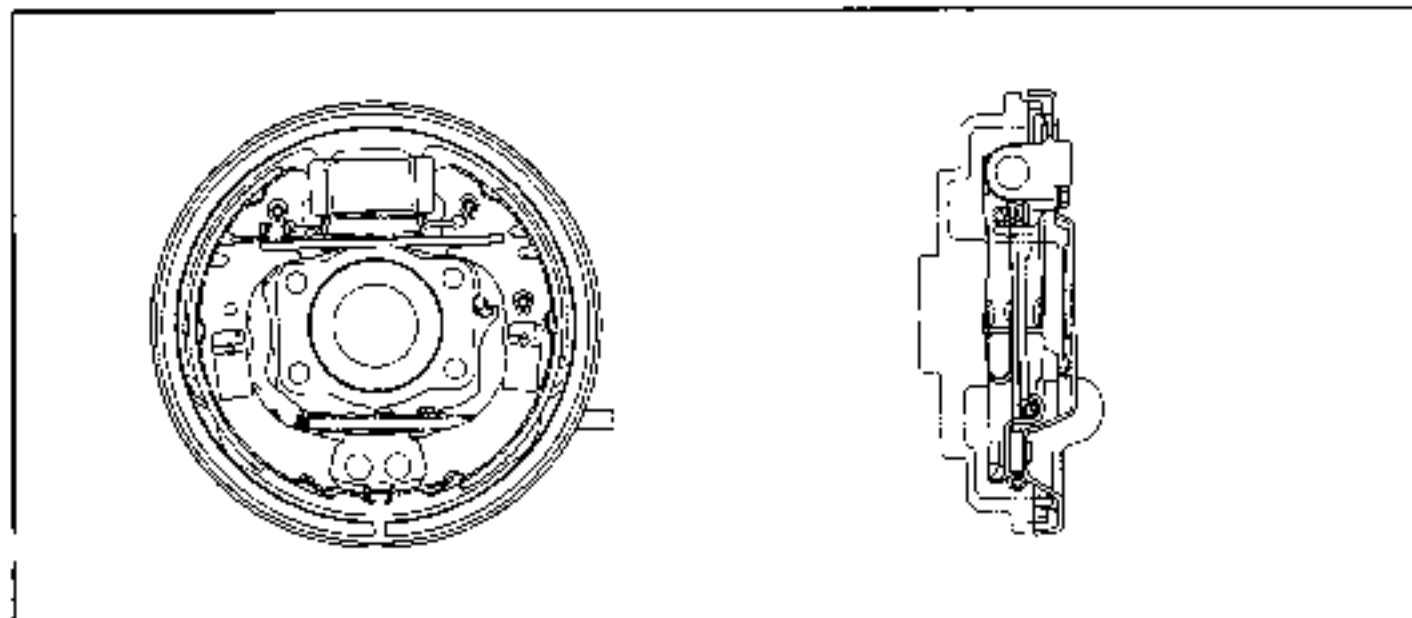

Fig. 8-109

W5-CB112

COMPONENTS

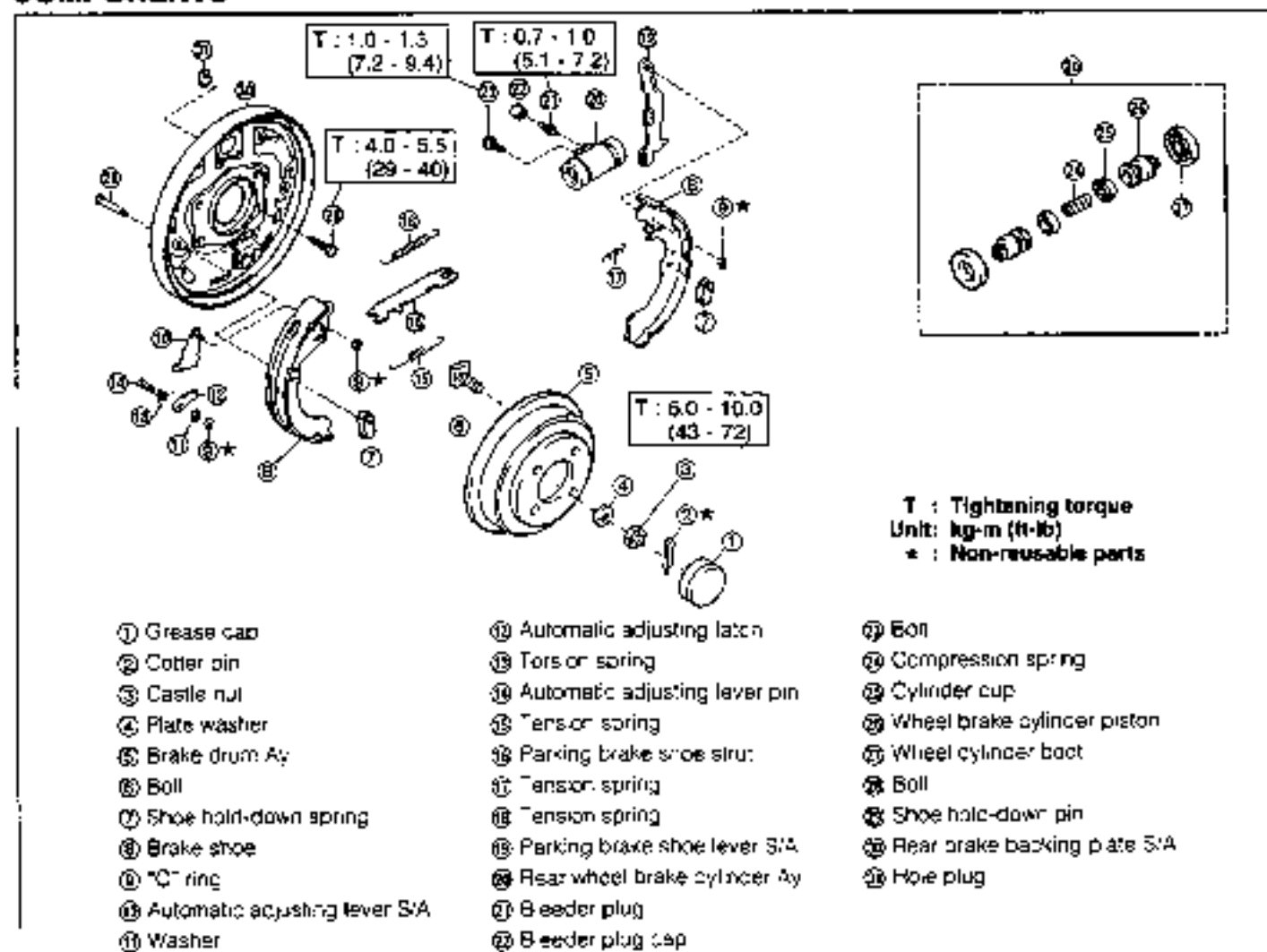

Fig. 8-110

W5-CB115

BRAKES

REMOVAL

1. Jack up the rear section of the vehicle. Support the body with safety stands. Remove the rear wheel.
2. Remove the grease cap, cotter pin, castle nut and plate washer.
3. Remove the brake drum, using the following SST
SST: 09510-87301-000
4. Remove the tension spring, using the following SST.
SST: 09703-30010-000
5. Detach the tension spring, using a common screwdriver.
6. Removal of brake shoe (leading side)
 - (1) Detach the shoe hold-down spring and pin.
 - (2) Remove the brake shoe, parking brake shoe strut and tension spring at the trailing side.

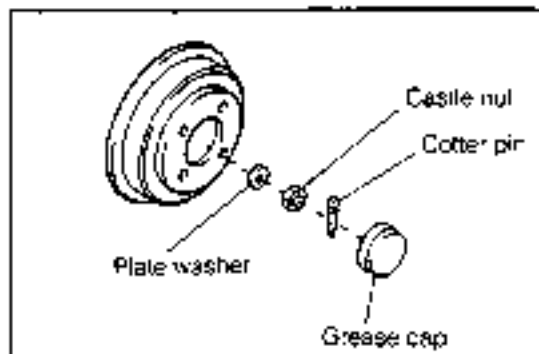

Fig. 8-111

WR-04-17

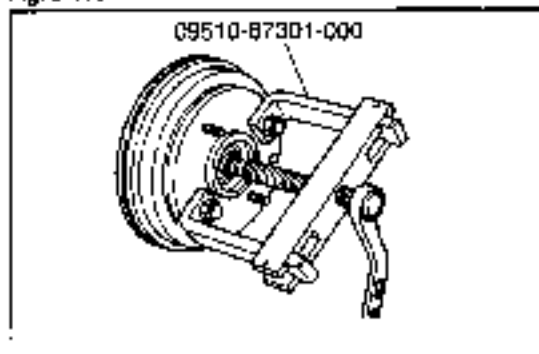

Fig. 8-112

WR-05-18

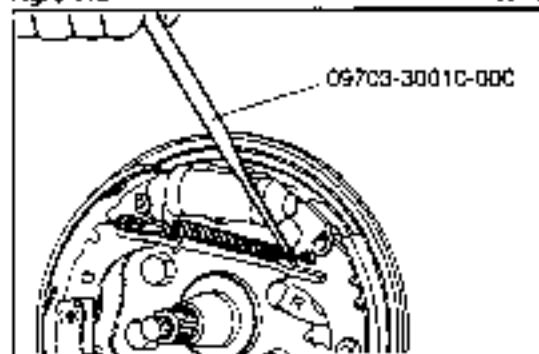

Fig. 8-113

WR-06-19

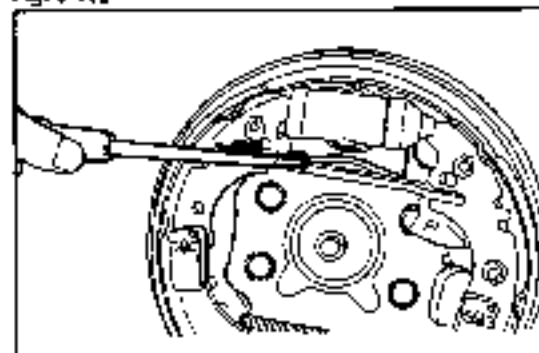

Fig. 8-114

WR-08-20

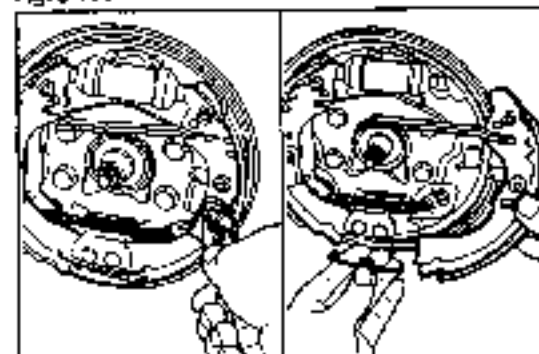

Fig. 8-115

WR-09-21

7. Brake shoe (trailing side) removal

- (1) Remove the shoe hold-down spring and pin.
- (2) Remove the parking brake cable from the parking brake shoe lever using pliers.

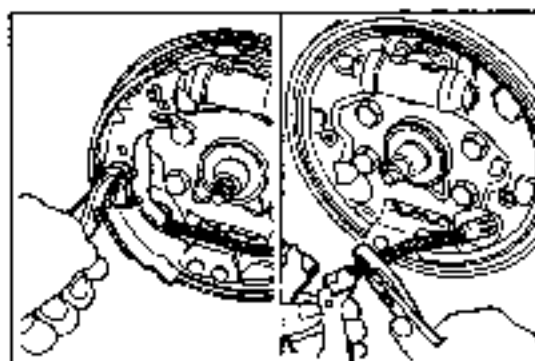

Fig. 8-116

W7-08-22

8. Detach the "C" ring, using a common screwdriver. Remove the parking brake shoe lever and automatic adjusting lever-related parts

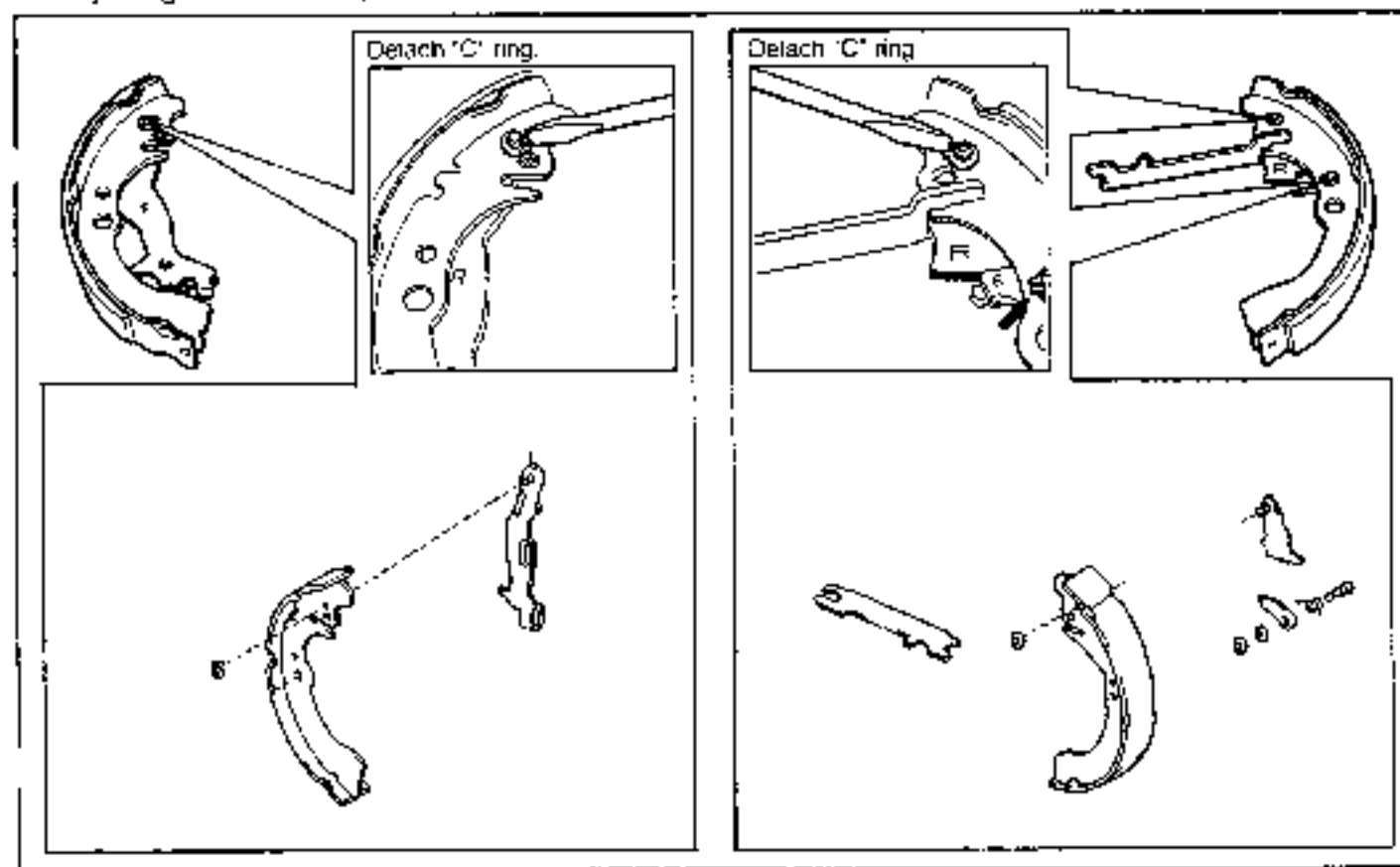

Fig. 8-117

W7-08-23

9. Wheel cylinder removal

- (1) Disconnect the brake tube from the wheel cylinder, using the following SST.
- SST: 09751-36011-000

- (2) Remove the two attaching bolts of the wheel cylinder. Proceed to remove the wheel cylinder from the backing plate

NOTE:

The wheel cylinder can be disassembled or checked with the wheel cylinder mounted on the backing plate. It is, therefore, unnecessary to remove the wheel cylinder from the backing plate except for cases where the wheel cylinder assembly is replaced.

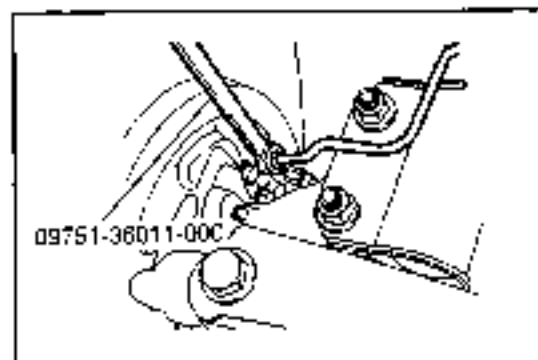

Fig. 8-118

W7-08-24

BRAKES

10. Remove the following parts from the wheel cylinder.
- (1) Wheel cylinder boots (2 pieces)
 - (2) Wheel cylinder pistons (2 pieces)
 - (3) Wheel cylinder piston cups (2 pieces)
 - (4) Compression spring

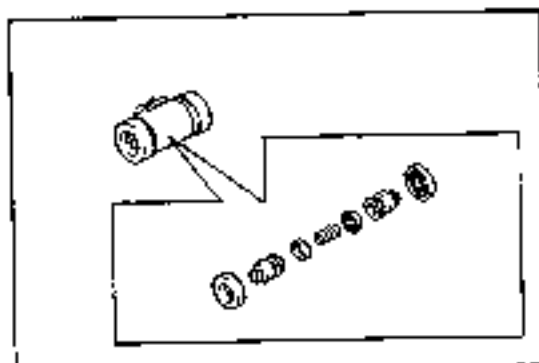

Fig. 8-119

WP-08125

INSPECTION

Inspect the following parts.

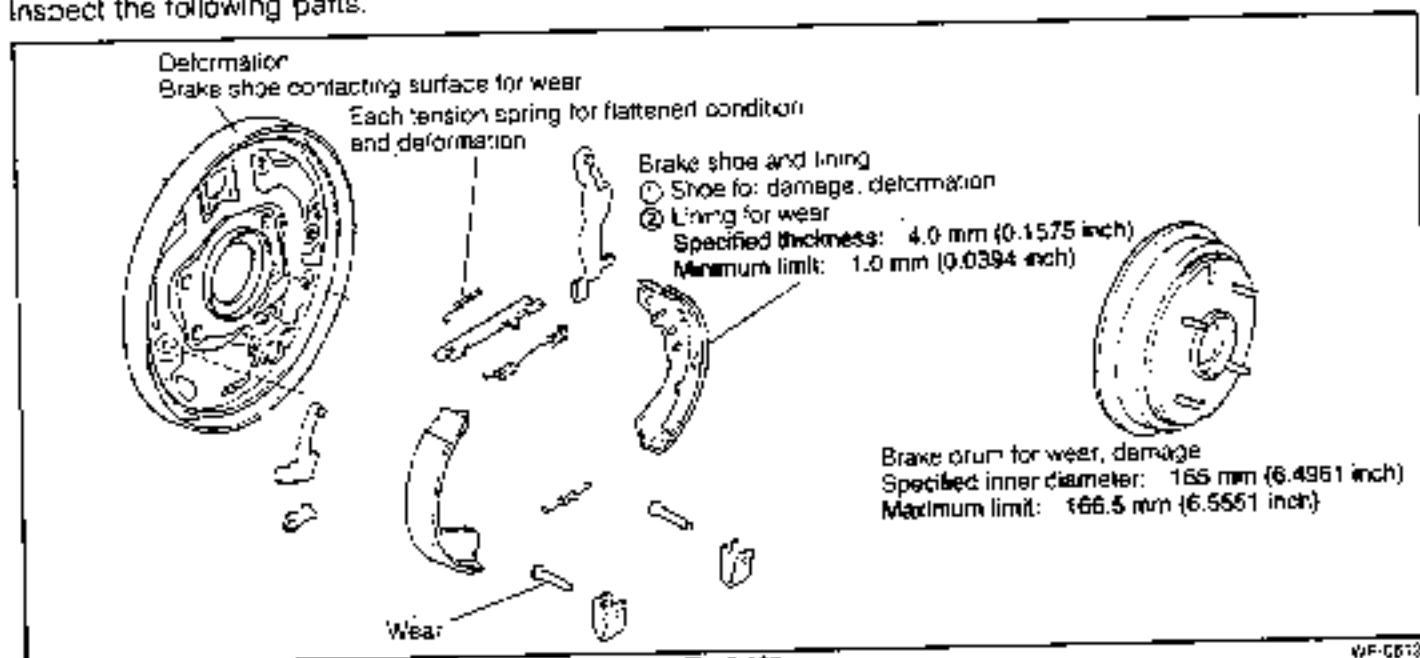

Fig. 8-120

WP-08136

1. Rear brake backing plate replacement
 - (1) Remove the four attaching bolts of the rear brake backing plate.
 - (2) Apply Daihatsu Bond No.4 (999-6304-6323-00) to the installation surface of the rear brake backing plate with the rear axle carrier. At this time, do not plug the grease releasing hole [5 mm (0.20 inch) dia.] with the grease.
 - (3) Install the rear brake backing plate, using the four bolts.

2. Brake drum replacement
 - (1) Apply Mq grease to the points indicated in the right figure.

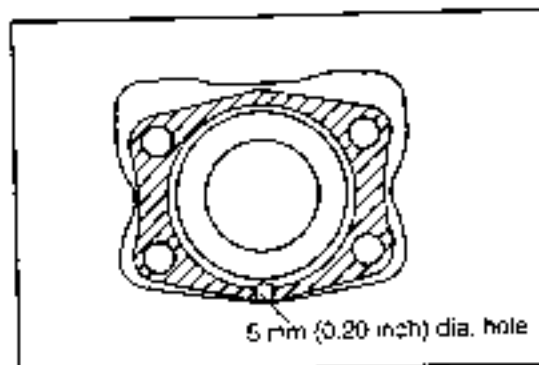

Fig. 8-121

WP-08127

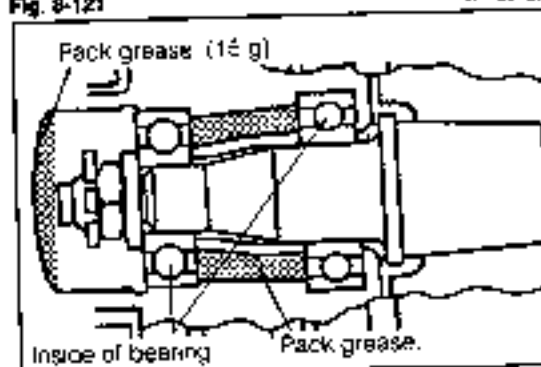

Fig. 8-122

WP-08128

- (2) Install the outer bearing, using the following SST
SST: 09608-12010-000 (No.13 in the set)
- (3) Install the outer retainer.
- (4) Install the inner bearing, using the following SST.
SST: 09608-12011-000 (No.5 in the set)

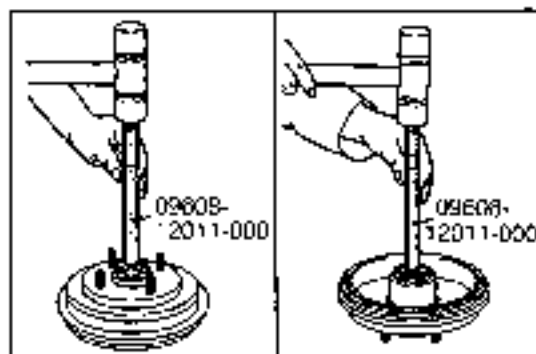

Fig. 8-123

WR-08-20

INSTALLATION

1. Assembly of wheel cylinder
 - (1) Apply rubber grease to the points indicated by arrows.
 - (2) Assemble the cup on the wheel cylinder piston
NOTE:
Be sure to install the cup in the correct direction.
 - (3) Install the two pistons and compression spring to the wheel cylinder.
 - (4) Assemble the two wheel cylinder boots.
2. Wheel cylinder installation
 - (1) Apply liquid gasket to the installation section of the rear brake backing plate with the wheel cylinder.
 - (2) Install the wheel cylinder to the rear brake backing plate, using the two bolts
Tightening Torque: 4.0 - 5.5 kg-m (28.9 - 39.8 ft-lb)
3. Brake tube installation
 - (1) Install the brake tube to the wheel cylinder temporarily by hands.
 - (2) Tighten the brake tube to the wheel cylinder, using the following SST
SST: 09751-36011-000

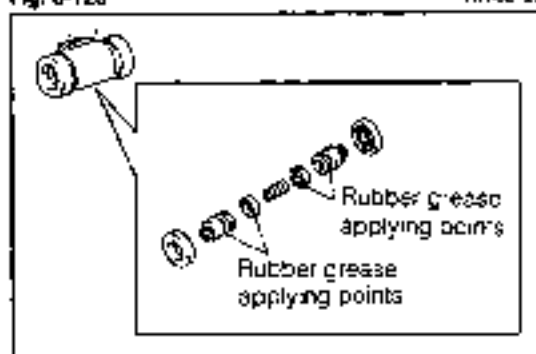

Fig. 8-124

WR-08-30

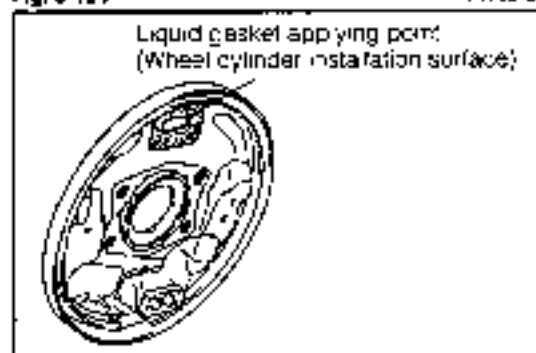

Fig. 8-125

WR-08-31

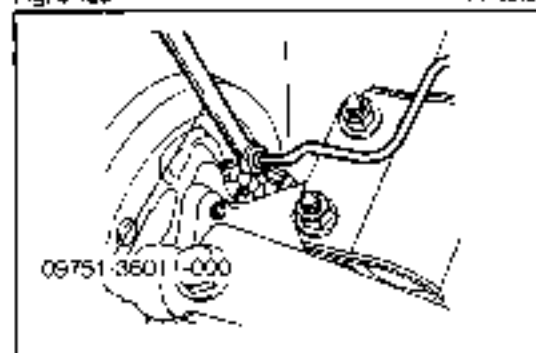

Fig. 8-126

WR-08-32

BRAKES

4. Install the parking brake shoe lever and automatic adjusting lever-related parts to the brake shoe.

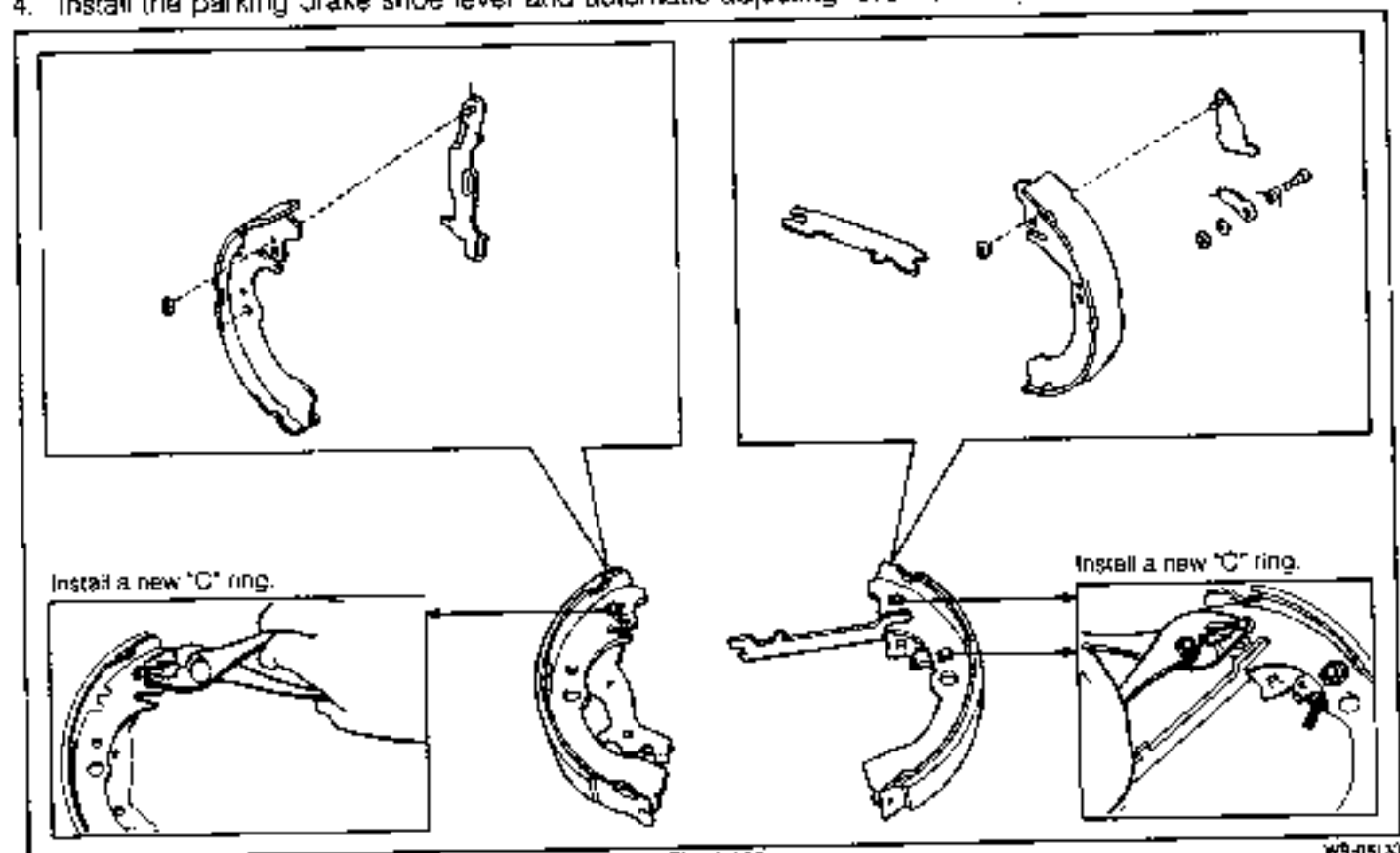

Fig. 8-127

WR-05130

5. Apply brake grease to the contacting points of the rear brake backing plate with the brake shoe.

NOTE:

Be careful not to allow lubricants, such as grease, to get to the wheel cylinder boot.

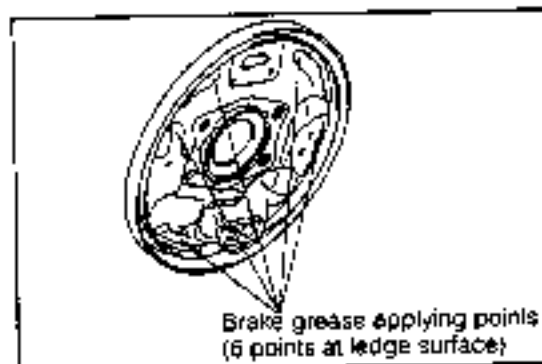

Fig. 8-126

WR-06134

6. Assembly of brake shoe (trailing side)

- (1) Assemble the parking brake cable to the parking brake shoe lever, using pliers.
- (2) Assemble the brake shoe on the rear brake backing plate. Install the shoe hold-down spring and pin.

NOTE:

Apply liquid gasket to the installation section of the rear brake backing plate with the shoe hold-down spring.

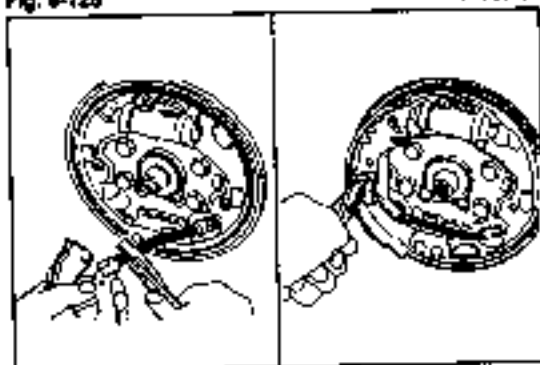

Fig. 8-128

WR-06135

7. Assemble the brake shoe (leading side) on the rear brake backing plate. Install the shoe hold-down spring and pin.

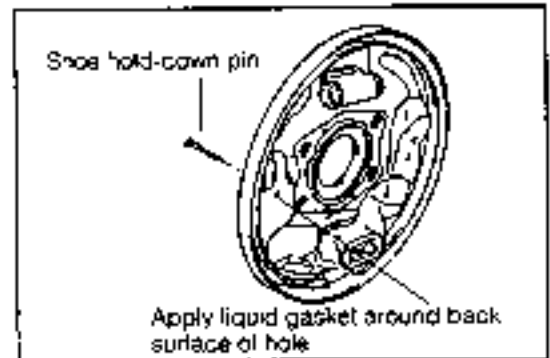

Fig. 8-130

WR-08130

8. Install the tension spring, using a cross point screwdriver.

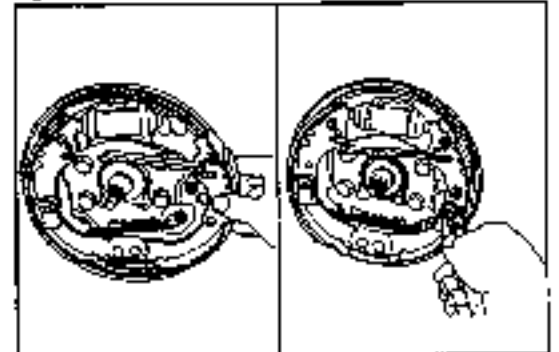

Fig. 8-131

WR-08131

9. Install the tension spring, using the following SST
SST: 09703-30010-000

NOTE:

Be careful not to damage the wheel cylinder boot during the installation.

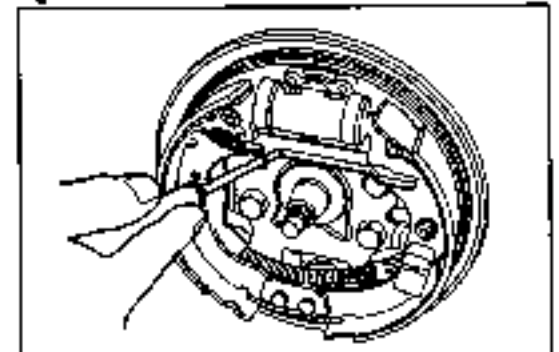

Fig. 8-132

WR-08132

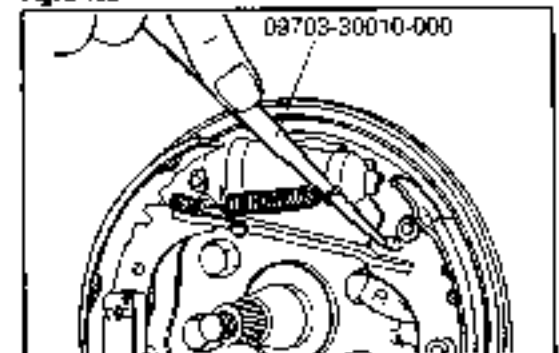

Fig. 8-133

WR-08133

BRAKES

10. Ensure that the rear brake components have been assembled properly.

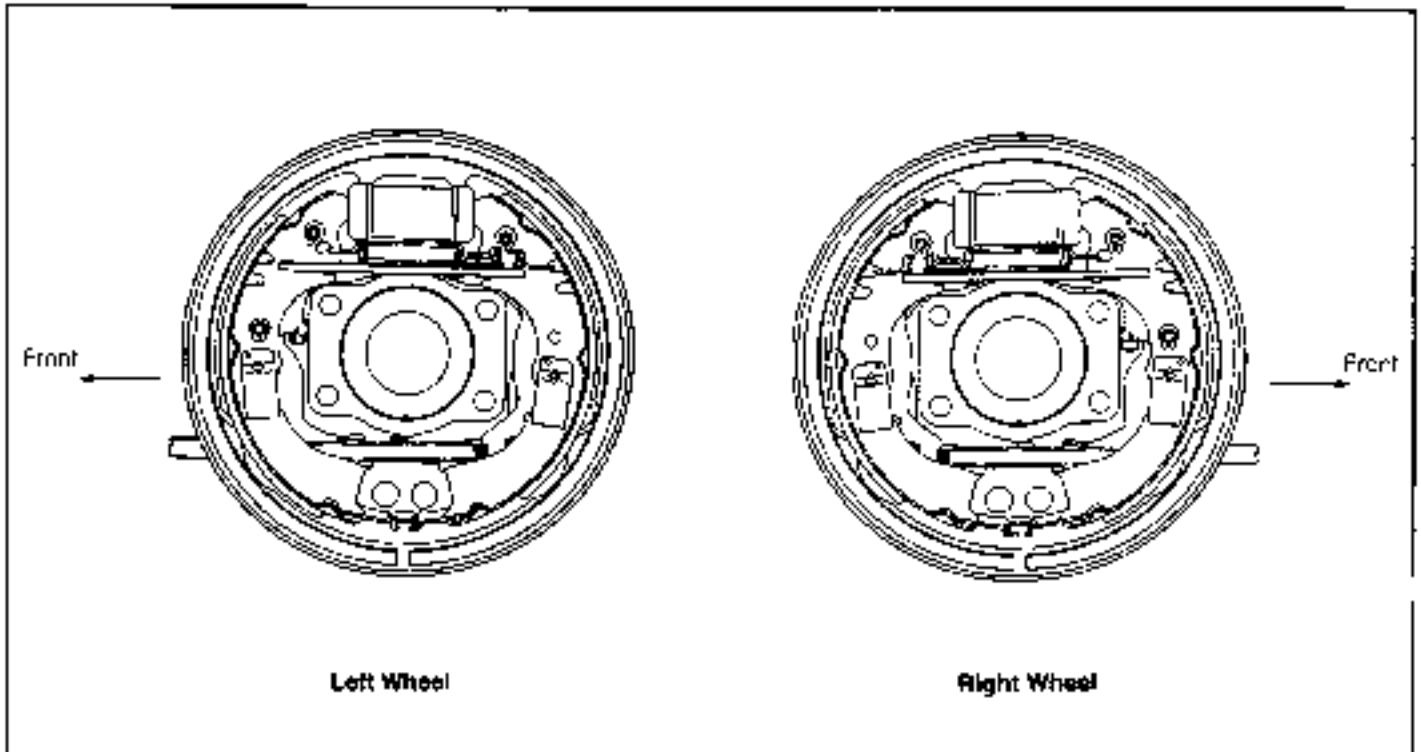

Fig. 8-134

WR-02142

11. Brake adjustment procedure

(1) Retract the shoe by moving the engagement of the parking brake shoe strut, using a common screwdriver or the like.

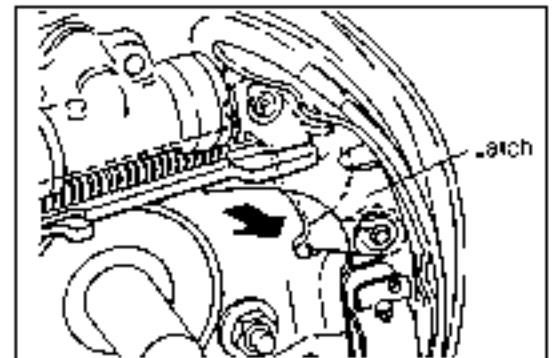

Fig. 8-135

WR-02142

(2) Brake drum installation

(Bearing inner retainer, brake drum, plate washer, castle nut, new cotter pin and grease cap)

Tightening Torque: 6.0 - 10.0 kg-m (43 - 72 ft-lb)

(3) Perform air bleeding for the brake system. (See page 8-5.)

(4) Check the brake system for brake fluid leakage.

(5) Depress the brake pedal and ensure that the automatic adjusting mechanism emits operating sound. Repeat this operation until you no longer hear the operating sound.

(6) Adjust the working travel of the parking brake lever. (See page 8-57.)

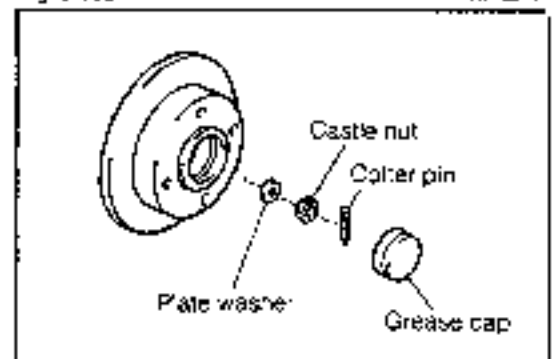

Fig. 8-138

WR-02142

REAR DISC BRAKE

SECTIONAL VIEW

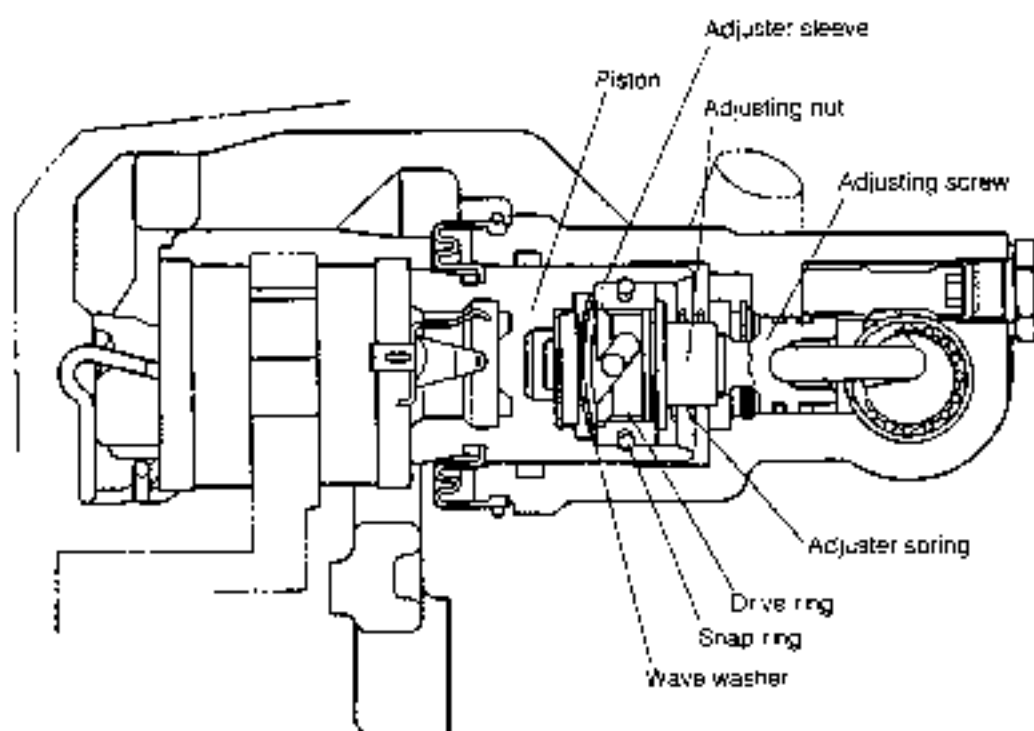
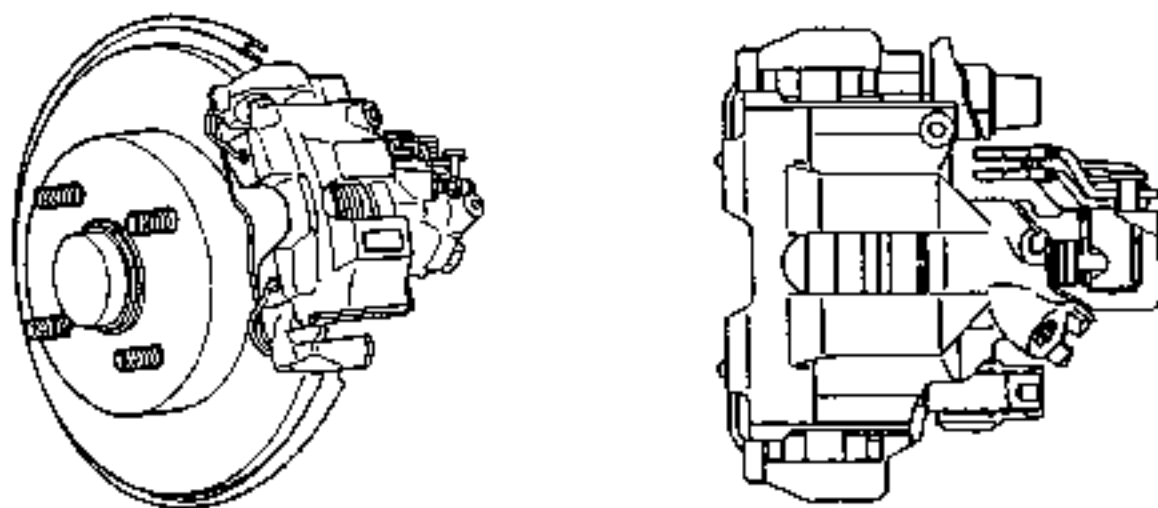
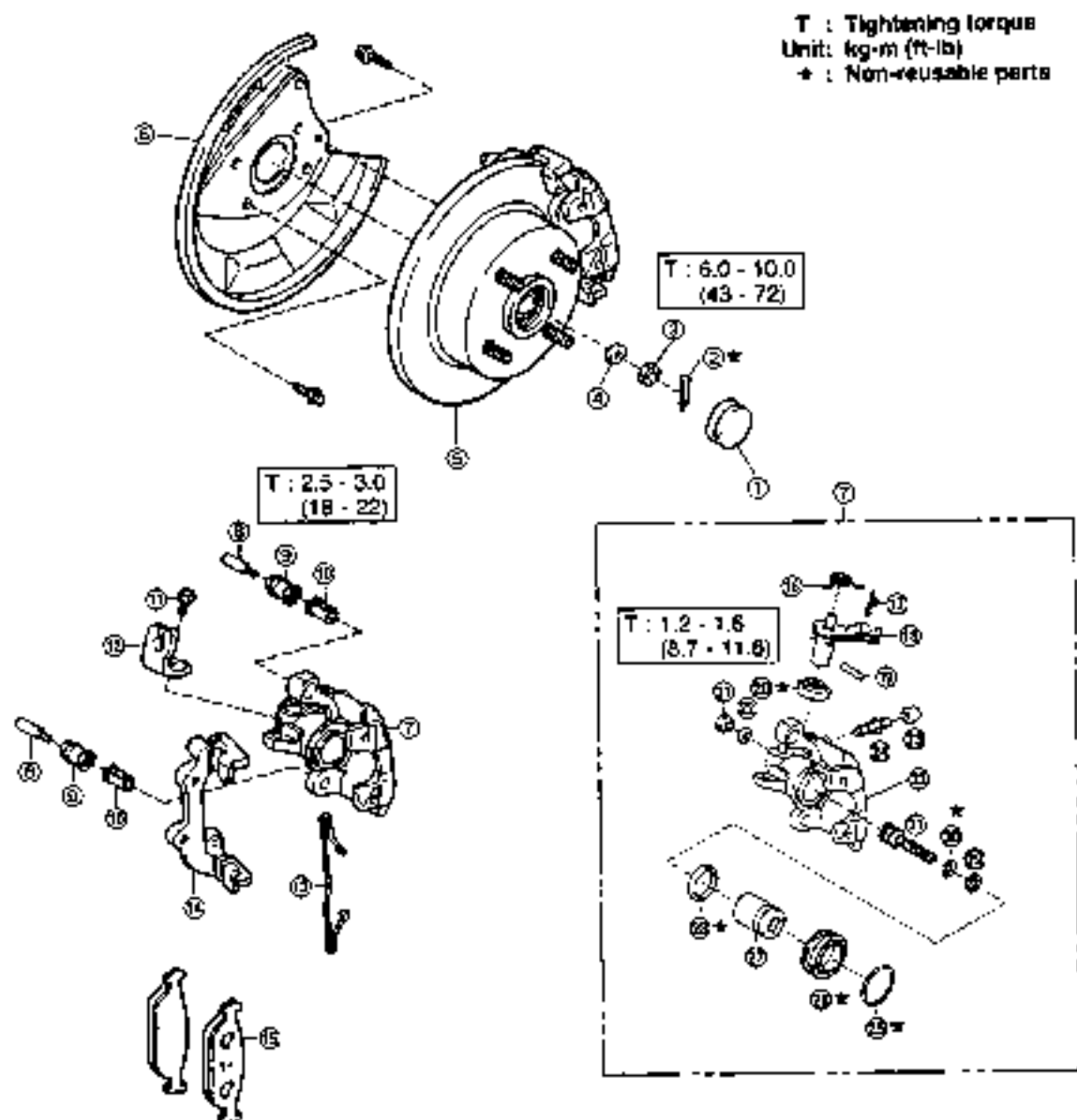

Fig. B-137

495.08-45

BRAKES

COMPONENTS



- ① Grease cap
- ② Cotter pin
- ③ Castle nut
- ④ Plate washer
- ⑤ Brake rear disc S/A
- ⑥ Brake dust cover
- ⑦ Disc brake caliper A_y
- ⑧ Hexagon socket head cap bolt
- ⑨ Bush dust boot
- ⑩ Cylinder side bush
- ⑪ Bolt
- ⑫ Cable support bracket
- ⑬ Anti-rattle spring
- ⑭ Disc brake cylinder mounting
- ⑮ Disc brake pad
- ⑯ Torsion spring

- ⑰ Clip
- ⑱ Parking brake clamp S/A
- ⑲ Parking brake strut
- ⑳ Oil seal
- ㉑ Screw plug
- ㉒ Gasket
- ㉓ Bleeder plug cap
- ㉔ Bleeder plug
- ㉕ Set ring
- ㉖ Cylinder boot
- ㉗ Disc brake piston S/A
- ㉘ Piston seal
- ㉙ Hole snap ring
- ㉚ "O" ring
- ㉛ Pad adjusting bolt
- ㉜ Disc brake rear cylinder

Fig. 8-138

WF-G0144

DISC BRAKE PAD REMOVAL

1. Jack up the rear section of the vehicle. Support the body with safety stands. Remove the rear wheel.
2. Inspect the pad thickness through the inspection hole provided in the disc brake caliper.

Specified Thickness: 9 mm (0.35 inch)

Minimum Limit: 1 mm (0.04 inch)

3. Remove the parking cable guide.
4. Detach the anti-rattle spring.

5. Remove the screw plug.
6. Turn the adjusting gear counterclockwise as far as it will go, using a hexagon wrench key, so that the piston may be retracted.

NOTE:

It should be noted that the adjusting gear can not be removed.

7. Remove the hexagon socket head cap bolts (2 pieces), using a hexagon wrench key.

8. Remove the disc brake pad.

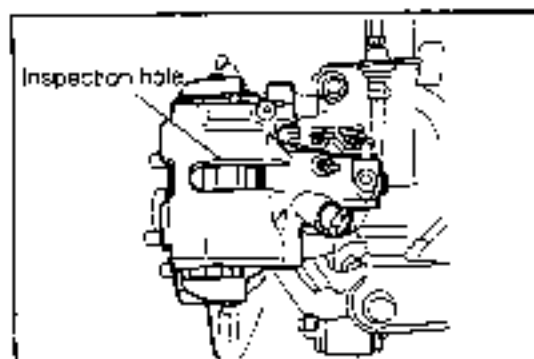

Fig. 8-139

WR-OR135

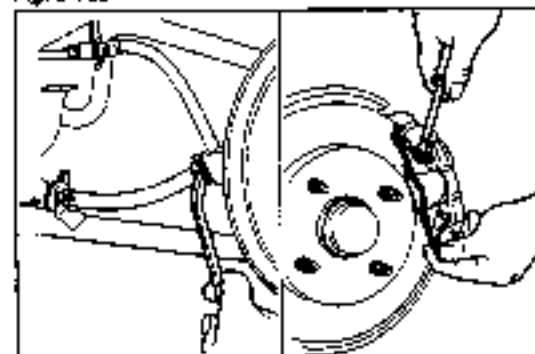

Fig. 8-140

WR-OR140



Fig. 8-141

WR-CB-47



Fig. 8-142

WR-OR142

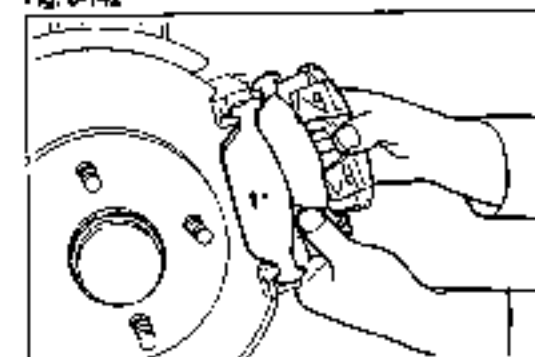

Fig. 8-143

WR-OR143

BRAKES

INSTALLATION

1. Disc brake pad installation
 - (1) Install the inner disc brake pad to the disc brake caliper.
 - (2) Install the outer disc brake pad to the disc brake cylinder mounting.

NOTE:
Be careful not to allow oil, grease and other dirt to get to the friction surfaces of the pad and brake disc.
2. Disc brake caliper assembly installation
 - (1) Tighten the hexagon socket head cap bolt, using a hexagon wrench key. Assemble the disc brake caliper assembly.
 - (2) Install the anti-rattle spring.
3. Turn the adjusting gear clockwise, using a hexagon wrench key, until the disc brake pad is pressed against the brake disc. Then, back off the adjusting gear about 180 degrees counterclockwise.
4. Install the gasket and screw plug.
5. Install the parking cable guide.
6. Depress the brake pedal about 40 times. (This operation makes it possible to adjust the clearance between the disc brake pad and the rear brake disc.)
7. Adjust the working travel of the parking brake lever. (See Fig 8-181.)
8. Install the rear wheel. Jack down the vehicle.

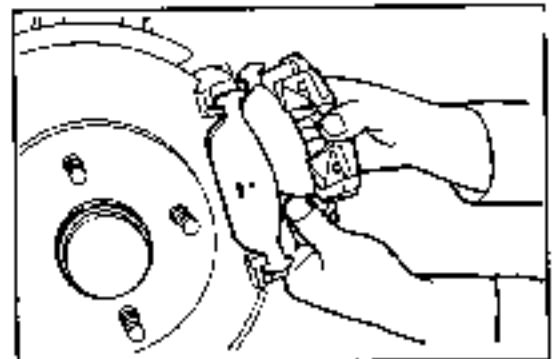

Fig. 8-144

WA-08-50

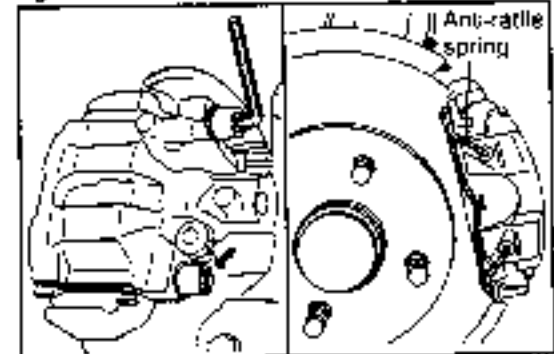

Fig. 8-145

WA-06151

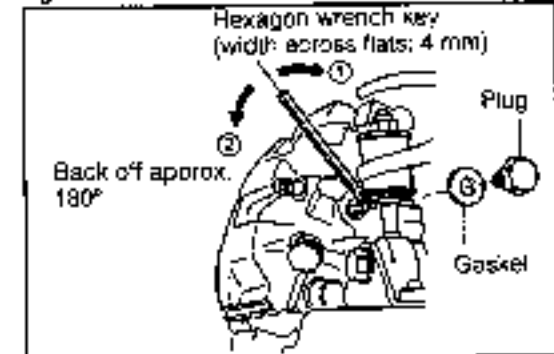

Fig. 8-146

WA-08152

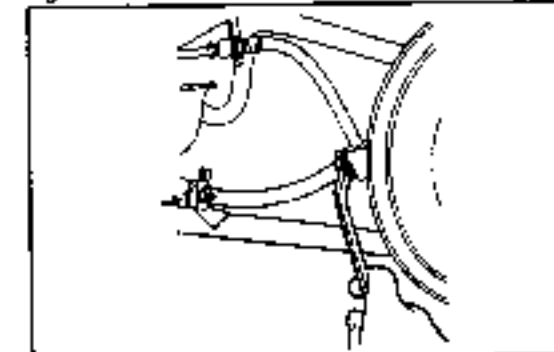

Fig. 8-147

WA-08153

WA-08154

DISC BRAKE REAR CYLINDER REMOVAL

1. Jack up the rear section of the vehicle. Support the body with safety stands. Remove the rear wheel.
2. Disconnect the brake hose from the disc brake rear cylinder.
3. Detach the clip and torsion spring.
4. Parking brake cable removal:
 - (1) Remove the parking brake cable guide.
 - (2) Remove the cable support bracket.
 - (3) Remove the parking brake cable from the disc brake cylinder.
5. Remove the anti-rattle spring.
6. Remove the hexagon socket head cap bolts (2 pieces), using a hexagon wrench key.
7. Remove the disc brake rear cylinder from the vehicle. Remove the disc brake pad.

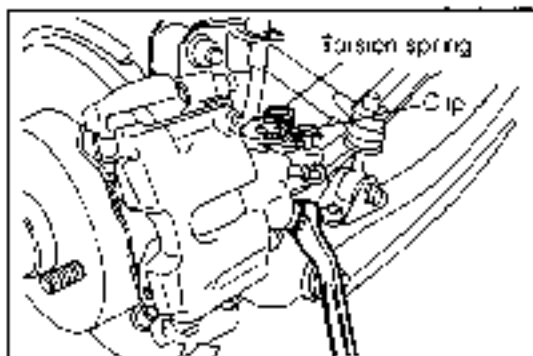

Fig. 8-148

WR 08 155

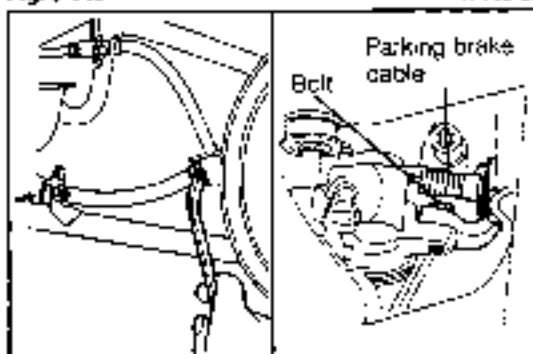

Fig. 8-149

WR 08 156

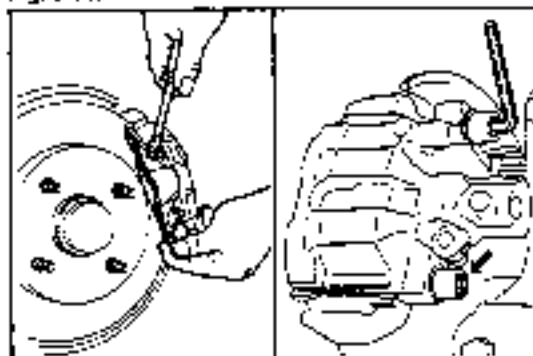

Fig. 8-150

WR 08 157

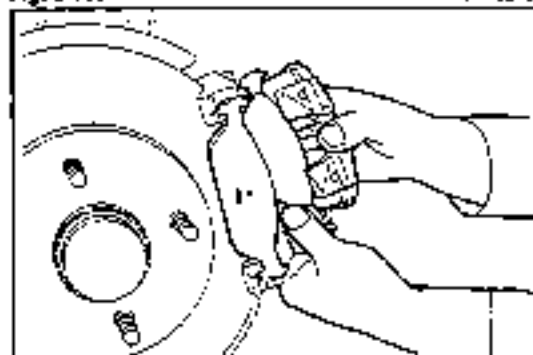

Fig. 8-151

WR 08 158

DISASSEMBLY

1. Remove the set ring and cylinder boot from the disc brake rear cylinder.

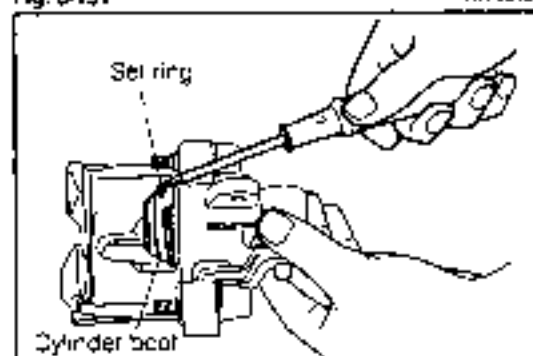

Fig. 8-152

WR 08 159

BRAKES

2. Disc brake piston assembly removal

- (1) Remove the screw plug and gasket.
- (2) Turn the adjusting gear clockwise, using a hexagon wrench key, so that the adjusting screw may be disengaged from the piston assembly. (Turn the adjusting gear, until it can be turned lightly.)
- (3) With a wooden piece or a cloth placed at the end of the disc brake cylinder, drive out the piston, using compressed air.

NOTE:

During this operation, care must be exercised as to the piston being jumped out from position.

3. Remove the piston seal

4. Pad adjusting bolt removal

- (1) Detach the hole snap ring, using the SST.
SST: 09905-87701-000
- (2) Take out the pad adjusting bolt from the disc brake cylinder. Remove the "O" ring from the pad adjusting bolt.

5. Remove the parking brake strut, parking brake clamp subassembly and oil seal from the disc brake cylinder.

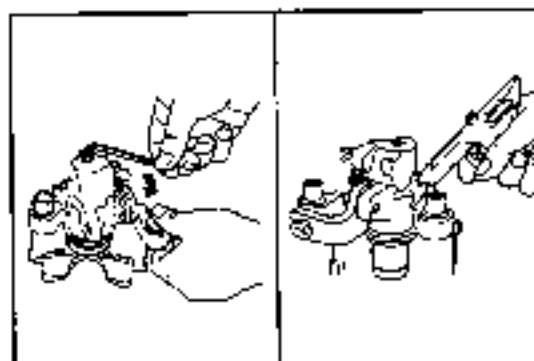

Fig. 8-153

WR-08153

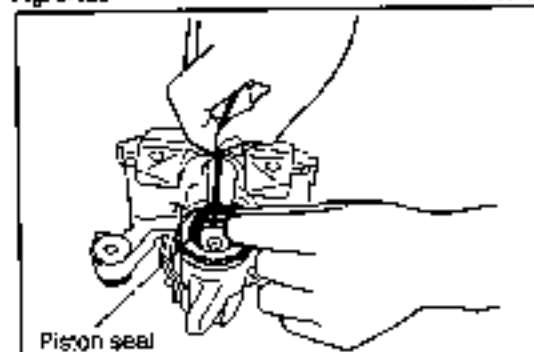

Fig. 8-154

WR-08154

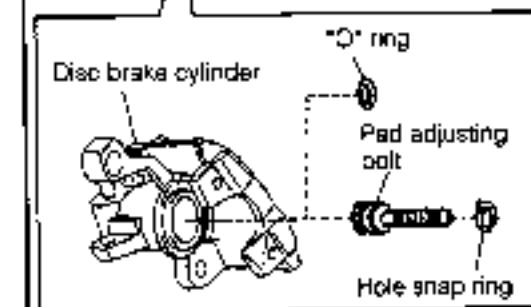
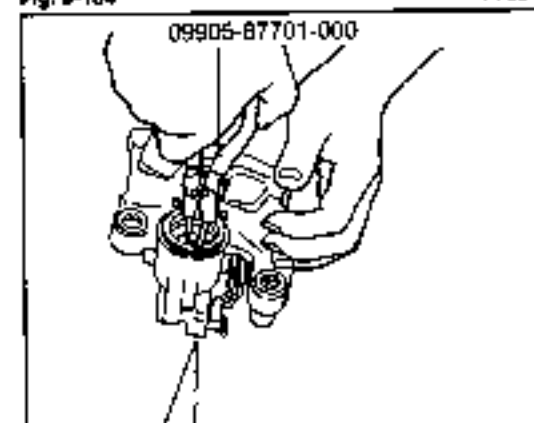

Fig. 8-155

WR-08155

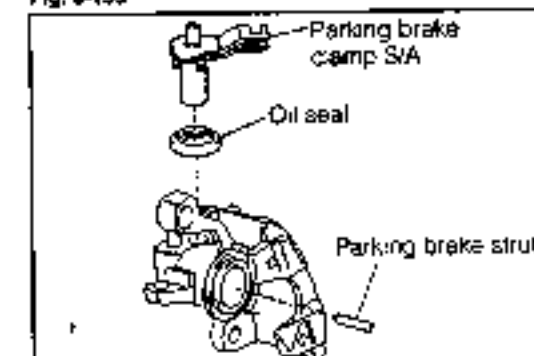

Fig. 8-156

WR-08156

6. Remove the bush dust boot and cylinder slide bush from the disc brake cylinder.

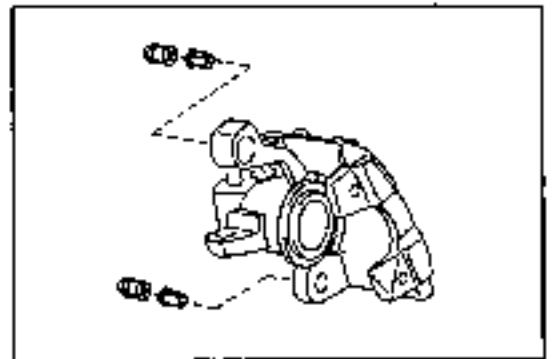

Fig. 8-157

WP-08164

INSPECTION

1. Inspect the following parts.

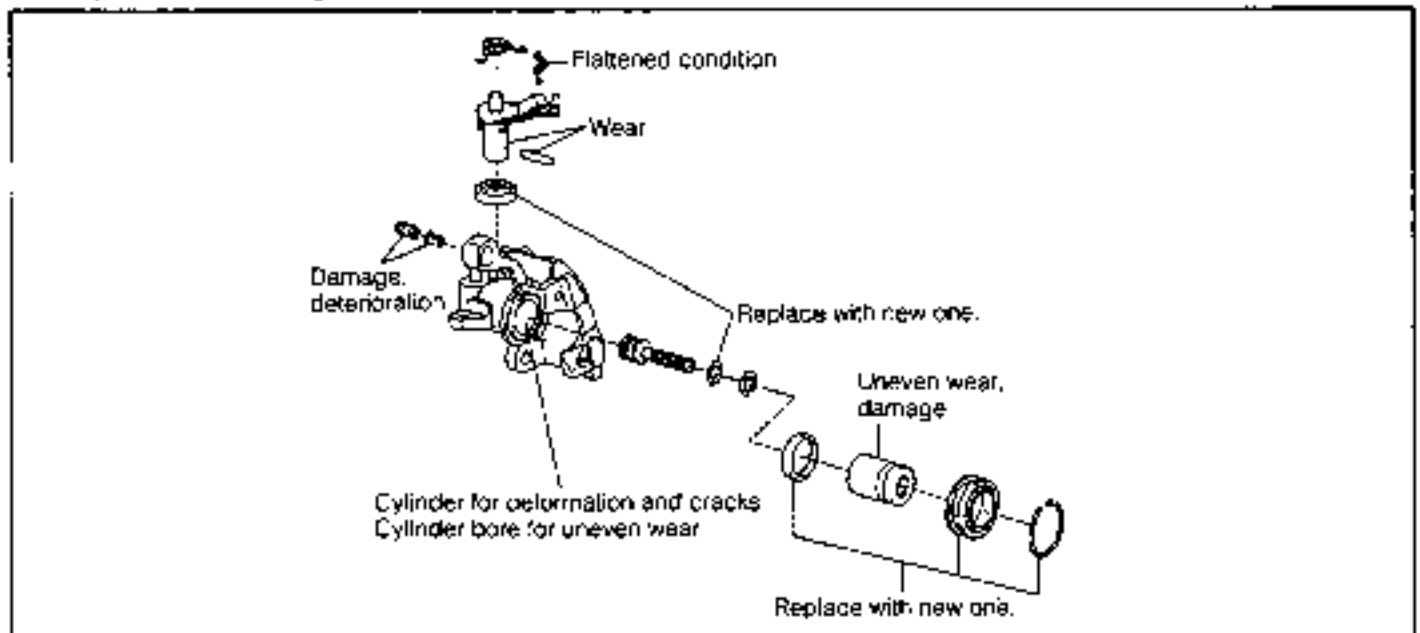

Fig. 8-158

WP-08165

2. Pad thickness measurement
Specified Thickness: 9 mm (0.35 inch)
Minimum Limit: 1 mm (0.04 inch)

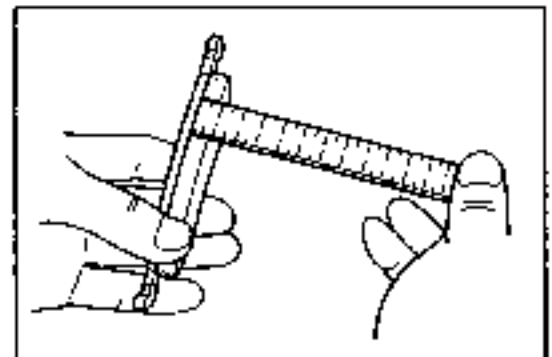

Fig. 8-159

WP-08166

3. Brake rear disc thickness check
Specified Thickness: 10 mm (0.39 inch)
Minimum Limit: 9 mm (0.35 inch)

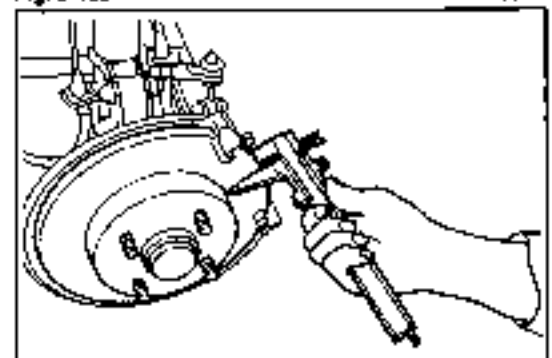

Fig. 8-160

WP-08167

BRAKES

4. Checking of brake rear disc for runout

- (1) Before the brake rear disc is checked for runout, ensure that the rear axle bearing exhibits no excessive looseness.
- (2) Measure the runout of the brake rear disc at the outer edge surface.

Maximum Limit: 0.08 mm (0.003 inch)

5. Brake rear disc replacement

- (1) Remove the disc brake cylinder mounting, grease retainer cap, cotter pin, castle nut and brake rear disc.
- (2) Check the brake dust cover for defects, such as damage, cracks and deformation. Replace the brake dust cover which exhibits any defect.

Tightening Torque: 4.0 - 5.5 kg-m (28.9 - 39.8 ft-lb)

- (3) Install the outer bearing, outer retainer and inner bearing to the brake rear disc, using the following SSTs

(Outer bearing)

SST: 09608-12010-000 (No.13)

(Inner bearing)

SST: 09608-12010-000 (No.5)

- (4) Apply chassis grease to the points indicated in the right figure.

- (5) Install the bearing inner retainer, brake rear disc, plate washer and castle nut.

Tightening Torque: 6.0 - 10.0 kg-m (43 - 72 ft-lb)

- (6) Install a new cotter pin. Attach the grease retainer cap.

- (7) Install the disc brake cylinder mounting.

Tightening Torque: 4.0 - 5.5 kg-m (29 - 40 ft-lb)

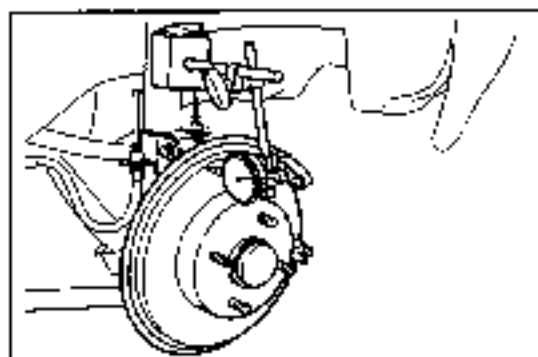

Fig. 8-161

WP-07-88

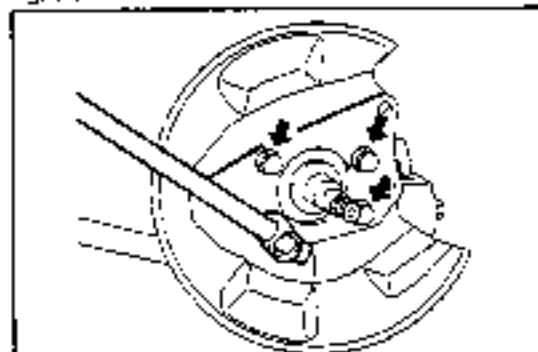

Fig. 8-162

WP-06-89

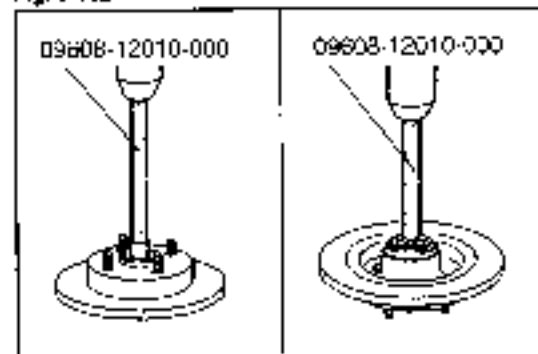

Fig. 8-163

WP-08-79

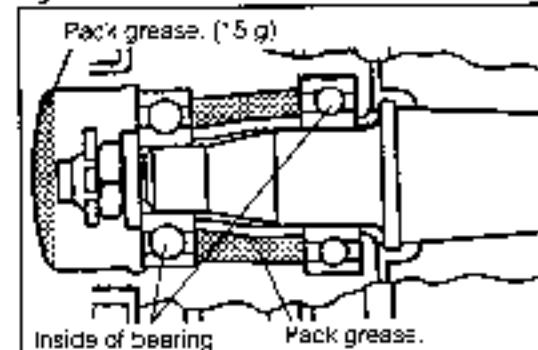

Fig. 8-164

WP-06-79

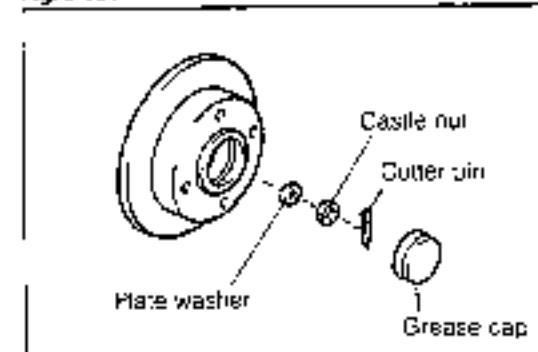
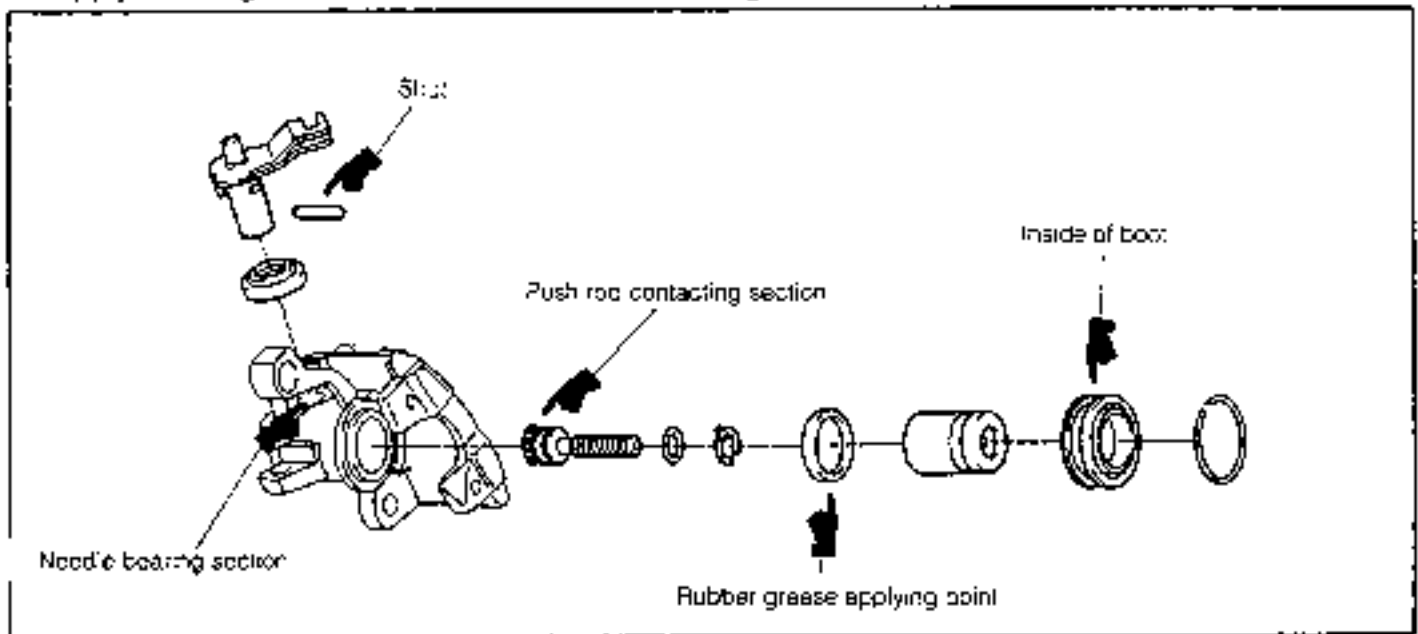

Fig. 8-165

WP-06-79

ASSEMBLY

1. Apply rubber grease to the points indicated in the figure below



2. Install the oil seal parking brake clamp subassembly and parking brake stopper to the disc brake cylinder.

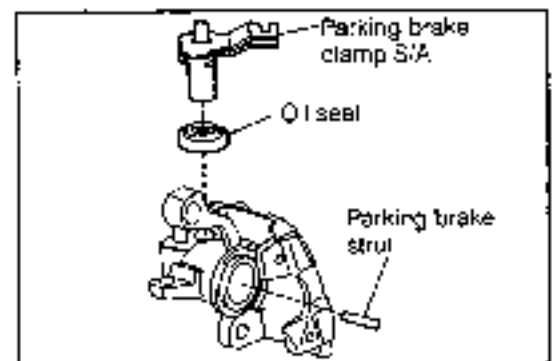

3. Pad adjusting bolt installation

- (1) Install the "O" ring to the pad adjusting bolt. Assemble the pad adjusting bolt to the disc brake cylinder.
- (2) Attach the hole snap ring, using the following SST.
SST: 09905-87701-000

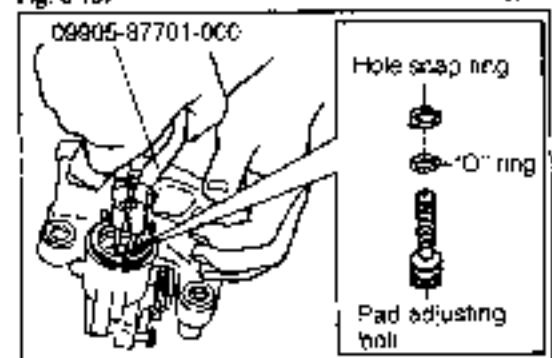

4. Installation of disc brake piston assembly

- (1) Install the piston seal in the disc brake cylinder.
- (2) Insert the piston into the caliper. With the piston pushed tightly, turn the adjusting gear counterclockwise as far as it will go, using a hexagon wrench key. Then, pull back the piston, until it is no longer possible to turn the adjusting gear.

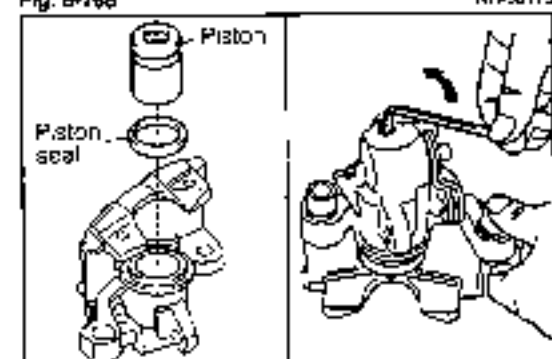

BRAKES

5. Install the cylinder boot and set ring to the disc brake cylinder.
6. Install the bush dust boot and cylinder slide bush to the disc brake cylinder.

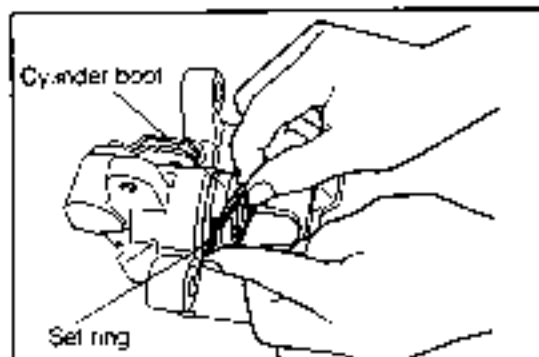

Fig. 8-170

WR-08177

INSTALLATION

1. Disc brake cylinder installation
 - (1) Install the disc brake cylinder to the disc brake cylinder mounting, using a hexagon wrench key.
 - (2) Install the anti-rattle spring.
2. Parking brake cable installation
 - (1) Attach the tip end of the parking brake cable to the parking brake clamp subassembly.
 - (2) Install the cable support bracket.

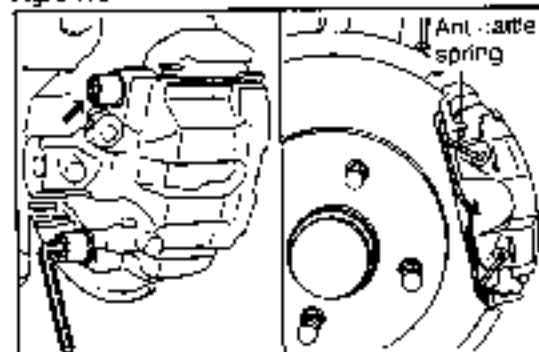

Fig. 8-171

WR-08178

3. Install the parking brake guide

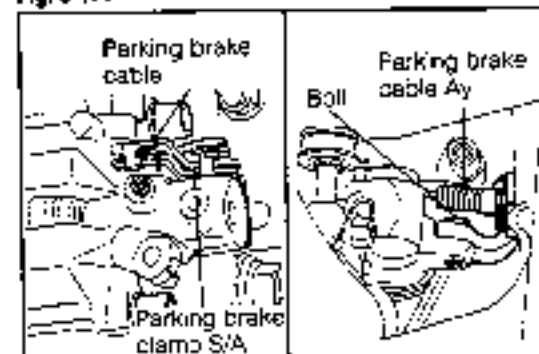

Fig. 8-172

WR-08179

4. Install the following parts to the disc brake cylinder.
 - (1) Install the torsion spring and clip.
 - (2) Connect the brake hose.
(Use a new gasket.)

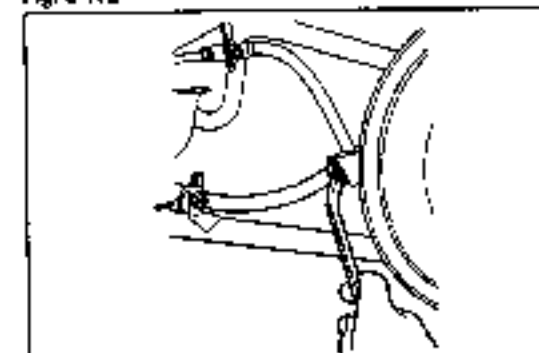

Fig. 8-173

WR-08180

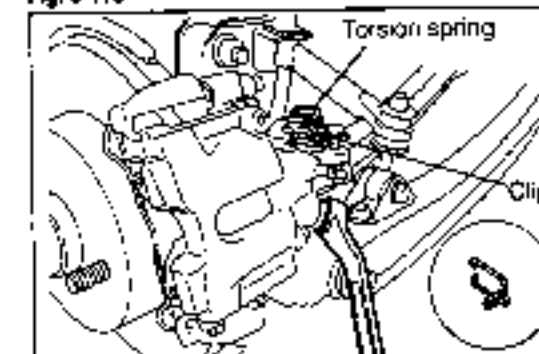

Fig. 8-174

WR-08181

5. Disc brake pad clearance adjustment

- (1) Turn the adjusting gear clockwise, using a hexagon wrench key, until the disc brake pad is pressed against the brake disc. Then, back off the adjusting gear about 180 degrees counterclockwise.
- (2) Install the gasket and screw plug.
- (3) Perform air bleeding for the brake system. Depress the brake pedal about 40 times. (This operation makes it possible to adjust the clearance between the disc brake pad and the brake disc.)
- (4) Adjust the working travel of the parking brake lever. (See Fig. 8-181.)

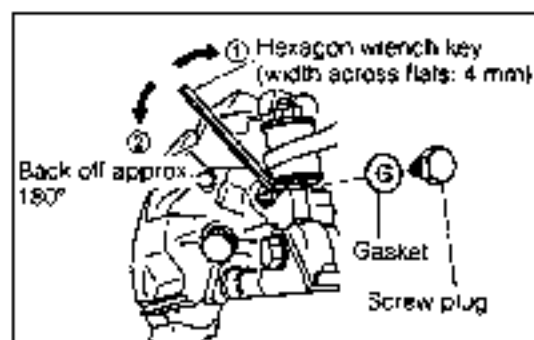

Fig. 8-175

W9-08192

Gasket

BRAKES

PARKING BRAKE

PARKING BRAKE LEVER COMPONENTS

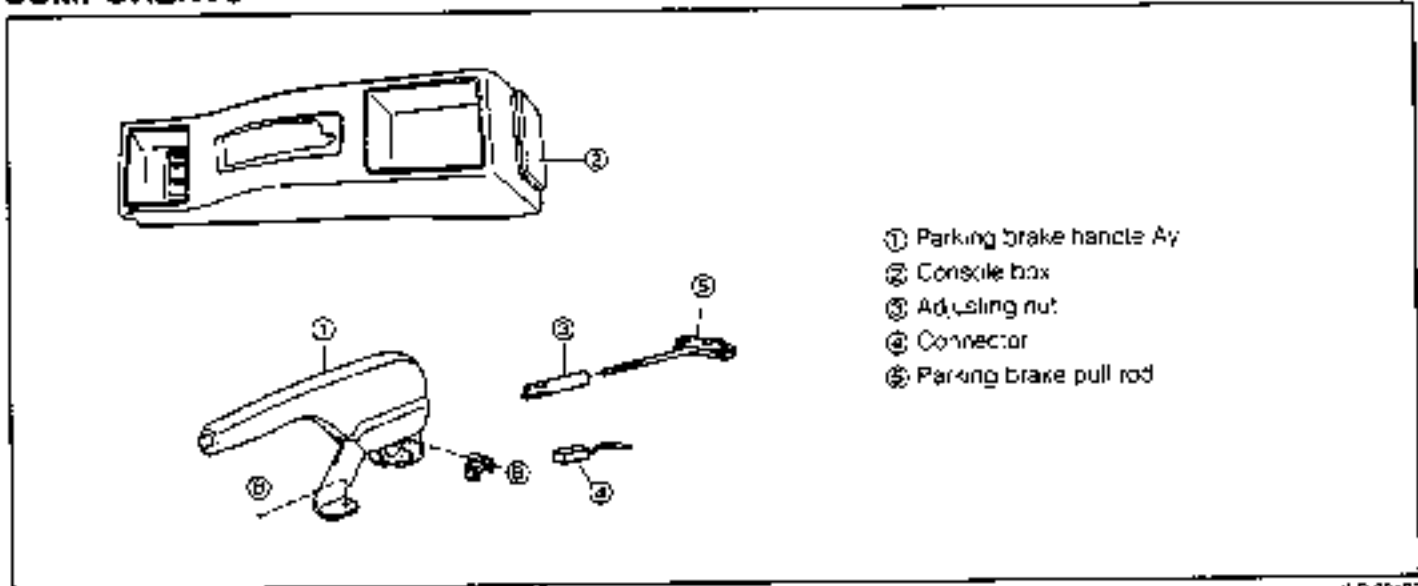

Fig. 8-176

WR-08183

REMOVAL

1. Console box
 - (1) Remove the coin box.
 - (2) Remove the console box from the vehicle by removing the bolts and screws, two each.
2. Remove the connector and adjusting nut.
3. Remove the two bolts. Remove the parking brake handle assembly from the vehicle.

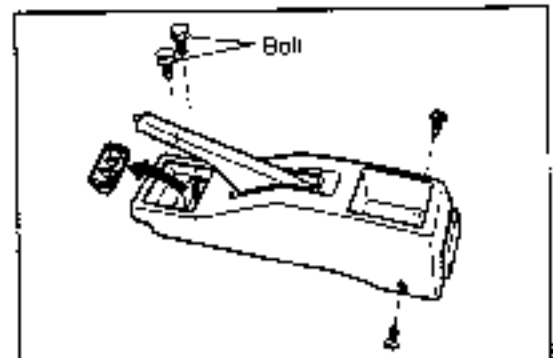

Fig. 8-177

WR-08134

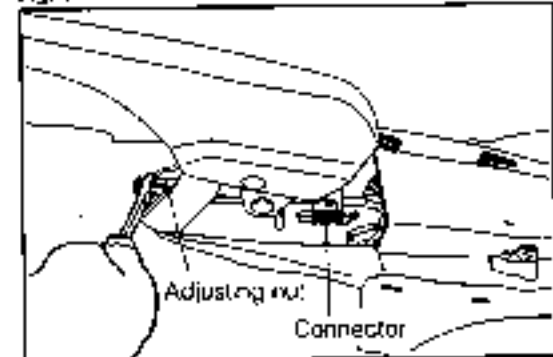

Fig. 8-178

WR-08185

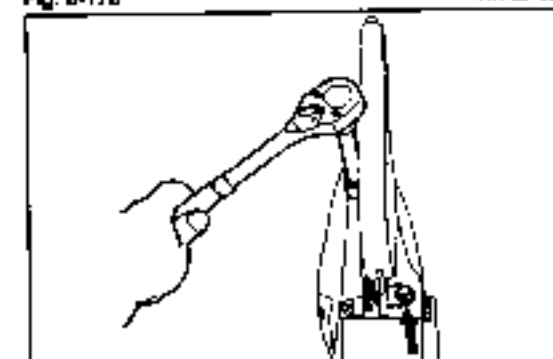

Fig. 8-179

WR-08186

INSTALLATION

1. Install the parking brake handle assembly with the two bolts.

Tightening Torque: 1.0 - 1.6 kg-m (7.2 - 11.6 ft-lb)

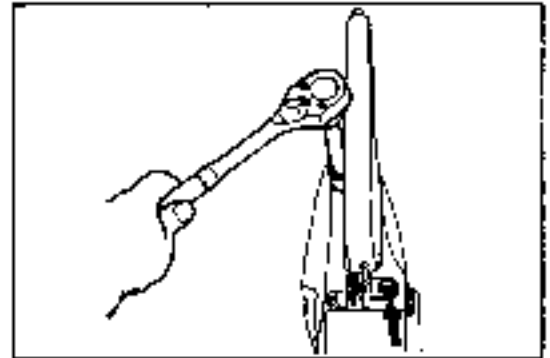

Fig. 8-180

WP-08137

2. Install the connector and adjusting nut. Adjust the working travel by turning the adjusting nut. (Check the parking brake indicator lamp for proper operation.)

Specified Value: 5 - 9 Notches

[When pulled by a force of 20 kg (44 lb)]

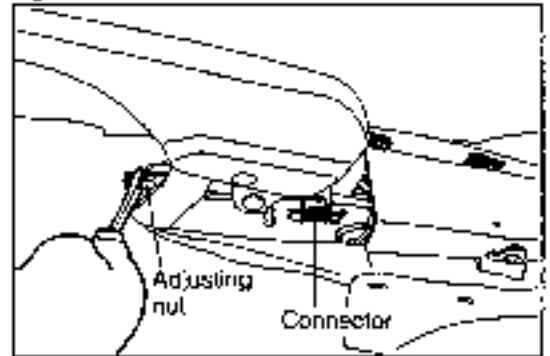

Fig. 8-181

WP-08138

3. Install the console box
 - (1) install the console box to the vehicle with the bolts and screws, two each.
 - (2) Install the coin box.

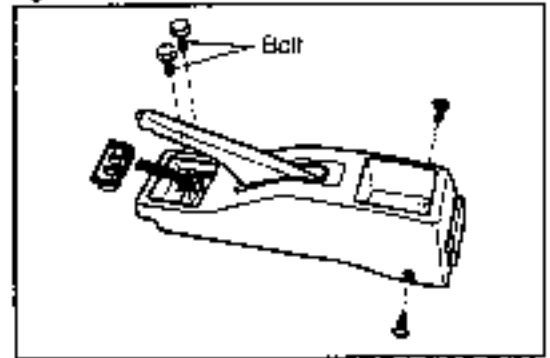

Fig. 8-182

WP-08139

BRAKES

PARKING BRAKE CABLE COMPONENTS

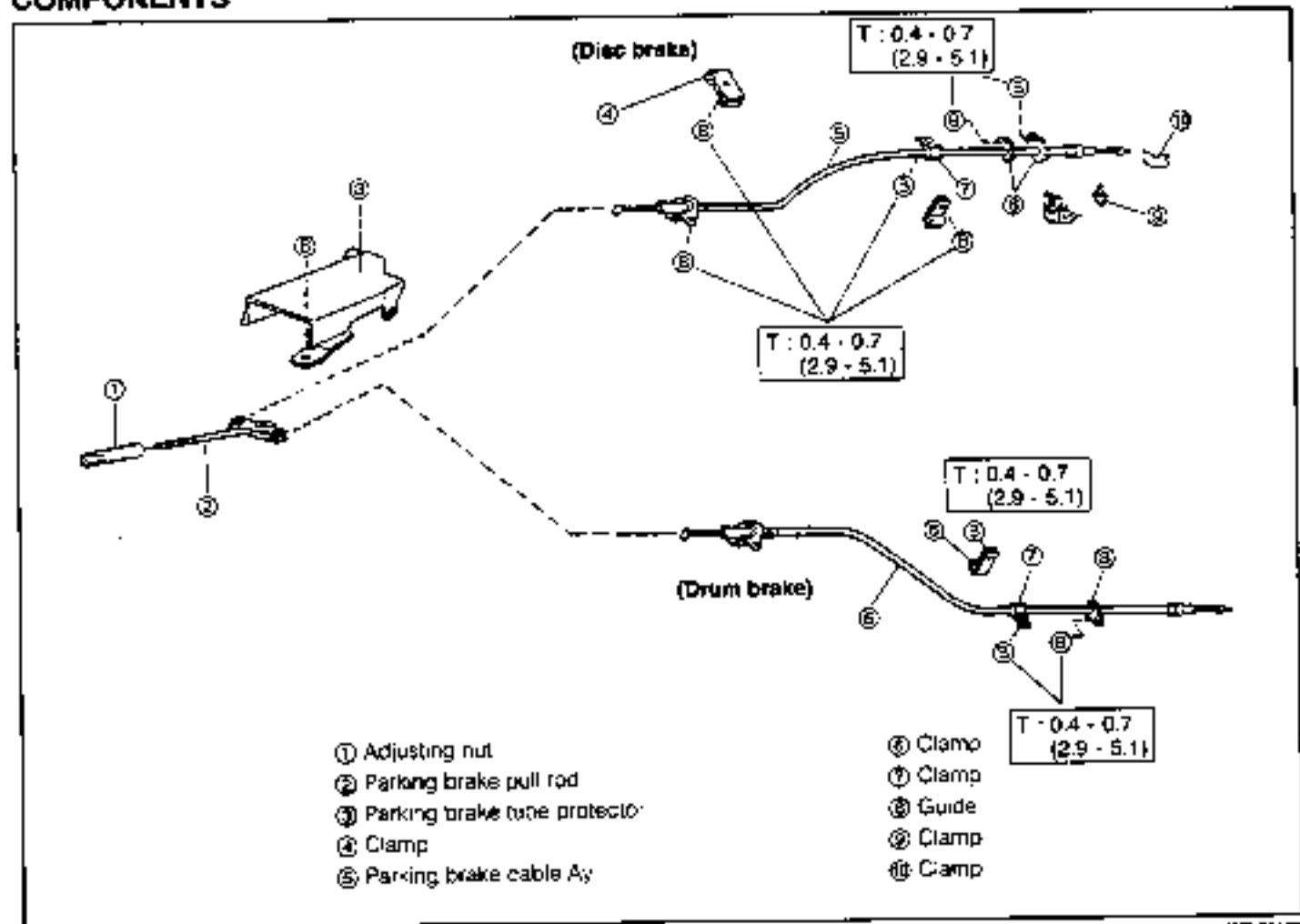

Fig. 8-183

WR 0819C

REMOVAL

1. Remove the console box. (See Fig. 8-177.)
2. Remove the parking brake tube protector

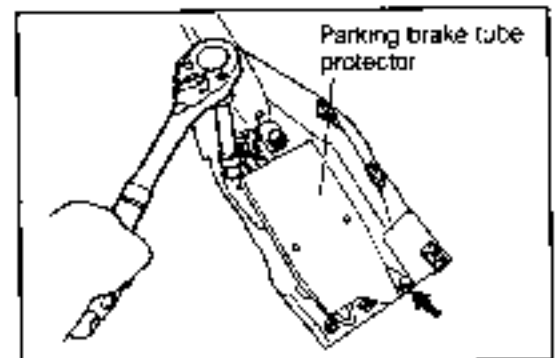

Fig. 8-184

WR 0819C

3. Remove the parking brake cable from the parking brake pull rod.

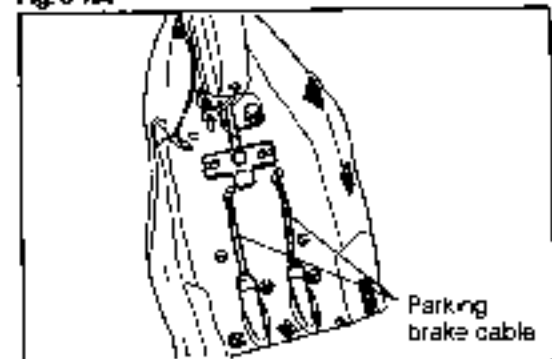

Fig. 8-185

WR 0819C

4. Jack up the vehicle. Remove the clamp-related parts provided under the body.

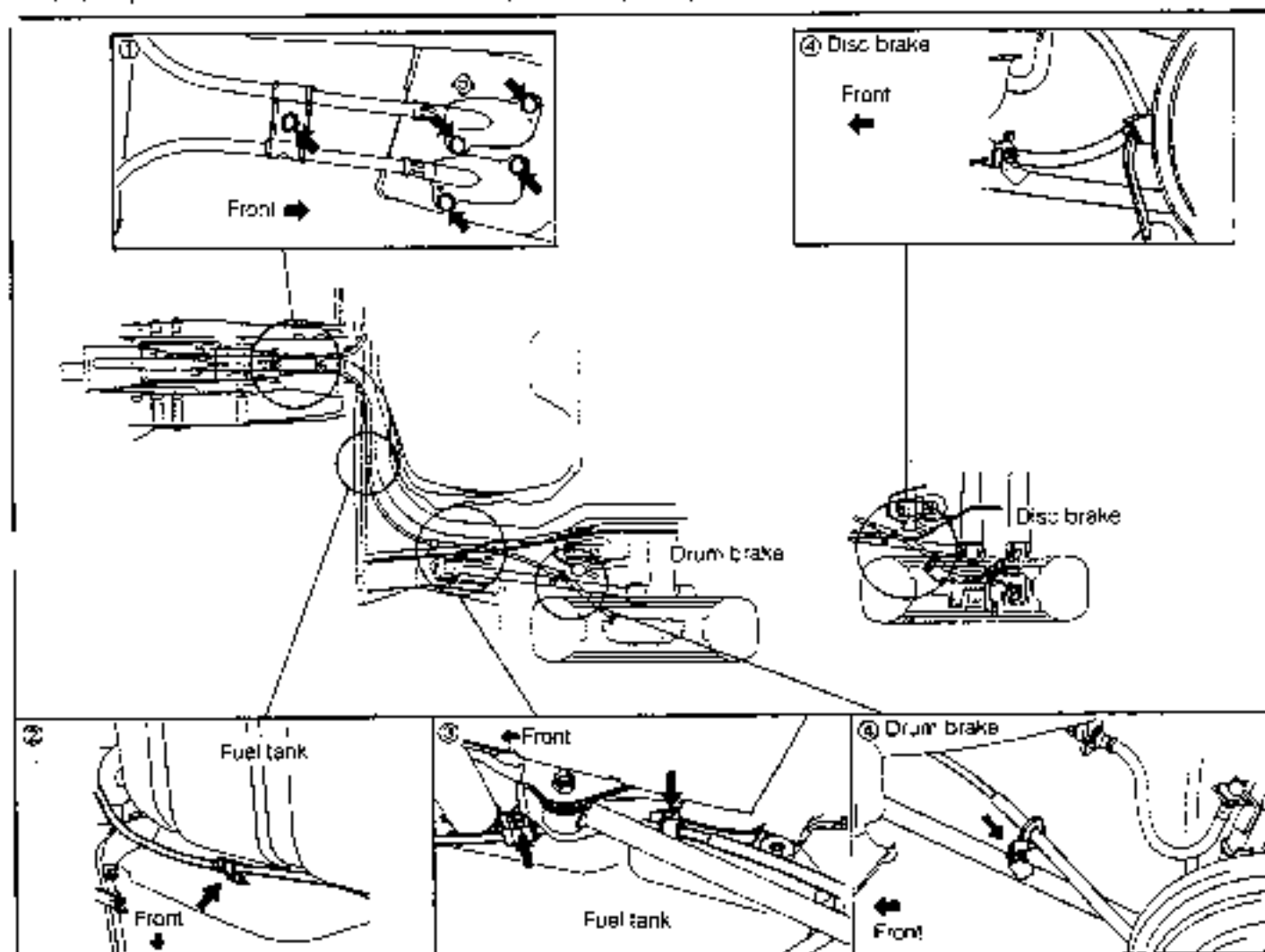

Fig. 8-186

WR-08192

5. Removal of rear brake-related parts

(Drum brake)

- (1) Remove the brake shoe. (See page 8-38.)
- (2) Remove the parking brake cable from the rear brake backing plate.

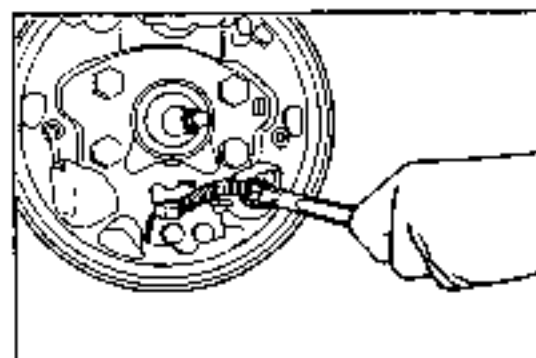

Fig. 8-187

WR-08194

(Disc brake)

- (1) Remove the clip attaching the parking brake cable to the cable support bracket.
- (2) Detach the clip from the parking brake clamp. Then, remove the parking brake cable.

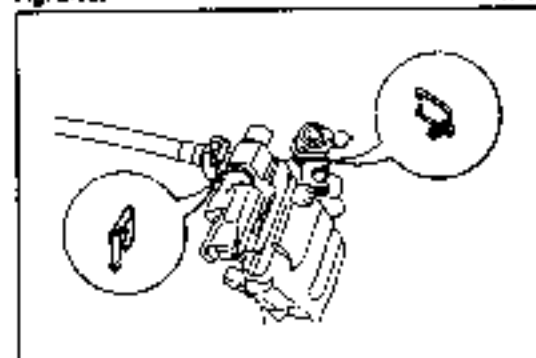

Fig. 8-188

WR-08195

BRAKES

INSTALLATION

1. Installation of rear brake-related parts

(Drum brake)

- (1) Install the parking brake cable to the rear brake backing plate.
- (2) Install the brake shoe-related parts. (See page 8-41.)

WR-08-96

(Disc brake)

- (1) Install the parking brake cable to the disc brake caliper.
- (2) Install the clips at two points.

2. Install the clamp-related parts provided under the body. (See Fig. 8-186.)

3. Attach the parking brake cable to the cable end.

4. Install the parking brake lube protector.

5. Rear brake adjustment

Drum brake (See Fig. 8-44.)

6. Adjust the working travel of the parking brake.

Specified Value: 5 - 9 Notches

[When pulled by a force of 20 kg (44 lb)]

7. Install the console box. (See Fig. 8-182.)

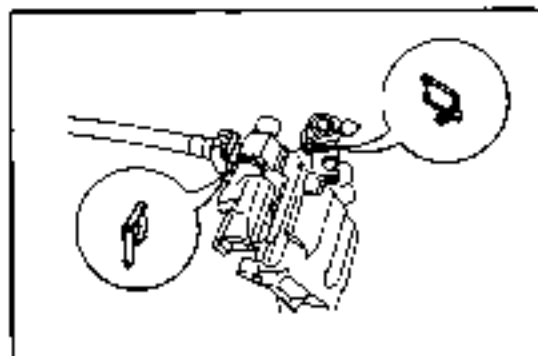

Fig. 8-188

WR-08197

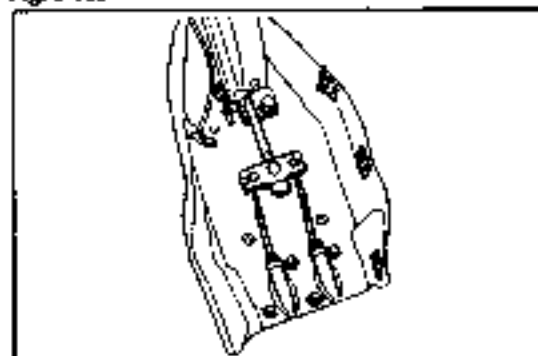

Fig. 8-189

WR-08198

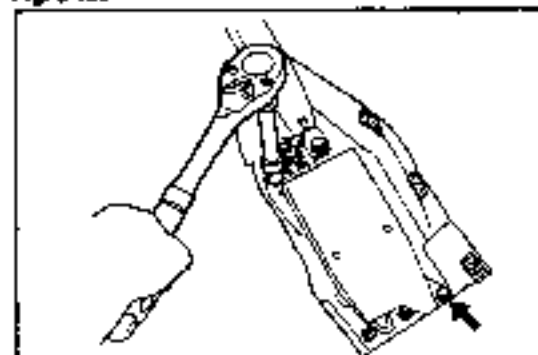

Fig. 8-191

WR-08199

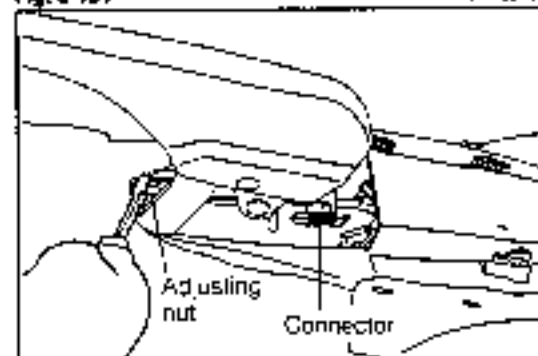

Fig. 8-192

DAIHATSU

CHARADE

Chassis

SECTION 9 BODY

ALIGNMENT ADJUSTMENTS	9- 2	BACK DOOR GARNISH	9-35
ENGINE HOOD ALIGNMENT ADJUSTMENT	9- 2	ARTICLES TO BE PREPARED	9-36
FRONT DOOR ALIGNMENT ADJUSTMENT	9- 3	INSTALLATION POSITION	9-35
REAR DOOR ALIGNMENT ADJUSTMENT	9- 4	REMOVAL	9-35
HATCHBACK DOOR ALIGNMENT ADJUSTMENT	9- 5	INSTALLATION	9-35
POWER SUNROOF ALIGNMENT ADJUSTMENT	9- 6	BACK DOOR OUTSIDE GARNISH NO.2	9-36
FRONT BUMPER	9- 9	ARTICLES TO BE PREPARED	9-36
COMPONENTS	9- 9	COMPONENTS	9-36
REMOVAL	9- 9	REMOVAL	9-36
INSTALLATION	9- 9	INSTALLATION	9-37
REAR BUMPER	9-12	FRONT DOOR	9-38
COMPONENTS	9-12	DOOR TRIM AND SERVICE HOLE COVER	9-38
REMOVAL	9-12	DOOR LOCK AND OUTSIDE DOOR HANDLE	9-42
INSTALLATION	9-13	DOOR GLASS AND REGULATOR	9-44
RADIATOR GRILLE	9-16	REAR DOOR	9-47
COMPONENTS	9-15	DOOR TRIM AND SERVICE HOLE	9-47
REMOVAL	9-15	DOOR LOCK AND OUTSIDE DOOR HANDLE	9-48
INSTALLATION	9-15	DOOR GLASS AND REGULATOR	9-47
COMPONENTS	9-16	BACK DOOR	9-53
REMOVAL	9-16	REMOVAL	9-53
FRONT FENDER	9-17	INSTALLATION	9-56
COMPONENTS	9-17	BACK DOOR OPENER AND FUEL LID OPENER	9-57
REMOVAL	9-17	POWER GLASS SUNROOF WITH	
INSTALLATION	9-19	TILT-UP MECHANISM	9-60
HOOD LOCK CONTROL CABLE	9-20	COMPONENTS	9-60
COMPONENTS	9-20	REMOVAL	9-61
REMOVAL	9-20	INSTALLATION	9-63
INSTALLATION	9-21	ROOF DRIP MOLDING	9-66
WINDOWS	9-22	INSTALLATION POSITION	9-66
FRONT WIND SHIELD	9-22	REMOVAL	9-66
BACK DOOR GLASS	9-28	INSTALLATION	9-67
QUARTER WINDOW GLASS	9-31	EXHAUST PIPE	9-67
OUTSIDE MOLDINGS	9-32	COMPONENTS	9-67
ARTICLES TO BE PREPARED	9-32	FRONT PIPE	9-67
COMPONENTS	9-32	CENTER PIPE	9-69
REMOVAL	9-32	TAIL PIPE	9-68
INSPECTION AND CLEANING	9-32	FUEL TANK	9-70
INSTALLATION	9-33	COMPONENTS	9-70
		FUEL INLET PIPE	9-71
		FUEL TANK	9-73

ALIGNMENT ADJUSTMENTS

ENGINE HOOD ALIGNMENT ADJUSTMENT

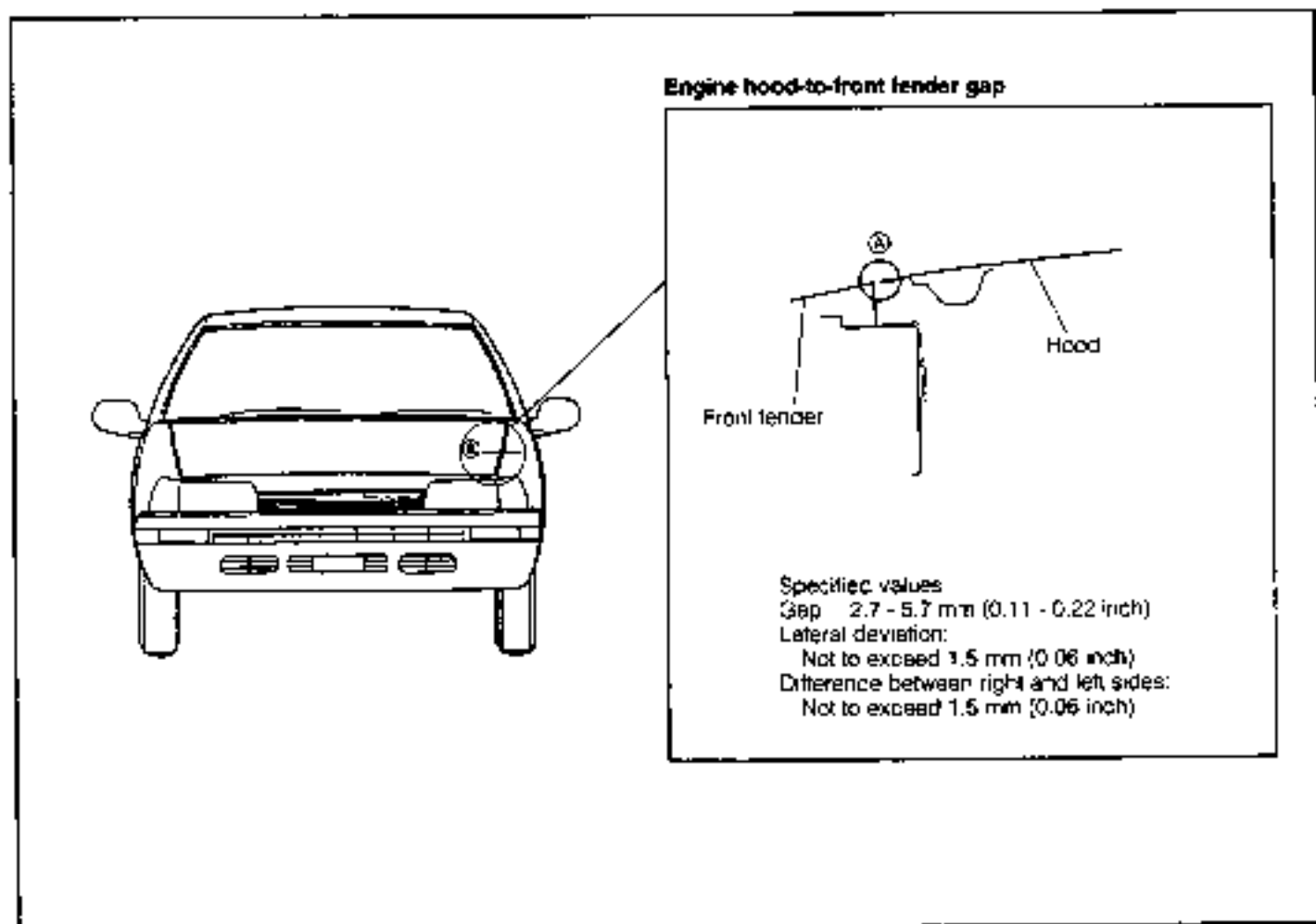

Fig. 9-1

WF-09002

1. Adjustment of engine hood-to-front fender gap
Loosen the bolts (a). Perform the adjustment by moving the hood.

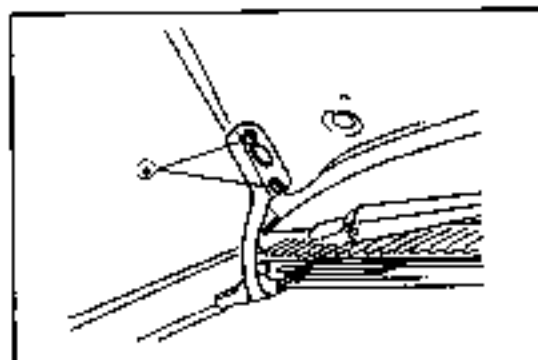

Fig. 9-2

WF-09003

2. Hood lock adjustment
Loosen the three attaching bolts of the hood lock. Perform the adjustment by moving the hood lock.
(Adjust the hood lock in such a way that you will feel a slight looseness when the center section of the hood end is pushed strongly)

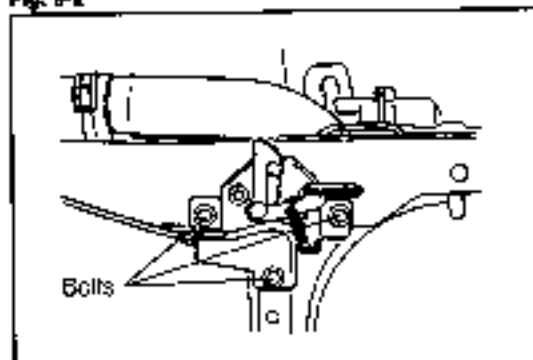

Fig. 9-3

WF-09004

FRONT DOOR ALIGNMENT ADJUSTMENT

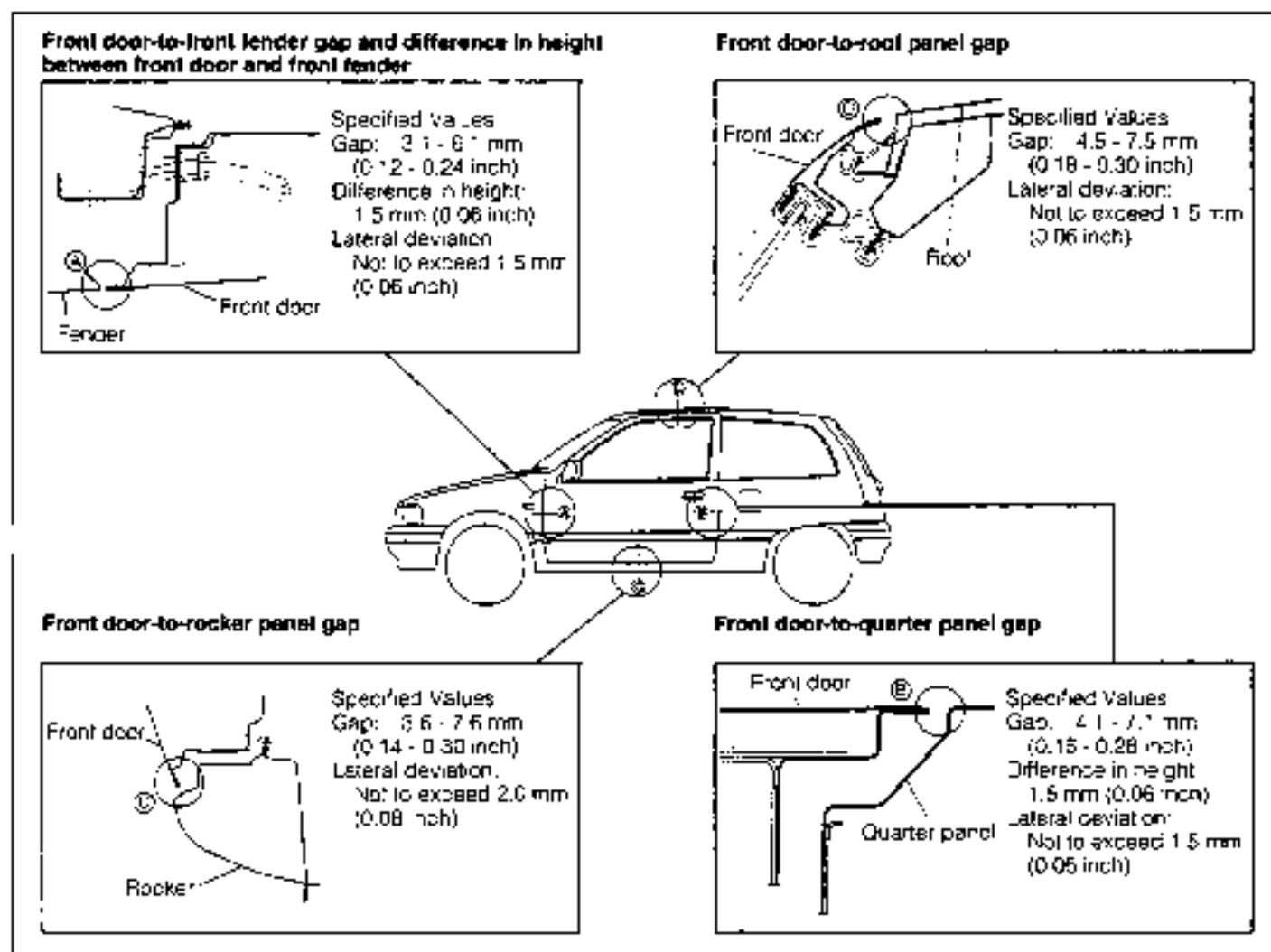

Fig. 9-4

W9-09005

- Adjustments of Front Door-to-Front Fender Gap and Front Door-to-Quarter Panel Gap

Replace the bolts (E). Perform the adjustment by moving the door panel in a fore-and-aft direction.

SST: 09812-30010-000

NOTE:

Adjustment-free bolts have been employed in the assembly plant. Hence, the adjustment should be performed after replacing the bolts with the following bolts.

Part Number of Bolt: 91661-60820-000

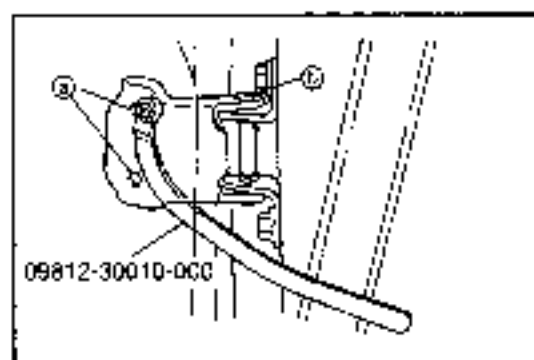

Fig. 9-5

W9-09006

- Adjustments of Front Door-to-Rocker Panel Gap and Front Door-to-Roof Panel Gap

Loosen the bolt (D). Perform the adjustment by moving the door panel in an up-and-down direction.

SST: 09812-30010-000

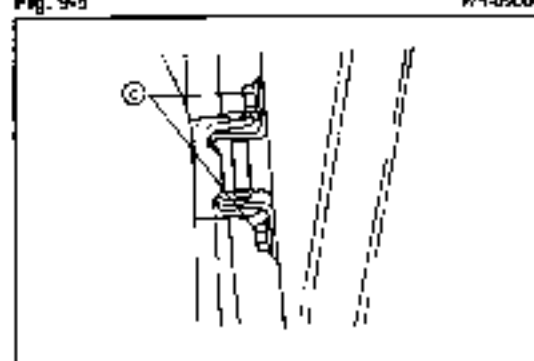

Fig. 9-6

W9-09007

- Adjustment of Difference in Height between Front Door and Front Fender

Loosen the bolts (C). Perform the adjustment by moving the door panel in a right-and-left direction.

BODY

4. Door Lock Adjustment

Loosen the screws (a) of the lock striker. Perform the adjustment by tapping the striker lightly.

NOTE:

Never attempt to correct the door sagging at its rear part by the adjustment of this lock striker. The correction should be made by adjusting the door hinge section.

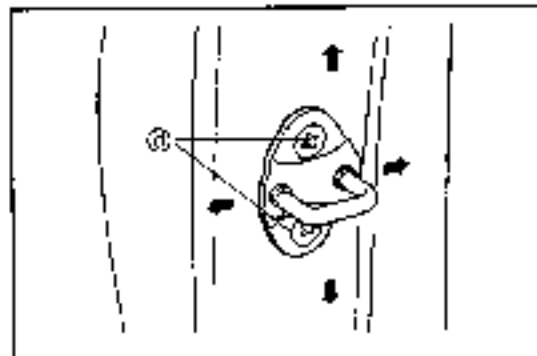

Fig. 9-7

WR-09005

REAR DOOR ALIGNMENT ADJUSTMENT

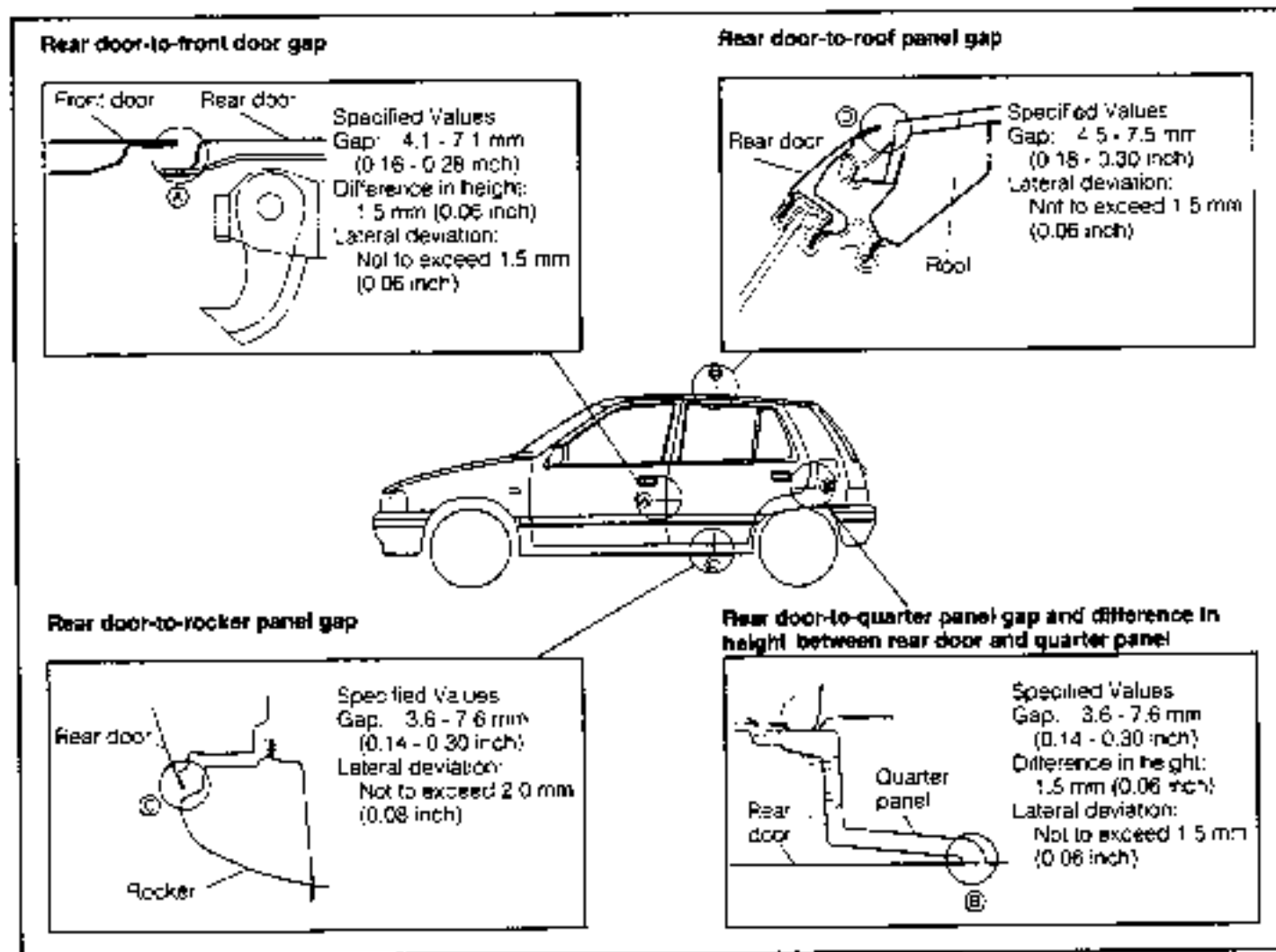

Fig. 9-8

WR-09002

1. Adjustments of Rear Door-to-Front Door Gap and Rear Door-to-Quarter Panel Gap

Replace the bolts (a). Perform the adjustment by moving the door panel in a fore-and-aft direction.

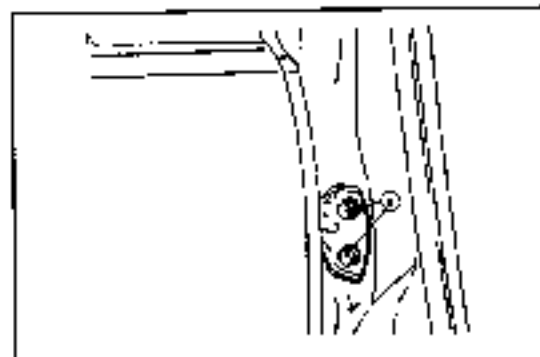

Fig. 9-9

WR-09010

- Adjustment of Difference in Height between Rear Door and Front Door
Loosen the bolts (b). Perform the adjustment by moving the door pane.

- Adjustments of Rear Door-to-Rocker Panel Gap and Rear Door-to-Roof Panel Gap

Loosen the bolt (c). Perform the adjustment by moving the door panel in an up-and-down direction.

NOTE:

As for the bolts (b), adjustment-free bolts have been employed in the assembly plant. Hence, the adjustments described in the steps 2 and 3 should be performed after replacing the bolts with the following bolts.

Part Number of Bolt: 91661-60820-000

- Adjustment of Difference in Height between Rear Door and Quarter Panel

Loosen the screws (c) of the lock striker. Perform the adjustment by moving the striker in a right-and-left direction.

- Door Lock Adjustment

Loosen the screws (c) of the lock striker. Perform the adjustment by tapping the striker lightly.

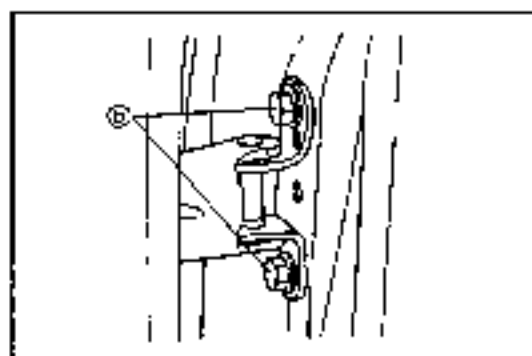

Fig. 9-10

WR-09011

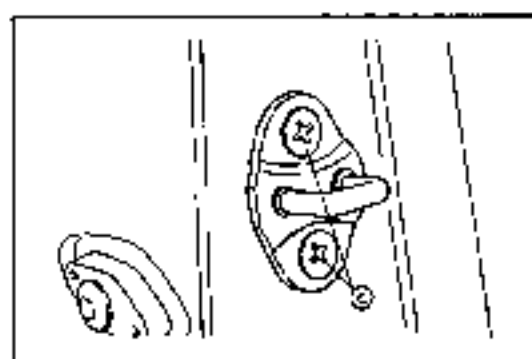

Fig. 9-11

WR-09012

HATCHBACK DOOR ALIGNMENT ADJUSTMENT

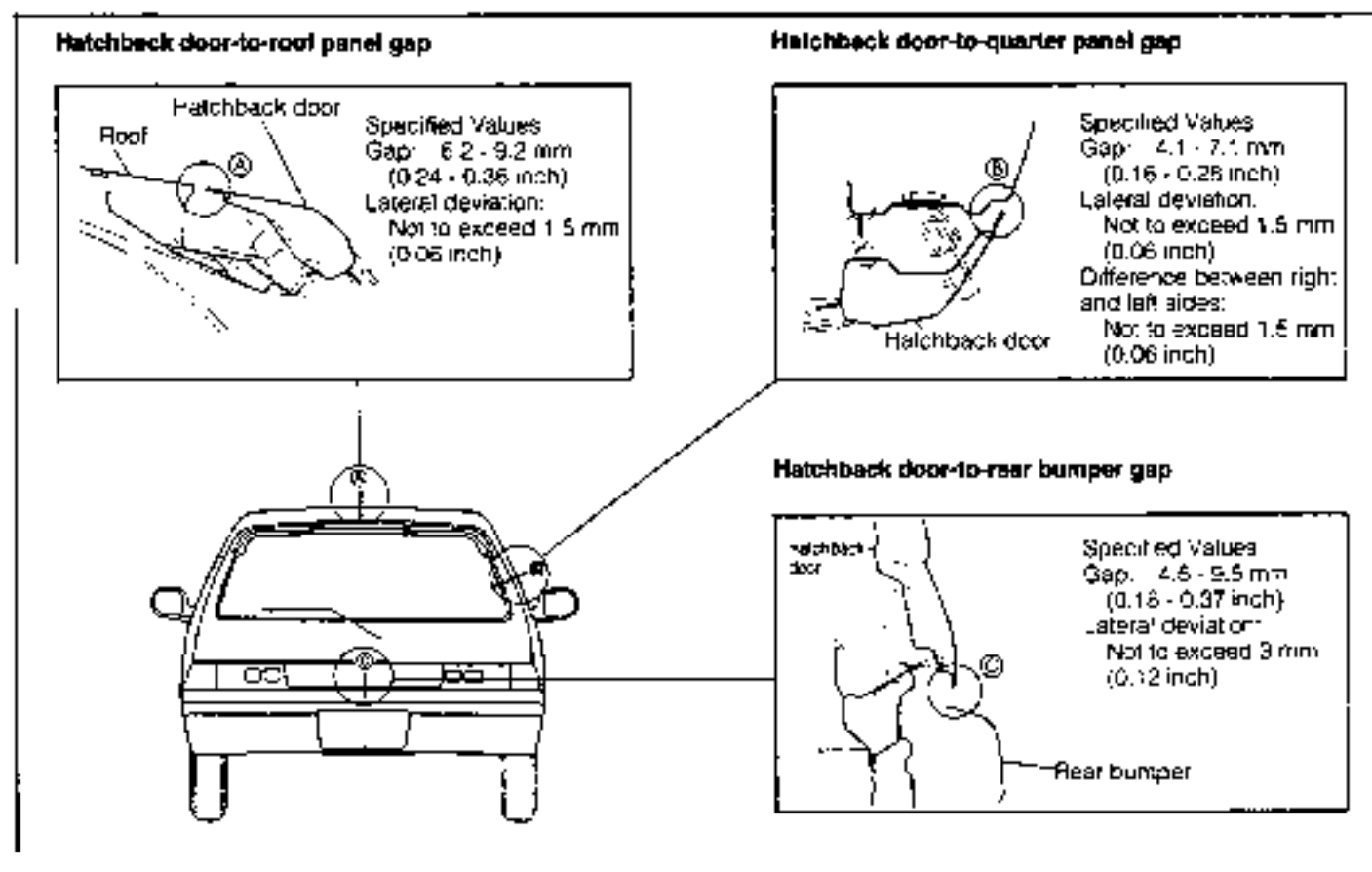

Fig. 9-12

WR-09013

BODY

1. Adjustments of Hatchback Door-to-Roof Panel Gap, Hatchback Door-to-Quarter Panel Gap and Hatchback Door-to-Rear Bumper Gap

- (1) Loosen the bolts (a). Perform the adjustment.
- (2) If the adjustment can not be performed properly, loosen the nuts (b) at the vehicle interior and perform the adjustment.

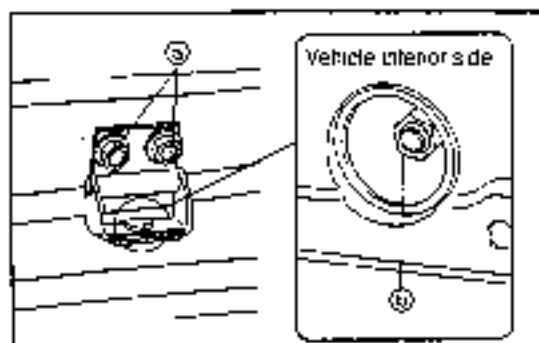

Fig. 9-13

WR-090-4

2. Hatchback Door Lock Adjustment:

Loosen the screws (a) of the lock striker. Perform the adjustment by tapping the striker lightly.

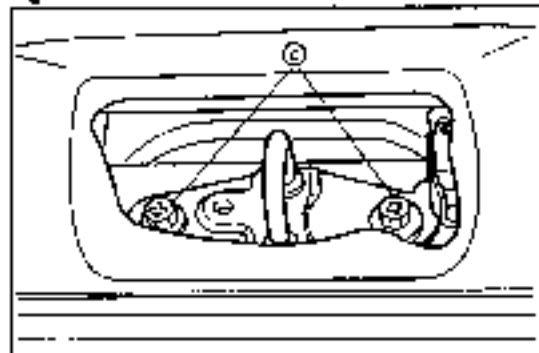

Fig. 9-14

WR-090-5

POWER SUNROOF ALIGNMENT ADJUSTMENT

1. Difference in Height (a) between Sliding Roof and Roof Pane

Specified Value:

Difference in height: 0 - 3 mm (0 - 0.12 inch)

Lateral deviation: Not to exceed 2 mm (0.08 inch)

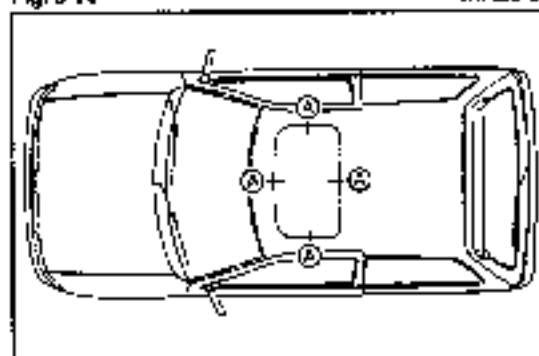

Fig. 9-15

WR-090-6

(How to Move Sunroof Manually)

- (1) Detach the sunroof switch cover.
- (2) Loosen the screw (a) located at the right side of the motor about one turn, using the wrench for exclusive use in the sunroof.
- (3) Move the sunroof by turning the screw (b) at the left side.

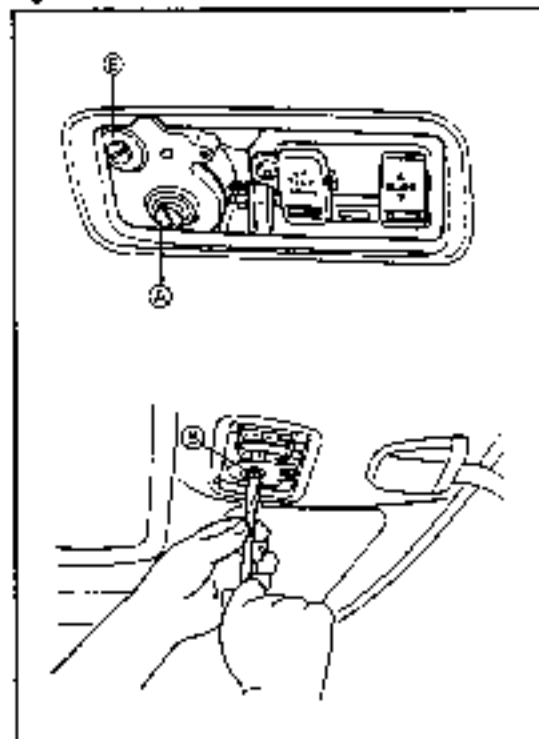

Fig. 9-16

WR-090-7

2. Adjustment of Difference in Height between Sliding Roof and Roof Panel

Correct any difference in height between the sliding roof and the roof panel by increasing or decreasing the adjusting shims provided between the sliding roof and the sliding roof drive cable bracket.

NOTE:

If the sliding roof is higher at the front section (even under a condition where no shims are employed), there is a possibility that the sliding roof is not closed fully. Hence, make sure that the sliding roof is closed fully.

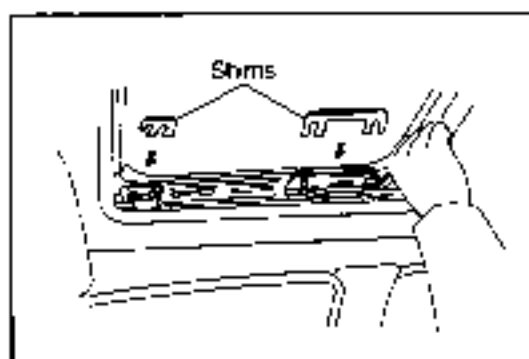

Fig. 9-17

WR-09015

3. Adjustment of Sliding Roof in a Fore-and-Aft Direction

Loosen the attaching bolts of the sliding roof at both sides. Perform the adjustment by moving the panel.

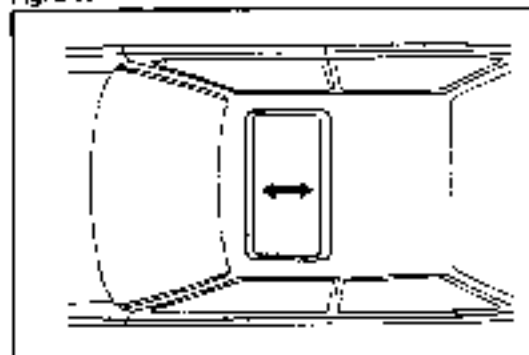

Fig. 9-18

WR-09016

4. Adjustment of Sliding Roof in a Right-and-Left Direction

Loosen the nut of the rear shoe. Perform the adjustment by moving the sliding roof in a right-and-left direction.

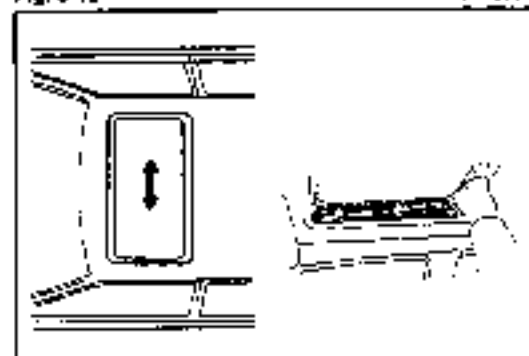

Fig. 9-19

WR-09020

5. Lateral Deviation in Sliding Roof-to-Roof Panel Gap

(1) If the sliding roof exhibits a deviation of about 2 mm (0.08 inch), detach the gear and advance the cable at the side having a wider gap one notch.

[One notch of cable: 2.5 mm (0.10 inch)]

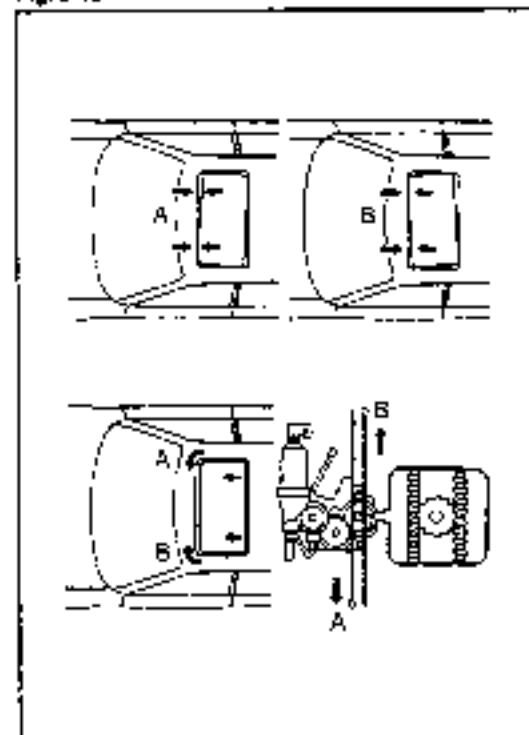

Fig. 9-20

WR-09021

BODY

- (2) If the gear has been detached, align the link position by inserting a pin or the like into the reference hole. Then, set the sliding roof in the tilt fully-closed condition and attach the gear.

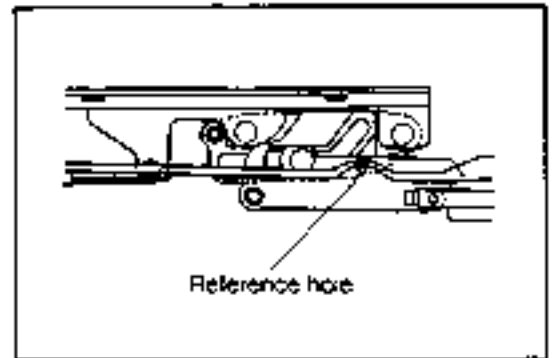

Fig. 9-21

WR-09022

- (3) If the sliding roof exhibits a deviation of about 1 mm (0.04 inch), loosen the nut of the rear shoe. Then, readjust the installation position of the sliding roof to the normal position.

Inspection After Adjustment:

1. Ensure that the sliding roof operates from the fully-opened position to the fully-closed position (while the engine is running).
2. Ensure that the sliding roof exhibits no binding or emits no abnormal noise during the operation.
3. Make sure that no water leaks into the vehicle when the sliding roof is fully closed.

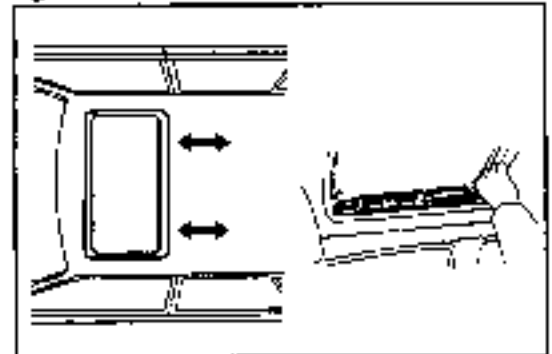

Fig. 9-22

WR-09023

FRONT BUMPER COMPONENTS

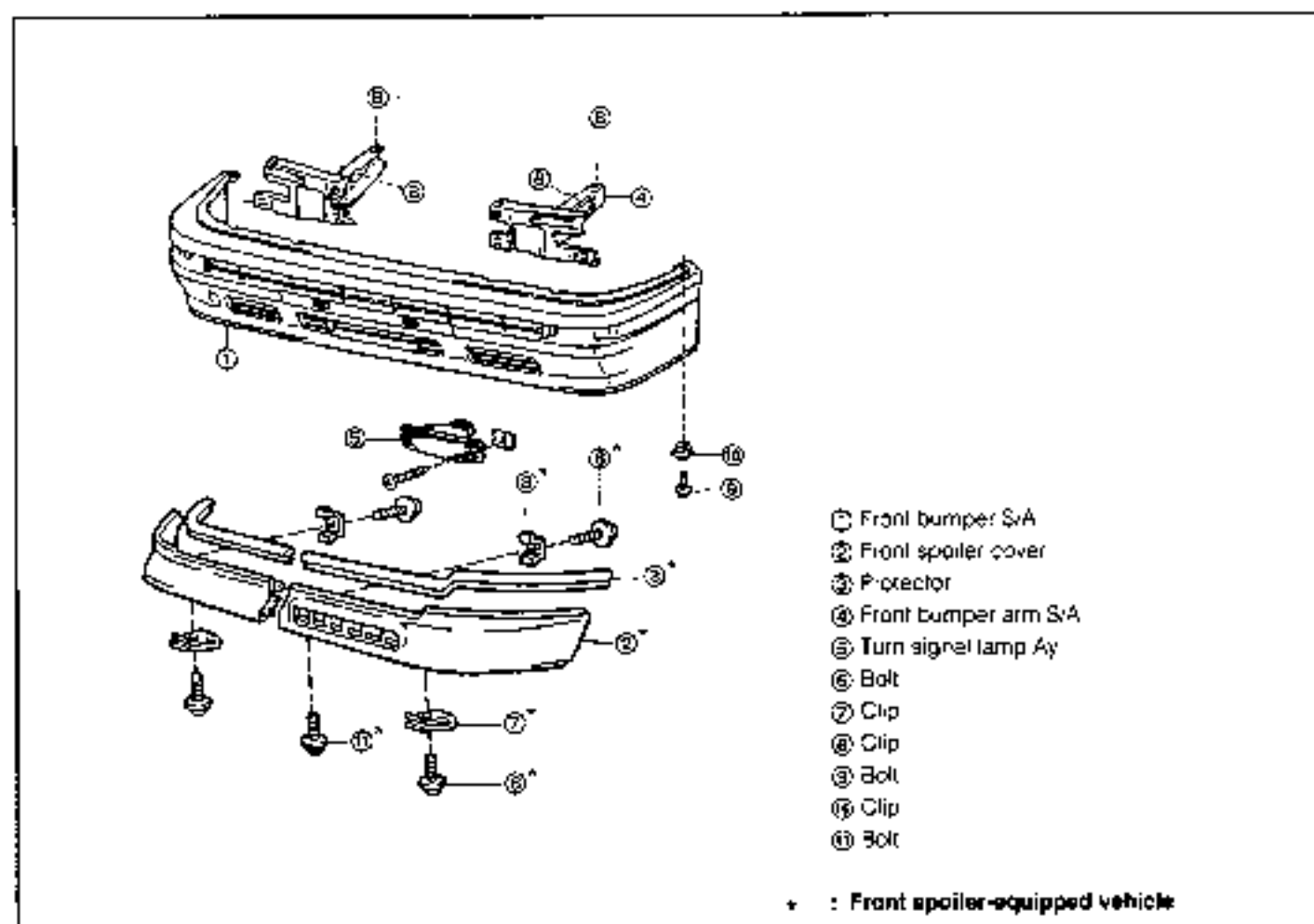

Fig. 9-23

WP-09022

REMOVAL

1. Remove the bolt attaching the front fender liner to the front bumper subassembly.
2. Remove the bolt attaching the front bumper subassembly to the front fender.
3. Remove the attaching bolts of the front bumper arm subassembly.

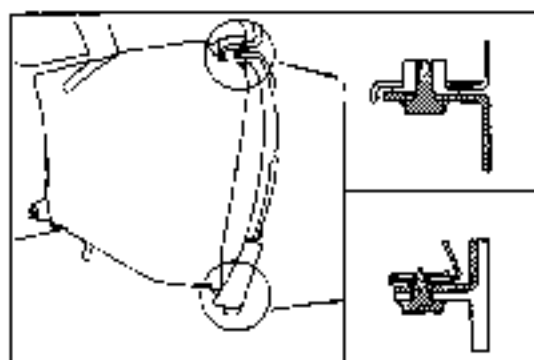

Fig. 9-24

WP-09025

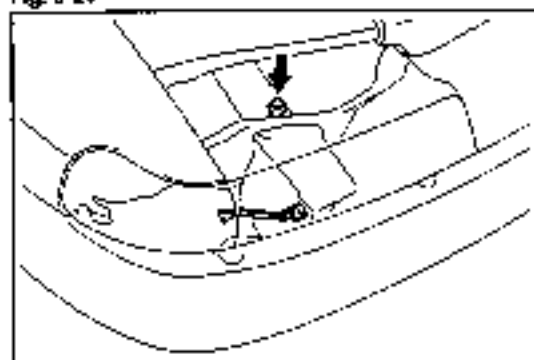

Fig. 9-25

WP-09026

BODY

4. Remove the coupler for turn signal lamp use. Remove the front bumper assembly from the vehicle.
5. Remove the turn signal lamp assembly from the front bumper subassembly.

6. Remove the front bumper arm subassembly from the front bumper subassembly.

7. Remove the front spoiler cover from the front bumper subassembly (GTti grade vehicle)

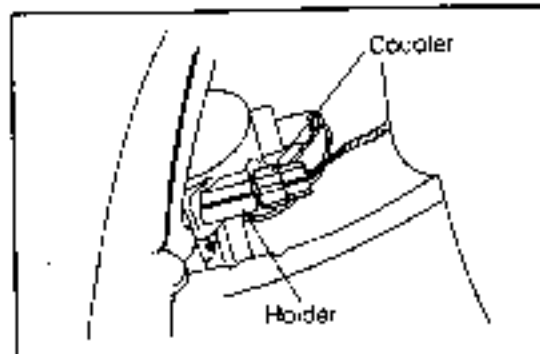

Fig. 9-26

WF-C9027

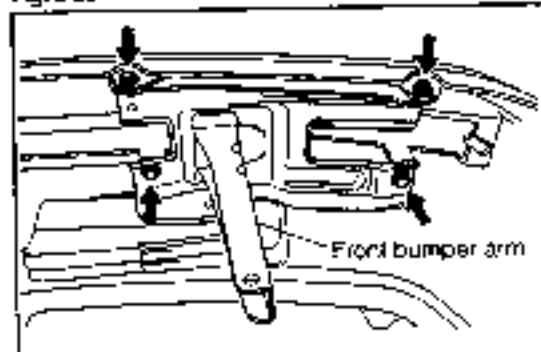

Fig. 9-27

WF-09029

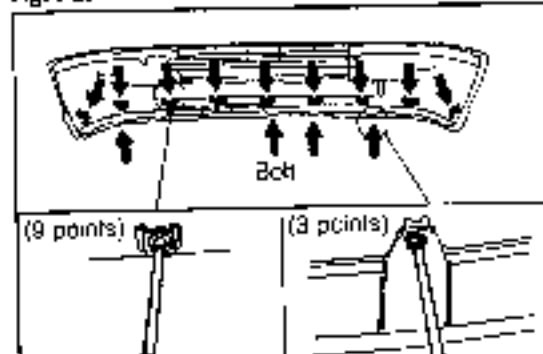

Fig. 9-28

WA-34109

INSTALLATION

1. Install the front spoiler cover to the front bumper subassembly. (GTti grade vehicle) (See Fig. 9-28.)
2. Install the front bumper arm subassembly to the front bumper subassembly. (See Fig. 9-27.)
3. Install the turn signal lamp assembly to the front bumper subassembly.
4. Connect the coupler for turn signal lamp use. Set it to the holder of the bumper.

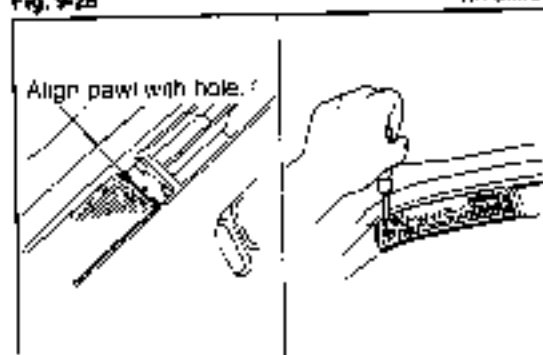

Fig. 9-28

WF-09030

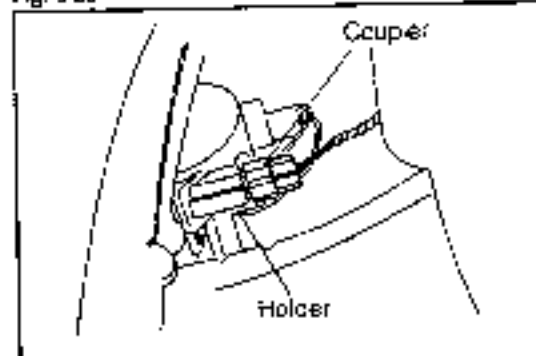

Fig. 9-30

WR-09027

5. Install the front bumper subassembly to the vehicle, as follows:
 - (1) Install the attaching bolts of the front bumper arm subassembly temporarily.

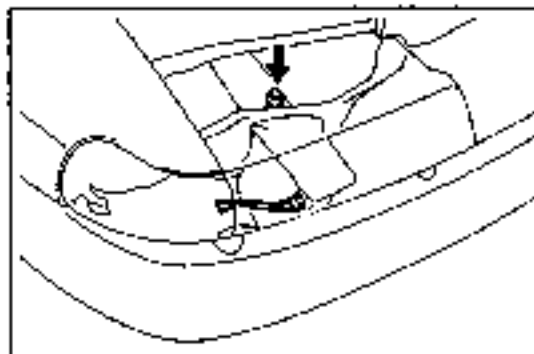

Fig. 8-31

WFI-09022

- (2) Install the fender liner to the front bumper subassembly with the clip and bolt.
- (3) Install the front fender to the front bumper subassembly with the clip and bolt.
- (4) Tighten the attaching bolts of the front bumper arm subassembly.

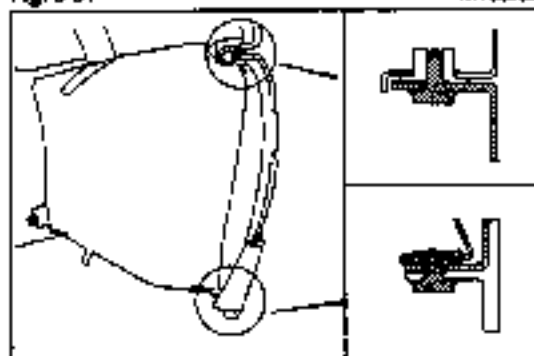

Fig. 9-32

WFI-09033

BODY

REAR BUMPER COMPONENTS

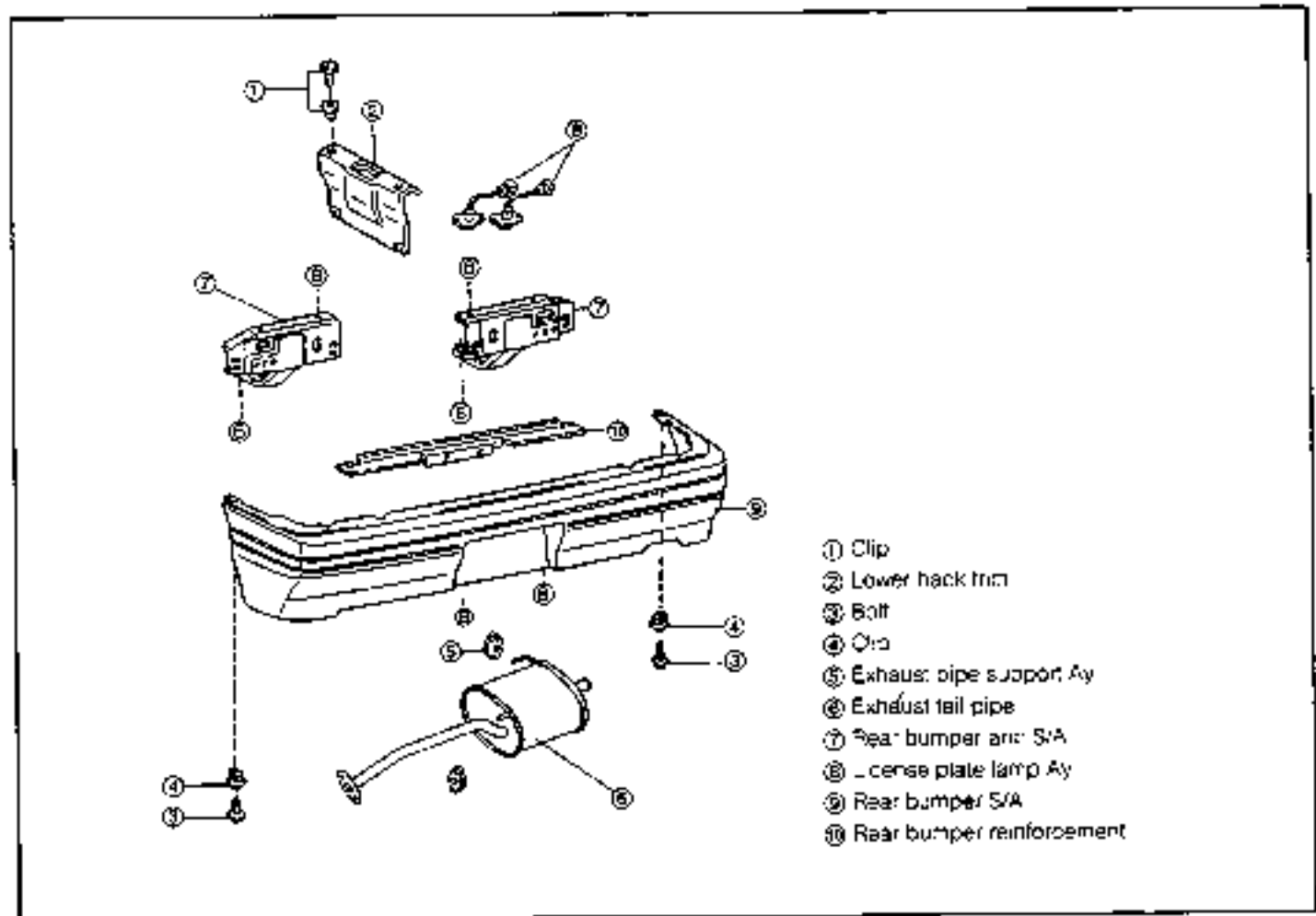

Fig. 9-33

WR-09034

REMOVAL

1. Lower Back Trim Removal

- (1) Detach the clips at four points by pushing the center section [2.5 mm (0.10 inch)] of each clip.
- (2) Remove the lower back trim.

2. Removal of Rear Bumper Subassembly

- (1) Remove the body attaching bolts located at both sides of the rear bumper subassembly.
- (2) Remove the attaching bolts at the central part of the rear bumper.
- (3) Remove the attaching bolts of the rear bumper arm subassembly.

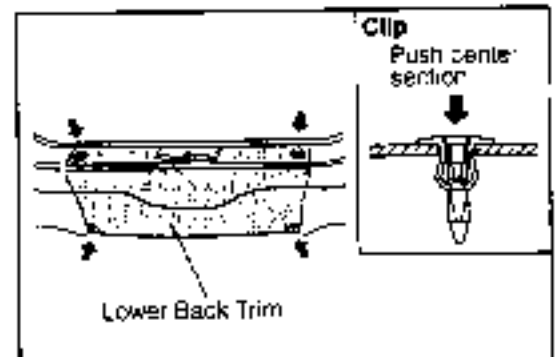
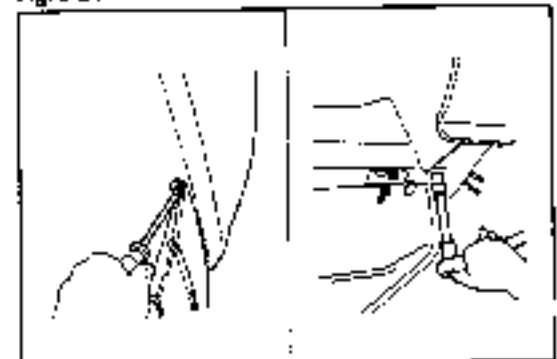

Fig. 9-34

WR-09035



WR-09036

NOTE:

Before removing the bolt at the right side, remove the exhaust pipe support assembly.

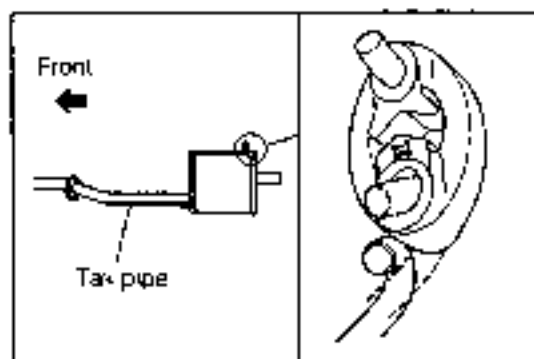

Fig. 9-36

WR-09017

- (3) Move the rear bumper subassembly to the rear. Disconnect the couplers for license plate lamp assembly use. Detach the harness clamp.
- (4) Remove the rear bumper subassembly from the vehicle.

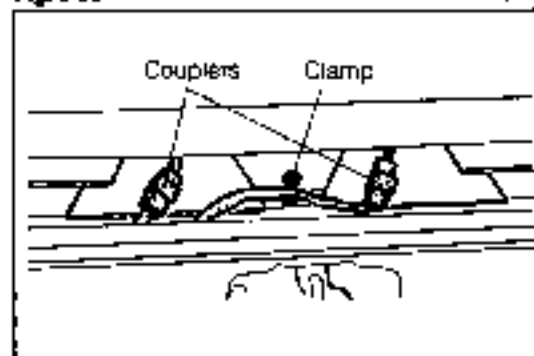

Fig. 9-37

WR-09038

- 3. Remove the license plate lamps assembly from the rear bumper subassembly.

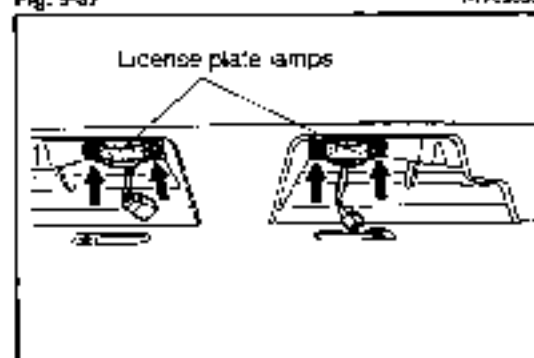

Fig. 9-38

WR-09039

- 4. Remove the rear bumper arm subassembly from the rear bumper subassembly.

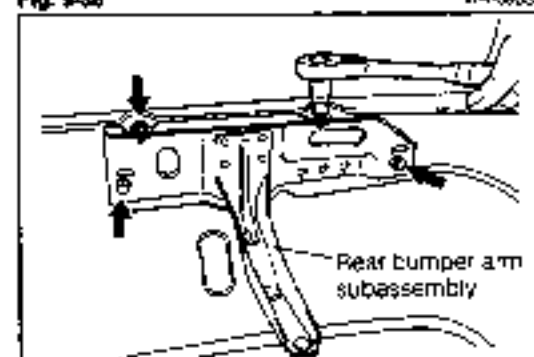

Fig. 9-39

WR-09040

INSTALLATION

- 1. Install the rear bumper arm subassembly to the rear bumper subassembly. (See Fig. 9-39.)
- 2. Install the license plate lamps assembly to the rear bumper subassembly. (See Fig. 9-38.)
- 3. Install the rear bumper subassembly to the vehicle, as follows:
 - (1) Connect the couplers for license plate lamp use. Attach the harness clamp.

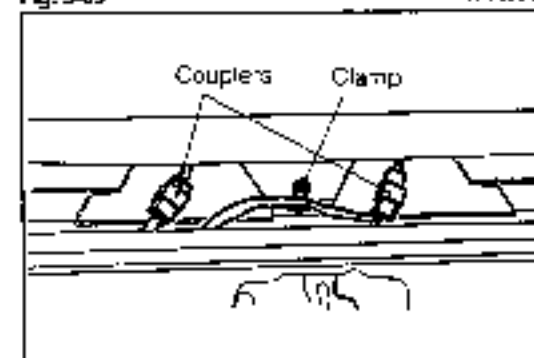

Fig. 9-40

WR-09041

BODY

- (2) Install the four attaching bolts of the rear bumper arm subassembly.
- (3) Install the rear bumper subassembly at both sides to the body with the bolts.
- (4) Install the attaching bolts at the central part of the rear bumper.
- (5) Install the exhaust pipe support.

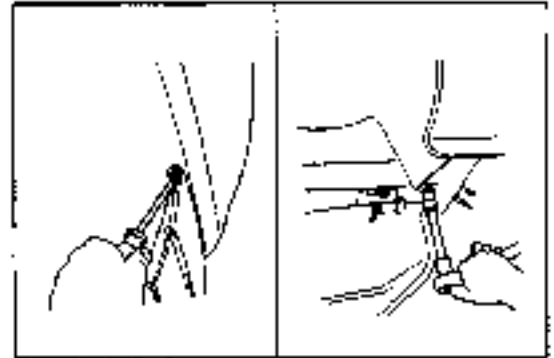

Fig. 9-41

WR-05GAE

RADIATOR GRILLE

COMPONENTS (EXCEPT FOR GT6 GRADE)

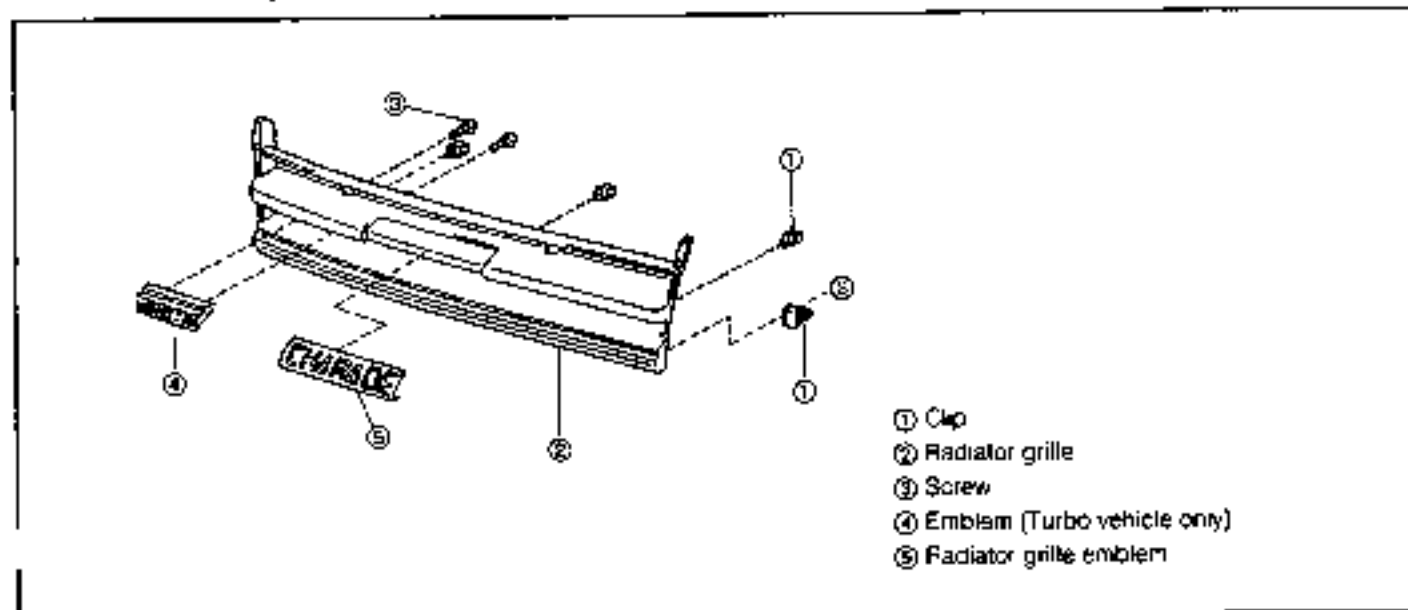

Fig. 9-42

WF-09043

REMOVAL

1. Remove the radiator grille by detaching the clips at five points
(Push the pawl section at the upper side of the clip, using a common screwdriver. Then, pull the radiator grille toward your side.)

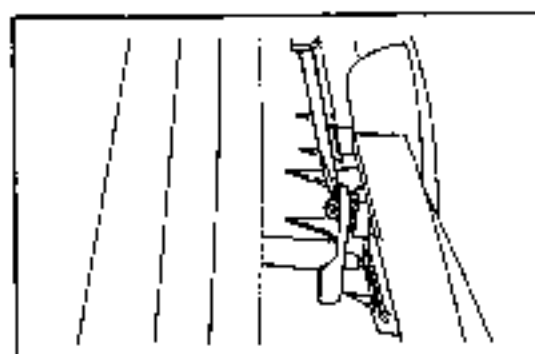

Fig. 9-43

XR-20044

2. Remove the emblem (TURBO) by loosening the two screws.

NOTE:

The radiator grille emblem is attached to the radiator grille by means of two-faced adhesive tape.

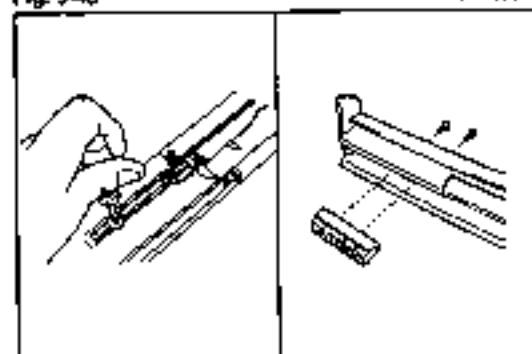

Fig. 9-44

WF-00045

INSTALLATION

1. Install the emblem (TURBO) with the two screws. (See Fig. 9-44.)
2. Radiator grille installation
 - (1) Ensure that five clips are attached to the radiator grille.
 - (2) Install the radiator grille to the vehicle.

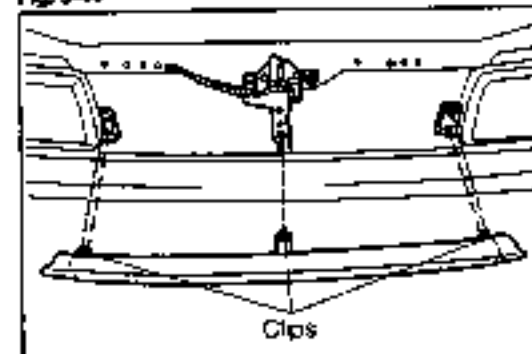
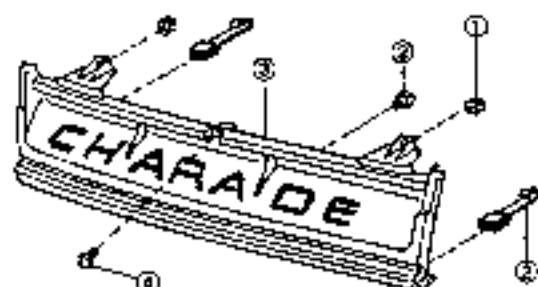

Fig. 9-45

WF-09046

BODY

COMPONENTS (GTi GRADE)



- ① Clip
- ② Clip
- ③ Radiator grille
- ④ Screw

Fig. 8-46

WA-09047

REMOVAL

1. Remove the attaching screw of the radiator grille.
2. Detach the two clips
To detach the clip, turn the center section of the clip 90 degrees clockwise, using a cross point screwdriver.
3. Detach the three clips, using a screwdriver.
4. Remove the radiator grille.

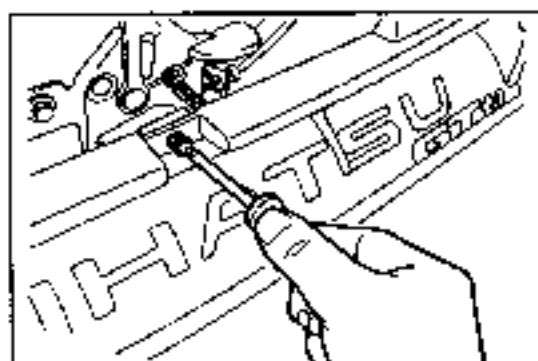

Fig. 9-47

WA-09048

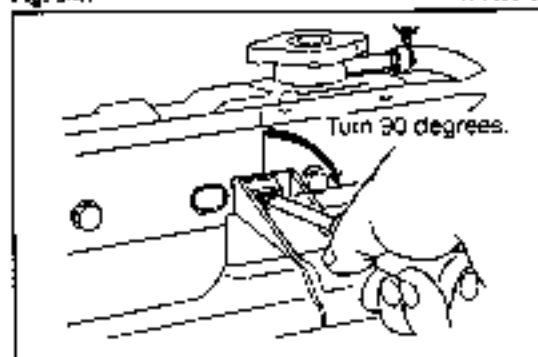

Fig. 9-48

WA-09049

INSTALLATION

1. Install the radiator grille, aligning the positions of the three clips.
2. Install the radiator grille to the vehicle. To attach the clip, turn the center section of the clip 90 degrees counter-clockwise, using a cross point screwdriver.
3. Install the screw at the center section of the radiator grille.

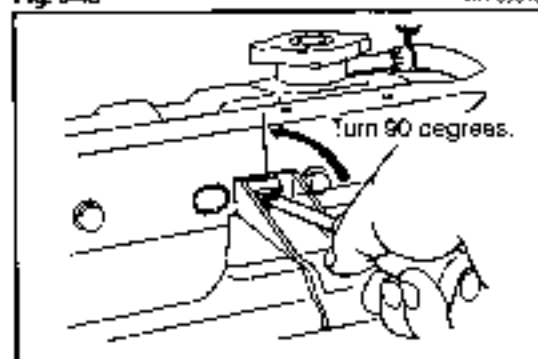

Fig. 9-49

WA-09050

FRONT FENDER COMPONENTS

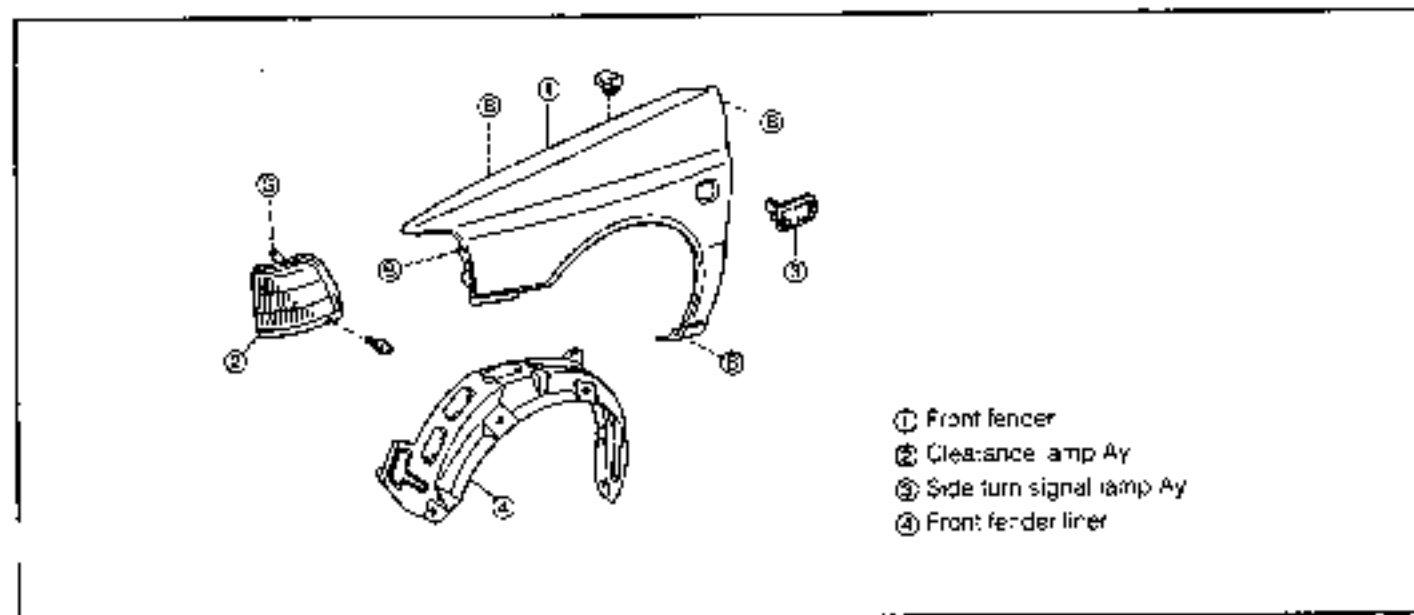

Fig. 9-50

WF-09051

REMOVAL

1. Front fender liner

- (1) Remove the three screws at the rear section of the front fender liner

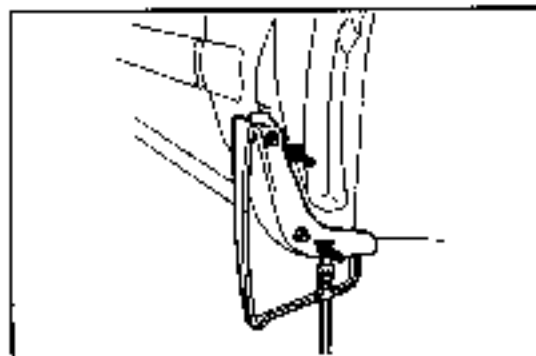

Fig. 9-51

WF-09052

- (2) Cut off the hem of each screw grommet (at three points) at the rear section of the front fender liner

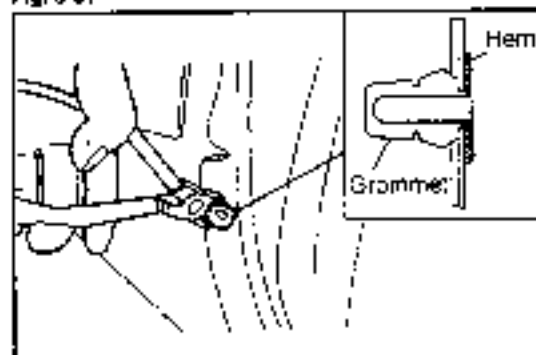

Fig. 9-52

WF-09053

- (3) Remove the screws attaching the front fender liner to the body and bumper.

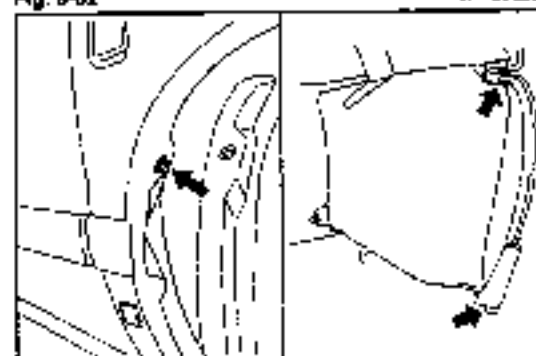

Fig. 9-53

WF-09054

BODY

- (4) Remove the front fender liner by detaching the three clips, using a cross point screwdriver.

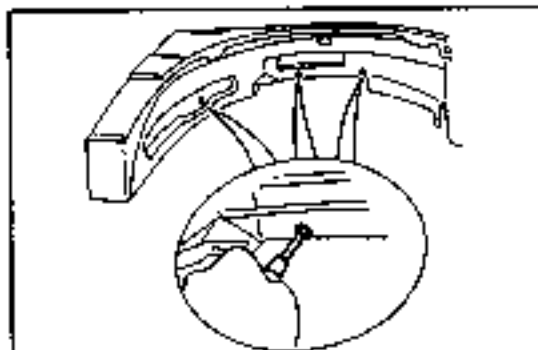

Fig. 9-54

WR-09035

2. Remove the clearance lamp assembly by removing the two screws.

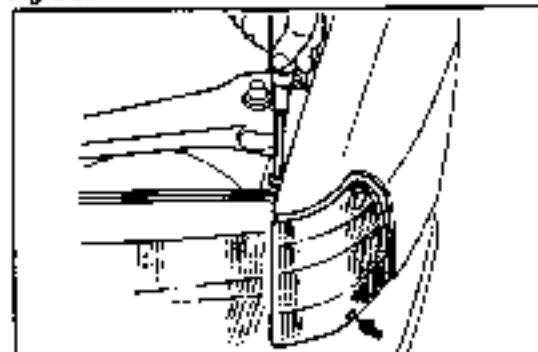

Fig. 9-55

WR-09036

3. Remove the front fender attaching bolts.

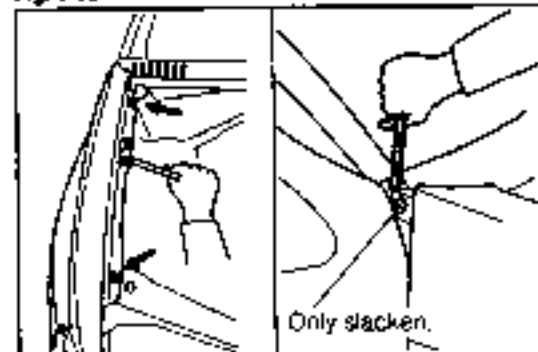

Fig. 9-56

WR-09037

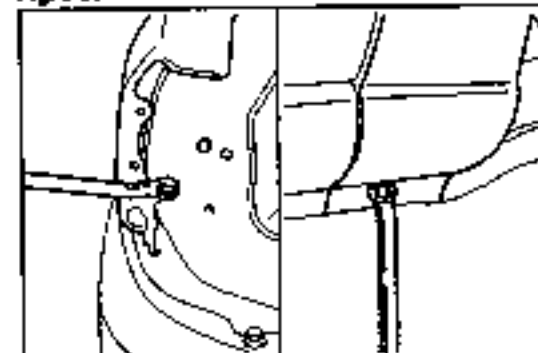

Fig. 9-57

WR-09038

4. Disconnect the coupler for side turn signal lamp use.
5. Remove the side turn signal lamp assembly from the front fender.

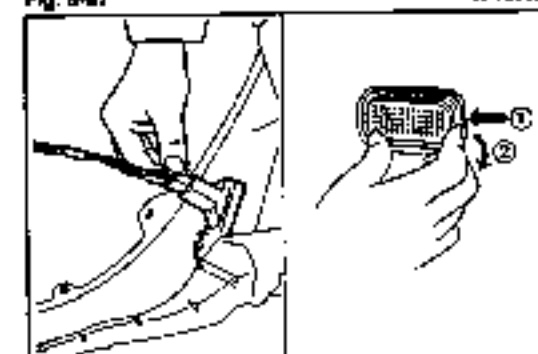

Fig. 9-58

WR-09039

INSTALLATION

1. Install the side turn signal lamp to the front fender.
2. Connect the coupler for side turn signal lamp use.

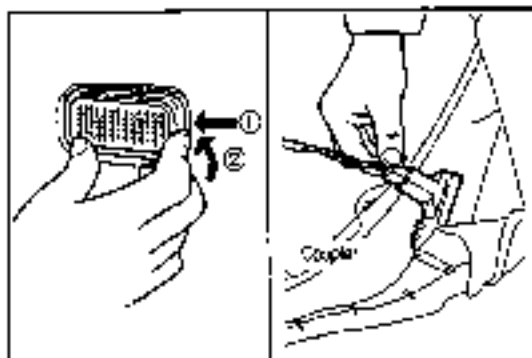

Fig. 9-59

WR-09050

3. Install the front fender.

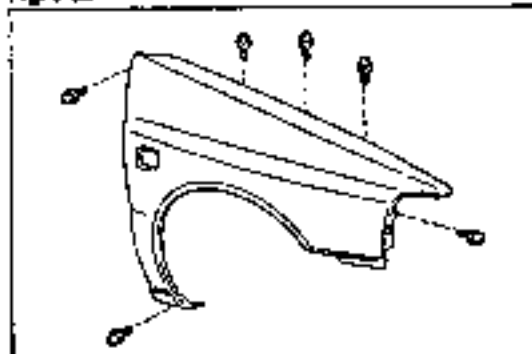

Fig. 9-50

WR-09051

4. Front fender liner installation

- (1) Attach the clips at three points, using a cross point screwdriver
- (2) Attach the screw at one point, using a cross point screwdriver.

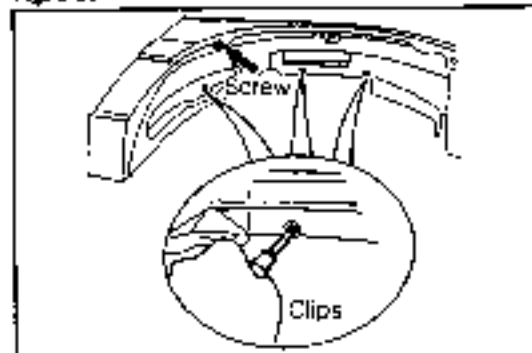

Fig. 9-51

WR-09052

- (3) Attach the three grommets at the rear section of the front fender liner. Install them with the three screws.

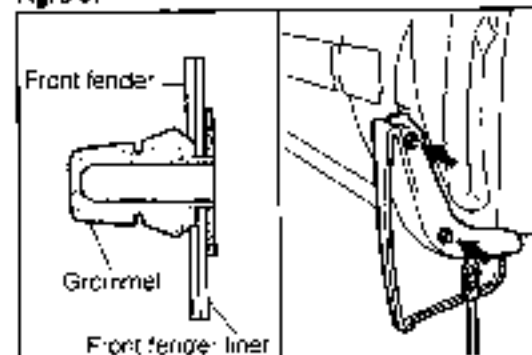

Fig. 9-62

WR-09053

- (4) Install the screws attaching the front fender liner to the body and bumper.

5. Install the clearance ramp with the two screws.
(See Fig. 9-55.)

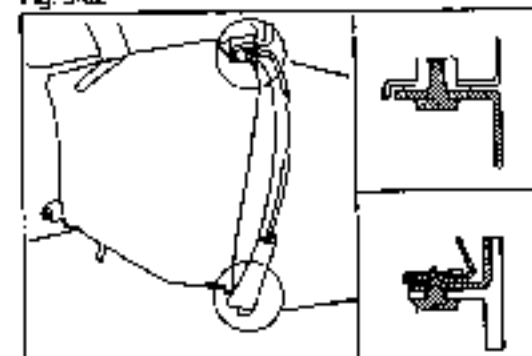

Fig. 9-63

WR-09054

BODY

HOOD LOCK CONTROL CABLE COMPONENTS

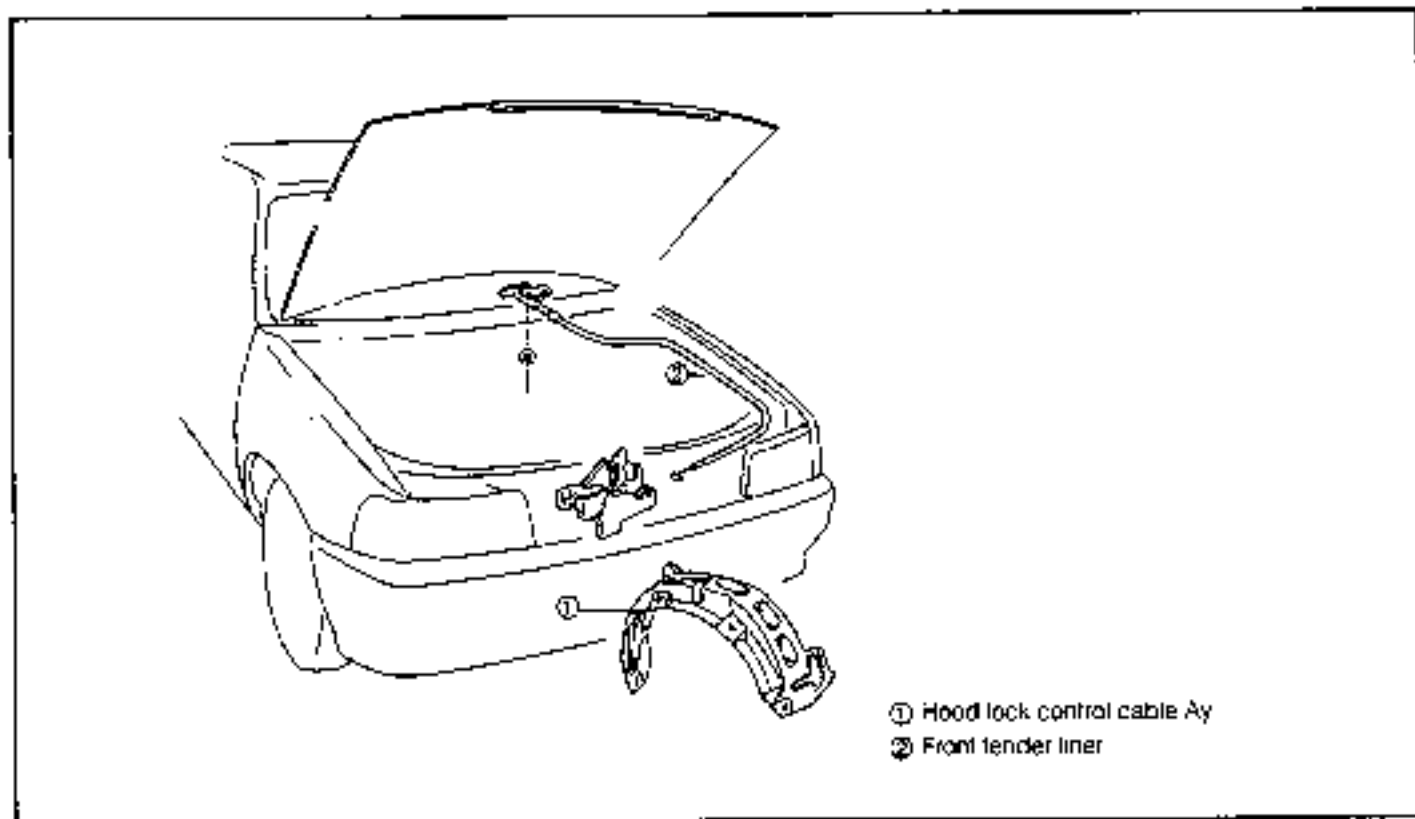
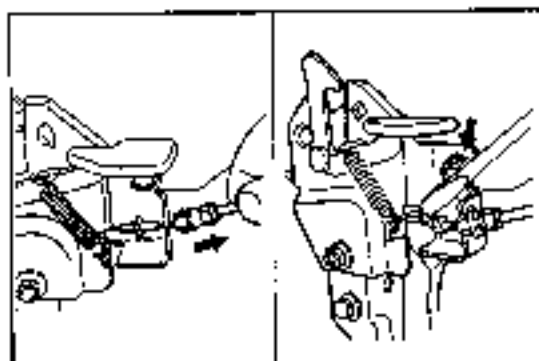

Fig. 9-64

WR-09065

REMOVAL

1. Remove the front fender liner. (See page 9-17.)
2. Hood lock control cable assembly
 - (1) Remove the cable at the hood lock side.
 - (2) Remove the hood lock control cable at the interior side.



WR-09066

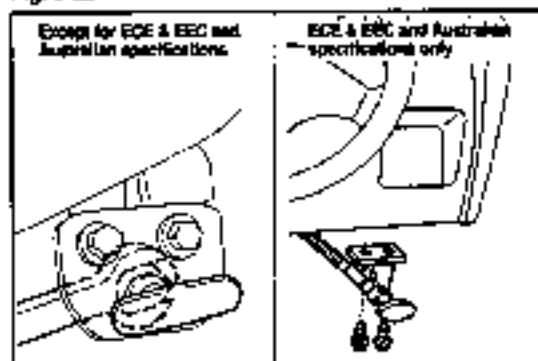

WR-09067

INSTALLATION

Install the hood lock control cable assembly, as indicated in the figure below.

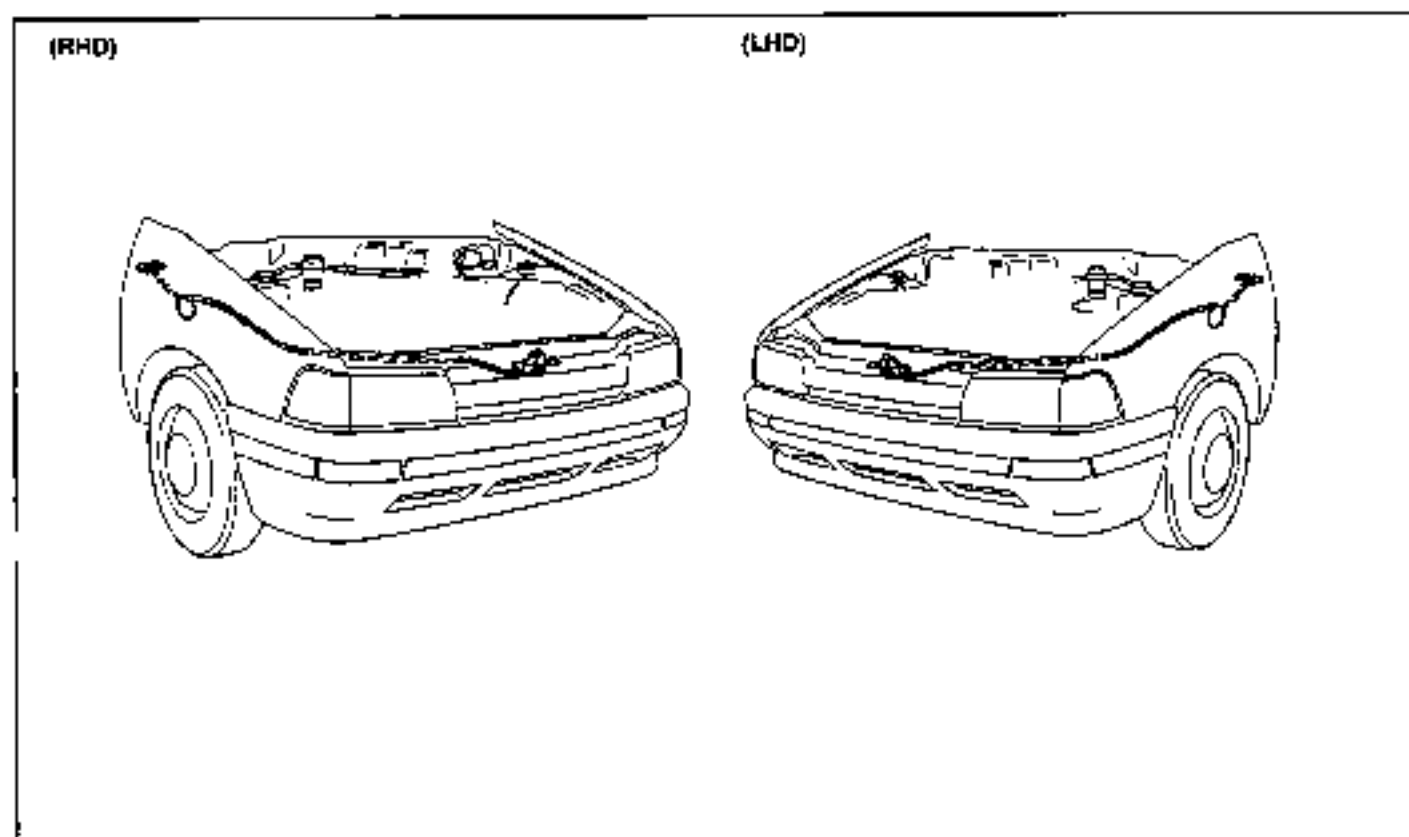

Fig. 9-67

W8-2060

BODY

WINDOWS

FRONT WINDSHIELD

ARTICLES TO BE PREPARED

Part nomenclature and item	Use
* Seal set 999-1114-9603-000 (Yokohama Rubber, Co., Ltd.)	For use in installing glass
Non-drying window sealer	For use in filling glass adhesive agent
Wooden piece, etc.	For use in retaining piano wire during glass removal
Sealant gun	For use in applying adhesive agent
Sucking rubber disc	For use in holding glass during glass installation
Solvent (Alcohol or white gasoline)	For use in cleaning adhesion surface
Eyeletter	For use in making hole at adhesion layer through which piano wire is passed
Cutter knife	For use in removing (cutting) molding For use in cutting adhesion layer surface and in cleaning glass
Spalula	For use in correcting surface after application of adhesive agent
Tape (Cloth tape)	Prevention of damage to paint surface

WR-09003

* Contents of Seal Set

Item	Quantity	Shape
① Adhesive agent (WS100) (300 cc)	1	
② Primer G for glass (20 g)	1	
③ Primer M for body (20 g)	1	
④ Piano wire ($\phi 0.6 \times 1 \text{ m}$)	1	
⑤ Gauze for primer application	4	
⑥ Nozzle	2	
⑦ Pin set	1	
⑧ Instruction manual	1	

WR-09070

* Handling Instructions on Seal Set

1. Store the seal set in a dark, cool place. (Be sure to use the seal set before the guarantee date indicated on the box expires.)
2. The adhesive agent and primer will begin curing when they are mixed with or brought into contact with water. Hence, be sure to store them under a sealed condition.
3. Once the adhesive agent and primer are opened, they can not be used again in the future by storing them.
4. If the seal set has been stored at a low temperature, previous to use, be sure to recover the working temperature of the materials.
5. The primer contains a flammable solvent. Hence, keep it away from the fire.

WR-05011

COMPONENTS

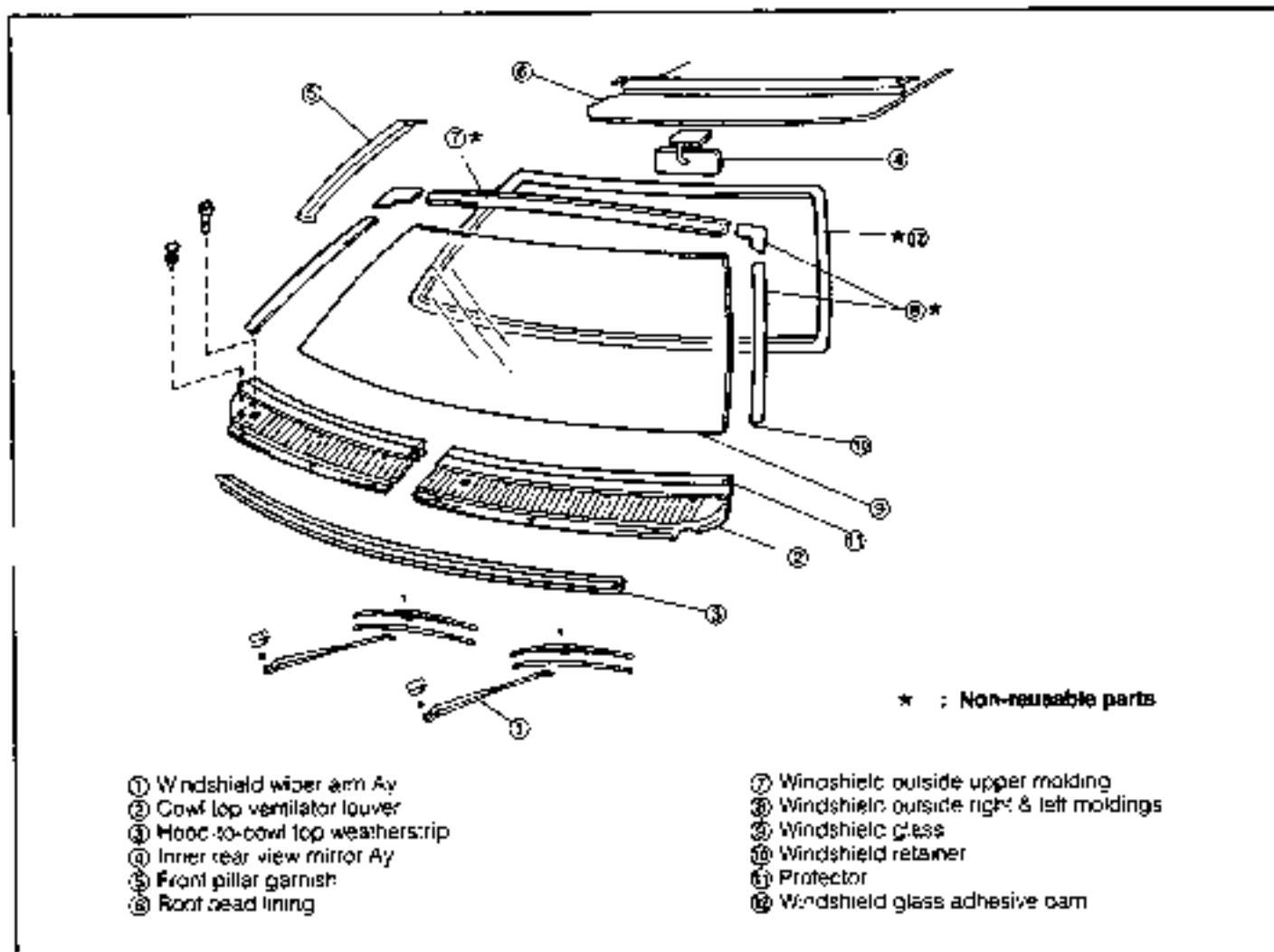

Fig. 9-66

WP-09072

REMOVAL

1. Affix the protective tape to the body

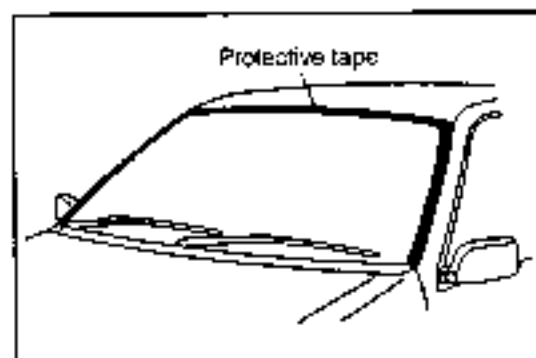

Fig. 9-69

WP-09073

2. Removal of windshield wiper arm assembly

- (1) Remove the front wiper arm cover.
- (2) Remove the windshield wiper arm assembly by removing the attaching nut of the front wiper arm assembly

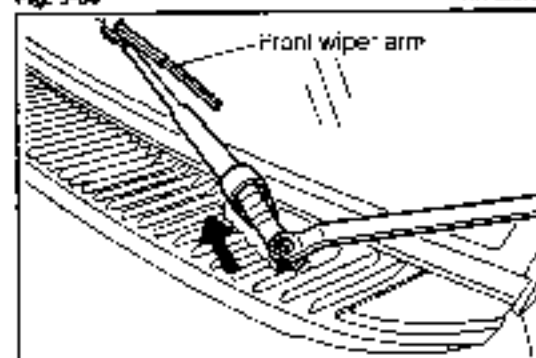

Fig. 9-70

WP-09074

BODY

3. Detach the clip. Remove the cowl top ventilator louver and the hood-to-cowl top weathers:rip.

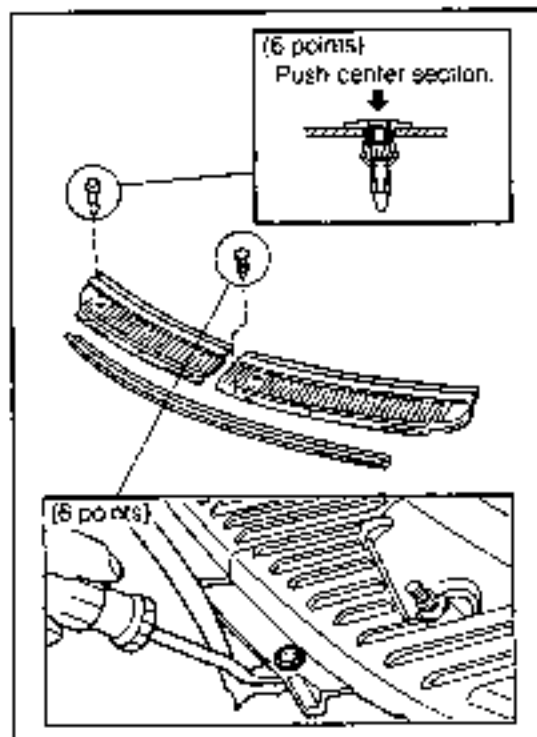

Fig. 9-71

WP-09075

4. Remove the inner rear-view mirror assembly by removing the cover and three screws.

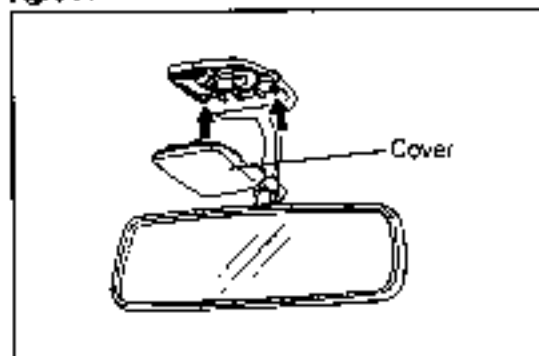

Fig. 9-72

WP-09076

5. Removal of front pillar garnish:
(1) Disengage the clip by prying its fitting position, using a screwdriver wrapped with a protective tape.
(2) Remove the front pillar garnish by pulling it up.

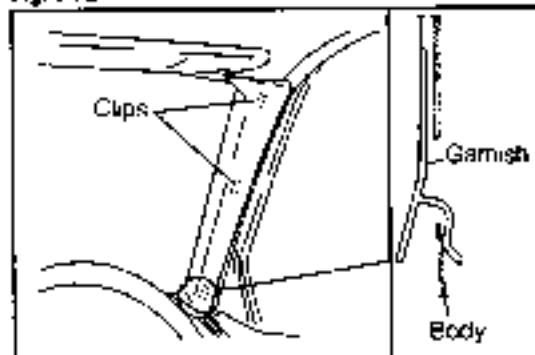

Fig. 9-73

WP-09077

6. Remove the windshield outside upper, right and left moldings.
Remove the molding by cutting off the leg section of the molding, using a cutter knife.

NOTE:

Be very careful not to scratch the paint finish surface of the body.

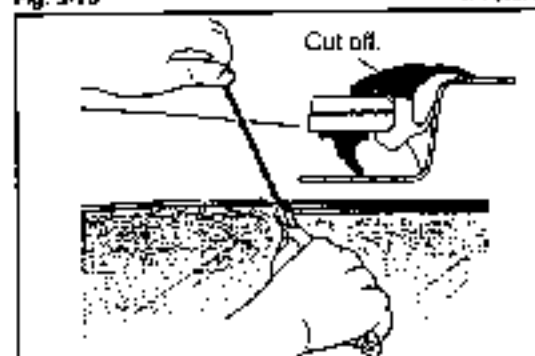

Fig. 9-74

WP-09078

7. Windshield glass removal

- (1) Pass a piano wire through the adhesion layer from the interior. Tie each end of the piano wire to a wooden piece or the like.

NOTE:

When passing the piano wire through the adhesion layer, care must be exercised not to scratch the interior or exterior appointment trim.

- (2) Separate the adhesion layer by pulling each end of the piano wire alternately.

NOTE:

- Cut the adhesion layer at the glass side whenever possible.
- Care must be exercised not to scratch the interior or exterior appointment trim during the cutting.

- (3) When glass at lower side is separated.

Apply a plastic protective plate, such as B4-sized board for stationary use, on the instrument panel section where the piano wire may contact during the operation.

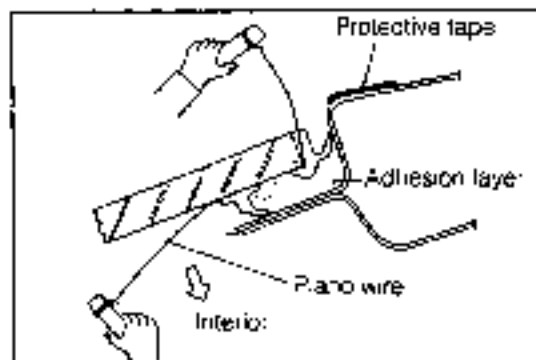

Fig. 9-75

WR-09075

CHECK AND CLEANING

1. Cleaning of Adhesion Surface of Body

- (1) Smooth any irregularities on the adhesion surface of the body, using a knife or the like. Clean the body surface and adhesion surface with white gasoline.

NOTE:

Do not remove the adhesion layer to such an extent that the body may be exposed. After the adhesion layer has been removed, allow the adhesion surface to dry.

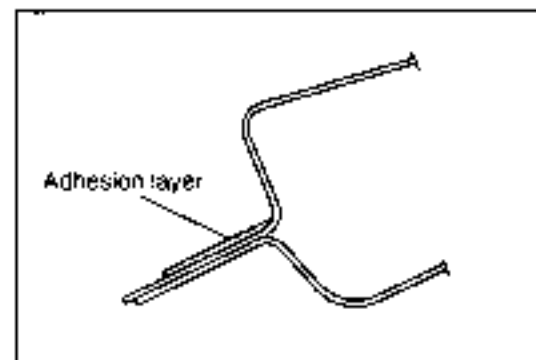

Fig. 9-76

WR-09080

2. Cleaning of Glass Surface

- (1) If the glass is reused, scrape away thoroughly any adhesive agent or dirt which may have collected on the glass. Then, clean the adhesion surface with white gasoline.

NOTE:

As for the laminated glass, there is a possibility that white gasoline may penetrate into the glass from the edges, affecting the intermediate film. Hence, do not use white gasoline excessively during the cleaning.

- (2) When a new glass is used, clean the glass margin 20 - 30 mm (0.79 - 1.18 inches) from the glass edge with white gasoline.

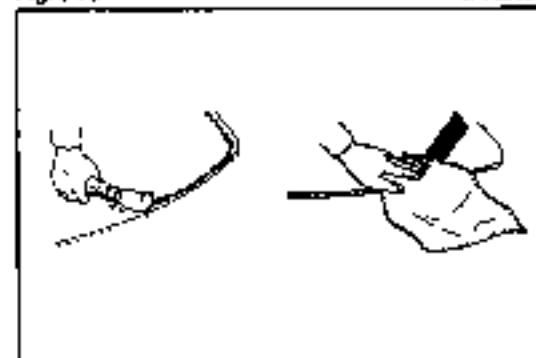

Fig. 9-77

WR-09021

BODY

INSTALLATION

1. Windshield retainer installation
2. Window glass adhesive dam installation
 - (1) Affix the dam at the position 8 mm (0.31 inch) from the glass edge.
 - (2) Make cut-out sections at two or three points on the corner, using a cutter knife.

NOTE:

When affixing the dam, do not touch the cleaned surface by your hand.

3. Primer application
 - (1) Apply the primer M for paint surface use to the roof pillar section and cowl section, using a clean brush or gauze.
 - (2) Allow these sections to dry at least five minutes after the application.
 - (3) Apply the primer G for glass surface use to the glass adhesion surface and glass side surface, using a sponge or gauze.

- (4) After completion of the primer application, install the glass within the time given below.

Specified Time

Primer G: Within 70 Minutes

Primer M: Within 120 Minutes

NOTE:

1. The primer application strengthens the adhesive force. Hence, make sure that the primer is applied without any skipped portion. Also, it should be noted that the adhesive force drops if the primer is applied too thickly.
2. The primer once opened should not be reused.

4. Windshield glass installation

- (1) Application of adhesive agent
 - Cut the discharge port of the adhesive agent cartridge to the following dimension given in the table below.

Unit: mm (inch)

Presence/nonpresence of adhesion layer at body side	Height of adhesive agent	Discharge port of cartridge
When layer is removed:	8 - 10 (0.31 - 0.39)	10 (0.39)
When layer is not removed	3.5 - 5 (0.14 - 0.20)	5 (0.20)

- Using a sealant gun or air gun, apply a bead of adhesive agent over the entire periphery of the glass adhesion surface along the dam

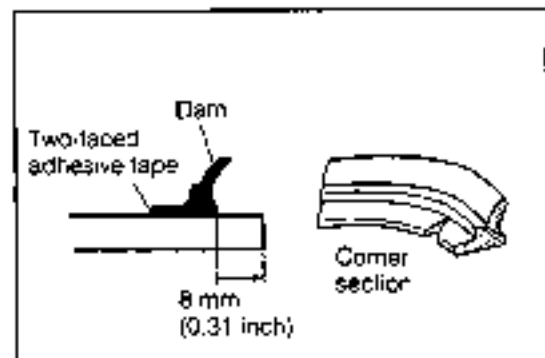

Fig. 9-78

WR-09062

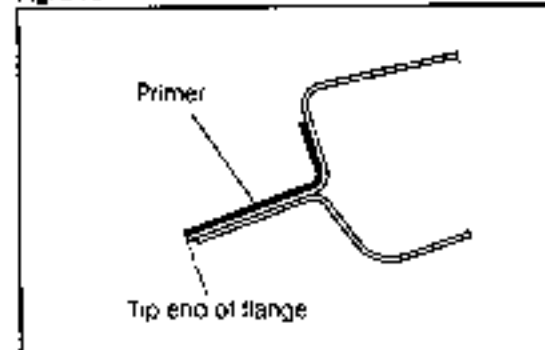

Fig. 9-79

WR-09083

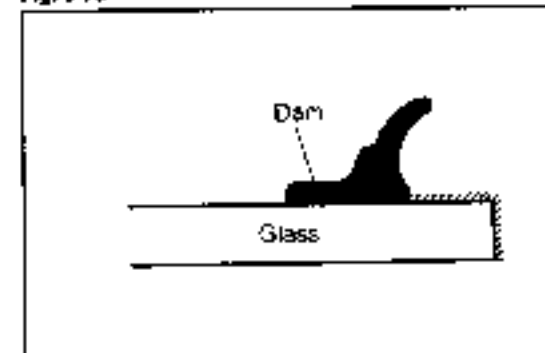

Fig. 9-80

WR-09084

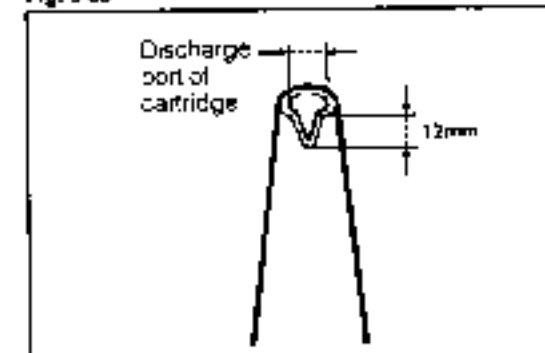

Fig. 9-81

WR-09085

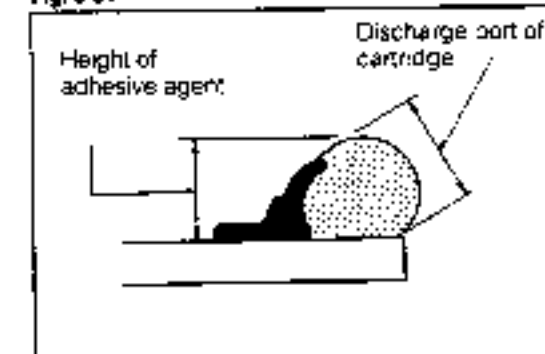

Fig. 9-82

WR-09086

(2) Glass installation

While aligning the mating marks of the glass with the windshield retainers, install the glass on the retainers, using a sucking disc or the like.

Press the glass against the opening flange thoroughly, while pushing the entire surface of the glass lightly.

(3) Using a spatula, remove any excessive adhesive agent or add the adhesive agent where it is lacking.

NOTE:

Be sure to thoroughly apply the adhesive agent up to the glass edge.

5. Installation of windshield outside moldings

Attach the side moldings (RH & LH) to the upper molding. Then, install them in place.

NOTE:

Remove any excessive adhesive agent on the paint finish surface with white gasoline.

6. Water leakage check and repairs

Perform the water leakage check about one hour after the glass installation. If the water leakage exists, dry the leaky point. Then, repair the leaky point with the adhesive agent or non-drying window sealer.

7. Install the roof headlining.

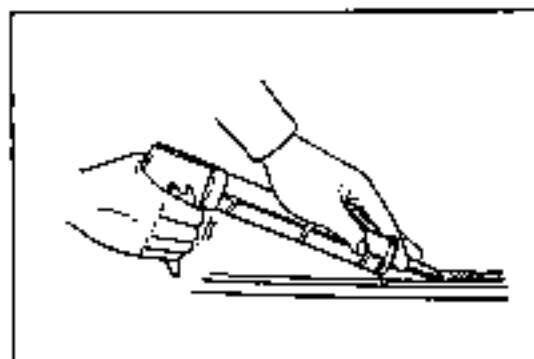

Fig. 9-83

WP-08057

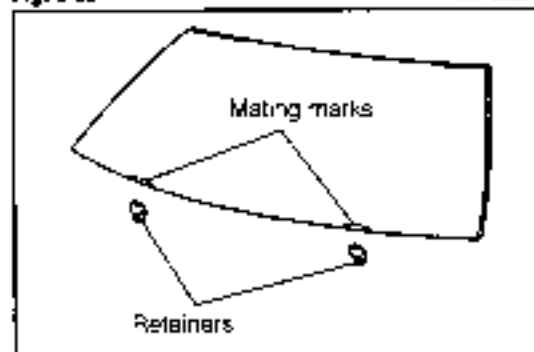

Fig. 9-84

WP-08058

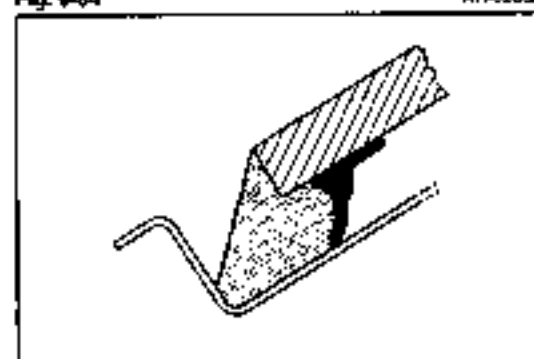

Fig. 9-85

WP-08058

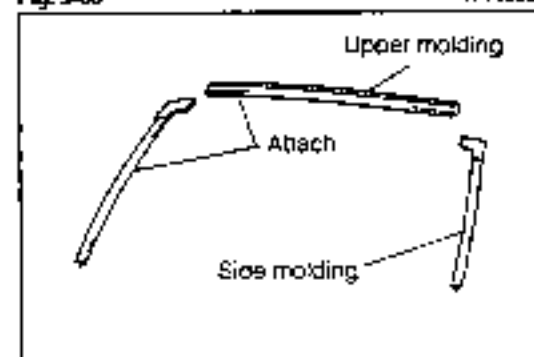

Fig. 9-86

WP-08059

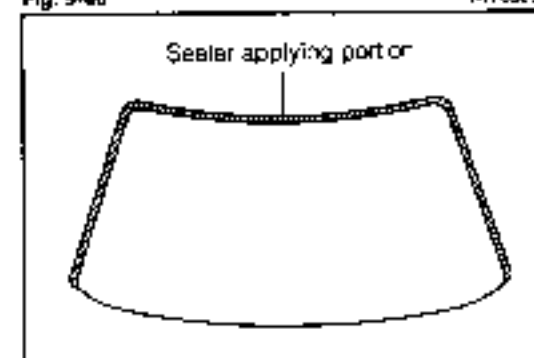

Fig. 9-87

WP-08061

BODY

8. Install the front pillar garnish.
9. Install the inner rear-view mirror assembly. (See Fig. 9-72.)
10. Install the cowl top ventilator louver and hood-to-cowl top weatherstrip.

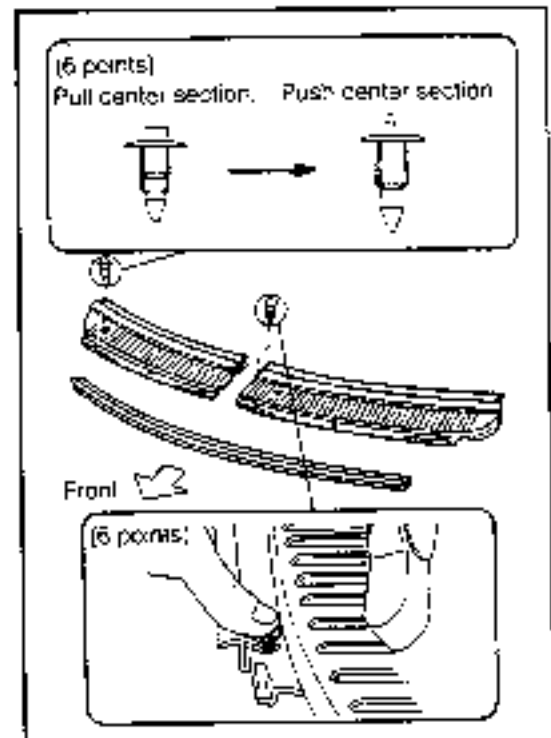

Fig. 9-88

WR-0907

11. Installation of windshield wiper arm assembly
 - (1) Operate the wiper motor, until it assumes the automatic stopping position.
 - (2) Set the wiper arms at the positions indicated in the right figure.
 - (3) Tighten the nut and attach the front wiper arm cover.

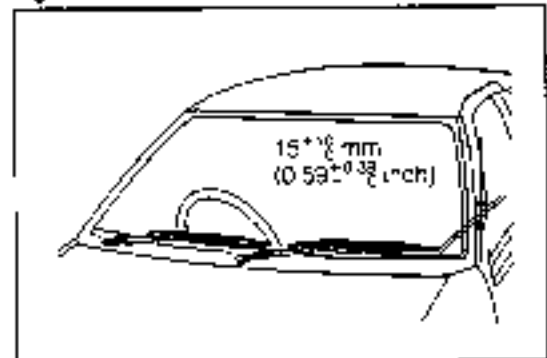

Fig. 9-89

WR-0908

BACK DOOR GLASS

ARTICLES TO BE PREPARED

Part nomenclature	Use
Non-drying window sealer	For use in filling after glass installation or in repairing water leakage
Tape	Prevention of damage to paint finish surface
Brush	For use in applying soap water
Cutter or knife	For use in cutting molding
Operation rope (approx. 3 - 4 mm dia.)	For use in installing glass
Soac water	For use in installing glass
Solvent (Alcohol, white gasoline)	For use in cleaning adhesion surface

WR-0909

COMPONENTS

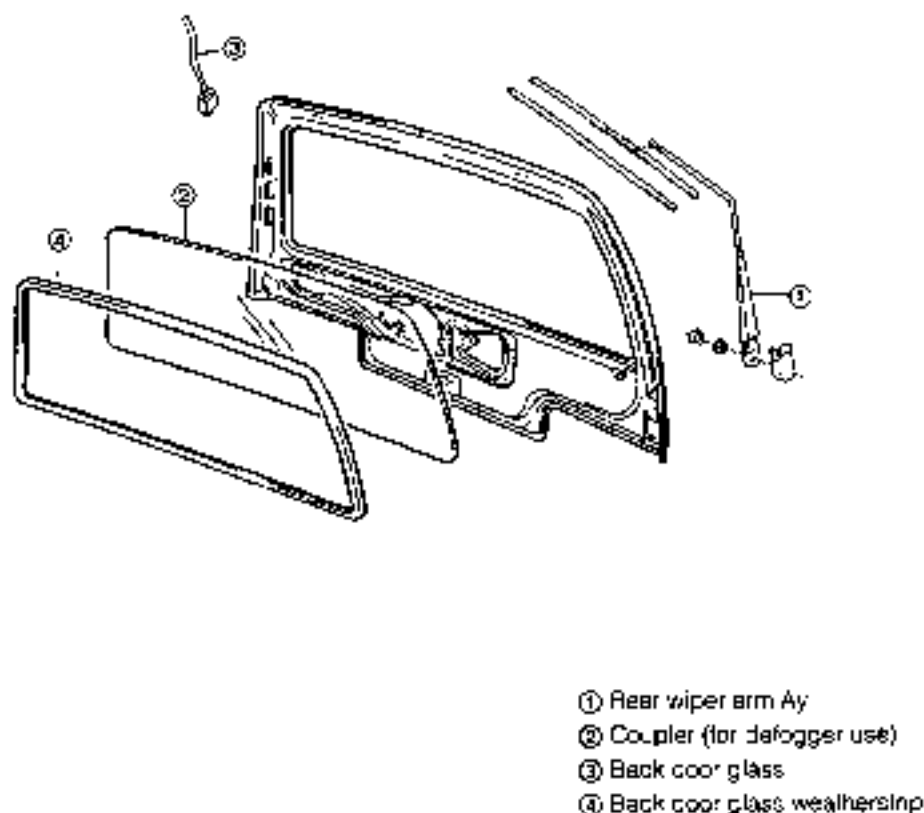

Fig. 9-80

WF-20026

REMOVAL

- (1) Remove the rear wiper arm assembly [Rear wiper-equipped vehicle only. (See Fig. 9-166.)]
- (2) Remove the coupler for defogger use. [Defogger-equipped vehicle only.]
- (3) Remove the rear spoiler. [Rear spoiler-equipped vehicle only. (See page 9-36.)]
- (4) Back door glass

Push the lip section of the weatherstrip outward from the body flange, using a common screwdriver or a bamboo spatula. This operation is performed from the vehicle interior.

NOTE:

Be very careful not to scratch the body paint finish surface.

- (5) Remove the back door weatherstrip from the back door glass.

INSPECTION AND CLEANING

Clean the adhesion sections of the glass and body, using a solvent such as alcohol or white gasoline.

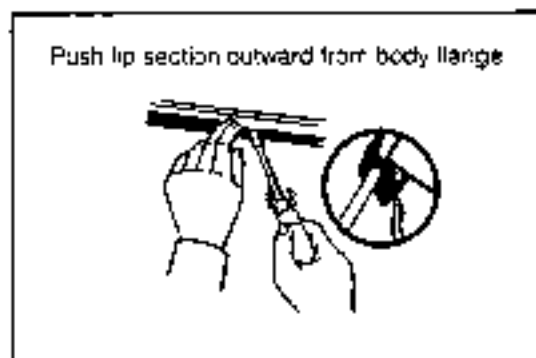

Fig. 9-81

WF-20026

WF-43027

BODY

INSTALLATION

1. Install the back door glass weatherstrip to the back door glass.
2. Install the back door glass, as follows:
 - (1) Set an operation rope to the weatherstrip.

NOTE:

Never reuse any weatherstrip which exhibits deterioration. Failure to observe this instruction will cause water leakage.

(2) Soap water application

Apply soap water to the body flange contact sections of the weatherstrip. Also, apply soap water to the body flange.

(3) Install the back door glass to the body

- (4) Hold the one end of the rope that is suspending in the vehicle interior. Pull the rope in such an angle that allows the weatherstrip to cross over the flange. While so doing, pound the surface of the glass at points adjacent to the weatherstrip using one's palm from the vehicle exterior in order that the windshield may be installed into position.
- (5) Pound the surface of the glass using one's palm from the vehicle exterior so that the windshield may be settled in place.
- (6) Application of non-drying window sealer. Working from the outside, apply the non-drying window sealer between the weatherstrip and the glass as well as between the weatherstrip and the body.

NOTE:

Remove any excessive sealer.

(7) Water leakage check

If water leakage exists, dry the leaky point thoroughly. Then, fill the leaky point with the non-drying sealer.

3. Connect the coupler for defogger use. [Defogger-equipped vehicle only.]
 4. Installation of rear wiper arm assembly [Rear wiper-equipped vehicle only]
 - (1) Operate the wiper motor, until it assumes the automatic stopping position.
 - (2) Install the rear wiper arm, aligning the arm with the bottom line of the defogger pattern.Installation position:
Bottom line of pattern ± 5 mm (± 0.2 inch)
 - (3) Install the wiper link cap.
5. Install the rear spoiler [Rear spoiler-equipped vehicle only. (See page 9-37.)]

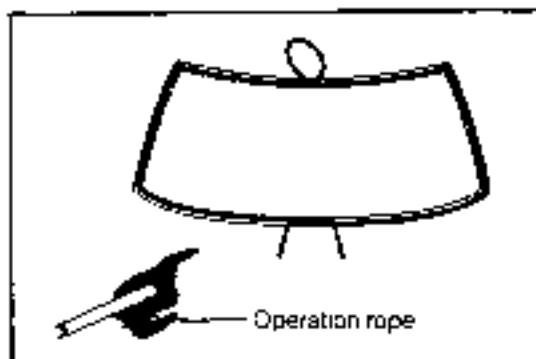

Fig. 8-82

WR-09090

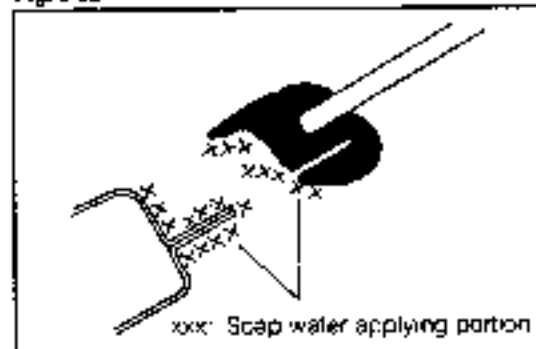

Fig. 9-93

WR-09090

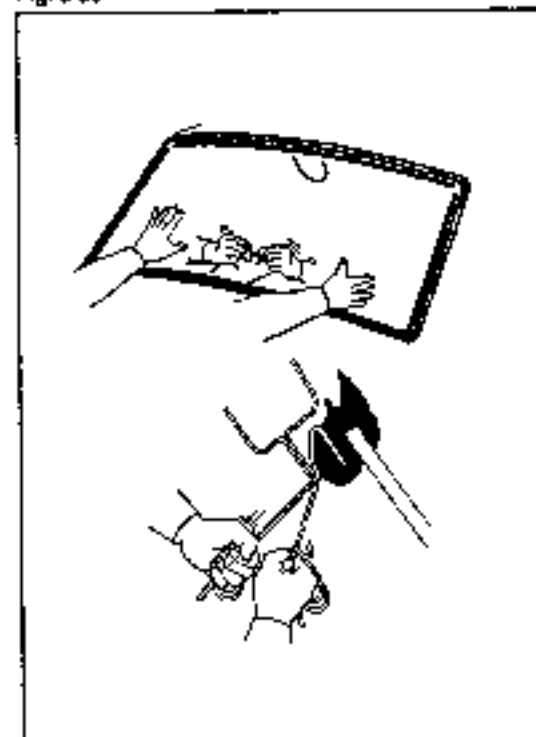

Fig. 9-94

WR-09100

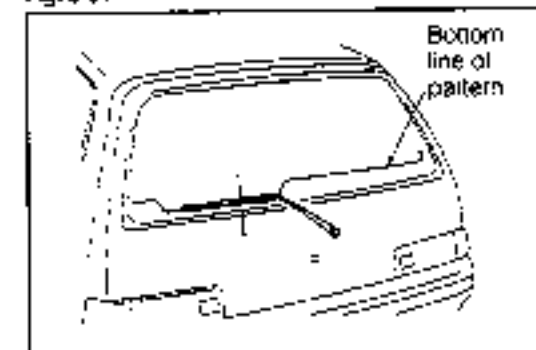
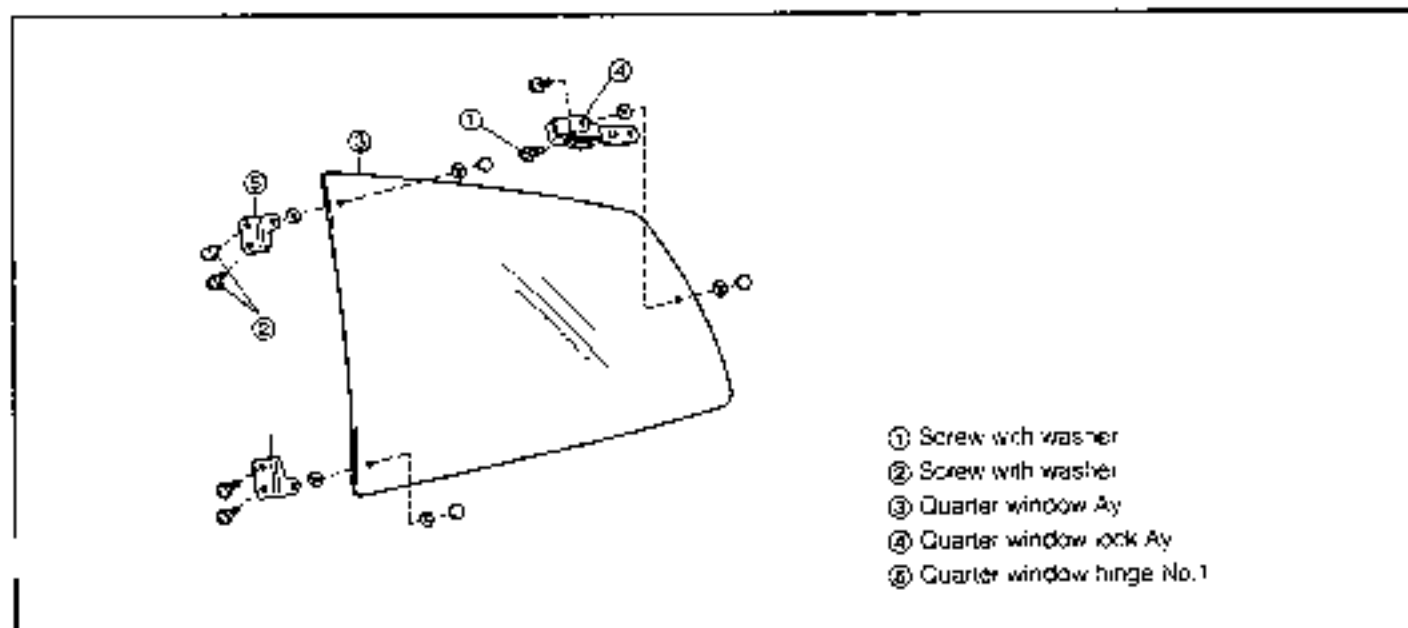

Fig. 9-96

WR-05101

QUARTER WINDOW GLASS COMPONENTS



- ① Screw with washer
- ② Screw with washer
- ③ Quarter window Ay
- ④ Quarter window lock Ay
- ⑤ Quarter window hinge No.1

Fig. 9-98

W4-09'02

REMOVAL

1. Removal of quarter window assembly
 - (1) Remove the screws attaching the quarter window lock to the body.
 - (2) Remove the screws attaching the quarter window hinge No.1 to the body.
 - (3) Remove the quarter window assembly from the body.
2. Remove the quarter window lock and quarter window hinge No.1 from the quarter window assembly.

INSTALLATION

1. Install the quarter window lock and quarter window hinge No.1 to the quarter window assembly.
2. Install the quarter window assembly to the body, as follows:
 - (1) Install the quarter window hinge No.1 to the body with the screws
 - (2) Install the quarter window lock to the body with the screws

NOTE:

When tightening the screw, fill the nut with an adhesive agent (instantaneous adhesive agent).

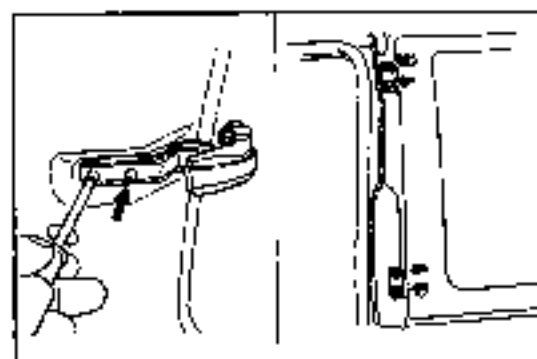

Fig. 9-97

W4-09'03

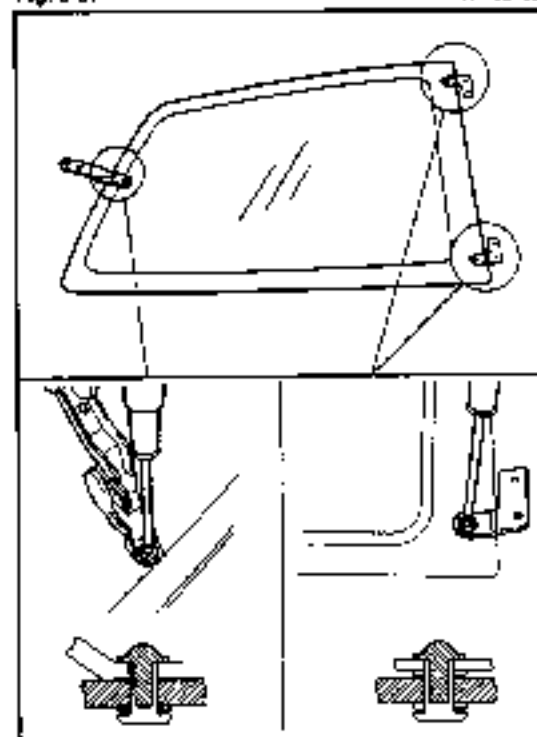

Fig. 9-98

W4-09'04

BODY

OUTSIDE MOLDINGS

ARTICLES TO BE PREPARED

	Shape and nomenclature of item	Use
Lubricants and others	Beta seal 552 (Adhesive agent) (Cartridge capacity: 333 ml)	For use in installing outside moldings
	Solvents (Alcohol white gasoline)	For use in cleaning body surface and molding surface
	Plastic spatula	For use in removing outside moldings

WR-09105

COMPONENTS

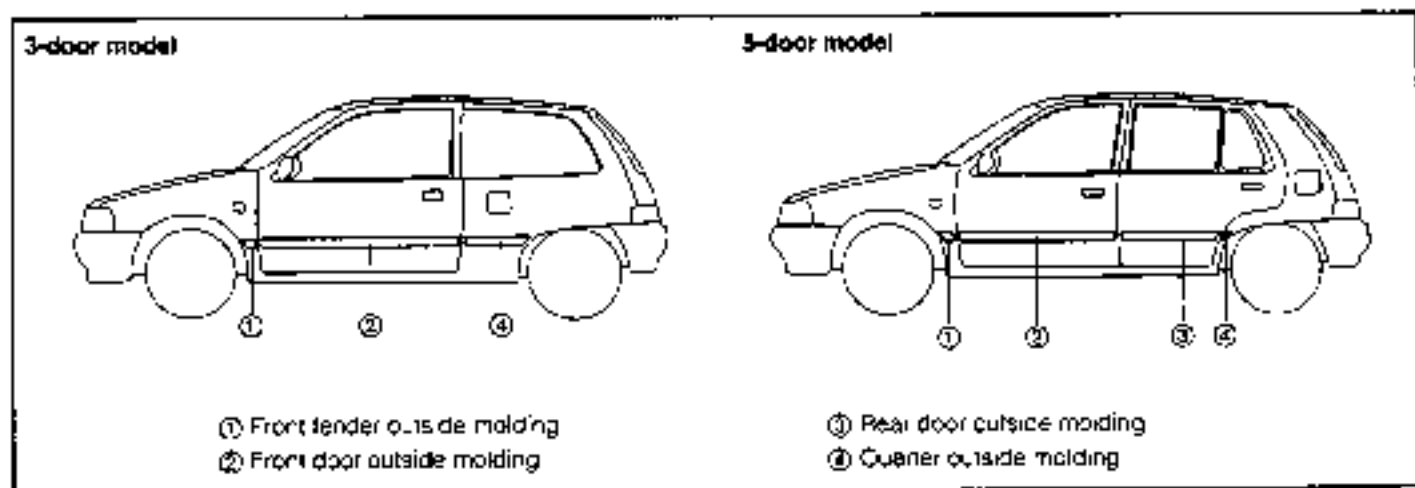

Fig. 9-99

WR-09106

REMOVAL

1. Removal of Outside Moldings

- (1) Raise the lower end of the molding. Insert a plastic spatula into that section.

- (2) While raising the lower side of the molding, remove the molding with a plastic spatula.

NOTE:

Be very careful not to scratch the body.

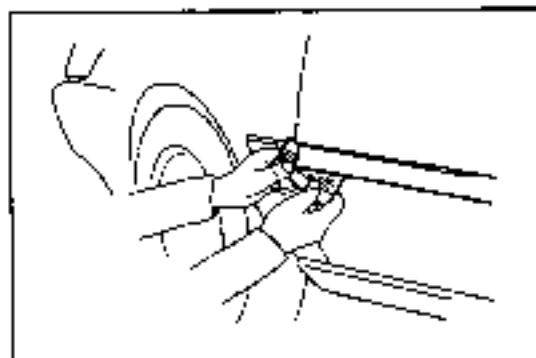

Fig. 9-100

WR-09107

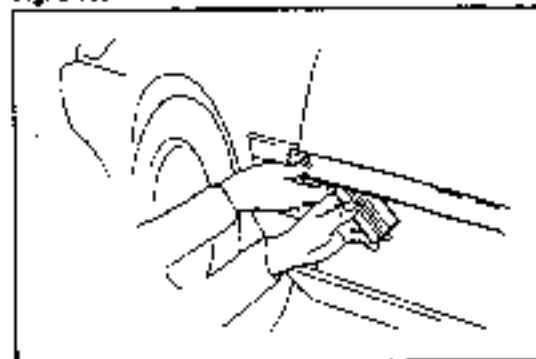

Fig. 9-101

WR-09108

INSPECTION AND CLEANING

Remove any adhesive agent remaining on the body surface with a cloth dampened with white gasoline.

WR-09109

INSTALLATION

- (1) Heat the outside molding and body with an infrared lamp or the like.
- (2) Remove the liner paper from the molding. Apply the adhesive agent to the points indicated in the figure below.

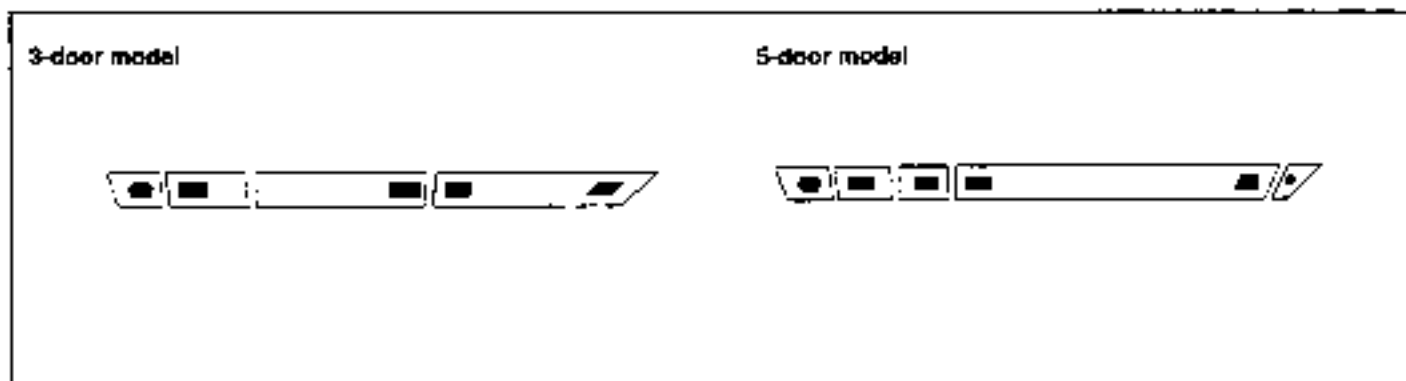
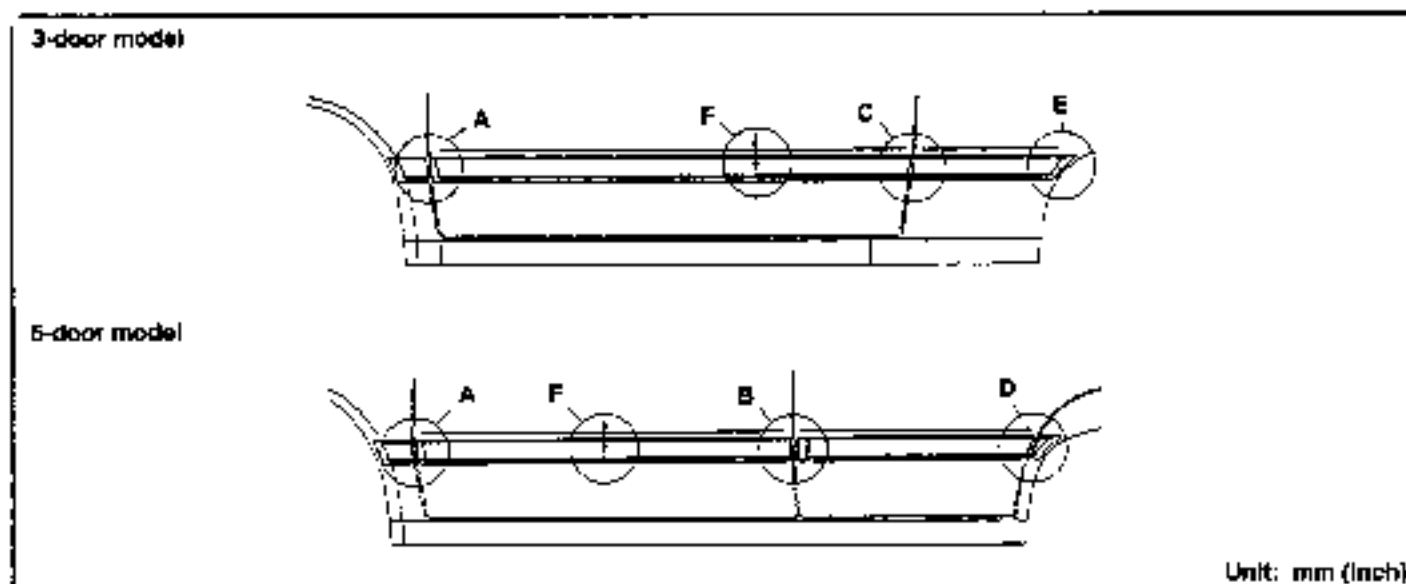

Fig. 9-102

WP-09'10

- (3) Position the molding at the specified points of the body. Press the molding lightly



Unit: mm (Inch)

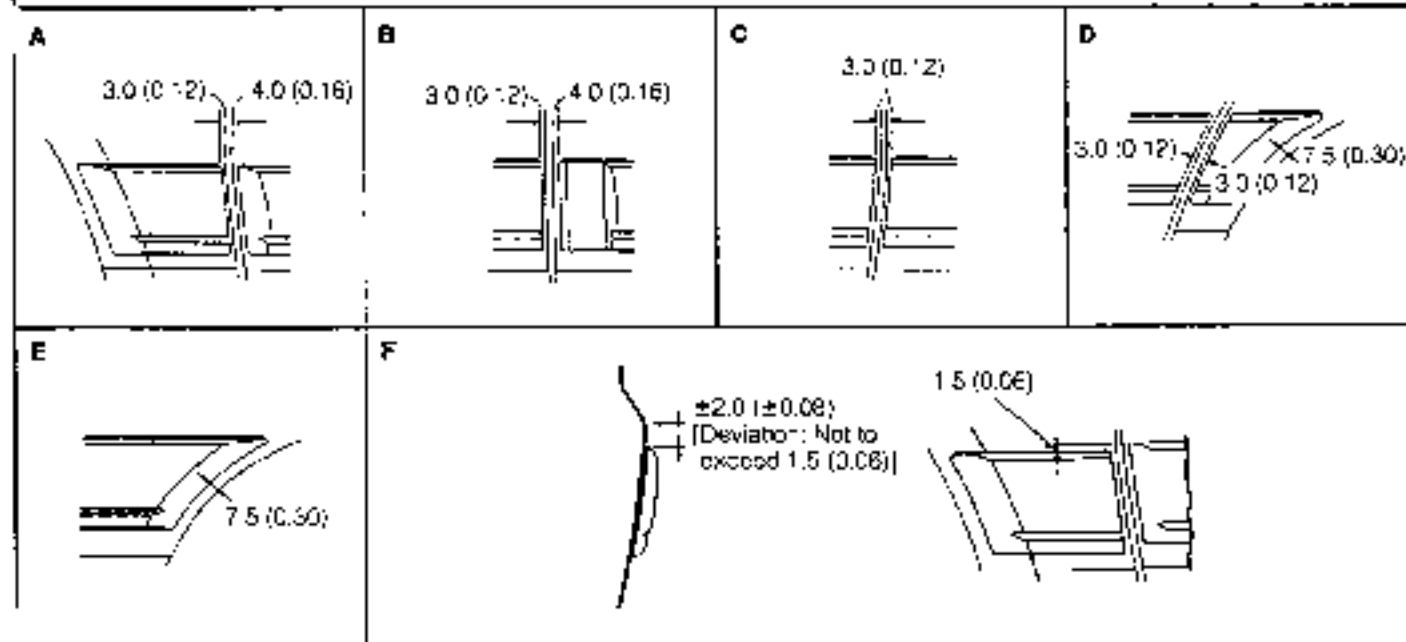

Fig. 9-103

WP-09'11

BODY

- (4) Press the molding against the body, using a roller or the like. Applying pressure: about 5 kg (11 lb)
- (5) Press the end sections of the molding firmly by your hand.

NOTE:

1. When removing the liner paper, care must be exercised to ensure that no dirt or the like may get to the surface of the two-faced adhesive tape.
2. Never allow the adhesive agent to get to the two-faced adhesive tape.
3. Affix the molding within three minutes after the adhesive agent has been applied.

WR-09-12

BACK DOOR GARNISH

ARTICLES TO BE PREPARED

	Shape	Nomenclature and part number	Use
Tools		Screwdriver type clip clamping tool by Banzai, Ltd.	For use in removing back door garnish
Lubricants and others	Alcohol, white gasoline		

4R-09112

INSTALLATION POSITION

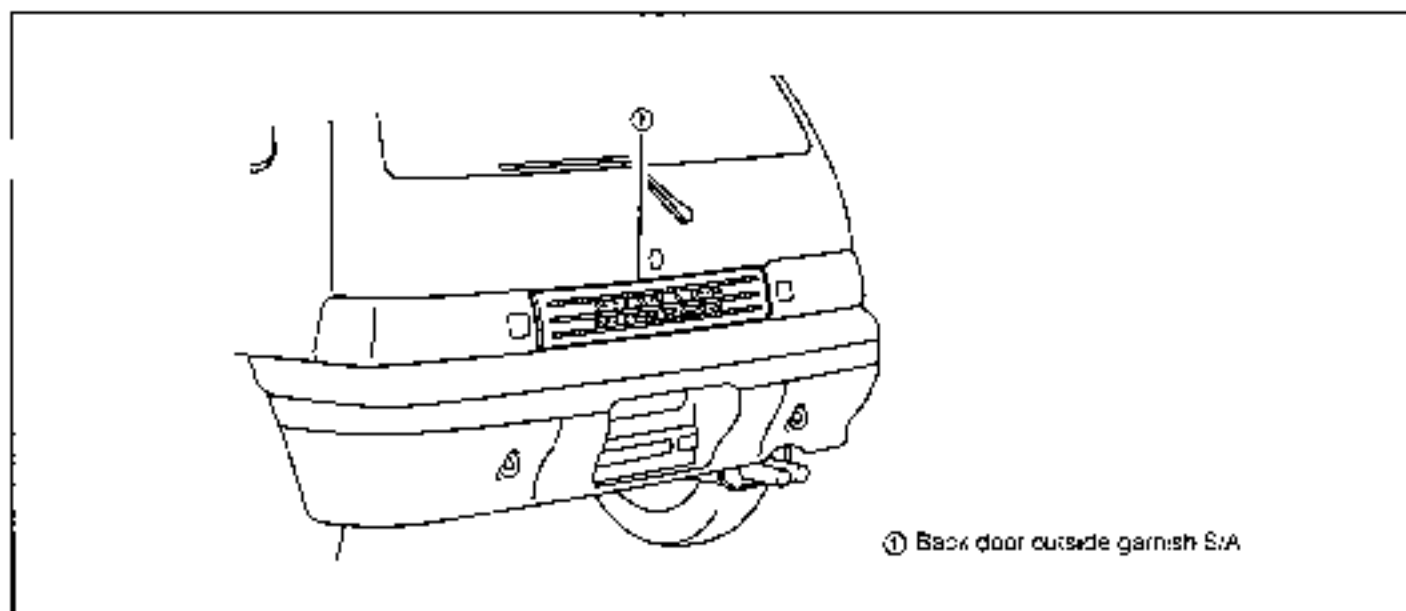

Fig. 9-104

WR-05114

REMOVAL

1. Detach the clip sections from the body, using a screwdriver type clip clamping tool wrapped with a protective tape.
2. Remove the garnish slowly, starting from the end of it.

NOTE:

Remove the garnish slowly, for it has been attached by a two-faced adhesive tape.

INSTALLATION

1. Clean the body surface with alcohol or white gasoline.
2. Install the garnish and press the two-faced adhesive tape section.

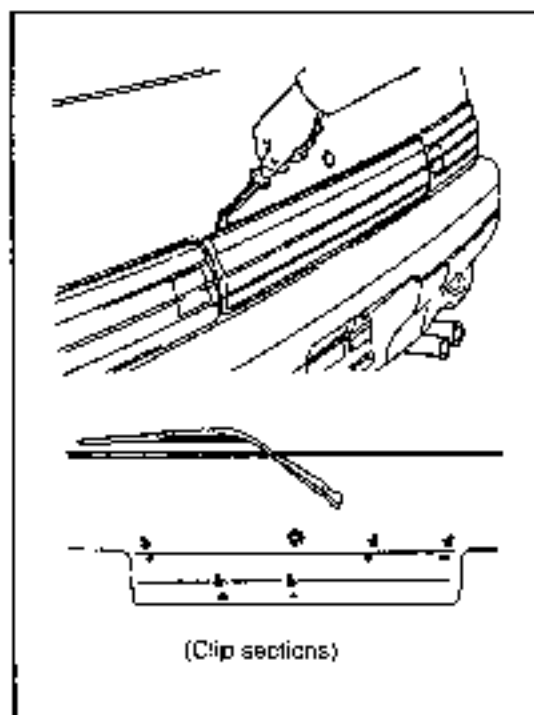



Fig. 9-105

WR-05115

BODY

BACK DOOR OUTSIDE GARNISH NO.2

ARTICLES TO BE PREPARED

	Shape	Nomenclature and part number	Use
Tools		Screwdriver type clip clamping tool by Banzai, Ltd	For use in removing back door garnish.
Lubricants and others	Alcohol, white gasoline		

WR-0811B

COMPONENTS

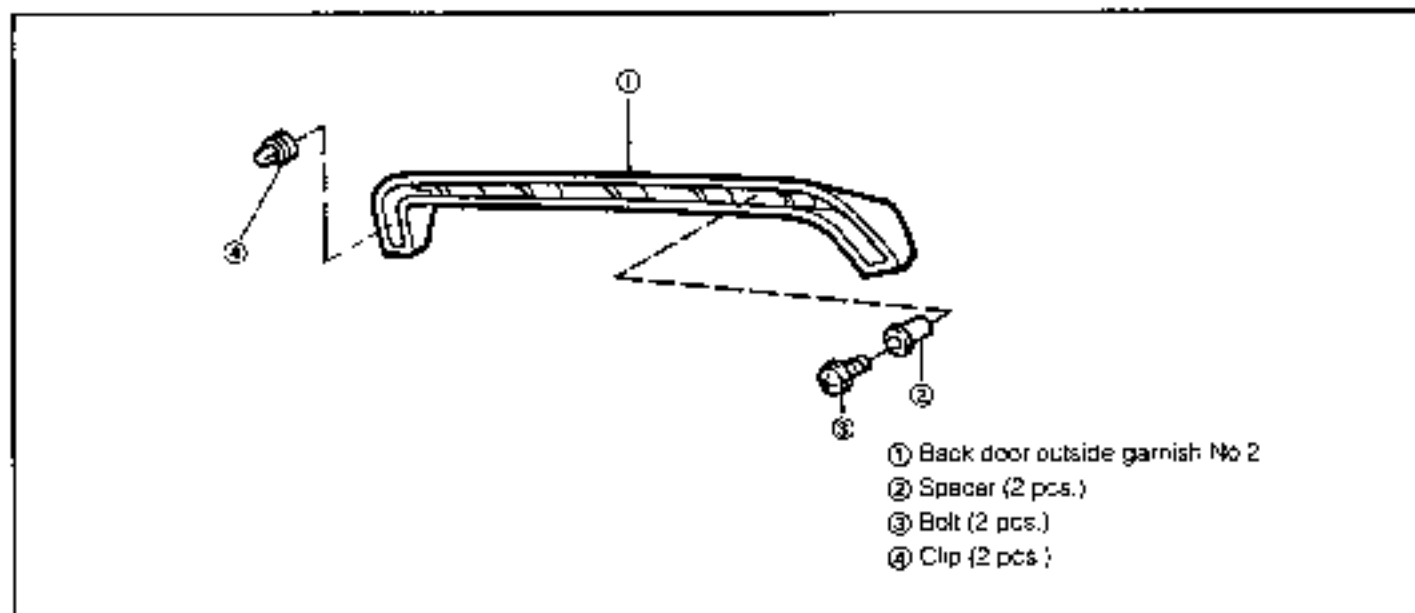

Fig. 9-106

WR-0811B

REMOVAL

- Remove the attaching bolt of the back door outside garnish No.2, using a socket wrench.
- Back door outside garnish No.2
 - Detach the clip sections from the body, using a screwdriver type clip clamping tool wrapped with a protective tape.

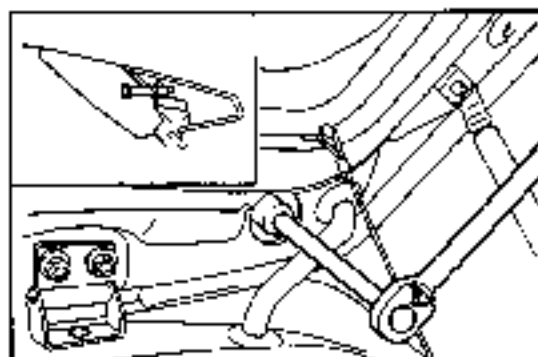

Fig. 9-107

WR-0811B

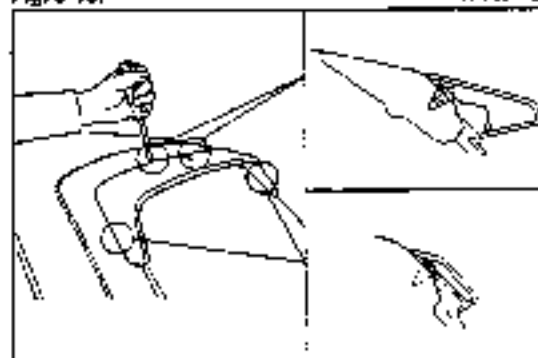

Fig. 9-108

WR-0811B

INSTALLATION

1. Clean the installation surface (body side) of the back door outside garnish No.2 with alcohol or white gasoline.
2. Installation of back door outside garnish No.2
 - (1) Attach the clips to the back door outside garnish No.2. Then install the garnish to the body.
 - (2) Secure the back door outside garnish No.2 to the body with the two bolts.

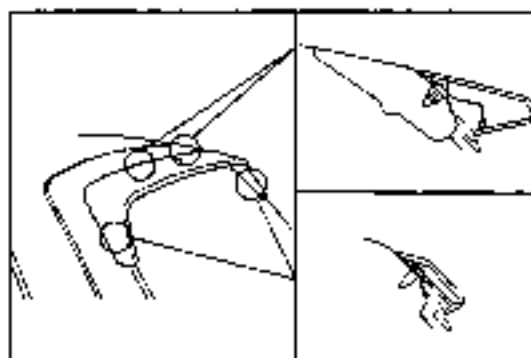

Fig. 9-109

vR-cs120

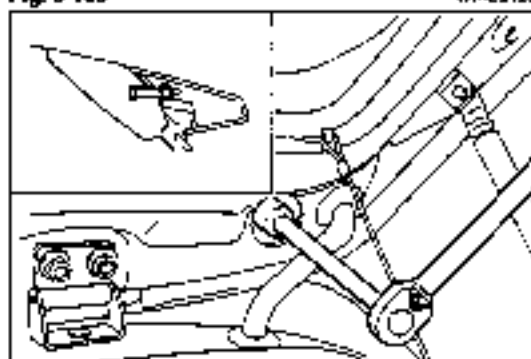



Fig. 9-110

vR-cs121

BODY

FRONT DOOR

ARTICLES TO BE PREPARED

	Shape	Nomenclature and part number	Use
Tools		Screwdriver type clip clamping tool by Banza Ltd.	For use in removing door trim
Lubricants and others	MP grease, butyl tape, soap and brush, etc.		

AF-29122

DOOR TRIM AND SERVICE HOLE COVER COMPONENTS

3-door model

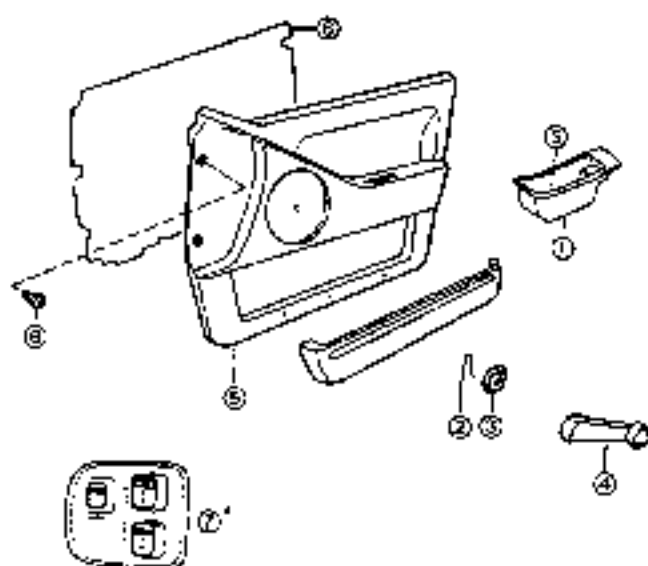

- ① Door pull handle
- ② Shaft snap ring
- ③ Regulator inside handle plate
- ④ Front door window regulator handle A
- ⑤ Front door trim panel A
- ⑥ Clip
- ⑦ Power window master switch A
- ⑧ Front door service hole cover S/A

6-door model

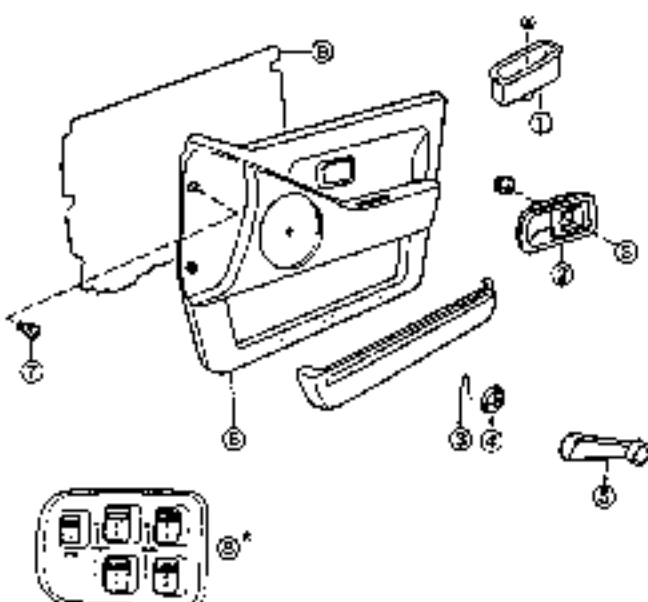

- ① Door pull handle
- ② Door inside handle A
- ③ Shaft snap ring
- ④ Regulator inside handle plate
- ⑤ Front door window regulator handle A
- ⑥ Front door trim panel A
- ⑦ Clip
- ⑧ Power window master switch A
- ⑨ Front door service hole cover S/A

⑧ : Power window-equipped vehicle only

Fig. 9-111

WN-38121

REMOVAL

1. Remove the door pull handle
(3-door model: two screws, 5-door model: one screw)
2. Remove the one attaching screw of the door inside handle (5-door model only)

3. Removal of front door window regulator handle assembly
 - (1) Detach the shaft snap ring, using a cloth.
 - (2) Remove the front door window regulator handle assembly and regulator inside handle plate.

4. Detach the two clips by pushing the center section of each clip

NOTE:

Never push the center section excessively. If pushed excessively, the center section of the clip may fall off.

5. Removal of front door trim panel assembly
 - (1) Remove the front door trim panel assembly, using the clip clamping tool
 - (2) Remove the coupler for power window use. (Power window-equipped vehicle only)
 - (3) Remove the power window master switch assembly from the front door trim panel assembly. (Power window-equipped vehicle only)

6. Remove the door inside handle assembly and bracket.

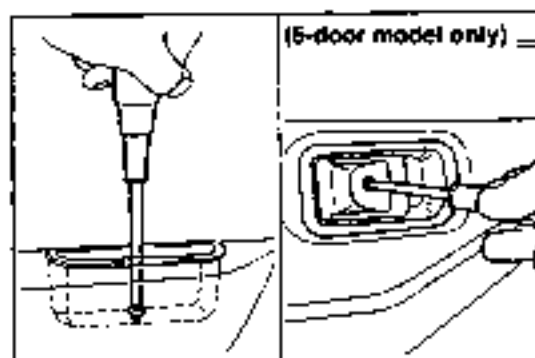

Fig. 9-112

WR-08-2-

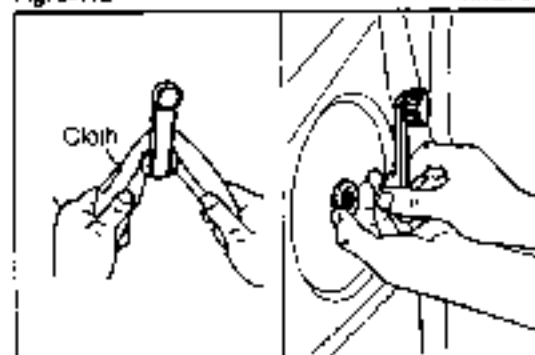

Fig. 8-113

WR-09-2E

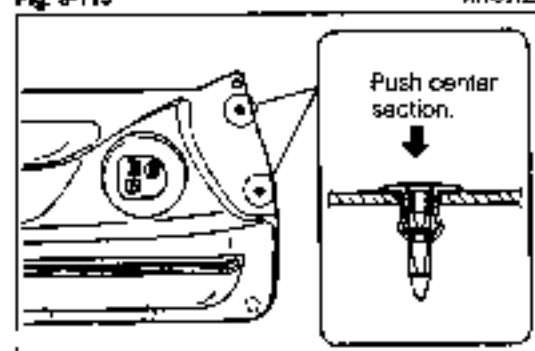

Fig. 9-114

WR-08-126

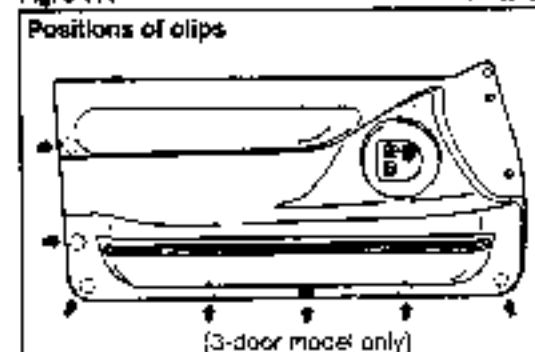

Fig. 8-115

WP-08-127

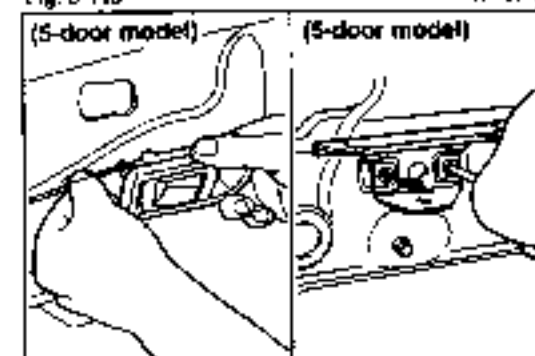

Fig. 9-116

WR-09-128

BODY

7. Remove the front door service hole cover subassembly.

INSTALLATION

1. Installation of front door service hole cover subassembly
 - (1) Affix butyl tape to the points indicated in the right figure.
 - (2) Insert the cover at the lower end into the aperture at the lower side of the door panel. Affix adhesive tape on the holes.
- NOTE:**
1. Never plug the clip hole of the door trim with adhesive tape.
 2. Replace any service hole cover which exhibits rupture.
2. Install the door inside handle assembly and bracket
 - (5-door model: See Fig. 9-116.)
 - (3-door model: See Fig. 9-117.)

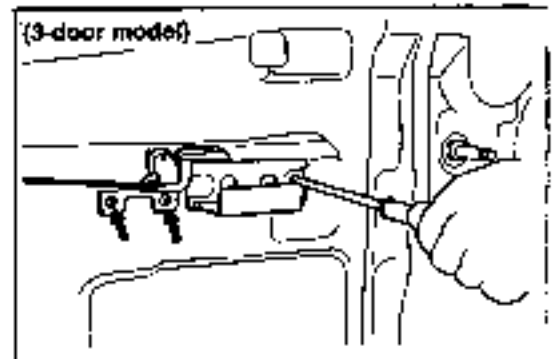
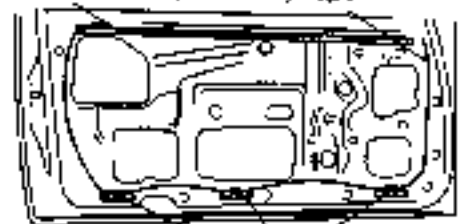

Fig. 9-117

WR-09129

3-door model

Affix adhesive tape. Butyl tape



5-door model

Butyl tape



Fig. 9-118

WR-09130

3. Installation of front door trim panel assembly
 - (1) Ensure that the clips are attached to the front door trim panel assembly.
 - (2) Install the power window master switch assembly to the front door trim panel assembly (Power window-equipped vehicle only)
 - (3) Connect the coupler for power window use. (Power window-equipped vehicle only)
 - (4) Install the front door trim panel assembly to the front door.

3-door model



5-door model

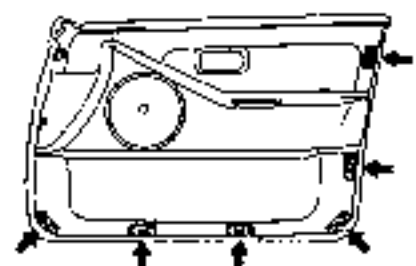

Fig. 9-119

WR-09131

1. Attachment of clips
 - (1) Pull up the center section of each clip. Set it to the front door trim panel.
 - (2) Push the center section of the clip.

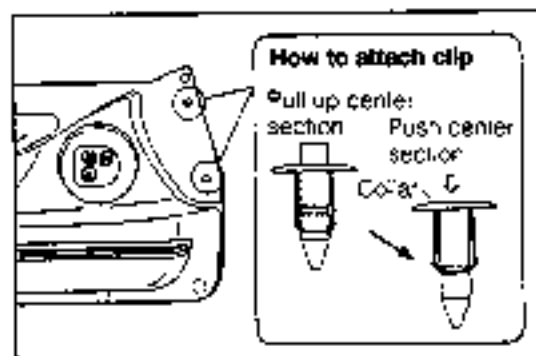

Fig. 8-120

WP-09-32

5. Installation of front door window regulator handle assembly
 - (1) Close the door glass fully.
 - (2) Set the regulator inside handle plate to the trim side.
 - (3) Set the shaft's snap ring to the front door window regulator handle.

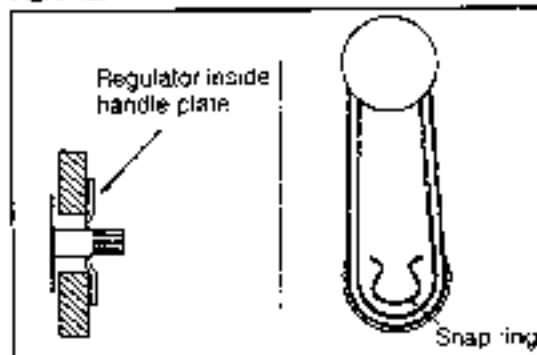

Fig. 9-121

WP-09-33

- (4) Install the front door window regulator handle in the angle specified in the right figure.

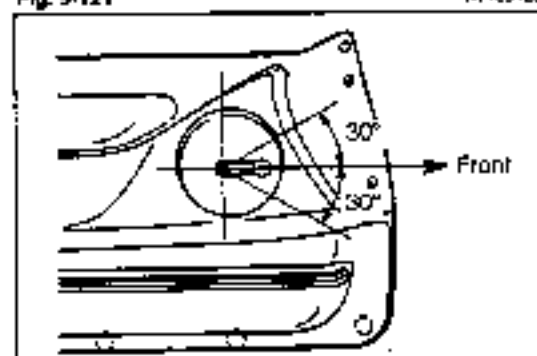

Fig. 9-122

WP-09-34

5. Install the door pull handle
(3-door model: two screws, 5-door model: one screw)
7. Install the door inside handle assembly. (5-door model only)

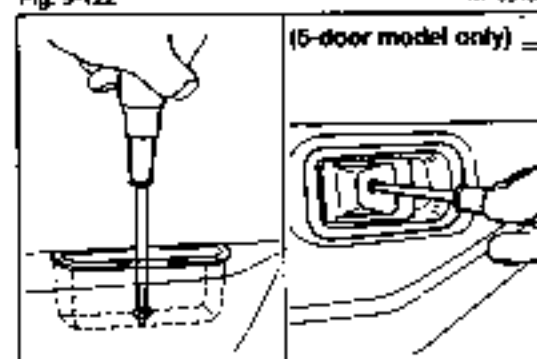

Fig. 9-123

WP-09-35

BODY

DOOR LOCK AND OUTSIDE DOOR HANDLE COMPONENTS

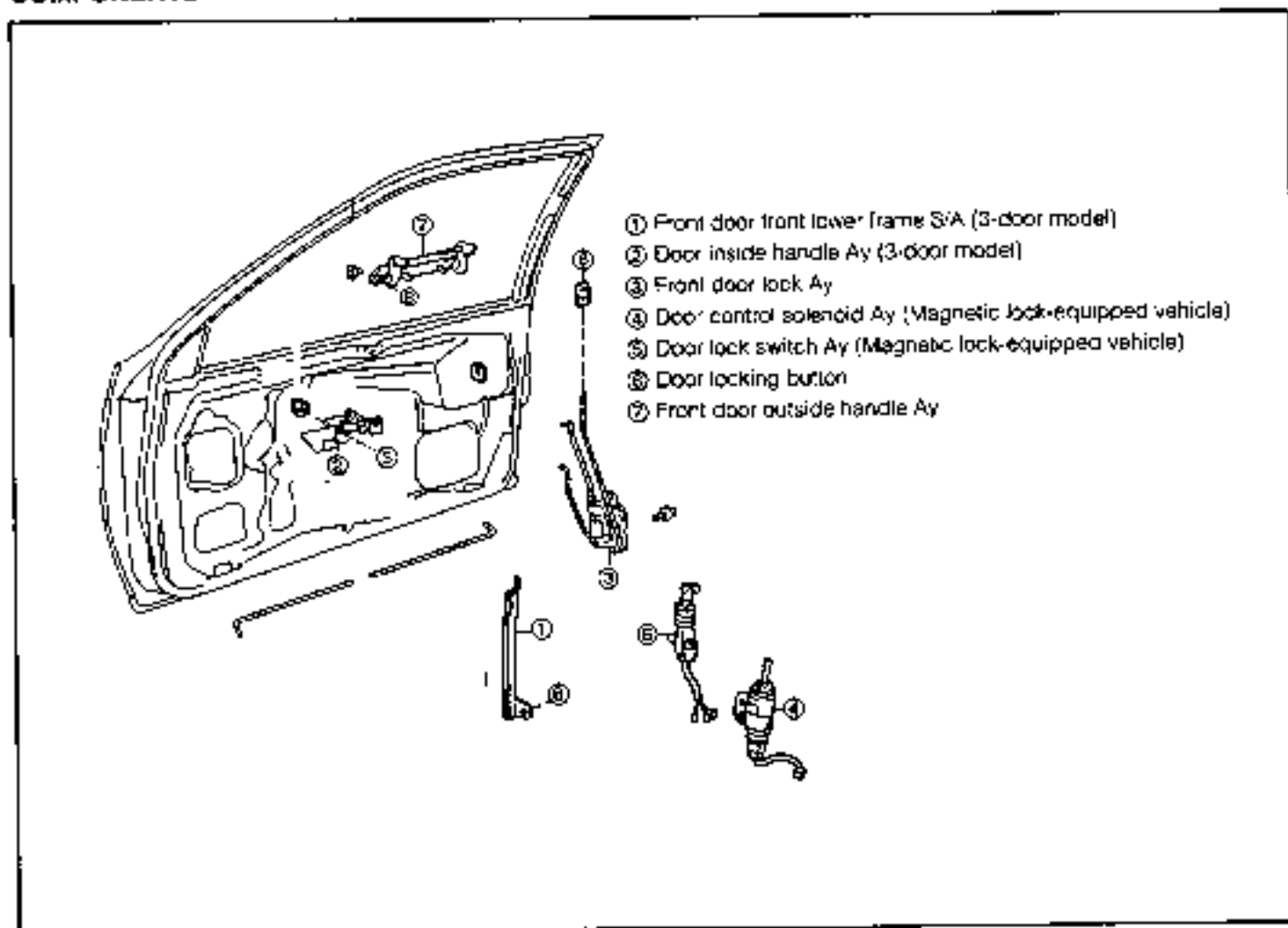

Fig. 9-124

WR-09136

REMOVAL

1. Remove the door trim-related parts. (See page 9-39.)
2. Remove the front door front lower frame subassembly. (3-door model only)

3. Removal of front door lock assembly

- (1) Detach the door locking button from the front door lock assembly.
- (2) Remove the link-related parts.
- (3) Remove the three attaching screws of the front door lock assembly. (In the case of the passenger side on the magnetic lock-equipped vehicle, remove the bolt ④.)
- (4) Take out the front door lock assembly from the front door.

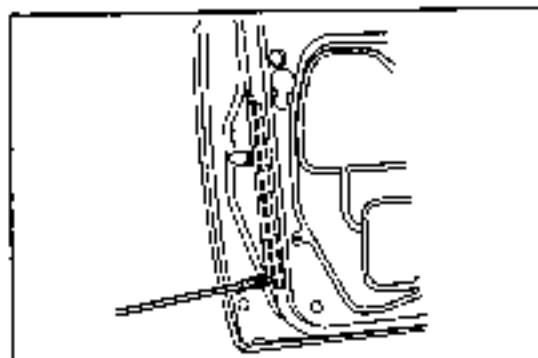

Fig. 9-125

WR-09137

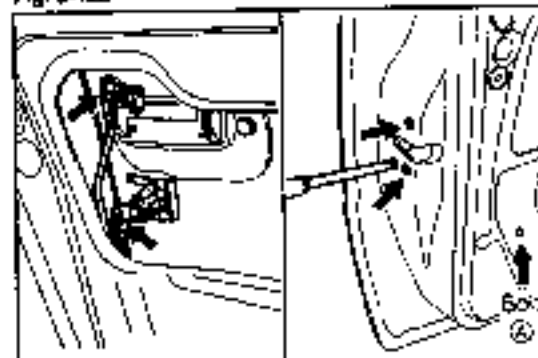

Fig. 9-126

WR-09138

- (5) Remove the door control solenoid assembly from the front door lock assembly. (Sides other than the driver's seat on the magnetic lock-equipped vehicle)
- (6) Remove the door lock switch assembly from the front door lock assembly. (Driver's seat only on the magnetic lock-equipped vehicle)

- 4. Detach the front door outside handle assembly by removing the two bolts.
- 5. Detach the clip. Remove the key cylinder.

INSTALLATION

- 1. Install the front door outside handle assembly with the two bolts. (See Fig. 9-128.)
- 2. Install the key cylinder into position with the clip. (See Fig. 9-128.)
- 3. Installation of front door lock assembly
 - (1) Apply MP grease to the sliding sections.
 - (2) Install the door lock switch assembly in the front door lock assembly. (Driver's seat only on the magnetic lock-equipped vehicle)
 - (3) Install the door control solenoid assembly in the front door lock assembly (Sides other than the driver's seat on the magnetic lock-equipped vehicle)
 - (4) Place the solenoid in a locking state. Adjust the solenoid assembly so that the clearance may become zero, as indicated in the right figure. Tighten the solenoid assembly securely. (Magnetic lock-equipped vehicle only)

- (5) Install the front door lock assembly in the front door using the three screws (In the case of the passenger side on the magnetic lock-equipped vehicle, install the bolt ⑤.)

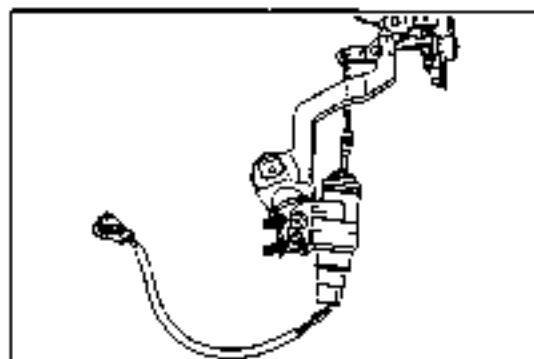

Fig. 9-127 6P-09139

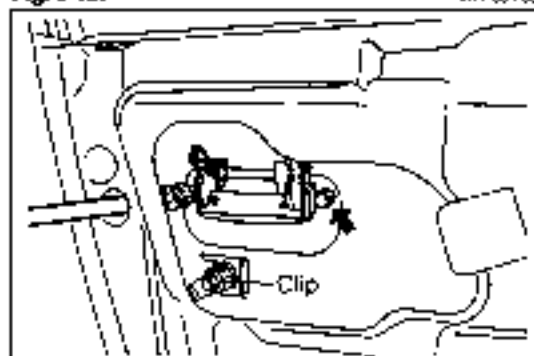

Fig. 9-128 WF-09140

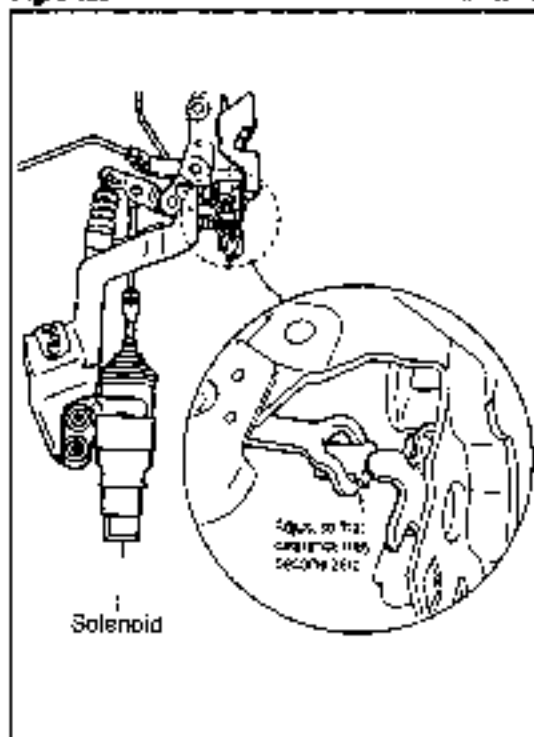

Fig. 9-129 W3-09141

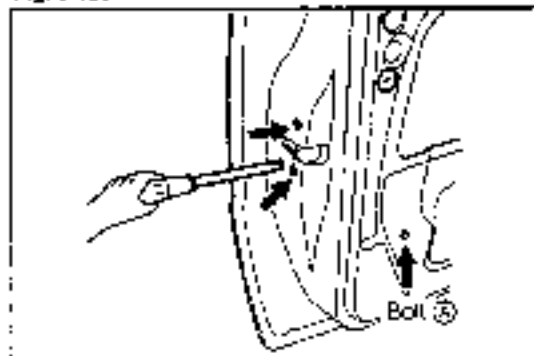

Fig. 9-130 WF-13142

BODY

- (6) Install the link-related parts.
- (7) Attach the door locking button
4. Install the front door front low frame subassembly in the front door. (3-door model only)
5. Install the door trim-related parts. (See page 9-40.)

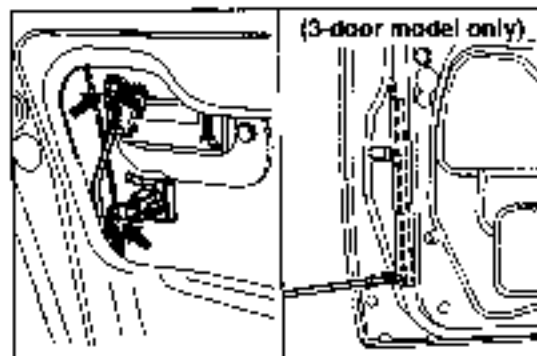

Fig. 9-131

WR-09-13

DOOR GLASS AND REGULATOR COMPONENTS

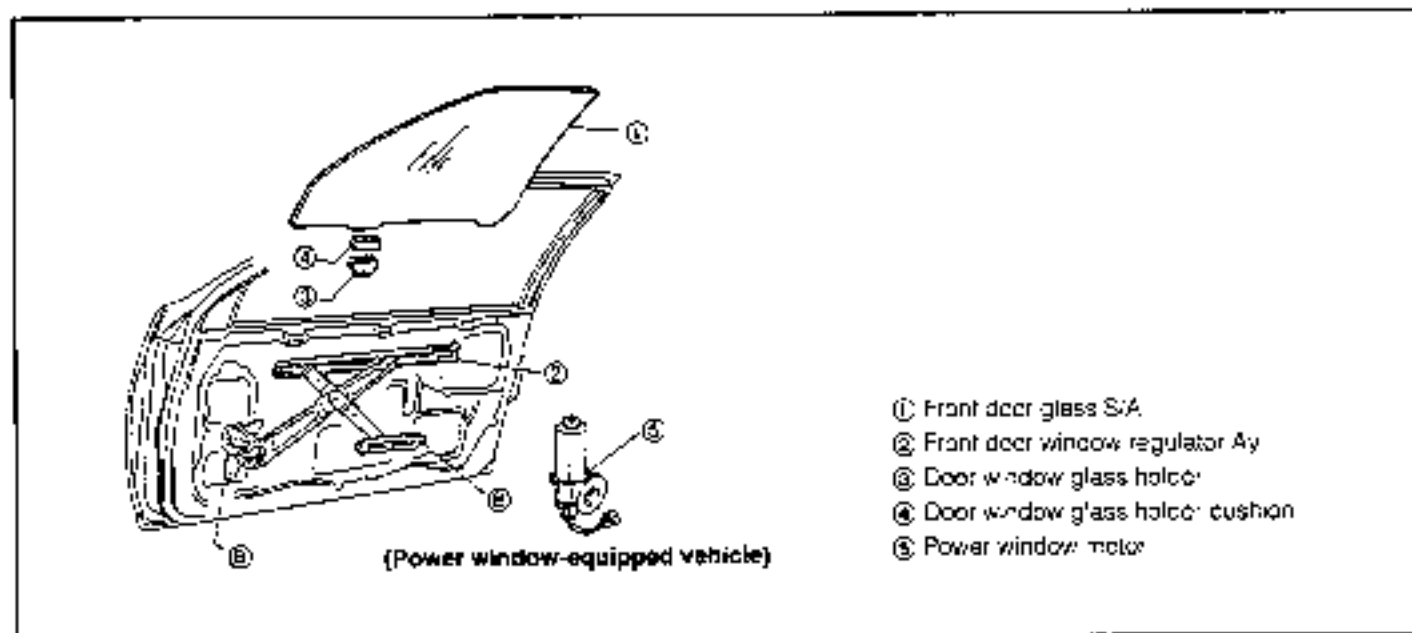

Fig. 9-132

WR-09-44

REMOVAL

1. Remove the door trim-related parts. (See page 9-39.)
2. Remove the two attaching bolts of the front door glass subassembly. Remove the front door glass subassembly from the front door.
3. Remove the door window glass holder & cushion from the front door glass subassembly.

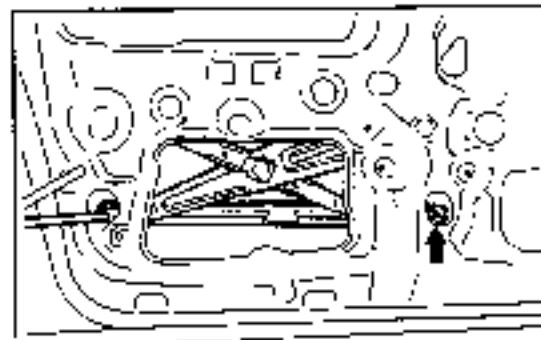

Fig. 9-133

WR-09-45

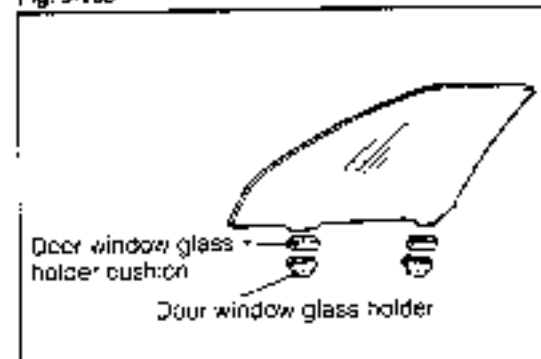

Fig. 9-134

WR-09-46

4. Remove the front door window regulator assembly.

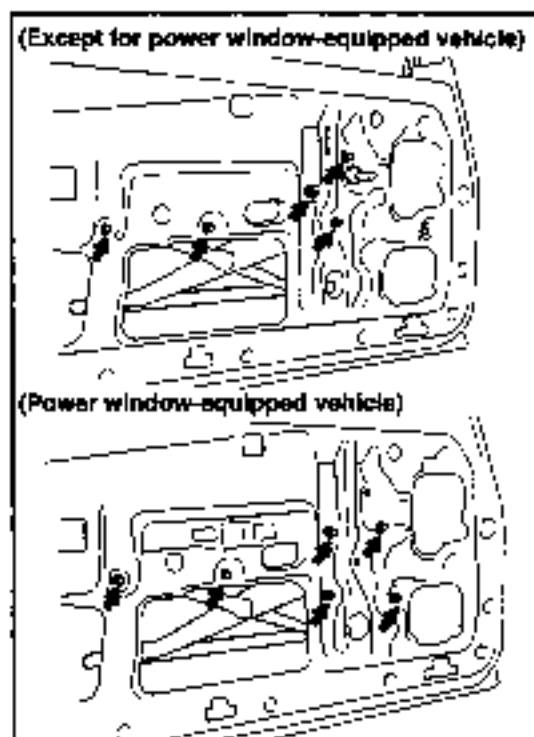

Fig. 9-136 WIR-09147

5. Remove the power window motor from the front door window regulator assembly. (Power window-equipped vehicle)
6. Remove the front door glass outer weatherstrip and front door glass run.

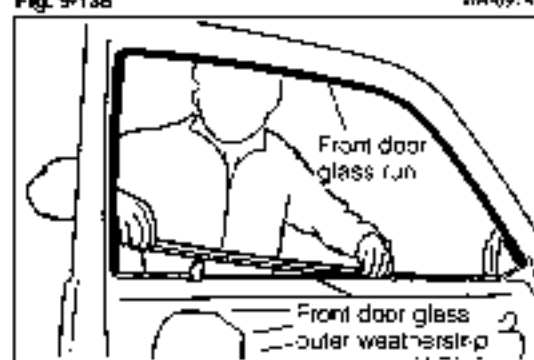

Fig. 9-136 WIR-09148

7. Remove the front door front and rear lower frame sub-assembly.

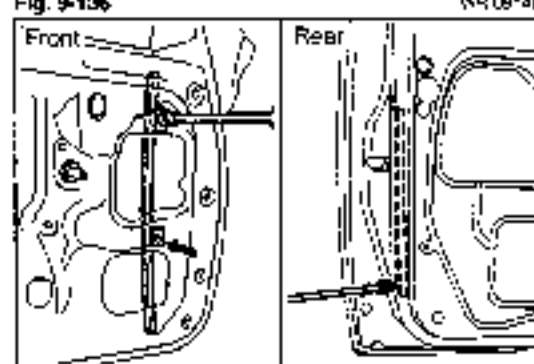

Fig. 9-137 WIR-09145

BODY

INSTALLATION

1. Install the front door front and rear lower frame sub-assembly.
 2. Install the front door glass outer weatherstrip and front door glass run.
 3. Install the door window glass holder and cushion to the front door glass.
4. Installation of front door window regulator assembly
 - (1) Apply MP grease to the sliding section.
 - (2) Install the power window motor to the front door window regulator assembly. (Power window-equipped vehicle)
 - (3) Install the front door window regulator assembly. (Tighten the bolts other than the bolts **A**. Then, tighten the two bolts **A** at the center section of the elongated hole of the door panel.)
 5. Installation of front door glass subassembly
 - (1) Install the front door glass subassembly. (See Fig. 9-133.)
 - (2) Close the front door glass fully. Then, lower the front door glass 40 mm (1.57 inches).
 - (3) First loosen the bolts **A** and then tighten them again.
 6. Install the door trim-related parts. (See page 9-40.)

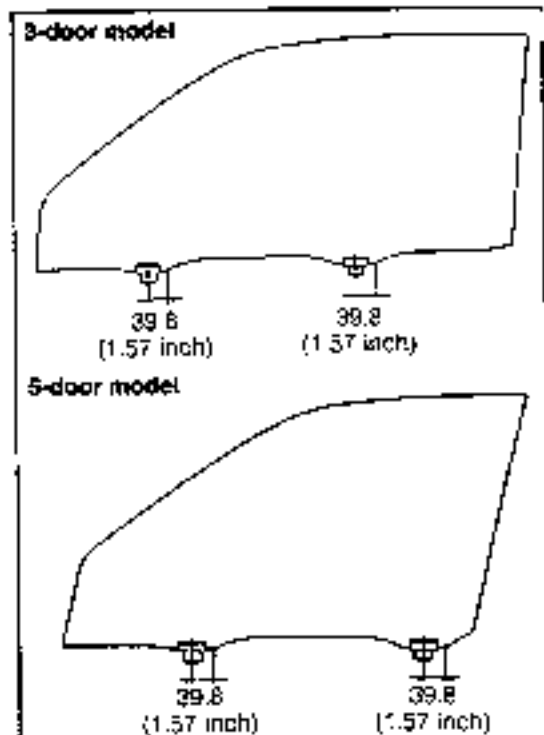

Fig. 9-138

WA-0913C

Grease applying points

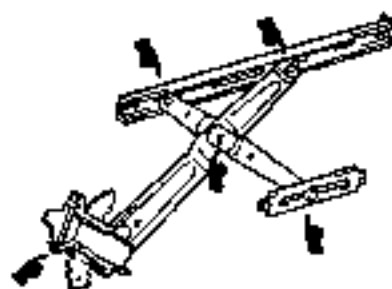

Fig. 9-139

WA-0913D

(Except for power window-equipped vehicle)



(Power window equipped-vehicle)

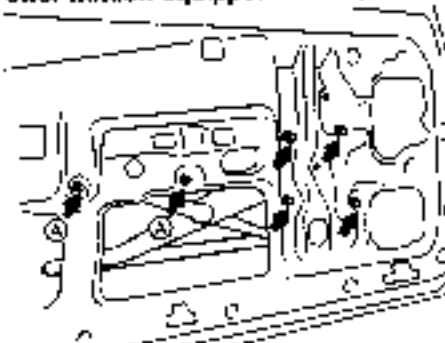



Fig. 9-140

WA-0915C

REAR DOOR

ARTICLES TO BE PREPARED

Tools	Shape	Nomenclature and part number	Use
		Screwdriver type clip clamping tool by Banzai, Ltd.	For use in removing door trim.
Lubricants and others	MP grease and butyl tape		

WR-09-53

DOOR TRIM AND SERVICE HOLE COMPONENTS

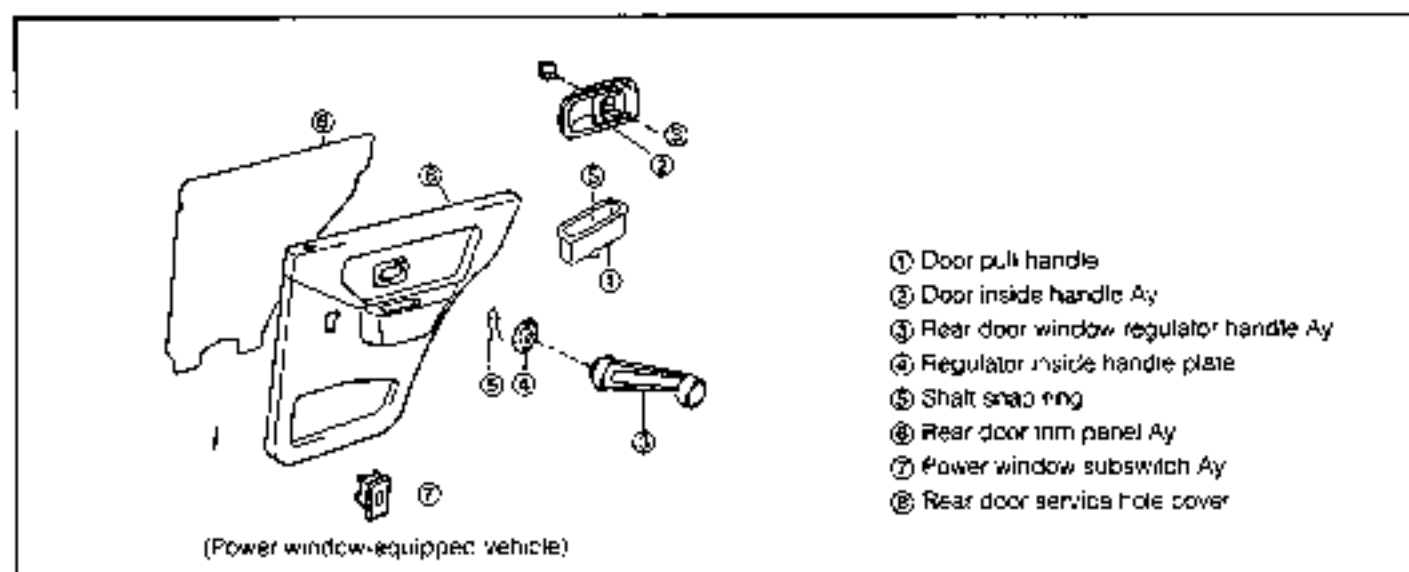

Fig. 9-141

WR-09-54

REMOVAL

- Detach the door pull handle.
- Remove the door inside handle assembly.
- Removal of rear door window regulator handle assembly
 - Detach the shaft snap ring, using a cloth.
 - Take out the rear door window regulator handle assembly and regulator inside handle plate.

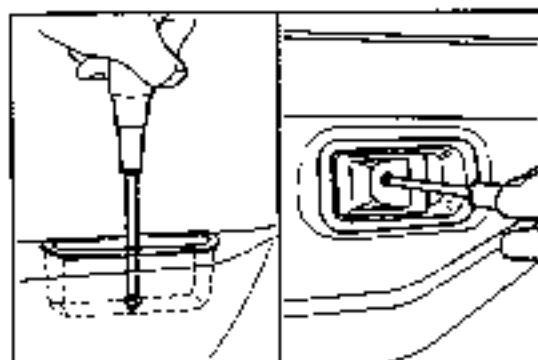

Fig. 9-142

WR-09-55

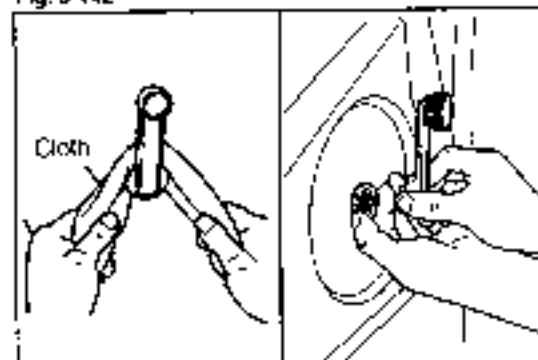

Fig. 9-143

WR-09-56

BODY

4. Removal of rear door trim panel assembly
 - (1) Detach the rear door trim panel assembly, using a clip remover.
 - (2) Remove the coupler for power window use. (Power window-equipped vehicle only)
 - (3) Remove the power window subswitch assembly from the rear door trim panel assembly.
5. Remove the door inside handle assembly and bracket.
6. Detach the rear door service hole cover subassembly.

INSTALLATION

1. Installation of rear door service hole cover subassembly
 - (1) Affix butyl tape on the position specified in the right figure.
 - (2) Place the lower edge of the cover in the aperture provided at the lower part of the door panel. Then, affix adhesive tape on it.

NOTE:

1. Be sure not to plug the clip hole with the adhesive tape.
 2. Replace the service hole cover if it exhibits rupture.
2. Install the door inside handle assembly and bracket.
 3. Installation of rear door trim panel assembly
 - (1) Ensure that the clip is attached to the rear door trim panel assembly.
 - (2) Install the power window subswitch assembly on the rear door trim panel assembly. Connect the coupler. (Power window-equipped vehicle only)
 - (3) Attach the rear door trim panel assembly on the rear door.
 4. Installation of rear door window regulator handle assembly
 - (1) Close the door glass fully.
 - (2) Set the regulator inside handle plate at the trim side.
 - (3) Set the shaft snap ring in the rear door window regulator handle.

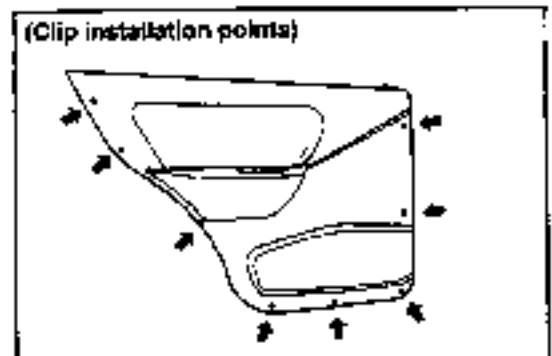

Fig. 9-144

WR-09157

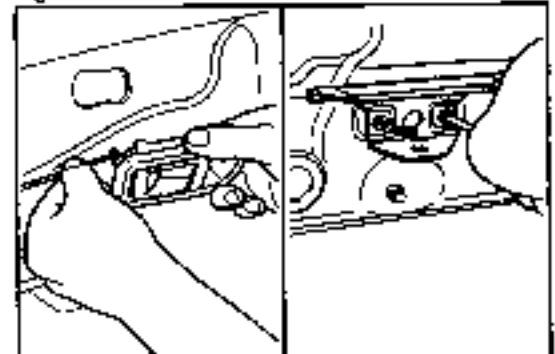

Fig. 9-145

WR-09158

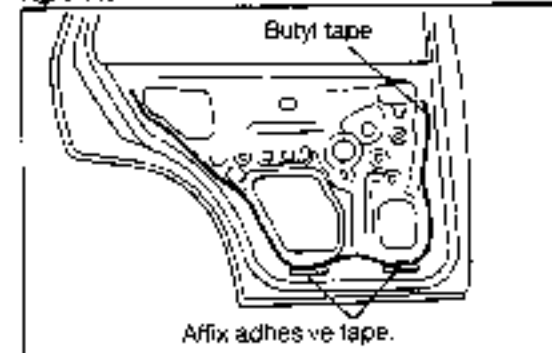

Fig. 9-146

WR-09159

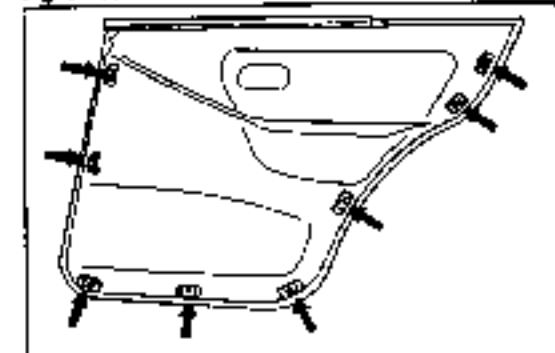

Fig. 9-147

WR-09160

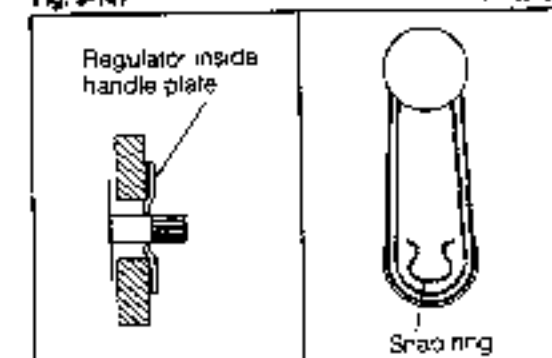

Fig. 9-148

WR-09161

- (4) Install the rear door window regulator handle in such a way that the handle may come within the angle indicated in the right figure.

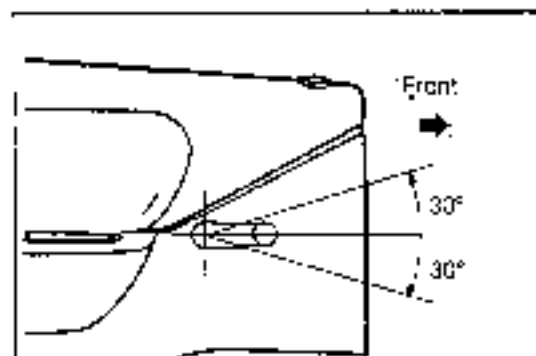

Fig. 9-149

WR-05152

5. Install the door pull handle.
6. Install the door inside handle assembly.

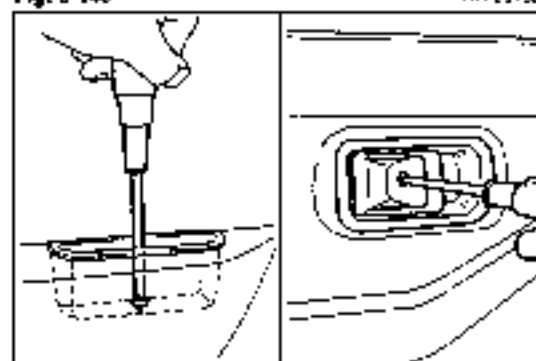

Fig. 9-150

WF-03163

DOOR LOCK AND OUTSIDE DOOR HANDLE

Components

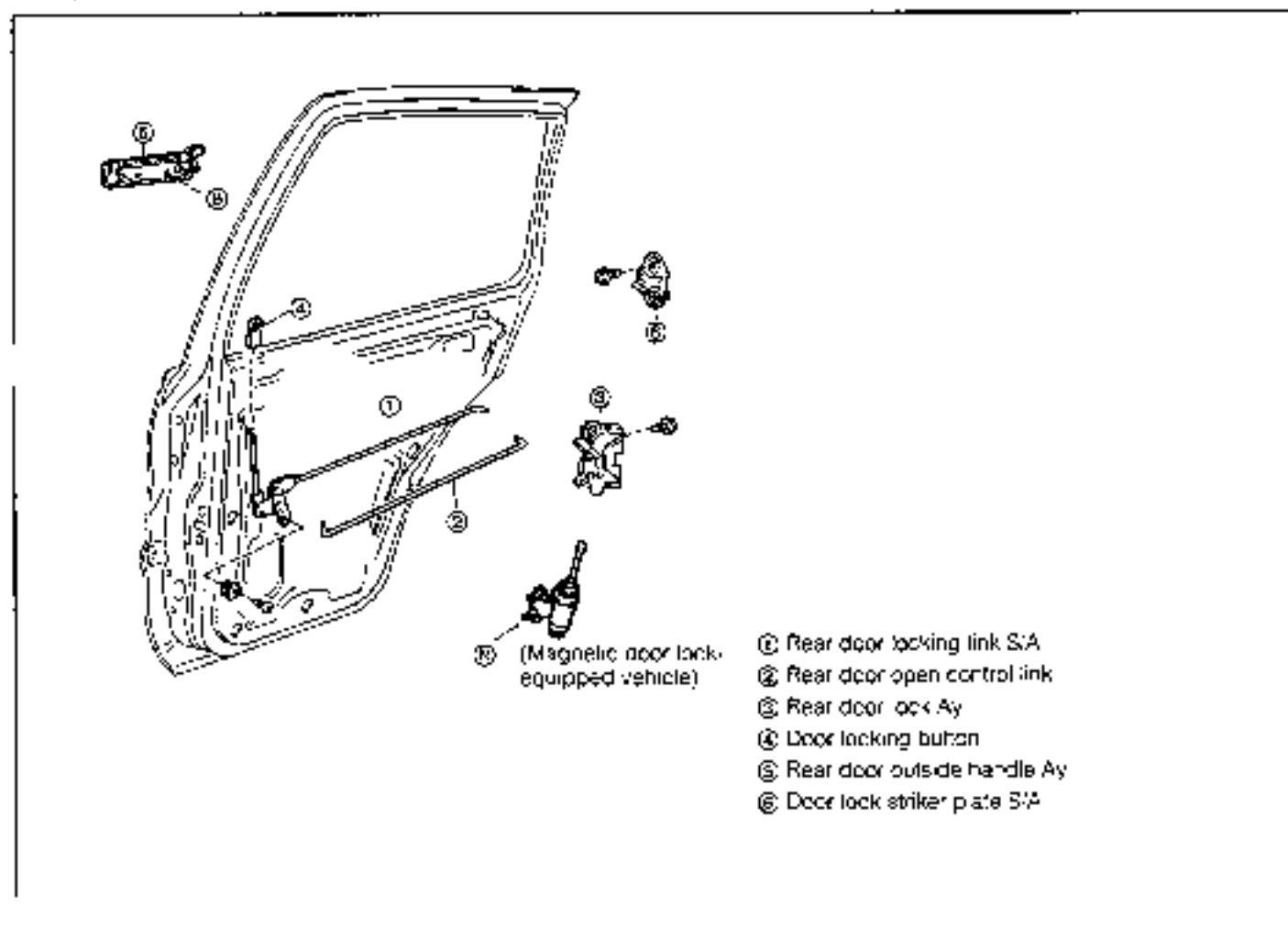

Fig. 9-151

WR-05152

BODY

REMOVAL

1. Remove the door trim-related parts. (See page 9-47.)
2. Remove the door control solenoid assembly by removing the two nuts and coupler.

3. Removal of rear door lock assembly

- (1) Remove the rear door locking button.
- (2) Remove the attaching screw of the rear door locking link subassembly.
- (3) Remove the three attaching screws of the rear door lock assembly.
- (4) Remove the rear door lock assembly (link-related parts) from the door.

4. Remove the following parts from the rear door lock assembly.

- (1) Remove the rear door locking link subassembly.
- (2) Remove the rear door opening control link.

5. Remove the rear door outside handle assembly.

INSTALLATION

1. Install the rear door outside handle assembly.
2. Install the following parts in the rear door lock assembly.
 - (1) Install the rear door opening control link.
 - (2) Install the rear door locking link subassembly.
3. Install the rear door lock assembly and rear door locking button in the rear door. (See Fig. 9-153.)
4. Install the rear control solenoid assembly. (See Fig. 9-157.)

The solenoid assembly should be installed at such a position that the lock button stroke may become at least 10 mm (0.37 inch).

5. Install the door trim-related parts. (See page 9-48.)

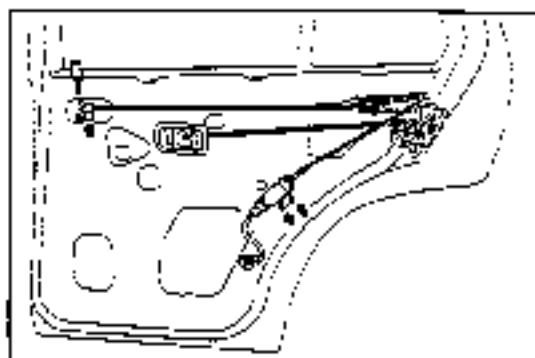

Fig. 9-152

WA-09145

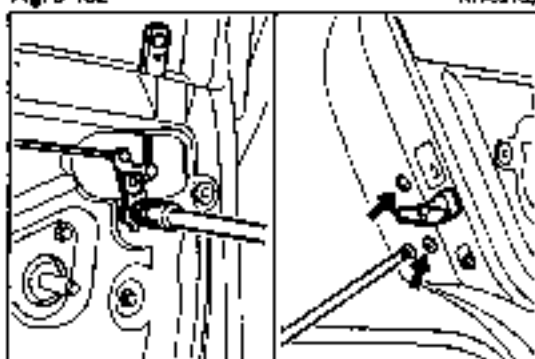

Fig. 9-153

WA-09146

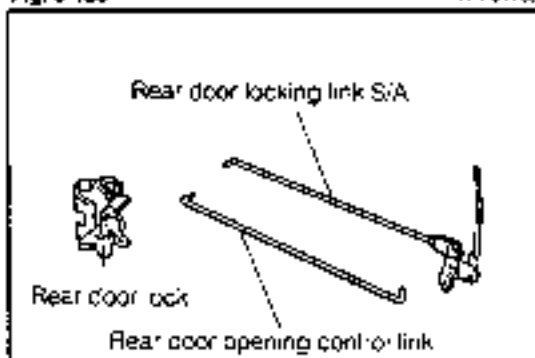

Fig. 9-154

WA-05167

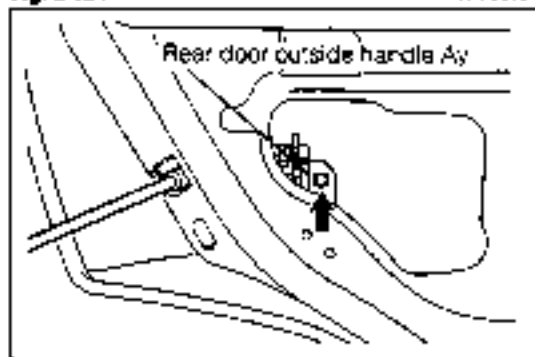

Fig. 9-155

WA-09168

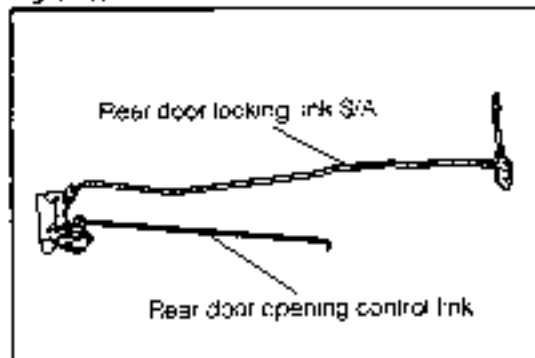

Fig. 9-156

WA-09169

DOOR GLASS AND REGULATOR COMPONENTS

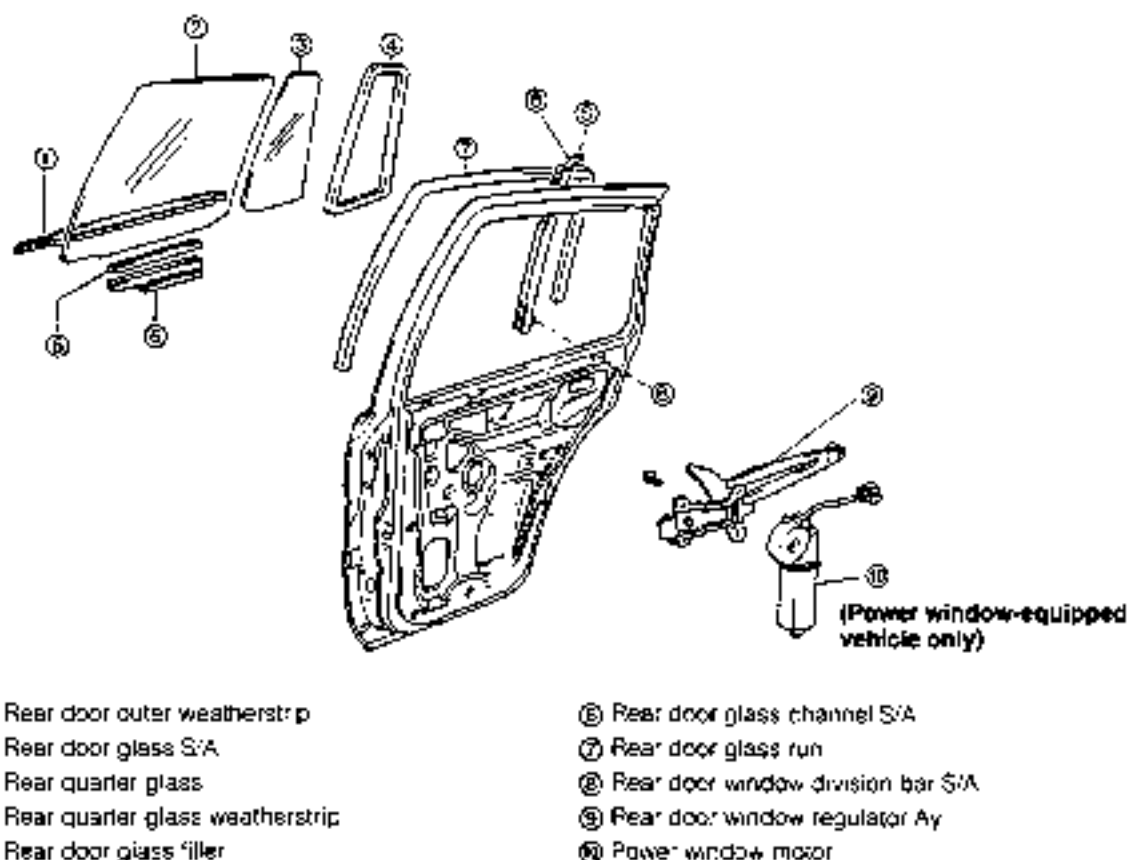

Fig. 9-157

WR-09170

REMOVAL

1. Remove the rear door trim board-related parts. (See page 9-47.)
2. Remove the rear door weatherstrip.
3. Removal of rear door window division bar subassembly
 - (1) Remove the upper attaching screw and lower bolt of the rear door window division bar subassembly.
 - (2) Remove the rear door window division bar subassembly from the rear door.
4. Remove the rear quarter glass and rear quarter glass weatherstrip.

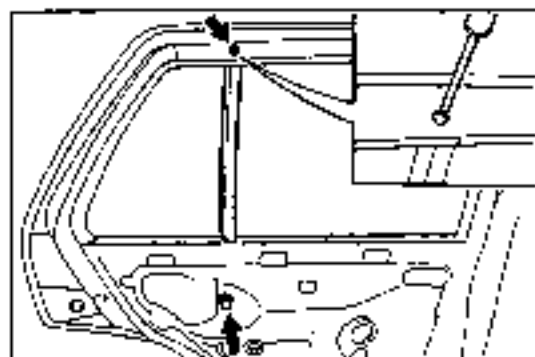

Fig. 9-158

WR-09171

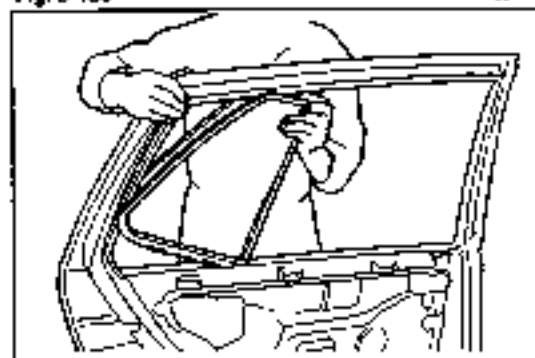

Fig. 9-159

WR-09172

BODY

5. Removal of rear door glass subassembly
 - (1) Slide the rear door glass subassembly backward. Detach the roller of the rear door window regulator assembly from the rear door glass channel.
 - (2) Remove the rear door glass subassembly from the rear door.
6. Removal of rear door window regulator assembly
 - (1) Remove the rear door window regulator assembly by removing the three bolts.
 - (2) Remove the power window motor from the rear door window regulator assembly. (Power window-equipped vehicle only)
7. Remove the rear door glass outer weatherstrip.

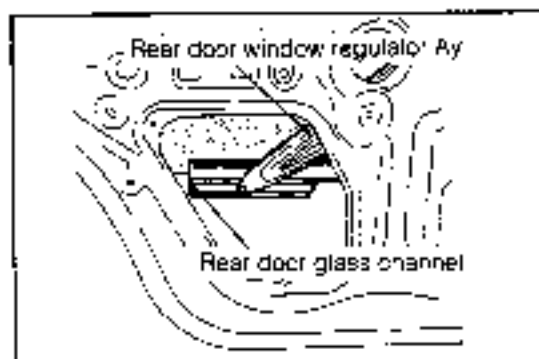

Fig. 9-160

WR-08173

6. Removal of rear door window regulator assembly
 - (1) Remove the rear door window regulator assembly by removing the three bolts.
 - (2) Remove the power window motor from the rear door window regulator assembly. (Power window-equipped vehicle only)
7. Remove the rear door glass outer weatherstrip.

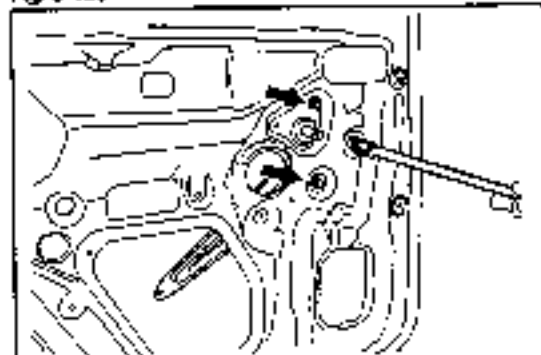

Fig. 9-161

WR-08174

INSTALLATION

1. Install the rear door glass outer weatherstrip.
2. Installation of rear door window regulator assembly
 - (1) Apply MP grease to the sliding sections.
 - (2) Install the power window motor in the rear door regulator assembly. (Power window-equipped vehicle only)
 - (3) Install the rear door window regulator assembly in the rear door. (See Fig. 9-161.)
3. Installation of rear door glass subassembly
 - (1) Apply soap water, etc. to the inner surface of the rear door glass filler. Install the glass filler in the glass channel.
 - (2) Install the rear door glass filler and channel in the rear door glass subassembly. (Install these parts by tapping them lightly with a wooden hammer or the like.)
4. Install the rear quarter glass and rear quarter glass weatherstrip.
5. Install the rear door window division bar subassembly.
6. Install the rear door glass weatherstrip.
7. Install the rear door trim board-related parts. (See Fig. 9-48.)

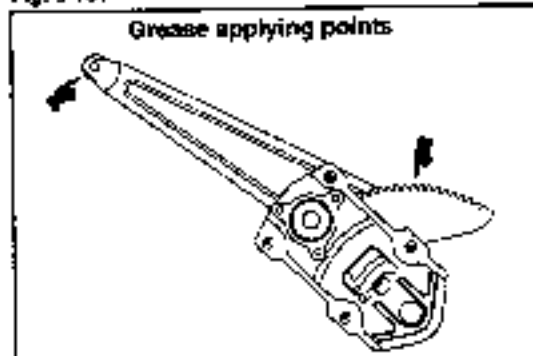

Fig. 9-162

WR-08175

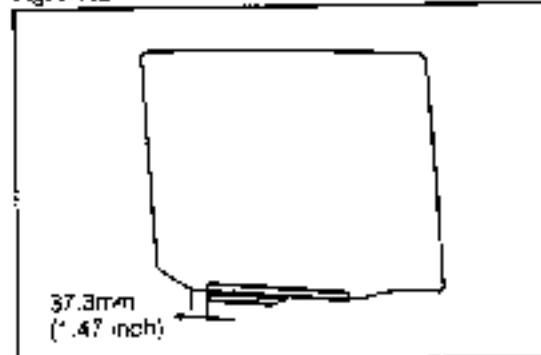

Fig. 9-163

WR-08176

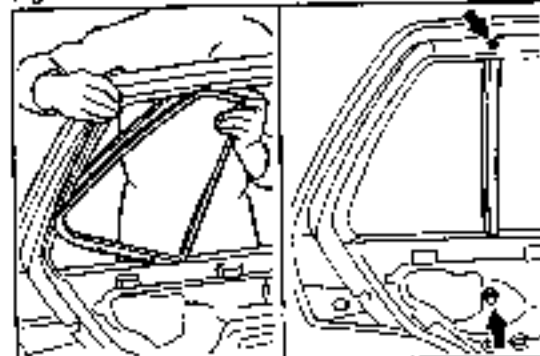

Fig. 9-164

WR-08177

BACK DOOR

ARTICLE TO BE PREPARED

Lubricants and others

Adhesive tape, operation rope, non-drying window sealer and MP grease

WR-CR17B

COMPONENTS

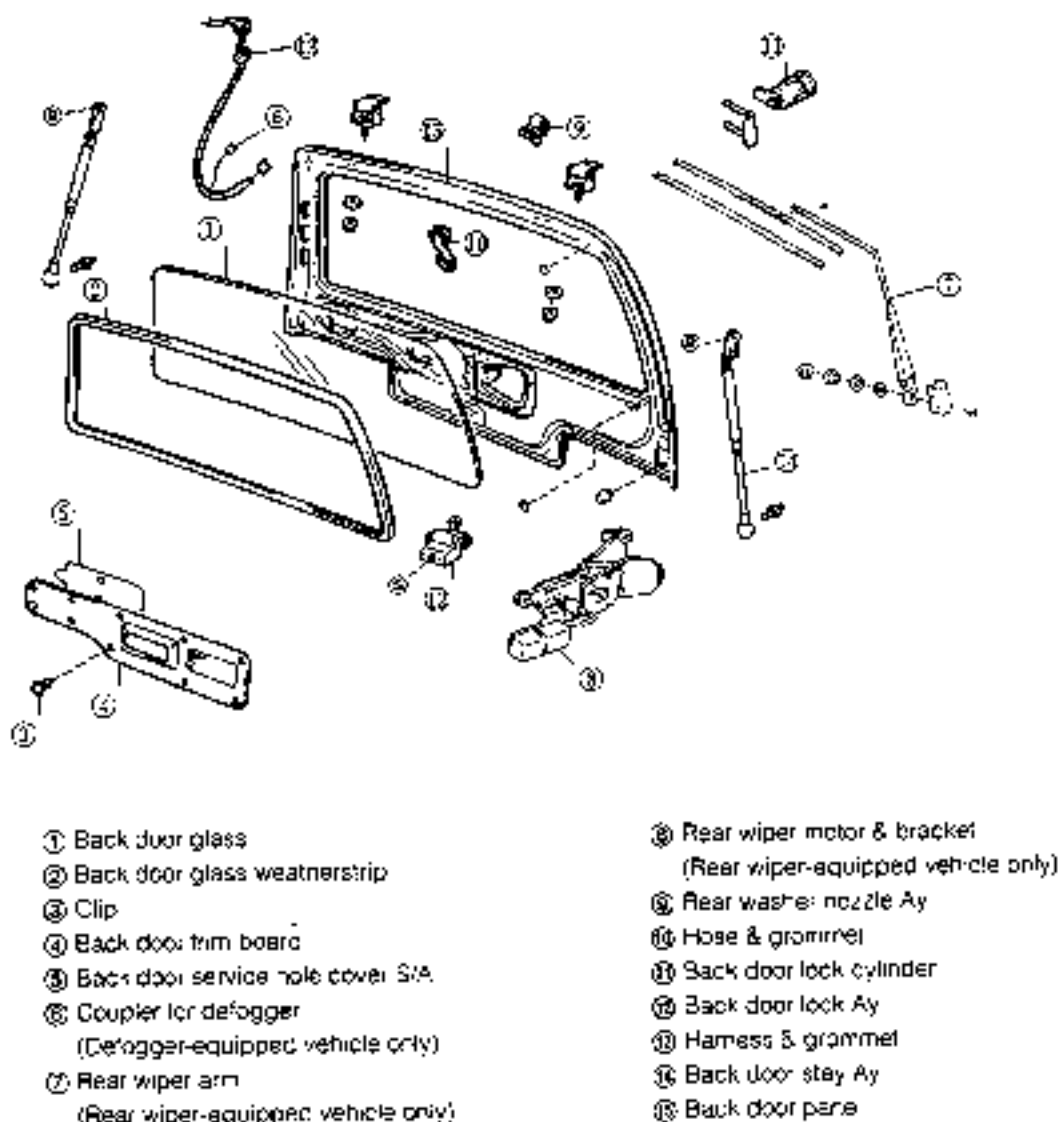

Fig. 9-165

4/9-09/79

REMOVAL

1. Remove the rear wiper arm attaching nut. Detach the rear wiper arm. (Rear wiper-equipped vehicle only)
2. Disconnect the couplers for defogger use at two points.
3. Remove the rear spoiler. (See page 9-36.)
4. Remove the back door glass and weatherstrip. (See page 9-29.)

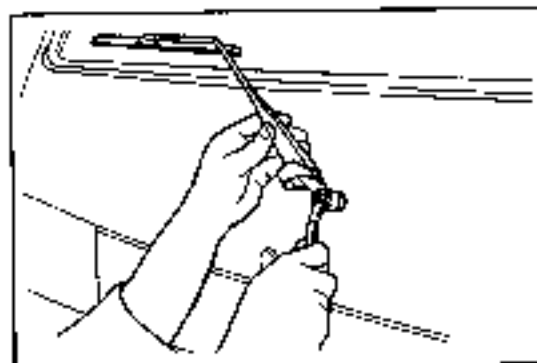

Fig. 9-166

AR-7813/

BODY

5. Removal of back door trim board

- (1) Detach the back door trim board by removing the 10 clips. To remove the clip, push its central part.

NOTE:

Be very careful not to push the central part of the clip too strongly. Application of excessive force may drop the clip.

- (2) Detach the back door service hole cover sub-assembly.

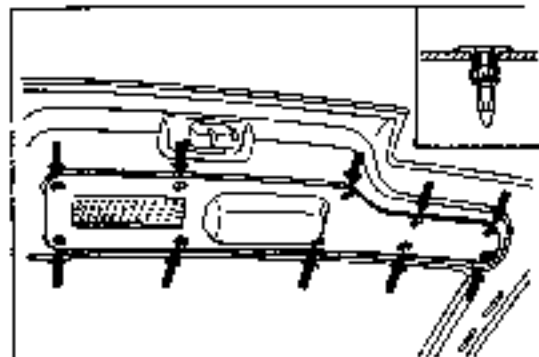

Fig. 9-167

WR-09181

6. Remove the rear wiper motor and bracket assembly as follows:

- (1) Working from the outside of the back door, remove the boot, nut, spacer and bush.
- (2) Working from the inside of the back door, disconnect the coupler, using a piece of wire.
- (3) Remove the rear wiper motor and bracket assembly by removing the three bolts.

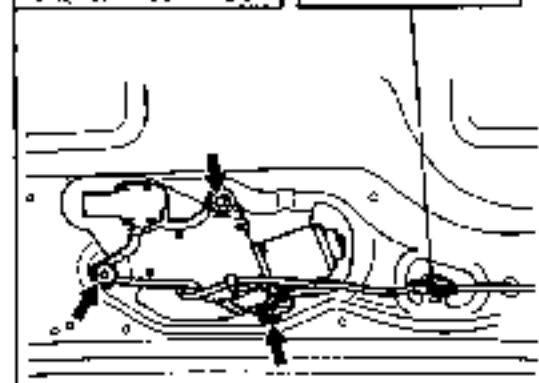
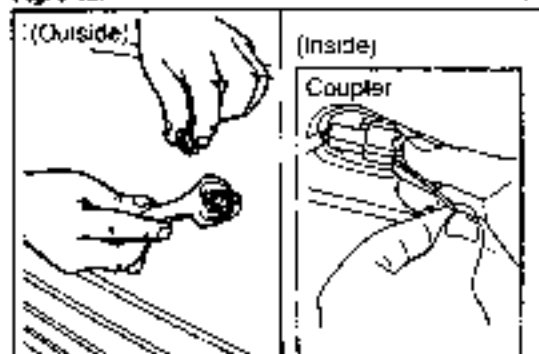

Fig. 9-168

WR-09182

7. Removal of rear washer nozzle assembly

- (1) Remove the rear washer nozzle assembly. Detach the hose from the nozzle assembly.
- (2) Remove the hose and grommet from the back door.

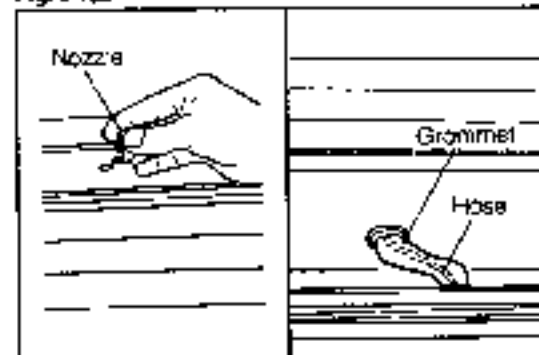

Fig. 9-169

WR-09183

8. Detach the clip and remove the back door lock cylinder.

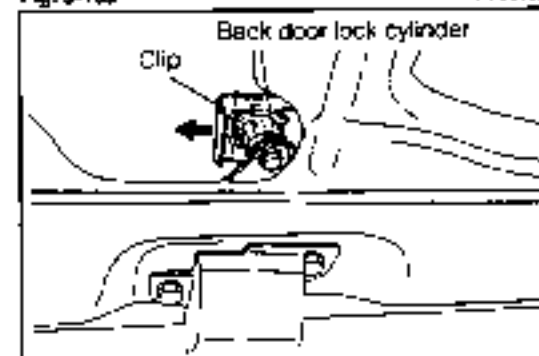

Fig. 9-170

WR-09184

3. Remove the harness and grommet from the back door

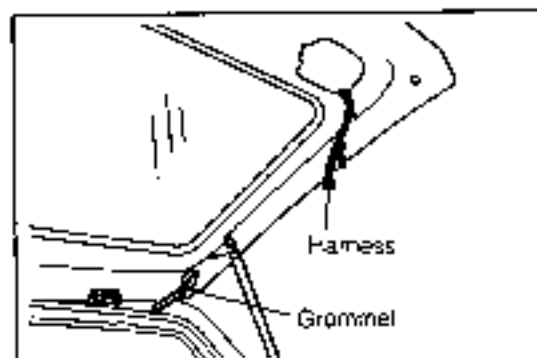

Fig. 9-171

WP-08125

- 10 Remove the back door lock assembly.

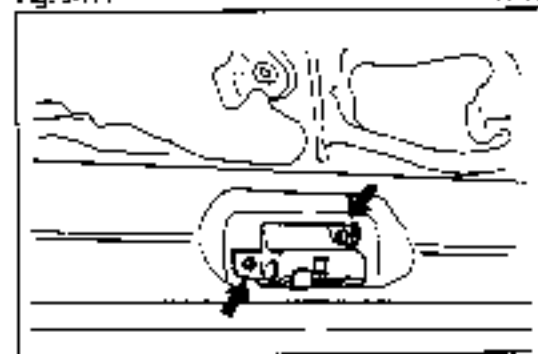

Fig. 9-172

WR-08186

- 11 Remove the back door stay assembly as follows:

- (1) Detach the attaching section at the body side.

NOTE:

Be sure to protect the body surface by means of adhesive tape or like, as indicated in the right figure.

- (2) Remove the back door stay assembly by removing the two attaching bolts at the back door side.

NOTE:

- Never attempt to disassemble the door stay assembly, for the cylinder is filled with high-pressure gas.
- After the damper stay has been replaced, be certain to discharge the high-pressure gas from it, by making a 2 to 3 mm dia. hole at the bottom of the cylinder of the removed damper stay.
(The discharging gas is colorless, odorless and non-poisonous. However, be very careful as to drilled metal chips being blown off.)
- Utmost caution must be exercised as to the handling of the damper stay. Never let scratch, paint or oil get to the exposed section of the piston rod.
- When the damper stay is in an extended state, be sure not to turn the piston rod or the cylinder.

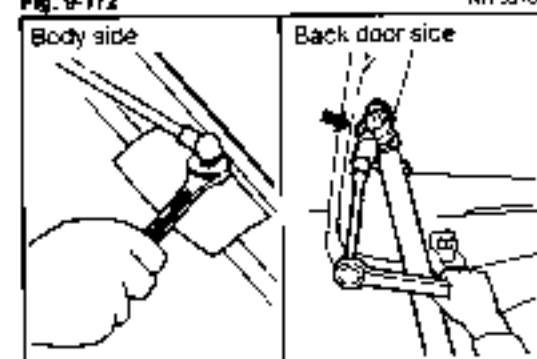

Fig. 9-173

WR-09107

12. Removal of back door panel

- (1) Detach the rear section of the roof headlining
 (2) Working from the vehicle interior, remove the back door panel from the vehicle by removing the two attaching nuts (a) of the back door panel

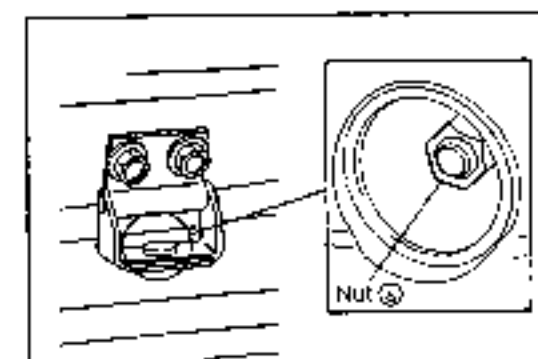

Fig. 9-174

WP-09188

BODY

INSTALLATION

1. Install the back door panel on the body.
2. Install the back door stay.
3. Install the back door lock assembly.
4. Install the harness and grommet.

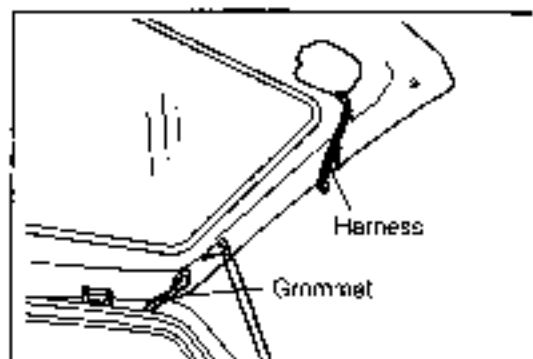

Fig. 9-175

WR-09169

5. Place the back door lock cylinder on the back door. Secure the lock cylinder with the clip.
6. Installation of rear washer nozzle
 - (1) Attach the washer hose to the rear washer nozzle. Attach the rear washer nozzle to the back door.
 - (2) Install the grommet.

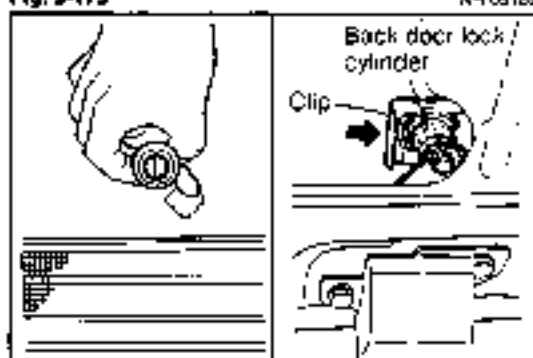

Fig. 9-176

WR-09190

7. Install the rear wiper motor and bracket assembly as follows:
 - (1) Install the rear wiper motor and bracket assembly, using the three bolts.
 - (2) Connect the coupler.
 - (3) Working from the outside, install the bush, spacer, nut and boot.

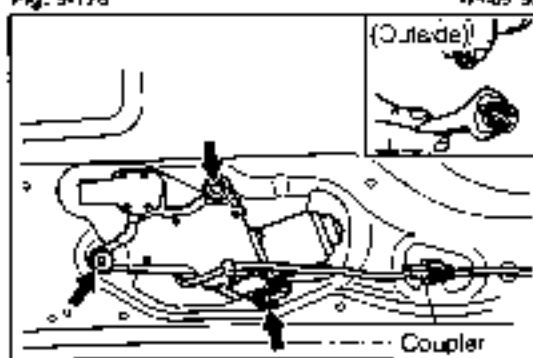

Fig. 9-177

WR-09191

8. Installation of back door trim board
 - (1) Affix butyl tape on the position specified in the right figure. Install the back door service hole cover sub-assembly.

NOTE:

Replace the service hole cover if it exhibits rupture.

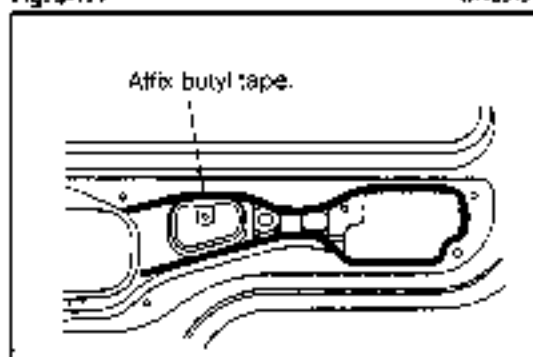

Fig. 9-178

WR-09192

- (2) Attach the back door trim board using the 10 clips. With the central part of the clip pulled out, set the clip on the trim. Push the central part of the clip so that the clip may retain the trim.

9. Install the back door glass and weatherstrip. (See page 9-30.)
10. Install the rear spoiler. (See page 9-37.)

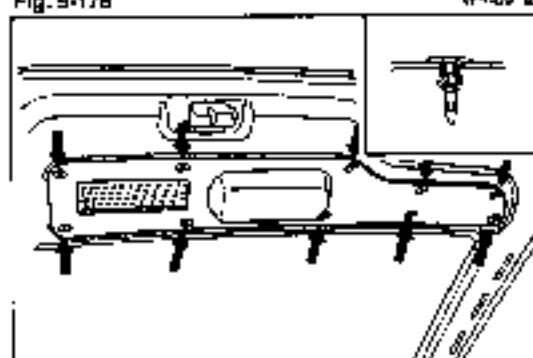

Fig. 9-179

WR-09193

- *1. Connect the coupler for defogger use at two points.
 - 12. Installation of rear wiper
 - (1) Install the battery terminals. Operate the wiper motor, until it assumes the automatic stopping position
 - (2) Attach the rear wiper arm so that it may align with the lowest line of the defogger pattern.
- Installation position:
 Lowest line of pattern ± 5 mm (± 0.2 inch)
- (3) Install the wiper link cap.

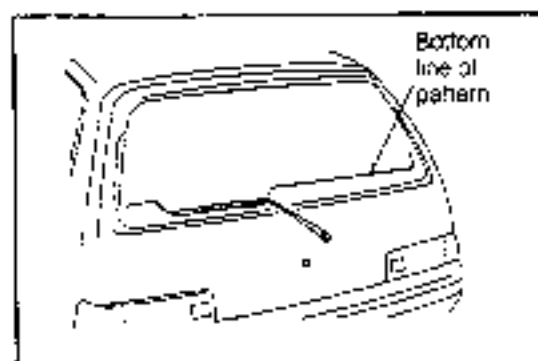
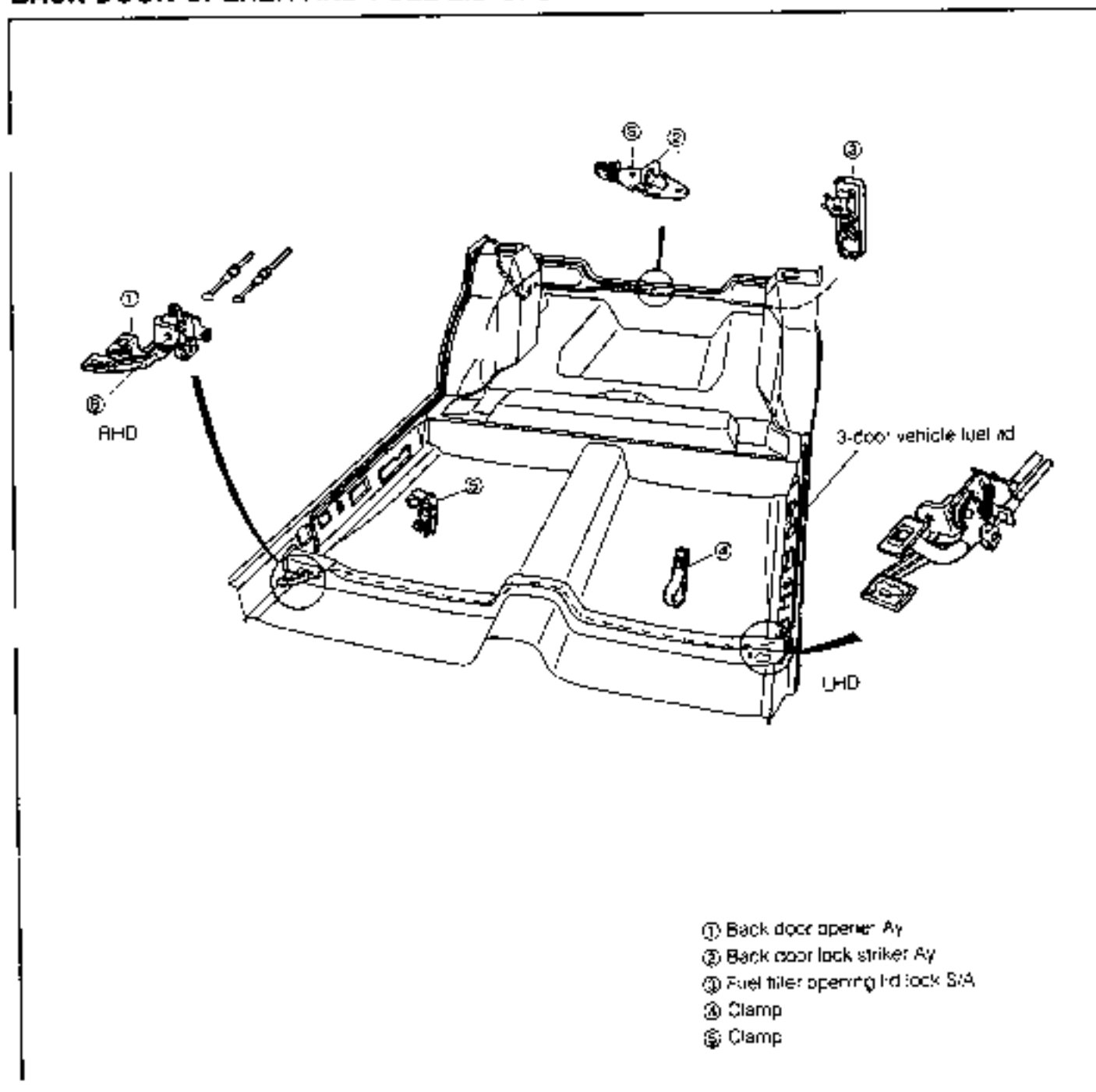

Fig. 9-180

WB-09192

BACK DOOR OPENER AND FUEL LID OPENER



- ① Back door opener: A₁
- ② Back door lock striker: A₁
- ③ Fuel filler opening lid lock: S/A
- ④ Clamp
- ⑤ Clamp

Fig. 9-181

WB-09195

BODY

REMOVAL

1. Remove the front seal.
2. Remove the rear seal.
3. Remove the trim-related parts.
(3-door model fuel lid opener)
Remove the front door scuff plate at the left side. Remove the quarter trim at the right side.
(3-door model back door opener)
Remove the front door scuff plate at the right side, the package tray side trim at the right side, the quarter trim at the right side, the deck side trim at the right side and lower deck trim.
(5-door model fuel lid opener)
Remove the front door scuff plate at the right side, the rear door scuff plate at the right side, the package tray side trim at the right and left sides, the quarter wheel house cover at the right side, the deck side trim at the right and left sides and the lower deck trim.
(5-door model back door opener)
Remove the front door scuff plate at the right side, the rear door scuff plate at the right side, the package tray side trim at the right side, the quarter wheel house cover at the right side, the deck side trim at the right side and the lower deck trim.

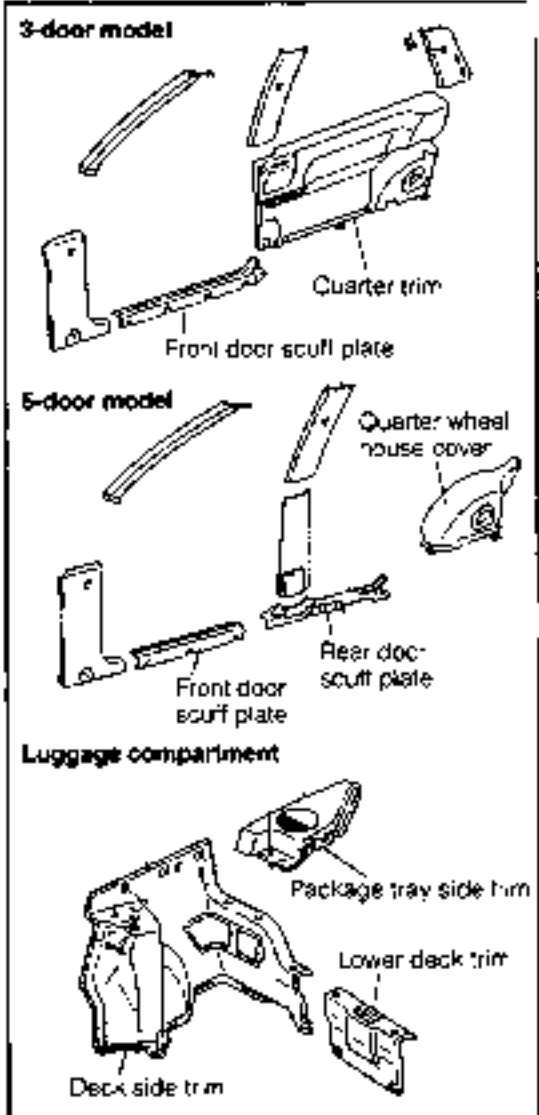

Fig. 9-182

4/9-09-96

4. Remove the back door opener assembly as follows:
(1) Remove the attaching bolt. Remove the back door opener assembly.
(2) Detach the spring. Remove the cable.

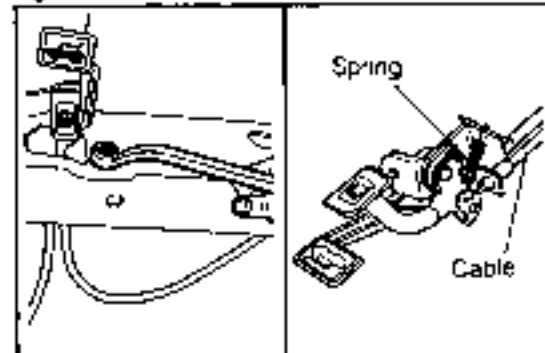

Fig. 9-183

4/9-09-97

5. Removal of fuel filter opening lid lock subassembly.
(1) Remove the fuel filler opening lid lock subassembly.
(2) Detach the fuel lid cable.

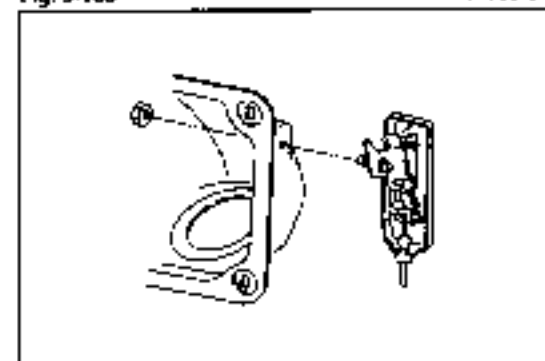

Fig. 9-184

4/9-09-98

Removal of back door lock striker assembly

- (1) Remove the back door lock striker assembly by removing the two bolts.
 - (2) Detach the back door cable
7. Remove the fuel lid cable and back door cable

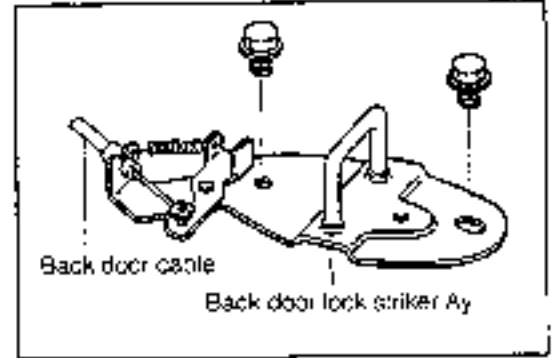

Fig. 9-185

WR-03193

INSTALLATION

1. Install the fuel lid cable and back door cable.

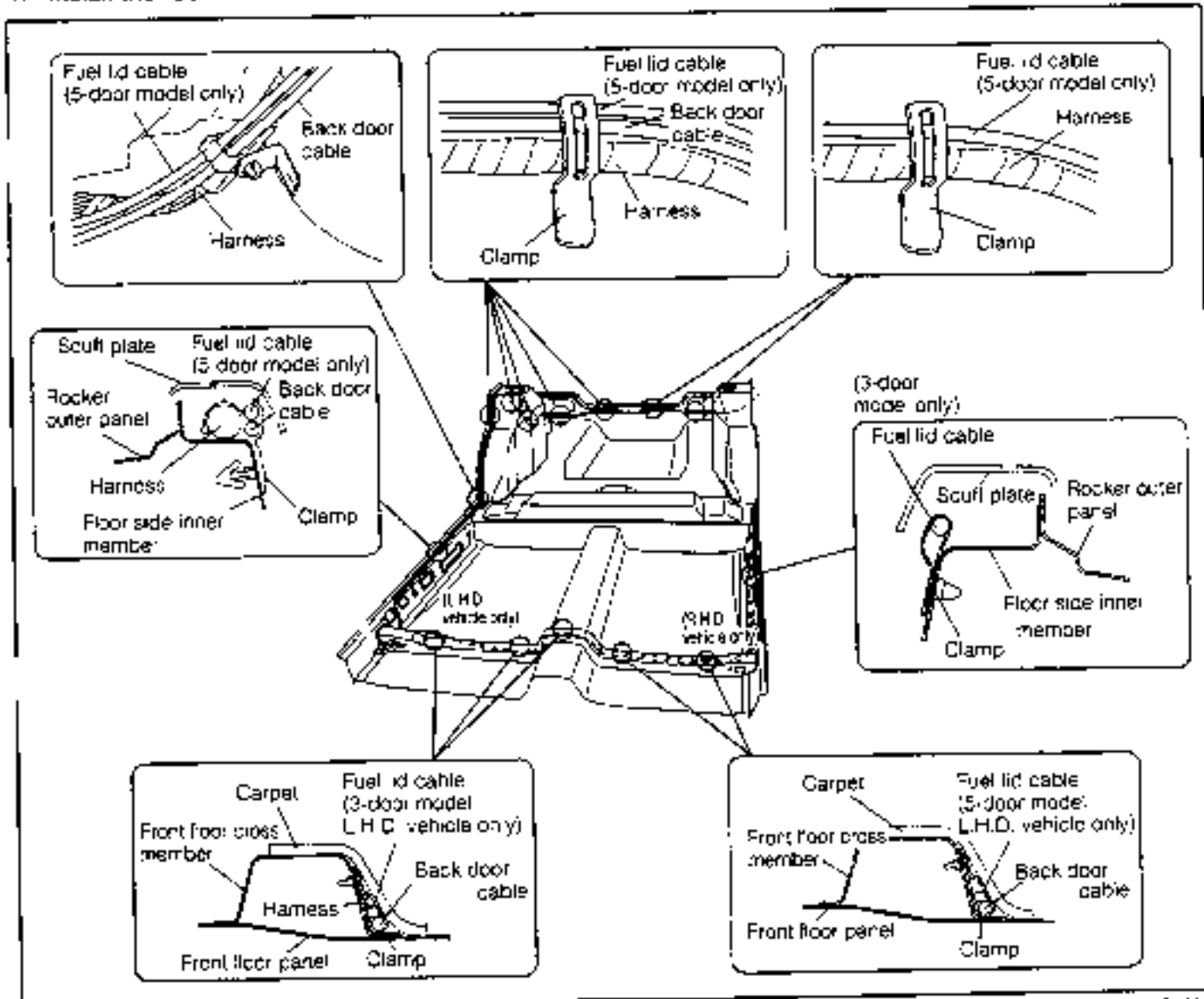

Fig. 9-186

WR-03220

2. Install the back door lock striker assembly.
3. Install the fuel filler opening lid lock subassembly. (Perform the operation check.)
4. Install the back door opener assembly. (Perform the operation check.)
5. Install the trim-related parts.
 - Install the rear seal.
 - Install the front seal.

WR-05201

BODY

POWER GLASS SUNROOF WITH TILT-UP MECHANISM

ARTICLES TO BE PREPARED

	Shape	Nomenclature and part number	Use
Tools		Screwdriver type clip clamping tool by Banzai, Ltd.	For use in removing door trim
Lubricants and others	MP grease and butyl tape		

WR-09202

COMPONENTS

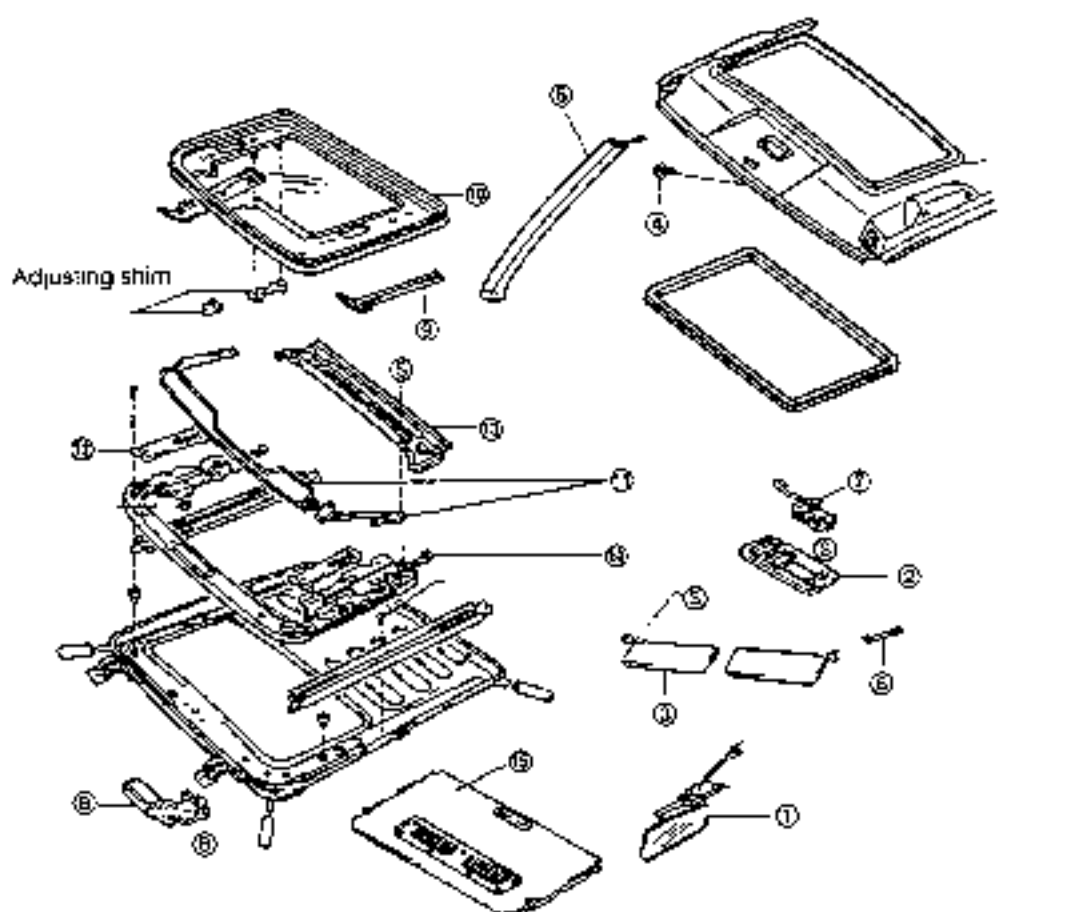

- | | |
|---|---|
| ① Inner rear-view mirror W/room lamp | ⑩ Slide roof garnish (sunroof) |
| ② Switch bezel | ⑪ Sliding roof glass S/A |
| ③ Sun visor | ⑫ Roof window deflector arm S/A & roof window deflector panel S/A |
| ④ Clip (at front side of roof headlining) | ⑬ Guide rail cover |
| ⑤ Front pillar garnish | ⑭ Roof drip rear channel |
| ⑥ Assist grip Ay (Detach the front section of the roof headlining.) | ⑮ Sliding roof drive cable S/A |
| ⑦ Sliding roof switch Ay | ⑯ Sun shade trim S/A |
| ⑧ Sliding roof drive gear Ay | |

Fig. 9-187

WR 09203

REMOVAL

1. Open the sunroof fully.
2. Affix adhesive tape at the front side as well as at the right & left sides of the sunroof aperture.

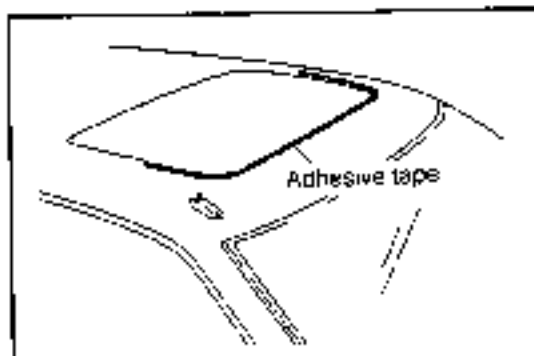

Fig. 9-188

WA-09204

3. Removal of front pillar garnish
 - (1) Disengage the fitting of the garnish by prying the clip section by means of a common screwdriver.
 - (2) Remove the front pillar garnish by pulling it upward

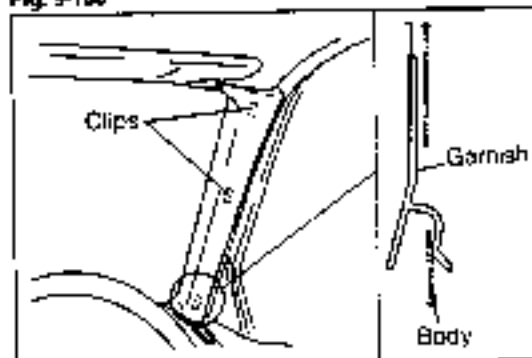

Fig. 9-189

WA-09205

4. Detach the front section of the roof headlining
 - (1) Prior to the operations given below, disconnect the negative \ominus terminal of the battery.
 - (2) Remove the sun visor assembly.
 - (3) Remove the inner rear-view mirror with room lamp.
 - (4) Remove the switch bezel.
 - (5) Detach the sunroof opening trim molding.

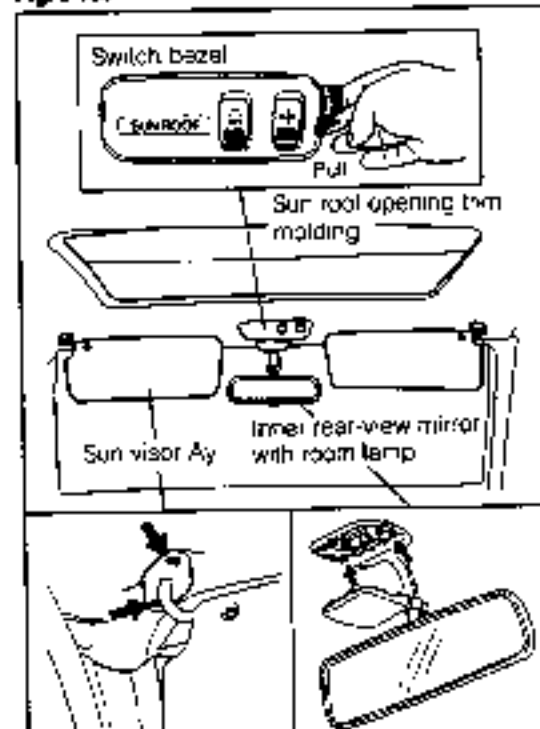

Fig. 9-190

WA-09206

- (6) Remove the assist grip assembly.
- (7) Remove the clip, using the clip removing tool.

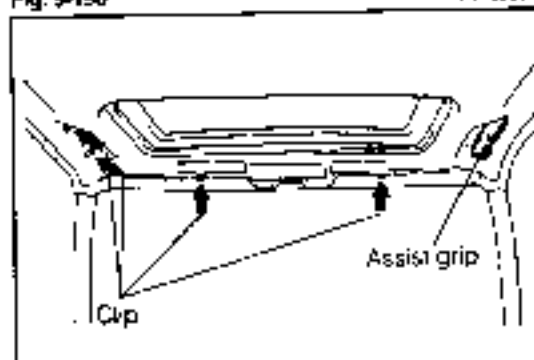
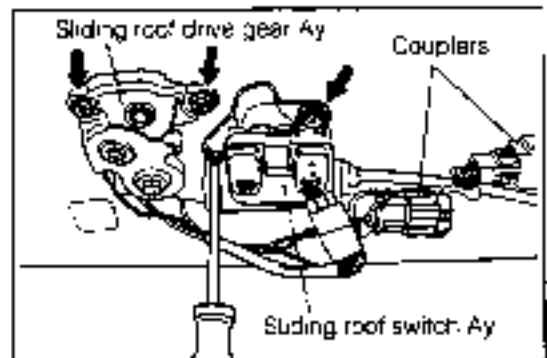

Fig. 9-191

WA-09207

BODY

5. Remove the sliding roof switch assembly by removing the two screws and coupler.
6. Remove the sliding roof drive gear assembly by removing the two bolts and coupler.



7. Detach the sliding roof glass subassembly from the vehicle by removing the eight attaching nuts of the sliding roof glass subassembly.

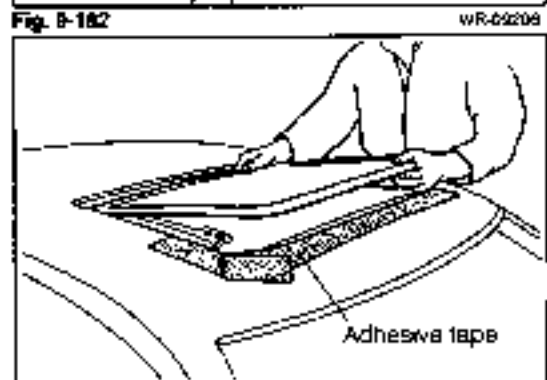

8. Remove the roof window deflector arm subassembly and the roof window deflector panel subassembly by removing the four screws.

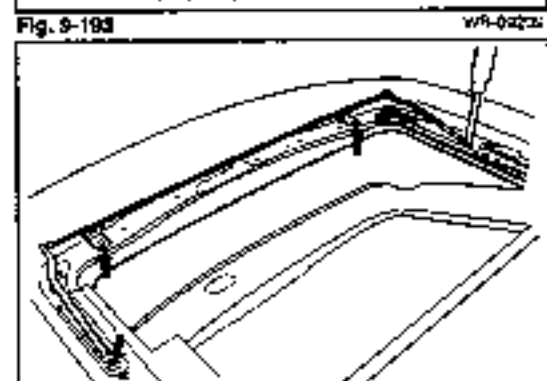

9. Detach the guide rail cover by removing the screws, one each at the right and left sides.

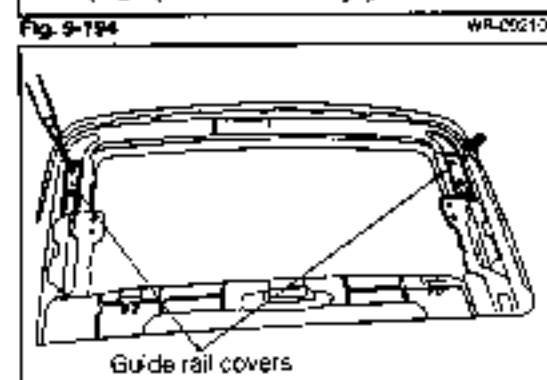

10. Remove the roof drip rear channel by removing the two screws.

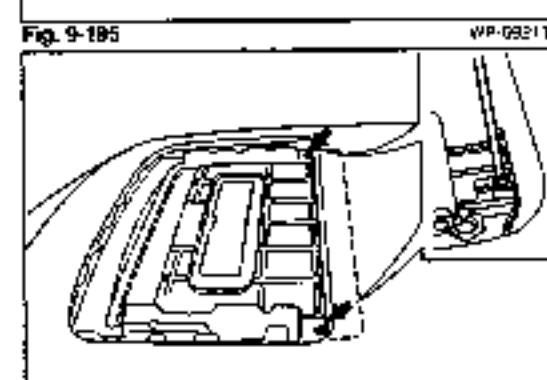

11. Remove the sliding roof drive cable subassembly from the vehicle by removing the three screws.

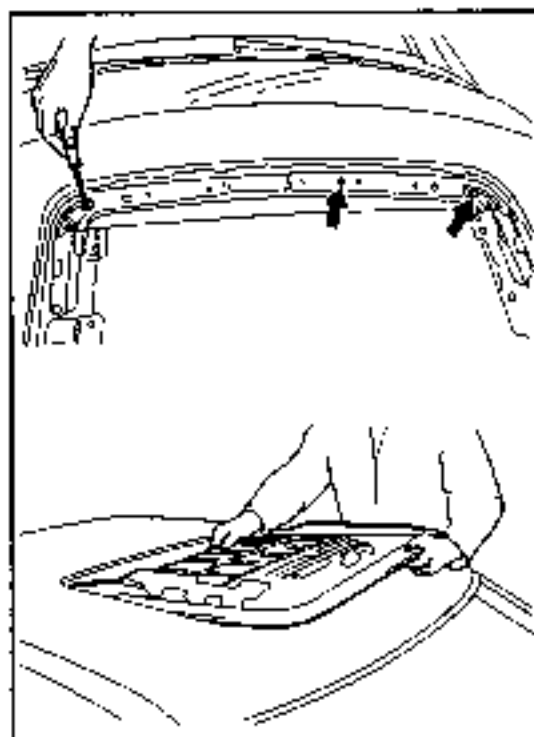

Fig. 9-197

WR-09213

12. Remove the sun shade trim subassembly from the back side of the sliding roof drive cable subassembly.

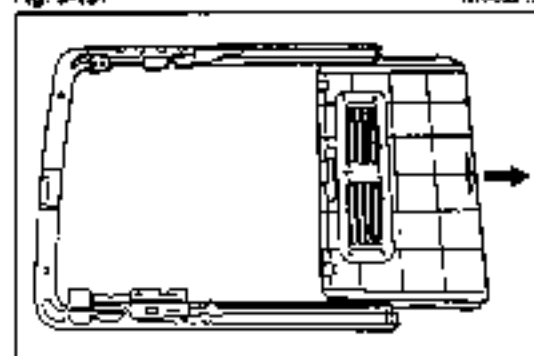

Fig. 9-198

WR-09214

INSTALLATION

1. Install the sun shade trim from the back side of the sliding roof drive cable subassembly.

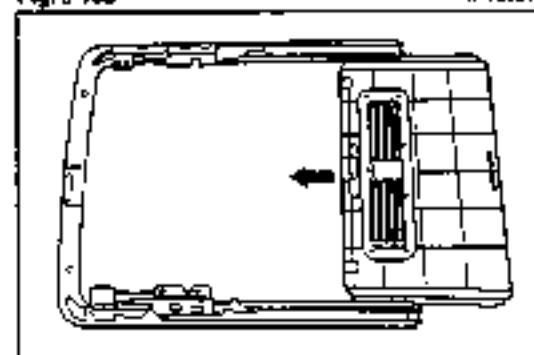

Fig. 9-199

WR-09215

2. Installation of sliding roof drive cable subassembly
 - (1) Align the link position with each other by inserting a pin or the like into the reference hole. Set the roof in a fully-closed state.
 - (2) Place the drive cable subassembly into position from the front side of the roof while holding the both sides of the rail by hands.

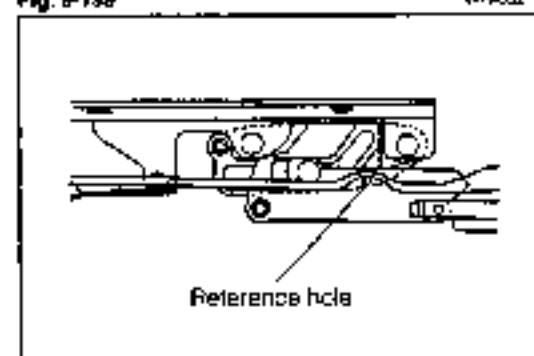

Fig. 9-200

WR-09216

BODY

- (3) Secure the sliding roof cable subassembly on the vehicle with the three screws.

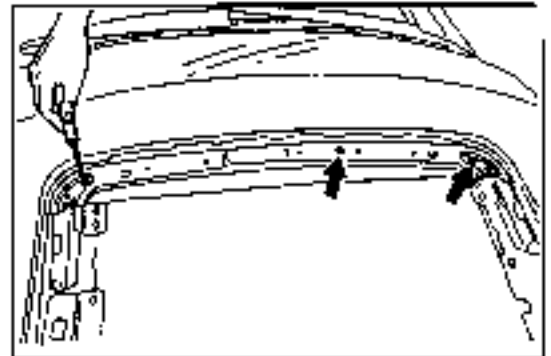

Fig. 9-201

WR-09217

3. Installation of roof drip rear channel

- (1) Align the channel with the claw section of the rail at the right and left sides.
- (2) Install the roof drip rear channel with the two screws.

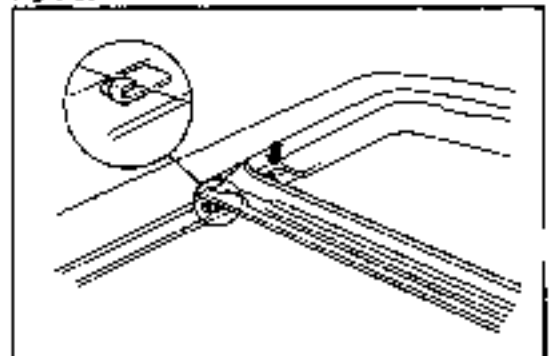

Fig. 9-202

WR-09218

4. Attach the guide rail cover.

5. Install the roof window deflector arm subassembly and the roof window deflector panel subassembly with the four screws

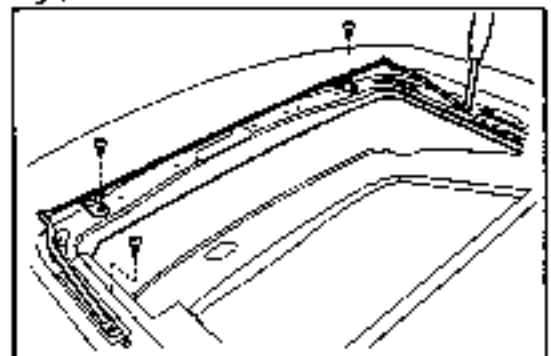

Fig. 9-203

WR-09219

6. Install the sliding roof glass subassembly with the eight nuts.

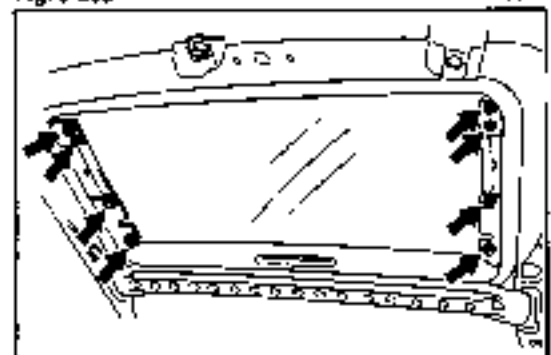

Fig. 9-204

WR-09220

7. Installation of sliding roof drive gear assembly

- (1) Remove the cover by removing the screws.
- (2) Turn the cam manually, until the punched marks on the housing and gear are aligned with each other so that the cam may be set to the fully-closed position
- (3) Attach the cover.
- (4) Install the sliding roof drive gear assembly with the two bolts. Connect the coupler.

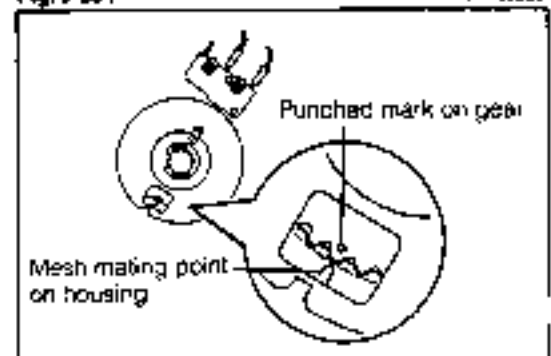

Fig. 9-205

WR-09221

Installation of sliding roof switch assembly

- (1) Install the sliding roof switch with the two screws. Connect the coupler
- (2) Connect the negative \ominus terminal of the battery.
- (3) Check the sunroof for proper operation. Perform the alignment adjustment

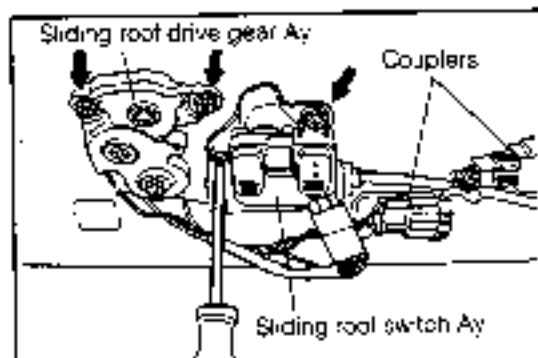

Fig. 9-206

WR-09223

9. Install the front section of the roof headlining

- (1) Install the clip and assist grip assembly.

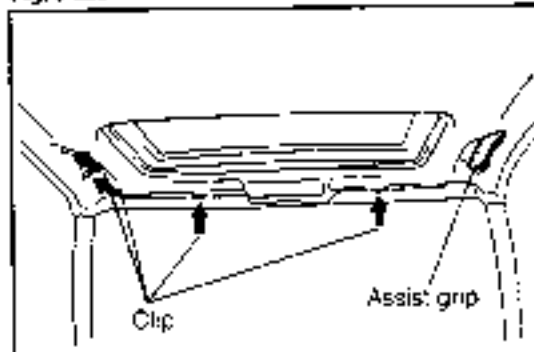

Fig. 9-207

WR-09223

- (2) Install the sun visor.
- (3) Install the inner rear-view mirror with room lamp.
- (4) Install the switch bezel.
- (5) Attach the sunroof opening trim molding.

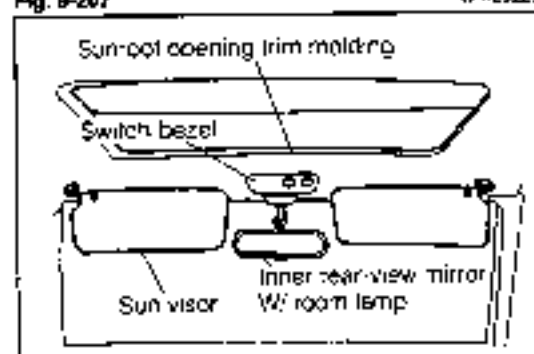

Fig. 9-208

WR-09224

10. Installation of front pillar garnish

- (1) Attach the hanger provided at the lower part of the front pillar garnish to the body.
- (2) Align the positions of the two clips. Attach the garnish by tapping the garnish lightly by hands.

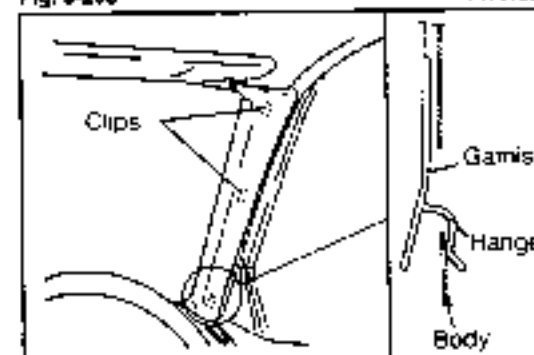

Fig. 9-209

WR-09225

BODY

ROOF DRIP MOLDING

ARTICLES TO BE PREPARED

	Nomenclature	Use
Lubricants and others	Sealant gun	For use in applying adhesive agent
	Alcohol	For use in clearing installation surface of roof drip molding
	Cutter knife or the like	For use in separating roof drip molding
	* Beta seal 552 (adhesive agent) (Cartridge capacity 333 ml)	Adhesive agent for roof drip molding

* Handling of Beta seal 552

1. Be sure to store this sealant in a cold, dark place. Avoid moisture, (for it will harden quickly.)
2. Once it is opened (after the nozzle is cut off), it will harden in two or three days. It is therefore, necessary to open it immediately prior to use.

INSTALLATION POSITION

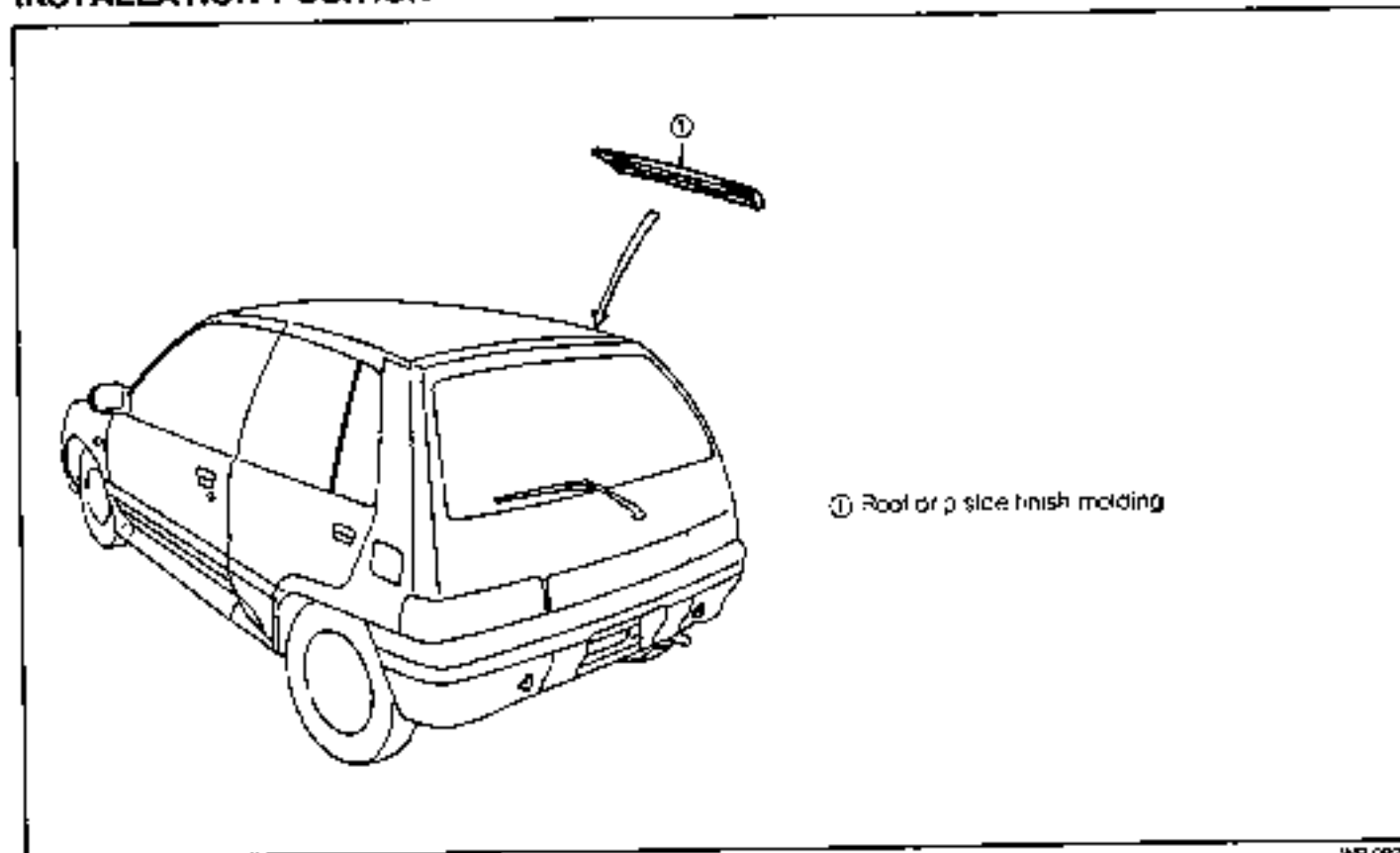

Fig. 9-210

WR 09227

REMOVAL

1. Detach the roof drip side finish molding by inserting a common screwdriver into the rear end of the molding.

NOTE:

When the molding is pried with a screwdriver, be very careful not to scratch the body.

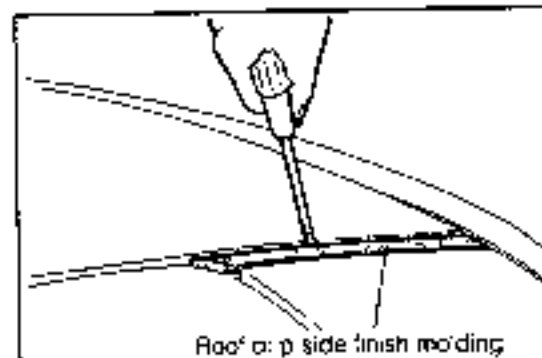

Fig. 9-211

WR 09228

INSTALLATION

1. Install the roof drip side finish molding
 - (1) When a new finish molding is used, paint the molding to the same color as the vehicle body.
 - (2) Clean the body attaching surface using alcohol or white gasoline
 - (3) Set the molding and clips in position. Peel off the lining paper.
 - (4) Heat the body attaching surface to 40 to 60°C
 - (5) Apply the adhesive agent to the points indicated in the right figure. Install the finish molding by aligning it with the body

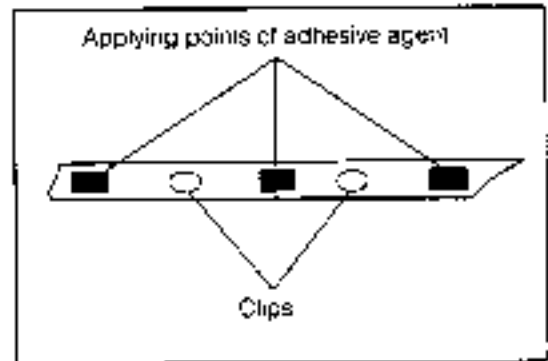
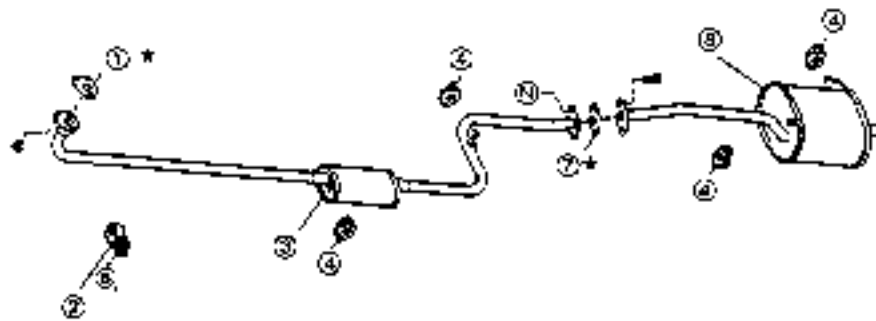

Fig. 9-212

W4-09229

EXHAUST PIPE COMPONENTS

Gasoline-fueled vehicle



Diesel-powered vehicle

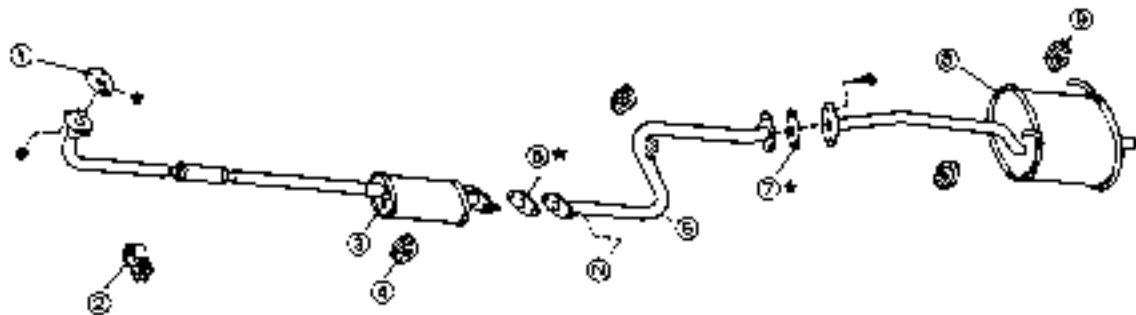

* : Non-reusable parts

- ① Gasket
- ② Clamp
- ③ Exhaust front pipe
- ④ Exhaust pipe support

- ⑤ Gasket
- ⑥ Exhaust center pipe
- ⑦ Gasket
- ⑧ Exhaust tail pipe

Fig. 9-213

WP-C9233

BODY

FRONT PIPE

REMOVAL

1. Jack up the vehicle and support it with safety stands.
2. Separate the front pipe from the exhaust manifold by removing the three nuts.
3. Separate the bracket support No. 1 by removing one bolt.

4. Separate the tail pipe or the center pipe from the front pipe by removing the two nuts.
5. Separate the exhaust pipe support.
CB-23, CB-61 and CB-80 engines: Two points
CL-11 and CL-16 engines: One point

INSTALLATION

1. With a new gasket interposed, connect the tail pipe or the center pipe to the front pipe by tightening the two nuts temporarily.
2. With a new gasket interposed, connect the front pipe to the exhaust manifold by tightening the two nuts temporarily.
3. Install the exhaust pipe support.
CB-23, CB-61 and CB-80 engines: Two points
CL-11 and CL-16 engines: One point

NOTE:

Replace any exhaust pipe support which exhibits damage.

4. Tighten the nuts attaching the tail pipe or the center pipe to the front pipe.
Tightening Torque: 4.0 - 6.0 kg-m (29 - 43 ft-lb)
5. Tighten the nuts attaching the front pipe to the exhaust manifold.
Tightening Torque: 4.0 - 6.0 kg-m (29 - 43 ft-lb)
6. Install the bracket support No.1.
Tightening Torque: 3.5 - 5.0 kg-m (25 - 36 ft-lb)
7. Remove the safety stands and jack down the vehicle.

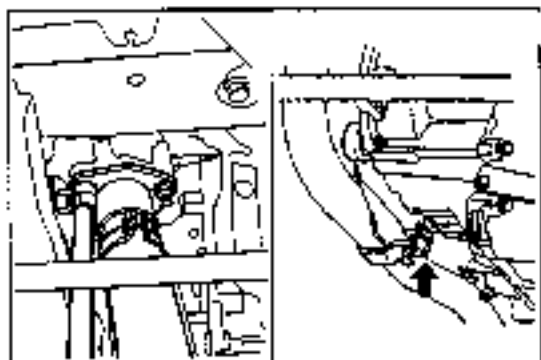

Fig. 9-214

WR-06231

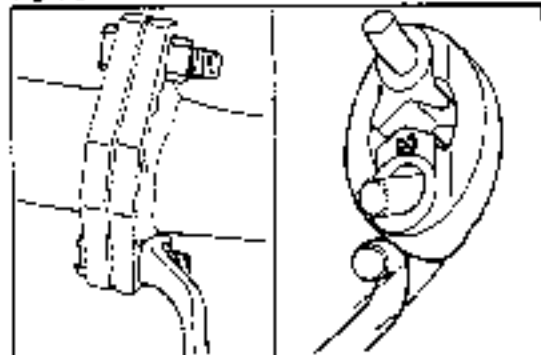

Fig. 9-215

WR-09232

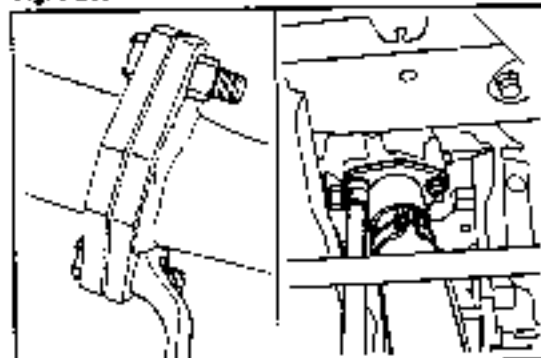

Fig. 9-216

WR-09232

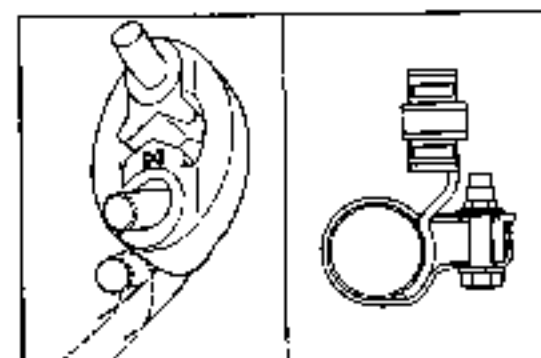

Fig. 9-217

WR-09234

ENTER PIPE (CL-11 and CL-61 Engines)**REMOVAL**

1. Jack up the vehicle and support it with safety stands.
2. Separate the front pipe and tail pipe from the center pipe.
3. Remove the exhaust pipe support and take out the center pipe.

INSTALLATION

1. With new gaskets interposed, connect the front pipe and tail pipe to the center pipe by tightening the nuts temporarily.
2. Install the exhaust pipe support.
3. Tighten the center pipe attaching nuts.

Tightening Torque: 4.0 - 6.0 kg-m (39.8 - 43.4 ft-lb)

4. Remove the safety stands and jack down the vehicle.

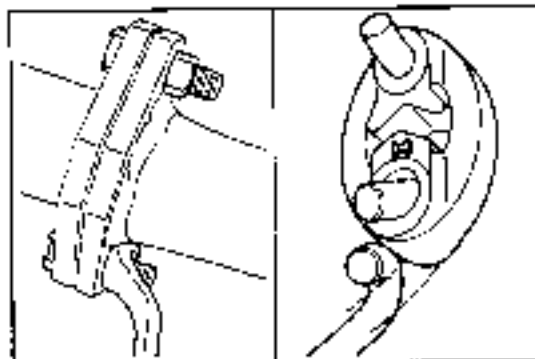

Fig. 9-218

WR-09235

TAIL PIPE**REMOVAL**

1. Jack up the vehicle and support it with safety stands.
2. Separate the tail pipe from the front pipe or the center pipe.
3. Remove the two exhaust pipe supports.

INSTALLATION

1. With a new gasket interposed, connect the tail pipe to the front pipe or the center pipe by tightening the nuts temporarily.
2. Install the two exhaust pipe supports.
3. Tighten the tail pipe attaching nuts.

Tightening Torque: 4.0 - 6.0 kg-m (29 - 43 ft-lb)

4. Remove the safety stands and jack down the vehicle.

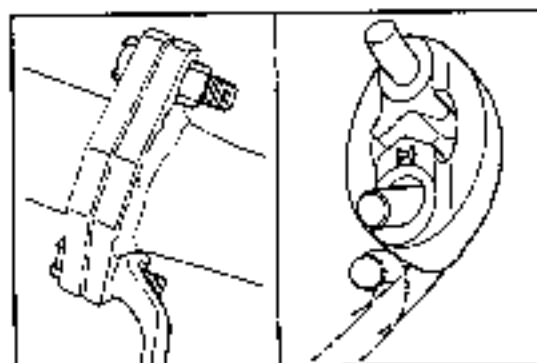
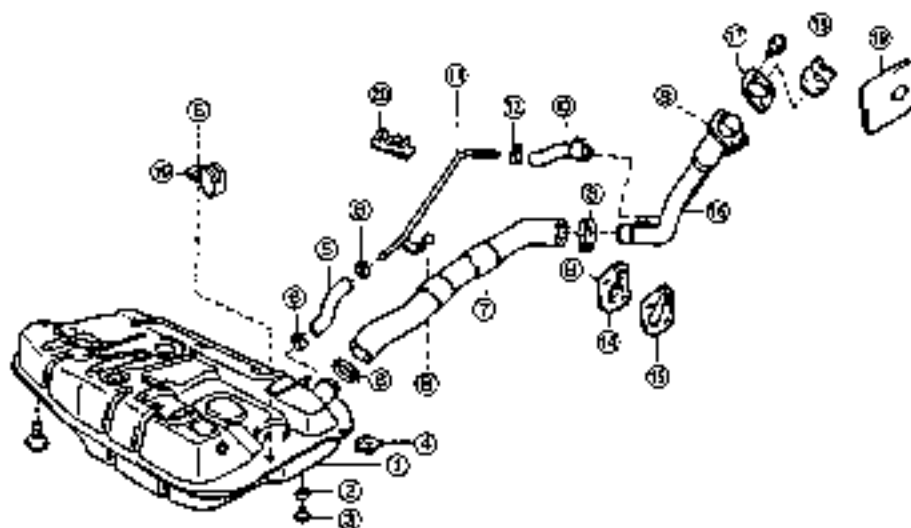

Fig. 9-219

WR-09235

FUEL TANK
COMPONENTS

3-door model



5-door model

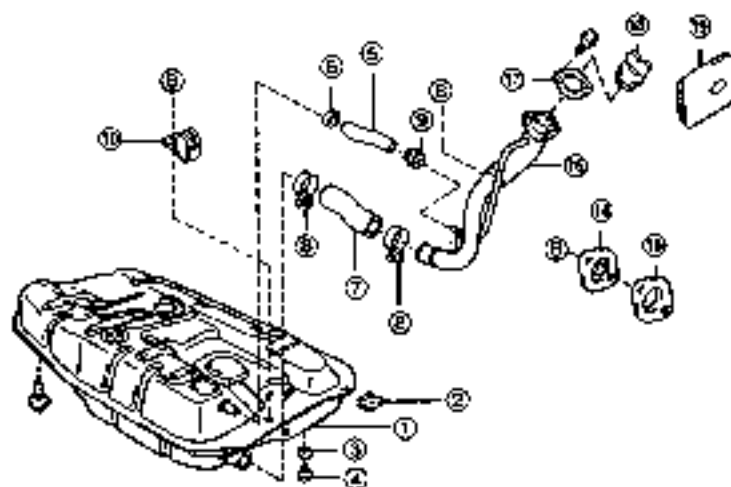

- | | |
|----------------------------------|------------------------------------|
| ① Fuel tank Ay | ⑪ Breather tube |
| ② Fuel tank flange reinforcement | ⑫ Clip |
| ③ Gasket | ⑬ Fuel hose No.4 |
| ④ Drain plug | ⑭ Fuel inlet pipe seal lower plate |
| ⑤ Fuel hose No.5 | ⑮ Fuel inlet pipe lower plate |
| ⑥ Clip | ⑯ Fuel inlet pipe S/A |
| ⑦ Fuel tank sub inlet hose | ⑰ Fuel tank inlet pipe shield |
| ⑧ Clamp | ⑱ Fuel tank cap Ay |
| ⑨ Grommet | ⑳ Fuel filter opening lid S/A |
| ⑩ Clamp | ㉑ Clamp |

Fig. 9-220

4/9-05237

FUEL INLET PIPE

3-Door Model

1. Drain the fuel from the fuel tank by removing the drain plug. After the fuel has been drained, install the drain plug.
2. Remove the rear seatback and seat cushion (fixed type only) (See page 9-101.)
3. Remove the quarter trim panel assembly at the left side

WP-0923X

4. Remove the two attaching screws of the fuel inlet pipe.

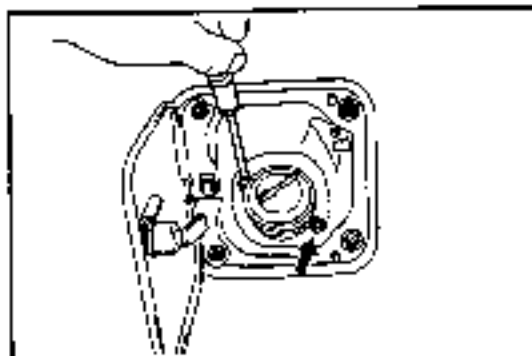

Fig. 9-221

WP-0923Z

5. Detach the clamp and separate the fuel tank subinlet hose.
6. Remove the fuel inlet pipe seal lower plate and the fuel inlet pipe lower seal by removing the two bolts.
7. Detach the clip and remove the breather hose.

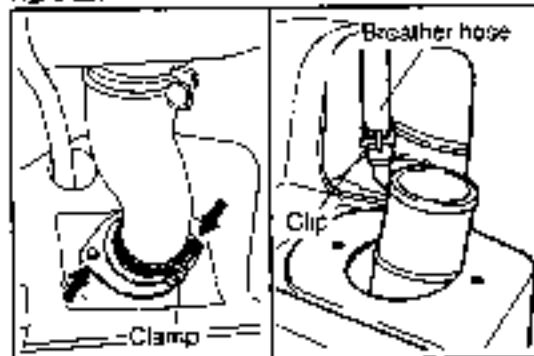

Fig. 9-222

WP-0923A

8. Working from the vehicle interior, remove the fuel inlet pipe attaching bolt. Detach the fuel inlet pipe sub-assembly
9. Detach the boot.

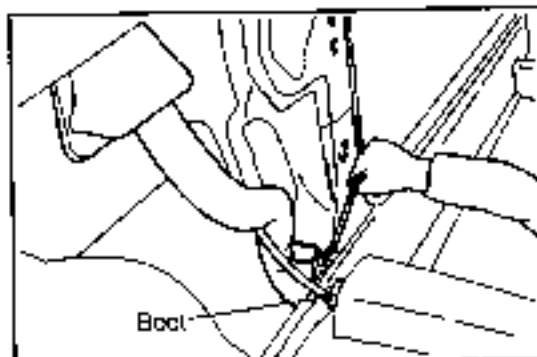

Fig. 9-223

WP-0924

INSTALLATION

1. Attach the boot. Set the fuel inlet pipe in the vehicle.
2. Install the fuel inlet pipe attaching bolt at the vehicle interior, using the four bolts.
3. Working from the outside, install the fuel inlet pipe, using the two attaching screws.

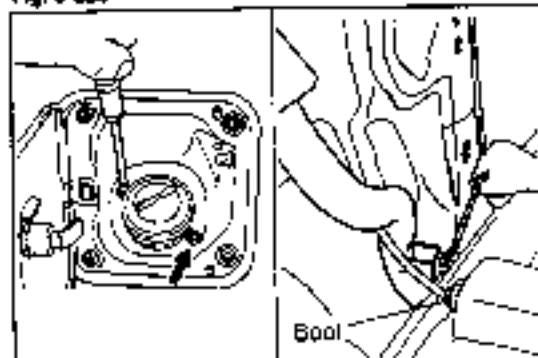

Fig. 9-224

WP-0924Z

BODY

4. Attach the breather hose to the fuel inlet pipe. Secure it with the clip.
5. Install the fuel inlet pipe seal lower plate and the fuel inlet pipe lower seal using the two bolts.
6. Attach the fuel tank subinlet hose to the fuel inlet pipe. Secure it with the clamp.
7. Install the quarter trim panel assembly.
8. Install the rear seatback and seat cushion.

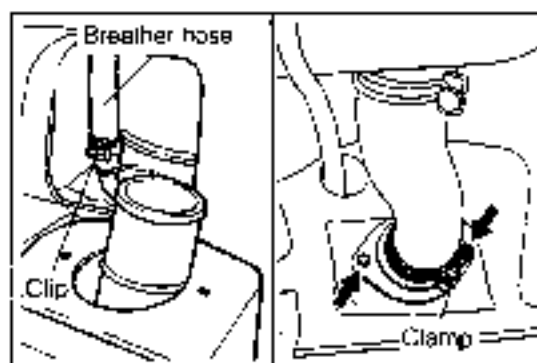

Fig. 9-225

WR-09243

5-Door Model

1. Drain the fuel from the fuel tank by removing the drain plug. After the fuel has been drained, install the drain plug.
2. Remove the rear seatback and seat cushion (fixed type only) (See page 9-701.)
3. Remove the package tray, package tray side trim, rear scuff plate, quarter wheel house and cover deck side trim.

WR-3244

4. Remove the fuel inlet box and fuel filler opening lid subassembly by removing the six screws.

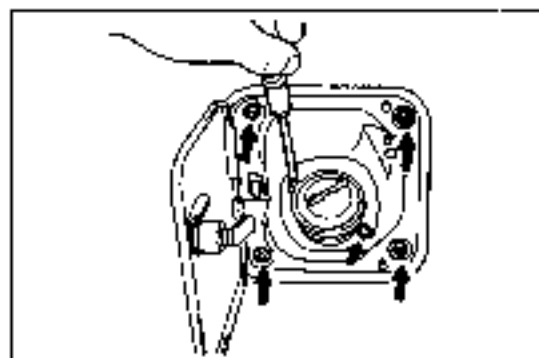

Fig. 9-226

WR-09245

5. Detach the clamp and separate the fuel tank subinlet hose.
6. Detach the clip and remove the breather hose.
7. Remove the fuel inlet pipe seal lower plate and the fuel inlet pipe lower seal by removing the two bolts.

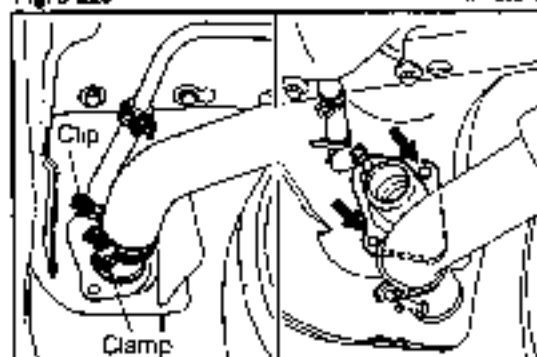

Fig. 9-227

WR-09246

8. Working from the vehicle interior, remove the three attaching bolts of the fuel inlet pipe subassembly. Detach the fuel inlet pipe subassembly.

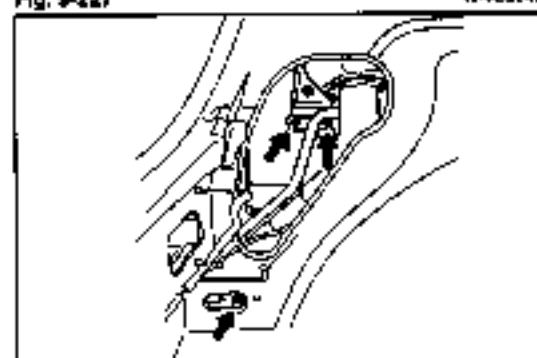

Fig. 9-228

WR-09247

INSTALLATION

1. Working from the vehicle interior, install the fuel inlet pipe subassembly with the three bolts.
2. Working from the outside, install the fuel inlet box and fuel filter opening lid subassembly with the six screws.
3. Install the fuel inlet pipe seal lower plate and the fuel inlet pipe lower seal, using the two bolts.
4. Attach the breather hose to the fuel inlet pipe subassembly. Secure it with the clip.
5. Install the fuel tank subinlet hose. Secure it with the clamp.
6. Install the cover deck side trim, quarter wheel house, rear scuff plate, package tray side trim and package tray.
7. Install the rear seatback and seat cushion.

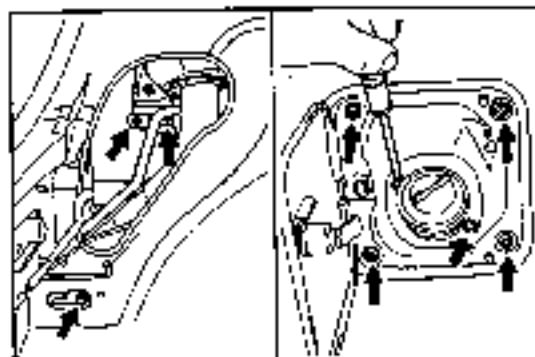

Fig. 9-228

WF 03048

3. Install the fuel inlet pipe seal lower plate and the fuel inlet pipe lower seal, using the two bolts.
4. Attach the breather hose to the fuel inlet pipe subassembly. Secure it with the clip.
5. Install the fuel tank subinlet hose. Secure it with the clamp.
6. Install the cover deck side trim, quarter wheel house, rear scuff plate, package tray side trim and package tray.
7. Install the rear seatback and seat cushion.

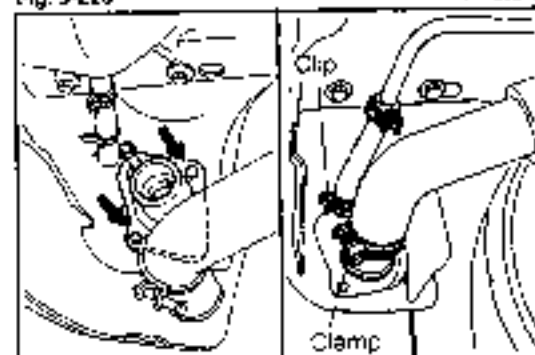

Fig. 9-230

WF 03049

FUEL TANK

REMOVAL

1. Jack up the vehicle and support it with safety stands.
2. Drain the fuel from the fuel tank by removing the drain plug. After the fuel has been drained, install the drain plug.
3. Removal of fuel sender gauge and fuel pump connector

WR 05230

- (1) Remove the rear seat.
- (2) Detach the rear quarter trim at the right side (3-door model).
- (3) Detach the rear scuff plate at the right/rear side (5-door model).
- (4) Disconnect the connector. Take out the connector together with the grommet to the vehicle exterior.

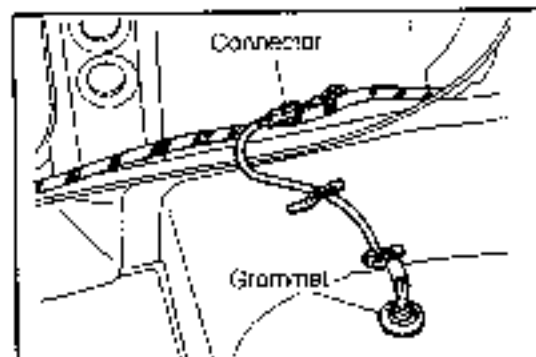

Fig. 9-231

WR 05231

4. Removal of fuel tank subinlet hose and breather hose

3-Door Model

- (1) Detach the clamp. Remove the fuel tank subinlet hose.
- (2) Detach the clip. Remove the breather hose.

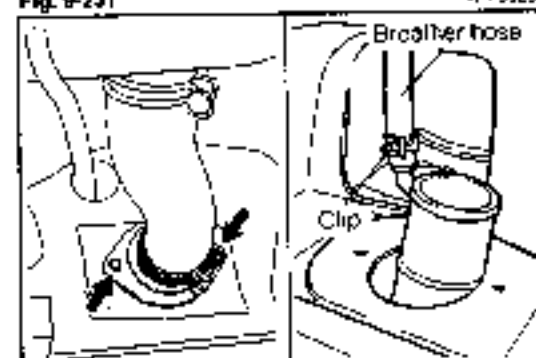

Fig. 9-232

WF 03052

BODY

5-Door Model

- (1) Detach the clamp. Remove the fuel tank suction hose.
- (2) Detach the clip and hose from both ends of the breather pipe.
- (3) Remove the breather pipe by removing its attaching bolt.

5. Removal of fuel hose

- (1) Disconnect the main fuel hose.
- (2) Disconnect the return fuel hose.
- (3) Disconnect the fuel hose for emission control.

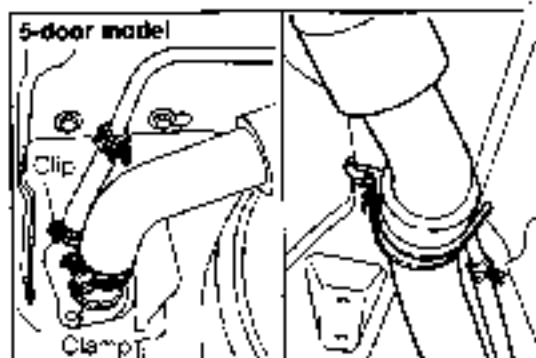

Fig. 9-233

WR-03253

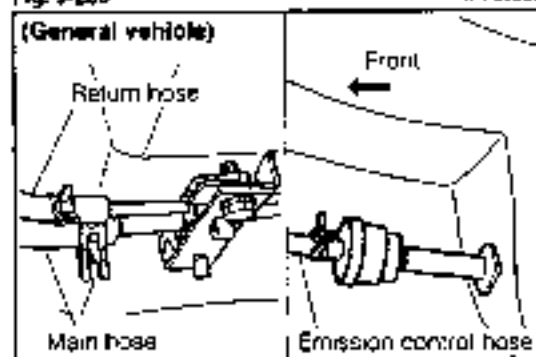

Fig. 9-234

WR-03254

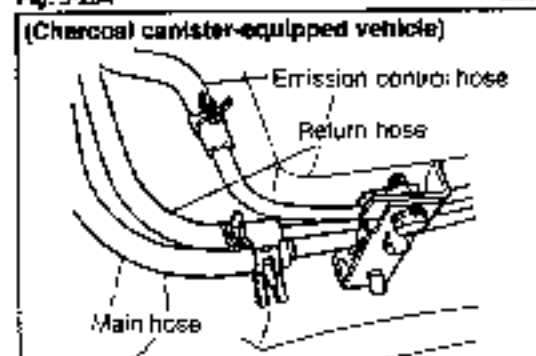

Fig. 9-235

WR-03255

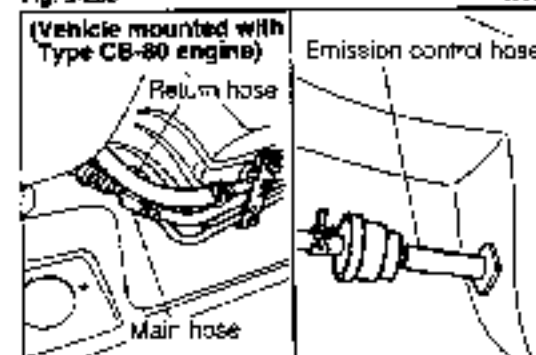

Fig. 9-236

WR-03256

6. Removal of fuel tank assembly

- (1) Support the fuel tank assembly with a jack.
- (2) Remove the four attaching bolts of the fuel tank.
- (3) Remove the fuel tank assembly from the vehicle.

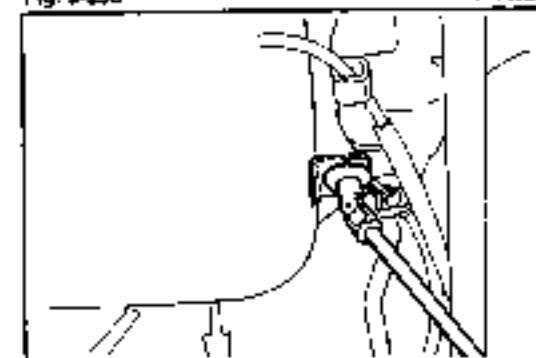

Fig. 9-237

WR-03257

7. Remove the fuel hose and pipe.
8. Remove the fuel sender gauge assembly by removing the coupler and five screws.
9. Remove the fuel pump assembly with bracket by removing the eight screws.

INSTALLATION

1. Install the fuel pump assembly with bracket and the fuel sender gauge assembly.
2. Install the fuel hose and pipe.
3. Install the fuel tank assembly with the four bolts.

NOTE:

Prior to the fuel tank installation, be sure to route the fuel gauge-related harness through the inside.

4. Installation of fuel hose
 - (1) Connect the main fuel hose.
 - (2) Connect the return fuel hose
 - (3) Connect the emission control fuel hose.

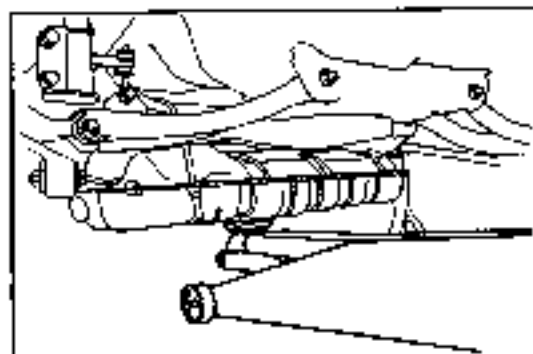

Fig. 9-238 WR-04258

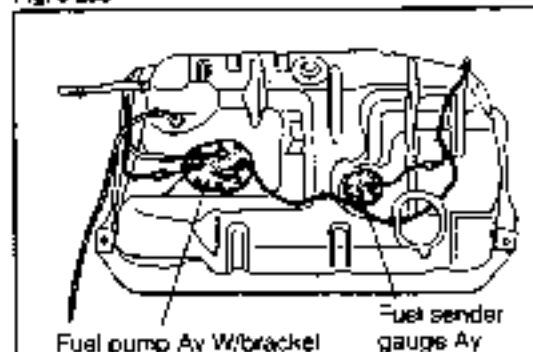

Fig. 9-239 WR-04259

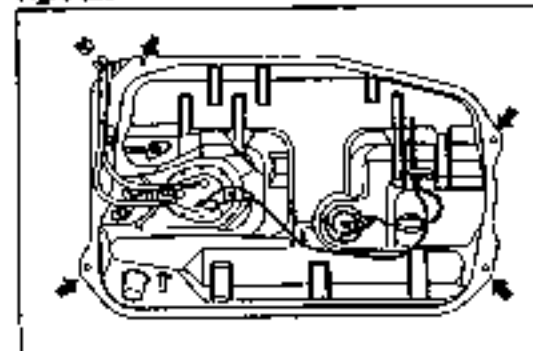

Fig. 9-240 WR-04260

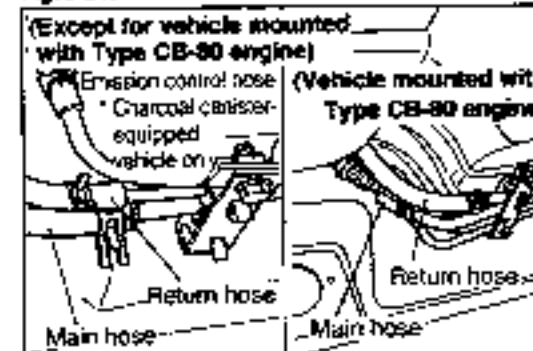

Fig. 9-241 WR-04261

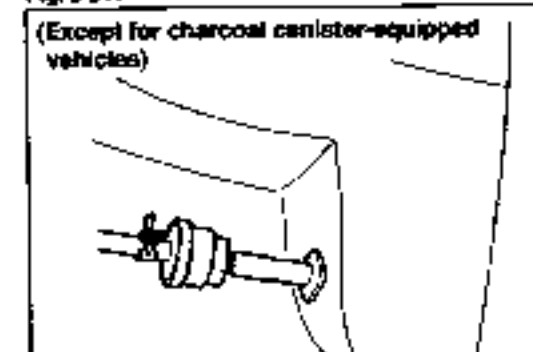

Fig. 9-242 WR-04262

BODY

5. Install the fuel tank subinlet hose and breather hose

3-door model

- (1) Connect the breather hose. Secure it with the clip
- (2) Connect the fuel tank subinlet hose. Secure it with the clamp

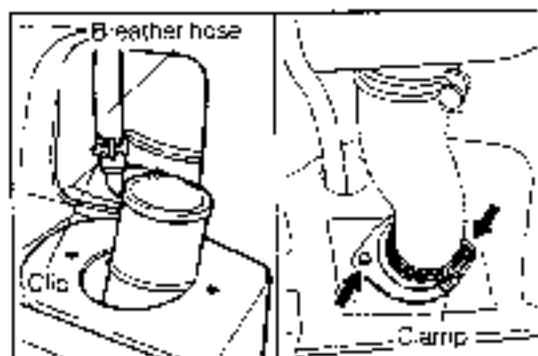

Fig. 9-243

WP-09260

5-door model

- (1) Connect the fuel tank subinlet hose. Secure it with the clamp.
- (2) Connect the hoses to both ends of the breather pipe. Secure them with the clips.
- (3) Install the breather pipe with one bolt.

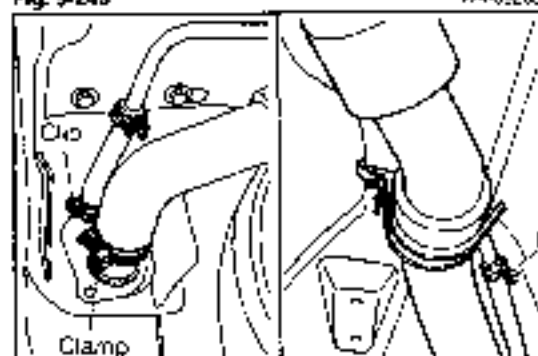

Fig. 9-244

WP-09264

6. Installation of fuel sender gauge and fuel pump connectors

- (1) Connect the connectors and install the grommet
- (2) Attach the rear quarter trim at the right/rear side. (3-door model)
- (3) Attach the scuff plate at the right/rear side. (5-door model)
- (4) Install the rear seat.

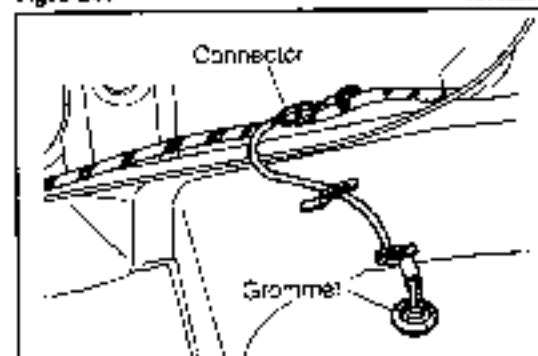
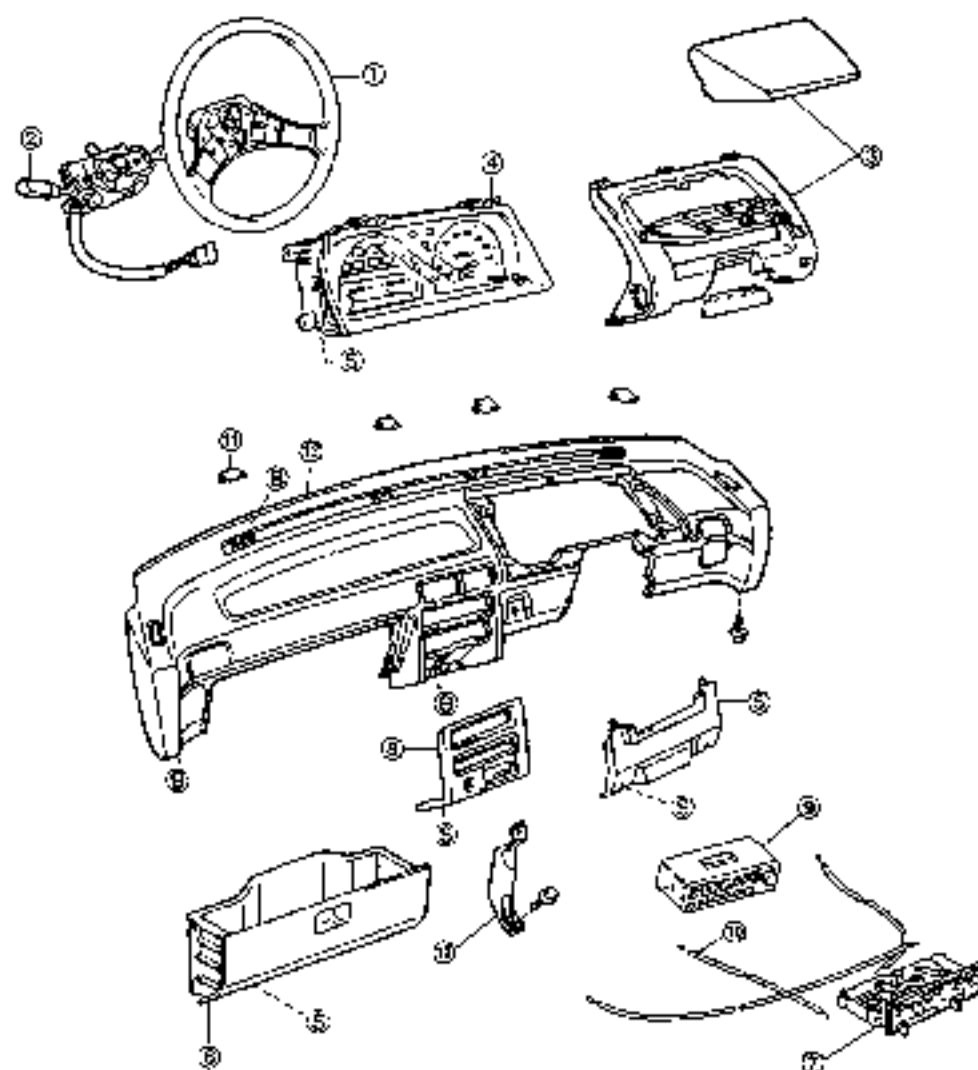

Fig. 9-245

WP-09265

INSTRUMENT PANEL COMPONENTS



- | | |
|---------------------------------------|--|
| ① Steering wheel A/y | ⑩ Instrument cluster finish center panel |
| ② Turn signal switch A/y | ⑪ Radio A/y |
| ③ Instrument cluster finish panel S/A | ⑫ Heater control cable (3 pcs.) |
| ④ Combination meter A/y | ⑬ Instrument panel hole cover |
| ⑤ Instrument panel finish lower panel | ⑭ Instrument panel-to-floor brace |
| ⑥ Glove compartment door S/A | ⑮ Instrument panel A/y |
| ⑦ Heater control A/y | |

Fig. 9-246

7/7-6266

BODY

REMOVAL

1. Disconnect the negative \ominus terminal of the battery.
2. Remove the instrument lower finish panel by removing the two screws.
3. Remove the instrument panel lower reinforcement by removing the four bolts.
4. Remove the steering column by removing the attaching bolts and nuts of the steering column.
5. Removal of instrument cluster finish panel subassembly
 - (1) Remove the four attaching screws of the instrument cluster finish panel subassembly.
 - (2) Slightly pull out the instrument cluster finish panel subassembly toward your side. Then, disconnect the couplers of the rear window defogger and rear wiper switch.
 - (3) Remove the instrument cluster finish panel subassembly.

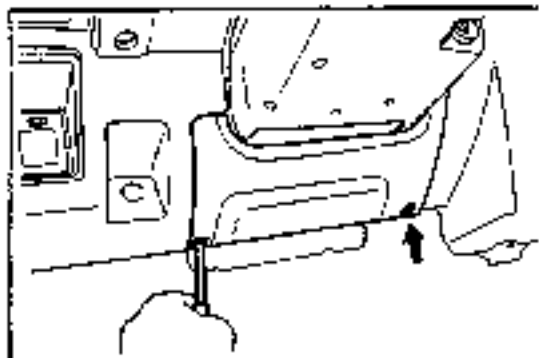

Fig. 9-247

WM-0816/

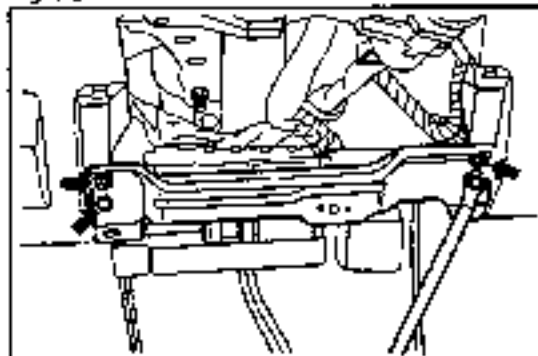

Fig. 9-248

WM-08208

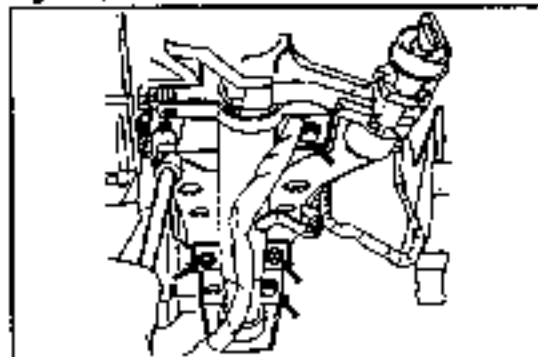

Fig. 9-249

WM-09256

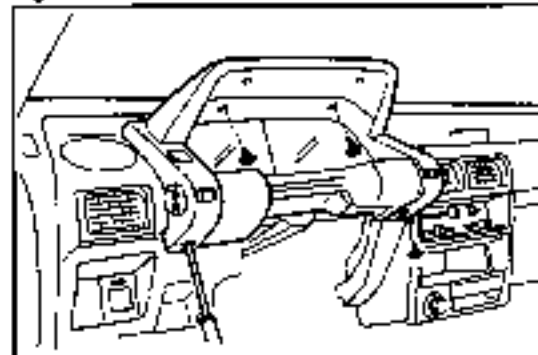

Fig. 9-250

WM-09270

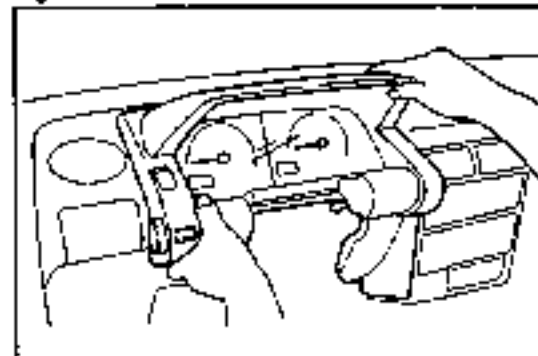

Fig. 9-251

WM-09671

Removal of combination meter assembly

(1) Disconnect the speedometer cable at the transmission side.

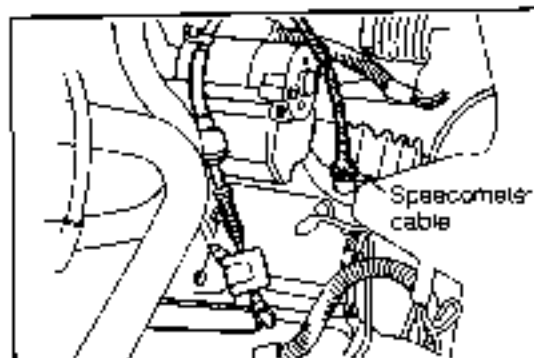

Fig. 9-252

WR-09272

(2) Remove the four attaching screws of the combination meter assembly.

(3) Pull out the combination meter assembly toward your side. Disconnect the speedometer cable and the coupler of the wire harness. Remove the combination meter assembly.

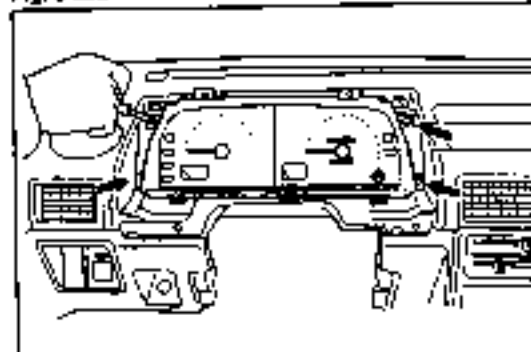

Fig. 9-253

WR-09273

7. Remove the glove compartment door subassembly by removing the two screws.

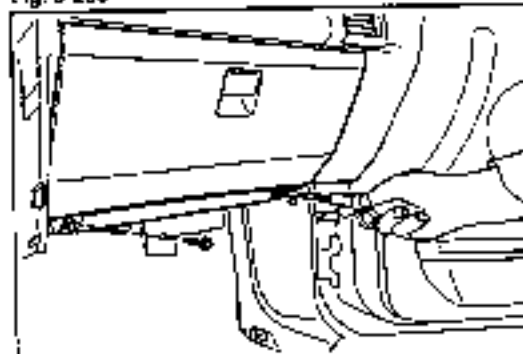

Fig. 9-254

WR-09274

8. Removal of instrument cluster finish center panel

(1) Remove the instrument cluster finish center panel by removing the four screws and pulling out the panel toward your side

(2) Disconnect the connectors of the cigar lighter.

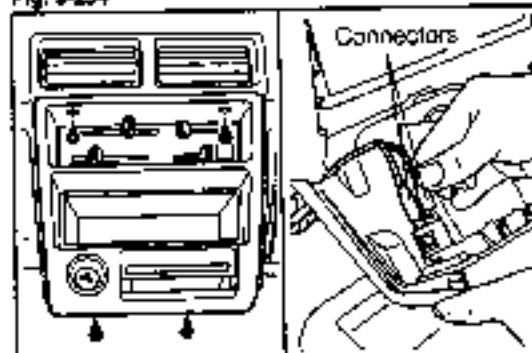

Fig. 9-255

WR-09275

9. Remove the heater control assembly by removing the three screws.

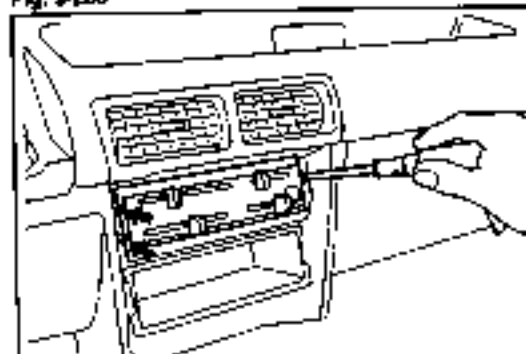

Fig. 9-256

WR-09276

BODY

10. Disconnect the couplers and the wire harness clamps of the ECU (for EFI or 3-speed A/T use), blower fan motor, clock and remote controlled mirror switch

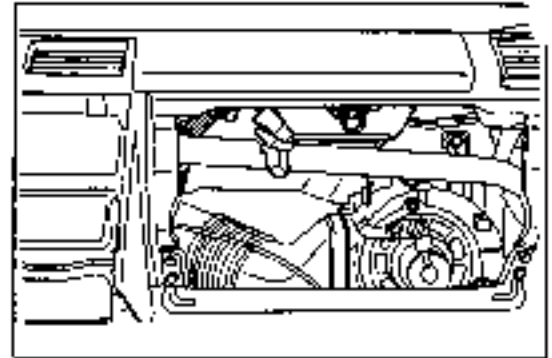

Fig. 9-257

WA-05277

11 Removal of instrument panel assembly

- (1) Remove the instrument hole covers and bolts at the four points of the upper section of the instrument panel assembly
- (2) Remove the two attaching bolts at both sides of the instrument panel assembly.
- (3) Remove the two attaching bolts at the center of the instrument panel assembly.
- (4) Remove the instrument panel assembly from the vehicle.

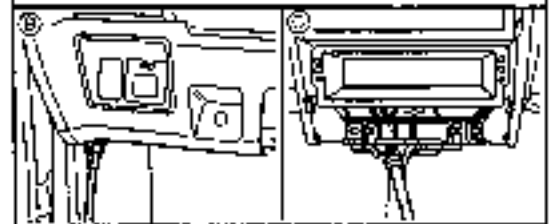
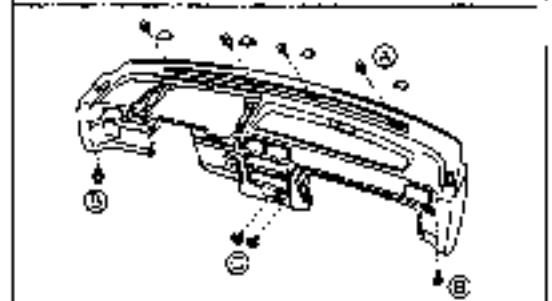
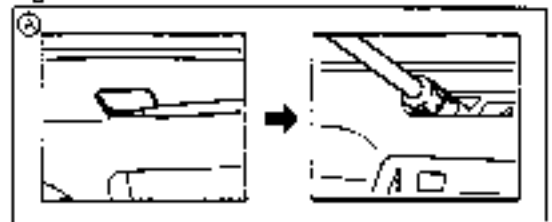

Fig. 9-258

WA-05278

12. Remove the following parts from the instrument panel assembly.

- (1) Remove the defroster nozzle assembly, side defroster nozzle duct, evaporator-to-register duct subassembly and front ventilator duct by removing the six screws.

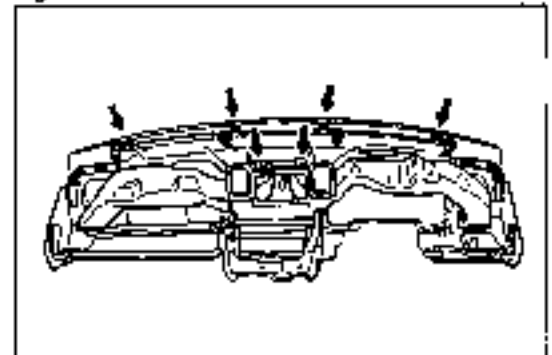

Fig. 9-259

WA-05279

- (2) Remove the ECU together with the bracket by removing the two screws and one bolt.
- (3) Remove the clock by removing the two screws. (LHD vehicle only)

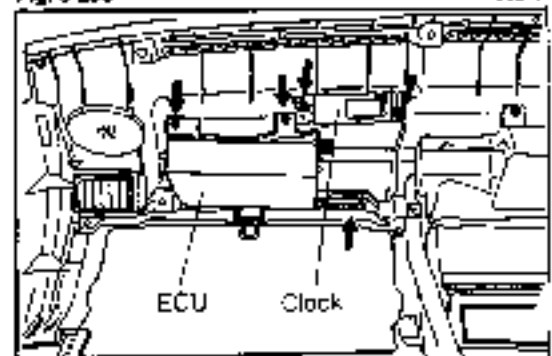

Fig. 9-260

WA-05280

- (4) Remove the glove compartment door lock striker by removing the two screws.
- (5) Remove the instrument panel reinforcement by removing the five screws and one bolt. (A/T-equipped vehicle and GTi grade)
- (6) Remove the instrument panel reinforcement by removing the three screws. (Except for A/T-equipped vehicle and GTi grade)

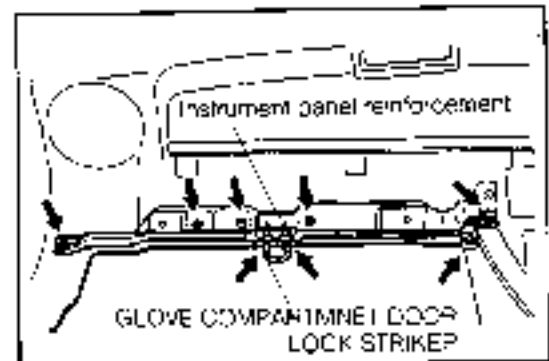

Fig. 9-261 W4-0328

- (7) Remove the instrument panel center stay by removing the three screws.

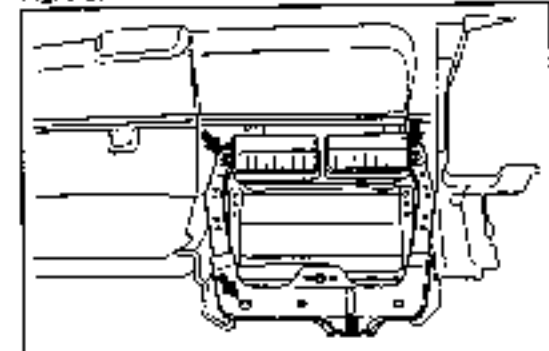

Fig. 9-262 WR-03922

- (8) Detach the clamps by removing the screws. (Two points)
- (9) Remove the instrument box or the remote controlled mirror switch.

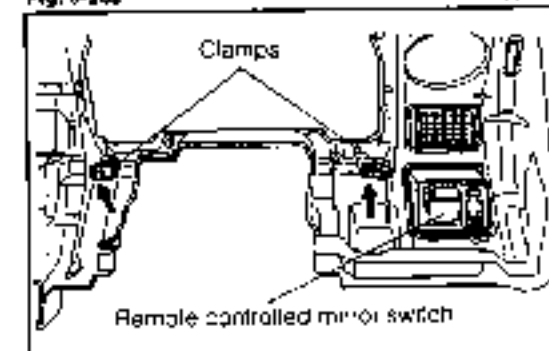

Fig. 9-263 W4-04293

- (10) Remove the instrument panel registers (R & L) and instrument panel center register
- (11) Remove the instrument panel safety pad by removing the eight screws. (LHD vehicle only)

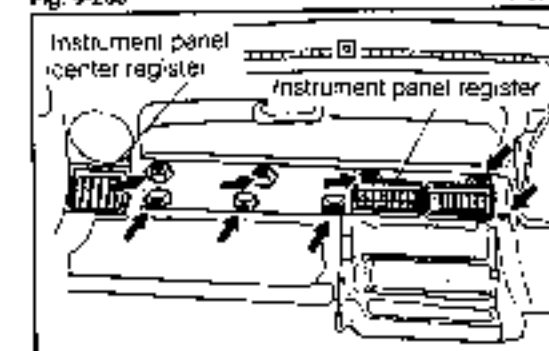

Fig. 9-264 WR-02354

- (12) Remove the radio tuning opening cover by removing the two screws.
- (13) Remove the instrument panel reinforcement No.3 by removing the four bolts

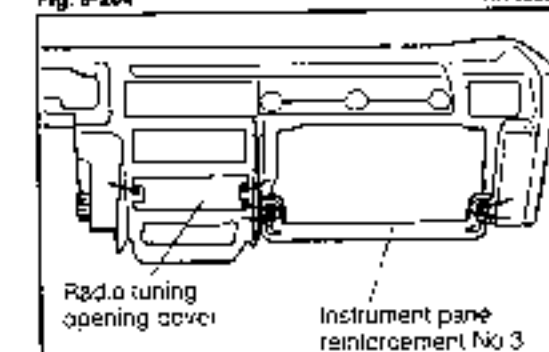

Fig. 9-265 W4-0368

BODY

- (14) Remove the instrument panel bracket No.2 by removing the four screws.
- (15) Remove the instrument panel bracket No.1 by removing the two screws.

INSTALLATION

1. Install the following parts to the instrument panel assembly.

- (1) Install the instrument panel bracket No.1 (two screws) and instrument panel bracket No.2 (four screws).
- (2) Install the instrument panel reinforcement No.3 with the four bolts.
- (3) Install the radio tuning opening cover with the two screws.

(4) Install the instrument panel safety pad with the eight screws. (LHD vehicle only)

(5) Install the instrument panel registers (R & L) and instrument panel center register.

(6) Install the instrument box or the remote controlled mirror switch.

(7) Attach the clamps with the screws (Two points)

(8) Install the instrument panel center stay with the three screws.

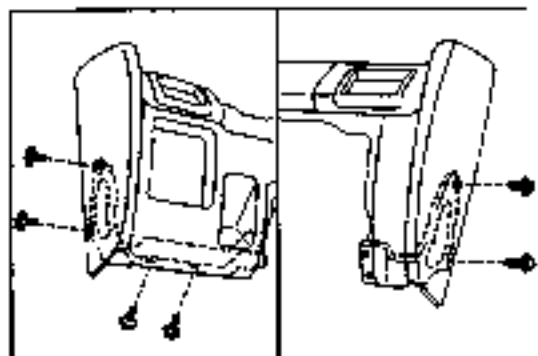

Fig. 9-266

WR-09266

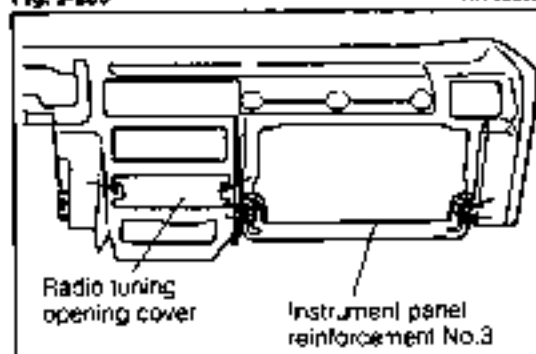

Fig. 9-267

WR-09267

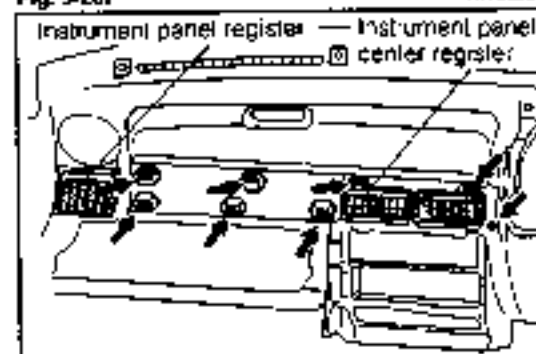

Fig. 9-268

WR-09268

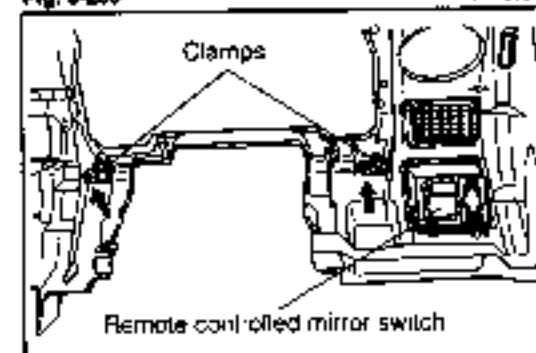

Fig. 9-269

WR-09269

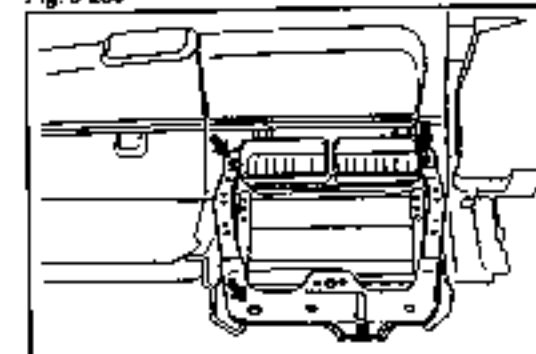

Fig. 9-270

WR-09270

- (9) Install the instrument panel reinforcement with the five screws and one bolt. (A/T-equipped vehicle and GTi grade)
- (10) Install the instrument panel reinforcement with the three screws. (Except for A/T-equipped vehicle and GTi grade)
- (11) Install the glove compartment door lock striker with the two screws.

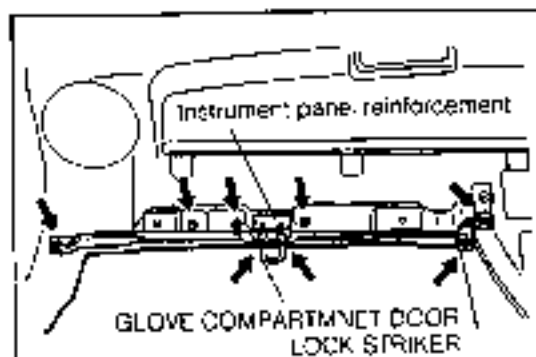

Fig. 9-271 WR-09251

- (12) Install the clock with the two screws. (LHD vehicle only)
- (13) Install the ECU together with the bracket by means of the two screws and one bolt.

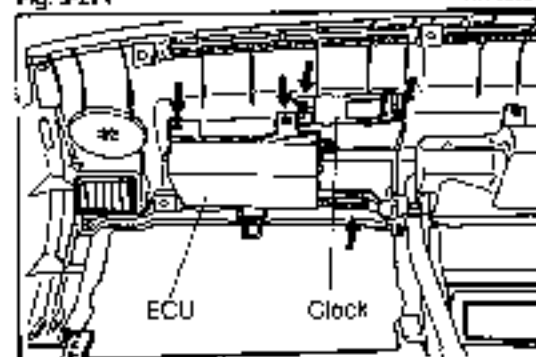

Fig. 9-272 WR-09252

- (14) Install the evaporator-to-register duct subassembly, front ventilator duct, defroster nozzle assembly and side defroster nozzle.

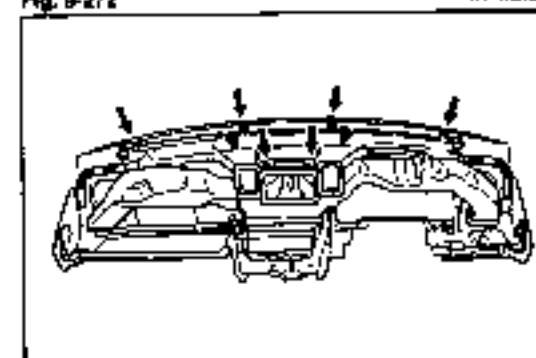

Fig. 9-273 WR-09253

2. Installation of instrument panel assembly

- (1) Temporarily install the four bolts (A) at the upper side of the instrument panel assembly.
- (2) Temporarily install the two bolts (B) at both sides of the instrument panel assembly.
- (3) Temporarily install the two bolts (C) at the center of the instrument panel assembly.
- (4) Settle the instrument panel assembly and tighten the eight bolts.
- (5) Install the instrument panel hole covers.

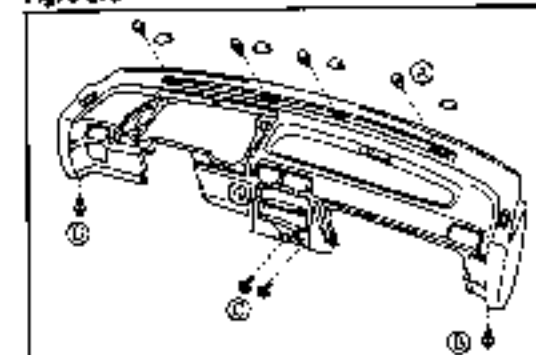

Fig. 9-274 WR-09254

- 3. Connect the couplers and wire harness clamps of the ECU (for EFI or A/T use), blower fan motor, clock and remote controlled mirror switch.
- 4. Install the heater control assembly with the three screws.

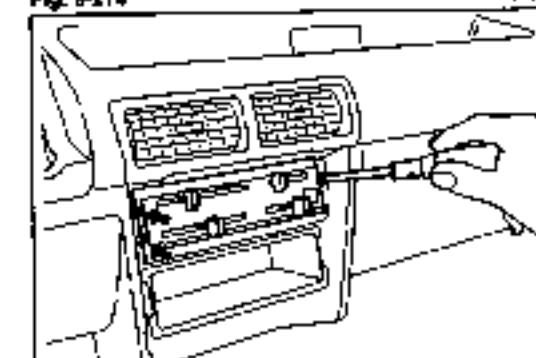

Fig. 9-275 WR-09255

BODY

5. Installation of instrument cluster finish center pane.
 - (1) Connect the connectors of the cigar lighter.
 - (2) Install the instrument cluster finish center pane with the four screws.
6. Install the glove compartment door subassembly with the two screws. (See Fig. 9-254.)

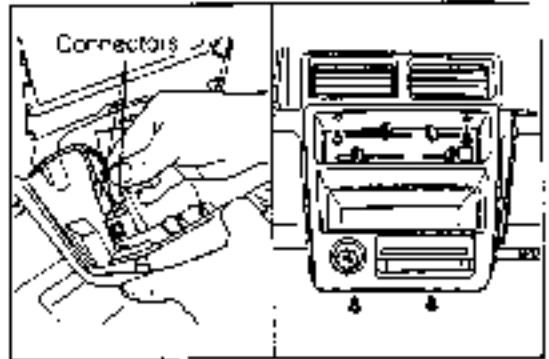

Fig. 9-276

WR-0929C

7. Installation of combination meter assembly.
 - (1) Connect the coupler of the wire harness and speedometer cable to the combination meter assembly.
 - (2) Install the combination meter assembly with the four screws.
 - (3) Connect the speedometer cable at the transmission side.

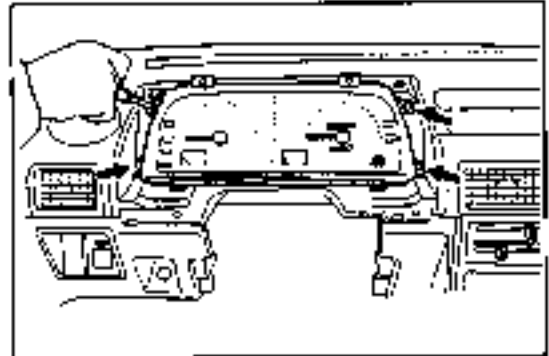

Fig. 9-277

WR-0929F

8. Installation of instrument cluster finish panel subassembly.
 - (1) Connect the couplers of the rear window defogger and rear wiper switch.
 - (2) Install the instrument cluster finish panel subassembly with the four screws.

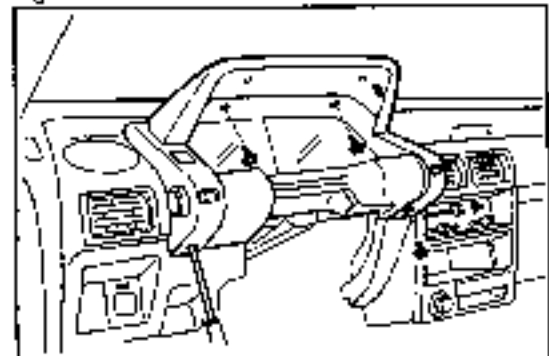

Fig. 9-278

WR-0929E

9. Install the steering column with the bolts and nuts.

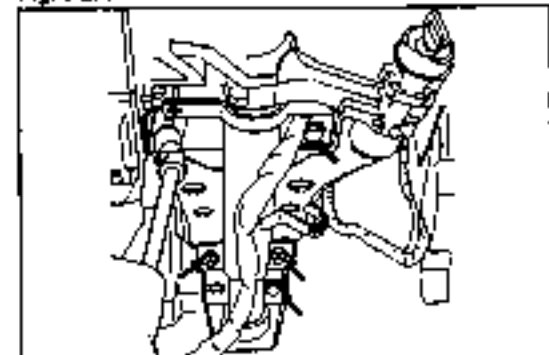

Fig. 9-279

WR-0929G

10. Install the instrument panel lower reinforcement with the four bolts.

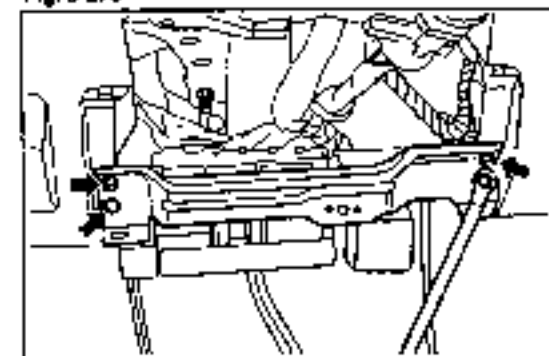

Fig. 9-280

WR-0930A

1. Install the instrument lower finish panel with the two screws.
12. Connect the negative \ominus terminal of the battery.

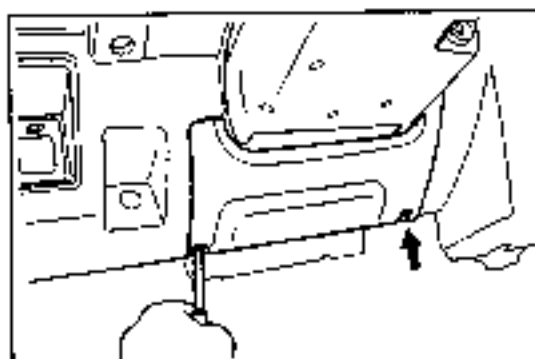

Fig. 9-281

AR08301

BODY

TRIMS COMPONENTS

3-door model

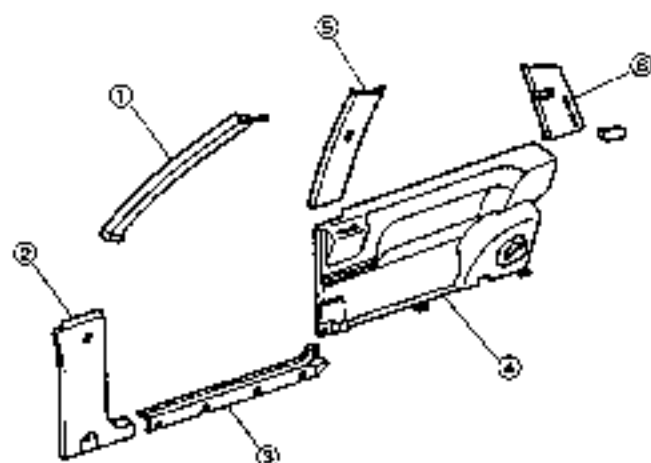

- ① Front pillar garnish
- ② Cowl side trim
- ③ Front door scuff plate
- ④ Quarter trim
- ⑤ Center pillar upper garnish
- ⑥ Roof side inner garnish

5-door model

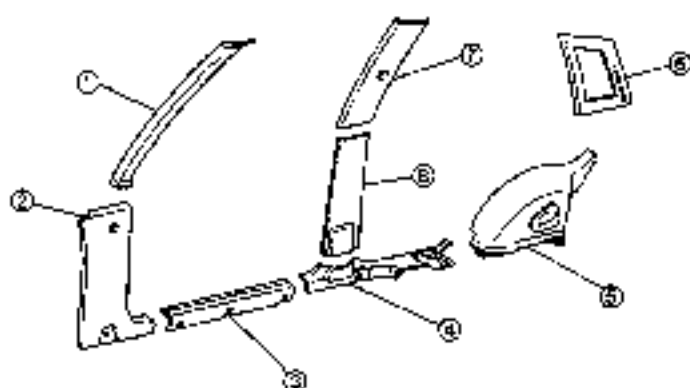

- ① Front pillar garnish
- ② Cowl side trim
- ③ Front door scuff plate
- ④ Rear door scuff plate
- ⑤ Quarter wheel house cover
- ⑥ Roof side inner garnish
- ⑦ Center pillar upper garnish
- ⑧ Center pillar lower garnish

Luggage room

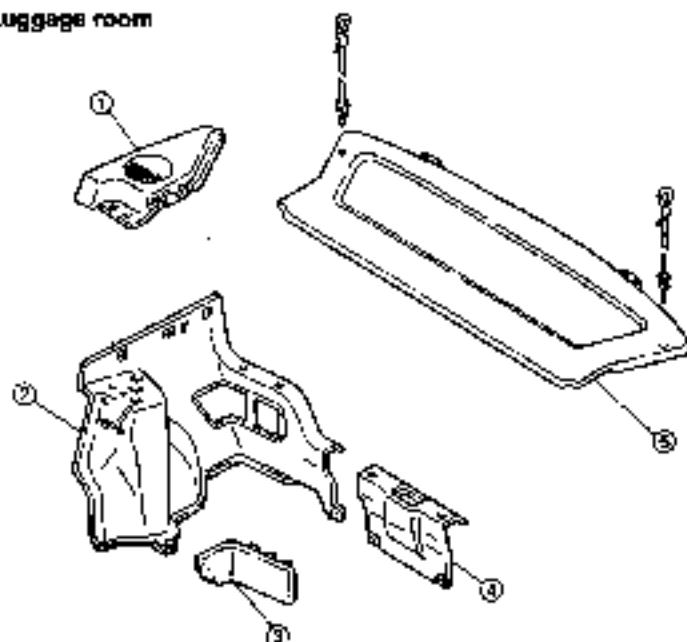

- ① Package tray side trim
- ② Deck side trim
- ③ Rear combination lamp service hole cover
- ④ Lower back trim
- ⑤ Package tray trim

Fig. 9-282

W7-05302

FRONT PILLAR GARNISH

Removal

1. Disengage the clip section by prying the clip with a common screwdriver.
2. Remove the front pillar garnish by pulling it upward.

Installation

1. Hang the hanger located at the lower part of the front pillar garnish to the body.
2. Align the two clips in place. Install the front pillar garnish by tapping it lightly by your hand.

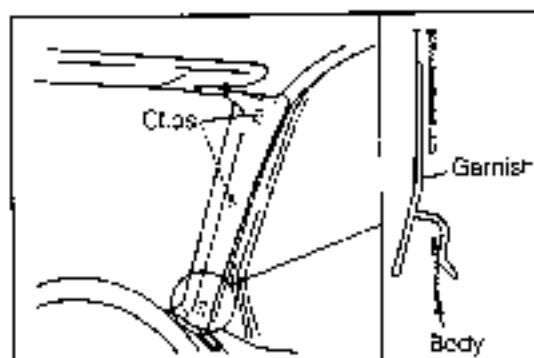

Fig. 9-283

WF-09303

COWL SIDE TRIM

Removal

Remove the cowl side trim by detaching the two clips, using a clip clamping tool.

Installation

Install the cowl side trim with the two clips.

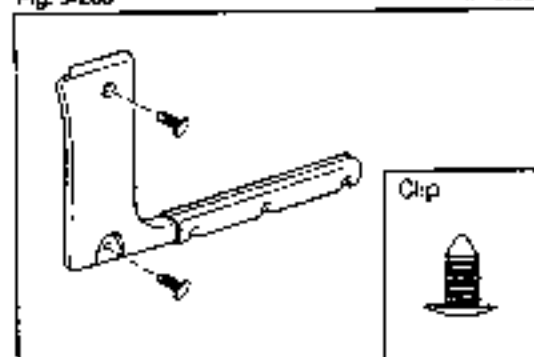

Fig. 9-284

WF-09304

FRONT DOOR SCUFF PLATE (3-DOOR MODEL)

Removal

Remove the front door scuff plate by removing the five screws.

Installation

Install the front door scuff plate with the five screws.

(5-DOOR MODEL)

Removal

Remove the front door scuff plate by removing the three screws.

Installation

Install the front door scuff plate with the three screws.

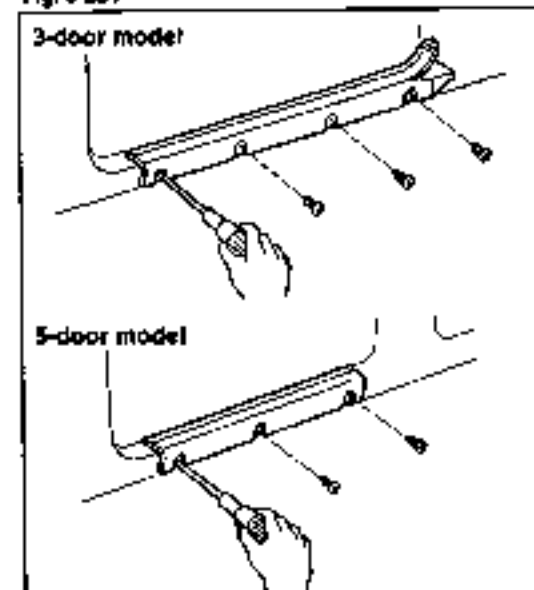

Fig. 9-285

WF-09305

QUARTER TRIM (3-DOOR MODEL)

Removal

1. Remove the two screws at the lower end of the trim.
2. Detach the three clips (A) by pushing the center sections of the clips.
3. Detach the clips (B) (at six points), using a common screwdriver.
4. Remove the quarter trim by pulling it toward the front.

Installation

1. Attach the clip (C).
2. Attach the clips (B) (at six points).
3. Attach the clips (A) (at three points).
4. Install the two screws at the lower end of the trim.

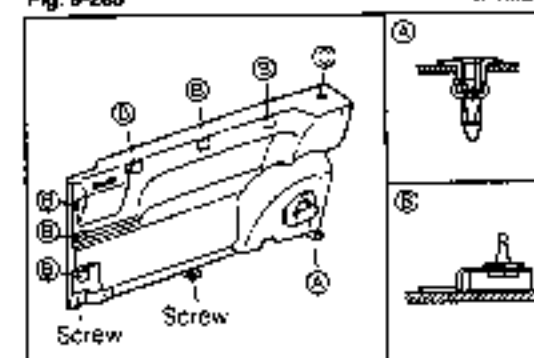

Fig. 9-286

WF-09306

BODY

REAR DOOR SCUFF PLATE (5-DOOR MODEL)

Removal

Remove the rear door scuff plate by removing the two screws.

Installation

Install the rear door scuff plate with the two screws.

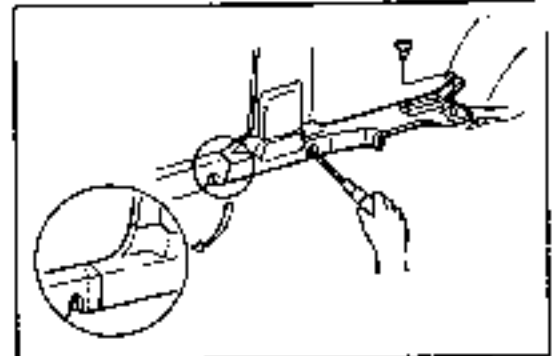

Fig. 9-287

WA-02907

QUARTER WHEEL HOUSE COVER (5-DOOR MODEL)

Removal

1. Remove the rear door scuff plate. (See Fig. 9-287)
2. Remove the one screw and two clips (A).
3. Detach the four clips (B), using a common screwdriver.

Installation

1. Align the clips (B) in place. Install the quarter wheel house cover by lightly tapping around the clips by hand.
2. Install the one screw and two clips (A).
3. Install the rear door scuff plate.

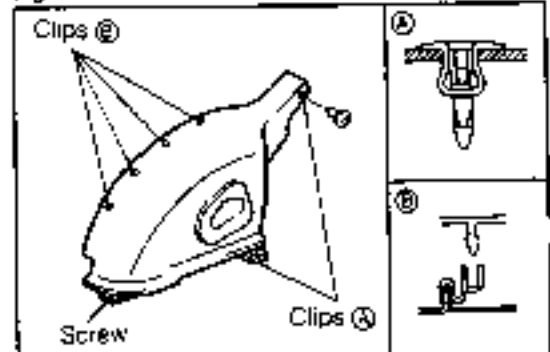

Fig. 9-288

WA-02908

CENTER PILLAR LOWER GARNISH

Removal

1. Disengage the clips (A), using a common screwdriver.
2. Disengage the clips (B), using a common screwdriver.
3. Remove the center pillar lower garnish.

Installation

1. Hang the lower end of the center pillar lower garnish to the rear door scuff plate.
2. Align the clips (A) and (B) in place. Install the center pillar lower garnish by lightly tapping around the clips by hand.

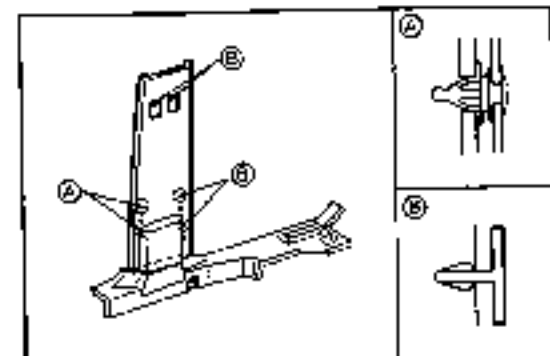

Fig. 9-289

WA-35001

ROOF SIDE INNER UPPER GARNISH

Removal

1. Remove the quarter window lock cover.
2. Remove the two attaching screws of the quarter window lock assembly.
3. Disengage the clips (A), using a common screwdriver.
4. Disengage the clips (B) and (C), using a common screwdriver.
5. Remove the roof side inner upper garnish.

Installation

1. Align the clips (A), (B) and (C) in place. Install the roof side inner upper garnish by lightly tapping around the clips by hand.
2. Install the quarter window lock assembly with the two screws.
3. Install the quarter window lock cover.

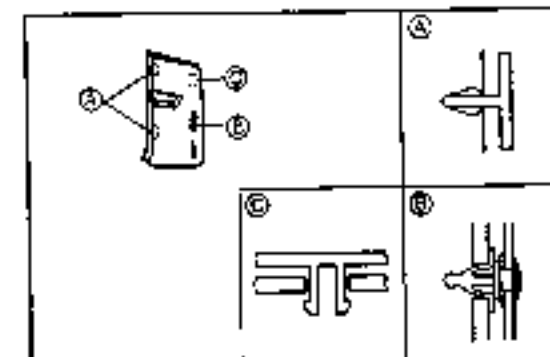

Fig. 9-290

WA-08010

CENTER PILLAR GARNISH**Removal**

1. Remove the attaching bolt of the front seat outer belt shoulder anchor.
2. Disengage the clips, using a common screwdriver.
3. Remove the center pillar garnish.

Installation

1. Align the clips in place. Install the center pillar garnish by lightly tapping around the clips by hand.
2. Install the attaching bolt of the front seat outer belt shoulder anchor.

Tightening Torque: 2.9 - 5.4 kg-m (21 - 39 ft-lb)

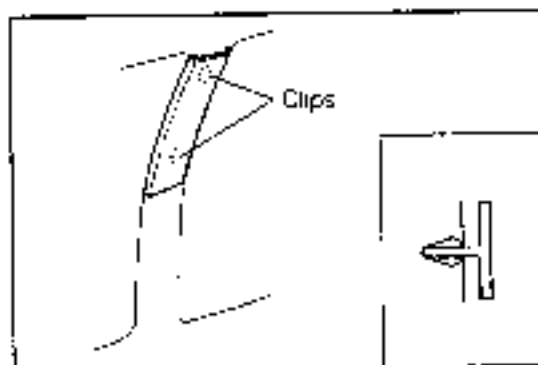

Fig. 9-291

WR-09311

DECK SIDE TRIM**Removal**

1. Remove the package tray.
2. Remove the quarter trim.

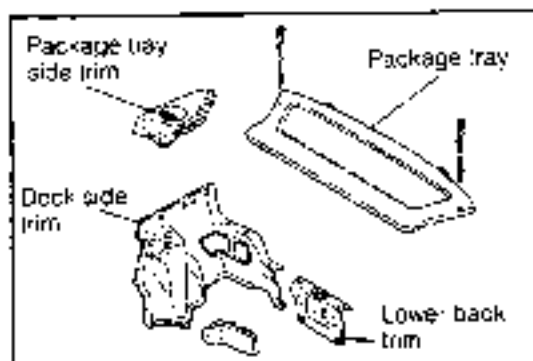

Fig. 9-292

WR-09312

3. Removal of package tray side trim
 - (1) Remove the four bolts
 - (2) Remove the package tray side trim.

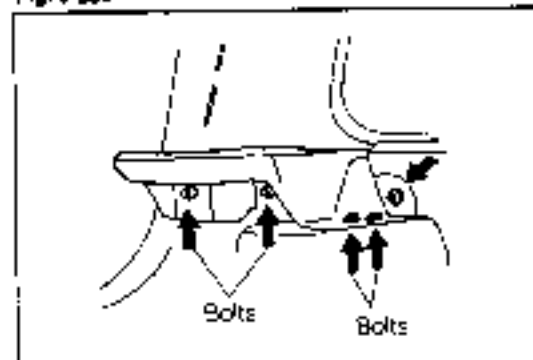

Fig. 9-293

WR-09313

4. Removal of lower back trim
 - (1) Detach the four clips by pushing the center sections of the clips.
 - (2) Remove the lower back trim.

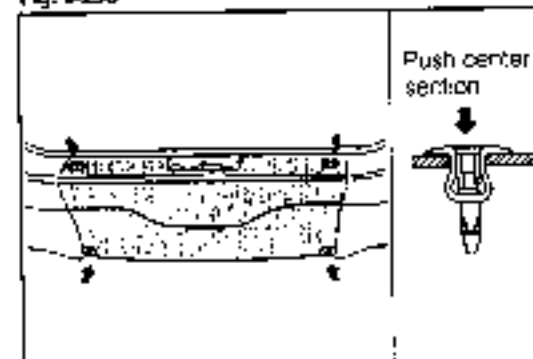

Fig. 9-294

WR-09314

BODY

5. Deck side trim

- (1) Detach the five clips by pushing the center sections of the clips.
- (2) Remove the deck side trim.
- (3) Remove the rear combination lamp service hole cover from the deck side trim.

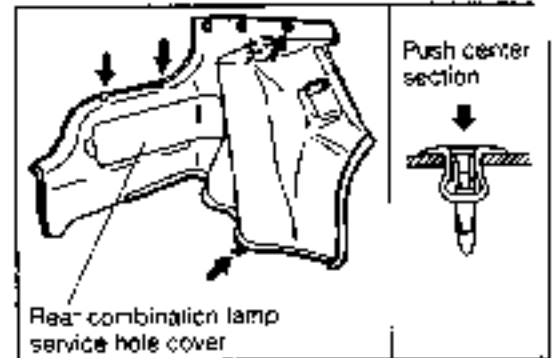

Fig. 8-295

WR-09315

Installation

1. Installation of deck side trim

- (1) Install the deck side trim with the four clips.
- (2) Install the rear combination lamp service hole cover.

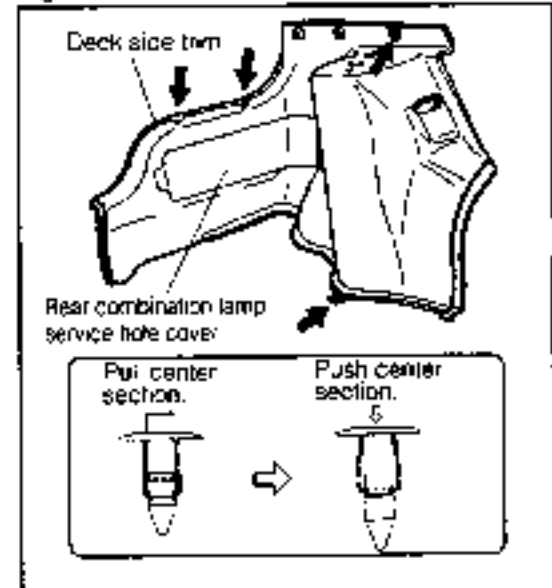

Fig. 8-296

WR-09316

2. Install the lower back trim with the four clips.

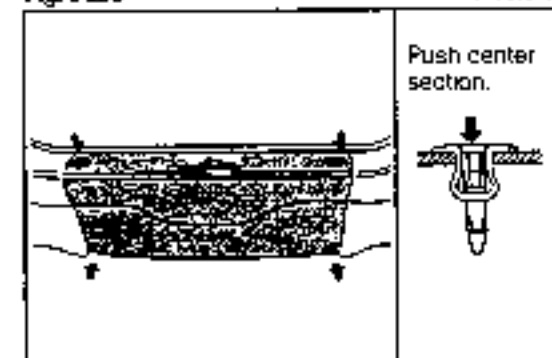

Fig. 9-297

WR-09317

3. Install the package tray side trim with the four bolts.
4. Install the package tray.
5. Install the quarter trim.

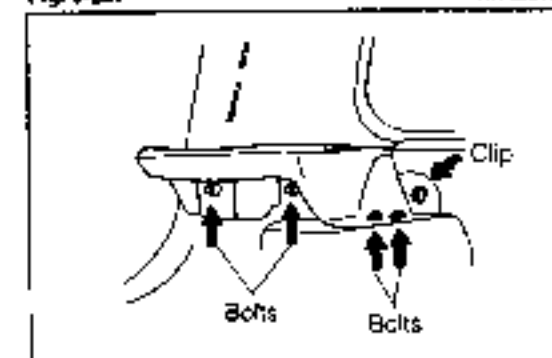

Fig. 9-298

WR-09318

ROOF HEADLINING

Suspended ceiling

(3-door model)

(5-door model)

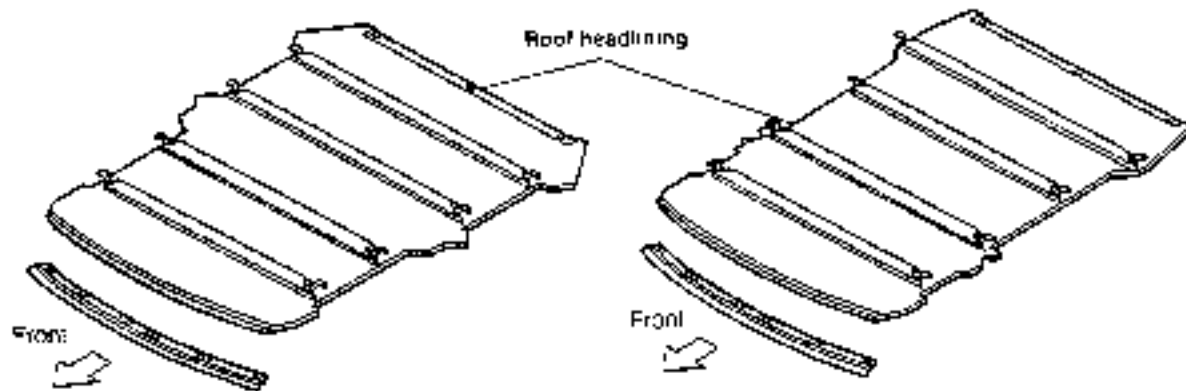

Molded ceiling

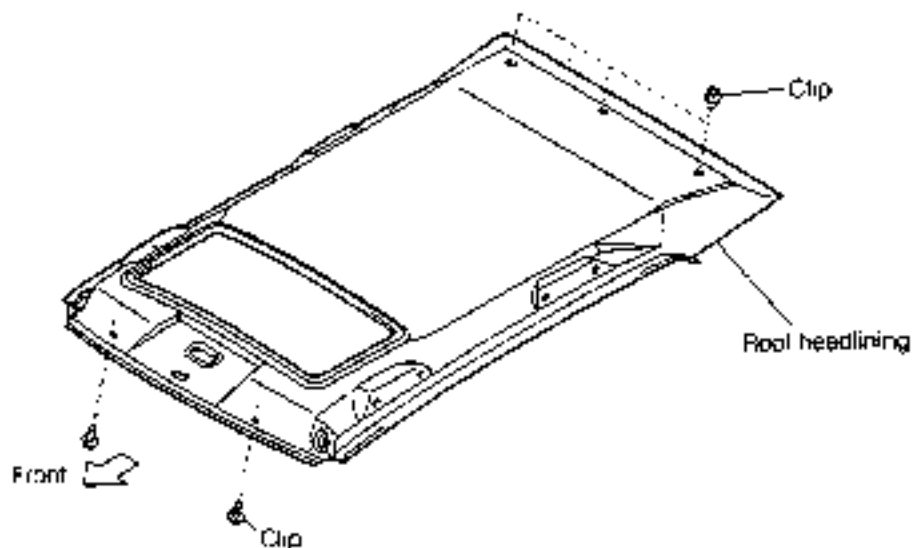

Fig. 9-299

WA-08319

SUSPENDED CEILING

Removal

1. Remove the sun visor assembly.
2. Remove the inner rear-view mirror with room lamp.
3. Remove the front pillar garnish, center pillar garnish and roof side inner upper garnish. (Only vehicle equipped with those garnishes.)

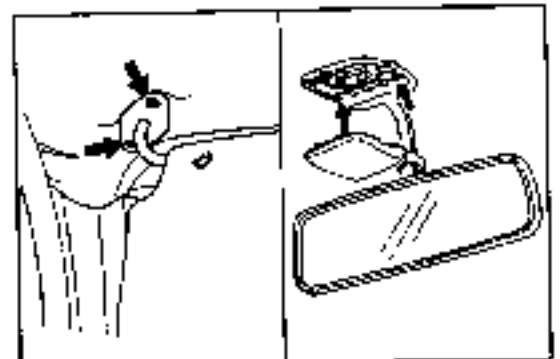

Fig. 9-300

WA-08320

BODY

4. Remove the upper side of the front and rear door opening trim molding. Proceed to disengage the hook of the roof headlining.
5. Remove the two-faced adhesive tapes at the quarter pillar and center pillar sections. Then, remove the roof headlining.

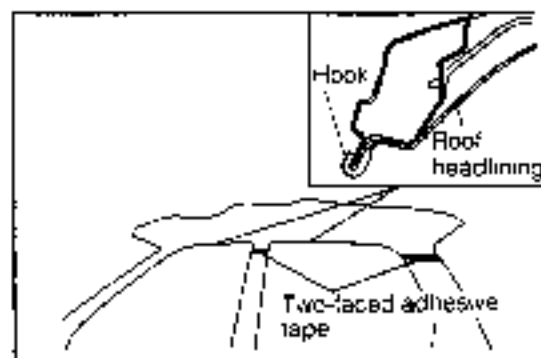

Fig. 9-301

4F-09321

6. Disengage the three hooks at the rear of the roof headlining.

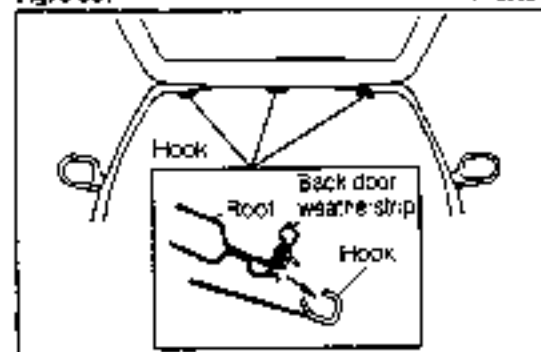

Fig. 9-302

WF-09323

7. Remove the lifting wires from the body side rail holes one by one, starting from the rear of the roof headlining.

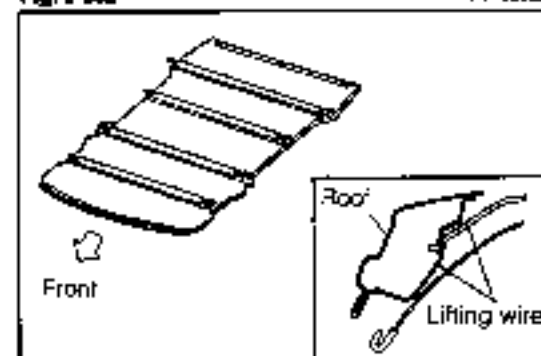

Fig. 9-303

WP-09323

8. Remove the roof headlining retainer and roof headlining by removing the five screws.

Installation

1. Install the roof headlining retainer by tightening the five screws in the sequence indicated in the right figure.

NOTE:
Install the roof headlining retainer in such a direction that a cut-out section at the center section of the retainer faces forward.

2. Insert each lifting wire into the body side rail hole one by one, starting from the front of the roof headlining retainer. Each hole should be held at the uppermost position.
3. Attach the three hooks at the rear of the roof headlining.

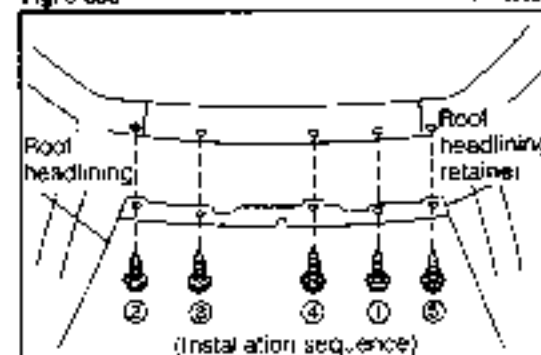

Fig. 9-304

WR-09324

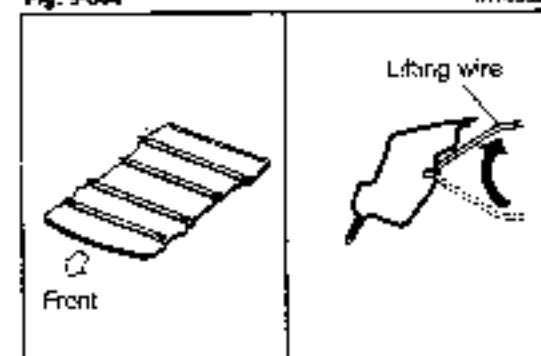

Fig. 9-305

WP-09325

Hang the roof headlining hook at the front and rear door opening section. Install the opening trim molding.

5. Install the roof headlining at the quarter pillar and center pillar sections to the body, using a two-faced adhesive tape.
6. Install the front door garnish, center pillar garnish and roof side inner upper garnish. (Only vehicle equipped with those garnishes)

NOTE:

Cut the roof headlining around the clip hole of the center pillar section, using a cutter.

7. Install the inner rear-view mirror with room lamp.
8. Install the sun visor assembly.

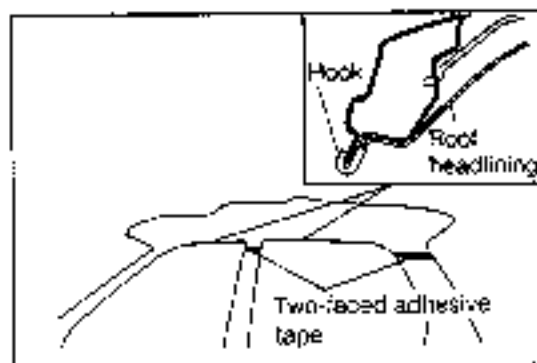

Fig. 9-306

WR-09326

MOLDED CEILING

Removal

1. Remove the sun visor assembly.
2. Remove the inner rear-view mirror with room lamp.
3. Detach the switch bezel.
4. Remove the sunroof opening trim molding.
5. Remove the front pillar garnish, center pillar garnish and roof side inner upper garnish.

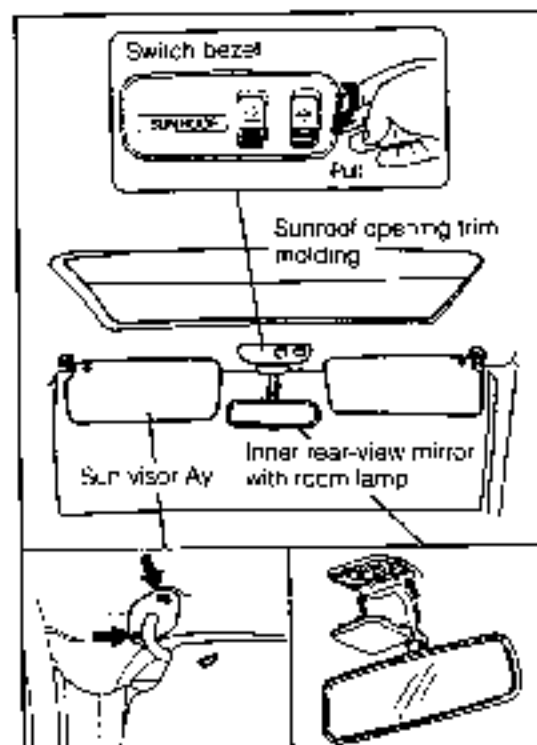

Fig. 9-307

WR-09627

Remove the front and rear door opening trim molding (quarter window weatherstrip). Proceed to remove the roof headlining.

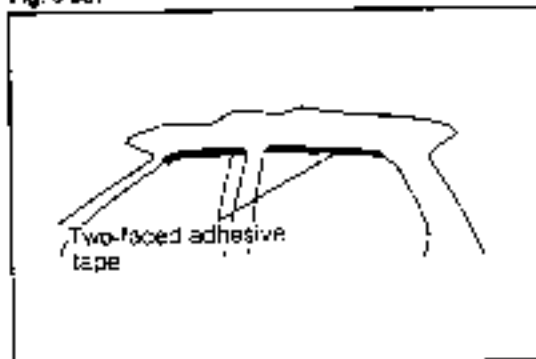

Fig. 9-308

WR-09326

BODY

7. Removal of roof headlining

(1) Remove the assist grips or clips.

NOTE:

Remove the clip, using a clip clamping tool.

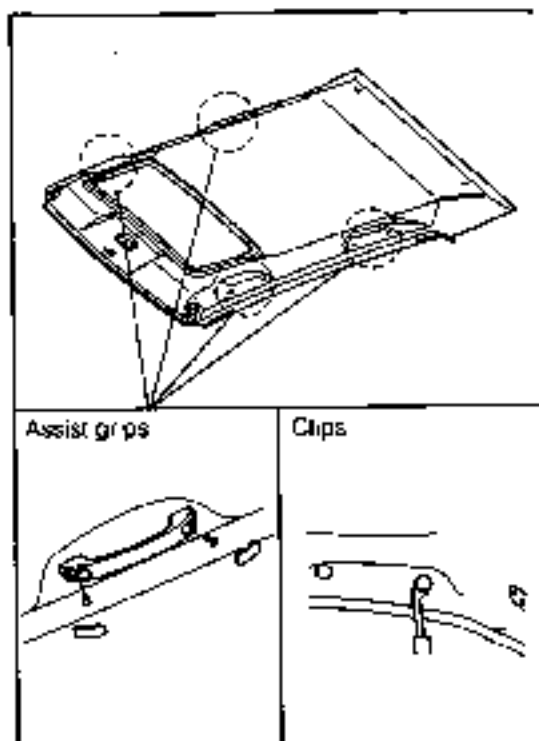

Fig. 9-309

WI-09029

(2) Detach the three clips at the rear of the roof headlining.

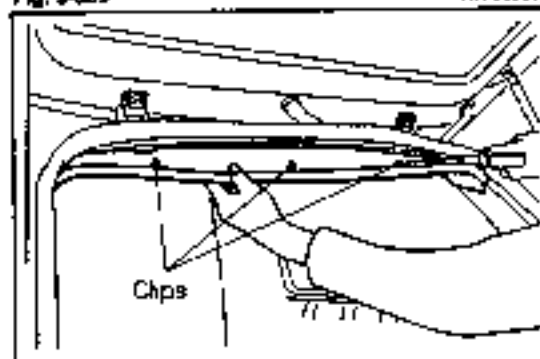

Fig. 9-310

WI-09030

(3) Detach the two clips at the front of the roof headlining.
(4) Remove the roof headlining from the vehicle.

Installation

1. Installation of roof headlining

(1) Attach the front of the roof headlining with the two clips.

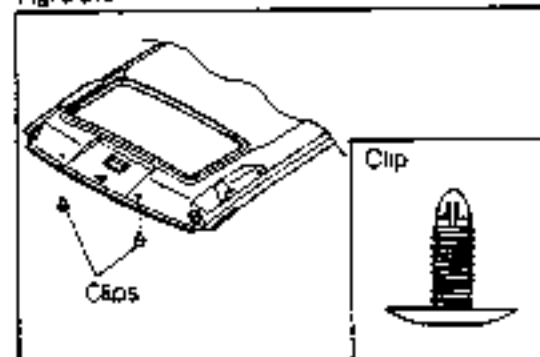

Fig. 9-311

WI-09031

(2) Attach the rear of the roof headlining with the three clips.

NOTE:

Be sure to replace any damaged clip with a new one during the operations (1) and (2).

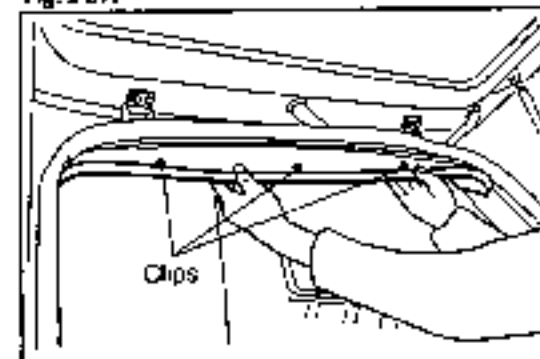

Fig. 9-312

WI-09032

(3) Install the assist grips or clips

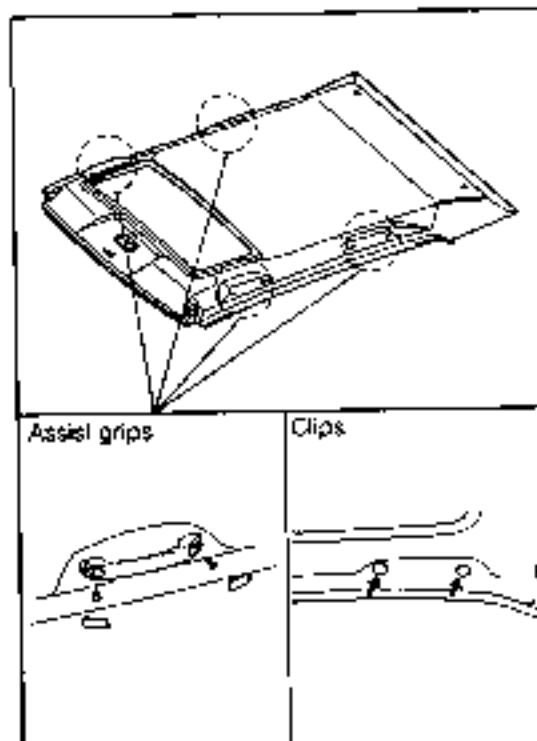

Fig. 9-313

WR-09333

2. Installation of front and rear door opening trim molding (quarter window weatherstrip)

- (1) Affix the roof headlining at the front and rear door (quarter window) section, using a two-faced adhesive tape.
- (2) Install the front and rear door opening trim molding (quarter window weatherstrip).

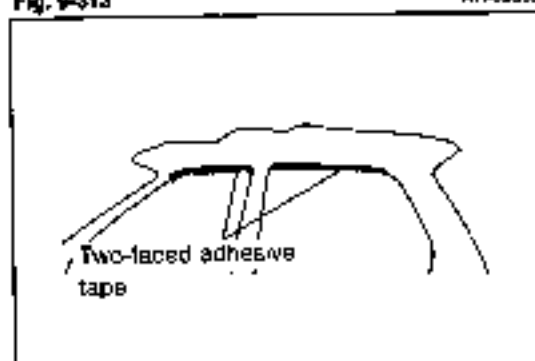

Fig. 9-314

WR-09334

3. Install the front pillar garnish, center pillar garnish and roof side inner upper garnish

1. Install the sunroof opening trim molding.
3. Install the switch bezel.
6. Install the inner rear-view mirror with room lamp.
7. Install the sun visor assembly.

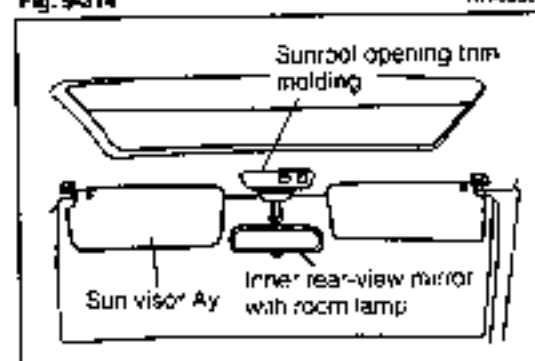

Fig. 9-315

WR-09335

BODY

FRONT SEAT COMPONENTS

VAN, TS, TC, TX and CX grades

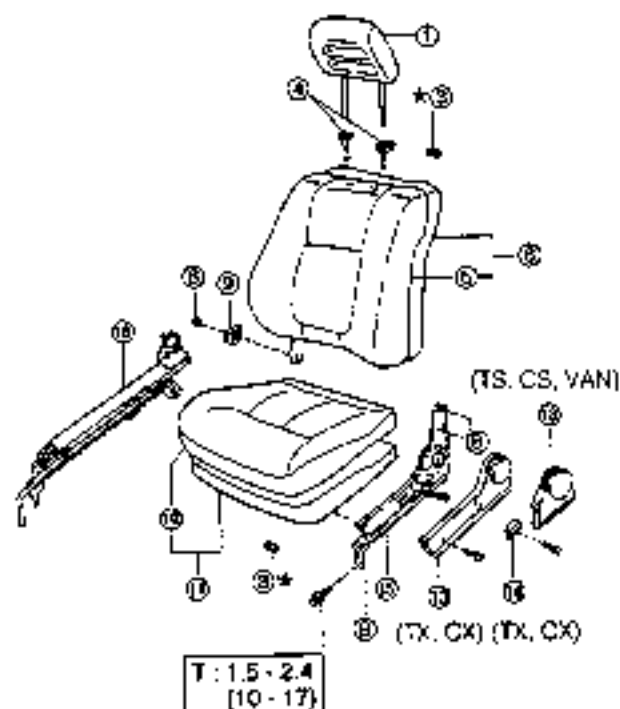

TURBO and GTd grades

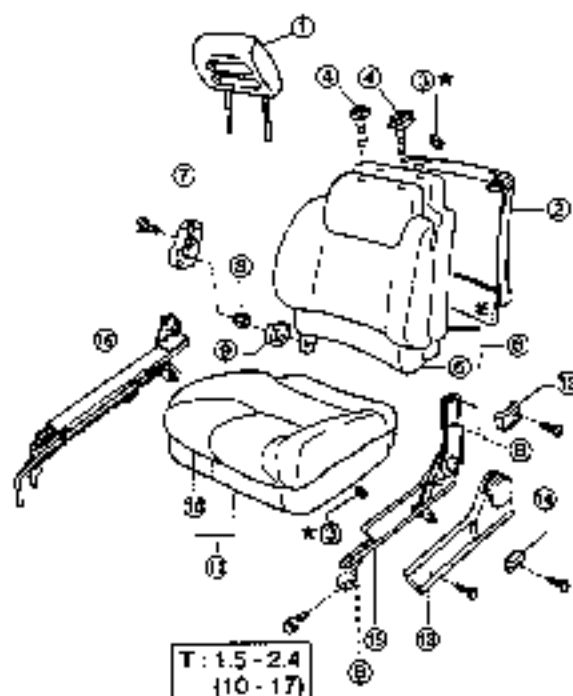

T : Tightening torque
Unit: kg-m (R-lb)
* : Non-reusable parts

- ① Headrest Ay
- ② Front seatback cover
- ③ Hug strap ring
- ④ Front headrest support
- ⑤ Front seatback cover
- ⑥ Front seatback Ay
- ⑦ Front seat hinge cover
- ⑧ Nut

- ⑨ Front seat hinge cover
- ⑩ Front seat cushion cover
- ⑪ Front seat cushion Ay
- ⑫ Reclining hinge cover
- ⑬ Front seat cushion shield
- ⑭ Adjusting reclining release handle
- ⑮ Reclining seat adjuster Ay
- ⑯ Seat track Ay

Fig. 9-315

WP-09336

REMOVAL

Remove the front seat from the vehicle by removing the four bolts.

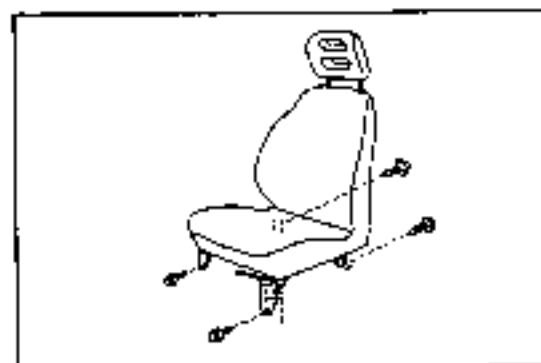

Fig. 9-317

WP-09337

DISASSEMBLY

1. Remove the headrest with the stopper pushed toward "Unlock" direction.

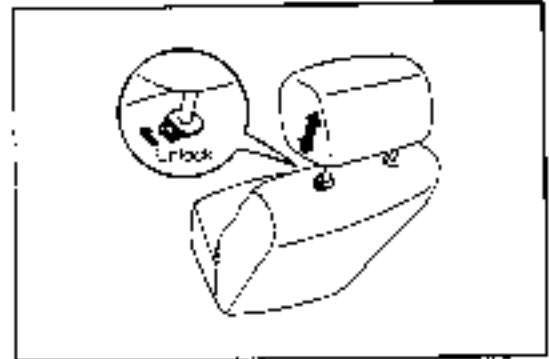

Fig. 9-318

WP-09338

2. Remove the adjusting reclining release handle by removing the one screw.
3. Remove the reclining hinge cover by removing the one screw. (TURBO and GTi grades only)

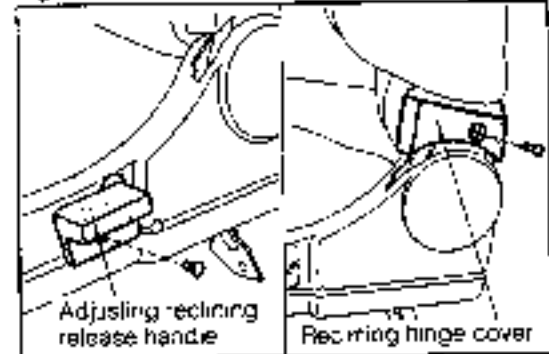

Fig. 9-319

WP-09330

4. Remove the front seat cushion shield by removing the attaching screws.
 VAN, TX and TC grades: two screws
 Except for VAN, TX and TC grades: three screws

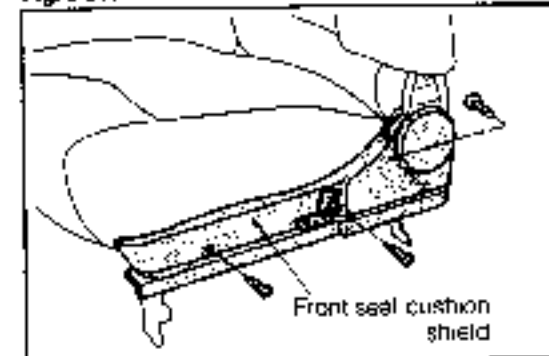

Fig. 9-320

WP-09341

5. Remove the front seat hinge cover by removing the one screw (TURBO and GTi grades only)
 Remove the front seatback cover by pulling its lower end. (TURBO and GTi grades only)

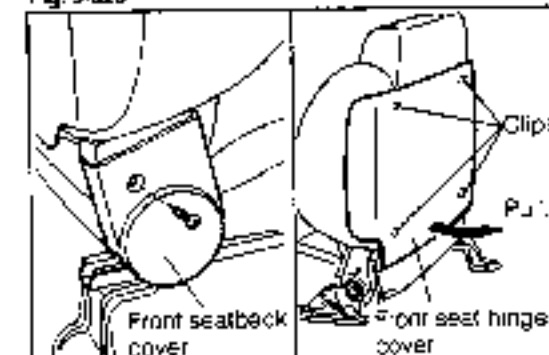

Fig. 9-321

WP-09341

7. Remove the front seatback assembly.
 - (1) Remove the four hug rings at the lower section of the seatback. (Except for TURBO and GTi grades)
 - (2) Remove the two hug rings at the reclining seat adjuster assembly side (TURBO and GTi grades only)

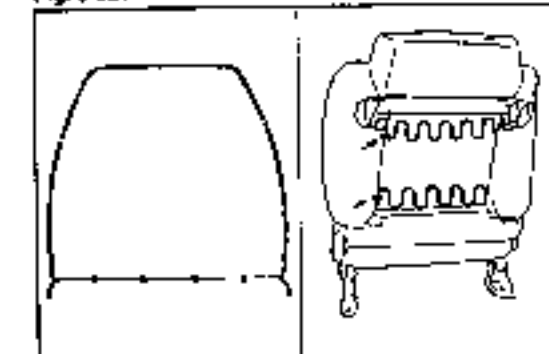

Fig. 9-322

WP-09342

BODY

- (3) Remove the seatback by removing the one nut and two bolts which are attaching the seatback.
- (4) Remove the front seat hinge cover from the seatback.

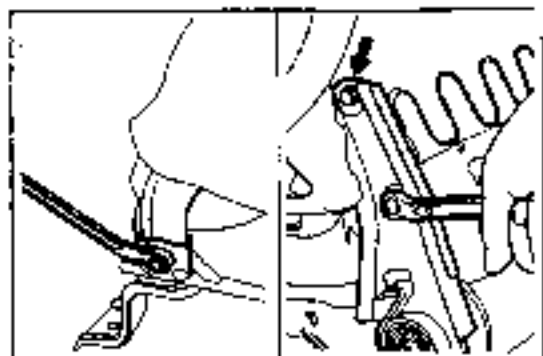

Fig. 9-323

47-09345

9. Remove the seat cushion, reclining seat adjuster assembly and seat track assembly by removing the four bolts

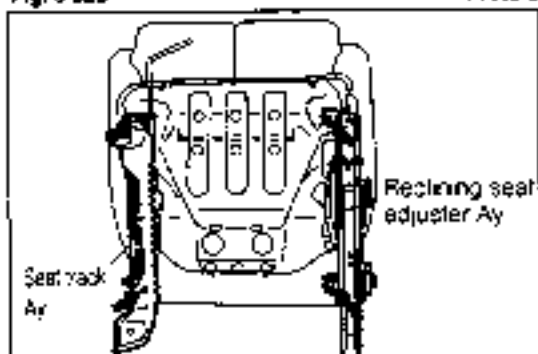

Fig. 9-324

47-09344

10. Removal of front seatback cover

- (1) Remove the hug rings at the back side of the seatback. (TURBO and GTi grades only)

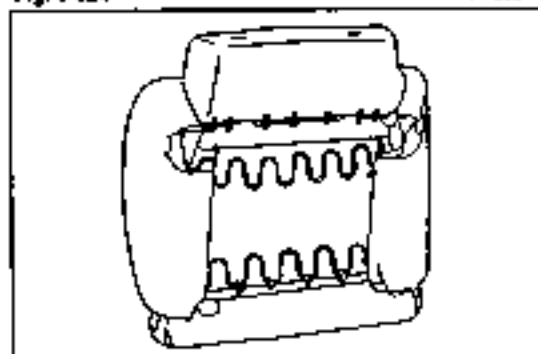

Fig. 9-325

47-09343

- (2) Remove the front headrest support by compressing the end of the front headrest support and pulling it upward by your fingers.

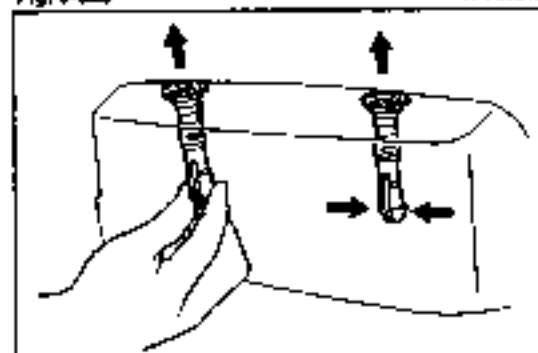

Fig. 9-326

47-09342

- (3) Turn over the front seatback cover. Remove the front seatback cover by removing the hug rings at the upper section of the seatback.

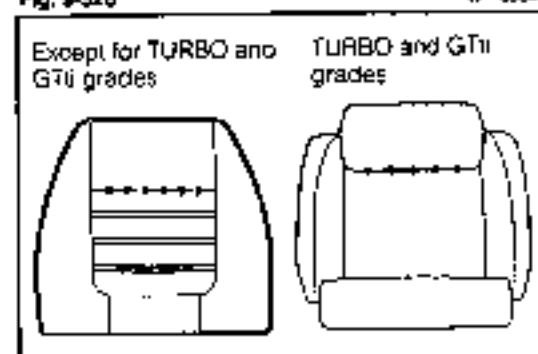

Fig. 9-327

47-09341

1. Removal of front seat cushion cover

- (1) Remove the hug rings at the back side of the front seat cushion

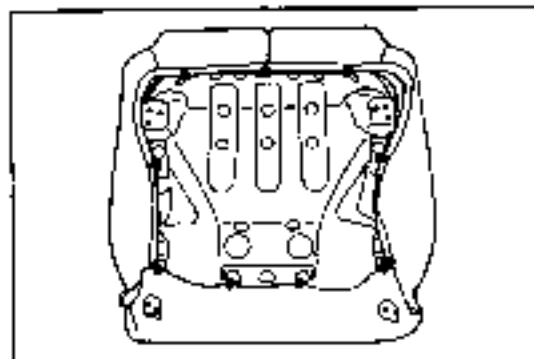

Fig. 9-328 WR-09348

- (2) Turn over the front seat cushion cover. Remove the hug rings at the front side.
- (3) Remove the front seat cushion cover.

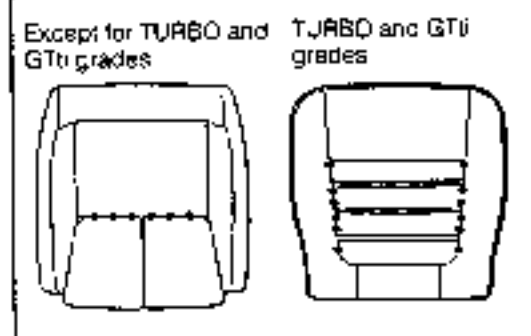

Fig. 9-329 WR-09349

ASSEMBLY

1. Installation of front seat cushion cover

- (1) Install the hug rings at the front side of the front seat cushion. (See Fig. 9-329)
- (2) Install the hug rings at the back side of the front seat cushion

NOTE:

- Be very careful not to smear or scratch the seat cover during the assembly.
- When installing the hug rings, make sure that no wrinkle is formed on the front seat cushion cover wherever possible.

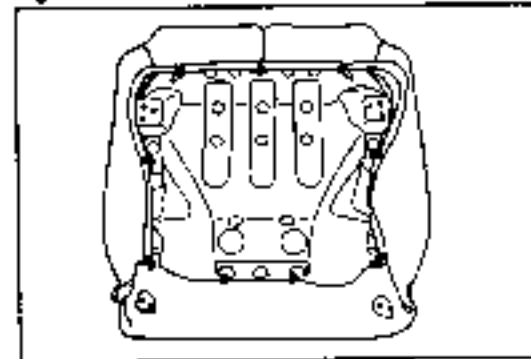

Fig. 9-330 WR-09350

2. Installation of front seatback cover

- (1) Install the hug rings at the front side of the front seatback.
- (2) Install the front headrest support.

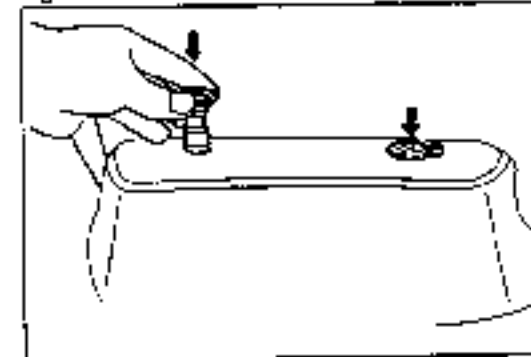

Fig. 9-331 WR-09351

- (3) Install the hug rings at the rear of the seatback at positions indicated in the right figure. (TURBO and GTi grades only)

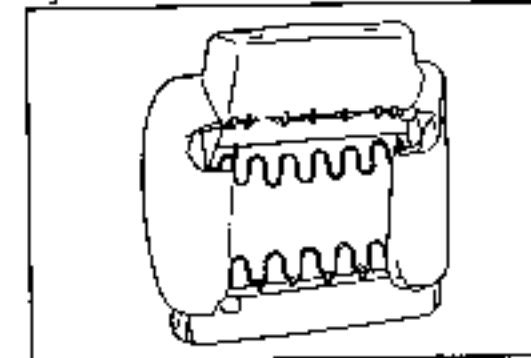

Fig. 9-332 WR-09352

BODY

3. Install the reclining seat adjuster assembly and seat track assembly to the seat cushion with the four bolts.

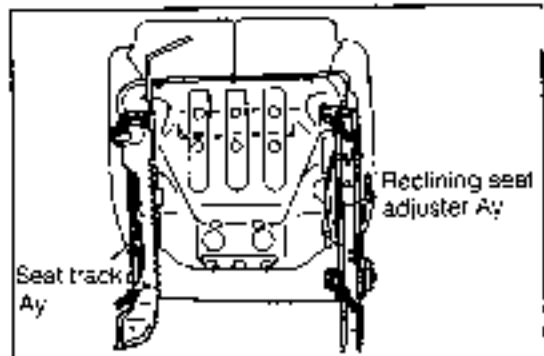

Fig. 9-333

WR-08353

4. Installation of front seatback assembly
 - (1) Install the front seat hinge cover to the front seatback assembly. Then, install them to the seat cushion with the two bolts and one nut.
 - (2) Install the hug rings from the rear of the seatback.

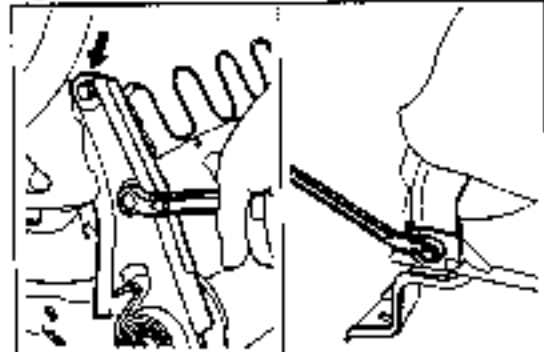

Fig. 9-334

WR-08354

5. Hook the two clips at the upper section of the front seatback cover to the seatback. Then, install the front seatback cover by pushing its lower side. (TURBO and GTti grades only)
6. Install the front seat hinge cover with one screw. (TURBO and GTti grades only)

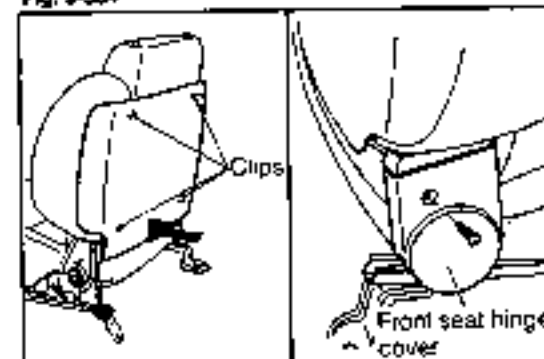

Fig. 9-335

WR-08355

7. Install the front seat cushion shield with the screws
VAN, TC and TX grades: Two screws
Except for VAN, TC and TX grades: Three screws

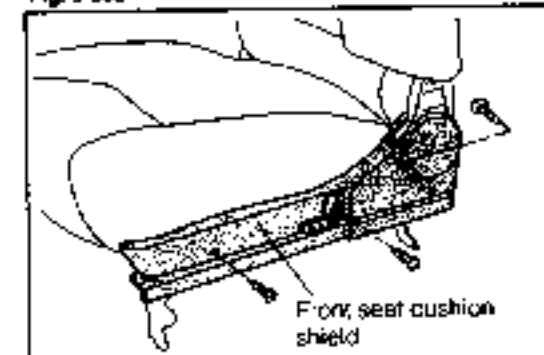

Fig. 9-336

WR-08356

8. Install the reclining hinge cover with the one screw. (TURBO and GTti grades only)
9. Install the adjusting reclining release handle with the one screw.
10. Install the headrest

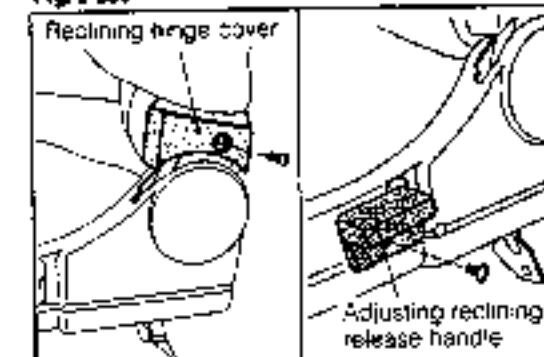

Fig. 9-337

WR-08357

INSTALLATION

Install the front seat with the four bolts.

Tightening Torque: 1.5 - 2.4 kg-m (11 - 17 ft-lb)

REAR SEAT COMPONENTS

Seatback

(Bench type)

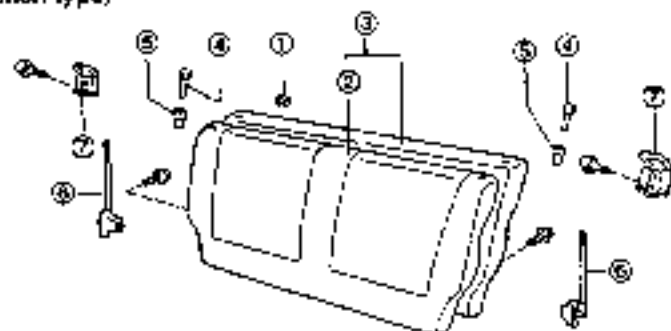

- ① Hug ring
- ② Rear seatback cover
- ③ Rear seatback Ay
- ④ Rear seatback stop release button
- ⑤ Rear seatback stop button grommet
- ⑥ Rear seatback lock Ay
- ⑦ Rear seatback lock striker S/A

(Split type)

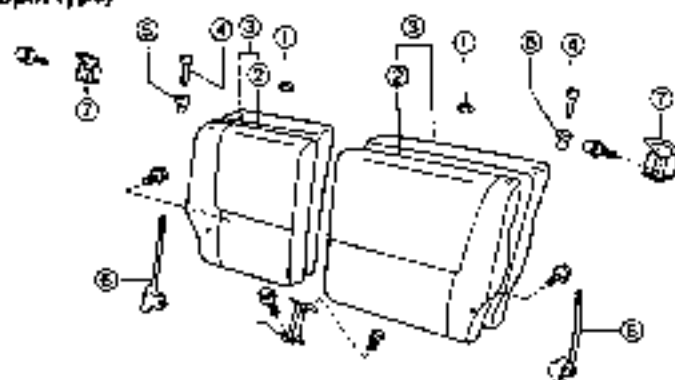

Seat Cushion

(Fixed type)

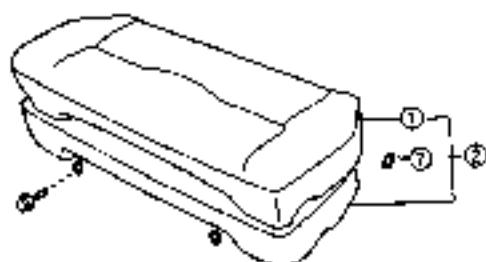

- ① Rear seat cushion cover
- ② Rear seat cushion Ay
- ③ Rear seat turn lock Ay
- ④ Cushion
- ⑤ Rear seat cushion hinge cover
- ⑥ Rear seat cushion hinge Ay
- ⑦ Hug ring

(Rise-up type)

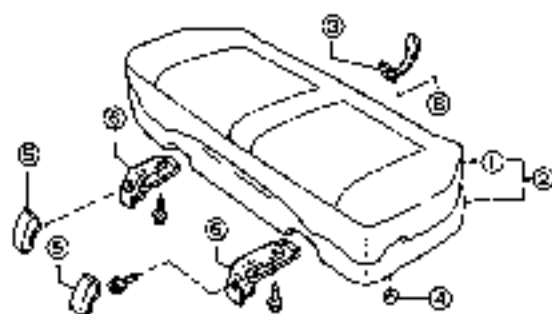

Fig. B-338

W7-09152

BODY

REAR SEATBACK ASSEMBLY

Removal

1. Removal of rear seatback assembly
 - (1) Turn over the deck carpet. Remove the attaching bolts of the rear seatback assembly.
Bench type: Bolts 4 pcs.
Split type: Bolts 8 pcs.
 - (2) Remove the rear seatback assembly from the vehicle

Disassembly

1. Remove the deck carpet from the rear seatback assembly by detaching the clips.
Bench type: Clips 10 pcs.
Split type: Clips 14 pcs.

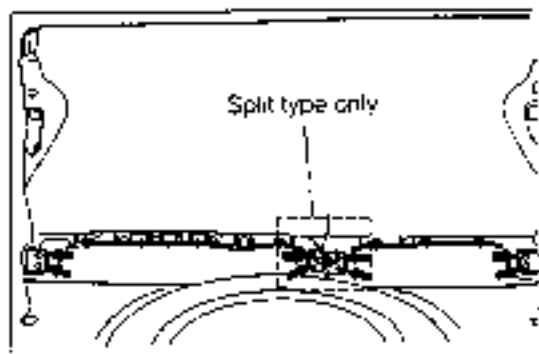

Fig. 9-339

WF-C9399

Bench type



Split type

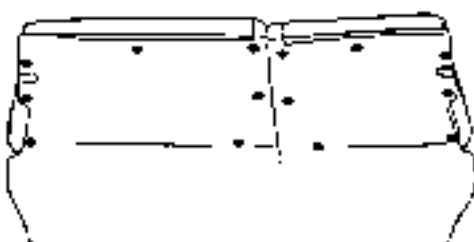

● Clip positions

Fig. 9-340

WF-C9300

2. Detach the rear seatback stop release buttons and rear seatback stop button grimmets from the rear seatback assembly.

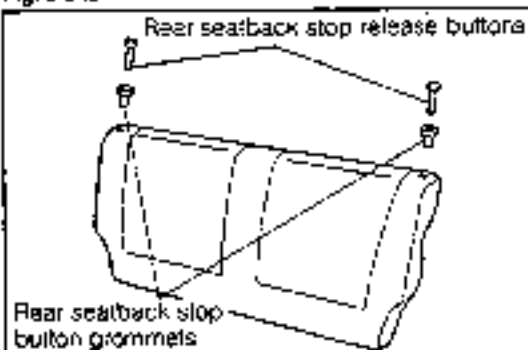

Fig. 9-341

WF-C9261

3. Removal of rear seatback cover
 - (1) Detach the hug rings at the back side of the rear seatback.

Bench type



Fig. 9-342

WF-C9362

- (2) Turn over the rear seatback cushion cover. Detach the hug rings at the front side
- (3) Remove the rear seatback cushion cover

Assembly

1. Installation of rear seatback cover
 - (1) Install the hug rings at the front side of the rear seatback.
 - (2) Install the hug rings at the back side of the rear seatback.
- NOTE:**
- Be very careful not to smear or scratch the rear seatback cover during the assembly.
 - When installing the hug rings, make sure that no wrinkle is formed on the rear seatback cover whenever possible.
2. Install the rear seatback stop button grommets and rear seatback stop release buttons on the rear seatback assembly.
 3. Install the deck carpet on the rear seatback assembly with the clips. (See Fig. 9-340.)
 - Bench type: Clips 10 pcs.
 - Split type: Clips 14 pcs.

Installation

1. Installation of rear seatback assembly
 - (1) Temporarily install the rear seatback assembly on the vehicle with the bolts.
 - Bench type: Bolts 4 pcs.
 - Split type: Bolts 8 pcs.
- NOTE:**
- The rear seatback attaching bolts should be installed at those positions specified in the right figure.
- (2) Tighten the bolts.
 - Tightening Torque: 0.4 - 0.7 kg·m (2.9 - 5.1 ft·lb)

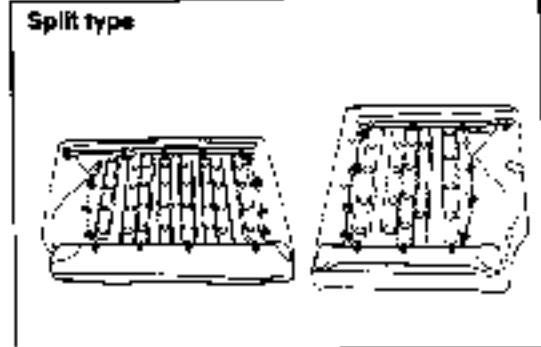

Fig. 9-343 WR-00363

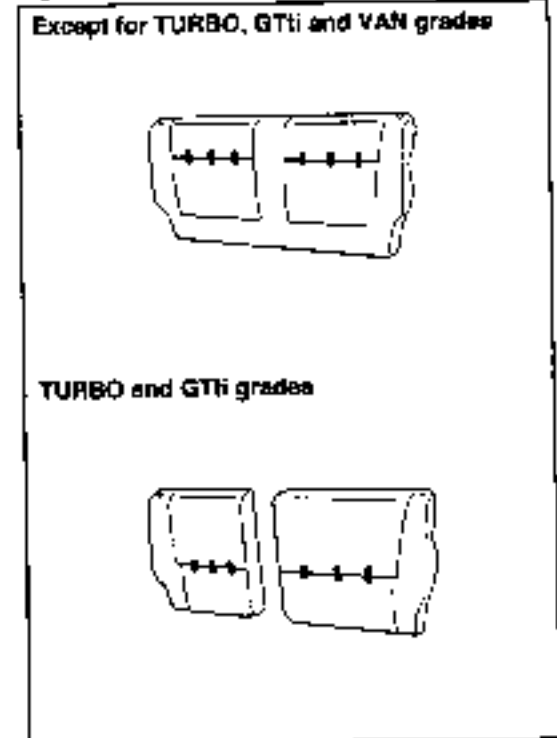

Fig. 9-344 WF-09254

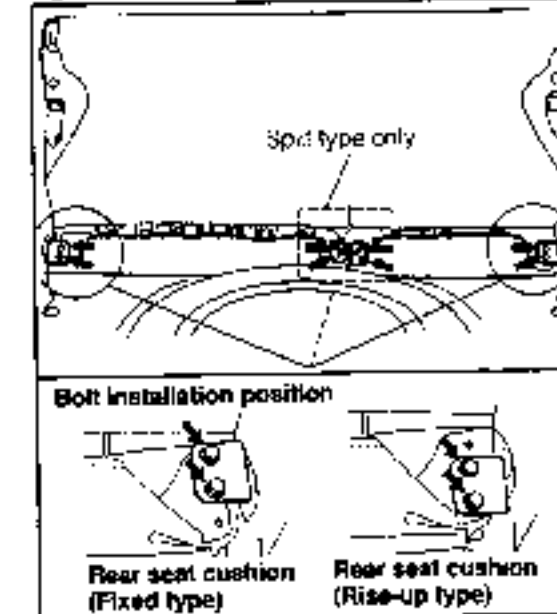

Fig. 9-345 WF-09265

BODY

REAR SEAT CUSHION ASSEMBLY

Removal

1. Removal of fixed type rear seat cushion
 - (1) Remove the rear seatback assembly (See Fig 9-339.)
 - (2) Remove the two attaching bolts of the rear seat cushion assembly.
 - (3) Slightly raise the forward section of the rear seat cushion assembly and push it backward so as to disengage the hook.
 - (4) Remove the rear seat cushion assembly from the vehicle.
2. Removal of rise-up type rear seat cushion assembly
 - (1) Remove the hinge cover.
 - (2) Remove the rear seat cushion hinge attaching bolts.
 - (3) Pull the belt and disengage the lock.
 - (4) Remove the rear seat cushion assembly from the vehicle.

Disassembly

1. Detach the lug rings at the back side of the rear seat cushion assembly. (Fixed type only)
2. Remove the rear seat cushion hinge assembly and rear seat turn lock assembly. (Rise-up type only)
3. Remove the rear seat cushion cover from the rear seat cushion frame. (Rise-up type only)

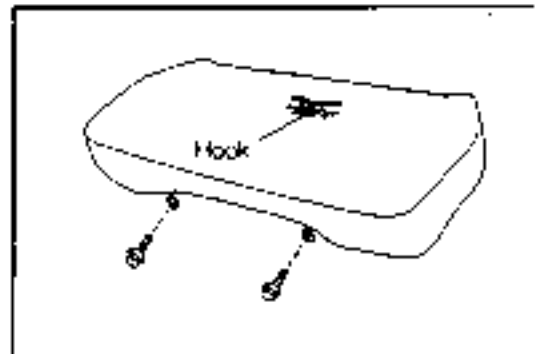

Fig. 9-346

WF-08265

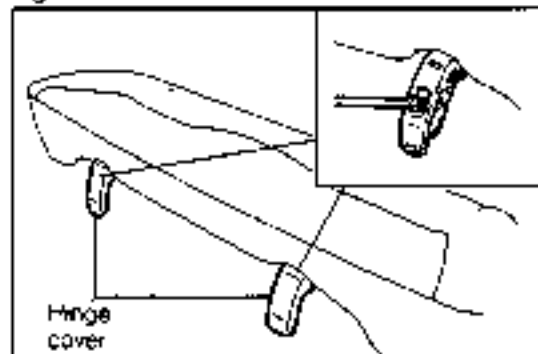

Fig. 9-347

WF-08357

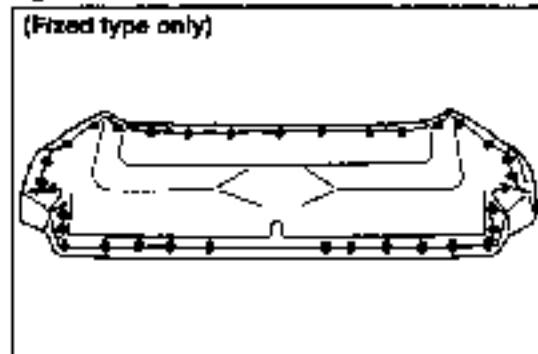

Fig. 9-348

WF-08388

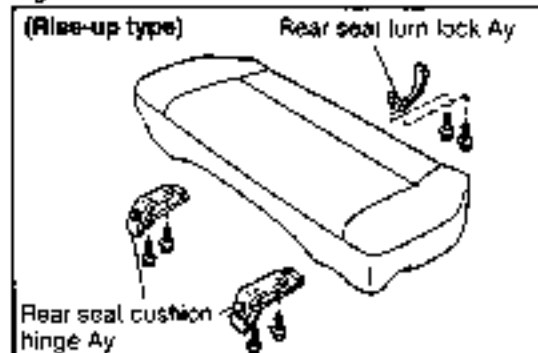

Fig. 9-349

WF-08389

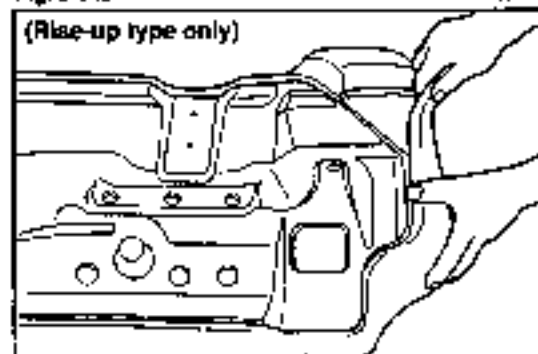

Fig. 9-350

WF-08370

Turn over the rear seat cushion cover. Detach the hug rings at the front side of the cover.

5. Remove the rear seat cushion cover.

Assembly

1. Install the hug rings at the front side of the rear seat cushion.
2. Install the hug rings at the back side of the rear seat cushion. (Fixed type only)
3. Attach the rear seat cushion cover to the rear seat cushion frame. (Rise-up type only)

NOTE.

- Be very careful not to smear or scratch the rear seat cushion cover during the assembly
- When installing the rear seat cushion cover, make sure that no wrinkle is formed whenever possible.

4. Install the rear seat cushion hinge assembly and rear seat turn lock assembly on the back side of the rear seat cushion. (Rise-up type only)

Installation

1. Installation of fixed type rear seat cushion assembly
 - (1) Align and engage the hook at the rear seat cushion side with the hook at the floor side, as indicated in the right figure.
 - (2) Install the rear seat cushion assembly with the two bolts.

Tightening Torque: 1.5 - 2.4 kg-m (11 - 17 ft-lb)
 - (3) Install the rear seatback assembly. (See Fig. 9-345.)

2. Installation of rise-up type rear seat cushion assembly
 - (1) Temporarily install the attaching bolts of the rear seat cushion hinge assembly.
 - (2) Ensure that the rear seat turn lock is functioning properly.
 - (3) Tighten the attaching bolts of the rear seat cushion hinge assembly.

Tightening Torque: 1.5 - 2.4 kg-m (11 - 17 ft-lb)
 - (4) Install the hinge cover.

Except for TURBO and GTI grades



TURBO and GTI grades



Fig. 9-351

WR-0371

Rear seat turn lock Ay

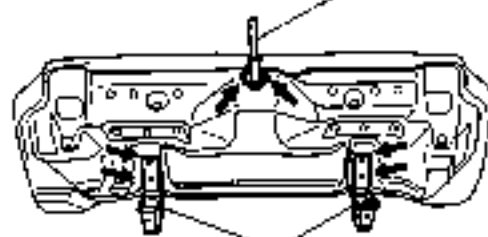

Rear seat cushion hinge Ay

Fig. 9-352

WR-0372

Hook

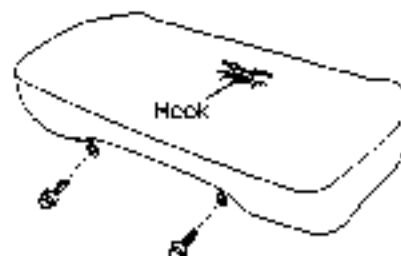

Fig. 9-353

WR-0373

Hinge cover

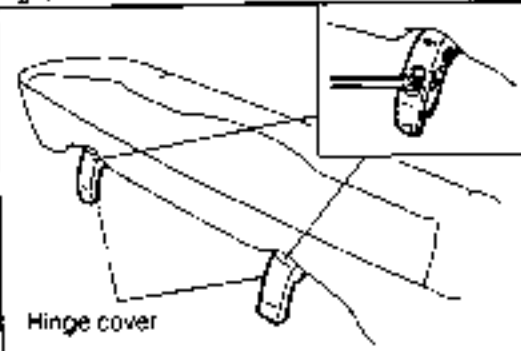
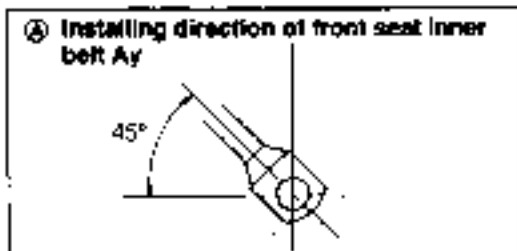
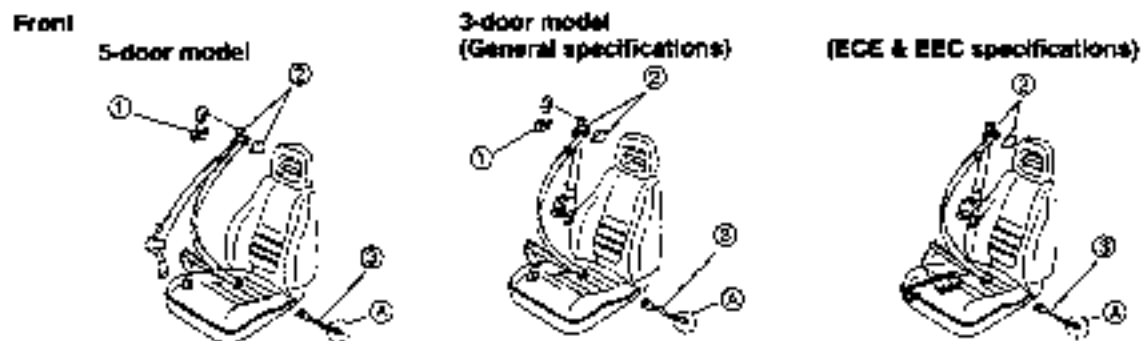

Fig. 9-354

WR-0374



**Bolt Tightening Torque T: 2.9 - 5.4 kg-m
21 - 39 ft-lb**

- ① Front seat belt adjuster Ay
- ② Front seat outer belt Ay
- ③ Front seat inner belt Ay

Rear **2-point (NR) × 3** **3-point (NR) × 2 and 2-point (NR)** **3-point (ELR) × 2 and 2-point (NR)**

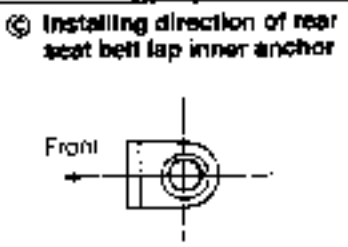
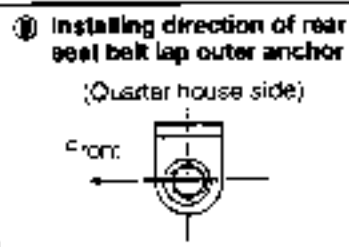
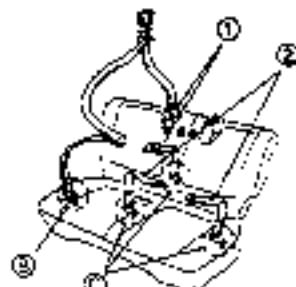
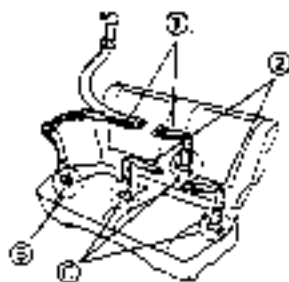
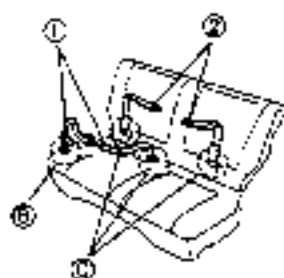

**Bolt Tightening Torque T: 2.9 - 5.4 kg-m
21 - 39 ft-lb**

- ① Rear seat lap belt Ay
- ② Rear seat lap center belt Ay

Fig. 9-356

WR-09375

Inspection

ELR Locking Check

Slowly tilt the retractor from the installation angle. Ensure that no belt locking takes place within 15 degrees in all directions. Also, ensure that the locked state is retained when the retractor is tilted 45 degrees or more.

NOTE:

- Never attempt to disassemble the retractor.
- After the anchor bolts have been tightened, make sure that each anchor can move in the bolt's circumferential direction.
- Be sure that the belt in the installed state can be pulled out smoothly and also it can be retracted smoothly into position.

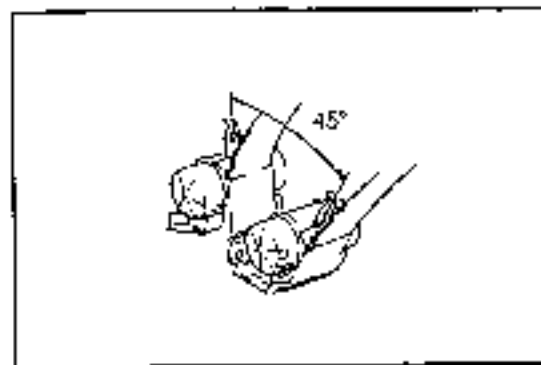
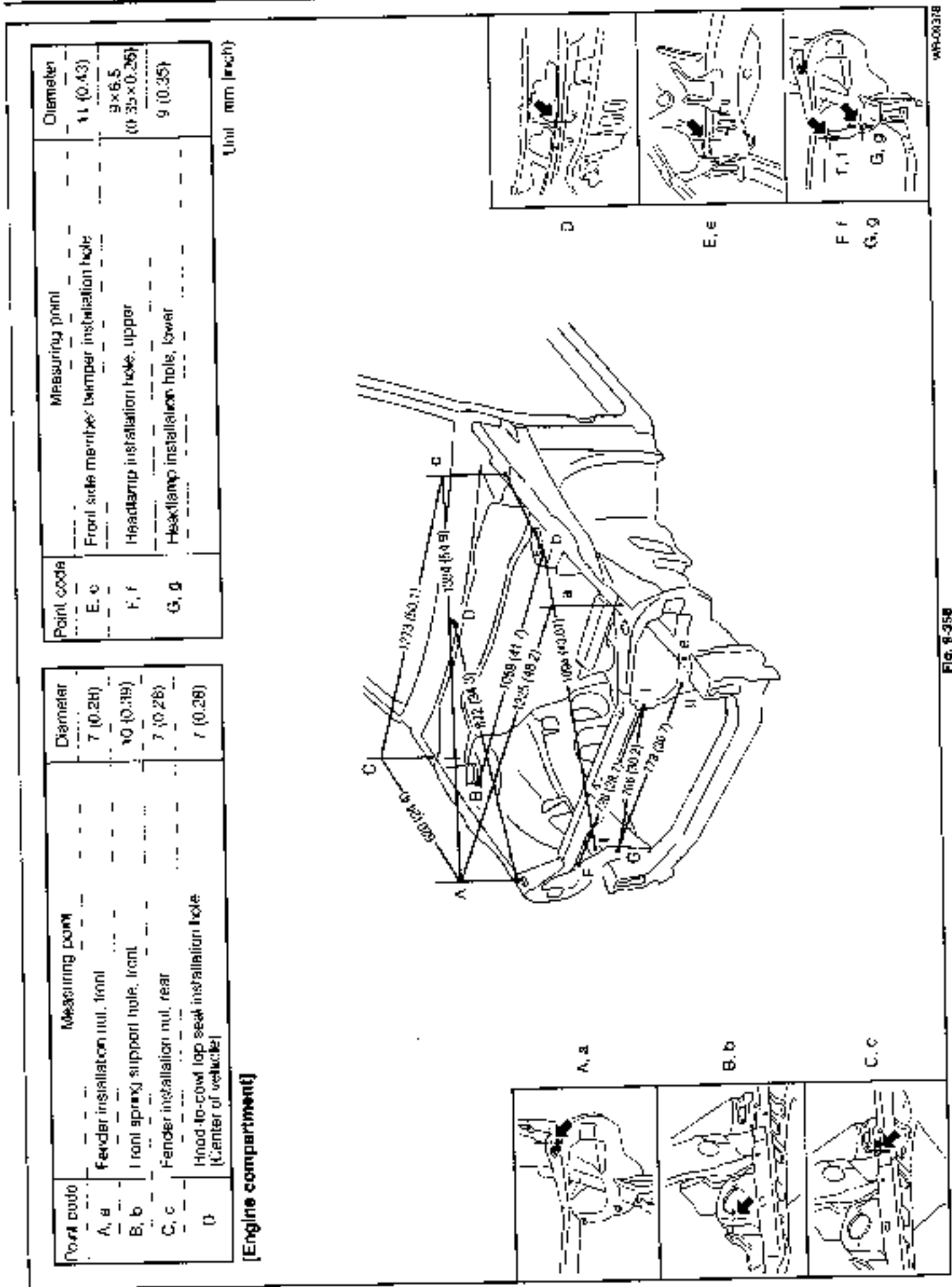

Fig. 9-356

WR-0937E



WP-08378

FIG. 9-358

DAIHATSU

CHARADE

Chassis

SECTION 10 BODY ELECTRICAL SYSTEM

HANDLING INSTRUCTIONS	10- 3	CROSS COIL TYPE GAUGE CIRCUIT	10-27
HANDLING AND INSTRUCTION OF		FUEL RECEIVER GAUGE	10-27
WITH LOCK TYPE CONNECTOR	10- 3	FUEL SENDER GAUGE	10-28
REPLACEMENT	10- 3	WATER TEMPERATURE RECEIVER GAUGE	10-28
WIRING HARNESSSES	10- 4	WATER TEMPERATURE SENDER GAUGE	10-29
SCHEMATIC DIAGRAM	10- 4	WARNING AND INDICATOR SYSTEM	10-30
FUSES	10- 5	BRAKE LEVEL WARNING LAMP	10-30
FUSIBLE LINK BLOCK	10- 8	PARKING BRAKE SWITCH	10-30
LAMPS	10-10	BRAKE LEVEL WARNING SWITCH	10-31
TROUBLE SHOOTING	10-10	OIL PRESSURE WARNING LAMP	10-31
CLEARANCE LAMP	10-11	OIL PRESSURE SWITCH	10-31
HEADLAMP	10-11	FUEL DRAIN WARNING LAMP	10-31
FRONT TURN SIGNAL LAMP	10-14	SHIFT INDICATOR LAMP	10-32
SIDE TURN SIGNAL LAMP	10-14	DIMMER DEVICE FOR TURBO AND AT	
LICENSE PLATE LAMP	10-15	INDICATORS	10-33
REAR COMBINATION LAMP	10-16	MULTI-USE LEVER SWITCH	10-34
ROOM LAMP	10-17	LIGHTING SWITCH	10-35
LUGGAGE ROOM LAMP	10-18	TURN SIGNAL AND HAZARD SWITCH	10-36
COMBINATION METER	10-19	TURN SIGNAL FLASHER	10-37
COMPONENTS	10-20	FRONT WIPER AND WASHER SWITCH	10-37
SINGLE-METER TYPE	10-21	CONTINUITY TABLE OF MULTI-USE LEVER	
TWO-METER TYPE	10-22	SWITCH BY DESTINATION	10-38
FUEL GAUGE AND WATER			
TEMPERATURE GAUGE	10-24		
FUEL RECEIVER GAUGE	10-24		
FUEL SENDER GAUGE	10-25		
WATER TEMPERATURE RECEIVER GAUGE	10-26		
WATER TEMPERATURE SENDER GAUGE	10-26		

(To be continued)

SWITCHES	10-47	POWER GLASS SUN ROOF	10-71
IGNITION KEY SWITCH	10-47	CIRCUIT DIAGRAM	10-77
STOP LAMP SWITCH	10-47	SUN ROOF SWITCH	10-77
REAR WINDOW DEFOGGER SWITCH	10-48	SUN ROOF MOTOR	10-78
REAR WINDOW DEFOGGER WIRE	10-49	HEATER	10-79
FRONT WIPER AND WASHER	10-50	HEATER UNIT	10-79
FRONT WIPER CIRCUIT DIAGRAM	10-50	HEATER CONTROL ASSEMBLY	10-83
FRONT WIPER AND BLADES	10-50	RADIO	10-87
FRONT WASHER TANK	10-54	RELATED PARTS	10-87
FRONT WIPER CONTROL RELAY	10-55	SPEAKER ASSEMBLY AND ANTENNA	
REAR WIPER AND WASHER	10-57	ASSEMBLY	10-88
REAR WIPER MOTOR AND BLADE	10-57	RELATED PARTS	10-88
REAR WASHER TANK	10-61	HEADLAMP CLEANER	10-90
REAR WIPER AND WASHER SWITCH	10-62	OPERATION CHECK	10-90
ELECTRICAL REMOTE CONTROL		NOZZLE	10-90
DOOR MIRROR	10-63	ADJUSTING PROCEDURE FOR	
DOOR MIRROR SWITCH	10-63	NOZZLE INJECTION ANGLE	10-91
ELECTRICAL REMOTE CONTROL		HEADLAMP WASHER TANK	10-92
DOOR MIRROR	10-64	DIM-DIP LAMP	10-93
CENTRAL DOOR LOCK	10-67	CIRCUIT DIAGRAM	10-93
DOOR LOCK SWITCH AND SOLENOID	10-67	OPERATION CHECK	10-93
DOOR LOCK SWITCH	10-69	DAY-LIGHT DELAY	10-94
DOOR CONTROL RELAY	10-69	CIRCUIT DIAGRAM	10-94
POWER WINDOW	10-71	OPERATION CHECK	10-94
CIRCUIT DIAGRAM	10-71		
POWER WINDOW MASTER SWITCH	10-71		
POWER WINDOW SWITCH	10-74		
POWER WINDOW REGULATOR MOTOR	10-74		
CIRCUIT BREAKER	10-75		

HANDLING INSTRUCTIONS OF WITH LOCK TYPE CONNECTOR

HANDLING AND INSPECTION

Removal

To disconnect the connector, simply pull out the connector while the lock lever is being pressed down, as indicated in the right figure.

Inspection

When you conduct continuity checks or voltage checks using a circuit tester, if you insert a test prod from the connector side, it is impossible to get an adequate fitting. Hence, be sure to positively insert the test prod from the harness side, as indicated in the right figure.

REPLACEMENT

Removal

- (1) From the aperture, insert a miniature type common screwdriver into between the locking lug and the terminal.
- (2) While the locking lug is being pried upward by means of a screwdriver, pull out the terminal from the backside.

Installation

- (1) Insert the terminal, until the locking lug is locked positively.
- (2) Ensure that the locking lug is locked positively by raising the wire.

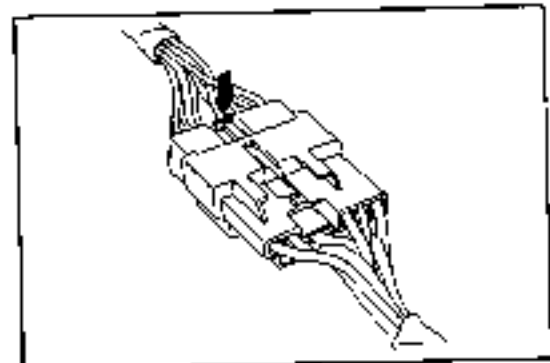

Fig. 10-1

WR-10002

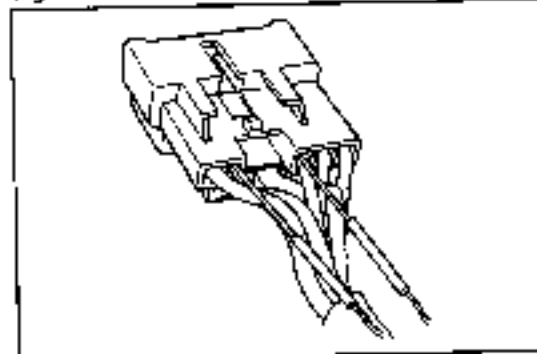

Fig. 10-2

WR-10003

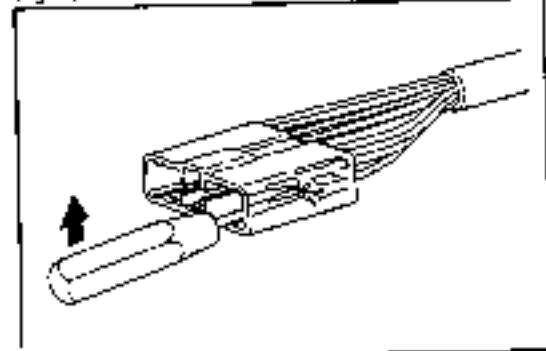

Fig. 10-3

WR-10004

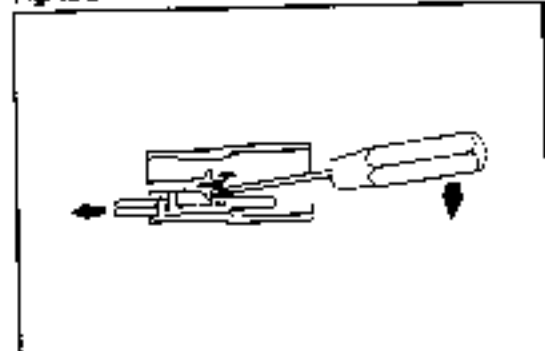

Fig. 10-4

WR-10005

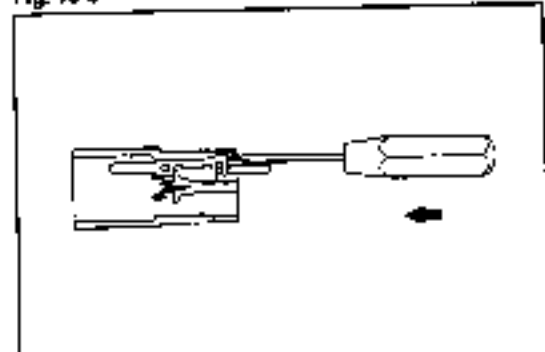

Fig. 10-5

WR-10006

BODY ELECTRICAL SYSTEM

WIRING HARNESSES

SCHEMATIC DIAGRAM

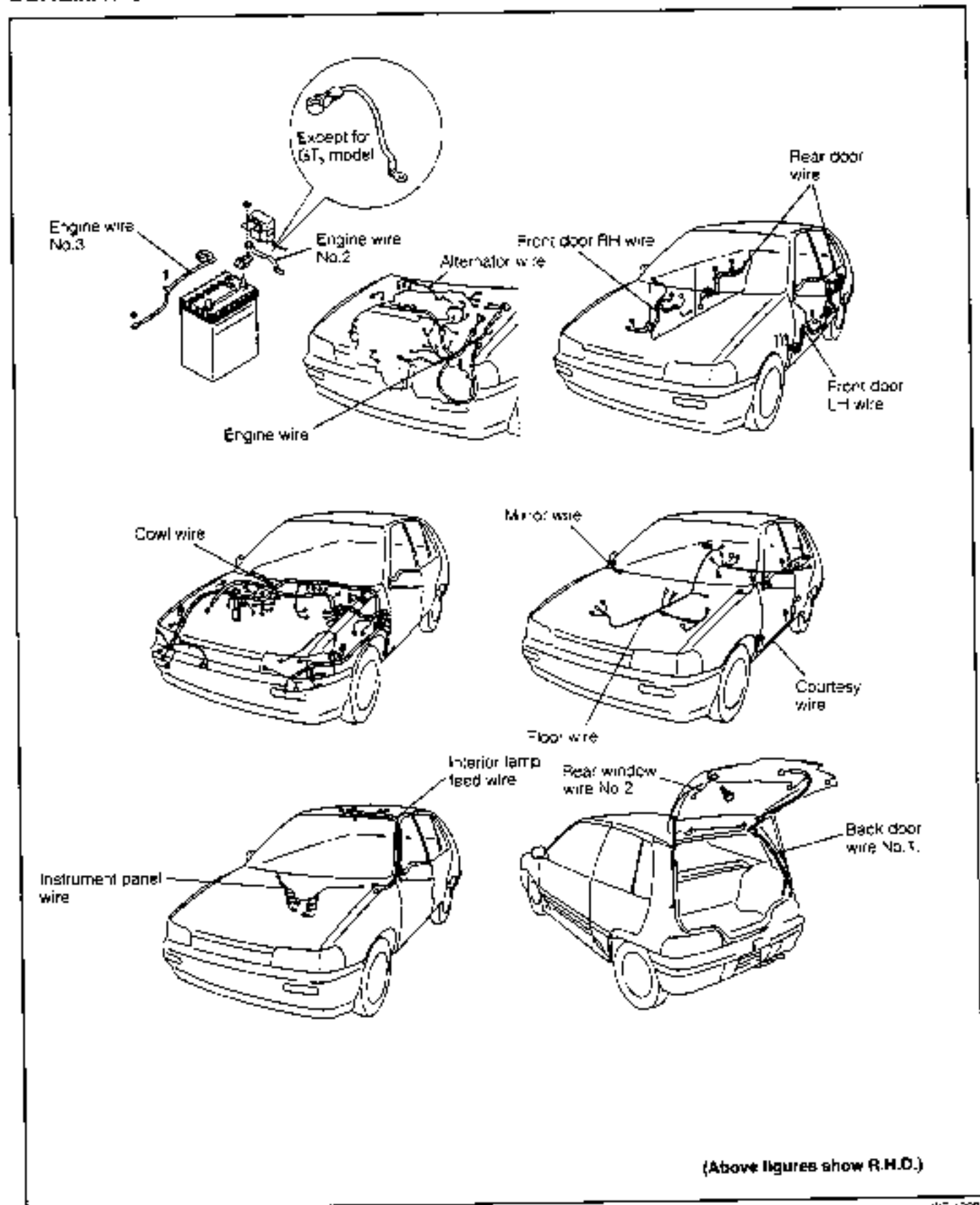

Fig. 10-8

W-1-0007

USES

Fuse Block

The fuse block is located below the steering post, at the driver's seat side.

Detach the cover, as required, by removing the two screws.

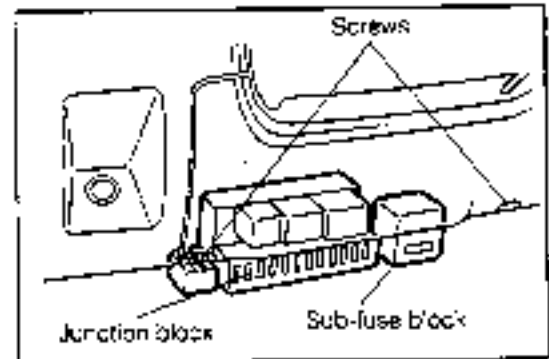
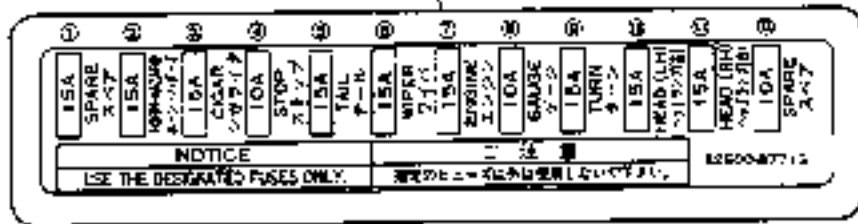
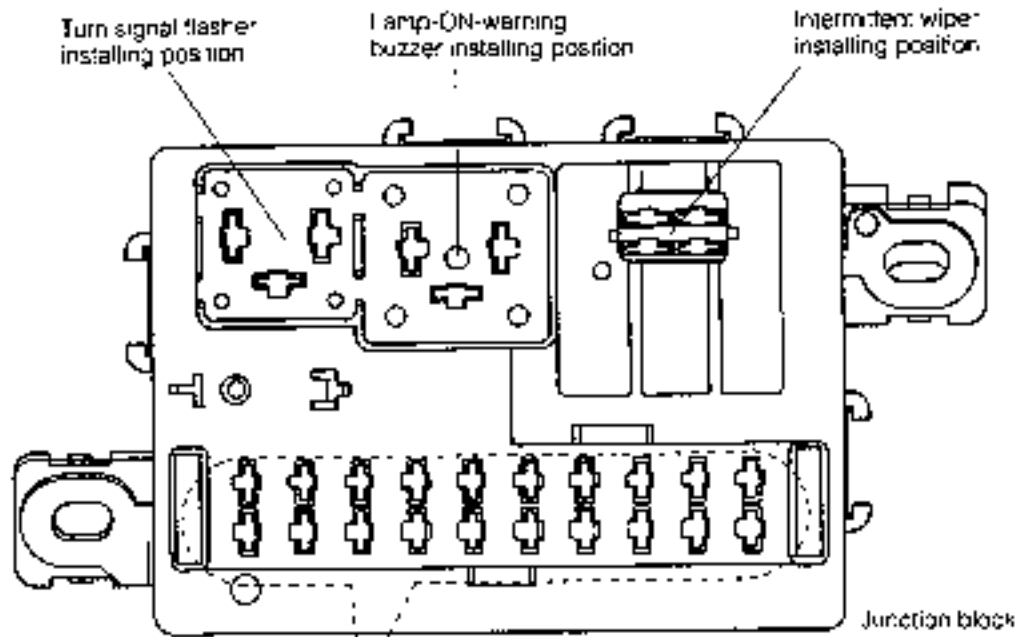

Fig. 10-7

AF-10026



Except for West German specifications

West German specifications only

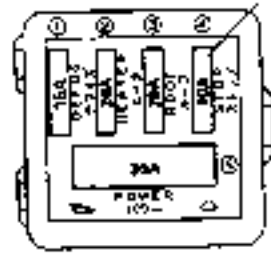

Sub-fuse block

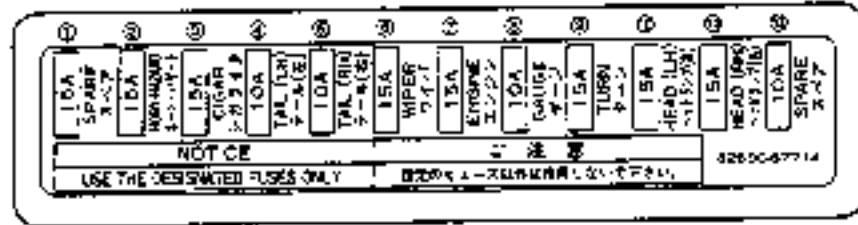

For West German specifications

Fig. 10-8

AF-1008

BODY ELECTRICAL SYSTEM

Fuse replacement

The fuse replacement must be made at all times by using a new fuse with the correct amperage

NOTE:

- (1) Before any fuse is replaced, be certain to turn OFF all electrical equipment and ignition switch. Never use any fuse in excess of the designated rating.
- (2) Be sure to employ a puller for removing/installing fuses. Also, the removal/installation of fuses must be performed straight.

If the fuse is removed or installed in a twisted condition, the terminal will be expanded unduly, resulting in poor contact.

If any fuse is blown out repeatedly, the likelihood is that there exists a short in the relevant system. Hence, perform checks for possible systems, referring to Page 10-9 and Section 11 under "Wiring Diagram."

Relay and fuse block

(Vehicles mounted with Type CB-80 engines)

The relay and fuse block are located next to the battery in the engine compartment.

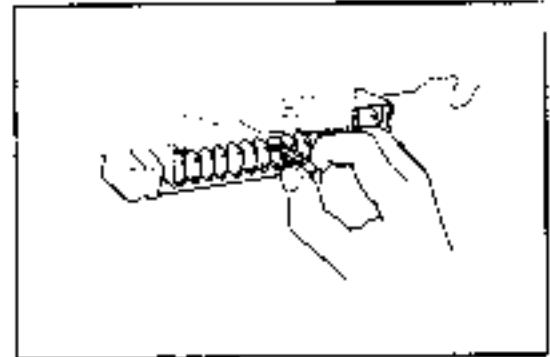

Fig. 10-9

WR 1001

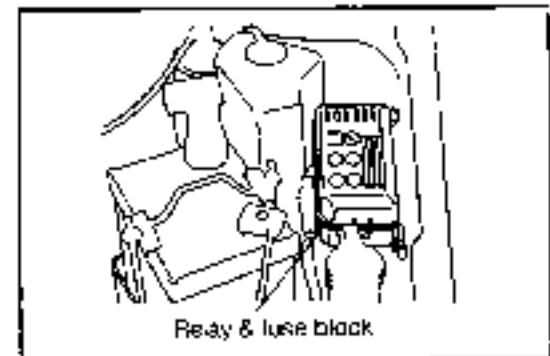

Fig. 10-10

WR 1001

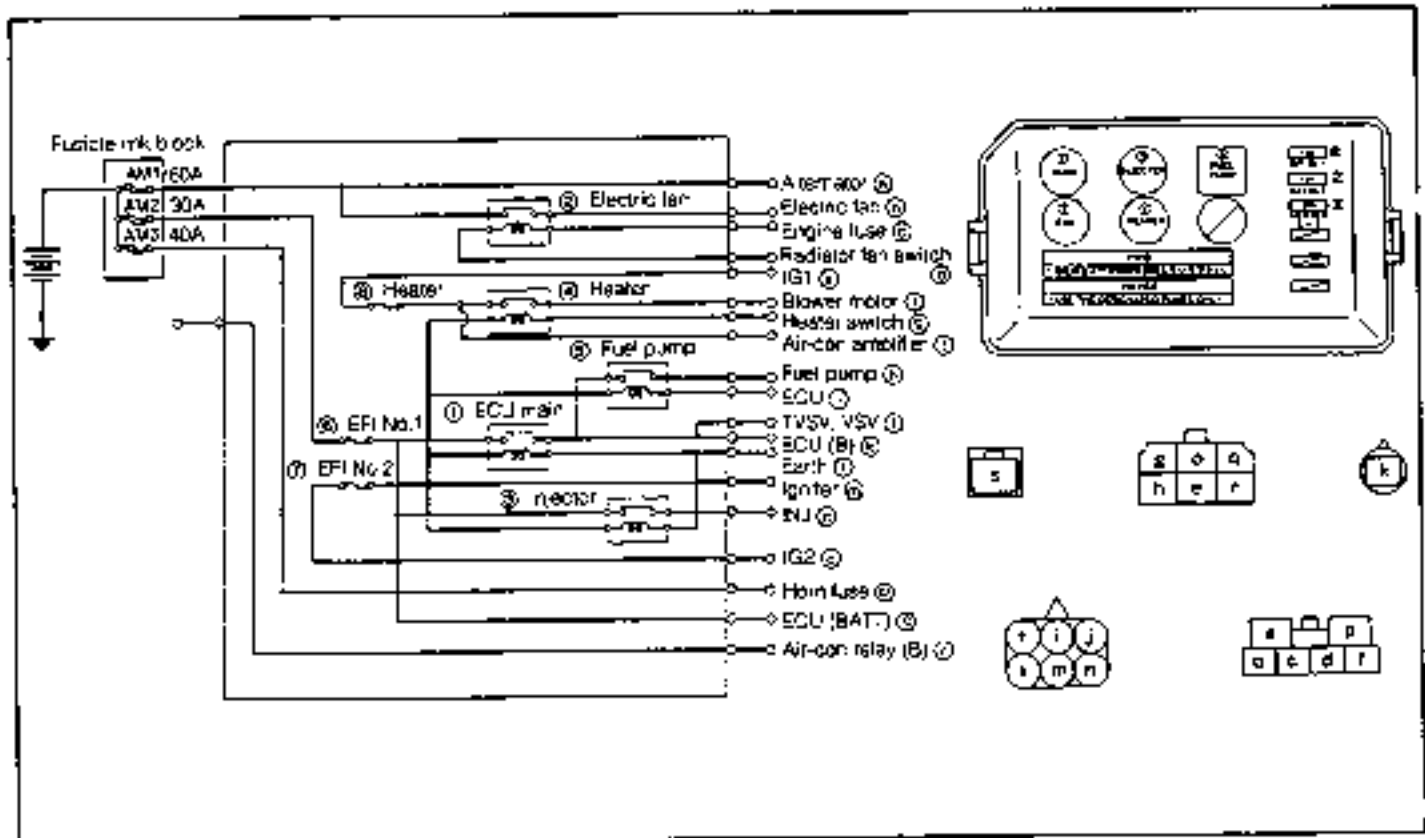

Fig. 10-11

WR 10012

unction block circuit diagram

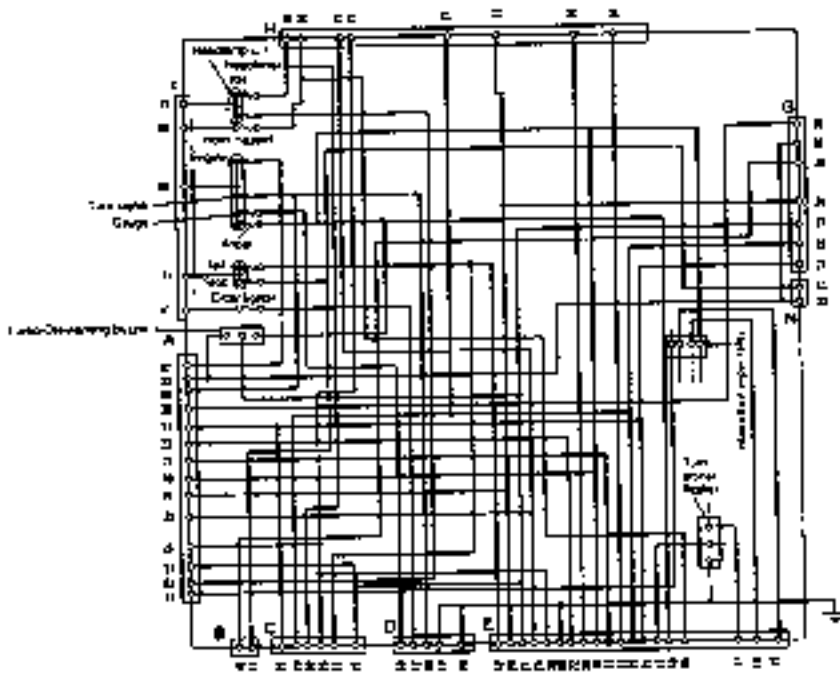
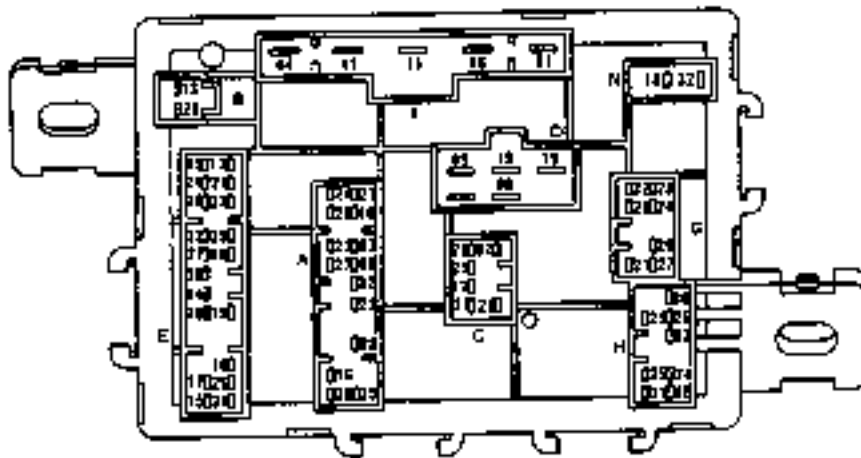

Fig. 10-12

WH-10010

Connectors

Code	Connected system	Code	Connected system
A	Cowl harness	H	Cowl harness
B	Cowl harness	I	Cowl harness
C	Cowl harness	N	—
D	Cowl harness	K	Intermittent wiper relay
F	Multi-use lever switch harness	L	Lamp-On-warning buzzer relay
G	—	M	Flasher relay

TR65-C8004

BODY ELECTRICAL SYSTEM

FUSIBLE LINK BLOCK (Vehicles Mounted with Type CB-80 Engine)

On vehicles mounted with Type CB-80 engine, a cartridge type fusible link block is employed.

Replacement

1. If visual inspection reveals that the fusible link is blown out, replace it with a new fusible link with the designated rating.

NOTE:

1. Before the fusible link is replaced, be sure to turn OFF the ignition key.
 2. Care must be exercised to ensure that the fusible link is not twisted during the removal/installation. If the fusible link is replaced forcibly, it will cause breakage or poor contact.
-
2. If the fusible link is blown out repeatedly, the likelihood is that there exists a short in the relevant system. Hence, perform checks for possible systems, referring to Page 10-5 and Section " " under "Wiring Diagram."

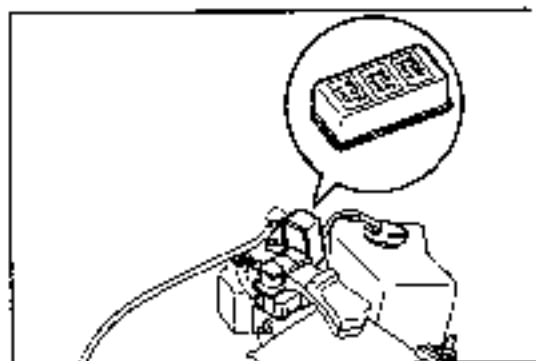

Fig. 10-13

W9-10014

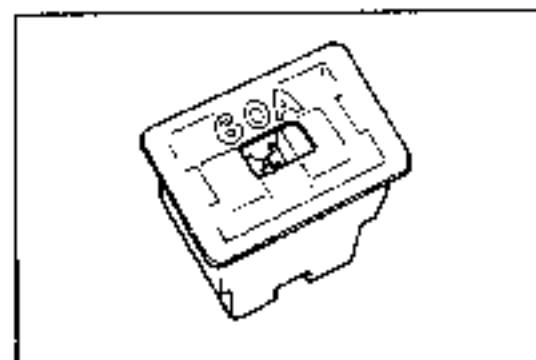

Fig. 10-14

W9-10015

BODY ELECTRICAL SYSTEM

use Connecting Circuits

Fuse nomenclature	Capacity (A)	Connecting circuit	Remarks
HORN-HAZARD	15	Horn, Hazard	
CIGAR	15	Cigar lighter, Clock, Electric remote control door mirror	
STOP	10	Stop lamp, Room lamp, Luggage lamp, clock (for West Germany)	
TAIL (LH)	10	Tail lamp (LH), Clearance lamp (LH), License lamp, Rear fog lamp	West German specifications only
TAIL	15	Clock, License lamp, Clearance lamp, Tail lamp, Meter illumination, Heater control illumination, Ashtray illumination, Day-light relay, Dim-up relay, Rheostat (for AUS), A/TECU (B)	Except for West German specifications
TAIL (RH)	10	Tail lamp (RH), Clearance lamp (RH), Ashtray illumination, Meter illumination	West German specifications only
WIPER	15	Front wiper, Rear wiper, Headlamp cleaner	
ENGINE	15	Alternator, Radiator fan motor, Fuel pump relay (CB), CSD switch (CL), Fuel cut governor (CL), Outer vent solenoid (CB), Fuel cut solenoid (CB), Vacuum warning relay, Day-light relay, Dim-dio relay	
GAUGE	10	Meter	
TURN	15	Back lamp switch, Lamp-ON-warning buzzer	
HEADLAMP (LH)	15	Headlamp (LH)	
HEADLAMP (RH)	15	Headlamp (RH), High-beam indicator	
DEFOG	15	Rear window defogger	
HEATER	20	Heater Blower motor	
ROOF	20	Power glass sunroof	
EFI 1	15	EFI main	
EFI 2	15	EFI relay, IG coil	

WA-10016

Circuit breaker nomenclature	Capacity (A)	Connecting circuit	Remarks
POWER	30	Power window	

WA-10017

BODY ELECTRICAL SYSTEM

LAMPS

TROUBLE SHOOTING

Symptom	Possible causes	Remedies	Page
One headlamp will not glow.	<ul style="list-style-type: none"> ● Burnt bulb ● Faulty socket ● Faulty wiring or earth 	<ul style="list-style-type: none"> ● Replace bulb ● Repair, as required 	10-11
Headlamps will not glow	<ul style="list-style-type: none"> ● Fusible link and/or fuse blown out ● Faulty lighting switch ● Faulty wiring or earth 	<ul style="list-style-type: none"> ● Replace fusible link and/or fuse ● Check switch. ● Repair, as required. 	10-6 10-35
High beam or low beam will not glow.	<ul style="list-style-type: none"> ● Faulty lighting switch or dimmer switch ● Faulty wiring 	<ul style="list-style-type: none"> ● Check switch. ● Repair, as required. 	10-35
Clearance lamp, tail lamp or license lamp will not glow	<ul style="list-style-type: none"> ● "Tail" fuse blown out ● Fusible link blown out ● Faulty side lamp switch ● Faulty wiring or earth 	<ul style="list-style-type: none"> ● Check for short. Replace fuse. ● Replace fusible link. ● Check switch. ● Repair, as required 	10-6 10-8 10-38
Turn signal lamps at one side will not glow.	<ul style="list-style-type: none"> ● Faulty turn signal lamp switch ● Faulty wiring or earth 	<ul style="list-style-type: none"> ● Check switch. ● Repair, as required 	10-36
Turn signal lamps at both sides will not glow	<ul style="list-style-type: none"> ● "Turn" fuse blown out ● Faulty turn signal/hazard switch ● Faulty turn signal flasher relay ● Faulty wiring or earth 	<ul style="list-style-type: none"> ● Check for short. Replace fuse ● Check switch ● Check flasher relay ● Repair, as required. 	10-6 10-36 10-37
Stop lamp will not glow	<ul style="list-style-type: none"> ● "Stop" fuse blown out ● Faulty stop lamp switch ● Faulty wiring or earth 	<ul style="list-style-type: none"> ● Check for short. Replace fuse. ● Check switch. ● Repair, as required 	10-6 10-47
Stop lamp remains in glow state	<ul style="list-style-type: none"> ● Faulty stop lamp switch. 	<ul style="list-style-type: none"> ● Adjust or replace switch. 	10-47
Hazard warning lamp will not glow.	<ul style="list-style-type: none"> ● "Horn" fuse blown out. ● Faulty flasher relay ● Faulty hazard switch ● Faulty wiring or earth 	<ul style="list-style-type: none"> ● Check for short. Replace fuse ● Check flasher ● Check switch. ● Repair, as required. 	10-6 10-38

#FA1003E

LEARANCE LAMP

Removal

1. Remove the clearance lamp by removing the two screws.
2. Detach the bulb from the socket.

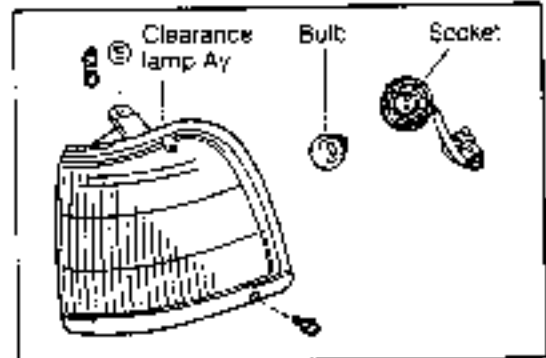

Fig. 10-15 WR-10019

Installation

1. When the bulb is burnt out, install a new bulb with the designated wattage.
2. Install the clearance lamp with the two screws

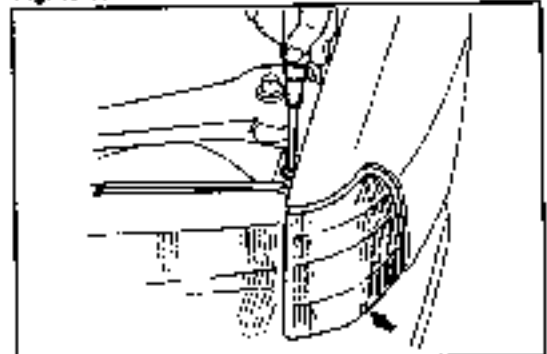

Fig. 10-16 WR-10020

HEADLAMP

NOTE:

It should be noted that the bulb replacement can be performed only after socket cover has been detached.

Removal

1. Remove the radiator grille as follows.
 Except GT_{II} grade Pul. the grille toward you, while the upper part of the claw is being pushed down, using a common screwdriver.
 GT_I grade ... Detach the grille by turning the central part of of the clip 90 degrees, using a cross point screwdriver.
2. Remove the clearance lamp.
 See the section under "Clearance Lamp" above.
3. Remove the headlamp assembly.
4. Remove the socket cover.
5. Detach the bulb.

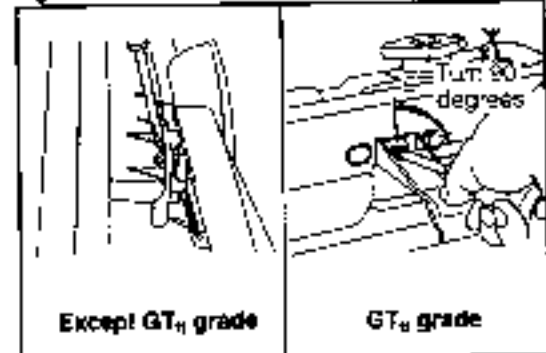

Fig. 10-17 WR-10021

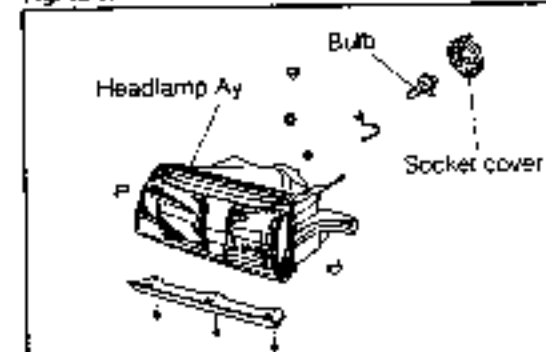

Fig. 10-18 WR-10022

CAUTION:

The halogen bulb reaches a very high temperature while it is put into use. If any lubricant gets on the bulb surface, it will result in significantly reduced lamp life. Hence, be very careful not allow your fingers, etc. to touch with the glass portion during the replacement. Be sure to hold the flange section to replace the bulb.

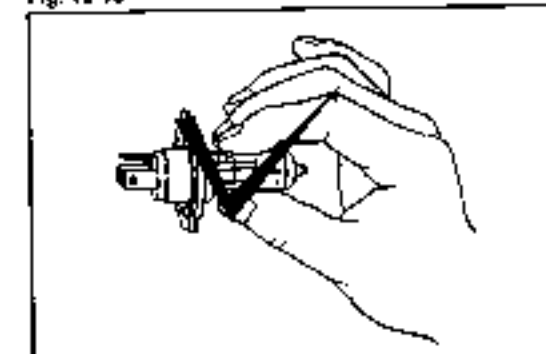

Fig. 10-19 WR-10023

BODY ELECTRICAL SYSTEM

Installation

1. When the bulb is burnt out, install a new bulb with the designated wattage.
2. Install the socket cover in place.

NOTE:

Make sure that the socket cover is fitted securely.

3. Install the headlamp assembly with one bolt and two nuts.
4. Install the clearance ramps and radiator grille.

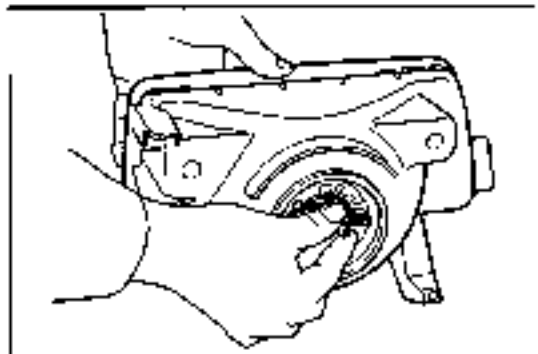

Fig. 10-20

WA-10020

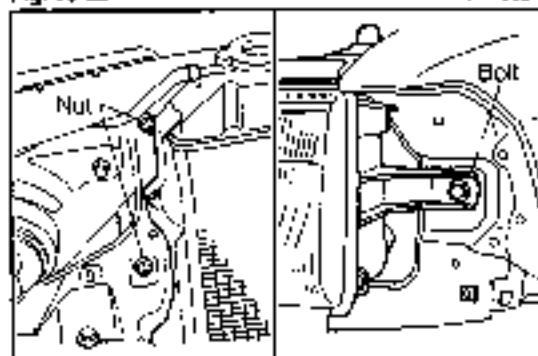

Fig. 10-21

WA-10021

Headlamp aiming adjustment (Screen type)

Conditions of vehicle during aiming adjustment

1. Perform the aiming adjustment with the tire air inflation pressure set to the specified value and with one person seated at the driver's seat.
2. Rock the vehicle in an up-and-down direction as well as in a right-and-left direction so that the suspensions may be settled in a normal state.
3. Carry out the headlamp aiming adjustment while the engine is running at 1500 rpm or more.
(If the revolution speed is too low, the lamp terminal voltage drops, thus making it difficult to recognize the hot zone.)

Halogen headlamps

1. Setting of reference points on screen
 - (1) Measure the center height "H" of the headlamps. Draw an adjustment line on the screen at a height 29 mm (1.14 inches) below the center height "H".
 - (2) Draw a vertical straight line on the screen at each center of the headlamps on both right and left sides. Thus, establish each intersection "F" made by the vertical center line and the adjustment line.
2. Headlamp aiming adjustment
 - (1) Position the vehicle in front of the screen so that the headlamps of the vehicle come at a distance of 3 m (9.84 ft). Also, ensure that the vehicle is positioned normal to the screen.
 - (2) When the headlamps are turned ON with the lower beam selected, you can get a light distribution pattern as indicated in the right figure. Therefore, the aiming adjustment can be carried out at an intersection made by the line "a" and the line "b" of cut-off lines.
 - (3) Turn ON the headlamps with the low beam selected. Perform the adjustment using the adjusting screws in such a way that each intersection of the cut-off lines comes at the respective intersection "F" on the screen.

Tire size & air pressure

kg/cm² (psi)

Vehicle	Tire size	Front		Rear	
		Permissible range	Dark section	Permissible range	Dark section
1000-2400	5.00R13 (4.75)	1.8 (27)	2.1 (30)	1.9 (27)	1.9 (27)
1400-2400	7.00R13 (6.75)	1.8 (27)	2.0 (29)	1.8 (26)	2.0 (29)
1455R13	6.50R13 (6.25)	1.8 (27)	2.0 (29)	1.8 (26)	2.0 (29)
1650-2400	7.50R13 (7.25)	1.8 (27)	2.0 (29)	1.8 (26)	2.0 (29)
	7.50R14 (7.25)	1.8 (27)	-	1.8 (26)	-
	1650R-1.50-13 (1.25)	1.8 (27)	-	1.8 (26)	-

WR-10028

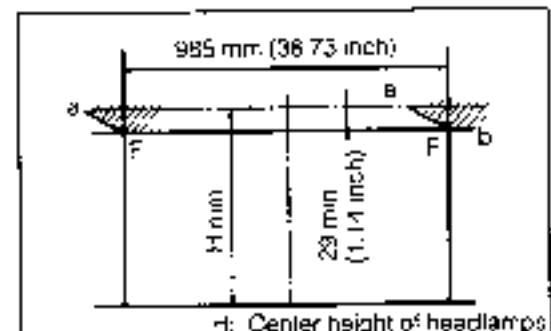

R.H.D. vehicle

Fig. 10-22

WR-10025

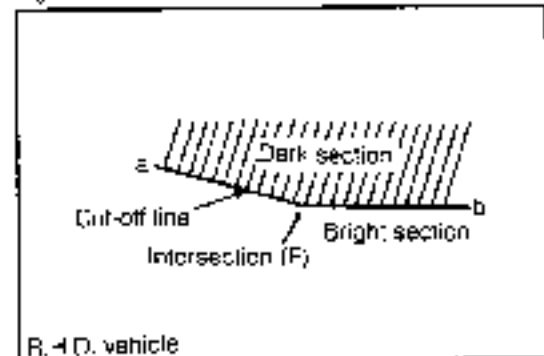

Fig. 10-23

WR-10035

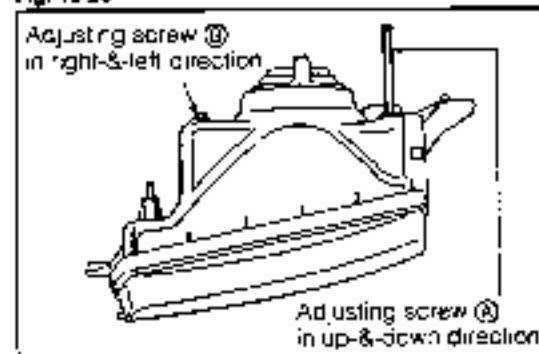

Fig. 10-24

WR-10028

BODY ELECTRICAL SYSTEM

- Upon completion of the headlamp aiming adjustment, switch the low beam to the high beam. Ensure that each main beam is directed downward and it is aiming straight toward the forward direction of the vehicle.

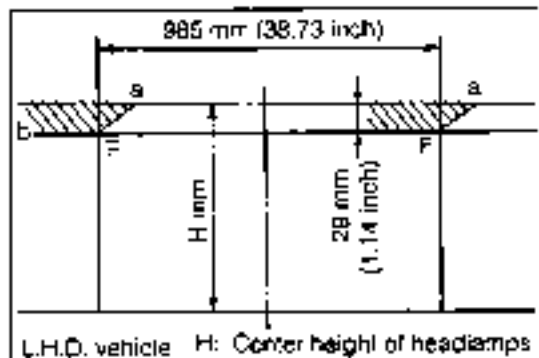

Fig. 10-25

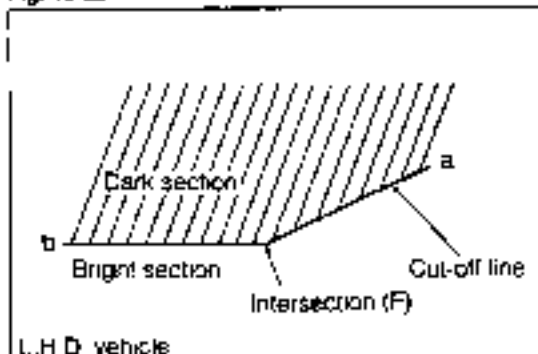

Fig. 10-26

WR-10031

FRONT TURN SIGNAL LAMP

Removal

- Remove the front turn signal lamp by removing one screw.
- After detaching the lens, remove the bulb.

Installation

- When the bulb is burnt out, install a new bulb with the designated wattage.
- Install the lens. Secure the front turn signal lamp assembly with the screw.

SIDE TURN SIGNAL LAMP

Removal

- Using a common screwdriver, remove the side turn signal lamp assembly by pushing it toward the front part of the vehicle. This removal must be performed carefully with a cloth or the like placed on the body that no scratch may be made to the paint finish surface.
- After detaching the lens, remove the bulb.

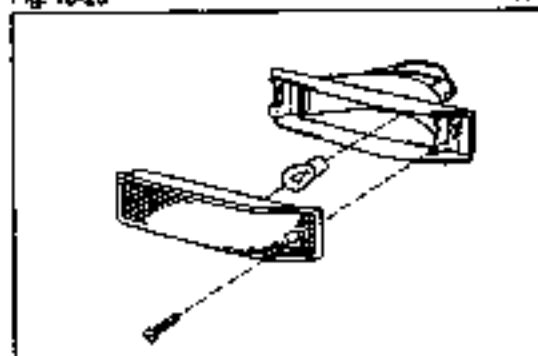

Fig. 10-27

WR-10032

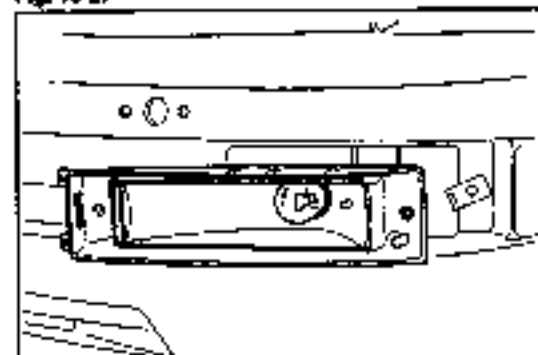

Fig. 10-28

WR-10033

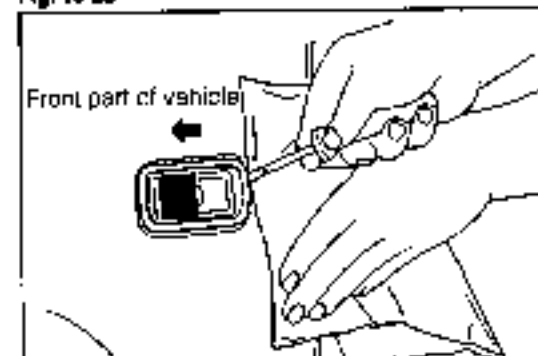

Fig. 10-29

WR-0004

Installation

1. When the bulb is burnt out, install a new bulb with the designated wattage.
2. Install the lens on the side turn signal lamp assembly
3. Attach the side turn signal lamp assembly to the fender section

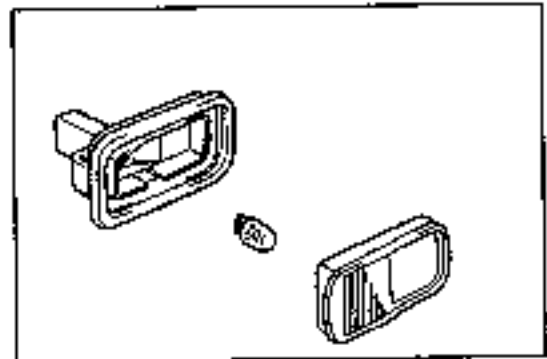

Fig. 10-30 WR-10035

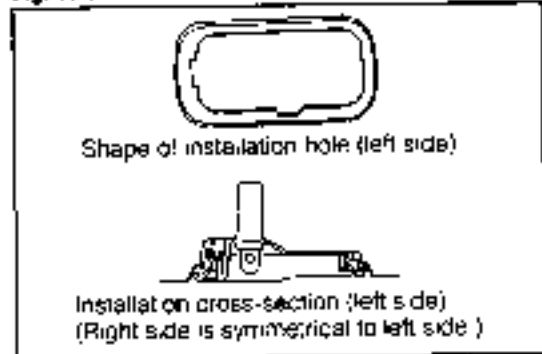

Fig. 10-31 WR-10035

LICENSE PLATE LAMP

Removal

1. Detach the clip. Remove the lower back trim.
NOTE:
It should be noted that the bulb replacement can be carried out without removing the lower back trim.
2. Disconnect the coupler.
3. Remove the license plate assembly and lens by removing the two tapping screws.
Take out the bulb.

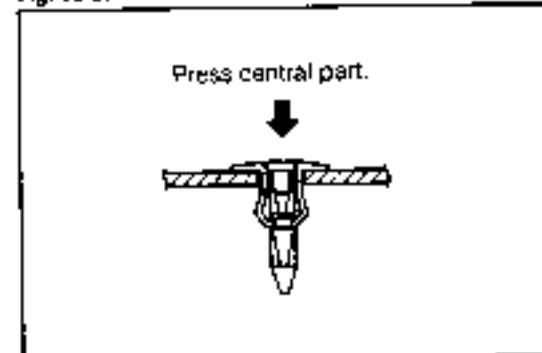

Fig. 10-32 WR-10037

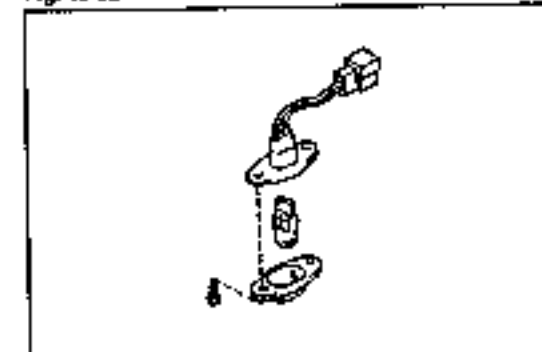

Fig. 10-33 WR-10038

Installation

1. When the bulb is burnt out, install a new bulb with the designated wattage.
2. Ensure that the spring nut is mounted properly on the bumper rib

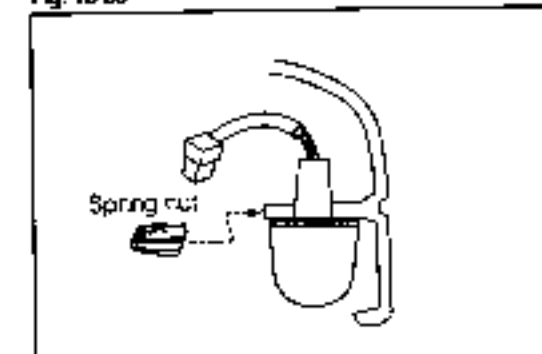

Fig. 10-34 WR-10038

BODY ELECTRICAL SYSTEM

3. Install the lens. Secure the lens with the tapping screws.
4. Connect the coupler.

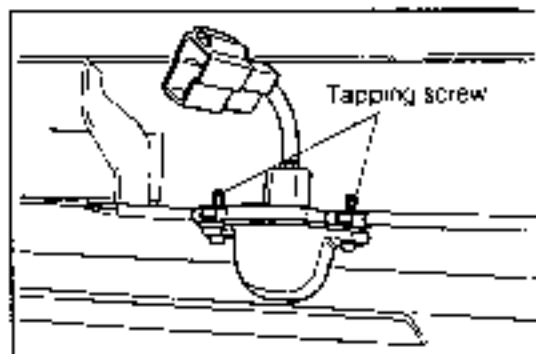

Fig. 10-35

WR-1004C

5. Attach the lower back trim.
As for the clip, install it with the central part in a pulled-out state. Then, push the central part, until the part becomes flush with the other part.

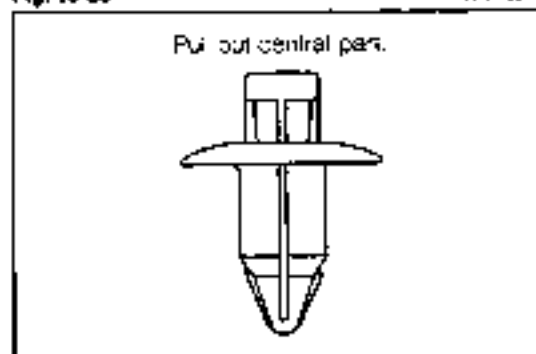

Fig. 10-36

WR-1004C

REAR COMBINATION LAMP

NOTE:

It should be noted that the bulb replacement can be performed only after the rear combination lamp service cover has been detached.

Removal

1. Remove the rear bumper. (Refer to page 9-12.)
2. Detach the rear combination lamp service cover.
3. Remove the rear combination lamp assembly from the body.
4. Detach the socket and bulb.

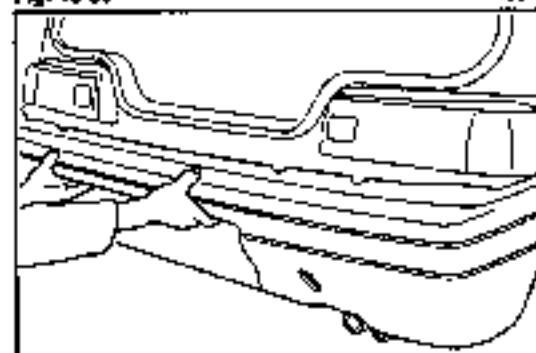

Fig. 10-37

WR-1004C



Fig. 10-38

WR-1004C

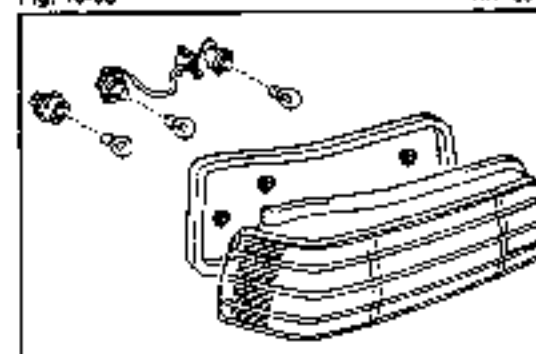

Fig. 10-39

WR-1004C

Installation

1. Install the bulb and socket in the rear combination lamp assembly.

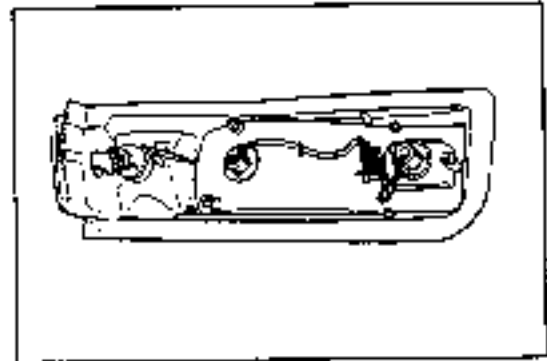

Fig. 10-40

WR-10045

2. Install the rear combination lamp assembly
 - (1) Remove any remaining butyl tape (body gasket) from the body surface as well as from the gasket surface of the rear combination lamp.

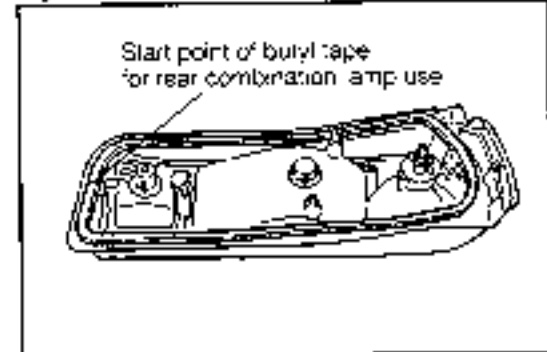

Fig. 10-41

WR-10046

- (2) Affix the butyl tape exclusively for this application onto the rear combination lamp.

NOTE:

1. Make sure that the application of butyl is limited only within the marked area.
 2. Be sure that the application of butyl is started at around the mid-point of the inner side of the rear combination lamp.
 3. Be certain that the ends of the butyl tape are overlapped about 10 mm (0.39 inch).
3. Attach the rear combination lamp service cover.
 4. Install the rear bumper.

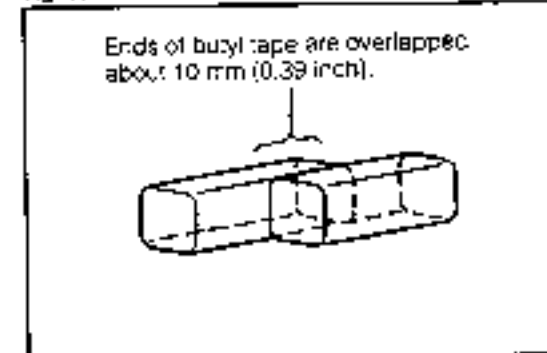

Fig. 10-42

WR-10047

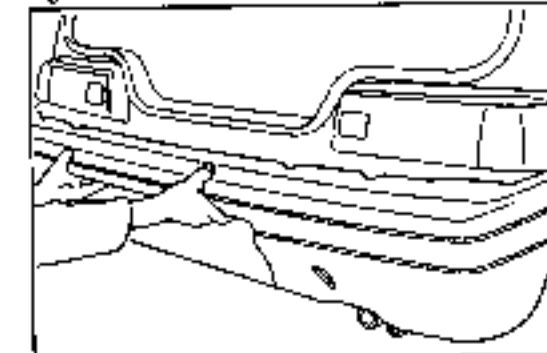

Fig. 10-43

WR-10048

ROOM LAMP

Removal

1. Detach the room lamp cover. Remove the bulb.

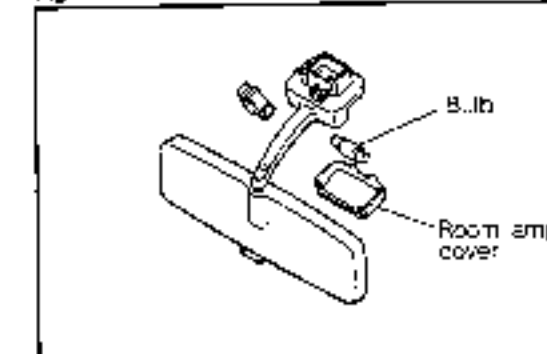

Fig. 10-44

WR-10049

BODY ELECTRICAL SYSTEM

Installation

1. When the bulb is burnt out, install a new bulb with the designated wattage.
2. Install the room lamp cover.

WR-10350

LUGGAGE ROOM LAMP

NOTE:

It should be noted that the bulb replacement can be performed only after the lens has been detached.

Removal

1. Detach the rear combination lamp service cover.
2. Disconnect the connector. Tie a string to the connector section. Working from above, remove the luggage room lamp assembly.
3. Remove the lens and bulb.

Installation

1. When the bulb is burnt out, install a new bulb with the designated wattage.
2. Attach the lens to the luggage room lamp assembly.

3. Install the luggage room lamp assembly. For easier operation, install the lamp assembly by tying the string which was used during the removal to the connector section.
4. Connect the connector. Attach the rear combination lamp service cover.

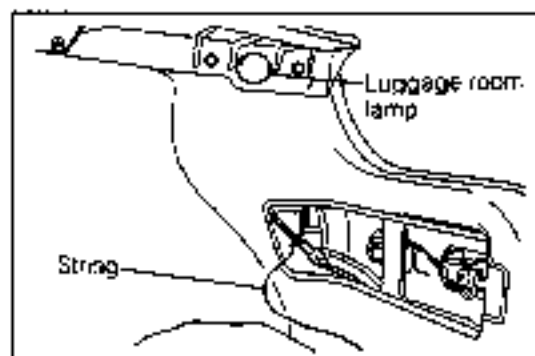

Fig. 10-45

WR-10051

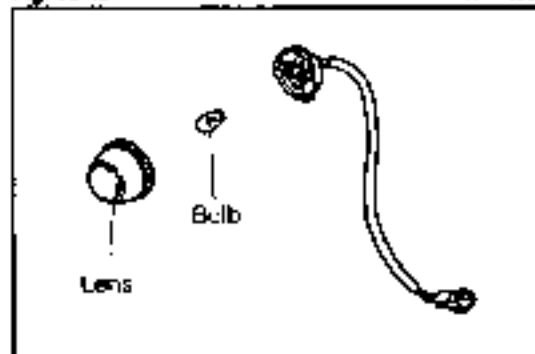

Fig. 10-46

WR-10052

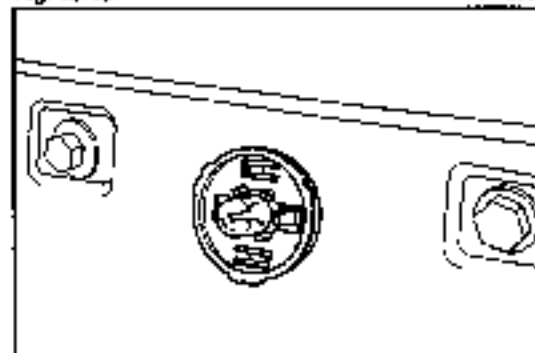

Fig. 10-47

WR-10053

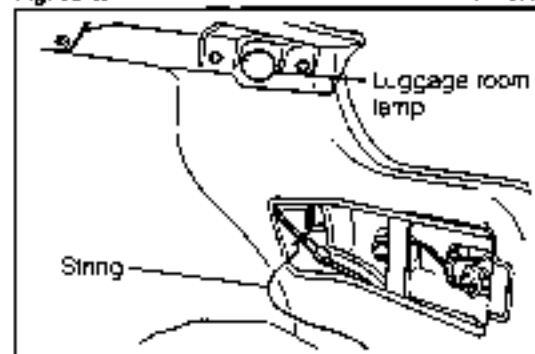

Fig. 10-48

WR-10054

COMBINATION METER

Removal

1. Remove the instrument cluster panel finish panel sub-assembly from the instrument panel. (See page 9-78.)

2. Disconnect each connector. Remove the combination meter assembly from the instrument panel.

Installation

1. Connect each connector. Install the combination meter Ay to the instrument panel.
2. Install the instrument cluster panel finish panel S/A to the instrument panel. (See page 9-82.)

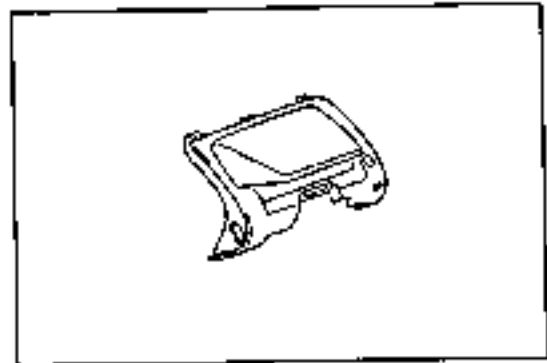

Fig. 10-49

WFI-10455

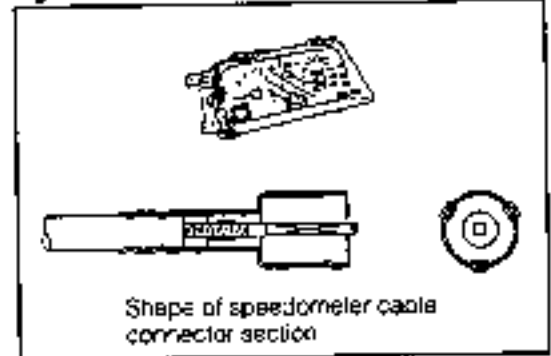

Fig. 10-50

WFI-10456

BODY ELECTRICAL SYSTEM

COMPONENTS

Single-meter type standard

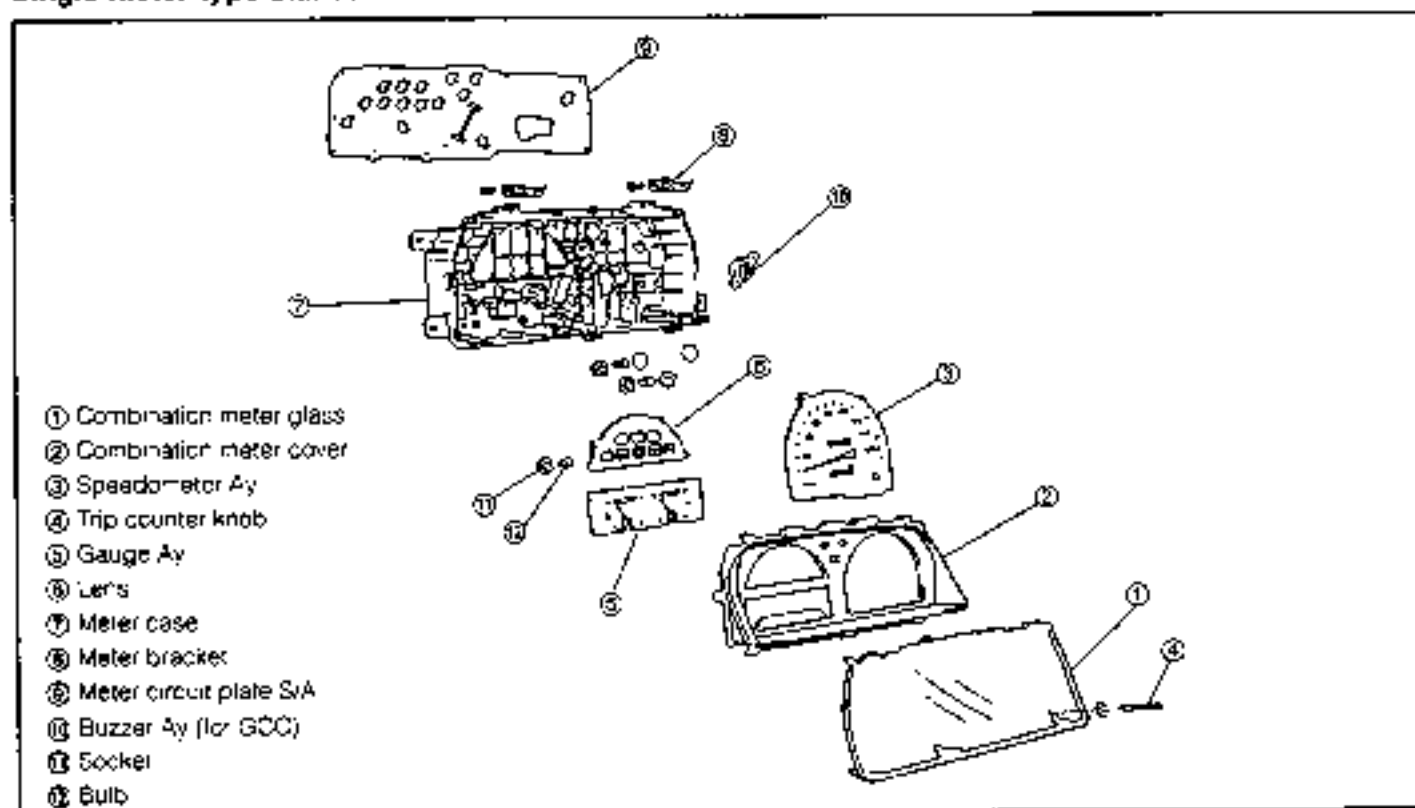

Fig. 10-51

WA-10057

Two-meter type standard

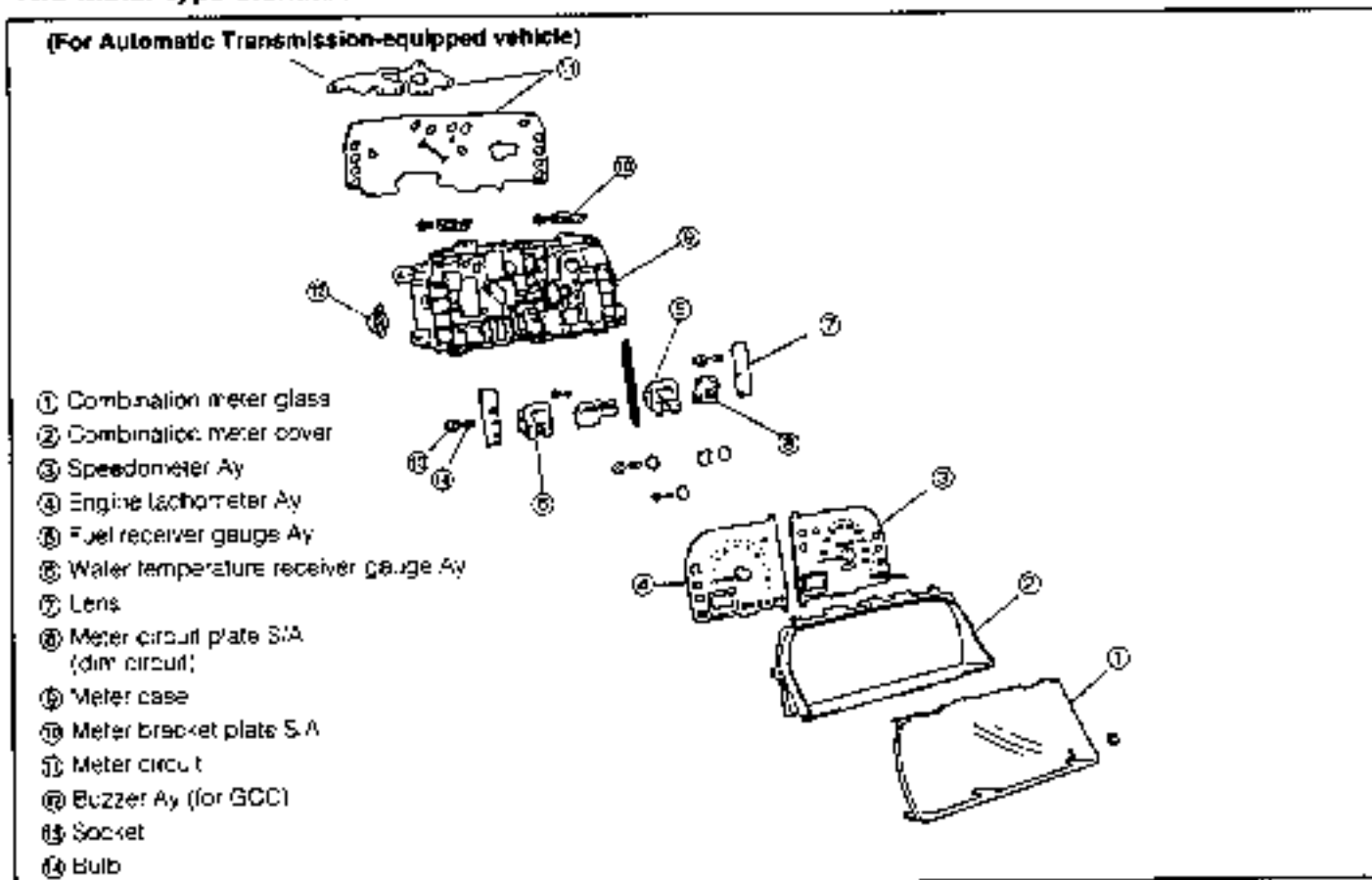

Fig. 10-52

WA-10058

ANGLE-METER TYPE

Circuit panel

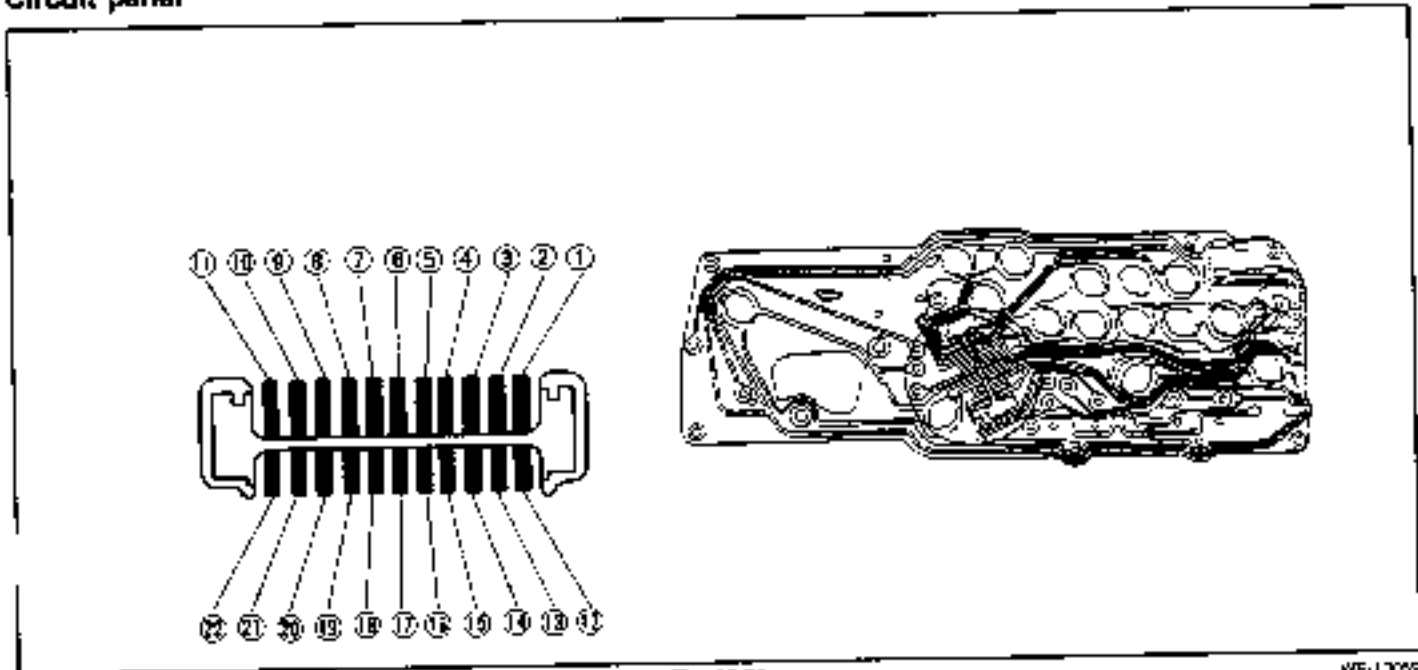

Fig. 10-53

WP-10059

Circuit diagram

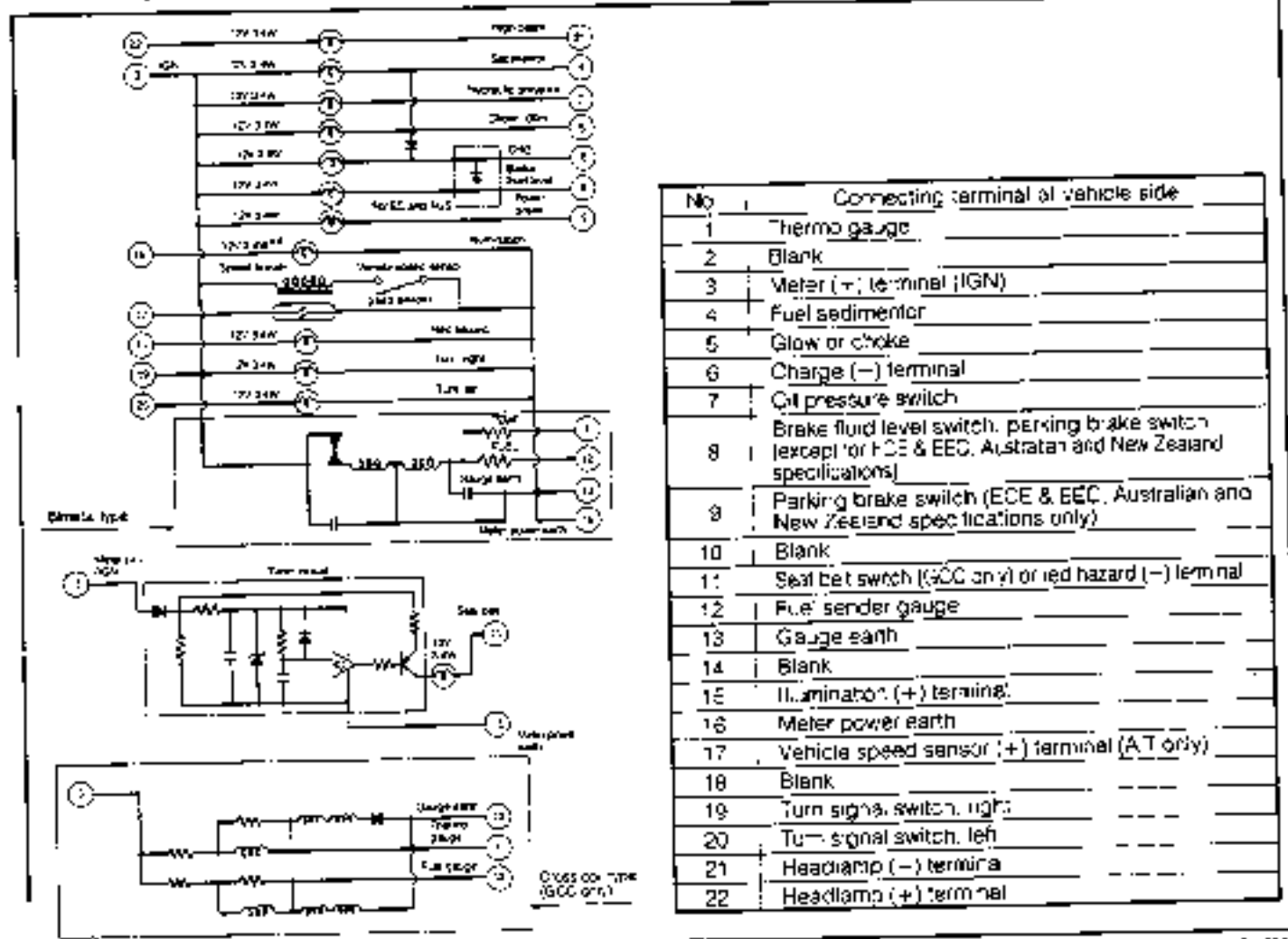

Fig. 10-54

WP-10059

BODY ELECTRICAL SYSTEM

TWO-METER TYPE

Circuit panel

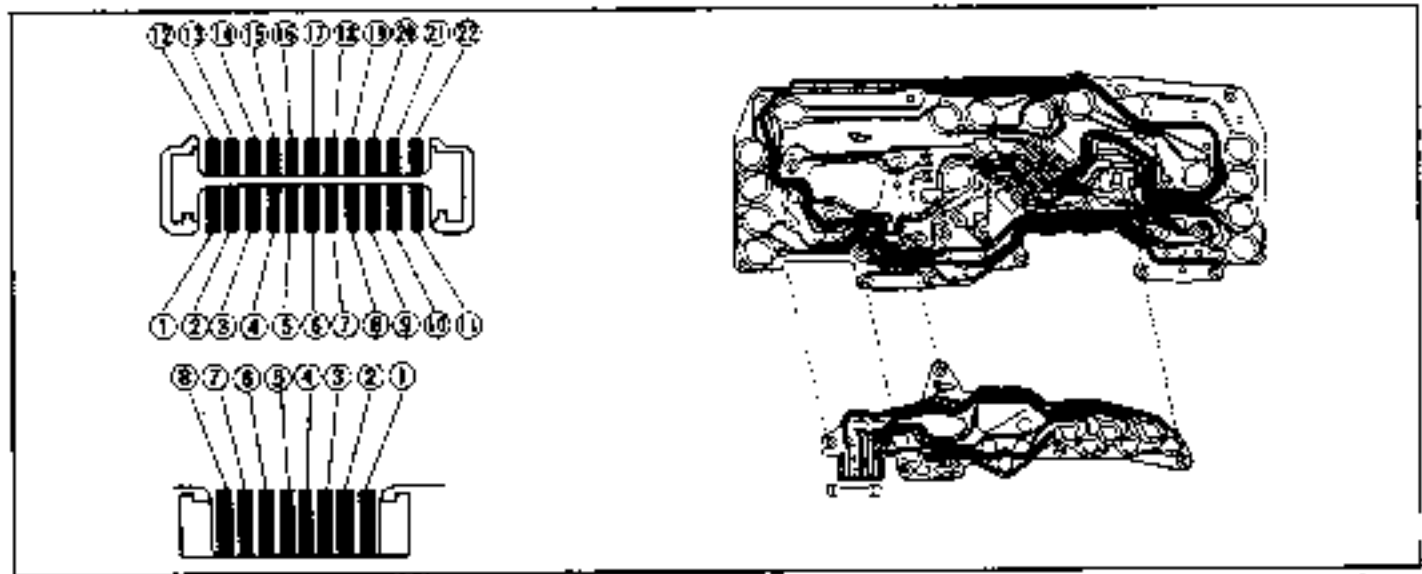

Fig. 10-55

WI-10061

Circuit diagram

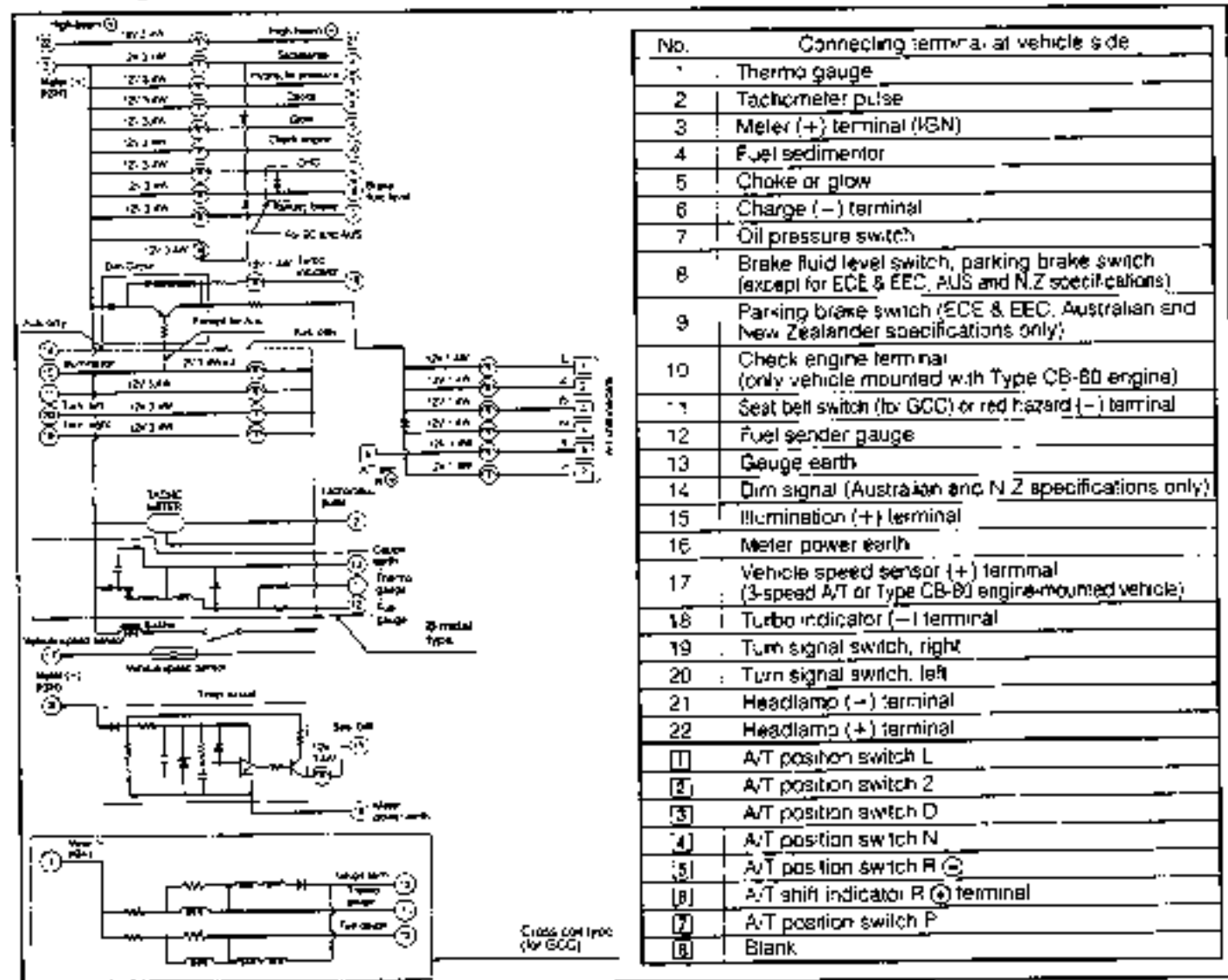

Fig. 10-58

WI-10062

PEEDOMETER

1. In-vehicle check

Using a speedometer tester, check the speedometer for any indication error, pointer fluctuation and abnormal noise. Furthermore, check to see if the odometer and speed warning device (GCC specifications only) are functioning properly.

NOTE:

1. It should be noted that excessive tire wear, over-inflation or under-inflation will cause indication errors of the speedometer.
2. Fluctuations of the meter pointer are often attributable to a faulty meter cable.
3. The meter contains a mechanism using contact points. Hence, there will be instances where the pointer slightly fluctuates in the neighborhood of operating points of contacts points (changeover points between ON and OFF). However, this does not constitute any malfunction.

Item	Meter indication	Remarks
Indication error	For Australia within +10% - 10% For ECE & EEC within +10% - 0%	Relative to tester reading at a time when the actual vehicle speed is 35 km/h (22 mph) or more
Pointer fluctuation	Within ± 1 km/h (0.6 mph)	
Speed warning device operating speed	124 ± 4 km/h	GCC specifications only

**2. Speed warning buzzer check
(GCC specifications only)**

Apply the battery voltage across the terminals of the buzzer unit. Ensure that the buzzer is set off.

NOTE:

Be sure to connect the buzzer's side having a (+) mark to the positive (+) terminal of the battery.

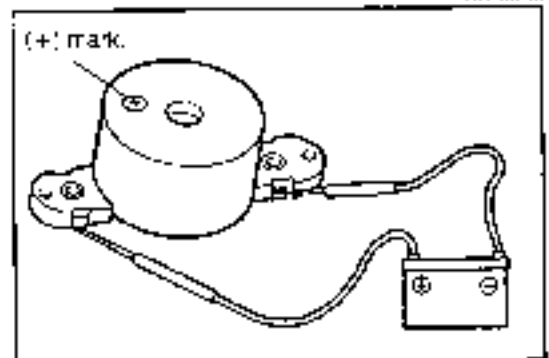

Fig. 10-57

**3. Checking of reed switch for vehicle speed sensor use
(Only vehicles mounted with 3-speed A/T or Type CB-80 engine)**

- (1) Remove the combination meter
- (2) Ensure that continuity occurs four times at the reed switch (between Ⓑ and Ⓒ) while the speedometer drive shaft completes a turn.

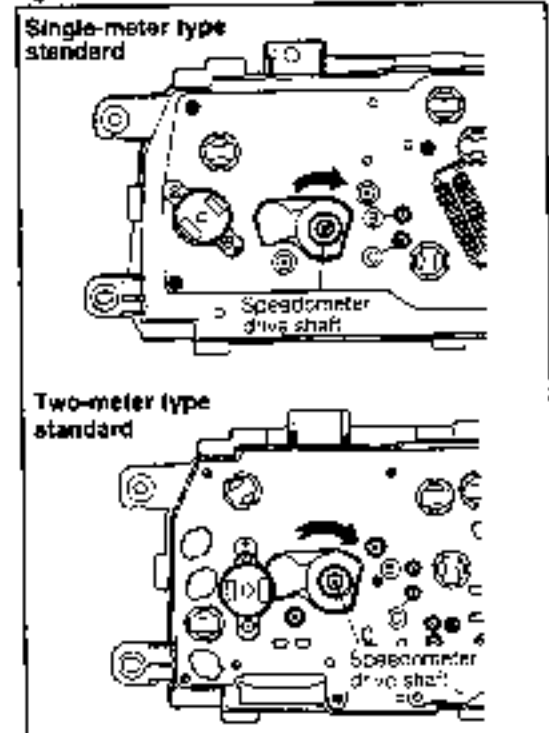

Fig. 10-58

BODY ELECTRICAL SYSTEM

FUEL GAUGE AND WATER TEMPERATURE GAUGE

Circuit Diagram of Pin Type, Bimetal Gauge

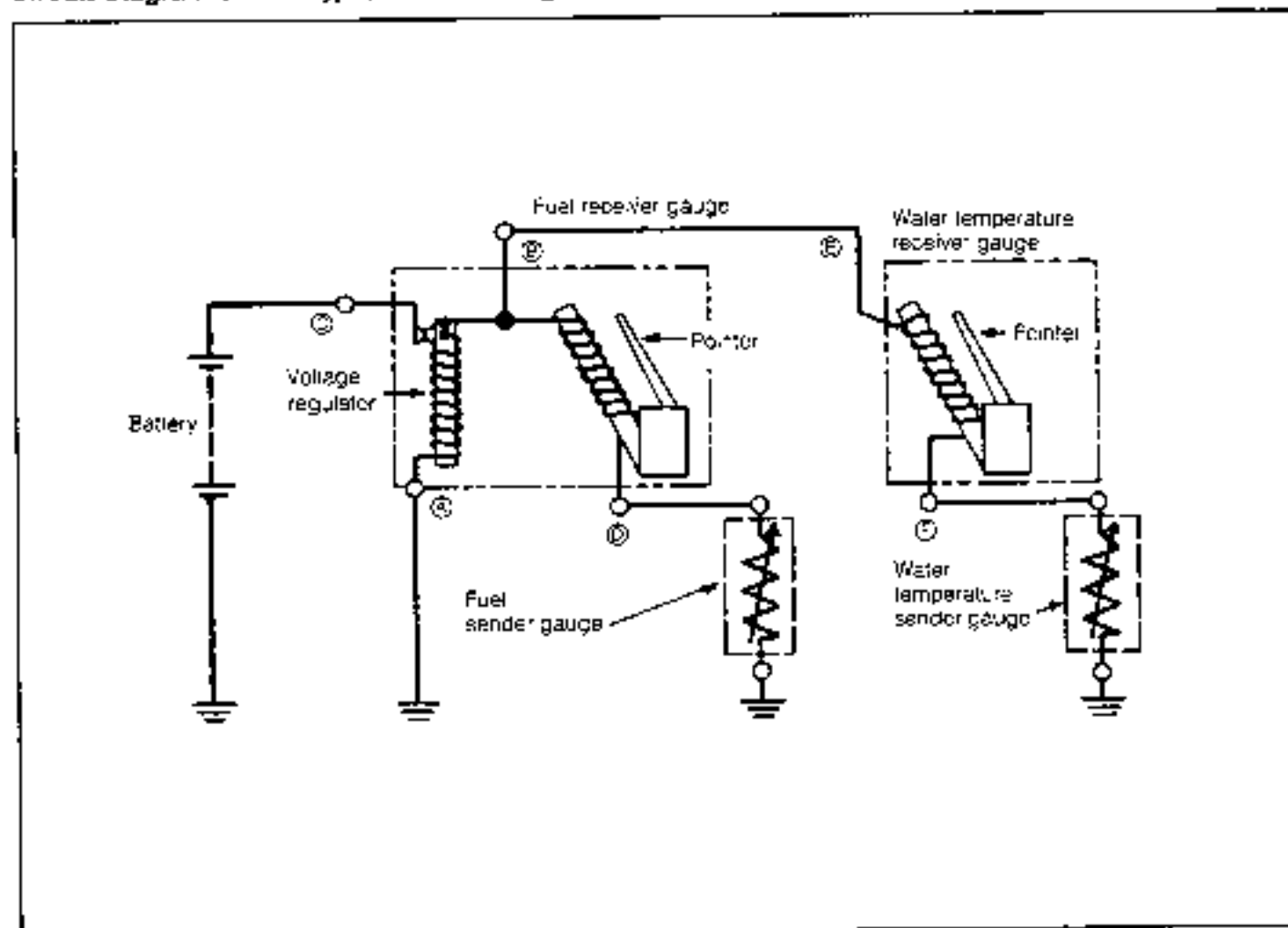

Fig. 10-59

WH-1006

FUEL RECEIVER GAUGE

1. In-Vehicle Inspection

Disconnect the connector located at the upper part of the fuel tank. Carry out the following checks at the terminal at the receiver side.

- (1) Disconnect the connector from the harness of the fuel sender gauge. Ground the gauge through a test lamp (12 V - 3.4 W).
- (2) Turn ON the engine switch. Ensure that the test lamp goes on and, several seconds later, the test lamp starts flashing.

- (3) Ensure that the pointer of the receiver gauge starts to rise gradually.

NOTE:

In case that the fuel sender earth terminal is used, in advance, make sure that it has continuity with the body earth.

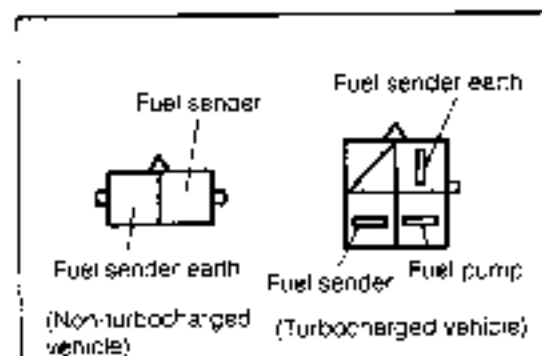

Fig. 10-60

WH-1006

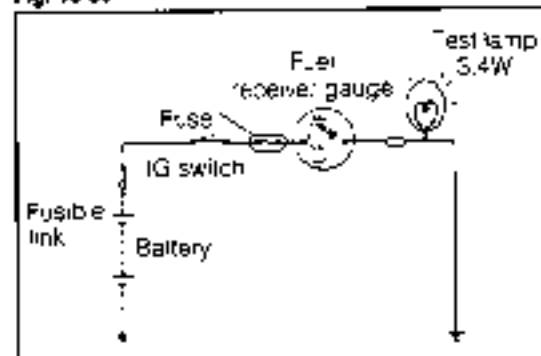

Fig. 10-61

WH-1006

Unit Check

- (1) Remove the combination meter.
- (2) Measure the resistance between the terminals ③ and ④.

Specified Value: 55 Ω

- (3) Connect the multi-pole connector to the combination meter. Turn ON the engine key. Ensure that the battery voltage is applied between the terminal ③ and the body earth.
- (4) Under the conditions in the step (3) ensure that a voltage varying approximately from 2 to 7 V is applied between the terminal ③ and the body earth.

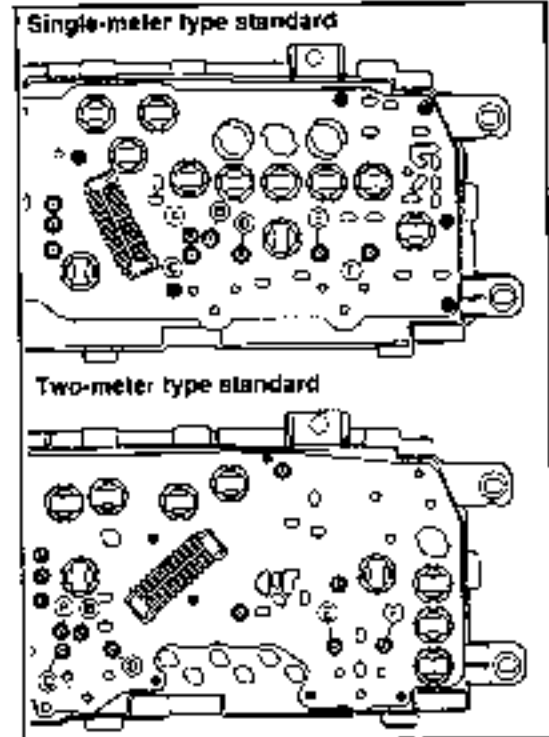

Fig. 10-62

WP 10079

FUEL SENDER GAUGE

The fuel sender gauge is located at the upper part of the fuel tank.

1. Measurement of Resistance of Fuel Sender Gauge

- (1) Ensure that the resistance varies when the float is moved from the upper position to the lower position.

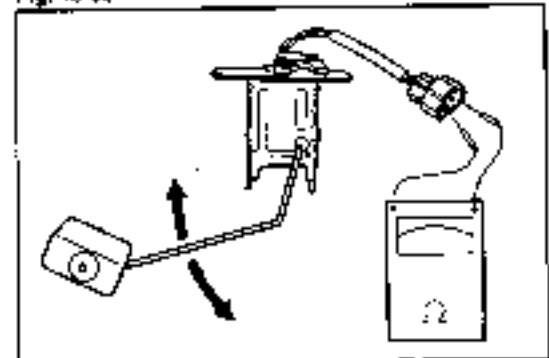

Fig. 10-63

WP 10079

- (2) Measure the resistance between the fuel terminal and the body at each float level.

Float position	Resistance (Ω)	Reference dimension mm (inch)	
		Type CB-23, CL-11 and CL 61 engines	Type CB-61 and CB-80 engines
F	1 - 5	40 (1.56)	28 (1.1)
1/2	28.5 - 36.5	91 (3.58)	86 (3.4)
E	103 - 117	129 (5.08)	133 (5.2)

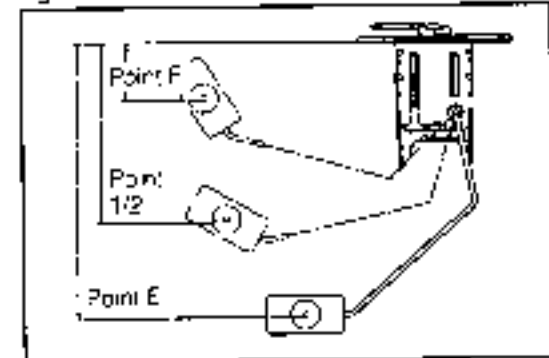

Fig. 10-64

WP 10079

BODY ELECTRICAL SYSTEM

WATER TEMPERATURE RECEIVER GAUGE

1. In-Vehicle Inspection

- (1) Disconnect the connector from the harness of the water temperature sender gauge. Ground the gauge to the connector at the harness through a test lamp (12 V - 3.4 W).
- (2) Turn ON the engine switch. Ensure that the test lamp goes on and, several seconds later, the test lamp starts flashing.
- (3) Ensure that the pointer of the receiver gauge starts to rise gradually.

2. Unit Check

- (1) Remove the combination meter.
- (2) Measure the resistance between the terminals (E) and (F).
Specified Value: Approx. 25 Ω
- (3) Connect the multi-pole connector to the combination meter. Turn ON the engine key. Ensure that the battery voltage is applied between the terminal (C) and the body earth.
- (4) Under the conditions in the step (3), ensure that a voltage varying approximately from 2 to 7 V is applied between the terminal (E) and the body earth.

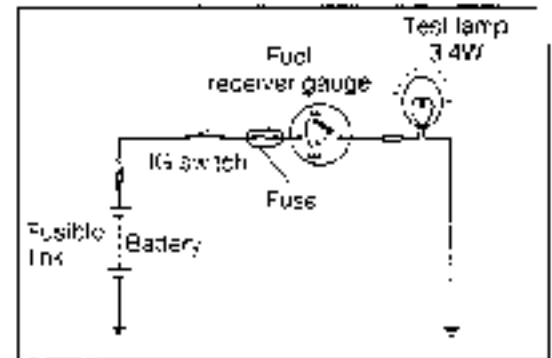

Fig. 10-65

WR-0213

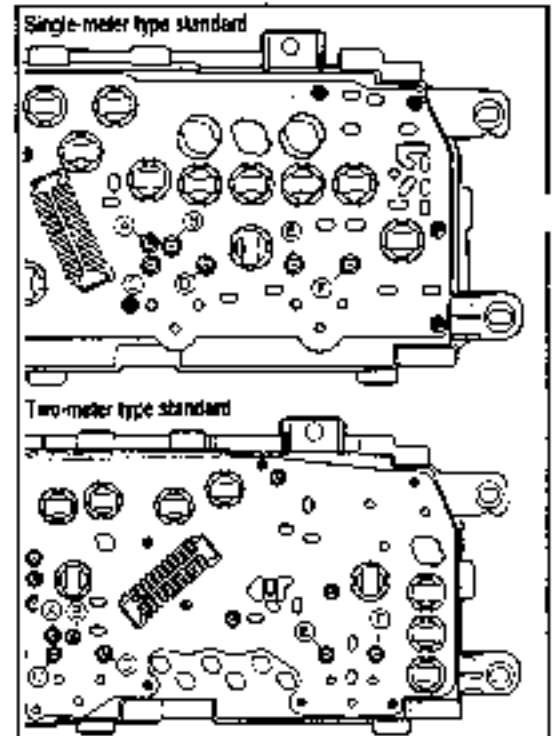

Fig. 10-66

WR-0213

WATER TEMPERATURE SENDER GAUGE

The water temperature sensor gauge is located at the following points given below:

- Type CB engine . . . Rear end of cylinder head
- Type CL engine . . . Left/rear section of cylinder head

Unit Inspection

Measure the resistance between the terminal and the earth, as indicated in the right figure.

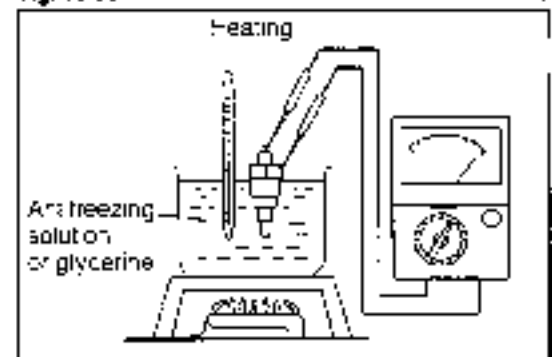

Fig. 10-67

WR-0214

Temperature (°C)	Resistance (Ω)
50	226 \pm 34
115	26.4 \pm 0.30

CROSS COIL TYPE GAUGE CIRCUIT (GCC SPECIFICATIONS ONLY)

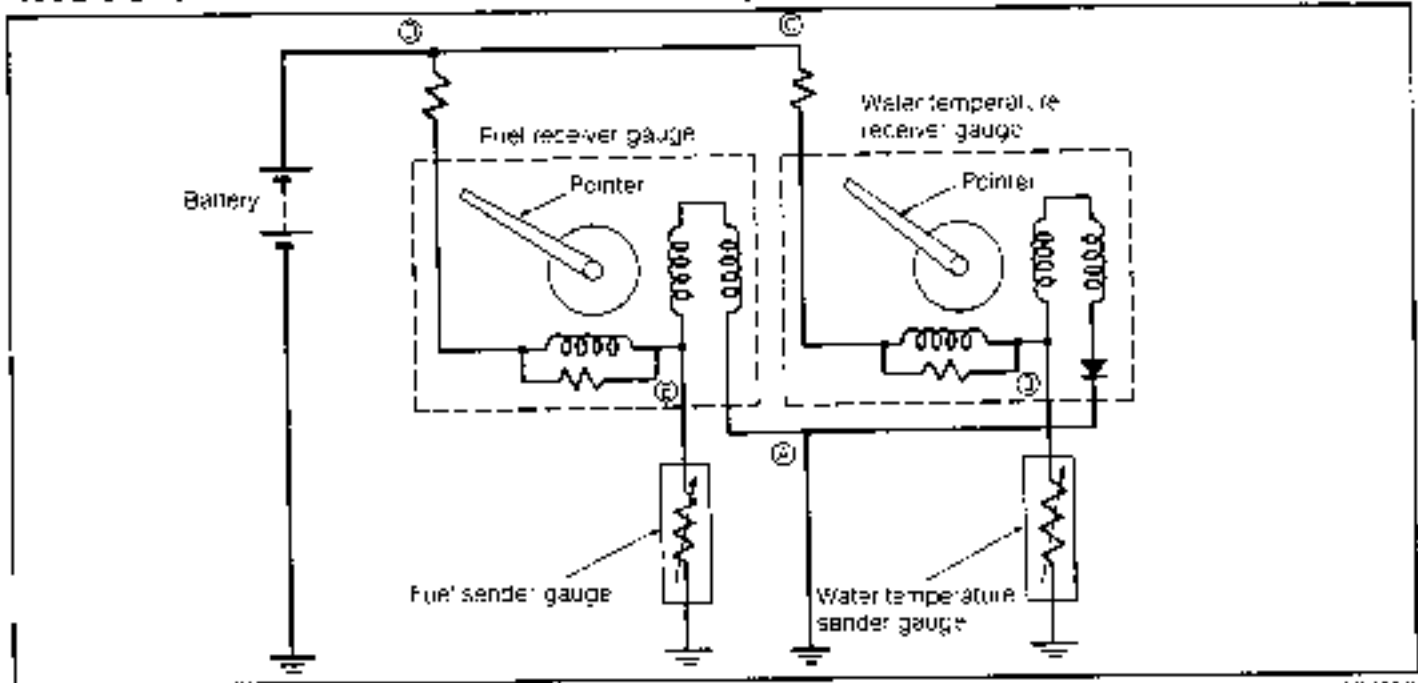

Fig. 10-68

WR-10075

**FUEL RECEIVER GAUGE
(POINTER REMAINING TYPE)**

1. In-Vehicle Inspection

(1) Disconnect the connector of the fuel sender gauge located at the upper part of the fuel tank. Under this condition, turn ON the engine switch. Ensure that the pointer of the receiver gauge returns to the position "E".

(2) Turn OFF the engine switch. Ground the harness connector of the fuel sender gauge. Under this condition, turn ON the engine switch. Ensure that the pointer of the receiver gauge rises gradually and registers the position "F".

(3) Turn OFF the engine switch. Ensure that the pointer of the receiver gauge remains stationary and registers the position "F".

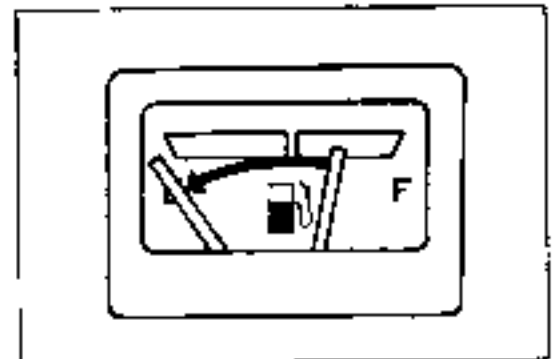

Fig. 10-69

WR-10075

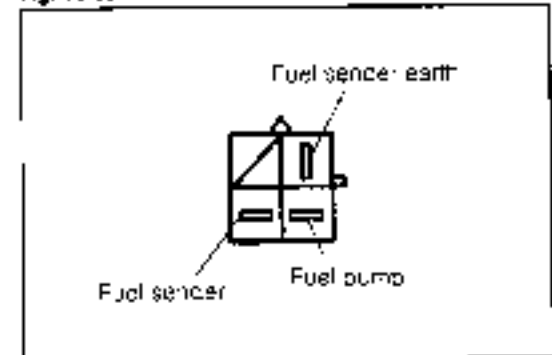

Fig. 10-70

WR-10075

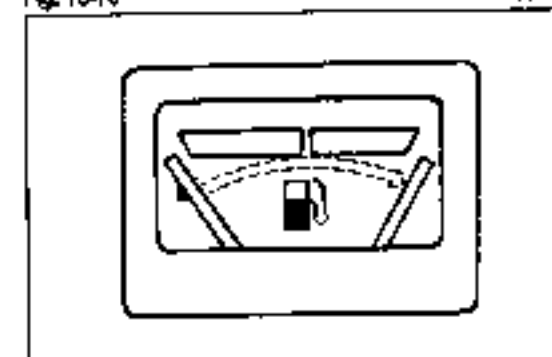

Fig. 10-71

WR-10075

BODY ELECTRICAL SYSTEM

2. Unit Check

- (1) Remove the combination meter. Measure the resistance between the terminals (C) and (E).
Specified Value. Approx. 82 Ω
- (2) Connect the multi-pole connector to the combination meter. Turn ON the engine switch. Ensure that the battery voltage is applied between the terminal (C) and the body earth.

FUEL SENDER GAUGE

Inspection

Remove the sender gauge located at the upper part of the fuel tank. Measure the resistance between the terminal and the body at each float level.

Float position	Resistance (Ω)	Reference dimension mm (inch)
F	1.5	28 \pm 3 (1.1 \pm 0.12)
1/2	26.5 - 36.5	96.4 (3.80)
E	103 - 117	133 \pm 3 (5.24 \pm 0.12)

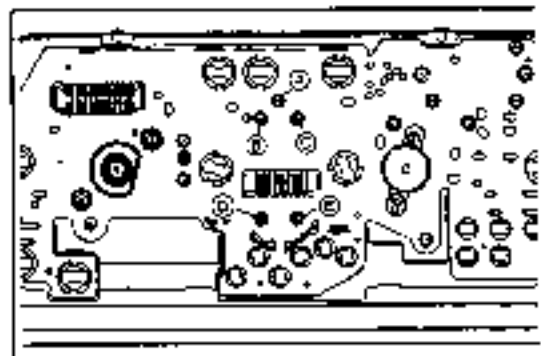

Fig. 10-72

WP-1007E

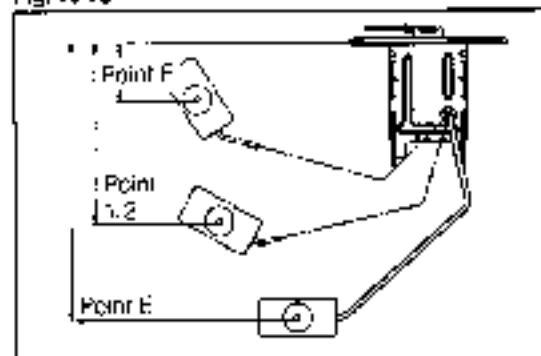

Fig. 10-73

WP-1008U

WATER TEMPERATURE RECEIVER GAUGE

1. In-Vehicle Inspection

- (1) Disconnect the connector from the harness of the water temperature sender gauge. Ground the gauge through a test lamp (12 V - 3.4 W).
- (2) Turn ON the engine switch. Ensure that the test lamp goes on and the pointer of the receiver gauge starts to rise gradually.

2. Unit Check

- (1) Remove the combination meter. Measure the resistance between the terminals (B) and (C).
Specified Value: Approx. 134 Ω
- (2) Connect the multi-pole connector to the combination meter. Turn ON the engine switch. Ensure that the battery voltage is applied between the terminal (C) and the body earth.

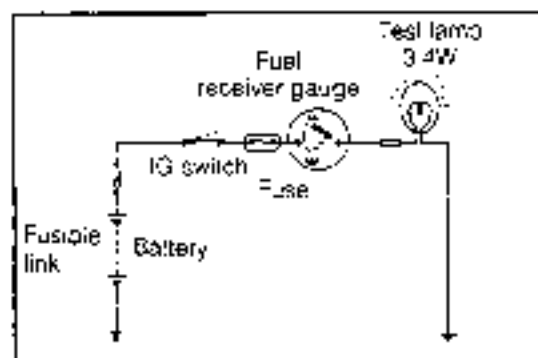

Fig. 10-74

WP-1008V

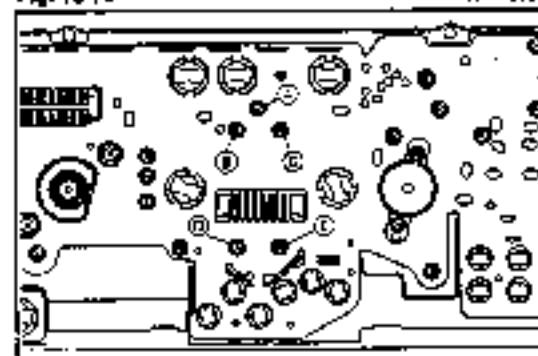

Fig. 10-75

WP-1008Z

WATER TEMPERATURE SENDER GAUGE

The water temperature sensor gauge is located at the rear end of the cylinder head.

Unit Inspection

Measure the resistance between the terminal and the earth, as indicated in the right figure.

Temperature (°C)	Resistance (Ω)
50	226 ± 3
115	26.4 ± 0.8

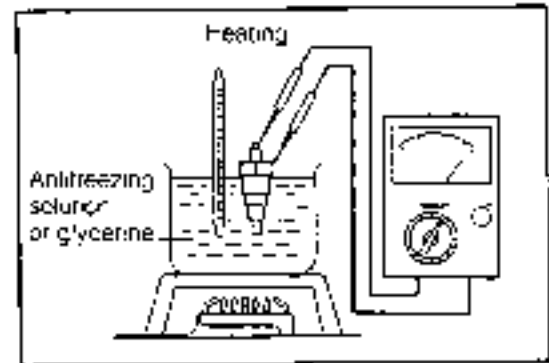

Fig. 10-76

WP-10063

WARNING AND INDICATOR SYSTEM

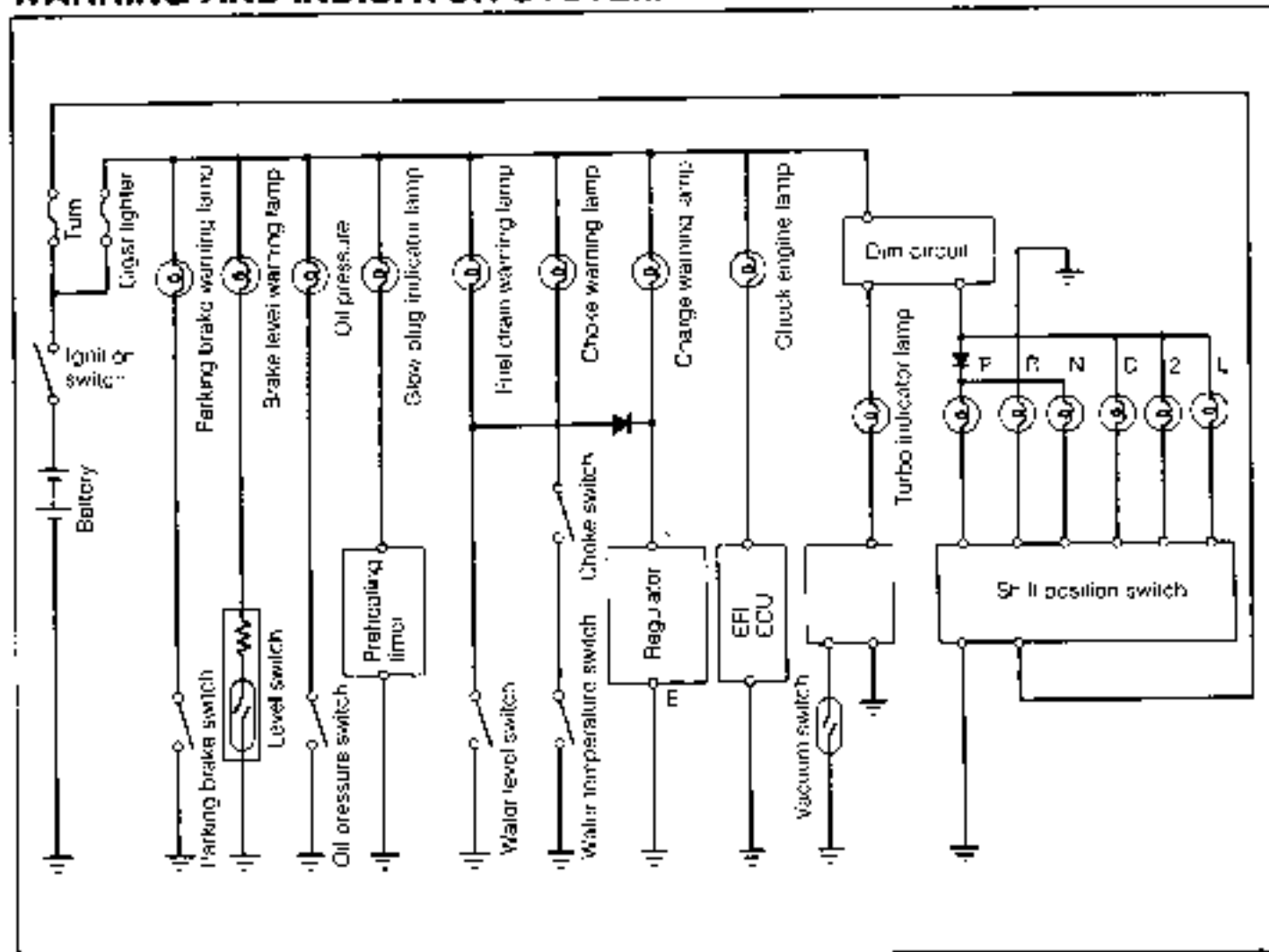

Fig. 10-77

WR-10054

BRAKE LEVEL WARNING LAMP

Inspection

1. Start the engine
2. Return the parking brake lever to the original position (General specifications only)
3. Pull out the connector of the brake fluid level warning switch and short the connector at the harness side. Ensure that the level warning lamp glows.

PARKING BRAKE SWITCH

Inspection

1. Pull out the connector of the parking brake switch and conduct continuity checks between the terminal and the body earth.
 - (1) Ensure that continuity exists between the terminals when the parking brake lever is pulled upward.
 - (2) Ensure that no continuity exists between the terminals when the parking brake lever is returned.

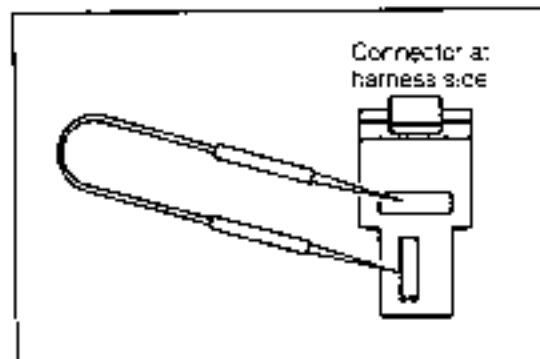

Fig. 10-78

WR-10055

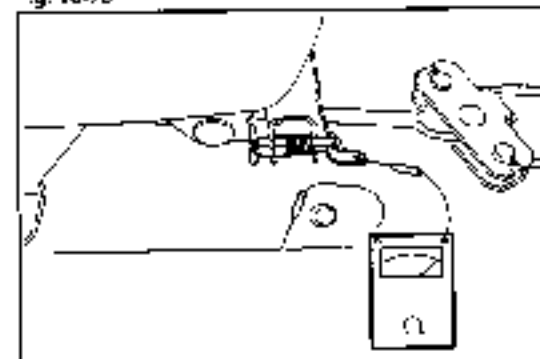

Fig. 10-79

WR-10056

RAKE LEVEL WARNING SWITCH

Inspection

1. Pull out the connector of the brake fluid level warning switch and connect a tester.

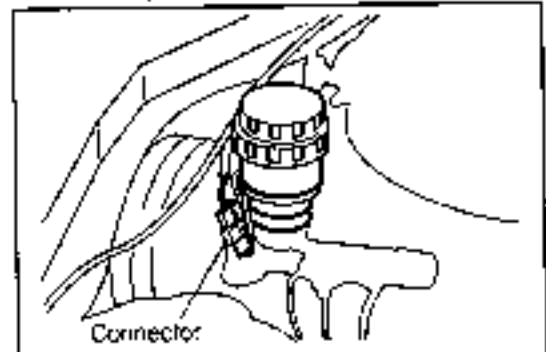

Fig. 10-80

WR-10087

2. Press down the brake fluid level warning switch (float) with a rod. Ensure that continuity exists between the connector terminals.

NOTE:

As for a rod to be used for pressing down the float, be sure to thoroughly clean it. Special care must be exercised to ensure that no dust nor water gets into the reservoir.

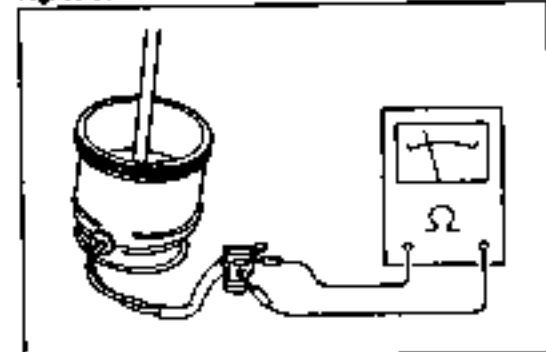

Fig. 10-81

WR-10088

OIL PRESSURE WARNING LAMP

Inspection

1. Pull out the connector located at the right/rear part of the cylinder block. Ground the connector at the harness side.
2. Ensure that the oil pressure warning lamp glows when the engine switch is turned ON.

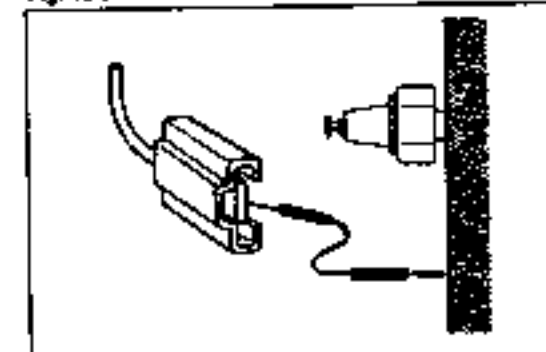

Fig. 10-82

WR-10090

OIL PRESSURE SWITCH

Inspection

1. Pull out the connector located at the right/rear part of the cylinder block.
2. Ensure that continuity exists between the oil pressure switch terminal and the earth.

NOTE:

It should be noted that continuity exists while the engine is stopped, whereas no continuity exists while the engine is running.

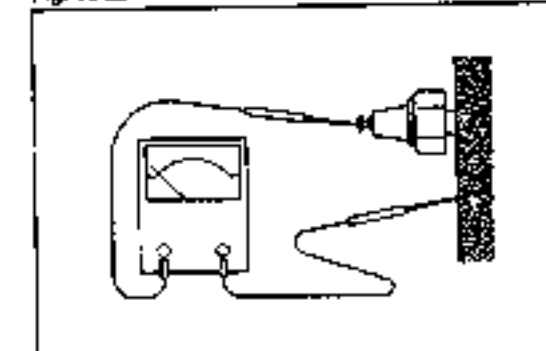

Fig. 10-83

WR-10091

FUEL DRAIN WARNING LAMP (DIESEL-POWERED VEHICLES ONLY)

Inspection

1. Start the engine. Disconnect the connector of the sedimentor.
2. Ensure that the warning lamp glows when short is made between the terminals of the connector at the harness side.



Fig. 10-84

WR-10091

BODY ELECTRICAL SYSTEM

Water level sensor

1. Remove the water level sensor from the sedimentor. Pull out the connector.
2. Connect a circuit tester to the connector. Ensure that continuity exists between the connector terminals when the float is lifted (when the switch is turned ON).

NOTE:

After the water level sensor has been installed, be certain to fill the fuel filter with fuel, using the priming pump.

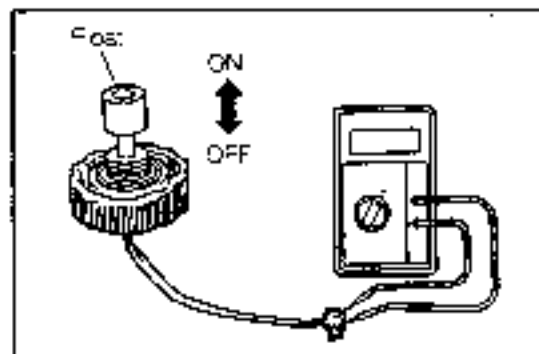

Fig. 10-85

WA-10092

SHIFT INDICATOR LAMP (3-SPEED A/T VEHICLE)

Inspection

1. Remove the combination meter. Disconnect the connector (8-pole) for shift indicator use.

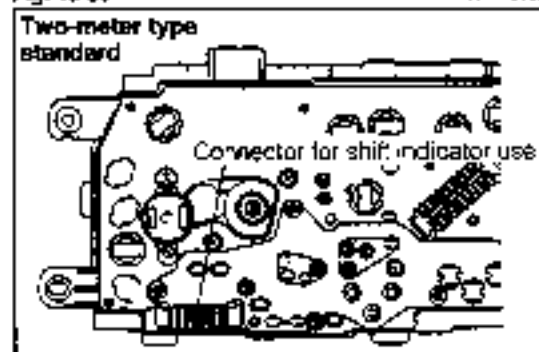

Fig. 10-86

WA-10093

2. With the ignition switch turned OFF, perform continuity check for each terminal of the connector for shift indicator use (at the vehicle harness side).

- (1) Ensure that continuity exists between ⑤ and the body earth.
- (2) Ensure that continuity exists between ① and ⑤ when the range [L] is selected.
- (3) Ensure that continuity exists between ② and ⑥ when the range [2] is selected.
- (4) Ensure that continuity exists between ③ and ⑤ when the range [D] is selected.
- (5) Ensure that continuity exists between ④ and ⑤ when the range [N] is selected.
- (6) Ensure that continuity exists between ⑦ and ⑤ when the range [P] is selected.
- (7) Turn ON the ignition switch. Ensure that the battery voltage is applied between ⑧ and the body earth when the range [R] is selected.

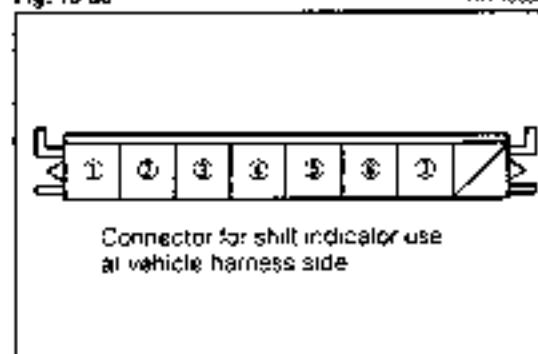

Fig. 10-87

WA-10094

3. Under conditions where the connector for shift indicator use and other connectors are installed, turn ON the ignition switch. Ensure that the indicator lamp goes on in accordance with each relevant shift position.

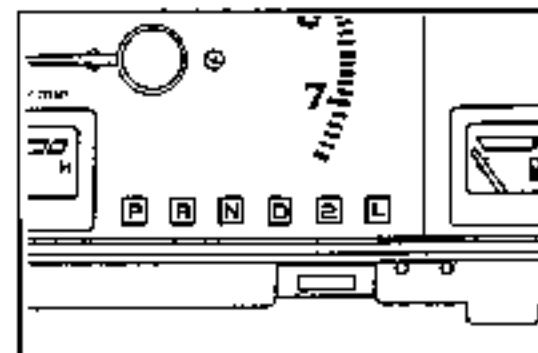

Fig. 10-88

WA-10095

DIMMER DEVICE FOR TURBO AND A/T INDICATORS

(Vehicles Mounted with Type CB-61, CB-80 Engines and 3-speed A/T)

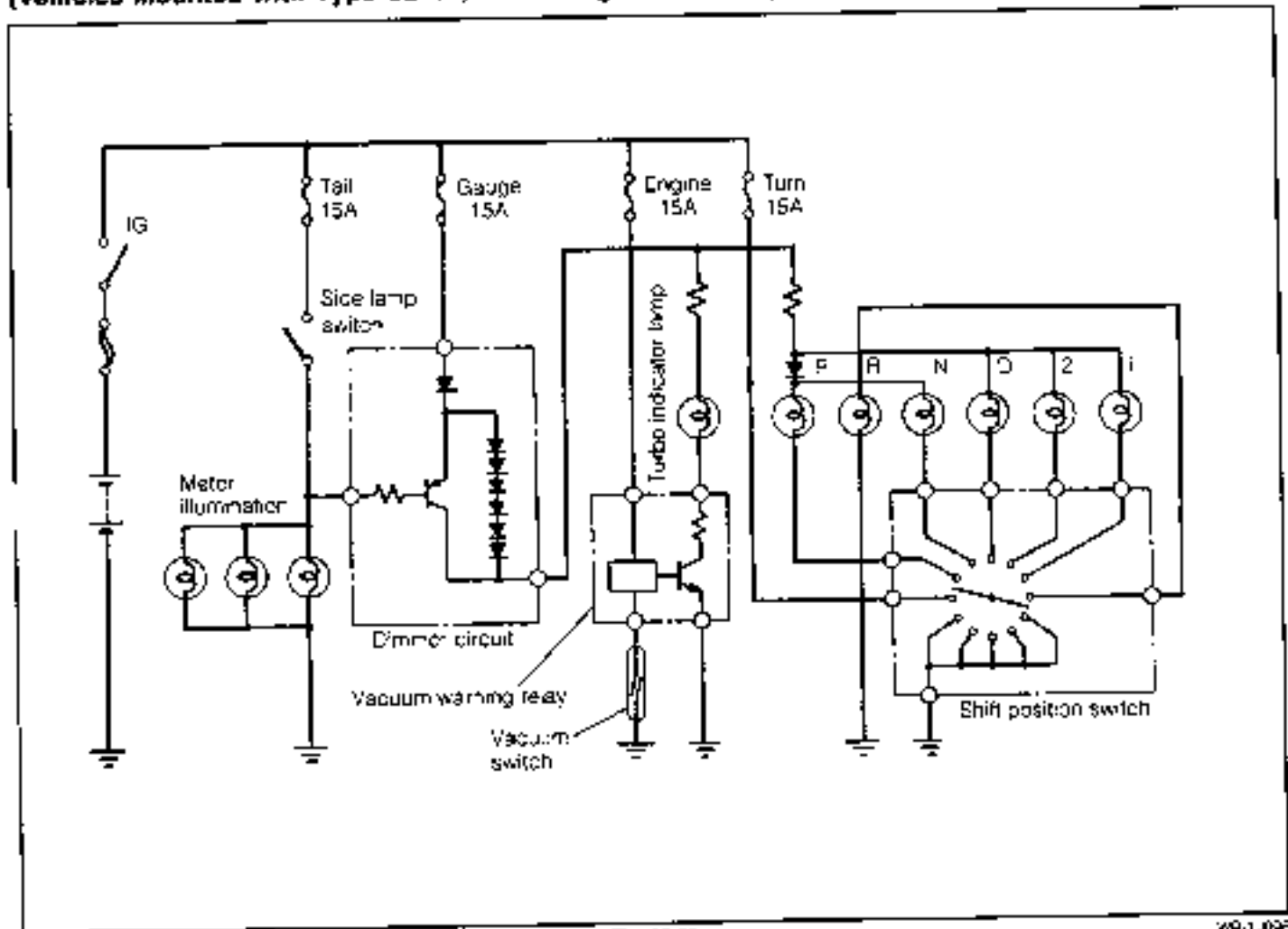

Fig. 10-89

WR-1-0026

In-Vehicle Check

1. Remove the combination meter (with the connector in a connected state) and turn ON the ignition switch. Ensure that the battery voltage is applied between the terminal (A) and the body earth.
2. Ensure that a voltage of 10.5 to 11.5 V is applied between the terminal (B) and the body earth when the turbo indicator terminal (multi-pole connector section) is grounded in the case of the turbocharged vehicle. Also, ensure that the same voltage is applied between the terminal (C) and the body earth when the shift switch is turned ON (L, 2, D, N and P) in the case of the automatic transmission-equipped vehicle.
At this point, the indicator should be illuminated normally.
3. Under the conditions described above, turn ON the side lamp switch. Ensure that a voltage of 6.0 to 6.5 V is applied between the terminal (B) and the body earth.
At this point, the indicator should be illuminated dimly.

NOTE:

For the turbo indicator terminal at the connector section, see page 10-22.

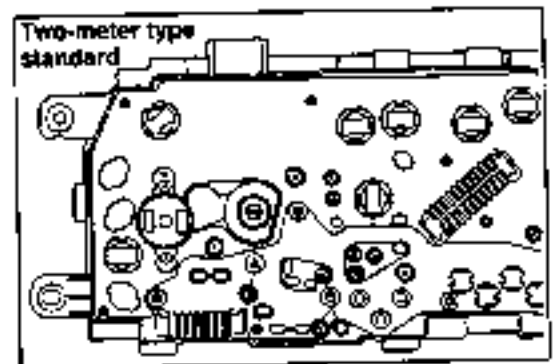

Fig. 10-90

WR-1-0027

BODY ELECTRICAL SYSTEM

MULTI-USE LEVER SWITCH

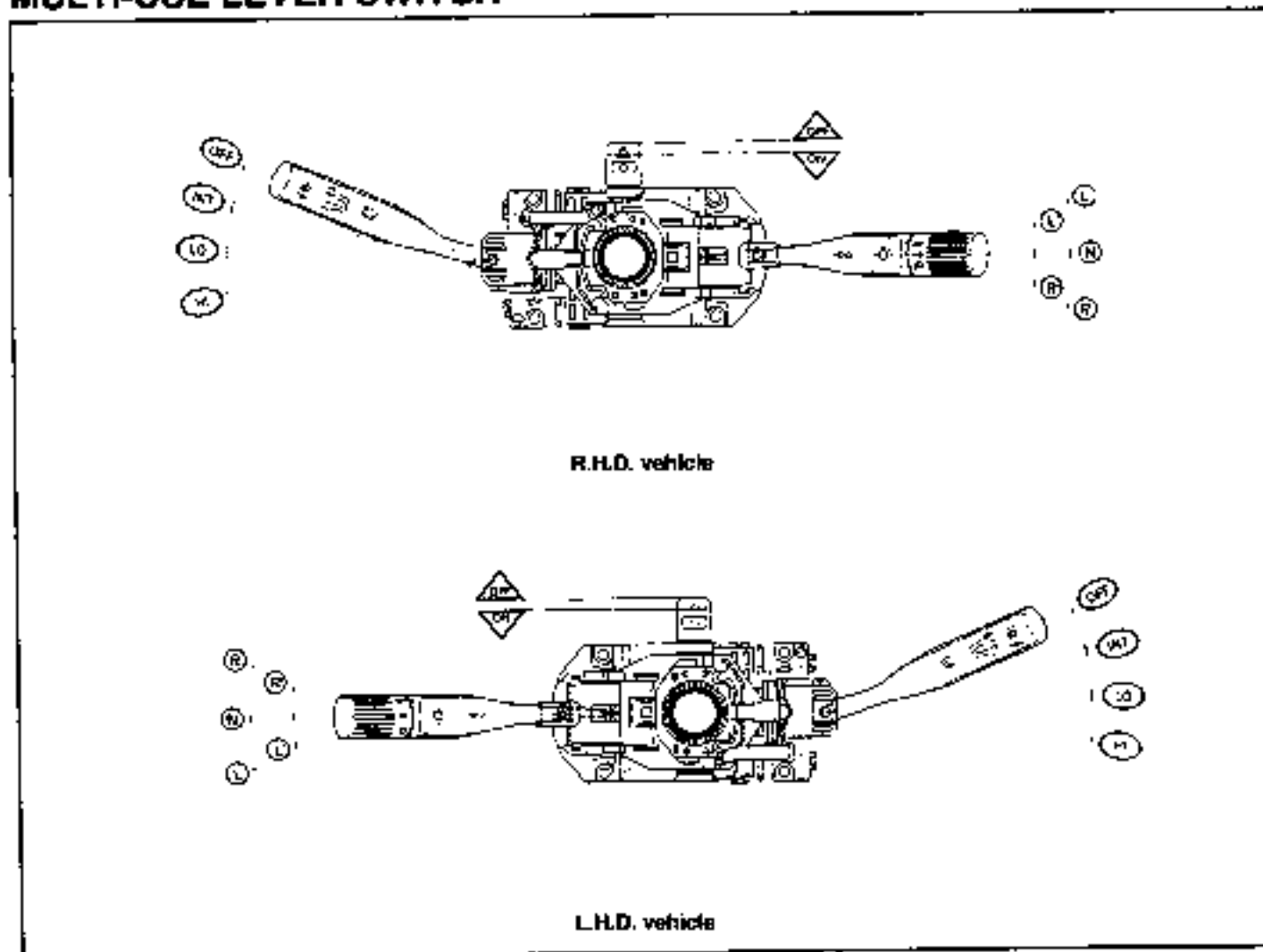

Fig. 10-01

WR-10093

INSPECTION

1. Ensure that each of the turn signal, dimmer, lighting, hazard warning and front wiper switches is functioning smoothly with a positive dent feeling.
2. Disconnect the connector for multi-use lever switch. Ensure that continuity exists between the respective terminals in accordance with the continuity table in pages 10-38 through 10-46.

Code	Kind of wires
TB	0.5 R (2W in case of West German specifications)
L	0.5GY
+2	0.5L
R	0.5GW
WB	0.5LW
E	1.25WB
HS	0.65RY
HO	0.3G
B ₁	0.5GR
HM	0.65RW
+1	0.5LY
S	0.5 RG (2WG in case of West German specifications)
W	0.3LG
WS	0.5LR
F	0.5GC
F	0.5GB
INT	0.5LB
DM	0.5GL
M	0.5G
RF	0.5Lg
B ₂	0.5GL
D1	2RW
D2	2R

WR-10093

LIGHTING SWITCH

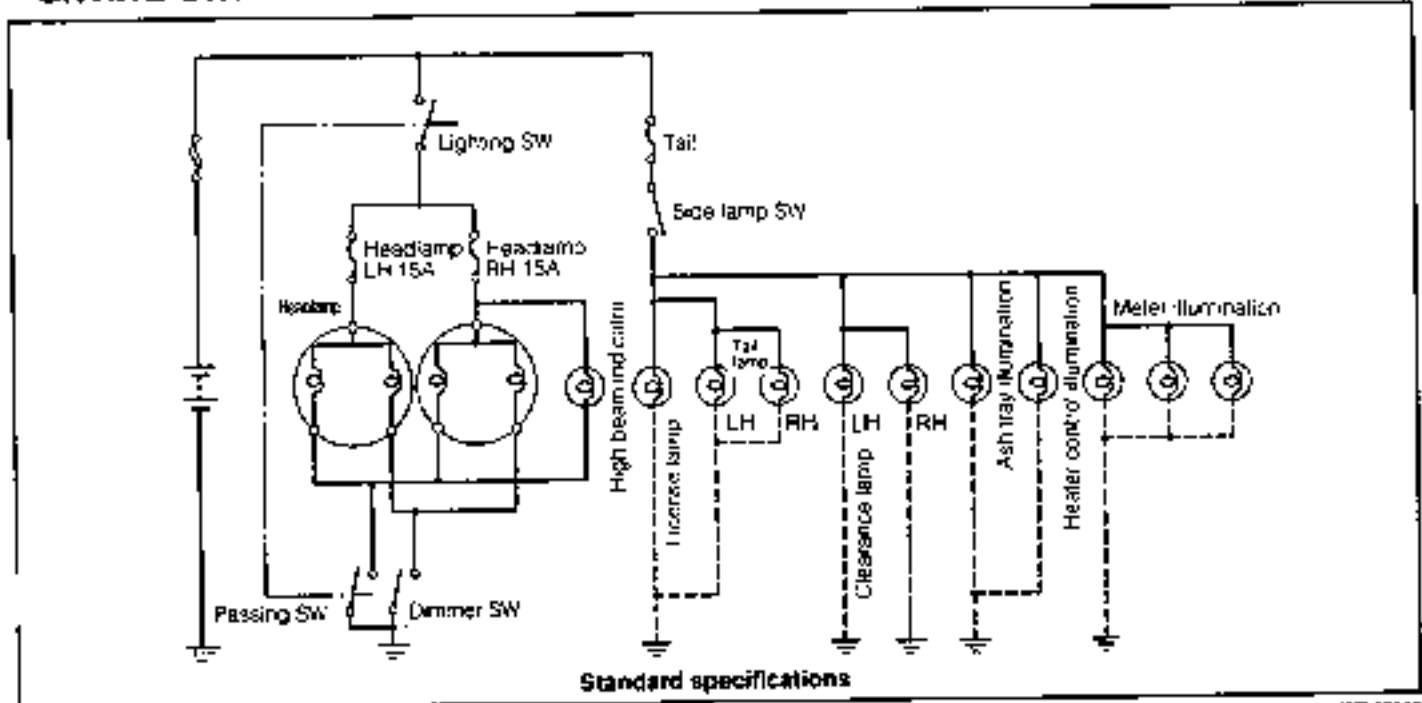

Standard specifications

Fig. 10-92

WB-1C100

○—○ Continuity exists.

R.H.D. vehicles with general specifications and Australian specifications (without intermittent wiper)
L.H.D. vehicles with general specifications

R.H.D. vehicles with ECE & EEC and Australian specifications (with intermittent wiper)
L.H.D. vehicles with ECE & EEC Specifications (except for West Germany)

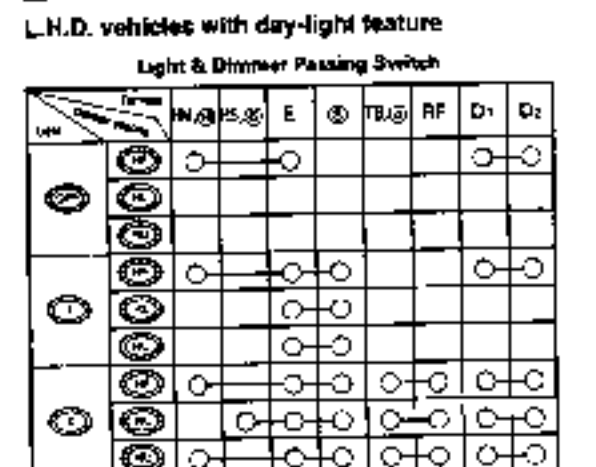
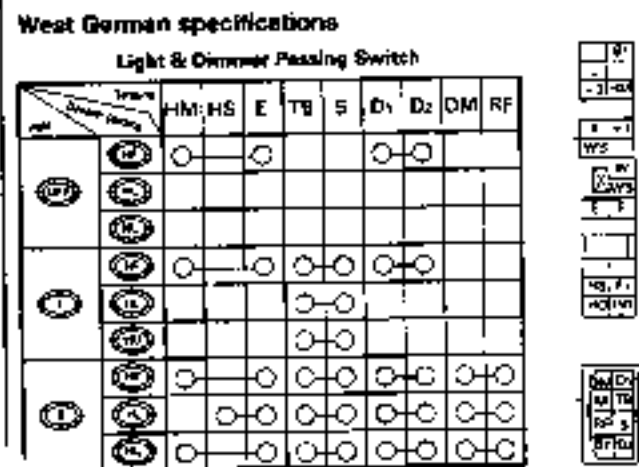
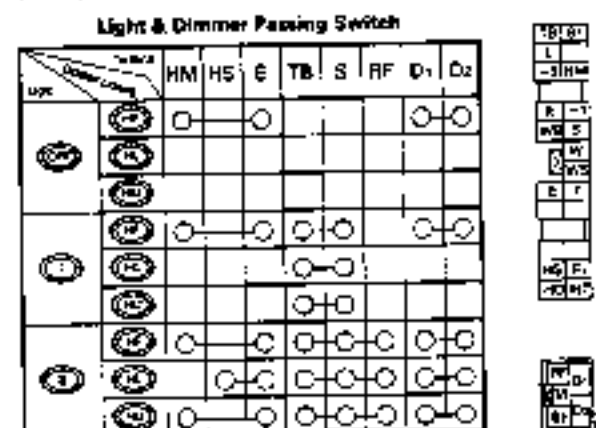
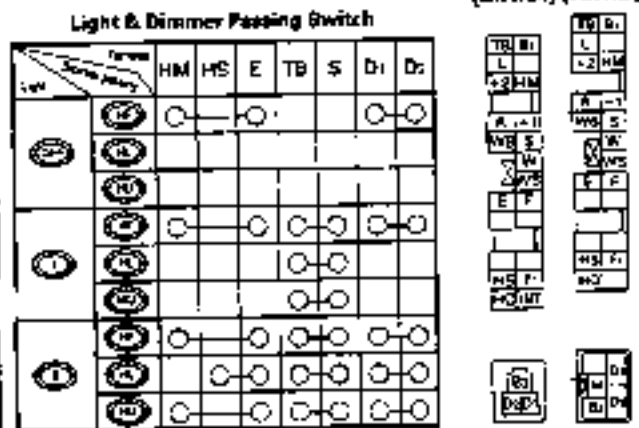

Fig. 10-93

WB-1310

BODY ELECTRICAL SYSTEM

TURN SIGNAL AND HAZARD SWITCH

Circuit diagram

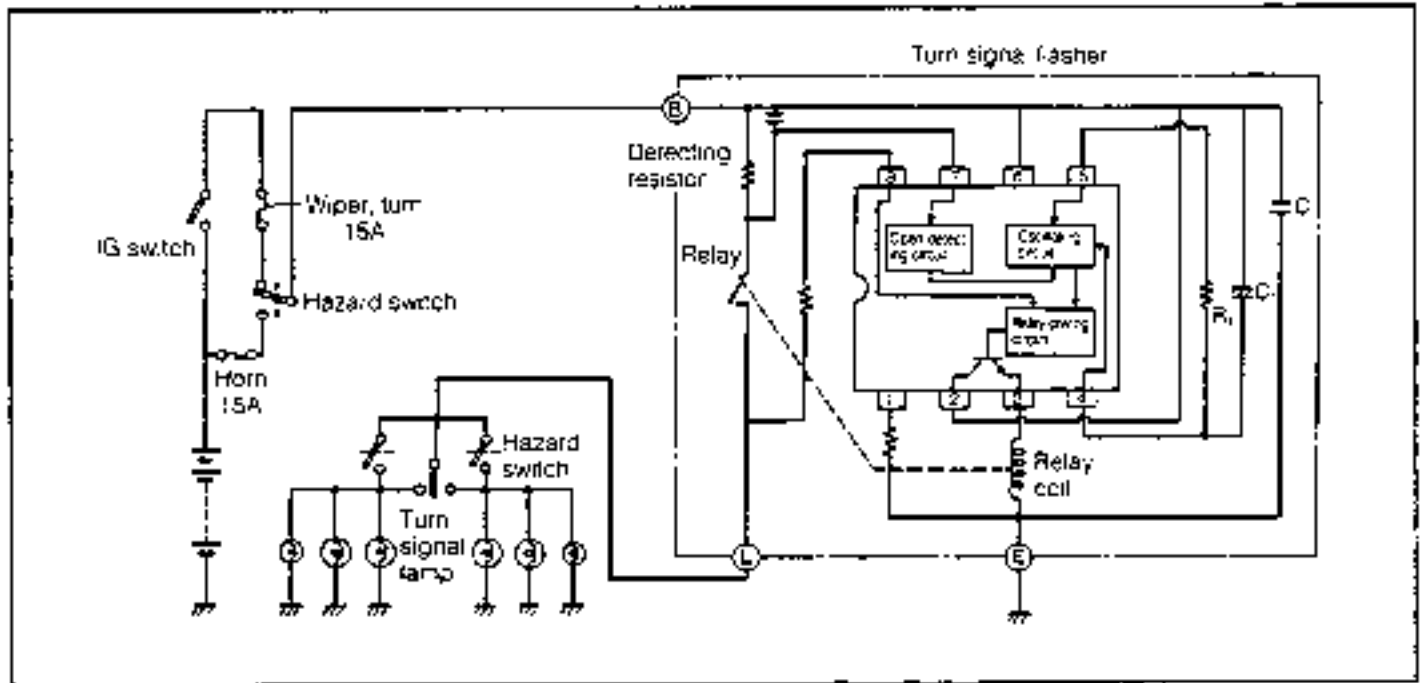

Fig. 10-84

WP-1010E

INSPECTION

Disconnect the multi-pole connector. Ensure that continuity exists between the respective terminals as indicated in the continuity table below.

NOTE:

Upon completion of the inspection, make sure that each connector is connected positively.

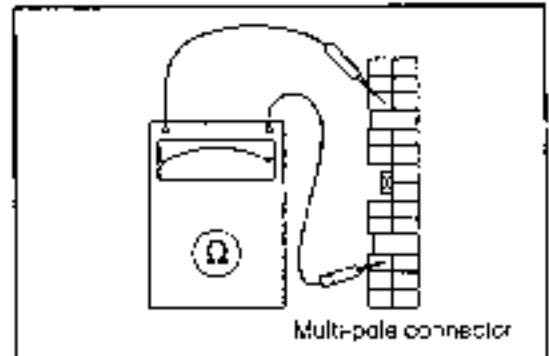

Fig. 10-85

WP-1010E

L.H.D. Vehicles with General Specifications

○—○ Continuity exists

	Terminal	F	L	R	B ₂	B ₁	F ₁
Hazard	①②	○—○			○—○	○—○	
	③				○—○	○—○	
	④⑤	○—○	○—○		○—○	○—○	
Turn signal	①②③	○—○	○—○				
	④⑤⑥	○—○	○—○	○—○			

Vehicles Other Than L.H.D. with General Specifications

	Terminal	F	L	R	M	B ₂	B ₁	F ₁
Hazard	①②	○—○				○—○	○—○	
	③					○—○	○—○	
	④⑤	○—○	○—○			○—○	○—○	
Turn signal	①②③	○—○	○—○					
	④⑤⑥	○—○	○—○	○—○	○—○			

Code	Kind of wires
F	0.5GC
L	0.5GY
R	0.5GW
M	0.5G
B ₂	0.5GL
B ₁	0.5GR
F ₁	0.5GB

WP-1010E

JRN SIGNAL FLASHER

The turn signal flasher is located at the upper part of the fuse block.

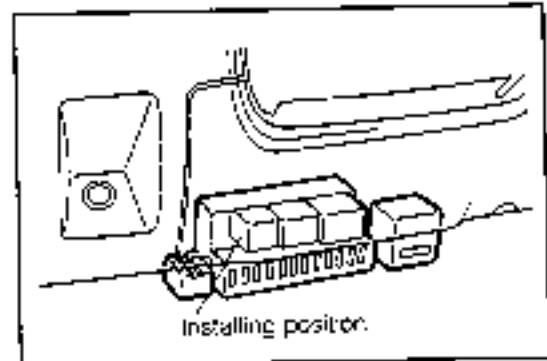

Fig. 10-86

WA-10105

INSPECTION

Check the flashing speed of the turn signal lamp

Specified Flashing Speed: 85 ± 10 times/min.

NOTE:

If any of the front or rear turn signal lamps has open wire, the flashing speed will exceed 120 times /min.

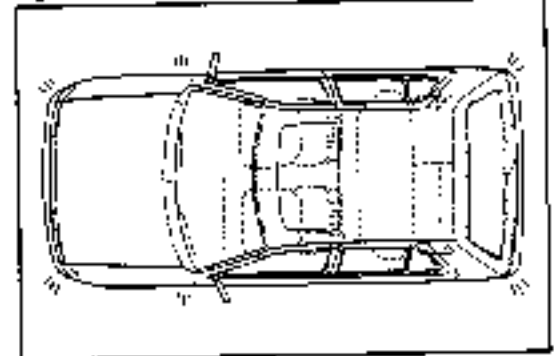

Fig. 10-87

WA-10106

FRONT WIPER AND WASHER SWITCH

INSPECTION

Disconnect the multi-pole connector. Ensure that continuity exists between the respective terminals as indicated in the continuity table below

Switch with Intermittent Wiper

○—○ Continuity exists

Lever position	Terminal	WS	+1	+2	INT	E	WB	W
Wiper switch	OFF	○—○						
	INT	○—○			○—○	○—○		
	LC		○—○				○—○	
	HI			○—○			○—○	
Washer switch	OFF							
	ON					○—○	○—○	

Code	Kind of wires
WS	0.5LR
+1	0.5LY
+2	0.5L
INT	0.5LB
E	1.25WB
WB	0.5LW
W	0.3LG

WA-10107

Switch without Intermittent Wiper

○—○ Continuity exists

Lever position	Terminal	WS	+1	+2	E	WB	W
Wiper switch	OFF	○—○					
	LC		○—○				○—○
	HI			○—○			○—○
Washer switch	OFF						
	ON					○—○	○—○

BODY ELECTRICAL SYSTEM

CONTINUITY TABLE OF MULTI-USE LEVER SWITCH BY DESTINATION

L.H.D. Vehicles with General Specifications (Two-speed Wiper)

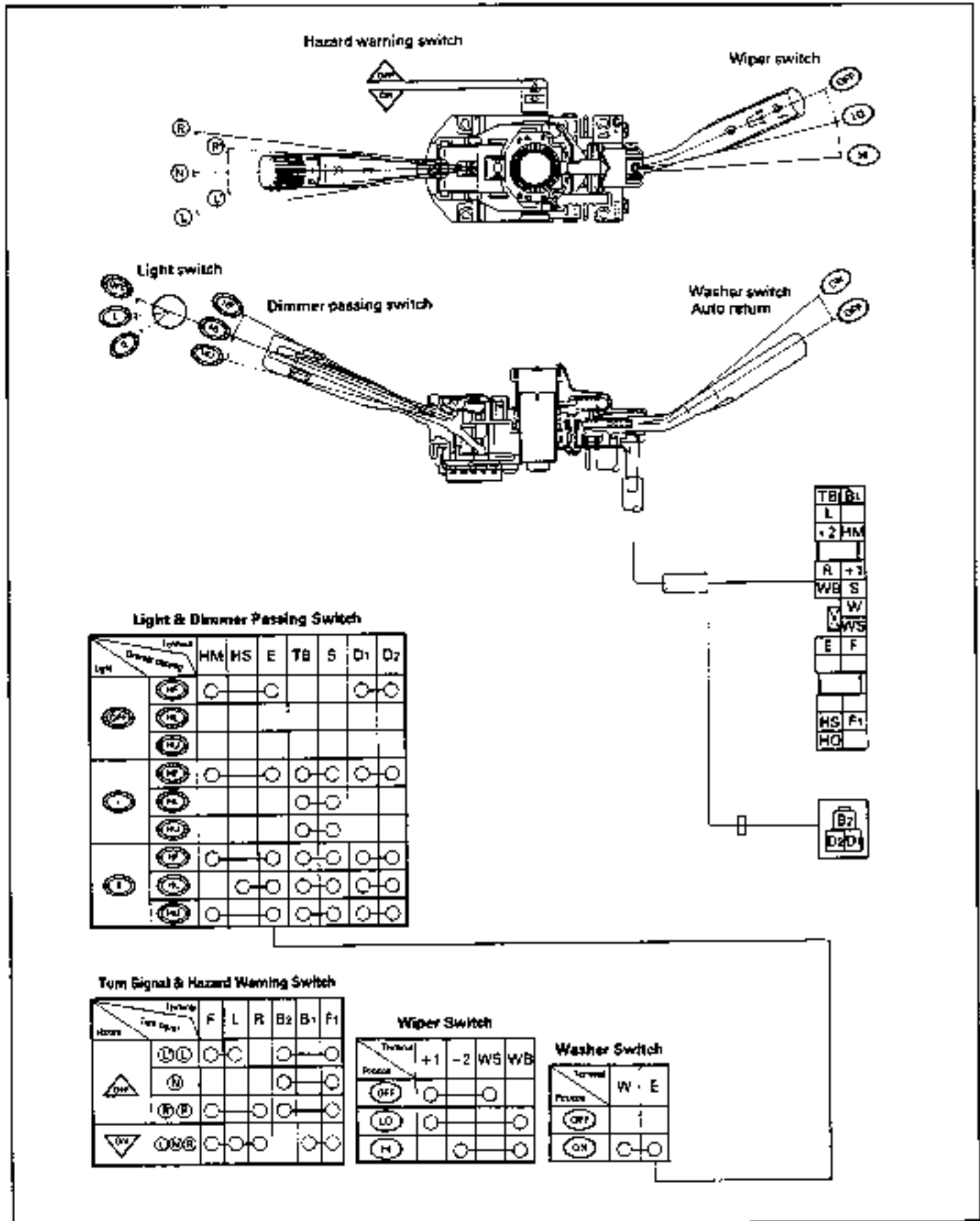
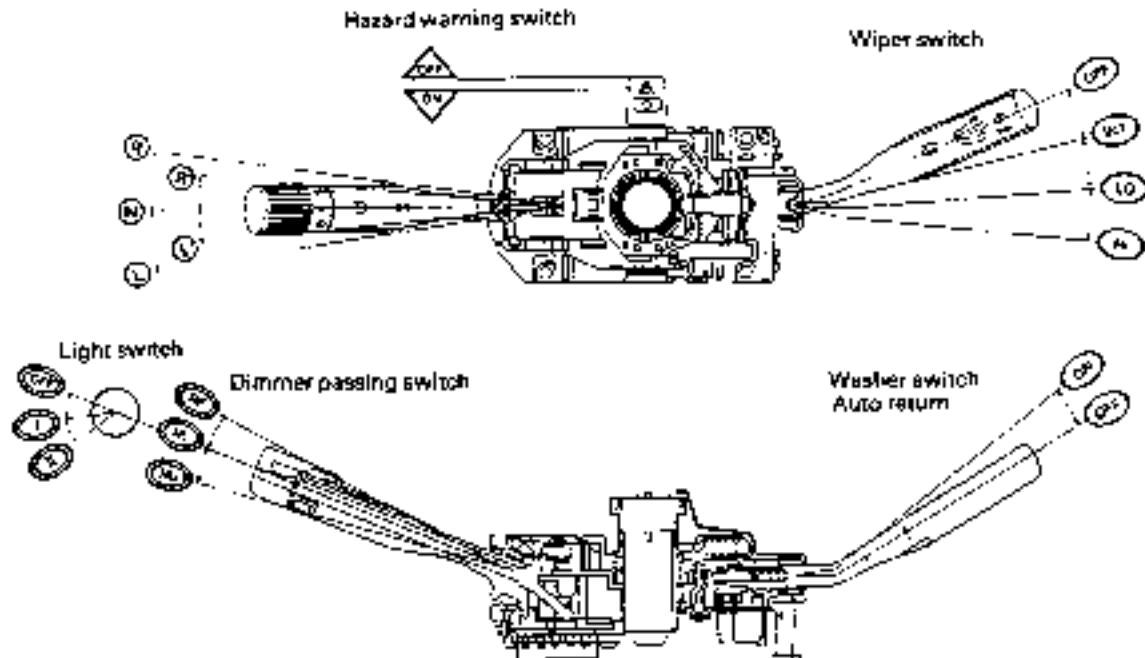

Fig. 10-96

1A35-0019

H.D. Vehicles with General Specifications (Two-speed, Intermittent Wiper)



Light & Dimmer Passing Switch

Terminal	Dimmer passing	HM	HS	E	TB	S	D1	D2
OFF	(OFF)							
L	(L)							
R	(R)							
L	(L)							
R	(R)							
L	(L)							
R	(R)							

TB	B-
L	
-2	HM
R	+1
WB	S
W	
WS	
E	F
HS	F1
HO	INT

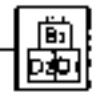

Turn Signal & Hazard Warning Switch

Terminal	Turn Signal	F	L	R	B2	B1	F1
OFF	(OFF)						
(R)	(R)						
(L)	(L)						
(OFF)	(OFF)						

Wiper Switch

Terminal	WS	+1	-2	INT	E	WB
OFF						
(INT)						
(LO)						
(H)						

Washer Switch

Terminal	W	E
OFF		
(OFF)		

Fig. 10-39

BODY ELECTRICAL SYSTEM

R.H.D. Vehicles with ECE & EEC, General and Australian Specifications
(Two-speed, Intermittent Wiper)

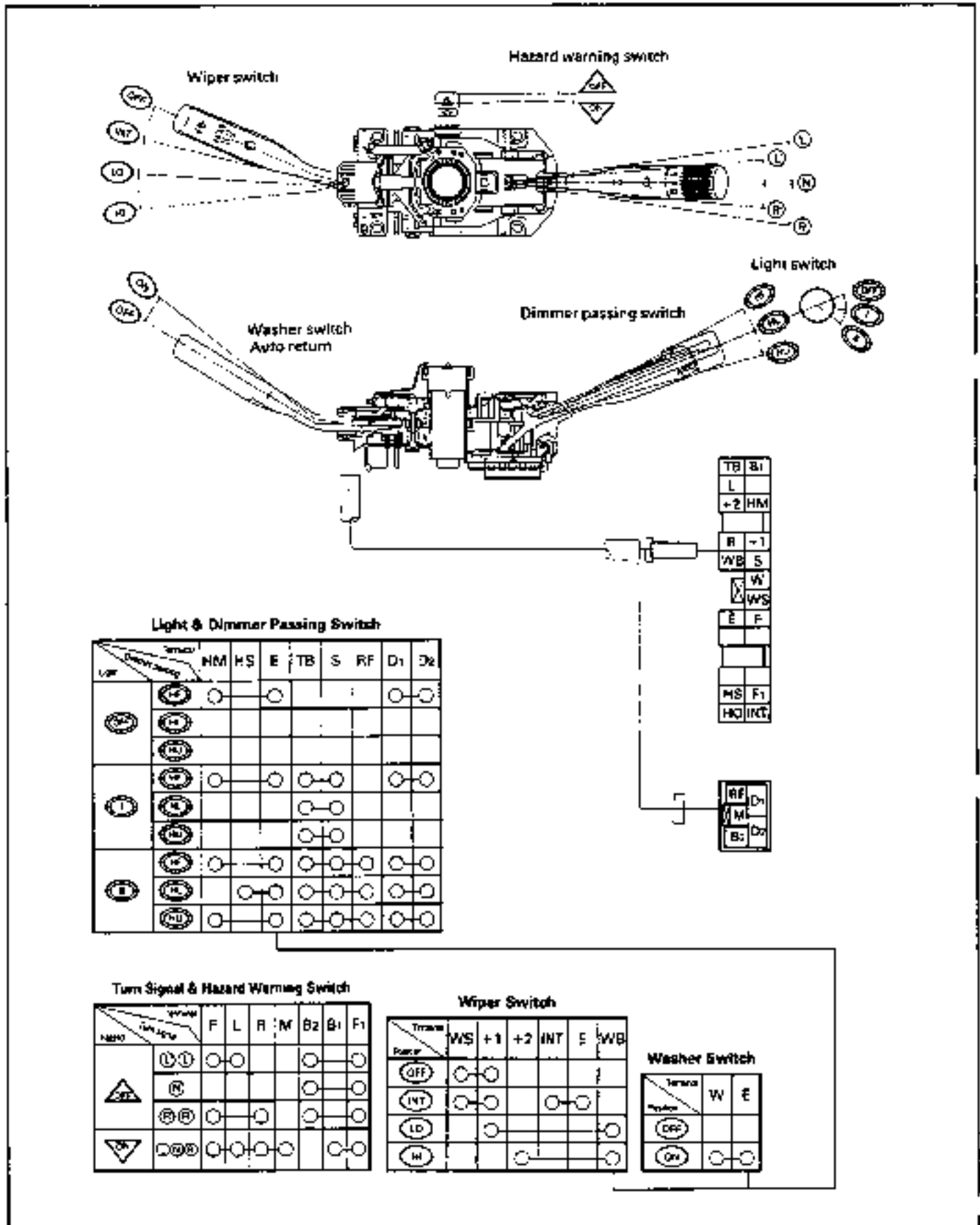
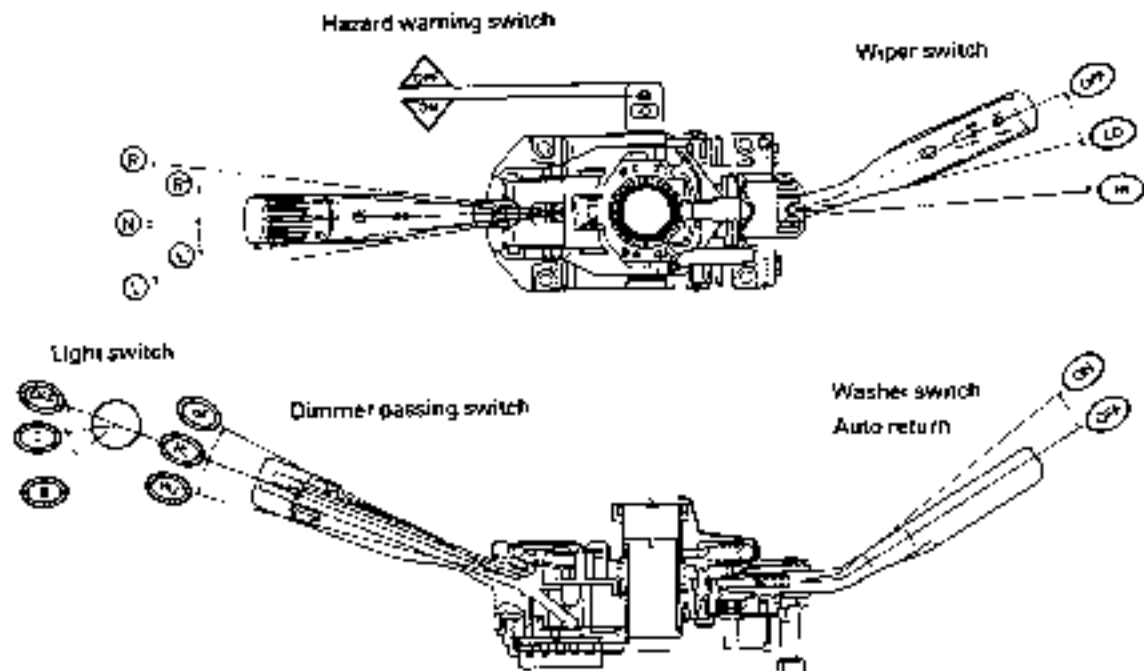

Fig. 10-100

T-86-08021

4.D. Vehicles with ECE & EEC Specifications, Except for West Germany (Two-speed Wiper)



Light & Dimmer Passing Switch

Position	Light	Dimmer	HM	H5	E	TB	S	RF	D1	D2
OFF	⊙	⊙	○	○	○	○	○	○	○	○
1	⊙	⊙	○	○	○	○	○	○	○	○
2	⊙	⊙	○	○	○	○	○	○	○	○
3	⊙	⊙	○	○	○	○	○	○	○	○

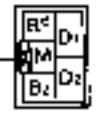
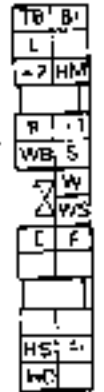

Turn Signal & Hazard Warning Switch

Position	F	L	R	M	B2	B1	F1
OFF	○	○	○	○	○	○	○
1	○	○	○	○	○	○	○
2	○	○	○	○	○	○	○

Wiper Switch

Position	+1	+2	WS	WB
OFF	○	○	○	○
LD	○	○	○	○
H	○	○	○	○

Washer Switch

Position	W	E
OFF	○	○
ON	○	○

Fig. 10-101

1205-10322

BODY ELECTRICAL SYSTEM

L.H.D. Vehicles with ECE & EEC Specifications, Except for West Germany
(Two-speed, Intermittent Wiper)

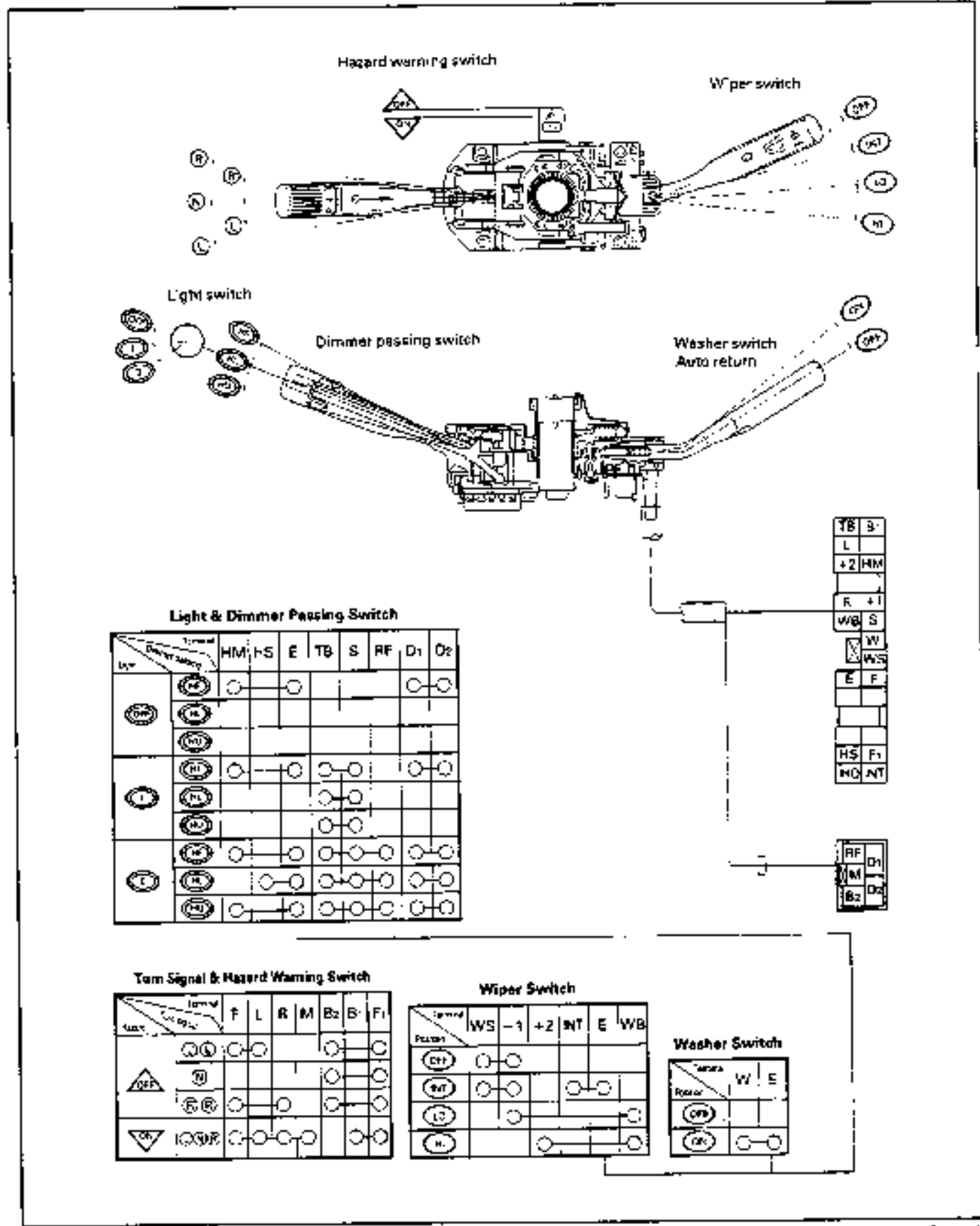

Fig. 10-102

1300-0W25

ehicles with West German Specifications (Two-speed Wiper)

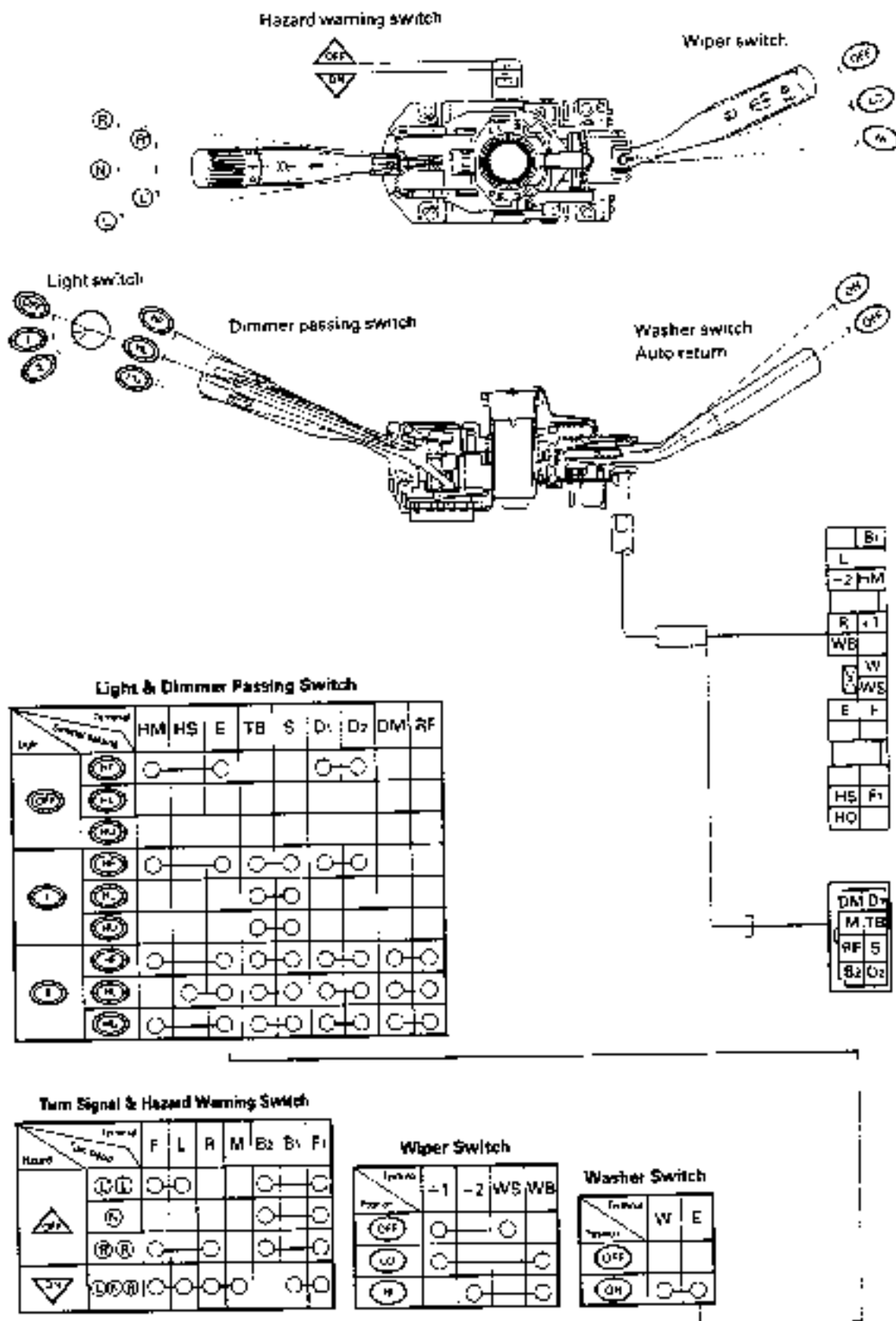
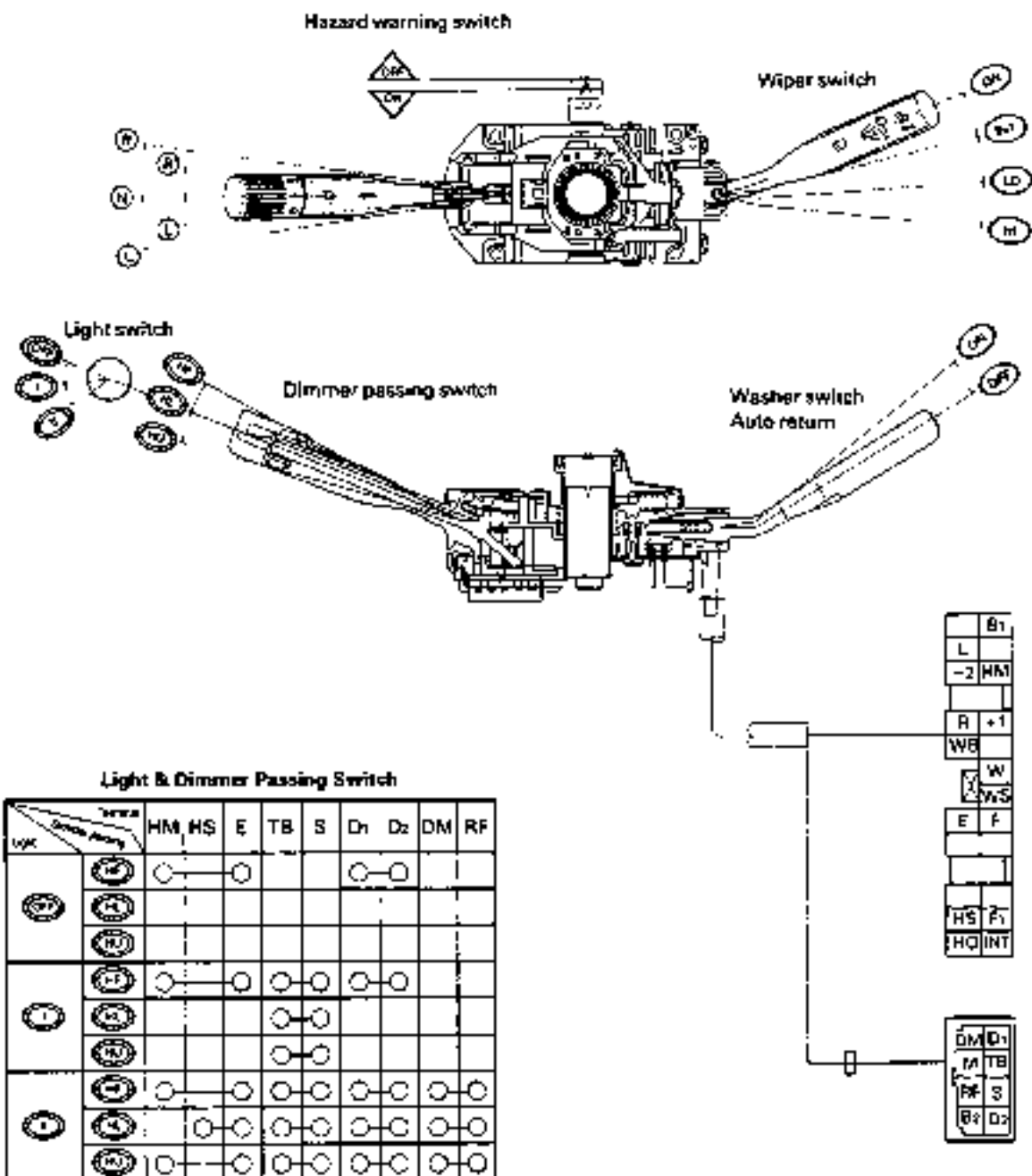

Fig. 10-103

1965-00-1

BODY ELECTRICAL SYSTEM

Vehicles with West German Specifications (Two-speed, Intermittent Wiper)



Turn Signal & Hazard Warning Switch

Turn Signal	F	L	R	M	B2	B1	F1
OFF	<input type="checkbox"/>	<input type="checkbox"/>	<input type="checkbox"/>	<input type="checkbox"/>	<input type="checkbox"/>	<input type="checkbox"/>	<input type="checkbox"/>
I	<input type="checkbox"/>	<input type="checkbox"/>	<input type="checkbox"/>	<input type="checkbox"/>	<input type="checkbox"/>	<input type="checkbox"/>	<input type="checkbox"/>
II	<input type="checkbox"/>	<input type="checkbox"/>	<input type="checkbox"/>	<input type="checkbox"/>	<input type="checkbox"/>	<input type="checkbox"/>	<input type="checkbox"/>

Wiper Switch

Wiper	WS	+1	-2	INT	E	WE
OFF	<input type="checkbox"/>	<input type="checkbox"/>	<input type="checkbox"/>	<input type="checkbox"/>	<input type="checkbox"/>	<input type="checkbox"/>
I	<input type="checkbox"/>	<input type="checkbox"/>	<input type="checkbox"/>	<input type="checkbox"/>	<input type="checkbox"/>	<input type="checkbox"/>
II	<input type="checkbox"/>	<input type="checkbox"/>	<input type="checkbox"/>	<input type="checkbox"/>	<input type="checkbox"/>	<input type="checkbox"/>

Washer Switch

Washer	W	E
OFF	<input type="checkbox"/>	<input type="checkbox"/>
ON	<input type="checkbox"/>	<input type="checkbox"/>

Fig. 10-10A

TR3E-3525

H.D. Vehicles with Day-light Specifications (Two-speed, Intermittent Wiper)

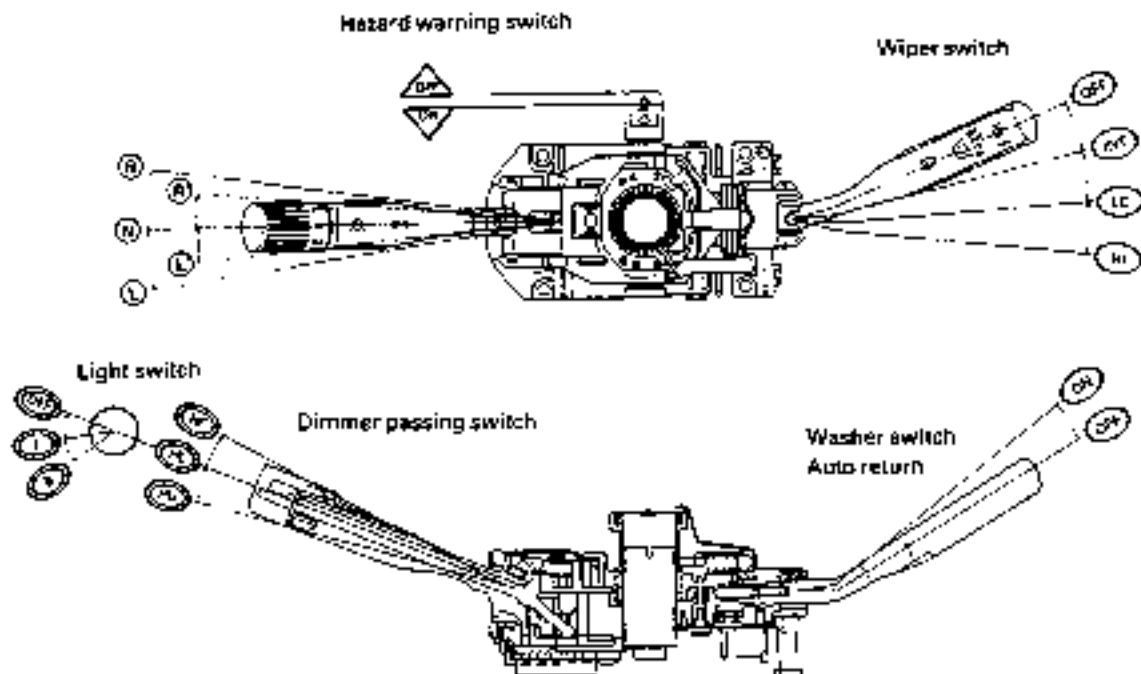

Light & Dimmer Passing Switch

Terminal		WV	HS	E	TE	RF	D1	D2
OFF	ON							
L	R							
M	N							
OFF	ON							
L	R							
M	N							
OFF	ON							
L	R							
M	N							

TB	B1
L	
-2	MM
F	-1
WB	S
M	
VS	
E	F
MS	F1
MC	INT

B	B7
E	D1
I	
D2	
RF	
M	

Turn Signal & Hazard Warning Switch

Terminal		F	L	R	M	B2	B1	F1
OFF	ON							
L	R							
M	N							
OFF	ON							
L	R							
M	N							

Wiper Switch

Terminal		WS	+1	-2	INT	E	WB
OFF	ON						
INT							
LO							
HI							

Washer Switch

Terminal		W	E
OFF	ON		
ON			

Fig. 10-105

BODY ELECTRICAL SYSTEM

R.H.D. Vehicles with General Specifications and Australian Specifications (Two-speed, Wiper)

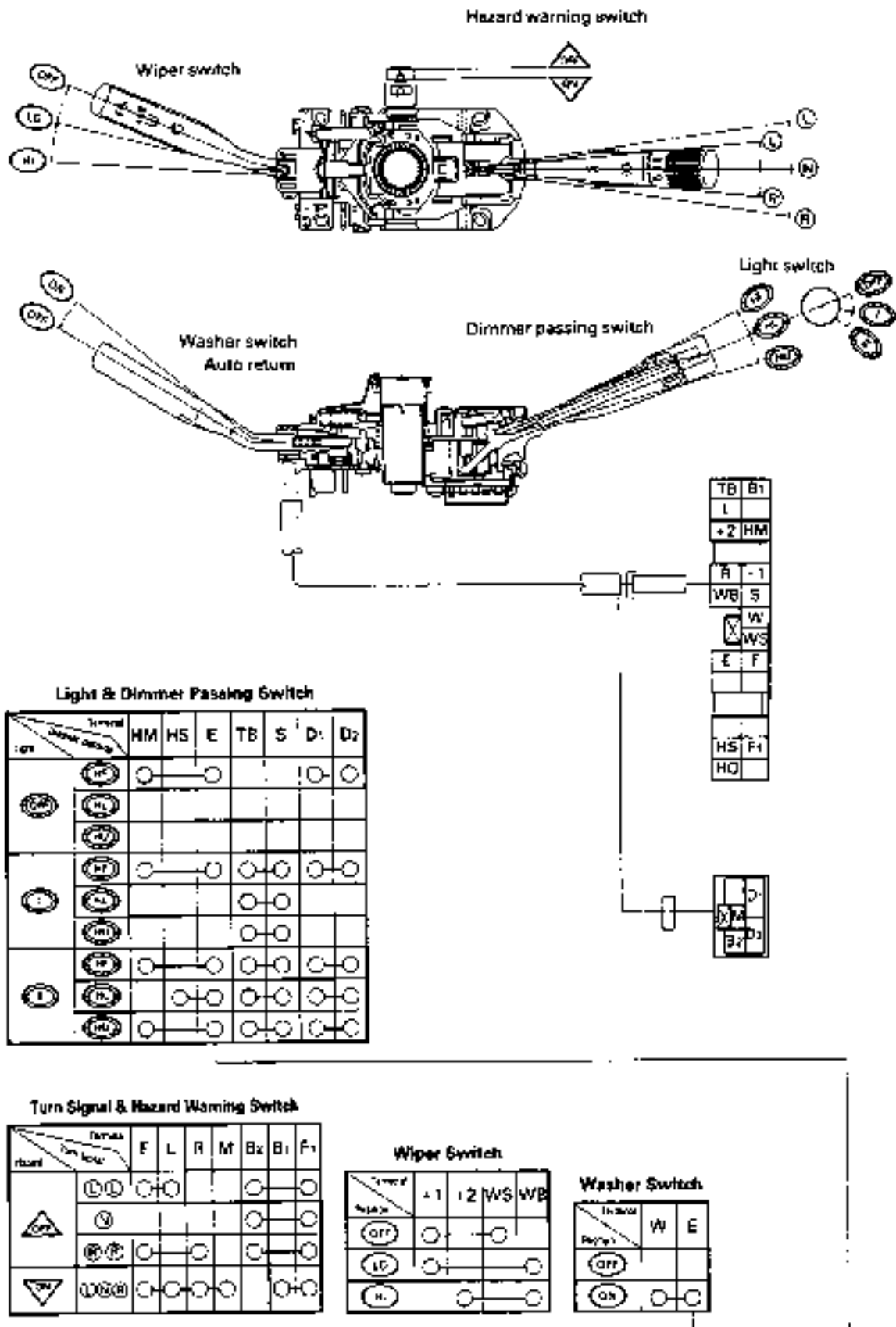

Fig. 10-108

TFBS-CAUG7

SWITCHES

IGNITION KEY SWITCH

For the removal/installation procedure for the ignition key switch lock cylinder assembly, see page 7-5.

INSPECTION

Disconnect the connector of the ignition key switch. Ensure that continuity exists between the respective terminals as indicated in the continuity table.

Continuity Table (Except for GT_U)

	AM	ACC	IG	ST
LOCK				
ACC	○	○		
ON	○	○	○	
START	○		○	○

Continuity Table (For GT_U)

	AM	ACC	IG ₁	IG ₂	ST
LOCK					
↓					
ACC	○	○			
↓	○	○			
ON	○	○	○	○	
↓	○		○	○	
START	○		○	○	○

STOP LAMP SWITCH

The stop lamp switch is located at the pedal bracket section.

INSPECTION

1. Disconnect the connector of the stop lamp switch.
2. Ensure that continuity exists between the terminals when the brake pedal is depressed.

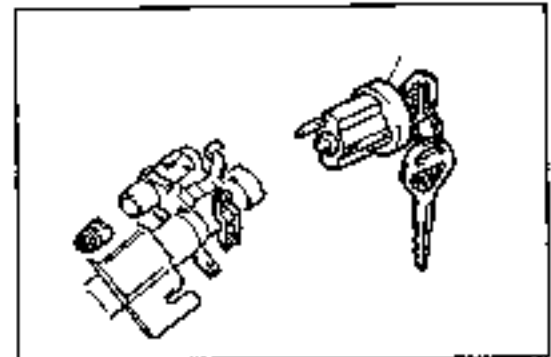

Fig. 10-107

WF-10'08

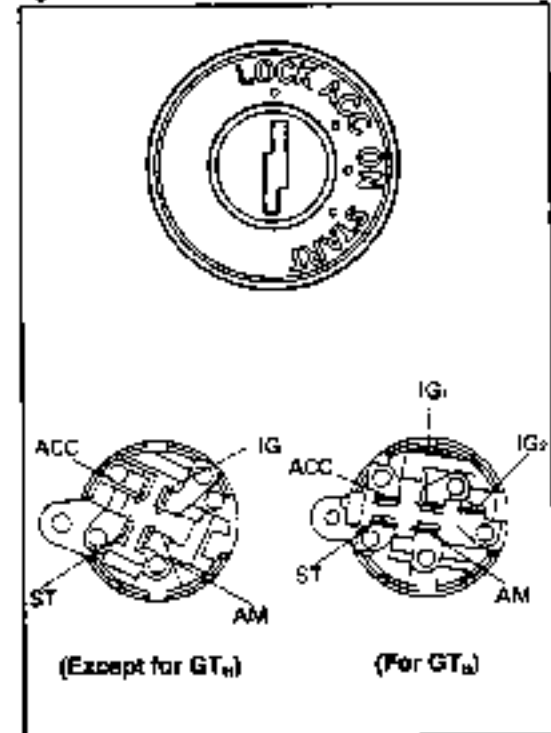

Fig. 10-108

WF-10'09



Fig. 10-109

WF-10'13

BODY ELECTRICAL SYSTEM

3. Ensure that no continuity exists between the terminals when the brake pedal is not depressed.

REAR WINDOW DEFOGGER SWITCH

On the R.H.D. vehicles, the rear window defogger switch is located at the right side of the instrument cluster finish panel. On the L.H.D. vehicles, this switch is located at the left side of the instrument cluster finish panel.

Removal

1. Remove the four screws. Pull the instrument cluster finish panel assembly toward your side.
2. Remove the switch by removing the connector and two screws.

INSPECTION

Disconnect the connector. Ensure that continuity exists between the respective terminals as indicated in the continuity table below.

Continuity Table

○—○ Bulb in installed state

Terminal	B	D	E
Knob position			
OFF		○—○	○—○
ON	○—○	○—○	○—○

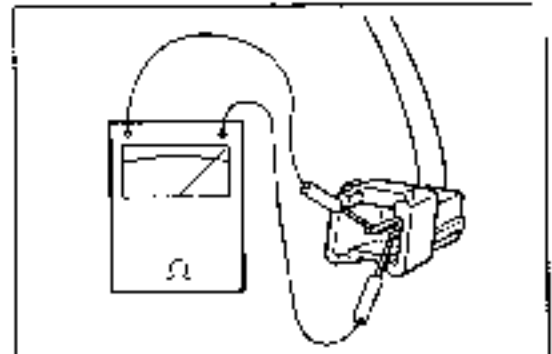

Fig. 10-110

WR-10-11



Fig. 10-111

WR-10-12

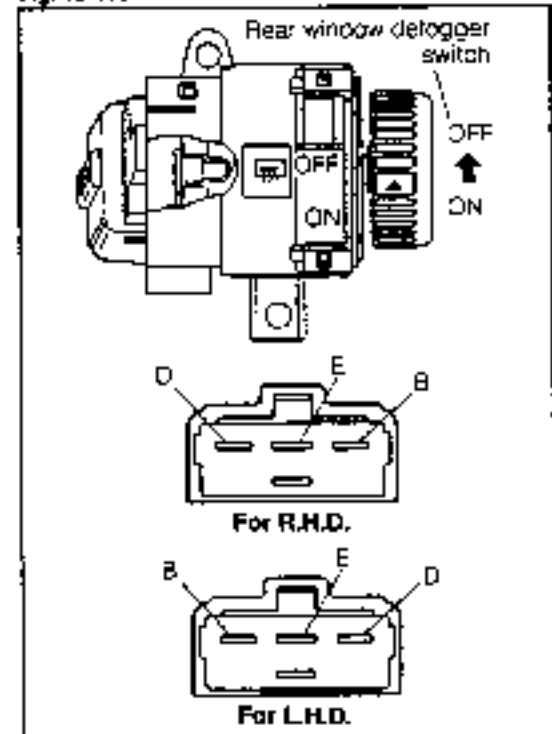

Fig. 10-112

WR-10-13

INSTALLATION

1. Install the defogger switch to the cluster finish panel with the two screws.
2. Connect the connector securely.
3. Attach the cluster finish panel to the instrument panel by tightening the two screws.

WR-10-14

EAR WINDOW DEFOGGER WIRE

NOTE:

- (1) When wiping the glass surface, use a soft, dry cloth. Move the cloth along the wire. Be careful not to damage the wire.
- (2) Never use washing agent or glass cleaner which contains abrasive compound.
- (3) Wrap the tip end of the tester probe with foil strip so that the tester probe causes no damage on the heat wire during the voltage measurement. Check the voltage by pushing the foil strip against the heat wire by your finger, as shown in the figure.

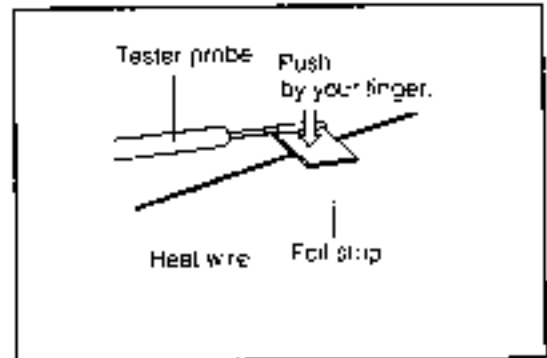

Fig. 10-113

WP-10-113

1. Open wire check

- (1) Turn ON the ignition key switch
- (2) Turn ON the defogger switch so as to energize the defogger wire
- (3) Check the voltage at the center section of each heat wire.

Voltage	Judgement criteria
Approx. 5 V	Good (No open wire)
Approx. 10 V or 0 V	Open wire

Reference:

If the voltage is 10 V, it means that open wire exists between the center of the wire and the end of the positive (+) side. If the voltage is 0 V, it means that open wire exists between the center of the wire and the end of the earth side.

2. Locating Point of Open Wire

- (1) Connect the positive (+) terminal of the voltmeter to the positive (+) side of the defogger wire
- (2) Slide the voltmeter's negative (-) terminal wrapped with foil strip on the defogger wire from its positive (+) side to its negative (-) side.
- (3) The voltmeter reading changes from 0 V to several volts at the point where open wire exists.

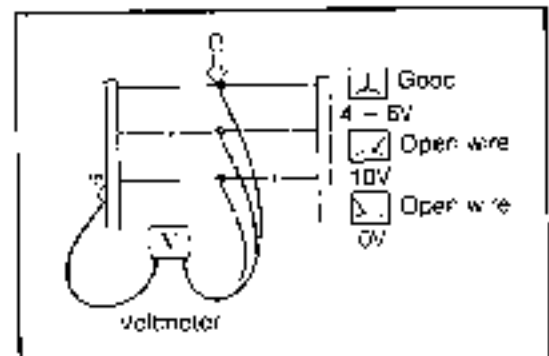

Fig. 10-114

WP-10-114

3. Repairing Point of Open Wire

- (1) Clean the point of open wire with white gasoline.
- (2) Affix masking tapes to both upper and lower portions of the point to be repaired.
- (3) Stir repair agent (Du Pont Paste No. 4817) thoroughly. Apply a small amount of the repair agent to the repairing point, using a fine brush.
- (4) Two to three minutes later, peel off the masking tapes.
- (5) Do not energize the defogger wire within 24 hours after the repair.

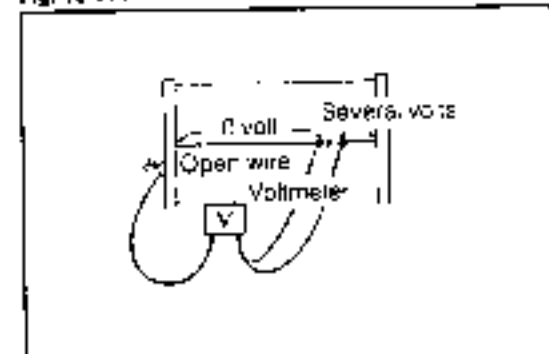

Fig. 10-115

WP-10-115

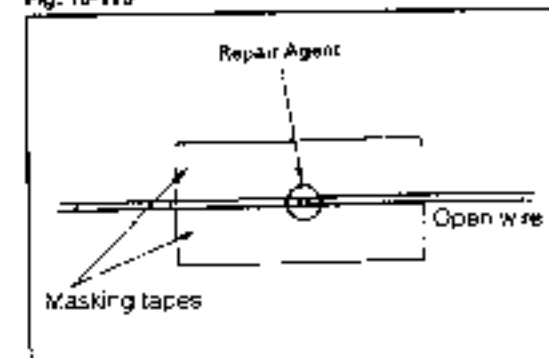

Fig. 10-116

WP-10-116

BODY ELECTRICAL SYSTEM

FRONT WIPER AND WASHER

FRONT WIPER CIRCUIT DIAGRAM

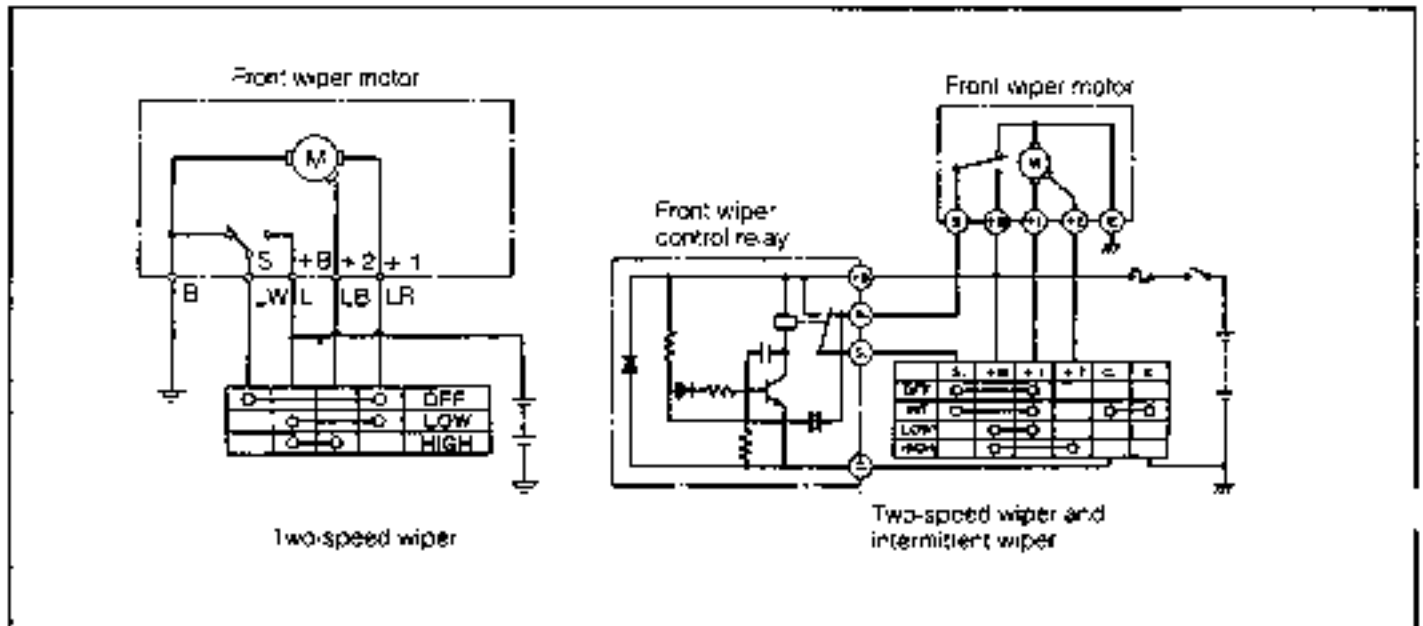

Fig. 10-117

WR-10119

FRONT WIPER AND BLADES COMPONENTS

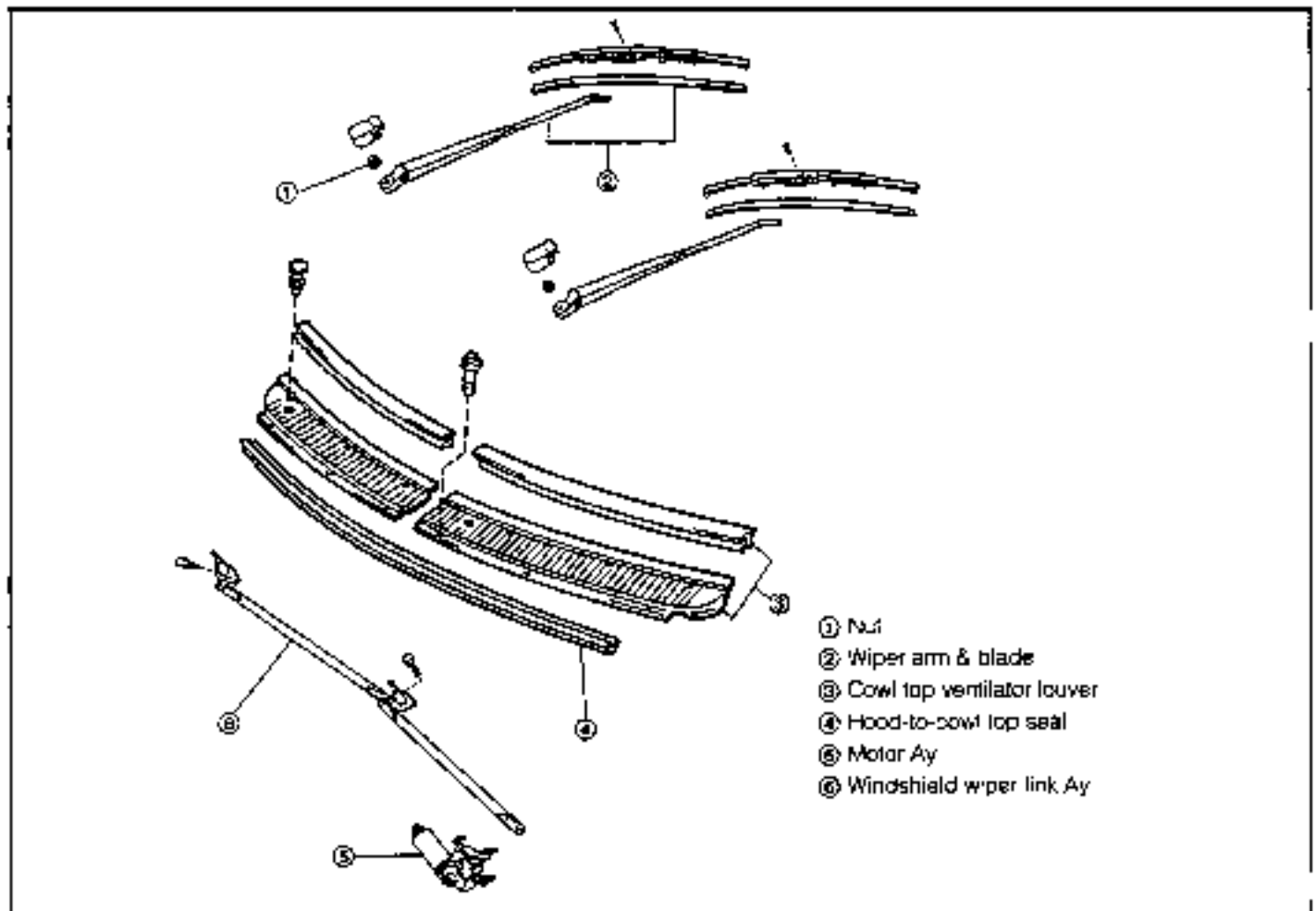

Fig. 10-118

WR-10120

REMOVAL

1. Remove the front wiper arm cover. Remove the nut.
NOTE:
 Care must be exercised to ensure that no scratch is made to the engine hood.

2. Remove the wiper arm and blades.

3. Remove the cowl top ventilator louver.
4. Remove the hood-to-cowl top seal.

5. Remove the wiper motor assembly.
 - (1) Disconnect the connector.
 - (2) Remove the set bolt.
 - (3) Disconnect the motor from the link. Remove the motor.

6. Remove the wiper link assembly.
 - (1) Remove the set bolt

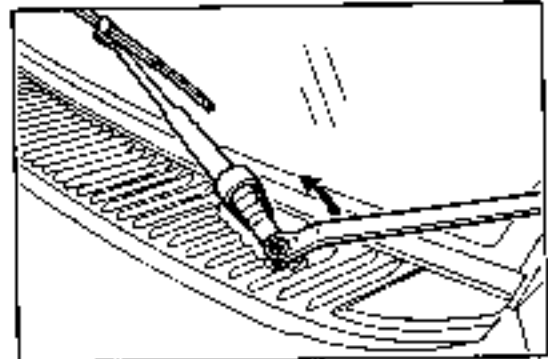

Fig. 10-119

WR-13-21

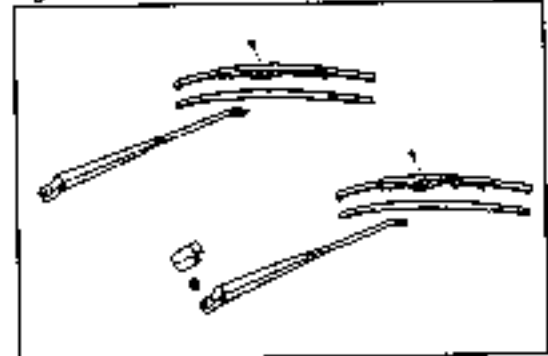

Fig. 10-120

WR-10-22

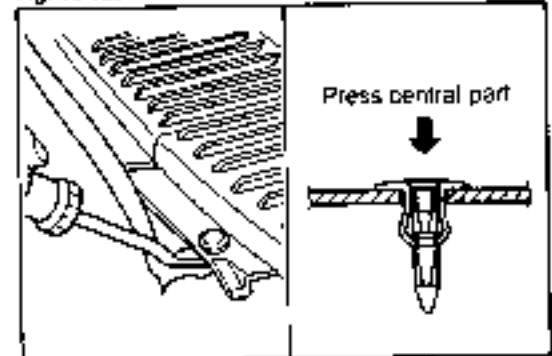

Fig. 10-121

WR-11-23

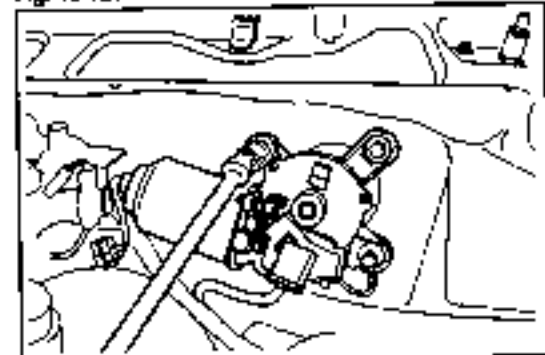

Fig. 10-122

WR-10-24

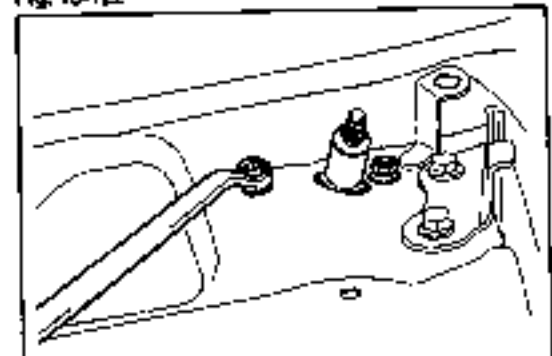

Fig. 10-123

WR-10-25

BODY ELECTRICAL SYSTEM

- (2) Take out the wiper link assembly from the cowl louver hole.

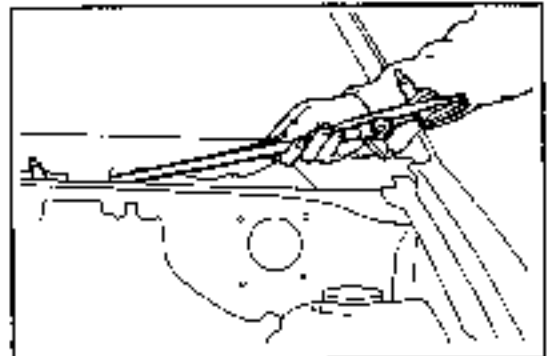

Fig. 10-124

WR-10128

Checking of Front Wiper Motor Unit

1. Low Speed Operation Check

- (1) Connect the terminal +1 to the positive \oplus terminal of the battery; the body to the negative \ominus terminal of the battery. Ensure that the wiper operates at the low speed.

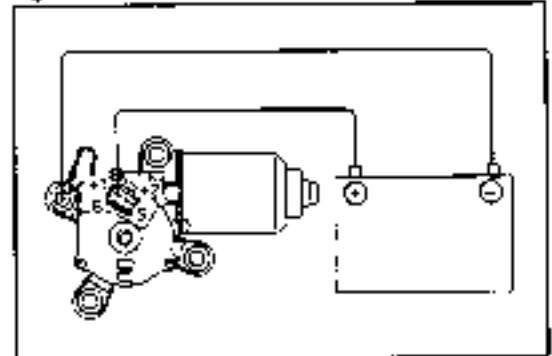

Fig. 10-125

WR-10127

2. High Speed Operation Check

- (1) Connect the terminal +2 to the positive \oplus terminal of the battery; the body to the negative \ominus terminal of the battery. Ensure that the wiper operates at the high speed.

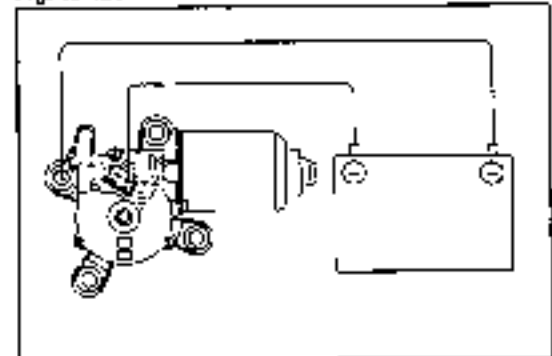

Fig. 10-126

WR-10129

3. OFF Operation Check

With the wiper motor body connected to the negative \ominus terminal of the battery, perform the following checks.

- (1) Connect the terminal B to the positive \oplus terminal of the battery.
(2) Operate the wiper at the low speed by connecting the terminal -1 to the positive \oplus terminal of the battery.

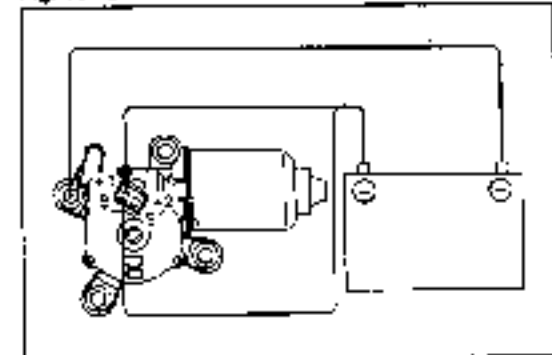

Fig. 10-127

WR-10128

- (3) Under the operating conditions in the step (2), disconnect the terminal +1 so as to interrupt the wiper motor operation.

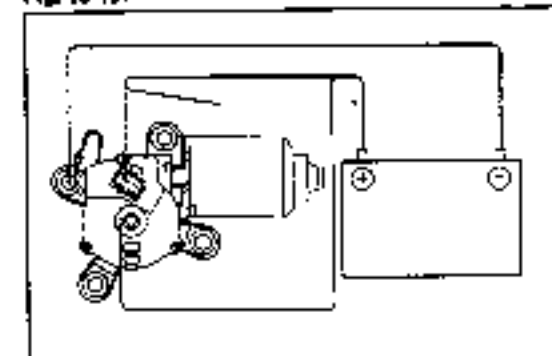

Fig. 10-128

WR-10129

- (4) Connect the terminal +1 to the terminal S. Ensure that the wiper operates and stops at the automatic stopping position.

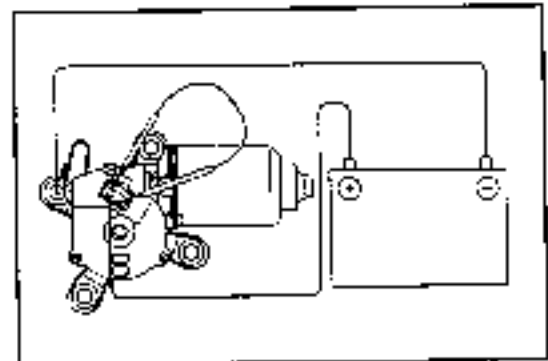

Fig. 10-129

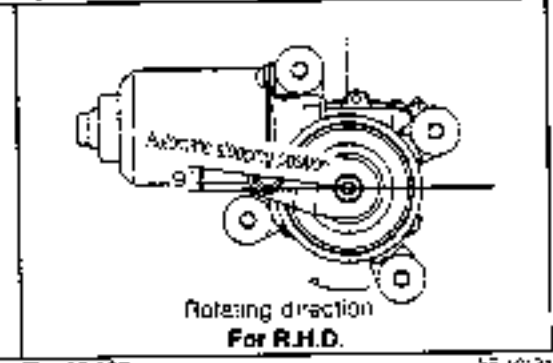
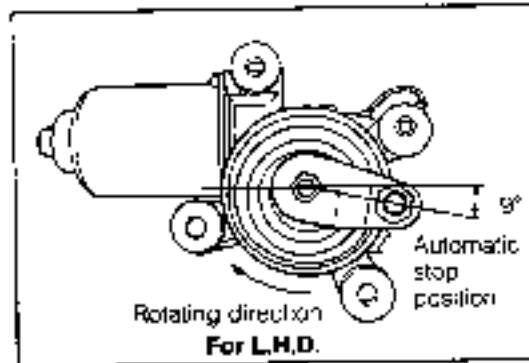

Fig. 10-130

AF-10-31

INSTALLATION

1. Install the windshield wiper link assembly.
2. Install the motor assembly.

NOTE:

Connect the motor assembly with the link securely.

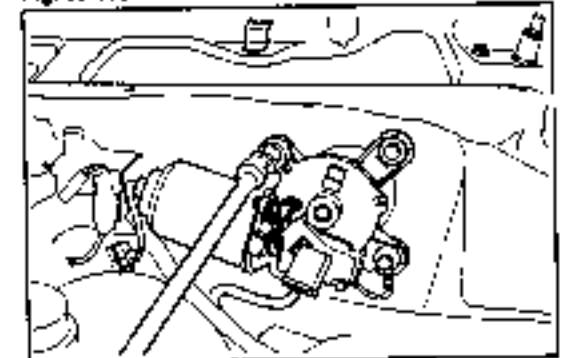

Fig. 10-131

AF-10-32

3. Install the hood-to-cowl top seal. Install the cowl top ventilator louver.

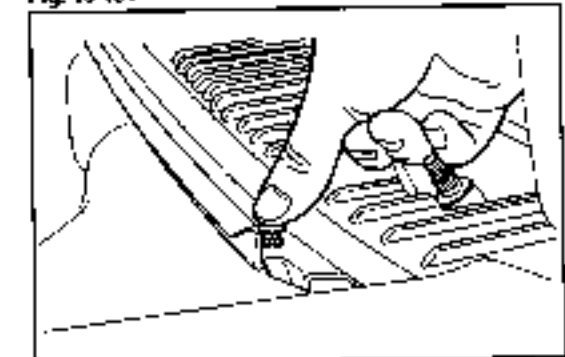

Fig. 10-132

AF-10-33

4. Install the wiper arm and blade.
 - (1) Operate the wiper arm and set it to the automatic stopping position.
 - (2) Set the wiper arm to the position as indicated in the right figure.
5. Install the front wiper arm cover.

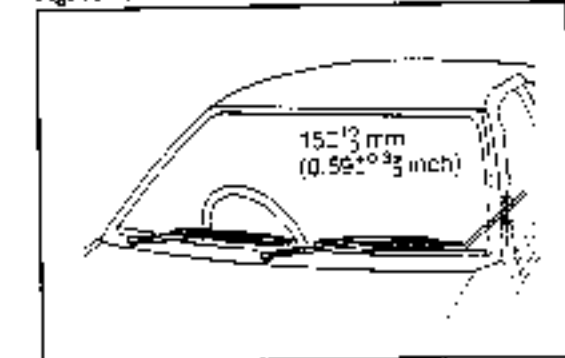

Fig. 10-133

AF-10-34

BODY ELECTRICAL SYSTEM

FRONT WASHER TANK

INSTALLATION POSITION

1. Standard vehicle (1.2ℓ) . . . Right side of engine compartment
2. Vehicles mounted with turbocharged engine or ECE & EEC specifications (2.5ℓ)
... Inside of left front fender

REMOVAL (VEHICLES MOUNTED WITH TURBOCHARGED ENGINE OR ECE & EEC SPECIFICATIONS)

1. Remove the front part of the left front fender liner.
2. Remove the left headlamp assembly.
3. Remove the left clearance lamp.
4. Remove the washer tank assembly.
(1) Remove the connector, hose, two bolts (one is to be removed during the fender liner removal) and nut.

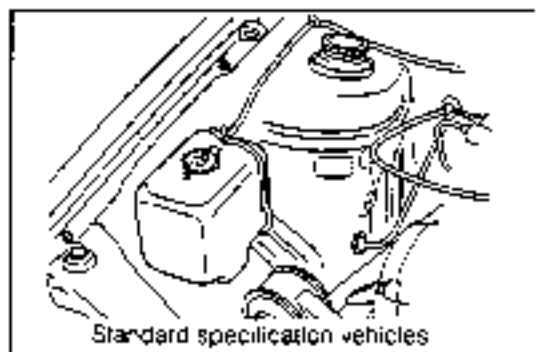

Fig. 10-134

WF-10135



Fig. 10-135

WF-10136

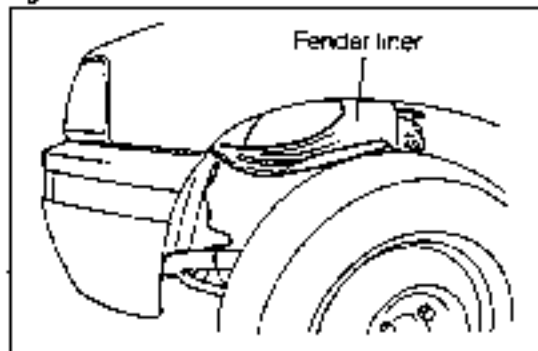

Fig. 10-136

WF-10137

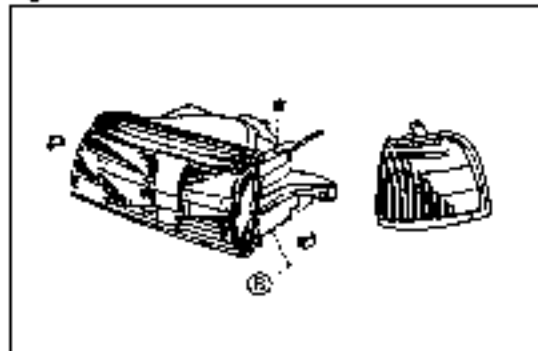

Fig. 10-137

WF-10138

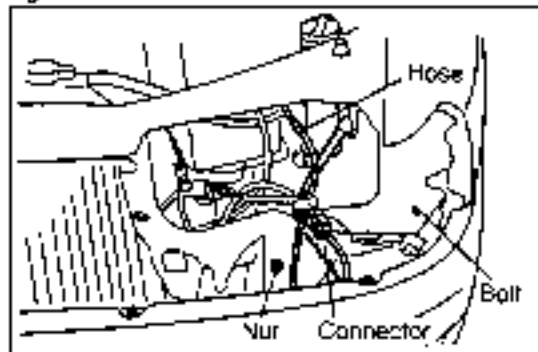

Fig. 10-138

WF-10139

- (2) Remove the washer tank assembly from the back side of the fender.

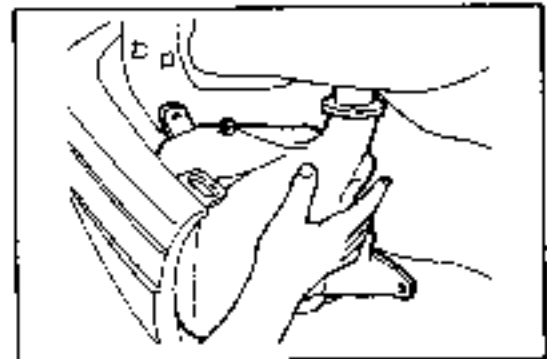

Fig. 10-139

WR-10140

INSTALLATION

1. Install the washer tank assembly.
2. Install the left headlamp assembly.
3. Install the left clearance lamp.
4. Install the left front fender liner.

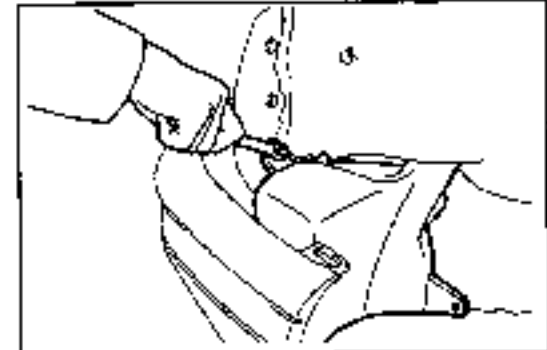

Fig. 10-140

WR-10141

FRONT WIPER CONTROL RELAY

The front wiper control relay is located at the upper side of the fuse block.

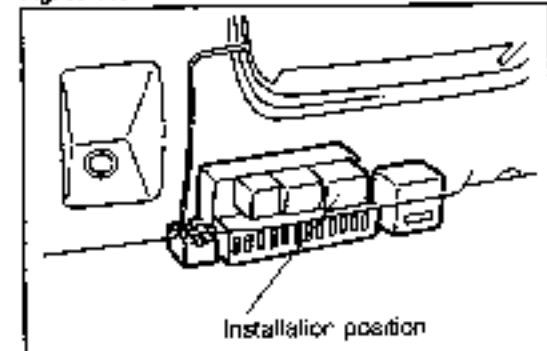

Fig. 10-141

WR-10142

INSPECTION

1. Perform continuity checks between terminals given below.

- (1) Between terminals ② and ③ ... Continuity exists.
- (2) Between terminals ② and ④ ... No continuity exists

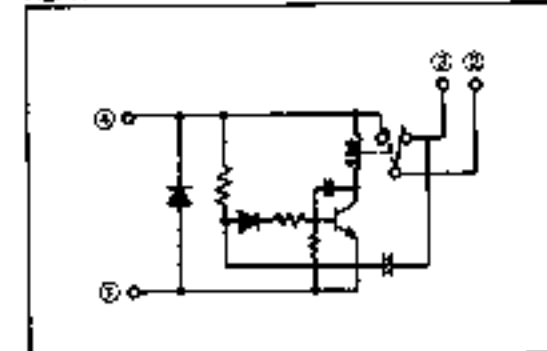

Fig. 10-142

WR-10143

2. Relay operation check

Connect the terminal ④ to the positive \oplus terminal of the battery; terminal ① to the negative \ominus terminal of the battery. Ensure that the relay emits an operating sound (clicking sound).

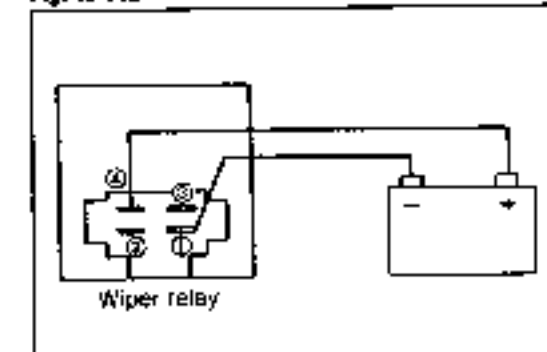

Fig. 10-143

WR-10144

BODY ELECTRICAL SYSTEM

3. Intermittent operation check

- (1) Connect the terminal ④ to the positive (+) terminal of the battery, terminal ① to the negative (-) terminal of the battery.

(At this time, the relay emits an operating sound.): The relay is turned ON

- (2) Connect the terminal ③ to the positive (+) terminal of the battery for about one second. Then, ground the terminal ③.

(The relay emits an operating sound.) The relay is turned OFF.

- (3) Ensure that, about four seconds later, the relay emits an operating sound (intermittent operation).

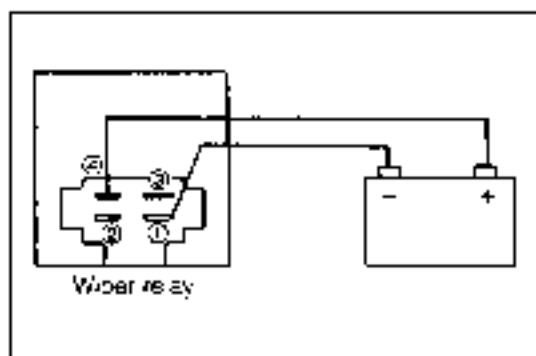

Fig. 10-144

WR-10145

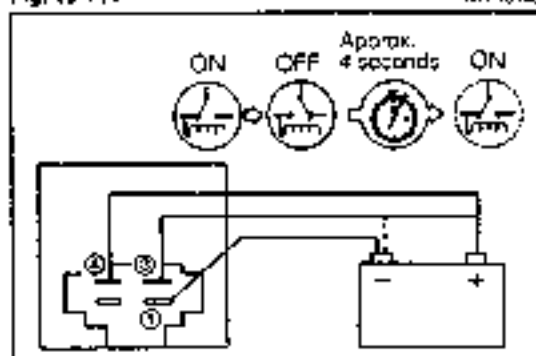

Fig. 10-145

WR-10146

REAR WIPER AND WASHER

REAR WIPER CIRCUIT DIAGRAM

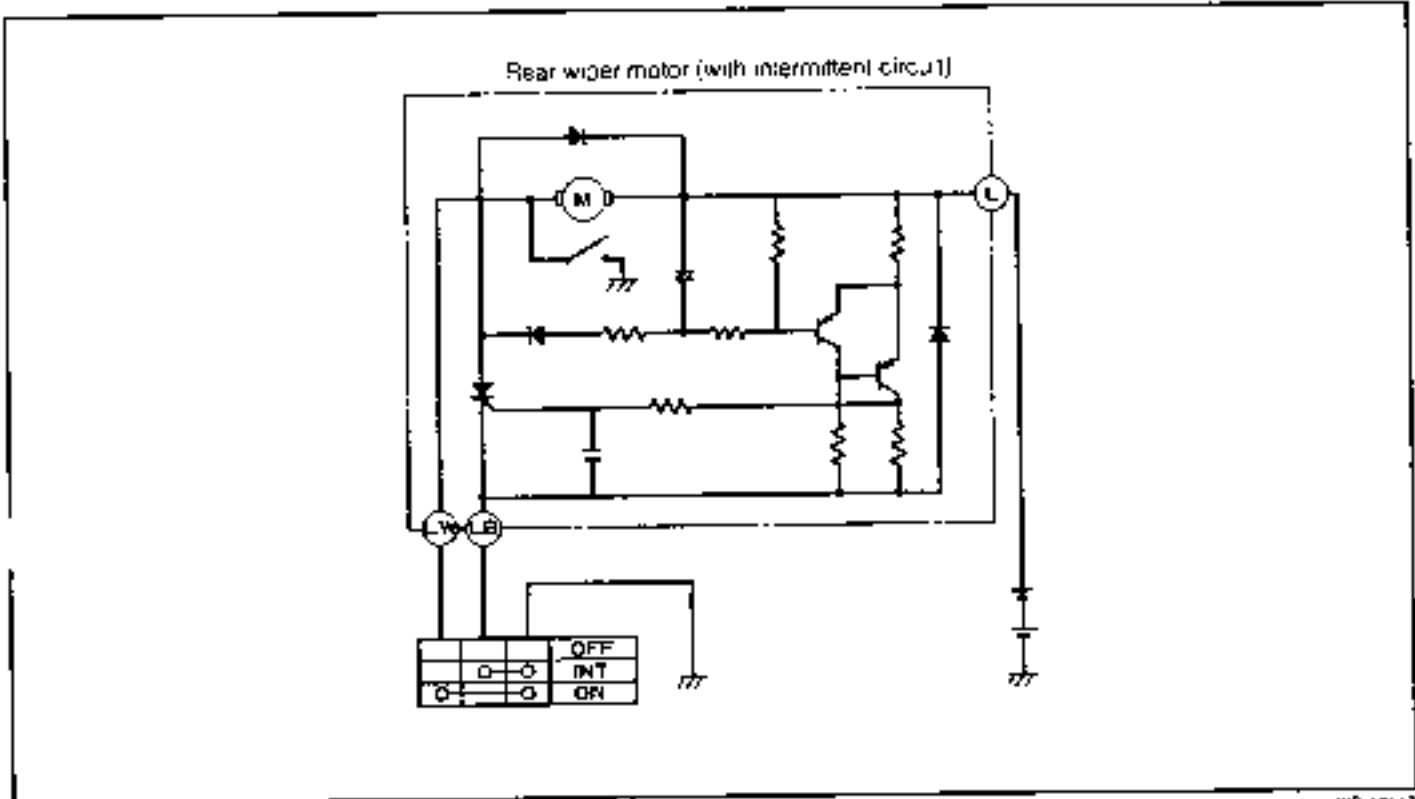

Fig. 10-146

WB-10147

REAR WIPER MOTOR AND BLADE COMPONENTS

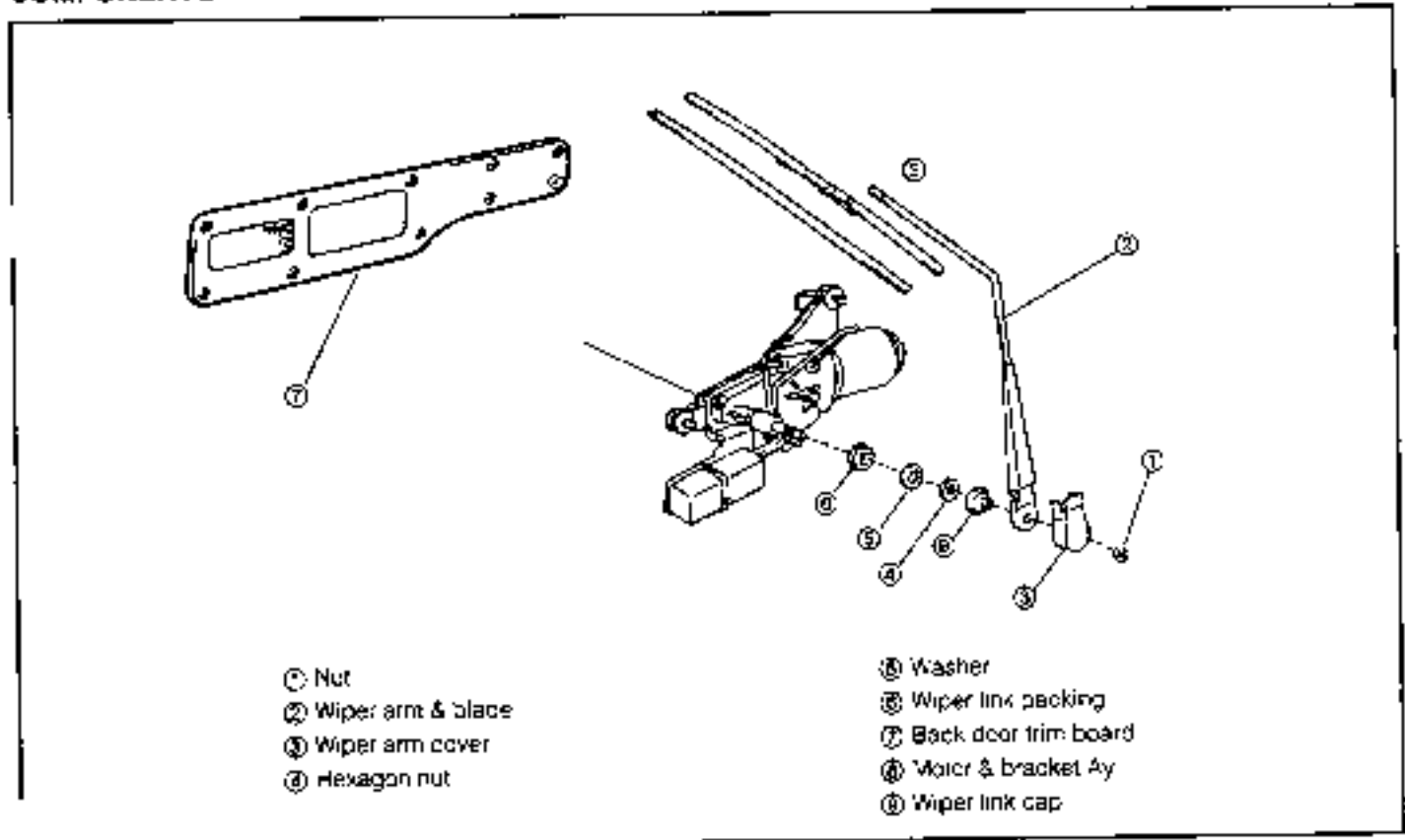

Fig. 10-147

WB-10148

BODY ELECTRICAL SYSTEM

REMOVAL

1. Remove the wiper arm cover.
2. Remove the wiper arm and blade by removing the nut.
3. Remove the wiper link cap.
Remove the washer and wiper link packing by removing the hexagon nut.
4. Remove the back door trim board, as follows:
 - (1) Release the lock by pushing the center section of the clip. Then, detach the clip.
 - (2) Remove the back door trim board (10 pieces of clips)
5. Disconnect the connector. Remove the rear wiper motor assembly.

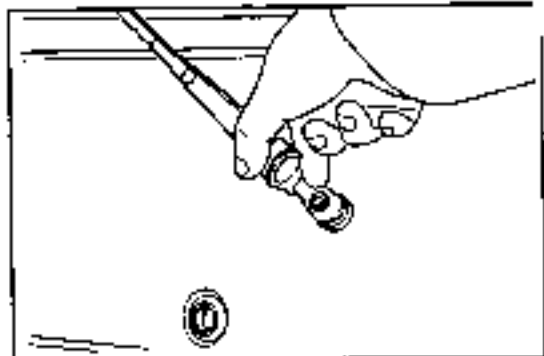

Fig. 10-148

WR-10-49

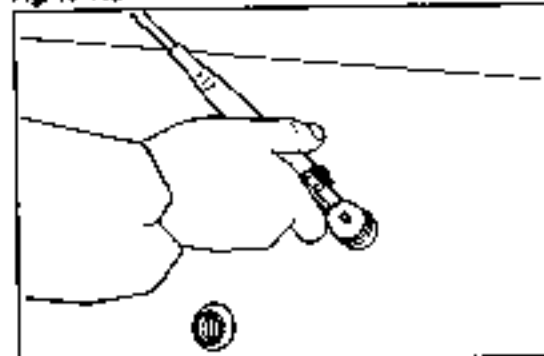

Fig. 10-149

WR-10-50

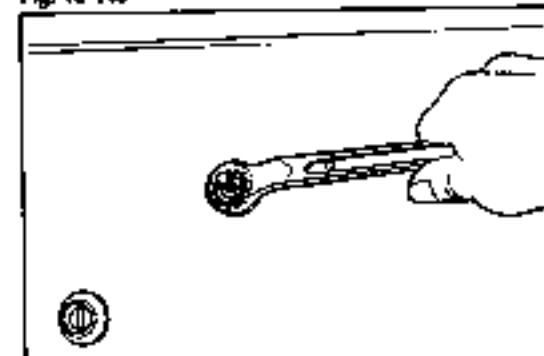

Fig. 10-150

WR-10-51

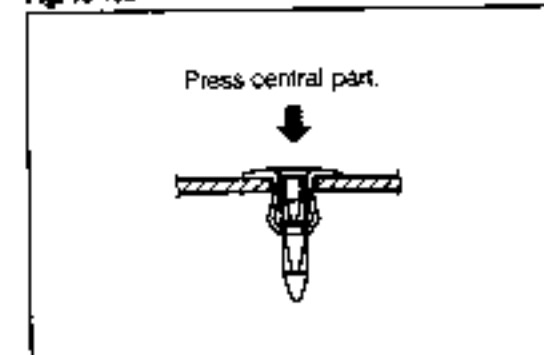

Fig. 10-151

WR-10-52

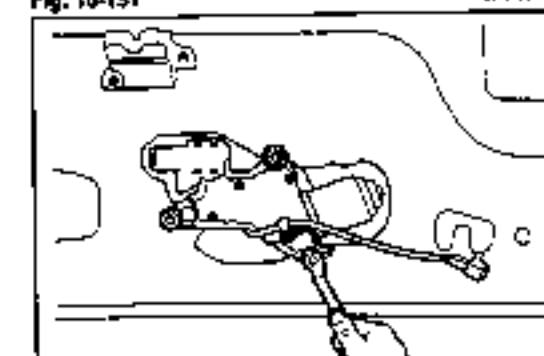

Fig. 10-152

WR-10-53

REAR WIPER MOTOR CHECK

Ensure that the wiper motor is grounded to the body properly. Proceed to the following checks.

1. Connect the terminal L of the connector to the positive \oplus terminal of the battery; terminal LW to the negative \ominus terminal of the battery. Ensure that the wiper operates.

2. Disconnect the terminal LW from the negative \ominus terminal of the battery. Ensure that the wiper stops at the automatic stopping position.

3. Connect the terminal L to the positive \oplus terminal of the battery; terminal LB to the negative \ominus terminal of the battery. Ensure that the wiper operates intermittently.

4. Disconnect the terminal LB from the negative \ominus terminal of the battery. Ensure that the wiper stops at the automatic stopping position.

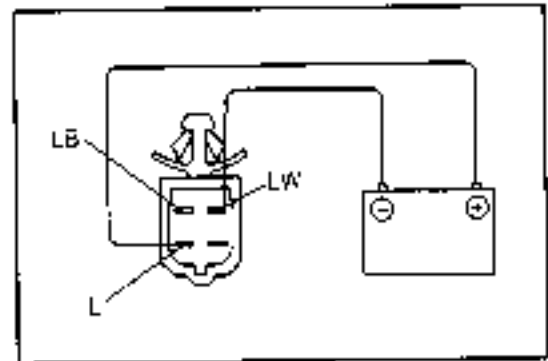

Fig. 10-153

WR-10154

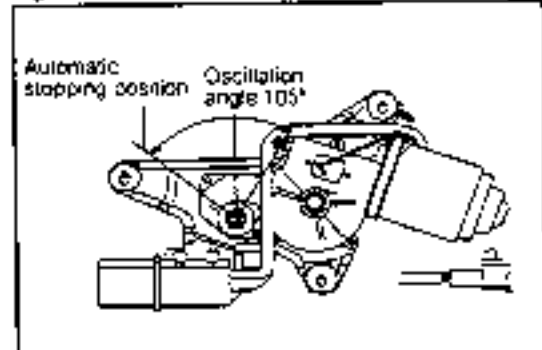

Fig. 10-154

WR-10155

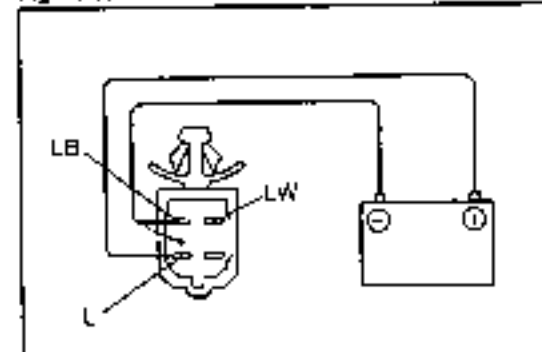

Fig. 10-155

WR-10156

INSTALLATION

1. Install the rear wiper motor assembly, as follows:
 - (1) Install the rear wiper motor assembly by tightening the set bolt.

NOTE:

Make sure that the body earth is provided properly.

- (2) Connect the connector.

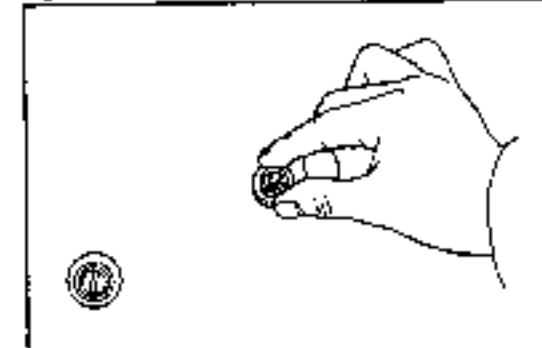

Fig. 10-156

WR-10157

2. Install the back door trim, as follows:
 - (1) Pull out the center section of the clip. Attach the clip to the trim. Push the center section so as to lock the clip.
 - (2) Install the back door trim boards (10 pieces).

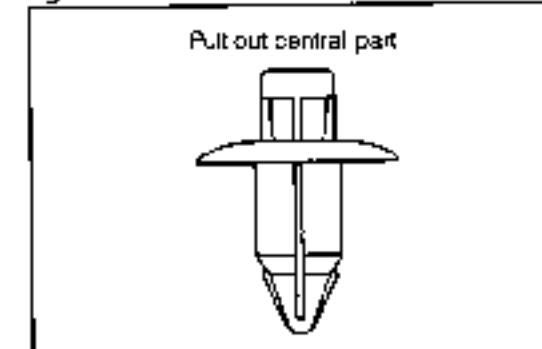

Fig. 10-157

WR-10158

BODY ELECTRICAL SYSTEM

3. Install the wiper link packing and washer by tightening the hexagon nut.
Install the wiper link cap.

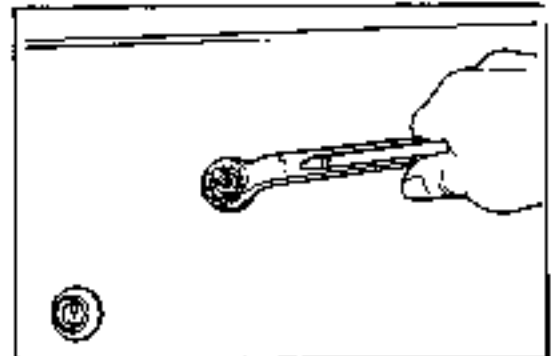

Fig. 10-158

WR-2159

4. Install the wiper arm and blade, as follows.
 - (1) Operate the wiper motor and set the wiper arm to the automatic stopping position.
 - (2) Align the blade with the bottom line of the defogger pattern.Installation position:
Bottom line of pattern ± 5 mm (± 0.2 inch)

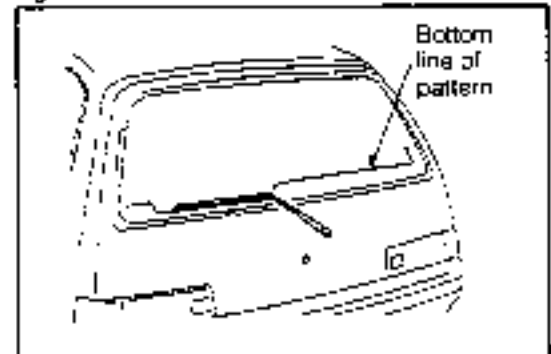

Fig. 10-159

WR-1018C

5. Tighten the nut. Install the wiper arm cover.

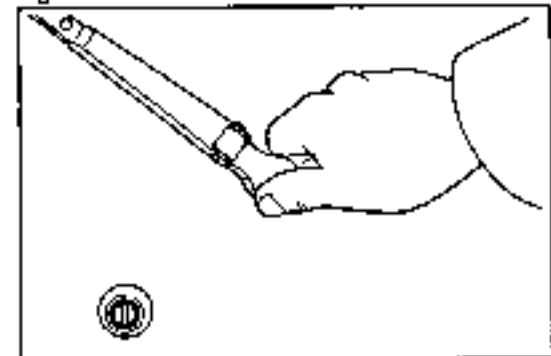

Fig. 10-160

WR-10161

**EAR WASHER TANK
COMPONENTS**

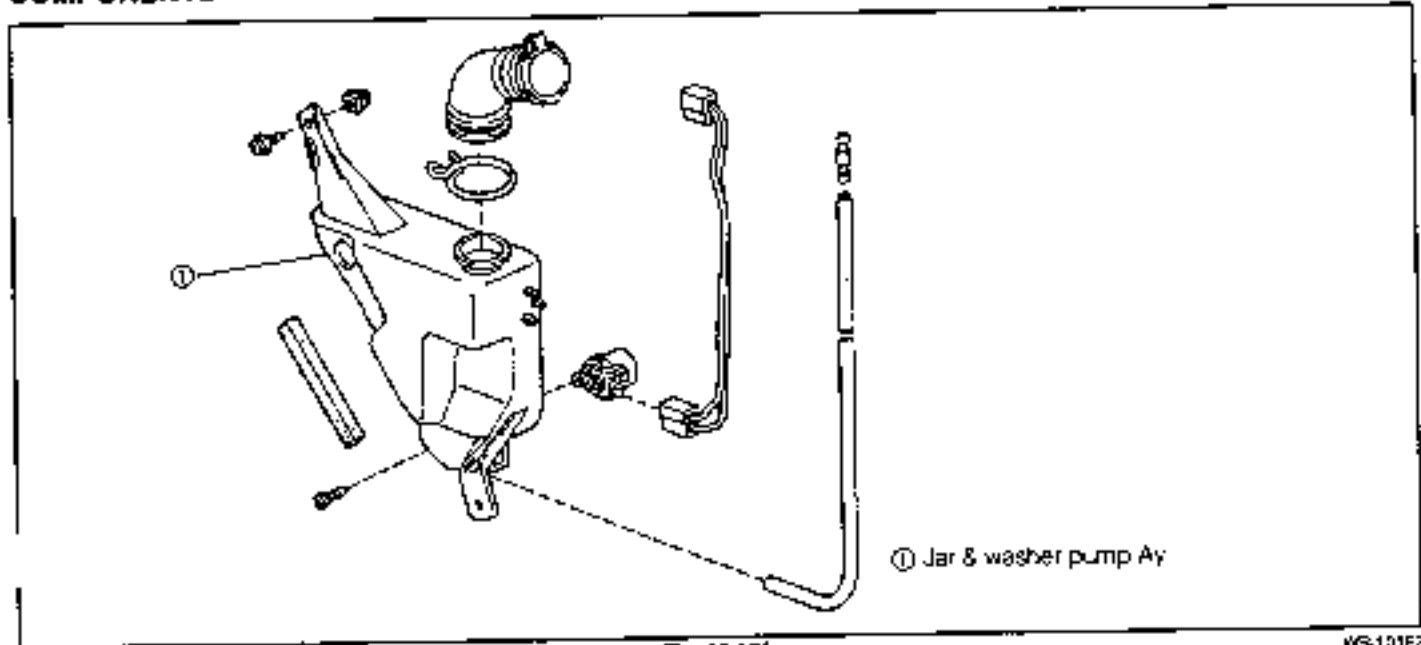

Fig. 10-151

WR-10152

REMOVAL

1. Remove the deck side trim RH.
2. Disconnect the connector and water hose. Remove the washer tank assembly.

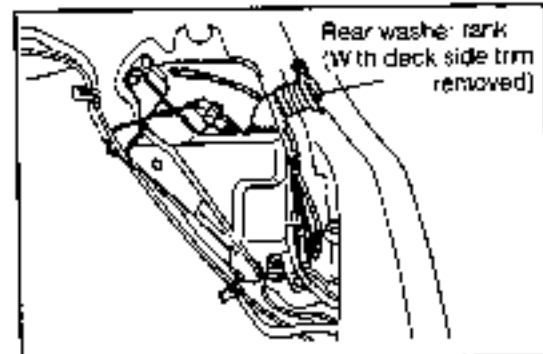

Fig. 10-152

WR-10153

INSTALLATION

1. Install the washer tank assembly by tightening the screws (2 pcs).
2. Connect the connector and water hose.

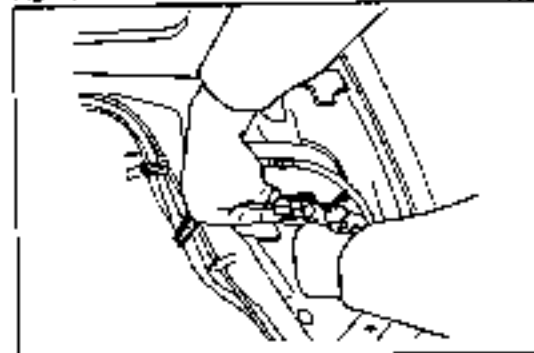

Fig. 10-153

WR-10154

3. Install the deck side trim RH.

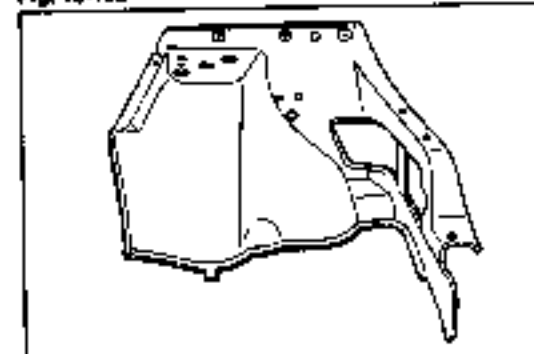

Fig. 10-154

WR-10155

BODY ELECTRICAL SYSTEM

REAR WIPER AND WASHER SWITCH

INSTALLATION POSITION

R.H.D. vehicles ... Left side of instrument cluster finish panel
 L.H.D. vehicles ... Right side of instrument cluster finish panel

INSPECTION

Ensure that continuity exists between the respective terminals as indicated in the continuity table.

○—○ Continuity exists.

Knob position		Terminal	R+1	RINT	E ₃	RW
Wiper switch:	OFF					
	INT			○—○		
	ON		○—○			
Washer switch:	OFF					
	ON				○—○	

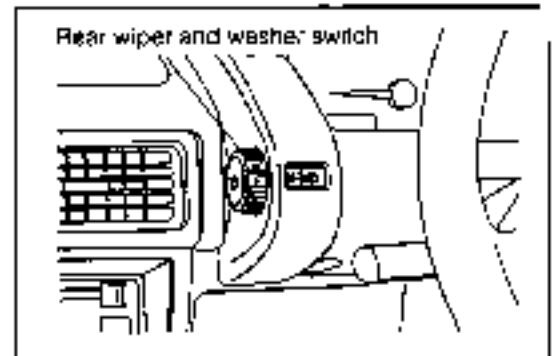

Fig. 10-165

WR-10166

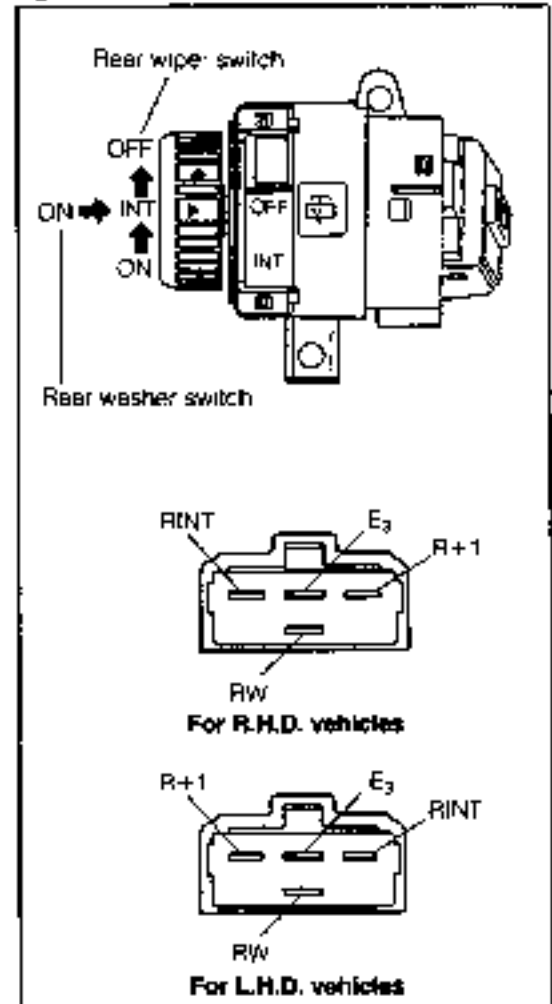

Fig. 10-166

WR-10167

ELECTRICAL REMOTE CONTROL DOOR MIRROR

CIRCUIT DIAGRAM

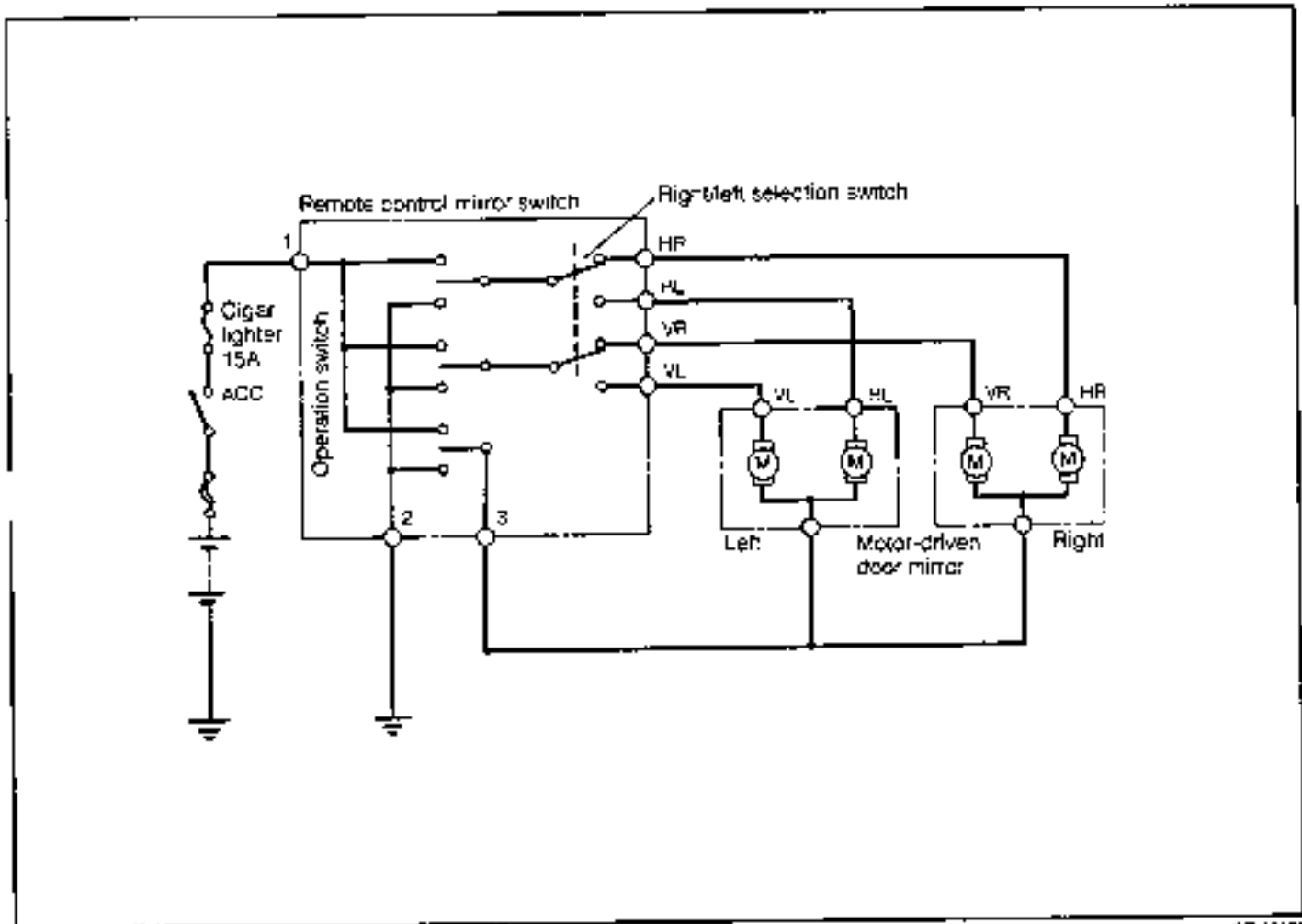

Fig. 10-167

WR-10-65

DOOR MIRROR SWITCH

INSTALLATION POSITION

- R.H.D. vehicles ... Right side of steering post
- L.H.D. vehicles ... Left side of steering post

REMOVAL

Working from the back side of the instrument panel, push the switch toward your side.

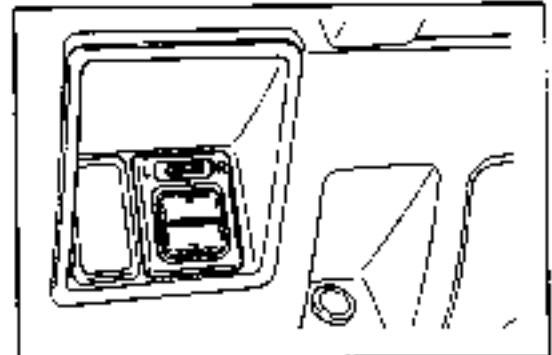

Fig. 10-168

WR-10-69

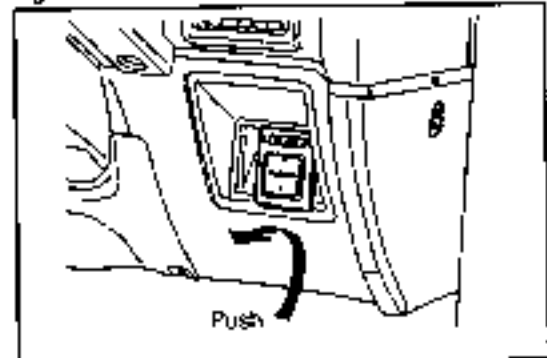

Fig. 10-169

WR-10-70

BODY ELECTRICAL SYSTEM

INSPECTION

Ensure that continuity exists between the respective terminals as indicated in the continuity table.

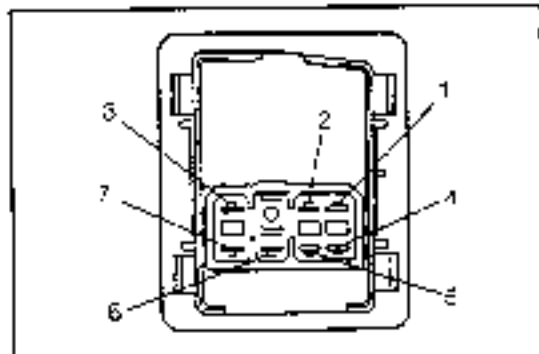

Fig. 10-170

WB-10771

Continuity Table

Mirror	Left					Right				
	Terminal	7	6	1	2	3	2	1	5	4
JP		○	○	○	○	○	○	○	○	○
DOWN		○	○	○	○	○	○	○	○	○
LEFT		○	○	○	○	○	○	○	○	○
RIGHT		○	○	○	○	○	○	○	○	○

WFO-0172

ELECTRICAL REMOTE CONTROL DOOR MIRROR RELATED PARTS

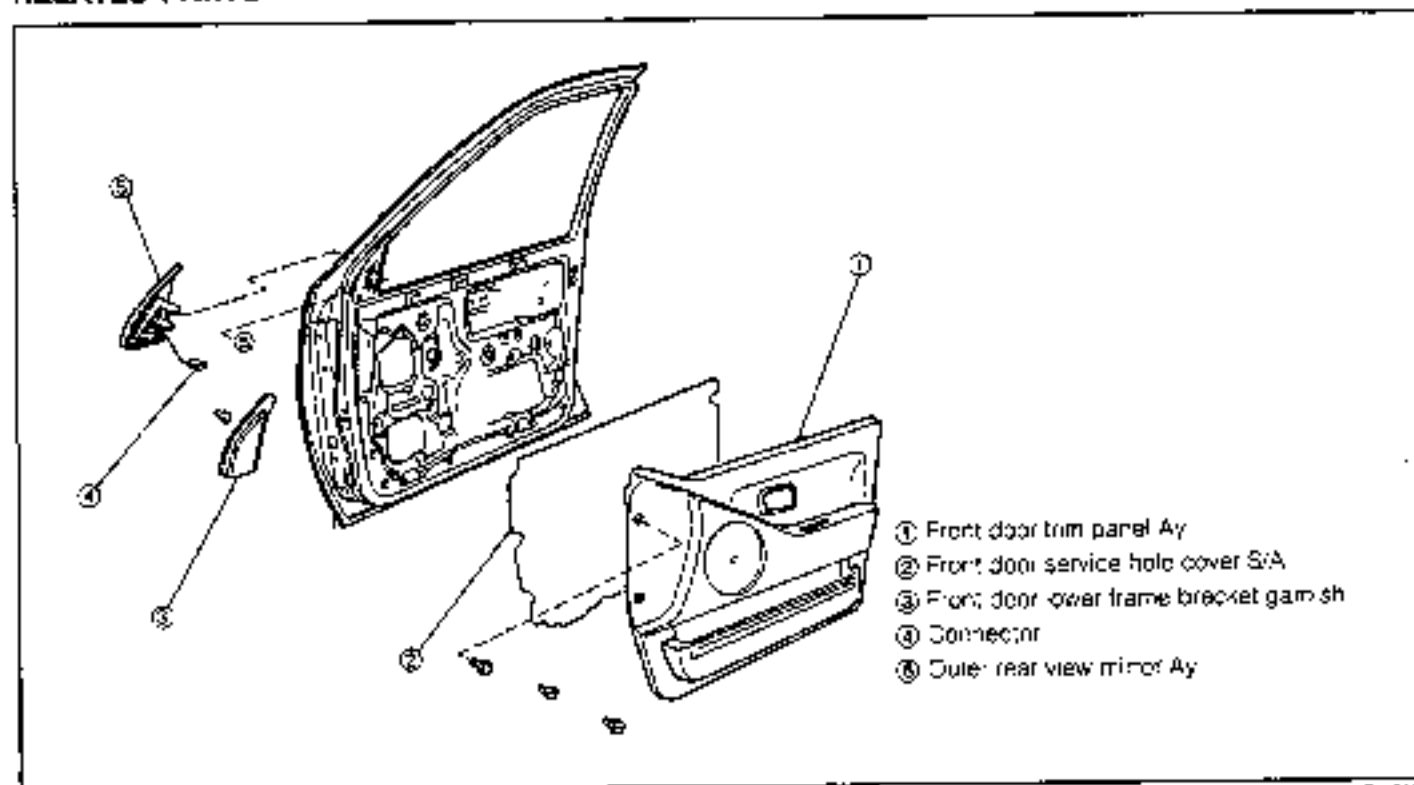

- ① Front door trim panel Ay
- ② Front door service hole cover S/A
- ③ Front door lower frame bracket gam sh
- ④ Connector
- ⑤ Outer rear view mirror Ay

Fig. 10-171

WB-0173

REMOVAL

1. Remove the front door trim assembly.
 - (1) Release the lock by pushing the center section of the clip. Detach the clip.
 - (2) Remove the front door trim assembly.
2. Remove the front door service hole cover.
3. Remove the lower frame bracket garnish by pulling it toward you.
4. Disconnect the door mirror connector. Remove the outer rear view mirror assembly by removing the attaching bolt.

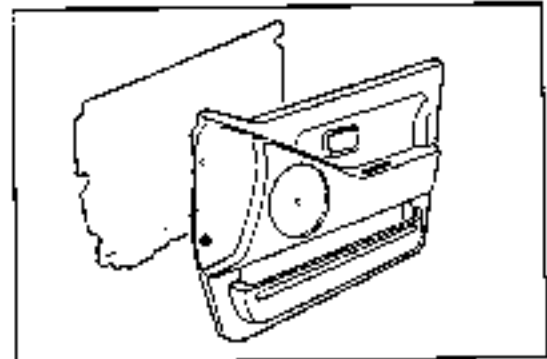

Fig. 10-172

WF-10-74

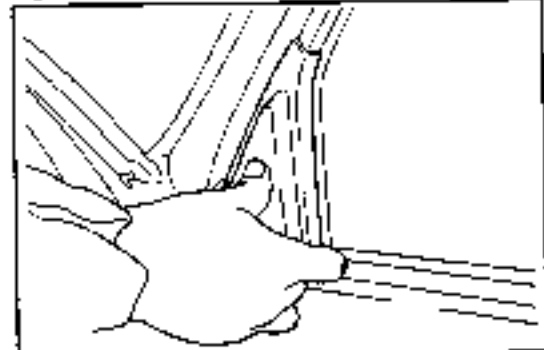

Fig. 10-173

WF-10-75

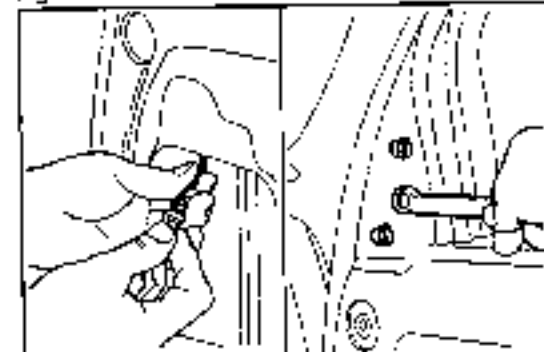

Fig. 10-174

WF-10-76

INSPECTION

1. Apply the battery voltage to each terminal, as indicated in the table below. Ensure that the mirror operates properly.

Terminal	Right door mirror	COM	MVR	MHR	Operation direction
	Left door mirror	COM	MVL	MHL	
Connection		⊖	⊕		UP
		⊕	⊖		Down
		⊖		⊖	Left
		⊕		⊖	Right

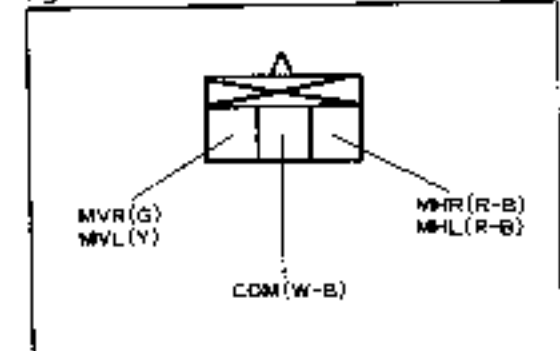

Fig. 10-175

WF-10-77

BODY ELECTRICAL SYSTEM

INSTALLATION

1. Connect the connector. Install the outer rear view mirror.
2. Install the lower frame bracket garnish.

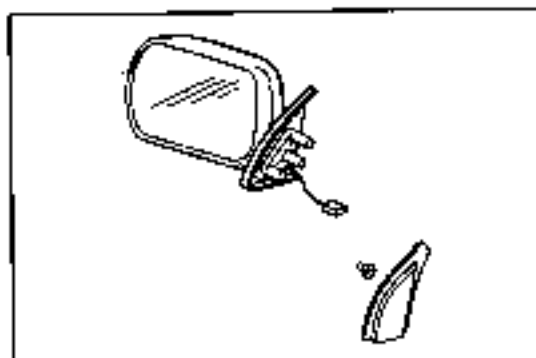

Fig. 1D-176

W0-10105

3. Install the front service hole cover subassembly.
4. Install the front door trim assembly.

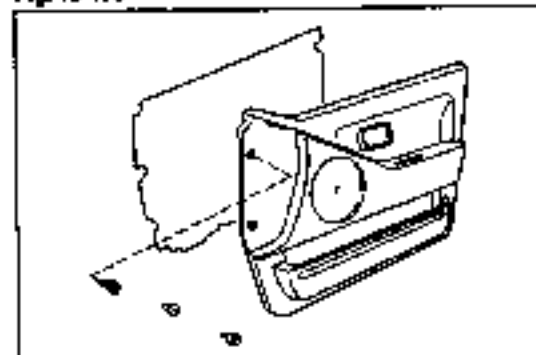

Fig. 1D-177

W0-10179

CENTRAL DOOR LOCK

CIRCUIT DIAGRAM

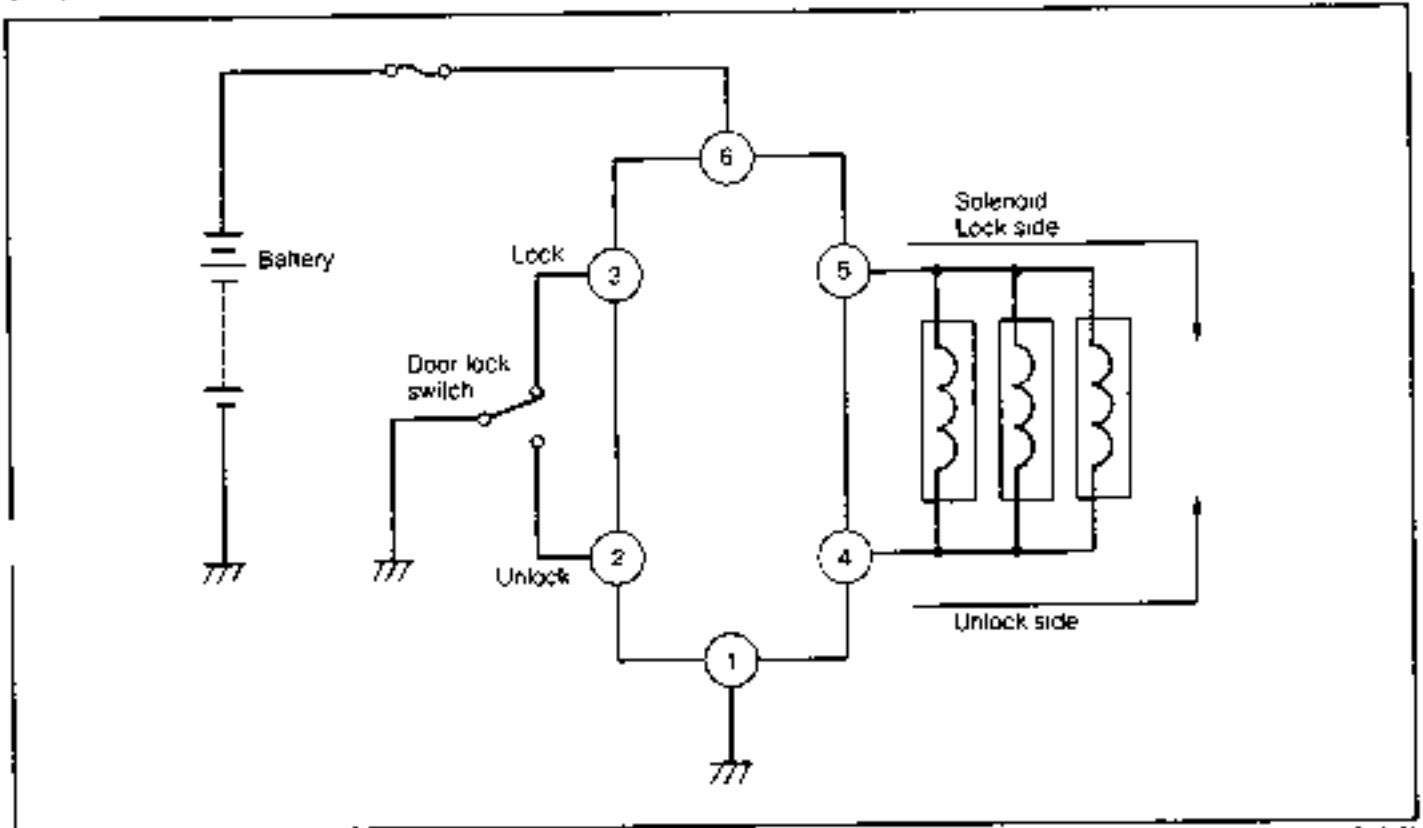

Fig. 10-17B

WR-10150

DOOR LOCK SWITCH AND SOLENOID RELATED PARTS

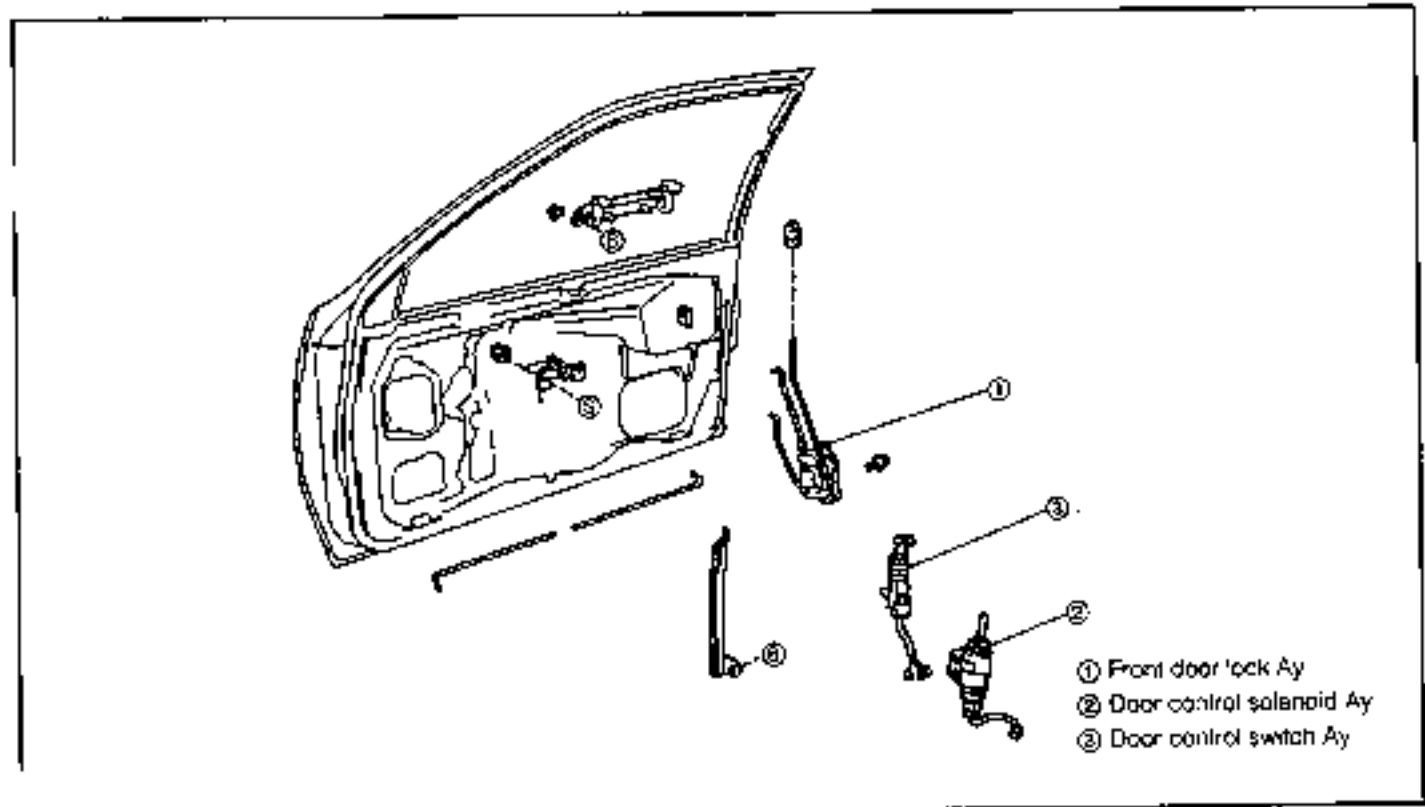

Fig. 10-179

WR-018

BODY ELECTRICAL SYSTEM

REMOVAL

1. Remove the front door trim panel assembly and service hole cover subassembly.
2. Disconnect the lock knob from the link section. Remove the front door lock assembly by removing the attaching bolt.
3. Disconnect the connector. Remove the door control solenoid assembly or switch assembly by removing the attaching bolt.

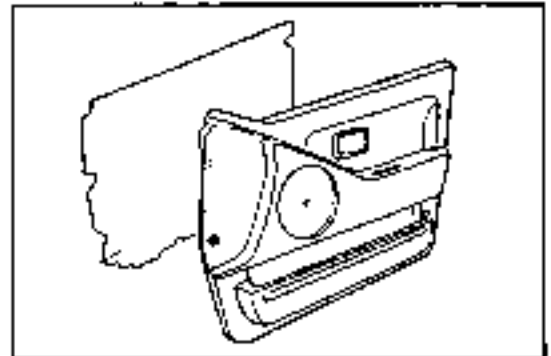

Fig. 10-180

WA-10182

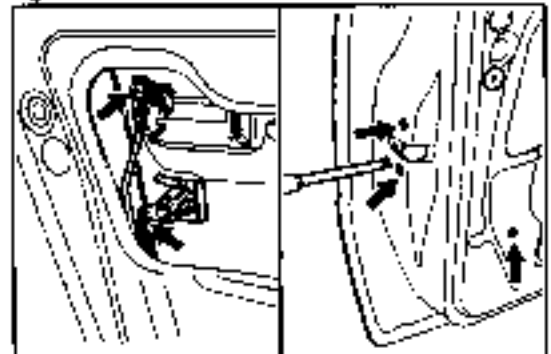

Fig. 10-181

WR-0123

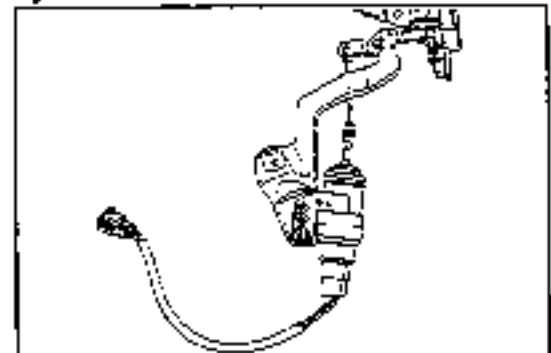

Fig. 10-182

WR-C124

INSPECTION

Solenoid Assembly

(Front Doors on 3-Door Vehicles and 5-Door Vehicles)

Apply a voltage of 12 V between the following two terminals. Ensure that the plunger operates in accordance with the table below.

Operation direction	Terminal ①	Terminal ②
UNLOCK	+	-
LOCK	-	+

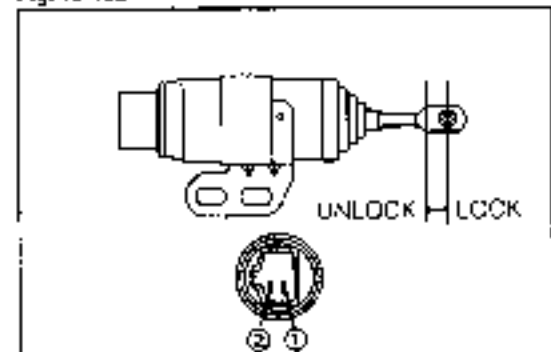

Fig. 10-183

WA-C185

(Rear Doors on 5-Door Vehicles)

Apply a voltage of 12 V between the following two terminals. Ensure that the plunger operates in accordance with the table below.

Operation direction	Terminal ①	Terminal ②
LOCK	+	-
UNLOCK	-	+

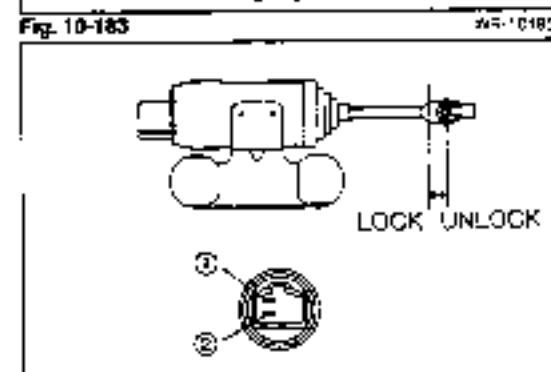
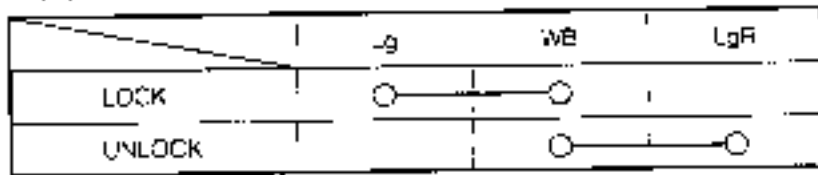

Fig. 10-184

WA-C186

DOOR LOCK SWITCH



INSTALLATION

1. Install the door control switch assembly.
2. Install the door control solenoid assembly.

3. Install the front door lock assembly. Install the link and lock knob.
4. Install the service hole cover subassembly and front door trim panel assembly. (See page 9-39.)

NOTE:

Before connecting the battery, make sure that the lock knob is in an unlocked state.

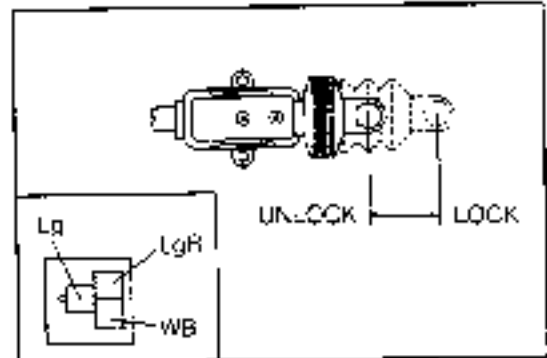

Fig. 10-185

WB-1318*

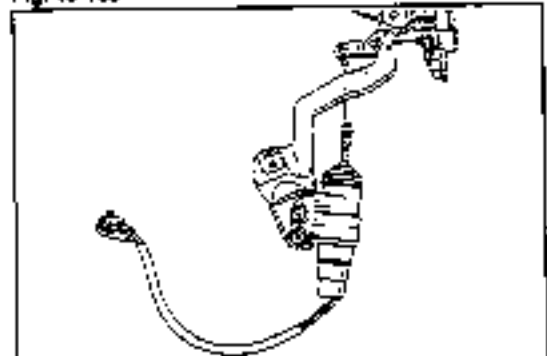

Fig. 10-186

WA-10188

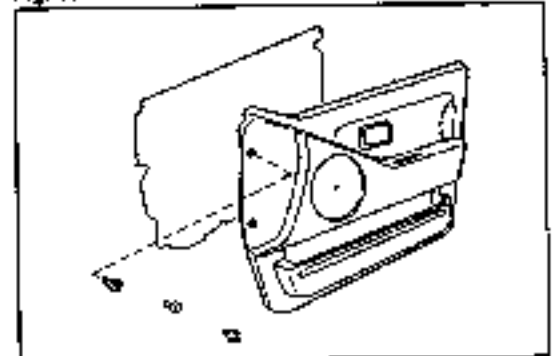

Fig. 10-187

WA-10189

DOOR CONTROL RELAY

CIRCUIT DIAGRAM

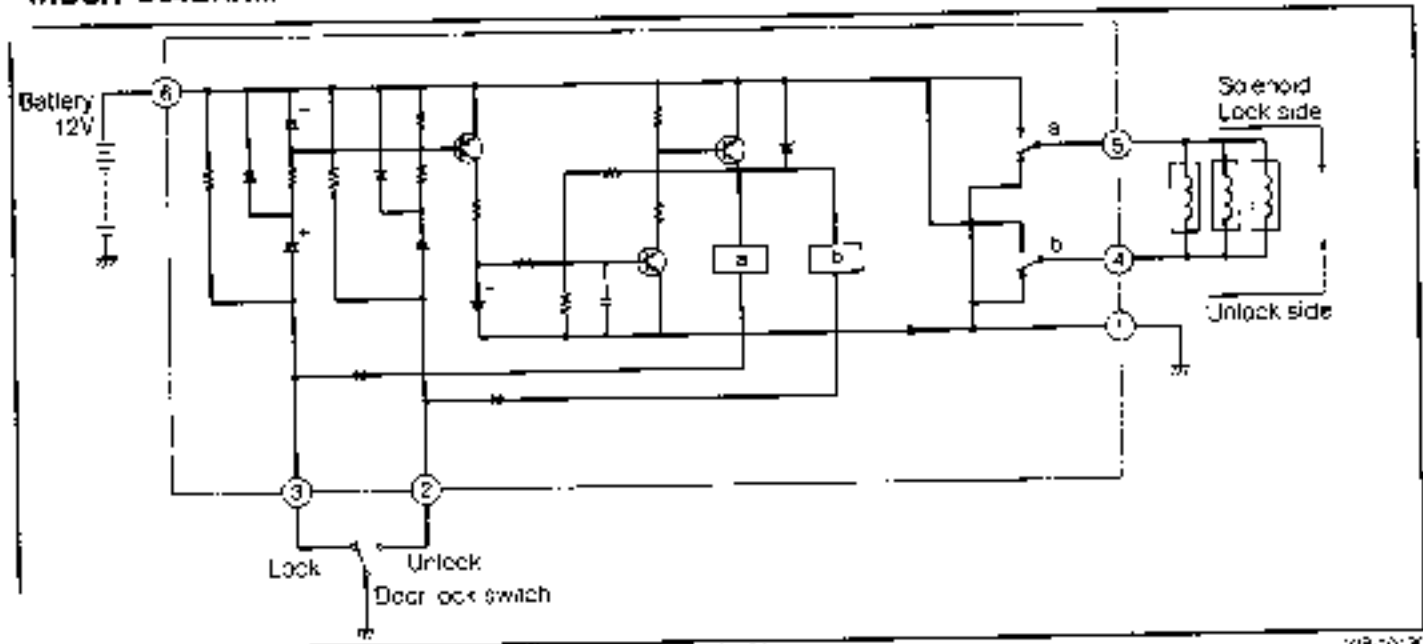

Fig. 10-188

WA-10190

BODY ELECTRICAL SYSTEM

INSTALLATION POSITION

R.H.D. vehicles ... Right cowl side

L.H.D. vehicles ... Left cowl side

INSPECTION

Connect the terminal ⑥ to the positive \oplus terminal of the battery; terminal ③ to the negative \ominus terminal. Perform the following checks.

1. When the negative \ominus terminal is connected to the terminal ②, ensure that the relay operates as follows: The relay "a" is turned ON, accompanying an operating sound. A voltage of 12 V is applied to the terminal ⑤. Immediately after this (about 0.2 seconds later), the relay is turned OFF, accompanying an operating sound. Then, the voltage at the terminal ③ drops to 0 V.
2. When the negative \ominus terminal is connected to the terminal ②, ensure that the relay operates as follows: The relay "b" is turned ON, accompanying an operating sound. A voltage of 12 V is applied to the terminal ④. Immediately after this (about 0.2 seconds later), the relay is turned OFF, accompanying an operating sound. Then the voltage at the terminal ④ drops to 0 V.

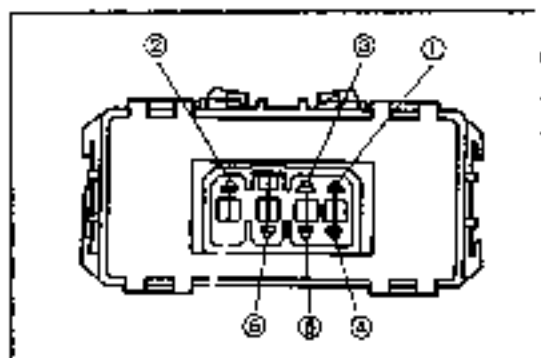

Fig. 10-189

WR-10121

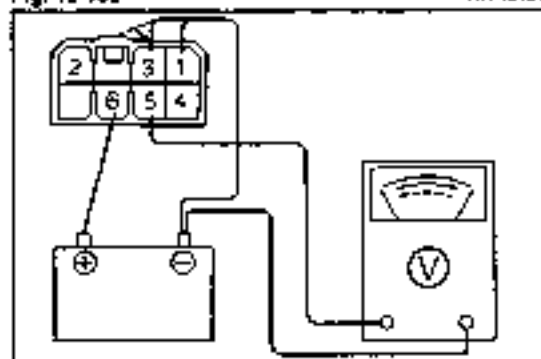

Fig. 10-190

WR-10122

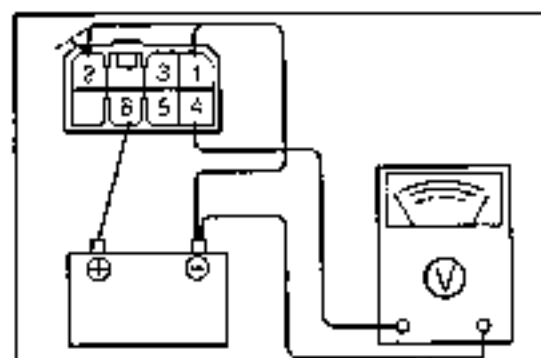

Fig. 10-191

WR-0183

POWER WINDOW
CIRCUIT DIAGRAM

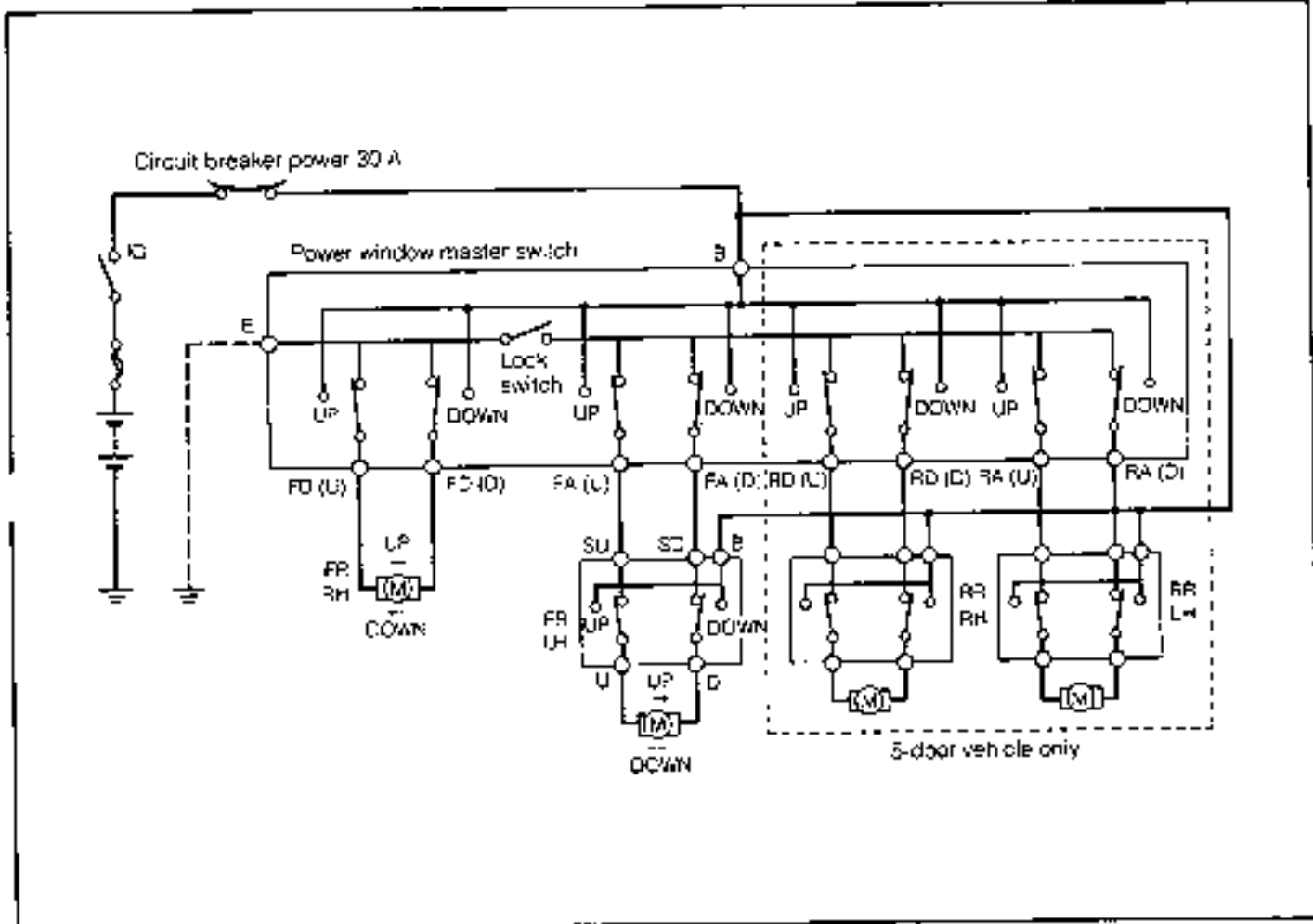

Fig. 10-192

WA-10124

POWER WINDOW MASTER SWITCH

The power window master switch is located at the door trim at the driver's seat side.

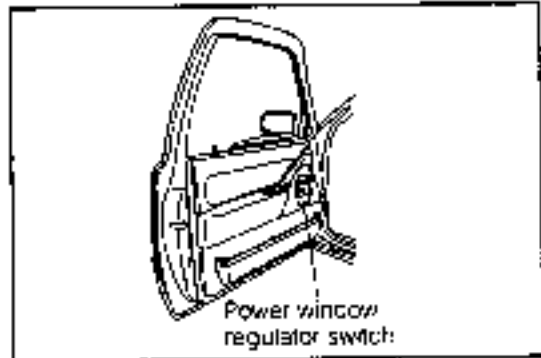

Fig. 10-193

WA-10125

BODY ELECTRICAL SYSTEM

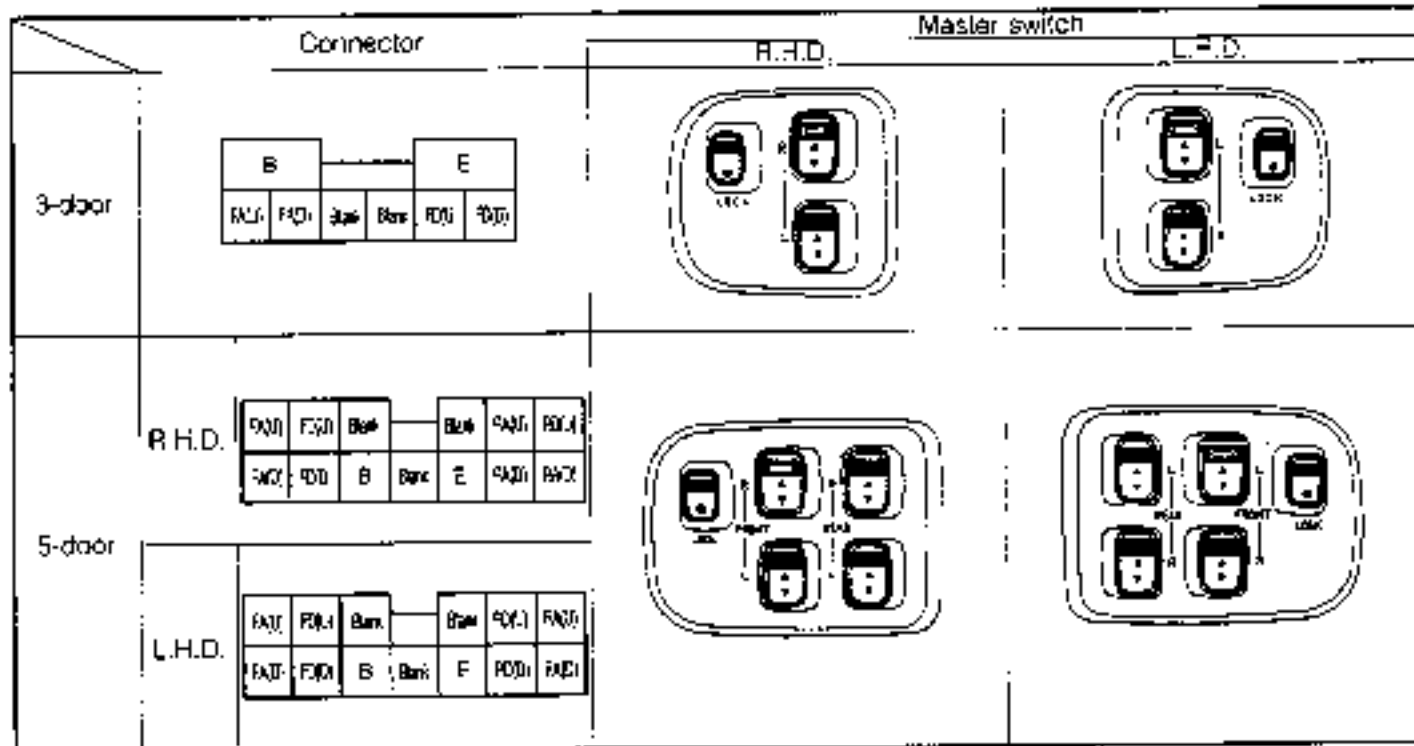

Fig. 10-194

WR-10190

REMOVAL

- Remove the front door trim panel Ay.
See page 9-39
- Remove the power window master switch from the door trim, as follows.
 - Disconnect the connector.
 - Remove the master switch from the door trim.

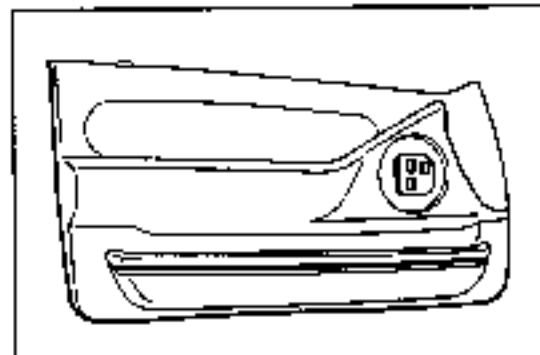

Fig. 10-195

WR-10197

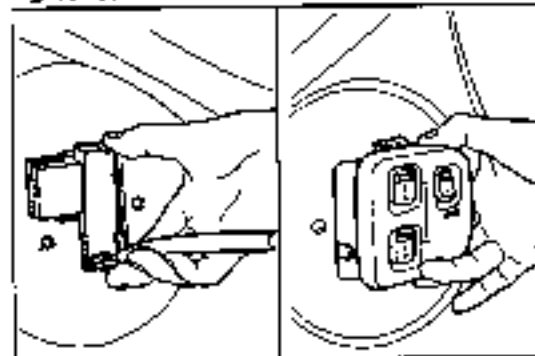

Fig. 10-196

WR-10198

INSPECTION

Ensure that continuity exists between the respective terminals of the power window master switch connector.

1. 3-Door Vehicle

○—○ Continuity exists.

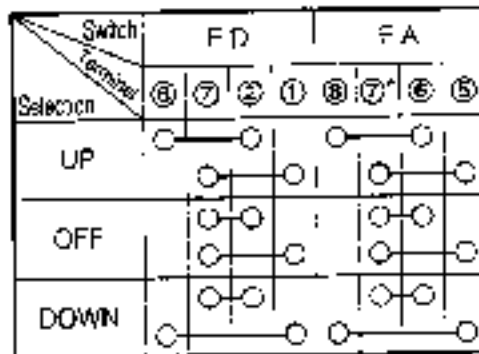

* Make sure that the lock switch is in the lock state.

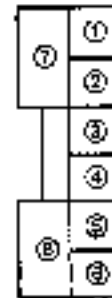

Connector

No.	Terminal	Kind of wire
①	F.D (D)	2 R
②	F.D (U)	2 G
③		Blank
④		Blank
⑤	F.A (D)	2 RL
⑥	F.A (U)	2 GL
⑦	E	2 WB
⑧	B	2 L

WR-13-90

2. 5-Door Vehicle (R.H.D. vehicles)

○—○ Continuity exists

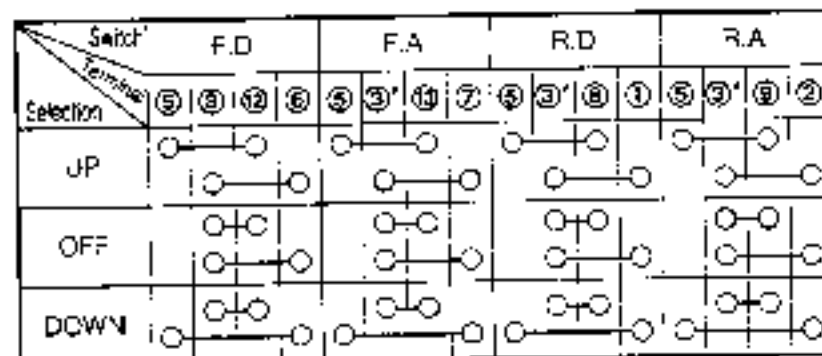

* Make sure that the lock switch is in the lock state.

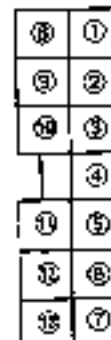

Connector

No.	Terminal	Kind of wire
①	R.D (D)	2 RB
②	R.A (D)	2 RY
③	E	2 WB
④		Blank
⑤	B	2 L
⑥	F.D (D)	2 R
⑦	F.A (D)	2 RL
⑧	R.D (U)	2 LB
⑨	R.A (U)	2 GY
⑩		Blank
⑪		Blank
⑫	F.D (U)	2 G
⑬	F.A (U)	2 LW

WR-10-00

3. 5-Door Vehicle (L.H.D. vehicles)

○—○ Continuity exists

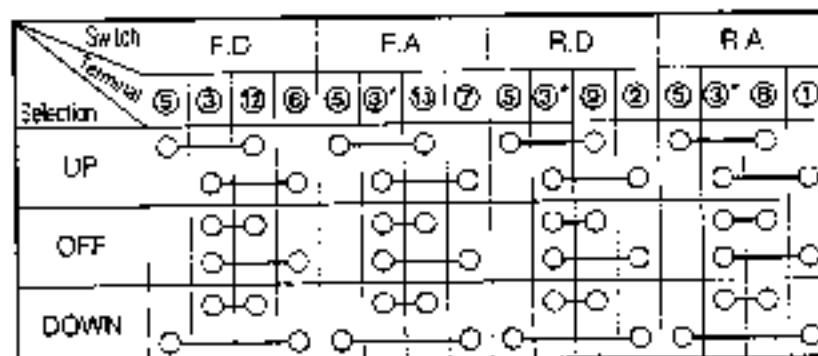

* Make sure that the lock switch is in the lock state.

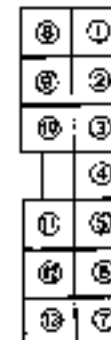

Connector

No.	Terminal	Kind of wire
①	R.A (D)	2 RY
②	R.D (D)	2 RB
③	E	2 WB
④		Blank
⑤	B	2 L
⑥	F.D (D)	2 R
⑦	F.A (D)	2 RL
⑧	R.A (U)	2 GY
⑨	R.D (U)	2 LB
⑩		Blank
⑪		Blank
⑫	F.D (U)	2 G
⑬	F.A (U)	2 LW

WR-13-01

BODY ELECTRICAL SYSTEM

4. Checking of Operation of Window Lock Switch

○—○ Continuity exists.

Selection	Terminal	Window lock switch			
		3-door	5-door	3-door	5-door
NORMAL	⑦	③	⑥	⑩	
LOCK					

* Perform the checks with the power window master switch in an inoperative state.

POWER WINDOW SWITCHES

The power window switch is located at each door trim except for that at the driver's seat side.

NOTE:

For the removal/installation procedure for the door trim, see page 9-39.

INSPECTION

Ensure that continuity exists between the respective terminals as indicated in the continuity table.

Selection	Terminal					
		B	SJ	SD	U	D
UP		○	○	○	○	○
OFF			○	○	○	○
DOWN		○	○	○	○	○

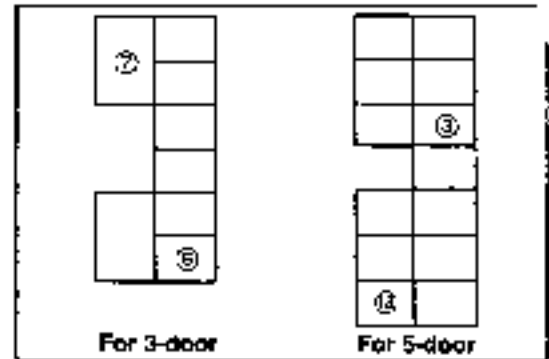

Fig. 10-197

WP-0302

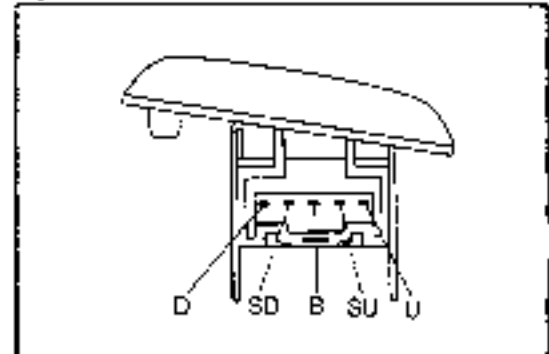

Fig. 10-198

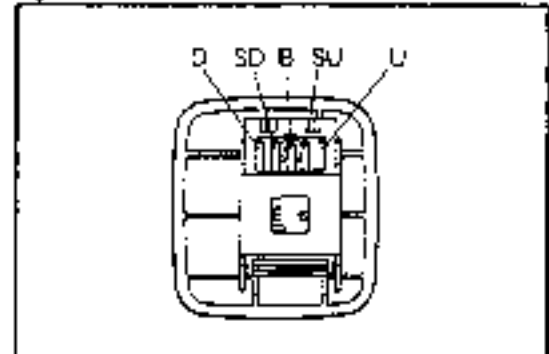

Fig. 10-199

WP-0203

POWER WINDOW REGULATOR MOTOR RELATED PARTS

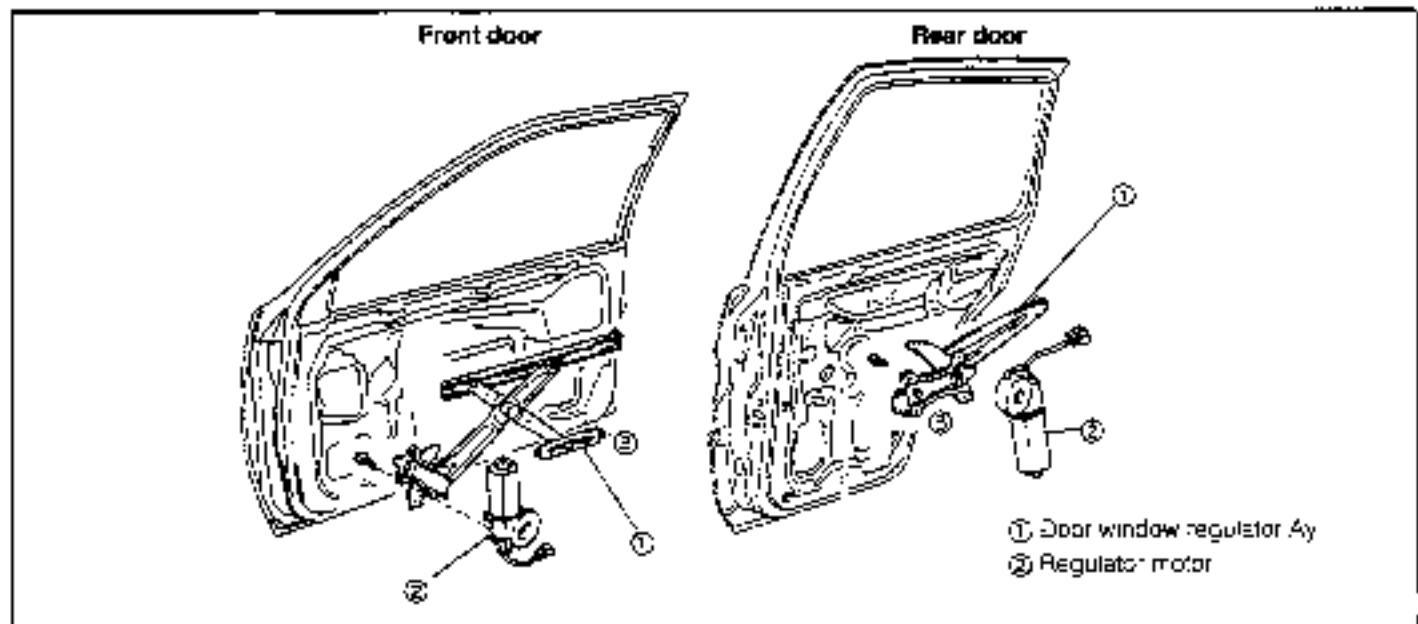

Fig. 10-200

WP-0004

NOTE:

For the removal/installation procedure of the regulator motor, see page 9-52.

INSPECTION

(For Left side door)

1. Connect the terminal R to the positive (+) terminal of the battery, the terminal G to the negative (-) terminal of the battery. Ensure that the motor makes right rotation, as viewed from the driving shaft.
2. Connect the terminal R to the negative (-) terminal of the battery, the terminal G to the positive (+) terminal of the battery. Ensure that the motor makes left rotation, as viewed from the driving shaft.

(For Right side door)

The motor rotates opposite direction of the left side door motor.

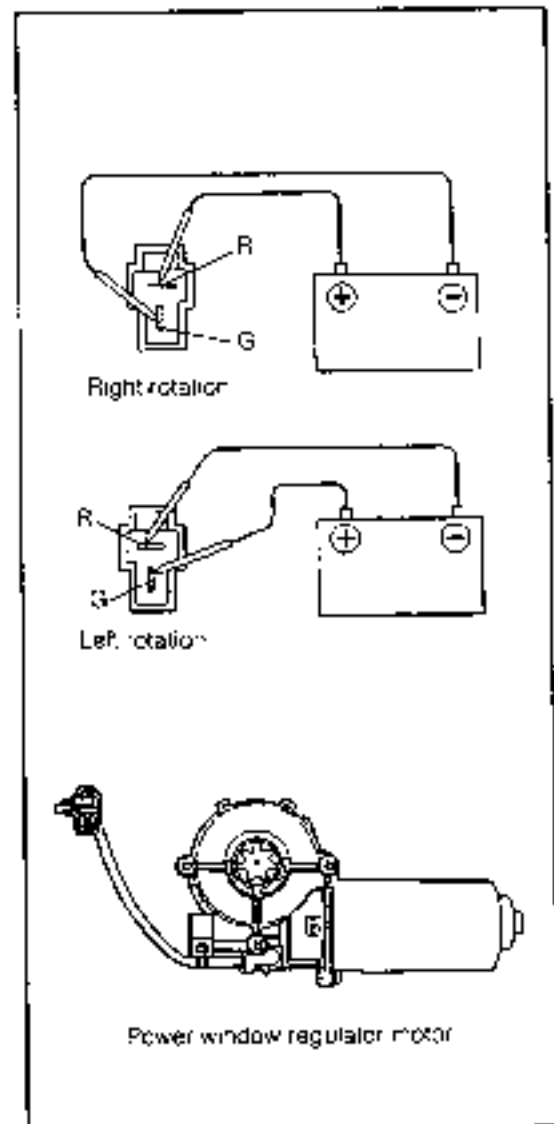

Fig. 10-201

WP-1003

CIRCUIT BREAKER

The circuit breaker is located inside of the sub-fuse block.

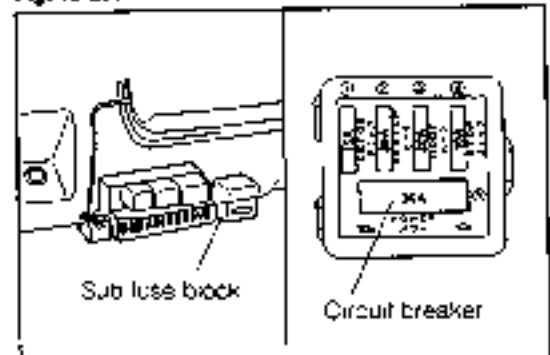

Fig. 10-202

WP-1003E

BODY ELECTRICAL SYSTEM

INSPECTION

With the circuit breaker turned ON, ensure that continuity exists between the terminals.

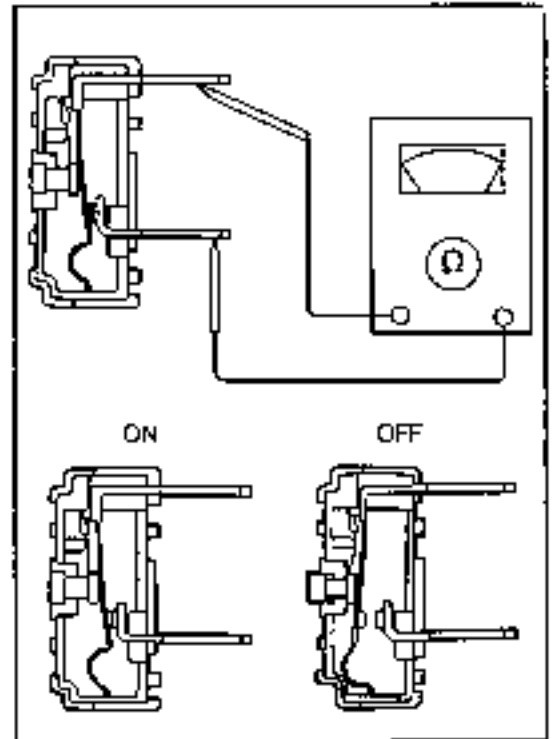

Fig. 10-203

WR-10257

LOWER GLASS SUN ROOF (TILT-UP AND SLIDING) CIRCUIT DIAGRAM

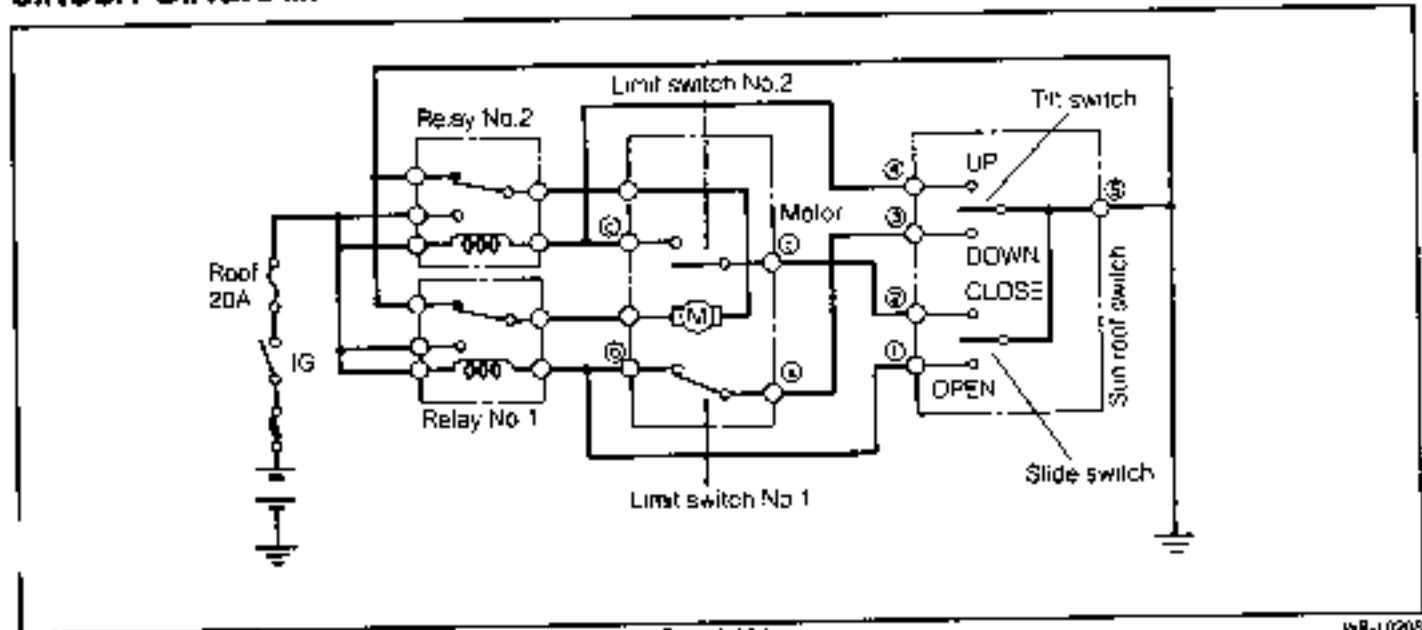

Fig. 10-204

WR-10208

SUN ROOF SWITCH

The sun roof switch is located at the front end of the roof.

NOTE:

For the removal/installation procedure for the sun roof switch, see page 9-61.

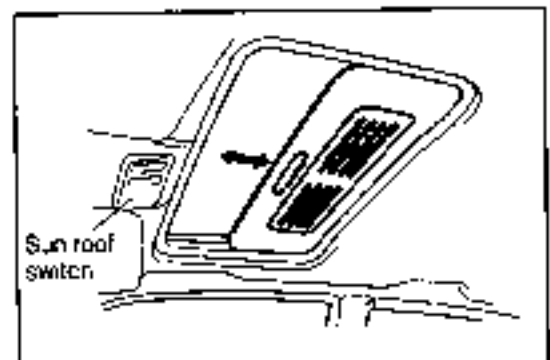

Fig. 10-205

WR-10208

INSPECTION

When the tilt switch and slide switch are operated, ensure that continuity exists between the respective terminals as indicated in the continuity table.

Switch		Terminal				
		①	②	③	④	⑤
Slide switch	OPEN	○				○
	OFF					
	CLOSE		○			○
Til switch	UP				○	○
	OFF					
	DOWN			○		○

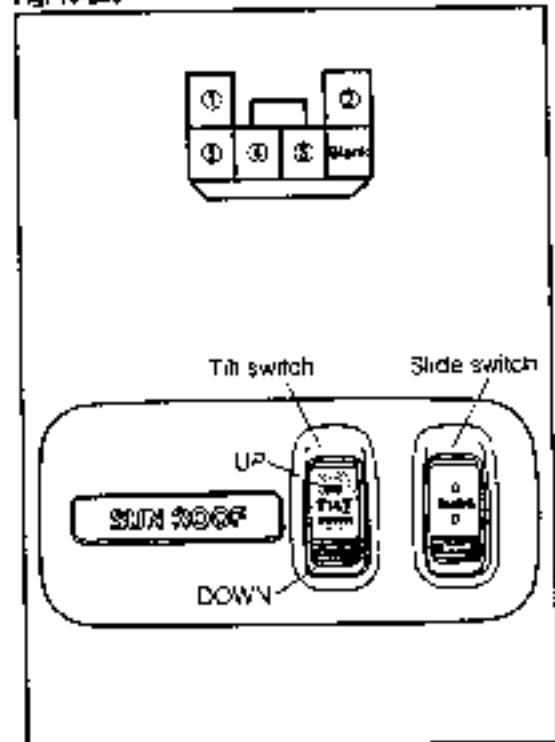

Fig. 10-206

WR-13510

BODY ELECTRICAL SYSTEM

SUN ROOF MOTOR

The sun roof motor is located at the back side of the sun roof switch.

NOTE:

For the removal/installation procedure for the sun roof motor, see page 9-62.

Motor Operation Check

1. Connect the terminal ① to the positive (+) terminal of the battery; the terminal ② to the negative (-) terminal of the battery. Ensure that the drive gear rotates to the right.
2. Connect the terminal ① to the negative (-) terminal of the battery; the terminal ② to the positive (+) terminal of the battery. Ensure that the drive gear rotates to the left.

Limit Switch Check

Remove the limit switch from the motor.

1. Limit switch No 1
Ensure that no continuity exists between ② and ③ when the switch is turned ON. Ensure that continuity exists between ② and ③ when the switch is turned OFF.
2. Limit switch No 2
Ensure that continuity exists between ④ and ⑤ when the switch is turned ON. Ensure that no continuity exists between ④ and ⑤ when the switch is turned OFF.

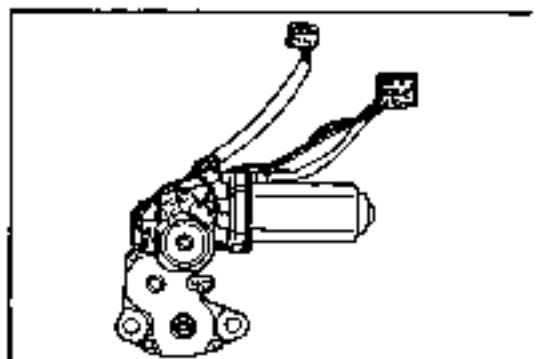

Fig. 10-207

WF-10211

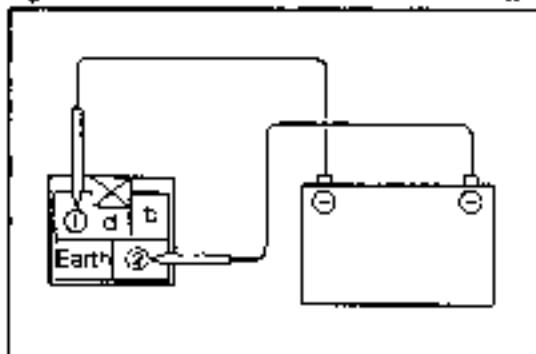

Fig. 10-208

WF-10212

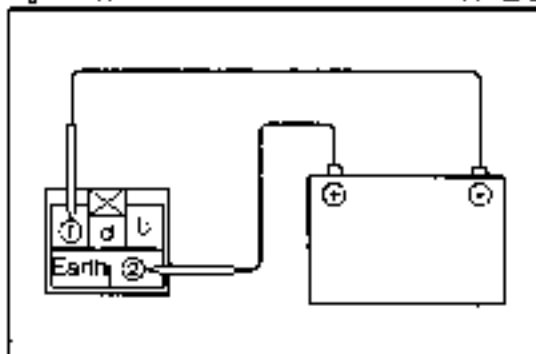

Fig. 10-209

WF-10213

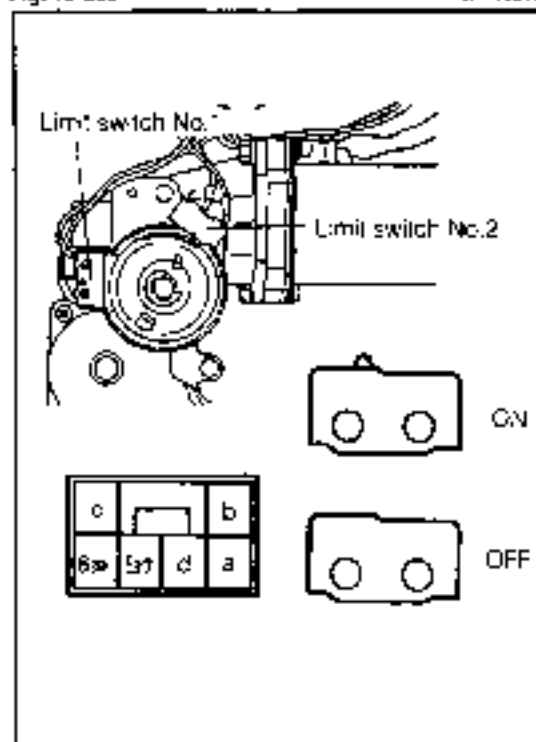

Fig. 10-210

WF-10214

HEATER
HEATER UNIT
RELATED PARTS

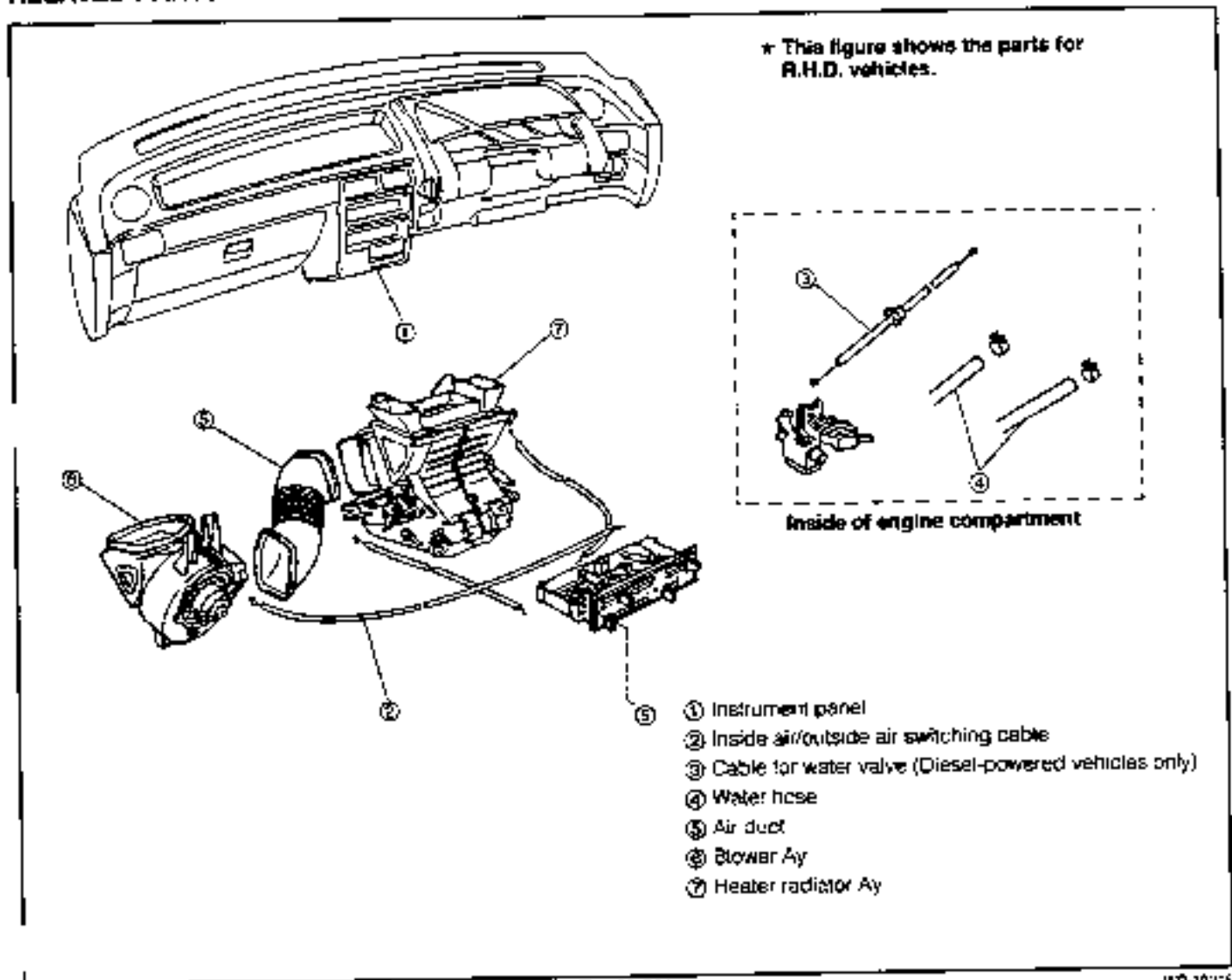

Fig. 10-211

WA-10215

OPERATION PRIOR TO REMOVAL

1. Disconnect the negative \ominus terminal of the battery.
2. Drain the cooling water from the radiator. (As for the diesel-powered vehicles, perform this operation with the temperature regulating lever of the heater control set to the WARM side.)

WA-10216

REMOVAL

1. Remove the instrument panel.
 See page 9-78.

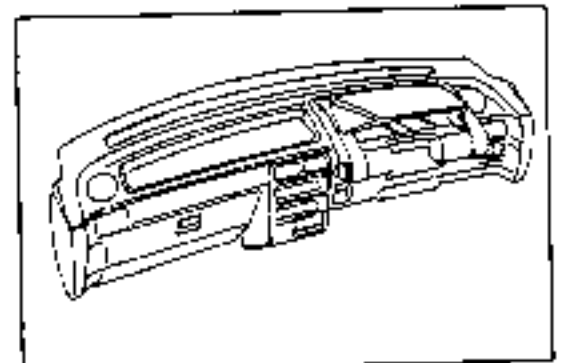

Fig. 10-212

WA-10217

BODY ELECTRICAL SYSTEM

2. Disconnect the inside air/outside air switching cable from the blower assembly.

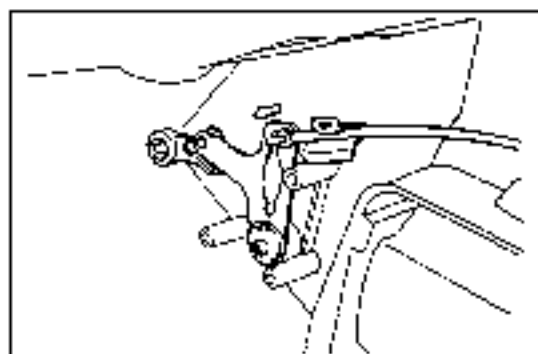

Fig. 10-213

W9-10213

3. Disconnect the cable for the water valve in the engine compartment. (Diesel-powered vehicles only)

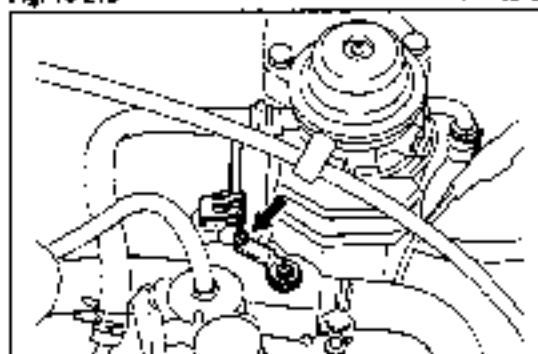

Fig. 10-214

W9-10214

4. Disconnect the two water hoses from the heater assembly.

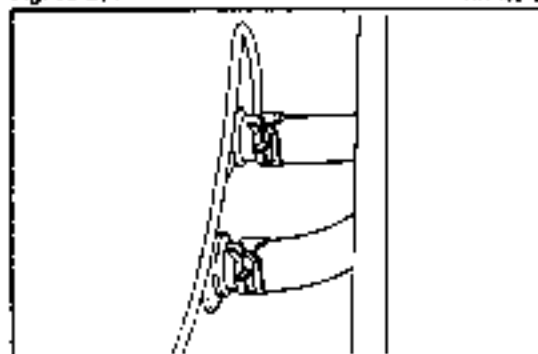

Fig. 10-215

W9-10226

5. Remove the air duct.

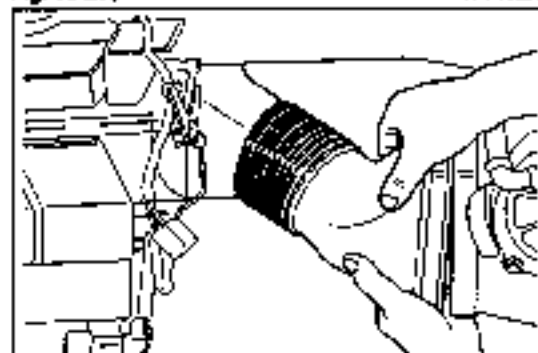

Fig. 10-216

W9-10221

6. Remove the blower assembly by removing the two nuts, bolt and connector.

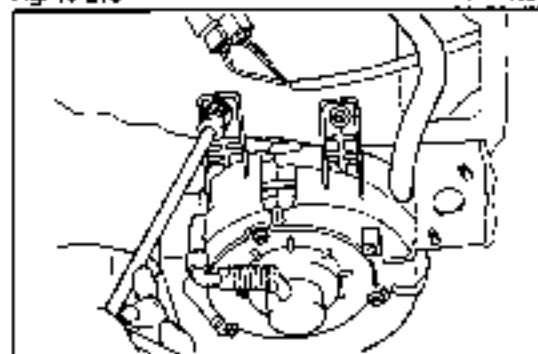

Fig. 10-217

W9-10222

Remove the heater radiator assembly by removing the two nuts and two bolts.

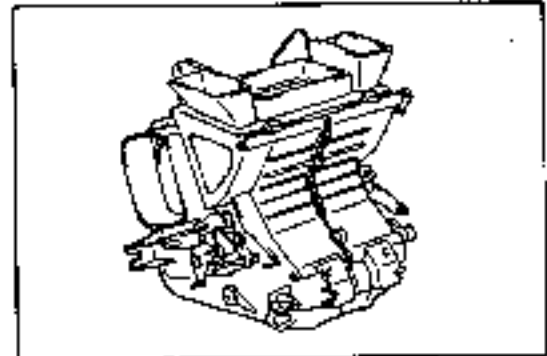

Fig. 10-218

WP-10222

INSPECTION

1. Blower Register

Ensure that the resistance between the respective terminals conforms to the specifications below.

Specified Values:

- Between Terminals (L) and (M₁): 1.37Ω
- Between Terminals (L) and (M₂): 2.10Ω
- Between Terminals (H) and (M₂): 0Ω

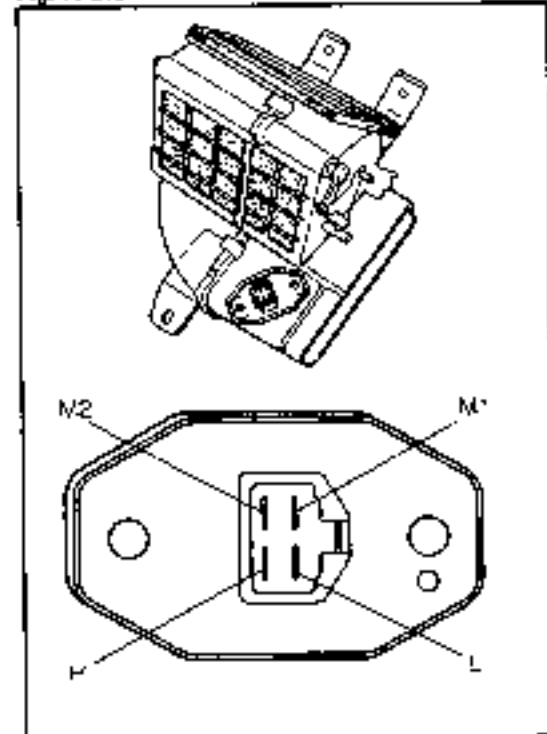

Fig. 10-219

WP-10224

2. Blower Motor

Connect the connector positive (+) terminal of the blower motor to the positive (+) terminal of the battery, the negative (-) terminal of the blower motor to the negative (-) terminal of the battery. Ensure that the motor rotates.

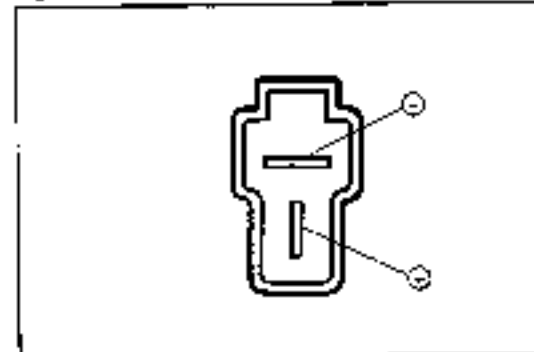

Fig. 10-220

WP-10225

BODY ELECTRICAL SYSTEM

3. Blower Switch

When the blower switch is set to each stage, ensure that continuity exists between the respective terminals as indicated in the continuity table.

○—○ Continuity exists.

Switch \ Terminal	①	②	③	④	⑤	⑥	⑦	⑧
OFF								
I		○—○	○—○					
II		○—○	○—○	○—○	○—○			
III	○—○	○—○	○—○	○—○				
Always		○—○		○—○				○—○

○—○ Bulb in installed state

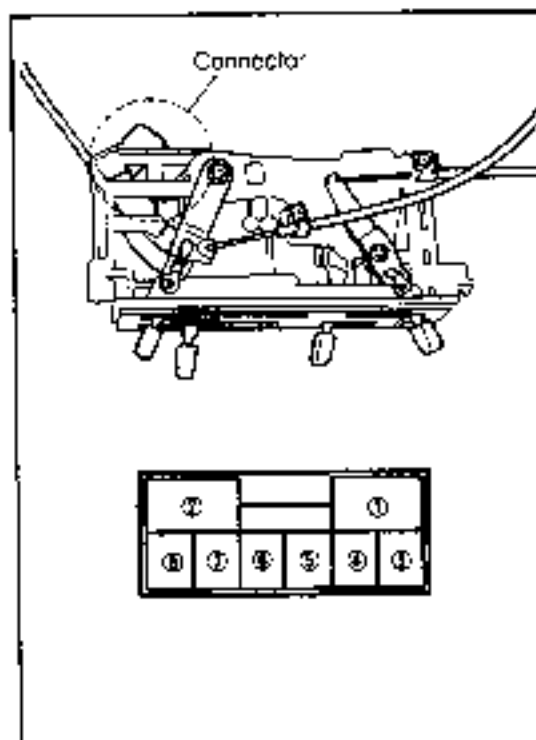

Fig. 10-221

4F-10221

INSTALLATION

1. Install the radiator heater assembly to the dash panel.
2. Install the blower register and blower motor connector to the blower assembly.
3. Install the blower assembly by tightening the two nuts and one bolt.
4. Install the air duct. Connect the water hose at the engine compartment side to the heater assembly.
NOTE:
Connect the hose securely and clamp it.
5. Install the cable for the water valve, as follows:
(Diesel-powered vehicle only)
Set the water valve in the engine compartment to the close mode; the mode switching lever of the heater unit to the COOL side. Then, insert and clamp the cable.

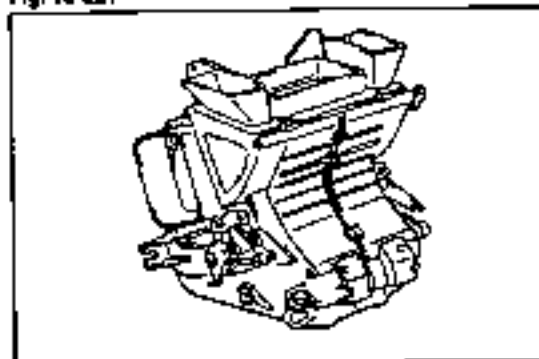

Fig. 10-222

4F-10222



Fig. 10-223

4F-10223

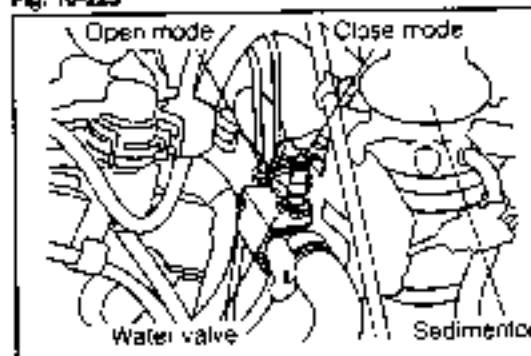



Fig. 10-224

4F-10224

Install the inside air/outside air switching cable to the blower assembly, as follows:

- (1) Set the inside air/outside air switching lever of the heater control to the  (RECIRC) side; the inside air/outside air switching lever of the blower assembly to the RECIRC side
- (2) Insert and clamp the cable securely.

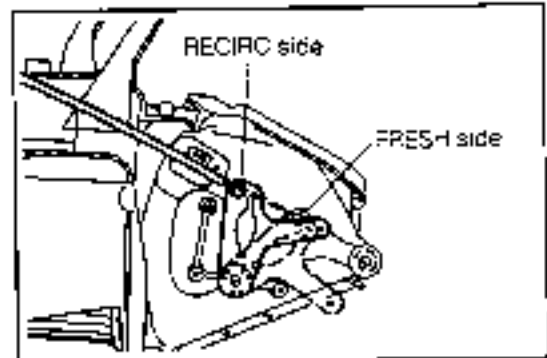

Fig. 10-225

WR-1023

Operation After Installation

1. Fill the cooling water (For the diesel-powered vehicles, perform this operation with the temperature regulating lever of the heater control set to the WARM side.)
2. Install the negative terminal \ominus of the battery.
3. As for the vehicle equipped with a clock, set the time.

Inspection After Installation

Ensure that the air amount and air flowing direction vary correctly in accordance with the position of the heater control lever.

WR-1023

HEATER CONTROL ASSEMBLY RELATED PARTS

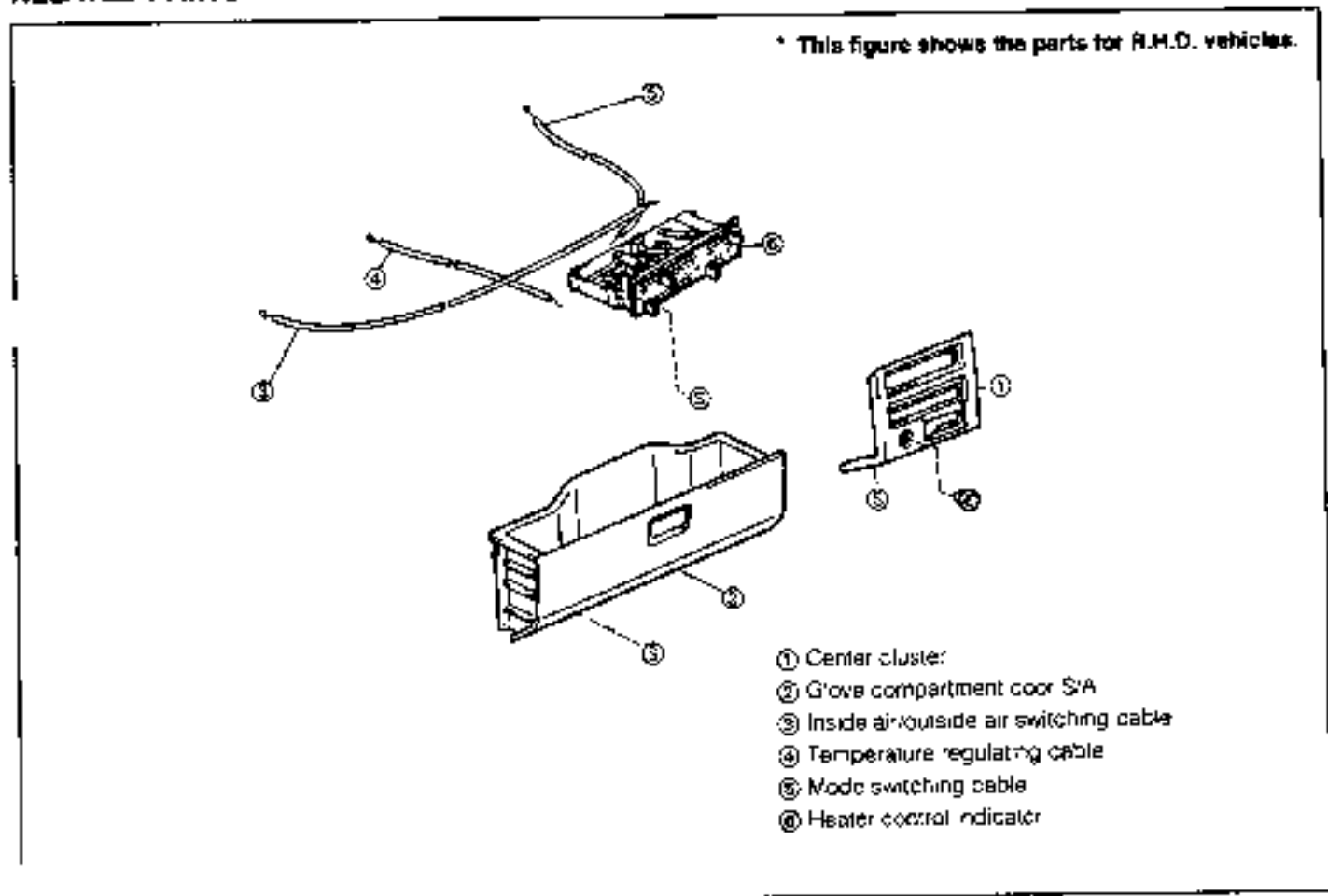

Fig. 10-228

WR-10232

BODY ELECTRICAL SYSTEM

REMOVAL

1. Remove the four tapping screws and take out the center cluster.
2. Remove the glove compartment door subassembly by removing the two screws at the lower side.
3. Disconnect the inside air/outside air switching cable from the blower assembly.
4. Disconnect the temperature regulating cable and mode switching cable from the heater assembly.
5. Remove the heater control indicator, as follows.
 - (1) Remove the three screws. Remove the heater control indicator toward the back side of the instrument panel.
 - (2) Take out the heater control indicator from the glove compartment door section.

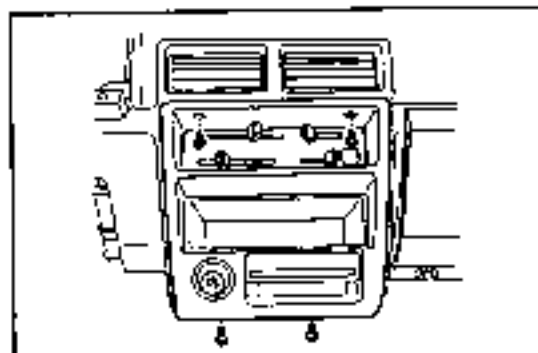

Fig. 10-227

WR-0233

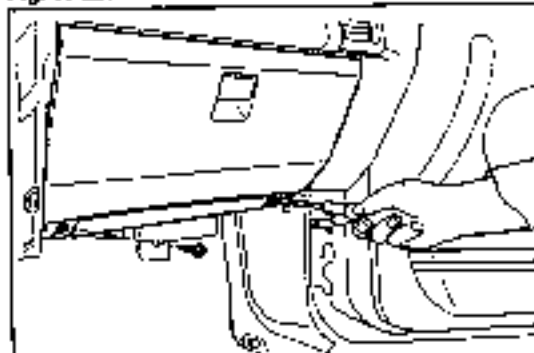

Fig. 10-228

WR-10254

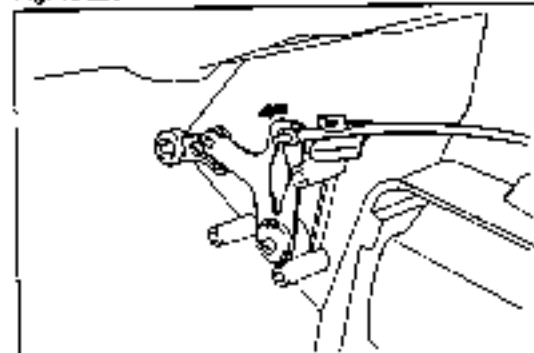

Fig. 10-229

WR-0235

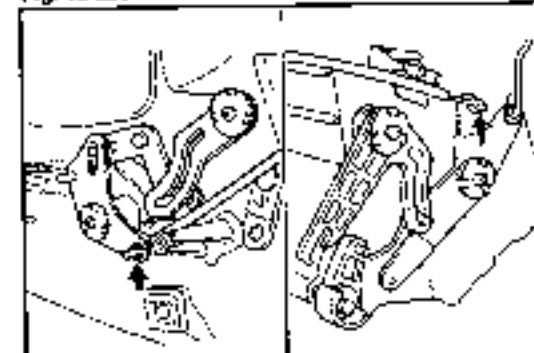

Fig. 10-230

WR-0236

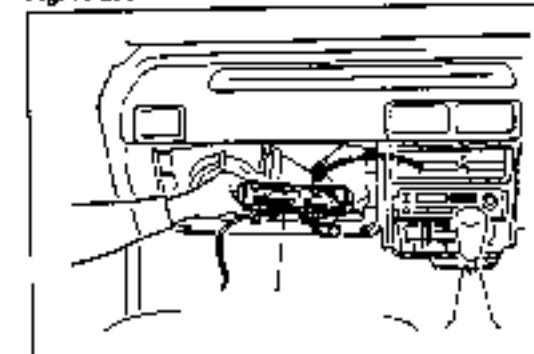

Fig. 10-231

WR-10237

INSPECTION

Blower switch

With the blower switch set to each stage ensure that continuity exists between the respective terminals as indicated in the continuity table.

○—○ Continuity exists

Switch	Terminal	①	②	③	④	⑤	⑥	⑦	⑧
OFF									
I			○—○						
II			○—○	○—○	○—○				
III		○—○	○—○	○—○	○—○				
Always						○—○	○—○	○—○	○—○

○—(B)—○ Bulb in installed state

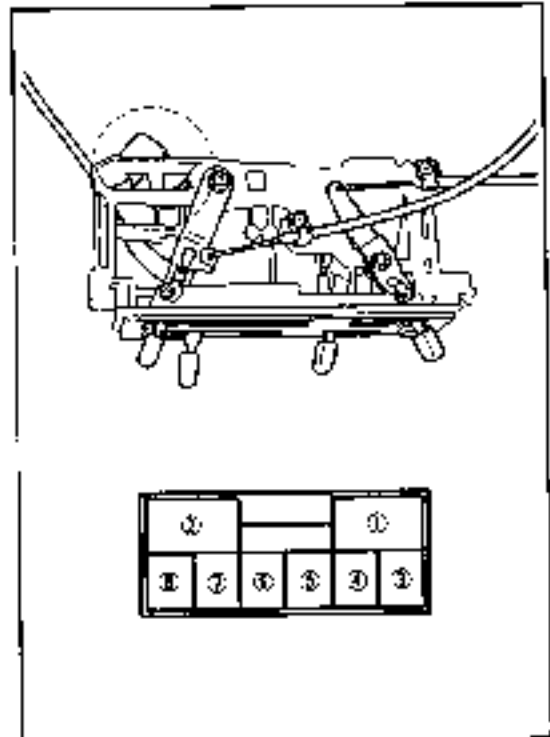

Fig. 10-232

WR-10232

INSTALLATION

1. Install the heater control indicator by tightening the three screws.

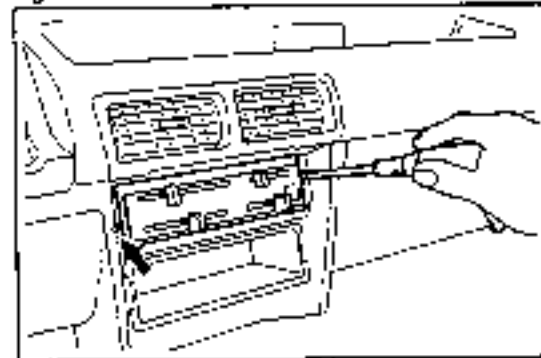

Fig. 10-233

WR-10233

2. Install the mode switching cable as follows:

- (1) Set the mode switching lever of the heater control to the DEF (DEF) side, the mode switching lever of the heater unit to the DEF side
- (2) Connect the mode switching cable. Insert it into the clamp securely.

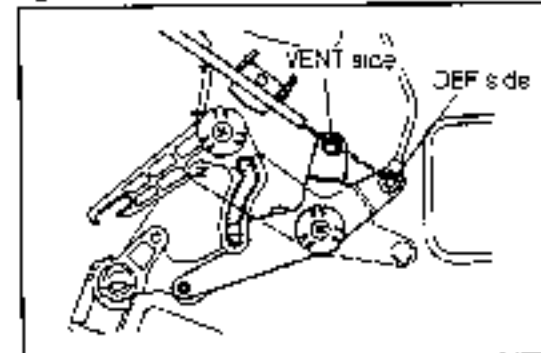

Fig. 10-234

WR-10234

3. Install the temperature regulating cable, as follows:

- (1) Set the temperature regulating lever of the heater control to the COOL (COOL) side; the temperature regulating lever of the heater unit to the COOL side
- (2) Connect the temperature regulating cable. Insert it into the clamp securely.

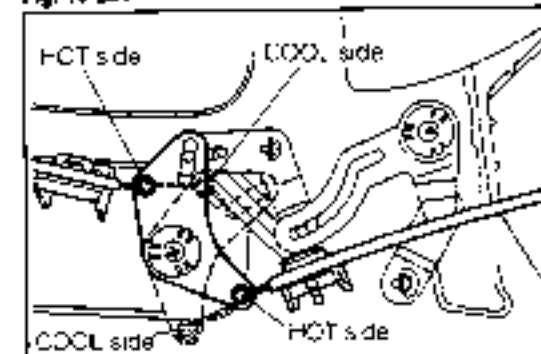



Fig. 10-235

WR-10235

BODY ELECTRICAL SYSTEM

4. Install the inside air/outside air switching cable, as follows:
 - (1) Set the inside air/outside air switching lever of the heater control to the  (RECIRC) side, the inside air/outside air switching lever of the blower assembly to the RECIRC side.
 - (2) Connect the inside air/outside air switching cable. Insert it to the clamp securely.
5. Install the glove compartment door subassembly by tightening the two screws.
6. Install the center cluster by tightening the four screws.

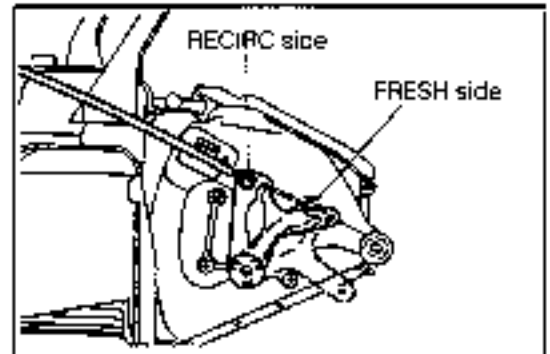

Fig. 10-236

WR-10242

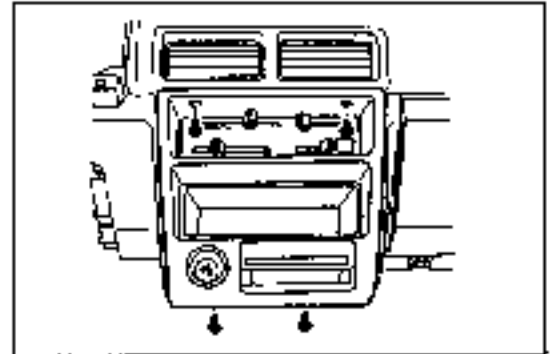

Fig. 10-237

WR-10243

Inspection After Installation

Ensure that the air amount and air flowing direction vary correctly in accordance with the position of the heater control lever.

WR-10244

RADIO
RELATED PARTS

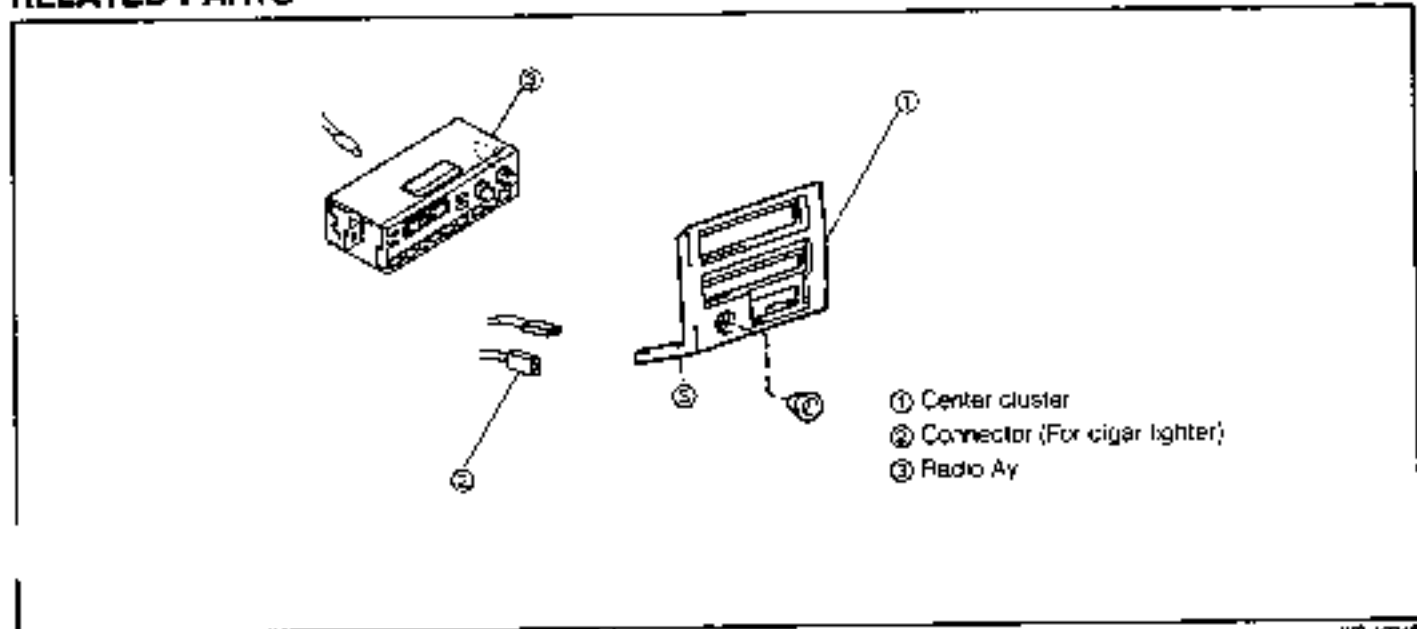

Fig. 10-238

WR-10245

REMOVAL

1. Remove the center cluster by removing the four screws.
2. Disconnect the connector for the cigar lighter.
3. Remove the radio assembly.

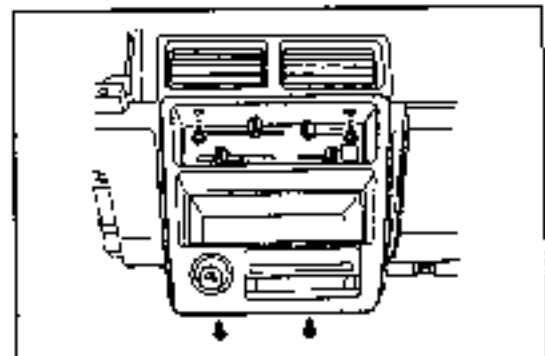

Fig. 10-239

WR-10246

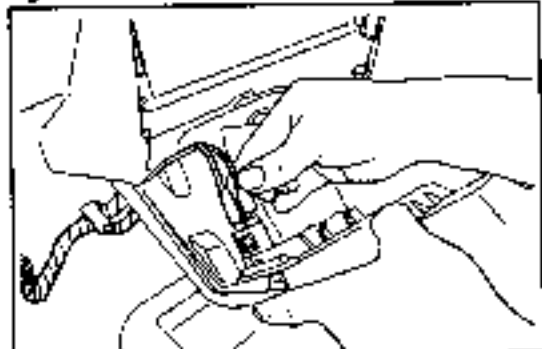

Fig. 10-240

WR-10247

INSTALLATION

1. Install the radio assembly.
2. Connect the connector for the cigar lighter.
3. Install the center cluster by tightening the four screws.

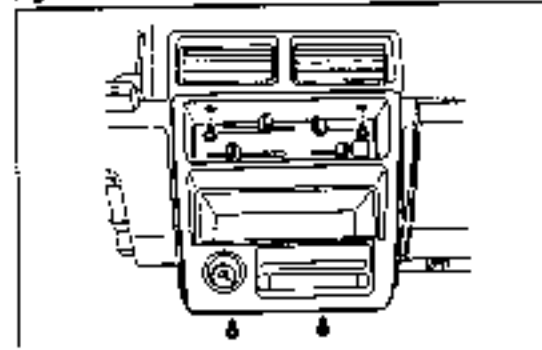

Fig. 10-241

WR-10248

BODY ELECTRICAL SYSTEM

SPEAKER ASSEMBLY AND ANTENNA ASSEMBLY

RELATED PARTS

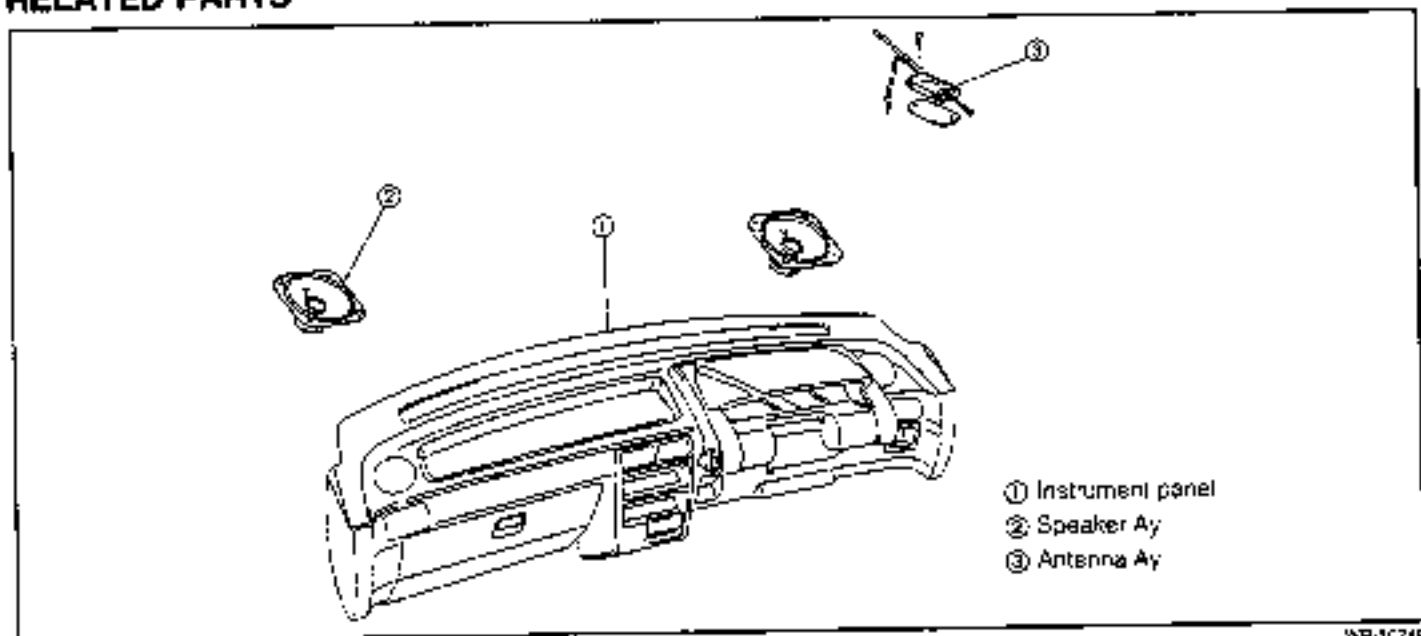

Fig. 10-242

WR-10248

SPEAKER REMOVAL

1. Remove the instrument panel.
See page 9-78
2. Disconnect the connector of the speaker. Remove the speaker assembly.

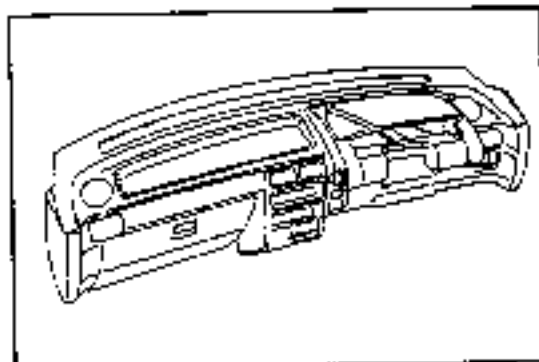

Fig. 10-243

WR-10250

ANTENNA REMOVAL

1. Disconnect the feeder cord connector.

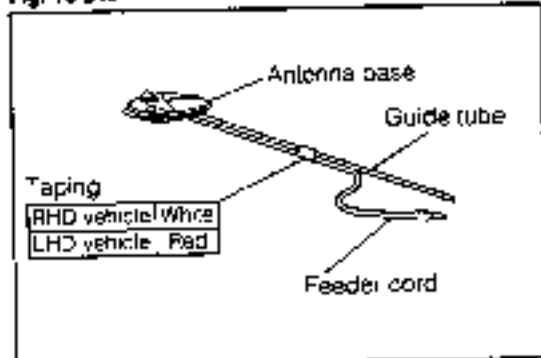

Fig. 10-244

WR-10251

2. Remove the antenna base, using a Torx bit.

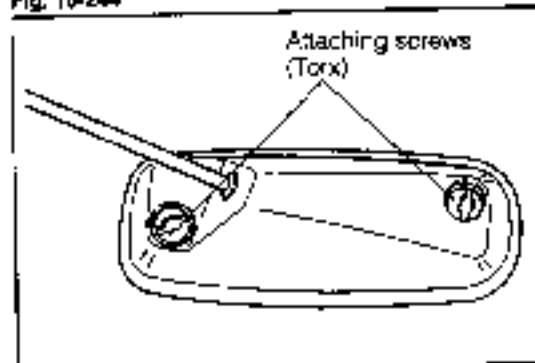

Fig. 10-245

WR-10252

ANTENNA INSTALLATION

1. Insert the guide tube and feeder cord into the roof opening section.

NOTE:

Insert the guide tube in such a way that it comes to the vehicle front section.

2. Connect the antenna cord to the radio proper

NOTE:

1. As for the intersection of the feeder wire and the vehicle harness section, route wiring in such a way that the feeder wire comes under the harness section. ... (A)
2. As for the heater unit section, make sure that the link does not interfere with other parts when it is moved. (B)

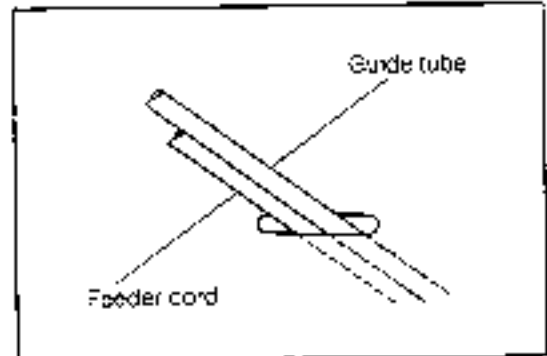

Fig. 10-246

WR-10252

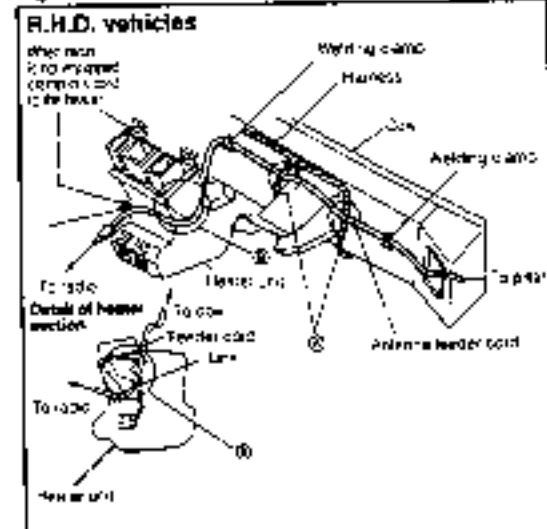

Fig. 10-247

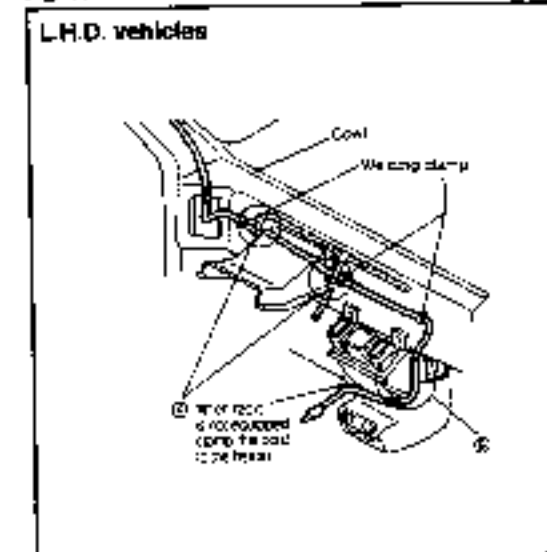

Fig. 10-248

WR-10253

SPEAKER INSTALLATION

1. Connect the connector for the speaker. Install the speaker to the instrument panel.
2. Install the instrument panel.
See page 9-82.

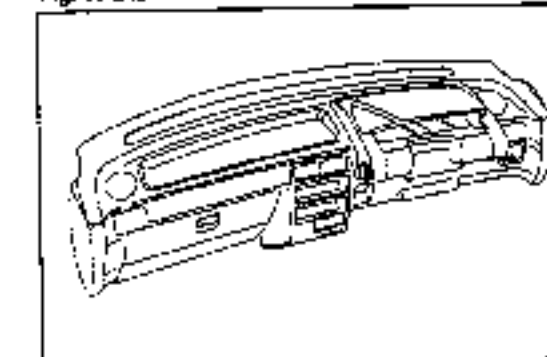

Fig. 10-249

WR-10254

HEADLAMP CLEANER (Option for Finland and Swedish Specifications)

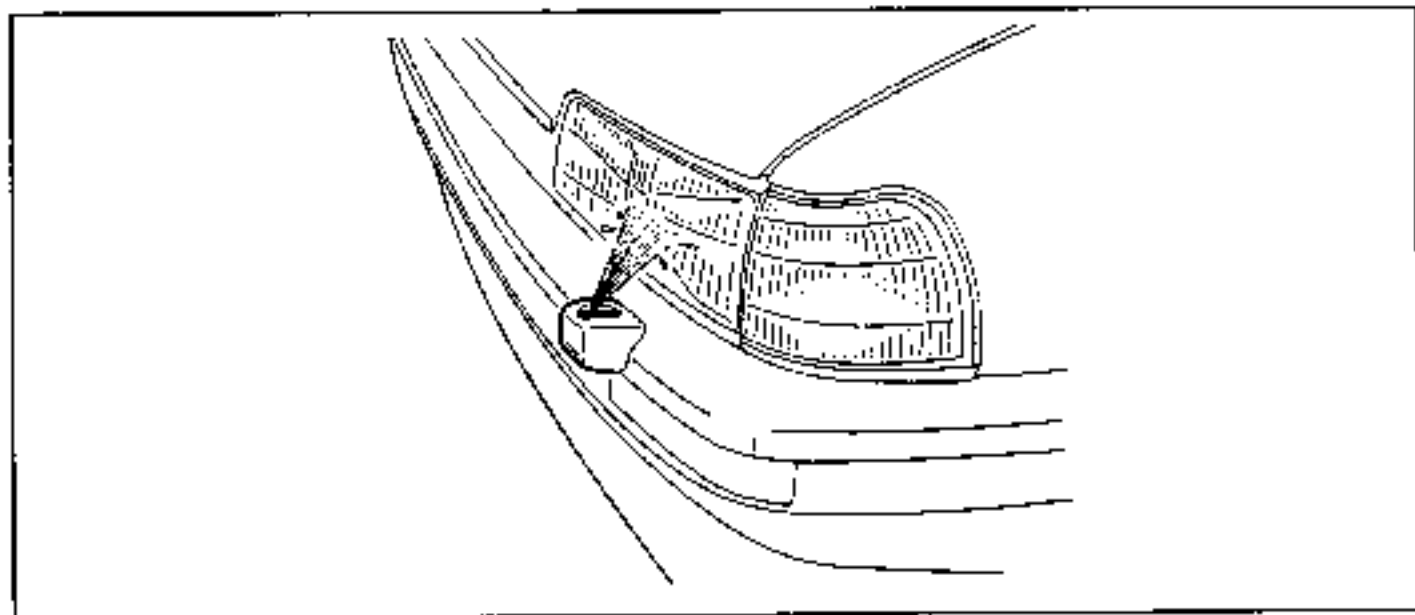

Fig. 10-250

WA-10255

OPERATION CHECK

1. Vehicles with Day-Light Feature

While the engine is running, carry out the following check. Operate the washer switch one time. Within about 0.8 second, operate the washer switch again. Ensure that the cleaner motor operates for about 0.5 second, regardless of the position of the lighting switch.

2. Vehicles without Day-Light Feature

While the ignition switch is turned ON, carry out the following check: Operate the washer switch one time. Within about 0.8 second, operate the washer switch again. Ensure that the cleaner motor operates for about 0.5 second.

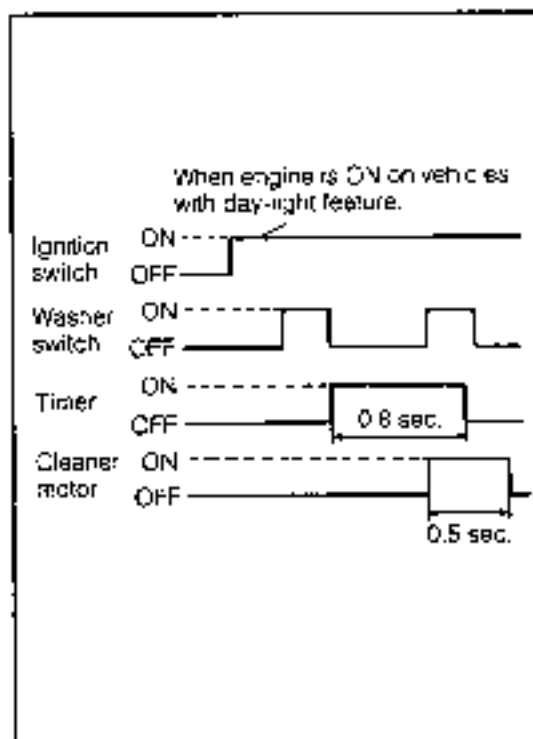

Fig. 10-251

WA-10257

NOZZLE

Removal

1. Remove the front bumper. (See page 9-9.)
2. Disconnect the water hose joint section located at the back side of the bumper.
3. Remove the nozzle assembly by slackening the two nuts.

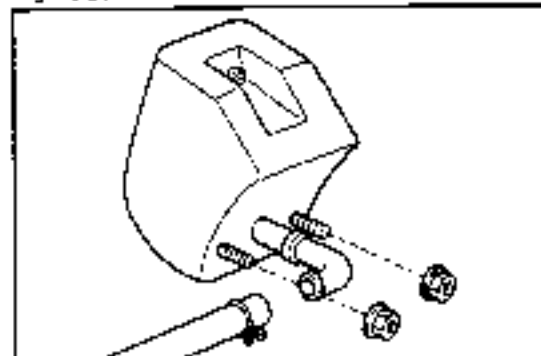

Fig. 10-252

WA-10258

Installation

1. Insert the nozzle into the bumper cover from the joint side, while rotating the nozzle 90 degrees.
2. Install the nozzle proper with the two nuts. Connect the water hose.

NOTE:

Clamp the water hose securely.

3. Install the front bumper. (See page 9-10.)

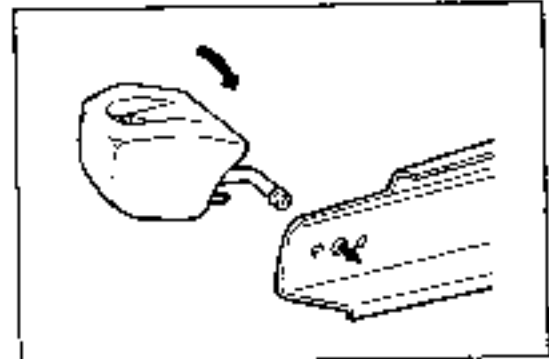

Fig. 10-253

WP-10250

ADJUSTING PROCEDURE FOR NOZZLE INJECTION ANGLE

Operation Prior to Adjustment

1. Perform the headlamp aiming operation. (See page 10-13.)

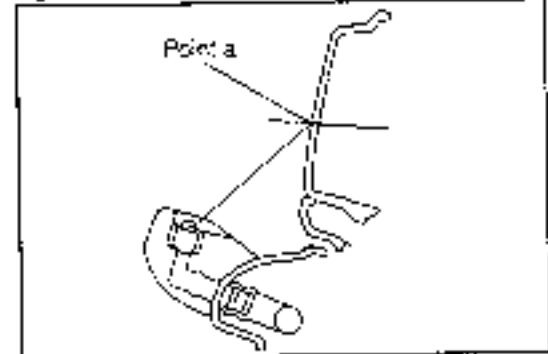

Fig. 10-254

WP-10260

Adjustment

1. Set the nozzle so that the center of squirt comes to the bulb installation position of the headlamp. (Bulb center point: a)
2. Ensure that the variation in the squirting angle is within the allowable range

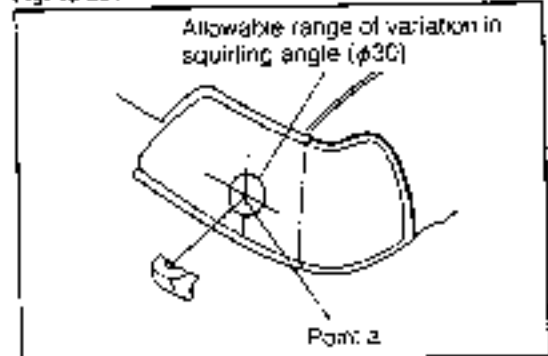

Fig. 10-255

WP-10261

BODY ELECTRICAL SYSTEM

HEADLAMP WASHER TANK

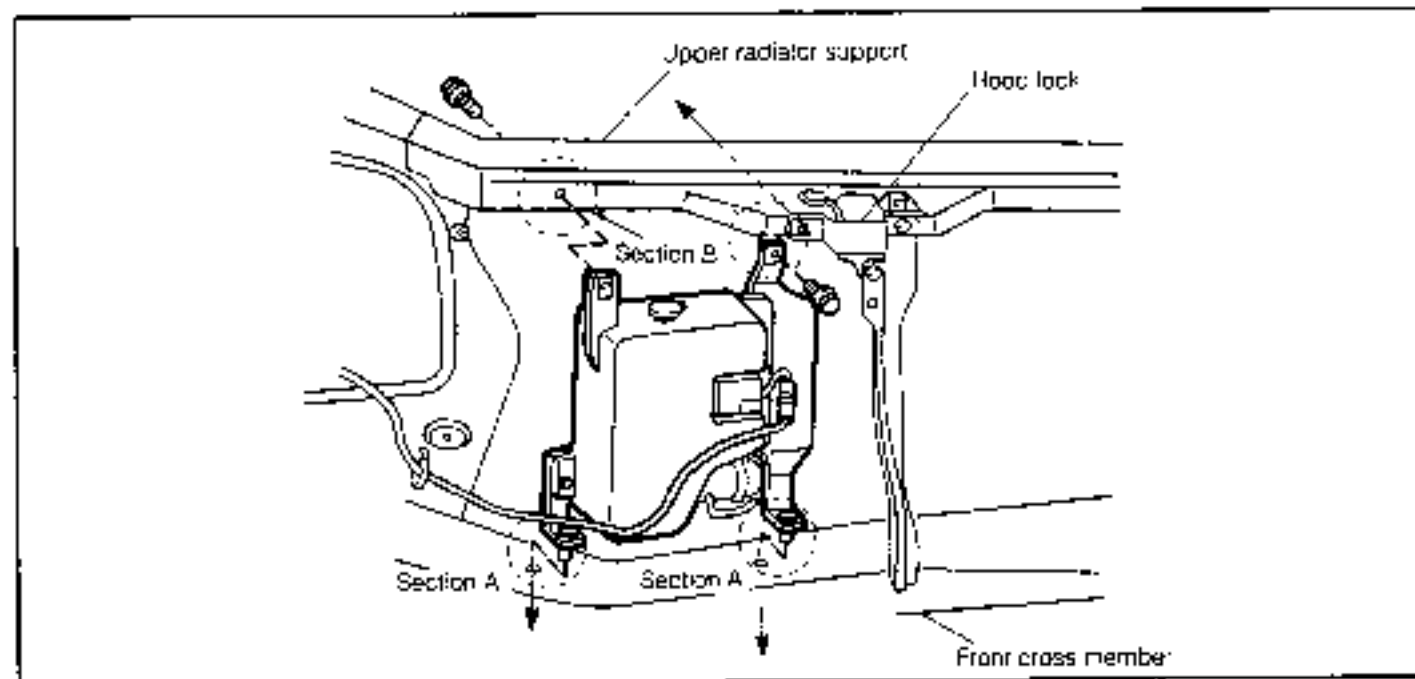

Fig. 10-256

WR-10256

Removal

1. Remove the front grille and front bumper.
See page 9-78.
2. Disconnect the water hose from the washer motor. Disconnect the harness clamp.
3. Remove the washer tank assembly by removing the two bolts.

Installation

1. Insert the washer tank into the front cross member (at two points)
2. Working from the engine compartment, tighten the bolt at the vehicle outside. Working from the front of the vehicle tighten the bolt at the vehicle inside together with the hood lock.

3. Connect the water hose to the washer motor. Connect the harness connector.

NOTE:

Tighten the clamp securely.

4. Install the front bumper and front grille
See page 9-10

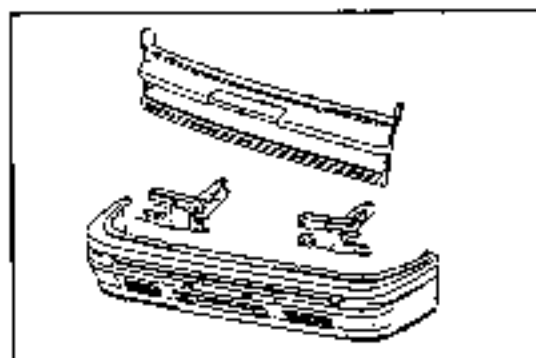

Fig. 10-257

WR-C257

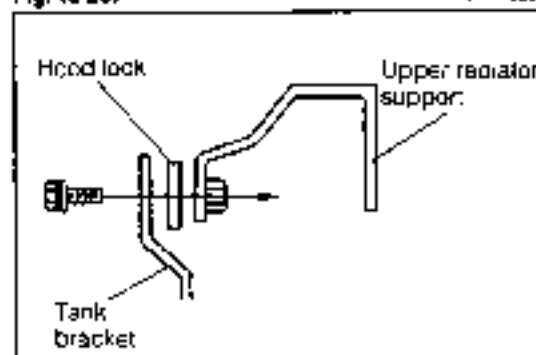

Fig. 10-258

WR-C258

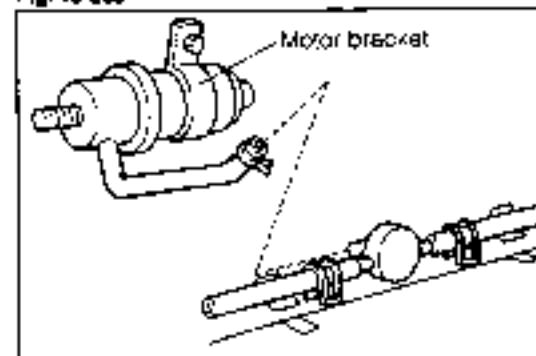

Fig. 10-259

WR-10259

**DM-DIP LAMP
CIRCUIT DIAGRAM**

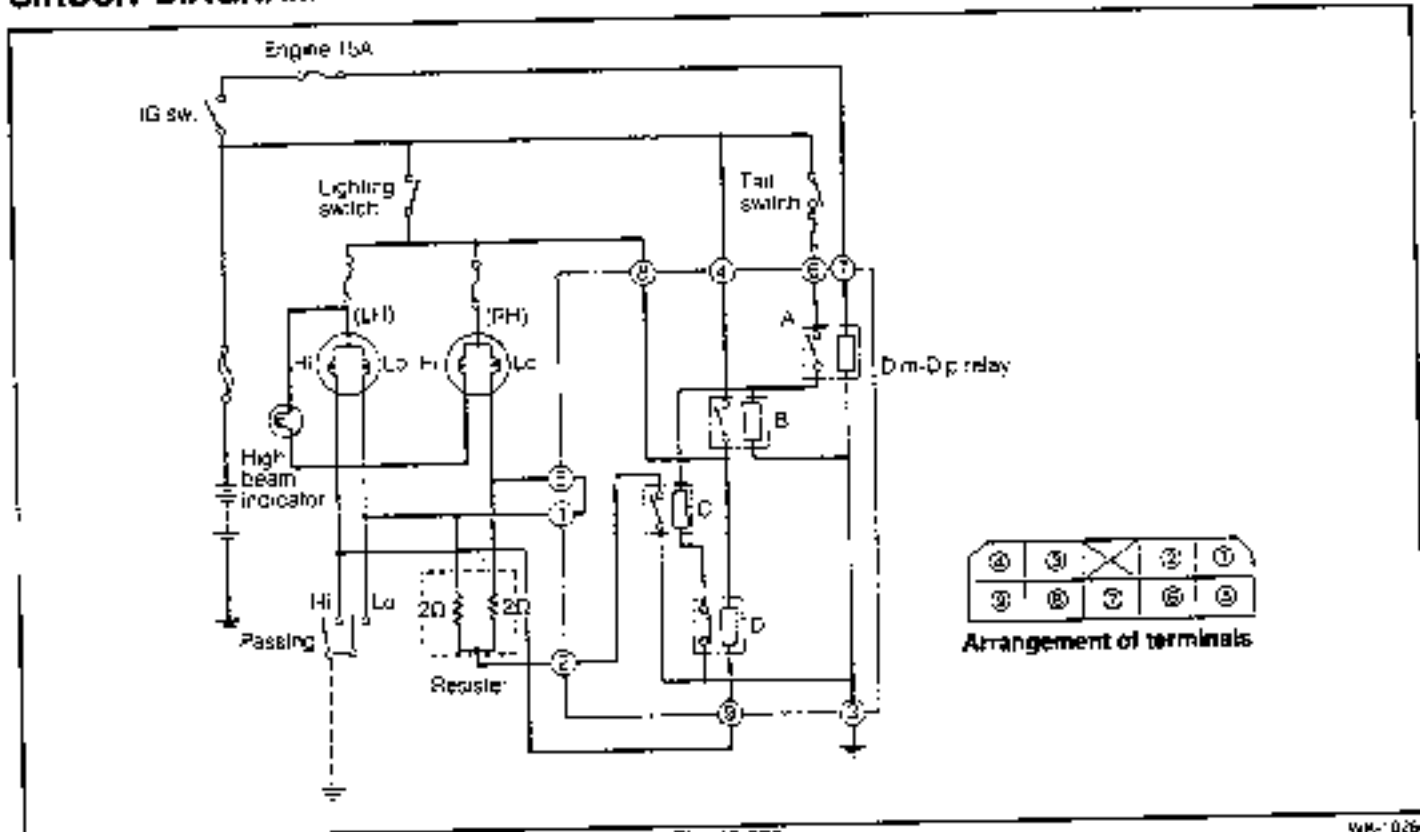

Fig. 10-280

WA-10266

OPERATION CHECK

Under the conditions given below, ensure that the luminous intensity of the dim-dip lamp is reduced 10% compared with the normal operation

Ignition switch	Switch condition			Headlamp condition	Remarks
	Tail switch	Lighting switch L	Lighting switch H		
OFF	OFF	OFF	OFF	OFF	
	ON	OFF	OFF	OFF	Tail lamp only goes on
	ON	ON	OFF	Lo	
	ON	OFF	ON	Hi	
	OFF	OFF	ON	Hi	Passing
ON	OFF	OFF	OFF	OFF	
	ON	OFF	OFF	Dim-dip	
	ON	ON	OFF	Lo	
	ON	OFF	ON	Hi	
	OFF	OFF	ON	Hi	Passing

WA-10267

BODY ELECTRICAL SYSTEM

DAY-LIGHT RELAY CIRCUIT DIAGRAM

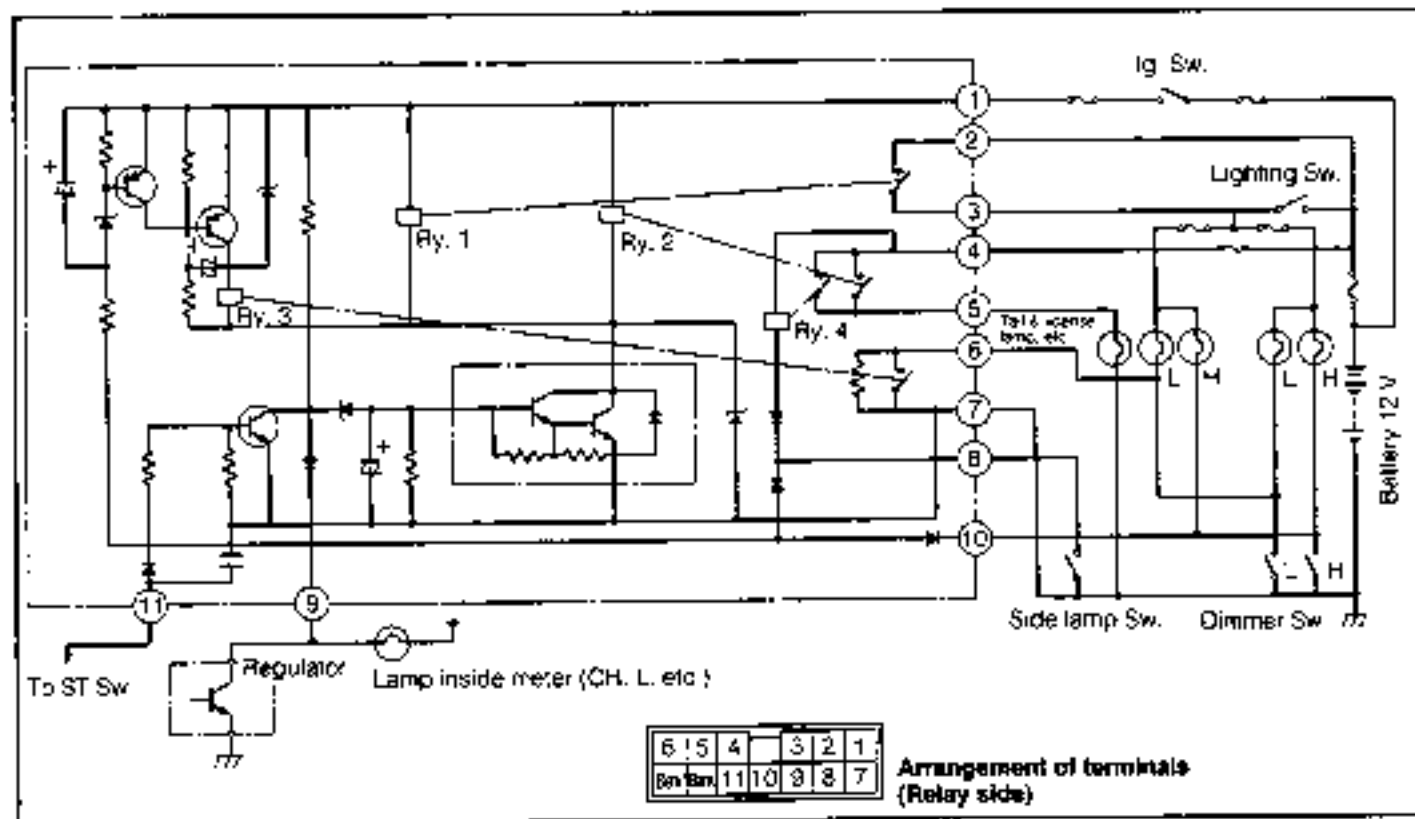

Fig. 10-261

WR-10263

OPERATION CHECK

While the engine is rotating, ensure that the day-light goes on under the conditions given below.

○ ... Goes on
× ... Goes off.

Engine	Ignition switch	Side lamp switch	Lighting switch	Dimmer switch	Tail & license lamp	Headlamp		
						Lo	Hi	
STOP	ON	Normal glowing mode						
	OFF							
RUN	ON	OFF	OFF	OFF	○	○	×	
	ON	ON	OFF	OFF	○	×	×	
	ON	ON	ON	Lo	○	○	×	
	ON	ON	ON	Hi	○	×	○	
	ON	ON	Passing	Passing	○	×	○	

WR-10263

DAIHATSU

CHARADE

Chassis

SECTION 11











APPENDIX

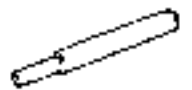
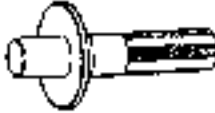

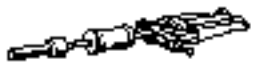





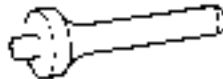

SST (Special Service Tools)	11- 2
SERVICE SPECIFICATIONS	11- 6
CLUTCH	11- 6
MANUAL TRANSMISSION AND DIFFERENTIAL	11- 6
AUTOMATIC TRANSMISSION	11- 7
STEERING	11- 8
BRAKE PEDAL	11- 9
FRONT BRAKE	11- 9
REAR BRAKE	11- 9
SUSPENSION	11-10
TIGHTENING TORQUE	11-11
METHOD TO IDENTIFY STRENGTH DIVISION	
OF BOLTS	11-11
CLUTCH, MANUAL TRANSMISSION	11-13
AUTOMATIC TRANSMISSION	11-13
DRIVE SHAFT, FRONT SUSPENSION	11-14
REAR AXLE, REAR SUSPENSION	11-14
STEERING	11-15
BRAKE	11-15
BODY AND OTHERS	11-15
WIRING DIAGRAMS	11-16
SYSTEM INDEX	11-16
WIRING DIAGRAM FOR TYPE CB ENGINE	11-17
WIRING DIAGRAM FOR TYPE CL ENGINE	11-21

(NR-11301)



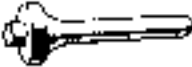

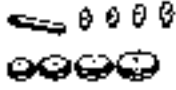







APPENDIX













SST (Special Service Tools)

Shape	Part No. & Part Name	Section	Clutch	Manual Transmission	Automatic Transmission	Front axle & suspension	Rear axle & suspension	Steering	Brakes	Body
	09201-60011-000 Valve guide bush remover & replacer			<input type="checkbox"/>						
	09301-87701-000 Clutch guide tool					<input type="checkbox"/>				
	09301-87202-000 Clutch guide tool		<input type="checkbox"/>	<input type="checkbox"/>						
	09302-87701-000 09302-87701-000 Clutch diaphragm spring height No.4 gauge		<input type="checkbox"/>							
	09306-87302-000 Counter gear front bearing puller			<input type="checkbox"/>						
	09306-00010-000 Oil seal puller			<input type="checkbox"/>						
	09309-87201-000 Transmission bearing replacer			<input type="checkbox"/>				<input type="checkbox"/>		
	09334-87201-000 Transmission bearing puller					<input type="checkbox"/>				
	09506-30011-000 Differential rear bearing cone replacer					<input type="checkbox"/>				
	09506-87302-000 Differential drive pinion bearing cone replacer					<input type="checkbox"/>				
	09510-87301-000 Front hub & drum puller					<input type="checkbox"/>	<input type="checkbox"/>		<input type="checkbox"/>	
	09511-87202-000 Brake drum stopper					<input type="checkbox"/>				
	09515-87201-000 Rear axle shaft bearing replacer			<input type="checkbox"/>						

Shape	Part No. & Part Name	Clutch	Manual Transmission	Automatic Transmission	Front axle & suspension	Rear axle & suspension	Steering	Brakes	Body
	09517-87701-000 Oil seal replacer (Transmission case side)		<input type="checkbox"/>						
	09517-87702-000 Oil seal replacer (Clutch housing side)		<input type="checkbox"/>						
	09527-87301-000 Rear axle shaft bearing remover				<input type="checkbox"/>				
	09547-87301-000 Differential drive pinion bearing cone remover				<input type="checkbox"/>				
	09547-87501-000 Differential drive pinion bearing cone remover				<input type="checkbox"/>				
	09602-87301-000 Counter gear bearing puller		<input type="checkbox"/>						
	09550-10012-000 Replacer set "B"				<input type="checkbox"/>				
	09606-87201-000 Front hub bearing remover & replacer		<input type="checkbox"/>						
	09608-12010-000 Front hub & drive pinion bearing replacer set				<input type="checkbox"/>	<input type="checkbox"/>			
	09608-30011-000 Front hub & drive pinion bearing tool set			<input type="checkbox"/>					
	09508-87501-000 Axle hub & drive pinion bearing tool set				<input type="checkbox"/>				
	09609-20011-000 Steering wheel puller						<input type="checkbox"/>		
	09611-87701-000 Tie rod end puller		<input type="checkbox"/>		<input type="checkbox"/>		<input type="checkbox"/>		

APPENDIX

Shape	Part No. & Part Name	Section:							
		Clutch	Manual Transmission	Automatic Transmission	Front axle & suspension	Rear axle & suspension	Steering	Brakes	Body
	09612-10061-000 Steering pinion bearing replacer							○	
	09616-87701-000 Steering pinion bearing adjusting socket wrench							○	
	09617-22030-000 Worm bearing adjusting screw lock nut wrench							○	
	09618-87301-000 Transmission bearing replacer		○		○				
	09620-30010-000 Steering gear box replacer set				○				
	09628-10020-000 Ball joint lock nut wrench				○				
	09636-20010-000 Differential replacer				○				
	09648-87201-000 Drive shaft replacer	○	○	○	○				
	09703-30010-000 Brake shoe tension spring							○	
	09718-87701-000 Front disc brake dust cover replacer				○				
	09720-00010-000 Shock absorber overhaul tool set				○				
	09722-87702-000 Camber caster kingpin gauge attachment				○				
	09727-87701-000 Front coil spring compressor				○	○			

Shape	Section	Part No. & Part Name	Clutch	Manual Transmission	Automatic Transmission	Front axle & suspension	Rear axle & suspension	Steering	Brakes	Body
		09737-22011-000 Brake booster push rod gauge							<input type="checkbox"/>	
		09737-87001-000 Brake booster push rod gauge							<input type="checkbox"/>	
		09753-87701-000 Brake booster overhaul tool S/A							<input type="checkbox"/>	
		09612-30010-000 Door hinge set bolt wrench set								<input type="checkbox"/>
		09842-87702-000 Transmission control computer check subharness			<input type="checkbox"/>					
		09843-87702-000 ATX computer check lamp			<input type="checkbox"/>					
		09905-00012-000 Snap ring expander		<input type="checkbox"/>						
		09905-87701-000 Snap ring plier							<input type="checkbox"/>	
		09912-87501-000 Side hammer puller			<input type="checkbox"/>					
		09921-00010-000 Spring tension tool		<input type="checkbox"/>						
		09950-20014-000 Universal puller				<input type="checkbox"/>		<input type="checkbox"/>		
		09992-00092-000 Oil pressure gauge for AT			<input type="checkbox"/>					
		09950-87702-000 Automatic transmission tool set			<input type="checkbox"/>					

APPENDIX
SERVICE SPECIFICATIONS
CLUTCH

Unit: mm (inch)

Item		Specified value	Allowable limit	Remarks
Clutch pedal	Installation height	R.H.D	189.5 - 194.5 (7.46 - 7.66)	—
		L.H.D	181.5 - 186.5 (7.15 - 7.34)	—
Free travel		15 - 30 (0.59 - 1.18)	—	
Thickness		7.3 - 7.9 (0.29 - 0.31)	—	
Clutch disc	Runout	—	1.34 (0.053)	
	Lining wear	—	0.3 (0.012)	Rivet depth
Clutch cover	Deviation in height	—	0.7 (0.028)	

WF-1005

MANUAL TRANSMISSION AND DIFFERENTIAL

Unit: mm (inch)

Item		Specified value	Allowable limit	Remarks
2nd gear bush	Inner diameter	28.870 - 28.885 (1.1366 - 1.1372)	28.840 (1.1354)	
	Outer diameter	36.920 - 36.960 (1.4535 - 1.4551)	36.890 (1.4524)	
	Overall length	32.470 - 32.530 (1.2783 - 1.2807)	32.470 (1.2783)	
4th and 5th gear bush	Inner diameter	25.027 - 25.042 (0.9853 - 0.9859)	25.020 (0.9850)	
	Outer diameter	36.920 - 36.960 (1.4535 - 1.4551)	36.890 (1.4524)	
	Overall length	28.970 - 29.030 (1.1405 - 1.1423)	28.970 (1.1405)	
	Thickness	2.940 - 3.060 (0.1157 - 0.1205)	2.940 (0.1157)	Flange section
End play	1st gear	0.10 - 0.37 (0.0039 - 0.0146)	0.5 (0.0197)	
	2nd gear	0.10 - 0.23 (0.0039 - 0.0091)	0.4 (0.0157)	
	3rd gear	0.10 - 0.37 (0.0039 - 0.0146)	0.5 (0.0197)	
	4th gear	0.10 - 0.23 (0.0039 - 0.0091)	0.4 (0.0157)	
	5th gear	0.10 - 0.23 (0.0039 - 0.0091)	0.4 (0.0157)	
Gear oil clearance		0.040 - 0.105 (0.0016 - 0.0041)	0.160 (0.0063)	
Gear width	1st gear	32.23 - 32.30 (1.2689 - 1.2717)	32.20 (1.2677)	Except for GT(i) model
		30.23 - 30.30 (1.1902 - 1.1930)	30.20 (1.1890)	GT(i) model
	2nd gear	32.30 - 32.37 (1.2717 - 1.2744)	32.20 (1.2677)	
		27.23 - 27.30 (1.0720 - 1.0748)	27.20 (1.0709)	
	4th gear	25.80 - 25.87 (1.0157 - 1.0185)	25.70 (1.0118)	
	5th gear	25.80 - 25.87 (1.0157 - 1.0185)	25.70 (1.0118)	

WR-1007

MANUAL TRANSMISSION AND DIFFERENTIAL (Cont'd)

Unit: mm (inch)

Item		Specified value	Allowable limit	Remarks
Reverse idler gear and shaft	Bush inner diameter	17.000 - 17.027 (0.6693 - 0.6704)	17.050 (0.6713)	
	Shaft outer diameter	16.941 - 16.968 (0.6670 - 0.6680)	16.900 (0.6654)	
	Bush-to-shaft clearance	0.032 - 0.086 (0.0013 - 0.0034)	0.150 (0.0059)	
Input shaft outer diameter		25.002 - 25.017 (0.9843 - 0.9849)	24.990 (0.9839)	Bush installing position
Output shaft outer diameter	Front	29.973 - 30.000 (1.1803 - 1.1811)	29.960 (1.1795)	
	Rear	31.971 - 31.991 (1.2587 - 1.2595)	31.960 (1.2583)	
Synchronizer ring-to-gear clearance		0.85 - 1.45 (0.0335 - 0.0571)	0.5 (0.0197)	
Differential inion	Gear inner diameter	15.003 - 15.008 (0.5907 - 0.0571)	15.03 (0.5917)	
	Shaft outer diameter	14.950 - 14.988 (0.5886 - 0.5893)	14.97 (0.5894)	
	Gear-to-shaft clearance	0.035 - 0.053 (0.0014 - 0.0021)	0.06 (0.0024)	
Differential side gear-to-pinion backlash		0.02 - 0.20 (0.0008 - 0.0079)	—	
Shift fork	Fork tip end section thickness	7.0 (0.276)	6.3 (0.248)	
	Shift inner lever contact groove width	12.1 - 12.2 (0.476 - 0.480)	12.7 (0.500)	
	Reverse shift arm pin contact groove width	14.957 - 15.000 (0.5889 - 0.5906)	15.100 (0.5945)	
Reverse shift arm	Pin diameter	14.907 - 14.950 (0.5869 - 0.5886)	14.850 (0.5845)	
	Tip end section width	7.884 - 7.920 (0.3104 - 0.3118)	7.900 (0.3071)	

WR 11005

AUTOMATIC TRANSMISSION

Item		Specified value	Allowable limit	Remarks
Stall revolution speed	rpm	2100 - 2300	—	
Time lag N→D	second	1.0 or less	—	
Time lag N→R	second	1.4 or less	—	
Line pressure (at 2000rpm)	kg/cm ² (psi)	7 - 8 (100 - 114)	—	'L', 'D' and 'R' line pressure of each range

WR 11005

APPENDIX

AUTOMATIC TRANSMISSION (Cont'd)

Unit: mm (inch)

Position & Item		Specified value	Allowable limit	Remarks
Oil pump	Side clearance	0.02 - 0.05 (0.0008 - 0.0019)	0.1 (0.0039)	
	Body clearance	0.07 - 0.15 (0.0028 - 0.0059)	0.30 (0.011)	
	Tip clearance	0.11 - 0.14 (0.0043 - 0.0055)	0.30 (0.011)	
Clutch & Brake	2nd brake piston stroke	1.5 - 3.0 (0.059 - 0.118)	—	
	Direct clutch clearance	0.89 - 1.46 (0.035 - 0.057)	—	
	Forward clutch clearance	0.41 - 1.08 (0.016 - 0.043)	—	
	1st & reverse brake clearance	0.58 - 1.92 (0.023 - 0.075)	—	
Gear	Counter gear backlash	0.1 or less (0.0039)	0.1 or less (0.0039)	
Input shaft	End play	0.3 - 0.9 (0.012 - 0.035)	—	
Planetary gear	Side clearance	0.20 - 0.50 (0.0079 - 0.020)	0.7 (0.028)	
Drive plate	Drive plate runout	—	0.2 (0.008)	
Clutch	Clutch disc thickness	2.5 (0.098)	2.3 (0.091)	
	Clutch plate thickness	1.6 (0.063)	—	

WR-110-3

STEERING

Item		Specified value	Allowable limit	Remarks	
Front wheel alignment	Camber	$0^{\circ}20' \pm 2^{\circ}$ $\begin{matrix} +40' \\ -20' \end{matrix}$	Pos. —	Difference between RH & LH — 1°	
	Caster	$2^{\circ}55' \pm 1^{\circ}$	Pos. —	Difference between RH & LH — 1°	
	Kingpin inclination angle	$12^{\circ}00' \pm 30'$	—	Difference between RH & LH — 1°	
	Turning angle	Inner	$39^{\circ}55' \pm 2^{\circ}$	—	Difference between RH & LH — 2°
		Outer	$35^{\circ}00' \pm 2^{\circ}$	—	Difference between RH & LH — 2°
	Toe-in	mm (inch) -1 - +3 (-0.039 - +0.118)	Pos. — + - 2mm		
	Sideslip	mm (inch) -3 - +3 (-0.118 - +0.118)	—		
Rear wheel alignment	Camber	$-0^{\circ}40' \pm 35'$	—		
	Toe-in	mm (inch) 5 (0.197) ± 3	—		
	Sideslip	mm (inch) +1 - +7 (-0.039 - +0.276)	—		
Steering wheel play		mm (inch) Within 10 (0.39)	—		

WR-10-1

BRAKE PEDAL

Item		Specified value	Allowable limit	Remarks
Brake pedal mm (inch)	Free travel	6-inch booster	3 - 7 (0.1 - 0.3)	When engine is stopped
		7-inch booster	0.5 - 2 (0.02 - 0.08)	
	Height	176 - 181 (6.93 - 7.13)	—	
	Reserve travel	Not less than 102 (4.0)	—	Distance between center of pedal pad upper sur- face and dash panel

MR-11010

FRONT BRAKE

Item		Specified value	Allowable limit	Remarks
Wheel cylinder inner diameter or caliper bore mm (inch)	General specifications mounted with Type CB-23, CL-11, 61 engines	48.1 (1.89)	—	
	Except for vehicles above	50.8 (2.0)	—	
Pad thickness	mm (inch)	10 (0.394)	1 (0.039)	Effective disc diameter: 179 (7.05)
		9 (0.354)	1 (0.039)	Effective disc diameter: 189 (7.44)
Disc mm (inch)	Thickness	Solid type	11 (0.433)	10 (0.394)
		Ventilated type	16 (0.709)	17 (0.669)

MR-11013

REAR BRAKE

Item		Specified value	Allowable limit	Remarks	
Wheel cylinder inner diameter	mm (inch)	15.67 (0.62)	—	General specifications mounted with Type CB-23, CL-11, 61 engines	
		17.46 (0.69)	—	Except for vehicles above	
Brake drum inner diameter	mm (inch)	180 (7.09)	181 (7.126)		
Brake lining thickness	mm (inch)	4.0 (0.16)	1.0 (0.039)		
Disc brake	Wheel cylinder inner diameter	mm (inch)	30.16 (1.187)	—	
	Pad thickness	mm (inch)	9 (0.35)	1 (0.039)	Effective disc diameter: 202 (7.95)
	Thickness	mm (inch)	10 (0.39)	9 (0.354)	
Disc	Runout	mm (inch)	—	0.08 (0.003)	Position 108 mm from center
Parking brake lever working travel	Notch	5 - 9	—	Pulling force: 20 kg	

MR-11014

APPENDIX

SUSPENSION

Item				Specified value	Allowable limit	Remarks
Free length of front coil spring mm (inch)	Standard and European standard	CB-23	M/T	339 (13.3)	—	Identification color: White
		CB-23	A/T	346 (13.7)	—	identification color: Brown
		CL-11	V/T			
	Hard	CL-61	M/T	358 (14.1)	—	Identification color: Green
		CB-61	M/T	326 (12.8)	—	identification color: Pink
		CB-80	M/T	338 (13.3)	—	Identification color: Red
Free length of rear coil spring mm (inch)	Standard		331 (13.0)	—	Identification color: Green	
	European standard		331 (13.0)	—	Identification color: Yellow	
	Hard		331 (13.0)	—	Identification color: Red	

WR-1-015









TIGHTENING TORQUE FOR MAIN COMPONENTS

- When you want to find out a suitable tightening torque for a bolt, first determine the strength division of the said bolt, using the table below. Then, locate suitable tightening torque in the tightening torque table described later.
- As for the tightening torque for a nut, find out suitable tightening torque in the same way as with the paragraph 1 above, based on the mating bolt.
- Tightening torque posted in the workshop manual is a standard value for steel fasteners. It is, therefore, necessary to modify these tightening torque when you tighten fasteners made of materials other than steel. This rule also applies to such instances where bolts are undergoing heat or other stress, such as vibratory loads and so forth.

WT-19025

METHOD TO IDENTIFY STRENGTH DIVISION OF BOLTS

1. Identification Method by Checking Bolts Themselves

	Configuration and how to determine strength division	Strength division		Configuration and how to determine strength division	Strength division	
Hexagon bolt	 Bolt having an embossed or stamped figure at its head section	4 = 4T 5 = 5T 6 = 6T 7 = 7T	Welded bolt		4T	
	 No mark	4T				No mark
	 Bolt having two embossed lines at its head section	5T 6T	Stud bolt		Bolt having about 2 mm. deep recess at one end or both ends	6T
	 Bolt having three embossed lines at its head section	7T				

WT-19026

2. Identification Method by Part Numbers

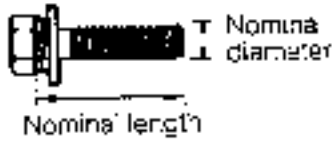
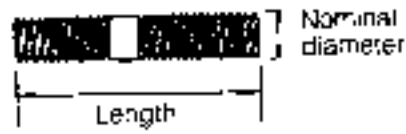
<p>Hexagon Bolt</p> <p>Part number example: 9 1 1 1 1 - 4 0 6 2 0</p> <p style="margin-left: 100px;"> ┌─── Nominal length (mm) └─── Nominal diameter (mm) └─── Strength division </p> 	<p>Stud Bolt</p> <p>Part number example: 9 2 1 3 2 - 4 0 6 2 0</p> <p style="margin-left: 100px;"> ┌─── Nominal length (mm) └─── Nominal diameter (mm) └─── Strength division </p> 
--	--

APPENDIX

[Tightening Torque Table for General Standard Bolts]

Category	Nominal diameter	Pitch	Standard tightening torque kg-m (ft-lb)	
			Standard torque	Tightening range
4T (Bolt having a mark of "4" at its head section) Example of part number (910000 - 400000)	6	1	0.47 (3.4)	0.4 - 0.7 (2.9 - 5.1)
	8	1.25	1.11 (8.0)	1.0 - 1.6 (7.2 - 11.6)
	10	1.25	2.25 (16.3)	1.9 - 3.1 (14 - 22.5)
	10	1.5	2.4 (15.5)	1.8 - 3.0 (13 - 22)
	12	1.25 (ISO)	4.40 (31.8)	3.5 - 5.5 (25 - 40)
	12	1.5	3.89 (28.1)	3.5 - 5.5 (25 - 40)
	12	1.75	3.74 (27.1)	3.0 - 5.0 (22 - 36)
	13	1.5	5.08 (36.7)	4.5 - 7.0 (33 - 51)
	14	1.5	6.33 (45.8)	5.0 - 8.0 (36 - 58)
	14	2	5.93 (42.9)	4.7 - 7.7 (34 - 56)
5T (Bolt having a mark of "5" at its head section) Example of part number (910000 - 500000)	6	1	0.71 (5.1)	0.6 - 0.9 (4.3 - 6.5)
	8	1.25	1.66 (12.0)	1.5 - 2.2 (11 - 16)
	10	1.25	3.37 (24.4)	3.0 - 4.5 (22 - 33)
	10	1.5	3.20 (23.1)	2.7 - 4.2 (19.5 - 30.5)
	12	1.25 (ISO)	5.84 (42.2)	5.0 - 7.0 (36 - 51)
	12	1.5	5.84 (42.2)	5.0 - 7.0 (36 - 51)
	12	1.75	5.60 (40.5)	4.8 - 6.8 (34 - 49)
	13	1.5	7.63 (55.2)	6.5 - 9.0 (47 - 65)
	14	1.5	9.50 (68.7)	7.5 - 11.0 (54 - 79.5)
	14	2	8.90 (64.4)	7.0 - 10.5 (51 - 76)
6T (Bolt having a mark of "6" at its head section) Example of part number (910000 - 600000)	6	1	0.71 (5.1)	0.6 - 0.9 (4.3 - 6.5)
	8	1.25	1.66 (12.0)	1.5 - 2.2 (11 - 16)
	10	1.25	3.37 (24.4)	3.0 - 4.5 (22 - 33)
	10	1.5	3.20 (23.1)	2.7 - 4.2 (19.5 - 30.5)
	12	1.25 (ISO)	5.84 (42.2)	5.0 - 7.0 (36 - 51)
	12	1.75	5.84 (42.2)	5.0 - 7.0 (36 - 51)
7T (Bolt having a mark of "7" at its head section) Example of part number (910000 - 700000)	6	1	0.95 (6.87)	0.8 - 1.2 (5.8 - 8.7)
	8	1.25	2.20 (15.9)	2.0 - 3.0 (14.5 - 22)
	10	1.25	4.50 (32.5)	4.0 - 5.5 (29 - 40)
	10	1.5	4.30 (31.1)	3.7 - 5.2 (27 - 38)
	12	1.25 (ISO)	7.78 (56.3)	7.0 - 9.0 (51 - 65)
	12	1.5	7.78 (56.3)	7.0 - 9.0 (51 - 65)
	12	1.75	7.48 (54.1)	6.0 - 8.5 (43 - 61.5)
	13	1.5	10.17 (73.6)	8.0 - 12.0 (58 - 88)
	14	1.5	12.67 (91.6)	10.0 - 15.0 (72 - 108)
	14	2	11.86 (85.8)	9.5 - 14.0 (69 - 101)
16	1.5	19.15 (138.5)	15.0 - 23.0 (108 - 166)	
16	2	18.11 (131.0)	14.9 - 22.0 (108 - 159)	

WT-13029

Unit: kg-m (ft-lb)

CLUTCH, MANUAL TRANSMISSION

Tightening component	Tightening torque
Transmission x Cylinder block	5.0 - 7.0 (36 - 51)
Output shaft hexagon nut	10.0 - 14.0 (72 - 101)
Input shaft hexagon nut	10.0 - 14.0 (72 - 101)
Transmission case x Clutch housing	1.5 - 2.2 (11 - 16)
Transmission case cover x Case	1.5 - 2.2 (11 - 16)
Drain plug	3.0 - 5.0 (22 - 36)
Back-up lamp switch	3.0 - 5.0 (22 - 36)
Speedometer sleeve lock plate	0.7 - 1.0 (5.1 - 7.2)
Breather plug	1.0 - 1.3 (7.2 - 9.4)
Differential ring gear	4.5 - 5.5 (33 - 39)
Clutch cover	0.7 - 1.0 (5.1 - 7.2)
Clutch release lever x Pre-engage lever yoke	3.0 - 4.0 (22 - 29)
Shift & selector shaft x Shift inner lever	Bolt 4.0 - 5.0 (29 - 36) Nut 2.0 - 3.0 (14.5 - 22)
Shift & selector shaft x Transmission case	2.0 - 3.0 (14.5 - 22)
Differential case x Differential ring gear	8.0 - 9.0 (58 - 65)

WR-1018

AUTOMATIC TRANSMISSION

Unit: kg-m (ft-lb)

Tightening component	Tightening torque
Transmission case x Torque converter housing	1.8 - 2.3 (12 - 16)
Transmission case x Oil pan	0.4 - 0.6 (3.0 - 4.3)
Transmission case x Oil filler tube	0.3 - 0.7 (2.4 - 5.1)
Transmission case x Valve body A ₁	0.80 - 1.20 (6.0 - 8.5)
Transmission case x Side cover	0.7 - 0.9 (5.1 - 6.5)
Transmission case x Rear cover	Bolt 1.6 - 2.3 (12 - 16)
Transmission case x Rear cover	Nut 1.1 - 1.5 (8 - 10)
Transmission case x Oil pump A ₁	1.8 - 2.7 (14 - 19)
Transmission case x Neutral start switch	1.5 - 2.3 (12 - 16)
Transmission case x Test plug	0.6 - 0.9 (4.3 - 6.5)
Transmission case x Lower left mounting bracket	3.0 - 4.5 (22 - 33)
Valve body x Valve body cover	0.5 - 0.6 (3.6 - 4.3)
Valve body x Throttle valve cam	0.6 - 0.9 (4.3 - 6.5)
Valve body x Solenoid A ₁	0.64 - 0.96 (4.6 - 6.9)
Valve body x Oil strainer	0.4 - 0.6 (3.0 - 4.3)
Upper valve body x Lower valve body	0.50 - 0.60 (3.6 - 4.3)
Oil pan x Drain bolt (plug)	1.8 - 2.3 (13 - 17)
Oil pump body x Stator shaft	0.8 - 1.2 (6.0 - 8.5)
Torque converter x Drive plate	1.5 - 2.2 (11 - 16)
Torque converter housing x Cylinder block	5.0 - 7.0 (36 - 51)
Manual shift shaft x Manual valve outer lever	2.7 - 3.3 (20 - 24)
Reduction driven gear x Counter shaft	11 - 15 (80 - 108)

WR-1017

APPENDIX**DRIVE SHAFT, FRONT SUSPENSION**

Unit: kg-m (ft-lb)

Tightening component	Tightening torque
Lower arm bracket x Body	7.5 - 10.5 (54 - 76)
Lower arm x Lower arm bracket	7.0 - 10.3 (51 - 72)
Stabilizer bracket x Front stabilizer lower bracket	4.0 - 6.0 (29 - 43)
Lower arm x Stabilizer	7.5 - 10.5 (54 - 76)
Lower arm ball joint x Steering knuckle	8.0 - 10.5 (58 - 76)
Front shock absorber piston rod x Suspension support	3.5 - 5.5 (25 - 40)
Suspension support x Body	2.0 - 3.0 (14.5 - 22)
Front shock absorber x Steering knuckle	9.0 - 13.0 (65 - 94)
Drive shaft x Front axle hub	18.0 - 23.0 (130 - 166)
Disc wheel x Front axle hub	8.0 - 12.0 (65 - 87)
Front drive bearing shaft x Bracket	3.0 - 4.5 (22 - 32)

WR-1015

REAR AXLE, REAR SUSPENSION

Unit: kg-m (ft-lb)

Tightening Component	Tightening torque
Rear stabilizer x Stabilizer link	1.0 - 1.6 (7.2 - 11.6)
Stabilizer bracket x Rear suspension arm	1.0 - 1.6 (7.2 - 11.6)
Stabilizer bracket x Stabilizer bracket No.2	1.9 - 3.1 (14 - 22)
Rear suspension arm No.1 x Body	7.5 - 10.5 (54 - 76)
Rear suspension arm No.1 x Rear axle carrier	7.5 - 10.5 (54 - 76)
Rear suspension arm No.2 x Body	7.1 - 8.8 (51 - 64)
Rear suspension arm No.2 x Rear axle carrier	7.5 - 10.5 (54 - 76)
Rear strut rod x Body	7.5 - 10.5 (54 - 76)
Rear strut rod x Rear axle carrier	7.5 - 10.5 (54 - 76)
Rear axle carrier x Rear shock absorber	9.0 - 12.0 (65 - 87)
Suspension support x Body	1.0 - 1.6 (7.2 - 11.6)
Rear axle shaft x Brake drum (disc)	6.0 - 10.0 (43 - 72)
Rear brake hub x Disc wheel	8.0 - 12.0 (65 - 87)
Rear axle carrier x Rear brake backing plate	4.0 - 5.5 (29 - 40)

WR-1019

STEERING

Unit: kg-m (ft-lb)

Tightening component	Tightening torque
Steering wheel x Steering main shaft	3.5 - 5.5 (25 - 40)
Steering column tube x steering joint dust cover x Body	0.4 - 0.7 (2.9 - 5.0)
Steering rack end x Tie rod end	3.0 - 5.2 (22 - 38)
Steering rack housing x Rack guide lock nut	3.5 - 4.5 (25 - 32.5)
Steering rack housing x Body	4.0 - 5.5 (29 - 40)
Tie rod end x Steering knuckle	3.0 - 4.5 (22 - 32.5)
Steering rack end x Steering rack	5.0 - 6.5 (36 - 47)

WR-11-020

BRAKE

Unit: kg-m (ft-lb)

Tightening component	Tightening torque
Master cylinder x Brake booster	1.2 - 1.8 (8.7 - 13.0)
Brake booster x Body x Pedal support	1.0 - 1.6 (7.2 - 11.6)
Disc brake caliper x Knuckle	3.2 - 4.2 (23 - 30)
Caliper x Bleeder plug	0.7 - 1.0 (5.1 - 7.2)
Rear wheel cylinder Backing plate	1.0 - 1.3 (7.2 - 9.4)
Rear wheel cylinder x Bleeder plug	0.7 - 1.0 (5.1 - 7.2)
Brake tube each union nut	1.5 - 1.8 (9.4 - 13.0)

BODY AND OTHERS

Unit: kg-m (ft-lb)

Tightening component	Tightening torque
Back door hinge x Body	2.5 - 3.0 (18 - 22)
Back door stay x Quarter panel	1.8 - 2.3 (13 - 16.6)
Back door stay x Back door	1.6 - 2.3 (11.6 - 16.6)
Engine lower mounting x Body	1.2 - 2.2 (8.7 - 16)
Exhaust manifold x Exhaust front pipe	3.0 - 5.0 (22 - 36)
Exhaust front pipe x Exhaust tail pipe	3.0 - 5.0 (22 - 36)

WR-11-021

APPENDIX

WIRING DIAGRAM SYSTEM INDEX

SYSTEMS	LOCATION		SYSTEMS	LOCATION	
	TYPE CB E/G	TYPE CL E/G		TYPE CB E/G	TYPE CL E/G
Air Conditioner	1-5	1-3	Luggage Room Lamp	3-6	3-4
Alternator & Regulator	1-2	1-1	Light-on-Warning Buzzer	3-5	3-3
Automatic Transmission ECU	4-2	—	Power Window	2-6	2-4
Battery	1-1	1-1	Preheating Timer	—	1-2
Central Door Lock	2-7	2-4	Radiator Fan Motor	1-6	1-4
Cigar Lighter	2-5	2-3	Radio	2-5	2-2
Clock	2-5	2-2	Rear Window Defogger	3-6	3-4
Combination Meter	3-2	2-6	Rear Wiper & Washer	3-7	3-6
Daylight Relay	2-3	2-1	Room Lamp	3-5	3-3
Dim-dip Relay	2-4	1-7	Side Lamp	2-1	1-5
Distributor	1-1	—	Sun Roof	3-1	2-5
EFL ECU (CB-80)	4-5	—	Starter	1-1	1-1
Electronic Door Mirror	2-5	2-3	Stop Lamp	3-6	3-4
Fuel Pump (Turbo)	1-3	—	Turn Signal & Hazard Lamp	3-4	3-1
Front Wiper & Washer	3-7	3-5			
Glow Plug	—	1-2			
Headlamp	2-3	1-7, 2-1			
Headlamp Cleaner	3-7	3-5			
Heater	1-7	1-5			
Horn	3-5	3-2			
Ignition Coil	1-1, 4-3	—			

1986-08002