



ISTRUZIONI
PER L'USO E LA MANUTENZIONE
DELLA VETTURA

OFFICINE ALFIERI MASERATI S.P.A.
MODENA (ITALIA)
VIALE CIRO MENOTTI, 322
TEL. 30-101



I N T R O D U C T I O N

This manual contains a brief description of the principal data relating to the car, and information concerning its normal use and maintenance.

To obtain the best possible results from the car, we strongly recommend that users should follow our instructions. For all servicing and repairs, we advise clients, in their own interest to apply to our distributors or agents who will arrange for the efficient, speedy and accurate execution of all servicing and repairs.

WHEN ORDERING SPARE PARTS, PLEASE STATE CHASSIS AND ENGINE NUMBERS.

IDENTIFICATION NUMBERS OF CAR

A special identification number is marked on each car:

A M 101 IS ☆ 10 ☆

This number is stamped on the left hand side of the crossmember, between the Company's star symbol.

Engines are numbered consecutively and the engine number is stamped on the clutch bell housing, opposite the starter motor. For ease of reference, these numbers are given also on a Maserati plate which is fixed inside the engine compartment. These are the only marks used for the identification of the car for purpose of sale, and as required by law. They are also indicated in the certificate of origin and in the log book.

SPECIFICATION AND GENERAL DATAENGINE

Number of cylinders	6
Bore and stroke	86 x 100 mm
Swept volume of single cylinder.....	580,88 c.c.
Total cylinder capacity.....	3485,29 c.c.
B.H.P. 5500 r.p.m.	235 h.p.
Tax rating	33 h.p.

Light alloy cylinder block with special inset cast iron liners.
Light alloy cylinder head with overhead valves and hemispherical combustion chambers.
Dynamically and statically balanced seven bearing crankshaft with lead indium shells.
Cast steel 'H' section connecting rods with lead indium small end bearings, and bronze bushes in the big ends.
Light alloy pistons with two compression rings and two scraper rings. Fully-dampened flywheel on crankshaft.
Light alloy inlet manifold with water circulation for preheating of mixture.

VALVE TIMING

Inclined overhead valves operated by two overhead camshafts, with triplex chain drive, equipped with chain tensioner. The camshafts control the valves direct through cast iron tappets. The valves are adjusted by means of casehardened steel pads.

Valve clearance is 0,12 mm for inlet, with tappet resting on heel of cam and 0,20 mm for exhaust. Measurements to be taken with cold engine.

Inlet valve lift at T.D.C. 1,5 mm
Exhaust valve lift at T.D.C. 1,2 mm

FUEL SYSTEM (INJECTION TYPE)

The LUCAS equipment used, with indirect injection into the inlet manifolds, comprises a petrol pump, distributor and governor.

CHOKE

To facilitate starting the engine when cold, and especially during the Winter, an additional quantity of petrol and air must be supplied to allow the engine to warm up smoothly. This is controlled by the choke which increases the volume to three times that of the normal supply.
The driver should gradually reduce the richness of this mixture by progressively using less choke until the engine is at running temperature.

MASERATI



AUTOMOBILI
MODENA

TYPE: SEBRING 3700

Cylinders	6
Bore and stroke	86 x 106 mm
Swept volume of single cylinder	615 cmc.
Total cylinder capacity	3692 cmc.
B. H. P. 5500 r.p.n.	245 CV
Tax rating	36 CV

Fuel consumption: 15 liter x 100 Km.

The car marked with identification number:

AM 101 S ☆ ☆



Fig. 1

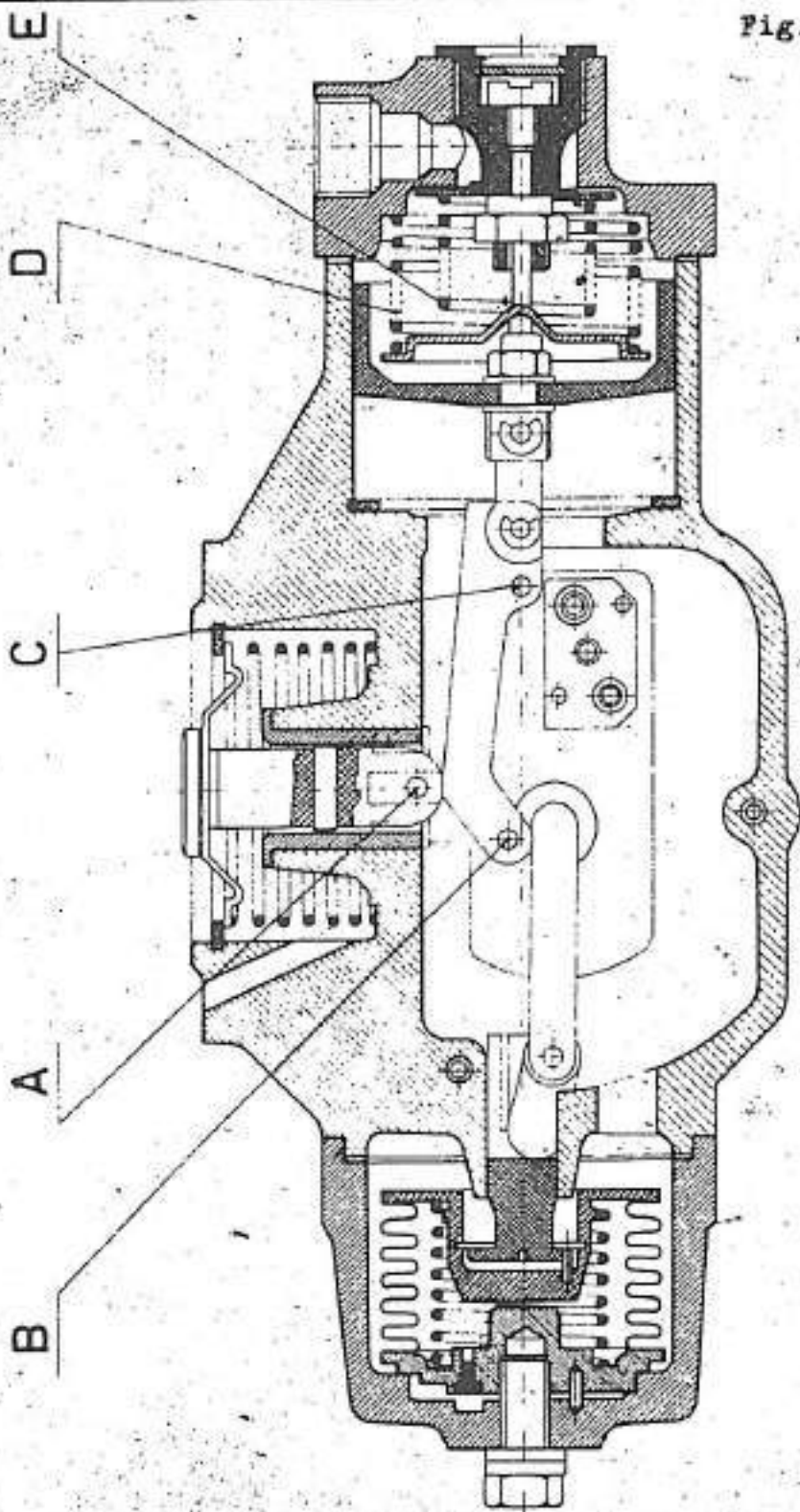
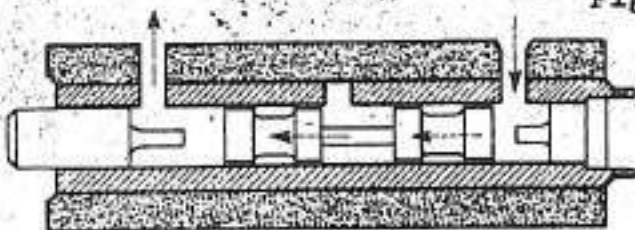

Fig. 2





LUBRICATION

Pressurised lubrication of all main parts of the engine is by a pump mounted direct into the crankshaft.

The pump draws the oil via a filter from the engine sump, and conveys it to the assemblies to be lubricated. The two oil filters are housed in an oil cooler, in which cold water from the radiator and the oil to be filtered circulate through copper ducts.

The oil cooler serves a dual purpose:

- 1) It heats the oil when cold by using the water which bypassing the thermostat, does not pass through the radiator.
- 2) It reduces the temperature of the oil when hot by using the cooled water from the radiator.

The filter is on the right hand side of the sump and it can be removed from underneath the car.

The normal oil pressure is 3 to 5 Kg / sq cm. This pressure, is governed by a control valve mounted on the filter housing itself.

The oil filler is on the cylinder head.

The oil level can be checked by means of the dipstick situated on the left hand side of the sump, below the exhaust manifold. The capacity of the sump is 16 pints.

COOLING SYSTEM

The engine is cooled by the circulation of water. The circulation is controlled by a centrifugal pump and fan of the electromagnetic type, with operation controlled by thermostat on the radiator. The fan operates above a temperature of 75°/85°. The flow of water through the radiator is also regulated by means of a thermostat mounted in the cylinder head. This device facilitates the heating of the engine, specially when starting from cold. A water temperature gauge is situated on the instrument panel.

The temperature of the water must not exceed 90°.

The drain tap will be found beneath the radiator.

The total quantity of cooling water is approximately 25 pints.

IGNITION

Ignition is by a distributor situated at the front of the engine, on the left hand side. It is controlled by a helical gear coupling and it is battery-fed.

Marelli S 109 A 12 V. 15° Distributor with automatic advance. Left hand rotation, as viewed from above.



Static advance = 8°
 Range of automatic advance to 30° (on the crankshaft)
 Max. total ignition advance to 38° (on the crankshaft)
 Order of ignition : 1 - 5 - 3 - 6 - 2 - 4
 Contact breaker gap = .0016"
 Sparking plugs gap = .0020"
 Diameter and pitch of long reach plugs : 14 x 1,25 M
 MARELLI coils N° 2 type B Z R 201 A

Sparking plugs for normal use : BOSCH KE 4189 B
 BOSCH W 215 P21
 LODGE H L N
 CHAMPION N 6 Y
 MARELLI CW 240 L

Sparking plugs for heavy duty : BOSCH W 235 P21
 BOSCH WG 235 T
 LODGE 3 HLN
 CHAMPION N 60 Y
 MARELLI CW 230 LPS

ENGINE MOUNTING

The engine is offset at an angle of 4° in relation to the chassis, with a displacement of 37 mm. to the right and it rests on 4 silentblocs, two for the engine and two for the gear box.
 longitudinal inclination = $3^{\circ} 30'$

CLUTCH

Flexible single dry plate , with hydraulic control by two pumps one on the pedal $\varnothing 3/4"$ and the other on the clutch $\varnothing 7/8"$.
 The pedal travel is regulated by a nut on the receiving pump.

GEAR BOX

Five forward speeds and reverse. Synchromesh on all forward gears. Gears in constant engagement. Direct control lever mounted on the centre of gear box. To check the oil level in the gear box a long pipe arrive under bonnet. The disptich, that is not signed, must touch oil only at the end.

GEAR RATIOS (S5 20)

1st ratio	0,347	=	3,00
2nd "	0,586	=	1,705
3rd "	0,806	=	1,24
4th "	1	=	1
5th overdrive	1,18	=	0,85
REVERSE	0,315	=	3,17

REAR AXLE

Rigid rear axle with hypoid bevel coupling.

Standard reduction ratio	:	13/49	=	3,77	=	0,265
This may be substituted by	:	13/46	=	3,54	=	0,280
"	:	13/43	=	3,31	=	0,302
"	:	11/45	=	4,09	=	0,244

The rear axle is connected to the chassis by semi elliptic springs.

CHASSIS

Main dimensions:

Track width, at ground level	front:	55 inches
Track width, at ground level	rear :	53 1/2 inches
Wheelbase		99 inches
Weight of car, unloaded (approx)		28 cwt.

The chassis, which is exceptionally strong, consists of box section side-members and cross-members and tubular crosspieces.

FRONT SUSPENSION

Upper and lower links, adjustable type with large coil springs and telescopic shock-absorbers. Anti roll bar.

REAR SUSPENSION

Semi elliptic springs with telescopic shock-absorbers and anti roll bar.

STEERING

The steering, which is adjustable, is mounted on ballbearings. Flexibly-coupled steering wheel to eliminate vibration. Steering rode symmetrical with steering box assembly. The position of the steering wheel is adjustable on splines, controlled by a small hand wheel.

B R A K E S

Dual hydraulic braking system, with servo assistance. Braking of front wheels entirely independent of that of rear wheels by two Girling vacuum-type units.

The front brakes are of the Girling disc type, diam. 12"; friction surface 310 sq. ins.

The rear brakes are also of the Girling disc type, \varnothing 291 mm. 11 1/4" with friction surface of 248 sq. ins.

Adjustment of clearance (due to wear of brake linings) is automatic. The handbrake operates on the rear wheels only and is a mechanical system.

W H E E L S

Disc type 600 x 16" locked by 4 nuts.
On request spoke type.

F R O N T A L I G N M E N T

The toe-in of the wheels, measured on the rims at the height of the hubs, is 4 mm. (3/16").

The camber, in the straight ahead position, is 1°

The inclination of the plane in which the wheels act as springs, in the vertical-transversal plane, or angle of incidence of the pins is 2° (Caster).

The transversal inclination king pin angle (seen from the front of the pins) is 7° 30'.

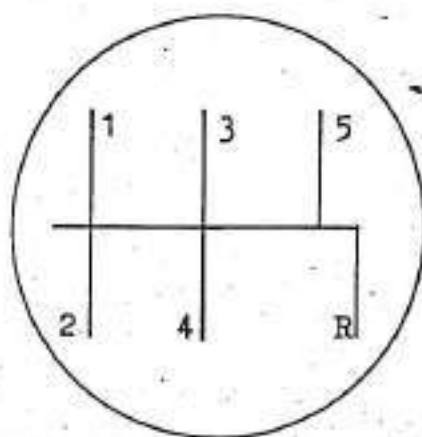

Position of gears in box: 35 20

TYRES

Front and rear: Pirelli

TYRE PRESSURE (cold):

Recommended tyre pressure
for normal touring:

Front	31 p.s.i.
Rear	33 p.s.i.

Tyre pressure for high speed
driving (over 100 m.p.h.)

Front	35 p.s.i.
Rear	38 p.s.i.

PETROL TANKS

Two tanks, situated at the sides of the car at the rear. Connected by a 1 3/16" tube below for transfer of the petrol, and a 9/16" tube above to balance the pressure.

ELECTRICAL INSTALLATION

Battery: Behind left hand seat and easily accessible for inspection.

Capacity: 62 amp/hour. Voltage 12 V.

Alternator: Bosch type, with mechanical voltage regulator. Situated on left hand side of engine and controlled by drive shaft with adjustable V-belt.

Normal rating 400 watts. Direction of rotation as seen from driver's seat: right hand.

Starter motor: Marelli type SM 271 A 1,3 h.p.

Horn: The Fiamm pneumatic horns with electric compressor type MC/1 and horns TA/2 with pushbutton control in centre of steering wheel.

Fuses: The 12 fuses of the electrical installation are grouped together on a square fuse board under the instrument panel, on the right hand side.



Normal axle ratio $13/49 = 0,265 - 3,77$
Tyres - 185 x 16" average circumference 83 inches

SPEED - MILES/h (with gear box S5 20)

Engine revs.	1st Gear 3	2nd Gear 1,705	3rd Gear 1,24	4th Gear 1	5th Gear 0,85
1000	7	12,3	16,9	21	24,7
1500	10	18,5	25	31	36
2000	14	23	34	42	49
2500	18	31	42	52	61
3000	21	37	51	63	72
3500	25	43	59	73	85
4000	28 45	49 78	68 109	84 134	99 148
4500	32	55	76	94	110 176
5000	35	62	84	105	121 194
5500	39	68	93	115	133 219
6000	42 67	74	101	126	144 230

At high speed the above specifications are to be multiplied by the tyre expansion coefficient which is caused by the centrifugal force.

4000

FUEL SUPPLIES LUBRICATION: CONSUMPTION AND SPECIFICATION

Normal fuel consumption (according to Cuna Standard) 20.2 miles per gallon.

The driver is advised never to exceed 6000 r.p.m.

Autonomy: 281 miles.

ITEM CAPACITIES

REMARKS

Petrol tank	Gallons 15	SUPERCORTE MAGGIORE N.° 98/100 S.R.
Cooling system	Gallons 3.0	Distilled water if possible
Engine sump	Gallons 2	Winter / AGIP F 1 RACING SAE 30 Summer / AGIP F 1 RACING SAE 50
Gear box	2 Pints	AGIP F 1 ROTRA HYPOID SAE 90
Differential	2 1/2 pints	AGIP F 1 ROTRA HYPOID SAE 140
Differential	2 1/2 pints	AGIP F 1 ROTRA HYPOID SAE 90 for temperature below 17 F.
Steering box		AGIP F 1 ROTRA SAE 250
Brake fluid		CASTROL GIRLING BRAKE FLUID AMBER
Clutch		LOCKHEED HYDRAULIC HEAVY DUTY
Bushes & bearings		AGIP GRASSO 951 or AGIP F 1 GREASE 30
Steering joints		AGIP F 1 GREASE 15



90

250



140

LUBRICATION SCHEME SYMBOL FOR TABLE X

AGIP F 1 RACING SAE 30 : Winter
AGIP F 1 RACING SAE 50 : Summer

AGIP F 1 ROTRA HYPOID SAE 90

AGIP F 1 ROTRA SAE 250

AGIP GRASSO 951 or AGIP F 1 GREASE 30

AGIP F 1 GREASE 15

AGIP F 1 ROTRA HYPOID SAE 140

In Countries where AGIP F 1 RACING SAE 30 and SAE 50 are not available use AGIP F 1 MOTOR HD SAE 40 and SAE 50, taking care to change oil and filter element for the first time after not more than 500 miles.



DIAGRAM SHOWING LUBRICATION POINTS

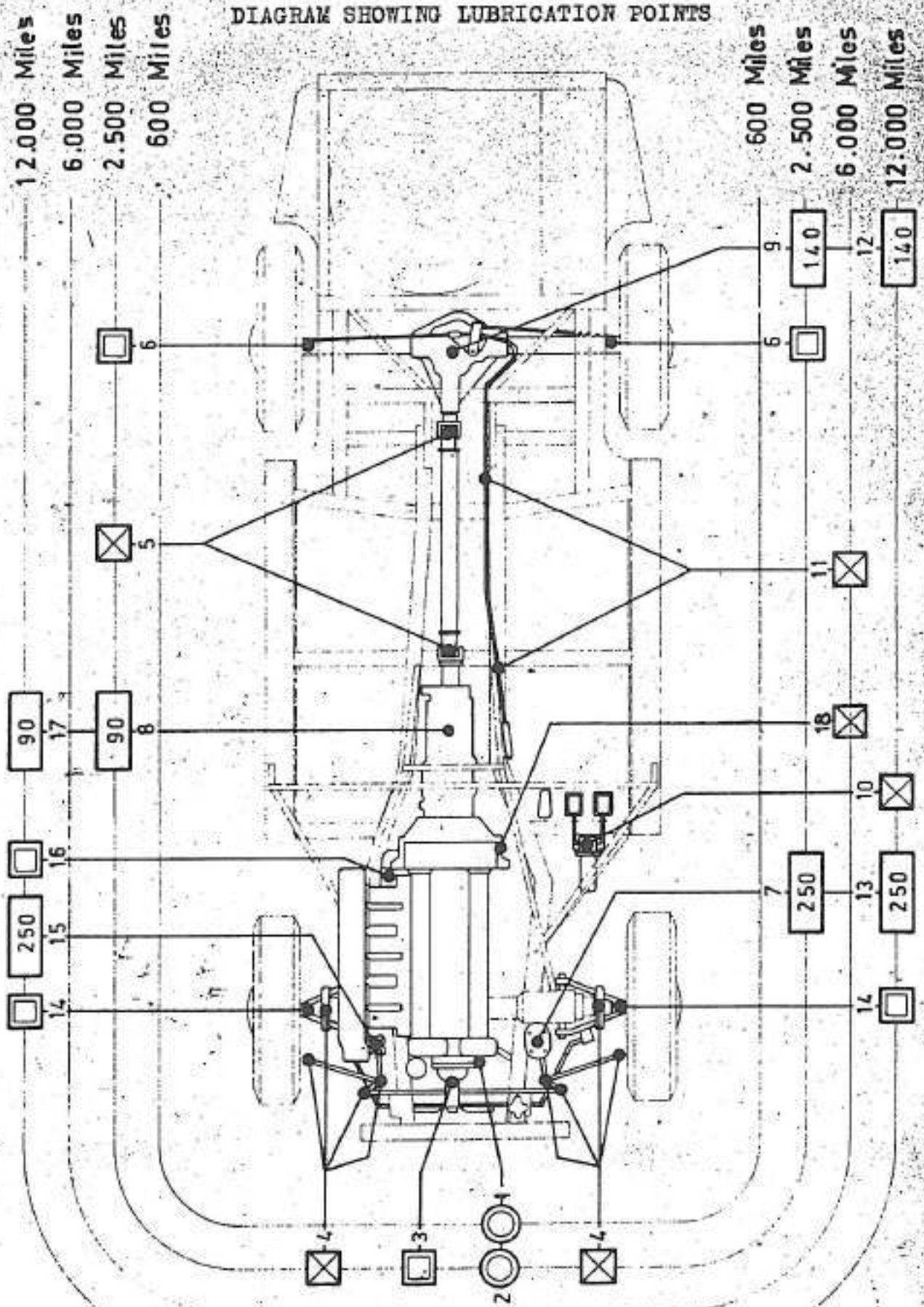

POSITION INDICATED ON LUBRICATION CHART

- | | | |
|-----|----|-------------------------|
| No. | 1 | Engine |
| | 2 | Engine |
| | 3 | Water pump |
| | 4 | Steering and suspension |
| | 5 | Universal joints |
| | 6 | Axle shafts |
| | 7 | Steering box |
| | 8 | Gear box |
| | 9 | Differential housing |
| | 10 | Pedals |
| | 11 | Handbrake |
| | 12 | Rear axle |
| | 13 | Steering box |
| | 14 | Front hubs |
| | 15 | Steering arms |
| | 16 | Starter motor |
| | 17 | Gear box |
| | 18 | Thrust clutch shaft |

STANDARD EQUIPMENT SUPPLIED

The tool bag supplied with the car contains:

- 1 Jack for raising the car
- 1 Jack support arm
- 1 Set of fixed 6/22 mm. spanners
- 1 Plug spanner
- 1 Monkey wrench
- 1 Carburettor spanner
- 1 Wheel spanner
- 1 Steel hammer
- 1 Pair universal pliers
- 1 Screwdriver



INSTRUMENT PANEL

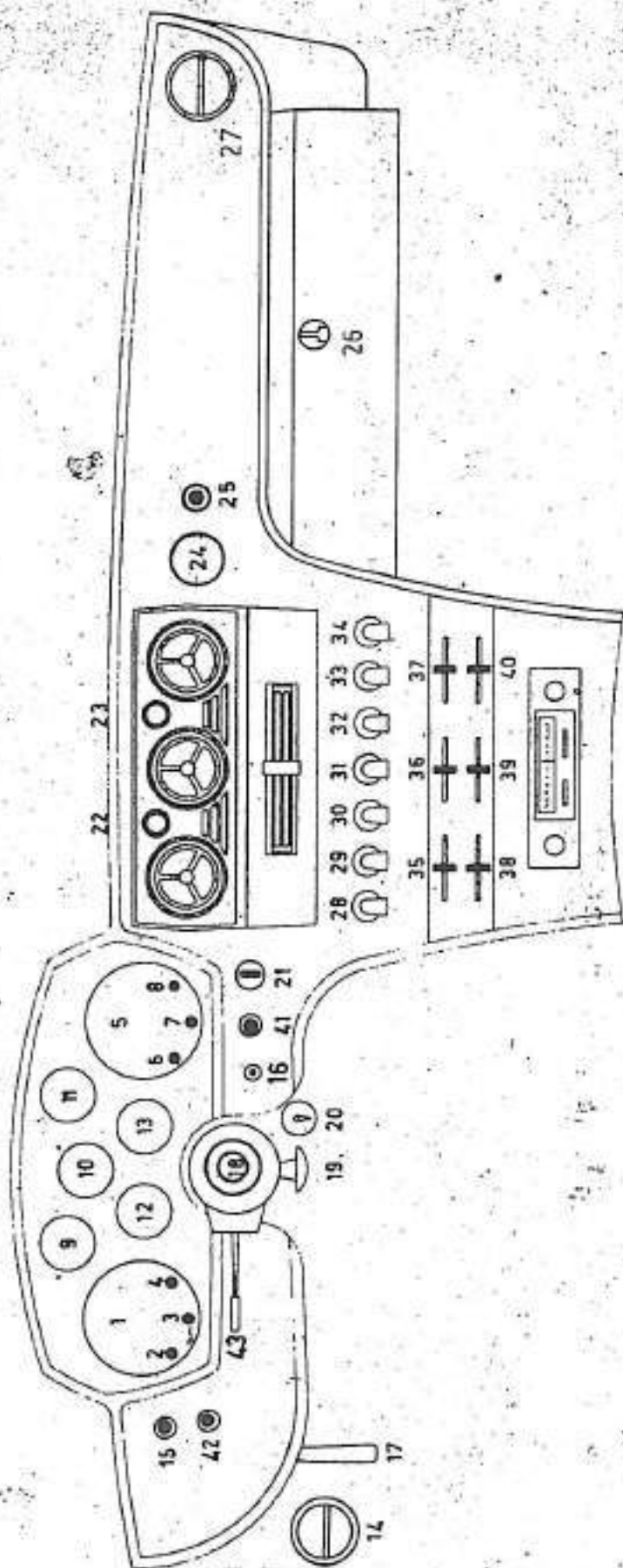

DASHBOARD INSTRUMENTS

- 1 Revolution counter
- 2 Main beam warning light
- 3 Flasher indicators warning light
- 4 Sidelights warning light
- 5 Mile counter
- 6 Warning light cooling fan left side.
- 7 Starter warning light
- 8 Warning light cooling fan right side
- 9 Water temperature indicator
- 10 Oil pressure gauge
- 11 Oil temperature gauge
- 12 Fuel gauge
- 13 Ammeter
- 14 Left swiveling heating and ventilation control
- 15 Handbrake warning light
- 16 Trip counter zero setting
- 17 Bonnet release
- 18 Horn
- 19 Steering wheel adjusting
- 20 Anti theft device
- 21 Ignition and starting switch
- 22 Rheostat and conditioning system electric fan switch
- 23 Conditioning system thermostat
- 24 Watch
- 25 Cigar lighter
- 26 Glovebox
- 27 Right swiveling heating and ventilation control
- 28 Left hand fan switch
- 29 Windscreen wiper switch
- 30 Sidelight switch
- 31 Rear fan switch
- 32 Fog lamps switch
- 33 Instrument panel light switch
- 34 Right hand fan switch
- 35 Secondary valve control, conveying air to the radiator to heat left hand side (open when the control is moved to the right)
- 36 Hot water circulation (heating) control (open when the control is moved to the left)
- 37 Secondary valve control, conveying air to radiator to heat right hand side (open when the control is moved to the right)
- 38 Left trunk line main valve control (open when control is moved to the right)
- 39 Starter (open when the lever is to the right)
- 40 Right trunk line valve control (open when control is moved to the right)
- 41 Warning light alternator
- 42 Rear air fan warning light
- 43 Lights, direction lights, and clacson control



HEATING AND VENTILATION

As per table Fig.2 Pag 17 there is a double system, which can be operated independently on the driver's or on the passenger's side. Each side incorporates a lateral trunk pipe with front intake (1), a centrifugal fan (2), a radiator (3), a distributor (4), and a duct for the air inlet when the car is in motion.

VENTILATION SYSTEM

When the car is moving the air passes through main valve (5) and secondary valve (7) and enters the interior of the car through flaps (8) controlled under the dashboard.

In these circumstances a further amount of air enters the interior of the car through the electric fan and radiator. When the dynamic air pressure is not sufficient it is advisable to close the secondary valves to avoid circulation and to eliminate the electric fan.

HEATING SYSTEM

Hot water is admitted into the two radiators by a single tap (14) operated by a lever on the dashboard, at the same time opening the main valve closing the secondary valve. The volume of air passing through the radiator can be increased by switching on the electric fan.

DE-MISTING

The air outlets at the windscreen (9) are always open, and in order to obtain quick de-misting, flaps (8) should be closed and the heating turned on. The levers controlling the valves and the hot water circulation are as follows:

- No. 10 Left hand side main valve control (the valve is open when the lever is moved to the left).
- No. 11 Right hand side main valve control (the valve is open when the lever is moved to the left).
- No. 12 Left hand side secondary valve control (the valve is open when the lever is moved to the right).
- No. 13 Right hand side secondary valve control (the valve is open when the lever is moved to the right).
- No. 14 Hot water circulation control in the two radiators (water circulates when lever is moved to the left).
- No. 15 Left hand side electric fan control.
- No. 16 Right hand side electric fan control.

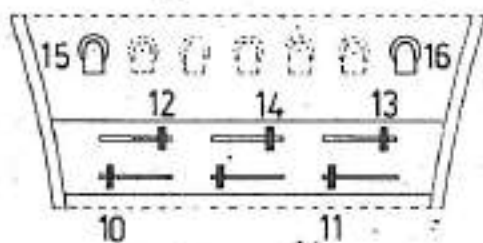
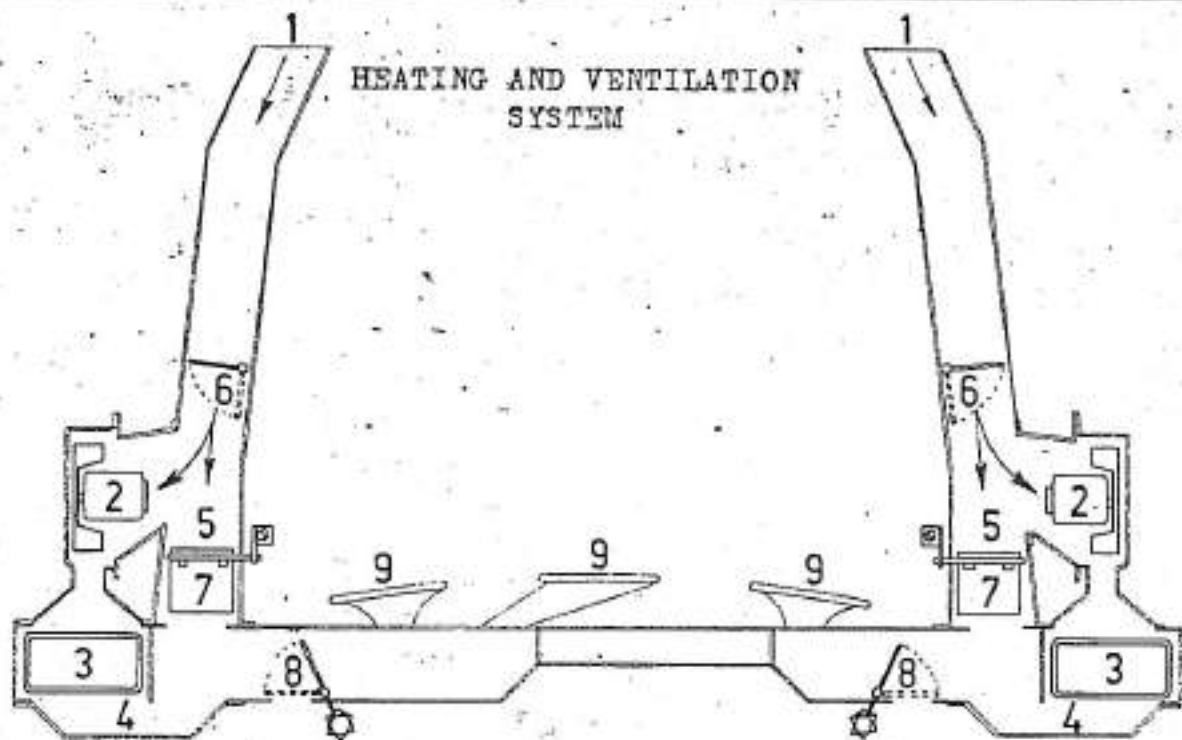

FULL VENTILATION WITHOUT FAN POSITION

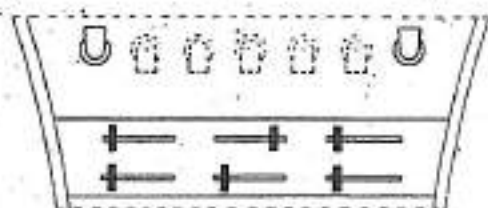

FULL VENTILATION WITH FAN POSITION

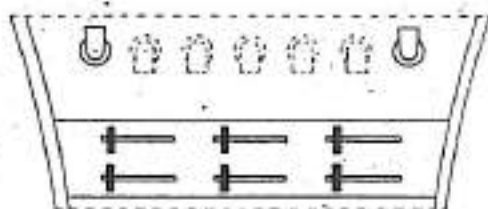

FULL VENTILATION WITH OR WITHOUT FAN POSITION

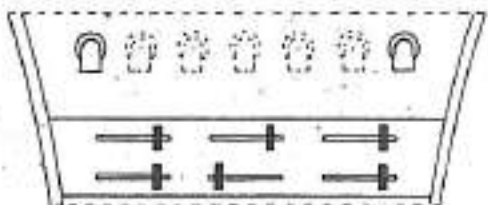

OFF POSITION



CONDITIONING SYSTEM

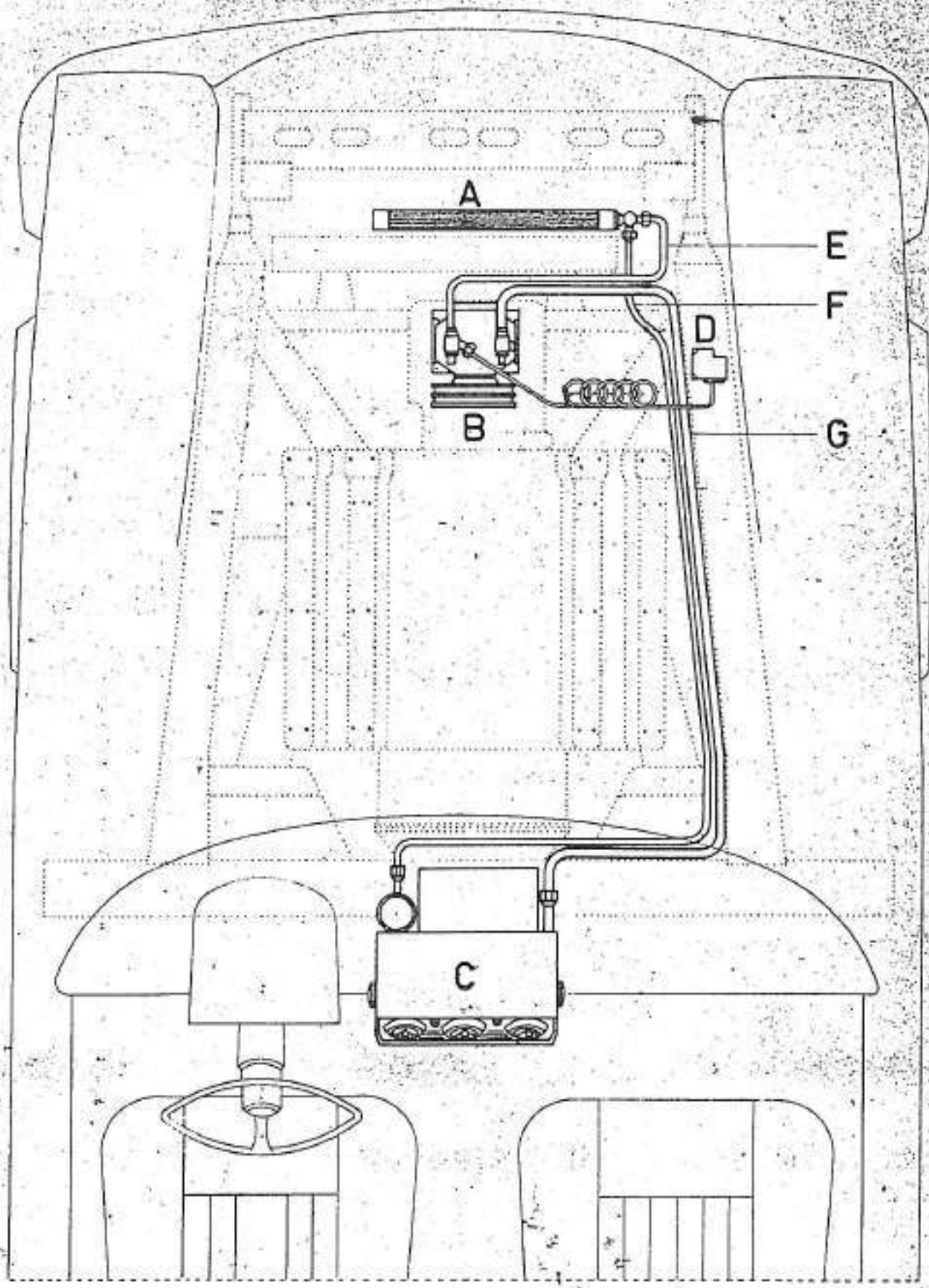

AIR CONDITIONING SYSTEM (ON REQUEST)

A very efficient air conditioning system enables one to obtain the desired climatic conditions, very quickly and irrespective of outside temperature.

Keeping the windows closed will prevent the entry of harmful fumes and will also keep out noise and draughts, making the journey safe and more pleasant.

This system consists of the following parts (See fig. 3 pag. 18):

- 1) Evaporator C consisting of the following: a finned radiator, generating cold by expansion of freon 12; a motor driving the air recirculation impellers; a thermostat automatically controlling the temperature and maintaining it at the desired level within a range of 14° C (from 16° C to 30° C); baffles, which direct the flow of air in the required direction. The air flow varies according to the speed of rotation of the motor, which can be manually controlled by knob (H) to turn between 500 and 5000 r.p.m.
- 2) Compressor B this is an open type unit capable of perfect operation at speed between 500 and 6000 r.p.m. The power required, and consequently the potentiality in refrigeration units, varie from 1/3 to 3 H.P. The compressor is driven by two "V" belts directly coupled to the crankshaft.
- 3) Electromagnetic coupling: engagement and disengagement of the compressor is automatically controlled by the thermostat which actuates an electromagnetic coupling between engine and compressor. The coupling electric absorption is 2,5 amps.
- 4) Condenser the unit consists of a copper coil with aluminium fins, and it is fitted in front of the water radiator. The air stream on the condenser provides the cooling and condensing of the freon gas.
- 5) Pressure switch D if, due to overwork or to the failure of the evaporator to operate, the compressor should cause the circuit pressure to be raised excessively, a pressure regulator will automatically disengage the compressor drive.

MAINTENANCE

The following is a list of the operations normally necessary for the proper maintenance of the car:

WEEKLY

- 1 Engine: Check oil level and top up if necessary
- 2 Radiator: Check water level and add, preferably distilled, water if necessary.
- 3 Tyres: Check pressure

After every 2,500 MILES, as above plus

- 4 Engine: Renew oil and filter element
- 5 Lubricate water pump
- 6 Lubricate front suspension joints
- 7 Lubricate universal joints
- 8 Lubricate steering and ball joints; check oil level in steering box.
- 9 Lubricate rear hubs
- 10 Check level of clutch fluid and top up if necessary
- 11 Check level of battery and add distilled water if necessary
- 12 Check level of brake fluid and top up if necessary
- 13 Clean sparking plugs: and check gap between points
- 14 Clean contact breaker points: and check clearance
- 15 Check tension of fan belts
- 16 Check tension of timing chain and adjust if necessary
- 17 Examine water pump seal: for possible leakage in gasket and renew, if necessary
- 18 Check clutch pedal clearance: make sure there is 3/8" free travel before pedal pressure.
- 19 Brakes: make visual check for wear
- 20 Steering box: check clearance

6,000 MILES all above plus

- 21 Change gear box oil
- 22 Change oil in rear axle
- 23 Check tappet clearances
- 24 Handbrake: lubricate the outer cable
- 25 Renew petrol filter elements in pump and filter at bottom of tank.
- 26 Thrust clutch shaft: lubricate

12,000 MILES all above plus

- 27 Steering box: change oil completely
- 28 Front hubs pack with grease
- 29 Renew oil filter in injection distributor

FURTHER INFORMATIONS CONCERNING THE FOLLOWING ADJUSTMENTS:8 - 15 - 16 - 18 - 19 - 25 - PROCEED AS FOLLOWS:

- 8 Steering: During the appropriate service a thorough examination should be made of the steering assembly including cleaning and lubricating the joints of the tie-rods and the main steering unit in the steering box
- 15 Dynamo belt: To adjust the belt, loosen the nut on the bracket holding the dynamo at the base and adjust the tension of the belt by altering the position of the alternator itself.
- 16 Timing chain: If after a certain time, it becomes necessary to tighten the chain, slacken the centre nut, remove the washer and shim beneath, using the extractor provided. Turn the pulley, and block it in required position by means of the shim and the two sets of holes. Then tighten washer and nut.
- 18 Clutch adjustment: The clearance between the clutch plate and disc must be approx $3/32$ ".
- 19 Disc brakes: Ensure that the surfaces of the disc are parallel to the inside face of the brake pads. A tolerance of a few hundredths of a millimetre only is permissible. The brake pads should be renewed every 12500 miles.
- 25 Petrol filters: It must not be overlooked that there are three filters in the petrol circuit.
- 1 Nylon filter in the lower part of the right hand tank
 - 2 A paper cartridge filter in the pump.
 - 3 A felt filter in the injection distributor.
- The wire gauze does not require renewal. The nylon filter should be examined and if necessary cleaned with petrol and after every 5,000 miles. The cartridges must be renewed, keeping the pump in a vertical position. (In addition to the cartridges, renew the sealing ring every 10,000 miles and the felt filter after every 15,000 miles).

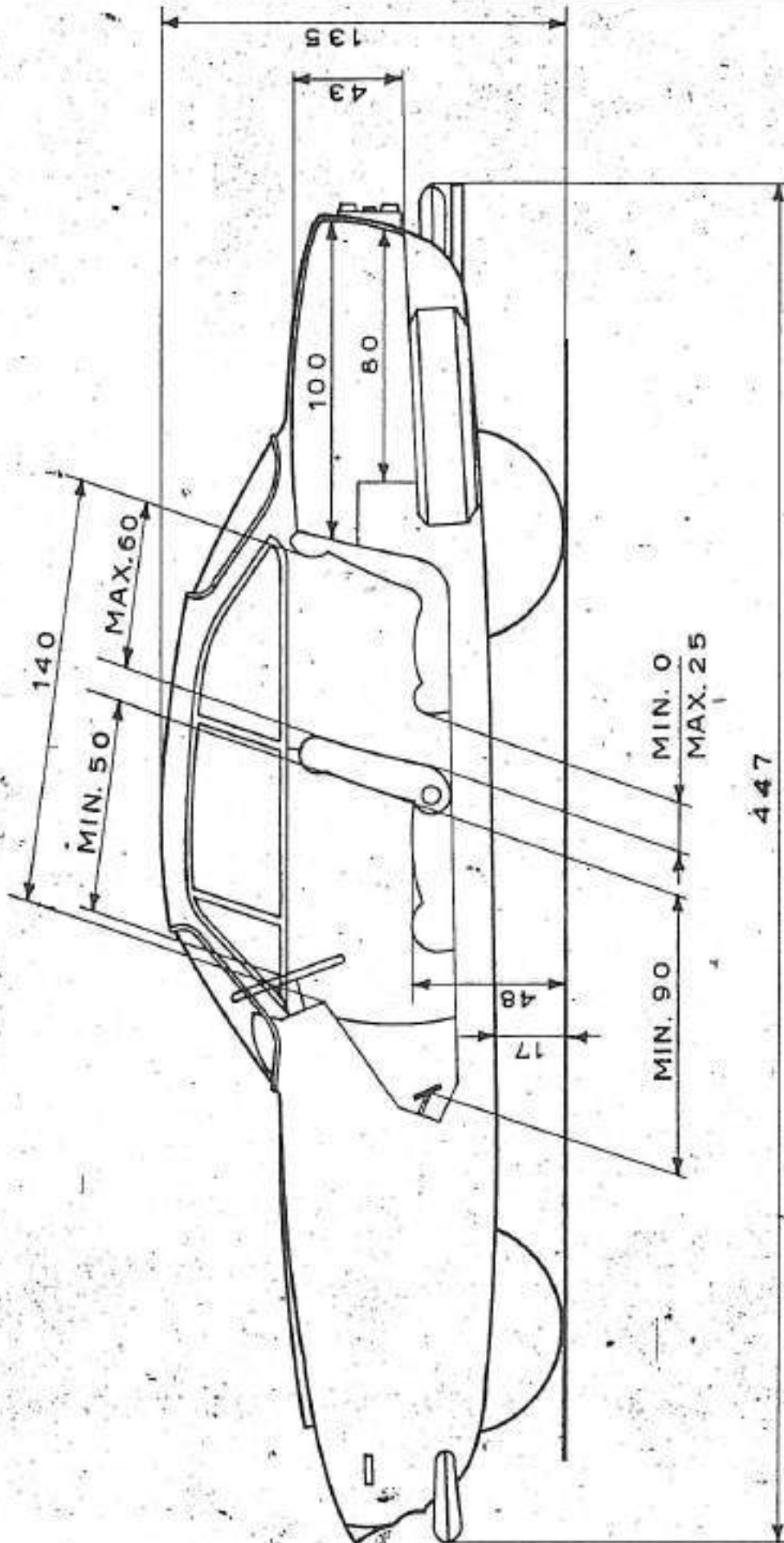



FUSE BOARD

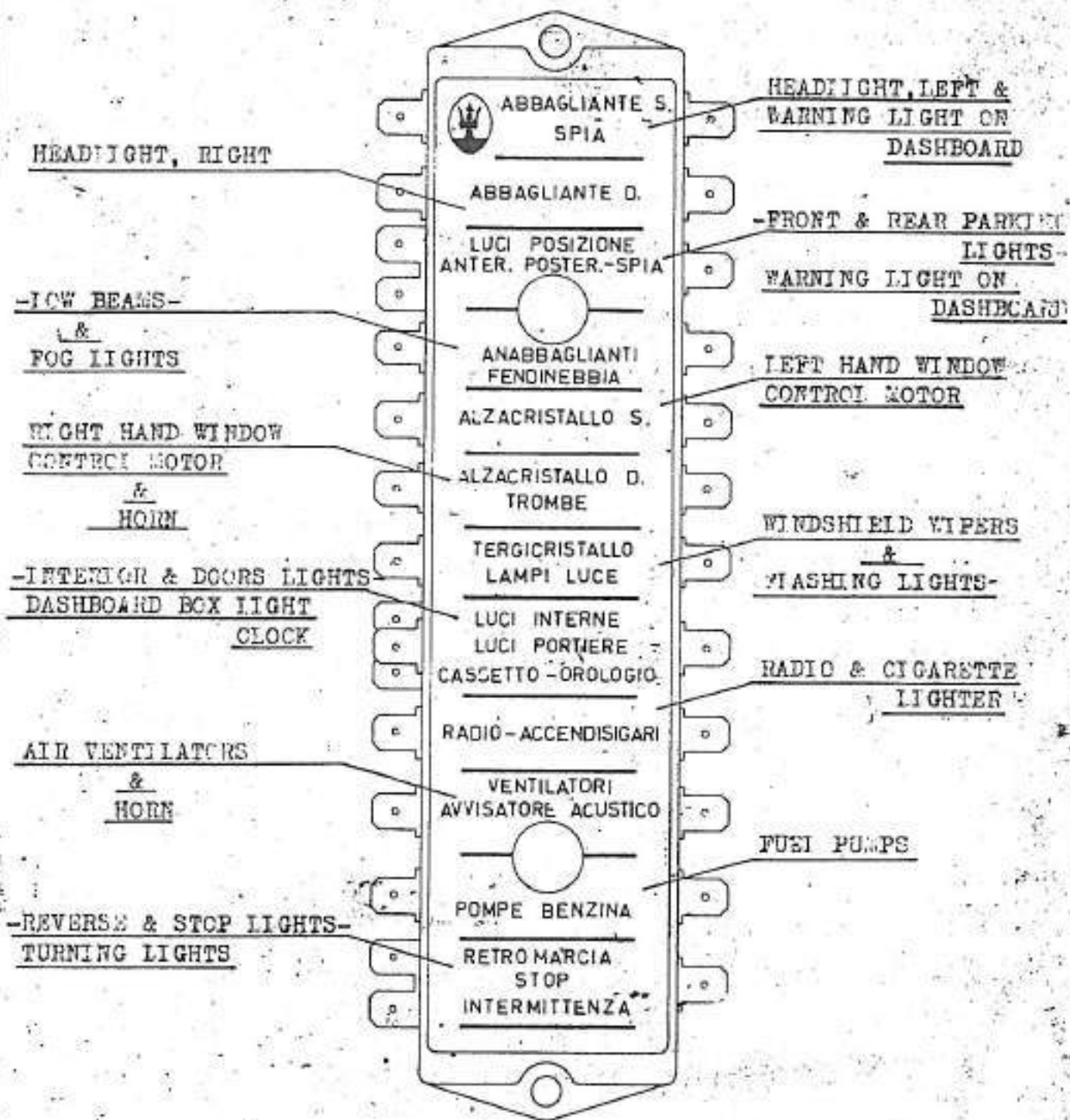

LIST OF ELECTRICAL COMPONENTS

- 1 Left headlamp- main beam and dipper
- 2 Left headlamp- main beam
- 3 Left fog lamp
- 4 Left side trafficator lamp
- 5 Right headlamp- main beam and dipper
- 6 Right headlamp- main beam
- 7 Right fog lamp
- 8 Right side trafficator lamp
- 9 Hydraulic switch for stop lights
- 10 Electric horns, diaphragm type
- 11 Pneumatic horns with electric compressor
- 12 Heater switch for control of electromagnetic fan
- 13 Generator alternator
- 14 Electromagnetic clutch for fan drive
- 15 Water temperature transmitter
- 16 Coilignition and distributor
- 17 Electromagnetic clutch - compressor control
- 18 Ignition coil
- 19 Ignition coil with circuit through revolutions counter
- 20 Oil temperature transmitter
- 21 Oil thermal pressure transmitter
- 22 Automatic aerial with electric motor incorporated
- 23 Bonnet lamp
- 24 Under bonnet
- 25 Windscreen wiper motor
- 26
- 27 Starter motor
- 28 Voltage regulator
- 29 Main connection - electrical installation
- 30 Petrol injection pump
- 31 Left heater fan
- 32 Right heater fan
- 33 Engine.
- 34 Fan and radiator, for air-conditioning installation
- 35 Voltage regulator for panel instruments
- 36 Red warning light for alternator control
- 37 Water temperature gauge
- 38 Oil pressure gauge
- 39 Oil temperature gauge
- 40 Yellow warning light for rear defroster motor
- 41 Red warning light "handbreke on"
- 42 Petrol level gauge
- 43 Ammeter
- 44 Revolution counter with:
 - a) Blue warning light for headlamps (main beam position)
 - b) Red warning light - direction indicator
 - c) Green warning light, for parking lamps



- 45 Speedometer with
 - a) Yellow warning lamp for left heater fan
 - b) Yellow warning light "handbrake on"
 - c) Yellow warning lamp for right heater fan
- 46 Left fan switch
- 47 Windsceen wiper control switch
- 48 Direction indicator switch
- 49 Rear defroster control switch
- 50 Change over switch between fog and dipper lamp
- 51 Instrument panel light control switch
- 52 Right fan switch
- 53
- 54 Pushbutton control "starter on"
- 55 Radio receiver
- 56 Aerial movement control
- 57
- 58
- 59 Horns - remote control
- 60 Direction indicator control switch
- 61 Front cigar lighter
- 62 Glove box light
- 63 Sliding contact controls for pneumatic horns
- 64 Headlamps and direction indicators controls
- 65 Starter and signal switch
- 66 Relay switch "main beam"
- 67 Pushbutton switch "handbrake on"
- 68 Reversing light switch
- 69 Fuse box
- 70 Lamp on front ash receptacle
- 71 Switch left door
- 72 Right window regulator switch at left side
- 73 Left window regulator switch
- 74 Left window regulator engine
- 75 Warning lamp on left door
- 76 Right door switch
- 77 Right door window regulator switch
- 78 Right door window regulator engine
- 79 Warning lamp on right door
- 80 Mirror lamp
- 81 Roof lamp on left side
- 82 Roof lamp on right side
- 83 Screw clamp for rear connection
- 84 Rear windshield defroster motor
- 85 Battery
- 86 Loudspeaker
- 87 Luggage boot light fitting
- 88 Pushbutton switch for luggage boot light
- 89 Petrol level indicator float



- 90 Left rear lamp (three lights):
 - a) Direction indicator
 - b) Parking and stop lights
 - c) Reversing lamp
- 91 Right rear lamps (three lights):
 - a) Direction indicator
 - b) Parking and stop lights
 - c) Reversing lamp
- 92 Number plate lights

ALFIERI MASERATI S.p.A. PLACE THEIR WORKS IN VIA CIRO MENOTTI 322, MODENA ENTIRELY AT THE DISPOSAL OF CLIENTS OR OTHERS WHO DESIRE TO HAVE FURTHER INFORMATION CONCERNING THE USE AND MAINTENANCE OF THE CAR AND THEY WILL BE PLEASED TO GIVE ALL POSSIBLE ASSISTANCE IN THIS CONNECTION TO OBTAIN THE BEST POSSIBLE PERFORMANCE AND ENSURE FULL SATISFACTION OF THE CLIENTS WHO USE THEIR VEHICLES.

Questo impianto vale con eliminazione apparato di controllo iniezione

VEETTURA TIPO .101/10

