

P R E F A C E

In this booklet we have briefly gathered the main principles covering this car, together with informations for the knowledge and for the normal operations of use and maintenance of the car.

In order to obtain the best results from the car as far as minimum cost, long life and best performance are concerned, one should bear in mind the suggestions given in this book.

For those operations and repairs not easily done with normal tools at one's disposal (supplied with an ordinary tool kit), as well for complete or partial overhauling, we suggest those Owners, in their own interest, to avail themselves of the services of our Agents who will look to the prompt, accurate and rational execution of any job of repair or overhauling.

All spare parts must be original for the best functioning results. Engine and chassis numbers must be given when ordering spares.

D A T A F O R I D E N T I F I C A T I O N O F A V E H I C L E

Each car is identified by special numbers, i.e.:

A M . 1 0 1 .  

The chassis serial number is stamped on the right hand side of the cross member and on both sides of this number appear the Maserati trade mark. The engine number is stamped on the clutch housing near the starting motor. These numbers, for easy reading, are repeated on two plaques mounted on the radiator shroud, and are the only ones suitable both for identification and sale of the car. They also appear on the certificate of origin and on the registration certificate.

S P E C I F I C A T I O N S

Number of cylinders	6	in line
Bore and stroke	(3.38x3.93 inch.)	86x100 mm.
Individual cylinder capacity (35.4 cu. inch.)	580.8	cc.
Total capacity (212 cu. inch.)	3485.29	cc.
Max. power at 5500 revs/min	36	CV.
Taxable power	33.80	CV.

Cylinder block is of light alloy with liners of special cast iron.

Cylinder head is made of a light alloy with overhead valves, in which the valve seats have been inserted.

Combustion chambers are hemispherical.



The crankshaft is dynamically balanced and is supported by seven lead-indium alloy bearings.

The conrods are made of forged steel in H section with the big-end bearing made of lead-indium alloy. The little end bearing is a bronze bush.

Pistons are made of light alloy with two compression rings and two oil rings.

Crankshaft has a torsional damper.

DISTRIBUTION

The inclined valves in the head are actuated by 2 overhead camshafts driven by a 3-cog chain. Valves are operated directly by the camshaft with the interposition of a small steel tappets operating in cast-iron seats. Valve clearance is by means of casehardened steel inserts, which may be easily replaced. The proper clearances (cold) between tappets and the base radius of the lobe of cam are 0.1 mm. inlet and 0.20 mm. exhaust.

This will give the following data:

lift of the inlet valve at top dead centre = 1 mm. (0.04 in).

lift of the exh. valve at top dead centre = 0.9 mm. (0.039 in)

INLET MANIFOLD

The inlet manifold is of light alloy and with a water jacket to warm up the mixture.

Petrol is pumped from the tank by means of two FISPA electric pumps. The tank is fitted with a float indicating the petrol level.

The petrol filter is situated on the right hand side and immediately in back of the electric pump and is fitted with an easily replaceable cartridge.

Carburation is by means of three twin Weber type 42DCOE3 with mechanical pump and starter.

Carburetors take in air through one larger filter fitted with a replaceable cartridge.

LUBRICATION

Lubrication is by forced circulation through all the main components of the engine, and is obtained by means of a rotor pump situated inside the sump. The pump sucks oil from the sump, passes it through a filter and then sends it to the components to be lubricated.

To ensure a low oil temperature a small helical pump, immersed in oil, and driven by a V belt circulates the oil through an oil radiator which is situated next to the water radiator.

The oil filter is located on the right side of the engine block and is desmontable from underneath the car.

The normal oil pressure from low to high revolutions is of 3 - 5 kilos per sq. cm. (80 - 100 lbs. per sq. inch.) This pressure is controlled by means of a pressure relief valve installed in the oil filter mounting. Oil is realaced through the pipe union situated on the front of the oil cylinder head.

The level is ascertained by means of a dipstick inserted in the pipe which is situated on the left hand of the sump under the exhaust manifold.

Oil capacity is approx. 9 liters - (2 gallons).

COOLING SYSTEM

Engine cooling is obtained by circulating water with a centrifugal pump and a fan driven directly from the engine shaft by means of a V belt of variable tension.

Water flow through the radiator is regulated by means of a thermostat situated on the cylinder head.

This thermostat facilitates the warming up of the engine especially when starting. The temperature of the water is measured by means of an indicator on the dash-board connected to a thermoelectric bulb, which is inserted into the upper part of the radiator.

The temperature of the water should not exceed 90° c. (190° F.).

The draining water tap is placed in the lower portion of the radiator. Radiator capacity is approx. 14 liters.

IGNITION SYSTEM

The distributor is situated on the front right hand side of the engine, driven by a pair of helicoidal gears and fed by a battery. The distributor is a MARELLI ST 111 DTEM KB. (DESTRO) with automatic advance.

The spark is set at 12° advance.

Range of automatic advance is 30°.

Max. Total advance of the coil ignition is 42°.

Firing order is 1 - 5 - 3 - 6 - 2 - 4.

The gap between the breaker points is 0.4 mm. (0.016 in). *at 30*

Gap between spark plug points is 0.5 mm. (0.02 in).

Diameter and gauge of the plugs are 14 x 11.25 mm.

MARELLI type SB 11 DT. coils.

Spark plugs for light duty:	Marelli	250 B
	Bosch	250 T2
	Lodge	2 HL or 3 HLN
	Campion	NA 10
	KLG	FE 80
	Marshal	34 HF

for heavy duty:

	Marelli	CBW 1000 B
	Bosch	270 T2
	Champion	NA 12
	Lodge	47 RL
	KLG	FE 250
	Marshal	33 HFS

STARTING

The starter motor is a MARELLI type MT 23 A CV 1,2.

Starter is operated by means of a key switch on the dashboard.

ENGINE MOUNTS

Engine has an inclination of 4° to the vertical-longitudinal plane, and is offset 38 mm. to the right-hand side.

Engine is mounted on 4 silentblocs.

SPINTEROSINO MARRELLI S. 111 D. I. E. M. - KG. METR. 892 (P. AUTOMAT.)

PER VERTICARE G. T. 3500 TIPO 101

DIREZIONE MA. ANTICIPA AUTOMATICA

ESCAVATIONS MA. 15°

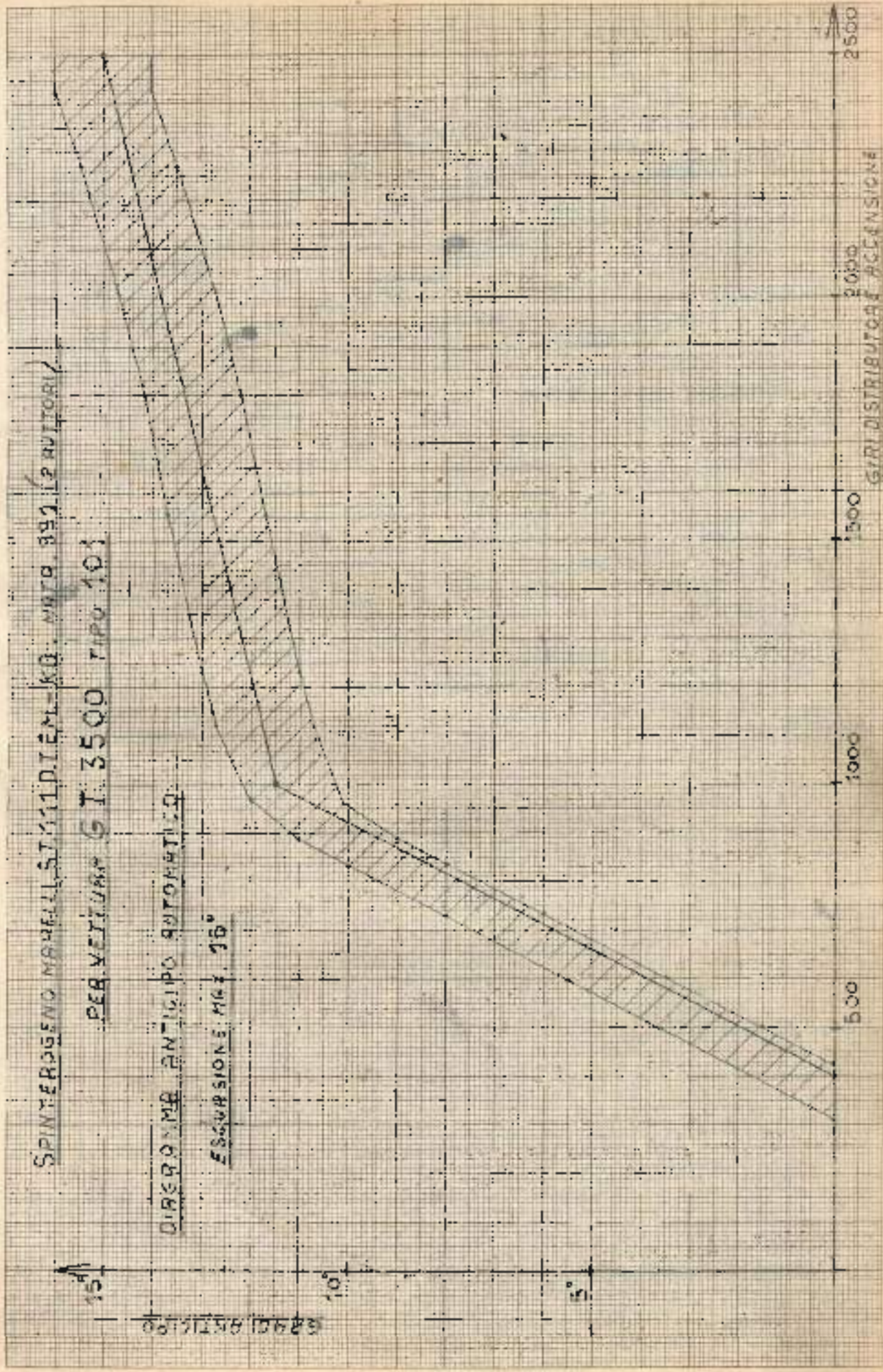

2500

2000

1500

1000

500

GIRI DISTRIBUTORI ACCENSIONE

15°

10°

5°

62901 ANTICIPA

TRANSMISSION

Clutch - The dray spring-loaded single-plate clutch is hydraulically operated by two little pumps: one is a 3/4" pump on the pedal and the other is a 7/8" pump on the clutch. The pedal travel is regulated by means of a screw nut situated on the strut of the inlet side of the pump.

Transmission

There are 4 forward speeds and a reverse ones.

There is synchromesh in all forward gears.

The gear lever is situated directly on the top centre of the gear box.

Gear ratios:	Normal
1 ratio	0.333
2 "	0.544
3. "	0.770
4. "	1.
reverse	0.315

AXLE

Rear axle is a rigid hypoid -type with two conical shafts.

The normal reduction ratio is:	13/46	=	3.54
It can be substituted by:	13/45	=	3.31
	13/49	=	3.77
	12/49	=	4.09

CHASSIS

Principal dimensions :

Front Tread	1380 mm. (54.3 in)
Rear "	1360 mm. (53.5 in)
Wheel base	2600 mm. (102 in.)
Min. heigh from ground	130 mm. (5.1 in.)
Weight of the empty car	1300 kilos (2750 lbs.)
Weight laden	1400 kilos (3100 lbs.)

The frame is exceptionally rigid and is made of longitudinal and transverse members, which are tubular and elliptical in shape. The size and strength of these members is proportional to the stress which they will undergo.

FRONT SUSPENSION

Front suspension is a quadrilateral transverse type with coil springs and with pivots acting on rubber suspensions. Telescopic shock absorber type GIRLING F. 4.5 or KONI 82.1019. There is a transverse stabilizer bar to counteract sway.

REAR SUSPENSION

Rear suspension is by cantilever leaf springs, with 2 Girling F 7,5 shock absorbers.

Koni 82-1145



There is a transverse stabilizer bar which steadies the car when cornering.

STEERING

The steering box is mounted on the left hand side and is of the type with variable play.

It is operated through a column with a flexible joint to dampen vibrations, and acts directly on the steering bars through a double lever.

The toe-in of the front wheels is between 5 and 6 mm. The min. turning radius is 6 meters (20 feet).

BRAKES

The brakes are hydraulic acting on all four wheels with disc brakes at the front and drum brakes at the rear. Rear drums measure 305x76 mm. (12" x 3").

The front brakes have an automatic adjustment while the rear brakes are adjusted by cams situated on the brake plate.

Clearance must be 0.3 mm. (0.012").

Rear brakes are also mechanically operated by means of a hand lever located under the dashboard.

The braking system is equipped with a vacuum control situated on the right hand side of the engine which reduces the foot pressure required on the brake pedal to a minimum.

A vacuum of approx. 280 mm. of mercury is obtained in the servo brake chamber by connecting this unit to the inlet manifold of the engine.

WHEELS

The wheel discs are 550 x 16, perforated and attached to the hub by means of 4 stud bolts.

TYRES

Front and rear: Pirelli 6.50 x 16" - Continental or Firestone 6.00x16

Pressure cold: front 1.7 kilos / sq. cm. (24 lb/sq.in)

rear 1.7 kilos / sq. cm. (24 lb/sq.in)

Pressure for sports use: front and rear 1.9 kilos: sq.cm.(27 lb/sq.in)

ELECTRICAL SYSTEM

Battery: The battery is located in the boot and is easily accessible.

Capacity: 64 Amp/h. - 12 volts

Type : Marelli - 6 VL 7

Generator: Marelli Y 44 A250W 120V type, with a voltage regulator.

It is situated on the left hand side of the engine and it is operated from the crankshaft through an adjustable V belt. Normal output 250 W. Rotation is to the right when viewed from the driving side.

Starting motor: Marelli type MT 23A 1,2 12D9.

LIGHTS

<u>No. of lights</u>	<u>Description</u>
2	Headlight reflectors with dual filament. Ducellier bulbs 36-45 W.
2	front lights (parking lights) with Svam. bilux 20/30 W. bulbs.
2	rear lights, 5 W. and elongated, for illuminating the number plate and boot.
2	stop lights with Svam 25 W. globes.
2	position and direction lights with Svam bilux 5/25 W. globes.
2	reverse lights with Svam 25 W. globes.
2	elongated ceiling lights - globe 5 W.
7	2.5 W. globes to illuminate the dashboard.
1	Warning light of 22.5 W. for town use.
1.	2.5 generator warning light
1	2.5 W. indicator light for direction.
1	5 W. elongated light for illumination of engine under the bonnet.
3	2.5 W. warning light for ventilation fans.
2	Ducellier bulbs 36 W. for fog lamps.

HORN

2 Electric Marelli Type Argento TT 11 Horns operated by means of a button in the centre of the steering wheel.

FUSES

The 12 electric fuses of the electrical system are located together on a small fuse board which, for sake of convenience, is situated under the dash-board on the right-hand side, easily accessible.

HEATING AND DEFROSTER

The car is equipped with complete ventilation and heating system which, besides improving the condition of the temperature into passenger's compartment, prevents at the same time the formation of frost on the windscreen.

The heater, which is illustrated in the annexed scheme, consists of the following parts:

- 1 - Warm water inlet in the radiator
- 2 - Throttle controlling cool air to passenger
- 3 - Cool air inlet to passenger's side
- 4 - Radiator group
- 5 - Regulator's control for water circulation
- 6 - Throttle's control and ventilator introducing air in the radiator.
- 7 - Throttle's control and ventilator on passenger's side



- 8 - Half throttle control and ventilator on driver's side.
- 9 - Radiator's door
- 10 - Water outlet from the radiator
- 11 - Throttle directing air flow to the radiator
- 12 - Air inlet on driver's up side
- 13 - Air inlet on driver's down side
- 14 - Throttle controlling air inlet on driver's up side
- 15 - Throttle controlling air inlet on driver's down side
- 16 - Air inlet to radiator with ventilator
- 17 - Air inlet on driver's side with ventilator
- 18 - Water return on motor pump intake
- 19 - Warm water inlet on the head of the engine
- 20 - Cool air inlet on driver's side with ventilator
- 21 - Regulator for warm water low
- 22 - Air switch on the front windscreen
- 23 - Air switch on the rear window
- 24 - Air inlet without ventilator motor

Working of the heater is based on introducing warm or cool air in the inside of driving compartment by means of conductors with frontal inlets (17 - 18 - 21) which are equipped with ventilator with an electrical motor, and by 25 without motor.

The radiator (4) through which air increase is thermic content, consists of a pipe installation where the warm water of the engine is circulated and is drawn out at warmest point (20) of the outlet nozzle from the head and is circulated again on the intake conductor of the motor's pump (19).

Circulation of warm water is obtained by means of the lever (5) on the control panel, which operates on a plug-governor (22). The auxiliary tap is near the water pump and must be closed in warm weather.

After a few minutes running of the engine, the water will be warm enough to be able to heat up the air which may then be introduced by opening the induction throttle (12) by means of the lever (6). On this inductor the ventilator is engaged by the same lever (6) at which time it actuates the automatic cutout.

The other two air inlets are (21-18) equipped with electric ventilator, which are operated by the levers (6-7) respectively which work on throttles (2 - 16).

Inlet (18) directs air on driver's feet by conductor (14) or by opening the throttle (15) by means of the lever (8).

The left hand ventilator is actuated by 50 W electric motor which extracts warm air from the engine compartment to the exterior via the left hand mudguard grille. This blower is started when lever 7 is depressed all the way down.

In other words the electrical ventilators (18-19-21) are respectively operated by the levers (8 - 6) when depressed to their lowermost position.

Their running is indicated by three pilot-lamps, placed on the dashboard in relation to each lever.

For greater security the three fans can only be operated when the cars' ignition switch is on.

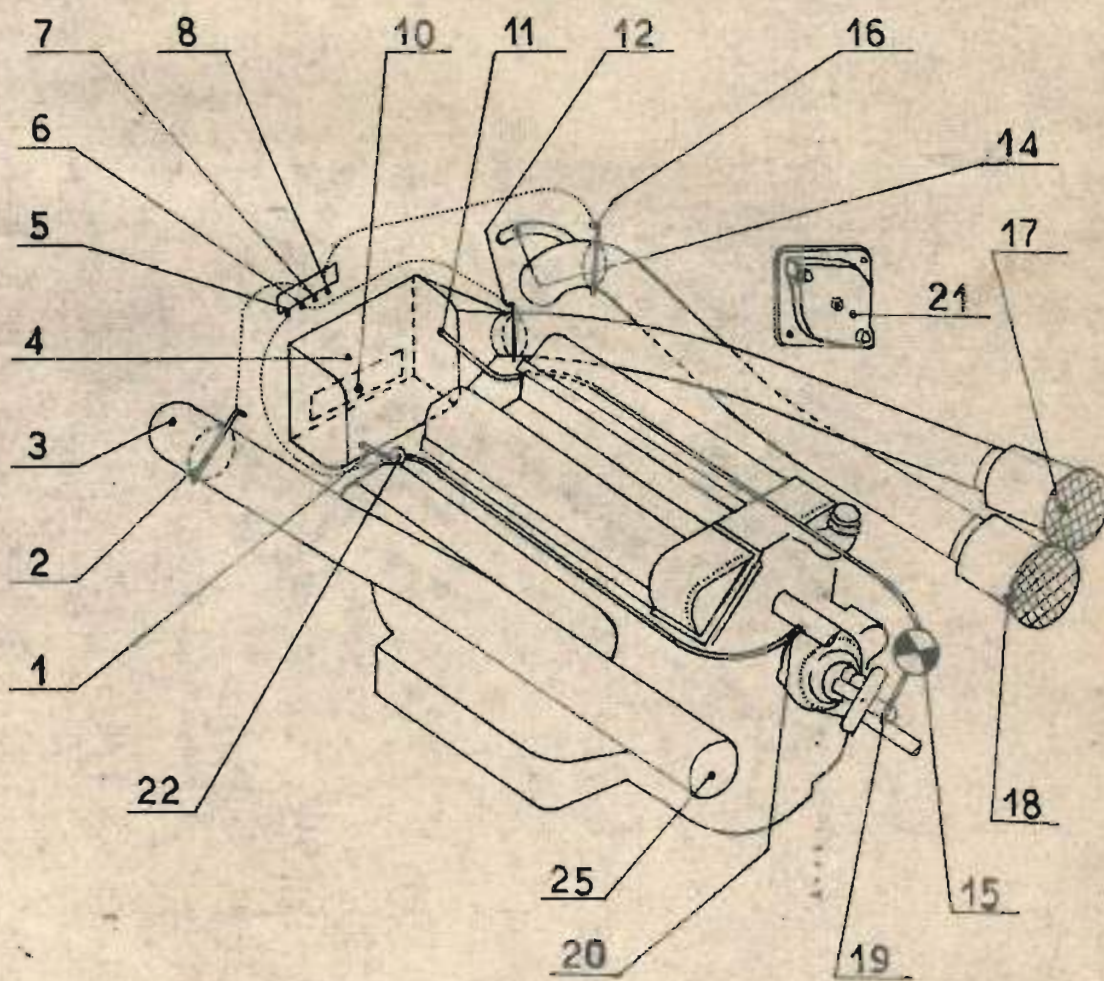
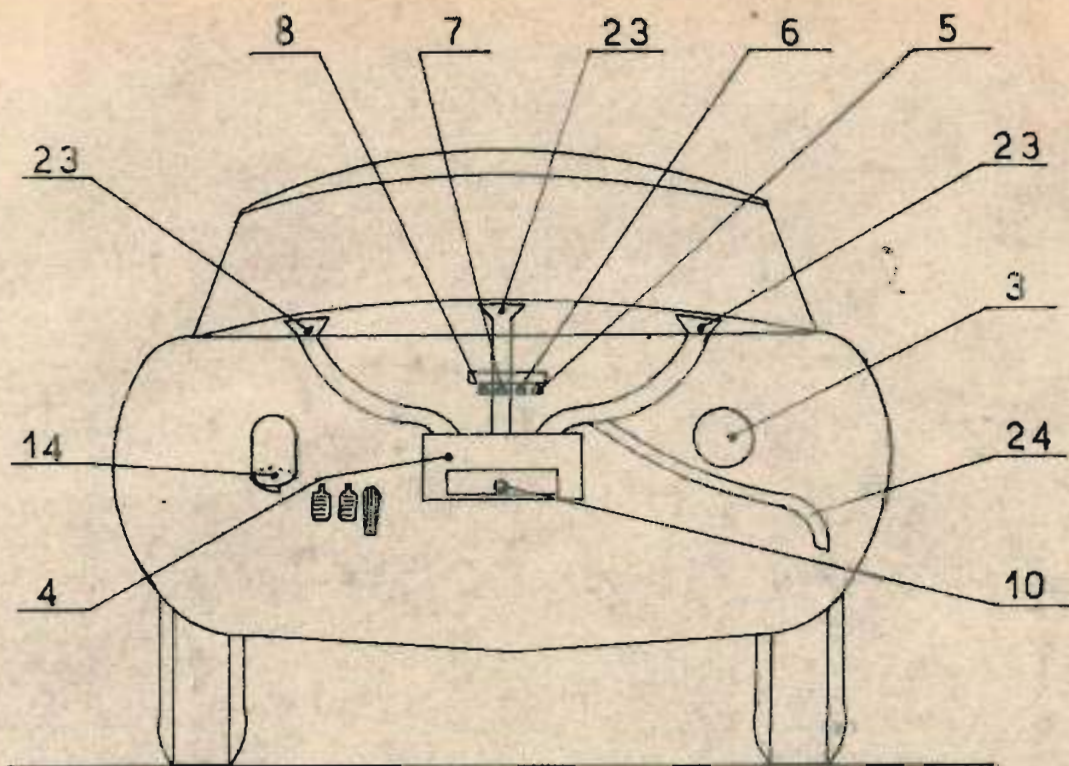

IMPIANTO VENTILAZIONE E RISCALDAMENTO TAV. V.

VEHICLES' SPECIFICATIONSAxle ratio $13/46 = 0.2825 = 3.54$

Tyres : 6.50 x 16" - average circumference 2.3 meters (90.5 in).

Speed - Kilometers/h.

<u>Engine revs.</u>	<u>1st gear</u>	<u>2nd gear</u>	<u>3rd gear</u>	<u>4th gear</u>
	0.333	0.544	0.770	1
1000	12.95	81.16	29.95	39
1500	19.43	31.7	44.9	58.5
2000	25.9	42.3	59.9	78
2500	32.3	52.9	74.8	97.5
3000	38.8	63.4	89.8	117
3500	45.3	74	104.8	136.5
4000	51.8	84.6	119.8	156
4500	58.2	95.2	134.7	176
5000	64.7	105.8	149.7	195
5500	71.2	116.3	164.7	215

MAINTENANCE

The normal maintenance operations have been listed hereunder as follows: - (after the first 500 km. or 300 miles the differential oil must be changed).

Every 1000 kms. (600 miles)

- 1 - engine Check level and top up if necessary
- 2 - radiator Check level and top up if necessary, preferably with distilled water).
- 3 - tyres Check pressure

Every 4000 Kms. (2400 miles)

- 4 - engine Change oil and change oil filter cartridge
- 5 - water pump Lubricate with grease nipple. Dont exceed a pressure of 0.2 - 0.3 atmospheres.
- 6 - front suspension pivots - Lubricate by means of the special grease nipple.
- 7 - transmission junctions These are to be lubricated by means of the grease nipples.
- 8 - Steering and articulated joints lubricate by means of the grease nipples and check oil level in the steering box.
- 9 - Rear wheel hub Lubricate by means of the grease nipples.
- 10 - Clutch - Check oil level in the tank of the pump and if necessary top up.
- 11 - Battery - Check level of distilled water and top up.
- 12 - Brake master cylinder - Check the level and if necessary add brake fluid.

CON RAPPORTO AL PONTE 46/43

1 KM DA FERMO IN 25" = 128 KM/H
1 KM LANCiato 15"5 = 232 KM/H

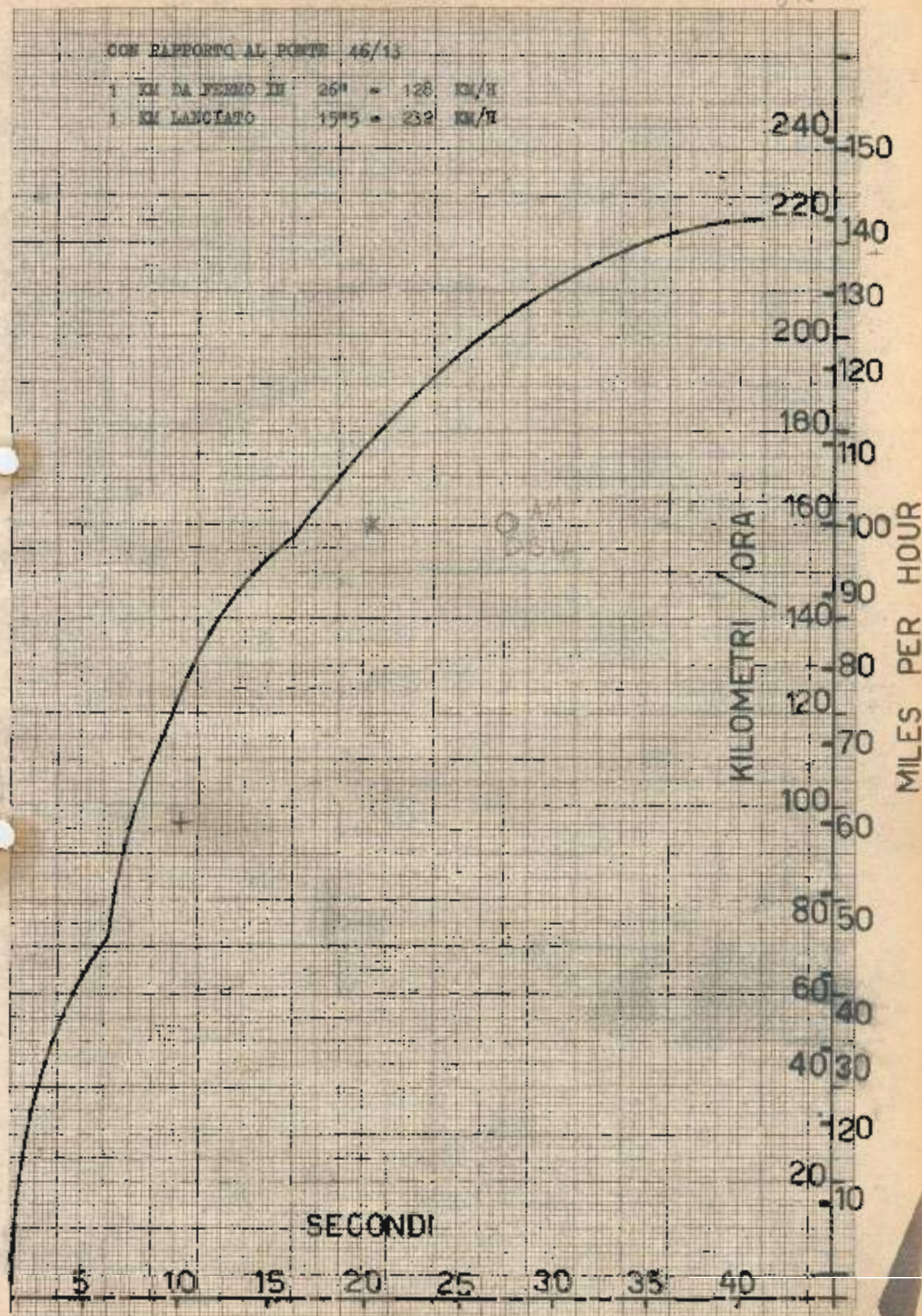



- 15 - Generator belt - Should the tension require adjustment, it is necessary to loosen the bolt on the stirrup which is joined to the bottom of the generator, after which the required tension is obtained by moving the generator itself. The adjustment of the belt for the oil cooler pump is effected by removing one or more of the spacers on the driven (pump) pulley.
- 16 - Timing chain - If after a certain period it is found necessary to adjust the timing chain tension unscrew the central nut holding the plate which is left front of the engine block. Remove the washer and locking dowel underneath using the proper extractor tool. Turn the eccentric, using a torque stress of approx. 0.1 Kgm. (0.75 lb.ft.) and lock it in the desired position by placing locking dowel in the adjustment holes which are now aligned.
- 16 - Clutch adjustment - The play between the clutch and the thrust disc which must be approx. 2.5 mm. (0.1 in) will be eliminated by the wear of the antifriction material, which results in the slipping of the clutch itself. This inconvenience is eliminated by adjusting the play back to the original specifications by means of the adjustable tracer point situated on the second pump. The play of 0.1 in. on the thrust disc corresponds to 0.15 in. displacement of the pedal.
- 19 - Brakes - When mounting new brake linings, it is important to ensure that the lining and the rim of the brake drum are absolutely parallel, to avoid excessive wear of the lining. This adjustment is performed by means of two regulating screws.

CAPACITIES AND CONSUMPTIONS

The normal petrol consumption (according to CUNA standard)

13 liters x 100 Km. (5.5 US gallons x 100 miles).

Average consumption varies according to speed, road surface and amount of acceleration and deceleration.

It is advisable never to let the engine exceed 5800 revs/min.

The car can travel approx. 450 Kms. without refuelling (280 miles).

<u>Item</u>	<u>Quantity</u>	<u>Remarks</u>
Petrol tank	lts. 75 (US Gallons 20)	It is advisable to use premium petrol - octane No. MM 88-90
Radiator-engine	lts. 14 (US Gallons 37)	Distilled water if possible
Engine sump	Kg. 10 (22 lbs)	In winter it is advisable to use Energol SAE 40 - in summer SAE 50.
Differential	Kg. 2 (2.2 lbs)	It is advisable to use Energol oil SAE 90 E.P.
Gear box	Kg. 1.5 (3.3 lbs)	It is advisable to use SAE 90



<u>Item</u>	<u>Quantity</u>	<u>Remarks</u>
Steering box	Kg. 0.2(0.44 lbs)	Energol Oil SAE 250 E.P.
Master cyl. (brakes)	Kg. 0.4(0.88 lbs)	Girling Crimson Brake fluid
Master cyl. (clutch)	Kg. 0.2(0.44 lbs)	Girling crimson Brake fluid
Bushes & bearings	-	Energrease L. 3.
Steering joints	-	Energrease A.1.

USE OF THE CAR

The car is delivered to customers after it has undergone a very strict test and a prolonged running-in of engine and transmission unit, and therefore it can be run to full capacity without endangering its ultimate efficiency.

In this way it is not necessary to fit locks to the carburettors or to change the oil filter after the first 1000 kilometers, as is usually done with ordinary vehicles.

- 1 - Before driving off, it is advisable to check and see if the petrol is of the advised octane contents, if the radiator and the engine sump are full, and if the tyres have the right pressure.
- 2 - While going through the normal starting operations, remember to check if gear lever is in neutral; in such a position this lever can freely move from left to right. To facilitate starting of the engine when cold pull out the hand throttle and twist the key situated on the left hand side of the panel, to engage the starter motor.
Until engine is slightly warm, especially during the cold season, avoid sudden acceleration but give the oil time to warm up, so that it may freely circulate.
- 3 - When driving occasionally check the oil pressure gauge. In order to avoid clutch wear do not rest your foot on the clutch pedal when not shifting gears.
- 4 - To switch off the engine, turn the ignition key.
- 5 - Winter precautions. If during winter months the vehicle has to remain standing outside in a temperature below freezing point, add antifreeze to the water.

IRREGULARITIES AND REMEDIES

Engine will not start if the battery is flat, it should be recharged or replaced.

Engine too tight; oil is too dense or some part is too tightly fitted. (The latter case is possible when the car has been improperly overhauled by a non-specialist workshop).

Low voltage at spark plugs: damaged earth terminal, oxidised contacts of the coil ignition (a very rare case). No petrol in carburettor: damaged pumps, filters dirty or clogged.

20'000 Km
10'000 Km
4'000 Km
1'000 Km

1'000 Km
4'000 Km
10'000 Km
20'000 Km

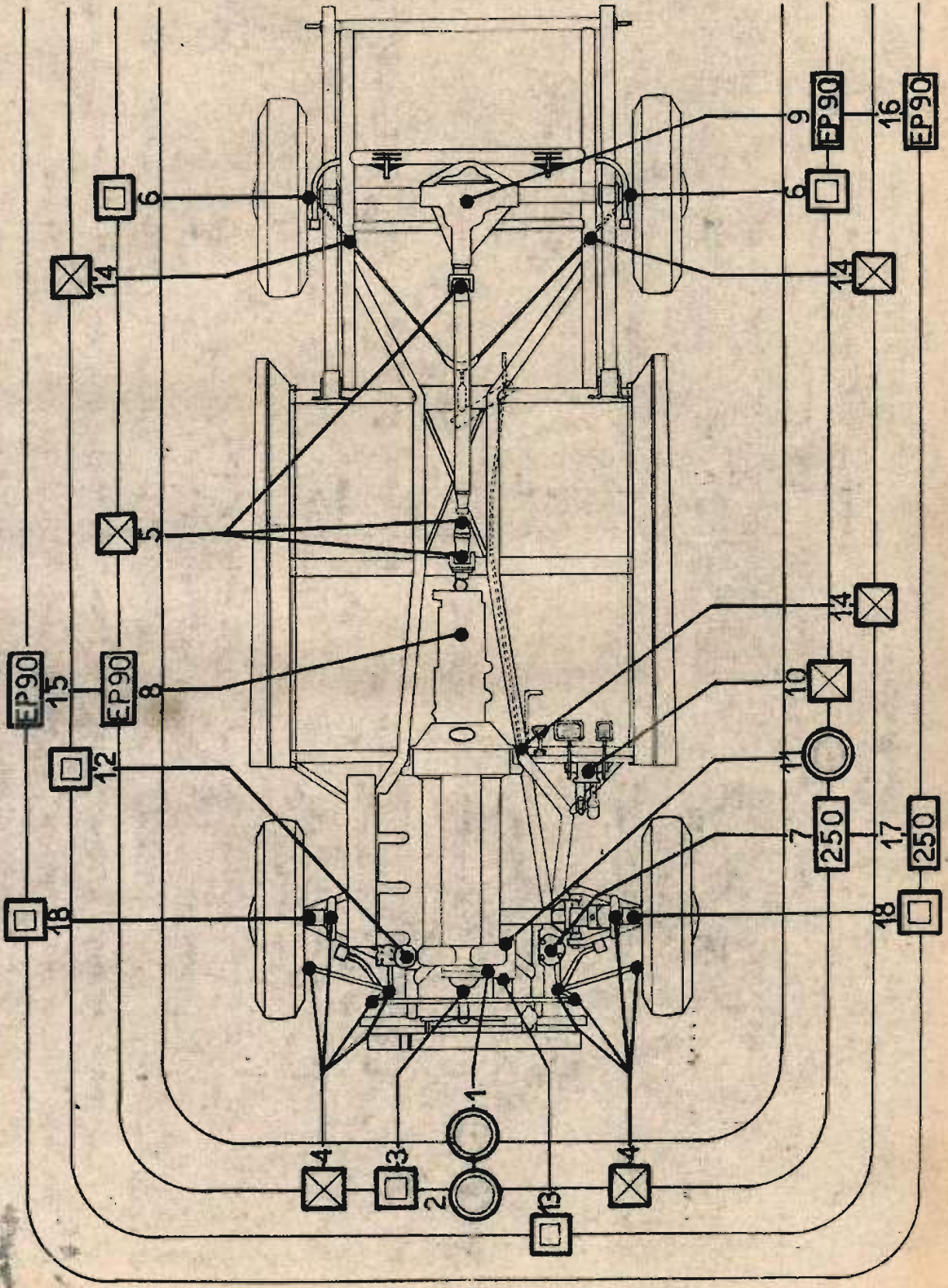

- SCHEMA DI LUBRIFICAZIONE - TAV. X -

TAV. X - LUBRICATION SCHEME

- N° 1 - Engine
- N° 2 - Engine
- N° 3 - Water Pump
- N° 4 - Steering unit and suspension
- N° 5 - Drive shaft points
- N° 6 - Rear end
- N° 7 - Steering box
- N° 8 - Gear box
- N° 9 - Differential Case
- N° 10 - Pedals
- N° 11 - Generator
- N° 12 - Distributor
- N° 13 - Generator
- N° 14 - Hand Brakes
- N° 15 - Gear box
- N° 16 - Differential case
- N° 17 - Steering box
- N° 18 - Front hubs



Low compression: excessive scoring of the cylinders, or excessive wear, or valves not having a gas-tight fit, or valve adjustment too tight.

Oily spark plugs: heat range too cold or fouled by excessive attempts to start.

Lack of power in engine

Low compression: the engine emits fumes from the crank case breather pipe; the piston rings are worn or broken: replace same. Spark plugs with white insulating china: plugs too hot: replace them with recommended type.

Incorrect type of petrol: unless suitable antiknock petrol is used, self ignition takes place: the petrol is too cold and therefore does not ignite at the proper time.

Incorrect engine timing: this can happen after an incompetent overhaul. Check and time.

Broken valve springs: the engine misfires.

Incorrect spark advance: check and reset according to the above data.

DIMENSIONS AND TOLERANCES

Pistons	Min. play between piston and cylinder is 0.002 in. to 0.0024 at the base of the piston.
Piston rings	These are to be replaced when the gap between their extremities reaches 0.024 to 0.025 in. of mm. The rings must be very loose in their grooves.
Cylinders	In the event of the gap between the cylinder and piston reaching, when cold, 0.006 in. it will be necessary to bore the cylinders increasing the diameter by 0.008 in. and then replace the piston. The fitting of the cylinder liner to the crankcase is executed by heating the crankcase to a temperature of 160° centigrade in an oil bath, and then fitting the cold cylinder liner.

Connecting rods and main bearings

The gaps between the journals and the connecting rods and main bearings must be of 5/100 mm. (0.002 in.) and 6/100 (0.0024 in.) respectively. In the event of this gap reaching a 0.004 in. and crankshaft being ruined, it will be necessary to grind the crankshaft and mount undersized bearings, keeping well in mind that the thin shelled bearings must not be touched, not even superficially in order not to scratch the surfaces which have been specially treated. The main bearing bushes are placed on the market undersize by 0.02" - 0.03" - 0.04" - while those of the connecting rods can be found undersize by 0.01" - 0.02" - 0.03" - 0.04".

The torsional stress in tightening the stud bolts of main bearing supports must not exceed 68 lb.ft., while for the connecting rod stud bolts it should not exceed 45 lb.ft.

VALVE GUIDES

The draught on the head is between 0.015 + 0.02 mm. (0.0006 + 0.008)
The gap between the valve guide and the valve itself is of 0.04 mm.
(0.016 in) on the diameter.

GAM JOURNALS

The clearance on the supports is between 5 and 7/100. (0.002+0.0028)
The axle end play must be within 1 and 2.5/10 mm. (0.004+0.01 in).

SHOCK ABSORBERS

The shock absorbers, before the assembly, are to be bled of air through 3 complete strokes of the connecting rod, from all closed to all open. After this operation they must be kept in vertical position while waiting to be put on.

FRONT WHEELS

Front wheel toe-in measured from the hubs is 5 + 6 mm.

Front wheel camber measured in a vertical, longitudinal plane: 1°

Caster angle : 2°

King pin angle: 1° 30'

TOOL BOX

The tool kit supplies with the car contains:

- 1 jack to lift the car
- 1 base on which to rest the jack
- 1 set of spanners ranging from 6 to 22 mm.
- 1 spanner for sparking plugs
- 1 roll spanner
- 1 spanner for carburetors
- 1 curved spanner for wheel nuts
- 1 steel hammer
- 1 pair universal pliers
- 1 screw driver

ELECTRIC PLANTFittings

- 1 front left headlight
- 2 front left position and flashing lights bulbs
- 3 left fog light bulbs
- 4 right fog lights
- 5 front right position and flashing lights
- 6 front right headlight
- 7 direction indicator - left
- 8 electric horn
- 9 light illuminating under bonnet and engine
- 10 switch for light illumination of engine
- 11 generator
- 12 starter motor
- 13 battery



- 14 - Direction indicator light
- 15 - Windscreen wipers
- 16 - Coils
- 17 - Air intake with fan and motor
- 18 - Air " " " " "
- 19 - Under bonnet heat exhaust blower
- 20 - Starter
- 21 - Mileage meter
- 22 - Water thermometer
- 23 - Fuel gauge
- 24 - oil pressure counter
- 25 - revolution counter
- 26 - Red warning light for flashing direction indicator
- 27 - High beam indicator
- 28 - Red warning light for generator
- 29 - Sliding contact of the horn button
- 30 - Windscreen wiper motor
- 31 - Yellow warning light for the fan
- 32 - Internal switch for ceiling lights
- 33 - Switch for reverse light
- 34 - Switch for fog lights and low beam lights
- 35 - Operating panel for lights
- 36 - Cigarette lighter
- 37 - Dip switch on steering column control
- 38 - Air conditioning control
- 39 - Generator regulator
- 40 - Yellow warning light for the fan
- 41 - Horn relay
- 42 - Direction relay
- 43 - Devoilux relay
- 44 - Hydraulic stop switch
- 45 - Radio
- 46 - Fuse for radio
- 47 - Fuse for left high beam light
- 48 - Fuse for right high beam light
- 49 - Fuse for low beam lights
- 50 - Fuse for city driving lights and warning head lights
- 51 - Fuse for number plate light and rear position lights
- 52 - Fuse for horns and interior illumination lights
- 53 - Fuse for fog lights and lubrication pump
- 54 - Fuse for reversing lights
- 55 - Fuse for cigarette lighter and internal engine lights
- 56 - Fuse for second electric pump
- 57 - Fuse for first electric pump
- 58 - Fuse for petrol gauge, thermocouple, generator warning light
- 60 - Rubber terminal board
- 61 - Switch right door light
- 62 - Yellow warning light for the fan
- 63 - Motor for right door window lift
- 64 - Fuse
- 65 - Ceiling light
- 66 - Ceiling light
- 69 - Motor for left door window lift



- 70 - Switch - left door light
- 71 - Left wireless aerial
- 72 - Petrol level float
- 73 - Petrol pump
- 74 - Right Wireless aerial
- 75 - Right position and flashing light
- 76 - Right stop light
- 77 - Right reverse light
- 78 - number plate light
- 81 - Left reverse light
- 82 - Left stop light
- 83 - Left position and flashing lights

-
- A - Electric pumpWire
 - B - Electric pump"
 - C - Position and No. plate"
 - D - Left rear flashing lights"
 - E - Right rear flashing lights"
 - F - Stop light"
 - G - Reverse light"
 - H - Fuel gauge"
 - I - Fuel gauge"
 - L - Left aerial"
 - M - Switch for left radio aerial"
 - N - Right aerial"
 - O - Switch for right radio aerial"
 - P - Lights illuminating interior"

SIZE, COLOUR AND LENGTH OF THE WIRES FROM THE REAR TERMINAL BOARD
TO THE VARIOUS FITTINGS

A	- to the first electric pump	1	sq.mm.	Red	0.90 mts.
B	- " " second " "	1	" "	Red	0.90 "
C	- " " number plate light	0.50	" "	Black	1.40 "
C	- " " left position light	0.50	" "	Black	2.40 "
C	- " " right " "	0.50	" "	Black	1.00 "
D	- " " left flashing light	0.50	"	"Sky Bleu	2.40 "
E	- " " right " "	0.50	"	"Sky Bleu	1.00 "
F	- " " right stop " "	1.00	" "	White	1.00 "
F	- " " left stop " "	1.00	" "	White	2.40 "



G	- to the right reverse light	1.00	sq.mm.	Brown	1.00	mts.
G	- " " left " "	1.00	" "	Brown	2.40	"
H	- " " petrol gauge	0.50	" "	Yellow	1.20	"
I	- " " " "	0.50	" "	Yellow	1.20	"
L	- to wire of left aerial	1.60	" "	Orange	2.40	"
M	- " Switch left radio aerial	0.80	" "	Black	2.40	"
N	- " Wire right aerial	1.60	" "	Black	0.50	"
O	- " Switch right radio aerial	0.80	" "	Black	0.50	"
P	- " To interior illumination	0.80	" "	Green	5.00	"
Q	- " Return interior illumination	0.80	" "	Green	5.00	"

FROM FUSE BOX TO THE VARIOUS FITTINGS

From 47	to 1 (left headlight)	1.6	sq.mm.	red	3.20	meters
" 48	" 6 (right ")	1.6	" "	red	2.50	"
" 49	" 1 (left low beam)	1.	" "	White	3.20	"
" 49	" 6 (right " ")	1.	" "	White	2.50	"
" 50	" 2 (right position)	0.50	" "	Black	2.50	"
" 50	" 5 (left " ")	0.50	" "	Black	3.20	"
" 50	" 27 (warning lights)	1.	" "	White	1.40	"
" 51	" C (terminal board)	0.80	" "	Black	4.10	"
" 52	" 41 (horns)	2.50	" "	White	1.50	"
" 52	" P (terminal board)	0.80	" "	Green	4.10	"
" 52	" 33 (switch reverse)	1.	" "	Red	1.30	"
" 53	" 34 (" front lights)	2.50	" "	White	1.00	"
" 53	" (17-40-62-18-19 (fans)	1.60	" "	White	3.50	"
" 53	" 31 (fan warning light)	1.	" "	Red	1.20	"
" 53	" 30 (windscreen wiper)	1.	" "	Red	1.25	"
" 54	" 36 (cigar lighter)	1.60	" "	White	1.00	"
" 54	" 9-10 (illum.engine)	0.50	" "	Black	1.00	"
" 56	" B (electric pump)	1.	" "	Red	4.20	"
" 57	" A (" ")	1.	" "	Red	4.20	"
" 58	" 28 (war.ligt gen.)	1.	" "	Red	1.20	"
" 42	" 42 (relay flash. light)	1.	" "	Red	1.80	"
" 48	" 43 (56 B deviolux)	2.50	" "	White	1.40	"
" 49	" 43 (56 A deviolux relay)	2.50	" "	White	1.60	"
" 51	" 35 (light switch)	1.	" "	Black	0.90	"



From 52 to	20 (starter switch 30)	2.50 sq.mm.	White	1.50 meters
" 53 "	35 (lights ")	2.50 " "	White	0.90 "
" 54 "	45 (radio wire)	2.50 " "	White	0.60 "
" 55 "	39 (voltage reg.)	4.00 " "	Black	0.70 "
" 58 "	20 (starter switch)	2.50 " "	White	1.50 "

FROM BOARD TO THE VARIOUS FITTINGS

From 39 to	11	1 sq.mm.	Sky Blue	4.10 meters
" 39 "	12	6 " "	Black	1.70 "
" 39 "	11	4 " "	Black	4.10 "
" 39 "	28	0.80 "	Yellow	1.30 "
" 39 "	earth	1.60 "	White	0.70 "
" 42 "	37	1.00 "	White	0.80 "
" 42 "	26	0.80 "	Yellow	0.80 "
" 42 "	44	1.00 "	White	" "
" 43 "	35	2.50 "	White	1.00 "
" 43 "	37	0.50 "	Black	0.60 "
" 43 "	35	2.50 "	White	1.00 "
" 41 "	8	2.50 "	White	4.80 "
" 41 "	29	1.00 "	Black	1.00 "

FROM ONE FITTING TO THE OTHER

From 13 to	12	25 sq.mm.	Black	4.40 meters
" 4 "	34	1.60 "	Orange	0.80 "
" 6 "	earth	1.00 "	Black	0.60 "
" 1 "	earth	1.00 "	Black	3.60 "
" 17 "	38	0.80 "	Green	3.30 "
" 14 "	22	0.80 "	Yellow	4.30 "
" 30 "	15	1.00 "	Red	0.60 "
" 30 "	15 (i)	1.00 "	White	0.60 "
" 30 "	15 (df)	1.00 "	Sky Blue	0.60 "
" 30 "	15	0.80 "	Green	0.60 "
" 20 "	12	1.6 "	White	2.60 "
" 20 "	16	1.6 "	White	2.60 "
" 32 "	Q	0.8 "	Green	4.60 "



From	32 to 70	0.8	sq.mm.	Green	2.50	meters
"	32 " 61	0.8	"	Green	1.60	"
"	33 " G	1.00	"	Brown	4.90	"
"	37 " E	0.80	"	Sky bleu	4.80	"
"	44 " F	1.00	"	White	3.90	"
"	37 " D	0.80	"	Sky bleu	4.80	"
"	37 " 2	0.80	"	Sky bleu	3.90	"
"	37 " 5	0.80	"	Sky bleu	3.10	"
"	23 " H	0.80	"	Yellow	4.70	"
"	23 "	0.80	"	Yellow	4.70	"
"	45 " L	1.60	"	Orange	4.20	"
"	45 " M	0.80	"	Black	4.20	"
"	45 " N	1.60	"	Orange	4.20	"
"	45 " O	1.00	"	Black	4.20	"
"	35 " 25-24-23-22-21	0.80	"	Sky blue	0.70	"
"	28 " 23-22	1.00	"	Red	1.50	"
"	38 " 31	0.80	"	Yellow	0.40	"
"	34 " 3-4	1.60	"	Orange	4.40	"
"	13 " earth	25.00	"	Black	0.50	"
"	18 " 38	0.80	"	Green	3.30	"
"	19 " 38	0.80	"	Green	2.60	"
"	31 " 40	1.00	"	Red	0.20	"
"	40 " 38	62	"	Yellow	0.80	"

I M P O R T A N T

This vehicle has a silencing device duly approved by the Italian General Inspector of Civil Motor Transport, and the approval mark is stamped on the silencer.

This test has been made, according to the regulations, with the car at a standstill and the engine going at full power with a sound meter placed a distance of 7 meters from the longitudinal axis of the car, in line with the end of the exhaust pipe, both on the right and left side, in the open and without trees or reflecting surfaces and with negligible background noises.

Nevertheless, every car, even though it bears the type approval stamp, is liable to exceed the limits set down by the regulation. This is because the engine at high revolutions while accelerating swiftly, can exceed the legal limit. This is unavoidable if the car is to perform in accordance with the speed characteristics of this vehicle.

MASERATI



AUTOMOBILI
MODENA

VETTURA MASERATI 3500 G.P.

MISURE IN CENTIMETRI

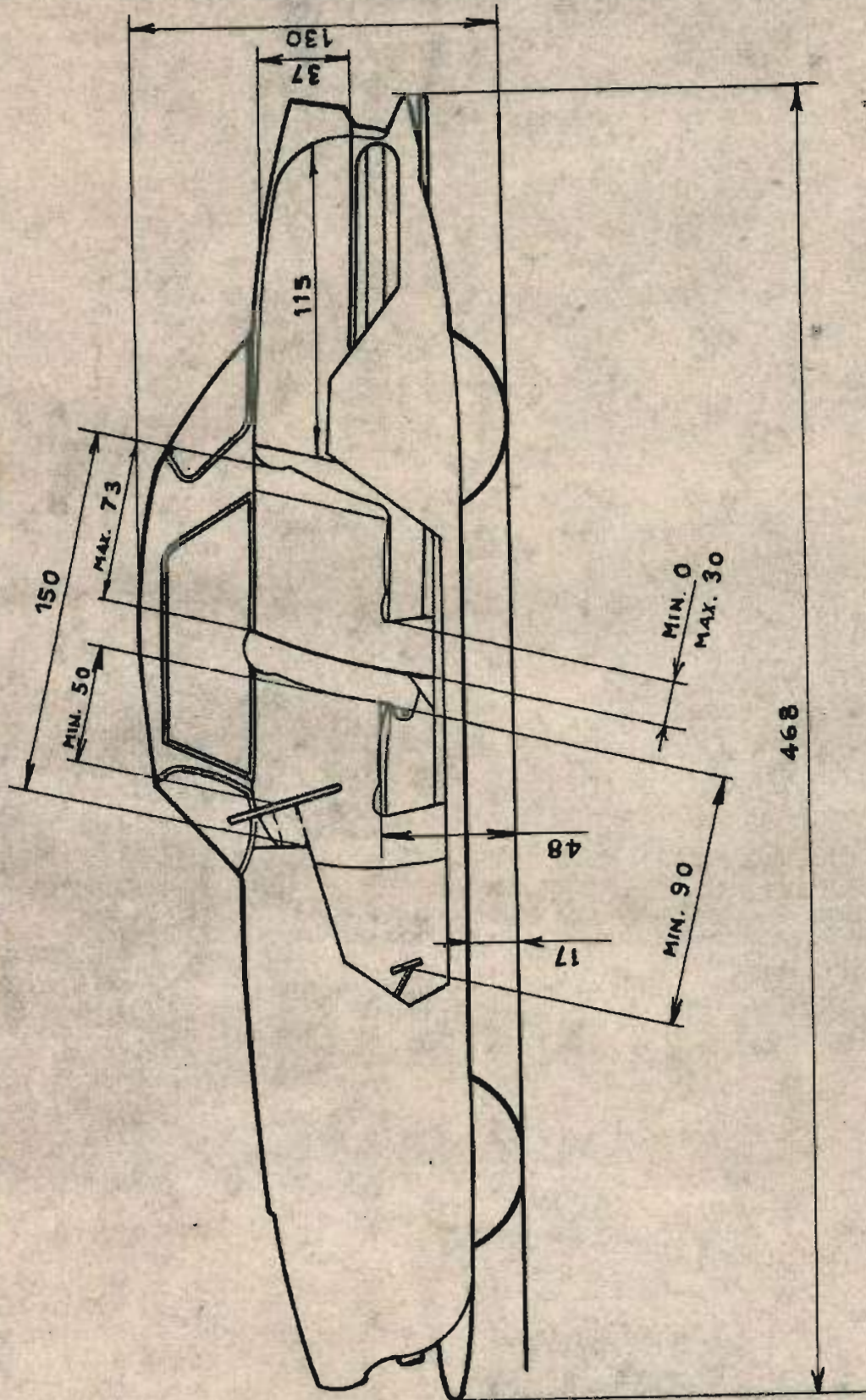

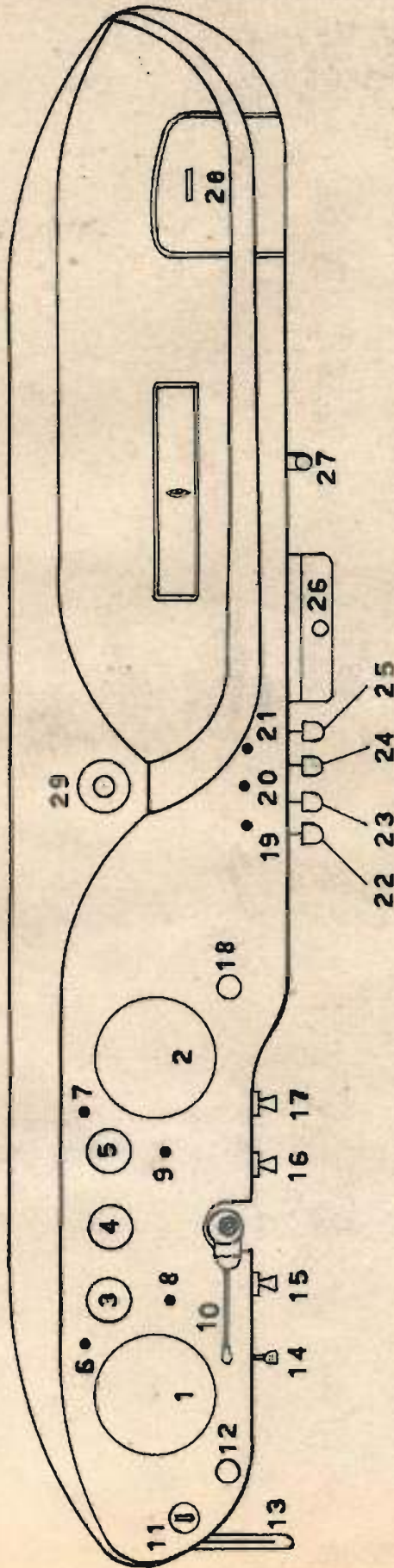

INSTRUMENT AND CONTROL PANEL

1	SPEEDOMETER	17	FOG AND LOWER DEAN SWITCH
2	REVS. COUNTER	18	DASHBOARD LIGHTS
3	MILLETER THE METER	19	LOWER FAN WARNING LIGHT
4	FUEL GAUGE	20	CENTRAL FAN WARNING LIGHT
5	OIL GAUGE	21	CENTRIFUGAL FAN WARNING LIGHT
6	DIRECTION INDICATOR WARNING LIGHT	22	AIR AND FAN CONTROL OVER DRIVER
7	GENERATOR WARNING LIGHT	23	PASSENGER'S AIR - FAN CONTROL - UNDER
8	HIGH LIGHT INDICATOR	24	BONNET HOT AIR RELEASE.
9	POSITION LIGHT INDICATOR	25	RADIATOR INLET AND FAN CONTROL
10	DIRECTION LIGHT AND HEAD LIGHT CONTROL LEVER	26	HOT WATER CONTROL
11	IGNITION KEY	27	HOT AND COLD AIR RADIATOR INLET OPENING
12	WINDSCREEN WASHER CONTROL	28	MANUAL CHOKE
13	BONNET OPENING LEVER	29	PANEL BOX
14	RESET KNOB FOR TRIP COUNTER		CIGAR LIGHTER
15	WINDSCREEN WIPERS		
16	INTERIOR ILLUMINATION SWITCH		

MASERATI



AUTOMOBILI
MODENA

VETTURA MASERATI 3500 G.T.
DISTACCO MINIMO GIOCO FRIZIONE

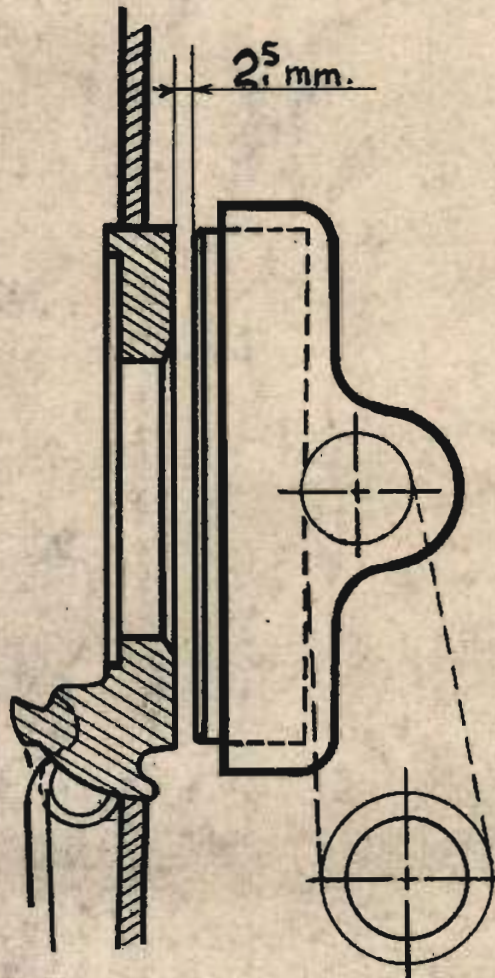

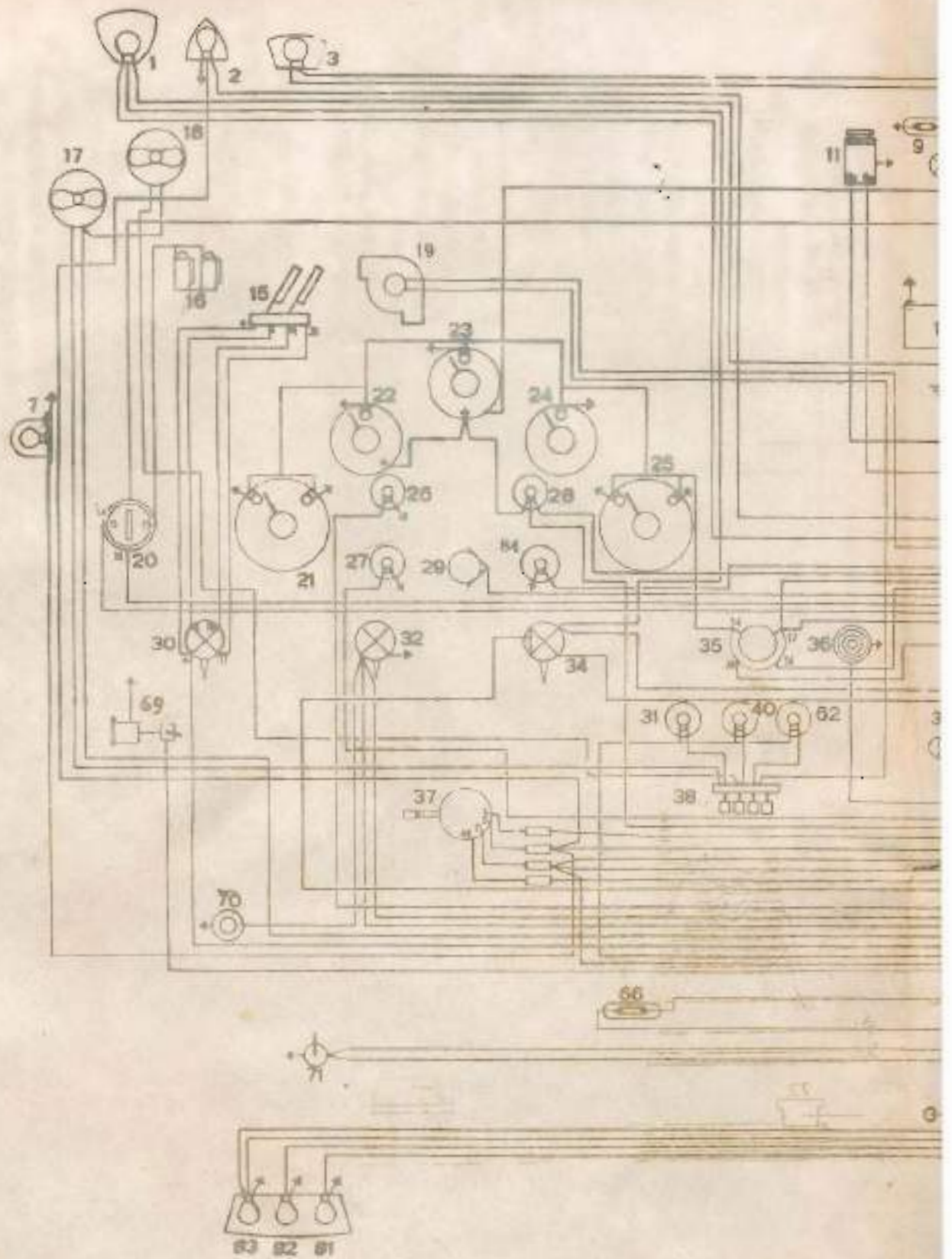

SCHEMA IMPIANT

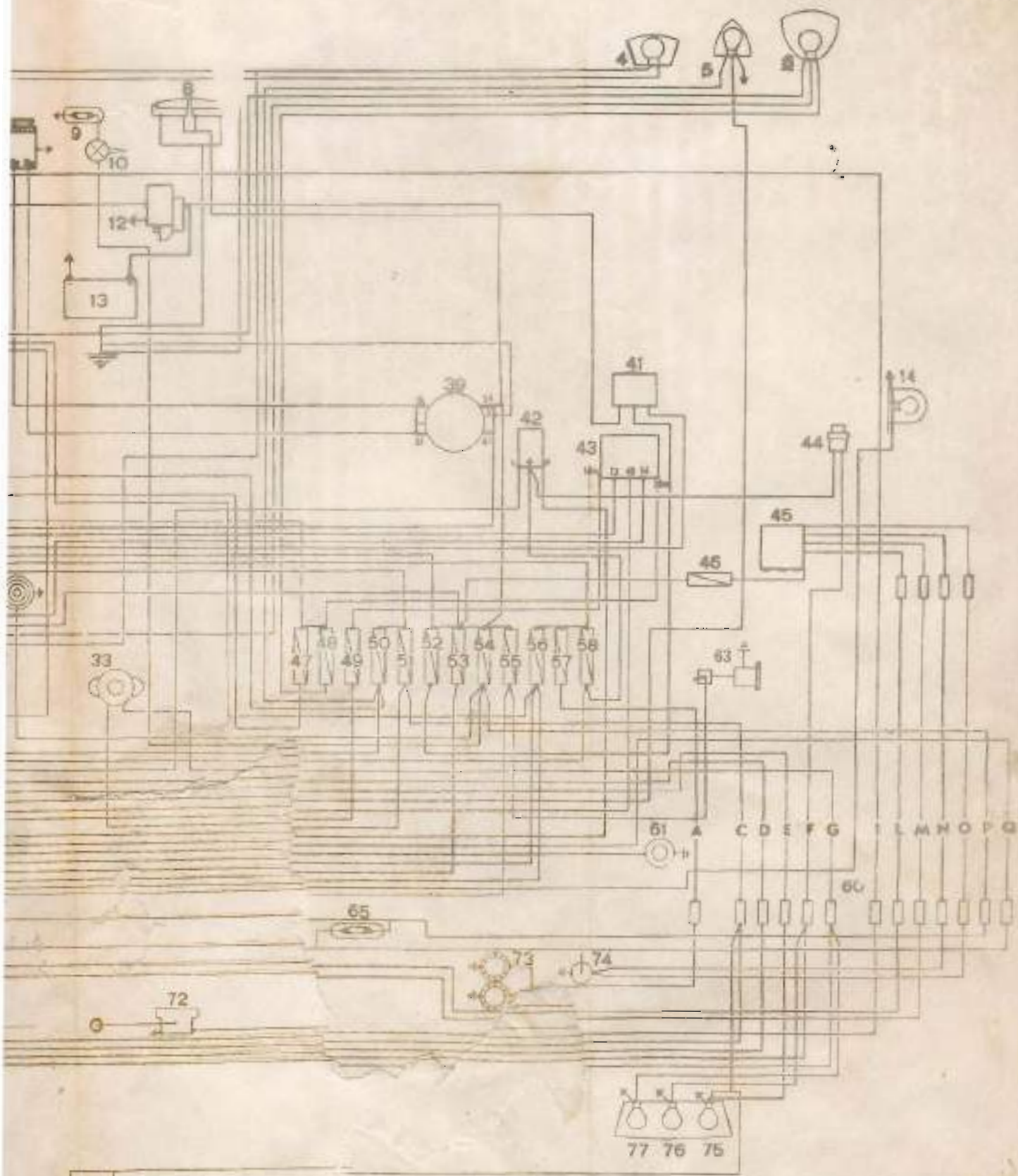

IMPIANTO ELETTRICO

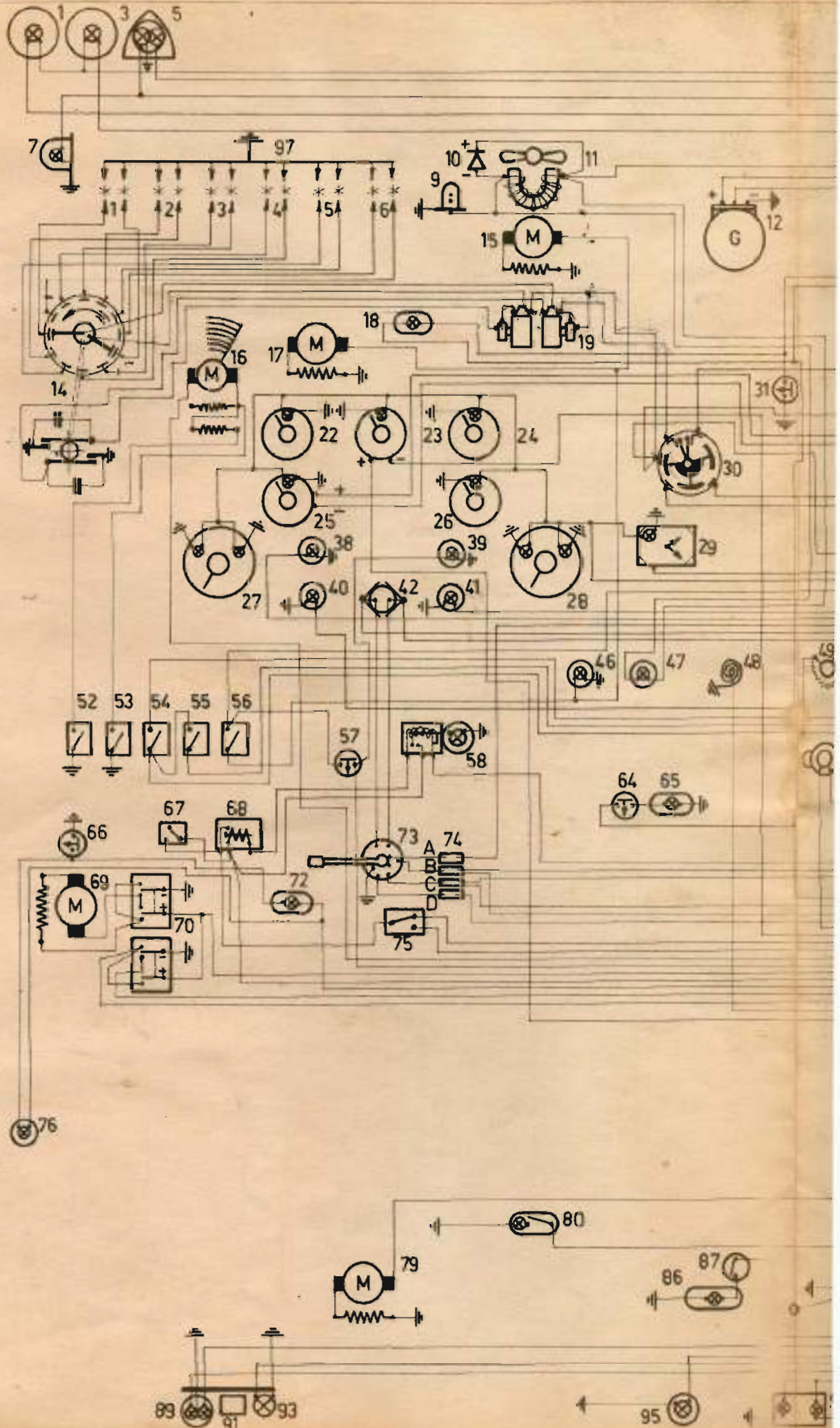

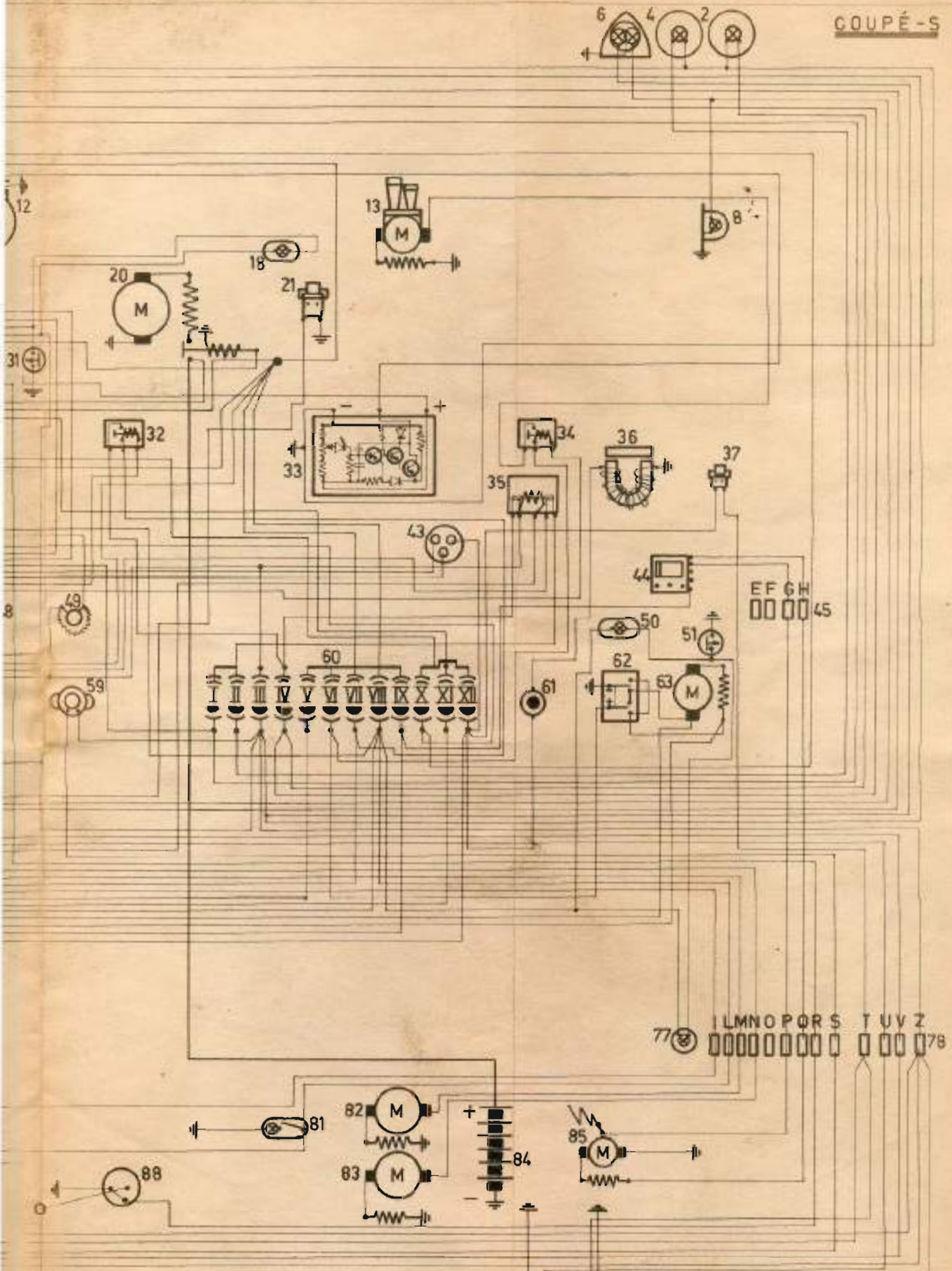

IMPIANTO ELETTRICO
ELECTRICAL SYSTEM

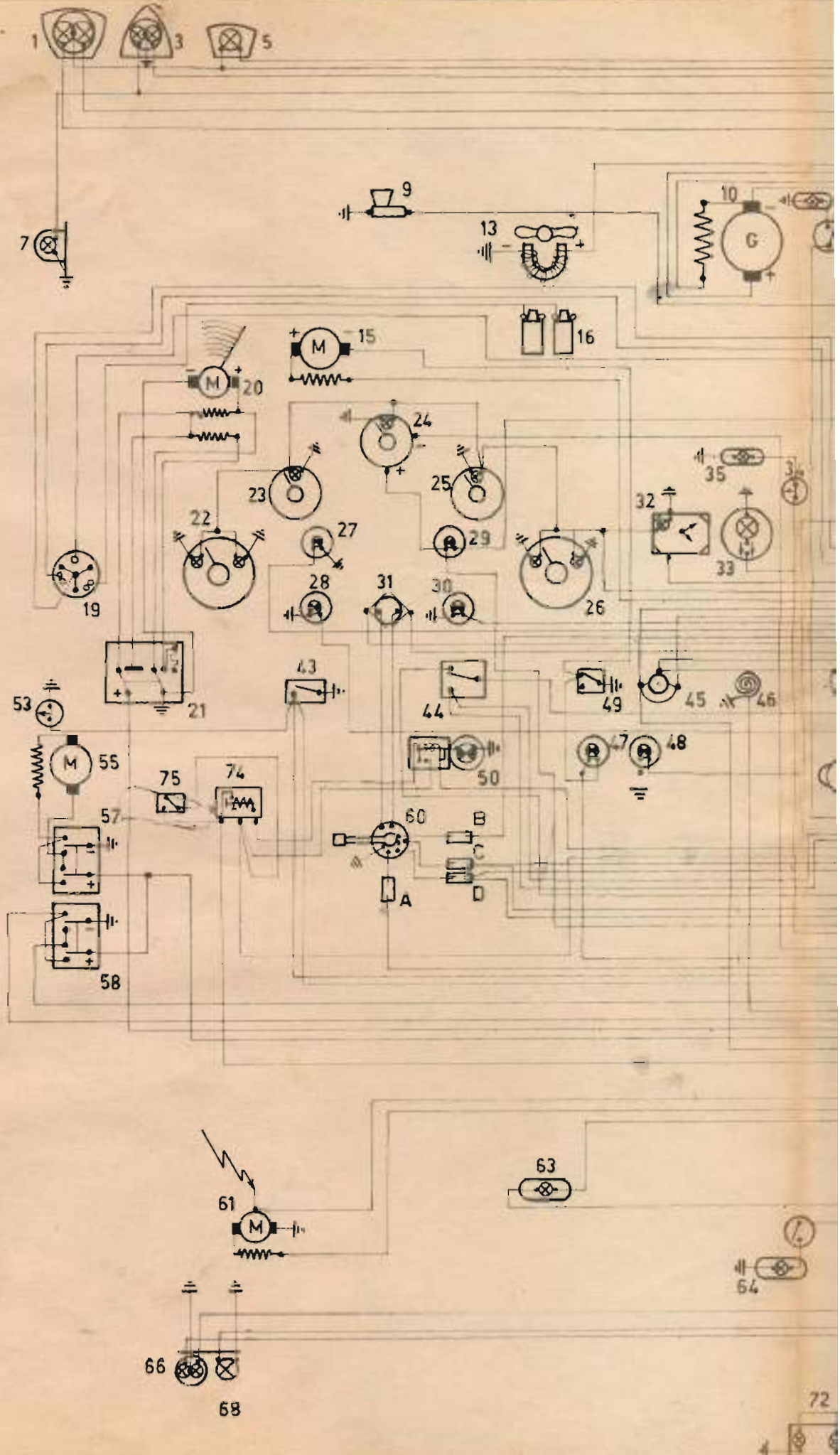

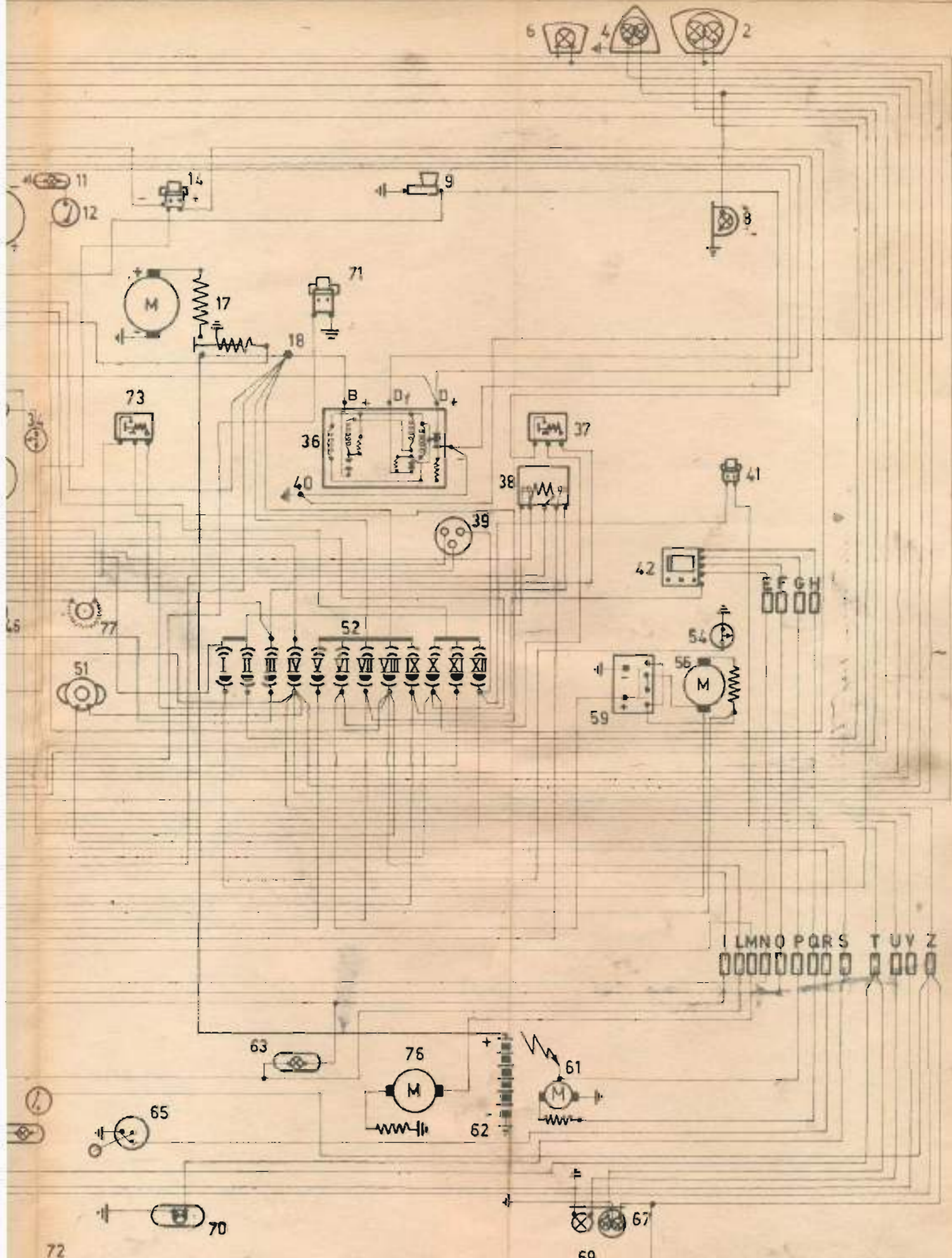

IMPIANTO ELETTRICO

 ELECTRICAL SYSTEM

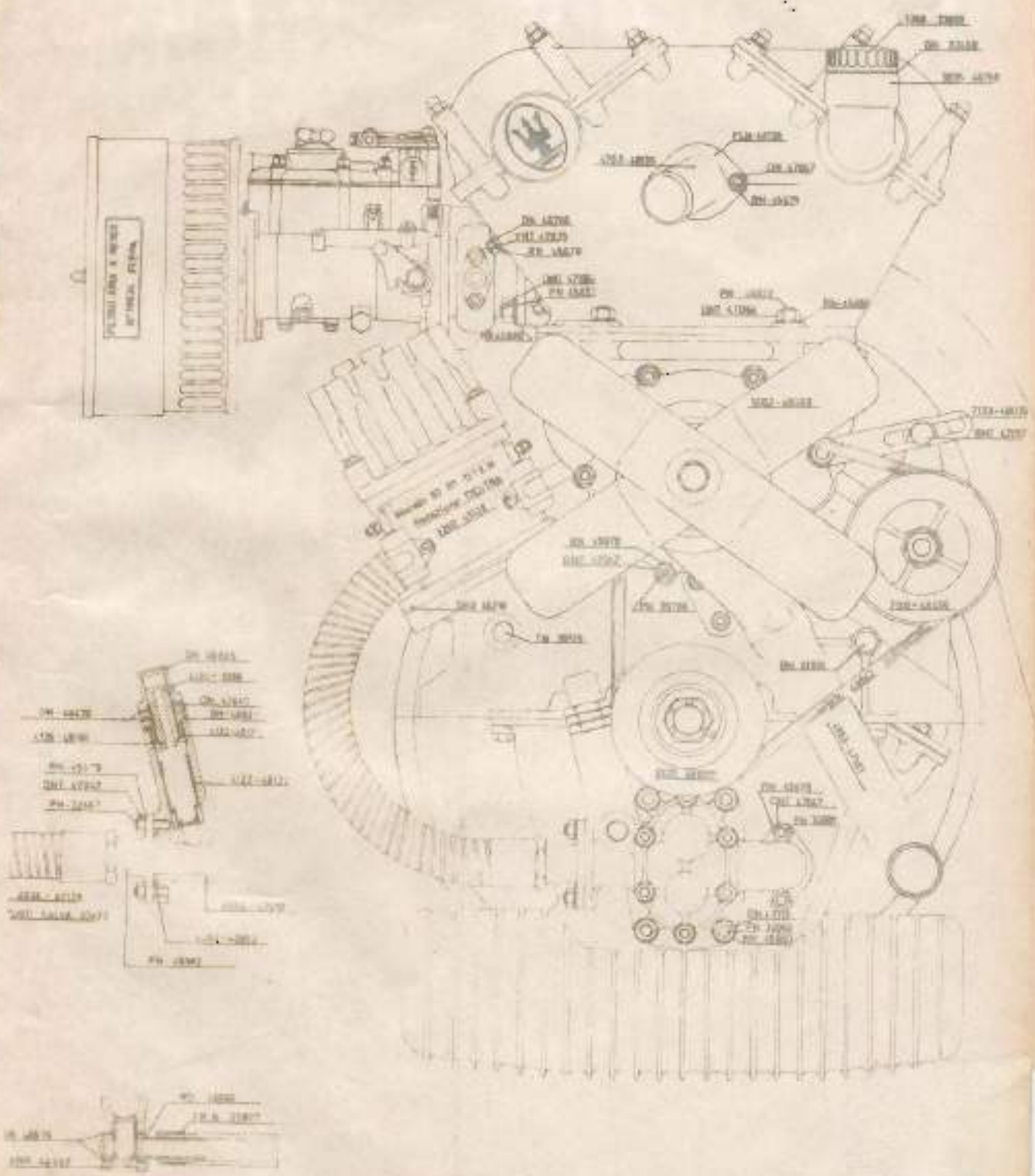

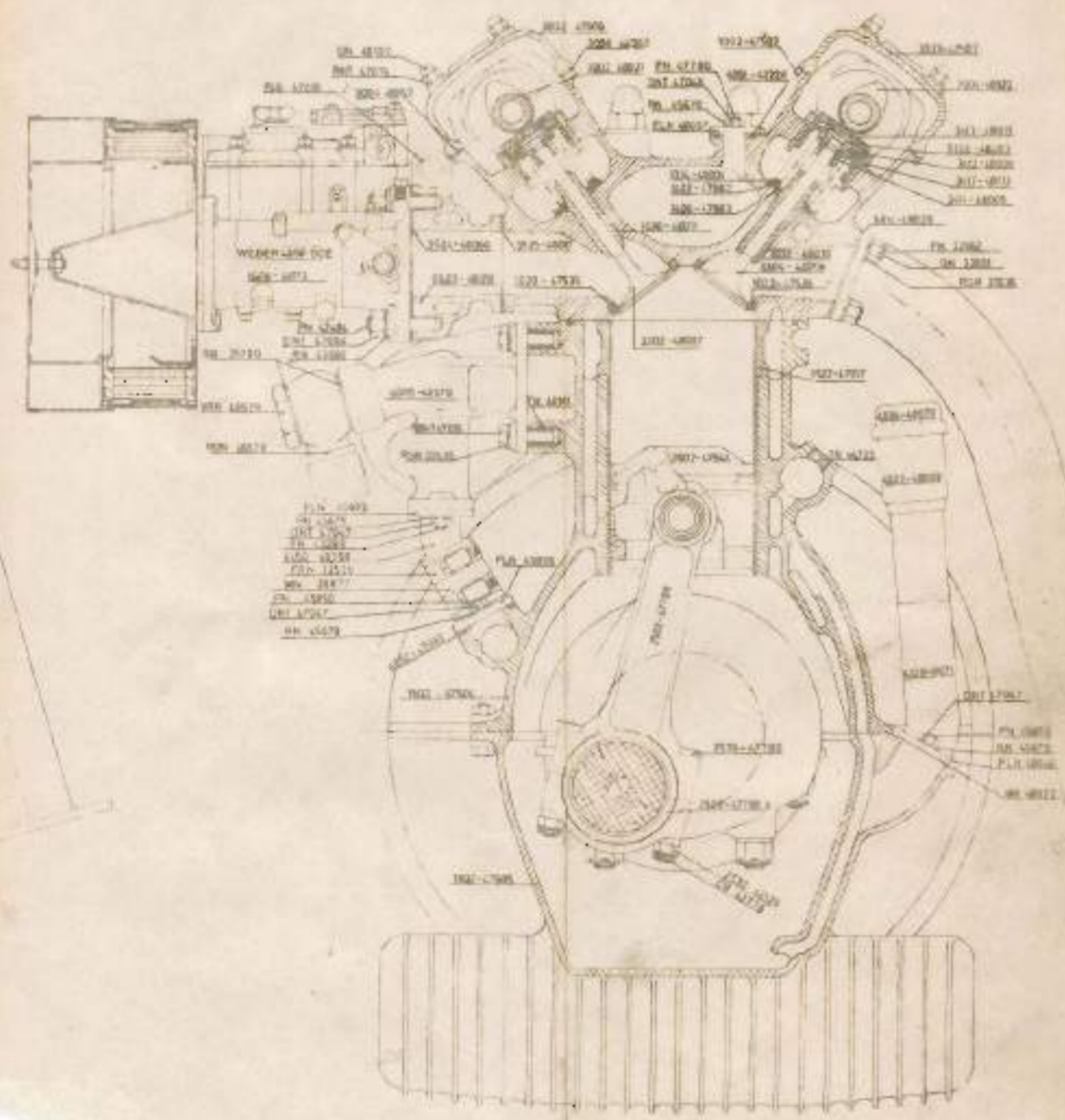

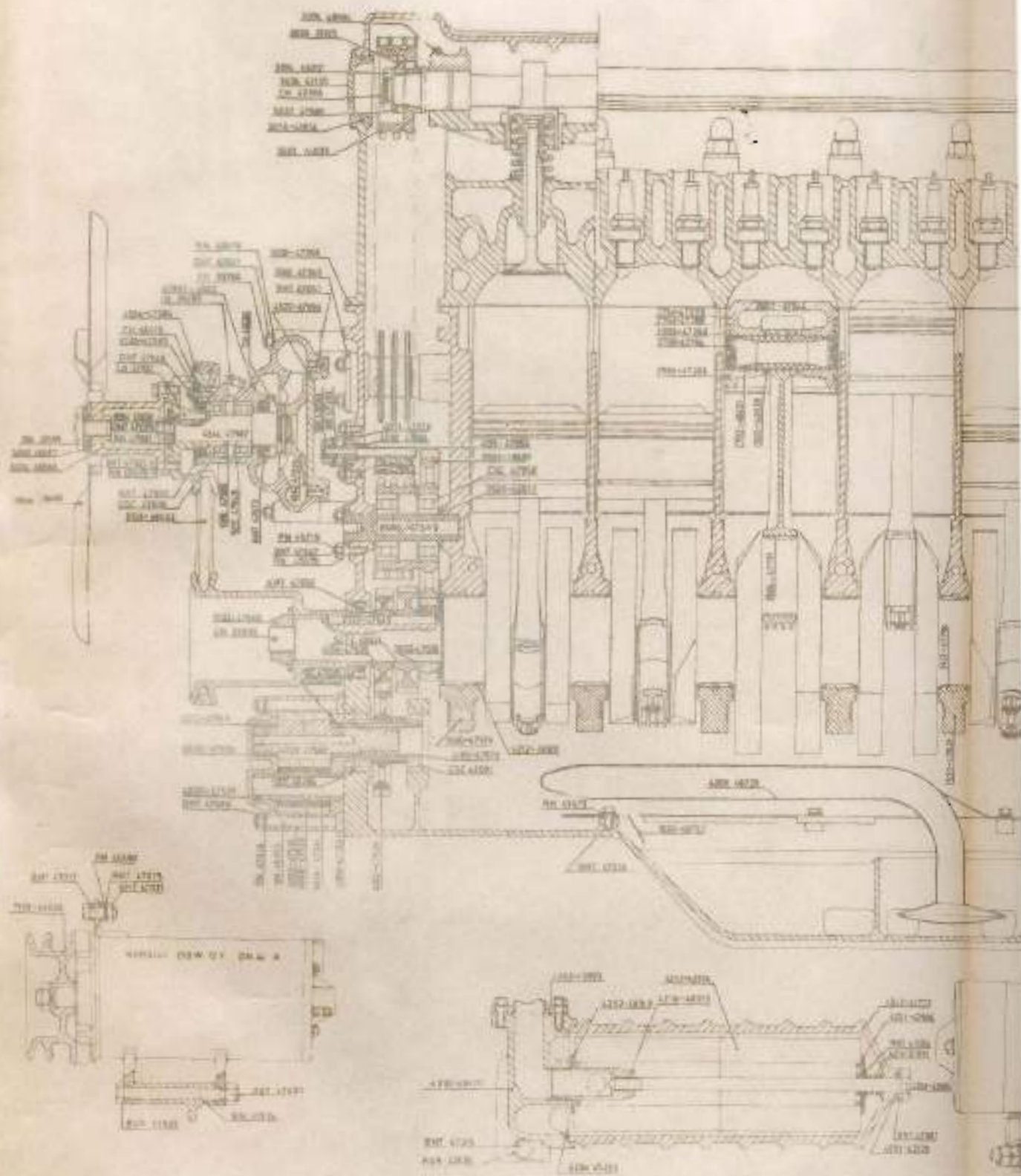

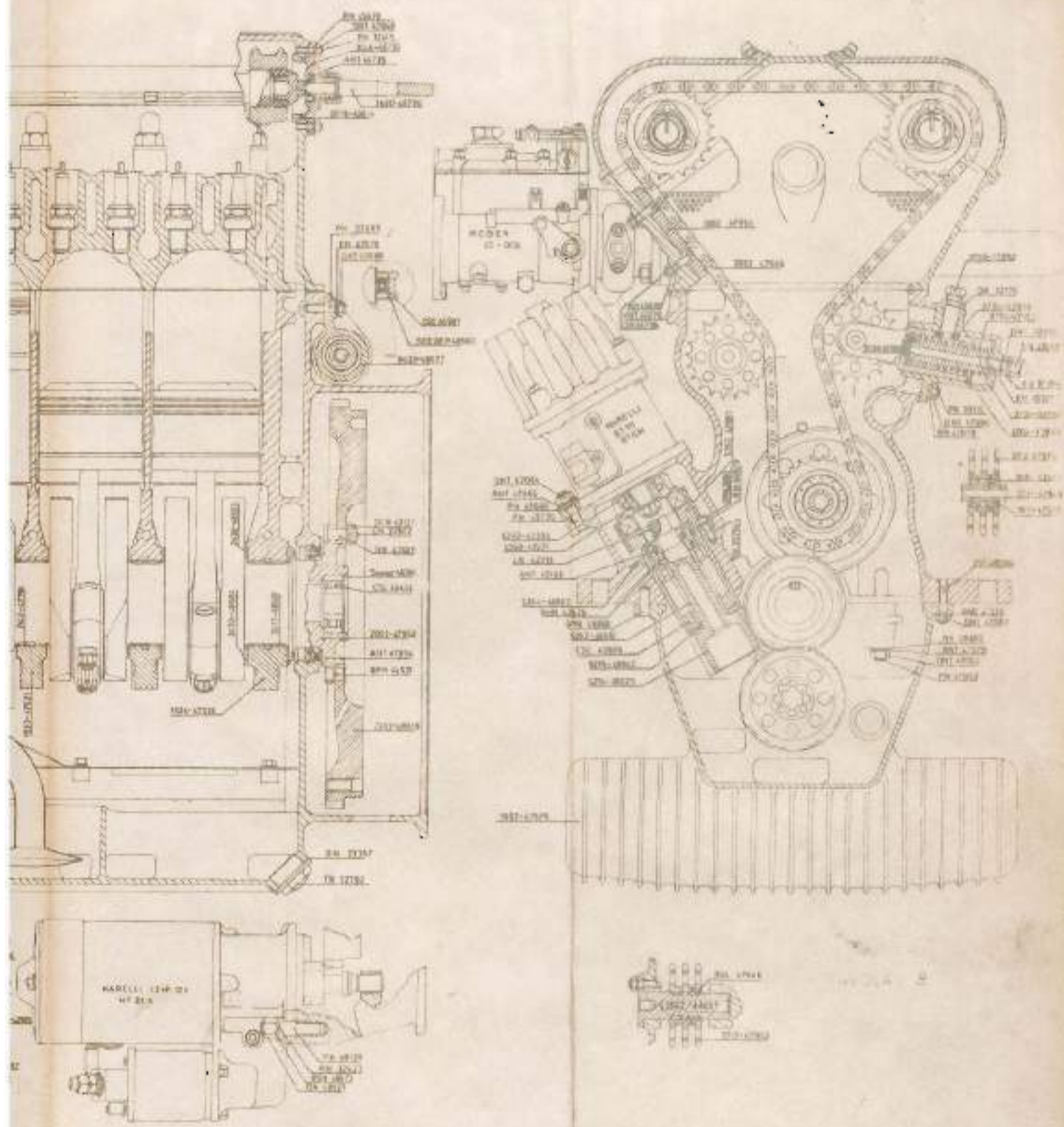

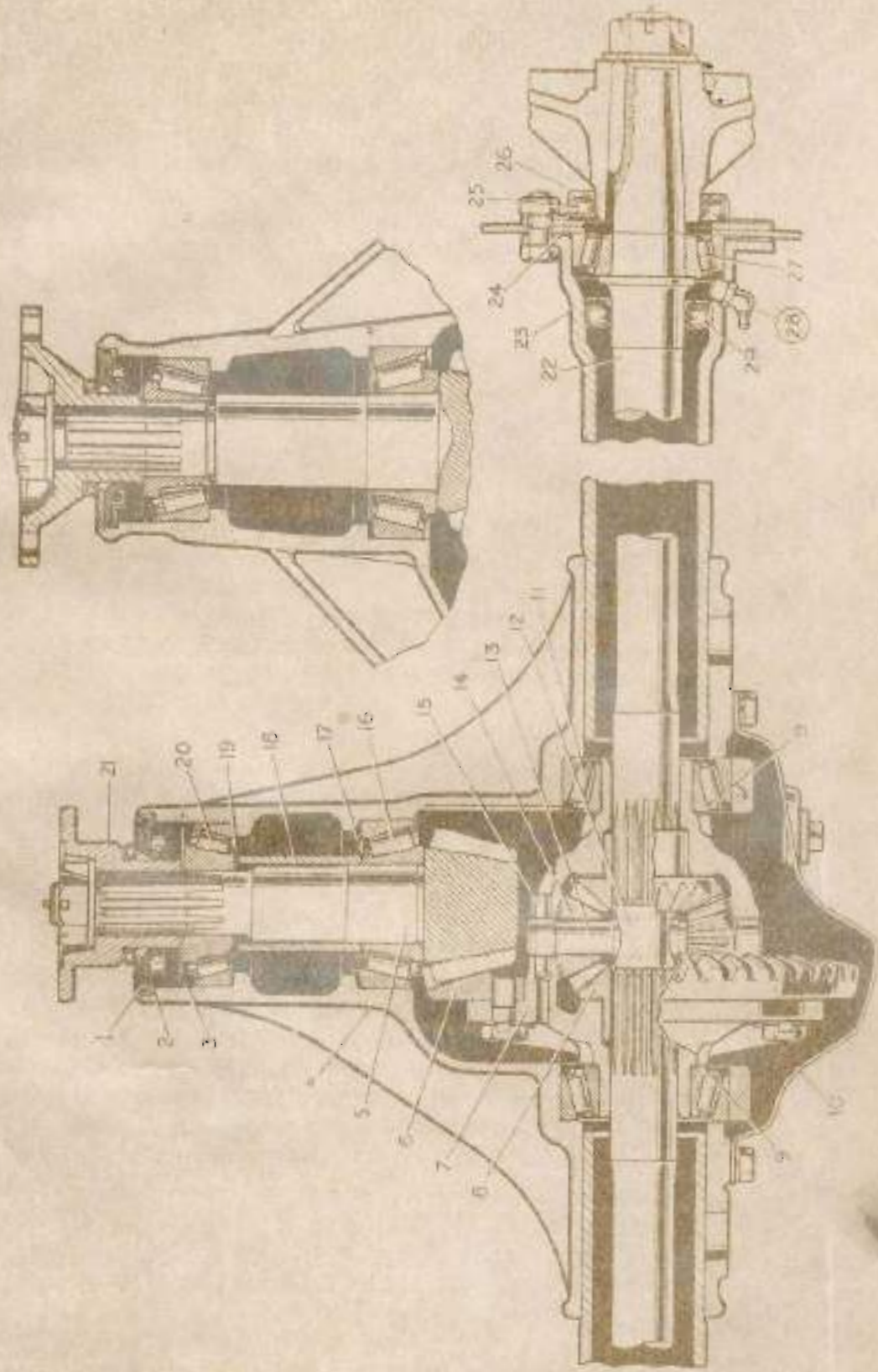

PONTE E DIFFERENZIALE

818 00 071 W
 818 00 071 S
 818 00 071 S
 818 00 071 S
 818 00 071 S

818 00 071 S
 818 00 071 S
 818 00 071 S

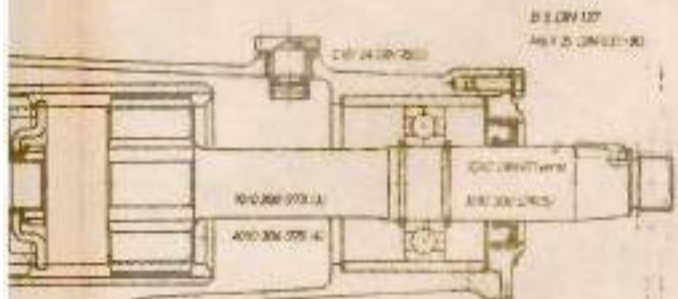

818 00 071 S
 818 00 071 S

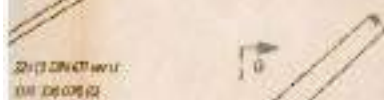

818 00 071 S
 818 00 071 S

818 00 071 S

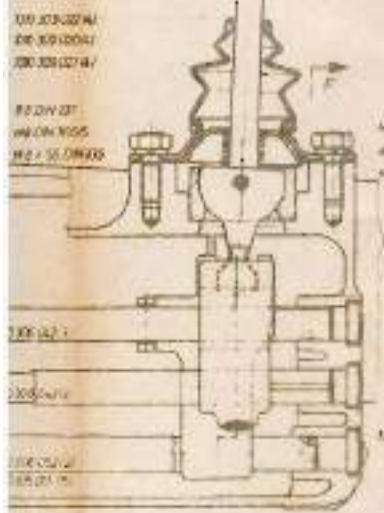

818 00 071 S
 818 00 071 S
 818 00 071 S

818 00 071 S
 818 00 071 S
 818 00 071 S

818 00 071 S
 818 00 071 S

818 00 071 S
 818 00 071 S

818 00 071 S

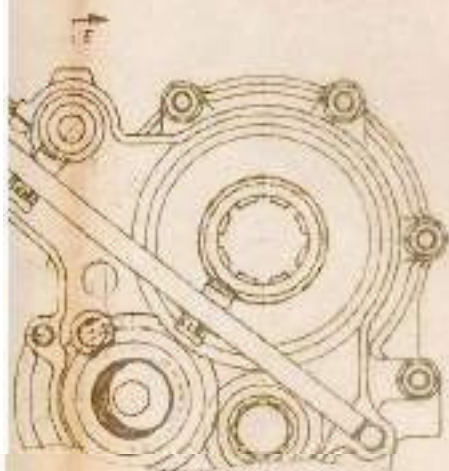

Schnitt C

818 00 071 S
 818 00 071 S
 818 00 071 S
 818 00 071 S

818 00 071 S

818 00 071 S

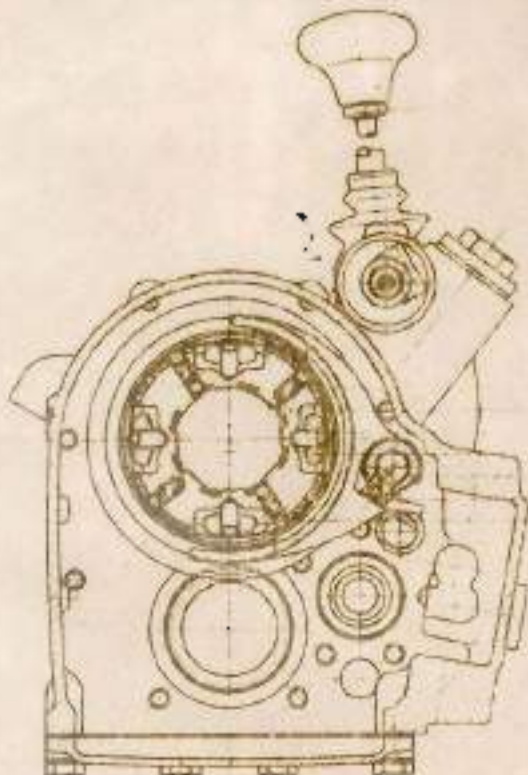

818 00 071 S
 818 00 071 S

818 00 071 S
 818 00 071 S
 818 00 071 S
 818 00 071 S
 818 00 071 S
 818 00 071 S

Schnitt A

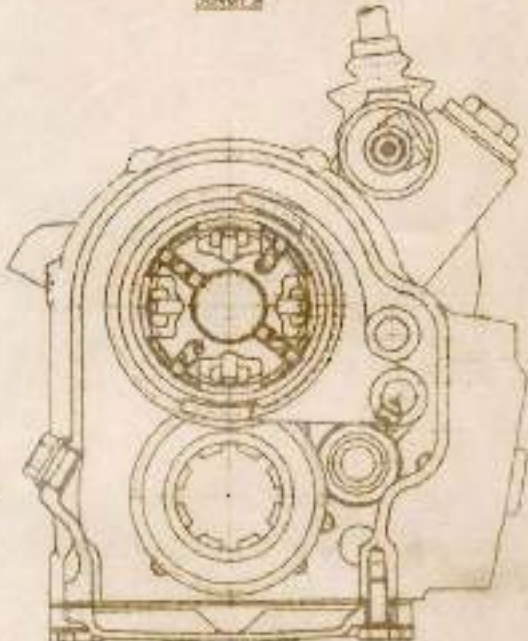

818 00 071 S
 818 00 071 S
 818 00 071 S
 818 00 071 S
 818 00 071 S
 818 00 071 S

Schnitt B

818 00 071 S
 818 00 071 S

ITALIA

- BARI** - Vendita e Servizio: S.C.A.I. Società Commercio
Automobili Idroscali
Piazza Massari 6 - Telef. 14.195
- BOLOGNA** - Vendita: Rag. CESARE PENDISA
Via Fossolo 7/2.
- BOLZANO** - Servizio: OFFICINA ALLEGRI & SPADON
Presso Garage "FLORENZA"
Via Vicenza 25 - Telef. 31749
- FIRENZE** - Vendita e Servizio: GRANDE GARAGE INDIPENDENZA
Via E. Poggi 16 - Telef. 45.825
- GENOVA** - Vendita e servizio: AUTOMAR S.R.L.
Piazza Murani 1 - Telef. 303528 - 302852
- MILANO** - Vendita: S.R.L. Comm. FRANCO CORNACCHIA
Via Piave 27 - Telef. 798848
Servizio: GARAGE CORNACCHIA
Via Fontana 20 - Telef. 70.91.88
- MODENA** - Servizio: OFFICINE ALFIERI MASERATI S.P.A.
Via G. Menotti 322 - Telef. 24262 - 23451
- NAPOLI** - Vendita: SORRENTINO VINCENZO
Via Chiatamone 53 - 54 - Telef. 393287
Servizio: OFFICINA SABATINO PAGANELLI
Via S. Pasquale a Chiaia 9 - Telef. 83780
- PALESTRO** - Vendita e Servizio: ADRIA S.P.A.
Via E. Amari 27
- ROMA** - Vendita: S.R.L. Comm. FRANCO CORNACCHIA
Via Pinciano 65 - Telef. 84.12.46
Servizio: OFFICINA FRANCO MELONI
Lungotevere della Vittoria 6 - Telef. 386366
- TORINO** - Vendita e Servizio: AUTOSALONE BONDESE
Via Nizza 31 - Telef. 683.213 - 683.681
- TRENTO** - Servizio: Off. ALBERTO HARTMAN
Corso Buonarroti 54 - Telef. 26355
- VICENZA** - Vendita e Servizio: Sig. ORFEO FERASIN
Viale Verdi 16 - Telef. 21001
- PADOVA** - OFFICINA MARCHIORI OSCAR - Strada S. Marco n.39
Telef. 28382.

MASERATIAUTOMOBILI
MODENA

ORGANIZZAZIONE DI VENDITA ED ASSISTENZA

ARGENTINA

BUENOS AYRES - MASERATI ARGENTINA S.A.I.C. - Y.F.
Roque Saenz Pena 1219 - 8° P.

CANADA

VANCOUVER - Distributore e Servizio:
MERCEDES - BENZ DISTRIBUTORS WESTERN LTD.
1190 West Georgia Street - Telef. MARINE 0406.

FRANCIA

PARIGI - Distributore e Servizio:
J. THEPENIER & J. SIMONE
2728 Qua Carnot - Saint Cloud (S. & O.)
Telef. MOLITOR 39. 91.

LYON - Vendita e Servizio:
HENRY PEIGNAUX - 29 Rue Danton

MARSEILLE - Vendita e Servizio:
GARAGE DE ST. BARNABE* - 2 Rue Montaigne

NIZZA - Vendita:
UNIVERSAL MOTORS - 29 Rue Pastorelli
- Servizio Assistenza: - Spett/ I.M.A.O.
1; Boulevard Armée des Alpes
Telef. 557-32 - 557-33

PERPIGNAN - Vendita e Servizio:
GRAN GARAGE FA

BORDEAUX - GARAGE FRANCE AUTO
47, 49 Rue Huguerie
BORDEAUX (Gironde)

INGHILTERRA

FLEETWOOD (Lancashire) Distributore e Servizio:
MURRAY MOTORS
Beach Road - Telef. FLEETWOOD 2752

LONDRA - Servizio:
GARAGE GIULIO RAMPONI
47 Lancaster Mews - Lancaster Garden
Telef. AMBASSADOR 4392

MEXICO

MEXICO D.F. - Distributore e Servizio:
AUTOMOTRIZ O'FARRILL
Alfonso Herrera 67.

SVEVIA

STOCKHOLM

-

Distributore e Servizio:
ITALIENSKA SPORTVAORAR
Kungätern 44SVIZZERA

CHIASSO

-

Distributore e Servizio:
MARTINELLI & BONVICI
Via Dante 4 - Telef. (091) 4 21 04

LUGANO

Riva Cassia 12 - Telef. (091) 2 74 64

BASILEA

Vendita e Servizio:
GARAGE TOSIN
Cottlingerstr. 49 - Telef. (061) 33 90 80

GINEVRA

Vendita:
BASADONNA - ITALCAR
5 Rue Mette D'Aubignà - Telef. (022) 36 39 05
Servizio:
GARAGE CH. PASCHE
27 Bis Rue de Lyon - Telef. (022) 34 76 90

LA CHAUX-DE-FONDS

Servizio:
SCHEIDER - ETBLS. DU GRAND PONT
Av. Robert 165 - Telef. (039) 2 31 35

LOSANNA

Vendita e Servizio:
J.P. PAVRE - GARAGE LES FOISES
16 Av. Bellefontaine - Telef. (021) 22 84 40

OPFRINGEN

Vendita e Servizio:
W RUF GARAGE - Telef. (062) 7 35 20

S. GALLO

Servizio:
H. GRUNNIFELDER
Fürstentandenstr. N. 149 - Telef. (071) 22 44 44

SURIKO

Vendita e Servizio:
ERNEST BYARSON
Badenstr. N. 531 - Telef. (051) 52 10 88BELGIO

Bruxelles

-

Vendita e Servizio:
Ets. BARRISMAN DEMOEN
207 Avenue Brugman



- 13 - Spark plugs - Clean and set the points to a gap of 0.5 mm. (0.02)
- 14 - Distribution points - clean and set the gap to 0.4 mm. (0.015)
- 15 - Generator belt - Adjust the tension
- 16 - Timing chain - Check and adjust tension
- 17 - Water pump packing gland - Make sure that it is water tight and if necessary replace it.
- 18 - Clutch pedal free play - Make sure there is 10 mm. (0.4 in) travel in the pedal before the clutch starts to disengage. Free play in clutch pedal should be 10 mm. (0.4 in).
- 19 - Front brakes - Automatically adjusted
- 20 - Steering box - Regulate the play by means of the screw bolt. The max. torque stress not to exceed 7 Kilograms (kilogrameters) (48 lb/fr).

Every 10.000.= Kilometers (6000 miles).

- 21 - Ignition distributors - Dismantle and lubricate bearings and bushes.
- 22 - Gear box - Check level and if necessary top up with oil
- 23 - Rear axle - Check the level and if necessary top up with oil.
- 24 - Commutator - Inspect, clean and lubricate with the special oil can and grease from side of driving belt.
- 25 - Valves - Adjust valve clearance
- 26 - Rear brakes - Adjust the gap between the brake-shoe and brake drum by turning the regulating screw as far as it will go and turn back half a turn. This will give the correct clearance.
- 27 - Hand brake - Lubricate the cable through the 3 grease nipples.
- 28 - Petrol filter - Check and if necessary replace cartridge.

Every 20.000.= Kilometers (12.000 miles)

- 29 - Gear box - drain oil and refill
- 30 - Differential - Drain oil and refill
- 31 - Steering box - Drain oil and refill
- 32 - Front wheel bearings - Repack with grease
- 33 - Disk brakes - check pads and if necessary replace them.

Further details regarding the operations Nos. 8-15-16-18-19-26 referred to above

- 8 - Steering - During the course of normal overhauling it is necessary to examine all steering parts in order to clean and lubricate the tierod joints as well as the steering box unit.

MASERATI

AUTOMOBILI
MODENA

VETTURA MASERATI 3500 G.T.
PASTIGLIA PER REGOLAZIONE GIOCO

3A

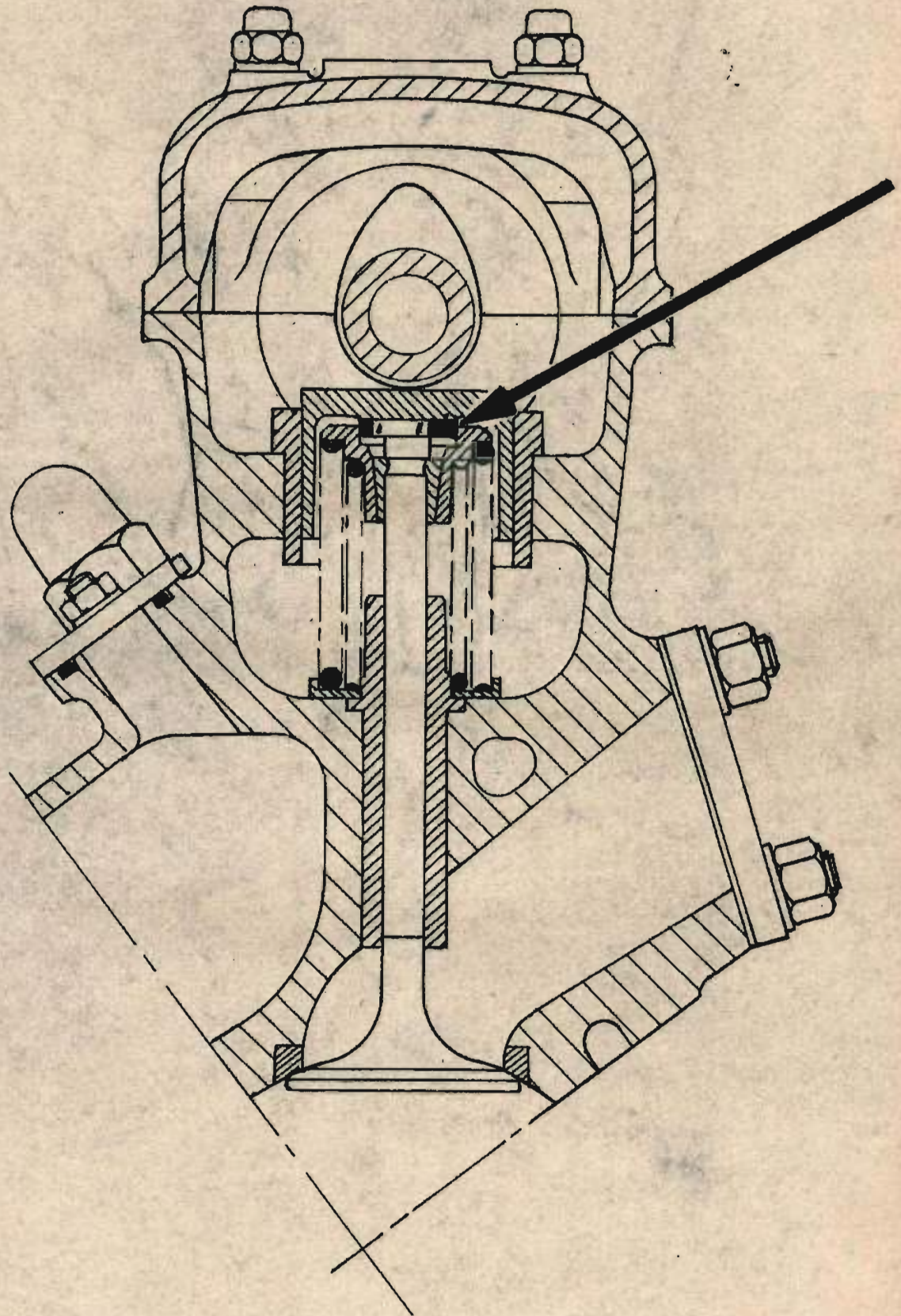

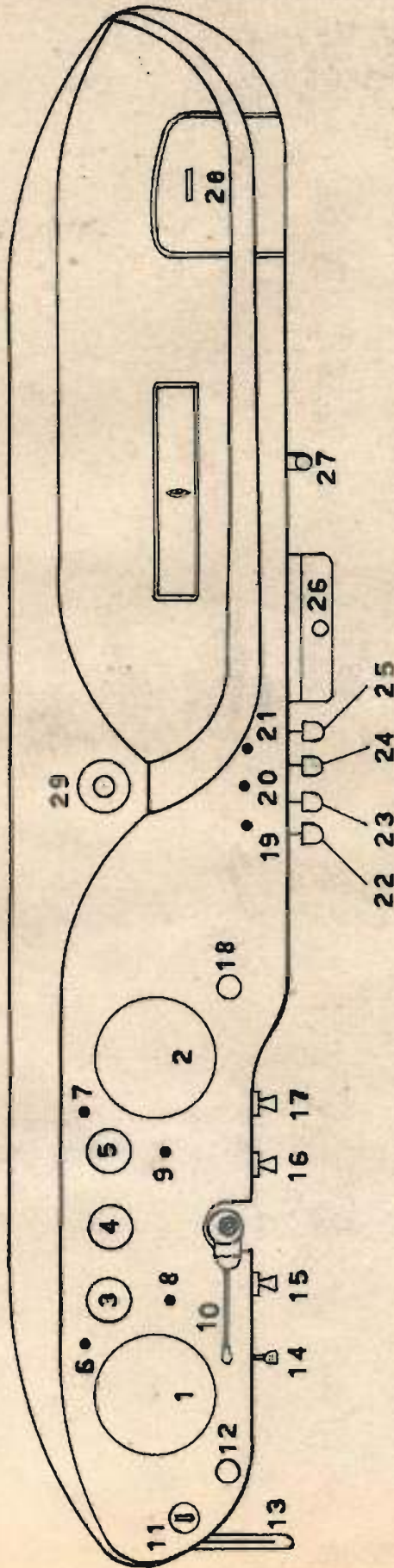

INSTRUMENT AND CONTROL PANEL

1	SPEEDOMETER	17	FOG AND LOWER DEAN SWITCH
2	REVS. COUNTER	18	DASHBOARD LIGHTS
3	MILLETER THE BAROMETER	19	LOWER FAN WARNING LIGHT
4	FUEL GAUGE	20	CENTRAL FAN WARNING LIGHT
5	OIL GAUGE	21	CENTRIFUGAL FAN WARNING LIGHT
6	DIRECTION INDICATOR WARNING LIGHT	22	AIR AND FAN CONTROL OVER DRIVER
7	GENERATOR WARNING LIGHT	23	PASSENGER'S AIR - FAN CONTROL - UNDER
8	HIGH LIGHT INDICATOR	24	BONNET HOT AIR RELEASE.
9	POSITION LIGHT INDICATOR	25	RADIATOR INLET AND FAN CONTROL
10	DIRECTION LIGHT AND HEAD LIGHT CONTROL LEVER	26	HOT WATER CONTROL
11	IGNITION KEY	27	HOT AND COLD AIR RADIATOR INLET OPENING
12	WINDSCREEN WASHER CONTROL	28	MANUAL CHOKE
13	BONNET OPENING LEVER	29	PANEL BOX
14	RESET KNOB FOR TRIP COUNTER		CIGAR LIGHTER
15	WINDSCREEN WIPERS		
16	INTERIOR ILLUMINATION SWITCH		