

DIAGNOSTIC TROUBLE CODE DIAGNOSIS

CLEARING TROUBLE CODES

Notice: To prevent Engine Control Module (ECM) damage, the key must be OFF when disconnecting or reconnecting the power to the ECM (for example battery cable, ECM pigtail connector, ECM fuse, jumper cables, etc.). When the ECM sets a Diagnostic Trouble Code (DTC), the Malfunction Indicator Lamp (MIL) lamp will be turned on only for type A, B and E but a DTC will be stored in the ECM's memory for all types of DTC. If the

problem is intermittent, the MIL will go out after 10 seconds if the fault is no longer present. The DTC will stay in the ECM's memory until cleared by scan tool. Removing battery voltage for 10 seconds will clear some stored DTCs.

DTCs should be cleared after repairs have been completed. Some diagnostic tables will tell you to clear the codes before using the chart. This allows the ECM to set the DTC while going through the chart, which will help to find the cause of the problem more quickly.

DIAGNOSTIC TROUBLE CODES

DTC	Function	Error Type	Illuminate MIL
P0107	Manifold Absolute Pressure Sensor Low Voltage	A	YES
P0108	Manifold Absolute Pressure Sensor High voltage	A	YES
P0112	Intake Air Temperature Sensor Low Voltage	E	YES
P0113	Intake Air Temperature Sensor High voltage	E	YES
P0117	Engine Coolant Temperature Sensor Low Voltage	A	YES
P0118	Engine Coolant Temperature Sensor High voltage	A	YES
P0122	Throttle Position Sensor Low Voltage	A	YES
P0123	Throttle Position Sensor Hig voltage	A	YES
P0131	Oxygen Sensor Low Voltage	A	YES
P0132	Oxygen Sensor High Voltage	A	YES
P0133	Oxygen Sensor No Activity	E	YES
P0137	Heated Oxygen Sensor Low Voltage	E	YES
P0138	Heated Oxygen Sensor high voltage	E	YES
P0140	Heated Oxygen Sensor No Activity	E	YES
P0141	Heated Oxygen Sensor Heater Malfuction	E	YES
P0171	Fuel Trim System Too Lean	E	YES
P0172	Fuel Trim System Too Rich	E	YES
P1230	Fuel Pump Relay Low Voltage	A	YES
P1231	Fuel Pump Relay High Voltage	A	YES
P0261	Injector 1 Low Voltage	A	YES
P0262	Injector 1 high voltage	A	YES
P0264	Injector 2 Low Voltage	A	YES
P0265	Injector 2 high voltage	A	YES
P0267	Injector 3 Low Voltage	A	YES
P0268	Injector 3 high voltage	A	YES
P0300	Multifle Cylinder Misfire	A/E	BLINKING/ON
P1320	Crankshatft Segment Period Segment Adaptation At Limit	E	YES
P1321	Crankshatft Segment Period Tooth Error	E	YES
P0327	Knock Sensor Circuit Fault	E	YES
P0335	Magnetic Crankshaft Position Sensor Electrical Error	E	YES

Diagnostic Trouble Codes (Cont'd)

DTC	Function	Error Type	Illuminate MIL
P0336	58X Crankshaft Position Sensor Extra/missing Pulse	E	YES
P0337	58X Crankshaft Sensor No Signal	E	YES
P0341	Camshaft Position Sensor Rationality	E	YES
P0342	Camshaft Position Sensor No Signal	E	YES
P0351	Ignition Signal Coil A Fault	A	YES
P0352	Ignition Signal Coil B Fault	A	YES
P0353	Ignition Signal Coil C Fault	A	YES
P1382	Rough Road Data Invalid (Non ABS)	Cnl	NO
P1382	Rrough Road Data Invalid (ABS)	Cnl	NO
P1385	Rough Road Sensor Circuit Fault (Non ABS)	Cnl	NO
P1385	Rough Road Sensor Circuit Fault (ABS)	Cnl	NO
P0400	Exhaust Gas Recirculation Out of Limit	E	YES
P1402	Exhaust Gas Recirculation Blocked	E	YES
P1403	Exhaust Gas Recirculation Valve Failure	E	YES
P0404	Electric Exhaust Gas Recirculation (EEGR) Opend	E	YES
P1404	Electric Exhaust Gas Recirculation (EEGR) Closed	E	YES
P0405	EEGR Pintle Position Sensor Low Voltage	E	YES
P0406	EEGR Pintle Position Sensor High voltage	E	YES
P0420	Catalyst Low Efficiency	E	YES
P0444	EVAP Purge Control Circuit No Signal	E	YES
P0445	EVAP Purge Control Circuit Fault	E	YES
P0462	Fuel Level Sensor Low Voltage	Cnl	NO
P0463	Fuel Level Sensor High voltage	Cnl	NO
P0480	Low Speed Cooling Fan Relay Circuit Fault (Without A/C)	Cnl	NO
P0480	Low Speed Cooling Fan Relay Circuit Fault (With A/C)	Cnl	NO
P0481	High Speed Cooling Fan Relay High Voltage (Without A/C)	Cnl	NO
P0481	High Speed Cooling Fan Relay High Voltage (With A/C)	Cnl	NO
P0501	Vehicle Speed No Signal (M/T Only)	A	YES
P0505	Idle Air Control Valve (IACV) Error	E	YES
P1535	Evaporator Temperature Sensor High Voltage	Cnl	NO
P1536	Evaporator Temperature Sensor Low Voltage	Cnl	NO
P1537	A/C Compressor Relay High Voltage	Cnl	NO
P1538	A/C Compressor Relay Low Voltage	Cnl	NO
P0562	System Voltage (Engine Side) Too Low	Cnl	NO
P0563	System Voltage (Engine Side) Too High	Cnl	NO
P0601	Engine Control Module Checksum Error	E	YES
P0604	Engine Control Module RAM Error	E	YES
P0605	Engine Control Module NMVY Write Error	E	YES
P1610	Main Relay High Voltage	A	YES
P1611	Main Relay Low Voltage	A	YES
P1628	Immobilizer No Successful Communication	Cnl	NO
P1629	Immobilizer Wrong Computation	Cnl	NO
P0656	Fuel Level Gauge High Circuit Fault	Cnl	NO

Diagnostic Trouble Codes (Cont'd)

DTC	Function	Error Type	Illuminate MIL
P1660	Malfunction Indicator Lamp(MIL) High Voltage	E	YES
P1661	Malfunction Indicator Lamp(MIL) Low Voltage	E	YES

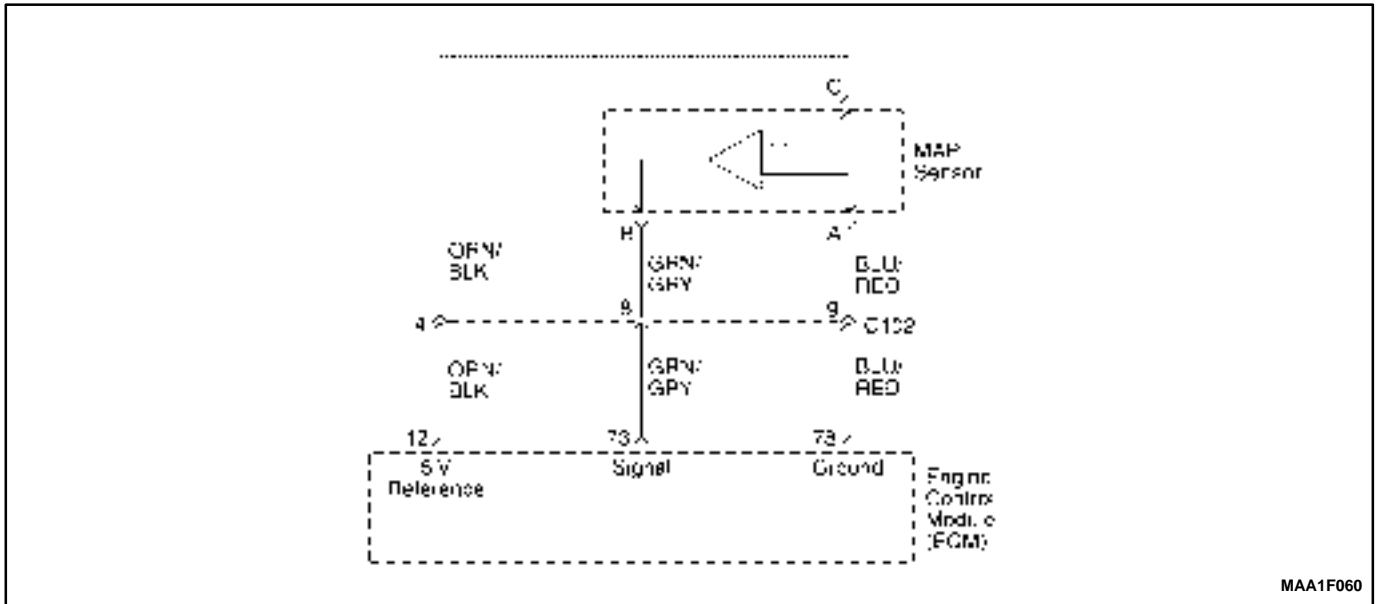

MAA1F060

DIAGNOSTIC TROUBLE CODE (DTC) – P0107 MANIFOLD ABSOLUTE PRESSURE SENSOR LOW VOLTAGE

Circuit Description

The engine control module (ECM) uses the Manifold Absolute Pressure (MAP) sensor to control the fuel delivery and the ignition timing. The MAP sensor measures the changes in the intake manifold pressure, which results from engine load (intake manifold vacuum) and the rpm changes; and converts these into voltage outputs. The ECM sends a 5 volt-reference voltage to the MAP sensor. As the manifold pressure changes, the output voltage of the MAP sensor also changes. By monitoring the MAP sensor output voltage, the ECM knows the manifold pressure. A low-pressure (low voltage) output voltage will be about 1.0 to 1.5 volts at idle, while higher pressure (high voltage) output voltage will be about 4.5 to 5.0 at wide open throttle (WOT). The MAP sensor is metric pressure, allowing the ECM to make adjustments for different altitudes.

Conditions for Setting the DTC

- This DTC can be stored in “key-on” status.

(Case A)

- When the engine idling.
- No throttle position (TP) sensor fail conditions present.
- Engine speed (rpm) is less than 2,500rpm.
- The MAP is less than 15kPa.

(Case A)

- When the engine part load.
- The engine revolution speed is less than 4,000rpm.
- No Throttle Position (TP) Sensor fails conditions present.
- The Throttle Position (TP) angle greater than 20.0

- The MAP is less than 15 kPa.

An open or low voltage condition exists.

Action Taken when the DTC Sets

- The Malfunction Indicator Lamp (MIL) will illuminate.
- The ECM will record operating conditions at the time the diagnostic fails. This information will be stored in the Freeze Frame and Failure Records buffers.
- A history DTC is stored.
- The coolant fan turns ON.
- The ECM will substitute a fixed MAP value and use TP to control the fuel delivery (the scan tool will not show defaulted)

Conditions for Clearing the MIL/DTC

- The MIL will turn off after four consecutive ignition cycles in which the diagnostic runs without a fault.
- A history DTC will clear after 40 consecutive warm-up cycles without a fault.
- DTC(s) can be cleared by using the scan tool.

Diagnostic Aids

With the ignition ON and the engine stopped, the manifold pressure is equal to atmosphere pressure and the signal voltage will be high.

The ECM as an indication of vehicle altitude uses this information. Comparison of this reading with a known good vehicle with the same sensor is a good way to check the accuracy of a suspect sensor. Readings should be the same ± 0.4 volt.

If a DTC P 0107 is intermittent, refer to “Manifold Absolute Pressure Check” in this Section for further diagnosis.

If the connections are OK monitor the manifold absolute pressure (MAP) sensor signal voltage while moving related connectors and the wiring harness. If the failure is

induced, the display on the scan tool will change. This may help to isolate the location of an intermittent malfunction.

DTC P0107 – Manifold Absolute Pressure Sensor Low Voltage

Step	Action	Value(s)	Yes	No
1	Perform an Euro On-Board Diagnostic (EOBD) System Check. Is the system check complete?	–	Go to <i>Step 2</i>	Go to “On-Board Diagnostic System Check”
2	1. Connect the scan tool to the data link connector (DLC). 2. Turn the ignition switch to ON. Does the scan tool show the manifold absolute pressure (MAP) sensor voltage above the value specified?	4V	Go to <i>Step 3</i>	Go to <i>Step 4</i>
3	1. Disconnect the vacuum line from the MAP sensor. 2. Apply 88kPA (20in.of Hg) of vacuum to the MAP sensor. Does the scan tool show the MAP sensor voltage within the value specified?	1.0–1.5V	Go to “Diagnostic Aids”	Go to <i>Step 4</i>
4	1. Turn the ignition switch to LOCK. 2. Disconnect the MAP sensor connector. 3. Turn the ignition switch to ON. 4. Measure the voltage between the MAP sensor connector terminals A and C. Does the voltage measure within the value specified?	4.5–5.0V	Go to <i>Step 5</i>	Go to <i>Step 6</i>
5	Connect a fused jumper between the MAP sensor connector terminals B and C. Does the scan tool show the MAP sensor voltage above the value specified?	4V	Go to <i>Step 11</i>	Go to <i>Step 9</i>
6	Measure the voltage between the MAP sensor connector terminal A and ground. Does the voltage measure within the value specified?	4.5–5.0V	Go to <i>Step 7</i>	Go to <i>Step 8</i>
7	1. Turn the ignition switch to LOCK. 2. Check for open wires between the MAP sensor connector terminal A and the ECM connector terminal 78. Is the problem found?	–	Go to <i>Step 10</i>	Go to <i>Step 12</i>
8	1. Turn the ignition switch to LOCK. 2. Check for an open or short to ground in the wire between the MAP sensor connector terminal C and the ECM connector terminal 12. Is the problem found ?	–	Go to <i>Step 10</i>	Go to <i>Step 12</i>
9	1. Turn the ignition switch to LOCK. 2. Check for an open or short to ground in the wire between the MAP sensor connector terminal B and the ECM connector terminal 73. Is the problem found ?	–	Go to <i>Step 10</i>	Go to <i>Step 12</i>

DTC P0107 – Manifold Absolute Pressure Sensor Low Voltage (Cont'd)

Step	Action	Value(s)	Yes	No
10	1. Repair the wire or the connector terminal as needed. 2. Clear any DTCs from the ECM. 3. Perform the diagnostic system check. Is the repair complete?	–	System OK	–
11	1. Replace the manifold absolute pressure sensor. 2. Clear any DTCs from the ECM. 3. Perform the diagnostic system check. Is the replacement complete?	–	System OK	–
12	Replace the ECM. Is the replacement complete?	–	Go to <i>Step 13</i>	Go to <i>Step 2</i>
13	Check if any additional DTCs are set. Are any DTCs displaced that have not been diagnosed?	–	Go to applicable DTC table	System OK

BLANK

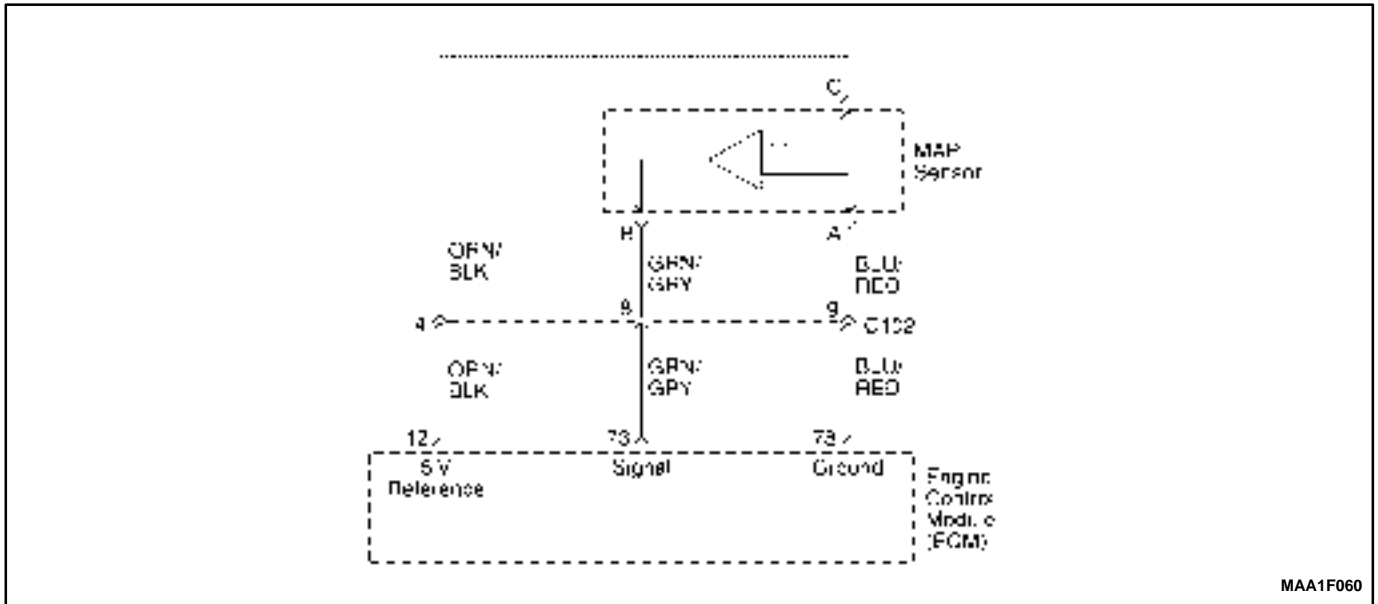

MAA1F060

DIAGNOSTIC TROUBLE CODE (DTC) – P0108 MANIFOLD ABSOLUTE PRESSURE SENSOR HIGH VOLTAGE

Circuit Description

The engine control module (ECM) uses the Manifold Absolute Pressure (MAP) sensor to control the fuel delivery and the ignition timing. The MAP sensor measures the changes in the intake manifold pressure, which results from engine load (intake manifold vacuum) and the rpm changes; and converts these into voltage outputs. The ECM sends a 5 volt-reference voltage to the MAP sensor. As the manifold pressure changes, the output voltage of the MAP sensor also changes. By monitoring the MAP sensor output voltage, the ECM knows the manifold pressure. A low-pressure (low voltage) output voltage will be about 1.0 to 1.5 volts at idle, while higher pressure (high voltage) output voltage will be about 4.5 to 4.8 at wide open throttle (WOT). The MAP sensor is metric pressure, allowing the ECM to make adjustments for different altitudes.

Conditions for Setting the DTC

- This DTC can be stored in “key-on” status.
- Engine speed is greater than 2,000rpm.
- No throttle position sensor (TPS) fail conditions present.
- The MAP is greater than 600m bar.
- A high voltage condition exists.

Action Taken when the DTC Sets

- The Malfunction Indicator Lamp (MIL) will illuminate.
- The ECM will record operating conditions at the time the diagnostic fails. This information will be stored in the Freeze Frame and Failure Records buffers.

- A history DTC is stored.
- The ECM will substitute a fixed MAP value and use TP to control the fuel delivery (the scan tool will not show defaulted)

Conditions for Clearing the MIL/DTC

- The MIL will turn off after four consecutive ignition cycles in which the diagnostic runs without a fault.
- A history DTC will clear after 40 consecutive warm-up cycles without a fault.
- DTC(s) can be cleared by using the scan tool.

Diagnostic Aids

With the ignition ON and the engine stopped, the manifold pressure is equal to atmosphere pressure and the signal voltage will be high.

The ECM as an indication of vehicle altitude uses this information. Comparison of this reading with a known good vehicle with the same sensor is a good way to check the accuracy of a suspect sensor. Readings should be the same ± 0.4 volt.

If a DTC P 0108 is intermittent, refer to “*manifold absolute pressure check*” in this Section for further diagnosis.

If the connections are OK monitor the manifold absolute pressure(MAP) sensor signal voltage while moving related connectors and the wiring harness. If the failure is induced, the display on the scan tool will change. This may help to isolate the location of an intermittent malfunction.

DTC P0108 – Manifold Absolute Pressure Sensor High Voltage

Step	Action	Value(s)	Yes	No
1	Perform an Euro On-Board Diagnostic (EOBD) System Check. Is the system check complete?	–	Go to <i>Step 2</i>	Go to “On-Board Diagnostic System Check”
2	1. Connect the scan tool to the data link connector (DLC). 2. Turn the ignition switch to ON. Does the scan tool show the manifold absolute pressure (MAP) sensor voltage above the value specified?	4V	Go to <i>Step 3</i>	Go to <i>Step 4</i>
3	1. Disconnect the vacuum line from the MAP sensor. 2. Apply 66kPA (20in.of Hg) of vacuum to the MAP sensor. Does the scan tool show the MAP sensor voltage within the value specified?	1.0–1.5V	Go to “Diagnostic Aids”	Go to <i>Step 4</i>
4	1. Turn the ignition switch to LOCK. 2. Disconnect the MAP sensor connector. 3. Turn the ignition switch to ON. 4. Measure the voltage between the MAP sensor connector terminals A and C. Does the voltage measure within the value specified?	4.5–5.0V	Go to <i>Step 5</i>	Go to <i>Step 6</i>
5	Connect a fused jumper between the MAP sensor connector terminals B and C. Does the scan tool show the MAP sensor voltage above the value specified?	4V	Go to <i>Step 11</i>	Go to <i>Step 9</i>
6	Measure the voltage between the MAP sensor connector terminal A and ground. Does the voltage measure within the value specified?	4.5–5.0V	Go to <i>Step 7</i>	Go to <i>Step 8</i>
7	1. Turn the ignition switch to LOCK. 2. Check for open wires between the MAP sensor connector terminal A and the ECM connector terminal 78. Is the problem found?	–	Go to <i>Step 10</i>	Go to <i>Step 12</i>
8	1. Turn the ignition switch to LOCK. 2. Check for an open or short to ground in the wire between the MAP sensor connector terminal C and the ECM connector terminal 12. Is the problem found ?	–	Go to <i>Step 10</i>	Go to <i>Step 12</i>
9	1. Turn the ignition switch to LOCK. 2. Check for an open or short to ground in the wire between the MAP sensor connector terminal B and the ECM connector terminal 73. Is the problem found ?	–	Go to <i>Step 10</i>	Go to <i>Step 12</i>
10	1. Repair the wire or the connector terminal as needed. 2. Clear any DTCs from the ECM. 3. Perform the diagnostic system check. Is the repair complete?	–	System OK	–

DTC P0108 – Manifold Absolute Pressure Sensor High Voltage (Cont'd)

Step	Action	Value(s)	Yes	No
11	1. Replace the manifold absolute pressure sensor. 2. Clear any DTCs from the ECM. 3. Perform the diagnostic system check. Is the replacement complete?	–	System OK	–
12	Replace the ECM. Is the replacement complete?	–	Go to <i>Step 13</i>	Go to <i>Step 2</i>
13	Check if any additional DTCs are set. Are any DTCs displaced that have not been diagnosed?	–	Go to applicable DTC table	System OK

BLANK

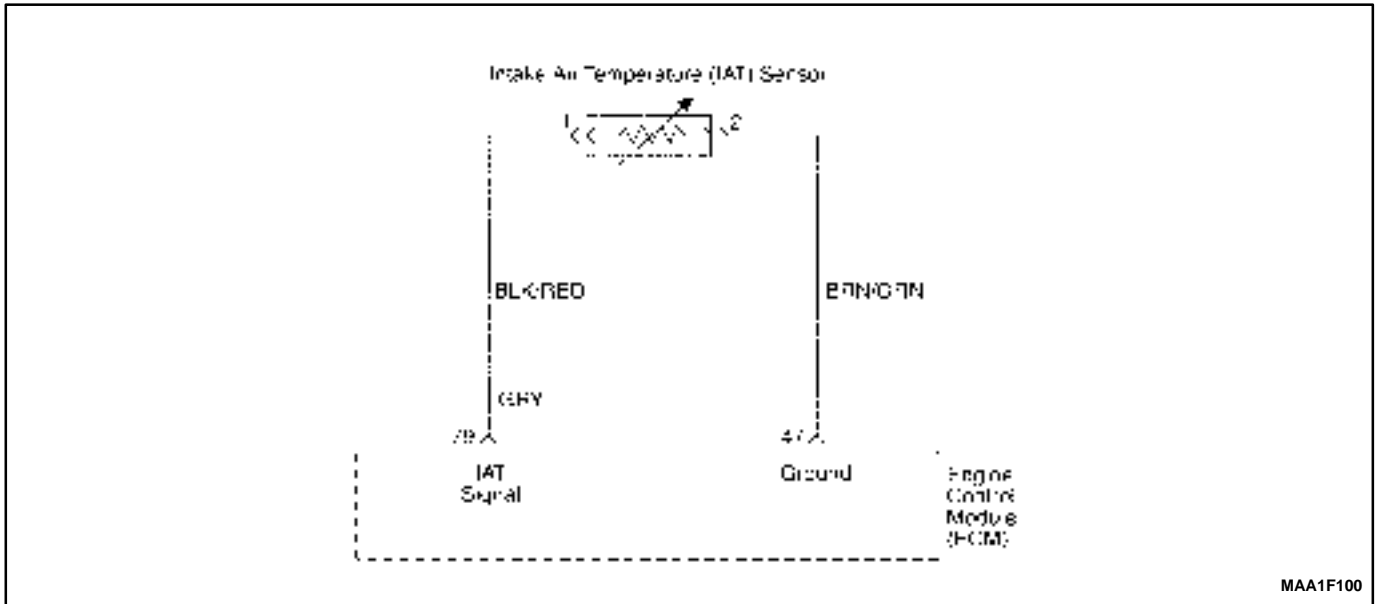

DIAGNOSTIC TROUBLE CODE (DTC) – P0112 INTAKE AIR TEMPERATURE SENSOR LOW VOLTAGE

Circuit Description

The Intake Air Temperature (IAT) Sensor uses a thermistor to control the signal voltage to the engine control module (ECM). The ECM supplies a 5 volt reference voltage and a ground to the sensor. When the air is cold, the resistance is high ; therefore IAT sensor signal voltage will be high. If the intake air is warm, resistance is low ; therefore the IAT sensor signal voltage will be low.

Conditions for Setting the DTC

- The engine run time is greater than 3 seconds.
- IAT voltage is less than 0.01V

Action Taken when the DTC Sets

- Emission related.
- “Armed” after two trip with a fail.
- “Disarmed” after one trip with a pass.
- MIL on if failure is detected in three consecutive trips.
- Stores a History DTC on the third consecutive with a fail (The DTC will be armed after the second fail).

- Stores a Freeze Frame on the third consecutive trip with a fail (if empty).
- The ECM will default to 60°C(140°F)for intake air temperature. The scan tool will not show the defaulted value.

Conditions for Clearing the MIL/DTC

- The MIL will turn off after four consecutive ignition cycles in which the diagnostic runs without a fault.
- A history DTC will clear after 40 consecutive warm up cycles without a fault.
- DTC(s) can be cleared by using the scan tool.

Diagnostic aids

If the vehicle is at ambient temperature, compare the IAT sensor to the engine coolant temperature(ECT) sensor. The IAT sensor and the ECT sensor should be relatively close to each other. Use the temperature vs. Resistance Values table to evaluate the possibility of a skewed sensor. Refer to “*Temperature vs. Resistance*” in this Section.

DTC P0112 – Intake Air Temperature Sensor Low Voltage

Step	Action	Value(s)	Yes	No
1	Perform an Euro On-Board Diagnostic (EOBD) System Check. Is the system check complete?	–	Go to <i>Step 2</i>	Go to “On-Board Diagnostic System Check”
2	1. Connect the scan tool to the data link connector(DLC). 2. Run the engine until it reaches operating temperature. Does the scan tool show the IAT sensor reading within the value specified?	15–80°C	Go to “Diagnostic Aids”	Go to <i>Step 3</i>
3	1. Turn the ignition switch to LOCK. 2. Disconnect the IAT sensor connector. 3. Turn the ignition switch to ON. Does the scan tool show the IAT sensor reading within the value specified?	≤ -30°C	Go to <i>Step 4</i>	Go to <i>Step 5</i>
4	Check for a faulty connector or terminals at the IAT sensor connector. Is the problem found?	–	Go to <i>Step 7</i>	Go to <i>Step 6</i>
5	Check for wire for a short to ground between the IAT connector terminal 1 and the ECM connector terminal 79. Is the problem found?	–	Go to <i>Step 7</i>	Go to <i>Step 6</i>
6	Check for wire for a short to ECM reference voltage between the IAT sensor connector terminal 2 and the ECM connector terminal 47. Is the problem found?	4.5–5.0V	Go to <i>Step 7</i>	Go to <i>Step 9</i>
7	1. Turn the ignition switch to LOCK. 2. Repair the wire or the connector terminal as needed. 3. Clear any DTCs from the ECM. 4. Run the engine until it reaches operating temperature. 5. Perform the diagnostic system check. Is the repair complete?	–	System OK	–
8	1. Turn the ignition switch to LOCK. 2. Replace the IAT sensor. 3. Clear any DTCs from the ECM. 4. Run the engine until it reaches operating temperature. 5. Perform the diagnostic system check. Is the repair complete?	–	System OK	–
9	1. Turn the ignition switch to LOCK. 2. Replace the engine control module(ECM). 3. Run the engine until it reaches operating temperature. 4. Perform the diagnostic system check. Is the repair complete?	–	Go to <i>Step 10</i>	–
10	Check if any additional DTCs are set. Are any DTCs displaced that have not been diagnosed?	–	Go to applicable DTC table	System OK

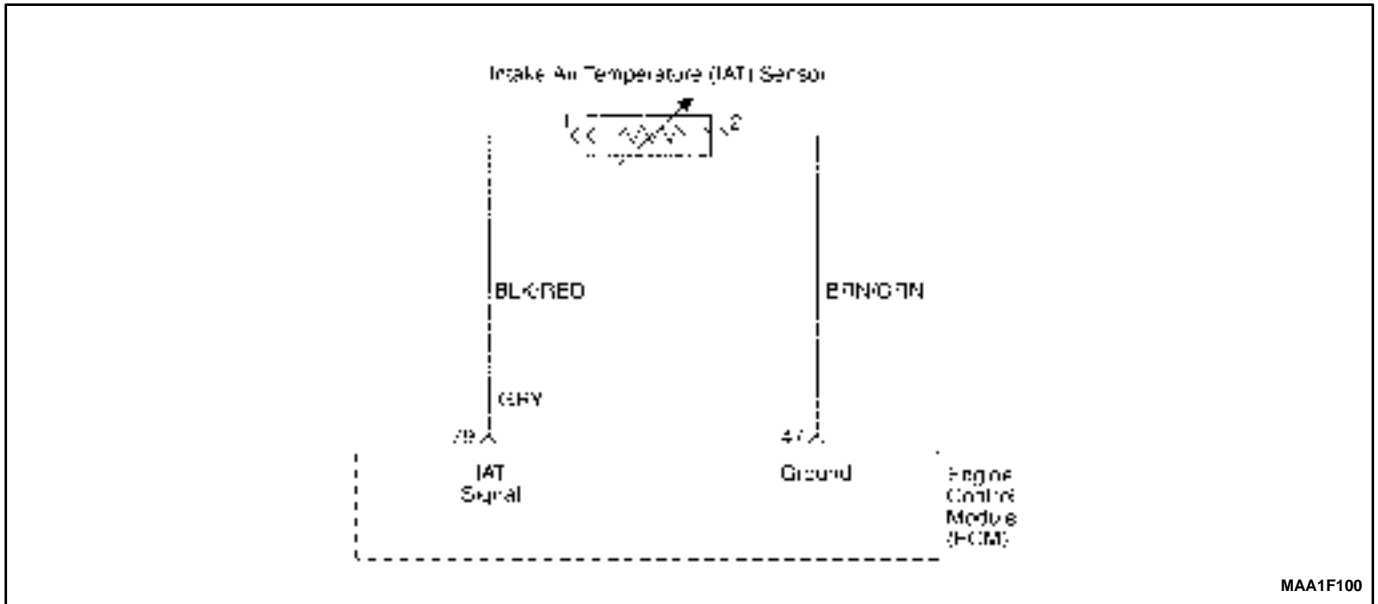

DIAGNOSTIC TROUBLE CODE (DTC) – P0113 INTAKE AIR TEMPERATURE SENSOR HIGH VOLTAGE

Circuit Description

The Intake Air Temperature (IAT) Sensor uses a thermistor to control the signal voltage to the engine control module (ECM). The ECM supplies a 5 volt reference voltage and a ground to the sensor. When the air is cold, the resistance is high; therefore IAT sensor signal voltage will be high. If the intake air is warm, resistance is low; therefore the IAT sensor signal voltage will be low.

Conditions for Setting the DTC

- The engine run time is greater than 3 seconds.
- IAT voltage is greater than 4.99V.

Action Taken when the DTC Sets

- Emission related.
- “Armed” after two trip with a fail.
- “Disarmed” after one trip with a pass.
- MIL on if failure is detected in three consecutive trips.
- Stores a History DTC on the third consecutive with a fail (The DTC will be armed after the second fail).

- Stores a Freeze Frame on the third consecutive trip with a fail (if empty).
- The ECM will default to last valid value for intake air temperature. The scan tool will not show the defaulted value.

Conditions for Clearing the MIL/DTC

- The MIL will turn off after four consecutive ignition cycles in which the diagnostic runs without a fault.
- A history DTC will clear after 40 consecutive warm up cycles without a fault.
- DTC(s) can be cleared by using the scan tool.

Diagnostic Aids

If the vehicle is at ambient temperature, compare the IAT sensor to the engine coolant temperature (ECT) sensor. The IAT sensor and the ECT sensor should be relatively close to each other.

Use the temperature vs. Resistance Values table to evaluate the possibility of a skewed sensor. Refer to “Temperature vs. Resistance” in this Section.

DTC P0113 – Intake Air Temperature Sensor High Voltage

Step	Action	Value(s)	Yes	No
1	Perform an Euro On-Board Diagnostic (EOBD) System Check. Is the system check complete?	–	Go to <i>Step 2</i>	Go to “On-Board Diagnostic System Check”
2	1. Connect the scan tool to the data link connector (DLC). 2. Run the engine unit it reaches operating temperature. Does the scan tool show the intake air temperature (IAT) sensor reading within the value specified?	15~80°C (10~176°F)	Go to “Diagnostic Aids”	Go to <i>Step 3</i>
3	1. Turn the ignition switch to LOCK. 2. Disconnect the IAT sensor connector. 3. Jumper to IAT sensor connector terminals. 4. Turn the ignition switch to ON. Does the scan tool show the IAT sensor reading the value specified?	180°C (356°F)	Go to <i>Step 4</i>	Go to <i>Step 5</i>
4	Check for a faulty connector or terminals 1 and 2 of the IAT sensor connector. Is the problem found?	–	Go to <i>Step 10</i>	Go to <i>Step 9</i>
5	Measure the voltage between terminals 1 and 2 of IAT sensor connector. Does the voltage measure within the value specified?	4.5~5.5V	Go to <i>Step 11</i>	Go to <i>Step 6</i>
6	Measure the voltage between the IAT sensor connector terminal 2 and the battery ground(negative) post. Does the voltage measure within the value specified?	4.5~5.5V	Go to <i>Step 7</i>	Go to <i>Step 8</i>
7	1. Turn the ignition switch to LOCK. 2. Check for an open or short to battery voltage in the wire between the IAT sensor connector terminal 2 and the engine control module(ECM) connector terminal 47. Is the problem found?	–	Go to <i>Step 10</i>	Go to <i>Step 11</i>
8	1. Turn the ignition switch to LOCK. 2. Check for an open or short to battery voltage in the wire between the IAT sensor connector terminal 1 and the ECM connector terminal 79. Is the problem found?	–	Go to <i>Step 10</i>	Go to <i>Step 11</i>
9	1. Turn the ignition switch to LOCK 2. Replace the IAT sensor. 3. Clear any DTCs from the ECM. 4. Perform the diagnostic system check. Is the repair complete?	–	System OK	–
10	1. Turn the ignition switch to LOCK. 2.Repair the wire of the connector terminals as needed. 3. Clear any DTCs from the ECM. 4. Perform the diagnostic system check. Is the repair complete?	–	System OK	–

DTC P0113 – Intake Air Temperature Sensor High Voltage (Cont'd)

Step	Action	Value(s)	Yes	No
11	1. Replace the ECM 2. Perform the diagnostic system check. Is the repair complete?	–	Go to <i>Step 12</i>	–
12	Check if any additional DTCs are set. Are any DTCs displaced that have not been diagnosed?	–	Go to applicable DTC table	System OK

BLANK

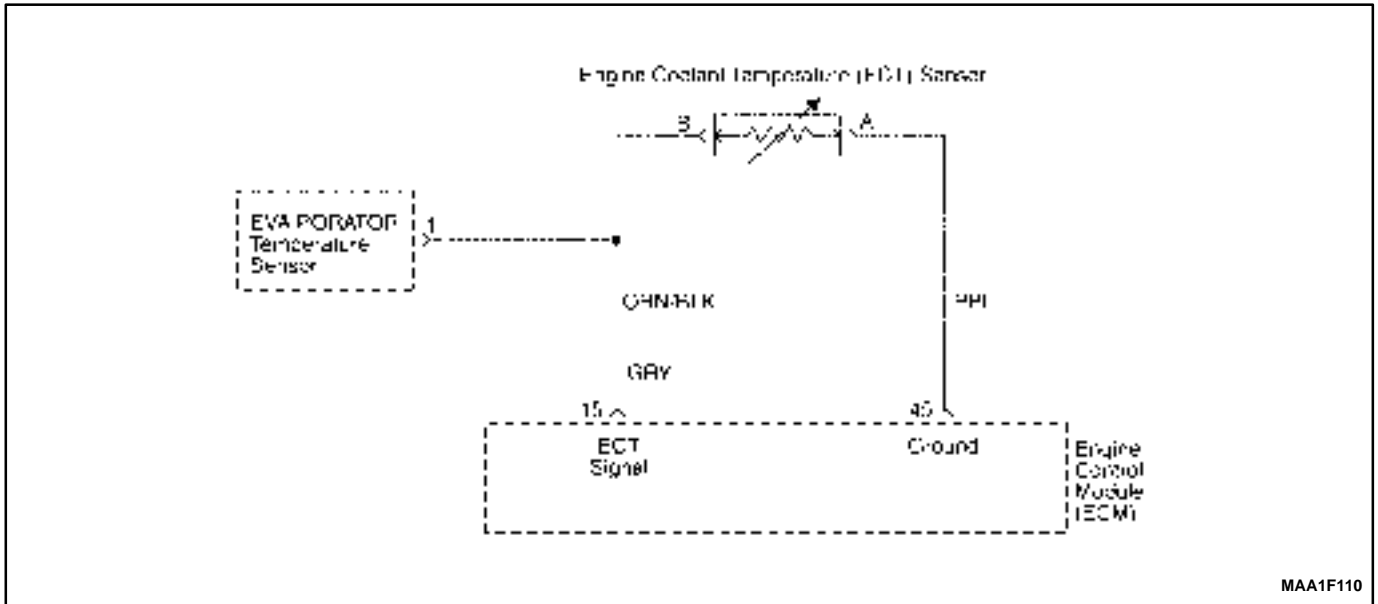

DIAGNOSTIC TROUBLE CODE (DTC) – P0117 ENGINE COOLANT TEMPERATURE SENSOR LOW VOLTAGE

Circuit Description

The Engine Coolant Temperature sensor (ECT) uses a thermistor to control the signal voltage to the engine control module (ECM).

The ECM supplies a voltage on the signal circuit to the sensor. When the engine coolant is cold, the resistance is high; therefore the ECT signal voltage will be high.

As the engine warms, the sensor resistance becomes less, and the voltage drops. At normal engine operating temperature, the voltage will be between 1.5 and 2.0 volts at the ECT signal terminal.

The ECT sensor is used to the following items:

- Fuel delivery.
- Lock Up Clutch (LUC).
- Ignition.
- Evaporator Emission (EVAP) Canister Purge Valve.
- Electric cooling fan.

Conditions for Setting the DTC

- This DTC can be stored in “key-on” status.
- The engine run time is greater than 3 seconds.
- A low voltage condition exists.
- ECT voltage is less than 0.03V.

Action Taken when the DTC Sets

- The Malfunction Indicator Lamp (MIL) will illuminate.

- The ECM will record operating conditions at the time the diagnostic fails. This information will be stored in the Freeze Frame and Failure Records buffers.
- A history DTC is stored.
- The coolant fan turns ON.
- The ECM will default to 20°C(68°F) for the first 60 seconds of the engine run time, and then 92°C(198°F).
- the scan tool will not show the defaulted value.

Conditions for Clearing the MIL/DTC

- The MIL will turn off after four consecutive ignition cycles in which the diagnostic runs without a fault.
- A history DTC will clear after 40 consecutive warm-up cycles without a fault.
- DTC(s) can be cleared by using the scan tool.

Diagnostic Aids

After the engine has started, the ECT should rise steadily to about 90°C(194°F) then stabilize when the thermostat opens.

Use the temperature vs. resistance values table to evaluate the possibility of a skewed sensor. Refer to “Temperature vs. Resistance” in this Section.

MAA1F110

DTC P0117 – Engine Coolant Temperature Sensor Low Voltage

Step	Action	Value(s)	Yes	No
1	Perform an Euro On-Board Diagnostic (EOBD) System Check. Is the system check complete?	–	Go to <i>Step 2</i>	Go to “On-Board Diagnostic System Check”
2	1. Connect the scan tool to the data link connector (DLC). 2. Run the engine until it reaches operating temperature. Does the scan tool show the ECT sensor reading within the value specified?	80~110°C (176~230°F)	Go to “Diagnostic Aids”	Go to <i>Step 3</i>
3	1. Turn the ignition switch to LOCK. 2. Disconnect the ECT sensor connector. 3. Turn the ignition switch to ON. Does the scan tool show the IAT sensor reading within the value specified?	≥-30°C(-22°F)	Go to <i>Step 4</i>	Go to <i>Step 6</i>
4	1. Jumper the ECT sensor signal circuits at terminal A and B. 2. Turn the ignition switch to ON. Does the scan tool show the ECT sensor reading within the value specified?	≥ 120°C	Go to <i>Step 5</i>	Go to <i>Step 6</i>
5	1. Replace the ECT sensor. 2. Clear any DTCs from the ECM. 3. Perform the diagnostic system check. Is the replacement complete?	–	System OK	–
6	Measure the voltage between ECT terminal A and ground. Does the voltage measure within the value specified?	4.5–5.0V	Go to <i>Step 7</i>	Go to <i>Step 8</i>
7	1. Turn the ignition switch to LOCK. 2. Disconnect the ECM wiring connector. 3. Check for a faulty connector or terminals at the ECT sensor connectors and ECM connectors for short to ECM reference voltage. Is the problem found?	–	Go to <i>Step 9</i>	Go to <i>Step 8</i>
8	1. Turn the ignition switch to LOCK. 2. Repair the wire of the connector terminals as needed. 3. Clear any DTCs from the ECM. 4. Run the engine until it reaches operating temperature. 5. Perform the diagnostic system check. Is the repair complete?	–	System OK	–
9	1. Replace the ECM. 2. Run the engine until it reaches operating temperature. 3. Perform the diagnostic system check. Is the repair complete?	–	Go to <i>Step 10</i>	–
10	Check if any additional DTCs are set. Are any DTCs displaced that have not been diagnosed?	–	Go to applicable DTC table	System OK

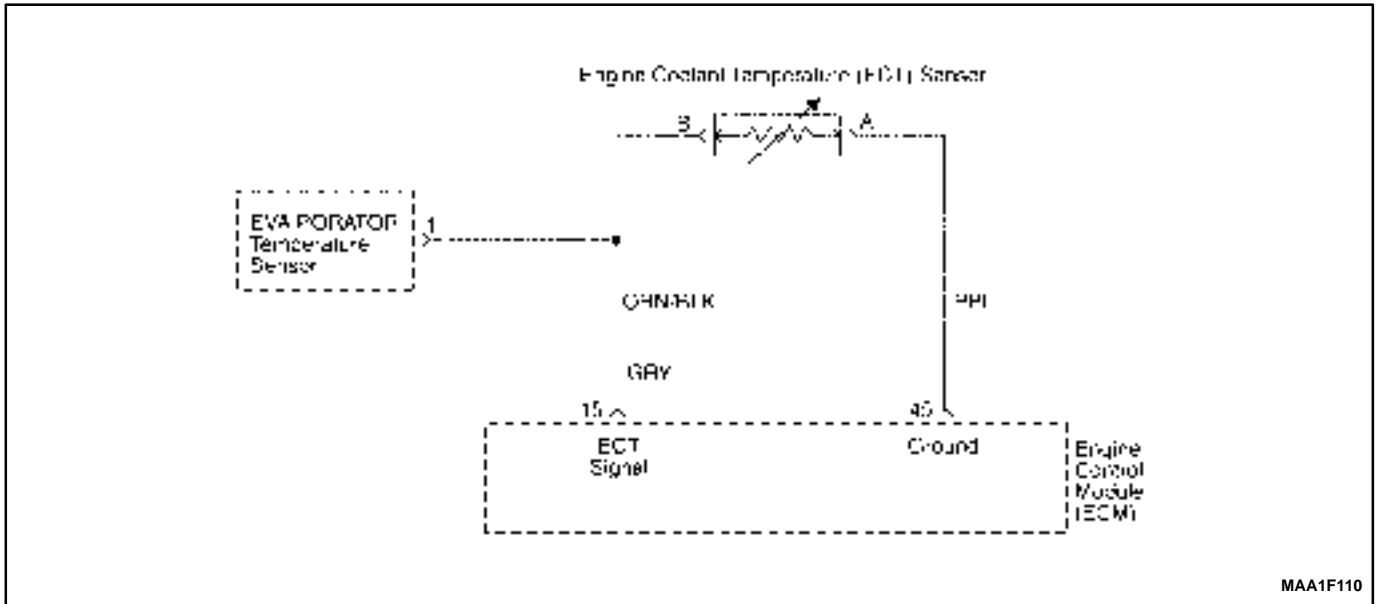

DIAGNOSTIC TROUBLE CODE (DTC) – P0118 ENGINE COOLANT TEMPERATURE SENSOR HIGH VOLTAGE

Circuit Description

The coolant temperature sensor (ECT) uses a thermistor to control the signal voltage to the engine control module (ECM).

The ECM supplies a voltage on the signal circuit to the sensor. When the air is cold, the resistance is high; therefore the ECT sensor signal voltage will be high.

As the engine warms, the sensor resistance becomes less, and the voltage drops. At normal engine operating temperature, the voltage will be between 1.5 and 2.0 volts at the ECT sensor signal terminal.

The ECT sensor is used to the following items:

- Fuel delivery.
- Lock Up Clutch (LUC).
- Ignition.
- Evaporator Emission (EVAP) Canister Purge Valve.
- Idle Air Control (IAC) valve.
- Electric cooling fan.

Conditions for Setting the DTC

- This DTC can be stored in “key-on” status.
- The engine run time is greater than 3 seconds.
- The ECT sensor indicates that the engine coolant temperature is less than -40°C (-40°F).
- ECT voltage is greater than 4.98V.

- A low voltage condition exists.

Action Taken when the DTC Sets

- The Malfunction Indicator Lamp (MIL) will illuminate.
- The ECM will record operating conditions at the time the diagnostic fails. This information will be stored in the Freeze Frame and Failure Records buffers.
- A history DTC is stored.
- The coolant fan turns ON.
- The ECM will substitute a fixed MAP value and use TP to control the fuel delivery (the scan tool will not show defaulted)

Conditions for Clearing the MIL/DTC

- The MIL will turn off after four consecutive ignition cycles in which the diagnostic runs without a fault.
- A history DTC will clear after 40 consecutive warm-up cycles without a fault.
- DTC(s) can be cleared by using the scan tool.

Diagnostic Aids

After the engine has started, the ECT should rise steadily to about 90°C (194°F) then stabilize when the thermostat opens.

Use the temperature vs. resistance values table to evaluate the possibility of a skewed sensor. Refer to “Temperature vs. Resistance” in this Section.

MAA1F110

DTC P0118 – Engine Coolant Temperature Sensor High Voltage

Step	Action	Value(s)	Yes	No
1	Perform an Euro On-Board Diagnostic (EOBD) System Check. Is the system check complete?	–	Go to <i>Step 2</i>	Go to “On-Board Diagnostic System Check”
2	1. Connect the scan tool to the data link connector (DLC). 2. Run the engine until it reaches operating temperature. Does the scan tool show the ECT sensor reading within the value specified?	80~110°C (176~230°F)	Go to “Diagnostic Aids”	Go to <i>Step 3</i>
3	1. Turn the ignition switch to LOCK. 2. Disconnect the ECT sensor connector. 3. Turn the ignition switch to ON. Does the scan tool show the ECT sensor reading within the value specified?	≥ -30°C	Go to <i>Step 4</i>	Go to <i>Step 6</i>
4	1. Jumper the ECT sensor signal circuits at terminal B and A. 2. Turn the ignition switch to ON. Does the scan tool show the ECT sensor reading within the value specified?	≥180°C (356°F)	Go to <i>Step 5</i>	Go to <i>Step 6</i>
5	1. Replace the ECT sensor. 2. Clear any DTCs from the ECM. 3. Perform the diagnostic system check. Is the replacement complete?	–	System OK	–
6	Measure the voltage between ECT terminal B and ground. Does the voltage measure within the value specified?	4.5–5.0V	Go to <i>Step 7</i>	Go to <i>Step 8</i>
7	1. Turn the ignition switch to LOCK. 2. Disconnect the ECM wiring connector. 3. Check for a faulty connector or terminals at the ECT sensor connector terminal A and the ECM connector terminal 45 for an open or short to battery voltage. Is the problem found?	–	Go to <i>Step 8</i>	Go to <i>Step 9</i>
8	1. Turn the ignition switch to LOCK. 2. Repair the wire of the connector terminals as needed. 3. Clear any DTCs from the ECM. 4. Run the engine until it reaches operating temperature. 5. Perform the diagnostic system check. Is the repair complete?	–	System OK	–
9	1. Replace the ECM. 2. Run the engine until it reaches operating temperature. 3. Perform the diagnostic system check. Is the repair complete?	–	Go to <i>Step 10</i>	–
10	Check if any additional DTCs are set. Are any DTCs displaced that have not been diagnosed?	–	Go to applicable DTC table	System OK

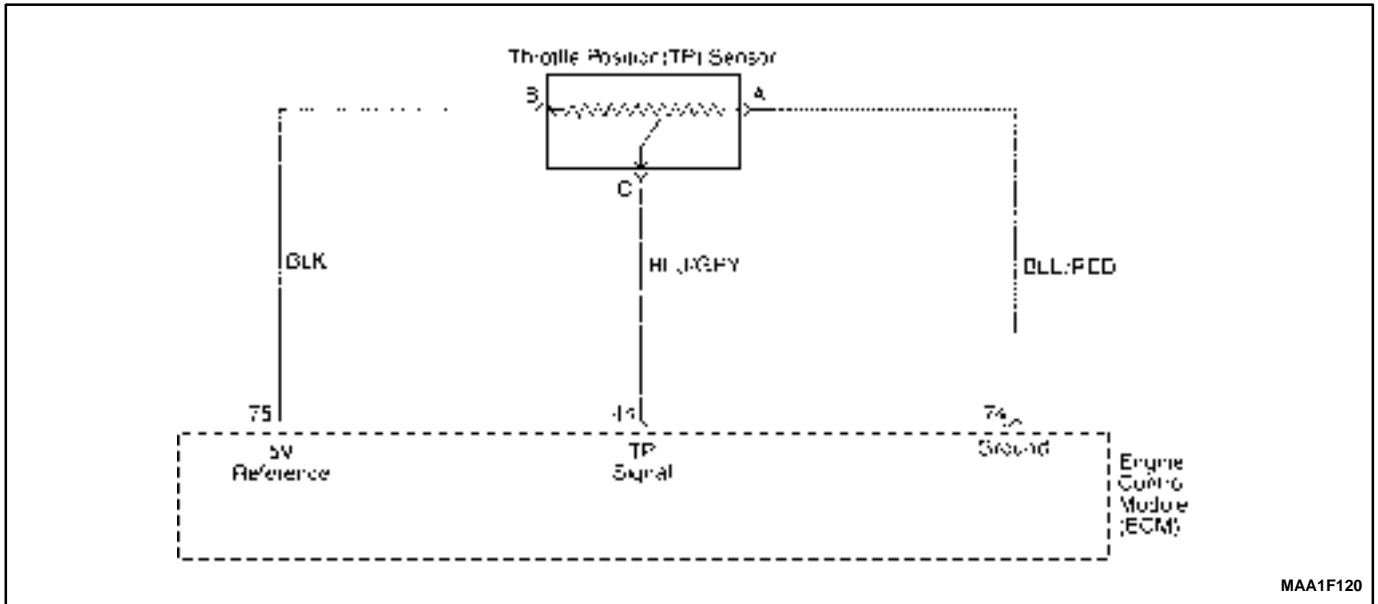

DIAGNOSTIC TROUBLE CODE (DTC) P0122 THROTTLE POSITION SENSOR LOW VOLTAGE

Circuit Description

The Engine Control Module (ECM) supplies a 5 volt reference voltage signal and a ground to the Throttle Position (TP) sensor. The TP sensor sends a voltage signal back to the ECM relative to the throttle plate opening. The voltage signal will vary from approximately 0.33 volts at closed throttle, to over 4.3 volts at Wide Open Throttle (WOT).

The TP signal is used by the ECM for fuel control and for most of the ECM controlled outputs. The TP signal is one of the most important inputs used by the ECM for fuel control and most of the ECM controlled outputs.

Conditions for Setting the DTC

- TP sensor voltage indicates a throttle voltage less than 0.14 volts.

Action Taken When the DTC Sets

- The Malfunction Indicator Lamp (MIL) will illuminate.
- The ECM will record operating conditions at the time the diagnostic fails. This information will be stored in the Freeze Frame and Failure Records buffers.

- A history DTC is stored.
- The TP angle will default to 0% when the vehicle speed is less than 3 km/h (2 mph) and 10% when the vehicle speed is greater than 3 km/h (2 mph). The scan tool will not display the default value.

Conditions for Clearing the MIL/DTC

- The MIL will turn off after four consecutive ignition cycles in which the diagnostic runs without a fault.
- A history DTC will clear after 40 consecutive warm-up cycles without a fault.
- DTC(s) can be cleared by using the scan tool.
- Disconnecting the ECM battery feed for more than 10 seconds.

Diagnostic Aids

If the DTC P0122 cannot be duplicated, the information included in the Freeze Frame data can be useful. Use a scan tool information data to determine the status of the DTC. If the dc occurs intermittently, using the Diagnostic table may help isolate the problem.

DTC P0122 – Throttle Position Sensor Low Voltage

Step	Action	Value(s)	Yes	No
1	Perform an On-Board Diagnostic (EOBD) System Check. Was the check performed?	–	Go to <i>Step 2</i>	Go to “On-Board Diagnostic System Check”
2	1. Install a scan tool to the Data Link Connector (DLC). 2. Turn the ignition ON. Is the Throttle Position (TP) sensor voltage below the specified value?	0.20 V	Go to <i>Step 4</i>	Go to <i>Step 3</i>
3	1. Turn the ignition ON. 2. Review the Freeze Frame data and note the parameters. 3. Operate the vehicle within the Freeze Frame conditions and Conditions for Setting the DTC as noted. Is the TP sensor voltage below the specified value?	0.20 V	Go to <i>Step 4</i>	Go to <i>Step 12</i>
4	1. Turn the ignition OFF. 2. Disconnect the TP sensor connector. 3. Turn the ignition ON. 4. Jump the 5 volt reference circuit terminal B and the TP signal circuit terminal C at the TP sensor connector. Is the TP sensor voltage over the specified value?	4.0 V	Go to <i>Step 10</i>	Go to <i>Step 5</i>
5	Connect a test light between B+ and the TP sensor signal circuit terminal C. Is the TP sensor voltage greater than the specified value?	4.0 V	Go to <i>Step 6</i>	Go to <i>Step 8</i>
6	Check the TP sensor 5 volt reference circuit for an open or short to ground and repair as needed. Is the repair complete?	–	Go to <i>Step 12</i>	Go to <i>Step 7</i>
7	Check the 5 volt reference circuit for a poor connection at terminal 75 of the Engine Control Module (ECM) and repair as needed. Is the repair complete?	–	Go to <i>Step 12</i>	Go to <i>Step 11</i>
8	Check the TP sensor signal circuit between terminal C of the TP sensor and terminal 44 of the ECM for an open or a short to ground and repair as needed. Is the repair complete?	–	Go to <i>Step 12</i>	Go to <i>Step 9</i>
9	Check the TP sensor signal circuit, terminal 44 of the ECM for a poor connection and repair as needed. Is the repair complete?	–	Go to <i>Step 12</i>	Go to <i>Step 11</i>
10	Replace the throttle body assembly. Is the action complete?	–	Go to <i>Step 12</i>	–
11	1. Turn the ignition switch OFF. 2. Replace the ECM. Is the action complete?	–	Go to <i>Step 12</i>	–

DTC P0122 – Throttle Position Sensor Low Voltage (Cont'd)

Step	Action	Value(s)	Yes	No
12	1. Using the scan tool, clear the Diagnostic Trouble Codes (DTCs). 2. Start the engine and idle at normal operating temperature. 3. Operate the vehicle within the Conditions for setting this DTC as specified in the supporting text. Does the scan tool indicate that this diagnostic has run and passed?	–	Go to <i>Step 13</i>	Go to <i>Step 2</i>
13	Check if any additional DTCs are set. Are any DTCs displayed that have not been diagnosed?	–	Go to Applicable DTC Table	System OK

BLANK

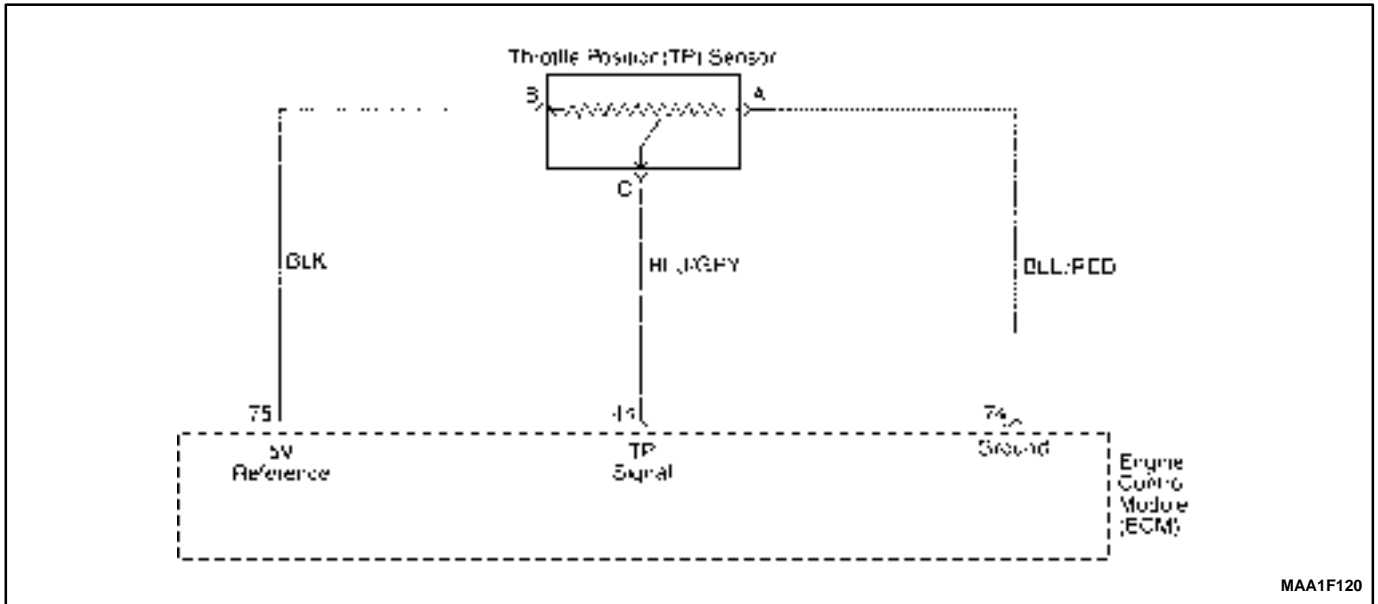

DIAGNOSTIC TROUBLE CODE (DTC) P0123 THROTTLE POSITION SENSOR HIGH VOLTAGE

Circuit Description

The Engine Control Module (ECM) supplies a 5 volt reference voltage signal and a ground to the Throttle Position (TP) sensor. The TP sensor sends a voltage signal back to the ECM relative to the throttle plate opening. The voltage signal will vary from approximately 0.33 volts at closed throttle, to over 4.3 volts at Wide Open Throttle (WOT).

The TP signal is used by the ECM for fuel control and for most of the ECM controlled outputs. The TP signal is one of the most important inputs used by the ECM for fuel control and most of the ECM controlled outputs.

Conditions for Setting the DTC

- TP sensor voltage indicates a throttle voltage greater than 4.9 volts.

Action Taken When the DTC Sets

- The Malfunction Indicator Lamp (MIL) will illuminate.
- The ECM will record operating conditions at the time the diagnostic fails. This information will be stored in the Freeze Frame and Failure Records buffers.
- A history DTC is stored.
- The TP angle will default to 0% when the vehicle speed is less than 3 km/h (2 mph) and 10% when the

vehicle speed is greater than 3 km/h (2 mph). The scan tool will not display the default value.

Conditions for Clearing the MIL/DTC

- The MIL will turn off after four consecutive ignition cycles in which the diagnostic runs without a fault.
- A history DTC will clear after 40 consecutive warm-up cycles without a fault.
- DTC(s) can be cleared by using the scan tool.
- Disconnecting the ECM battery feed for more than 10 seconds.

Diagnostic Aids

If the DTC P0123 cannot be duplicated, the information included in the Freeze Frame data can be useful. Use a scan tool information data to determine the status of the DTC. If the dc occurs intermittently, using the Diagnostic table may help isolate the problem.

With ignition ON and the throttle at closed position, the voltage should read between 0.2 and 0.90 volts and increase steadily to over 4.3 volts at WOT.

DTCs P0123 and P0113 stored at the same time could be result of an open sensor ground circuit.

MAA1F120

DTC P0123 – Throttle Position Sensor High Voltage

Step	Action	Value(s)	Yes	No
1	Perform an On-Board Diagnostic (EOBD) System Check. Was the check performed?	–	Go to <i>Step 2</i>	Go to “On-Board Diagnostic System Check”
2	1. Install a scan tool to the Data Link Connector (DLC). 2. Turn the ignition ON. Is the Throttle Position (TP) sensor voltage greater than the specified value?	1.0 V	Go to <i>Step 4</i>	Go to <i>Step 3</i>
3	1. Turn the ignition ON. 2. Review the Freeze Frame data and note the parameters. 3. Operate the vehicle within the Freeze Frame conditions and Conditions for Setting the DTC as noted. Is the TP sensor voltage greater than the specified value?	3.9 V	Go to <i>Step 4</i>	Go to <i>Step 12</i>
4	1. Turn the ignition OFF. 2. Disconnect the TP sensor connector. 3. Turn the ignition ON. Is the TP sensor voltage less than the specified value?	0.2 V	Go to <i>Step 5</i>	Go to <i>Step 6</i>
5	Probe the TP sensor ground circuit, terminal A at the TP sensor connector with a test light connected to B+. Does the test light illuminate?	–	Go to <i>Step 7</i>	Go to <i>Step 9</i>
6	Check the TP sensor signal circuit for an short to voltage and repair as needed. Is the repair complete?	–	Go to <i>Step 12</i>	Go to <i>Step 11</i>
7	Check the 5 volt reference circuit for a short to B+ and repair as needed. Is the repair complete?	–	Go to <i>Step 12</i>	Go to <i>Step 8</i>
8	Check the TP sensor electric connector for a poor connection and repair as needed. Is the repair complete?	–	Go to <i>Step 12</i>	Go to <i>Step 10</i>
9	Check the TP sensor ground circuit for an open and repair as needed. Is the repair complete?	–	Go to <i>Step 12</i>	Go to <i>Step 11</i>
10	Replace the throttle body assembly. Is the action complete?	–	Go to <i>Step 12</i>	–
11	1. Turn the ignition switch OFF. 2. Replace the Engine Control Module (ECM). Is the action complete?	–	Go to <i>Step 12</i>	–
12	1. Using the scan tool, clear the Diagnostic Trouble Codes (DTCs). 2. Start the engine and idle at normal operating temperature. 3. Operate the vehicle within the Conditions for setting this DTC as specified in the supporting text. Does the scan tool indicate that this diagnostic has run and passed?	–	Go to <i>Step 13</i>	Go to <i>Step 2</i>

DTC P0123 – Throttle Position Sensor High Voltage (Cont'd)

Step	Action	Value(s)	Yes	No
13	Check if any additional DTCs are set. Are any DTCs displayed that have not been diagnosed?	–	Go to Applicable DTC Table	System OK

BLANK

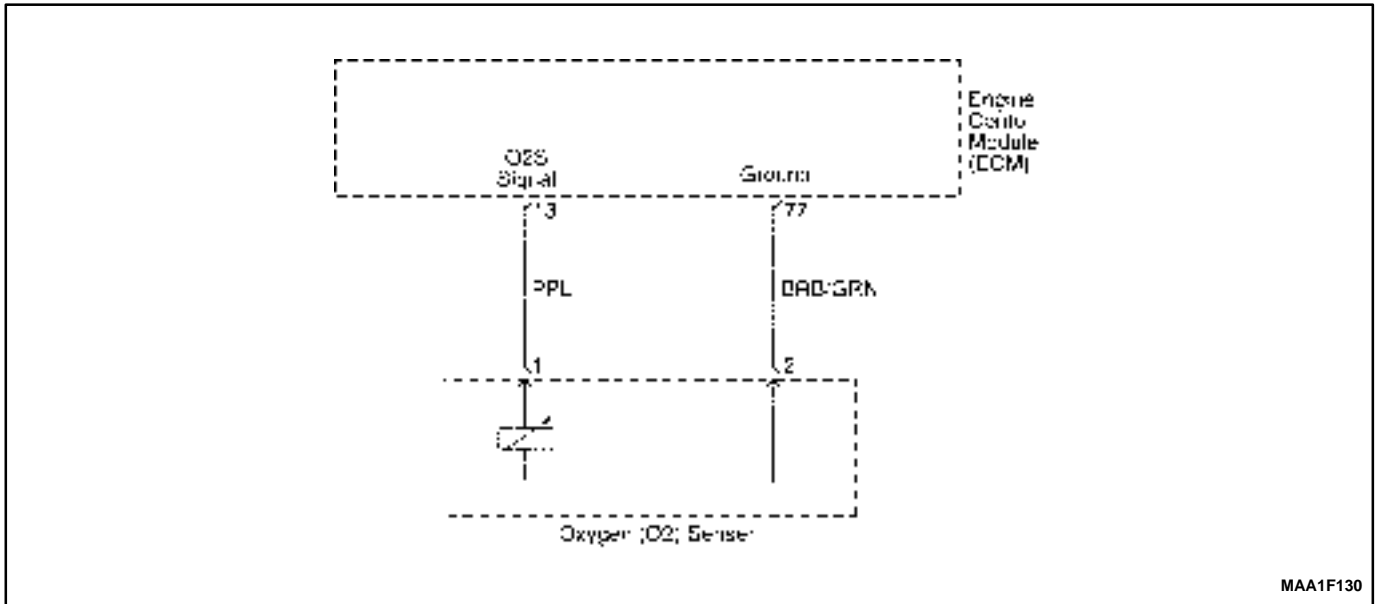

DIAGNOSTIC TROUBLE CODE (DTC) – P0131 OXYGEN SENSOR LOW VOLTAGE

Circuit Description

The engine control module (ECM) supplies a voltage of about 450m volts between the ECM terminals 44 and 13. The oxygen (O₂) sensor varies the voltage within a range of about 1volt if the exhaust is rich, down to about 100mm volts if the exhaust is lean. The O₂ sensor is like an open circuit and produces no voltage when it is below 350°C(600°F). An open O₂ sensor circuit or a cold O₂ sensor causes “open loop” operation.

Conditions for Setting the DTC

(Case A)

- The engine controls system is in closed loop.
- Engine speed is less than 6,000rpm.
- The oxygen sensor voltage is below 0.07V for at least 40seconds.
- DTCs P0107, P0108, P0117, P0118, P0122, P0123, P0335, P0336, P0341, P0342, P0400, P0404, P0405, P0406, P0445, P0444 are NOT SET.

(Case B)

- The engine controls system is in closed loop.
- Engine speed is less than 6,000rpm.
- The oxygen sensor voltage is between 0.352 and 0.499 at least 10seconds.

Action Taken when the DTC Sets

- The Malfunction Indicator Lamp (MIL) will illuminate.

- The ECM will record operating conditions at the time the diagnostic fails. This information will be stored in the Freeze Frame and Failure Records buffers.
- A history DTC is stored.

Conditions for Clearing the MIL/DTC

- The MIL will turn off after four consecutive ignition cycles in which the diagnostic runs without a fault.
- A history DTC will clear after 40 consecutive warm-up cycles without a fault.
- DTC(s) can be cleared by using the scan tool.
- Disconnecting the ECM battery feed for more than 10 seconds.

Diagnostic Aids

Normal scan tool voltage varies between 0.1volts and 0.9 volts while in closed loop.

Inspect the oxygen (O₂) sensor wire. The O₂ sensor may be positioned incorrectly and contacting the exhaust manifold.

Check for an intermittent ground in the wire between the O₂ sensor and the engine control module.

Perform an injector 2alance test to determine if a restricted fuel injector may be causing the lean condition. Vacuum of crankcase leaks will cause a lean running condition.

An exhaust manifold gasket leak of a cracked exhaust manifold may cause outside air to be pulled into the exhaust and past the sensor.

DTC P0131 – Oxygen Sensor Low Voltage

Step	Action	Value(s)	Yes	No
1	Perform an Euro On-Board Diagnostic (EOBD) System Check. Is the system check complete?	–	Go to Step 2	Go to “On-Board Diagnostic System Check”
2	1. Connect the scan tool to the data link connector(DLC). 2. Run the engine until it reaches operating temperature. 3. Check for closed loop operation. Does the engine control module(ECM) go into closed loop?	–	Go to Step 3	Go to Step 9
3	1. Run the until until it reaches operating temperature? 2. Run the engine at 1,200rpm. Does the scan tool read the upstream oxygen(O ₂) sensor signal voltage between the valve specified?	0.15~0.7V	Go to Step 5	Go to Step 4
4	Does the scan tool read the Oxygen sensor signal voltage fixed below the valve specified?	0.01V	Go to Step 7	Go To “Diagnostic Aids”
5	1. Disconnect the Oxygen sensor connector. 2. Run the warm engine at idle. Does the scan tool read the Oxygen sensor signal voltage between the valve specified?	0.15~0.7V	Go To “Diagnostic Aids”	Go to Step 6
6	1. Turn the ignition switch to LOCK. 2. Check the Oxygen sensor wire between the Oxygen sensor and the ECM connector terminal 77 and 13 is open. Is the problem found?	–	Go to Step 8	Go to Step 11
7	1. Turn the ignition switch to LOCK. 2. Check the Oxygen sensor wire between the Oxygen sensor and the ECM connector terminal 77 for a short to ground. Is the problem found?	–	Go to Step 8	Go to Step 11
8	1. Repair the wire or the connector terminal as needed. 2. Clear the any DTCs from the ECM. 3. Road tests the vehicle. 4. Perform the diagnostic system check. Is the repair complete?	–	System OK	–
9	1. Turn the ignition switch to LOCK. 2. Disconnect the Oxygen sensor connector. 3. Turn the ignition switch to ON. Does the scan tool the Oxygen sensor signal voltage between the valve specified?	0.15~0.7V	Go to Step 11	Go to Step 10
10	1. Replace the Oxygen sensor. 2. Clear the DTCs from the ECM. 3. Perform the diagnostic system check. Is the repair complete?	–	System OK	–
11	1. Replace the ECM. 2. Perform the diagnostic system check. Is the repair complete?	–	Go to Step 12	–

DTC P0131 – Oxygen Sensor Low Voltage (Cont'd)

Step	Action	Value(s)	Yes	No
12	Check if any additional DTCs are set. Are any DTCs displaced that have not been diagnosed?	–	Go to applicable DTC table	System OK

BLANK

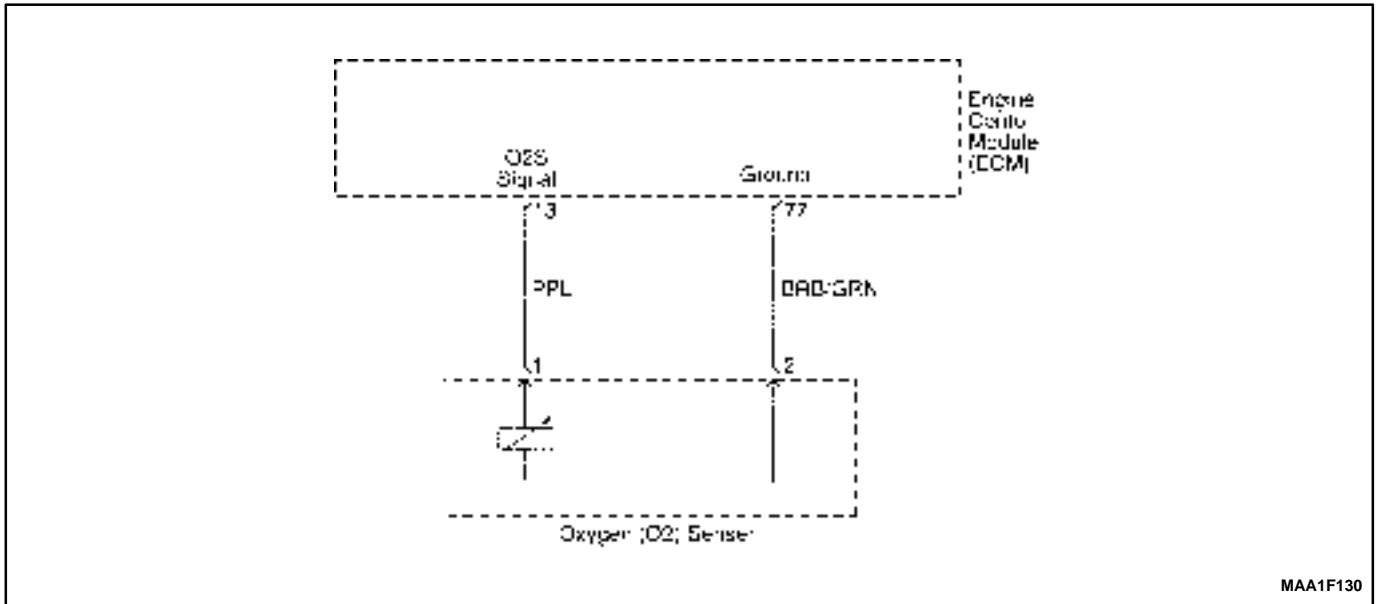

DIAGNOSTIC TROUBLE CODE (DTC) – P0132 OXYGEN SENSOR HIGH VOLTAGE

Circuit Description

The engine control module (ECM) supplies a voltage of about 450mV between the ECM terminals 44 and 13. The oxygen (O₂) sensor varies the voltage within a range of about 1V if the exhaust is rich, down to about 100mV if the exhaust is lean. The O₂ sensor is like an open circuit and produces no voltage when it is below 350°C(600°F). An open O₂ sensor circuit or a cold O₂ sensor causes “open loop” operation.

Conditions for Setting the DTC

- The oxygen sensor voltage is more than 4.8V for at least 0.2 seconds.
- A high voltage condition exists.

Action Taken when the DTC Sets

- The Malfunction Indicator Lamp (MIL) will illuminate.
- The ECM will record operating conditions at the time the diagnostic fails. This information will be stored in the Freeze Frame and Records buffers.
- A history DTC is stored.

Conditions for Clearing the MIL/DTC

- The MIL will turn off after consecutive ignition cycles in which the diagnostic runs without a fault.

- A history DTC will clear after 40 consecutive warm up cycles without a fault.
- DTC(s) can be cleared by using the scan tool.
- Disconnecting the ECM battery feed for 10 seconds.

Diagnostic Aids

Normal scan tool voltage varies between 0.1V and 0.9V while in closed loop.

Inspect the oxygen (O₂) sensor wire. The O₂ sensor may be positioned incorrectly and contacting the exhaust manifold.

Check for an intermittent ground in the wire between the O₂ sensor and the engine control module.

Perform an injector balance test to determine if a restricted fuel injector may be causing the lean condition.

Vacuum of crankcase leaks will cause a lean running condition.

An exhaust manifold gasket leak or a cracked exhaust manifold may cause outside air to be pulled into the exhaust and past the sensor.

DTC P0132 – Oxygen Sensor High Voltage

Step	Action	Value(s)	Yes	No
1	Perform an Euro On-Board Diagnostic (EOBD) System Check. Is the system check complete?	–	Go to <i>Step 2</i>	Go to “On-Board Diagnostic System Check”
2	1. Turn the ignition switch to ON, with the engine OFF. 2. Install a scan tool. 3. Engine at operating temperature. 4. Run the engine at 1,200rpm. Does the scan tool the upstream oxygen(O2) sensor1 voltage within the value specified?	More than 1.2V	Go to <i>Step 3</i>	Go to <i>Step 6</i>
3	1. Turn the ignition switch to LOCK. 2. Disconnect the O2 sensor connector and engine control module (ECM) connector. 3. Check the O2 sensor wire between the O2 sensor and ECM connector terminal 13 for short to battery voltage. Is the problem found?	–	Go to <i>Step 4</i>	Go to <i>Step 5</i>
4	1. Repair the wire of the connector terminal as needed. 2. Clear the DTCs from the ECM. 3. Road tests the vehicle. 4. Perform the diagnostic system check. Is the repair complete?	–	System OK	–
5	1. Turn the ignition switch to LOCK. 2. Replace the O2 sensor. 3. Road tests the vehicle. 4. Perform the diagnostic system check. Is the replacement complete?	–	Go to <i>Step 7</i>	–
6	1. Turn the ignition switch to LOCK. 2. Replace the ECM. 3. Road tests the vehicle. 4. Perform the diagnostic system check. Is the replacement complete?	–	Go to <i>Step 7</i>	–
7	Check if any additional DTCs are set. Are any DTCs displaced that have not been diagnosed?	–	Go to applicable DTC table	System OK

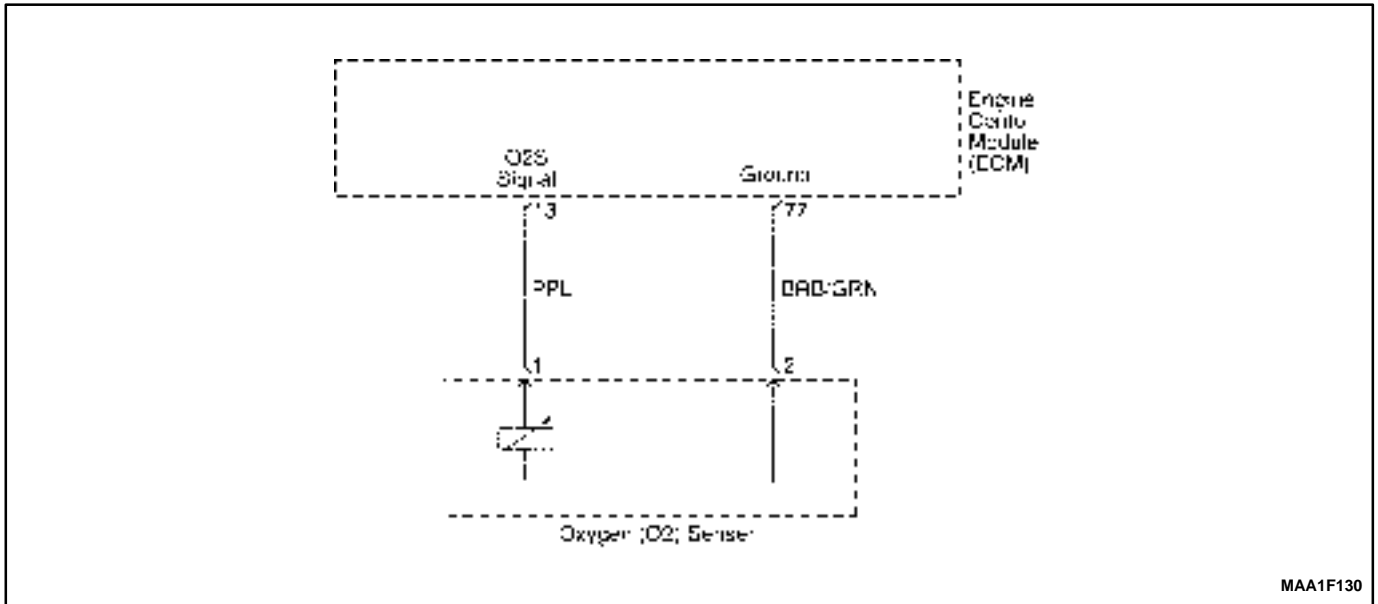

DIAGNOSTIC TROUBLE CODE (DTC) – P0133 OXYGEN SENSOR NO ACTIVITY

Circuit Description

The engine control module (ECM) supplies a voltage of about 450mV between the ECM terminals 44 and 13. The oxygen (O₂) sensor varies the voltage within a range of about 1V if the exhaust is rich, down to about 100mV if the exhaust is lean. The O₂ sensor is like an open circuit and produces no voltage when it is below 360°C(600°F). An open O₂ sensor circuit or a cold O₂ sensor causes “open loop” operation.

Conditions for Setting the DTC

- The engine controls system is in closed loop.
- Engine Coolant Temperature is higher than 60°C (140°F).
- The mass air flow(MAF) is between 75mg/tdc and 100mg/tdc.
- The engine speed is between 3,008rpm and 3,500rpm.
- The vehicle speed is between 45km/h(27.96mph) and 55km/h(34.2mph).
- The manifold air pressure is higher than 90kPa.
- The ignition is at 10 volts.
- The upstream O₂ sensor periods higher than 1.6 seconds.
- A number of glitches higher than 5 during the test.

- DTCs P0107, P0108, P0112, P0113, P0117, P0118, P0122, P0123, P0131, P0132, P0131, P0132, P0137, P0138, P1671, P0300, P0335, P0336, P0341, P0400, P0404, P0405, P0444, P0445 are NOT SET.

Action Taken when the DTC Sets

- Emission related.
- “Armed” after two trip with a fail.
- “Disarmed” after one trip with a pass.
- MIL on if failure is detected in three consecutive trips.
- Stores a History DTC on the third consecutive with a fail (The DTC will be armed after the second fail).
- Stores a Freeze Frame on the third consecutive trip with a fail (if empty).

Conditions for Clearing the MIL/DTC

- The MIL will turn off after four consecutive ignition cycles in which the diagnostic runs without a fault.
- A history DTC will clear after 40 consecutive warm up cycles without a fault.
- DTC(s) can be cleared by using the scan tool.

Diagnostic Aids

Normal scan tool voltage varies between 0.15 to 8.5mV while in Closed Loop. If DTC P0133 is intermittent, refer to “Intermittent” in this Section.

DTC P0133 – Oxygen Sensor No Activity

Step	Action	Value(s)	Yes	No
1	Perform an Euro On-Board Diagnostic (EOBD) System Check. Is the system check complete?	–	Go to <i>Step 2</i>	Go to “On-Board Diagnostic System Check”
2	1. Connect the scan tool to the data link connector (DLC). 2. Run the engine until it reaches operating temperature. 3. Check for the closed loop operation. Does the scan tool indicate the closed loop?	–	Go to <i>Step 3</i>	Go to <i>Step 4</i>
3	1. Turn the ignition switch to LOCK. 2. Review the freeze frame data and note the parameters. 3. Operate the vehicle within the freeze frame conditions and Conditions for Setting the DTC. Does the scan tool indicate the closed loop?	–	Go to <i>Step 12</i>	Go to <i>Step 4</i>
4	1. Disconnect the upstream oxygen(O ₂) sensor connector 2. Jumper the oxygen sensor connector terminal 1 to ground. 3. Turn the ignition switch to ON. Does the scan tool read the oxygen sensor signal voltage the specified value?	0.4~0.5V	Go to <i>Step 5</i>	Go to <i>Step 8</i>
5	Check the oxygen sensor connector for malfunction terminals or poor connection and repair as necessary. Is repair necessary?	–	Go to <i>Step 12</i>	Go to <i>Step 6</i>
6	1. Run the engine at idle. 2. Remove the jumper wire. 3. Measure the voltage between the oxygen sensor connector terminal 2 and ground. Does the oxygen sensor voltage measure above the specified value?	0.6V	Go to <i>Step 7</i>	Go to <i>Step 11</i>
7	1. Turn the ignition switch to LOCK 2. Measure the voltage between the upstream O ₂ sensor connector terminal 2 and ground. Does the oxygen sensor voltage measure above the specified value?	0.3V	Go to <i>Step 9</i>	Go to <i>Step 11</i>
8	Repair the wire or the connector between the upstre O ₂ sensor terminal 1 and the engine control module (ECM) terminal 13 is open or a short to ground. Is the repair complete?	–	Go to <i>Step 11</i>	Go to <i>Step 9</i>
9	Repair the wire and the connector terminal between the oxygen sensor connector terminal 2 and the ECM connector terminal 77 is open or a short to ground. Is the repair complete?	–	Go to <i>Step 12</i>	Go to <i>Step 10</i>
10	1. Turn the ignition switch to LOCK 2. Replace the ECM. 3. Perform the diagnostic system check. Is the repair complete?	–	System OK	–

DTC P0133 – Oxygen Sensor No Activity (Cont'd)

Step	Action	Value(s)	Yes	No
11	Replace the O ₂ sensor. Is the repair complete?	–	Go to <i>Step 12</i>	–
12	1. Clear any DTCs from the ECM 2. Perform the diagnostic system check Is the repair complete	–	Go to <i>Step 13</i>	–
13	Check if any additional DTCs are set. Are any DTCs displaced that have not been diagnosed?	–	Go to applicable DTC table	System OK

BLANK

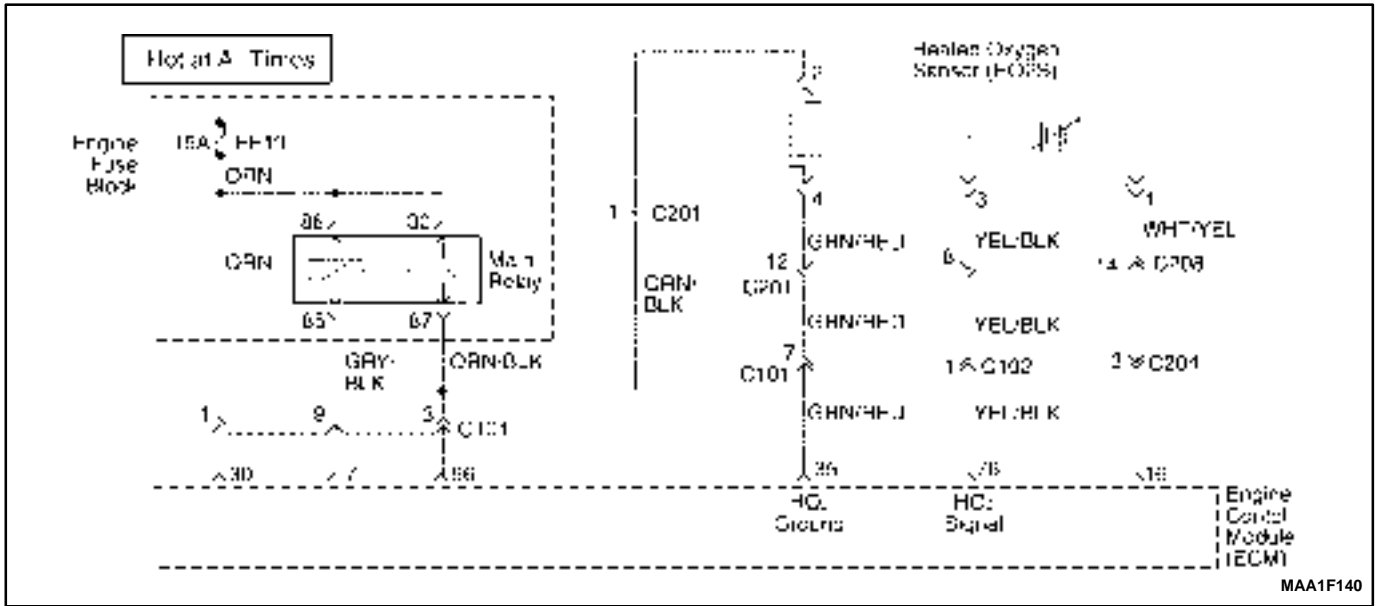

DIAGNOSTIC TROUBLE CODE (DTC) – P0137 HEATED OXYGEN SENSOR LOW VOLTAGE

Circuit Description

The engine control module (ECM) supplies a voltage of about 450mm volts between the ECM terminals 44 and 13. The oxygen (O₂) sensor varies the voltage within a range of about 1volt if the exhaust is rich, down to about 100mm volts if the exhaust is lean. The O₂ sensor is like an open circuit and produces no voltage when it is below 360°C(600°F). An open O₂ sensor circuit or a cold O₂ sensor causes “open loop” operation.

Conditions for Setting the DTC

(Case A)

- The engine controls system is in closed loop.
- Engine speed is less than 6,000rpm.
- The heated oxygen sensor voltage is below 0.07V for at least 40 seconds.
- DTCs P0107, P0108, P0117, P0118, P0122, P0123, P0335, P0336, P0341, P0342, P0400, P0404, P0405, P0406 are NOT SET.

(Case B)

- The engine controls system is in closed loop.
- Engine speed is less than 6,000rpm.
- The heated oxygen sensor voltage is between 0.352 and 0.499 at least 60 seconds.

Action Taken when the DTC Sets

- Emission related.
- “Armed” after two trip with a fail.
- “Disarmed” after one trip with a pass.

- MIL on if failure is detected in three consecutive trips.
- Stores a History DTC on the third consecutive with a fail (The DTC will be armed after the second fail).
- Stores a Freeze Frame on the third consecutive trip with a fail (if empty).

Conditions for Clearing the MIL/DTC

- The MIL will turn off after four consecutive ignition cycles in which the diagnostic runs without a fault.
- A history DTC will clear after 40 consecutive warm up cycles without a fault.
- DTC(s) can be cleared by using the scan tool.

Diagnostic Aids

- Normal scan tool voltage varies between 0.1 volts and 0.9 volts while in closed loop.
- Inspect the oxygen (O₂) sensor wire. The O₂ sensor may be positioned incorrectly and contacting the exhaust manifold.
- Check for an intermittent ground in the wire between the O₂ sensor and the engine control module.
- Perform an injector balance test to determine if a restricted fuel injector may be causing the lean condition.
- Vacuum of crankcase leaks will cause a lean running condition.
- An exhaust manifold gasket leak of a cracked exhaust manifold may cause outside air to be pulled into the exhaust and past the sensor.

DTC P0137 – Heated Oxygen Sensor Low Voltage

Step	Action	Value(s)	Yes	No
1	Perform an Euro On-Board Diagnostic (EOBD) System Check. Is the system check complete?	–	Go to <i>Step 2</i>	Go to “On-Board Diagnostic System Check”
2	1. Turn the ignition switch to ON, with the engine OFF. 2. Install a scan tool. 3. Engine at operating temperature. 4. Run the engine at 1,200rpm. Does the scan tool the downstream oxygen (O ₂) sensor1 voltage within the value specified?	0.07–0.352V	Go to <i>Step 4</i>	Go to <i>Step 3</i>
3	Does the scan tool the heated oxygen (O ₂) sensor1 voltage within the value specified?	0.1V	Go to <i>Step 9</i>	Go to “Diagnostic Aids”
4	1. Turn the ignition switch to LOCK. 2. Disconnect the Heated O ₂ sensor connector and engine control module (ECM) connector. 3. Check the Heated O ₂ sensor wire between the Heated O ₂ sensor connector terminal 4 and ECM connector terminal 35 for short to ground. Is the problem found?	–	Go to <i>Step 5</i>	Go to <i>Step 6</i>
5	1. Repair the wire of the connector terminal as needed. 2. Clear the DTCs from the ECM. 3. Road tests the vehicle. 4. Perform the diagnostic system check. Is the repair complete?	–	System OK	–
6	1. Turn the ignition switch to LOCK. 2. Disconnect the Heated O ₂ sensor connector and engine control module (ECM) connector. 3. Check the O ₂ sensor wire between the O ₂ sensor connector terminal 3 and ECM connector terminal 76 for short to ground. Is the problem found?	–	Go to <i>Step 7</i>	Go to <i>Step 8</i>
7	1. Repair the wire of the connector terminal as needed. 2. Clear the DTCs from the ECM. 3. Road tests the vehicle. 4. Perform the diagnostic system check. Is the repair complete?	–	System OK	–
8	1. Turn the ignition switch to LOCK. 2. Replace the Heated O ₂ sensor. 3. Road tests the vehicle. 4. Perform the diagnostic system check. Is the replacement complete?	–	Go to <i>Step 10</i>	–
9	1. Turn the ignition switch to LOCK. 2. Replace the ECM. 3. Road tests the vehicle. 4. Perform the diagnostic system check. Is the replacement complete?	–	Go to <i>Step 10</i>	–

DTC P0137 – Heated Oxygen Sensor Low Voltage (Cont'd)

Step	Action	Value(s)	Yes	No
10	Check if any additional DTCs are set. Are any DTCs displaced that have not been diagnosed?	–	Go to applicable DTC table	System OK

BLANK

DTC P0138 – Heated Oxygen Sensor High Voltage

Step	Action	Value(s)	Yes	No
1	Perform an Euro On-Board Diagnostic (EOBD) System Check. Is the system check complete?	–	Go to <i>Step 2</i>	Go to “On-Board Diagnostic System Check”
2	1. Turn the ignition switch to ON, with the engine OFF. 2. Install a scan tool. 3. Engine at operating temperature. 4. Run the engine at 1,200rpm. Does the scan tool the Heated oxygen(O2) sensor voltage within the value specified?	More than 1.2V	Go to <i>Step 3</i>	Go to <i>Step 6</i>
3	1. Turn the ignition switch to LOCK. 2. Disconnect the Heated O2 sensor connector and engine control module (ECM) connector. 3. Check the Heated O2 sensor wire between the Heated O2 sensor connector terminal 4 and ECM connector terminal 35 for an open or short to battery voltage. Is the problem found?	–	Go to <i>Step 4</i>	Go to <i>Step 5</i>
4	1. Repair the wire of the connector terminal as needed. 2. Clear the DTCs from the ECM. 3. Road tests the vehicle. 4. Perform the diagnostic system check. Is the repair complete?	–	System OK	–
5	1. Turn the ignition switch to LOCK. 2. Replace the Heated O2 sensor. 3. Road tests the vehicle. 4. Perform the diagnostic system check. Is the replacement complete?	–	Go to <i>Step 7</i>	–
6	1. Turn the ignition switch to LOCK. 2. Replace the ECM. 3. Road tests the vehicle. 4. Perform the diagnostic system check. Is the replacement complete?	–	Go to <i>Step 7</i>	–
7	Check if any additional DTCs are set. Are any DTCs displaced that have not been diagnosed?	–	Go to applicable DTC table	System OK

DTC P0140 – Heated Oxygen Sensor No Activity

Step	Action	Value(s)	Yes	No
1	Perform an Euro On-Board Diagnostic (EOBD) System Check. Is the system check complete?	–	Go to <i>Step 2</i>	Go to “On-Board Diagnostic System Check”
2	1. Run the engine to above the specified operating temperature. 2. Install a scan tool. 3. Operate the engine above the specified rpm for 2 minutes. Does the scan tool the indicate Closed Loop?	80°C(176°F) 1,200 rpm	Go to <i>Step 3</i>	Go to <i>Step 4</i>
3	1. Turn the Turn the ignition switch to ON. 2. Review the Freeze Frame data and note the parameters. 3. Operate the vehicle within the freeze frame conditions and Conditions for Setting the DTC as noted? Does the scan tool the indicate Closed Loop?	–	Go to <i>Step 12</i>	Go to <i>Step 4</i>
4	Disconnect the Heated O2 sensor connector and jumper the Heated O2 sensor low circuit, terminal 4 to ground. Is the HO2 voltage below the specified value and does the scan tool indicate the heated oxygen sensor heater voltage within the specified value?	0.5V	Go to <i>Step 5</i>	Go to <i>Step 6</i>
5	Check the Heated O2 sensor connector for malfunction terminals or poor connection and repair as necessary. Is repair necessary?	–	Go to <i>Step 12</i>	Go to <i>Step 9</i>
6	1. Turn the ignition switch to On. 2. Remove the jumper wire. 3. Using a digital voltmeter(DVM), measure the voltage between the Heated O2 sensor signal circuit, terminal 3 to ground. Does the Heated O2 sensor voltage measure above the specified value?	0.6V	Go to <i>Step 10</i>	Go to <i>Step 9</i>
7	Does the Heated O2 sensor voltage measure below the specified value?	0.3V	Go to <i>Step 11</i>	Go to <i>Step 8</i>
8	Check the Heated O2 sensor ground circuit, terminal 4 for an open or poor connection and repair as necessary. Is repair necessary?	–	Go to <i>Step 12</i>	Go to <i>Step 8</i>
11	Check the Heated O2 sensor signal circuit, terminal 3 for an open or poor connection and repair as necessary. Is repair necessary?	–	Go to <i>Step 12</i>	Go to <i>Step 8</i>
10	1. If disconnected, reconnect Heated O2 sensor connector. 2. Using the scan tool, clear the DTCs. 3. Start the engine and idle at normal operating temperature. 4. Operate the vehicle within the conditions for setting this DTC as specified in the supporting text. Does the scan tool indicated that this diagnostic has run and passed?	–	Go to <i>Step 13</i>	Go to <i>Step 2</i>

DTC P0140 – Heated Oxygen Sensor No Activity (Cont'd)

Step	Action	Value(s)	Yes	No
11	1. Turn the ignition switch to LOCK. 2. Replace the Heated O2 sensor. 3. Road tests the vehicle. 4. Perform the diagnostic system check. Is the replacement complete?	–	Go to <i>Step 15</i>	–
12	1. Turn the ignition switch to LOCK. 2. Replace the ECM. 3. Road tests the vehicle. 4. Perform the diagnostic system check. Is the replacement complete?	–	Go to <i>Step 15</i>	–
13	Check if any additional DTCs are set. Are any DTCs displaced that have not been diagnosed?	–	Go to applicable DTC table	System OK

BLANK

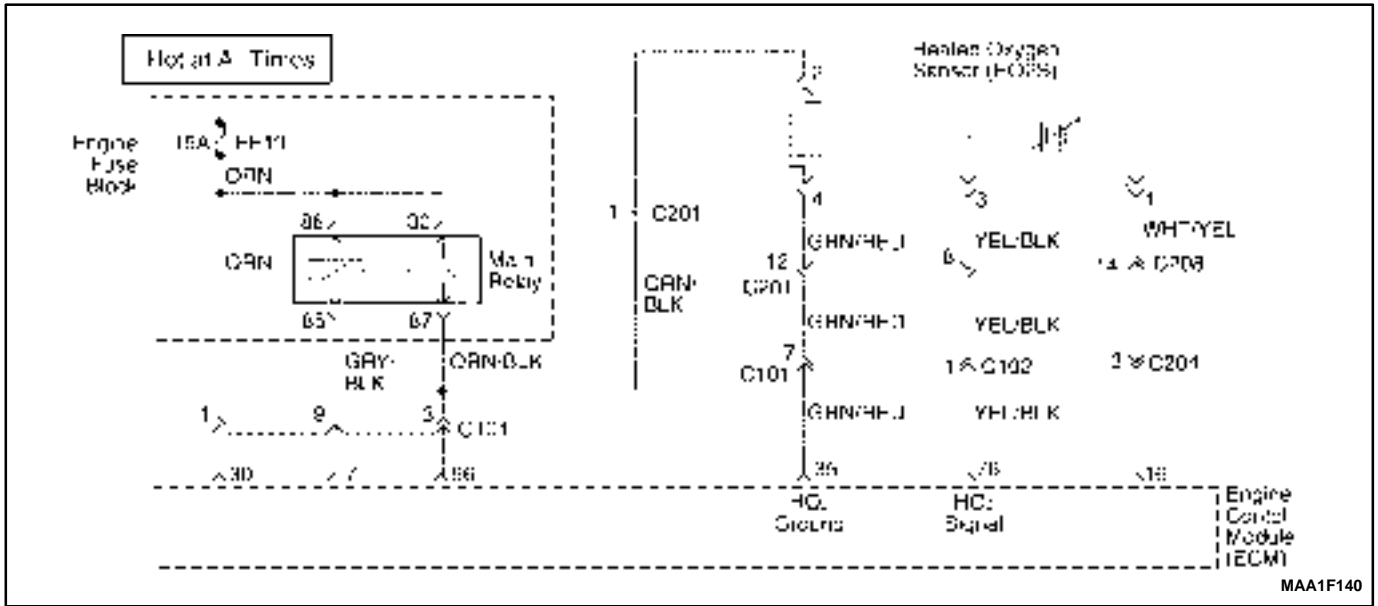

DIAGNOSTIC TROUBLE CODE (DTC) – P0141 HEATED OXYGEN SENSOR HEATER MALFUNCTION

Circuit Description

The engine control module (ECM) supplies a voltage of about 450mm volts between the ECM terminals 44 and 13. The oxygen (O₂) sensor varies the voltage within a range of about 1volt if the exhaust is rich, down to about 100mm volts if the exhaust is lean. The O₂ sensor is like an open circuit and produces no voltage when it is below 360°C(600°F). An open O₂ sensor circuit or a cold O₂ sensor causes “open loop” operation.

Conditions for Setting the DTC

- Heated oxygen sensor 5V reference voltage supply circuit high voltage or ground.
- Heated oxygen sensor 5V reference voltage supply circuit open.

Action Taken when the DTC Sets

- Emission related.
- “Armed” after two trip with a fail.
- “Disarmed” after one trip with a pass.
- MIL on if failure is detected in three consecutive trips.
- Stores a History DTC on the third consecutive with a fail (The DTC will be armed after the second fail).
- Stores a Freeze Frame on the third consecutive trip with a fail (if empty).

Conditions for Clearing the MIL/DTC

- The MIL will turn off after four consecutive ignition cycles in which the diagnostic runs without a fault.
- A history DTC will clear after 40 consecutive warm up cycles without a fault.
- DTC(s) can be cleared by using the scan tool.

Diagnostic Aids

- Normal scan tool voltage varies between 0.1volts and 0.9 volts while in closed loop.
- Inspect the oxygen (O₂) sensor wire. The O₂ sensor may be positioned incorrectly and contacting the exhaust manifold.
- Check for an intermittent ground in the wire between the O₂ sensor and the engine control module.
- Perform an injector 2alance test to determine if a restricted fuel injector may be causing the lean condition.
- Vacuum of crankcase leaks will cause a lean running condition.
- An exhaust manifold gasket leak of a cracked exhaust manifold may cause outside air to be pulled into the exhaust and past the sensor.

DTC P0141 – Heated Oxygen Sensor Heater Malfunction

Step	Action	Value(s)	Yes	No
1	Perform an Euro On-Board Diagnostic (EOBD) System Check. Is the system check complete?	–	Go to <i>Step 2</i>	Go to “On-Board Diagnostic System Check”
2	1. Turn the ignition switch to LOCK. 2. Disconnect the Heated O2 sensor connector and engine control module (ECM) connector. 3. Check the Heated O2 sensor heater wire between the Heated O2 sensor connector terminal 4 and ECM connector terminal 35 for an open or short to ground. Is the problem found?	–	Go to <i>Step 3</i>	Go to <i>Step 4</i>
3	1. Repair the wire of the connector terminal as needed. 2. Clear the DTCs from the ECM. 3. Road tests the vehicle. 4. Perform the diagnostic system check. Is the repair complete?	–	System OK	–
4	1. Turn the ignition switch to LOCK. 2. Replace the Heated O2 sensor. 3. Road tests the vehicle. 4. Perform the diagnostic system check. Is the replacement complete?	–	Go to <i>Step 6</i>	–
5	Check if any additional DTCs are set. Are any DTCs displaced that have not been diagnosed?	–	Go to applicable DTC table	System OK

DIAGNOSTIC TROUBLE CODE (DTC) – P0171 FUEL TRIM SYSTEM TOO LEAN

System Description

To provide the best possible combination of driveability, fuel economy, and emission control, a Closed Loop air/fuel metering system is used. While in Closed Loop, the Engine Control Module (ECM) monitors the oxygen sensor (O2S) signal voltage and adjusts fuel delivery based on signal voltage. A change made to fuel delivery will be indicated by the long and short term fuel trim values which can be monitored with the scan tool. Ideal fuel trim values are around 128 (0%). If the O2S signal is indicating a lean condition, the ECM will add fuel resulting in fuel trim values above 128 (0% to 100%). If a rich condition is detected, the fuel trim values will be below 128 (0% to -100%), indicating that the ECM is reducing the amount of fuel delivered. If exhaust emissions reach an excessive level due to a lean or rich condition, a fuel trim Diagnostic Trouble Code (DTC) is set.

Conditions for Setting the DTC

- No intrusive tests active.
- DTCs P0106, P0107, P0108, P0112, P0113, P0117, P0118, P0122, P0123, P0125, P0131, P0132, P0133, P0134, P0137, P0138, P0140, P0141, P1167, P1171, P0201, P0202, P0203, P0204, P0300, P0336, P0337, P0341, P0342, P0402, P0404, P1404, P0405, P0406, P0443, P0506, and P0507 are not set.
- The average of short term fuel trim value is greater than or equal to 120.
- Throttle Position (TP) is less than 95%.
- Engine speed is between 700 and 6000 rpm.
- Barometric Pressure (BARO) is greater than 92.0 kPa (10.4 psi).
- Coolant temperature is between 80°C (176°F) and 115°C (239°F).
- Manifold Absolute Pressure (MAP) is more than 90 kPa (10.2 psi).
- System is in closed loop.
- Adaptive index is ready.

Action Taken when the DTC Sets

- Emission related.
- “Armed” after two trip with a fail.
- “Disarmed” after one trip with a pass.
- MIL on if failure is detected in three consecutive trips.
- Stores a History DTC on the third consecutive with a fail (The DTC will be armed after the second fail).

- Stores a Freeze Frame on the third consecutive trip with a fail (if empty).

Conditions for Clearing the MIL/DTC

- The MIL will turn off after four consecutive ignition cycles in which the diagnostic runs without a fault.
- A history DTC will clear after 40 consecutive warm up cycles without a fault.
- DTC(s) can be cleared by using the scan tool.

Diagnostic Aids

Important: After repairs, use the scan tool Fuel Trim Reset function to reset the long-term fuel trim to 128 (0%).

- Fuel pressure – The system will be lean if the pressure is too low. It may be necessary to monitor fuel pressure while driving the vehicle at various road speeds and/or loads to confirm.
- Map sensor – An output that causes the ECM to sense a lower than normal manifold pressure (high vacuum) can cause the system to go lean. Disconnecting the MAP sensor will allow the ECM to substitute a fixed (default) value for the MAP sensor. If the lean condition is gone when the sensor is disconnected, substitute a known good sensor and recheck.
- Fuel contamination – Water, in even small amounts, near the in-tank fuel pump inlet can be delivered to the injector. The water causes a lean exhaust and can set DTC P0171.

Check for poor O2S or MAP sensor connection at the ECM. Inspect the harness connectors for the following conditions:

- Backed-out terminals
- Improper mating
- Broken locks
- Improperly formed
- Damaged terminals
- Poor terminal-to-wire connection

Inspect the wiring harness for damage. If the harness appears to be OK, observe the O2S display on the scan tool while moving the connectors and the wiring harness related to the engine harness. A change in the display will indicate the location of the fault.

Check the brake power booster check valve for possible leaks.

DTC P0171 – Fuel Trim System Too Lean

Step	Action	Value(s)	Yes	No
1	Perform an Euro On-Board Diagnostic (EOBD) System Check. Is the system check complete?	–	Go to <i>Step 2</i>	Go to “On-Board Diagnostic System Check”
2	1. Install the scan tool to the Data Link Connector (DLC). 2. Turn the ignition ON. Are any component related Diagnostic Trouble Codes (DTCs) set?	–	Go to Applicable DTC table	Go to <i>Step 3</i>
3	With the engine running, operate the vehicle until the LOOP STATUS indicates closed. Is the Long Term Fuel Trim value below the specified value?	–22%	Go to <i>Step 4</i>	Go to <i>Step 5</i>
4	1. Turn the ignition switch ON, with the engine OFF. 2. Review the Freeze Frame data and note the parameters. 3. Operate the vehicle within the Freeze Frame conditions and Conditions for Setting The DTC as noted. Does the Long Term Fuel Trim value go below the specified value while operating under the specified conditions?	–22%	Go to <i>Step 16</i>	Go to <i>Step 5</i>
5	Visually/physically check the following items: <ul style="list-style-type: none"> ● Vacuum hoses for splits, kinks and improper connections. ● Crankcase ventilation oil/air separator for proper installation. ● Exhaust system for corrosion, leaks, loose or missing hardware. ● Oxygen sensor (O2S) is installed securely and the pigtail harness is not contacting exhaust manifold or engine. ● Fuel for excessive water, alcohol, or other contaminants. ● Engine Control Module (ECM) and sensor grounds are clean, tight, and in their proper locations. Do any of the above checks isolate a condition requiring repair?	–	Go to <i>Step 7</i>	Go to <i>Step 6</i>
6	1. Disconnect the Manifold Absolute Pressure (MAP) sensor electrical connector. 2. Operate the vehicle in Closed Loop while monitoring the Long Term Fuel Trim value. Is the Long Term Fuel Trim value below the specified value?	–22%	Go to <i>Step 15</i>	Go to <i>Step 9</i>
7	1. Repair the malfunction found in Step 5. 2. Recheck the Long Term Fuel Trim value while operating the engine. Is the Long Term Fuel Trim value below the specified value?	–22%	Go to <i>Step 8</i>	Go to <i>Step 9</i>
8	Lean condition is not present. Does a driveability problem exist?	–	Go to “Symptom Diagnosis”	Go to <i>Step 16</i>

DTC P0171 – Fuel Trim System Too Lean (Cont'd)

Step	Action	Value(s)	Yes	No
9	1. Visually/physically inspect the following items for vacuum leaks: <ul style="list-style-type: none"> ● Intake manifold. ● Throttle body. ● Injector O-rings. 2. Repair any leaks found as necessary. Is the repair complete?	–	Go to Step 16	Go to Step 16
10	Allow the engine to idle. Are the Idle Air Control (IAC) counts above the specified value?	5	Go to Step 11	Go to Step 12
11	Check the fuel for excessive water, alcohol, or other contaminants and correct the contaminated fuel condition if present. Is the repair complete?	–	Go to Step 16	Go to Step 13
12	Check the IAC valve performance. Refer to “DTC P0506 Idle Speed RPM Lower Than Desired Idle Speed” or “DTC P0507 Idle Speed RPM Higher Than Desired Idle Speed” in this section and repair as necessary. Is the repair complete?	–	Go to Step 16	Go to Step 13
13	1. Connect a fuel pressure gauge to the fuel system. 2. Turn the ignition OFF for at least 10 seconds. 3. Turn the ignition ON, with the engine OFF. The fuel pump will run for approximately 2–3 seconds. It may be necessary to cycle the ignition switch ON more than once to obtain maximum fuel pressure. 4. Note the fuel pressure with the fuel pump running. The pressure should be within the specified value. When the fuel pump stops, the pressure may vary slightly then hold steady. Is the fuel pressure steady and does the fuel pressure hold?	380 KPa (55 psi)	Go to Step 14	Go to “Fuel System Diagnosis”
14	1. Start and idle the engine at normal operating temperature. 2. The fuel pressure noted in the above step should drop by the indicated value. Does the fuel pressure drop by the indicated value?	21–69 KPa (3–10 psi)	Go to “Fuel Injector Balance Test”	Go to “Fuel System Diagnosis”
15	Replace the MAP sensor. Is the action complete?	–	Go to Step 16	–
16	1. Using the scan tool, clear the Diagnostic Trouble Codes (DTCs). 2. Start the engine and idle at normal operating temperature. 3. Operate the vehicle within the Conditions for setting this DTC as specified in the supporting text. Does the scan tool indicate that this diagnostic has run and passed?	–	Go to Step 17	Go to Step 2
17	Check if any additional DTCs are set. Are any DTCs displayed that have not been diagnosed?	–	Go to applicable DTC table	System OK

DIAGNOSTIC TROUBLE CODE (DTC) – P0172 FUEL TRIM SYSTEM TOO RICH

System Description

To provide the best possible combination of driveability, fuel economy, and emission control, a Closed Loop air/fuel metering system is used. While in Closed Loop, the Engine Control Module (ECM) monitors the oxygen sensor (O2S) signal voltage and adjusts fuel delivery based on signal voltage. A change made to fuel delivery will be indicated by the long and short term fuel trim values which can be monitored with the scan tool. Ideal fuel trim values are around 128 (0%). If the O2S signal is indicating a lean condition, the ECM will add fuel resulting in fuel trim values above 128 (0% to 100%). If a rich condition is detected, the fuel trim values will be below 128 (0% to -100%), indicating that the ECM is reducing the amount of fuel delivered. If exhaust emissions reach an excessive level due to a lean or rich condition, a fuel trim Diagnostic Trouble Code (DTC) is set.

Conditions for Setting the DTC

- No intrusive tests active.
- DTCs P0106, P0107, P0108, P0112, P0113, P0117, P0118, P0122, P0123, P0131, P0132, P0133, P0134, P0137, P0138, P1167, P1171, P0300, P0336, P0337, P0341, P0342, P0402, P0404, P1404, P0405, P0406, P0443, P0506, and P0507 are not set.
- The average of short term fuel trim value is greater than or equal to 120.
- Throttle Position (TP) is less than 95%.
- Engine speed is between 700 and 6000 rpm.
- Barometric Pressure (BARO) is greater than 90.0 kPa (10.4 psi).
- Coolant temperature is between 80°C (176°F) and 115°C (239°F).
- Manifold Absolute Pressure (MAP) is more than 70 kPa (10.2 psi).
- System is in closed loop.
- Adaptive index is ready.

Action Taken when the DTC Sets

- Emission related.

- “Armed” after two trip with a fail.
- “Disarmed” after one trip with a pass.
- MIL on if failure is detected in three consecutive trips.
- Stores a History DTC on the third consecutive with a fail (The DTC will be armed after the second fail).
- Stores a Freeze Frame on the third consecutive trip with a fail (if empty).

Conditions for Clearing the MIL/DTC

- The MIL will turn off after four consecutive ignition cycles in which the diagnostic runs without a fault.
- A history DTC will clear after 40 consecutive warm up cycles without a fault.
- DTC(s) can be cleared by using the scan tool.

Diagnostic Aids

Important: After repairs, use the scan tool Fuel Trim Reset function to reset the long-term fuel trim to 128 (0%).

Check for poor connection at the ECM. Inspect the harness connectors for the following conditions:

- Backed-out terminals.
- Improper mating.
- Broken locks.
- Improperly formed.
- Damaged terminals.
- Poor terminal-to-wire connection.

Inspect the wiring harness for damage. If the harness appears to be OK, observe the O2S display on the scan tool while moving the connectors and the wiring harness related to the engine harness. A change in the display will indicate the location of the fault.

If a DTC P1404 is also set, check the 5 volt reference circuits for a short to voltage.

Check for a restricted exhaust system.

A shorted 5 volt reference circuit may cause a DTC P0172 to set. Check the 5 volt reference sensors for abnormal readings.

DTC P0172 – Fuel Trim System Too Rich

Step	Action	Value(s)	Yes	No
1	Perform an Euro On-Board Diagnostic (EOBD) System Check. Is the system check complete?	–	Go to <i>Step 2</i>	Go to “On-Board Diagnostic System Check”
2	Install the scan tool to the Data Link Connector (DLC). Turn the ignition ON. Are any component related Diagnostic Trouble Codes (DTCs) set?	–	Go to Applicable DTC table	Go to <i>Step 3</i>
3	1. With the engine running, operate the vehicle until the LOOP STATUS indicates closed. Is the Long Term Fuel Trim value above the specified value?	30%	Go to <i>Step 4</i>	Go to <i>Step 5</i>
4	1. Turn the ignition switch ON, with the engine OFF. 2. Review the Freeze Frame data and note the parameters. 3. Operate the vehicle within the Freeze Frame conditions and Conditions for Setting The DTC as noted. Does the Long Term Fuel Trim value above the specified value while operating under the specified conditions?	30%	Go to <i>Step 21</i>	Go to <i>Step 5</i>
5	Visually/physically check the air cleaner filter for excessive dirt or being plugged and repair as needed. Is the repair complete?	–	Go to <i>Step 21</i>	Go to <i>Step 6</i>
6	Visually/physically check the air intake system for collapsed or restricted and repair as needed. Is the repair complete?	–	Go to <i>Step 21</i>	Go to <i>Step 7</i>
7	Inspect the throttle body inlet for damaged or foreign objects which may partially block the airflow and repair as needed. Is the repair complete?	–	Go to <i>Step 21</i>	Go to <i>Step 8</i>
8	1. Turn the ignition OFF. 2. Inspect the throttle bore, throttle plate and Idle Air Control (IAC) passages for clogging and foreign objects and repair as needed. Is the repair complete?	–	Go to <i>Step 21</i>	Go to <i>Step 9</i>
9	Start the engine with the vehicle in park or neutral and A/C off and note the idle quality. Is a low or unsteady idle being experienced?	–	Go to <i>Step 10</i>	Go to <i>Step 12</i>
10	Idle the engine. Are the IAC counts below the specified value?	100	Go to <i>Step 12</i>	Go to <i>Step 11</i>
11	1. Turn the ignition OFF. 2. Disconnect the Manifold Absolute Pressure (MAP) sensor electrical connector. 3. Start the engine. 4. Operate the vehicle in Closed Loop while monitoring the Long Term Fuel Trim value. Does the Long Term Fuel Trim value increase above the specified value?	30%	Go to <i>Step 20</i>	Go to <i>Step 12</i>

DTC P0172 – Fuel Trim System Too Rich (Cont'd)

Step	Action	Value(s)	Yes	No
12	Check the IAC valve performance. Refer to “DTC P0506 Idle Speed RPM Lower Than Desired Idle Speed” or “DTC P0507 Idle Speed RPM Higher Than Desired Idle Speed” in this section and repair as necessary. Is the repair complete?	–	Go to Step 21	Go to Step 13
13	1. Disconnect the vacuum hose from the fuel pressure regulator and inspect the hose for the presence of fuel. 2. If fuel is presence in the vacuum hose, replace the fuel pressure regulator. Is the repair complete?	–	Go to Step 21	Go to Step 14
14	1. Turn the ignition ON. 2. Slowly press the acceleration pedal. Does the Throttle Position (TP) sensor display increase steady and evenly from its minimum voltage at closed throttle to its maximum voltage at Wide-Open Throttle (WOT).	–	Go to Step 15	Go to Step 19
15	1. Perform the Fuel System Diagnosis. 2. If the table isolate a problem, repair as needed. Is the repair complete?	–	Go to Step 21	Go to Step 16
16	1. Perform the Evaporative Emission (EVAP) Control System Diagnosis. 2. If the table isolate a problem, repair as needed. Is the repair complete?	–	Go to Step 21	Go to Step 17
17	1. Perform the Fuel Injector balance Test. 2. If the table isolate a problem, repair as needed. Is the repair complete?	–	Go to Step 21	Go to Step 18
18	1. Remove the Oxygen Sensor (O2S) 2. Visually/physically inspect the O2S for silicone contamination. 3. Note: this will be indicated by a powdery white deposit on the portion of the O2S exposed to the exhaust stream. 4. If contamination is present on the O2S, find the source and repair as needed. Is the repair complete?	–	Go to Step 21	Go to “Diagnostic Aids”
19	1. Check the TP sensor mounting screws. 2. If they are too loose or missing tighten or replace them as needed. 3. If the screws are OK, replace the TP sensor. Is the repair complete?	–	Go to Step 21	–
20	1. Turn the ignition OFF. 2. Replace the MAP sensor. Is the repair complete?	–	Go to Step 21	–

DTC P0172 – Fuel Trim System Too Rich (Cont'd)

Step	Action	Value(s)	Yes	No
21	1. Using the scan tool, clear the Diagnostic Trouble Codes (DTCs). 2. Start the engine and idle at normal operating temperature. 3. Operate the vehicle within the Conditions for setting this DTC as specified in the supporting text. Does the scan tool indicate that this diagnostic has run and passed?	–	Go to <i>Step 21</i>	Go to <i>Step 2</i>
22	Check if any additional DTCs are set. Are any DTCs displayed that have not been diagnosed?	–	Go to applicable DTC table	System OK

BLANK

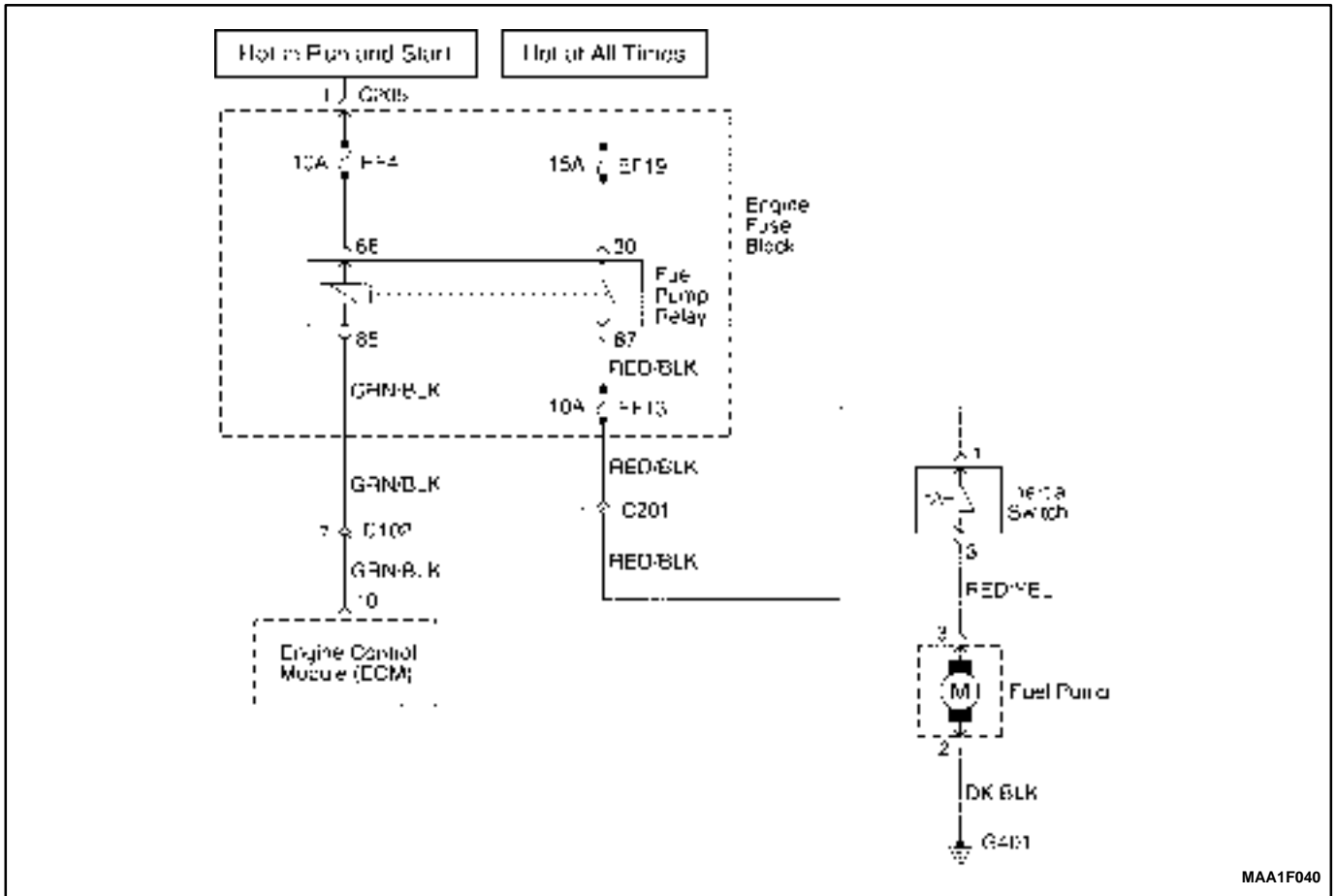

MAA1F040

DIAGNOSTIC TROUBLE CODE (DTC) – P1230 FUEL PUMP RELAY LOW VOLTAGE

Circuit Description

When the ignition switch is turned ON, the ECM will activate the fuel pump relay and run the in-tank fuel pump.

The fuel pump will operate as long as the engine is cranking or running and the ECM is receiving ignition reference pulses.

Conditions for Setting the DTC

- This DTC can be stored in “key-on” status.
- An open or low voltage condition exists.

Action Taken when the DTC Sets

- The Malfunction Indicator Lamp (MIL) will illuminate.
- The ECM will record operating conditions at the time the diagnostic fails. This information will be stored in the Freeze Frame and Records buffers.
- A history DTC is stored.
- Coolant fan turns ON.

Conditions for Clearing the MIL/DTC

- The MIL will turn off after 4 consecutive ignition cycles in which the diagnostic runs without a fault.

- A history DTC will clear after 40 consecutive warm up cycles without a fault.
- DTC(s) can be cleared by using the scan tool.

Diagnostic Aids

An Intermittent problem may be caused by a poor connection, rubbed through wire insulation, or wire that is broken inside the insulation.

Any circuitry, that is suspected as causing the complaint, should be thoroughly checked for the following conditions.

- Backed-out terminals
- Improper mating
- Broken locks
- Improperly formed
- Damaged terminals
- Poor terminals to wire connection
- Physical damage to the wiring harness

DTC P1230 – Fuel Pump Relay Low Voltage

Step	Action	Value(s)	Yes	No
1	Perform an Euro On-Board Diagnostic (EOBD) System Check. Is the system check complete?	–	Go to <i>Step 2</i>	Go to “On-Board Diagnostic System Check”
2	1. Turn the ignition switch to LOCK for 10 seconds. 2. Turn the Turn the ignition switch to ON. 3. Listen for in-tank fuel pump operation. Does the fuel pump operate?	2.55 seconds	Go to “Diagnostic Aids”	Go to <i>Step 3</i>
3	1. Turn the Turn the ignition switch to ON. 2. Disconnect the fuel pump relay. 3. Connect a test light between the fuel pump relay connector terminal 85 and ground. 4. Turn the Turn the ignition switch to ON. Is the test light ON?	–	Go to <i>Step 4</i>	Go to <i>Step 10</i>
4	1. Turn the Turn the ignition switch to ON. 2. Disconnect the fuel pump relay. 3. Connect a test light between the fuel pump relay connector terminal 66 and B+. 4. Turn the Turn the ignition switch to ON. Is the test light ON?	–	Go to <i>Step 5</i>	Go to <i>Step 9</i>
5	1. Turn the ignition switch to LOCK. 2. Connect a test light between the fuel pump relay connector terminal 30 and ground. Is the test light ON?	–	Go to <i>Step 6</i>	Go to <i>Step 8</i>
6	Check for short to ground in the wire between the fuel pump relay connector terminal 87 and fuel pump connector. Is the problem found?	–	Go to <i>Step 7</i>	Go to <i>Step 8</i>
7	1. Repair the wire between the fuel pump relay connector terminal 87 and fuel pump connector terminal 3. 2. Install the fuel pump relay. 3. Turn the engine OFF for 10 seconds. 4. Clear any DTCs from ECM. 5. Turn the ignition switch to ON. Does the fuel pump operate?	2.55 seconds	Go to <i>Step 14</i>	–
8	1. Replace the fuel pump relay. 2. Turn the ignition OFF for 10 seconds. 3. Clear any DTCs from ECM. 4. Turn the Turn the ignition switch to ON. Does the fuel pump operate?	2.55 seconds	Go to <i>Step 14</i>	Go to <i>Step 9</i>
9	Check for a short to ground wire between the fuel pump relay connector terminal 66 and the ignition after key ON 1(IGN 1). Is the problem found?	–	Go to <i>Step 11</i>	Go to <i>Step 10</i>
10	Check for a short to ground wire between the fuel pump relay connector terminal 85 and the ECM connector terminal 10. Is the problem found?	–	Go to <i>Step 12</i>	Go to <i>Step 13</i>

DTC P1230 – Fuel Pump Relay Low Voltage (Cont'd)

Step	Action	Value(s)	Yes	No
11	<ol style="list-style-type: none"> 1. Repair the wire between the fuel pump relay connector terminal 66 and the ignition key ON (IGN1). 2. Install the fuel pump relay. 3. Turn the ignition OFF for 10 seconds. 4. Clear any DTCs from ECM. 5. Turn the ignition switch to ON. Does the fuel pump operate?	2.55 seconds	System OK	Go to <i>Step 13</i>
12	<ol style="list-style-type: none"> 1. Repair the wire between the fuel pump relay connector terminal 85 and the ECM connector terminal 10. 2. Install the fuel pump relay. 3. Turn the ignition OFF for 10 seconds. 4. Clear any DTCs from ECM. 5. Turn the ignition switch to ON. Does the fuel pump operate?	2.55 seconds	System OK	Go to <i>Step 13</i>
13	<ol style="list-style-type: none"> 1. Replace the ECM. 2. Turn the ignition OFF for 10 seconds. 3. Clear any DTCs from ECM. 4. Turn the ignition switch to ON. Does the fuel pump operate?	2.55 seconds	System OK	Go to <i>Step 14</i>
14	<ol style="list-style-type: none"> 1. Using the scan tool, clear the DTCs. 2. Start the engine and idle at normal operating temperature. 3. Operate the vehicle within the conditions for setting this DTC as specified in the supporting text. Does the scan tool indicate that this diagnostic has run and passed?	–	Go to <i>Step 15</i>	Go to <i>Step 2</i>
15	Check if any additional DTCs are set. Are any DTCs displayed that have not been diagnosed?	–	Go to applicable DTC table	System OK

BLANK

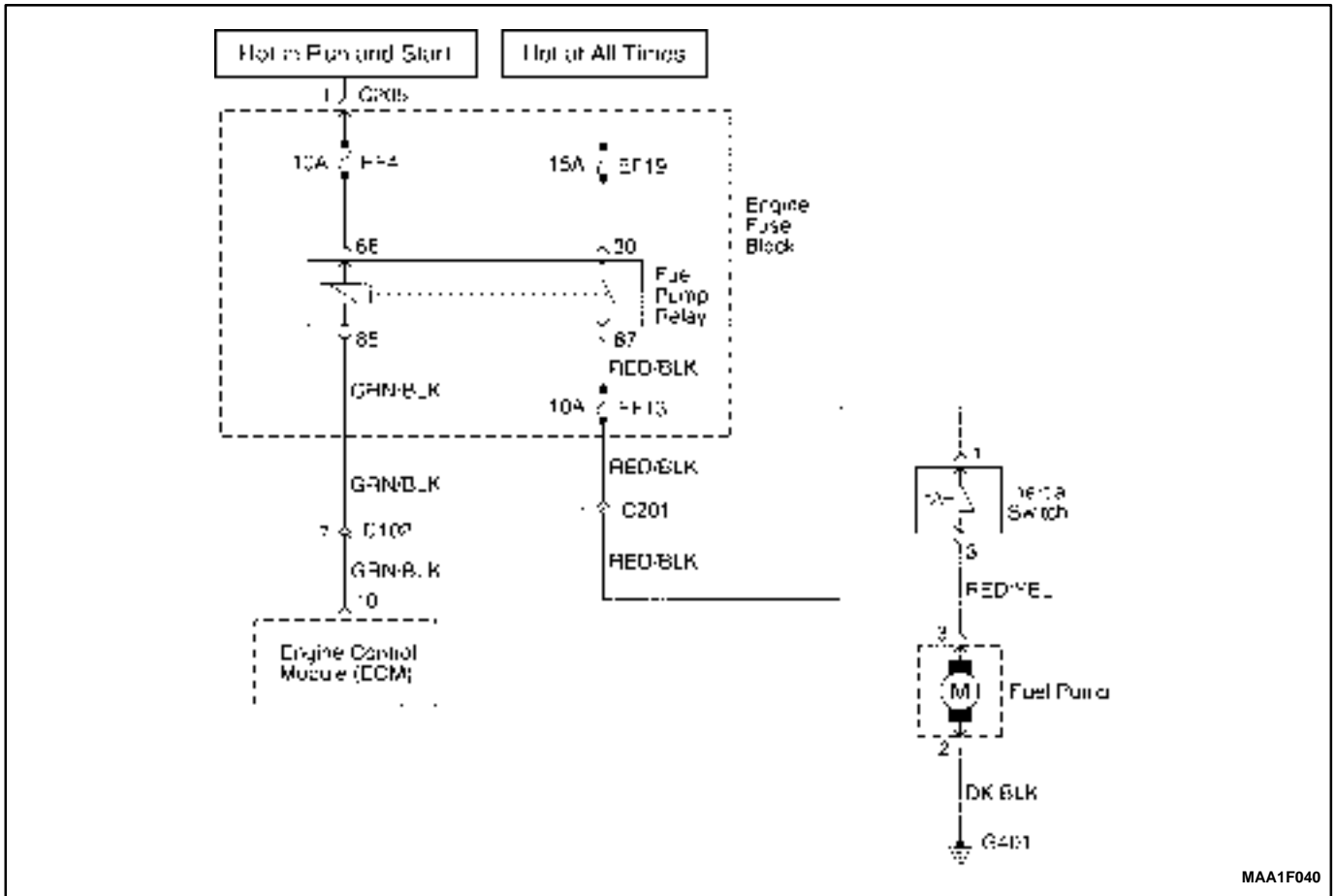

MAA1F040

DIAGNOSTIC TROUBLE CODE (DTC) – P1231 FUEL PUMP RELAY HIGH VOLTAGE

Circuit Description

When the ignition switch is turned ON, the ECM will activate the fuel pump relay and run the in-tank fuel pump.

The fuel pump will operate as long as the engine is cranking or running and the ECM is receiving ignition reference pulses.

Conditions for Setting the DTC

- This DTC can be stored in “key-on” status.
- A high voltage condition exists.

Action Taken when the DTC Sets

- The Malfunction Indicator Lamp (MIL) will illuminate.
- The ECM will record operating conditions at the time the diagnostic fails. This information will be stored in the Freeze Frame and Records buffers.
- A history DTC is stored.
- Coolant fan turns ON.

Conditions for Clearing the MIL/DTC

- The MIL will turn off after 4 consecutive ignition cycles in which the diagnostic runs without a fault.

- A history DTC will clear after 40 consecutive warm up cycles without a fault.
- DTC(s) can be cleared by using the scan tool.
- Disconnecting the ECM battery feed for 10 seconds.

Diagnostic Aids

An Intermittent problem may be caused by a poor connection, rubbed through wire insulation, or wire that is broken inside the insulation.

Any circuitry, that is suspected as causing the complaint, should be thoroughly checked for the following conditions.

- Backed-out terminals
- Improper mating
- Broken locks
- Improperly formed
- Damaged terminals
- Poor terminals to wire connection
- Physical damage to the wiring harness

DTC P1231 – Fuel Pump Relay High Voltage

Step	Action	Value(s)	Yes	No
1	Perform an Euro On-Board Diagnostic (EOBD) System Check. Is the system check complete?	–	Go to <i>Step 2</i>	Go to “On-Board Diagnostic System Check”
2	1. Turn the ignition switch to LOCK for 10 seconds. 2. Turn the Turn the ignition switch to ON. 3. Listen for in-tank fuel pump operation. Does the fuel pump operate?	2.55 seconds	Go to “Diagnostic Aids”	Go to <i>Step 3</i>
3	Check for short to battery voltage or low voltage in the wire between the fuel pump relay connector terminal 87 and fuel pump connector 3. Is the problem found?	–	Go to <i>Step 7</i>	Go to <i>Step 5</i>
4	1. Repair the wire between the fuel pump relay connector terminal 87 and fuel pump connector terminal 3. 2. Install the fuel pump relay. 3. Turn the engine OFF for 10 seconds. 4. Clear any DTCs from ECM. 5. Turn the ignition switch to ON. Does the fuel pump operate?	2.55 seconds	Go to <i>Step 14</i>	–
5	1. Replace the fuel pump relay. 2. Turn the ignition OFF for 10 seconds. 3. Clear any DTCs from ECM. 4. Turn the Turn the ignition switch to ON. Does the fuel pump operate?	2.55 seconds	Go to <i>Step 11</i>	Go to <i>Step 6</i>
6	Check for short to battery voltage wire between the fuel pump relay connector terminal 66 and the ignition after key ON 1(IGN 1). Is the problem found?	–	Go to <i>Step 8</i>	Go to <i>Step 7</i>
7	Check for an open wire between the fuel pump relay connector terminal 85 and the ECM connector terminal 10. Is the problem found?	–	Go to <i>Step 9</i>	Go to <i>Step 10</i>
8	1. Repair the wire between the fuel pump relay connector terminal 66 and the ignition key ON (IGN1). 2. Install the fuel pump relay. 3. Turn the ignition OFF for 10 seconds. 4. Clear any DTCs from ECM. 5. Turn the ignition switch to ON. Does the fuel pump operate?	2.55 seconds	System OK	Go to <i>Step 13</i>
9	1. Repair the wire between the fuel pump relay connector terminal 85 and the ECM connector terminal 10. 2. Install the fuel pump relay. 3. Turn the ignition OFF for 10 seconds. 4. Clear any DTCs from ECM. 5. Turn the ignition switch to ON. Does the fuel pump operate?	2.55 seconds	System OK	Go to <i>Step 10</i>

DTC P1231 – Fuel Pump Relay High Voltage (Cont'd)

Step	Action	Value(s)	Yes	No
10	1. Replace the ECM. 2. Turn the ignition OFF for 10 seconds. 3. Clear any DTCs from ECM. 4. Turn the ignition switch to ON. Does the fuel pump operate?	2.55 seconds	System OK	Go to <i>Step 11</i>
11	1. Using the scan tool, clear the DTCs. 2. Start the engine and idle at normal operating temperature. 3. Operate the vehicle within the conditions for setting this DTC as specified in the supporting text. Does the scan tool indicate that this diagnostic has run and passed?	–	Go to <i>Step 12</i>	Go to <i>Step 2</i>
12	Check if any additional DTCs are set. Are any DTCs displayed that have not been diagnosed?	–	Go to applicable DTC table	System OK

BLANK

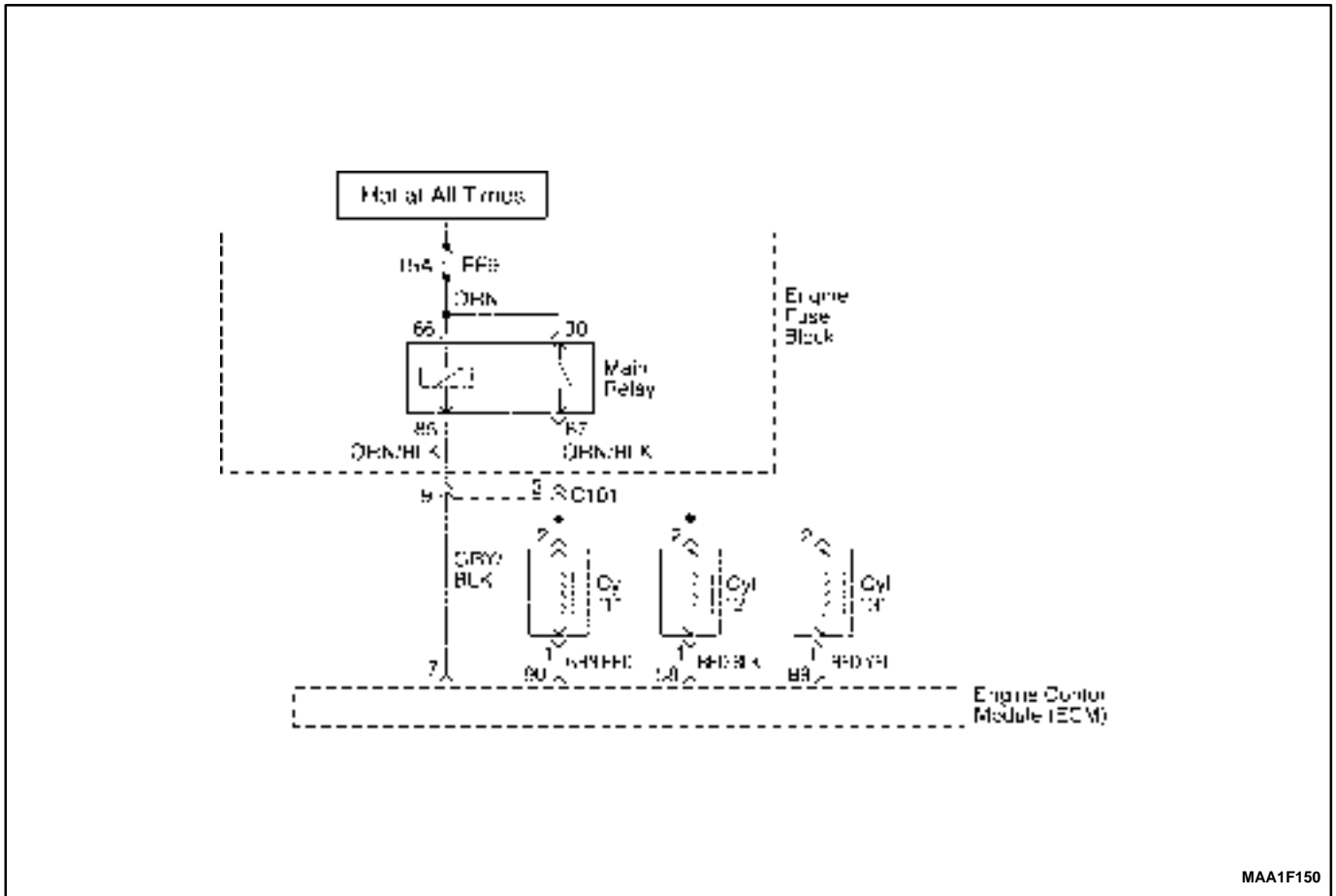

MAA1F150

DIAGNOSTIC TROUBLE CODE (DTC) – P0261 INJECTOR 1 LOW VOLTAGE

Circuit Description

The engine control module (ECM) has three individual injector driver circuits, each of which controls an injector. When a driver circuit is grounded by the ECM, the injector is activated. The ECM monitors the current in each driver circuit. The ECM measures a voltage drop through a fixed resistor and controls it. The voltage on each driver is monitored to detect a fault. If the voltage is not what the ECM expects to monitor on the circuit, a Diagnostic Trouble Code (DTC) is set. This DTC detects a low voltage and/or an open circuit and high voltage conditions for low-side drive injector outputs.

Conditions for Setting the DTC

- This DTC can be stored in “key-on” status.
- The injector voltage does not equal the ignition voltage when the injector is commanded OFF, or the injector voltage does not equal 0 volts when the injector is commanded ON.
- The battery voltage is less than 9 volts.
- The above conditions are met for 5seconds.

Action Taken when the DTC Sets

- The Malfunction Indicator Lamp (MIL) will illuminate.

- The ECM will record operating conditions at the time the diagnostic fails. This information will be stored in the Freeze Frame and Records buffers.
- A history DTC is stored.

Conditions for Clearing the MIL/DTC

- The MIL will turn off after 4 consecutive ignition cycles in which the diagnostic runs without a fault.
- A history DTC will clear after 40 consecutive warm up cycles without a fault.
- DTC(s) can be cleared by using the scan tool.

DIAGNOSTIC AIDS

An injector driver circuit that is open or shorted to voltage will cause a DTC P0261 to set. It will also cause a misfire due to an inoperative injector. A misfire DTC should also be set indicating which injector is inoperative.

Long-term and short-term fuel trims that are excessively high or low are a good indication that an injector is malfunctioning. Refer to “Fuel Injector Balance Test” in this Section to check for malfunctioning injectors.

The injector resistance tested at the ECM connection is slightly more than it tested directly at the injector because it includes resistance of the harness wires. The normal value is about 13.5Ω.

DTC P0261 – Injector 1 Low Voltage

Step	Action	Value(s)	Yes	No
1	Perform an Euro On-Board Diagnostic (EOBD) System Check. Is the system check complete?	–	Go to <i>Step 2</i>	Go to “On-Board Diagnostic System Check”
2	With the engine start?	–	Go to <i>Step 3</i>	Go to “Engine Crank but will not Run”
3	1. Install a scan tool and clear the Diagnostic Trouble Codes (DTCs). 2. Idle the engine for one minuet. Does DTC P0261 reset?	–	Go to <i>Step 5</i>	Go to <i>Step 4</i>
4	1. Review the Freeze Frame data with the ignition ON and the engine OFF and note the parameters. 2. Operate the vehicle within the Freeze Frame conditions as notes. Does DTC P0261 reset?	–	Go to <i>Step 5</i>	Go to “Diagnostic Aids”
5	1. Turn the ignition switch to LOCK. 2. Check for short to ground in the wire between the injector 1 connector terminal 1 and ECM connector terminal 90. Is the problem found?	–	Go to <i>Step 7</i>	Go to <i>Step 6</i>
6	1. Turn the ignition switch to LOCK. 2. Check for short to ground in the wire between the injector 1 connector terminal 2 and battery positive. Is the problem found?	–	Go to <i>Step 7</i>	Go to <i>Step 8</i>
7	1. Repair the wire or the connector terminal as needed. 2. Clear any DTCs from ECM. 3. Perform the Diagnostic System Check. Is the repair complete?	–	System OK	–
8	1. Replace the injector valve. 2. Clear any DTCs from ECM. 3. Perform the Diagnostic System Check. Is the repair complete?	–	Go to <i>Step 9</i>	System OK
9	1. Turn the ignition switch to LOCK. 2. Replace the ECM. 3. Perform the Diagnostic System Check. Does DTC P0261 reset?	–	Go to <i>Step 10</i>	–
10	Check if any additional DTCs are set. Are any DTCs displaced that have not been diagnosed?	–	Go to applicable DTC table	System OK

DTC P0262 – Injector 1 High Voltage

Step	Action	Value(s)	Yes	No
1	Perform an Euro On-Board Diagnostic (EOBD) System Check. Is the system check complete?	–	Go to <i>Step 2</i>	Go to “On-Board Diagnostic System Check”
2	With the engine start?	–	Go to <i>Step 3</i>	Go to “Engine Crank but will not Run”
3	1. Install a scan tool and clear the Diagnostic Trouble Codes (DTCs). 2. Idle the engine for one minuet. Does DTC P0262 reset?	–	Go to <i>Step 5</i>	Go to <i>Step 4</i>
4	1. Review the Freeze Frame data with the ignition ON and the engine OFF and note the parameters. 2. Operate the vehicle within the Freeze Frame conditions as notes Does DTC P0262 reset?	–	Go to <i>Step 5</i>	Go to “Diagnostic Aids”
5	1. Turn the ignition switch to Lock. 2. Check for an open or short to battery voltage in the wire between the injector 1 connector terminal 1 and ECM connector terminal 90. Is the problem found?	–	Go to <i>Step 7</i>	Go to <i>Step 6</i>
6	1. Turn the ignition switch to Lock. 2. Check for short to battery voltage in the wire between the injector 1 connector terminal 2 and battery positive. Is the problem found?	–	Go to <i>Step 7</i>	Go to <i>Step 8</i>
7	1. Repair the wire or the connector terminal as needed. 2. Clear any DTCs from ECM. 3. Perform the Diagnostic System Check. Is the repair complete?	–	System OK	–
8	1. Replace the injector valve 2. Clear any DTCs from ECM. 3. Perform the Diagnostic System Check. Does DTC P0262 reset?	–	Go to <i>Step 9</i>	System OK
9	1. Turn the ignition switch to LOCK. 2. Replace the ECM. 3. Perform the Diagnostic System Check. Is the repair complete?	–	Go to <i>Step 10</i>	–
10	Check if any additional DTCs are set. Are any DTCs displaced that have not been diagnosed?	–	Go to applicable DTC table	System OK

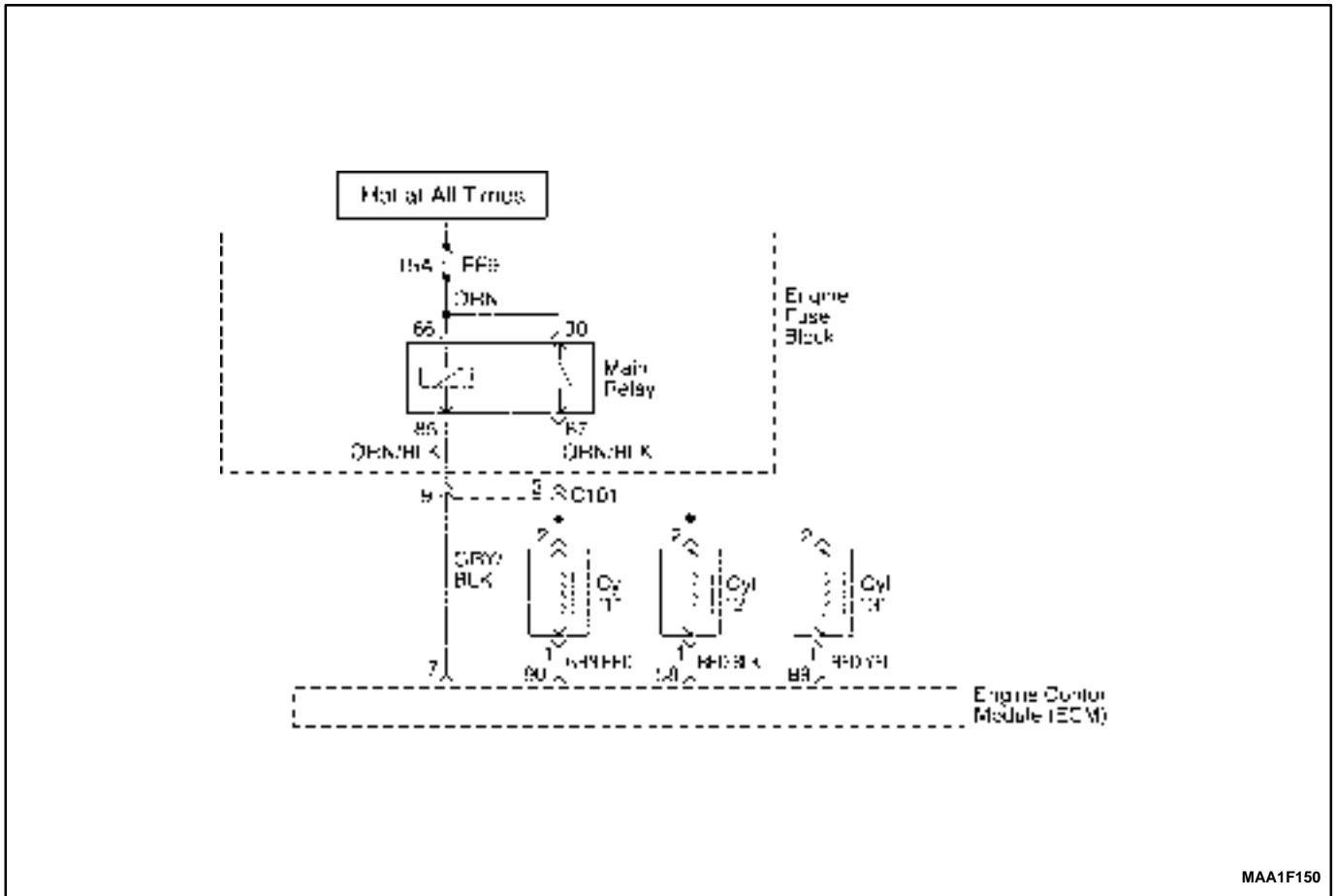

MAA1F150

DIAGNOSTIC TROUBLE CODE (DTC) – P0264 INJECTOR 2 LOW VOLTAGE

Circuit Description

The engine control module (ECM) has three individual injector driver circuits, each of which controls an injector. When a driver circuit is grounded by the ECM, the injector is activated. The ECM monitors the current in each driver circuit. The ECM measures a voltage drop through a fixed resistor and controls it. The voltage on each driver is monitored to detect a fault. If the voltage is not what the ECM expects to monitor on the circuit, a Diagnostic Trouble Code (DTC) is set. This DTC detects a low voltage and/or an open circuit and high voltage conditions for low-side drive injector outputs.

Conditions for Setting the DTC

- This DTC can be stored in “key-on” status.
- The injector voltage does not equal the ignition voltage when the injector is commanded OFF, or the injector voltage does not equal 0 volts when the injector is commanded ON.
- The battery voltage is less than 9 volts.
- The above conditions are met for 5 seconds.

Action Taken when the DTC Sets

- The Malfunction Indicator Lamp (MIL) will illuminate.

- The ECM will record operating conditions at the time the diagnostic fails. This information will be stored in the Freeze Frame and Records buffers.
- A history DTC is stored.

Conditions for Clearing the MIL/DTC

- The MIL will turn off after 4 consecutive ignition cycles in which the diagnostic runs without a fault.
- A history DTC will clear after 40 consecutive warm up cycles without a fault.
- DTC(s) can be cleared by using the scan tool.

DIAGNOSTIC AIDS

An injector driver circuit that is open or shorted to voltage will cause a DTC P0264 to set. It will also cause a misfire due to an inoperative injector. A misfire DTC should also be set indicating which injector is inoperative.

Long-term and short-term fuel trims that are excessively high or low are a good indication that an injector is malfunctioning. Refer to “Fuel Injector Balance Test” in this Section to check for malfunctioning injectors.

The injector resistance tested at the ECM connection is slightly more than it tested directly at the injector because it includes resistance of the harness wires. The normal value is about 13.5Ω.

DTC P0264 – Injector 2 Low Voltage

Step	Action	Value(s)	Yes	No
1	Perform an Euro On-Board Diagnostic (EOBD) System Check. Is the system check complete?	–	Go to <i>Step 2</i>	Go to “On-Board Diagnostic System Check”
2	With the engine start?	–	Go to <i>Step 3</i>	Go to “Engine Crank but will not Run”
3	1. Install a scan tool and clear the Diagnostic Trouble Codes (DTCs). 2. Idle the engine for one minuet. Does DTC P2064 reset?	–	Go to <i>Step 5</i>	Go to <i>Step 4</i>
4	1. Review the Freeze Frame data with the ignition ON and the engine OFF and note the parameters. 2. Operate the vehicle within the Freeze Frame conditions as notes Does DTC P0264 reset?	–	Go to <i>Step 5</i>	Go to “Diagnostic Aids”
5	1. Turn the ignition switch to LOCK. 2. Check for short to ground in the wire between the injector 2 connector terminal 1 and ECM connector terminal 58. Is the problem found?	–	Go to <i>Step 7</i>	Go to <i>Step 6</i>
6	1. Turn the ignition switch to LOCK. 2. Check for short to ground in the wire between the injector 2 connector terminal 2 and battery positive. Is the problem found?	–	Go to <i>Step 7</i>	Go to <i>Step 8</i>
7	1. Repair the wire or the connector terminal as needed. 2. Clear any DTCs from ECM. 3. Perform the Diagnostic System Check. Is the repair complete?	–	System OK	–
8	1. Replace the injector valve. 2. Clear any DTCs from ECM. 3. Perform the Diagnostic System Check. Does DTC P0264 reset?	–	Go to <i>Step 9</i>	System OK
9	1. Turn the ignition switch to LOCK. 2. Replace the ECM. 3. Perform the Diagnostic System Check. Is the repair complete?	–	Go to <i>Step 10</i>	–
10	Check if any additional DTCs are set. Are any DTCs displaced that have not been diagnosed?	–	Go to applicable DTC table	System OK

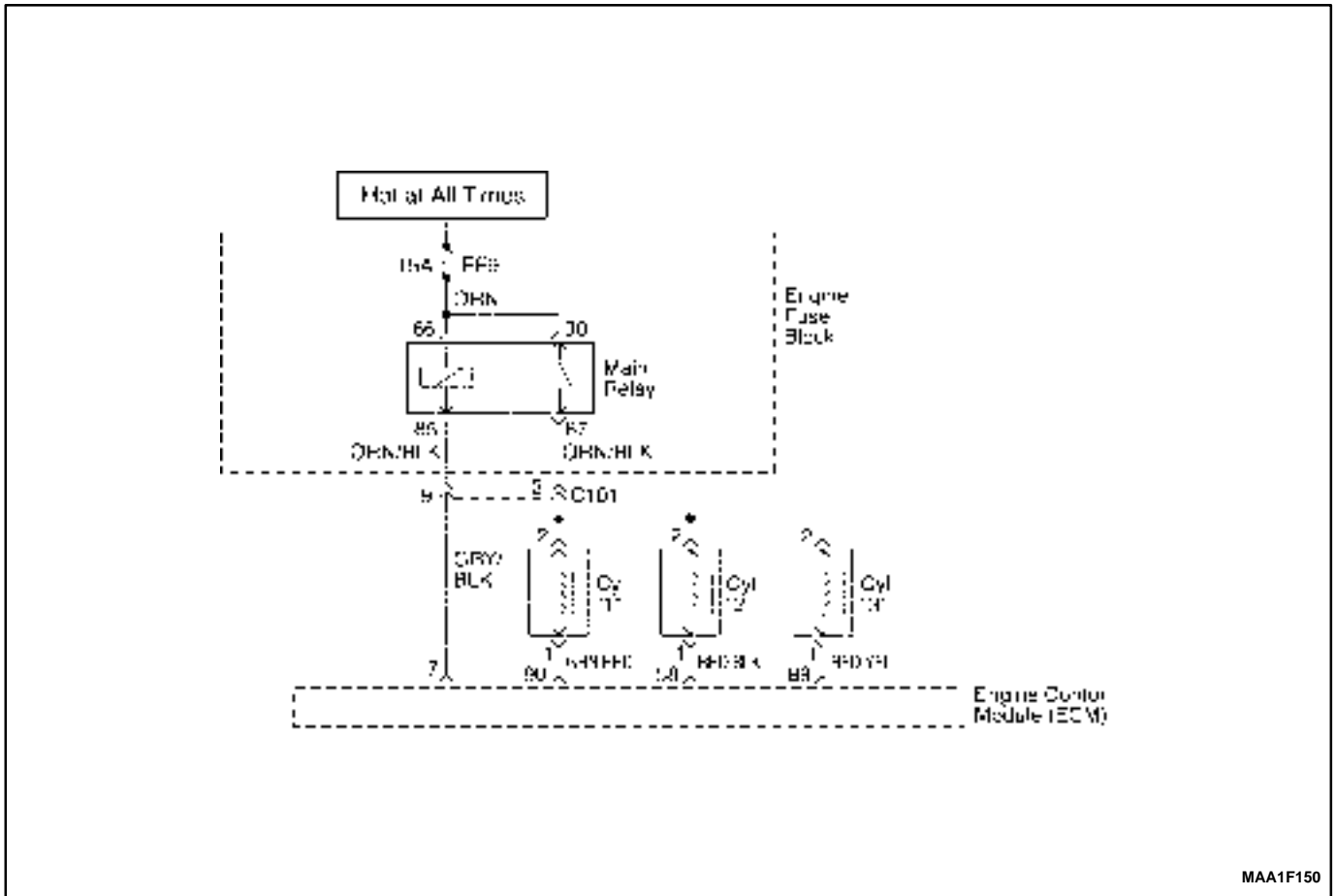

MAA1F150

DIAGNOSTIC TROUBLE CODE (DTC) – P0265 INJECTOR 2 HIGH VOLTAGE

Circuit Description

The engine control module (ECM) has three individual injector driver circuits, each of which controls an injector. When a driver circuit is grounded by the ECM, the injector is activated. The ECM monitors the current in each driver circuit. The ECM measures a voltage drop through a fixed resistor and controls it. The voltage on each driver is monitored to detect a fault. If the voltage is not what the ECM expects to monitor on the circuit, a Diagnostic Trouble Code (DTC) is set. This DTC detects a low voltage and/or an open circuit and high voltage conditions for low-side drive injector outputs.

Conditions for Setting the DTC

- This DTC can be stored in "key-on" status.
- The injector voltage does not equal the ignition voltage when the injector is commanded OFF, or the injector voltage does not equal 0 volts when the injector is commanded ON.
- The battery voltage is more than 16 volts.
- The above conditions are met for 5 seconds.

Action Taken when the DTC Sets

- The Malfunction Indicator Lamp (MIL) will illuminate.

- The ECM will record operating conditions at the time the diagnostic fails. This information will be stored in the Freeze Frame and Records buffers.
- A history DTC is stored.

Conditions for Clearing the MIL/DTC

- The MIL will turn off after 4 consecutive ignition cycles in which the diagnostic runs without a fault.
- A history DTC will clear after 40 consecutive warm up cycles without a fault.
- DTC(s) can be cleared by using the scan tool.

DIAGNOSTIC AIDS

An injector driver circuit that is open or shorted to voltage will cause a DTC P0265 to set. It will also cause a misfire due to an inoperative injector. A misfire DTC should also be set indicating which injector is inoperative.

Long-term and short-term fuel trims that are excessively high or low are a good indication that an injector is malfunctioning. Refer to "Fuel Injector Balance Test" in this Section to check for malfunctioning injectors.

The injector resistance tested at the ECM connection is slightly more than it tested directly at the injector because it includes resistance of the harness wires. The normal value is about 13.5Ω.

DTC P0265 – Injector 2 High Voltage

Step	Action	Value(s)	Yes	No
1	Perform an Euro On-Board Diagnostic (EOBD) System Check. Is the system check complete?	–	Go to <i>Step 2</i>	Go to “On-Board Diagnostic System Check”
2	With the engine start?	–	Go to <i>Step 3</i>	Go to “Engine Crank but will not Run”
3	1. Install a scan tool and clear the Diagnostic Trouble Codes (DTCs). 2. Idle the engine for one minuet. Does DTC P0265 reset?	–	Go to <i>Step 5</i>	Go to <i>Step 4</i>
4	1. Review the Freeze Frame data with the ignition ON and the engine OFF and note the parameters. 2. Operate the vehicle within the Freeze Frame conditions as notes. Does DTC P0265 reset?	–	Go to <i>Step 5</i>	Go to “Diagnostic Aids”
5	1. Turn the ignition switch to Lock. 2. Check for an open or short to battery voltage in the wire between the injector 2 connector terminal 2 and ECM connector terminal 58. Is the problem found?	–	Go to <i>Step 7</i>	Go to <i>Step 6</i>
6	1. Turn the ignition switch to Lock. 2. Check for short to battery voltage in the wire between the injector 2 connector terminal 2 and battery positive. Is the problem found?	–	Go to <i>Step 7</i>	Go to <i>Step 8</i>
7	1. Repair the wire or the connector terminal as needed. 2. Clear any DTCs from ECM. 3. Perform the Diagnostic System Check. Is the repair complete?	–	System OK	–
8	1. Replace the injector valve. 2. Clear any DTCs from ECM. 3. Perform the Diagnostic System Check. Does DTC P0265 reset?	–	Go to <i>Step 9</i>	System OK
9	1. Turn the ignition switch to LOCK. 2. Replace the ECM. 3. Perform the Diagnostic System Check. Is the repair complete?	–	Go to <i>Step 10</i>	–
10	Check if any additional DTCs are set. Are any DTCs displaced that have not been diagnosed?	–	Go to applicable DTC table	System OK

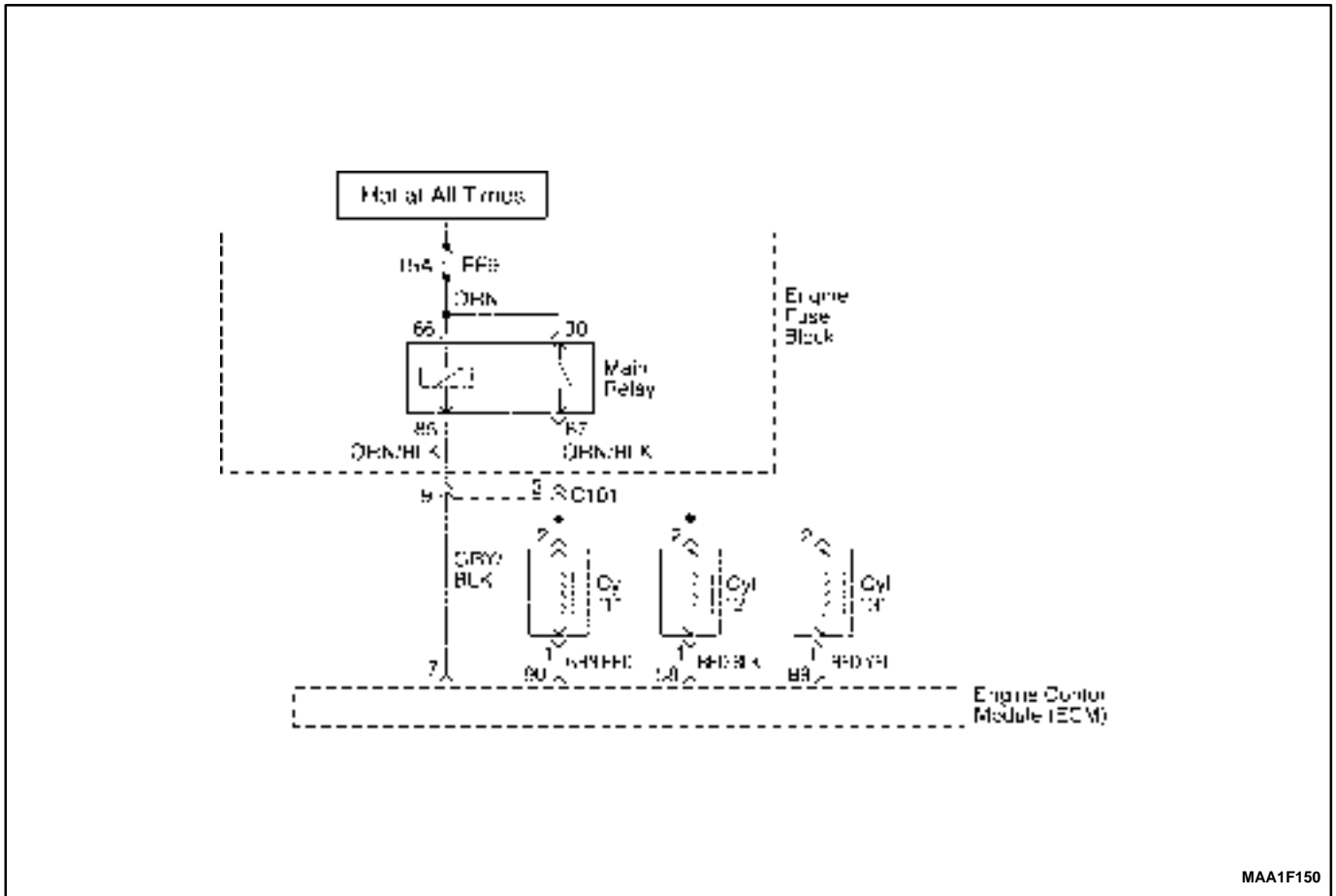

MAA1F150

DIAGNOSTIC TROUBLE CODE (DTC) – P0267 INJECTOR 3 LOW VOLTAGE

Circuit Description

The engine control module (ECM) has three individual injector driver circuits, each of which controls an injector. When a driver circuit is grounded by the ECM, the injector is activated. The ECM monitors the current in each driver circuit. The ECM measures a voltage drop through a fixed resistor and controls it. The voltage on each driver is monitored to detect a fault. If the voltage is not what the ECM expects to monitor on the circuit, a Diagnostic Trouble Code (DTC) is set. This DTC detects a low voltage and/or an open circuit and high voltage conditions for low-side drive injector outputs.

Conditions for Setting the DTC

- This DTC can be stored in "key-on" status.
- The injector voltage does not equal the ignition voltage when the injector is commanded OFF, or the injector voltage does not equal 0 volts when the injector is commanded ON.
- The battery voltage is less than 9 volts.
- The above conditions are met for 5 seconds.

Action Taken when the DTC Sets

- The Malfunction Indicator Lamp (MIL) will illuminate.

- The ECM will record operating conditions at the time the diagnostic fails. This information will be stored in the Freeze Frame and Records buffers.
- A history DTC is stored.

Conditions for Clearing the MIL/DTC

- The MIL will turn off after 4 consecutive ignition cycles in which the diagnostic runs without a fault.
- A history DTC will clear after 40 consecutive warm up cycles without a fault.
- DTC(s) can be cleared by using the scan tool.

DIAGNOSTIC AIDS

An injector driver circuit that is open or shorted to voltage will cause a DTC P0267 to set. It will also cause a misfire due to an inoperative injector. A misfire DTC should also be set indicating which injector is inoperative.

Long-term and short-term fuel trims that are excessively high or low are a good indication that an injector is malfunctioning. Refer to "Fuel Injector Balance Test" in this Section to check for malfunctioning injectors.

The injector resistance tested at the ECM connection is slightly more than it tested directly at the injector because it includes resistance of the harness wires. The normal value is about 13.5Ω.

DTC P0267 – Injector 3 Low Voltage

Step	Action	Value(s)	Yes	No
1	Perform an Euro On-Board Diagnostic (EOBD) System Check. Is the system check complete?	–	Go to <i>Step 2</i>	Go to “On-Board Diagnostic System Check”
2	With the engine start?	–	Go to <i>Step 3</i>	Go to “Engine Crank but will not Run”
3	1. Install a scan tool and clear the Diagnostic Trouble Codes (DTCs). 2. Idle the engine for one minuet. Does DTC P0267 reset?	–	Go to <i>Step 5</i>	Go to <i>Step 4</i>
4	1. Review the Freeze Frame data with the ignition ON and the engine OFF and note the parameters. 2. Operate the vehicle within the Freeze Frame conditions as notes. Does DTC P0267 reset?	–	Go to <i>Step 5</i>	Go to “Diagnostic Aids”
5	1. Turn the ignition switch to LOCK. 2. Check for short to ground in the wire between the injector 3 connector terminal 1 and ECM connector terminal 89. Is the problem found?	–	Go to <i>Step 7</i>	Go to <i>Step 6</i>
6	1. Turn the ignition switch to LOCK. 2. Check for short to ground in the wire between the injector 3 connector terminal 2 and battery positive. Is the problem found?	–	Go to <i>Step 7</i>	Go to <i>Step 8</i>
7	1. Repair the wire or the connector terminal as needed. 2. Clear any DTCs from ECM. 3. Perform the Diagnostic System Check. Is the repair complete?	–	System OK	–
8	1. Replace the injector valve. 2. Clear any DTCs from ECM. 3. Perform the Diagnostic System Check. Does DTC P0267 reset?	–	Go to <i>Step 9</i>	System OK
9	1. Turn the ignition switch to LOCK. 2. Replace the ECM. 3. Perform the Diagnostic System Check. Is the repair complete?	–	Go to <i>Step 10</i>	–
10	Check if any additional DTCs are set. Are any DTCs displaced that have not been diagnosed?	–	Go to applicable DTC table	System OK

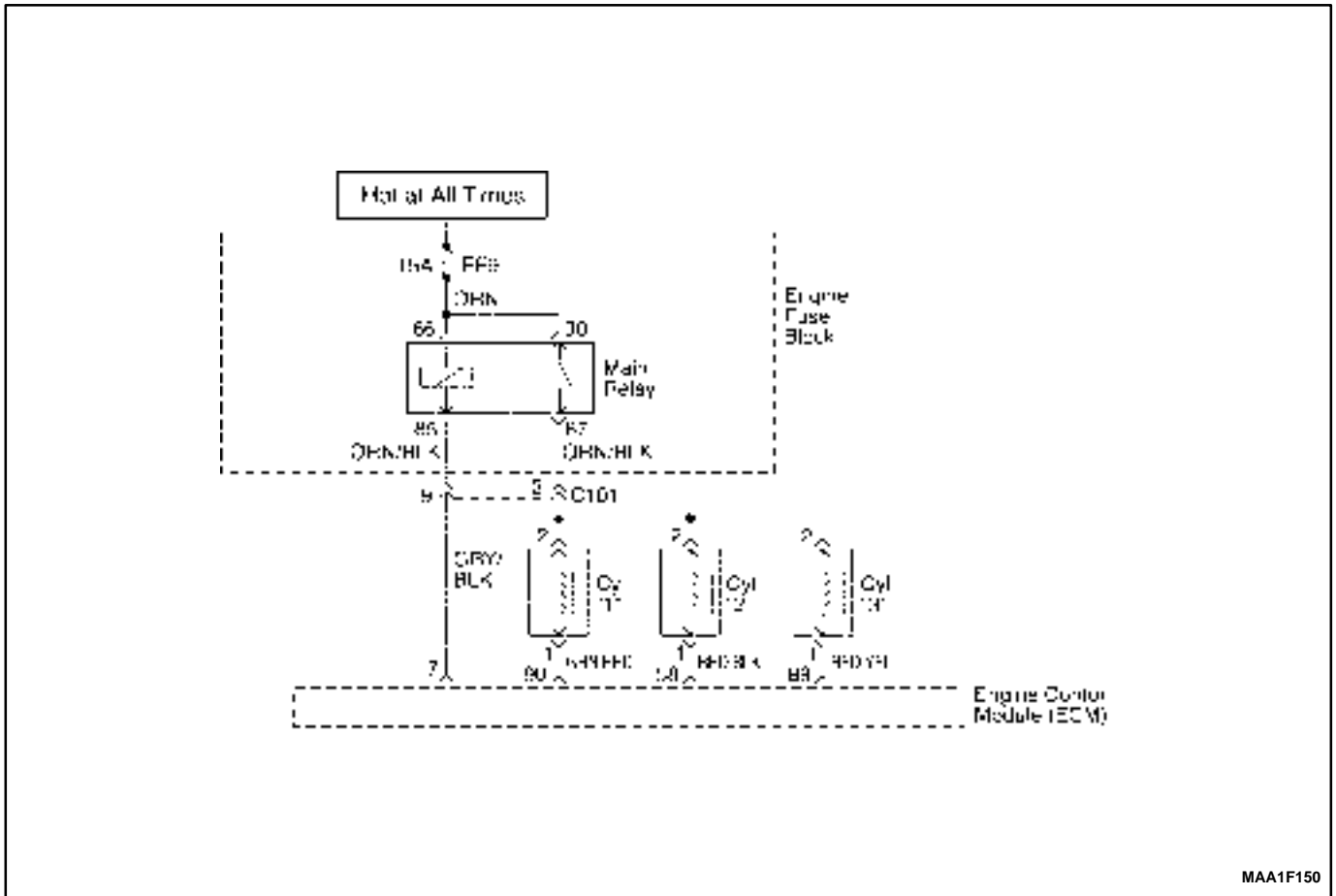

DIAGNOSTIC TROUBLE CODE (DTC) – P0268 INJECTOR 3 HIGH VOLTAGE

Circuit Description

The engine control module (ECM) has three individual injector driver circuits, each of which controls an injector. When a driver circuit is grounded by the ECM, the injector is activated. The ECM monitors the current in each driver circuit. The ECM measures a voltage drop through a fixed resistor and controls it. The voltage on each driver is monitored to detect a fault. If the voltage is not what the ECM expects to monitor on the circuit, a Diagnostic Trouble Code (DTC) is set. This DTC detects a low voltage and/or an open circuit and high voltage conditions for low-side drive injector outputs.

Conditions for Setting the DTC

- This DTC can be stored in “key-on” status.
- The injector voltage does not equal the ignition voltage when the injector is commanded OFF, or the injector voltage does not equal 0 volts when the injector is commanded ON.
- The battery voltage is more than 16 volts.
- The above conditions are met for 5 seconds.

Action Taken when the DTC Sets

- The Malfunction Indicator Lamp (MIL) will illuminate.

- The ECM will record operating conditions at the time the diagnostic fails. This information will be stored in the Freeze Frame and Records buffers.
- A history DTC is stored.

Conditions for Clearing the MIL/DTC

- The MIL will turn off after consecutive ignition cycles in which the diagnostic runs without a fault.
- A history DTC will clear after 40 consecutive warm up cycles without a fault.
- DTC(s) can be cleared by using the scan tool.
- Disconnecting the ECM battery feed for 10 seconds.

DIAGNOSTIC AIDS

An injector driver circuit that is open or shorted to voltage will cause a DTC P0268 to set. It will also cause a misfire due to an inoperative injector. A misfire DTC should also be set indicating which injector is inoperative.

Long-term and short-term fuel trims that are excessively high or low are a good indication that an injector is malfunctioning. Refer to “Fuel Injector Balance Test” in this Section to check for malfunctioning injectors.

The injector resistance tested at the ECM connection is slightly more than it tested directly at the injector be-

cause it includes resistance of the harness wires. The normal value is about 13.5Ω.

DTC P0268 – Injector 3 High Voltage

Step	Action	Value(s)	Yes	No
1	Perform an Euro On-Board Diagnostic (EOBD) System Check. Is the system check complete?	–	Go to <i>Step 2</i>	Go to “On-Board Diagnostic System Check”
2	With the engine start?	–	Go to <i>Step 3</i>	Go to “Engine Crank but will not Run”
3	1. Install a scan tool and clear the Diagnostic Trouble Codes (DTCs). 2. Idle the engine for one minuet. Does DTC P0268 reset?	–	Go to <i>Step 5</i>	Go to <i>Step 4</i>
4	1. Review the Freeze Frame data with the ignition ON and the engine OFF and note the parameters. 2. Operate the vehicle within the Freeze Frame conditions as notes. Does DTC P0268 reset?	–	Go to <i>Step 5</i>	Go to “Diagnostic Aids”
5	1. Turn the ignition switch to Lock. 2. Check for an open or short to battery voltage in the wire between the injector 3 connector terminal 1 and ECM connector terminal 89. Is the problem found?	–	Go to <i>Step 7</i>	Go to <i>Step 6</i>
6	1. Turn the ignition switch to Lock. 2. Check for short to battery voltage in the wire between the injector 3 connector terminal 2 and battery positive. Is the problem found?	–	Go to <i>Step 7</i>	Go to <i>Step 8</i>
7	1. Repair the wire or the connector terminal as needed. 2. Clear any DTCs from ECM. 3. Perform the Diagnostic System Check. Is the repair complete?	–	System OK	–
8	1. Replace the injector valve. 2. Clear any DTCs from ECM. 3. Perform the Diagnostic System Check. Does DTC P0268 reset?	–	Go to <i>Step 9</i>	System OK
9	1. Turn the ignition switch to LOCK. 2. Replace the ECM. 3. Perform the Diagnostic System Check. Is the repair complete?	–	Go to <i>Step 10</i>	–
10	Check if any additional DTCs are set. Are any DTCs displaced that have not been diagnosed?	–	Go to applicable DTC table	System OK

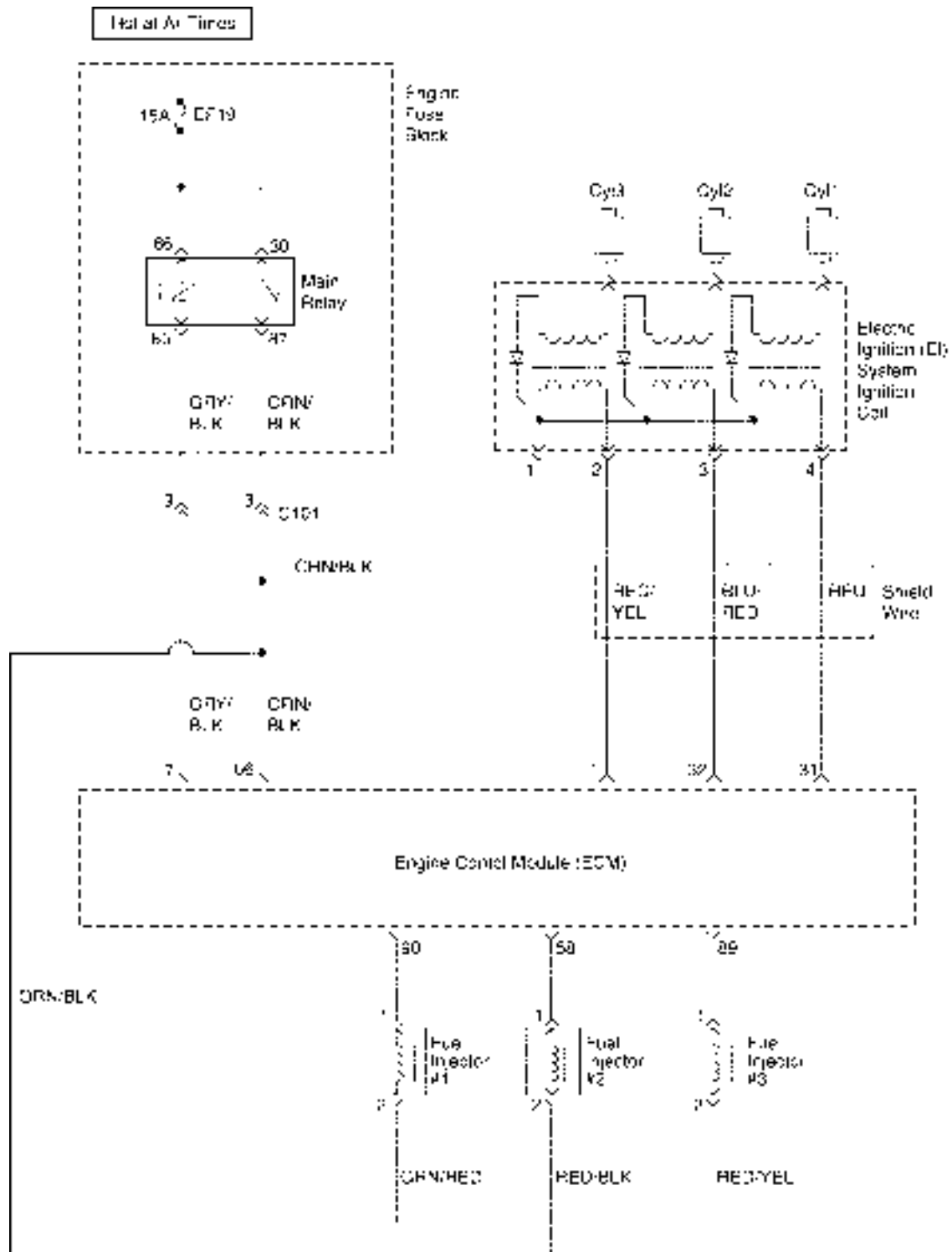

DIAGNOSTIC TROUBLE CODE (DTC) – P0300 MULTIPLE CYLINDER MISFIRE

System Description

The Engine Control Module (ECM) monitors the crankshaft and camshaft positions to detect if the engine is misfiring. The ECM looks for a quick drop in crankshaft speed. This test is executed in blocks of 100 engine revolution tests. It may take between one to several tests to store a Diagnostic Trouble Code (DTC) and illuminate the Malfunction Indicator Lamp (MIL). Under light misfire conditions, it may also take more than one trip to set a DTC. Severe misfire will flash the MIL, indicating that catalyst damage is possible.

Conditions for Setting the DTC

- Emission threshold is 3.0% for manual transaxle.
- 20 engine cycles have occurred since cranking has started.
- A/C compressor clutch has not just engaged or disengaged.
- Engine load and engine speed are in a detectable region and are at or above zero torque.
- Camshaft Position (CMP) sensor is in synchronization.
- Electric Exhaust Gas Recirculation (EEGR) flow diagnostic is not in progress.
- Fuel level is greater than or equal to 20% of rated tank capacity.
- Decel Fuel Cutoff (DFCO) not active.
- Fuel is not shutoff from high engine speed of 6500 rpm for manual transaxle vehicle.
- Fuel is not shutoff at 255 km/h (158 mph).
- Throttle position change is less than 3% per 125 ms.
- Vehicle has not encountered an abusive engine speed of 7000 rpm.

- Crankshaft speed patters are normal.
- Throttle position is less than 4% when vehicle speed is greater than 10 km/h (6 mph).
- Engine speed is between 800 and 4500 rpm.
- Vehicle voltage is between 11 and 16 volts.
- Engine Coolant Temperature (ECT) is between -7°C (20°F) and 120°C (248°F).
- The engine speed is less than or equal to 1800 rpm or the crank angle sensing error has not been learned.
- There is the correct ratio between Crankshaft Position (CKP) sensor pulses and CMP sensor pulses.
- DTCs P0106, P0107, P0108, P0117, P0118, P0122, P0123, P0320, P0337, P0341, P0342 and P0502 are not set.

Action Taken when the DTC Sets

- The malfunction Indicator Lamp (MIL) will blinking.
- The ECM will record operating conditions at the time the diagnostic fails. The information will be stored in the Freeze Frame and failure records buffers.
- A history DTC is stored.

Conditions for Clearing the MIL/DTC

- A history DTC will clear after 40 consecutive warm up cycles without a fault.
- DTC(s) can be cleared by using the scan tool.

Diagnostic Aids

An intermittent can also be the result of a defective reluctor wheel. Remove the CKP sensor and inspect the reluctor wheel through the sensor mount hole. Check for porosity and the condition of wheel. If the DTC is intermittent refer to “*Symptoms Diagnosis*” in this section.

DTC P0300 – Multiple Cylinder Misfire

Step	Action	Value(s)	Yes	No
1	Perform an Euro On-Board Diagnostic (EOBD) System Check. Was the check performed?	–	Go to <i>Step 2</i>	Go to “On-Board Diagnostic System Check”
2	1. Install a scan tool to the Data Link Connector (DLC). 2. Turn the ignition ON, with the engine OFF. 3. Request Diagnostic Trouble Codes (DTCs) Are DTCs P0201, P0202, P0203, P0204 set?	–	Go to Applicable DTC table	Go to <i>Step 3</i>
3	Perform a visual/physical inspection. Make any repairs that are necessary. Is the repair complete?	–	Go to <i>Step 27</i>	Go to <i>Step 4</i>
4	Start the engine and allow it to idle. Are any Misfire Current counters incrementing?	–	Go to <i>Step 5</i>	Go to <i>Step 6</i>
5	Are all counters equal (within a percentage of each other)?	–	Go to <i>Step 7</i>	Go to <i>Step 11</i>

DTC P0300 – Multiple Cylinder Misfire (Cont'd)

Step	Action	Value(s)	Yes	No
6	1. Turn the ignition ON, with the engine OFF. 2. Review the Freeze Frame data, and note the parameters. 3. Operate the vehicle within the Freeze Frame conditions and conditions for setting this DTC as noted. Are any Misfire Current counters incrementing?	–	Go to <i>Step 5</i>	Go to “Diagnostic Aids”
7	1. Turn the engine OFF. 2. Install a fuel pressure gauge to the fuel rail. 3. Observe the fuel pressure with the engine running. Is the fuel pressure within the specified value?	284–325 kPa (41–47 psi)	Go to <i>Step 8</i>	Go to “Fuel System Diagnosis”
8	Check the fuel for contamination. Is the fuel OK?	–	Go to <i>Step 9</i>	Go to <i>Step 10</i>
9	Check for a basic engine problem and repair as necessary. Is the repair complete?	–	Go to <i>Step 27</i>	–
10	Replace the contaminated fuel. Is the repair complete?	–	Go to <i>Step 27</i>	–
11	1. Turn the engine OFF. 2. Disconnect the fuel injector harness connector. 3. Install a spark tester on cylinder #1 spark plug cable. 4. Crank the engine and check for spark. 5. Repeat the above procedure on cylinders #2, #3. Is a spark observed on all four spark plug cables?	–	Go to <i>Step 12</i>	Go to <i>Step 20</i>
12	Replace any malfunctioning spark plugs if necessary. Is the repair complete?	–	Go to <i>Step 27</i>	Go to <i>Step 13</i>
13	1. Turn the engine OFF. 2. Disconnect the fuel injector connectors from the injectors. 3. Install an injector test light on the injector harness connector for the cylinders that had misfired. 4. Crank the engine and note the test light. Does the injector test light blink?	–	Go to <i>Step 14</i>	Go to <i>Step 15</i>
14	Perform the Fuel Injector Balance Test. Are the fuel injectors OK?	–	Go to <i>Step 9</i>	Go to <i>Step 16</i>
15	1. Disconnect the injector test light. 2. With a test light connected to ground, probe the ignition feed terminal 1 of the injector harness connector for each cylinder that had misfire. 3. Crank the engine. Does the test light illuminate?	–	Go to <i>Step 17</i>	Go to <i>Step 19</i>
16	Replace any malfunctioning fuel injectors. Is the repair complete?	–	Go to <i>Step 27</i>	–
17	Check the affected fuel injector driver circuit at terminals 90, 58 and 89 for an open, short, or short to voltage. Is a problem found?	–	Go to <i>Step 18</i>	Go to <i>Step 24</i>

DTC P0300 – Multiple Cylinder Misfire (Cont'd)

Step	Action	Value(s)	Yes	No
18	Repair the open or the shorted fuel injector driver circuit. Is the repair complete?	–	Go to <i>Step 27</i>	–
19	Repair the open ignition feed circuit between the fuel injector harness connector and the fuel injector connector. Is the repair complete?	–	Go to <i>Step 27</i>	–
20	Measure the resistance of the spark plug cable that the spark plug tester did not spark. Is the resistance of the spark plug cable less than the specified value?	30000Ω	Go to <i>Step 21</i>	Go to <i>Step 25</i>
21	Inspect the Engine Control Module (ECM) connector and connections. Are the connections OK?	–	Go to <i>Step 22</i>	Go to <i>Step 23</i>
22	Check the affected cylinders ignition control circuit for an open or short and repair as necessary. Is the repair complete?	–	Go to <i>Step 27</i>	Go to <i>Step 26</i>
23	Repair the connector or connections. Is the repair complete?	–	Go to <i>Step 27</i>	–
24	1. Turn the ignition OFF. 2. Replace the ECM. Is the repair complete?	–	Go to <i>Step 27</i>	–
25	Replace the spark plug cable. Is the repair complete?	–	Go to <i>Step 27</i>	–
26	Replace the faulty ignition coil. Is the repair complete?	–	Go to <i>Step 27</i>	Go to <i>Step 24</i>
27	1. Using the scan tool, clear the DTCs. 2. Start the engine and idle at normal operating temperature. 3. Operate the vehicle within the conditions for setting this DTC as supported in the text. Does the scan tool indicate that this diagnostic ran and passed?	–	Go to <i>Step 28</i>	Go to <i>Step 2</i>
28	Check if any additional DTCs are set. Are any DTCs displayed that have not been diagnosed?	–	Go to Applicable DTC table	System OK

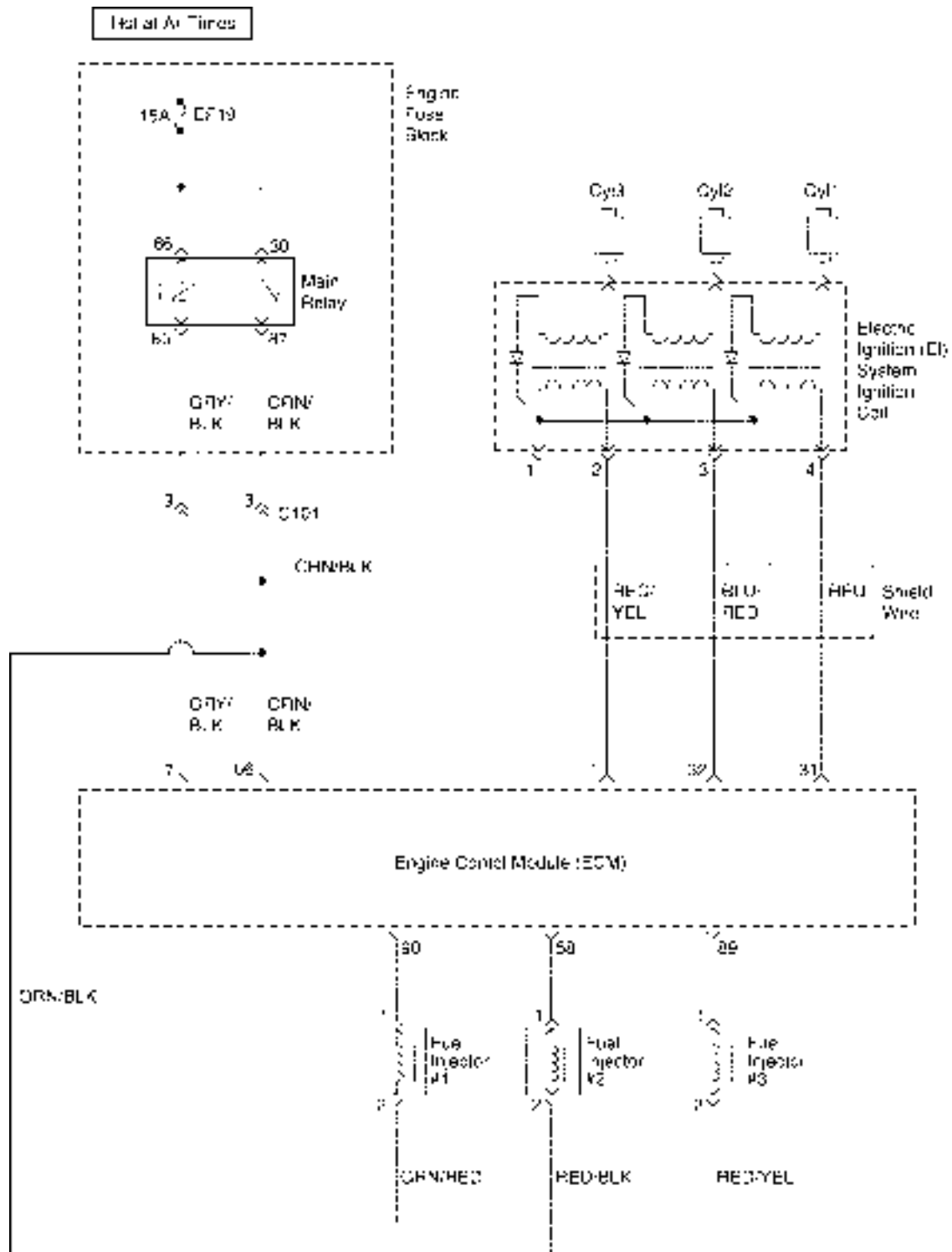

DIAGNOSTIC TROUBLE CODE (DTC) – P0300 MULTIPLE CYLINDER MISFIRE

System Description

The Engine Control Module (ECM) monitors the crankshaft and camshaft positions to detect if the engine is misfiring. The ECM looks for a quick drop in crankshaft speed. This test is executed in blocks of 100 engine revolution tests. It may take between one to several tests to store a Diagnostic Trouble Code (DTC) and illuminate the Malfunction Indicator Lamp (MIL). Under light misfire conditions, it may also take more than one trip to set a DTC. Severe misfire will flash the MIL, indicating that catalyst damage is possible.

Conditions for Setting the DTC

- Emission threshold is 3.0% for automatic transaxle and 3.0% for manual transaxle.
- 20 engine cycles have occurred since cranking has started.
- A/C compressor clutch has not just engaged or disengaged.
- Engine load and engine speed are in a detectable region and are at or above zero torque.
- Camshaft Position (CMP) sensor is in synchronization.
- Electric Exhaust Gas Recirculation (EEGR) flow diagnostic is not in progress.
- Fuel level is greater than or equal to 20% of rated tank capacity.
- Decel Fuel Cutoff (DFCO) not active.
- Fuel is not shutoff from high engine speed of 6500 rpm for manual transaxle vehicle or 6500 rpm in drive and 6250 rpm in park for automatic transaxle vehicles.
- Fuel is not shutoff at 255 km/h (158 mph).
- An automatic transmission is not shifting.
- Throttle position change is less than 3% per 125 ms.
- Vehicle has not encountered an abusive engine speed of 7000 rpm.
- Crankshaft speed patterns are normal.

- Throttle position is less than 4% when vehicle speed is greater than 10 km/h (6 mph).
- Engine speed is between 600 and 4500 rpm.
- Vehicle voltage is between 11 and 16 volts.
- Engine Coolant Temperature (ECT) is between -7°C (20°F) and 120°C (248°F).
- The engine speed is less than or equal to 1800 rpm or the crank angle sensing error has not been learned.
- There is the correct ratio between Crankshaft Position (CKP) sensor pulses and CMP sensor pulses.
- DTCs P0106, P0107, P0108, P0117, P0118, P0122, P0123, P0320, P0337, P0341, P0342 and P0502 are not set.

Action Taken when the DTC Sets

- Emission related.
- “Armed” after two trip with a fail.
- “Disarmed” after one trip with a pass.
- MIL on if failure is detected in three consecutive trips.
- Stores a History DTC on the third consecutive with a fail (The DTC will be armed after the second fail).
- Stores a Freeze Frame on the third consecutive trip with a fail (if empty).

Conditions for Clearing the MIL/DTC

- The MIL will turn off after four consecutive ignition cycles in which the diagnostic runs without a fault.
- A history DTC will clear after 40 consecutive warm up cycles without a fault.
- DTC(s) can be cleared by using the scan tool.
- Disconnecting the ECM battery feed for 10 seconds.

Diagnostic Aids

An intermittent can also be the result of a defective reluctor wheel. Remove the CKP sensor and inspect the reluctor wheel through the sensor mount hole. Check for porosity and the condition of wheel. If the DTC is intermittent refer to “Symptoms Diagnosis” in this section.

DTC P0300 – Multiple Cylinder Misfire

Step	Action	Value(s)	Yes	No
1	Perform an Euro On-Board Diagnostic (EOBD) System Check. Was the check performed?	–	Go to Step 2	Go to “On-Board Diagnostic System Check”
2	1. Install a scan tool to the Data Link Connector (DLC). 2. Turn the ignition ON, with the engine OFF. 3. Request Diagnostic Trouble Codes (DTCs) Are DTCs P0201, P0202, P0203, P0204 set?	–	Go to Applicable DTC table	Go to Step 3

DTC P0300 – Multiple Cylinder Misfire (Cont'd)

Step	Action	Value(s)	Yes	No
3	Perform a visual/physical inspection. Make any repairs that are necessary. Is the repair complete?	–	Go to Step 27	Go to Step 4
4	Start the engine and allow it to idle. Are any Misfire Current counters incrementing?	–	Go to Step 5	Go to Step 6
5	Are all counters equal (within a percentage of each other)?	–	Go to Step 7	Go to Step 11
6	1. Turn the ignition ON, with the engine OFF. 2. Review the Freeze Frame data, and note the parameters. 3. Operate the vehicle within the Freeze Frame conditions and conditions for setting this DTC as noted. Are any Misfire Current counters incrementing?	–	Go to Step 5	Go to “Diagnostic Aids”
7	1. Turn the engine OFF. 2. Install a fuel pressure gauge to the fuel rail. 3. Observe the fuel pressure with the engine running. Is the fuel pressure within the specified value?	284–325 kPa (41–47 psi)	Go to Step 8	Go to “Fuel System Diagnosis”
8	Check the fuel for contamination. Is the fuel OK?	–	Go to Step 9	Go to Step 10
9	Check for a basic engine problem and repair as necessary. Is the repair complete?	–	Go to Step 27	–
10	Replace the contaminated fuel. Is the repair complete?	–	Go to Step 27	–
11	1. Turn the engine OFF. 2. Disconnect the fuel injector harness connector. 3. Install a spark tester on cylinder #1 spark plug cable. 4. Crank the engine and check for spark. 5. Repeat the above procedure on cylinders #2, #3. Is a spark observed on all four spark plug cables?	–	Go to Step 12	Go to Step 20
12	Replace any malfunctioning spark plugs if necessary. Is the repair complete?	–	Go to Step 27	Go to Step 13
13	1. Turn the engine OFF. 2. Disconnect the fuel injector connectors from the injectors. 3. Install an injector test light on the injector harness connector for the cylinders that had misfired. 4. Crank the engine and note the test light. Does the injector test light blink?	–	Go to Step 14	Go to Step 15
14	Perform the Fuel Injector Balance Test. Are the fuel injectors OK?	–	Go to Step 9	Go to Step 16
15	1. Disconnect the injector test light. 2. With a test light connected to ground, probe the ignition feed terminal 1 of the injector harness connector for each cylinder that had misfire. 3. Crank the engine. Does the test light illuminate?	–	Go to Step 17	Go to Step 19

DTC P0300 – Multiple Cylinder Misfire (Cont'd)

Step	Action	Value(s)	Yes	No
16	Replace any malfunctioning fuel injectors. Is the repair complete?	–	Go to <i>Step 27</i>	–
17	Check the affected fuel injector driver circuit at terminals 90, 58, and 89 for an open, short, or short to voltage. Is a problem found?	–	Go to <i>Step 18</i>	Go to <i>Step 24</i>
18	Repair the open or the shorted fuel injector driver circuit. Is the repair complete?	–	Go to <i>Step 27</i>	–
19	Repair the open ignition feed circuit between the fuel injector harness connector and the fuel injector connector. Is the repair complete?	–	Go to <i>Step 27</i>	–
20	Measure the resistance of the spark plug cable that the spark plug tester did not spark. Is the resistance of the spark plug cable less than the specified value?	30000Ω	Go to <i>Step 21</i>	Go to <i>Step 25</i>
21	Inspect the Engine Control Module (ECM) connector and connections. Are the connections OK?	–	Go to <i>Step 22</i>	Go to <i>Step 23</i>
22	Check the affected cylinders ignition control circuit for an open or short and repair as necessary. Is the repair complete?	–	Go to <i>Step 27</i>	Go to <i>Step 26</i>
23	Repair the connector or connections. Is the repair complete?	–	Go to <i>Step 27</i>	–
24	1. Turn the ignition OFF. 2. Replace the ECM. Is the repair complete?	–	Go to <i>Step 27</i>	–
25	Replace the spark plug cable. Is the repair complete?	–	Go to <i>Step 27</i>	–
26	Replace the faulty ignition coil. Is the repair complete?	–	Go to <i>Step 27</i>	Go to <i>Step 24</i>
27	1. Using the scan tool, clear the DTCs. 2. Start the engine and idle at normal operating temperature. 3. Operate the vehicle within the conditions for setting this DTC as supported in the text. Does the scan tool indicate that this diagnostic ran and passed?	–	Go to <i>Step 28</i>	Go to <i>Step 2</i>
28	Check if any additional DTCs are set. Are any DTCs displayed that have not been diagnosed?	–	Go to Applicable DTC table	System OK

DIAGNOSTIC TROUBLE CODE (DTC) – P1320 CRANKSHAFT SEGMENT PERIOD SEGMENT ADAPTATION AT LIMIT

Circuit Description

The 58X reference signal is produced by the Crankshaft Position (CKP) sensor. During one crankshaft revolution, 58 crankshaft pulses will be produced. The Engine Control Module (ECM) uses the 58X reference signal to calculate engine rpm and CKP. The ECM constantly monitors the number of pulses on the 58X reference circuit and compares them to the number of Camshaft Position (CMP) signal pulses being received. If the ECM receives an incorrect number of pulses on the 58X reference circuit, Diagnostic Trouble Code (DTC) P0320 will set.

Conditions for Setting the DTC

- Engine is running.
- Number of extra or missing teeth is greater than or equal to 2 per revolution.
- Above condition is detected in 10 of 100 crankshaft rotations.

Action Taken When the DTC Sets

- The Malfunction Indicator Lamp (MIL) will illuminate.
- The ECM will record operating conditions at the time the diagnostic fails. This information will be stored in the Freeze Frame and Failure Records buffers.
- A history DTC is stored.

Conditions for Clearing the MIL/DTC

- The MIL will turn off after four consecutive ignition cycles in which the diagnostic runs without a fault.
- A history DTC will clear after 40 consecutive warm-up cycles without a fault.
- DTC(s) can be cleared by using the scan tool.

Diagnostic Aids

An intermittent may be caused by a poor connection, rubbed-through wire insulation or a wire broken inside the insulation. Check for:

- Poor connection – Inspect the ECM harness and connectors for improper mating, broken locks, improperly formed or damaged terminals, and poor terminal-to-wire connections.
- Damaged harness – Inspect the wiring harness for damage. If the harness appears to be OK, disconnect the ECM, turn the ignition ON and observe a voltmeter connected to the 58X reference circuit at the ECM harness connector while moving the connectors and the wiring harnesses related to the ECM. A change in voltage will indicate the location of the fault.
- Reviewing the Failure Records vehicle mileage since the diagnostic test last failed may help determine how often the condition that caused the DTC to be set occurs. This may assist in diagnosing the condition.

DTC P1320 – Crankshaft Segment Period Segment Adaptation At Limit

Step	Action	Value(s)	Yes	No
1	Perform an Euro On-Board Diagnostic (EOBD) System Check. Was the check performed?	–	Go to <i>Step 2</i>	Go to “On-Board Diagnostic System Check”
2	Attempt to start the engine. Does the engine start?	–	Go to <i>Step 3</i>	Refer to “Engine Cranks But Will Not Run”
3	1. Turn the ignition OFF. 2. Install a scan tool to the Data Link Connector (DLC). 3. Turn the ignition ON, with the engine OFF. 4. Review and record Failure Records information. 5. Clear the Diagnostic Trouble Codes (DTCs). 6. Start the engine and idle for 1 minute. Is DTC P1320 set?	–	Go to <i>Step 4</i>	Go to “Diagnostic Aids”
4	1. Remove the crankshaft. 2. Check for a problem with the crankshaft’s visual deflection and tooth. Is a problem found?	–	Go to <i>Step 5</i>	Go to <i>Step 6</i>
5	Replace the crankshaft. Is the replacement complete?	–	System OK	–
6	1. Turn the ignition OFF. 2. Replace the ECM. Is the repair complete?	–	Go to <i>Step 7</i>	–
7	1. Using the scan tool, clear the DTCs. 2. Start the engine and idle at normal operating temperature. 3. Operate the vehicle within the conditions for setting this DTC as supported in the text. Does the scan tool indicate that this diagnostic ran and passed?	–	Go to <i>Step 8</i>	Go to <i>Step 2</i>
8	Check if any additional DTCs are set. Are any DTCs displayed that have not been diagnosed?	–	Go to Applicable DTC table	System OK

DIAGNOSTIC TROUBLE CODE (DTC) – P1321 CRANKSHAFT SEGMENT PERIOD TOOTH ERROR

Circuit Description

The 58X reference signal is produced by the Crankshaft Position (CKP) sensor. During one crankshaft revolution, 58 crankshaft pulses will be produced. The Engine Control Module (ECM) uses the 58X reference signal to calculate engine rpm and CKP. The ECM constantly monitors the number of pulses on the 58X reference circuit and compares them to the number of Camshaft Position (CMP) signal pulses being received. If the ECM receives an incorrect number of pulses on the 58X reference circuit, Diagnostic Trouble Code (DTC) P0320 will set.

Conditions for Setting the DTC

- Engine is running.
- Number of extra or missing teeth is greater than or equal to 2 per revolution.
- Above condition is detected in 10 of 100 crankshaft rotations.

Action Taken When the DTC Sets

- The Malfunction Indicator Lamp (MIL) will illuminate.
- The ECM will record operating conditions at the time the diagnostic fails. This information will be stored in the Freeze Frame and Failure Records buffers.
- A history DTC is stored.

Conditions for Clearing the MIL/DTC

- The MIL will turn off after four consecutive ignition cycles in which the diagnostic runs without a fault.

- A history DTC will clear after 40 consecutive warm-up cycles without a fault.
- DTC(s) can be cleared by using the scan tool.
- Disconnecting the ECM battery feed for more than 10 seconds.

Diagnostic Aids

An intermittent may be caused by a poor connection, rubbed-through wire insulation or a wire broken inside the insulation. Check for:

- Poor connection – Inspect the ECM harness and connectors for improper mating, broken locks, improperly formed or damaged terminals, and poor terminal-to-wire connections.
- Damaged harness – Inspect the wiring harness for damage. If the harness appears to be OK, disconnect the ECM, turn the ignition ON and observe a voltmeter connected to the 58X reference circuit at the ECM harness connector while moving the connectors and the wiring harnesses related to the ECM. A change in voltage will indicate the location of the fault.
- Reviewing the Failure Records vehicle mileage since the diagnostic test last failed may help determine how often the condition that caused the DTC to be set occurs. This may assist in diagnosing the condition.

DTC P1321 – Crankshaft Segment Period Tooth Error

Step	Action	Value(s)	Yes	No
1	Perform an Euro On-Board Diagnostic (EOBD) System Check. Was the check performed?	–	Go to <i>Step 2</i>	Go to “On-Board Diagnostic System Check”
2	Attempt to start the engine. Does the engine start?	–	Go to <i>Step 3</i>	Refer to “Engine Cranks But Will Not Run”
3	1. Turn the ignition OFF. 2. Install a scan tool to the Data Link Connector (DLC) 3. Turn the ignition ON, with the engine OFF. 4. Review and record Failure Records information. 5. Clear the Diagnostic Trouble Codes (DTCs). 6. Start the engine and idle for 1 minute. Is DTC P1321 set?	–	Go to <i>Step 4</i>	Go to “Diagnostic Aids”
4	1. Remove the crankshaft. 2. Check for a problem with the crankshaft's visual deflection and tooth. Is a problem found?	–	Go to <i>Step 5</i>	Go to <i>Step 6</i>
5	Replace the crankshaft. Is the replacement complete?	–	System OK	–
6	1. Turn the ignition OFF. 2. Replace the ECM. Is the repair complete?	–	Go to <i>Step 7</i>	–
7	1. Using the scan tool, clear the DTCs. 2. Start the engine and idle at normal operating temperature. 3. Operate the vehicle within the conditions for setting this DTC as supported in the text. Does the scan tool indicate that this diagnostic ran and passed?	–	Go to <i>Step 8</i>	Go to <i>Step 2</i>
8	Check if any additional DTCs are set. Are any DTCs displayed that have not been diagnosed?	–	Go to Applicable DTC table	System OK

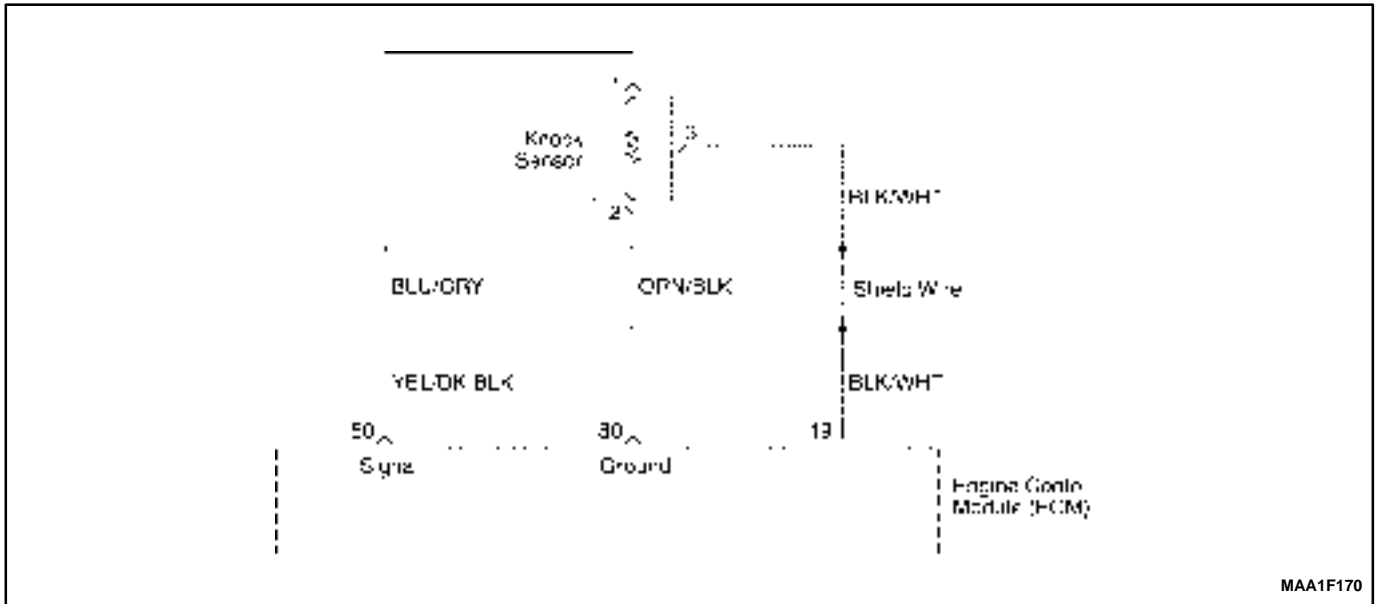

MAA1F170

DIAGNOSTIC TROUBLE CODE (DTC) – P0327 KNOCK SENSOR CIRCUIT FAULT

Circuit Description

The knock sensor (KS) system is used to detect engine detonation, allowing the engine control module (ECM) to retard ignition control spark timing based on the KS signal being received. The KS produces an AC signal so that under a no knock condition the signal on the KS circuit measures about 0.007V AC. The KS signal's amplitude and frequency depend upon the amount of knock being experienced. The ECM contains a non-replaceable knock filter module called a signal-to-noise enhancement filter (SNEF) module. This filter module in the ECM determines whether knock is occurring by comparing the signal level on the KS circuit with the voltage level on the noise channel. The noise channel allows the ECM to reject any false knock signal by knowing the amount of normal engine mechanical noise present. Normal engine noise varies depending on engine speed and load. When the ECM determines that an abnormally low noise channel voltage level is being experienced, a DTC P0327 will set.

Conditions for Setting the DTC

- Knock sensor SPI bus in failure during 7 seconds.
- The knock sensor voltage is below 0.2V.
- Engine Coolant Temperature is higher than 80°C (176°F).
- Engine rpm is more than 2,500rpm.
- Mass air flow is higher than 180mg/tdc.

Action Taken When The DTCs Sets

- The Malfunction Indicator Lamp (MIL) will illuminate.
- The ECM will record operating conditions at the time the diagnostic fails. This information will be stored in the Freeze Frame and Failure Records buffers.
- A history DTC is stored.

Conditions for Clearing the MIL/DTC

- The MIL will turn off after four consecutive ignition cycles in which the diagnostic runs without a fault.
- A history DTC will clear after 40 consecutive warm-up cycles without a fault.
- DTC(s) can be cleared by using the scan tool.

DIAGNOSTIC AIDS

Check and correct any abnormal engine noise before using the diagnostic table.

Any circuitry that is suspected as causing engine noise complaint should be thoroughly checked for the following conditions :

- Backed-out terminals.
- Improper mating.
- Broken locks.
- Improperly formed.
- Damaged terminals.
- Poor terminal-to-wire connections.
- Physical damage to the wiring harness.

DTC P0327 – Knock Sensor Circuit

Step	Action	Value(s)	Yes	No
1	Perform an Euro On-Board Diagnostic (EOBD II) System Check. Is the system check complete?	–	Go to <i>Step 2</i>	Go to “On-Board Diagnostic System Check”
2	1. Start the engine. 2. Install a scan tool. 3. Clear the Diagnostic Trouble Codes (DTCs). 4. Operate the vehicle within the Freeze Frame conditions and conditions for setting the DTC as noted. Does the Malfunction Indicator (MIL) illuminate?	–	Go to <i>Step 4</i>	Go to <i>Step 3</i>
3	1. Turn the ignition switch ON, with the engine OFF. 2. Review the Freeze Frame data and note the parameters. 3. Operate the vehicle within the Freeze Frame conditions and conditions for Setting The DTC as noted. Does the Malfunction Indicator (MIL) illuminate?	–	Go to <i>Step 4</i>	Go to <i>Step 12</i>
4	Listen to the engine while raising and lowering the engine speed. Is a knock or audible noise present?	–	Go to <i>Step 5</i>	Go to <i>Step 6</i>
5	Repair the mechanical engine problem or a loose bracket or component. Is the repair complete?	–	Go to <i>Step 12</i>	–
6	1. Turn the ignition switch to lock. 2. Disconnect the engine control module(ECM). 3. With a digital voltmeter (DVM) connected to ground, measure the resistance of the knock sensor through the knock sensor signal circuit, terminal 50. Is the measured value within the specified value?	90–110K Ω	Go to <i>Step 7</i>	Go to <i>Step 9</i>
7	Check for a poor connection at the ECM connector, knock sensor (KS) signal circuit and repair as necessary. Is a repair necessary?	–	Go to <i>Step 12</i>	Go to <i>Step 8</i>
8	Replace the engine control module(ECM). Is the replacement complete?	–	Go to <i>Step 12</i>	Go to <i>Step 10</i>
9	Check the KS electrical connector for a poor connection and repair an necessary. Is a repair necessary?	–	Go to <i>Step 12</i>	Go to <i>Step 10</i>
10	Check the KS signal circuit for an open or a low voltage or voltage and repair as necessary. Is a repair necessary?	–	Go to <i>Step 12</i>	Go to <i>Step 11</i>
11	Replace the KS. Is the replacement complete?	–	Go to <i>Step 12</i>	–

DTC P0327 – Knock Sensor Circuit (Cont'd)

Step	Action	Value(s)	Yes	No
12	1. Using the scan tool, clear the DTCs. <ul style="list-style-type: none"> ● Start the engine and idle at normal operating temperature. ● Operate the vehicle within the conditions for setting this DTC as specified in the supporting text. Does the scan tool indicate that this diagnostic has run and passed?	–	Go to <i>Step 13</i>	Go to <i>Step 2</i>
13	Check if any additional DTCs are set. Are any DTCs displayed that have not been diagnosed?	–	Go to Applicable DTC table	System OK

BLANK

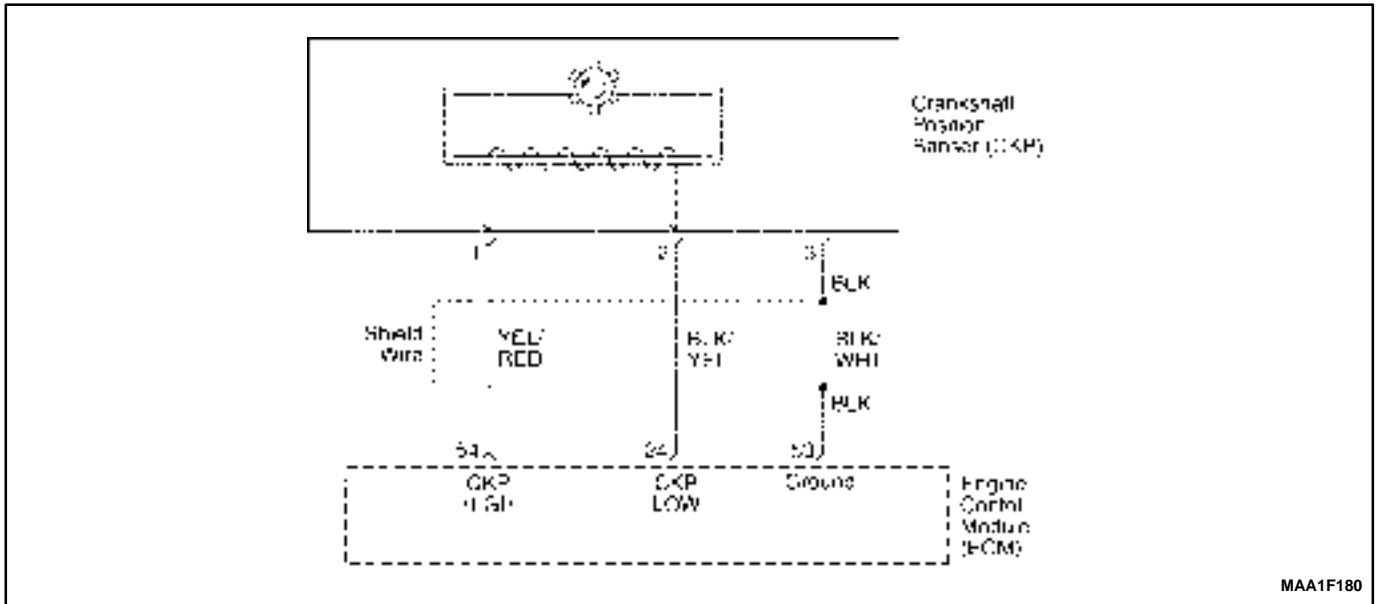

MAA1F180

DIAGNOSTIC TROUBLE CODE (DTC) – P0335 MAGNETIC CRANKSHAFT POSITION SENSOR ELECTRICAL ERROR

Circuit Description

The 58X reference signal is produced by the crankshaft position (CKP) sensor. During one crankshaft revolution, 58 crankshaft pulses will be produced. The engine control module (ECM) uses the 58X reference signal to calculate engine rpm and CKP. The ECM constantly monitors the number of pulses on the 58X reference circuit and compares them to the number of camshaft position (CKP) signal pulses being received. If the ECM receives an incorrect number of pulses on the 58X reference circuit, DTC P0335 will set.

Conditions for Setting the DTC

- This DTC can be stored in "key-on" status.
- Extra or missing pulses is detected between consecutive 58X reference pulses.
- The value of Magnetic Crankshaft position sensor is higher than 0.2V.
- The minimum value of Magnetic Crankshaft position sensor is less than 1.5V.
- The Maximum value of Magnetic Crankshaft position sensor is higher than 2.2V.

Action Taken When the DTC Sets

- The Malfunction Indicator Lamp (MIL) will illuminate.
- The ECM will record operating conditions at the time the diagnostic fails. This information will be stored in the Freeze Frame and Failure Records buffers.

- A history DTC is stored.

Conditions for Clearing the MIL/DTC

- The MIL will turn off after four consecutive ignition cycles in which the diagnostic runs without a fault.
- A history DTC will clear after 40 consecutive warm-up cycles without a fault.
- DTC(s) can be cleared by using the scan tool.

DIAGNOSTIC AIDS

An intermittent may be caused by a poor connection, rubbed-through wire insulation or a wire broken inside the insulation. Check for :

Poor connection – inspect the ECM harness and connectors for improper mating, broken locks, improperly formed or damaged terminals, and poor terminal-to-wire connection.

Damaged harness – inspect the wiring harness for damage. If the harness appears to be OK, disconnect the ECM, turn the ignition ON and observe a voltmeter connected to the 58X reference circuit at the ECM harness connector while moving the connectors and the wiring harness related to the ECM. A change in voltage will indicate the location of the fault.

Review the failure records vehicle mileage since the diagnostic test failed may help determine how often the condition that caused the DTC to be set occurs. This may assist in diagnosing the condition.

DTC P0335 – Magnetic Crankshaft Position Sensor Electrical Error

Step	Action	Value(s)	Yes	No
1	Perform an Euro On-Board Diagnostic (EOBD) System Check. Is the system check complete?	–	Go to Step 2	Go to “On-Board Diagnostic System Check”
2	Attempt to start the engine. Does the engine start?	–	Go to Step 3	Refer to “Engine Cranks But Will Not Run”
3	1. Review and record Failure Records information. 2. Clear the DTC P0335. 3. Start the engine and idle for 1 minute. 4. Observe the diagnostic trouble codes (DTCs). Is the DTC P0335 set?	–	Go to Step 4	Go to “Diagnostic Aids”
4	1. Disconnect the engine control module (ECM) and the crankshaft position (CKP) sensor. 2. Check for an open or an open or short to ground in the CKP sensor connector and the ECM harness connector. Is the problem found?	–	Go to Step 5	Go to Step 6
5	Repair the open or an open or short to ground in the 58X reference circuit between the CKP sensor connector and the ECM harness connector. Is the repair complete?	–	Go to Step 11	–
6	1. Reconnect the ECM and CKP sensor. 2. Connect a digital voltmeter (DVM) to measure voltage on the 58X reference circuit, terminal 54 at the ECM connector. 3. Observe the voltage while cranking the engine. Is the voltage near the specified value?	2.5V	Go to Step 9	Go to Step 7
7	Check the connection at the CKP sensor and replace the terminals if necessary. Do any terminals require replacement?	–	Go to Step 11	Go to Step 8
8	Replace the CKP sensor. Is the replacement complete?	–	Go to Step 11	–
9	Check the connections at the ECM and replace the terminals if necessary. Do any terminal require replacement?	–	Go to Step 11	Go to Step 10
10	Replace the ECM. Is the replacement complete?	–	Go to Step 11	–
11	1. Using the scan tool, clear the DTCs. 2. Start the engine and idle at normal operating temperature. 3. Operate the vehicle within the conditions for setting this DTC as specified in the supporting text. Does the scan tool indicate that this diagnostic run and passed?	–	Go to Step 12	Go to Step 2
12	Check if any additional DTCs are set. Are any DTCs displaced that have not been diagnosed?	–	Go to Applicable DTC table	System OK