

SAAB 9000

WIRING DIAGRAMS - 1997 U.S. SPECIFICATION

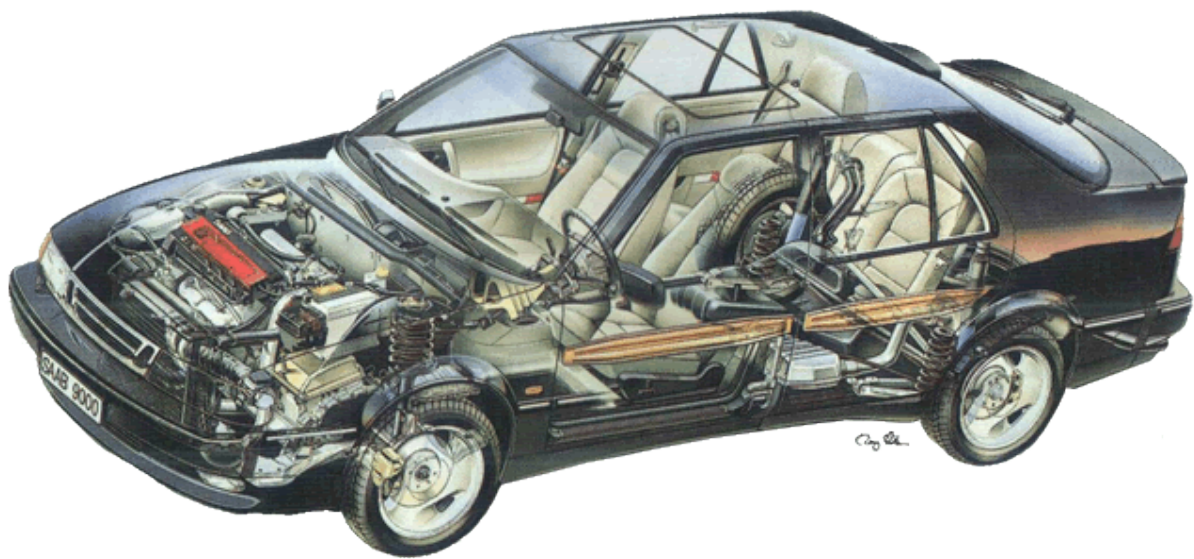

CONTENTS

3. 2.3 Turbo Engine performance circuits 1
4. 2.3 Turbo Engine performance circuits 2
5. ABS
6. Aircon 1
7. Aircon 2
8. Alarm circuit with immobiliser
9. Alarm circuit without immobiliser
10. Backup lamps circuit
11. Boot-tailgate-fuel door
12. Charging circuit
13. Computer data lines
14. Cooling fan circuit
15. Courtesy lamps circuit
16. Cruise control circuit
17. Defogger circuit with auto AC
18. Defogger circuit without auto AC
19. Driver memory seat circuit
20. Exterior lamps circuit
21. External lamps circuit 2
22. Front and headlight washer-wiper circuit
23. Ground distribution circuit
24. Headlamp-Front fog lamps circuit
25. Heated seats circuit
26. Horn circuit
27. Instrument cluster 1
28. Instrument cluster 2
29. Instrument illumination
30. Power antenna
31. Power distribution 1
32. Power distribution 2
33. Power distribution 3
34. Power door lock
35. Power mirror
36. Power seats
37. Power window
38. Rear fog lamp
39. Rear wiper-washer
40. Shift interlock
41. Starting
42. Sunroof
43. Supplemental restraint
44. Trip computer
45. Warning system

SYSTEM WIRING DIAGRAMS

2.3L Turbo, Engine Performance Circuits (1 of 2)

1997 Saab 9000

For DIAKOM-AUTO <http://www.diakom.ru> Taganrog support@diakom.ru (8634)315187
Copyright © 1998 Mitchell Repair Information Company, LLC
Friday, December 15, 2000 02:19PM

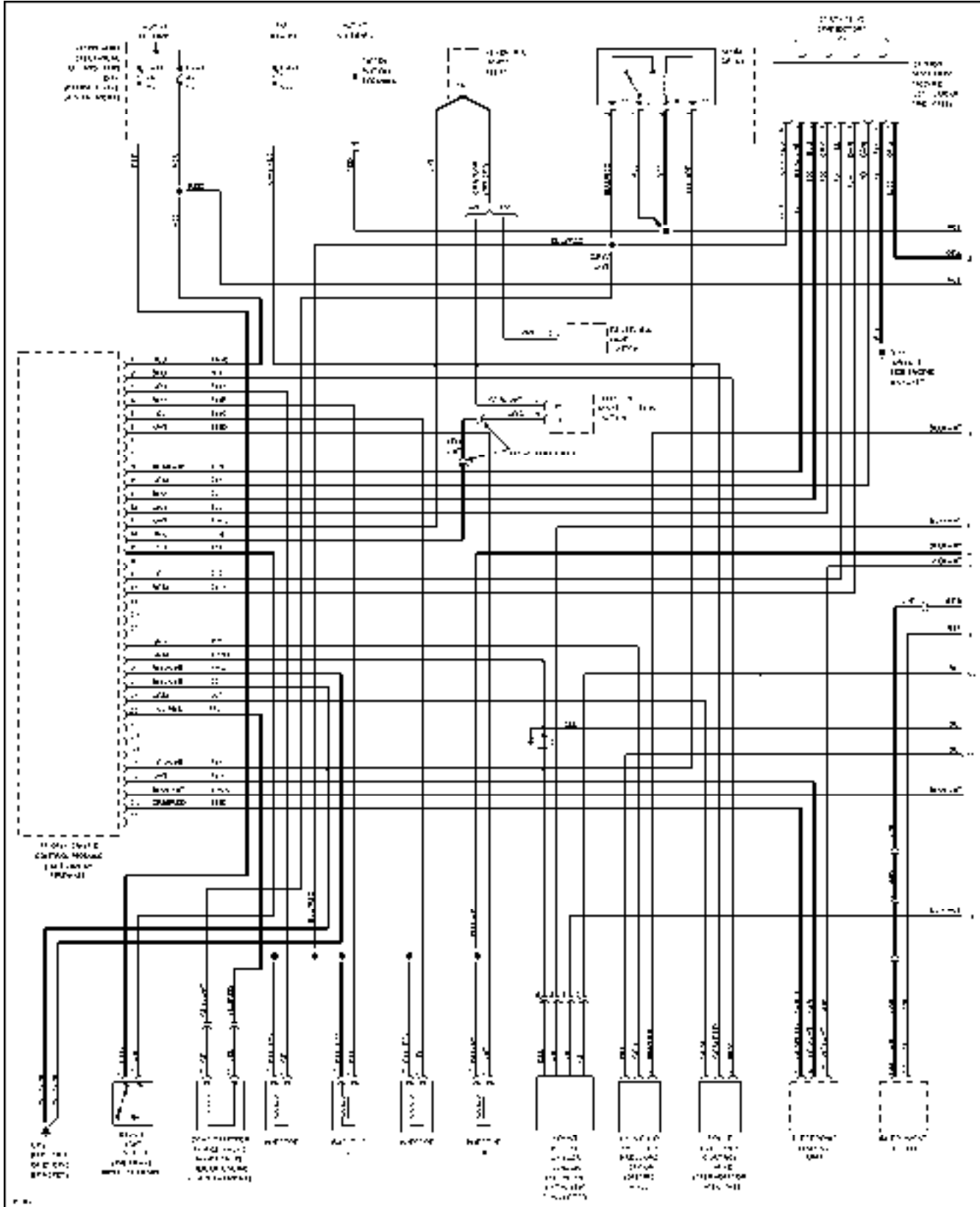

SYSTEM WIRING DIAGRAMS

2.3L Turbo, Engine Performance Circuits (2 of 2)

1997 Saab 9000

For DIAKOM-AUTO <http://www.diakom.ru> Taganrog support@diakom.ru (8634)315187

Copyright © 1998 Mitchell Repair Information Company, LLC

Friday, December 15, 2000 02:20PM

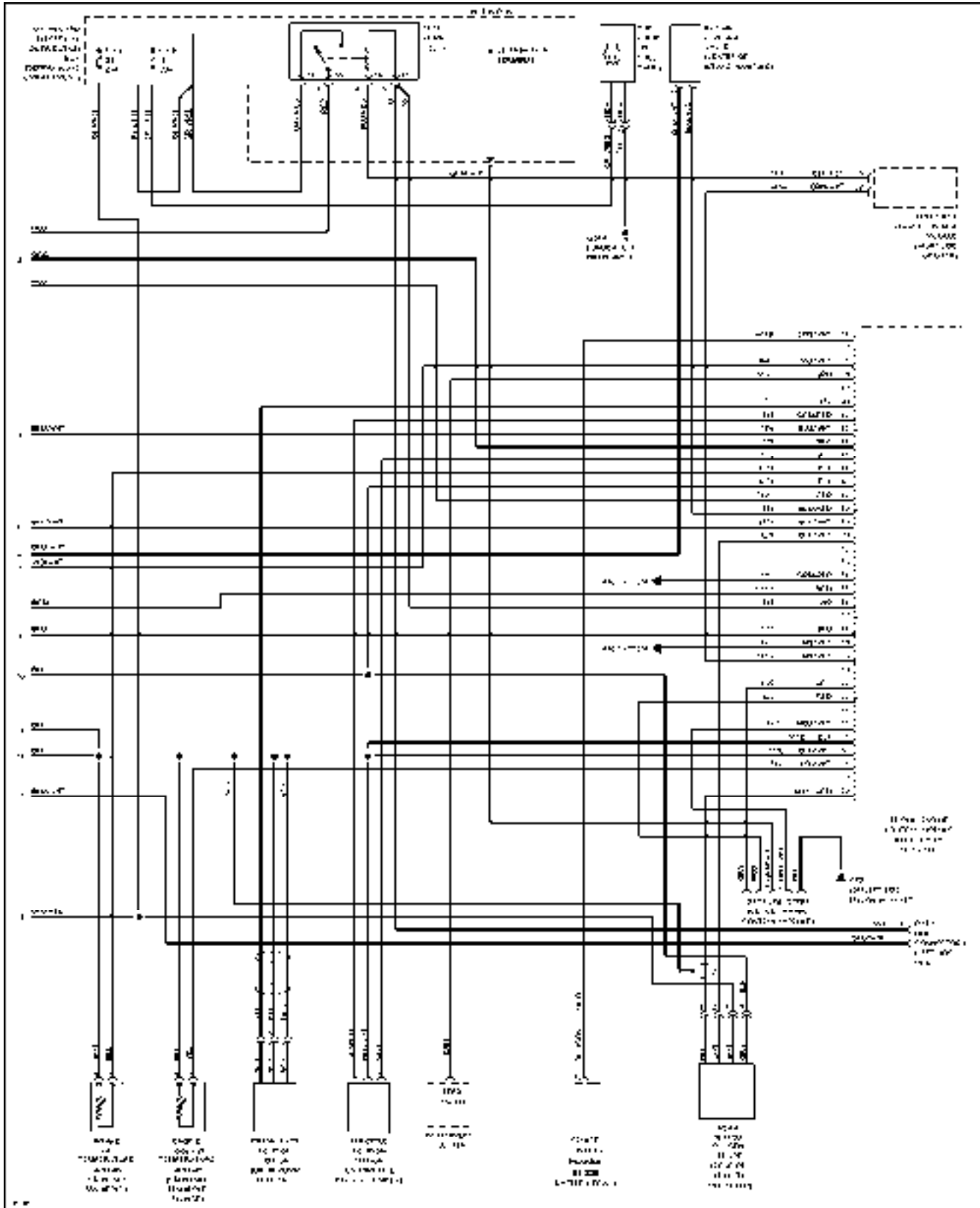

SYSTEM WIRING DIAGRAMS

Anti-Lock Brakes Circuit

1997 Saab 9000

For DIAKOM-AUTO <http://www.diakom.ru> Taganrog support@diakom.ru (8634)315187

Copyright © 1998 Mitchell Repair Information Company, LLC

Friday, December 15, 2000 02:18PM

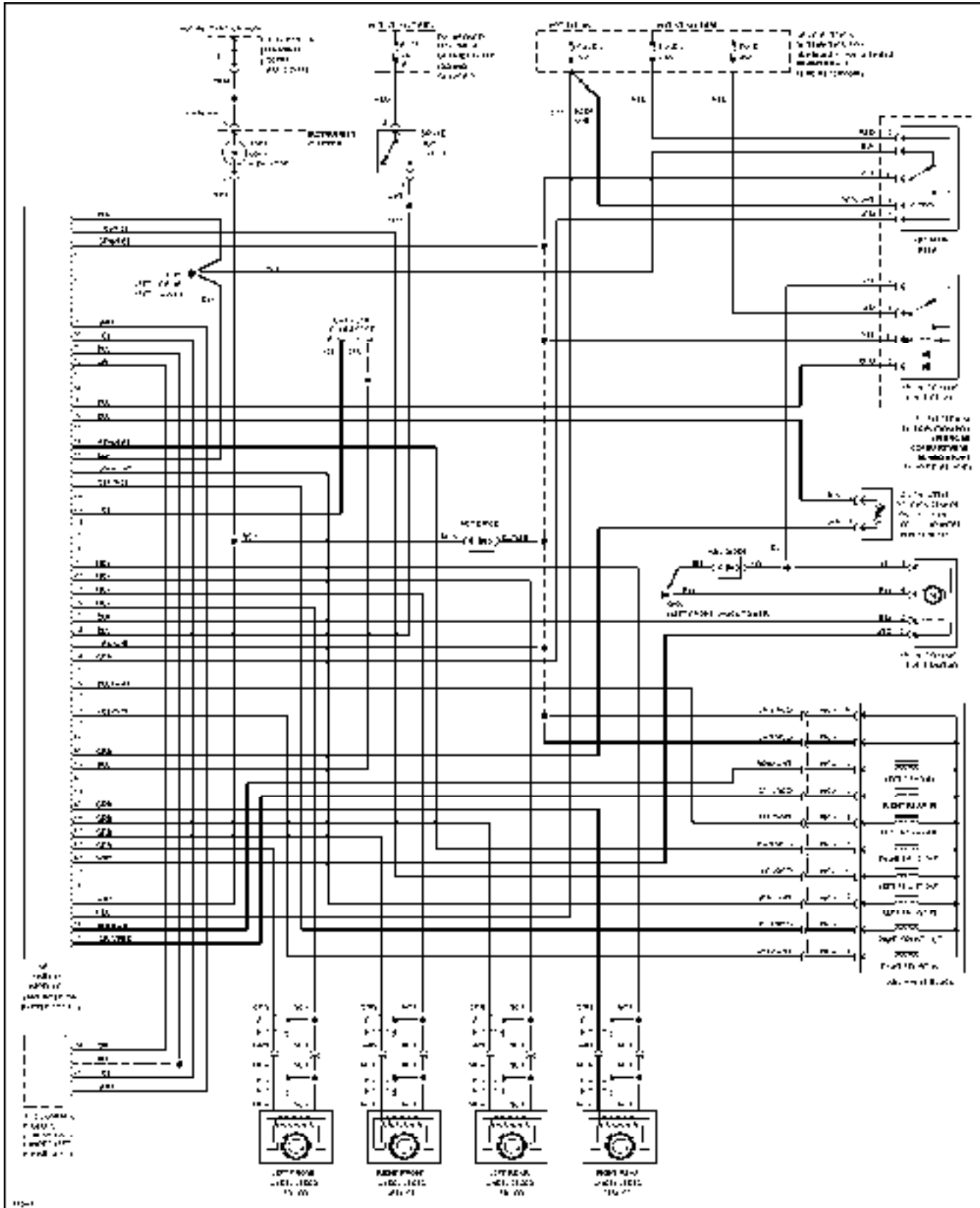

SYSTEM WIRING DIAGRAMS

Air Conditioning Circuits (1 of 2)

1997 Saab 9000

For DIAKOM-AUTO <http://www.diakom.ru> Taganrog support@diakom.ru (8634)315187

Copyright © 1998 Mitchell Repair Information Company, LLC

Friday, December 15, 2000 02:17PM

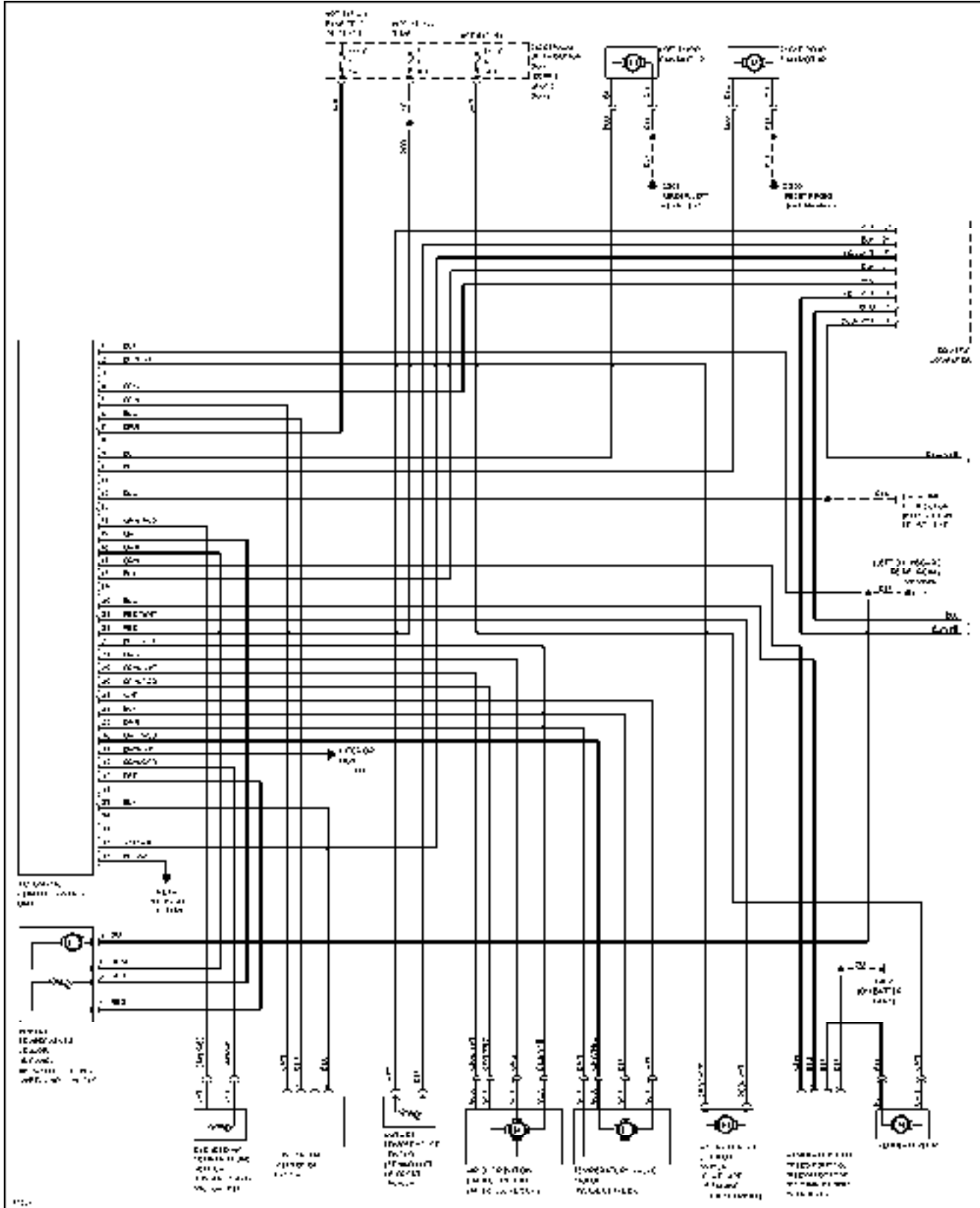

SYSTEM WIRING DIAGRAMS

Air Conditioning Circuits (2 of 2)

1997 Saab 9000

For DIAKOM-AUTO <http://www.diakom.ru> Taganrog support@diakom.ru (8634)315187

Copyright © 1998 Mitchell Repair Information Company, LLC

Friday, December 15, 2000 02:18PM

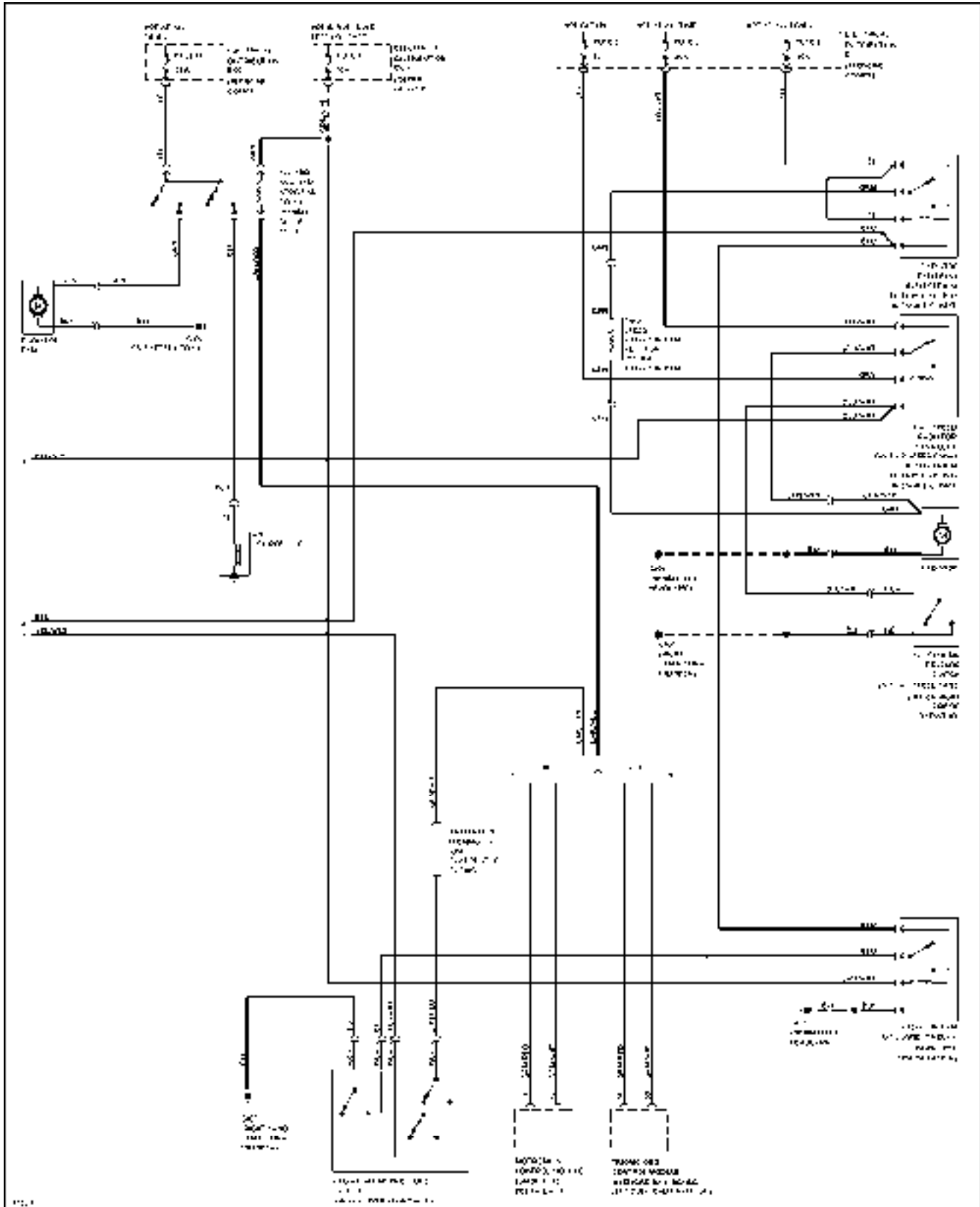

SYSTEM WIRING DIAGRAMS

Anti-theft Alarm Circuit, W/ Immobilizer

1997 Saab 9000

For DIAKOM-AUTO <http://www.diakom.ru> Taganrog support@diakom.ru (8634)315187

Copyright © 1998 Mitchell Repair Information Company, LLC

Friday, December 15, 2000 02:18PM

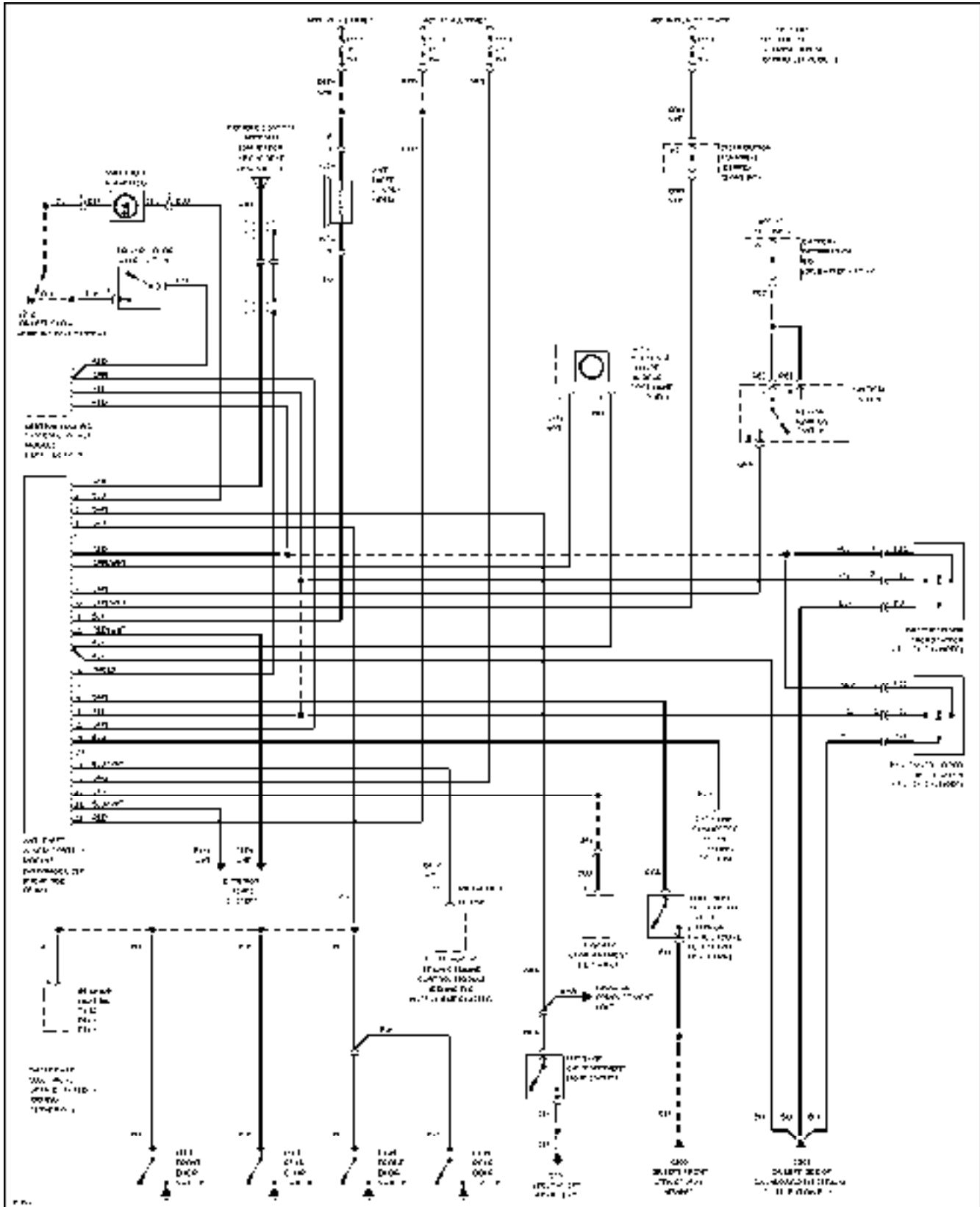

SYSTEM WIRING DIAGRAMS

Anti-theft Alarm Circuit, W/O Immobilizer

1997 Saab 9000

For DIAKOM-AUTO <http://www.diakom.ru> Taganrog support@diakom.ru (8634)315187
Copyright © 1998 Mitchell Repair Information Company, LLC
Friday, December 15, 2000 02:18PM

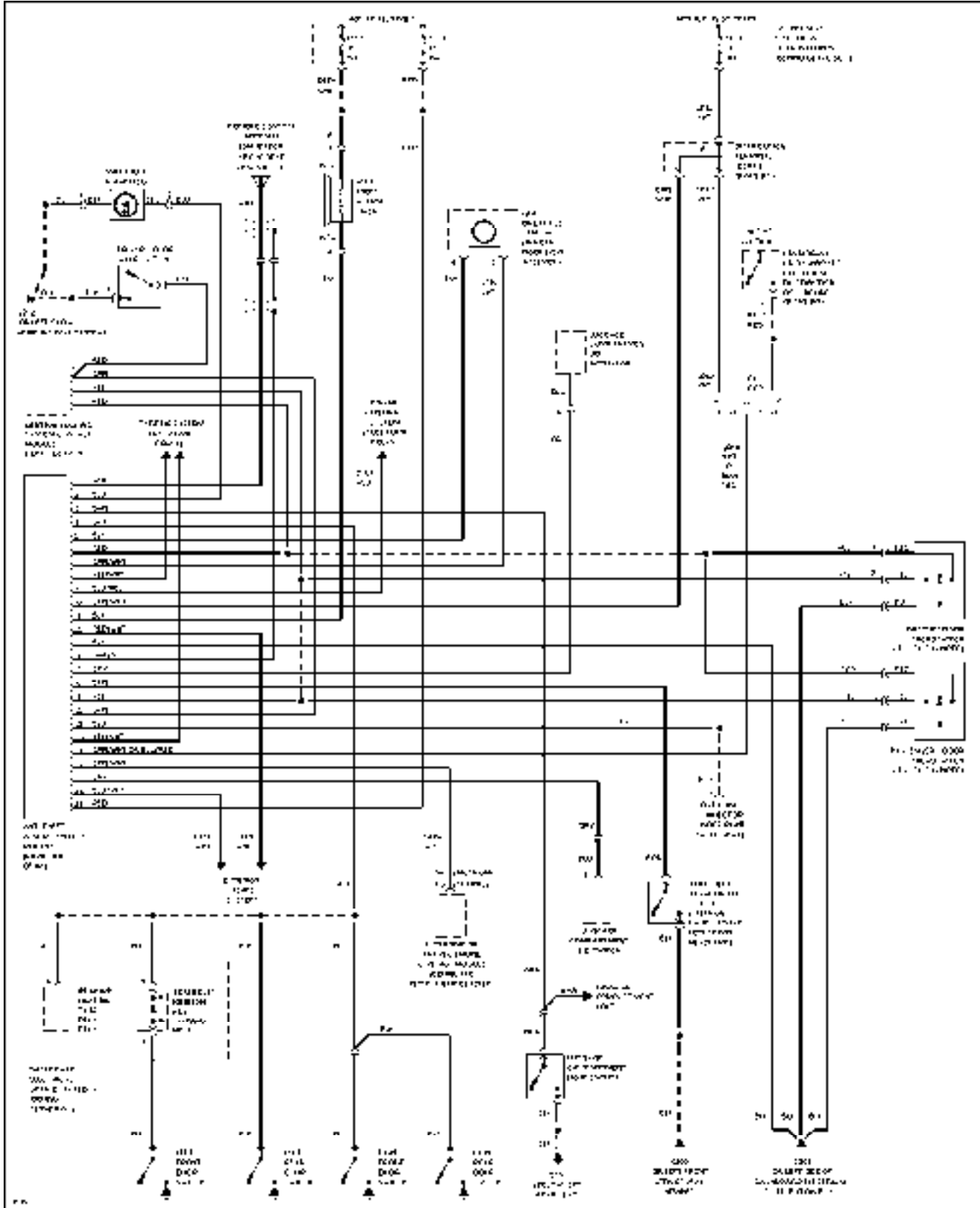

SYSTEM WIRING DIAGRAMS

Backup Lamps Circuit

1997 Saab 9000

For DIAKOM-AUTO <http://www.diakom.ru> Taganrog support@diakom.ru (8634)315187

Copyright © 1998 Mitchell Repair Information Company, LLC

Friday, December 15, 2000 02:20PM

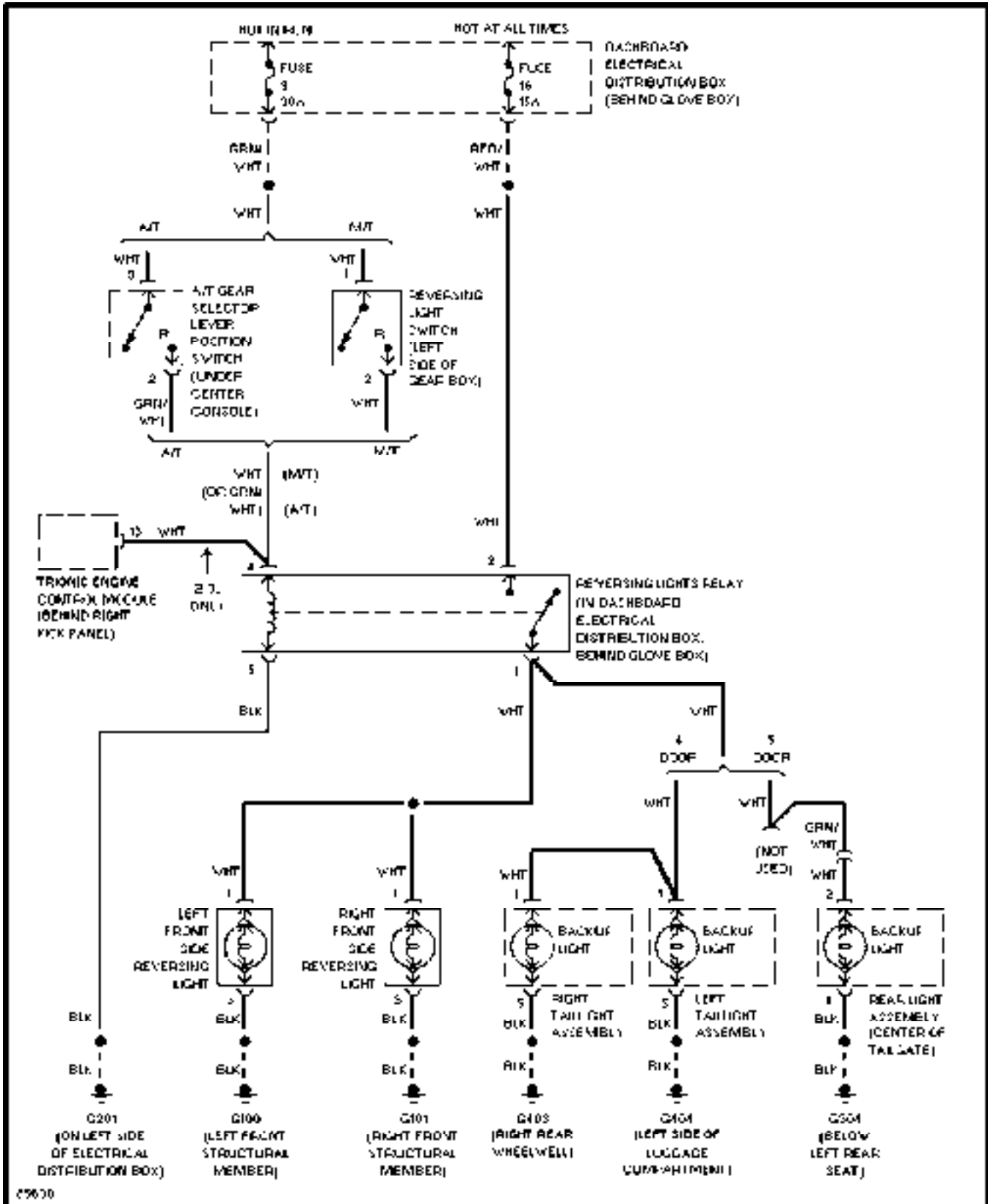

SYSTEM WIRING DIAGRAMS

Trunk, Tailgate, Fuel Door Circuits

1997 Saab 9000

For DIAKOM-AUTO <http://www.diakom.ru> Taganrog support@diakom.ru (8634)315187

Copyright © 1998 Mitchell Repair Information Company, LLC

Friday, December 15, 2000 02:24PM

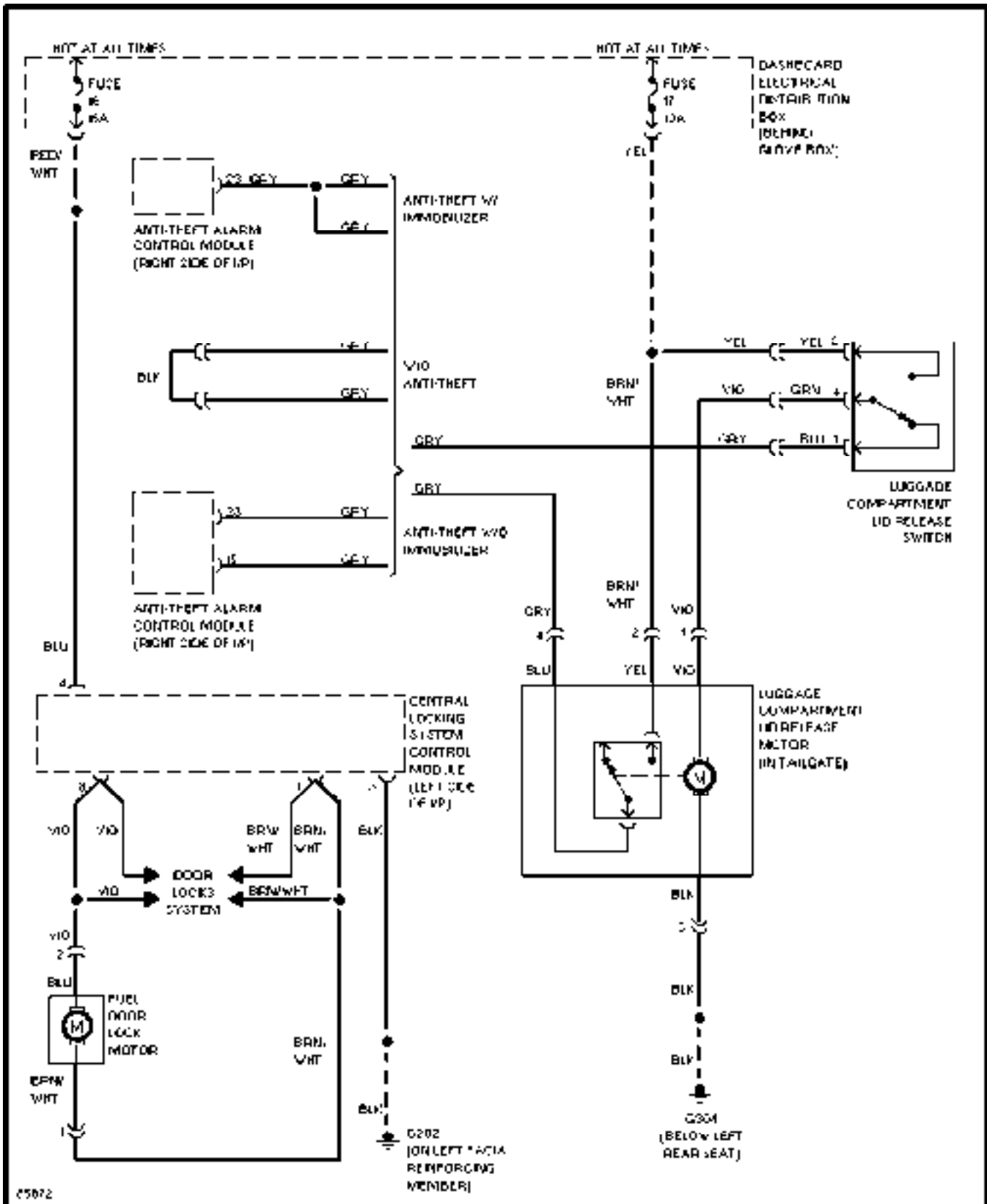

SYSTEM WIRING DIAGRAMS

Charging Circuit

1997 Saab 9000

For DIAKOM-AUTO <http://www.diakom.ru> Taganrog support@diakom.ru (8634)315187

Copyright © 1998 Mitchell Repair Information Company, LLC

Friday, December 15, 2000 02:24PM

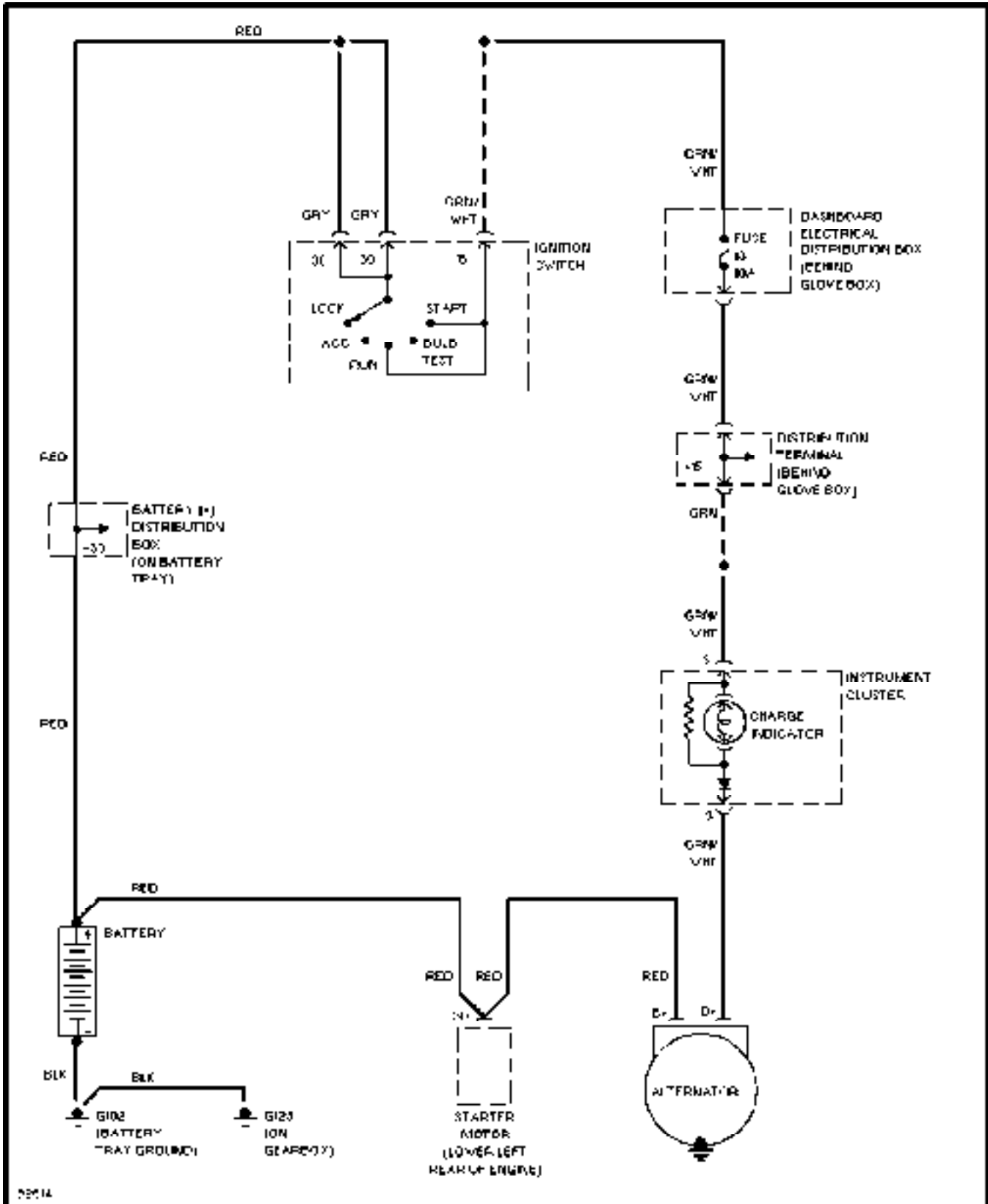

SYSTEM WIRING DIAGRAMS

Computer Data Lines

1997 Saab 9000

For DIAKOM-AUTO <http://www.diakom.ru> Taganrog support@diakom.ru (8634)315187

Copyright © 1998 Mitchell Repair Information Company, LLC

Friday, December 15, 2000 02:19PM

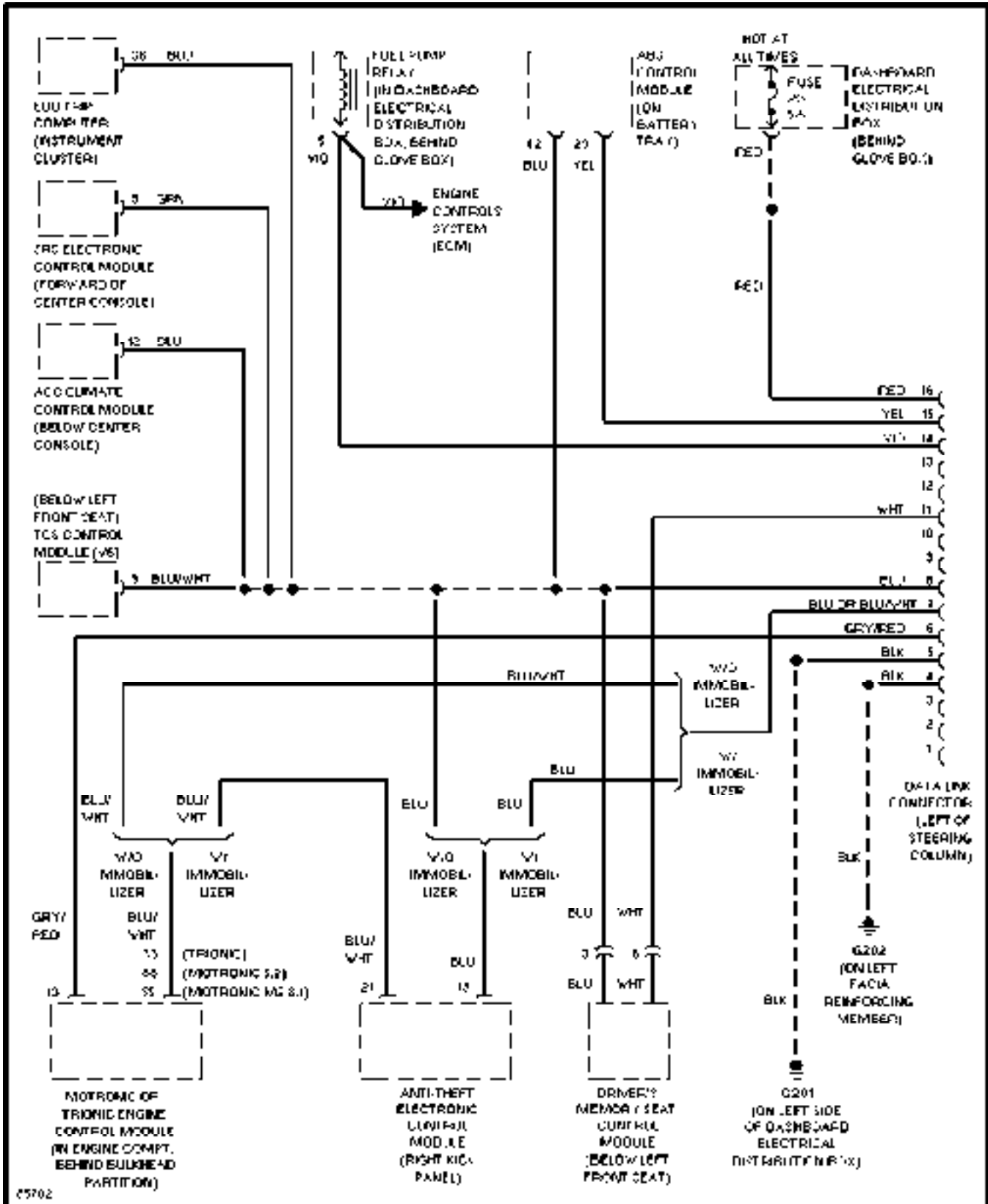

SYSTEM WIRING DIAGRAMS

Cooling Fan Circuit

1997 Saab 9000

For DIAKOM-AUTO <http://www.diakom.ru> Taganrog support@diakom.ru (8634)315187

Copyright © 1998 Mitchell Repair Information Company, LLC

Friday, December 15, 2000 02:19PM

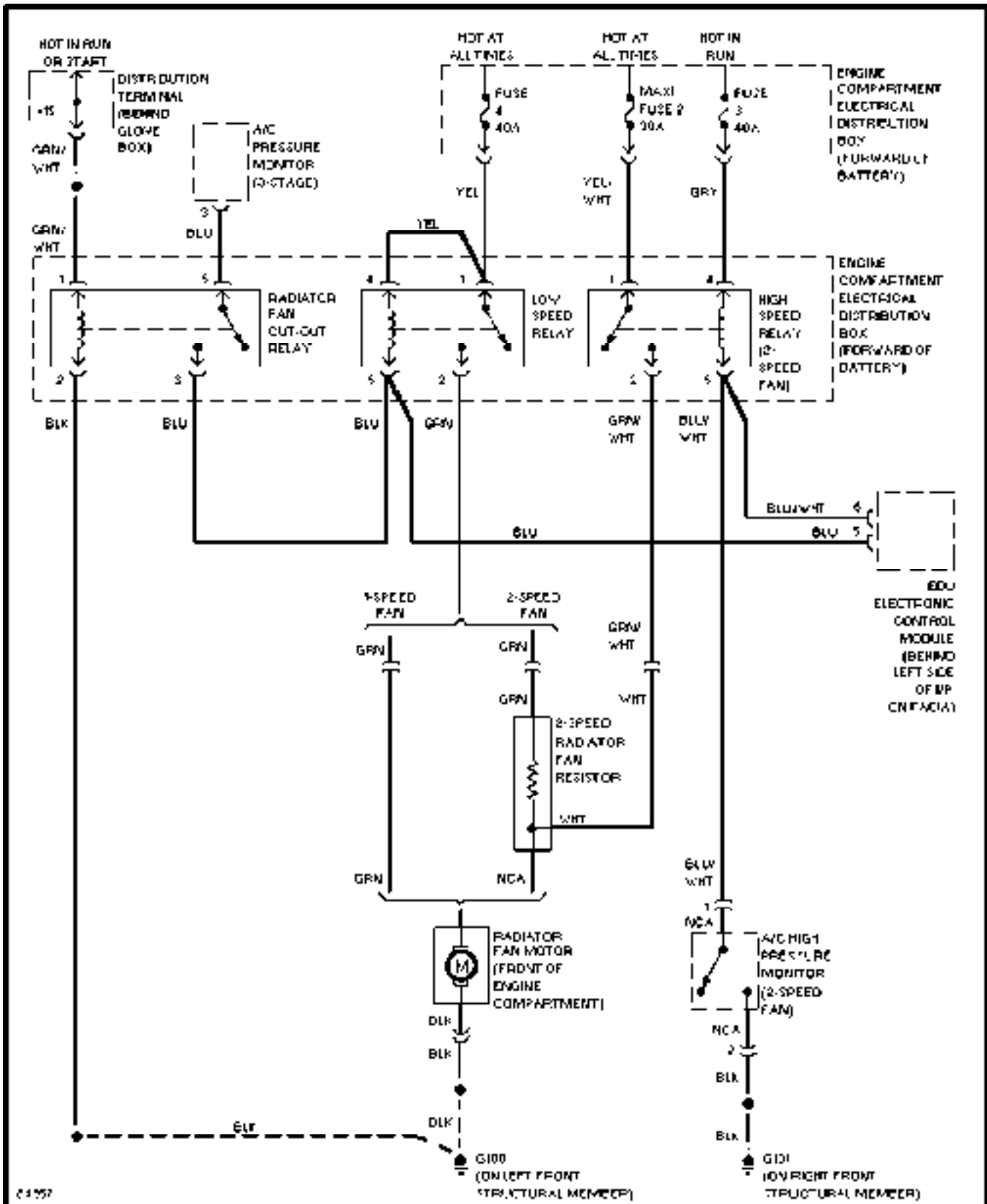

SYSTEM WIRING DIAGRAMS

Cruise Control Circuit

1997 Saab 9000

For DIAKOM-AUTO <http://www.diakom.ru> Taganrog support@diakom.ru (8634)315187

Copyright © 1998 Mitchell Repair Information Company, LLC

Friday, December 15, 2000 02:19PM

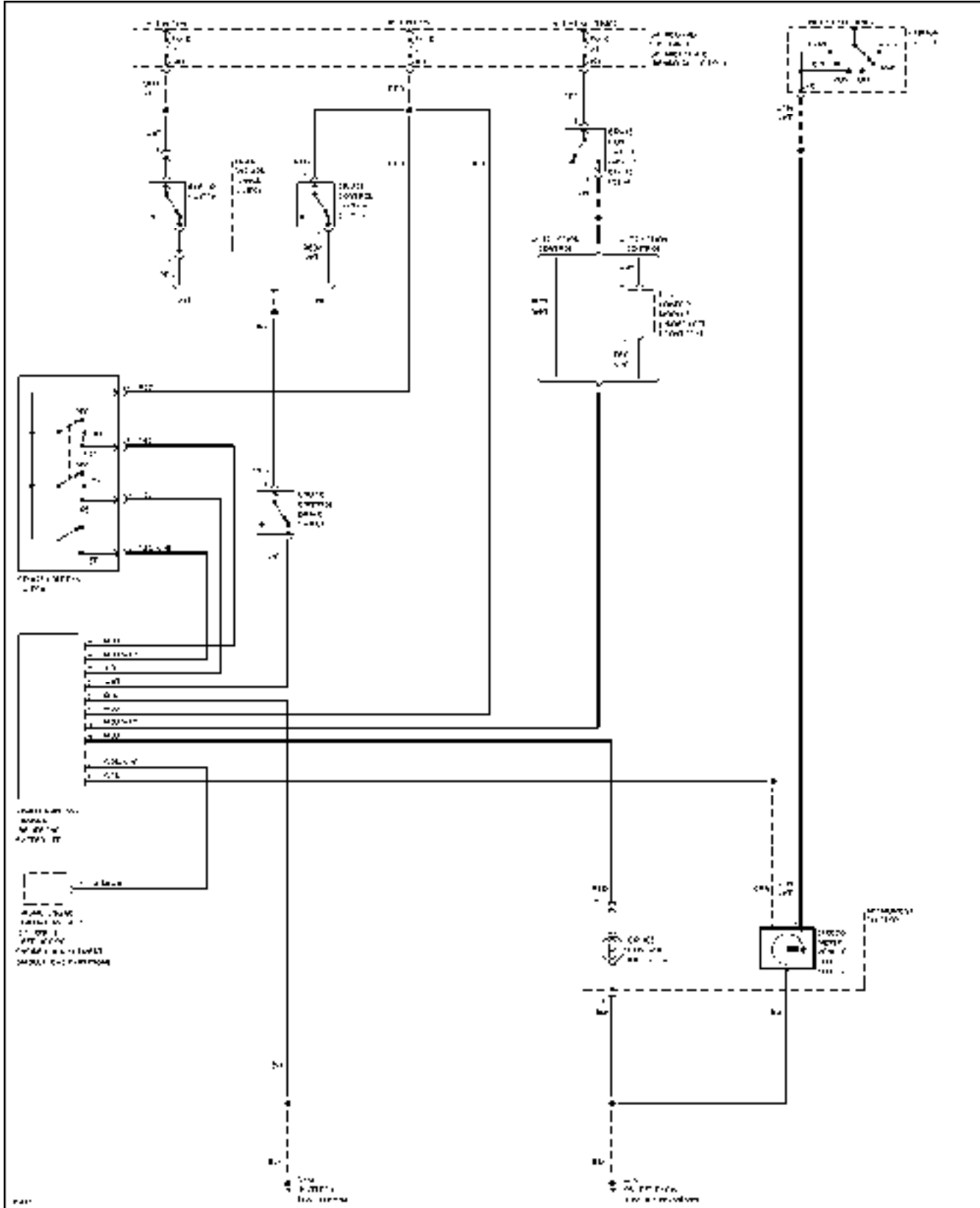

SYSTEM WIRING DIAGRAMS

Defogger Circuit, W/ Auto A/C

1997 Saab 9000

For DIAKOM-AUTO <http://www.diakom.ru> Taganrog support@diakom.ru (8634)315187

Copyright © 1998 Mitchell Repair Information Company, LLC

Friday, December 15, 2000 02:19PM

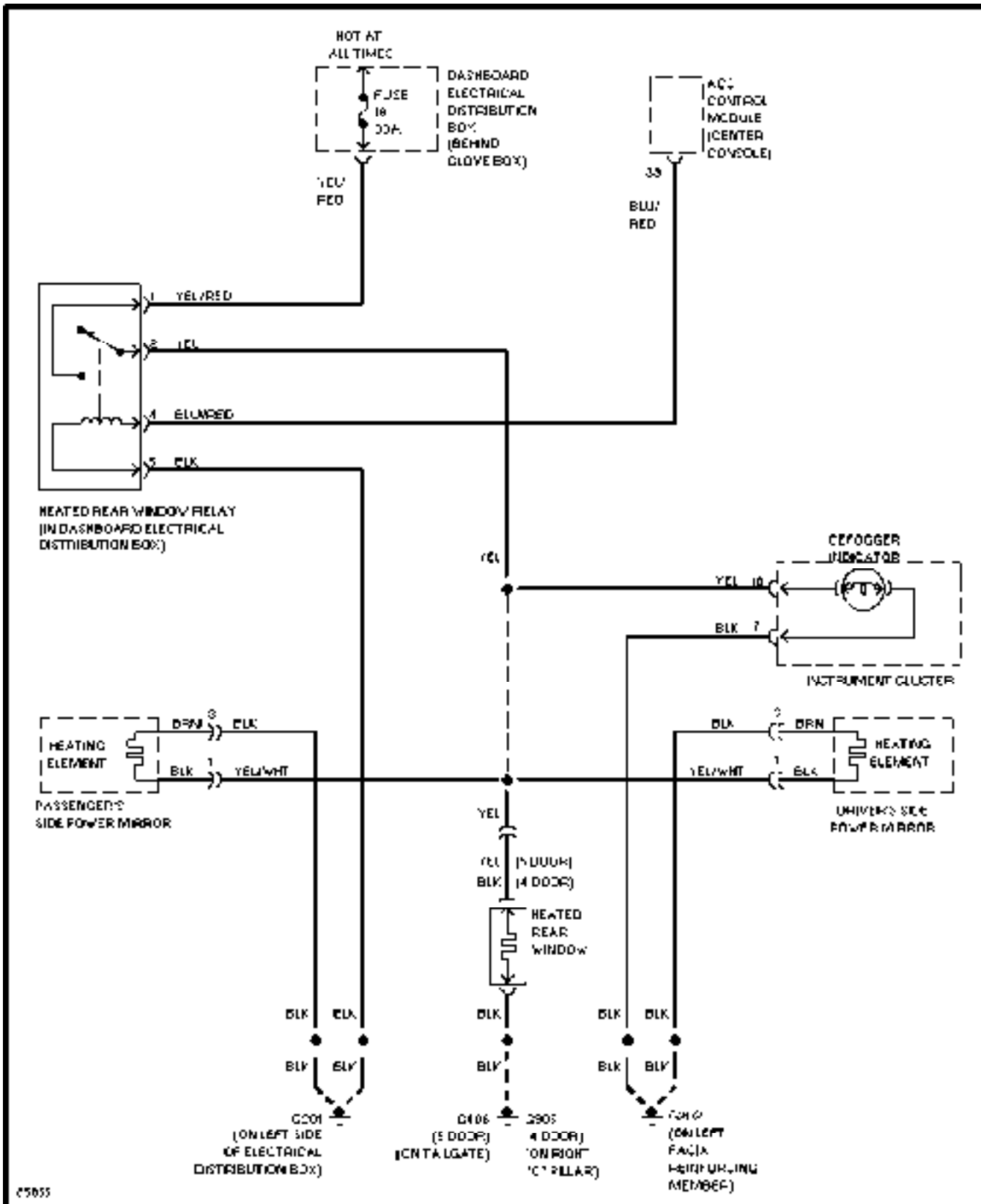

SYSTEM WIRING DIAGRAMS

Defogger Circuit, W/O Auto A/C

1997 Saab 9000

For DIAKOM-AUTO <http://www.diakom.ru> Taganrog support@diakom.ru (8634)315187

Copyright © 1998 Mitchell Repair Information Company, LLC

Friday, December 15, 2000 02:19PM

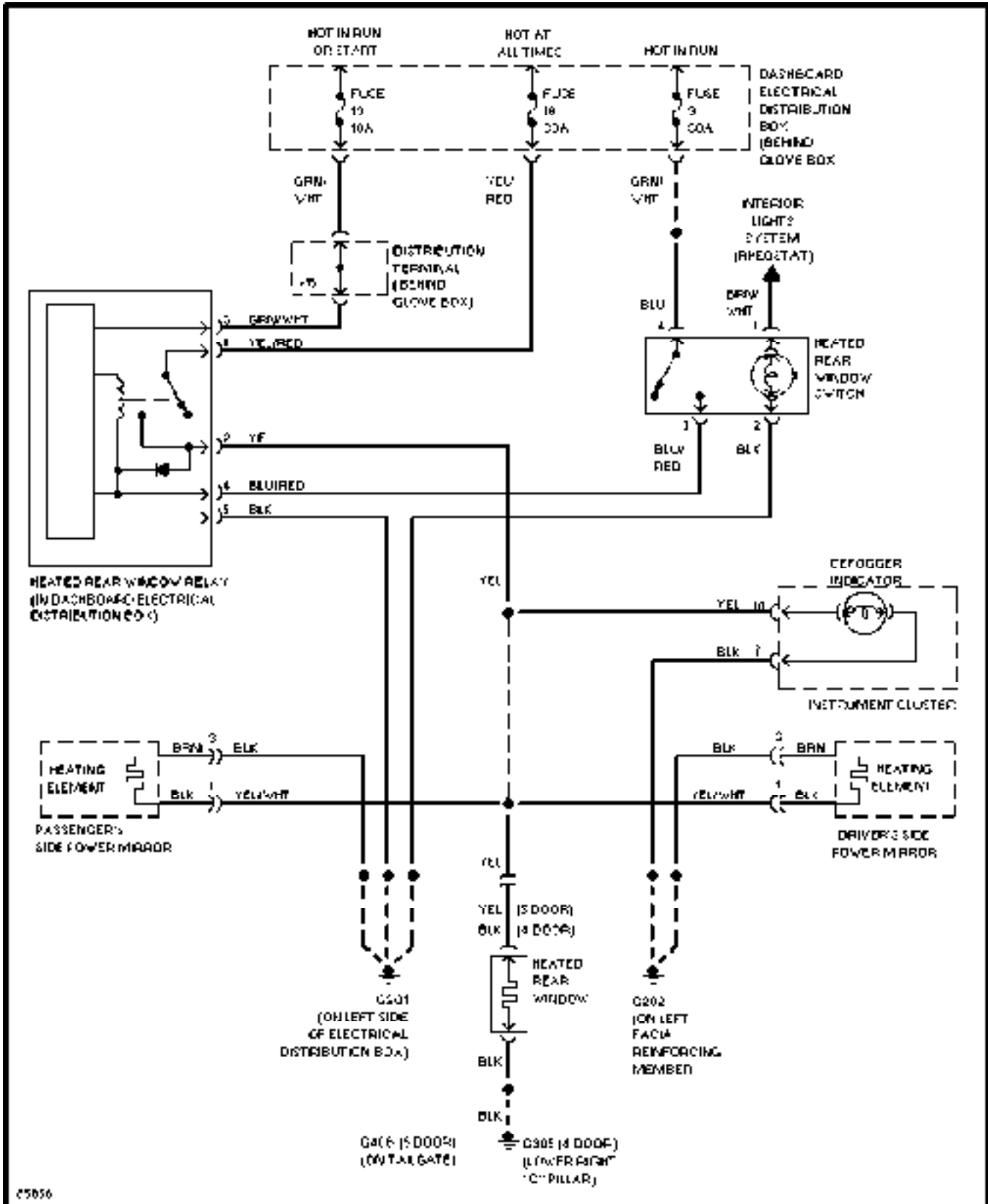

SYSTEM WIRING DIAGRAMS

Exterior Lamps Circuit (1 of 2)

1997 Saab 9000

For DIAKOM-AUTO <http://www.diakom.ru> Taganrog support@diakom.ru (8634)315187

Copyright © 1998 Mitchell Repair Information Company, LLC

Friday, December 15, 2000 02:20PM

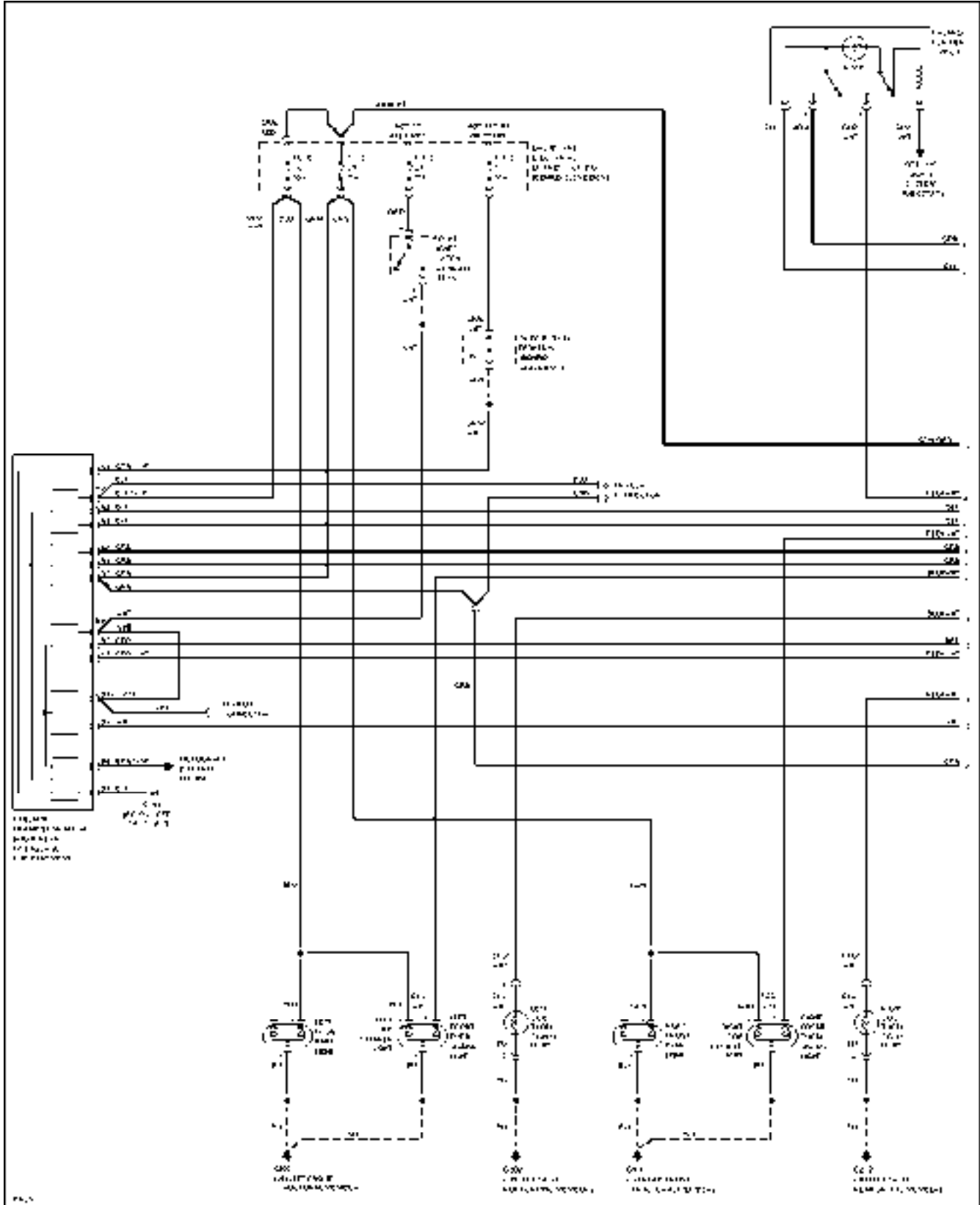

SYSTEM WIRING DIAGRAMS

Exterior Lamps Circuit (2 of 2)

1997 Saab 9000

For DIAKOM-AUTO <http://www.diakom.ru> Taganrog support@diakom.ru (8634)315187

Copyright © 1998 Mitchell Repair Information Company, LLC

Friday, December 15, 2000 02:20PM

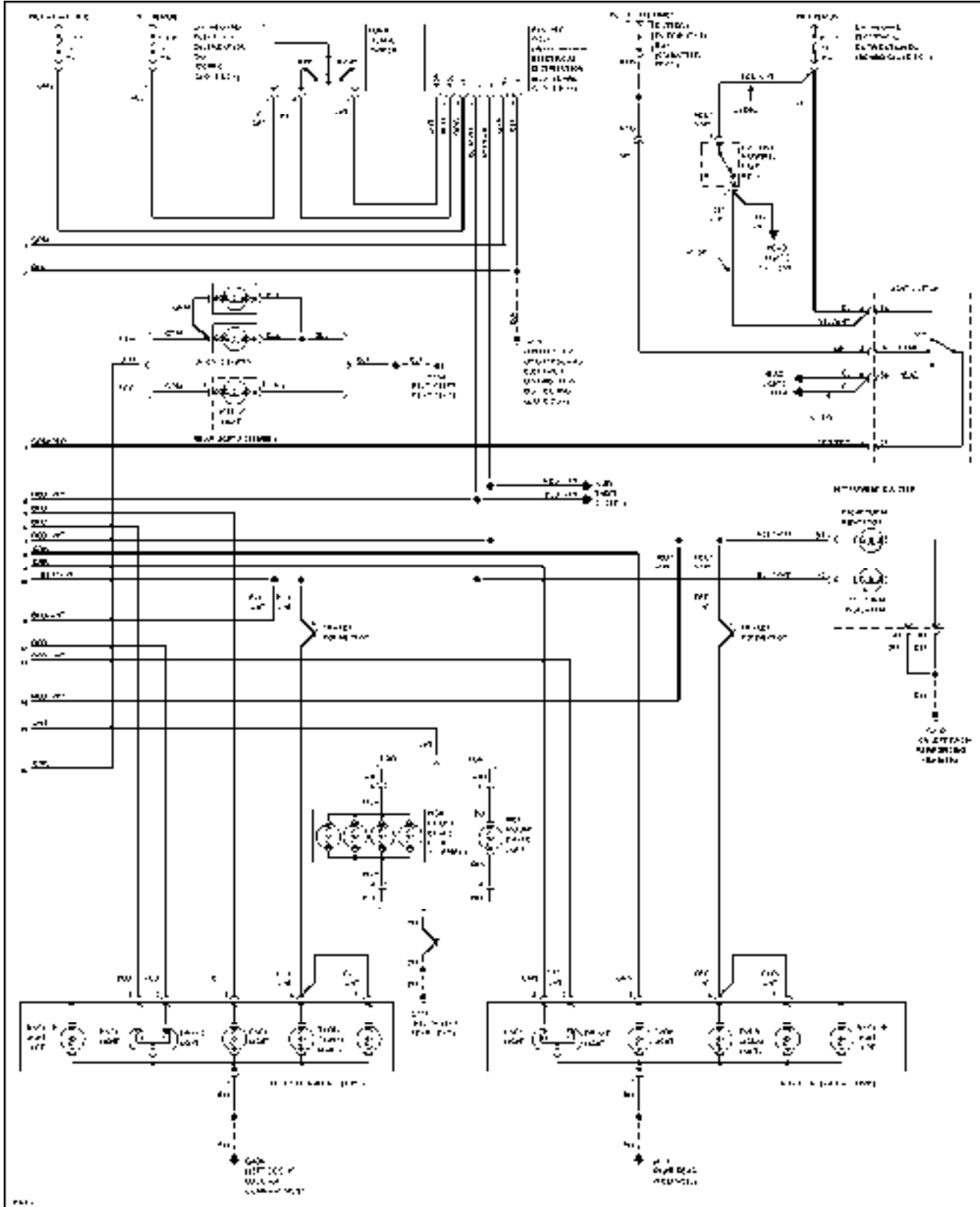

SYSTEM WIRING DIAGRAMS

Front & Headlight Washer/Wiper Circuit

1997 Saab 9000

For DIAKOM-AUTO <http://www.diakom.ru> Taganrog support@diakom.ru (8634)315187

Copyright © 1998 Mitchell Repair Information Company, LLC

Friday, December 15, 2000 02:25PM

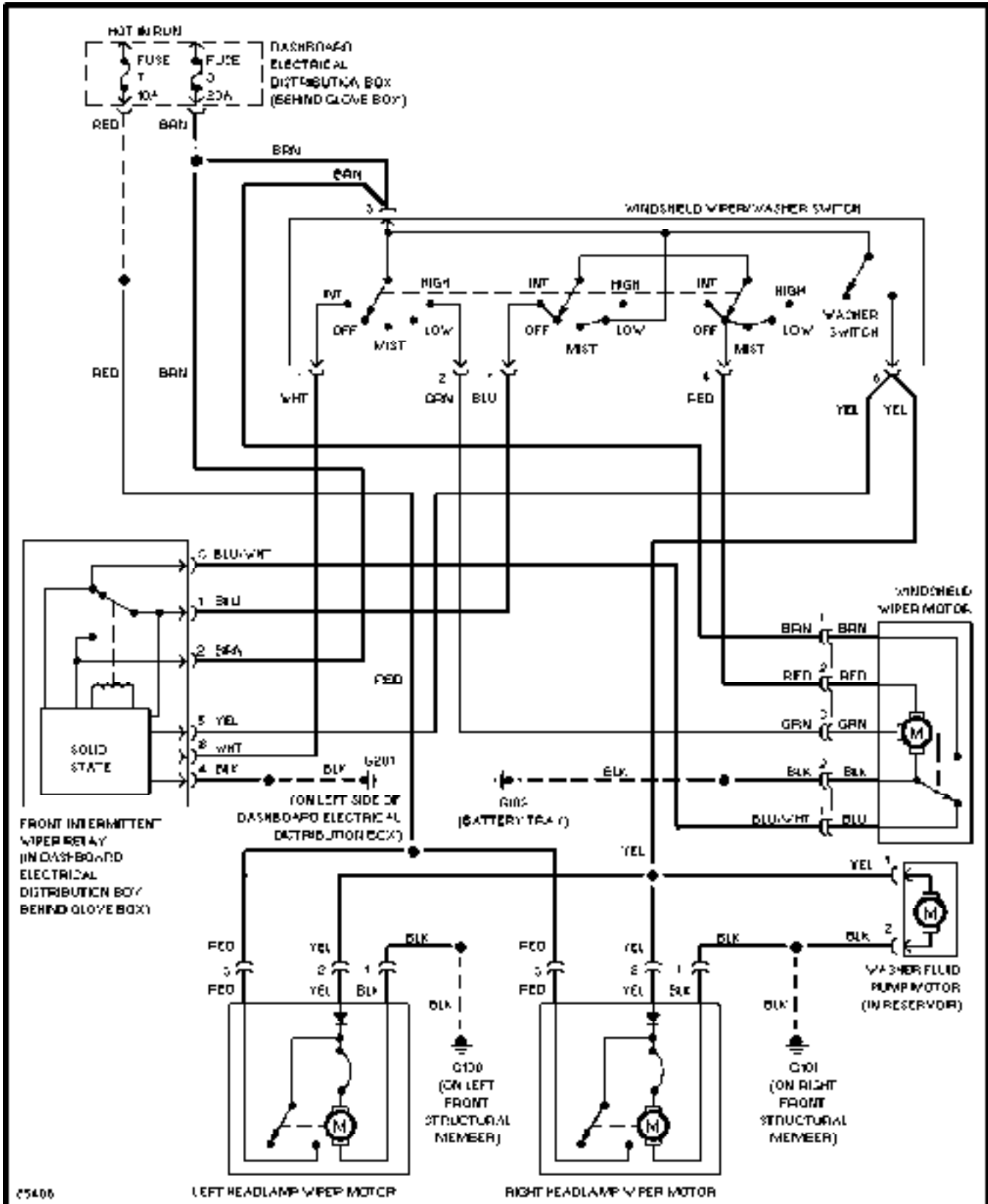

SYSTEM WIRING DIAGRAMS

Ground Distribution Circuit

1997 Saab 9000

For DIAKOM-AUTO <http://www.diakom.ru> Taganrog support@diakom.ru (8634)315187

Copyright © 1998 Mitchell Repair Information Company, LLC

Friday, December 15, 2000 02:20PM

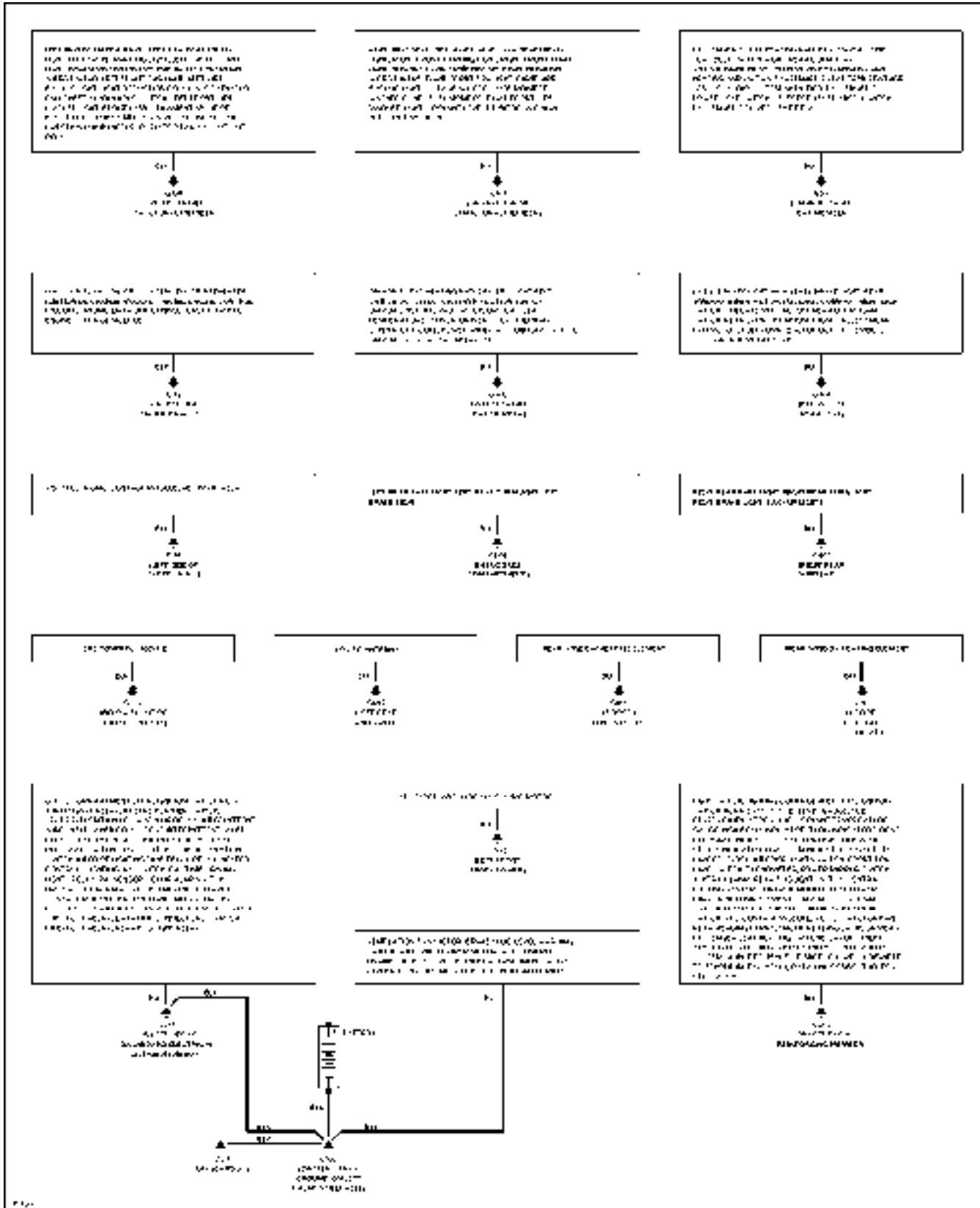

SYSTEM WIRING DIAGRAMS

Headlamps/Front Fog Lamps Circuit

1997 Saab 9000

For DIAKOM-AUTO <http://www.diakom.ru> Taganrog support@diakom.ru (8634)315187

Copyright © 1998 Mitchell Repair Information Company, LLC

Friday, December 15, 2000 02:21PM

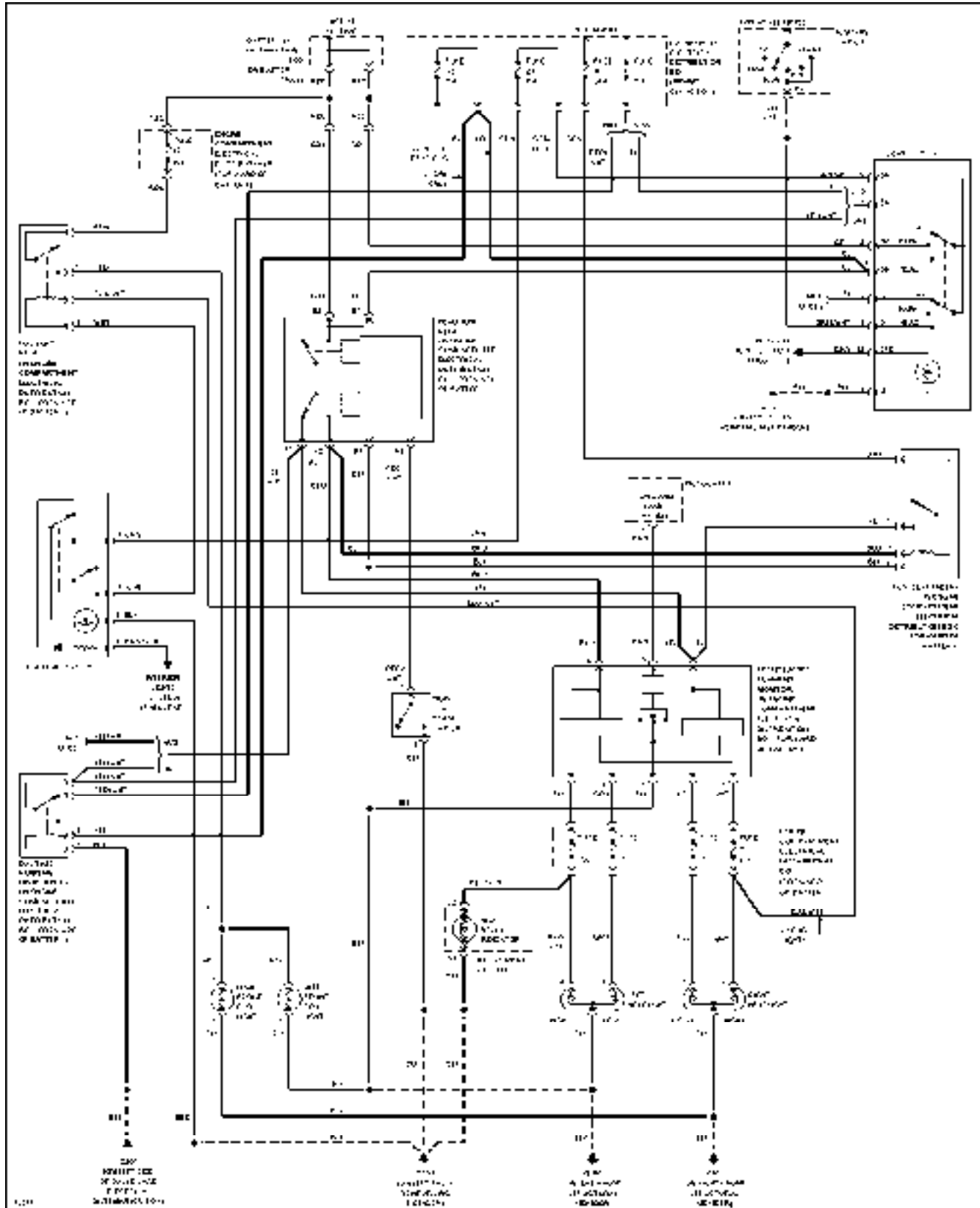

SYSTEM WIRING DIAGRAMS

Heated Seats Circuit

1997 Saab 9000

For DIAKOM-AUTO <http://www.diakom.ru> Taganrog support@diakom.ru (8634)315187

Copyright © 1998 Mitchell Repair Information Company, LLC

Friday, December 15, 2000 02:23PM

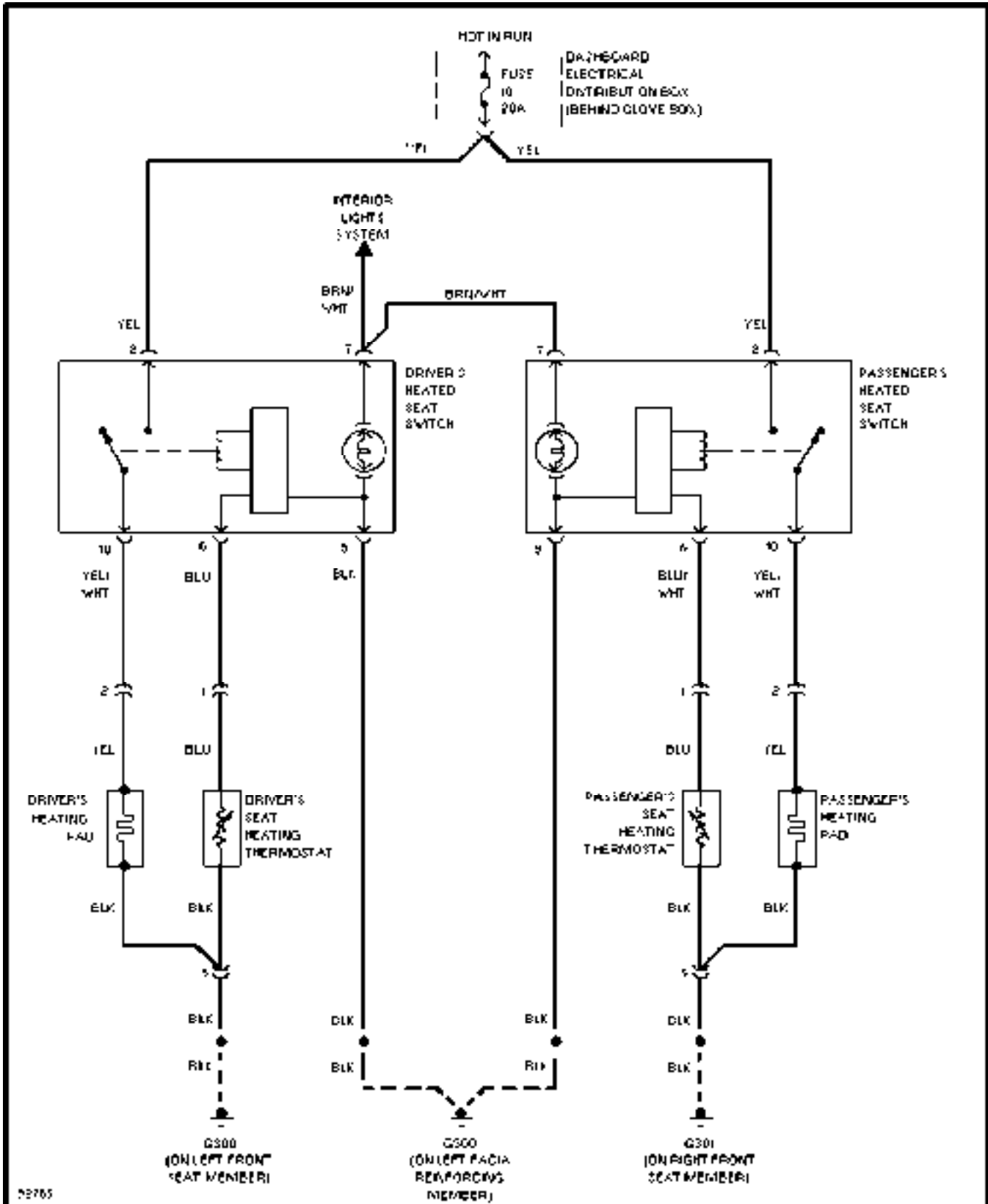

SYSTEM WIRING DIAGRAMS

Horn Circuit

1997 Saab 9000

For DIAKOM-AUTO <http://www.diakom.ru> Taganrog support@diakom.ru (8634)315187

Copyright © 1998 Mitchell Repair Information Company, LLC

Friday, December 15, 2000 02:21PM

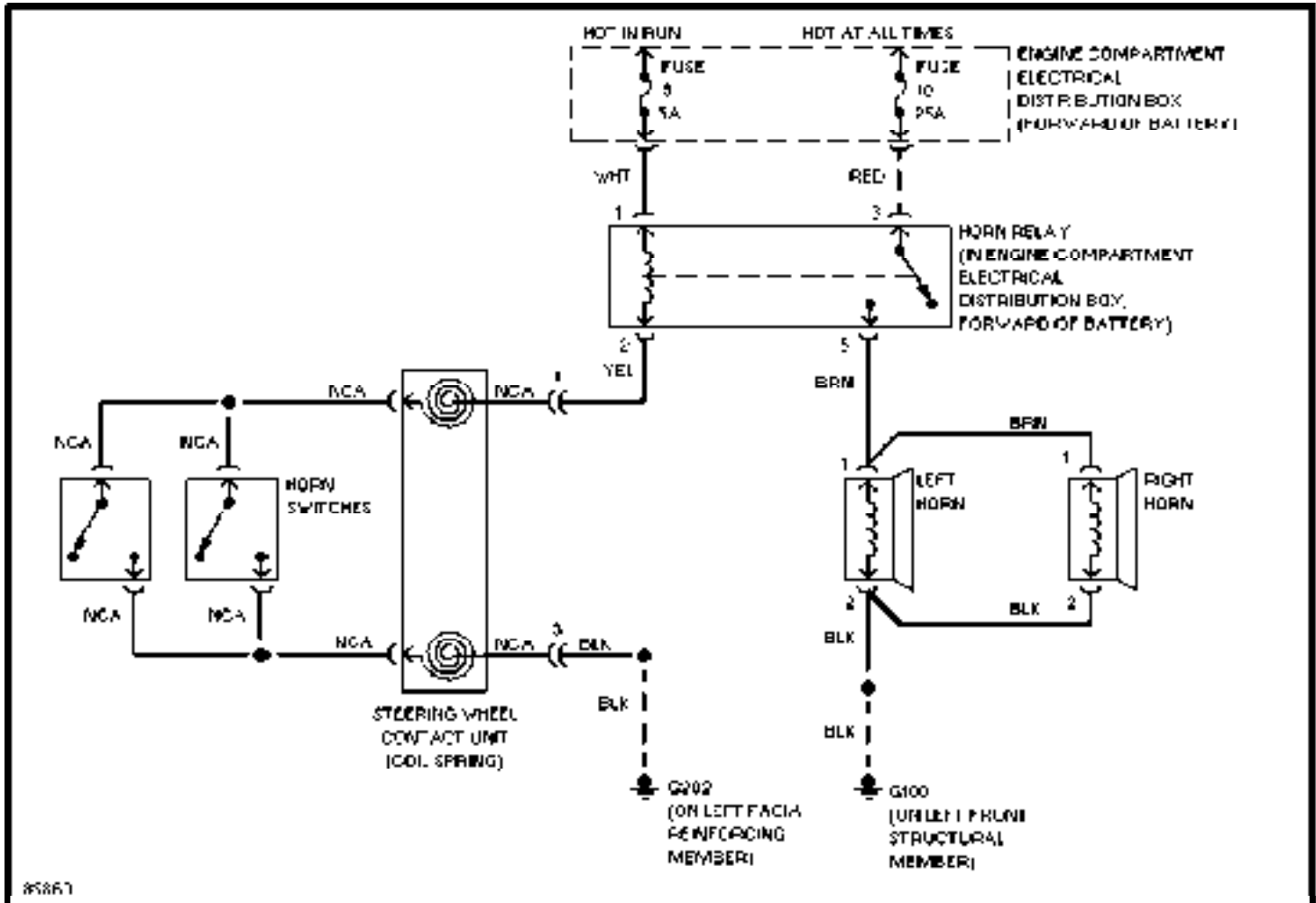

SYSTEM WIRING DIAGRAMS

Instrument Cluster & Pictogram Circuit (1 of 2)

1997 Saab 9000

For DIAKOM-AUTO <http://www.diakom.ru> Taganrog support@diakom.ru (8634)315187

Copyright © 1998 Mitchell Repair Information Company, LLC

Friday, December 15, 2000 02:21PM

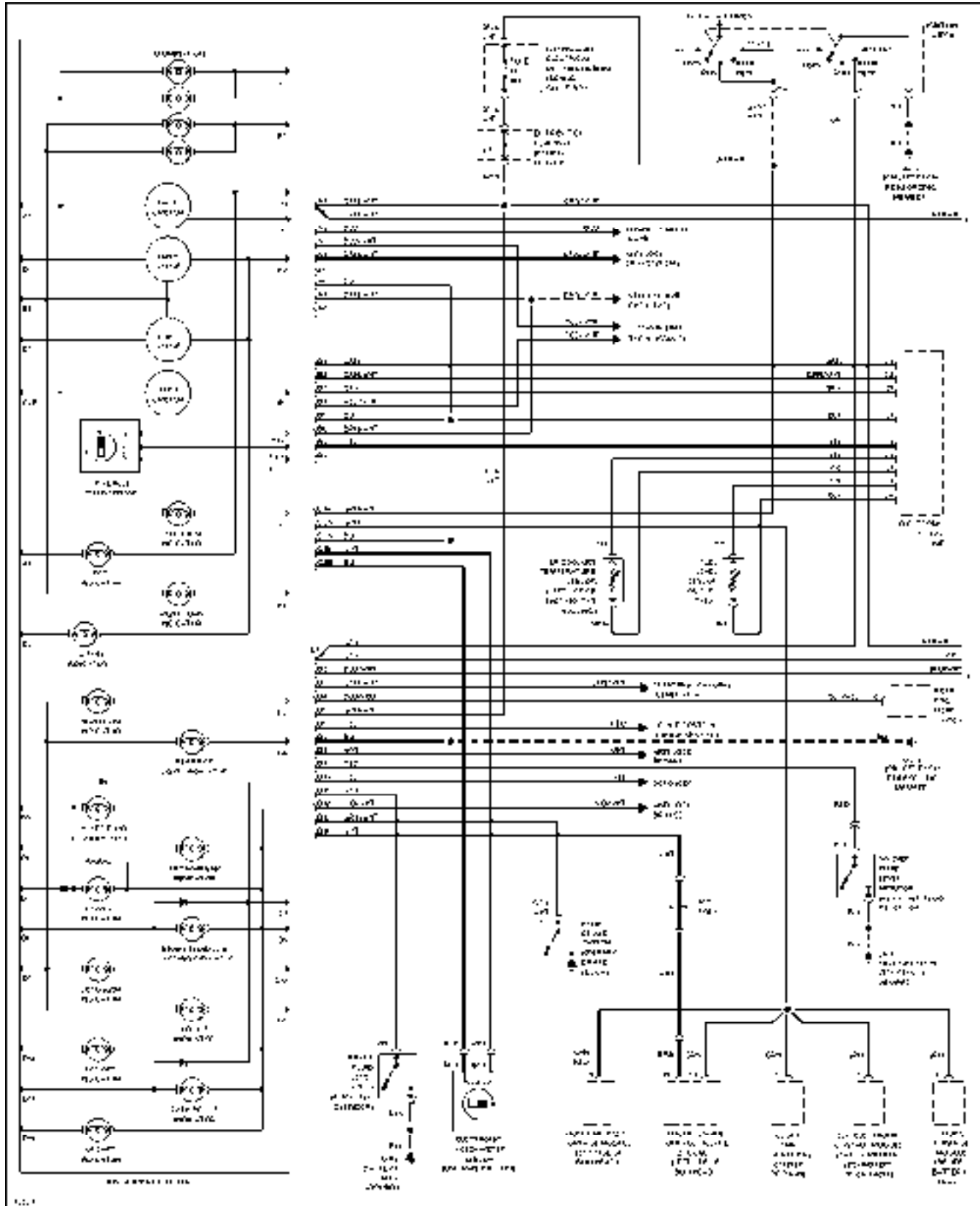

SYSTEM WIRING DIAGRAMS

Instrument Illumination Circuit

1997 Saab 9000

For DIAKOM-AUTO <http://www.diakom.ru> Taganrog support@diakom.ru (8634)315187

Copyright © 1998 Mitchell Repair Information Company, LLC

Friday, December 15, 2000 02:22PM

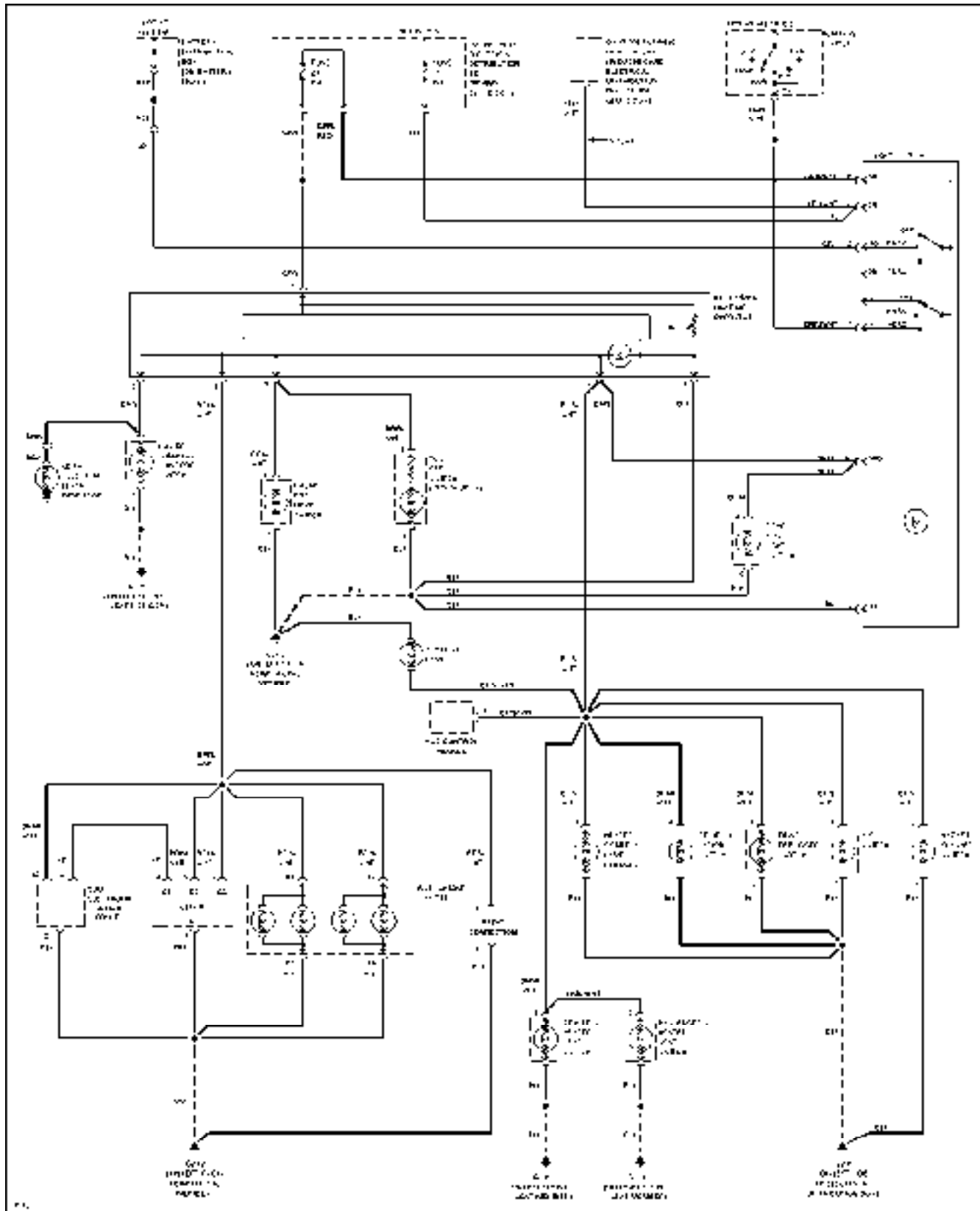

SYSTEM WIRING DIAGRAMS

Power Antenna Circuit

1997 Saab 9000

For DIAKOM-AUTO <http://www.diakom.ru> Taganrog support@diakom.ru (8634)315187

Copyright © 1998 Mitchell Repair Information Company, LLC

Friday, December 15, 2000 02:22PM

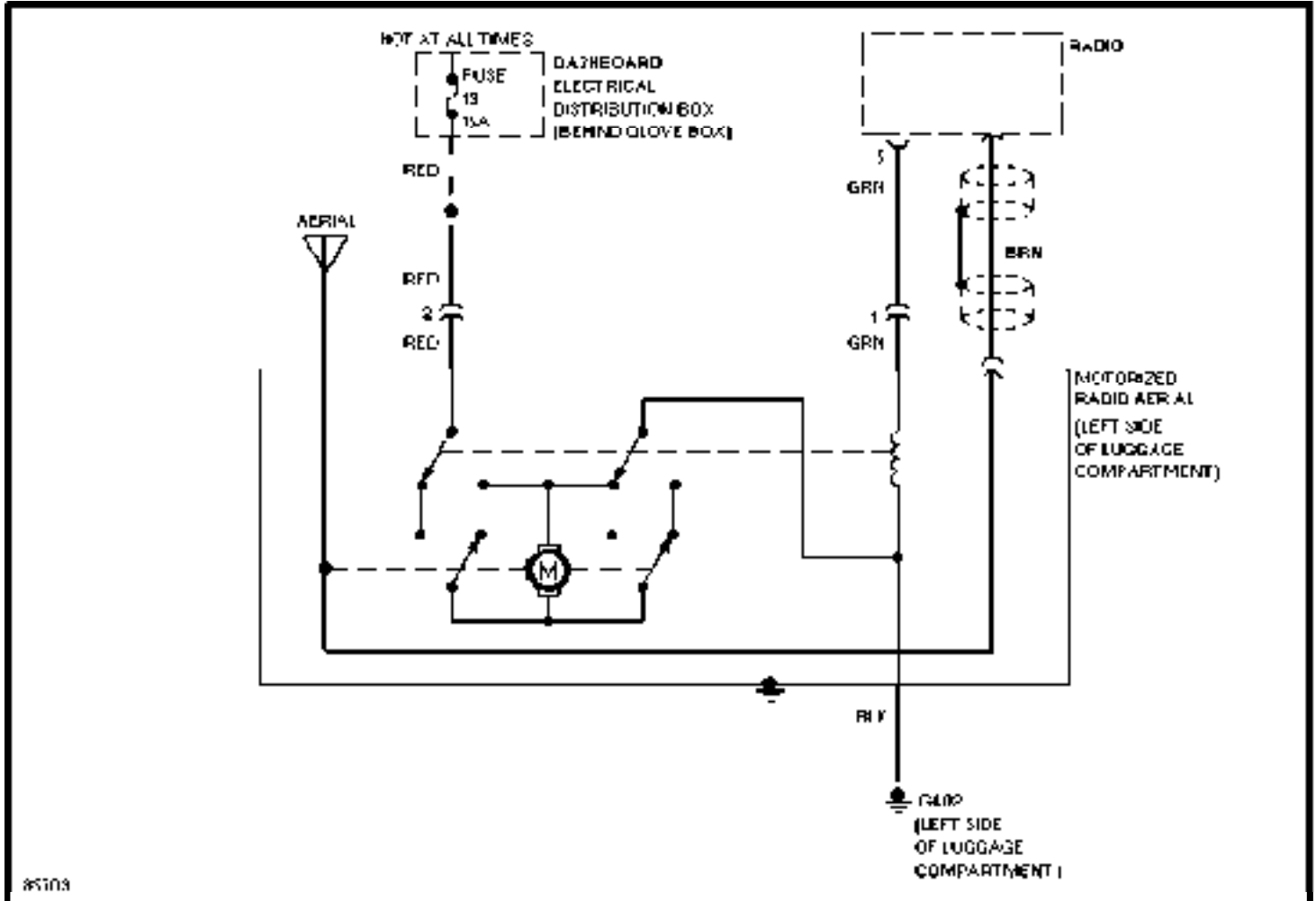

SYSTEM WIRING DIAGRAMS

Power Distribution Circuit (1 of 3)

1997 Saab 9000

For DIAKOM-AUTO <http://www.diakom.ru> Taganrog support@diakom.ru (8634)315187

Copyright © 1998 Mitchell Repair Information Company, LLC

Friday, December 15, 2000 02:22PM

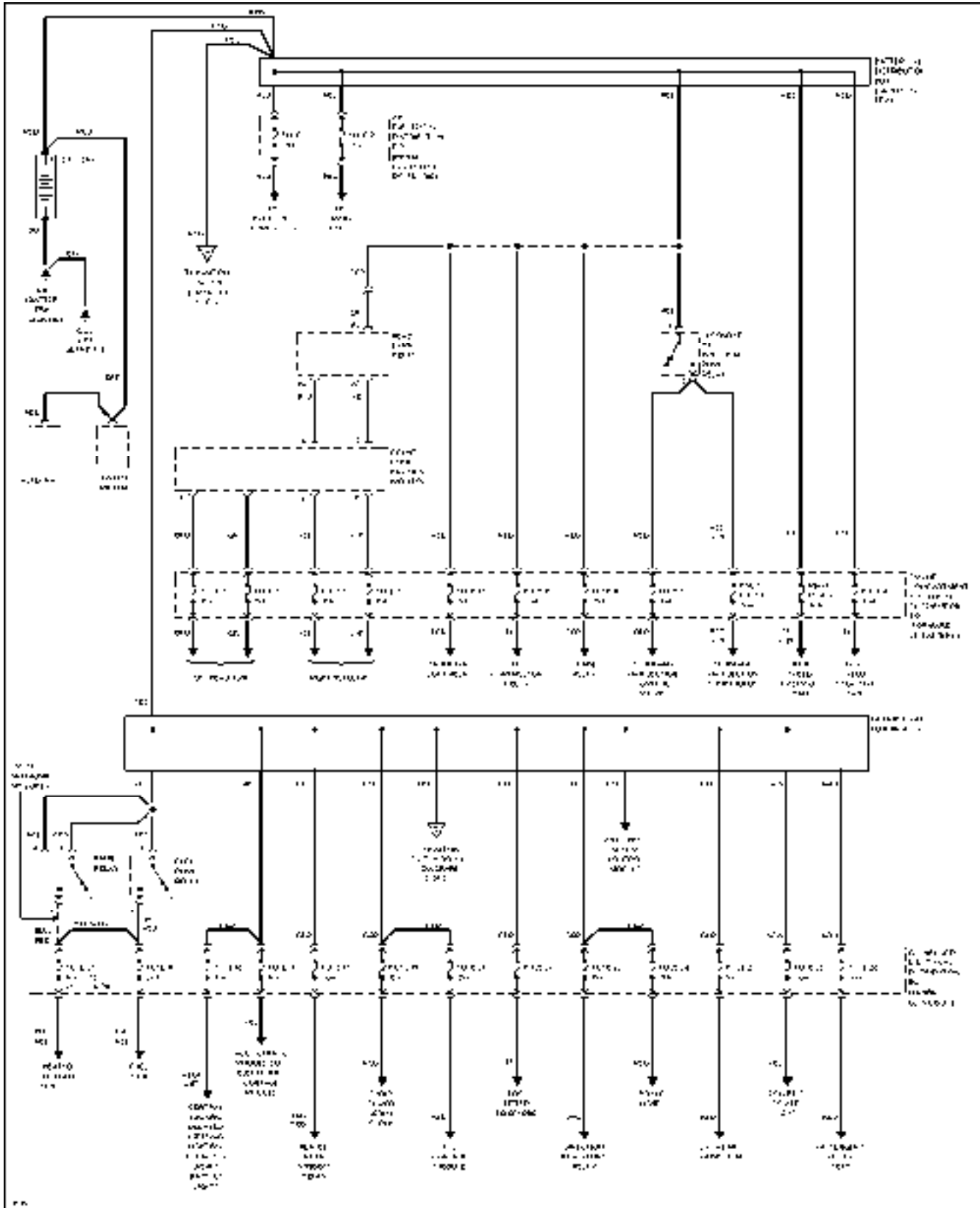

SYSTEM WIRING DIAGRAMS

Power Distribution Circuit (2 of 3)

1997 Saab 9000

For DIAKOM-AUTO <http://www.diakom.ru> Taganrog support@diakom.ru (8634)315187

Copyright © 1998 Mitchell Repair Information Company, LLC

Friday, December 15, 2000 02:22PM

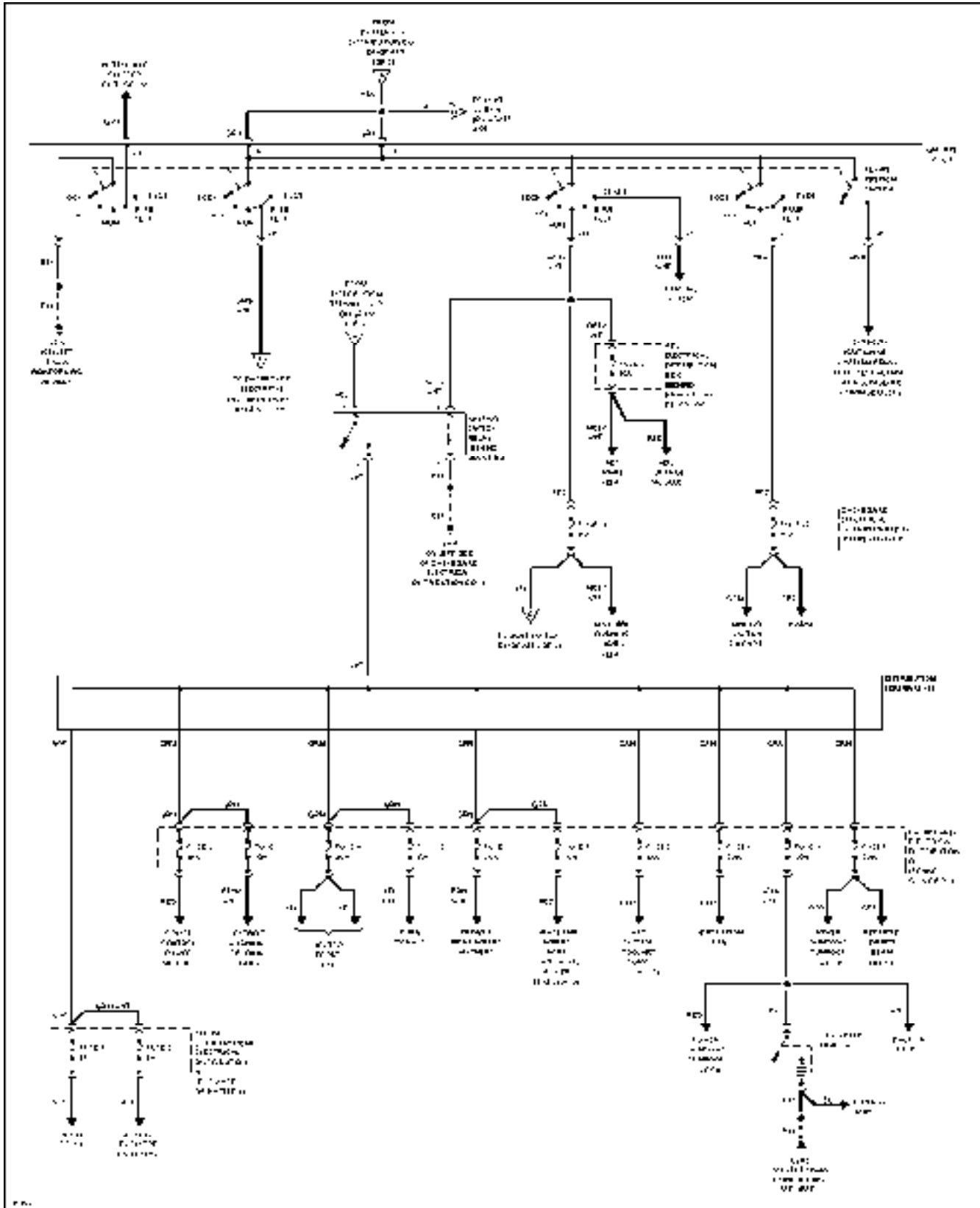

SYSTEM WIRING DIAGRAMS

Power Door Lock Circuit

1997 Saab 9000

For DIAKOM-AUTO <http://www.diakom.ru> Taganrog support@diakom.ru (8634)315187

Copyright © 1998 Mitchell Repair Information Company, LLC

Friday, December 15, 2000 02:23PM

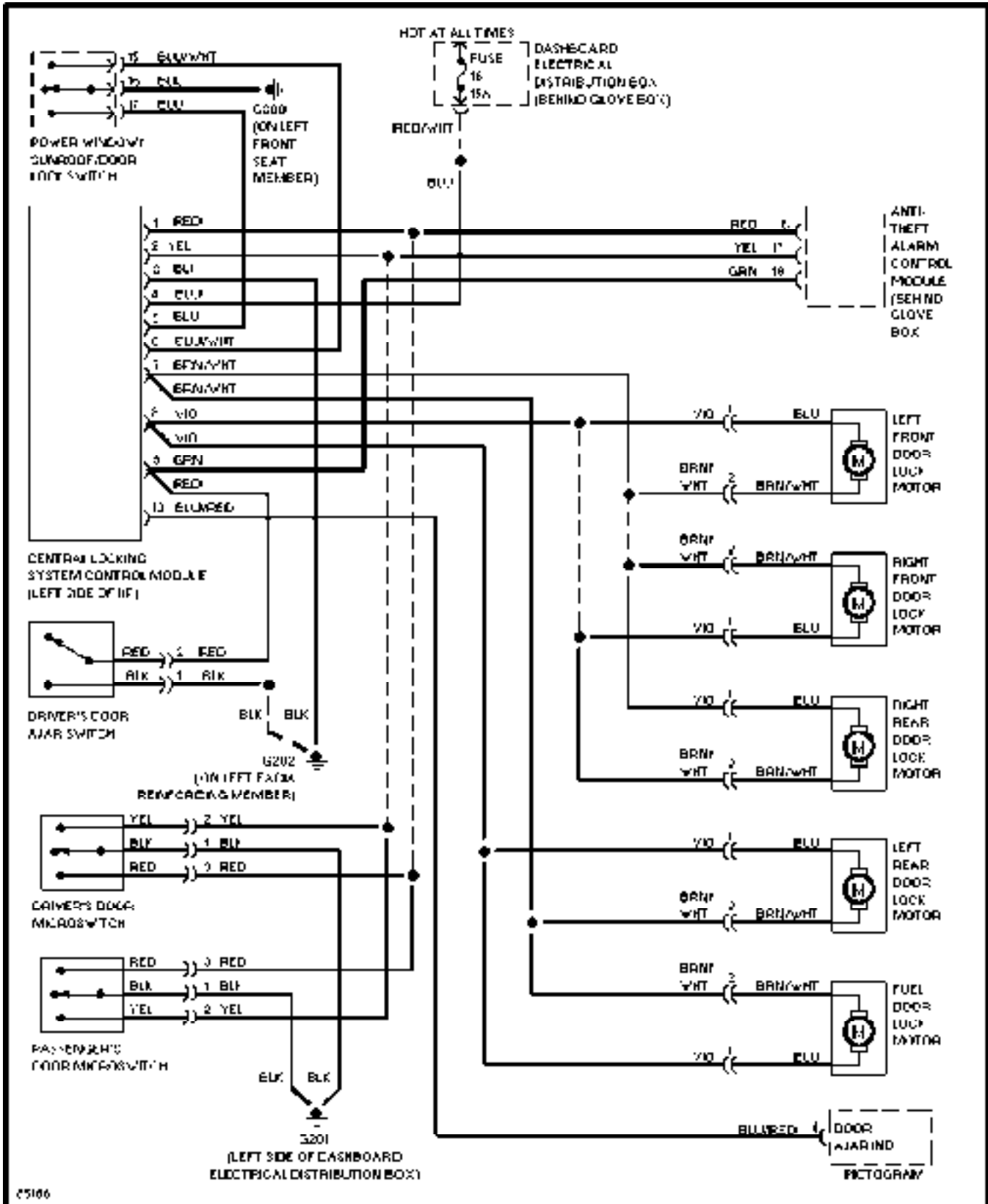

SYSTEM WIRING DIAGRAMS

Power Mirror Circuit

1997 Saab 9000

For DIAKOM-AUTO <http://www.diakom.ru> Taganrog support@diakom.ru (8634)315187

Copyright © 1998 Mitchell Repair Information Company, LLC

Friday, December 15, 2000 02:23PM

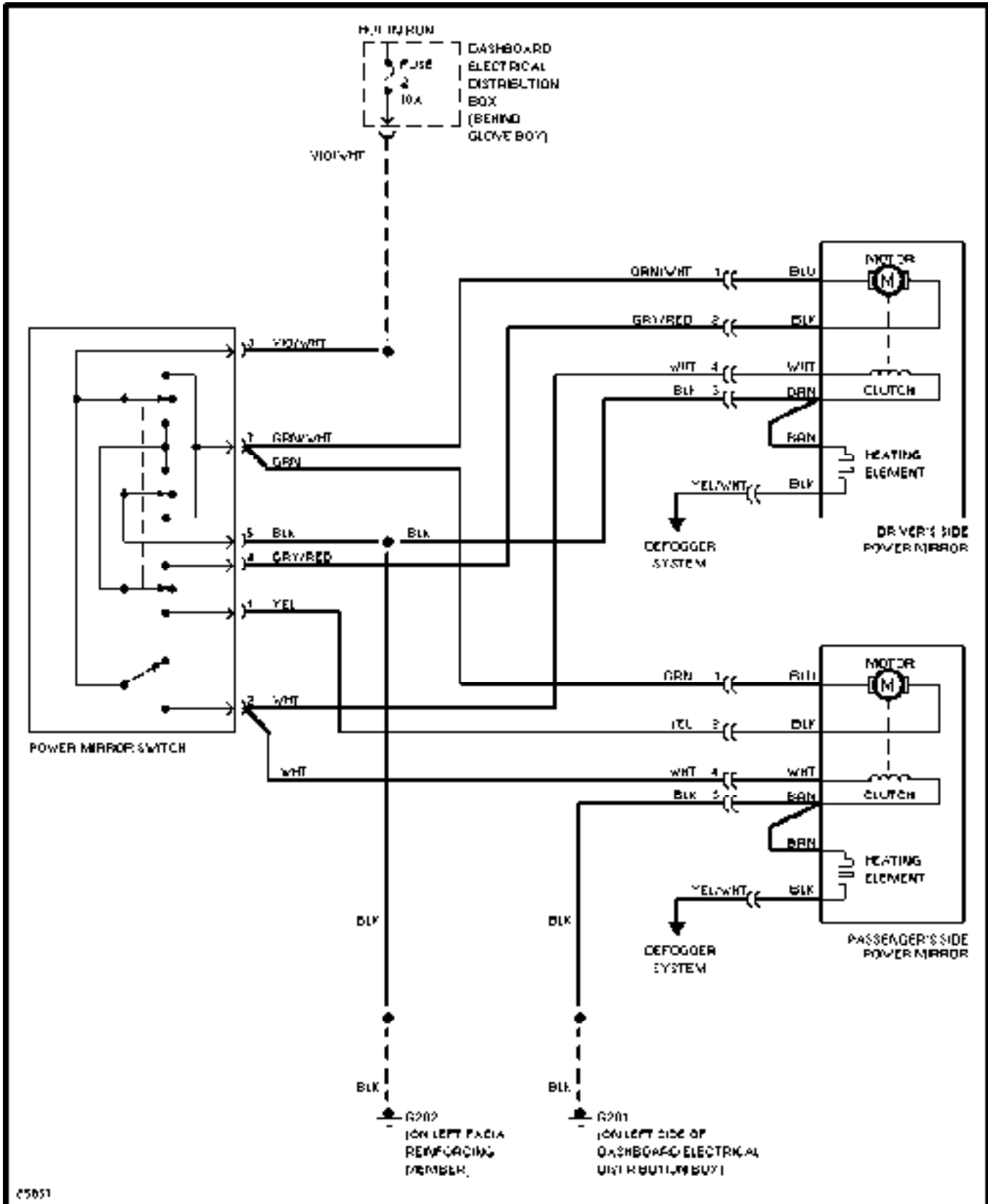

SYSTEM WIRING DIAGRAMS

Power Seats Circuit

1997 Saab 9000

For DIAKOM-AUTO <http://www.diakom.ru> Taganrog support@diakom.ru (8634)315187

Copyright © 1998 Mitchell Repair Information Company, LLC

Friday, December 15, 2000 02:23PM

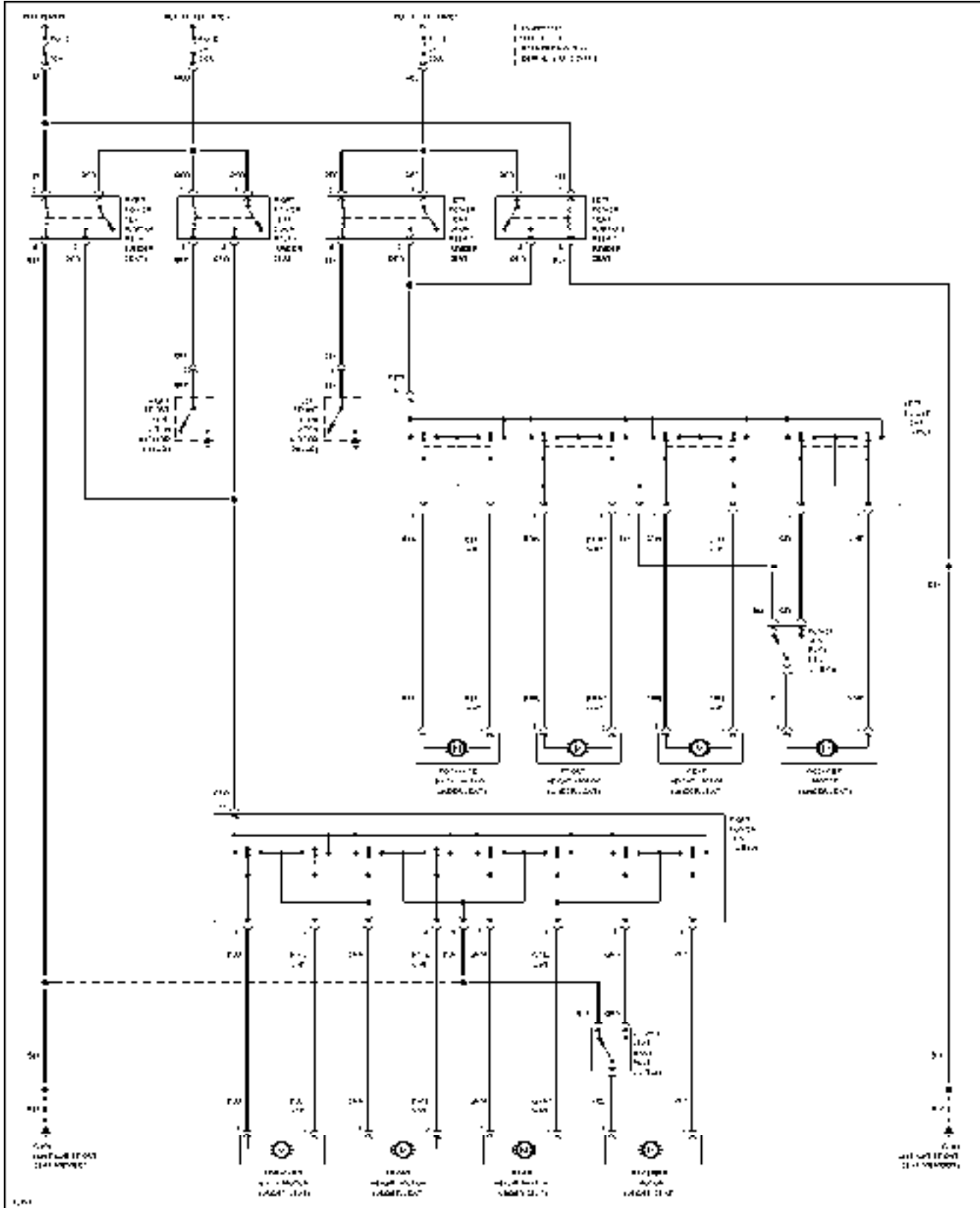

SYSTEM WIRING DIAGRAMS

Shift Interlock Circuit

1997 Saab 9000

For DIAKOM-AUTO <http://www.diakom.ru> Taganrog support@diakom.ru (8634)315187

Copyright © 1998 Mitchell Repair Information Company, LLC

Friday, December 15, 2000 02:24PM

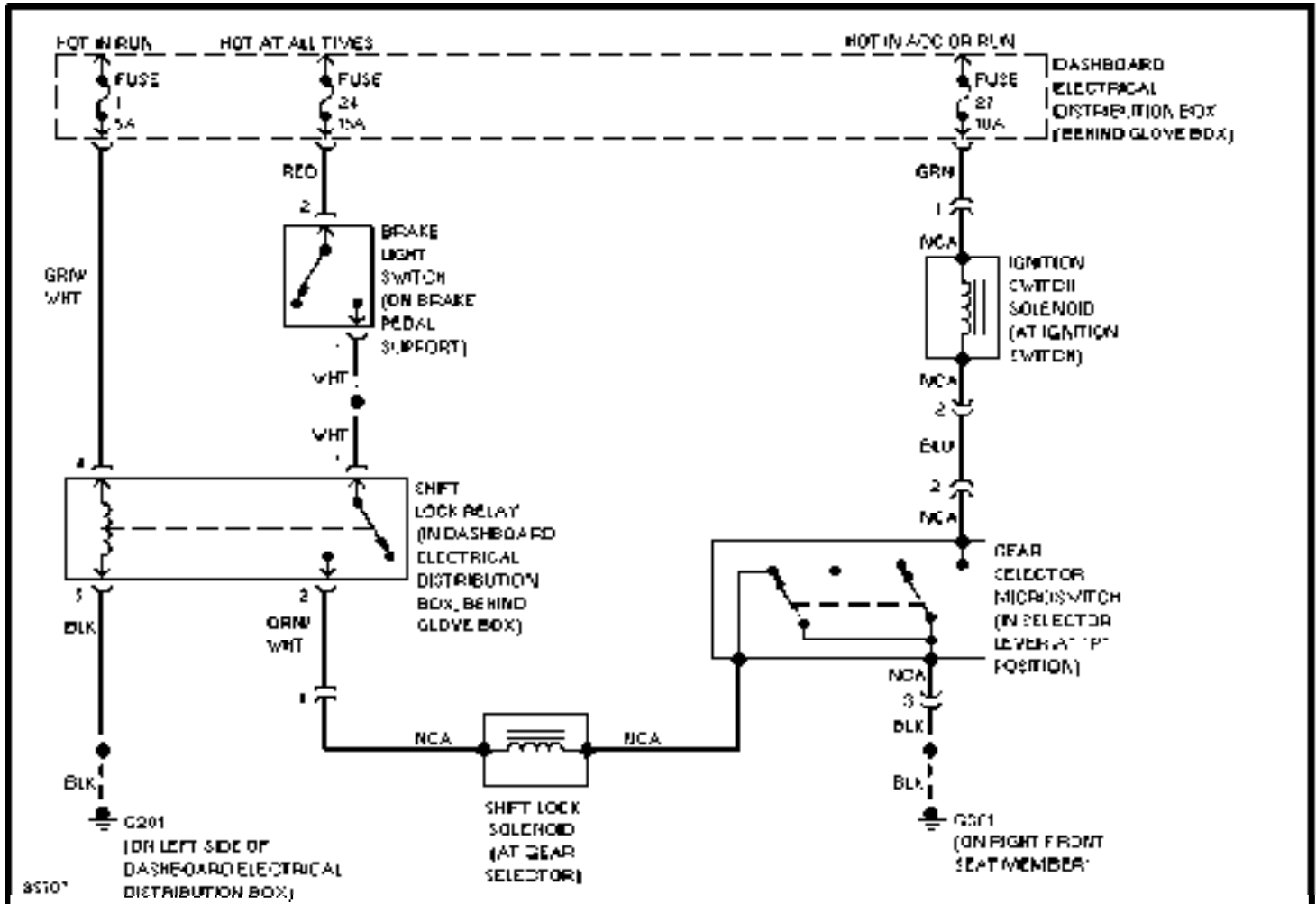

SYSTEM WIRING DIAGRAMS

Starting Circuit

1997 Saab 9000

For DIAKOM-AUTO <http://www.diakom.ru> Taganrog support@diakom.ru (8634)315187

Copyright © 1998 Mitchell Repair Information Company, LLC

Friday, December 15, 2000 02:24PM

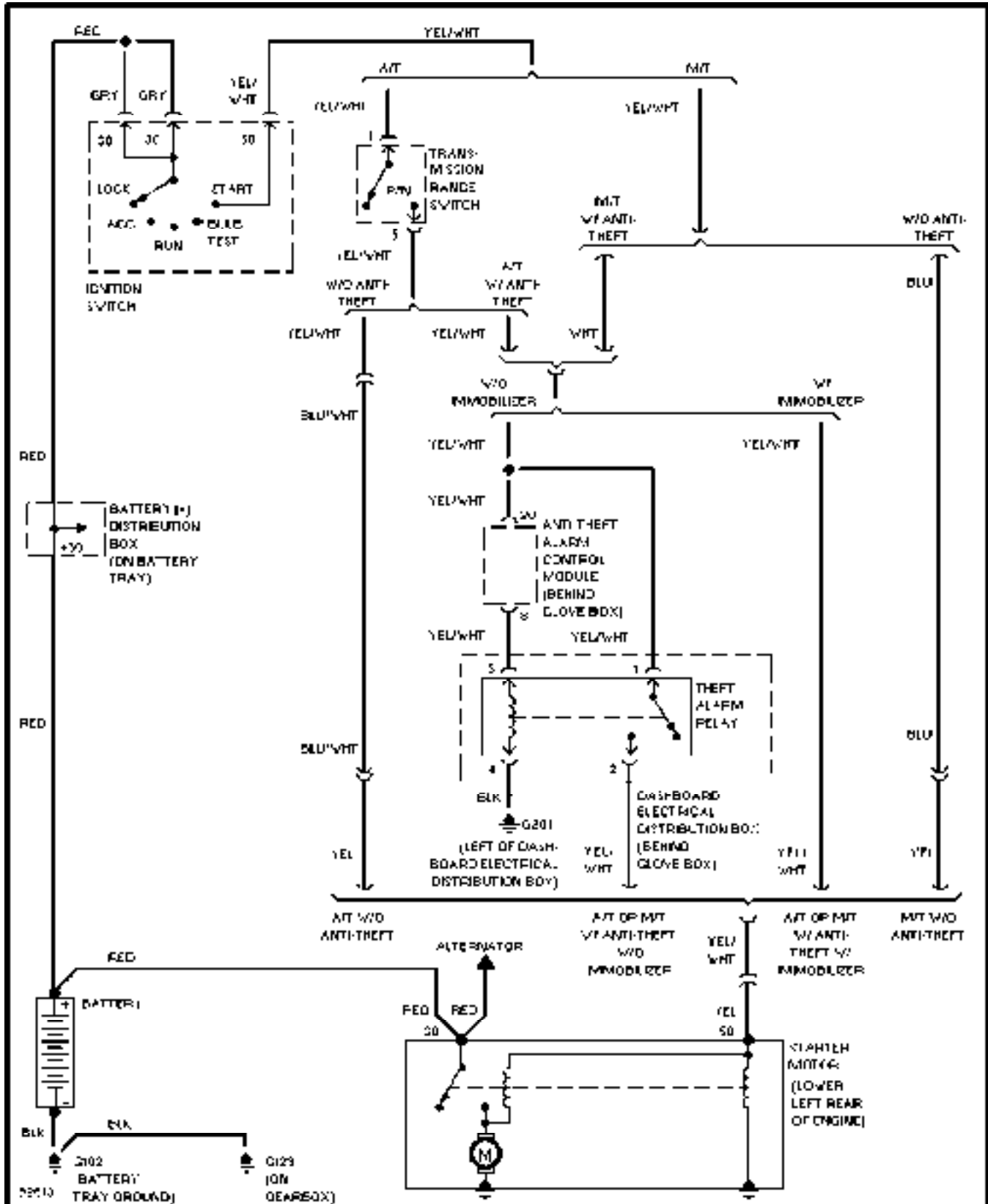

SYSTEM WIRING DIAGRAMS

Sunroof Circuit

1997 Saab 9000

For DIAKOM-AUTO <http://www.diakom.ru> Taganrog support@diakom.ru (8634)315187

Copyright © 1998 Mitchell Repair Information Company, LLC

Friday, December 15, 2000 02:23PM

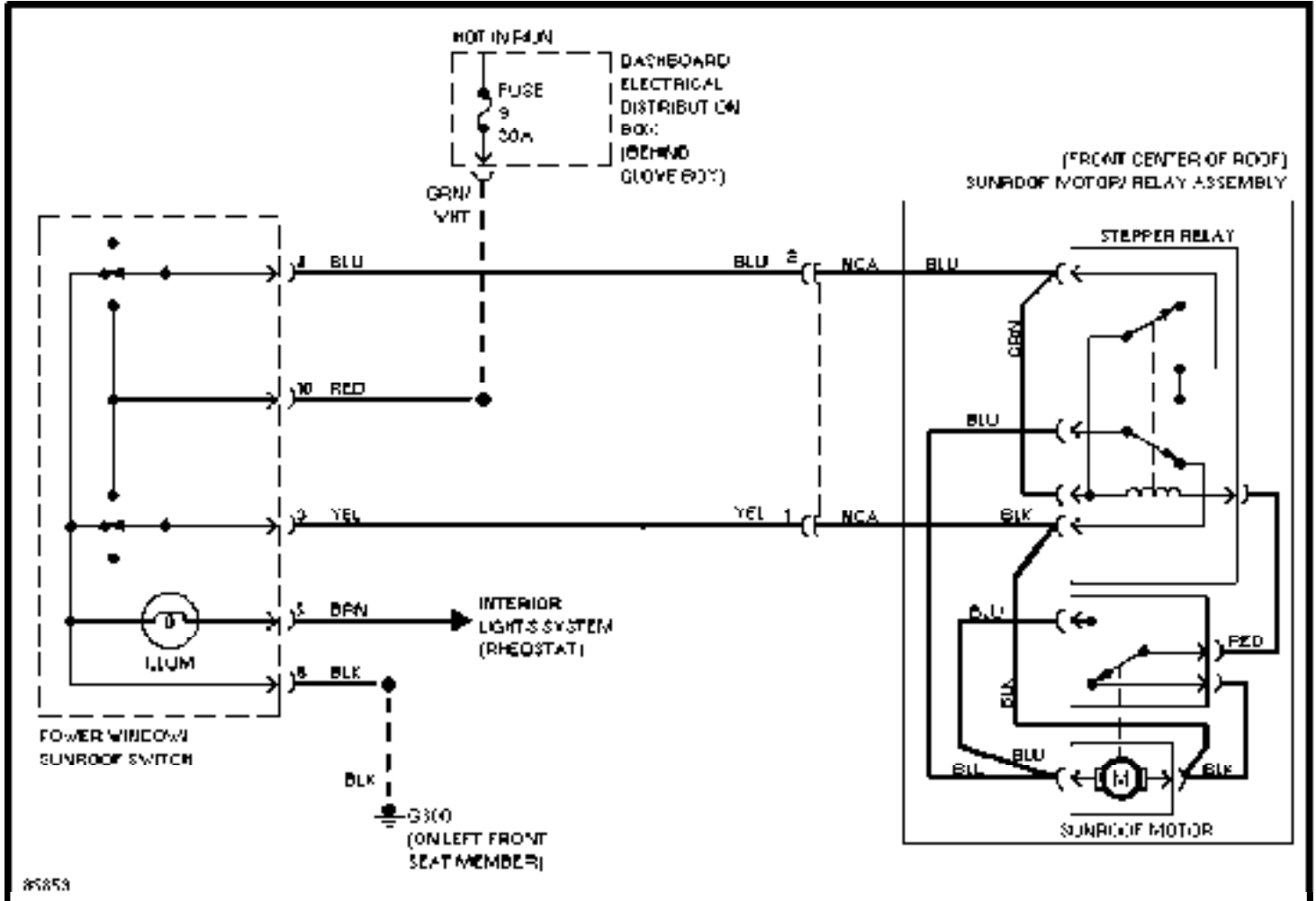

SYSTEM WIRING DIAGRAMS

Supplemental Restraint Circuit

1997 Saab 9000

For DIAKOM-AUTO <http://www.diakom.ru> Taganrog support@diakom.ru (8634)315187

Copyright © 1998 Mitchell Repair Information Company, LLC

Friday, December 15, 2000 02:24PM

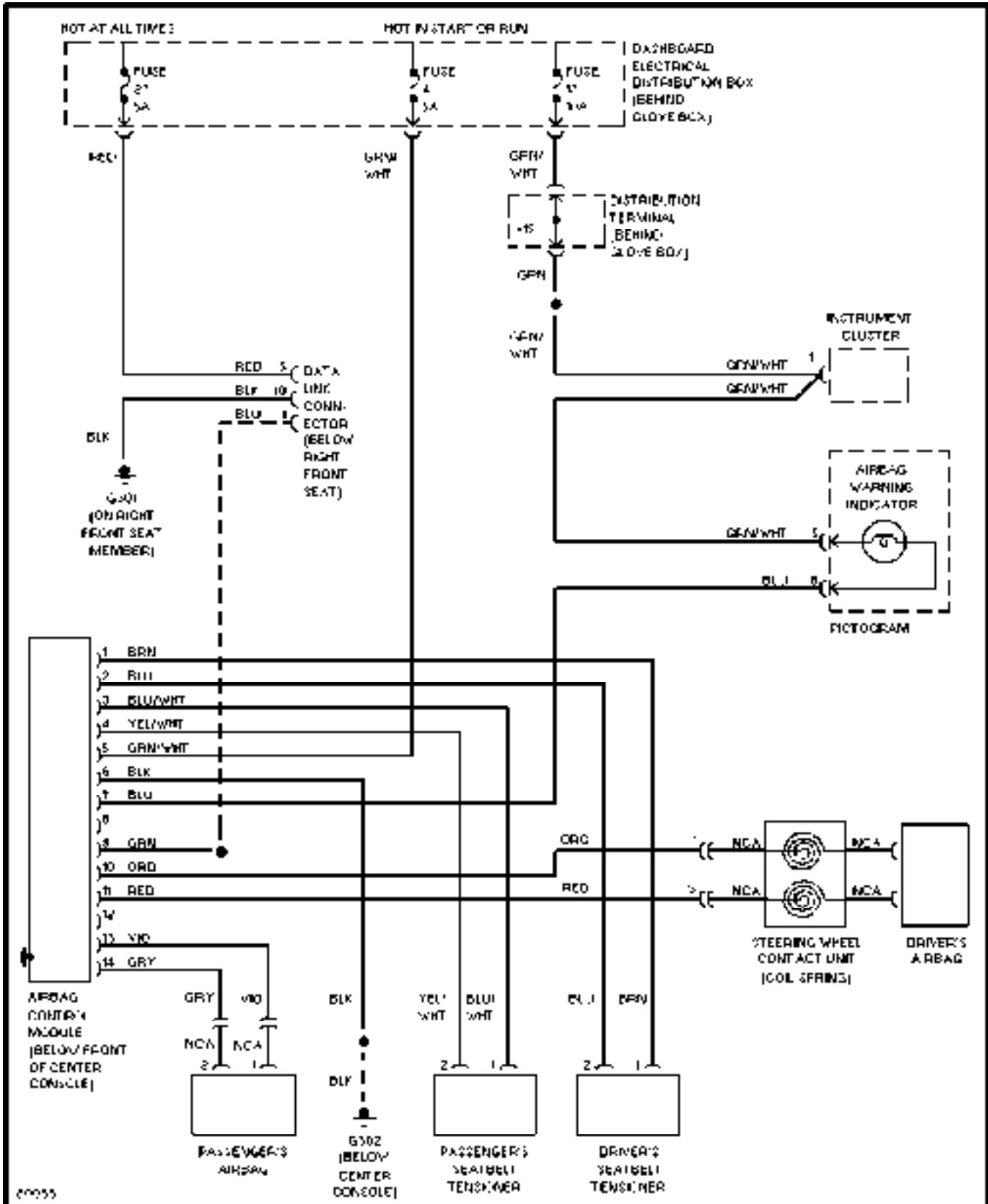

SYSTEM WIRING DIAGRAMS

Warning System Circuits

1997 Saab 9000

For DIAKOM-AUTO <http://www.diakom.ru> Taganrog support@diakom.ru (8634)315187

Copyright © 1998 Mitchell Repair Information Company, LLC

Friday, December 15, 2000 02:24PM

