Owner's Manual

Saab 9-5, Model Year 2002

| | |
|------------------------------------|-----|
| Safety | 11 |
| Security | 37 |
| Instruments and controls | 49 |
| Saab 9-5 Audio System | 83 |
| OnStar - Telematics | 105 |
| Interior equipment and trunk | 117 |
| Starting and driving | 145 |
| Car care and technical information | 187 |
| Maintenance and owner assistance | 243 |
| Specifications | 247 |
| Index | 261 |



Introduction

This manual provides practical guidance on driving and caring for your Saab.

The Saab 9-5 is available with the following engine variants:

- 2.3t Ecopower.
- 2.3 Turbo Ecopower.
- 3.0t V6 Ecopower.

Although this manual describes the most important differences between model variants, it does not include precise specifications of the different variants. Some differences also occur to meet special legal requirements in different countries.

Importation and distribution of Saab automobiles, spare parts and accessories are handled exclusively by General Motors of Canada Limited in Canada and by Saab Cars USA, Inc. in the U.S.A.

We recommend that you read through the manual before taking the car out for the first time and that you keep it in the car for future reference.

To find a specific item, use the overviews given on pages 3-7. A list of contents is given at the beginning of each section of the manual, and there is also a comprehensive index at the back of the book.

Supplied with the car is a Warranties and Service Record booklet and a tire warranty folder which specifies the regular maintenance to be carried out. The book also contains important warranty conditions.

WARNING

WARNING texts warn against the danger of injury if the specified instructions are not followed.

NOTE

NOTE texts warn of potential damage to the car if the recommendations are not followed.

Since the policy at Saab is one of continual improvement, we retain the right to incorporate modifications and to alter specifications during production without prior notice.

If you have any queries concerning your car, its equipment, the warranty conditions or the like, your Saab dealer will be pleased to help.

Best wishes,
Saab Automobile AB

Saab Automobile AB does not accept liability for any damage caused by the fitting of spare parts, exchange parts or accessories that are not approved by Saab Automobile AB.

The specifications, design particulars and illustrations included in the manual are not binding.

Instrument panel

| | |
|-------------------------------|-----|
| Parking lights _____ | 65 |
| High/low beam _____ | 65 |
| Daytime running lights _____ | 65 |
| Rear fog light _____ | 66 |
| Instrument illumination _____ | 67 |
| Changing bulbs _____ | 204 |

| | |
|---|-----|
| High/low beam control stalk _____ | 65 |
| Turn signal and lane change indicator _____ | 67 |
| Cruise control _____ | 164 |

| | |
|------------------------|----|
| Front fog lights _____ | 68 |
|------------------------|----|

| | |
|--|-----|
| Audio system steering-wheel controls _____ | 100 |
|--|-----|

| | |
|------------------------------|-----|
| Seat heating controls _____ | 121 |
| Ventilated front seats _____ | 121 |

| | |
|------------------------------------|----|
| Indicator and warning lights _____ | 50 |
| Speedometer _____ | 57 |
| Odometer and trip meter _____ | 56 |
| Fuel gauge _____ | 57 |
| Engine temperature gauge _____ | 57 |

| | |
|---|---------|
| Trip computer (Saab Information Display, SID) _____ | 59 |
| Night panel _____ | 63 |
| Clock _____ | 64 |
| Traction Control (TCS) Switch _____ | 55, 167 |
| OnStar switch _____ | 106 |

| | |
|-----------------------------|----|
| Hazard warning lights _____ | 68 |
|-----------------------------|----|

| | |
|------------------------------|-----|
| Wipers and washers _____ | 70 |
| Rear wiper _____ | 71 |
| Washer fluid _____ | 202 |
| Replacing wiper blades _____ | 202 |

| | |
|-------------------------------|-----|
| Audio system _____ | 83 |
| Steering-wheel controls _____ | 100 |

| | |
|--|-----|
| Climate control system: automatic _____ | 72 |
| Air conditioning: simple fault diagnosis _____ | 231 |

| | |
|--------------------------------|-----|
| Ashtrays (accessory) _____ | 128 |
| Cigarette lighter socket _____ | 129 |

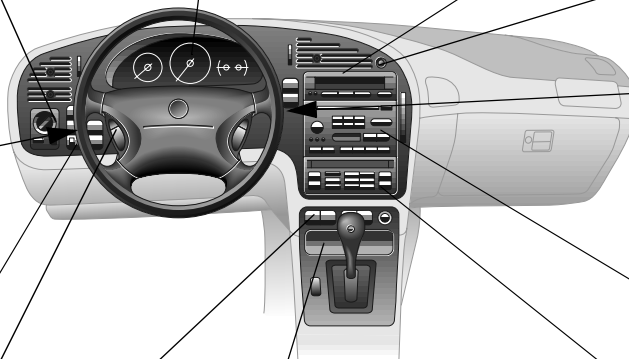

IB1080

Exterior

| | |
|--------------------------------|-----|
| Sunroof _____ | 126 |
| Washing the car _____ | 233 |
| Waxing and polishing _____ | 233 |
| Touching-up of paintwork _____ | 235 |
| Anticorrosion treatment _____ | 235 |

| | |
|----------------------|-----|
| Light switches _____ | 65 |
| Changing bulbs _____ | 204 |
| • Taillights _____ | 209 |
| • Stop lights _____ | 209 |

| | |
|------------------------------|-----|
| Driving with a trailer _____ | 173 |
| Towing _____ | 180 |
| Towrope attachment eye _____ | 180 |

| | |
|--|----------|
| Luggage compartment _____ | 132 |
| Folding down the rear seat, 9-5 Sedan _____ | 132 |
| Folding down the rear seat, 9-5 Wagon _____ | 135 |
| Trunk _____ | 132 |
| Tool kit _____ | 142 |
| Spare wheel _____ | 142, 179 |
| Jack _____ | 227 |

| | |
|------------------------------------|-----|
| Roof-rack load _____ | 176 |
| Mounting holes for roof rack _____ | 176 |
| Maximum loads _____ | 248 |
| Rearview mirrors _____ | 123 |

| | |
|-----------------------------------|-----|
| Hood _____ | 188 |
| Engine compartment: washing _____ | 233 |

| | |
|---|-----|
| Front lights _____ | 65 |
| Headlight switch _____ | 65 |
| High/low beam control stalk _____ | 65 |
| Turn signal & lane change indicators _____ | 67 |
| Headlight washers _____ | 70 |
| Changing bulbs _____ | 204 |

| | |
|------------------------------------|----|
| Central lock _____ | 38 |
| Interior locking buttons _____ | 40 |
| Child safety lock catch _____ | 41 |
| Trunk/tailgate lid lock _____ | 41 |
| Car alarm (anti-theft alarm) _____ | 43 |

| | |
|---------------------------|-----|
| Fuel gauge _____ | 57 |
| Fuel filler flap _____ | 152 |
| Refueling _____ | 152 |
| Fuel economy _____ | 170 |
| Fuel grade _____ | 250 |
| Economical motoring _____ | 170 |

| | |
|-------------------------------------|------------|
| Tire pressure _____ | back cover |
| Wheel and tire specifications _____ | 256 |
| Brakes and braking _____ | 165 |
| Winter driving _____ | 171 |
| Wheels and tires _____ | 222 |
| Wheel changing _____ | 227 |
| Spare wheel _____ | 179 |

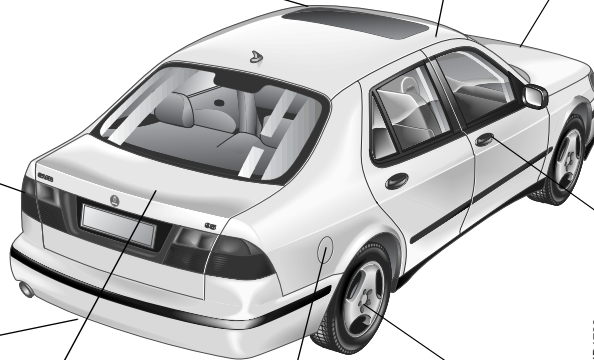

1B1736

Interior

| | |
|---|-----|
| Steering-wheel adjustment | 122 |
| Airbag (SRS) | 28 |
| Power steering | 198 |
| Audio system steering-wheel controls | 100 |

| | |
|--|-----|
| Seat adjustment | 118 |
| Seat heating | 121 |
| Ventilated front seats | 121 |
| Safety belts | 12 |
| Child seats | 19 |
| Folding down the rear seat, 9-5 Sedan | 132 |
| Folding down the rear seat, 9-5 Wagon | 135 |
| Upholstery: cleaning | 232 |
| Side airbags (SRS) | 32 |

| | |
|-----------------------------------|-----|
| Interior lighting | 69 |
| Sunroof | 126 |
| Interior lighting: changing bulbs | 213 |

| | |
|--------------------------|-----|
| Internal rearview mirror | 123 |
| Door mirrors | 123 |
| Sun visors | 128 |

| | |
|-------------------------|-----|
| Safety belts | 12 |
| Airbag (SRS) | 28 |
| Child seats | 19 |
| Child safety lock catch | 41 |
| Safety belt care | 232 |

| | |
|-------------------|-----|
| Glove compartment | 129 |
|-------------------|-----|

| | |
|------------------------|-----|
| Manual transmission | 156 |
| Automatic transmission | 157 |

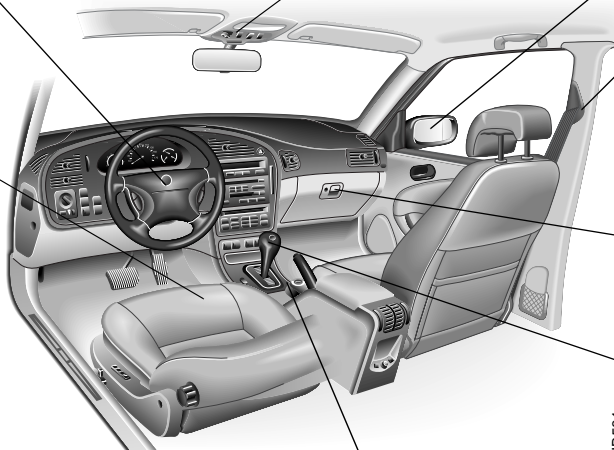

1B581

| | |
|------------------------|-----|
| Electric windows | 125 |
| Ignition switch | 146 |
| Starting the engine | 147 |
| Break-In period | 155 |
| Driving in hot weather | 173 |
| Driving in winter | 171 |
| Parking | 185 |

Engine compartment, 4-cyl engine

| | |
|----------------------|-----|
| Warning labels _____ | 8 |
| V.I.N. number _____ | 257 |
| Engine number _____ | 257 |
| Gearbox number _____ | 257 |
| Color code _____ | 257 |

| | |
|-----------------------------|-----|
| Power steering _____ | 198 |
| Steering fluid: grade _____ | 198 |

| | |
|---------------------------|-----|
| Ignition system _____ | 146 |
| Drive belts _____ | 201 |
| Spark plugs _____ | 253 |
| Catalytic converter _____ | 150 |

| | |
|---|-----|
| Important considerations for driving _____ | 149 |
| Turbo unit _____ | 189 |
| Engine: technical data _____ | 250 |

| | |
|----------------------------------|-----|
| Engine: description _____ | 192 |
| Engine oil level: checking _____ | 193 |
| Engine oil: changing _____ | 194 |
| Engine oil specification _____ | 251 |

| | |
|--------------------------|-----|
| Brakes and braking _____ | 165 |
| ABS brakes _____ | 165 |
| Brake system _____ | 197 |
| Brake fluid _____ | 255 |
| Brake pads _____ | 255 |

| | |
|-----------------------|-----|
| Fuse panels _____ | 216 |
| Changing a fuse _____ | 216 |
| Table of fuses _____ | 218 |
| Relays _____ | 219 |

| | |
|-------------------------------|-----|
| Temperature gauge _____ | 57 |
| Driving in hot weather _____ | 173 |
| Driving in winter _____ | 171 |
| Coolant _____ | 196 |
| Cooling-system capacity _____ | 250 |

| | |
|----------------------------------|-----|
| Wiper/washer control stalk _____ | 70 |
| Washer fluid: topping up _____ | 203 |
| Washer jets _____ | 203 |

| | |
|------------------------------------|-----|
| Manual transmission _____ | 156 |
| Automatic transmission _____ | 157 |
| Manual transmission oil _____ | 254 |
| Automatic transmission fluid _____ | 254 |

| | |
|----------------------|-----|
| Jump starting _____ | 182 |
| Battery _____ | 199 |
| Battery charge _____ | 199 |

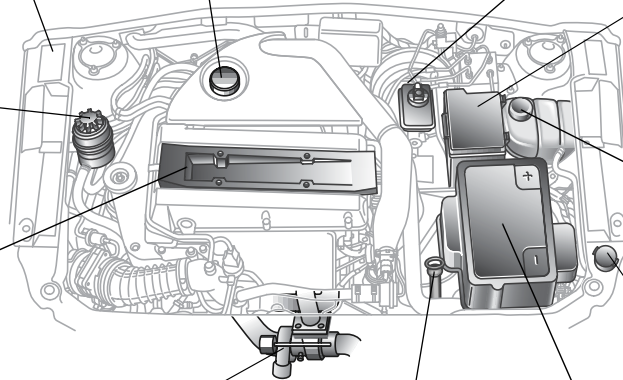

Engine compartment, 3.0t V6

| | |
|----------------------|-----|
| Warning labels _____ | 8 |
| V.I.N. number _____ | 257 |
| Engine number _____ | 257 |
| Gearbox number _____ | 257 |
| Color code _____ | 257 |

| | |
|-----------------------------|-----|
| Power steering _____ | 198 |
| Steering fluid: grade _____ | 198 |

| | |
|---------------------------|-----|
| Ignition system _____ | 146 |
| Drive belts _____ | 201 |
| Spark plugs _____ | 253 |
| Catalytic converter _____ | 150 |

| | |
|---|-----|
| Important considerations for driving _____ | 149 |
| Turbo unit _____ | 189 |
| Engine: technical data _____ | 250 |

| | |
|----------------------------------|-----|
| Engine: description _____ | 192 |
| Engine oil level: checking _____ | 193 |
| Engine oil: changing _____ | 194 |
| Engine oil specification _____ | 251 |

| | |
|--------------------------|-----|
| Brakes and braking _____ | 165 |
| ABS brakes _____ | 165 |
| Brake system _____ | 197 |
| Brake fluid _____ | 255 |
| Brake pads _____ | 255 |

| | |
|-----------------------|-----|
| Fuse panels _____ | 216 |
| Changing a fuse _____ | 216 |
| Table of fuses _____ | 218 |
| Relays _____ | 219 |

| | |
|-------------------------------|-----|
| Engine temperature gauge _ | 57 |
| Driving in hot weather _____ | 173 |
| Driving in cold climate _____ | 171 |
| Coolant _____ | 196 |
| Cooling-system capacity _ | 250 |

| | |
|------------------------------|-----|
| Wiper/washer control stalk _ | 70 |
| Washer fluid: topping up _ | 203 |
| Washer jets _____ | 203 |

| | |
|------------------------------------|-----|
| Automatic transmission _____ | 157 |
| Automatic transmission fluid _____ | 254 |

| | |
|----------------------|-----|
| Jump starting _____ | 182 |
| Battery _____ | 199 |
| Battery charge _____ | 199 |

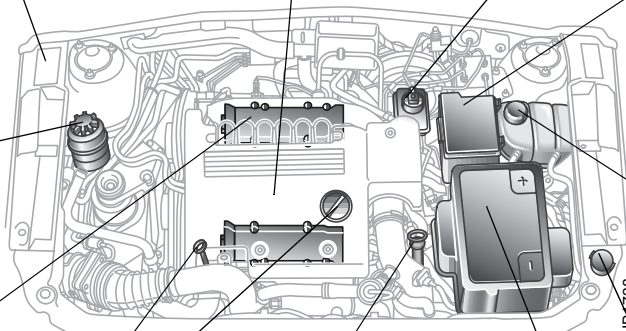

Warning labels



Drive belt

Moving belt. Do not touch while engine running.



Radiator fan

The radiator fan can cut in even after engine has been switched off.

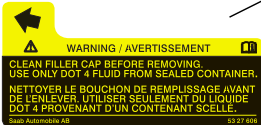

Brake fluid

CLEAN FILLER CAP BEFORE REMOVING. USE ONLY DOT 4 FLUID FROM SEALED CONTAINER. NETTOYER LE BOUCHON DE REMPLISSAGE AVANT DE LE LEVIER. UTILISER SEULEMENT DU LIQUIDE DOT 4 PROVENANT D'UN CONTENANT SCELLE.

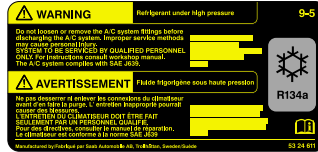

A/C system

Refrigerant at high pressure.

Always drain the A/C system before undoing any connections. Failure to follow prescribed procedures can result in injury. **System to be serviced by authorized personnel only.** See Workshop Service Manual for correct procedures.

The A/C system complies with SAE J639.

Refrigerant: 875 g of R134a.

Refrigeration oil: 145 cc of PAG ND-8 oil or Saab 4319752 SK 20 oil

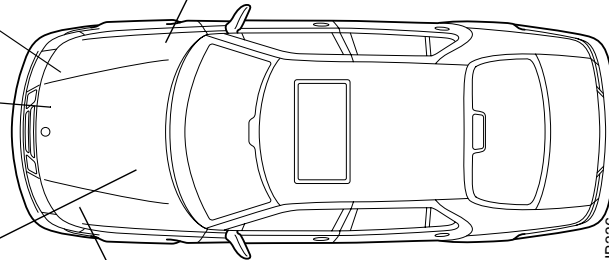

Battery

- No sparks, flames or smoking.
- Shield eyes, explosive gases can cause blindness or injury.
- Sulphuric acid can cause blindness or severe burns.
- Flush eyes immediately with water. Get medical help fast.
- Do not tip battery. Do not open battery.

KEEP OUT OF REACH OF CHILDREN



- AVOID SPARKS AND OPEN FLAMES, NO SMOKING
- WEAR EYE PROTECTION
- KEEP OUT OF REACH OF CHILDREN
- ACID
- SEE OWNER'S MANUAL
- FLAMMABLE GAS



Contact an authorized Saab workshop if a Xenon headlight requires replacement. (Only cars with Xenon headlights.)

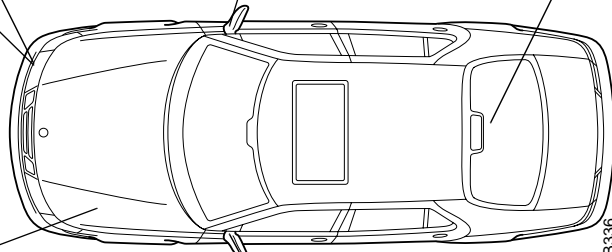

Coolant:
Never open when engine hot!



Door mirrors
Do not trap your fingers when folding out the mirrors



Door mirrors
Do not trap your fingers when folding out the mirrors



Long loads

Always **SECURE LOAD** to prevent it from shifting during transport.

An unsecured load could cause passenger injuries in braking situations or in the event of a crash.

Cover sharp edges with a protective wrap.

IB336



CANADA



USA

AIR BAG WARNING
Flip visor over



CANADA

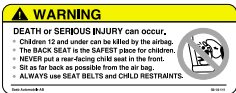

USA

WARNING

DEATH or SERIOUS INJURY can occur.

- Children 12 and under can be killed by the air bag.
- The BACK SEAT is the SAFEST place for children.
- NEVER put a rear-facing child seat in the front.
- Sit as far back as possible from the air bag.
- ALWAYS use SEAT BELTS and CHILD RESTRAINTS.

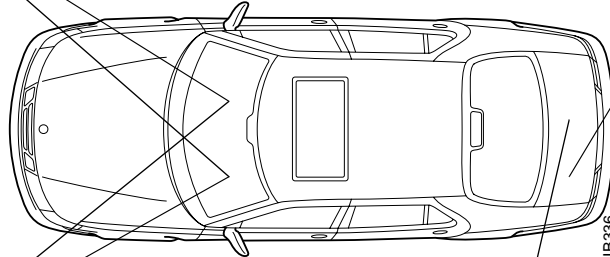

Jack (Text printed on jack)

Use on Saab 9-5 & 9-3. Use on level ground only. Use vehicle support stands. Safe working load 2000 lbs. (1,000 kg). For more information see your owner's manual.

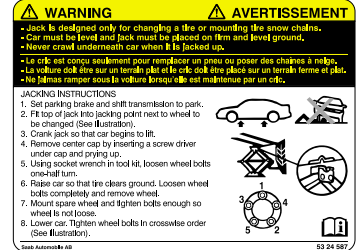

(This label only used in some countries)

Jack is designed only for changing a tire or mounting tire snow chains. Car must be level and the jack must be placed on a firm and level ground. Never crawl under the car when it is jacked up.

Jacking Instructions

- 1 Set parking brake and shift transmission to park.
- 2 Fit top of jack into jacking point next to wheel to be changed (See illustration).
- 3 Crank jack so that car begins to lift.
- 4 Remove center cap by inserting a screw driver under cap and prying up.
- 5 Using socket wrench in tool kit, loosen wheel bolts using one-half turn.
- 6 Raise car so that tire clears ground. Loosen wheel bolts completely and remove wheel.
- 7 Mount spare wheel and tighten bolts enough so wheel is not loose.
- 8 Lower car. Tighten wheel bolts in crosswise order. (See illustration) Observe max. speed limit for spare tire.

Safety

| | |
|---|----|
| Safety belts..... | 12 |
| Head restraint..... | 18 |
| Child safety..... | 19 |
| Airbag (Supplemental Restraint System "SRS"). | 28 |

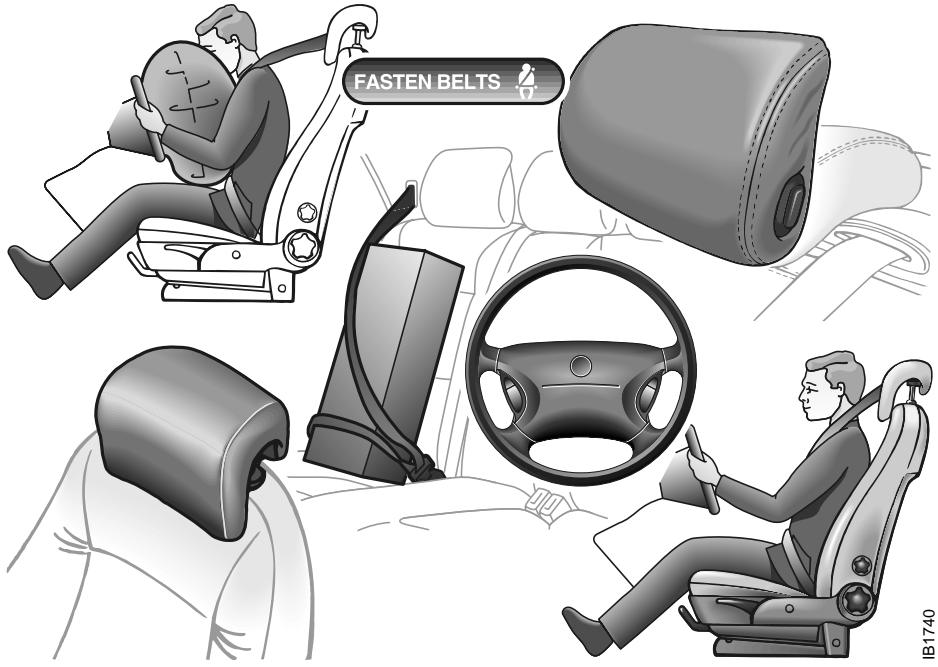

IB1740

Safety belts

WARNING

Safety belts must be worn **at all times** by all car occupants.

Child safety, see page 19.

Check that the locking tongue is properly locked in the belt lock.

Three-point inertia-reel safety belts are provided for all seats.

Research has established that it is dangerous for rear seat passengers not to wear their safety belts.

WARNING

In the event of a crash, the rear-seat passengers can be thrown forward against the front-seat backrests, imposing much higher stresses on the front-seat passengers and belts and resulting in needless injury to everyone in the car.

WARNING

Adjustments of the safety belt should be done when the car is stationary so that attention to traffic is not reduced.

Bear in mind that in certain states it is a legal requirement for all occupants of the car to wear a safety belt.

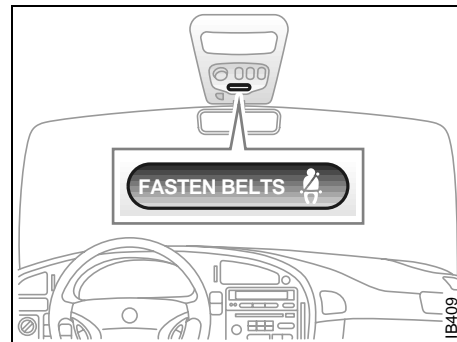

Safety-belt reminder

When the ignition is switched on, the "fasten belts" reminder will light up until the driver fastens the safety belt. In addition an audible signal sounds for 6 seconds, or until the driver fastens his belt.

Safety belt pretensioners

The belts of the front seats are fitted with automatic pretensioners, which are activated in the event of a severe frontal or rear-end crash, provided that the safety belts are being worn. They serve to reduce the forward movement of the body by tensioning the belt.

The safety belt pretensioners are not activated by vehicle rollover.

The belt pretensioners do not activate in less severe frontal or rear-end crashes.

WARNING

If the car is involved in a crash, the safety belts, belt pretensioners and other components must be inspected by an authorized Saab dealer and replaced as necessary.

Never make any alterations or repairs to the safety belt yourself. Visit an authorized Saab dealer for any necessary repairs.

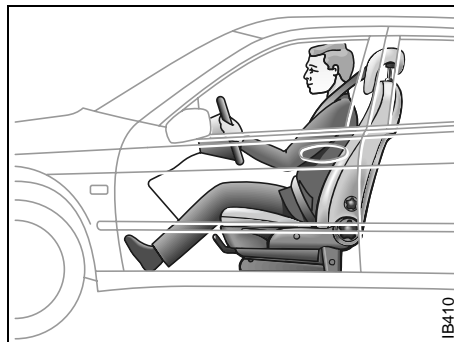

Correctly positioned safety belt

Correct position for safety belt

- The lap portion of the belt should be pulled as tightly as comfortable and as low as possible across the hips, so that it is just touching the top of the thighs. The shoulder belt should be well in on the shoulder but not touching the neck.

WARNING

Proper positioning of the safety belt is extremely important. An out of position safety belt can result in the wearer sliding underneath the belt in a crash (submarining) and injury can result from the lap portion cutting into the abdomen.

- Check to ensure that the belt is not twisted or rubbing against any sharp edges.
- There should not be any slack in the belt. Pull the belt tight – particularly important when thick outer clothing is worn.
- Refrain from tilting the backrest more than necessary, as the safety belt provides better protection when the seat is in the more upright position.
- Only one person per safety belt!

WARNING

If two people share a belt, they risk injury by being crushed together in the event of a crash.

- For most of the time a safety belt is worn, the retractor will allow the wearer freedom of movement. The retractor locks up automatically if the belt is jerked or withdrawn sharply, the car tilts, the brakes are applied hard or a crash occurs.

- Children who have grown out of a child seat should be restrained by the car's standard three-point belts. Make sure that the shoulder belt is not in contact with the neck or throat. If it is, a booster seat/cushion may be necessary.

! WARNING

Never fasten the safety belt with the shoulder belt behind the body or pull the belt off the shoulder and under the arm.

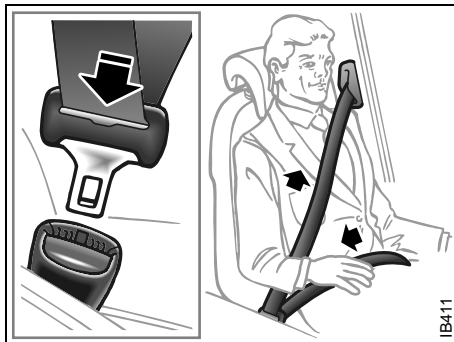

To fasten the belt



Press the red button to release the belt

Front safety belts

Fasten the belt by pulling the belt and inserting the tongue in the buckle. Check that it is securely fastened.

Grasp the shoulder belt close to the buckle and pull the belt towards the shoulder to tighten the lap belt part.

Then grip the belt at the shoulder, pull it out and, without letting go, allow the slack to be taken up by the reel. Make sure that the belt is well in on the shoulder.

Because the lower belt-anchorage points are on the seat, the belt buckle follows the movement of the seat during seat adjustment.

To release the belt, press the red button on the belt buckle, as illustrated.

See page 232 for the checking of belt function, cleaning, etc.

Belt height adjustment

The front safety belts and the outside belts in the rear (9-5 Sedan) are equipped with automatic height adjustment.

After fastening the belt, grasp it at chest height, pull it out and, without letting go, allow the slack to be taken up by the reel. Make sure that the belt is well in on the shoulder.

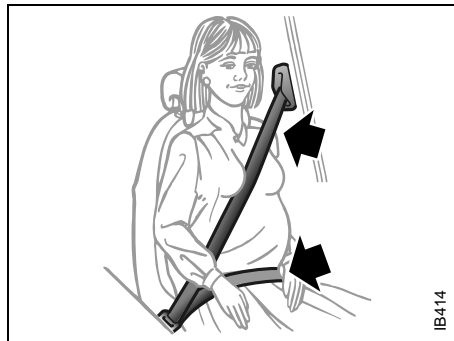

Safety belt use during pregnancy

Pregnant women must **always** wear a safety belt to protect both themselves and the unborn child.

The lap belt should be placed low, across the hips and over the upper thighs.

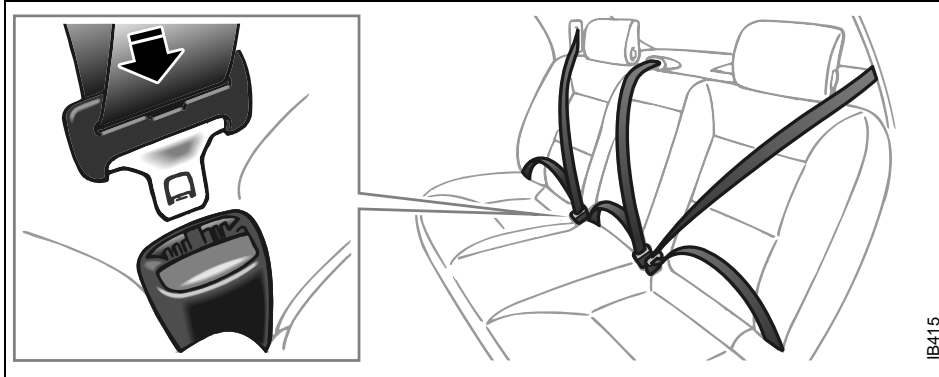

IB415

Safety belt, rear seat

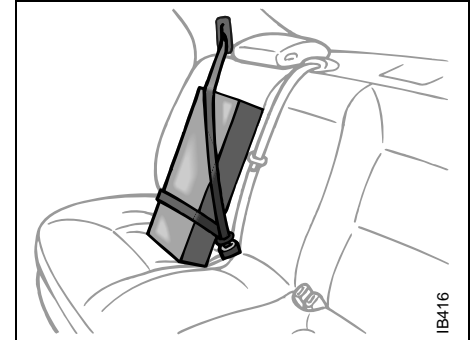

IB416

Securing an item on the rear seat

Safety belt, rear seat

Three-point safety belts are provided for all three rear seat passengers.

Fasten the belt by pulling out the strap carefully and inserting the tongue in the lock. Check that it is securely fastened.

Then grip the diagonal part of the strap near the lock and pull the belt upwards towards the shoulder to tighten the lap strap. The lap strap should lie low over the hips.

The diagonal part should lie as far in on the shoulder as possible.

To release the belt, press the red button on the belt lock.

See page 232 for the checking of belt function, cleaning, etc.

⚠ WARNING

- Make sure that the belt does not become trapped when the backrest is folded down or raised (see page 132).
- If a cargo has to be placed on a seat, it must be properly secured with the safety belt. This reduces the risk of the cargo being thrown about during hard braking or a possible crash, which could cause personal injury.
- Check that the belt is not twisted or lying against sharp edges.

 **WARNING**

Safety belts are designed to bear upon the bony structure of the body, and should be worn low across the front of the pelvis or the pelvis, chest and shoulders, as applicable; wearing the lap portion of the belt across the abdominal area must be avoided.

Safety belts should be adjusted as firmly as possible, consistent with comfort, to provide the protection for which they have been designed. A loose belt will greatly reduce the protection afforded to the wearer.

Care should be taken to avoid contamination of the webbing with polishes, oils and chemicals, and particularly battery acid. Cleaning may safely be carried out using mild soap and water. The belt should be replaced if webbing becomes frayed, contaminated or damaged.

It is essential to replace the entire assembly after it has been worn in a severe impact even if damage to the assembly is not obvious.

Belts should not be worn with straps twisted.

Each belt assembly must only be used by one occupant; it is dangerous to put a belt around a child being carried on the occupant's lap.

No modifications or additions should be made by the user which will either prevent the safety belt adjusting device from operating to remove slack, or prevent the safety belt assembly from being adjusted to remove slack.

Head restraint

WARNING

- Adjust the head restraint so that the head is well supported and the center of the head restraint is at ear height, thus reducing the likelihood of neck injury in a crash.
- The rear head restraint should not be folded down when the seat is occupied.

The front seats in the Saab 9-5 are equipped with Saab Active Head Restraints (SAHRs). These reduce the risk of whiplash injury if the car is hit from behind.

In the event of a rear-end crash, the body is forced back against the backrest. This, in turn, causes the mechanism to press the head restraint forward and upwards, thus limiting the backward movement of the head.

The SAHR is a mechanical system, actuated by body weight. The mechanism is built into the top of the backrest, where it is connected to the head restraint.

Therefore, the SAHR does not need to be replaced after a minor rear-end crash.

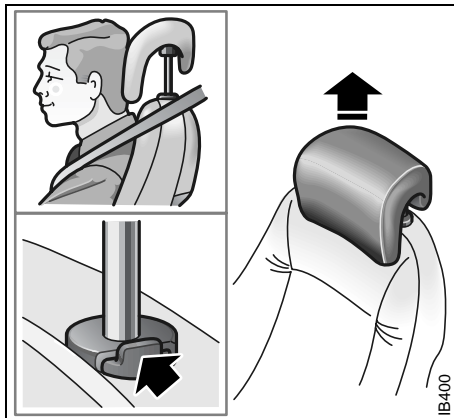

The head restraint can be raised or lowered and is adjustable in various positions.

- Raising: grasp the head restraint on both sides and pull it straight up.
- Lowering: press the catch on the left-hand side of the attaching point and press down the head restraint.

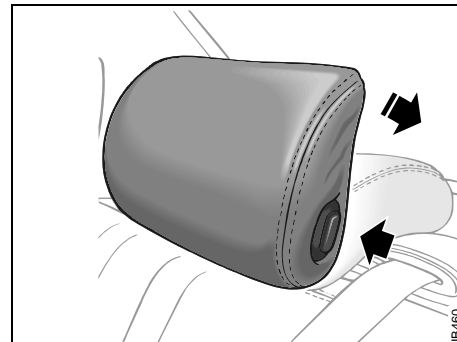

Rear-seat head restraints

9-5 Sedan: The rear head restraints have three adjustment positions for passenger comfort.

They can also be folded down to increase the driver's rearward vision when the seat is unoccupied.

9-5 Wagon: The height of the rear head restraints can be adjusted by depressing the catch on the left-hand collar in the same way as the front head restraints.

Child safety

WARNING

- NEVER put a rear-facing child seat in the front.



- Children must **always** be suitably restrained in the car. All child restraints and booster seats are designed to be secured in vehicle

seats by the lap belt of a lap-shoulder belt or LATCH. If the child restraint is not properly secured, a child can be injured in a crash.

- Children 12 and under can be killed by the airbag.
- According to crash statistics, the **BACK SEAT** is **SAFER** for properly restrained children than the front seat.
- Sit as far back as possible from the air bag.

Car safety tips

WARNING

- Never leave your children unattended in a car, even for a short time.
 - Children can suffer heat stroke - perhaps die - in a matter of minutes.
 - Children can put the car into gear and hurt themselves or others.
- At gas stations, take the keys from the car while filling the tank.
- Never allow children to climb on top of - or under motor vehicles.
- Always look for children before backing your motor vehicle out of a garage or driveway.
- To avoid carbon monoxide poisoning, never let a car idle in the garage.
- Supervise young children around buckets of water while washing your car. Small children can drown in seconds in less than an inch of water.

Protect your children from getting trapped in the trunk of a car

WARNING

- Teach your kids not to play in or around cars.
- Watch your children when loading or unloading the car so they don't get locked in by mistake.
- Always lock the doors and trunk of your car, and keep the keys out of children's sight and reach.
- Keep the rear fold-down seats closed to help prevent kids from getting into the trunk from inside the car.

For Trunk Release Handle info see page 42 and 141.

The same attention must be given to child safety in the car as is given to adults.

Saab recommends rearward facing child restraints.

Children travel most safely when properly restrained, but restraints must be suitable for the size of the child. Always follow the child seat/booster cushion manufacturer's instructions when installing these devices in your vehicle.

Make sure you are acquainted with the legal requirements for seating children in the car.

Make sure that it is possible to fit a child restraint in accordance with the manufacturer's child seat instructions.

When fitting child seats in cars you must always read the instructions supplied by the manufacturer.

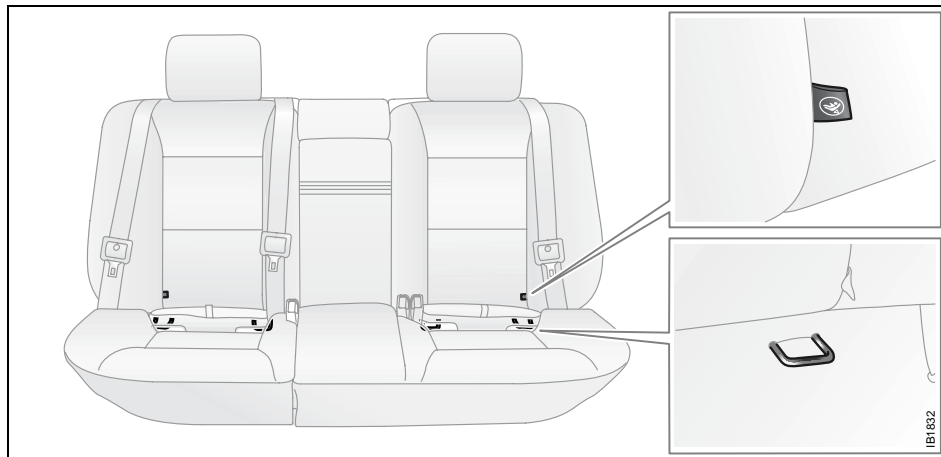

LATCH

LATCH (Lower Anchorages & Top tethers for CHildren) consists of top tether and lower anchorage ("ISOFIX") for child restraints in two outboard the rear seats.

ISOFIX are lower attachments located where the seat and back cushions come together. Top tether are upper attachments located between belt beam and parcel shelf, see page 23 and 24.

Saab recommends rearward facing child restraints for children 3 and under.

LATCH installation

To facilitate the proper fitting of new specially-designed child restraints rigid lower anchorages (ISOFIX) have been installed to the vehicle that shall be used with the top tether anchorages in the two outboard rear seating positions. There is an additional top tether anchorage for the center rear seating position that is to be used together with the safety belt.

LATCH is a U.S./Canadian government standard for an uniform method of fitting child restraints without using the standard safety belts. Only certain child restraints are equipped to utilize these rigid lower anchorages behind where the seat cushion and seat back come together. LATCH child seats also utilize a top tether strap that is found on some newer child seats that still require installation with the standard safety belts.

There are two bars attached to the car body for each specially designed LATCH child restraint. A small label is located on the seat back just above the outer attachment bars to facilitate installing the child restraint. The label contains a circle and a rearward facing child restraint.

- 1 Open the LATCH (ISOFIX)- lid (1) on one of the designated outboard rear seating position by pulling the strap located on the lid and rotate (2) the lid upwards. See illustration.
- 2 Place the child restraint on the seat cushion.
- 3 Press the child restraint rearward into the opening between the lid and the cushion, lining up the restraint attachment arms with the labels.
- 4 Follow the child restraint instructions to confirm that both restraint arms are properly attached to the bars.
- 5 Attach the top tether strap to the in-car anchorage and tighten according to the restraint instructions, see page 23 and 24.
- 6 Pull the child restraint to make a second check that restraint is securely attached at both the lower anchorage bars and the top tether strap.

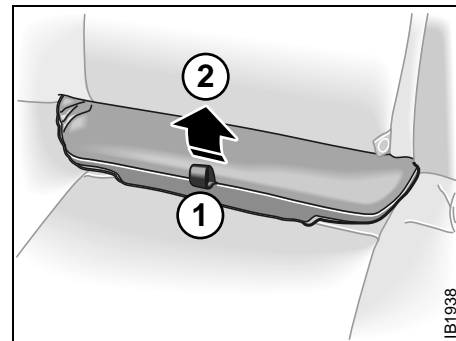

Open the LATCH-lid.



Rigid 2-point lower attachment with top tether



Semi-rigid 2-point lower attachment with top tether

For the top tether, only use the strap supplied with the child restraint.

Always follow the installation instructions supplied with the child restraint.

The availability of LATCH child restraints may be limited.

When fitting child seats in cars you must always read the instructions supplied by the car seat manufacturer.

Child tether anchorages for forward facing child car seats



WARNING

Child tether anchorages are designed to withstand only those loads imposed by correctly fitted child restraints.

Under no circumstances are they to be used for adult safety belts.

Child restraints with a tether strap must be anchored according to Canadian and USA laws.

If you have any questions regarding child tether anchorages please contact your Saab dealer.

9-5 Sedan:

- 1 Open the cover that is right behind the child restraint. Make sure it locks.
- 2 Place the child restraint in the rear seat.
- 3 Secure the lower part of the child restraint by means of the lower anchorages (ISOFIX) or the safety belts as described in the child restraint mounting instruction.
- 4 Route the tether under the headrest.
- 5 Attach the tether to the anchorage.
- 6 Tighten the tether so that the back of the child restraint is pressed hard against the backrest.
- 7 Pull the child restraints to make a second check that the restraints are securely attached at both the lower anchorages bars and the top tether strap.

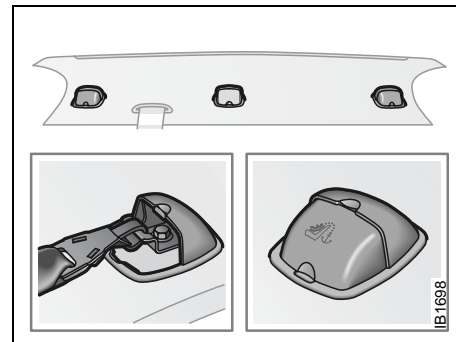

Child tether anchorages in parcel shelf, Saab 9-5 Sedan

9-5 Wagon:

- 1 Fold the backrest of the rear seat forward, see page 132.
- 2 Fold the anchor that is right behind the child restraint to its upright position.
- 3 Place the child restraint in the rear seat.
- 4 Raise the head restraint to its upper position and then route the tether under the head restraint.
- 5 Attach the tether to the anchor.
- 6 Raise the backrest of the rear seat. Make sure it locks properly.
- 7 Secure the lower part of the child restraint by means of the safety belt or lower anchorages (ISOFIX) as described in the child restraint mounting instruction on the previous page.

- 8 Tighten the tether so that the back of the child restraint is pressed hard against the backrest.
- 9 Pull the child restraints to make a second check that the restraints are securely attached at both the lower anchorages bars and the top tether strap.

| |
|---|
|  WARNING |
| <p>Make sure the child-restraint anchorages are folded all the way up or down otherwise it can obstruct locking the rear seat backrest.</p> |

It is not possible to route the tether through the cargo net (accessory), if one is fitted. Instead we recommend a cargo guard (accessory).

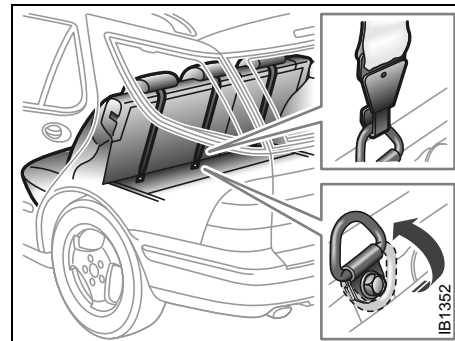

Child tether anchorages, Saab 9-5 Wagon

Lockable belt tongue

In fitting a child seat that is intended to be secured in position by the lap portion of the safety belt, make use of the locking function of the buckle.

Locking the lap portion of the belt lessens the risk that the seat will work loose while the car is in motion.

The button for the locking function is located on the back of the buckle.

- 1 Position the child seat in the back of the car.
- 2 To activate the locking function, move the locking button on the tongue of the belt to the position marked "CHILD SEAT" (item 1 in the figure) in order to activate the locking function.
- 3 Secure the base of the child seat with the lap portion of the safety belt in accordance with the installation instructions accompanying the child seat.
- 4 Grasp the shoulder part of the safety belt and pull it upwards to tighten the lap portion against the child seat.
- 5 Check for correct locking function by pulling on the lap portion of the belt. The belt must not unreel.

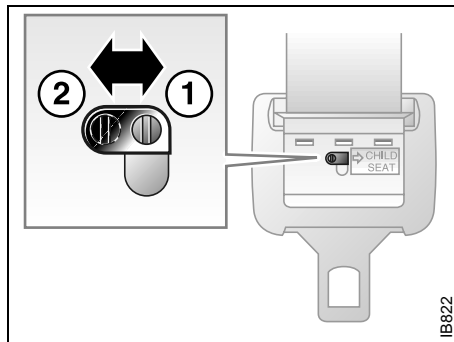

Locking the lap belt

- 1 Locked
- 2 Unlocked

Installation of child restraint using the standard safety belt

Child restraint that are approved for rearward facing installation in the rear seat can be positioned in any of the three rear places. If you intend to install another make of child restraint make sure that it is possible to fit it in accordance with the manufacturer's instructions.

! WARNING

Failure to follow all the manufacturer's instructions on the use of this child restraint system can cause your child to strike the vehicle's interior during a sudden stop or crash.

Saab recommends rearward facing child restraints up to 3 years.

! WARNING

A special accessory is available for locking the center armrest so that a child seat can be installed in the middle seat. See your Saab dealer for details.

When a rear-facing child seat is fitted in the center position of the rear seat in the Saab 9-5 Sedan the center armrest **must** be secured in place with this strap. If this is not done, the center armrest could swing down in the event of a frontal crash and cause injury to the child.

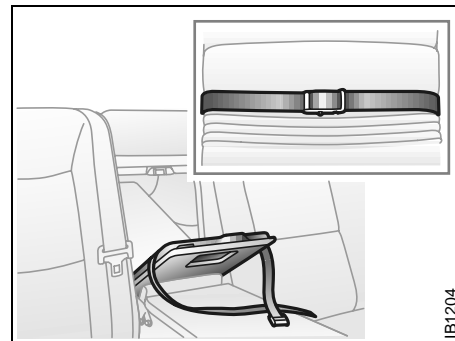

IB1204

Fitting the locking strap on the center armrest, Saab 9-5 Sedan (not needed on Wagon). The locking strap is standard equipment in certain markets.

Integrated booster seat (accessory)

The integrated booster seat in the back is intended for children weighing 33-80 lbs. (15-36 kg) and between 38 and 54 inches (97 and 137 cm) tall.

When seated in the integrated booster seat, the child must wear the standard three-point safety belt.

Whatever the age or weight of the child, it is vital that the safety belt be worn correctly. The seat should always be kept clean and intact to ensure that it continues to function as intended.

Folding down

- 1 Pull the opening strap on the side of the booster seat outwards to release the catch securing the seat.
- 2 Fold down the booster seat cushion by grasping the upper edge and pulling outwards.

Fastening the safety belt



WARNING

Never wear a safety belt with the diagonal strap positioned behind your back or slipped off the shoulder and under your arm.

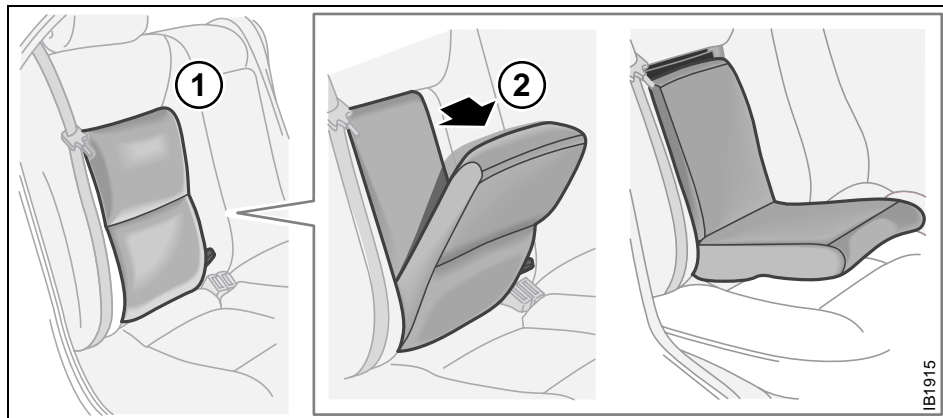

- Seat the child well back in the seat, snug against the backrest.
- Pull out the safety belt smoothly and insert the tongue in the lock. Check that it is securely fastened.
- Ensure that the lap strap is positioned low across the hips and that the diagonal strap is well in on the shoulder, although not touching the neck or in a position that creates discomfort.
- For optimum protection, the safety belt should be snug against the body. Pull the diagonal strap towards the shoulder to take up any slack.
- After fastening the belt, grasp the strap at the shoulder, pull it out and, without letting go, allow the slack to be taken up by the reel. Make sure that the strap is well in on the shoulder.
- Check that the belt runs freely between the reel and the lock.

To fold the seat away

Fold back the seat and ensure that it is locked in position.

WARNING

- Use only the vehicle's lap and shoulder belt system when restraining the child in the booster seat.
- The seat must not be modified or changed in any way.
- Never leave a child unattended.
- The car's regular head restraint must always be turned 180° back to its original position after the integrated booster seat is folded away.
- Check to ensure that the belt is not twisted or rubbing against any sharp edges.

INTEGRATED BOOSTER SEAT

This child restraint is designed for use only by children who weigh between 15 and 36 kg (33 and 80 lbs) and whose height is between 970 and 1370 mm (38 and 51 inches).
Position safetybelt properly. Do not use lap belt only. Always adjust the headrest to give best possible head support for the Child's head. For further information, consult the owners manual.

This child restraint system conforms to all applicable U.S. Federal Canadian Motor Vehicle Safety Standards.

 **WARNING**

FAILURE TO FOLLOW THE MANUFACTURER'S INSTRUCTIONS ON THE USE OF THIS CHILD RESTRAINT SYSTEM CAN RESULT IN YOUR CHILD STRIKING THE VEHICLES INTERIOR DURING A SUDDEN STOP OR CRASH.

COUSSIN D'APPOINT INTÉGRÉ

Le siège de sécurité présent est destiné uniquement des enfants pesant entre 15 et 36 kg (33 et 80 livres est et d'une taille allant de 970 et 1370 mm (38 and 51 pouces).
Placer la ceinture de sécurité de façon appropriée. Ne pas utiliser la ceinture ventrale seulement. Toujours ajuster l'appui-tête à l'enfant de façon à lui donner le meilleur support possible pour plus d'information, consulter le guide l'automobiliste.

Ce dispositif de protection pour enfant est conform à toutes les normes canadiennes et américaines de sécurité automobile applicables.

 **ATTENTION**

L'ENFANT RISQUE DE HEURTER L'INTERIEUR DE L'HABITACLE EN CAS D'ARRÊT BRUSQUE OU DE COLLISION SI LES INSTRUCTIONS D'UTILISATION DU COUSSIN D'APPOINT INTÉGRÉ, DONNÉES PAR LE FABRICANT, NE SONT PAS RESPECTÉES.

Right hand side

Pour Coussin
placé à droite

Right hand side

Pour Coussin
placé à gauche

VEHICLE SPECIFIC
15-36 kg

030001

Saab Automobile AB, Trollhattan, Sweden.

Date of manufacture: See inside the booster cushion.

Part No. 51 27 691

Label in integrated booster seat

Airbag (Supplemental Restraint System "SRS")



WARNING

To reduce risk of injury:

- **Always** wear your safety belt.
- **Always** adjust your seat so that you are as far back as possible but still able to reach the steering wheel and controls comfortably.
- Children 12 and under or shorter than 140 cm (55 inches) should **always** travel in the rear as the vehicle is equipped with an airbag on the passenger side.

The supplementary restraint system (SRS) comprises an airbag in the steering wheel, a front passenger airbag and side airbags in the front seats.

The system supplements the protection provided by the safety belts to further enhance the safety of the occupants.

If a fault is detected in the SRS, the AIR BAG warning light on the main instrument panel will come on (see pages 52 and 34).

When the system is triggered by impact of a frontal crash, the airbags in the steering wheel and passenger side of the dash board are inflated, after which they deflate through vents in the back of the bags.

The front airbags are inflated in two stages. The first stage process is a less severe, softer inflation of the airbag. This stage is used in lower force crashes, or if the seat is positioned close to the steering wheel or dashboard. The second stage process is a more forceful and quicker inflation of the airbag. This stage is used in more severe crashes and/or when the seat adjustment is back a significant distance from the steering wheel or dashboard.

The entire process takes less than 0.1 second – literally, faster than the blinking of an eye.

These airbags are triggered only by moderate to severe frontal or near-frontal crashes. They will not be activated by minor front-end impacts, rear-end or side impacts, or by the car rolling over.

WARNING

- Even if the car is equipped with SRS (airbag), safety belts must still **always** be worn by all occupants.
- Note that because an airbag inflates and deflates extremely rapidly, it will not provide protection against a second impact occurring in the same incident. **Always** use your safety belt.
- Always sit with the whole of your back in contact with the backrest of the seat, and with your seat as far back as is practical. This is to reduce the risk of injury from contact with the backrest of the seat when the airbag inflates and also because the airbag needs space in which to inflate.
- Never attach anything to the steering wheel or passenger side of the instrument panel, as this could result in injury if the airbag should inflate. The same applies to anything you might have in your mouth, such as a pipe, for instance.
- Some components of the airbag will be warm for a short time. In some circumstances the airbag can cause minor burns or abrasions to the body when the airbag inflates/deflates.

- Never rest your hands or forearms on the steering-wheel center padding.
- If the AIR BAG warning light remains on after the car has been started or comes on while you are driving, have the car checked immediately by an authorized Saab dealer. The warning light could signify that the airbags may not inflate in a crash, or they could even inflate without a crash. See page. 52.



Moment of impact.



Sensor detects deceleration and sends a signal via the control module to a gas generator that inflates the airbag.



The inflating airbag cushions the driver.



Airbag now fully inflated.

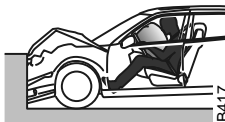

The airbag starts to deflate.

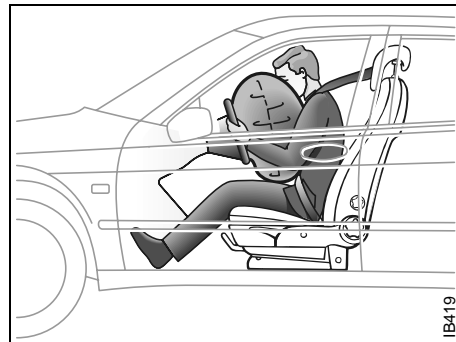

IB419

*Inflated airbag (driver side)
Inflation and deflation together take less than 0.1 second.*

IB417

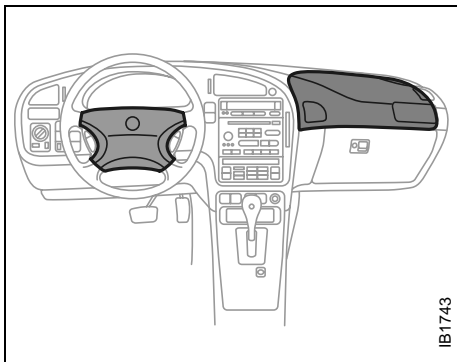

Accessories and other equipment must not be fitted to the surfaces marked as these are where the airbags inflate in the event of a crash.

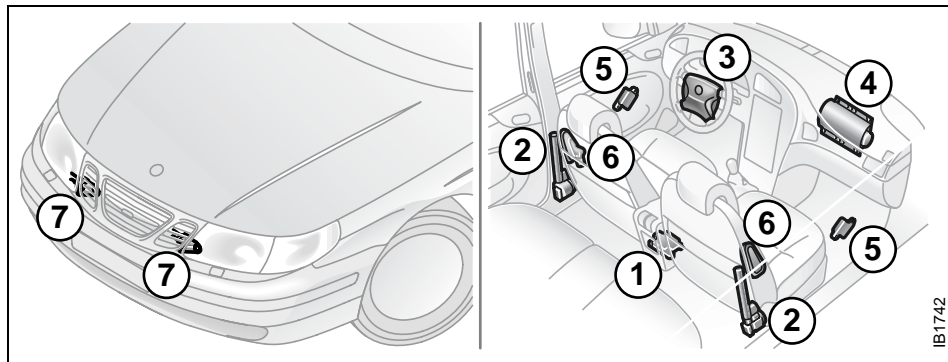

SRS (airbag) system with belt pretensioners

- 1 Electronic control module and sensor
- 2 Belt pretensioners (for both front safety belts)
- 3 Steering wheel with integral airbag
- 4 Passenger airbag
- 5 Side-airbag sensor
- 6 Side airbag
- 7 Front sensors

Front passenger seat

 **WARNING**

Never secure a rear-facing child seat in the right front seat of a car equipped with a passenger airbag. Inflation of the airbag in the event of a crash could seriously injure or kill a child.

The airbags are interconnected and have a common warning light. The passenger airbag module is housed in the fascia above the glove compartment and is marked "SRS AIRBAG".

Both airbags will be inflated in the event of a moderate to severe frontal, or near-frontal crash, even if the passenger seat is unoccupied.

 **WARNING**

- Children 12 and under can be killed by the airbag
- The back seat is the safest place for children
- Never allow a child to stand in front of the seat or to sit on the lap of a front-seat passenger. Serious injury or death could result if the airbag is inflated in a crash.
- Never place anything on the dash or in front of the seat as, in addition to being a hazard to passengers, this could interfere with the function of the airbag in the event of a crash. The same applies to the mounting of accessories on the dash.
- Keep feet on the floor - never put feet up on the fascia, on the seat or out of the window.
- Do not carry anything in your lap.

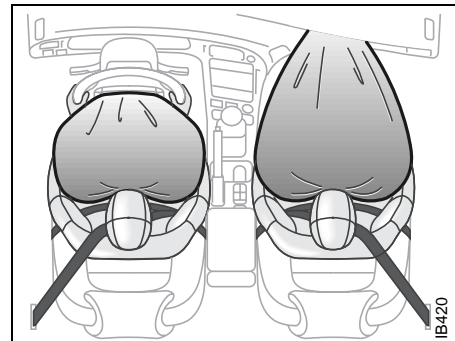

Passenger airbag and driver's airbag both inflated

Side airbags

Side airbags are housed inside the backrests of the front seats and are designed to protect the driver and front passenger in the event of a side impact.

In a side impact, only the airbag on that side will be activated, and only then if certain pre-determined conditions are met such as the force and angle of the impact, the speed of the car on impact, and at which point on the car's side the impact occurs.

The sensors, which are fitted in the front doors, sense the rise in pressure caused by the door panel being pressed in during an

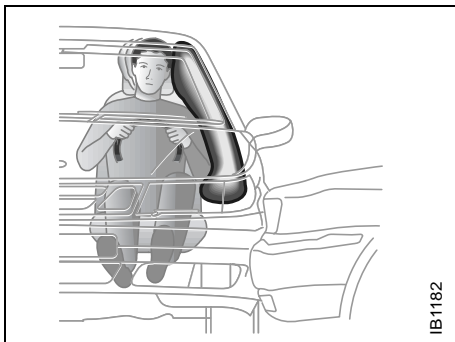

IB1182

Side airbag inflated

impact condition. The side airbag trigger will be commanded based on the characteristics of this pressure rise.

WARNING

- This car is equipped with side airbags and no extra interior trim should be fitted. Failure to observe this warning could result in the side airbags not inflating as intended and thus not providing the intended protection either.
 - Never place any object in the area that would be occupied by the inflated airbag.
 - For optimum protection, sit upright in the seat, with your safety belt correctly fastened.
 - The sensors for the side airbags are fitted in the front doors.
 - We advise against doing any work on the doors that could affect the moisture barrier in the door or the airbag sensors. It is essential that the moisture barrier (thick plastic film) in the front door is not damaged in any way.
 - Improvement of the anticorrosion treatment of the doors should only be carried out by an authorized Saab dealer. Otherwise there is a risk that the side impact sensor and the moisture barrier in the front door could be damaged.
- The side airbags will inflate only in the event of a side impact; not in the event of a front or rear-end crash or of the car's rolling over.
 - Damage or wear to the seat cover, or the seat seam, in the area of the side airbag must immediately be repaired by an authorized Saab dealer.
 - Do not modify the speaker installation in the front doors or install speakers other than those specifically approved by Saab.

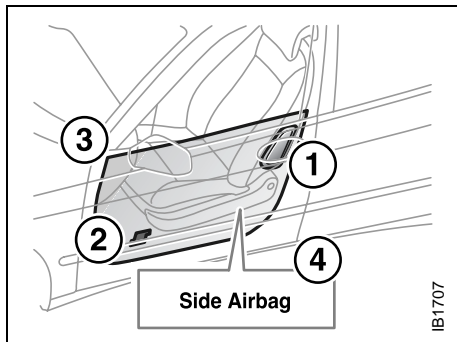

Side airbag components

- 1 Side airbag
- 2 Sensor
- 3 Moisture barrier
- 4 Text on seat

AIR BAG warning light

⚠ WARNING

- If the air bag readiness light stays on after you start your vehicle, it means the air bag system may not be working properly.
- The air bags in your vehicle may not inflate in a crash, or they could even inflate without a crash.
- To help avoid injury to yourself or others, have your vehicle serviced right away if the air bag readiness light stays on after you start your vehicle.

SRS servicing

The SRS must be inspected as part of the normal service program but otherwise may be regarded as maintenance-free.

Scrapping or working on airbags and belt pretensioners

⚠ WARNING

- Under no circumstances may any modifications be made that affect the steering wheel or the airbag's electrical circuitry.
- Before starting any welding work on the car, always disconnect the negative (-) battery lead and cover the conductor.
- Airbags and belt pretensioners must be deployed under controlled conditions before the car is scrapped or any of the system's components are removed. Airbags or belt pretensioners that have been deployed as a result of a crash must be replaced by new ones.
- Airbag-system components must never be transferred for use in another vehicle.
- All work involving the scrapping or replacement of airbags or belt pretensioners must only be carried out by knowledgeable personnel.

Frequently asked questions on function of airbags

Do you still need to wear a safety belt if airbags are fitted?

Yes, always! The airbag merely supplements the car's normal safety system. Moreover, the airbag will only be actuated in a moderate to severe frontal, or near-frontal crash, which means, of course, that it provides no protection in minor frontal crashes, major rear-end or side-on crashes or if the car rolls over.

The safety belts help reduce the chance of the car occupants from being thrown around and injured inside the car.

But they also ensure that, if a crash occurs in which the airbags are inflated, the airbag will make the optimum contact with the occupant, i.e. square on from the front. If the occupant meets the airbag in an offset position, the protection afforded will be reduced.

In addition, airbags provide no protection against a secondary impact occurring in the same incident. So there is no doubt about the benefit of wearing safety belts at all times.

Do not sit too close to the airbag: it needs room to inflate.

The airbag inflates very quickly and powerfully in order to protect an adult person, before they are thrown forward, in a serious frontal crash.

How do I position the seat to leave room for the airbag to inflate?

Don't have your seat too far forward.

Recline the seat back to increase the distance between you and the airbag. For short drivers, special accessory pedal extensions are available through your Saab dealer.

Airbags inflate extremely rapidly and with great force - to be fast enough to protect an adult in the seat.

When do the front airbags inflate?

The airbag will only be inflated under certain predetermined conditions in a moderate to severe frontal, or near-frontal crash, depending on such factors as the force and angle of the impact, the speed of the car on impact, and the resistance to deformation of the impacting object.

The airbag can only be activated once in the same incident.

Do not attempt to drive the car after an airbag has been inflated, even if it is possible.

What won't trigger the front airbags?

The airbag will not be activated in all front-end crashes. For instance, if the car has hit something relatively soft and yielding (e.g. a snow drift or a hedge) or a solid object at a low impact speed, the airbag will not necessarily be triggered.

How loud is the inflation?

The noise of the inflation is certainly loud, but it is very short-lived and will not damage your hearing. For a short time afterwards you could experience a buzzing noise in your ears.

Most people who have experienced it cannot remember the noise of the inflation at all - all they remember is the noise of the crash.

Can you still use a child seat in the front if a passenger airbag is installed?

Definitely not!

Children 12 and under can be injured or killed by the airbag.

The BACK SEAT is the SAFEST place for children.

NEVER put a child seat in the front.

Are the smoke and fumes given off when the airbag operates at all harmful?

Most people who have remained in a car with little or no ventilation for several minutes complained only of minor irritation of the throat and eyes. Avoid as far as possible getting dust on your skin as there is a risk of skin irritation.

If this trouble persists, you should consult a doctor.

If you suffer from asthma, the incident may bring on an attack, in which case you should follow the normal procedure advised by your doctor. It is advisable to consult a doctor afterwards.

 **WARNING**

When an airbag is inflated there is dust in the air.

Because the dust sometimes contains particles of a substance resembling dish detergent, the following precautions should be taken:

- As soon as possible, wash any exposed skin using a mild soap and water.
- If there is irritation of the eyes, flush them liberally with clean water for at least 20 minutes.

What should I do if the AIR-BAG warning light comes on?

If the warning light is on, it means that a fault has been detected in the system. The airbag cannot be relied on to operate as intended and it might even be activated erroneously. You should therefore take the car to an authorized Saab dealer as soon as possible.

 **WARNING**

To reduce the risk of head injuries in the event of a crash, the headliner and pillar trims incorporate energy absorbing material. These areas must not be modified in any way. Work on these areas must only be carried out at an authorized Saab dealer.

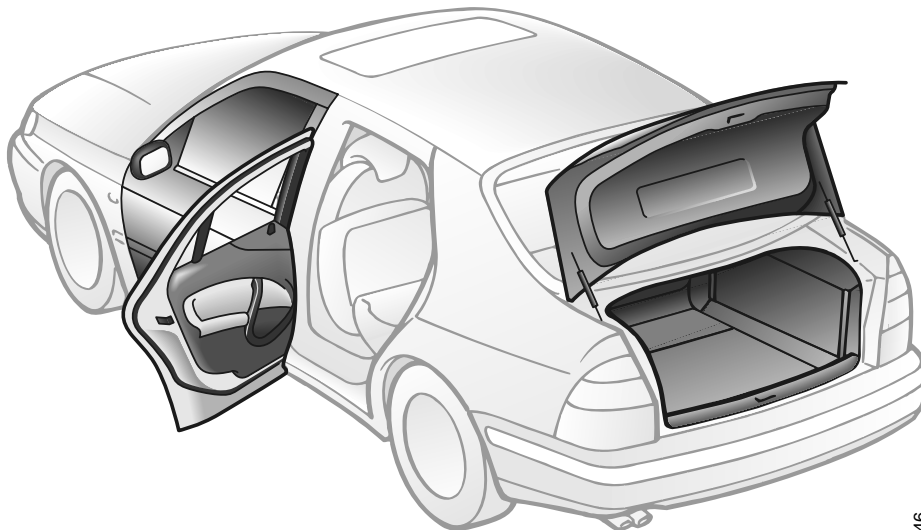

Security

| | |
|----------------------|----|
| Doors..... | 38 |
| Central locking..... | 38 |
| Car alarm | 43 |

IB446

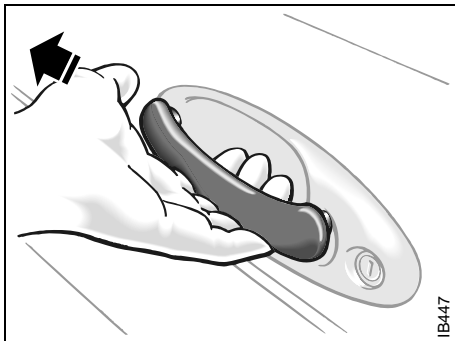

IB447

Door handle

Doors

Door handles

Pull the handle to open the door.

If the door is stuck (e.g. if frozen), hold the handle from above to secure a better grip.

Central locking

! WARNING

Leaving children or pets unattended in a locked car is dangerous. It is also dangerous to leave children in a vehicle with the ignition key. A child or others could be badly injured or even killed.

Key / Remote control

The key unit consists of a mechanical key with integrated remote control.

The mechanical key is used for manual locking and unlocking.

The remote control is used for remote locking and unlocking.

The key fits all the car's locks

The key supplied with the car has a code number on a black plastic tag that needs to be quoted for ordering additional keys. You should therefore make a careful note of the number.

The key contains a unique electronic code for your car. When the key is inserted in the ignition, the code is checked. If it matches, the car can be started.

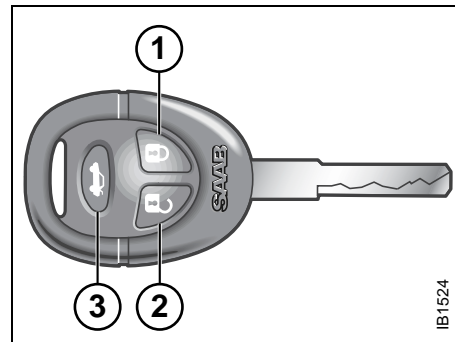

IB1524

Key / Remote control

- 1 To lock
- 2 To unlock
- 3 Opening the trunk (9-5 Sedan)
Unlocking the tailgate (9-5 Wagon)

Two keys are supplied with the car. It is possible to have up to four at one time that are coded for your car. If one is lost, contact your authorized Saab dealer to obtain a replacement.

NOTE: For this reason, we strongly advise you to take two keys with you on long journeys and to keep them separate. If all keys are lost, it will be necessary to replace costly electronic components as well as the keys. This loss and replacement cost is not covered by the new car warranty.

If an additional key is to be added, all of the original keys must be brought to the dealer so that the control module can "learn" to recognize the new components.

NOTE

The key contains delicate electronics.

- Do not expose it to water.
- Avoid rough handling.
- Do not place the key where it may be subjected to high temperatures, e.g. on the instrument panel.
- The key may malfunction if it becomes very cold. Warm it in your hands for a couple of minutes.

Never open the key except to change the battery. For changing the battery, see page 40.

To check the number of keys that are programmed for the car; see page 47.

Electronic starting interlock (immobilizer)

Each time the key is removed from the ignition, the electronic starting interlock is activated and the car is thus immobilized, see also page 44.

Reprogramming lock system functions

Certain lock system functions can be reprogrammed by your authorized Saab workshop; see page 259.

Locking/unlocking the car

When the car is locked and unlocked the theft alarm is also affected.

Remote locking (1)

Press  once on the control: all doors locked.

The hazard warning lights will flash once and the horn chirps once to confirm.

The tailgate cannot be opened now from inside using the switch on the driver's door.

Remote unlocking (2)

Press  once on the control: the driver's door is unlocked. Press a second time to unlock the rest of the doors.

The hazard warning lights will flash twice and the horn chirps twice to confirm.

If remote unlocking should fail to work

Unlock the driver's door with the key. To silence the alarm, insert the key into the ignition switch and turn it to the ON position.

The car can now be started. Contact your local Saab dealer to have the system checked and rectified.

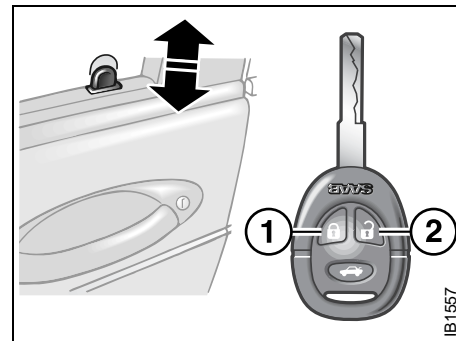

Locking/unlocking by remote control.

- 1 To lock
- 2 To unlock

! WARNING

The remote control also works from inside the car. Therefore, hold the key in such a way that the buttons are not unintentionally pressed when the key is turned, or inserted or removed from the ignition switch.

Otherwise, the doors may be unintentionally locked or the tailgate unlocked. On Sedan models, the trunk may even be opened.

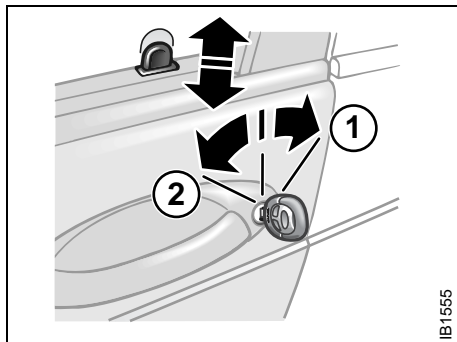

IB1555

Locking/unlocking by key

- 1 To lock
- 2 To unlock

Locking by key (1)

When the car is locked and unlocked the theft alarm is also affected.

Turn the key clockwise: all doors locked.

The trunk lid/tailgate cannot be opened now from inside using the switch on the driver's door.

Unlocking by key (2)

Turn the key counterclockwise once: the driver's door will unlock.

Turn the key counterclockwise twice: all doors, but not trunk lid/tailgate, unlocked.

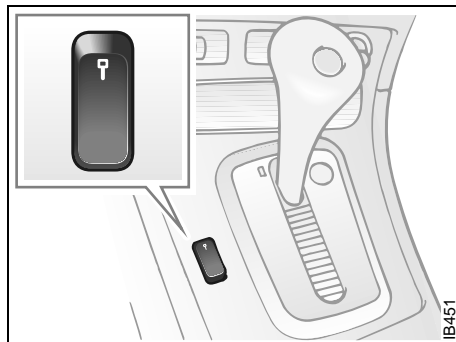

IB451

Switch for operation of central locking

The central locking can also be operated from inside the car by means of the  switch on the center console.

- To lock all doors: press the symbol side of the switch once.
- To unlock the driver's door: press the switch once.
- To unlock all doors: press the switch twice.

This switch is inoperative when the car is locked from the outside.

The interior locking buttons on each door affect only the respective door.

If the car is left with the doors open, the interior lighting and the courtesy lights in the doors will be switched off automatically after 20 minutes, to prevent a flat battery. In such cases the electrically operated seats will not function.

| |
|---|
|  WARNING |
| <p>Having the doors locked when you are driving will reduce the likelihood of:</p> <ul style="list-style-type: none"> • Passengers, especially children, opening doors and falling out of the car. • Intruders entering the car when it is moving slowly or stopped. • Being thrown out of the car in a crash. |

Changing the key battery

When the battery voltage in the key falls below a predetermined level the SID will issue the following message: "REPLACE KEY BATTERY". Press the CLEAR button on the SID to acknowledge this message. You must then replace the battery without delay to avoid malfunctions. The life of the battery is normally 4 years. Contact a Saab dealer to have the battery replaced.

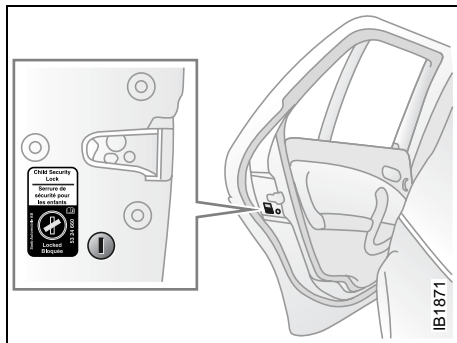

Child safety lock on rear doors

Child safety locks

The rear doors are equipped with child safety locks that are operated by means of a catch adjacent to the door lock.

Insert a key and turn the catch 45° clockwise or counterclockwise as indicated by the label on the door.

When the child safety catch is in the locked position, the door cannot be opened from the inside.



WARNING

If small children are carried in the rear seat, the safety locks on rear doors should be activated to prevent unintentional opening from the inside.

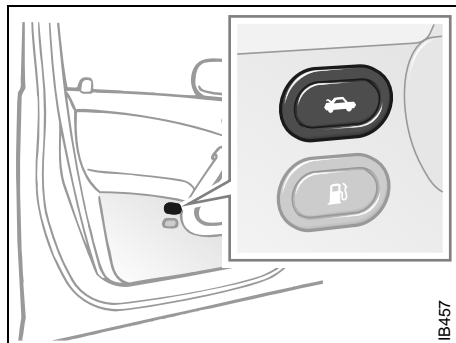

Trunk lid switch

Trunk lid lock, 9-5 Sedan

The trunk lid lock is independent of the central-locking system. The trunk lid release switch on the driver's door is inoperative when the car is locked from the outside or moving at a speed greater than 2.7 mph (4 km/h).

Unlocking

The trunk lid is unlocked using:

- The  button on the key
- The trunk lid switch on the inside of the driver's door (if the car is unlocked and at a standstill)

Remote unlocking is confirmed by the direction indicators flashing three times.

The trunk lid switch on the driver's door is inoperative when the car is locked.

If the alarm is activated (the car is locked), the alarm will sound if the trunk lid is unlocked with a key. However, if the trunk lid is opened using remote unlocking, the alarm will not be triggered.

Locking

The trunk lid release is locked automatically when closed.

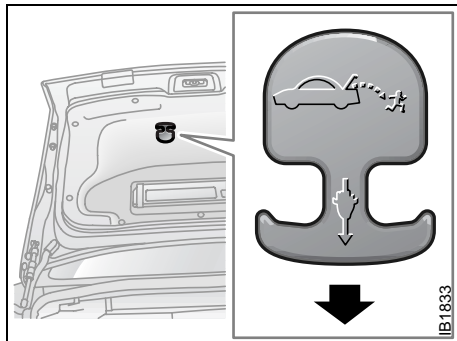

Trunk Release Handle

Trunk Release Handle

There is a glow-in-the-dark trunk release handle located inside the trunk on the latch. This handle will glow following exposure to light. Pull the release handle down to open the trunk from the inside.

NOTE

The trunk release handle was not designed to be used to tie down the trunk lid or as an anchor point when securing items in the trunk. Improper use of the trunk release could damage it.

Tailgate, 9-5 Wagon

The tailgate is not unlocked when the other car doors are unlocked. The tailgate button on the driver's door is inoperative when the car is locked or moving at a speed greater than 4 km/h.

Unlocking



The tailgate is unlocked using:

- The  button on the key
 - The tailgate switch on the inside of the driver's door (if the car is unlocked and at a standstill) or
 - Manually, using the key in the trunk lock.
- Remote unlocking is confirmed by the direction indicators flashing three times.

If the alarm is activated (the car is locked), the alarm will sound if the tailgate is unlocked with a key. However, if the tailgate is opened using remote unlocking, the alarm will not be triggered.

Locking

The tailgate is locked using:

- The  button on the key
- The  button on the centre console
- The key in the driver's door.

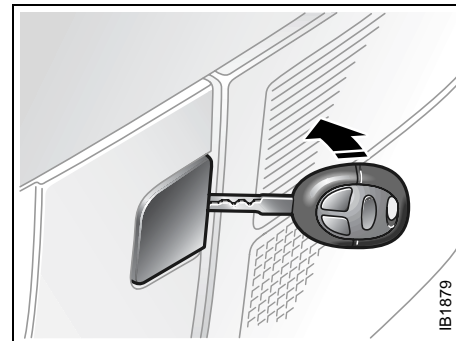

Use the key to prise out the cover plate covering the lock, 9-5 Wagon

Unlocking the tailgate with a key, 9-5 Wagon

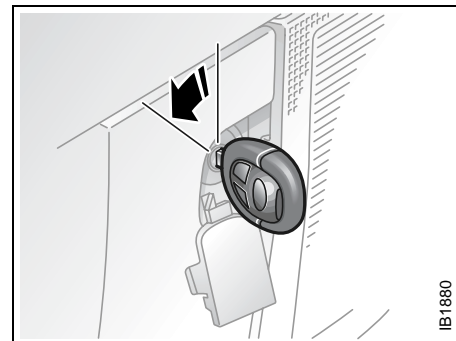

Car alarm

WARNING

Leaving children or pets unattended in a locked car is dangerous. It is also dangerous to leave children in a vehicle with the ignition key. A child or others could be badly injured or even killed.

The car alarm (anti-theft system) is activated/deactivated when the car is locked/unlocked by the remote control or by the key, see page 39.

The antenna for the alarm system is located in the center console.

All the doors plus trunk lid/tailgate and hood are monitored by microswitches, and window-glass sensors will trigger the alarm if any glass is broken.

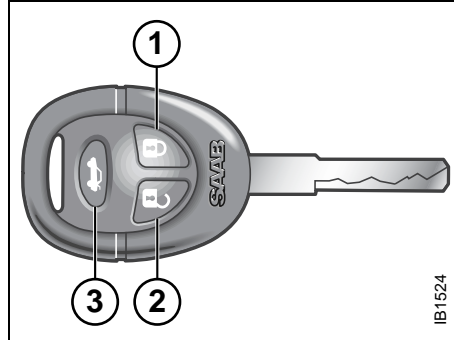

Remote control

- 1 Activate/lock
- 2 Deactivate/unlock
- 3 Unlock trunk/tailgate
Unlocking the tailgate (9-5 Wagon)

Your Saab 9-5 is equipped with an Electronic starting interlock (immobilizer), see page 44 for details.

The car alarm is armed 10 seconds after the car has been locked by the remote control. During this ten-second delay period, the doors, trunk lid/tailgate and hood may still be opened without the alarm being triggered.

The LED indicator on the instrument panel fascia will be on continuously during this period, at the end of which it will start to flash (once every other second).

If a door or the trunk lid/tailgate or hood has been left open when the car is locked, the LED on the fascia will flash (three times per second) for ten seconds to indicate this.

Check to ensure that all the doors, plus trunk lid/tailgate and hood, are closed properly.

If the fault persists (LED flashing when renewed attempt made to activate the car alarm by remote control), lock the car using the key instead. The car alarm will not have been activated and you should get in touch with an authorized Saab dealer.

To avert inconvenience caused by the alarm being triggered inadvertently, make sure that anyone else using the car is familiar with how both the car alarm and the locking system work.

If the alarm is tripped (the direction indicators are flashing and the siren is on) it can be turned off by unlocking the car using the



button.

Activating the car alarm

The car alarm cannot be activated if the driver's door is open or if the ignition switch is in ON position.

If, on the other hand, one of the other doors or the trunk or hood is open or opened and not closed again during the 10-seconds delay period, it will be excluded from the alarm function.

If it is then closed, a new delay period of ten seconds will start, and the door (or trunk or hood) will once again be secured by the alarm system.

As usual, the LED will be on continuously during the new delay period and will start to flash once every other second after the 10-seconds period has elapsed.

Window glass sensor

The car-alarm system incorporates a sensor that monitors the window glass for the sound of breakage. The sensor is fitted inside the rear dome light.

To avoid false alarms, such as the alarm being triggered by noise from passers by when the windows have been left open, or when children or pets are left inside the car, the sensor can be temporarily disabled.

To disable the sensor

To disable the sensor, first turn off the ignition and remove the key from the switch.

Next, press and hold the NIGHT PANEL button until "DOOR ALARM ONLY" appears on the SID and a chime sounds. The car alarm must now be activated within three minutes, or the glass sensor will become active again.

The glass sensor will be enabled again automatically when the car is next unlocked. The sensor can also be enabled again by repeating the procedure for disabling it. When the sensor has been enabled, "FULL THEFT ALARM" will appear on the SID.

If a fault is detected in the glass sensor, "SERVICE THEFT ALARM" will appear on the SID.

Electronic starting interlock (immobilizer)

When the key is inserted in the ignition, a signal is sent to the receiver. If the signal is verified, the engine can be started.

Each time the key is removed from the ignition, the electronic immobilizer is activated. This means that the car cannot be started without the correct key inserted in the ignition and the immobilizer thus deactivated.

If a fault is detected (e.g. in the transmitter) "KEY NOT ACCEPTED" will appear on the SID.

In this case, you can still start the car if you turn the ignition key to ON and press one of the buttons on the key (providing that the receiver gets the right signal from the key). Take the car to an authorized Saab dealer to have the system checked.

The LED double-flashes when the car is immobilized.

Alarm signals

When the car alarm is armed, it will be triggered if any door, or the trunk lid or hood, is opened or if a window is broken.

The alarm will also be triggered if an attempt is made to bypass or short-circuit the ignition switch, or to disconnect the battery.

If the alarm is triggered, the following alarm signals will be set off:

- Flashing of hazard warning lights for five minutes.
- Siren wailing for 30 seconds.

The alarm signals will stop if the alarm is deactivated (car unlocked) during the alarm period.

The alarm siren has a long-life battery (approx. 10 years), see "SERVICE THEFT ALARM", on page 47. When the battery goes dead, the siren must be replaced: it is not possible to change the batteries.

NOTE

- It is possible to inadvertently deactivate the car alarm and at the same time unlock the car, if the button on the key is pressed by mistake when the car is still within its range.
- When locking the car by remote control in extremely cold weather, it is advisable to check that the lock system has operated properly. To do so, check that the interior locking buttons are all down.
If not, unlock and relock the car again.

Panic-function

In the car alarm system is a function called "Panic-function".

To activate panic function:

- Push and hold one of the buttons on the key for 2 seconds. Or, if you are sitting inside the car, push the LOCK-switch on the center console for 2 seconds.

These actions will trigger the alarm (hazard warning lights and siren).

To deactivate panic function:

- Push one of the buttons on the key, push the LOCK-switch in the center console, turn the key in the driver's door or turn the ignition to ON.

When the panic-function is activated the car will be locked/unlocked depending upon which button was pushed.

When the ignition is ON the panic-function cannot be activated.

Overview of functions

| | |
|--|---|
| Locking/ activation | Hazard warning lights flash once and the horn chirps once. The LED will come on for 10 seconds. |
| Unlocking/ deactivation | Hazard warning lights flash twice and the horn chirps twice. The LED will come on for two seconds. |
| Unlocking/ deactivation of trunk lid/tailgate alarm | Hazard warning lights flash three times and the horn chirps three times. The LED will flash three times per second for 10 seconds. |
| Alarm triggered | Hazard warning lights flash for 5 min. Siren wails for 30 seconds. To switch off the alarm, deactivate the system in the normal way (unlocking). |
| Window-glass sensor | The sensor detects if any window is broken and triggers the alarm. To disable the sensor, see page 44. |
| Key | The range of the key is normally 5-10 yds. (5-10 metres), although it can be substantially more than this in ideal conditions. If the key is not working, it may be because the code signal has not been synchronized with that in the control module for the car alarm. To rectify this, press the unlock button on the key at least four times in quick succession. When it is recognized, the door locks will cycle. If a key is lost, the new one will have to be programmed (all keys must be present) to match the car's unique security code. Contact an authorized Saab dealer. |

| | |
|------------------------|--|
| Battery for key | The battery for the key will normally have a life of 4 years. When the battery needs changing, "REPLACE KEY BATTERY" will appear on the SID. Contact an authorized Saab dealer. |
| Car-battery voltage | If the battery is disconnected while the alarm is active (car is locked), for example during an attempt to steal the car, the alarm will be triggered. |

Alarm signals may differ between model variants for different countries.

Some of the car-alarm functions can be reprogrammed – consult your Saab dealer for further details (see page 259).

Overview of LED signals and SID messages

| Status | LED signal |
|--|--|
| Activation (during 10-second delay). | Comes on for 10 seconds. |
| Alarm activated (after delay). | Flashes once every other second. |
| Deactivation. | Comes on for 2 seconds. |
| Alarm not activated. | Off. |
| Door, trunk lid/tailgate or hood open or opened during delay period. | Flashes three times per second for 10 seconds. |
| Unlocking the trunk lid/tailgate. | Flashes three times per second for 10 seconds. |
| Closing of door, trunk lid/tailgate or hood after delay period. | Comes on for 10 seconds. |
| Car immobilized but not locked. Car alarm not activated. | Flashes twice at three seconds intervals. |
| Fault in a switch serving doors, hood or trunk lid. | Flashing (instead of being on continuously) during delay period. |

Some signals may differ between model variants for different countries.

| SID message | Reason/action |
|--|--|
| SERVICE THEFT ALARM | Probably a fault in one of the sensors or the alarm siren. Have the car checked by an authorized Saab dealer. |
| KEY NOT ACCEPTED | Fault in key transmitter or in ignition-switch receiver. Turn ignition switch to ON and press the unlock button on the key. Start the engine. Have the car checked by an authorized Saab dealer. |
| REPLACE KEY BATTERY | Fit a new battery in the key, see page 40. |
| DOOR ALARM ONLY | Window-glass sensor disabled. |
| FULL THEFT ALARM | Window-glass sensor in circuit. |
| <ul style="list-style-type: none"> • REMOTE KEY • TRANSPONDR | Turn the ignition key to position ON and then press the button for opening the trunk lid. SID displays the number of keys and transmitters (transponders) coded to the car. |

This device complies with Part 15 of the FCC Rules. Operation is subject to the following two conditions: (1) this device may not cause harmful interference, and (2) must accept any interference received, including interference that may cause undesired operation.

Changes or modifications not expressly approved by the manufacturer could void the user's authority to operate the equipment.

Canada only:

This device complies with RSS-210 of Industry Canada. Operation is subject to the following two conditions: (1) this device may not cause interference, and (2) this device must accept any interference, including interference that may cause undesired operation of the device.

Instruments and controls

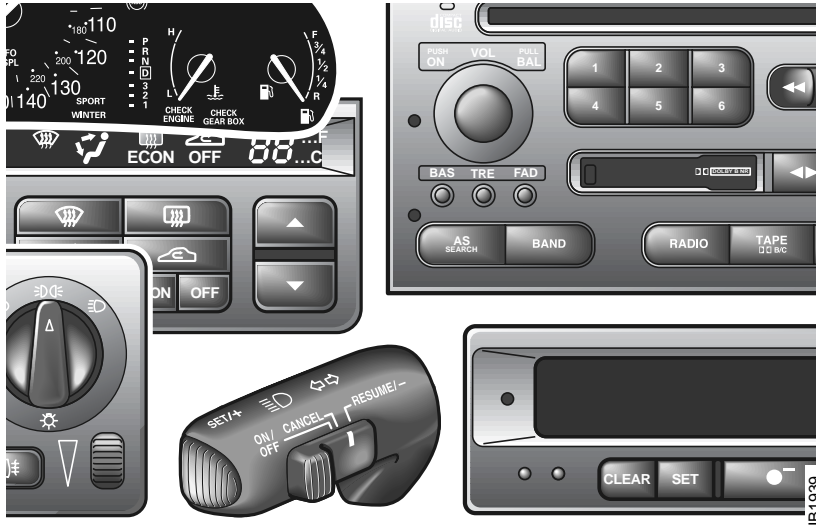

| | |
|---------------------------------------|----|
| Indicator and warning lights | 50 |
| Instruments | 56 |
| Trip computer SID | 59 |
| Switches | 65 |
| Automatic climate control (ACC) | 72 |

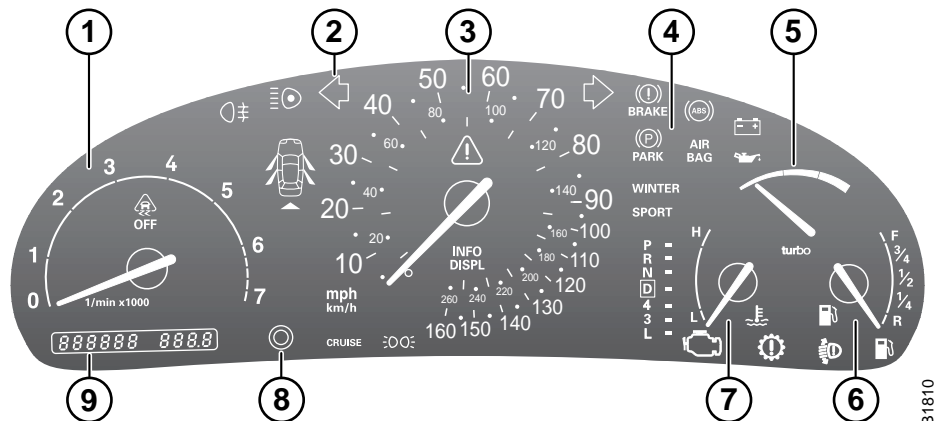

IB1810

Main instrument panel

- 1 Tachometer
- 2 Indicator and warning lights
- 3 Speedometer
- 4 Indicator and warning lights
- 5 Pressure gauge

- 6 Fuel gauge
- 7 Engine temperature gauge
- 8 Trip meter reset button
- 9 Odometer and trip meter

Indicator and warning lights

A number of indicator and warning lights will come on when the ignition is switched on prior to starting. Under normal conditions, these should go out a few seconds after the engine has started (see page 56).



Warning, oil pressure (engine oil)

This light will come on together with  if the engine oil pressure is dangerously low. If the light flashes or comes on while you are driving, stop the car, switch off the engine and check the engine oil level (see page 193).

NOTE

Under no circumstances must the car be driven when the warning light is on. Low oil pressure can result in serious engine damage.



Warning, charging

This light will come on together with  if the battery is discharging. If it comes on while you are driving, stop the car as soon as possible and switch off the engine.

Check the alternator drive belt (see page 201). If the belt has broken, the engine may overheat (cooling system will not function properly), the battery will not be charged, the A/C compressor will not run and power assistance for the steering will be lost.



Brake warning light

This light will come on together with  if there is insufficient brake fluid in the reservoir (see pages 197 / 197).

If the ABS warning light is on at the same time, the ABS system may be inoperative because of a fault (see "Anti-lock brake warning", page 52).

WARNING

Never drive the car when these warning lights are on. Danger of brake failure!

Have the brake system checked by an authorized Saab dealer.



Parking brake warning light

This light will show when the parking brake is on (see page 185).

If the car is driven with the parking brake still on,  will also come on and a chime will sound.

The parking brake is mechanical and operates on the rear wheels.



WARNING

- Always apply the parking brake when parking, see page 185.
- Always apply the parking brake before removing the ignition key.
- Do not apply the parking brake while the car is moving.



Anti-lock brake warning

This light will come on if a fault has occurred in the ABS system.

On certain variants  and  as well as  can light up to indicate a fault in the electronic brake force distribution system (distribution of the brake pressure between the front and rear wheels).

Conventional braking without the ABS function will still be available.

For safety reasons, stop the car and check the level of the brake fluid (see page 197).

If the level is normal, depress the brake pedal firmly two or three times. Now check the level again. If the level is still normal, you may drive the car, with considerable caution, to the nearest authorized Saab dealer to have the brake system checked.

WARNING

- If the ABS is inoperative, there is a danger of the rear wheels locking up on hard braking.
- If the level of brake fluid in the reservoir is below the MIN mark, the car should be towed to an authorized Saab dealer.

AIR BAG

Airbag warning light

This light together with  will come on if a potentially serious fault has occurred in the airbag system.

WARNING

- If the airbag readiness light stays on after you start your vehicle, it means the airbag system may not be working properly. One or more of the following conditions may occur:
 - Non-deployment of the airbags in the event of a crash.
 - Deployment of the airbags without a crash.
 - Deployment of the airbags in crashes less severe than intended.
- To help avoid injury to yourself or others, have your vehicle serviced right away if the airbag readiness light stays on after you start your vehicle.

The light will come on for about three seconds when the ignition switch is turned to the Start or Drive position. It should go out after the engine has started.

**INFO
DISPL****CHECK message indicator**

This light indicates that there is a message in the SID. A chime will also sound (see page 63).

**Central warning light**

This light will come on and a chime will sound if a fault has been detected in any system that is critical to safety. Any of the following can activate the central warning light and alarm:

- Airbag system.
- Low oil pressure in engine.
- Parking brake is on (when car is moving).
- Brake fluid level low.
- Fault detected in ABS system.
- Electronic brake force distribution (distribution of brake pressure between front and rear wheels).
- Engine overheating.
- Alternator not charging properly.

**Engine malfunction
(CHECK ENGINE)****! WARNING**

An illuminated "Engine malfunction (CHECK ENGINE)" indicator light indicates a serious engine-related problem. While your car may be able to be driven with the "Engine malfunction (CHECK ENGINE)" indicator light illuminated (Limp-home mode), you are advised to have your car serviced at an authorized Saab dealer as soon as possible.

Continued driving without this problem being corrected might cause serious further damage to your car and create unsafe driving conditions. The operator should be prepared to take action if such unsafe conditions arise (e.g., apply the brakes, disengage transmission, turn off the ignition etc.).

This light indicates a malfunction in the fuel-injection or ignition system. The car may still be driven with care and with somewhat diminished performance (see page 149).

NOTE

The car should be checked immediately at an authorized Saab dealer to prevent more serious faults from arising.

**Indicator, fuel**

This light comes on when there is less than about 2.5 gallons (10 liters) of fuel left in the tank.

NOTE

If the car runs out of fuel, air can be drawn in with the fuel, which, in turn, can cause the catalytic converter to be damaged by overheating.

CRUISE**Indicator, cruise control**

This light shows when the cruise-control system is active (see page 164).

**Indicator, high beam**

This light shows when the headlights are on high beam (see page 65).

**Indicator, rear fog light**

This light shows when the rear fog light is on (see page 66).

The rear fog light is switched off automatically when the engine is switched off. When the fog light is next needed, it will have to be switched on manually again.

The rear fog light consists of one light so it should not be mistaken for brake lights.

**Xenon headlight fault indicator (certain variants only)**

This light indicates that there is a fault in the xenon headlight system, which consists of xenon headlights and an automatic levelling system.

If a fault arises in the xenon headlight system, the headlights will be angled down to avoid dazzling drivers in oncoming traffic. Adjust your speed accordingly as visibility will be reduced.

NOTE

If the xenon headlight fault indicator lights up, have your car checked as soon as possible at an authorized Saab dealer.

If you do not rectify the problem, nighttime visibility will be poor since the range of the headlights is reduced.

**Indicator, open door**

If a door has not been closed properly, the pictogram will indicate the door concerned (or tailgate).

SPORT**Indicator, SPORT-mode automatic transmission**

This light will come on in cars with automatic transmission when the S (SPORT) button on the selector lever has been pressed (position D, 4, 3 or L) see page 163.

In this mode, the gear changes occur later, at higher engine revs, giving the engine and transmission a sportier feel.

To cancel the SPORT mode, press the S button on the selector lever again. The mode is also deselected automatically when the selector lever is moved to P or R.

WINTER**Indicator, WINTER-mode automatic transmission**

This light shows when the WINTER mode has been selected in cars with automatic transmission (see page 163).

In the WINTER mode, the car pulls away in 3rd gear, to help prevent wheelspin on an icy road.

To cancel the WINTER mode, press the W button.



Automatic transmission, fault indicator

On a car with an automatic transmission, this warning symbol is illuminated if a fault has been detected in the transmission. Switch the ignition off and on again to check if the fault persists.

Even if the fault persists, it is still possible in most cases to drive the car (see page 159). Have the automatic transmission checked by an authorized Saab dealer as soon as possible.

NOTE

If the control module has actuated the Limp-home function for the automatic transmission, the car will remain in 5th gear when D is selected, making it very sluggish. To overcome this, select position L to prevent unnecessary wear on the transmission. The transmission then starts in 2nd gear. When the car is moving you can select position D, 3 or 4.

When the indicator light is on, the car must not be driven with a trailer attached.



Indicator TCS/ESP OFF (option, certain models only)

The indicator light goes on when the Electronic Stability Program/Traction Control System is switched off with the TCS/ESP button.

IMPORTANT: the system is automatically engaged every time the engine is started (see page 167).

The indicator light also goes on when there is a fault in the system. In this case the light cannot be turned off by means of the TCS/ESP button. If a fault is indicated, have the system checked by an authorized Saab dealer.

See also "Traction Control System (TCS)", on page 167 and "Electronic Stability Program (ESP) on page 168.



Indicator TCS/ESP (option, certain models only)

The TCS/ESP indicator light is located in the tachometer and will be illuminated when TCS/ESP regulation is occurring, i.e. when there is insufficient traction between the tires and the road surface to provide the grip required for the acceleration called for. The driver can also sense that the engine is not responding normally to the accelerator.

Operation of the TCS/ESP indicates reduced traction between the tires and the road, and that extra care should be taken by the driver.

In normal driving, the TCS/ESP will help to improve both ride comfort and safety, but must not be regarded as a system to enable the driver to drive at or maintain a higher rate of speed. The same precautions for safe cornering and driving on slippery roads must still be applied (see page 167).

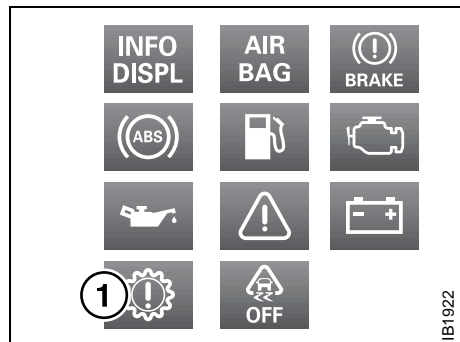



1 Cars with automatic transmission

Autochecking of lights, main instrument panel

The above warning and indicator lights should come on when the ignition is switched on prior to starting. They should go out after about 3 seconds.

The following lights light up until the engine is started, presuming that no fault exists:

- Central warning light .
- Oil pressure warning light .
- Warning, charging .



Instruments

Tachometer

The tachometer indicates the engine speed in thousands of revolutions per minute. The needle may be allowed to enter the broken red zone on the dial only for an instant.

A safety cut-out function (in the fuel system) prevents the engine speed from exceeding approximately 6,200 rpm.



Odometer and trip meter

The odometer records the distance traveled in miles on U.S. vehicles and on Canadian vehicles the distance indicated is in kilometres, and the trip meter in miles and tenths (kilometres and tenths of kilometres on Canadian vehicles).

Reset button

The reset button has two functions, determined by whether the ignition is ON or OFF.

- When the ignition is ON, pressing the button will reset the trip meter.
- When the ignition is OFF, the display lights up for 20 seconds enabling you to read the odometer and trip meter. Pressing the button a second time within these 20 seconds will reset the trip meter.



Speedometer (U.S. speedometer shown)

The speedometer receives signals from the wheel sensors in the ABS system.

If the NIGHT PANEL mode has been selected, the scale will be illuminated up to 87 mph (140 km/h). The remainder of the scale will be illuminated if the speed of the car exceeds 84 mph (135 km/h).

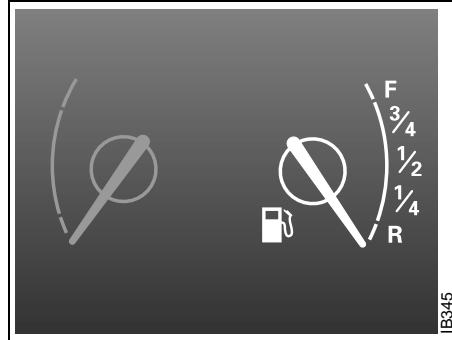

Fuel gauge

Fuel-tank capacity, 18.5 US gal. (70 liters). The fuel gauge shows the amount of fuel left in the tank. When this is down to about 2.5 gal. (10 liters), a warning light on the main instrument panel will come on (see page 53).

Use the Saab Information display (SID) to check the approximate distance that can be traveled on the remaining fuel (see page 59).



Temperature gauge

The temperature gauge shows the temperature of the coolant. The needle should be in the middle of the scale when the engine is at normal operating temperature.

If the needle approaches the red zone, which can occur in very hot weather or when the engine is under a heavy load, drive in the highest gear possible, keep the engine revs low and avoid shifting down.

If the needle enters the red zone, the  warning light will come on and an alarm chime will sound.

NOTE

If the needle, despite the above action, enters the red zone, stop the car immediately, let the engine idle.

If the needle stays in the red zone, stop the engine.

Check fuse 15 (radiator fan) in the fuse panel under the hood, see page 220.

If the needle repeatedly enters the red zone, stop the car as soon as it is safe to do so and check the coolant level by looking at the level visible through the plastic tank - do not remove the cap.

If the coolant level falls below the MIN mark, the SID will display the message "FILL COOLANT FLUID".

 **WARNING**

Never open the cap of the expansion tank completely when the engine is hot, open with care. The pressure in the cooling-system can cause hot coolant and steam to be released.

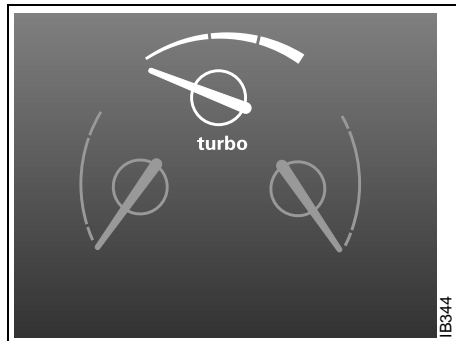
**Pressure gauge**

The turbo gauge indicates the air volume for combustion, which is equivalent to the engine load.

At low loads, the needle will move within the white zone. At higher loads and during heavy acceleration, the needle will enter the yellow area. At very high loads (certain variants only) the needle may enter the first part of the red zone without indicating that there is a fault.

Under certain barometric conditions the needle may enter the first part of the red zone without necessarily indicating that a fault has arisen.

If the needle repeatedly enters the red zone and the engine at the same time loses power, because the monitoring system is holding the charging pressure down, you should contact an authorized Saab dealer.

If the speed exceeds 143 mph (230 km/h), the increase in speed will be limited by the lowering of the boost pressure. The pressure gauge then moves towards the middle of the orange zone, indicating reduced engine output and thus reduces the speed of the car as well.

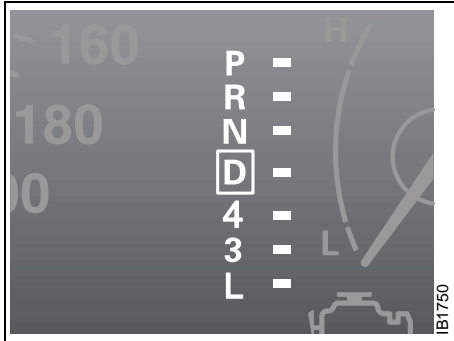

**Selector lever indication
(Automatic transmission)**

The position of the selector lever is indicated on the main instrument panel.

**Trip computer SID
(Saab Information Display (SID))**

The SID displays CHECK messages and has eight trip-computer functions (Saab Car Computer, SCC)

The SID is also used by the Audio System.

⚠ WARNING

It is strongly recommended that the SID settings be changed only when the car is stationary. The driver's attention can otherwise easily be distracted from the road.



IB346

**SCC
Selecting the function**

Use the button to scroll through the following functions:

- DIST Distance to destination / Trip meter.
- ARRIV Estimated time of arrival.
- ALARM Alarm function.
- SPD W Speed warning (chime).

Use the button to scroll through the following functions:

- TEMP Outdoor temperature and Date.
- D.T.E. Estimated range (distance to empty fuel tank).
- FUEL ∅ Average fuel consumption since function last reset.
- SPD ∅ Average speed since function last reset.

Outdoor temperature (Frost warning)

Regardless of which function has been selected, except Night Panel Mode, SID will automatically display the outdoor temperature when it is between 26° and 38°F (-3° and +3°C). This also applies if the temperature has moved outside the range of 21° to 43°F (-6° to +6°C) but is again between 26° and 38°F (-3° and +3°C).



WARNING

Remember that roads can be icy even at temperatures of above 38°F (+3°C), especially on bridges and stretches of road that are sheltered from the sun.

Entering values for the functions

Values can be entered for the following functions: SPD Ø, DIST, ARRIV, ALARM and SPD W.

- 1 Select the desired function using or .
- 2 Press the SET button for at least one second (figures start to flash and a chime sounds).
- 3 Use or to increase or decrease the value (press CLEAR to reset).
- 4 Press SET to record the value.

Average fuel consumption

The average fuel consumption is calculated using the values for fuel consumed and distance driven since last reset. This value is stored in the car's trip computer even when the engine is switched off.

- Select FUEL Ø with .

To reset the value, press the CLEAR button for 4 seconds. A chime will be heard and CLEARED will be displayed.

Setting the date

- 1 Use to select TEMP.
- 2 Press the SET button for at least one second (year starts to flash and a chime sounds).
- 3 Set the year using or .
- 4 Touch SET.
- 5 Set the month in the same way.
- 6 Touch SET.
- 7 Set the day in the same way.
- 8 Press SET to save the date setting.

Turning the Alarm and Speed warning on or off

- 1 Select the Alarm or Speed-warning function.
- 2 Press SET to turn on the function.
Press CLEAR to turn off the function.

When either function is on, ALARM/SPD W respectively will be visible on the display. An asterisk * will be visible on the far right of the display when either function is selected.

The Alarm and Speed-warning settings will not be cancelled when the engine is switched off.

When the Alarm has been set to come on at a specified time, it will only be activated once – it will not come on at the same time every day. Press SET to turn it on again. The Alarm will continue to beep for one minute if not switched off.

Calculation of arrival time and average speed

The settings must be made before the journey is started.

Calculation of arrival time:

- 1 Select DIST using the  button.
- 2 Set the destination distance.
- 3 Press SET.

When ARRIV is selected during the journey, the arrival time based on the average speed over the past 20 minutes will be displayed. The trip computer will include any stops in the calculation of the estimated time of arrival.

Press DIST and the distance remaining to the destination will be displayed in the same way.

After the distance to destination has decreased to zero, the DIST will function as a trip meter (see "Using DIST as a trip meter"). The starting value for the trip meter will be the last distance set in the DIST function.

Example: The DIST setting was 100 miles. Once 100 miles (160 km) has been covered, the DIST will start to function as a trip meter, the initial reading of which will be 100 miles (160 km).

Using DIST as a trip meter

If no value has been set for the DIST function, DIST will now function as a trip meter (indicated by an arrow on the far right of the display).



Press CLEAR to reset the trip meter.

Under 1000 miles the distance will be shown in increments of 0.1 miles, there-after, the reading will change in increments of 1.0 mile.

Metric units: for just under a kilometer, the distance will be shown in increments of 10 meters, there-after, the reading will change in increments of 100 meters.



When DIST is functioning as a trip meter, the ARRIV function will display the current time.

To calculate the arrival time if a specified average speed is maintained

- 1 Select DIST using the  button.
- 2 Set the distance to be covered.
- 3 Press  to select SPD Ø.
- 4 Set the average speed you intend to drive.
- 5 Press SET to display the estimated arrival time.

At the beginning of a journey, the SPD Ø and ARRIV functions will display current values. If values are set during the journey, the new values will be displayed after a delay of about 10 seconds.

Calculating the requisite average speed:

- 1 Press  to select DIST.
- 2 Set the distance to be covered.
- 3 Press  to select ARRIV.
- 4 Set the desired arrival time.
- 5 Press SET to display the average speed you need to maintain to arrive at the desired time.

At the beginning of a journey, the SPD Ø and ARRIV functions will display current values. If values are set during the journey, the new values will be displayed after a delay of about 10 seconds.

Resetting values

To reset the values, press CLEAR for at least four seconds.

The following functions will be reset simultaneously:

- Estimated range on remaining fuel (function based on a fuel consumption of 28 mpg).
- Average fuel consumption.
- Average speed.
- Arrival time (function based on current speed).

Programmed values for DIST, ALARM and SPD W will not be reset (see the respective function).

CHECK messages

When the engine is started, CHECKING will appear on the display for about four seconds, while the SID checks are being performed.

When a CHECK message is generated while the car is being driven, a chime will sound, INFO DISPL will illuminate on the main instrument panel, and the message will appear on the SID. The number of messages that can be displayed by the SID varies with the specification of the car.

If more than one CHECK message has been generated, the + symbol will appear to the left of the text on the display. The messages appear in order of priority.

If a new fault occurs while another message is being displayed, the message relating to the new one will appear for 10 seconds, after which the display will return to the earlier one.

Press CLEAR once to acknowledge a message, whereupon it will be cleared from the display. It will not be displayed again before the ignition has been switched off and then on again.

The following messages may be displayed:

| Message | See page |
|--------------------------------|----------|
| FRONT LIGHT FAILURE | 205 |
| REAR LIGHT FAILURE | 209 |
| FOG LIGHT FAILURE | 209 |
| BRAKE LIGHT FAILURE | 209 |
| WASHER FLUID LEVEL LOW | 203 |
| FILL COOLANT FLUID | 196 |
| REPLACE KEY BATTERY | 40 |
| KEY NOT ACCEPTED | 47 |
| SERVICE THEFT ALARM | 47 |
| TRANSMISSION OVERHEATING | 160 |
| TIGHTEN FUEL FILLER CAP | 152 |
| TIME FOR SERVICE ¹⁾ | 244 |

¹ This message will be displayed approximately 600 miles (1,000 km) before the next scheduled service is due, or when 365 days have elapsed since the last service. The message should be cleared at the time of that service (see the Saab Warranties & Service Record Booklet).

This message can also be deleted by first briefly pressing the CLEAR button, then depressing it a second time for at least eight seconds until "SERVICE" appears on the display and a chime sounds. The message can only be deleted when it is shown on the SID.

Night panel

To improve night-driving conditions inside the car, the Night Panel mode can be selected. In this mode, the amount of information displayed is reduced, and only the most important instruments and displays will be illuminated.

When the Night Panel button is pressed, only the speedometer will be illuminated (up to the 87-mph or 140-km/h graduation), all the other instruments illumination being extinguished and their needles moved to zero. Both the SID and the ACC displays will be extinguished and the backlighting for switches and other controls will be dimmed.

Note: All indicator and warning lights, together with the display of CHECK messages, will operate as normal, except "Outdoor temperature (Frost warning)", see page 60.

The following conditions will wake up the respective displays in the Night-Panel mode:

- Setting of the Audio system, SID or ACC (display comes on for ten seconds).
- CHECK message generated in the SID.
- High engine revs cause the rev counter to be illuminated until the engine speed has fallen again.
- If the quantity of fuel remaining falls below 4 gallons (15 liters), the fuel gauge will be illuminated.
- If the engine temperature rises above normal, the temperature gauge will be illuminated.
- If the speed of the car exceeds 84 mph (135 km/h), the entire speedometer will be illuminated.
- In cars with automatic transmission, if the selector lever is moved from D to position 4, 3 or L, the selector indication on the main instrument panel will be illuminated.

To restore the displays and lighting to the normal mode, press the Night-Panel button.





Units and language versions

The SID has four sets of units:

| METRIC | IMP. 1 | IMP. 2 | US |
|---------|---------|---------|---------|
| km | miles | miles | miles |
| km/h | mph | mph | mph |
| liters | UK gal | UK gal | US gal |
| °C | °F | °C | °F |
| 24-hour | 12-hour | 12-hour | 12-hour |

CHECK messages can be displayed in six language options: English, Swedish, German, French, Italian and Spanish.

Selecting units and language

- 1 Press CLEAR and SET simultaneously for four seconds until a chime sounds.
- 2 Press  or  to select the required units.
- 3 Touch SET.
- 4 Press  or  to select the required language.
- 5 Touch SET.



Clock

Set the clock by means of the two buttons under the digital clock on the left of the display.

When the ignition key is in the OFF position or removed, the clock can be illuminated (approx. 10 seconds) by pressing one of the SID buttons (not the NIGHT PANEL button).

Switches

Daytime running lights

The parking lights and daytime running lights come on automatically when the ignition switch is ON.

Note to owners in the U.S.: If you do not want Daytime Running Lights, this feature can be disconnected: switch off the engine and remove fuse No. 35 (see page 218).

Note to owners in Canada: Daytime Running Lights must not be disconnected as they are a Canadian Federal legal requirement.

Parking lights

The parking lights can be switched on regardless of the position of the ignition switch. Do not use parking lights when driving.

Note: The lighting switch must be in parking light or headlight position (low beam position only) to operate the fog lights (see page 68).

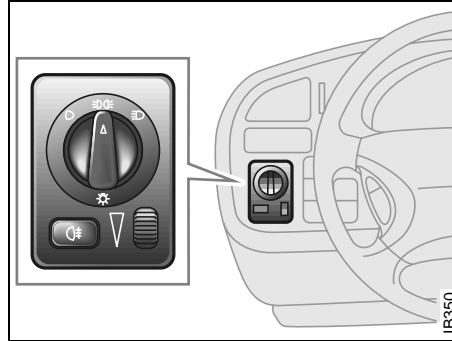

Light switches

Headlights

The headlights come on automatically when the ignition is ON and go off when the ignition switch is turned to the LOCK position. The parking lights, however, can be on when the ignition switch is in the LOCK position.

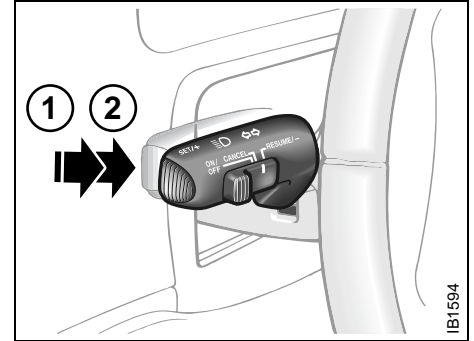

- 1 High beam signal
- 2 High/low beam switching

High/low beam

To switch between high and low beam, lift the control stalk fully towards you (position 2). When the high beam is on, the indicator on the main instrument panel will be illuminated.

High beam flasher

The headlights come on to high beam when the stalk is lifted to the first spring-loaded position (position 1) and remain on until the stalk is released.

Courtesy Headlight Feature

A delay function allows the headlights to remain on low beam for about 30 seconds after the driver's door has been closed.

To activate this function,

- Switch off the ignition and remove the key
- Open the driver's door
- Pull the high/low beam control stalk towards the steering wheel like you are flashing the high beam, see page 65. The low beam headlights will now come on immediately after the driver's door has been closed (within 30 seconds) and will remain on for about 30 seconds.

The length of time for this function can be adjusted by your authorized Saab dealer.

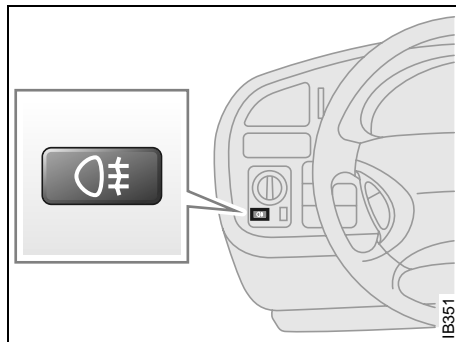

Rear fog light

Rear fog light

Press the button to switch on the rear fog light, which will only come on if the headlights are on.

The rear fog light will go off automatically when the engine is switched off. When the fog light is next needed, it will have to be switched on manually again.

The rear fog light consists of one light so it should not be mistaken for brake lights.

Make sure you are familiar with the applicable provincial/state law regarding the use of rear fog lights.

WARNING

In poor visibility, avoid following the tail lights of the vehicle in front. If the vehicle stops suddenly, you may be unable to avoid a crash and therefore risk injury to yourself and others.

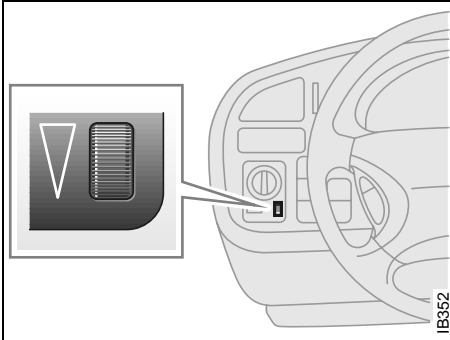

Instrument illumination

Instrument illumination

The brightness of the instrument illumination can be varied by means of the dimmer switch adjacent to the headlight switch. (See also Night panel on page 63).

In daylight or other equally bright light, the instrument and switch illumination is automatically extinguished.

Turn signal and lane change indicators

To switch on the turn signals/lane change indicators, move the stalk up or down.

The stalk has fixed positions for indicating a right or left turn, and the indicators are cancelled automatically (stalk returns to off position).

The stalk also has an intermediate, spring-loaded position that is useful for signalling when changing lanes or passing.

The respective indicator lights on the instrument panel flash at the same frequency as the direction indicators.

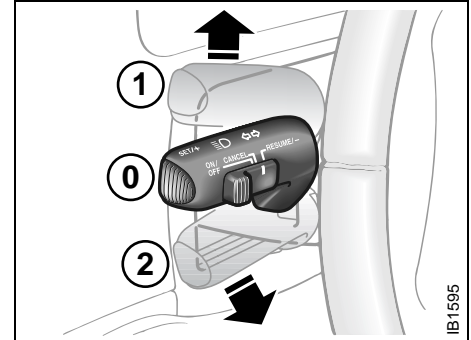

Turn signal and lane change indicators

- 1 Right indicators
- 2 Left indicators

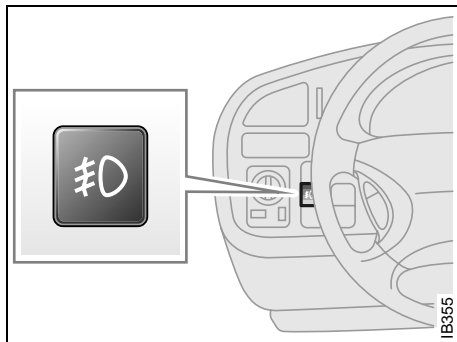

Front fog lights

The front fog lights can be activated in both dimmed headlight and parking light positions. Fog lights should only be used in poor visibility conditions.

Make sure you are familiar with the applicable provincial/state law regarding the use of fog lights.

Reversing lights

The reversing lights come on automatically when reverse gear is engaged or selected with the ignition switched on.

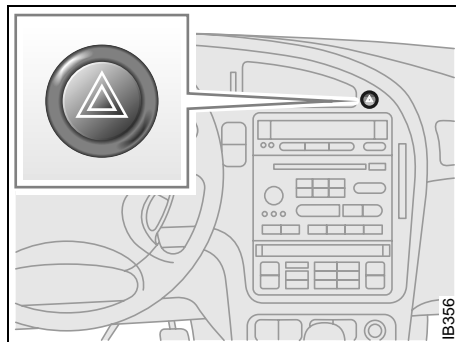

Hazard warning lights

Hazard warning lights

When this button is pressed, all the turn signal indicators and a symbol in the button flash simultaneously. If the ignition is on, both indicator lights on the instrument panel will also flash.

If the hazard warning lights are left on for some time, the flasher frequency will be reduced to save the battery.

Hazard warning lights should only be used if the car constitutes a hazard to other road users.

WARNING

Switch on the hazard flashers if the car has to be left at the roadside on account of a crash, engine trouble or a puncture. If you carry a warning triangle or flares, they should be set up along side of the road 300 ft. (100 m) behind your vehicle. If the car is not clearly visible (e.g. over the brow of a hill or bridge), place the triangle/flare even further back.



- 1 Interior lighting on continuously
- 2 Lighting comes on when a door is opened
- 3 Lighting always off

Interior lighting

The interior lighting consists of one dome light in the front and one in the back, a map-reading light in the front, two reading lights in the back, floor courtesy lights in the front (in some model variants) and door courtesy lights on all doors.

The courtesy lights come on automatically when the respective door is opened. Each reading light has its own switch adjacent to the lamp.

The switch for the dome lights is on the front overhead panel. When the switch is in the mid-position (door-activated), the interior lighting will come on:

- When the car is unlocked from the outside.
- When any door is opened.
- When the ignition key is withdrawn from the ignition switch.

When the switch on the overhead panel is in the mid-position, the lighting is switched off automatically 30 seconds after the last door has been closed or when the ignition is switched ON.

There is also a light in the sun visors. The light comes on when the cover over the vanity mirror is opened.

When the ignition is OFF, if a door has been left open for 20 minutes, the interior lighting will be switched off automatically to save the battery.

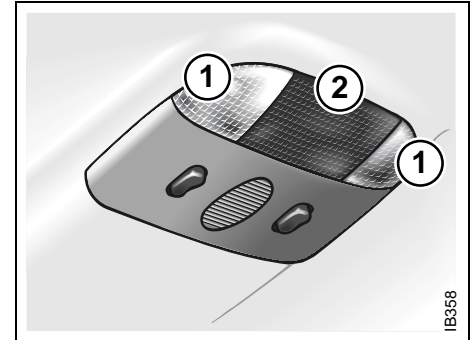

- 1 Reading lights
- 2 Dome light

Luggage-compartment lighting

The luggage-compartment lighting comes on automatically when the trunk is opened and goes out when the trunk is closed.

The lighting will also be switched off automatically after 20 minutes if the trunk has been left open.

Wipers and washers

There are three intermittent wiper positions. Moving the control stalk to the spring-loaded position between 0 and 2 will produce a single sweep of the wipers.

The wipers are designed for optimal cleaning at all driving speeds. At higher speeds, it may be possible to detect a slight "sweeping" sound. This may be due to the increased air pressure on the blades at higher speeds.

Headlight washers

If dim-dipped beam is on, the headlights are washed every seventh time the windshield washers are used or if 2 minutes have elapsed since the windshield was last washed. If the headlights are not on they are only washed the first time the windshield is washed. The headlight washers cannot be activated separately.

The headlight washers are of the high-pressure type, which means that other parts of the car may become wet if you activate the washers while the car is stationary.

Rain sensing wipers (option)



WARNING

To avoid personal injury, turn the rain sensor off if the ignition is ON when clearing snow and ice from the windscreen.

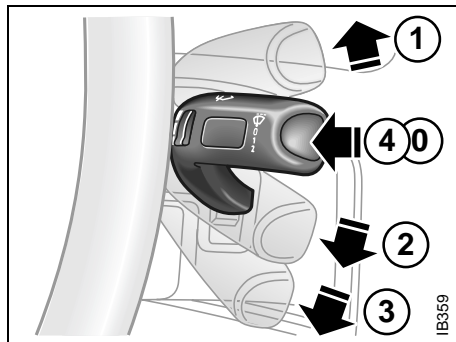

- 0 OFF
- 1 Intermittent operation
- 2 Low speed
- 3 High speed
- 4 Washers

NOTE

To avoid damaging the windshield wipers, turn the rain sensor off before washing the car in an automatic carwash.

The rain sensor automatically controls the windshield wipers. The sensor is located on the windshield beside the rearview mirror.

The system varies between single sweeps of the windshield and continuous wiping depending on how much water or snow there is on the windscreen.

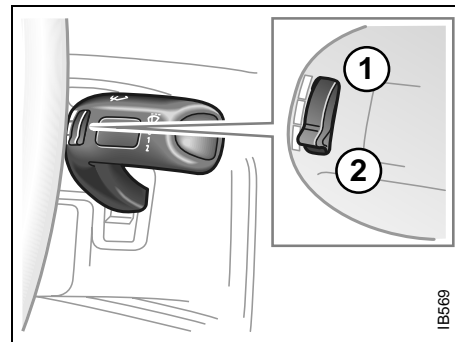

Control for setting wiper delay

- 1 Long delay
- 2 Short delay

Activate the system by lifting the control stalk to position 1. The wipers make one sweep for reference to see how much water and snow is on the windshield. In future, the sensor compares the amount of water and snow on the windshield with this reference value. When the engine has been switched off, the control stalk must be moved to position 0 and back to position 1 to reactivate the sensor.

Set the sensitivity using the control on the wiper stalk (the same control as used for wiper delay on cars not fitted with a rain sensor). The sensor has three sensitivity settings. It is most sensitive when in the uppermost position (1). When a higher degree of

sensitivity is selected, the wipers make one sweep of the windshield for reference.

The rain sensor has a daylight and a night time mode. The sensor measures the amount of available light and automatically selects the appropriate mode. The sensor is more sensitive at night. The function of the rain sensor is impaired by dry snow.

Rear-window wiper (9-5 Wagon)

The rear-window wiper and washer are operated with the same stalk switch as used for washing and wiping the windshield and headlights.

This stalk has two additional switches, ON/OFF and .

The ON position provides intermittent wiping.

The  position provides washing and wiping. After a few sweeps the wiper stops or reverts to intermittent wiping, if this has been chosen. About 15 seconds after completion of the washing/wiping of the rear window, the wiper makes a single sweep to wipe away any remaining washer fluid.

A spring-loaded position between the OFF and ON positions allows for a single sweep of the rear-window wiper.

Intermittent wiping of the rear window occurs when reverse gear is engaged if the windshield wipers are in position 1, 2 or 3, see page 70.

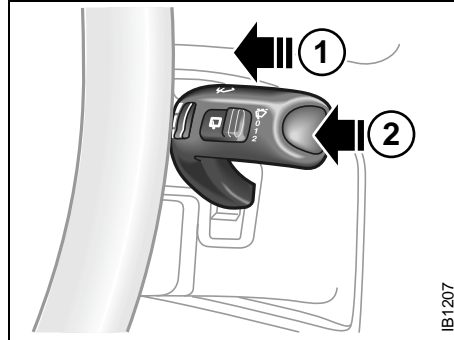

Rear-window wiper

- 1 Intermittent wiping
- 2 Washers

IB1207

Automatic climate control (ACC)

The ACC system automatically works to maintain the desired temperature inside the car.

The system will achieve the desired temperature in the quickest possible way. Note that selecting a higher or lower temperature than that desired will not speed up the process.

For the ACC system to be most effective, all windows (and sunroof, if fitted) should be closed.

Fresh air for the cabin is drawn in through an inlet grille adjacent to the bottom edge of the windshield. The air flows through a filter upstream of the ACC system before delivery to the cabin. Cabin air is evacuated via openings in the rear parcel shelf and then through outlets on either side of the car behind the rear bumper.

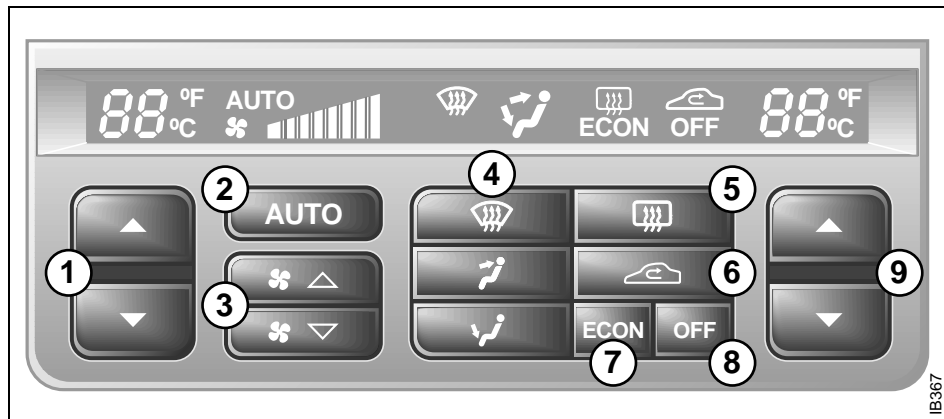

ACC panel

- 1 Temperature setting: LH side
- 2 AUTO: All settings selected automatically
- 3 Manual setting of fan speed
- 4 Manual setting of air distribution
- 5 Rear-window heating: ON/OFF
- 6 Recirculation: ON/OFF
- 7 A/C compressor: ON/OFF
- 8 ACC system: ON/OFF
- 9 Temperature setting: RH side

The incoming air is treated in three stages: first it passes through a filter; it is then dehumidified and cooled and, finally, if required, heated.

The filter is a combined particle and charcoal filter. It is so efficient that levels of noxious substances such as benzene and toluene are also reduced.

To reduce the likelihood of misting on the insides of the windows, the glass should be cleaned with a quality window cleaner. How often this will need to be done depends on how clean the air is – if there are smokers in the car, cleaning will need to be done more frequently.

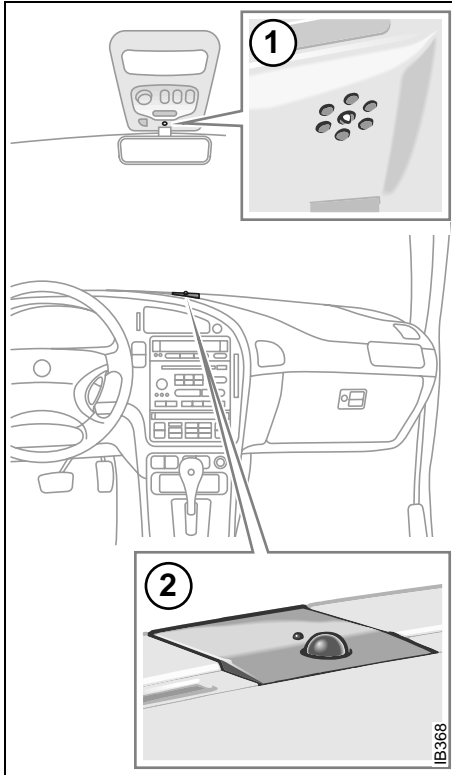

- 1 Interior-temperature sensor
- 2 Sun sensor

The system has five sensors:

- Outdoor temperature sensor.
- Interior temperature sensor.
- Sun sensor (mounted on top of the fascia).
- Two blended-air temperature sensors (mounted inside the front floor vents).

Caution If anything is placed over the sun sensor, the ACC system will not function properly.

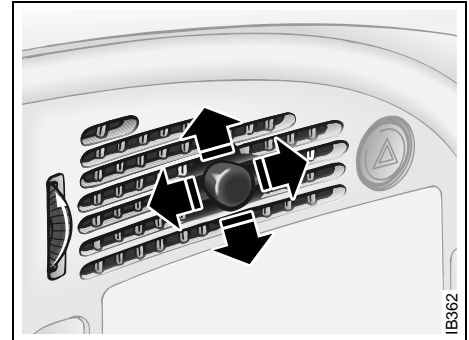

Panel vent

Panel vents

The panel vents swivel universally, so that air can be directed as desired. In winter, for instance, the outer vents can be directed onto the door windows for enhanced demisting.

The flow of air through the panel vents can be controlled individually for each vent by means of the adjacent control. The climate control system works best if the panel vents are open. If you find the air cold or that it is drafty, start by directing the air away from the body. If the center vent is aimed up, it will cool the interior temperature sensor and you may need to adjust ACC up or down, depending upon temperature desired.

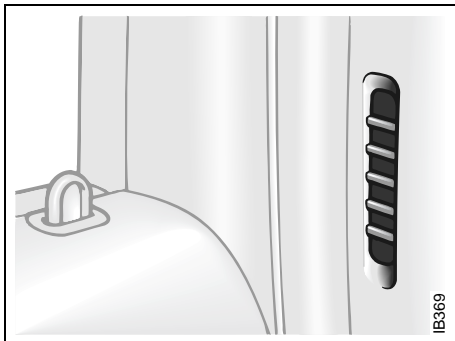

Air vent at rear side window

Temperature control

The cabin is divided into two temperature zones:

- The driver's zone.
- The passenger zone (front and rear seats).

The desired temperature can be set between 58 and 82°F (15 and 27°C). In addition, there are also HI and LO settings (see below). The HI and LO settings for the passenger zone can only be selected if they are also selected for the driver's zone.

The displayed temperature is not the absolute temperature but corresponds to the comfort level normally experienced at that temperature after allowance has been made for the air flow, relative humidity, solar radiation, etc., currently prevailing inside the car.

- The most usual temperature setting is 64-76°F (18-24°C), depending on personal preference and what clothing is worn.
- It is recommended that changes in the temperature setting be made in steps of 2°F (1°C).
- Once the desired climate has been achieved, the rear center vents can be closed to prevent warm air being distributed at face height.

Settings when HI selected:

- Maximum heat.
- Air distribution to windshield and floor.
- Recirculation OFF (even if manually selected before).
- Fan: high speed.
- Settings shown on ACC display.

Settings when LO selected:

- Maximum cooling (A/C compressor will run even if ECON manually selected before).
- Air distribution through panel vents.
- Fan: maximum speed.
- Recirculation ON.
- Settings shown on ACC display.

Functions

Pressing AUTO will cancel all manual settings. If a manual function is selected it will be locked in but other functions will be controlled automatically. The selected temperature is always maintained automatically.

| | |
|---|--|
| AUTO | |
| <p>Temperature, air distribution, fan speed and recirculation will all be controlled automatically. In falling temperatures the A/C compressor is switched off at 32°F (0°C). In rising temperatures the A/C compressor is switched on at 41°F (+5°C). If at the start the outside air temperature is 32 - 41°F (0 - +5°C), the A/C compressor is switched off.</p> <ul style="list-style-type: none"> • <i>Pressing AUTO once will cancel all previous manual selections.</i> • <i>Pressing AUTO a second time will result in all the automatically selected settings being displayed.</i> <p>When the engine is started, the A/C system is in AUTO mode, apart from any currently set program, see page 78 and 79).</p> | |

| | |
|--|--|
| ECON | |
| <p>A/C compressor OFF. No cooling of inlet air. Temperature, air distribution and fan speed still under automatic control.</p> | |

| | |
|--|--|
| OFF | |
| <p>ACC system OFF. Fan OFF. A/C compressor OFF. Warm air OFF. Air-distribution selections locked in current settings. Recirculation can be selected manually. Pressing the AUTO button will put the system into automatic mode. Pressing the OFF button again will result in the system reverting to any previous manual settings.</p> | |



The rear-window and door-mirror heating is controlled manually.
Switch off the heating as soon as the rear window is clear, to avoid imposing a heavy load on the battery longer than necessary. Note, however, that the heating will go off automatically after 2-10 minutes (depending on the outdoor temperature) or sooner if the voltage in the electrical system falls below 10 V.

The ACC system can be programmed to switch on the heating automatically when the outdoor temperature is below 41°F (+5°C) and the temperature inside the car is below 50°F (+10°C) (see "Programming I and II", on pages 78 and 79).



Recirculation is selected automatically for effective cooling, but it can also be switched on/off manually. Although recirculation does not substantially affect the air quality, it is useful to prevent unpleasant smells or fumes being drawn into the car from outside.



To increase the fan speed in steps.
 If, after being off, the ignition is switched on but the engine is not started, the fan will run at low speed until the engine is running.



To decrease the fan speed in steps.
 If the fan is set to 0, the A/C compressor will cut out and ECON will appear on the display.
 If, after being off, the ignition is switched on but the engine is not started, the fan will run at low speed until the engine is running.

Air distribution

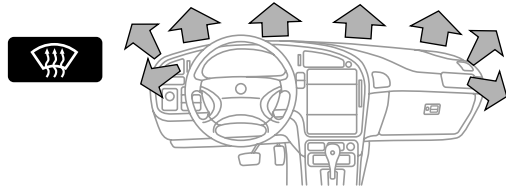

ACC65

Press once: Defrosting of all windows will take place (air flow to rear side windows shut off) with:

- The fan running at high speed.
- Air being distributed to the defroster vents.
- Normal temperature control will operate.
- Recirculation will be OFF.
- Heating of the rear window and door mirrors will be switched ON.

The defroster function will continue to operate until a new selection is made, although the heating for the rear window and door mirrors will be switched off automatically after 2-10 minutes, depending on the temperature outside.

Press twice: Air will be directed onto the windshield with no increase in the fan speed. The heating for the rear window will not be switched on.

To revert to the previous selection, press the AUTO button.

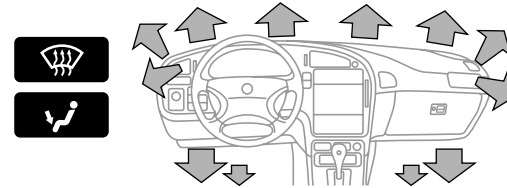

ACC66

Defroster & floor vents

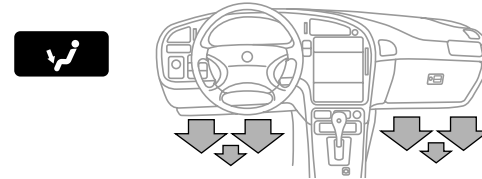

ACC67

Floor vents and rear side windows

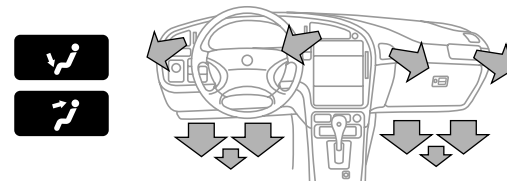

ACC68

Floor & panel vents

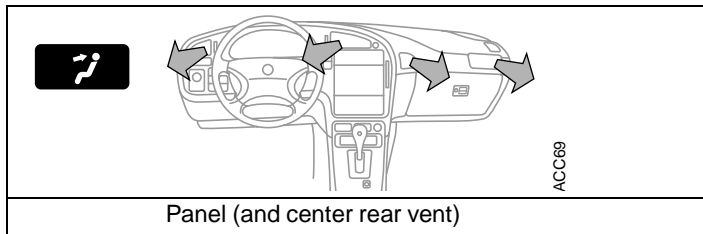

Starting in cold weather

To start with, the system will automatically select the defroster setting, maximum heat and low fan speed.

As the engine warms up, air will also be distributed through the floor vents and the fan speed will be increased.

As the temperature inside the car nears the selected value, both the fan speed and the heat will be decreased to a level determined by the system.

Starting in hot weather

The system will automatically distribute air through the panel vents at high fan speed and will switch on the A/C compressor (unless the ECON switch has been pressed).



If the outdoor temperature is above 86 °F (30°C), the system might select recirculation after approximately 45 seconds if this is required in order to reach the desired temperature.

As the temperature inside the car nears the selected value, the fan speed will be decreased to a value determined by the system.

Programming I

Manual selections can be programmed into the ACC system so that these will take effect when the car is started. Note that the ignition must be switched off for at least ten minutes after programming for the selections to be saved in the system's memory.

- 1 Make sure the ignition is ON.
- 2 Select the desired settings.
- 3 Press **OFF** and , simultaneously (the display will flash to confirm that the settings have been recorded).



Example: If you want air distribution through the panel vents when you start the car, press  and then save the setting by pressing **OFF** and .

Cancelling the programmed settings (I)

To cancel the programmed settings, press **AUTO** and  simultaneously (the display will flash to confirm that the settings have been cancelled).

Programming II

It is also possible to customize the ACC system, e.g. to adapt to driving and weather conditions.

| Function | Operation in AUTO mode after Programming II | Standard operation in AUTO mode |
|--|---|--|
|  | <p>The A/C compressor will not activate unless the outdoor temperature is above 55 °F (+13°C).</p> <p>–This function saves fuel by delaying the activation of the A/C compressor. However, in wet weather it is advisable to have the A/C compressor running when outdoor temperatures are below 57° (+14°C), as the A/C system reduces the likelihood of the windows fogging up.</p> | <p>A/C compressor cuts in when outdoor temperature is above 41 °F (+5°C)</p> |
|  | <p>Recirculation will be switched on if the speed of the car is less than 6 mph (10 km/h) and will be switched off when the speed has risen above 20 mph (30 km/h), but not if the ECON mode has been programmed according to "Programming II".</p> <p>–This function is useful to prevent fumes being drawn into the car in traffic jams.</p> | <p>Recirculation is switched on about 45 seconds after starting if the outdoor temperature is above 86 °F (+30°C) and the selected temperature for the cabin is well below the actual temperature in both temperature zones.</p> |





The heating will come on about five seconds after the engine has started if the outdoor temperature is below 41 °F (+5°C).

–This function helps to prevent ice or mist forming on the rear window in cold, damp weather. Fuel consumption may increase slightly.

Rear-window heating can only be switched on manually.

To program a function or to cancel a programmed function, press and hold in the relevant button until the corresponding symbol has flashed four times on the display and a chime has sounded.

Make sure the ignition is ON.

| Function | Text displayed on SID during programming | Text displayed on SID when cancelling program |
|--|--|---|
|  | ACC: LO TEMP A/C CTRL | ACC: NORMAL A/C CTRL |
|  | ACC: RECIRC ACC: SPEED CTRL | ACC: RECIRC ACC: NORMAL CTRL |
|  | ACC: AUTO RDEFR CTRL | ACC: MANUAL RDEFR CTRL |

Example: To have the ACC system switch the heating for the rear window and door mirrors ON/OFF automatically, press and hold in



until the symbol has flashed four times on the display and a chime has sounded.

The display shows:

ACC: AUTO
RDEFR CTRL

Once a function has been recorded under "Programming II", it will remain in the system until you cancel the program.

AUTO will still show on the display after a function has been saved in "Programming II".

Calibration

If the battery has been disconnected or has died, the system will need to be recalibrated.

To start the calibration procedure:

- 1 Start the engine.
- 2 Press **AUTO** and **OFF** simultaneously.

Calibration takes about 30 seconds. During this time and for about 3 seconds after the operation has been completed, the number of fault codes (if any) stored in the system will appear in the temperature display on the left. The fault codes themselves will be shown in the temperature display on the right.

Useful tips

(Before driving the car to an authorized Saab dealer)

- If AUTO is not shown on the display, see "Cancelling the programmed settings (I)" on page 78.
- If you suspect that the ACC system is not functioning properly, cancel (delete) all programmed settings and then recalibrate the system.
See "Cancelling the programmed settings (I) and (II)", pages 78 and 79, and "Calibration" above.
Note that AUTO will show on the display even if you have completed Programming II, but that this does not apply to Programming I.
- If the battery has been disconnected or has died, the ACC system will need to be recalibrated. See "Calibration" above.

Condensation

When the A/C system is running, the intake air is dehumidified, and the resultant condensation is drained off through two outlets underneath the floor of the car, in the vicinity of the front doors.

It is therefore perfectly normal for water to be seen dripping from these outlets when the car is parked. Greater amounts of condensation will result in warmer, more humid ambient air.

Formation of ice and mist in extremes of weather

It is only in the most extreme conditions that icing and misting of window glass are likely to be a problem, e.g. in torrential rain or severe cold coupled with high relative humidity, or when passengers are perspiring heavily or wearing wet clothes.

The following measures are recommended if such problems should occur:

- 1 Select AUTO and 70 °F (21°C) for both temperature zones.
- 2 Select Defroster.
If this is not enough...
- 3 Increase the fan speed.
If this is not enough...
- 4 Select a higher temperature.

The following measures are recommended if the occupants feel that it is cold and drafty in the car:

- 1 Make sure that all the air vents are fully open, including the center rear vent.
If this is not enough...
- 2 Direct the air flow away from the body (but not towards the interior temperature sensor).
If this is not enough...
- 3 Raise the temperature setting a degree or two. If this is not enough...
- 4 Lower the fan speed.

Fault diagnosis and maintenance, see page 231.

Afterheater, V6-engine cars

The afterheater enables a comfortable temperature to be maintained inside the car even after the engine has been switched off. The heater can be activated up to 10 minutes after the engine has stopped, although the coolant temperature must be at least 104°F (40°C) for the heater to operate.

To start the heater:

- 1 The ignition should be OFF.
- 2 Press and hold the AUTO button on the ACC panel for about a second, until a chime is sounded and the following appears on the SID:
"SPARE HEATER
ACTIVATED".

After five seconds, the SID will indicate how much heat is available (0 – 100%).

To switch off the heater:

- 1 Press the OFF button on the ACC panel. The heater will also be switched off if the ignition is turned ON.

The following settings will be used when the heater is running:

- Air distribution in AUTO mode.
- Recirculation not active but can be selected manually.
- Fan speed is automatic and cannot be changed.
- Only the fan speed is shown on the display. If AUTO is pressed, the system selections will be indicated.

The following controls do not operate while the afterheater is on:

- Rear-window heating.
- ECON.
- User presets.

Some of the functions can be reprogrammed. For further information, please consult your Saab dealer (see page 259).

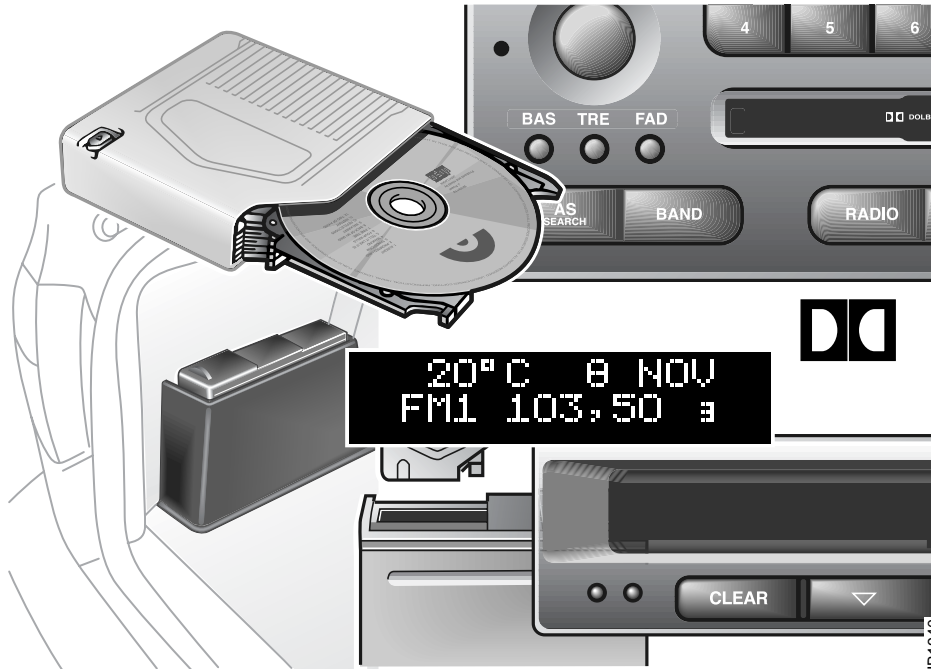

Saab 9-5 Audio System

| | |
|---|-----|
| Quick guide to the Saab 9-5 Audio System..... | 85 |
| Sound controls..... | 87 |
| Radio..... | 88 |
| Cassette player | 90 |
| CD player | 93 |
| CD changer..... | 95 |
| Programmable functions. | 99 |
| Steering-wheel controls .. | 100 |
| Security lock..... | 100 |
| Technical data | 101 |
| Fault codes | 103 |

To get the best out of your Saab 9-5 Audio System, we recommend that you read through this entire section.

The Saab 9-5 Audio System is available in two versions: Premium on the 9-5 Linear and Prestige on the 9-5 Arc and 9-5 Aero (Prestige system is also available as an option in the U.S. on the 9-5 Linear model.) Both models have been specially matched to the Saab 9-5 cabin.

The two models are comprised of a radio, CD player and cassette player.

A six-disc CD changer for installation in the luggage compartment is available as a dealer-installed accessory/option.

The Premium model has seven speakers: three mounted in the fascia (the center speaker further enhances the overall sound image) and one in each door.

The Prestige model (harman kardon) has nine speakers (9-5 Sport Wagon has eight speakers): three mounted in the fascia (the center speaker further enhances the sound image), one in each door and two subwoofers in the rear window shelf (9-5 Sport Wagon: one subwoofer in the luggage compartment). The subwoofers enhance reproduction of the lowest bass notes.

The Audio System is connected to the Saab Information Display (SID), which is at the top of the main instrument panel. Messages, indicators and the like for the Audio System are shown on this display.

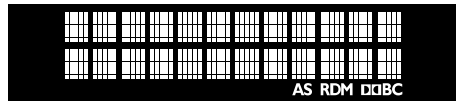

| | |
|--|--|
| Indicator | |
| AS | Radio is in Autostore mode |
| RDM | Random playback of CD tracks when CD player selected |
|  (DOLBY B/C) | DOLBY B/C noise reduction on for cassette player |

Quick guide to the Saab 9-5 Audio System

Radio (see page 88)



ON

To switch the system ON, press the volume button. The last settings used will be activated. If the Audio System is switched on when the ignition key is not in the switch, the system will automatically be switched off after one hour has elapsed since a control button on the radio was last pressed.

OFF

To switch the system OFF, press the volume button or remove the ignition key.

VOL

To adjust the volume, rotate the VOL control.

BAL

To adjust the balance between the left and right channels, pull out and turn the VOL control.



BAS

Press to release the button, and adjust the bass level. Lock the setting by pushing the button in.

TRE

Press to release the button, and adjust the treble. Lock the setting by pushing the button in.

FAD

Press to release the button, and adjust the fade between the front and rear sets of speakers. Lock the setting by pushing the button in.

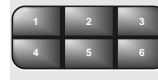

Preset station buttons

Press once: play the preset station.

Press & hold briefly: store a new station.



Auto tuning

Press once: auto (seek) tuning.

Press & hold briefly (a chime will sound): manual tuning.



Press once: Autostore ON/OFF.

Press & hold briefly: automatic tuning and storing of the 6 strongest stations.



Press once: change to radio when CD active.



Press once: change waveband.

Cassette player. See page 90



Press once: Selects cassette player when other source active.
When tape playing: Dolby B/C ON/OFF.



Switch to playback other side of tape.



Eject.



Press once: Music search (next track).
Press & hold briefly: Fast forward/rewind.
Press SEEK (mid-segment) (a chime will sound): Blank skip ON/OFF.

CD player. See page 93

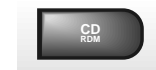

Press once: switch to CD player when other source active.
Press & hold briefly (a chime will sound): Random playback.



Press once: Track search.
Press & hold briefly: Rapid play (passage search) or Fast track search.
Press SEEK (mid-segment) once (a chime will sound): Switches between Rapid play (PLAY) and Fast track search (TRACK).
Press SEEK (mid-segment) & hold briefly (a chime will sound): Scan disc.



Remove CD.

CD changer (accessory/option). See page 95

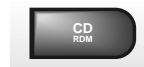

Press once: Change to CD changer when CD player is active.
Press twice: Change to CD changer when radio or cassette player is active.
Press & hold briefly (a chime will sound): Random playback of entire magazine.



Press once: Track search on current disc.
Press & hold briefly: Rapid play.
Press SEEK (mid-segment) once: Switch between Rapid play (PLAY) and Fast track search (TRACK).
Press SEEK (mid-segment) & hold briefly (a chime will sound): Scan/disc.
Press SEEK (mid-segment) & hold (2 chimes): Scan/magazine.



Selects disc in magazine.

Sound controls

ON/OFF

The Audio System will come on:

- When the volume control is pressed.
- When the ignition is switched ON, if the Audio System was on when the ignition key was last removed.

The Audio System will be switched off:

- When the volume control is pressed.
- When the ignition key is removed.
- One hour after the ignition was switched OFF, if the ignition key has not been removed.
- When one hour has elapsed since a control button on the Audio System was last pressed after the ignition key was removed.

VOL - Volume

BAL - Balance

Pull out and rotate the VOL control to adjust the balance between the left and right speakers. When the control is released, it reverts to the volume function.



BAS - Bass

TRE - Treble

Rotate clockwise to increase the level and counter-clockwise to reduce it.

The Bass and Treble controls must be pressed first to release them.

FAD - Fader

The fader control adjusts the balance between the front and rear sets of speakers. The Fader controls must be pressed first to release it.

Radio

Press the RADIO button to switch to the radio when another source is active.

Preset station buttons (1)

Press once (release within a second) to select a preset station, e.g.



The small figure on the far right of the display is the number of the preset button selected.

Presetting a station

Press and hold in the desired button (for more than a second) to store the currently tuned station. During this time, the radio will be mute. The sound will return as soon as the station has been stored.

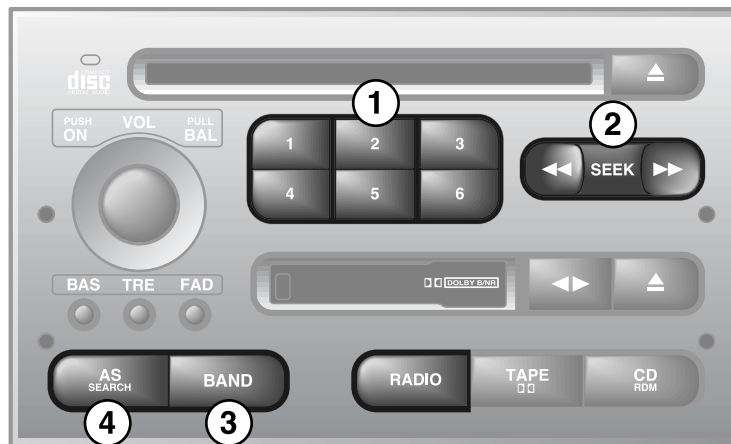

Tuning (2)

Automatic seek tuning:

Press **SEEK** (right arrow) briefly to search for higher frequencies or **SEEK** (left arrow) for lower frequencies.

Manual tuning:

To switch to the manual-tuning function, press **SEEK** (right arrow) or **SEEK** (left arrow) and release quickly (a chime will sound and the M indicator will appear on the display).

The function will revert to automatic seek tuning two seconds after the last manual frequency change has been made.

Waveband selector (3)

Press the BAND button repeatedly to move through the waveband selections: FM1, FM2, and AM.

AS, Autostore (4)

The autostore mode provides an additional preset function that can be used to search for and to store stations when you are in an area where you are unfamiliar with the stations and their frequencies.

Press the AS/SEARCH button to switch the Autostore mode ON/OFF. When the Autostore mode is ON, the AS indicator will show at the bottom of the display.

Press and hold in the AS/SEARCH button for more than a second to initiate a search for the six strongest stations.

Each time the system finds and stores a station, the number on the far right of the display will change. If the system cannot find six stations with good reception, the remaining preset buttons will be empty. If one of these empty buttons is pressed, U**** (FM) or AM**** will appear on the display.

When the system leaves the AS mode, it returns to the station that was selected before the AS mode was activated.

The AS mode can also be used in the AM band.

Cassette player

Before playing a tape, make sure that the label is secure and that the cassette is not warped, otherwise the cassette can become jammed in the deck. The cassette player automatically senses whether the tape is normal or metal (Type I or Type II).

TAPE (1)

Turn on the cassette player by pressing



or by inserting a cassette in the

deck, with the exposed tape to the right. Playback will start with the side that is facing up (indicated by A on the display). The display will now be as follows:



Playback direction (2)

To play the other side of the tape,

press  .

The deck will automatically change the playback direction when the end of the tape is reached, be it during playback, fast forward/rewind or music search.

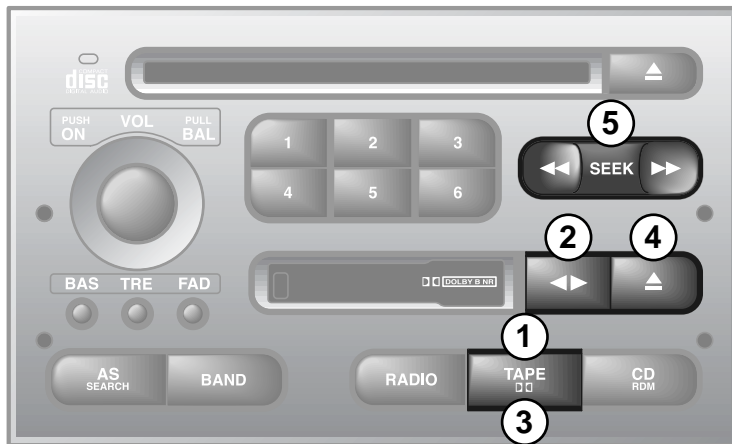

Dolby® noise reduction (3)

Press TAPE/DOLBY to switch on Dolby NR B/C.

Dolby B/C should be on for playback of tapes recorded with Dolby B/C, and off for those recorded without Dolby B/C.

Eject button (4)

To stop playback of a tape, press the eject button  or select another source.

If you select another source without pressing the eject button, the tape will remain in the deck but the head and pinch rollers will be clear of the tape. The same applies if the Audio System is switched off while a tape is being played. Tapes can still be ejected when the system is turned off.

Music search forward/reverse (5)

To search forward for a track, press **SEEK▶▶** and release quickly (within half a second). The following will now appear on the display:



To perform a backward search, press **◀◀SEEK** instead.

A forward search will continue until a gap of at least 4 seconds is found, or until you press **SEEK▶▶** or **◀◀SEEK▶▶** (mid-segment).

Pressing and holding the button during a search will initiate the fast-forward function.

Fast forward/rewind

Press and hold **SEEK▶▶** to start fast-forward to the end of the tape. The following will now appear on the display:



Press **SEEK▶▶** once to cancel fast-forward.

Press and hold **◀◀SEEK▶▶** (mid-segment) briefly to switch to music search.

Fast rewind (<< WIND) is performed in the same way as fast forward.

Auto music search (Blank skip)

To switch the Blank-skip function ON/OFF, press and hold **◀◀SEEK▶▶** (mid-segment).

When the Blank-skip function is active (display: BL SKIP ON), unrecorded gaps that are longer than 15 seconds will automatically be skipped.

When auto music search is in progress, the following will show on the display:



If a track has been recorded at an unusually low level and is therefore identified incorrectly as a gap between tracks, it could initiate a spurious "auto music search".

To cancel such a search, press and hold **◀◀SEEK▶▶** (mid-segment) during playback. The following will now appear on the display:



Type II (metal) tapes

The cassette has an automatic tape-type selector.

Cleaning-due indicator

After 30 hours' playing time, the following message will appear on the display:



The message will be displayed for ten seconds each time the cassette player is selected.

A cleaning tape should be used to clean the heads inside the cassette player to maintain good reproduction and to prevent unnecessary wear.

To reset the playing-time meter:

- 1 Remove the current tape.
- 2 Load the cleaning tape and play it for the required time.
- 3 Remove the cleaning tape and reload the other one.

Tape care

Do not expose cassette tapes to direct sunlight or to extremes of temperature as this can damage the cassette and the tape.

Always keep cassettes in their boxes when not in use.

If a cassette should become jammed in the deck, contact an authorized Saab dealer.

CD player

NOTE

Do not use writeable CDs in your Audio System. In certain cases, this type of CD is only suitable for home use and can therefore cause operational problems.

To select the CD mode, load a CD into the deck or, if one is already loaded, press the CD/RDM button.

Insert the CD, label-side up, and allow the mechanism to load it automatically. Playback of the first track will start and the following message will appear on the display:

```
20°C  8 NOV
CD PLAY 1
```

A tiny, amber-colored LED indicator to the left of the disc tray is illuminated when a disc is loaded.

When all the tracks have been played, the CD player will restart playback from track 1. To cancel playback, press the eject, RADIO or TAPE button.



IB1845

Track search (1)

Press **◀SEEK** or **SEEK▶** repeatedly to move to preceding or following tracks. Pressing **◀SEEK** once will restart playback from the beginning of the current track. Thus, to play the preceding track, press **◀SEEK** twice.

Rapid play (passage search)

When **◀SEEK** or **SEEK▶** is pressed and held, rapid play will be initiated, with the time and track showing on the display, e.g.:

```
20°C  8 NOV
CD 2:34 9
```

If the button is depressed for more than 5 seconds, the rapid play will be even faster. Rapid play stops when the button is released.

Fast track search

Press **◀SEEK▶** (mid-segment) once to switch between the CD-PLAY and CD-TRACK modes.



The CD-PLAY and CD-TRACK modes change the function of **◀SEEK** and **SEEK▶**. The selected mode will also be active the next time the system is switched on. Choose the mode that you find most convenient:

| | |
|----------|--|
| CD PLAY | Pressing and holding ◀SEEK or SEEK▶ briefly starts Rapid play |
| CD TRACK | Pressing and holding ◀SEEK or SEEK▶ briefly starts Fast track search |

Random playback (RDM) (2)

Press and hold the CD/RDM button to select/deselect random playback of the current disc. When this function is selected, RDM will appear at the bottom of the display.

Press **SEEK▶** once to move from the current track to the next during random playback.

Press **◀SEEK** once to repeat the current track during random playback.

Pressing and holding **◀SEEK** or **SEEK▶** will start Rapid play.

SCAN

To start the SCAN function, which enables you to hear a sample of each track on the disc, press and hold **◀SEEK▶** (mid-segment). The display shows that SCAN is in progress and which track is currently being sampled. For instance, if you started SCAN while playing the first track, the following display will appear:



The sample playback starts 30 seconds after the start of the track and lasts for 8 seconds.

When all the tracks on the disc have been scanned, the system will revert to playback of the track that was playing when SCAN was selected.

Press any segment of the SEEK button during scanning to play the current track from the beginning and simultaneously cancel the SCAN function.

Eject (3)

Press  to remove the disc.

If you press the eject button to open the tray but do not remove the disc, the CD player will automatically close the tray again after 10 seconds, without restarting playback.

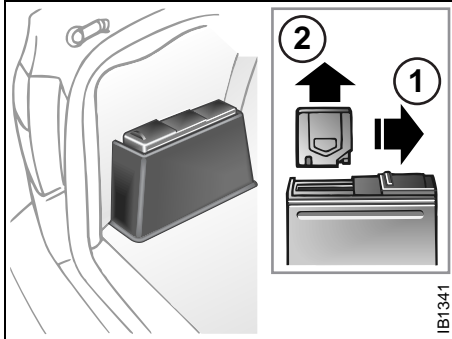

IB1341

CD changer in luggage compartment,
Saab 9-5 Sedan

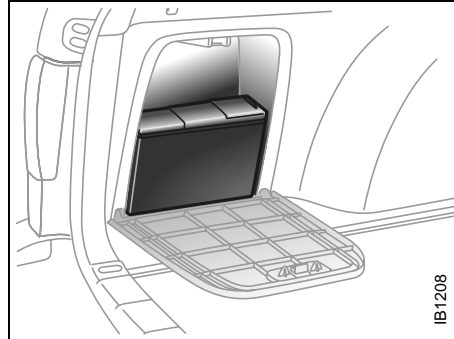

IB1208

CD changer in luggage compartment,
Saab 9-5 Wagon

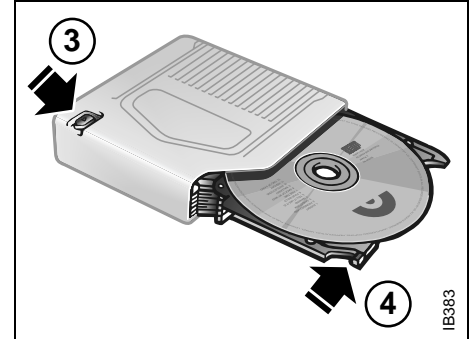

IB383

Changing a CD

CD changer (accessory)

NOTE

Do not use writeable CDs in your Audio System. In certain cases, this type of CD is only suitable for home use and can therefore cause operational problems.

Important! Always keep the sliding cover closed to keep dust out of the CD changer, so that it will continue to provide satisfactory service for a long time.

To load the CD changer (which is installed in the luggage compartment and can accommodate six CDs) proceed as follows:

- 1 Slide the top back.
- 2 Lift out the CD magazine.
- 3 Press back the catch on the magazine.
- 4 Withdraw one CD tray at a time and swap/load the CD (label side up). Slide the tray back into the magazine.

Note the position of the magazine for loading (see picture).

Insert the entire magazine carefully inside the CD changer and slide back the cover.

To select the CD changer

- If the Audio System is in the RADIO or TAPE mode, press the CD/RDM button twice.
- If the CD player is active, press the CD/RDM button once.

If the CDs in the magazine have not been changed, the system will start playback from where it left off before.

If there is no magazine in the CD changer, the following will appear on the display:

20°C 8 NOV
NO MAGAZINE

If the magazine in the CD changer is empty, the following will appear on the display:



If the CD changer is activated right after a magazine has been loaded, the following will appear on the display:



The CD number will change as each CD is played.

After a magazine has been loaded, playback will start with the first track on the first CD when the CD changer is selected, and the following will appear on the display:

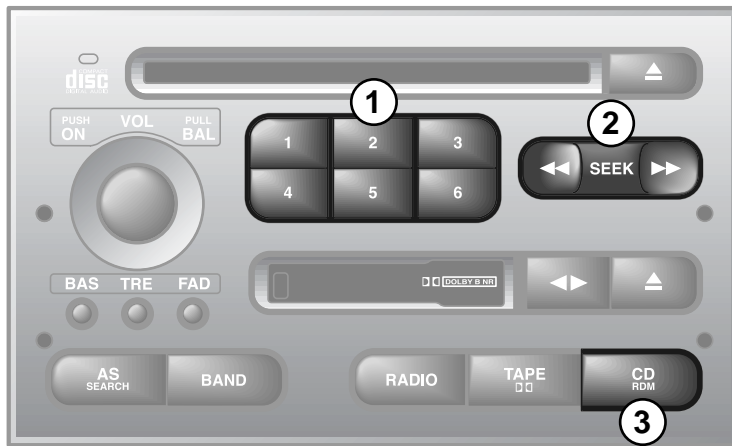

IB1846

Selecting CDs (1)

When the CD changer is operating, the radio preset buttons work for the six CDs in the magazine. Press the button for the corresponding CD.

If the selected CD is already being played, playback will restart from the first track.

If the selected CD-tray is empty, the following will appear on the display:



After two seconds, the status of the trays in the magazine (i.e. loaded or empty) will be shown on the display, e.g.:



If for some reason the CD selected by the preset button cannot be played, playback of the current CD will continue.

Track search (2)

Press **◀SEEK** or **SEEK▶** repeatedly to move to preceding or following tracks. Pressing **◀SEEK** once will restart playback from the beginning of the current track. Thus, to play the preceding track, press **◀SEEK** twice.

Rapid play

When **◀SEEK** or **SEEK▶** is pressed and held, rapid play will be initiated, with the time and track showing on the display, e.g.:



If the button is depressed for more than 5 seconds, the rapid play will be even faster. Rapid play stops when the button is released.

Fast track search

Press SEEK (mid-segment) once to switch between the CD-PLAY and CD-TRACK modes.



The CD-PLAY and CD-TRACK modes change the function of **◀SEEK** and **SEEK▶**. The selected mode will also be active the next time the system is switched on.

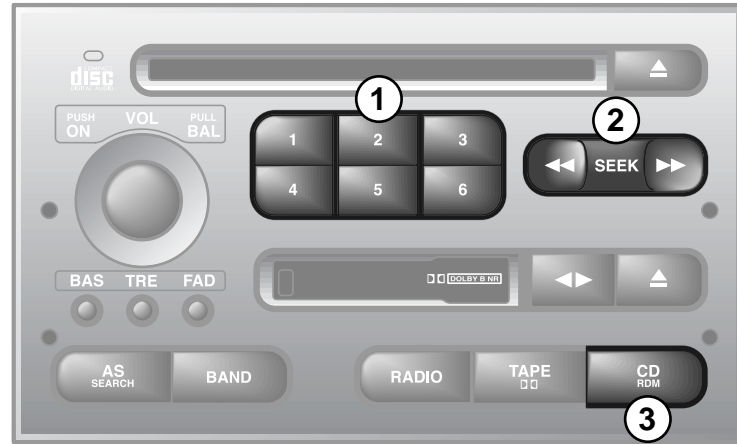

IB1846

Choose the mode that you find most convenient:

CD PLAY Pressing and holding **◀SEEK** or **SEEK▶** briefly starts Rapid play

CD TRACK Pressing and holding **◀SEEK** or **SEEK▶** briefly starts Fast track search

SCAN**Scanning the current CD:**

To start the SCAN function, which enables you to hear a sample of each track on the disc, press and hold **◀SEEK▶** (mid-segment). The display shows that SCAN is in progress and which track is currently being sampled. For instance, if you started SCAN while playing track one, the following display will appear:



The sample playback starts 30 seconds after the start of the track and lasts for 8 seconds.

When all the tracks on the disc have been scanned, the system will revert to playback of the track that was playing when SCAN was selected.

Press any segment of the SEEK button during scanning to play the current track from the beginning and simultaneously cancel the SCAN function.

Scanning the entire magazine:

Press and hold **◀◀SEEK▶▶** (mid-segment - two chimes) to start a scan of the entire magazine. A message similar to the following will appear on the display:



The sample playback starts 30 seconds after the beginning of the first track on each CD and lasts for 8 seconds.

After the first track of each CD has been sampled, the CD changer will revert to playback of the track that was playing when SCAN was selected.

Press any segment of the SEEK button during scanning to play the current track from the beginning and simultaneously cancel the SCAN function.

Random playback (RDM) (3)

Press and hold the CD/RDM button to select/deselect random playback of the CDs in the magazine. When this function is selected, RDM will appear at the bottom of the display.

Press **SEEK▶▶** once to move from the current track to the next during random playback.

Press **◀◀SEEK** once to repeat the current track during random playback.

Pressing and holding **◀◀SEEK** or **SEEK▶▶** will start Rapid play.

To stop playback from the CD changer, simply select once to move from the current track to the next during random playback (RADIO/TAPE/CD). The CD changer will now enter stand-by mode.

Programmable functions



WARNING

These functions should only be carried out when the car is stationary.

Volume-preset mode

To select the volume-preset mode, press and hold the BAND button at the same time as you switch the Audio System on.

Use the **◀SEEK▶** button to select the desired function.

The following volume settings can be preselected:

- START VOL - **maximum** volume level when the Audio System is switched on
- TEL VOL - preset volume level when an in-car phone is activated
- SP D VOL - speed-dependent volume. The Audio System will automatically adjust the volume level to adjust to an increase in vehicle speed.
- LOUDNESS ON/OFF - boosting of the highest and lowest frequency ranges to enhance the sound image when the volume is set to a low level.

Adjusting the volume

The default setting for START VOL is volume setting 9, and that for TEL VOL is volume setting 14 (the highest volume setting is 30).

• Maximum START VOL

20°C 8 NOV
START VOL 09

• TEL VOL

20°C 8 NOV
TEL VOL 14

To change the volume setting:

- Press and hold the BAND button at the same time as you switch on the Audio System.
- Adjust the volume
- Wait 10 seconds or press one of the buttons on the bottom row of the Audio System, e.g. RADIO, to save the new volume setting.

Speed-dependent volume (SP D VOL) ON/OFF

20°C 8 NOV
SP D VOL ON

To change the default setting:

The default setting for this function is ON.

- Press and hold the BAND button at the same time as you switch on the Audio System.
- Select SP D VOL using **◀SEEK▶**
- Select ON/OFF using the VOL control.
- Wait 10 seconds or press one of the buttons on the bottom row of the Audio System, e.g. RADIO, to save the new default setting.

Loudness ON/OFF

20°C 8 NOV
LOUDNESS ON

To change the default setting:

The default setting for this function is ON.

- Press and hold the BAND button at the same time as you switch on the Audio System.
- Select LOUDNESS using **◀SEEK▶**
- Select ON/OFF using the VOL control.
- Wait 10 seconds or press one of the buttons on the bottom row of the Audio System, e.g. RADIO, to save the new default setting.

Steering-wheel controls

To facilitate use of the Audio System and to promote safer driving, most of the functions can be operated using the integral remote controls on the steering wheel.

Control functions:

NEXT:

RADIO mode: preselect buttons

1⇒2⇒...⇒6⇒1⇒...

TAPE mode: Play other side of tape.

CD mode: Inoperative.

CD-changer mode: Select CD in magazine

1⇒2⇒...⇒6⇒1⇒...

<< SEEK >>:

RADIO mode: Auto/manual tuning.

TAPE mode:

Music search/Fast forward or rewind.

CD/CD-changer mode:

Track search/Rapid play.

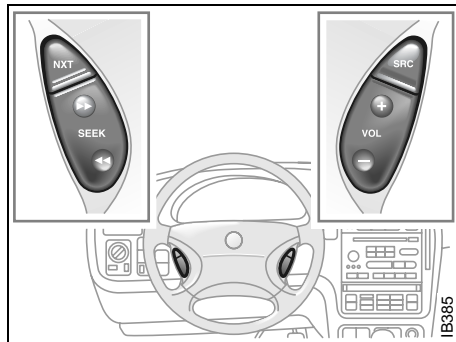

Audio System controls on steering wheel

SRC (source)

Press repeatedly to switch between
RADIO ⇒ TAPE ⇒ CD ⇒ (CD changer)
⇒RADIO ⇒...

VOL +/-:

Volume adjust.

Security lock

The Audio System is equipped with an electronic security lock. The special code is unique to the car in which the Audio System is fitted.

Each time the Audio System is switched on, a check is made to ensure that the codes match.

If not, the following will appear on the display:

20°C 8 NOV
RADIO LOCKED

If a CD changer has been installed, it will also have been security coded.

If the security code for the CD changer does not match when the changer is selected, the following will appear on the display:

20°C 8 NOV
CDC LOCKED

If a CD changer is to be retrofitted or if you wish to move the main Audio System module and/or CD changer to another car (Saab 9-5), you *must* consult an authorized Saab dealer so that the modules can be given the correct security codes.

Technical data

Tone controls

Bass _____ ± 10 dB at 100 Hz
 Treble _____ ± 10 dB at 10,000 Hz

Power output

Premium _____ 150 W
 110 W at 1% THD (total harmonic distortion) and 13.5 V
 Prestige _____ 200 W
 150 W at 1% THD (total harmonic distortion) and 13.5 V

Radio module

Radio system _____ PLL dual-synthesizer tuner

Number of presets:

FM _____ 3 x 6
 AM _____ 2 x 6

Frequency range:

FM _____ 87.9 – 107.9 MHz
 AM _____ 530 – 1710 kHz

Tuning steps:

Automatic seek tuning: _____ FM 200 kHz
 AM 10 kHz

Manual tuning: _____ FM 200 kHz
 AM 10 kHz

Frequency range (FM) _____ 40-15000 Hz
 ± 1 dB

Distortion (FM) _____ $< 0.5\%$

Cassette player

Fast forward/rewind _____ < 120 seconds (C-60)

Frequency range _____ 40 – 16000 Hz
 ± 2 dB

Wow and flutter _____ 0.2% WRMS

Signal-to-noise ratio _____ 45 dB

Dolby B/C NR effect _____ 8/16 dB

CD player and CD changer

1-bit system and 8 x oversampling

Frequency range _____ 20-20000 Hz
 ± 0.5 dB

Distortion _____ $< 0.008\%$

Dynamics _____ > 80 dB (1 kHz)

CD-changer capacity _____ 6 discs

- These specifications comply with the new IHF Standard
- Since the policy at Saab is one of continual improvement, we retain the right to alter specifications and design without prior notice.
- Dolby noise reduction is produced under licence from Dolby Laboratories Licensing Corporation
- "Dolby" and the double-D symbol  are trademarks of Dolby Laboratories Licensing Corporation

Changes or modifications not expressly approved by the manufacturer for compliance could void the user's authority to operate the equipment.

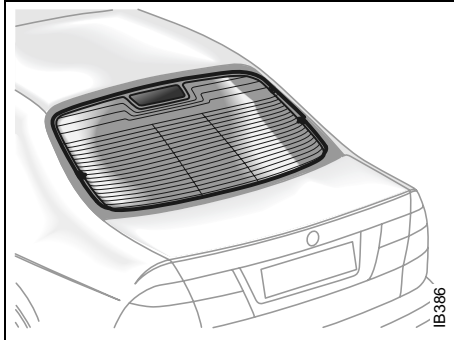

Antennas

The Audio System has three antennas incorporated in the rear window; two for FM diversity and one for AM.

NOTE

Refrain from placing hard or sharp objects on the rear parcel shelf, to avoid damaging the antenna leads.

Do not use sun protective film which contains metal particles on the rear window, this can be the cause of radio interference.

The car has a factory-fitted roof antenna for a mobile phone/OnStar. Roof loads may negatively affect telecommunication.

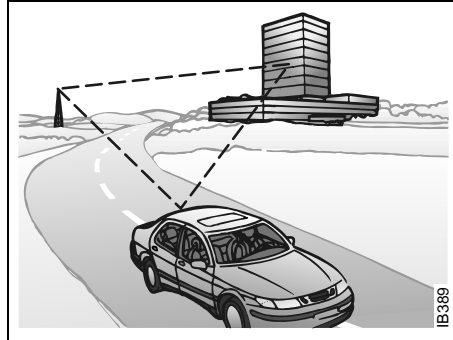

Multipath propagation

Multipath propagation occurs when radio waves from an FM transmitter are reflected by, e.g. large buildings, causing them to arrive slightly later than the direct waves. This can create interference to radio reception. To avoid this problem as much as possible the system is equipped with two FM antennas, so called FM diversity.

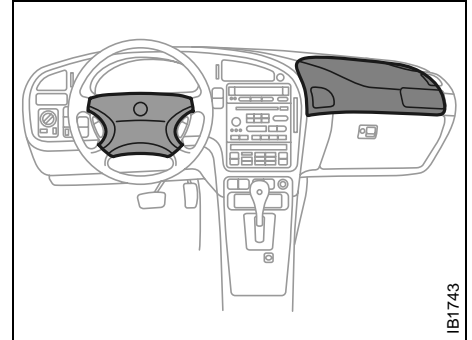

Accessories and other equipment must not be fitted to the surfaces marked as these are where the airbags inflate in the event of a crash

WARNING

To reduce the risk of head injuries in the event of a crash, the headliner and pillar trims incorporate energy absorbing material. These areas must not be modified in any way. Work on these areas must only be carried out at an authorized Saab dealer.

Adjusting the frequency steps North America/Europe

If the car is taken from North America to Europe, the radio's frequency steps can be adjusted.

- Press and hold  (mid-segment) and switch the radio on at the same time.

The preset stations will be cancelled and replaced by default frequencies.

Fault codes

NOTE

Great care should be exercised in trying to rectify a fault. If you are at all unsure, contact an authorized Saab dealer.

The Audio System has a built-in diagnostics function. If a fault is detected, a fault code is generated to help dealer technicians to diagnose the fault. Below are the codes for some faults that you might be able to rectify yourself.

| Fault code | Possible cause |
|--------------------------|---|
| CD/CDC ERROR 12/17/19 | CD is dirty, loaded wrong side up or defective. |
| TAPE ERR 01 | Tape broken or mechanical fault in deck. |
| TAPE ERR 02/03 | Tape snarled up or mechanical fault in deck. |
| TAPE ERR 11 | Cassette jammed: cannot be loaded/ejected. |

WARNING

The CD player/CD changer is classified as Class 1 laser equipment

- Service and repair work must only be carried out by authorized technicians.
- If the casing is damaged, hazardous laser radiation can occur.

NOTE

All work on the Audio System must be carried out by an authorized Saab dealer.

OnStar System

Your vehicle may be equipped with OnStar, a vehicle telematics communications and navigation system. Please consult the separate chapter in this owner's manual, page 105.

(This page has been left blank)

OnStar - Telematics



Using OnStar..... 106
 OnStar is Easy..... 106
 OnStar Services Button..... 106
 Emergency button 107
 White dot button 107
 System status light 107

The OnStar Center..... 108
 Connecting to the OnStar center 108
 Your personal identification number (PIN)..... 108

The OnStar Safety and Security Plan..... 108
 Automatic notification of air bag deployment 108
 Emergency services 108
 Roadside assistance..... 109
 Stolen vehicle tracking 109
 Accident Assist™ 109
 OnStar Med-Net..... 109
 Hands-free communication..... 109

The OnStar Premium Services Plan 109
 Route support..... 109
 Ride Assist..... 109
 Information and Convenience services 109
 Concierge services..... 110

Additional Services..... 110
 Personal Calling:..... 110

Virtual Advisor: 114
OnStar Subscriber Website 115

Limitations..... 115

Additional Information.... 116
 Warranty 116
 A Note About Privacy 116
 Transferring OnStar..... 116
 OnStar Subscription Information 116

Your new vehicle comes equipped with advanced telematics hardware and one full year of OnStar Premium Service. Saab telematics is a sophisticated in-vehicle system allowing convergence of wireless communications, GPS (Global Positioning System) satellites and advanced vehicle electronics.

You must activate immediately to ensure you receive your full year of service, as your prepaid subscription begins at the time of delivery.

Here's how to activate your OnStar service:

- 1 Push the blue OnStar button located in your Saab. After a prerecorded message explaining the benefits of onStar, you will be greeted by a live OnStar advisor. The advisor will activate your OnStar service.
- 2 Provide the information requested by the advisor to activate your account and set up your personal profile. This will take approximately 10-15 minutes.

Using OnStar

Welcome to OnStar. This section gives you all the information you need to get started using OnStar, including descriptions of all OnStar services. It also introduces the added services of Personal Calling, Virtual advisor, and the OnStar Subscriber website. For a complete explanation of these additional services, please see pages 110, 114 and 115.

NOTE: In order for OnStar to operate, the car audio system must be switched on.

OnStar is Easy

It's easy to start using your OnStar system. In fact, pressing the OnStar button is usually all you need to do. Once you are connected, an OnStar advisor will help you with the services in your plan.

Inoperative if battery is discharge or disconnected.

OnStar is powered by your vehicle's battery and will not operate if the battery is discharged or disconnected.

Potentially inoperative if vehicle is in a crash

If your vehicle is in a crash, some components could be damaged or disconnected, potentially rendering OnStar inoperative.

Your onboard OnStar System consists of three buttons:

OnStar Services Button



Press this button, and you are connected to an OnStar advisor. You will hear a chime, followed by the words "Connecting to OnStar." Allow 20-30 seconds for initial connection to the OnStar Call Center. An advisor will then help you with any of the services included in your OnStar plan. If cellular service is unavailable, OnStar will generate a fast busy tone. The OnStar system will retry calls a number of times before returning to the ready mode. To cancel the automatic dialing, press the White dot button.

Emergency button



In an emergency, press this button to connect with an OnStar advisor. Your call will be given the highest priority, and you will hear a tone followed by the words "Connecting to OnStar Emergency." An advisor will locate your Saab, find out what kind of assistance you require, and contact the nearest emergency services provider who can dispatch ambulance, fire, police or other emergency services. Please use this button only for true emergencies.

White dot button



Press this button at the end of a call. You'll hear the words "OnStar Request Ended." Also, press this button to answer a call from the OnStar Center, or cancel a call if one of the other buttons is accidentally pressed. This button is also used to access OnStar Personal Calling services which are described on page 110.

System status light

Solid Green — Indicates the OnStar system in the vehicle is powered ON and ready to make calls or receive calls from the OnStar Center.

Blinking Green — The light blinks green to indicate a call is being connected or in progress. If you notice this light blinking while you are not on a call, press the White dot button.

Red — This signals that your OnStar system may not be functioning properly. Press the OnStar button to attempt to contact an OnStar advisor. If the connection is made, the advisor will assist you in making sure your OnStar system is operating properly. If you cannot contact the OnStar Center, please take your car to the nearest Saab dealer for diagnosis and service.

The OnStar Center is the heart of your service — staffed 24 hours a day, 7 days a week with knowledgeable OnStar advisors. Even on weekends and holidays, there is always someone ready to help.

OnStar uses sophisticated Global Positioning System (GPS) satellites to locate your Saab, and wireless technology to provide the communications link and seamless integration into your Saab. This system allows the OnStar advisors to pinpoint your Saab's location precisely. This way, advisors can provide you with a range of helpful services to protect you and your Saab. Plus, with the Premium Services Plan* included for 12 months with your Saab, advisors can also access an extensive database to assist you with directions, making reservations and other convenience services.

*) New retail deliveries only.

The OnStar Center

Connecting to the OnStar center

In addition to using the 3-button system found in your Saab, there are two other ways to connect to the OnStar Center.

Toll-Free Call

To take advantage of your OnStar services from outside your Saab, you can call OnStar toll-free at 1-888-4-OnStar (1-888-466-7827). Remember to have your Personal Identification Number (PIN) handy.

Automatic Notification

A priority signal will be sent to the OnStar Center with your exact location if an airbag deploys.

(Vehicle electrical system and cellular service must be operable.)

Your personal identification number (PIN)

When you signed up with OnStar, you were asked to provide a Personal Identification Number (PIN). You'll need your PIN to access many of OnStar's services. If, for example, your vehicle has been stolen, an OnStar advisor will ask for your PIN in order to provide assistance.

Changing your PIN is easy. Call the OnStar Center and provide the advisor with your current number, and he or she will assist you in setting up a new number. If you have forgotten your PIN, just call the OnStar Center. For security reasons, we will send your PIN to you in the mail.

The OnStar Safety and Security Plan

The OnStar Safety and Security Plan is part of the Premium Services Plan that comes with your vehicle.* With it, you have access to a complete range of services providing you with an unsurpassed level of safety and security — 24 hours a day, 7 days a week. And you have it all at the touch of a button.

So whether you're on a lonesome country road or stuck in highway traffic, you have at your disposal a complete range of services providing you with unsurpassed security. And you have it all at the touch of a button.

Automatic notification of air bag deployment

Should your front air bags deploy, a priority signal will be sent to the OnStar Center with your Saab's location (as long as cellular service and the vehicle's electrical system are operable). An advisor will attempt to contact you to assess the nature of your emergency, and then notify the appropriate emergency services provider.

Emergency services

Should you require emergency assistance, press the red emergency button and OnStar or an advisor will contact the nearest emergency services provider with your exact location and your request for help.

* New retail deliveries only.

Roadside assistance**

There's nothing worse than being stranded on the road with car trouble. No matter what the problem is (flat tire, out of gas, or engine trouble), just call OnStar. They will contact the help you need to get you quickly back on the road.

Stolen vehicle tracking

OnStar doesn't just protect you, it protects your Saab, too. If your vehicle is ever stolen, just contact OnStar by calling 1-888-4-ONSTAR. They will put you in touch with the authorities and aid them in locating your Saab. Ask your insurance carrier about possible premium discounts.

Accident Assist™

Accident Assist™ provides step-by-step guidance about what to do in case of a crash. Working with leading insurance companies OnStar has developed a "best practices" list to assist you through most accident situations. OnStar Accident Assist™ can make the process of completing a police report and/or insurance claim less stressful.

OnStar Med-Net***

OnStar MED-NET securely stores your personal medical information (e.g., physician's name, emergency contacts, medications, chronic conditions) and, in an emergency, can quickly send it to a medical facility. This important information can help assist with diagnosis and treatment. ****

**There will be no charge for Roadside Assistance as long as your vehicle is under warranty.

***Requires activation and additional fee.

****Availability in Canada was undetermined at time of publication. Please contact your local dealer in Canada.

Hands-free communication

Talking to an OnStar advisor is easy and hands-free. Simply press the OnStar button, and a small microphone picks up your voice while the OnStar advisor talks to you through your stereo speakers. Note: Audio system must be switched on. You can even adjust the volume to your liking with the steering wheel controls or the radio volume knob. Your hands remain on the steering wheel, while your eyes remain on the road.

*Being safe on the road is important, but there's more to life than security. There's living. That's why we have created the OnStar Premium Services Plan. It gives you not only the important protections of the Safety and Security Plan, but also a whole range of services which truly change driving from a chore to a luxury. All new Saab models come with one full year of the OnStar Premium Services Plan.**

* New retail deliveries only.

The OnStar Premium Services Plan ***Route support**

With OnStar Route Support, an advisor can help you find your way, no matter how far off course you are. You can get exact street directions, or guidance to nearby gas stations, restaurants, hotels or ATMs.

Ride Assist

If you need a lift, anytime of the day or night, just call OnStar. They'll contact transportation and send it right to you.

Information and Convenience services

OnStar advisors have access to over five million service listings including hotels, restaurants, gas stations, dealerships, hospitals, ATMs and airports — more than 250 service categories in all. OnStar advisors can even assist you with hotel and restaurant reservations.

*All Saab models come with a full year of Premium Service. New retail deliveries only.

Concierge services

From the simple to the extraordinary, OnStar Concierge is always ready to help. Whether it's tickets to that "hard-to-get" play, or even complete planning of your next vacation, OnStar Concierge can make all the arrangements you need — at home or on the road. There is no additional cost to you for the efforts of the OnStar Concierge. You will not pay more than retail value for goods and services, or current market value for tickets, specialty items or unique services. For your convenience, they will bill your credit card for any purchases and/or shipping you authorize.

Additional Services

Personal Calling

As an OnStar Safety and Security Plan or Premium Services Plan subscriber, you have access to OnStar Personal Calling. OnStar Personal Calling provides you with a nationwide wireless phone service in your Saab that you can activate simply by pressing a button and using your voice. You can use Personal Calling in your Saab to place or to receive calls. The voice-activated system will dial the number. Your party will answer through your stereo speakers.

With OnStar Personal Calling, you can enjoy the simplicity of a one-touch wireless connection. Whether you are placing or receiving a call, once you press the button, you never have to take your hands off the wheel or your eyes off the road. The ease of the hands-free communication service allows you to enjoy an even greater level of safety, security and convenience while driving.

This new service is not yet available in all areas. Complete availability in the U.S. is anticipated in 2001*. For system limitations and details, call OnStar at 1-800-ONSTAR-7.

* Availability in Canada was undetermined at time of publication. Please contact your local dealer in Canada.

Signing Up for Personal Calling

As an OnStar subscriber, the Personal Calling capability is already built into your Saab's OnStar hardware. In order to use this service, an OnStar advisor must set up your cellular account. You must also provide a credit card in order to establish your prepaid cellular account. Usage charges will be deducted from this prepaid account of "units." Units are easily replenished using the credit card on file at OnStar. Once you sign up for OnStar Personal Calling, you will be given your own personal phone number that others can use to call into your Saab.

To sign up for Personal Calling, simply

- Press the OnStar button in your Saab.
- Inform the advisor that you would like to sign up for Personal Calling.
- The advisor will set up your account. You will need to provide account and credit card information.

Voice Commands

Personal Calling is made available through your voice commands to the system. This allows you to verbally control all of the phone functions.

Your OnStar wireless phone system has been programmed to respond to a wide variety of voices and accents. You should speak distinctly in a normal speaking volume. It is not necessary to exaggerate your voice or to speak loudly. Speak numerical digits one at a time, and then wait for confirmation before going to the next digit.

Voice Command Error Messages

Pardon – The system has not been able to match your command with a word that it knows. Repeating the command distinctly should fix the problem.

Slower Please – Repeat the command after a short pause. This response normally happens if you say a command before the system is ready for it or if there is substantial background noise.

Universal Commands

Help – The system will provide a list of available commands.

Clear – When you are entering digits, this command will erase the last digit entered.

Cancel – This command takes you from the current function to the "Ready" prompt. If the last response from the system was "Ready," this command will exit voice recognition.

Placing a Call

There are three ways to place a call:

- 1 By using a particular number, say "DIAL"
- 2 By using a stored nametag, say "CALL"
- 3 By dialing the last number, say "REDIAL"

To dial a number:

- | | |
|--|--|
| 1 Press the OnStar White Dot button | OnStar will respond "Ready" |
| 2 Say "DIAL" | OnStar will respond "Number Please" |
| 3 Say the 1st Digit | OnStar will repeat the number |
| 4 Say the 2nd Digit | OnStar will repeat the number |
| <i>Continue saying numbers in this manner until finished</i> | |
| 5 Say "DIAL" | OnStar will respond "Dialing <number>," then make the call |

To dial using a "Nametag":

- | | |
|-------------------------------------|---|
| 1 Press the OnStar White Dot button | OnStar will respond "Ready" |
| 2 Say "CALL" | OnStar will respond "Nametag Please" |
| 3 Say "<stored nametag>" | OnStar will respond "Calling <nametag>," then make the call |

To redial the last number dialed:

- | | |
|-------------------------------------|---|
| 1 Press the OnStar White Dot button | OnStar will respond "Ready" |
| 2 Say "REDIAL" | OnStar will respond "Redialing", then make the call |

Receiving a Call

If someone calls your wireless phone number, the entertainment system in your Saab will mute (if it is on), and you will hear a phone ringing sound. To answer the call, simply press the White Dot button.

Ending a Call

When your call is finished, press the White Dot button to end the call. It is not possible to end a call using voice commands.

Storing/Deleting Numbers in Memory (Nametags)

Storing a number

Your OnStar system can store up to 20 numbers (up to 32 digits each) in memory that can be dialed by simply repeating the "nametag."

To store a number:

| | |
|--|---|
| 1 Press the OnStar White Dot button | OnStar will respond "Ready" |
| 2 Say "STORE" | OnStar will respond "Number Please" |
| 3 Say the 1st Digit | OnStar will repeat the number |
| 4 Say the 2nd Digit | OnStar will repeat the digit |
| <i>Continue saying numbers in this manner until finished</i> | |
| 5 Say "STORE" again | OnStar will respond "Nametag Please" |
| 6 Say "<new nametag>" | OnStar will respond "Again" |
| 7 Say "<new nametag>" | OnStar will respond "Once More" |
| 8 Say "<new nametag>" | OnStar will respond "Storing <nametag>" |

Deleting a Number from Memory

To delete a nametag:

| | |
|-------------------------------------|---|
| 1 Press the OnStar White Dot button | OnStar will respond "Ready" |
| 2 Say "DELETE" | OnStar will respond "Nametag Please" |
| 3 Say "<nametag>" | OnStar will respond "Delete <nametag>, YES or NO" |
| 4 Say "YES" | OnStar will respond "Deleting <nametag>" |

Setting Tone or Voice Response

Your system comes from the factory with voice responses to your commands to confirm that the system received the command or number you intended. For example, when you are entering a number, OnStar repeats the number back to you. You may change the system to respond with a tone response if you prefer. A ready tone, a digit tone, or a goodbye tone will respond instead of the voice. All other responses will still be by voice.

| | |
|-------------------------------------|--|
| 1 Press the OnStar White Dot button | OnStar will respond "Ready" |
| 2 Say "Voice Feedback" | OnStar will respond "Voice Feedback is now ON/OFF" |

Units Remaining

OnStar keeps track of the amount of calling time you have purchased and used in units. The number of total remaining units is stored within the OnStar system, and can be accessed easily.

| | |
|-------------------------------------|--|
| 1 Press the OnStar White Dot button | OnStar will respond "Ready" |
| 2 Say "Units" | OnStar will respond "Verify or Add" |
| 3 Say "Verify" | OnStar will respond "You have # units remaining" |

Adding More Calling Minutes / Units

You can charge additional calling units with automatic refill by contacting OnStar, or by authorizing automatic unit refill on the OnStar subscriber website. For more information about the OnStar subscriber website, please see page 115.

Automatic Replenishment

If you run out of units during a call, your call will be terminated and you will be connected to OnStar for approval to replenish. You will be warned at the beginning of a call when you have ten or fewer calling units remaining.

Contact OnStar

| | |
|-------------------------------------|-----------------------------|
| 1 Press the OnStar White Dot button | OnStar will respond "Ready" |
|-------------------------------------|-----------------------------|

| | |
|---------------|-------------------------------------|
| 2 Say "Units" | OnStar will respond "Verify or Add" |
|---------------|-------------------------------------|

| | |
|-------------|---|
| 3 Say "Add" | You will be connected to OnStar for replenishment |
|-------------|---|

You will need your OnStar Personal Identification Number (PIN) to authorize the charge to your credit card on file.

If you are not in your Saab, you may call an OnStar Advisor at 1-888-4-ONSTAR (1-888-466-7827) to request unit replenishment.

Security/Locking your System

You can set up a four-digit Personal Security Code to ensure that unauthorized people do not use the calling capability of your system. With security set to ON, the system will not allow any personal calls. You must turn security OFF before calls can be made.

| | |
|-------------------------------------|-----------------------------|
| 1 Press the OnStar White Dot button | OnStar will respond "Ready" |
|-------------------------------------|-----------------------------|

| | |
|------------------|--|
| 2 Say "Security" | OnStar will respond "Enter Four-Digit Security Code" |
|------------------|--|

| | |
|---------------------|------------------------------|
| 3 Say the 1st Digit | OnStar will repeat the digit |
|---------------------|------------------------------|

| | |
|---------------------|------------------------------|
| 4 Say the 2nd Digit | OnStar will repeat the digit |
|---------------------|------------------------------|

| | |
|---------------------|------------------------------|
| 5 Say the 3rd Digit | OnStar will repeat the digit |
|---------------------|------------------------------|

| | |
|---------------------|--|
| 6 Say the 4th Digit | OnStar reply "Security (code # # # #) is now ON/OFF" |
|---------------------|--|

Volume Control

The volume of the audio portion of Personal Calling is controlled with your steering wheel volume controls or with the radio volume knob.

Virtual Advisor

Once you have activated Personal Calling, you can enjoy your time in your Saab even more with the OnStar Virtual Advisor. This service allows you to listen to your favorite news and information topics, such as weather reports, stock quotes and sports scores. You can even listen to your e-mail, whenever you want, without ever taking your eyes off the road. Using simple voice commands, you can browse your personal topics and skip or listen to those you choose. You can also search for additional information on special topics that interest you.

To find out how to set up a customized profile, visit the OnStar subscriber website at www.onstar.com, or turn to the OnStar subscriber website section on page 31 of this guide. If you do not have Internet access, you can still take advantage of the OnStar Virtual Advisor services as a default profile will be set up for you.

Calling the Virtual Advisor

| | | |
|---|-----------------------------------|--|
| 1 | Press the OnStar White Dot button | OnStar will respond "Ready" |
| 2 | Say "Virtual Advisor" | You will be connected to Virtual Advisor |

Getting Information from the Virtual Advisor

The OnStar Virtual Advisor will prompt you for information you desire. These offerings will change to provide you with services and information that you and other subscribers want and need. The prompts are very clear and easy to understand and use.

Information Available

OnStar will continue to add new features and categories to the Virtual Advisor. The following general categories will give you an overview of the types of information available to you. For complete up-to-date categories, you can go to the Saab Cars USA, Inc. website at www.saabusa.com or the OnStar website at www.onstar.com, and then click on the link to the subscriber website.

Weather

The OnStar Virtual advisor will deliver an up-to-date weather forecast for the current location of the vehicle. The forecast includes current temperature, daily high/low, tomorrow's high/low, precipitation forecast, and unusual conditions.

Stock Quotes

The OnStar Virtual advisor can provide you with current quotes for the stocks you have specified in your customized profile as well as other requested stocks. All market data is delayed by twenty minutes. If you have not set your profile, you can still access the stock quote feature through your default profile and then request the stock of your choice.

Sports Scores

The OnStar Virtual advisor can provide you with scores for your favorite college and professional teams with up-to-the-minute highlights, even if they are being broadcast on a local station. See the team selection option in your Mobile Profiler section of the subscriber section of OnStar.com.

If you have not set your profile or are still using the default profile, you can access the sports option of the Virtual advisor and ask for an update on your favorite sport. You always have access to the options in the Virtual Advisor.

News Headlines

The OnStar Virtual Advisor will provide current headlines for many different categories, including:

- International News Headlines
- National News Headlines
- Technology Headlines
- Business Headlines
- Sports Headlines
- Entertainment Headlines

E-mail Reader

The OnStar Virtual Advisor allows you to listen, and soon respond, to your e-mails any time you want. E-mail availability is based on the address(es) you provide to OnStar. Every Virtual Advisor enrollee will receive an E-mail account.

OnStar Subscriber Website

As an OnStar subscriber, you have access to the OnStar subscriber website. The subscriber website will provide you with important facts about your OnStar subscription and allow you to customize your Virtual Advisor Mobile Profile. All this allows you to access up-to-the-minute information that can make your driving experience safer and more enjoyable.

The subscriber website was designed to provide you with easy access to personalized information, learn more about OnStar, update your account information, plan your travel, receive weather information and interact with OnStar.

You can also act like an OnStar advisor and pinpoint your Saab. To access the subscriber website, simply go to www.onstar.com, and then click on the OnStar subscriber link. The OnStar Subscriber website is a secured site that is password protected. You will be required to provide your OnStar account number and personal identification number (PIN). If you do not know your account number or PIN, contact OnStar at 1-888-4-ONSTAR. For security reasons, your PIN will be mailed to your address on record.

Limitations

Notwithstanding anything contained herein, OnStar's nonperformance hereunder shall be excused if caused by act or omission of a cellular carrier or a third-party service provider, equipment failure, acts of God, strikes, equipment or facility shortage, or other causes beyond OnStar's reasonable control. In addition, the liability of OnStar, if any, for any mistake, omission, interruption, delay, error, defect or other failure in the service furnished, or in the equipment used in furnishing service, shall in no event exceed the amount of OnStar's charges to subscriber for said service during the period so affected, provided that no liability shall result for outages of 24 hours or less.

This manual includes the latest information at the time it was printed. We reserve the right to make changes to the products and services without prior notification.

In order to provide you with excellent service, any call to the OnStar Center may be monitored or recorded.

All features may not be available on all models. Please consult your dealer for details.

OnStar Operation:

OnStar uses existing emergency service providers and cellular and satellite technologies. OnStar requires cellular service to be available and operating for features to function properly.

Personal Calling:

Existing OnStar service agreement required. Additional usage charges apply for Personal Calling. Interim 2001 model year availability in select markets. For system limitations and details, call 1-800-ONSTAR-7 or visit www.onstar.com.

Virtual Advisor:

Existing OnStar and Personal Calling service agreement required. Additional usage charges apply for Personal Calling. Interim 2001 model year availability in select markets. For system limitations and details, call 1-800-ONSTAR-7 or visit www.onstar.com.

Additional Information

Warranty

OnStar is warranted as part of the General Motors new vehicle limited warranty.

A Note About Privacy

At OnStar, we know you want to protect your privacy, and we take subscriber privacy very seriously. We never provide your personal information to another company or person unless you authorize it, or we are required to by the legal process, or in such cases where you have provided it for billing purposes or you have requested a hotel reservation, are sending flowers, etc. Having this information on file with OnStar is a real advantage and helps you avoid repeating your credit card information over a cellular connection. Your trust is what we most value.

Transferring OnStar

Because your OnStar 3-button system is an integral part of your Saab, it cannot be transferred to another vehicle. Each OnStar system stays with the original car or truck in which it was installed.

The one-year OnStar prepaid subscription applicable to new retail deliveries cannot be transferred to another vehicle. However, if you've purchased additional years of service and decide to dispose of your Saab, any remaining service will be refunded to you. Or, if you choose, you can have it transferred to another vehicle on your account. Any service that is refunded or transferred will be prorated at the monthly rate in effect at the time of transfer.

OnStar Subscription Information

To renew your subscription or upgrade your plan, just push the OnStar button, or call the OnStar customer service department at 1-888-864-2801 between 8 am and 6 pm EST.

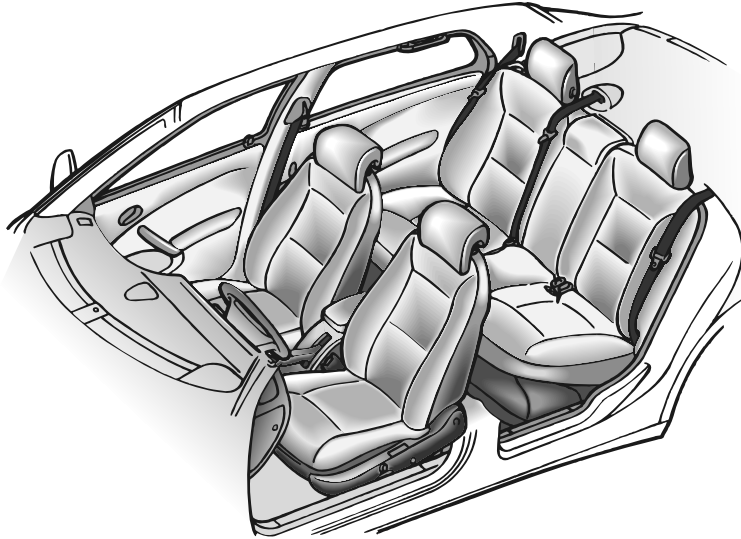

IB394

Interior equipment and trunk

| | |
|---|-----|
| Seats | 118 |
| Steering wheel adjustment..... | 122 |
| Rearview mirrors..... | 123 |
| Electric windows..... | 125 |
| Sunroof | 126 |
| Sun visors..... | 128 |
| Ashtrays (accessory)..... | 128 |
| Glove compartment | 129 |
| Cup holders | 131 |
| Trunk..... | 132 |
| Spare wheel and tools | 142 |
| Fuel filler flap..... | 143 |
| Opening the fuel filler flap in an emergency..... | 143 |

Seats

WARNING

The seats are actuated by powerful motors. Ensure that nothing can be trapped when adjusting the seat.

Bear in mind that children can be injured if they play with the electrically-operated seats

Both front seats are electrically operated. On certain models the driver's seat is equipped with a memory function.

To facilitate getting into the car, both seats can be adjusted when either of the front doors is open.

For safety reasons, if the door is closed, the seat can only be adjusted when the ignition is ON.

Note, however, that both seats can be adjusted for 30 seconds after both doors have been closed.

The following seat adjustments can be made to achieve a comfortable driving position:

- Height.
- Legroom.
- Backrest rake angle.
- Lumbar support.
- Head-restraint height.

We recommend that adjustments to the driver's seat be performed in the following order:

- 1 Height.
- 2 Legroom.
- 3 Seat tilt angle.
- 4 Backrest rake angle.

Lastly, adjust the steering wheel (see page 122).

WARNING

Never adjust the driver's seat except when the car is stationary.

Side airbags

(see page 32).

Head restraint

(see page 18).

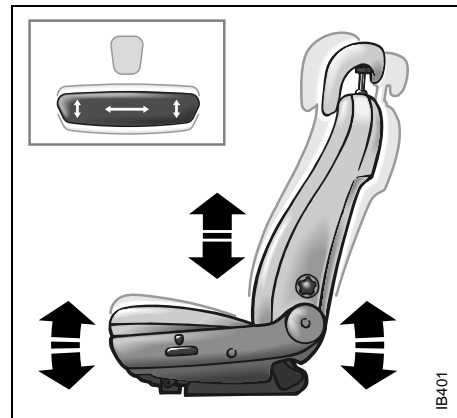

Height

To raise the seat, lift the lower control straight up.

To lower the seat, press the lower control down.

The same control can be used to adjust the height of the front and rear edges of the seat independently.

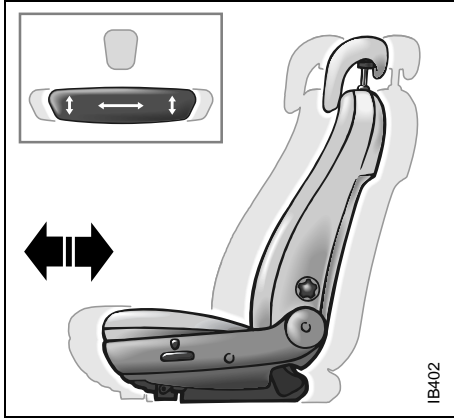

IB402

Legroom adjustment

To adjust the legroom, push the lower control forward or back.

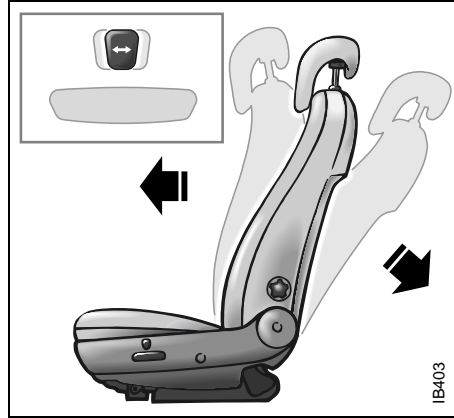

IB403

Backrest rake angle

To adjust the backrest, move the upper control forward or back.

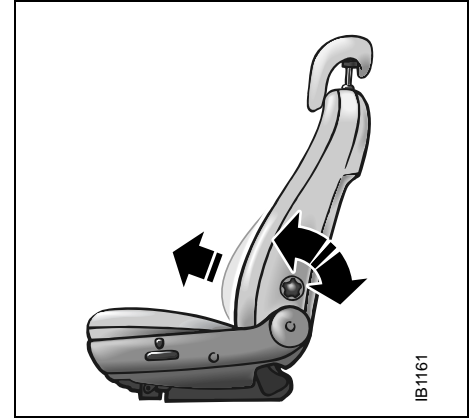

IB1161

Lumbar support

Turn the smaller wheel for stepless adjustment of the lumbar support.

! WARNING

The backrest should be upright during driving, so that the safety belt, airbag and backrest can provide optimum protection in the event of emergency braking or a crash.

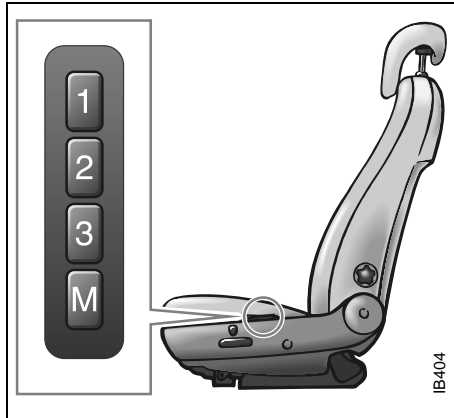

Programmable driver's seat (certain models only)

In certain models the driver's seat is equipped with a programmable memory function. This function also includes the door mirrors.

Adjust the seat and door mirrors.

To save the settings, press and hold the M button and, at the same time, press one of the preselect buttons (1, 2 or 3). The SID will chime to confirm that the settings have been saved.

To recall the programmed settings, press the appropriate preset button, whereupon the seat and mirrors will be adjusted automatically.

To change the settings stored in a preset button, adjust the seat and mirrors as before and save the new settings by pressing M and the appropriate preset button.

To facilitate reversing, the passenger side door mirror can be tilted down automatically, e.g. to show the curb. To do this, select reverse and press the tiny button adjacent to the door-mirror control. When you deselect reverse, the mirror will return to its original setting automatically (see page 123).

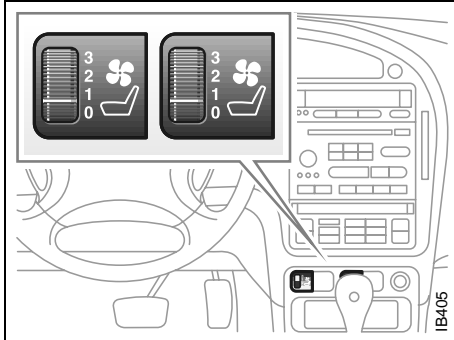

Ventilated front seats (standard on 9-5 V6 Arc model)

Ventilated front seats, that enhance seating comfort in hot weather, are available only on 9-5 V6 Arc models.

Ventilated seats are equipped with two fans that extract the moist air from between the seat and the body.

The fans have three speeds and are OFF when the switch is set to 0.

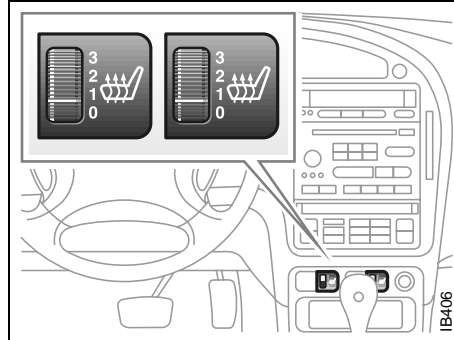

Electric heating, front seats (option)

Both front seats have adjustable and thermostat-controlled heating of the seat cushion and backrest, available as an option.

Heating is adjustable in three stages. In position 0 it is turned off.

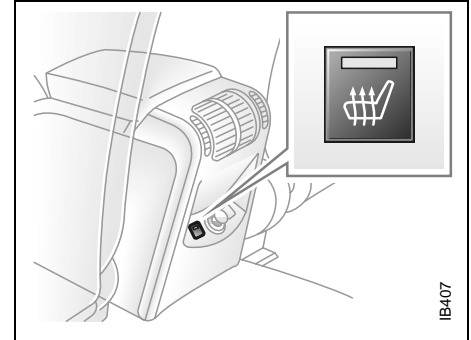

Electrically heated seat cushions in the rear seat (option)

Electrically heated seat cushions for the two outer seats in the rear are available as an option.

The ON/OFF control button for the cushion heating is located on the back of the center console.

The warming-up time varies with the temperature outside.

The button has an integral indicator that is illuminated when the heating is on.

Steering wheel adjustment

Fore-and-aft and tilt adjustment of the steering wheel is possible.

Pull down the lever fully until you hear a click. Move the steering wheel to the desired position and then raise the lever. The lever should lock with a click.

Make sure that the lever is fully locked before driving off.



Never adjust the steering wheel unless the car is stationary.

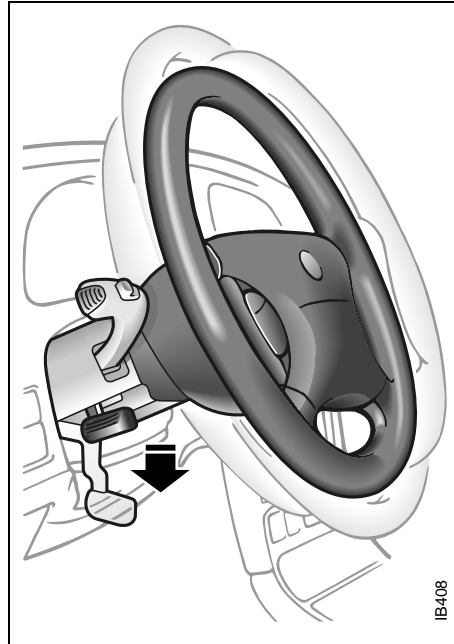

IB408

To adjust the steering wheel

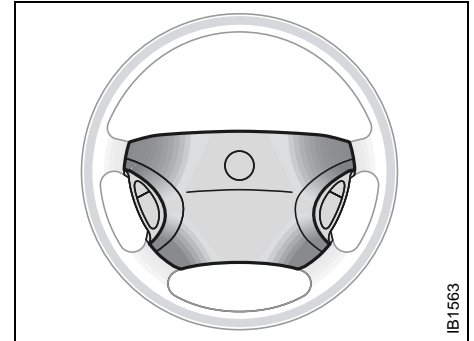

IB1563

Horn

The horn is sounded by pressing the central part of the steering wheel. Press closest to the steering wheel rim.

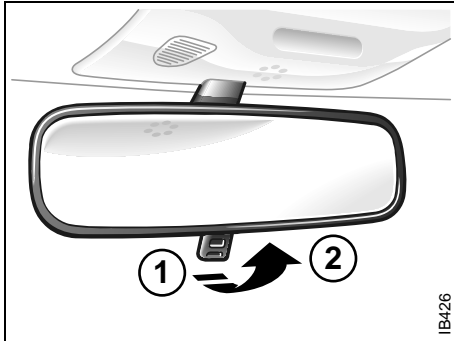

Rearview mirror

- 1 Day position
- 2 Night position

Rearview mirrors

The rear-view mirror has day/night positions that can be selected by means of a knob beneath the mirror. Adjust the mirror in day position.

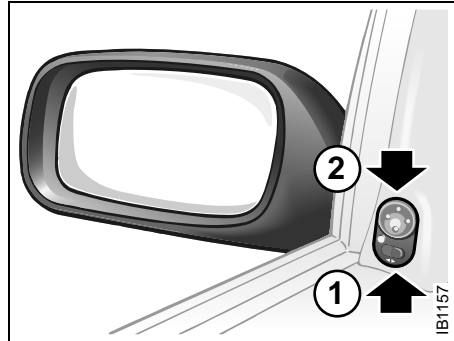

Adjusting the door mirrors

- 1 Select mirror
- 2 Use touch pad to adjust mirror

Door mirrors

The passenger side door mirror is of the wide-angle “aspheric” type.

The adjusting switch is on the driver's door. If the car is equipped with a programmable driver's seat, the settings of the door mirrors can also be stored in the preset buttons for the seat (see page 120).

The mirrors are heated, and the heating comes on and goes off with the rear-window heater.

The mirror glass can also be adjusted manually by gently pressing the glass in the desired direction.

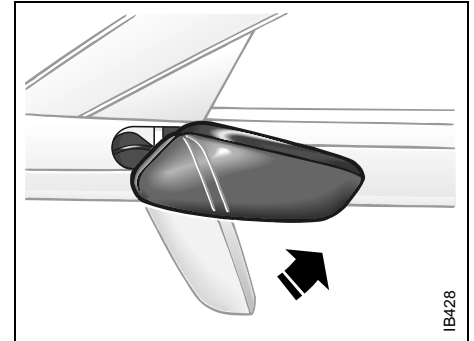

Door mirror folded in

The door mirrors are designed to fold back if knocked. They can also be fully retracted for parking in tight spaces, such as on the car deck of a ferry. Remember to fold them out again before driving off.

WARNING

Take care not to trap your fingers between the door and the mirror when folding the mirror out again.

NOTE

The door mirrors should be fully retracted before the car enters an automatic car wash.

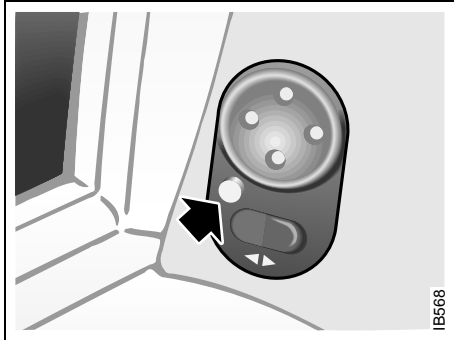

Button for angling passenger's mirror down on reversing

Cars equipped with a programmable driver's seat also have the ability to angle the passenger's mirror down when reversing, e.g. for a better view of the curb.

After selecting reverse, press the tiny button adjacent to the doormirror switch to tilt the mirror. The mirror will be reset automatically when reverse gear is deselected.

Rearview mirror with auto dimming function

The interior rearview mirror has two sensors, one forward-facing and one rear-facing.

The system is activated when the forward-facing sensor detects that it is dark outside and the rear-facing sensor detects, for example, if the car following has not dimmed its headlights. The rearview mirror is then darkened to prevent the strong light source from dazzling the driver. This darkening is stepless.

The mirror returns to its normal state when the strong light source diminishes.

The auto dimming function can be turned OFF with the switch on the lower edge of the rear-view mirror.

NOTE

Towing a trailer can cause the system to malfunction, as the rear-facing sensor may sense light from the trailer.

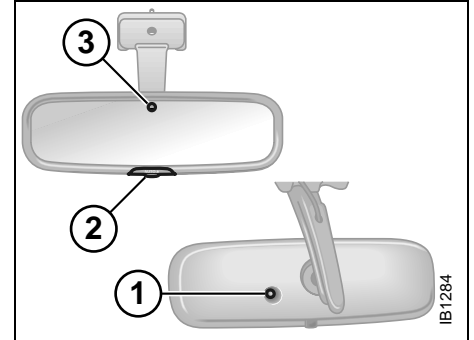

- 1 Forward-facing sensor
- 2 ON/OFF switch, auto dimming function
- 3 Rear-facing sensor

Electric windows

WARNING

- Bear in mind the pinch hazard when the side windows are being raised. Make sure that all passengers keep their heads, hands and fingers clear of the window openings before raising the windows. Serious personal injury may otherwise be caused.
- **Always** remove the ignition key when leaving the car to avert the danger of injury arising from unattended children operating the windows.

The electric motors of the front windows are equipped with overload protection (integrated thermal protection). This protection operates when the windows are wound down automatically (switch pressed fully down).

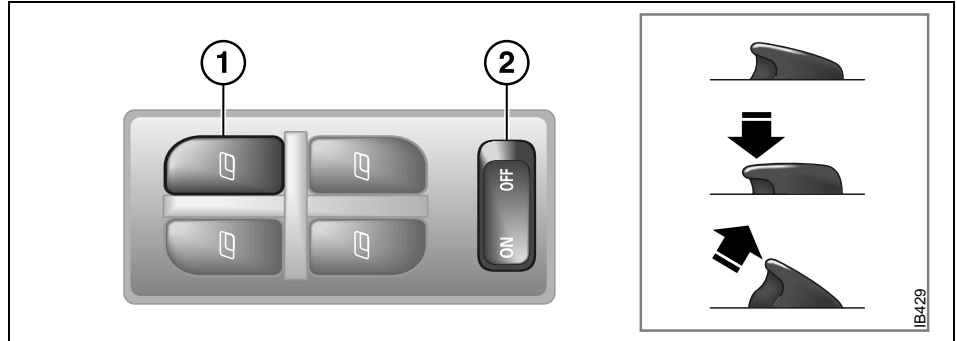

- 1 Window switches
- 2 Switch for rendering rear door window switches inoperative

To open:

Front windows: press the front of the switch
 Rear windows: Press the back of the switch.
 The switches for the front windows have a third position for automatic opening of the window. Press the switch fully down to lower the window completely.
 To cancel automatic lowering of the window, lift the switch briefly.

To close:

Front windows: Lift the front of the switch.
 Rear windows: Lift the back of the switch.
 The actuating motor will be switched off automatically when the window is fully closed or when the switch is released.

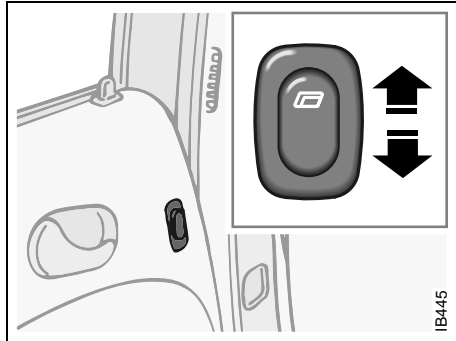

Switch for rear side window

Child safety: rear windows (ON/OFF)

The window switches on the rear doors can be rendered inoperative by the ON/OFF switch in the panel on the center console.

When the switch is ON, the rear side windows can be operated by the switch on each rear door. The switch's back lighting will be activated.

When the switch is OFF, the rear side windows can only be operated from the panel on the center console. When off, the switch's back lighting will also be switched off.

Sunroof (Option in Canada)

WARNING

- Bear in mind the pinch hazard when operating the sunroof. Make sure that all passengers keep their heads, hands and fingers clear of the opening before operating the sunroof. Serious personal injury may otherwise be caused.
- **Always** remove the ignition key when leaving the car, to avert the danger of injury arising from unattended children operating the sunroof.

The sunroof is operated by the switch on the overhead panel above the rearview mirror. The sunroof can be opened partially or fully.

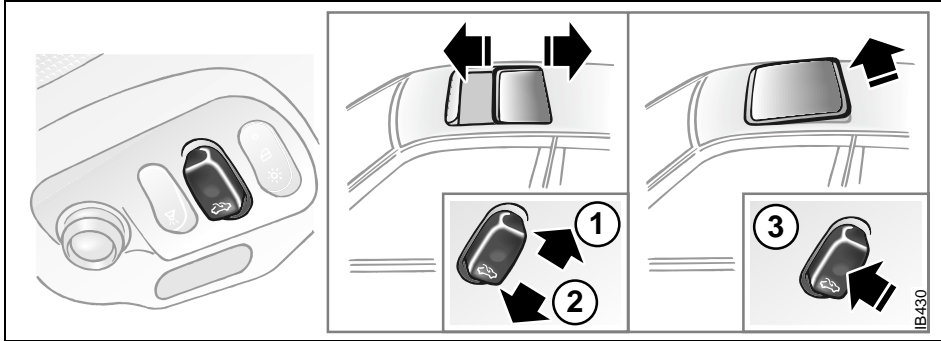

Sunroof control

- 1 To open
- 2 To close
- 3 Ventilation position

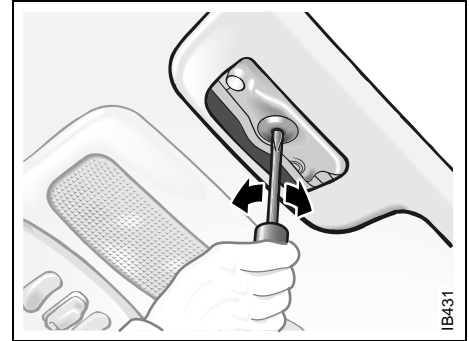

Manual operation of sunroof

Emergency operation of sunroof

In an emergency (e.g. if there is an electrical failure) the sunroof can be operated by a screwdriver. Remove the cover at the front of the sunroof opening, insert a screwdriver in the groove, and rotate.

Rotate counterclockwise to close sunroof.

To open:

- Slide the control towards the rear to open the sunroof to the comfort position. To open it fully, slide the control back a second time. Press the control to stop it earlier.

To close:

- Slide the control forwards until the sunroof is closed.

Ventilation position

- Press the middle of the control (when sunroof closed).
- To close: slide the control forwards.

To fully open the sunroof from the ventilation position, slide the control back.

The sunroof incorporates an interior, manual, sliding sun blind.

After the car has been waxed, the sunroof may squeak or squeal on opening to the ventilation position. If this should occur, fully open the sunroof and, using washer fluid, wash the seal along the front edge, together with the paintwork that is in contact with the seal when the roof is closed.

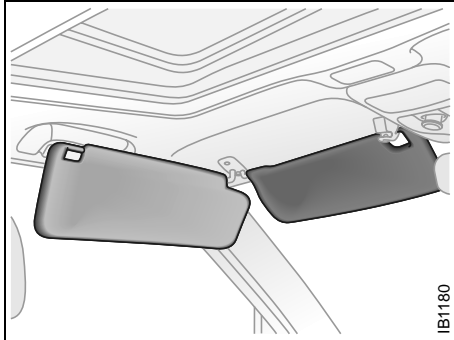

Sun visor with vanity mirror

Sun visors

The car is equipped with double sun visors. One section of the visor can be independently pivoted to the side window. A vanity mirror is provided on the back of the sun visors. The vanity mirrors are illuminated when the cover is raised.

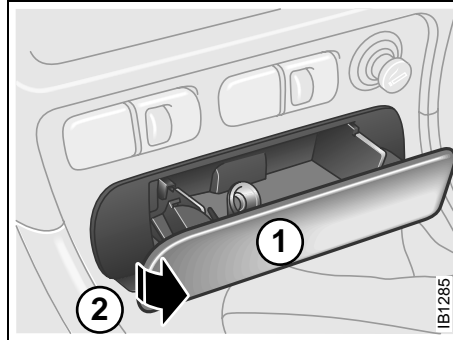

Front ashtray

- 1 Press soft to open/close
- 2 Pull out one side at an angle

Ashtrays (accessory)

The car can be equipped with three ashtrays: one in the instrument panel fascia, and one in each rear door. A cigarette lighter is fitted adjacent to the front ashtray, and there is also one in the back of the center console.

Front ashtray

- 1 To open the ashtray, push gently on the center/upper part of the front and release to allow it to spring out.
- 2 Close the ashtray in the same way.

To remove the ashtray, open it and after that pull left side out at an angle.

To refit, line up the slots on either side and slide it closed.

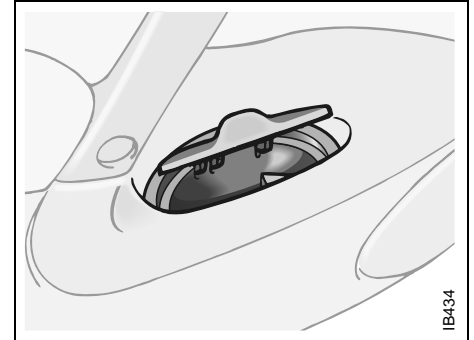

Rear ashtray

Rear ashtrays

Open the lid to use ashtray.

To remove the ashtray, fully open the lid and lift the ashtray straight out.

To refit the ashtray, make sure it engages the two square recesses in the door trim.

**Cigarette lighters (accessory)
(certain markets only)**

The car is provided with cigarette lighters next to the front ashtray and in the rear end of the center console.

The cigarette lighter socket can also be used as power point, e.g. for a mobile phone. The ignition should be in the ON position.

The cigarette lighter sockets can also be used for accessories (e.g. to charge a mobile phone) when the ignition is ON.

! WARNING

The maximum combined load for the two cigarette lighter sockets is 240 W (20 A).

Glove compartment

! WARNING

Keep the glove compartment closed when not in use. The lid could cause injury in the event of a crash.

The glove compartment can be cooled by the air conditioning (ACC) system. Cold air can be directed to the glove compartment for keeping drinks cool, etc.

Slide the cover towards you to admit cold air.

Additional storage facilities are provided (see next page).

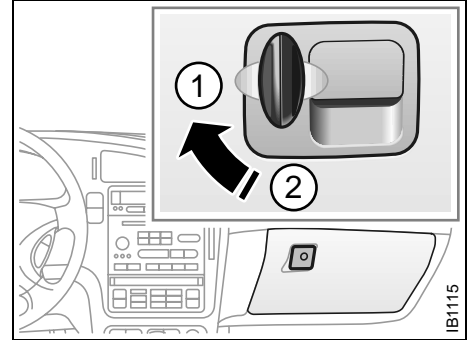

Glove compartment.

- 1 To lock
- 2 To unlock

Sliding cover in glove compartment to admit cold air

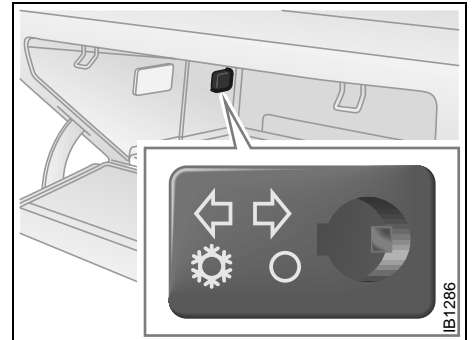

130 Interior equipment and trunk

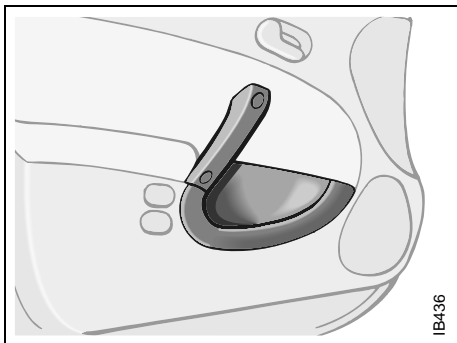

In the doors

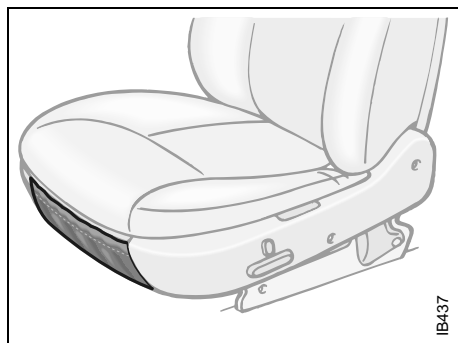

On leading edge of front seats

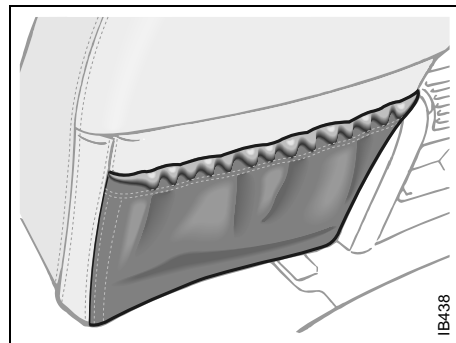

On the back of the front seats

Console between front seats

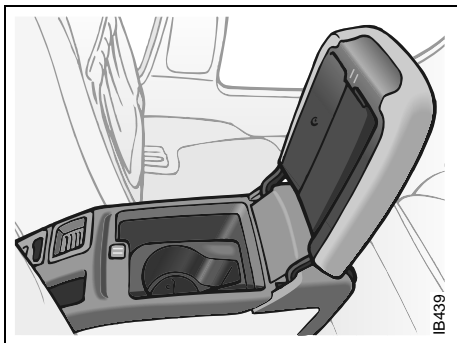

At bottom of door pillars adjacent to front-seat backrests

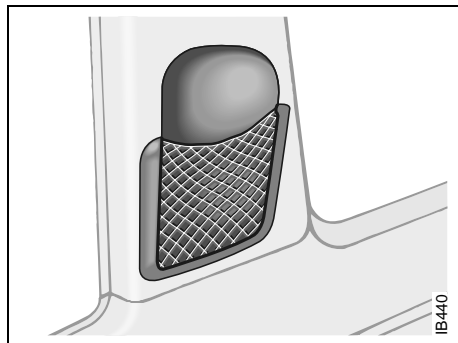

Center armrest for rear seat



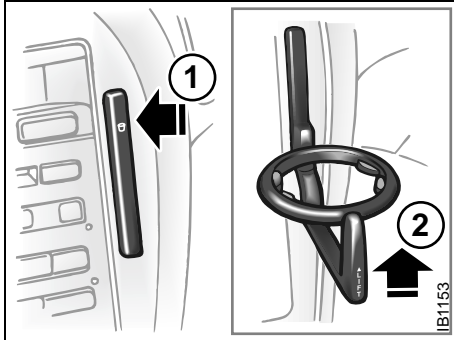

Cup holder in fascia

- 1 Press symbol to open
- 2 Lift bottom to close

! WARNING

- The cup holder should not be used to hold cups made of china, glass or hard plastic as these can cause injury in the event of a crash.
- Use only for paper cups or aluminium cans.
- Avoid spillage, particularly of hot drinks.
- Avoid putting oversized cups in the cup holder.

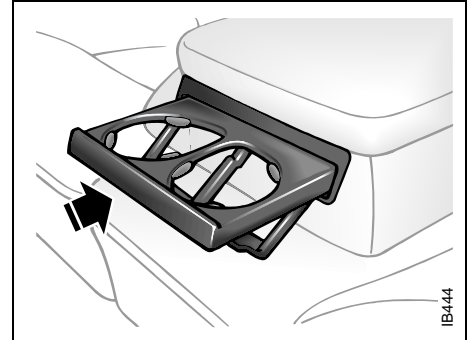

*Cup holder in rear armrest
Press the edge to open/close.*

Cup holders

Cup holders are provided in the instrument panel fascia, in the center console compartment between the front seats, and in the rear-seat armrest.

To access the cup holder in the instrument panel, press the symbol and release.

To access the cup holder in the rear seat armrest, lower the armrest and press the front edge of the holder. Close in the same way.

The number of cup holders provided may vary between models.

Cup holder in center console

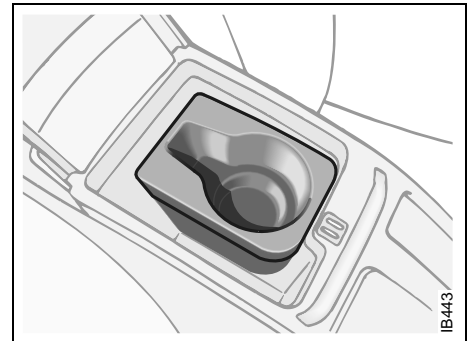

Trunk

Folding the rear seat, 9-5 Sedan

The rear seat is split and the two sections can be folded independently. Folding down of the rear seat is easier if the front seats are not all the way back, and the rear head restraints are folded down.

- 1 Raise the rear seat cushions by pulling the loop located between the cushion and the backrest. A small pad will open up first. Continue pulling the loop until the entire rear seat cushion is raised.
- 2 Tip the seat cushion forward.
- 3 Press the button adjacent to the respective backrest to release it.
- 4 Fold down the backrest.



WARNING

- Rear-seat passengers should always ensure that the head restraint is raised and in proper position.
- Keep hands well clear of all moving parts.
- Never place heavy objects on the rear window shelf. There is always a danger of loose objects flying about and causing injury if the car should brake suddenly or be involved in a crash.
- Before folding up the backrest, hang the outer safety belts onto the hook on the respective courtesy handle to prevent them from becoming trapped.
- Check that the back rest release button (3) is flush with the surround before entering the rear seat.

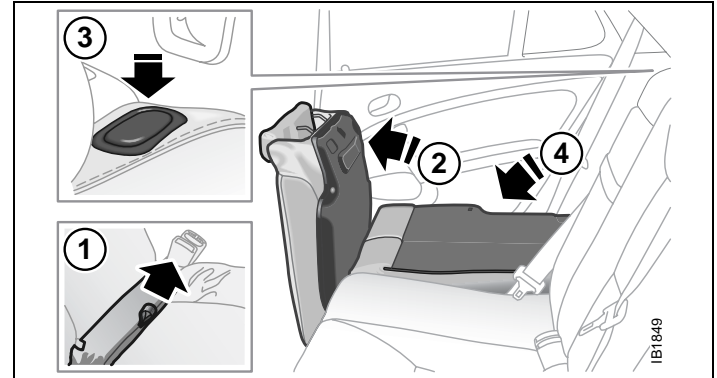

Outer safety belt hooked onto courtesy handle

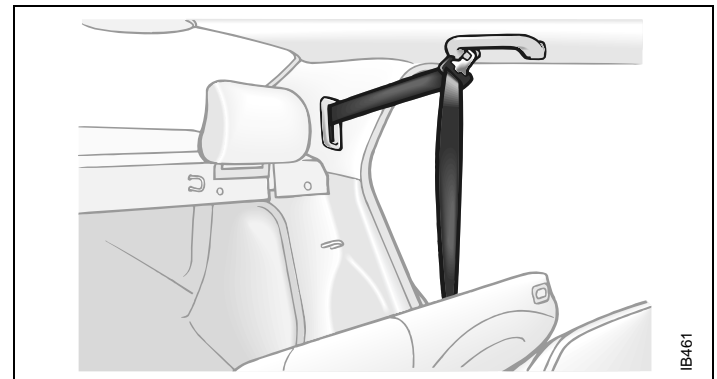

**WARNING**

- Place heavy items closest to the backrest and stow smaller and lighter items on top.
- Secure heavy and bulky items using the four tie down points provided in the trunk. This will avert the danger of luggage flying around if the car should brake suddenly or be involved in a crash (see page 134).
- When the backrest is folded down or the trunk pass-through hatch is open, even small items can be thrown around inside the car. It is therefore advisable to secure these as well.
- Do not exceed the load capacity of the car, as this will alter its handling characteristics (see page 248).
- Make sure that the seat cushions and backrests are properly secured when folding them back to their normal position. Check that the button (item 3 on page 132) is flush with the surround before entering the back seat.

The tail pipe of the exhaust system can become very hot during driving. Bear this in mind when loading and unloading the car so that children, for example, do not burn themselves.

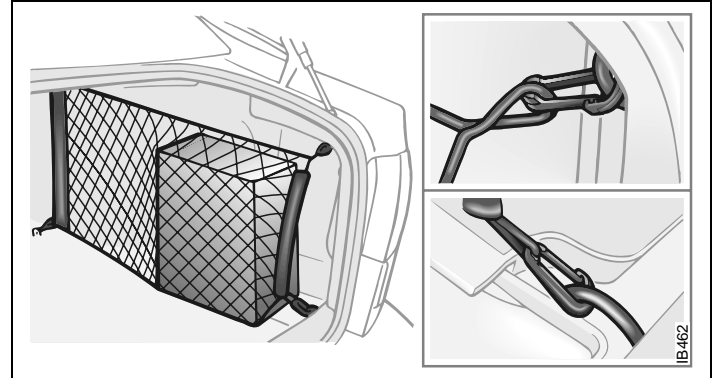

Trunk pass-through hatch

A trunk pass-through hatch is incorporated in the rear seat backrest to enable long, narrow items to be carried inside the car.

Items should not weigh more than 33 lbs. (15 kg) nor be more than 2 yards (2 metres) in length. See the label on the hatch.

- 1 Fold down the armrest.
- 2 Raise the hatch by lifting the handle.

Before loading or unloading long items, switch off the engine and apply the handbrake. This averts the danger of the car moving off suddenly if a long item were to knock the gear or selector lever into gear.

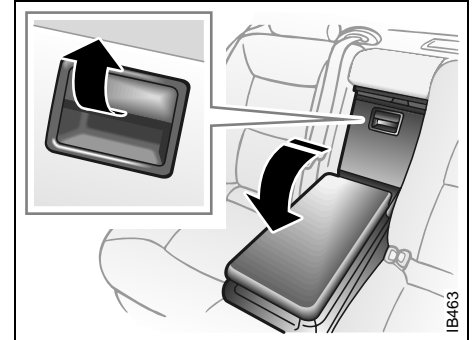

WARNING

- Anchor the load securely (e.g. using middle safety belt) to avoid danger of injury resulting from displacement of load on hard braking.
- Do not exceed the load capacity of the car, as this will alter its handling characteristics (see page 248).

Tie Downs

Four tie downs for securing the load are fitted inside the trunk. Place the load as far in as possible.

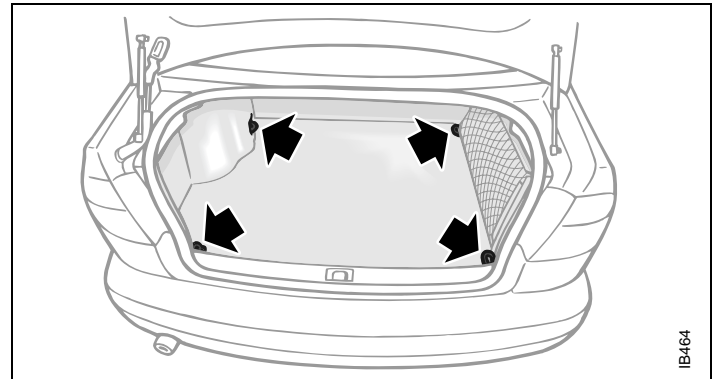

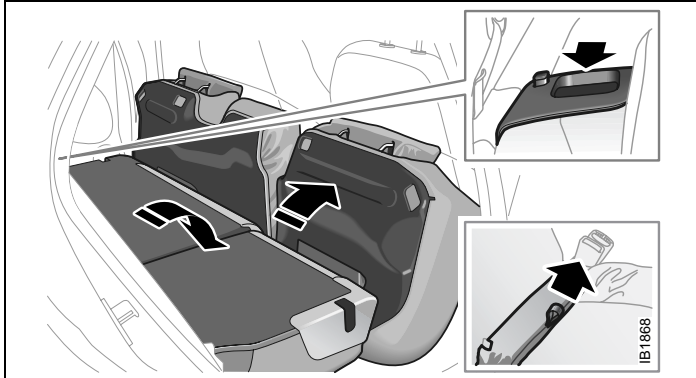

Folding the rear seat, 9-5 Wagon

Both the narrow and wide sections of the rear seat can be folded separately. Folding is facilitated if the front seats are not located too far back. The wide section cannot be folded separately if a cargo net is mounted on the rear of the backrest.

- 1 Make sure that the head restraint is in the down position. For height adjustment refer to page 18.
- 2 Put the safety belts for the outer seat places in their respective belt clips, which are located near the backrest (see illustration).
- 3 Raise the rear seat cushions by pulling the loop located between the cushion and the backrest. A small pad will open up first. Continue pulling the loop until the entire rear seat cushion is raised.
- 4 Fold the narrow section (right) of the backrest forward by raising the opening handle on the right-hand side.
- 5 Fold the wide section of the backrest forward in the corresponding manner.
- 6 Adjust the front seats for optimal driving/passenger comfort.

Safety belt located in its belt clip

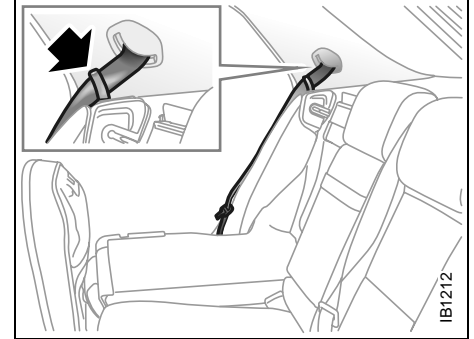

NOTE

The safety belts for the outer seating positions should be put in their respective belt clips near the backrest to prevent them from being pinched when the rear seat is raised to the upright position.

Alternative location of the parcel shelf if this is removed:

- Folded up on the floor at the rear of the luggage compartment.
- On edge behind the backrests of the front seats.

⚠ WARNING

- Do not travel in the back seat without ensuring that the head restraint is set at a suitable height.
- Never allow anyone to sit on a folded backrest.
- Always be aware of the risk of pinching when handling moving parts of the seating.
- Never place heavy objects on the parcel shelf. There is always a danger of loose objects flying about and causing injury if the car should brake suddenly or be involved in a crash.
- Make sure that the backrests are locked when they are folded back upright. Check that the two red warning-indication flags are fully down. This indicates that the backrests are locked.
- Check that the safety belt lock is not trapped under the seat cushions when these are raised back up.
- If the car is equipped with a pull-out cargo net on the rear of the backrest, take extra care when folding the rear seat so that no one is injured by the net's storage cassette on the right-hand side.

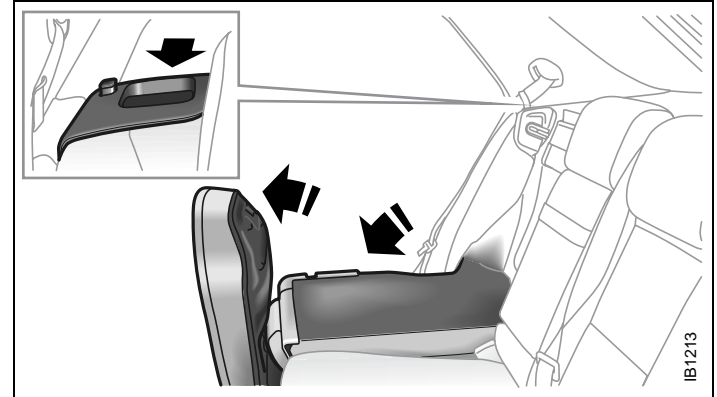

Folding the narrow section of the backrest

The folding is facilitated if the front seat is not too far back.

- 1 Make sure that the head restraint is in the down position. For height adjustment refer to page 18.
- 2 Put the safety belt in the belt clip near the backrest.
- 3 Raise the rear seat cushion by pulling the loop located at the rear of the cushion. A small pad will open up first. Continue pulling the loop until the entire rear seat cushion is raised.
- 4 Fold the narrow section (right) of the backrest forward by raising the opening handle.
- 5 Adjust the front seat for optimal passenger comfort.

NOTE

The safety belts for the outer seating positions should be put in their respective belt clips near the back rest to prevent them being pinched when the rear seat is raised to the upright position, see illustration page 135.

Load anchoring **WARNING**

- Put heavy loads as low down and as far forward as possible in the luggage compartment, i.e. against the back of the rear seat.
- Never stack cargo so high that any part of the cargo lies above the edge of the backrest, if a cargo guard (accessory) is not being used.
- Always tie down the cargo so that it cannot be thrown forward during heavy braking or in the event of a crash.
- Unsecured and heavy cargo can increase the risk of injury during hard braking, sudden avoidance maneuvers and in the event of a crash.
- For the best load anchoring, use the special cargo bolts and load straps (accessory).
- Load the cargo bolts evenly. Never attach more than one strap to each tie down eye.
- Provide protection on sharp edges to prevent damage to the load straps.

- Never use the elastic floor net and elastic side net when the rear seat is folded down. These nets are only intended to keep light objects tidy, not for the anchoring of loads.
- If possible, avoid having the rear seat folded down when driving with a heavy load because the anchoring possibilities are restricted when the rear seat is in this position. That the rear seat is in the upright position is a basic requirement for protection against cargo displacement in the event of a crash.
- Cargo can intrude into the passenger compartment during a sudden stop or front crash if the outer safety belts are not fastened. Check that the two red warning-indication flags are fully down. This shows that the backrests are locked.

 **WARNING**

- The driving characteristics of the car can be affected because the center of gravity is altered when there is a cargo in the luggage compartment. Therefore match the speed and driving style according to how the car is loaded.
- An object weighing 55 lbs. (25 kg) corresponds to a weight of 2200 lbs. (1000 kg) in a head on crash at 32 mph (50 km/h).
- Adjust the car's load (passengers and luggage) so that the gross vehicle weight or the axle weight is not exceeded, see page 248.

Driving with the trunk lid/tailgate open, see page 179.

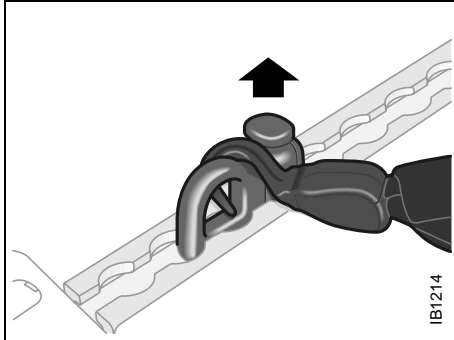

Cargo bolts mounted on the longitudinal rails

On the floor of the luggage compartment there are two longitudinal aluminium rails (CargoTracks™) where special cargo bolts can be mounted.

The protective strip on the CargoTracks™ is removed by lifting its back edge and pulling it straight upwards. Replace the strip by pressing it down on the CargoTracks™.

When the cargo bolts are not being used the protective strip should be in place.

The cargo bolts are mounted by lifting their locks and inserting them into the rail. Each cargo bolt is moved in the following way: pull up its lock and at the same time move it forwards or backwards to the desired position.

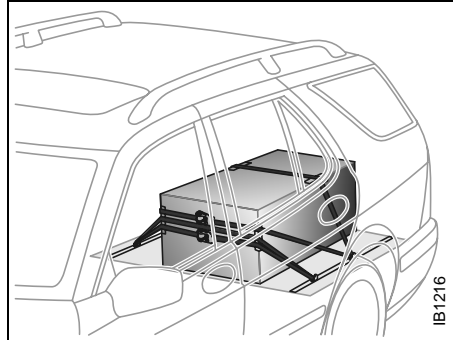

Example of cargo anchoring

Items for load anchoring:

- Cargo bolts (standard).
- Special load straps (accessory).

Items to keep light objects tidy:

- Elastic floor cargo net.
- Elastic side cargo net for the right-hand side of the luggage compartment.

The elastic nets may only be used to keep light objects tidy, not for anchoring.

The floor net should be attached to the cargo bolts that are mounted on the CargoTracks™. Place the tie down eyes as far forward and as far back as possible on the CargoTracks™.

The side netting should be attached to the two tie down eyes which are included in the

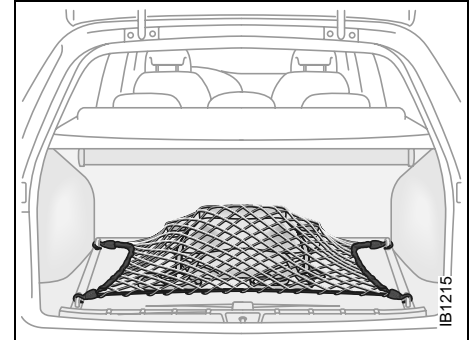

Elastic cargo net for lighter objects.

accessory kit and to two of the eyes mounted on the right-hand CargoTrack™ on the floor.

The cargo bolts, load straps and elastic nets are stored in the two floor lockers on the right- and left-hand side of the luggage compartment. The lockers are opened by lifting the respective fabric loop.

NOTE

Do not place any objects so that the demisting and antenna elements on the inside of the window could be damaged.

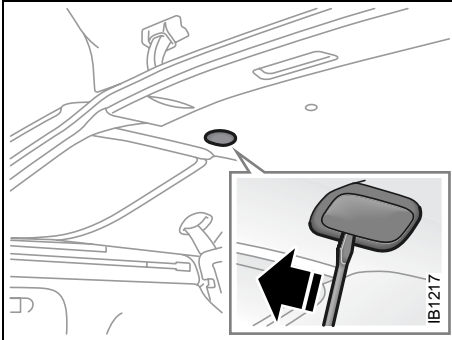

Cover over the fixing point for the cargo net

! WARNING

- The cargo in the luggage compartment must be anchored properly, even if the cargo net is correctly in position. The only purpose of the net is to prevent objects from being thrown about in the cabin during heavy braking or in the event of a crash.
- Take extra care when tipping the wide section of the rear seat forwards if the car has a pull-out cargo net on the rear of the backrest. Make sure that no one is injured by the cargo net's storage cassette on the right-hand side where the backrest is already folded.

Cargo net (accessory)

The pull-out cargo net's storage cassette is mounted on the rear of the backrest.

- 1 Remove the covers near the two rear fixing points in the roof. Carefully bend in the lower edge of the cover with a screwdriver.
- 2 Pull the cargo net out directly backwards.
- 3 Snap the net's two fasteners into the two fixing points on the roof.
- 4 Make sure that the hooks on the net's own storage cassette fit against the net mesh.

The pull-out cargo net can also be used when the whole rear seat is folded. There are two front attachment points in the roof for this purpose.

Removing the cargo net storage cassette

- 1 Fold down the entire rear seat (see page 135).
- 2 Push the cassette to the right.

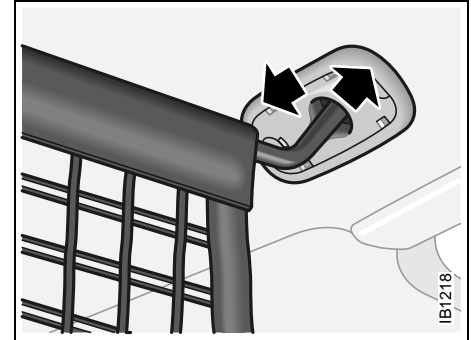

Attaching the cargo net to the roof

Hooks on the net's storage cassette

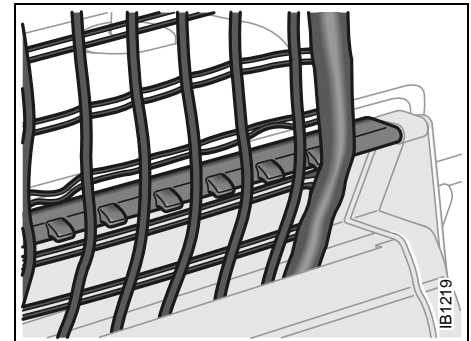

Sliding floor (accessory)

! WARNING

To avoid personal injury take note of the following:

- Do not leave children unsupervised when the sliding floor is drawn out.
- Be aware of the risk of pinching when handling the sliding floor.
- Never drive the car with the sliding floor pulled out.
- Always use the car's regular cargo anchoring when transporting a cargo.
- Provide protection on sharp edges to prevent damage to the anchoring straps.
- The sliding floor must not be changed or modified in any way.
- Put the sliding floor in the folded-down position when it is not in use.

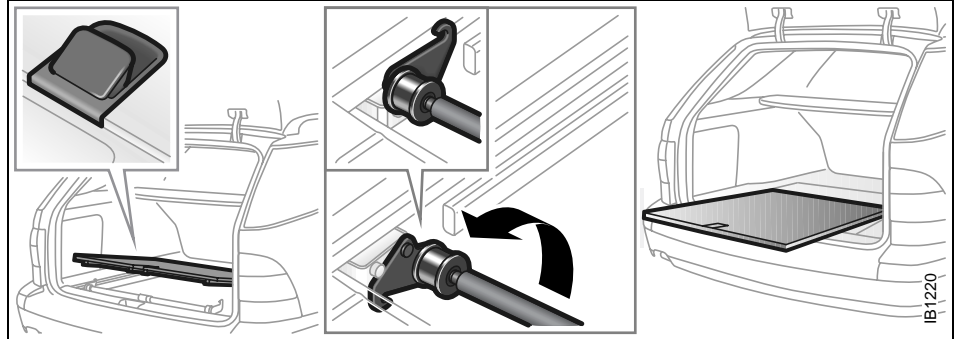

Setting up the sliding floor

The function of the sliding floor is to facilitate loading and unloading.

Securing loads, see page 134.

When the car is parked and the floor is pulled out, it can bear the weight of two people (maximum 440 lbs./200 kg).

The maximum load that can be anchored by anchorage straps and cargo bolts is 170 lbs./80 kg.

Setting up

- 1 Lift up the floor.
- 2 Fold out the support wheels.
- 3 Set the floor down on the support wheels.

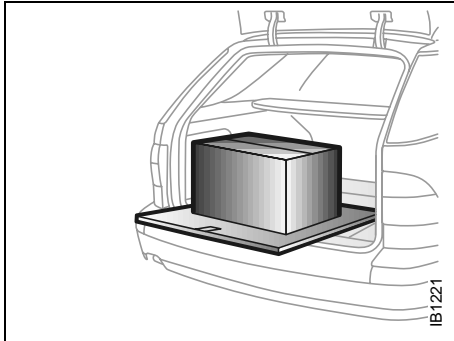

Loading

Loading/Unloading

- 1 Lift the handle and pull out the sliding floor to the outer locking position. Make sure that the floor is locked correctly.
- 2 Put on the cargo, but make sure that it does not cover the handle.
- 3 Lift the handle and push in the floor to the inner locking position. Make sure that the floor is locked correctly.
- 4 Tie down the load with Saab's load straps according to the instructions, see page 137.

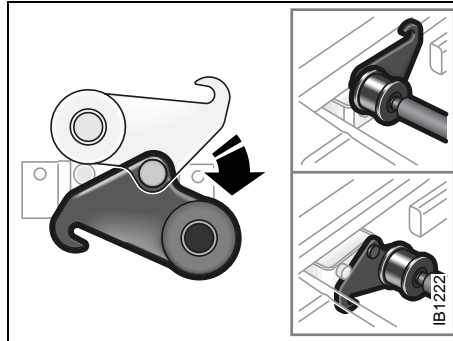

Folding down the sliding floor

When the floor is not in use

- 1 Lift up the floor.
- 2 Fold down the support wheels.
- 3 Lay down the sliding floor and make sure that it is locked in its lower position.

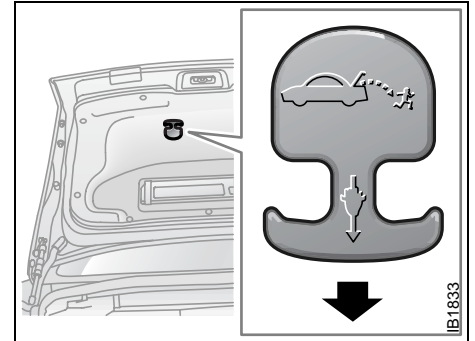

Trunk Release Handle

Trunk Release Handle

There is a glow-in-the-dark trunk release handle located inside the trunk on the latch. This handle will glow following exposure to light. Pull the release handle down to open the trunk from the inside.

NOTE

The trunk release handle was not designed to be used to tie down the trunk lid or as an anchor point when securing items in the trunk. Improper use of the trunk release could damage it.

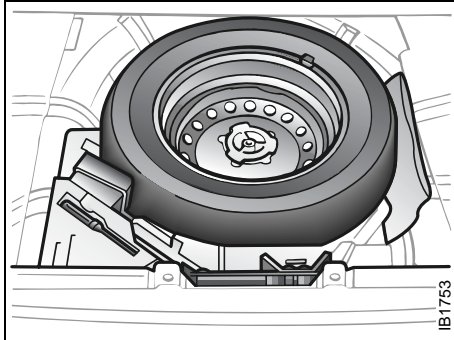

Stowage of spare wheel and tools under trunk floor

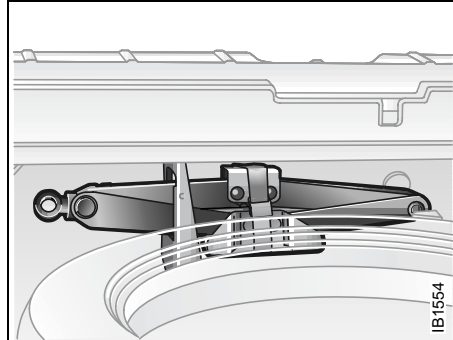

Jack location, between spare wheel and sill

Spare wheel and tools

The spare wheel, together with the jack and jack handle, front towrope attachment eye and toolkit, are stowed away underneath the trunk. There is also room for a spare bulb wallet (accessory).

WARNING

Stow all tools carefully away after use, so that they cannot get loose and cause injury in the event of a crash.

Keep plastic bags away from children.

Driving considerations with compact spare wheel/tire fitted, see page 179.

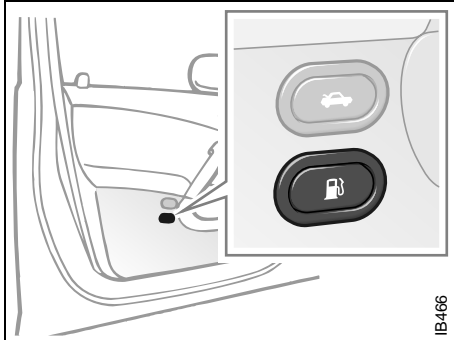

IB466

Button for releasing filler flap

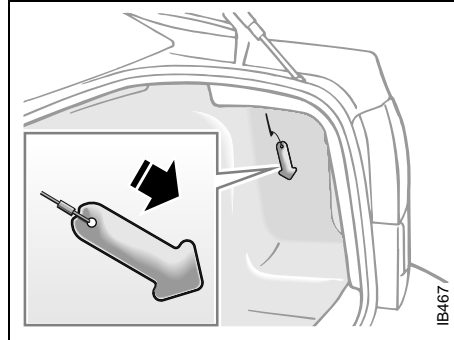

IB467

*To open fuel filler flap in an emergency
9-5 Sedan*

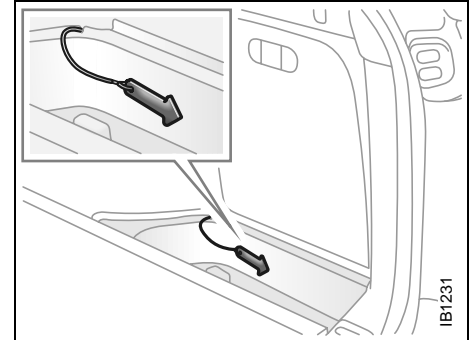

IB1231

*To open filler flap in an emergency,
9-5 Wagon*

Fuel filler flap

The fuel filler flap is opened by means of a button on the driver's door. The flap is spring-loaded, so it opens slightly automatically when released.

Refueling, see page 152.

Opening the fuel filler flap in an emergency

If the fuel filler flap fails to open after the button on the driver's door has been pressed, it can be opened manually from inside the trunk.

9-5 Sedan:

Start by checking fuse 25 (see page 218).

A thin cable on the right-hand side in the trunk is connected to the catch for the filler flap. To open the flap, pull the yellow plastic arrow on the end of the cable.

9-5 Wagon:

Start by checking fuse 25 (see page 218).

On the right-hand side of the luggage compartment, in the storage locker, is a thin wire that is tied to the locking arm of the filler flap. To open the flap pull the yellow plastic arrow attached to the end of the wire.

(This page has been left blank)

Starting and driving

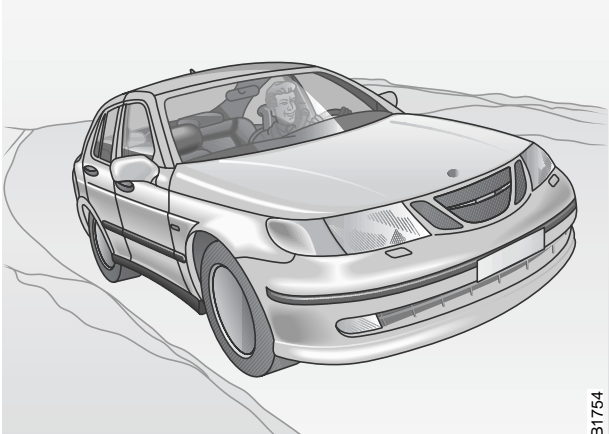

B1754

| | | | | | |
|--|------------|---|------------|-----------------------------------|------------|
| Ignition switch | 146 | Economical motoring | 170 | Driving in deep water..... | 179 |
| Starting the engine | 147 | Driving in cold weather... | 171 | Towing the car..... | 180 |
| Important considerations for driving..... | 149 | Driving in hot weather | 173 | Jump starting | 182 |
| Refueling | 152 | Towing a trailer..... | 173 | Saab Parking Assistance | 184 |
| Engine Break-In Period ... | 155 | Driving with a roof rack load..... | 176 | Parking brake | 185 |
| Gear changing | 156 | Driving with a load | 178 | Parking..... | 185 |
| Cruise control | 164 | Driving considerations with compact spare wheel/tire fitted..... | 179 | | |
| Braking | 165 | Driving with the trunk lid/tailgate open..... | 179 | | |
| Traction Control System. | 167 | | | | |
| Electronic Stability Program (ESP) | 168 | | | | |

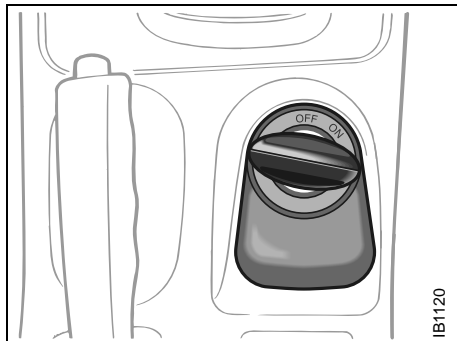

Ignition switch

The combined ignition switch and gear-lever lock is located in the center console between the front seats. The ignition key can only be removed when reverse is engaged (automatic transmission: selector in "P" position).

The key fits all the locks on the car. The key number is specified on the small plastic strap that comes with the keys when the car is delivered. Keep a note of the key number in a safe place, as you will need to quote it if ordering a replacement key.

See also page 38.

| | |
|--|--|
| | <p>LOCK position Engage reverse and turn the key to LOCK. Automatic transmission: select "P". The gear lever is locked. This is the only position in which the key can be removed. The parking lights, hazard warning lights and interior lighting all work.</p> |
| | <p>OFF position Gear lever no longer locked. Certain electrical circuits operational</p> |
| | <p>ON position All electrical circuits working. Do not leave the key in the ON position when the engine is not running. Turn the key to OFF to switch off the electrical circuits. In the ON position certain warning and indicator lights come on as a check, and they normally are extinguished after about 3 seconds.</p> |
| | <p>ST (starter) position The starter operates when the key is turned to this position. When released, the key will spring back to the ON position. If the engine fails to start, the key must first be turned back to the position between OFF and LOCK before the starter can be operated again. When the starter motor is running, several electrical circuits are disconnected to facilitate starting.</p> |

NOTE

Take care not to spill drinks or to drop crumbs over the ignition switch. If dirt or liquid gets into it, the switch may not operate properly.

! WARNING

- Always remove the key before leaving the car.
- Always apply the parking brake before removing the ignition key.

If the car does not start

If the text "KEY NOT ACCEPTED" is shown on the SID, after a failed start attempt, the cause could be a fault in the transmitter in the key, or in the receiver in the ignition lock. The following should be done:

- Turn the key back to the LOCK position.
- Turn the key to ON.
- Press one of the buttons on the remote control (the LED stops blinking).
- Start the engine.

Try another key. If this works, then the fault is in the first key.

Contact an authorized Saab dealer for checking and rectification.

Starting the engine**! WARNING**

- When starting the engine:
 - Sit down in the driver's seat.
 - Depress the clutch pedal fully. The clutch pedal must be fully depressed or the starter will not engage.
 - Never start the car from outside the vehicle, e.g. through a wound down window. This could lead to serious personal injury.
- Engage reverse (R) (position P for automatic transmission) to remove the ignition key. The key can only be removed in this gear position.
- Carbon monoxide (CO) is a colorless, odorless, poisonous gas. Be alert to the danger of CO – always open the garage doors before starting the engine in the garage.
- There is also a danger of CO poisoning if the exhaust system is leaking.

- The tail pipe of the exhaust system can become very hot during driving. Bear this in mind when loading and unloading the car.
- Do not rest or sleep in the car when parked with the engine running. There is a risk of depressing the accelerator which could lead to engine damage.

It is possible for air to enter the lubricating system in conjunction with an oil or oil-filter change, or if the car has been stored for some time. This air can cause the hydraulic cam followers to emit a ticking noise, which can persist for up to 15 minutes after starting. Although this is quite normal and does not indicate any malfunction, it is advisable not to exceed 3,000 rpm before the noise has disappeared.

The hydraulic cam lifters are completely service free; the valve clearance is set up at the factory and will not need any subsequent adjustment.

Starting the engine

Avoid racing the engine or putting a heavy load on it before it has warmed up. Drive away as soon as the oil warning light has been extinguished to enable the engine to attain its normal temperature as quickly as possible.

The engine has an automatic choke and should be started as follows:

Cars with manual transmission

To start the engine the clutch pedal must be fully depressed.

- 1 Depress the clutch pedal fully but do not touch the accelerator.
- 2 Start the engine. Let the ignition key spring back as soon as the engine has started and is running smoothly – at very low temperatures, you may need to run the starter for up to 25 seconds. Wait 20-30 seconds before running the starter again, to give the battery time to recover.

Let the engine idle for about 10 seconds. Do not open the throttle wide for at least 2-3 minutes after starting.

Cars with automatic transmission

- 1 The selector lever must be in the P or N position.
- 2 Keep your foot on the brake pedal.
- 3 Start the engine. Let the ignition key spring back as soon as the engine has started and is running smoothly – at very low temperatures, you may need to run the starter for up to 25 seconds. Wait 20-30 seconds before running the starter again, to give the battery time to recover.

Let the engine idle for about 10 seconds. Do not open the throttle wide for at least 2–3 minutes after starting.

Useful tips on cold climate starting

If the engine has failed to start after several attempts in very cold weather, press and hold the accelerator down to the floor and run the starter for 5–10 seconds. This will prevent the engine being flooded (excessively rich fuel-air mixture).

Now start the engine in the normal way – do not touch the accelerator.

If the engine stalls immediately after starting (e.g. if the clutch was released too quickly), do not touch the accelerator when restarting the engine.

Limp-home mode

The car's engine-management system includes a diagnostic function that checks numerous internal functions after the engine has been shut off. If a fault is detected in the throttle system, the engine-management system puts the throttle system into the limp-home mode. This limits idling control, disables the cruise-control system and limits the capacity of the A/C compressor.

If the limp-home mode is in operation ("Engine malfunction (CHECK ENGINE)" light on, see below) and the outside temperature is close to or below freezing, you may need to use some throttle on starting (some pressure on the accelerator).

If the diagnostic system has detected a fault in the engine-management system, the "Engine malfunction (CHECK ENGINE)"

light  on the main instrument panel will come on (see page 53), indicating that you should have the car checked as soon as possible by an authorized Saab dealer.

NOTE

If the CHECK ENGINE warning light  starts to flash, ease off the accelerator slightly. If the light does not cease to flash within 5 seconds, stop the car in a suitable place as soon as possible and turn off the engine. The car must be towed to an authorized Saab dealer.

If the CHECK ENGINE warning light flashes, it indicates that the engine is misfiring which can result in damage to the catalytic converter.

Important considerations for driving

The engine-management system in the Saab 9-5 is called Saab Trionic T7. The system manages the ignition, fuel injection and turbo boost pressure.

The Trionic T7 system developed by Saab is an intelligent engine-management system designed to achieve optimum drivability under differing driving conditions. The system makes adjustments automatically, for instance, if the car is being driven at altitude (oxygen-deficient air), for different grades of fuel (AON 87–93) and for different load conditions.

1 Starting and driving

- Refrain from using full throttle before the engine has warmed up (before needle in mid-range on temperature gauge).
- A safety function prevents the engine from revving faster than 6,000 rpm by limiting the induction air.

2 Stopping the engine

- Do not rev the engine immediately before switching it off - stop the engine when it is idling.

3 Regulating the boost pressure

- The system is optimized for fuel with an octane rating of AON 90. The 2.3 T (Aero) and 3.0t V6 are optimized for

AON 93. One of the advantages of the system is that it enables the engine to be run safely on lower-grade fuel, although not lower than AON 87.

- The maximum boost pressure is adjusted automatically to the knocking or pinging tendency of the engine. Occasional, short-lived knocking when the engine is under a heavy load is perfectly normal; the extent will depend on the grade of fuel in the tank.
- Isolated instances of knocking are more likely to occur with low-octane fuel. This controlled form of knocking, followed by a reduction in the boost pressure, is a sign that the wastegate is functioning and is perfectly safe for the engine.

NOTE

If constant knocking occurs every time a load is put on the engine, this indicates a malfunction in the system.

Have the car checked without delay by an authorized Saab dealer.

WARNING

If the engine is being run with the car on a rolling road or dynamometer, to ensure adequate cooling, air must be blown into the engine compartment and under the car at a rate equivalent to the ram-air effect that would be obtained at the corresponding road speed.

Important considerations with catalytic converters

NOTE

Use only unleaded gasoline. Leaded gasoline is detrimental to the catalyst and oxygen sensor and will seriously impair the function of the catalytic converter.

The catalytic converter is an emission-control device incorporated in the car's exhaust system. It consists of a metal canister with a honeycomb insert, the cells of which have walls coated in a catalytic layer (mixture of precious metals).

To ensure that the catalytic converter continues to function properly, and also to avoid damage to the converter and its associated components, the following points must be observed:

- Have the car serviced regularly in accordance with the service program. The fuel and ignition systems are particularly important in this context.
- Always be alert to any misfiring of the engine (not running on all cylinders) and any loss of power or performance. At the first sign of a malfunction, reduce speed and take the car to an authorized Saab dealer as soon as possible.
- If the engine fails to start (in very cold weather or if the battery is flat), the car can be push started (manual gearbox only) or started using jumper cables to a donor

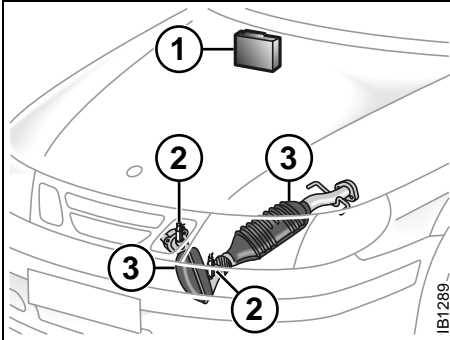

Oxygen-sensor-controlled injection system

- 1 Engine control module
- 2 Oxygen sensor (lambda probe)
- 3 Catalytic converters

battery. However, as soon as you have started the engine, it is important that it runs on all cylinders. If it is misfiring, allow it to idle for up to five minutes to give it time to settle and run smoothly. If, after this time, the engine still fails to run properly, turn off the engine and get in touch with an authorized Saab dealer for advice.

- Never park the car on dry grass or other combustible material. The catalytic converter gets very hot and could therefore start a fire.
- Never drive off if the engine is misfiring.
- If you jump start the car when the engine is already up to normal temperature, the engine must start to run on all cylinders. Stop jump-starting if the engine fails to start immediately.

NOTE

If the car runs out of fuel, it is possible for air to get into the fuel system. If this happens, the catalytic converter may overheat and be damaged.

Failure to follow these directions could result in the catalytic converter and associated components being damaged, and could represent a breach of the warranty conditions.

3.0t V6: When starting the engine from cold an electrical pump is activated. This pump forces air into the exhaust system so that the catalytic converter will reach its normal operating temperature more rapidly. The pump is active for 30-60 seconds.

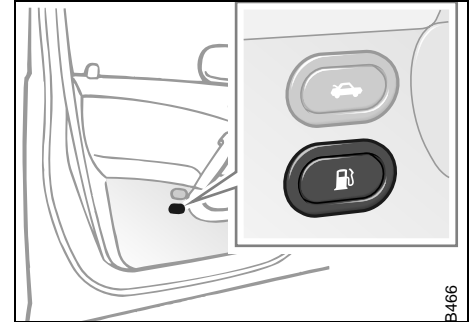

Button for releasing filler flap

Fuel filler flap

The fuel filler flap is opened by means of a button on the driver's door. The flap is spring-loaded, so it opens slightly automatically when released.

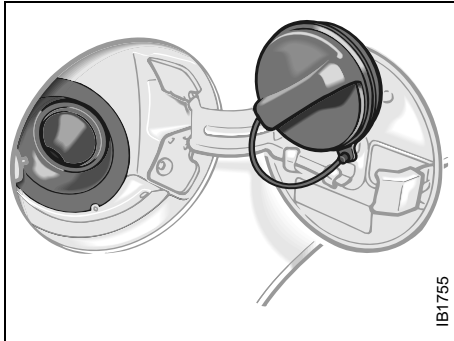

Refueling

WARNING

- Never use fuel for any purpose other than as engine fuel.
- Fuel is highly flammable and can cause severe burns. Never use an open flame in the vicinity of gasoline and do not smoke when refuelling.
- Do not use the phone when refueling. Gasoline fuels are highly explosive.

Only fuel from well-known oil companies should be used.

All Saab gasoline engines can be driven on fuel of grade AON 87-93.

For optimum performance we recommend:

- **AON 90** for 4-cylinder engines
- **AON 93** for 3.0t V6 and 2.3T Aero, (see page 250).

If fuel containing a mixture of alcohol is used, the following restrictions apply:

Methanol: max. 5% by volume.

Ethanol: max. 10% by volume.

MTBE: max. 15% by volume.

The fuel filler cap is located in the right rear quarter panel.

Switch off engine.

Open fuel door

Insert the fuel-pump nozzle beyond the flange on the filler pipe. Do not withdraw the nozzle while fueling is in progress.

Stop refueling the first time the pump turns off, indicating the tank is full.

NOTE

Do not overfill. Fuel should not come right up the filler pipe as expansion room is needed.

Fuel-tank capacity: 18.5 US gal. (70 liters)
Screw on the filler cap and keep turning until it has clicked at least **three** times.

The most effective way to prevent condensation forming in the tank (and thus avoid possible running problems) is to keep the tank well filled.

Before the onset of freezing temperatures in winter, it may be advisable to add gasoline anti-freeze to the fuel a few times to dispel any condensation in the system.

NOTE

- Fill to maximum filling capacity
- Stop filling after the first time that the nozzle trips to shut off the flow of fuel
- Filling capacity can differ between different fuel stations and outside temperature. Fuel tank volume when nozzle trips to shut off, may vary by 0.5 gal. (2 liters).
- Do not fill fuel all the way up the filler pipe. The gasoline must be allowed room for expansion especially during hot weather.

Opening the fuel filler flap in an emergency, see page 143.

Recommended fuel:

The engine in your Saab 9-5 is designed to operate on unleaded gasoline that has an octane rating of 87 or higher. Octane rating is determined according to the formula:

$$\frac{\text{MON} + \text{RON}}{2}$$

where MON is the Motor Octane Number, and RON is the Research Octane Number.

The average of these two values is the octane rating of the gasoline as it appears on the pump at a retail gas station. This value is sometimes referred to as the "Anti-Knock Index" (AKI) or the "Average Octane Number" (AON).

To avoid deposit formation on the fuel injectors which can cause poor driveability, use only quality gasolines that contain detergents and corrosion inhibitors. Because gasolines sold at retail gas stations vary in their composition and quality, you should switch to a different brand if you begin experiencing driveability and/or hard starting problems shortly after refueling your car. In recent years, a variety of fuel additives and alcohols or oxygenates have been blended with gasoline. These types of gasolines may be found in all parts of the United States and Canada, but particularly in geographic areas and cities that have high carbon monoxide levels. Saab approves the use of such "reformulated" gasolines in its products, which help in reducing pollution from all motor vehicles, provided that the following

blending percentages are met by such fuels:

- Up to 10% ethanol by volume, with corrosion inhibitors.
- Up to 15% MTBE by volume (methyl tertiary butyl ether).
- Up to 5% methanol by volume, with an equal amount of a suitable co-solvent and added corrosion inhibitors.

Other, less common, fuel additives used by some gasoline dealers are also acceptable, provided that the resultant gasoline is not more than 2.7% oxygen by weight.

Some Canadian and U.S. gasolines contain an octane enhancing additive called methylcyclopentadienyl manganese tricarbonyl (MMT). If such fuel is used, your emission control system performance may deteriorate and the malfunction indicator lamp on your instrument panel may turn on. If this occurs, return to your authorized Saab dealer for service.

However, these blended gasolines are regulated and should never exceed these recommended blend percentages and service station operators should know if their gasolines contain detergents and oxygenates, and have been reformulated to reduce vehicle emissions. Nevertheless, if you begin to notice a problem with the way your car starts or runs shortly after it has been refueled, try a different brand of gasoline.

NOTE

Higher concentrations of methanol than listed above, or the use of methanol-blended gasoline without suitable co-solvents and corrosion inhibitors, can damage your car's fuel system, leading to the need for repairs which are not covered by Saab's product warranty.

NOTE

The engine control module (ECM) monitoring the engine parameters also stores fault codes.

Under certain circumstances, this may cause constant illumination of the "Engine malfunction (CHECK

ENGINE)" lamp , thus indicating a fault that must be checked by your Saab dealer.

NOTE: always observe the following two measures:

- Make sure that the fuel filler cap is screwed on correctly before the engine is started. Screw on the fuel filler cap until you hear 3 distinct clicks.
- Avoid driving with the fuel low level indicator illuminated. The symbol illuminates when less than approximately 2 gallons (8 litres) of fuel remains in the tank.

Fuel (Gasoline Engine)

Use regular unleaded gasoline rated at 87 octane or higher. It is recommended that the gasoline meet specifications which were developed by the American Automobile Manufacturers Association (AAMA) and endorsed by the Canadian Motor Vehicle Manufacturers Association for better vehicle performance and engine protection. Gasolines meeting the AAMA specification could provide improved driveability and emission control system performance compared to other gasolines.



In Canada, look for the "Auto Makers' Choice" label on the fuel pump.

Canada Only

Be sure the posted octane is at least 87. If the octane is less than 87, you may get a heavy knocking noise when you drive. If it's bad enough, it can damage your engine. If you're using fuel rated at 87 octane or higher and you hear heavy knocking, your engine needs service. But don't worry if you hear a little pinging noise when you're accelerating or driving up a hill. That's normal, and you don't have to buy a higher octane fuel to get rid of pinging. It's the heavy, constant knock that means you have a problem. If your vehicle is certified to meet California Emission Standards (indicated on the underhood emission control label), it is designed to operate on fuels that meet California specifications. If such fuels are not available in states adopting California emissions standards, your vehicle will operate satisfactorily on fuels meeting federal specifications, but emission control system performance may be affected. The "Engine malfunction (CHECK ENGINE)" indicator on your main instrument panel may turn on and/or your vehicle may fail a smog-check test. See "Engine malfunction (CHECK ENGINE)" indicator on page 53. If this occurs, return to your authorized Saab dealer for diagnosis to determine the cause of failure. In the event it is determined that the cause of the condition is the type of fuels used, repairs may not be covered by your warranty.

Some gasolines that are not reformulated for low emissions may contain an octane-enhancing additive called methylcyclopentadienyl manganese tricarbonyl (MMT); ask your service station operator whether or not the fuel contains MMT. Saab Automobile AB does not recommend the use of such gasolines. If fuels containing MMT are used, spark plug life may be reduced and your emission control system performance may be affected. The malfunction indicator lamp on your instrument panel may turn on. If this occurs, return to your authorized Saab dealer for service.

Engine Break-In Period

Pistons, bores and bearings need time to obtain uniform, wear-resistant surfaces.

If a new engine is driven too hard, this gradual process of bedding-in will not be possible and the life of the engine will be shortened.

During the first 1,200 miles (2,000 km), do not exceed 5,000 rpm.

In addition, refrain from driving the car at full throttle, other than for brief instances, during the first 1,800 miles (3,000 km).

Wearing in new brake pads

New brake pads take time to bed in, about 90 miles (150 km) if the car is driven largely under stop-and-go conditions or about 300 miles (500 km) of highway driving.

To extend the useful life of the pads, avoid hard braking as much as possible during this period.

Gear changing

Manual transmission

To start the engine the clutch pedal must be fully depressed.

The gear positions are marked on the gear lever. Before reverse (R) can be engaged, you must lift the ring underneath the gear-lever knob.

To change gear, fully depress the clutch pedal and then release it smoothly. It is inadvisable to drive with your hand resting on the gear lever, as this can increase the wear on the transmission.

When changing down from 5th to 4th gear, ease the gear lever straight back, without applying any lateral pressure. This will prevent 2nd gear being engaged by mistake, which can result in overrevving and possible damage to the engine.

Before engaging reverse, wait till the car is at a standstill, release the accelerator and fully depress the clutch. From neutral, press the gear lever firmly to the right before easing it back into reverse.

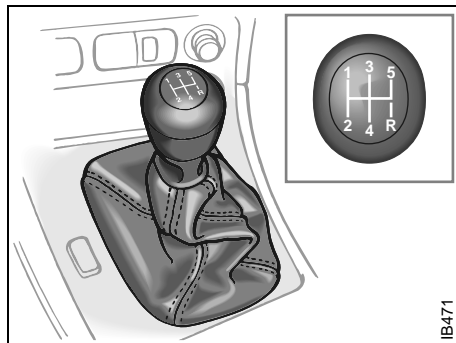

Shift-up indicator for improved fuel economy (U.S. models only)

Cars equipped with a manual transmission have a "Shift-up" light on the instrument panel. The light begins to work after the vehicle is warmed up and provides you with a good indication when to shift to a higher gear.

It is not necessary or recommended to follow the shift-up recommendations in all driving conditions, for example, when driving in heavy urban traffic or steep downhill grades.

However, shifting with the light should result in improved fuel economy. Therefore, for reduced fuel consumption and better energy conservation, you should make a habit of shifting before or when the shift-up light comes on.

Towing

Towing of cars with manual transmission, see page 180.

Automatic transmission

WARNING

- Make it a habit to keep your foot on the brake when selecting a drive position, to prevent the car from creeping forward (or backward if reverse is selected).
- The car must be at a standstill before P, R or N is selected. You have to have your foot on the brake pedal to move the lever out of P. If the car is still moving when a drive position is subsequently selected, this could cause a crash or damage the automatic transmission.
- Never park the car with the selector lever in a drive position, even if the parking brake is on.
- Always select "P" position and apply the parking brake when leaving the vehicle unattended.



Selector lever

The electronic control module for the automatic transmission receives information on engine torque and road speed, and also controls the hydraulic pressure in the transmission to ensure that gear changing is as smooth as possible.

The position of the selector lever is shown by the symbols adjacent to the lever and also by an indicator on the main instrument panel.

The ignition key can only be removed when the selector lever is in the P position.

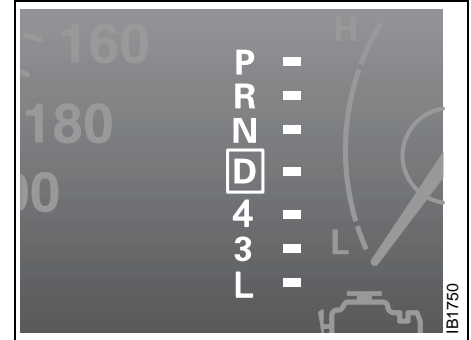

Selector-lever indicator on main instrument panel

When the car is stationary, the engine must be at idling speed when the selector lever is moved.

You must have your foot on the brake pedal to move the lever out of park.

If the accelerator is depressed while the lever is moved, this will result in abnormal wear in the transmission.

NOTE

After selecting a drive position, pause to allow the gear to engage before you accelerate.



Detent positions for selector movement

The detent button on the selector lever has to be pressed before the selector can be moved between certain positions.

Three modes for the automatic transmission can be selected: Normal, Sport and Winter.

The Normal mode, which provides the best fuel economy, is the default setting when the engine is started.

When the Sport mode is selected, the throttle angle is altered to provide more power at the same throttle setting. The transmission also changes up later than in Normal mode to provide higher performance. In this mode, the SPORT indicator will appear on the main instrument panel (see page 163).

The Winter mode is intended for use when pulling away and driving on icy roads. In this mode, the transmission starts in 3rd gear, to provide better grip, and the WINTER indicator appears on the main instrument panel. When the ignition is turned to OFF, the automatic transmission will automatically revert to Normal mode (see page 163).

Adaptive gear-change pattern is a transmission function in the Normal and Sport modes which matches gear changing to current driving conditions. The transmission control module senses the load on the engine and selects one of three available gear-change patterns, and so avoids unnecessary changing up or down.

Lock-up function

The automatic transmission has a lock-up function, which renders the torque converter inoperative in 3rd, 4th and 5th gears, the result of which is to reduce the engine speed and, hence, fuel consumption.

When the lock-up function comes into operation, it may give the impression of an overdrive being engaged.

Kick-down

When the accelerator is pressed down hard, a change-down to the next gear will be effected to provide maximum acceleration, e.g. for overtaking.

The change-up to the next gear again will take place either when the accelerator is released or when maximum engine speed is reached.

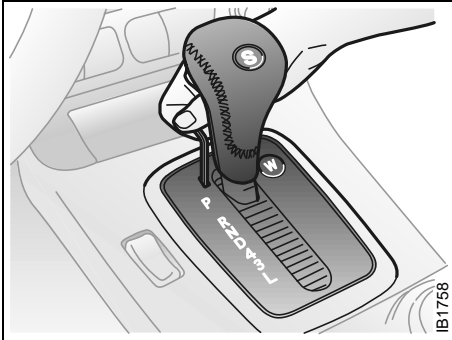

Park Brake Shift lock

The transmission has a security function known as Park Brake Shift Lock. To move the gear selector out of the P position, the brake pedal must be depressed at the same time as the gear selector catch (detente) is pressed in.

Shift Lock override

NOTE

Due to electrical problems it may not be possible to move the selector out of the park position, even if the ignition is ON. If for some reason the selector has to be moved out of the park position (i.e. to tow the car a short distance) do as described below.

- 1 Apply the parking brake
- 2 Make sure the key is in position ON
- 3 Use a small tool such as a screwdriver and push the lever (see picture) downwards so that the detent button can be pressed approx. 10 mm
- 4 Move the selector out of position P to N
- 5 Remove the tool
- 6 Release the parking brake if the car is to be moved immediately; otherwise keep it applied

Check fuse No. 1 (see page 218). If the fuse is OK, check the battery regarding the voltage.

If the problem was cured by changing the fuse or battery, you do not have to contact a Saab dealer.

If the fuse blows again as soon as the Shift Lock feature is activated you should contact your Saab dealer.



Automatic transmission, fault indicator

If "Automatic transmission, fault indicator" light appears on the main instrument panel, the system has detected a fault in the automatic transmission or its control module (see page 55).

This also means that the Limp-home mode has been selected, to guard against further damage being done to the transmission. In this mode, the automatic transmission starts in 5th gear, and gear changes (if necessary) will have to be made manually.

It is not possible to select the SPORT or WINTER mode when the Limp-home mode is active.

You should have the automatic transmission checked as soon as possible by an authorized Saab dealer.

The following gears will be engaged in the respective selector positions when the automatic transmission is in the Limp-home mode:

| Position | R | D | 4 | 3 | L |
|----------|---------|-----|-----|-----|-----|
| Gear | Reverse | 5th | 5th | 5th | 2nd |

NOTE

If the control module has actuated the Limp-home function for the automatic transmission, the car will remain in 5th gear when D is selected, making it very sluggish. To overcome this, move the selector lever to position L.

Overheated transmission fluid

If the automatic-transmission fluid should overheat, the following message will appear on the SID:
"TRANSMISSION OVERHEATING". If this happens, stop the car and wait for the message to be extinguished. Continue driving in a locked gear that produces an engine speed of about 3,000 rpm.

Overheating of the automatic-transmission fluid can occur when the car is towing a heavy load, such as a camping trailer in hilly country, with the wrong gear selected, resulting in abnormally frequent gear changing. Try selecting position L, 3 or 4. High ambient temperatures can also increase the temperature of the transmission fluid or the oil cooler may be faulty. Contact an authorized Saab dealer (see also page 173).

Driving on hilly roads with a heavy load

The transmission fluid can overheat when the gearbox is strained, for example, when driving with a trailer on hilly roads with the wrong gear is selected, resulting in many extra gear changes. To avoid the transmission fluid overheating, always drive in Normal mode. The adaptive gear change patterns are then active.

High air temperatures or a faulty oil cooler can also cause the transmission fluid to overheat. Overheating reduces the service life of the fluid. Contact an authorized Saab dealer (see also page 173).





Remember to use engine-braking (selector position L, 3, or 4) to spare the brakes when you are driving on a long or steep downhill slope.



Brake failure can result from overheated brakes!

Towing

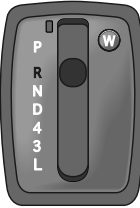
Towing of cars with automatic transmission, see page 180.

Selector positions

| | |
|--|--|
|  | <p>P To shift out of the P position you must depress the brake pedal and the ignition must be ON. The parking position (P) must only be selected when the car is at a complete standstill. The selector lever is locked and the transmission is mechanically immobilized. Always apply the parking brake after parking the car. The engine can be started. The key can be removed.</p> |
|  | <p>R The reverse (R) position must only be selected when the car is at a complete standstill. The detent-release button must be pressed before the selector lever can be moved to R. Wait until reverse gear has engaged (car starts to creep) before touching the accelerator.</p> |
|  | <p>N In the Neutral position (N), the transmission is disengaged from the engine. The engine can be started, but first ensure that the parking brake is on, to prevent the car from moving off unexpectedly. To prevent the engine and transmission from becoming hotter than necessary, select N for stops other than brief ones, e.g. if stuck in a traffic jam. The normal drive position (D) is recommended for waiting at traffic lights.</p> |

| | |
|---|---|
|  | <p>D The Drive position (D) is the position for normal motoring. Gear changes between 1st and 5th will take place automatically, the timing of which is determined by the throttle (accelerator) position and the speed of the car. After moving the selector lever to D, pause to give the gear time to engage (car starts to pull).</p> |
|  | <p>4 In position 4, 5th gear is locked out. The car will start in 1st gear and normal gear changing (up and down) will take place automatically between gears 1, 2, 3 and 4. Moving the selector lever from D to 4 will effect a change-down to 4th gear, which will give better engine-braking. Do not move the selector to position 4 at speeds in excess of 90 mph (150 km/h).</p> |
|  | <p>3 Position 3 is recommended in hilly country as it provides effective engine-braking. Normal gear changing (up and down) between 1st and 3rd gear will take place automatically. Fourth and 5th gears are locked out. Do not move the selector to position 3 at speeds in excess of 70 mph (110 km/h).</p> |



L Select position L if you wish to drive in 1st or 2nd gear. This provides maximum engine braking. The transmission shifts down from 2nd to 1st if the speed of the car drops below 20 mph (35 km/h).

If the gear selector lever is moved from position D to L, a change-down to 4th gear will occur at about 110 mph (180 km/h). It will then change-down to 3rd gear at 80 mph (130 km/h), to 2nd gear at 45 mph (75 km/h) and 1st at 20 mph (35 km/h). Manual gear-changing is not recommended on slippery roads.

NOTE

- Do not move the selector to position 4 at speeds in excess of 90 mph (150 km/h).
- Do not move the selector to position 3 at speeds in excess of 70 mph (110 km/h).

Adaptive gear-change patterns

Adaptive gear-change patterns are selected automatically depending on the engine load and the present temperature of the transmission. The function is available in Normal and Sport modes.

The changes occur at a higher engine speed and the car remains in the same gear for longer, if the transmission control module senses that the load has not decreased. These gear-change patterns prevent unnecessary changing up and down, when for example driving up long slopes with a trailer or caravan, and to prevent overheating the transmission oil. The adaptive gear-change function is also selected automatically when the transmission oil becomes too hot, to protect the transmission itself from damage and to lower the oil temperature.

The adaptive gear-change pattern function is deselected when:

- Winter mode is selected.
- The engine is switched off.
- The load is reduced so much that the function is no longer required.
- "Automatic transmission, fault indicator"  appears on main instrument panel, see page 159.

SPORT and WINTER modes



To select Sport mode, press the "S" button on the selector lever when the selector lever is in position N, D, 4, 3 or L. In this mode, gear changes will take place at higher engine speeds than in Normal mode, in other words, the transmission will change up later and change down earlier for the same throttle (accelerator) position.

The Sport mode will be deselected if:

- The S button is pressed.
- The selector lever is moved to position P or R.
- The engine is switched off.
- The Winter mode is selected.
- "Automatic transmission, fault indicator"  appears on main instrument panel, see page 159.

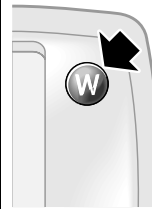

The Winter mode facilitates pulling away and driving on icy roads. Third gear is selected automatically for pulling away to reduce wheelspin. Winter mode can be selected when the engine is running by pressing the "W" button on the selector-lever surround. It cannot be selected when the selector lever is in position L.

Note: It is still possible to use kick-down in the Winter mode, in which case a change-down to 1st or 2nd will take place.

The Winter mode will be deselected if:

- The W button is pressed.
- The engine is switched off.
- The selector lever is moved to position L.
- The automatic-transmission fluid overheats.
- "Automatic transmission, fault indicator"  appears on main instrument panel, see page 159.

Cruise control

! WARNING

- Do not use the Cruise control system on wet or icy roads, in dense traffic or on winding roads.
- Set the control to OFF when you do not want to use the system, to prevent the system being activated inadvertently.

For safety reasons (brake system function) the brakes must be applied once, when the engine has started, before the cruise control system can be activated.

The system is operated by means of the controls on the stalk switch:

- ON/OFF (switch on/off).
- RESUME/– (Resume preset speed).
- SET/+ (to set the desired speed).
- CANCEL (Cancel operation of system, e.g. to reduce speed temporarily).

When the system is ON, the CRUISE indicator light will appear on the main instrument panel and will be extinguished when the system is switched OFF. If CANCEL is selected, CRUISE will flash once.

To set the desired speed

Move the switch to ON. Accelerate to the desired speed (minimum speed: 25 mph (40 km/h)) and press SET/+.

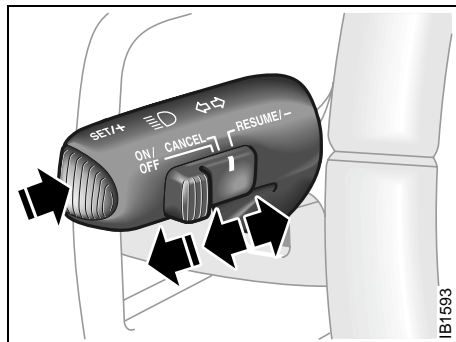

Cruise-control switches

To increase the preset speed

Accelerate to the desired speed and press SET/+.

You can also increase the speed of the car using the SET/+ button. Press it once to increase the speed by 1 mph (1.6 km/h) or hold it in and release when the desired speed is reached.

Temporary increase in speed

Press the accelerator to override the preset speed, e.g. for overtaking.

When you release the accelerator, the system will revert to the preset speed.

To cancel temporarily

Move the control stalk to CANCEL (spring-loaded position before OFF position). This will disengage the system but the preset speed will be retained in the system

memory. (The memory is deleted when the engine is switched off.)

To re-engage the system

To revert to the preset speed, slide the switch to RESUME/–. This will only operate when the car's speed is above 25 mph (40 km/h).

To reduce the preset speed

The cruise control system will always disengage automatically the moment that either the brake pedal or the clutch pedal is depressed.

It is also possible to reduce the speed by means of the RESUME/– button.

Sliding the button to RESUME/– once will reduce the speed by 1 mph (1.6 km/h). Holding the button in the RESUME/– position will effect a gradual reduction in speed until the button is released.

Disengaging the system

The system will be disengaged:

- When the brake or clutch pedal is depressed.
- When the switch is moved to CANCEL.
- When the switch is moved to OFF.
- When the engine is switched off.
- When the selector lever is moved to position N (cars with automatic transmission).

Braking

To avoid the brakes becoming overheated, (e.g. when negotiating long descents with a drop of several hundred feet), select a low gear to use the braking effect of the engine. If the car has automatic transmission, move the selector lever to position 1 or 2.

When driving fast, you can help to prolong the life of the brakes by thinking ahead and braking harder for short periods, rather than braking more moderately over long stretches.

Brake pad wear indicators

The outboard brake pads on the front wheels incorporate pad-wear indicators. When the lining is down to 3 mm, the pad will produce a screeching, squealing or scraping noise when the brakes are applied. New pads should be fitted without delay.

Brake pads should only be replaced by an authorized Saab dealer.

To ensure optimum brake performance, it is recommended that you use only Saab original brake pads.

WARNING

- It is prudent to try your brakes from time to time, especially when driving in heavy rain, through water collected on the road, in snow, on a wet road surface or in salty slush. In such conditions, the brakes may take longer than normal to take effect. To rectify this, touch the brake pedal periodically to dry the brakes out.
- The same applies after the car has been washed or when the weather is very humid.
- Avoid parking the car with wet brakes. Before parking, and if the traffic conditions allow, brake quite heavily so that the brake discs and pads warm up and dry.
- The brakes are power assisted and it should be kept in mind that the servo unit only provides the power assistance when the engine is running.
- The brake pressure required when the engine is off, (e.g. when the car is on tow) is roughly four times the normal pedal force required. The pedal also feels hard and unresponsive.

ABS brakes

WARNING

- The additional safety afforded by the ABS system is not designed to allow drivers to drive faster but to make normal driving safer.
- To stop as quickly as possible, without loss of directional stability, whether the road surface is dry, wet or slippery, **press the brake pedal down hard - without letting up, declutching simultaneously, and steer the car to safety.**

ABS (antilock braking system) modulates the brake pressure to the respective wheels. Wheel sensors detect if a wheel is about to lock, and the control module reduces the pressure to that wheel and then increases it once more until the tendency is detected again.

The brake system is equipped with an Electronic Brake-force Distribution device (EBD), which distributes the brake pressure between the front and rear wheels, in such a way as to achieve optimum braking performance irrespective of the car's speed and load.

The ABS system has a built-in diagnostic function which will switch on the Anti-lock brake warning light if a fault is detected in the system (see page 52).

The ABS system will not reduce the braking distance on loose gravel or on snow or ice but, because the wheels cannot lock up, some steering control is retained.

When the ABS system is working, i.e. modulation of the brake pressure is in progress, the brake pedal will pulsate and a ticking noise will be heard. All this is perfectly normal.

Press the pedal **down hard** (you cannot press too hard) and steer the car to safety.

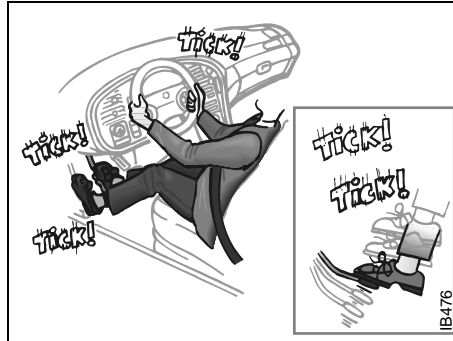

*Braking with ABS brakes.
When the system is operating, the brake pedal will pulsate gently and the system will make a ticking noise.*



Braking with ABS – evasive steering

Do not release the brake pedal before the car has come to a halt or the danger is past!

That is critical.

If the road is slippery, the ABS system will operate even when only light pressure is applied to the pedal. This means that you can brake gently to test the condition of the road and adapt your driving accordingly.

It is well worth practicing the use of ABS brakes on a skid pad or other suitable facility.

Traction Control System

How the system works

The traction control system (TCS) is designed to prevent wheelspin. This enables the car to achieve the best possible grip and, hence, maximum tractive effort, together with greater stability.

The TCS system uses information from the ABS system's wheel sensors to detect when the front (driving) wheels are rotating faster than the rear wheels. It then monitors whether one driving wheel is rotating faster than the other. If so, the faster wheel is retarded until both wheels are rotating at the same speed.

If the two front wheels are rotating at the same speed but are turning faster than the rear wheels, the torque from the engine is reduced to eliminate the difference.

The process continues until all the wheels are rotating at the same speed.

The advantages of the TCS system become most apparent when the cohesion between the front wheels and the road surface is so low that one or both of the wheels would lose their grip were the car not equipped with the TCS, e.g.:

- When the car is pulling away or accelerating with the front wheels on different surfaces (e.g. one slippery and one dry). The TCS then functions like an electronic differential lock.
- When the car is pulling away or accelerating on a slippery road, in which case the TCS eliminates wheelspin. The same applies when the car is reversing.
- On cornering, if there is a tendency for the inner front wheel to rotate faster than the other wheels.
- On overtaking.

WARNING

In normal driving, the TCS system will help to improve the safety of the car, but it does not mean that the car can be driven faster. The same care and prudence normally applied should be displayed on cornering and when driving on slippery roads.

TCS OFF

The  indicator on the main instrument panel will come on:

- If a fault has been detected and the system has therefore been switched off.
- If there is a fault in the ABS system.
- If the system has been switched off manually.

The indicator light will also come on for 4 seconds when the ignition key is turned to ON, while an internal system check is performed.

TCS indicator

The indicator light will come on for 4 seconds when the ignition key is turned to ON, while an internal system check is performed.

The  light in the tachometer comes on when the system is operative, i.e. when the wheels are not rotating at the same speed.

The fact that the TCS system is operative indicates that the limit for grip has been exceeded and that the driver must exert greater care.

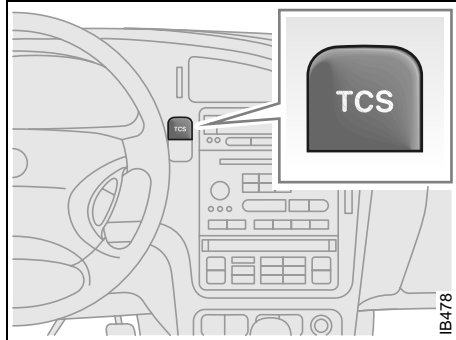

Turning the TCS off

The TCS is switched on automatically when the engine is started.

The system can be switched off manually by the TCS button, whereupon  on the main instrument panel will come on. The TCS system cannot be switched off if the car is travelling faster than 35 mph (60 km/h).

It may be necessary to switch off the system if the car has become bogged down, for instance. Press TCS to switch it on again.

If a fault is detected in the ABS system, the TCS will be switched off automatically.

The cruise-control system will automatically be disengaged after one second if it is active when the TCS starts to operate.

Electronic Stability Program (ESP) (option/certain models only)

The Electronic Stability Program employs both the antilock braking system (ABS) and the traction control system (TCS). It is a safety system that helps the driver to stabilize the car in unusual circumstances that can otherwise be difficult to handle.

How the ESP system works

The Electronic Stability Program can help to prevent the car from skidding by braking one or several wheels independently of the driver. The engine output is then also reduced to prevent the driving wheels from spinning. The car has sensors that measure wheel speed, yaw acceleration, lateral acceleration, steering wheel position and braking pressure. The values provided by these sensors are used to calculate the actual direction of the car. If this direction does not agree with that intended by the driver, calculated from the steering wheel position, the ESP is engaged.

ESP improves the driver's chances of retaining control over the car in critical situations.



ESP OFF

The  light in the rev counter comes on if:

- A fault has been detected and the system has therefore been switched off.
- The system has been switched off manually.
- When the ignition key is turned to the ON position, the lamp is lit for about four seconds while the system undergoes a self-test.

ESP indicator light

The  indicator light in the rev counter comes on for a short period of time when the ESP system is operative.

Operation of the ESP indicates reduced cohesion between the tires and the road, and that extra care should be taken by the driver.

Turning ESP off

The system can be turned off manually with the ESP button, whereupon the  light on the main instrument panel will come on. The ESP system cannot be switched off if the car is travelling faster than 35 mph (60 km/h).

The ESP is always operative during braking, even if it has been switched off manually.

WARNING

When driving normally, ESP will help to improve the stability of the car. This does not mean that car can be driven faster. The same care and prudence as normally applied should be displayed on cornering and when driving on slippery roads.

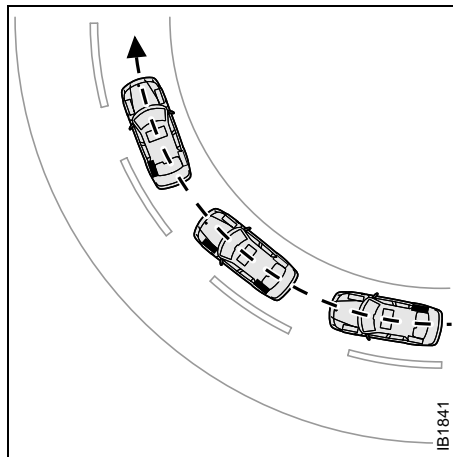

*Increased stability with ESP.
The system applies the brakes to the wheels as shown to prevent the car from skidding*

NOTE

Suspension modifications, such as changing the type of wheels, dampers or springs, can affect the function of the ESP system.

Always consult a Saab dealer before changing any suspension components.

Economical motoring

Factors affecting fuel consumption

Fuel consumption is greatly affected by the general driving conditions, the way in which the car is driven and at what speeds, the weather, the state of the road, the condition of the car, etc.

Breaking-in

Fuel consumption may be somewhat higher during the break-in period (the first 3,000–4,000 miles (5,000–7,000 km) than stated under "Technical data".

Weather conditions

Fuel consumption can be as much as 10 % lower in summer than in winter. The higher consumption in cold weather is explained by the longer time it takes for the engine to reach normal operating temperature, and for the transmission and wheel bearings to warm up. Fuel economy is also affected by the distance driven: short journeys of 3-5 miles (5-8 km) do not give the engine enough time to reach normal temperature. Strong winds can also affect fuel consumption.

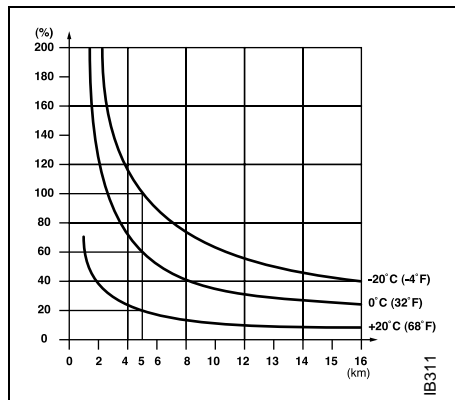

Percentage increase in fuel consumption of engine starting from cold compared to engine at normal temperature.

How to read the graph on the right:

If fuel consumption with the engine at normal temperature is 28 mpg (10l/100 km), the actual fuel consumption 3 miles (5 km) after the engine has started from cold will be:

- 23.5 mpg (12l/100 km) at outside temp. of 68°F (20°C) (increase of 20%).
- 17.7 mpg (16l/100 km) at outside temp. of 32°F (0°C) (increase of 60%).
- 14 mpg (20l/100 km) at outside temp. of –4°F (–20°C) (increase of 100%).

As can be seen, both the distance travelled by the car and the outside temperature have

a major impact on fuel consumption after the engine has started from cold. Thus, if the car is mainly used for short journeys of 3–5 miles (5–8 km), the fuel consumption will be 60–80 % higher than normal.

Driving technique

- To obtain the best running economy, not only regarding fuel consumption but general wear also, regular service is required.
- High speed, unnecessary acceleration, heavy braking and much low gear work all gives rise to higher fuel consumption.
- Frequent gear changing in traffic, starting in cold weather, the use of studded tires and roof racks, and towing a trailer all increase fuel consumption.
- Do not run the engine when the car is stationary. If idling, it will take much longer before the engine becomes hot. Engine wear is greatest during this warming-up phase. Therefore drive away as soon as possible after the engine is started and avoid high revving.

- Driving in a low gear results in higher fuel consumption than in a high gear because of the higher engine speed for a given road speed. Always change up to a higher gear as soon as traffic conditions allow and use the highest gear as much as possible.
- Check the air pressure in the tires once a month. Incorrect pressures increase tire wear. It is better to have slightly higher pressure than lower.
- Check fuel consumption regularly. Increased consumption can indicate that something is wrong and that the car needs to be checked by an authorized Saab dealer.

Practical trials on the roads have demonstrated that substantial savings in fuel consumption can be made if the above advice is heeded.

Road conditions

Wet roads increase fuel consumption, as do unpaved roads and driving in hilly country (the amount of fuel saved driving downhill is less than the additional amount required to climb the hill).

WARNING

Never switch the engine off while driving as the effect of the brakes and power steering will be greatly reduced.

Engine block heater (standard equipment in Canada, accessory in U.S.)

The following are just some of the benefits to the car and the environment of using an engine block heater:

- Lower fuel consumption.
- Reduced wear on the engine.
- Inside of car warms up faster.
- Exhaust emissions substantially reduced over short runs.

The engine heater is effective at outside temperatures up to +15-20°C. The warmer it is outside, the shorter the time the engine heater needs to be connected. Longer than 1.5 hours is unnecessary.

If the car is equipped with a removable, electrical cabin heater that is not in use, this should be stored in the luggage compartment.

Driving in cold weather

Before starting a journey in cold weather you should check the following:

- That the wiper blades have not become frozen to the windshield/glass.
- Brush any snow away from the air intake for the heater system (opening between hood and windshield).
- It may be advisable to lubricate the door-lock cylinder (use molybdenum disulphide, MoS₂) to prevent its freezing. If the lock has frozen, take care not to break the key (or use the remote control) – heat it first or spray it with de-icer.
- Periodically during the winter, add gasoline anti-freeze to the fuel to dispel any condensation in the fuel tank which could freeze and cause problems in the system. Keep the tank well filled to reduce the risk of condensation forming. If the car is parked outside in freezing weather, fuel additives (gasoline anti-freeze) will not do any good as it cannot remove water that has already frozen. Park the car in a warm place so that any ice that may have built up melts, then add gasoline anti-freeze when filling up the tank. Condensation is caused by changes in the outdoor temperature or by the car being parked alternately in a garage and outside.
- It is particularly important when the roads are slippery that the brakes and tires be in good condition.

- Check the anti-freeze in the engine coolant, see page 196.

The car's trip computer will warn you when there is a risk of slippery conditions. For further information on this function, see page 60.

The car is equipped with tires designed to provide optimum grip on both wet and dry roads, although this has been achieved at the expense of somewhat reduced grip on snow and ice. For regular driving on snow and ice, we therefore recommend that winter (snow) tires be fitted.

Winter (snow) tires, particularly studded tires (where use is legally permitted), generally make driving safer on snow and ice.

Acquaint yourself with the legal provisions governing the use of different types of winter tires and snow chains. Studded tires are not allowed in some countries.

If winter tires are fitted, the same type must be fitted on all wheels. Your Saab dealer will be pleased to advise you on the best tires for your car.

Remember that tires age. It may therefore be necessary to change them before they reach the legal wear limit, as they gradually lose their friction properties.

The best response if the car gets into a front-wheel skid is to freewheel (manual gearbox only), i.e. disengage the clutch (so that the wheels are neither driven or retarded by the engine.

If the car has automatic transmission, ease up on the accelerator and steer carefully in the desired direction.

In a rear-wheel skid, steer in the same direction that the rear of the car is moving.

Tire chains

If you want to fit tire chains (where legally permitted) they should only be fitted to the tires recommended under "Specifications" (see page 256).

Consult your Saab dealer for details of approved tire chains.

WARNING

- Do not exceed 30 mph (50 km/h) when tire chains are fitted.
- Tire chains can reduce the directional stability of the car.
- Tire chains must not be used on the rear wheels.

NOTE

- Check the links frequently for wear.
- Check that the chains do not contact the wheel-arch liner at full lock.
- See section "Specifications", page 256, for information on allowable wheel dimensions for the fitting of tire chains.

Driving in hot weather

- Always check the coolant level before starting a journey. The level should be just below the MAX mark.
- At the end of a journey, if the engine has worked hard, allow it to idle for two or three minutes before switching it off.

If the needle on the temperature gauge enters the red zone:

- 1 Bring the car to a standstill but leave the engine running. Do **not** remove the cap on the expansion tank even if the tank is empty. If the needle on the temperature gauge continues to rise while the engine is idling, switch off the engine.

- 2 Wait until the needle has dropped back to indicate normal temperature (roughly midway, in the white zone) before stopping the engine. If the coolant needs topping up, unscrew the cap on expansion tank **carefully**.

Top up, as necessary, ideally with a 50/50 mixture of Saab-approved coolant and water. If only water is available, use that, but remember to have the coolant mixture checked as soon as possible.



WARNING

Always undo the expansion tank filler cap carefully, releasing the pressure and any vapor before removing the cap completely.

- 3 As soon as possible, have the cooling system checked by an authorized Saab dealer.

Towing a trailer

Trailer hitch attachment

Trailer hitch attachments are available as accessories. These are designed for a maximum trailer weight of 3500 lbs. (1588 kg), see also page 249.

Use only the electrical trailer hitch socket provided in the trailer hitch kit.

Saab recommends:

- Use a Saab original hitch kit attachment which is designed and tested by Saab.
- Consult your Saab dealer regarding the appropriate hitch kit for your car.

NOTE

Use only a genuine Saab trailer hitch and wiring, since other wiring methods can cause expensive damage to the car's body and electrical system.

Consult an authorized Saab dealer for guidance on how to connect the trailer hitch electrical system.

Trailer weight

Maximum recommended trailer weights for different gradients, with a view to comfort and drivability for manual and automatic cars, are shown on the drawing.

Make sure you are familiar with the law regarding speed limits for towing, maximum trailer weights, trailer-braking requirements, and also any special driving-licence provisions (see also page 249).

WARNING

When towing a trailer, do not attempt to negotiate a hill having a gradient in excess of 15%. The weight distribution over the front wheels of the car will be insufficient to prevent wheelspin, making further progress impossible.

In addition, the parking brake may not always be able to hold the car and trailer securely, with the result that the wheels can start to slide downhill.

The specified trailer weights and gradients assume that the journey starts at the hill and therefore apply only to short periods.

Maximum recommended trailer weights for different gradients

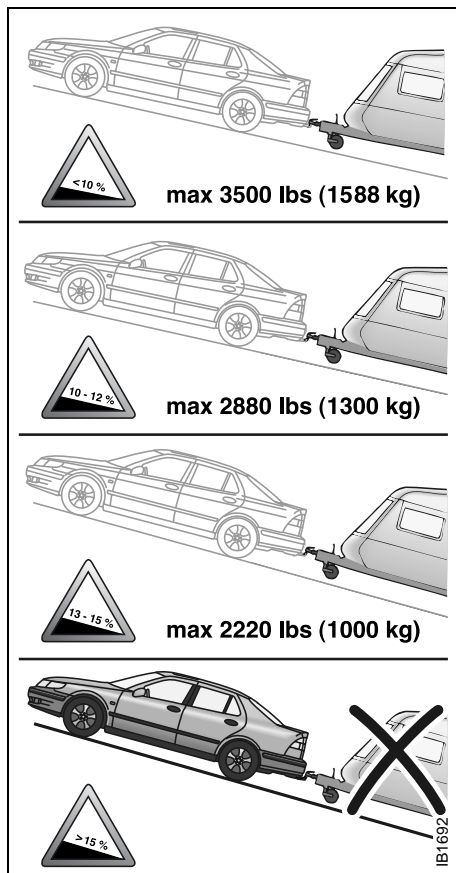

Recommendations for driving in hilly terrain

The following time limits are based on the capacity of the cooling system in warm weather, i.e. approximately 86°F (30°C).

| Gradient of hill, % | Maximum trailer weight, lbs. (kg) | Maximum duration, minutes |
|---------------------|-----------------------------------|---------------------------|
| 6-7 | 3300 (1500) | unlimited |
| 8-9 | 3300 (1500) | 15 max |
| 10-15 | 1870 (850) | 15 max |

The following time limits are based on the capacity of the cooling system in hot weather, i.e. approximately 104°F (40°C).

| Gradient of hill, % | Maximum trailer weight, lbs. (kg) | Maximum duration, minutes |
|---------------------|-----------------------------------|---------------------------|
| 6-7 | 2000 (900) | unlimited |
| 8-9 | 2000 (900) | 15 max |
| 10-15 | 1000 (450) | 15 max. |

Use Normal mode when driving with a trailer or trailer on hilly roads. The adaptive gear change pattern function will prevent the transmission from overheating.

Rises in coolant temperature are indicated by the temperature gauge in the main instrument panel.

The following can also occur:

- the A/C-compressor can be shut off
- the gear-change pattern is changed
- the CHECK message TRANSMISSION OVERHEATING can appear on the SID

If TRANSMISSION OVERHEATING appears on the SID, stop the car as soon as it is safe to do so and wait until the warning has been extinguished. When continuing your journey, select a locked gear (1, 2 or 3) that will allow you to drive at an engine speed of about 3,000 rpm (see page 161).

⚠ WARNING

Remember to use engine-braking (selector position L, 3, or 4) to spare the brakes when you are driving on a long or steep downhill slope.

Brake failure can result from overheated brakes!

Do not drive continuously with the WINTER mode selected in hilly country when you are towing a trailer, as this will increase fuel consumption and risk overheating the transmission.

Driving considerations

Always take extra care when towing a trailer, as the car's handling will be different and its braking effect reduced. The trailer's braking system and suspension also have a considerable effect on these characteristics, see also "Driving with a load" page 178. If the car is equipped with automatic transmission, select position L when ascending or descending steep hills.

NOTE

If the "Automatic transmission, fault indicator" indicator  comes on, cease towing until the problem has been rectified.

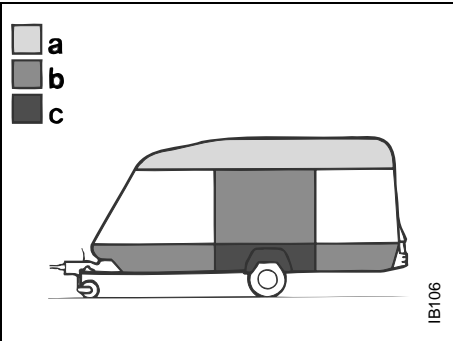

Distribution of load in trailer

a Light
b Moderate
c Heavy

Trailer hitch load

The weight distribution on the trailer makes a lot of difference to the handling properties of the car and trailer combination. As regards single-axle trailers, whenever possible, concentrate the load over the wheels and keep it as low as possible.

The trailer should be loaded so that the maximum load on the towbar ball is 5% to 7% of the trailer weight with a maximum permissible tongue weight of 165 lbs. (75 kg).

Note that this load must be added to the total load for the car. If this now exceeds the specified load capacity, the load in the luggage compartment will have to be reduced by a corresponding amount.

Driving with a roof rack load

WARNING

- A roof load will affect the car's center of gravity and aerodynamics. Be aware of this when cornering and driving in crosswinds.
- Suit your speed to the prevailing conditions.
- Due to higher aerodynamic drag, fuel economy may suffer when driving with a roof rack.

The maximum permissible roof load is 220 lbs. (100 kg).

Note that the roof load is included in the car's maximum permissible load (see page 248).

Strong, sturdy roof carriers designed specially for the car are available from your Saab dealer. Always secure the roof load safely.

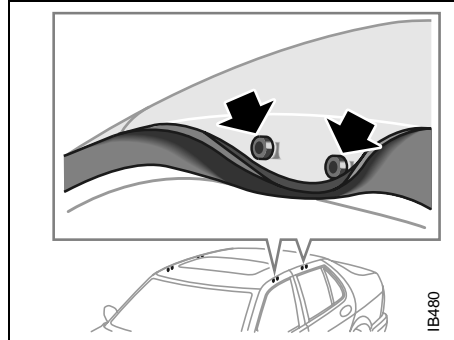

Fitting the roof carriers (accessory)

9-5 Sedan

The carrier feet are marked with a top view of the car and arrow indicating their positions.

- 1 Slip the plastic cover onto the adjustable foot of the carrier (foot with knob for tightening) to protect the paintwork during assembly.
- 2 Open all the doors. Fold back the rubber strip and find the fixing holes.
- 3 Start on the left-hand side of the car. Rest the carrier carefully across the roof, with the rigid foot towards you. Hold the foot clear of the roof to avoid damaging the paintwork. Fold back the rubber strip and insert the pins on the foot into the fixing holes. Make sure that the rubber strip comes inside the plastic cover on the carrier.

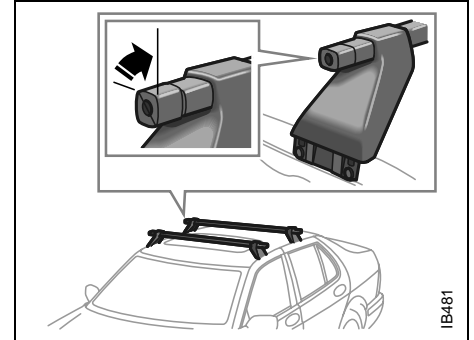

Repeat the procedure with the other carrier.

- 4 Close the doors on the left-hand side of the car gently, to hold the carrier feet in place.
- 5 Now go around to the other side of the car and remove the plastic cover from the carrier's adjustable foot. Fold back the rubber strip and insert the pins on the foot into the fixing holes. Do the same with the other carrier and close the doors gently.
- 6 Tighten each carrier by turning the knob clockwise (by hand). Tighten just enough to bring the foot up against the edges of the fixing holes.

Remove the carriers when not in use, as they increase fuel consumption.

The instructions that accompany the carriers also include advice on driving with a roof load - we strongly recommend that you read them carefully.

Fitting the roof carriers (accessory)

9-5 Wagon

- 1 Clean the car's roof rails.
- 2 Check the markings on the cross members to see which is the front and which is the rear roof carrier.
- 3 Place the cross members on the roof rails, on their respective sides of the center supports. The cross members must not be placed beyond the front or rear joint on the rail. Ensure that the distance between the cross members is at least 28 inches (700 mm).
If a roof box is to be fitted, the cross members must be positioned so that the tailgate can be opened fully without hitting the roof box.
- 4 Using your thumb, press the bracket so that it lies snugly against the outside of the roof rail. Make sure that the roof carriers are seated centrally on the rubber spacers and that these sit correctly on the roof rail. Pull the spacers down slightly on the inside of the roof rail.
- 5 Center the roof carriers so that they protrude equally on both sides.
- 6 Tighten the roof carriers by hand. Ensure that the tightening knobs are upright once the roof carriers have been tightened.
- 7 Make sure the roof carriers are securely in place.

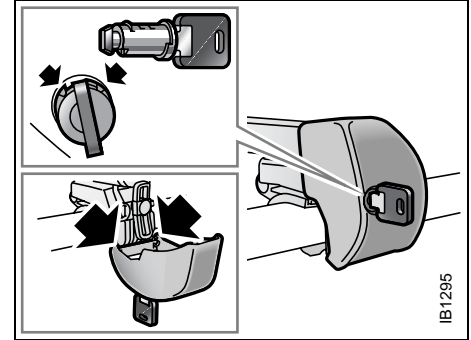
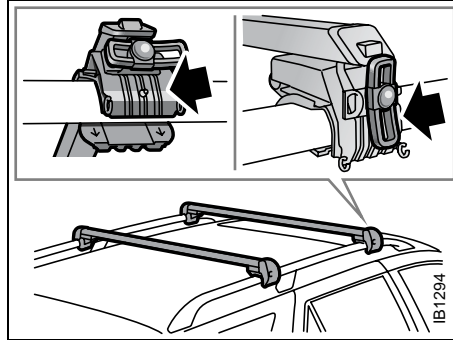

Driving with a load

The driving characteristics of the car are affected by the way it is loaded.

- Place heavy loads as far forward and as low as possible in the trunk.
- Secure the load to the tie downs, see page 134.
- The load should be such that the car's total weight or axle weight are not exceeded, see page 248.
- Heavy loads mean that the car's center of gravity is further back. As a result, the car will sway more during evasive steering.
- Never exceed the permissible load in the roof box, even if there is room for more.
- Ensure that the tire pressure is correct – slight overinflation is preferable to underinflation.
- The braking distance of a loaded car is always greater. Keep your distance from the vehicle in front.
- Roof loads can negatively affect telecommunication.

Tire pressure, see page 257 and back cover.

Tires

NOTE

Check the tire pressure **at least once a month**. Underinflation is the main cause of:

- Damage to the wheels.
- Premature tire wear.
- Damage to the sidewalls.

The tire pressure should match the current load and speed of the car; see the back cover or the tire pressure label on page 257.

The tire pressures given apply to **cold** tires, that is tires that are the same temperature as the outside air temperature.

The tire pressure increases as the tires become warm (e.g. during highway driving) with approximately 0.3 bar (4 psi). When the temperature of the tires changes by 50° (10°C), the tire pressure will change 0.1 bar (2 psi).

Never reduce the pressure of a hot tire. If the tires are hot when you check them, only increase the pressure, if necessary.

Underinflated tires wear more quickly than slightly overinflated tires.

If a valve is leaking, simply unscrew it and fit a new one.

Important! Remember to adjust the tire pressures if you change the load in the car or intend to drive at substantially lower or higher speeds than normal.

Driving considerations with compact spare wheel/tire fitted

WARNING

Do not exceed 50 mph (80 km/h) as the tire can overheat and adversely affect the handling of the car.

The tire should be inflated to 60 psi (420 kPa).

The following should be observed when the compact spare wheel (T115/70 R16) is fitted:

The compact spare is light and easy to handle when changing the wheel. Do not drive further than necessary with the compact spare fitted – the maximum life of the wheel is only just over 2000 miles (3,500 km). Have the standard wheel repaired and refitted as soon as possible.

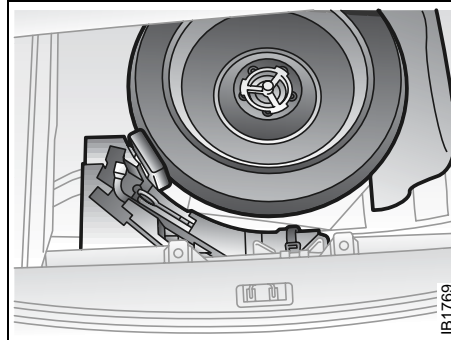

The car's ground clearance is reduced with the compact spare fitted. Note that only one compact spare wheel may be used at any time. Take care not to hit the curb and do not fit snow chains. Leave the wheel cover off, so that the warning text is readily visible.

NOTE

To avoid damaging a punctured alloy wheel it can be placed outside up in the spare-wheel well but **only** while driving to the closest workshop.

A general rule is that all heavy loads must be well secured in the luggage compartment, see page 134 and 137.

Driving with the trunk lid/tailgate open

Avoid driving with the trunk lid/tailgate partly or fully open, since exhaust fumes can be drawn into the cabin.

If you must drive with the trunk lid/tailgate open, all windows and the sunroof (if fitted) must be closed and the cabin fan on at its highest speed setting.

Driving in deep water

NOTE

Do not drive in water deeper than 12 inches (30 cm) and do not drive faster than at idling speed. Water can otherwise be sucked into the engine. The engine will be damaged if water enters the intake system. The car's electrical systems may also be affected.

Towing the car

WARNING

- Remember that the brake servo does not operate when the engine is off. Much greater pressure than normal will therefore be required to operate the brake pedal.
- Nor does the steering servo operate when the engine is off. The steering will therefore be much heavier than usual.
- The towing vehicle should always be heavier than the vehicle on tow.
- Never allow passengers to ride in the car being towed.
- Always seek professional help if the car needs to be towed.

Transporting the car

NOTE

If a car with a sport (lowered) chassis is transported, for example on a flat bed truck, take extra care not to damage the spoiler and/or underbody.

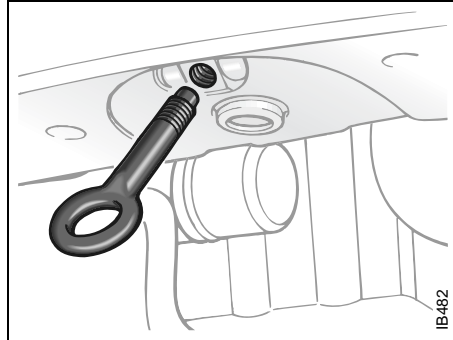

Front towing eye

Front towing eye

WARNING

- Make sure that the towing eye at the front is screwed in tightly.
- The towing eye is only designed for use when the car is being towed on the road. It **must not be used** to pull the car out of a ditch, for example. If the towing eye were to shear suddenly, it could cause serious injury.
- Always seek professional help if the car needs to be recovered.

NOTE

- Do not drive the car with the front towing eye in position. If it catches the curb, for example, the engine sub-frame could be damaged.
- Refit the plastic plug in the hole when the towing eye has been removed, to keep dirt and moisture out of the threads.

The front towing eye is stored with the spare wheel.

The attachment point (tapped hole) for the towing eye is midway along the engine sub-frame at the front of the car.

Remove the plastic plug and screw in the towing eye securely.

To ensure that the towing eye is in far enough, insert the handle of the wheel wrench through the eye for additional leverage.



Rear towing eye

Rear towing eye

The car has a permanently mounted towing eye at the back. If the car is equipped with a trailer hitch, this can be used instead of the towing eye.

Considerations when towing the car with manual transmission

Gear lever in neutral and parking lights on.

Drive carefully and do not exceed the speed limit for vehicles being towed.

Always try to keep the towrope taut by gently applying the brake, as necessary. This will avoid the towrope being jerked violently.

Considerations when towing the car with automatic transmission

Selector lever at N (neutral) and parking lights on.

Drive carefully and do not exceed the speed limit for vehicles being towed.

Always try to keep the towrope taut by gently applying the brake, as necessary. This will avoid the towrope being jerked violently.

NOTE

- The car must be towed front first.
- If the car is to be towed with the front wheels off the ground, make sure the parking brake is off, as this acts on the rear wheels.

- 1 Selector lever in position N.
- 2 The local regulations on towing speeds must be followed.

The highest permissible towing speed is 30 mph (50 km/h), unless the legal limit is lower. The longest permissible towing distance is 25-30 miles (40-50 km). If the car has to be transported farther than that, summon a tow truck. A flat bed tow truck is the preferred method to tow.

Failure to follow these guidelines can result in damage.

Cars with automatic transmission cannot be bump started. In an emergency, it is possible to start the engine using jump leads (see the section, "Jump starting" on page 182).

Jump starting

If your battery has run down, you may want to use another vehicle and some jumper cables to start your Saab. Follow the steps below to do it safely.

WARNING

Batteries can cause injury. They can be dangerous because:

- They contain acid that can burn you.
- They contain gas that can explode or ignite.
- They contain enough electricity to injure you.

If you do not follow these steps exactly, some or all of these things can hurt you.

NOTE

Ignoring these steps could result in costly damage to your vehicle that would not be covered by your warranty.

Trying to start your car by pushing or pulling it could damage your vehicle, even if you have a manual transmission. If you have an automatic transmission, your vehicle cannot be started by pushing or pulling it.

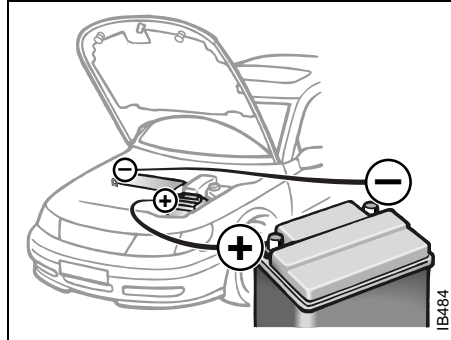

To jump start your vehicle:

- 1 Check the other vehicle. It must have a 12-volt battery with a negative ground system.

NOTE

If the other system is not a 12-volt system with a negative ground, both vehicles can be damaged.

- 2 Get the vehicles close enough so the jumper cables can reach, but be sure the vehicles are not touching each other. If a poor connection on the negative jumper cable should exist, it is possible for damage to be caused to electrical systems/components of either vehicle should inadvertent contact be made. You would not be able to start your car

and bad grounding could damage electrical systems.

WARNING

You could be injured if the vehicles roll. Set the parking brake firmly on each vehicle. Put an automatic transmission in P (Park) or a manual transmission in Neutral.

- 3 Turn off the ignition on both vehicles. Turn off all lights that are not needed, and radios. This will avoid sparks and help save both batteries and it could save your radio.

NOTE

If you leave your radio on, it could be badly damaged. The repairs would not be covered by your warranty.

- 4 Open the hood and locate the battery. Find the positive (+) and negative (-) terminals on the battery.

 **WARNING**

An electric fan can start up even when the engine is not running and can injure you. Keep hands, clothing and tools away from any underhood electric fan.

 **WARNING**

Using a match or flame of any kind near a battery can cause battery gas to explode. You can suffer burns or be blinded. Use a flashlight if you need more light.

Be sure the battery has enough water. The battery installed in your new Saab has filler caps. Be sure the right amount of water is there. Add distilled or boiled water if the level is too low. If you don't, explosive gas could be present.

Be sure the electrolyte in the battery is not frozen. Discharged batteries will freeze. When connecting jumper cables to a frozen battery, gas from the chemical reaction inside the battery can build up under the ice and cause an explosion.

Battery fluid contains acid that can burn you. Do not get it on you. If you accidentally get it in your eyes or on your skin, flush the area with water and get medical help immediately.

- 5 Check that the jumper cables do not have loose or missing insulation. If they do, you could get a shock and also the vehicles could be damaged. Before you connect the cables, here are some basic things you should know. Positive (+) will go to positive (+) and negative (-) will go to a major metal engine part with a good ground. Do not connect (+) to (-) or you will get a short that could injure you or would damage the battery and maybe other parts as well.
- 6 Connect the red positive (+) cable to the positive (+) terminal of the vehicle with the discharged battery.
- 7 Do not let the other end touch metal. Connect it to the positive (+) terminal of the good battery. Use a remote positive (+) terminal if the vehicle has one.
- 8 Now connect the black negative (-) cable to the good battery's negative terminal.

 **WARNING**

Do not let the other end touch anything until the next step. The other end of the negative cable **does not** go to the dead battery. It goes to a major metal part with a good ground on the engine of the vehicle with the discharged battery.

- 9 Attach the cable at least 18 inches (45 cm) away from the discharged battery, but not near engine parts that move. To avoid an arc which could detonate the hydrogen gas around the battery, the final connection must be at least 18" from the battery.
- 10 Start the vehicle with the good battery and run the engine for a while.
- 11 Try to start the vehicle with the discharged battery. If it does not start after a few tries, it probably needs service.
- 12 Remove the cables in reverse order to prevent electrical shorting. Take care that they do not touch each other or any other metal.

Saab Parking Assistance

(Option)

WARNING

Responsibility **always** lies with the driver when reversing.

- Saab Parking Assistance can facilitate reversing at low speeds, such as when reverse parking.
- Bear in mind that small and/or narrow objects cannot always be detected by the system.

The parking aid system facilitates parking and reversing. There are four sensors in the rear bumper that detect objects up to 6 feet (1.8 metres) behind the car.

The system uses four sensors in the rear bumper. These emit ultrasound signals that bounce back to the sensors off any objects behind the car. The system, however, cannot always detect small or narrow objects or objects that do not reflect ultrasound back towards the car, such as pipes, or the corner of a house or rectangular post.

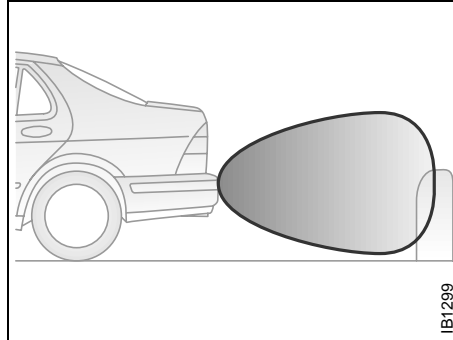

Area monitored by the sensors seen from the side

The system is activated automatically when reverse is engaged or selected. When the sensors detect an object within the monitored area, the SID will display the text "PARK ASSIST" and pulses of sound (- - - -) will be heard. The frequency of the pulses increases as the car comes closer to the object.

When the distance to the object is less than 12 in. (30 cm), a continuous tone will be heard.

NOTE

Reverse slowly so that you have time to stop the car when the continuous tone is heard at approx. 30 cm.

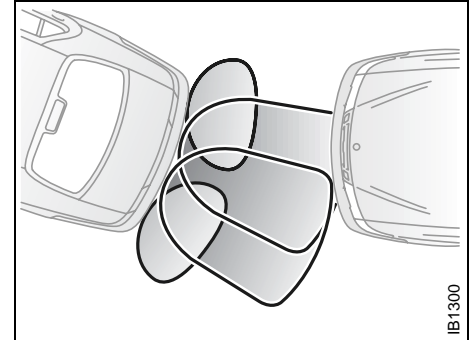

Area monitored by the sensors seen from above

When an object is approximately 3 feet (90 cm) from the car, the sound pulses change character markedly. A distance of about 3 feet (90 cm) is suitable if you wish to load or unload the luggage compartment. If the distance between an object and the corner sensors does not change for three seconds, e.g. if you are reversing alongside a wall, the system will switch to monitoring straight back. The system indicates if the distance to the wall decreases again.

The system can be disengaged for when driving with a caravan or trailer. Press and hold the CLEAR button on the SID when the display shows "PARK ASSIST", until the display shows "PARK ASSIST OFF". The system is re-engaged in the same way. The system is also always activated when the ignition key is turned to ON.

Pressing a SID button briefly will not disengage the system, the display will simply show the previously selected function.

NOTE

To function well, the sensors must be kept clean. Ice snow and dirt can affect their sensitivity.

Do not spray the sensors or closer than 8 in. (20 cm) to the sensors with a pressure washer, as this could damage them.

Ice, snow and dirt can affect the sensitivity of the sensors. In such cases a continuous tone will sound warning the driver that the system cannot measure the distance to an object. You can turn the system off by pressing and holding the CLEAR button for 1.5 seconds.

If the text "PARK ASSIST FAILURE" is displayed on the SID, have the system checked by an authorized Saab dealer.

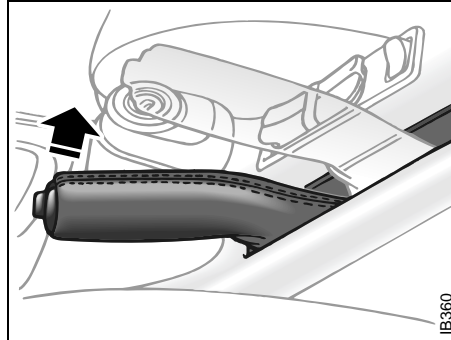

Parking brake

! WARNING

- **Always** apply the parking brake when parking.
- **Always** apply the parking brake before removing the ignition key.
- Do not use the parking brake when the car is moving.

The parking brake is situated between the front seats and acts on the rear wheels.

When the parking brake is on, the indicator light on the main instrument panel will be on. To release the parking brake, lift the lever slightly, press the release button and release the lever by pushing down on it.

Parking

! WARNING

- Park where the vehicle will not create an obstruction or a hazard to other road users.
- Do not park on dry grass or other combustible material. The catalytic converter gets very hot and could start a fire.
- Do not leave children or pets unattended in the car. In warm, sunny weather, the temperature inside the car can reach 160–180°F (70–80°C).
- Apply the parking brake.
- Engage reverse (automatic transmission: move selector lever to P (Park)), and remove the ignition key and lock the car.

Parking on a hill

When parking on a steep hill, turn the front wheels so that they will be blocked by the curb if the car should move.

Long-term parking

If the car is not going to be used for some time, e.g. 3–4 months, the following steps are recommended:

- Run the engine to normal temperature before long-term parking.
- Drain the washer-fluid reservoir and hoses.
- Wash and wax the car. Clean the rubber seals on the hood, luggage compartment lid and doors, and lubricate them with glycerol (glycerin).
- After washing the car, dry the brake discs by taking the car out on the road and applying the brakes a few times.
- Fill the fuel tank with fuel to prevent condensation forming in it.
- Top up the coolant and check the anti-freeze before the onset of winter.
- Park the car in a dry, covered and well-ventilated building. Leave the parking brake OFF!
- Disconnect the negative (-) battery lead. If frost is likely to occur during the long-term parking, remove the battery and store it away from the frost.
- Ideally, the car should be put up on blocks, with the wheels off the ground. If this is not possible, inflate the tires to about 43 psi (300 kPa).

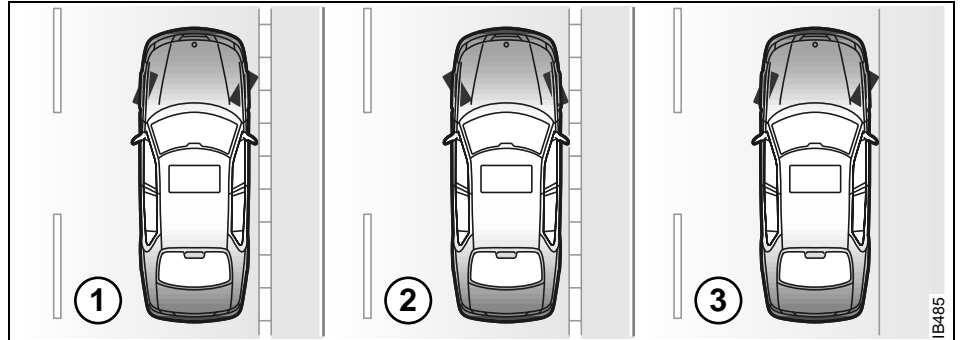
**1 Pointing downhill and against the curb**

– Turn the wheels into the curb and edge the car forward until the wheels touch the curb.

2 Pointing uphill and against the curb

– Turn the wheels away from the curb and edge the car back until the wheels touch the curb.

3 Pointing uphill or downhill – no curb

– Turn the wheels towards the edge of the road. If the car should start rolling, it will not run into the road.

- Leave all the windows open a crack and cover the car with a fabric tarpaulin - not one made of plastic.



Car care and technical information

| | | | | | |
|---|-----|----------------------------|-----|---|-----|
| Hood release handle | 188 | Battery | 199 | Waxing and polishing | 233 |
| Engine compartment, 4-cyl. engine | 189 | Drive belts | 201 | Engine compartment | 237 |
| Engine compartment, 6-cyl. (3.0t V6) | 190 | Wipers and washers | 202 | Touching up the paint | 234 |
| Emission control systems | 191 | Changing bulbs | 204 | Anti-corrosion treatment. | 235 |
| Engine | 192 | Fuses | 216 | For long trips | 237 |
| Engine oil | 193 | Wheels | 222 | Recovery and/or recycling of automotive materials. | 237 |
| Transmission fluid | 195 | Compact spare wheel | 226 | Headlight aiming | 239 |
| Coolant | 196 | Flat spotting | 230 | | |
| Brake and clutch fluid | 197 | Air conditioning (ACC) ... | 231 | | |
| Power steering fluid | 198 | Safety belts | 232 | | |
| Air filter | 198 | Upholstery and trim | 232 | | |
| | | Textile carpeting | 232 | | |
| | | Washing the car | 233 | | |

Hood release handle

The hood release handle is located underneath the instrument panel. To open the hood:

- 1 Pull the release handle.
- 2 The front of the hood will now spring up, providing access to the secondary safety catch.
- 3 Push the catch upwards, lifting the hood at the same time. The hood can now be lifted right up.

To close the hood, release it from a height of about 8 in (20 cm). **Do not** press down on it.

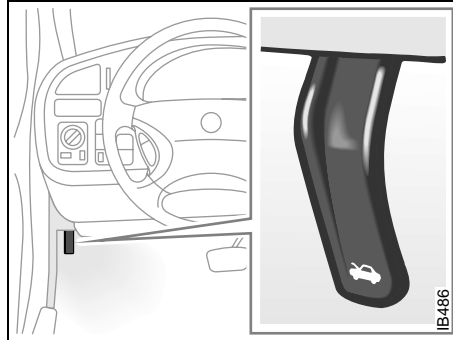

Hood release handle

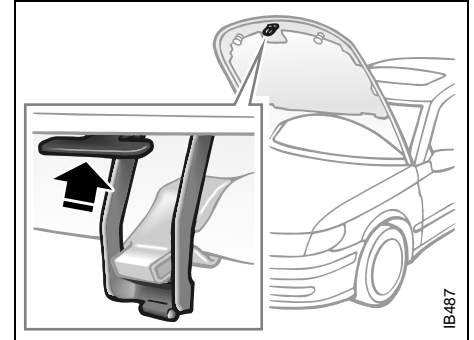

Hood secondary safety catch

WARNING

Make sure not to hold your fingers between the hood and the hood safety catch if you lay the hood down but not closing it.

In cold weather, when the mechanism is stiff, the hood might need to be released from twice the height to lock properly. Check that the hood is now closed securely.

Engine compartment, 4-cyl. engine

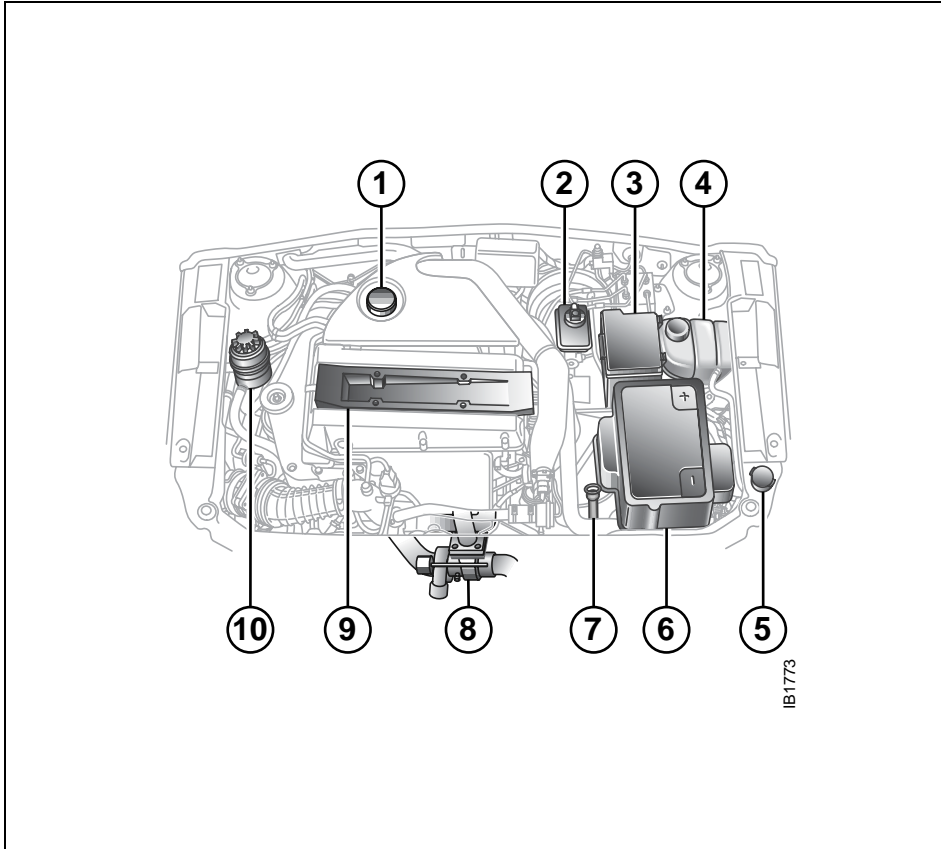

Engine compartment, 4-cyl. engine

- 1 Engine-oil dipstick/filler cap
- 2 Reservoir, brake/clutch fluid
- 3 Fuse box
- 4 Expansion tank, coolant
- 5 Washer-fluid filler cap
- 6 Battery
- 7 Dipstick, automatic transmission fluid
- 8 Turbo unit
- 9 Ignition discharge module
- 10 Reservoir, power-steering fluid

Engine compartment, 6-cyl. (3.0t V6)

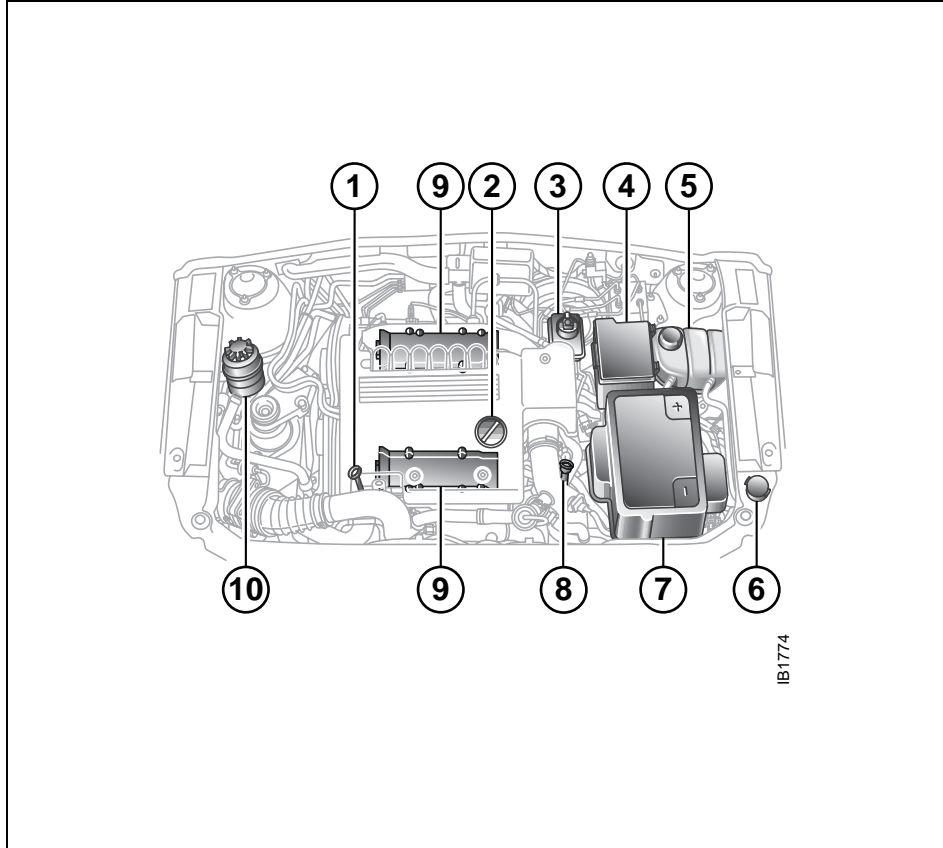

IB1774

Engine compartment, 6-cyl. (3.0t V6)

- 1 Engine-oil dipstick
- 2 Engine-oil filler cap
- 3 Reservoir, brake/clutch fluid
- 4 Fuse box
- 5 Expansion tank, coolant
- 6 Washer-fluid filler cap
- 7 Battery
- 8 Dipstick, automatic transmission fluid
- 9 Ignition discharge module
- 10 Reservoir, power-steering fluid

Engine families

Saab cars imported into the United States and Canada meet all applicable emission control standards. The engine family and appropriate tune-up specifications are identified on a label affixed to the left front inner fender.

These engine families meet applicable EPA Federal Standards, California State Standards and Canadian Federal Standards and are equipped with the following systems:

- Sequential multiport fuel injection system.
- Three way catalytic converter.
- Crankcase emissions control system.
- Evaporative emission control system.
- On-Board diagnostic (OBD II) system.

Emission control systems

The systems for controlling emissions to the atmosphere require regular checking and adjustment at the intervals specified in the service program.

In addition to meeting the exhaust emission regulations and thereby helping to keep the environment clean, a correctly tuned engine will also give maximum fuel economy.

Saab Trionic engine management system

The Saab Trionic engine management system is a unique Saab development that combines sequential multiport fuel injection, electronic distributorless ignition and turbo-charger boost pressure control into one system.

The Trionic engine control module (ECM) monitors many different engine parameters such as:

- Intake manifold pressure.
- Intake air temperature.
- Crankshaft position.
- Engine coolant temperature.
- Throttle position and
- The oxygen content of the exhaust gases.

The ECM receives information regarding engine knocking from a sophisticated feedback function in the ignition discharge unit. By processing all of this information, the Trionic system can control fuel injector open-

ing duration, ignition timing and turbo-charger boost pressure to provide excellent engine performance while maintaining low emissions and fuel consumption.

NOTE

The Trionic engine management systems continuously monitors the operation of these systems and have on-board diagnostic capabilities (OBD II).

If the "Engine malfunction (CHECK

ENGINE)" lamp  in the main instrument illuminates, this indicates that the Trionic ECM has detected a problem. The car will continue to operate, but performance may be diminished. You should have your car checked by a Saab dealer as soon as possible.

ORVR (Onboard Refueling Vapor Recovery)

Hydrocarbon vapors formed when refueling will be recovered by the car and not released into the atmosphere. The hydrocarbons are absorbed in a evaporative emission canister. When the engine is subsequently started, the evaporative emission canister is gradually purged as air is sucked into it through a shut-off valve. The hydrocarbon/air mixture passes through the evap canister purge valve and into the engine where it is burned.

When refueling, make sure you screw the filler cap on and keep turning until it has clicked at least 3 times. Otherwise, it is possible for the CHECK ENGINE light to illuminate and a "TIGHTEN FUEL FILLER CAP" message to appear on SID.

Refueling, see page 152.

Engine**2.3-liter engine**

The 2.3-liter model is a transverse, 4-cylinder in-line engine with twin overhead camshafts and 4 valves per cylinder.

This engine is equipped with balance shafts that reduce engine vibration to a minimum.

The balance shafts are chain driven and rotate at twice the speed of the crankshaft. They produce forces and torques that are opposed to those generated by the pistons and connecting rods, an effect that occurs twice for each revolution of the engine.

Engine noise is also reduced as the counter-rotating shafts counteract the vibration from the moving parts of the engine.

The transmission, located on the right (viewed from the front), is integrated with the engine. All models have front-wheel drive.

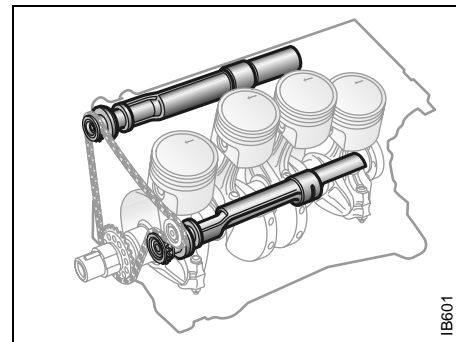

Balance shafts, 4-cyl. engine

3.0t V6 engine

The 3.0-liter engine is a transverse, V6 engine with each bank of cylinders having double overhead camshafts and 4 valves per cylinder.

The transmission, located on the right (viewed from the front), is integrated with the engine. All models have front-wheel drive.

Engine oil

Checking the oil level

Check the engine-oil level regularly. This should be done after the engine has been run to normal temperature and then allowed to cool for 2–5 minutes, with the car standing on level ground. Remove the dipstick and wipe it clean before checking the level.

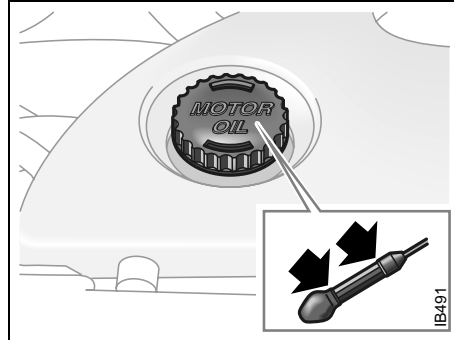

*Engine-oil filler cap and dipstick,
4-cylinder engine*

4-cylinder engine

The oil level must not be allowed to drop below the MIN mark on the dipstick, nor should oil be filled beyond the MAX mark, as this can lead to excessive oil consumption.

The distance between the MIN and MAX marks on the dipstick corresponds to a volume of approximately 1.05 qts (1 liter).

When necessary, add oil of the recommended grade via the dipstick tube.

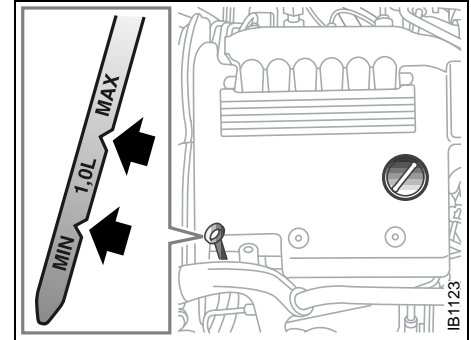

Engine-oil dipstick and filler cap, 3.0t V6

3.0t V6 engine

The oil level must not be allowed to drop below the MIN mark on the dipstick, nor should oil be filled beyond the MAX mark, as this can lead to excessive oil consumption.

The distance between the MIN and MAX marks on the dipstick corresponds to a volume of approximately 1.05 qts (1 liter).

When necessary, add oil of the recommended grade via the dipstick tube.

Oil changing

The engine oil must be changed in accordance with the service program, see page 244.

Oil volume and grade, see page 251.

Oil changing should be carried out on a warm engine.

- 1 Unscrew the drain plug in the bottom of the sump and leave the oil to drain into an oil tray or other suitable receptacle for at least ten minutes. Take care, as the oil may be hot.
- 2 After the oil has been drained, unscrew and remove the oil filter.
- 3 Fit a new filter and tighten it by hand.
- 4 Refit the drain plug with a new washer.
- 5 Fill with new engine oil.

Run the engine to normal temperature and check the oil level.

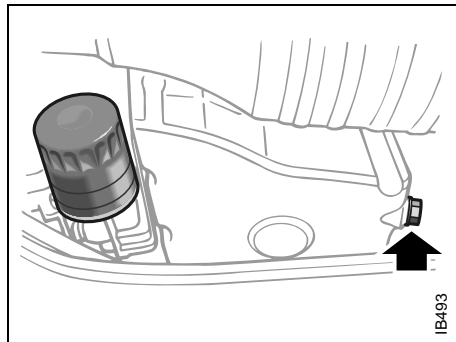

Drain plug and oil filter, 4-cylinder engine

Drain plug and oil filter, 3.0t V6

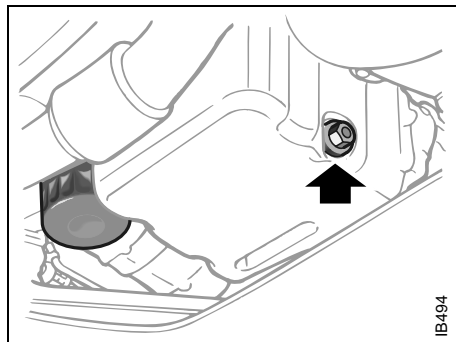

NOTE

Change of engine oil and oil filter may be required more frequently (5000-mile intervals (8,000 km)) if any one of the following conditions apply to the car:

- Most trips are less than 5 to 10 miles (8 to 16 km). This is particularly important when outside temperatures are below freezing.
- Most trips include extensive idling (such as frequent stop-and-go driving).
- Most trips are through dusty areas.
- You frequently tow a trailer or use a carrier on top of your vehicle.
- If the vehicle is used for delivery service, police, taxi or other commercial applications.

! WARNING

- Prolonged and repeated exposure of the skin to engine oil can cause serious skin disorders.
- Avoid prolonged skin contact whenever possible. Wash the affected area thoroughly with soap and water after any contact.
- Keep oil out of reach of children.
- Do not touch the turbocharger or manifold. These get very hot when the engine has been running.
- Do not spill oil on hot parts of the engine as this could cause a fire. Used engine oil is particularly flammable.
- Protect the environment. Do not dispose of oil in the ground or down a drain. Dispose of all used oil and oil filters at an appropriate disposal facility.

Transmission fluid

Manual transmission

Check and top up the fluid in accordance with the service program.

If original fluid cannot be obtained for topping up (see page 254), automatic transmission fluid Dextron III (synthetic fluid) can be used. If so, the car should be taken to an authorized Saab dealer as soon as possible to have the reason for low fluid level corrected and original fluid installed.

Automatic transmission

Check the fluid level as follows:

- 1 Stand the car on level ground and apply the parking brake. The automatic transmission fluid must be at normal running temperature, approximately 175°F (80°C). This can be achieved by driving the car for about 30 min on the open road.
- 2 With the engine idling, move the selector lever to D and wait for at least 15 seconds. Next, move the selector lever to R and wait for 15 seconds again. Finally, move the selector lever to P. Let the engine idle.
- 3 Wipe the dipstick clean with a lint-free cloth and put it back.
- 4 With the fluid at normal temperature, the level should be between the MAX and MIN marks on the dipstick. Top up, as necessary, with Saab 3309 automatic transmission fluid (mineral oil-based), adding it through the dipstick pipe. The

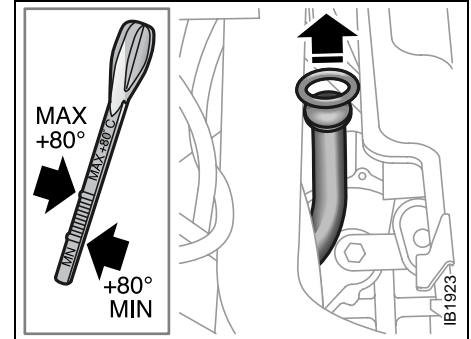

Dipstick for automatic-transmission fluid

distance between the MIN and MAX marks on the dipstick corresponds to a volume of approximately 0.4 qts (0.4 liter).

NOTE

If there is a smell of burning fluid or the fluid is black, change the fluid.

If the outside temperature is below 50°F (10°C), the fluid will not reach the specified temperature of 175°F (80°C). In this case, the correct fluid level may be 0.8 in (20 mm) below the MAX mark.

Coolant

! WARNING

- Proceed with caution if the radiator is boiling when you open the hood. Never remove the expansion-tank filler cap when the radiator is boiling. Loosen the cap carefully, and let the engine cool before removing the cap.
- The cooling system is pressurized – hot coolant and vapor can escape when the filler cap is released.
- Exercise care when adding coolant. Coolant on hot surfaces constitutes a fire risk.

The expansion tank is transparent to facilitate checking of the coolant level.

When the engine is cold, the coolant must not lie over the KALT/COLD mark on the expansion tank.

If the message "FILL COOLANT FLUID" is displayed on the SID, check the level of fluid in the expansion tank.

Top up, as necessary, with equal parts of clean water and Saab-approved coolant.

If the expansion tank is empty when coolant is added, run the engine to normal temperature and top up again, as necessary.

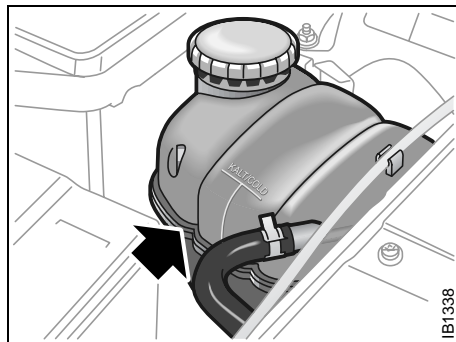

Coolant expansion tank

Coolant

The cooling system is charged at the factory with coolant containing a 50% concentration of a combined antifreeze and corrosion inhibitor. A weaker mixture will result in reduced anticorrosion protection. For protection against freezing in very cold weather, a stronger concentration will be needed.

A 60% concentration of antifreeze will provide protection at temperatures down to -58 F (-50°C).

The coolant does not normally have to be changed during the service life of the car. The type of coolant used has a reddish color and should not be mixed with other types of coolant. Saab Original coolant should be used all year round. Only use coolant approved by Saab.

NOTE

Always mix the antifreeze with the appropriate volume of water before adding it to the cooling system.

If pure antifreeze is added, the engine could still freeze and be damaged. This is because the antifreeze will not mix properly with the coolant before the thermostat has opened to allow full circulation.

Brake and clutch fluid

WARNING

Brake fluid deteriorates as it becomes old. Because it is hygroscopic, it absorbs water from the air and, in time, could allow vapor to form in the brake system, thus reducing its performance. It is therefore important that brake fluid be changed regularly, as specified in the service program.

Checking the fluid level

The combined brake and clutch-fluid reservoir is transparent to facilitate checking of the fluid level.

The level should be between the MAX and MIN marks. Top up, as necessary, with **DOT 4** fluid. Do *not* use DOT 5 brake fluid.

Use only new brake fluid from a sealed container.

Check that there are no leaks in the brake system.

The brake fluid level will fall somewhat as the brake pads wear. The MAX level in the reservoir corresponds to the amount of brake fluid required with new brake pads. If the fall in fluid level is moderate, due to normal brake pad wear, topping up is not necessary.

Changing of the brake fluid should be carried out by an authorized Saab dealer.

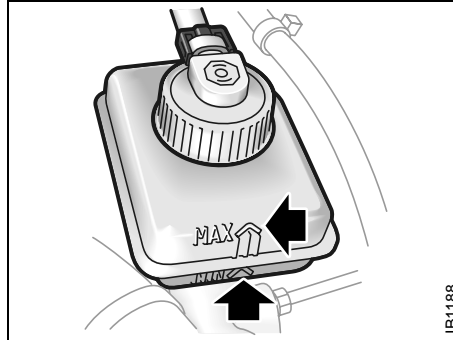

Brake and clutch-fluid reservoir

The vehicle's regular braking system is adjusted automatically, but the parking brake has to be adjusted manually. This work, involving adjustment of the parking brake cables and brake pads, must only be carried out by an authorized Saab dealer.

It is not possible to detect, through abnormal pedal or parking brake-lever travel, whether brake pads are worn and need replacing. It is therefore essential that brake pads be checked regularly, as specified in the service program.

NOTE

Avoid spilling brake fluid onto paintwork, since it can cause the paint to bubble and lift. If any brake fluid is spilled, the area should be flushed with large quantities of water as quickly as possible.

Brake pad wear indicators

The outboard brake pads on the front wheels incorporate pad-wear indicators. When the lining is down to 0.11 in (3 mm), the pad will produce a screeching, squealing or scraping noise when the brakes are applied. New pads should be fitted without delay.

Brake pads should only be changed by an authorized Saab dealer. To ensure optimum brake performance, use only Saab original brake pads.

Power steering fluid

WARNING

Do not fill the power steering fluid to above the MAX mark. Too much fluid can result in leakage.

Power steering fluid on hot engine components constitutes a fire risk.

Check the level of the power steering fluid in the reservoir regularly, in accordance with the service program.

The wheels should point forward during the check.

Clean around the cap before it is unscrewed. Clean the dipstick. Screw in the cap completely again before checking the level.

The oil should lie between the MAX and MIN marks when the oil temperature is about 70°F (+20°C). If the oil is colder the level can be lower, and in higher temperatures the level can be higher, both of which are acceptable.

Top up with "Power Steering Fluid CHF 11S" (part number 8996860).

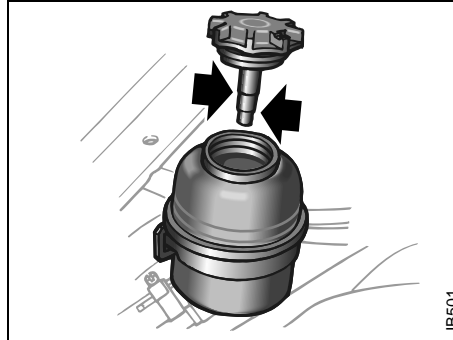

Power steering fluid reservoir

Air filter

WARNING

For Service and Repair, parts equivalent to those used by Saab should be used.

Be aware that some non standard replacement parts may put you in an unsafe condition, even if they might fit.

Battery

WARNING

- The battery emits hydrogen which, when mixed with the oxygen in the air, forms a highly explosive gas. Avoid causing sparks and keep open flames well away from the vicinity of the battery.
- The battery contains corrosive sulfuric acid. Always wear a face mask or goggles when working on the battery.
- If battery acid gets into the eyes or splashes the skin or clothing, wash affected area liberally with water. If acid gets into the eyes or a large quantity makes contact with the skin, seek medical help.

The battery is provided with a cover to protect it from radiated heat. If the battery is exposed to high temperatures, its life will be shortened. To remove the cover, release the two clips along its long sides.

The cover fits the standard battery installed in the car. If a new battery is to be fitted, make sure that its dimensions are the same as the standard one.

The battery is maintenance free and should be changed if the electrolyte level is too low. The indicator on the top side of the battery will be white if the battery needs replacing.

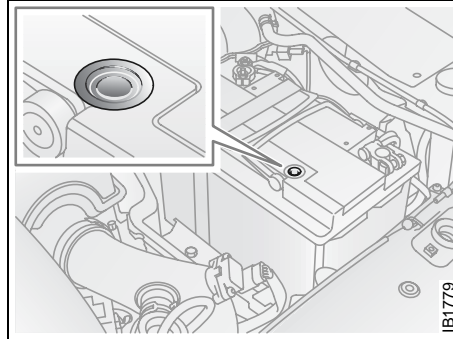

Electrolyte level indicator

The fluid level and the charge level should be checked regularly.

NOTE

A discharged battery can freeze and fracture. Batteries should therefore always be stored away from frost.

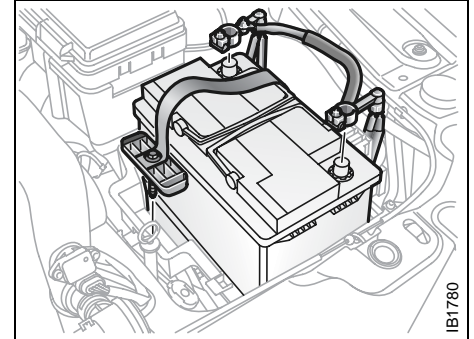

Battery

If frequent short journeys are made, the battery may need to be given a booster charge. This can be done either using a battery charger or by taking the car for a long run.

A car with a standard equipment specification and a fully charged battery can be left for up to 40 days and still have a sufficient charge for starting. If extra equipment is fitted, such as a car phone, the charge may only be sufficient for about 15 days.

Charging/replacing the battery

NOTE

To avert the danger of short-circuiting between the positive (+) terminal on the battery and the inlet manifold on the engine, always disconnect the negative (-) battery lead first and reconnect it last.

Connect the positive lead to the positive (+) battery terminal (red), and the negative lead to a good ground point, e.g. the lifting lug at the front of the engine.

To remove the battery, always disconnect the negative (black) lead first and reconnect it last when fitting the new battery.

The battery size must comply with DIN 53735 MFI 230/2.16.

NOTE

- Never reverse the polarity of the battery by connecting the leads to the wrong terminals. The red, positive lead connects to the positive (+) terminal, and the black, negative lead to the negative (-) terminal.
- Serious damage can be done to the car's electrical system if a battery or alternator lead is disconnected while the engine is running.
- The nut on the battery clamp should be tightened to a torque of 10 Nm.

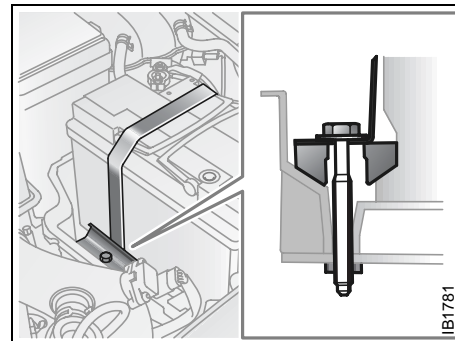

Correct position for battery clamp

Drive belts

WARNING

- Keep hands and clothing well clear of drive belts when engine is running.
- Always stop engine before inspecting drive belts.
- The fan can start even when the engine is switched off.

The alternator is situated on the right-hand side of the engine, adjacent to the bulkhead. It is driven via a Poly-V-belt from the crankshaft pulley.

The Poly-V-belt also drives the water pump, the A/C compressor and the steering servo pump.

NOTE

Serious damage can be done to the car's electrical system if an alternator lead is disconnected while the engine is running.

The belt tension is critical and is adjusted automatically by the belt tensioner.

See also page 51, "Warning, charging".



*Routing of the Poly-V-belt:
4-cylinder engine*

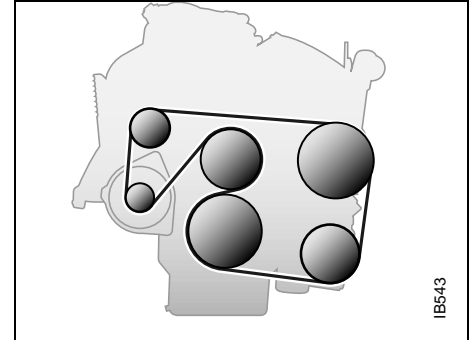

*Routing of the Poly-V-belt:
3.0t V6*

Wipers and washers

Check and clean all wiper blades regularly. If poor wiper performance is experienced, clean the windshield with a quality glass cleaner. This is particularly important if the car has been through an automatic car wash, as these sometimes leave a wax coating on the windshield.

If wiper performance is still unsatisfactory, fit new blades.

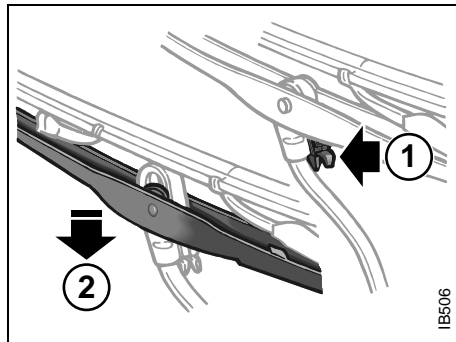

Changing the windshield wiper blades

Lift the wiper arm off the windshield

- 1 Depress the catch.
- 2 Pull the complete blade assembly down to free it from the wiper arm, and then lift it off the arm.

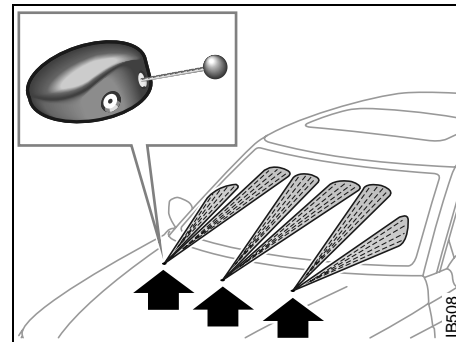

Cleaning/adjusting the washer jets

Washer jets

The washer jets can be adjusted and, if necessary, unclogged by means of a pin.

Washers

The washer-fluid reservoir holds 6.4 quarts (6 liters). When "WASHER FLUID LEVEL LOW" comes up on the SID, the reservoir is down to about 1 quart (1 liter) of fluid. Add at least 50% of washer- fluid to water to prevent freezing and for effective cleaning.

WARNING

Take care not to spill washer fluid concentrate onto hot surfaces as this constitutes a fire hazard.

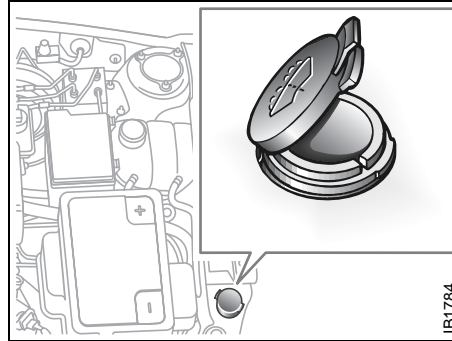

Washer-fluid filler cap

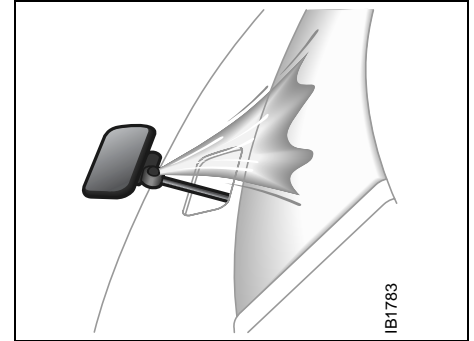

The headlights have high-pressure washers

Changing bulbs



WARNING

Before changing a bulb in the engine bay, switch off the engine to avoid danger of fingers and hands being injured by moving parts. The radiator fan can start up even when the engine is switched off.

Xenon headlights are high tension and must therefore be changed at an authorized Saab workshop. Work involving high-tension components is potentially lethal.

NOTE

- Since the headlight lenses are made of plastic, rinse dried-on dirt with water and allow it time to soften up before cleaning the lenses. Avoid rubbing the lenses when dry and never use solvents.
- Use de-icer spray instead of scraping the ice off.

Check that the new bulb is working when finished.

Some bulbs are of the "Long-Life" type. Make sure the same type is fitted when changing one of these.

Headlight aiming, see page 239.

NOTE

- Do not fit bulbs with a higher rating than 55 W, since the headlight reflector and the wiring of the car are not designed for a higher wattage.
- Switch off the ignition before changing a bulb, to avoid possible short-circuiting.

Xenon headlight (certain models only)

Xenon headlights produce roughly twice as much light as halogen bulbs and have a significantly longer service life.

The lamp units consist of a gas discharge lamp containing xenon. When the lights are switched on a very high voltage activates the xenon gas. The lamps soon reach full intensity.

Cars with xenon headlights have automatic levelling. The levelling system comprises two sensors on the front axle, one on the rear axle and a control unit under the headlight housing. Headlight alignment is regulated automatically to prevent dazzling oncoming traffic. Alignment is also adjusted during braking.

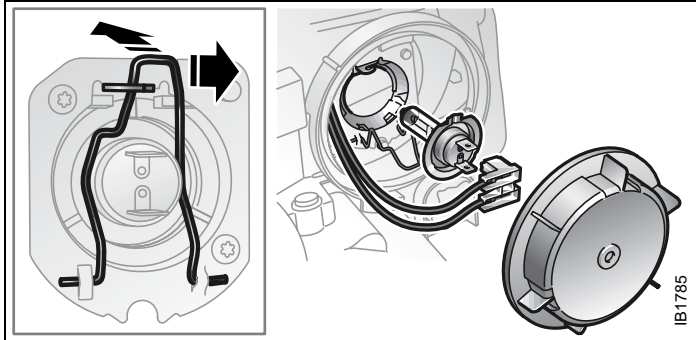

Headlight bulb for high beam

On cars equipped with xenon lamps the Halogen lamps are used only for high beam flasher.

- 1 Unscrew the cover from the back of the lamp unit. To improve accessibility to the right-hand headlight, hold aside the induction air hose. To improve accessibility to the left-hand headlight, remove the battery cover. Release the two clips along the long sides of the cover.
- 2 Unplug the connector.
- 3 To remove the spring clip, push it in and then move it to the right.
- 4 Remove the bulb.
- 5 Without touching the glass with your fingers, insert the new bulb.
- 6 Line up the bulb with the guide in the reflector and secure it with the spring clip. Look through the headlight lens to help fit the bulb correctly.
- 7 Plug in the connector.
- 8 Screw on the cover. Make sure that the guide on the cover is aligned with the recess in the lamp housing.

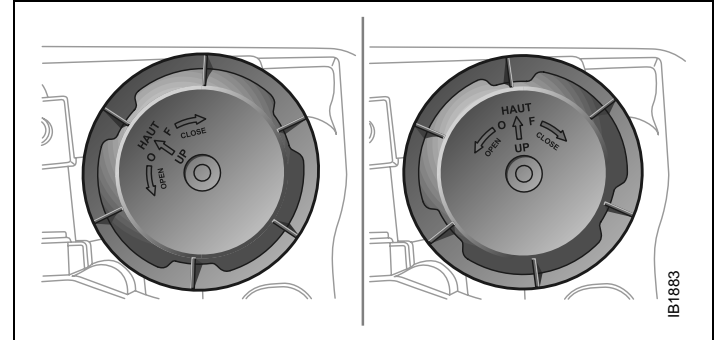

Make sure the cover is correctly fitted before locking it in place

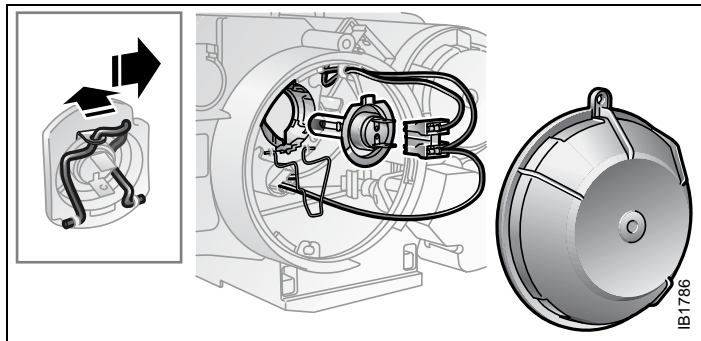

Headlight bulb for low beam (Halogen)

- 1 Unscrew the cover from the back of the lamp unit. To improve accessibility to the right-hand headlight, hold aside the induction air hose. To improve accessibility to the left-hand headlight, remove the battery cover. Release the two clips along the long sides of the cover.
- 2 Unplug the connector.
- 3 To remove the spring clip, push it in and then move it to the right.
- 4 Remove the bulb.
- 5 Without touching the glass with your fingers, insert the new bulb. Look through the headlight lens to help fit the bulb correctly.
- 6 Line up the bulb with the guide in the reflector and secure it with the spring clip.
- 7 Plug in the connector.
- 8 Screw on the cover. Make sure that the guide on the cover is aligned with the recess in the lamp housing.

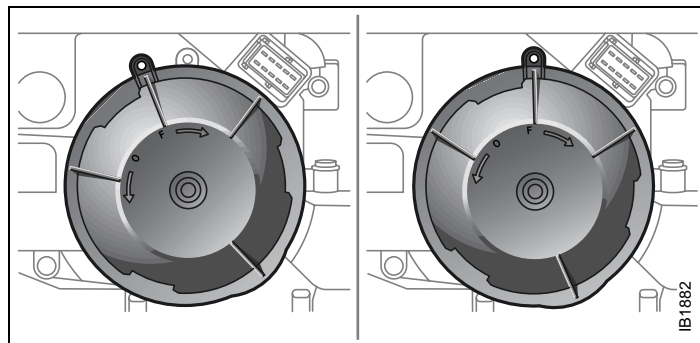

Make sure the cover is correctly fitted before locking it in place

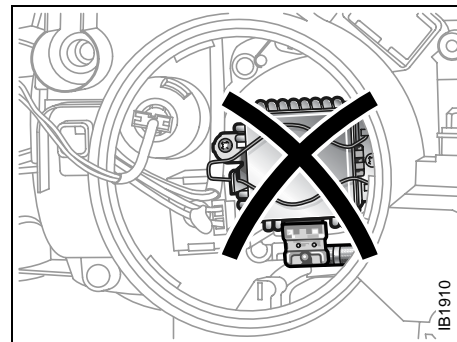

Contact an authorized Saab workshop if a xenon headlight requires replacement

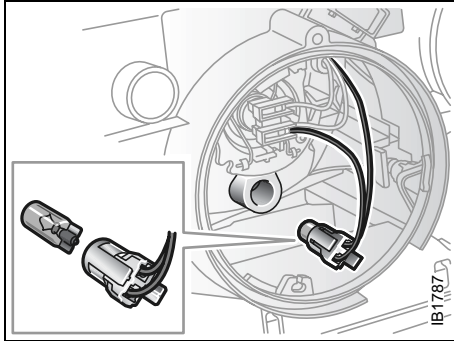

Parking-light bulb (cars with halogen low beam)

Parking-light bulb (cars with halogen low beam)

The parking-light bulb is adjacent to the bulb for low beam.

- 1 Unscrew the cover from the back of the lamp unit.
- 2 Withdraw the bulb holder.
- 3 Change the bulb.

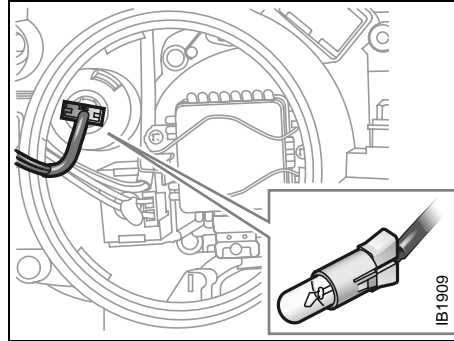

Parking-light bulb (cars with xenon low beam)

Parking-light bulb (cars with xenon low beam)

The parking light bulb is adjacent to the xenon lamp.

- 1 Unscrew the cover from the back of the lamp unit.
- 2 Take hold of the lamp leads and pull out the bulb holder. The lamp leads are reinforced to facilitate changing bulbs.
- 3 Change the bulb. Look through the headlight lens to help fit the bulb correctly.

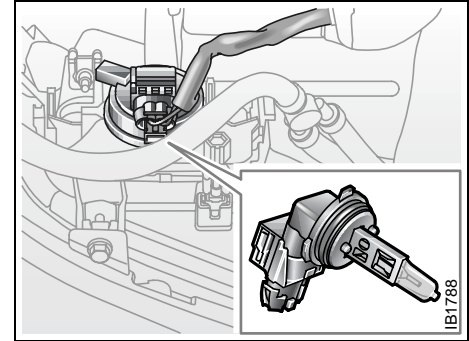

Front fog lights

Front fog lights

- 1 From under the front bumper, grip the bulb holder and twist counterclockwise.
 - 2 Unplug the connector.
 - 3 Change the bulb.
- Refit in the reverse order.

| |
|---|
|  WARNING |
| <ul style="list-style-type: none"> • Never crawl under a car that is supported only by a jack. • Always use axle stands. Refer to the information on jacks on page 227. |

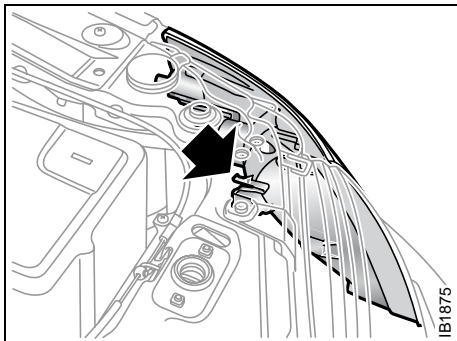

Catch seen from engine bay, left-hand side

Catch seen from engine bay, right-hand side

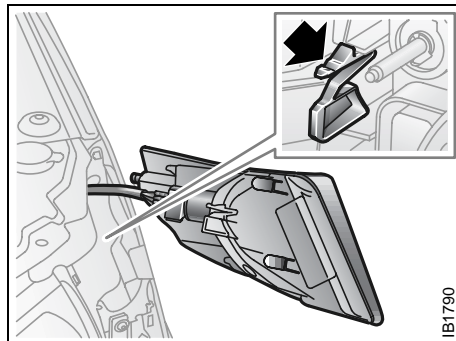
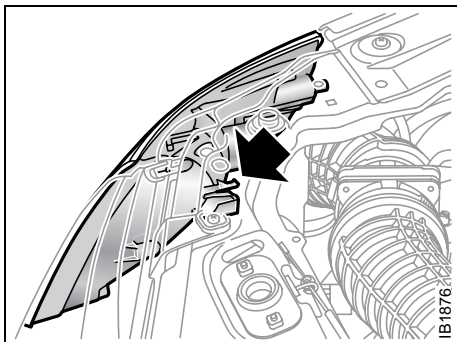

Front turn signal bulbs

To change the bulb, the complete lamp unit has to be removed.

- 1 Depress the catch, accessed from the engine bay.
- 2 Carefully pull out the lamp unit.
- 3 The bulb holder has a bayonet fitting. Grip the holder and twist it counterclockwise.
- 4 Withdraw the bulb holder from the lamp unit.
- 5 The bulb also has a bayonet fitting. Press in the bulb and twist it counterclockwise.
- 6 Fit the new bulb and check that it is correctly seated.

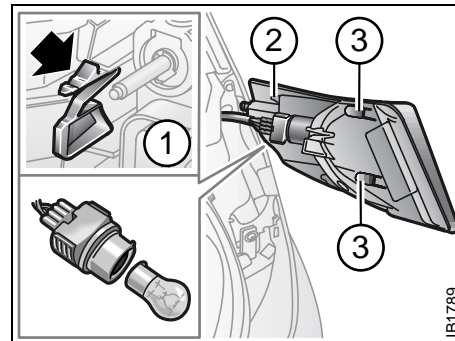

Front turn signal bulb

- 1 Catch
- 2 Bayonet pin
- 3 Plastic lugs

To re-install the lamp unit

- 1 Align the catch with the recess in the lamp housing holder.
- 2 Press the lamp housing towards the headlight slightly and press the housing towards the rear of the car.
- 3 Make sure the locating pin and the two plastic lugs enter their respective holes.
- 4 Press the lamp housing until it click into place.

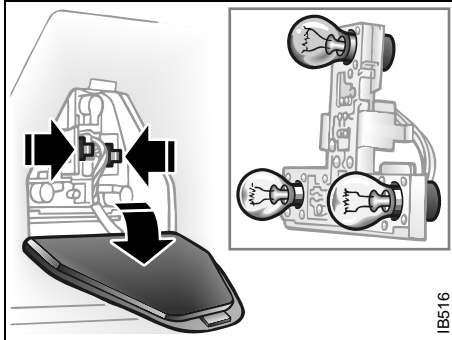

IB516

Rear light cluster, 9-5 Sedan

The bulbs for the lamps in the rear light cluster are accessed from the luggage compartment.

- 1 Lower the flap (secured with catches).
- 2 Squeeze the two plastic lugs and remove the bulb holder.
- 3 The bulb has a bayonet fitting. Press in the bulb and twist it counterclockwise.
- 4 Change the bulb.

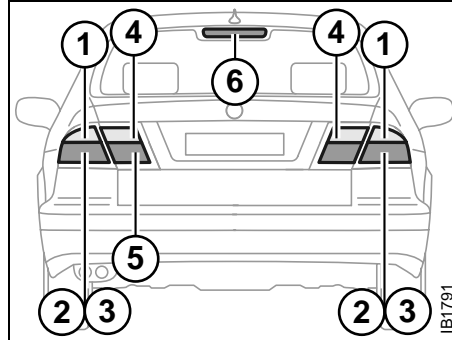

IB1791

Trunk lid light and taillights,

Rear light clusters

- 1 Direction indicators
- 2 Taillights
- 3 Stop lights and taillights
- 4 Reversing lights
- 5 Rear fog light
- 6 High-mounted brake light

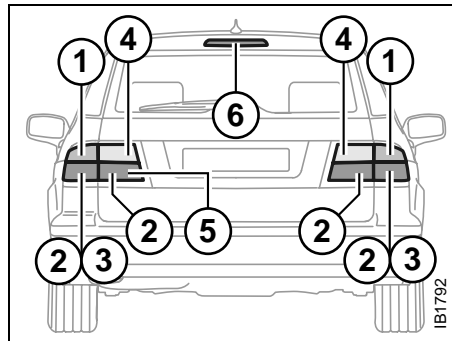

IB1792

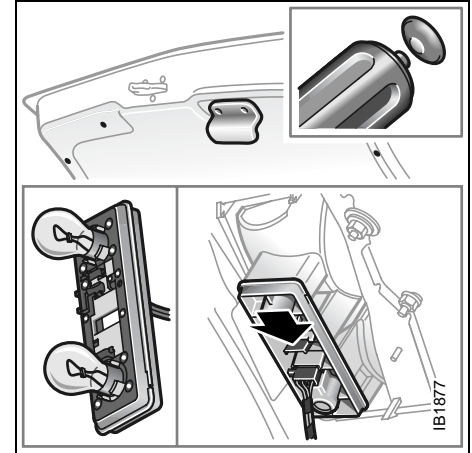

IB1877

9-5 Sedan

Before changing bulbs in the trunk, you must first release the trim at the foot of the trunk. This involves removing the handle and the three trim fasteners (studs).

- 1 Unscrew the handle on the inside of the tailgate.
- 2 Using the peg in the top of the screwdriver handle, push in the button in the center of the studs.
- 3 Remove the studs.

Changing bulbs

- 1 Squeeze together the silver plastic lug and the electrical connection and withdraw the lamp holder.

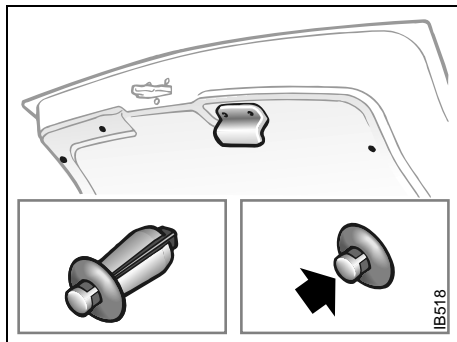

- 2 The bulb has a bayonet fitting. Press in the bulb and twist it counterclockwise.
- 3 Change the bulb.

Refitting the trim

- 1 Reset the studs by pushing back the center buttons so that they protrude by 0.2 inch (5 mm).
- 2 Insert the studs through the trim and tailgate panel. Press the center buttons in, flush with the collar.
- 3 Screw the handle back onto the trunk.

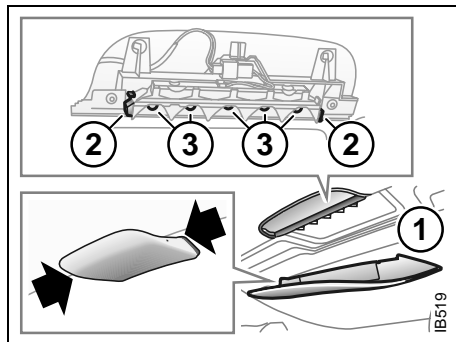

High-mounted stop lights

- 1 Panel
- 2 Retaining clips
- 3 Bulbs

High-mounted stop lights, 9-5 Sedan

The bulbs can be accessed after the panel in the rear headlining has been removed.

- 1 Remove the panel by carefully pushing in the two clips, one at a time.
- 2 Release the bulb holder, which is retained by a clip at either end.
- 3 Withdraw the bulb gently straight back.
- 4 Push in the new bulb.
- 5 Refit the bulb holder.
- 6 Replace the panel by carefully pushing the panel towards the headlining so that the two clips engage their respective slot.

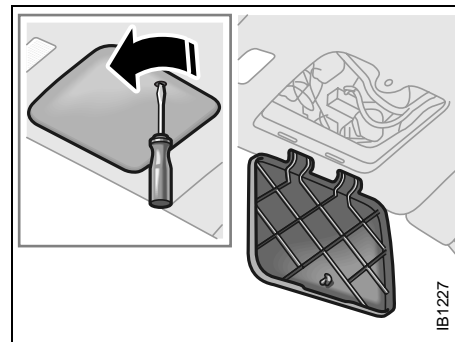

Tailgate bulbs, 9-5 Wagon

- 1 Turn the lock a quarter turn (90°) with a screwdriver or the ignition key.
- 2 Open and remove the cover.
- 3 Take out the bulb holder by twisting it slightly counterclockwise.
- 4 Press in the bulb and twist it counterclockwise.
- 5 Change the bulb.
- 6 Check that the new bulb is working.

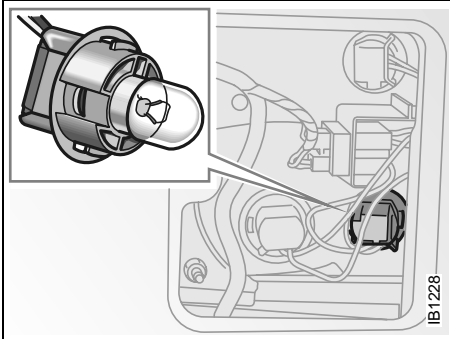
**Reassembly:**

- 1 Place the two "hinges" in the recess in the tailgate.
- 2 Then push the "hinges" into the recess and close the cover.
- 3 Turn the lock a quarter turn.

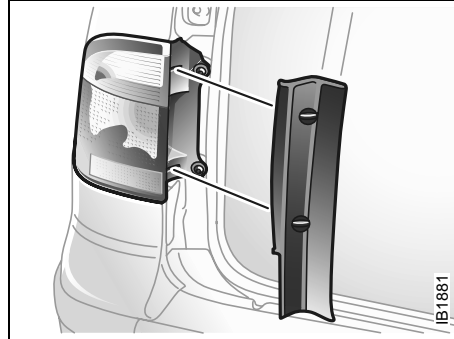
**Rear lights clusters, 9-5 Wagon**

- 1 Open the tailgate.
- 2 Remove the cover by turning the two catches anticlockwise one quarter turn.
- 3 Remove the two screws securing the light cluster to the body.

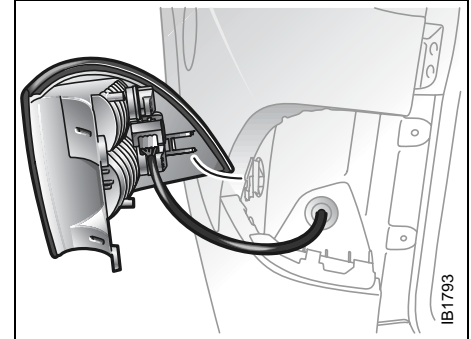

- 4 Pull the light cluster rearwards and angle it outwards (it is seated quite firmly).
- 5 Release the fastener from the body. Reinsert the fastener into the groove in the light cluster. Press in the fastener until you hear a click.
- 6 Take out the bulb holder by twisting it slightly counterclockwise.
- 7 Press in the bulb and twist it counterclockwise.
- 8 Change the bulb.
- 9 Check that the new bulb works.

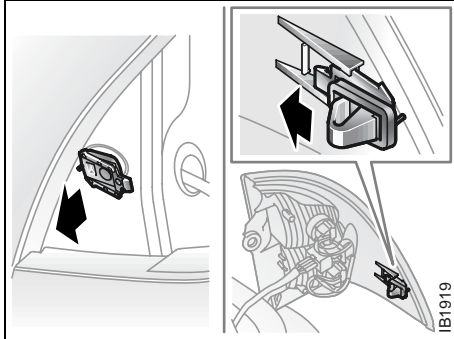

Reassembly:

- 1 Align the fastener with the hole in the body.
- 2 Press the lamp unit home into the body until you hear a click.
- 3 Fit the screws and cover.

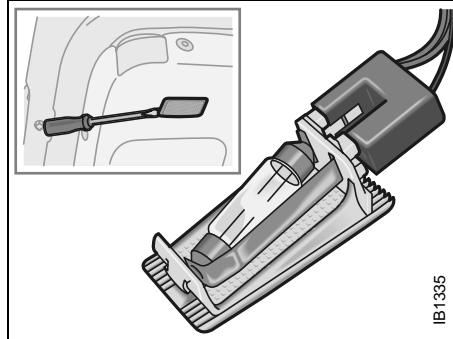

Loading lighting, 9-5 Wagon

- 1 Pull down the glass cover at the outer edge.
 - 2 Bend one of the contacts so that the bulb can be removed.
 - 3 Change the bulb.
- On refitting, insert the connector-end of the lamp fitting first.

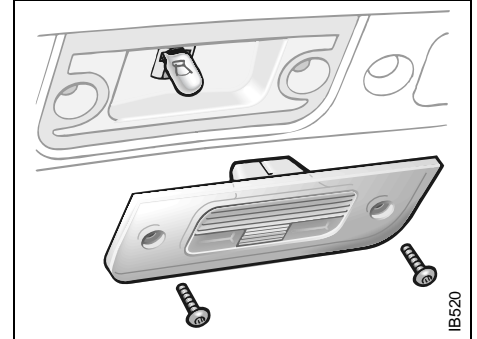

License-plate light

- 1 Undo the two screws and remove the lamp glass.
- 2 Withdraw the bulb.
- 3 Change the bulb.
- 4 Check the seal before fitting the glass.

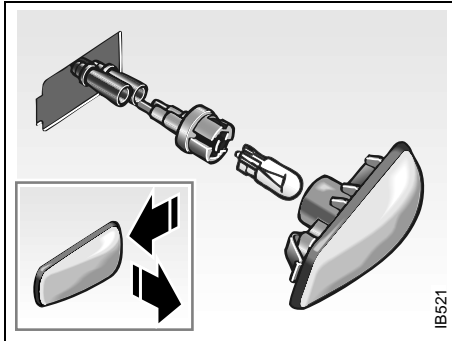

IB521

Side direction indicators

- 1 Slide the lamp fitting forward and pull out the back.
- 2 Remove the bulb.
- 3 Change the bulb.

On refitting, make sure that the spring in the lamp fitting engages the edge of the opening in the body panel.

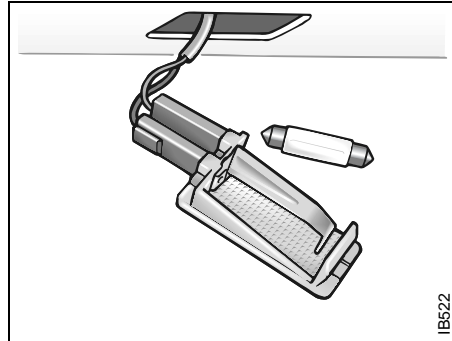

IB522

Courtesy lights (doors and floor) and luggage-compartment lighting

- 1 Insert a screwdriver carefully into the slot in the end of the lamp fitting. Ease the fitting off to gain access to the bulb.
- 2 Bend out one of the contacts and remove the bulb.
- 3 Change the bulb.

On refitting, insert the connector-end of the lamp fitting first.

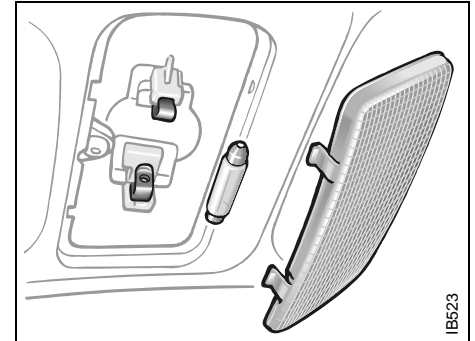

IB523

Dome light, front

- 1 Ease the leading edge of the glass out of the overhead panel by inserting a small screwdriver alternately in each of the two slots.
- 2 Release one of the contacts and remove the bulb.
- 3 Fit the new bulb.

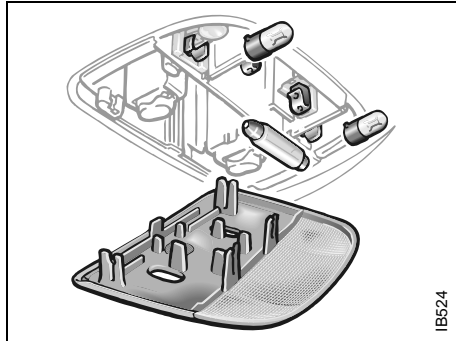

Dome light, rear

- 1 Remove the entire overhead panel: ease out the trailing end first, and then both front edges.
- 2 Fit the new bulb.

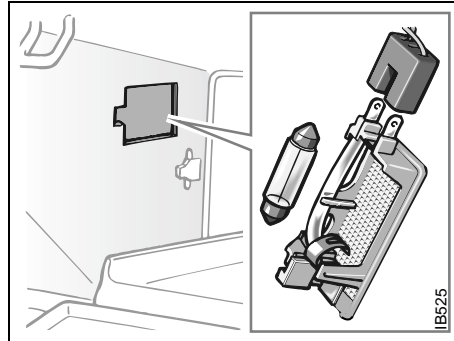

Glove-compartment illumination

- 1 Insert a small screwdriver in the slot in the end of the lamp fitting and ease it out to gain access to the bulb.
 - 2 Bend out one of the contacts and remove the bulb.
 - 3 Fit the new bulb.
- On refitting, insert the connector-end of the lamp fitting first.

Other bulbs

If any other bulbs need changing, you are advised to take the car to an authorized Saab dealer.

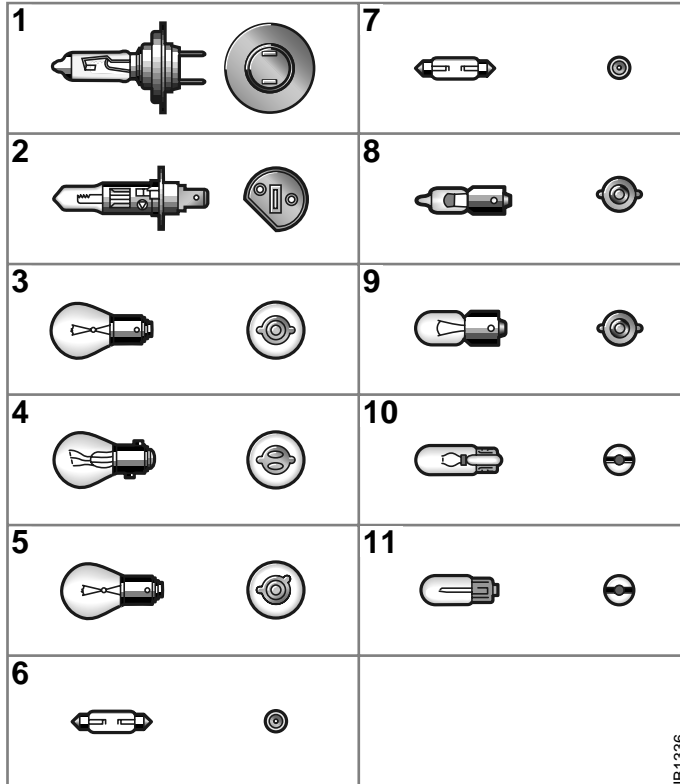

IB1336

Bulb table

| # | Cap | Wattage | |
|----|--------------|---------|--|
| 1 | H7 | 55 | Headlight |
| 2 | H1 | 55 | Fog light |
| 3 | P21W | 21 | Reversing lamp; side reversing lamp; rear fog lamp; cornering lamp |
| 4 | P21/5W | 21/5 | Stop/tail lamp |
| 5 | P21W | 21 | Direction indicator, front/rear |
| 6 | R10W | 10 | Dome light; courtesy lights; glove compartment; luggage compartment |
| 7 | R5W | 5 | Safety belt reminder |
| 8 | H6W | 5 | Reading light, overhead panel |
| 9 | T4W | 4 | Reading light, rear |
| 10 | WY5W/ W5W | 5 | Side indicators (yellow);/ High-mounted stop light (9-5 Sedan); parking lights; license plate illumination |
| 11 | W2W | 1,2 | Switches; front ashtray |

NOTE

Do not interchange. Always use the correct Wattage bulb according to application.

A special kit containing spare bulbs and fuses is available as an accessory from your Saab dealer. A storage space for this is provided adjacent to the toolkit and jack, under the panel in the luggage compartment.

Fuses

The fuses are housed in two fuse panels: one at the end of the instrument panel on the driver's side, and one under the hood.

To check if a fuse has blown, first remove it from the panel (see below). If the filament is broken, the fuse has blown.

A special tool for removing fuses is provided at the bottom of the fuse panel. Simply push the tool onto the fuse, squeeze and remove the fuse.

WARNING

To avert the risk of short-circuiting and/or fire breaking out in the electrical system, the following advice should be heeded:

- Always consult an authorized Saab dealer before modifying or adding any electrical equipment. Failure to do so can result in the electrical system being damaged.
- Never replace a fuse with one having a higher/lower rating than specified (see page 218). The color of the fuse indicates its amperage.
- If the same fuse blows repeatedly, have the electrical system checked by an authorized Saab dealer.
- If a MAXI fuse blows, there is a major fault in the electrical system. Have the car checked by an authorized Saab dealer.

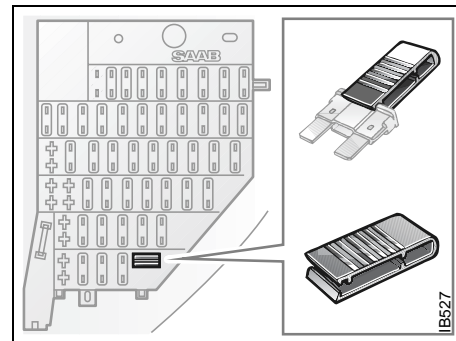

Fuse panel in instrument panel

Fuse box under the hood

Sound fuse / Blown fuse

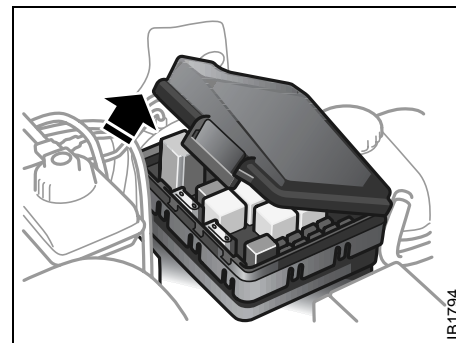
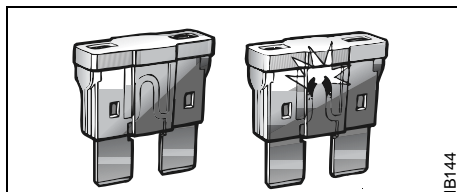

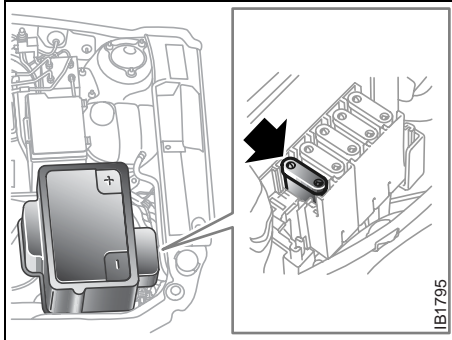

Maxi fuses under the hood

Maxi fuses

The Maxi fuses are housed in the fuse box under the hood. These fuses can be checked in the same way as the other fuses. The Maxi fuses are designed to protect the car's electrical system from being damaged. Each Maxi fuse protects a number of electrical circuits and functions and therefore has a higher rating (amperage) than the standard fuses. No spare Maxi fuses are supplied with the car.

NOTE

If a Maxi fuse blows, it means that there is a major fault in the electrical system. Have the car checked without delay by an authorized Saab dealer.

DICE / TWICE

DICE = Dashboard Integrated Central Electronics

TWICE = Theft-Warning Central Electronics

DICE and TWICE are electronic control modules that monitor and control a variety of functions, including:

DICE controls (among other things):

- Front lights and interior lighting.
- Instrument illumination.
- Intermittent wiper operation.
- Electric heating of rear window and door mirrors.
- Cooling fans.

TWICE controls (among other things):

- Central locking.
- Car alarm (Anti-theft system).
- Engine immobilizer.
- Autochecking of lights.
- Electric heating of rear seat.
- Safety belt reminder.
- Electrically adjustable passenger seat.

The DICE and TWICE control modules are linked to a data bus, which is basically an information carrier that allows information to be exchanged between all the control modules and components connected to the bus. If a fault occurs in any of these components, diagnostic faults codes are set in the relevant control module, which facilitates fault diagnosis at the Saab dealer.

The scan tool connector for fault diagnosis is located under the instrument panel on the drivers side.

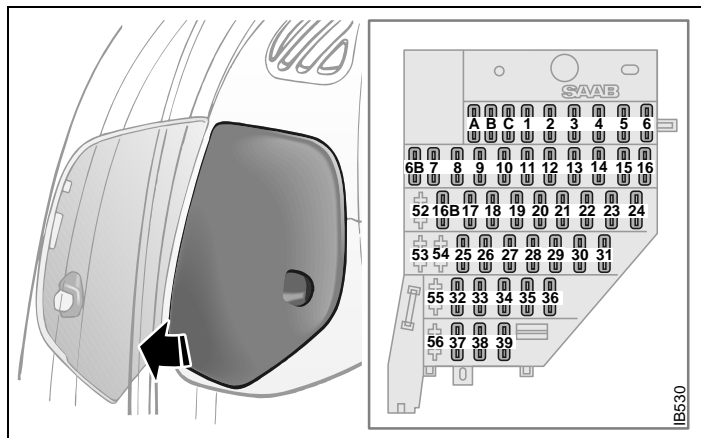

Fuse panel in instrument panel

| # | Amp | Function |
|----|-----|--|
| A | 30 | Trailer lights |
| B | 10 | Automatic transmission |
| C | 7,5 | Electric door mirrors; DICE |
| 1 | 15 | Brake lights |
| 2 | 15 | Reversing lights |
| 3 | 10 | Parking lights, left |
| 4 | 10 | Parking lights, right |
| 5 | 7,5 | DICE / TWICE |
| 6 | 30 | Electric windows, right ; trailer charging |
| 6B | 5 | Brake lights, trailer |
| 7 | 10 | Engine injectors |

| | | |
|-----|-----|--|
| 8 | 15 | Trunk lighting; trunk lock; door lighting, circulation pump; parking assistant |
| 9 | 15 | Audio System; diagnostic instrument; CD changer |
| 10 | 15 | Door mirrors; heating, rear seat |
| 11 | 30 | Central locking; electrically adjusted passenger seat |
| 12 | 7,5 | Automatic transmission |
| 13 | 20 | Audio System, amplifier |
| 14 | 30 | Ignition system, engine |
| 15 | 20 | Preheated oxygen sensor (catalytic converter); fuel pump |
| 16 | 20 | DICE (direction indicators) |
| 16B | – | – |
| 17 | 20 | Engine-management system |
| 18 | 40 | Door-mirror heating; rear-window heating |
| 19 | 10 | OnStar; Telematics |
| 20 | 15 | ACC; interior lighting; rear fog light |
| 21 | 10 | Audio System; rear-view mirror with auto dimming function; low beam headlight (xenon) left/right; navigation (accessory); Cruise Control |
| 22 | 40 | Interior fan |
| 23 | 15 | Sunroof |
| 24 | 40 | Air pump (3.0t V6 only) |
| 25 | 30 | Electrically adjustable driver's seat; fuel-filler flap |
| 26 | 7,5 | Driver seat memory; mirrors memory; sunroof; parking assistant; rain sensor |
| 27 | 10 | Engine-management system; SID |

| | | |
|-------|-----|---|
| 28 | 7,5 | Airbag (SRS) |
| 29 | 7,5 | ABS/TCS/ESP |
| 30 | 7,5 | Starter motor |
| 31 | 7,5 | Cruise control; water valve; fog lights, front |
| 32 | 15 | Ventilated front seats |
| 33 | 7,5 | Direction-indicator switch |
| 34 | 30 | Cigarette lighter (front/rear) |
| 35 | 15 | Daytime running light |
| 36 | 30 | Electric windows, left |
| 37 | 30 | Windshield wipers |
| 38 | 30 | Electric heating, front seats |
| 39 | 20 | Limp-home solenoid (automatic transmission); OnStar; telematics |
| 52-56 | | Spare fuses |

Relay panel under instrument panel

| # | Function |
|----|---------------------------------------|
| A | - |
| B | Electric heating of rear seat |
| C1 | - |
| C2 | - |
| D | - |
| E | Main relay (engine management system) |
| F | Fuel filler flap |

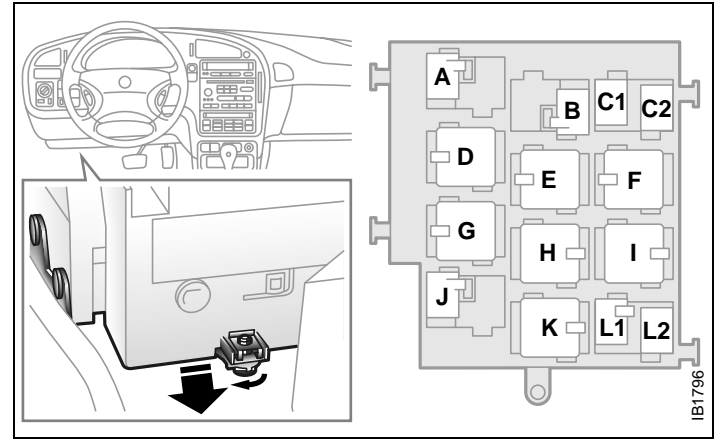

Relay panel under instrument panel (cont.)

| | |
|----|------------------------------------|
| G | Fuel pump |
| H | Ignition switch |
| I | Rear-window / door mirrors heating |
| J | - |
| K | Starter relay |
| L1 | Limp-home function |
| L2 | Bootlid |

Fuse box under hood**Fuses**

| # | Amp | Function |
|----|-----|--|
| 1 | 40 | Radiator fan, high speed |
| 2 | 60 | ABS/TCS/ESP |
| 3 | – | – |
| 4 | 7,5 | Load angle sensor (cars with xenon headlights) |
| 5 | 15 | Heater |
| 6 | 10 | A/C; car alarm siren |
| 7 | 15 | Bulb test |
| 8 | – | – |
| 9 | – | – |
| 10 | 15 | High beam headlight, left |
| 11 | 15 | Low beam headlight left |
| 12 | 15 | High beam headlight, right |
| 13 | 15 | Low beam headlight, right |
| 14 | 30 | Radiator fan, high speed |
| 15 | 15 | Fog lights (front spoiler) |
| 16 | 30 | Wiper, rear ; headlight washers |
| 17 | 15 | Horn |
| 18 | – | – |

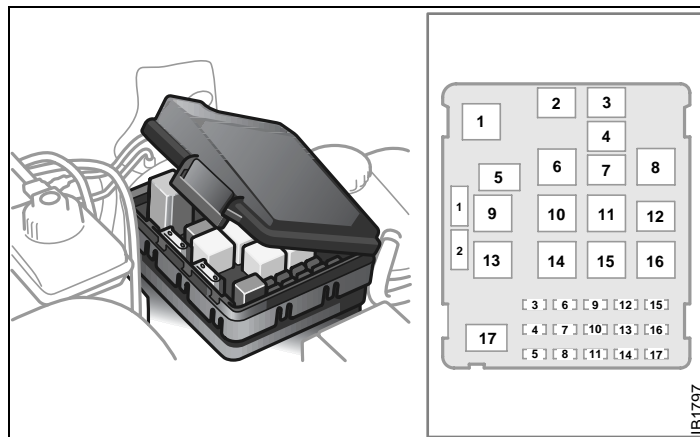
**Relays**

| # | Function |
|----|--|
| 1 | Bulb test; head light; high beam flasher |
| 2 | Headlight washer |
| 3 | Front fog lights |
| 4 | Wiper, rear (9-5 Wagon) |
| 5 | – |
| 6 | – |
| 7 | Rain sensor |
| 8 | Radiator fan, low speed |
| 9 | Radiator fan, high speed |
| 10 | A/C-compressor |
| 11 | Radiator fan, high speed, right fan |

| | |
|----|--------------------------|
| 12 | Horn |
| 13 | Extra lights (accessory) |
| 14 | High beam headlight |
| 15 | Low beam headlight |
| 16 | – |
| 17 | Windshield wipers |

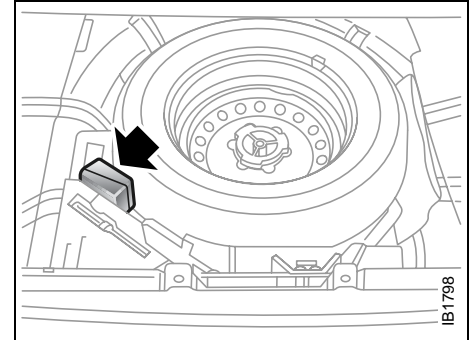

Location of wallet for spare bulbs and fuses (accessory)

Wheels

Alternative wheels and tires

If you wish to fit other tires or wheels than those supplied with the car, consult your Saab dealer first as to the possibilities available.

Wheels/tires combinations that are not approved by Saab can negatively affect the car's directional stability, steering and braking in both wet and dry conditions.

Do not assume that a wheel/tire combination will function properly just because it will bolt on.

The wheels and tires have been carefully matched to the characteristics of the car and play a key role in its outstanding roadholding and handling.

To ensure that the speedometer is as accurate as possible it should be reprogrammed if wheels of a different dimension are fitted. Contact an authorized Saab workshop.

NOTE

Always consult your Saab dealer before changing the wheels and tires on your Saab.

For wide wheels and/or low-profile tires, bear in mind the following:

- Tires and wheels can be damaged in potholes etc.
- Springs, shock absorbers and wheel bearings and body mountings can be overloaded.
- The wheels can come into contact with chassis and body components.
- The speed and load limits for the tires must not be exceeded; see page 223.
- Wheels larger than 17" must not be fitted. The maximum permissible offset is 49 mm.
- Tire and wheel size can affect the function of the Electronic Stability Program (ESP).

Tire pressure

NOTE

Check the tire pressures **at least once per month**.

Underinflation is the main cause of:

- Tires wearing out prematurely.
- Damage to the sidewalls.
- Damage to the wheels.

Tires need to be inflated to suit the load carried and the maximum speed the car will be driven (see the recommended tire pressures on the back cover). Note that all values apply to cold tires. For tires with an aspect ratio less than /60, increase the tire pressure by 3 psi (20 kPa) for rough roads with potholes to minimize the risk of rim damage.

Never reduce the pressure of a hot tire. If the tires are hot when you check them, only increase the pressure, if necessary.

Soft tires will cause faster wear than over-pressurized tires. They also increase fuel consumption.

If a valve is leaking, simply unscrew it and fit a new one.

Important! Remember to adjust the tire pressures if you change the load in the car or intend to cruise at a substantially higher or lower speed than normal.

Rotating tires



When fitting just **one** new pair of tires, these should be fitted to the rear wheels, as these are more critical to the directional stability of the car (e.g. on braking or in a skid). The existing rear wheels should therefore be moved to the front. Always move left rear to left front and right rear to right front, so that the direction of rotation remains the same.

Because the car has front-wheel drive, the front tires tend to wear faster than the rear ones. New tires should always be fitted in pairs, so that tires on the same axle have the same amount of tread.

The wheels should be marked, L (left) and R (right), when changing between summer and winter (snow) tires. This ensures that the direction of rotation of the wheels is the same when they are refitted. Fit the tires in best condition to the rear wheels.

Store wheels lying flat or hanging – **never** standing upright.

Tire markings

An example of the meaning of the different markings in a tire size is given below for a tire size of:

205/65 R15 94 V

- 205 Tire section width, mm
- 65 Aspect ratio, i.e. the section height is 65% of the section width
- R Radial ply
- 15 Wheel rim diameter 15 in at bead seats
- 94 Tire load code
- V Speed marking

Speed ratings

- S Tire approved for speeds up to 100 mph (180 km/h)
- T Tire approved for speeds up to 118 mph (190 km/h)
- H Tire approved for speeds up to 130 mph (210 km/h)
- V Tire approved for speeds up to 150 mph (240 km/h)
- W Tire approved for speeds up to 167 mph (270 km/h)
- Y Tire approved for speeds up to 186 mph (300 km/h)

Winter tires

Winter (snow) tires are recommended for winter climates where the majority of your driving will be done on snow and ice. Winter tires should be fitted to all four wheels to maintain a proper balance. Your Saab dealer can advise you as to the correct size tire for your car (if different from the original size) and also supply Saab approved winter tires.

Tire quality grading (cars sold in U.S.)

New tires must be graded and labeled in accordance with new Federal regulations. Standard tests are conducted to measure performance in the areas of traction and temperature resistance. Refer to the tire sidewall for the specific quality grades of the tires provided on your new Saab. Compact spare tires are exempt.

DOT QUALITY GRADES

- Treadwear
- Traction AA, A, B, C
- Temperature A, B, C

All passenger car tires must conform to Federal safety requirements in addition to these grades.

Uniform Tire Quality Grading (US)

Quality grades can be found where applicable on the tire sidewall between tread shoulder and maximum section width. For example:

**Treadwear 200 Traction AA
Temperature A**

Treadwear

The treadwear grade is a comparative rating based on the wear rate of the tire when tested under controlled conditions on a specified government test course. For example, a tire graded 150 would wear one and one half (1 1/2) times as well on the government course as a tire graded 100. The relative performance of tires depends upon the actual conditions of their use, however, and may depart significantly from the norm due to variations in driving habits, service practices and differences in road characteristics and climate.

Traction



The traction grade assigned to a tire is based on straight-ahead braking, traction test and does not include acceleration, cornering, hydroplaning or peak traction characteristics.

The traction grades, from highest to lowest, are AA, A, B and C. These grades represent the tire's ability to stop on wet pavement as measured under controlled conditions on specified government test surfaces of asphalt and concrete. A tire marked C may have poor traction performance.

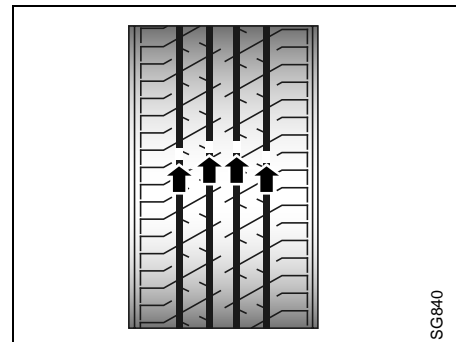

Wear indicators

Wear indicators

The tires incorporate wear indicators in the form of smooth, treadless strips across the width, which become visible when only 1.6 mm of tread remains. As soon as the indicators become visible, new tires should be fitted without delay.

Make sure you are familiar with the legal limit for minimum tread depth in your country and also any regulations governing the use of winter tires.

Temperature

WARNING

The temperature grade for a tire is established for a tire that is properly inflated and not overloaded. Excessive speed, underinflation, or excessive loading, either separately or in combination, can cause heat buildup and possible tire failure.

The temperature grades are A (the highest), B, and C, representing the tire's resistance to the generation of heat and its ability to dissipate heat when tested under controlled conditions on a specified indoor laboratory test wheel. Sustained high temperature can cause the material of the tire to degenerate and reduce tire life, and excessive temperature can lead to sudden tire failure. The grade C corresponds to a level of performance which all passenger car tires must meet under the Federal Motor Vehicle Safety Standard No. 109.

Grades B and A represent higher levels of performance on the laboratory test wheel than the minimum required by law.

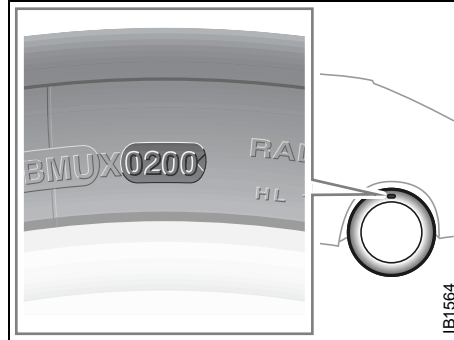

Date code

Date code

Tires should be regarded as perishable goods. As the tires age, the rubber becomes progressively harder, and the roadholding ability of the tires diminishes. This is particularly true on winter tires.

Tires now have a date-code marking for the year of manufacture. The first two digits denote the week number and the two last digits the year. The "<" symbol points to the year.

Accordingly, a date code of 0200 signifies that the tire was manufactured in week 02, 2000.

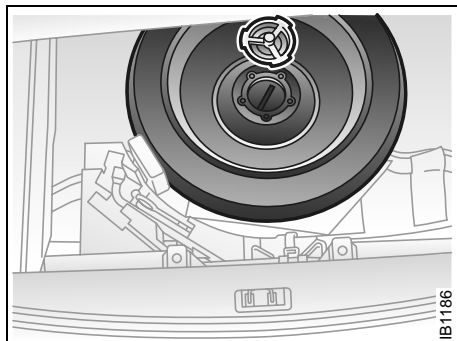

Spare wheel (under panel in luggage compartment)

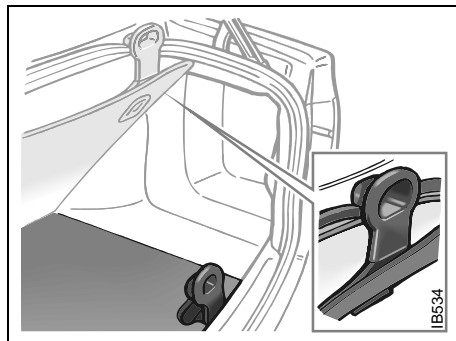

Panel hooked back, 9-5 Sedan

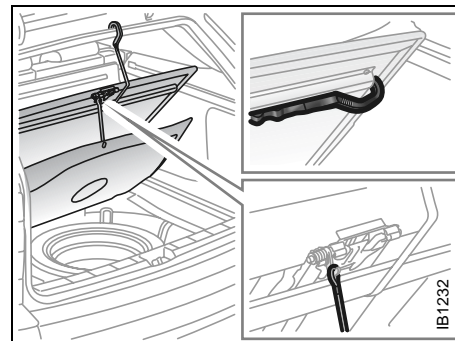

Hanging up the cover and spare wheel compartments mats, 9-5 Wagon

Compact spare wheel

The compact spare is light and easy to handle when changing the tire. Its use is only permitted when a standard tire has sustained a puncture. The maximum life of the tire is only 2000 miles (3,500 km).

Do not exceed 50 mph (80 km/h) with the compact spare fitted.

The compact spare should be inflated to 60 psi (420 kPa). Carry the punctured tire in the spare-wheel well under the luggage-compartment floor.

Have the standard tire repaired and refitted as soon as possible (see also page 179).

NOTE

To avoid damaging a punctured alloy wheel it can be placed outside up in the spare-wheel well but **only** while driving to the closest workshop.

A general rule is that all heavy loads must be well secured in the luggage compartment, see page 134 and 137.

The spare wheel, together with the jack, front towrope attachment eye and toolkit, is stowed away underneath a panel in the luggage-compartment floor. The jack handle is kept in a cover beside the spare wheel.

If you need to change a wheel, remove the tool kit first and then the spare wheel.

The panel over the spare wheel can be held open by hooking the handle onto the rubber seal.

Changing a wheel

WARNING

- The car jack is designed solely for use in changing a wheel or fitting snow chains. It must not be used to support the car during repair work or servicing.
- Never crawl under a car that is supported only by a jack.
- Special care must be taken if the car is on a slope – use wheel chocks!
- Position chocks, one ahead and one behind, the wheel that is diagonally opposite to the one to be changed.
- Switch on the hazard warning lights if the car is on a road.
- Apply the parking brake and leave the car in gear (1st or reverse). Automatic transmission: move selector to the P position.
- Ensure that everybody is out of the car before jacking it up.
- Never start the engine while the car is jacked up.
- The jack must stand on a firm, level surface.

- Stow the jack in the place provided for it under the panel in the floor of the luggage compartment. Secure it properly to avert injury to passengers in the event of a crash.
- Do not use the jack for any purpose other than for jacking up the car.

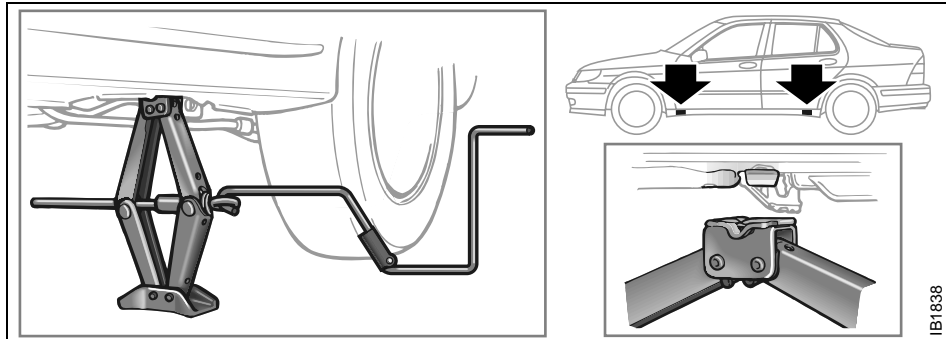

IB1838

Position for jack

To jack up the car, apply the jack to one of the special jacking points under the sills.

The collapsible jack handle is stowed in a cloth bag by the spare wheel. With the help of your foot, extend the handle as illustrated

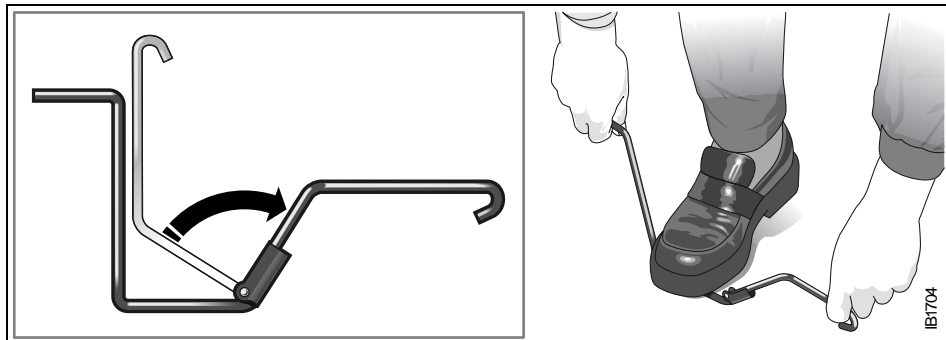

IB1704

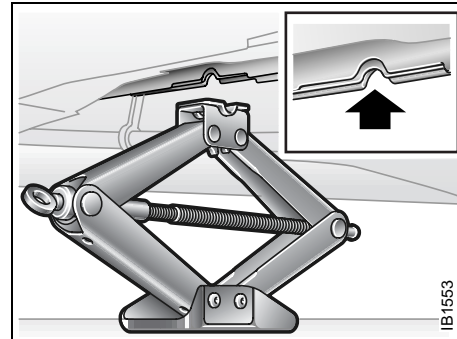

IB1553

Positioning the jack

Jack location, between spare wheel and sill

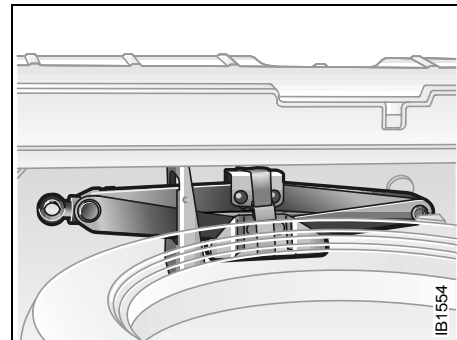

IB1554

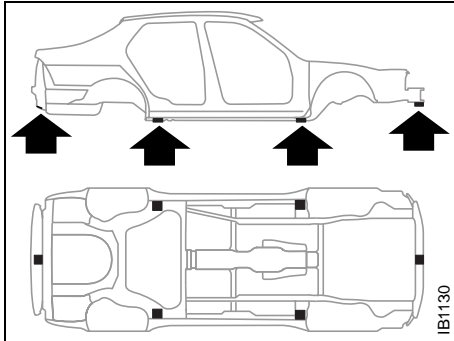

Jacking points for a trolley jack

If a floor jack is used, it can be applied to the standard jacking points used by the dealer. A floor jack can lift both front wheels or both rear wheels off the ground simultaneously. A jack stand must then be applied underneath the front of the engine subframe (at the fixing point for the towrope-attachment eye) or to the rear towrope-attachment eye (or under the trailer hitch, if fitted).

NOTE

Apply the jack only to the jacking points indicated.

- 1 Put the car in 1st gear (automatic transmission: move selector to the P position) and apply the parking brake.

- 2 Wind the jack up to a suitable height before placing it under the recess in the sill. Make sure that the jack fully engages the recess in the sill and that the base of the jack is steady and flat on the ground.
- 3 Remove the wheel cover (where applicable). Loosen the wheel bolts by half a turn.
- 4 Wind the jack to raise the wheel clear of the ground. Remove the wheel bolts and lift off the wheel.
- 5 Clean the contact surfaces between the wheel and brake disc.
- 6 Fit the wheel and screw in the bolts in the sequence shown (opposite pairs). Tighten the bolts enough for the bolts and wheel to be seated correctly.

- 7 Lower the car and tighten the wheel bolts to the correct torque in the sequence shown (opposite pairs).
Tightening torque
 Light-alloy wheels: 80 ft.lbs. (110 Nm)
 Steel wheels: 80 ft.lbs. (110 Nm)
 Do not overtighten the bolts using a percussion nut tightener: not only can this damage the wheels but it can also make

it impossible to undo the bolts using the wheel wrench in the car's toolkit.

NOTE

When refitting wheel covers (where applicable), make sure that the valve protrudes through the hole in the wheel cover.

- 8 Check-tighten the wheel bolts after a few miles.
Tightening torque
 Light-alloy wheels: 80 ft.lbs. (110 Nm)
 Steel wheels: 80 ft.lbs. (110 Nm)

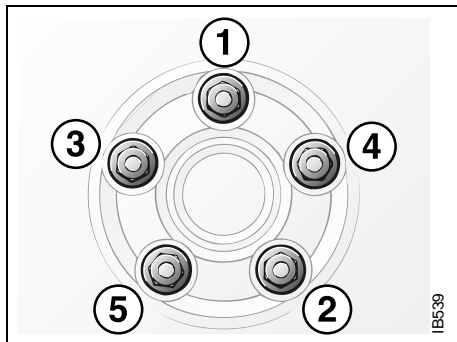

Tightening sequence, wheel bolts

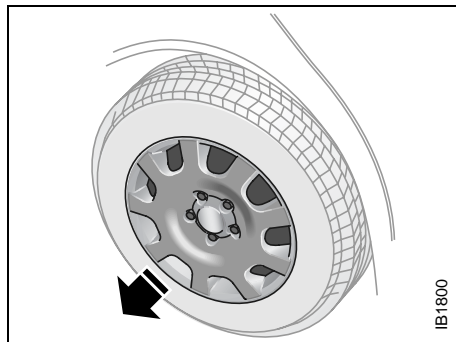

Removing the wheel cover

Flat spotting

All tires get hot, especially on long journeys or when the car is driven hard. After the car has been parked with hot tires and the tires have cooled down, a flat spot can appear in the tire, where it is in contact with the ground. The same can occur if the car has not been moved for a long time.

Flat spots can give rise to vibration that can be felt through the steering wheel, similar to that experienced when the wheels need balancing. Flat spots of this type disappear once the tires get hot again, usually after 10–15 miles (20–25 km) of driving at cruising speed.

WARNING

If the car has been driven for several years exclusively with alloy wheels and steel wheels are now fitted, the bolt hole threads in the brake hubs should be cleaned before the thinner steel wheels are fitted. Grit, salt and rust can clog the inner threads making it impossible to achieve the correct tightening torque.

Air conditioning (ACC)

NOTE

- The A/C system is designed for use with R134a refrigerant.
- Refrigerant handling requires special equipment and special procedures for charging and draining the system.
- All repairs and adjustments on the A/C system must be carried out by a Saab dealer authorized for this kind of work.
- Never mix R134a and R12 refrigerants.



WARNING

- The A/C system is pressurized. Do not break any connections or undo A/C system components.
- Escaping gas can cause visual impairment or other injury.

Fault diagnosis

If a fault occurs in the A/C system, there are a number of checks you can perform yourself. If the fault persists, however, have the system checked by an authorized Saab dealer.

Important!

When the A/C system is running, the intake air is dehumidified, and the resultant condensation is drained off through two outlets underneath the floor of the car in the vicinity of the front doors. It is therefore perfectly normal for water to be seen dripping from these outlets when the car is parked. The warmer the ambient air and the higher the humidity, the greater will be the amount of condensation formed.

Inadequate cooling:

- Check that the condenser (forward of the radiator) has not become clogged with dirt and insects.
- Make sure that the drive belt for the compressor is not slipping.
- Check the fuses for the ventilation fans and compressor.

Maintenance

- The drive belt for the compressor should be inspected under the regular service program.
- Clean dirt and insects away from the condenser and radiator to prevent clogging. When washing the car, use the hose to spray the radiator and condenser (located forward of the radiator) from both sides (both from the front of the car and from inside the engine bay). Do not use a pressure washer.

Caution: Do not use the hose when the engine is hot.

Other than in extremely cold weather, do not screen the radiator, e.g. with netting, as this will greatly diminish its cooling capacity.

Note: The A/C system will only operate when the outdoor temperature is above the freezing point (0°C, 32°F).

Safety belts



If the car is involved in a crash, the safety belts, belt pretensioners and other components must be inspected by an authorized Saab dealer.

Never make any alterations or repairs to the safety belt yourself but visit an authorized Saab dealer.

Regularly check the function of the safety belts as follows:

- Hold the diagonal strap and pull it sharply. The safety belt should **lock** and it should not be possible to withdraw it further.

Check the anchorage points in the floor. They must not have suffered rust damage. There must be no frayed threads in the webbing.

Safety belts must not come into contact with substances such as polishes, oils or other chemicals. If the straps are dirty, wash them with warm water and a detergent or have them replaced.

Upholstery and trim

To remove fluff or hairs from the seat upholstery or headlining, use a moist, lint-free cloth or a special lint remover (brush or roller). Remove any dirty marks using a cloth moistened with lukewarm soapy water.

When using a stain remover, always work from the outside towards the center to avoid leaving a ring. If a soiled ring or spot should remain, it can usually be removed using lukewarm soapy water or water alone.

Wet patches left by spilt soft drinks or thin oil must be wiped off immediately using an absorbent material, such as kitchen paper, and treated with stain remover.

Alcohol is recommended for removing grease or oil stains, and a semi-stiff brush may also be used.

Cleaning and caring for leather upholstery

The principal reason for treating leather upholstery is to maintain its elegant appearance and to provide it with a protective film. Discoloration caused by dust and wear mainly affects the lighter shades, although this is not detrimental to the leather – indeed, the patina resulting from use is often considered desirable in leather. But if the leather is allowed to become too grubby, it can start to look shabby.

It is a good idea to clean and recondition the leather twice a year – in conjunction with a general spring-cleaning of the car – after the winter and in the autumn, for instance. In hot, dry climates, the leather will need to be treated more frequently. Recommended conditioner – Saab Leather Care Lotion.

Do not use unknown harsh polishing agents, cleaning agents, sprays, coarse soap or hot water.

Textile carpeting

Vacuum clean the carpeting regularly. Carpets can also be cleaned using a brush, or carpet shampoo applied with a sponge. Do not use vacuum cleaners outdoors unless they are properly grounded.

Washing the car

The bodywork must be washed frequently. When the car is new, the body should be washed by hand using plain cold water and a clean, soft brush, or in a brushless car-wash that uses mild detergent. Automatic car washes with brushes should be avoided when the car is new. Do not use automatic car washes for the first five or six months, before the paintwork has hardened properly. Thereafter, use a high quality car wash soap added to lukewarm water.

Do not use a pressure washer at close range on stone chip damage, scratches or other damage to the paintwork. The paint can otherwise start to flake.

Remove any bird droppings without delay, as these can discolor the paintwork and prove difficult to polish out.

Use a soft cloth moistened with methyl alcohol to remove splashes of tar or asphalt. Do not use strong cleaners, as these can dry out the paintwork.

NOTE

Avoid using any alcohol-based cleaners on the front and rear light clusters, as these can cause cracking of the lenses.

The underside of the car also needs washing regularly, and this should be done extra thoroughly at the end of winter. Clean the underside of the car by hand if the car is usually washed in an automatic car wash without special facilities for underbody cleaning. Never wash or leave the car to dry in the sun, but wipe it dry with a chamois leather immediately after washing to avoid smears and streaks.

Clean the window glass inside and out using a high quality window cleaner. This is particularly important when the car is new, as upholstery and trim have a tendency to sweat a little at first.

Keep the glass well cleaned, as this helps to prevent misting.

NOTE

- The door mirrors must be fully retracted before the car enters an automatic car wash.
- Remove fixed antennas, e.g. for mobile phone, before putting car through an automatic car wash.
- Try your brakes on leaving a car wash. Wet brake discs reduce the braking effect.

Waxing and polishing

Do not wax a new car during the first three or four months. In fact, there is no need to polish the car before the paintwork has started to go dull through oxidation. Other than in exceptional cases, do not use abrasive polishes containing a cutting agent on a new car. Always wash the car thoroughly before waxing or polishing.

Engine compartment

Clean the engine compartment using an engine detergent and rinse with hot water. Cover the headlights. Do not use high-pressure washer. Avoid spraying the hood liner, as this can become heavy and hang down and touch the engine when the hood is closed.

Do not use gasoline as a cleaning agent or solvent when carrying out repairs or maintenance. Saab recommends the use of environmentally safe degreasing agents.

Touching up the paint

Damaged paintwork should be treated as soon as it is discovered: the longer it is left, the greater the risk of corrosion. The anti-perforation warranty does not cover corrosion resulting from untreated defects.

Paintwork damage sustained in a crash is usually extensive and can only be properly restored by professionals.

However, you can repair small scratches and stone-chip damage yourself. The necessary tools and materials, such as primer, touch-up paint and brushes, are available from your Saab dealer.

In the case of minor flaws in the paintwork, where the metal has not been exposed and an undamaged layer of paint remains, touch-up paint can usually be applied directly, after any dirt has been scraped away using a pointed knife.

If corrosion has already set in, e.g. as a result of stone-chip damage, use a pointed knife to scrape off all surface rust. If possible, the damaged area should be taken back to the bare metal. The metal should then be primed with two thin coats of primer applied by brush.

After the primer has dried, apply several thin layers of topcoat enamel until the surface of the repaired area is flush with the surrounding paintwork.

Stir both primer and touch-up enamel thoroughly before use and allow each coat to dry before applying the next.

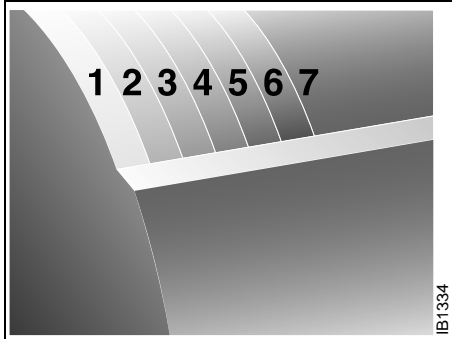

IB1334

Surface-treatment composition

- 1 Body panel
- 2 Zinc (certain panel sections only) 7.5 μm
- 3 Phosphate coating
- 4 Cathodic ED 28 μm
- 5 Intermediate coat 35 μm
- 6 Metallic base 15 μm
- 7 Clear enamel /solid enamel 40 μm

Two-coat enamel

As the name implies, two-coat enamel is applied in two operations. The first coat, the base color, contains the pigment, metal flakes and binder. The second coat consists of a clear enamel, which provides the final gloss for the paintwork and protects the base from moisture and environmental contaminants.

Touch-up stone-chip damage as follows:

- 1 Thoroughly clean the damaged area.
- 2 Apply the primer, base color and finally, the enamel. To achieve the best finish, apply two or three coats of primer.

Anti-corrosion treatment

The entire car is corrosion-protected at the factory in different stages by an electrolytic immersion coating and a polyester-based protective coating to protect against corrosion caused by stones flung up by the wheels. A thin penetrating anti-rust oil is also applied in cavities and body members.

In addition to conventional anti-corrosion treatment like painting, underbody treatment and cavity treatment, most of the body panel surfaces are galvanized. These include the hood, the doors and the underbody.

The anti-corrosion treatment on the underside of the car and inside the wheel arches is particularly exposed to constant wear and possible damage, the degree of which will obviously depend on driving conditions.

What causes rust?

Steel body panels of automobiles are subject to rusting whenever air and moisture manage to penetrate the protective finish, and body panels may rust through if the process is unchecked. Rusting can occur whenever water is trapped or where the car's panels are continuously damp. Damage to paint and undercoating by stones, gravel and minor crashes immediately exposes metal to air and moisture. Road salts used for de-icing will collect on the bottom of the car and promote rusting. Areas of the country with high humidity have great potential for rust problems, especially where salt is used on roads or there is moist sea air. Industrial pollution (fallout) may also damage paint and promote rusting.

Preventive maintenance

The following procedures are necessary to help protect against rusting. Refer also to the terms and conditions of the Sheet Metal Coverage described in the warranty booklet.

- 1 **Wash the car frequently, and wax at least twice a year.** Under adverse conditions, where there is a rapid buildup of dirt, sand or road salt, wash your car at least once a week. After extreme exposure to salted snow or slush, evidenced by a white film on the car, wash the car immediately. Frequent washing will prevent paint damage from acid rain and other airborne contaminants such as tree sap and bird droppings. If any of these contaminants are noticed on the car the finish should be washed immediately.
 - Begin washing by rinsing the entire car with water to loosen and flush off heavy concentrations of dirt (include the underbody).
 - Sponge the car with a solution of either a good quality car soap or mild general purpose (dish washing) detergent and water.
 - Rinse car thoroughly with clean water.
 - After washing, check and clear all drains in doors and body panels.
 - Wipe the car dry, preferably using a chamois.

- 2 **Clean the underside of the car during the winter.** Use high pressure water to clean the car's underside (floor panels, wheel wells) at least at mid-winter and in the spring.

- 3 **Inspect the car frequently for leaks or damage, and arrange for needed repairs promptly.** After washing or after heavy rain, check for leaks. When washing the car inspect body surfaces for paint damage. While checking for leaks, lift the floor mats and check beneath them. Water can collect in these areas and remain for prolonged periods. Dry any wet areas including the floor mats. Have leaks repaired as soon as possible.

Use touch-up paint to repair small scratches or minor finish damage. Areas where metal is exposed will rust quickly and **MUST** be repaired immediately by touch-up or professional repainting. Rust must be removed, the bare metal primed and painted. Major body damage should be repaired immediately and new panels or exposed areas should be undercoated with anti-corrosion material.

Repairs of this type are the owner's responsibility and are not covered under warranty.

4 Inspect the undercoating and touch up if necessary. Pay particular attention to the fenders and wheel housings, which are exposed to abrasion by flying gravel, etc. If the composition has worn or flaked off, the steel must be thoroughly cleaned and dried before a fresh coat is applied. The cleaning is best done with a scraper and a steel wire brush, followed by washing with solvent. Apply the new coating thinly, as otherwise it may run off or fall off when dry.

For long trips

Before setting off on a long journey, it is advisable to have your car checked over by your Saab dealer.

Obtain a few important items to take along on your journey such as spare bulbs, wiper blades, fuses, a Poly-V-belt and the like. You can check some points yourself beforehand:

- Make sure that the engine is in good condition.
- Check that no oil or gasoline leaks out of the engine or gearbox/transmission.
- Check the coolant and power steering fluid levels. Check also for leaks.
- Inspect the Poly-V-belt and replace it if it shows any signs of hard wear.
- Check the battery charge.
- Check the tires for tread pattern and air pressure, including the compact spare wheel.
- Check the brakes.
- Check all bulbs.
- Check for the presence of the tool kit and the jack in the car.

Recovery and/or recycling of automotive materials

A typical car consists of metals (65–75%), plastics (10–14%), rubber (5%) and small quantities of glass, wood, paper and textiles.

Some of these materials can be recycled, while others can be recovered in chemical processes for reuse in new products or as a source of energy.

While the Saab 9-5 was still at the drawing-board stage, Saab engineers were giving serious consideration to how the maximum quantity of materials could be reclaimed from the car on its eventual scrapping. To facilitate sorting, plastic parts, for instance, have been marked to identify the precise nature of the plastic.

Approximately 90% of the materials in the car can be recycled or recovered, where facilities exist.

Before the car is scrapped, all the oils and other fluids that could pollute the environment should be recovered from the car. It may be of interest in this context to learn that the refrigerant used in the Saab 9-5's ACC systems (R134a) contains neither CFCs nor any other chlorine compounds.

- 1 A-pillar trim: PP, PP/EPDM
- 2 Windshield trim: PP, PP/EPDM
- 3 Seals: EPDM
- 4 C-pillar trim: ABS
- 5 Rear light cluster: PMMA
- 6 Rear bumper, cellular core: expanded PP; sheathing: PP/EPDM
- 7 Side-window casing: PP/EPDM
- 8 Fuel tank: PE
- 9 Side trim: PVC
- 10 A-pillar upholstery trim: PC/ABS, textile
- 11 Rearview mirror: ABS
- 12 Sill scuff plate: PP/EPDM
- 13 Wheel-arch liner: PP
- 14 Wheel cover: PA
- 15 Direction-indicator lamp lens: PMMA
- 16 Washer-fluid reservoir: PE
- 17 Front spoiler: PP/EPDM
- 18 Front bumper, cellular core: expanded PP; sheathing, grille: PP/EPDM
- 19 Fan shroud: PP
- 20 Scuttle panel finisher: PC/ASA

- ABS Acrylonitrile-butadiene-styrene
- ASA Acrylonitrile-styrene (acrylic plastic)
- EPDM Ethylene-propylene rubber
- PA Polyamide (plastic)
- PC Polycarbonate (plastic)
- PE Polyethylene
- PMMA Polymethyl methacrylate
- POM Acetal plastic
- PPO Polyphenylene oxide (plastic)
- PP Polypropylene
- PUR Polyurethane
- PVC Polyvinyl chloride

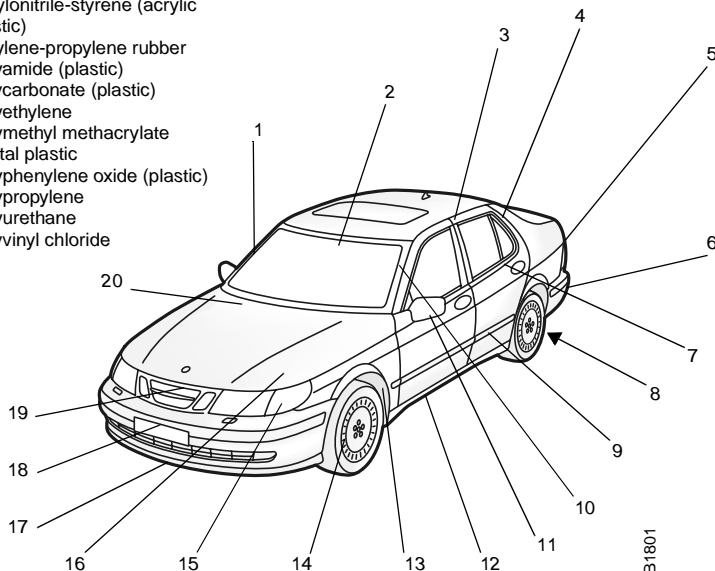

IB1801

Headlight aiming

WARNING

Before checking/adjusting the headlight aiming, switch off the engine to avoid danger of fingers and hands being injured by moving parts.

The radiator fan can start up even when the engine is switched off.

The vehicle has a visual optical headlight aiming system equipped with vertical aiming device. The aim has been preset at the factory and should normally not need further adjustments.

If your headlights are damaged in a crash, the headlight aim may be affected. If you believe your headlights need to be re-aimed, we recommend that you take it to your Saab dealer for service, however, it is possible for you to re-aim your headlights as described in the following procedure.

NOTE

To make sure that your headlights are aimed properly read all instructions before beginning. Failure to follow these instructions could cause damage to headlight parts or a not correctly aimed headlight.

To check the aim, the vehicle should be properly prepared as follows:

- The vehicle shall be placed so that the headlights are 25 ft (7.6 m) from a light colored wall or other flat surface. The aiming area should be darkened, this will improve your ability to see the beam of the low beam headlight being aimed.
- The vehicle must have all four wheels on a perfectly level surface which is level all the way to the wall or other flat surface.
- The vehicle should be placed so it is perpendicular to the wall or other flat surface.
- The vehicle should be unloaded and fuel tank full, and one person or 160 lbs. (75 kg) on the drivers seat.

- The vehicle should be fully assembled and all other work stopped while headlight aiming is being done.
- The vehicle should not have any snow, ice or mud attached to it.
- Tires should be inflated to the prescribed pressure.
- Close all doors.
- Rock the vehicle to stabilize the suspension.

Headlight aiming is done with the vehicle low beam lamps. The high beam lamps will be correctly aimed if the low beam lamps are aimed properly.

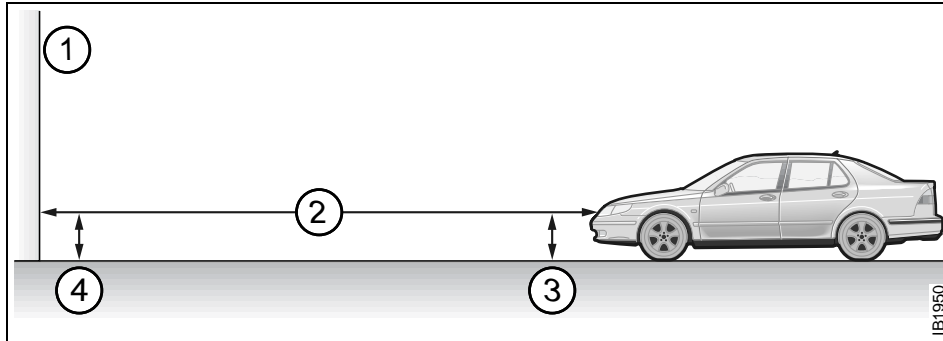

IB1950

- 1 Wall or garage door
- 2 25 ft (7.6 m) between wall and headlight lens.
- 3 Measurement from the ground to the low beam aiming marker on the headlight lens.
- 4 Same measurement as (3) but subtract 2 inches for vehicles with halogen lamps and 3 inches for vehicles with xenon lamps.

If you find that the headlight needs adjustment follow these steps:

- 1 Open the hood and locate the vertical aiming device.
- 2 Locate the marker on the lens.
- 3 Measure the distance from the ground to the aim marker on each lens. Subtract 2 inches if the vehicle is equipped with halogen lamps, record this distance. Subtract 3 inches if the vehicle is equipped with xenon lamps, record this distance.

- 4 At the wall or other flat surface, measure from the ground to the recorded distance (see point 4) and draw a horizontal line the width of the vehicle.

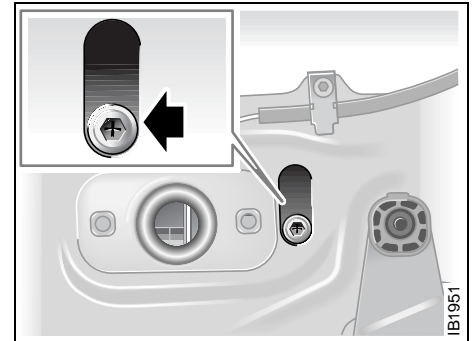

IB1951

Vertical aiming device

Aiming marker on headlight lens

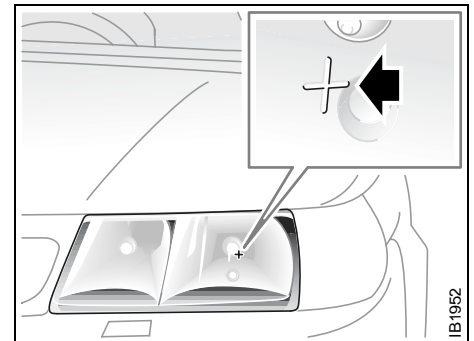

IB1952

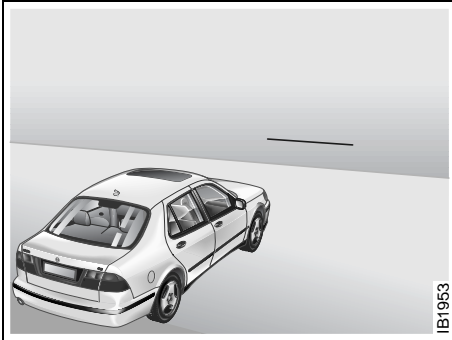

Horizontal line on wall or other flat surface

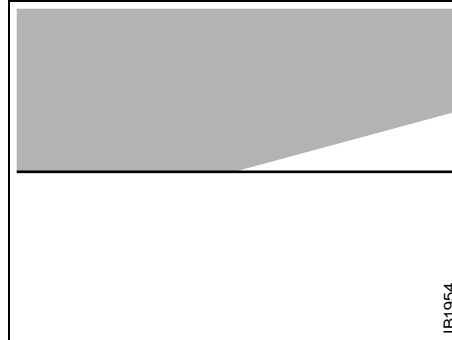

Correctly adjusted low beam

5 Turn on the low beam headlights and place a piece of cardboard or equivalent (although not directly on the lens) in front of the headlight not being aimed. This should allow the beam cut-off of the headlight being aimed to be seen on the flat surface.

6 Turn the vertical aiming screw until the horizontal cut-off of the headlight is aligned with the horizontal line on the wall.

NOTE

Do not cover a headlight to improve beam cut-off when aiming. Covering a headlight may cause excessive heat build-up which may cause damage to the headlight.

(This page has been left blank)

Maintenance and owner assistance

| | |
|---|-----|
| Maintenance schedule..... | 244 |
| Owner assistance | 245 |
| Reporting Safety Defects (U.S.A.) | 246 |
| Reporting Safety Defects to the Canadian government | 246 |

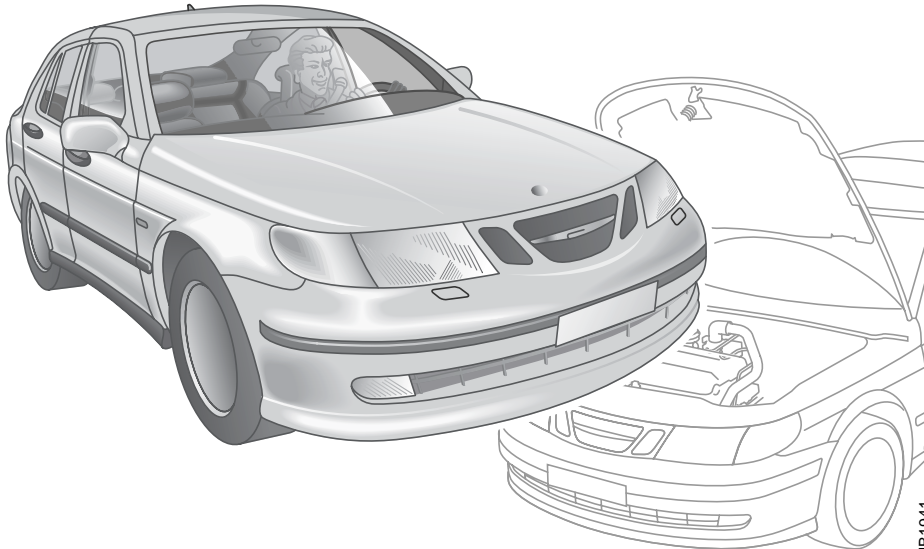

Maintenance schedule

The Maintenance Schedule prescribes a service program to the purchaser/operator of a Saab that is reasonable and necessary to ensure the proper emission control systems function, safety and reliability of the Saab automobile in normal use. Additional maintenance is recommended for specific components when the car is operated under certain severe conditions. Proper maintenance is always good advice!

Authorized Saab dealers are equipped and trained to meet your Saab's service needs. They regularly receive up-to-date Saab service manuals and parts and technical service bulletins from Saab and are able, through their franchise agreement, to attend Saab service schools, obtain Saab special tools and technical assistance and purchase original equipment service and replacement parts.

Today's complex automobiles should only be entrusted to the most knowledgeable service professionals. A Saab dealer is your best choice.

Service intervals

The maintenance schedule is comprised of a Check-up 30 days after retail delivery, followed by services at every 10,000 miles (16,000 km) thereafter (10,000, 20,000, 30,000 miles/16,000 32,000, 48,000 km etc.).

NOTE

The Check-up will be done by your Saab dealer at no charge and should be done as close as possible to the scheduled 30 days.

Engine oil and filter changes

Changing the engine oil and filter is required at every service point. Use only a Saab approved long-life oil filter and engine oils meeting the SAE viscosity ratings and API service classifications stated in the Specification section of this Owner's Manual. The use of extra additives in the oil is not necessary and is not recommended, and may be harmful to turbochargers.

More frequent oil changes are recommended if your vehicle is operated under the following conditions:

- Most trips are less than 5 to 10 miles (8 to 16 km). This is particularly important when outside temperatures are below freezing.
- Most trips include extensive idling (such as frequent stop-and-go driving).
- Most trips are through dusty areas.
- You frequently tow a trailer or use a carrier on top of your vehicle.
- If the vehicle is used for delivery service, police, taxi or other commercial applications.

If your driving habits match this description, have the engine oil and filter changed in-between normal services at 5,000 mile (8,000 km) intervals. The Warranties and Service Record Booklet has provisions to record extra oil changes.

Service record retention

Service instruction coupons and record stubs are provided in the Saab Warranties and Service Record Booklet which accompanies this Owner's Manual. The coupons are arranged in the order that normal service should be performed. The edge of each coupon is shaded to correspond to the type of service point:

- Striped - "Check Up"
- Blue - Oil change/inspection service
- Black - Major service

Note that in Canada a combined service and warranty book is used, but not service coupons.

When scheduled services are performed, your dealer will tear out the applicable coupon and use it to check off the operations performed and enter it into the service file at the dealership. The servicing dealer's stamp, along with the date and mileage at which the service was done, should be entered on the corresponding stub which remains in your booklet. The booklet is your permanent record of the services performed. It also includes a log sheet for unscheduled repairs.

It is advisable to retain receipts and, if possible, copies of shop work orders for all service and repair work, wherever performed.

Service costs

Dealer pricing practices and labor for service work vary. Saab's recommended service times for each service point do not include the labor required to replace wear items, such as wiper blades, brake pads or tires. Nor is labor to perform other service or repairs found to be necessary as a result of the inspections included in these times. Additional labor and parts will be charged for such work when necessary, except as covered under an applicable Saab warranty or any optional extended service contract. Transmission fluid changes or suspension alignment, when necessary, are also additional.

Dealer charges for general shop material, regulated hazardous waste removal, recycling expenses or other operation costs may also be applied to service and repair invoices and are apt to vary by dealer and locality.

Owner assistance

Warranties and service problem assistance

For complete information about all applicable warranties, including the New Car Warranty, Perforation Warranty, Vehicle Emission Warranty and Emission Perforation Warranty, consult the Warranties and Service Record Booklet which accompanies this Owner's Manual. It also contains owner assistance information including Saab Roadside Assistance. If the booklet is lost or misplaced, a new one may be ordered through a Saab dealer or by contacting Saab.

In the U.S. there is a national Customer Assistance Center at Saab Cars USA, Inc. The toll-free number to call from all 50 states is 1-800-955-9007.

In Canada, please call the Saab Customer Assistance Centre at 1-800-263-1999.

A list of authorized Saab sales and service dealers is available for those planning to travel in the United States and Canada.

Canadian or U.S. travelers may call the Customer Assistance Center in the country in which they are traveling.

Change of Address Notification (U.S. and Canada)

Two change of address cards are provided at the end of the Warranties and Service Record Booklet. Knowing your current address allows Saab to contact you in the event of a recall or service campaign. Please help us keep our records up to date for your own peace of mind.

Service information

Factory Service Manuals for the Saab 9-5 car line can be ordered through the dealer. These are comprehensive manuals on CD rom, geared to use by professional technicians.

Consult your Saab dealer for prices and for a listing for your model.

Reporting Safety Defects (U.S.A.)

If you believe that your vehicle has a defect which could cause a crash or could cause injury or death, you should immediately inform the National Highway Traffic Safety Administration (NHTSA) in addition to notifying Saab Cars USA, Inc.

If NHTSA receives similar complaints, it may open an investigation, and if it finds that a safety defect exists in a group of vehicles, it may order a recall and remedy campaign. However, NHTSA cannot become involved in individual problems between you, your dealer, or Saab Cars USA, Inc.

To contact NHTSA, you may either call the Auto Safety Hotline toll-free at 1-800-424-9393 (or 202/366-0123 in Washington D.C. area) or write to: NHTSA, U.S. Department of Transportation, Washington, D.C. 20590. You can also obtain other information about motor vehicle safety from the Hotline.

Reporting Safety Defects to the Canadian government

If you live in Canada, and believe that your vehicle has a safety defect, you should immediately notify Transport Canada, in addition to notifying General Motors of Canada Limited.

You may write to Transport Canada at Box 8880, Ottawa, Ontario, K1G 3J2.

In addition to notifying Transport Canada in a situation like this, we certainly hope you will notify us. In Canada, please call our Saab Customer Assistance Centre at 1-800-263- 1999.

Or write:

General Motors of Canada Limited
Customer Assistance Centre,
1908 Colonel Sam Drive,
Oshawa, Ontario, L1H 8P7.

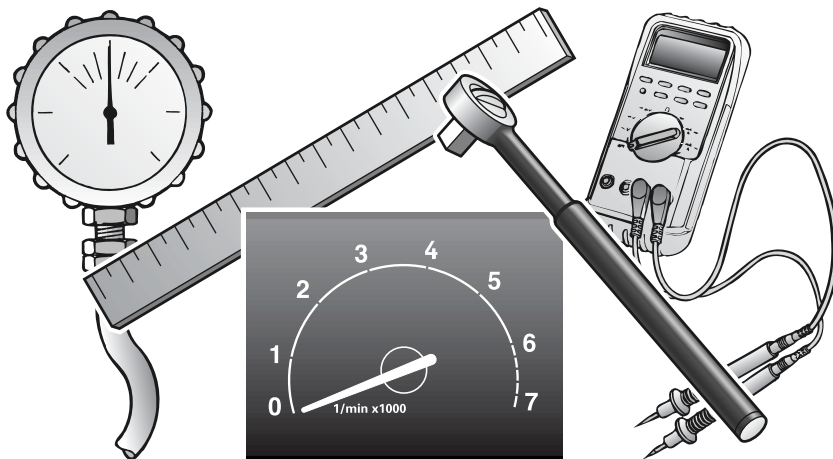

IB603

Specifications

| | |
|----------------------------------|------------|
| General..... | 248 |
| Engine | 250 |
| Fuel..... | 250 |
| Engine oil..... | 251 |
| Engine variants | 252 |
| Electrical system..... | 253 |
| Drive belts..... | 253 |
| Manual gearbox..... | 254 |
| Automatic transmission .. | 254 |
| Suspension..... | 255 |
| Steering..... | 255 |
| Brake system..... | 255 |
| Wheels and tires | 256 |
| Plates and labels..... | 257 |

General

Overall length, including bumpers:

9-5 Sedan _____ 190.0 in (4827 mm)

9-5 Wagon _____ 190.1 in (4828 mm)

Overall width, including door mirrors _____ 80.4 in (2042 mm)

Maximum height:

9-5 Sedan _____ 58.1 in (1475 mm)

9-5 Wagon _____ 59.1 in (1501 mm)

Wheelbase _____ 106.4 in (2703 mm)

Ground clearance _____ approx. 6.6 in (167 mm)

Track:

Front _____ 59.9 in (1522 mm)*)

Rear _____ 59.9 in (1522 mm)*)

Turning circle (curb to curb) _____ 37,1 ft (11.3 m)

Turning circle (measured at vehicle extremities) _____ 39,0 ft (11.9 m)

Number of seats (incl. driver) _____ 5

*) Specified track applies to wheel sizes: 6 x 15 & 6.5 x 16

Gross vehicle weight (GVW)

Maximum train weight (GVW + max. trailer weight)

Maximum axle load, front

Maximum axle load, rear

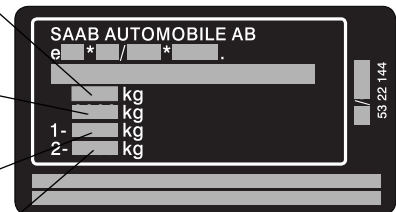

IB1917

Permissible load (in addition to driver) = GVW minus curb weight
The maximum permissible axle load, front or rear, must not be exceeded.

The maximum permissible axle load, front or rear, must not be exceeded.

Chassis number in engine bay

Weight ready for driving (i.e. with full fuel tank, washer-fluid reservoir, standard tools and spare wheel) _____ 3370–3790 lbs. (1530–1720 kg)

Gross vehicle weight (GVW) _____ 4370–4720 lbs. (1980–2140 kg)

Maximum axle load:

Front _____ 2590 lbs. (1175 kg)

Rear, 9-5 Sedan _____ 2310 lbs. (1050 kg)

Rear, 9-5 Wagon _____ 2480 lbs. (1125 kg)

Weight distribution:

Curb weight, front/rear _____ 60/40%

GVW, front/rear _____ 50/50%

Maximum roof load _____ 220 lbs (100 kg)

Luggage compartment

Volume (SAE):

| | |
|------------------------------------|-------------------------------|
| 9-5 Sedan _____ | 15.9 cu.ft. (450 litres) |
| 9-5 Wagon, rear seat upright _____ | 31.4 cu. ft. (890 litres) |
| 9-5 Wagon, rear seat folded _____ | 73.0 cu. ft. (2067 litres) |

Maximum permissible luggage-compartment load:

At curb weight + 4 passengers at 154 lbs. (70 kg) _____ 176 lbs (80 kg)

or each passenger fewer in the rear seat, the load may be increased by 110 lbs (50 kg).

With entire rear seat lowered _____ 594 lbs (270 kg)

Luggage compartment, length, 9-5 Sedan:

Rear seat upright _____ 43.0 in (1092 mm)

Rear seat folded down _____ 67.5 in (1714 mm)

Luggage compartment, length, 9-5 Wagon:

Rear seat upright _____ 42.8 in (1087 mm)

Rear seat folded _____ 61.2 in (1732 mm)

Trailer:

Maximum towing speed, trailer with brakes 60 mph (100 km/h)

Trailer with brakes _____ Maximum weight:
3500 lbs (1588 kg)

Trailer without brakes _____ Maximum weight:
1000 lbs (450 kg)

Maximum load on ball hitch _____ 165 lbs (75 kg)

The above speed and weight restrictions are those specified by Saab Automobile AB.

Note that local restrictions may apply to trailer speeds and weights (see page 173).



WARNING

The GVW and maximum axle loads must not be exceeded. Note that if some accessories (e.g. towbar, CD changer) are fitted, the available load capacity is reduced by the weight of these.

When carrying a load in the luggage compartment, make sure that it is tied down securely, particularly when part or all of the rear seat is folded down.

250 Specifications

Engine

| | |
|-------------------------|---|
| 4-cylinder _____ | Four cylinders, twin overhead camshafts, 16 valves and two balancer shafts. |
| 3.0t V6 _____ | V-6 engine, double overhead camshafts on each cylinder bank, 24 valves |
| Cylinder bores _____ | 3.54 in (90 mm) |
| Stroke: | |
| 4-cylinder engine _____ | 3.54 in (90 mm) |
| 3.0t V6 _____ | 3.34 in (85 mm) |
| Swept volume: | |
| 4-cylinder engine _____ | 139.7 cu.in (2.290 litres) |
| 3.0t V6 _____ | 180.6 cu.in (2.962 litres) |
| Idling speed: | |
| 4-cylinder _____ | 825 rpm |
| 3.0t V6 _____ | 700 rpm |
| Antifreeze _____ | Saab-approved antifreeze |
| Coolant capacity: | |
| 4-cylinder _____ | 7.6 qts (7.4 litres) |
| 3.0t V6 _____ | 7.4 qts (7.2 litres) |

Fuel

| | |
|--|------------------------------|
| Fuel grade _____ | Unleaded gasoline AON 87–93. |
| For optimum performance Saab recommend the following fuel grades: | |
| 2.3t _____ | AON 90 |
| 2.3 Turbo Aero and 3.0t V6 _____ | AON 93 *) |
| *) If AON 90 is used and the ambient temperature is above 77 – 86°F (25– 30°C) some decrease in engine power can occur to some extent. | |
| Fuel-tank capacity _____ | 18.5 gal. (70 litres) |

Engine oil

Oil recommendation:

We recommend the use of oils that are available from your Saab dealer, for regular oil changes. These oils fulfill the most stringent requirements set by API and ACEA classifications.

Basic recommendations for Saab engines:

SAE 5W-30 or 0W-30, 5W-40.

The oil should be semi or fully synthetic and fulfill grade requirements for ACEA A3/B3, API SJ or higher. In addition to API and ACEA the ILSAC GF-3 specification is approved for use in applicable markets.

Fully synthetic oils with viscosity's 0W-40/50 of well known brands and fulfilling minimum ACEA A3/B3 are also recommended, especially for extreme driving conditions.

Oil specification.

Oil for gasoline engines is classified by the API (American Petroleum Institute) and ACEA (European Automobile Manufacturers Associations) standards.

API classifies engine oil into grade classes SH (since 1993) and SJ (since 1996). The SJ class fulfils more stringent requirements and has lower phosphorous level. A new grade API SL, introduced 2001, fulfils even higher requirements.

These grade classes are most often combined with corresponding classes for diesel engines. The class designations for diesel engines begins with the letter "C" (Commercial). For example a grade combination suitable for both types of engine could be API SH/CD, SJ/CF or SL/CF.

Under the ACEA nomenclature, oils are divided into Class A for gasoline engines and Class B for diesel engine passenger cars. There is a further class for heavy diesel engines. Each class is divided into grades: 1,2 and 3 where grades 2 and 3 normally encompass semi- and fully synthetic oils. The diesel class also has a fourth grade, B4, which encompasses tests and regulations aimed at improving the performance of direct injection diesel engines.

In the same way as in the API system, gasoline and diesel engine specifications are combined for products that can be used in both types of engine. For example, a grade designation could be ACEA A2/B2 or ACEA A3/B3, B4.

Viscosity:

The viscosity of oil is classified according to the SAE standard. Nowadays, multigrade oils are always used in cars. The properties of these oils facilitate starting the car in cold weather but mean that the oil is also viscous enough to coat all moving parts under high pressures and with high outside air temperatures. Multigrade oils are graded with two viscosity's, e.g. 5W-30, where 5W meets certain viscosity requirements at -4°F (-20°C), while 30 fulfils requirements at 212°F (100°C).

Oil capacity incl. filter (on changing):

| | |
|------------------|----------------------|
| 4-cylinder _____ | 4.1 qts (4.0 litres) |
| 3.0t V6 _____ | 4.6 qts (4.5 litres) |

Engine variants

2.3t Ecopower

| | |
|---------------------------------------|-------------------------|
| Rating, EEC at 5500 rpm _____ | 185 hp (136 kW) |
| Maximum torque, EEC at 1800 rpm _____ | 207.2 ft.lb (280 Nm) |
| Compression ratio _____ | 9.3:1 |

2.3 Turbo Ecopower ("Aero" model engine), manual transmission

| | |
|---------------------------------------|--------------------------|
| Rating, EEC at 5500 rpm _____ | 250 hp (184 kW) |
| Maximum torque, EEC at 1900 rpm _____ | 259.0 ft.lb. (350 Nm) |
| Compression ratio _____ | 9.3:1 |

2.3 Turbo Ecopower, ("Aero" model engine) automatic transmission

| | |
|---------------------------------------|--------------------------|
| Rating, EEC at 5500 rpm _____ | 250 hp (184 kW) |
| Maximum torque, EEC at 1900 rpm _____ | 244.2 ft.lb. (330 Nm) |
| Compression ratio _____ | 9.3:1 |

3.0t V6 Ecopower

| | |
|---------------------------------------|-------------------------|
| Rating, EEC at 5500 rpm _____ | 200 hp (147 kW) |
| Maximum torque, EEC at 2500 rpm _____ | 229.4 ft.lb (310 Nm) |
| Compression ratio _____ | 9.5:1 |

Electrical system

| | |
|------------------------|---------------------|
| Voltage _____ | 12 V |
| Battery capacity _____ | 70 Ah |
| Starter motor _____ | 1.4 kW |
| Alternator rating | |
| 4-cylinder _____ | 140 A/14 V |
| 3.0t V6 _____ | 130 A/14 V |
| Firing order: | |
| 4-cylinder _____ | 1-3-4-2 |
| 3.0t V6 _____ | 1-2-3-4-5-6 |
| Spark plugs: | |
| 2.3t _____ | NGK BCPR 6ES-11 |
| Electrode gap _____ | 0.0414 in (1.05 mm) |
| 2.3 Turbo Aero _____ | NGK PFR 6H-10 |
| Electrode gap _____ | 0.0374 in (0.95 mm) |
| 3.0t V6 _____ | NGK BKR 7ES-11 |
| Electrode gap _____ | 0.0414 in (1.05 mm) |

Drive belts

| | |
|-------------------------------|------------------------|
| Engine variants | Outside length |
| 4-cylinder, poly-V-belt _____ | 102.84 in (2612 mm) |
| 3.0t V6, poly-V-belt _____ | 79.53 in (2020 mm) |



Drive belt, 4-cylinder

IB542

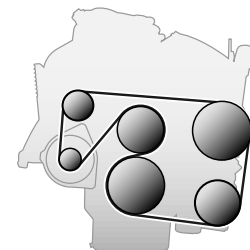

Drive belt, 3.0t V6

IB543

Manual gearbox

| | |
|---|--|
| Type _____ | All-synchromesh 5-speed with final drive and differential |
| Oil _____ | Saab synthetic manual gearbox oil |
| Oil capacity _____ | 1.9 qts (1.8 litres) |
| Oil volume (on changing) _____ | 1.6 qts (1.5 litres) |
| Clutch type _____ | Hydraulic, single dry-plate clutch of diaphragm-spring type |
| Speed (mph / km/h) at 1000 rpm in 5th gear: 4-cylinder _____ | 27–28 / 43–44 |

Automatic transmission

| | |
|---|--|
| Type _____ | Electronically controlled 5-speed, fully automatic with hydraulic torque converter, planetary gear set and integral final drive |
| Selector-lever positions _____ | Lock-up function in selector positions 3, 4 and 5. P R N D 4 3 L |
| Transmission-fluid capacity, dry transmission (incl. torque converter and oil cooler) _____ | 7.5 qts (7 litres) |
| If fluid change required, approximately 3.5 litres can be drained through the drain plug in the transmission casing | |
| Transmission fluid _____ | Saab 3309 (mineral oil based) |
| Clutch type _____ | Hydraulic plate clutches, brake bands and one-way couplings |
| Speed (mph / km/h) at 1000 rpm in 5th gear: 4- cylinder engines and 3.0t V6 _____ | 29 / 47–48 |

Suspension

Spring type, front and rear _____ Coil springs
 Maximum deflection of springs:
 Front _____ 7.09 in (180 mm)
 Rear _____ 7.87 in (200 mm)
 Dampers, front and rear _____ Gas-filled dampers

Steering

Steering _____ Power-assisted steering of rack-and-pinion type; telescopic steering-column shaft with universal joints
 Number of turns, lock to lock _____ 2,9
 Power-steering fluid _____ Power-steering fluid CHF 11S

Brake system

Footbrake (ABS) _____ Hydraulic disc brakes with vacuum servo unit. Diagonally split circuits; ventilated discs on front wheels. EBD function, see page 165.
 Handbrake _____ Acts on rear wheels
 Brake fluid _____ DOT 4
 Brake-fluid capacity _____ 0.925 qts (900 ml)
 Disc diameter:
 Front _____ 11.34 in (288 mm)
 Front, certain variants *) _____ 12.05 in (306 mm)
 Rear _____ 11.26 in (286 mm)
 Rear, certain variants *) _____ 11.81 in (300 mm)
 *) 15" wheel must not be used on these variants.
 Total friction area of brake pads:
 Front _____ 36.3 in² (234 cm²)
 Rear _____ 15.5 in² (100 cm²)

Wheels and tires

Wheel size _____ 6.5 x 16 or 7 x 17

2.3 Turbo Aero _____ Use only 6.5 x 16 or 7 x 17 only

Contact an authorized Saab dealer if you wish to fit other wheels than those fitted as standard.

Tire size (summer tires):

6.5 x 16 wheels _____ 215/55 R16

7 x 17 wheels _____ 225/45 R17

Tire size (winter tires):

6 x 15 wheels (Linear only: not 2.3 Turbo Aero or 3.0 V6) _____ 195/65 R15 M+S

6.5 x 16 wheels _____ 205/55 R16 M+S

Recommended wheels for snow chains 6 x 15 (not 9-5 2.3 Turbo Aero) or 6.5 x 16

Compact spare:

Wheel _____ 4 x 16

Tire _____ T115/70 R16

Pressure _____ 60 psi (420 kPa)

Maximum life _____ 2,200 miles (3500 km)

Maximum speed _____ 50 mph (80 km/h)

NOTE

Snow chains:

Snow chains must **not** be fitted to the rear wheels, and may only be used with the following wheel-tire combinations:

Wheels

Tires

6.5 x 15 _____ 195/65 R15 M+S
(Linear only: not 2.3 Turbo Aero or 3.0L V6)

205/65 R15
(Linear only: not 2.3 Turbo Aero or 3.0L V6)

6.5 x 16 _____ 205/55 R16 M+S or
215/55 R16

Snow chains must not be fitted to 17" wheels.

Max. permissible speed with snow chains fitted is 30 mph (50 km/h).

Contact an authorized Saab dealer for advice on snow chains.

NOTE

Wheels larger than 17" must not be fitted.

The wheel offset must not exceed 49 mm.

Vehicles with 12.05 in (306 mm) front brake discs must not use 15" rims.

Plates and labels

When consulting your Saab dealer, it may be necessary to quote the car's V.I.N., engine and gearbox numbers.

- 1 Modification identity plate.
- 2 V.I.N. number, inside windshield.
- 3 Certification label.
- 4 Gearbox number.
- 5 Engine number.
- 6 Tire pressures and color codes (body & trim), label.
- 7 Chassis number plate.
- 8 Chassis number, stamped on body.
- 9 Vehicle Emission Control Information.

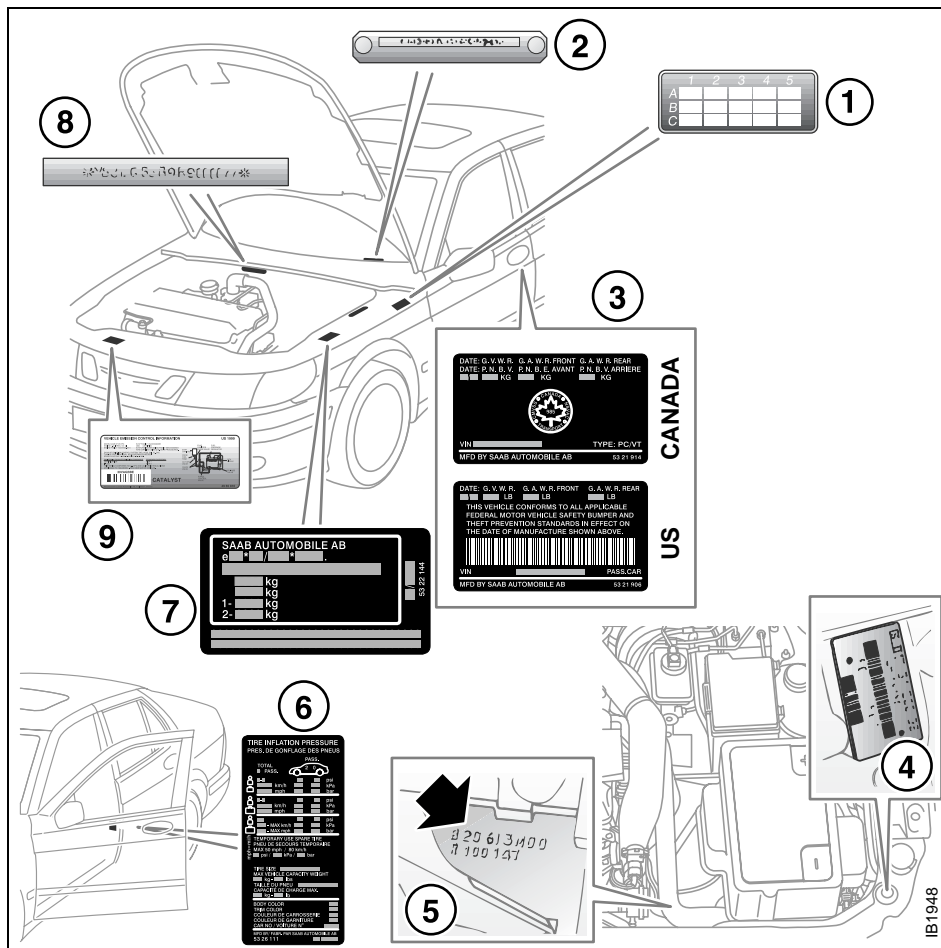

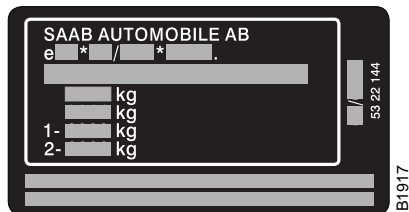

position: 1 2 3 4 5 6 7 8 9 10 11 12
 | | | | | | | | | | | |
 V.I.N.: Y S 3 E D 4 9 E 6 2 3 045842

| | | | | |
 1 2 3 4 5 6 = identification codes for certain chassis details

- 1 **Region** _____ Y = Northern Europe
- 2 **Country** _____ S = Sweden
- 3 **Manufacturer** _____ 3 = Saab Automobile AB
- 4 **Product line** _____ E = 9-5
- 5 **Model series** _____ B = 9-5 Linear with driver's and passenger-side airbags
 D = 9-5 Arc with driver's and passenger-side airbags
 H = 9-5 Aero with driver's and passenger-side airbags
- 6 **Body version** _____ 4 = 4-door
 5 = 5-door
- 7 **Gearbox** _____ 5 = Manual 5-speed
 9 = Automatic 5-speed

- 8 **Engine variant** _____ E = 2.3t
 G = 2.3 Turbo
 Z = 3.0t V6
- 9 **Check digit** _____ 0-9/X
- 10 **Model year** _____ 2 = 2002
- 11 **Factory** _____ 3 = Trollhättan
- 12 **Serial number** _____ 000001-999999

Several of the systems in your Saab car can be adjusted to better fit your individual needs

Some functions are governed by legal requirements and cannot therefore be reprogrammed.

Consult an authorized Saab dealer for further information.

Car alarm/central locking system:

- The sound level of the siren when locking/unlocking, HIGH or LOW.
- The number of blinks when locking/unlocking, 1 to 7.
- Automatic locking of the trunk when the car is driven, 1 to 8 mph (2-14 km/h), YES or NO.
- Preclude the unlocking of the trunk while the car is driven, YES or NO.
- Automatic locking of the trunk after 1 second-4 minutes if it has not been opened, YES or NO.
- Automatic locking of the trunk when it is closed, YES or NO.
- Automatic locking of all doors when the car is driven above 7.5 mph (12 km/h), YES or NO.

Saab Information Display:

- Outdoor temperature display can be adjusted.

Miscellaneous:

- Select the on-time for heated rear seat.
- Coolant temperature gauge adjustment can be increased/decreased.
- Fuel level gauge adjustment can be increased/decreased.
- Additional sweep of the wipers after windshield washer function (ON or OFF).
- Follow me home on-time can vary from 20 to 50 seconds.
- Night panel illumination deactivation speed for the speedometer can be adjusted.

Following adjustments can be done by the driver:

Automatic Climate Control (ACC):

To alter the preprogrammed "AUTO" start up mode with your own preferences you can manually select the desired settings for:

- Temperature.
- Fan speed.
- Air distribution.

See "Programming I" on page 78 and "Programming II" on page 79.

Saab 9-5 Audio System (see page 99):

- Maximum starting volume (when the radio is switched on).
- Telephone volume (if the car is equipped with a phone connected to the audio system).
- Speed dependent volume (volume increases or decreases with vehicle speed).
- Loudness.

Alarm system:

The glass breakage sensor can be temporarily disabled, see page 44.

Daytime Running Lights:

To disable, turn off the ignition and pull out fuse 35, see page 218.

(This page has been left blank)

Index

A

| | |
|--|----------|
| A/C system, fault diagnosis _____ | 231 |
| A/C system, maintenance _____ | 231 |
| ABS brakes _____ | 165 |
| ACC _____ | 72 |
| ACC functions _____ | 75 |
| ACC, automatic climate control _____ | 72 |
| ACC, calibration _____ | 80 |
| ACC, condensation _____ | 81 |
| ACC, programming _____ | 78 |
| ACC, useful tips _____ | 80 |
| Adjusting the steering wheel _____ | 122 |
| Adjustment, seats _____ | 118 |
| Afterheater, V6-engine cars _____ | 82 |
| Air conditioning (A/C), fault diagnosis and maintenance _____ | 231 |
| Air distribution, ACC _____ | 77 |
| Airbag _____ | 29 |
| Alarm _____ | 43 |
| Alarm functions _____ | 46 |
| Alarm signals _____ | 43, 46 |
| Alternator _____ | 201 |
| Alternator drive belt _____ | 201, 253 |
| Alternator rating _____ | 253 |
| Anticorrosion treatment _____ | 235 |
| Antidazzle rear-view mirror _____ | 124 |
| Ashtrays _____ | 128 |
| Audio System _____ | 83 |
| Audio System, quick guide _____ | 85 |

| | |
|---|-----|
| Autochecking of lights on starting _____ | 56 |
| Automatic climate control (ACC) _____ | 72 |
| Automatic transmission, technical data _____ | 254 |

B

| | |
|---------------------------------------|-----|
| Battery _____ | 199 |
| Battery charging/replacing _____ | 200 |
| Battery, boost starting _____ | 182 |
| Belt guide _____ | 12 |
| Boost starting using jump leads _____ | 182 |
| Booster cushion _____ | 27 |
| Brake and clutch fluid _____ | 197 |
| Brake-fluid reservoir _____ | 197 |
| Brakes, technical data _____ | 255 |
| Bulbs, changing _____ | 204 |
| Bulbs, table of _____ | 215 |

C

| | |
|--|-----|
| CD changer _____ | 95 |
| CD player _____ | 93 |
| CHECK messages _____ | 63 |
| CHECKING _____ | 63 |
| Calibration, ACC _____ | 80 |
| Cancelling the programmed settings _____ | 78 |
| Car alarm _____ | 43 |
| Car care _____ | 187 |
| Cargo net, 9-5 Wagon _____ | 139 |
| Carpeting, care of _____ | 232 |
| Cassette player _____ | 90 |

| | |
|--|--------|
| Catalytic converter, important considerations _____ | 150 |
| Central locking _____ | 38 |
| Change language in SID _____ | 64 |
| Change of address notification _____ | 246 |
| Changing a wheel _____ | 227 |
| Changing bulbs _____ | 204 |
| Changing the wheels round _____ | 223 |
| Changing wiper blades _____ | 202 |
| Chassis number _____ | 257 |
| Chassis number, key to _____ | 258 |
| Child safety _____ | 19 |
| Child safety locks, rear doors _____ | 41 |
| Child seat, integral _____ | 27 |
| Cleaning, engine bay _____ | 233 |
| Clock _____ | 63, 64 |
| Color code, body _____ | 257 |
| Color code, trim _____ | 257 |
| Compact spare wheel _____ | 226 |
| Condensation, ACC _____ | 81 |
| Coolant _____ | 196 |
| Courtesy Headlight Feature _____ | 66 |
| Cruise control _____ | 164 |
| Cup holder _____ | 131 |

D

| | |
|----------------------------|-----|
| DICE/TWICE _____ | 217 |
| Dampers _____ | 255 |
| Date code, tires _____ | 225 |
| Dim-dipped beam _____ | 65 |
| Direction indicators _____ | 67 |

| | |
|--------------------------------------|-----|
| Door handles _____ | 38 |
| Door mirrors _____ | 123 |
| Doors, locks & luggage compartment _ | 37 |
| Drive belt _____ | 253 |
| Drive belt, alternator _____ | 201 |
| Drive belts, length _____ | 253 |
| Driver's seat, programmable _____ | 120 |
| Driving in hot weather _____ | 173 |
| Driving with a load _____ | 178 |

E

| | |
|---|----------|
| Electric heating seat _____ | 121 |
| Electric heating, front seats _____ | 121 |
| Electric windows _____ | 125 |
| Electrical system, technical data _____ | 253 |
| Electrically heated rear seat _____ | 121 |
| Electronic Stability Program, ESP _____ | 168 |
| Electronic starting interlock _____ | 39 |
| Emergency operation of sunroof _____ | 127 |
| Emission control systems _____ | 191 |
| Engine bay, 3.0t V6 _____ | 190 |
| Engine bay, 4-cyl _____ | 189 |
| Engine bay, cleaning _____ | 233 |
| Engine number _____ | 257 |
| Engine oil, grade _____ | 251 |
| Engine, description _____ | 192, 193 |
| Engine, technical data _____ | 250 |
| Engine, temperature gauge _____ | 57 |
| Engine-oil level, checking _____ | 193 |
| Expansion tank, coolant _____ | 196 |

F

| | |
|--|-----|
| Fault codes, Audio System _____ | 103 |
| Flat spot, tire _____ | 230 |
| Fluid level, automatic transmission _____ | 195 |
| Folding the rear seat, 9-5 Sedan _____ | 132 |
| Folding the rear seat, 9-5 Wagon _____ | 135 |
| Frequently asked questions on airbag _____ | 35 |
| Front fog lights _____ | 68 |
| Frost warning _____ | 60 |
| Fuel _____ | 152 |
| Fuel consumption _____ | 59 |
| Fuel filler flap _____ | 143 |
| Fuel gauge _____ | 57 |
| Fuel grade _____ | 250 |
| Fuse box under hood _____ | 220 |
| Fuse panel _____ | 216 |
| Fuses _____ | 216 |

G

| | |
|--------------------------------|-----|
| Gearbox number _____ | 257 |
| Gearbox oil, checking _____ | 195 |
| Gearbox, technical data, _____ | 254 |
| Glove compartment _____ | 129 |

H

| | |
|-----------------------------|-----|
| Handbrake _____ | 185 |
| Hazard warning lights _____ | 68 |
| Head restraint _____ | 18 |
| Headlight flasher _____ | 65 |
| Headlights _____ | 65 |

| | |
|-------------------------|-----|
| Holidaying abroad _____ | 237 |
| Hood _____ | 188 |
| Horn _____ | 122 |

I

| | |
|------------------------------------|-----|
| Ignition switch _____ | 146 |
| Immobilizer _____ | 39 |
| Indicator and warning lights _____ | 50 |
| Indicator lights _____ | 50 |
| Instrument illumination _____ | 67 |
| Instruments and controls _____ | 49 |
| Integral child seat _____ | 27 |
| Interior equipment _____ | 117 |
| Interior lighting _____ | 69 |
| Interior rearview mirror _____ | 123 |

J

| | |
|------------|-----|
| Jack _____ | 228 |
|------------|-----|

K

| | |
|-----------------------------|-----|
| Key _____ | 38 |
| Key to chassis number _____ | 258 |
| Key, remove _____ | 146 |

L

| | |
|-----------------------------------|-----|
| LATCH (child safety) _____ | 20 |
| Labels _____ | 8 |
| Leather upholstery, care of _____ | 232 |
| Light horn _____ | 65 |

| | |
|------------------------------------|----|
| Light switches _____ | 65 |
| Luggage-compartment lighting _____ | 69 |

M

| | |
|--------------------------------------|-----|
| Main instrument panel _____ | 50 |
| Main/dipped beam _____ | 65 |
| Maintenance schedule _____ | 244 |
| Manual gearbox, technical data _____ | 254 |
| Maxi fuses _____ | 217 |
| Milometer _____ | 56 |
| Motoring abroad _____ | 237 |

N

| | |
|-------------------|----|
| Night Panel _____ | 63 |
|-------------------|----|

O

| | |
|----------------------------|-----|
| Oil capacity, engine _____ | 250 |
| Oil change, engine _____ | 194 |
| Oil specification _____ | 250 |
| OnStar _____ | 105 |
| Outdoor temperature _____ | 59 |
| Owner assistance _____ | 245 |

P

| | |
|------------------------------|-----|
| Paintwork, touching-in _____ | 234 |
| Parking Assistance _____ | 184 |
| Parking lights _____ | 65 |
| Plates and labels _____ | 257 |
| Poly-V-belt _____ | 201 |

| | |
|----------------------------|-----|
| Power steering _____ | 198 |
| Power-steering fluid _____ | 198 |
| Pressure gauge _____ | 58 |
| Programming I, ACC _____ | 78 |
| Programming II, ACC _____ | 79 |
| Programming the ACC _____ | 78 |

Q

| | |
|---------------------------------------|----|
| Questions on function of airbag _____ | 35 |
| Quick guide, Audio System _____ | 85 |

R

| | |
|---|-----|
| Radio _____ | 88 |
| Rain sensor _____ | 70 |
| Rear fog light _____ | 66 |
| Rear seat, 9-5 Sedan, folding _____ | 132 |
| Rear seat, 9-5 Wagon, folding _____ | 135 |
| Rear-seat head restraints _____ | 18 |
| Rear-view mirror, antidazzle _____ | 124 |
| Rearview mirrors _____ | 123 |
| Reclamation _____ | 237 |
| Recommendations for cars with automatic transmission, towing a caravan or trailer _____ | 174 |
| Refuelling _____ | 152 |
| Relay panel _____ | 219 |
| Remote control _____ | 38 |
| Remote-control battery, changing _____ | 40 |
| Remove the key _____ | 146 |
| Reporting safety defects _____ | 246 |

| | |
|---------------------------------------|-----|
| Reprogramming of systems _____ | 259 |
| Reservoir, power-steering fluid _____ | 198 |
| Rev counter _____ | 56 |
| Reversing lights _____ | 68 |
| Roof load _____ | 176 |
| Running-in _____ | 170 |

S

| | |
|--|-----|
| SID _____ | 59 |
| SRS (airbag) _____ | 29 |
| SRS, supplementary restraint system _____ | 29 |
| Saab 9-5 Audio System _____ | 83 |
| Saab Information Display (SID) _____ | 59 |
| Saab Parking Assistance _____ | 184 |
| Safety belts _____ | 12 |
| Safety belts, care of _____ | 232 |
| Safety-belt pretensioners _____ | 13 |
| Safety-belt reminder _____ | 12 |
| Seats _____ | 118 |
| Securing a load _____ | 41 |
| Selector lever indication, automatic transmission _____ | 59 |
| Service costs _____ | 245 |
| Service information _____ | 246 |
| Service intervals _____ | 244 |
| Service record retention _____ | 245 |
| Settings, seats _____ | 118 |
| Side airbags _____ | 32 |
| Signalling, horn _____ | 122 |
| Sliding floor, 9-5 Wagon _____ | 140 |
| Snow chains _____ | 171 |

| | |
|-------------------------------------|--------|
| Spare wheel _____ | 226 |
| Spare wheel and tools _____ | 142 |
| Spark plugs _____ | 253 |
| Speed rating _____ | 222 |
| Speedometer _____ | 56, 57 |
| Starting in cold weather, ACC _____ | 78 |
| Starting in hot weather, ACC _____ | 78 |
| Steering wheel adjustment _____ | 122 |
| Steering, technical data _____ | 255 |
| Stone-chip damage, repairing _____ | 234 |
| Storage compartments _____ | 129 |
| Sun visors _____ | 128 |
| Sunroof _____ | 126 |
| Suspension _____ | 255 |
| Suspension, technical data _____ | 255 |
| Switches _____ | 65 |
| Systems, adjustment _____ | 259 |

T

| | |
|---------------------------------|-----|
| TCS OFF _____ | 55 |
| Table of fuses _____ | 218 |
| Tachometer _____ | 56 |
| Tailgate, opening _____ | 41 |
| Tank gauge _____ | 57 |
| Technical data _____ | 247 |
| Telematics _____ | 105 |
| Temperature control, ACC _____ | 74 |
| Temperature gauge, engine _____ | 57 |
| Temperature zones, ACC _____ | 74 |
| Textile carpeting _____ | 232 |
| Through-load hatch _____ | 134 |

| | |
|--------------------------------------|----------|
| Tie Downs _____ | 134 |
| Tightening torque, wheel studs _____ | 227 |
| Tire markings _____ | 222, 223 |
| Tire pressure _____ | 178, 222 |
| Tires _____ | 222, 256 |
| Tools _____ | 142 |
| Touching-in the paintwork _____ | 234 |
| Towbar attachment _____ | 173 |
| Towbar load _____ | 175 |
| Towing the car _____ | 180 |
| Towing, automatics _____ | 180 |
| Traction _____ | 167 |
| Trailer weights _____ | 249 |
| Trionic _____ | 191 |
| Trip computer _____ | 59 |
| Trip meter _____ | 56 |
| Trunk _____ | 132 |
| Trunk lid, opening _____ | 41 |
| Turbo gauge _____ | 58 |
| Turbo, points to note _____ | 149 |

U

| | |
|------------------------------------|-----|
| Under the hood, 3.0t V6 _____ | 190 |
| Under the hood, 4-cyl _____ | 189 |
| Upholstery and trim _____ | 232 |
| Upholstery and trim, care of _____ | 232 |
| Useful tips, ACC _____ | 80 |

V

| | |
|----------------------|-----|
| Vanity mirrors _____ | 128 |
|----------------------|-----|

| | |
|------------------------------|-----|
| Ventilated front seats _____ | 121 |
| Viscosity, engine oil _____ | 250 |

W

| | |
|--------------------------------------|----------|
| Warning labels _____ | 8 |
| Warning light, AIR BAG _____ | 34 |
| Warning lights _____ | 50 |
| Washers _____ | 202 |
| Washers, windshield _____ | 203 |
| Washing the car _____ | 233 |
| Waxing and polishing _____ | 233 |
| Wear indicators, tires _____ | 224 |
| Wheel, change _____ | 227 |
| Wheels and tires _____ | 222, 256 |
| Wheels and tires, sizes _____ | 256 |
| Window glass sensor, car alarm _____ | 44 |
| Windshield washers _____ | 70 |
| Windshield wipers _____ | 70 |
| Wiper blades, replacing _____ | 202 |
| Wipers and washers _____ | 70, 202 |

