



Section 12 Electrical System

TABLE OF CONTENTS

Audio		Digital Ratio Adapter	12-74.1
Antenna System Test	12-157	Fuel System	
CD Changer (Delco) Replacement	12-140	Fuel Lift Pump Inoperative	12-44
Diagnosis-Delco Audio System	12-144	Fuel Lift Pump Schematic	12-46
Corrective Action	12-145	Fuel Manager Schematic	12-50
Identifying Concerns	12-144	Fuel Selector Valve Schematic	12-49
Electrical Harness Replacement, Delco Monsoon (Model 83, 84 & 91)	12-142	Fuel Tank Selector System Inoperative	12-47
Electrical Harness Replacement, Delco Standard (Model 89)	12-143	General Information	
Electrical Harness Replacement, Delco Standard (Model 90)	12-144	Auxiliary Power Point, Interior Fuse Box	12-10
Electrical Harness Replacement, Delco Standard (Model 83, 84 & 91)	12-143	Auxiliary Power Studs, Exterior Fuse Box	12-13
Generator Whine Concerns	12-146	Circuit Faults	12-4
Overhead Console, Speaker and Amplifier Replacement (Delco Monsoon)	12-140	Diagnostic Tests	12-5
Radio (Delco) Replacement	12-140	Fuse/Relay Location and Identification	12-10
Rear Seat Audio (RSA) Unit Replacement	12-141	Ground Points	12-13
Symptom Table	12-151	Preliminary Checks	12-3
System Description	12-139	Glow Plugs	
Test Antenna	12-146	Diagnostics	12-40
Battery		Schematic	12-43
Battery Charging	12-14	Heated Glass	
Cable Maintenance	12-16	Both Heated Windshields Inoperative	12-92
Power Distribution	12-21	Heated Windshield Schematic	12-93
Replacement	12-18	Left Heated Windshield Inoperative	12-90
Splash Shield and Seal Service	12-19	Rear Window Defroster Inoperative	12-94
Tray Replacement	12-18	Rear Window Defroster Schematic	12-95
Brake Shift Interlock System		Right Heated Windshield Inoperative	12-91
Brake Shift Interlock Cable Inoperative	12-51	Horn	
Ignition Switch Replacement	12-51	Horn Replacement	12-61
Shift Interlock Cable Schematic	12-52	Horn Schematic	12-63
Charging System		Horns Inoperative	12-62
Alternator	12-22	HVAC Systems	
Alternator Overhaul	12-23	HVAC Blower Schematic	12-80
Diagnostics	12-28	HVAC Compressor Inoperative	12-75
Cigarette Lighter Replacement	12-68	HVAC Compressor Schematic	12-82
Cruise Control		HVAC Main Blower Inoperative ALL BUT High	12-75
Cruise Control Inoperative VIN Z	12-135	HVAC Temp Blend Door/Rear Blower	12-81
Cruise Control Schematic	12-137	HVAC Temperature Door Inoperative	12-77
Cruise Control Systems	12-134	Instrument Panel	
CTIS		Engine Temperature Gauge Inoperative	12-73
CTIS Compressor Inoperative	12-53	Fuel Gauge Inoperative	12-72
CTIS Exhaust Valve Inoperative	12-54	Gauge Replacement	12-65
CTIS Front Inflate Valve Inoperative	12-55	Gauges and Switches	12-64
CTIS Rear Inflate Valve Inoperative	12-56	Gauges Schematic	12-74
CTIS Schematic	12-57	Low Coolant Lamp Inoperative	12-69
		Oil Pressure Gauge Inoperative	12-71
		Replacement	12-64
		Lighting Systems	
		Key/Headlight Chime Schematic	12-60
		Lights Schematic	12-58



Power Locks

Cargo Door Lock Inoperative	12-113
Front Door Harness Replacement	12-120
General Replacement	12-102
Keyless Entry & Theft Deterent System Operating Instructions	

Instructions

Keyless Entry Programming	12-108
Keyless Entry System Features	12-106
Power Locks HMC4, XLC2, HMSB	12-117
Power Locks HMCS W/ Remote Entry	12-115
Power Locks Inoperative	12-110
Rear Door and Jumper Harness	12-121
Remote Entry Module Power/Ground	12-119
Remote Entry System Inoperative	12-114
Slant Door Lock Inoperative	12-112

Power Mirrors

Ambient Temperature Sensor	12-131
Auto-Dimming Compass Mirror Calibration and Zone Adjustments	12-129
Auto-Dimming Rear View Mirror	12-129
Compass Mirror Display Inoperative	12-132
Compass Mirror Schematic	12-133
Power Side Mirror	12-134.1

Power Window and Door Locks

Front Door Harness Replacement	12-123
--------------------------------	--------

Power Windows

Power Window Schematic	12-101
Power Windows Inoperative, All Windows	12-96

Power Windows and Door Locks

Rear Door Harness Replacement	12-126
-------------------------------	--------

Starter

Diagnostics	12-37
Overhaul	12-31

Windshield	12-83, 12-84
------------	--------------

Wipers

Rear Window Wiper Inoperative	12-87
Rear Wiper Motor Schematic	12-89
Windshield Wiper Motor Inoperative All Speeds	12-83
Windshield Wipers Intermittent Speeds Inoperative	12-84
Wiper/Washer Schematic	12-86



DIAGNOSTICS

The following section of the service manual deals with electrical diagnostics. The section consists of three main tools:

1. Diagnostic charts
2. Wiring diagrams
3. Connector legend

Diagnostic Charts

Diagnostic charts are designed to take you through individual steps to locate a problem. The steps start at a point in the electrical system and progress to find the problem without overlooking items that may be contributing to the problem. In most cases the chart will refer to a wiring diagram, and connector callouts, both of which are provided for reference. The charts are designed to find problems which are current, not intermittent. These charts do not include preliminary visual checks. The preliminary checks must be done prior to using the charts for diagnosis. If the checks are not done, a simple problem such as a blown fuse may be overlooked.

Wiring Diagrams

Wiring diagrams give a visual representation of the vehicle wiring the diagnostic charts refer to. The wiring diagrams in this section are broken down into systems. The diagrams will include any part of the electrical system which pertains to the system being diagnosed. Refer to the connector legend for connector identification of system connectors.

Connector Legend

The connector legend is a reference library of all the vehicle connectors that are called out in the wiring diagrams. Included are drawings of both male and female connector halves called out with pin/cavity arrangement, and a listing of all included circuits.

Preliminary Checks

The diagnostics in this section are designed to find problems that are not obvious. Before starting any formal diagnostic chart, preliminary checks must be performed. Preliminary checks should include:

- Visual inspection of all components
- Inspection of any fuses related to the system
- Connector inspection
- Inspection of electrical harnesses
- Charging system and batteries

These types of checks are not included in the diagnostic chart. In fact, most of the charts rely on the fact that you, the technician, has performed these initial inspections.

Diagnostic Strategy

Whenever a vehicle is being diagnosed for a problem, a strategy should be used. The following charts are strategy based, meaning they all follow the principle of starting simple and

working step by step to more complex tests. This allows problems which may be small in nature to be found quickly, and not overlooked. NEVER skip steps in a diagnostic chart. Each step relies on a previous step for correct diagnosis. Avoid random diagnostics and parts replacement which can lead to long, expensive diagnostic times and may not reveal the problem.

Intermittent Failures

ALL of the charts in this section are for use on current failures. Do not attempt to use these charts to diagnose a problem unless you are sure the problem currently exists. If the problem is intermittent, parts will be unnecessarily replaced, or no problem will be found.

BASIC ELECTRICAL CIRCUITS

WARNING: *When removing battery cables, disconnect ground cable first. Ensure all switches are off before disconnecting battery ground cable*

General

An electrical circuit is a number of electrical devices which are connected in a loop from a positive voltage source (battery positive) to a negative ground source.

Parallel Circuits

The Hummer electrical system is a parallel circuit. In a parallel circuit, the electrical devices form more than one current path to and from the power supply. The supply voltage is the same in each path.

Circuit Components

A normal circuit path starts at the power supply (battery system or alternator). Next in line is the circuit protection: fusible link, fuse, or circuit breaker. The circuit load, such as lights, motors, or solenoids completes the circuit to the ground system.

Circuit protection devices

Fusible Links

A fusible link is a section of wire, usually two gauge sizes smaller than the circuit it protects. If the current rating of a fusible link is compromised, the fusible link will melt open. A special insulation prevents wire fires, and swells when heated to indicate the position of the open in the wire.

Circuit Breakers

Circuit breakers are electrical mechanical devices that will act as a fuse to prevent excess current flow in a circuit. Unlike fuses, the mechanical opening of contacts stops current flow. The contacts will reset in a short period of time. This process will repeat until the current excess is stopped.



Fuses

The most common protector in the vehicle electrical circuit is a fuse. A fuse is a metallic connector within a circuit that is made of a low melting point metal that acts as a “weak link”. If current rises above the fuses’ rating, the metal will melt and separate, leaving an open. The fuse is surrounded by a non flammable plastic covering, and will limit current to a specific amperage. Fuses can be found in range from 1A to 30A, and be mini or maxi types. All fuses used on the HUMMER® are blade type.

Circuit Controllers

Circuit controllers are used to turn the current off and on in a circuit. Controllers can be mechanical or solid state.

Solid state controllers combine the use of semi conductors along with electromechanical devices to control current in a circuit. Solid state controllers are typically associated with computers, and engine control systems. Most solid state controllers are specific to a purpose.

Mechanical controllers are the most common type, and can be seen as switches or relays. Switches are a primary controller while relays are typically secondary controllers.

Primary mechanical controllers are very simple contacts that are either open or closed, and can be changed state. Primary controllers are usually limited in their ability to handle large current flows due to the restriction of size.

Secondary mechanical controllers are used in conjunction with the primary controllers to handle larger current draws in a circuit. Primary controllers are used to operate the secondary controllers from a remote location, placing less or no restriction on

the size of a secondary controller. The secondary controller is usually a relay.

Circuit Faults

The following are the four electrical fault conditions that cause a malfunction in a circuit: open, short, short to ground, and high resistance connection

Open

An open circuit occurs whenever there is a break in the circuit continuity. The break can be caused by a connector disconnect, a broken wire, or a defective component (Figure 12-1).

Short

A short circuit happens when the current bypasses part of the normal circuit. This bypassing is usually caused by wire pinching or chaffing. Usual symptoms are inappropriate activation or deactivation of a load device (Figure 12-2).

Short To Ground

A grounded circuit is also a short circuit, except the current flows directly to ground with very little restriction. This is usually caused by wire pinching or chaffing against the frame or body (Figure 12-3).

High Resistance Connection

A high resistance connection is an electrical connection that is corroded or loose. High resistance connections cause a decrease in current flow that can affect the proper operation of an electrical load.

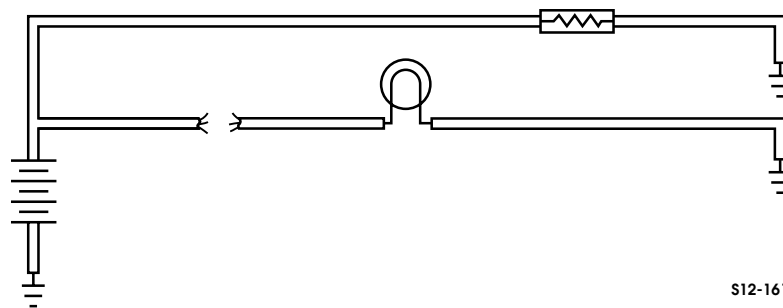

Figure 12-1: Open Circuit

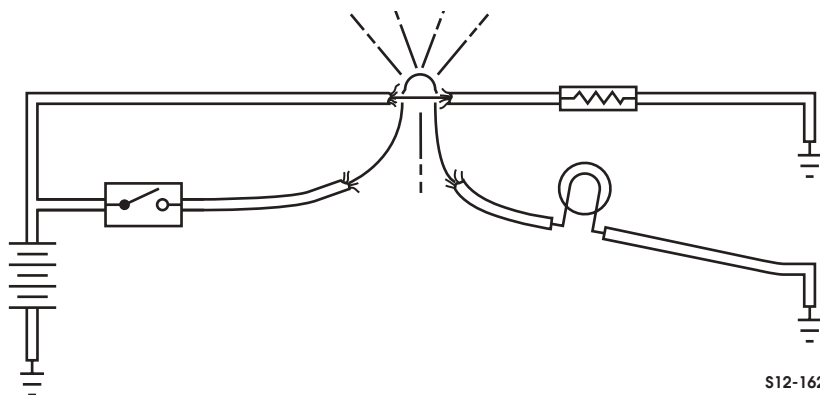

Figure 12-2: Short Circuit

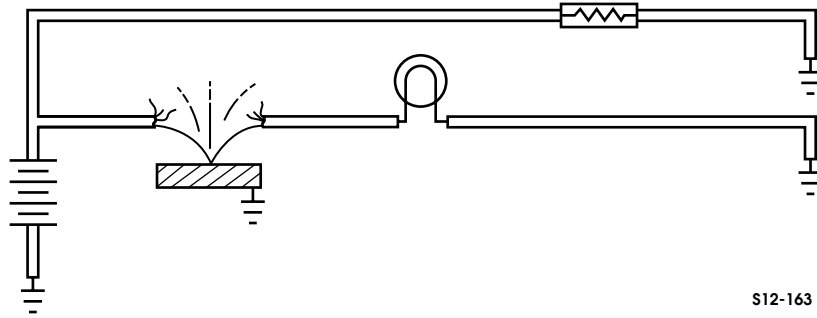

Figure 12-3: Grounded Circuit

DIAGNOSTIC TOOLS

Digital Multimeter

A digital multimeter (J-39200) is required to safely test for electrical malfunctions on the Hummer. Due to the complexity of the electrical system, a test light should not be used to test electrical circuits.

- Test lights do not have current limiting capabilities. The use of a test light may actually cause an electronic component to fail.
- Sharp test light probes may break wire strands, causing circuit failure.
- Breaks in the insulation allow moisture and contaminants to enter connectors and components, increasing the chances for corrosion. Even a small increase in resistance can give false readings from a sensor to an electronic component.

A digital multimeter performs all the tests a test light can perform with a greater degree of accuracy. In addition, a multimeter can be used to test for current in a circuit.

DIAGNOSTIC TESTS

NOTE: Follow all manufacturer's recommendations when testing for current. All multi-meters have a maximum current rating. Not all multimeters contain a fuse that protects the multimeter from excess current draw.

Amperage Test

Use caution when testing for current. Always check multimeter owner's manual for maximum current to be tested. Most multimeters are fuse-protected when measuring current. However, some meters are not protected and therefore can be damaged by excessive current. Position multimeter leads after closed switch and before load (Figure 12-4).

Voltage Test

Multimeters have a number of different voltage scales to choose from. Always use the lowest scale possible to test the

circuit. For example, if you select the 200 volt scale and you are testing for battery voltage, most multimeters will display 12 volts. By selecting the next smallest scale, 20 volts, the display will read 12.8 volts, a more accurate measurement. Position multimeter leads on each side of the load (Figure 12-5).

OHM Test

CAUTION: Before using a multimeter, ensure the circuit is not energized. Even a small voltage applied to an multimeter will damage it.

Continuity - Testing for continuity in a circuit requires the use of the lowest ohm scale available. Position the multimeter leads on each side of the circuit or component being tested. A reading of less than one ohm is acceptable continuity (Figure 12-6).

Resistance - To test for resistance, first touch the meter leads together to ensure that the meter zeros out, then position the leads of the multimeter on each side of the circuit or component. Adjust the multimeter ohm setting until an acceptable reading is observed. Verify the reading with the specification.

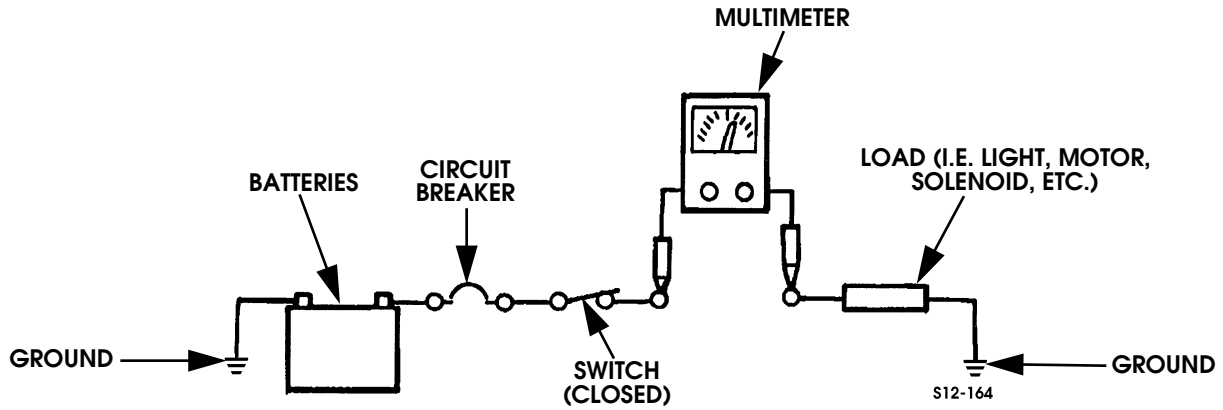

Figure 12-4: Amperage Test

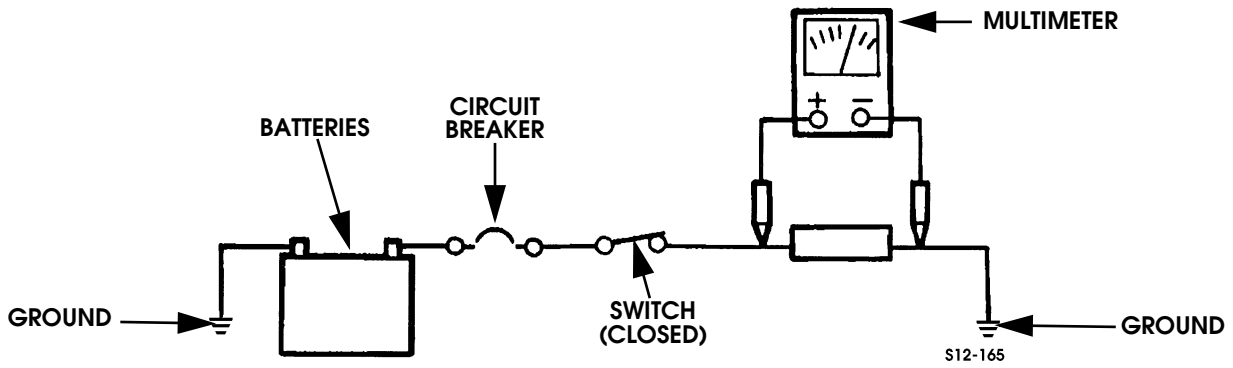

Figure 12-5: Voltage Drop Test

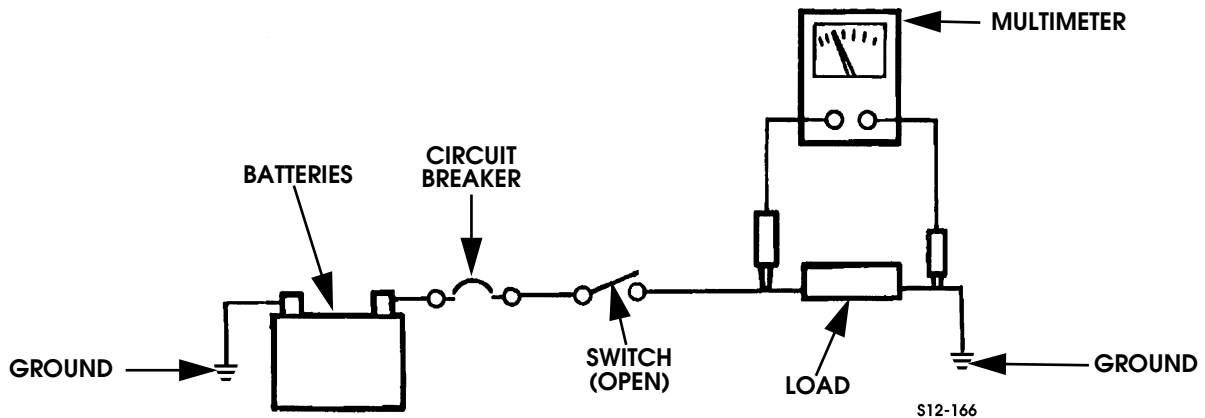

Figure 12-6: Ohm Test



CIRCUIT MAINTENANCE AND REPAIR

All electrical connections must be kept clean and tight. Loose or corroded connections may cause a discharged battery, weak starting, dim lights, or possible electrical system damage.

Wires must be replaced or repaired if insulation becomes burned, cracked, or deteriorated. When replacing a wire, it is important that the same gauge size wire be used. Refer to wiring diagram for proper wire gauge sizes. Never replace a wire with one of a smaller size or replace a fusible link wire with a wire of a larger size. It should also be noted that fusible link wire utilizes a special insulation covering. When replacing a fusible link wire, the replacement wire should be the type in accordance with SAE J156. Further, fusible link wire should never be shortened or spliced. If a repair is necessary, entire fusible link wire must be replaced with one of the proper gauge size, length and insulation type.

Any wire repair must maintain the waterproof integrity of the vehicle. Any splice located below the 30 in. (76 cm.) fording level or in a high splash area must be waterproof and heavy duty adhesive wall shrink tubing should be used as a minimum in these areas.

Each harness or wire must be held securely in position to prevent damage to insulation caused by vibrating and chafing.

NOTE: Before performing any wire repair, disconnect battery ground cable.

Ground Point Legend

- G1 - Engine ground-Intake Manifold
- G2 - Ground Buss Exterior Fuse Box
- G3 - Body Ground
- G4 - Instrument Panel Ground Buss Interior
- G5 - Frame Ground

Wiring Repair

Wiring harness and wires - All wires are of a specific insulation color indicated on the wiring diagrams. Insulation color helps to identify circuits and make correct connections. Insulation colors and their abbreviations are as follows:

BK - Black	PK - Pink
BR - Brown	PP - Purple
DB - Dark Blue	RD - Red
DG - Dark Green	GY - Gray
TN - Tan	LB - Light Blue
WH - White	LG - Light Green
YL - Yellow	OR - Orange

Wire repair is very important for the continued, reliable operation of the vehicle. This repair must be done as described in the following procedure:

Single Wire Repair (Exposed)

1. Remove damaged area, removing as little wire as possible (Figure 12-8).

NOTE: Care should be exercised in stripping the wire insulation to avoid cutting wire conductor strands.

2. Strip wire ends to the appropriate length required by the splice clip (Figure 12-9).

NOTE: Heat shrink tubing is available in various diameters. Typically the heat shrink tubing will shrink to approximately one-half of its original diameter, therefore the tubing diameter selected for the repair should not be greater than twice the wire insulation diameter to ensure a proper seal.

3. Slide heat shrink tubing over one of the wire ends (Figure 12-10).

NOTE: Splice clips are available for different wire gauge sizes. Therefore, it is important to select the appropriate size for the wire gauge being repaired.

4. Slide both ends of wire into splice clip and crimp splice clip to wire ends (Figure 12-11).
5. Pull wires, by hand, in opposite directions to test the crimp of the splice clip.
6. Center heat shrink tubing over splice clip (Figure 12-12).
7. Using a heat gun or equivalent heat source, apply heat to heat shrink tubing until tubing conforms to splice clip and wire insulation (Figure 12-13).
8. After the splice cools, apply two layers of vinyl adhesive electrical tape to complete the repair (Figure 12-14).

Single Wire Repair (In a Harness)

1. Remove harness covering in the affected area (Figure 12-15).
2. Repair damaged wire using the exposed single wire repair procedures. (Go to Step 1.)
3. After completing the wire repair, apply two layers of vinyl adhesive electrical tape over the affected area to complete the repair (Figure 12-16).

Multiple Wire Repair (In a Harness)

NOTE: Since more than one splice is required in this case, stagger the wire splices such that they are no closer than 3 in. (7.6 cm) from each other.

Repair affected wires using the single wire repair (in a harness) procedures.



FUSIBLE LINK MAINTENANCE

The following procedure covers the replacement of fusible links encountered through circuit diagnosis.

1. Disconnect battery ground cable.
2. Carefully remove old fusible link from termination (alternator, power stud, starter).
3. Locate original wiring harness splice between fusible link and wiring harness (Figure 12-7).
4. Cut fusible link splice on harness side. Do not splice into original fusible link; this may be weakened and cause a premature failure and repeat problem.
5. Identify the original fuse link size and length of fuse link cut from vehicle.
6. Matching the wire size, cut a length of fusible link wire to the total length cut from vehicle in Step 4. Be sure to compensate for any harness wire removed with original wire. This will avoid overtight wiring that may become separated with normal operation.
7. Install a new crimp on connector of the same type and size as the original lug or connector. Seal connection with low temperature heat shrink tubing.
8. Place a piece of heat shrink tubing onto the wire and install a butt connector onto the fusible link.
9. Install the fusible link by connecting it to the wiring harness with the butt connector and heat shrink tubing.
10. Connect terminal end to original location, alternator, power stud, or starter. Reconnect battery ground cable and check circuit(s) affected for proper operation.

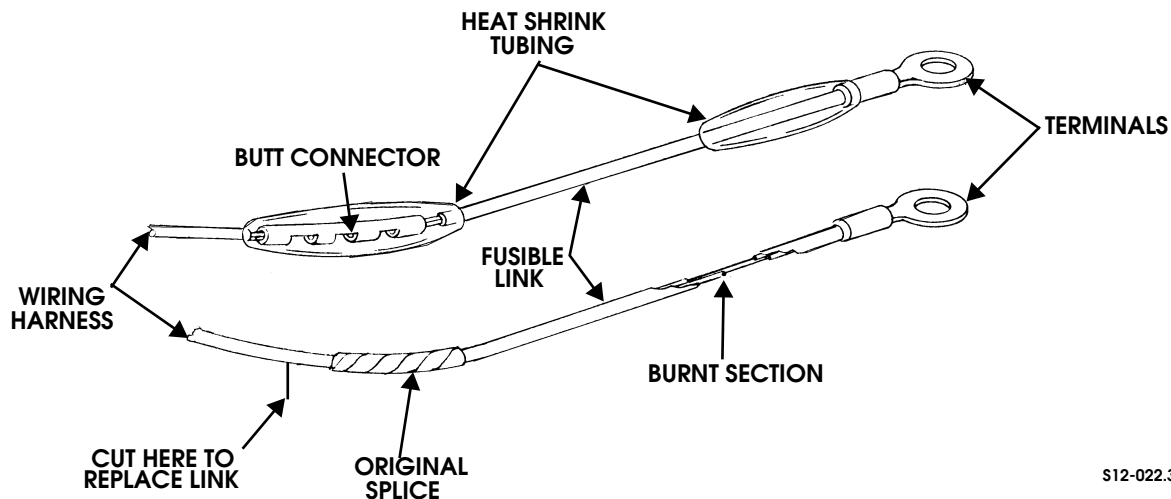

S12-022.3

Figure 12-7: Fusible Link

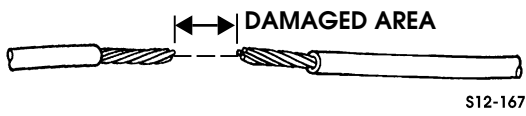

Figure 12-8: Damaged Wire

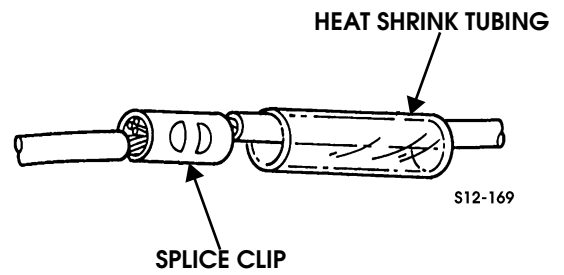

Figure 12-13: Splice Clip

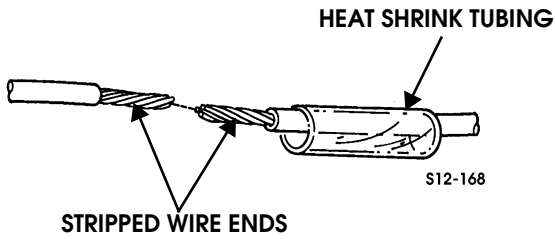

Figure 12-9: Heat Shrink Tubing

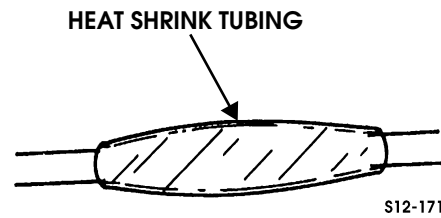

Figure 12-14: Heat Shrink Tubing

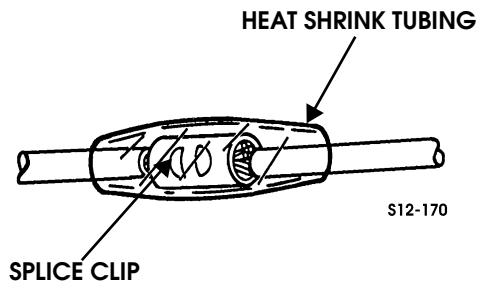

Figure 12-10: Splice Clip

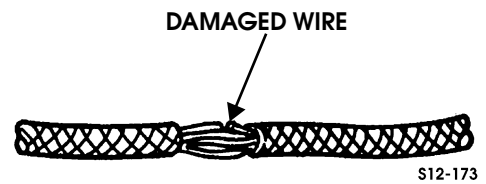

Figure 12-15: Damaged Wire

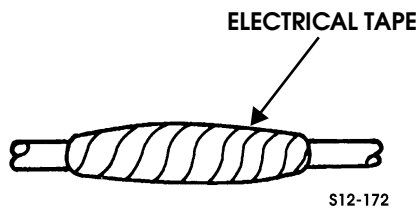

Figure 12-11: Electrical Tape

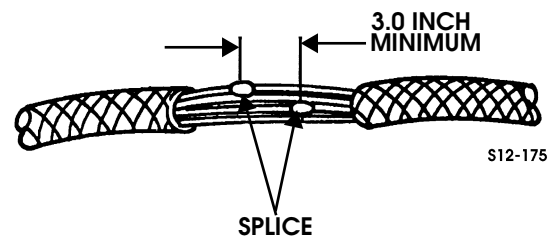

Figure 12-16: Multiple Wire Splice

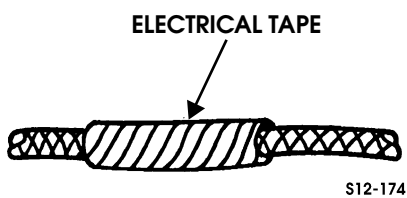

Figure 12-12: Electrical Tape



FUSE/RELAY LOCATION AND IDENTIFICATION

Interior Fuse Box

The interior fuse box, is located under the instrument panel to the left of the steering column. The fuse box is divided into two mini-fuse junction blocks, relays, and a auxilliary power point. The mini-fuse blocks may be accessed without removing the main fuse box cover (Figure 12-17).

To access relays, the main fuse box cover must be removed. Before removing any of the fuse box access covers, refer to the illustrations and charts in this section for the location of specific fuses, relays, and circuit breakers. Doing this will enable you to go directly to the fuse or circuit breaker you want to inspect.

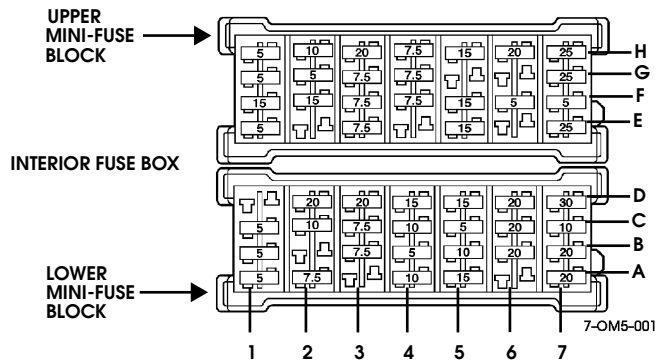
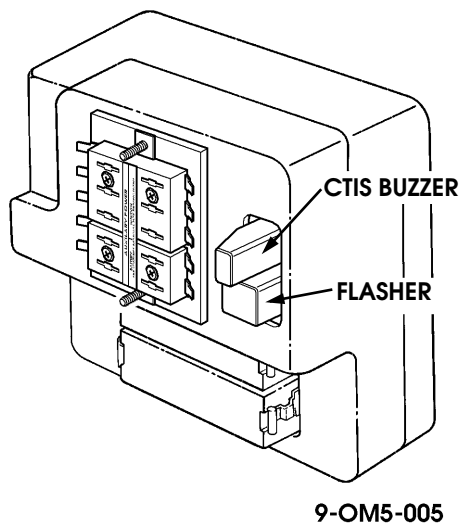

Figure 12-17: Interior Fuse Box and Mini Fuse Layout

Fuses and circuit breakers protect the vehicle's electrical system from damage caused by overloading. An overloaded circuit breaker will switch the circuit on again, causing intermittent operation. A blown fuse will permanently disable the circuit until the fuse is replaced.

Whenever a fuse blows or a circuit breaker opens a circuit, all electrical components using that circuit will not operate. Therefore, during diagnosis of any of these electrical components, check the appropriate fuses and circuit breakers for damage (Figure 12-20).

In Line Fuses

Some fuses are placed in-line with the components they are protecting, meaning they are not located in the fuse box but in the actual wire supplying current to the device. The only inline fuse used on the Hummer is in the power feed to the HVAC high blower relay. This fuse is located on the passenger side of the engine compartment inside a black plastic cover.

Auxiliary Power Point

An auxiliary power point is provided to ease installation of after-market electrical accessories. The power point is divided into 2 sections: Ignition and Battery. When a power supply is needed, a fuse must be installed into one of the empty slots, and a connection made to the adjacent terminal. The main supply circuits to both sections of the aux. power point are fused to 30 amps. Total amperage draw on either section should not exceed 30 amps.

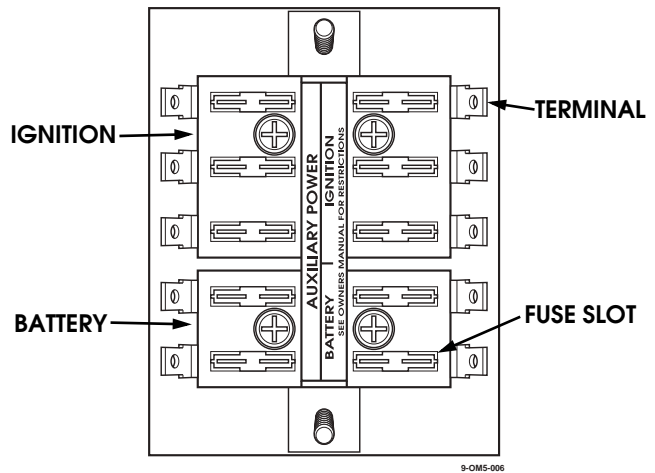
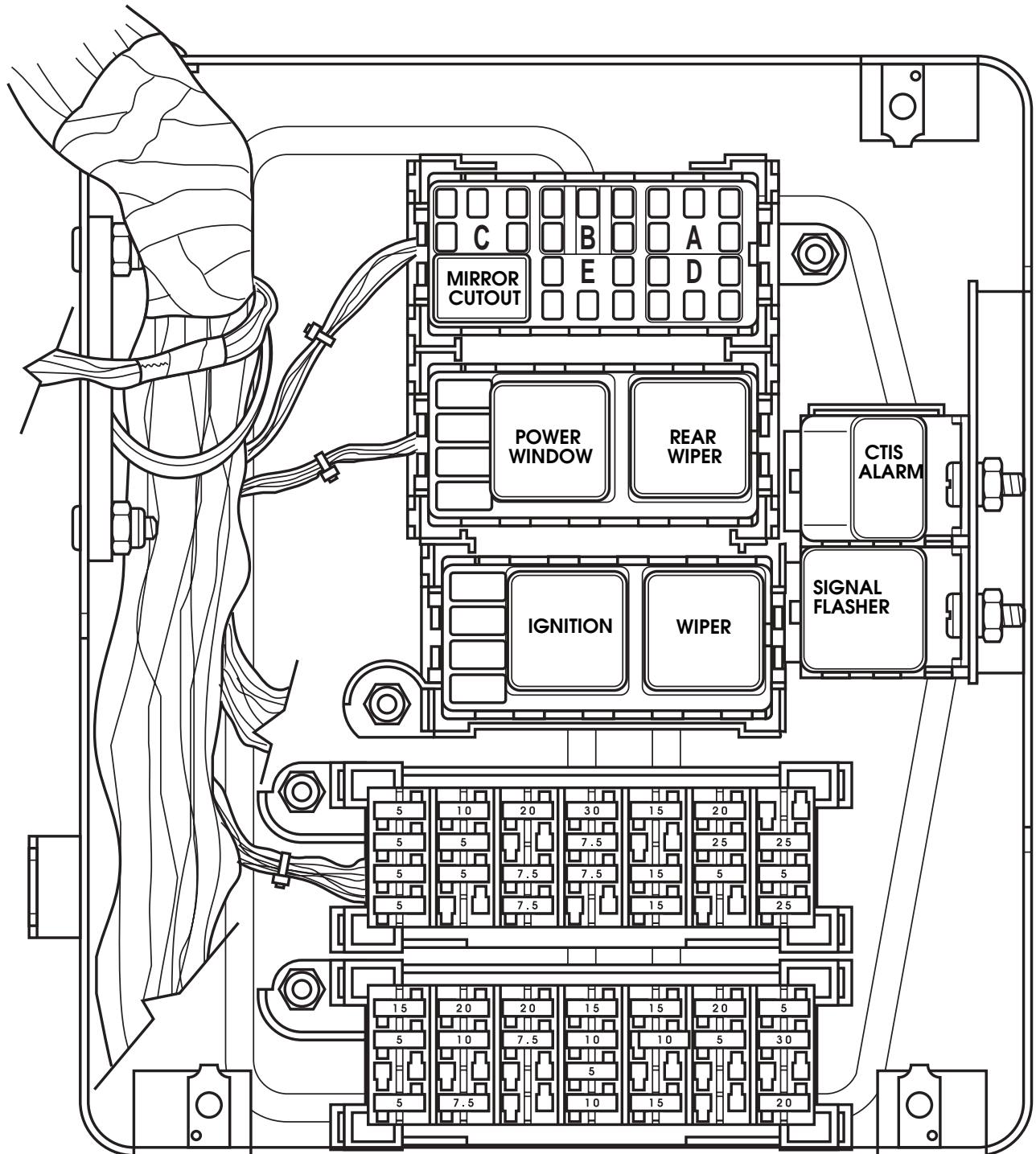

Figure 12-18: Auxiliary Power Point



9-S12-083

Figure 12-19: Relay Location (Interior Fuse Box)



Upper Mini-Fuse Location

FUSE	AMPERAGE	CIRCUIT PROTECTED
1E	5	Spare Fuse
2E	–	Blank
3E	7.5	Spare Fuse
4E	–	Blank
5E	15	Spare Fuse
6E	–	Blank
7E	25	Spare Fuse
1F	5	Radio Lights
2F	5	Panel Lights Dimmer Module
3F	7.5	Front Parking/Running Lights
4F	7.5	Rear Parking/Running Lights
5F	15	Trailer Lights
6F	5	Underhood and Trouble Lights
7F	5	Light Circuit to Chime
1G	5	CTIS/Key Chime
2G	5	Power Windows
3G	30	Auxilliary Power Point (Ignition)
4G	7.5	Radio Ignition
5G	–	Blank
6G	25	Rear Wiper/Washer (Slant Back Only)
7G	25	Windshield Wiper/Washer
1H	5	DLC Power Terminal 16
2H	10	Radio Memory/Clock
3H	20	Power Door Locks/Power Mirror/ Remote entry Battery
4H	30	Auxilliary Power Point (Battery)
5H	15	Dome/Courtesy Lights
6H	20	Auxiliary Power Outlet (console)
7H	25*	Trailer Brake Controller

Lower Mini-Fuse Location

FUSE	AMPERAGE	CIRCUIT PROTECTED
1A	5	Spare Fuse
2A	7.5	Spare Fuse
3A	–	Blank
4A	10	Spare Fuse
5A	15	Spare Fuse
6A	–	Blank
7A	20	Spare Fuse
1B	–	Blank
2B	–	Blank
3B	–	Blank
4B	5	Gauges/Indicator Lights/MIL
5B		Blank
6B	5	Transmission Brake Switch
7B	5	Remote entry igniton Feed
1C	5	Transmission Shifter Lock/ Heated Windshield
2C	10	A/C Clutch/Rear Defrost/ HVAC Ignition Feed Relay
3C	7.5	Backup Lights
4C	10	Turn Signals
5C	10	Cruise Control
6C	20	HVAC System
7C	30	HVAC Blower
1D	15	Radio Amplifier-Monsoon only
2D	20	PCM Battery/Fuel Lift Pump
3D	20	Cigar Lighters
4D	15	Stoptlights
5D	15	Flashers
6D	–	Blank
7D	5	Compass Mirror Battery Feed

*May not be provided.

Figure 12-20: Mini Fuse Identification (Interior Fuse Box)



Exterior Fuse Box

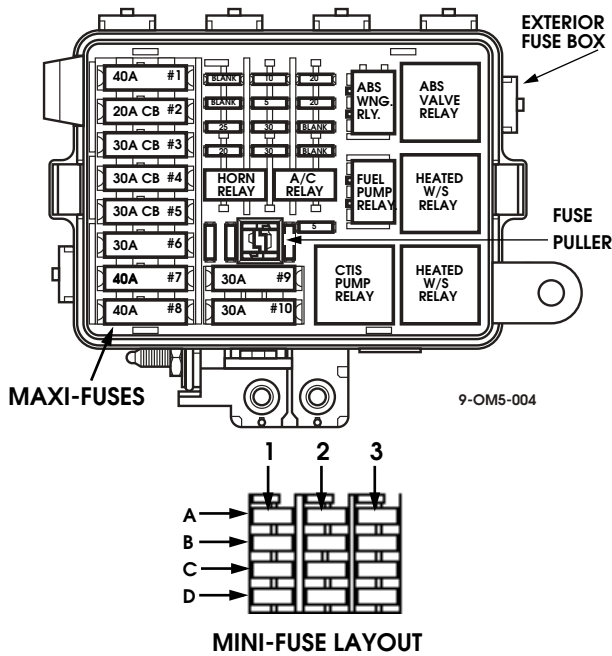

Figure 12-21: Exterior Fuse Box

The exterior fuse box is located under the hood on the driver's side of the engine compartment. The exterior fuse box houses mini and maxi fuses, circuit breakers, and relays which supply power to many of the electrical components in the engine compartment. The exterior fuse box can be accessed by first removing the left side cowl cover then removing the fuse box cover itself. Fuse and relay locations are labeled on the inside of the cover. Spare mini fuses are located in the exterior fuse box for convenient replacement. A fuse puller is also provided to ease fuse removal.

FUSE	AMPERAGE	CIRCUIT PROTECTED
1A	-	Blank
2A	10	PCM Ignition Feed
3A	20	Engine Ignition Feed
1B	-	Blank
2B	5	ABS Controller
3B	20	Engine Ignition Feed
1C	25	ABS Valve Relay
2C	30	Heated Windshield
3C	-	Blank
1D	20	Horn
2D	30	Heated Windshield
3D	-	Blank

Figure 12-22: Mini-Fuse Identification (Exterior Fuse Box)

Fuse/ CB	Amperage	Circuit Protected
1	40A	Starter Circuit
2	20A CB	Parking Lights
3	30A CB	Headlights
4	30A CB	Rear Defrost
5	30A CB	Power Windows
6	30A	CTIS Compressor
7	40A	ABS/TT4 Hyd. Pump
8	40A	Ignition Switch Batt Feed
9	30A	Auxiliary power stud A
10	30A	Auxiliary power stud B

Figure 12-23: Maxi-Fuse Identification (Exterior Fuse Box)

Auxiliary Power Studs

The external fuse box provides 2 threaded studs for use as auxiliary power connections. Each stud is fused for up to 30 amps with maxi-fuses located in the external fuse box. Both studs provide battery power.

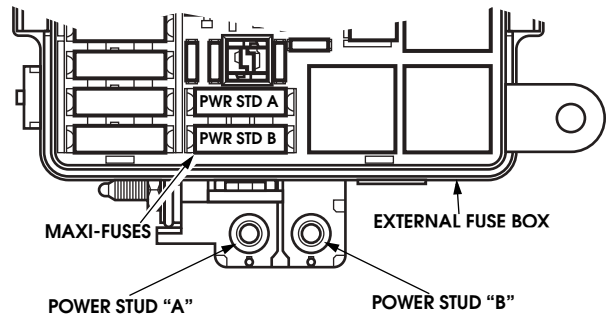

Figure 12-24: Auxiliary Power Studs

Ground Points

Two main grounding points are provided to ground vehicle systems and add-on items. The main grounding stud is located on the driver's side of the engine compartment next to the exterior fuse box. The second grounding point is located to the left of the instrument panel on the interior of the vehicle.

NOTE: Never drill holes in the body to ground electrical items, the corrosion resistance is compromised, and bad grounding could result.



BATTERY CHARGING

General Information

A low charge or discharged battery can be recharged as long as the cells are not shorted, sulfated, or damaged. Batteries can be recharged quickly at 20 amp charge levels, or for longer periods at 10, 5, or 2 amps. A 5 amp charge is preferable.

The battery charger should be equipped with a polarity sensor to avoid damage through incorrect hookup. Charger capacity should range from 5 to 20 amps for slow and fast charge rates.

The time and amp rate of charge required will vary depending on battery condition and temperature. Generally, it takes longer to recharge a cold battery. State of charge will also affect charging time as a partially discharged battery may only require one third the charge time of a fully discharged battery. There are a number of safety precautions that must be observed before charging a battery. The following precautions are necessary to avoid personal injury:

Battery Charging Precautions

- Battery electrolyte contains sulfuric acid which can cause severe burns. Avoid contact with electrolyte by wearing protective gloves and a face shield. Flush skin or eyes with water if contact occurs and seek medical assistance immediately.
- Always wear eye and facial protection when connecting charging equipment.
- Never attempt to charge a frozen battery. The case could fracture at the first surge of current.
- Never charge a battery with a low electrolyte level. Internal arcing and battery explosion could occur.
- Never exceed a 20 amp charge with a cold battery. Use a lower (5-10 amp) rate until the battery warms up.
- Never use excessive charge rates. Reduce charge rate if the battery becomes overly warm, or if a steady stream of gas starts to exit the vents.
- Do not use high charge rates on a completely discharged battery. Use low rates or a trickle charge only.
- Never allow sparks, or an open flame near a charging battery. The charging process generates hydrogen gas which is highly inflammable.
- Charge batteries in properly ventilated areas only. Do not allow hydrogen gas to accumulate and concentrate in poorly ventilated areas.

Charge Rate and Time

Charge rate will depend on battery temperature and degree of discharge. Ideally, charging should not proceed until battery temperature has reached 60°F (16°C). However, in cases where a cold battery must be charged, start with a 5 amp rate and increase it as battery temperature rises.

In the case of a fully discharged battery, a 24 hour trickle charge of 1-2 amps is recommended. A 20 amp charge rate should be used when a battery is only partially discharged.

Suggested charge times are outlined in the charge rate chart (Figure 12-25). Note that the chart suggested times and rates are for a battery at 70°F (21°C). Charge times will be greater if battery temperature is below 55°F (13°C).

No-Load Test Voltage	CHARGE RATE		
	5 Amps	10 Amps	20 Amps
12.25 to 12.39	6 Hrs.	3 Hrs.	1.5 Hrs.
12.00 to 12.24	8 Hrs.	4 Hrs.	2 Hrs.
11.95 to 12.09	12 Hrs.	6 Hrs.	3 Hrs.
9.80 to 11.95	14 Hrs.	7 Hrs.	3.5 Hrs.

6-S12-105

Figure 12-25: Charge Rate Chart

Battery Checking Procedures

Visual Inspection

Check for obvious damage, such as a cracked or broken case or cover or overcharging of the electrical system that could permit loss of electrolyte. If obvious damage is noted, replace the battery.

Load Test

Before proper testing, the battery must be in a fully charged state to obtain an accurate test. Load testing requires the use of battery side terminal adapters to ensure good connections. Do not attempt to load test a side post battery by screwing bolts into the terminals as connections.

NOTE: When load testing, batteries must be disconnected from each other.

1. Using a battery load tester, measure voltage across the battery terminals. Normal battery voltage should be 12v or higher. Recent cranking or load testing will lower the normal voltage. If no cranking or load testing has been performed, and battery voltage is below 12v, replace the battery.
2. Connect battery load tester to the battery to be tested. If battery has been recently charged, apply a 300 amp load for 15 seconds to remove the surface charge. Skip this step if the battery has not been charged.
3. Wait 15 seconds for the battery to recover. Apply the necessary load test for the battery being tested. The load required should be listed on the battery label, if it is not, use the cold crank amperage divided by 2. (300 cca/2=150 cca) This load should be applied for 30 seconds
4. If the voltage does not drop below the minimum value, the battery is good and should be returned to service. The battery temperature must be estimated by feel and by the temperature the battery has been exposed to for the proceeding few hours. If the battery has been exposed to temperatures below ambient, use the chart below to adjust the minimum test voltage (Figure 12-26).



Estimated Temperature	Minimum Voltage
70°F(21°C)	9.6
50°F(10°C)	9.4
30°F(0°C)	9.1
15°F(-10°C)	8.8
0°F(-18°C)	8.5
0°F(Below -18°C)	8.0

Figure 12-26: Load Test Values vs. Temperature

5. If voltage drops below the minimum value listed, replace the battery.

Parasitic Draw Test

Tools Required:

- J-38758 Parasitic Draw Test Switch
- J-39200 Digital Multimeter

1. Remove the negative battery cable from the rear battery.
2. Install the male end of the parasitic draw test switch over the crossover negative battery cable using the long battery bolt from the battery cable removed in step 1.
3. Open the parasitic draw test switch
4. Connect the negative battery cable to female end of the parasitic draw test switch using a short battery bolt.
5. Close the parasitic draw test switch.
6. Road test the vehicle while activating all accessories, such as the radio and air conditioning.
7. Turn the ignition switch to the off position and remove the key.

NOTE: It is important that from this point on, electrical continuity must be maintained in the ground circuit to the battery, either through J-38758 in the on position, or through J-39200.

8. Some components, such as the PCM or TCM, have timers that draw several amps of current while they cycle down. This can give a false parasitic drain reading. Wait 15 minutes for these components to power down before continuing this test.

NOTE: If another DVOM is being used other than J-39200, ensure that the ammeter will handle 10 amps of current without damage.

9. Install a jumper wire with a 10 amp fuse between the two terminals on the parasitic draw test switch. Open the switch and wait 10 seconds. If the fuse does not blow, the parasitic load is less than 10 amps and the J-39200 can be used. Close the switch on the tester and remove the jumper wire and fuse.
10. Set J-39200 to the 10 amp scale and place leads in the correct ports in the meter for amperage testing on the 10 amp scale.
11. Connect the meter leads to the two terminals on the parasitic load test switch and open the switch.
12. Wait 60 seconds then take a reading from the meter. If the current reading is at or below 2 amps, turn the test switch to the on position. Reset the meter to read milliamps.
13. Open the switch and take the reading in milliamps.
14. Find the reserve capacity of the batteries on the vehicle. Since there are 2 batteries, add the reserve capacities together. (100 minutes + 100 minutes = 200 minutes reserve capacity). Divide the number by 4 and the answer, given in milliamps, is the maximum allowable parasitic drain the batteries will support.

NOTE: Always turn the switch knob to the “on” position before removing each fuse to maintain continuity in the electrical system and to avoid damaging the meter due to accidental overloading, such as opening a door to change a fuse.

15. If current draw is too high, remove system fuses one at a time until the draw returns to a value less than or equal to the maximum allowable for the batteries. Repeat the test for parasitic drain after any repair has been performed.
16. When the cause of excessive current draw has been located and repaired, remove the meter, test switch and terminal adapters and connect the negative battery cable to the battery.



BATTERY CABLE REPLACEMENT

Battery Negative Cables - Removal

1. Remove caps from battery negative cable (Figure 12-27).
2. Remove battery cable bolts.
3. Disconnect winch negative cable, if equipped (Figure 12-27).

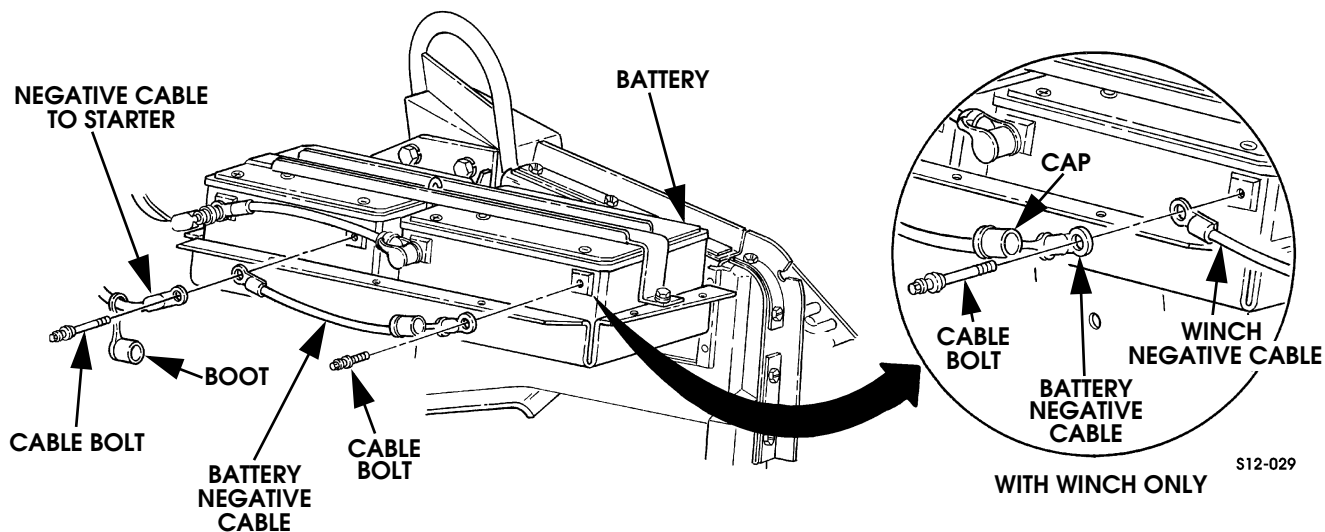

Figure 12-27: Battery Negative Cable Connections

4. Remove fasteners securing negative cable to cable hanger and starter then remove negative cable (Figure 12-28).

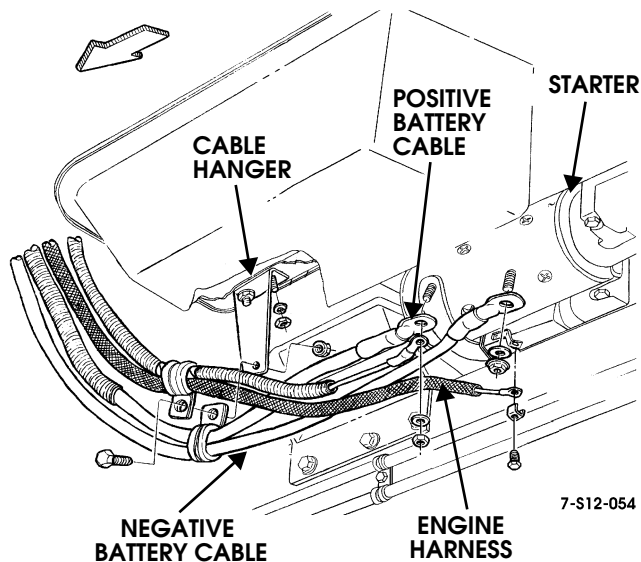

Figure 12-28: Negative Cable to Cylinder Block Attachment

Battery Negative Cables - Installation

1. Connect negative cables to starter, cable hanger, and batteries.
2. Tighten battery cable bolts to 8-12 lb-ft. (11-16 N•m).
3. Install caps on battery cable bolts.

Battery Positive Cable - Removal

1. Disconnect battery negative cables.
2. Remove caps from battery positive cable(s) (Figure 12-29).
3. Disconnect starter cable at battery.
4. Disconnect battery positive cable, and winch cable, if equipped, at battery.
5. Remove locknut, washer, capscrew, and clamp securing starter cable to bracket.
6. Disconnect starter cable at starter.

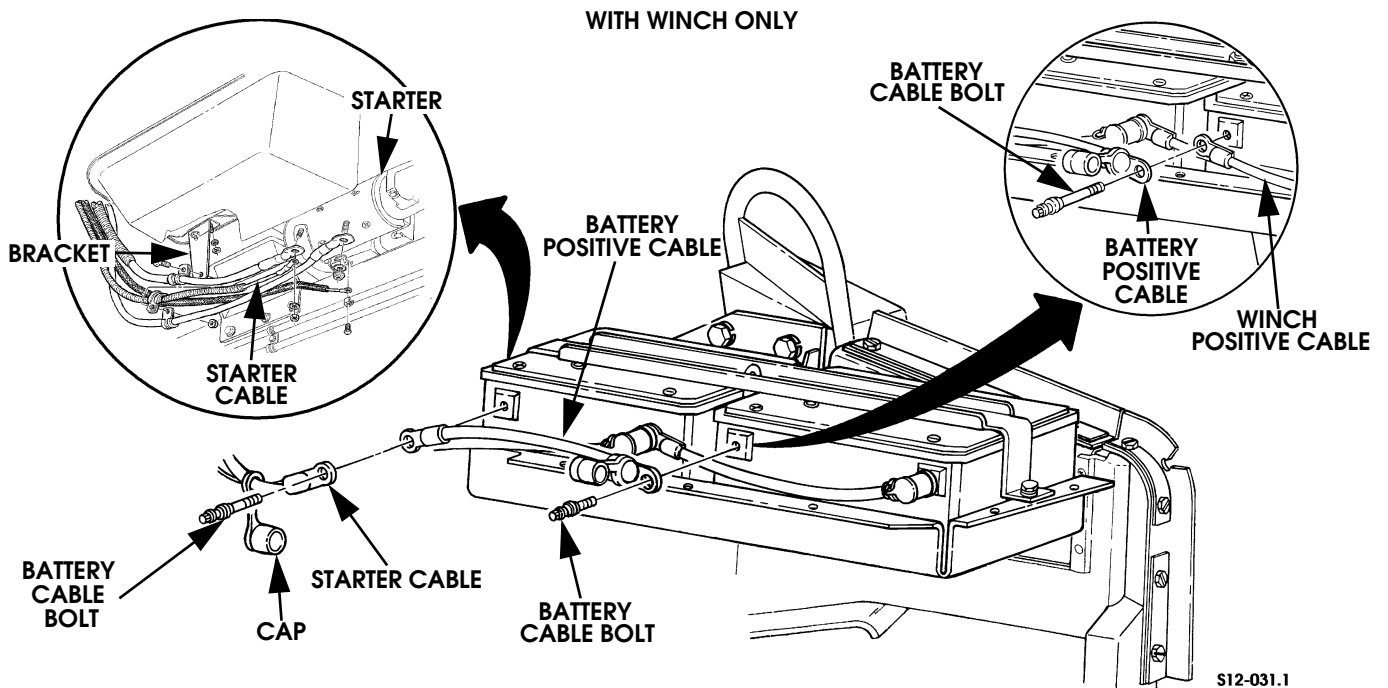

Figure 12-29: Battery Positive Cable Connections

Battery Positive Cables - Installation

1. Connect starter cable to starter with lockers and nut. Tighten nut to 12-16 lb-ft (16-22 N•m).
2. Secure starter cable to bracket with clamp, capscrew, washer, and locknut.
3. Connect battery positive cable to battery.
4. Connect winch cable to battery positive post (Figure 12-29).
5. Connect battery negative cables.
6. Tighten cable-to-battery bolts to 8-12 lb-ft. (11-16 N•m).



BATTERY REPLACEMENT

WARNING: Battery electrolyte contains sulfuric acid which can cause severe burns. If acid contacts eyes or skin, flush affected areas liberally with water and obtain medical assistance immediately. If acid contacts clothing, flush with water and replace affected clothing. Always wear eye protection, and remove all jewelry before working on batteries.

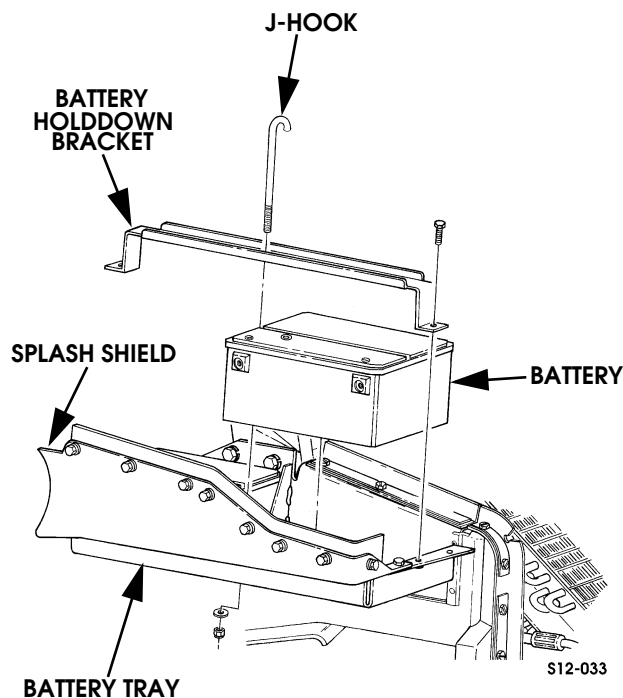

Figure 12-30: Battery Removal/Installation

1. Disconnect battery cables.
2. Remove J-hook, and holddown bracket bolts (Figure 12-30).
3. Remove holddown bracket.
4. Remove one or both batteries as required.
5. Clean battery tray.
6. Install one or both batteries in tray (Figure 12-30).
7. Install holddown bracket and J-hook.
8. Connect battery cables.

BATTERY TRAY REPLACEMENT/INSTALLATION

1. Disconnect and remove batteries.
2. Remove splash shield and battery tray shield.
3. Remove battery tray from airlift bracket (Figure 12-31).
4. Install battery tray on airlift bracket.
5. Install battery tray shield and splash shields.
6. Install and connect batteries.

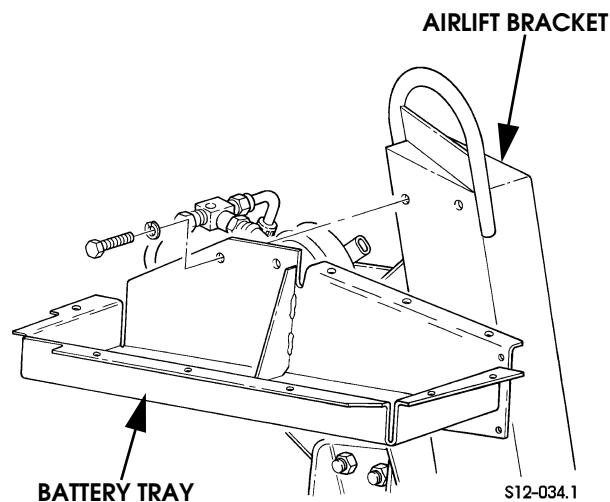

Figure 12-31: Battery Tray



BATTERY SPLASH SHIELD AND SEAL SERVICE

Splash Shield Removal

1. Remove upper splash shield and seal (Figure 12-32).
2. Remove retainer bolts, and remove seal from battery tray and lower shield (Figure 12-33).
3. Remove lower splash shield bolts and remove lower splash shield.

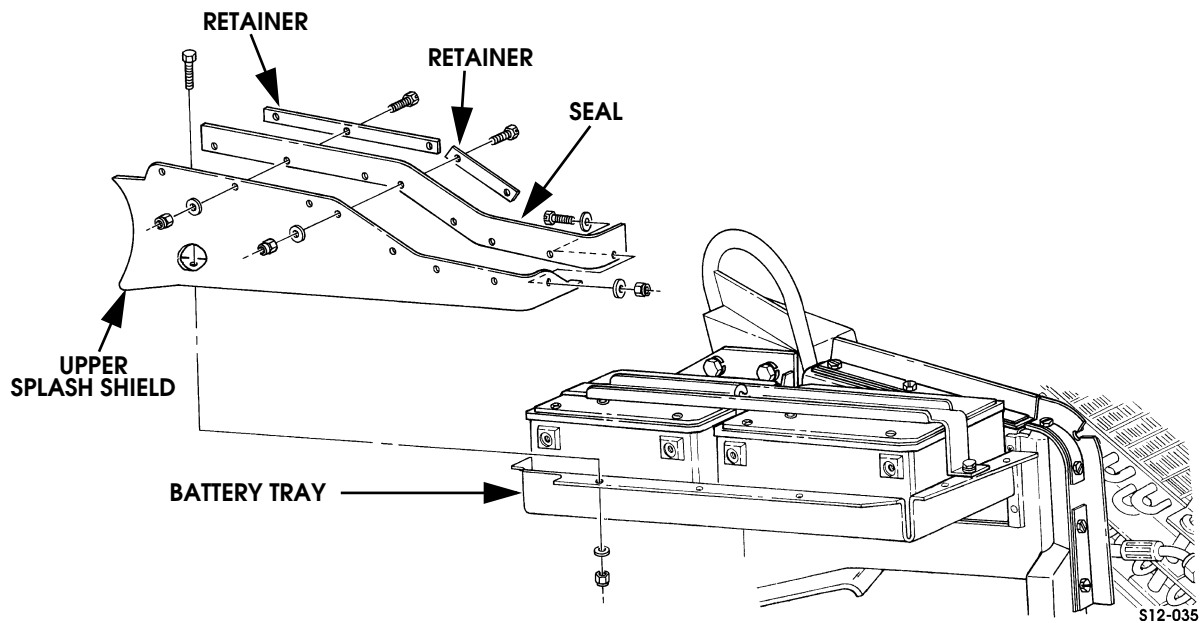

Figure 12-32: Upper Splash Shield Attachment

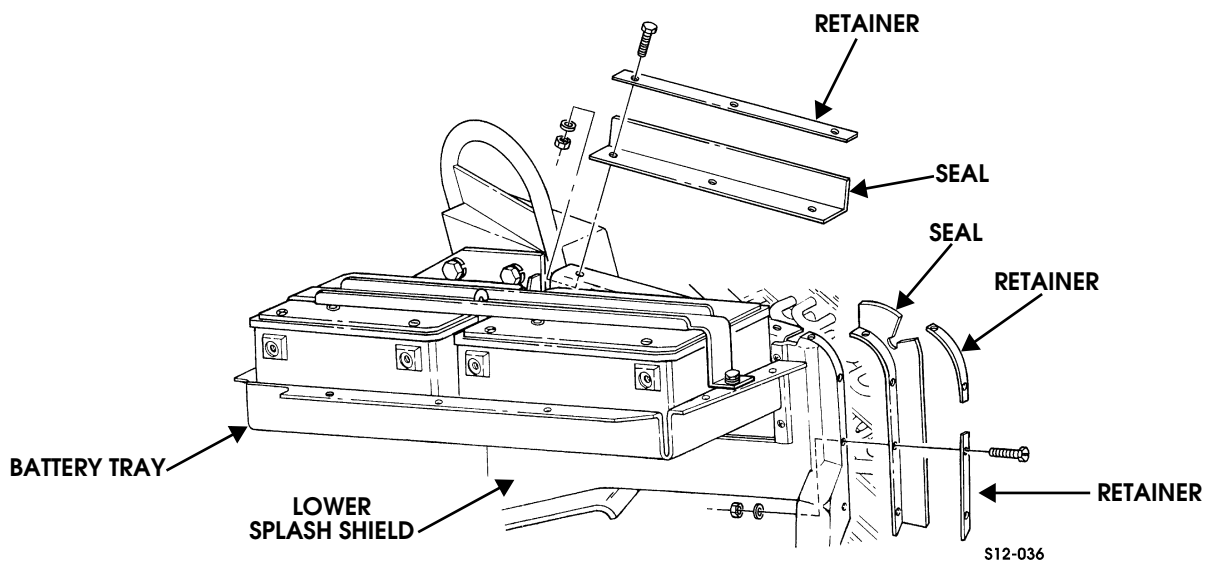

Figure 12-33: Seal and Retainer Attachment



Splash Shield Installation

1. Position lower shield on bracket and install fasteners (Figure 12-34).
2. Install retainer on upper shield.
3. Install upper shield on tray.
4. Install seals and retainers (Figure 12-33).

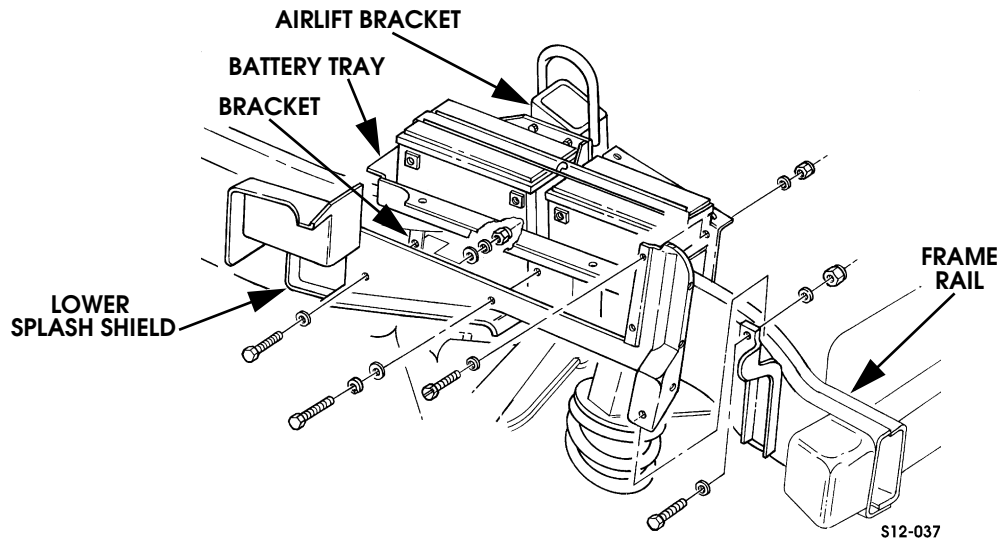

Figure 12-34: Lower Splash Shield Removal/Installation



MAJOR POWER DISTRIBUTION

The following charts and illustrations convey how power is distributed from the vehicle batteries to the fuse/relay centers.

Power is supplied to the fuse boxes from the batteries through fusible links. Each fuse box has internal power busses that direct the power to the fuses. The busses are indicated on the fuse charts as follows: I = Ignition, B = Battery, A = Accessory, L = Lamps.

The fuse charts contain a listing of the **cavities** in the fuse box, the corresponding **circuits**, wire **colors** and **gauges (ga.)**.

Power is supplied to an individual fuse by the **bus** indicated in the left **bus** column. The **circuit number (CKT No.)** contains two entries for a fuse: the power supply **bus** and the outgoing **circuit number**. The numbers in the **cavity** column relate to the cavities indicated on the fuse/relay cavity I.D. illustrations.

Using this information, you can determine which cavity of a fuse is the power supply cavity and which other fuses are supplied by the same bus.

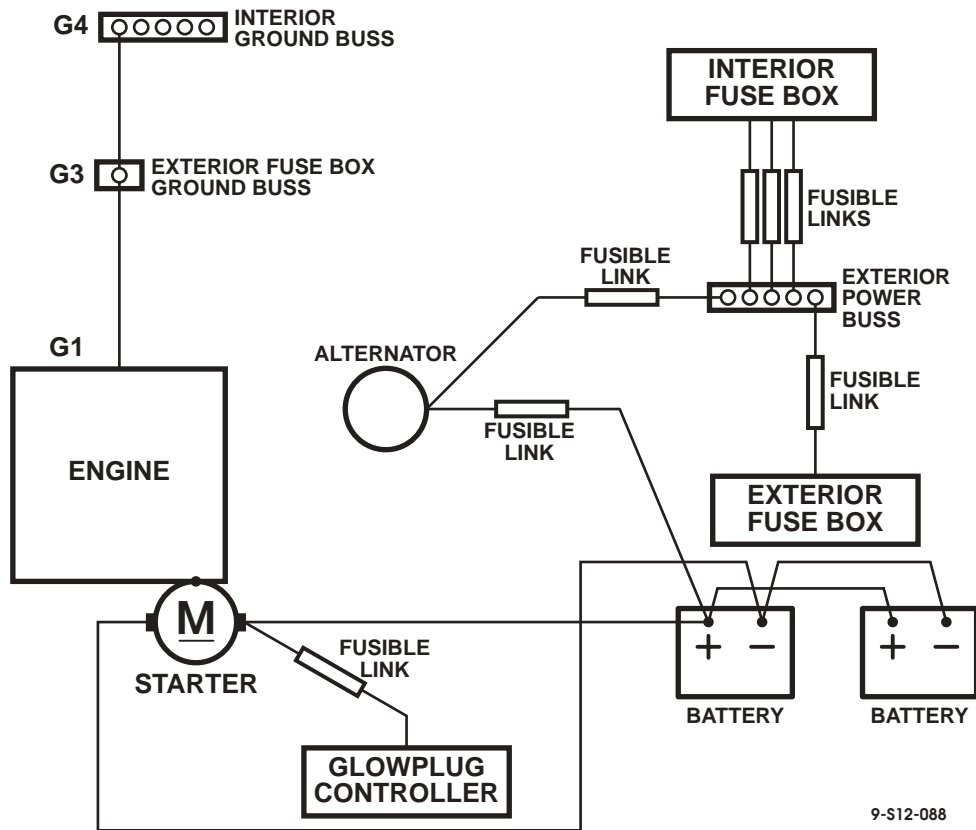

Figure 12-35: Major Power And Ground Schematic



ALTERNATOR

Removal

1. Disconnect battery negative cable.
2. Remove serpentine drivebelt from alternator pulley.
3. Loosen pivot bolt and remove front and rear alternator bolts (Figure 12-36).
4. Pull alternator away from engine. Remove nut and lockwasher and disconnect battery wires from battery alternator terminal (Figure 12-37).
5. Unlock and disconnect field wire (Figure 12-37).
6. Remove pivot bolt and alternator from engine.

Installation

1. Position alternator in bracket and install pivot bolt finger tight.
2. Connect battery wires to alternator. Secure with lockwasher and nut. Tighten nut to 62-80 lb-in (7-9 N•m).
3. Connect field wire to alternator.
4. Move alternator into alignment with lower bracket and install front and rear mounting bolts. Tighten bolts 18 lb-ft (25 N•m).
5. Tighten pivot bolt to 37 lb-ft. (50 N•m).
6. Install serpentine drivebelt on pulley and adjust belt.
7. Connect battery negative cable.

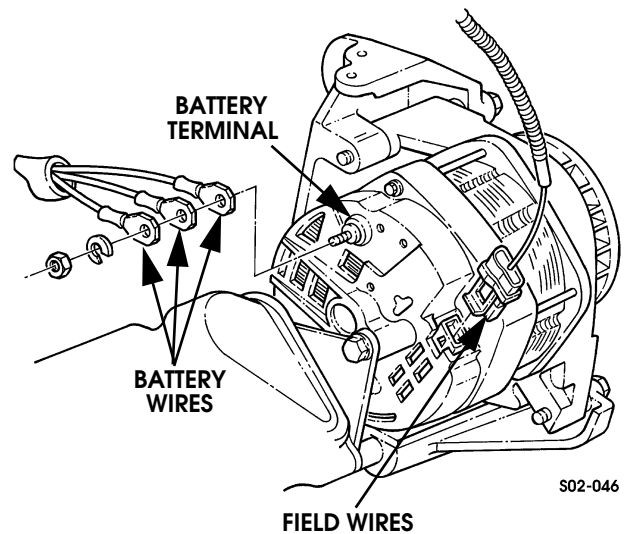

Figure 12-37: Alternator Connections

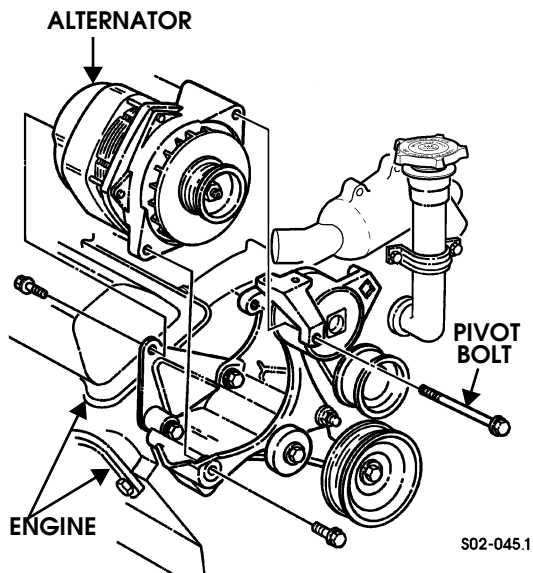

Figure 12-36: Alternator Mounting



ALTERNATOR OVERHAUL

Alternator Disassembly

1. Remove alternator.
2. Mark drive end frame and slip ring end frame for assembly alignment reference.
3. Hold rotor shaft with allen wrench and remove nut, washer, pulley, fan, and thin collar from rotor shaft (Figure 12-38).
4. Remove four through-bolts from slip ring end frame and drive end frame.
5. Remove drive end frame and thick collar from rotor shaft.
6. Remove three nuts from stator leads and rectifier bridge.
7. Remove stator from slip ring end frame.
8. Remove standard screws, insulated screws, and washer from components in slip ring end frame.
9. Remove nut and output stud with insulator from slip ring end frame.
10. Remove rectifier bridge, capacitor strap, regulator connector strap, and brush holder from slip ring end frame.
11. Unsolder and separate brush holder and regulator connector.
12. Unsolder and separate connector strap from regulator.

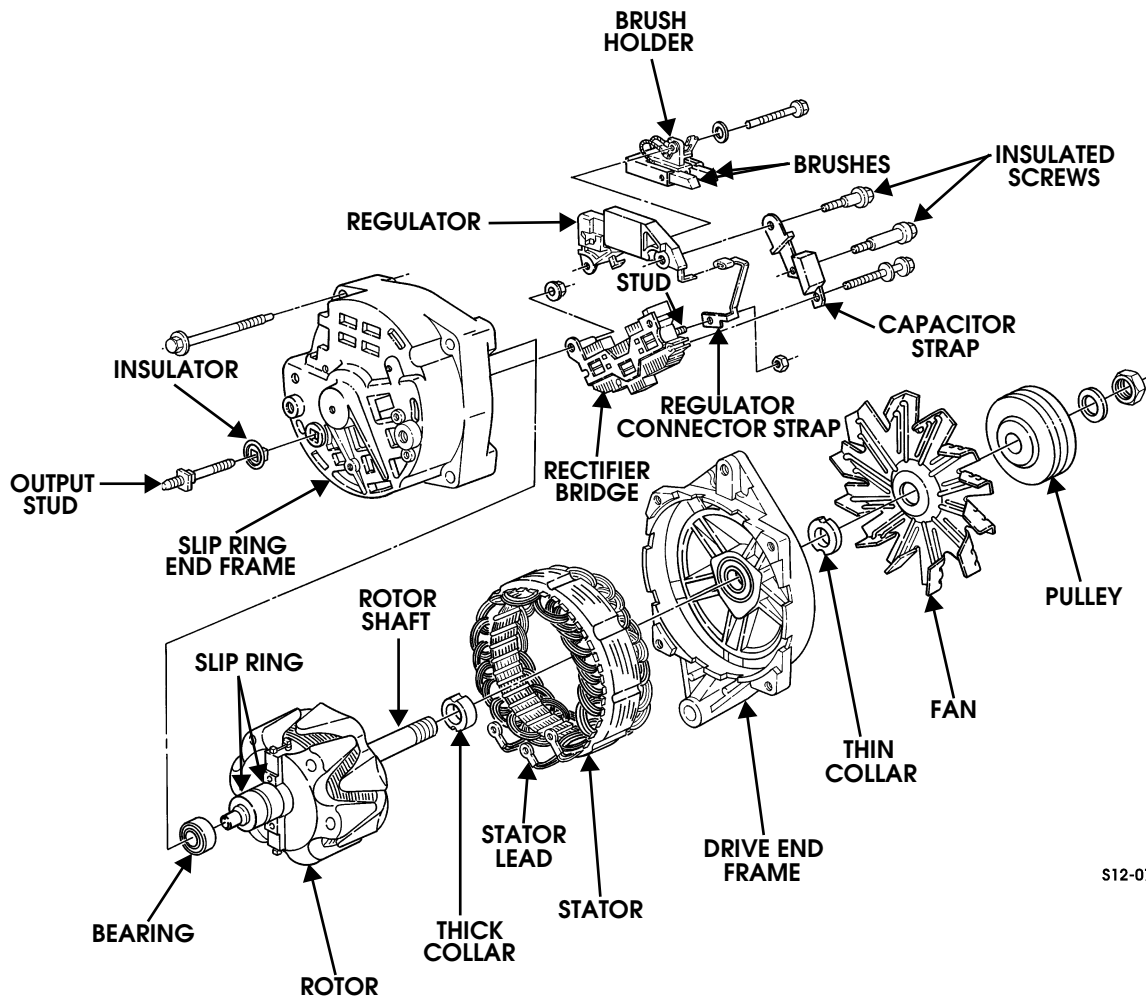

S12-079

Figure 12-38: Alternator Components



Alternator Parts

Cleaning

Use part cleaning solvents on metal parts only. The insulating coatings on wires in the field coil and stator can be damaged by cleaning solvents.

Clean encapsulated and exposed wire items by wiping with a clean cloth.

Inspection and Repair

Rotor

Inspect for cracked slip rings, damaged threads, and galling or scoring on bearing journal surfaces on shaft (Figure 12-39).

Corrosion or light scoring on the slip rings may be removed with 400 grit emery cloth.

Test the slip rings and field coil for opens (high resistance), shorts (very low resistance), and grounds (low resistance) to frame and shaft. Replace the rotor if a fault is detected.

Inspect the ball bearing for free play, roughness, leaking seals, and other damage. Replace the bearing if necessary. Seat the new ball bearing against the rotor shoulder.

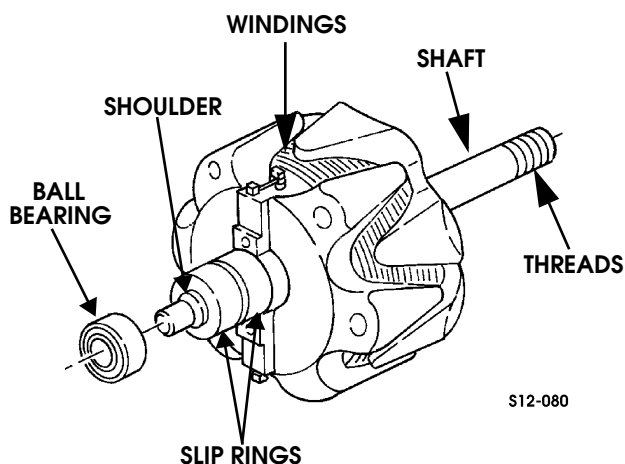

Figure 12-39: Rotor Inspection Points

Stator

Check the stator leads for continuity to ground (laminations). Any continuity indicates a grounded stator which should be replaced (Figure 12-40).

Examine the stator winding for discoloration due to overheating or short to ground. Normal color is reddish brown to purple. Bare copper, dark spots, or dull black color indicates burned spots.

Replace the stator if damaged, shorted or grounded.

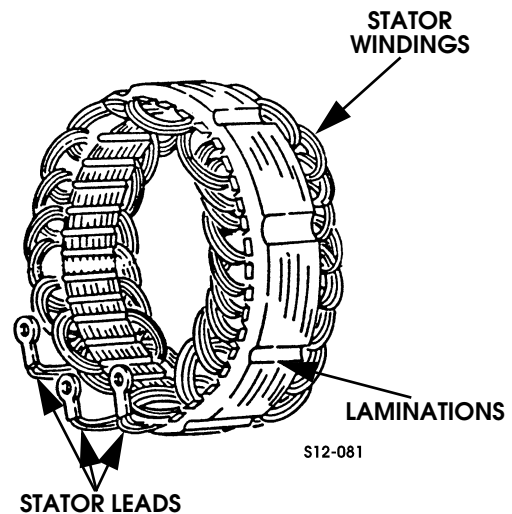

Figure 12-40: Stator Inspection Points

Rectifier Bridge

Test the rectifier bridge as follows:

1. The bridge studs are embedded in insulation. To obtain diode readings, the ohmmeter leads must contact the copper strap.
2. Connect the ohmmeter leads to the grounded side and strap as shown and take readings at each strap (Figure 12-41).
3. Repeat step 1 with test leads reversed.
4. All three readings in steps 1 or 2 should read high resistance in one case and low resistance in other case.
5. Connect ohmmeter leads on positive side and strap as shown, and take readings at each strap (Figure 12-41).
6. Repeat process of step 4 with leads reversed.
7. All three readings in steps 4 and 5 should be the same, with resistance high in one set and low in the other set.
8. If any one reading in steps 1, 2, 3, and 4 is not the same as the other two readings, replace rectifier bridge.

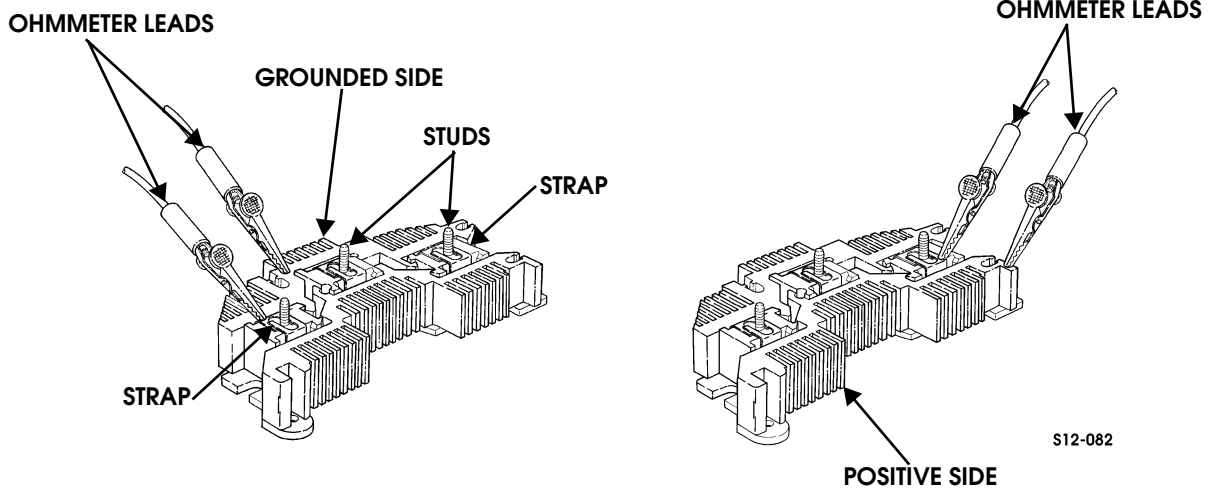

Figure 12-41: Rectifier Bridge Check

Regulator

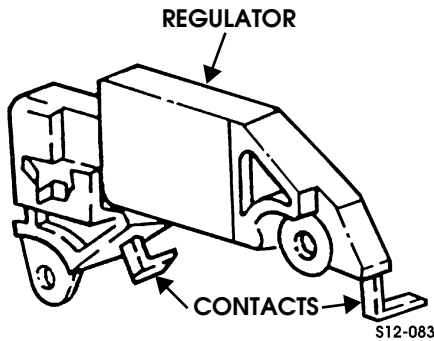

Figure 12-42: Regulator Inspection Points

Inspect the regulator for cracks, breaks, broken contacts, or surface defects and replace if damaged (Figure 12-42).

Brushes and Brush Holders

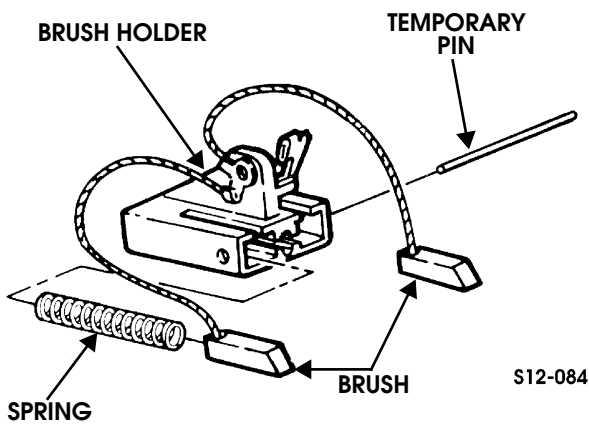

Figure 12-43: Brush Holder and Brushes

Check for broken or disconnected brushes, worn brushes with length less than 0.5 in. (12.7 mm), and broken or distorted springs. Replace brush holder and brushes as an assembly if necessary (Figure 12-43).

NOTE: The pin that retains the brushes temporarily can be made from locally obtained parts. A standard paper clip can be used.

Assemble springs and brushes in the brush holder. Compress the springs and brushes in the holder and hold them in position with the temporary pin (pin will be removed after assembly) (Figure 12-43).

Drive End Frame and Bearing

Inspect the bearing for roughness, looseness in bore, inner race free play, or damaged seals. Replace the end frame and bearing as an assembly if damaged (Figure 12-44).

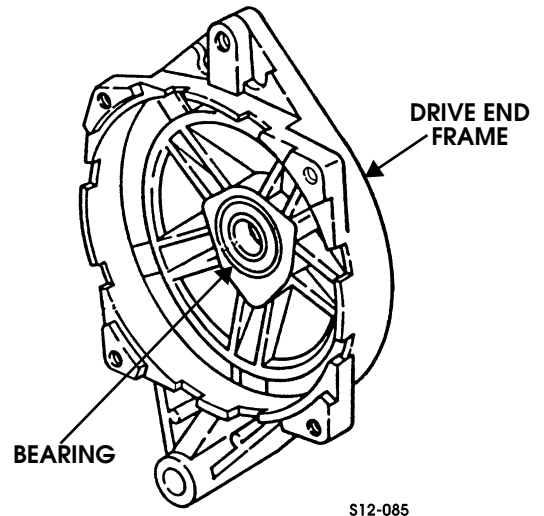

Figure 12-44: Drive End Frame Inspection

Inspect the drive end frame for cracks, breaks, or damaged threads. Replace the assembly if casting is cracked or broken.

Repair minor through-bolt and adjusting bolt thread damage using a tap. For more serious through-bolt thread damage, replace the end frame.



Fan

Inspect the fan for distortion, cracked blades, or broken blades. Minor bending repair is permissible. For broken or missing blade ends, cracks or breaks, replace the fan (Figure 12-45).

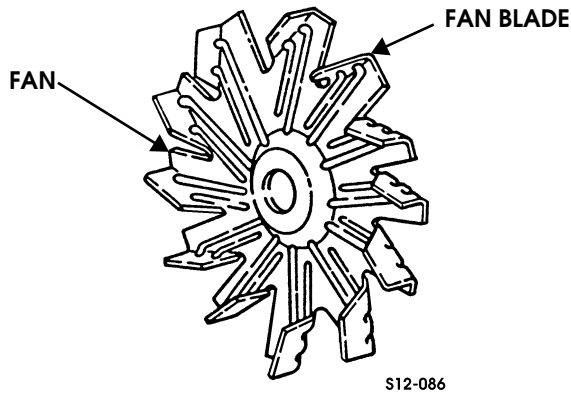

Figure 12-45: Fan Inspection Points

Slip Ring End Frame and Bearing

Inspect the bearing for roughness, looseness in retainer ring, free play, loose inner race, or damaged seals. Replace the bearing if damaged or loose (Figure 12-46).

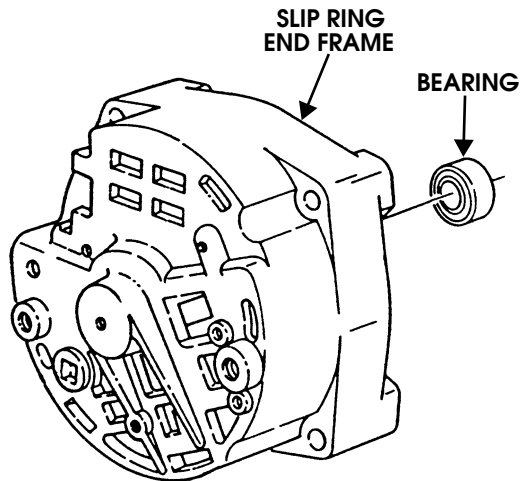

Figure 12-46: Slip Ring End Frame

Inspect the slip ring end frame for breaks, cracks, evidence of spun ball bearing, or damaged threads. Repair minor thread damage. Replace the end frame if otherwise damaged.

Collars

Inspect both collars for cracks, bends, or scoring. Replace either part if damaged (Figure 12-47).

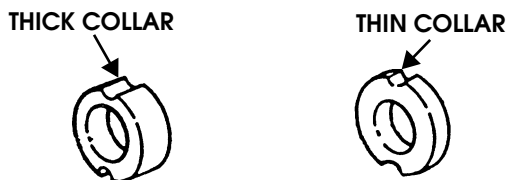

Figure 12-47: Fan Spacers

Output Stud Assembly

Inspect the output stud assembly for cracked, or broken insulator, distortion, or damaged threads. Replace the stud assembly if any part is damaged (Figure 12-48).

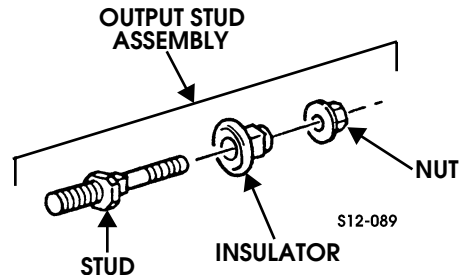

Figure 12-48: Output Stud Inspection

Pulley

Inspect the pulley for distortion, breaks, or sharp edges in the belt grooves. Remove minor burrs and sharp edges with fine tooth file. Replace the pulley if damaged (Figure 12-49).

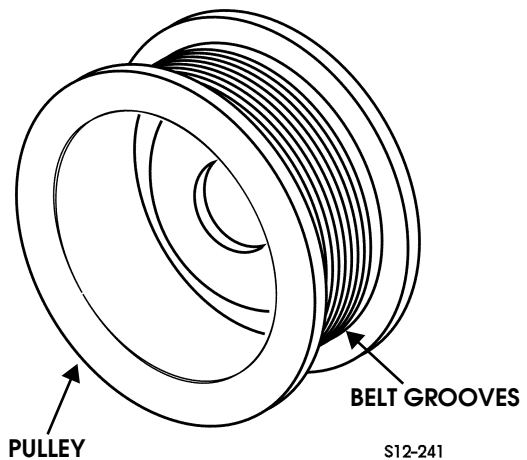

Figure 12-49: Alternator Pulley

Capacitor Strap

Inspect the capacitor strap for breaks, cracks, distorted case, or surface defects. Check capacitor for continuity. Replace if damaged (Figure 12-50).

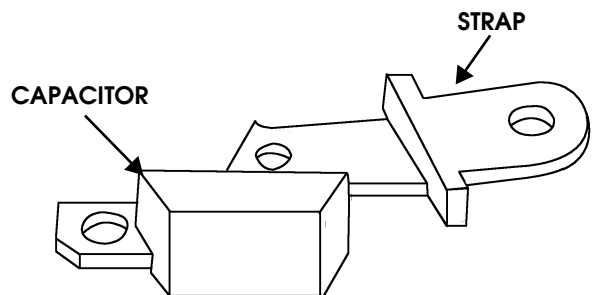

Figure 12-50: Capacitor Strap



Alternator Assembly

1. Install bearing on rotor shaft. Seat bearing against shoulder (Figure 12-38).
2. Assemble springs and brushes in brush holder and retain with fabricated pin. Pin holds brushes compressed in brush holder and will be removed after assembly.
3. Install rectifier bridge in slip ring end frame and install screw, output stud insulator, and nut.
4. Assemble and install brush holder and regulator. Solder connection between brush holder and regulator if either part was replaced.
5. Slide regulator connector strap into regulator contact and solder together.
6. Slip capacitor strap under connector strap and position on rectifier bridge and regulator. Secure capacitor strap with screw and two insulated screws (Figure 12-51).

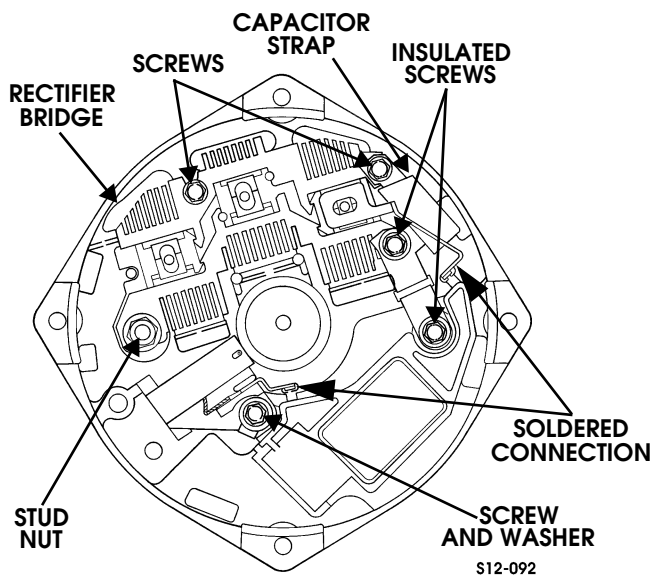

Figure 12-51: Rectifier Bridge and Capacitor Strap Location

7. Attach stator leads to rectifier bridge and secure leads with nuts.
8. Install thick collar on rotor shaft (Figure 12-38).
9. Insert rotor shaft through drive end frame and seat bearing against thick collar.
10. Install thin collar, fan, and pulley on rotor shaft and secure with washer and nut. Tighten nut to 40-80 lb-ft (54-109 N•m).
11. Carefully insert rotor through stator and seat ball bearing in slip ring end frame. Be sure drive end frame and stator are aligned and seated.
12. Install through-bolts. Tighten through-bolts evenly to remove any slack.
13. Verify that rotor turns smoothly.
14. Remove brush retaining pin from brush holder. Be sure brushes extend out brush holder and contact slip rings.



Alternator Inoperative (No Charge)

Step	Action	Value(s)	Yes	No
1	Perform visual inspection on belt, pulleys and battery cables. Is everything in normal operating condition		Go to step 2.	Repair and recheck system.
2	Using a battery load tester, place amp pickup on the alternator fusible link wire. Start and run vehicle at 1500 rpm, load the vehicle batteries with 100 amps for 15 seconds. Does charging system produce equivalent amperage.	>100 amps	Go to step 7.	go to step 3.
3	Perform battery check, refer to “battery checking procedure” in this section. Are batteries in good condition		Go to step 4.	Replace batteries and recheck charging system.
4	Using a DVOM set to measure voltage, place the negative lead on a good engine ground. Probe the Batt. terminal on the back of the alternator. Is voltage present?	12v	Go to step 8.	Go to step 5.
5	Using a DVOM set to measure resistance, measure resistance between the alternator case and a negative battery connection. Is resistance below specification.	<.2Ω	Go to step 6.	Locate and repair bad ground connection.
6	Disconnect the positive battery cables, using a DVOM set to measure resistance, measure resistance between the positive battery connection and the Batt. terminal. Is resistance below specification.?	<.2Ω	Go to step 8.	Inspect/repair fusible link at alternator Batt terminal.
7	Does voltage gauge indicate a low charge condition?		Replace gauge and check operation.	No problem found at this time.
8	Using a DVOM set to measure voltage, and the pink ignition lead disconnected from the alternator, place the negative lead on a good engine ground and the positive lead on the pink ignition lead. Turn the ignition key to on, is voltage present?	12v	Go to step 9.	Locate and repair open or short to ground in engine ignition feed circuit.
9	Check for expanded female terminal in engine harness connector in the alternator ignition feed connector. Is a faulty connection found?		Replace female terminal	Replace the alternator

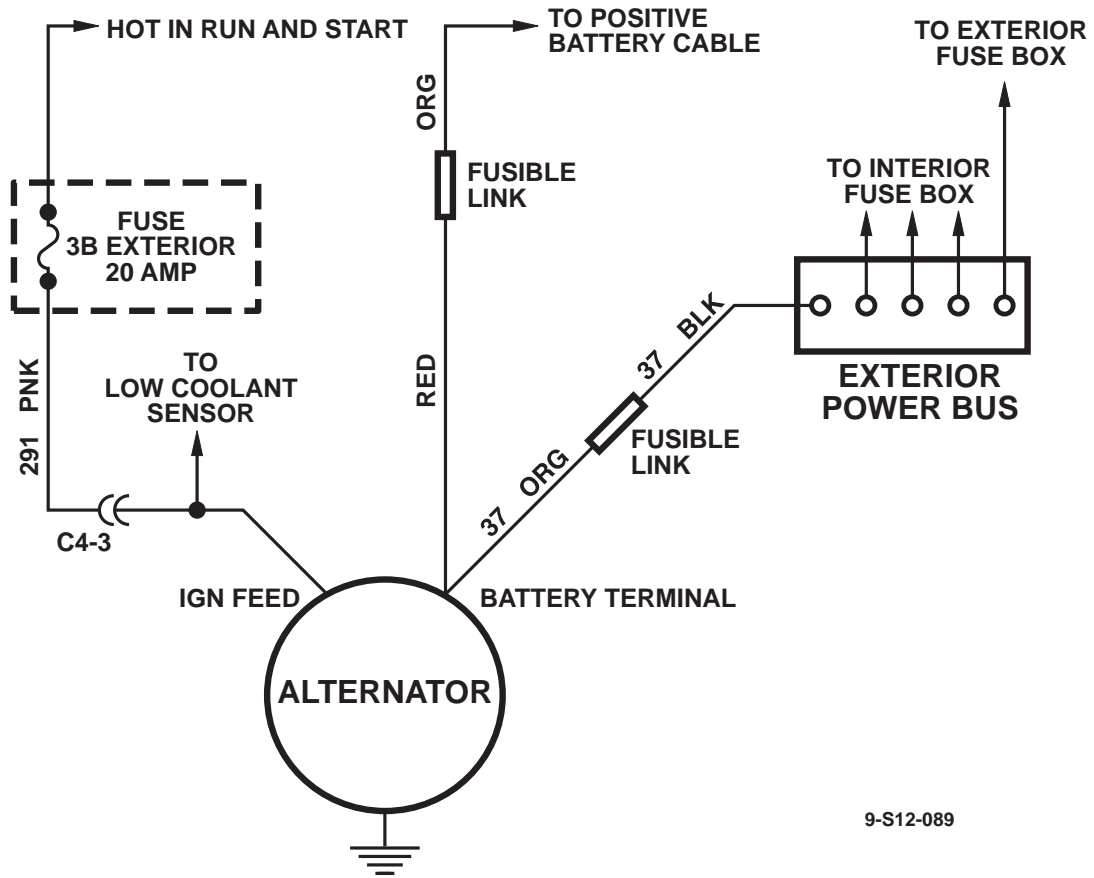

9-S12-089

Figure 12-52: Alternator Schematic



STARTER

Removal

1. Disconnect battery negative cable(s) and winch negative cable, if equipped.
2. Remove converter housing cover.
3. Remove cap and/or adhesive sealant from starter terminal (Figure 12-53).
4. Disconnect starter cable or cables from starter terminals (Figures 12-53 and 12-54).
5. Disconnect solenoid wire from solenoid.
6. Remove starter cable clamp.
7. Loosen locknut and washer securing stud at front of starter to bracket.
8. Have helper support starter and remove starter bolts. Then lower and remove starter and shim (if used).

Installation

1. Position shim pack on starter.
2. Position starter in converter housing.
3. Slide starter stud into chassis bracket. Be sure stud nut and washer are behind bracket.
4. Install and tighten starter bolts to 40 lb-ft (54 N•m).
5. Tighten stud nut to 24 lb-ft (33 N•m).
6. Attach starter cable clamp to chassis.
7. Connect solenoid wire to solenoid terminal with clip and screw. Tighten screw to 22 lb-in. (2 N•m).
8. Connect starter cable to starter terminal. Tighten nut to 25-31 lb-ft (34-42 N•m).
9. Cover starter terminal and solenoid terminal with silicone sealer.
10. Install converter housing covers.
11. Connect battery negative cable.

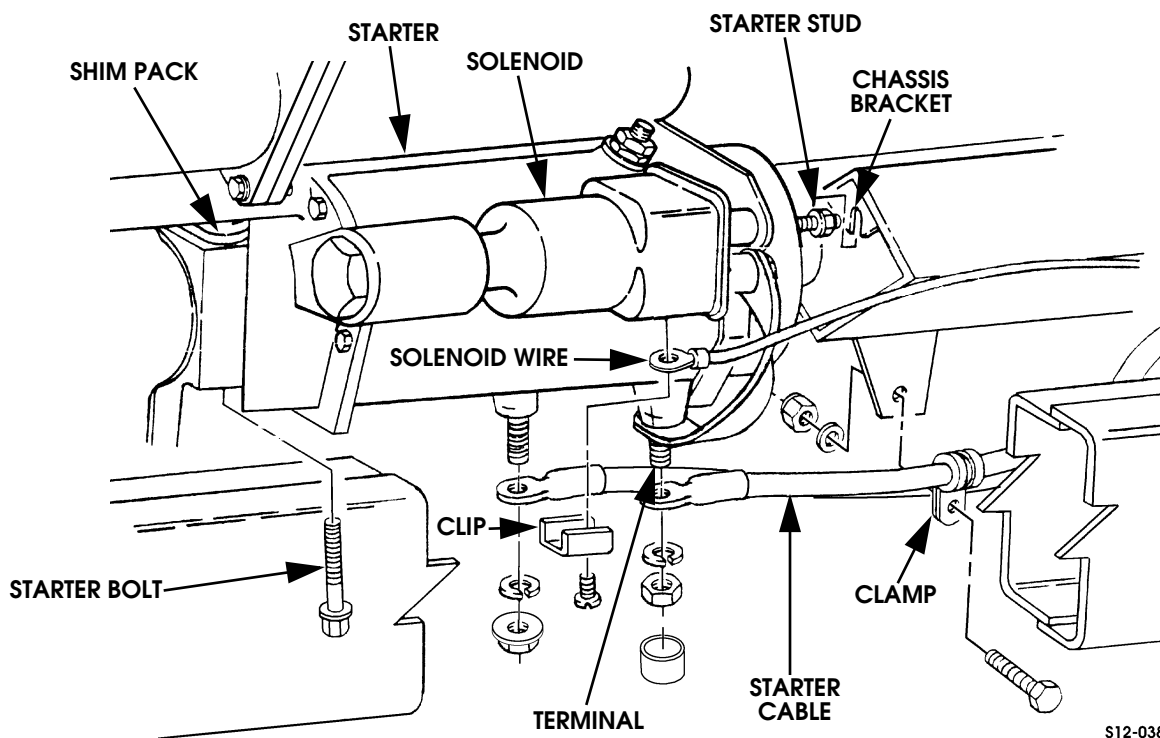

S12-038

Figure 12-53: Starter Mounting

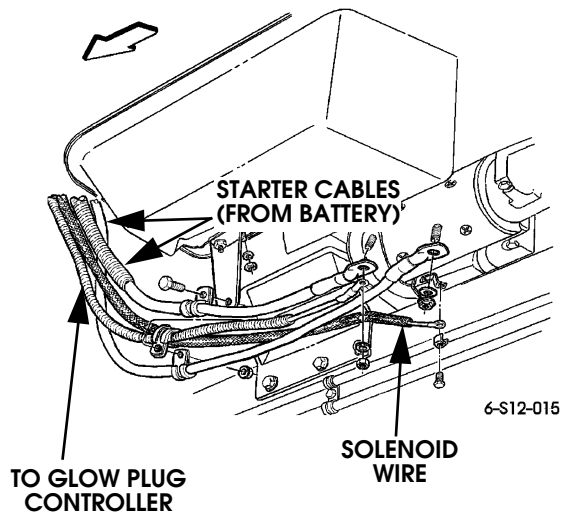

Figure 12-54: Starter Connections

STARTER OVERHAUL

Disassembly

1. Remove starter.
2. Remove plug and gasket from pinion housing (Figure 12-55).

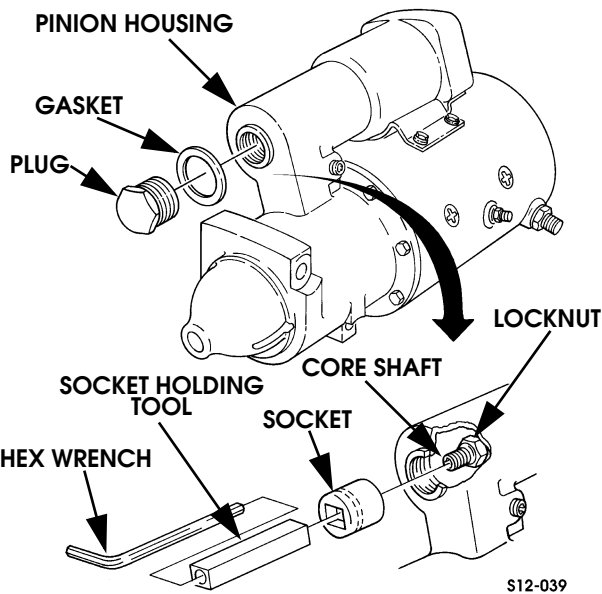

Figure 12-55: Core Shaft Nut Removal

3. Remove core shaft nut with socket, fabricated socket holding tool, and hex wrench (Figure 12-55). Holding tool can be fabricated from suitable size square tube. Or, a suitable size thin wall, deep socket can be used.
4. Remove connector nuts and remove solenoid connectors from frame assembly and solenoid (Figure 12-56).

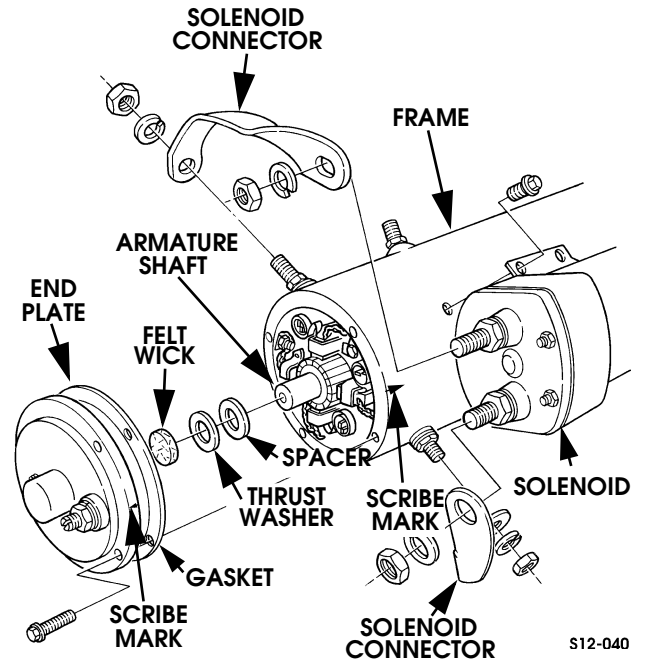

Figure 12-56: End Plate Removal

5. Remove solenoid screws and remove solenoid.
6. Scribe alignment marks on end plate and frame.
7. Remove end plate bolts and remove end plate and gasket.
8. Remove thrust washer and spacer from armature shaft.
9. Remove felt wick from end plate.
10. Scribe alignment marks on pinion housing and frame (Figure 12-57).

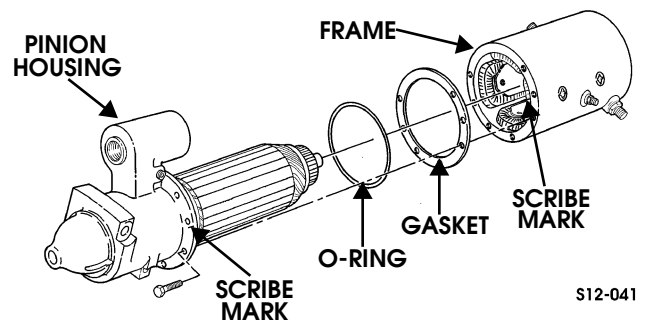
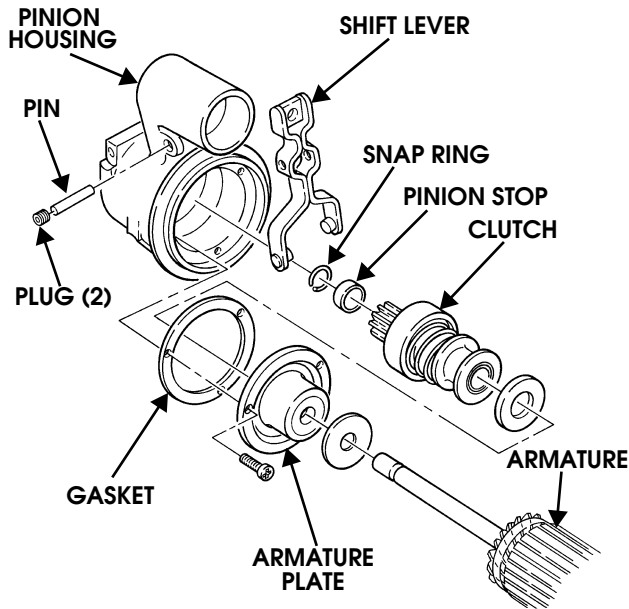

Figure 12-57: Frame Removal

11. Remove screws attaching pinion housing to frame.
12. Remove frame, gasket, and O-ring from pinion housing.
13. Remove two plugs and pin from pinion housing and shift lever (Figure 12-58).



S12-042

Figure 12-58: Starter Drive Disassembly

14. Clamp pinion housing in vise and remove screws from end plate and pinion housing (Figure 12-59).
15. Slide armature, end plate, and shift lever out of pinion housing.

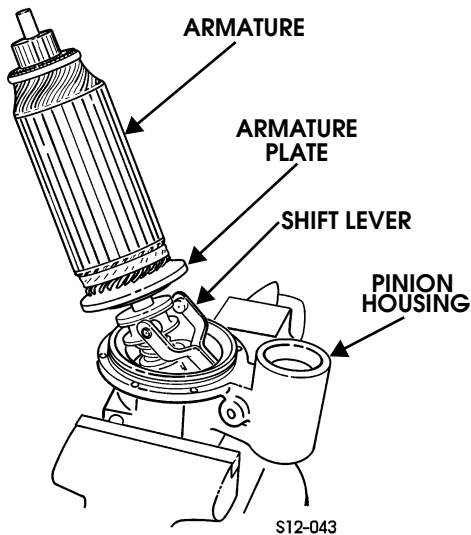

S12-043

Figure 12-59: Armature Removal/Installation

16. Remove snap ring and pinion stop from armature shaft, and slide clutch off armature shaft (Figure 12-58).
17. Remove washer and plate from armature shaft (Figure 12-58).
18. Remove gasket from armature plate.
19. Remove nuts, lockwashers, screws, copper washers, and negative brush leads from frame. Remove brushes from brush holders (Figure 12-60).

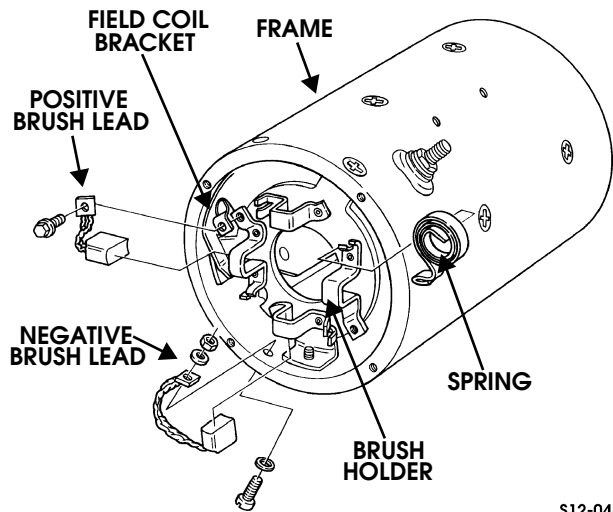

S12-044

Figure 12-60: Brush and Holder Removal/Installation

20. Remove screws and positive brush leads from field coil brackets. Then remove brushes from holders.
21. Remove springs from brush holders.
22. Remove nut and lockwasher assemblies and rubber washers from solenoid housing. Discard rubber washers (Figure 12-61).

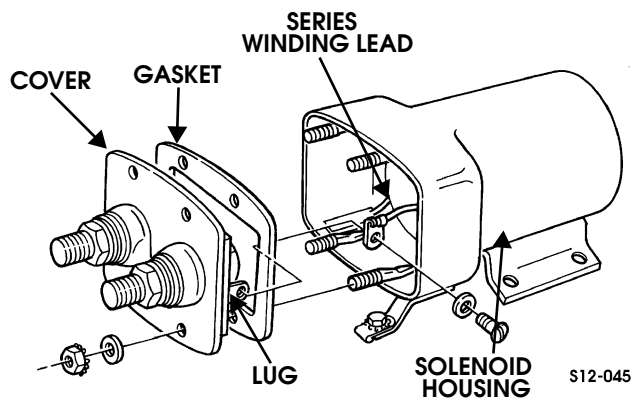

S12-045

Figure 12-61: Solenoid Housing Disassembly/Reassembly

23. Pull cover away from solenoid housing and remove screw and washer from lug on cover and series winding lead.
24. Remove cover and gasket from solenoid housing.
25. Holding core shaft, remove locknut, washer, and contact from core shaft (Figure 12-62).
26. Remove and separate spring from core shaft and washer.
27. Remove snap ring, spring retainer, spring, spring retainer, rubber boot, and washer from core shaft (Figure 12-62).

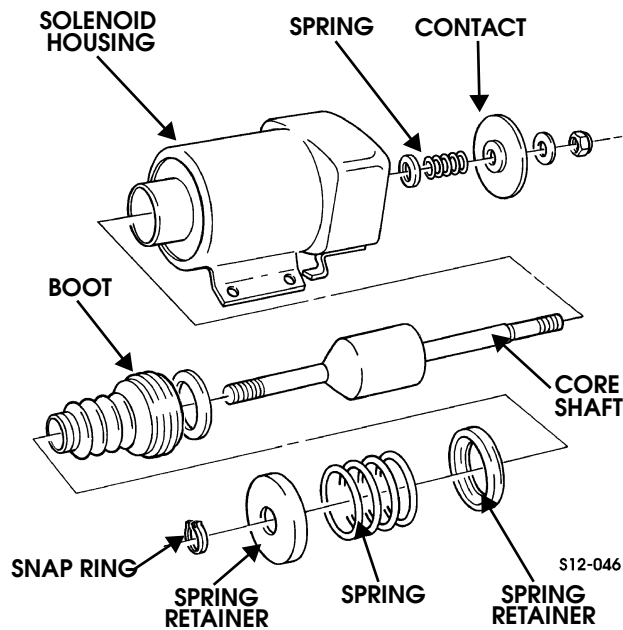

Figure 12-62: Solenoid Components

Inspection

Inspect clutch for broken spring, damaged gear or splines, and non-lockup. Replace clutch if damaged (Figure 12-63).

Inspect brushes for cracks, roughness, galling, wear, or damaged lead. If one brush length is less than 0.315 in. (8 mm) or has other damage, replace all brushes as a set.

Inspect springs for breaks, distortion, or other damage. Replace any damaged springs.

Inspect bearings in head end and pinion housing for cracks, roughness, galling, or damage. Replace bearings if defective (Figure 12-63).

Inspect pinion housing for cracks, damaged pinion bearing, and damaged threads. Repair minor thread damage. Replace starter if otherwise damaged.

Inspect commutator for damage due to arcing (burned spots and pitting), damaged shaft, splines, or threads. Replace starter if commutator is damaged.

Test armature, field coils, and brush holders for shorts, grounds, and open circuits with an armature tester. Replace starter if any one of these parts is defective.

Inspect core spring, core shaft, and rubber boot for damage. Replace parts if damaged (Figure 12-64).

Inspect contact for burns or damage. Replace contact if burned or damaged.

Inspect housing of frame assembly, head end, and solenoid housing for cracks or damage. Replace starter if any part is damaged (Figures 12-64 and 12-65).

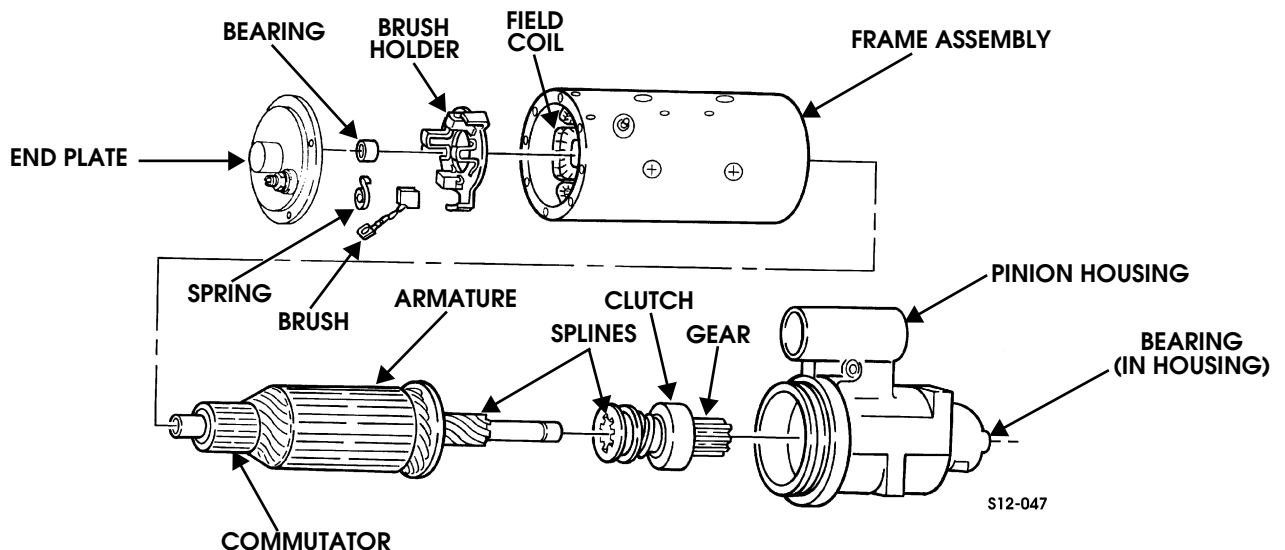

Figure 12-63: Starter Components

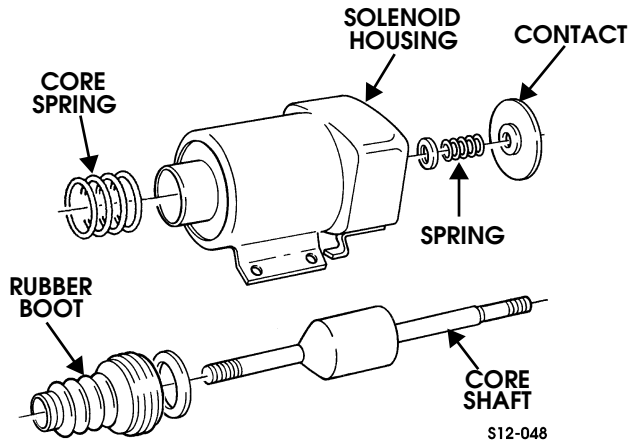

Figure 12-64: Solenoid Components

Starter Assembly

1. Assemble washer, rubber boot, spring retainer, spring, and spring retainer on core shaft and secure with snap ring (Figure 12-61).
2. Place core shaft assembly in solenoid housing.
3. Install washer, spring, contact, washer and locknut on core shaft.
4. Place gasket on cover and secure series winding lead to lug with screw and washer (Figure 12-61).
5. Install cover and gasket on solenoid housing and secure with four rubber washers and nut and lockwasher assemblies.
6. Install negative brushes and positive brushes in brush holders and retain with four springs (Figure 12-60).
7. Connect positive brush leads to field coil brackets with two screws.
8. Connect negative brush leads to frame with copper washers, screws, lockwashers, and nuts.
9. Cover negative lead screw heads with silicone adhesive sealant.
10. Apply chassis grease to armature shaft, shift lever studs, groove of clutch, and inside diameter of end plate (Figure 12-63).
11. Place washer, end plate, and gasket on armature shaft.
12. Place washer, clutch, and pinion stop on armature shaft and retain with snap ring. Position armature and shift lever in position shown for installation (Figure 12-59).
13. Install shift lever on clutch with shift lever studs engaged in clutch groove.
14. Start shift lever into pinion housing as armature is positioned in large bore of pinion housing. Then install screws through armature plate into pinion housing. Tighten screws to 40 lb-in. (5 N•m) (Figure 12-59).
15. Insert pin through pinion housing and shift lever. Then install two plugs in pinion housing (Figure 12-58).

16. Install O-ring and gasket in pinion housing (Figure 12-66).
17. Coat end plate-to-frame screws with adhesive sealant.

CAUTION: As armature is inserted into frame assembly, carefully align brushes on commutator. Brushes chip and break easily.

18. Align scribe marks on frame and pinion housing, and install armature and pinion housing in frame assembly. Install and tighten screws to 50 lb-in. (6 N•m).
19. Saturate felt wick with engine oil and install in end plate (Figure 12-65).

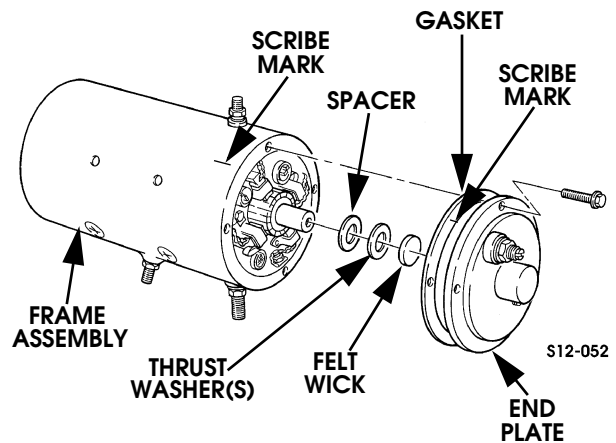

Figure 12-65: Starter End Plate Installation

20. Install spacer and thrust washers on armature shaft.
21. Align scribe marks on end plate and frame and install end plate. Tighten end plate screws to 25 lb-in. (3 N•m).
22. Coat threads of end plate screws with adhesive sealant.
23. Install end plate screws.
24. Check end play as described in following procedure.
25. Coat ribbed area of core shaft boot with lithium grease (Figure 12-67).
26. Align end of core shaft in hole in shift lever and install solenoid on frame. Tighten solenoid screws to 50 lb-in. (6 N•m).
27. Install core shaft nut. Tighten nut with socket, fabricated tool, and hex wrench (Figure 12-55)

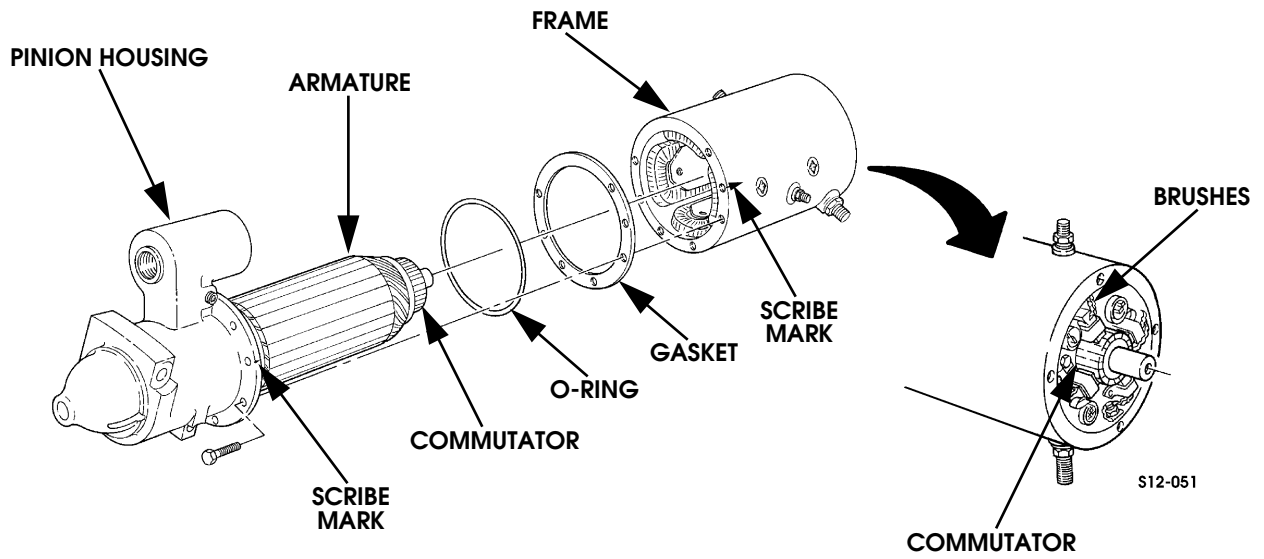

Figure 12-66: Assembling Frame, Armature, and Pinion Housing

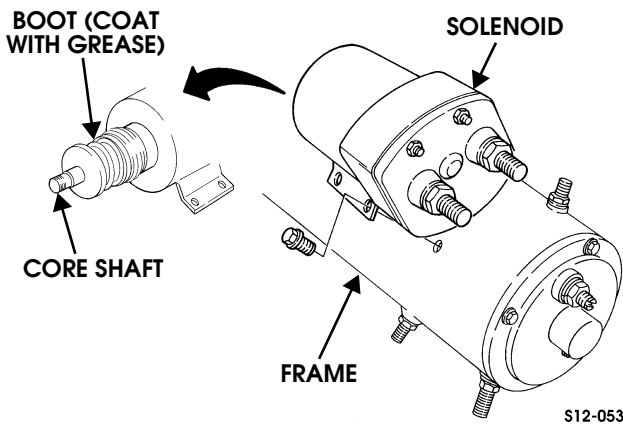

Figure 12-67: Solenoid Boot Installation

Starter Pinion Clearance

Adjustment

1. Connect battery and jumper to starter as shown (Figure 12-68). Momentarily touch jumper to solenoid frame to shift pinion into cranking position.

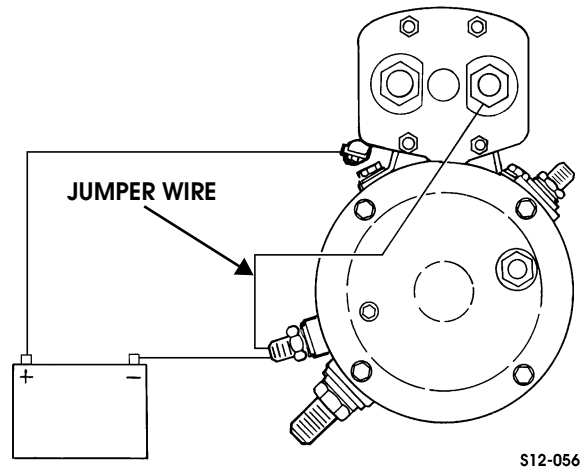
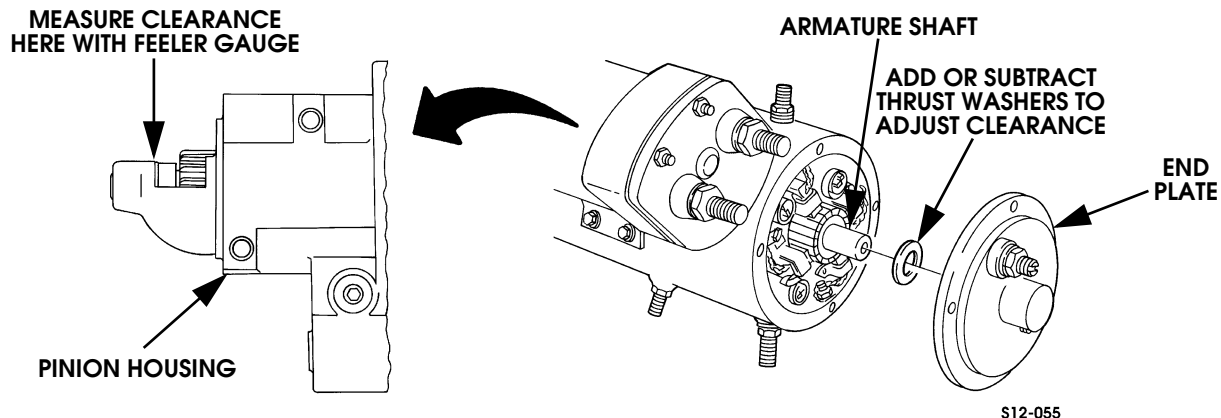

Figure 12-68: Battery and Jumper Connections for Pinion Clearance Check

2. Check clearance between pinion and snap ring with feeler gauge (Figure 12-69).
3. Disconnect battery.
4. Pinion clearance should be 0.005-0.030 in. (0.127-0.762 mm). If adjustment is necessary, remove end plate and add or remove thrust washer(s) (Figure 12-69).



S12-055

Figure 12-69: Starter Pinion Clearance Measurement and Adjustment

Starter Test

1. Connect voltmeter, ammeter, switch and battery to starter as shown (Figure 12-70).

CAUTION: Do not operate the starter motor for more than 10 seconds at a time. Allow the starter motor to cool at least 2 minutes between tests to avoid overheat damage.

WARNING: Starter must be secured to prevent movement from start up torque. Test cables must be of a sufficient gauge size to conduct starter current.

2. Close switch, adjust voltage to 9.5 volts on voltmeter using carbon pile. Check rotating speed of armature with tachometer. Read current draw on ammeter.
3. Maximum current draw should be 65 amps with a minimum armature speed of 5000 rpm. If a low speed, high current condition exists, check armature for shorts or grounds. If a low speed, low current draw exists, inspect starter motor for bad connections or poor brush contact.

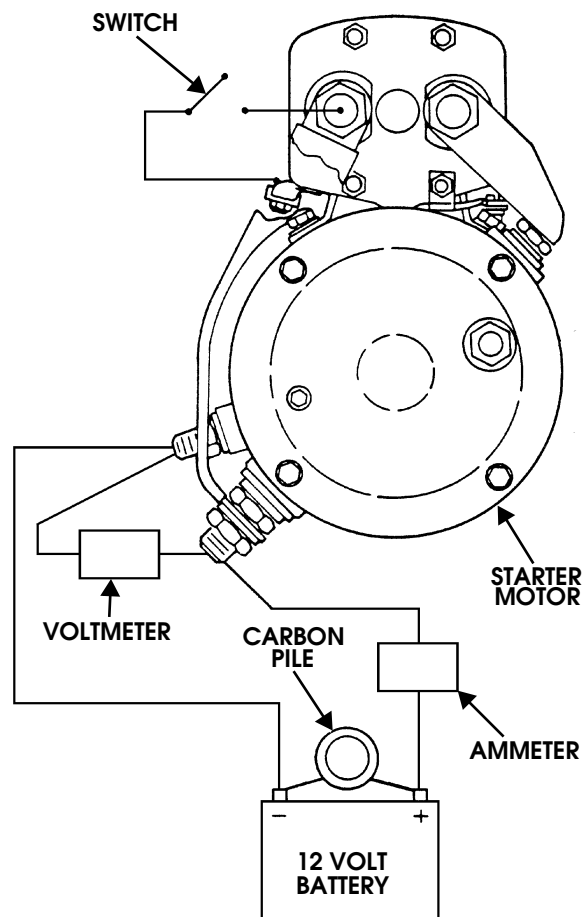

S12-060

Figure 12-70: Starter Test Connections

**Starter Inoperative**

Step	Action	Value(s)	Yes	No
1	Inspect battery condition and charge (Refer to battery checking procedure this section). Are batteries in good working condition and charged?		Go to step 2	Recharge/Replace batteries as necessary
2	Using a DVOM set to measure voltage, place the ground lead on a known good ground, and the positive lead on the large blue wire at the starter solenoid (CKT34). Have a helper turn the key to start. Does the meter display adequate voltage?	12v	Repair or replace starter and/or solenoid as necessary	Go to step 3
3	Using a DVOM set to measure resistance, measure resistance between starter body and ground terminal at the batteries. Does resistance meet specifications?	<.2Ω	go to step 4	Repair open or bad connection in ground circuit between starter and batteries
4	Locate the start relay attached to the exterior fuse box bracket. Using a DVOM set to measure voltage Back probe the 10 ga. lt. blue wire (CKT34). Rotate the ignition to start. Is voltage present?	12v	Repair open or short to ground in CKT34 between the start relay and the starter solenoid.	Go to step 5
5	Using a DVOM set to measure voltage, place the ground lead on a known good ground, and the positive lead on the 10 ga. yel wire(CKT37) at the start relay. Is voltage present ?	12v	Go to step 6	Repair open or short to ground in CKT37 between start relay and batteries.
6	Using a DVOM set to measure voltage, place the ground lead on a known good ground, and the positive lead on the small light blue wire at the start relay (CKT32). Rotate the ignition to start. Does the meter display adequate voltage?	12v	Go to step 7	Go to step 8
7	Using a DVOM set to measure ohms, place the negative lead on a known good ground and probe the black wire at the start relay(CKT59). With the ignition switch off, does resistance read below specified?	<.2Ω	Replace Start Relay.	Repair open or bad connection in CKT59 between start relay and ground.
8	Disconnect the white wire (CKT33) at the shifter under the vehicle. Using a DVOM set to measure voltage, place the negative lead on a known good ground, and the positive lead on the white wire (CKT33) on the vehicle body harness. Have a helper rotate the key to start. Is adequate voltage displayed?	12v	Go to step 9	Go to step 11
9	Disconnect the blue wire(CKT32)at the shifter housing. Tag leads for installation. Using a DVOM set to measure ohms, measure resistance across the neutral safety switch. Is resistance below specification?	<.2Ω	Go to step 10	Replace neutral safety switch and recheck.



Starter Inoperative (Continued)

Step	Action	Value(s)	Yes	No
10	Repair open or bad connection in CKT32 between neutral safety switch and start relay. Is condition repaired		Repair complete	Go to step 1.
11	Remove lower cover of steering column to access the ignition switch connector. Back probe the white wire (CKT33) with the positive lead of a DVOM set to measure voltage. Place the ground lead on a known good ground. Turn the ignition switch to crank. Is voltage present?	12v	Repair open or short to ground in CKT33 between Ignition switch and the neutral safety switch.	Go to step 12
12	Using a DVOM set to measure voltage, place the negative lead on known good ground and back-probe the yellow wires (CKT37) at the ignition switch connectors. Is voltage present?	12v/12v	Replace ignition switch.	Repair open or short to ground in CKT37 between maxi fuse and Ignition switch.

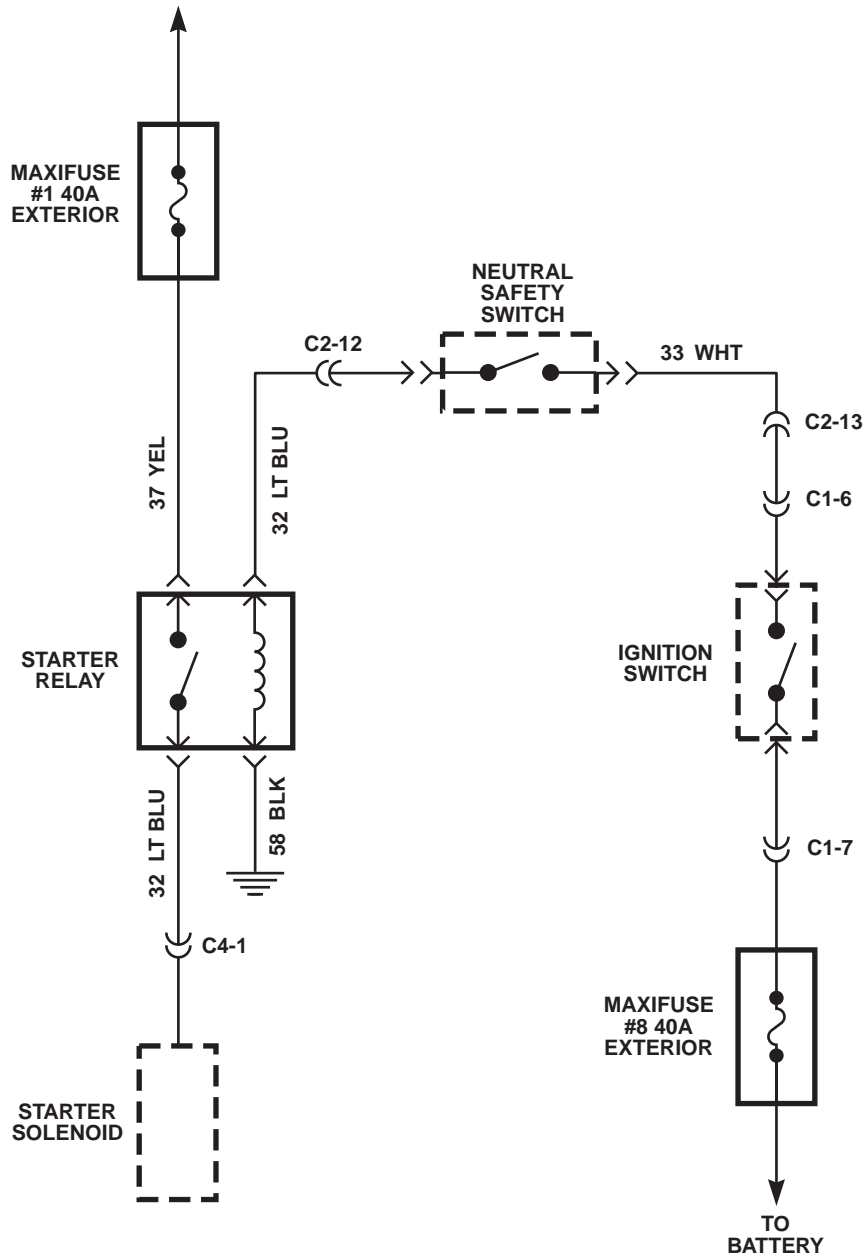

9-S12-087.2

Figure 2-71: Starter System Schematic



Glow Plugs Inoperative

Step	Action	Value	Yes	No
1	Before clearing any DTC's, use the scan tool Capture Info to save the Freeze Frame and Failure Records for reference. The PCM's data is deleted once the Clear Info function is used. Did you perform the On-Board Diagnostic (OBD) System Check?		Go to step 2.	
2	If DTC P0380 is set after a PCM reflash. Connect a scan tool. Turn the ignition ON leaving the engine OFF. Observe the Glow Plug System Type parameter on the scan tool. Does the scan tool display the Glow Plug System Type as California?		Go to step 3.	Go to (LINK-GO TO-REPAIR-609502) Glow Plug System Type Relearn
3	Connect a scan tool. Turn the ignition ON leaving the engine OFF. Use the scan tool to command the glow plugs ON and OFF. Observe the Glow Plug System Type parameter on the scan tool. Does the digital multimeter (DMM) display a voltage near the first specified value with the glow plug commanded ON and near the second specified value with the glow plug commanded OFF?	5.0-5.6 Volts 0.9-1.5 Volts	Go to step 7.	Go to step 4.
4	Does the scan tool display a glow plug voltage greater than the specified value?	5.6 Volts	Go to step 21.	Go to step 5.
5	Does the scan tool display a glow plug voltage greater than the specified value?	0.3 Volts	Go to step 10.	Go to step 6.
6	Turn the ignition ON leaving the engine OFF. Touch the battery feed stud on the glow plug controller with an unpowered test lamp connected to ground. Is the test light ON?		Go to step 8.	Go to step 25.
7	The DTC is intermittent. If any additional DTC's were stored, refer to those table(s). Were there any additional DTC's stored?		Go to the applicable DTC table.	Go to Diagnostic Aids.
8	Disconnect the glow plug relay control connector. Turn the ignition ON with the engine OFF. With an unpowered test lamp connected to ground, probe the glow plug relay harness ignition feed circuit (CKT 239 PK). Is the test light ON?		Go to step 9.	Go to step 16.
9	Turn the ignition ON with the engine OFF. Connect an unpowered test lamp to B+, probe the glow plug relay ground circuit (BK). Is the test light ON?		Go to step 10.	Go to step 17.



Glow Plugs Inoperative (Cont'd)

Step	Action	Value	Yes	No
10	Turn the ignition ON with the engine OFF. Verify that the glow plug relay control harness is disconnected. With a DMM connected to ground, probe the glow plug relay control circuit (466 YL) at the glow plug relay harness connector. Use a scan tool to command the glow plugs ON and OFF. Does the DMM display a voltage near the first specified value with the glow plugs commanded ON and near the the second specified voltage with glow plugs commanded OFF?	9-12 Volts 0 volts	Go to step 12.	Go to step 11.
11	Is the voltage equal to or more than the specified value all the time?	1.0 Volt	Go to step 23.	Go to step 18.
12	Turn the ignition ON leaving the engine OFF. Reconnect the glow plug relay control harness. With a DMM connected to ground, backprobe the glow plug relay signal circuit (506 LB) at the PCM harness connector. Use a scan tool to command the glow plugs ON. Observe the DMM while the glow plugs are commanded ON. Is the voltage at the specified value?	5.0-5.6 Volts	Go to step 21.	Go to step 13.
13	Turn the ignition OFF. Disconnect the right and left bank glow plug output circuit connectors at the glow plug relay. With an unpowered test lamp connected to B+, probe each circuit. Does each circuit turn ON the test lamp?		Go to step 26.	Go to step 14.
14	Turn the ignition OFF. Disconnect each glow plug connector at the glow plug that did not illuminate the test lamp. With an unpowered test lamp connected to B+, probe the terminal on the glow plug. Does each glow plug illuminate the test lamp?		Go to step 26.	Go to step 25.
15	Turn the ignition OFF. Disconnect each glow plug connector at the glow plug. With an unpowered test lamp connected to B+, probe each circuit at the glow plug output connectors. Is the test lamp OFF at each of the circuits?		Go to step 20.	Go to step 27.
16	Repair an open or a short to ground in the glow plug relay ignition feed circuit (CKT 239 PK). Did you complete the repair?		Go to step 30.	
17	Repair any opens or poor connections in the glow plug relay ground circuit (BK). Did you complete the repair?		Go to step 30.	
18	Inspect the glow plug relay control circuit (466 YL) for an open or short to ground. If the glow plug relay control circuit is open or shorted to ground, repair as necessary. Did you find and correct the condition?		Go to step 30.	Go to step 19.



Glow Plugs Inoperative (Cont'd)

Step	Action	Value	Yes	No
19	Inspect the glow plug relay control circuit (CKT 466 YL) for a proper connection at the PCM and replace the terminal if necessary. Did you find an improper connection and make the necessary repair?		Go to step 30.	Go to step 29.
20	Inspect the glow plug relay signal circuit (CKT 506 LB) for an open or short to ground. If the glow plug relay signal circuit is open or shorted to ground, repair as necessary. Did you find and correct the condition?		Go to step 30.	Go to step 28.
21	Inspect the glow plug relay signal circuit (CKT 506 LB) for a proper connection at the PCM and replace the terminal if necessary. Did you find an improper connection and make the necessary repair?		Go to step 30.	Go to step 22.
22	Test for a short to voltage in the glow plug relay signal circuit (CKT 506 LB). Did you find the improper condition?		Go to step 30.	Go to step 28.
23	Test for a short to voltage in the glow plug relay control circuit (CKT 466 YL) . Did you find and correct the condition?		Go to step 30.	Go to step 29.
24	Repair the open or poor connection on the battery feed circuit. Did you complete the repair?		Go to step 30.	
25	Replace any glow plug that did not illuminate the test lamp. Did you complete the repair?		Go to step 30.	
26	Repair the open or poor connections in the glow plug harness. Did you complete the repair?		Go to step 30.	
27	Repair the short to ground in the glow plug harness. Did you complete the repair?		Go to step 30.	
28	Replace the glow plug relay. Did you complete the repair?		Go to step 30.	
29	THE NEW PCM MUST BE PROGRAMMED. Replace the PCM. Did you complete the repair?		Go to step 30.	



Glow Plugs Inoperative (Cont'd)

Step	Action	Value	Yes	No
30	Use a scan tool to clear the DTC's. Start the engine. Allow the engine to idle until the engine reaches normal operating temperature. Select the DTC and the specific DTC function. Enter the DTC number which was set. Operate the vehicle, with the Conditions for Setting this DTC, until the scan tool indicates the diagnostic Ran. Does the scan tool indicate the diagnostic Passed?		Go to step 31.	Go to step 2.
31	Does the scan tool display any addition undiagnosed DTC's?		Go to the applicable DTC table.	System OK.

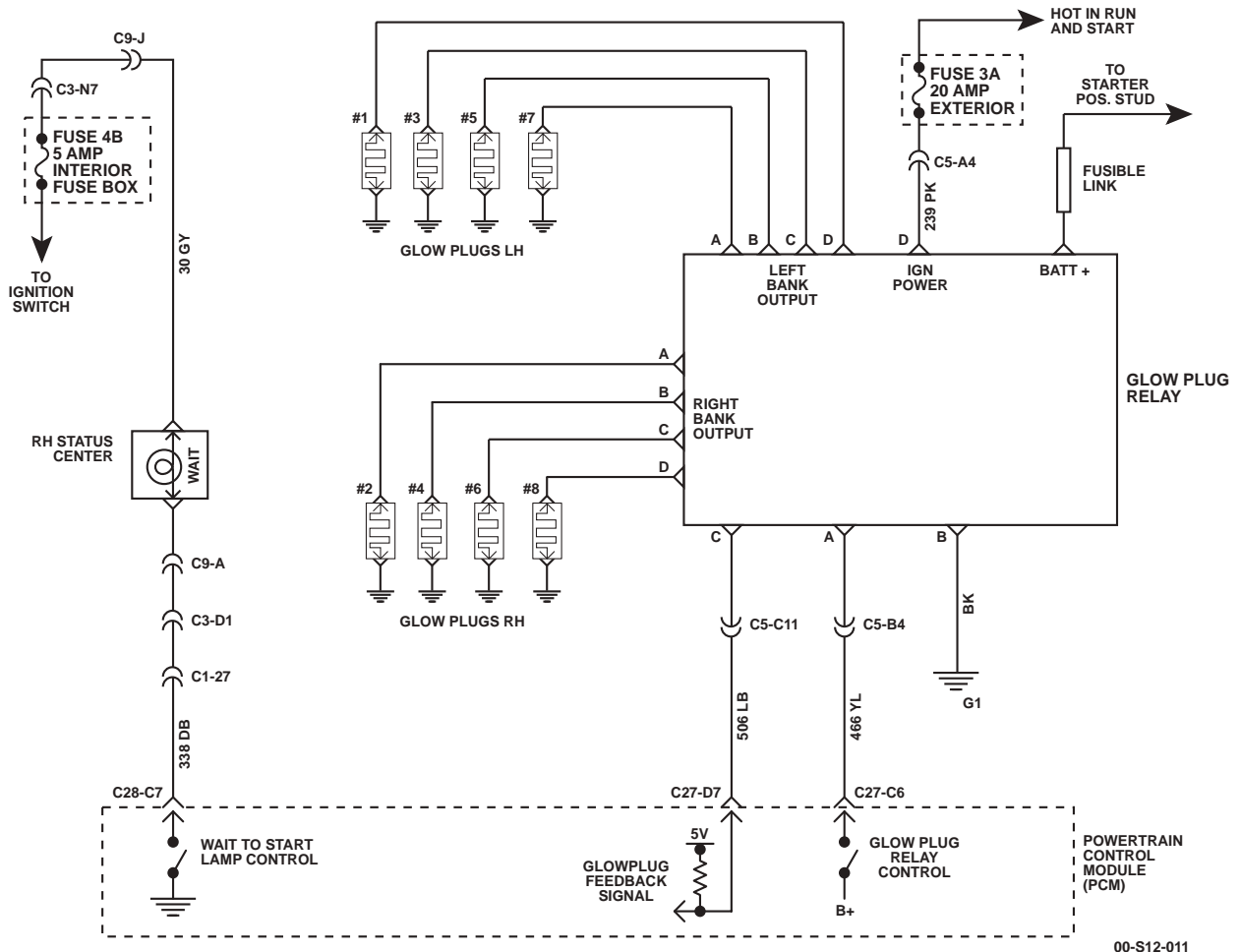

Figure 2-72: Glow Plug Control Circuit Schematic



Fuel Lift Pump Inoperative VIN Z

Step	Action	Value(s)	Yes	No
1	Important: Before clearing the DTC's use the scan tool Capture Info in order to record the Freeze Frame and the failure records for reference, as the data will be lost when the clear function is used. Was the On-Board Diagnostic (OBD) System Check performed?		Go to step 2.	Go to Powertrain OBD system check.
2	Turn the ignition OFF for 10 seconds. Turn the ignition ON. Does the fuel pump operate during the glow plug cycle?		System OK, problem may be intermittent.	Go to step 3.
3	Disconnect the fuel lift pump connector. Using a DVOM set to measure voltage, place the ground lead on a known good ground, and the positive lead on the grey wire (CKT787) at the fuel lift pump engine harness connector. Turn the ignition OFF for 10 seconds. Turn the ignition ON. Is voltage present?	12v	Go to step 4.	Go to step 5.
4	Place ground lead of DVOM on the black wire (CKT57) at the fuel lift pump engine harness connection. With the positive lead still on the grey wire (CKT787) Turn the ignition OFF for 10 seconds. Turn the ignition ON. Is voltage present?	12v	Replace fuel lift pump.	Go to step 5.
5	Reconnect the fuel lift pump, Disconnect the fuel lift pump relay. Using a DVOM set to measure voltage, place the ground lead on known good ground, and place the positive lead on the org wire (CKT537). Is voltage present?	12v	Go to step 6.	Repair open or short to ground in CKT537 between fuel pump relay and fuse 2D.
6	Place the ground lead of the DVOM set to measure voltage on the black wire (CKT57). With the positive lead still on the org wire (CKT537). Is voltage present?	12v	Go to step 7.	Repair open or short to ground in CKT57 between fuel pump relay and engine ground.
7	Using a DVOM set to measure voltage, place the ground lead on the black wire (CKT57) on the fuel lift pump relay connection. Place the positive lead on the dark green wire (CKT238). Turn the ignition OFF for 10 seconds. Turn the ignition ON. Is voltage present?	12v	Replace the fuel lift pump relay.	Go to step 8.
8	Reconnect the fuel lift pump relay. Using the scan tool, command the fuel pump relay "on". Does the pump run?	12v	Check for open in CKT787 between the fuel lift pump relay and the PCM 32pin xxxx connector pin D5.	Go to step 9.



Fuel Lift Pump Inoperative VIN Z (Cont'd)

Step	Action	Value(s)	Yes	No
9	Disconnect fuel lift pump relay. Using a DVOM set to measure ohms, measure resistance between C27-D5, and the fuel lift pump relay dark green wire (CKT238). Does resistance exceed specifications?	$<.2\Omega$	Repair open or bad connection in CKT 238 between PCM and fuel lift pump relay.	Go to step 10.
10	Using a DVOM set to measure ohms, measure continuity to ground between the dark green wire (CKT238) and engine ground. Is continuity present?		Repair short to ground in CKT238.	Go to step 11.
11	Replace PCM. Is repair complete?		Go to step 12.	
12	Turn the ignition OFF for 10 seconds. Turn the ignition ON. Does the fuel pump operate during the glow plug cycle?		Repair completed.	Go to step 1.

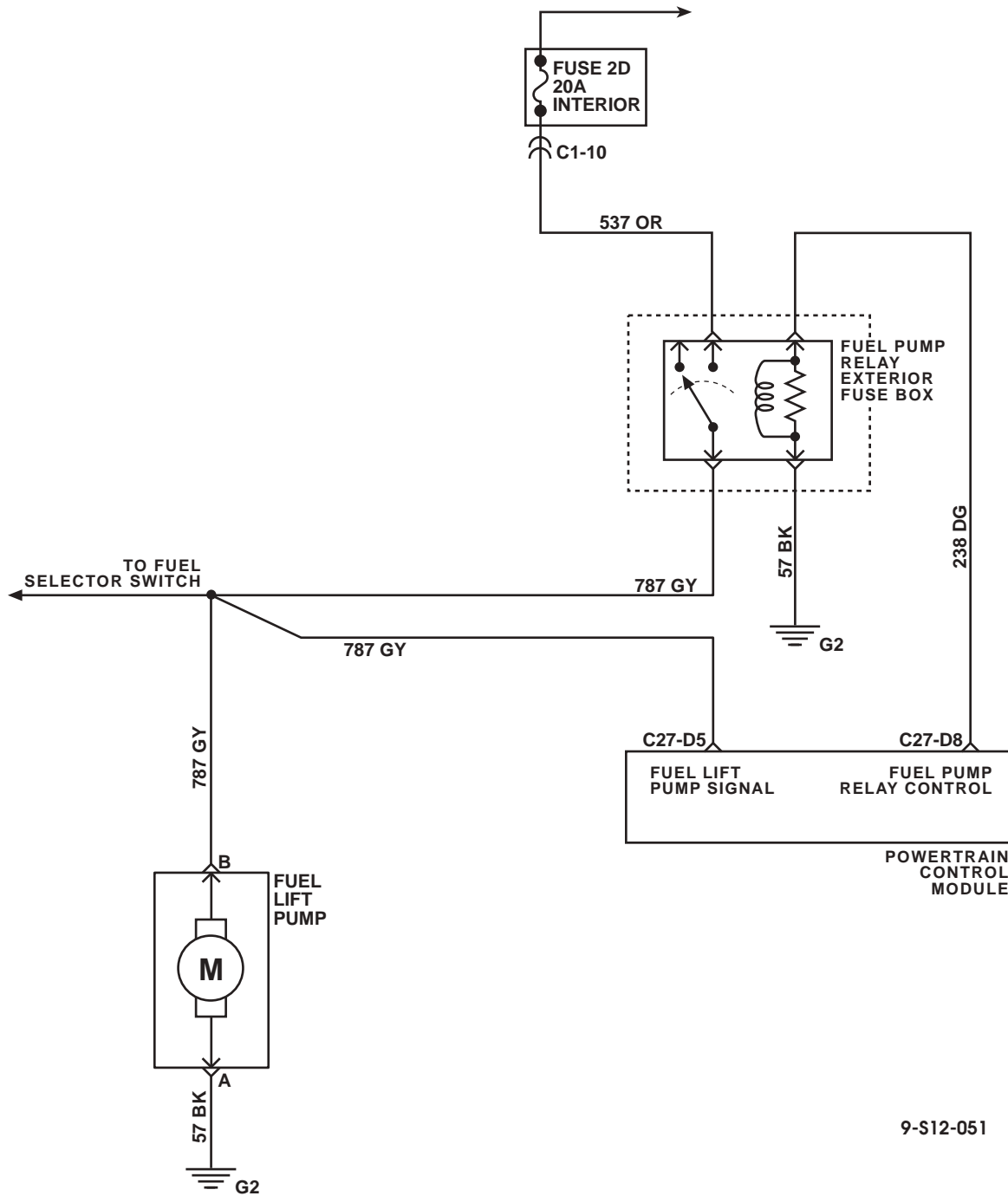

9-S12-051

Figure 2-73: Fuel Lift Pump Schematic

**Fuel Tank Selector System Inoperative (No Tank Switch)**

Step	Action	Value(s)	Yes	No
1	<p>Important: Before clearing the DTC's use the scan tool Capture Info in order to record the Freeze Frame and the failure records for reference, as the data will be lost when the clear function is used.</p> <p>Was the On-Board Diagnostic (OBD) System Check performed?</p>		Go to step 2.	Go to Powertrain OBD system check.
2	Turn the ignition OFF for 10 seconds. Turn the ignition ON. Does the fuel pump operate during the glow plug cycle?		Go to step 3.	Diagnose Fuel lift pump first.
3	Remove fuel tank selector switch from dash, and disconnect switch from harness. Using a DVOM set to measure resistance, probe the black wire of the fuel selector switch connector (CKT 59) with the black lead, and the positive lead on the ground studs at left of dash. Is resistance below specification?	$<.2 \Omega$	Go to step 4	Repair open or bad connection in CKT 59 between fuel selector switch and IP ground studs.
4	Using a DVOM set to measure voltage, place the ground lead on the negative studs to right of the IP panel. Place the positive lead on the grey wire (CKT 787) at the fuel tank selector switch. Turn the ignition OFF for 10 seconds. Turn the ignition ON. Does the meter read voltage?	12 v	Go to step 5	Repair open or short to ground in CKT 787 fuel pump relay and fuel selector switch
5	Re-connect fuel tank selector switch. Using a DVOM set to measure voltage, backprobe the red wire (CKT 786) with the negative lead and brown wire (CKT 789) with the positive lead. Turn the ignition OFF for 10 seconds. Turn the ignition ON. With the switch in the AUX position voltage should be present, when the switch is moved to the MAIN position, reverse polarity voltage should be present. If fuel pump shuts off during test, repeat cycle of key. Does meter show opposite voltages when moved between AUX and MAIN	12 v+=AUX 12 v-=MAIN	Go to step 5.	Replace fuel tank selector switch and recheck system.
6	Disconnect fuel selector valve electrical connection. Using a DVOM set to measure voltage, probe the brown wire with the positive lead, and the red lead with the negative lead. Turn the ignition OFF for 10 seconds. Turn the ignition ON. With the switch in the AUX position voltage should be present, when the switch is moved to the MAIN position, reverse polarity voltage should be present. Does meter show opposite voltages when moved between AUX and MAIN	12 v+=AUX 12 v-=MAIN	Replace fuel selector valve	Go to step 7.



Fuel Tank Selector System Inoperative (No Tank Switch)

Step	Action	Value(s)	Yes	No
7	Relocate the ground lead of the DVOM set to measure voltage to a known good ground. Turn the ignition OFF for 10 seconds. Turn the ignition ON, and the tank selector switch in the AUX position, probe the brown wire (CKT 789) with the positive meter lead. Is voltage present?	12 v	Go to step 8.	Repair open, bad connection or short to ground in CKT 789 between the fuel selector switch and valve.
8	Turn the ignition OFF for 10 seconds. Turn the ignition ON, and the tank selector switch in the MAIN position, probe the red wire (CKT 786) with the positive meter lead, the ground lead should be on a know good ground. Is voltage present?	12 v	No electrical problems found, problem may be intermittent or mechanical.	Repair open, bad connection or short to ground in CKT 786.

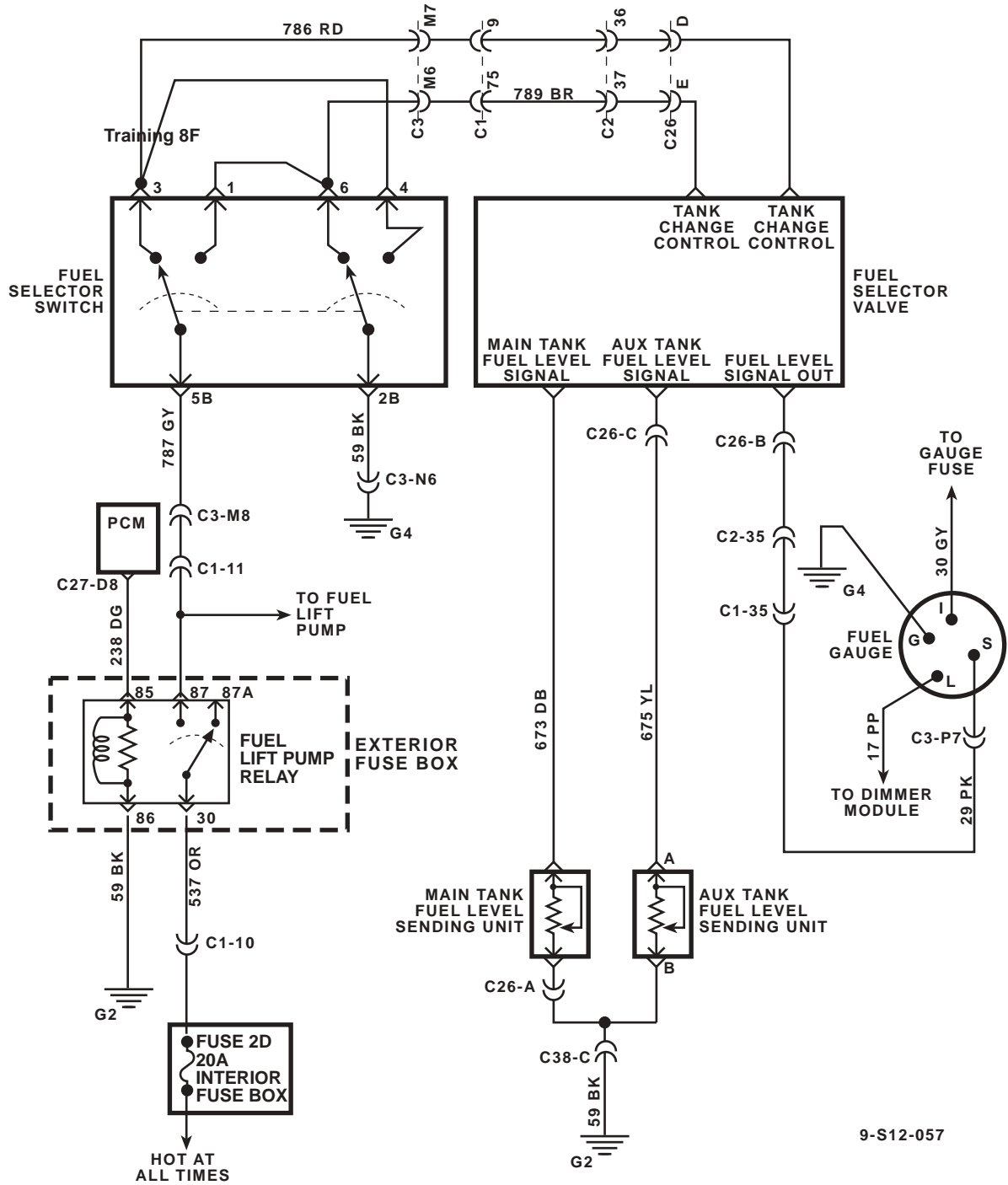

9-S12-057

Figure 2-74: Fuel Selector Valve Schematic

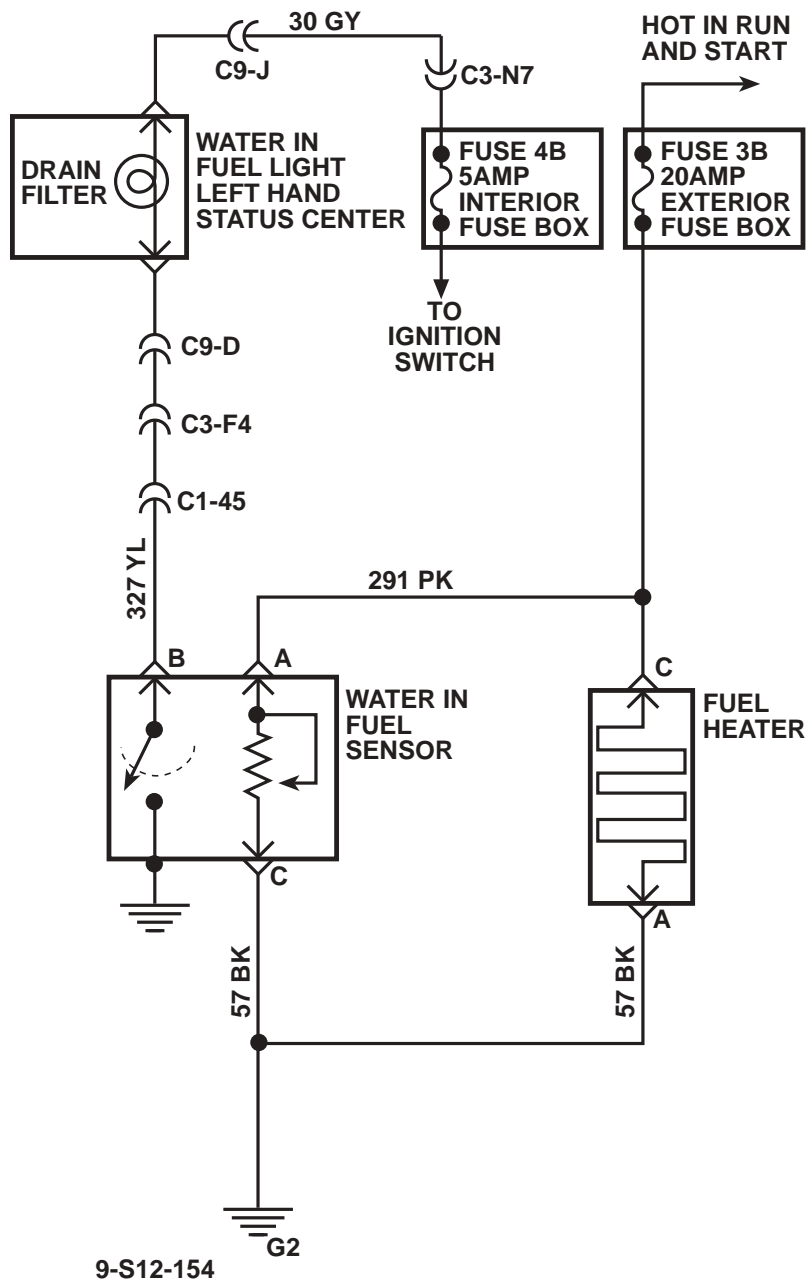

Figure 2-75: Fuel Manager Schematic



IGNITION SWITCH REPLACEMENT

Removal

1. Remove steering column covers.
2. Remove multi switch.
3. Remove screw and interlock cable from ignition switch (Figure 2-76).
4. Remove two capscrews and ignition switch from steering column.

Installation

1. Apply thread-locking compound to capscrew threads and install ignition switch on steering column with two capscrews.
2. Install interlock cable on ignition switch with screw.
3. Install multi switch.
4. Install steering column covers.
5. Ensure ignition switch operates properly.

Brake Shift Interlock Cable System Description (Figure 2-76)

The purpose of the brake shift interlock cable is to prevent a driver from engaging a transmission gear before the brakes are applied. When the brake pedal is depressed, voltage from the brake switch de-energizes the interlock solenoid and the cable relaxes. The transmission shift lever can then be pulled out of the park position. If electrical power is lost due to a dead battery or system failure, the solenoid defaults to the open position. With the brake/shift interlock solenoid in the open position the shifter may be moved to any position.

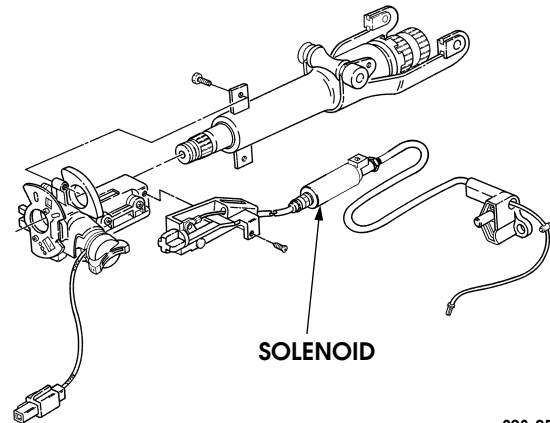

S08-058

Figure 2-76: Brake Shift Interlock Cable

Brake Shift Interlock Cable Inoperative

STEP	ACTION	VALUES	YES	NO
1	Gain access to the brake/shift interlock solenoid. Using a DVOM check for ground on the black wire (CKT 59). Does the resistance meet the specifications?	<.2 Ω	Go to step 2.	Repair the open or bad connection in CKT 59 between the interlock solenoid and G4.
2	With the ignition switch in the “run” position check the voltage at the tan wire (CKT 83). Is the specified voltage present?	12v	Go to step 3.	Repair the open or bad connection in CKT 83 between the interlock cable and fuse 1C in the interior fuse box.
3	With the ignition switch in the “run” position and the brake switch applied check the voltage at the red wire (CKT 22) on the brake shift interlock solenoid. Is the specified voltage present?	12v	Replace the brake shift interlock cable.	Go to step 4.
4	Gain access to the brake switch. With a DVOM check the voltage at the orange wire (CKT 10). Is the specified voltage present?	12v	Replace the brake switch.	Repair the open or bad connection on CKT 10 between the brake switch and fuse 4D.

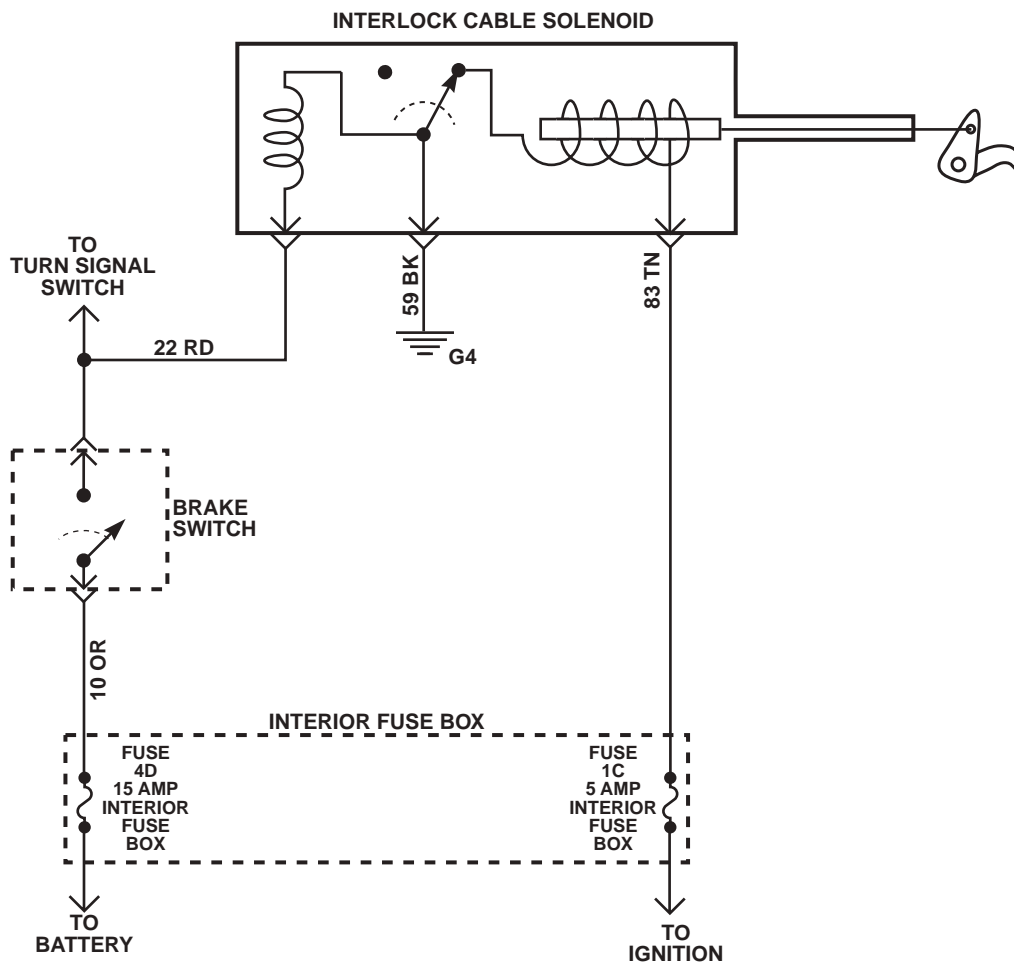

9-S12-001

Figure 2-77: Shift Interlock Cable Schematic



CTIS Compressor Inoperative

Step	Action	Value(s)	Yes	No
1	Using a DVOM set to measure voltage, probe the terminals on the CTIS compressor. With the CTIS compressor switch set to inflate, and the ignition on, is voltage present?	12v	Replace the compressor	Go to step 2.
2	Move the ground lead to a known good ground and the positive lead still on the compressor, ignition on, compressor switch on inflate. Is voltage present?	12v	Repair open or bad connection in CKT57 between compressor and G2.	Go to step 3.
3	Remove compressor relay from the exterior fuse box. Using a DVOM set to measure voltage, Probe cavity 1(CKT46) of the CTIS compressor relay socket with the positive lead, and cavity 2(CKT59) with the negative lead. Ignition on, CTIS compressor switch to on, is voltage present?	12v	Go to step 7.	Go to step 4.
4	Using a DVOM set to measure voltage, check continuity to ground at cavity 2 of the compressor relay socket. Is resistance below specification?	<.2Ω	Go to step 5.	Repair open or bad connection in CKT59 between compressor relay and G2.
5	Remove compressor switch from the dash. Using a DVOM set to measure voltage. Ignition on, compressor switch set to inflate. Check for voltage on white wire(CKT46). Is voltage present?	12v	Repair open or bad connection in CKT46 between compressor switch and relay.	Go to step 6.
6	Using a DVOM set to measure voltage, turn the ignition on. Check for voltage at both orange wires(CKT640) at the rear of the compressor switch. Is voltage present?	12v	Replace the compressor switch.	Repair open, bad connection or short in CKT640 between compressor switch and fuse 1G.
7	Using a DVOM set to measure continuity measure continuity between cavity 5(CKT437) of the compressor relay socket and the green wire(CKT437) at the compressor. Is resistance below specifications?	<.2Ω	Go to step 8.	Repair open, bad connection, or short in CKT437 between relay and compressor.
8	Using a DVOM set to measure voltage, place the positive lead in cavity 3 (CKT436) of the compressor relay. Place the ground lead in cavity 86(CKT59). Is voltage present?	<.2Ω	Replace the compressor relay.	Repair open, bad connection or short in CKT436 between compressor relay and Maxi fuse#6.



CTIS Exhaust Valve Inoperative

Step	Action	Value(s)	Yes	No
1	Disconnect exhaust solenoid. Using a DVOM set to measure voltage, probe the light green wire(CKT47) with the positive lead, and the black wire(CKT57) with the negative lead. Ignition on, move the compressor switch to deflate. Is voltage present?	12v	Replace exhaust solenoid.	Go to step 2.
2	Check continuity to ground on the black wire(CKT57) at the exhaust solenoid. Is resistance below specification?	<.2Ω	Go to step 3.	Repair open or bad connection in CKT57 between exhaust solenoid and G2.
3	Remove compressor switch. Using a DVOM set to measure voltage, check for voltage at both orange wires (CKT640). With ignition on is voltage present?	12v	Go to step 4.	Repair open, bad connection or short in CKT640 between compressor switch and fuse 1G.
4	Using a DVOM set to measure voltage, check for voltage at the light green wire(CKT47) with the ignition on and compressor switch to deflate. Is voltage present?	12v	Repair open bad connection or short in CKT 47 between compressor switch and exhaust solenoid.	Replace compressor switch.



CTIS Front Inflate Valve Inoperative

Step	Action	Value(s)	Yes	No
1	Disconnect front inflate solenoid. Using a DVOM set to measure voltage connect the positive lead to the tan wire(CKT91), and the negative lead to the black wire(CKT57). With the ignition on, selector switch set to both, and the compressor switch to inflate, is voltage present?	12v	Replace front inflate solenoid.	Go to step 2.
2	Check continuity to ground on the black wire(CKT57) at the front inflate solenoid. Is resistance below specification?	<.2Ω	Go to step 3.	Repair open or bad connection in CKT57 between front inflate valve and G2.
3	Remove selector switch and compressor switch from the I/P. Using a DVOM set to measure voltage, ignition on, and compressor switch set to inflate. Check for voltage on both yellow wires(CKT144) at rear of selector switch. Is voltage present.	12v	Go to step 6.	Go to step 4.
4	Ignition on, compressor switch on inflate, check for voltage on yellow wires(CKT144)at rear of compressor switch. Is voltage present?	12v	Repair open, bad connection or short in CKT144 between compressor switch and selector switch.	Go to step 5.
5	Ignition on, check for voltage at both orange wires(CKT640) at back of compressor switch. Is voltage present?	12v	Replace compressor switch.	Repair open, bad connection or short in CKT640 between compressor switch and fuse 1G.
6	Ignition on, compressor switch set to inflate, selector switch set to both. Check for voltage at the tan wire(CKT91) at the back of the selector switch. Is voltage present?	12v	Repair open, bad connection, or short in CKT91 between selector switch and front inflate valve.	Replace the selector switch.



CTIS Rear Inflate Valve Inoperative

Step	Action	Value(s)	Yes	No
1	Disconnect front inflate solenoid. Using a DVOM set to measure voltage connect the positive lead to the grey wire(CKT92), and the negative lead to the black wire(CKT57). With the ignition on, selector switch set to both, and the compressor switch to inflate, is voltage present?	12v	Replace rear inflate solenoid.	Go to step 2.
2	Check continuity to ground on the black wire(CKT57) at the rear inflate solenoid. Is resistance below specification?	<.2Ω	Go to step 3.	Repair open or bad connection in CKT57 between rear inflate solenoid and G2.
3	Remove selector switch and compressor switch from the I/P. Using a DVOM set to measure voltage, ignition on, and compressor switch set to inflate. Check for voltage on both yellow wires(CKT144) at rear of selector switch. Is voltage present.	12v	Go to step 6.	Go to step 4.
4	Ignition on, compressor switch on inflate, check for voltage on yellow wires(CKT144)at rear of compressor switch. Is voltage present?	12v	Repair open, bad connection or short in CKT144 between compressor switch and selector switch.	Go to step 5.
5	Ignition on, check for voltage at both orange wires(CKT640) at back of compressor switch. Is voltage present?	12v	Replace compressor switch.	Repair open, bad connection or short in CKT640 between compressor switch and fuse 1G.
6	Ignition on, compressor switch set to inflate, selector switch set to both. Check for voltage at the grey wire(CKT92) at the back of the selector switch. Is voltage present?	12v	Repair open, bad connection, or short in CKT92 between selector switch and front inflate valve.	Replace the selector switch.

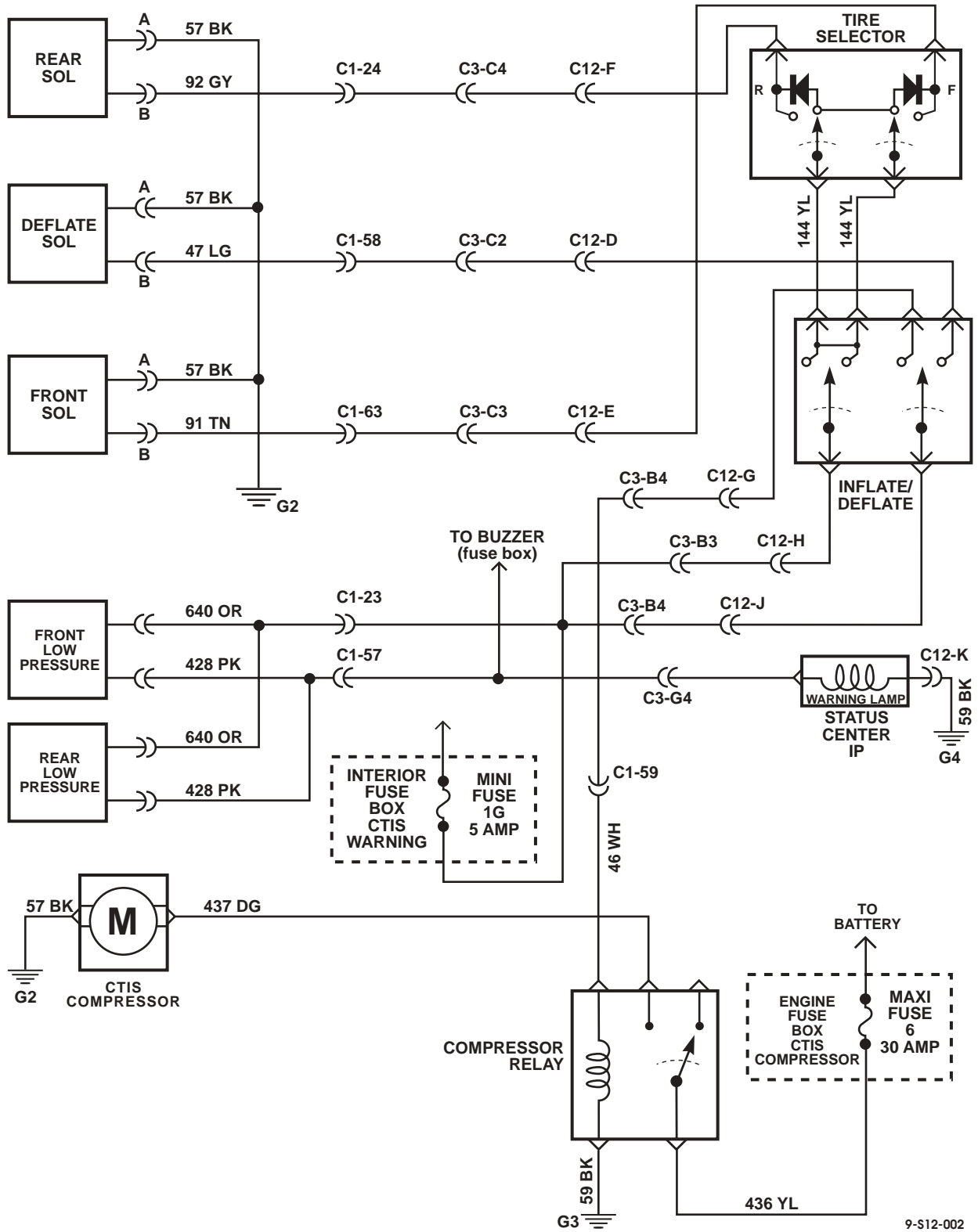
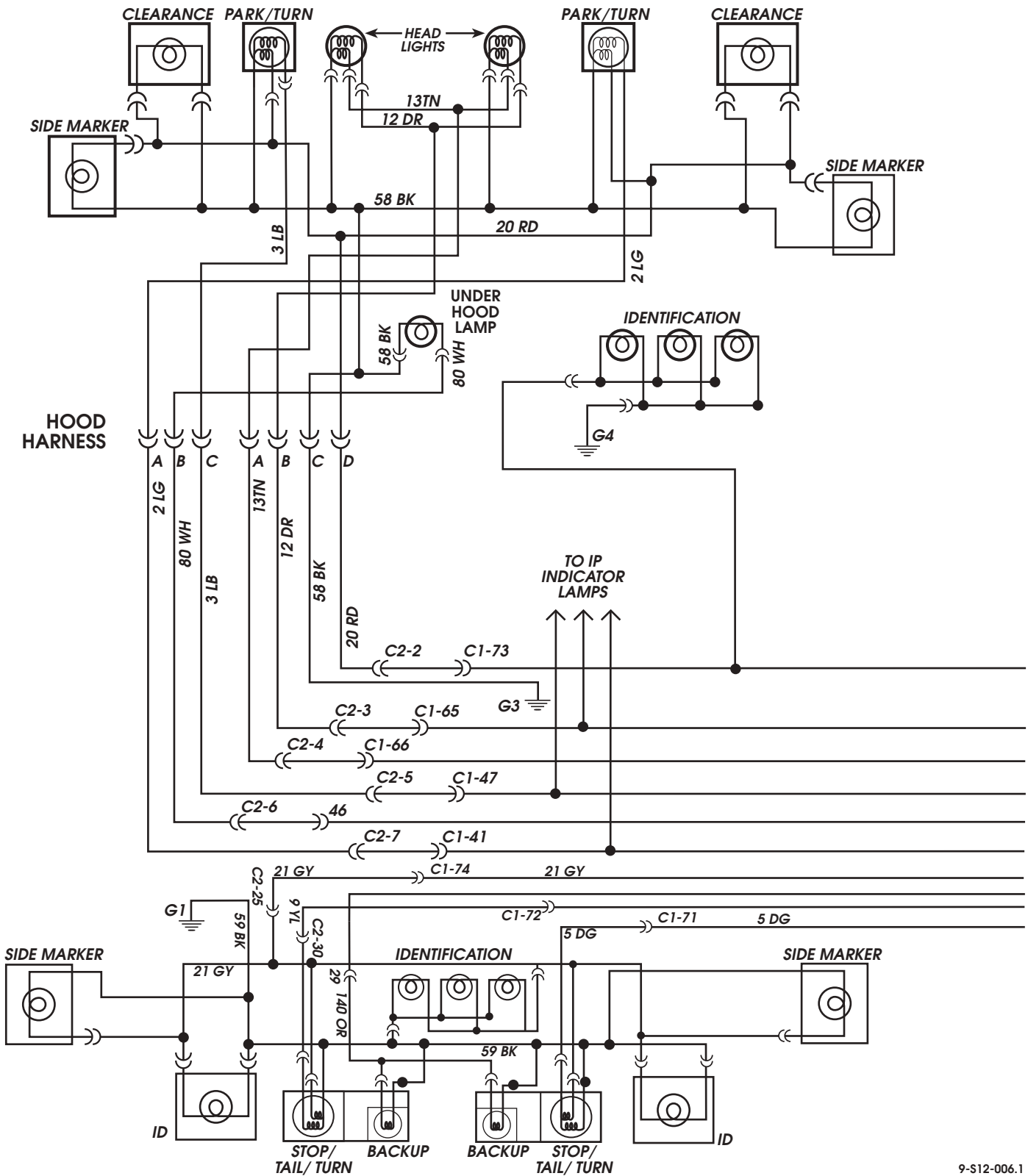
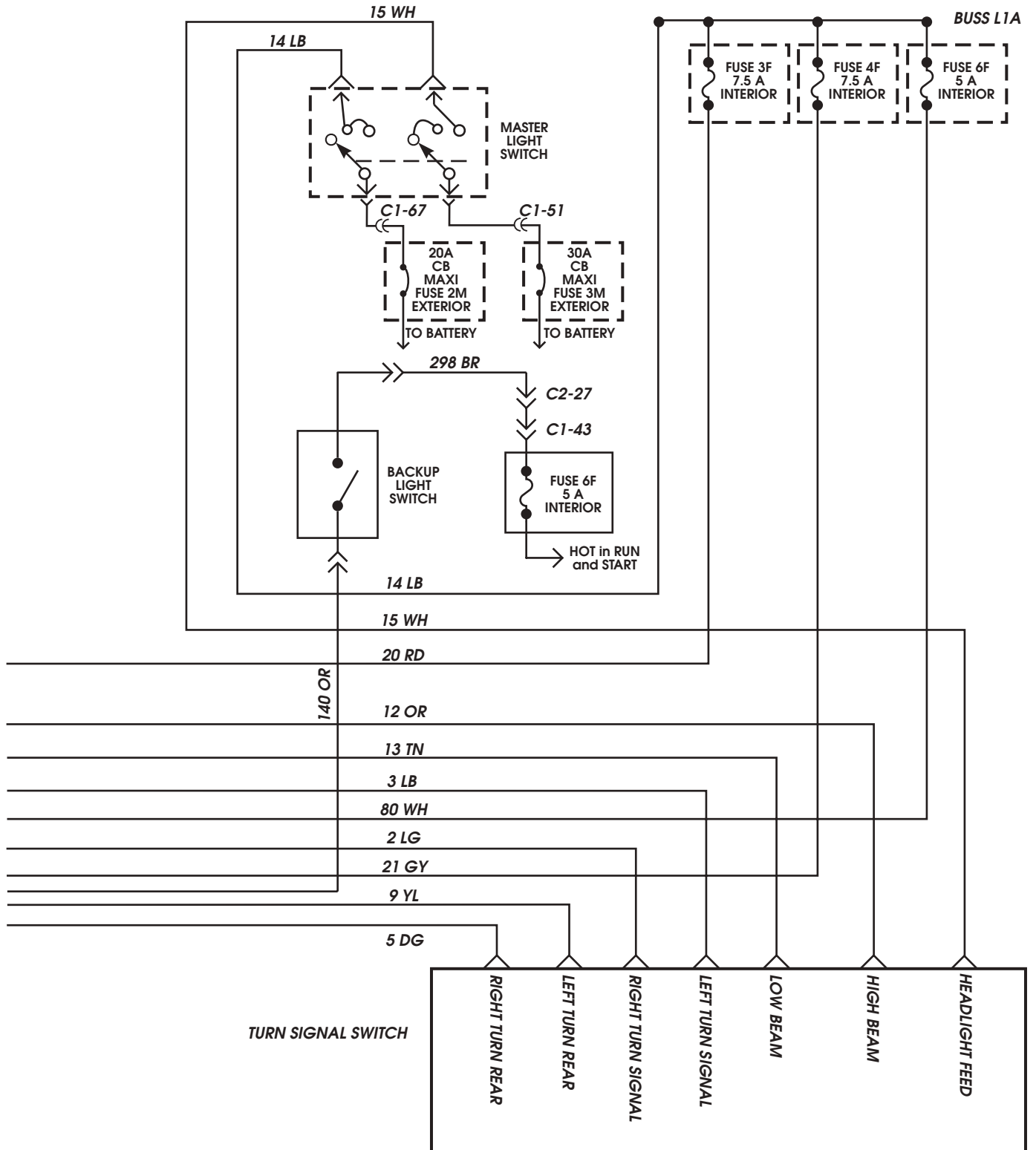

Figure 2-78: CTIS Schematic



9-S12-006.1

Figure 2-79: Lights Schematic (Sheet 1 of 2)



9-S12-007.1

Figure 2-79: Lights Schematic (Sheet 2 of 2)

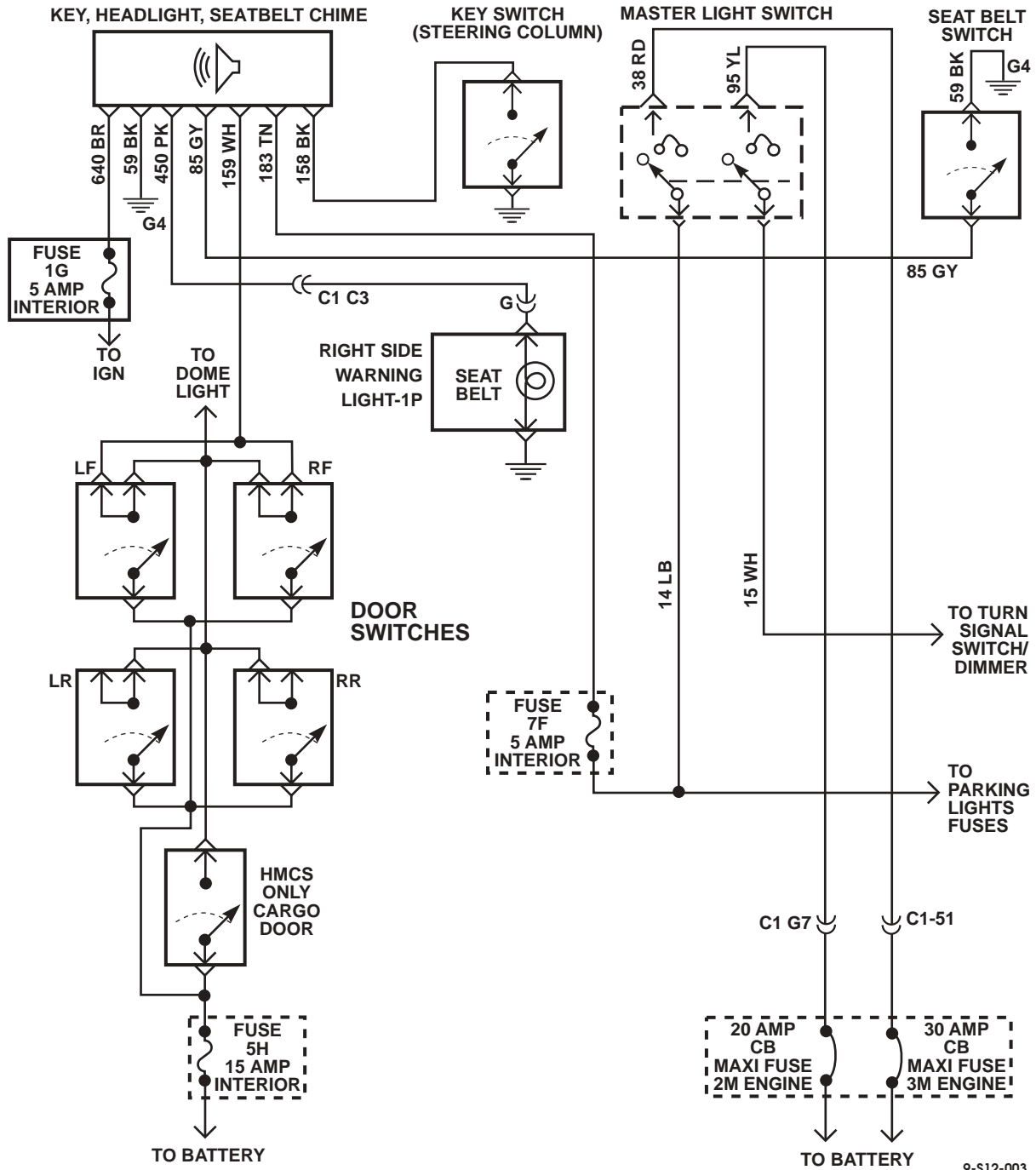

Figure 2-80: Key/Headlight Chime Schematic



HORN

Horn Replacement

Removal

1. Remove harness connectors and adapters from horn.
2. Remove nut and horn from mounting bracket (Figure 2-81).

NOTE: Overtightening horn mounting nut will distort the horn bellows and result in an “off-key” horn tone.

Installation

1. Secure horns to mounting bracket with nuts.
2. Plug harness connectors and adapters into horns.

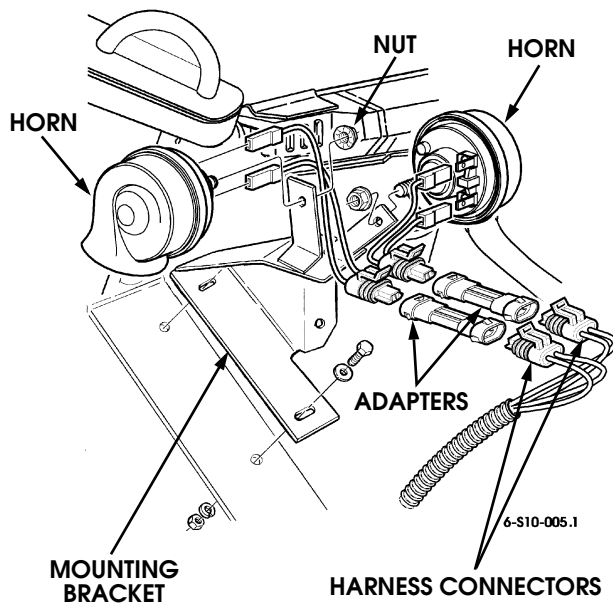

Figure 2-81: Horn and Horn Mounting Bracket Replacement

Horn Mounting Bracket Replacement

Removal

1. Remove two horns.
2. Remove bolts, washers, lockwashers, nuts, and horn mounting bracket from airlift bracket (Figure 2-81).

Installation

1. Secure horn mounting bracket to airlift bracket with bolts, washers, lockwashers, and nuts (Figure 2-81).
2. Install two horns.



Horns Inoperative

Step	Action	Value	Yes	No
1	Locate the horn assemblies under the hood. Disconnect the harness from the horn assemblies. With a DVOM check the black wires (CKT 58) for resistance to ground. Do both wires meet with specifications?	<.2 Ω	Go to step 2.	Repair the open or bad connection on CKT 58 between the horn assemblies and G2.
2	With a DVOM back probe the white wires on the horn assemblies and check for voltage when the horn button is pushed. Is the specified voltage present?	12v	Replace the horn assemblies.	Go to step 3.
3	Remove the horn relay from the exterior fuse box. With a DVOM check resistance between the relay cavity 1F and the white wire (CKT 6) on the horn assembly. Does the resistance meet the specifications?	<.2 Ω	Go to step 4.	Repair the open or bad connection in CKT 6 between the horn relay and the horn assembly.
4	With a DVOM check for voltage in cavities 3E and 1E of the exterior fuse box. Is the specified voltage present?	12v	Go to step 5.	Repair the open or bad connection in CKT 7 between the horn relay and the exterior fuse box.
5	With a DVOM check the resistance to ground on cavity 3F, of the exterior fuse box, when the horn switch is pressed. Does the resistance meet the specifications?	<.2 Ω	Replace the horn relay.	Go to step 6.
6	Gain access to connector C39. With a DVOM back probe cavity C on connector 39. Activate the horn switch and watch the resistance on the meter. Does the resistance meet the specifications?	<.2 Ω	Repair the open or bad connection on CKT 1 between the horn switch and the horn relay.	Replace the turn signal assembly.

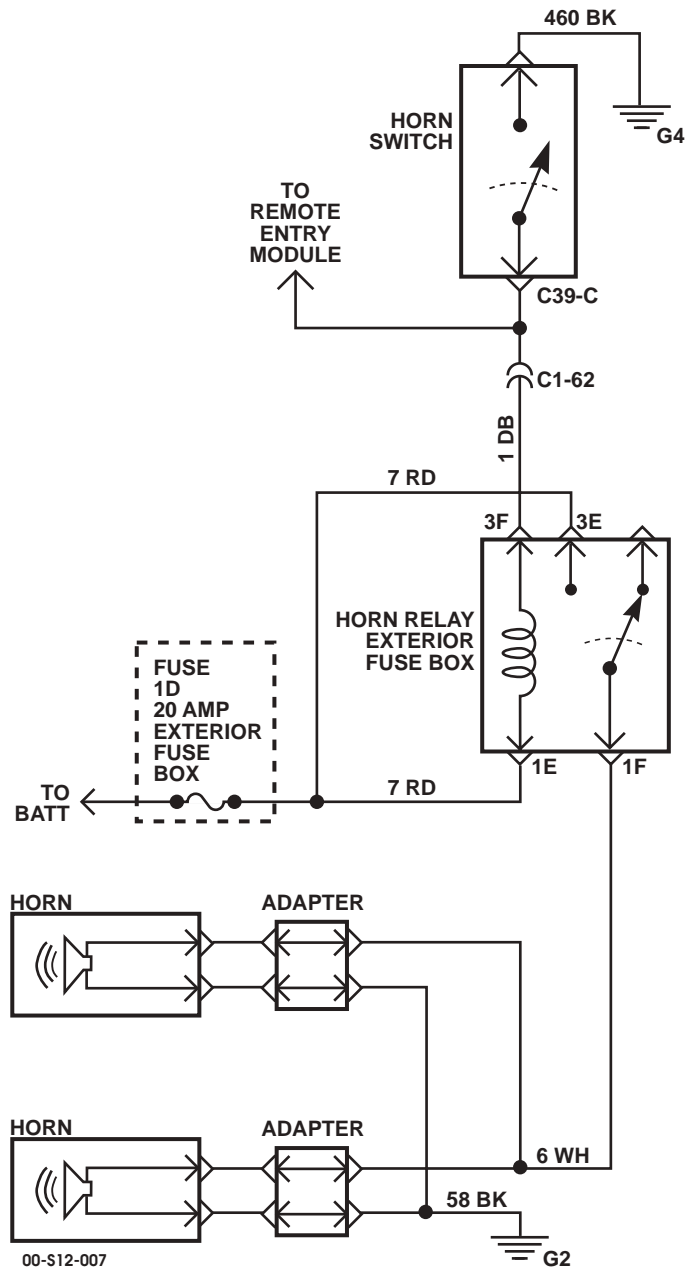

00-S12-007

Figure 2-82: Horn Schematic



INSTRUMENT PANEL, GAUGES, AND SWITCHES

Instrument Panel (I.P.) Replacement

Removal

NOTE: Tag all leads prior to removal for installation. If replacing instrument panel, refer to procedures in this section to remove and/or disconnect the various lamps, switches, and gauges.

1. Disconnect negative battery cables (Section 12).
2. Remove left side crashpad.
3. Remove close-out panel.
4. Remove wiring harness close-out plate.
5. Remove tachometer and clock assembly from I.P. to access right side I.P. mounting bolt.
6. Remove right side I.P. mounting bolt.
7. Remove two bolts securing I.P. to steering column.
8. Remove two left side I.P. mounting bolts securing I.P. to A-pillar.
9. Disconnect air hose from side window defrost vent.
10. Remove I.P.

Installation

1. Maneuver I.P. into position between steering wheel and firewall.
2. Connect air hose side window defrost vent.
3. Loosely install left side I.P. mounting bolts.
4. Loosely install I.P. to steering column mounting bolts.
5. Install right side I.P. mounting bolts
6. Tighten loosely installed bolts from steps 3 and 4.
7. Install tachometer and clock assembly.
8. Install wiring harness close-out plate.
9. Install close-out panel.
10. Install left side dashpad.
11. Connect negative battery cables (Section 12).

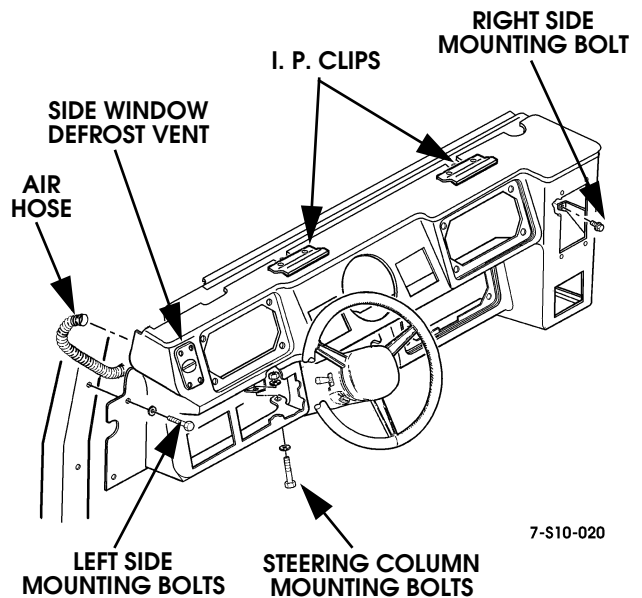

Figure 2-83: Instrument Panel Replacement



Crashpad Replacement (Right Side)

Removal

1. Remove screw/washers, and crashpad from dashboard (Figure 2-84).
2. Disconnect air hose from vent duct.
3. Remove screws, side window vent, and vent duct from crashpad.

Installation

1. Secure vent duct and window vent to crashpad with screws (Figure 2-84).
2. Connect air hose to vent duct.
3. Secure crashpad to dashboard with screw/washers.

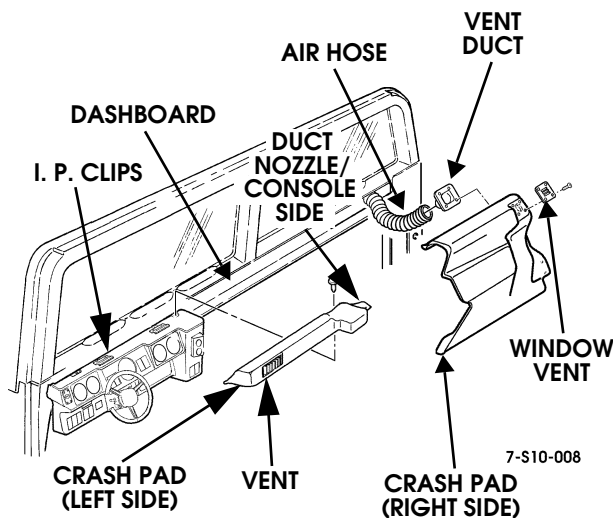

Figure 2-84: Crashpad Replacement

Crashpad Replacement (Left Side)

Removal

1. Remove screw/washers from top of crashpad.
2. Tug gently on crashpad toward steering wheel to free crashpad clips from I. P. clips (Figures 2-83 and 2-84).
3. Lift vent side of crashpad and work console side (duct nozzle) out of front console.

Installation

1. Work console side (duct nozzle) of crashpad into front console plenum.
2. Position crashpad on edge of I. P. closest to steering wheel and push crashpad onto I. P. clips (Figures 2-83 and 2-84).
3. Secure crashpad to I. P. with screw/washers.

Gauge Replacement

NOTE: Gauge replacement is basically the same for all instrument panel gauges.

Removal

1. Remove screws and pull gauge panel away from instrument panel (Figure 2-85).
2. Disconnect lamp connector from gauge.

NOTE: Tag all leads prior to removal for installation.

3. Remove nut and lockwasher assemblies securing three leads to gauge.
4. Remove hold-down bracket.
5. Remove gauge through front of gauge panel.

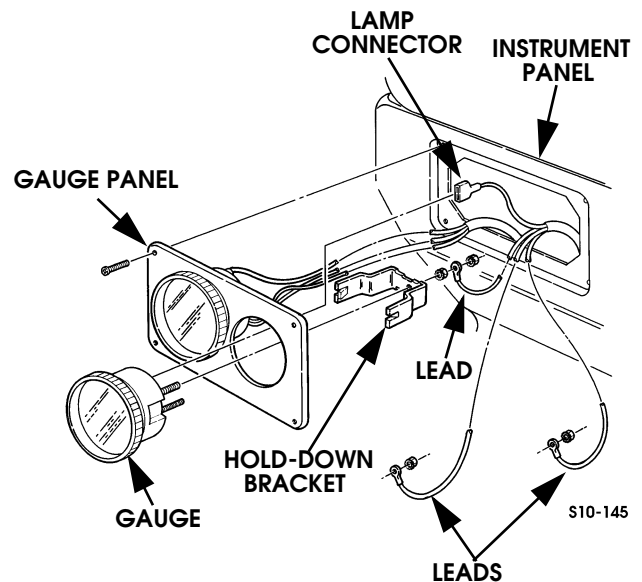

Figure 2-85: Gauge Replacement

Installation

1. Insert gauge through front of gauge panel (Figure 2-85).
2. Secure hold-down bracket and lead to gauge with nut and lockwasher assembly.
3. Secure leads to gauge with nut and lockwasher assemblies.
4. Connect lamp connector to back of gauge.
5. Start engine and ensure gauge operates properly.
6. Secure gauge panel to instrument panel with screws.



Instrument Panel Indicator Lamp Replacement

NOTE: All instrument panel indicator lamps are replaced basically the same.

Removal

1. Remove instrument panel.
2. Turn lamp socket one-quarter turn counterclockwise, and remove socket from indicator light housing.
3. Pull lamp from socket (Figure 2-86).

Installation

1. Push lamp into socket (Figure 2-86).
2. Insert socket into status center and secure by turning socket clockwise one-quarter turn.
3. Install instrument panel.
4. Start engine and ensure lamp operates properly.

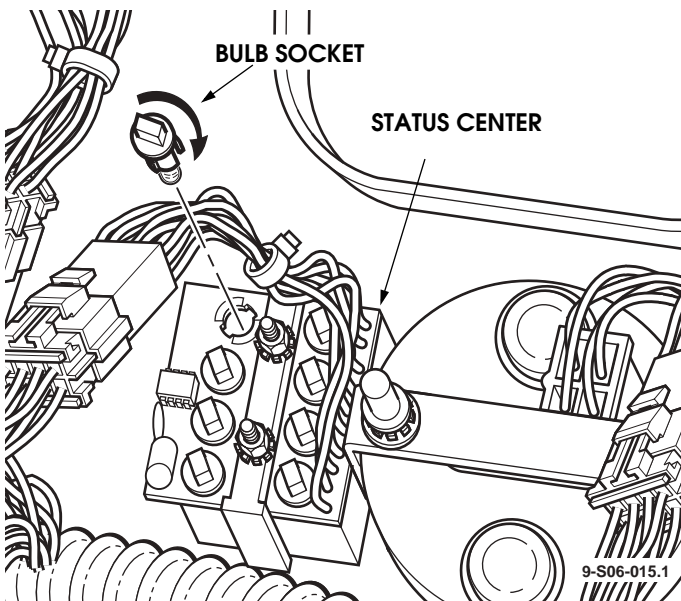

Figure 2-86: Instrument Panel Indicator Light Replacement

Instrument Panel Switch Replacement

NOTE: All instrument panel switches are replaced similarly, with the exception of the dimmer control switch. This procedure covers the main light switch.

CAUTION: Some connectors can be installed incorrectly and cause damage to the electrical system. Make note of connector position prior to removal.

Removal

1. Remove closeout panel.
2. Reach up behind IP and push switch from switch housing.
3. Remove connector from switch (Figure 2-87).

Installation

1. Install connector on switch (Figure 2-87).
2. Install switch in switch housing.
3. Install closeout panel.

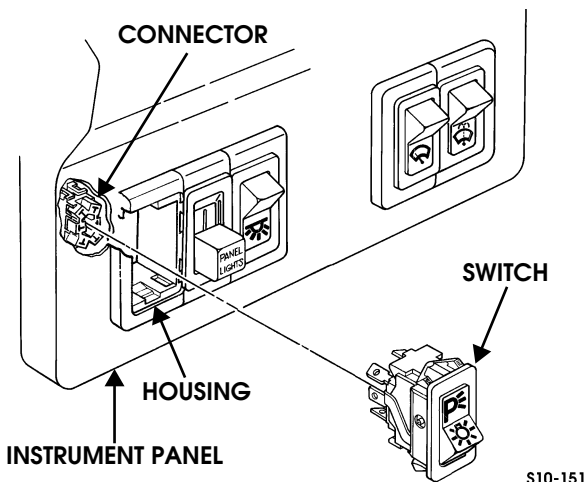

Figure 2-87: Instrument Panel Switch Replacement

Instrument Panel Dimmer Control Switch Replacement

Removal

1. Remove closeout panel.
2. Reach up behind instrument panel and push switch from switch housing.
3. Unplug connector from wiring harness (Figure 2-88).

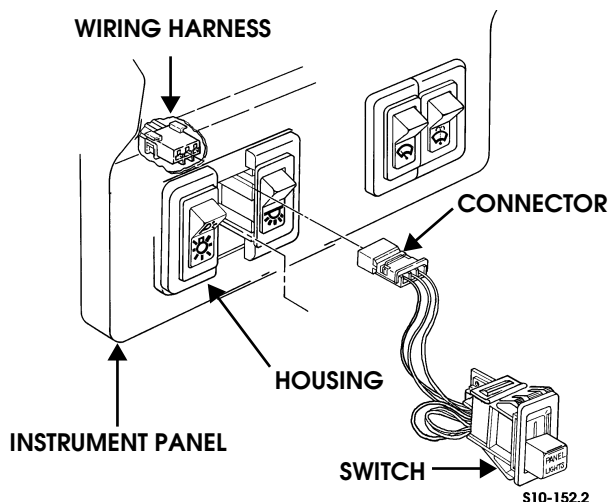

Figure 2-88: Instrument Panel Dimmer Control Switch Replacement

Installation

1. Plug connector into wiring harness.
2. Install switch in switch housing (Figure 2-88).
3. Install closeout panel.



Speedometer/Odometer Replacement

Removal

1. Remove the left A-pillar dash trim (closeout).
2. Remove the left footwell closeout panel and disconnect the courtesy light plug, diagnostic link connector and the footwell vent hose from the closeout panel.
3. If equipped with power mirrors, pop the switch from dash and let hang to gain access to the crossbolt nut.
4. Remove the two screws securing the harness hanger to the steering column mount bracket and remove the harness hanger.
5. Loosen the two bolts at the forward steering column pivot point.
6. Remove the steering column crossbolt, nut and washer and tilt the steering column downward.
7. Remove two trim screws from the crashpad and pull rearward to release the crashpad.
8. Remove the two speedometer/odometer hold-down bracket nuts and lockwashers and the hold-down bracket.

9. Pull the speedometer/odometer from the dash Remove the wire connector from the backside of the speedometer.

Installation

1. Insert speedometer/odometer into instrument panel (Figure 2-89).
2. Install the crashpad using two trim screws.
3. Install the left and right gauge bezels.
4. Tilt the steering column up and install the crossbolt, nut and washer.
5. Tighten the two bolts at the forward pivot point of the steering column.
6. Screw the harness hanger to the steering column mount bracket.
7. Install the power mirror switch if removed in step 3 above.
8. Install the footwell vent hose, the DLC, the courtesy light plug and the left footwell closeout panel.
9. Install the left A-pillar dash trim (closeout).

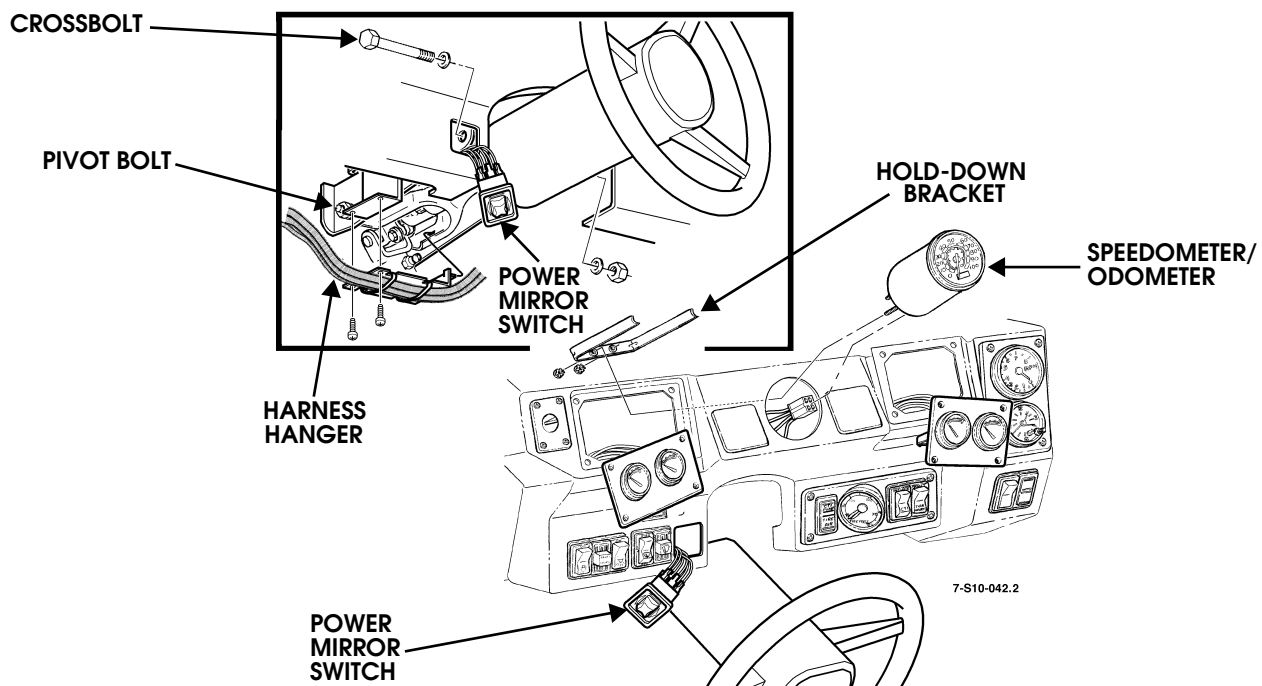

Figure 2-89: Speedometer/Odometer Replacement



Tachometer Replacement

NOTE: Mark position of set screws in relationship to tachometer clock panel before disassembly. Tachometer mounting clamp must be installed in factory position to have proper clearance for reassembly.

NOTE: It may be necessary to remove clock for access to tachometer mounting clamp hardware.

Removal

1. Remove screws and tachometer/clock panel from I.P.
2. Unplug tachometer electrical connector from I.P. wiring harness.
3. Loosen set screws and tachometer mounting clamp hardware. Remove clamp from tachometer housing.
4. Remove tachometer from tachometer/clock panel.

Installation

1. Position tachometer in tachometer/clock panel.
2. Slide tachometer mounting clamp onto tachometer housing; close enough to tachometer/clock panel for set screws to make contact.
3. Tighten clamp securely onto tachometer body and tighten setscrews until they contact tachometer/clock panel.
4. Plug tachometer electrical connector into I.P. wiring harness.
5. Secure tachometer/clock panel to I.P. with screws.

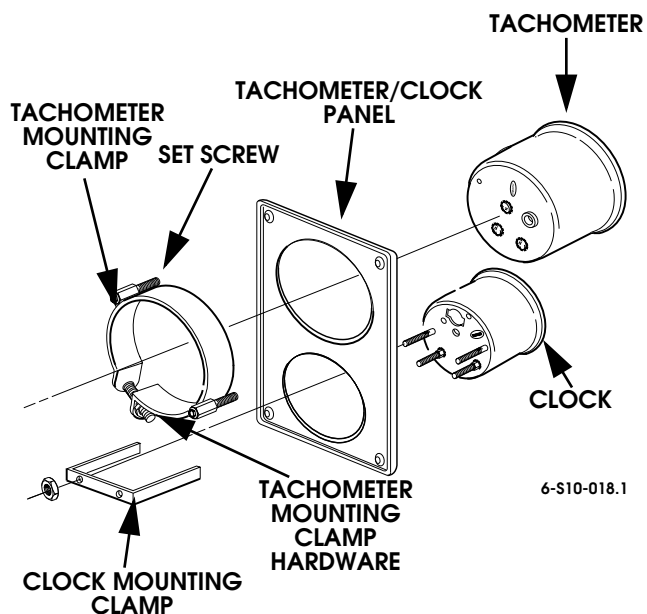

Figure 2-90: Tachometer Mounting

CIGARETTE LIGHTER REPLACEMENT

Removal

1. Pull front console away from dashpad enough to gain access to wiring harness connector.
2. Remove wiring harness connector from lighter assembly.
3. Remove element from lighter assembly heater (Figure 2-91).
4. Remove shell from heater, and remove shell, heater, and bezel from console.

Installation

1. Install bezel and heater in console (Figure 2-91).
2. Install shell on heater.
3. Install wiring harness connector on lighter assembly.
4. Install element in lighter assembly.
5. Engage cigarette lighter to ensure proper operation.
6. Install front console.

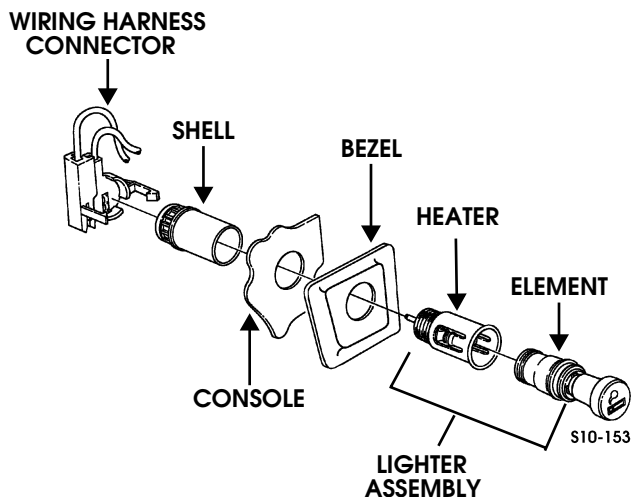

Figure 2-91: Cigarette Lighter Breakdown



LOW COOLANT LAMP INOPERATIVE

The coolant level sensor is a solid-state semi-conductor device. The sensor's resistance varies as a function of its temperature. As voltage/current flows through the sensor, sensor temperature increases. In the presence of a liquid, in this case engine coolant, the temperature of the sensor is controlled by transferring heat to the coolant. Should the coolant level drop below the sensor, the heat and resistance of the sensor will rise. The "Low Coolant" warning light will then illuminate in response to the increased resistance at the sensor.

Step	Action	Value(s)	Yes	No
1	Disconnect connector C35 from low coolant sensor pigtail. Turn ignition switch to ON. Check terminal A (pink wire) for voltage. Is voltage present?	Approximate battery voltage.	Go to step 2.	Repair circuit 291 from fuse 3B in exterior fuse box.
2	Disconnect connector C35 from low coolant sensor pigtail. Turn ignition switch to ON. Connect a fused jumper from terminal A (pink wire) to terminal B (red wire) of the harness side of connector C35. Does the low coolant lamp light?		Go to step 3.	Check/repair signal circuit 794 and lamp in status center.
3	Check/repair circuit 57 (black wire) from sensor to engine ground. Does the low coolant lamp light?		Repair complete.	Repair connection at connector C35 or replace sensor

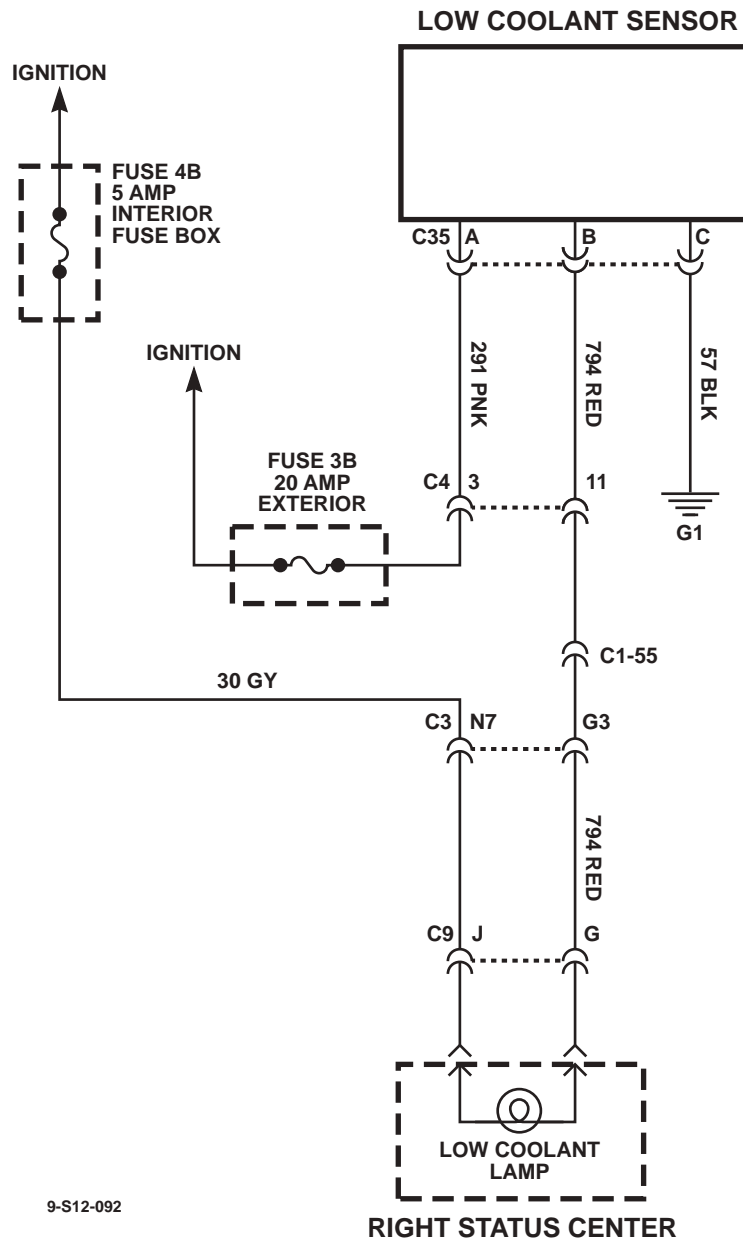

Figure 2-92: Low Coolant Sensor Schematic



Oil Pressure Gauge Inoperative

Step	Action	Value(s)	Yes	No
1	Is gauge maxed out?		Repair open or bad connection in CKT31 or gauge sending.	Go to step 2.
2	Using a DVOM set to measure voltage, check for voltage at the rear of the oil pressure gauge on the grey wire(CKT30) connect negative meter lead to ground on black wire(CKT59). With ignition on, is voltage present?	12v	Go to step 4.	Go to step 3.
3	Move the negative meter lead to a known good ground. Is voltage present?	12v	Repair open or bad connection in CKT59 between oil pressure gauge and G4.	Repair open, bad connection or short in CKT30 between oil pressure gauge and fuse 4B.
4	Ignition on, remove the tan wire (CKT 31) from the oil pressure gauge. Does the gauge max out?		Go to step 5.	Replace the oil pressure gauge.
5	Reconnect signal wire to gauge. Disconnect signal wire(CKT31) at sending unit. With ignition on does gauge max out?		Replace sending unit.	Repair short to ground in CKT31.



Fuel Gauge Inoperative

Step	Action	Value(s)	Yes	No
1	Using a DVOM set to measure voltage, check for voltage at the rear of the fuel gauge on the grey wire(CKT30) connect negative meter lead to ground on black wire(CKT59). With ignition on, is voltage present?	12v	Go to step 3.	Go to step 2.
2	Move the negative meter lead to a known good ground. IS voltage present?	12v	Repair open or bad connection in CKT59 between fuel gauge and G4.	Repair open, bad connection or short in CKT30 between fuel gauge and fuse 4B.
3	With the ignition on, ground the signal lead does the gauge go to Full?	Full	Go to step 4.	Replace gauge.
4	Disconnect fuel selector valve. Using a jumper wire, ground the pink wire(CKT29). With the ignition on does the fuel gauge go to full?	Full	Go to step 5.	Repair open or bad connection in CKT29 between fuel gauge and fuel selector valve?
5	Determine fuel level in the main tank. Using a DVOM set to measure resistance, measure resistance to ground on the blue wire(CKT673). Does resistance value correspond with fuel level in tank.	Empty=268Ω Half=124.4Ω Full=19.3Ω	Go to step 6.	Go to step 7.
6	Determine fuel level in the auxiliary tank. Using a DVOM set to measure resistance, measure resistance to ground on the yellow wire(CKT675). Does resistance value correspond with fuel level in tank.	Empty=268Ω Half=124.4Ω Full=19.3Ω	Replace fuel selector valve.	Go to step 7.
7	Gain access to fuel level sending unit connectors. Using a DVOM set to measure resistance, check resistance through the sending unit. Does resistance value correspond with the fuel level in the tank?	Empty=268Ω Half=124.4Ω Full=19.3Ω	Repair open, bad connection or short in CKT 673, 675, or 58.	Replace sending unit.



Engine Temperature Gauge Inoperative

Step	Action	Value(s)	Yes	No
1	Is gauge maxed out with ignition on?		Repair short to ground in CKT 39 or faulty sending unit.	Go to step 2.
2	Using a DVOM set to measure voltage, check for voltage at the rear of the oil pressure gauge on the grey wire(CKT39) connect negative meter lead to ground on black wire(CKT59). With ignition on, is voltage present?	12v	Go to step 4.	Go to step 3.
3	Move the negative meter lead to a known good ground. Is voltage present?	12v	Repair open or bad connection in CKT59 between oil pressure gauge and G4.	Repair open, bad connection or short in CKT30 between oil pressure gauge and fuse 4B.
4	With the ignition on, momentarily ground the dark green wire(CKT30) at the rear of the gauge. Does the gauge go to maximum?		Go to step 5.	Replace the temperature gauge.
5	With the ignition on, momentarily ground the signal wire(CKT39) at the sending unit. Does the gauge go to maximum?		Replace the sending unit.	Repair open, or bad connection in CKT39 between gauge and sending unit.

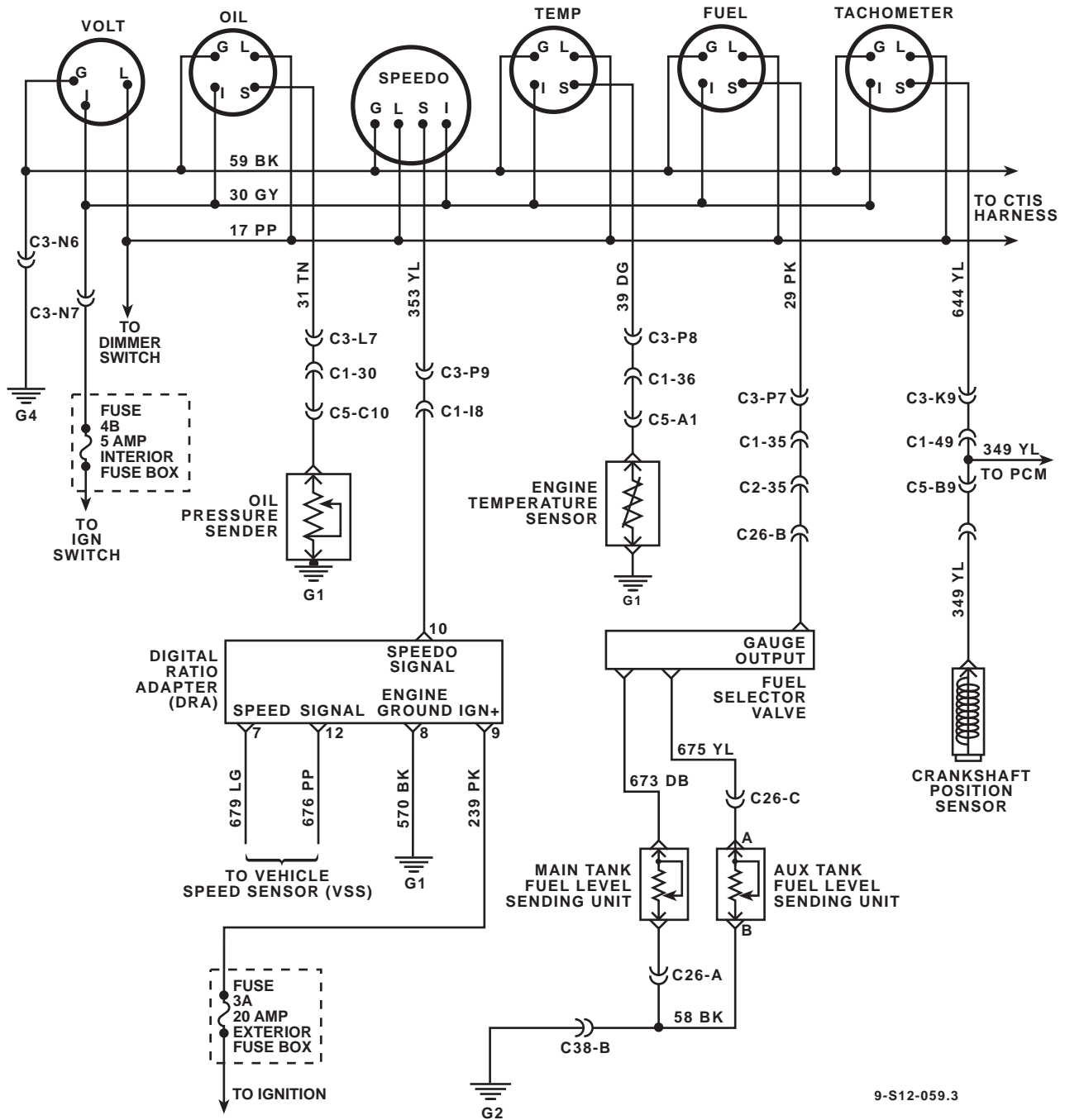

9-S12-059.3

Figure 2-93: Gauges Schematic



Digital Ratio Adapter

Location

The digital ratio adapter is located under the center console on the engine cover, just above the powertrain control module.

Removal

1. Remove the cup holder from the center console.
2. Disconnect the two harness connectors from the digital ratio adapter.

3. Pull the digital ratio adapter off of the hook and loop and remove from the center console.

Installation

1. Install the digital ratio adapter in the center console on the hook and loop.
2. Connect the harness connectors to the bottom of the digital ratio adapter.
3. Install the cup holder in the center console.

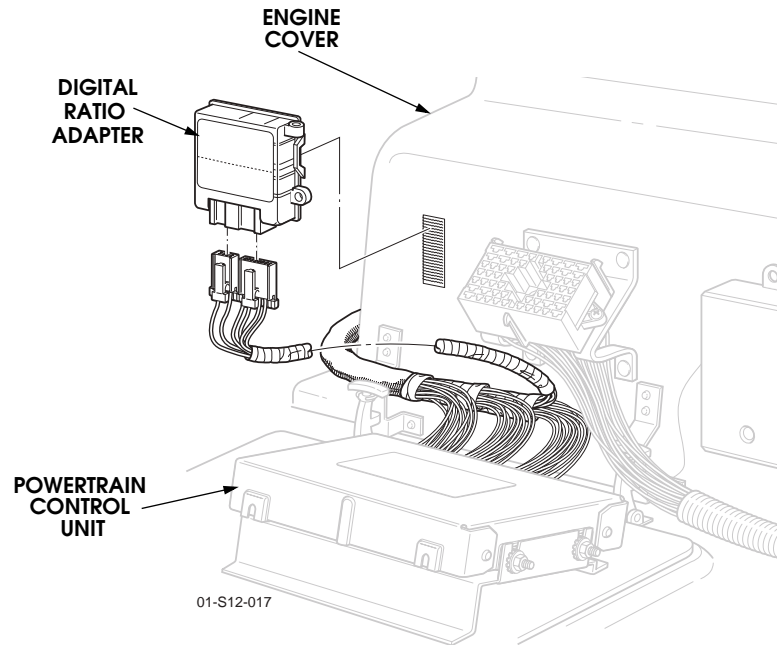

Figure 12-93.1 Digital Ratio Adapter Removal

Circuit Description

The speed sensor circuit consists of a magnetic induction type sensor, a Digital Ratio Adapter (DRA) and wiring. Geared teeth pressed on the output shaft induce an alternating current in the sensor. This A/C signal is transmitted to the DRA. The DRA compensates for various axle ratios and converts the signal into a digital signals for use by the speedometer, cruise control, and the PCM. The DRA sends two different signal to

the PCM. Circuit 565 sends a signal of 40 pulses per revolution of the output shaft to the PCM. This signal is used to control shift points, line pressure, TCC and diagnostic codes. Circuit 223 sends a signal of 4000 pulses per mile to the PCM. This signal is used for cruise and DTCs. The DRA sends a separate signal to the speedometer on circuit 353. This signal is a 128,000 pulse per mile signal.

Digital Ratio Adapter Out Put Signal to Speedometer

Approximate Reading	Input	Ascending	Descending
30 MPH	1066.6 Htz	X	
60 MPH	2133.3 Htz	X	
30 MPH	1066.6 Htz		X

NOTE: The above table only applies to 2000 model year vehicles.

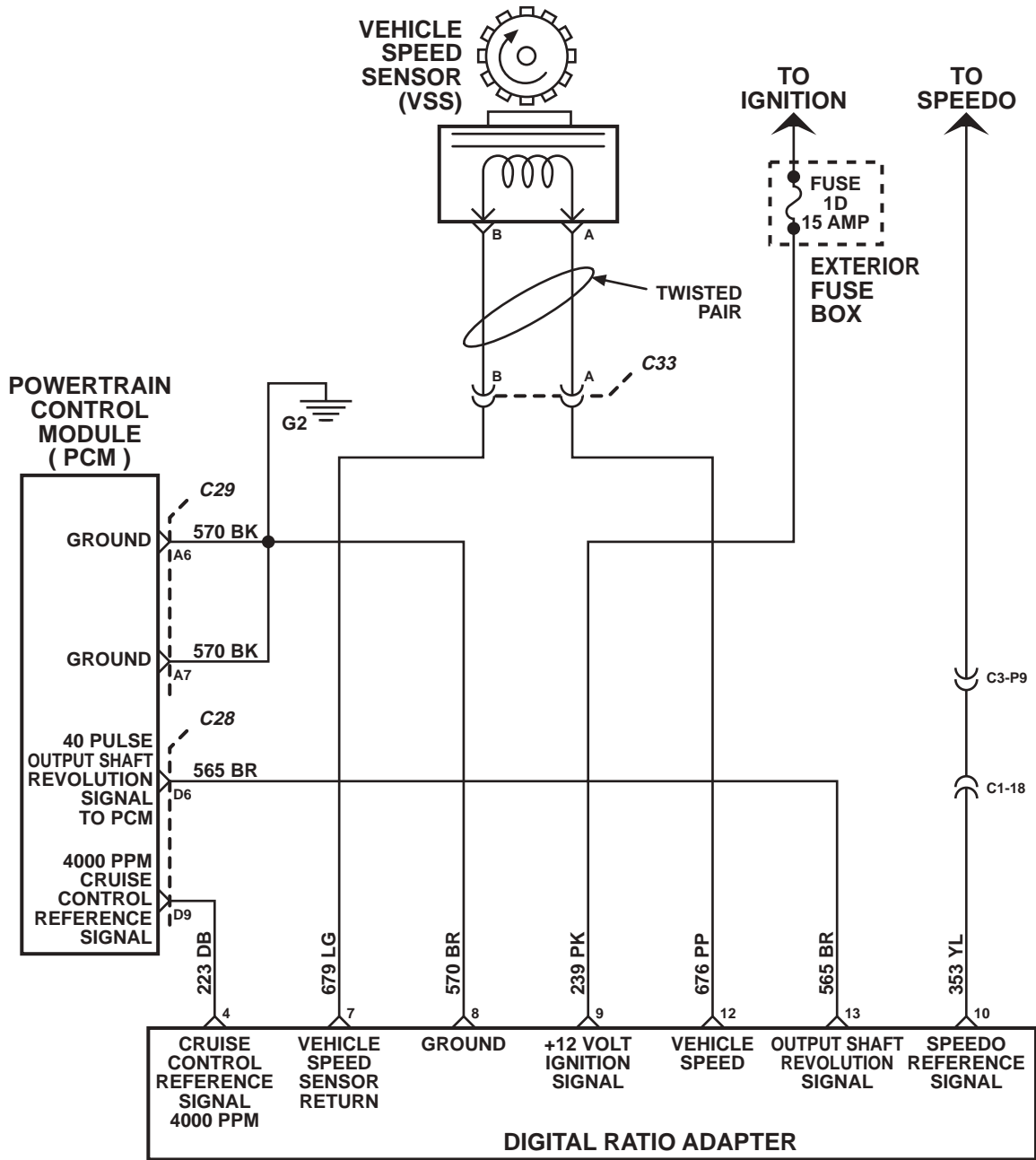

00-S12-038

Figure 12-93.2 Digital Ratio Adapter Wiring Diagram



HVAC Main Blower Inoperative ALL BUT High

Step	Action	Value(s)	Yes	No
1	Ignition on, blower switch set to Med2, mode dial set to face. Measure voltage on the yellow wire(CKT754) at the blower relay. Is voltage present?	8 -10v	Replace the blower relay.	Go to step 2.
2	Ignition on, blower switch set to Med2, mode dial set to face. Measure voltage on the grey wire(CKT752) at the blower resistor. Is voltage present?	12v	Replace blower resistor.	Go to step 3.
3	Ignition on, blower switch set to Med2, mode dial set to face. Measure voltage on the grey wire(CKT752) at pin C of the 8pin connector on the back of the HVAC control head. Is voltage present?	12v	Repair open, bad connection or short to ground in CKTS 751, 752, and 755 between HVAC control head and resistor block.	Replace control head.

HVAC Compressor Inoperative

Step	Action	Value(s)	Yes	No
1	Perform On-board diagnostic system check. Is system functioning properly?		Go to step 2.	Diagnose problem in on-board diagnostic system first.
2	Does A/C system have an adequate charge?		Go to step 3.	Diagnose leak and recharge.
3	Is engine in an overheated condition?		Cool down and recheck.	Go to step 4.
4	Connect scan tool to vehicle. Ignition on, find misc. tests and command compressor clutch on. Does clutch come on?		Go to step 10.	Go to step 5.
5	Disconnect the compressor clutch. Connect a test lamp to ground, and probe the brown wire at the clutch connector. Using the scan tool, command the clutch on. Does the test light come on?		Replace the compressor clutch.	Go to step 6.
6	Remove A/C relay from the exterior fuse box. Using a DVOM set to measure voltage, ignition on, check for voltage at cavities 4E and 6E (CKT400) in the exterior fuse box. Is voltage present?	12v	Go to step 7.	Repair open, bad connection or short in CKT400 between exterior fuse box and ignition switch.



HVAC Compressor Inoperative (Continued)

Step	Action	Value(s)	Yes	No
7	Using a DVOM set to measure voltage, place the positive lead on a battery power source. Place the ground lead in cavity 6F(CKT440). Using the scan tool, command the compressor clutch on. Does meter display battery voltage?	12v	Go to step 8.	Go to step 9.
8	Using a DVOM set to measure resistance. Check resistance between cavity 4F(CKT348) and the brown wire(CKT348)at the compressor clutch connector. Is resistance below specification?	<.2Ω	Replace compressor relay.	Repair open or bad connection in CKT348 between clutch relay and compressor clutch.
9	Ignition on, using a DVOM set to measure voltage, backprobe pin D5 in C28 at the PCM(CKT440) with the negative lead. Place the positive lead on a battery voltage source. Using the scan tool, command the compressor clutch on. Does the meter display battery voltage?	12v	Repair open, or bad connection in CKT440 between PCM and A/C clutch relay.	Replace the PCM.
10	Ignition on, locate engine data list, and "A/C Request". Turn mode dial on HVAC control head to MAX A/C. Does scan tool display indicate A/C request?		Replace PCM.	Go to step 11.
11	Ignition on, mode dial set to MAX A/C. Using a DVOM set to measure voltage, backprobe the tan wire(CKT198) at the temperature cutout switch on the HVAC unit with the positive probe. Place the negative lead on a known good ground. Is voltage present?	12v	Go to step 14.	Go to step 1.
12	Ignition on, mode dial set to MAX A/C. Using a DVOM set to measure voltage, backprobe the yellow wire(CKT347) at the temperature cutout switch on the HVAC unit with the positive probe. Place the negative lead on a known good ground. Is voltage present?	12v	Replace the temperature cut-out switch.	Go to step 13.
13	Using a DVOM set to measure voltage, ignition on, mode dial set to MAX A/C, backprobe for voltage on pin H (CKT347) in the 8 wire connector at the rear of the HVAC control head. Is voltage present?	12v	Repair open, bad connection or short in CKT347 between HVAC control head and temperature cut-out switch.	Replace control head.



HVAC Compressor Inoperative (Continued)

Step	Action	Value(s)	Yes	No
14	Ignition on, mode dial set to MAX A/C. Disconnect the high pressure cutout switch on the compressor. Using a DVOM set to measure voltage, check for voltage on the tan wire(CKT198). Is voltage present?	12v	Go to step 15.	Repair open, bad connection, or short in CKT198 between temperature cutout switch and high pressure cutout switch.
15	Using a DVOM set to measure resistance, check continuity across the two pins on the high pressure cutout switch. Is resistance below specification?	<.2Ω	Go to step 16.	Replace the high pressure cutout switch.
16	Ambient temperature above 45°. Disconnect the ambient temperature switch. Using a DVOM set to measure resistance, measure continuity across the ambient temperature switch terminals. Is resistance below specification?	<.2Ω	Go to step 17.	Replace ambient temperature switch.
17	Disconnect low pressure cutout switch. Using a DVOM set to measure resistance, measure continuity across the low pressure cutout switch. Is resistance below specification?	<.2Ω	Repair open, bad connection or short in CKT439 between high pressure cutoff switch and PCM.	Replace the low pressure cutout switch.

HVAC Temperature Door Inoperative

Step	Action	Value(s)	Yes	No
1	With the ignition switch in the run position, operate temperature control dial and observe the motor. Does door move?		Condition is intermittent.	Go to step 2.
2	Remove the temperature blend door motor from the side of the HVAC case. With the ignition switch in the run position, operate the temperature control dial and observe the motor. Is the motor turning?		Mechanical problem in the HVAC case.	Go to step 4.
3	Disconnect electrical connector from the temperature blend door motor. Using a DVOM set to measure voltage, and using J-35616-92 test adapters, probe the GN wire (CKT 399) with the positive lead and the BK wire (CKT 58) with the negative lead. Turn the ignition switch to the run position. Is voltage present?	12v	Go to step 6.	Go to step 4.



HVAC Temperature Door Inoperative (Continued)

Step	Action	Value(s)	Yes	No
4	With ignition on, using a DVOM set to measure voltage and using J-35616-92 test adapters probe the GN wire (CKT 399) with the positive lead. Place the negative lead on a known good ground. Is voltage present?	12v	Go to step 5.	Repair open or short to ground between temperature blend door motor and fuse 7C.
5	With the ignition off, and using a DVOM set to measure ohms, check for resistance between the BK wire (CKT 58) of the temperature blend door, and a good ground. Does resistance exceed specifications?	<.2Ω	Locate open or bad connection between temperature blend door motor and G4.	Go to step 6.
6	Using a DVOM set to read volts, the ignition switch on the run position, and using J-35616-92 test adapters, probe the blue wire (CKT 402) with the positive lead, and the BK wire (CKT 58) with the negative lead. Rotate temperature control dial on the HVAC control head from cold to hot and back. Is voltage present at the cold setting and 0v on the hot setting?	Cold = 12v Hot = 0v Cold = 12v	Replace the temperature blend door motor.	Go to step 7.
7	Disconnect the 8 wire connector at the HVAC control head. Using a DVOM set to measure ohms, check resistance between pin F (CKT 402) of the 8 wire connector and the blue wire (CKT 402) of the temperature blend door connector. Does resistance exceed specifications?	62KΩ	Go to step 9.	Go to step 8.
8	Check for open or bad connection between the HVAC control head 8 wire connection and the temperature blend door motor connection. Check for loose terminals at the control head. Was a bad connection found?		Repair or replace harness as necessary.	Go to step 9.
9	Using a DVOM set to measure voltage, probe pin E (CKT 399) of the 8 wire connector on the HVAC control head with the positive lead, and pin B (CKT 58) of the three wire HVAC control head connector with the negative lead. With ignition on, is voltage present?	12v	Replace faulty HVAC control head.	Go to step 10.
10	Using a DVOM set to measure voltage, probe pin E (CKT 399) of the HVAC control head eight wire connector with the positive lead. Attach the negative lead to a known good ground. With the ignition switch in the run position, is voltage present?	12v	Go to step 11.	Locate short or open between the HVAC control head and fuse 7C.



HVAC Temperature Door Inoperative (Continued)

Step	Action	Value(s)	Yes	No
11	Using a DVOM set to measure ohms, check resistance between pin B (CKT 58) of the HVAC control head connector and a good ground. Does resistance exceed specifications?	$<.2\Omega$	Replace faulty HVAC control head.	Locate and repair open or poor connection in the ground circuit between pin B and G4.

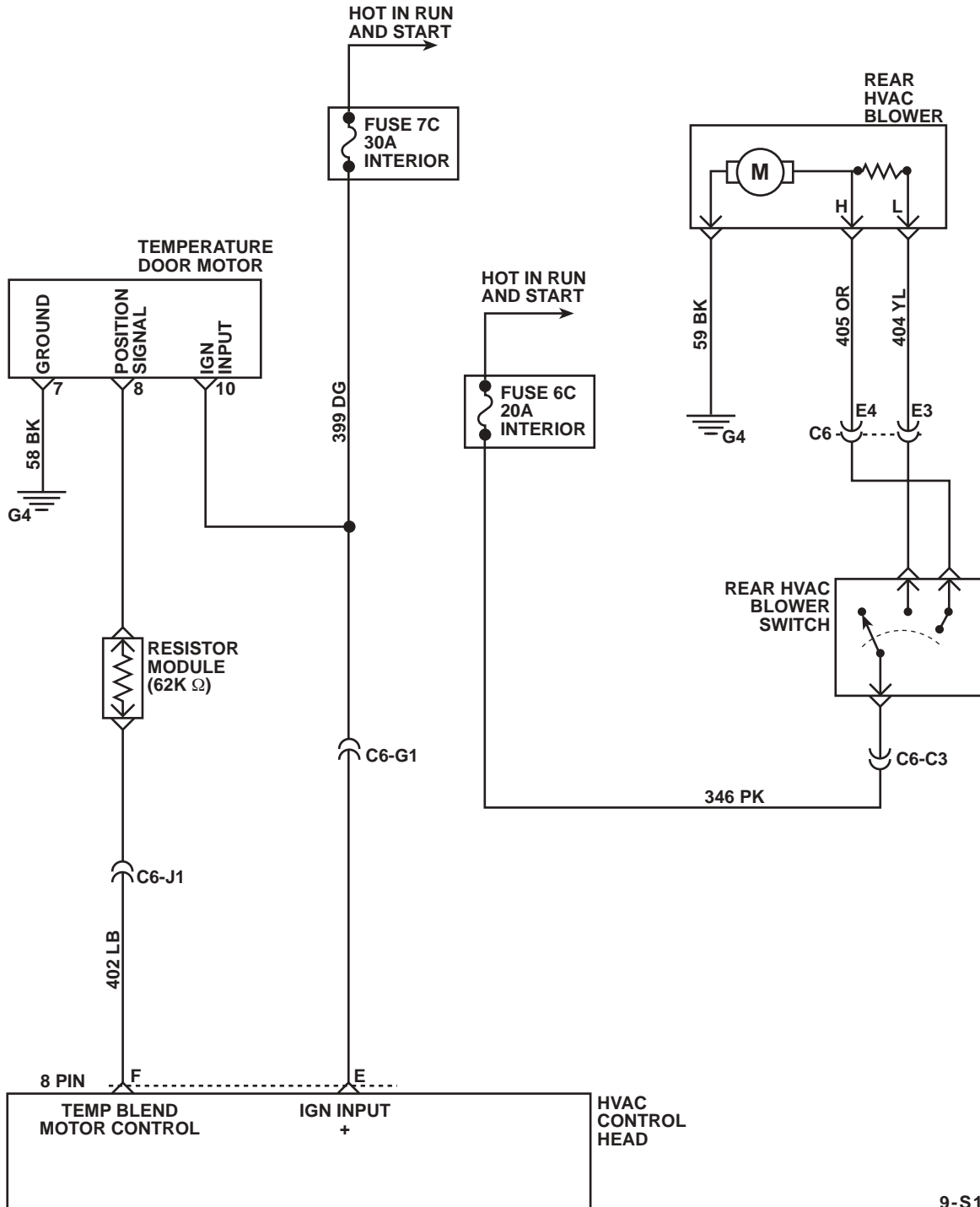

9-S12-063

Figure 12-95: HVAC Temp Blend Door/Rear Blower

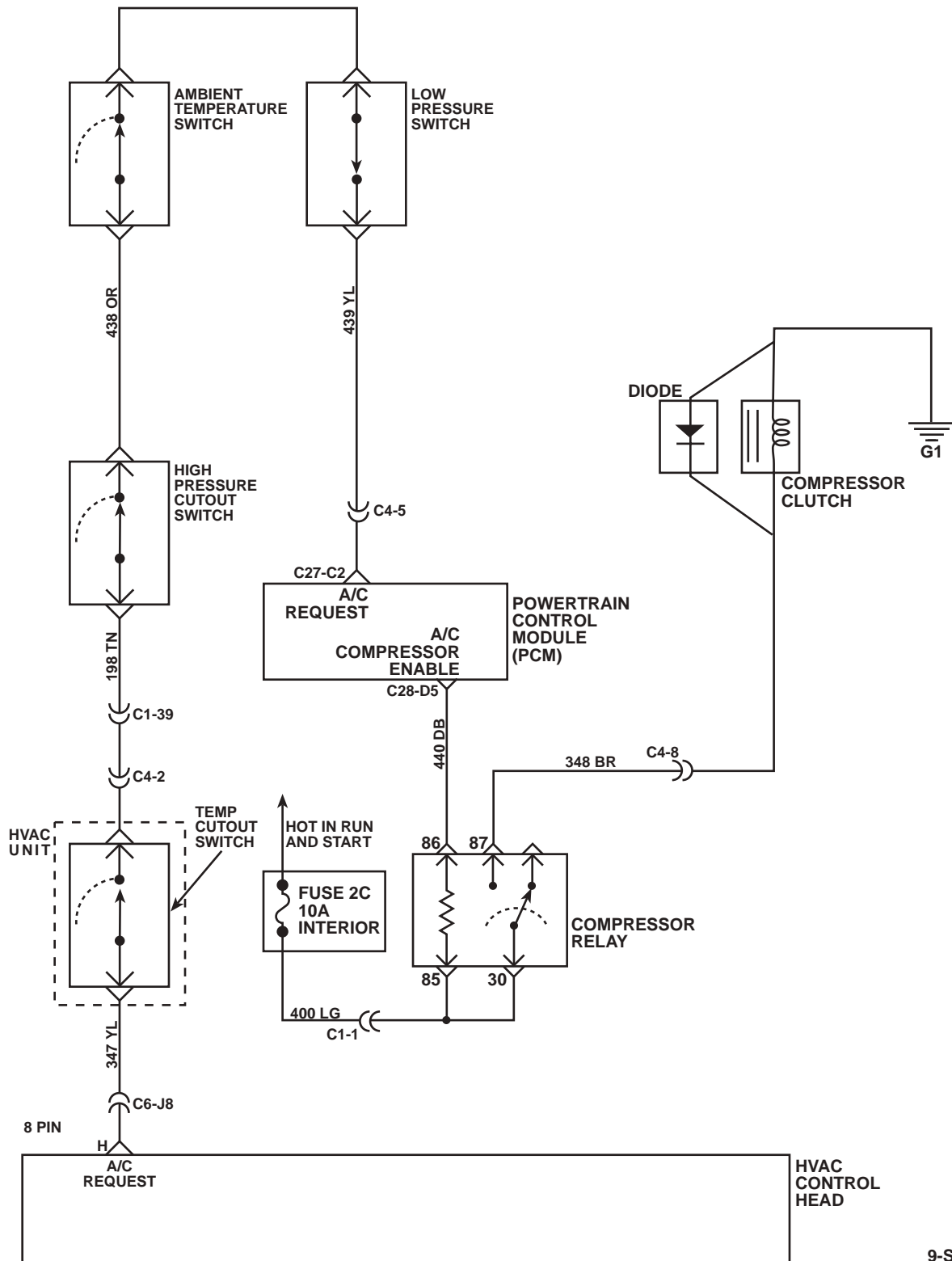

9-S12-061

Figure 12-96: HVAC Compressor Schematic



Windshield Wiper Motor Inoperative All Speeds

Step	Action	Value(s)	Yes	No
1	Gain access to the wiper motor connector under the windshield trim. Using a DVOM set to measure resistance, check resistance to ground on the brown wire (CKT 59). Is the resistance below the specified value?	<.2 Ω	Go to step 2.	Repair open or bad connection in CKT 59 between the wiper motor and G4.
2	Turn the ignition switch to the "RUN" position and the wiper switch to "LOW". Using a DVOM set to measure voltage, check for voltage at the dark green wire (CKT 63). Is the specified voltage present?	12v	Replace the wiper motor.	Go to step 3.
3	Remove the wiper switch from the instrument panel and turn the ignition to the "RUN" position. Using a DVOM set to measure voltage, back probe the yellow wire (CKT 65) at the wiper switch. Is the specified voltage present?	12v	Replace wiper switch.	Repair the open or bad connection in CKT 65 between the wiper switch and fuse 7G.

Windshield Wiper Motor Inoperative on LOW

Step	Action	Value(s)	Yes	No
1	Remove the wiper switch from the instrument panel. Turn the ignition to the "RUN" position and the wiper switch to "LOW". Using a DVOM set to measure voltage, back probe the green wire (CKT 63). Is the specified voltage present?	12v	Go to step 3.	Go to step 2.
2	Using a DVOM set to measure voltage, back probe the yellow wire (CKT 65) at the wiper switch. Place the ground lead on a known good ground. With the ignition on, is the specified voltage present?	12v	Replace the wiper switch.	Repair open or bad connection in CKT 65 between the wiper switch and fuse 7G.
3	Gain access to the wiper motor connector behind the windshield trim. Using a DVOM set to measure voltage, backprobe the dark green wire (CKT 63). Turn the ignition switch to the "RUN" position, and set the wiper switch to "LOW". Is the specified voltage present?	12v	Replace the wiper motor.	Repair the open or bad connection in CKT 63 between the wiper motor and the wiper switch.



Windshield Wiper Motor Inoperative on High

Step	Action	Value(s)	Yes	No
1	Remove the wiper switch from the instrument panel. Turn the ignition to the "RUN" position and the wiper switch to "HIGH". Using a DVOM set to measure voltage, back probe the red wire (CKT 61). Is the specified voltage present?	12v	Go to step 3.	Go to step 2.
2	With the ignition switch in the RUN" position, check the voltage at the yellow wire (CKT 65). Is the specified voltage present?	12v	Replace the wiper switch.	Repair the open or bad connection on CKT 65 between the wiper switch and fuse 7G.
3	Gain access to the wiper motor connector under the windshield trim. Turn the ignition switch to the "RUN" position and the wiper switch to the "HIGH" position. Using a DVOM check the voltage at the red wire (CKT 61). Is the specified voltage present?	12v	Replace the wiper motor.	Repair the open or bad connection on CKT 61 Between the wiper motor and the wiper switch.

Windshield Wipers Intermittent Speeds Inoperative

Step	Action	Value(s)	Yes	No
1	Do the windshield wipers work normally on the low and high speeds?		Go to step 2.	Refer to the diagnostic chart for the specific problem on the standard wiper diagnosis.
2	Remove the wiper switch from the instrument panel. Disconnect the wiper switch from the harness. Using a DVOM measure resistance between terminals 2 and 3. Is the resistance below the specified value?	<.2 Ω	Connect the intermittent wiper switch to the harness. Go to step 3.	Replace the wiper switch.
3	Turn the ignition switch to the "RUN" position and the intermittent wiper switch to "MEDIUM DELAY" . Using a DVOM set to measure voltage, back probe the brown wire (CKT 945) at the intermittent switch. Voltage should pulse from 12 volts to 0 volts every 2-7 seconds depending on position of switch. Is the voltage in the specified range.	12v pulse 2-7 seconds	Go to step 5.	Go to step 4.



Windshield Wipers Intermittent Speeds Inoperative (Continued)

Step	Action	Value(s)	Yes	No
4	Ignition should be in the "RUN" position. Using a DVOM set to measure the voltage, back probe the yellow wire (CKT 65) at the intermittent wiper switch. Is the specified voltage present?	12v	Replace the intermittent wiper switch.	Repair the open or bad connection in CKT 65 between the intermittent wiper switch and fuse 7G.
5	Remove the intermittent wiper relay from the fuse box. Turn the ignition switch to the "RUN" position. Using a DVOM measure voltage drop between cavity B1 (CKT 945) and cavity C3 (CKT 59). The voltage should pulse from 12 volts to 0 volts every 2 to 7 seconds. Is the voltage in the specified ranges?	12v pulse 2-7 seconds	Go to step 7.	Go to step 6.
6	Using a DVOM set to measure resistance, measure resistance to ground at cavity C3 (CKT 59) of the fuse box. Is resistance below specification?	<2 Ω	Repair the open or bad connection, in CKT 945 between the intermittent wiper switch and the intermittent wiper relay.	Repair open or bad connection in CKT 59 between the intermittent wiper relay and G4.
7	Turn the ignition to the "RUN" position. Use a DVOM to measure voltage drop between cavity C1 (CKT 65) and cavity C3 (CKT 59). Is the specified voltage present?	12v	Go to step 8.	Repair the open or bad connection in CKT 65 between fuse 7G and the intermittent wiper relay.
8	With the ignition switch in the "RUN" position and the wipers on "LOW", check the voltage drop between cavity C2 (CKT 28) and cavity C3 (CKT 59). Does the voltage switch from 12 volts to 0 volts as the wiper completes its cycle?	0v – 12v – 0v	Replace the intermittent wiper relay.	Go to step 9.
9	Gain access to the wiper motor connection. Back probe the black wire (CKT 65) with the positive lead, and the brown wire(CKT 59) with the negative lead. With the ignition on is the voltage drop in the specified range?	12v	Replace the wiper motor.	Repair the open or bad connection in CKT 65 between the wiper motor and fuse 7G



WIPER/WASHER

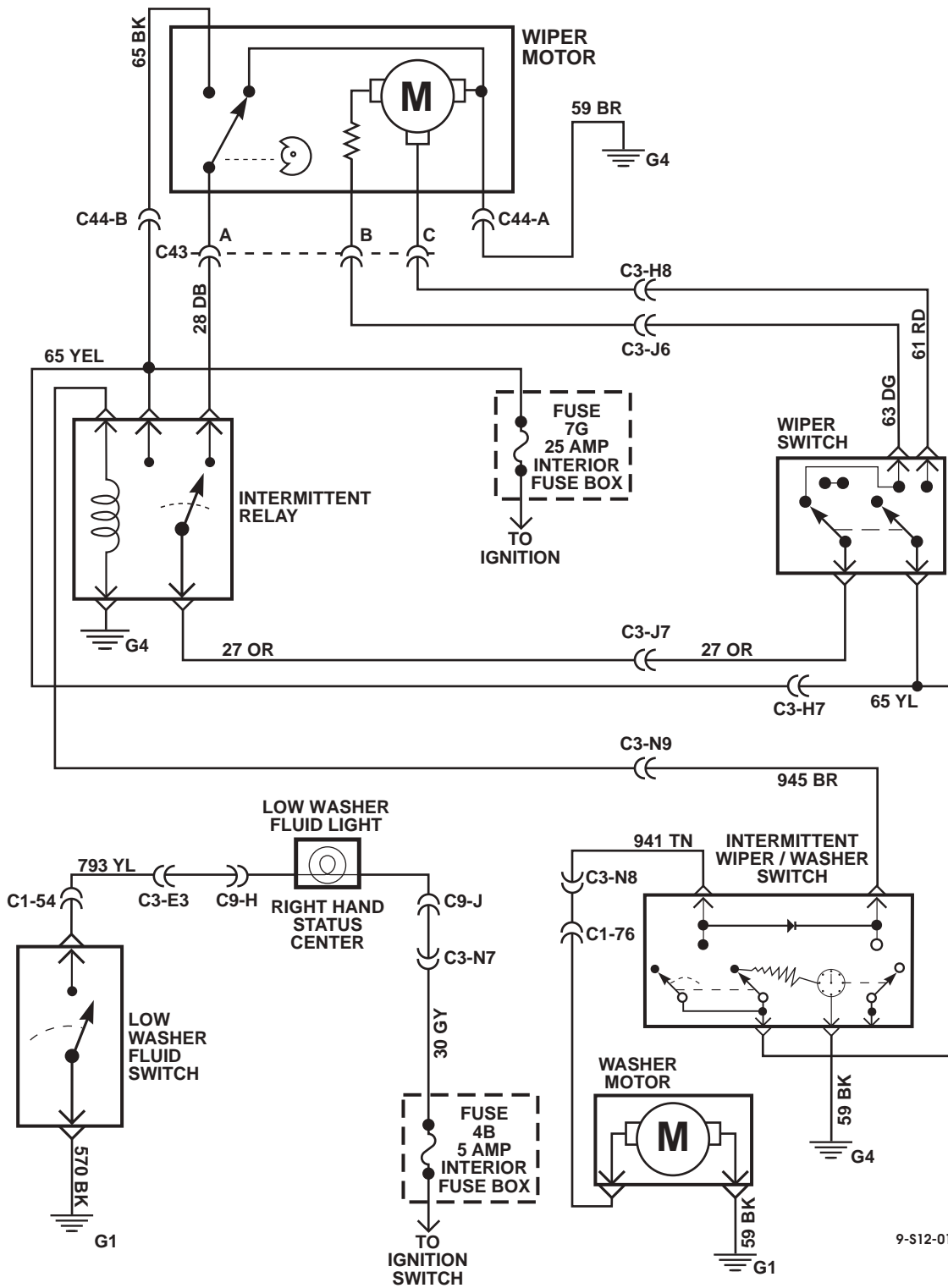

9-S12-012

Figure 12-97: Wiper/Washer Schematic



Rear Window Wiper Inoperative

Steps	Action	Values	Yes	No
1	Gain access to the wiper motor connector under the slant door trim. Using a DVOM check resistance on the black wire (CKT 59). Is the resistance in the specified range?	<.2 Ω	Go to step 2.	Repair the open or bad connection in CKT 59 between wiper motor and G4.
2	Turn the ignition switch to the "RUN" position and the rear wiper switch on. Using a DVOM back probe the red wire (CKT 66). Is the specified voltage present?	12v	Replace the wiper motor.	Go to step 3.
3	Turn the ignition switch to the "RUN" position. Unplug the wiper motor harness. With a DVOM check the voltage on the light green wire (CKT 64). Is the specified voltage present?	12v	Go to step 4.	Repair the open or bad connection in CKT 64 between wiper and fuse 11G.
4	Turn the ignition switch "OFF". With a DVOM check resistance between the light blue wire (CKT 62) and the red wire (CKT 66) on the wiper motor harness. Is resistance in the specified range?	<.2 Ω	Go to step 7.	Go to step 5.
5	Remove the rear wiper relay (RY-3) from the interior fuse box. With a DVOM check the resistance between cavity F3 in the interior fuse box (** 12-153) and the red wire (CKT 66) in the rear wiper motor harness. Is the resistance in the specified range?	<.2 Ω	Go to step 6.	Repair the open or bad connection in CKT 66 between rear wiper and relay.
6	With a DVOM check resistance between cavity G2 in the interior fuse box and the light blue wire (CKT 62) in the rear wiper motor harness. Is the resistance in the specified range?	<.2 Ω	Replace the relay (RY-3).	Repair the open or bad connection in CKT 62 between rear wiper and relay.
7	Remove the rear wiper relay (RY-3). Turn the ignition switch to the "RUN" position. With a DVOM check voltage at cavity G1 in the interior fuse box. Is the specified voltage present?	12v	Go to step 8.	Repair the open or bad connection in CKT 64.
8	With a DVOM check cavity G3 in the interior fuse box for a ground. Is a ground present?	<.2 Ω	Go to step 9.	Repair open or bad ground.
9	Turn the ignition switch to the "RUN" position and the rear wiper switch above the medium selection. Using a DVOM, watch the voltage at cavity F1 in the interior fuse box. Does the voltage pulse from 0v to 12v and back?	0v - 12v - 0v	Replace the relay (RY-3).	Go to step 10.

**Rear Window Wiper Inoperative (Continued)**

Steps	Action	Values	Yes	No
10	Remove the rear wiper switch from the instrument panel. Disconnect the wiper switch harness from the switch. Turn the ignition switch to the "RUN" position. With a DVOM check voltage on the yellow wire (CKT 65). Is the specified voltage present?	12v	Go to step 11.	Repair the open or bad connection on CKT 65.
11	With a DVOM check the black wire CKT 59 for ground. Is a ground present?	<.2 Ω	Go to step 12.	Repair open or bad ground CKT 59.
12	Using a DVOM check the resistance between the brown wire (CKT 67) and cavity F1 in the interior fuse box. Is resistance in specified range?	<.2 Ω	Replace rear wiper switch.	Repair open or bad connection in CKT 67.



Left Heated Windshield Inoperative

Step	Action	Value(s)	Yes	No
1	Gain access to the heated windshield connections. With the ignition in the "RUN" position, perform a voltage drop test between the yellow wire (CKT 740) and the black wire (CKT 59) going to the left hand windshield. Turn the heated windshield "ON". Is the specified voltage present?	12v	Replace the heated windshield.	Go to step 2.
2	Using a DVOM check the resistance to ground at the black wire (CKT 59) going to the left side windshield. Does the resistance to ground meet the specified range?	<.2 Ω	Go to step 3.	Repair the open or bad connection in CKT 59 between the windshield and G4.
3	Remove the left hand heated windshield relay from the exterior fuse box. Check the voltage drop between cavities 1 (CKT 580) and 2 (CKT 59). With the ignition in the run position, turn the heated windshield switch to "ON". Is the specified voltage present?	12v	Go to step 4.	Repair the open or bad connection in CKT 580 between the heated windshield switch and Heated windshield relay (R-4).
4	With the ignition still in the run position. Perform a voltage drop test between cavities 2 (CKT 59) and 3 (CKT 738). Is the specified voltage present?	12v	Go to step 5.	Repair the open or bad connection in CKT 738 between fuse 2C and R-4.
5	With a DVOM check the resistance between cavity 5 (CKT 740) and the yellow wire (CKT 740) going to the left side windshield. Does the resistance meet the specified value?	<.2 Ω	Replace relay R-4.	Repair the open or bad connection in CKT 740 between the left side heated windshield and R-4.

**Right Heated Windshield Inoperative**

Step	Action	Value(s)	Yes	No
1	Gain access to the heated windshield connections. With the ignition in the "RUN" position and the heated windshield switch on, perform a voltage drop test between the purple wire (CKT 739) and the black wire (CKT 59) going to the right hand windshield. Turn the heated windshield "ON". Is the specified voltage present?	12v	Replace the heated windshield.	Go to step 2.
2	Using a DVOM check the resistance to ground at the black wire (CKT 59) going to the right side windshield. Does the resistance to ground meet the specified range?	<.2 Ω	Go to step 3.	Repair the open or bad connection in CKT 59 between the windshield and G4.
3	Remove the right hand heated windshield relay from the exterior fuse box. Check the voltage drop between cavities 1 (CKT 580) and 2 (CKT 59). With the ignition in the "RUN" position, turn the heated windshield switch to "ON". Is the specified voltage present?	12v	Go to step 4.	Repair the open or bad connection in CKT 580 between the heated windshield switch and the heated windshield relay (R-2).
4	With the ignition still in the "RUN" position. Perform a voltage drop test between cavities 2 (CKT 59) and 3 (CKT 737). Is the specified voltage present?	12v	Go to step 5.	Repair the open or bad connection in CKT 738 between fuse 2C and R-2.
5	With a DVOM check the resistance between cavity 5 (CKT 739) and the purple wire (CKT 739) going to the right side windshield. Does the resistance meet the specified value?	<.2 Ω	Replace relay R-2.	Repair the open or bad connection in CKT 739 between the left side heated windshield and R-2.



Both Heated Windshields Inoperative

Step	Action	Value(s)	Yes	No
1	Gain access to the heated windshield connections. Using a DVOM check the resistance to ground on the black wires at both windshields. Does the resistance meet the specified value?	<.2 Ω	Go to step 2.	Repair the open or bad connection in CKT 59 between the windshields and G4.
2	Remove the heated windshield switch from the bezel. Turn the ignition switch to the "RUN" position and turn the heated windshield switch to the "ON" position. Using a DVOM check the voltage drop between the brown wire (CKT 580) and the black wire (CKT 58). Is the specified voltage present?	12v	Repair the open or bad connection in CKT 580 between the heated windshield switch and the relays.	Go to step 3.
3	Using a DVOM measure the resistance to ground on the black wire (CKT 58) at the heated windshield switch. Does the resistance meet the specification?	<.2 Ω	Go to step 4.	Repair the open or bad connection in CKT 58 between the heated windshield switch and G4.
4	With the ignition in the "RUN" position and the heated windshield switch in the "ON" position. Use a DVOM to check for voltage at both tan wires (CKT 83) at the heated windshield switch. Is the specified voltage present?	12v	Replace the heated windshield switch.	Repair the open or bad connection in CKT 83 between the windshield switch and fuse 1C interior.



HEATED WINDSHIELDS

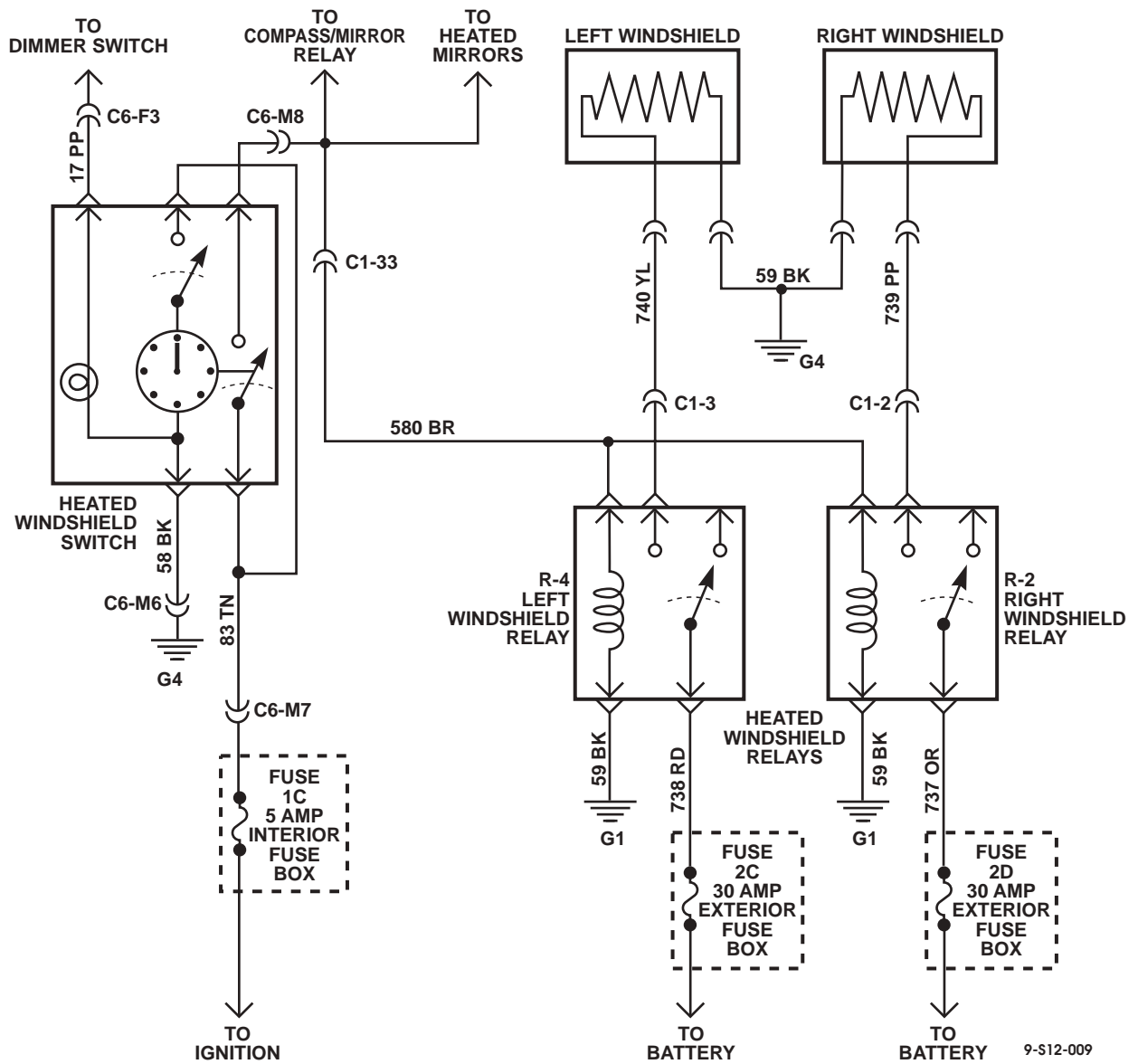

Figure 12-99: Heated Windshield Schematic



Rear Window Defroster Inoperative

Step	Action	Value(s)	Yes	No
1	Gain access to the male side of connector C45 on the C-pillar intermediate. Turn the key to the "RUN" position and the heated rear window switch to the "ON" position. With a DVOM check the voltage drop between the pink wire (CKT 689) and the black wire (CKT 58). Is the specified voltage present?	12v	Replace the heated rear window.	Go to step 2.
2	Check the black wire (CKT 58) for resistance to ground. Does the resistance meet the specified value?	<.2 Ω	Go to step 3.	Repair the open or bad connection on the CKT 58 between the heated rear window and G4.
3	Remove the HVAC control unit from the center console. Turn the ignition switch to the "RUN" position and activate the rear window defroster switch. With a DVOM check the voltage drop, on connector C46, between terminals D (CKT 689) and C (CKT 59). Is the specified voltage present?	12v	Repair the open or bad connection on CKT 689 between the HVAC control and the rear window defroster.	Go to step 4.
4	Disconnect connector C46 from the back of the HVAC control unit. With a DVOM check the resistance to ground on terminal C (CKT 59). Does the resistance meet the specifications?	<.2 Ω	Go to step 5.	Repair the open or bad connection on CKT 59 between the HVAC control and G4.
5	With a DVOM check terminal A (CKT 688) for battery voltage. Is the specified voltage present?	12v	Go to step 6.	Repair the open or bad connection on CKT 688 between the HVAC control and fuse 4M.
6	Turn the ignition switch to the "RUN" position. With a DVOM check terminal B (CKT 399) for battery voltage. Is the specified voltage present?	12v	Replace the HVAC control unit.	Repair the open or bad connection on CKT 399 between the HVAC control and fuse 7C.

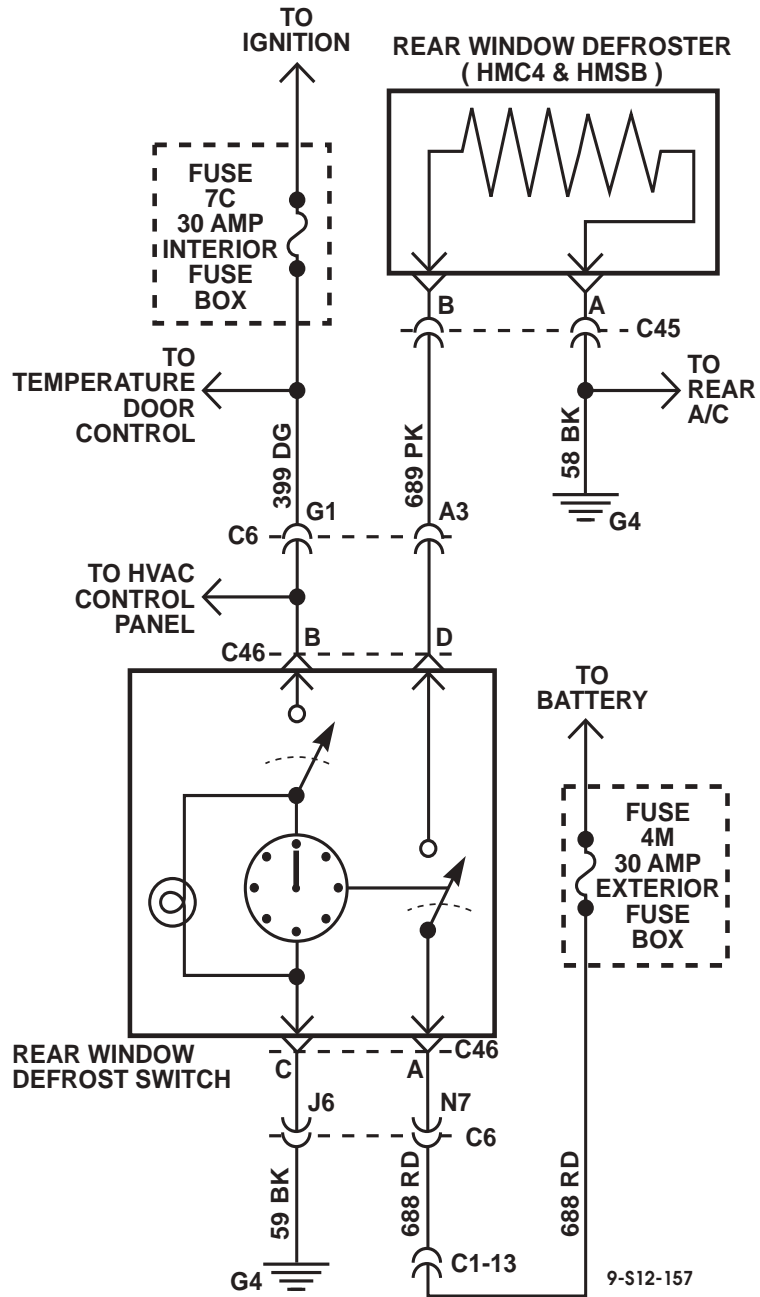

Figure 12-100: Rear Window Defroster Schematic



Power Windows Inoperative, All Windows

Step	Action	Value(s)	Yes	No
1	Remove relay R4 from the interior fuse box. With a DVOM check cavity G7 for resistance to ground. Does the resistance meet the specified value?	<.2 Ω	Go to step 2.	Repair the open or bad connection in CKT 59 between relay R4 and Ground G4.
2	With a DVOM check the voltage at cavity F7. Is the specified voltage present?	12v	Go to step 3.	Repair the open or bad connection in CKT 175 between R4 and fuse 5M in the exterior fuse box.
3	Turn the ignition switch to the "Run" position. With a DVOM check the voltage at cavity F5. Is the specified voltage present?	12v	Go to step 4.	Repair the open or bad connection in CKT 296 between R4 and fuse 2G in the interior fuse box.
4	Remove the drivers door window switch and harness from the bezel. Disconnect the power window switch from the harness. With a DVOM check the resistance between cavity 3 on the drivers power window switch harness and cavity G5 of the interior fuse box. Does the resistance meet the specification?	<.2 Ω	Replace relay R4 in the interior fuse box.	Repair the open or bad connection in circuit 171 between the drivers window switch and R4.



Drivers Window Inoperative

Step	Action	Value(s)	Yes	No
1	Do all the other windows operate as designed?	—	Go to step 2.	Refer to proper chart.
2	Remove the drivers power window switch and harness from the bezel. With a DVOM check the resistance to ground on cavities 2 (CKT 56) and 4 (CKT 56). Does the resistance on each wire meet the specifications?	<.2 Ω	Go to step 3.	Repair the open or bad connection in CKT 56 between the power window switch and G4.
3	Turn the ignition switch to the "Run" position and check the voltage on terminal 3 (CKT 170). Is the specified voltage present?	12v	Go to step 4.	Repair the open or bad connection on CKT 170 between the power window switch and relay R4.
4	Connect the power window switch to the harness. With the ignition in the "Run" position back probe cavities 1 (CKT 227) and 5 (CKT 226) with a DVOM set to measure voltage. Operate the window switch and observe the voltage polarity. The voltage should switch from +12v to -12v with the operation of the switch. Does the polarity switch?	+12v to -12v	Go to step 5.	Replace the drivers door power window switch.
5	Gain access to the window motor. Disconnect the harness and with a DVOM check the wires for polarity change when the power window switch is operated. Does the polarity change?	+12v to -12v	Replace the power window motor.	Repair the open or bad connection on circuits 226 and 227 between the power window switch and the power window motor.



Power Windows Only Operate Using The Console Switches

Step	Action	Value(s)	Yes	No
1	Does the drivers door window operate as designed?	—	Go to step 2.	Refer to the proper chart.
2	If the window lock out switch is in the “Lock” position move it to the “Unlock” position. Are the power windows operating as designed?	—	No further repair is needed at this time.	Go to step 3.
3	Gain access to the power window switches on the console. With a DVOM check for a ground on terminals 2 and 4 of all three power window switches. Do all six wires meet with the specified value for resistance to ground?	<.2 Ω	Go to step 4.	Repair the open or bad connection between the power window switches and ground G4.
4	Turn the ignition switch to the “Run” position. With a DVOM back probe the purple wire on the power window lock out switch. Make sure the switch is in the “Unlock” position. Is the specified voltage present?	12v	Refer to the individual window charts.	Go to step 5.
5	With the ignition still in the “Run” position check the voltage on the red wire (CKT 171) of the power window lockout switch harness. Is the specified voltage present?	12v	Replace the power window lock out switch.	Repair the open or bad connection between the power lock out switch and relay R4.

**Passenger Front Door Power Window Inoperative**

Step	Action	Value(s)	Yes	No
1	Do all the other windows operate as designed?	---	Go to step 2.	Refer to the proper chart.
2	Gain access to the passenger front power window switch harness in the door. Turn the ignition switch to the run position. With a DVOM check the voltage at terminal 3 (CKT 170). Is the specified voltage present?	12v	Go to step 3.	Repair the open or bad connection in CKT 170 between the power window switch and the power window lock out switch.
3	Disconnect the power window switch from the harness. Using a DVOM check for resistance to ground on terminals 2 (CKT 314) and 4 (CKT 313). Does the resistance meet the specifications?	<.2 Ω	Go to step 4.	Repair the open or bad connection on CKT 313 or 314 between the passenger door window switch and the console window switch.
4	Connect the power window switch to the harness and make sure that the ignition switch is in the run position. With a DVOM back probe terminals 1 (CKT 227) and 5 (CKT 226) at the same time. Check the voltage while operating the switch from "Up" to "Down". Is the specified voltage present and does the polarity change from positive to negative with the action of the switch?	+12v to -12v	Go to step 5.	Replace the passenger front power window switch.
5	Gain access to the power window motor and disconnect the harness. With a DVOM back probe the red wire (CKT 227) and the yellow wire (CKT 226). Operate the power window switch and watch the voltage. Is the specified voltage present and does it change from positive to negative with the action of the switch.	+12v to -12v.	Replace the passenger front window motor.	Repair the open or bad connection on either CKTS 226 or 227 between the power window motor and switch.



(Passenger/Drivers) Rear Door Power Window Inoperative

NOTE: Refer to the wiring diagram for the circuit numbers.

Step	Action	Values	Yes	No
1	Do all the other windows operate as designed?	—	Go to step 2.	Refer to the proper chart.
2	Gain access to the rear power window switch harness in the door. Turn the ignition switch to the run position. With a DVOM check the voltage at terminal 3 (CKT 170). Is the specified voltage present?	12v	Go to step 3.	Repair the open or bad connection in CKT 170 between the power window switch and the power window lock out switch.
3	Disconnect the power window switch from the harness. Using a DVOM check for resistance to ground on terminals 2 and 4. Does the resistance meet the specifications?	<.2 Ω	Go to step 4.	Repair the open or bad connection on the tan wire or the light green wire between the door window switch and the console window switch.
4	Connect the power window switch to the harness and make sure that the ignition switch is in the run position. With a DVOM back probe terminals 1 and 5 at the same time. Check the voltage while operating the switch from “Up” to “Down”. Is the specified voltage present and does the polarity change from positive to negative with the action of the switch?	+12v to -12v	Go to step 5.	Replace the power window switch.
5	Gain access to the power window motor and disconnect the harness. With a DVOM back probe the red wire and the yellow wire, Operate the power window switch and watch the voltage. Is the specified voltage present and does it change from positive to negative with the action of the switch.	+12v to -12v.	Replace the window motor.	Repair the open or bad connection in the wires between the power window motor and switch.



POWER WINDOWS

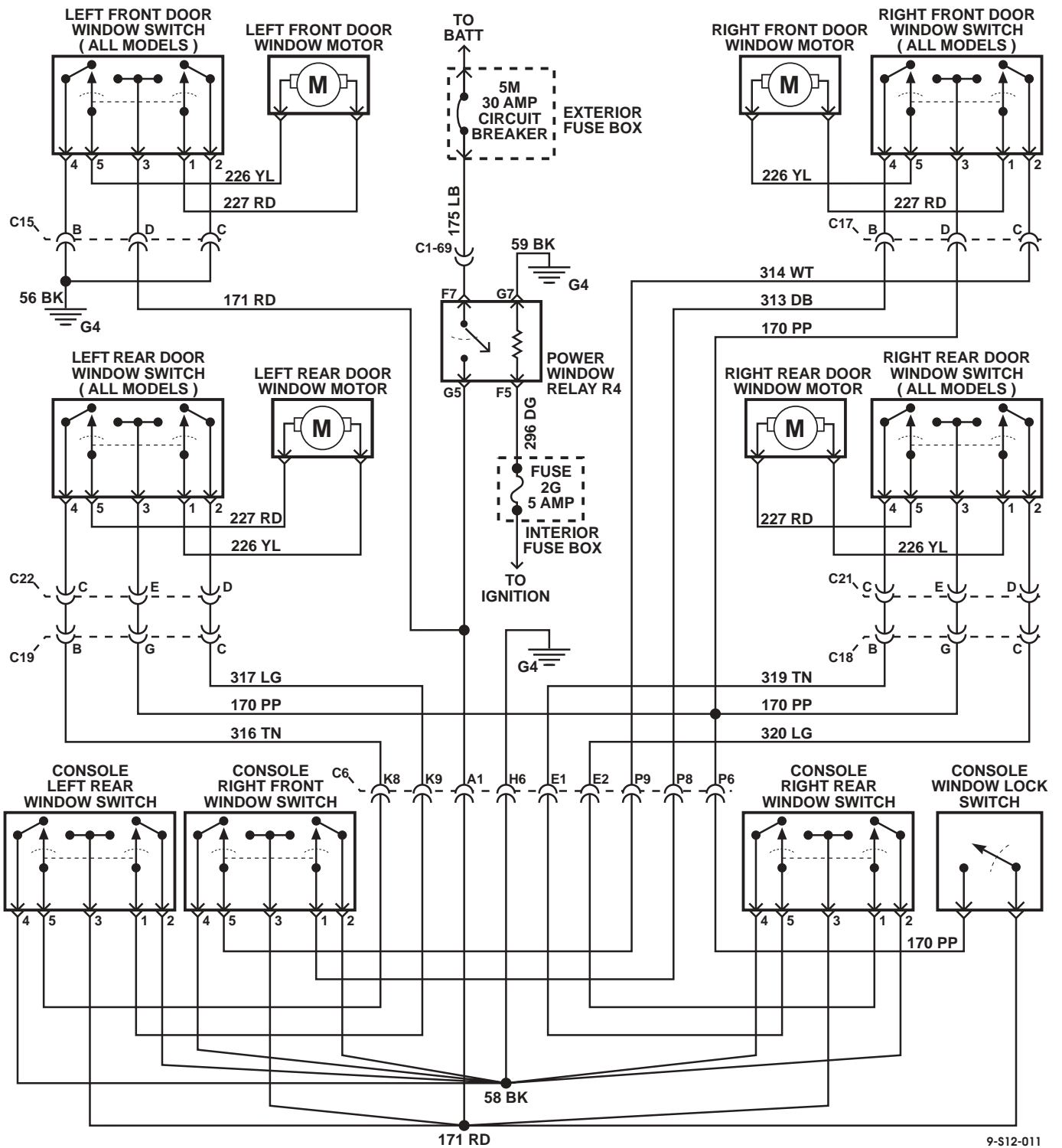

Figure 12-101: Power Window Schematic



POWER DOOR LOCK SWITCH REPLACEMENT

NOTE: Switch replacement is the same for all doors.

Removal

1. Remove mounting plate, capscrews, and remove switch from switch bezel (Figure 12-102).
2. Disconnect door harness from switch.

Separate switch from mounting plate.

Installation

1. Assemble switch and mounting plate.
2. Connect switch to door harness.
3. Install switch and mounting plate on bezel and secure with screws.

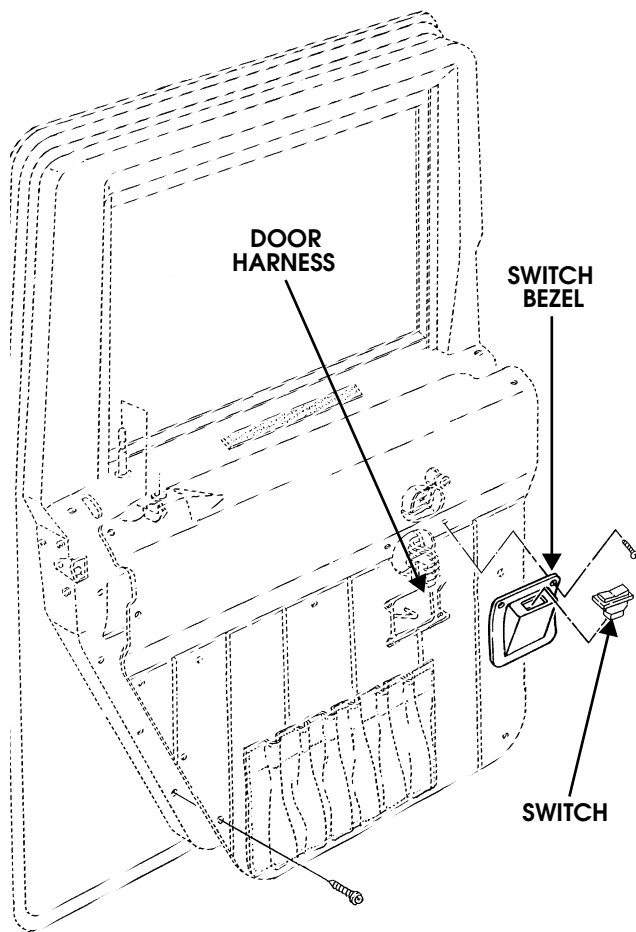

P12-052

Figure 12-102: Power Door Lock Switch Mounting

POWER DOOR LOCK ACTUATOR REPLACEMENT

Removal

NOTE: Actuator replacement is the same for all doors.

1. Raise window.
2. Remove door trim panel.
3. Remove vapor barrier (Figure 12-103).

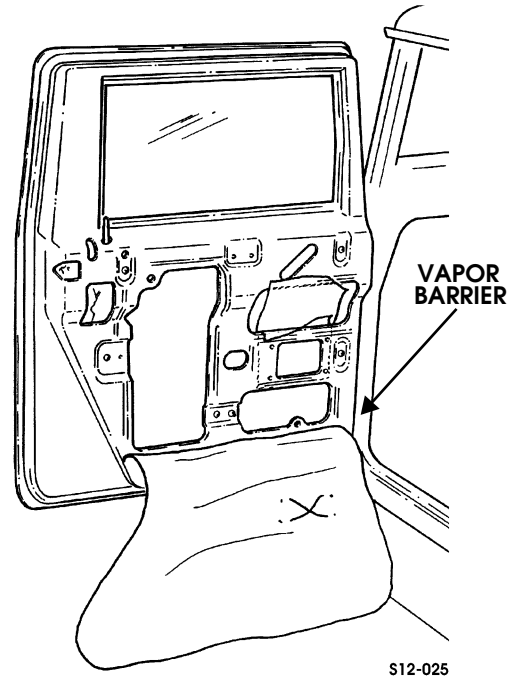

Figure 12-103: Vapor Barrier Removal/Installation

4. Detach door harness connector from door actuator (Figure 12-104).

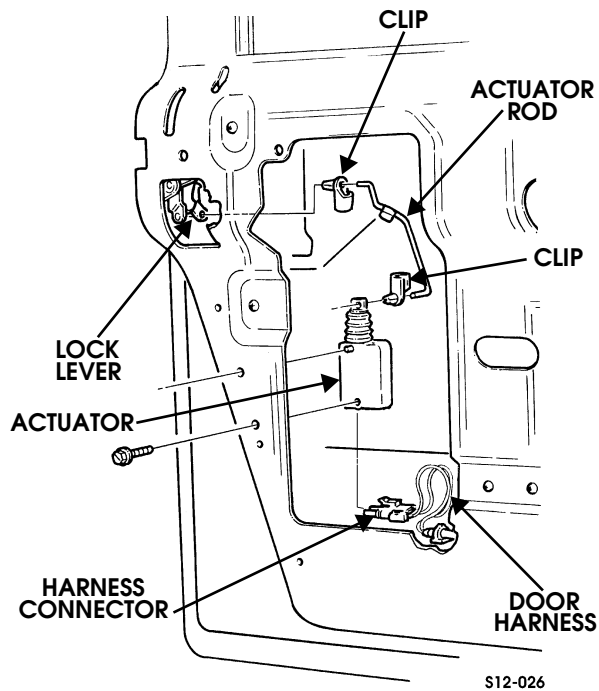

Figure 12-104: Door Lock Actuator Removal/Installation

5. Remove actuator attaching screws.
6. Remove actuator from door and disconnect actuator rod from clips and actuator.

Installation

NOTE: Color coding on actuator rod is positioned away from actuator during installation. Actuator rods are color coded as follows: left front, red; right front, green; left rear, yellow; and right rear, blue.

1. Connect clip and actuator rod to lock lever (Figure 12-104).
2. Install opposite clip on actuator and connect rod to actuator.
3. Secure actuator with mounting screws.

CAUTION: The actuator threads will strip if overtightened.

4. Connect harness wires to actuator.

NOTE: Vapor barrier must be completely sealed at all edges to prevent water entry into the interior of the vehicle.

5. Install vapor barrier (Figure 12-103).
6. Install door trim panel.

Door Lock Actuator Replacement For Rear Cargo Door (HMCS Only)

Removal

1. Remove window from primary rear door.
2. Remove (4) screws and interior door handle.
3. Remove (12) screws securing inner door panel to door.
4. Remove inner door panel.
5. Disconnect link rod from lock actuator by rotating plastic lock clip clockwise.
6. Remove link rod from plastic clip, and plastic clip from actuator.
7. Remove screw securing door lock actuator to bracket.
8. Disconnect door lock harness from actuator.
9. Remove actuator from bracket (Figure 12-105).

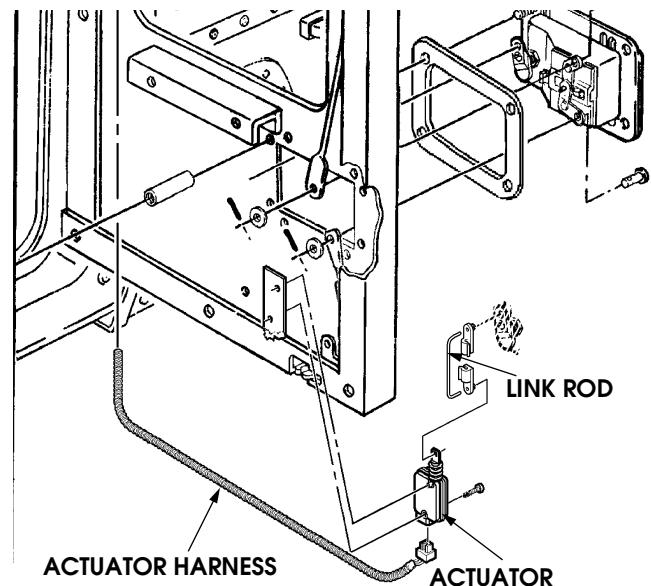

Figure 12-105: Cargo Door Lock Actuator

Installation

1. Connect door lock harness to new door lock actuator.
2. Place actuator on bracket so actuator plunger is on the left side of the actuator.
3. Install screw securing door lock actuator to bracket.
4. Install plastic clip into hole in actuator plunger.
5. Install link rod into plastic clip and rotate counter clockwise to lock in place (Figure 12-105).
6. Install inner door pane with (12) screws.
7. Install inner door handle with (4) screws.
8. Verify operation of door handle and door locks.



Rear Cargo Door Lock Module Replacement (HMCS Only).

Removal

1. Remove right rear seat.
2. Remove right rear seat belt ratchet assembly.
3. Remove right rear corner trim assembly (Figure 12-106).

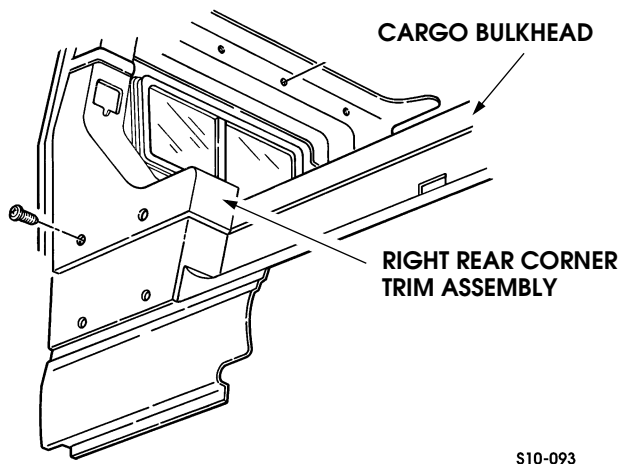

Figure 12-106: Removing Right Rear Trim Piece

4. Disconnect rear door lock harness jumper assembly from the rear door lock module.
5. Pull the module loose from the velcro attaching it to the body.

Installation

1. Apply new velcro strip to new rear door lock module
2. Affix new module to body and connect rear door lock harness jumper.
3. Verify operation of rear door locks.
4. Install right rear trim piece (Figure 12-106).
5. Apply loctite 242 to seat belt ratchet bolt.
6. Install seat belt ratchet bolt and torque to 35-40 ft-lbs (47-55 Nm).
7. Install right rear seat.

Rear Cargo Door Lock Harness Jumper Replacement

Removal

1. Remove right rear seat.
2. Remove right rear seat belt ratchet assembly.
3. Remove right rear corner trim assembly (Figure 12-106).
4. Disconnect harness from rear door lock module.
5. Remove slide out bulkhead.
6. Remove closeout panel from passenger side of rear cargo door frame.
7. Disconnect harness from door hinge contacts.
8. Pull the padding and carpet on the cargo area wall upward to expose the harness.
9. Remove remaining trim pieces behind right rear passenger seat.
10. Remove lower passenger side B-pillar trim.
11. Remove passenger side righthand kick panel.
12. Disconnect rear cargo door lock jumper.
13. Remove the harness from the vehicle.

Installation

1. Connect rear cargo door lock jumper harness to the connector at the B-Pillar.
2. Route harness along same locations to the rear cargo door lock module.
3. Connect the harness to the door lock module.
4. Route harness to the door hinge contacts and connect it.
5. Install passenger side cargo door frame closeout panel.
6. Reposition the cargo area padding.
7. Install trim pieces behind right rear passenger seat.
8. Install rear passenger righthand side kick panel.
9. Install passenger side lower B-pillar trim.
10. Install removable cargo area bulkhead.
11. Install passenger right rear seat.



KEYLESS ENTRY & THEFT DETERRENT SYSTEM OPERATING INSTRUCTIONS

Keyless Entry & Theft Deterrent System

The optional keyless entry system allows convenient operation of the vehicle door locks from a distance. Equipped vehicles are supplied with two, three button remote transmitters used to operate the system. Two additional remote transmitters can be added.

NOTE: Vehicles not equipped with keyless entry will have a jumper harness installed in place of the receiver module.

LOCKING THE DOORS & ARMING THE THEFT DETERRENT SYSTEM

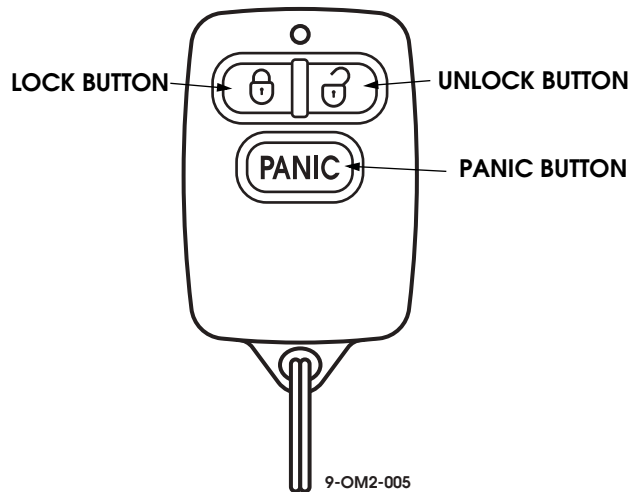

Figure 12-107: 3-Button Transmitter

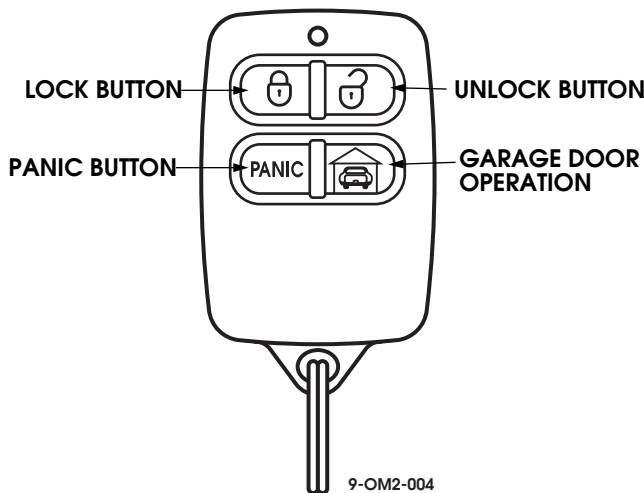

Figure 12-108: 4-Button Transmitter

Locking the Doors

To lock the vehicle doors, press the lock button on the remote transmitter once. A red L.E.D. on the remote transmitter will illuminate while the button is depressed, indicating that the remote transmitter is functioning. The vehicle parking lights will flash once, and the horn will beep softly to confirm that the command was received. The theft deterrent system arms at this time.

The theft deterrent system will beep the horn and flash the lights if any door is opened before disarming with the remote transmitter by unlocking the doors.

Unlocking the Doors

When approaching the vehicle press the unlock button on the remote transmitter once. This will unlock the drivers door. The vehicle lights will flash 2 times, and the horn will beep twice softly to confirm that the command was received. The interior lights will turn on and remain activated for approximately 30 seconds, and the theft deterrent system will disarm. To unlock the remaining doors, press the unlock button on the remote transmitter a second time.

Theft Deterrent System Override

If the battery in the remote transmitter is dead, or the remote transmitter is not operating, the theft deterrent system will need to be overridden once the door is opened. The alarm will start as soon as a door is opened. To override the alarm, place the key in the ignition, and turn it to the "on" then "off" position 3 times. The system will remain in override until the doors are locked again with the remote transmitter.

Panic Activation

The panic feature can be used to activate the vehicle audio and visual theft deterrent features to draw attention to yourself during an emergency situation. Simply press and hold the PANIC button for 3 seconds. This will cause the vehicle horn and lights to pulse on and off for approximately 30 seconds. To deactivate the panic feature before the time period expires, press and release the panic button.



SYSTEM FEATURES

System features can be activated or deactivated as required by the owner. Some system features are active when the vehicle is purchased.

Passive Theft Deterrent Arming

This feature will automatically arm the theft deterrent system 30 seconds after you depart the vehicle. The arming will take place even if the lock button isn't pushed on the remote transmitter. Passive locking can also be activated with this feature.

Passive Locking

This feature will lock the doors 30 seconds after the vehicle is departed. The doors will lock automatically even if the lock button is not pushed on the remote transmitter. When this feature is active, the ignition keys should never be left in the vehicle because the system will still lock the doors. This feature requires that the theft deterrent system also be set to **passive arming**.

Automatic Door Lock*

This feature will lock the doors 3 seconds after the ignition key is turned to the on position. The system will not lock the doors if a door is ajar when the key is turned on.

Automatic Door Unlock*

This feature will automatically unlock the driver's door when the ignition key is turned off. The system can be programmed by an authorized HUMMER dealer to unlock all the doors.

Horn Chirp*

This feature chirps the horn when the doors are locked and unlocked.

Disarming the Horn Chirp

The horn chirp feature can be disabled so that only the parking lights will flash during lock and unlock. To disable the horn chirp:

1. Press and release the unlock button on the remote transmitter button once.
2. Open the drivers door and leave it open
3. Turn the ignition "on" then "off" 5 times within 5 seconds. Do not start the vehicle.
4. When the key is turned on for the fifth time, the horn will chirp twice to indicate that the feature has been disabled. If it does not, the key cycles were not within the 5 second time frame, and the procedure must be started over.
5. Turn the ignition key "off", and test the system with the remote transmitter.
6. To reactivate, repeat the procedure

NOTE: * Indicates features which are active when the vehicle is manufactured

OPTIONAL GARAGE DOOR ACCESSORY PACKAGE

The Garage Door Accessory Package provides the owner with the ability to operate their existing garage door opener with the same keyless entry remote transmitter used to open and lock your HUMMER. This system includes two 4-button remote transmitters and a garage door receiver that must be installed in your existing garage door system. The package must be purchased from a HUMMER dealership and the remote transmitters programmed to the HUMMER. Installation of the garage door receiver is the responsibility of the Hummer Owner.

Synchronizing the Remote Transmitters

If the keyless entry remote transmitter is operated 50 times or more outside the range of the vehicle, the remote transmitter codes will not match the code that the receiver expects. If the remote transmitter does not activate the lock system, and the batteries are not dead, the remote transmitter may need to be synchronized with the receiver. Stand close to the vehicle and press the lock button twice within one second. If there is no response, try pressing the button twice faster, then slower. If there is still no response, the system must be checked.

Battery Replacement

It is suggested that the batteries in your remote transmitters be replaced every 12 months to maintain optimum performance. Should the remote transmitter range begin to decrease or the red L.E.D. on the remote transmitter stop functioning, the battery will need to be replaced. To replace the batteries:

1. Remove the phillips screw from the back of the remote transmitter
2. Carefully pry the top of the remote transmitter away from the bottom part.
3. Remove the old battery making note of battery polarity.
4. Replace the old battery with a new GP27A type.
5. Assemble the remote transmitter.

Batteries can be obtained where small camera and watch batteries are sold.



REMOTE ENTRY SYSTEM

Remote Entry Receiver Replacement

Removal

1. Remove front console enough to gain access to receiver (Section 10).
2. Disconnect two receiver harness connectors from receiver (Figure 12-109).
3. Remove receiver from two velcro strips.

Installation

4. Install receiver on two velcro strips.
5. Connect receiver harness connectors to receiver.
6. Program receiver to accept remotes.
7. Check remote entry system for proper operation.
8. Install front console (Section 10).

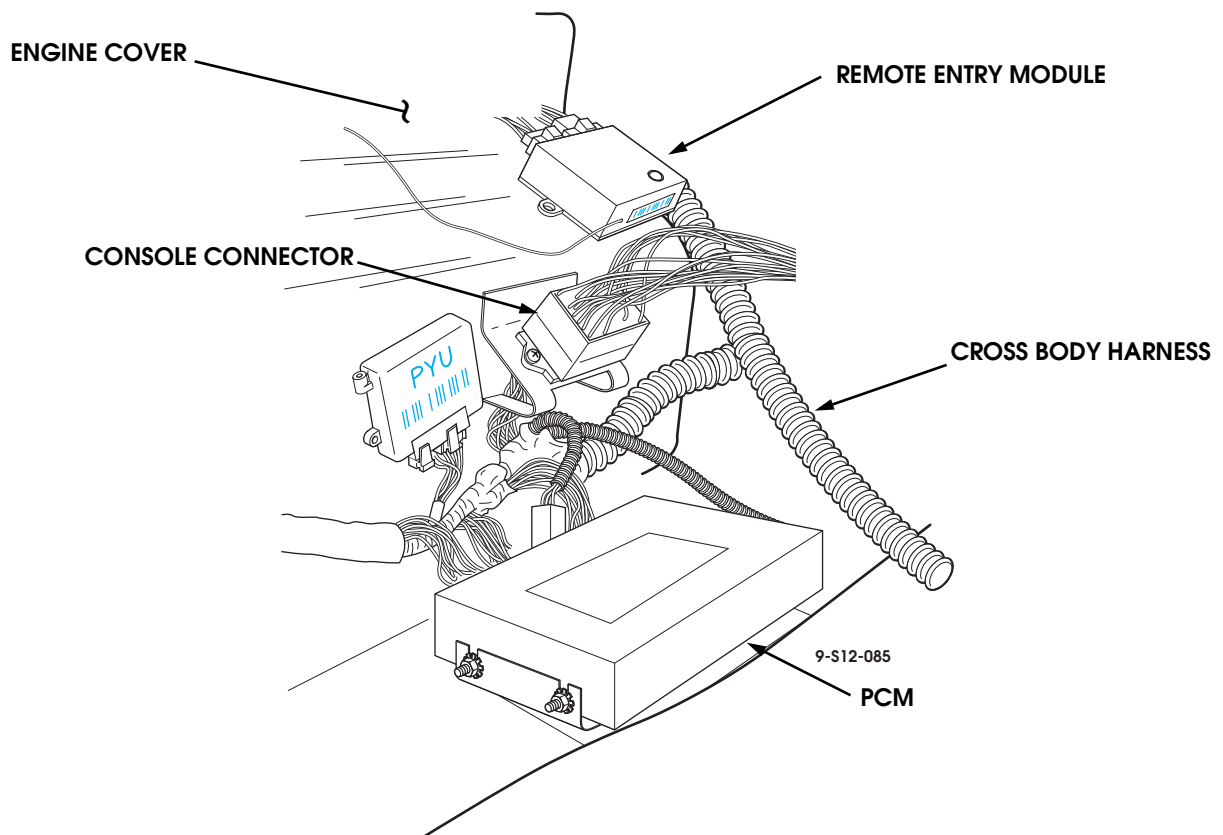

Figure 12-109: Remote Entry Receiver



REMOTE ENTRY RECEIVER/TRANSMITTER REPLACEMENT

Removal

1. Remove center console.
2. Disconnect wire connection at receiver and remove receiver from engine cover (Figure 12-109).
3. Installation
 1. Place hook and loop on back of receiver and place receiver on engine cover.
 2. Connect wire harness and reprogram system.

PROGRAMMING NEW OR REPLACEMENT REMOTE TRANSMITTERS

Keyless Entry Remote Transmitter Troubleshooting

1. If the customer's complaint indicates a gradual decrease in range of the remote transmitter, or intermittent operation of the remote transmitter, the battery may need replacement. The red Light Emitting Diode on the keyless entry remote transmitter should illuminate brightly when a remote transmitter button is pressed.
2. The remote transmitter may operate when the battery voltage drops below 4.0V DC, however range and reliability will be sacrificed at this level. When this same battery is measured under load, the voltage will drop close to or below the 3.0 VDC level. Battery replacement is usually recommended when the voltage drops to or below 5.0 VDC with no load.
3. If the battery voltage is at an acceptable level, but the remote transmitter will not activate the system, it may need to be synchronized. To re-synchronize the remote transmitter to the receiver, stand close to the vehicle and press and release the LOCK button 2 times within one second. The vehicle's horn should chirp one time indicating that you have locked the doors and armed the system. If re-synchronizing does not work on your first attempt, try again slower, then again faster.

Programming The Keyless Entry Remote Transmitters

You should have access to all keyless entry remote transmitters that will ultimately operate the unit, even if they are currently programmed to do so.

Each keyless entry receiver module will learn and store up to four different remote transmitter codes. When a fifth remote transmitter programmed, the first remote transmitter that was originally programmed to the unit will be bumped out of the system memory.

1. To start programming, make sure that the Theft Deterrent System is disarmed, either by using a remote transmitter that is currently programmed, or by using the Theft Deter-

rent System Override procedure explained in the operating instructions.

2. Gain access to the programming push-button switch located on the keyless entry control module, which is mounted under the center console of the vehicle.
3. Turn the ignition key to the ON position.
4. Within 15 seconds, press and release the programming switch 3 times. The vehicle horn will sound one time indicating that the system is in program mode
5. Press and hold the LOCK button on the remote transmitter until the vehicle horn sounds one long chirp.
6. Repeat step 5 for all remote transmitters that you wish to program (up to four).
7. Turn the ignition key to the OFF position, or wait 15 seconds, and the system will automatically terminate the programming mode. This is indicated by a 3 chirp signal from the vehicle horn.

Remote Transmitter Programming Hints

1. If you wait more than 15 seconds between steps in the programming mode, the system will automatically terminate the programming mode. This is indicated by the 3 chirp signal from the vehicle's horn. Simply start over to complete programming of all remote transmitters,
2. Test all programmed remote transmitters to be sure that all buttons are operating. Remember the system will not remotely lock the doors while the ignition key is in the ON position.

CHANGING THE SELECTABLE FEATURES

Some of the features of the keyless entry and theft deterrent system can be changed or tailored to the needs of the owner. The following is a list of alterable features included in the HUMMER remote entry system

1. Auto Door Lock
2. Auto Driver's Door Unlock
3. Auto passenger doors unlock
4. Active theft deterrent
5. Active door locking

Programming the Selectable Features

1. To start programming, make sure that the Theft Deterrent System is disarmed, either by using a remote transmitter that is currently programmed, or by using the Theft Deterrent System Override procedure.
2. Gain access to the programming pushbutton switch located on the keyless entry control module, which is mounted in the center console of the vehicle.
3. Turn the ignition key to the "ON" position.
4. Within 15 seconds, press and release the programming switch 3 times. The vehicle's horn will sound one time indicating that the system is in remote transmitter program mode.



5. Immediately turn the ignition key off (3 chirps indicates exit remote transmitter program mode) and then back on. The vehicle's horn will sound 2 chirps indicating that the system is in feature programming mode.
6. Press and release the programming switch on the keyless entry module 1 time to advance to feature number 1. The vehicle's horn will chirp 1 time If feature 1 is in the ON position, Or 2 times if feature 1 is in the OFF position
7. To change the feature, press and release the LOCK button on the keyless entry remote transmitter, and the appropriate 1 or 2 chirp signal from the horn will identify the new selection for that feature (Refer to the table shown above).
8. To advance to selectable feature number 2, press and release the programming switch on the keyless entry module a second time, and again the vehicle's horn will identify the selection of that feature as "on" or "off". Use the lock button on the keyless entry remote transmitter to

change the feature or proceed to the next step if no change is desired

9. Turn the ignition key off or allow 15 seconds to pass, and the vehicle's horn will sound 3 chirps indicating programming mode has been terminated.

Feature Programming Hints

1. Unless otherwise specified, if you wait more than 15 seconds between steps in the programming mode, the system will automatically terminate the programming mode. This is indicated by the 3 chirp signal from the vehicle's horn. Simply start over to complete programming of all features.
2. Test the system to be sure that all selectable features are functioning according to your customers requests. If you have missed a feature or changed the wrong feature, simply re-enter the feature programming mode to make the appropriate changes.

Feature #	Function	ON or active, one chip indication	OFF or passive, two chip indication
1	Auto door lock Factory preset ON	When active, doors will lock three seconds after the ignition is turned on. Will not operate if a door is ajar.	No auto lock
2	Auto drivers door unlock. Factory preset ON	When active, drivers door will unlock three seconds after the ignition is turned off	No drivers auto door unlock
3	Auto passenger doors unlock. Factory preset OFF	When active, passenger doors will unlock three seconds after the ignition is turned off	No passenger door auto unlock
4	*Active or passive theft deterrent. Factory preset ACTIVE <i>*This feature must be set to passive prior to setting feature 5 to passive</i>	When active, the theft deterrent system arms when the remote transmitter LOCK button is pushed	When the feature is off, or passive, the theft deterrent system automatically arms 30 seconds after the ignition is turned off and the vehicle is departed. All doors must be closed.
5	*Active or passive door locking. Factory preset ACTIVE <i>*Passive feature requires feature 4 to be set to passive</i>	When active, doors will lock when LOCK button is pressed, or Auto ignition LOCK feature is active.	When this feature is passive, and feature four is passive, the doors will lock 30 seconds after the ignition is turned off and the vehicle is departed. All doors must be closed



Power Locks Inoperative w/o Keyless

Step	Action	Value(s)	Yes	No
1	Remove the passenger door lock switch from the bezel. Using a DVOM measure voltage on pin 3 (CKT 517). Is the specified voltage present?	12v	Go to step 2.	Repair the open, or bad connection in CKT 517 between the passenger side door lock switch and fuse 3H.
2	Disconnect the passenger door lock switch from the harness. Using a DVOM check the resistance to ground on pins 2 (CKT 120), and 4 (CKT 119). Is the resistance below the specified value?	<.2 Ω	Go to step 5.	Go to step 3.
3	Remove the drivers door lock switch from the bezel, and disconnect it from the harness. On the drivers harness place a jumper wire between pins 1 (CKT 120) and 5 (CKT 119). With a DVOM check for continuity between pins 2 (CKT 120) and 4 (CKT 119) on the passenger door lock harness. Does the resistance meet the specified value?	<.2 Ω	Go to step 4.	Repair the open, or bad connection in CKT 120, and/or CKT 119 between the drivers and passenger door switches.
4	Remove the jumper wire from the drivers door lock switch harness. With a DVOM check the resistance to ground on the drives door lock switch harness pins 2 (CKT 58) and 4 (CKT 58). Does the resistance meet the specified values on both pins?	<.2 Ω	Replace the drivers door lock switch.	Repair the open or bad connection in CKT 58 between the drivers door lock switch and G4.
5	Connect the door lock switches to their harnesses. Using a DVOM back probe pins 1 and 5 of the passenger door lock switch. Move the switch to “Lock”, then “Unlock”. Does the voltage alternate between +12v and -12v?	+12v and -12v	Go to step 6.	Replace the passenger door lock switch.
6	Locate connector C31 under the center console. Using a DVOM probe pin F (CKT 121), and pin B (CKT 122). Move the passenger lock switch to “Lock” then “Unlock”. Does the voltage alternate between +12v and -12v?	+12v and -12v	Locate the open or bad connection, in CKTS 117 or 118 between C 31 and the door lock actuator.	Locate the open or bad connection in CKTS 121 or 122 between the passenger door lock switch and C31.



Power Door Locks Inoperative, W/ Remote Entry

Step	Action	Value(s)	Yes	No
1	Remove the passenger door lock switch from the bezel. Using a DVOM measure voltage on pin 3 (CKT 517). Is the specified voltage present?	12v	Go to step 2.	Repair the open, or bad connection in CKT 517 between the passenger side door lock switch and fuse 3H.
2	Disconnect the passenger door lock switch from the harness. Using a DVOM check the resistance to ground on pins 2 (CKT 120), and 4 (CKT 119). Does the resistance meet the specified value?	$<.2 \Omega$	Go to step 5.	Go to step 3.
3	Remove the drivers door lock switch from the bezel and disconnect it from the harness. On the drivers harness place a jumper wire between pins 1 (CKT 120) and 5 (CKT 119). With a DVOM check for continuity between pins 2 (CKT 120) and 4 (CKT 119) on the passenger door lock harness. Does the resistance meet the specified value?	$<.2 \Omega$	Go to step 4.	Repair the open, or bad connection in CKT 120, and/or CKT 119 between the drivers and passenger door switches.
4	Remove the jumper wire from the drivers door lock switch harness. With a DVOM check the resistance to ground on the drives door lock switch harness pins 2 (CKT 58) and 4 (CKT 58). Does the resistance meet the specified value on both pins?	$<.2 \Omega$	Replace the drivers door lock switch.	Repair the open or bad connection in CKT 58 between the drivers door lock switch and G4.
5	Connect the door lock switches to their harnesses. Using a DVOM backprobe pins 1 and 5 of the passenger door lock switch. Move the switch to "Lock", then "Unlock". Does the voltage alternate between +12v and -12v?	+12v and -12v	Go to step 6.	Replace the passenger door lock switch.
6	Locate connector C31 under the center console. Using a DVOM probe pin F (CKT 121), and pin B (CKT 122). Move the passenger lock switch to "Lock" then "Unlock". Does the voltage alternate between +12v and -12v?	+12v and -12v	Go to step 7	Locate the open or bad connection in CKTS 121 or 122 between the passenger door lock switch and C31.
7	Using a DVOM Check the voltage drop between connector C31 at pin D (CKT 517) and connector C30 at pin A (CKT 58) with the negative lead. Is the specified voltage present?	12v	Go to step 9.	Go to step 8.



Power Door Locks Inoperative, W/ Remote Entry (Continued)

Step	Action	Value(s)	Yes	No
8	Using a DVOM measure resistance to ground at C30 pin A (CKT 58). Does the resistance meet the specified value?	<.2 Ω	Repair the open or bad connection in CKT 517 between the remote entry module and fuse 3H.	Repair the open or bad connection in CKT 58 between the remote entry receiver and G4.
9	Using a DVOM check the voltage drop on C30 at pins G (CKT 554) and A (CKT 58). Is the specified voltage present?	12v	Go to step 10.	Repair the open or bad connection in CKT 554 between the remote entry module and fuse 1H.
10	Harness should be connected to the module. Using a DVOM, set to measure voltage, back probe C31 at pins G (CKT 117) and A (CKT 118). Move the lock switch from "Lock" to "Unlock" and observe the voltage polarity. Does the voltage switch from +12v to -12v?	+12v and -12v	Repair the open or bad connection in CKT 117 or 118 between the remote entry module and door lock actuator.	Replace remote entry module.

Slant Door Lock Inoperative

Step	Action	Value(s)	Yes	No
1	Do the other door locks function correctly?		Go to step 2.	Refer to the diagnostic chart(s) that apply.
2	Gain access to the connector C41. Using a DVOM, set to measure voltage, back probe pins E (CKT 118) and F (CKT 117). Move the drivers lock switch to "Lock", then "Unlock". Does the voltage alternate between +12v and -12v?	+12v and -12v	Go to step 3.	Repair the open or bad connection in CKT 117 or 118, between C41 and C18.
3	Gain access to the slant door actuator motor. Disconnect the harness form the actuator. Using a DVOM, back probe CKTS 117 and 118. Operate the door locks in both "Lock" and "Unlock". Does the voltage pulse +12v then -12v?	+12v and -12v	Replace the slant door lock actuator.	Repair the open or bad connection in CKT 117 or 118, between the actuator and C41.



Cargo Door Lock Inoperative

Step	Action	Value(s)	Yes	No
1	Does power the lock system on vehicle operate correctly?		Go to step 2.	Refer to the diagnostic charts that apply.
2	Open the primary cargo door. Using a DVOM measure the voltage across the brass door contacts on the body. Operate the door locks in both "Lock" and "Unlock". Does the voltage pulse +12v then -12v?	+12v then -12v	Go to step 3.	Go to step 4.
3	Remove inner door panel and disconnect door lock actuator. Using a DVOM set to measure resistance, measure continuity between the door contacts and door lock actuator on CKTS 117 and 121. Does the resistance meet the specification?	<.2 Ω	Replace the door lock actuator.	Locate the open or bad connection in CKT 117 or 121.
4	Gain access to cargo door lock delay module. Disconnect the module connector. Using a DVOM set to measure voltage, probe pins 9 (CKT 517), and 3 (CKT 59). Is the specified voltage present?	12v	Go to step 6.	Go to step 5.
5	Check the voltage drop on pin 9 (CKT 517). Is the specified voltage present?	12v	Repair the open or bad connection in CKT 59 between the cargo door lock delay module and G4.	Repair the open or bad connection in CKT 517 between the cargo door lock delay module and fuse 3H.
6	Using a DVOM set to measure voltage, probe pin 5 (CKT 118) of the cargo door lock delay module and pin 3. Move a door switch to "Unlock". Is the specified voltage present?	12v	Go to step 7.	Repair the open or bad connection, in CKT118 between the cargo door lock module and door lock switches.
7	Using a DVOM probe pins 6 (CKT 117), and 10 (CKT 121) at the cargo door lock delay module connector. Operate the door lock switch in both "Lock" and "Unlock". Does the voltage alternate between +12v and -12v?	+12v and -12v	Repair open or bad connection in CKT 117 or 118 between the cargo door lock delay module and door contacts.	Replace cargo door lock delay module.



Remote Entry System Inoperative

Step	Action	Value(s)	Yes	No
1	Does the panic feature operate when the button is depressed on the transmitter?		Go to step 6.	Go to step 2.
2	Does the L.E.D. illuminate on the keyless transmitter when a button is depressed?		Go to step 4.	Go to step 3.
3	Measure the battery voltage of the transmitter battery. Is the specified voltage present?	$\geq +5v$	Replace the transmitter.	Replace the transmitter battery
4	Attempt to re-synchronize the transmitter to the receiver. Is the problem repaired.		No further action required.	Go to step 5.
5	Reprogram the receiver to the transmitters. Is the problem solved?		No further action required.	Go to step 6.
6	Gain access to the receiver under the console. Disconnect connector C30 from the receiver. Using a DVOM measure the voltage drop between pins G (CKT 554) and A(CKT 58). Is the specified voltage present?	12v	Go to step 8.	Go to step 7.
7	Using a DVOM measure the resistance to ground at C30 pin A(CKT58). Does the resistance meet the specified value?	$<.2 \Omega$	Repair the open or bad connection in CKT 554 between the receiver and fuse 1H	Repair the open or bad connection in CKT58 between receiver and G4
8	Using a DVOM check the voltage drop between C30 pin A (CKT 58) and C31 pin D (CKT 517). Is the specified voltage present?	12v	Go to step 9.	Repair the open or bad connection in CTK 517.
9	Reconnect C30, and C31 to the remote entry module. Using a DVOM, back probe C31, pins G (CKT 117) and A (CKT 118). Using the remote entry transmitter, attempt to lock and unlock drivers door. Does voltage alternate between +12v and -12v?	+12v and -12v	Refer to the "Power Lock INOP" diagnostic chart.	Replace the remote entry receiver.

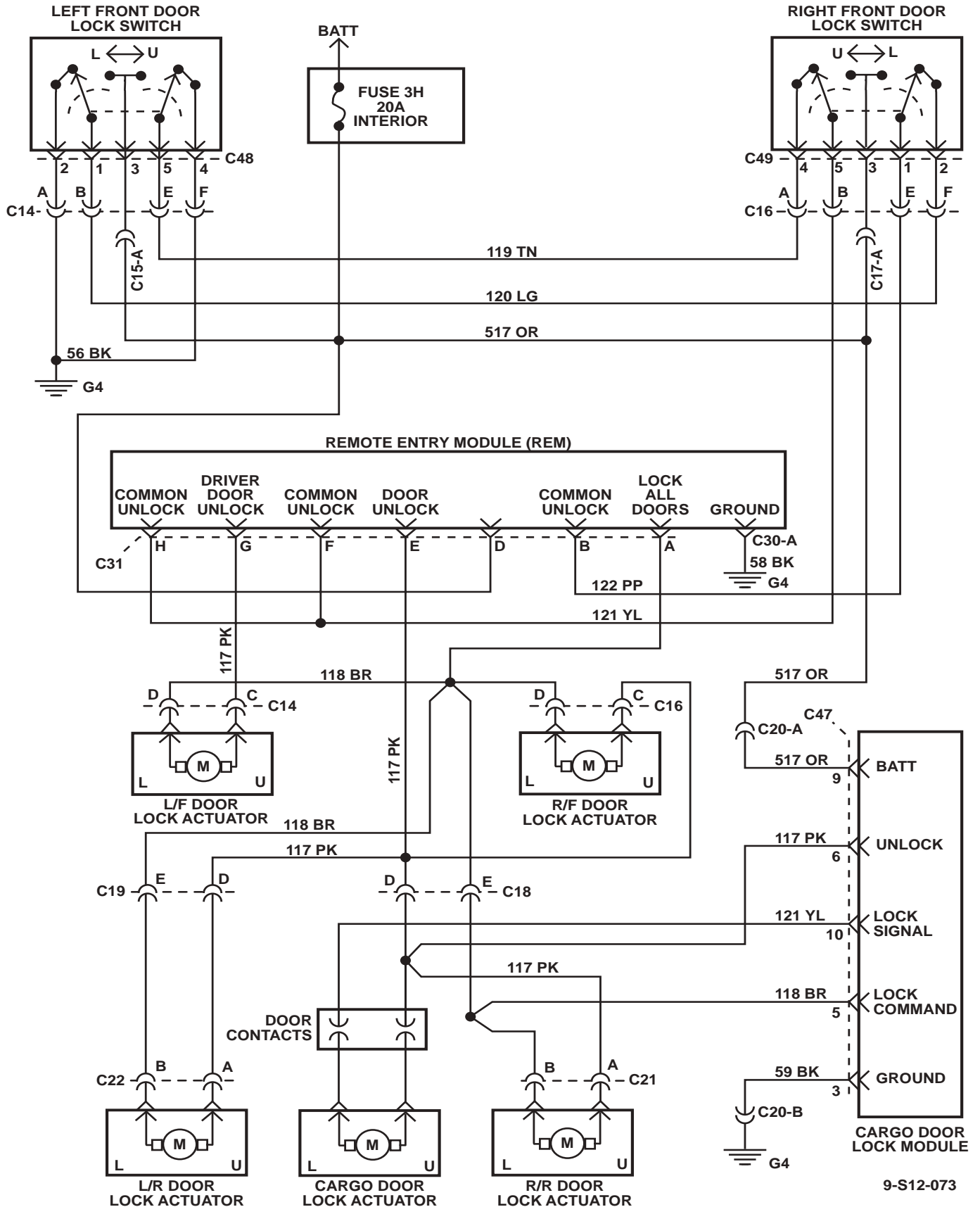

Figure 12-110: Power Locks HMCS W/ Remote Entry

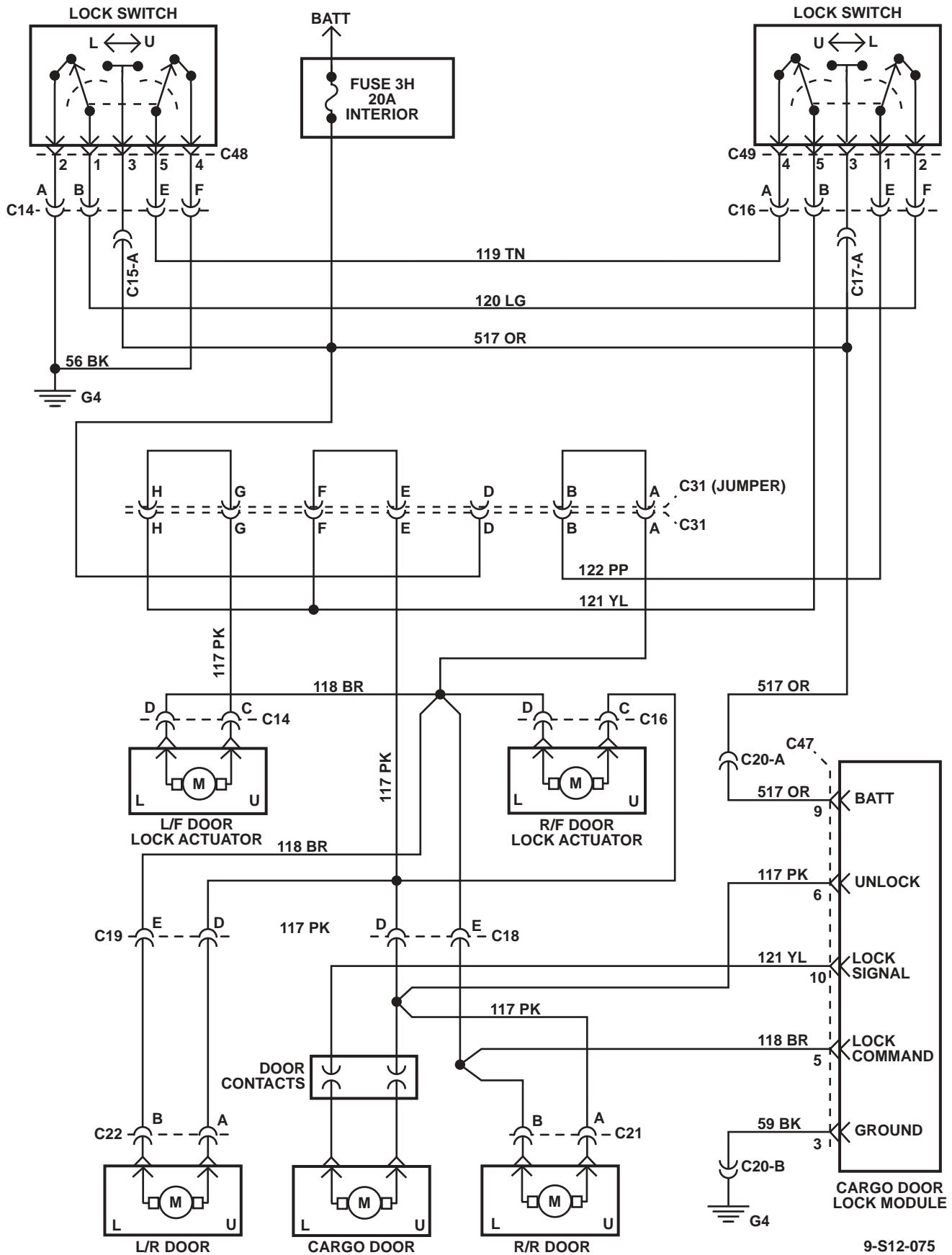
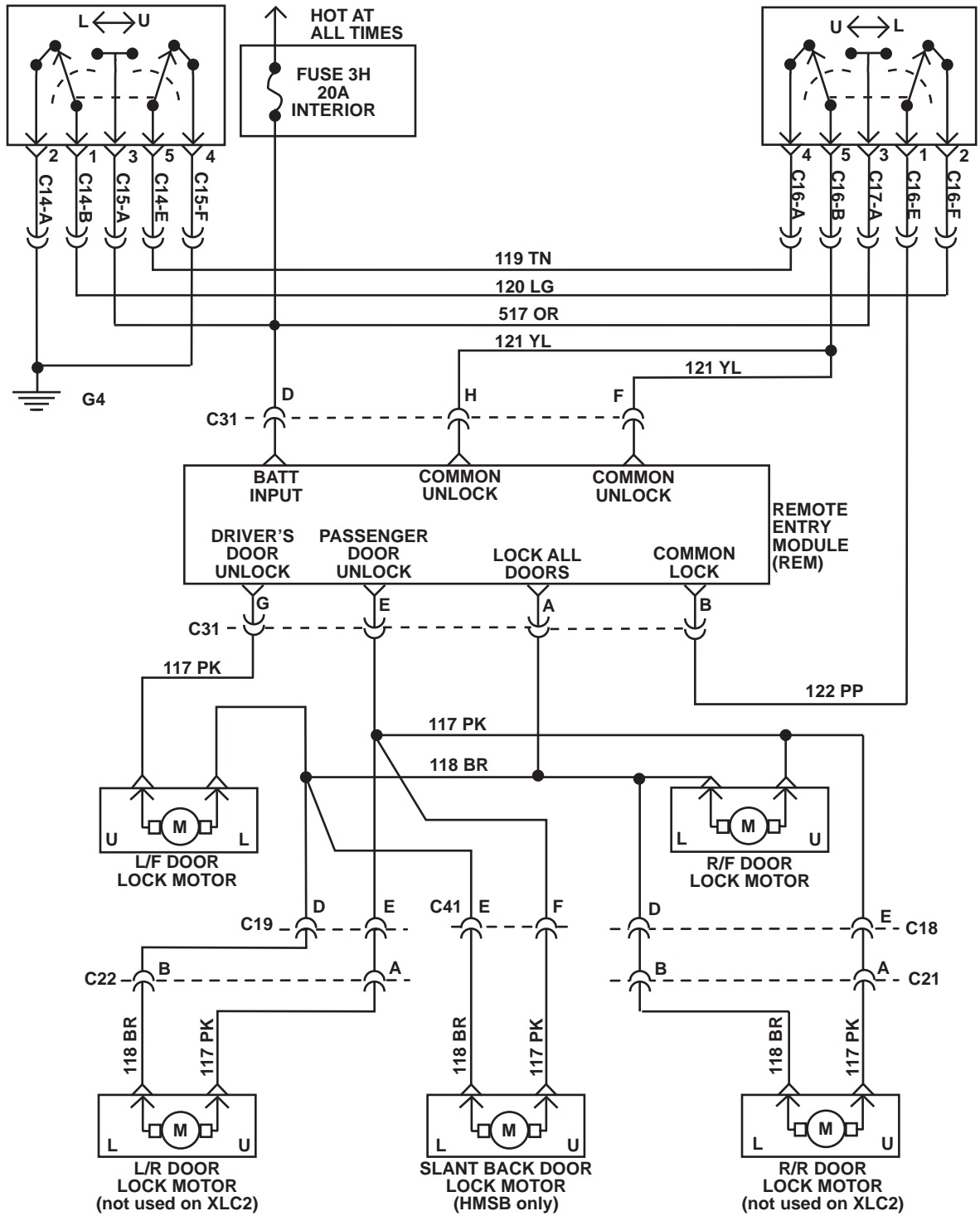

Figure 12-111: Power Locks HMCS W/O Remote Entry



00-S12-017

Figure 12-112: Power Locks HMC4, XLC2 , HMSB W/ Remote Entry

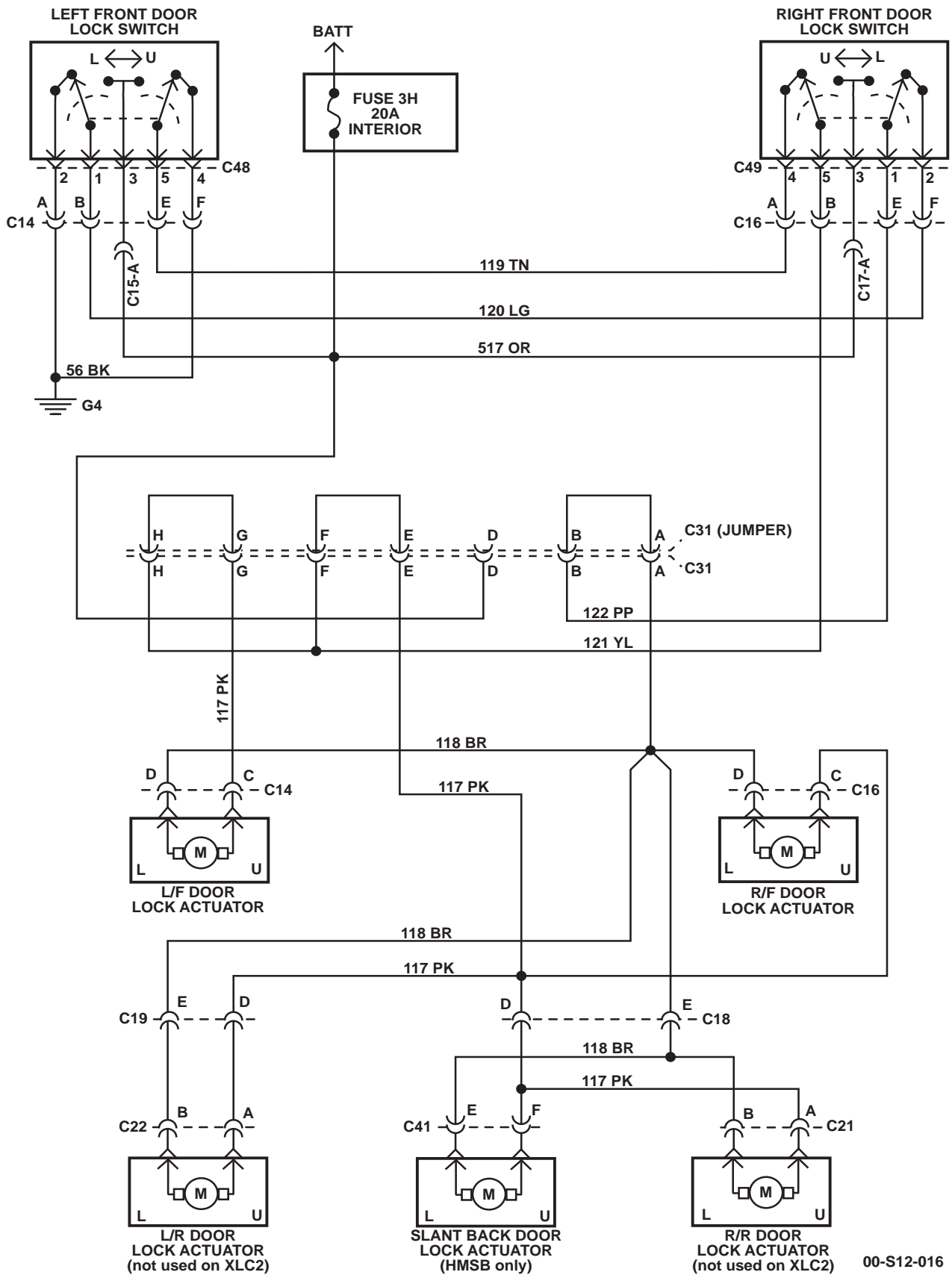
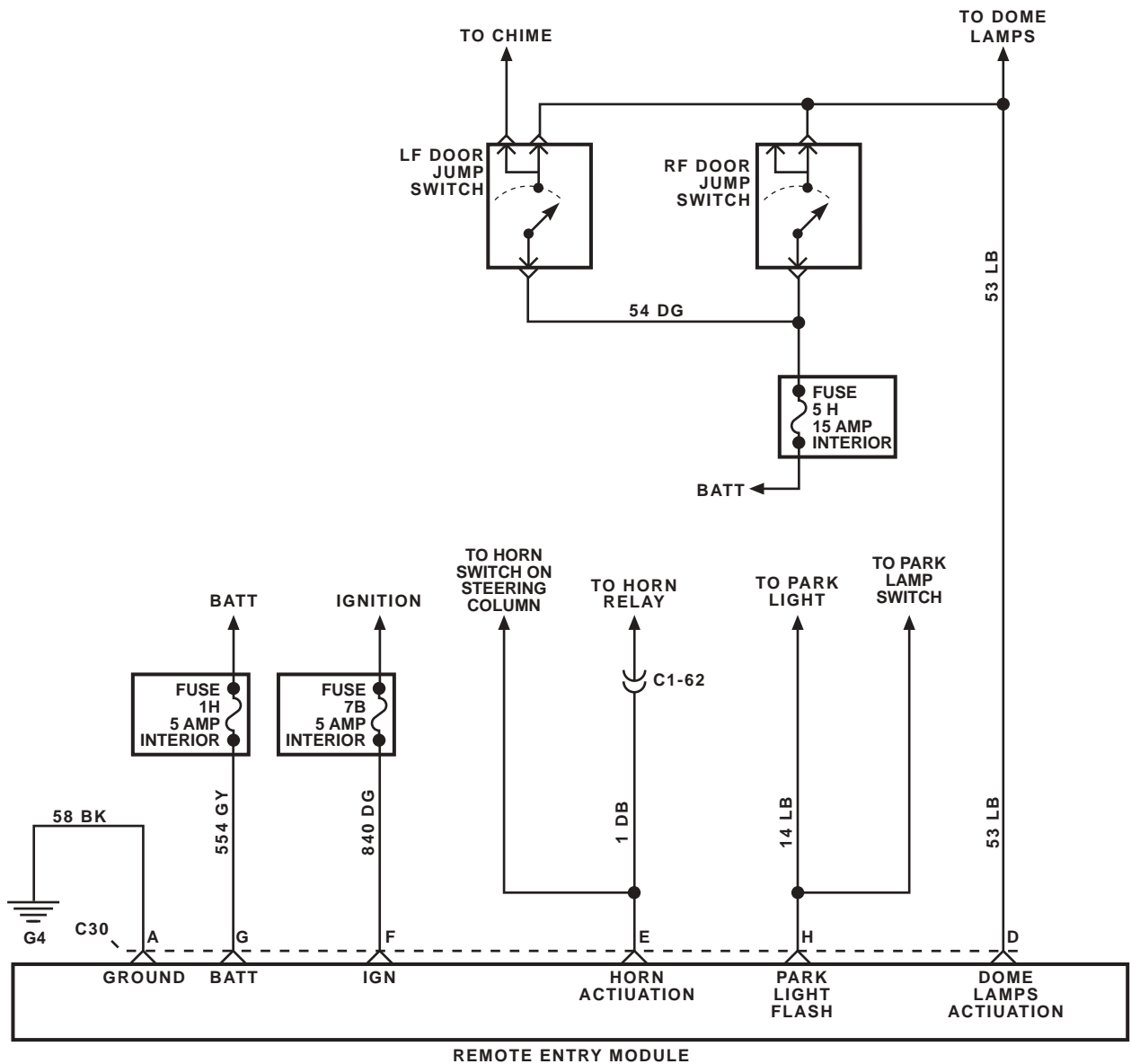

Figure 12-113: Power Locks HMC4, XLC2, HMSB W/O Remote Entry



9-S12-065

Figure 12-114: Remote Entry Module Power/Ground



POWER DOOR LOCK FRONT DOOR HARNESS REPLACEMENT

Removal

NOTE: Left and right front power door lock harness replacement procedures are similar.

1. Remove front seat.
2. Remove outer kick panels.
3. Remove power door locks switch from door trim.
4. Remove front door trim.

NOTE: Vapor barrier may be positioned under velcro strip, if so, cut around velcro strip to remove vapor barrier.

5. Remove vapor barrier and moisture barrier flap from door (Figure 12-115).

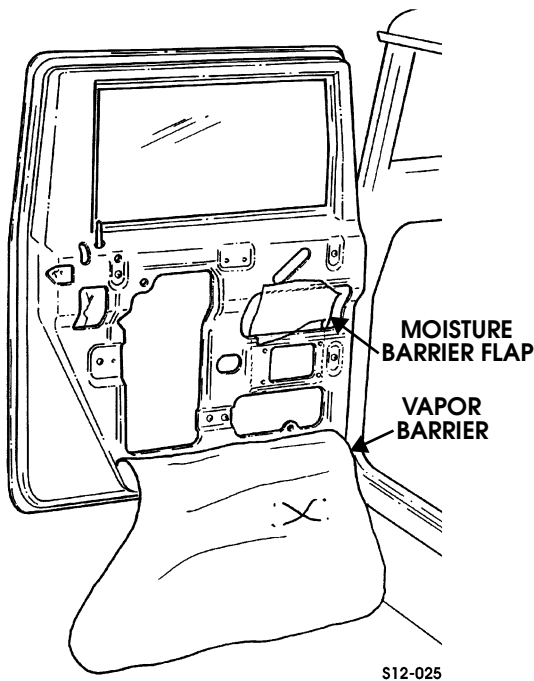

Figure 12-115: Vapor Barrier

6. Remove capscrew and clamp securing door harness to door reinforcement.
7. Remove capscrew, nut and lockwasher assembly, and P-clamp securing door harness to A-pillar.
8. Disconnect harness from lock motor, window motor and mirror (if equipped).
9. Disconnect four-lead and six-lead connectors. Remove door harness wires from connectors with extraction tool. Note position of wires for installation of the new harness.

NOTE: Lubricate bushings, grommet, and door harness teflon cover with silicone spray.

10. Pull harness through A-pillar rubber grommet.
11. Remove and inspect A-pillar rubber grommet. Discard if damaged.
12. Remove two capscrews and support bracket from inner door.
13. Pull harness through door bushing. Inspect door bushing. Replace if damaged.
14. Pull support bracket from harness. Inspect support bracket bushing. Replace if damaged.
15. Disconnect clip from door reinforcement and remove from door harness.
16. Remove tie strap securing door harness to access hole and remove harness. Discard tie strap.

Installation

1. Install harness in support bracket.
2. Install harness through door bushing and support bracket. Install support bracket on inner door with two capscrews.
3. Install rubber grommet in A-pillar.
4. Install harness through grommet until yellow tape touches A-pillar front.
5. Install six-lead and one-lead connectors to door harness leads, matching colors to dash harness. Connect door harness to dash harness.
6. Install P-clamp and door harness on A-pillar with capscrew and nut and lockwasher assembly.
7. Install clamp and door harness at yellow tape area with capscrew.
9. Install clip on door harness and connect harness to door lock actuator, window motor and power mirror (if equipped) Lower window.
10. Route lock switch lead up through lower access hole between support bracket and window channel. Secure at top access hole with tie strap (left front door only).

NOTE: Vapor barrier must be completely sealed at all edges to prevent water entry into the interior of the vehicle.

11. Route lock switch lead through vapor barrier and moisture barrier flap and install moisture barrier and vapor barrier flap on door.
12. Install front door trim.
13. Install power door locks switch.
14. Install outer kick panels.
15. Install front seat.
16. Verify operation.



POWER DOOR LOCK REAR DOOR AND JUMPER HARNESS REPLACEMENT

Removal

NOTE: Left and right rear power door locks harness replacement procedures are identical.

1. Remove front seat.
2. Remove trim from B-beam and B-pillar (Section 10).
3. Remove side trim and outer kick panel (Section 10).
4. Remove rear door trim (Section 10).

NOTE: Vapor barrier may be positioned under velcro strip. If so, cut around velcro strip to remove vapor barrier.

5. Remove vapor barrier and moisture barrier flap.
6. Remove capscrew and clamp securing rear door harness to door reinforcement.
7. Disconnect rear door harness from jumper harness.
8. Remove convoluted tubing from rear door harness.

9. Remove two-lead connector from rear door harness with pin extraction tool.
10. Remove capscrew, washer, nut and lockwasher assembly, and P-clamp from rear door harness and B-pillar.
11. Pull harness through rubber grommet in B-pillar.
12. Remove and inspect grommet. Discard if damaged.
13. Remove two capscrews and support bracket from rear door.
14. Pull harness through door bushing and remove support bracket from harness. Inspect support bracket bushing. Replace if damaged.
15. Inspect bushing in rear door. Replace if damaged.
16. Disconnect door harness connector from actuator lead.
17. Disconnect clip from door reinforcement and remove from rear door harness.
18. Remove rear harness from door.
19. Disconnect jumper harness from dash harness at A-pillar. Remove tie straps and jumper harness (Figure 2-116).

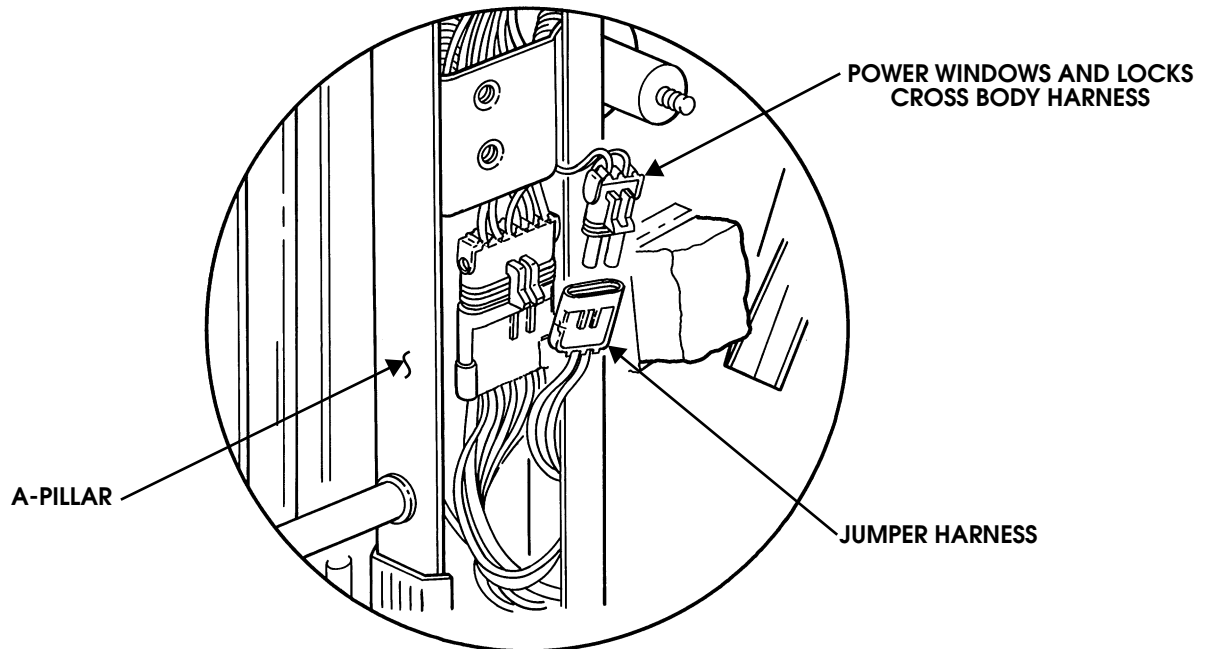

S12-156

Figure 2-116: Door Harness Connection



Installation

NOTE: Lubricate bushings, rubber grommet, and door harness teflon cover with silicone spray. Install clip and support bracket on rear door harness (Figure 2-117).

1. Install harness in door bushing.
2. Install support bracket in rear door with two capscrews.
3. Install rubber grommet in B-pillar.
4. Install harness through grommet until yellow tape touches the back of B-pillar.
5. Install P-clamp on harness at yellow tape and B-pillar with capscrew, washer and lockwasher and nut assembly.
6. Install two-lead connector on rear door harness, matching wire colors to jumper harness. Connect harness to jumper harness.
7. Route rear door harness along bottom of rear door. Secure harness to door reinforcement with clip.
8. Attach door harness connector to actuator. Tighten power window motor mounting screws, if loose.
9. Install convoluted tubing on rear door harness wires and secure with black electrical tape.
10. Install P-clamp on rear door harness at yellow tape area and secure to door reinforcement with one capscrew.
11. Install vapor barrier and moisture barrier flap.
12. Install rear door trim (Section 10).
13. Install side trim and outer kick panel (Section 10).
14. Install trim on B-pillar and B-beam (Section 10).
15. Install front seat (Section 10).

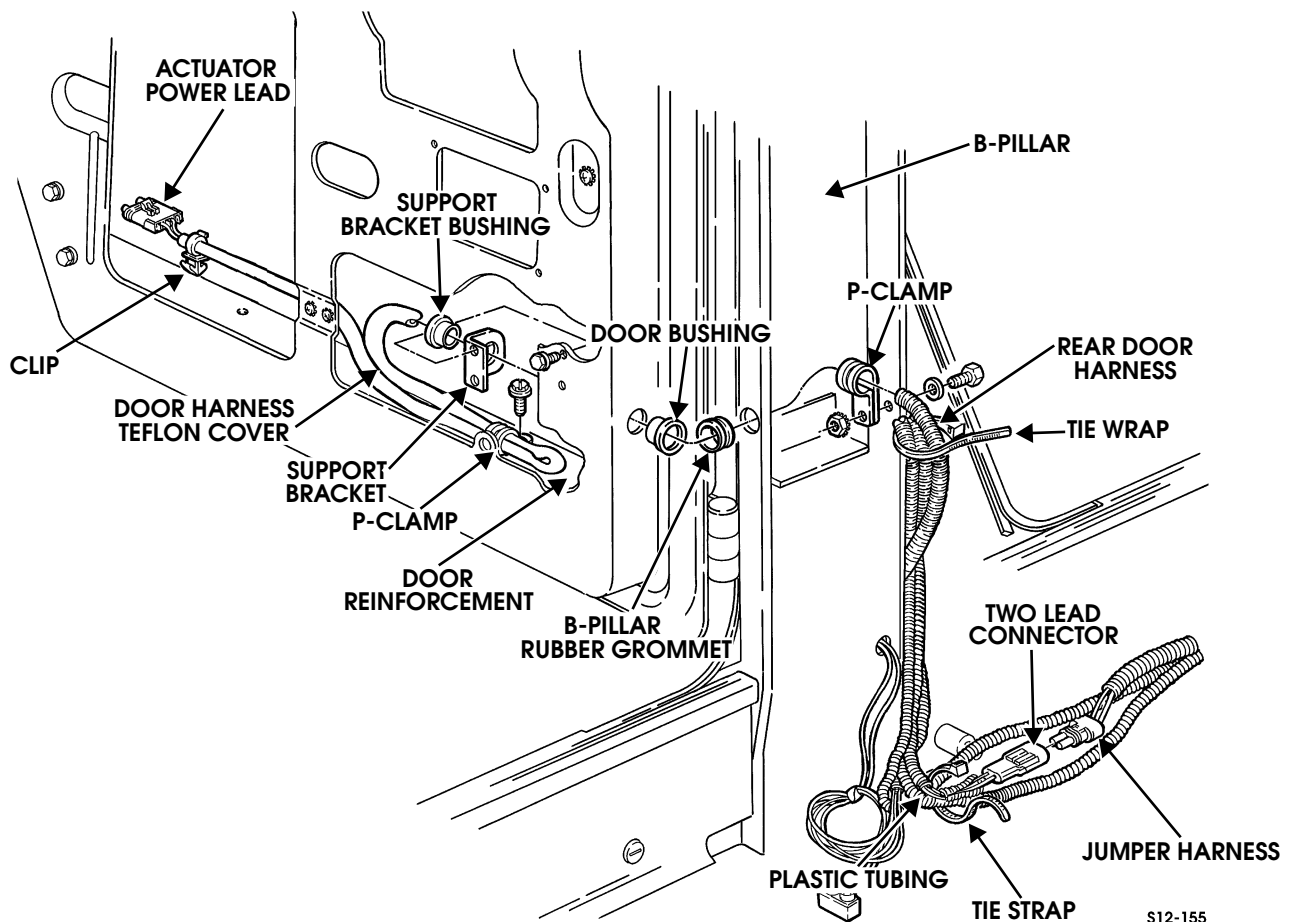

Figure 2-117: Door Harness Routing



POWER WINDOW AND DOOR LOCKS FRONT DOOR HARNESS REPLACEMENT

Removal

1. Remove front outer kick panels (Section 10).
2. Remove power window and door lock switches from door.
3. Remove front door trim, vapor barrier, and moisture barrier flap from door (Section 10).

NOTE: Tag leads for installation.

4. Disconnect 4-way and 6-way harness connectors from power windows and door locks body harness connectors (Figure 2-118).

NOTE: Perform step 6 for vehicles equipped with power mirrors.

5. Disconnect two harness connectors from power mirrors body harness connectors.
6. Remove screw, nut and lockwasher assembly, and clamp securing harness to A-pillar. Discard nut and lockwasher assembly
7. Remove harness wires from 4-way and 6-way connectors.

NOTE: Lubricate bushings, grommet, and harness teflon cover with silicone spray.

8. Pull harness through A-pillar rubber grommet.
9. Remove and inspect A-pillar rubber grommet. Replace if damaged.

NOTE: Perform step 11 for vehicles equipped with power mirrors.

10. Disconnect two harness connectors from power mirrors door jumper harness connectors (Figure 2-120).
11. Remove self-tapping screw and clamp securing harness to door reinforcement (Figure 2-120).
12. Remove two self-tapping screws and harness mounting bracket from door assembly.
13. Pull harness through door bushing.
14. Inspect door bushing and replace if damaged.
15. Remove harness mounting bracket and mounting bracket bushing from harness. Inspect bushing and replace if damaged.
16. Disconnect harness connector from power window regulator (push locking tab up on bottom of connector).
17. Disconnect harness connector from power door locks actuator.
18. Remove retainer and harness from door assembly.

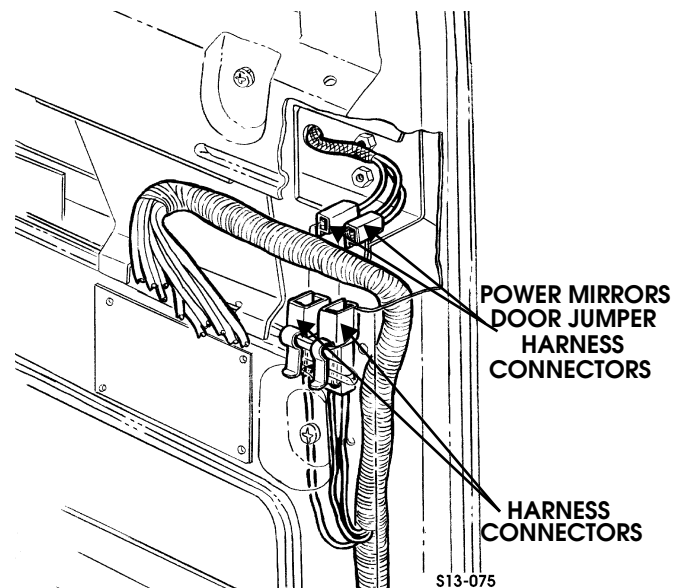

Figure 2-118: Power Mirrors Door Jumper Harness

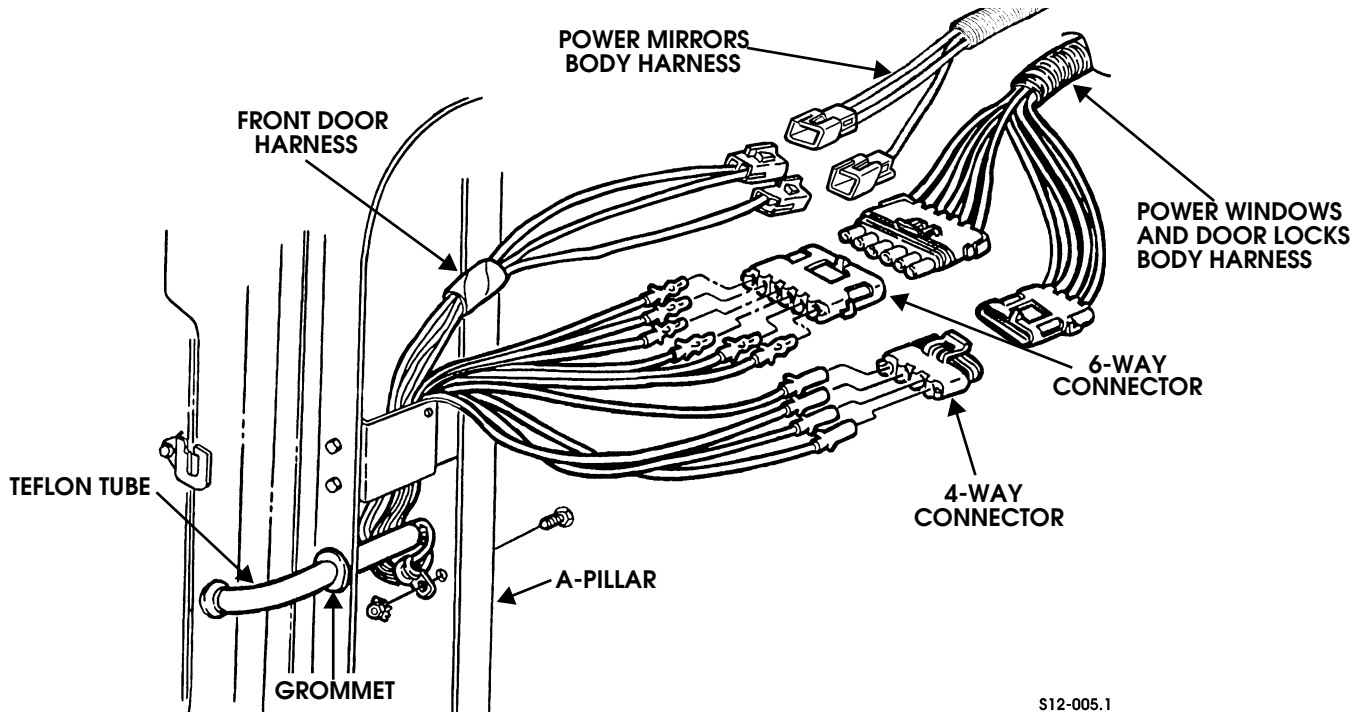

Figure 2-119: Power Windows and Door Locks Connections

Installation

NOTE: Lubricate bushing, grommet, and harness teflon cover with silicone spray.

1. Route harness through harness mounting bracket, mounting bracket bushing, and door bushing (Figure 2-120).
2. Install harness mounting bracket on door assembly with two self-tapping screws (Figure 2-121).
3. Route harness through A-pillar rubber grommet (Figure 2-119).

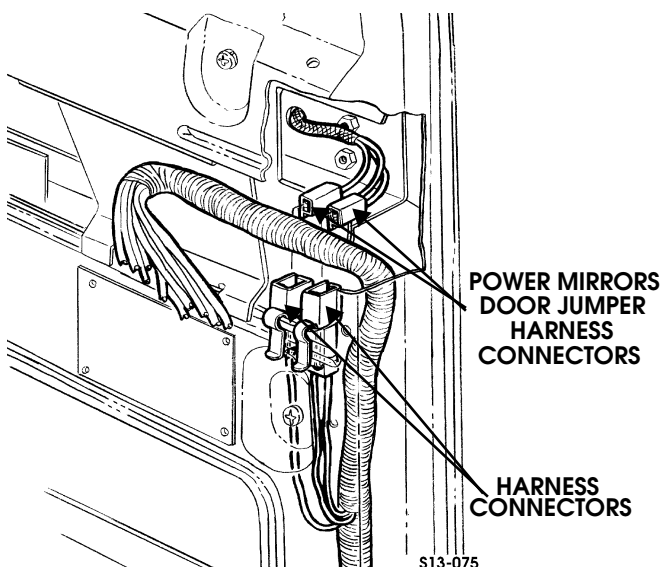

Figure 2-120: Power Mirrors Door Jumper Harness

NOTE: When connecting harness wires to 4-way and 6-way connectors, ensure wire colors align with mating connector wires.

4. Connect harness wires to 4-way and 6-way connectors.
5. Connect 4-way and 6-way harness connectors to power windows and door locks body harness connectors.

NOTE: Perform step 6 for vehicles equipped with power mirrors.

6. Connect two harness connectors to power mirrors body harness connectors.
7. Secure harness to A-pillar with clamp, self-tapping screw, and nut and lockwasher assembly.

NOTE: Perform step 8 for vehicles equipped with power mirrors.

NOTE: Be careful to match the wire colors, since the harness connectors can be interchanged.

8. Connect two harness connectors to power mirrors door jumper harness connectors (Figure 2-119).
9. Connect harness connector to power window regulator (Figure 2-121).
10. Connect harness connector to power door lock actuator.
11. Secure harness to door reinforcement with clamp and self-tapping screw.
12. Secure harness to door assembly with retainer.
13. Install moisture barrier flap, vapor barrier, and door trim panel on door (Section 10).
14. Install power window and door lock switches on door.
15. Install front outer kick panels (Section 10).
16. Connect battery ground cable (Section 12).
17. Check power windows and door locks for proper operation.

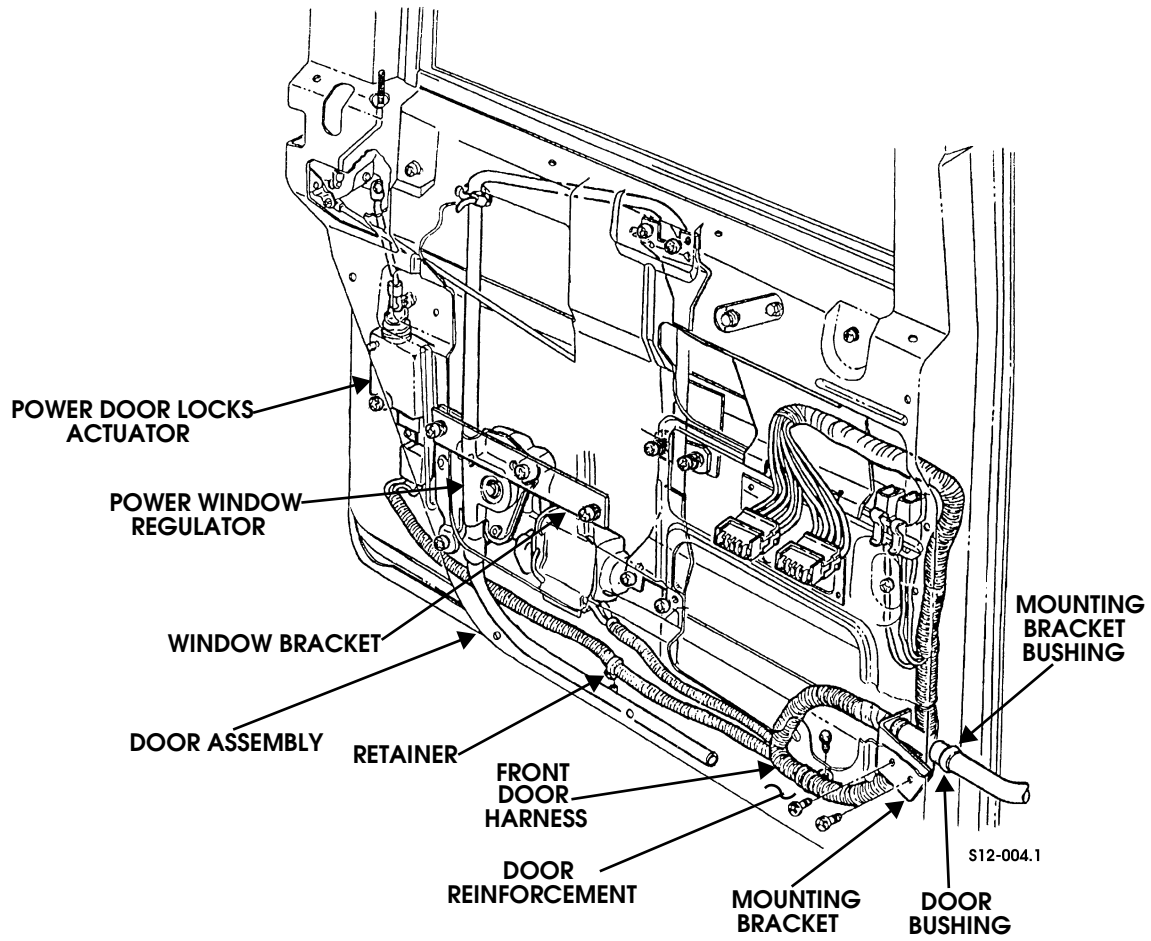

Figure 2-121: Power Windows and Door Locks Door Harness



POWER WINDOWS AND DOOR LOCKS REAR DOOR HARNESS REPLACEMENT

Removal

1. Remove center outer kick panel and lower B-pillar trim (Section 10).
2. Remove power windows switch from door.
3. Remove rear door trim, vapor barrier, and moisture barrier flap from door (Section 10).

NOTE: Tag leads for installation.

4. Disconnect 6-way harness connector from power windows and door locks rear door jumper harness connector (Figure 2-122).

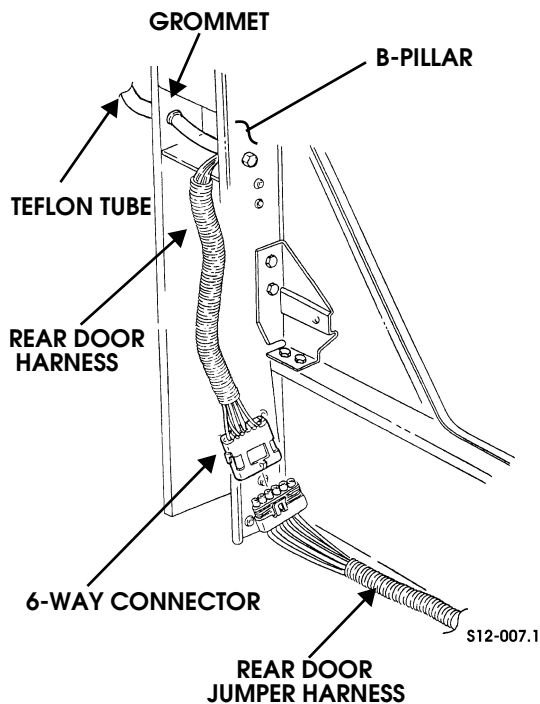

Figure 2-122: Rear Door Harness and Rear Door Jumper Harness

5. Remove harness wires from 6-way connector.
6. Remove screw, nut and lockwasher assembly, and clamp securing harness to B-pillar. Discard nut and lockwasher assembly.

NOTE: Lubricate bushings, grommet, and harness teflon cover with silicone spray.

7. Pull harness through B-pillar rubber grommet.
8. Remove and inspect B-pillar rubber grommet. Replace if damaged.
9. Remove two self-tapping screws and harness mounting bracket from door assembly (Figure 2-123).
10. Pull harness through door bushing.
11. Inspect door bushing and replace if damaged.
12. Remove harness mounting bracket and mounting bracket bushing from harness. Inspect bushing and replace if damaged.
13. Remove self-tapping screw and clamp securing harness to door reinforcement.
14. Disconnect harness connector from power window regulator (push locking tab up on bottom of connector).
15. Disconnect harness connector from power door lock actuator.
16. Remove retainer securing harness to door assembly.
17. Remove tie strap and harness from door assembly. Discard tie strap.

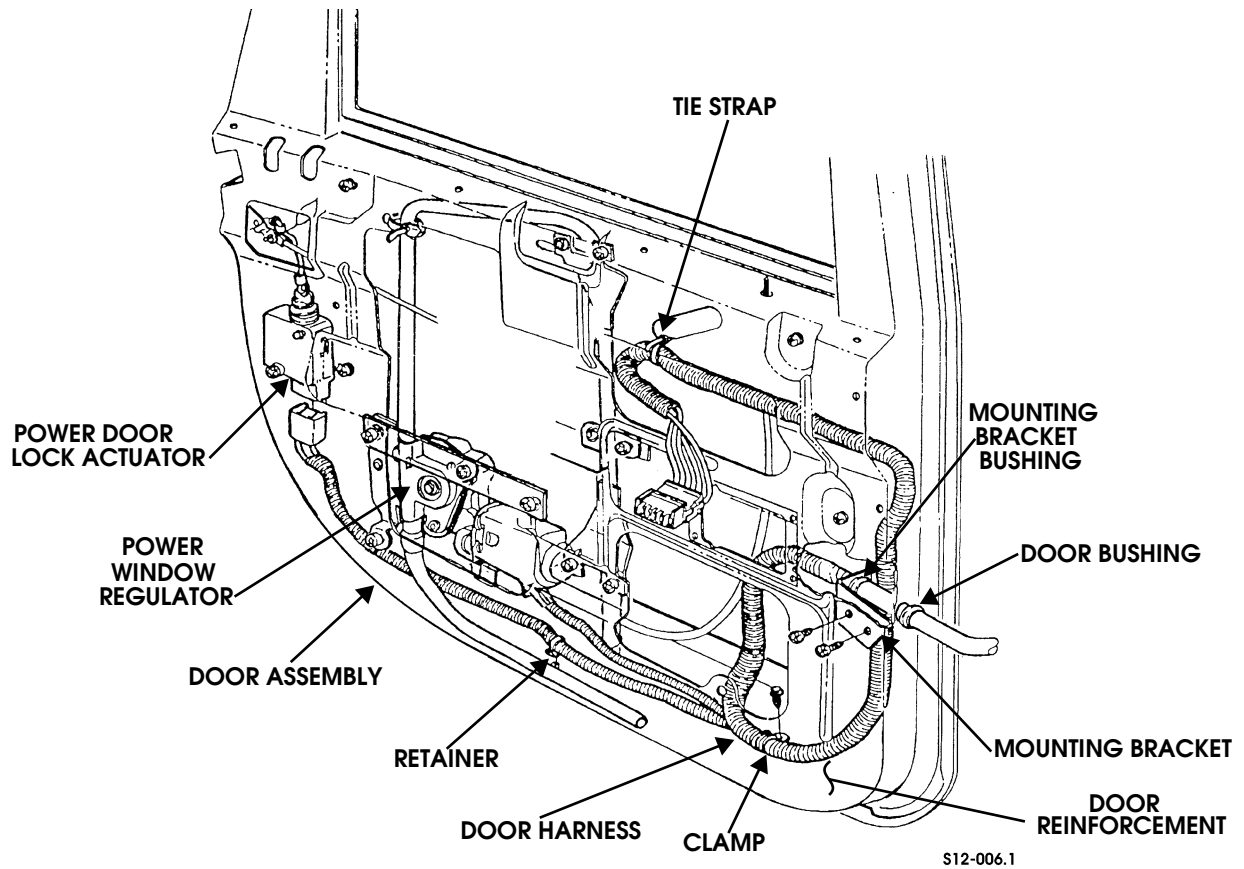

Figure 2-123: Rear Door Harness

Installation

NOTE: Lubricate bushings, grommet, and harness teflon cover with silicone spray.

1. Route harness through harness mounting bracket, mounting bracket bushing, and door bushing (Figure 2-123).
2. Install harness mounting bracket on door assembly with two self-tapping screws
3. Route harness through B-pillar rubber grommet (Figure 2-124).

NOTE: When connecting harness wires to 6-way connector, ensure wire colors align with mating connector wires.

4. Connect harness wires to 6-way connector.
5. Connect 6-way harness connector to power windows and door locks rear door jumper harness connector.
6. Secure harness to B-pillar with clamp, screw, and nut and lockwasher assembly.

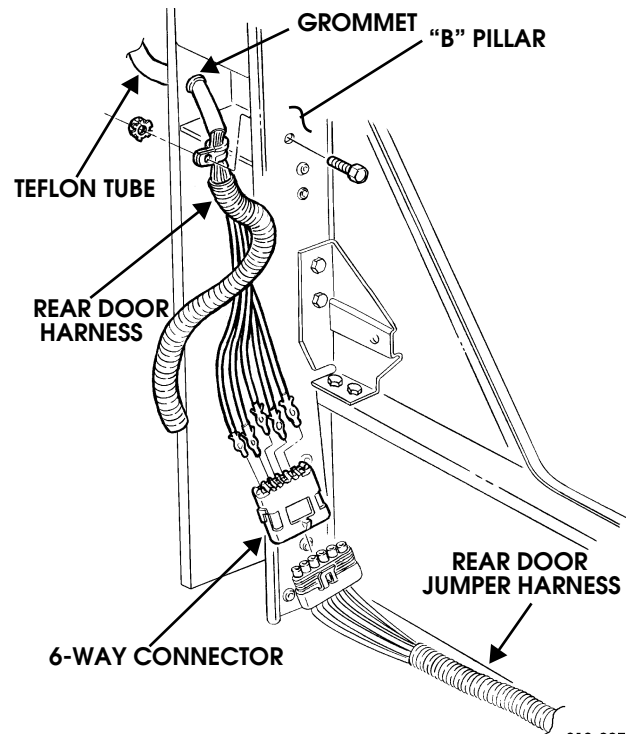

Figure 2-124: Rear Door Harness and Rear Door Jumper Harness



7. Connect harness connector to power window regulator (Figure 2-123).
8. Connect harness connector to power door lock actuator.
9. Secure harness to door reinforcement with clamp and self-tapping screw.
10. Secure harness to door assembly with retainer.
11. Secure harness to door assembly with tie strap.
12. Install moisture barrier flap, vapor barrier, and door trim panel on door (Section 10).
13. Install power windows switch on door.
14. Install lower B-pillar trim and center kick panel (Section 10).
15. Connect battery ground cable (Section 12).
16. Check power windows and door locks for proper operation.
17. Remove nut and ground lead from ground stud.
18. Disconnect two window and lock harness connectors from door harness connectors (Figure 2-125).
19. Repeat step 10 for opposite side.
20. Remove B-pillar lower trim from both sides of the vehicle.
21. Disconnect lock and window harness connector from rear door harness connector (HMCS, HMC4, HMCO)
22. Repeat step 12 for opposite side (HMCS, HMC4, HMCO).
23. Disconnect vertical door lock jumper from window and door lock harness on the passenger side.(HMCS)
24. Remove tie straps securing harness to vehicle body harness and remove harness. Discard tie straps.

Installation

1. Route harness through instrument panel and along A-pillar to both sides of vehicle.
2. Connect harness connector to rear door harness connectors on both sides of vehicle (HMCS, HMC4, HMCO).
3. Connect vertical door lock jumper to window and door lock harness on the passenger side.(HMCS)
4. Connect two front lock and window harness connectors to door harness connectors on both sides of vehicle.
5. Install ground lead on ground stud with nut.
6. Connect two lock and window harness leads to vehicle body harness power leads.
7. Connect two power windows and door locks harness connectors to receiver harness connectors.
8. Secure harness to vehicle body harness with tie straps.
9. Install CTIS gauge panel
10. Install tachometer and clock harness into instrument panel
11. Install two gauge panels on instrument panel with eight screws (Section 12).
12. Install console cover (Section 10).
13. Install front outer kick panels (Section 10).

14. Install crash pad (Section 10).
15. Check power windows and door lock for proper operation

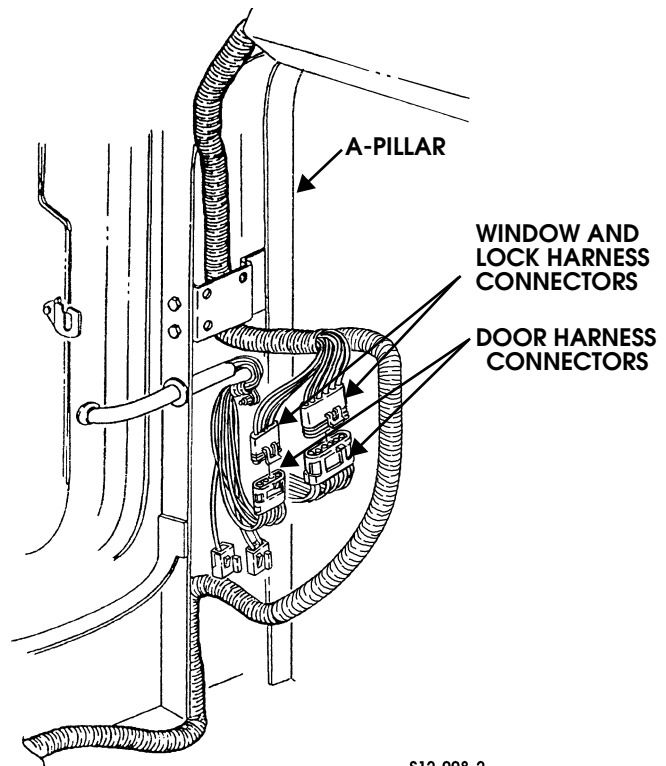

S12-008.2

Figure 2-125: Door Harness Connectors



AUTO-DIMMING REAR VIEW MIRROR WITH ELECTRONIC COMPASS AND TEMPERATURE (OPTION)

Description

The Auto-Dimming rear view mirror has the capability to change the opacity of the mirror glass to prevent glare. When a following vehicles head lamps hit the rear light detection sensor, the mirror's opacity will lessen. The now translucent mirror will allow light to pass through it. This effectively lessens the glare on the driver, much like moving the angle on a manual mirror.

Removal

1. Disconnect mirror jumper harness from the rear of the mirror assembly (See Figure 2-126).
2. Gently push upward on the mirror head and the compass pod together until the mirror assembly is free of the windshield button.

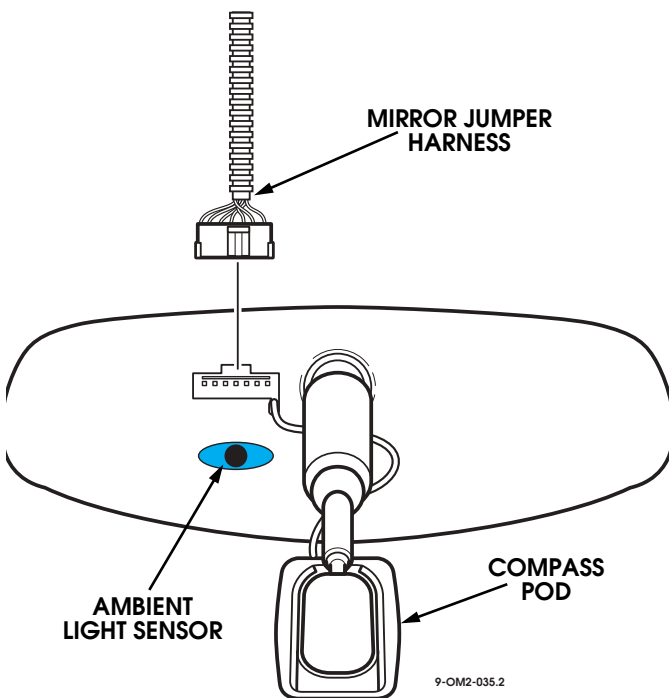

Figure 2-126: Auto-Dimming Mirror Jumper Harness Connection

Installation

1. Grasp the mirror head with both hands
2. Slide the mirror down onto the window mount and gently rock side to side until mirror base is seated. Do not force the mirror onto the mount.
3. Connect the mirror jumper harness to the rear of the newly installed mirror.
4. Set calibration and zone adjustments. (Refer to Auto-Dimming compass mirror calibration and zone adjustment).

AUTO-DIMMING COMPASS MIRROR CALIBRATION AND ZONE ADJUSTMENTS

Calibration Adjustment

1. Start the engine.
2. Press and hold the auto-dimming power button until "CAL" appears in the display and release (Figure 2-127).
3. Drive **slowly** in a circle away from large metal buildings and power lines until the "CAL" disappears.

Zone Adjustment

1. Press and hold the mode button until "ZONE" appears in the display (See Figure 2-127).
2. Each depression of the mode button will change the zone number in sequence. Refer to the zone chart below for the zone number of your area of operation (Figure 2-128).
3. When the desired zone is reached, allow the mirror to go to normal mode then turn off the ignition.

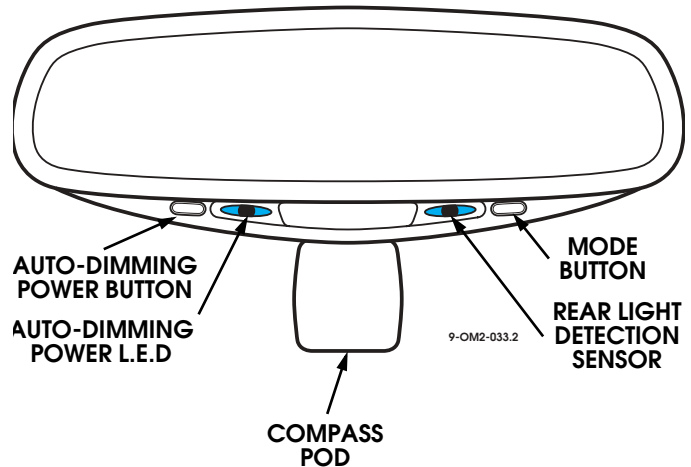
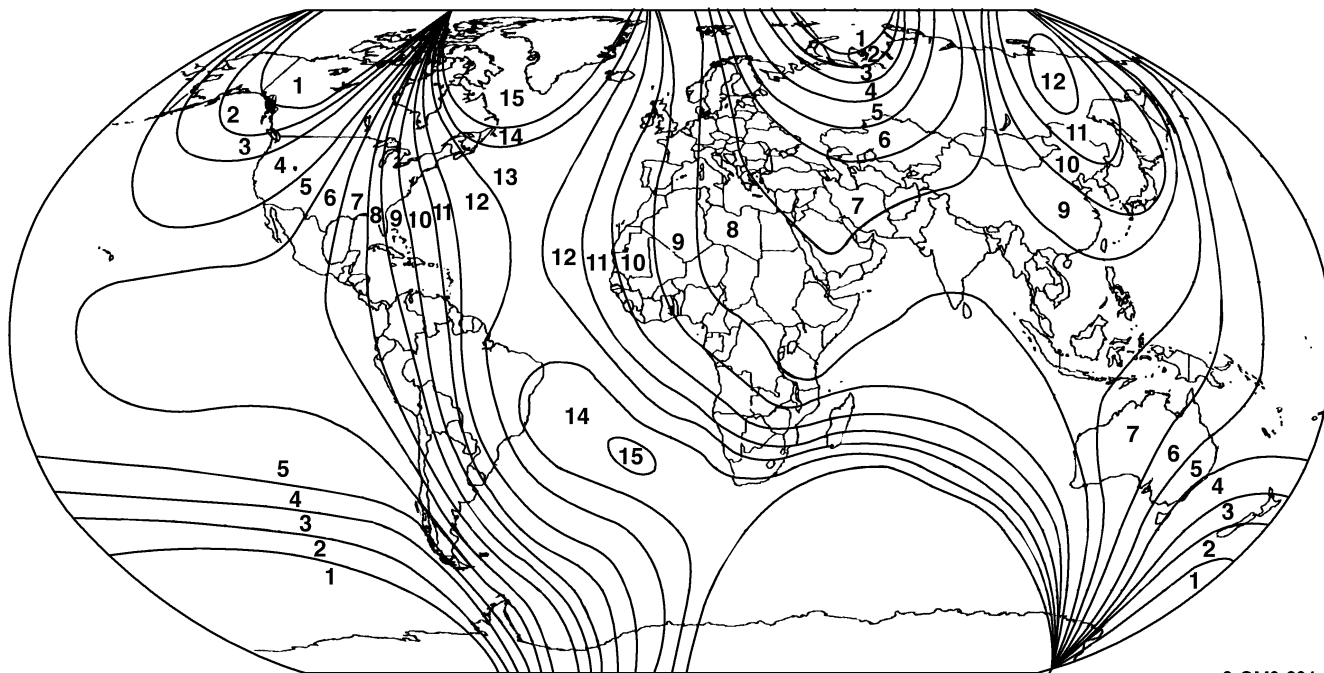

Figure 2-127: Auto-Dimming Rear View Mirror



9-OM2-024

Figure 2-128: Magnetic Zone Chart



AMBIENT TEMPERATURE SENSOR

Removal

1. Remove existing nut, cushioned clamp, and ambient temperature sensor jumper harness from the body harness (Figure 12-129).
2. Disconnect the ambient temperature sensor jumper harness from the sensor.
3. Remove self-tapping screw and ambient temperature sensor from the frame.

Installation

1. Install ambient temperature sensor to the frame with self-tapping screw (Figure 12-129).
2. Connect the ambient temperature sensor harness to the sensor.
3. Connect the ambient temperature sensor harness to the body harness.
4. Using cushioned clamp, secure jumper harness to body harness mounting clamp with existing nut and bolt.

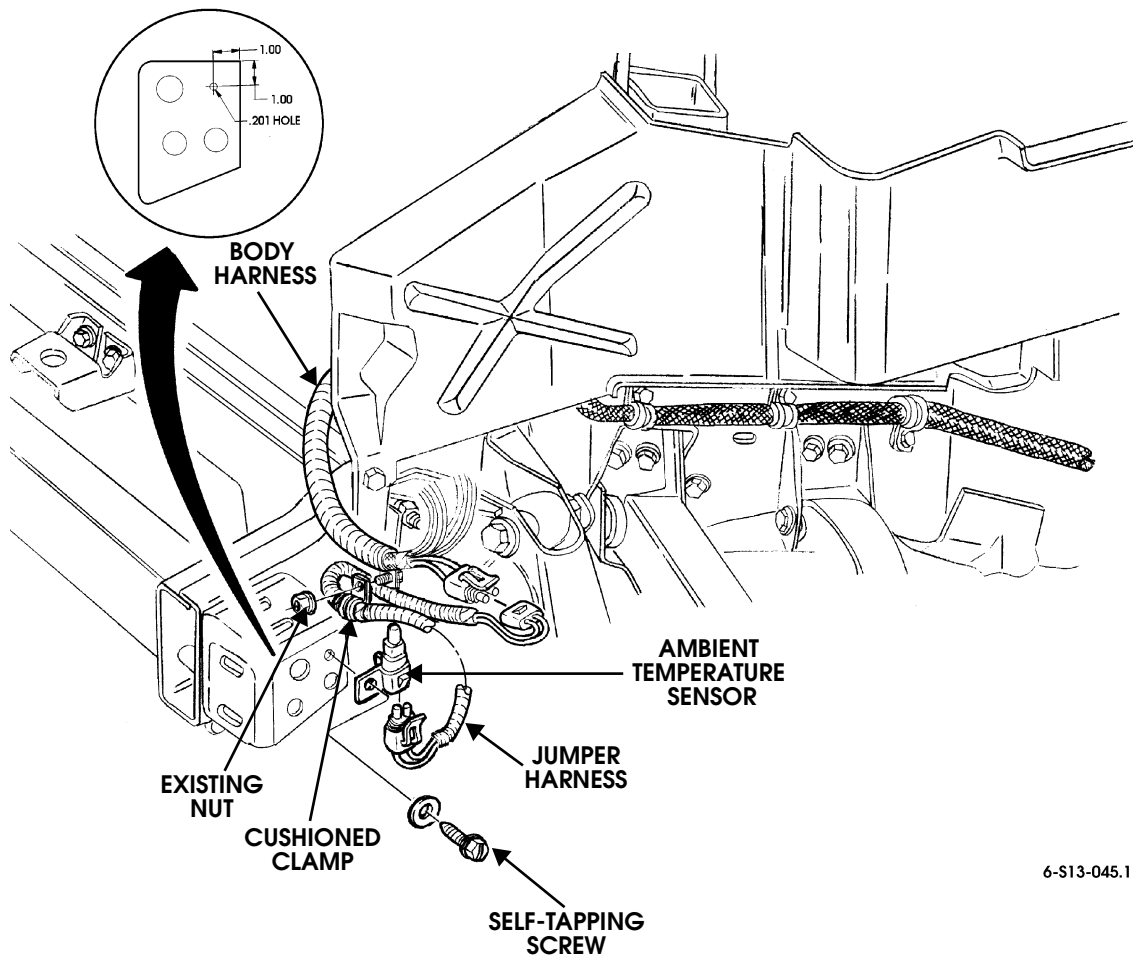

6-S13-045.1

Figure 12-129: Ambient Temperature Sensor



Compass Mirror Display Inoperative

Step	Action	Value(s)	Yes	No
1	Turn the ignition to the ON position, and heated windshields OFF. Is compass mirror display operating?		No problem found, or intermittent.	Go to step 2.
2	Gain access to C13, with the ignition ON measure voltage at pin B. Is voltage present?	Approximate battery voltage	Go to step 4.	Go to step 3.
3	Check for open, or short to ground in CKT 407 between compass cutout relay and compass mirror, and CKT 400 between compass cutout relay and fuse 2C in the interior fuse box. Are any problems found?		Repair open or short to ground in CKT 407 and CKT 400.	Replace mirror cutout relay.
4	Check continuity to ground at C13 pin A, is resistance to ground below specified?	$>.2 \Omega$	Replace compass mirror	Go to step 5.
5	Check for open or bad connection in CKT 59 between compass mirror and G4. Are any problems found?		Repair open or bad connection in CKT 59.	No problem found, go to step 1.

Compass Mirror Temperature Display Showing OC, SC or Wrong Temp

Step	Action	Value(s)	Yes	No
1	Does compass mirror display show "OC" or "SC" in place of the temperature?		Go to step 3.	Go to step 2.
2	Gain access to C13, measure resistance between pin D and ground. With the vehicle at room temperature (70°F), does resistance measured match specifications?	Approx. 12 K Ω	Replace compass mirror.	Go to step 3.
3	Measuring resistance to ground at C13 Pin D, does meter display open?	OL	Go to step 4.	Repair bad connection at C13.
4	Disconnect temperature sensor from underbody harness. Measure resistance between the two pins of the sensor. With the vehicle at room temperature (70°F), is resistance in range specified? Higher temperature gives lower resistance readings.	Approx. 12 K Ω	Go to step 5.	Replace the temperature sensor.
5	Measure resistance to ground at temperature sensor connector pin A. Is resistance below specified?	$<.2 \Omega$	Go to step 6.	Repair open or bad connection in CKT 58 between temperature sensor and G2.
6	Check for open, bad connection, or short to ground in CKT 767 between temperature sensor and compass mirror. Are any problems found?		Repair open, bad connection, or short to ground in CKT 767.	Replace the compass mirror.

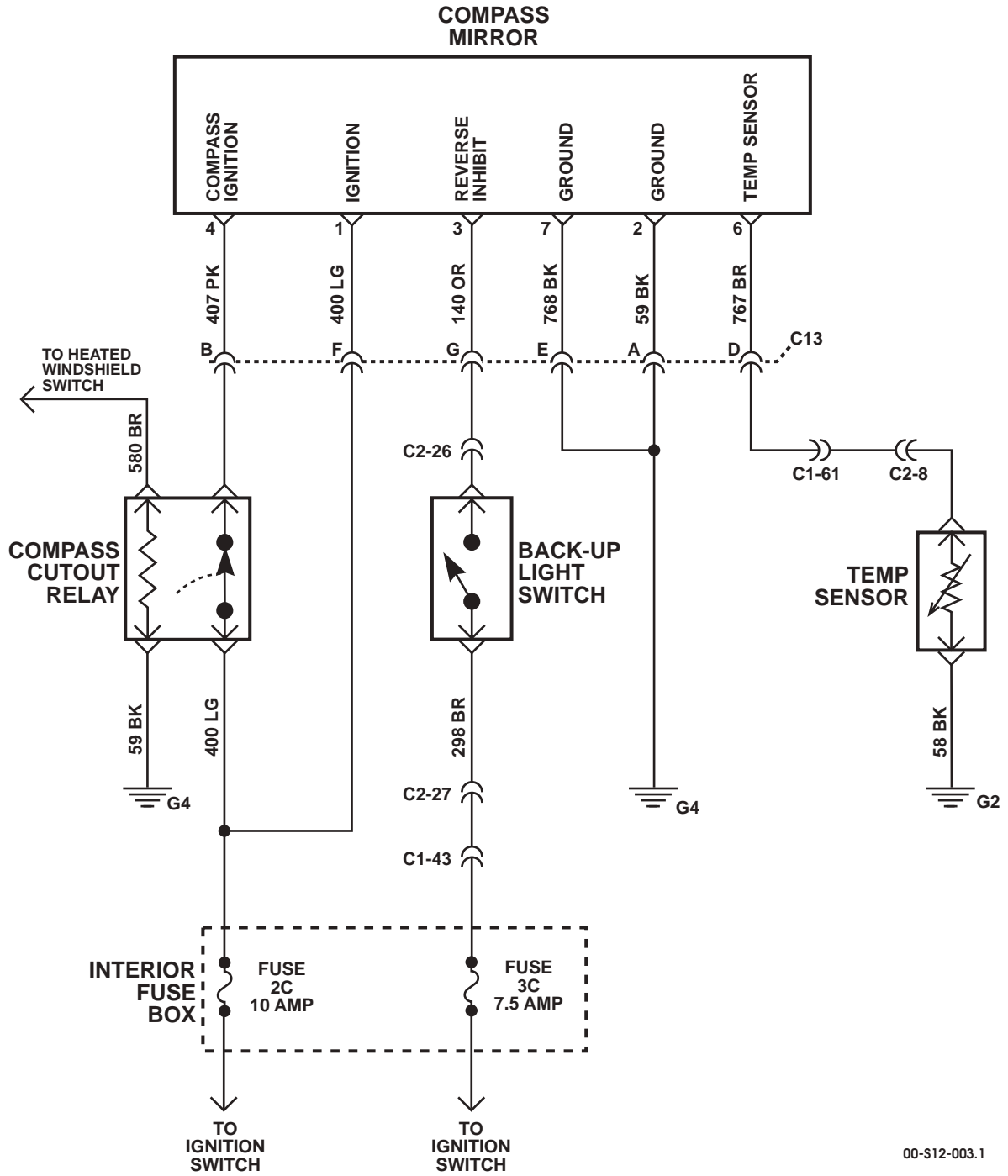

00-S12-003.1

Figure 12-130: Compass Mirror Schematic



POWER SIDE MIRROR

Description

The side mirrors have an option of an internal heater element to aid in defrosting. Heated side mirrors will only be available if the truck is equipped with a heated windshield.

The power side mirror system components are: two side mirrors with internal vertical and horizontal control motors (and optional heater elements), the power mirror switch, and the heated windshield switch (optional).

Power Side Mirror Replacement

Removal

1. Remove the three mounting screws securing the power mirror assembly and gasket to mounting plate (Figure 12-130.2).
2. Disconnect the power mirror assembly connector from the door jumper harness.
3. Inspect the gasket and replace if damaged.

Installation

NOTE: Ensure the door jumper harness is routed through the gasket before connecting the harness to the power mirror assembly.

1. Connect the power mirror assembly connector to the door jumper harness (Figure 12-130.2).

NOTE: Wires from the power mirror assembly must be coiled in the mirror housing to ensure clearance to the attachment points.

2. Align the power side mirror and the gasket with the mounting plate on the door.
3. Install the three mounting screws

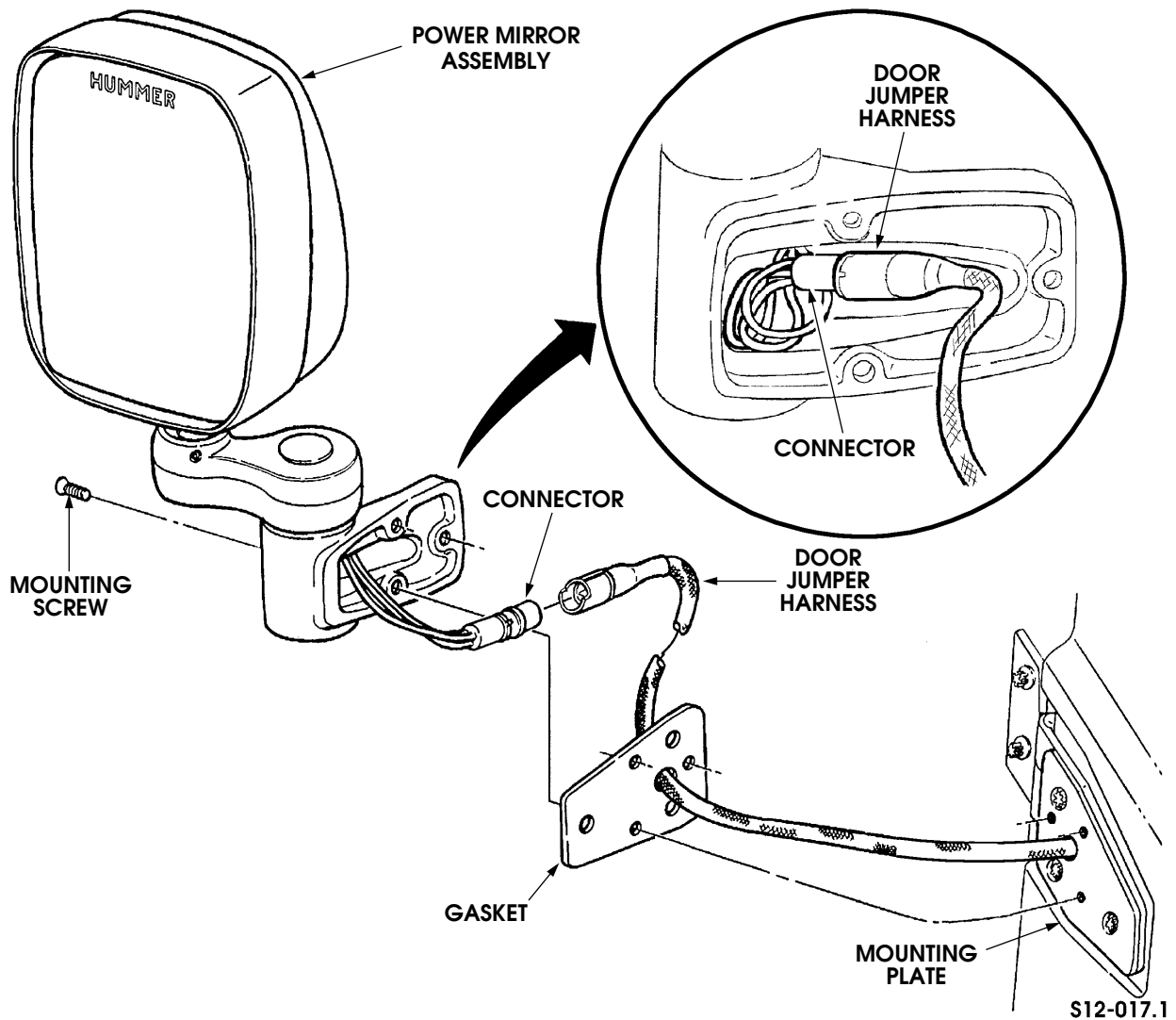

Figure 12-130.2 Power Mirror Assembly Removal



Power Side Mirrors Inoperative

Step	Action	Value(s)	Yes	No
1	Are both mirrors INOP?		Go to step 2.	Go to step 4.
2	Remove the power mirror switch. With a DVOM check circuit 517 (PK) for battery voltage. Is the specified voltage present?	> 12.6v	Go to step 3.	Repair circuit 517 (PK) between the power mirror switch and fuse 3H in the interior fuse box.
3	With a DVOM check the resistance to ground on circuit 59 (BK). Does the resistance meet the specifications?	< 0.2 Ω	Replace the power mirror control switch.	Repair circuit 59 (BK) between the power mirror switch and ground G4.
4	Is only the left side power mirror INOP?		Go to step 5.	Go to step 7
5	Remove the left side power mirror. With a DVOM back probe circuits 942 (OR) with the positive lead, and circuit 59 (BK) with the negative lead. With the DVOM set to check voltage move the power mirror switch to the left side and then up. In both cases the voltage should change from 0v to 12v. Does the voltage change?	0v - off 12v - left 0v - off 12v - up	Replace the power side mirror.	Go to step 6.
6	With a DVOM check resistance on circuit 942 (OR) between the power side mirror and the power mirror control switch. Does the resistance on the circuit meet specifications?	< 0.2 Ω	Replace the power mirror switch.	Repair circuit 942 (OR) between the power side mirror and the power window switch.
7	Remove the left side power mirror. With a DVOM back probe circuits 944 (OR) with the positive lead, and circuit 59 (BK) with the negative lead. With the DVOM set to check voltage move the power mirror switch to the left side and then up. In both cases the voltage should change from 0v to 12v. Does the voltage change?	0v - off 12v - left 0v - off 12v - up	Replace the power side mirror.	Go to step 8.
8	With a DVOM check resistance on circuit 944 (OR) between the power side mirror and the power mirror control switch. Does the resistance on the circuit meet specifications?	< 0.2 Ω	Replace the power mirror switch.	Repair circuit 944 (OR) between the power side mirror and the power window switch.

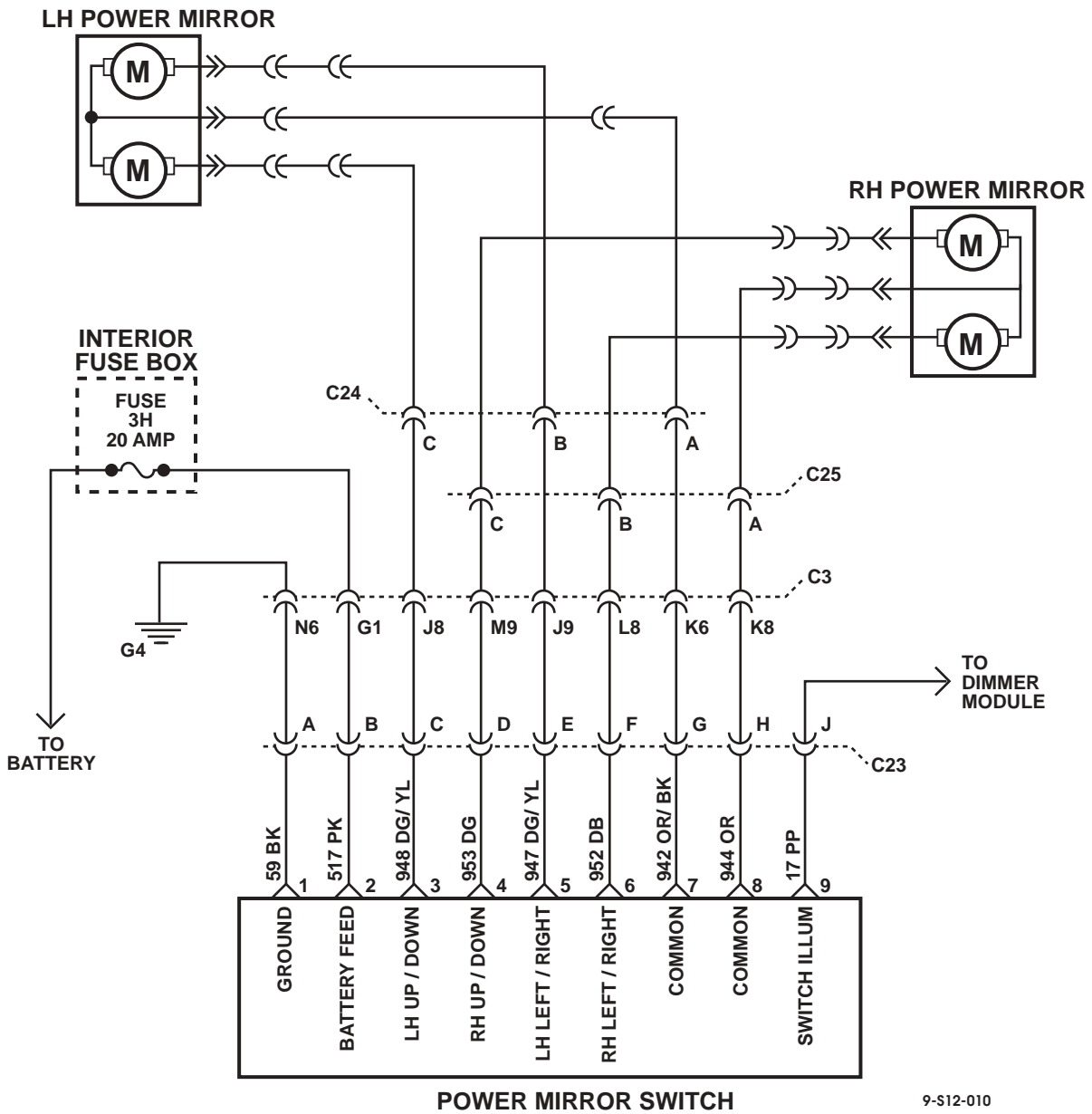

Figure 12-131: Power Side Mirror Schematic



CRUISE CONTROL SYSTEMS

WARNING: *Testing of cruise control should only be performed in areas where traffic is light and the road conditions are stable.*

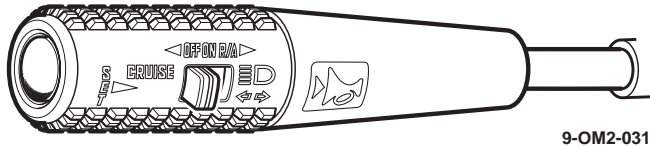

Figure 12-130.1 : Cruise Control

Operation of Cruise Control

1. Move the cruise control switch to the “ON” position.
2. Accelerate to the desired speed.
3. Push in the “SET” button on the end of the turn signal lever and release it at the desired speed. This will set the vehicle speed. **NOTE:** *The vehicle speed will decrease while the “SET” button is pushed in.*

The cruise control will not operate under 35 MPH.

Accelerating with the Cruise Control On

Vehicle speed can be momentarily increased after the desired speed has been set. By pressing the accelerator pedal the speed will increase. This action will not interfere with the preset cruising speed. The preset speed will resume after the accelerator pedal is released.

Resetting the Cruise Control to a Higher Speed

There are two ways to reset the cruise control to a higher speed.

1. Press the accelerator pedal until the desired speed is reached. Push the “SET” button and release it. Speed should set like normal.
2. Move the cruise control switch from “ON” to “R/A”. Hold the switch in place until you reach the desired speed and then hold the control switch in the “R/A” position for half a second and release. Each time this is done the vehicle speed will increase by 1 MPH.

Turning Off the Cruise Control

There are two ways to turn the cruise control off while driving:

1. Move the cruise control switch to the “OFF” position.
2. Depress the brake pedal slightly. This turns off the cruise control operation, but does not erase the speed memory. To resume cruise control after touching the brake pedal, follow the instructions under “Resuming a set Speed”.

In addition, the cruise control is automatically disabled each time you turn the engine off, Or shift into “P” (Park) “N” (Neutral) position, or if the “Check Throttle Light” is illuminated.

Resuming a Set Speed

If the cruise control was turned off by depressing the brake pedal slightly, move the cruise control switch from “ON” to “R/A” and hold for approximately one second and release. The vehicle will gradually return to the previously set speed and maintain it.

Resuming a set speed will not function if the cruise control was turned off using the cruise control switch, or if the vehicle speed is below cruise control minimum (35 MPH).

Using Cruise Control on Hills

Driving on a hill can affect the performance of the cruise control. This performance can be greatly affected if the vehicle is loaded or towing a trailer. Use of the accelerator pedal will help maintain vehicle speed but brakes will turn cruise off. If vehicle speed is being significantly reduced or increased when using the cruise control on a hill, turn the cruise control off and manually control the vehicle speed.

Inspection

When working on the cruise control system make sure that there are no other problems with the PCM or fueling system. Always road test and verify the problem before attempting any repairs.

Intermittent problems

All of the charts in this section are for use on current failures. Do not attempt to use these charts to diagnose a problem unless the problem has been verified and currently exists. If the problem is intermittent, parts will be replaced, or no problem will be found.



Cruise Control Inoperative VIN Z

Step	Action	Value(s)	Yes	No
1	Important: Before clearing the DTC's, use the scan tool Capture Info in order to record the Freeze Frame and the failure records for reference, as the data will be lost when the Clear Info function is used. Was the Powertrain On-Board Diagnostic (OBD) System check performed?		Go to step 2.	Perform on-board diagnostic system check.
2	Disconnect cruise control lever from cross body harness under dash. Using a DVOM set to measure resistance, Probe the BRN wire with the negative lead and the RD wire with the positive lead. Turn the cruise on/off switch to "on". Does the resistance meet specification?	<.2Ω	Go to step 3.	Replace cruise control arm.
3	Leave the negative lead in the BRN wire, place the positive lead in the YL wire. With the resume switch in the neutral position, the switch should be open. When the resume switch is moved to the spring loaded position, the switch should close and meet the resistance specification?	neutral-open closed<.2Ω	Go to step 4.	Replace cruise control arm.
4	Leave the negative lead in the BRN wire, place the positive lead in the GRN wire. With the set switch in the neutral position, the meter should display an open, with the switch pushed in the meter should display continuity, does it?	neutral-open closed<.2Ω	Go to step 5.	Replace cruise control arm.
5	Connect scan tool to vehicle, locate cruise control On/Off switch in the engine data list. When the switch is moved on and off, does the engine data list reflect the change?		Go to step 6.	Go to step 9.
6	Locate resume/accel switch in engine data list. When the switch is moved to the resume/accel position, does the engine data list reflect the change?		Go to step 7.	Go to step 10.
7	Locate set/coast in engine data list. When the switch is pushed, does the data list reflect the change?		Go to step 8.	Go to step 11.
8	Locate the brake switches in the engine data list, depress the brake pedal, does the data list reflect the change?		Check for loose or poor connection at PCM if none are found replace the PCM.	Go to step 16.



Cruise Control Inoperative VIN Z (Continued)

Step	Action	Value(s)	Yes	No
9	Using a DVOM set to measure voltage, place the ground lead on the IP ground point. Back probe cavity A11 in C29(CKT151) with the positive lead. With the ignition on and the cruise control switch on, is voltage present?	12v	Check for loose or poor connection at PCM if none are found replace the PCM.	Repair open, bad connection or short to ground in CKT151 between the PCM and cruise control arm.
10	Using a DVOM set to measure voltage, place the ground lead on the IP ground point. Back probe cavity D10 in C27(CKT153) with the positive lead. With the ignition on and the cruise control resume/accel button depressed, is voltage present?	12v	Check for loose or poor connection at PCM if none are found replace the PCM.	Repair open, bad connection or short to ground in CKT153 between the PCM and cruise control arm.
11	Using a DVOM set to measure voltage, place the ground lead on the IP ground point. Back probe cavity B11 in C29(CKT152) with the positive lead. With the ignition on and the cruise control set button depressed	12v	Check for loose or poor connection at PCM if none are found replace the PCM.	Repair open, bad connection or short to ground in CKT152 between the PCM and cruise control arm.
12	Using a DVOM set to measure voltage, place the ground lead on the IP ground point. Back probe cavity B10 in C29(CKT22) with the positive lead. Depress the brake switch. Is voltage present?	12v	go to step 13.	Check for open or short to ground/voltage in CKT 22, if none found replace brake switch.
13	Using a DVOM set to measure voltage, place the ground lead on the IP ground point. Back probe cavity B9 in C29(CKT810) with the positive lead. With the ignition on, is voltage present with the brake NOT applied, and disappear when the brake is depressed?	Brake OFF 12v Brake ON 0v	Check for loose or poor connection at PCM if none are found replace the PCM.	Check for open or short to ground/voltage in CKT 810, if none found replace brake switch.

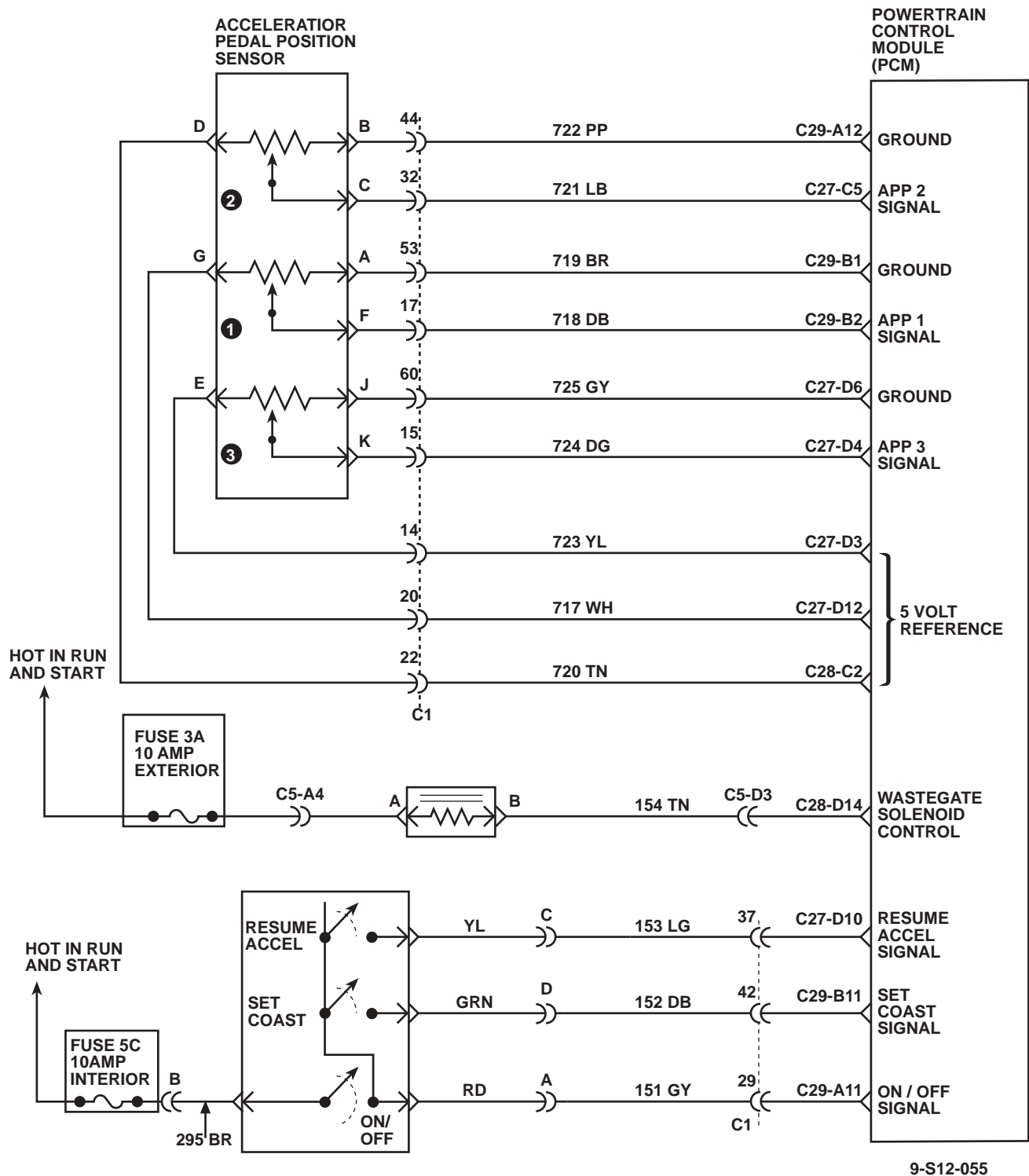

Figure 12-132: Cruise Control Schematic (Sheet 1 of 2)

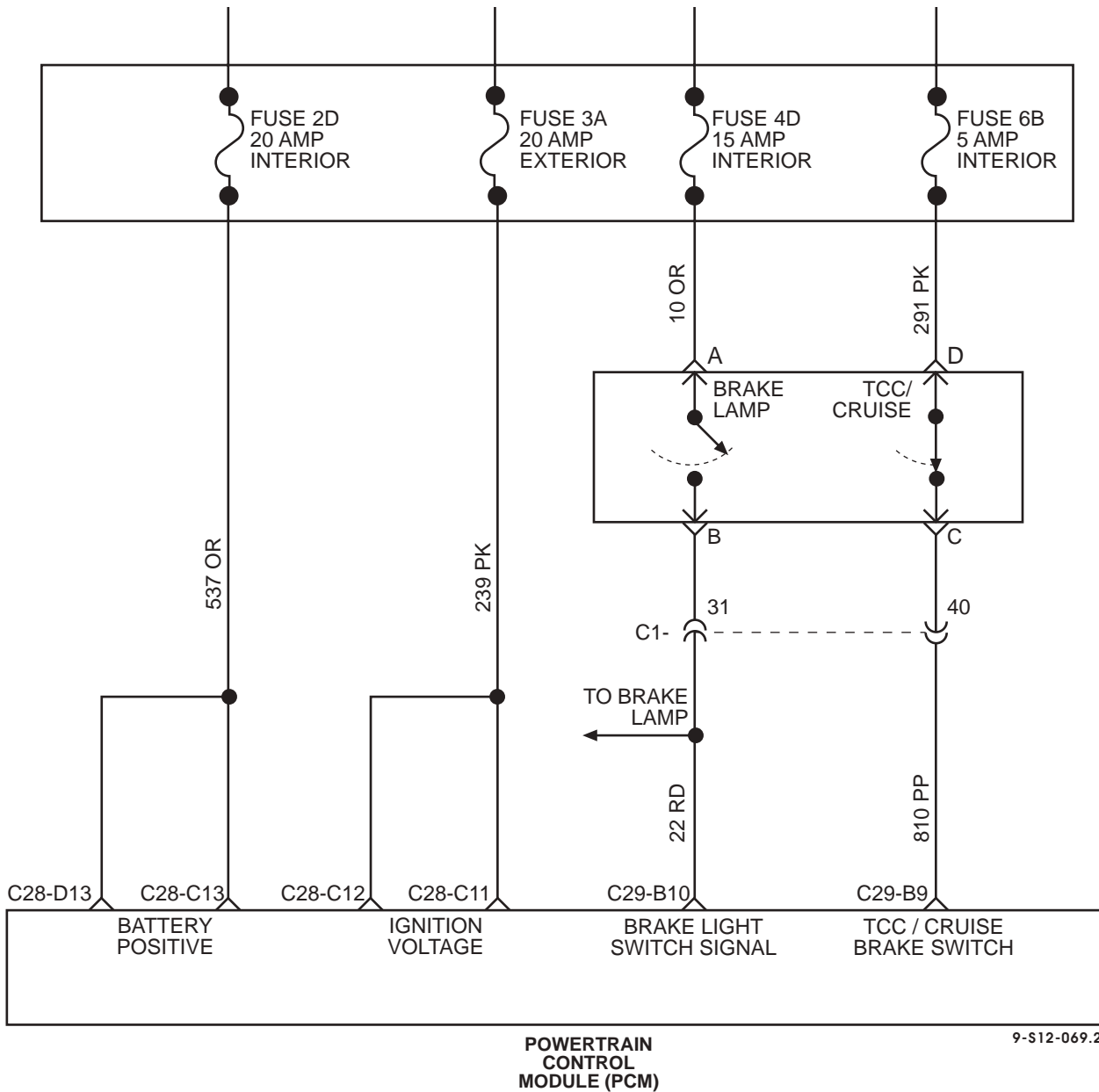

Figure 2-132: Cruise Control Schematic (Sheet 2 of 2)



DELCO AUDIO SYSTEM DESCRIPTION

Delco audio systems are available in two configurations:

The standard system (Figure 12-133), available on all models, consists of a radio head with cassette player (Hummer logo), either two or four coaxial speakers and an optional 6 disc CD changer. An optional infrared remote control for the radio, cassette player and CD changer is available.

The Monsoon system (Figure 12-134), available on models 83 and 84 and 91, uses a radio head and cassette player (Monsoon logo) with a total of six coaxial speakers and two subwoofers. Two coaxial speakers are located in an overhead console and

the two subwoofers are housed in a box located under the left rear seat. An amplifier producing 200 watts on eight channels is mounted in the overhead console. The amplifier is activated by output on the left rear channel from the radio. The 6 disc CD changer is standard with the Monsoon system. A 6 disc stacker magazine inserted in the CD changer is controlled by the radio head and optional remote control. The radio and the cassette player can also be controlled by the remote. Rear seat audio, included in the monsoon package, provides second audio access to the radio system with the aid of headphones.

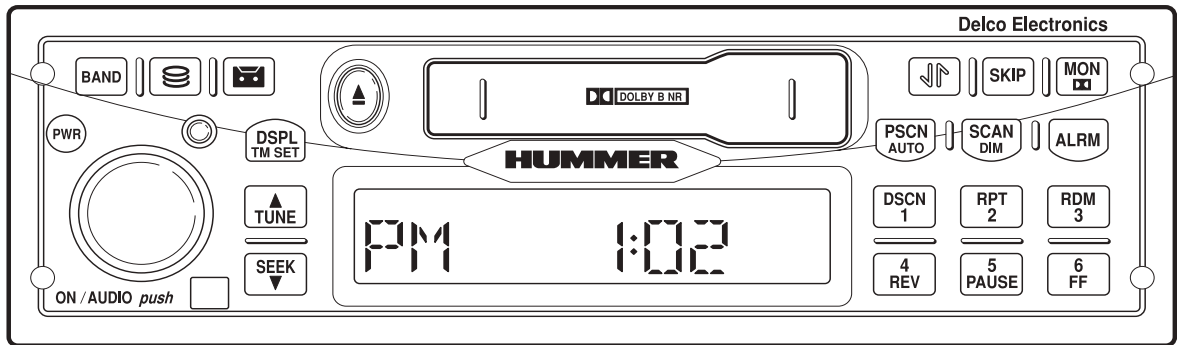

Figure 12-133: Delco Standard Radio Face

00-OM3-001

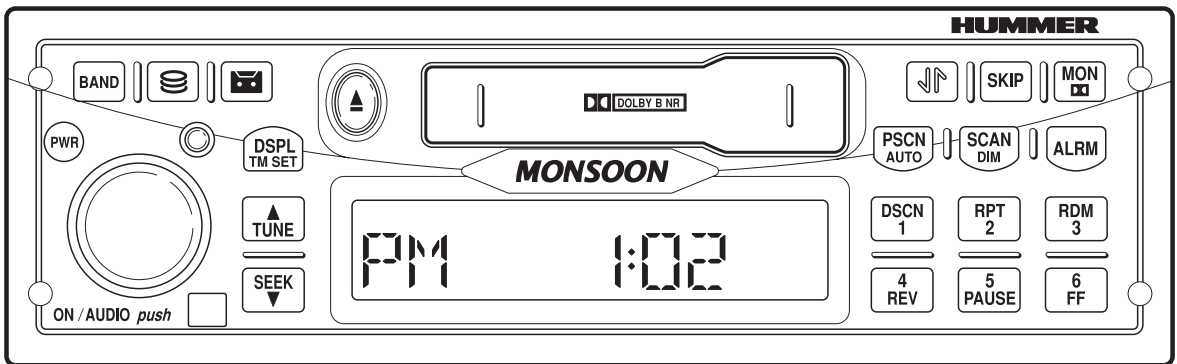

Figure 12-134: Delco Monsoon Radio Face

00-OM3-005

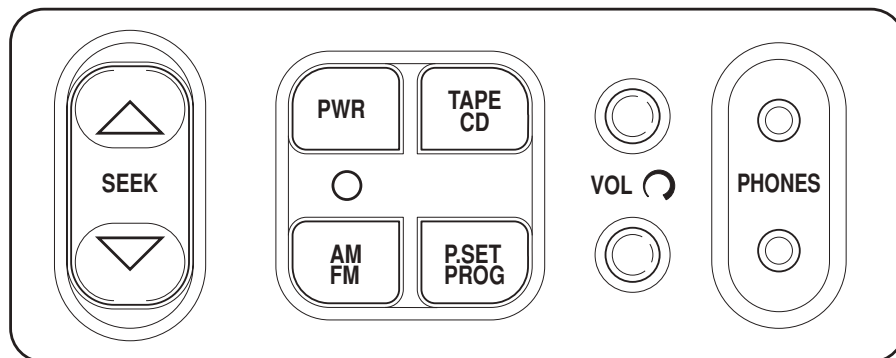

Figure 12-135: Rear Seat Audio Face

00-OM3-002



RADIO (DELCO) REPLACEMENT

Removal

1. Insert a radio removal key in the holes in each side of the face of the radio to disengage locking clips from the mounting sleeve (Figure 12-136).
2. Pull radio out of mounting sleeve far enough to expose wire connections and disconnect audio harness connector, antenna cable and CD harness connector if equipped.

NOTE: Sleeve may not need to be replaced when radio head is replaced.

3. Straighten locking tabs and pull mounting sleeve out of face plate.

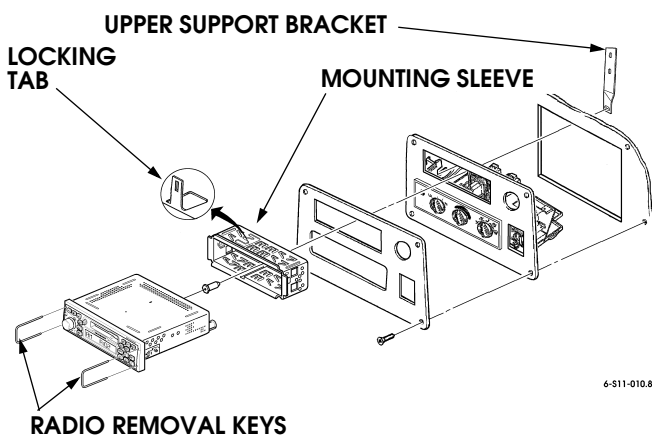

Figure 12-136: Radio Removal.

Installation

1. Install mounting sleeve through face plate and support plate and bend locking tabs to secure.
2. Connect harness connectors and antenna cable to radio.
3. Insert radio into mounting sleeve, align rear mount pin with upper support bracket and push in until locking clips engage. Take care not to damage wiring in radio cavity.
4. Advise end user to reprogram theft lock.

COMPACT DISC CHANGER (DELCO) REPLACEMENT

Removal

1. Remove four screws retaining the CD changer bezel to the console and remove bezel (Figure 12-137).
2. Remove four screws retaining the CD changer mounting brackets to the console.
3. Pull the CD changer out far enough to remove the wire harness connector from the changer.
4. If CD changer wire harness is to be replaced, radio must be removed to gain access to harness connection at the radio.

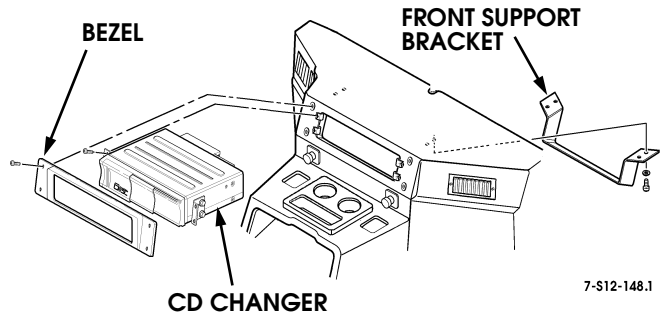

Figure 12-137: CD Changer Removal.

Installation

1. Assure angle adjustments on the sides of the changer are set at 45° before installation.
2. Connect wire harness to the connector on the CD changer and insert changer into the console and the front support bracket.
3. Install four screws in the changer mount brackets and tighten.
4. Install changer bezel with four screws and tighten.

OVERHEAD CONSOLE, SPEAKER AND AMPLIFIER (DELCO MONSOON) REPLACEMENT

Removal

1. Remove upper B-bar cover screws and cover.
2. Remove dome light lens, screws securing ground wires and housing (Figure 12-138).
3. Remove bulb holder and dome light housing.

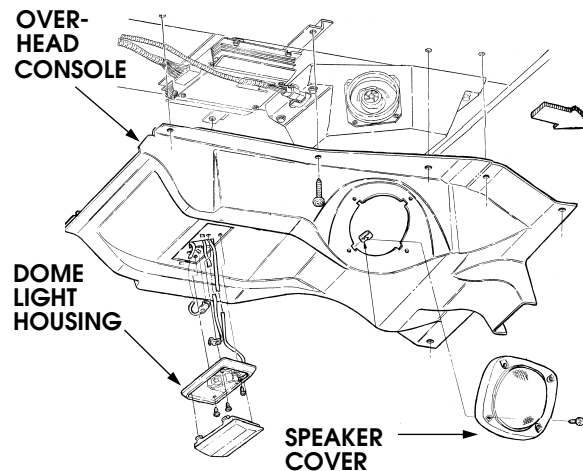

Figure 12-138: Overhead Console Removal.

4. Remove windshield divider bar cover.
5. Remove screws securing overhead console and pull console down to gain access to wiring.
6. Remove blue wire and connector from dome light mount plate.



7. Disconnect green wire connection and remove console.
8. Disconnect 32 pin connector from amplifier and four screws securing amplifier to mounting bracket (Figure 12-139).
9. Remove amplifier.
10. Disconnect 4 pin connector from overhead console speaker enclosure.
11. Remove speakers and wiring from overhead console speaker enclosure.

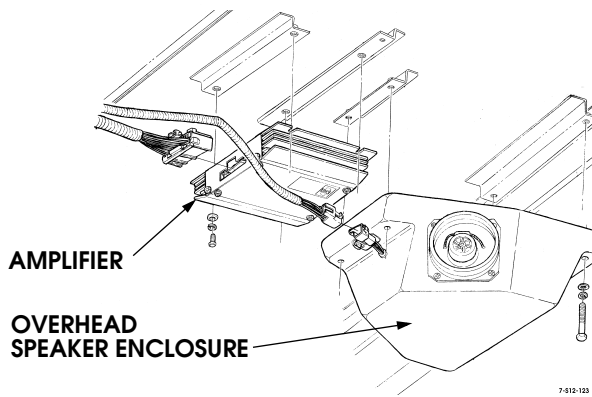

Figure 12-139: Overhead Speaker & Amplifier Removal.

Installation

1. Install speakers and wiring in overhead console speaker enclosure and connect 4 pin connector to audio harness.
2. Mount amplifier to mounting bracket with four screws and connect 32 pin connector to audio harness.
3. Connect dome light wiring and screw overhead console to roof.
4. Install windshield divider bar cover.
5. Install dome light housing and bulb holder with 3 screws, and dome light lens.
6. Install upper B-bar cover.

REAR SEAT AUDIO (RSA) UNIT REPLACEMENT

Removal

1. Remove the cup holders from the auxiliary A/C unit cover (Figure 12-140).
2. Reach through the cup holder holes in the cover and release the tension tabs securing the RSA unit to the cover.
3. Pull the RSA unit out enough to expose the harness connector and disconnect the connector.

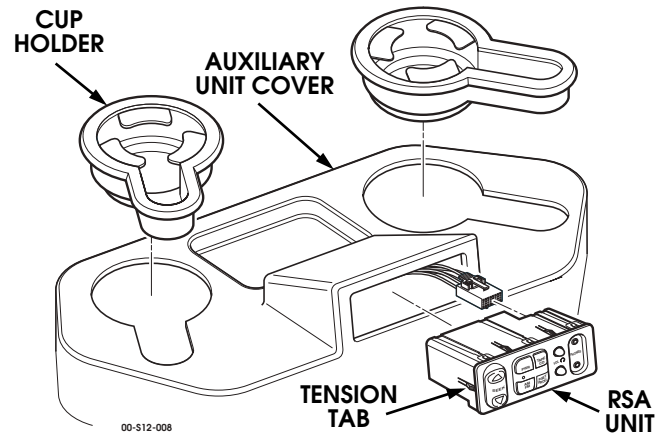

Figure 12-140: RSA Unit Replacement.

Installation

1. Connect the harness connector to the RSA unit and insert into the auxiliary unit cover. Push the RSA unit in until the tension tabs lock the unit in place.
2. Press the cup holders in place in the auxiliary unit cover.



AUDIO (DELCO MONSOON) ELECTRICAL HARNESS (MODELS 83, 84 & 91) REPLACEMENT

Removal

1. Remove engine cover console.
2. Disconnect harness connector from radio head.
3. Remove Rear Seat Audio (RSA) unit from auxiliary heat and AC cover console. Disconnect RSA connector from RSA unit.
4. Remove four screws, clips, cover, and right front speaker from trim (Figure 12-141).
5. Disconnect two leads from right front speaker.
6. Repeat steps 3 and 4 for left front speaker.
7. Remove screws from B-bar cover, windshield divider cover, and overhead console. Disconnect dome light wiring connections and overhead console speaker enclosure connector.
8. Remove four screws, clips, cover, and right rear speaker from trim.
9. Disconnect two leads from right rear speaker.
10. Repeat steps 7 and 8 for left rear speaker.
11. Disconnect lead from subwoofer under left rear seat.
12. Remove trim as necessary to gain access to audio harness.
13. Remove audio harness from vehicle.

Installation

1. Route audio harness to approximate mounting position.
2. Secure audio harness to vehicle with duct tape, where necessary.
3. Connect two leads to right rear speaker.
4. Install right rear speaker and cover on trim with four clips and screws.
5. Repeat steps 3 and 4 for left rear speaker.
6. Connect lead to subwoofer.
7. Connect lead to overhead console speaker enclosure.
8. Connect two leads to right front speaker (Figure 12-141).
9. Install right front speaker and cover on trim and secure with four clips and screws.
10. Repeat steps 7 and 8 for left front speaker.
11. Connect harness lead to radio head.
12. Install engine cover console.
13. Connect RSA connector to RSA unit and install RSA unit in auxiliary heat and AC cover console.
14. Install trim.

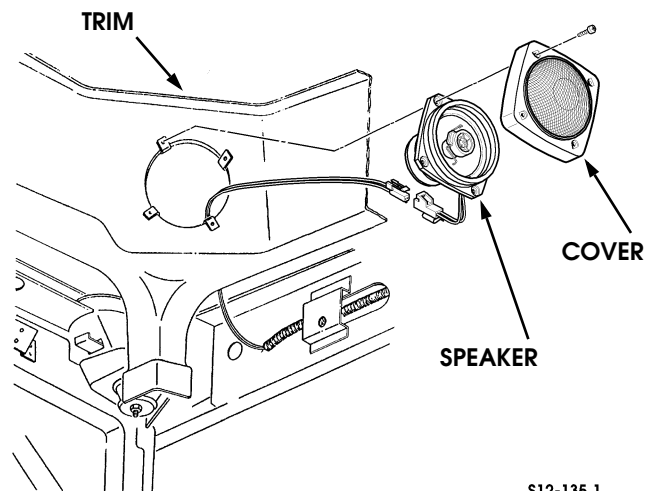

Figure 12-141: Right Front Speaker Models 83, 84 & 91.



AUDIO (DELCO STANDARD) ELECTRICAL HARNESS (MODEL 89) REPLACEMENT

Removal

1. Remove engine cover console.
2. Disconnect radio harness lead from harness connector (Figure 12-142).

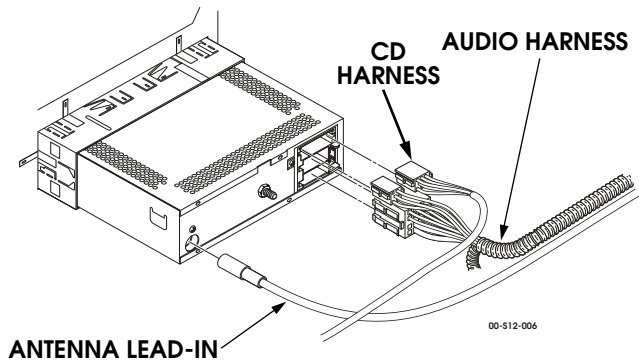

Figure 12-142: Audio Harness Connections.

3. Remove four screws, clips, cover, and right speaker from trim (Figure 12-143).

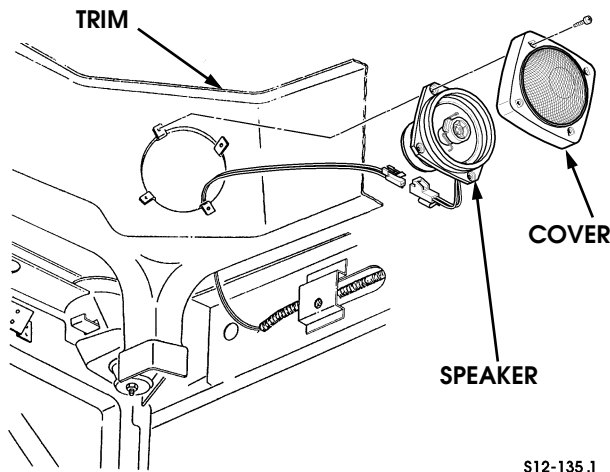

Figure 12-143: Right Front Speaker Model 89.

4. Disconnect two leads from right speaker.
5. Repeat steps 3 and 4 for left speaker.
6. Remove trim as necessary to gain access to audio harness.
7. Remove audio harness from vehicle.

Installation

1. Route audio harness to approximate mounting position.
2. Secure audio harness to vehicle with duct tape, where necessary.
3. Install trim.
4. Connect two leads to right speaker (Figure 12-143).

5. Install right speaker and cover on trim with four clips and screws.
6. Repeat steps 4 and 5 for left speaker.
7. Connect harness lead to audio harness connector (Figure 12-142).
8. Install engine cover console.

AUDIO (DELCO STANDARD) ELECTRICAL HARNESS (MODELS 83, 84 & 91) REPLACEMENT

Removal

1. Remove engine cover console.
2. Disconnect harness lead from audio harness connector (Figure 12-142).
3. Remove four screws, clips, cover, and right front speaker from trim (Figure 12-143).
4. Disconnect two leads from right front speaker.
5. Repeat steps 3 and 4 for left front speaker.
6. Remove four screws, clips, cover, and right rear speaker from trim.
7. Disconnect two leads from right rear speaker.
8. Repeat steps 7 and 8 for left rear speaker.
9. Remove trim as necessary to gain access to audio harness.
10. Remove audio harness from vehicle.

Installation

1. Route audio harness to approximate mounting position.
2. Secure audio harness to vehicle with duct tape, where necessary.
3. Install trim.
4. Connect two leads to right rear speaker.
5. Install right rear speaker and cover on trim with four clips and screws.
6. Repeat steps 4 and 5 for left rear speaker.
7. Connect two leads to right front speaker (Figure 12-143).
8. Install right front speaker and cover on trim and secure with four clips and screws.
9. Repeat steps 7 and 8 for left front speaker.
10. Connect harness lead to audio harness connector.
11. Install engine cover console.



AUDIO (DELCO STANDARD) ELECTRICAL HARNESS (MODEL 90) REPLACEMENT

Removal

1. Remove engine cover console.
2. Disconnect harness lead from radio head (Figure 12-142).
3. Remove four screws, clips, cover, backing plate and right front speaker from trim (Figure 12-144).

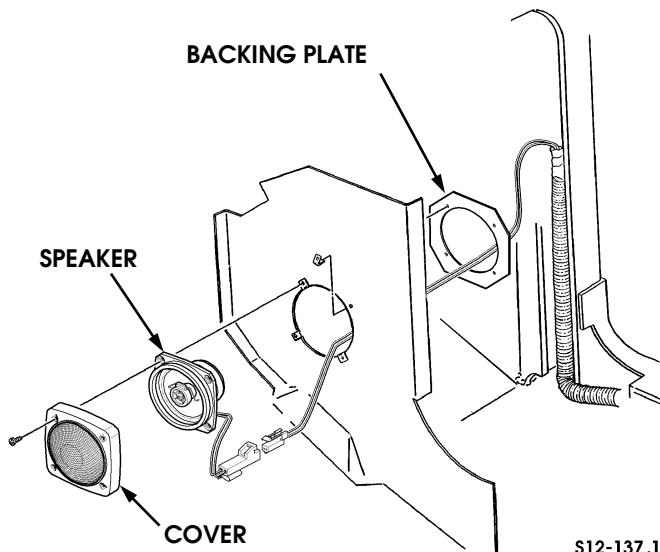

Figure 12-144: Right Front Speaker Model 90.

4. Disconnect two leads from right front speaker.
5. Repeat steps 3 and 4 for left front speaker.
6. Remove four screws, clips, cover, and right rear speaker from trim (Figure 12-145).

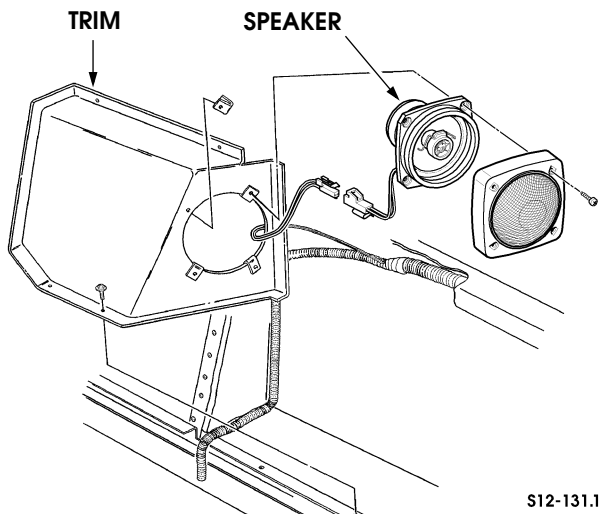

Figure 12-145: Right Rear Speaker Model 90.

7. Disconnect two leads from right rear speaker.
8. Repeat steps 7 and 8 for left rear speaker.
9. Remove trim as necessary to gain access to harness.
10. Remove audio harness from vehicle.

Installation

1. Route audio harness to approximate mounting position.
2. Secure harness to vehicle with duct tape, where necessary.
3. Install trim.
4. Connect two leads to right rear speaker (Figure 12-145).
5. Install right rear speaker and cover on trim and secure with four clips and screws.
6. Repeat steps 4 and 5 for left rear speaker.
7. Connect two leads to right front speaker (Figure 12-144).
8. Install right front speaker and cover on trim with four clips and screws.
9. Repeat steps 7 and 8 for left front speaker.
10. Connect harness lead to radio head.
11. Install engine cover console.

DIAGNOSIS -DELCO AUDIO SYSTEM

1. Verify customer complaint.
2. Follow radio service procedures.
3. If technical service is required, have all the pertinent information ready before placing the call.

NOTE: Before performing any diagnostic procedures or using any diagnostic tools, check wiring schematics for component circuitry to determine the location of fuses and circuit breakers in the circuit. Fuses and circuit breakers must be in good working order to perform proper diagnostic procedures.

Delco Audio System Diagnostic Kit J-39916-A is available from Kent-Moore. The kit contains a diagnostic CD and cassette, a head cleaner cassette and instructions. This kit is designed to isolate the type of malady and the area of its origin by producing tones of various frequencies. By adjusting the fade and balance, a technician can evaluate the sound quality produced in different areas of the system.

Identifying Concerns

- Check for technical service bulletins.
- For reception concerns, determine if the station is obtainable in the customer's listening area.
- To test for audio reception/noise, position the vehicle outside the building with the hood down.
- Duplicate the customer's complaint before trying to diagnose the system. Have the customer demonstrate the condition. Test drive the vehicle with the customer and then test drive another similar model vehicle (with a similar audio system) to do a comparison of the two vehicles to determine if the condition is abnormal.
- Before diagnosing, identify components, their features and the customer's complaint.
- Determine if any aftermarket equipment is installed on the vehicle. Disconnect the aftermarket equipment and determine if the customer's complaint still exists.
- Perform the following steps to identify a noisy component:



1. Identify ignition switch key position in which the noise appears, such as: accessory, key on engine not running, and key on engine running.
2. Remove fuses one at a time until the complaint condition has been eliminated.
3. Mark the complaint fuse(s) and reinstall all fuses and circuit breakers.
4. Identify all systems and components powered by the complaint fuse(s).
5. Disconnect the components powered by the complaint fuse(s) one at a time until the complaint condition has been eliminated and the noisy component has been identified.
6. Check the ground integrity of the complaint causing component.
 - An interference condition is not necessarily an audible noise.
 - Most noises can be found on weak stations near the low end of the band and are considered to be a normal condition.
 - Malfunctioning and marginal components, relays, and solenoids may induce noise and/or poor reception.
7. Check for a broken (or partially broken) wire inside of the insulation which could cause system malfunction but prove “good” in a continuity/voltage check with a system disconnected. These circuits may be intermittent or resistive when loaded, and if possible, should be checked by monitoring for a voltage drop with the system operational (under load).

Corrective Action

- Use proper tools for diagnostics and repairs.
- Follow electrical system diagnostic guidelines.
- Use available noise suppression devices:
 - Filter package P/N 05744279

Utilize the test tape /CD Diagnostic Kit Kent-Moore P/N J-39916-A to optimize proper audio diagnostics.

- If the condition requires the radio to be sent to the service center, describe the symptoms on the warranty form exactly.
- Do not leave a CD disc or tape in the vehicle. Extreme heat could cause permanent damage.
- Cassette tapes could be damaged if not stored in the case. The vibration in the vehicle can cause the tape to unwind inside the cartridge.
- Use available trouble trees.
- Before removing speaker(s), check all connectors and wiring to the speakers. Examine the connectors for bent or loose pins. Refer to troubleshooting procedures.
- If a test antenna is used in diagnostics, ground the antenna base to the vehicle body and do not hold the mast.

NOTE: Check the antenna coax connectors for corrosion or bad connections/crimps. Route coax separately from the other wires. Shield antenna coax interconnections with aluminum or nickel tape. Check all vehicle grounds, not just antenna and radio grounds. Refer to the antenna diagnostic section.

- Coated screws or bolts can act as poor grounds.
- Always use a braided ground strap when applying grounds. Keep the ground strap as short as possible, the shorter the ground strap the better.
- When shielding the dash, wires, hoses (most hoses are conductive unless they have a white stripe), use aluminum foil tape or nickel tape to shield against magnetically induced interference. For optimum performance try varying the following ground techniques:
 - Add a ground at both ends of the tape.
 - Add a ground to just one end of the tape.
 - Do not add ground to the tape.
- When shielding a harness with tape, attach a ground strap to the end of the tape and then wrap the strap 360 degrees around the tape securing the other end of the strap to a known good chassis ground.
- Any interference is best corrected by suppression at the source of the interference, if possible.
- Care should be used when applying suppression. Signal wires (such as sensor outputs, clock, and communication circuits) cannot be suppressed. After adding any suppression, all vehicle systems (even those not related to the audio system) should be checked for proper operation and function.
- Interference can usually be eliminated by shielding/grounding or suppressing.
- Capacitors work best on switch pops and low frequency noise. Filters work best on high frequency whines and static.
- Whenever possible, make a test harness that includes filters and capacitors. Always check the effectiveness and operation before permanently installing a fix.
- Recommended capacitor application for an audible pop induced from a switching operation is:
 - Add a capacitor across the contacts of the switch.
 - Add a capacitor from the hot side of the switch to ground.
 - Add a capacitor to each side of the switch to ground.
- If a complaint condition is only present with the ignition key in the run position and the engine running, perform the following checks:
 - Check the integrity of the engine compartment grounds.
 - Check for malfunctioning relays, solenoids, or other components which may be inducing “noise” or poor reception.
 - Check the ground integrity of the complaint causing component.
- For noise and/or poor reception, perform the antenna system test and make the necessary repairs.



TEST ANTENNA

The test antenna is simply an antenna that is not mounted on the vehicle. This tool is used as a substitute for the antenna mounted on the vehicle. The technician should connect the test antenna to the antenna input of the radio. Ground the base of the antenna to the antenna input of the radio. Ground the base of the antenna to the vehicle's chassis. **Do not hold the mast of the antenna.** This will decrease the capability of the antenna to receive a station.

GENERATOR WHINE CONCERNS

- Check the ground terminal on the battery.
- Check for coated mounting bolts on the generator bracket.
- Check for a faulty mounting of the generator to the engine.
- Make sure grounds at starter and intake manifold are clean and tight.
- Try the following:
 1. If noise is still present, check the charging system.
 2. If the charging system is functioning normally, check for technical service bulletins on generator whine.
 3. Install a filter P/N 05744279 in the battery feed to the radio.
 4. Try installing the filter with the following variations if the noise is not eliminated.
 - a. Install the filter with the single wire side toward the radio and the ground wire attached to a good ground.
 - b. Remove the ground to the filter.
 - c. Reverse the filter so the two wire side is toward the radio with the ground wire attached to a good ground.
 - d. Remove the ground from the filter.
 5. If the noise is still present, install another filter P/N 05744279 in the ignition feed to the radio. Install using the same variations as the first filter. If the installation of this filter causes turn on or turn off delays or other noticeable performance concerns, remove it and install a 0.47 mf (microfarad) capacitor in its place.
 6. Remove any unneeded filters after repair, before reassembling the vehicle.

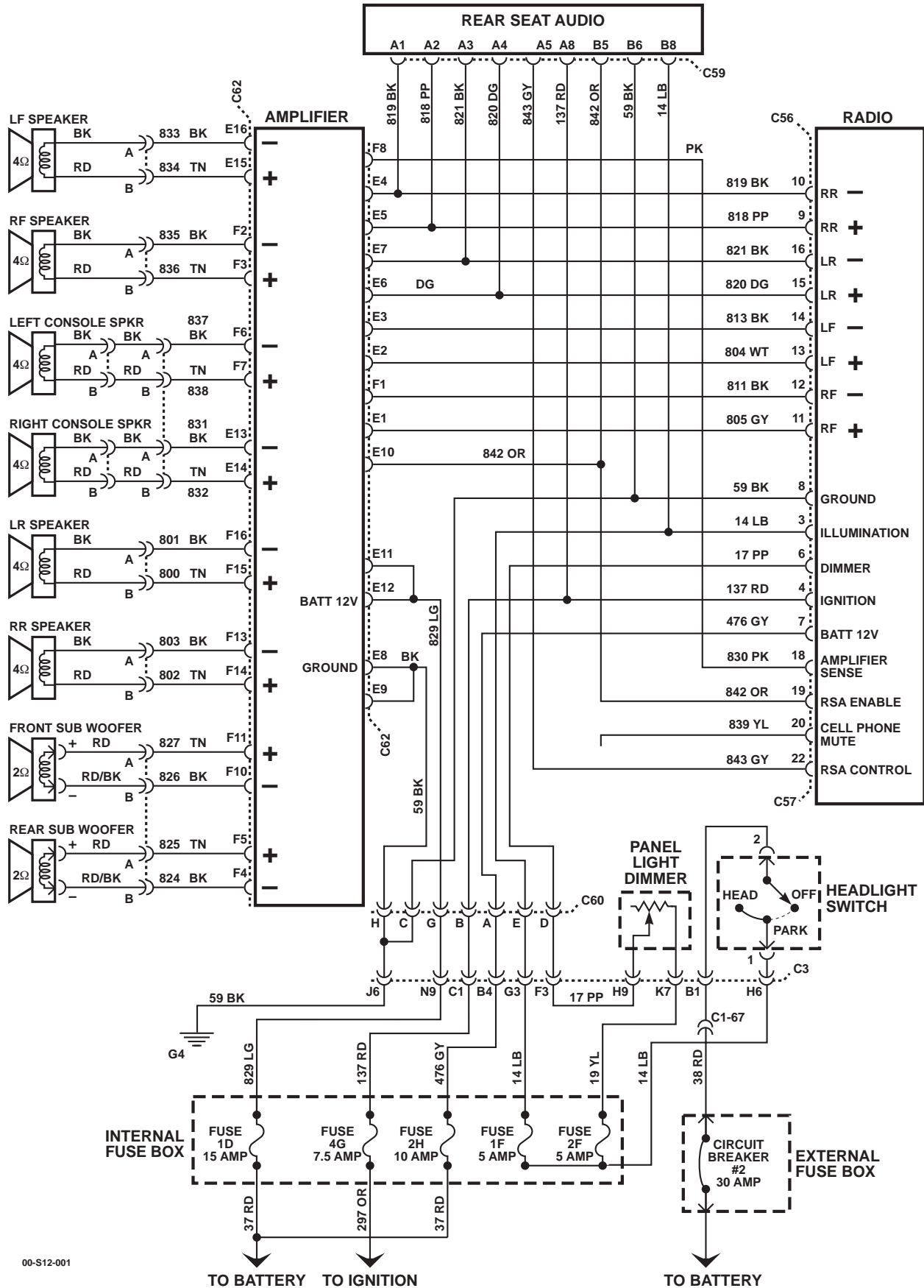

00-S12-001

Figure 12-146: Monsoon Audio Harness Schematic Models 83, 84 & 91.

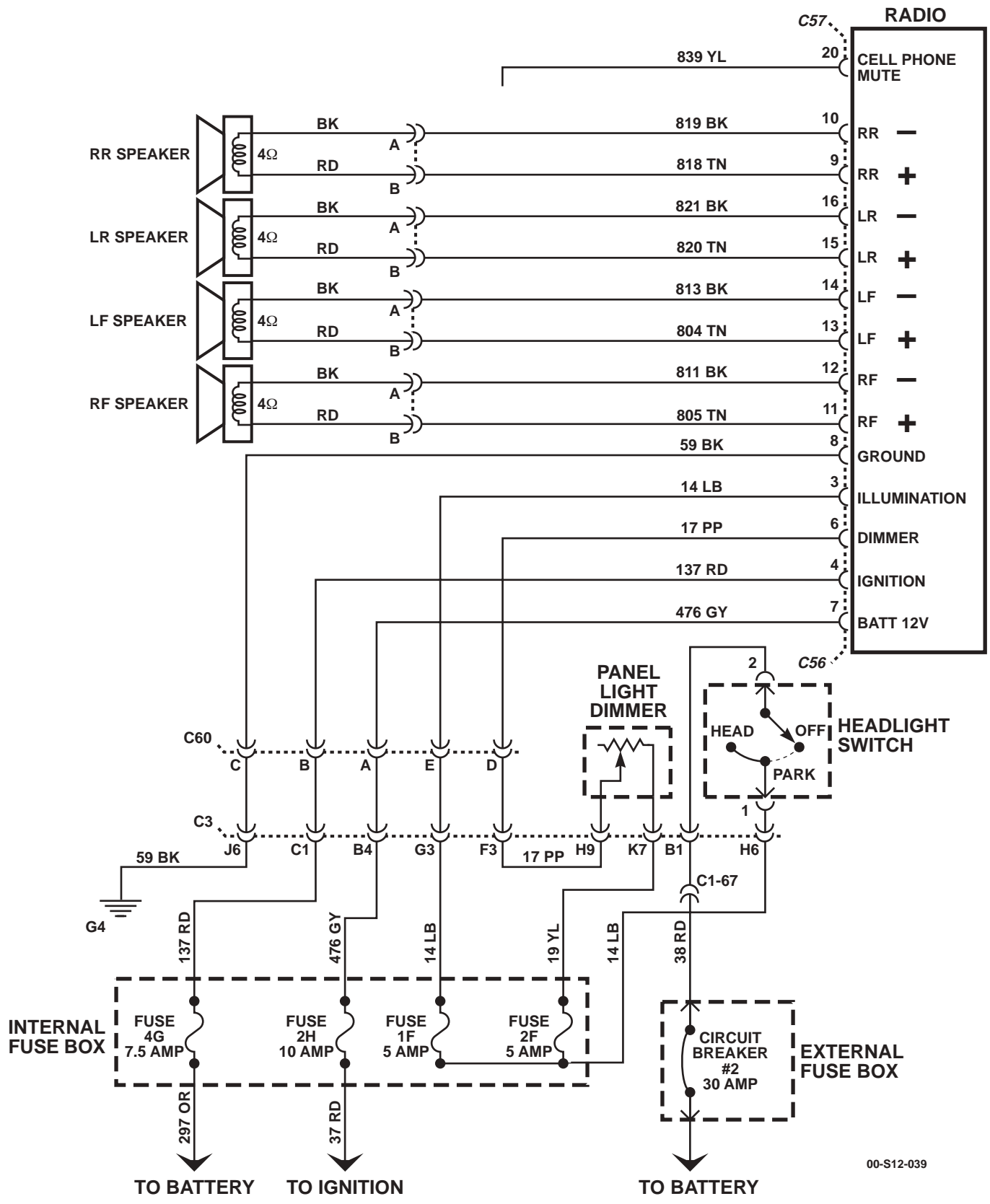

00-S12-039

Figure 12-147: Standard Audio Harness Schematic Models 83, 84, 90 & 91.

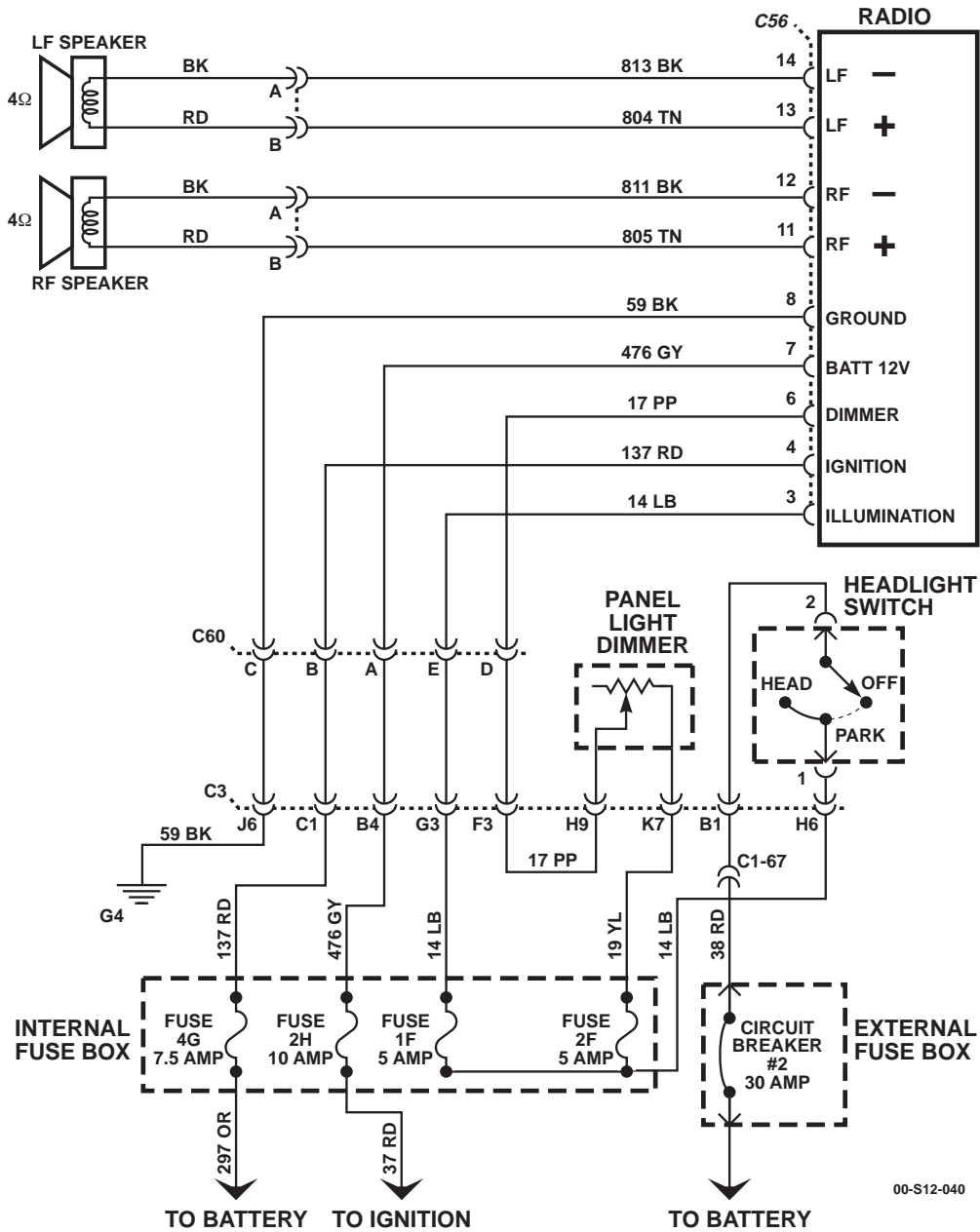
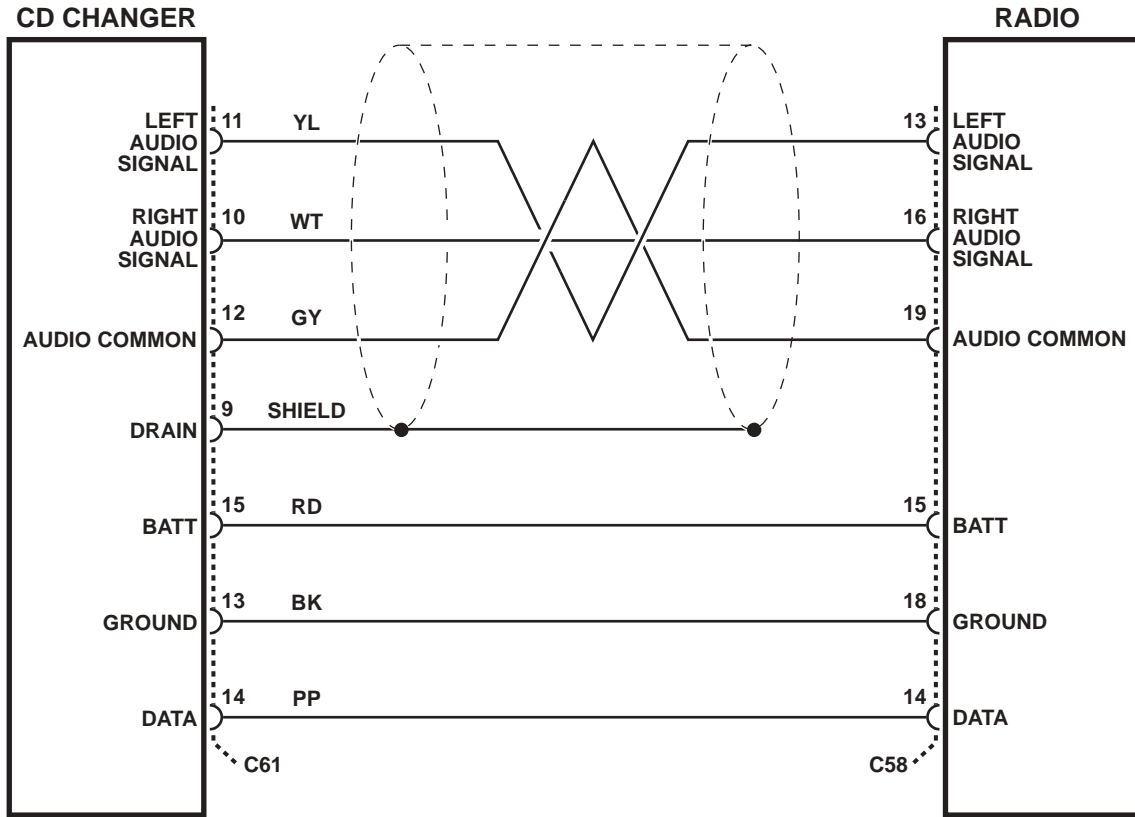

Figure 12-148: Standard Audio Harness Schematic Model 89.



00-S12-002

Figure 12-149: CD Changer To Radio Harness, All Models.



SYMPTOM TABLE

SYMPTOM	PROCEDURE	PAGE NUMBER
Display inoperative, no sound from any speaker.	Chart #1	12-152
No sound from one speaker (Delco std.).	Chart #2	12-152
No sound from one speaker (Monsoon).	Chart #3	12-153
No sound from any speaker, radio display operates normally (Monsoon).	Chart #4	12-154
Compact disc player does not operate properly.	Chart #5	12-155
Cassette player does not operate properly.	Chart #6	12-156
Antenna system test.	Chart #7	12-157
Rear seat audio does not operate.	Chart #8	12-160
Radio controls are inoperative.	Service radio.	
Radio does not turn off.	Service radio.	
Radio memory (clock and station presets) is inoperative.	Check the gray wire (CKT 476) for an open or high resistance between C56 terminal 7 and fuse 2H of the interior fuse box.	
Display dimming does not vary using the I/P dimmer switch (I/P dimming works).	Check the purple wire (CKT 17) for an open or high resistance between C56 terminal "6" and the panel light dimmer.	
Speaker output distorted at high volume (Monsoon).	Check for open or poor connection in the black wire (CKT 59) from C62 terminals "E8" and "E9" to the ground G4. Check for open or poor connection in the light green wire (CTK 829) from C62 terminals "E11" and "E12" to fuse 1D. If OK, replace amplifier.	



DISPLAY IS INOPERATIVE, NO SOUND FROM ANY SPEAKER

CHART #1

STEP	ACTION	VALUE(S)	YES	NO
1	Disconnect connector C56. Turn the ignition switch to the "Run" position. With a DVOM, measure voltage between terminal "7" and ground G4.	+12v	Go to step 2.	Repair the poor connection or open the gray wire (CKT 476) between connector C56 terminal "7" and fuse 2H of the interior fuse box.
2	With a DVOM, measure the voltage at connector C56 between terminal "7" and terminal "8".	+12v	Go to step 3.	Repair the poor connection or open in the black wire (CKT 59) between connector C56 terminal "8" and ground G4.
3	With a DVOM measure the voltage at connector C56 between terminal "4" and terminal "8".	+12v	Go to step 4.	Repair open in the red wire (CKT 137) between connector C56 terminal 4 and fuse 4G of the interior fuse box.
4	Check for a poor connection at the radio. If OK, service radio.			

NO SOUND FROM ONE SPEAKER (DELCO STANDARD)

CHART #2

	ACTION	VALUE(S)	YES	NO
1	Turn the ignition switch to the "off" position. Disconnect connectors C56, C57 and C58. With a DVOM, measure the resistance at the connector C56 between speaker + and - circuits (see schematics).	4Ω	Go to step 3.	Go to step 2.
2	With a DVOM, measure the resistance at the speaker connection from terminal "A" to terminal "B".	4Ω	Repair open or short circuit in speaker + and - circuits.	Replace speaker.
3	With a DVOM measure the resistance at the radio connector of the speaker + and - circuits to ground.	Infinite resistance.	Go to step 4.	Repair short to ground in speaker + or - circuit.
4	Check for poor connections at radio or speaker. If OK, service radio.			



NO SOUND FROM ONE SPEAKER (DELCO MONSOON)

CHART #3

STEP	ACTION	VALUE(S)	YES	NO
1	Turn ignition switch to the "Run" position. Turn radio "On". Insert cassette or compact disc from Delco Audio system Diagnostic Kit J-39916-A. Set radio balance and fade controls to the detente (center) position. Set volume at normal listening level. While playing the combination test tone from cassette or compact disc, use a DVOM to backprobe the speaker connector between terminals "A" and "B". Is the voltage greater than 0v AC?	> 0v AC	Go to step 2.	Go to step 3.
2	Check for a poor connection at the inoperative speaker. If OK, replace the speaker. Is the repair complete?		System OK.	
3	Check the + and - speaker circuits for a short to B+ or ground between the speaker and amplifier. Is there a short?		Repair short to ground or B+.	Go to step 4.
4	Turn the ignition switch to the "Off" position. Disconnect connector C62. Using a DVOM set to measure resistance, probe the amplifier connector between the + and - speaker circuits of the inoperative speaker (see schematics). Is the resistance approximately 2-4 ohms?	2-4 ohms	Go to step 6.	Go to step 5.
5	Using a DVOM, check the resistance at the speaker connection between terminals "A" and "B". Is the resistance 2-4 ohms?	2-4 ohms	Repair open in speaker + or - circuit between speaker connection and amplifier connection.	Replace the speaker.
6	Check for poor connection at connector C62. Is connection OK?		Replace amplifier.	Repair connection.



NO SOUND FROM ANY SPEAKER, RADIO DISPLAY OPERATES NORMALLY (DELCO MONSOON)

CHART #4

STEP	ACTION	VALUE(S)	YES	NO
1	Disconnect connector C62. Turn ignition switch to the "Run" position. Turn radio "On". Insert the cassette or compact disc from Delco Audio System Diagnostic Kit J-39916-A. Set radio balance and fade controls to the detente (center) position. Set radio volume at normal listening level. While playing the combination test tone from the cassette or compact disc, use a DVOM to measure AC voltage between connector C62 terminals "E6" and "E7". Is the voltage greater than 0v AC?	> 0v AC	Go to step 2.	Go to step 4.
2	Check for a poor connection at the connector C62 terminals "E6" and "E7". Was a poor connection found?		Repair connection.	Go to step 3.
3	Using a DVOM, check for +12v between the light green wire and the black wire (ckts 829 and 59) at the amplifier connection.	+12v	Replace amplifier.	Repair open or poor connection in ckts 829 and 59.
4	Turn the ignition switch to the "Run" position. Turn the radio to the "On" position. Insert the cassette or compact disc from Delco Audio System Diagnostic Kit J-39916-A. Set radio balance and fade controls to the detente (center) position. Set radio volume at normal listening level. While playing the combination test tone from the cassette or compact disc, use a DVOM and backprobe connector C56 between terminals "16" and "15". Is the voltage greater than 0v AC?	> 0v AC	Repair the open or short in ckts 821 or 820 between radio and amplifier.	Go to step 5.
5	Check for a bad connection at connector C56 terminals "16" or "15". Is bad connection found?		Repair connection.	Replace radio.



COMPACT DISC CHANGER DOES NOT OPERATE PROPERLY

NOTE: Steps 1-4 cover the CD changer having no function with the radio operating normally

NOTE: Step 5 is used to diagnose a skipping or muted complaint.

NOTE: Step 6 is used if the display reads "FOCUS" or the disc ejected.

CHART #5

STEP	ACTION	VALUE(S)	YES	NO
1	Disconnect connector C61. Turn ignition switch to the "Run" position. Turn the radio "On". Select "CD mode" on radio display. Using a DVOM, check for voltage on connector C61 between terminals 13 and 15. Is the minimum voltage present?	+12v	Go to step 3.	Go to step 2.
2	Back probe connector C58 between terminals 18 and 15. Is the minimum voltage present?	+12v	Repair power and/or ground circuits between radio and CD changer. System OK.	Check for a poor connection at the radio. If OK, service radio.
3	Using a DVOM, check for voltage on connector C61 terminal 14. Is the minimum voltage present?	+12v	Check for a poor connection at the CD changer. If OK, service CD changer.	Go to step 4.
4	Back probe connector C58 and check the voltage. Is the minimum voltage present?	+12v	Repair the power control circuit between the radio and the CD changer.	Check for a poor connection at the radio. If OK, service radio.
5	Check disc for proper insertion, scratches, dirt or finger prints and clean if necessary. Is usual route over a rough road (off road environment)? If so, condition may be normal. Attempt to duplicate on good road surface. Test with known good disc (preferably new disc). Some discs may contain marks not readily visible that may make one track or the entire disc unplayable. Check mounting angle adjustment on both sides of changer. Is angle adjusted to 45 degrees? If checks and adjustments do not cure problem, service changer.	45 degrees	Service changer.	Loosen screws and adjust mount angle to 45 degrees.
6	"FOCUS" appears if disc is inserted upside down, dirty, badly scratched or wet. "FOCUS" appears if moisture condenses on the disc (if a cold disc is inserted into a hot player and vice versa). Allow up to an hour to evaporate condensation. Check with known good disc - verify to customer. Very high internal instrument panel temperatures may cause eject. If checks and adjustments do not cure problem, service changer.			



CASSETTE PLAYER DOES NOT OPERATE PROPERLY

CHART #6

STEP	ACTION	VALUE(S)	YES	NO
	Tape plays weak, slow or garbled.		Go to step 1.	
	Tape inoperative.		Go to step 3.	
1	Inspect and clean moving parts and tape head or use Delco Audio System Diagnostic Kit J-39916-A cleaning cassette. Does tape play OK?		Advise periodic cleaning.	Go to step 2.
2	Perform motor speed test with diagnostic test tape from Delco Audio System Diagnostic Kit J-39916-A. Is motor speed OK?		Fault is in tape. System OK.	Service radio.
3	Check player for obstruction through tape door. Is there an obstruction?		Go to step 4.	Service radio.
4	Remove obstruction. CAUTION: improper removal may damage tape player. Inspect and clean moving parts and tape head or use cleaning cassette. Use diagnostic test tape from J-39916-A. Does test tape operate?		System OK.	Service radio.



ANTENNA SYSTEM TEST

CHART #7

STEP	ACTION	VALUE(S)	YES	NO
1	<p>Disconnect negative battery cable. Disconnect antenna lead-in cable at the radio receiver. With a DVOM, measure resistance between the coax (outer conductor) connector and the negative battery cable.</p> <p>NOTE: To avoid misdiagnosis be sure to zero the meter before taking measurements.</p> <p>Is resistance value greater than .15 ohms?</p>	> .15 ohms	<p>Check the base of the antenna for a good connection to body ground. Check the coaxial cable interconnects for a poor connection or corrosion. Check the ground connection from the battery negative cable to the body. Repair the antenna ground circuit as necessary.</p>	Go to step 2.
2	<p>Grasp the antenna mast. While observing the DVOM, wiggle the antenna and the lead-in cable ground strap. Does the meter indicate intermittent continuity?</p>		<p>Check the lead-in cable ground strap for a good connection to body ground. Check the coaxial cable interconnects for a poor connection or corrosion. Check the ground connection from the battery negative cable to the body. Repair the antenna ground circuit as necessary.</p>	Go to step 3.
3	<p>With a DVOM, measure the resistance between the radio coax lead-in connector (center conductor) and the antenna mast.</p> <p>NOTE: To avoid misdiagnosis be sure to zero the meter before taking measurements.</p> <p>Does the measured resistance equal approximately the value listed?</p>	Less than 3.5 ohms	Go to step 4.	<p>Check the coaxial cable interconnects for a poor connection or corrosion. Repair/replace the antenna coaxial circuit as necessary.</p>
4	<p>While observing the DVOM, wiggle the antenna. Does the meter indicate intermittent continuity?</p>		<p>Check the coaxial cable interconnects for a poor connection or corrosion. Repair/replace the antenna coaxial circuit as necessary.</p>	See troubleshooting hints for noise and poor reception.



REAR SEAT AUDIO (RSA) DOES NOT OPERATE

CHART #8

STEP	ACTION	VALUE(S)	YES	NO
1	With ignition on, check for voltage at C59 pin A8 (CKT 819 BK). Is voltage present?	+12v	Go to step 2.	Check/repair open circuit between C59 pin A8 and C56 pin 4.
2	With ignition in the "RUN" position and the radio "ON", check for voltage at C59 pin B5 (CKT 842 OR). Is voltage present?	+12v	Go to step 3.	Check/repair open circuit between C59 pin B5 and C57 pin 19.
3	Check for continuity between C56 pin 8 (CKT 59 BK) and ground G4. Is there continuity?	< 0.2 Ω.	Go to step 4.	Repair circuit 59 BK between C56 and ground point G4.
4	Check for continuity between C56 pin 8 and C59 pin 6. Is there continuity?	< 0.2 Ω.	Go to step 5.	Repair circuit 59 BK between C56 and C59.
5	With ignition in the "RUN" position and the RSA on, back probe C59 pin A5 (CKT 843 GY) and check for specified voltage. Is the specified voltage present?	+ 5v	Go to step 6.	Replace RSA unit.
6	With ignition on and RSA on, check for voltage at C57 pin 22 (CKT 843 GY). Is the specified voltage present?	+ 5v	Go to step 7.	Check/repair open circuit between C59 pin A5 and C57 pin 22.
7	Check for an open circuit between C56 pin 15 and C59 pin A4 (CKT 820 DG). Is there continuity?	< 0.2 Ω.	Go to step 8.	Check/repair open circuit between C59 pin A4 and C56 pin 15.
8	Check for an open circuit between C56 pin 16 and C59 pin A3 (CKT 821 BK). Is there continuity?	< 0.2 Ω.	Go to step 9.	Check/repair open circuit between C59 pin A3 and C56 pin 16.
9	Check for an open circuit between C56 pin 9 and C59 pin A2 (CKT 818 PP). Is there continuity?	< 0.2 Ω.	Go to step 10.	Check/repair open circuit between C59 pin A2 and C56 pin 9.
10	Check for an open circuit between C56 pin 10 and C59 pin A1 (CTK 819 BK). Is there continuity?	< 0.2 Ω.	Go to step 1.	Check/repair open circuit between C59 pin A1 and C56 pin 10.



CONNECTOR LEGEND

NOTE: Connector gender is determined by the terminals.

76 WAY BULKHEAD LOCATION: LEFT SIDE FIREWALL

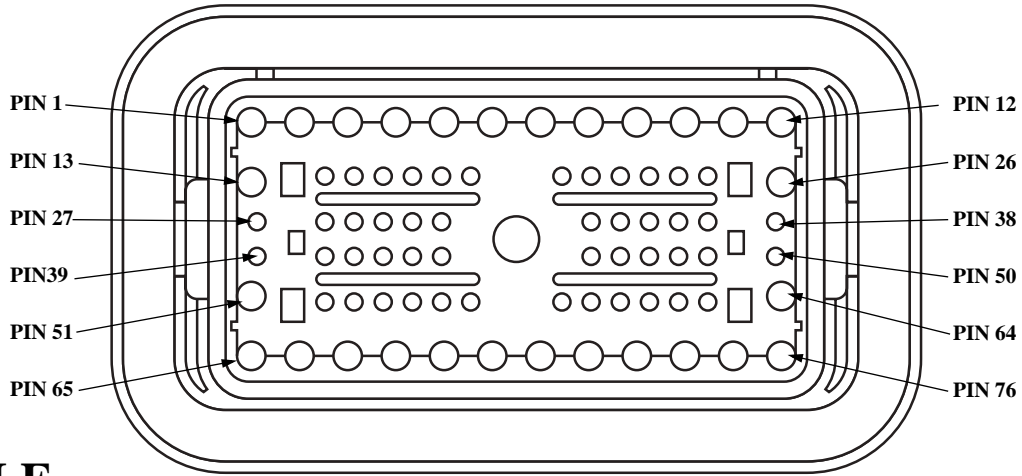

9-S12-048

C1 MALE

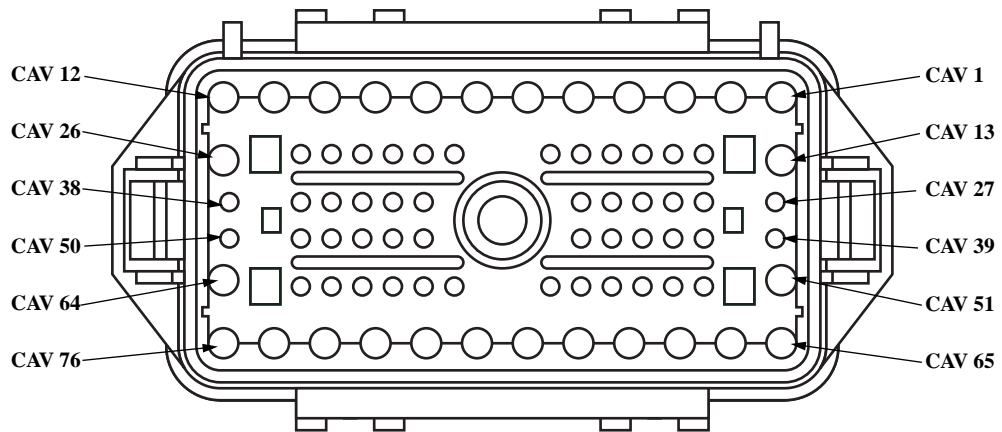

9-S12-047

C1 FEMALE

PIN	CKT	COLOR	CIRCUIT DESCRIPTION
1	400	LG	Ignition Feed +
2	739	PP	Left heated windshield power +
3	740	YL	Right heated windshield power +
4	43	DB	Trailer Brake activation
5	962	BR	Trailer lights
6	33	WH	neutral safety switch feed
7	37E	YL	start relay feed
8	37D	YL	Ignition switch feed
9	786	RD	Fuel selector valve control
10	537	OR	Battery

12-160 Electrical System



PIN	CKT	COLOR	CIRCUIT DESCRIPTION
11	787	GY	Fuel pump + to selector valve
12	37	RD	Ignition relay feed
13	688	RD	Rear window defrost feed
14	723	YL	APP 3 5volt reference
15	724	DG	APP 3 signal
16	17	PP	+ FROM DIMMER MODULE
17	718	DB	APP 1 signal
18	353	YL	Speedometer signal
19	607	TN	ABS module diagnostic line
20	717	WH	APP 1 5volt reference
21	961	PP	TT4 lamp activation
22	720	TN	APP 2 5volt reference
23	640	OR	IGN+ CTIS warning circuits
24	92	GY	CTIS rear inflate solenoid activation
25	714	DB	Check throttle lamp activation
26	37	RD	Battery feed to interior accessories
27	338	DB	Wait lamp activation
28	658	BR	Check engine lamp activation
29	151	GY	Cruise control ON/OFF signal
30	31	TN	Oil pressure signal
31	22	RD	Brake switch signal – rest
32	721	LB	APP 2 sensor signal
33	580	BR	Not Used for 99 and 2000
34	606	OR	ABS diagnostic line
35	29	PK	Fuel gauge signal
36	39	DG	Engine temperature signal
37	153	LG	Cruise resume/accelerate signal
38	42	BR	Low brake fluid lamp activation
39	198	TN	A/C request
40	810	PP	TCC brake switch signal
41	2	LG	Right front turn signal
42	152	DB	Cruise set/coast signal
43	298	BR	Backup light switch feed
44	722	PP	APP 2 ground
45	327	YL	Water-in-fuel lamp activation
46	80	WH	Underhood lamp power



PIN	CKT	COLOR	CIRCUIT DESCRIPTION
47	3	LB	Left front turn signal
48	914	PP	PCM class 2 communication line to DLC
49	644	YL	Tachometer signal
50	210	DG	Low washer fluid level lamp activation
51	195	YL	Headlight switch feed
52	603	RD	ABS lamp activation
53	719	BR	APP 1 ground
54	793	YL	Low coolant lamp activation
55	794	RD	Low air warning lamp activation
56	41	TN	Brake fluid level sensor feed
57	428	PK	CTIS buzzer activation
58	47	LG	Deflate solenoid activation
59	46	WH	CTIS compressor relay activation
60	725	GY	APP 3 Ground
61	767	BR	Compass mirror temperature signal
62	1	DB	Horn relay activation
63	91	TN	CTIS front inflate solenoid activation
64	37	RD	Batt feed to interior fuse box
65	12	OR	Headlamp high beam feed
66	13	TN	Headlamp low beam feed
67	38	RD	Headlamp switch feed
68	16	LG	Ignition supply to exterior fuse box fuses 2A, 2B, and 3B
69	175	LB	Power window relay feed
70	943	TN	Upper windshield washer pump activation
71	5	DG	Right rear turn signal
72	9	YL	Backup light activation
73	20	RD	Left rear turn signal
74	21	GY	Rear tail lamp feed
75	789	BR	Fuel selector valve control
76	941	TN	Lower windshield washer pump activation



42 WAY UNDERBODY LOCATION: LOWER LEFT FOOTWELL NEAR ENGINE

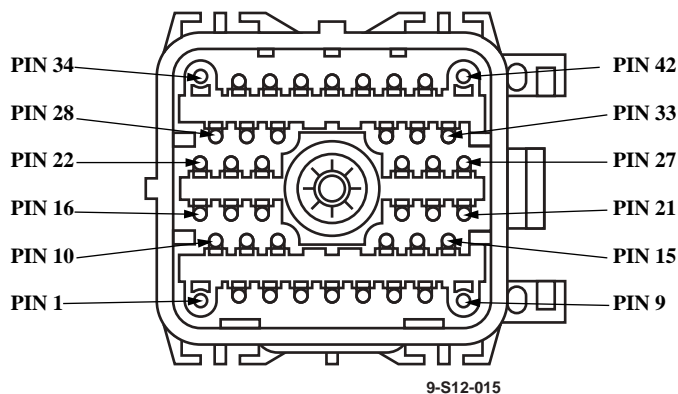

C2 MALE

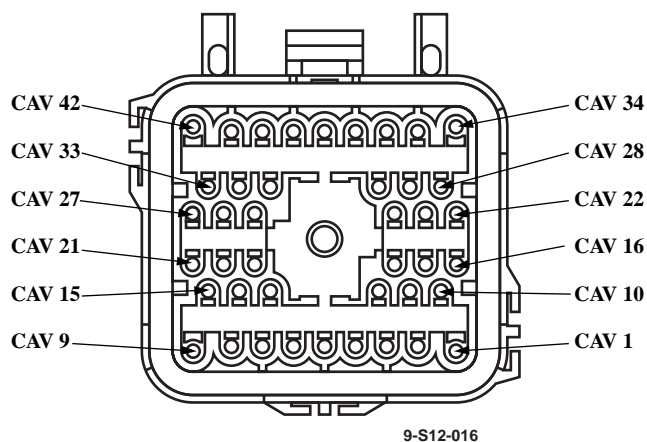

C2 FEMALE

PIN	CKT	COLOR	DESCRIPTION
1	43	DB	Trailer brake activation
2	20	RD	Front parking lamp feed
3	12	OR	Headlamp high beam feed
4	13	TN	Headlamp low beam feed
5	3	LB	Left front turn signal
6	80	WH	Underhood lamp power
7	2	LG	Right front turn signal
8	767	BR	Compass mirror temperature signal
9	49	OR	Battery power to trailer connector
10	996	BR	Left front wheel speed sensor low signal
11	997	BK	Left front wheel speed sensor high signal
12	32	LB	Neutral safety switch feed to start relay
13	33	WH	Neutral safety switch ignition feed



PIN	CKT	COLOR	DESCRIPTION
14	17	PP	Light power from dimmer module
15			
16			
17			
18			
19	999	BK	Right front wheel speed sensor high signal
20	998	BR	Right front wheel speed sensor low signal
21			
22	994	BR	Right rear wheel speed sensor low signal
23	995	BK	Right rear wheel speed sensor high signal
24	41	TN	Parking brake lamp activation
25	21	GY	Rear marker lamp feed
26			
27	298	BR	Backup lamp switch feed
28			
29	5	DG	Right rear turn signal
30	9	YL	Left rear turn signal
31	992	BR	Left rear wheel speed sensor low signal
32	993	BK	Left rear wheel speed sensor high signal
33			
34			
35	29	PK	Fuel gauge signal
36	786	RD	Fuel selector valve control
37	789	BR	Fuel selector valve control
38			
39			
40	962	BR	Trailer tail lamps
41			
42			



56 WAY INSTRUMENT PANEL LOCATION: BEHIND INSTRUMENT PANEL

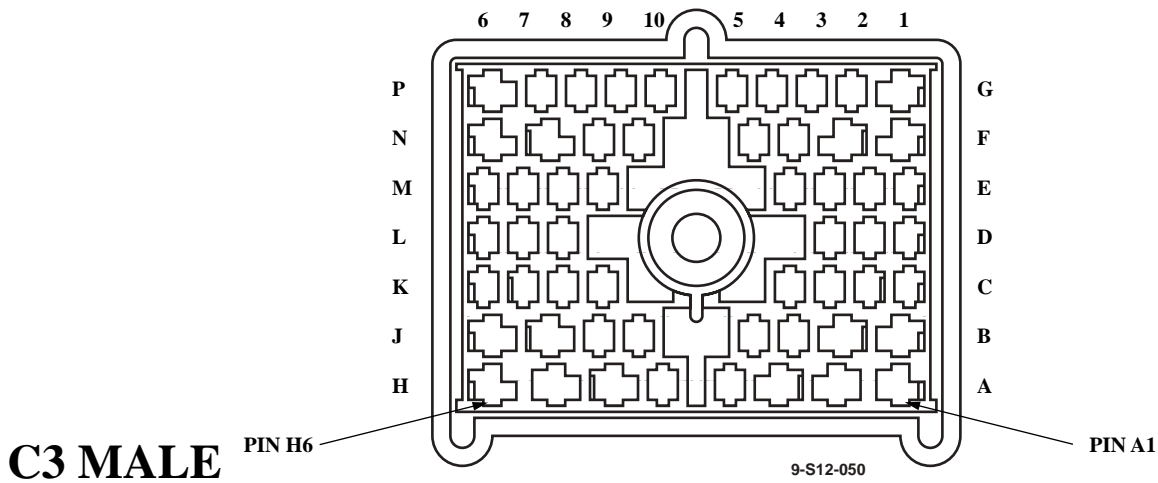

C3 MALE

PIN H6

PIN A1

9-S12-050

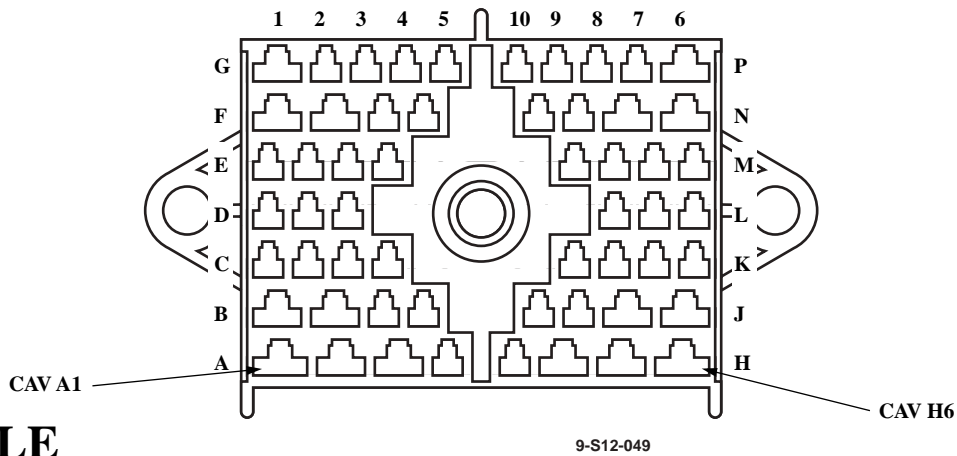

C3 FEMALE

CAV A1

CAV H6

9-S12-049

PIN	CKT	COLOR	DESCRIPTION
A1	195	YL	Headlight switch feed
A2	54	DG	Dome lamp switch feed
A3	53	DB	Dome lamps feed
B1	38	RD	Headlamp switch feed
B2	15	WH	Headlamp feed to dimmer module
B3	640	OR	CTIS switch ignition feed
B4	46	WH	CTIS compressor indicator lamp activation
C1	450	PK	Seat belt lamp activation
C2	47	LG	Deflate solenoid activation
C3	91	TN	Front inflate solenoid activation
C4	92	GY	Rear inflate solenoid activation



PIN	CKT	COLOR	DESCRIPTION
D1	338	DB	Glow plug wait lamp activation
D2	2	LG	Right turn indicator lamp activation
D3	961	PP	TT4 indicator lamp activation
E1	42	BR	Brake indicator lamp activation
E2	603	RD	ABS indicator lamp activation
E3	793	YL	Low washer fluid activation
E4	943	TN	Rear Wiper feed (not used 99)
F1	12	OR	High Beam indicator lamp activation
F2	3	LB	Left turn indicator lamp activation
F3	658	BR	Check engine lamp activation
F4	327	YL	Drain Filter lamp activation
G1	517	PK	Power mirror switch battery feed
G2	210	DG	Transfer case lock lamp activation
G3	794	RD	Low coolant lamp activation
G4	428	PK	Low tire air lamp activation
G5	714	DB	Check throttle lamp activation
H6	14	LB	Headlamp switch feed
H7	65	YL	Ignition feed to intermittent wiper switch
H8	61	RD	High speed windshield wiper signal
H9	17	PP	+ from dimmer module
J6	63	DG	Low speed windshield wiper signal
J7	27	OR	Intermittent wiper signal
J8	948	DG/YL	Left hand power mirror up/down signal
J9	947	DB/YL	Left hand power mirror left/right signal
K6	942	OR/BK	Left hand power mirror common +/-
K7	19	YL	Power supply to dimmer module
K8	944	OR	Right hand power mirror common +/-
K9	644	YL	Tachometer signal
L6	476	GY	Clock battery feed
L7	31	TN	Oil pressure signal to gauge
L8	952	DB	Right hand power mirror left/right signal
M6	789	BR	Fuel selector valve control
M7	786	RD	Fuel selector valve control

12-166 Electrical System



PIN	CKT	COLOR	DESCRIPTION
M8	787	GY	Fuel selector switch feed from fuel pump relay
M9	953	DG	Right hand power mirror up/down signal
N6	59	BK	Ground
N7	30	GY	Ignition feed to gauges
N8	941	TN	Windshield wiper washer pump activation
N9	945	BR	Intermittent wiper relay activation
P6	55	OR	Rear cargo lamp activation
P7	29	PK	Fuel gauge signal
P8	39	DG	Engine temperature gauge signal
P9	353	YL	Speedometer signal
P10	59	BK	Ground



12 WAY AMG ENGINE LOCATION: LEFT INTAKE MANIFOLD

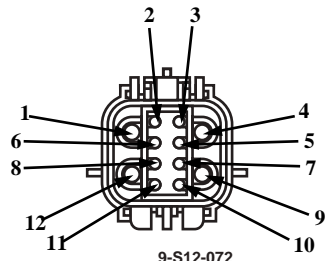

C4 MALE

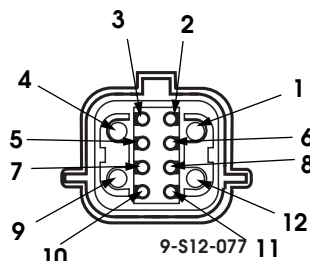

C4 FEMALE

PIN	CKT	COLOR	DESCRIPTION
1	34	LB	Starter solenoid activation
2	198	TN	A/C request from control head
3	291	PK	Ignition feed to alternator and low coolant sensor
4			
5	439	YL	A/C request to PCM
6			
7			
8	348	BR	A/C compressor clutch activate
9			
10			
11	794	RD	Low coolant lamp activation
12			



40 WAY GM ENGINE LOCATION: LEFT INTAKE MANIFOLD

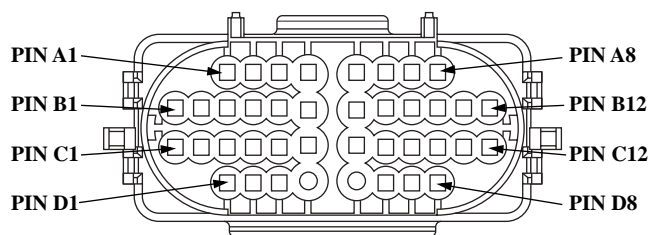

C5 MALE

9-S12-019

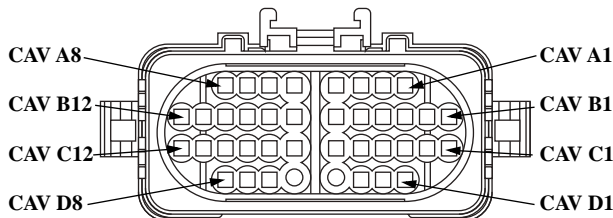

C5 FEMALE

9-S12-020

PIN	CKT	COLOR	DESCRIPTION
A1	39	DG	Engine temperature signal to gauge
A2	708	TN	Injection timing stepper motor LO
A3	709	RD	Injection timing stepper motor HI
A4	239	PK	Engine ignition feed
A5	291	PK	Engine ignition feed
A6	710	OR	Injection timing stepper motor LO
A7	711	YL	Injection timing stepper motor HI
A8	713	RD	Closure signal to solenoid driver
B1	712	LG	Fuel inject signal to solenoid driver
B2	491	BK	Closure ground to solenoid driver
B3	701	DB	Engine shutoff solenoid enable
B4	466	YL	Glow plug controller enable
B5	651	PP	Crankshaft position sensor ground
B6	57	BK	Ground
B7			
B8	442	BR	CAM signal
B9	349	YL	Crankshaft position signal
B10	394	LG	Boost Pressure Signal
B11	359	BK	Sensor ground
B12	350	GY	Sensor 5 volt reference
C1	703	OR	High resolution signal
C2	225	YL	Fuel temperature signal
C3	375	GY	Optical Sensor 5 volt reference



PIN	CKT	COLOR	DESCRIPTION
C4	354	YL	Engine coolant temperature signal
C5	357	TN	Intake air temperature signal
C6			
C7			
C8			
C9			
C10	31	TN	Oil pressure signal to gauge
C11	506	LB	Glow plug feedback signal
C12	156	PK	Optical sensor ground
D1			
D2			
D3	154	TN	Wastegate solenoid control
D4			
D5			
D6			
D7			
D8			



56 WAY CONSOLE LOCATION: CENTER CONSOLE

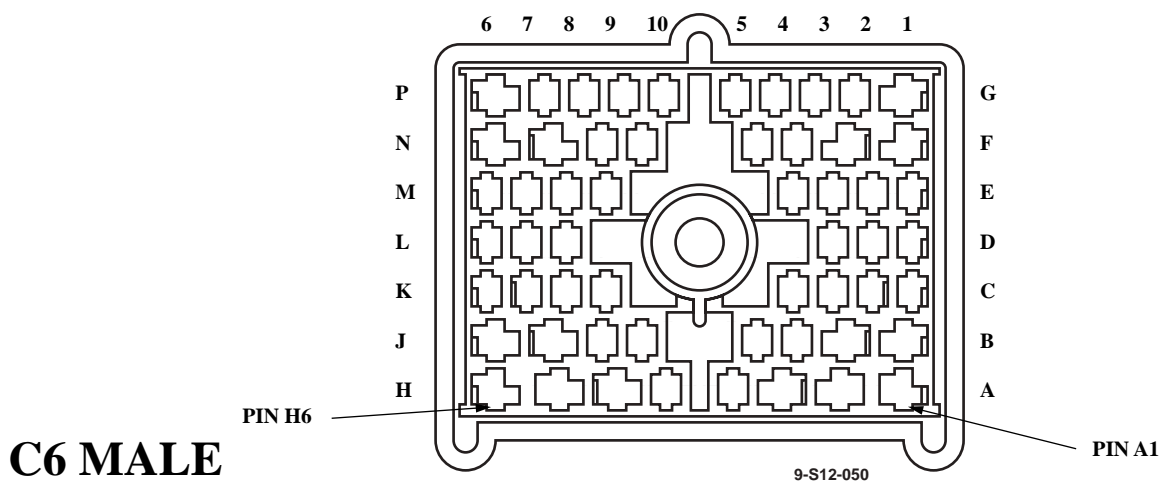

C6 MALE

PIN H6

PIN A1

9-S12-050

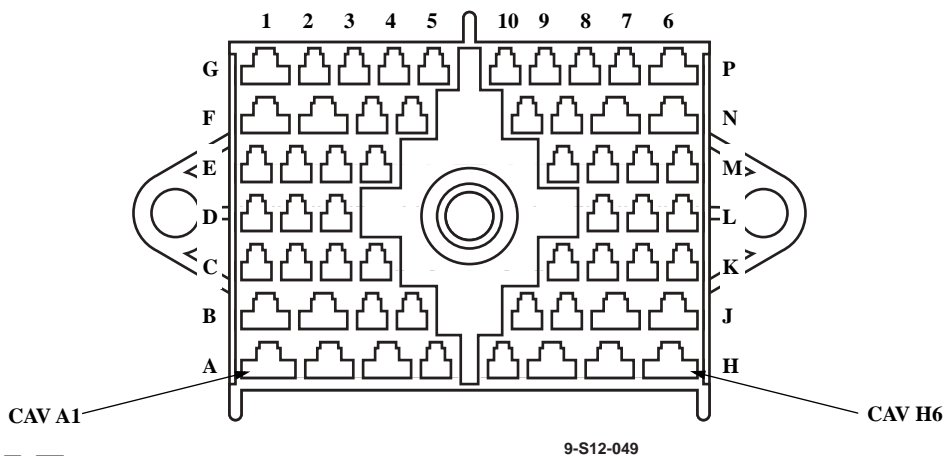

C6 FEMALE

CAV A1

CAV H6

9-S12-049

PIN	CKT	COLOR	DESCRIPTION
A1	171	RD	Feed to RF, RR, LR power window switches
A2			
A3	689	PK	Rear window defrost activation
A4			
B1	751	OR	Medium 1 HVAC blower speed
B2			
B3	40	DB	Cigarette lighters battery feed
B4	476	GY	Battery feed to radio
C1	137	RD	Ignition feed to radio
C2			



PIN	CKT	COLOR	DESCRIPTION
C3	346	PK	Ignition feed to rear HVAC blower switch
C4			
D1	45	WH	Battery feed to auxiliary power outlet
D2			
D3			
E1	319	TN	To right rear power window master switch
E2	320	LG	To right rear power window master switch
E3	404	YL	Rear HVAC blower low fan speed activation
E4	405	OR	Rear HVAC blower high fan speed activation
F1			
F2			
F3	17	PP	Feed from dimmer module
F4			
G1	399	DG	Ignition feed to HVAC control head
G2			
G3	14	LB	Park lamp input to radio
G4	815	PK	
G5			
H6	58	BK	Ground
H7			
H8			
H9			
J6	59	BK	Ground
J7			
J8	347	YL	A/C request
J9	402	LB	Temperature door motor control line
K6			
K7	752	GY	Med 2 HVAC blower speed
K8	316	TN	To left rear power window master switch
K9	317	LG	To left rear power window master switch
L6	757	LB	High HVAC blower speed
L7			
L8	755	DB	Low HVAC blower speed

12-172 Electrical System



PIN	CKT	COLOR	DESCRIPTION
M6			
M7	83	TN	Ignition feed to heated windshield switch/timer
M8	580	BR	Heated windshield relay activation
M9			
N6			
N7	688	RD	Battery feed for rear defrost
N8			
N9	829	LG	Battery feed to radio
P6	170	PP	Battery feed to power window lockout switch
P7			
P8	313	DB	To right front power window master switch
P9	314	WH	To right front power window master switch
P10			



35 WAY ABS ECU LOCATION: WSW RESERVOIR RECESS

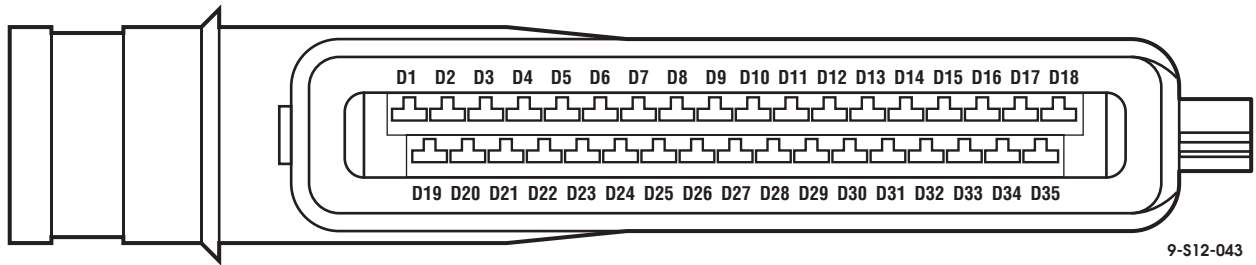

C7 FEMALE ONLY

PIN	CKT	COLOR	DESCRIPTION
1	990	PK	ABS valve relay input
2			
3	961	PP	TT4 lamp activation
4	977	WH	Right rear inlet valve activation
5	976	RD	Right rear outlet valve activation
6	973	OR	Right front inlet valve activation
7	972	YL	Right front outlet valve activation
8	991	LB	ABS valve relay activation
9	601	PK	Ignition feed
10			
11	605	PP	Positive pump relay activation
12	610	RD	Negative pump relay activation
13	606	OR	Diagnostic line
14	607	TN	Diagnostic line
15	997	BK	Left front wheel speed sensor low
16	995	BK	Right rear wheel speed sensor low
17	999	BK	Right front wheel speed sensor low
18	993	BK	Left rear wheel speed sensor low
19	990	PK	ABS valve relay redundant input
20			
21	975	LB	Left rear inlet valve activation
22	974	DB	Left rear outlet valve activation
23	971	PP	Left front inlet valve activation

12-174 Electrical System



PIN	CKT	COLOR	DESCRIPTION
24	970	TN	Left front outlet valve activation
25	677	GY	Shuttle valve switch signal
26	603	DG	ABS warning lamp activation
27	570	BK	Ground
28			
29			
30	609	YL	Pump motor monitor
31	978	BK	Reference ground
32	996	BR	Left front wheel speed sensor high
33	994	BR	Right rear wheel speed sensor high
34	998	BR	Right front wheel speed sensor high
35	992	BR	Left rear wheel speed sensor high



6 WAY ROOF HARNESS LOCATION: CENTER WINDSHIELD PILLAR TRIM

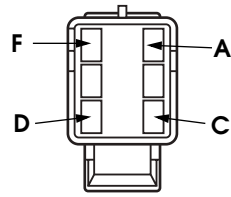

C8 MALE

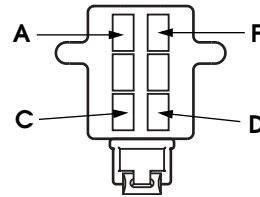

C8 FEMALE

9-S12-078

PIN	CKT	COLOR	DESCRIPTION
A	53	DB	Dome lamps feed
B	55	OR	Cargo lamp feed
C	54	DG	Map light feed
D	59	BK	Ground
E			
F			



10 WAY STATUS CENTER-RH LOCATION: INSTRUMENT PANEL

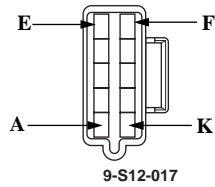

C9 MALE

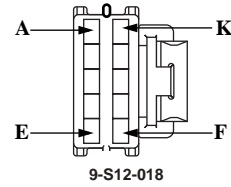

C9 FEMALE

PIN	CKT	COLOR	DESCRIPTION
A	338	DB	Wait lamp
B	2	LG	Right turn lamp
C	961	PP	TT4 (atc) lamp
D	42	BR	Brake lamp
E	210	DG	Transfer case lock lamp
F	428	PK	Low tire air lamp
G	794	RD	Low coolant lamp
H	793	YL	Washer fluid low lamp
J	30	GY	Ignition feed
K	59	BK	Ground



10 WAY STATUS CENTER-LH LOCATION: INSTRUMENT PANEL

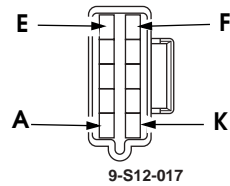

C10 MALE

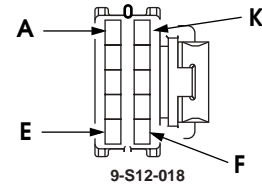

C10 FEMALE

PIN	CKT	COLOR	DESCRIPTION
A	12	OR	Headlamp high beam lamp
B	3	LB	Left turn lamp
C	658	BR	Check engine lamp
D	327	YL	Drain filter lamp
E	603	RD	ABS lamp
F	450	PK	Seat belt lamp
G	46	WH	CTIS pump lamp
H	714	DB	Check throttle lamp
J	30	GY	Ignition feed
K	59	BK	Ground



13 WAY ABS MODULATOR LOCATION: BELOW BRAKE MASTER CYLINDER

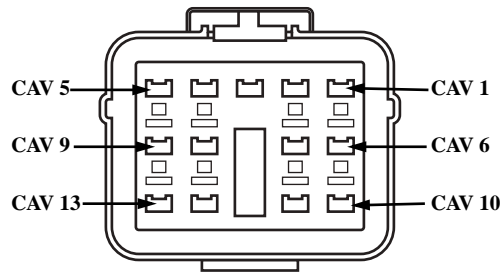

9-S12-014

C11 FEMALE ONLY

PIN	CKT	COLOR	DESCRIPTION
1	970	TN	Left front outlet valve activation
2	971	PP	Left front inlet valve activation
3			
4	977	WH	Right rear inlet valve activation
5	976	RD	Right rear outlet valve activation
6	978	BK	Reference ground
7			
8			
9	677	GY	Shuttle valve switch signal
10	972	YL	Right front outlet valve activation
11	973	OR	Right front inlet valve activation
12	975	LB	Left rear inlet valve activation
13	974	DB	Left rear outlet valve activation



10 WAY CTIS LOCATION: INSTRUMENT PANEL, RIGHT

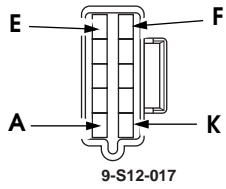

C12 MALE

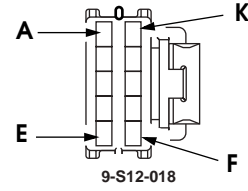

C12 FEMALE

PIN	CKT	COLOR	DESCRIPTION
A			
B	17	PP	Light power from dimmer module
C	59	BK	Ground
D	47	LG	Deflate solenoid activation
E	91	TN	Front inflate/deflate solenoid activation
F	92	GY	Rear inflate/deflate solenoid activation
G	46	LB	Compressor Relay activation
H	640	OR	Ignition feed
J	640	OR	Ignition feed
K			



8 WAY COMPASS MIRROR LOCATION: WINDSHIELD CENTER PILLAR TRIM

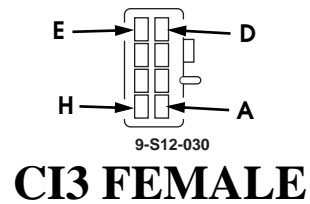
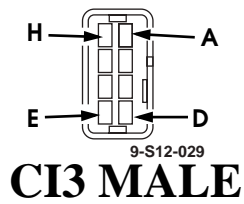

PIN	CKT	COLOR	DESCRIPTION
A	59	BK	Ground
B	400	LG	Ignition feed
C	841	RD	Battery feed
D	767	BR	Temperature signal from sensor
E			
F			
G			
H	53	DB	Dome lamp feed



6 WAY LF DOOR LOCATION: LEFT FRONT OUTSIDE KICK PANEL

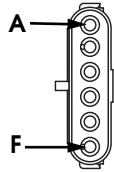

9-S12-031

C14 MALE

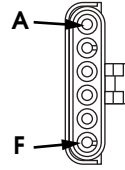

9-S12-032

C14 FEMALE

PIN	CKT	COLOR	DESCRIPTION
A	56	BK	Ground G4
B	120	LG	Oscillating power/ground circuit
C	117	PK	Unlock signal to the drivers door lock actuators
D	118	BR	Lock signal to the drivers door lock actuators
E	119	TN	Oscillating power/ground circuit
F	56	BK	Ground G4



4 WAY LF DOOR LEFT FRONT OUTSIDE KICK PANEL

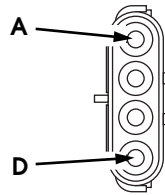

9-S12-033

C15 MALE

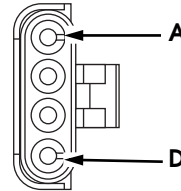

9-S12-034

C15 FEMALE

PIN	CKT	COLOR	DESCRIPTION
A	517	OR	Fused battery input to the drivers door lock switch
B	56	BK	Ground G4
C	56	BK	Ground G4
D	171	RD	Fused ignition feed to the power window circuit



6 WAY RF DOOR RIGHT FRONT OUTSIDE KICK PANEL

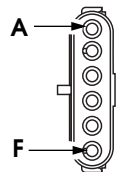

9-S12-031

C16 MALE

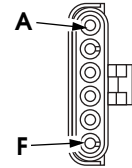

9-S12-032

C16 FEMALE

PIN	CKT	COLOR	DESCRIPTION
A	119	TN	Oscillating power/ground circuit
B	121	YL	Unlock signal to the module from the switch
C	117	PK	Unlock signal to the passenger front door lock actuator
D	118	BR	Lock signal to the passenger front door lock actuator
E	122	PP	Lock signal to the module from the switch
F	120	LG	Oscillating power/ground circuit



4 WAY RF DOOR RIGHT FRONT OUTSIDE KICK PANEL

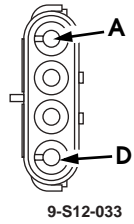

C17 MALE

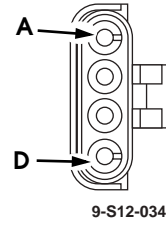

C17 FEMALE

PIN	CKT	COLOR	DESCRIPTION
A	517	OR	Fused battery input to the passenger door lock switch
B	313	DB	Up/down signal to the power window motor
C	314	WH	Down/up signal to the power window motor
D	170	PP	Fused ignition input to the power window switch



8 WAY RR DOOR RIGHT FRONT OUTSIDE KICK PANEL

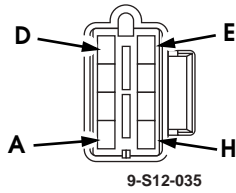

C18 MALE

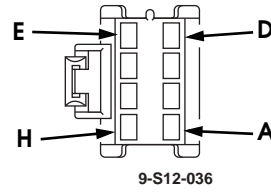

C18 FEMALE

PIN	CKT	COLOR	DESCRIPTION
A	54	DG	Map light activation
B	319	TN	Up/down signal to the power window motor
C	320	LG	Down/up signal to the power window motor
D	117	PK	Unlock signal to the power lock actuator
E	118	BR	Lock signal to the power lock actuator
F	53	DB	Dome lamps activation
G	170	PP	Fused ignition input to the power window switch
H	59	BK	Ground G4



8 WAY LR DOOR LEFT FRONT OUTSIDE KICK PANEL

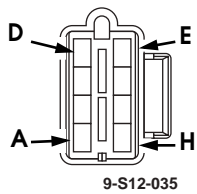

C19 MALE

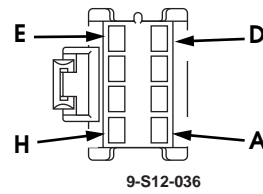

C19 FEMALE

PIN	CKT	COLOR	DESCRIPTION
A	54	DG	Map lights activation
B	316	TN	Up/down signal to the power window motor
C	317	LG	Down/up signal to the power window motor
D	117	PK	Lock signal to the drivers side rear door lock actuator
E	118	BR	Unlock signal to the drivers side rear door lock actuator
F	53	DB	Dome lamps activation
G	170	PP	Fused ignition input to the power window switch
H	59	BK	Ground G4



6 WAY CARGO DOOR-MODEL 84 RIGHT LOWER B PILLAR

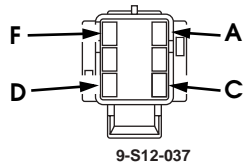

C20 MALE

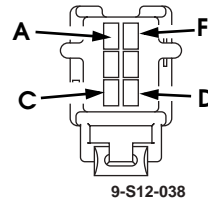

C20 FEMALE

PIN	CKT	COLOR	DESCRIPTION
A	517	OR	Fused battery input to the cargo lock delay module (HMCS only)
B	59	BK	Ground G4
C	66	RD	Fused battery voltage to the rear wiper motor (HMSB only)
D			Empty
E	64	LG	Rear wiper motor intermittent 12 volt supply (HMSB only)
F	62	LB	Rear wiper motor intermittent (HMSB only)



6 WAY RR DOOR JUMPER LOCATION: RIGHT LOWER B PILLAR

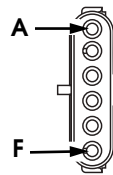

9-S12-031

C21 MALE

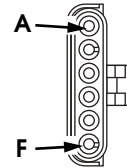

9-S12-032

C21 FEMALE

PIN	CKT	COLOR	DESCRIPTION
A	117	BR	Unlock signal to the passenger side rear door lock actuator
B	118	PK	Lock signal to the passenger side rear door lock actuator
C	319	TN	Up/down signal to the power window motor
D	320	LG	Down/up signal to the power window motor
E	170	PP	Fused ignition input to the power window switch
F			



6 WAY LR DOOR JUMPER LOCATION: LEFT LOWER B PILLAR

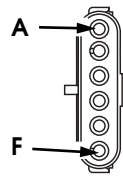

9-S12-031

C22 MALE

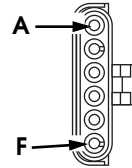

9-S12-032

C22 FEMALE

PIN	CKT	COLOR	DESCRIPTION
A	118	BR	Lock signal to the drivers side rear door lock actuator
B	117	PK	Unlock signal to the drivers side rear door lock actuator
C	316	TN	Up/down signal to the power window motor
D	317	LG	Down/up signal to the power window motor
E	170	PP	Fused ignition input to the power window switch
F			



10 WAY POWER MIRROR SWITCH LOCATION: INSTRUMENT PANEL, LEFT

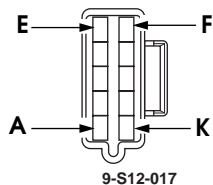

C23 MALE

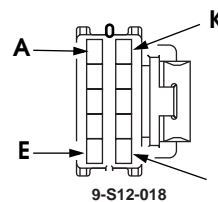

C23 FEMALE

PIN	CKT	COLOR	DESCRIPTION
A	59	BK	Ground G4
B	517	PK	Fused battery input to the power mirror switch
C	948	DG/YL	Left power mirror vertical control
D	952	DB	Right power mirror vertical control
E	947	DG/YL	Left power mirror horizontal control
F	953	DG	Right hand power mirror horizontal control
G	942	OR/BK	Left power mirror common
H	944	OR	Right power mirror common
J	17	PP	Power mirror switch illumination
K			



4 WAY LH POWER MIRROR LOCATION: LEFT DOOR

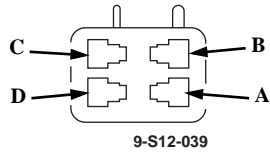

C24 MALE

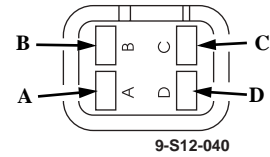

C24 FEMALE

PIN	CKT	COLOR	DESCRIPTION
A	942	OR/BK	Left power mirror common
B	947	DG/YL	Left power mirror horizontal control
C	948	DG/YL	Left power mirror vertical control.
D			



4 WAY RH POWER MIRROR LOCATION: RIGHT DOOR

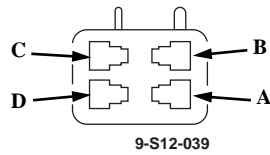

C25 MALE

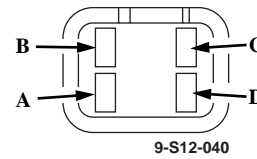

C25 FEMALE

PIN	CKT	COLOR	DESCRIPTION
A	944	OR	Right power mirror common
B	952	DB	Right power mirror horizontal control
C	953	DG	Right power mirror vertical control
D			



6 WAY FUEL TANK JUMPER LOCATION: C BEAM ABOVE PROP SHAFT

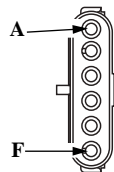

9-S12-031

C26 MALE

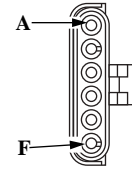

9-S12-032

C26 FEMALE

PIN	CKT	COLOR	DESCRIPTION
A	59	BK	Ground
B	29	PK	Fuel level signal to fuel gauge
C	675	YL	Fuel level signal from auxiliary tank
D	786	RD	Fuel selector valve control +/-
E	789	BR	Fuel selector valve control -/+
F			



32 WAY PCM-BROWN LOCATION: CENTER CONSOLE, PCM

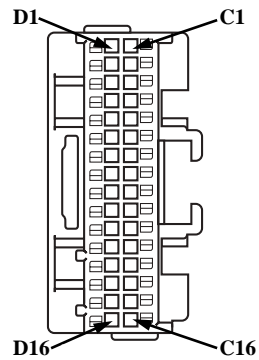

9-S12-042

C27 MALE

PIN	CKT	COLOR	DESCRIPTION
C1	651	PP	Crankshaft position sensor ground –
C2	439	YL	A/C request+
C3			
C4	357	TN	Intake air temp sensor signal
C5	721	LB	APP sensor (2) signal
C6	466	YL	Glow plug enable +
C7	264	RD	Pressure Control Solenoid (Hi)
C8	225	YL	Fuel temperature signal
C9	923	BR	Transmission fluid temp signal
C10			
C11	354	YL	Engine coolant temp signal
C12			
C13	713	RD	Closure signal
C14	394	LG	Boost pressure sensor signal
C15	265	LB	Pressure Control Solenoid (Low)
C16			
D1	495	DB	Transmission input speed sensor (Low)
D2	784	DB	4wd low switch signal
D3	723	YL	APP sensor (3) 5 volt ref.
D4	724	DG	APP (3) signal
D5	787	GY	Lift pump feedback signal



PIN	CKT	COLOR	DESCRIPTION
D6	725	GY	APP (3) ground
D7	506	LB	Glow plug feedback signal
D8	238	DG	Lift pump relay enable +
D9	156	PK	Optical sensor ground -
D10	153	LG	Cruise control resume/accelerate
D11	496	GY	Transmission input speed signal (hi)
D12	717	WH	APP (1) 5 volt ref.
D13	350	GY	Boost sensor/crankshaft position sensor 5 volt ref.
D14	375	GY	Optical sensor 5 volt reference
D15			
D16			



32 WAY PCM-BLUE LOCATION: CENTER CONSOLE, PCM

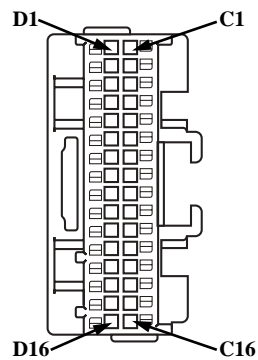

9-S12-042

C28 MALE

PIN	CKT	COLOR	DESCRIPTION
C1			
C2	720	TN	APP (2) 5 volt ref.
C3	712	LG	Fuel inject signal
C4	237	LG	1-2 shift solenoid control
C5	924	TN	Torque converter clutch solenoid control
C6	315	YL	2-3 shift solenoid control
C7	338	DB	Wait to start lamp control
C8	914	PP	Class 2 communications (dlc)
C9			
C10			
C11	239	PK	Ignition / axle switch jumper
C12	239	PK	Ignition
C13	537	OR	Battery
C14	658	BR	Malfunction indicator lamp control
C15	701	DB	Engine shutoff solenoid control
C16			
D1			
D2			
D3			
D4			
D5	440	RD	Compressor clutch enable



PIN	CKT	COLOR	DESCRIPTION
D6	570	BK	Ground G2
D7	570	BK	Ground G2
D8			
D9			
D10			
D11	714	RD	Check throttle lamp control
D12			
D13	537	OR	Battery
D14	154	TN	Waste gate solenoid control
D15			
D16			



24 WAY PCM-BROWN LOCATION: CENTER CONSOLE, PCM

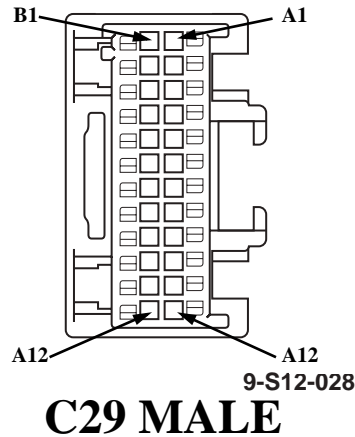

PIN	CKT	CKT	DESCRIPTION
A1	491	BK	Closure ground
A2	703	OR	High resolution sensor signal
A3	565	BR	Transmission output speed sensor/VSS
A4	442	BR	Cam sensor signal
A5	349	YL	Crankshaft position sensor signal
A6	223	DB	Vehicle speed sensor
A7	709	DB	Injection timing stepper motor (HI)
A8	708	TN	Injection timing stepper motor (LO)
A9	710	OR	Injection timing stepper motor (LO)
A10	711	YL	Injection timing stepper motor (HI)
A11	151	GY	Cruise control on/off signal
A12	722	PP	APP (2) ground
B1	719	BR	APP (1) ground
B2	718	DB	APP (1) signal
B3	351	PK	Front axle switch signal + from jumper
B4	764	PP	
B5	763	DB	
B6	762	OR	
B7			PTO (1360 rpm) user installed
B8			PTO (1070 rpm) user installed
B9	810	PP	Cruise control brake switch
B10	22	RD	TCC brake switch
B11	152	DB	Cruise control set/coast signal
B12	359	BK	Boost, engine temp, intake air temp, trans temp sensor ground



8 WAY REMOTE ENTRY, GRAY LOCATION: CENTER CONSOLE

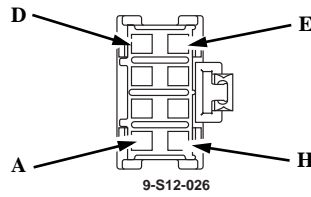

C30 FEMALE

PIN	CKT	COLOR	DESCRIPTION
A	58	BK	Module ground G4
B			
C			
D	53	LB	Dome lamp activation
E	1	DB	Horn Activation
F	840	DG	Fused ignition input to the remote entry module
G	554	GY	Fused battery input to the remote entry module
H	14	LB	Parking lamps activation



8 WAY REMOTE ENTRY, BLACK LOCATION: CENTER CONSOLE

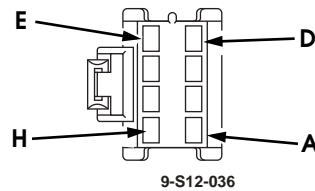

C31 FEMALE

PIN	CKT	COLOR	DESCRIPTION
A	118	BR	Lock signal to the door lock actuators
B	122	PP	Lock signal from the switch to the module
C			
D	517	OR	Fused battery input
E	117	PK	Unlock signal to the door lock actuators
F	121	YL	Unlock signal from the switch to the module
G	117	PK	Unlock signal to the drivers door lock actuator
H	121	YL	Unlock signal from the switch to the module



10 WAY TRANSMISSION-GREY LOCATION: A BEAM, LEFT NEAR LIFT PUMP

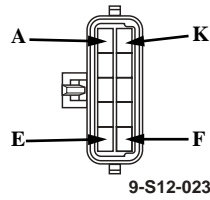

C32 MALE

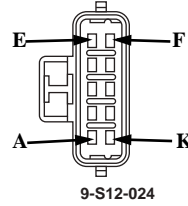

C32 FEMALE

PIN	CKT	COLOR	DESCRIPTION
A	495	DB	Transmission Input Speed Sensor low
B	496	GY	Transmission Input Speed Sensor high
C	237	LG	1-2 shift solenoid control
D	315	YL	2-3 shift solenoid control
E	924	TN	Torque Converter Clutch solenoid activation
F	264	RD	Pressure Control Solenoid high
G	265	LG	Pressure Control Solenoid low
H	763	DB	Transmission fluid pressure manual valve position switch range "B"
J	764	PP	Transmission fluid pressure manual valve position switch range "C"
K	762	OR	Transmission fluid pressure manual valve position switch range "A"



10 WAY TRANSMISSION-BLACK LOCATION: A BEAM, LEFT NEAR LIFT PUMP

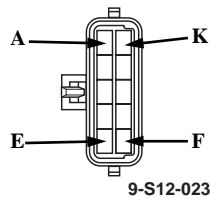

C33 MALE

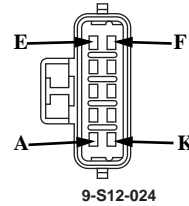

C33 FEMALE

PIN	CKT	COLOR	DESCRIPTION
A	676	PP	Vehicle Speed Sensor high
B	679	LG	Vehicle Speed Sensor low
C			
D			
E	210	DG	Transfer case lock switch light activation
F	351	PK	Transmission ignition feed
G			
H	923	BR	Transmission Fluid Temperature signal
J	359	BK	Transmission Fluid Temperature sensor ground
K	784	DB	Transfer case range switch signal



20 WAY TRANSMISSION PASS THROUGH LOCATION: TRANSMISSION, LEFT

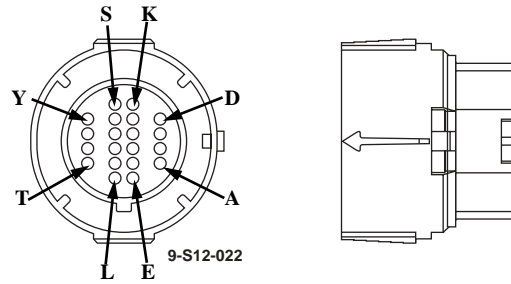

C34 FEMALE

PIN	CKT	COLOR	DESCRIPTION
A	237	LG	1-2 Shift Solenoid activation
B	315	YL	2-3 Shift Solenoid activation
C	264	RD	Pressure Control Solenoid high
D	265	LB	Pressure Control Solenoid low
E	351	PK	Transmission ignition feed
F			
G			
H			
J			
K			
L	923	BR	Transmission Fluid Temperature signal
M	359	BK	Transmission Fluid Temperature sensor ground
N	762	OR	Transmission fluid pressure manual valve position switch range "A"
P	764	PP	Transmission fluid pressure manual valve position switch range "C"
R	763	DB	Transmission fluid pressure manual valve position switch range "B"
S	924	TN	Torque Converter Clutch solenoid activation
T			
W			
X			
Y			



3 WAY LOW COOLANT SENSOR LOCATION: SURGE TANK

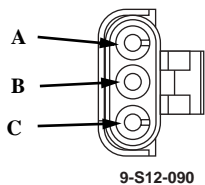

C35 FEMALE

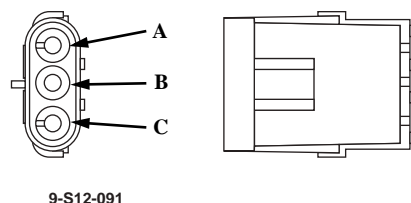

C35 MALE

PIN	CKT	COLOR	DESCRIPTION
A	291	PK	Ignition power
B	794	RD	Signal output
C	57	BK	Ground

2 WAY HVAC BLOWER LOCATION: RIGHT A-PILLAR

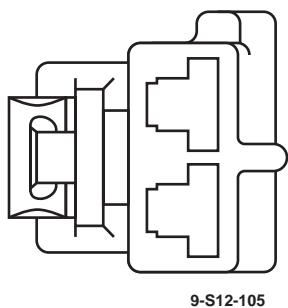

C36 FEMALE

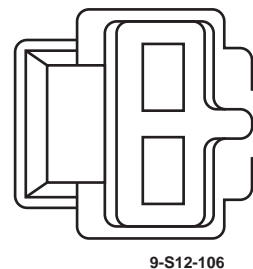

C36 MALE

PIN	CKT	COLOR	DESCRIPTION
A	364	RD	Blower relay power
B	58	BK	Blower motor ground



4 WAY HVAC BLOWER RESISTOR HARNESS LOCATION: RIGHT A-PILLAR

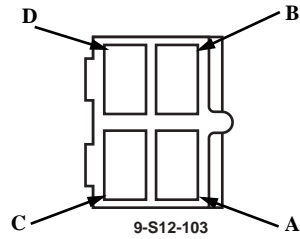

C 37 FEMALE

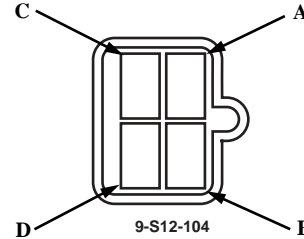

C 37 MALE

PIN	CKT	COLOR	DESCRIPTION
A	754	YL	Blower activation
B	751	OR	Medium 1 blower
C	755	DB	Low blower
D	752	GY	Medium 2 blower

3 WAY LOCATION: LEFT A-BEAM NEAR FUEL MANAGER

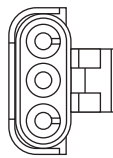

9-S12-152

C 38 FEMALE

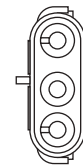

9-S12-151

C 38 MALE

PIN	CKT	COLOR	DESCRIPTION
A	206	WH	Trailer connector ground
B	58	BK	Ambient temp sensor ground
C	59	BK	Main and auxiliary fuel sending units, rear lamps ground



7 WAY TURN SIGNAL SWITCH HARNESS LOCATION: STEERING COLUMN

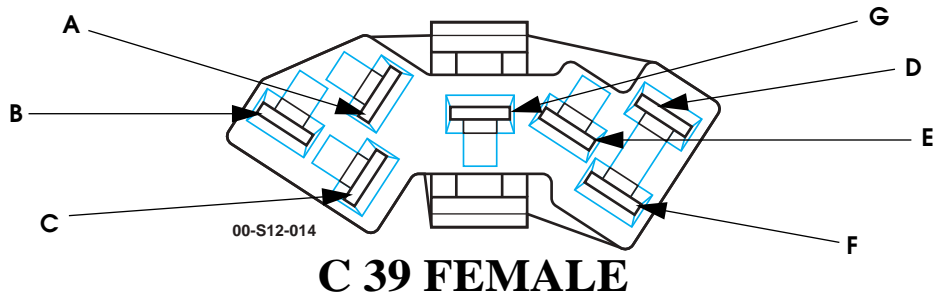

C 39 FEMALE

PIN	CKT	COLOR	DESCRIPTION
A	3	LB	Left front turn signal, status center signal.
B	9	YL	Left rear turn signal
C	1	DB	Horn circuit ground
D	13	TN	Low beam circuit
E	12	OR	High beam signal
F	15	WH	Head lamp feed
G			Empty

6 WAY TURN SIGNAL SWITCH HARNESS LOCATION: STEERING COLUMN

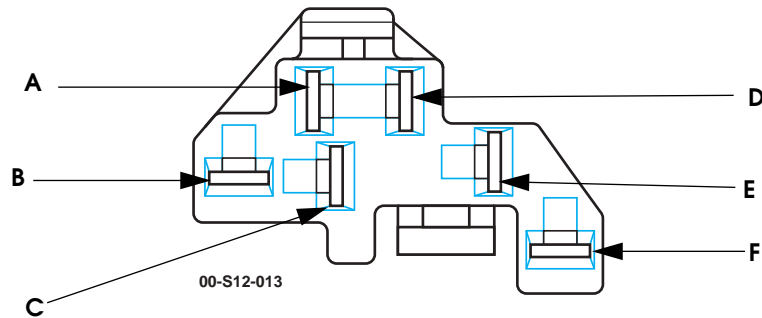

C 40 FEMALE

PIN	CKT	COLOR	DESCRIPTION
A	385	TN	Hazard signal ground
B	22	RD	Brake lamp switch signal (receives 12v with brakes applied.)
C	460	BK	Ground
D	44	LB	Indicator signal ground
E	2	LG	Right turn signal, status center signal
F	5	DG	Right rear turn signal



8 WAY LIFT GATE JUMPER HARNESS LOCATION:

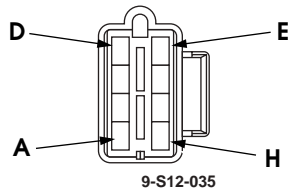

C 41 MALE

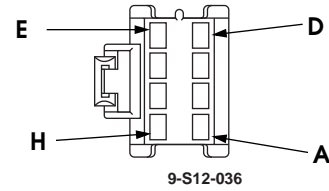

C41 FEMALE

PIN	CKT	COLOR	DESCRIPTION
A	59	BK	Ground G4
B	66	RD	Rear wiper 12 v common supply
C	64	LG	Rear wiper 12 v start supply
D	62	LB	Rear wiper 12 v run supply
E	118	BR	Unlock/lock signal to power door lock motor
F	117	PK	Lock/unlock signal to power door lock motor
G			Empty
H			Empty

4 WAY SLANT DOOR WIPER PLUG TOP OF SLANT DOOR BEHIND TRIM.

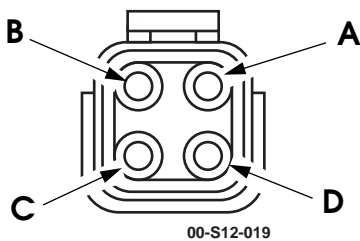

C 42 MALE

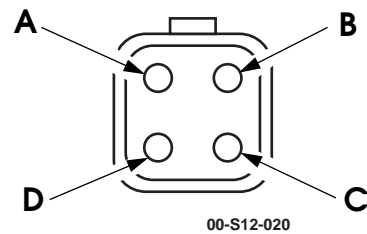

C 42 FEMALE

PIN	CKT	COLOR	DESCRIPTION
A	59	BK	Ground G4
B	66	RD	Rear wiper 12 v Common Supply
C	64	LG	Rear wiper 12 v Start Supply
D	62	LB	Rear wiper 12 v Run Supply



3 WAY FRONT WIPER HARNESS NEAR MOTOR BEHIND A-PILLAR TRIM

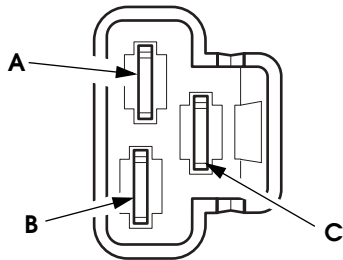

C 43 MALE

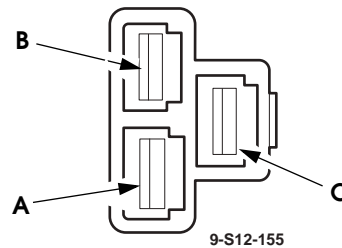

C 43 FEMALE

PIN	CKT	COLOR	DESCRIPTION
A	28	DB	Intermittent Power Supply
B	63	DG	Low Speed Power Supply
C	61	RD	High Speed Power Supply

2 WAY WIPER MOTOR CONNECTOR NEAR MOTOR BEHIND THE A-PILLAR TRIM

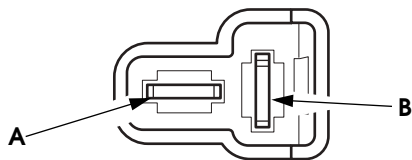

C 44 MALE

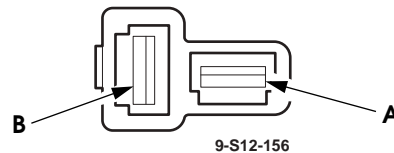

C 44 FEMALE

PIN	CKT	COLOR	DESCRIPTION
A	59	BR	Ground G4
B	65	BK	Intermittent Start Supply



2 WAY REAR WINDOW DEFROSTER HARNESS LOCATION: C-PILLAR INTERMEDIATE

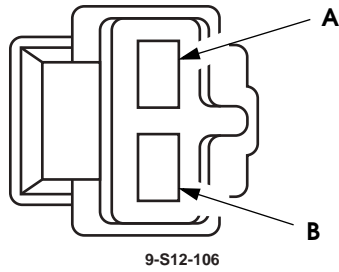

C45 MALE

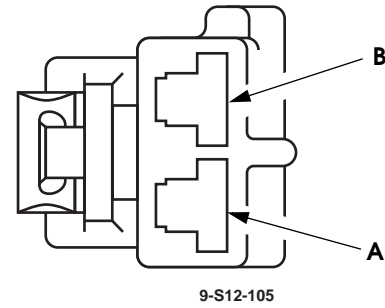

C45 FEMALE

PIN	CKT	COLOR	DESCRIPTION
A	58	BK	Ground for the rear window defroster G4
B	689	PK	Rear window defroster 12 volt supply

4 WAY REAR WINDOW DEFROSTER SWITCH CONNECTOR LOCATION: BACK OF THE HVAC

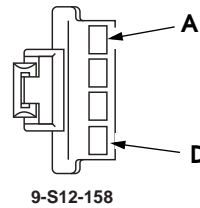

C46 FEMALE

PIN	CKT	COLOR	DESCRIPTION
A	688	RD	Fused battery voltage to the rear window defroster switch
B	399	DG	Fused ignition voltage to the rear window defroster switch
C	59	BK	Ground G4
D	689	PK	Rear window defroster 12 volt supply



10 WAY CARGO DOOR LOCK DELAY MODULE CONNECTOR LOCATION: ON MODULE

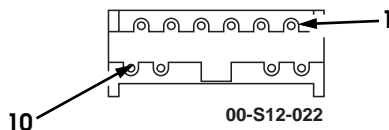

C47 FEMALE

PIN	CKT	COLOR	DESCRIPTION
1			Empty
2			Empty
3	59	BK	Ground G4
4			Empty
5	118	BR	Lock signal to the cargo door lock delay module
6	117	PK	Unlock signal to the cargo door lock delay module
7			Empty
8			Empty
9	517	OR	Fused battery input to the cargo door lock delay module
10	121	YL	Lock signal to the cargo door lock actuator

5 WAY DRIVERS DOOR LOCK SWITCH CONNECTOR LOCATION: IN THE DRIVERS DOOR

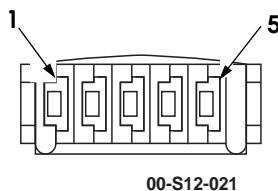

C48 FEMALE

PIN	CKT	COLOR	DESCRIPTION
1	120	LG	Oscillating power/ground circuit
2	56	BK	Ground G4
3	517	OR	Fused battery input to the drivers door lock actuator
4	56	BK	Ground G4
5	119	TN	Oscillating power/ground circuit.



5 WAY PASSENGER DOOR LOCK SWITCH CONNECTOR LOCATION: IN THE PASSENGERS DOOR

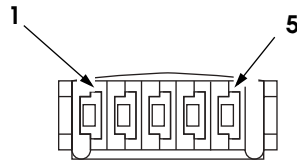

00-S12-021

C49 FEMALE

PIN	CKT	COLOR	DESCRIPTION
1	122	PP	Lock signal from the switch to the module
2	120	LG	Oscillating power/ground circuit
3	517	OR	Fused battery input to the passenger door lock switch
4	119	TN	Oscillating power/ground circuit
5	121	YL	Unlock signal from the switch to the module



16 WAY RADIO HARNESS LOCATION: BACK OF THE RADIO

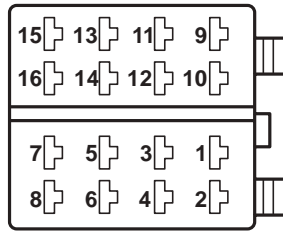

00-S12-004

C56 FEMALE

PIN	CKT	COLORS	DESCRIPTION
1			Empty
2			Empty
3	14	LB	Radio illumination
4	137	RD	Fused battery input to the radio (Ignition)
5			
6	17	PP	Dimmer Circuit
7	476	GY	Fused radio memory feed (Battery)
8	59	BK	Ground G4
9	818	PP	Right rear speaker signal (Positive)
10	819	BK	Right rear speaker signal (Negative)
11	805	GY	Right front speaker signal (Positive)
12	811	BK	Right front speaker signal (Negative)
13	804	WH	Left front speaker signal (Positive)
14	813	BK	Left front speaker signal (Negative)
15	820	DG	Left rear speaker signal (Positive)
16	821	BK	Left rear speaker signal (Negative)2



6 WAY RADIO ACCESSORY CONNECTOR LOCATION: BACK OF THE RADIO

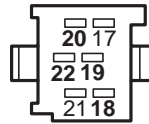

00-S12-102

C57 FEMALE

PIN	CKT	COLOR	DESCRIPTION
17			
18	830	PK	Amplifier sense
19	842	OR	Rear seat audio enable
20	839	YL	Cell phone mute
21			
22	843	GY	Rear seat audio control

8 WAY RADIO JUMPER CONNECTOR LOCATION: BACK OF THE RADIO

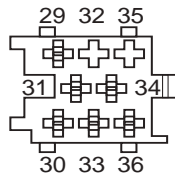

01-S12-029

C58 FEMALE

PIN	CKT	COLOR	DESCRIPTION
29	—	YL	Left audio signal
30	—	PP	CD changer to radio data buss
31	—	RD	+12v Fused battery voltage
32	—	WH	Right audio signal
33	—		
34	—	BK	Ground G4
35	—	GY	Audio common
36	—		

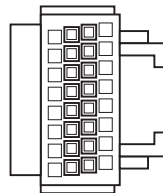

A1 B1
C59 FEMALE
 01-S12-028

PIN	CKT	COLOR	DESCRIPTION
A1	819	BK	Right rear speaker signal (Negative)
A2	818	PP	Right rear speaker signal (Positive)
A3	821	BK	Left rear speaker signal (Negative)
A4	820	DG	Left rear speaker signal (Positive)
A5	843	GY	Rear seat audio control
A6			
A7			
A8	137	RD	Fused battery input to the rear seat audio (Ignition)
B1			
B2			
B3			
B4			
B5	842	OR	Rear seat audio enable
B6	59	BK	Ground G4
B7			
B8	14	LB	Rear seat audio illumination



8 WAY BODY TO CONSOLE CONNECTOR LOCATION: BEHIND THE CENTER CONSOLE

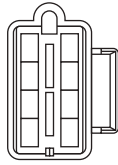

9-S12-035

C60 MALE

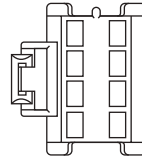

9-S12-036

C60 FEMALE

PIN	CKT	COLOR	DESCRIPTION
A	476	GY	Fused radio memory input (Battery)
B	137	RD	Fused battery input to the radio (Ignition)
C	59	BK	Ground G4
D	17	PP	Dimmer Circuit
E	14	LB	Radio Illumination
F			
G	829	LG	Fused battery input to the amplifier
H	59	BK	Ground G4



CD CHANGER CONNECTOR LOCATION: BACK OF THE CD CHANGER

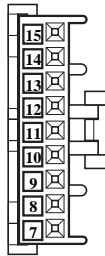

C61 FEMALE
01-S12-029

PIN	CKT	COLOR	DESCRIPTION
7	—		
8	—		
9	—	BR	Shielding for the audio circuits
10	—	WH	Right audio signal
11	—	YL	Left audio signal
12	—	GY	Audio common
13	—	BK	Ground G4
14	—	PP	CD changer to radio data buss
15	—	RD	+12v Fused battery



AMPLIFIER CONNECTOR LOCATION: ON THE AMPLIFIER

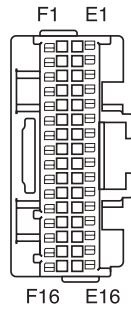

01-S12-027

C62 FEMALE

PIN	CKT	COLOR	DESCRIPTION
E1	805	GY	Right front channel positive input
E2	804	WH	Left front channel positive input
E3	813	BK	Left front channel negative input
E4	819	BK	Right rear channel negative input
E5	818	PP	Right rear channel positive input
E6	820	DG	Left rear channel positive input
E7	821	BK	Left rear channel negative input
E8	59	BK	Ground G4
E9	59	BK	Ground G4
E10	842	OR	Rear seat audio enable
E11	829	LG	+12v battery input
E12	829	LG	+12v battery input
E13	831	BK	Right console speaker negative signal
E14	832	TN	Right console speaker positive signal
E15	834	TN	Left front speaker positive signal
E16	833	BK	Left front speaker negative signal
F1	811	BK	Right front channel negative input
F2	835	BK	Right front speaker negative signal
F3	836	TN	Right front speaker positive signal
F4	824	BK	Rear subwoofer negative signal
F5	825	TN	Rear subwoofer positive signal
F6	837	BK	Left console negative signal
F7	838	TN	Left console positive signal
F8	830	PK	Amplifier sense circuit
F9			

12-218 Electrical System



PIN	CKT	COLOR	DESCRIPTION
F10	826	BK	Front subwoofer negative signal
F11	827	TN	Front subwoofer positive signal
F12			
F13	803	BK	Right rear speaker negative signal
F14	802	TN	Right rear speaker positive signal
F15	800	TN	Left rear speaker positive signal
F16	801	BK	Left rear speaker negative signal



INTERIOR MINI FUSE BLOCK 1 (LOWER)

Buss	Cavity	CKT. No.	Color & Ga.	Fuse	
II	1A	-	-	ES (5 AMP)	
	2A	-	-	-1A-	
	3A	-	-	ET (7.5 AMP)	
	4A	-	-	-2A-	
	5A	-	-	-	
	6A	-	-	-3A-	
	7A	-	-	EU (10 AMP)	
	8A	-	-	-4A-	
	9A	-	-	EW (15 AMP)	
	10A	-	-	-5A-	
	11A	-	-	-	
	12A	-	-	-6A-	
	13A	-	-	EU (10 AMP)	
	14A	-	-	-7A-	
	1B	-	-	-	
	2B	-	-	-1B-	
	3B	-	-	-	
	4B	-	-	-2B-	
	5B	-	-	-	
	6B	(BUSS II)	-	-	-3B-
	7B	30 A	16 GY	ES (5 AMP)	
	8B	(BUSS II)	-	-	-4B-
	9B	-	-	-	
	10B	(BUSS II)	-	-	-5B-
	11B	291 A	18 PK	ES (5 AMP)	
	12B	16 D (BUSS II)	12 LG	-6B-	
	13B	840 A	18 DG	ES (5 AMP)	
	14B	16 C (BUSS II)	12 LG	-7B-	
A2A	1C	83 C	16 TN	ES (5 AMP)	
	2C	(BUSS A2A)	-	-1C-	
	3C	400 A 400 B	14 LG 18 LG	EU (10 AMP)	
	4C	687 C (BUSS A2A)	14 LG	-2C-	
A2	5C	298 A	16 BR	ET (7.5 AMP)	
	6C	687 C (BUSS A2)	14 LG	-3C-	
	7C	8 A	14 PP	EU (10 AMP)	
	8C	(BUSS A2)	-	-4C-	
	9C	295 A	18 BR	EU (10 AMP)	
	10C	(BUSS A2)	-	-5C-	
	11C	346 A	14 PK	EX (20 AMP)	
	12C	(BUSS A2)	-	-6C-	
	13C	399 B	12 DG	EZ (30 AMP)	
14C	687 B (BUSS A2)	10LLG	-7C-		
B2A	1D	829 A	14 LG	EW (15 AMP)	
	2D	(BUSS B2A)	-	1D	
	3D	537 A	14 OR	EX (20 AMP)	
	4D	37 M (BUSS B2A)	14 RD	-2D-	
B2	5D	40 A	14 DB	EX (20 AMP)	
	6D	37 M (BUSS B2)	14 RD	-3D-	
	7D	10 A	14 OR	EW (15 AMP)	
	8D	(BUSS B2)	-	-4D-	
	9D	383 A	14 YL	EW (15 AMP)	
	10D	(BUSS B2)	-	-5D-	
	11D	-	-	-	
	12D	(BUSS B2)	-	-6D-	
	13D	841 A	18 RD	ES (5 AMP)	
	14D	37 b (BUSS B2)	10 RD	-7D-	



INTERIOR MINI FUSE BLOCK 2 (UPPER)

Buss	Cavity	CKT. No.	Color & Ga.	Fuse
L1	1E	-	-	ES (5 AMP)
	2E	-	-	-1E-
	3E	-	-	-
	4E	-	-	-2E-
	5E	-	-	ET (7.5 AMP)
	6E	-	-	-3E-
	7E	-	-	-
	8E	-	-	-4E-
	9E	-	-	EW (15 AMP)
	10E	-	-	-5E-
	11E	-	-	-
	12E	-	-	-6E-
	13E	-	-	EY (25 AMP)
	14E	-	-	-7E-
	1F	14 D	16 LB	ES (5 AMP)
	2F	(BUSS L1)	-	-1F-
	3F	19 A	14 YL	ES (5 AMP)
	4F	14 B (BUSS L1)	14 LB	-2F-
	5F	20 A 20 B	14 RD 18 RD	ET (7.5 AMP)
	6F	(BUSS L1)	-	-3F-
7F	21 A	14 GY	ET (7.5 AMP)	
8F	14 C (BUSS L1)	14 LB	-4F-	
9F	962 A	14 BR	EW (15 AMP)	
10F	14 A (BUSS L1)	12 LB	-5F-	
L1A	11F	80 A	16 WH	ES (5 AMP)
	12F	14 B (BUSS L1A)	14 LB	-6F-
	13F	183 A	18 TN	ES (5 AMP)
	14F	(BUSS L1A)	-	-7F-
A1A	1G	640 D	16 OR	ES (5 AMP)
	2G	(BUSS A1A)	-	-1G-
	3G	296 A	16 DG	ES (5 AMP)
	4G	297 B (BUSS A1A)	14 OR	-2G-
A1	5G	71 A	12 WH	EZ (30 AMP)
	6G	297 B (BUSS A1)	14 OR	-3G-
	7G	137 A	16 RD	ET (7.5 AMP)
	8G	(BUSS A1)	-	-4G-
	9G	-	-	-
	10G	(BUSS A1)	-	-5G-
	11G	64 C	14 LG	EY (25 AMP)
	12G	(BUSS A1)	-	-6G-
13G	65 B	14 YL	EY (25 AMP)	
14G	297 A (BUSS A1)	12 OR	-7G-	
B1A	1H	554 A 554 B	18 GY 18 GY	ES (5 AMP)
	2H	(BUSS B1A)	-	1H
	3H	476 B 476 A	20 GY 16 GY	EU (10 AMP)
	4H	37 D (BUSS B1A)	14 RD	-2H-



INTERIOR MINI FUSE BLOCK 2 (UPPER) (Cont'd)

Buss	Cavity	CKT. No.	Color & Ga.	Fuse
B1	5H	517 A	12 OR	EX (20 AMP)
	6H	37 D (BUSS B1)	14 RD	-3H-
	7H	70 A	12 YL	EZ (30 AMP)
	8H	(BUSS B1)	-	-4H-
	9H	54 B	14 DG	EW (15 AMP)
	10H	(BUSS B1)	-	-5H-
	11H	45 A	14 WH	EX (20 AMP)
	12H	(BUSS B1)	-	-6H-
	13H	51 A	12 YL	-
	14H	37 A (BUSS B1)	10 RD	-7H-



INTERIOR FUSE BOX RELAYS

IGNITION RELAY RY-1				
MINI- FUSE / RELAY BLOCK ③	Cavity	CKT. No	Color & Ga.	Relay
	B5	687 A	12 GY	FB
	C7	59 H	18 BK	
		59 A	18 BK	
	B7	37 C	10 RD	
	C6	–	–	
C5	687 B	10 LG		
WIPER RELAY RY-2				
MINI- FUSE / RELAY BLOCK ③	Cavity	CKT. No	Color & Ga.	Relay
	B1	945 A	16 BR	FB
	C3	59 A	18 BK	
		59 B	18 BK	
	B3	27 A	14 OR	
	C2	28 A	14 DB	
C1	65 C	14 YL		
REAR WIPER RELAY RY-3				
MINI- FUSE / RELAY BLOCK ④	Cavity	CKT. No	Color & Ga.	Relay
	F1	67 A	20 BR	FB
	G3	59 B	18 BK	
		59 C	18 BK	
	F3	66A	14 RD	
	G2	62 A	14 LB	
G1	64 B	14 LG		
POWER WINDOW RELAY RY-4				
MINI- FUSE / RELAY BLOCK ④	Cavity	CKT. No	Color & Ga.	Relay
	F5	296 A	16 DG	FB
	G7	59 C	18 BK	
		59 D	18 BK	
	F7	175 A	12 LB	
	G6	–	–	
G5	171 A	12 RD		
MIRROR CUT-OUT RELAY RY-5				
MICRO RELAY BLOCK ⑤	Cavity	CKT. No	Color & Ga.	Relay
	J7	580 E	18 BR	FA
	K9	59 D	18 BK	
		59 E	18 BK	
	J9	–	–	
	J8	400 C	18 LG	
400 B		18 LG		
K7	407 A	18 PK		
TURN / HAZARD FLASHER RELAY RY-6				
⑥	Cavity	CKT. No	Color & Ga.	Relay
	1	44 A	14 LB	EM
	2	8 A	14 PP	
	3	383 A	14 YL	
	4	385 A	14 TN	
	5	59 G	14 BK	
CTI BUZZER RELAY RY-7				
⑦	Cavity	CKT. No	Color & Ga.	Relay
	1	59 E	18 BK	NOT INSTALLED
		59 F	18 BK	
	2	DIODE	20 PK	
		428 A	–	
	3	–	–	
4	–	–		
5	DIODE	16 PK		
428 B	–	–		

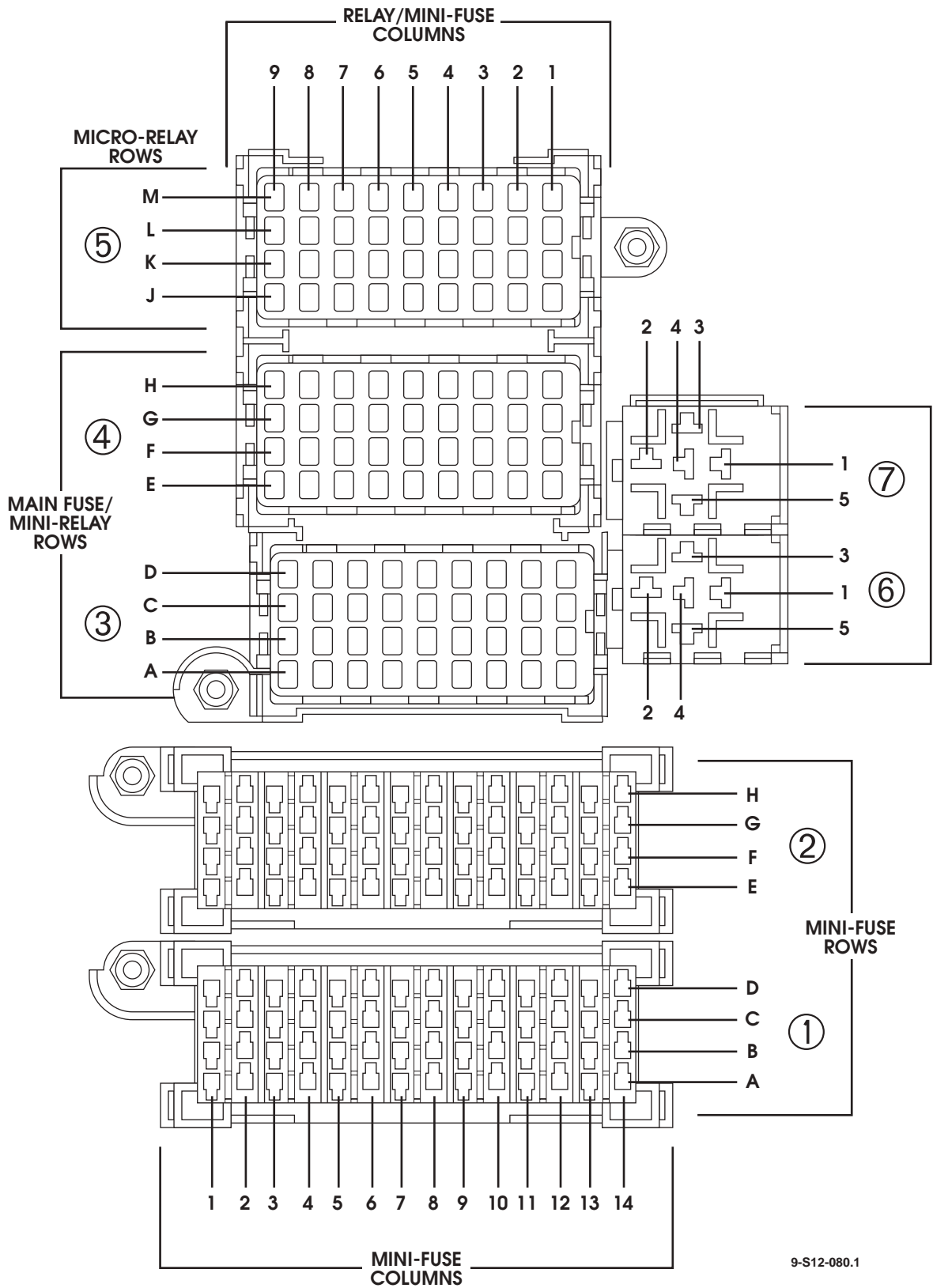

Figure 2-150: Interior Fuse Box Fuse/Relay Cavity I.D.



EXTERIOR MINI FUSE BLOCK

Buss	Cavity	CKT. No.	Color & Ga.	Fuse
I1	1A	-	-	(FOR DIODE USE ONLY)
	2A	-	-	-1A-
	3A	351C	18 PK	H (10 AMP)
	4A	16A(BUSS I1)	10 LG	-2A-
	5A	239C	14 PK	J (20 AMP)
	6A	(BUSS I1)	-	-3A-
	1B	-	-	(FOR DIODE USE ONLY)
	2B	-	-	-1B-
I2	3B	601A	-	G (5 AMP)
	4B	16A(BUSS I2)	10 LG	-2B-
	5B	291C	14 PK	J (20 AMP)
	6B	168(BUSS I2)	10 LG	-3B
B1	1C	575A	12 OR	I (25AMP)
	2C	(BUSS B1)	-	-1C-
	3C	738A	10 RD	K (30 AMP)
	4C	37M(BUSS B1)	10 RD	-2C-
	5C	-	-	-
	6C	(BUSS B1)	-	-3C-
B2	1D	7A 7B	14 RD 18 RD	J (20 AMP)
	2D	(BUSS B2)	-	-1D-
	3D	737A	10 OR	K (30 AMP)
	4D	37N (BUSS B2)	10 OR	-2D-
	5D	-	-	-3D-
	6D	(BUSS B2)	-	-
	1E	7B	18 RD	D (HORN RELAY)
	2E	-	-	-1E-
	3E	7A	14 RD	-
	4E	400B	18 LG	-2E-
	5E	-	-	D (A/C CLUTCH RELAY)
	6E	400B 400A	18 LG 14LG	-3E-
	1F	6A	16 WH	-
	2F	-	-	-1F-
	3F	1A	18 DB	-
	4F	348A	16 BR	-2F-
	5F	-	-	-
	6F	440A	18 DB	-3F-



EXTERIOR MAXI FUSE BLOCK

Buss	Cavity	CKT. No.	Color & Ga	Fuse or Circuit Breaker
BUSS BAR	8W	37F	10 YL	(40 AMP FUSE)
	8X	BUSS	-	-1M-
	7W	38A	14 RD	(20 AMP CD)
	7X	BUSS	-	-2M-
	6W	195A	12 YL	(30 AMP CB)
	6X	BUSS	-	-3M-
	5W	688A	12 RD	(30 AMP CB)
	5X	BUSS	-	-4M-
	4W	175A	12 LB	(30 AMP CB)
	4X	BUSS	-	-5M-
	3W	436A	12 YL	(30 AMP FUSE)
	3X	BUSS	-	-6M-
	2W	604A	10 PK	(40 AMP FUSE)
	2X	BUSS	-	-7M-
	1W	37D	12 YL	(40 AMP FUSE)
37E		12 YL		
1X	BUSS	-	-8M-	
M8 BUSS	2Y	-	-	(30 AMP FUSE)
	2Z	M8 BUSS	-	SPARE STUD A -(9M)-
	1Y	-	-	(30 AMP FUSE)
	1Z	M8 BUSS	-	SPARE STUD B -(10M)-
	Q1	37M	10RD	(TO MINI FUSE BUSS B1)
	Q2	37N	10RD	(TO MINI FUSE BUSS B2)



EXTERIOR FUSE BOX RELAYS

RELAY R-6				
	Cavity	CKT. No	Color & Ga.	Relay
ABS VALVE RELAY	1	991A	18 LB	E
	2	59G	18 BK	
	3	575A	12 OR	
	4	–	–	
	5	990A	12 PK	
RELAY R-5				
	Cavity	CKT. No	Color & Ga.	Relay
ABS WARNING RELAY	1	990B	16 PK	D
	2	59B	16 BK	
		59C	16 BK	
	3	603A	18 RD	
	4	59C	16 BK	
		59D	16 BK	
5	–	–		
RELAY R-4				
	Cavity	CKT. No	Color & Ga.	Relay
HEATED WINDSHIELD RELAY	1	580A	18 BR	E
		580B	18 BR	
	2	59F	18 BK	
		59G	18 BK	
	3	738A	10 RD	
	4	–	–	
5	740A	10 YL		
RELAY R-3				
	Cavity	CKT. No	Color & Ga.	Relay
FUEL LIFT PUMP RELAY	1	238A	18 DG	D
	2	59A	16 BK	
		59B	16 BK	
	3	787B	16 GY	
	4			
	5	537A	16 OR	
RELAY R-2				
	Cavity	CKT. No	Color & Ga.	Relay
HEATED WINDSHIELD RELAY	1	580A	18 BR	E
	2	59F	18 BK	
		59E	16 BK	
	3	737 A	10 OR	
	4	–	–	
5	739A	10 PP		
RELAY R-1				
	Cavity	CKT. No	Color & Ga.	Relay
CTIS COMPRESSOR RELAY	1	46A	16 WH	E
	2	59A	16 BK	
	3	436 A	12 YL	
	4	–	–	
	5	437A	12 DG	

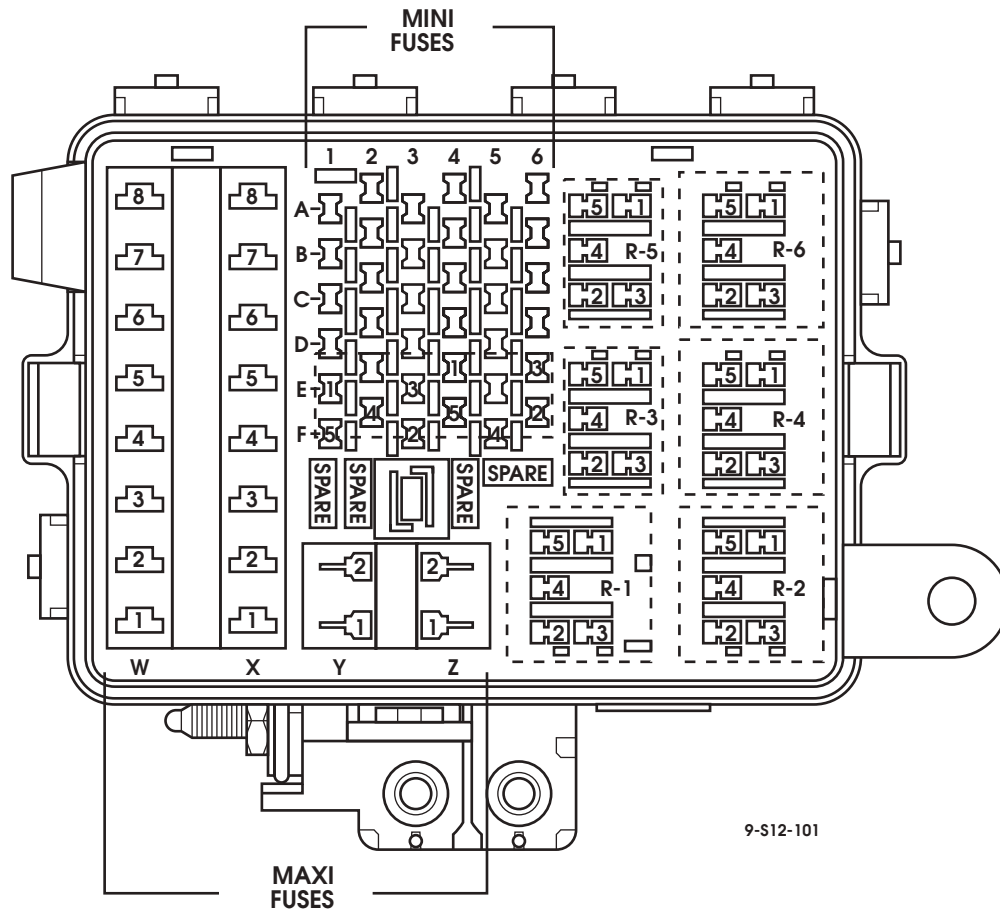

Figure 2-151: Exterior Fuse Box Relay Cavity I.D.



ESSENTIAL TOOLS



TK-O-A

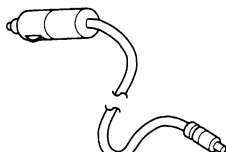

TA-1151

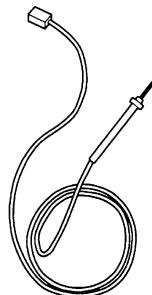

TA-1152

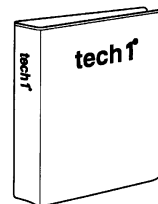

TA-1190-A

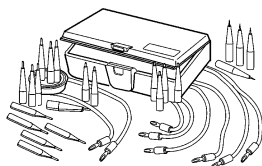

J-35616A

7-S12-115

Tool No.	Description
TK-O-A	Tech 1 Diagnostic Scanner Kit
TA-1151	Tech 1 Adapter, part of TK-O-A
TA-1152	Tech 1 Test Lead, part of TK-O-A
TA-1190-A	Operators Manual, Tech 1, part of TK-O-A
J-35616-A	Connector Test Adapter Set
J-42645-C	HUMMER Mass Storage Cartridge Kit (not shown)
J-43160	Adapter Cable, Tech 1A (14/16 pin) (not shown)
J-44237	ABS, DLC Jumper
J-24538-B	Tester, Gauge
J-35592	Pinout Box, ABS
J-42645-99SW	Software Package
7000041	Vehicle Interface Module (VIM) (not shown)

Procure from Kent-Moore.