



HOLDEN

DROVER

OWNER MANUAL
QB SERIES

This owner's manual applies to the following models of the Drover GB series:

8QS26 (CANVAS TOP (Half metal door))



8QS16 (METAL TOP)



8QT16 (METAL TOP, 4-Seat High Roof Deluxe)



8QS80 (PICK-UP)



8QS60 (CHASSIS CAB)



This vehicle may not comply with standards or regulations of other countries. Before attempting to register this vehicle in any other country, check all applicable regulations and make any necessary modifications.

GMH NUMBER: V500604

FOREWORD

Your Drover multipurpose vehicle is designed and built to be capable of performing both on pavement and off road. You should therefore remember that your Drover is distinctly different from ordinary passenger cars in handling as well as in structure. As with other vehicles of this type, failure to operate this vehicle correctly may result in loss of control or an accident. Be sure to read "on-pavement" and "off-road" driving guidelines which follow. It is very important to familiarize yourself with the proper operation of this vehicle before you start driving.

You will find in this Owner's Manual the basic information necessary for the proper use, care and maintenance of your new vehicle.

Please note, if any lubricants or additives specified in this manual are not available in Australia. You should consult your HOLDEN Dealer or the Drover Service Manual for the recommended equivalents.

GENERAL MOTORS-HOLDEN'S SALES
PTY. LTD.

IMPORTANT NOTICE

Please read this manual and follow its instructions carefully.

To emphasize special information the words **WARNING**, **CAUTION** and **NOTE** carry special meanings and should be carefully understood.

WARNING:

The personal safety of the driver or occupants may be involved. Disregarding this information could result in their injury.

CAUTION:

These instructions point out special service procedures or precautions that must be followed to avoid damaging the vehicle.

NOTE:

Special information to make maintenance easier or important instructions more clearer.

Copying, quoting or reproducing any part of this manual is not permitted without explicit approval by GENERAL MOTORS-HOLDEN'S LIMITED.

Please note that this manual applies to all models and all specifications for all respective destinations and explains all equipments including options available. Therefore, your model may have different standard features than shown in this manual.

CONTENTS

INFORMATION BEFORE DRIVING	2
INSTRUMENTS AND CONTROLS	10
OPERATING YOUR VEHICLE	20
SAFE DRIVING	24
DAILY INSPECTION	26
PERIODIC MAINTENANCE	27
INSPECTION AND MAINTENANCE	30
CORROSION PREVENTION	44
APPEARANCE CARE	45
BREAKDOWNS AND EMERGENCY REMEDIES	47
VEHICLE IDENTIFICATION NUMBER	48
SPECIFICATIONS	50

INFORMATION BEFORE DRIVING

KEY

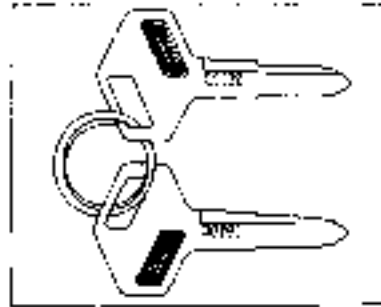

This vehicle comes equipped with a pair of identical keys. Keep the spare key in a safe place. The key can operate the following:

- Ignition switch
- Glove compartment lid lock
- Fuel tank cap lock
- Door lock (where fitted)
- Back door lock (where fitted)

The keys are stamped with an identifying number. This number is used when making replacement keys. Please write your key number in the box provided for your future reference.

KEY NUMBER: _____

DOOR LOCK

From outside

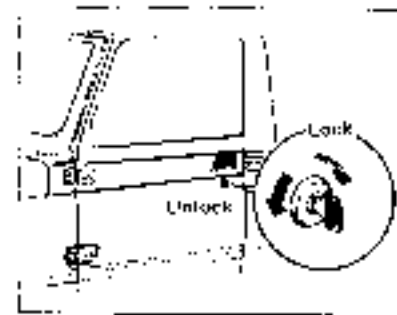

To lock the right door, insert the key and turn it clockwise. To unlock the door, turn the key counterclockwise.

To lock the left door, insert the key and turn it counterclockwise. To unlock the door, turn the key clockwise.

To lock the door without the key, push in the lock knob, then hold the handle up as you close the door. Be careful not to leave the key in the vehicle.

From inside

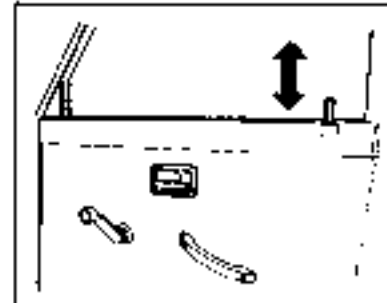

To lock a door, push in the lock knob. Pull it up to unlock.

WARNING:
Always lock the doors when driving. Locking the doors helps to prevent the occupants from being thrown from the vehicle in case of accident.

BACK DOOR LOCK (BQS16/BQT16)

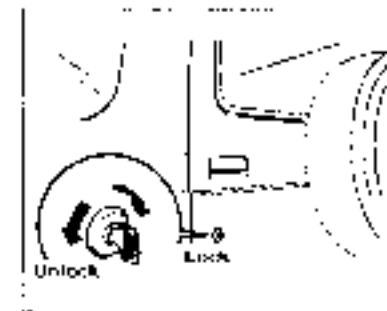

The back door is locked with the ignition key. To lock the door, turn the key clockwise. To unlock the door, turn the key counterclockwise.

WINDOWS

Door windows (Where fitted)

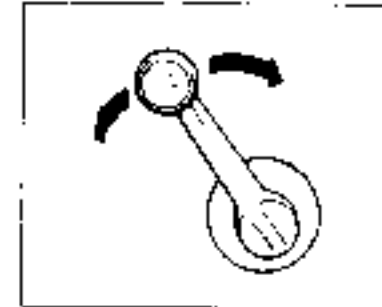

Turn the regulator handle clockwise to raise the right window and counterclockwise to raise the left window. Reverse the turning direction to lower the window.

Rear side window (BQS16/BQT16)

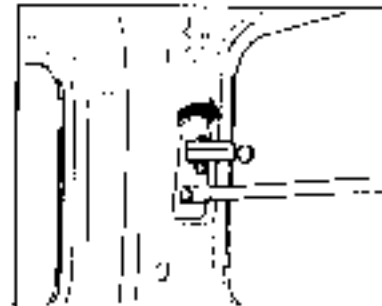

To open the rear side window, move the lock lever as far forward and outward as it will go. To close the window, pull the lever inward and rearward until it clicks into position.

Door windows (BQS26)

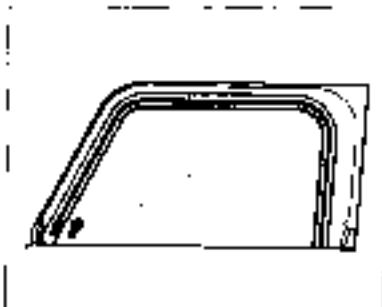

To open the windows, release the zippers.

FUEL FILLER CAP

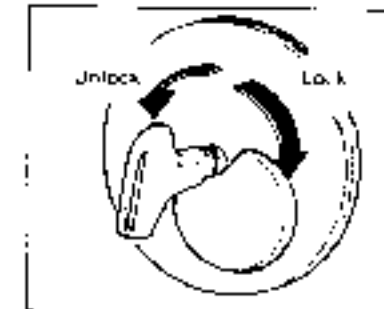

The fuel filler cap is located on the rear right side of the vehicle. Turn the cap counterclockwise to open and clockwise to close. A lock is provided on the cap which may be used when security is needed. To lock the cap, turn the key clockwise and with the key held in this position remove it from the cap. To unlock the cap, turn the key counterclockwise and with the key held in this position remove it from the cap.

FUEL TANK CAPACITY	40 l (10.6/8.8 US/Imp gal)
--------------------	-------------------------------

Use gasoline with an octane number of 85 or higher (Research Octane Number), preferably unleaded or low-lead.

CAUTION:
The fuel tank has an air space to allow for fuel expansion in hot weather. If fuel is continued to be added after the filler nozzle has automatically shut off or an initial blowback occurs, the air chamber will become full. Exposure to heat when fully fuelled in this manner will result in leakage due to fuel expansion. To prevent such fuel leakage, stop filling after the filler nozzle has automatically shut off, or when using an alternative non-automatic system, initial vent blowback occurs.

SEAT ADJUSTMENT

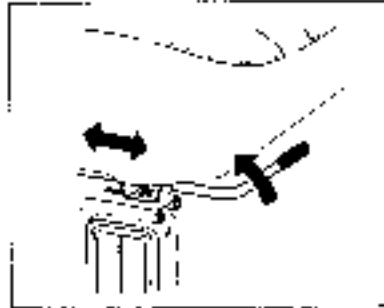

By means of the seat adjuster lever located under the driver's seat, slide the seat forward or backward. Pull the lever up and the seat will slide freely to the position you desire.

WARNING: Do not adjust the driver's seat while driving. The seat may suddenly jerk forward or backward, which could result in loss of control.

Reclining Seat



The seatback's angle can be freely controlled and adjusted to your preference. Pull the lever and the seatback freely moves, release it and the seatback instantly locks in place. The seatback can also be folded forward.

Walk-in type seat

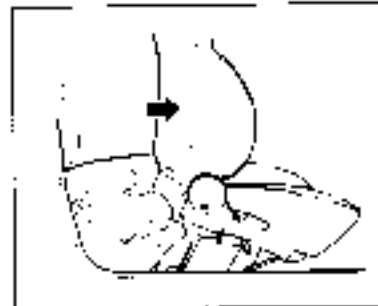
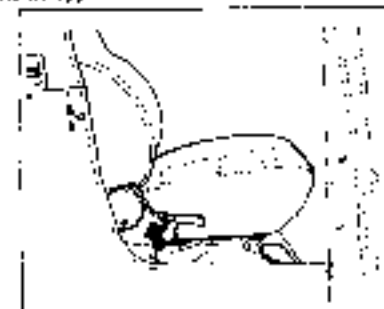

The front passenger seat is a walk-in type seat for easy entry to and exit from the rear seat.

To fold the seat forward, pull the lever in the direction of the arrow to unlock the seat and push the seatback forward. For operating the "walk-in" from the rear seat position, there is a similar unlocking lever on the opposite side of the same seat.

WARNING:

- After returning the seat to its normal seating position, make sure it is completely locked.
- Before returning the seat to its normal seating position, make sure that the feet of the rear seat passenger will not be under the front seat.

REAR SEAT (8QT16)

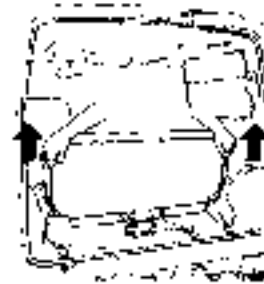

To fold ahead the rear seat, raise up the holders at the left and right sides together and fold the seat back ahead. Next, pull the hook  in the direction of arrow and raise up the entire rear seat.

FRONT AND REAR SEAT BELTS

(3-point, non-retractor type)

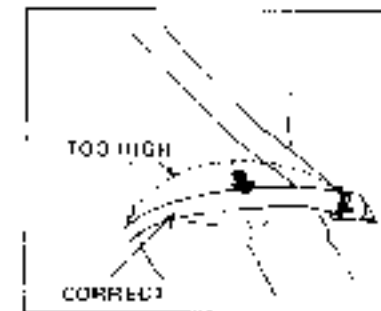
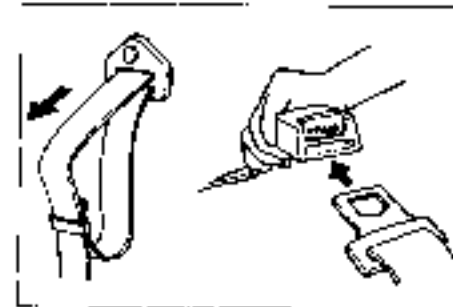

Draw the buckle tongue attached to the belt, across the body and press into the buckle catch unit, until a "click" is heard. The buckle catch unit is attached to a short length of belt passing between the seat cushions.

Adjustment of the belt length is very important. To adjust the lap belt and at the same time check that the buckle has locked correctly, pull upwards on the shoulder strap as if attempting to pull the buckle apart, until the lap belt fits tightly.

The adjuster for length of the diagonal shoulder strap is located on the strap, just forward of the upper anchorage point.

To tighten, pull the free end of the strap down alongside the diagonal shoulder strap until it is adjusted to a firm comfortable position.

To lengthen, turn the adjuster away from the belt and pull the belt through the adjuster until the belt is loose and then tighten to fit comfortably as described above.

To unfasten the belt, press the release button on the buckle.

WARNING:

- Seat belts are designed to bear upon the bony structure of the body, and should be worn low across the front of the pelvis, or the pelvis, chest and shoulders, as applicable; wearing the lap section of the belt across the abdominal area must be avoided.
- Seat belts should be adjusted as firmly as possible, consistent with comfort, to provide the protection for which they have been designed. A slack belt will greatly reduce the protection afforded to the wearer.
- Care should be taken to avoid contamination of the webbing with polishes, oils and chemicals, and particularly battery acid. Cleaning may safely be carried out using mild soap and water. The belt should be replaced if webbing becomes frayed, contaminated or damaged.
- It is essential to replace the entire assembly after it has been worn in a severe impact even if damage to the assembly is not obvious.
- Belts should not be worn with straps twisted.
- Each seat belt assembly must only be used by one occupant; it is dangerous to put a belt around a child being carried on the occupant's lap.
- No modifications or additions should be made by the user which will either prevent the seat belt adjusting devices from operating to remove slack, or prevent the seat belt assembly from being adjusted to remove slack.
- The positioning of the tongue restricter must never interfere with or stop the belt from fully retracting.

FABRIC TOP REMOVAL

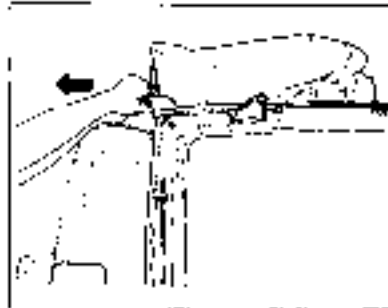
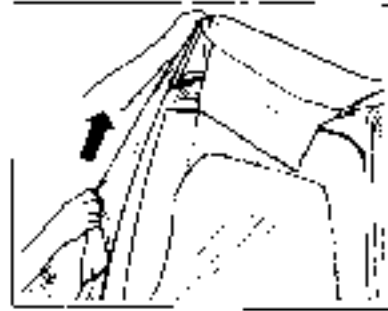

When removing the fabric top (80S28), follow the procedure below.

- 1) Unfasten the zippers and all the fasteners that fix the fabric top to its frame or vehicle body.
- 2) Pull up both the right and left side curtains along the center pillars to detach them.
- 3) Slide the front end of the fabric top either to the right or to the left to remove it from the windshield frame.

When stowing or removing the top frame, follow the procedure below.

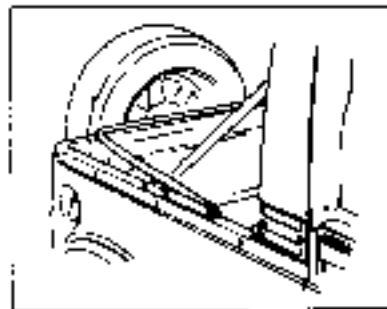

- 1) Fold down the frame as illustrated.
- 2) Secure the frame to the body on both sides with straps or something similar. The illustration shows the optional rubber bands and hooks designed for this purpose.

FRONT WINDSHIELD (80S26)

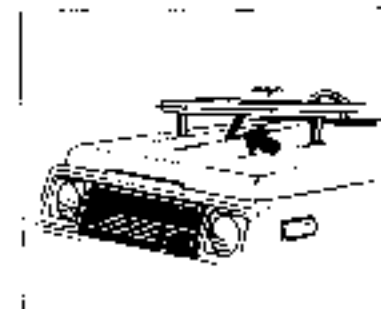

The front windshield can be folded forward. To fold the windshield, follow the procedure below.

1. Remove the top, if installed.
2. Remove the roof rails which support the windshield on top.
3. Release the lock handles on both sides of the dashboard.

4. Lower the windshield gently until the rubber pads contact the hood.
5. Secure the windshield with the strap (provided with the vehicle) as shown.
6. Return the lock handles to the "lock position."

WARNING:

- When the front windshield has been folded down, be sure to fasten it to the engine hood (bonnet) with the band (furnished).
- Do not operate the vehicle on streets or highways with the front windshield lowered.
- The front window is supported by both bracket and front roof rail. When driving with the front window turned up, be sure that the bracket and front roof rail are in place.

TAILGATE (80S28)

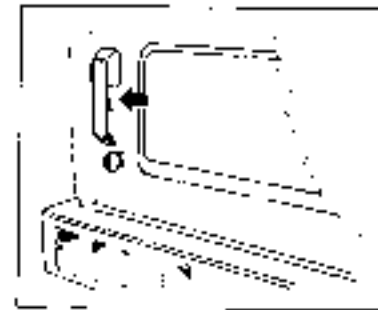

The tailgate can be opened by pushing the tailgate handle lever sideways. To close, push the tailgate into position and make sure it is completely locked. The tailgate can be also opened from inside by pulling the lock release lever located inside the tailgate.

LOADING DECK (80S80)

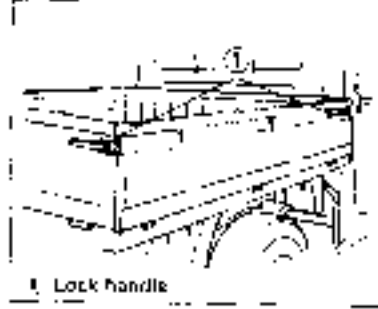

The loading deck can be opened in three separate ways. To open one of the gates, release both the right and left lock handles on that gate. To open all the three gates, release all of the four lock handles.

WARNING:

To ensure that turn signals, rear brake lights, etc. are clearly visible, never leave the tailgate down while driving.

TOWING HOOK

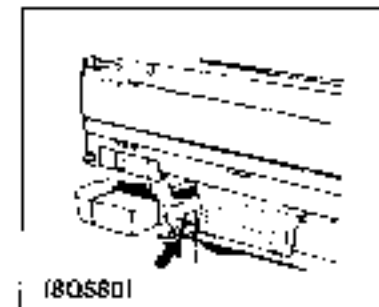
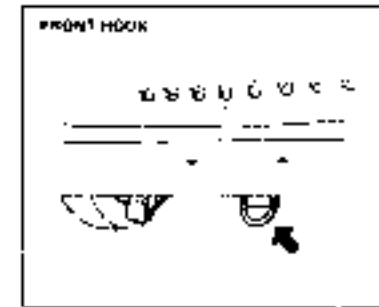

A towing hook is provided on both the front and rear of the vehicle.

ENGINE HOOD

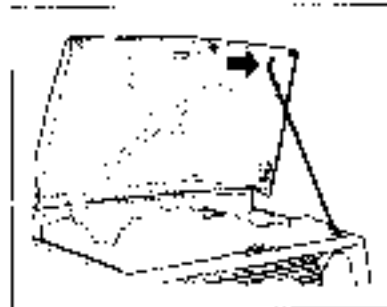
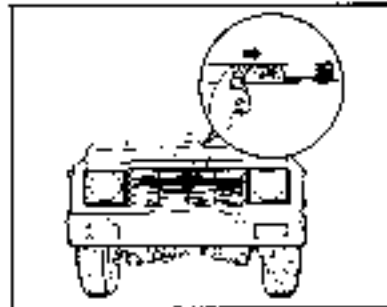
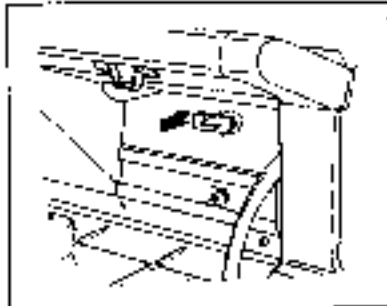

1. To open the engine hood (bonnet), first open the glove box, then pull the hood lock knob provided inside the glove box.
2. Now, the engine hood lock is disengaged half-way. Then, push the lever sideways using a finger, as indicated in the illustration. While pushing the lever, raise the engine hood.
3. Continue to raise the hood until it rests on the rubber stoppers on the windshield or until enough height is obtained to support it with the prop rod.

PORTABLE WORK TOOLS

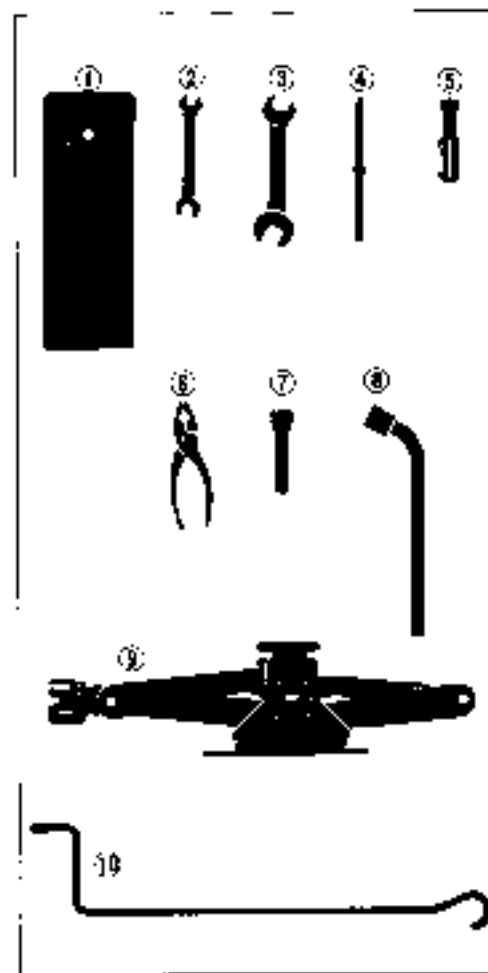

The work tools illustrated here come with your car. These tools can be used in your checkup or for minor repairs.

- 1 Tool case
- 2 10 x 12 mm open end wrench
- 3 14 x 17 mm open end wrench
- 4 Combination screwdriver
- 5 Screwdriver handle
- 6 Slip joint pliers
- 7 Spark plug socket wrench
- 8 Wheel wrench
- 9 Jack
- 10 Jack handle

JACK AND JACK HANDLE

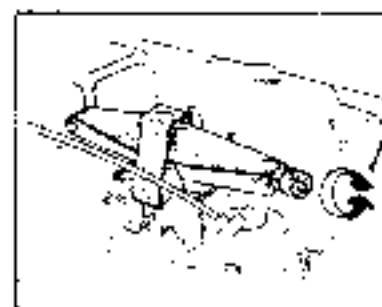

The jack is stowed on the side under the hood and the jack handle is under the driver's seat.

To remove the jack, turn its shaft counter-clockwise. To stow the jack, place it in the stowage bracket and turn the shaft clockwise until the jack is fixed firmly.

INSTRUMENTS AND CONTROLS

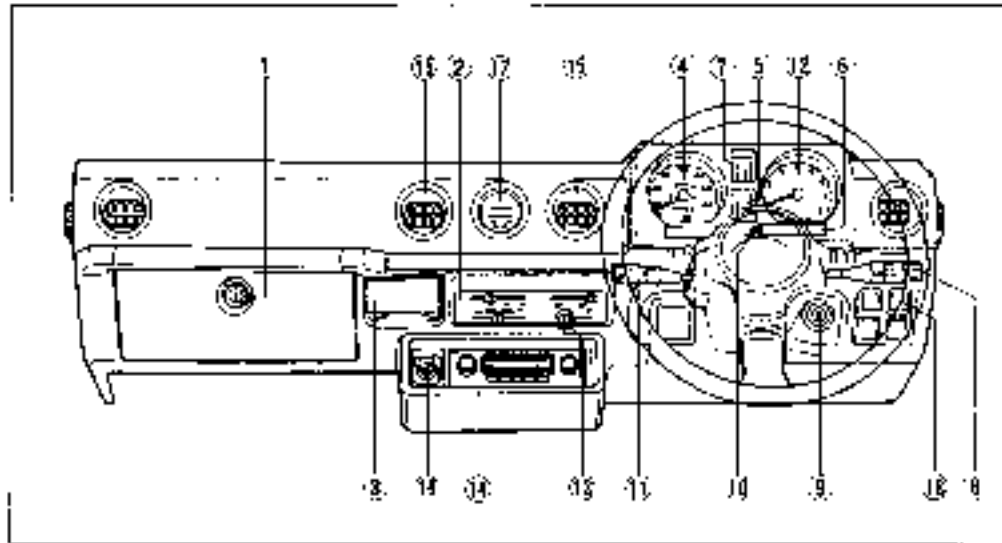

1. Glove box
2. Heater control panel
3. Ashtray
4. Speedometer
5. Fuel gauge
6. Warning and indicator lights
7. Temperature gauge
8. Lighting switch/Turn signal and dimmer switch
9. Ignition switch
10. Hazard warning switch
11. Windshield wiper and washer switch
12. Tachometer (Where fitted)
13. Blower switch
14. Radio
15. Center ventilator
16. Cigarette lighter (Where fitted)
17. Clock (Where fitted)
18. Rear window defroster switch (Where fitted)

SPEEDOMETER

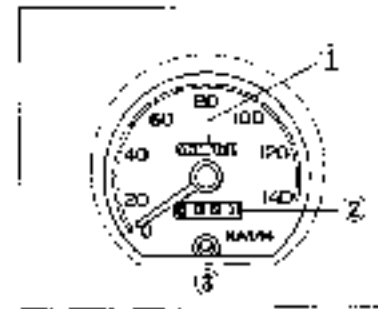

1. Odometer
2. Trip meter
3. Trip meter reset knob

The speedometer indicates running speed in km/h. The odometer records the total distance the car has been driven. The trip meter records the distance of an individual journey after resetting. Reset the trip meter to zero by pushing the reset knob.

CAUTION: Watch your mileage and check the maintenance schedule regularly against required services.

TACHOMETER

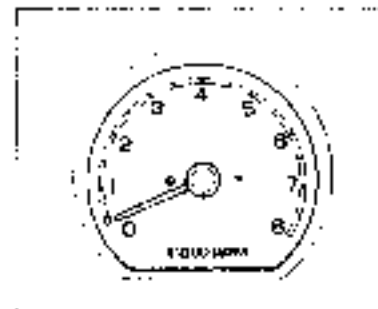

The tachometer records engine speed in revolutions per minute. Never drive in the red zone.

FUEL GAUGE

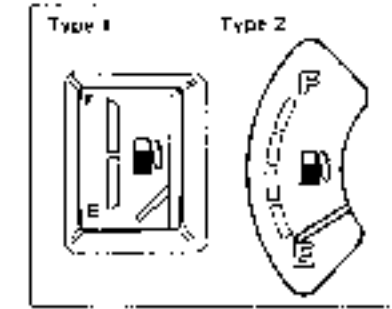

When the ignition switch is on, this gauge indicates the amount of gasoline in the tank. "F" stands for full and "E" means empty.

WATER TEMPERATURE GAUGE

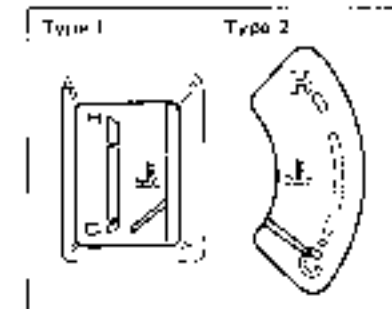

The engine coolant temperature is indicated by this gauge with the ignition switch turned on. Under normal driving conditions, the indicator should stay within the normal, acceptable temperature range shown by the line between "H" and "C." If the indicator exceeds this range and veers toward "H," overheating is indicated.

CAUTION:
Do not continue driving with the engine overheated.

INDICATOR AND PILOT LIGHT

Oil pressure light



This light comes on when the ignition switch is turned on, and goes off when the engine is started. However, it will remain on if something goes wrong with the engine lubrication system. If this occurs, the lubrication system should be inspected immediately by your HOLDEN dealer.

Charging light

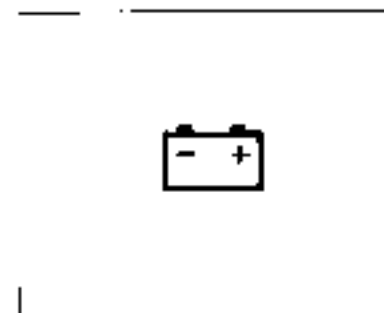

This light comes on when the ignition switch is turned on, and goes off when the engine is started. If it remains on, there is something wrong with the battery charging system. If this occurs, the charging system should be inspected immediately by your HOLDEN dealer.

Turn signal pilot light (1) & (2)

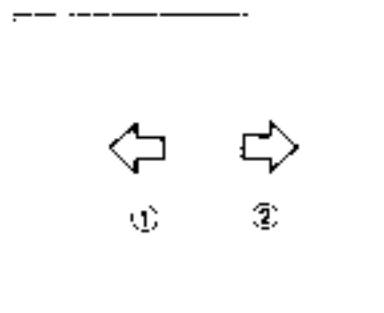

This light flashes together with the turn signal light when the turn signal is switched on. When the light on the left side flashes, light (1) flashes, and when the light on the right side flashes, light (2) flashes.

Brake fluid level warning light

BRAKE

This light comes on when the ignition switch is turned on, and goes off when the engine is started. However, it will remain on if the brake fluid level in the reservoir is low and requires replenishment. If the light still remains on or soon comes on even after replenishment, the brake system should be inspected immediately by your HOLDEN dealer.

NOTE:

Because the disc brake system is self-adjusting, the fluid level will drop as the brake pads become worn. Replenishing the brake fluid reservoir is considered normal periodic maintenance.

Parking brake indicator light

PARK BRAKE

This light comes on when the parking brake is not released and the ignition switch is in the "ON" position.

High beam indicator light (3)

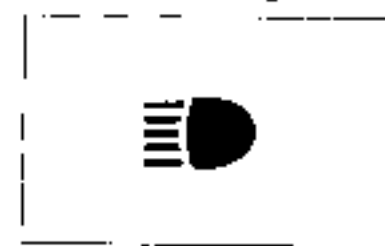

This light comes on when the headlight high beams are turned on. It does not come on when the headlights are on low beams.

4WD indicator light



With the ignition key in the "ON" position, the light comes on with the word "4WD" if the transfer gear is in the four-wheel drive position, either "4H" or "4L," and remains off in other transfer gear positions.

IGNITION SWITCH



LOCK

Normal parking position. Accessories and engine are off. This position locks the ignition and steering when the key is removed. The key can be removed only at this position. To release the steering lock, insert the key into the switch and turn it once to "ACC" or other positions. If you have trouble turning the key to unlock the steering, try to turn the steering slightly to

the right or to the left while twisting the key clockwise.

ACC

Accessories such as the radio operate, but the engine is off.

ON

This is the position at which the engine is ready to turn while all electrical systems are set.

START

This is the position for starting the engine by the starter motor. The key should be released from this position as soon as the engine starts.

CAUTION:

- Do not turn the starter for more than five seconds at a time. If the engine does not start, wait at least five to ten seconds before turning it again. If the engine still does not start after several attempts, check the fuel and ignition systems or consult your HOLDEN dealer.
- Do not leave the switch at the ON position for a prolonged period unless the engine is running. Otherwise, the battery will be discharged.

LIGHTS CONTROL LEVER

The switch lever is located on the right side of the steering column in the right-hand drive vehicle, and on the left side of the steering column in the left-hand drive vehicle. Operate the lever as follows:

Lighting operation

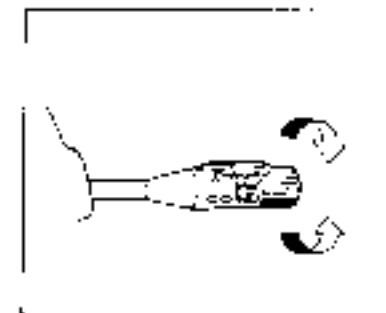

There are three positions. The OFF position turns all the lights off, the middle position turns on the front parking lights, taillights, license-plate light, and dashboard meter light but not the headlights; the other position turns on the headlights.

Turn signal operation

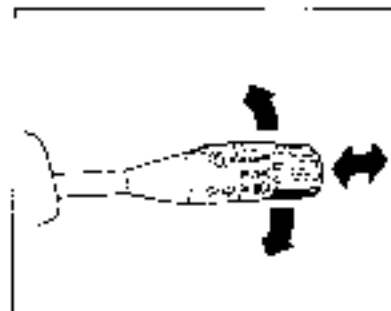

With the ignition switch in the "ON" position, move the lever up or down, as shown, for directional signals. In the right-hand drive vehicle, push the lever up for left turn signal and pull it down for right turn signal. In the left hand drive vehicle, pull the lever down for left turn signal and push it up for right turn signal. Once the turn has been completed, the lever will return to the neutral position.

Dimmer/Headlight flasher operation

With the headlights on, push the lever forward for high beams. Pull back for low beams. For headlight flasher, pull further toward the steering wheel.

HAZARD WARNING SWITCH

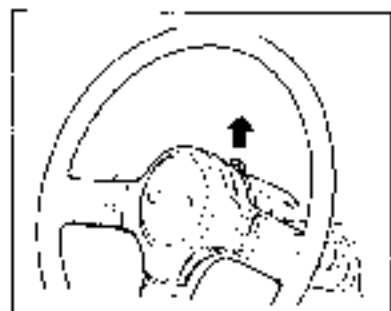

Use this hazard warning switch as a warning light to the other traffic during emergency parking or when your vehicle can otherwise become a traffic hazard.

CAUTION: Do not use this switch except in an emergency.

WINDSHIELD WIPER AND WASHER LEVER

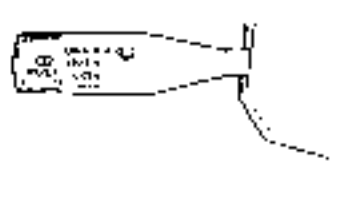

1. To operate the wipers, turn the wiper switch lever which has three positions. In the first position "INT", the wiper blades operate intermittently. In this setting, the wiper blades operate once per 5 - 6 seconds, which is very convenient for driving in mist or light rain. In the second position "LO" and the third "HI", the blades operate at low speed and high speed respect v.v.
2. Window washer fluid will spray out while the switch lever is pulled toward you.

CAUTION:

- (1) Release the switch lever when window washer fluid ceases to come out. The motor will be damaged if the washer lever is operated when there is no window washer fluid.
- (2) The windshield and the wiper blades will be damaged if dirt is attempted to be removed from the dry windshield with the wipers. Make sure always to wet the windshield with the washer fluid before operating the wipers.

INTERIOR LIGHT SWITCH

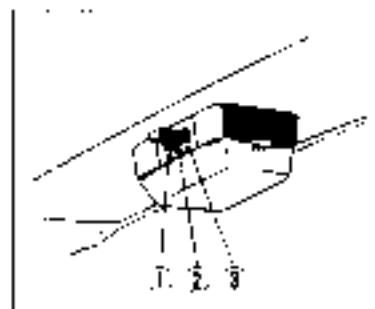

There are three position.

1. The light stays on regardless of whether the door opened or closed.
2. The light comes on while the driver's door is opened.
3. The light remains off even with a door opened.

CIGARETTE LIGHTER (Where fitted)



Push the cigarette lighter into the receptacle. The tip of the lighter will get red-hot after about ten seconds. The lighter may be taken out and used after it has returned automatically to its original position.

HORN BUTTON

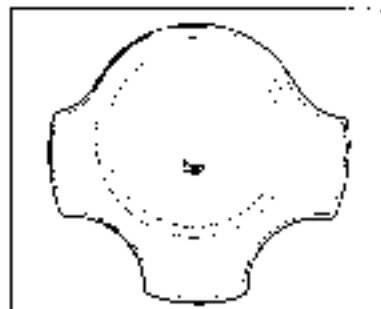

The horn will sound when the horn button is pressed regardless of the ignition switch position.

AM RADIO



The radio is turned on by pushing the knob on the right, and volume can be controlled by turning this knob. If the selector buttons in the center are set to the stations required, these particular stations can always be obtained simply by pushing the button.

If the knob on the left is turned, stations can be selected independently of the station selector buttons.

A station selector button can be set by pulling it out about one centimeter, selecting the station with the knob on the left and then pushing the button in.

REAR WINDOW DEFROSTER SWITCH (Where fitted)

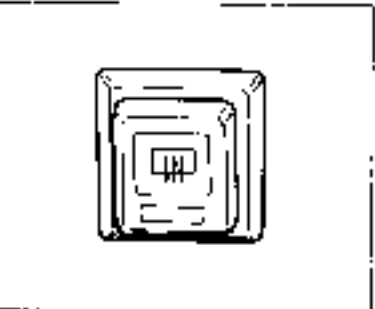

When the rear window is misted or frosted over, push this switch to clear the window. A pilot light is illuminated while the defroster is in operation. The defroster will not function if the ignition switch is turned off.

CAUTION: Since the defroster consumes a large amount of electricity, the switch should be turned off as soon as the mist on the rear window has disappeared.

DAY-NIGHT REARVIEW MIRROR
(Where fitted)

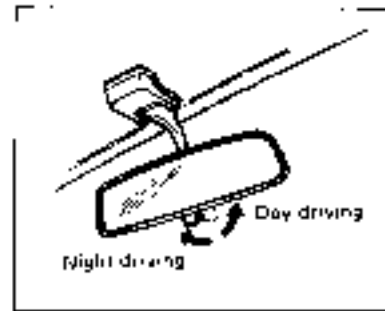

The inside rearview mirror may be set to either the day position or the night position by simply pushing or pulling the selector tab. The night position reduces glare from the headlights of vehicles behind you.

To adjust the mirror, first set the selector tab to the day position, then move the mirror up, down or sideways to obtain the best view.

WARNING:

- Do not adjust the mirror for the normal day vision with the selector set to the night position, or you will lose the rear view when the selector is operated later.
- The night position darkens the rear vision to reduce visibility. Remember; you may be unable to see some objects that are seen in the day position.

GLOVE BOX

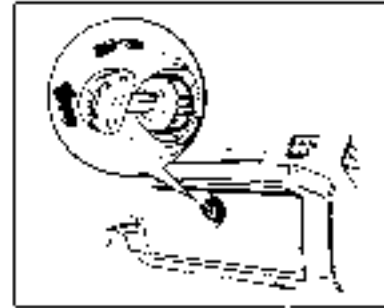
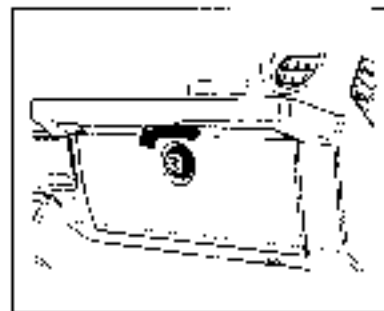

The spring-loaded glove compartment lid stays either in the closed or fully open position.

The glove box may be locked with the ignition key.

ASHTRAY

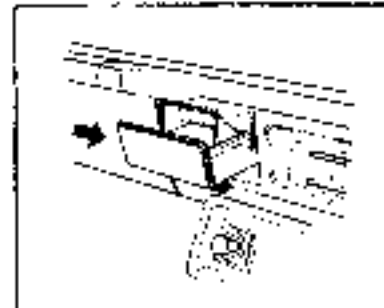

The ashtray can be used after pulling it out. To clean the ashtray, remove by pushing it downwards and pulling it completely out of its socket.

SUN VISOR

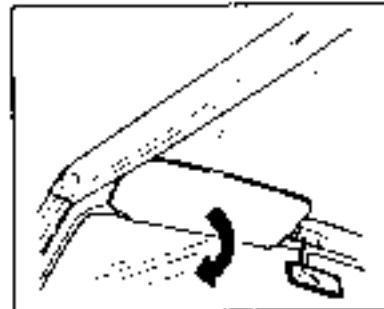

This gives protection against dazzle from the sun. If the sunlight is dazzling, pull the sun visor downwards.

HEATER SYSTEM

The heater system includes the forced ventilation function. Operate the system according to the following:

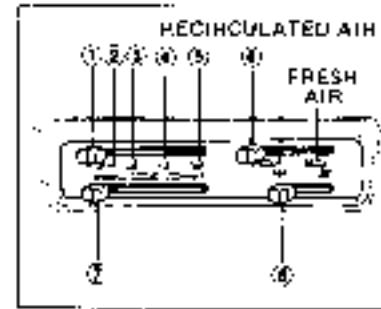

- Air Selector Lever ①:**
 - VENTILATION ②:** Air is discharged from the center outlets of the instrument panel and the side outlets.
 - BI-LEVEL ③:** Air is discharged from the center outlets and heated air from the floor outlets.
 - HEATER ④:** Heated air is discharged from the floor outlets and a small amount of heated air from the windshield and side defrosters.
 - DEFROST ⑤:** Heated air is discharged from the windshield defrosters and side defrosters.

Air Intake Control Lever ⑥: Recirculation or outside air intake can be selected with the air intake lever.

Temperature Control Lever ⑦: The temperature control lever can control heater temperature.

Blower Lever ⑧: The blower lever controls fan speed.

SYSTEM OPERATING INSTRUCTIONS

Natural Ventilation
Move the air selector lever to the "VENTILATION" position, the air intake lever to "FRESH AIR" and the temperature control lever to "COOL." Set the blower lever to the OFF position.

With this lever setting, ram-air is obtained during driving.

Forced Ventilation
The lever setting is the same as for natural ventilation except that the blower lever is set at any position of your preference.

Heating By Introducing Outside Air (Regular Heating)

Move the air selector lever to "HEATER" and the air intake lever to "FRESH AIR." Adjust the temperature control lever to regulate the temperature to your preference and set the blower lever to the desired fan speed. Setting it to a higher speed position increases the heating efficiency.

Heating By Using Interior Air (Quick Heating)

The lever setting is the same as for "Heating By Introducing Outside Air" except that the air intake lever is set to the "RECIRCULATED AIR" position. If this heating method is used for an extended period of time, the air in the car can become contaminated and the windows can become cloudy. Therefore, use this method only for quick heating and change to the heating method by introducing outside air as soon as possible.

Head Cooled/Feet Warmed Heating
Move the air selector lever to "BI-LEVEL" and the air intake lever to "FRESH AIR." Adjust the temperature control lever to the desired temperature and the blower lever to the desired fan speed. This lever setting allows heated air to be discharged from the floor outlets and fresh, unheated air from the center and side ventilator outlets.

Defrosting
Set the air selector lever to "DEFROST" and the air intake lever to "FRESH AIR." Adjust the temperature control lever to desired temperature. Set the blower lever to the "HIGH" speed position first and when the windshield has become clear, move it to a lower speed position. The defrosters are at the lower end of the windshield and the side defrosters are at the both ends of the instrument panel.

**Questo documento è stato
scaricato GRATUITAMENTE
Da www.iw1axr.eu/auto.htm**

**Questo documento è stato
scaricato GRATUITAMENTE
Da www.iw1axr.eu/auto.htm**

**Questo documento è stato
scaricato GRATUITAMENTE
Da www.iw1axr.eu/auto.htm**

**Questo documento è stato
scaricato GRATUITAMENTE
Da www.iw1axr.eu/auto.htm**

PARKING BRAKE LEVER

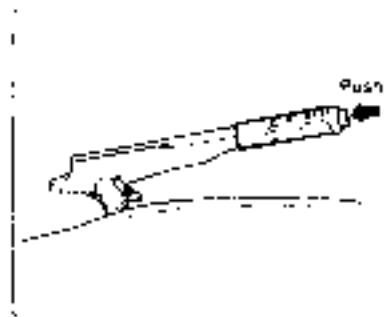

This lever must always be operated when parking. When the lever is pulled up, a parking brake is applied on the rear two wheels. To release the lever, raise it slightly, push the button at the end of the lever with the thumb and return the lever to its original position.

CAUTION:

The parking brake will not prevent the vehicle from moving unless the lever is fully and firmly pulled up. When parking the vehicle in extremely cold weather, do not use the parking brake. Instead, shift the gear to either the Low or the Reverse position and apply chocks to the tires.

PEDALS

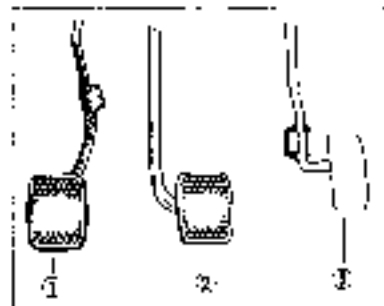

Clutch pedal (1):

The clutch pedal is used to disengage the drive to the wheels when starting the engine, driving off or shifting the transmission gear. Pressing the pedal disengages the clutch.

CAUTION: Do not drive with your foot resting on the clutch pedal. This may result in excessive clutch wear or damage.

Brake pedal (2):

Pressing the brake pedal will apply the brakes on all the four wheels. Occasional brake squeal could be caused by environmental conditions such as cold, wet, snow, etc. This is considered normal. If squeal is excessive and occurs each time the brakes are applied, the brakes should be checked.

Accelerator pedal (3):

This pedal controls the revolutions of the engine. When the pedal is pressed with the foot, the revolutions increase, and the power output and speed are raised.

GEARSHIFT LEVER

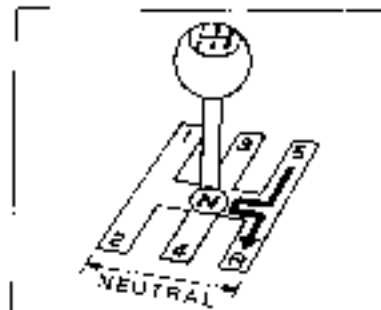
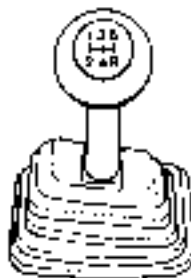

The 5-speed manual transmission is used in your vehicle and its gearshifting pattern is shown in the illustration.

NOTE:

The gearshift lever will not move directly from 5th position to Reverse position. To shift from 5th position to Reverse position, first bring the gearshift lever to the intermediate position in neutral, then shift to Reverse as shown in the illustration.

TRANSFER LEVER

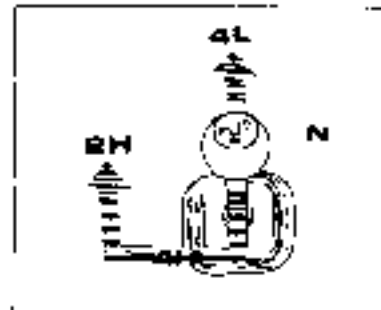

- **2H:** 2-wheel drive high range (rear-wheel drive). This position should be used for normal driving on dry, hard surfaces.
- **4H:** 4-wheel drive high range (high speed four-wheel drive). This position provides greater traction than 2-wheel drive. Use this for driving on slippery roads (wet, snow-covered, muddy roads etc.) or off-road.
- **N:** Neutral. Engine power is not transmitted to the wheels.
- **4L:** 4-wheel drive low range (low speed four-wheel drive). Use this for climbing or descending steep hills, or off-road driving.

Press the clutch when shifting the transfer lever. If you have trouble shifting the lever, try pressing the clutch again or move the vehicle very slightly, or stop and try shifting again.

CAUTION:

If the instructions below are not followed, the transfer gear may be damaged.

- Bring the vehicle to a complete stop before shifting the lever from "4H" to "4L" or from "4L" to "4H."
- The transfer lever may be shifted

from "4H" to "2H" or from "2H" to "4H" during driving when the vehicle is going straight ahead only.

FREE-WHEELING HUBS

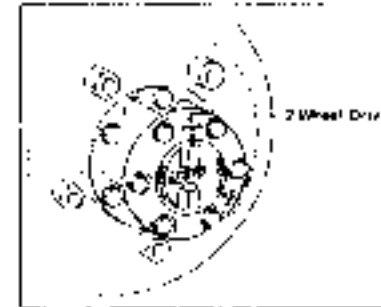

The free-wheeling hubs disconnect the drive at the front wheel hubs so that the front axle components do not need to be rotated when the vehicle is driven on the rear two wheels. This provides improved fuel economy, and reduces noise and wear.

Turn both the hub dials to the "FREE" position when the transfer lever is shifted to the 2H position. Turn both the dials to the "LOCK" position when the transfer lever is shifted to the 4-wheel drive position, either 4L or 4H.

NOTE:

- Make sure that both the hubs are set to the "LOCK" position when operating the vehicle in 4-wheel drive (4H or 4L). Setting one hub in the "LOCK" position and the other in the "FREE" position will not make 4-wheel drive possible even when the transfer is shifted

to the 4-wheel drive position. It is recommended to "lock" the hubs once a month and drive a few miles rather than operating the vehicle exclusively with the hubs in the "FREE" position. This keeps the operation of free-wheeling mechanism always smooth and provides lubrication to the axle components.

CAUTION:

- When shifting the hub, turn the hub dial all the way until it stops and brings two marks (A) in alignment. If the hub dial is set to a half turned position, the hub may be damaged when the driving power is applied.
- Be careful when you shift the hubs. The hub may be heated and could burn your finger after excessive application of brakes.

OPERATING YOUR VEHICLE

STARTING ENGINE

1. Set the parking brake firmly.
2. Press the clutch pedal to the floor and shift the transmission to NEUTRAL. Hold the clutch pedal to the floor while you are starting the engine.
3. Start the engine as follows for different conditions.

Cold Engine

- Do not press down the accelerator pedal. With your foot off the pedal, crank the engine by turning the ignition key to "START." Release the key when the engine starts.
- If the engine does not start after 3 seconds of cranking, press down the accelerator pedal to 1/3 of its travel while cranking. Release the key (and accelerator pedal) when the engine starts.
- If you tried the previous two (2) steps and the engine did not start, press the accelerator pedal to the floor and hold it there while cranking the engine. This should clear the engine if it is flooded.
- If the engine has been flooded with too much fuel, it may start to run but not have enough power to keep running. In that case, continue cranking with the accelerator pedal all the way to the floor until the engine clears itself of excess gasoline and runs smoothly. (But, do not crank more than 10 seconds at a time or you could damage the starter.)

After starting, the idle speed will automatically be reduced as the engine warms up.

In very cold weather or after vehicle has been standing idle several days, fully depress and release the accelerator pedal two or three times before cranking the engine. Then, with your foot off the accelerator pedal, crank the engine by turning the key to "START."

Warm Engine

Press down the accelerator pedal to 1/3 of its travel and hold. Crank the engine by turning the ignition key to "START." Release the key and accelerator pedal when the engine starts.

CAUTION:

- Turn off the starter immediately after the engine has started. Otherwise, starter system damage may result.
- Do not run the engine for more than 5 seconds at a time. If the first try fails, wait about 10 seconds (to let the battery recoup its strength) and then try again.

STARTING OFF AND DRIVING

First, check all around (front, side and rear) to see if any other vehicles are coming. While pressing the clutch, shift the transmission into low gear. If you experience any difficulty, press the clutch again and try again. Once the transmission is in low gear, release the hand brake and press the accelerator slowly while releasing the clutch. Listening to the engine sound is helpful when using the clutch. As you gradually release the clutch there will be a change in the engine's sound. It is at this time that the accelerator is to be pressed, while you continue to ease up on the clutch gradually.

Do not use your clutch pedal as a footrest while driving. Nor should you use a half-pressed clutch to keep the car stationary on a hill. Such misuse of the clutch damages it.

While driving the car the driver should at times observe the instruments and indicator lights. Avoiding sharp braking and fast acceleration whenever possible will increase fuel economy.

USE OF TRANSMISSION

When changing gears or starting off do not race the engine. This shortens the engine life and prevents smooth shifting. All forward speeds are synchronized, which provides for noiseless, easy gearshifting. Good gearshift control refers to keeping the engine rpm always within a certain range regardless of changes in car speed. If this is done well, fuel will be conserved and the car's lifespan will be prolonged. To help your gearshifting, the following chart shows the recommended speed range in each gear.

Transfer gear in "2H" or "4H" position.

Gear position	Speed range
Low	0-30 km/h 0-19 mile/h
Second	10-60 km/h 6-37 mile/h
Third	20-80 km/h 12-50 mile/h
Fourth	30 km/h—Max 19 mile/h—Max
Fifth	60 km/h—Max 37 mile/h—Max

Transfer gear in "4L" position.

Gear position	Speed range
Low	0-20 km/h 0-12 mile/h
Second	10-35 km/h 6-22 mile/h
Third	15-50 km/h 9-31 mile/h
Fourth	20-70 km/h 12-43 mile/h
Fifth	40-90 km/h 25-56 mile/h

BRAKING

The distance needed to bring a car to a halt increases with the speed of the car. The braking distance, for example, at 60 km/h (37 mile/h) will be 4 times greater than the braking distance at 20 km/h (13 mile/h). Start to brake the car an ample distance from the stopping point and slow the car down gradually.

If water gets into the brake drums, the brake performance may become poor and unpredictable. This may occur after driving through deep water or washing the underneath. In such cases, dry the brakes by gentle, repeated pedal action while driving at low speed.

Power assisted brakes

Even if power assistance is lost due to a stalled engine or other failures, the system is still fully operational on reserve power and can bring the vehicle to a complete stop by pressing the brake pedal once and holding it down. The reserve power is partly used up and reduces each time the pedal is pressed. Apply smooth and even pressure to the pedal. Do not pump the pedal.

WARNING:

Without the reserve power in the system, the vehicle can still be stopped by pressing the brake pedal harder than normally required. However, the stopping distance may be longer.

BREAK-IN

The best possible materials are used in the manufacturing process and all machine parts are finished to high standards but it is still necessary to allow the moving parts to "BREAK-IN" before subjecting the engine to maximum stresses. The future performance and reliability of the engine depends on the care and restraint exercised during its early life. The general rules are as follows:

- Never exceed the following breaking in speed limit.
- After starting, do not race the engine, but warm up gradually.

• Transfer gear in "2H" or "4H" position

	Gear position	Initial 1 000 km (600 miles)
Maximum recom- mended speed	Low	~ 15 km/h ~ 9 mile/h
	Second	~ 30 km/h ~ 19 mile/h
	Third	~ 50 km/h ~ 31 mile/h
	Fourth	~ 70 km/h ~ 43 mile/h
	Fifth	~ 90 km/h ~ 56 mile/h

• Transfer gear in "4L" position

	Gear position	Initial 1 000 km (600 miles)
Maximum recom- mended speed	Low	~ 10 km/h ~ 6 mile/h
	Second	~ 20 km/h ~ 12 mile/h
	Third	~ 30 km/h ~ 19 mile/h
	Fourth	~ 40 km/h ~ 25 mile/h
	Fifth	~ 50 km/h ~ 31 mile/h

TIPS ON DRIVING

High-speed driving

When driving at a high speed pay attention to the following:

- Stopping distance progressively increases with the vehicle speed. Apply brakes ahead of time to make up for the increased stopping distance.
- On rainy days not only is poor visibility a problem but a so "hydroplaning". This is the loss of the tire's direct contact with the road surface due to a water film forming between them. Steering or braking the vehicle while "hydroplaning" is almost impossible. If attempted, loss of control may result. Keep speed down when the road surface is wet.
- At high speeds, the vehicle may be affected by side winds. Therefore, reduce speed and assume the proper driving posture to prepare for unexpected shakes, which are usually experienced at the exits of tunnels, when passing a cut of a hill, or when being overtaken by large vehicles.

DRIVING ON HILLS

- When climbing steep hills, the car may begin to slow down and show lack of power. At this point you should shift to a lower gear so that the engine will again be operating in its normal power range. Shift rapidly to prevent the car from losing momentum.

- When driving down a hill, the engine may be used for braking by shifting to a lower gear.
- Be careful, however, not to allow the engine to over rev.

DRIVING ON ICE AND SNOW

To keep the tires from slipping or skidding when driving on ice or snow covered roads, tire chains, snow tires or studded snow tires can be used. Keep the following suggestions in mind.

- Rather than pressing down hard on the brake pedal, the pedal should be pumped steadily and evenly to prevent the wheels locking.
- Use care when starting, speeding up or shifting into lower gear while driving. Sudden acceleration or engine braking can cause the car to slide sideways due to wheel spin or skidding.
- Avoid large, quick movements of the steering wheel. Slow down to a safe speed and steer gently when making a turn.
- Use 4 wheel drive high range (4H) for better traction and directional stability.

DRIVING WITH FUEL ECONOMY

The following instructions will help you improve fuel economy.

Avoid excessive idling:

If you are to wait for more than a minute while you are not in traffic, stop the engine and start again later. When warming up a cold engine, allow the engine to idle until the temperature gauge pointer comes up to the "C" position. In this position, the engine is sufficiently warm for starting off.

Avoid "Jackrabbit" starts:

Fast starts away from lights or stop signs will consume unnecessary fuel and shorten the engine life. Start in a restrained manner.

Avoid sudden stops:

Avoid abrupt braking whenever possible. Fuel energy is wasted in braking. Acceleration to resume the driving speed also requires fuel energy.

Keep a steady cruising speed:

Keep as constant a speed as road and traffic conditions will permit.

Keep air cleaner clean:

A dirty air cleaner will cause the carburetor to supply too much fuel to the engine. The result is waste of fuel due to incomplete fuel burning.

Keep weight to the minimum:

The heavier the load, the more fuel the vehicle consumes. Take out any luggage or cargo when it is not necessary.

Keep tire pressures correct:

Underinflation can waste fuel due to increased running resistance of tires. Keep your tires inflated to the correct pressures shown on the label on the driver's side of instrument panel.

SAFE DRIVING

WARNING:
This multipurpose vehicle has handling characteristics that differ from a conventional passenger car. For the safety of you and your passengers, please read the following section very carefully.

Multipurpose vehicles such as your new HOLDEN have higher ground clearance and a narrower track than conventional passenger cars, to make them capable of performing in a wide variety of off-road applications. Specific design characteristics give them a higher center of gravity than ordinary cars. An advantage of the higher ground clearance is a better view of the road allowing you to anticipate problems. They are not designed for cornering at the same speeds as conventional 2-wheel drive vehicles any more than low-slung sports cars are designed to perform satisfactorily under off-road conditions. If at all possible, avoid sharp turns or abrupt maneuvers. As with other vehicles of this type, failure to operate this vehicle correctly may result in loss of control or vehicle rollover.

IMPORTANT DIFFERENCES BETWEEN YOUR 4WD VEHICLE AND ORDINARY 2WD VEHICLES

• Higher Ground Clearance

The higher ground clearance of your QB vehicle enables it to clear off-road obstacles such as rocks and tree stumps that ordinary passenger cars cannot drive over. An unavoidable result of this higher ground clearance is that the vehicle also has a higher center of gravity. Consequently, your QB vehicle will handle differently than a car with a lower center of gravity.

• Shorter Wheelbase

Along with its higher ground clearance, your QB vehicle has a shorter wheelbase and short front and rear overhangs. These features combine to allow you to drive your vehicle over hilly terrain without hanging up on them or damaging the frame and chassis components. The shorter wheelbase also makes the steering of your vehicle more responsive than vehicles with longer wheelbases.

• Narrower Body Width and Track

Your QB is narrower than the average passenger car so that it can pass through tight spaces. Without these essential differences — higher ground clearance, shorter wheelbase, and narrower body width and track — your QB vehicle could not provide you with excellent off-road driving performance. However, it is also true that on-pavement driving, handling, and steering will be different from what drivers experience with a conventional 2-wheel drive car.

ON-PAVEMENT DRIVING

Since you will often use your QB vehicle on paved roads, you should learn these guidelines for your on-road driving.

• Know Your Vehicle

Take the time to familiarize yourself with the unique handling characteristics of your QB by first driving around in an area away from traffic. Practice turning the vehicle at a variety of speeds and directions. Get a feel for the greater response in the steering that your QB has over a conventional car.

• Wear Your Seat Belts at All Times

The driver and passengers should be properly restrained at all times, using the seat belts provided. See page 5 of this manual for instructions on the use of your seat belts.

• Don't Make Sharp Turns

As mentioned before, small 4-wheel drive vehicles have specific design characteristics that allow them to perform in a wide variety of off-road applications. These characteristics also change the cornering behavior relative to conventional passenger cars. Remember, small 4-wheel drive vehicles have more responsive steering and a higher center of gravity than 2-wheel drive passenger cars. If at all possible, avoid making sharp turns in your QB vehicle.

• Slow Down on Curves

Learn to approach curves cautiously and at a conservative speed. Do not attempt to take curves at the same speeds that you would in a vehicle with a lower center of gravity. Just as you would not drive a sports car on a trail, you should not attempt to drive your QB vehicle around curves like a sports car.

• Slow Down in Crosswinds

The stability of any vehicle will be affected by strong gusting crosswinds. This is especially true with small 4-wheel drive vehicles because of the higher center of gravity. To minimize the effects of crosswinds on your QB vehicle you should drive slower under such conditions.

• Slow Down and Use Caution on Slippery Roads

Under wet road conditions you should drive at a lower speed than on dry roads due to possible slippage of tires at braking. When driving on icy, snowcovered, or muddy roads, reduce your speed and avoid sudden acceleration, abrupt braking, or sharp steering movements. Use 4-wheel drive high range (4H) for better traction.

OFF-ROAD DRIVING

Your QB vehicle is designed primarily for off-road driving. When you leave the pavement, you will encounter driving surfaces of all kinds which may change continually as you drive. In almost every case you will need to be in the 4-wheel drive mode. Consequently, off-road conditions call for different driving techniques from paved roads.

• Steep inclines require caution

Always inspect hills before you attempt to drive up them. Know what is on the other side and how you will get back down. If you have any doubt that it is safe do not attempt to drive over a hill. Never drive your QB vehicle up an extremely steep incline. Coming down a steep hill can be trickier than getting up one. Keep the vehicle heading straight down the hill and use low gear. Do not lock the brakes. If the vehicle begins to slide, accelerate slightly to regain steering control.

• Do not drive across the side of hills

Traveling across the side of a hill can be extremely hazardous. Most of the vehicle's weight will be transferred to the downhill tires, which could result in the vehicle rolling sideways. Whenever possible, avoid this potential hazard. Also, if you have to exit your vehicle on a side hill, always get out on the uphill side.

• Wear your seatbelt at all times

As in the case when you drive on the pavement, you and your passengers should use the provided seatbelts at all times when driving off the road. See page 5 of this manual for instructions on the correct use of the seat belts.

• Avoid sudden reactions in mud, ice, or snow

When off road conditions are slick, extra alertness by the driver is required. Reduce your speed and avoid sudden movements of the vehicle, as you would for similar conditions on the pavement. Driving in deep snow or mud can cause a loss of traction and an increase in the resistance to the vehicle's forward motion. Use 4WD low gear (4L) and maintain a steady but moderate speed with a light touch on the steering wheel and brakes under such

— 25 — conditions

**Questo documento è stato
scaricato GRATUITAMENTE
Da www.iw1axr.eu/auto.htm**

**Questo documento è stato
scaricato GRATUITAMENTE
Da www.iw1axr.eu/auto.htm**

**Questo documento è stato
scaricato GRATUITAMENTE
Da www.iw1axr.eu/auto.htm**

**Questo documento è stato
scaricato GRATUITAMENTE
Da www.iw1axr.eu/auto.htm**

WARNING:

In addition to the warnings listed above, the following are important warnings for off- and on-road driving.

- * Driver and passengers should wear seat belts while driving.
- * Do not let anyone else drive your vehicle unless they are also aware of these handling differences.
- * It is good policy to never loan your vehicle to anyone unless you accompany them.
- * Do not use worn out tires.
- * Always maintain the specified tire pressure. Refer to page 52 of this manual for specified.
- * Do not use tires other than those specified by HOLDEN. Never use different tire sizes or types on the front than the rear wheels. For the specified tires, refer to page 52 of this manual.
- * Never use oversized tires or special shocks and springs to raise (jack-up) your vehicle. This will raise the center of gravity of the vehicle and change its cornering characteristics.
- * Passing through water, muddy spots, or sandy ground will deteriorate the effect of braking. Therefore, immediately after passing such spots lightly "pump" the brake pedal to check for the braking effect, while running at very slow speed. Repeat this action until braking effectiveness returns to normal.
- * Do not use 4-wheel drive for normal driving on dry, hard surfaced roads.

CAUTION:

- * Do not overtax the engine with higher engine speed.
- * Wash your vehicle (including the underside) after running through sand, water pools, muddy spots, and off-road areas.
- * Bring the vehicle to a complete stop before shifting the transfer lever between 4WD high range (4H) and 4WD low range (4L).

DAILY INSPECTION

The condition of the car could change daily. Before driving every day, inspect the following items on your car.

- (1) Fan belt
- (2) Engine oil
- (3) Windshield washer fluid
- (4) Battery solution level
- (5) Engine coolant
- (6) Brakes
- (7) Tires
- (8) Clutch pedal play
- (9) Steering operation
- (10) Indicator lights, gauges and meter
- (11) Lighting system
- (12) Horn and turn signal
- (13) Exhaust gas
- (14) Fuel
- (15) Door lock
- (16) Mirrors
- (17) Number plate
- (18) Gear oil
- (19) Brake pedal stroke

PERIODIC MAINTENANCE

The following table indicates the times at which regular inspections are to be carried out, in km (miles) and months. Inspections, adjustments, lubrication and other servicing must be carried out at the various intervals as indicated. These intervals must be shortened if driving is usually done under severe conditions, for example at full throttle.

Please consult your HOLDEN dealer with regard to such intervals.

CAUTION: Periodic inspection will reveal the need for replacement of one or more parts after prolonged service of your vehicle. Whenever such a need arises, it is recommended that you use HOLDEN genuine replacement parts. Avoid taking chances. Do not use imitation parts.

PERIODIC MAINTENANCE SCHEDULE

Interval: This interval should be judged by odometer reading or months, whichever comes first	km (x 1 000)	1	10	20	30	40	50	60	70	80	
	miles (x 1 000)	1	6	12	18	24	30	36	42	48	
	months	1	6	12	18	24	30	36	42	48	
ENGINE											
* 1. Water pump (fan drive belt)						R				R	
* 2. Valve lash clearance											
* 3. Engine bolts (all cylinder head and manifold fixings)		-	-			T				T	
* 4. Engine oil filter		R	R	R	R	R	H	R	R	R	
5. Engine oil	API Grade SD, SE or SF	R	Replace every 10 000 km (6 000 miles)								
	API Grade SC	R	Replace every 5 000 km (3 000 miles)								
* 6. Engine coolant		-				H				R	
* 7. Cooling system hoses and connections		-									
* 8. Exhaust pipes and mountings		-									
IGNITION											
* 9. Ignition wiring		-									
* 10. Distributor cap and rotor		-									
* 11. Spark plugs		-	R	R	R	H	H	R	R	R	
* 12. Ignition timing											
* 13. Distributor advance		-									
FUEL											
14. Air cleaner filter element	Paved road Dusty condition		Clean every 10 000 km (6 000 miles) Clean every 2 500 km (1 500 miles) or as required Replace every 40 000 km (24 300 miles) More frequent replacement if under dusty driving condition								
* 15. Carburetor choke system		-	I&L	I&L	I&L	I&L	I&L	I&L	I&L	I&L	
* 16. Fuel tank cap, gas lines and connections						R				R	
* 17. Fuel filter											
* 18. Idle speed and air mixture											
EMISSION CONTROL SYSTEM											
* 19. Crankcase ventilation hoses and connections		-									
* 20. P.C.V. valve		-									
* 21. Fuel vapor storage system, hoses and connections		-									
ELECTRICAL											
* 22. Wiring harness, connections and head light		-									

Interval: This interval should be judged by odometer reading or months, whichever comes first	km (x 1 000)	1	10	20	30	40	50	60	70	80
	miles (x 1 000)	1	6	12	18	24	30	36	42	48
	months	1	6	12	18	24	30	36	42	48
CHASSIS AND BODY										
* 23. Clutch play										
* 24. Brake fluid						R				R
* 25. Brake pedal										
* 26. Brake lever and cable										
* 27. Brake discs and pads, Brake drums and shoes		-								
* 28. Brake hoses and pipes		-								
* 29. Tires (abnormal wear and pressure)		-								
* 30. Wheels, hub nuts and free wheeling hubs (optional)										
* 31. Shock absorbers										
* 32. Propeller shafts or Drive shafts			I&L		I&L		I&L		I&L	
* 33. Transmission, transfer and differential oil		R				R				R
* 34. Bolts and nuts		T		T		T		T		T
* 35. Steering condition										
* 36. Axle hub nut seats		-	R	R	R	R	R	R	R	R
* 37. Test drive										
38. Door hinges		L	L	L	L	L	L	L	L	L

Test drive on completion of each service

R: Replace or Change

I: Inspect and correct or replace if necessary

T: Tighten

L: Lubricate

CAUTION: Whether you're an expert or do-it-yourself mechanic, HOLDEN recommends that inspection of those items marked with an asterisk (*) be performed by your authorized HOLDEN dealer. Other items are relatively easy to handle and you can accomplish work by referring to the instructions set forth in this manual.

INSPECTION AND MAINTENANCE

PRECAUTIONS AGAINST ACCIDENTS

As with any machinery, extreme care should be taken when working on your vehicle to prevent accidental injury. Here are a few precautions that you should be especially careful to observe:

- When the engine is running, keep hands, clothing, tools, and others away from the moving fan and fan belt.
- Be careful not to touch hot exhaust components (manifold, pipes, mufflers).
- Do not allow smoking, sparks, or flames around gasoline or the battery, as the fumes are inflammable.
- Do not get under your vehicle if it is supported only with the portable jack provided in your vehicle.
- Be careful not to cause accidental short circuits between battery terminals (positive and negative).

CHECKING INSTRUMENTS

Turn the ignition switch to the "ON" position. Check that the pilot lights come on and that the fuel meter is working properly. After starting the engine, check the charge light and the water temperature gauge. When driving off, check that the speedometer is working properly.

CHECKING LIGHTS

Turn on the switches and check that the headlights, parking lights and other lights come on. Press the brake pedal and ensure that the braking lights light up. Put the shift lever into the R (reverse) position and check that the back lights come on. Finally, do not forget to check that the light lenses are not dirty or damaged.

HORN, TURN SIGNALS, WIPERS, WINDSHIELD WASHER & DEFROSTER

Check that the horn, turn signals, wipers, windshield washer and defroster are in proper working order.

CHECKING FUEL

Make sure that there is enough gasoline for the planned driving distance.

CHECKING DOOR LOCKS

Make sure that the doors lock properly.

CHECKING REAR MIRROR

Check that rear vision is clear from the driving position.

CHECKING REFLECTORS AND NUMBER PLATE

Check for dirt and damage. Check that the number plate is securely fixed and that the figures on it are clear.

CHECKING EXHAUST

Something is wrong if the exhaust is either excessively white or black. If this is the case, an inspection must be performed by your HOLDEN dealer. However, the exhaust gas may be found to be white on a cold day. This is quite normal as the exhaust gas contains water vapor that turns into mist with the exhaust system cold.

CAUTION: If you feel that there may be something wrong with any of the above inspection items, or if there is something wrong which you are unable to repair yourself, do not leave the car as it is but trust the repair works to your HOLDEN dealer.

FAN BELT

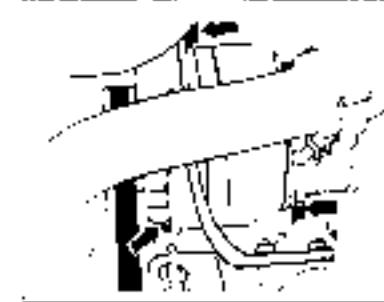
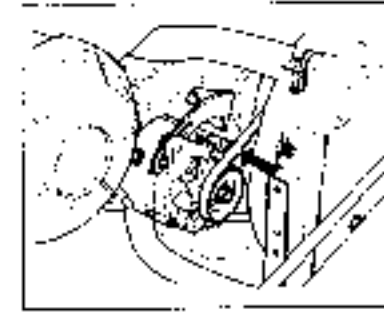

If the belt is too loose, insufficient battery charging, overheating or excessive belt wear will result. The tension of the belt should be such that there is a deflection of 10 - 15 mm when midway between the pulleys is pressed by your thumb. The belt should also be examined to ensure that it is not damaged. The belt should be adjusted or replaced in the following way.

1. Loosen the three bolts securing the alternator.
2. When stretching the belt, push the alternator outwards with the bolts loosened, tighten the bolts at the position in which the tension of the belt is within the limits specified above, and fix the alternator securely.
3. To replace the belt, slide the alternator inwards with the bolts loosened and replace the belt. Having replaced it, stretch the belt as specified in "2" above.

NOTE:

When replacing the belt with a new one, give tension slightly tighter than specification to allow for an initial stretch.

INITIAL TENSION: 8 - 10 mm (0.3 - 0.4 in) deflection with thumb pressure applied.

ENGINE OIL

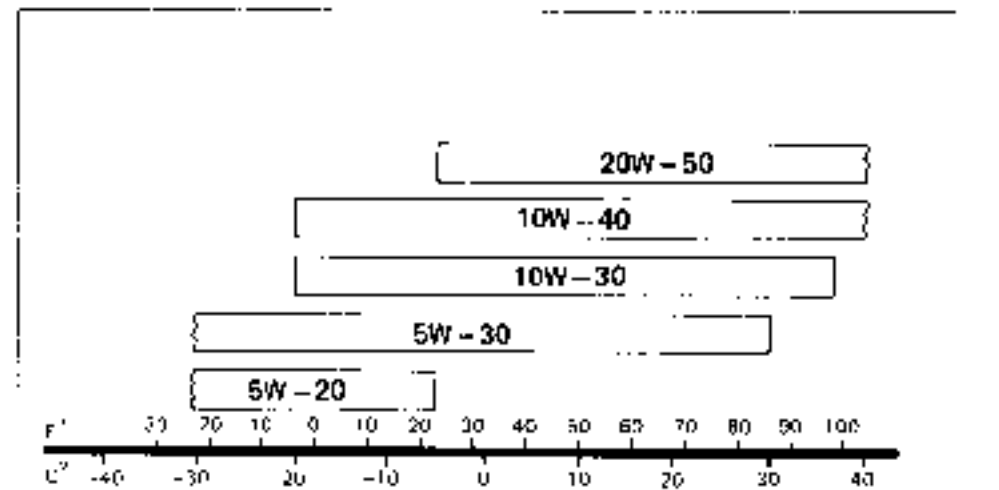

Specified oil

Be sure that the engine oil you use comes under the API classification of SE, SD or SF. Select the oil viscosity according to this chart.

Inspection

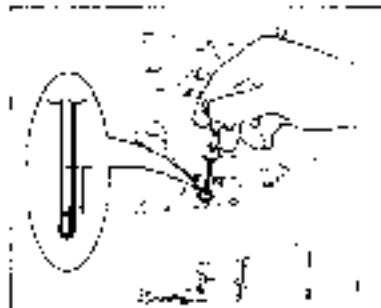

The oil level should be inspected with the car placed on a level surface. Incorrect level may be shown if the car is on a slope. The oil level should be checked either before starting the engine or at least two or three minutes after stopping the engine.

Pull out the oil dipstick, wipe oil off with a clean cloth, insert the dipstick all the way into the engine, then remove it again. The oil on the stick should be between the upper and lower limits. If it is near the lower limit, add oil to raise the level to the upper limit.

Refilling



Remove the filler cap and pour oil slowly through the filler hole to bring up the oil level on the dipstick to the upper limit. Be careful not to overfill. Too much oil is almost as bad as too little oil. After refilling, start and allow the engine to idle for about a minute. Stop the engine, wait for two or three minutes and check the oil level with the dipstick.

CHANGING ENGINE OIL AND FILTER

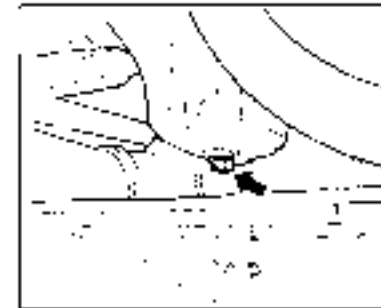

Drain the oil and reinstall the drain plug.

- Remove the oil filler cap.
- Place a drain pan under the drain plug.
- Using a wrench, remove the drain plug and drain out the engine oil while the engine is still warm.

WARNING: The engine oil temperature may be high enough to burn your fingers when the drain plug is loosened. Wait until the drain plug is cool enough to touch with bare hands.

- Reinstall the drain plug and gasket. Tighten the plug with a wrench.

Remove the old oil filter and install a new one.



A Oil filter wrench

- Using an oil filter wrench, unscrew the oil filter and remove it. It turns counter-clockwise.
- Using a clean rag, wipe off the mounting surface on the engine where the new filter will be seated.
- Smear a little engine oil around the rubber gasket of the new oil filter.
- Screw on the new filter by hand until the filter gasket contacts the mounting surface.

CAUTION:

To tighten the oil filter properly, it is important to accurately identify the position at which the filter gasket first contacts the mounting surface.

- Tighten the filter 2/3 turn from the point of contact with the mounting surface using an oil filter wrench.

CAUTION:

To prevent oil leakage, make sure that the oil filter is tight, but do not over-tighten it.

- Pour 3.5L of oil through the filler hole and install the filler cap.
- With the engine running, look carefully for leaks at the oil filter and drain plug. Run the engine at various speeds for at least 5 minutes.
- Stop the engine and wait a few minutes. Check the oil level again and add oil if necessary. Check for leaks again.

CAUTION:

When replacing the oil filter, it is recommended that you use a genuine HOLDEN replacement filter. If you use an aftermarket filter, make sure it is of good quality.

CAUTION:

Oil leaks from around the oil filter or drain plug indicate incorrect installation or gasket damage. If you find any leaks or are not sure that the filter has been properly tightened, have the vehicle inspected by your HOLDEN dealer.

CAUTION:

Failure to follow the instructions above may result in severe engine damage.

GEAR OIL

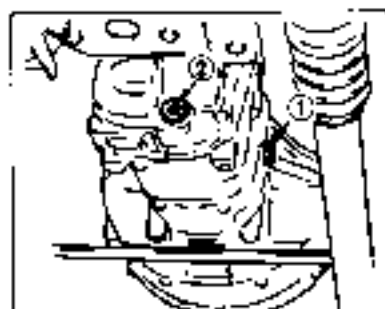

- 1 Oil filler plug
- 2 Oil drain plug

The transmission, transfer case and differentials are lubricated by gear oil. When replacing gear oil in any of the above three, follow the procedure below.

- Remove the oil filler plug.
- Drain the oil and replace the drain plug.
- Pour fresh gear oil through the filler hole until the oil level reaches the filler hole.
- Replace the filler plug.

NOTE:

When tightening the drain or filler plug, apply sealing compound Bond No. 1215 or equivalent to the plug threads to prevent oil leakage.

Differential oil change (front and rear)

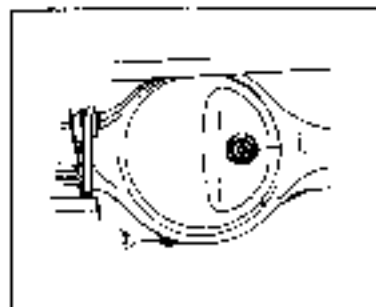

- 1 Oil filler plug
- 2 Oil drain plug

The type of oil to be used is "hypoid gear oil" of SAE #90. If the ambient temperature is below -15°C (5°F) use SAE 80W or 75W/80-85.

		DIL CAPACITY
TRANSMISSION		1.3L (2.7/2.5US/Imp pt)
TRANSFER CASE		0.8L (1.7/1.4US/Imp pt)
DIFFERENTIAL	FRONT	1.5L (3.2/2.8US/Imp pt)
	REAR	1.3L (2.7/2.3US/Imp pt)

ENGINE COOLANT

Recommended coolant

Use GOLDEN CRUISER 1200 properly mixed with water all year round. Change the coolant once every two years. Cooling water must be soft water—such as drinking water. Hard water (which includes well water and river water) contains many impurities (iron and the like) which may cause rust or foul inside the radiator leading to engine trouble.

GOLDEN CRUISER 1200 serves not only as an anti-freeze element, but also anti-foam, anti-rust and anti-corrosion besides being a lubricant for the water pump. To obtain these performances, it is necessary that the solution not be diluted to more than 30%.

When you replace the coolant, follow the instructions below.

Coolant mixture ratio

Lowest temperature	Concentration
-15°C (5°F) or above	30%
-16°C (3°F) or below	50%

Prepare the cooling solution according to the lowest ambient temperature expected in your area.

CAUTION:

If you use anti-freeze and summer coolant other than GOLDEN CRUISER 1200, observe the instructions given by each manufacturer.

Inspection



With the engine cool, check the coolant level in the reservoir tank. The level should be between the "FULL" and "LOW" marks. If the level is below the "LOW" mark, replenish the coolant following the procedure below.

- (1) Remove the reservoir cap.
- (2) Pour coolant into the reservoir tank until it reaches the "FULL" mark. The level must not exceed the "FULL" mark.
- (3) After the coolant has reached the "FULL" mark, refit the cap securely.

When there has been a large decrease in quantity of coolant, or when refilling has to be done frequently, it is possible that a leak may have occurred in the cooling system, and therefore an inspection should be carried out by your GOLDEN dealer.

Coolant replacement

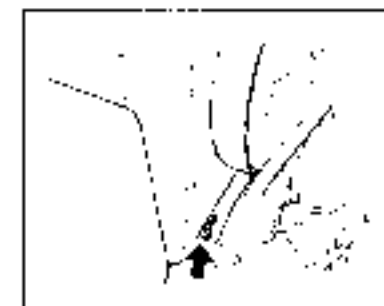
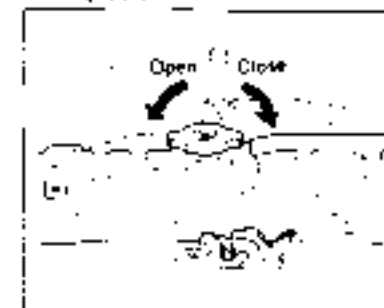

1. When the engine is cool, remove the radiator cap by turning it slowly to the left until a "stop" is felt. Do not press down while turning the cap. Wait until the remaining pressure is released, then press down on the cap and continue turning it to the left.
2. Remove the reservoir by lifting it up and drain completely.
3. Loosen the drain plug attached to the lower part of the radiator and drain off the coolant.
4. Fill the reservoir with coolant to the "FULL" line.

- Tighten the drain plug, fill the radiator with coolant and attach the radiator cap.
- After filling, let the engine idle for about 2 - 3 minutes to get rid of air within the cooling system.
- Since the coolant level may have gone down, check and refill the radiator to the filler inlet.

CAUTION: The coolant must be replaced with the car on level ground.

WARNING: It is dangerous to remove the radiator cap when the water temperature is high, because scalding fluid and steam may be blown out under pressure. The cap should only be taken off when the coolant temperature has lowered.

AIR CLEANER

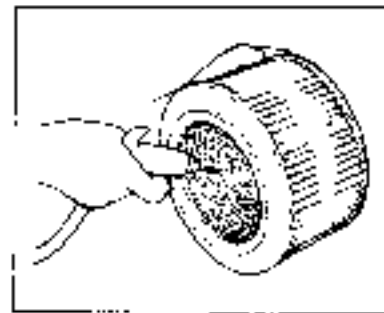
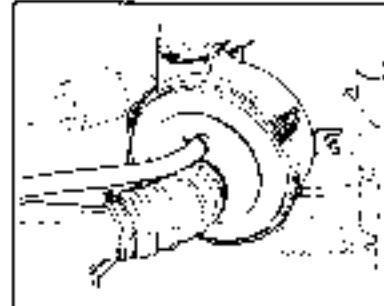

If the air cleaner is clogged with dust, intake resistance will be increased with a resultant decrease in output and increase in fuel consumption. Check and clean periodically according to the following procedure:

- Unhook the clamps and take off the air cleaner cap. Remove the element from the air cleaner case.
- This air cleaner element is of dry type. Remember that it needs cleaning according to the following method and interval.
- Blow off dust on cleaner element by compressed air from inside element.

Element cleaning interval	
Paved road	Clean every 10 000 km 16 000 miles
Dusty condition	Clean every 2 500 km (1 500 miles) or as required

NOTE: Replace every 40 000 km (24 000 miles). More frequent replacement if under dusty driving condition.

AIR INTAKE CONTROL LEVER



Based on the atmospheric temperature as listed below, the air intake control lever should be turned to position ①, ② or ③.

Atmospheric temperature	Position of lever
-5°C (23°F) below	①
-5°C (23°F) ~ 15°C (59°F)	②
15°C (59°F) above	③

With the lever turned to position ① or ②, air heated by the exhaust manifold is fed to the carburetor passing through the air cleaner. This assures the best engine efficiency even under cold weather.

CAUTION: As engine over-heating may result, do not turn the lever to position ① or ② when the air temperature exceeds 15°C (59°F).

SPARK PLUGS

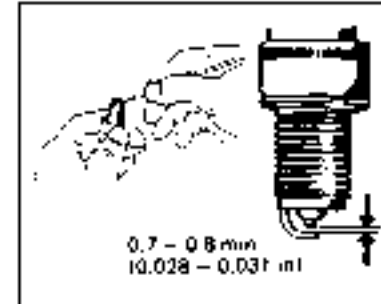
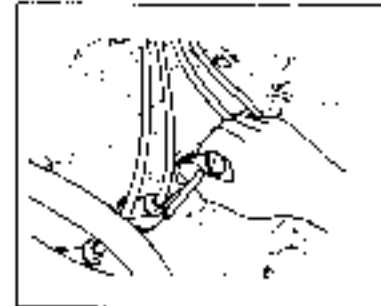

The standard spark plug for QB is either NGK BP5ES or NIPPON DENSO W16EX-U.

When carbon accumulates on the spark plug, a hot, strong spark will not be produced. Remove carbon deposits with a wire or pin and adjust the spark plug gap to 0.7 - 0.8 mm (0.028 - 0.031 in.).

	REMARKS
NGK BP5ES or NIPPON DENSO W16EX-U	Standard

CAUTION:

- When installing the spark plug, screw it in with your fingers, to avoid stripping the threads, then tighten with a torque wrench to 25.0-30.0 N.m (2.5-3.0 kg-m, 18.0-22.0 ft-lb).
- Do not use a spark plug with the wrong thread size. If the spark plug threads are either protruded or receded inside the cylinder head, carbon can accumulate on the exposed thread portion and this may cause damage to the threads when removing the plug or replacing with correct plug.
- If a brand of spark plug is to be used other than the NGK or NIPPON DENSO, consult your HOLDEN dealer.

STEERING

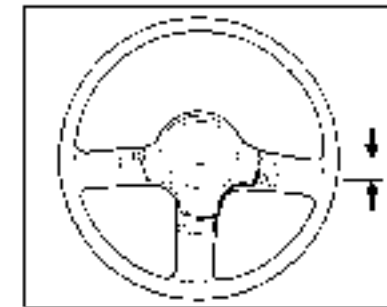

Check the play of the steering wheel by gently turning it from left to right. The play of the wheel should be below 15 mm around the circumference. When driving very slowly in an open area, turn the steering all the way to the right and to the left to check that the steering wheel turns lightly and smoothly without rattle. If anything is found to be wrong, an inspection must be performed by your HOLDEN dealer.

CLUTCH PEDAL

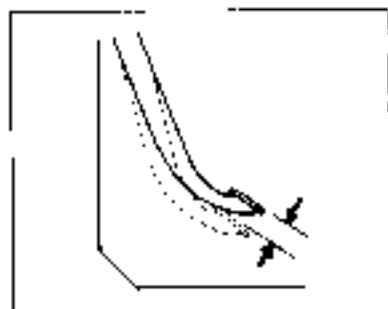

The play of the clutch pedal must be within 15–25 mm (0.6–1.0 in). If the play is more or less than the above, or clutch dragging is felt with the pedal pressed, contact a HOLDEN dealer, where it will be inspected and repaired.

BRAKES

Brake fluid

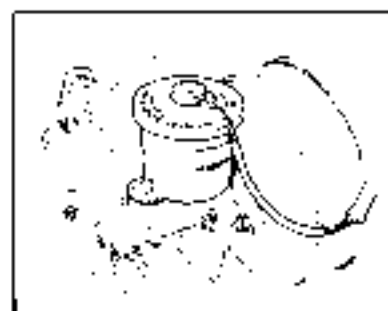

The brake fluid tank will be seen if the hood is opened. Check that the oil level is above the "MIN" line. If it is at or close to the "MIN" line, fill up with brake fluid listed below.

Brake fluid	Specifications
	SAE J1703 or DOT3

CAUTION:

- (1) Since the brake system of your vehicle is factory-filled with a glycol-based brake fluid, do not use or mix it with a different type of fluid when refilling the system, otherwise serious damage will be caused. Do not use a brake fluid taken from old or used or un-

- (2) sealed containers.
- (2) The brake fluid should be replaced once every two years.
- (3) Take every caution when filling the reservoir because brake fluid can harm your eyes and damage painted surfaces.

WARNING:

As the brake fluid level in the reservoir goes down, the brake warning light on the instrument panel comes on while the engine is running. Should the light come on, inspect the reservoir for the brake fluid level. If the fluid is found to be below the "MIN" level, immediately ask your HOLDEN dealer to inspect the brake system.

Brake pedal

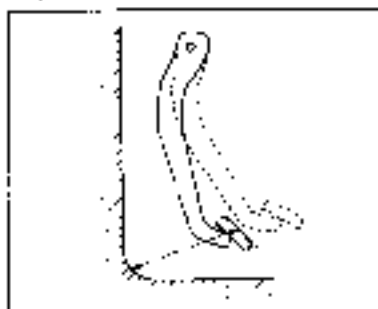

Check the brake pedal for the distance between the pedal and wall when the pedal is pressed with approximately 30kg (66 lbs) of force. The minimum distance required is 75mm (3.0 in).

NOTE:

Measure pedal-to-metal wall distance in the pedal stroke direction with the engine ON. Be sure not to include the mat or rubber on the wall.

As this brake system has a self-adjusting feature, there is no need of pedal adjustment. If, however, the pedal distance should be found abnormal, take your vehicle to your HOLDEN dealer.

If the following troubles are found in your brake system, an inspection and repairs must be immediately performed by your HOLDEN dealer.

- 1 Poor braking performance
- 2 Uneven braking (Brakes not working uniformly on all wheels)

- 3 Pedal stroke too large
- 4 Dragging brake
- 5 Excessive braking noise
- 6 Pedal pulsation (Pedal pulsates when pressed for braking.)

Parking brake

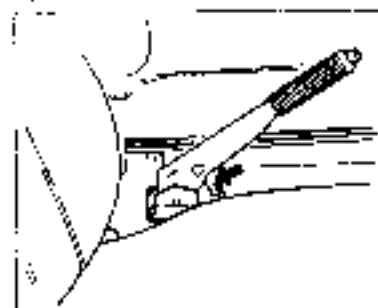

Set the parking brake lever by pulling it all the way up and check that the rear wheels are properly locked and that the parking brake lever stops at its 3rd ~ 6th ratchet tooth when the parking lever grip is held at its mid position and pulled up with approximately 20 kg (44 lbs) force. Also check that the brakes are not dragging when the brake lever is fully returned. If any of the above is found to be wrong, take your vehicle to HOLDEN dealer.

JACKING INSTRUCTIONS

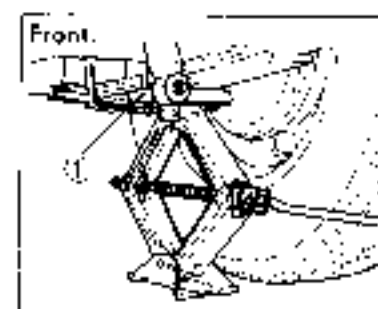

① Spring seat

- 1 Place the vehicle on level, hard ground.
- 2 Set the parking brake firmly. Block front and rear of the wheel diagonally opposite to the wheel being lifted.
- 3 Set the jack vertically and raise it until the jack head fits under the spring seat as illustrated.
- 4 Operate the jack slowly and smoothly until the tire clears the ground. Do not raise more than necessary.

WARNING:

- (1) Care should be taken to check that the vehicle is being raised vertically during the "jacking-up" process. If the jack begins to "tilt," lower the jack to correct the position.
- (2) Never jack-up the vehicle on an inclined surface.
- (3) To avoid chance of personal injury, never allow anyone to get under the vehicle while being jacked up.

TIRES

The following checks should be performed:

1. Measure the air pressure with a tire gauge.

CAUTION:

- (1) Air pressures should be checked when the tires are cold.
- (2) It is dangerous to give the tires too much air pressure. Pressure should not be in excess of 2.5 kg/cm² (36 psi, 250 kPa). Check the inflation pressure from time to time while inflating the tire gradually, until the specified pressure is obtained.

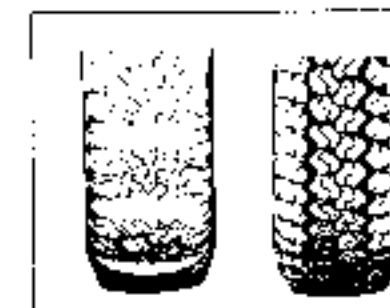

2. Check that the depth of the tread groove is more than 1.6 mm. To help you check this, the tires have molded-in tread wear indicators in the grooves. When the indicators appear on the tread surface, the remaining depth of the tread is 1.6 mm or less and the tire should be replaced.
3. Check for abnormal wear, for cracks and for damage. When there is abnormal wear, an inspection should be performed by a HOLDEN dealer. New tires should be fitted when there are cracks or damage.
4. Check for loose wheel nuts.
5. Check that there are no nails, stones or other objects sticking into the tires.

CAUTION:

When replacing the tires, use tires of the same size and type on each of the four wheels. If the same size and type are not used, satisfactory 4-wheel drive operation will not be possible or the drive train may be damaged.

TIRE ROTATION

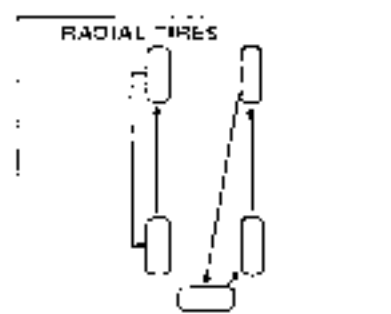

To avoid unbalanced wear of your tires and to prolong their lifespan, rotate tires, as illustrated. Tires should be rotated every 10 000 km (6 000 miles) as recommended in the periodic maintenance schedule. After rotation, adjust the front and rear tire pressures to the specification (see label on the driver's side of instrument panel).

Changing wheel

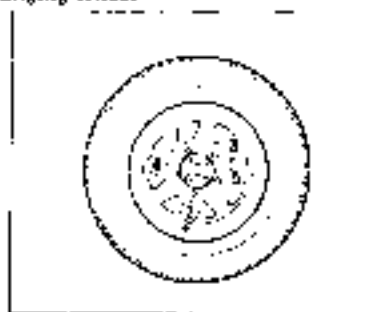

Follow the procedure below:

1. Remove jack, tools and spare wheel from the vehicle.
2. Loosen, but do not remove the wheel nuts.
3. Jack up the vehicle (follow the "Jacking instructions" in this manual).
4. Remove the wheel.
5. Install the wheel and replace the wheel nuts with their cone shaped end facing the wheel. Tighten each nut slightly until the wheel is seated on the hub.
6. Lower the jack and fully tighten the nuts in a criss-cross fashion by using a wrench.

WINDSHIELD WASHER FLUID



Check that there is washer fluid in the tank. Refill if it is not sufficient. Use good quality windshield washer fluid or mix it with water if necessary.

CAUTION: Damage will result if the motor is operated with no fluid in the washer tank. Never use engine anti-freeze as a substitute, or paint damage will result.

BATTERY

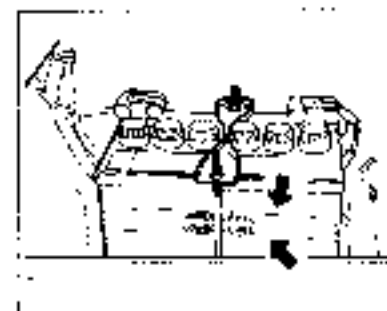

The level of the battery solution must be kept between the "UPPER" and the "LOWER" level lines at all times. If the level is found to be below the "LOWER" level line, add distilled water to "UPPER" level line. Loosening and corrosion of the terminals will result in poor contact. When found on the terminal section, white powder should be washed off with warm water and then grease or vaseline should be applied. Make sure that no warm water gets into the battery.

WARNING:

Since inflammable hydrogen gas is produced by the battery, keep away from fire or sparks whenever handling it. Otherwise, an explosion can occur. It is dangerous if battery fluid gets into the eyes or on the skin. In this respect care should be taken. If by any chance it should get on the skin, the part affected must be washed immediately with plenty of water for at least five minutes, and a medical specialist should be consulted.

FUSES

There are two basic types of fuse. One is the main fuse (fusible link), which takes the current directly from the battery. The other is the fuse present in each electrical circuit.

Main fuse (fusible link)



As mentioned above, the fusible link takes current directly from the battery. When this link has blown, no electrical component will function. If this happens, check the fusible link located at the battery positive terminal. When replacing the fusible link, use a HOLDEN genuine replacement.

CAUTION: If the fusible link blows, be sure to have an inspection carried out by a HOLDEN dealer. Always use a genuine HOLDEN fusible link for replacement. Never use a substitute such as wire even for a temporary fix. It can cause extensive electrical damage, possibly a fire.

Fuse box

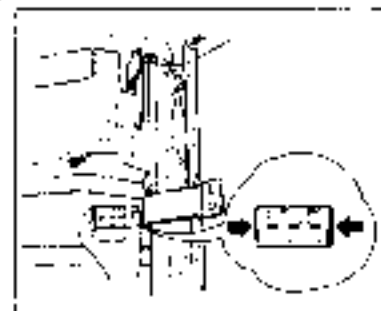

The fuse box is located under the driver's side of the dashboard. To remove the fuse, simply pull out after removing the fuse box cover. To identify the amperage and location, refer to the fuse list shown on the fuse box cover.

NOTE:

To remove the fuse box cover, press the cover at its left and right by hand as illustrated and pull it toward you.

CAUTION: Always be sure to replace a blown fuse with a fuse of the correct amperage. Never use a substitute, for example aluminum foil or wire, to replace a blown fuse. If the spare fuse installed blows in a short period of time it means that you could have a major electrical problem. You should consult your HOLDEN dealer immediately.

NOTE:

Make sure to replace the spare fuses if they are used so that the fuse box cover always carries three spare fuses, 10A and 15A.

BULB REPLACEMENT

CAUTION: Frequent replacement of bulb indicates the need for an inspection of the electrical system. This should be carried out by your HOLDEN dealer.

Interior light

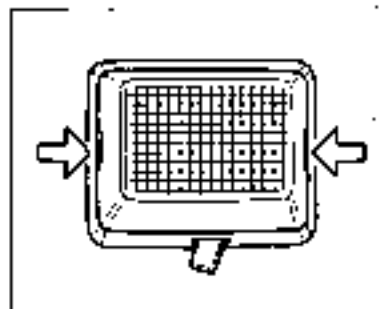

Press the lens at the positions indicated by the arrow and remove it. The bulb can be removed by simply pulling it down. When replacing the bulb, make sure that the contact springs are holding the bulb securely.

Headlights



Remove the plastic headlight surrounds by pushing their pegs from the back side. The headlights can be removed by turning to the left while pushing in the headlight unit. Remove the coupler on the back side of the headlight unit and the unit may be taken out. Do not loosen the three screws securing the headlight unit. Attach a new headlight unit in the reverse order.

CAUTION: Adjustment of the headlight beam is necessary after replacing the headlight unit. If you have performed the replacement work yourself, make sure you take the vehicle to your authorized HOLDEN dealer for proper adjustment.

Turn signal lights, combination light, back-up light and licence plate lights

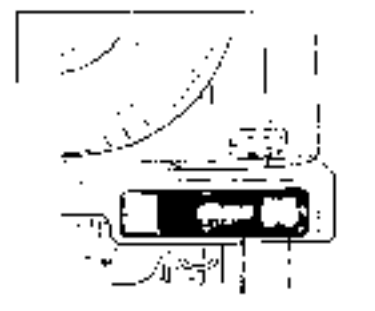

- 1- Turn signal light
- 2- Clearance light

Side turn signal light



Back up light

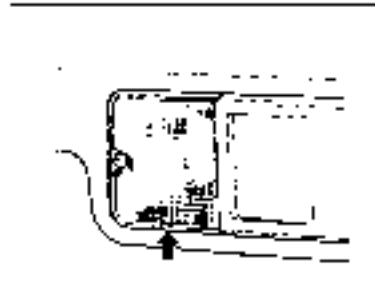

Licence plate light

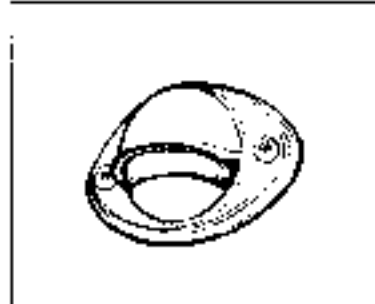

Undo the two screws holding in the lens and remove it. The bulb can be removed by pushing it in and turning it counterclockwise. A new bulb is installed by performing the same actions in reverse order.

CORROSION PREVENTION

Listed below are instructions on how you should maintain your vehicle to prevent corrosion. Please read and follow these instructions carefully.

IMPORTANT INFORMATION ABOUT CORROSION

Common Causes of Corrosion

1. The accumulation of road salt, dirt, moisture or chemicals in hard to reach areas of the vehicle underbody or frame.
2. Chipping, scratches and any damage to treated or painted metal surfaces resulting from minor accidents or by impact from stones and gravel.

Environmental Conditions Which Accelerate Corrosion

1. Road salt, dust control chemicals, sea air or industrial pollution will all accelerate the corrosion of metal.
2. High humidity will increase the rate of corrosion particularly when the temperature range is just above freezing point.
3. Moisture in certain areas of a vehicle for an extended period of time may promote corrosion even though other body sections may be completely dry.
4. High temperatures will cause an accelerated rate of corrosion to parts of the vehicle which are not well ventilated to permit quick drying.

The aforementioned information illustrates the necessity of keeping your vehicle (particularly the underbody) as clean and dry as possible. In addition to this, it is equally important to repair any damage to the paint or protective coatings as soon as possible.

Washing

The best way to preserve the finish on your vehicle and to help avoid corrosion is to keep it clean with frequent washing.

Wash your vehicle at least once during the winter and once immediately after the winter. Keep your vehicle, particularly the underside, as clean and dry as possible.

If you are frequently driving on salted roads, your vehicle should be washed at least once a month during the winter and once immediately after the winter.

If you are living near an ocean, your vehicle should be washed at least once a month throughout the year.

Wash your vehicle immediately after each use in off-road conditions. For washing instructions, refer to the section "APPEARANCE CARE."

Foreign Material Deposits

Foreign material such as salts, chemicals, road oil or tar, tree sap, bird droppings and industrial fall-out may damage the finish of your vehicle if it is left on painted surfaces. Remove these types of deposits as quickly as possible. If these deposits are difficult to wash off, an additional cleaner may be required. Ensure that any cleaner that you use is not harmful to painted surfaces and is specifically intended for the purposes which you intended. Follow the manufacturer's directions when using these special cleaners.

Finish Damage

Carefully examine your vehicle for damage to the painted surfaces, especially if it is used off-road. Should you find any chips or scratches in the paint, touch them up immediately to prevent corrosion from starting. If the chips or scratches have gone through to the bare metal, have a qualified body shop make the repair.

Passenger and Cargo Compartments

Moisture, dirt or mud can accumulate under the floor mats and may cause corrosion. Occasionally, check under these mats to ensure that this area is clean and dry. More frequent checks are necessary if the vehicle is used off road or in wet weather.

Certain cargos such as chemicals, fertilizers, cleaners, salts, etc are extremely corrosive by nature. These products should be transported in secure containers. If a spill or leak does occur, clean and dry the area immediately.

Mud and Gravel Shields

The use of mud and gravel shields will help protect your vehicle, especially if you frequently drive on gravel or salted roads. Full-size shields, which extend as close to the road as is practical are of course the best. The fittings for such shields should also be corrosion resistant. Please check with your authorized HOLDEN dealer for information on these shields.

Storage

Do not park your vehicle in a damp, poorly ventilated area. If you often wash your vehicle in the garage or if you frequently drive it in when wet, your garage may be damp. The high humidity in the garage may cause or accelerate corrosion. A wet vehicle may corrode even in a heated garage if the ventilation is poor.

APPEARANCE CARE

CAUTION:

When cleaning the interior or exterior of the vehicle, NEVER USE volatile solvents such as lacquer thinner, gasoline, benzene or such cleaning materials as bleaches, strong household detergents. Some of the above materials may be poisonous or flammable and their improper use may cause personal injury or damage to the vehicle.

CLEANING INTERIOR

Vinyl Upholstery

Prepare a solution of soap or neutral detergent mixed with warm water. Apply solution to the vinyl with a sponge or soft cloth and let it soak for a few minutes to loosen dirt. Rub the surface with a clean, damp cloth to remove dirt and soap solution. If some dirt still remains on the surface, repeat the procedure.

Fabric Upholstery

Remove loose dirt by vacuum cleaner. Rub the stained area with a clean cloth made damp with soap solution and then wipe by rubbing with another cloth slightly wet with water to absorb and remove soap. Repeat this until the stain is cleaned. You may use commercially available fabric cleaner. In this case, carefully follow the manufacturer's instructions and precautions.

Seat Belts

Clean seat belts with mild soap and water. Do not use a bleach or dye on the belts—it may weaken them.

Vinyl Floor Mats

Ordinary dirt can be removed from vinyl with water and mild soap. Use a brush to help loosen dirt. After dirt is loosened, rinse the mat thoroughly with water and dry it in the shade.

Carpets

Remove dirt and soil as much as possible by vacuum cleaner. Rub the stained area with clean cloth made damp with soap solution and then wipe by rubbing with another cloth slightly wet with water to absorb and remove soap. Repeat this until the stain is cleaned. You may use commercially available carpet cleaners. In this case, carefully follow the manufacturer's instructions and precautions.

CLEANING EXTERIOR

Dirt or any other foreign material on the painted surfaces can cause such problems as the following, as time goes on:

1. Faded paint
2. Body rust due to deteriorated paint film.
3. Body rust due to scratches possibly caused by dirt or foreign material
4. Body rust due to contact with damp dirt trapped in the body

Therefore, it is important that your HOLDEN vehicle should always be kept clean and free from dirt in order to maintain the paint in a good condition and to protect the entire body against corrosion.

Washing

When washing the vehicle, follow the instructions below.

1. Flush the underside of body and wheel housings with pressurized water to remove mud and debris. Use plenty of water to loosen and thoroughly remove dirt.
2. Remove dirt and mud from the body exterior with running water. You may use a soft sponge, brush or the like with water. Do not use hard materials which can scratch the paint.

CAUTION:

1. Hot water should not be used to wash the vehicle in cold weather as it may cause the paint to crack.
2. If washing only serves to wet caked-on mud and debris without removing it, then it will do more harm than good.
3. When using commercial car-wash products, observe the precautions as specified by the manufacturers. Never use strong household detergents or soaps.

3. Wash the entire exterior with neutral detergent or car wash soap lightly rubbing with sponge or soft cloth. The sponge or cloth should be frequently soaked in the solution.
4. Once the dirt has been completely removed, wash off the detergent with the running hose water.
5. After rinsing, wipe off the body lightly with a wet chamois or cloth and allow the body to dry in the shade.
6. Check carefully for damage to the painted surfaces. If any is found, "touch-up" the damage following the procedure below.
 - (1) Clean all damaged spots and allow them to dry.
 - (2) Stir the paint and "touch-up" the damaged spots lightly with a small brush.
 - (3) After painting, allow them to properly dry.

WARNING:

After washing, check the brakes are dry. If the brakes are not dry, dry them by gently and repeatedly applying brakes while driving at low speed.

Waxing

After washing the vehicle, waxing and polishing are recommended to further protect and beautify the paint.

- * Only use waxes and polishes of good quality.
- * When using waxes and polishes observe the precautions specified by the manufacturers.
- * Chrome parts should also be waxed.

Fender extensions

CAUTION:

1. Avoid directing steam or hot water of more than 80°C to the fender extension or other plastic parts when washing the car.
2. Do not apply white wax on the fender extension. If waxing is necessary, use black wax.
3. Be careful not to spill any brake fluid, battery fluid, grease or oil onto the fender extension or other plastic parts. Should a spill occur, wipe it off with a cloth that is damp with alcohol, then wash it off with water.

BREAKDOWNS AND EMERGENCY REMEDIES

When starter does not operate:

1. Try turning the ignition switch to the "START" position with the headlights turned on to determine the battery condition. If the headlights go dim excessively or go off, it usually means that either the battery has run down or battery terminal contact is poor. Recharge the battery or correct the contact when the cause is determined.
2. If the headlights remain bright, check the fuses. If the trouble persists, take your vehicle to your authorized HOLDEN dealer as there may be a major electrical problem.

Jump starting instructions:

If the engine will not start due to a discharged battery a well charged, separate battery or one in another vehicle may be connected to the system to help supply enough electric energy.

WARNING:

Batteries produce explosive gases, contain corrosive acid and supply levels of electrical current high enough to cause burns. To lessen the chance of personal injury when working near a battery, follow the instructions below.

- Always shield your eyes and avoid leaning over the battery.
- Do not expose the battery to open flames or sparks.
- Do not allow battery acid to contact eyes or skin. If any part of your skin does come into contact with battery acid, wash the affected area with water immediately and thoroughly, and get medical help.

When connecting a battery for jump starting, follow the instructions below.

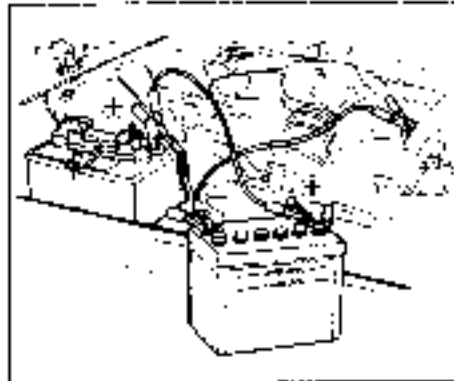

1. Place a good 12V battery close to the vehicle so that the jumper cables will reach the vehicle's battery. When using a battery installed on another vehicle, bring both the vehicles close to each other but do not let the vehicles touch.
2. Clamp one end of the first jumper cable to the positive (+) terminal on one battery and the other end to the positive (+) terminal on the other battery.
3. Clamp one end of the second jumper cable to the negative (-) terminal of the good battery and the final connection to an unpainted, heavy metal part of the engine that has the discharged battery. Make sure that the cables are not on or near pulleys, belt or fans.
4. Start the engine of the vehicle with the good battery. Then, start the engine that has the discharged battery.
5. Remove the jumper cables by reversing the above installation sequence.

When engine is flooded:

If the engine is flooded with gasoline, the engine may be hard to start. In that case, press the accelerator pedal all the way down and hold, but do not pump. Turn the engine until it fires, clears the excess gasoline and runs smoothly. (But, do not operate the starter motor for more than 10 seconds).

When engine overheats:

The engine could overheat temporarily during severe driving conditions. If the engine coolant temperature gauge indicates overheating during driving:

- Turn off air conditioner, if equipped;
- Take the vehicle to a safe place and park; and
- Let the engine run at normal idle speed for a few minutes until the gauge temperature goes down to the safe zone.

If the temperature does not go down, check the following.

WARNING:

If you see or hear escaping steam, stop the vehicle and turn off the engine immediately to let it cool. When no steam can be seen or heard, open the hood and check if the coolant is still boiling. If such is the case, wait until it stops.

- Check that water pump belt and pulleys are not damaged or slipping, and the fan operates with the ignition switch on. If any abnormality is found, adjust or correct the trouble.
- Check the coolant level in the reservoir. If it is found to be lower than the "LOW" line, look for leaks at the radiator, water pump, and radiator and heater hoses. If you locate the leaks that may have caused the overheating, do not run the engine until these problems have been corrected.
- If you do not find a leak, carefully add coolant to the reservoir and then radiator, if necessary. (See "ENGINE COOLANT" in "PERIODIC MAINTENANCE SERVICE" section for proper antifreeze and mixture.)

TOWING YOUR VEHICLE

If your vehicle needs to be towed, follow the instructions below to avoid accidents and damage to your vehicle.

Two-wheel towing:

If your vehicle is to be towed by a wrecker, lift the front wheels off the ground, shift the transmission to neutral, the transfer gear to the 2H position and release the parking brake.

4-wheel towing:

Your vehicle may be towed with all four wheels on the ground if the steering and drive train are in good condition. For such towing, unlock the steering, shift the transmission to neutral, transfer gear to the 2H position and release the parking brake. Be sure to use proper towing equipment exclusively designed for this type of towing.

CAUTION:

- A safety chain should be used for all towing.
- Do not tow your vehicle from the rear whether with all four wheels on the ground or with rear wheels lifted off the ground as the steering lock may be damaged due to road impact during towing.

VEHICLE IDENTIFICATION NUMBER

CHASSIS SERIAL NUMBER

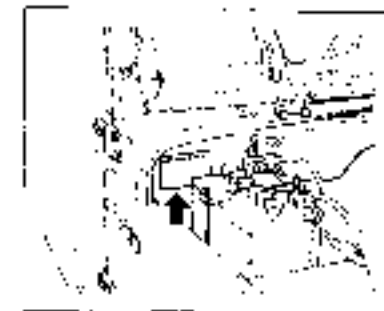

The chassis serial number is stamped on the frame member as shown in the illustration. The chassis and/or engine serial numbers are used to register the vehicle. They are also used to assist your dealer when ordering or referring to special service information. Whenever you have occasion to consult your HOLDEN dealer, remember to identify your vehicle with this number. Should you find the number difficult to read, you will also find it on the identification plate.

ENGINE SERIAL NUMBER



The engine serial number is stamped on the cylinder block as shown in the illustration.

SPECIFICATIONS

NOTE:
Specifications are subject to change without notice.

ITEM	BQS25	BQS16	BQT16
DIMENSIONS			
Overall length	3 430 mm (135.0 in)	3 440 mm (135.4 in)	—
Overall width	1 460 mm (57.5 in)	—	—
Overall height	1 680 mm (66.1 in)	1 680 mm (66.5 in)	1 640 mm (64.6 in)
Wheelbase	2 030 mm (79.9 in)	—	—
Tread, front	1 210 mm (47.6 in)	—	—
rear	1 220 mm (48.0 in)	—	—
Load deck size, length	870 mm (34.3 in)	840 mm (33.1 in)	—
width	1 270 mm (50.0 in)	1 215 mm (47.8 in)	—
height	1 020 mm (40.2 in)	1 045 mm (41.1 in)	1 185 mm (47.0 in)
Ground clearance	225 mm (8.9 in)	—	—
WEIGHT			
Curb weight	860 kg (1 896 lbs) (2 passenger)	870 kg (1 915 lbs) (2 passenger)	—
Gross axle weight rating, front	870 kg (1 918 lbs) (4 passenger)	890 kg (1 962 lbs) (4 passenger)	910 kg (2 005 lbs) (4 passenger)
rear	515 kg (1 135 lbs)	515 kg (1 135 lbs)	—
Gross vehicle weight rating	805 kg (1 775 lbs)	825 kg (1 819 lbs)	—
Seating capacity	2 or 4 persons	—	—

ITEM	BQS80	BQS60
DIMENSIONS		
Overall length	3 890 mm (153.1 in)	—
Overall width	1 460 mm (57.5 in)	—
Overall height	1 680 mm (66.1 in)	—
Wheelbase	2 375 mm (93.5 in)	—
Tread, front	1 210 mm (47.6 in)	—
rear	1 220 mm (48.0 in)	—
Load deck size, length	1 550 mm (61.0 in)	—
width	1 320 mm (52.0 in)	—
height	280 mm (11.0 in)	—
Ground clearance	225 mm (8.9 in)	—

ITEM	BQS80	BQS60
WEIGHT		
Curb weight	890 kg (1 962 lbs)	840 kg (1 852 lbs)
Gross axle weight rating, front	525 kg (1 157 lbs)	—
rear	865 kg (1 907 lbs)	—
Gross vehicle weight rating	1 390 kg (3 064 lbs)	—

ITEM	All models
ENGINE	
Type	Four-stroke cycle, water cooled, OHC
Number of cylinders	4
Lubrication system	Wet sump
Bore	74.0 mm (2.91 in)
Stroke	77.0 mm (3.03 in)
Piston displacement	1 324 cm ³ (1 324 cc, 80.8 cu.in)
Compression ratio	8.9 : 1
Carburetor	AISAN two-barrel down draft
Air cleaner	Polyester fiber element (Dry type)
ELECTRICAL	
Ignition timing	10° B.T.D.C. at 850 r/min
Standard spark plug	NGK BP5ES or NIPPON DENSO W16EX-U
Starter	Magnetic shift type
Generator	Alternator
Battery	12V 108 KC (30AH)/20HR
Main fuse	0.5 mm ² (fusible link)
Fuse box	10/10/10/10/15/15/15/15/10/10A
Headlight signal light	12V 80/50W
Side turn signal light	12V 5W
Clearance light	12V 5W
Tail/brake light	12V 5/21W
License plate light	12V 5W
Back-up light	12V 21W
Interior light	12V 5W
Meter pilot light	12V 3.4W
Brake system warning light	12V 3.4W
Parking brake indicator light	12V 3.4W

ITEM	8QS28/8QS16/8QT16	8QS80/8QS80
TRANSMISSION		
Clutch type	Dry, single disc	
Transmission type	5-forward all synchromesh, 1 reverse	
Final reduction ratio	3.908	
Gear ratios, low	3.650	
2nd	1.946	
3rd	1.472	
4th	1.000	
5th	0.793	
reverse	3.463	
Transfer gear ratios, low range	2.268	
high range	1.409	
WHEEL AND SUSPENSION		
Tire size, front and rear	FR78-15	6.00-16-4PR
Tire pressure, front	140 kPa (1.40 kg/cm ² , 20 psi)	-
rear	140 kPa (1.40 kg/cm ² , 20 psi) ... Untladen	210 kPa (2.1 kg/cm ² , 30 psi)
rear	180 kPa (1.80 kg/cm ² , 26 psi) ... Laden	
Suspension type, front and rear	Leaf spring	
STEERING		
Turning radius	4.9 m (16.1 ft)	5.7 m (18.7 ft) 18QS80/8QS80
Steering gear box	Ball nut	
Top-in	2 - 6 mm (0.08 - 0.24 in)	
Camber angle	1°00'	
Caster angle	3°30'	
Trail	19.0 mm (0.75 in)	
King pin angle	8°00'	

ITEM	All models
BRAKE SYSTEM	
Type	4-wheel, hydraulic
Wheel brake, front	Disc brake (floating caliper type)
rear	Drum brake (leading and trailing)
Parking brake	Mechanical actuated on propeller shaft
CAPACITIES	
Cooling solution	6.0 L (10.6/8.8 US/Imp pt)
Fuel tank	40 L (10.6/8.8 US/Imp gall)
Engine oil	3.5 L (7.4/6.2 US/Imp pt)
Transmission oil	1.3 L (2.7/2.3 US/Imp pt)
Differential gear oil, front	1.5 L (3.2/2.8 US/Imp pt)
rear	1.3 L (2.7/2.3 US/Imp pt)
Transfer gear box oil	0.8 L (1.7/1.4 US/Imp pt)

This document was downloaded free from

www.iw1axr.eu/carmanual.htm

Questo documento è stato scaricato gratuitamente da

www.iw1axr.eu/auto.htm