



**RollX**  
VANS

# CHRYSLER / DODGE MINIVAN

Service Manual



## 2011-2014 Model Year

Main: (800) 956-6668  
Local: (952) 890-7851  
Fax: (952) 808-2775

Your life. Your ride. <sup>TM</sup>  
6591 W. Hwy 13  
Savage, MN 55378  
[www.rollxvans.com](http://www.rollxvans.com)





**C hrYSler / d odge Minivan**  
**2011-2014 Model Year**  
**Service Manual**

#13315-004  
June 2014



Important Item Locations .....	1
Battery Information - General .....	6
Battery Information - Draw Test Procedure .....	8
Rollx Vans Door (Motor Bar) - Troubleshooting.....	9
Rollx Vans Door (Motor Bar) - Replacement Parts.....	10
OEM Power Door - Troubleshooting.....	11
Door Modifications.....	12
Exhaust System.....	14
Exterior / Van Dimensions .....	16
Fuel System.....	17
Front Suspension (Struts).....	23
Rear Suspension .....	24
Engine Mounting (Cradle Drop).....	25
Torque Specifications (Suspension) .....	26
Interior.....	27
Kneeler - Troubleshooting.....	29
Kneeler - Replacement Parts.....	30
One Touch System - Troubleshooting.....	31
One Touch System - Overview.....	32
One Touch System - v8.0 Basic Interface.....	34
One Touch System - v8.0 Advanced Interface - Setup.....	35
One Touch System - v8.0 Advanced Interface - Debugger .....	36
One Touch System - v8.0 Error Codes.....	38
One Touch System - Relay Board Troubleshooting.....	41
In The Floor - Troubleshooting .....	43
In The Floor - Replacement Parts .....	44
Folding Ramp - Troubleshooting .....	45



Folding Ramp - Replacement Parts .....	46
Folding Ramp - Motor Install / Removal and Adjustment .....	49
Rear Heat & Air.....	51
Remote System - Troubleshooting .....	52
Remote System - Location & Wiring .....	53
Seat Detector - Location & Description .....	54
Seat Wiring - Driver's Side (2011-2014).....	55
Seat Wiring - Passenger's Side (2011-2012) .....	63
Seat Wiring - Passenger's Side (2013-2014) .....	69
One Touch - Wiring (With Door Open Limit Switch).....	73
One Touch - Wiring (With Door Detector).....	75
One Touch - Wiring (No Can Bus).....	77
One Touch - Wiring (With Wing Window Interface).....	79
Rollx Vans Power Door (Motor Bar) - Wiring .....	81
Maintenance Information.....	83
Warranty .....	84

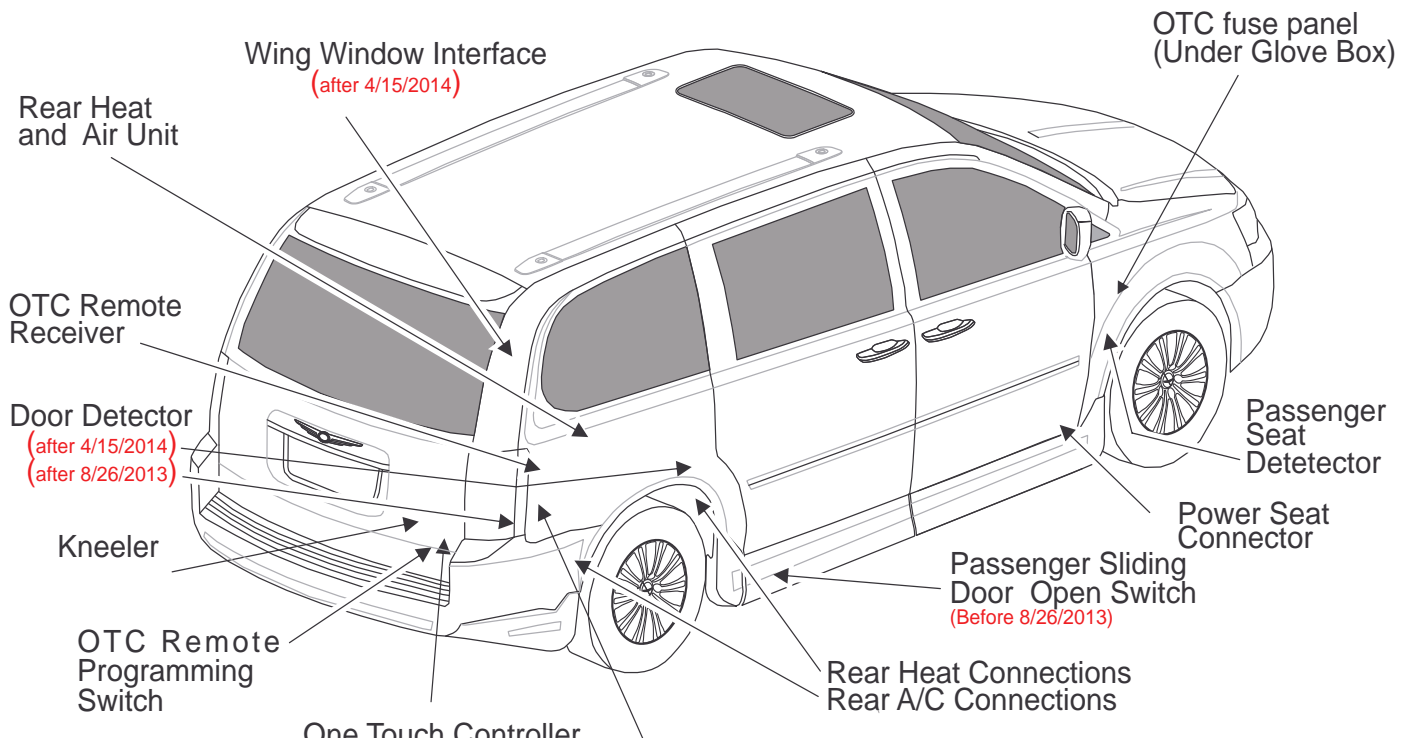
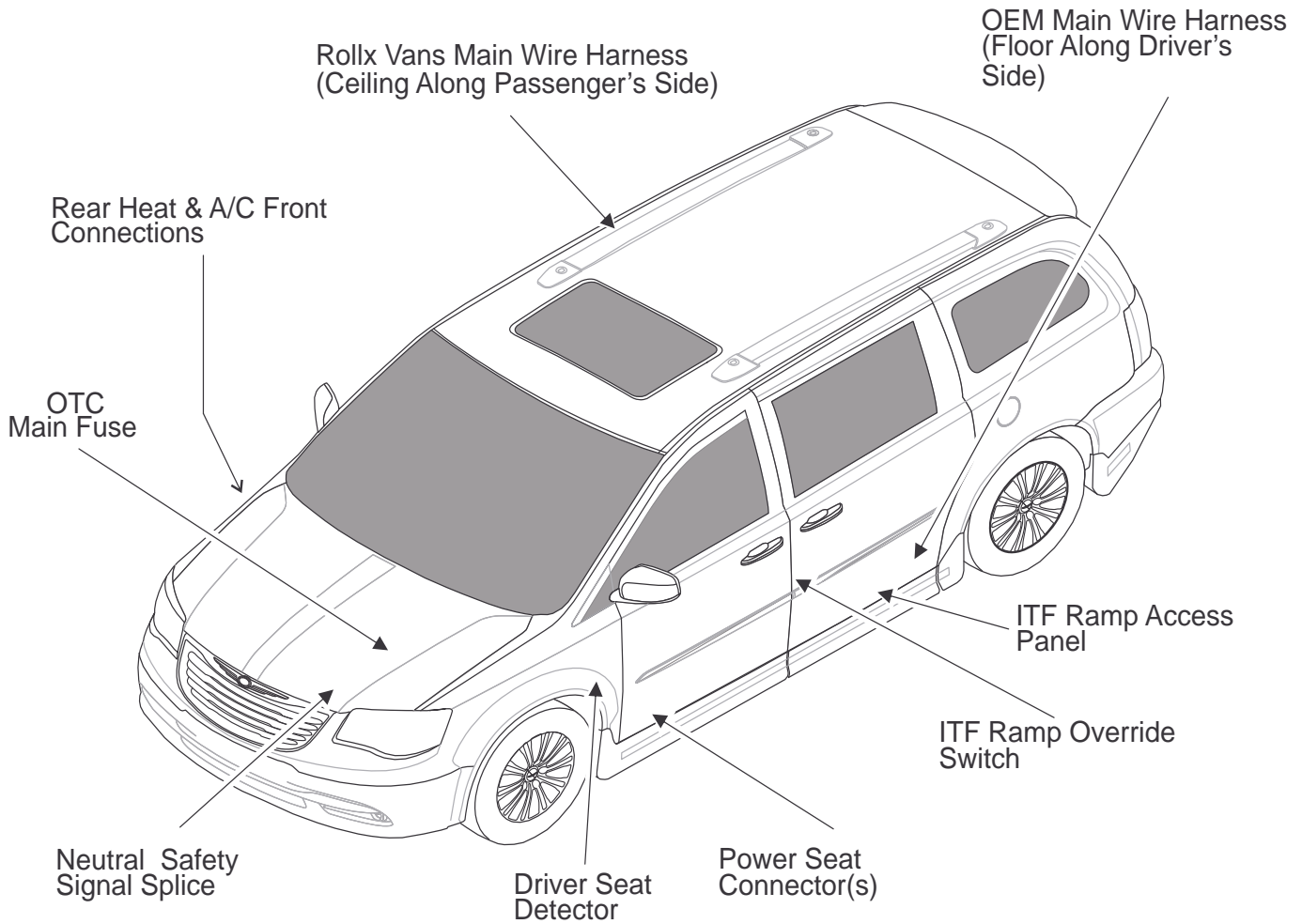



Main Fuse  
(Engine Compartment)

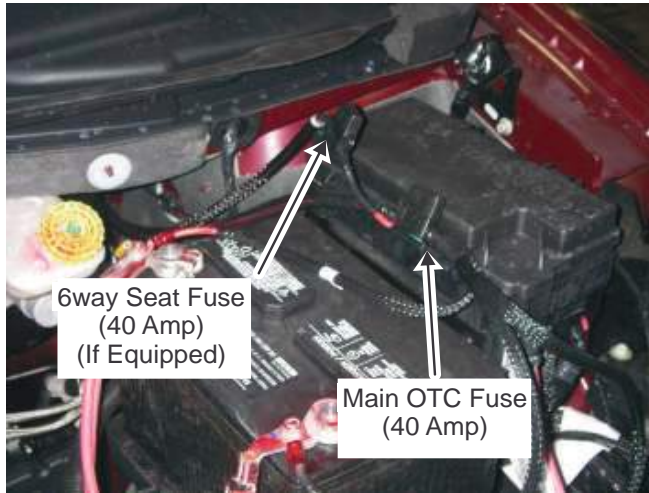

OTC Remote Receiver

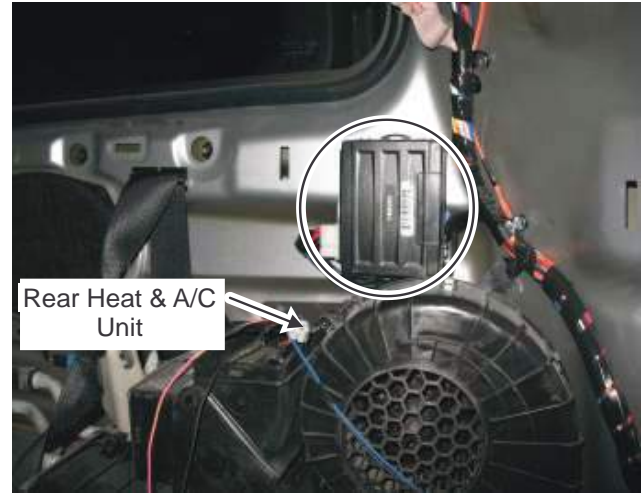

OEM Wire Harness

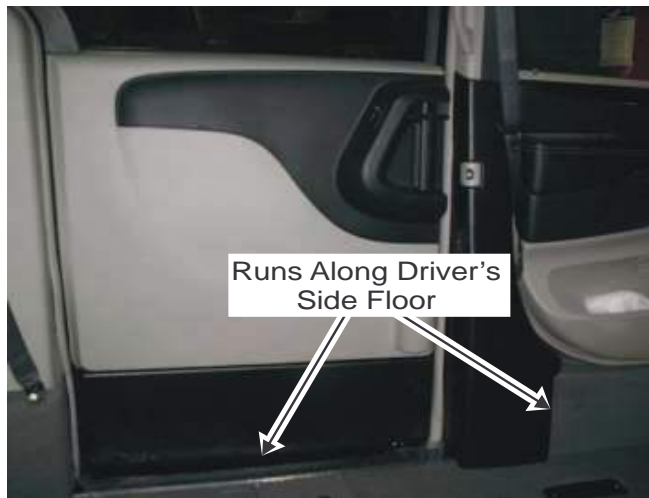

Rollx Vans Main Wire Harness

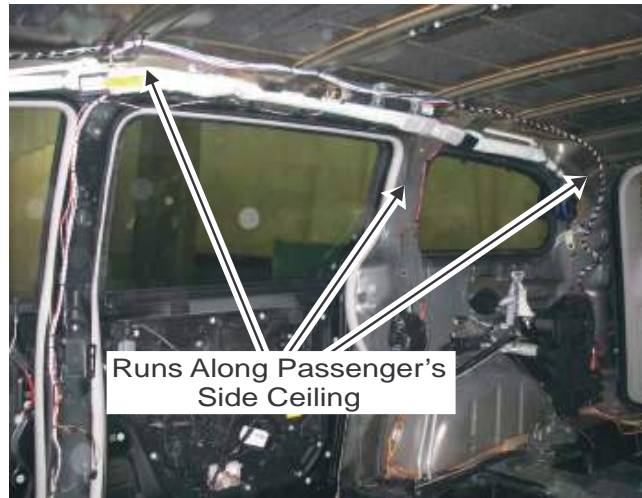

Passenger Sliding Door Open Switch



OTC Fuse Panel  
(Under Glove Box - Must Pull Back Fabric)

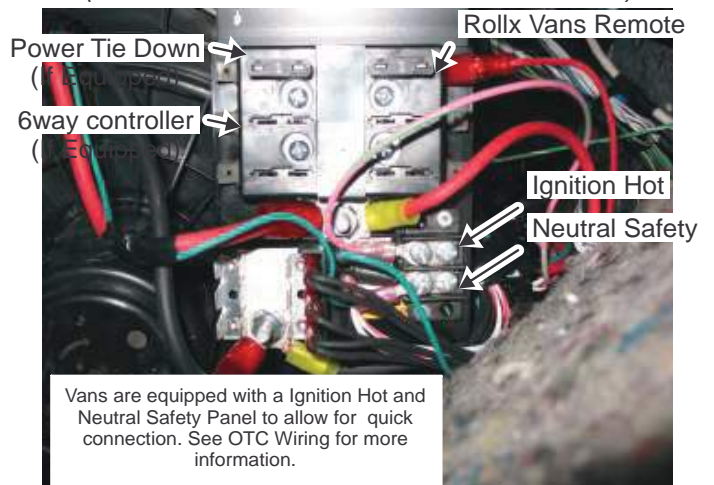



ITF Ramp Access Plate



Rear AC (Rear Connections)  
(Behind Rear Right Tire)



Rear Heat & A/C (Front Connections)  
(Under Passenger's Side Front Seat Area)

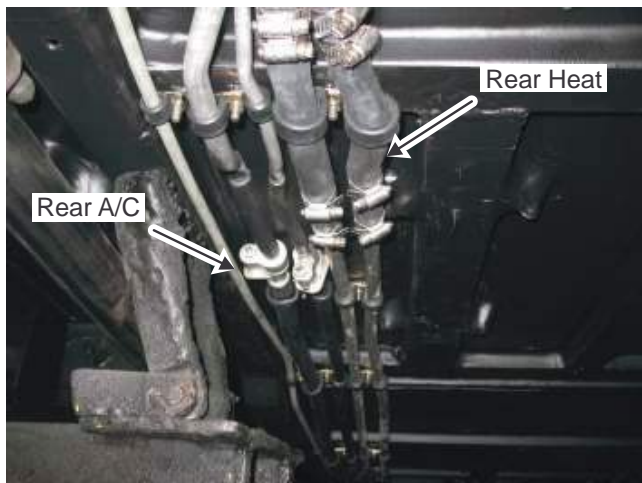

OTC Relay Board  
(Behind Rear Passenger Quarter Panel)

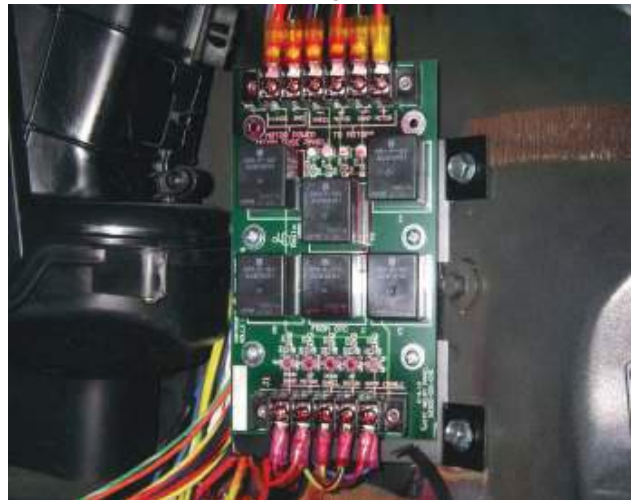

Rear Heat (Rear Connections)  
(Right Rear Tire)



Kneeler and One Touch Controller







Neutral Safety Signal

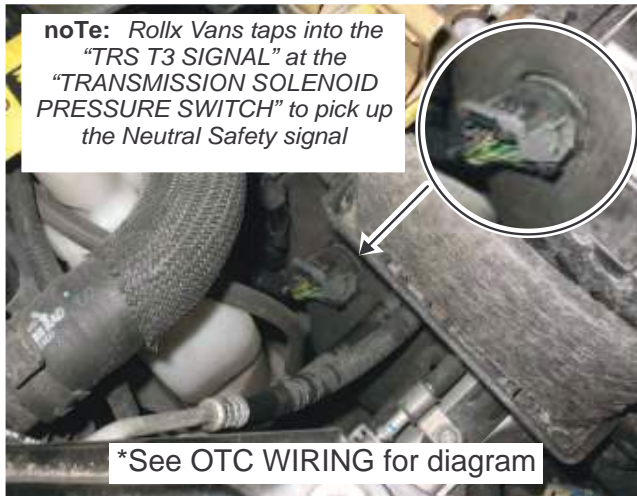

ITF Ramp Override Switch



Passenger's Door Detector (Built after 4/15/2014)  
(On Passenger's C-Pillar)



Wing Window Interface (Built after 4/14/2014)  
(Behind Rear Heat & Air Unit)

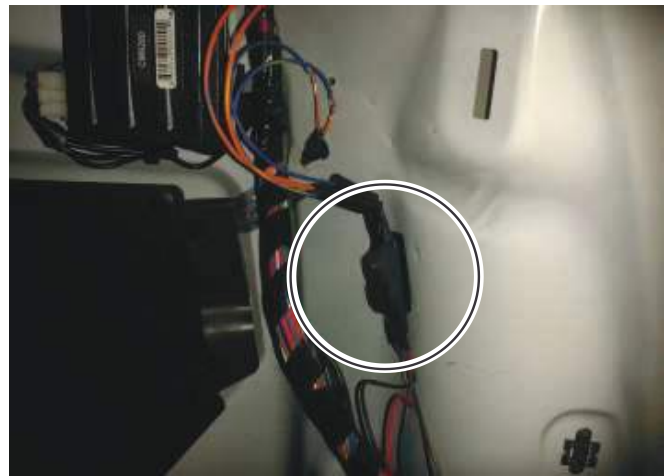

OTC Remote Programming Switch



Driver's Power Seat Connector  
(Passenger's Same)

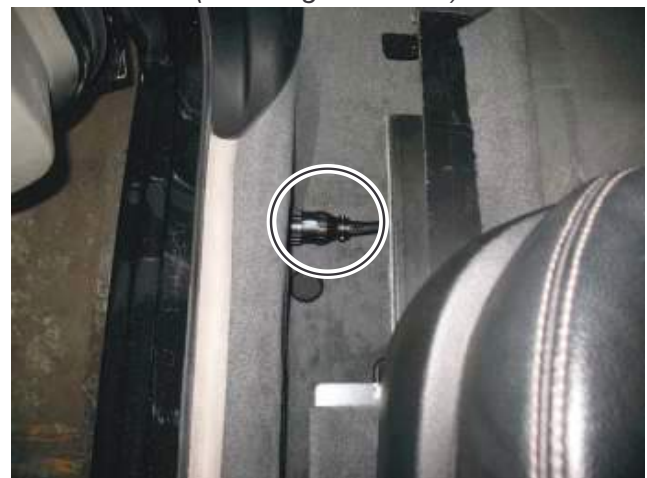



# Rollx Vans Ignition Hot & Neutral Safety Board Wiring 2008-2013 Chrysler Minivans (built after 5/28/2009)

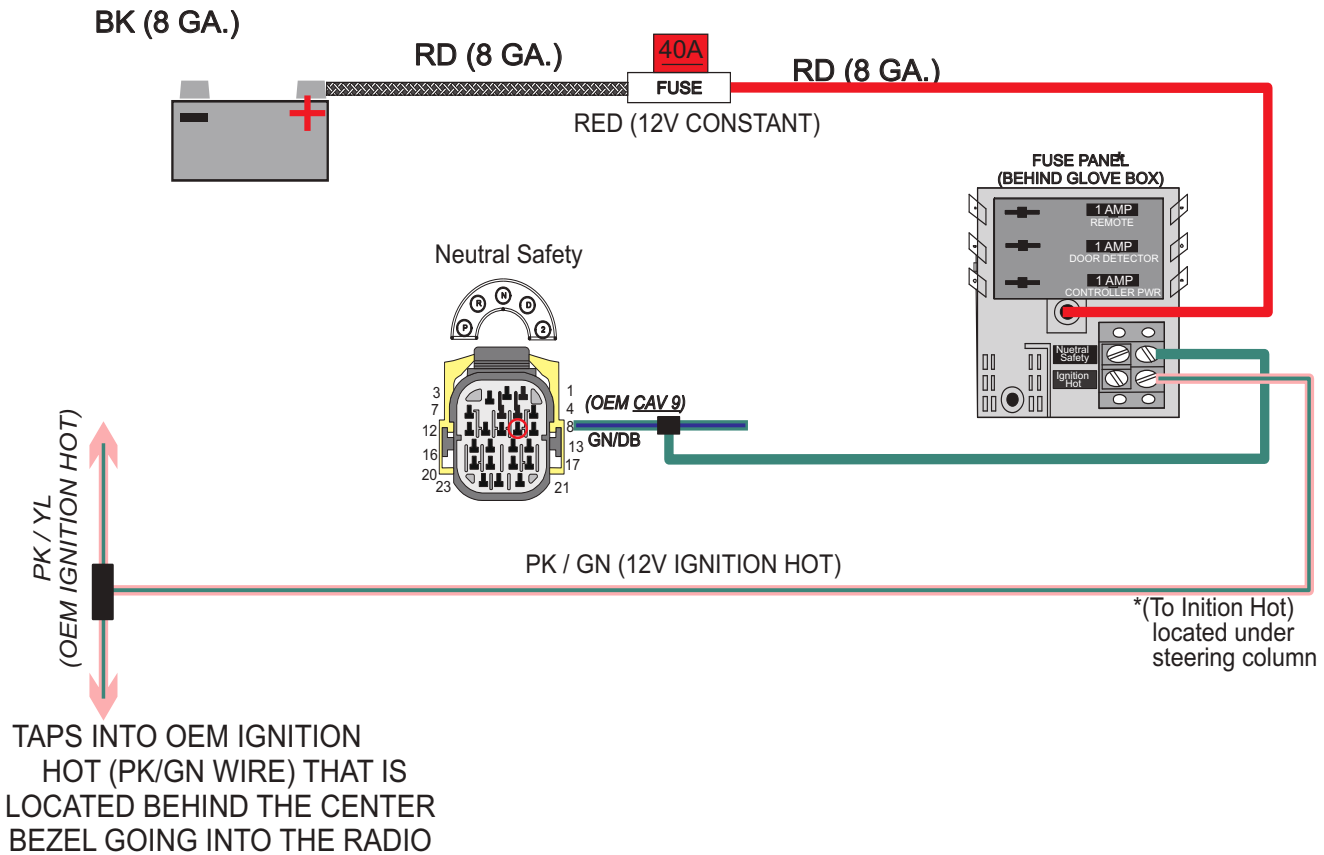

## Power Folding Rear Sofa

If the van is equipped with a Power Folding Rear Sofa, Rollx Vans disables the FOLD/TAILGATE SWITCH MUX which would allow the seat to be stowed into the floor. Rollx Vans cuts the LG/TN wire at the switch.

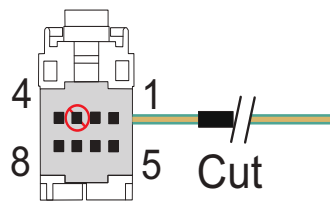

Pin	Wire Color	Gauge	Function
1			NO CONNECTION
2	LG/YL	22	SEAT SWITCH SELECTOR SIGNAL
3	LG/TN	22	SEAT FOLD SIGNAL
4	LG/DB	22	SEAT STOW SWITCH SIGNAL
5	LG/VT	22	FOLDING SEAT SWITCH RETURN
6			NO CONNECTION
7			NO CONNECTION
8			NO CONNECTION



The following procedure should be used to test the current draw from any battery used in our vans.

- 1) insure the battery is fully charged.
- 2) remove the key from the ignition switch.
- 3) close all the doors including the sliding doors and the rear tailgate.
- 4) close all the windows including the rear vent windows.
- 5) remove the negative (Black) cable from the battery and move it to a safe location away from both the positive (red) and negative terminals of the battery.
- 6) acquire a digital Multimeter with a 20 amp current range function. Note: a standard van can draw between 15 and 17 amps of current when it is first powered up (When the battery is reconnected). You must use a multimeter with a 20 amp range. using a Multimeter with a lower current range function will damage the meter if it does not have an internal fuse. if it has an internal fuse, it will be blown.

Note: do not run the rollX vanS or try to start the van when you have the meter connected! You will damage the meter!

- 7) Place the function switch of the Multimeter in the 20 amp current Measurement position.
- 8) connect the negative (black) probe (wire lead) to the black jack on the multimeter.
- 9) Most multimeters have more than one red jack for the positive (red) probe. They usually have one jack for measuring ac & dc voltage and resistance, along with a second Jack for measuring ac & dc current. Some multimeters have more than one red jack for measuring current (three red jacks total). as an example a meter might have two red jacks, one rated for 200 Milliamps and a second for 20 amps. You should use the 20 amp plug (or the one with the largest rating).
- 10) acquire two test jumpers with alligator clips (radio Shack # 278-002). attach one jumper to the positive (red) probe and the other to the negative (Black) probe.
- 11) Turn the multimeter on.
- 12) attach the other end of the jumper clipped on the positive (red) meter probe to the disconnected battery cable.

Note: Polarity does not matter much when measuring current. a positive current is the same as negative current. disregard the polarity indicator on the multimeter during these tests.

- 13) attach the jumper on the negative (black) meter probe to the negative terminal of the battery.

Note: You may get a spark when you attach the jumper. This is normal. all the current being used by the van is now running through the meter. as much as 15 -17 amps).



14) The Multimeter should now show a reading. Keep your eye on the meter and watch the draw. a typical van can have from 18 to 28 computer modules in it. They are all woke up when power was applied to the van by attaching your meter probes. as you watch the current reading you will note that it will start to fall. This happens as the computers in the van decide they are not needed and put themselves to sleep. chrysler says it can take up to thirty minutes for everything to go into sleep mode.

The current should drop in stages similar to the sequence below:

- a. The reading will start as high as 15-17 amps for a short period of time.
- b. it then fall to 6-8 amps for a short time.
- c. Then 1 to 1.5 amps for a period of time.
- d. it will then settle on around .800 amps (800 Milliamps) for a while.
- e. Then it may drop to .100 to .200 amps (100 to 200 Milliamps) for period of time.
- f. finally it will drop all the way into sleep mode, .040 to .100 amps (40 to 100 Milliamps) and will stay there until the van is woke up.
- g. note: The values you will see will vary from van to van, from van type to type and by the number and type of accessories installed on the van. The important thing is that it drops to a value less the 100 Milliamps (.100 amps) for a standard van when it goes into sleep mode.

15) You can wake the van simply by opening the driver's side door for a few seconds, then closing it.

16) Watch the meter again to see the van go into sleep mode again. You should repeat this test until you are satisfied the van's "Sleep Mode" is functioning correctly.



This picture shows a complete setup for a draw Test:



note the black probe attached to the negative terminal and the red probe attached to the negative battery cable.



This picture shows a typical multimeter. note the current range switch settings and current probe jack markings are all in yellow for ua (Microamps), ma (Milli amps and a (amps).

also note that the meter has two Jacks for current measurement, “20a” and “ua/ma”. on this meter, for our draw Test, we would place the function Switch in the “a” (for amps) position and plug the red Probe into the “20a” Jack. The Black Probe always goes in the Black Jack.



## Rollix VanS door (Motor Bar) Trouble Shooting

Symptom	Possible cause	remedy
Door does not operate.	Front passenger door is locked.	Unlock front passenger door.
	Switch is stuck.	Make sure all user switches are not stuck.
	Blown fuse.	Replace 30 or 15 amp blade fuse located underneath hood near battery.
	Manual release handle is not engaged.	Turn handle all the way counter-clockwise.
Door will open, but ramp will not deploy.	Door open limit switch needs adjustment.	Adjust the door open limit switch (#7 on next page). The switch can be accessed by the passenger side rear speaker area (remove the speaker first).
Door will open, but not close or door will "jump" closed.	Ramp up limit switch is not engaged.	Adjust the cam for up limit.
Door "ratchets" when operating (make sure kneeler is off).	Gear on motor is stripped.	Replace motor.
	Gear on bar is stripped.	Replace gear rack (bar).



# Rollix Vans Power Door Exploded View

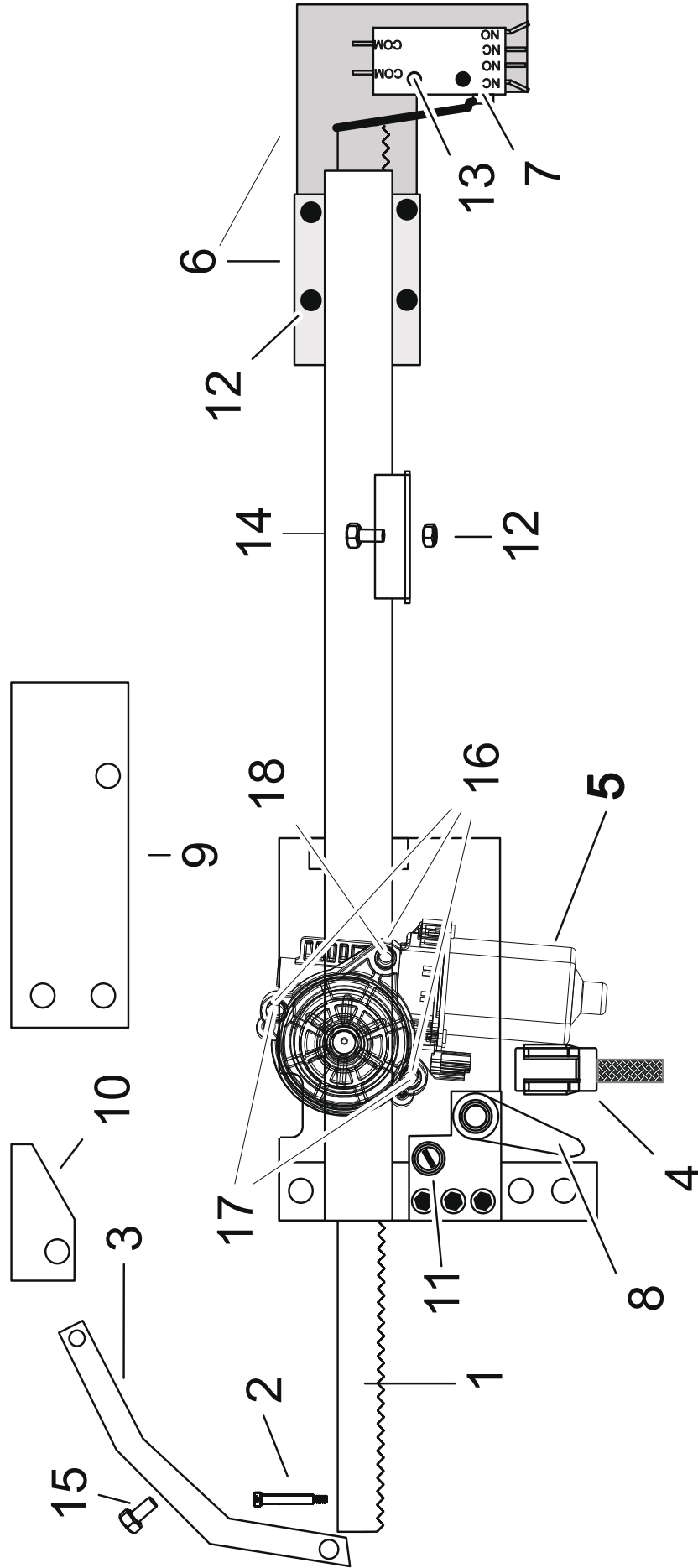

Item	Qty.	Description	Part #	Item	Qty.	Description	Part #
1	1	DOOR BAR ASM (INCLUDES THE 3 FOLLOWING)	10026ASM	6	1	BRKT MTR BAR LIMIT SWITCH	MB1006
1	1	MTR BAR DOOR OPENER (RACK AND ASSEMBLY)	10026	7	1	SWITCH DPDT (CHERRY)	E19-50H
1	1	WIRE HARNESS 5.5" FOR	310-1059	8	1	HANDLE CHROME INSIDE	6022
1	1	MTR 12V 70NM 10MM DOUBLE	210-1011	9	1	DOOR BRACKET A (DOOR BRACKET B -)	MB1001 (MB1002)
1	1	GEAR RACK (SPECIFY LONG OR SHORT)*	10026-4	10	2	DOOR ARM PLATE	MB1005
2	1	3/8 X 1 STRIP	1126318	11	N/A	MANUAL RELEASE TENSION ADJUSTMENT	NA
3	1	ARM BAR (FOR MOTOR BAR)	10026-22	12	N/A	1/4-20 NYLOCK NUT	SHOP SUPPLY
4	1	WIRE HARNESS 5.5" FOR	310-1059	13	2	#6 NYLOCK NUT	SHOP SUPPLY
5	1	MOTOR ONLY W/GEAR ASM (INCLUDES WIRE HARNESS AND SHIMS**)	10026-15ASM	14	1	1/4-20X3/4 HEX HEAD SCREW	SHOP SUPPLY
		* LONG USED BEFORE ~2001 IF NO REAR HEAT & AIR		15	1	5/8-20X1 HEX HEAD SCREW (ADJUSTMENT)	SHOP SUPPLY
		** SHIMS ONLY NEEDED IF BEFORE ~2003 BUT ALWAYS SENT WITH MOTOR		16	1	SHIM KIT FOR DOOR OPENERS (INCLUDES ALL 3 - VARYING SIZES)	10026-12
				17	2	#10-32X2 HEX HEAD (5/32) PARTIALLY THREADED SCREW	SHOP SUPPLY
				18	1	#10-32X2-1/2 HEX HEAD (5/32) PARTIALLY THREADED SCREW (NUT ON BACK)	SHOP SUPPLY



# oEM Power door TrouBleShooTing

Note: In order to disable the OEM door from closing when the ramp is out, Rollx Vans interrupts Chrysler's CAN BUS circuit to prevent the door from getting any signal to close. The Scan tool will read a "No Communication with the Right Rear Door Module" everytime the system deploys the ramp. This is a normal trouble code and is to be expected.

Symptom	Possible cause	r emedy
Passenger sliding door does NOT OPEN with interior Rollx Vans user button.	Van is NOT in park.	Place van into park.
	Overhead on/off switch is turned to the OFF position.	Turn switch to ON position.
	OTC program failure.	Press OTC reset button.
	OTC reads low voltage.	Start van's engine and press OTC reset button. If door still does not open review OTC board display and contact customer service.
	Bad OTC board.	Press the OTC reset button and while in Idle Mode press a user button and watch the LED. Notice if OTC appears to be working properly. Review error codes stored and call customer service.
	Main OTC fuse (40 amp) is blown.	Replace fuse under hood by battery.
Ramp sliding door does NOT OPEN with interior OEM push buttons after pressing OTC reset button.	OEM overhead ON / OFF switch is OFF.	Turn switch to ON position. This switch enables / disables the OEM buttons located on the B pillars that Rollx Vans uses to trigger the sliding door to open or close.
	Defective OEM door opener.	Operate door manually and contact customer service.
Ramp sliding door does NOT attempt to CLOSE after ramp stows.	Ramp up limit switch is not being activated properly.	Close door manually, press OTC reset button, and press Rollx Vans user button to operate system again. If door still does not attempt to close after ramp is stowed, review OTC board display and contact customer service.
Ramp sliding door attempts to close (door motor runs) after ramp stows, but door does not move.	Defective door open bracket.	Adjust the bracket and contact customer service.
	Defective OEM door opener.	Press OTC reset button, press interior OEM push button to see if door will close automatically. If door still does not respond, review OTC board display and contact customer service.
Ramp sliding door kicks back when opening or closing.	Obstruction.	Check door track for any debris and remove.
	Ramp needs adjustment (Foldout only).	Adjust folding ramp to stow more.
	OEM door sensitivity set low.	Contact local Chrysler Dealership.
Ramp sliding door opens and van kneels, but when door is all the way open, van unkneels and cycle ends.	OEM Door Ajar Pin Switch (Rollx Vans Door Close signal) is never deactivated when door begins to open.	If the OTC thinks the door is open and closed it will end the cycle. Examine switch / wiring.
Ramp sliding door does not seal when almost closed.	Ramp needs adjustment (Foldout only).	Adjust folding ramp to stow more.
	Defective OEM cinch motor.	Operate door manually and contact customer service.
Ramp sliding door does NOT OPEN manually.	Door is locked.	Unlock door. When pulling door handle, pull handle out and then slide door to open.
Ramp sliding door does NOT OPEN manually from interior handle, but does from exterior handle.	Child safety lock is activated.	See OEM owner manual to deactivate child safety lock.
Ramp sliding door closes half way and then moves back and forth.	Stuck door open limit swith, or CAN BUSS door opener Module.	Adjust swtich located in rear of lower door track, or unplug module & wait 2 seconds.
Ramp sliding door will NOT CLOSE manually.	Door handle is not releasing.	Pull handle to disengage latch and slide to close.
	Obstruction.	Check door track for any debris and remove.





Door extension kits part numbers and descriptions

- B08180-D5-KIT-ITF  
Door skin svc kit itf dr
- B08180-D5-KIT-FO  
door skin svc kit fo dr
- B08180-P5-KIT-ITF  
Door skin svs kit itf pass
- B08180-P5-KIT-FO  
Door skin svs kit fo pass

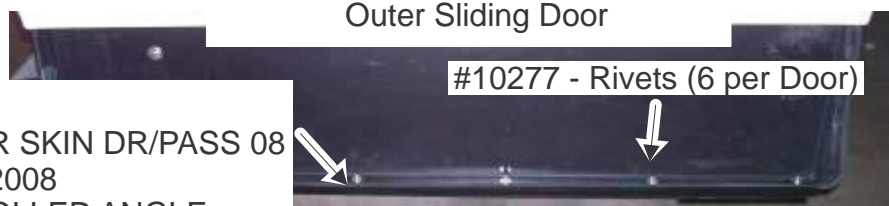

- Current  
#B08180-DP6 - L BRKT DOOR SKIN DR/PASS 08  
Before 10/20/2008  
#10503 - 1"X 1" 14GA ROLLED ANGLE

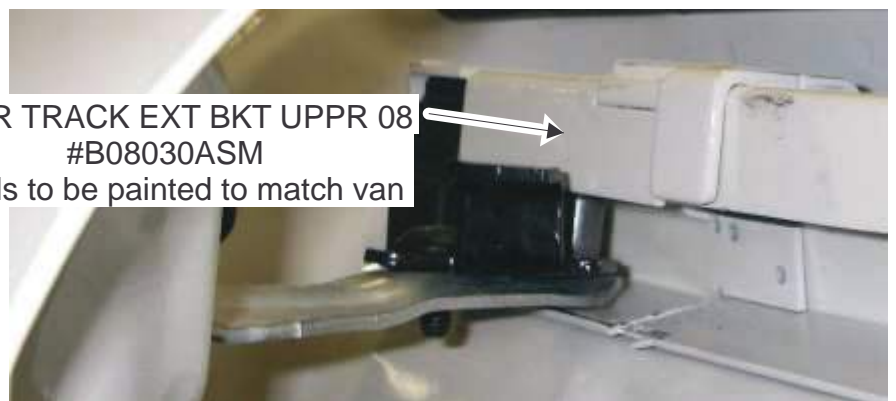
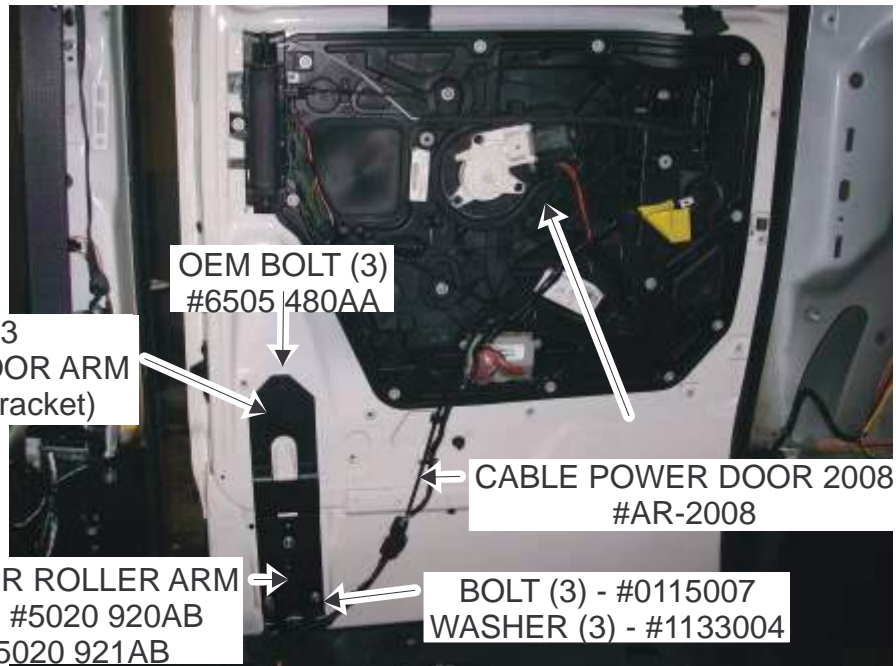

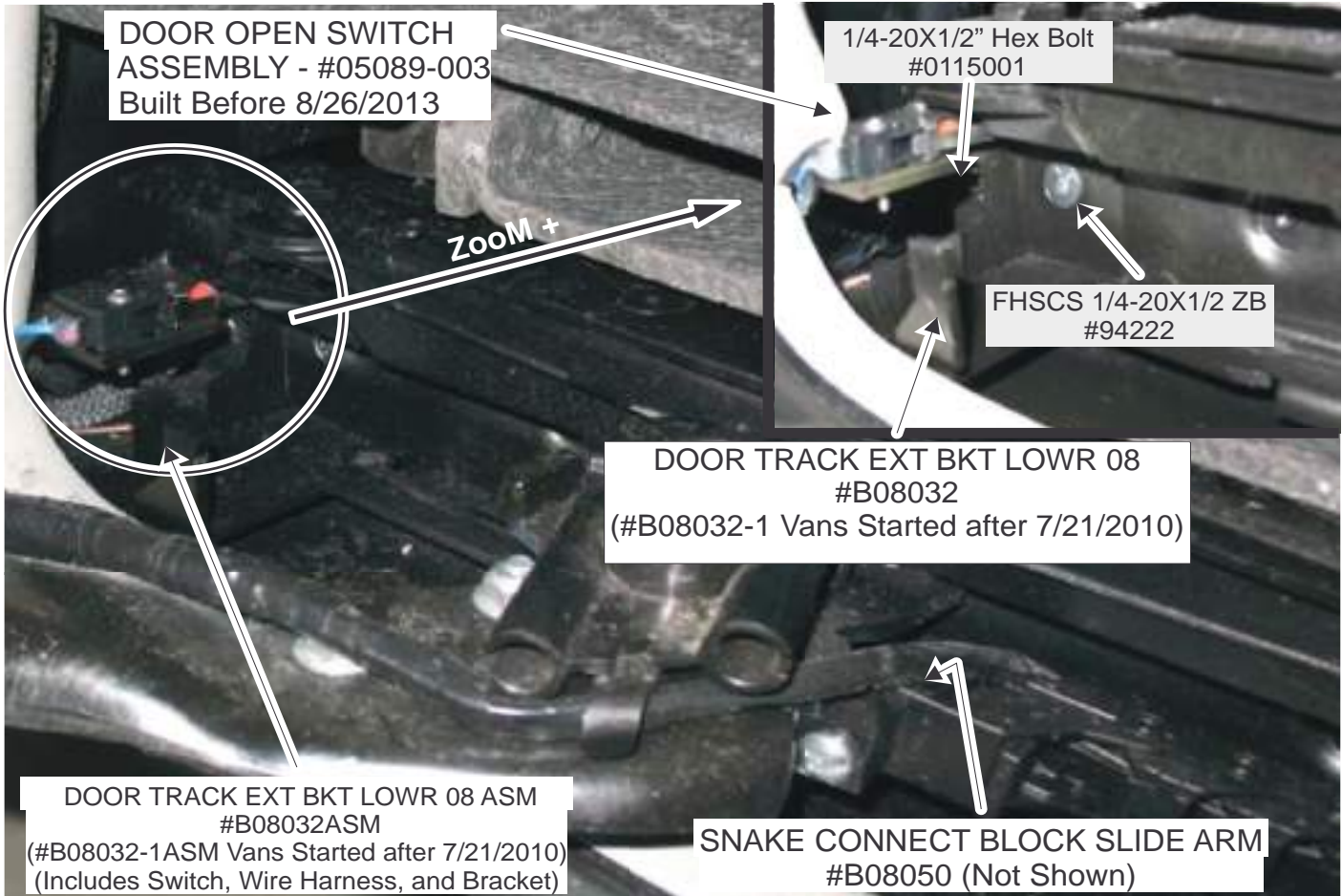

Door track kits and descriptions include OEM track and door open switch bracket

- B08059asm-dr - Door track asm 08-09 dr
- B08059asm-dr-2010 - Door track asm 10-13 dr
- B08059asm-ps - Door track asm 08-09 ps
- B08059asm-ps-2010 - Door track asm 10-13 ps

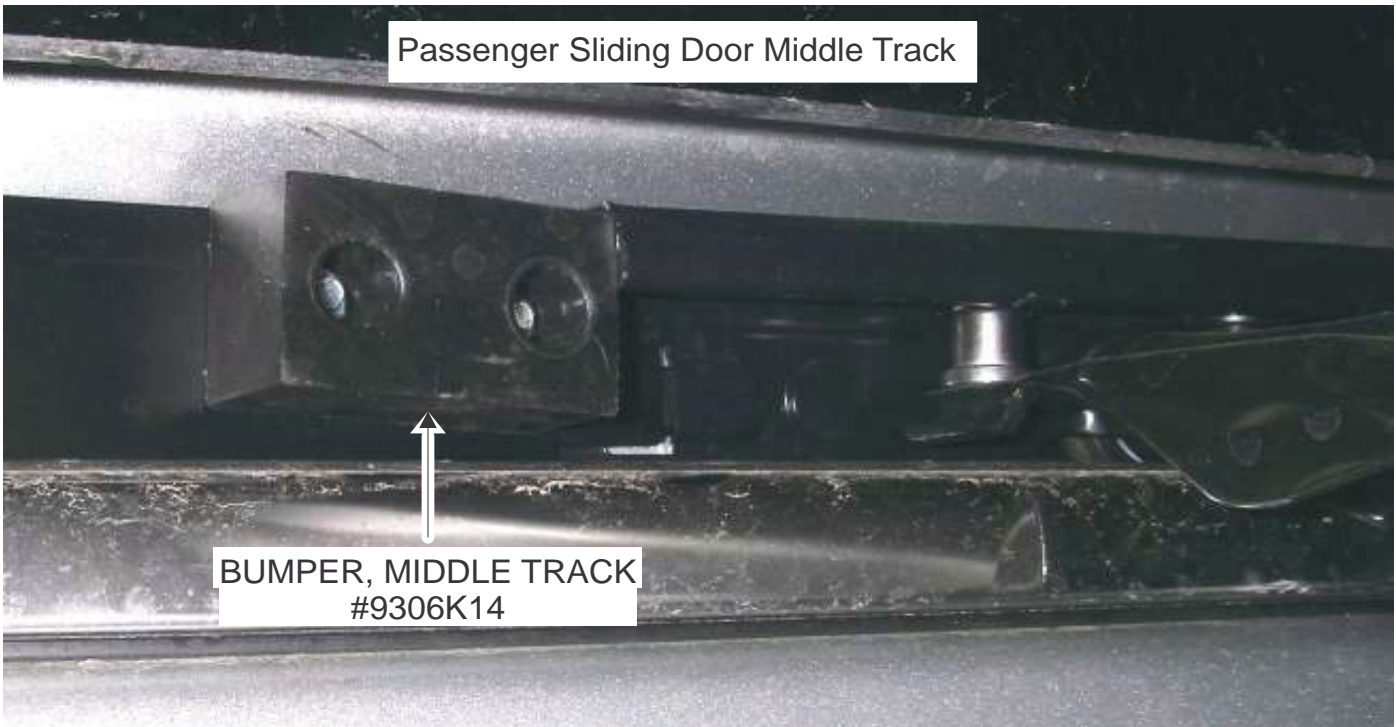

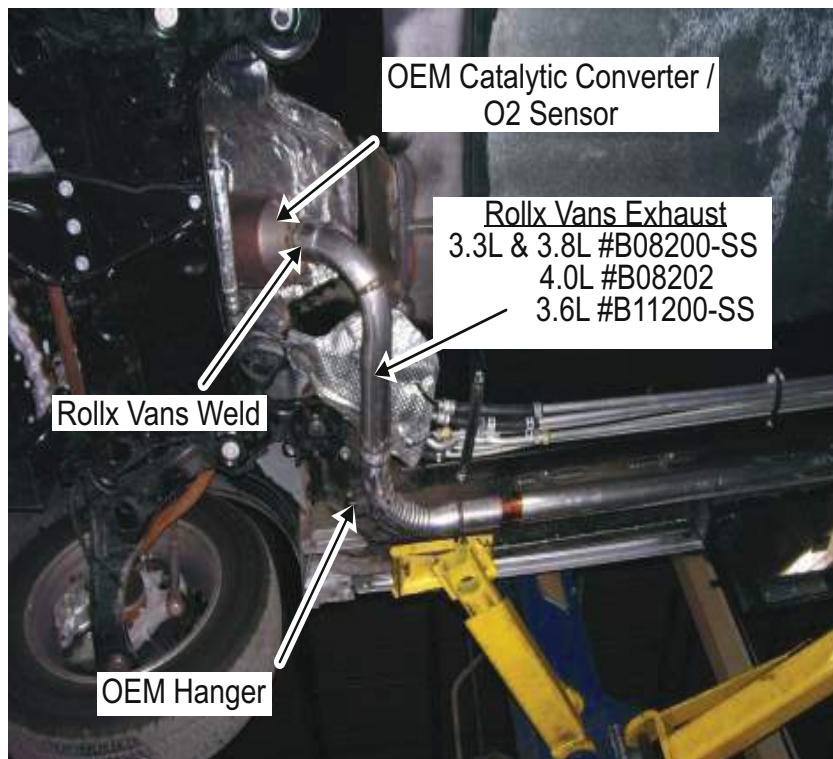

Rollx Vans begins their exhaust from the OEM Catalytic Converter (Rollx Vans does not modify the OEM Catalytic Converter or OEM O2 Sensor). Rollx Vans Exhaust is welded to the OEM Catalytic Converter and runs down the passenger side of the van.

Rollx Vans reuses the OEM Hangers to support the exhaust. Rollx Vans Exhaust is 2-1/4 inch diameter aluminized tubing and replaces the OEM 2-1/2 exhaust.

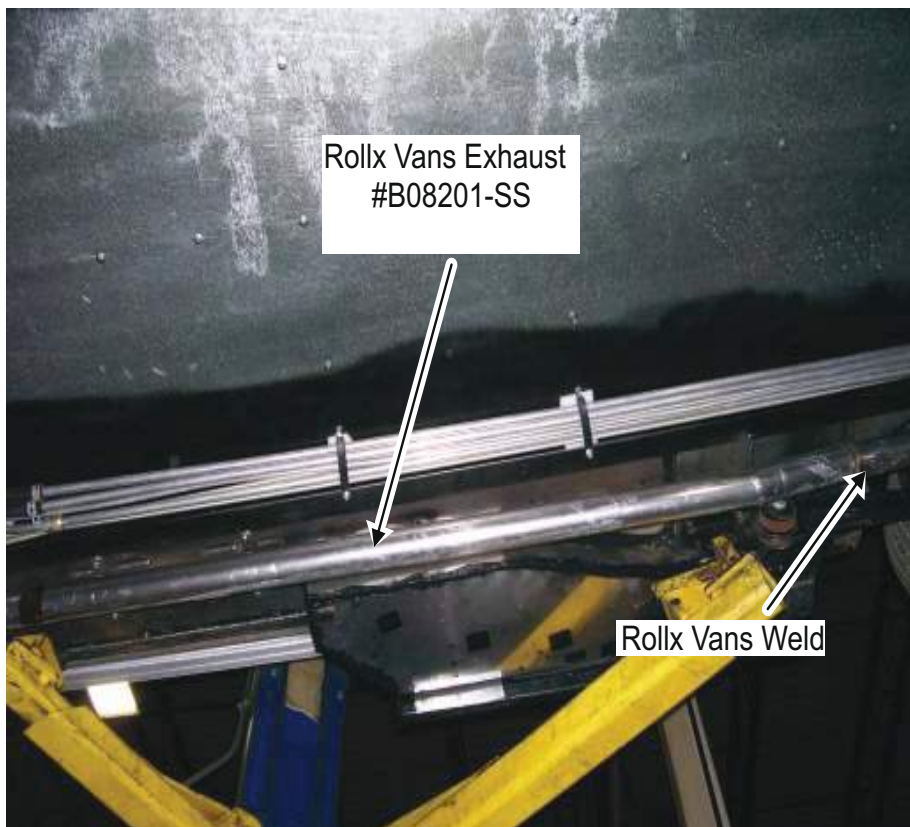

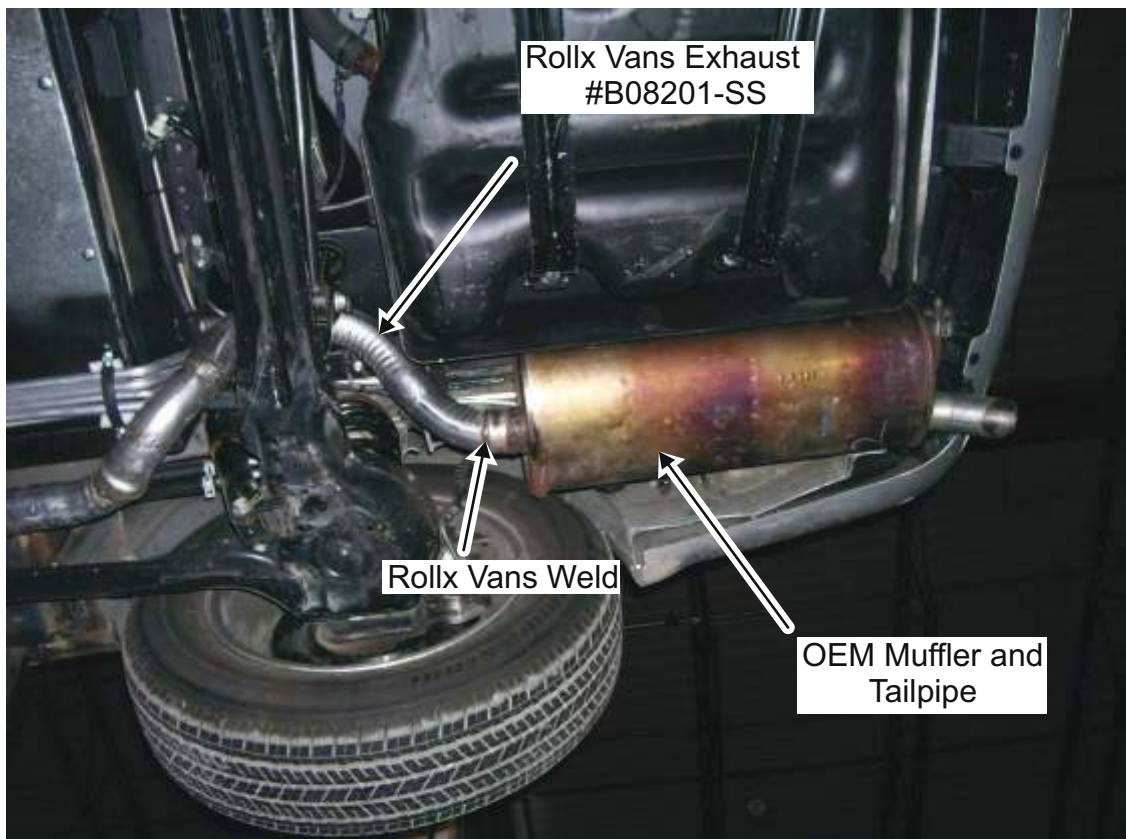

Rollx Vans Exhaust continues over the rear axle and is welded to the OEM Muffler and Tailpipe.

Rollx Vans eliminates the OEM Resonator.





#B08180-P = Passenger Side  
#B08180-D = Driver Side

(Chrysler Vans Only) #B08180-P4 #B08180-D4	(Before 12/2/08) #B08180-P3 #B08180-D3	(Before 12/2/08) #B08180-P2 #B08180-D2	#B08180-P1 #B08180-D1
(Dodge Vans Only) #B08180-P4D #B08180-D4D	(After 12/2/08) #B08180-P3.2 #B08180-D3.2	(After 12/2/08) #B08180-P2.2 #B08180-D2.2	

When replacing either of these ground effects on a 2008 Chrysler van built before 12/2/08, order as follows:

- D3 or P3 = it is necessary to replace both the D2 and D3 with the new D2.2 and D3.2 (same for passenger side).
- D2 or P2 = we have about 20 in stock of each so just replace that required piece until out of stock, then follow above rule.

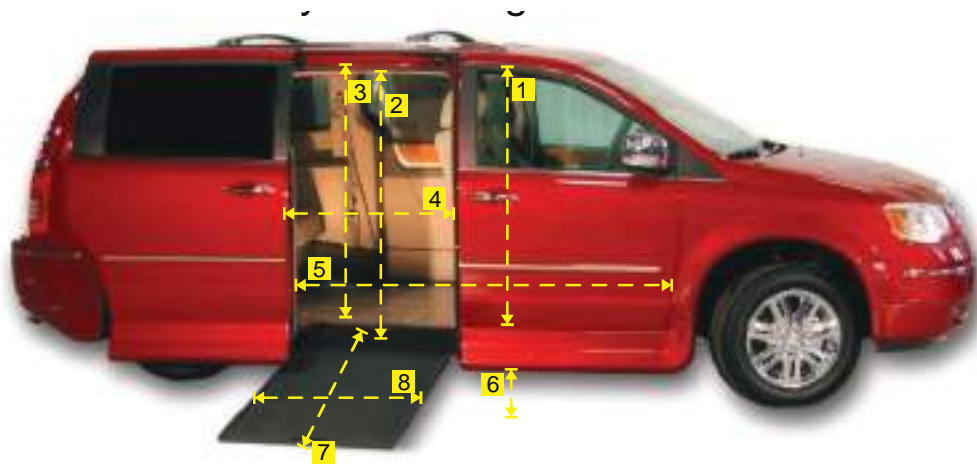

Measurement	description	r ollx vans c hrysler/dodge in The floor r amp 11 inch drop	r ollx vans c hrysler/dodge f olding ra mp 11 inch drop
1	Floor to Ceiling Height	58	58
2	Passenger Sliding Door Opening Height	54.5	54
3	Floor to Overhead Console	57	57
4	Passenger Sliding Door Opening Width	31.5	31.5
5	Cargo Area Length (Rear "z" to Firewall Along Floor)	84	84
6	Ground Clearance - Ground Effect	7	7
7	Ramp Length	50	55.5
8	Ramp Width (Inside Wall to Inside Wall)	30	29
	Cargo Area Width When Closed (Door to Door / Door to Ramp)	66.5	61.5
	Ground Clearance - Lowest Point (Exhaust)	5.5	5.5
	Cargo Area Length (Rear Sofa to Clip-in Base)	54.5	54.5

\* All measurements are subject to change depending on various van configurations and should be used as approximations.



# 2011-2014 Chrysler Town & Country / Dodge Grand Caravan (3.6L) Rollx Vans Fuel / Emission System Overview (V5)

\*See page 18 for Rollx Vans part #'s

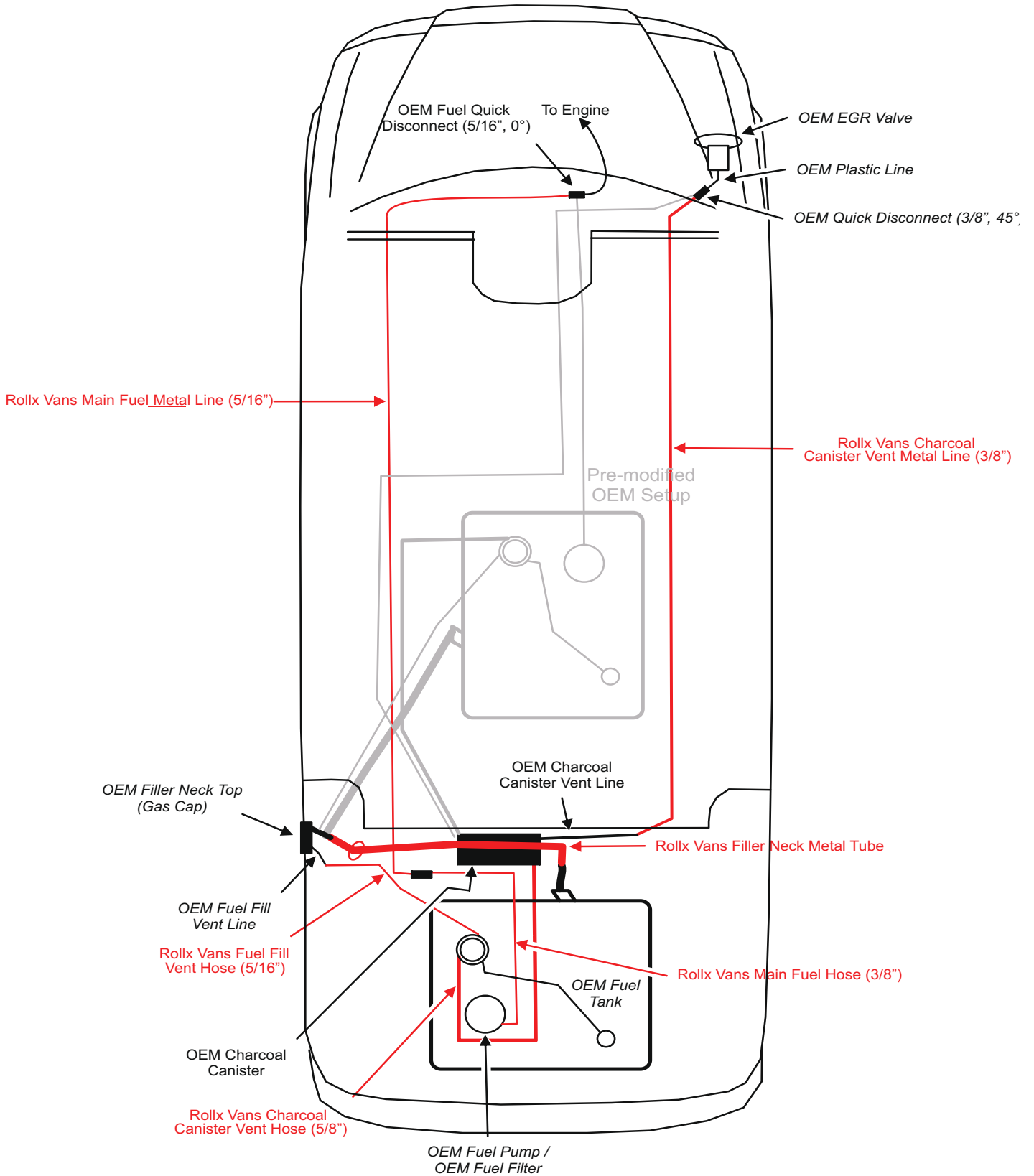

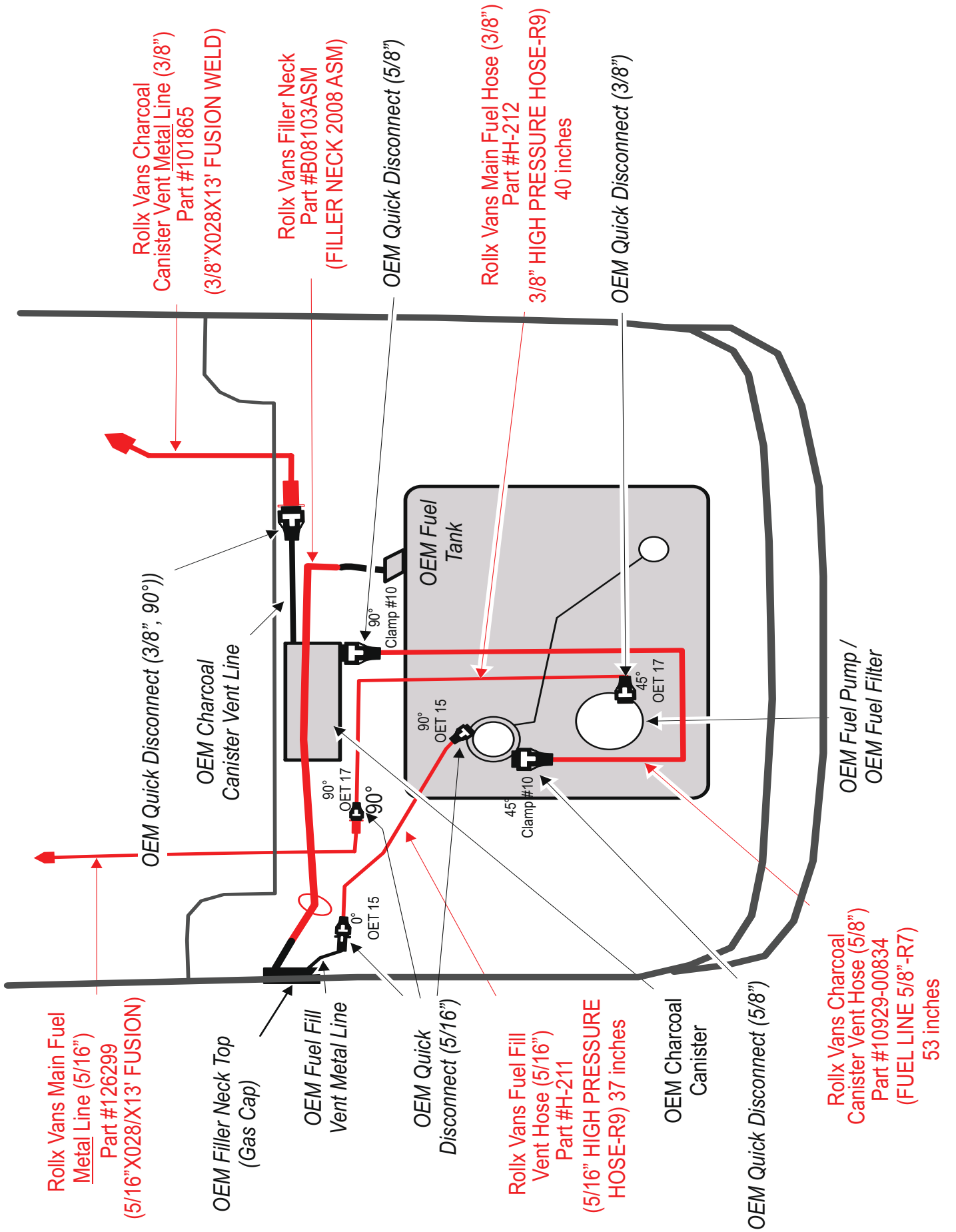

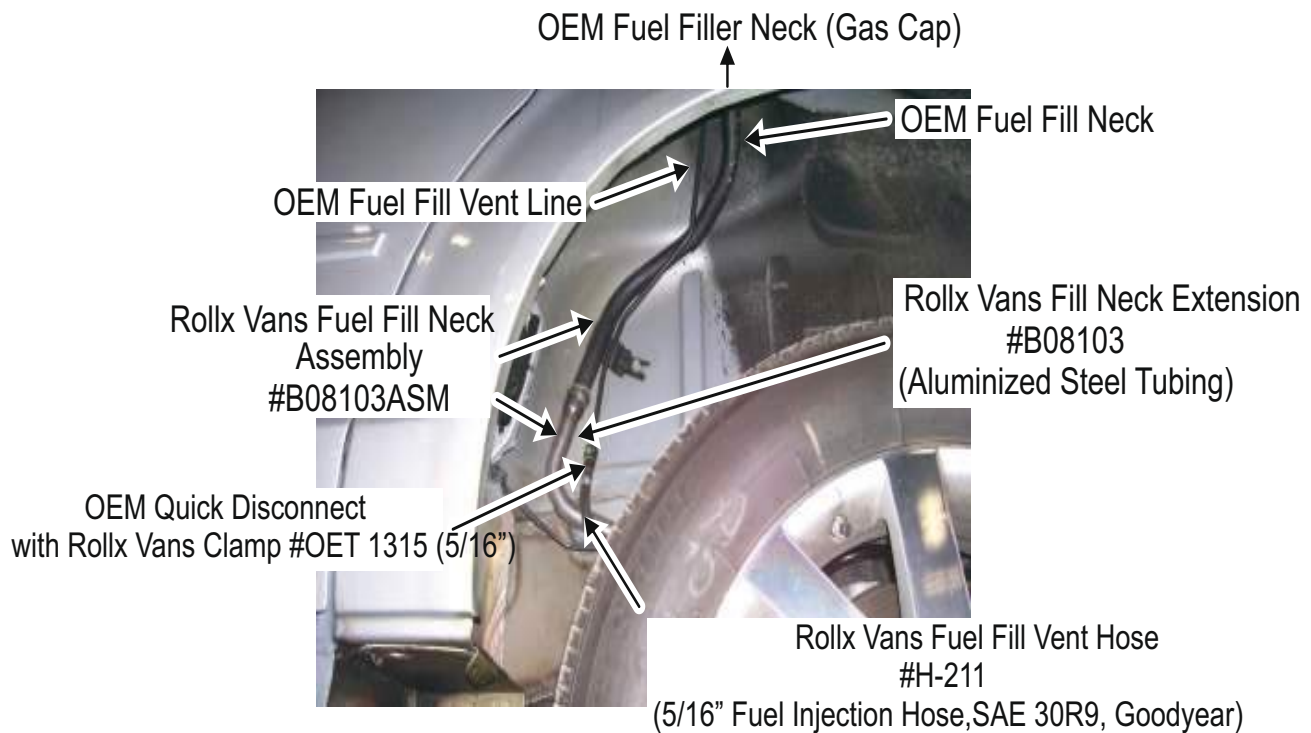

Rollx Vans welds a Fill Neck Extension onto OEM Fuel Fill Neck to extend the OEM Fuel Fill Neck to the OEM Fill Neck Hose that attaches to the tank. The completed assembly is #B08103ASM that includes the OEM Fuel Fill Neck welded to the Rollx Vans Fill Neck Extension. The modified filler neck is smoke tested for possible pin hole leaks.

Rollx Vans attaches a Fuel Fill Vent Hose that begins at the gas tank to the OEM Fuel Fill Vent Line with a 9/16" clamp. This hose and the filler neck tube are routed underneath the frame.



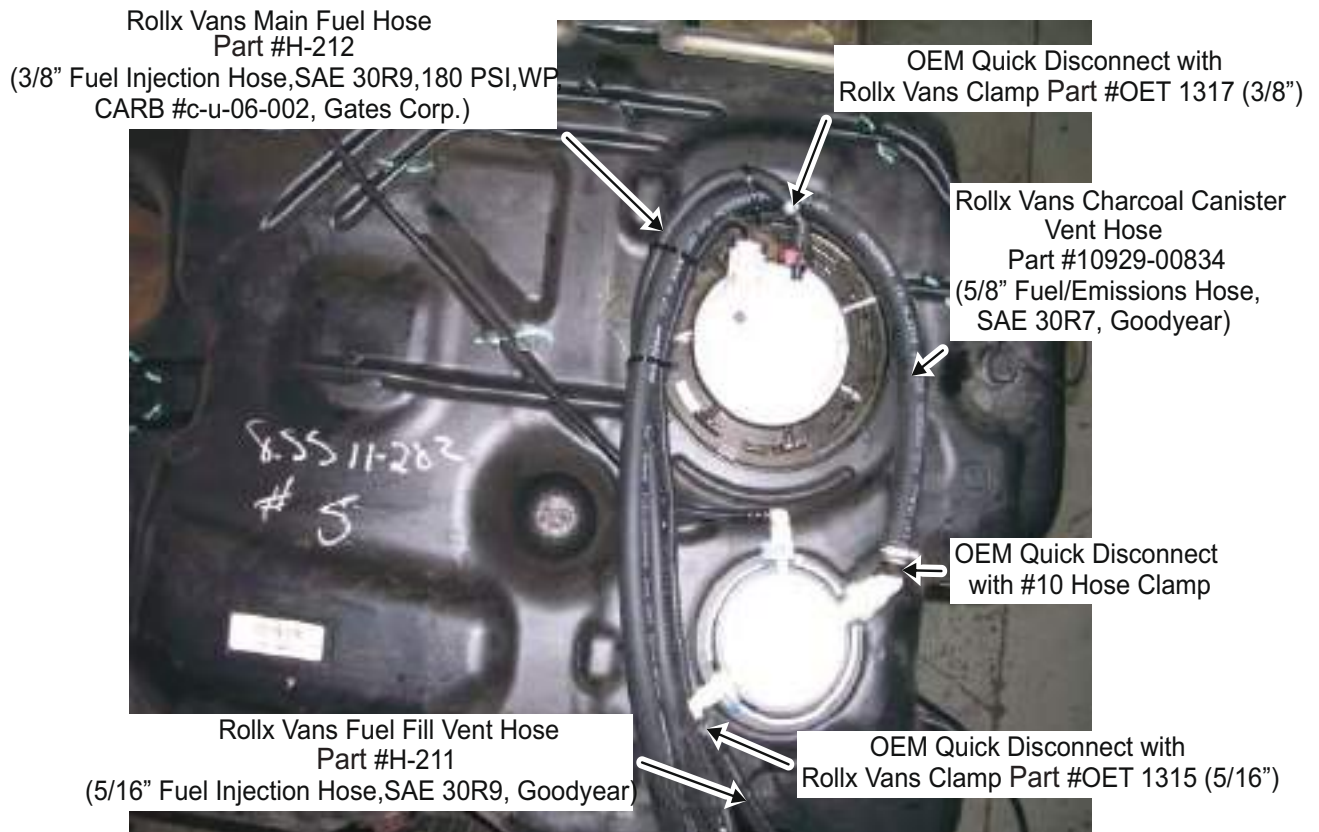

Rollx Vans re-uses the OEM Gas Tank.

Rollx Vans replaces OEM Fuel Fill Vent Hose with Rollx Vans Fuel Fill Vent Hose that runs to OEM Fuel Vent Line near Filler Neck top (Gas Cap).

Rollx Vans replaces OEM Charcoal Canister Vent Hose with Rollx Vans Charcoal Canister Vent Hose that runs to OEM Charcoal Canister. Rollx Vans does not modify the OEM Charcoal Canister or its mounting.

Rollx Vans replaces OEM Main Fuel Hose with Rollx Vans Main Fuel Hose that runs to Rollx Vans Main Fuel Metal Line where it is attached to the flared metal line with the OEM Quick Disconnect.

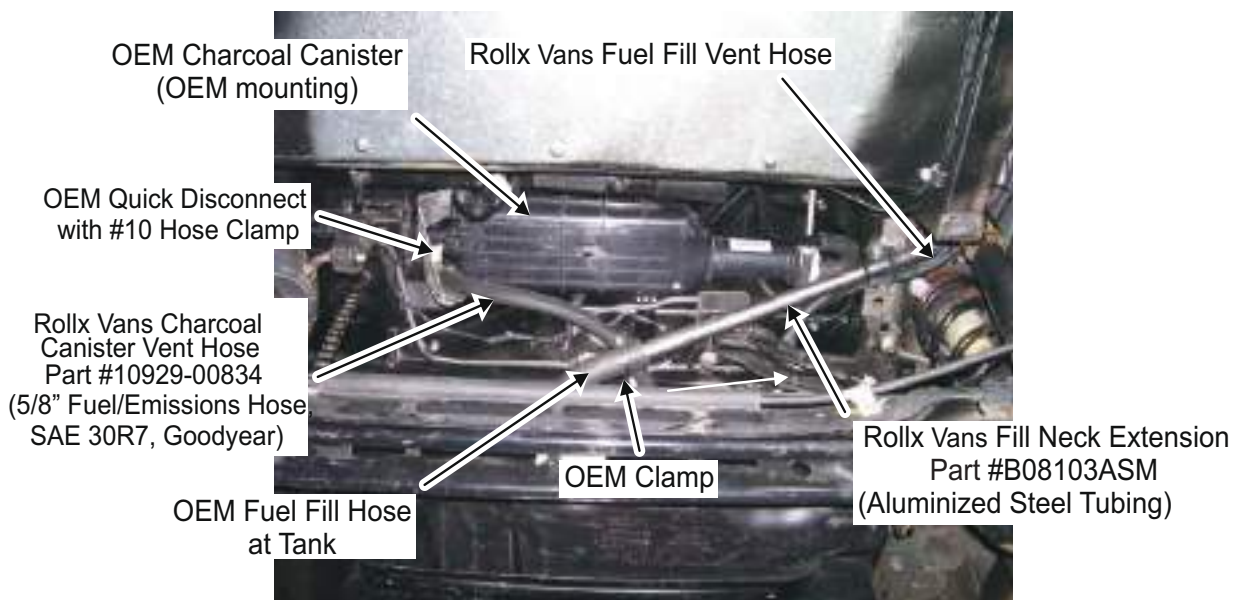



- A) Rollx Vans routes the Rollx Vans Main Fuel Metal Line (5/16") under the driver's side of the van using P-Clamps to secure.
- B) The Rollx Vans Main Fuel Metal Line (5/16") is routed up the rear z, flared and attached to OEM Quick Disconnect.
- C) The Rollx Vans Main Fuel Metal Line (5/16") is routed up under the engine compartment, flared and attached to OEM Quick Disconnect.

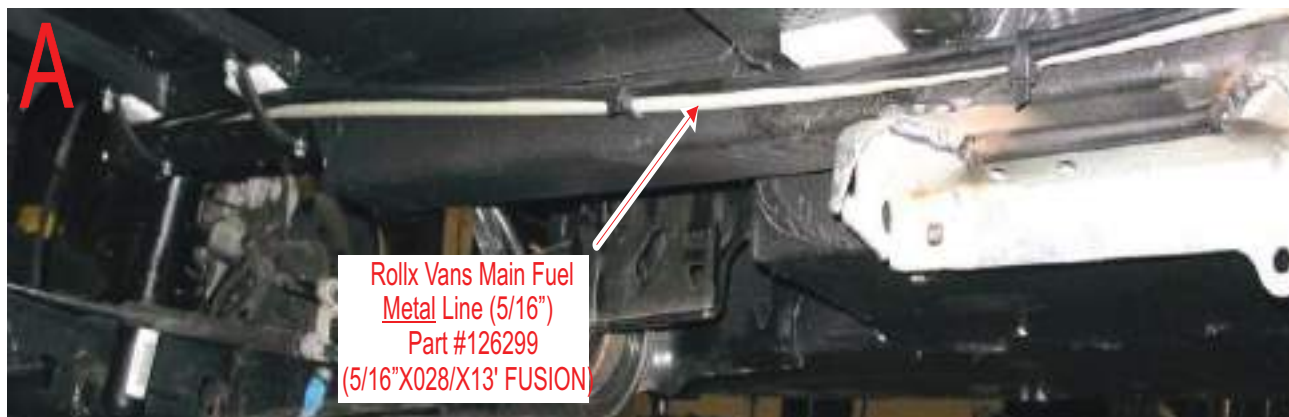
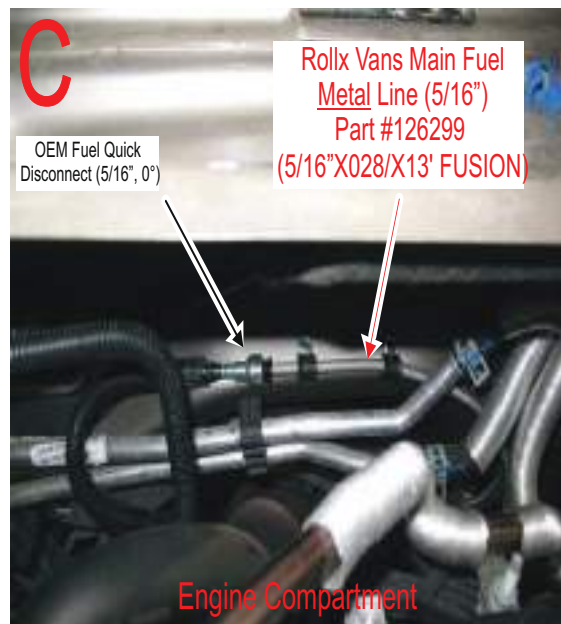
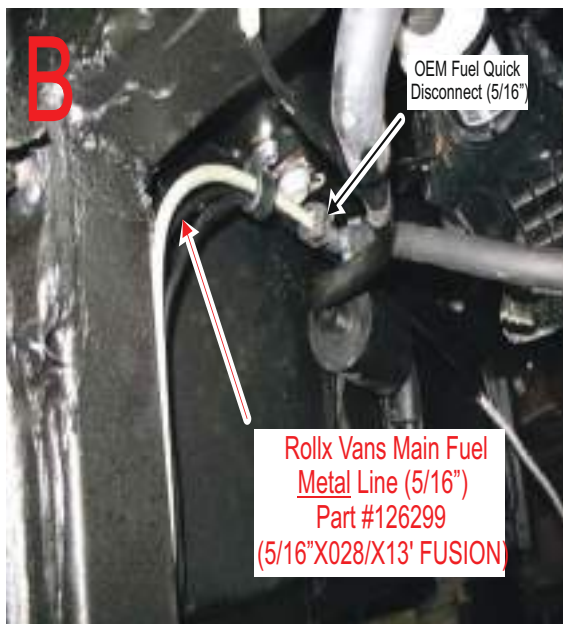



- A) Rollx Vans runs the Rollx Vans Canister Vent Metal Line (3/8") under the passenger side of the van using P-Clamps to secure.
- B) The Rollx Vans Canister Vent Metal Line (3/8") is routed up under the engine compartment, flared and attached to OEM Quick Disconnect.
- C) The Rollx Vans Canister Vent Metal Line (3/8") is routed up the rear z, flared and attached to OEM Quick Disconnect.

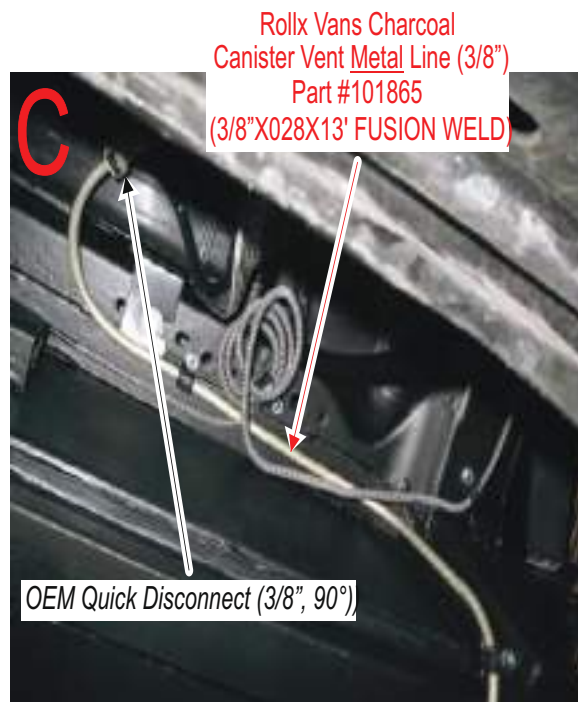
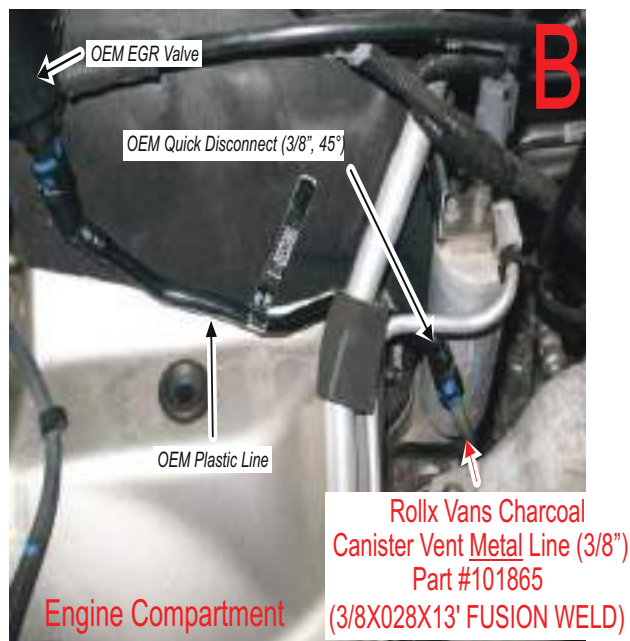



# Front Strut Mounting Bolts #B08001ASM

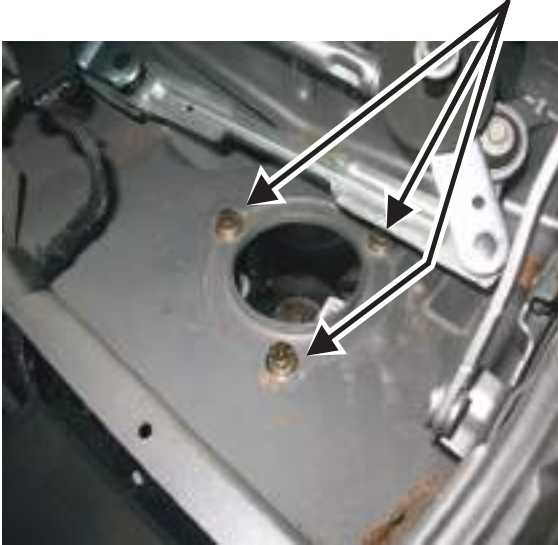

BOLTS:  
5/16" -18 x 1" (QTY 6)  
#0115055

WASHERS:  
1/4" ZINC FLAT(QTY 6)  
#1133004

LOCK WASHERS:  
5/16" (QTY 6)  
#1133892

# Strut Collar Assembly #B08001ASM

\*Reuse OEM strut collar nuts to fasten collar to strut.

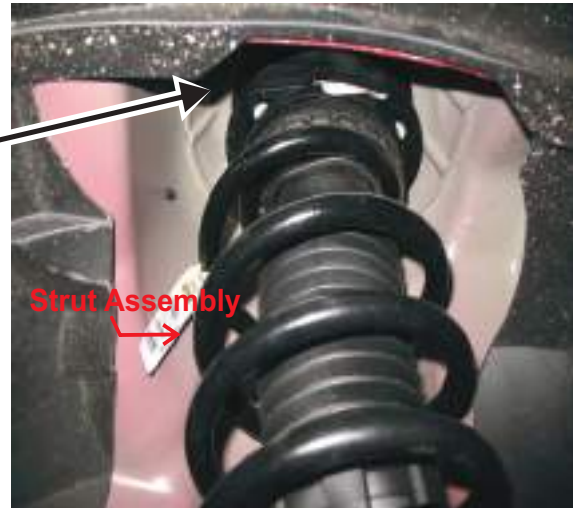
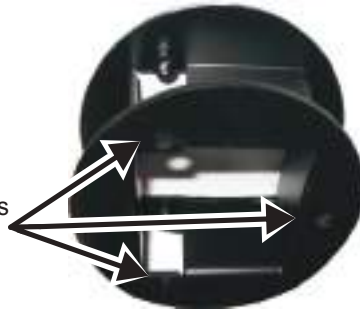

# Adjustable Camber Bolt #41-214

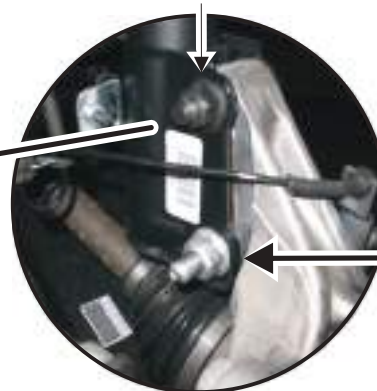

OEM Camber Bolt



## Vans Built Prior to 1-2-2013

### COIL SPACER ON BOTTOM

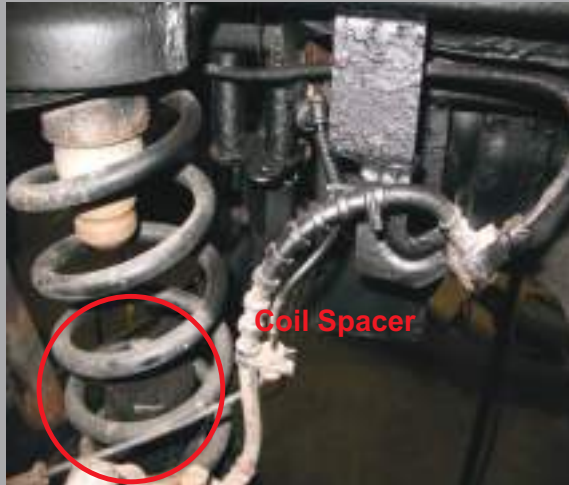

### SERVICE KIT #R0046

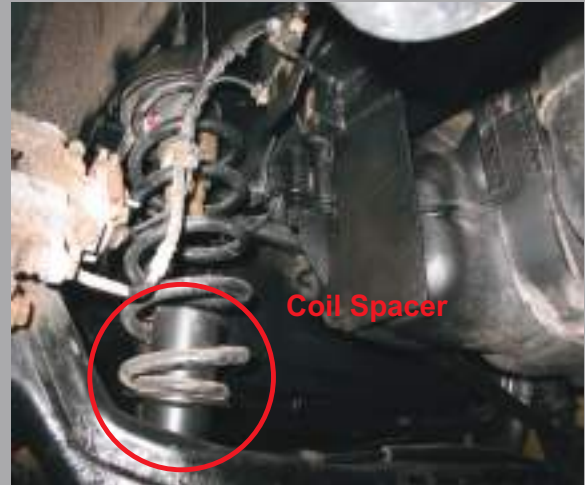

## Vans Built After 1-2-2013

### SNUBBER EXTENSION ON TOP

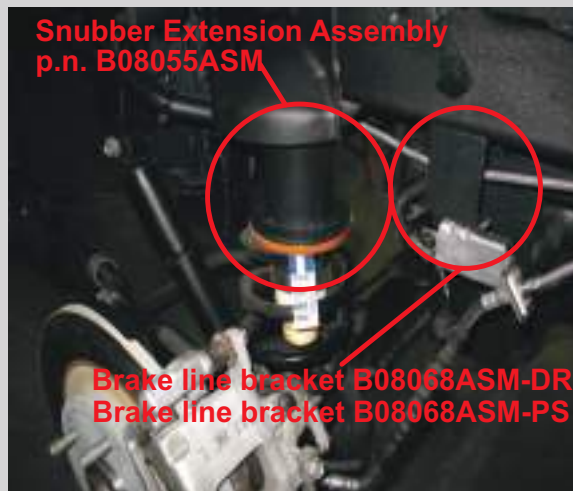

### Traction Bar Spacers B08065

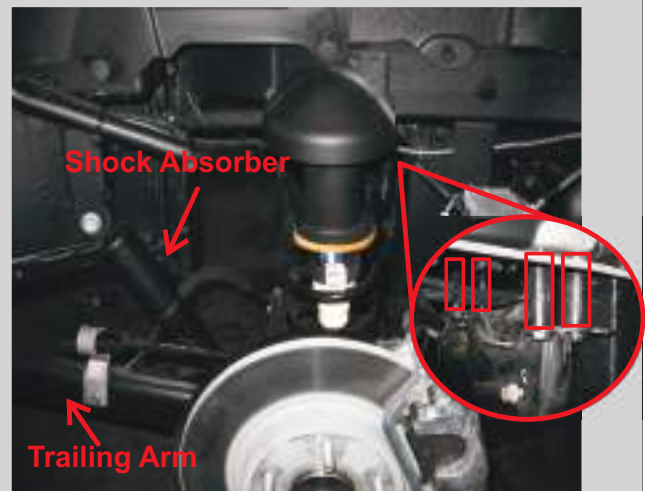

**BOLTS:** (QTY 4)  
M10-1.50 x 100mm  
#0153998

**WASHERS:** (QTY 4)  
1/2" ZINC FLAT  
#1133012

### Kneel Axel Mount B08022





# engine MounTing (Cradle droP)

**BOLTS:**  
M10-1.50 x 70mm (QTY 3)  
#0153994

**WASHERS:**  
3/8" ZINC FLAT(QTY 3)  
#1133008

**BOLTS:**  
M12-1.50 x 70mm (QTY 2)  
#38503

**WASHERS:**  
1/2" ZINC FLAT(QTY 2)  
#1133012



Right Side Engine Mount



Left Side Engine Mount

2.5" Motor Mount  
N05011 (QTY 5)



Front Engine Mount

Left Crossmember Bracket  
(Right side same)

OEM Isolator bolt  
#4721 746AB (QTY 1)

**BOLTS:**  
M12-1.75 x 50mm (QTY 4)  
#0122055

**WASHERS:**  
3/8" ZINC FLAT(QTY 4)  
#1133012

**BOLTS:**  
M14-2.0 x 190mm (QTY 4)  
#0122055

**WASHERS:**  
3/8" ZINC FLAT(QTY 4)  
#1133012

1" Motor Mount  
N05010 (QTY 4)



Left Cradle Mount  
(Right side same)



<b><u>Torque Specifications</u></b>		
<b><u>Location</u></b>	<b><u>Item</u></b>	<b><u>Torque</u></b>
Front Suspension	Wheel nuts	100 Ft. Lbs.
	Camber Bolts	116 Ft. Lbs.
	Stabilizer Bar Link Nuts	65 Ft. Lbs.
	Strut Collar-to-Body	21 Ft. Lbs.
	Strut Collar-to-Strut	21 Ft. Lbs.
Rear Suspension	Wheel nuts	100 Ft. Lbs.
	Trailing Arm Bracket-to Body Bolts	40 Ft. Lbs.
	Trailing Arm Pivot Thru-Bolts	129 Ft. Lbs.
	Traction Bar To Axle Bolts	60 Ft. Lbs.
	Shock Absorber Upper Mounting Bolts	55 Ft. Lbs.
	Shock Absorber Lower Mounting Bolts	55 Ft. Lbs.
Engine & Cradle	Front Engine Mount	83 Ft. Lbs.
Mounting	Right Side Engine Mount	40 Ft. Lbs.
	Left Side Engine Mount	70 Ft. Lbs.
	Left & Right Cradle Mounts	120 Ft. Lbs.
	Left & Right Cross Member Brackets (M14 Bolts)	120 Ft. Lbs.
	Left & Right Cross Member Brackets (M12 Bolts)	40 Ft. Lbs.

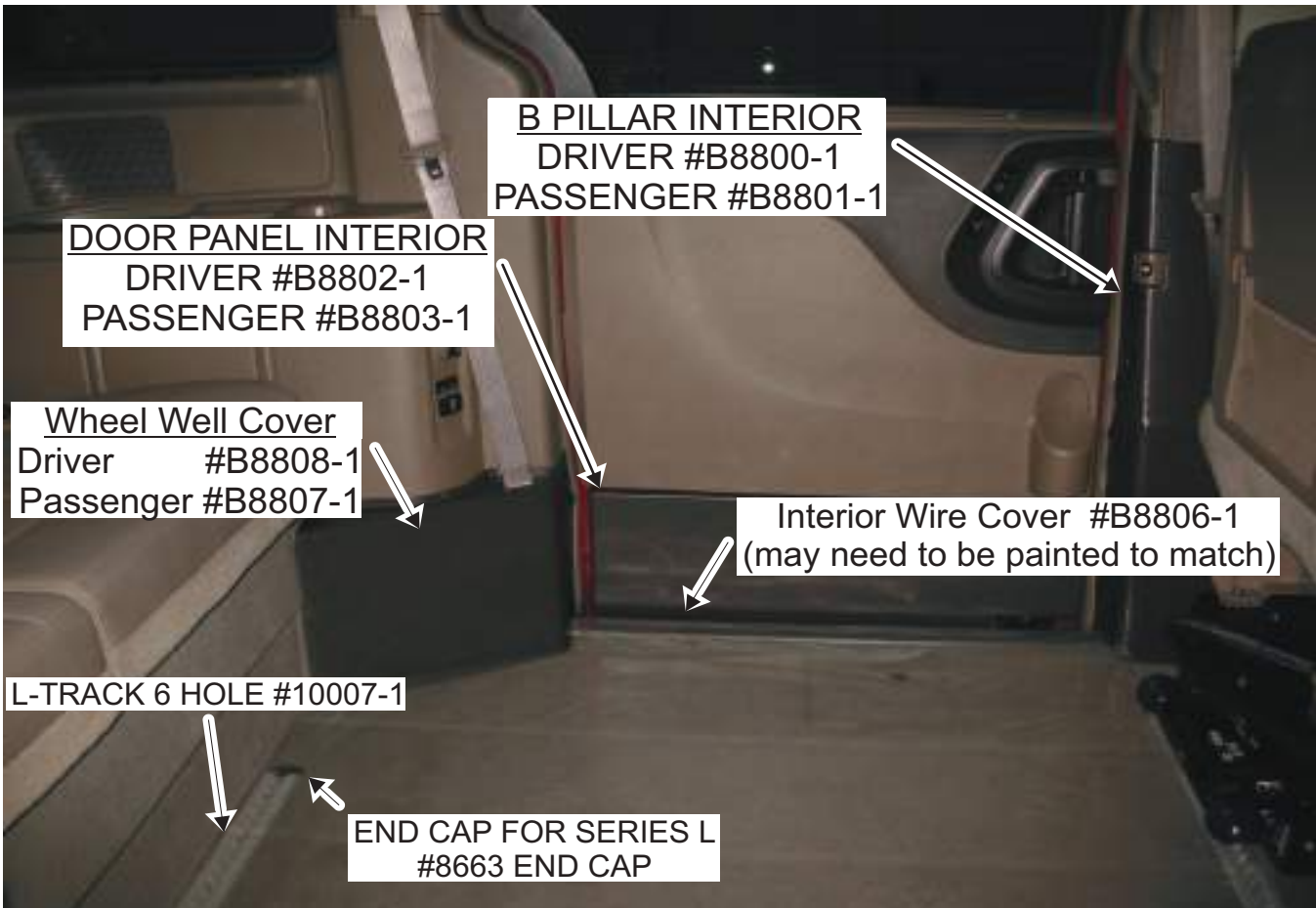
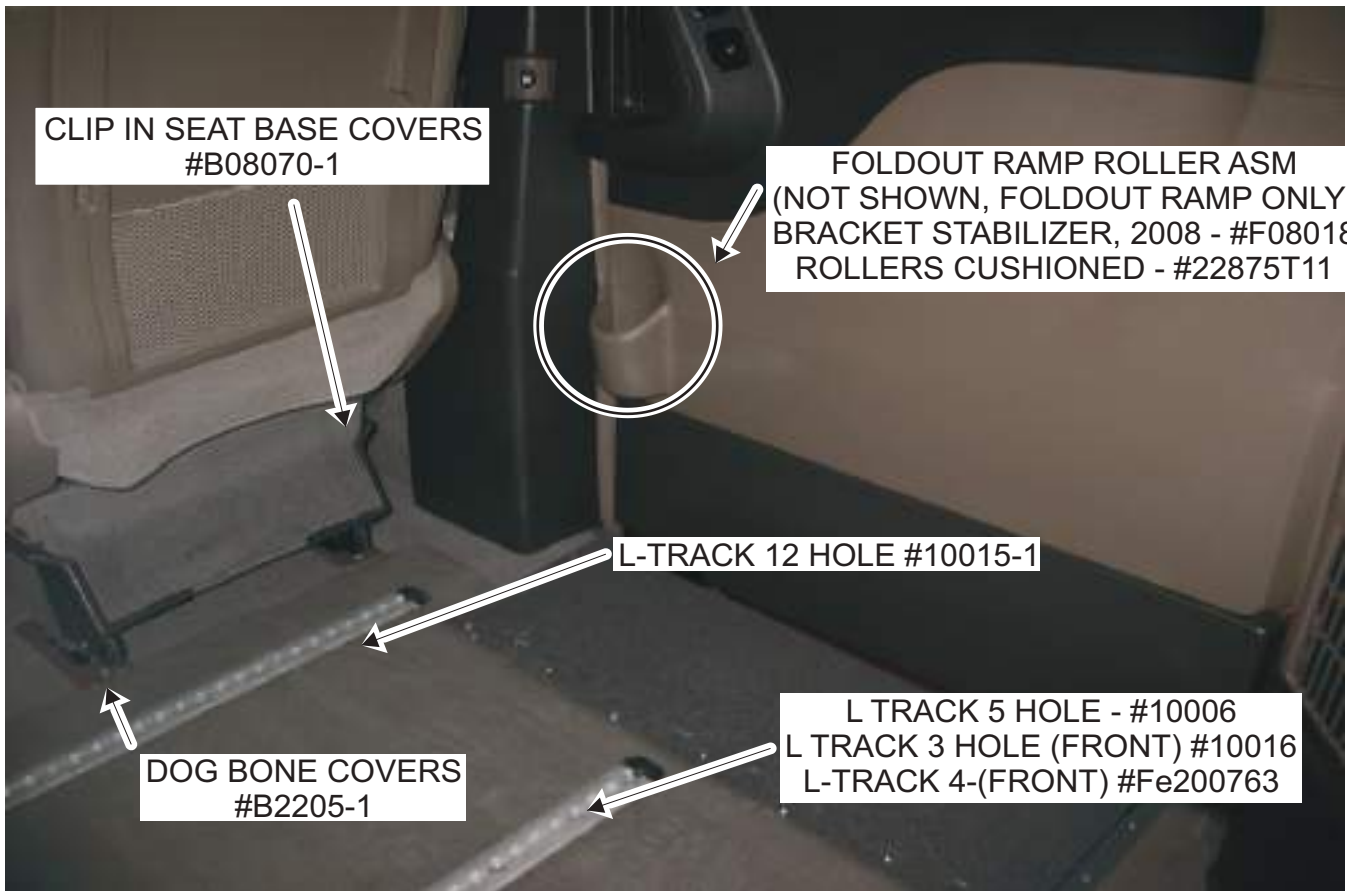



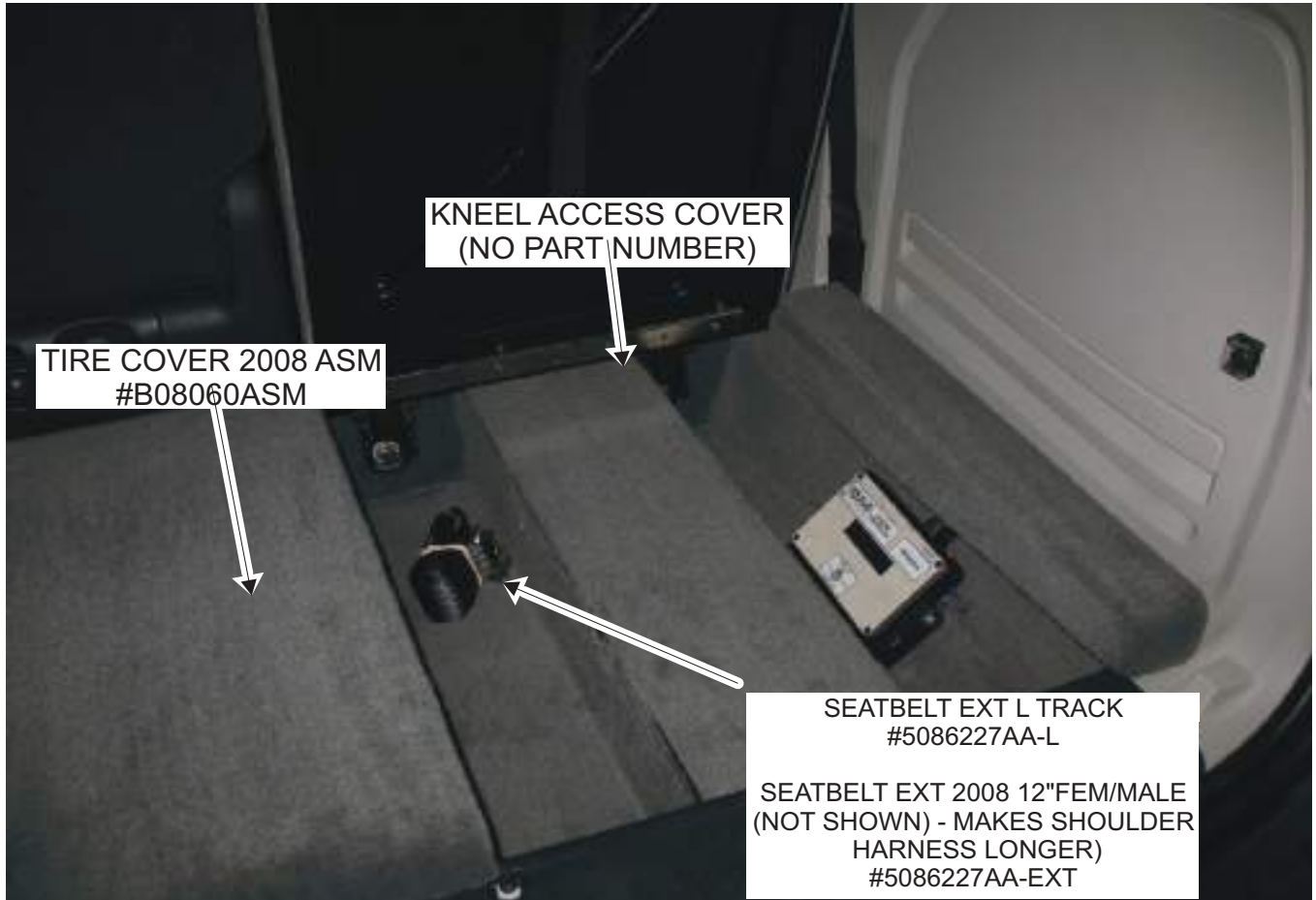



# Kneeler Troubleshooting

Symptom	Possible cause	remedy
Van does NOT LOWER to ground while door is opening after Rollx Vans user button is pressed.	Kneel on / off switch is turned OFF.	Turn kneel switch to the ON position.
	Kneel motor or Broken Chain	Review display board. Turn kneel switch to the OFF position and press OTC reset button. Operate without kneel option enables. Contact customer service.
After van is lowered to ground the kneeler makes a loud ratcheting sound.	Kneel down limit switch was not activated.	Adjust kneel down limit switch. Replace if broken. Contact customer service.
Van will NOT RAISE when ramp is stowed.	Kneel on / off switch is turned OFF.	Turn kneel switch to the ON position.
	Kneel motor .	Review display board. Manually un-kneel van, turn kneel switch to the OFF position and press OTC reset button. Contact customer service.
	Kneel up limit switch is activated incorrectly.	Adjust kneel up limit switch. Replace if broken. Contact customer service.
Van raises and while door closing the kneeler ratchets.	Kneel up limit switch is not activated.	Once door is closed and van is at normal height, turn kneeling switch to the OFF position.

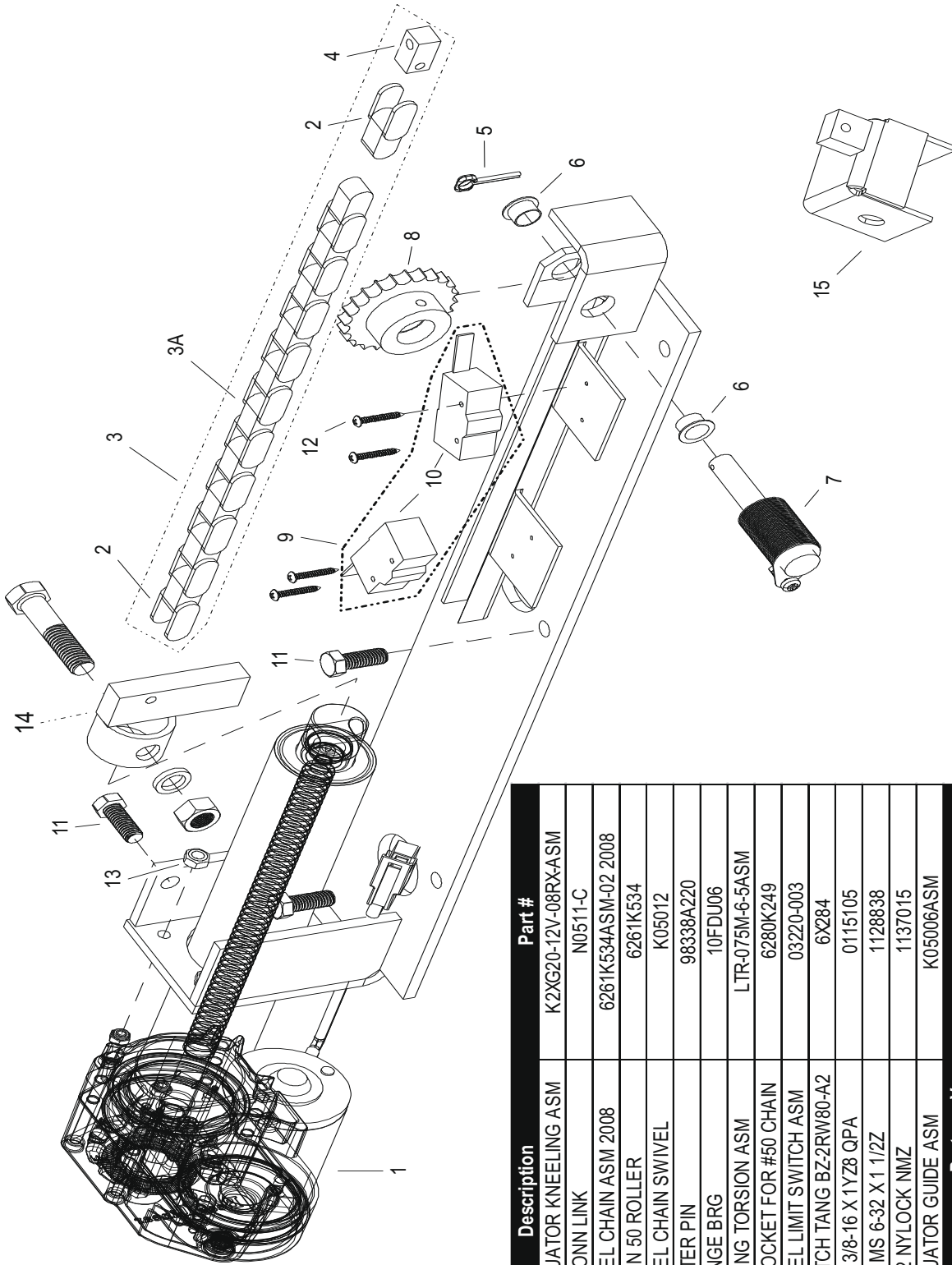

Part# KNEEL SNG OT-02 - Desc. KNEEL ASM CHRY, SNG,  
OTC, 2005-12v2 (COMPLETE ASM)

Item	Qty.	Description	Part #
1	1	ACTUATOR KNEELING ASM	K2XG20-12V-08RX-ASM
2	2	50 CONN LINK	N0511-C
3	1	KNEEL CHAIN ASM 2008	6261K534ASM-02 2008
3A	1.5	CHAIN 50 ROLLER	6261K534
4	1	KNEEL CHAIN SWIVEL	K05012
5	1	COTTER PIN	98338A220
6	2	FLANGE BRG	10FDU06
7	1	SPRING TORSION ASM	LTR-075M-6-5ASM
8	1	SPROCKET FOR #50 CHAIN	6280K249
9	1	KNEEL LIMIT SWITCH ASM	03220-003
10	2	SWITCH TANG BZ-2RW80-A2	6X284
11	3	HCS 3/8-16 X 1Y28 QPA	0115105
12	4	PPH MS 6-32 X 1 1/2Z	1128838
13	4	10-32 NYLOCK NMZ	1137015
14	1	ACTUATOR GUIDE ASM	K05006ASM
<b>Parts on Van</b>			
15	1	KNEEL AXLE MOUNT	B08022
	1	RATCHET REVERSIBLE	800-0072*
	1	SOCKET 3/8"	4PW71*
	1	BOOT BLK "2005" KNEELACT	152303*

\* Not Shown



**important:** If OTC Board is removed, the OEM System will not operate normally unless the CAN Bus Shunt is installed. The shunt is attached to the wire harness behind the OTC board. See OTC Wiring Diagram for more information.

Symptom	Remedy
No power to One Touch Controller (OTC).	Check that OTC ON/OFF switch is on. The power toggle switch is on the actual board.
	Ensure the connections on the back of the OTC board are tight.
	Check the OTC main fuse (40 amp) located near the vehicles main battery.
	Check the OTC Board fuse (1 amp) located in the Rollx Fuse Panel behind the glove box.
	Reset the OTC. The reset is located on the dash by the drivers left knee or on the OTC Board.
	Check battery voltage.
OTC beeps 4 times when the user tries to run a normal open/close cycle.	Battery is low. Turn off the OTC and charge battery. Note: The alarm will sound when the battery voltage is below 11.4 vdc. This is to prevent the OTC system from draining the battery far enough as to prevent the vehicle from starting. This level is adjustable in the board's Setup menu.
The van's battery is dead.	Van has been sitting for an extended period of time. Charge the battery.
	Check the current draw by placing an ammeter in series with the negative terminal on the battery with all doors closed and engine off. The draw varies, but awake, the system should be less than .850 amps and when sleeping, less than .050 amps. Additional equipment installed will also vary these numbers. See Battery section for more information.
The OTC display is garbled.	Reset the OTC. The reset is located on the dash by the drivers left knee or on the OTC Board.



The Rollx Vans One Touch Controller, known as the OTC, is a Single Board Computer specifically designed for the Rollx Vans system.

The OTC system was designed to be independent to the operation of the Chrysler computer system. When power is removed from the OTC, it has no effect on the operation of the Chrysler system as long as the OTC Shunt Plug is installed into the OTC Main Harness on all 2008 Chrysler Vans due to the CAN BUS system (see OTC Wiring Diagram for more information).

The OTC is a low power system. When the OTC is in Sleep Mode with the Display disabled, it typically draws less than 10ma of current from the battery. When awake in Idle Mode (not running a cycle) with the Display enabled, it typically draws less than 200ma of current from the battery.

The current state of the OTC can be determined by viewing the Display. During open or close operation the progress of the system can be tracked by watching the Display.

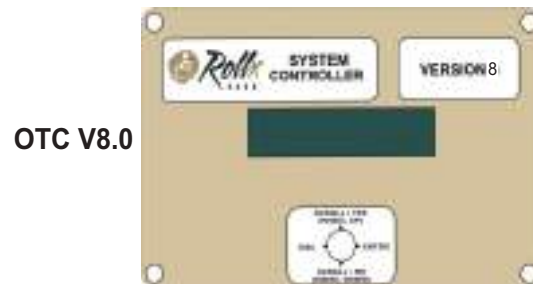

OTC V8.0

## Sequence of Operation

### Open Cycle

- 1) The OTC is activated by any Rollx Vans User Switch or Remote being pressed.
- 2) Door unlock command sent (1 sec.) To Front Passenger Door Control Module to unlock all doors.
- 3) Door open command sent to OEM B-Pillar Door Open/Close Button to open the passenger sliding door.
- 4) Door starts to open.
- 5) Kneeler motor is turned on and starts to lower van.  
\*If door fails to open within 2 seconds of User Switch being pressed, cycle stops (van unknuckles and cycle is ended)
- 6) Door reaches open position and activates Rollx Vans Door Open Limit Switch.
- 7) Passenger sliding door is disabled by OTC interrupting the CAN Bus signal with built in relay.
- 8) Ramp motor is turned on and starts to deploy.
- 9) Kneeler stops lowering when Kneel Down Limit Switch is activated.
- 10) Ramp stops deploying when Ramp Down Limit Switch is activated.
- 11) OTC enters Idle Mode.
- 12) OTC enters Sleep Mode.

### Close Cycle

- 1) The OTC is activated by any Rollx Vans User Switch or Remote being pressed.
- 2) Ramp motor is turned on and starts to stow.
- 3) After a few seconds (ramp is off the ground and begun to slide into van) kneeler motor is turned on and starts to raise the van.
- 4) Kneeler stops raising when Kneel Up Limit Switch is activated.
- 5) Ramp stops stowing when Ramp Up Limit Switch is activated.
- 6) Passenger sliding door is enabled by OTC reconnecting the CAN Bus signal with built in relay.
- 7) Door close command sent to OEM B-Pillar Door Open/Close Button to close the passenger sliding door.
- 8) OTC receives signal from OEM Door Ajar Pin Switch that door is closed.
- 9) OTC enters Idle Mode.
- 10) OTC enters Sleep Mode.

Note: There are "Watch Dogs" programmed in the OTC software that act as timers to end a function if the function does not complete within a certain amount of expected and very reasonable time.



## INPUTS

**KNEEL DISABLE SWITCH (Violet wire)** Allows the user to enable (the “I” position) or disable (the “O” position) the kneeling system. There is no display for this input.

**OTC CONTROLLER POWER (2 White/Red wires)** Supplies power to the OTC Board

**USER SWITCH INPUT (Blue wire)** Active while any Rollx Vans user button or Rollx Vans remote is pressed.

**NEUTRAL INPUT (Green wire)** Indicates the status of the gear shifter. When active, the van is either in neutral or park. The OTC system will not run a operational cycle unless the van is in neutral or park.

**DOOR OPEN LIMIT INPUT (Orange/Red wire)** Active when the right side sliding door is fully open.

**DOOR CLOSE LIMIT INPUT (Violet/Yellow wire)** Active when the right side sliding door is fully shut.

**RAMP UP LIMIT INPUT (Red/Green wire)** Active when the ramp is in the up position.

**RAMP DOWN LIMIT INPUT (Red/White wire)** Active when the ramp is in the down position.

**KNEEL DOWN LIMIT INPUT (Yellow/Green wire)** Active when the kneeler is in the down position.

**KNEEL UP LIMIT INPUT (Yellow/White wire)** Active when the kneeler is in the up position.

## OUTPUTS

**System Status:** Indicates if the system is ready to except a command. It is off when the OTC is in sleep mode. V8.0 Display will show Rollx Vans: Idle.

**RAMP DOWN MOTOR OUTPUT (Red wire)** Active when the OTC is driving the ramp down (V6.0 & V8.0 OTC boards have obstacle detection monitoring this output).

**RAMP UP MOTOR OUTPUT (Red/Black wire)** Active when the OTC is driving the ramp up (V6.0 & V8.0 OTC boards have obstacle detection monitoring this output).

**KNEEL DOWN MOTOR OUTPUT (Yellow/Black wire)** Active when the OTC is driving the kneeler up

**KNEEL UP MOTOR OUTPUT (Yellow/Red wire)** Active when the OTC is driving the kneeler up.

**DOOR DISABLE OUTPUT (Orange/Blue)** Used by the OTC to disable the Chrysler right side door controller anytime it wants to open the ramp. This prevents the right side door controller from banging the right side sliding door against the ramp.

**DOOR CONTROL OUTPUT (Orange)** OTC sends a command to the Chrysler system to open or close the right side sliding door.

**RAMP DISABLE OUTPUT (Red/Blue wire)** Active anytime when the OTC is driving the ramp up or down. It indicates the ramp manual mode is disabled.

**DOOR UNLOCK OUTPUT (Green/White)** OTC sends a command to the Chrysler system to unlock the doors at the beginning of an open cycle.



### One Touch Controller Basic Operation

- 1) How to manually kneel van
- 2) How to check software and hardware versions
- 3) How to review error codes in Data Logger

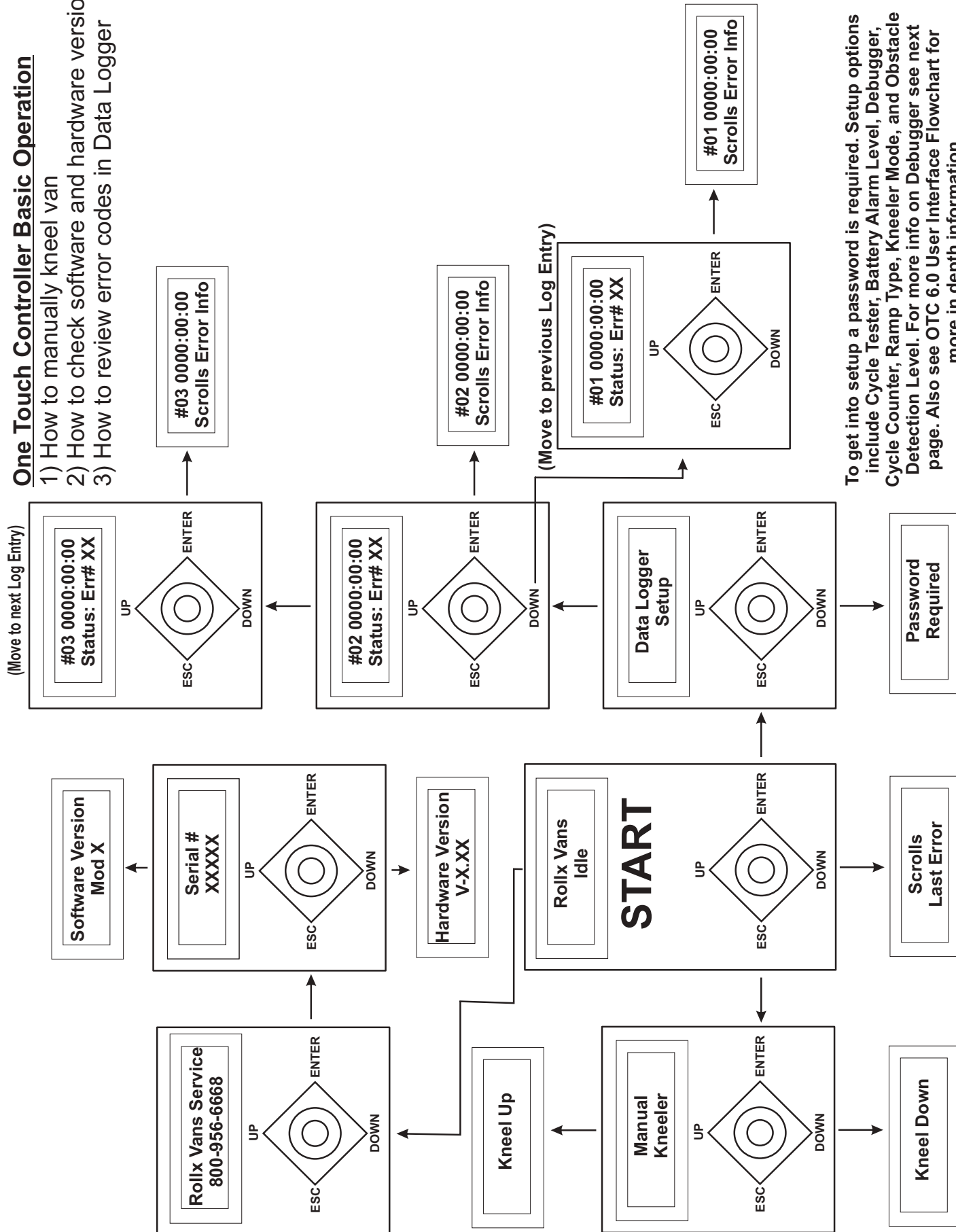

To get into setup a password is required. Setup options include Cycle Tester, Battery Alarm Level, Debugger, Cycle Counter, Ramp Type, Kneeler Mode, and Obstacle Detection Level. For more info on Debugger see next page. Also see OTC 6.0 User Interface Flowchart for more in depth information.



Options within Setup

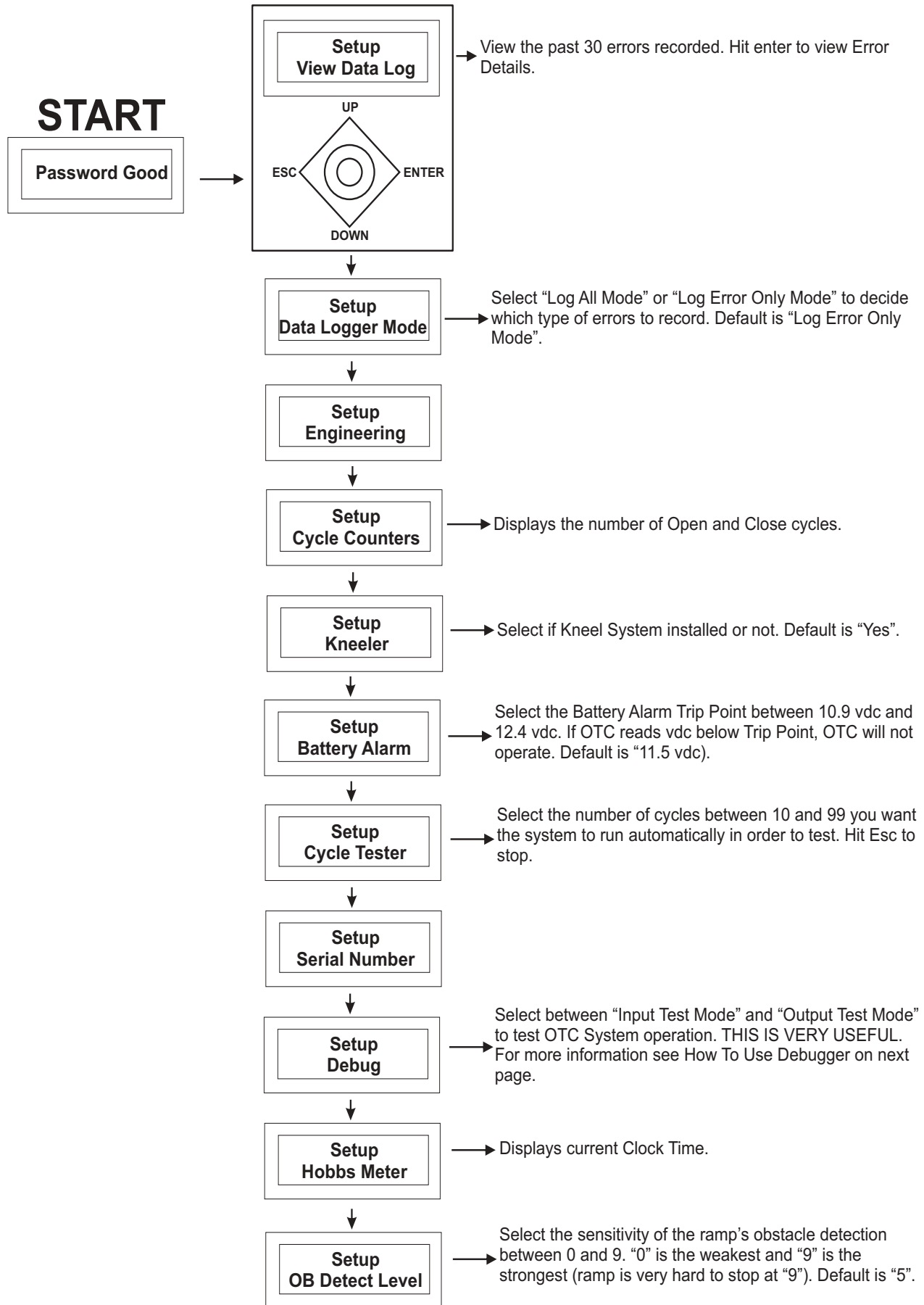





### How to Use Debugger (Output Test Mode)

Use extreme caution when using the Output Test Mode. The Output Test Modes sends the signal directly to the OTC Relay Board which results in power going to the called motor. No safeties are in place (ie. The Ramp Down will operate the ramp regardless if the door is open or closed).

## START

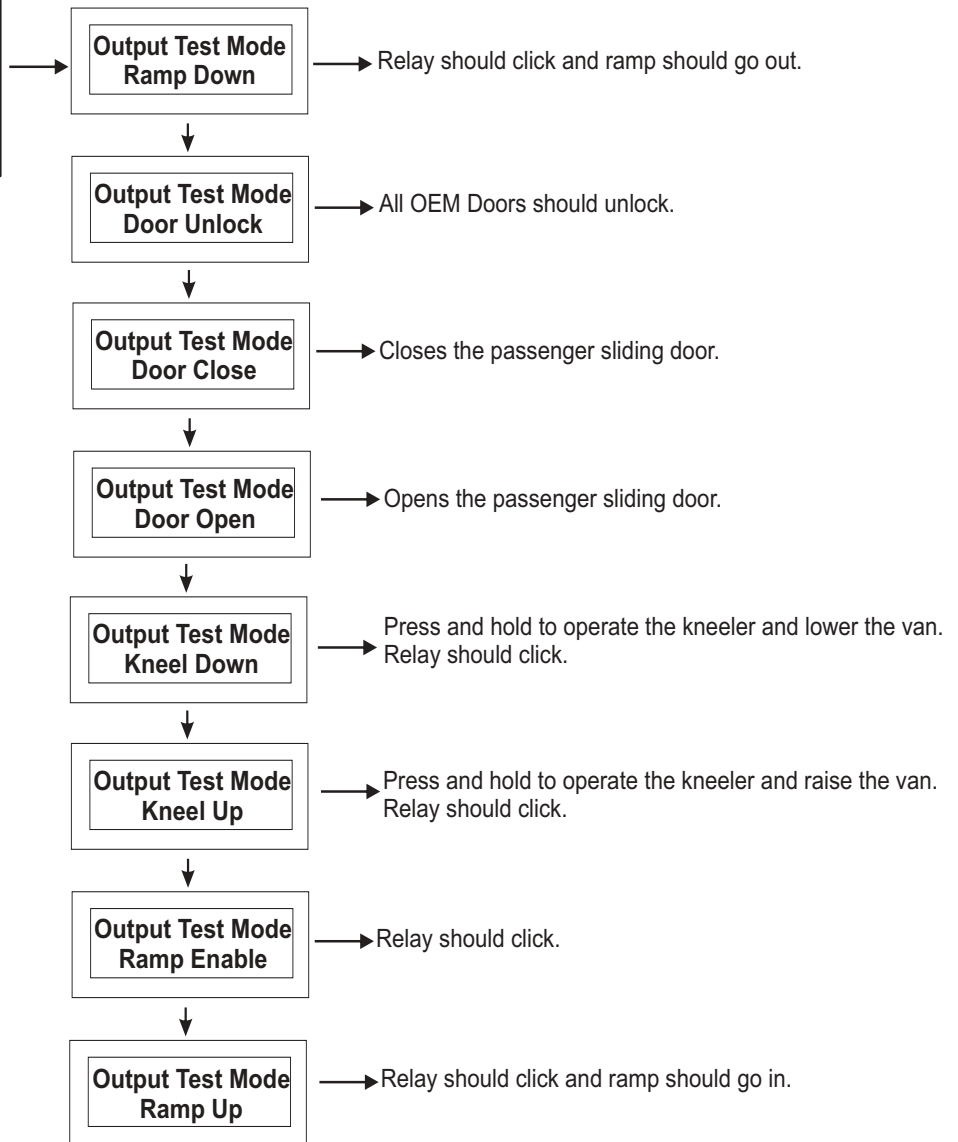
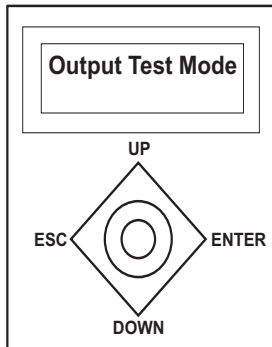



### How to Use Debugger (Input Test Mode)

The Input Test mode is very useful for testing the various limit switches the systems requires. To operate:

- 1) Select a Limit Switch (Input) you would like to test from the list below.
- 2) Notice if the Switch is "On" or "Off" when it is suppose to be.  
The audible beeps let you test the switch by hand without looking at the OTC Board.
  - On (activated) = Double Beeps
  - Off (not activated) = Single Beeps

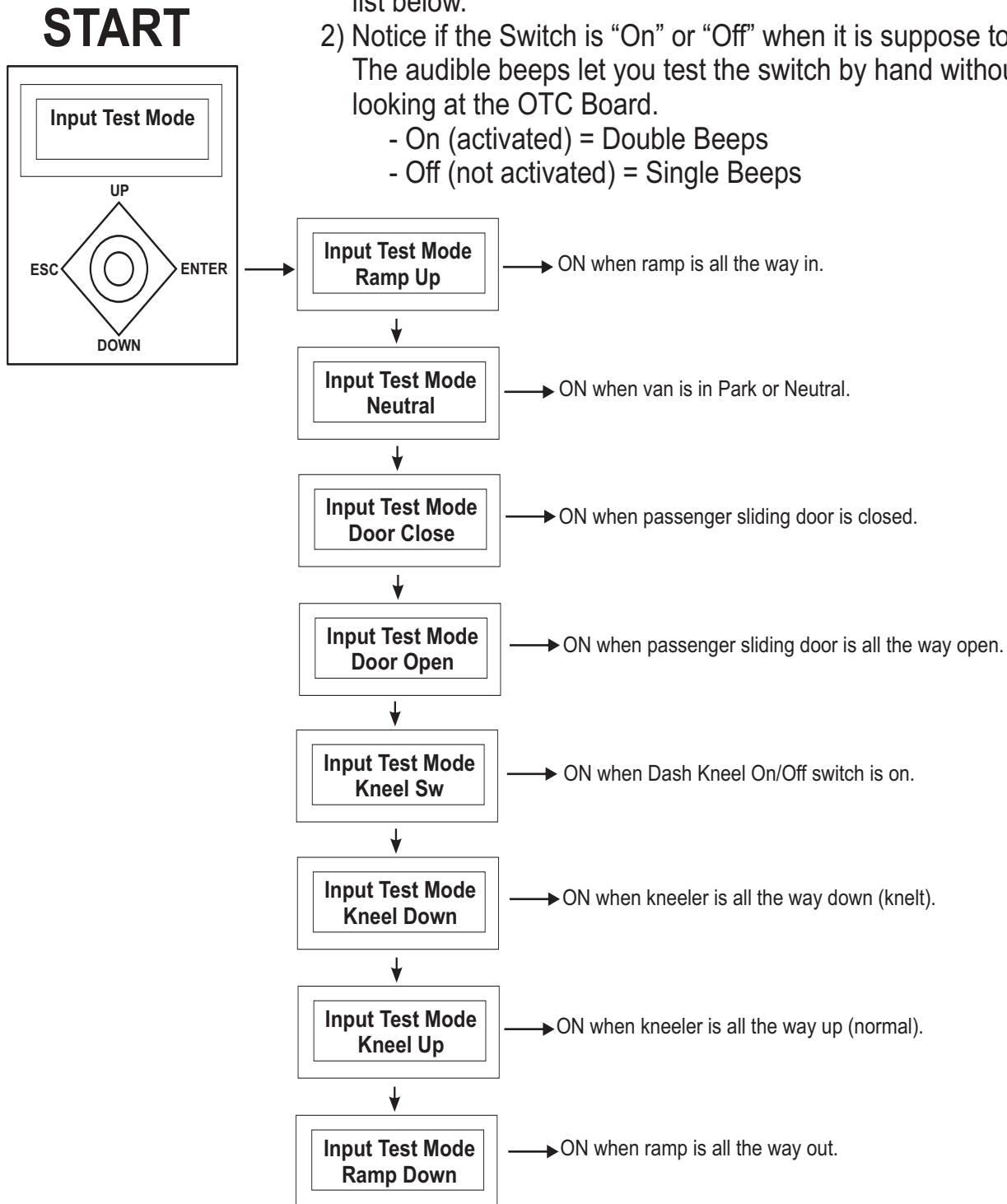



For information about OTC interface and how to use the debugger, please refer to 'One Touch System - v8.0 advanced interface' section. Remember, in Input Test Mode, double beeps indicate the switch is on or activated and single beeps indicate that it is not. Also refer to the 'One Touch System - Relay Board Troubleshooting' for more information about the Relay Board, its Override Switches and LED indicator lights.

code	description - What caused the code
<b>error 1 - Battery low error</b>	Everytime before the OTC cycles, it checks the Main Battery's voltage. If reading is below the value set in the OTC Setup, the OTC will continue to operate, but will indicate a low battery warning. The default value is 11.5 volts.
diagnostic Tests	More information
<b>Perform a Draw Test</b> Follow instructions in 'Battery information - Draw Test Procedure' Section	Rollx Vans recommends starting your van every 4-5 days, allow it to run 15-20 minutes to keep the battery at a sufficient state of charge. A timer is included on the OTC that will shut it off after 5 minutes UNLESS in Setup Mode. Update OTC if needed.

code	description - What caused the code
<b>error 11 - door control error</b>	Door Control Output failure (The OTC did not successfully control the door to open or close). The OTC did not receive the signal that the door came off the OEM Door Ajar Switch when opening or did not receive the signal that the door came off the Rollx Vans Door Open Switch when closing. Once the OTC sends the signal to open the door, it waits about 2 seconds to see if the Door Ajar Switch is not activated. If the Door Ajar Switch is still active, this message will appear.
diagnostic Tests	More information
<b>Output Test</b> Place OTC in Debug - Output Test Mode to verify OTC operates the door correctly by sending signal to OEM B-Pillar Switch and/or OEM Front Passenger Door unlock Switch. 1) check Door Open. 2) check Door close. 3) check Door unlock. 4) check ramp enable. This closes a relay on the OTC relay Board that enables the ramp to run (prevents the ramp from running if the door is not open, door open enables ramp enable).	<b>OEM B-Pillar Switch / door on/off</b> If off, the OEM Overhead Power Sliding Door On/Off Switch will prevent the door from operating from the OEM B-Pillar Switch. The OTC uses this switch to open or close the door. When off, the OTC can not control the door. Make sure the switch is on and try hitting the OEM B-Pillar switch. If the door still does not work, likely an OEM issue. If OEM function works, but OTC does not check wiring.
<b>Input Test</b> Place OTC in Debug - input Test Mode to verify limits operate correctly. 1) check Door Open (rollx vans Door Open Switch), by opening door all the way in Door Open. 2) check Door close (OEM Door ajar Switch), by close door all the way in Door close. rollx vans taps into OEM Door ajar Switch in lower B-Pillar (See OTC Wiring for more information).	<b>door unlock Switch</b> Door must be unlocked to open. First try OEM Unlock Switch in Passenger Front Door. The OTC uses this switch to unlock all the doors before an Door Open Command is sent. If OEM Switch does not unlock doors, likely an OEM issue. If OEM functions, but OTC does not check wiring.  <b>door ajar Switch</b> If the OEM Door Ajar Switch is not deactivated within 2 seconds of the start of the cycle, Door Control Error will be returned.



code	description - What caused the code
<b>error 18 - ramp obstacle detection error</b>	OTC detected that the ramp may have hit an obstruction on the in or out cycle. The OTC detects an obstruction by measuring the current generated from the ramp motor. The obstruction could be something in the way or a Ramp Limit is not recognized. If this current exceeds the set limit in the OTC Setup (default is 5, scale is 1-10 with 1 being the most sensitive)
diagnostic Tests	More information
check error log for multiple Obstacle Detection errors. if there are many, raise the level in Setup.	Setup - OB Detect Level (default is 5, scale is 1-10 with 1 being the most sensitive)
<b>Input Test</b> Place OTC in Debug - input Test Mode to verify limits operate correctly. 1) check ramp up [Limit Switch] by operating the ramp with Power Override Switch (iTF ramp) or manually raising (Folding ramp). 2) check ramp Down [Limit Switch] by operating the ramp with Power Override Switch (iTF ramp) or manually raising (Folding ramp).	If a Ramp Limit Switch fails, the Obstacle Detection should activate and cause an error. If the Obstacle Detection does not activate, the Ramp Watchdog Timer should. This will also cause an error (Error 27) and end the cycle.

code	description - What caused the code
<b>error 23 - neutral Status error</b>	Everytime before the OTC cycles, it checks to make sure the van is in Park. This is for safety and can not be changed.
diagnostic Tests	More information
<b>Input Test</b> Place OTC in Debug - input Test Mode to verify OTC recognizes if the van is in Park correctly 1) check neutral by placing the van in and out of Park and listening for the double beeps from the debugger.	Refer to Important Item Information or OTC Wiring Diagram for more information about where Rollx Vans gets this signal.

code	description - What caused the code
<b>error 25 - emergency Stop error</b>	Anytime a Rollx Vans User or Remote Button is pressed during an open or close cycle, the system will stop immediately. If a Hard Wired User Button is held down long enough, the OTC will think it has been pressed twice and thus, cause an error.
diagnostic Tests	More information
Operate user Button to verify working correctly.	This is a safety feature and can not be changed.

code	description - What caused the code
<b>error 27 - ramp Watchdog error</b>	Once the OTC sends the signal to start running the ramp motor in or out, a timer starts. If enough time passes before the proper limit switch is activated at the end of the cycle, the OTC will return this error. This is a safety feature to limit power to the motor in case of multiple failures.
diagnostic Tests	More information
Operate the In-The-Floor ramp with Power Override to help determine if motor and ramp are functioning correctly.	Not available on Folding Ramps.
<b>Output Test</b> Place OTC in Debug - Output Test Mode to verify OTC operates the ramp motor correctly. 1) check ramp Open. 2) check ramp close.	Several factors such as low battery, cold weather or debris can prevent the motor from operating correctly. If low battery, very cold or a bad motor, the motor may run too slow causing this watchdog to activate. Debris can also prevent the motor or ramp operating at correct speed, also causing this error.
<b>Input Test</b> Place OTC in Debug - input Test Mode to verify limits operate correctly. 1) check ramp up [Limit Switch] by operating the ramp with Power Override Switch (iTF ramp) or manually raising (Folding ramp). 2) check ramp Down [Limit Switch] by operating the ramp with Power Override Switch (iTF ramp) or manually raising (Folding ramp).	If a Ramp Limit Switch fails, the Obstacle Detection should activate and cause an error (Error 18). If the Obstacle Detection does not activate, the Ramp Watchdog Timer should. This will also cause an error.  If OTC Debug Output Test does not activate the motor being tested, try the overrides located on the OTC Relay Board. This will indicate a communication problem between the One Touch Controller and One Touch Relay Board.



code	description - What caused the code
<b>error 28 - door Watchdog error</b>	Once the OTC sends the signal to operate the OEM Door, a timer starts. If enough time passes before the proper limit switch is activated at the end of the cycle, the OTC will return this error.
diagnostic Tests	More information
Operate the OEM Door with the OEM B-Pillar Switch to determine if OEM Door is functioning properly.	If OEM B-Pillar Switch is not working, try the OEM Overhead Door Switch and make sure the OEM Overhead Door On/Off Switch is on.
<b>Input Test</b> Place OTC in Debug - input Test Mode to verify limits operate correctly. 1) check Door Open (roll over Door Open Switch), by opening door all the way in Door Open. 2) check Door Close (OEM Doorajar Switch), by close door all the way in Door Close. roll over taps into OEM Doorajar Switch in lower B-Pillar (See OTC Wiring for more information).	if Door limits function correctly and door cycles open and close okay, the issue is with the door taking too long to open or close. check a alignment or motor.
<b>Output Test</b> Place OTC in Debug - Output Test Mode to verify OTC operates the door correctly by sending signal to OEM B-Pillar Switch and/or OEM Front Passenger Door unlock Switch. 1) check Door Open. 2) check Door Close.	If an Output is an issue, the Door Control Error (Error 11) will likely display.

code	description - What caused the code
<b>error 29 - Kneeler Watchdog error</b>	Once the OTC sends the signal to operate the Kneeler, a timer starts. If enough time passes before the proper limit switch is activated at the end of the cycle, the OTC will return this error.
diagnostic Tests	More information
Operate the Kneeler with Power Override to help determine if motor is functioning correctly.	Reset - Esc - Kneel Up/Kneel Down
<b>Input Test</b> Place OTC in Debug - input Test Mode to verify limits operate correctly. 1) check Kneel up [limit Switch], by raising Kneeler until switch is activated or activate switch by hand. 2) check Kneel Down [limit Switch], by lowering Kneeler until switch is activated or activate switch by hand.	Testing with Power Override is preferred since it will indicate if limit switch is being properly activated by a actuator's Guide.  When Kneel actuator reaches its run limit, it will begin to ratchet making a terrible sound. This is simply the motor's clutch mechanism, is not damaging but should try and be minimized.
<b>Output Test</b> Place OTC in Debug - Output Test Mode to verify OTC operates the Kneeler correctly. 1) check Kneel up. 2) check Kneel Down.	If OTC Debug Output Test does not activate the motor being tested, try the overrides located on the OTC Relay Board. This will indicate a communication problem between the One Touch Controller and One Touch Relay Board.  Also a low battery, bad motor or cold weather causing the motor to run very slowly can return this error.

code	description - What caused the code
<b>error 33 - door ajar error</b>	The OTC will not run a cycle if the door is ajar (not fully opened or closed). if ramp deployed, open door fully. if ramp stowed, fully close and latch door.
diagnostic Tests	More information
Operate the OEM Door with the OEM B-Pillar Switch to determine if OEM Door is functioning properly.	If OEM B-Pillar Switch is not working, try the OEM Overhead Door Switch and make sure the OEM Overhead Door On/Off Switch is on.
<b>Input Test</b> Place OTC in Debug - input Test Mode to verify limits operate correctly. 1) check Door Open (roll over Door Open Switch), by opening door all the way in Door Open. 2) check Door Close (OEM Doorajar Switch), by close door all the way in Door Close. roll over taps into OEM Doorajar Switch in lower B-Pillar (See OTC Wiring for more information).	



RELAY BD OTC VERSION 2  
P.N. 08044-003  
ORDER #OTCV8 RELAY BD

## OUTPUTS

Run to the Kneeler and Ramp Motors

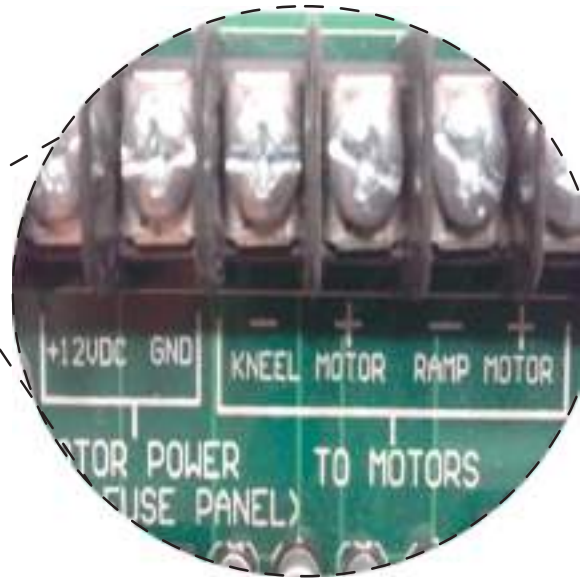
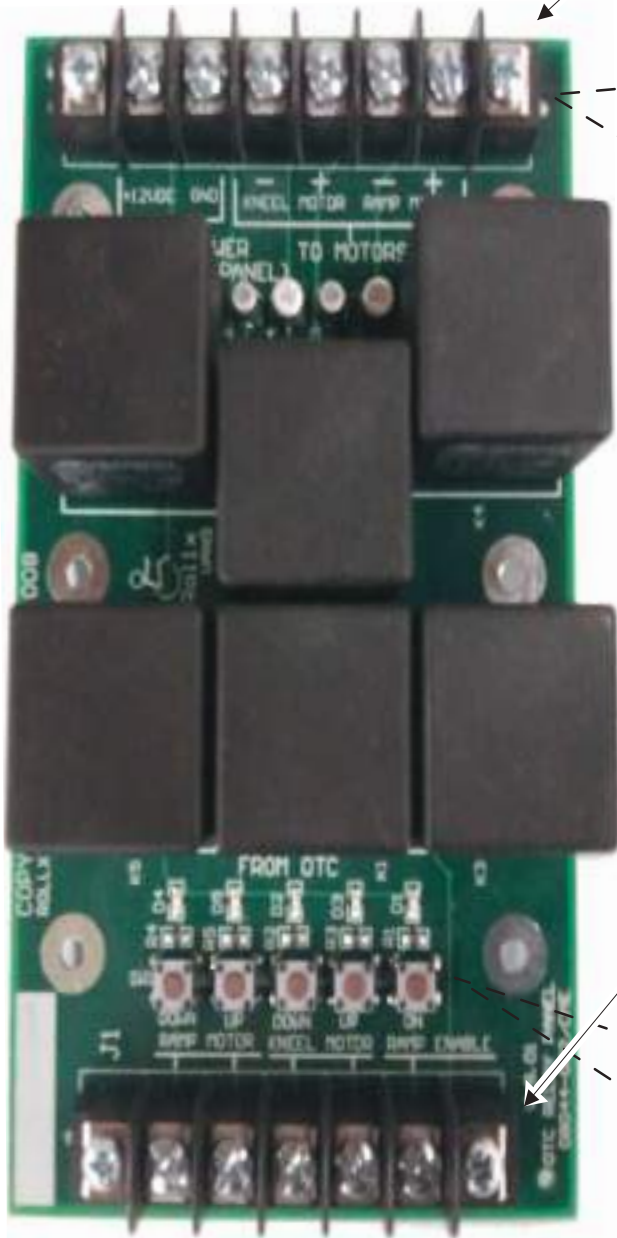

## INPUTS

Run from the OTC Control Board

### LED Indicator Lights

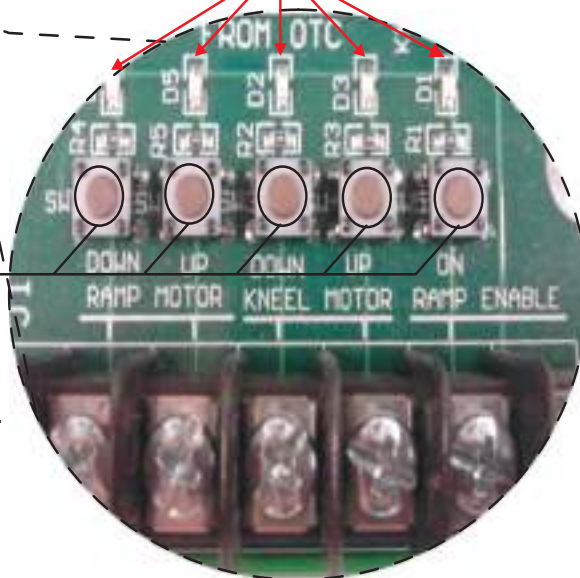

Manual push button test switches

\*Pressing the switches should operate each function as shown on the board as long as the board is working properly. Remember, in order to run the ramp, the Ramp Enable must also be pressed at the same time. Pressing a switch is the same as sending a ground to the terminal.

This page was intentionally left blank



Symptom	Possible cause	r emedy
Ramp will NOT DEPLOY after door opens automatically.	Door open limit switch is not being activated.	When a Open Cycle starts, the OTC will send a command to the Chrysler System to unlock the doors. It then sends a second command to the Chrysler System to open the Right Side Sliding Door. The OTC Computer then waits two seconds and checks the Door Closed Limit Switch. If it finds it still indicates the door is closed, it assumes that a person (or and obstacle) stopped the door opening sequence. It then ends the open cycle and goes back into Idle Mode. After ten to fifteen seconds it goes back into Sleep Mode. This is the sequence of events you will see if the Door Closed Limit Switch malfunctions (sticks closed).
	Ramp motor not engaged.	Engage ramp motor. Refer to the "Manual Operation" section of this manual.
	Ramp down limit switch needs adjustment to deactivate.	Press Rollx Vans user button again to unknée van and close door. Review display on OTC board and contact customer service.
	Ramp motor.	Review display on OTC board and contact customer service.
Ramp will NOT STOW automatically.	OTC program failure.	Press OTC reset button.
	Ramp motor not engaged.	Engage ramp motor. Refer to the "Manual Operation" section of this manual.
	Ramp motor.	Review display on OTC board and contact customer service.
	Low voltage from the battery.	Start vehicle. Press OTC reset button and press Rollx Vans user button again.
Ramp will deploy before door is all the way open.	Door open limit switch is shorted to ground or malfunctioning.	Examine door open limit switch, connections, and wiring.
Ramp will STOP AND REVERSE mid-cycle.	Obstacle is detected.	Clear obstruction and press Rollx Vans user button.
		Review display on OTC board and contact customer service.
Ramp will start to deploy or stow then stop functioning.	Pressure on cover plate.	Ensure that there are no objects on top of cover plate.





# in floor (MeTal Springs) r ePlacemEnt ParTs

Item	Qty.	Description	Part #
1	1	ITF ACCESS PLATE	N05019
1	1	MOTOR GEAR BOX ITF 2008 ASM	N08111ASM
1	1	MOTOR WITH GEAR ONLY	N08111-MTR/GEAR ASM
3	6	1/4-20 YZ NE NYLOCK	1137183
4	10	CHAIN ROLLER SS #35	35
5	1	TENSIONER/SPROCKET ASM ITF	10005
6	2	ROLLERS CUSHIONED	22875T11
7	8	SS TORX BHCS 1/4-20	10929-02112
8	1	FLAP ASM ITF RAMP	N05014ASM
3	3	PRECISION MINATURE IDLER*	2483K18
3	3	5/16" x 1/16" NYLN WSHR	76002
3	3	1/4-20 YZ NE NYLOCK*	0115007
9	7	SS TORX BHCS 1/4-20	10929-02112
10	2	HCS 1/4-20X1Y28 QPACK	0115005
12	2	HCS 1/4-20 X 3/4 Y28 QPA	0115003
13	1	CHAIN ANCHOR	N05033
14	4	FPH MS 10-32X3/8 Z K	29504
15	2	RAMP SPRING	N05044

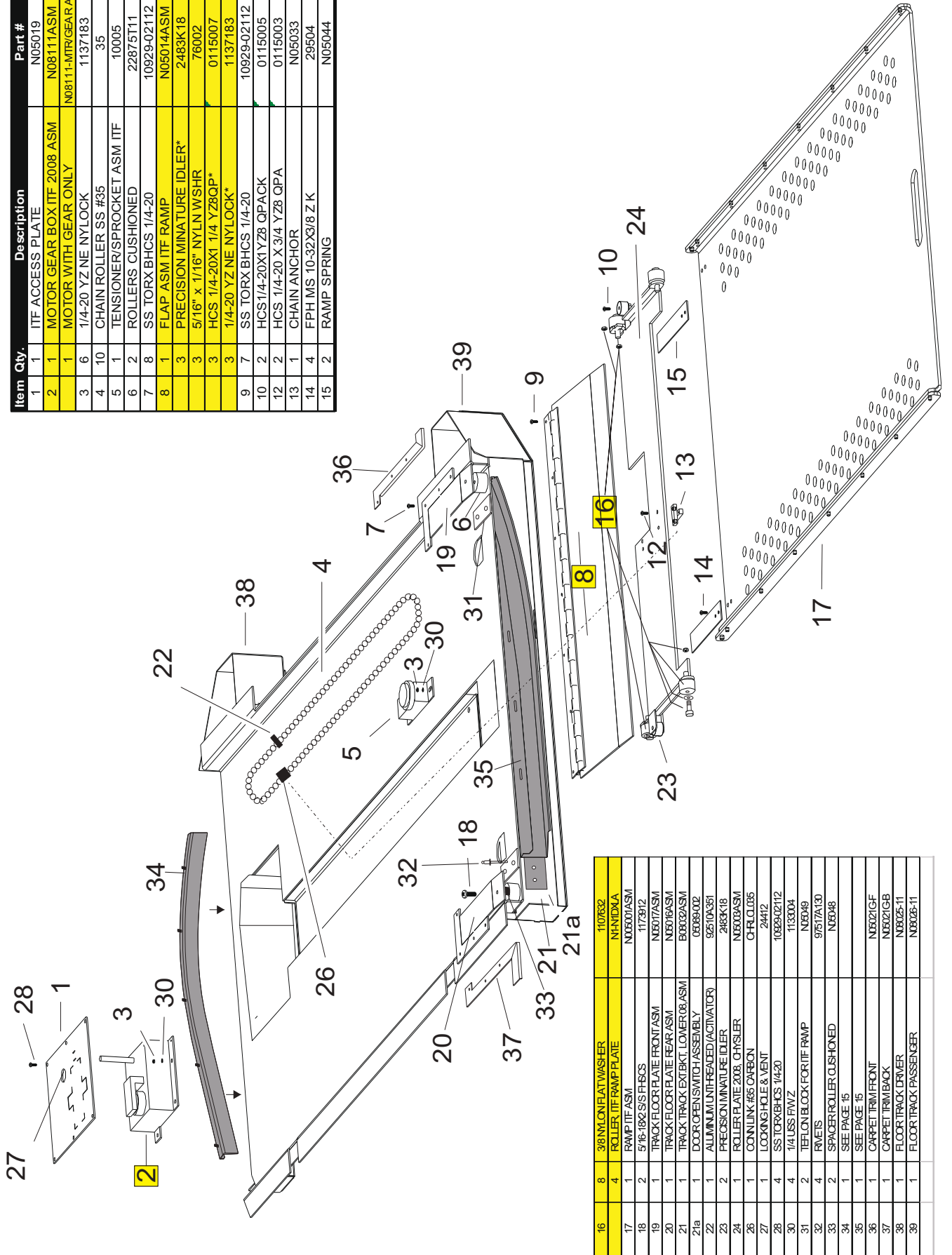

16	8	3/8 NYLN FLAT WASHER	1107632
4	1	ROLLER ITF RAMP PLATE	N10124A
1	1	RAMP ITF ASM	N06007ASM
2	1	5/16-18X2 SS FHCS	1173912
18	1	TRACK FLOOR PLATE FRONT ASM	N03077ASM
19	1	TRACK FLOOR PLATE REAR ASM	N03076ASM
20	1	TRACK TRACK EXT/BKT LOWER 08 ASM	B00032ASM
21	1	DOOR OPEN SWITCH ASSEMBLY	06089002
21a	1	ALUMINUM ITH REAR END (ACTIVATOR)	92510A351
22	2	PRECISION MINATURE IDLER	2483K18
23	1	ROLLER PLATE 2008 CHYSLER	N03003ASM
24	1	CONN LINK #65 CARBON	CHRLD085
26	1	LOCKING HOLE & VENT	24412
27	1	SS TORX BHCS 1/4-20	10929-02112
28	4	1/4 USS FHWZ	1133004
30	4	TEFLON BLOCK FOR ITF RAMP	N03049
31	2	RIVETS	97617A130
32	2	SPACER ROLLER CUSHIONED	N03048
33	1	SEE PAGE 15	
34	1	CARPET TRIM FRONT	N06021GF
35	1	CARPET TRIM BACK	N06021GB
36	1	FLOOR TRACK DRIVER	N08025-11
37	1	FLOOR TRACK PASSENGER	N08026-11
38	1		
39	1		



Symptom	Possible cause	remedy
Ramp will NOT DEPLOY after door opens automatically.	Ramp fuse or circuit breaker is blown.	Press Rollx Vans user button again to unkneel van and close door. Reset circuit breaker or check ramp fuse and replace if needed with 15 amp glass fuse located in glove box.
	Door open limit switch is not being activated.	When a Open Cycle starts, the OTC will send a command to the Chrysler System to unlock the doors. It then sends a second command to the Chrysler System to open the Right Side Sliding Door. The OTC Computer then waits two seconds and checks the Door Closed Limit Switch. If it finds it still indicates the door is closed, it assumes that a person (or and obstacle) stopped the door opening sequence. It then ends the open cycle and goes back into Idle Mode. After ten to fifteen seconds it goes back into Sleep Mode. This is the sequence of events you will see if the Door Closed Limit Switch malfunctions (sticks closed). This switch is located in the Right Side Sliding Door Latch Assembly.
	Ramp down limit switch needs adjustment to deactivate.	Press Rollx Vans user button again to unkneel van and close door. Review display on OTC board and contact customer service.
	Ramp motor.	Press Rollx Vans user button again to unkneel van and close door. Review display on OTC board and contact customer service.
Ramp will NOT STOW automatically.	OTC program failure.	Press OTC reset button.
	Ramp fuse or circuit breaker is blown.	Press Rollx Vans user button again to unkneel van and close door. Reset circuit breaker or check ramp fuse and replace if needed with 15 amp glass fuse located in glove box.
	Ramp motor.	Review display on OTC board and contact customer service.
Ramp will deploy before door is all the way open.	Door open limit switch is shorted to ground or malfunctioning.	Examine door open limit switch, connections, and wiring.
Ramp will STOP AND REVERSE mid-cycle.	Obstacle is detected.	Clear obstruction and press Rollx Vans user button.
		Review display on OTC board and contact customer service.



RLXR1000-04-OTC / RLXR1000-04-MB / RLXR1000-04-NARROW-MB

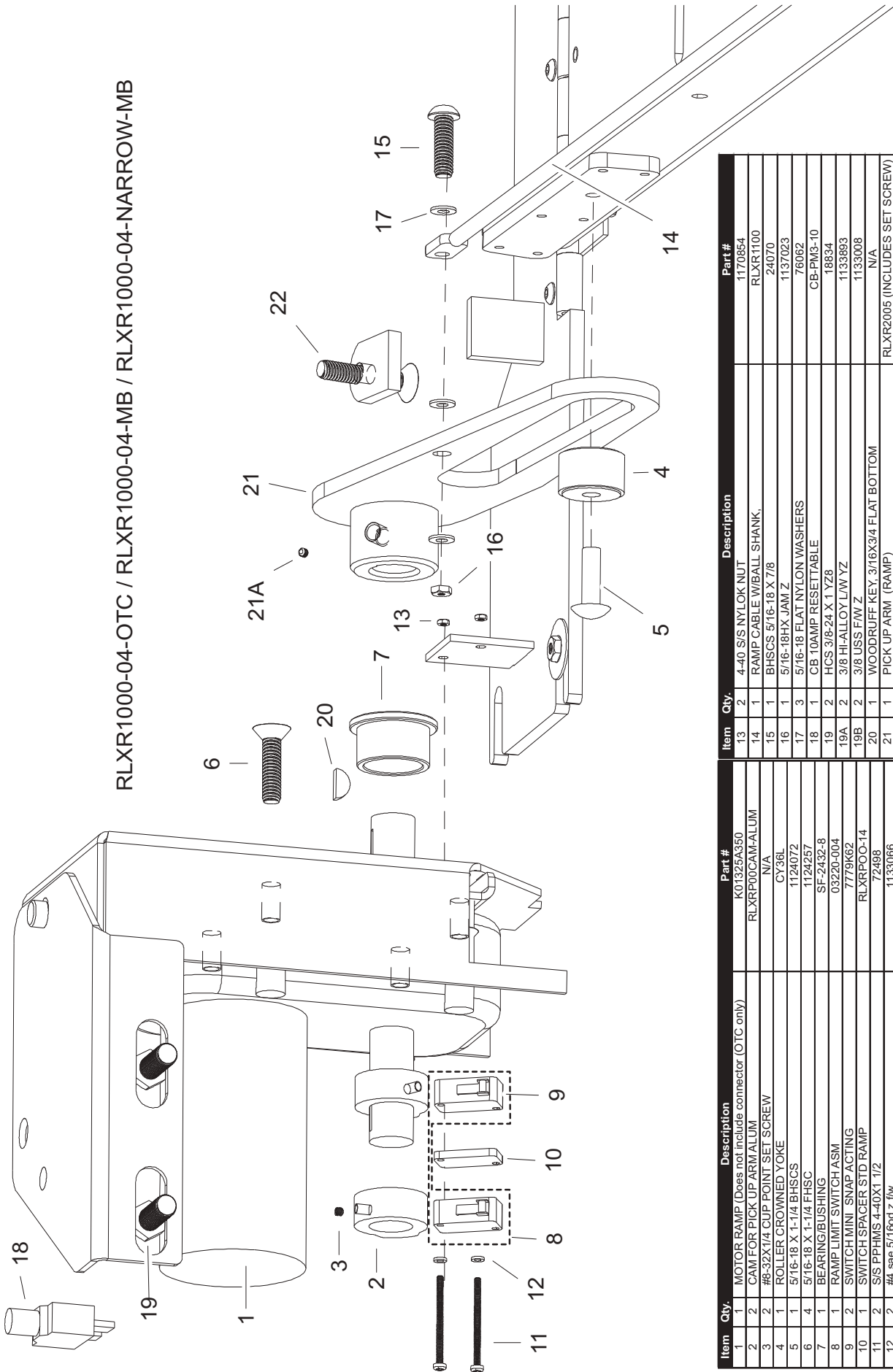

Item	Qty.	Description	Part #	Item	Qty.	Description	Part #
1	1	MOTOR RAMP (Does not include connector (OTC only))	K01325A350	13	2	4-40 S/S NYLON NUT	1170854
2	2	CAM FOR PICK UP ARM ALUM	RLXRP00CAM-ALUM	14	1	RAMP CABLE W/BALL SHANK,	RLXR1100
3	2	#8-32X1/4 CUP POINT SET SCREW	N/A	15	1	BHSCS 5/16-18 X 7/8	24070
4	1	ROLLER CROWNED YOKE	CY36L	16	1	5/16-18HX JAM Z	1137023
5	1	5/16-18 X 1-1/4 BHSCS	1124072	17	3	5/16-18 FLAT NYLON WASHERS	76062
6	4	5/16-18 X 1-1/4 FHSC	1124257	18	1	CB 10AMP RESETTABLE	CB-PM3-10
7	1	BEARING/BUSHING	SF-2432-8	19	2	HCS 3/8-24 X 1 YZ8	18834
8	1	RAMP LIMIT SWITCH ASM	03220-004	19A	2	3/8 HI-ALLOY L/W YZ	1133893
9	2	SWITCH MINI SNAP ACTING	7779K62	19B	2	3/8 USS F/W Z	1133008
10	1	SWITCH SPACER STD RAMP	RLXRP00-14	20	1	WOODRUFF KEY, 3/16X3/4 FLAT BOTTOM	N/A
11	2	S/S PPHMS 4-40X1 1/2	72498	21	1	PICK UP ARM (RAMP)	RLXR2005 (INCLUDES SET SCREW)
12	2	#4 ssa 5/16od z f/w	1133066	21A	1	1/4-20X3/8 CUP POINT SET SCREW	N/A
				22	1	5/16-18X1 3/4 FHSCS	1124259
				22	1	5/16-18X1 3/4 FHSCS*	1124259
				23	1	5/16-18HX JAM Z	1136204
						COVER RAMP NEW GENERATION	10068
							* For motor bar ramps only



RAMP HINGE AREA CROSS SECTION

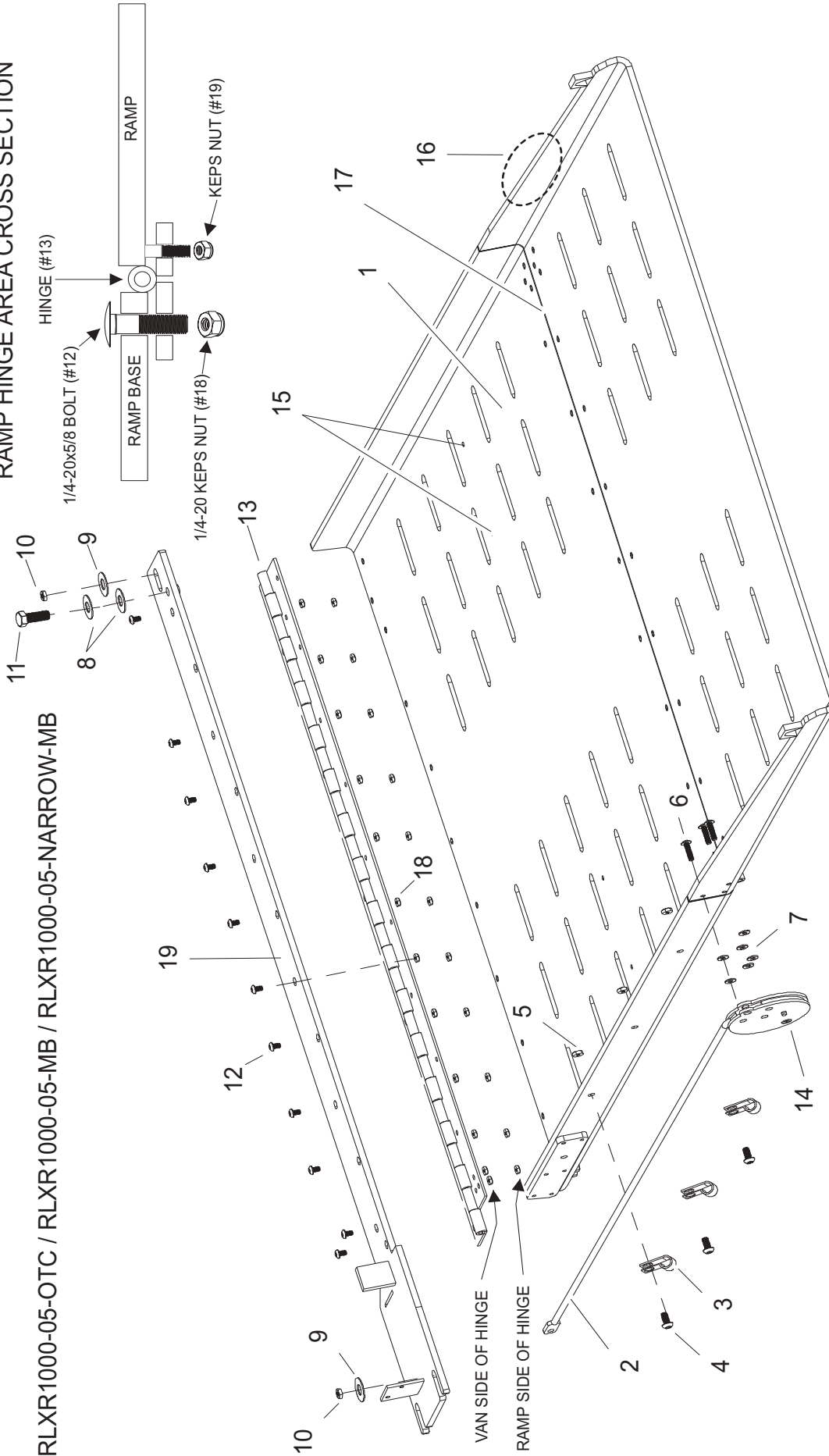

RLXR1000-05-OTC / RLXR1000-05-MB / RLXR1000-05-NARROW-MB

Item	Qty.	Description	Part #	Item	Qty.	Description	Part #
1	1	RAMP STANDARD (RAMP NARROW)	RLXR4000 (RLXR4000N)	11	1	HCS 1/4-20X1/2 YZ8 QPA	0115001
2	1	RAMP CABLE W/BALL SHANK,	RLXR1100	12	12	1/4-20X5/8 SS BUTTON HEAD CAP SCREW	10929-02786
3	3	CLAMP INSULATED 3/8"	8863T13	13	1	HINGE, RAMP FOLDING W/ BOLTS	RLRX4006
4	3	1/4-20 X 1/2 BHSCS	1124049	14	1	CABLE GUIDE (ROUND DISC)	RLXR1025
5	3	1/4-20 NTE JAM NYLOK	1137020	15	4	RIVETS*	97517A130
6	3	10-32 X 3/4 BHSCS	1124042	15	4	#4 sae 5/16od z f/w	1133066
7	6	#10 SAE F/W Z	1133074	16	1	RUBBER BULB SEAL BACK FOAM*	NX504B1
8	2	1/4 HI-ALLOY L/W YZ	1133891	16	0.4	ANTI-RATTLE RUBBER URETH FOR (Motor Bar Only)*	27036
9	2	3/8 USS F/W Z	1133008	17	1	HINGE UPPER RAMP FO PAINTED	RLXR1007
10	2	3/8-16 YZ8 NE NYLOCK	1137185	18	12	1/4-20 KEPS NUT	1137410
				19	1	Ramp Base Weldment Assembly	RLXR4003
							* Not Shown

This page was intentionally left blank



**folding ramp Motor install (steps 1-19)  
ramp removal instructions (steps 1-4 + 15-19)**

1. Remove carpeted motor panel. This is held on by two Phillip head screws.
2. Disconnect wires going to limit switches and motor.
3. Unbolt ramp. There are two bolts (3/8) that go into the side of the van above ramp motor and two nuts (3/8) on the floor of the van-one nut is by the motor and one nut is by b-pillar.
4. Remove ramp from van.
5. Extend ramp so it is laying flat.
6. Remove roller from pick up arm. Also, remove cable bolt.
7. Remove set screw from pick up arm. Then insert 5/16 bolt into pick up arm to pull pick up arm off of motor shaft. If this does not work, cut motor shaft with a saw and punch out scrap piece from pick up arm.
8. Remove limit switches off of ramp.
9. Take out the four Allen head bolts (3/16) holding ramp motor. Remove motor.
10. Insert new motor. Reinstall the four Allen head screws with lock tight.
11. Reinstall limit switches.
12. Remove cams off of old motor and install on the new ramp motor. You will need to adjust these cams at step 16.
13. Reinstall pick up arm. Line up pick up arm and key way. Ensure Woodruff key is all the way inserted into the pick up arm.
14. Reinstall set screw (3/16) with lock tight.
15. Reinstall ramp in the van. Secure ramp with original hardware.
16. Install wiring for limit switches and motor.
17. Adjust ramp cams. Refer to Ramp Adjustment Instructions.
18. Test ramp for proper limit switch adjustment.
19. Reinstall carpeted motor cover.

**folding ramp adjustment Process**

1. Bring folding ramp into the stow position so it resting in the van where you want it.
2. Remove carpeted motor panel. This is held on by two Phillip head screws.
3. Locate Adjustment Cam Set Screws and loosen.
4. Rotate the Up Limit Cam until it activates the Up Limit Switch and tighten set screw.
5. Push ramp out slowly and rest on something that is 6 inches off the ground as shown below.
6. Rotate Down Limit Cam until it activates the Down Limit Switch and tighten set screw.
7. Test ramp for proper limit switch adjustment and reinstall carpeted motor cover.



6 Inches

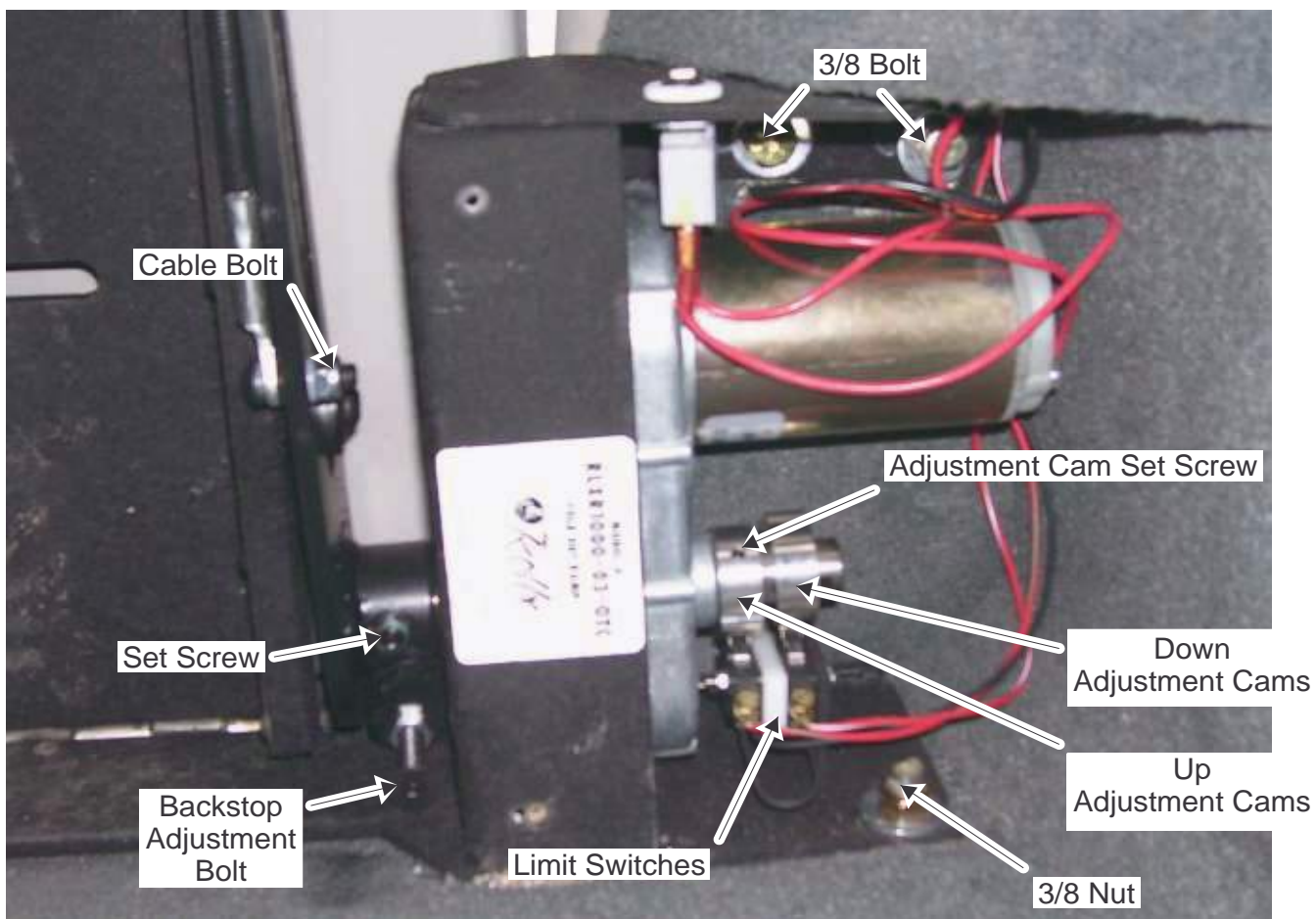
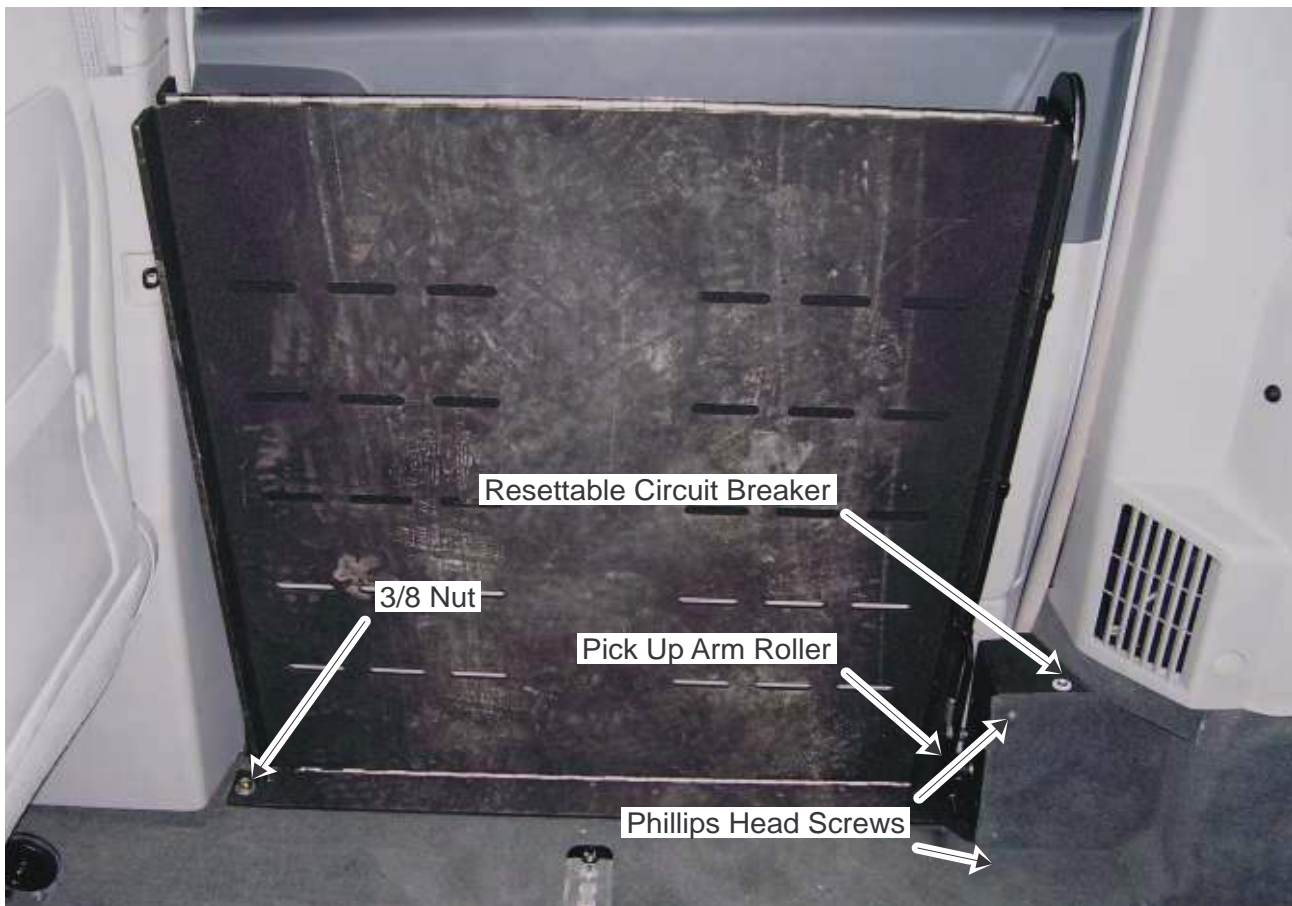

# REAR HEAT & A/C

MODEL YEAR 2012-2014

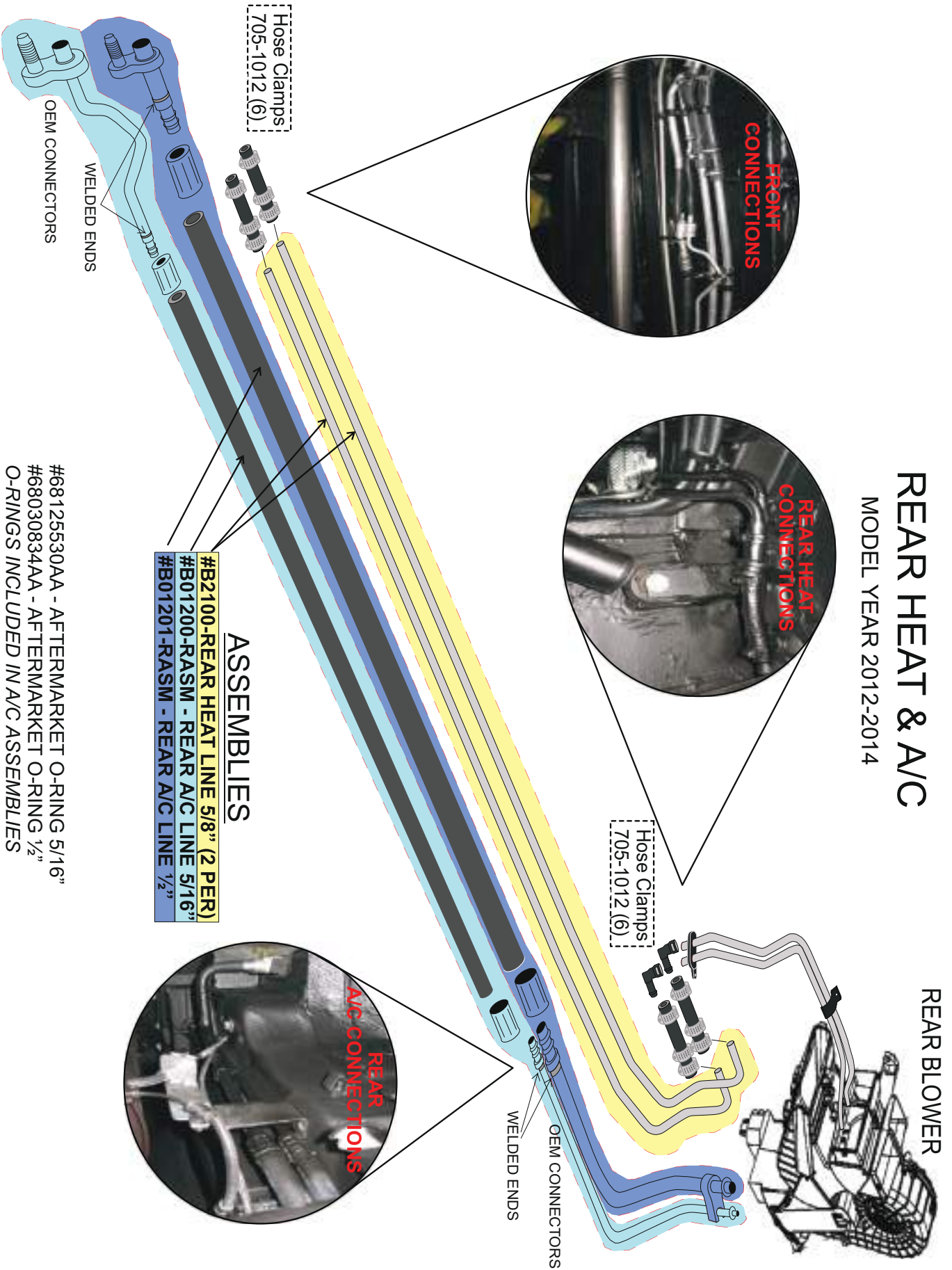

- #68125530AA - AFTERMARKET O-RING 5/16"  
 #68030834AA - AFTERMARKET O-RING 1/2"  
 O-RINGS INCLUDED IN A/C ASSEMBLIES





\* if remote does not work first try to operate door and ramp from any interior rollx vans user button. if interior rollx vans user button operates normally, see below for remote system troubleshooting

Symptom	Possible cause	remedy
Door does not open when One Touch remote is pressed.	Receiver out of range.	Try remote within 10 feet of van.
	Overhead on/off switch is turned to the OFF position.	Turn switch to ON position.
	Transmitter battery is dead.	Remove case by loosening screw on back and prying open. Replace battery with battery type A23. Use second remote or Rollx Vans user button.
Neither One Touch remote works.	Blown fuse.	Locate fuse box under glove box and check / replace fuse.
	Receiver malfunction.	Review display on OTC board and contact customer service.
	Lost Programming	Reprogram (See OTC Remote System)



OTC Remote Receiver  
(Behind Rear Passenger Quarter  
Panel Above Rear Heat Unit)



OTC Remote Receiver  
(Rear View)

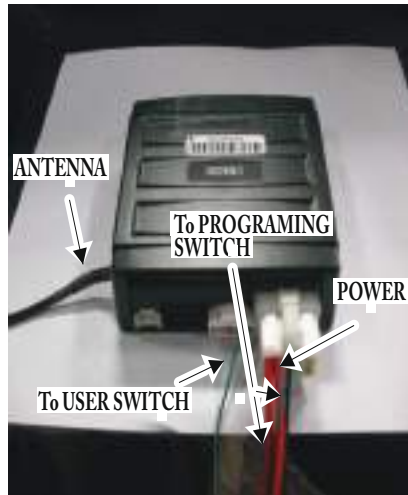

OTC Remote Transmitter



To Rollx Vans user switches

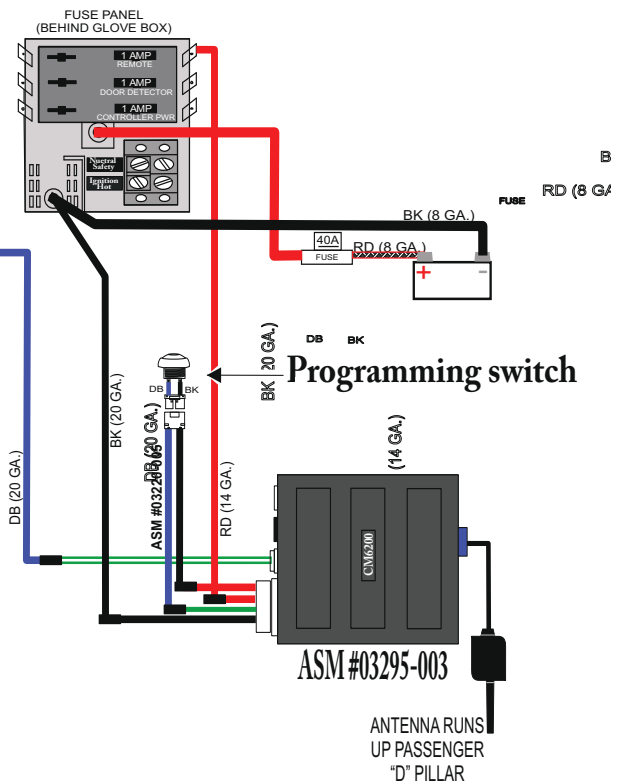

## Programming the Rollx Vans OTC Remote

- \*Activate the programming mode by pushing the button on the left side of the OTC controller (PROGRAMMING SWITCH) 5 times within 7 seconds.
- \* Within 2 seconds after pushing the button 5 times, press the single remote button for .5 Seconds. Wait 30 seconds and press the remote to operate the system.
- \*Repeat the sequence if programming an additional remote.



# Seat Detector Location



## Seat Detector Description

The Rollx Vans Seat Detector essentially simulates the functionality of a driver or passenger front seat in the event where the seats are disconnected from the van (FIG A & B).

The simulated functions are:

- Seat Belt Buckle Switches*
- Seat Belt Retractors*
- Active HeadRests*
- Seat Position Sensors*
- Seat Thorax*
- Occupant Detection*

FIG A

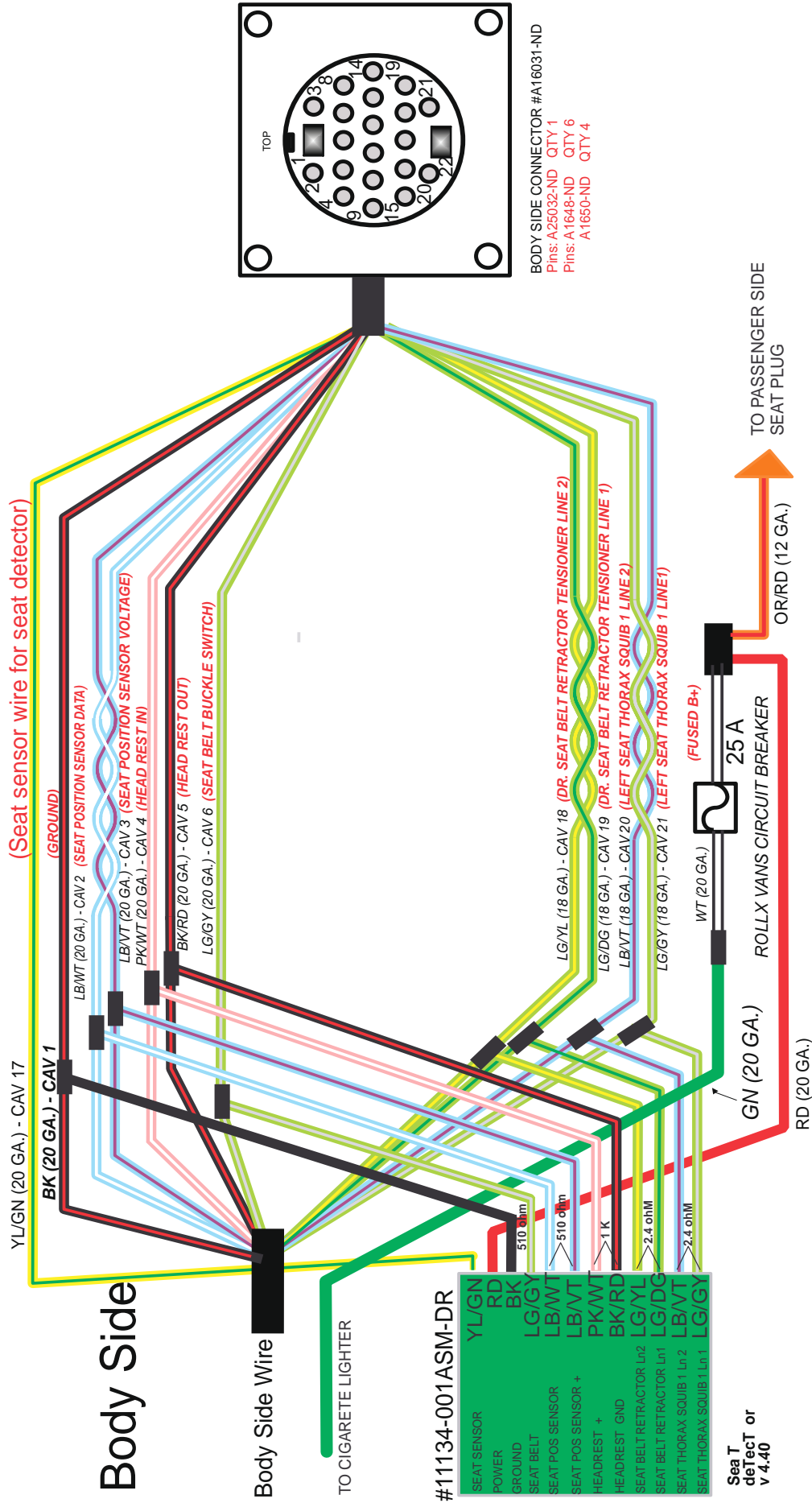

FIG B



# 2011-2014 Chrysler Minivan C376/1405 Driver Side with MANUAL SEAT With Seat Detector BODY SIDE

Updated on 6/3/2014



Sea T  
detect  
or  
v 4.40

Updated on 6/3/2014

# 2011-2014 Chrysler Minivan C376/I405 Driver Seat with **MANUAL SEAT - With Seat Detector** **SEAT SIDE**

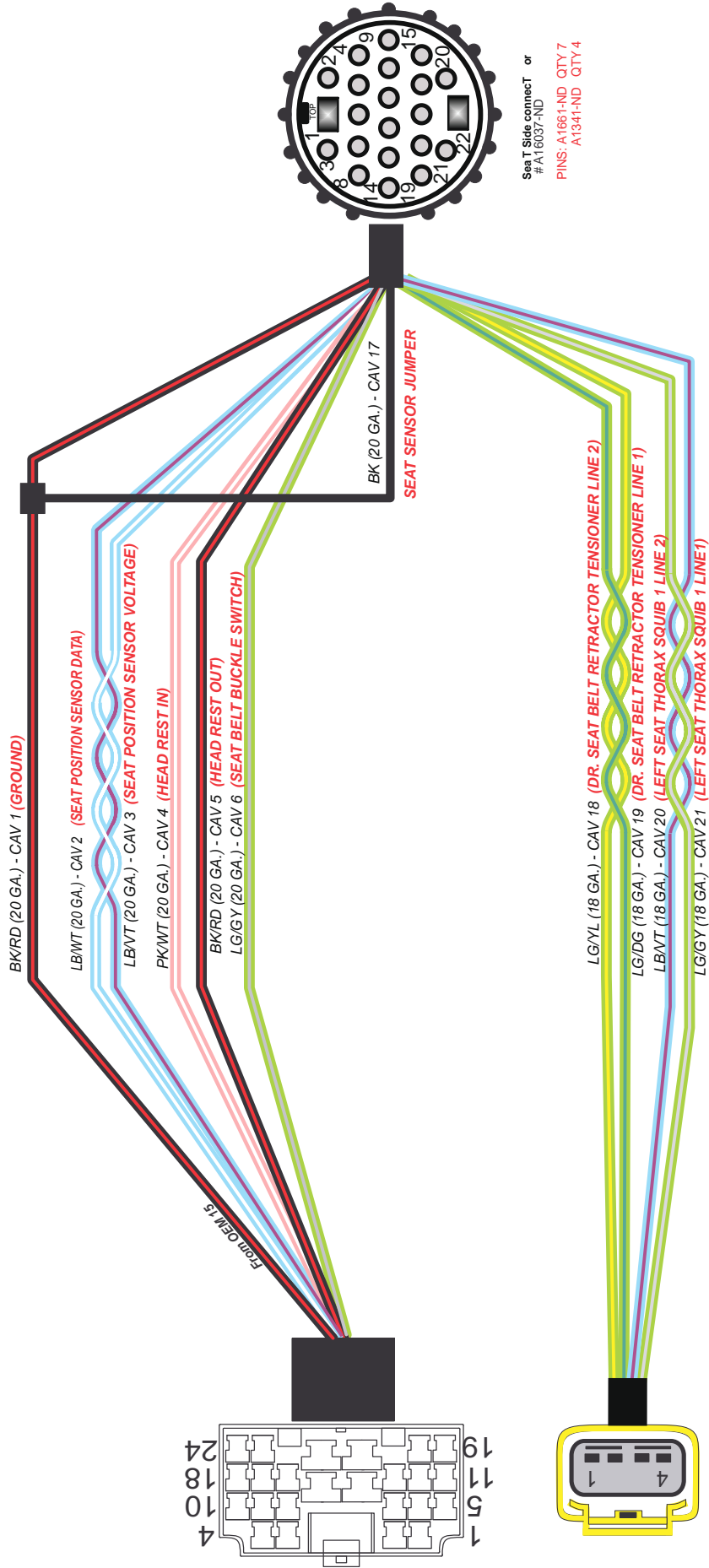

Sea T Side connect  
# A16037-ND  
PINS: A1661-ND QTY 7  
A1341-ND QTY 4

# 2011-2014 Chrysler Minivan C376/I405 Driver Side with **POWER ONLY** - With Seat Detector **BODY SIDE**

Updated on 6/3/2014

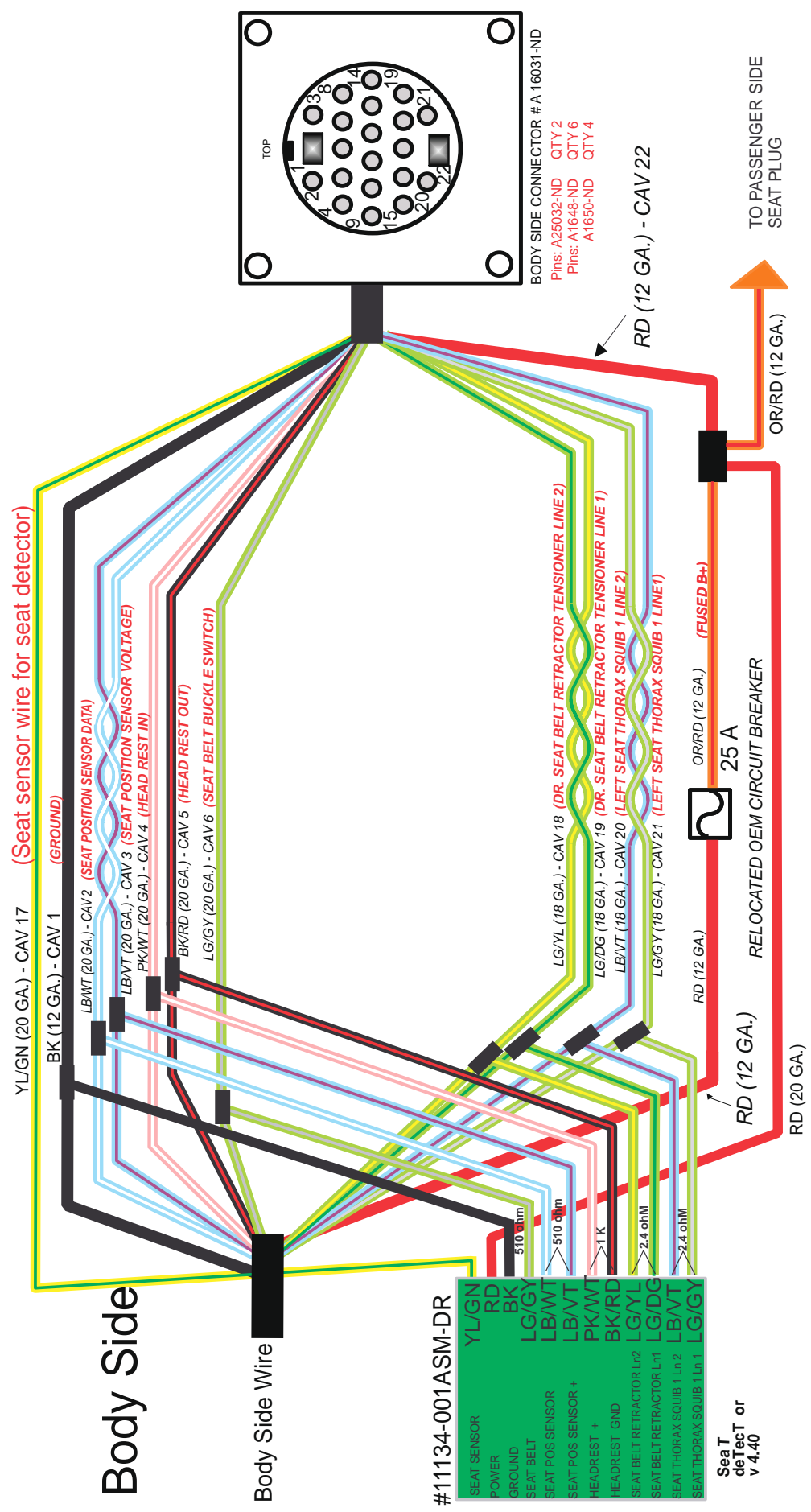

Body Side

Body Side Wire

#11134-001ASM-DR

SEAT SENSOR	YL/GN
POWER	RD
GROUND	BK
SEAT BELT	LG/GY
SEAT POS SENSOR	LB/WT
SEAT POS SENSOR +	LB/VT
HEADREST +	PK/WT
HEADREST GND	BK/RD
SEAT BELT RETRACTOR LIn2	LG/YL
SEAT BELT RETRACTOR LIn1	LG/DG
SEAT THORAX SQUIB 1 LIn2	LB/VT
SEAT THORAX SQUIB 1 LIn1	LG/GY

Seat T  
delect or  
v 4.40

Updated on 6/3/2014

# 2011-2014 Chrysler Minivan C376/I405 Driver Seat with POWER ONLY - With Seat Detector SEAT SIDE

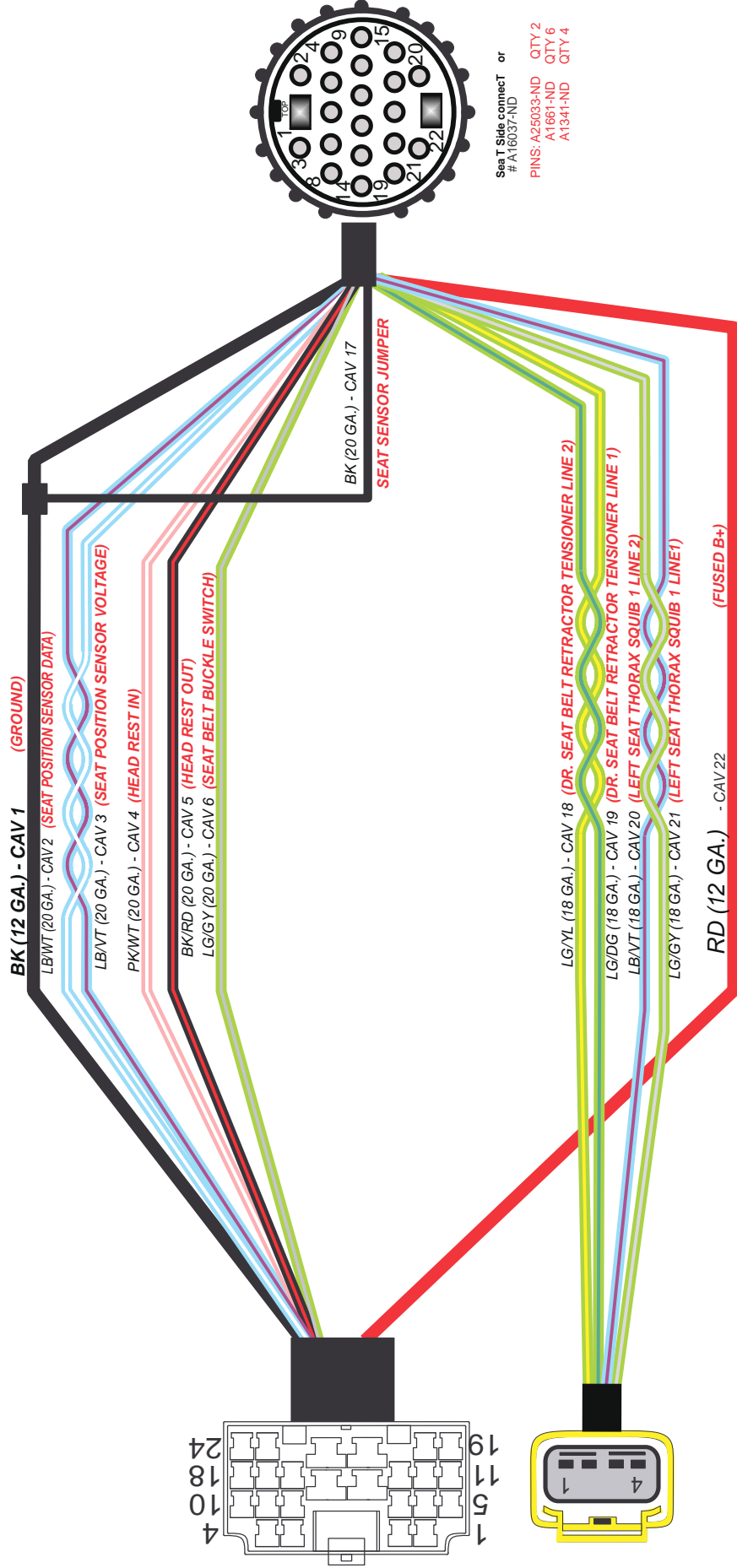

2011-2014 Chrysler Minivan  
 C376/1405 Driver Side with POWER & HEAT - With Seat Detector  
 BODY SIDE

Updated on 6/3/2014

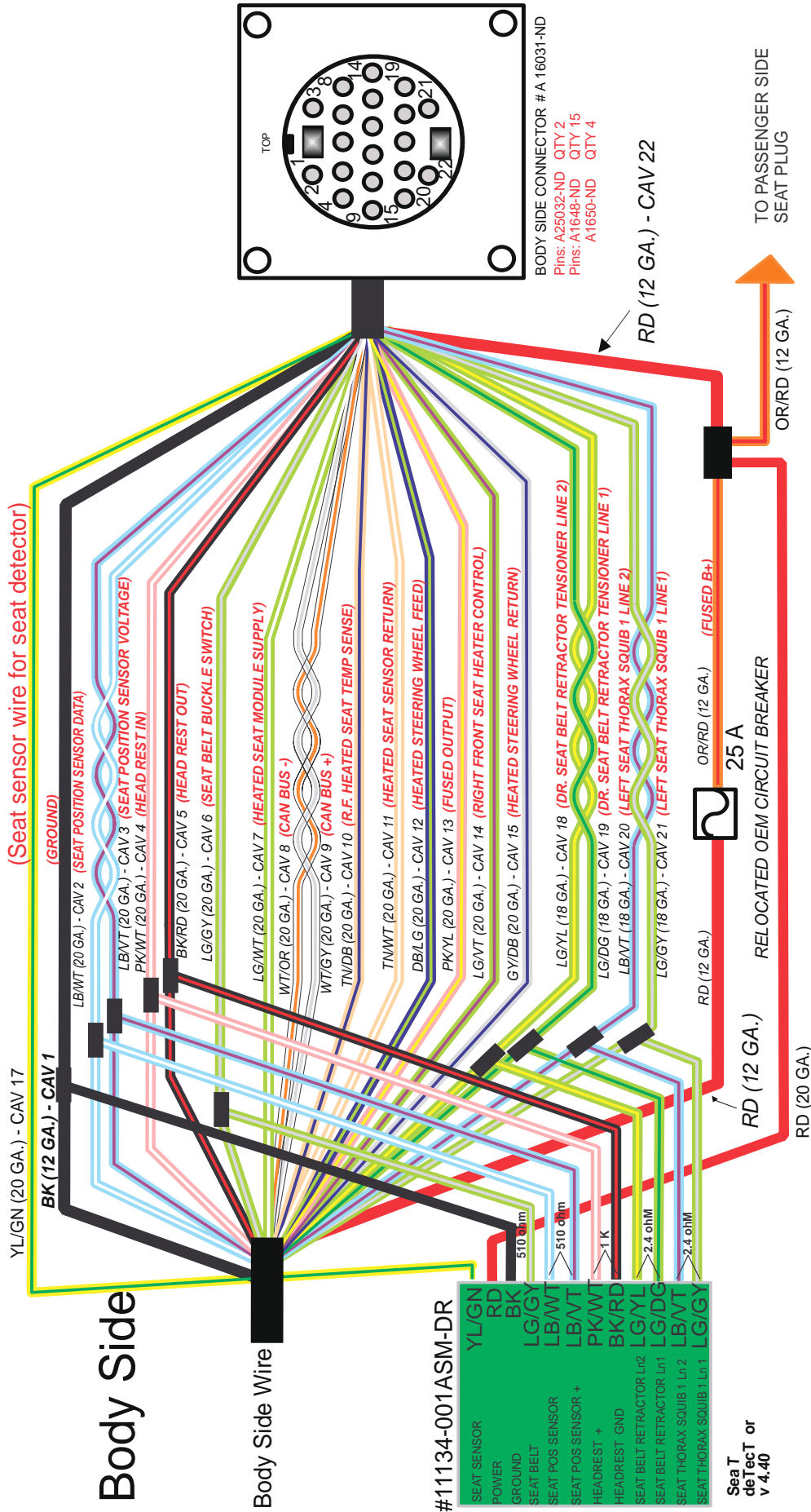



# 2011-2014 Chrysler Minivan C376/1405 Driver Seat with POWER AND HEAT - With Seat Detector SEAT SIDE

Updated on 6/3/2014

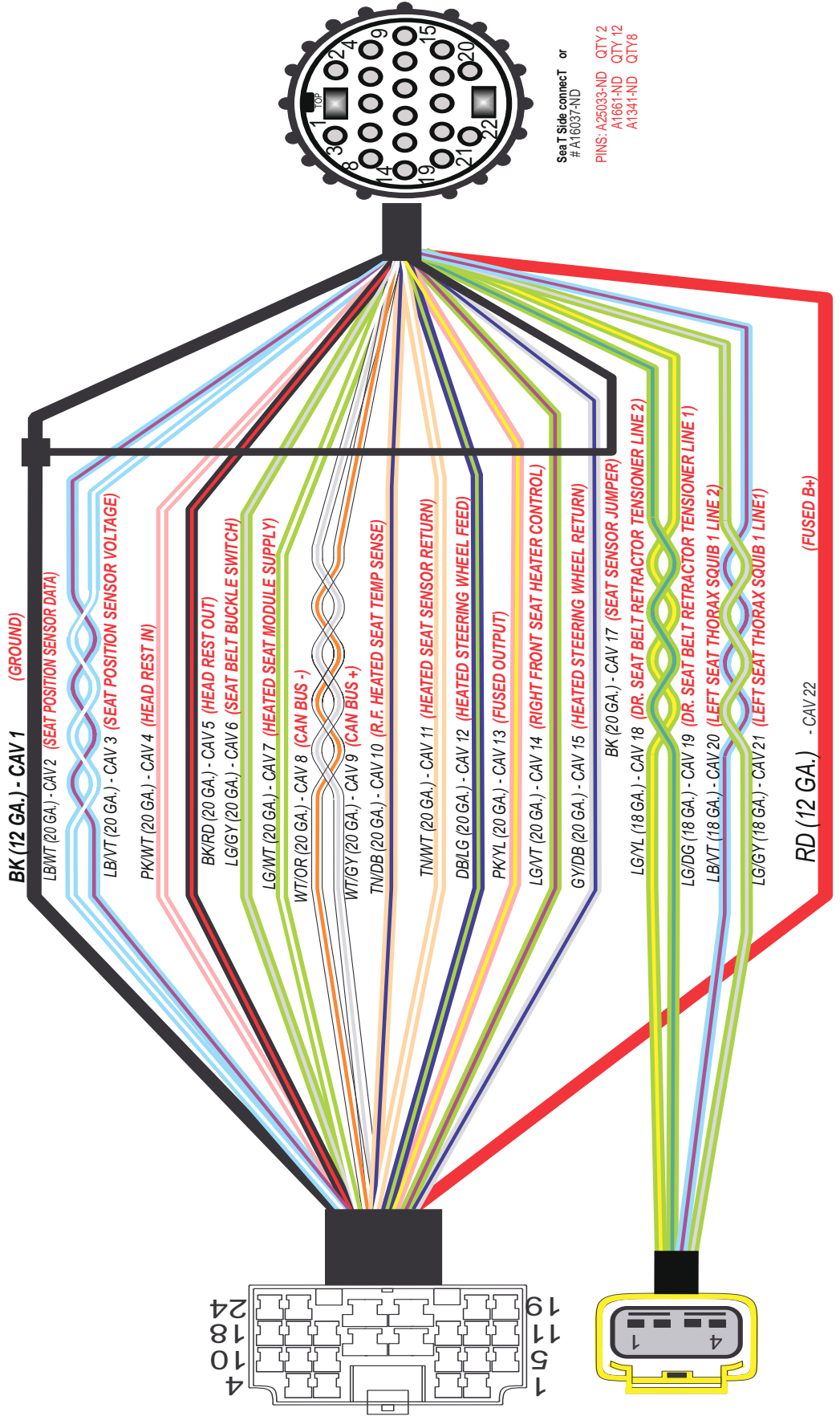

# C376/ 2011-2014 Chrysler Minivan I405 Drivers Side with POWER & HEAT & MEMORY With Seat Detector

Updated on 6/3/2014

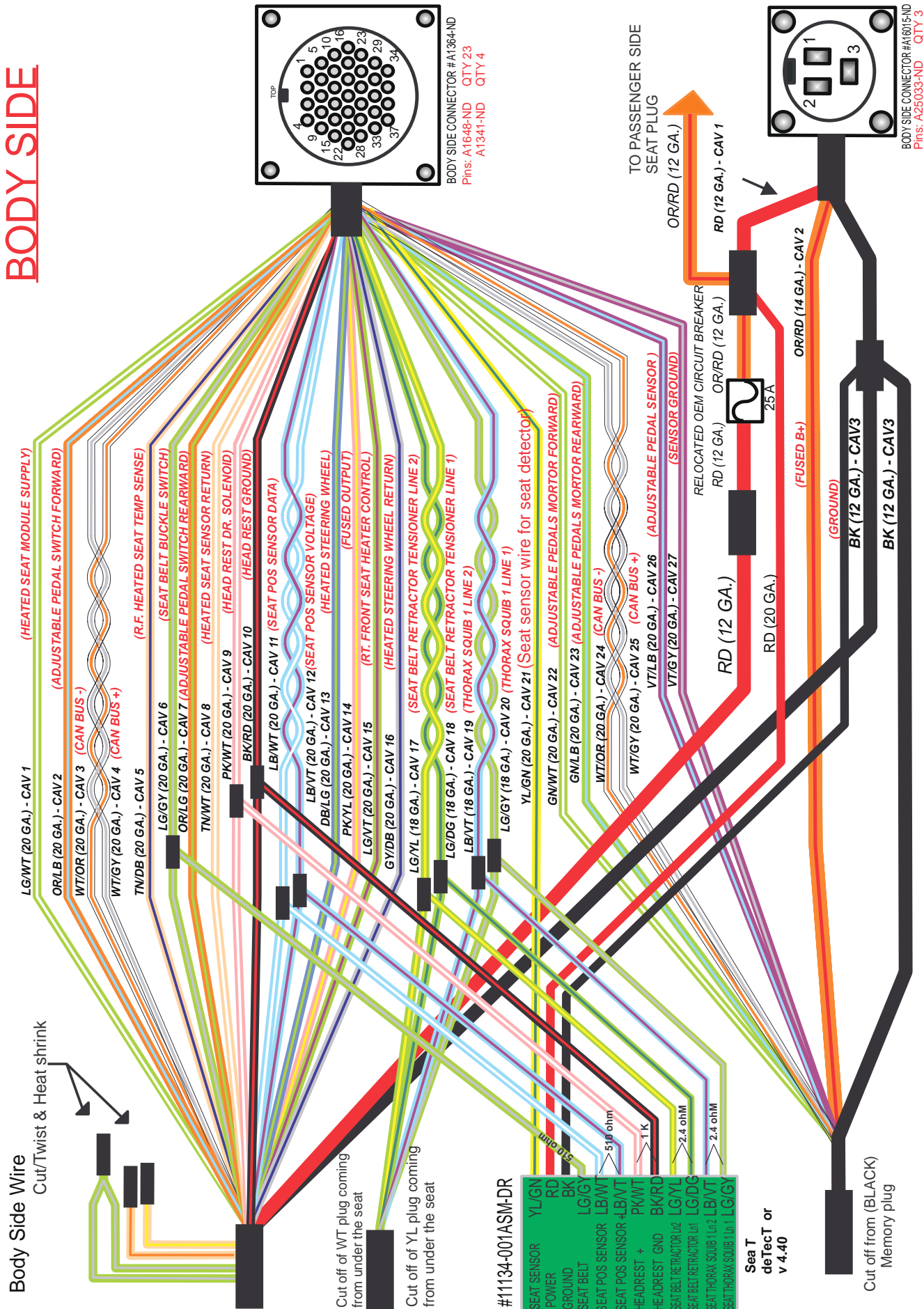

## BODY SIDE

I405 Drivers Seat with **POWER & HEAT- & MEMORY** With Seat Detector

**SEAT SIDE**

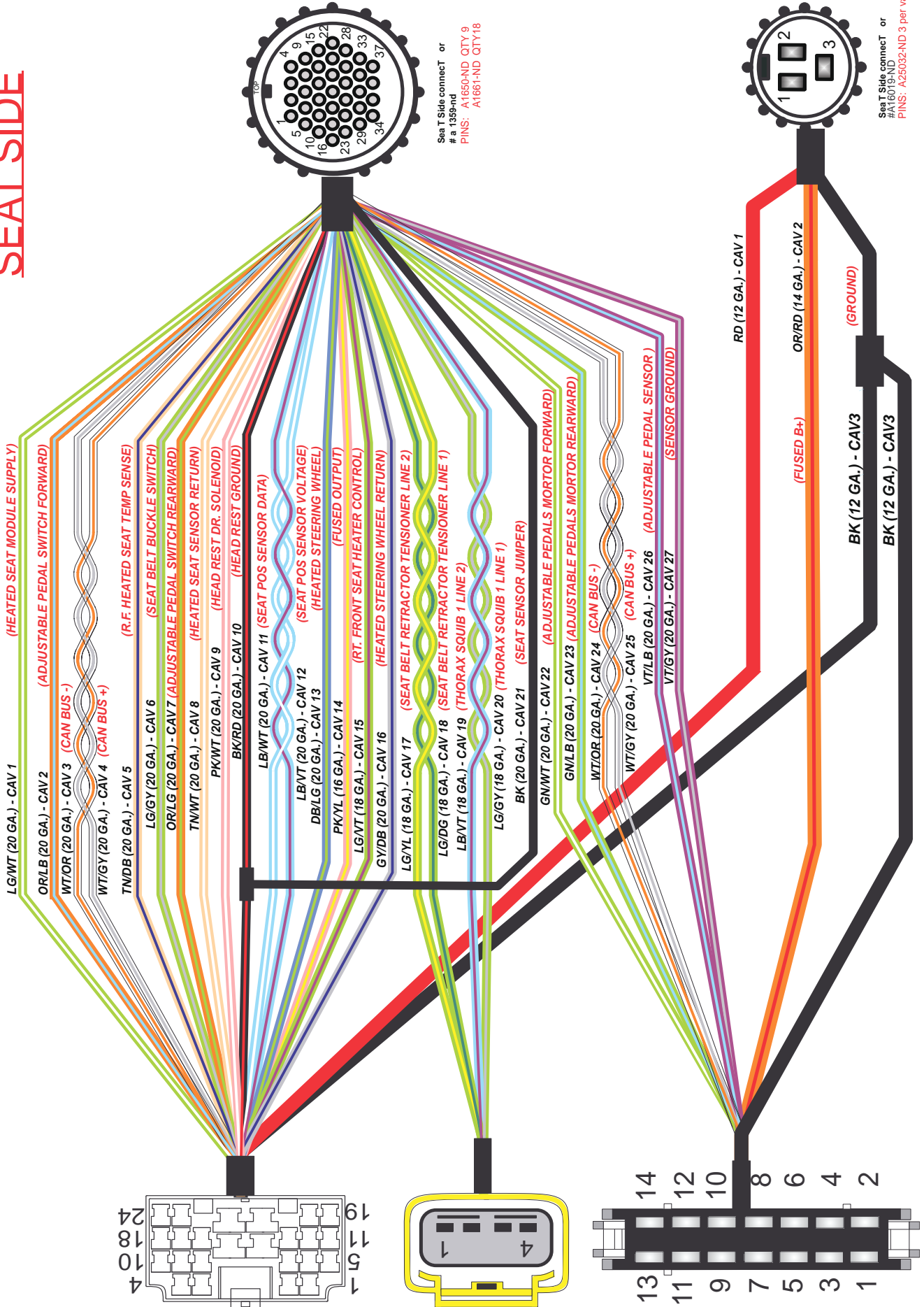

# 2011-2012 Chrysler Minivan C378 Passenger Side with MANUAL SEAT\_With Seat Detector BODY SIDE

Updated on 6/3/2014

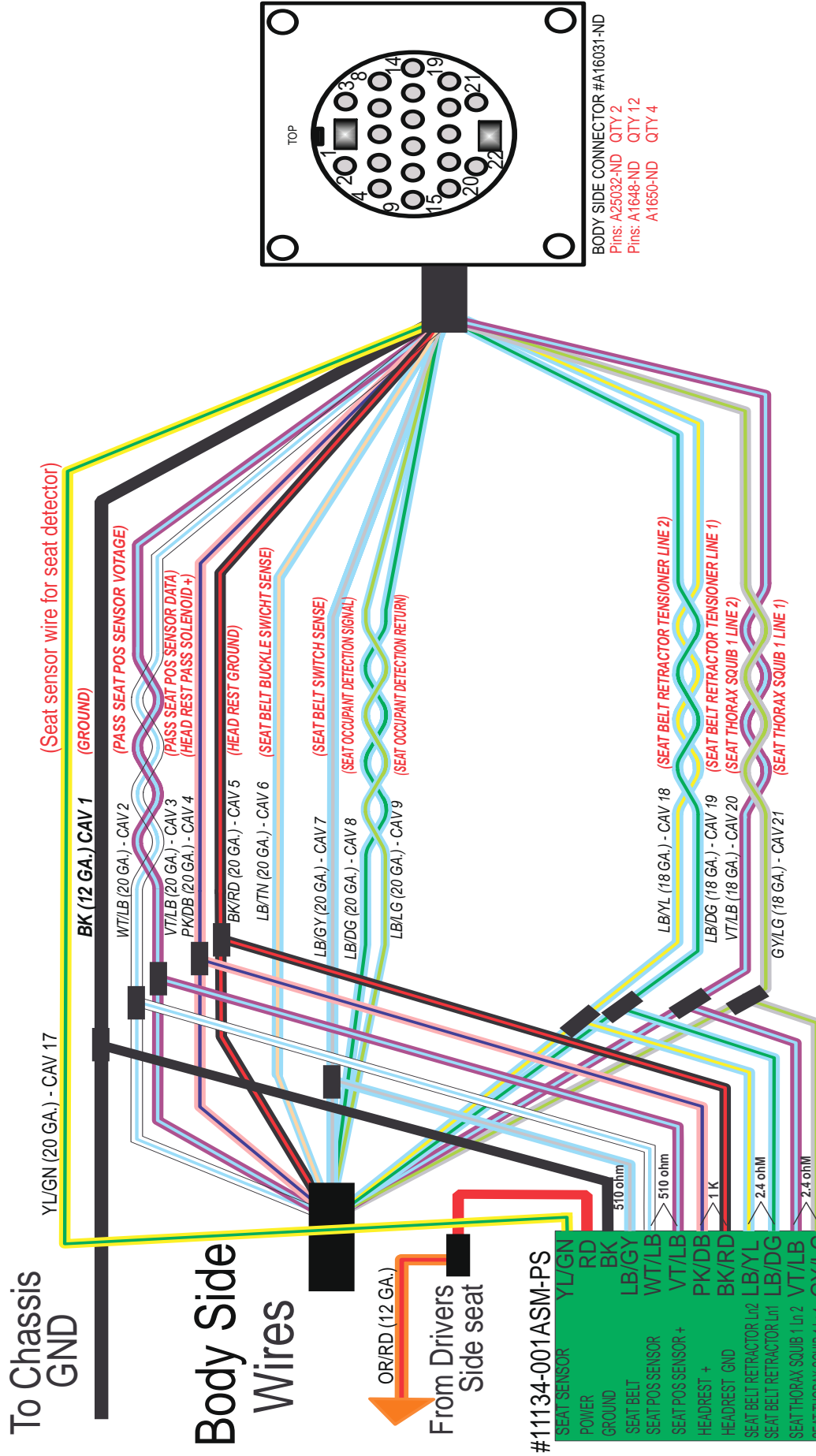

To Chassis  
GND

Body Side  
Wires

From Drivers  
Side seat

#11134-001ASM-PS

SEAT SENSOR	YLGN
POWER	RD
GROUND	BK
SEAT BELT	LB/GY
SEAT POS SENSOR	WT/LB
SEAT POS SENSOR +	VT/LB
HEADREST +	PK/DB
HEADREST GND	BK/RD
SEAT BELT RETRACTOR 1in2	LB/YL
SEAT BELT RETRACTOR 1in1	LB/DG
SEAT THORAX SQUIB 1in2	VT/LB
SEAT THORAX SQUIB 1in1	GY/LG

Sea T deTecT or v 4.40

Updated on 6/3/2014

# 2011-2012 Chrysler Minivan C378\_Passenger Seat with **MANUAL** - With Seat Detector **SEAT SIDE**

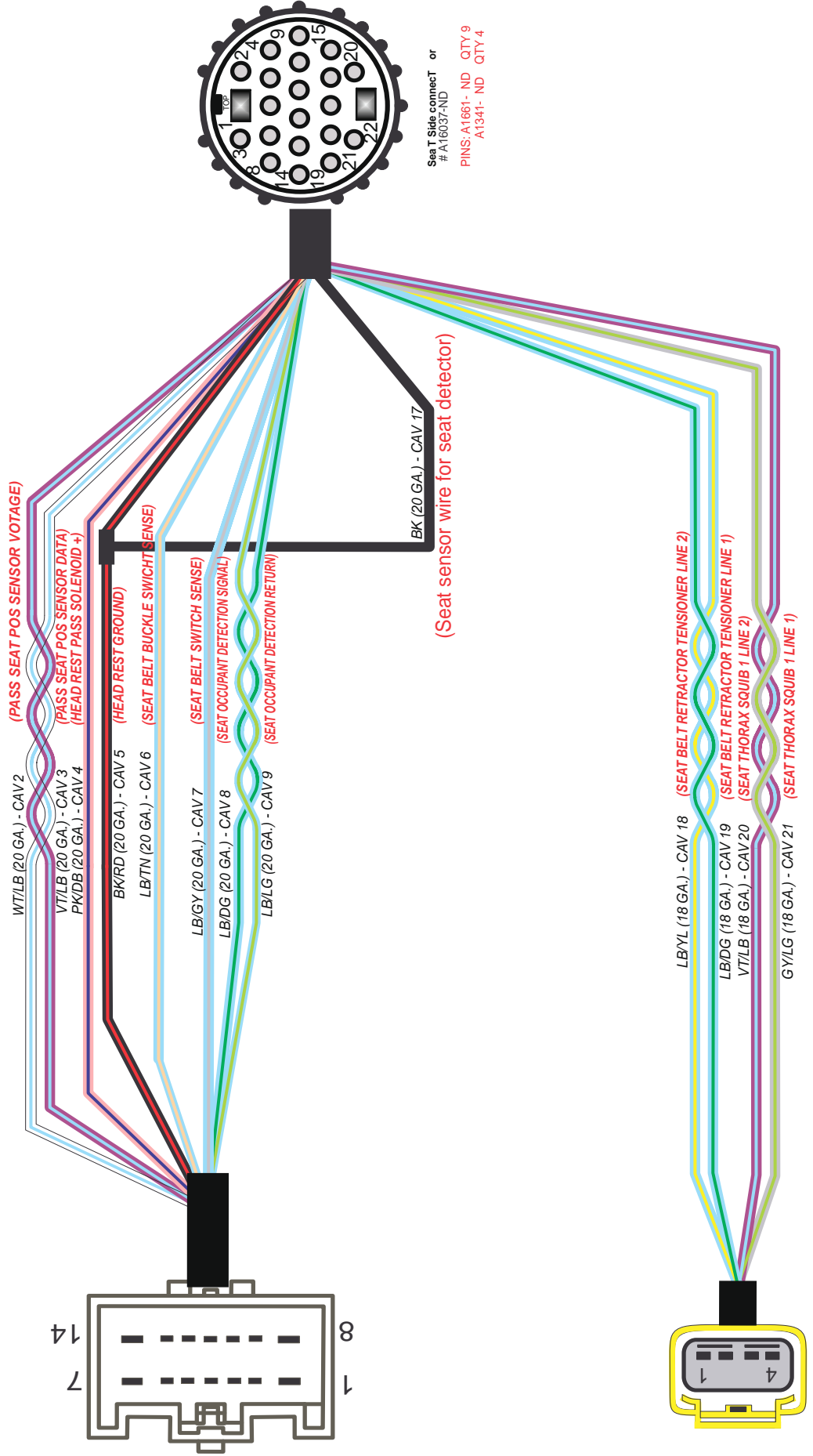

Updated on 6/3/2014

# 2011-2012 Chrysler Minivan C378 Passenger Side with POWER & HEAT - With Seat Detector

## BODY SIDE

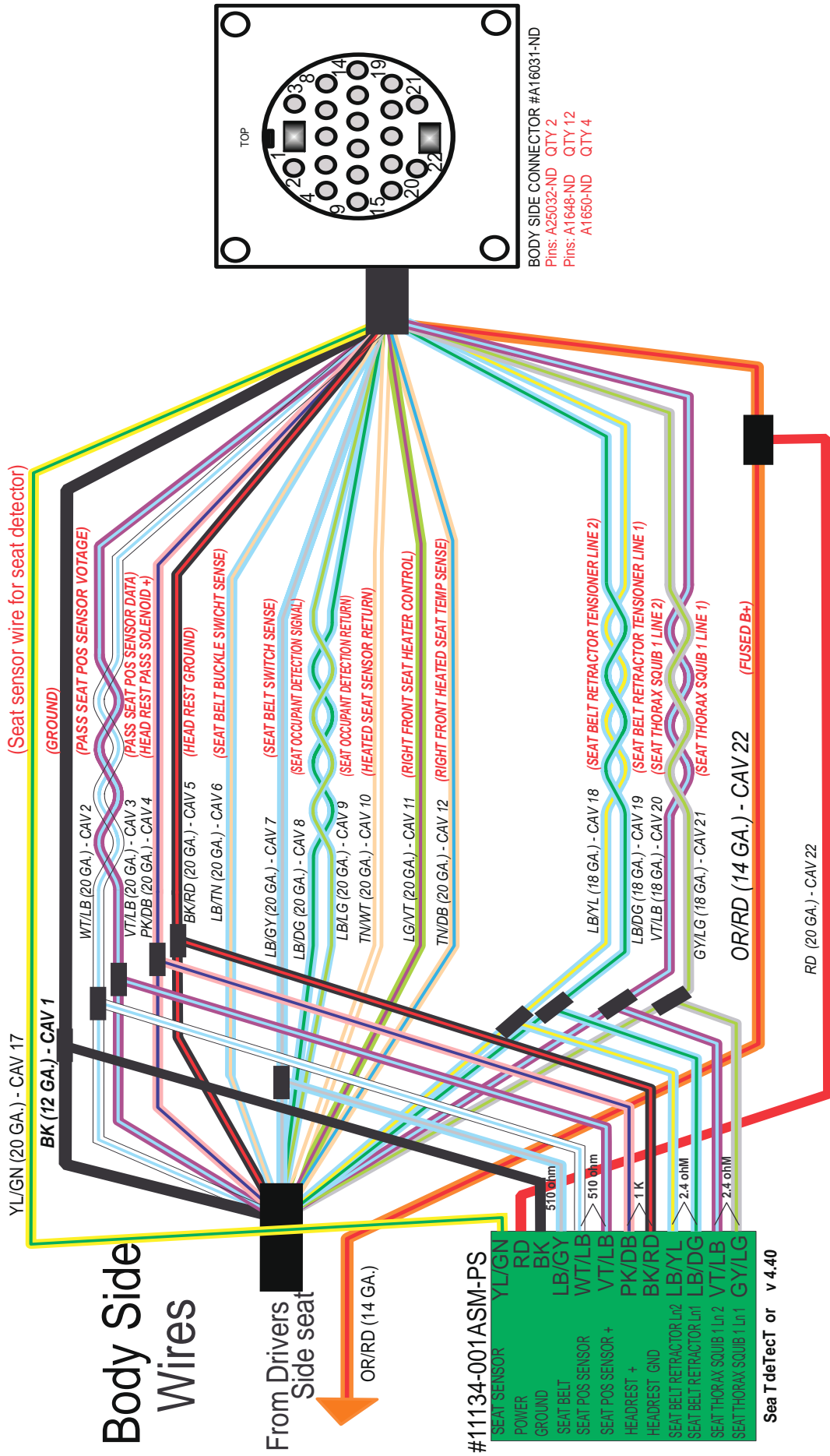

Updated on 6/3/2014

# 2011-2012 Chrysler Minivan C378 Passenger Seat with POWER & HEAT - With Seat Detector SEAT SIDE

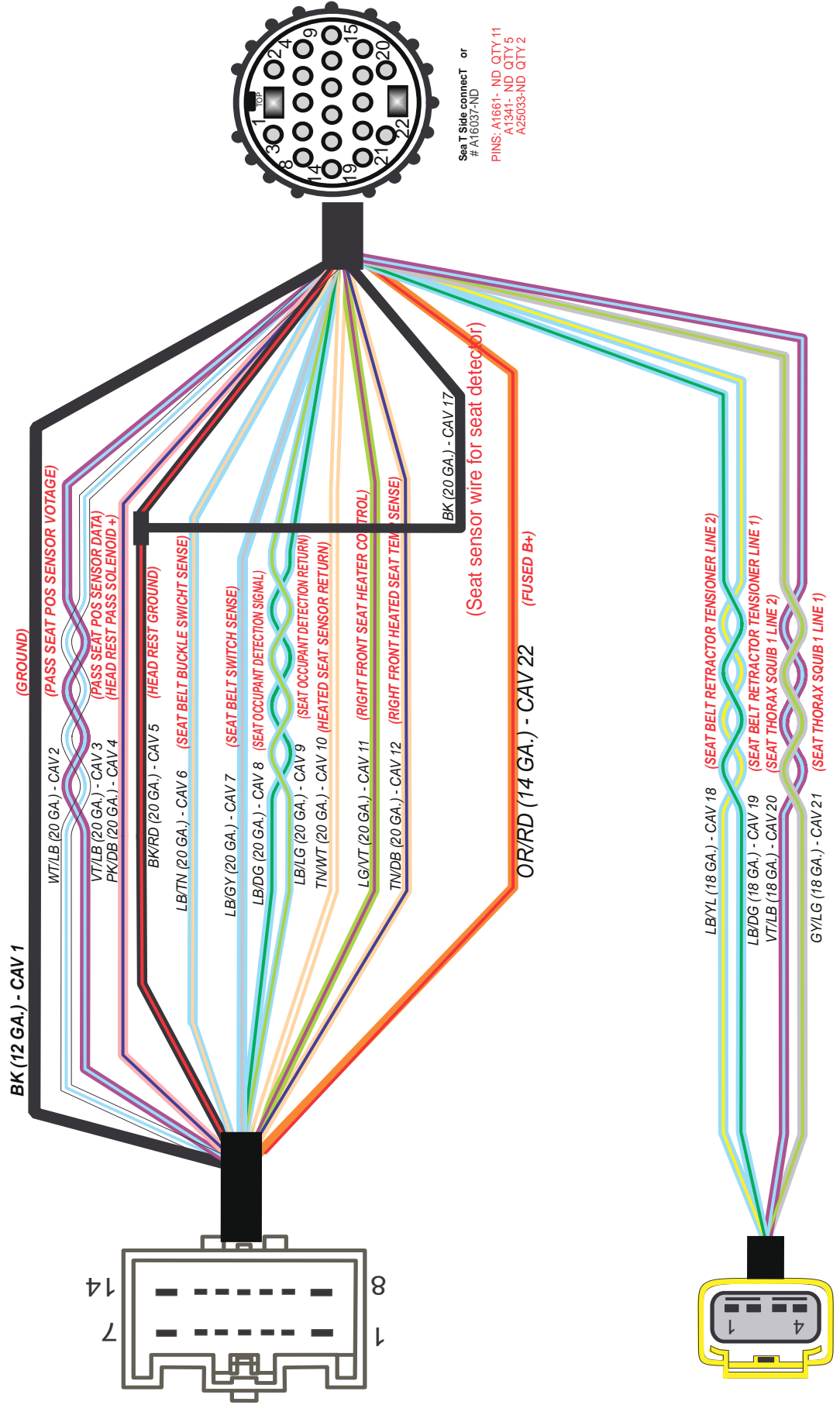

Seat Side connect or  
# A16037-ND  
PINS: A1661- ND QTY:11  
A1341- ND QTY:5  
A25033-ND QTY:2

# 2011-2012 Chrysler Minivan C378 Passenger Side with POWER & HEAT - With Seat Detector

Updated on 6/3/2014

## BODY SIDE (W/ OCCUPANT DETECTION CIRCUIT)

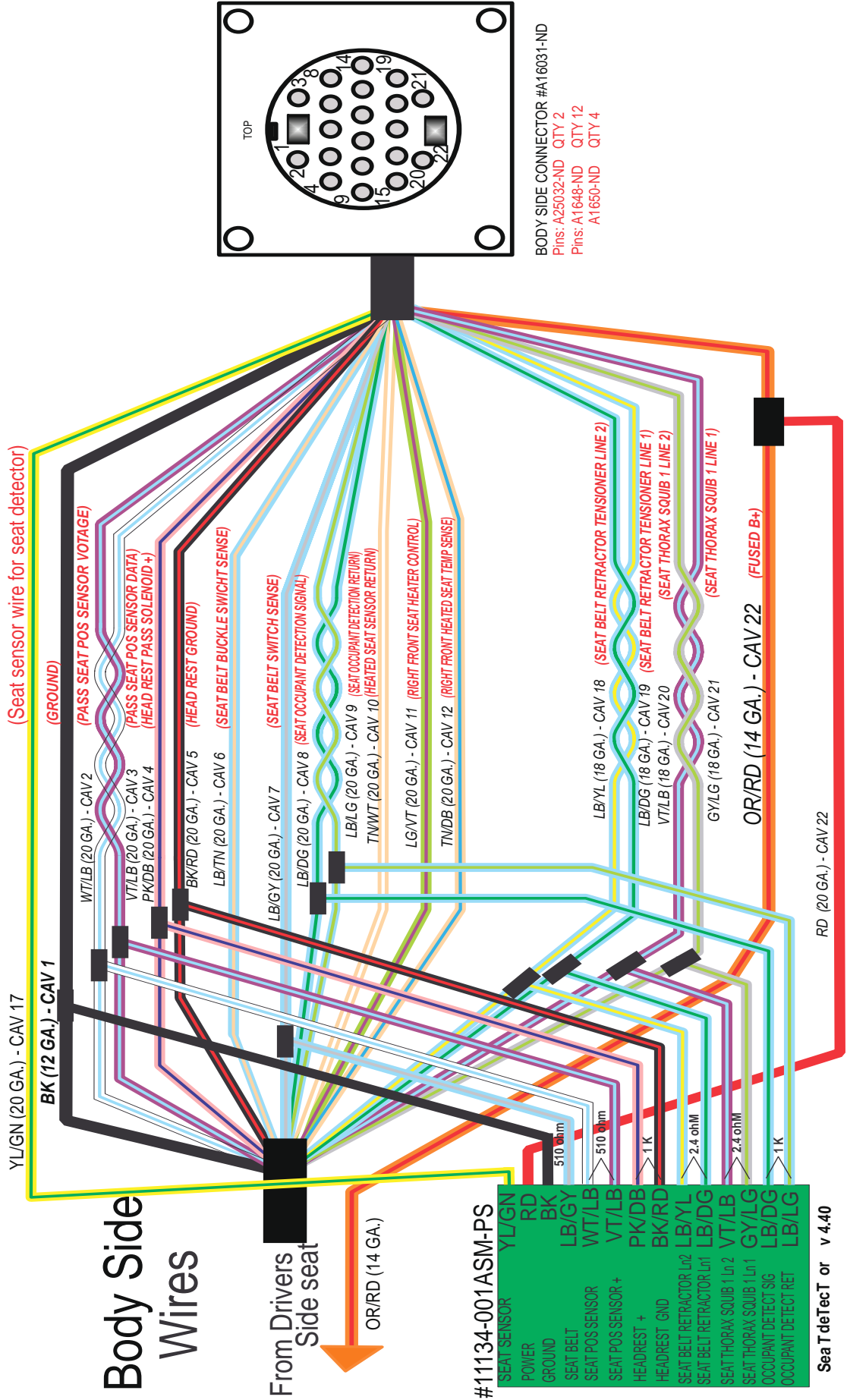



Updated on 6/3/2014

# 2011-2012 Chrysler Minivan

## C378 Passenger Seat with POWER & HEAT - With Seat Detector SEAT SIDE

**(W/ OCCUPANT DETECTION CIRCUIT)**

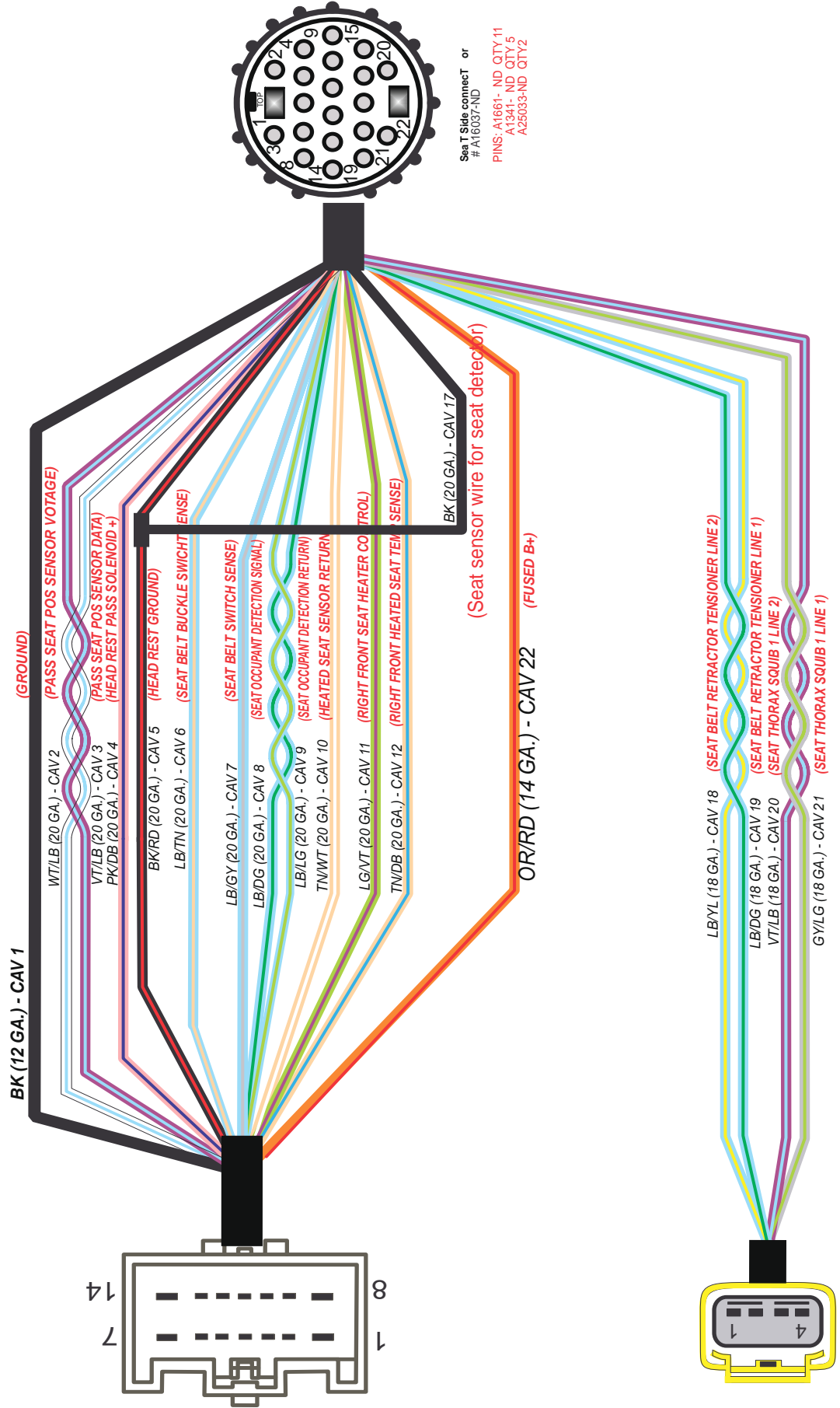

Updated on 6/3/2014

# 2013-2014 Chrysler Minivan

## I406/C378 Passenger Side with **MANUAL**- With Seat Detector **BODY SIDE (W/ OCCUPANT DETECTION CIRCUIT)**

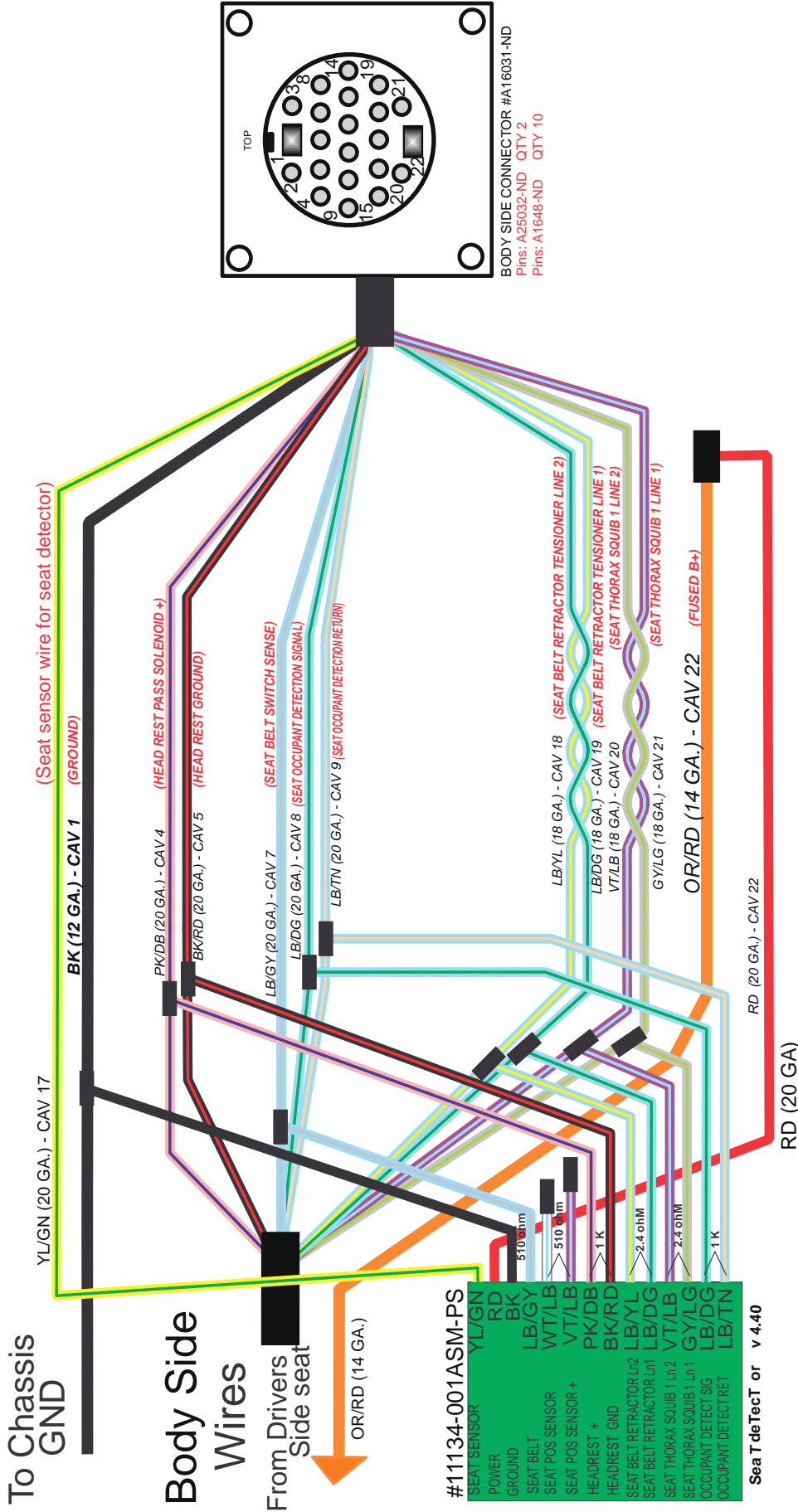

Vans built prior to 10/10/2012 have the LB/TN in CAV6 NOT CAV 9  
Stock # 47055 was the 1st van with LB/TN in CAV 9

Updated on 6/3/2014

# 2013-2014 Chrysler Minivan I406A/C378\_Passenger Seat with **MANUAL** - With Seat Detector **SEAT SIDE**

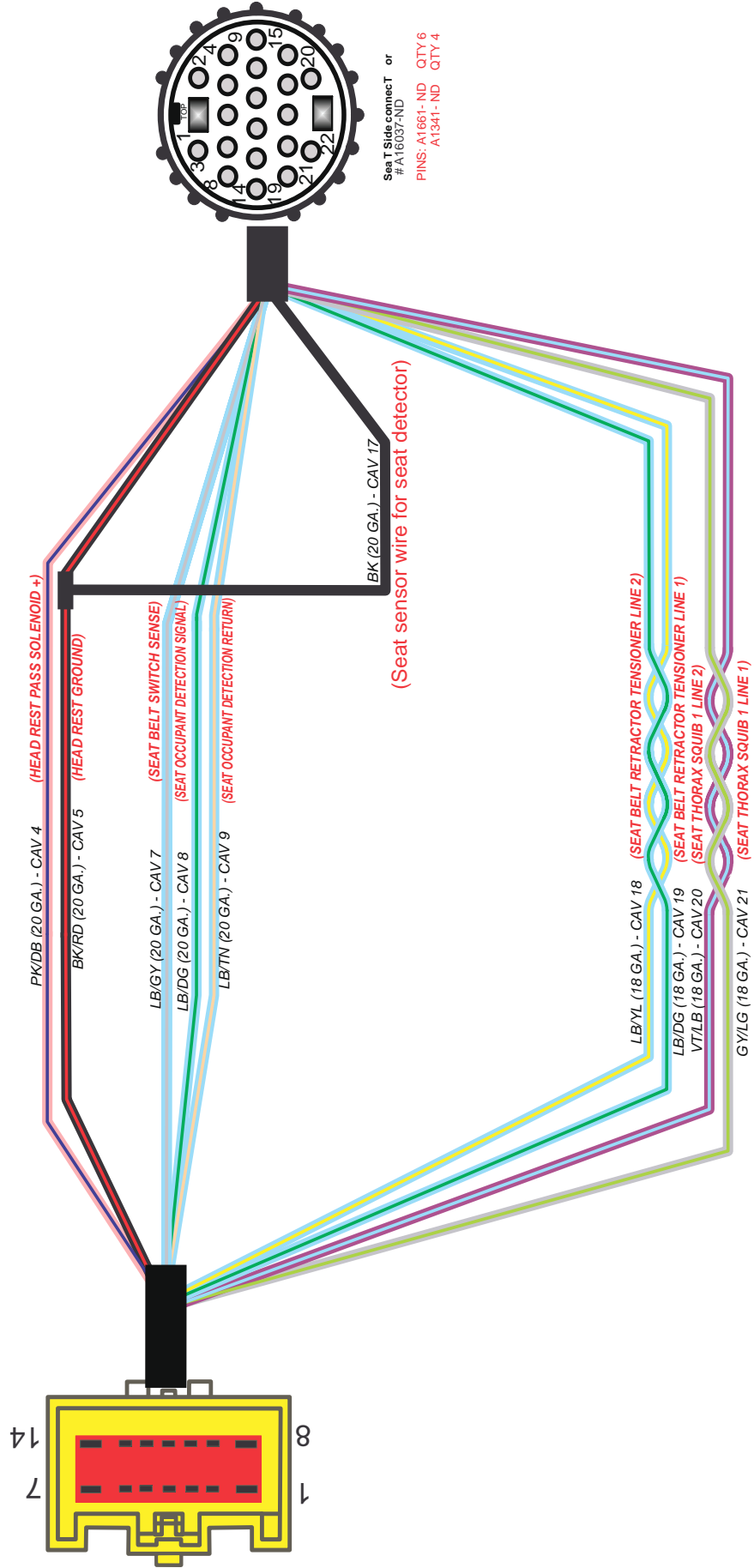

Vans built prior to 10/10/2012 have the LB/TN in CAV6 NOT CAV 9  
Stock # 47055 was the 1st van with LB/TN in CAV 9

# 2013-2014 Chrysler Minivan I406/C378 Passenger Side with **MANUAL** - With Seat Detector **BODY SIDE (W/ OCCUPANT DETECTION CIRCUIT)**

Updated on 6/3/2014

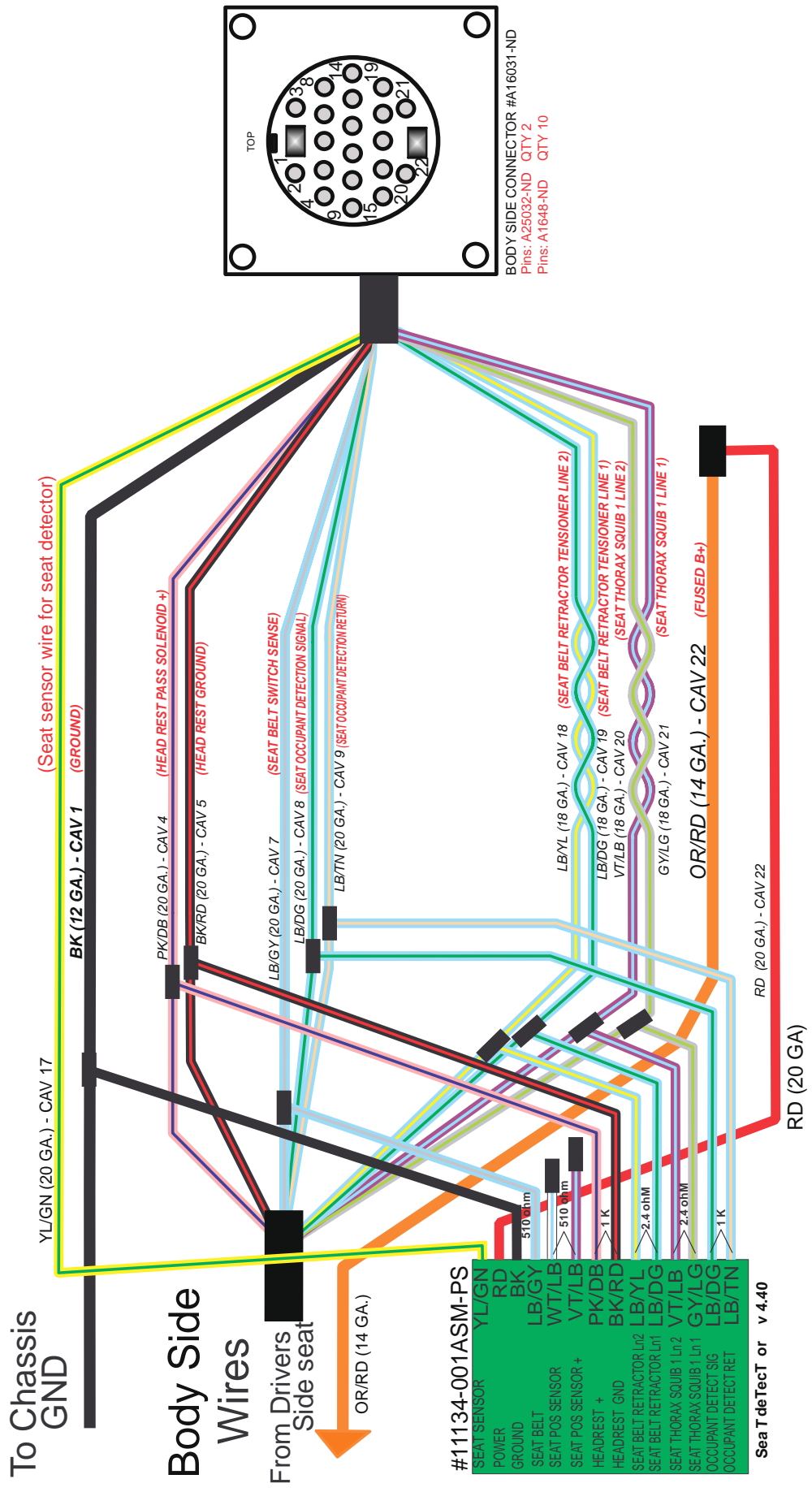

Vans built prior to 10/10/2012 have the LB/TN in CAV6 NOT CAV 9  
 Stock # 47055 was the 1st van with LB/TN in CAV 9

Updated on 6/3/2014

# 2013-2014 Chrysler Minivan I406A/C378 Passenger Seat with POWER & HEAT - With Seat Detector SEAT SIDE

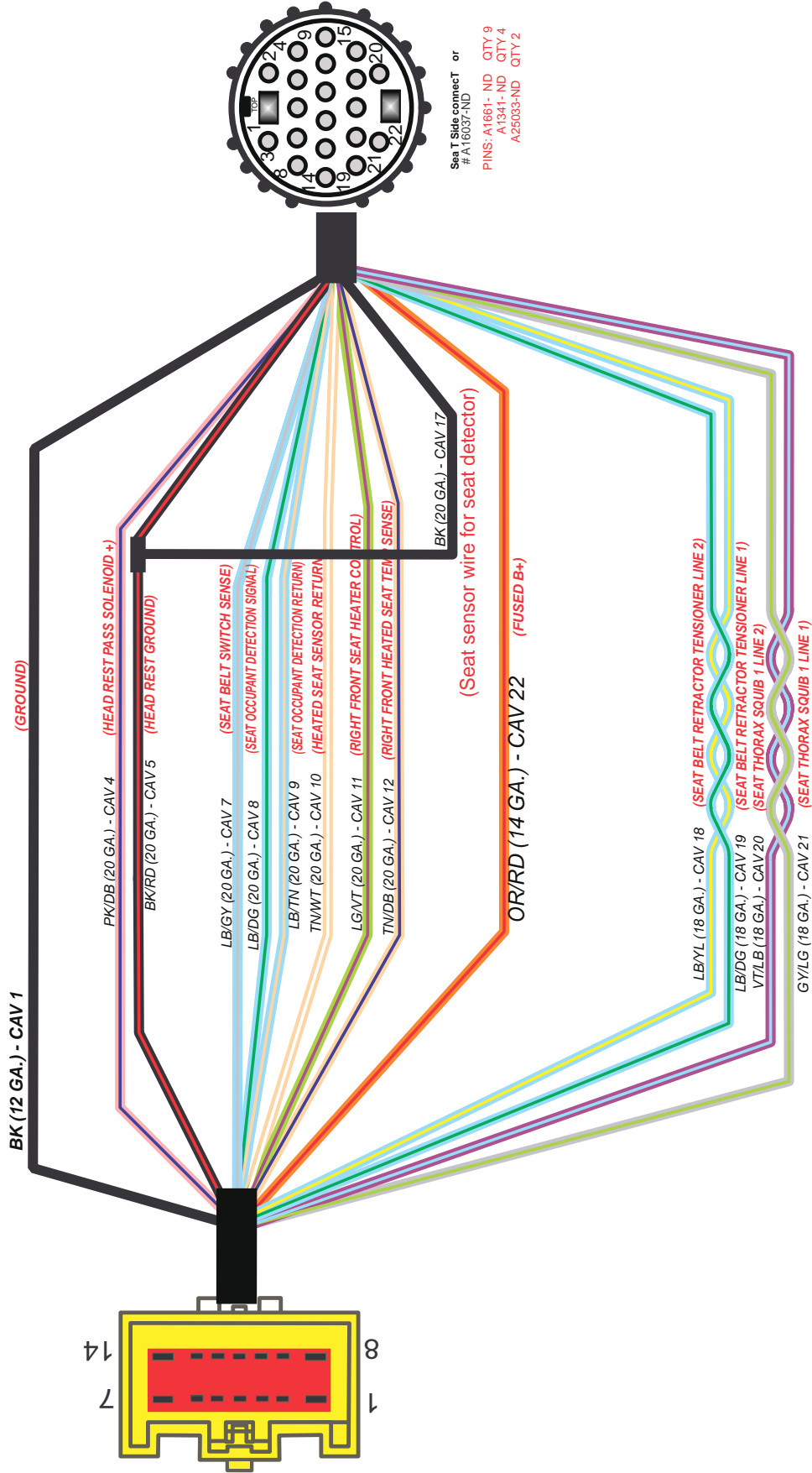

See T Side connect  
# A16037-ND  
or  
PINS: A1681-ND QTY 9  
A1341-ND QTY 4  
A25033-ND QTY 2

Vans built prior to 10/10/2012 have the LB/TN in CAV6 NOT CAV 9  
Stock # 47055 was the 1st van with LB/TN in CAV 9





# oTc Wiring (W iTh The door Open l iMiT SWiCh)

## CONTROLLER WIRING DIAGRAM BuilT Before 8/26/2013 12/27/12 MOD E-F (W/ Limit Switch)

### Compustar Remote

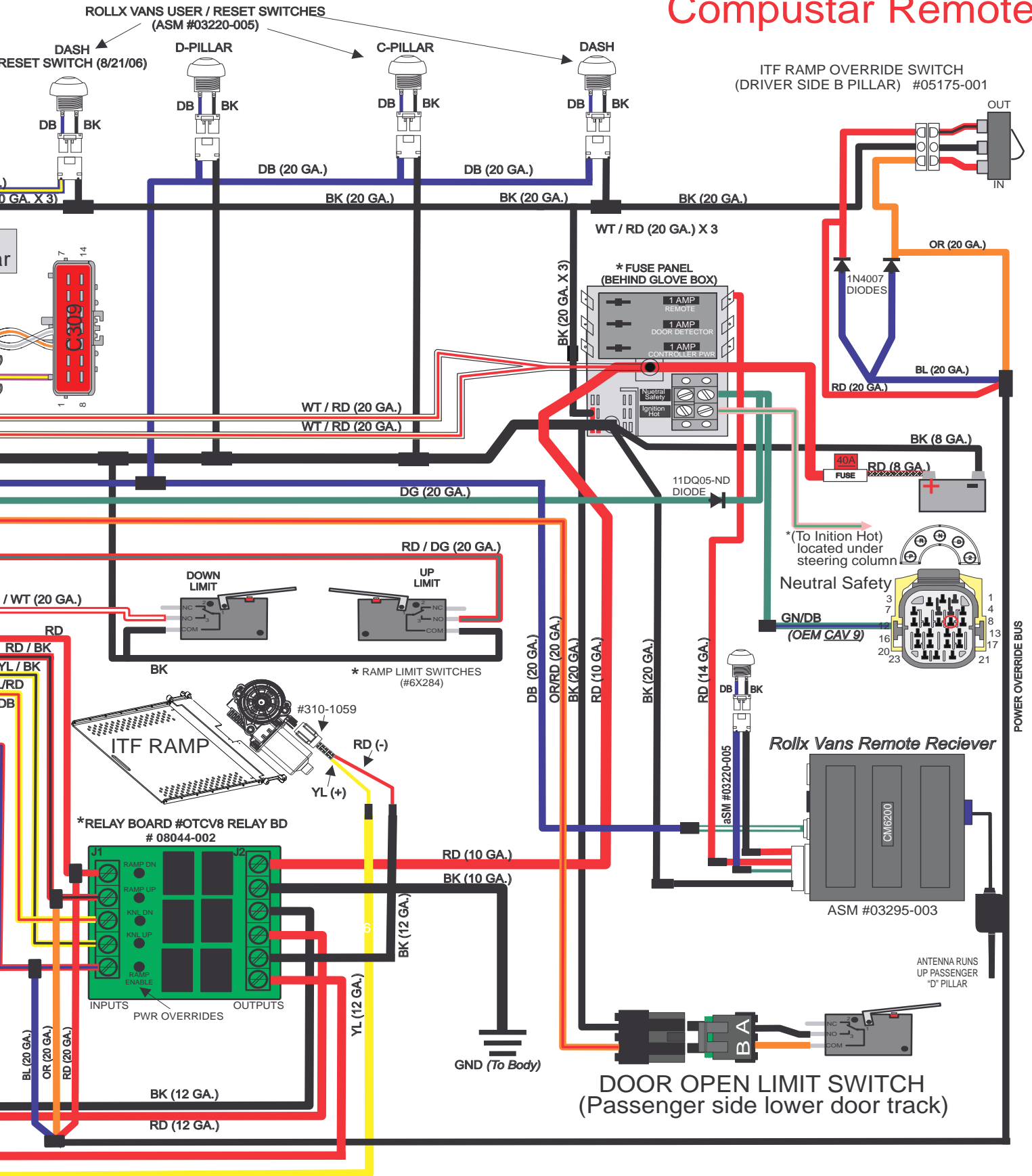



# oTc Wiring (W iTh The door deTeCtor )

\* = for pictures of location see important information and location Section in Service Manual

## ROLLX VANS ONE TOUCH C ITF Harness V6/ OTC Board V8 MO

*Italic Font = oem Wire*

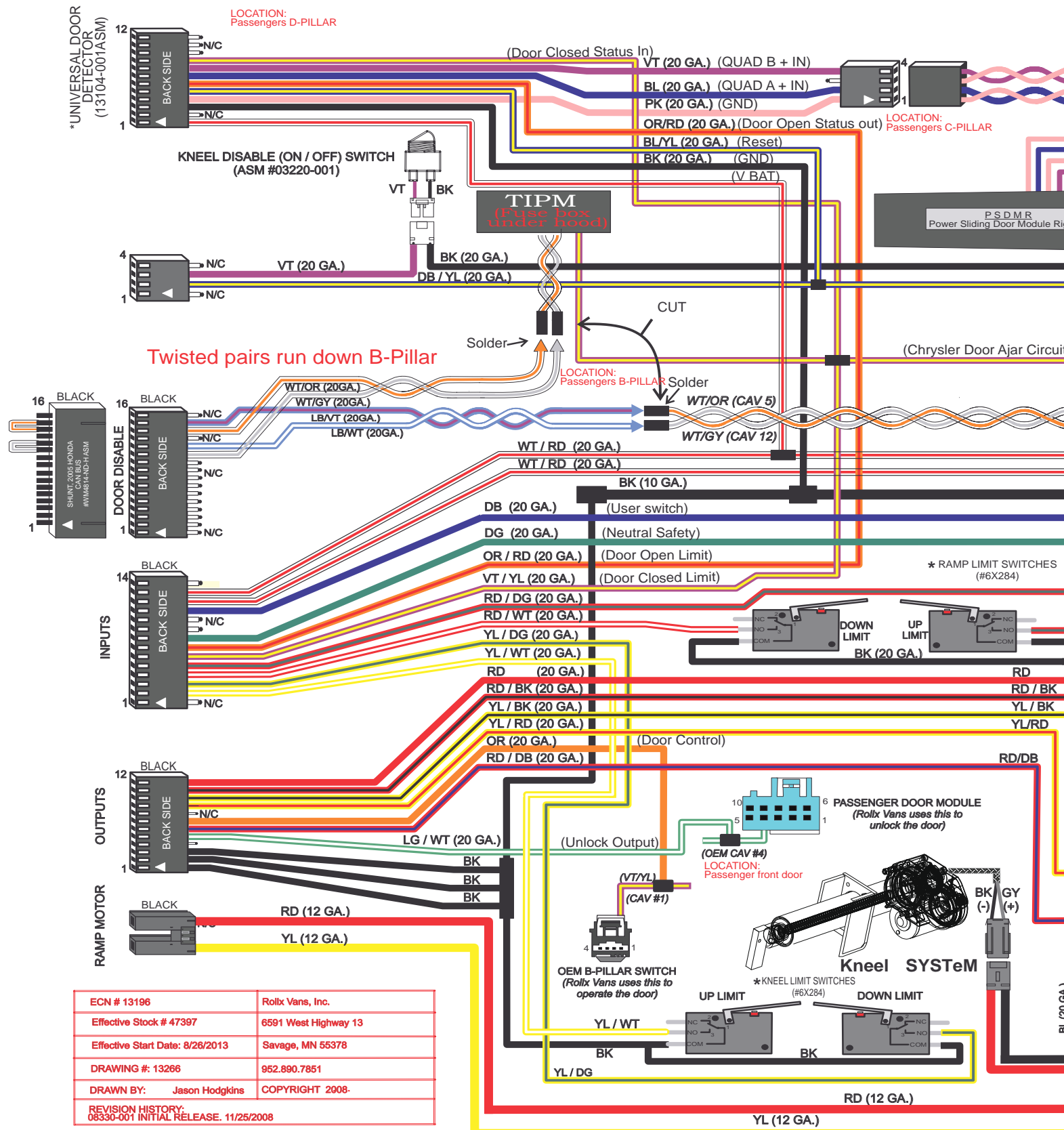

ECN # 13196	Rollx Vans, Inc.
Effective Stock # 47397	6591 West Highway 13
Effective Start Date: 8/26/2013	Savage, MN 55378
DRAWING #: 13266	952.890.7851
DRAWN BY: Jason Hodgkins	COPYRIGHT 2008.
REVISION HISTORY: 08330-001 INITIAL RELEASE. 11/25/2008	



# CONTROLLER WIRING DIAGRAM OD F (W/ Door Detector)

9/23/2013

Built after 8/26/2013

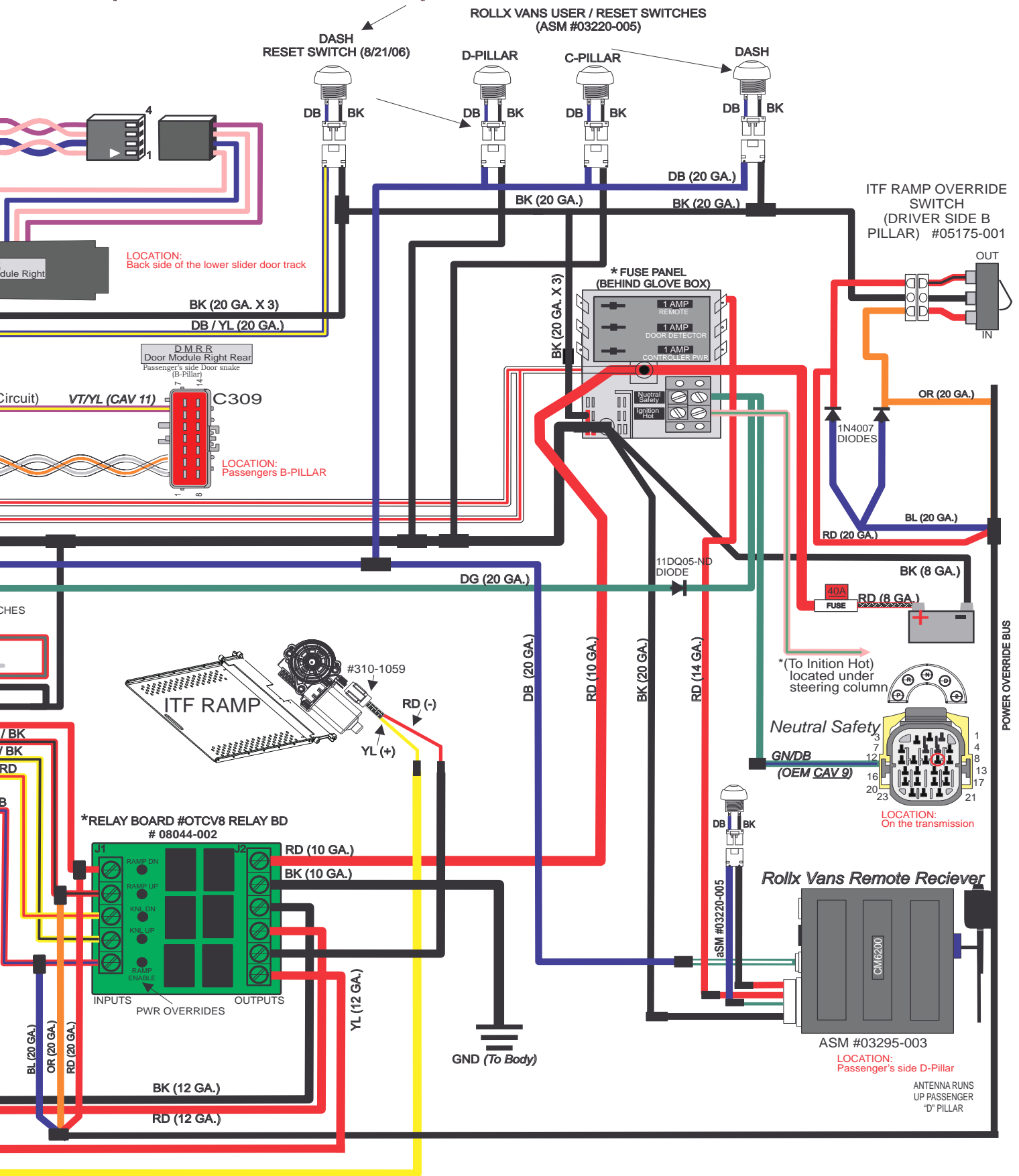



# oTc Wiring (W iTh The dOor deTeCtOr nO can BuS)

## ROLLX VANS ONE TOUCH CONT ITF Harness V6/ OTC Board V8 MO

\* = for pictures of location see important information and location Section in Service Manual

*Italic Font = oem Wire*

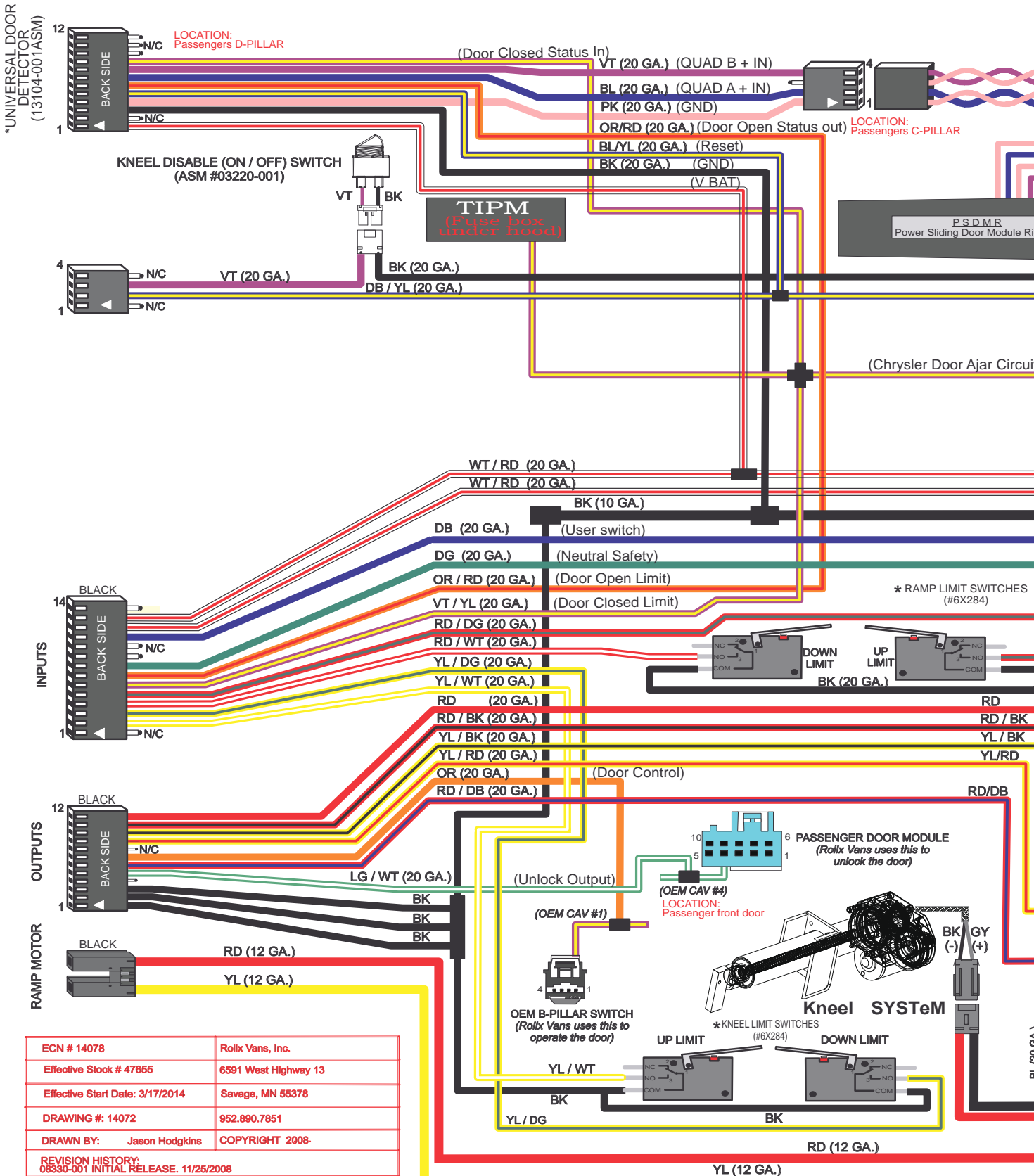

ECN # 14078	Rollx Vans, Inc.
Effective Stock # 47655	6591 West Highway 13
Effective Start Date: 3/17/2014	Savage, MN 55378
DRAWING #: 14072	952.890.7851
DRAWN BY: Jason Hodgkins	COPYRIGHT 2008.
REVISION HISTORY: 08330-001 INITIAL RELEASE. 11/25/2008	





# oTc Wiring (With Wing Window Interface)

\* = for pictures of location see important information and location Section in Service Manual

*Italic Font = oem Wire*

## ROLLX VANS ONE TOUCH CONTROL HARNESS V7/ OTC Board V8 MOD

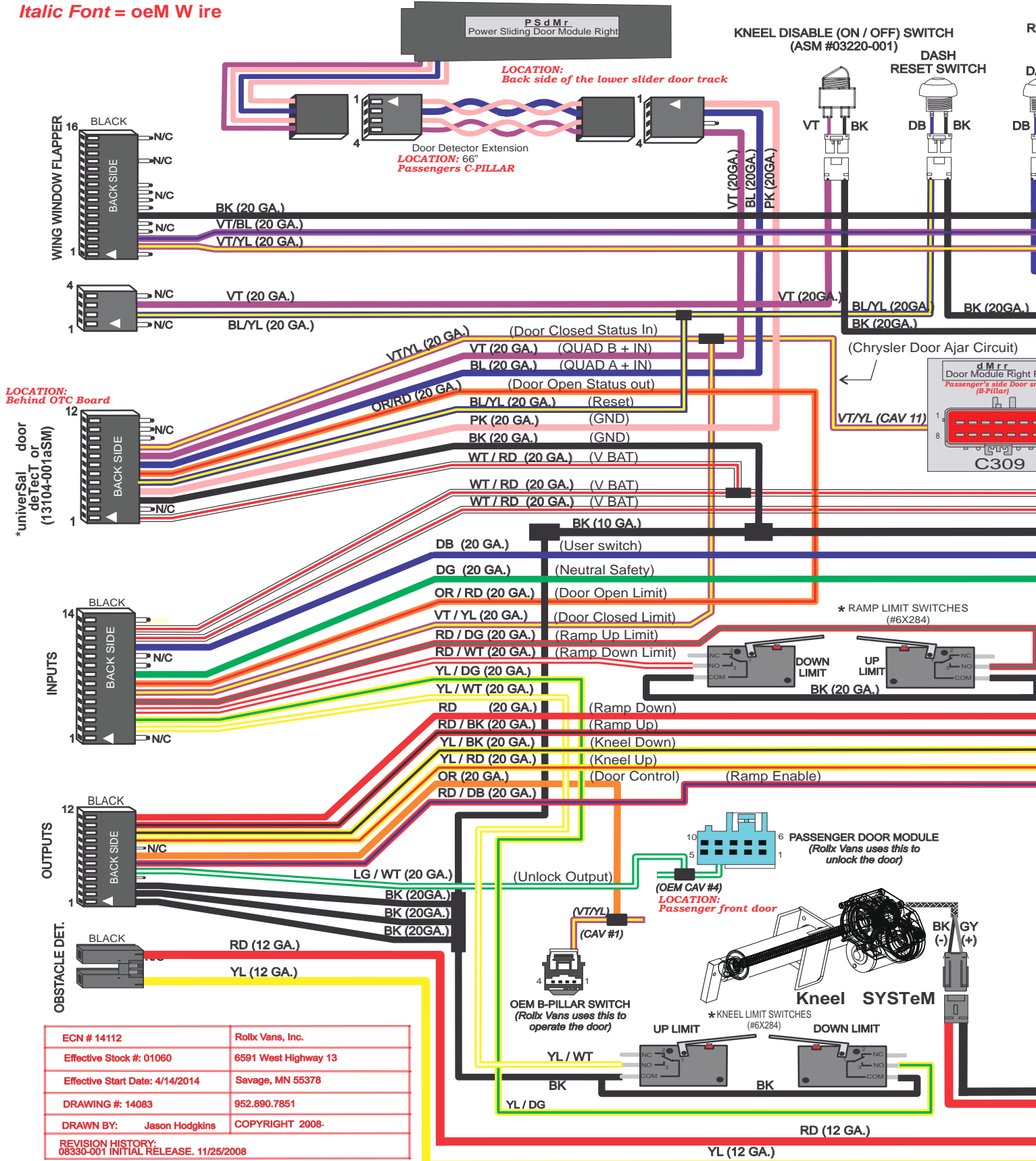

ECN # 14112	Rollx Vans, Inc.
Effective Stock #: 01060	6591 West Highway 13
Effective Start Date: 4/14/2014	Savage, MN 55378
DRAWING #: 14083	952.890.7851
DRAWN BY: Jason Hodgkins	COPYRIGHT 2008.
REVISION HISTORY: 08330-001 INITIAL RELEASE. 11/25/2008	

# CONTROLLER WIRING DIAGRAM MOD H (W/ Wing Window Interface)

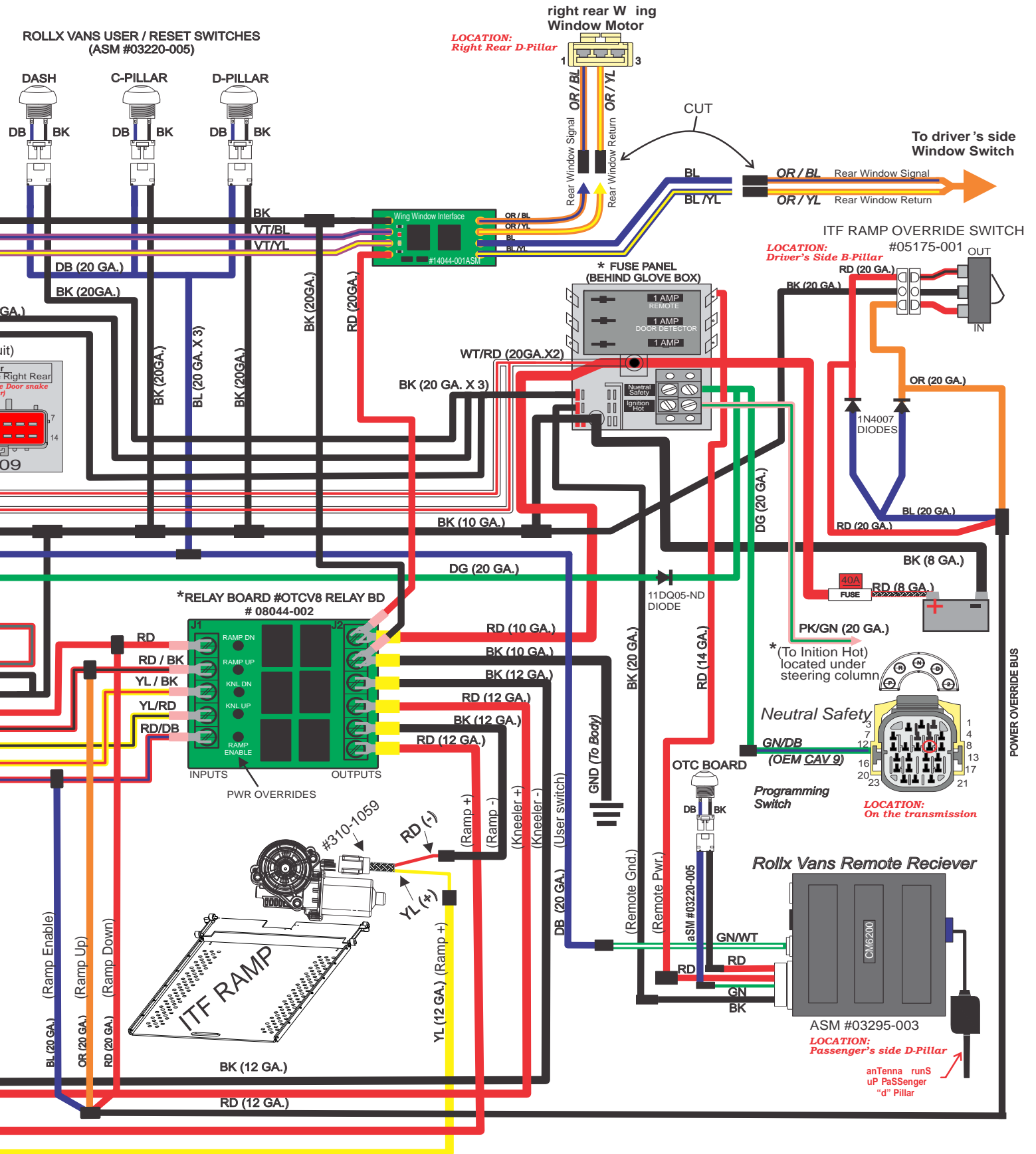



# Rollx Vans Power Door (Motor Bar) Touchtronic Power Touch 1550

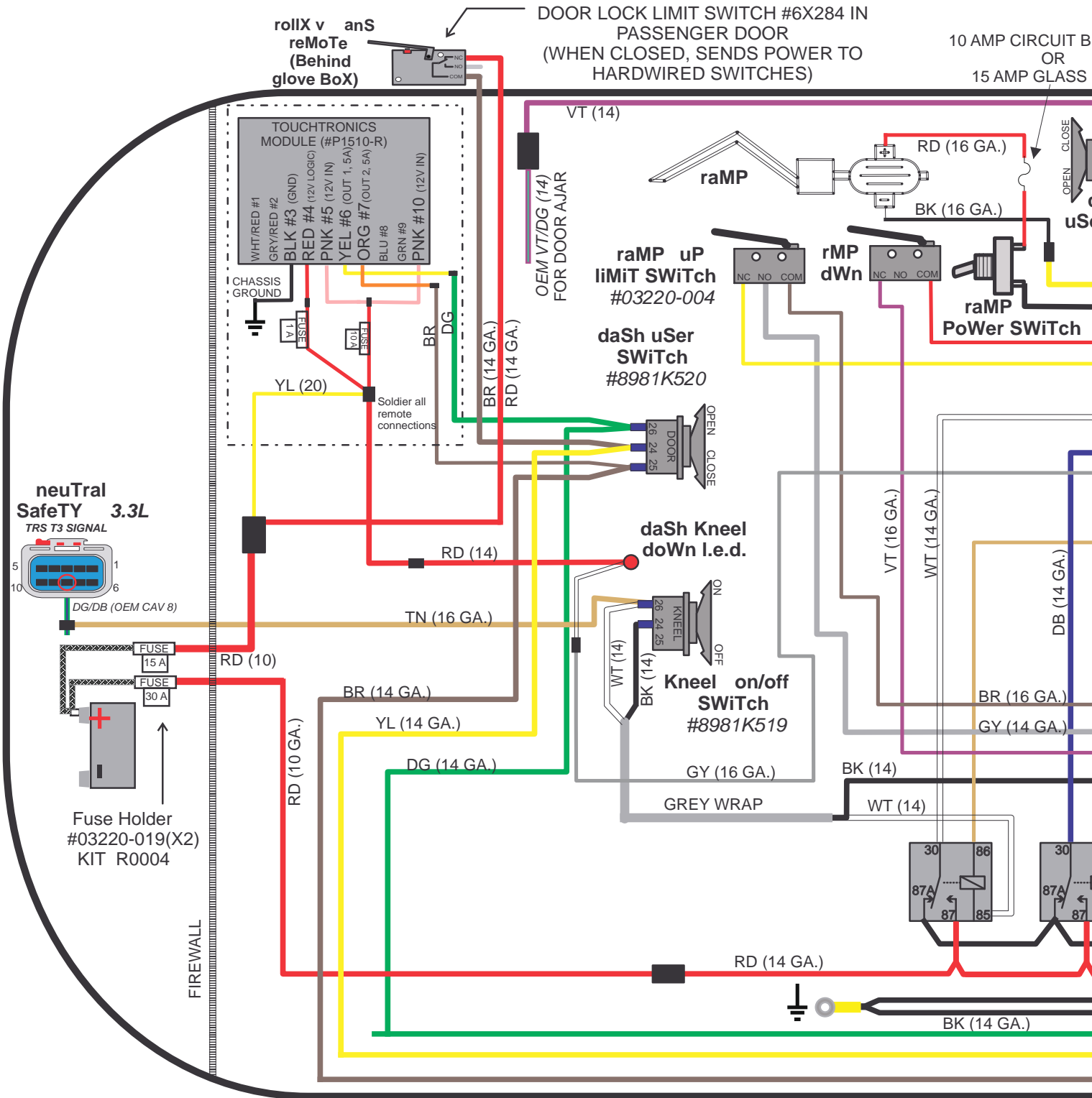

7/9/2013

# Motor Bar) Wiring Diagram v2

## 50-R Remote System (Jan. 2011)

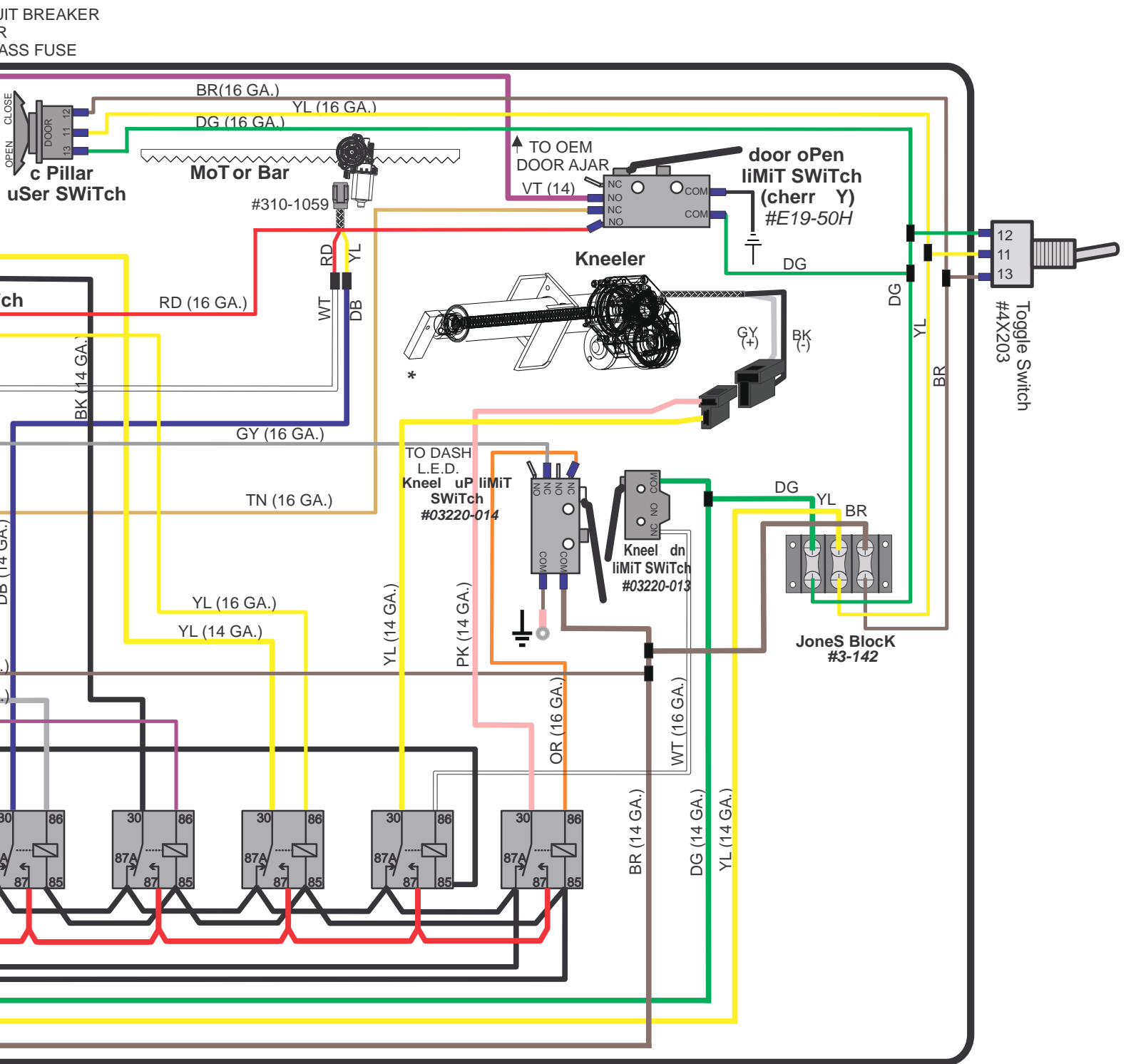

door cloSe    raMP doWn    raMP uP    Kneel doWn    Kneel uP  
 RELAYS (#5-1393302-8)  
 LOCATED IN OEM SPARE TIRE KIT COMPARTMENT



Door track - Periodically make sure lower door track is free of debris and vacuum track out. Make certain to clear out any water and ice that may be present. In the front of each door track there are plugs that can be removed to allow an air hose to be inserted to help remove debris.

Rollx Vans power door (If equipped) - Every 6 months lube the gear rack (bar) with a high quality white lithium grease. Make sure to clean off any old grease first.

### **Kneel System**

---

Kneel chain - Every 6 months spray the chain inside the rubber boot with a high quality oil to lubricate and protect. DO NOT USE WD40.

### **ramps**

---

Folding ramp - Every 6 months spray the ramp's lower and upper hinge with high quality silicon lubricant.

In The Floor ramp - Every 6 months spray the ramp access cover's flap hinge with a high quality silicon lubricant. Also spray the two silver strips on the underside of the ramp to reduce friction.





## New Rollx Vans Van Warranty Coverage Information

Rollx Vans provides a limited warranty on its minivan against defects in material or workmanship for a period of 3 years or 36,000 miles, whichever comes first. For warranty specifics please refer to an Owner's Manual or contact Rollx Vans Customer Service.

For all warranty or reimbursement needs, you must have prior authorization by the Rollx Vans Service Department.

1. Call 1-800-956-6668, and a Rollx Vans Customer Service Representative will assist you in any concerns or issues you have with your van.
2. The service representative will evaluate what repair is needed, and either set up an appointment with an "At Home" Service Technician or direct you to a nearby service facility. An authorization number must be issued.

Rollx Vans will work with many repair facilities. Rollx Vans reserves the right to approve a repair shop or recommend an alternative.

Rollx Vans may request that defective/damaged parts be returned to our Customer Service Department for inspection. If parts are found to be damaged because of abuse or neglect, reimbursement for the new replacement parts may be denied. Rollx Vans reserves the right to use rebuilt components.

Rollx Vans will ship all warranted replacement parts by nationwide carrier. In most cases, shipment will be by ground transport and absorbed by Rollx Vans. Any other mode of transportation will be at the expense of the customer.

### Our Mission

To improve the quality of life of people with disabilities of all income levels by delivering the best modified vehicle.

We intend to keep that customer for life by following up with a level of service that exceeds all of their expectations.

### Our Values

Quality • Compassion • Honesty • Integrity • Fairness

