



**Owner's Manual for the Vehicle.**  
With a quick reference guide  
for your convenience.



Congratulations, and thank you for choosing a BMW.

Thorough familiarity with your vehicle will provide you with enhanced control and security when you drive it. We therefore have this request:

Please take the time to read this Owner's Manual and familiarize yourself with the information that we have compiled for you before starting off in your new vehicle. It contains important data and instructions intended to assist you in gaining maximum use and satisfaction from the unique range of technical features on your BMW. The manual also contains information on care and maintenance designed to enhance operating safety and contribute to maintaining the value of your BMW throughout an extended service life.

This manual is supplemented by a Service and Warranty Information Booklet (US models) or a Warranty and Service Guide Booklet (Canadian models). We recommend that you read this publication thoroughly.

Your BMW is covered by the following warranties:

- New Vehicle Limited Warranty
- Limited Warranty Rust Perforation
- Federal Emissions System Defect Warranty
- Federal Emissions Performance Warranty
- California Emissions Control System Limited Warranty

Detailed information about these warranties is listed in the Service and Warranty Information Booklet (US models) or in the Warranty and Service Guide Booklet (Canadian models).

We wish you an enjoyable driving experience.

BMW AG

## Notes on the Owner's Manual

We have made every effort to ensure that you are able to find what you need in this Owner's Manual as quickly as possible. The fastest way to find certain topics is by using the detailed index at the end. If you wish to gain only an initial overview of your vehicle, you will find this in the first chapter.

The detailed table of contents that directly follows the summary of contents is intended to stimulate your curiosity regarding your BMW and to encourage you to read the manual.

Should you wish to sell your BMW at some time in the future, please remember to hand over this Owner's Manual to the new owner; it is part of the vehicle.

Should you have any further questions, your BMW center will be glad to assist at any time.

© 2000 BMW AG  
Munich, Germany  
Reprinting, including excerpts, only with the written consent of BMW AG, Munich.  
Part number 01 41 0 155 083  
US English III/00  
Printed in Germany  
Printed on environmentally friendly paper (bleached without chlorine, suitable for recycling).

## Symbols used



Indicates instructions or precautions that must be followed precisely in order to avoid the possibility of personal injury and serious damage to the vehicle. ◀



Contains either information that will assist you in gaining the optimum benefit from your vehicle and enables you to care more effectively for your vehicle. ◀



Refers to measures that can be taken to help protect the environment. ◀

◀ Marks the end of a specific item of information.

\* Indicates special equipment, country-specific equipment and optional extras.



Identifies systems or components, which your BMW center can either activate or adapt to suit an individual driver's requirements ("Car Memory", "Key Memory"). Refer to page 46. ◀

## The individual vehicle

If your BMW features equipment which is not described in this Owner's Manual (e.g. car radio, navigation system or telephone), Supplementary Owner's Manuals are enclosed. We ask you to read these manuals as well.

### **Status at time of printing**

BMW pursues a policy of continuous, ongoing development designed to ensure that our vehicles continue to embody the highest quality and safety standards combined with advanced, state-of-the-art technology. For this reason, it is possible that the features described in this Owner's Manual could differ from those on your vehicle. Nor can errors and omissions be entirely ruled out. You are therefore asked to appreciate that no legal claims can be entertained on the basis of the data, illustrations or descriptions in this Owner's Manual.

## For your own safety

 Use unleaded gasoline only. Fuels containing up to and including 10% ethanol or other oxygenates with up to 2.8% oxygen by weight (i. e. 15% MTBE or 3% methanol plus an equivalent amount of co-solvent) will not void the applicable warranties respecting defects in materials or workmanship. Field experience has indicated significant differences in fuel quality (volatility, composition, additives, others) among gasolines offered for sale in the United States and Canada. The use of poor-quality fuels may result in driveability, starting and stalling problems especially under certain environmental conditions such as high ambient temperature and high altitude. Should you encounter driveability problems which you suspect could be related to the fuel you are using, we recommend that you respond by switching to a recognized high-quality brand. Failure to comply with these recommendations may result in unscheduled maintenance. Follow the relevant safety rules when you are handling gasoline. ◀



## Important safety information.

For your own safety, use genuine parts and accessories approved by BMW. When you purchase accessories tested and approved by BMW and Original BMW Parts, you simultaneously acquire the assurance that they have been thoroughly tested by BMW to ensure optimum performance when installed on your vehicle. BMW warrants these parts to be free from defects in material and workmanship. BMW will not accept any liability for damage resulting from installation of parts and accessories not approved by BMW. BMW cannot test every product made by other manufacturers to verify if it can be used on a BMW safely and without risk to either the vehicle, its operation, or its occupants. Original BMW Parts, BMW Accessories and other products approved by BMW, together with professional advice on using these items, are available from all BMW centers.

Installation and operation of non-BMW approved accessories such as alarms, radios, amplifiers, radar detectors, wheels, suspension components, brake dust shields, telephones (including operation of any portable cellular phone from within the vehicle without using an externally mounted antenna) or transceiver equipment (such as C.B., walkie-talkie, ham radio or similar) may cause extensive damage to the vehicle, compromise its safety, interfere with the vehicle's electrical system or affect the validity of the BMW Limited Warranty. See your BMW center for additional information. ◀



Maintenance, replacement, or repair of the emission control devices and systems may be performed by any automotive repair establishment or individual using any certified automotive part. ◀

## Symbol for vehicle parts



Indicates that you should consult the relevant section of this Owner's Manual for information on a particular part or assembly.

The following applies only to vehicles owned and operated in the US.

## **REPORTING SAFETY DEFECTS**

If you believe that your vehicle has a defect that could cause a crash or could cause injury or death, you should immediately inform the National Highway Traffic Safety Administration (NHTSA) in addition to notifying BMW of North America, Inc., P.O. Box 1227, Westwood, New Jersey 07675-1227, Telephone (201) 307-4000.

If NHTSA receives similar complaints, it may open an investigation, and if it finds that a safety defect exists in a group of vehicles, it may order a recall and remedy campaign. However, NHTSA cannot become involved in individual problems between you, your dealer, or BMW of North America, Inc.

To contact NHTSA, you may either call the Auto Safety Hotline toll-free at 1-800-424-9393 (or 202-366-0123 in Washington, D.C. area) or write to: NHTSA, U.S. Department of Transportation, Washington, D.C. 20590. You can also obtain other information about motor vehicle safety from the Hotline.



Overview

Controls and features

Operation, care  
and maintenance

Owner service procedures

Advanced technology

Technical data

Index





# Contents

## Overview

- Cockpit 14
- Instrument cluster 16
- Indicator and warning lamps 18
- Hazard warning flashers 22
- Warning triangle 22
- First-aid kit 22
- Refueling 23
- Fuel quality 24
- Tire inflation pressure 24

## Controls and features

- Locks and security systems:**
  - Keys 28
  - Electronic vehicle immobilizer 29
  - Central locking system 30
  - Opening and closing – from outside 30
  - Using the key 30
  - Using the remote control 31
  - Opening and closing – from inside 34
  - Luggage compartment lid 35
  - Alarm system 36
  - Electric power windows 38
  - The automatic convertible top 39
- Adjustments:**
  - Seats 43
  - Steering wheel 45
  - Mirrors 45
  - Car Memory, Key Memory 46
- Passenger safety systems:**
  - Safety belts 48
  - Airbags 49
  - Child restraints 51
  - Child seat safety 52

## Driving:

- Steering/Ignition lock 53
- Starting the engine 54
- Turning the engine off 54
- Parking brake 55
- Manual transmission 56
- Turn signal indicator/Headlamp flasher 56
- Wiper/Washer system 57
- Rear window defroster 58
- Cruise control 59

## Everything under control:

- Odometer 60
- Tachometer 60
- Fuel gauge 60
- Coolant temperature gauge 61
- Service Interval Display 61
- Clock 62
- Multi-Information Radio (MIR) 62

## Technology for safety and driving convenience:

- Dynamic Stability Control (DSC) 63
- Dynamic Driving Control 64
- Tire Pressure Warning (RDW) 65

- Controls and features**
- Lamps:**
    - Side lamps/Low beams 67
    - Instrument lighting 67
    - High beams/Parking lamps 68
    - Rear foglamp 68
    - Interior lamps 68
    - Reading lamps 69
  - Controlling the climate for pleasant driving:**
    - Heating and ventilation/
      - Air conditioning 70
      - Seat heating 75
  - Interior conveniences:**
    - Glove compartment 76
    - Storage compartments 76
    - Beverage can holder 78
    - Cellular phone 79
    - Ashtray 79
    - Cigarette lighter 80
  - Loading and transporting:**
    - Cargo loading 81
- Operation, care and maintenance**
- Special operating instructions:**
    - Break-in procedures 84
    - Driving notes 85
    - Catalytic converter 85
    - Antilock Brake System (ABS) 86
    - Dynamic Brake Control (DBC) 88
    - Disc brakes 88
    - Brake system 89
    - Winter operation 90
    - Power steering 92
    - Cellular phone 92
    - Radio reception 92
    - Wind protection 93
    - Hardtop 94
  - Wheels and tires:**
    - Tire inflation pressure 96
    - Tire condition 97
    - Tire replacement 98
    - Tire rotation 100
    - Wheel and tire combinations 101
    - Winter tires 102
    - Snow chains 102
    - Approved wheel and tire specifications 103
  - Under the hood:**
    - Hood 104
    - Engine compartment 106
    - Washer fluids 108
    - Washer nozzles 108
    - Engine oil 109
    - Coolant 111
    - Brake fluid 112
    - Vehicle Identification Number 113
  - Maintenance and care:**
    - The BMW Maintenance System 114
    - Caring for your vehicle 115
    - Airbags 121
    - Storing your vehicle 122
  - Laws and regulations:**
    - Technical modifications 123
    - California Proposition 65 Warning 123
    - OBD interface socket 124

# Contents

## Owner service procedures

### Replacement procedures:

- Onboard tool kit [128](#)
- Windshield wiper blades [128](#)
- Lamps and bulbs [129](#)
- Changing a wheel [135](#)
- Battery [136](#)
- Fuses [138](#)

### In case of electrical malfunction:

- Fuel filler door [140](#)
- Luggage compartment lid, storage compartment [140](#)
- Passenger-side door [141](#)
- Closing the convertible top [141](#)

### Giving and receiving assistance:

- Jump starting [143](#)
- Towing [144](#)

## Advanced technology

- Airbags [148](#)
- Radio reception [148](#)
- Dynamic Stability Control (DSC) [149](#)
- Safety belt tensioner [149](#)
- Interior rearview mirror with automatic dimmer [150](#)
- Xenon lamps [151](#)

## Technical data

- Engine data [154](#)
- Dimensions [155](#)
- Weights [156](#)
- Capacities [157](#)
- Electrical system [158](#)
- Drive belts [158](#)

**Index**

- Everything from A to Z [162](#)
- Owner service procedures [167](#)





Cockpit 14  
Instrument cluster 16  
Indicator and warning lamps 18  
Hazard warning flashers 22  
Warning triangle 22  
First-aid kit 22  
Refueling 23  
Fuel quality 24  
Tire inflation pressure 24

## Overview

## Controls and features

## Operation, care and maintenance

## Owner service procedures

## Advanced technology

## Technical data

## Index

## 14 Cockpit

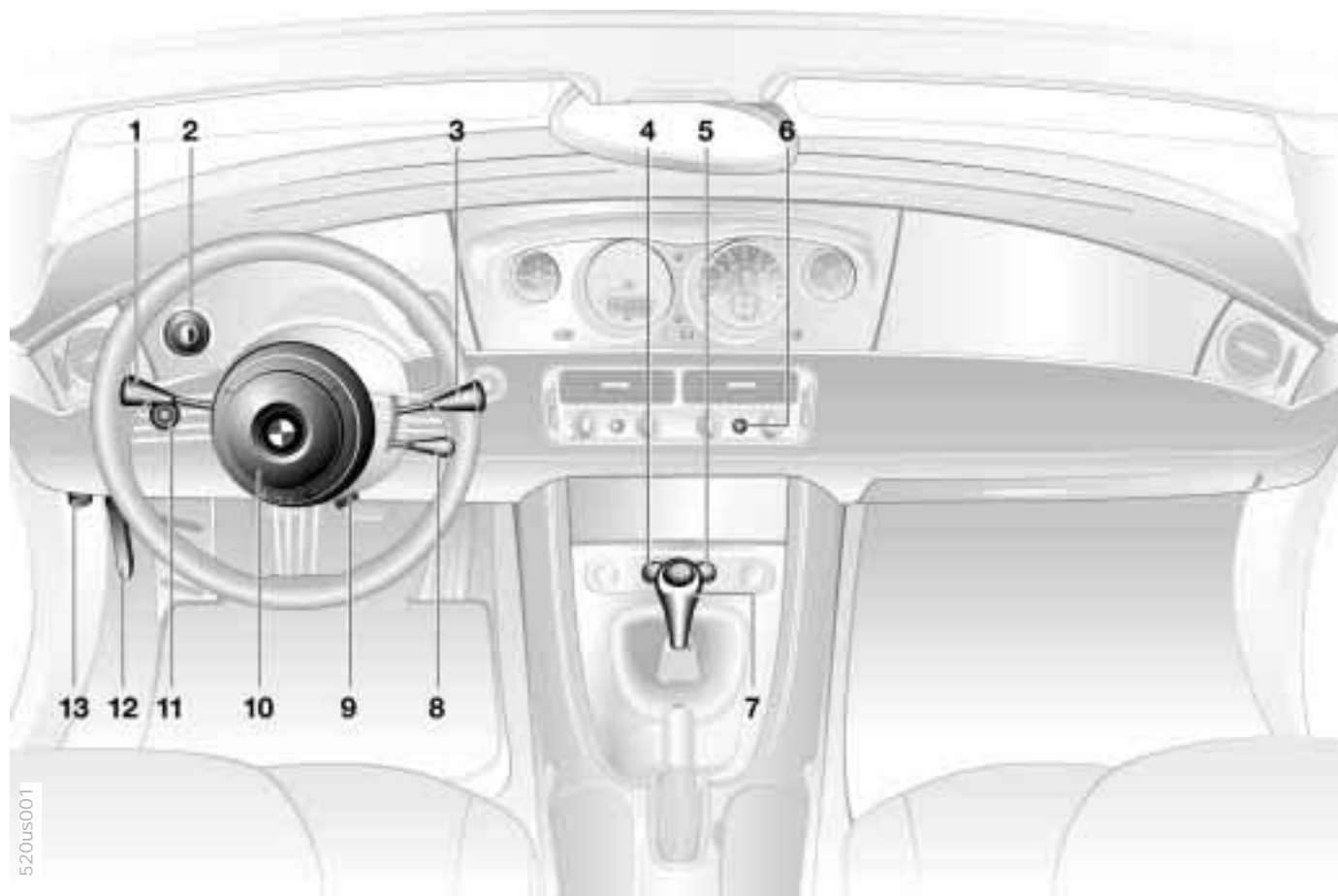

520us001

# Cockpit

- 1 ▷ Turn signal indicator [56](#)
  - ▷ Parking lamps [68](#)
  - ▷ High beams [68](#)
  - ▷ Headlamp flasher [56](#)
- 2 Side lamps/Low beams [67](#)
- 3 Washer/Wiper system [57](#)
- 4 Hazard warning flashers [22](#)
- 5 Central locking system [30](#)
- 6 Rear window defroster for the hardtop [58](#)
- 7 Shift lever [56](#)

To engage reverse gear, press the lever to the left and overcome the slight resistance you will encounter
- 8 Cruise control [59](#)
- 9 Adjusting the steering wheel [45](#)
- 10 Horn: the entire surface functions as the horn
- 11 Rear foglamps [68](#)
- 12 Unlocking the hood [104](#)
- 13 ▷ Unlocking the luggage compartment lid [35](#)
  - ▷ Unlocking the fuel filler door [23](#)



## 16 Instrument cluster

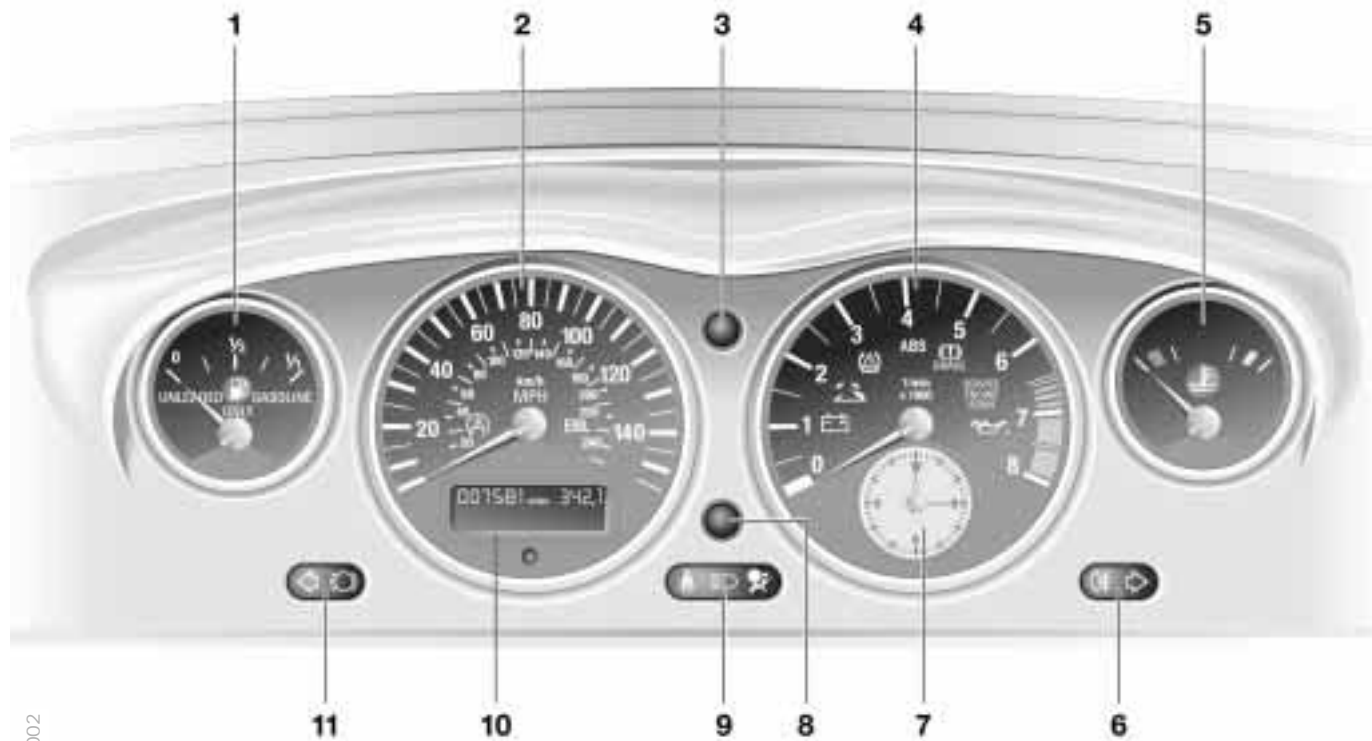

# Instrument cluster

- 1 Fuel gauge with indicator lamp for fuel reserve [60](#)
- 2 Speedometer with indicator and warning lamps for
  - ▷ Dynamic Stability Control (DSC) [20](#)
  - ▷ Engine electronics [20](#)
- 3 Instrument lighting [67](#)
- 4 Tachometer [60](#) with indicator and warning lamps for
  - ▷ Battery charge current [18](#)
  - ▷ Convertible top operation [39](#)
  - ▷ Tire Pressure Warning (RDW) [18](#)
  - ▷ Antilock Brake System (ABS) [19](#)
  - ▷ Parking brake/Brake hydraulic system/Cornering Brake Control (CBC) [18](#)
  - ▷ Service Engine Soon [20](#)
  - ▷ Engine oil pressure/Engine oil level [18, 19](#)
- 5 Engine coolant temperature gauge with "Coolant temperature too high" warning lamp [61](#)
- 6 Indicator and warning lamps for
  - ▷ Rear foglamps [20](#)
  - ▷ Turn signal indicator right [21](#)
- 7 Clock [62](#)
- 8 Control knob for
  - ▷ Clock [62](#)
  - ▷ Trip odometer, reset to zero [60](#)
- 9 Indicator and warning lamps for
  - ▷ Please fasten safety belts [19](#)
  - ▷ High beams [21](#)
  - ▷ Airbags [19](#)
- 10 Indicator for
  - ▷ Odometer [60](#)
  - ▷ Trip odometer [60](#)
  - ▷ Service Interval [61](#)
- 11 Indicator and warning lamps for
  - ▷ Turn signal indicator left [21](#)
  - ▷ Brake pads [20](#)

## 18 Indicator and warning lamps

### Technology that monitors itself

Many of the systems for your BMW monitor themselves automatically, both during engine starts and while you are driving. Indicator and warning lamps that are identified by "●" are tested for proper functioning whenever the ignition key is turned. They each light up once for different periods of time.

If a fault should occur in one of these systems, the corresponding lamp does not go out after the engine is started, or it lights up while the vehicle is moving. You will see how to react to this below.

### Red: stop immediately



**Battery charge current**  
The battery is no longer being charged. There is a malfunction in the alternator V-belt or in the charging circuit of the alternator. Please contact the nearest BMW center.



If the V-belt is defective, do not continue driving. The engine could be damaged due to overheating. If the V-belt is defective, increased steering effort is also required. ◀



**Engine oil pressure ●**  
Stop vehicle and switch off engine immediately. Check the engine oil level and top off as required. If the oil level is correct, please contact the nearest BMW center.



Do not continue driving. The engine could be damaged because of inadequate lubrication. ◀



**Tire Pressure Warning (RDW) ●**  
Flashing warning lamp in addition to an acoustic signal: a tire failure has occurred. Carefully reduce speed to less than 50 mph (80 km/h), thus preventing any hard braking or steering maneuvers.  
For additional information, refer to page 65.



**Brake warning indicator ●**  
If the lamp comes on when the parking brake is not engaged, check the brake fluid level. Before driving further, be sure to read the notes on pages 89 and 112.



**Brake warning lamp for Canadian models.**

# Indicator and warning lamps

## Red and yellow: continue driving cautiously



The red brake warning lamp comes on together with the yellow indicator lamps for ABS and DSC:



The entire ABS, CBC, DSC and DBC control system has failed.



Continue driving cautiously and defensively. Avoid full brake applications. Please have the system checked by your BMW center as soon as possible.

For additional information, refer to pages [63](#), [86](#).



Warning lamps for Canadian models.



## Red: an important reminder



Brake warning lamp ●

Comes on when the parking brake is applied – an additional acoustic signal sounds when starting off.

For additional information, refer to page [55](#).



Brake warning lamp for Canadian models.



Please fasten safety belts ●

Together with an acoustic signal. Comes on until the safety belts are fastened.

For additional information on safety belts, refer to page [48](#).



Airbags ●

Please have the system inspected by your BMW center.

For additional information, refer to pages [49](#), [148](#).

## Yellow: check as soon as possible



Antilock Brake System (ABS) ●  
ABS has been deactivated in response to system malfunction.

Conventional braking efficiency is available and unrestricted. Please have the system inspected by your BMW center. For additional information, refer to page [86](#).



Antilock Brake System (ABS) warning lamp for Canadian models.



Engine oil level

Comes on while driving: the oil level is at the absolute minimum; refill as soon as possible. Do not drive more than approx. 30 miles (50 km) until you add oil.

For additional information, refer to page [109](#).



Engine oil level

Comes on after the engine has been shut off: add engine oil at your earliest opportunity (when you stop to refuel).

For additional information, refer to page [109](#).

## 20 Indicator and warning lamps



### Brake pads ●

Have the brake pads checked. For additional information, refer to page [89](#).



### Dynamic Brake Control (DBC) ●

Malfunction in the DBC system. Conventional braking efficiency is available and unrestricted. For additional information, refer to page [88](#).



### Warning lamp, Dynamic Brake Control (DBC) for Canadian models.



### Dynamic Stability Control (DSC) ●

Indicator lamp flashes: The system is active and governs drive and braking force. If the indicator lamp does not go out after the engine is started, or if it comes on during normal driving and stays on: DSC has been switched off or has been deactivated because of a malfunction. In the event of a malfunction, have the system checked by your BMW center. For additional information, refer to page [63](#).



### Service Engine Soon ●

If the indicator lamp either remains on or comes on intermittently, this indicates a fault in the emissions-related electronic systems. Although the vehicle remains operational, you should have the systems checked by your BMW center at the earliest possible opportunity. For additional information, refer to page [124](#).



### "Service Engine Soon" warning lamp for Canadian models.



### Engine electronics

Malfunction in the engine electronic control system. The electronics will permit continued driving at reduced engine output or engine speed. Please have the system inspected by your BMW center.

## Yellow: for your information



### Rear foglamp

Lights up whenever the rear foglamp is turned on.

For additional information, refer to page [68](#).

# Indicator and warning lamps

## Green: for your information



Turn signal indicator

Flashes when the turn signals are operated. Rapid flashing indicates a system malfunction.

For additional information, refer to page [56](#).

## Blue: for your information



High beams

Lights up when the high beams are on or the headlamp flasher is actuated.

For additional information, refer to pages [56](#), [68](#).

## 22 Hazard warning flashers



The button flashes periodically when the hazard flashers are on.

To help you locate the switch in an emergency, the button is also illuminated whenever the vehicle's lamps are on.

## Warning triangle\*



The warning triangle is stored under the luggage compartment's floor panel for easy access.

 Comply with legal requirements that cover the availability of a hazard warning triangle in the vehicle. ◀

## First-aid kit\*

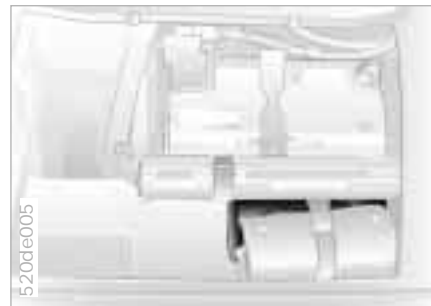

The first-aid kit is located under the luggage compartment's floor panel under the onboard tool kit.<sup>7</sup>

 Some of the articles in the first-aid kit may be used within a limited time only. For this reason, check the expiration dates of each of the items regularly, and replace any whose expiration dates have passed. You can get replacements in any drugstore or pharmacy. Comply with legal requirements regarding the availability of a first-aid kit in the vehicle. ◀



## Fuel filler door

 Before filling the tank, shut off the engine. If you do not, fuel cannot flow into the tank and the "Service Engine Soon" lamp may come on. ◀

Press on the lower part of the button to open (symbol fuel pump).

Unlocking in the event the central locking system fails, refer to page [140](#).

 When handling fuels, comply with all of the applicable safety precautions and regulations pertaining to fuels. Never carry spare fuel containers in your vehicle. Whether empty or full, these containers can leak, cause an explosion, or lead to fire in the event of a collision. ◀



## Simple and environmentally friendly

 Open the filler cap carefully to prevent fuel from spraying out. Fuel spray may cause injury. Do not top off. Topping off may cause fuel spillage. ◀

Keep the filler cap in the bracket attached to the fuel filler door.

When refueling, insert the filler nozzle completely into the filler pipe. Pulling the nozzle out of the pipe during refueling

- ▷ results in premature pump shutoff
- ▷ and will reduce the effect of the vapor recovery system on the pump.

If the filler nozzle is used correctly, the fuel tank is full when it shuts off for the first time.

Tank capacity, refer to page [157](#).

 Close the fuel cap carefully after refueling until a "click" is heard. While closing, be sure not to squeeze the strap which is fastened to the cap. A loose or missing cap will activate the Service Engine Soon warning lamp. ◀



## 24 Fuel quality

The engine uses lead-free gasoline only.

Required fuel:

- ▷ Premium Unleaded Gasoline, min. 91 AKI  
AKI = Anti Knock Index

 Do not use leaded fuels. The use of leaded fuels will cause permanent damage to the system's oxygen sensor and the catalytic converter. ◀

## Tire inflation pressure



You will find the tire inflation pressures on the door pillar (visible with door open).

### Check tire pressures

All pressure specifications are stated in psi (kilopascal) for tires at ambient temperature (refer also to the next page).

 Reactivate the Tire Pressure Warning (RDW) after changing a tire or a wheel. Refer to page [65](#). ◀

 Check tire inflation pressures regularly – at least every two weeks and before beginning a longer trip. Incorrect tire pressure can lead to tire damage and accidents. ◀

### Comply with tire approval specifications

The inflation pressures in the table apply to tires made by BMW-approved manufacturers. Your BMW center is familiar with these pressures. Higher pressures may be specified for tires made by other manufacturers.

You will find a list of approved tire sizes on page [103](#).

Your vehicle is equipped with tires that not only meet US standards, but also European standards. We recommend the exclusive use of BMW-approved tires.

# Tire inflation pressure

BMW	Tires		
	All pressure specifications in the table are indicated in psi (kilopascal) with cold tires (cold = ambient temperature)		
Z8	Front: 245/45 R 18 96 W	35 (240)	-
	Rear: 275/40 R 18 99 W	-	35 (240)
	245/45 R 18 96 H M+S	35 (240)	35 (240)

**Locks and security systems:**

Keys 28

Electronic vehicle

immobilizer 29

Central locking system 30

Opening and closing – from  
outside 30

Using the key 30

Using the remote control 31

Opening and closing – from  
inside 34

Luggage compartment lid 35

Alarm system 36

Electric power windows 38

The automatic convertible  
top 39

**Adjustments:**

Seats 43

Steering wheel 45

Mirrors 45

Car Memory, Key Memory 46

**Passenger safety systems:**

Safety belts 48

Airbags 49

Child restraints 51

Child seat safety 52

## Overview

## Controls and features

## Operation, care and maintenance

## Owner service procedures

## Advanced technology

## Technical data

## Index

### Driving:

- Steering/Ignition lock 53
- Starting the engine 54
- Turning the engine off 54
- Parking brake 55
- Manual transmission 56
- Turn signal indicator/Headlamp flasher 56
- Wiper/Washer system 57
- Rear window defroster 58
- Cruise control 59

### Everything under control:

- Odometer 60
- Tachometer 60
- Fuel gauge 60
- Coolant temperature gauge 61
- Service Interval Display 61
- Clock 62
- Multi-Information Radio (MIR) 62

### Technology for safety and driving convenience:

- Dynamic Stability Control (DSC) 63
- Dynamic Driving Control 64
- Tire Pressure Warning (RDW) 65

### Lamps:

- Side lamps/Low beams 67
- Instrument lighting 67
- High beams/Parking lamps 68
- Rear foglamp 68
- Interior lamps 68
- Reading lamps 69

### Controlling the climate for pleasant driving:

- Heating and ventilation/  
Air conditioning 70
- Seat heating 75

### Interior conveniences:

- Glove compartment 76
- Storage compartments 76
- Beverage can holder 78
- Cellular phone 79
- Ashtray 79
- Cigarette lighter 80

### Loading and transporting:

- Cargo loading 81

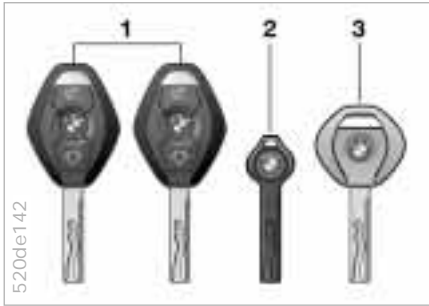

- 1 The master keys with remote control determine the Key Memory functions. Refer to page [46](#)

 There is an extended-life battery in every master key that is charged automatically in the steering lock every time you drive.

For this reason, if you have a master key that is not being used, use that key approximately once every year while driving for an extended period to charge the battery. Also refer to page [31](#). ◀

- 2 Spare key, store in a safe place, such as in your wallet. This key is not intended for continuous use

- 3 Door and ignition key

The lock for the glove compartment cannot be operated with this key. This is recommended for valet parking, for instance.

There is a key case available for using your master key on a regular basis.

## Replacement keys

Replacement keys are available exclusively through your BMW center. Your BMW center is obligated to ensure that a person requesting a key is authorized to do so, since the keys belong to a security system (refer to "Electronic vehicle immobilizer" in the following columns).

 If possible, take all of the master keys that belong to the vehicle with you when you pick up your replacement key.

Whenever you receive a new replacement key, turn it once to position 2 in the ignition lock (ignition switched on) and then back, so that the electronic vehicle immobilizer can "learn" the new key. ◀

# Electronic vehicle immobilizer



## The key to security

Your BMW is equipped with a passive anti-theft system. This electronic immobilization system is designed to reduce the susceptibility of your vehicle to theft by making it impossible to start the engine using any means other than the special keys furnished with the vehicle. Your BMW center can cancel the electronic system authorization for individual keys (in the event of loss, for instance). A deactivated key can no longer be used to start the engine.

## How the electronics work

At the heart of this system is an electronic chip that is integrated into the key. The lock mechanism itself is actually a dual-function device, simultaneously serving as a communications interface designed to allow the security system to maintain a continuous stream of variable, vehicle-specific signals with the electronic circuitry in the key. The system will release the ignition, electrical steering lock, fuel injection and starter for use only if it detects an "authorized" key.

 Forcing the key can damage the integrated electronic circuitry. A damaged key can no longer be used to unlock the steering column and start the engine. ◀

**The concept**

The central locking system is ready for operation whenever the driver's door is closed. The system engages and releases the locks on the:

- ▷ Doors
- ▷ Luggage compartment lid
- ▷ Fuel filler door
- ▷ Glove compartment
- ▷ Storage shelf for the cellular phone.

The central locking system can be operated:

- ▷ From outside via the driver's door lock, or by using the remote control
- ▷ From inside by pressing a button.

If you initiate central locking from inside, neither the fuel filler door, glove compartment, nor the storage shelf for the cellular phone are locked (refer to page 34).

If you do set it from outside, the anti-theft alarm is automatically activated as well. This prevents the door handles from unlocking the doors. The alarm system is also activated or deactivated.

If locked from inside, the central locking system unlocks automatically in the event of an accident. In addition, the hazard warning flashers and interior lamps come on.

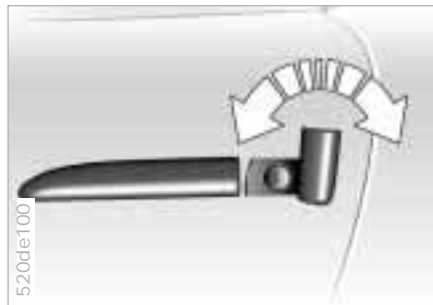
**Using the key**

Swing the cover panel for the door lock upward. After either locking or unlocking, return it to its original position until it clicks back into its final position.

Turning the key in the driver's door once will unlock the driver's door only; turning the key a second time will unlock the passenger door, the luggage compartment lid, fuel filler door, the glove compartment, and the storage shelf for the cellular phone.

If necessary, you can open the fuel filler door by pressing the respective button inside the vehicle; refer to page 23.

 You can have various signals set as an acknowledgment message when locking. ◀

**Convenience operation**

You can also operate the windows via the door lock.

- ▷ To open: with the door closed, turn the key to the "Unlock" position and hold it
- ▷ To close: with the door closed, turn the key to the "Lock" position and hold it.



Watch during the closing process to be sure that no one is inadvertently injured. Releasing the key stops the operation. ◀

**Manual operation**

(in the event of electrical malfunction)

Turn the key all the way to the extreme left or right to unlock/lock the driver's door.

Refer to page 141 for operating the passenger-side door.

## Opening and closing – from outside

### Using the remote control

The remote control gives you an exceptionally convenient method for unlocking and locking your vehicle. Furthermore, it provides three additional functions that you can only execute by means of the remote control:

- ▷ Switch on the interior lamps  
With this function, you can also "search for" your vehicle – if, for example, it is parked in an underground garage
- ▷ Open the luggage compartment lid
- ▷ Panic Mode  
In case of danger, you can trigger an alarm.

The anti-theft system is also deactivated/activated simultaneously with the unlocking or locking of the vehicle, and the alarm system is disarmed/armed, and the interior lamps are turned on/off.



### Master keys

Keys with remote control are master keys. Refer to page 28.



You can have various signals set as an acknowledgment message when locking. ◀



Children might be able to lock the doors from the inside. For this reason, always take the vehicle keys with you so that the vehicle can be opened again from the outside at any time. ◀



Master keys that are used repeatedly are always ready for operation since the battery in the key is charged automatically in the steering lock every time you drive.

If it is no longer possible to unlock the vehicle via the remote control, the battery is discharged. Use this key while driving for an extended period in order to charge the battery. Refer also to page 28.

To prevent unauthorized use of the remote control, surrender only the door and ignition key 3 or the spare key 2 (refer to page 28) when leaving the vehicle for valet parking, for example. In the event of a system malfunction, please contact your BMW center. You can also obtain replacement keys there. ◀



## 32 Opening and closing – from outside



### To unlock

Press button 1.

By pressing the button once, you will unlock the driver's door only; pressing the button a second time will unlock the passenger door, the luggage compartment lid, the fuel filler door, the glove compartment, and the storage shelf for the cellular phone.

If necessary, you can open the fuel filler door by pressing the button for it inside the vehicle; refer to page [23](#).

### Convenience opening mode

Press and hold button 1. The windows are then opened.



### To lock and secure

Press button 2.



You can have various signals set as an acknowledgment message when locking. ◀



### To deactivate the tilt sensor alarm system and interior motion sensor

Press button 2 again immediately after locking.

For additional information, refer to page [37](#).

### To switch on the interior lamps

After locking the vehicle, press button 2 again.

## Opening and closing – from outside



### To open the luggage compartment lid

Press button 3.

The luggage compartment lid will open slightly.

 Before and after a trip, be sure that the luggage compartment lid was not opened unintentionally. ◀

### Panic Mode

By pressing and holding button 3 for more than two seconds, you can trigger the alarm system if there is an impending danger. The alarm system must be armed in advance.

To switch off the alarm, press button 1.

### Local systems or devices

Local systems or devices in the area may interfere with remote control function. If this should occur, you can unlock and lock the vehicle via the door lock with a master key.

### For US owners only

The transmitter and receiver units comply with Part 15 of the FCC (Federal Communications Commission) regulations. Operation is governed by the following:

FCC ID: LX8EWS  
LX8FZVS  
LX8FZVE

Compliance statement:

This device complies with Part 15 of the FCC Rules. Operation is subject to the following two conditions:

- ▷ This device may not cause harmful interference, and
- ▷ this device must accept any interference received, including interference that may cause undesired operation.

 Any unauthorized modifications or changes to these devices could void the user's authority to operate this equipment. ◀

## 34 Opening and closing – from inside



Use this button to operate the central locking system when the doors are closed. The doors and luggage compartment lid are unlocked or locked only. The anti-theft alarm system is not activated.

 The central locking system can be unlocked automatically as soon as you begin to drive if you desire. You may also have this adjusted so that it is key-specific. ◀

- ▶  If only the driver's door was unlocked from the outside and you press the button,
  - ▷ the passenger door, the luggage compartment lid, the fuel filler door, the glove compartment and the storage area for the cellular phone will be unlocked, when the driver's door is open
  - ▷ the driver's door will be locked again if it is closed. ◀

### To unlock and open the doors

- ▷ Either unlock the doors together with the button for the central locking system and then pull each of the release handles above the armrests or
- ▷ pull the release handle for each door twice: the first pull unlocks the door, and the second one opens it.

### To engage the locks

- ▷ Lock both doors using the central locking system button.



Children might be able to lock the doors from the inside. For this reason, take the vehicle's keys with you so that the vehicle can be opened again from the outside at any time. ◀



## To unlock from inside

Press on the upper half of the button (luggage compartment lid symbol).

The luggage compartment lid opens slightly.

 This button will not open the luggage compartment lid if the glove compartment is locked. (Refer to page [76](#)). ◀

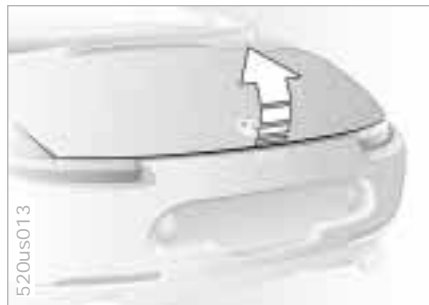

## To open from outside

Reach into the gap and open the luggage compartment lid all the way.

The luggage compartment is illuminated when the luggage compartment lid is opened.

## Manual operation

Should the electrical system malfunction, the luggage compartment lid can be opened from the inside. Refer to page [140](#).

## To close

The luggage compartment is locked again as soon as you close the lid.

 As with all closing procedures, be sure that the travel path for the luggage compartment lid is clear when being closed to avoid injury. Keep the luggage compartment lid closed while driving so that no exhaust fumes penetrate inside the vehicle. If, however, the luggage compartment lid has to stay open and the convertible top is closed while driving,

- ▷ close all the windows
- ▷ increase the air supply from the heating and ventilation system to a high level. Refer to page [70](#). ◀

### The concept

The vehicle alarm system responds:

- ▷ When a door, the hood or the luggage compartment lid is opened,
- ▷ To movement inside the vehicle (interior motion sensor)
- ▷ To variations in the vehicle tilt sensor such as those occurring during attempts to steal the wheels or tow the vehicle
- ▷ To interruption of battery voltage.

The system responds to unauthorized vehicle entry and attempted theft by simultaneously activating the following:

- ▷ Sounding an acoustical alarm for 30 seconds
- ▷ Activating the hazard warning flashers for approx. five minutes
- ▷ Flashing the high beams on and off in sync with the hazard warning flashers.

### To activate and deactivate the alarm system

When the vehicle is locked or unlocked via a door lock or with the remote control, the alarm system is also simultaneously armed or disarmed.

The interior motion sensor and tilt alarm sensor are activated approx. 30 seconds after you have finished locking the vehicle.

The system indicates that it has been correctly armed by switching on the hazard warning flashers for a single cycle and by emitting an acoustical signal.



You can have different signals set as acknowledgment messages for arming and disarming. ◀



### Indicator lamp displays

The indicator lamp is located in the inside rear view mirror's rotary knob.

- ▷ When the indicator lamp flashes continuously, the system is armed
- ▷ The indicator lamp flashes during arming: the door(s), the hood or luggage compartment lid are not completely closed. Even if you do not close the alerted area, the remaining areas are deadlocked, and the indicator lamp flashes continuously after 10 seconds. However, the interior motion sensor is not activated
- ▷ The indicator lamp goes out during disarming: no manipulation or attempted intrusions have been detected in the period since the system was armed

## Alarm system

- ▷ If the indicator lamp flashes for 10 seconds when the system is disarmed, an attempted entry has been detected in the period since the system was armed.

Following triggering of an alarm, the indicator lamp will flash continuously.

### Avoiding unintentional alarms

The tilt alarm sensor and interior motion sensor may be switched off at the same time to prevent a false alarm from being triggered (in garages with elevator ramps, for instance), or when the vehicle is transported by trailer or train:

Lock the vehicle twice (= arm the system) by pressing button 2 on the remote control twice in succession (refer to page 32), or lock the vehicle twice with the key (refer to page 30).

The indicator lamp lights up briefly and then flashes continuously. The tilt alarm sensor and the interior motion sensor are deactivated as long as the system is armed.

### Interior motion sensor

In order for the interior motion sensor to function properly, the windows and the luggage compartment lid must be closed.

Nevertheless, you should deactivate the interior motion sensor (refer to the previous column) if

- ▷ children or animals are left in the vehicle
- ▷ windows should remain open.



For US vehicles only:  
The interior motion sensor is not installed on US models as it has not received FCC (Federal Communications Commission) approval. ◀



### To open and close the windows

From ignition key position 1:

- ▷ Press the switch up to but not past the pressure point:  
As long as you continue to hold the switch down, the window will either lower or raise
- ▷ Press the switch briefly past the pressure point:  
The window moves automatically.  
Tapping it again stops the opening or closing action.

 The window on the passenger side cannot be closed with the one-touch mode function. ◀

Using switch number 2, you determine which window is to be opened or closed:

- ▷ Window on the driver side, push the switch all the way to the left
- ▷ Window on the passenger side, push the switch all the way to the right
- ▷ To move both windows at the same time, keep the switch in the center position.

The switch on the passenger-side door activates the window for that side alone.

After the ignition has been switched off:

You can still operate the electric windows for up to 15 minutes, provided that no door has been opened.



Because the power windows are sealed at high pressure to prevent wind noise when closed, a powerful motor is required for efficient closing. When closing the windows, always ensure that they are not obstructed in any way. Unsupervised use of these systems can result in serious personal injury. Remove the ignition key to deactivate the electric power windows whenever you leave the vehicle. Never leave the keys in the vehicle with unsupervised children. Never place anything that could obstruct the driver's vision on or next to the windows. ◀

To use the convenience mode via the door lock or the remote control, refer to pages [30](#) or [32](#).

# The automatic convertible top

## Weather protection

The fabric convertible top combines reliable protection from the elements with simple, convenient operation. Here are a few tips to ensure that you enjoy your roadster.

It is advisable to close the convertible top when the vehicle is parked. The closed convertible top not only protects the passenger compartment from unforeseeable damage from the weather, it also provides a certain degree of theft protection. Even if the convertible top is closed, store your valuables only in the locked luggage compartment.

To prevent damage, do not operate the convertible top at temperatures at the freezing point.



Operate the convertible top only when the vehicle is stationary, otherwise the procedure will be interrupted. Driving before the opening or closing procedure has been properly concluded can lead to either damage or injury.

Make sure that no objects or people get in the way while the convertible top is opening or closing, so that no damage or injuries occur.

The automatic operating procedure is interrupted immediately if the button for actuating the top is released. The procedure can be continued in the desired direction by pressing this button. ◀



## To open from inside

From ignition key position 1:

If at all possible, only operate the convertible top if the engine is running in order to save on the battery.

Press and hold the switch in the "Open" (1) direction until the opening procedure has ended with the convertible top being stored in the convertible top compartment and the indicator lamp on the instrument cluster has gone out (refer to page 16).

While the convertible top is in motion, the indicator lamp will stay on. If the opening procedure is not complete, the indicator lamp will flash after you release the button.



## 40 The automatic convertible top

 In order to avoid subsequent moisture damage, do not leave the convertible top open when it is wet (further reference to this made beginning on page 116, in the chapter "Caring for your vehicle"). ◀

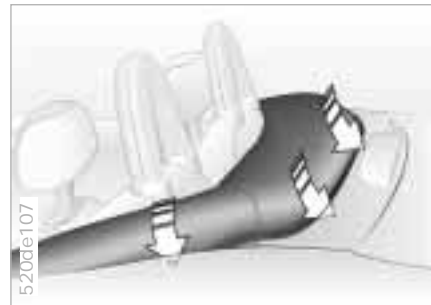

### To mount the cover

 In order to avoid damaging or getting dirt on the inside of the convertible top, always drive with the convertible cover installed. ◀

Take the folded up cover out of the luggage compartment and pull it out of its protective sleeve.

- 1 Unfold the cover and lay it out on top of the convertible top
- 2 First guide the front cover's left, then the right tab into the slot (arrow partial section)

 While guiding the tabs in, use one hand to press the inside part of the convertible top down inside, so that it does not get jammed in or damaged. ◀

- 3 Circling it around, push the cover under the rear edge of the convertible top well. Lightly pounding on the cover makes it easier to attach properly



- 4 Lock the cover by pressing down to the right and left
- 5 Pull on the knob to check that it is securely locked

 Each time you press down on the locking device, you will either lock or unlock the cover. ◀

 Be sure that the cover is secured properly on the vehicle. If it is not firmly secured, the flow of air while driving could loosen the cover at higher speeds. ◀



## To remove the cover

Follow the same steps as for assembly, however, in reverse sequence.

After removing, feed both of the outside ends for the cover under its respective retaining strap, fold it in the middle and then fold it toward the outside (leather on leather).

Put the folded up cover back into its protective sleeve and stow it in the luggage compartment.



## Closing

- 1 Press and hold the switch in the "Close" (2) direction until the automatic closing procedure stops of its own accord, right before the convertible top frame is lying on top of the window frame

## 42 The automatic convertible top



### Power loss or malfunction

Should the electrical system malfunction, an opened convertible top can be operated manually. Refer to page [141](#).

### Wind protection

Refer to page [93](#).

### Hardtop

Refer to page [94](#) and following.

- 2 Grab the recessed handle. Doing this will activate the button. Press and hold the button down
- 3 Pull the convertible top frame onto the window frame. The button you are pressing on releases the automatic locking device for the convertible top as it attaches to the window frame.

The closing procedure is finished after you hear the locking device audibly click into place; the indicator lamp on the instrument panel will then go out (refer to page [16](#)).

The indicator lamp stays on while the convertible top is in motion. The indicator lamp will flash if you let go of one of the buttons before the opening procedure has been completed.

## Seat adjustment

For maximum safety when adjusting the seating position, please observe the following:

**⚠** Never try to adjust your seat while driving the vehicle. The seat could respond with an unexpected movement, and the ensuing loss of vehicle control could lead to an accident. Be sure that the safety belt remains firmly against your body at all times. In the event of a frontal impact, a loose lap belt could slide over the hips, leading to abdominal injury. In addition, the safety belt's restraint effectiveness is reduced if the belt is worn loosely. Never ride with the backrest reclined to an extreme angle (especially important for the passenger to remember). If you do so, there is a risk that you will slide under the safety belt in an accident, thus reducing the protection provided by the safety belt. ◀

### Correct sitting posture

To reduce strain on the spinal column, sit all the way back in the seat and rest your back fully against the backrest. The ideal sitting posture is achieved with your head extending from your spine in a straight line. For long-distance driving, you may wish to increase the backrest tilt-angle slightly to reduce muscular tension. You should be able to grasp the steering wheel at its highest point with your arms slightly bent.

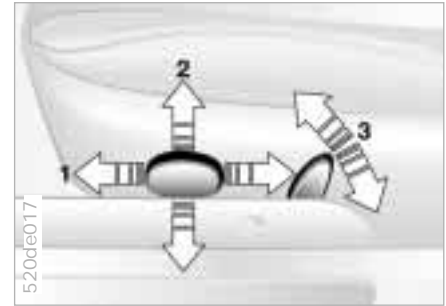

1 Backward/Forward adjustment

2 Cushion height

3 Backrest angle

Adjust the head restraint manually.

**⚠** Move the seat backward only if the backrest is first locked into place. Whenever the backrest has been flipped forward, moved back and subsequently folded back into place, it cannot lock, which can damage the back of the backrest and the rear trim panel.

Do not move a seat whose backrest has been tilted too far back, otherwise, the back of the backrest and the rear trim panel could be damaged. ◀

## 44 Head restraints



### Adjustments

Upward: by pulling.

Downward: unlock by first pressing the button located on the right under the leather (arrow 1).



Head restraints reduce the risk of spinal injury in the event of an accident.

Adjust the head restraint so that its center is approximately level with your ears. ◀

## Seat backrest



### To unlock

Pull on the outermost edge of the strap and tip the backrest forward.

The straps are located on the outer sides of the backrests. On the passenger seat straps are also located on the inner side of the backrest.



Lock both backrests while driving, otherwise there is a danger of an unexpected movement causing an accident.

Do not use the strap as a holder, e. g. for newspapers or other items. This could cause the backrests to unlock. ◀

## Belt guide



The strap for the belt guide can be opened: release the push button.

Should it be necessary, this can relieve the load or the access to the equipment in the rear well.

For further information regarding loading, refer to page 81.



Before each trip, insert the safety belt into the strap for the belt guide, otherwise, it will not hold securely and become ineffective due to a loosely worn safety belt. ◀



Press button: set the steering wheel vertical to the seating position.

 Do not adjust the steering wheel while the vehicle is moving. If you do so, there is a risk of accident from unexpected movement. ◀

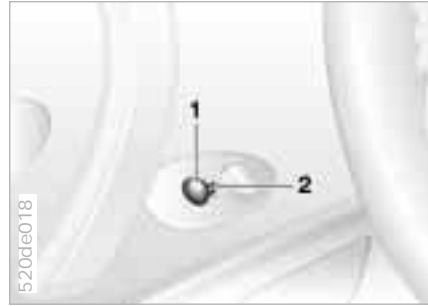

## Exterior mirrors

- 1 Switch for 4-way adjustment
- 2 Selection switch for changing between mirrors, switch either all the way to the left or the right

You can also adjust the mirrors manually by pressing against the outer edges of their lenses.

 When estimating the distance between yourself and other traffic, bear in mind that the objects reflected in the mirror are closer than they appear. This means that estimating of the distance to following traffic should not be regarded as precise. ◀

## Electric defrosting

Both mirrors are automatically defrosted with the ignition key in position 2.



### **Interior rearview mirror with automatic dimmer**

By responding to ambient light and the glare from traffic behind you, this mirror automatically dims through an infinitely variable range. Two photocells are responsible for this. One of the photocells is located in the mirror frame (arrow), while the other is slightly offset and located on the back side of the mirror.

The mirror switches to its clear, undimmed mode whenever you shift into reverse.

Keep the photocells clean for optimum performance and keep the area between the mirror and windshield clear, not even fastening any stickers or similar items.

For an explanation of the electro-chromic technology used in this mirror, refer to page [150](#).

## **Car Memory, Key Memory**

### **How the system functions**

You have probably frequently wished that you could configure your vehicle individual functions to reflect your own personal requirements. In engineering your vehicle, BMW has included several user-defined functions in the vehicle's design. Your BMW center can make these settings for you.

There are settings related to the vehicle ("Car Memory") and settings related to individuals ("Key Memory"). You can have up to four different basic settings adjusted for four different persons. The only requirement is that each person uses his or her own remote control key. When your vehicle is unlocked with the remote control, the vehicle recognizes the individual user by means of a data exchange with the key, and makes adjustments accordingly.

# Car Memory, Key Memory

## What the system can do

Your BMW center can provide you with details on the capabilities of the Car Memory and Key Memory systems. Below are a few examples:

Examples for Car Memory:

- ▷ Various signals you can use as acknowledgement for locking and unlocking your vehicle
- ▷ Deactivating/activating the "follow-me-home" lamps function

Example for Key Memory:

- ▷ Locking your vehicle after starting to drive



You will see this symbol throughout the Owner's Manual. It is to remind you at appropriate places of the settings that are available to you. ◀





Fasten your safety belt at the beginning of every trip.

To fasten:

Make sure you hear the lock engage in the belt buckle.

To release:

Press the red button in the buckle. Hold the belt and guide it back into its reel.

 For your safety, please comply with the following instructions for wearing safety belts. Otherwise, your personal safety will be diminished, and the safety belts' protective function impaired. The following information also applies to your passengers:

Never allow more than one person to wear a single safety belt. Infants or small children should never be held on the lap of a passenger.

Avoid twisting the belt while routing it firmly across the hips and shoulder. Do not allow the belt to rest against hard or fragile objects in your pockets. Never route the belt across your neck, do not run it across sharp edges, and ensure that the belt does not become caught or jammed.

Be sure that the safety belt fits snugly against your body at all times. You should avoid wearing bulky clothing that prevents it from doing so. Pull the belt periodically to re-tension it across your shoulder. In the event of a frontal impact, a loose lap belt could slide over your hips, leading to abdominal injury. In addition, the safety belt's restraint effectiveness is reduced if the belt is worn loosely.

Expectant mothers should always wear their safety belts, taking care to position the lap belt against the lower hips, where it will not exert pressure against the abdominal area. ◀

For care instructions, refer to "Caring for your vehicle," page [119](#).

 If the safety belt system has been subjected to the stresses involved in an accident or damaged in any other way, replace the entire safety belt mechanism through your BMW center, including the safety belt tensioner. If a child restraint system was in the vehicle during an accident, consult the manufacturer's instructions regarding replacement. ◀

### **Child restraint systems\***

 Because of the front passenger airbag, do not use any rear-facing child restraint system in the front passenger seat of your vehicle. If you do so, the child could be injured in an accident when the airbag is triggered. Do not modify the child restraint system in any way. If you do so, it will not provide your child with maximum protection. ◀

# Airbags

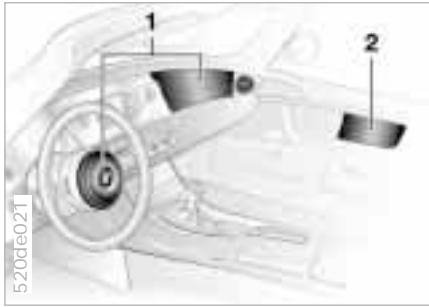

- 1 Front airbag for driver and passenger
- 2 Side airbags

## Protective effect

In addition to the three-point safety belts, the front airbags provide additional protection, in case safety belts are not enough in a severe frontal impact. The side airbags help provide protection in the event of a collision from the side. Each of the side airbags is designed to help support the seat occupant's upper body.



The illustration depicts schematically the primary directions of vehicle impact that initiate airbag deployment.

## Indicator lamp



The indicator lamp displays the operational status of the airbag system from ignition key position 1 and on.

System operational:

- ▷ The indicator lamp comes on briefly then goes out.

System malfunction:

- ▷ The indicator lamp fails to come on
- ▷ The indicator lamp comes on briefly before going out and then lighting up again.

If the system malfunctions, there is the danger that the airbags will not be triggered within their response range during an accident, even if the level of impact would normally have triggered them.

Have your BMW center inspect the system immediately.

**Sitting correctly with airbags**

 Comply with the following instructions for the airbags, otherwise, the airbags may not be able to provide their maximum protection, with resulting risks to personal safety. All passengers in the vehicle should be aware of and comply with this information:

The airbags are supplemental restraint devices designed to provide extra protection; they are not a substitute for safety belts. Wear your safety belt at all times. The airbags will not be triggered in the event of a minor accident, a vehicle roll-over, or collisions from the rear. In these instances, the safety belt provides optimal protection.

Airbags are located under cover panels in the steering wheel, in the instrument panel and in the door side trim panels. Assume a seating position that is comfortable and provides the greatest-possible distance between you and the airbags in your seating area. Always hold the steering wheel by the rim – hands in the "9 o'clock" and "3 o'clock" positions – otherwise, your hands or arms could be injured if the airbag is triggered.

Do not allow any objects to obstruct the area between the airbag and the driver/passenger.

Do not use the cover panel above the front passenger airbag as a storage area.

Do not apply adhesive materials to the cover panels of the airbags, or cover or modify them in any other way.

Do not use a rear-facing child seat in the front passenger seat. If you use a child restraint system, read carefully and comply with the instructions on page 51.

Be sure that child seats are installed correctly and with the greatest possible distance between them and the side airbag. Do not allow children to lean out of the child's seat in the direction of the side trim panels. If they do so, serious injuries can occur if the airbag is triggered. ◀

Even when all these guidelines are observed, there is still a small residual risk of injury to the face, hands and arms occurring from airbag deployment in isolated instances.

The ignition and inflation noise may cause a mild temporary hearing loss in extremely sensitive individuals.

For additional information concerning the airbag system, refer to pages 121 and 148.



The illustration shows the correct seating position for a child in a child restraint system\* with sufficient distance between him and the side airbag (arrow).

## Airbags



The illustration shows the correct seating position for an older child wearing a safety belt with sufficient distance between him and the side airbag (arrow).

## Child restraints\*

 Before installing any child restraint device or child seat, please read the following:

Never install a rear-facing child restraint system in the passenger seat of this vehicle.

If the airbag deploys and hits the backrest of the rear-facing child seat, it is likely that the child sitting in the rear-facing child seat will be seriously injured or killed.

Certain precautions should be taken if it is necessary for a child (not an infant) to ride in the vehicle. First, move the passenger seat as far away from the instrument panel as possible. This important precaution is intended to maximize the distance between the airbag and the child. Older children should be tightly secured with the safety belt. Younger children should be secured in an appropriate forward-facing child-restraint system that has first been secured with a safety belt.

In the interest of the child's safety, please read carefully and comply with the instructions for installation and use provided by the child restraint's manufacturer whenever you use such a device.

Do not allow children to lean out of a child restraint system toward the door or instrument panel, as otherwise serious injuries may result if the airbag deploys. Always ensure that all occupants (of all ages) remain properly and securely restrained at all times.

Read carefully and comply with the safety precautions regarding safety belts on page 48, otherwise, the protective function of the safety belts will be compromised. ◀

## 52 Child seat safety



The safety belt on the passenger side can be locked for mounting and securing child restraint systems.

A label with operating instructions is attached to the belt next to the sliding latch plate.

### **To lock the belt**

Extract the entire length of the belt from the inertia reel mechanism. Allow the reel to retract the belt somewhat and engage the buckle, then tighten the belt against the child restraint system. The retraction mechanism is now locked. The belt cannot be retracted further. Comply with the installation instructions provided by the manufacturer of the child restraint system.

### **To release the belt**

Release the buckle, remove the child restraint system and allow the inertia reel to retract the belt completely.

# Steering/Ignition lock



Your car has a steering-column lock driven by an electric motor.

## Releasing the steering and electricity supply

- ▷ Insert the key in position 0. The steering is audibly released. Encountering any resistance when turning the key to the right means: the steering column is still not unlocked. Turning the steering column to the right and left can make it easier to turn the key. The vehicle immobilizer is deactivated
- ▷ In position 1, the radio and certain electrical consumers are operational
- ▷ In position 2, the ignition, the starter and all electrical consumers are operational.

## Removing the key

The key is removed in position 0. Turn the steering wheel to engage the steering lock and activate the electronic vehicle immobilizer.

▶ With a discharged or disconnected battery, the steering column will not be locked or unlocked. Leaving the key in the ignition uses up a minimal amount of power. In order to avoid discharging the battery, remove the key if the vehicle is to be parked for an extended period of time. ◀

⚠ If the steering is locked and the battery discharged or disconnected, do not tow the vehicle, as it will not be possible to turn the steering wheel. ◀



### Before starting

- ▷ Engage the parking brake
- ▷ Manual-shift gear lever in idling position
- ▷ Depress the clutch pedal
- ▷ Key in position 2.

 Do not allow the engine to run in enclosed areas. The exhaust gases contain carbon monoxide, an odorless and colorless, but highly toxic gas. Breathing the exhaust gases poses an extreme health risk, and can lead to unconsciousness and death. Do not leave the vehicle unattended with the engine running. An unattended vehicle with a running engine represents a potential safety hazard. ◀

▷ Start the engine (by pressing the start button) but do not step on the accelerator pedal.

 Do not press on the starter button for too short a time, but do not hold it down for longer than 20 seconds, either. Do not allow the engine to warm up by leaving it running while the vehicle remains stationary. Instead, drive off immediately at a moderate engine speed. ◀

Cold starts at very low temperatures, from approx. +5 °F (-15 °C) and at altitudes above 3,300 ft (1,000 meters):

- ▷ On the first start attempt, engage the starter for a longer period (approx. 10 seconds)

Engine idle speed is controlled by the engine computer system. Increased speeds at startup are normal and should decrease as the engine warms up. If engine speed does not decrease, service is required.

To prevent the battery from discharging, always deactivate electrical devices that are not in use. Switch the ignition off when the vehicle is not being driven.

## Turning the engine off

Turn the ignition key to position 1 or 0.

 Never remove the ignition key while the vehicle is rolling. If you did so, the ignition lock would engage when the steering wheel is turned. When you leave the vehicle, always remove the ignition key and engage the steering lock.

Always engage the parking brake when parking on slopes and inclined surfaces, since placing the lever in first gear or reverse may not provide adequate resistance to rolling. ◀

## Parking brake



### To engage

The lock engages automatically when you lift the lever, and the indicator lamp in the instrument panel comes on when the ignition key is in position 2. Refer to page 19.

### To release

Pull up slightly on the lever, press the button and lower the lever.

The parking brake is designed primarily to prevent the vehicle from rolling when it is parked. It operates against the rear wheels.



If, in rare circumstances, it should be necessary to engage the parking brake while the vehicle is in motion, do not pull hard on the lever. Keep your thumb pressed against the release button while carefully pulling the lever up to apply moderate pressure.

Excessive pressure can lead to over-braking and loss of traction (fishtailing) at the rear axle.

The brake lamps do not come on when the parking brake is engaged.

Always engage the parking brake when parking on slopes and inclined surfaces, since placing the lever in first gear or reverse may not provide adequate resistance to rolling. ◀

To avoid corrosion and one-sided braking effect, apply the parking brake lightly from time to time when coasting to a standstill (at a traffic signal, for instance), provided that it is safe to do so.





Every time you shift gears, always depress the clutch pedal all the way down, pushing the manual-shift gear lever into the desired position.

Depress the clutch even when starting the engine, otherwise, a lock will prevent the engine from being started.

The shift lever's neutral plane is located between third and fourth gear.

When shifting from each gear into "Neutral," the shift lever returns automatically to this gear plane because of its spring loading.

 When shifting gears in the fifth/sixth gear, be sure to press the gear lever to the right in order to prevent inadvertent selection of a gear in the third/fourth. ◀

### Reverse

Select "Reverse" only when the vehicle is stationary. Press the shift lever to the left to overcome the resistance.

As you do this, the backup lamp will turn on automatically when the ignition key is in position 2.

 Do not hold the vehicle in place on slopes by slipping or "riding" the clutch. Use the parking brake instead. A slipping clutch increases clutch wear. ◀

## Turn signal/Headlamp flasher

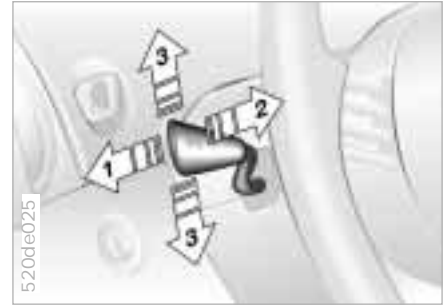

- 1 High beam (blue indicator lamp)
- 2 Headlamp flasher (blue indicator lamp)
- 3 Turn signal indicator (green indicator accompanied by periodic clicking sound from the relay).

If the indicator lamp and the clicking from the relay are faster than normal, one of the turn indicators has failed.

### To signal briefly

Press the lever up to but not beyond the pressure point. It then returns to the center position when released.

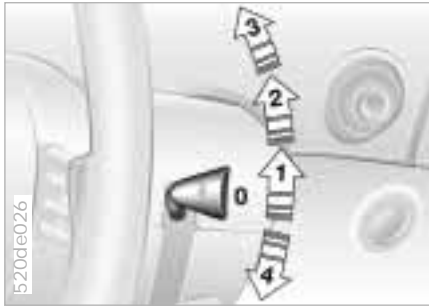

- 0 Wipers retracted
- 1 Intermittent wipe
- 2 Normal wipe
- 3 Fast wipe
- 4 Brief wipe

## 0 Wipers retracted (home position)

The wipers are partially hidden behind the hood. To bring the wipers up into their vertical position (important when changing the blades, or folding up when frost is expected):

With the lever in position 1, switch off the ignition as soon as the wipers come to a stop.

For changing the wiper blades, refer to page [128](#).



Fold the wipers back down onto the windshield before you turn the ignition key to position 1 or 2 again. If you do not, they could be damaged. ◀

## 1 Intermittent wipe

Wiper delay varies automatically, depending on actual road speed.

## 2 Normal wiper speed

The wipers automatically revert to intermittent operation when the vehicle is stationary.

## 3 Fast wiper speed

When the vehicle is stationary, the wipers operate at normal speed.

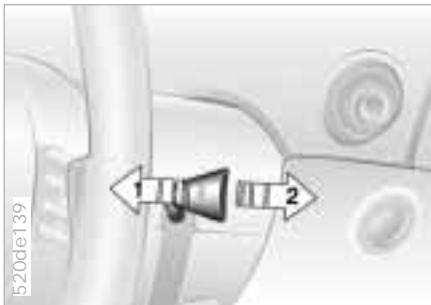

- 1 Automatic windshield washer
- 2 Automatic windshield washer/Headlamp washers

### 1 Automatic windshield washer

The system sprays washer fluid against the windshield and activates the wipers for a brief period.

If you only pull the lever briefly, the system sprays washer fluid onto the windshield without activating the wipers.

### 2 Automatic windshield washer/Headlamp washers

Automatic windshield washer and headlamp washers are activated. Every time they are actuated, both the windshield and the headlamps are cleaned.

 Do not use the washers if there is any danger that the fluid will freeze on the windshield. If you do so, your vision could be obscured. Use an antifreeze agent. Refer to page 108.

Do not use the washers when the reservoir is empty. If you do so, the washer pump could be damaged. ◀

### Windshield washer jets

The windshield washer jets are warmed automatically when the ignition key is in position 2.



### To activate

Once the hardtop is in place, press the button: as long as the indicator lamp remains on, the rear window defroster continues at high output (rapid thaw).

After the indicator lamp goes out, the defroster continues operating at reduced power for a limited period before deactivating automatically.

### To deactivate

If the indicator lamp is still on, press the button.

 The indicator lamp is always active. The rear window defroster will not work if the hardtop is not in place. ◀

## Cruise control

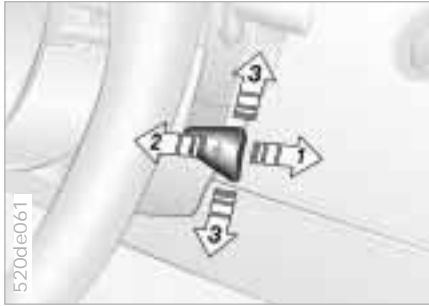

Above approx. 20 mph (30 km/h), the vehicle maintains the speed that you enter.

### To maintain speed or to accelerate

Press the lever briefly in direction 1: The system maintains the current vehicle speed. Every time you briefly press the lever, the speed increases by approx. 0.6 mph (1 km/h).

Press and hold the lever in position 1: The vehicle accelerates without pressure on the accelerator pedal. When you release the lever, the system maintains the current speed.

 If, on a downhill gradient, the engine's braking effect is not sufficient, the controlled speed can be exceeded. Speed can drop on uphill grades if the engine output is insufficient. ◀

### To decelerate

Press the lever briefly in direction 2: If you are already driving with active cruise control, the speed is decreased by approx. 0.6 mph (1 km/h) every time you briefly touch the lever.

Press and hold the lever in position 2: With the cruise control active, the system automatically reduces the throttle opening to slow the vehicle. When you release the lever, the system registers and maintains the current speed.

### To cancel the cruise control

Press the lever briefly in direction 3: The cruise control is immediately canceled.

In addition, cruise control is canceled automatically:

- ▷ When you apply pressure to the brake pedal
- ▷ When depressing the clutch pedal
- ▷ If you exceed or fall below the programmed speed for an extended period (by depressing the accelerator, for example).

### Deactivating the system

The system is deactivated when you turn the ignition key to position 0.

 Do not use cruise control on twist-ing roads, when high traffic density prevents driving at a constant speed, when the road surface is slick (snow, rain, ice), or when the road surface is loose (rocks, sand). ◀



### 1 Odometer

With the ignition key in position 0, you can activate the displays shown in the illustration by pressing the button in the instrument cluster (arrow).

### 2 Trip odometer

To reset the trip odometer to zero, press the button (arrow) with the ignition key in position 1.



Avoid engine speeds in the gauge's red warning zone.

If the needle gets into this range, fuel supply is interrupted to protect the engine, resulting in a noticeable loss of power.



When you switch on the ignition, the indicator lamp lights up briefly to confirm that the system is operational.

Once the indicator lamp comes on and stays on, there are approx. 2.6 gallons (10 liters) of fuel left in the fuel tank.

For fuel tank capacity, refer to page [157](#).

Certain operating conditions (such as those encountered in mountainous areas) may cause the needle to fluctuate slightly.



Please refuel early, since driving to the last drop of fuel can result in damage to the engine or catalytic converter. ◀

## Coolant temperature gauge



### Between the blue and red zones

Normal operating range. It is not unusual for the needle to rise as far as the edge of the red zone in response to high outside temperatures or severe operating conditions.

For checking coolant level, refer to page [111](#).

### Blue

The engine is still cold. Drive at moderate engine and vehicle speeds.

### Red

When you switch on the ignition, the warning lamp comes on briefly to confirm that the system is operational.

If the lamp comes on while operating the vehicle, the engine has overheated. Turn it off immediately and let it cool down.

## Service Interval Display 61



### Remaining distance before service

The displays shown in the illustration appear for a few seconds when the ignition key is in position 1 or after the engine is started.

The remaining distance in miles before the next scheduled service will appear together with the display OILSERVICE or INSPECTION.

The computer bases its calculations for the remaining distance on the preceding driving conditions.

A flashing display and a "-" in front of the number indicate that service is past due by the number of miles displayed. Please contact your BMW center for an appointment.



### **Set the clock**

From ignition key position 0 on:

To set ahead: turn the button to the right.

To set back: turn the button to the left.

If you keep holding the knob turned, you will find the setting faster.

## **Multi-Information Radio (MIR)**

With the Multi-Information Radio, you can operate the navigation system and few other cellular phone functions, in addition to your car radio.

Please refer to the supplementary Owner's Manual provided with your sound system for detailed information on adjusting and operating the Multi-Information Radio.

### **Outside temperature**

You can have the outside temperature shown on the Multi-Information Radio display. Refer to the supplementary Owner's Manual.

# Dynamic Stability Control (DSC)

## The concept

DSC maintains vehicle stability even in critical driving situations. The system optimizes vehicle stability during acceleration and when starting from a full stop, as well as optimizing traction. In addition, the system recognizes unstable vehicle conditions (understeering or oversteering, for example) and holds the vehicle on a sure course by intervening via the engine and by braking intervention at the individual wheels, within physically feasible limits.

The system starts up automatically each time you start the engine.

## Indicator lamp



The indicator lamp in the instrument cluster goes out shortly after you switch on the ignition.

Refer to page [20](#).

Indicator lamp flashes:

The system is active and governs drive force and braking force.

If the indicator lamp does not go out after the engine is started, or if it comes on during normal driving and stays on: There is a system malfunction or the system was deactivated with the button. You can continue to drive the vehicle normally, but without DSC. Please consult your BMW center for repairs.



## To deactivate the system

Press the button, and the indicator lamp comes on and stays on.

When the DSC is deactivated, you are operating the vehicle in the conventional drive mode.

In the following rare circumstances, it may be a good idea to deactivate the DSC for a short period of time:

- ▷ When rocking the vehicle or starting off in deep snow or on loose surfaces.

▷ To maintain vehicle stability, always drive with the system switched on when possible. ◀



### To reactivate the system

Press the button again; the indicator lamp goes out.

 The laws of physics cannot be repealed, even with DSC. An appropriate driving style remains the responsibility of the driver. For this reason, do not use the additional safety margin provided by the system as an excuse to take risks.

Do not make any modifications to the DSC system. Service procedures on the system are to be performed by authorized technicians only. ◀

For additional details concerning DSC, please refer to the chapter "Advanced technology" on page [149](#).



Whenever required, the system can be switched from sporty-comfortable orientation – based on what the driver is demanding in terms of vehicle performance via the accelerator pedal – to a purely sports-oriented response. This means that the switch-over is spontaneous and in response to the demands made on the system through the accelerator pedal (detecting the sport mode).

Every time the engine is started, the sporty-comfortable orientation is activated.

### Detecting the Sport Mode

#### Activating

In ignition position 2, press the button. The indicator lamp will come on.

#### Deactivating

Whenever the indicator lamp is on, it will go out if you press the button again.

# Tire Pressure Warning (RDW)

## The concept

The RDW monitors the tire pressure in all four wheels while driving. The system provides an alert whenever the inflation pressure drops significantly in one of the tires.

For RDW to "learn" the correct tire inflation pressure, check the inflation pressure in all tires, comparing them with the values in the inflation pressure table (refer to page 25), and make corrections as necessary. Then activate the system.



This indicator lamp in the instrument cluster will flash to inform you if the inflation pressure in one of the tires has dropped significantly.



## To activate the system

- 1 Turn the ignition key to position 2
- 2 Press the switch long enough for the indicator lamp in the instrument cluster to light up red for a few seconds
- 3 The RDW undergoes an automatic "learning" process while you are driving, and stores this data to aim for optimal conditions. This one-time "learning" process lasts at least 10 minutes, after which the RDW is able to detect and report any tire failure.

Repeat this process after any changes in tire inflation pressure, tire rotation or replacement.

Once the pressures have been adjusted to the reference values used in the "learning" process, do not activate the system a further time.

## Tire failure

The red indicator lamp will flash in the event of a tire failure.

A supplementary gong is also heard.

Carefully reduce speed to less than 50 mph (80 km/h), avoiding any hard braking or steering maneuvers while doing so.

For additional details, refer to page 135.



The RDW cannot alert you to severe and sudden tire damage caused by external factors. Nor can it detect the gradual loss of pressure at all four tires that normally occurs over a period of time. ◀

## 66 Tire Pressure Warning (RDW)



Check tire pressure on a regular basis and correct it if you need to.

Refer to page [24](#).

Do not carry out any system activation while driving with snow chains or while driving on curves. Malfunction warnings and undetected losses are possible while driving under these types of conditions.

In certain circumstances, there could be a delayed detection of any loss in inflation pressure while driving on snow-covered or slippery road surfaces.

A sporty driving style can also cause delayed RDW alerts (e.g. slippage in the drive wheels, high lateral acceleration). ◀

### **System interference**

The red indicator lamp in the instrument cluster will stay on for as long as there is a malfunction.

The indicator lamp will come on if the system malfunctions.

Please contact your BMW center for additional information.

## Side lamps/Low beams



### Side lamps (Side marker lamps)



With the switch in this position, the front, rear and side vehicle lighting is switched on. For lighting on one side for parking, refer to page 68.

### Low beams



When you switch off the ignition and the low beams are still on, only the side lamps (side marker lamps) remain on.



**"Follow-Me-Home" lamps:**  
If you actuate the headlamp flasher after you have parked the vehicle and shut off the engine, the low beams will remain on for a brief period. You may also have this function deactivated if you wish. ◀

### "LAMPS ON" warning

If you turn the ignition key in position 0, an acoustic signal will sound for a few seconds after the driver's door has been opened if the low beam headlamps have not been switched off.

### Daytime running lamps switch\*

The headlamps are automatically switched on for daylight driving when ignition key is in position 2.

## Instrument lighting



Turn the knob to adjust the lighting intensity.

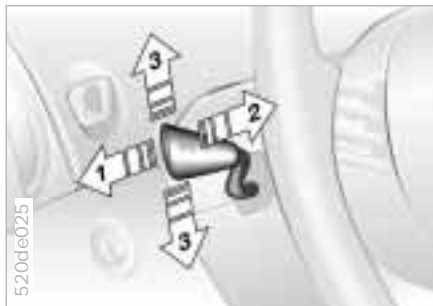

- 1 High beam (blue indicator lamp)
- 2 Headlamp flasher (blue indicator lamp)
- 3 Parking lamps

### Parking lamp, left or right

With the ignition key in position 0, engage the lever in the appropriate turn signal position.



 The yellow indicator lamp in the instrument cluster lights up whenever the rear foglamps are switched on. Obey the legal stipulations regarding foglamp use.



The interior lamps operate automatically.

### Switching the interior lamps on and off manually

Turn the knob.

If you want the interior lamps to remain turned off, keep the knob turned for approx. 3 seconds.

Turn the knob again to turn it back on.

### Footwell lamps

The footwell lamps operate in the same way as the interior lamps.

## Reading lamps

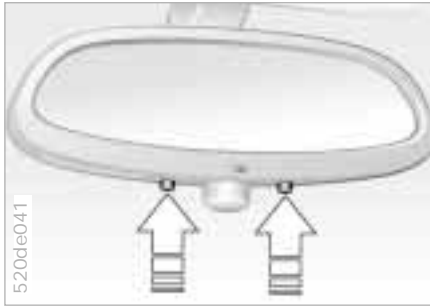



The reading lamps can be switched on and off using the push button located next to each lamp.

 In order to prevent battery discharge, all of the lamps in the vehicle are switched off automatically approx. 15 minutes after the ignition key has been turned to position 0. ◀

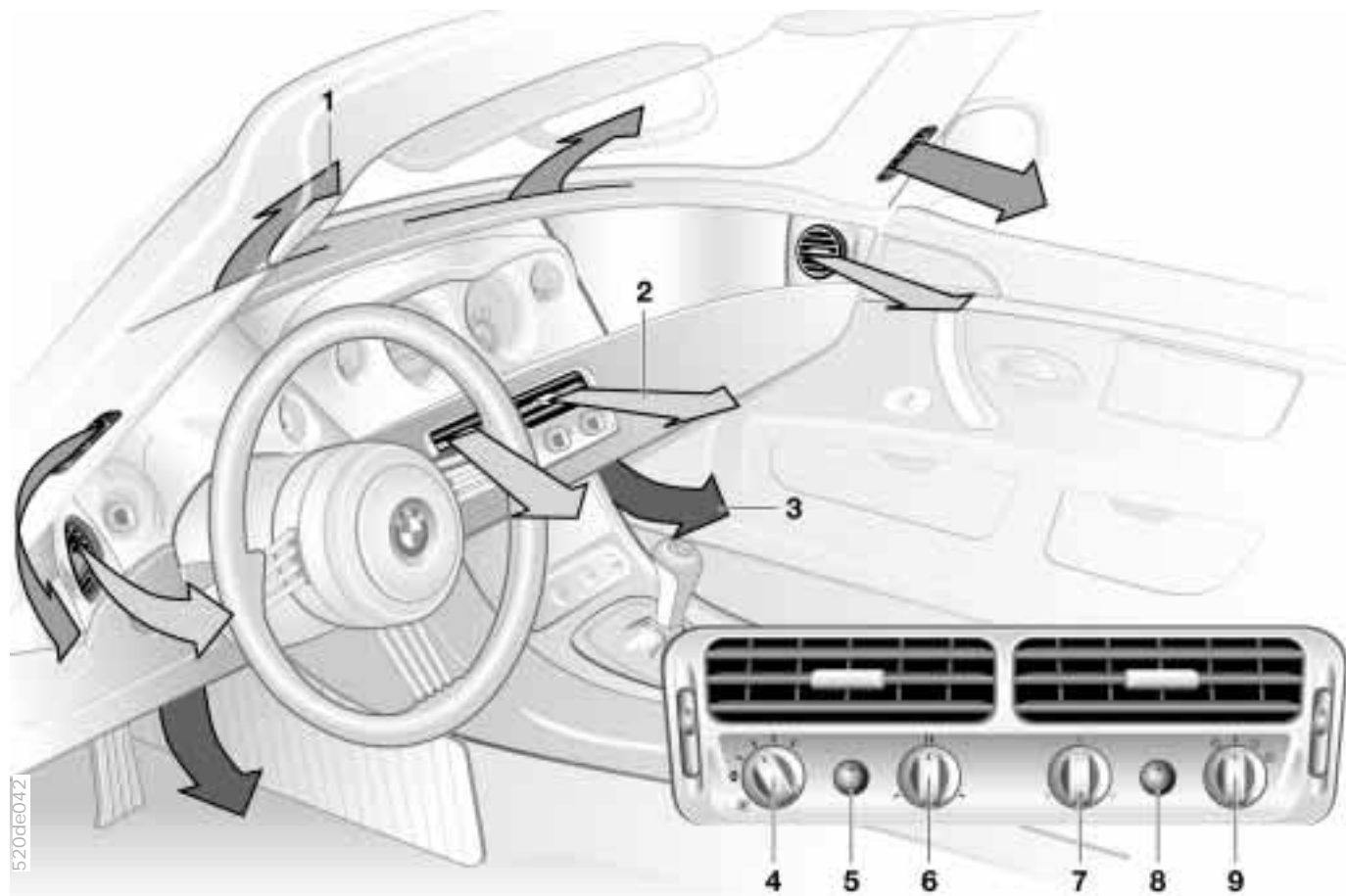
## 70 Heating and ventilation/Air conditioning



- 1 Air onto the windshield and the side windows
- 2 Air flow for the upper body  
The rotary dials make it possible for you to open and close the air supply through an infinitely-variable range, while the levers change the air-flow direction. Refer to page [73](#)
- 3 Front footwell ventilation
- 4 Air supply  
Both the heating and ventilation are available from position 1 on. Refer to page [72](#)
- 5 To defrost windows and remove condensation [73](#)
- 6 Temperature [72](#)
- 7 Air distribution toward
  - ▷ the windows 
  - ▷ the upper body 
  - ▷ the footwell All intermediate settings are possible, too. Refer to page [72](#)
- 8 Rear window defroster with the hardtop in place [73](#)
- 9 Operating
  - ▷ Recirculated air [72](#)
  - ▷ Incoming air [72](#)
  - ▷ Air conditioner/Incoming air [72](#)
  - ▷ Air conditioner/Recirculated air [72](#)



### Air supply



You can select blower speeds from 1 to 4. The higher the setting, the greater the amount of heat and air supply. In position 0, the blower, heating and air conditioner are switched off.



### Temperature



In order to increase the interior temperature, turn to the right. For rapid heating, turn completely to the right. Then select an interior temperature that is comfortable for you.

### Air distribution



You can direct the airflow onto the windows , toward the upper body  and into the footwell . You can also make all intermediate settings. The "6 o'clock" setting is recommended for normal conditions (refer also to the illustration and overview on page 70).

### Recirculated air mode



If there are unpleasant odors in the outside air, you can temporarily block the air supply. The system then recirculates the air currently within the vehicle.



If the windows fog over when using recirculated air, turn off the recirculated air mode and increase the airflow if necessary, or press the button for "defrosting and defogging the windows." 

### Venting in outside air



Recommended when driving with the convertible top open. The degree to which the passenger compartment is heated depends on temperature selection and air distribution.

### Air conditioner/Venting in outside air



The air is cooled and dehumidified and – depending on the temperature setting – warmed again when the air conditioner system is switched on. Depending on the weather, the windshield may fog over briefly when the engine is started.

Do not turn on the air conditioner if outside air temperature is below approx. 41 °F (5 °C). This will help to prevent the windows from fogging. If the windows fog over after switching the air conditioner off, switch it back on.

### Air conditioner/Recirculated air mode



Both systems are operating. Another advantage is that a hot vehicle cools down more quickly with the convertible top closed. This way, you will get the lowest possible vented air temperature (turn the temperature rotary dial all the way to the left).

 If the windows fog over when using recirculated air, turn off the recirculated air mode, and increase air flow if necessary, or press the button for "defrosting and defogging the windows." ◀

## To defrost windows and remove condensation

 This operation quickly removes ice and condensation from the windshield and the side windows.

## Rear window defroster

 Whenever the hardtop is on, the indicator lamp lights up when the rear window defroster is turned on. The rear window defroster switches off automatically. Refer to page 58.

 The indicator lamp is always active. The rear window defroster will not work if the hardtop is not in place. ◀

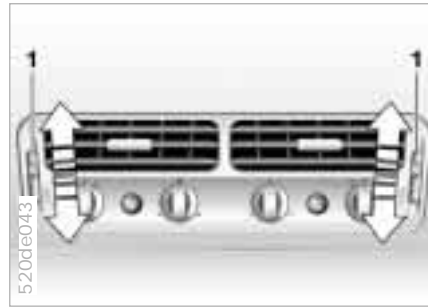

## Draft-free ventilation

You can adjust the air outlets for the upper body area for your personal comfort: Use rotary dials to open and close the air outlets through an infinitely-variable range.

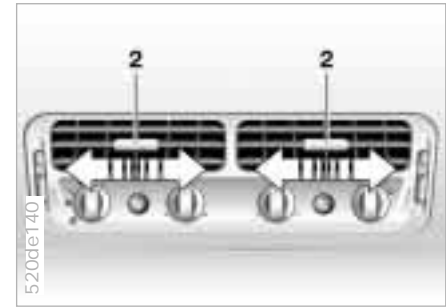

You can adjust the direction of the airflow using the levers 2.

Set the air outlets so that the air flows past you and is not directed straight at you.

## Microfilter

The microfilter removes dust and pollen from the incoming air. Your BMW center will change this filter during routine maintenance. A substantial reduction in air flow indicates that the filter needs to be replaced early.

## 74 Heating and ventilation/Air conditioning

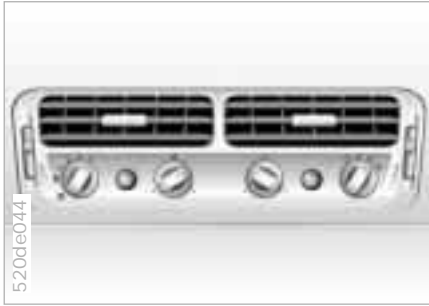

### Rapid ventilation

- 1 Set the rotary blower switch to position 4 for air intake
- 2 Turn the rotary temperature control completely to the left
- 3 Rotary control for air distribution in position ➡
- 4 Select outside air
- 5 Open the air outlets for the upper body area.



### Cooling

- 1 Set the rotary blower switch to position 2 for air intake
- 2 Use the rotary temperature control to select an interior temperature comfortable for you
- 3 Rotary control for air distribution in position ➡
- 4 Select air conditioning/outside air
- 5 Open the air outlets for the upper body area.

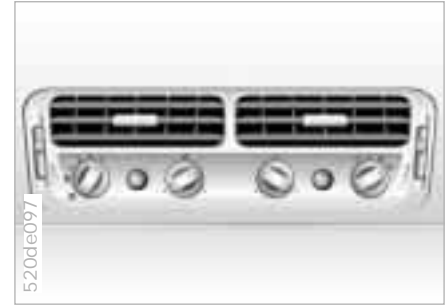

### Rapid cooling

- 1 Set the rotary blower switch to position 4 for air intake
- 2 Turn the rotary temperature control completely to the left
- 3 Rotary control for air distribution in position ➡
- 4 Select air conditioning/recirculating air
- 5 Open the outlets for the upper body area.

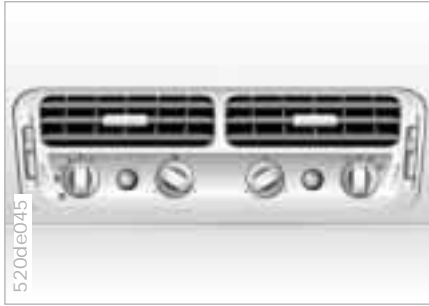

## Rapid heating

- 1 Set the rotary blower switch to position 3 for air intake
- 2 Turn the rotary temperature control completely to the right
- 3 Rotary control for air distribution in position ↓
- 4 Select incoming air mode.



## Heating

When the windows are free of ice and condensation, we recommend the following settings:

- 1 Set the blower speed control for the air flow rate to position 2
- 2 Use the rotary temperature control to select an interior temperature which is comfortable for you
- 3 Rotary control for air distribution in position ↓.



The seat cushion and backrest can be heated when the ignition key is in position 2.

By repeatedly pressing the button, you can select one of three different operation modes:

- ▷ Two indicator lamps on: heating at high temperature
- ▷ One on: heating at low temperature
- ▷ Indicator lamps off: seat heating deactivated.

## 76 Glove compartment



### To open

Pull the handle. The lamp comes on.  
A beverage can holder is stored in the glove compartment.  
For further information, refer to page 78.

### To close

Flip the door up.

 To prevent injury in the event of a crash, close the glove compartment immediately after every use. ◀

### To lock

Use one of the master keys. The glove compartment, the storage shelf for the cellular phone and the luggage compartment lid are now locked.  
A master key is also required for unlocking.

 If you turn over only your door and ignition key for valet parking (refer to page 28), for example, access to the glove compartment, the storage shelf for the cellular phone or the luggage compartment is not possible when the vehicle has been locked. ◀

### Manual operation

(in the event of electrical malfunction)

With the key in the last key positions, you can unlock or lock the glove compartment.

Refer to page 140 for operating the storage shelf for the cellular phone and the luggage compartment lid.

## Storage compartments

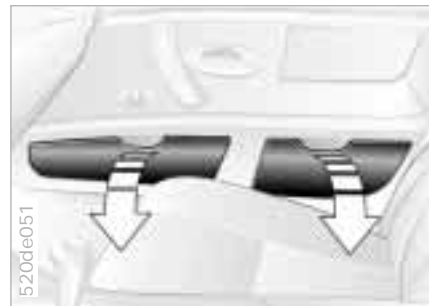

### In the doors

To open:  
Pull into the cut-outs.  
To close:  
Push the cover back.



## In the center console

To open:

Flip the cover up (arrow 1) – access to the ashtray and cigarette lighter.

When the glove compartment has been unlocked, press the button (arrow 2) – storage shelf for the cellular phone.

To close:

Flip the cover back into place.

## Manual operation

(in the event of electrical malfunction)

Refer to page 140 for operating the storage shelf for the cellular phone.



## Behind the seats

By way of example, the illustration shows the storage compartment behind the driver's seat.

To open:

Unlock by turning the master key all the way to the left.

The cover will open slightly and can then be flipped all the way up.

To close:

Press down until you hear it snap into place. The cover has been locked again.

 If you turn over only your door and ignition key for valet parking (refer to page 28), access is impossible. ◀



## Rechargeable flashlight

Located in the storage compartment behind the driver's seat.

Because of overload-protection, the flashlight can remain in its holder.

 Be sure that the flashlight is switched off when it is inserted into its holder. Failure to do so could lead to overcharging and damage. ◀



### Navigation computer

Located in the storage compartment behind the passenger's seat.

For further information regarding the navigation system, refer to the separate Owner's Manual.



### CD changer

Located in the storage compartment behind the driver's seat.

For further information regarding the CD changer, refer to the separate Owner's Manual.



- 1 Push the front passenger seat all the way back
- 2 Take the beverage can holder out of the glove compartment and
- 3 Hang it on the bracket located on the center console on the front passenger side. Refer to the illustration.

By using the removable plastic insert, you can place beverage cans or cups of various sizes in the holder.

 Do not place any open drinks in the holder while driving, otherwise the liquid could slop over the side and either dirty the fabric or cause burns. ◀

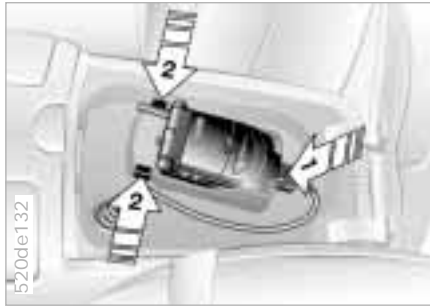

Located in the storage compartment in the center console.

### To remove

- 1 Push the button and pull the connector out
- 2 Push the button in and remove the cellular phone.

Reverse the sequence to reattach the cellular phone.

For further information on the cellular phone, refer to the separate Owner's Manual.



### Hands free system

Located over the interior rearview mirror.

For further information on the cellular phone, refer to the separate Owner's Manual.



### To open

Flip the cover up.

To extinguish your cigarette, first tap off the ash and gently press the tip into the funnel (arrow 1).

### To empty

Push the button (arrow 2), you can now pull the ashtray upward for removal.



## 80 Cigarette lighter

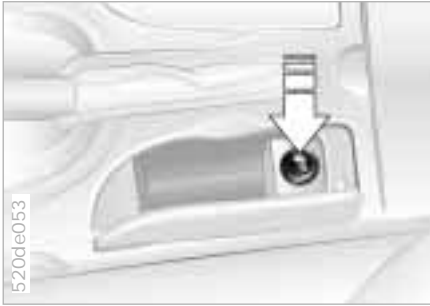

### Cigarette lighter socket

This socket is suitable for attaching power supplies for flashlights, car vacuum cleaners, or other appliances up to a rating of approx. 200 watts at 12 volts. Avoid damaging the socket by inserting plugs of improper shapes or sizes.

Press the lighter in. Remove as soon as the lighter jumps back out.



Hold or touch the hot cigarette lighter by the knob only. Holding or touching it in other areas could result in burns.

The cigarette lighter remains operational when the ignition key has been removed. Therefore do not leave unsupervised children in the vehicle. ◀

# Cargo loading

## Stowing cargo

If you are carrying cargo in the luggage compartment of your BMW Z8 roadster:

- ▷ Load heavy cargo as far forward as possible, directly behind the luggage compartment partition
- ▷ Cover sharp edges and corners.

If you are stowing cargo behind the seats in your BMW Z8 roadster:

- ▷ Stow only lightweight objects, such as clothing items
- ▷ Do not pile objects higher than the top edge of the backrest.



Do not stow either heavy cargo or cargo with sharp edges and corners behind the seats, or else they could damage the back of the seat or the rear trim panel.

Cargo that is too big or unwieldy and stowed behind the seats can also prevent the seat from locking properly into position. Therefore, check to make sure that the seat is properly locked into place, moving the seat forward if necessary. Refer to page [43](#).

Always position and secure the load correctly. If you do not, it can endanger the passengers during braking or evasive maneuvers.

Do not exceed the permissible gross weight and axle load (refer to page [156](#)), otherwise the vehicle's operating safety is no longer assured and you are in violation of the law.

Make sure to secure heavy or hard objects you stow in the passenger area, otherwise, these objects could be flung about during braking or evasive maneuvers and possibly injure vehicle occupants. ◀



**Special operating instructions:**

- Break-in procedures 84
- Driving notes 85
- Catalytic converter 85
- Antilock Brake System (ABS) 86
- Dynamic Brake Control (DBC) 88
- Disc brakes 88
- Brake system 89
- Winter operation 90
- Power steering 92
- Cellular phone 92
- Radio reception 92
- Wind protection 93
- Hardtop 94

**Wheels and tires:**

- Tire inflation pressure 96
- Tire condition 97
- Tire replacement 98
- Tire rotation 100
- Wheel and tire combinations 101
- Winter tires 102
- Snow chains 102
- Approved wheel and tire specifications 103

**Under the hood:**

- Hood 104
- Engine compartment 106
- Washer fluids 108
- Washer nozzles 108
- Engine oil 109
- Coolant 111
- Brake fluid 112
- Vehicle Identification Number 113

**Maintenance and care:**

- The BMW Maintenance System 114
- Caring for your vehicle 115
- Airbags 121
- Storing your vehicle 122

**Laws and regulations:**

- Technical modifications 123
- California Proposition 65 Warning 123
- OBD interface socket 124

**Overview****Controls and features****Operation, care and maintenance****Owner service procedures****Advanced technology****Technical data****Index**

## 84 Break-in procedures

To ensure that your vehicle provides maximum economy throughout a long service life, we request that you observe the following instructions:



Your BMW Z8 roadster is an especially high-quality vehicle. It is in your best interest to follow the break-in instructions very closely. Doing this will create the basis for a long, optimum service life. ◀

### Engine and differential

Up to 1,200 miles (2,000 km):

Drive at varying engine and road speeds, but do not exceed 4,500 rpm (4,500/min), or a road speed of 106 mph (170 km/h).

Obey your local and state maximum speed limits.

Absolutely refrain from the full-throttle position with the accelerator.

Once you have driven 1,200 miles (2,000 km), you can begin to gradually increase both the engine speed and road speed.

You should also comply with these break-in procedures if the engine or differential is replaced later in the course of the vehicle service life.

### Tires

Due to technical factors associated with their manufacture, tires do not achieve their full traction potential until an initial break-in period has elapsed. Thus, drive with extra care during the initial 200 miles (300 km).

Obey your local and state maximum speed limits.



When the vehicle is being driven on wet or slushy roads, a wedge of water may form between the tire and the road surface. This phenomenon is referred to as "aquaplaning," or "hydroplaning," and can lead to partial or complete loss of traction, vehicle control and braking effectiveness. Reduce your speed on wet roads. ◀

### Brake system

Approximately 300 miles (500 km) must elapse before the brake pads and rotors achieve the optimal pad-surface and wear patterns required for trouble-free operation and long service life.

To break in the separate parking brake drums, apply the parking brake lightly when coasting to a standstill (at a traffic signal, for instance), provided that traffic conditions allow you to do so.

To avoid corrosion, repeat this procedure from time to time.



The brake lamps do not come on when the parking brake is engaged.

Vacuum for the brake system servo unit on your BMW is available only when the engine is running. When you move the vehicle with the engine shut off – when towing, for instance – substantially higher levels of pedal force will be required to brake the vehicle. ◀

### Clutch

The clutch will also begin to function optimally after about 300 miles (500 km). Engage the gears carefully and without high engine speeds during this break-in period.

## Driving notes



### Brakes:

Do not rest your foot on the brake pedal while driving. Even light but consistent pressure on the brake pedal could lead to high temperatures, brake wear, and possibly, to brake system failure.

### Aquaplaning:

Reduce speed while driving on wet or slushy roads, otherwise, a wedge of water can form between the tires and the road surface. This phenomenon is referred to as "aquaplaning" or "hydroplaning." It is characterized by a partial or complete loss of contact between the tires and the road surface. The ultimate results are loss of steering and braking control.

### Driving through water:

When there is water on the roads, do not drive in it if it is deeper than 1 ft (30 cm), and even then, only at walking speed, otherwise the vehicle can sustain damage to the engine, the electrical systems and the transmission. ◀

## Catalytic converter

The catalytic converter reduces harmful exhaust emissions, and is designed for use with unleaded fuel only. Even minute quantities of lead would be enough to permanently damage both the catalytic converter and the system oxygen sensor.

To ensure efficient, trouble-free engine operation and to avoid potential damage:

- ▷ Be sure to comply with the scheduled maintenance requirements
- ▷ Fill the fuel tank well before it is empty
- ▷ Tow-start only when the engine is cold. If you attempt to tow-start with a warm engine, unburned residual fuel in the catalytic converter could ignite and cause damage. It is better to start the vehicle with an outside starting aid
- ▷ Avoid other situations where the fuel is either not burned or burns incompletely, such as engaging the starter frequently or for extended periods, or repeated start attempts in which the engine does not start (stopping and restarting an engine which is running properly does not present a problem). Never allow the engine to run with any of the spark plug cables disconnected.



Be sure to comply with the instructions above to prevent unburned fuel from reaching the catalytic converter. Otherwise, there is the danger of overheating and damage to the catalytic converter.

Extreme temperatures are present with the catalytic converter both on this and every catalytic converter-equipped vehicle. Heat shields are installed adjacent to some sections of the exhaust system. Never remove these shields; do not apply undercoating to their surfaces. When driving, standing at idle, and parking the vehicle, take care to avoid contact between the exhaust system and flammable materials (grass, hay, leaves etc.). Such contact could start a fire, resulting in serious personal injury and property damage. ◀

### **The concept**

ABS enhances active safety by helping to prevent the wheels from locking under braking. This is because: locked wheels are dangerous. When the front wheels slide, the driver loses steering control over the vehicle. Traction loss at the rear wheels can cause the rear end to break into an uncontrolled skid.

With ABS, you will achieve the shortest-possible braking distances under all given conditions (braking while driving straight ahead or in curves, different road surfaces).

ABS is designed to meet two essential requirements during every brake application:

- ▷ To help provide vehicle stability
- ▷ To help retain steering and maneuvering capability on all types of road surfaces (asphalt, concrete, dirt, wet surfaces, snow and ice).

### **Braking with ABS**

The system is operative once the vehicle exceeds a speed of approx. 6 mph (10 km/h). The ABS is deactivated whenever the vehicle's speed drops back below approx. 4 mph (6 km/h). This means that the wheels can tend to lock in the very final phase of a panic stop, which in actual practice is not critical.

The ABS system works best in situations requiring maximum pressure on the pedal (full braking). Since the vehicle maintains steering responsiveness, you can nevertheless avoid possible obstacles with a minimum of steering effort.

The ABS system's closed-loop control circuit cycles in fractions of a second. A pulsing of the brake pedal, combined with the sounds associated with the hydraulic controls, tells you that the brake system is within its maximum limit range and reminds you that you should adapt your vehicle's speed to road conditions.

On road surfaces that have a loose layer on a firm base (on gravel or snow, for instance), the braking distances with ABS may be longer than with the wheels locked. This also applies for driving with snow chains. However, ABS continues to provide enhanced vehicle stability and steering response under these conditions.

# Antilock Brake System (ABS)

## Information for your safety

Not even ABS can suspend the laws of physics. The consequences of brake applications with inadequate clearances for safety between vehicles, excessive speed or if aquaplaning occurs are always the responsibility of the driver. You should never allow the added safety of ABS to mislead you into taking risks of any kind.



Do not make any modifications to the ABS system.

Service procedures on ABS are to be performed by authorized technicians only. ◀

## In the event of a fault



If the ABS warning lamp comes on, refer to page 19. The brake system will then function the same as on vehicles without ABS. However, have the brake system checked by your BMW center as soon as possible. To prevent undetected defects and cumulative faults from adversely affecting the brake system, refer any problems to your BMW center at the earliest opportunity.



## Cornering Brake Control (CBC)

CBC is an advanced ABS engineering design. Vehicle stability is also enhanced when braking during cornering at high lateral acceleration, or when braking during a lane changing.



If you step on the brake rapidly, this system automatically produces maximum braking force boost and thus helps to achieve the shortest possible braking distance during "panic stops." All of the benefits of the ABS system are exploited under these circumstances.

Do not reduce the pressure on the brake pedal for the duration of the brake application. When the brake pedal is released, the DBC is deactivated.



In the event of a malfunction, the yellow brake warning lamp comes on. Normal braking efficiency and ABS are still fully available. Have the system checked and repaired at your BMW center as soon as possible.



### **Information for your safety**

Not even DBC can suspend the laws of physics. The consequences of brake applications with inadequate clearances for safety between vehicles, excessive speed or if aquaplaning occurs are always the responsibility of the driver. You should never allow the added safety provided by DBC to mislead you into taking risks of any kind.

## **Disc brakes**

Disc brakes furnish optimum deceleration and braking control and greater fade resistance under heavy use.

When the vehicle is driven only occasionally, during extended periods when the vehicle is not used at all, or in operating conditions where brake applications are less frequent, there is an increased tendency for corrosion of the rotors and accumulation of contamination on the brake pads. This occurs because the minimal pressure which must be exerted by the pads to clean the rotors by brake applications is not achieved.

If the brake rotors are corroded, they will tend to respond to braking with a pulsating effect that even extended brake applications will fail to cure.



For your own safety: use only brake pads BMW has approved for your specific vehicle model. BMW cannot evaluate non-approved brake pads to determine if they are suited for use, and therefore cannot ensure the operating safety of the vehicle if they are installed. ◀

## Driving notes

When driving in wet conditions and in heavy rain, it is effective to apply light pressure to the brakes every few miles or kilometers. Watch traffic conditions to ensure that this maneuver does not endanger other road users. The heat which is generated by the brake applications helps to dry the brake pads and rotors.

Maximum braking force is obtained while the wheels are not locked, but rather when they are still barely turning immediately prior to locking. ABS maintains this state automatically. If the ABS fails, you should revert to the staggered braking technique (refer to page 91).

Long or steep mountain descents do not necessarily lead to reduced braking efficiency if you drive downhill with the transmission in a gear requiring minimal brake applications.

Braking effect on the engine can be further increased by downshifting, into first gear, if necessary.

If engine braking should prove to be inadequate, you should still avoid extended, continuous braking. Instead of maintaining low to moderate pressure over an extended period of time, you should decelerate by applying more substantial pressure to the brake pedal (watch for following traffic), releasing the pedal, and then repeating the application (staggered braking). The cooling phases between active braking intervals prevent the brakes from overheating and retain full braking capacity.



Do not coast with the clutch depressed, the gear-shift lever in neutral, or, above all, with the engine shutt off; otherwise, the engine will provide no braking effect if the transmission is in neutral, and there is no braking or steering power assist if the engine is not running. Do not allow floor mats, carpets or any other objects to protrude into the area around the brake pedal, the clutch or the accelerator which could obstruct their freedom of movement. ◀

## Brake fluid level



The brake warning lamp comes on with the parking brake released:



The brake fluid level is too low in the reservoir (refer to page 112).

If the brake fluid level is too low and brake pedal travel has become noticeably longer, there may be a defect in one of the brake system's hydraulic circuits.



Proceed to the nearest BMW center. Higher brake application pressure may be necessary under these conditions, and brake pedal travel may be significantly longer. Please remember to adapt your driving style accordingly. ◀

**Brake pads**

The warning lamp for the brake pads comes on:

The brake pads have reached their minimum pad thickness. Proceed to the nearest BMW center as soon as possible to have the pads replaced.



For your own safety: use only brake pads which BMW has approved for your specific vehicle model. BMW cannot evaluate non-approved brake pads to determine if they are suited for use, and therefore cannot ensure the operating safety of the vehicle if they are installed. ◀

**Winter operation**

Winter is often accompanied by rapid changes in weather, requiring not only a different driving style, but also certain preparations to the vehicle itself to ensure that your vehicle operates safely and trouble-free throughout the winter months.

**Coolant**

Be sure that the coolant mixture contains the year-round ratio of 50:50 water and antifreeze/corrosion protection. This mixture provides protection against freezing down to approx.  $-34\text{ }^{\circ}\text{F}$  ( $-37\text{ }^{\circ}\text{C}$ ).

**Locks**

BMW door lock deicer can be used to free doors if frozen. This deicer also contains lubricant. After using the deicer, treatment with BMW lock cylinder grease is recommended.

**Rubber seals and components**

To prevent the weather-stripping from freezing, apply a spray-on rubber treatment or silicone spray to the door, hood and luggage compartment lid seals.



A full range of car care products is available from your BMW center. ◀

**Snow chains**

Mount BMW snow chains\* only in pairs on the rear wheels with approved winter tires. Always follow the manufacturer's safety precautions. Do not exceed a maximum speed of 30 mph (50 km/h). Do not activate the RDW system while using snow chains. Malfunction warnings and undetected losses in pressure are possible when driving with snow chains.

**Starting off**

When starting off in deep snow or when "rocking" the vehicle to free it, it may be advisable to temporarily deactivate the DSC system. Refer to page 63.



To maintain vehicle stability, always drive with the system switched on whenever possible. ◀

## Winter operation

### Driving on low-traction road surfaces

Do not activate the Sport Mode (refer to page 64). Use smooth, gentle pressure to control the accelerator pedal. Avoid excessive engine speeds and shift to the next higher gear at an early point. Shift down into the next lowest gear when approaching uphill or downhill grades. Maintain an adequate distance between yourself and the vehicle ahead.

### Brakes

Winter road conditions substantially reduce the amount of traction available between the tires and the road surface. The resulting increases in braking distance are considerable and should be kept in mind at all times.

ABS is intended to prevent the wheels from locking during brake applications, thus helping to maintain vehicle stability and steering response.

If the ABS does not respond in a critical braking situation and the wheels lock, reduce the pressure on the brake pedal until the wheels just start to roll again while still maintaining enough force to continue braking.

Then increase the pressure, reduce the pressure when the wheels lock, reapply pressure etc.

This staggered braking procedure will reduce braking distances while helping you maintain steering control. You can always then attempt to steer around hazards after you have reduced pressure on the brake pedal.



Do not shift down on slick road surfaces if you want to decelerate. Doing so could cause the wheels to lose traction and skid, thus resulting in the loss of vehicle control. ◀



Depress the clutch during hard braking on road surfaces that provide only poor or uneven traction. ◀

### Skid control

Depress the clutch and release the accelerator pedal. Countersteer carefully and attempt to regain control of the vehicle.

### Parking

Engage first or reverse gear. Depending on the steepness of the incline, you can apply the parking brake as well. In order to prevent the parking brake pads from locking due to frost or corrosion, dry them by gently applying the parking brake as the vehicle is coming to a stop. Make sure that following traffic is not endangered.



The brake lamps do not come on when the parking brake is engaged. ◀

If there is a change in steering response – e.g. difficult or over-responsive steering – at increasing speeds, consult a BMW center to have it checked.



If the power steering fails, increased effort will be required to steer the vehicle. ◀

Mobile communications systems (cellular phone, radio, etc.) are permitted with an output of up to 10 watts only. Mobile communications devices not specifically designed for use in your vehicle may trigger malfunctions while you are operating your vehicle. BMW can neither test nor assume responsibility for every individual product being offered on the market. We recommend that you consult your BMW center before purchasing any device of this kind. To ensure reliable and trouble-free operation of your BMW, do not use any cellular phones or other radio devices where the antenna is located either inside the passenger compartment or otherwise not attached to the outside of the vehicle.

You will find instructions for operating your cellular phone in a separate manual included with your Owner's Manual.

The reception and sound quality obtained from mobile radios vary according to a variety of factors, including the broadcast range of the transmitter and the directional orientation of the antenna. Interference factors such as high-tension power lines, structural or natural obstructions can all lead to unavoidable reception interference, regardless of how well the vehicle sound system is operating. Climatic factors such as intense solar radiation, fog, rain and snow can also interfere with reception.

Radio interference can also be caused by either cellular phones not recommended by BMW or by portable phones. This phenomenon assumes the form of a low-pitched hum emanating from the speaker system.

Please refer to the Owner's Manual that you received for detailed information on settings and operation of your radio.



## Mounting

Attach the wind protector while the convertible top is open and its cover not mounted.

- 1 Push the brackets for the wind protector, with the zippers fastened and facing to the front, onto both roll-over protection bars as far as to the upper edge of the chrome collars (arrow)



- 2 Guide the four fasteners to their respective slots, attach them at an angle, and press them into place using the strap hanging in front of them. Shove the four straps under the inner side of the convertible top
- 3 Shove both the center elements all the way to the vehicle's outside edge (arrows), so that the cover can then easily be mounted
- 4 Fit the cover if you wish to drive with the convertible top open (refer to page [40](#)).

## Removing

Loosen the mounting fasteners by pulling on the four straps, then reverse the sequence for attaching.

Put the folded up wind protector in its protective sleeve and stow it in the luggage compartment.

**While driving**

You can always drive with the wind protector installed. Whenever the convertible top is closed, flip the center section of the wind protector down to get a better view out of the back

- 1 With the two stud fasteners closed, first unfasten the zippers entirely
- 2 Release the two stud fasteners and lay down the center section either to the rear or the front, as shown in the illustration

When reattaching, first fasten the two stud fasteners, then zip the zippers up.

**Hardtop****Removing**

Your BMW Z8 roadster is fitted with a series standard hardtop. Two people are necessary to take the hardtop off. Exercise great care when doing so, in order to avoid any damage to paint, the vehicle body and the hardtop itself.

- 1 Lower the side windows
- 2 Unlock the side trim panel by pressing on it (arrow)



Every time you press on it, you either lock or unlock the side trim panel. ◀

- 3 Remove both the left and right side trim panels

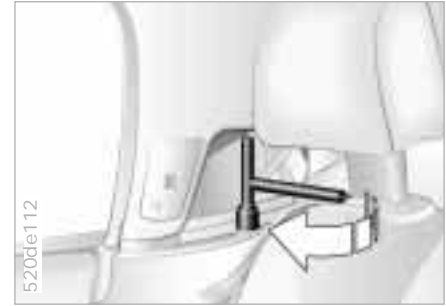

- 4 Remove the tool used for locking the hardtop, located next to the hardtop catch on the left side, position the tool and turn it forward until you hear an audible click. Do this both on the left and right side of the hardtop to release both catches.



- 5 Remove the two oval cover panels from the front of the hardtop frame, using a screw driver, if necessary
- 6 Position the tool for locking the hardtop in place, and turn it outward until you hear an audible click. Do this both on the left and right side of the hardtop frame to release both catches
- 7 The hardtop is now completely unlocked. With the help of one other person, lift the hardtop up and carry it over the vehicle to the rear
- 8 When removing it, be sure that the back end of the hardtop is resting on the catches.

 Do not let the hardtop rest on the edge of the roof, as this could cause damage. ◀

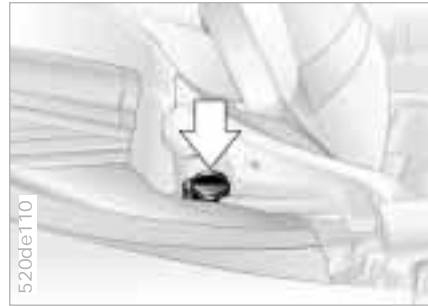

- 9 Press the left and right protective covers onto the hardtop brackets.

## Installing

Goes the same way as for taking the hardtop off, just do it in reverse order.

Whenever the hardtop is in constant use, the cloth convertible top does not need to be dismantled, even in winter. Before storing the cloth convertible top in the convertible top compartment, it has to be completely dry to keep any water or mildew stains from forming.

Two people are required for putting the convertible top on and taking it off. Exercise great care when doing so, in order to avoid any damage to the paint, the vehicle body, or the hardtop itself.



### **Information for your safety**

Factory-approved steel-belted radials with emergency driving characteristics are meant for your vehicle, offering optimum driving safety as well as the driving comfort you desire.

It is not merely the tire's service life, but also driving comfort and – above all else – driving safety that depend on the condition of the tires and the maintenance of the specified tire pressure.

Incorrect inflation pressure is a frequent cause of tire damage. It also significantly influences the roadholding ability of your BMW.



Check tire inflation pressures regularly (refer to page 24), at least every two weeks and before beginning a longer trip. If this is not done, incorrect tire pressures can cause driving instability and tire damage, ultimately resulting in accidents. ◀

### **Safety tires**

Your BMW Z8 roadster is equipped with safety tires.

The safety tires are made of self-supporting tires and customized wheel rims. Reinforcing the tires makes sure that they remain upright and still driveable to a limited degree even in the event of loss of pressure. Your vehicle is equipped with a tire pressure monitor that signals you in case of a flat tire.

For further information, refer to pages 65, 135.

## Tire condition



### Tire tread – tire damage

Inspect your tires frequently for tread depth, wear, signs of damage and for foreign objects lodged in the tread.

Tread depth should not be allowed to fall below 0.12 in (3 mm), even though the legally specified minimum tread depth is only 0.063 in (1.6 mm). At a tread depth of 0.063 in (1.6 mm), tread depth indicators (arrow) in the tread-groove base will indicate that the legally permissible wear limit has been reached. Below 0.12 in (3 mm) tread depth, there is an increased risk of aquaplaning, even at relatively moderate speeds and with only small amounts of water on the road.



Avoid overloading the vehicle so that the permitted load on the tires is not exceeded. Overloading can lead to overheating and increases the rate at which damage develops inside the tires. You could have a blowout as a result.

Unusual vibrations encountered during normal vehicle operation can indicate tire failure or some other vehicle defect, as can variations in normal vehicle response, such as a pronounced tendency to pull to the left or right. Should this occur, respond by immediately reducing your speed. Proceed carefully to the nearest BMW center or professional tire center, or have the vehicle towed in to have it and its tires inspected.

Tire damage can endanger the lives of both the vehicle occupants and other road users. ◀

## 98 Tire replacement

To maintain good handling and vehicle response, use only tires of a single tread configuration from a single manufacturer. BMW tests and approves wheel/tire combinations. Refer to page 103.

### DOT Quality Grades

Tread wear

Traction AA A B C

Temperature A B C



All passenger vehicle tires must conform to Federal Safety Requirements in addition to these grades. ◀

### Tread wear

The tread wear grade is a comparative rating based on the wear rate of the tire when tested under controlled conditions on a specified government test course.

For example, a tire graded 150 would wear one and one-half (1 1/2) times as well on the government course as a tire graded 100. The relative performance of tires depends upon the actual conditions of their use, however, and may depart significantly from the norm due to variations in driving habits, service practices and differences in road characteristics and climate.

### Traction

The traction grades, from highest to lowest, are AA, A, B and C.

Those grades represent the tire's ability to stop on wet pavement as measured under controlled conditions on specified government test surfaces of asphalt and concrete. A tire marked C may have poor traction performance.



The traction grade assigned to this tire is based on straight-ahead braking traction tests, and does not include acceleration, cornering, hydroplaning, or peak traction characteristics. ◀

### Temperature

The temperature grades are A (the highest), B and C, representing the tire's resistance to the generation of heat and its ability to dissipate heat when tested under controlled conditions on a specified indoor laboratory test wheel.

Sustained high temperature can cause the tire material to degenerate and reduce tire life, and excessive temperature can lead to sudden tire failure. The Grade C corresponds to a level of performance which all passenger vehicle tires must meet under the Federal Motor Vehicle Safety Standard No. 109. Grades B and A represent higher levels of performance on the laboratory test wheel than the minimum required by law.



The temperature grade for this tire is established for a tire that is properly inflated and not overloaded. Excessive speed, underinflation, or excessive loading, either separately or in combination, can cause heat buildup and possible tire failure. ◀

# Tire replacement

## Uniform Tire Quality Grading

Quality grades can be found where applicable on the tire sidewall between tread shoulder and maximum section width. For example:

Tread wear 200 Traction AA

Temperature A



Use only tires with emergency driving characteristics as there is no spare tire available if you get a flat. For further information, refer to page [135](#). ◀

## Tire age

The date on which the tire was manufactured is indicated by the code on the sidewall:

DOT ... 1200 indicates that the tire was manufactured in week 12 of 2000.

BMW recommends the replacement of all tires when the tires are no more than 6 years old, even if a tire life of 10 years is possible.

### **Between the axles**



If different tire sizes are mounted on the front and rear axles (refer to page 103), then the tires may not be rotated from one axle to the other. ◀

The tread wear patterns at the front end differ from those at the rear – the actual patterns will vary according to individual driving conditions. In the interests of safety and maintaining optimal handling characteristics, tire rotation is not recommended.

If a proposed interaxle rotation of tires is based on economic considerations, one should consider whether the costs for the rotation are likely to be recouped by any increase in the service life of the tires that might be realized. Rotation should always be carried out at short intervals, with a maximum of 3,000 miles (5,000 km). Consult your BMW center for more information.

Should you decide to rotate the tires, it is essential to comply with the following: Rotate tires on the same side only, since braking characteristics and road hugging ability could otherwise be adversely affected.

After rotating the tires, carefully check and adjust the tire pressure, and reactivate the RDW.

# Wheel and tire combinations

## The right choice

Use only BMW-approved tires with emergency driving characteristics. Refer to page 103.

Due to the maximum speeds this vehicle can reach, the use of specific brands and sizes is mandatory. Consult any BMW center for details. Comply with local/national regulations.

 The correct wheel/tire combination affects different systems, such as ABS, ATC, DSC and RDW. The function of these systems is impaired if improper wheel/tire combinations are used. For this reason, use only tires made by the same manufacturer that have the same tread configuration and possess emergency driving characteristics. And after a flat tire, for instance, restore the approved wheel-tire combination as soon as possible. ◀

## Codes on tires and wheels

The tire codes will aid you in selecting the correct tire.

Codes on radial tires:

For example: 245/45 R 18 96 W

Nominal width in mm ———— 245

Aspect ratio in % ———— 45

Radial tire code ———— R

Rim diameter in inches ———— 18

Load rating (not on ZR tires) ———— 96

Speed rating (before R on ZR tires) ———— W

The speed rating indicates the approved maximum speed for the tire.

Summer tires:

S = up to 112 mph (180 km/h)  
 T = up to 118 mph (190 km/h)  
 H = up to 130 mph (210 km/h)  
 V = up to 150 mph (240 km/h)  
 W = up to 167 mph (270 km/h)  
 Y = up to 186 mph (300 km/h)  
 ZR = over 150 mph (240 km/h)

Winter tires:

Q M+S = up to 100 mph (160 km/h)  
 T M+S = up to 118 mph (190 km/h)  
 H M+S = up to 130 mph (210 km/h)

Codes stamped on light-alloy wheels:

For example: 8 J x 18 H 2

Rim width in inches ———— 8

Code letter for flange type ———— J

Symbol for full-drop center rim ———— x

Rim diameter in inches ———— 18

Hump on the 2 rim shoulders ———— H 2

Protect tire valves from dirt by using screw-on valve stem caps. Dirt in the valves frequently leads to slow leaks.

Tires with emergency driving characteristics also possess an additional identification mark that varies by manufacturer, e.g.:

Bridgestone	RFT
Dunlop	DSST
Goodyear	EMT
Michelin	ZP

**Choosing the right tire**

For winter road driving, BMW recommends winter tires (M+S radial belt tires). Although all-season M+S tires provide better winter traction than standard summer tires with H, V, W and ZR speed ratings, they generally fail to provide the same levels of performance as standard snow tires in winter driving.

In the interests of safe tracking and steering response, install radial tires made by the same manufacturer and with the same tread configuration on all four wheels if you elect to mount winter tires.

Mount only winter tires that have been approved by BMW. Any BMW center will be glad to provide you with information on the best winter tires for your particular driving conditions.

 Use only winter tires with emergency driving characteristics as there is no spare tire available if you get a flat.

For further information, refer to page [135](#). ◀

**Do not exceed specified maximum speeds**

 Never exceed the maximum speed for which winter tires are rated. Unprofessional attempts by laymen to service tires can lead to damage and accidents.

Have this work performed by skilled professionals only. Your BMW center will be glad to assist you with both their expertise and the proper equipment for your vehicle. ◀

**Tire condition, tire pressure**

Once the tread depth on winter tires is less than 0.16 in (4 mm), they are no longer suitable for winter road driving, and in the interest of safety should be replaced.

Comply with the specified tire inflation pressures – and be sure to have the wheel and tire assemblies balanced every time you change the tires.

**Storage**

Always store tires in a cool, dry place. Store them away from light whenever possible. Protect the tires against contact with oil, grease and fuel.

**Snow chains\***

The use of narrow-link BMW snow chains is permissible in pairs only on the rear wheels with winter tires with tire size 245/45 R 18 96 H. Comply with all manufacturer's safety precautions when mounting the chains.

 Do not activate the RDW system while using snow chains. Malfunction warnings and undetected losses in pressure are possible when driving with snow chains. For further information, refer to page [65](#). ◀

Tire specifications	Light-alloy wheel
BMW Z8	
Summer tires	
Front: 245/45 R 18 96 W	8Jx18 EH2
Rear: 275/40 R 18 99 W	9Jx18 EH2
Winter tires	
245/45 R 18 96 H M+S	8Jx18 EH2

Comply with the specifications for tires and wheels in the vehicle's documents. If sizes not approved by the manufacturer are mounted, an entry in the vehicle's documents may be necessary.

### Snow chains\*

It is impossible to install snow chains when using summer tires 275/40 R 18 99 W.

 Do not activate the RDW system while using snow chains. Malfunction warnings and undetected losses in pressure are possible when driving with snow chains. For further information, refer to page 65. ◀



The use of rims and wheel bolts that do not meet the specifications of the original factory-installed equipment will affect the safe operation of your vehicle and may cause an accident and personal injury. Never mix tires of different design, such as steel-belted radials with radial bias belted or bias-ply tires, etc. Mixing tire types will adversely affect roadholding and can lead to loss of vehicle control. ◀



**To unlock**

Pull the lever located under the left-hand side of the instrument panel.

 Do not work on your vehicle without appropriate skills. Always switch off the engine and allow it to cool down before working in the engine compartment. Always disconnect the battery before working on any electrical systems or equipment, especially when these are located within the engine compartment. Comply with all applicable instructions and warnings. If you are not familiar with the guidelines specified for the work you are doing on your vehicle, have it done by a BMW center, otherwise, improper servicing of parts and materials constitutes a safety risk for vehicle occupants and other road users. ◀

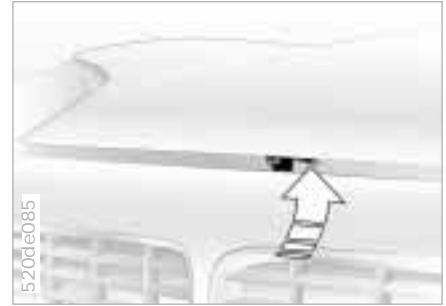
**To open**

Press the release handle upward and open the hood.

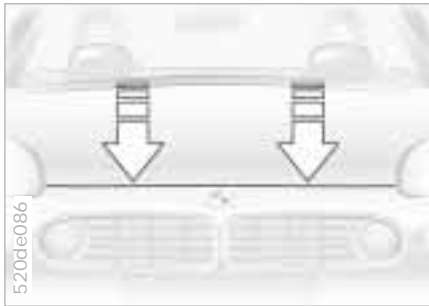

## To close

Allow the hood to fall from just a little height, and then press down on both sides of the hood at the same time until you hear it audibly engage.



To avoid injuries, be sure that the travel path of the hood is clear when it is being closed, as with all closing procedures.

If it is determined that the hood is not completely closed while driving, stop immediately and close it securely. ◀

## 106 Engine compartment

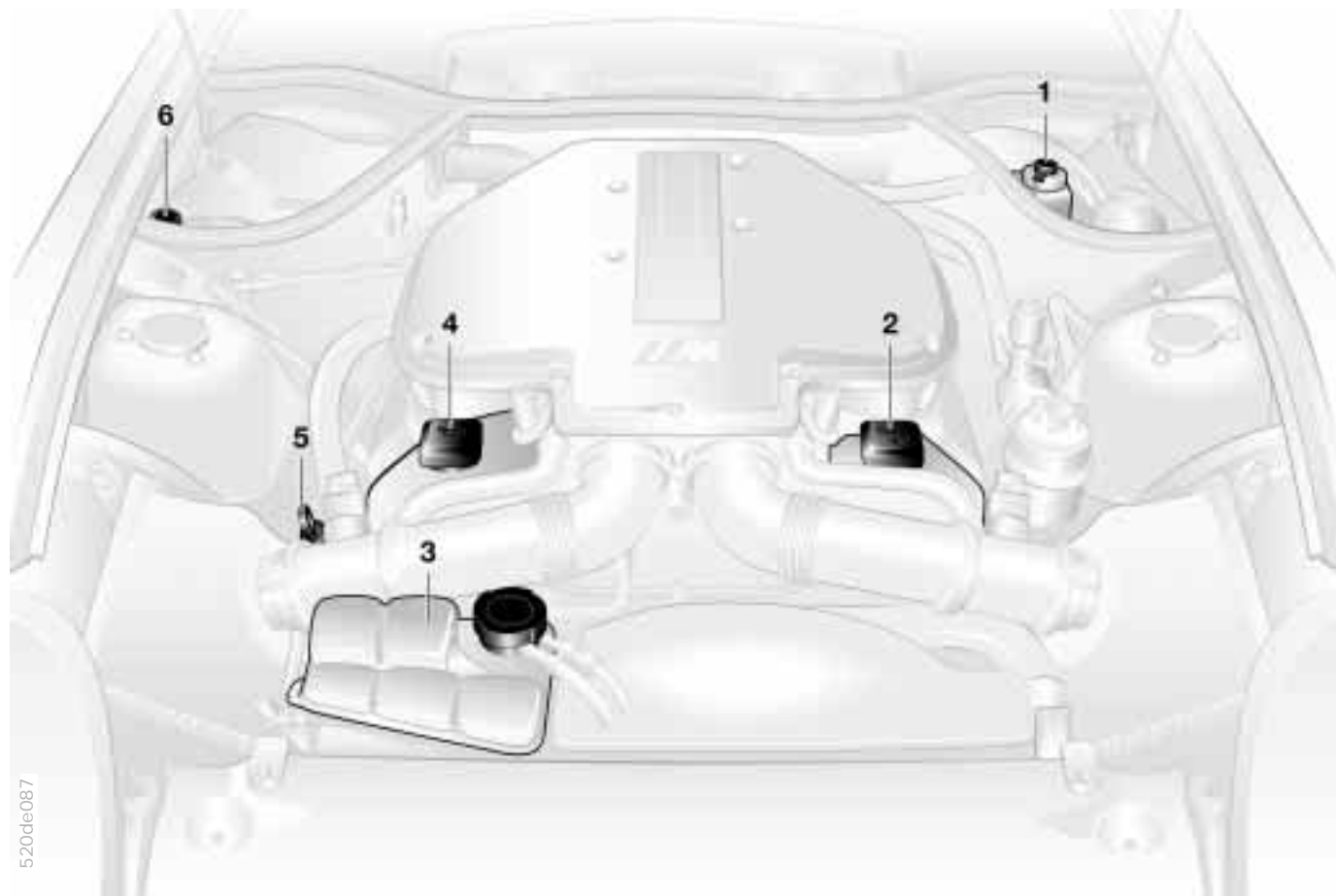

# Engine compartment

- 1 Brake fluid reservoir [112](#)
- 2 Auxiliary terminal for jump starting [143](#)
- 3 Coolant expansion tank [111](#)
- 4 Engine oil filler neck [109](#)
- 5 Engine oil dipstick [109](#)
- 6 Reservoir for windshield and headlamp washer system [108](#)



### **Headlamp and windshield washer system**

Capacity in US quarts (liters):  
approx. 5.6 (5.3)

Fill with water and – if required – with a washer antifreeze (according to manufacturer's recommendations).

 We recommend that you mix the washer fluid before adding it to the reservoir. ◀

 Antifreeze agent for the washer systems is inflammable. For this reason, keep them away from sources of flame and store them only in their original containers. Store them so that they are inaccessible to children. Comply with the instructions on the containers. ◀

## **Washer nozzles**

### **Windshield washer system**

The spray from the nozzles should be directed onto the windshield so as to ensure effective cleaning, even at high speeds. Use a needle to adjust the nozzles if required, or have them adjusted by your BMW center.

### **Headlamp washer system**

Have this system adjusted by your BMW center, if required.



## Checking the oil level

- 1 Park the vehicle on a level surface
- 2 Let the warmed-up engine idle for about 15 seconds, then turn it off
- 3 Pull the dipstick out after about 1 minute and wipe it off with a clean lint-free cloth, tissue, or similar material
- 4 Carefully push the dipstick all the way into the guide tube and pull it out again
- 5 The oil level should be between the two marks on the dipstick.

As with fuel economy, oil consumption is directly influenced by your driving style and vehicle operating conditions.



The oil volume between the two marks on the dipstick corresponds to approx. 1.1 US quarts (1 liter). Do not fill beyond the upper mark on the dipstick. Excess oil will damage the engine.



## Adding engine oil

Wait until the level has dropped to just above the lower mark before adding oil. However, never let the oil drop below the lower mark.

 BMW engines are designed to operate without oil additives; the use of additives could lead to damage in some cases. This also applies to the manual transmission, differential and the power steering system. ◀

**Specified engine oil**

The quality of the engine oil is extremely important for the function and life of an engine. Based on extensive testing, BMW has approved only certain types of engine oils.

Use only approved "BMW High Performance Synthetic Oil."

If you are unable to obtain "BMW High Performance Synthetic Oil," you can add small amounts of synthetic oil in between oil changes. Use only oils with the API SH specification or higher.

 Ask your BMW center for details concerning the specific "BMW High Performance Synthetic Oil" or "synthetic oils" that have been approved. ◀

You can also call BMW of North America at 1-800-831-1117 or visit this website, [www.bmwusa.com](http://www.bmwusa.com), to obtain this information.

**Viscosity ratings**

Viscosity is the oil flow rating as established in SAE classes.

Select the correct SAE class based on the climatic conditions in the area where you typically drive your BMW Z8 roadster.

 Approved oils are SAE classes 5W-40 and 5W-30. ◀

These oils may be used for driving in all outside temperatures.

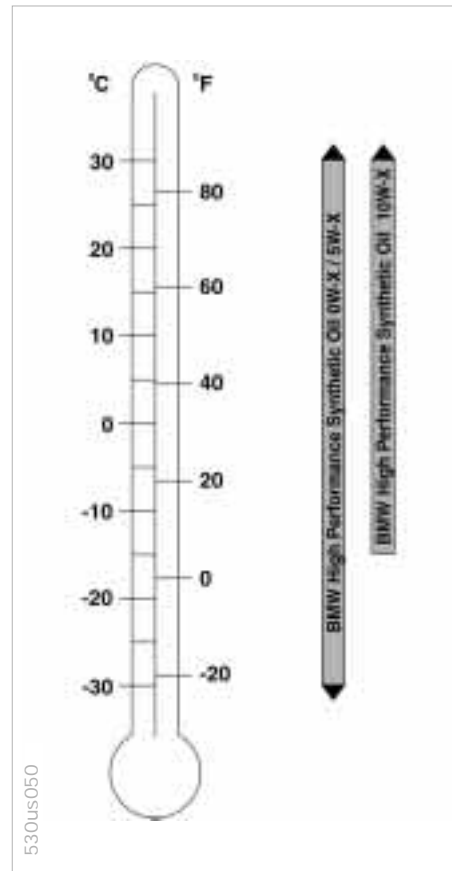

## Engine oil

 Comply with the applicable environmental laws regulating the disposal of used oil. ◀

Recommendation: Have the oil changed by your BMW center only.

 Continuous exposure to used oil has caused cancer in laboratory testing.

For this reason, thoroughly wash any areas of skin that come into contact with oil using soap and water.

Always store oils, grease, etc. so that they are inaccessible to children, and follow warning labels on containers. ◀

## Coolant

 Do not add coolant to the cooling system when the engine is hot, since escaping coolant can cause burns.

To avoid the possibility of damage later on, never use anything other than factory-approved, nitrite- and amino-free, extended-duty antifreeze with corrosion inhibitor. Your BMW center is familiar with the official specifications.

Antifreeze and anticorrosion agents are hazardous to health. You should always store them in their original containers and in a location that is inaccessible to children. Extended-duty antifreeze with corrosion inhibitor contains the flammable substance ethylene-glycol. For this reason, do not spill extended-duty antifreeze with corrosion inhibitor on hot engine components. If you do, it could be ignited and cause serious burns. ◀

 Comply with the applicable environmental laws regulating the disposal of extended-duty antifreeze with corrosion inhibitor. ◀



Adjust coolant level when the engine is cold (approx. 68 °F/20 °C):

Up to the MAX mark on the transparent reservoir.



**Adding coolant**

Wait until the engine cools before removing the cap from the expansion tank. The needle of the coolant gauge in the instrument cluster must fall within the blue zone. If it is not, there is a danger of scalding.

- 1 Turn the cap slightly counterclockwise in order to allow accumulated pressure to escape. Then open
- 2 If the coolant is low, slowly add coolant until the correct level is reached – do not overfill.

The coolant is a mixture of water and extended-duty antifreeze with corrosion inhibitor. Always maintain the prescribed all-season 50:50 mixture ratio for year-round protection against internal corrosion. No other additives are required.

Replace the coolant every three years.

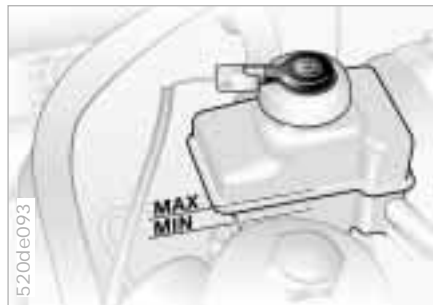
**Brake fluid**

If the brake warning lamp comes on and the parking brake has been released:

Check the brake fluid level. Fill it to the top mark ("MAX") if necessary.

For adding brake fluid or for determining and correcting the cause of brake fluid loss, consult your BMW center. Your BMW center is familiar with the specifications for factory-approved brake fluids (DOT 4).

Brake fluid loss can increase brake pedal travel. For this type of situation, refer to the notes on page 89.

 Brake fluid is hygroscopic, that is, it absorbs moisture from the air over time.

In order to ensure the safety and reliability of the brake system, have the brake fluid changed every two years by a BMW center. Refer also to the Service and Warranty Information Booklet (US models) or the Warranty and Service Guide Booklet (Canadian models). Brake fluid is toxic and eats away the vehicle's paintwork. You should always store it in its original container and in a location that is inaccessible to children. Do not spill the fluid and do not fill the brake fluid reservoir beyond the "MAX" mark. The brake fluid could ignite upon contact with hot engine parts and cause serious burns. ◀

 Comply with the applicable environmental laws regulating the disposal of brake fluid. ◀

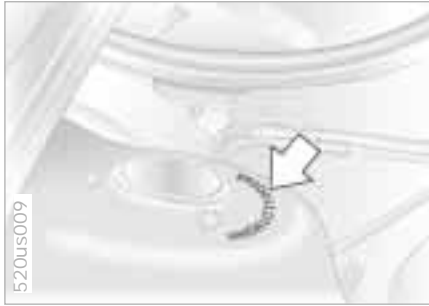

In the engine compartment, on the right-hand strut dome (arrow) and on the upper left-hand edge of the instrument panel.



The BMW Maintenance System has been designed so that it will ensure reliable vehicle transportation and operation with the least amount of cost and effort on your part as possible.

Please keep in mind that regular maintenance is not only necessary for the safety of your vehicle, but also plays a significant role in maintaining the resale value of the vehicle.

### **Service Interval Display**

Optimal maintenance intervals are calculated by using advanced technology; these are then indicated in the Service Interval Display. While conventional systems rely on distance traveled alone to determine when service is due, the BMW Maintenance System has for years considered the actual conditions under which the vehicle operates, because miles can be traveled in many different ways:

From the maintenance point of view, 62,000 miles (100,000 km) accumulated in short-distance urban driving are not equivalent to the same distance covered at moderate speeds in long-distance highway travel.

The BMW Maintenance System, which is based on operating conditions, includes the Engine Oil Service and Inspections I and II.

Determining the maintenance intervals according to the actual loads on the vehicle covers every kind of operating situation. However, even those drivers who put significantly less than 6,000 miles (10,000 km) on their vehicles annually, should have the engine oil changed at least every two years since oil deteriorates over time, regardless of use.

### **Service Warranty Information Booklet (US models)/Warranty and Service Guide Booklet (Canadian models)**

For additional information on maintenance intervals and procedures, please refer to the Service and Warranty Information Booklet (US models) or the Warranty and Service Guide Booklet (Canadian models).



Have your BMW center perform maintenance and repair work. Your BMW center is always informed on the latest maintenance work and repair techniques and equipped with the required special tools. In addition, checking parts known from experience to be subject to wear is a permanent part of the maintenance specifications. Be sure that all maintenance work is confirmed in the Service and Warranty Information Booklet (US models) or the Warranty and Service Guide Booklet (Canadian models). These entries are your proof of regular vehicle maintenance and the basis for warranty claims. ◀

# Caring for your vehicle

## Washing your vehicle

You can have your new BMW washed in an automatic car wash. Car wash systems that do not employ brushes are preferable.

Wipe away tough dirt and loosen and remove dead insects before washing the vehicle.

In order to avoid spots, do not wash the vehicle when the hood is warm, or during or immediately after exposure to strong sunlight.

In order to protect your convertible top, do not have any special waxing program done to your vehicle. The small amount of beading wax always used in automatic car washes will not harm the convertible top.

When using an automatic car wash, be sure that:

- ▷ The car wash system is suited for the dimensions of your vehicle
- ▷ No damage will occur on vehicles with attached body accessories (such as spoilers or antennas). Consult the car wash operator if necessary

- ▷ The wheels and tires of your vehicle cannot be damaged by the conveyance devices of the car wash system
- ▷ The vehicle is cleaned with minimum brush pressure, and that ample water is available for washing and rinsing.

Parts of the vehicle which are inaccessible to the automatic washer – such as door sills, door and hood edges, etc. – should be cleaned by hand.

In the winter months, it is especially important to ensure that the vehicle is washed on a regular basis. Large quantities of dirt and road salt are difficult to remove, and they also cause damage to the vehicle.

 If spray wands or high-pressure washers are used, be sure to maintain an adequate distance between the spray source and the vehicle's surface. Inadequate distance and excessive pressure can damage or weaken the finish, making it more susceptible to further damage. In addition, moisture could penetrate to vehicle components, leading to long-term damage. ◀



- When cleaning the headlamps, please observe the following:
- ▷ Do not clean by wiping with a dry cloth. Never use abrasives or strong solvents to clean the covers
  - ▷ Remove dirt and contamination (such as insects) by soaking with BMW Car Shampoo and then rinsing with plenty of water
  - ▷ Always use a deicer spray to remove accumulated ice and snow – never use a scraper. ◀



After washing the vehicle, apply the brakes briefly to dry them. Braking efficiency might otherwise be reduced by the moisture and the brake rotors could also be corroded. ◀

### **Cleaning and care of the convertible top**

The appearance and life of the convertible top are highly dependent on its proper care and operation. You should pay particular attention to the following instructions if your vehicle has a light-colored top.

Protect the vehicle from exposure to intense sunlight whenever possible by parking it in the shade. This will help to prevent the paint, rubber and fabric-covered parts from being attacked.

Never fold up the convertible top and store it in the convertible top compartment when wet, dirty or frozen, as mildew stains and chafe spots may result.

To prevent the formation of a crease in the rear window and to avoid mildew stains, do not leave the top folded in the convertible top compartment for long periods.

If the vehicle will be parked for lengthy periods in an enclosed space, be sure that the convertible top is dry and that there is adequate ventilation.

Clean off bird droppings immediately, since they attack the convertible top and cause the rubber seals to swell due to their caustic characteristics.

Besides water, treat rubber seals only with talcum powder, rubber care products or silicone spray, particularly when they feel dry or tend to stick.

Eliminate noises such as squeaks with lubricant spray.

Never use sharp-edged objects to clean the rear window of snow or ice. If using a deicer spray, make sure that none of the spray comes into contact with the convertible top. Because of the risk of damage and discoloration, do not apply adhesive tape, stickers, or similar materials to the window or cover with plastic film.

Dents and discoloration may show up on the convertible top because of improper care, cleaning or as the result of excessive usage. The convertible top and its seams may also develop leaks. These occurrences are not covered by the warranty. For repairs, please consult your BMW center.

### **Special wash for the top**

In the case of more extensive dirt, which is especially visible on light-colored top materials, clean the top with the BMW Convertible Cleaning Set. Please proceed as follows:

Spray the convertible top with the cleaning agent and then rub with a well-dampened sponge using circular motions until a foam develops. Then you can finish washing the vehicle in an automatic car wash. After three to five washings the convertible top should be treated with a special impregnating spray. Please follow the instructions on the spray can.

## Caring for your vehicle



To remove stains from the convertible top, use only BMW-approved cleaning agents. Do not use spot removers, paint thinners, solvents, gasoline or similar substances for removing stains because these agents destroy the rubber seals, which in turn leads to leaks. A full range of car-care products is available from your BMW center. ◀

### Hardtop

Please observe and follow the instructions for caring for your vehicle starting on page [115](#).

### Exterior finish

To provide effective protection, multi-layer paintwork is applied at the factory. These cataphoretic immersion priming techniques have been carried out using specially developed materials that have undergone several years' worth of testing.

Regular maintenance makes an important contribution to maintaining the safety and value of your vehicle.

Increasing awareness of the effects of harmful environmental factors on vehicle finishes have led paint and vehicle manufacturers to initiate programs designed to further improve the durability of their finishes. Despite this, environmental factors that occur locally or regionally can have negative effects on the finish of your vehicle. These should guide you in determining the frequency and extent of your efforts to maintain the vehicle finish.

Road dirt, tar spots, dead insects, animal droppings (strong alkali effect) and even tree secretions (resins and pollen), all contain substances capable of causing damage to the finish of your vehicle if allowed to remain for any extended period of time (such as stains, bumps, scratches and separation of the top coat).

In industrial areas, deposits of flue dust, lime, oily soot, precipitation containing sulfur-dioxide (acid rain) and other environmental pollutants will damage the vehicle's finish unless adequate care is provided – even though this is generally limited to the outside horizontal surfaces.

In tropical zones, temperatures of over 105 °F (40 °C) in the shade prevail, in addition to heavy ultraviolet radiation and high humidity. Under those conditions, light paints can reach temperatures up to 175 °F (80 °C) and dark paints up to 250 °F (120 °C).

### **Caring for the vehicle finish**

Regular washing is a preventive measure against long-term effects from substances that are harmful to the vehicle's finish, especially if you drive your vehicle in areas with high levels of air pollution or natural contaminants (tree resins, pollen).

Nevertheless, you should immediately remove especially aggressive substances. Failure to do so can lead to changes in the paint's chemical structure or to discoloration. Gasoline spilled during refueling, oil, grease, brake fluid and bird droppings should always be cleaned up immediately.

Any contamination remaining on the surface of the vehicle will be especially conspicuous after washing. Use cleaning fluid or alcohol and a clean cloth or cotton pad to remove. Remove tar spots with tar remover. After cleaning, the affected areas should be waxed to ensure continued protection.

 Use the cleaning and car-care products available at your BMW center. ◀

### **Waxing your vehicle**

Protect the finish using carnauba or synthetic-based waxes only.

The best way to determine when the finish needs to be waxed is by noting when water stops beading on the surface.

You can use a glass cleaner to remove any wax or silicone that may have been left on the windows during waxing.

 Use the cleaning and car-care products available at your BMW center. ◀

### **Repairing the paint**

You can touch up small areas of paint damage with a BMW spray paint or a BMW touchup stick.

The color code of your vehicle is provided on a tag located near the vehicle data plate and on the first page of the Service and Warranty Information Booklet (US models) or the Warranty and Service Guide Booklet (Canadian models).

More extensive paint damage should be repaired professionally in accordance with the manufacturer's instructions. Your BMW center uses original BMW finish materials in accordance with approved repair procedures.

## Caring for your vehicle

### Window care

You can use window and glass cleaner to clean inside window surfaces and mirrors without smearing and streaking. Never use polishing pastes or abrasive (quartz) cleansers on mirror lenses.

Clean the wiper blades with soapy water. The wiper blades should be replaced twice a year – before and after the cold season.



Use only wiper blades approved by BMW. ◀

### Caring for other vehicle components and materials

Light-alloy wheels should be treated with alloy wheel cleaner, especially during the winter months. However, do not use aggressive products containing acids, strong alkalis or abrasives. Do not use steam cleaners operating at temperatures above 140 °F (60 °C). Follow the manufacturer's instructions.

Carefully clean chrome parts such as lamp socket assemblies, door handles and similar items with an ample amount of clean water – and shampoo, too, if necessary – especially if there is an accumulation of road salt. Use a chrome polish for an additional treatment.

Use water to clean plastic components, headliners, lamp lenses, and surfaces sprayed dull black – adding vinyl shampoo, if necessary. Do not allow moisture to soak through the seats or headliner. Never use solvents such as lacquer thinner, heavy-duty grease remover, fuels, or similar substances. Use a soft, clean cloth to wipe off the lamp covers, using methylated spirits with distilled water as a cleaning solvent, if necessary, at a mixing ratio of 1:1.

Rubber components should be cleaned with water only; a rubber treatment or silicone spray may also be applied.

The safety belts should be cleaned with a mild soap and water solution without being removed from the vehicle. Never attempt chemical or dry cleaning, as damage to the belt fabric could result.

After cleaning, never allow the inertia reel to retract the belts until they are completely dry. Dirty safety belts prevent the inertia reel mechanism from retracting the strap properly, thus constituting a safety hazard.

Heavily soiled floor carpets and mats\* can be cleaned with an interior cleaner. The floor mats can be removed from the vehicle for cleaning.

Clean the aluminum surfaces with water and, if necessary, with a mild soap. Never use solvents such as lacquer thinner, heavy-duty grease remover, fuels, or similar substances.

Use only a wet cloth to clean the painted inner parts. Dry them afterwards with a soft cloth.



Use the cleaning and car-care products available at your BMW center. ◀



### **Leather care**

The leather upholstery used by BMW is a natural product of the highest quality, processed using state-of-the-art methods to ensure that it will maintain its high quality for years to come, provided that it is properly cared for.

Because you are working with a pure, natural product, its peculiarities – its special characteristics even – must be taken into account in its use and care.

Regular periodic cleaning and care are essential, as dust and road dirt act as abrasives in the pores and creases of the material. This leads to wear spots and premature brittleness on the surface of the leather. We therefore suggest that you clean the leather with a vacuum cleaner or cloth at frequent intervals.

For cleaning, use BMW leather cleaning foam.

Since dirt and grease gradually attack the protective layer of the leather, the cleaned surfaces should be treated with BMW leather care agent. This also prevents antistatic electricity.

For protection against dampness or moisture, treat the leather with a BMW impregnating agent.

We recommend that you perform this procedure twice a year on leather exposed to normal use.

Spills should be wiped up immediately. Remove grease and oil stains without rubbing, but rather by dabbing with spot remover.

If the upholstery is to be exposed to intense sunlight or if the vehicle is to be stored for an extended period, cover all leather surfaces (or, better yet, the windows) to prevent fading.



Use the cleaning and car-care products available at your BMW center. ◀



Cleaning agents can contain dangerous or health-threatening substances. Therefore, always comply with the warnings and danger notices on the package.

Open the doors or windows on your vehicle when cleaning the interior. Never clean your vehicle with solvents or other materials not specifically intended for this purpose. ◀

# Airbags

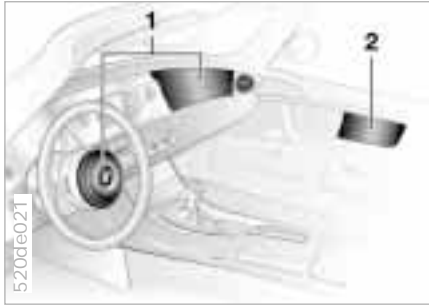

- 1 Front airbags for driver and passenger
- 2 Side airbags

## Important safety notices



Do not attempt to remove the gas generators of the airbag restraint system from the vehicle. Testing and servicing are to be performed only by trained technicians.

In the event of a malfunction, deactivation, or triggered actuation (as a response to an accident) of the airbag restraint system, consult your BMW center for repairs or service operations.

Do not modify or tamper with either the wiring or the individual components in the airbag system. These include the padded steering wheel hub, the instrument panel, and the side trim panels of the doors. Never apply adhesive materials to these components or cover or modify them in any way. Do not remove or dismantle the steering wheel yourself.

To ensure compliance with applicable safety regulations, have an BMW center dispose of airbag generators.

Unprofessional attempts to service the system could lead to failure in an emergency or undesired airbag activation, either of which could result in personal injury. ◀



If you plan on parking the vehicle for more than three months, please adhere the maintenance operations described below. ◀

### Preparations for storage

Have your BMW center perform the following procedures:

- 1 Clean and apply a rustproofing agent or other treatment to the engine, engine compartment, undercarriage, axles and major components in accordance with approved repair procedures. Wash the vehicle, clean the interior and treat painted and chromed parts. Clean the weatherstripping around the hood, luggage compartment and doors
- 2 Change engine oil and oil filter at operating temperature. As an additional corrosion protection measure, an anticorrosive agent can be added to the engine in accordance with the manufacturer's instructions
- 3 Check the coolant level and concentration and top off if necessary
- 4 Check the fluid level of the windshield washer fluid reservoir; top off if necessary
- 5 Fill the fuel tank completely to prevent the formation of condensation

- 6 Increase the tire inflation pressure to 51 psi (350 kPa).

### Before parking the vehicle

- 1 Dry the parking brake and footbrake by brake applications to prevent the brake discs and drums from corroding
- 2 Park the vehicle in a covered, dry, and well-ventilated area. Place the transmission in first gear or, if necessary, chock the wheels to prevent the vehicle from rolling. Do not engage the parking brake
- 3 Remove the battery, charge it completely and store it in a cool (but frost-free) room
- 4 Remove the hardtop and store it separately, refer to page 95
- 5 Close the convertible top.

### During storage

Recharge a battery that has been taken out of the car every six months. If it is not recharged, it will not be serviceable. Every time the battery is discharged, especially over extended periods, its service life is reduced.

### Removing the vehicle from storage

Recharge the battery if the "Magic Eye" turns black, refer to page 136.

Then have Inspection I performed by your BMW center, including a brake fluid replacement, if necessary. Refer to the Service and Warranty Information Booklet (US models) or the Warranty and Service Guide Booklet (Canadian models).

## Technical modifications

Any BMW center will be happy to advise you concerning the advisability, legal requirements and factory recommendations for technical modifications to the vehicle. The BMW center will therefore require the Vehicle Identification Number and, in some cases, the engine number as well.

### Light-Emitting Diodes (LEDs)

Light-emitting diodes installed behind translucent lenses serve as the light source for many of the controls and displays in your vehicle. These light-emitting diodes are similar to conventional lasers.

 Do not remove the protective lens and avoid staring directly at the unfiltered beam for extended periods (several hours). To do so could result in inflammation of the iris. ◀

## California Proposition 65 Warning

California laws require us to state the following warning:

 Engine exhaust, some of its constituents, and certain vehicle components contain or emit chemicals known to the State of California to cause cancer and birth defects or other reproductive harm. ◀



The OBD interface socket for onboard diagnostics is located on the driver's side at the left-hand bottom of the instrument panel and under a cover panel. The cover has the letters "OBD" on it.

The purpose of the OBD system is to ensure proper operation of the emission control system throughout the vehicle's lifetime by monitoring emission-related components and systems for deterioration and malfunction.



An illuminated indicator informs you of the need for service, but not of the need to stop the vehicle. However, the systems should be checked by your BMW center at the earliest possible opportunity.

Under certain conditions, the indicator will blink or flash. This indicates a rather severe level of engine misfire. When this occurs, you should reduce speed and consult the nearest BMW center as soon as possible. Severe engine misfire over only a short period of time can seriously damage emission control components, especially the catalytic converter.



Warning lamp "Service Engine Soon" for Canadian models.



When the filler cap is not properly tightened, the OBD system can detect the vapor leak and the indicator will light up. If the filler cap is subsequently tightened, the indicator should go out within a few days. ◀





**Replacement procedures:**

Onboard tool kit [128](#)  
 Windshield wiper blades [128](#)  
 Lamps and bulbs [129](#)  
 Changing a wheel [135](#)  
 Battery [136](#)  
 Fuses [138](#)

**In case of electrical malfunction:**

Fuel filler door [140](#)  
 Luggage compartment lid,  
 storage compartment [140](#)  
 Passenger-side door [141](#)  
 Closing the convertible top [141](#)

**Giving and receiving assistance:**

Jump starting [143](#)  
 Towing [144](#)

**Overview****Controls and features****Operation, care and maintenance****Owner service procedures****Advanced technology****Technical data****Index**





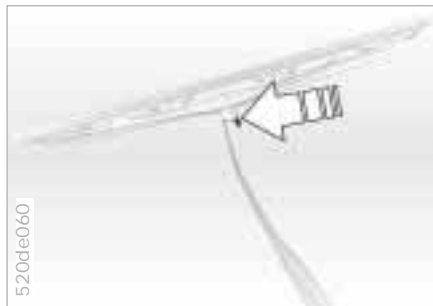

The onboard tool kit is located under the luggage compartment's floor panel.

## Windshield wiper blades



- 1 To move the wipers to the fold-out position:  
Turn the ignition on. Set the wiper lever in position 1 (intermittent setting). Turn the ignition back off during the wiper-delay pause. The wipers will then be in a rather vertical position
- 2 Rotate the wiper arm completely out from the windshield
- 3 Position the wiper blade at an angle and pull the release spring (arrow)
- 4 Fold the wiper blade down and unhook it toward the windshield
- 5 Pull the wiper blade past the wiper arm toward the top
- 6 Insert a new wiper blade and press it in until you hear it click into place.

 Fold the wipers back onto the windshield before turning the ignition key to position 1 or 2. If you do not, the wipers could be damaged. ◀

 Use only wiper blades approved by BMW. ◀

## Lamps and bulbs

The lamps and bulbs make essential contributions to the safety of your vehicle. Therefore, comply fully with the following instructions during bulb replacement. If you are not familiar with any of the procedures, consult your BMW center.

 Do not touch the glass portion of a new bulb with your bare hands since even small amounts of impurities burn into the surface and reduce the service life of the bulb. Use a clean cloth, paper napkin, or a similar material, or hold the bulb by its metallic base. ◀

A replacement bulb set is available from your BMW center.

 Whenever working on the electrical system, switch off the electrical accessory you are working on or disconnect the cable from the negative terminal of the battery. Failure to do this could result in short circuits.

To prevent injuries and damage, comply with any instructions provided by the bulb manufacturer. ◀

-  When cleaning the headlamps, please observe the following:
- ▷ Do not clean by wiping with a dry cloth. Never use abrasives or strong solvents to clean the covers
  - ▷ Remove dirt and contamination (such as insects) by soaking with BMW Car Shampoo and then rinsing with plenty of water
  - ▷ Always use a deicer spray to remove accumulated ice and snow – never use a scraper. ◀

### Xenon lamps

The main headlamps for your BMW Z8 roadster have been designed using xenon-light technology. The service life of these bulbs is very long and the probability of a failure is very low, provided that they are not switched on and off an unusual number of times. Should a lamp ever fail, however, please contact your BMW center for assistance.

 Because of the extremely high voltages involved, any work on the lighting system should be performed only by authorized technicians. Failure to comply with this creates a risk of fatal injury. ◀

### Neon lamps

The front turn signal indicators (side marker lamps), the rear turn signal indicators, the rear and brake lamps, as well as the high-mount brake lamp, are of neon-light technology. The service life for these lamps is very high and the likelihood of failure very minimal. Should a lamp ever fail, however, please contact your BMW center for assistance.

## 130 Lamps and bulbs

### Side turn signal indicators

5 watt bulb

Please contact a BMW center in the event of a malfunction.

### Side lamps

5 watt bulb

Please contact a BMW center in the event of a malfunction.

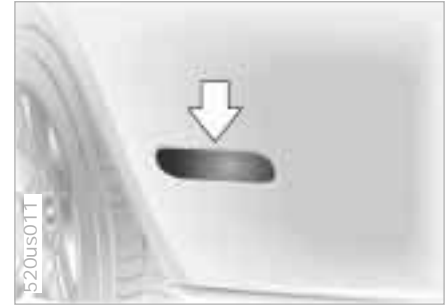
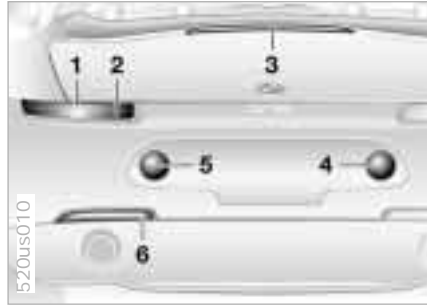

### Taillamps

1 Turn signal indicators	red
2 Taillamp/Brake lamp	red
3 High-mounted brake lamp	red
4 Backup lamp	red/white
5 Rear foglamp	red
6 Reflector	red

### Side marker lamps rear

Please contact a BMW center in the event of a malfunction.



## Replace the rear foglamp

21 watt bulb

- 1 Unlock the ventilation grille by giving it a 1/4 turn (use a screwdriver or coin) and remove it



- 2 Reach into the opening, turn the bulb holder to the left and take it out
- 3 Replace the bulb.

## Replace the backup lamp

21 watt bulb

Replacing this bulb is done the same as it is for the rear foglamp.

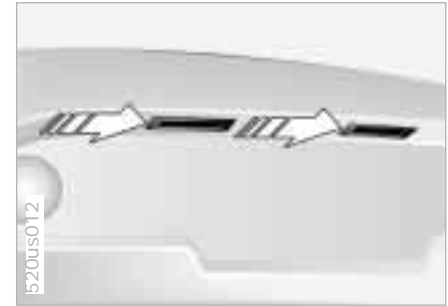

## Replace the license plate lamp

5 watt bulb

- 1 Turn the lamp to the right and take it out by pulling downward
- 2 Turn the lamp socket toward the rear and take it out
- 3 Replace the bulb.

## 132 Lamps and bulbs

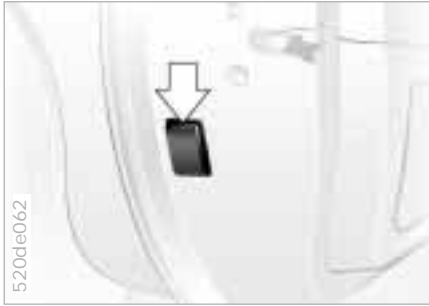

### Replace the door warning lamp

5 watt bulb

- 1 Pry the lamp out by pressing on the narrow side with a screwdriver
- 2 Turn the bulb holder to the left and remove it
- 3 Replace the bulb.

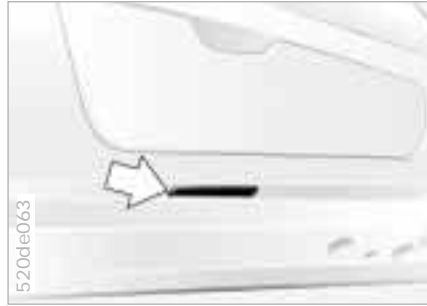

### Replace the exit lamp

5 watt bulb

- 1 Pry the lamp out by pressing on the narrow side with a screwdriver
- 2 Replace the bulb.

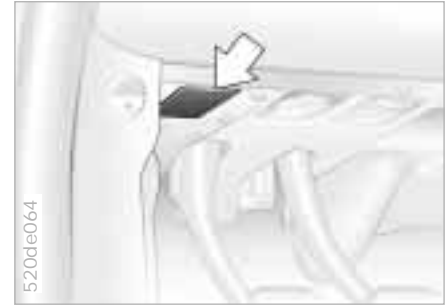

### Replace the footwell lamp

5 watt bulb

- 1 Pry the lamp out by pressing on the narrow side with a screwdriver
- 2 Replace the bulb.



## Replace the interior lamp

Front

Xenon bulb, 6 watts  
Interior lamp/Reading lamp

- 1 Pry the lens out using a screwdriver
- 2 Pull the lamp socket out of the lamp insert
- 3 Remove and replace the bulb.

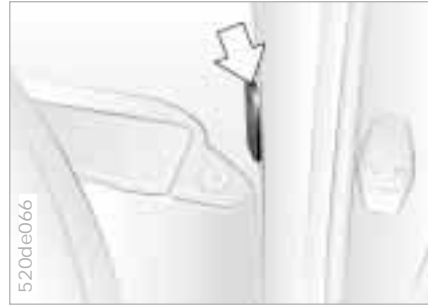

Rear

5 watt bulb

- 1 Use a screwdriver to remove the lens from the side
- 2 Replace the bulb.

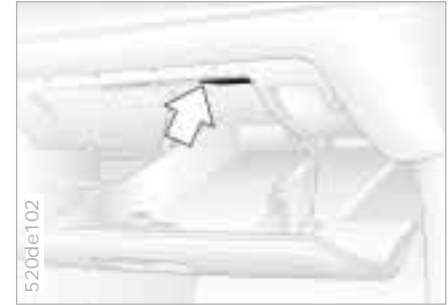

## Replace the bulb in the glove compartment

5 watt bulb

- 1 Pry the lamp out using a screwdriver
- 2 Remove the reflector
- 3 Replace the bulb.

## 134 Lamps and bulbs

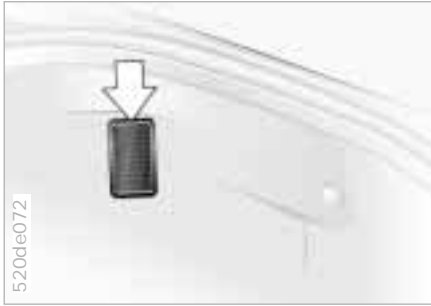

### Replace the luggage compartment lamp

6 watt bulb

- 1 Pry the lamp out using a screwdriver
- 2 Remove the reflector
- 3 Replace the bulb.



### Replace the engine compartment lamp

10 watt bulb

- 1 Using a screwdriver, press on the black detent and remove the lamp lens
- 2 Replace the bulb.

# Changing a wheel

## Safety tires

Your BMW Z8 roadster is equipped with safety tires.

The safety tires are made of self-supporting tires and customized wheel rims. Reinforcing the tires makes sure that they remain upright and still driveable to a limited degree even in the event of loss of pressure. Your vehicle is equipped with a tire pressure monitor that signals you in case of a flat tire.

## In the event of tire failure

The red indicator lamp on the instrument panel will flash in the event of a flat tire. In addition, a gong will sound. Refer to page 65.

Carefully reduce speed to less than 50 mph (80 km/h), avoiding any hard braking or steering maneuvers while doing so.

You will still be able to drive about 155 miles (250 km) on your safety tire, until you can get to a safe place to park, a gas station, or to your nearest BMW center. Under minimum vehicle loading, it could conceivably last more than 155 miles (250 km) sein.

If you cannot immediately determine which tire is defective just by looking at it, then check the tire pressure in all four tires.





Have your BMW center replace your tires. For safety reasons, do not have safety tires repaired. Your BMW center has been trained to work with the safety tires and is equipped with the necessary special tools. ◀



If necessary, please have your BMW center switch the tires on your vehicle from summer to winter tires, or the reverse. ◀

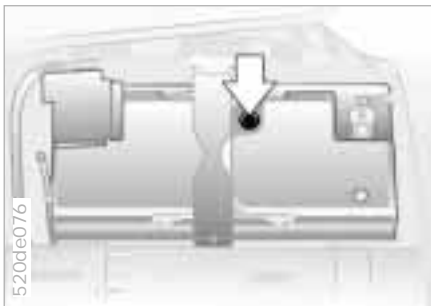



 Battery posts, terminals, and related accessories contain lead and lead compounds. Wash hands after handling. ◀

### Installation location

The battery is located under the luggage compartment's floor panel.

### Charge condition

You can read the charge condition of the battery with the "Magic Eye" (hydrometer):

- ▷ Green: adequate charge
- ▷ Black: not charged adequately. The battery must be recharged. Please contact your BMW center for additional information
- ▷ Yellow: replace the battery.

 The service life specified for the battery can be achieved only if it is always kept adequately charged. If the vehicle is primarily used for stop-and-go traffic, be sure to check the charge state often. ◀

### Maintenance

The battery is completely maintenance-free. That means that the original battery acid will normally last for the service life of the battery under moderate climate conditions.

 For all questions regarding the battery, please consult your BMW center. Since the battery is absolutely maintenance-free, the following is for your information only. ◀

### Symbols

You will find the following symbols on your vehicle battery. To avoid injury, please comply with the following precautions whenever you work with or near the battery.



Before handling the battery, please read the following information.



Wear eye protection. Do not allow particles containing battery acid or lead to come into contact with eyes, skin, or clothing.



Battery acid is extremely corrosive. Wear eye protection and protective gloves. Do not tip the battery. Battery acid can leak from the ventilation openings.



Be sure that children keep well away from batteries and battery acid.



Never allow sparks or open flame near the battery. Do not smoke in the vicinity of the battery. Avoid creating sparks when working around electrical cables or equipment. Turn the key to position 0 in the ignition when disconnecting or connecting the battery. Do not short-circuit the battery terminals. This creates a risk of injury from high-energy sparks.

# Battery



A highly explosive gas is generated when the battery is charged.



If you happen to get acid in your eyes, rinse thoroughly for some minutes with clear water.

Consult a physician immediately. If you get acid spray on your skin or clothing, rinse with plenty of water. If acid is accidentally ingested, consult a physician immediately.



In order to protect the battery case from ultraviolet radiation, do not place it in direct sunlight.

A discharged battery can freeze. Store the battery in areas where temperature remains above freezing.

## Removing and installing



Do not disconnect the battery cable when the engine is running. Disconnecting the battery cable when the engine is running will cause a voltage surge which will damage the vehicle's onboard electronics.

Do not make any modifications in the wires to the positive terminal. If you do so, the protective function of the safety battery terminal is no longer ensured. Repairs and disposal may only be performed by specially trained personnel. ◀

When removing, first disconnect the cable to the negative terminal, then disconnect the cable to the positive terminal. Loosen the center adjusting screw for the battery's retaining strap (use the screwdriver found in the onboard tool kit) and remove the bracket.

When installing, first connect the cable for the positive terminal, then the cable for the negative terminal.



When installing, make sure that the battery is seated properly, and that the battery bracket is installed with the center adjusting screw, because otherwise in the event of an accident, the battery will not be secure enough. ◀

## Charging the battery

Charge the battery in the vehicle only when the engine is not running. Use the connections provided in the engine compartment (for correct connections, refer to "Jump starting" on page 143).



Before performing any work on the electrical system, disconnect the cable from the negative terminal. If you do not, short circuits can create the risk of fire or personal injury. ◀

If you plan to park the vehicle for longer than 4 weeks, disconnect the battery from the vehicle's electrical system by disconnecting the cable at the negative terminal. Then recharge the battery with an appropriate battery charger.

If you intend to store the vehicle for longer than 12 weeks, remove the battery, charge it and store it in a cool and dust-free room where there is no danger of freezing. During storage, have the battery recharged every six months.

Also, recharge the battery before it is reinstalled. If this is not done, the battery will not be serviceable. Every time the battery is discharged, especially over extended periods, its service life is reduced.



Return used batteries to a recycling point or your BMW center. Maintain the battery in an upright position for transport and storage. Secure the battery to prevent it from tilting during transport. ◀

## Fuses

If an electrical accessory should fail, switch it off and check the fuse.

A list for both the fuses and their respective amperages, and the electrical devices, is located in the glove compartment on the fuse box lid, or in the storage area behind the passenger-side seat on the inside part of the storage lid.



### In the glove compartment

- ▷ Open the glove compartment
- ▷ Unlock the fuse box and swing it downward
- ▷ Remove the lid with the list on it. Spare fuses and plastic tweezers are located in the fuse box lid behind the passenger-side seat
- ▷ Use the plastic tweezers to remove the fuse for the accessory or equipment that has stopped working
- ▷ Replace a blown fuse, recognizable by its melted metal strip, with a new fuse that has the same color or ampere rating.



Do not attempt to repair a burned out fuse or replace it with a fuse having a different color or ampere rating. To do this could cause a fire in the vehicle resulting from a circuit overload. ◀

If the fuse continues to burn out, have the problem taken care of by a BMW center.

## Behind the passenger's seat

- ▷ Move the passenger's seat forward and open the storage compartment located behind it.  
The list is on the lid's inside cover
- ▷ Remove the fuse box lid containing the spare fuses and the plastic tweezers
- ▷ Use the plastic tweezers to remove the fuse for the accessory or equipment that has stopped working
- ▷ Replace a blown fuse, recognizable by its melted metal strip, with a new fuse that has the same color or ampere rating.

## 140 Fuel filler door

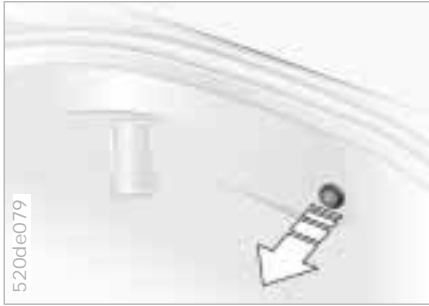

### Manual release

Pull the knob with the fuel pump symbol (arrow) on the right trim panel of the luggage compartment.

## Luggage compartment lid, storage compartment

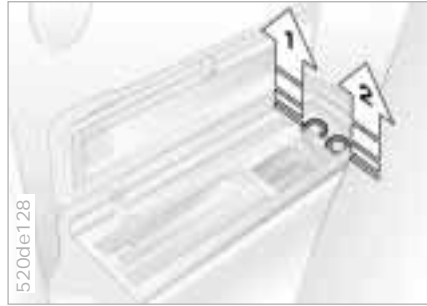

### Manual release

- 1 Flip the backrest for the passenger's seat forward and open the storage compartment located behind it
- 2 Lift the cover off the fuse box
- 3 Unlock the luggage compartment lid (arrow 1) or the storage compartment for the cellular phone (arrow 2) by pulling on the respective ring.



### Manual release

- ▷ Unlock from the inside and open (pull on the door handle twice; refer to page 34)
- ▷ Moving the lever of the passenger-side door upward or downward, upward: door is always unlocked downward: door is always locked, but can be opened from inside.

### Manual operation

 You can close the convertible top manually, but never open it manually, because this would cause damage. ◀

In the event of a malfunction, please consult your BMW center to have it corrected.

If you do close the convertible top manually, please proceed as instructed on the following page.

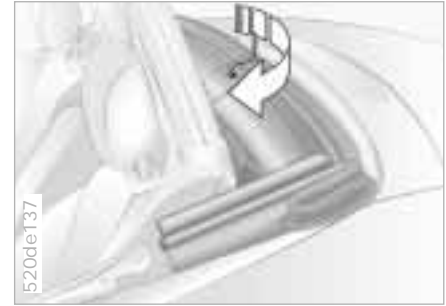

- 1 Take off the oval-shaped cover cap, using a screwdriver to help you if necessary
- 2 Put the long end of the Allen wrench (from the onboard tool kit) into the support
- 3 Unlock the locking retainer by turning it clockwise all the way to the right, and pull the Allen wrench out again

## 142 Closing the convertible top



4 Pull the convertible top on the convertible top frame forward and sideways (arrows) and, using a little effort, swing it forward over the window frame

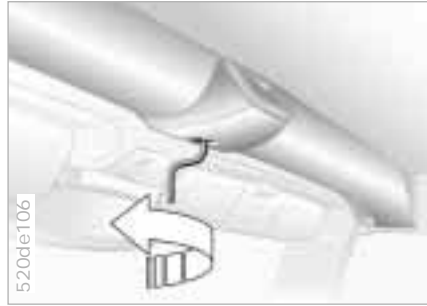

5 Gripping the recessed handle, pull the convertible top frame all the way on top of the window frame  
6 Place the Allen wrench (from the onboard tool kit) into the support  
7 If you keep turning the Allen wrench counter-clockwise, you will hear the convertible top lock with the window frame.

## Jump starting

Do not use spray starter fluids to start the engine.

If the battery is discharged, the engine can be started with the use of two jumper cables and the battery of another vehicle. Use only jumper cables with fully insulated grips on the terminal clamps.

 Do not touch the parts conducting current while the engine is running. There is a risk of fatal injury if you do this. ◀

Carefully comply with the following instructions to avoid personal injury or damage to one or both vehicles:

- 1 Be sure that the battery on the support vehicle is also rated at 12 volts, and that the capacities of the two batteries (Ah) are roughly comparable (printed on casing)
- 2 Leave the discharged battery connected to the vehicle's electrical system
- 3 Make sure that there is no contact between the bodywork of the two vehicles – short circuit risk!



- 4 Start by connecting the jumper cable from the positive terminal of the support vehicle to the positive terminal connector located in your BMW's engine compartment. The cover of the auxiliary terminal for jump starting is identified by a "+" sign. Refer to the illustration. Remove by pulling the tab (arrow)



- 5 Then connect the negative terminals. Attach the cable to either the support vehicle's negative battery terminal (-), or to a suitable ground on its engine or bodywork. Then connect the other end of the cable to a ground on the engine or on the bodywork of the vehicle that is to be started. This is a special nut that is provided on the BMW (refer to the illustration)

 Follow the same sequence for connecting the jumper cables if you assist in jump starting another vehicle, otherwise, you run the risk of injury caused by spark generation at the battery. ◀



- 6 Start the support vehicle's engine and let it run
- 7 Start the engine on the vehicle needing the jump start, and allow it to run as usual. If the first start attempt is not successful, wait a few minutes before another attempt in order to allow the discharged battery to recharge
- 8 Before disconnecting the jumper cables from your BMW, turn on the lamps, set the blower to the highest speed and allow the engine to run for at least 10 seconds. This will prevent a voltage surge from the voltage regulator to the electrical accessories
- 9 Then disconnect the jumper cables in reverse sequence.

Have the battery recharged if necessary.

## Towing

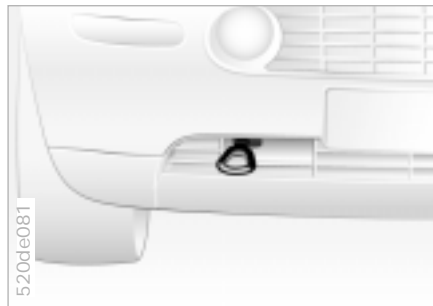

### Tow fitting

The screw-in tow fitting is stored in the onboard tool kit; be sure that it remains in the vehicle at all times. This fitting is designed for installation in the tow sockets located at the front and rear of the vehicle. It is intended for towing on paved road surfaces only.

It should not be used to pull a vehicle out of deep snow, mud, sand, etc. Always observe all applicable towing laws and regulations.

### Access to tow sockets

#### Front

The uppermost grille stub is clipped on the grille – which is located below the main grille on the lower right – and this grille can be pulled off, if you pull forward on it.

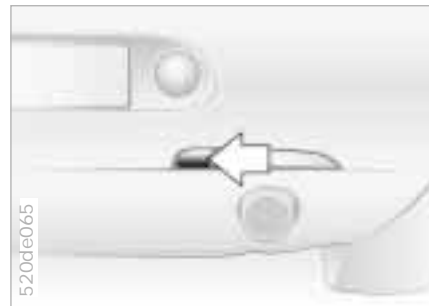

#### Rear

Use a screwdriver to press sideways on the opening to remove the cover (arrow).

 Screw the tow fitting in until it bottoms firmly. If this is not done, the threads could be damaged. Do not tow the vehicle by any components of the running gear, or lash them down in any way. If you do so, the components could be damaged, leading to possible accidents. ◀

Use only a nylon towing strap to tow the vehicle. The inherent resilience of this material helps protect both vehicles from sudden jerking movements.

## Towing

 Avoid "off-center" towing. Be sure that the tow rope is pulled tightly when the towing vehicle begins to move. ◀

 The towed vehicle should always be the lighter of the two vehicles. If this is not the case, it is no longer possible to control vehicle response. ◀

### Tow-starting

For instructions on jump starting, refer to page [143](#).

Never attempt to use your vehicle to push another vehicle, since damage to the energy-absorbing bumpers could result.

### Towing a vehicle

- 1 Put the manual-shift gear lever in neutral
- 2 Towing speed:  
Max. 45 mph (70 km/h)
- 3 Towing distance:  
Max. 95 miles (150 km)
- 4 Leave the ignition key at position 1 to ensure that the brake lamps, turn signals, horn and windshield wipers remain operative, and to prevent the steering lock detent from engaging
- 5 Switch on the hazard-warning system (comply with country-specific regulations).

Find some means of identifying the vehicle in tow, e.g. place a sign or warning triangle in the rear window.

 Make sure that the ignition key remains in position 1 even when the electrical system has failed to prevent the steering lock from engaging. The steering and brakes are without power assist when the engine is not running. This means that increased effort is required for steering and braking. ◀

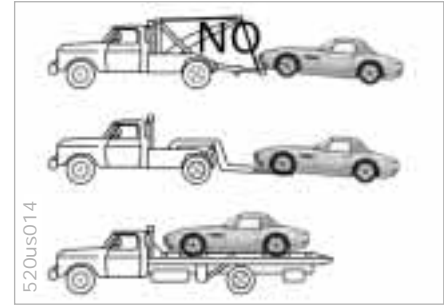

### Towing with a commercial tow truck

- ▷ Do not tow with sling-type equipment
- ▷ Use a wheel lift or flat bed equipment
- ▷ Please comply with applicable towing laws.

 Never allow passengers to ride in a towed vehicle for any reason. Never attach tie-down hooks, chains, straps, or tow hooks to the tie rods, control arms, or any other part of the vehicle suspension. If you do so, severe damage will occur to these components. ◀

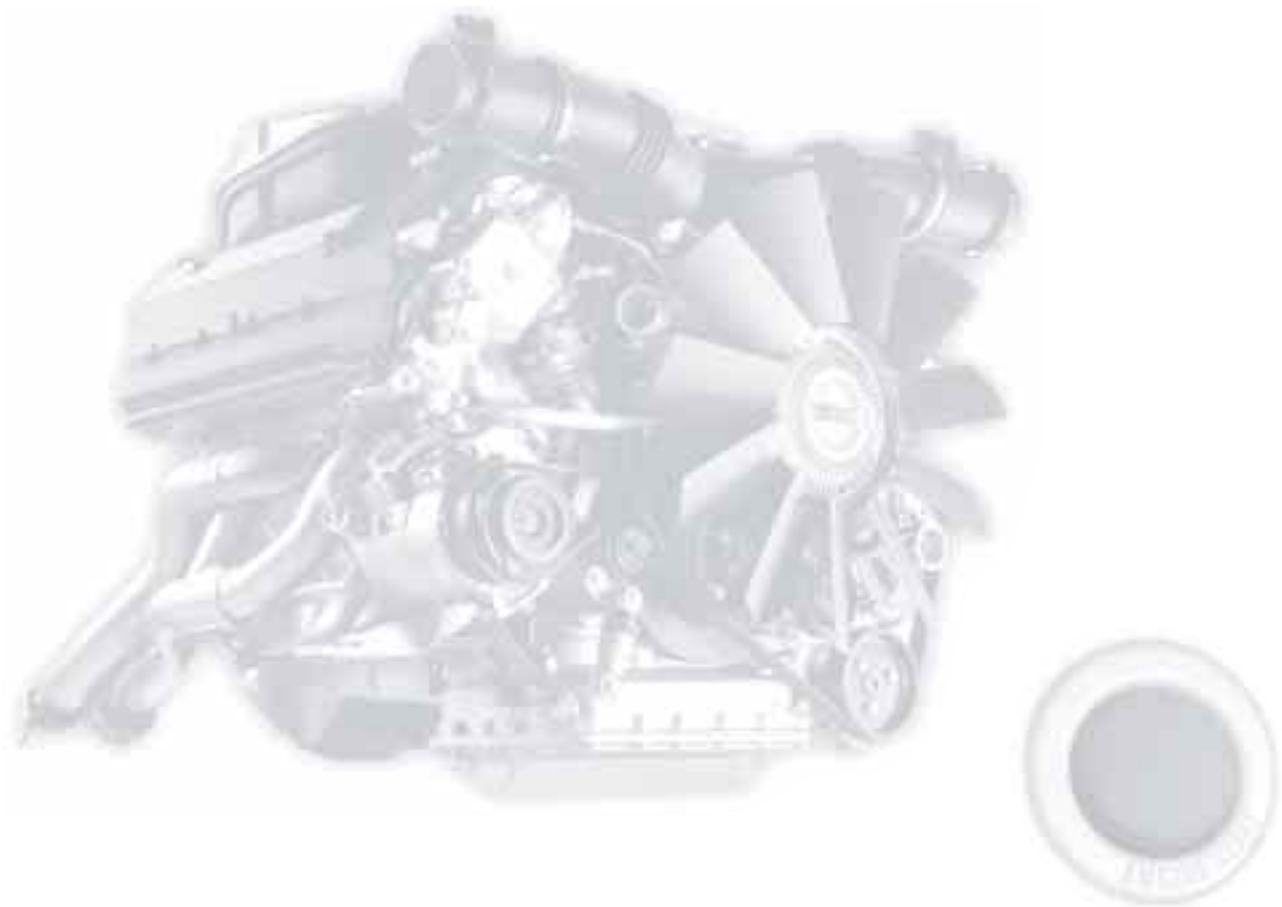



Airbags [148](#)  
Radio reception [148](#)  
Dynamic Stability Control  
(DSC) [149](#)  
Safety belt tensioner [149](#)  
Interior rearview mirror with  
automatic dimmer [150](#)  
Xenon lamps [151](#)

Overview

Controls and features

Operation, care  
and maintenance

Owner service procedures

Advanced technology

Technical data

Index

Overview

Controls

Car care

Repairs

Technology

Data

Index



Deceleration sensors continuously monitor the acceleration forces acting upon the vehicle. If, as the result of a frontal collision, a deceleration is reached at which the protection of the safety belts alone is no longer adequate, the gas generators of the driver and passenger airbags are ignited. However, the passenger airbag is only triggered if an additional sensor has recognized that the passenger seat is occupied.

In the event of a side collision, only the side airbags will be triggered if necessary. And only that airbag for that side of the vehicle where the collision occurred will be triggered.

The airbags located under the marked covers inflate and unfold in a matter of a few milliseconds. In this process, they tear through the designed separation points of the covers or press them out. Because the inflation process must be virtually instantaneous, it is necessarily accompanied by a certain amount of ignition and inflation noise. The gas required to inflate the airbags is not dangerous, and the associated smoke then dissipates.

The entire process is completed within fractions of a second.

## Radio reception

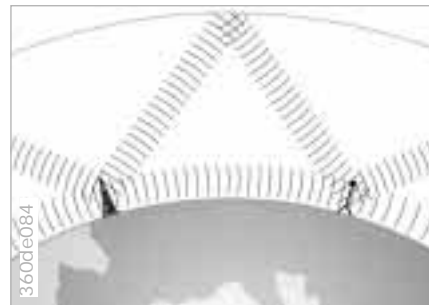

The AM frequency bands (medium-wave, long-wave and short-wave) make it possible to receive stations from a great distance, because the broadcast signals travel not only along the ground as surface waves, but also as atmospheric waves that are reflected from the ionosphere.

Frequency-modulation (FM) provides substantially better sound quality than the other frequency bands. However, because FM transmissions rely on line-of-sight broadcast waves, their effective reception range is limited.

The limitations inherent to radio reception in a moving vehicle have been minimized by a number of innovative system designs.

Highly sensitive sensors monitor the number of revolutions of the wheels, steering angle, lateral acceleration, brake pressure and the movement of the vehicle around its vertical axis. If differences in wheel speed should occur, the system will recognize the danger this loss of traction causes and reduce the drive torque going to the wheels. The system will also apply the brakes specifically to the rear wheels, if necessary.

In addition, DSC permanently monitors the vehicle's current operating condition and compares it with an ideal condition that is calculated from the sensor's signals. If differences such as under- or oversteering should occur, DSC will stabilize the vehicle in fractions of a second by reducing engine power output, applying the brakes to individual rear wheels – and to specific front wheels, too, if necessary. As a result, dangerous skids can be prevented even as they are beginning.

You may need some time to become accustomed to this system's intervention. However, it provides optimum drive force and vehicle stability. The braking intervention may be accompanied by sounds specific to the system.



The safety belt tensioner responds to severe frontal collisions by tightening the belt to ensure that occupants remain firmly positioned in their seats. A gas-pressure system retracts the buckle assembly to tension the shoulder and lap belts within fractions of a second. This reduces the tendency to slide under the lap belt.

## 150 Interior rearview mirror with automatic dimmer

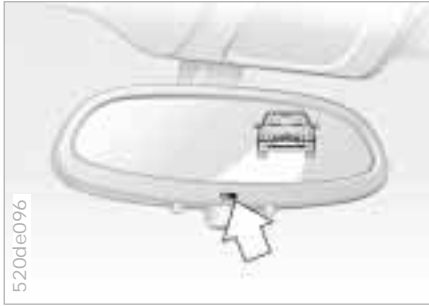

The interior rearview mirror with automatic dimmer reduces blinding from following traffic by adapting the intensity of the reflected images to correspond to levels of light registered by the unit's sensors. The mirror reverts to its undimmed setting as soon as the light source disappears. One light sensor is mounted on the front of the mirror housing. This sensor, that is directed forward, measures light intensity in the area ahead of the vehicle. The second light sensor is integrated within the mirror's frame. The electronic control system compares the light intensity from front and rear. The difference provides the basic parameter used to modulate an electrical current and induce chemical changes in a semisolid layer incorporated in the lens.

The semisolid reacts chemically to this electrical current, thus providing dimming of the mirror through an infinitely-variable range (electrochromic technology).

As a result, it is no longer necessary to dim the mirror manually, and the driver can concentrate completely on traffic conditions.

## Xenon lamps\*

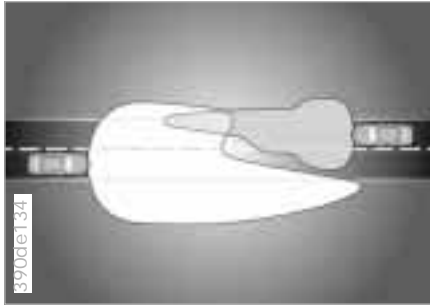

Xenon lamps illuminate the side and front areas of the vehicle much more brightly and with greater uniformity than traditional halogen lamps.

In a xenon lamp, an electric arc replaces the filament to generate intense illumination. A gas mixture in a quartz glass tube with metal vapor is ignited by a high electric voltage. The arc that is generated is then sustained by a lower voltage. When the lamp is turned on, there is a brief warm-up period. Maximum brightness is attained in approx. 15 seconds.

Xenon lamps provide significantly improved visibility, especially during adverse weather and poor driving conditions, e.g. driving at night in heavy rain or through road repair areas where there are no lane markers.

Vehicles with xenon lamps are equipped with automatic headlamp range control. Thus the highway is always optimally lighted and drivers in oncoming traffic are not blinded.

Xenon lamps make a significant contribution to highway safety since other highway users, bicyclists and motorcyclists in the right lane, and pedestrians are more easily detected.



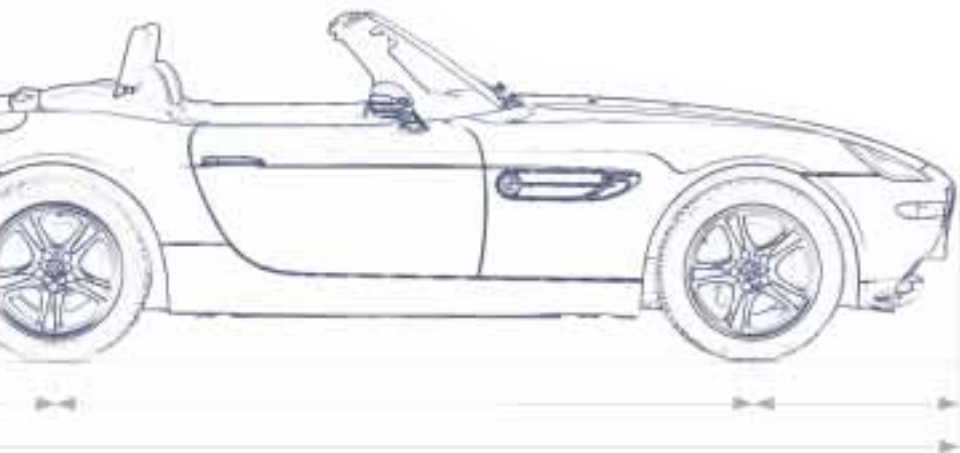

Engine data [154](#)  
Dimensions [155](#)  
Weights [156](#)  
Capacities [157](#)  
Electrical system [158](#)  
Drive belts [158](#)



[Overview](#)

[Controls and features](#)

[Operation, care  
and maintenance](#)

[Owner service procedures](#)

[Advanced technology](#)

[Technical data](#)

[Index](#)

Overview

Controls

Car care

Repairs

Technology

Data

Index

## 154 Engine data

		BMW Z8
Displacement	cu in (ccm)	301.5 (4,941)
Number of cylinders		8
Maximum output at engine speed	hp rpm	394 6,600
Maximum torque at engine speed	ft lbs (Nm) rpm	368 (500) 3,800
Compression ratio	$\varepsilon$	11
Stroke	in (mm)	3.50 (89.0)
Bore	in (mm)	3.70 (94.0)
Fuel-injection system		Digital electronic Engine- Management System

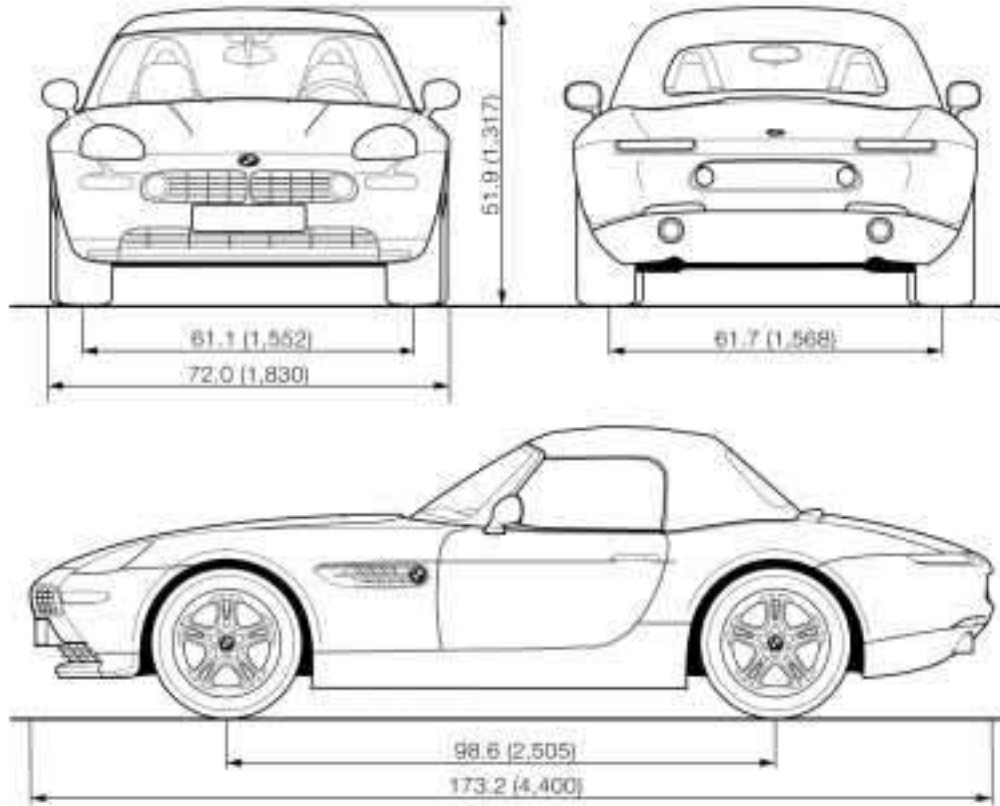

All dimensions are given in inches (mm). Min. turning circle dia.: 38.0 ft (11.6 m)

156 **Weights**

		BMW Z8
Curb weight (with one person, ready for operation, full tank of fuel, options not included)	lbs. (kg)	3,725 (1,690)
Approved gross vehicle weight	lbs. (kg)	4,255 (1,930)
Approved front axle weight	lbs. (kg)	2,028 (920)
Approved rear axle weight	lbs. (kg)	2,359 (1,070)
Approved roof load capacity	lbs. (kg)	–
Luggage compartment capacity	cu ft (liters)	7.2 (203)

Permitted axle loads and permitted total vehicle weight may not be exceeded.

			Notes
Fuel tank	gal. (liters)	approx. 19.3 (approx. 73)	Fuel quality: page <a href="#">24</a>
Reserve	gal. (liters)	approx. 2.6 (approx. 10)	
Windshield washer system/ Headlamp washer system	quarts (liters)	approx. 5.6 (approx 5.3)	For details: page <a href="#">108</a>
Cooling system including heater circuit	quarts (liters)	16.4 (15.5)	For details: page <a href="#">111</a>
Engine oil filter change	quarts (liters)	7.9 (7.5)	"BMW High Performance Synthetic Oil." For details: page <a href="#">110</a>
Manual transmission	quarts (liters)	2.0 (1.9)	Lifetime fluid; no fluid change required
Differential	quarts (liters)	1.3 (1.2)	Fluid change at the 1,200 Mile Service, then lifetime fluid; no fluid change required

## 158 Electrical system

### Battery

12V, 90 Ah

### Spark plugs

NGK BKR 6 EQUIP

This spark ignition system meets all requirements of the Canadian Interference-Causing Equipment Regulations (ICES-2).

## Drive belts

Water pump – Alternator – Power steering

Ribbed V-belt 7 PK 1440

A/C compressor

Ribbed V-belt 5 PK 980



You can obtain Original BMW Parts and Accessories, as well as professional advice from your BMW center. ◀





A B C

P Q R

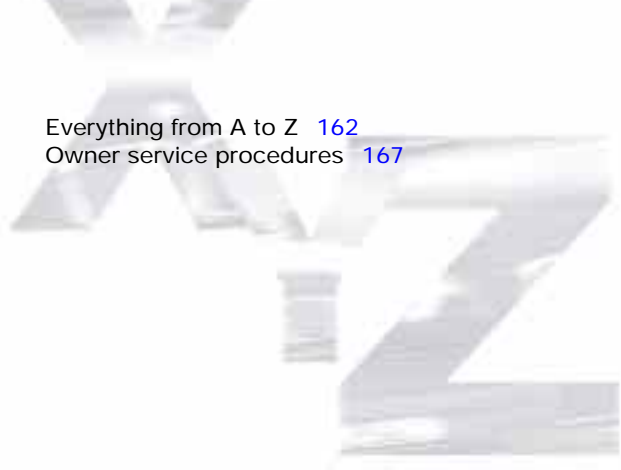

Everything from A to Z [162](#)  
Owner service procedures [167](#)

[Overview](#)

[Controls and features](#)

[Operation, care  
and maintenance](#)

[Owner service procedures](#)

[Advanced technology](#)

[Technical data](#)

[Index](#)

Overview

Controls

Car care

Repairs

Technology

Data

Index

# Everything from A to Z

## A

ABS (Antilock Brake System) 19, 86  
Accessories 4  
Activated charcoal filter 73  
Adding engine oil 109  
Adding washer fluid 108, 157  
Adjusting the temperature 72  
Adjusting seats 43  
Air conditioner 70  
Air distribution 72  
Air nozzles 70  
Air outlets 70  
Air pressure 96  
Air supply 72  
Airbags 19, 49, 121, 148  
Alarm system 36  
Antenna 92  
Antifreeze 111  
Antilock Brake System (ABS) 19, 86  
Anti-theft alarm system 36  
Anti-theft protection 30  
Aquaplaning 85, 97  
Ashtray 79  
Attach vehicle vacuum cleaner 80  
Automatic car washes 115  
Automatic speed control 59

Automatic windshield washer 58  
Avoiding unwanted alarm 37  
Axle loads 156

## B

Backrest, unlock 44  
Backup lamps 56  
bulb replacement 130  
Battery 136, 158  
charge 137  
discharged 143  
Battery capacity 158  
Battery charge current 18  
Belts 48  
Beverage can holder 78  
Blower 72  
BMW High Performance Synthetic Oil 110  
Bore 154  
Brake fluid 112  
Brake hydraulic system 18  
Brake pads 20  
Brakes 88  
brake faults 89  
Breaking in the vehicle 84  
Bulb replacement 129

## C

California Proposition 65 Warning 123

Can holder 78  
Car Memory 46  
Car radio 62, 92  
refer also to the car radio Owner's Manual  
Car radio reception 92, 148  
Car telephone 79  
Car wash 115  
Care exterior 117  
interior 119  
Caring for the vehicle finish 118  
Catalytic converter 85  
CBC (Cornering Brake Control) 19  
CD mode, refer to the radio Owner's Manual  
Cellular phone 92  
refer also to "Radio and Information Systems Owner's Manual"  
Central locking system 30  
key 34  
Changing the oil filter 157  
Check air pressure 24  
Child restraint systems 51  
Child seat safety 52  
Child seats 51  
Cigarette lighter 80  
Clock 62  
Cockpit 14

Code, refer to the radio Owner's Manual  
Combination switch 56  
Compartments 76, 77  
Compartments for stowing items 76  
Compression 154  
Configuring the settings 46  
Connector for On-Board-Diagnostics 124  
Consumption display 60  
Controls 14  
Convertible top 39  
closing after an electrical malfunction 141  
Coolant 111, 157  
Coolant temperature gauge 61  
Cornering Brake Control (CBC) 19  
Cruise control 59  
Curb weight 156  
Current check indicator 18

## D

Dashboard 14  
Data dimensions 155  
engine 154  
technical 154  
weights 156

# Everything from A to Z

- Daytime running lamps  
switch 67
- Daytime-driving lamp  
switch 67
- DBC (Dynamic Brake Control) 88
- Defrost position 73
- Defroster, rear  
window 58, 73
- Defrosting the windows 73
- Dimensions 155
- Dipstick 109
- Disc brakes 88
- Displacement 154
- Display lighting 67
- Displays 16
- Door keys 28
- Door warning lamp  
bulb replacement 132
- Doors  
emergency actuation 30  
remote control 31  
unlocking and locking 30
- DOT Quality Grades 98
- Draft-free ventilation 73
- Drive belts 158
- Driving hints 85
- Driving lamps 67
- DSC (Dynamic Stability Control) 20, 63, 149
- Dynamic Brake Control (DBC) 88
- Dynamic Stability Control (DSC) 20, 63, 149
- ## E
- Electric power seat  
adjustment 43
- Electric power windows 38
- Electrical defect  
passenger-side door 141
- Electrical equipment  
failure 138
- Electrical system 158
- Electronic vehicle  
immobilizer 29
- Emergency actuation  
doors 30
- Emergency operation  
fuel filler door 140  
passenger-side door 141
- Emergency compartment 106
- Engine coolant 111
- Engine cooling 157
- Engine data 154
- Engine oil 109  
consumption 109  
fill capacity 157  
quality 110  
specifications 110  
viscosity 110
- Engine oil level 19  
check 109
- Engine oil pressure 18
- Engine output 154
- Engine speed 154
- Engine, starting 54
- Exit lamps  
bulb replacement 132
- Exterior mirrors 45
- ## F
- Fault, ABS 87
- Fill capacities 157
- Filler cap cover 23
- Filling capacities 157
- Filling the washer  
reservoir 157
- Filling the windshield washer  
reservoir 157
- First aid 22
- First-aid kit 22
- Fittings, tow starting and  
towing 144
- Flashlight 77
- Flat tire 135
- Foglamps  
bulb replacement 131
- Follow-Me-Home lamps 67
- Footbrake 88
- Footwell lamps 68  
bulb replacement 132
- For car phones and  
telephones, please refer to  
the manufacturer's  
Owner's Manual
- Front seat adjustment 43
- Frost protection,  
radiator 111
- Fuel 24  
preparation 154
- Fuel filler door  
release after an electrical  
defect 140
- Fuel gauge 60
- Fuel indicator 60
- Fuel quality 24
- Fuel tank capacity 157
- Fuses 138
- ## G
- Gasoline 24
- Glove compartment 76
- Glove compartment lamp  
bulb replacement 133
- Gross vehicle weight 156
- ## H
- Handbrake 55
- Handsfree system 79
- Hardtop 94
- Hazard warning flashers 22
- Hazard warning triangle 22
- Head restraint 44
- Headlamp covers,  
care 115, 129
- Headlamp flasher 68

# Everything from A to Z

Headlamp washer system 108, 157  
Headlamp washers 58  
Heating and ventilation 70  
Heating, rapid 75  
Heavy loads 81  
Height 155  
High beams 21, 56, 68  
Holder for beverage cans 78  
Hood release 104  
Horn 15

**I**  
Identification, tires 101  
Ignition keys 28  
Ignition lock 53  
Indicator lamps 18  
Inflation pressure 24, 96  
  monitoring 65  
INSPECTION 61  
Instrument cluster 16  
Instrument lighting 67  
Instruments 16  
Interaxle tire rotation 100  
Interface socket for On-Board-Diagnostics 124  
Interference  
  cellular phone 92  
Interior lamps 32, 68  
  bulb replacement 133  
  remote control 32

Interior motion sensor 36  
Interior rearview mirror  
  with automatic dimmer 46, 150  
Intermittent wipe 57

**J**  
Jump starting 143

**K**  
Key Memory 46  
Key with remote control 28  
Keys 28

**L**  
Lamps on warning 67  
Leather care 120  
Length 155  
License plate lamp  
  bulb replacement 131  
Light switch 67  
Light-alloy wheels 103  
Lighter 80  
Loading 81  
Louvers 70  
Low beam headlamps 67  
Low beam light inside  
  rearview mirror 46  
Low traction road  
  surfaces 91

Luggage compartment  
  capacity 156  
  emergency release 35  
  remote control 33  
Luggage compartment lamp  
  bulb replacement 134  
Luggage compartment lid 35  
  emergency release 35

**M**  
M+S tires 102  
Maintenance 61, 114  
Manual transmission 56  
Microfilter 73  
MID (Multi-Information Radio) 62  
Mirrors 45  
Mobile cellular phones 92  
Modifications,  
  technical 4, 123  
Multi-Information Radio (MID) 62

**N**  
Navigation system, refer to the radio Owner's Manual  
Neckrest 44

**O**  
OBD interface socket 124

Odometer 60  
Oil  
  additives 109  
  consumption 109  
  fill capacity 157  
  quality 110  
  specifications 110  
  viscosity 110  
Oil change intervals, see the Service and Warranty Information Booklet (US models) or the Warranty and Service Guide Booklet (Canadian models)

Oil dipstick 109  
Oil level  
  check 109  
  indicator lamp 19  
Oil pressure  
  indicator lamp 18  
OILSERVICE 61  
Onboard tool kit 128  
Opening and closing  
  from inside 34  
  from outside 30  
Outlets, ventilation 70  
Outside temperature display 62

**P**  
Paint blemishes 117  
Paint, care 117

# Everything from A to Z

- Paintwork, minor repairs 118
  - Paintwork, waxing 118
  - Parking brake 55
  - Parking lamps 68
  - Parking, winter 91
  - Performance 154
  - Pocket flashlight 77
  - Pollen 73
  - Power steering 92
  - Power windows 38
  - Pressure monitoring, tires 65
  - Pressure, tires 24, 96
  - Pre-warmed seats 75
- R**
- Radio 62
    - refer also to the radio Owner's Manual
  - Radio reception 92, 148
  - Radios 92
  - RDW (Tire Pressure Warning) 65
  - Reading lamps 69
  - Rear foglamps 68
  - Rear lamp 130
  - Rear window
    - defroster 58, 73
  - Rearview mirror 45
  - Recirculated air mode 72
- R**
- Refueling 23
  - Remaining fuel indicator 60
  - Remote control 31
  - Removing condensation from the windows 73
  - Removing the vehicle from storage 122
  - Replacement keys 28
  - Reporting Safety Defects 5
  - Restraint systems 51
  - Reverse 15, 56
  - Roof load capacity 156
  - Rotating the tires 100
  - Rubber parts 90
- S**
- Safety belt tensioner 149
  - Safety belts 48
  - Safety buttons 34
  - Seat heating 75
  - Securing cargo 81
  - Self-defrosting mirrors 45
  - Service and Warranty Information Booklet (US models) 114
  - Service Interval
    - Display 61, 114
  - Shelves 76, 77
  - Side airbags 49
  - Side lamps 67
- S**
- Side marker lamps 67
    - bulb replacement 129, 130
  - Sliding 91
  - Slippery roads 91
  - Snow chains 90, 103
  - Socket 80
  - Spare key 28
  - Spark plugs 158
  - Speaker 79
  - Speed control 59
  - Speedometer 16
  - Starting 54
  - Starting
    - problems 85, 143, 144
  - Steel wheels 103
  - Steering 92
  - Steering wheel lock 53
  - Stopping the vehicle 54
  - Storage areas 76, 77
  - Storing your vehicle 122
  - Stroke 154
  - Summer tires 101
  - Switching off the engine 54
  - Symbols 2, 136
- T**
- Tachometer 60
  - Taillamps
    - bulb replacement 130
  - Tank capacity 157
  - Technical data 154
- T**
- Technical
    - modifications 4, 123
  - Telephone 79
  - Temperature display
    - outside temperature 62
  - Temperature gauge
    - engine coolant 61
  - Temperature layering 73
  - Tilt alarm 32
  - Tilt sensor alarm sensor 37
  - Tire codes 101
  - Tire damage 97
  - Tire inflation
    - pressure 24, 96
  - Tire pressure monitoring 65
  - Tire Pressure Warning (RDW) 65
  - Tire replacement 98, 99
  - Tire rotation 100
  - Tire specifications 103
  - Tire tread 97
  - Together 19
  - Tools 128
  - Torque 154
  - Tow fittings 144
  - Tow starting 144
  - Towing 144
  - Track 155
  - Traction Control System
    - refer to DSC 63
  - Transmission 56
  - Transmitter key 28
  - Tread depth, tires 97

# Everything from A to Z

Trip odometer [60](#)  
Trunk lid, refer to luggage  
  compartment lid [35](#)  
Trunk lights  
  bulb replacement [134](#)  
Turn signal indicator [21](#), [56](#)  
Turning radius [155](#)

## U

Uniform Tire Quality  
  Grading [99](#)  
Used batteries [138](#)

## V

Vehicle  
  starting [54](#)  
Vehicle battery [136](#), [158](#)  
Vehicle care  
  exterior [117](#)  
  interior [119](#)  
Vehicle Identification  
  Number (VIN) [113](#)  
Vehicle immobilizer [29](#)  
Vehicle painting [117](#)  
Vehicle storage [122](#)  
Vehicle weight [156](#)  
Ventilation [70](#)  
  draft-free [73](#)  
Vinyl upholstery, care [119](#)

## W

Warning lamps [18](#)  
Warranty and Service Guide  
  Booklet (Canadian  
  models) [114](#)  
Washer reservoir, filling [108](#)  
Washing your car [115](#)  
Water on roadways  
  deep water [85](#)  
Waxing, paintwork [118](#)  
Weights [156](#)  
Wheel rims [101](#)  
Wheelbase [155](#)  
Wheels and tires [101](#), [103](#)  
Width [155](#)  
Wind protector [93](#)  
Windows  
  comfort use [30](#)  
  remote control [32](#)  
Windshield washer nozzle  
  adjustment [108](#)  
Windshield washer reservoir,  
  filling [108](#)  
Windshield wipers [57](#)  
  blade replacement [128](#)  
Winter tires [101](#), [102](#)  
Wiper blade  
  replacement [128](#)  
Wiper system [57](#)  
Work in the engine  
  compartment [104](#)

## X

Xenon lamp [129](#), [151](#)

- A**  
Add brake fluid 112  
Add engine coolant 112  
Adding engine oil 109  
Adjust washer nozzles 108  
Avoiding a false alarm 37  
Avoiding unwanted alarm 37
- B**  
Backup lamps  
bulb replacement 130  
Battery  
add distilled water 136  
charging 137  
Brakes, brake faults 89, 90
- C**  
Changing a wheel 135  
Changing tires 135  
Checking air pressure 24  
Checking engine oil level 109  
Convertible top  
closing in event of electrical malfunction 140
- D**  
Defrost position 73  
Defrosting the windows 73
- Difficult steering 92  
Doors  
emergency actuation 30
- E**  
Electrical defect  
convertible top 140  
Electrical equipment failure 138  
Electrical failure  
fuel filler door 140  
Emergency activation  
convertible top 140  
Emergency actuation doors 30  
Emergency release  
fuel filler door 140  
Engine oil  
add 109  
quality 110  
specifications 110  
viscosity 110
- F**  
Fittings, tow starting and towing 144  
Flat tire 135  
Fuel filler door  
manual release after electrical fault 140
- H**  
Hazard warning flashers 22  
Hazard warning triangle 22  
Headlamp cover, care 129  
Hood release 104
- I**  
Indicator lamps 18  
Inflation pressure 24  
Interior lamps  
bulb replacement 133
- L**  
License plate lamp  
bulb replacement 131  
Luggage compartment lid,  
emergency release 35
- M**  
Maintenance 114
- O**  
Oil  
quality 110  
specifications 110  
viscosity 110  
Onboard tool kit 128
- P**  
Pressure, tires 24
- R**  
Rear foglamp  
bulb replacement 130  
Refill washer reservoir 108  
Refill windshield washer reservoir 108  
Removing condensation from the windows 73  
Replacing fuses 138  
Replacing lamp bulbs 129  
Replacing windshield wiper blades 128  
Replenish washer fluid 108  
Return used batteries 138
- S**  
Starting  
problems 54, 85, 144  
Switching off the interior motion sensor 37  
Switching off the tilt sensor alarm system 37
- T**  
Taillamp 130  
Tire damage 97  
Tools 128  
Tow fittings 144  
Tow starting 144  
Towing 144  
Trunk, emergency release 35



# Owner service procedures

## U

Use anti-freeze [112](#)  
radiator [112](#)

## W

Warning lamps [18](#)  
Work in the engine  
compartment [104](#)

# Refueling

So that you will have important specifications available when you stop to refuel, we recommend that you supplement this table with data which apply to your vehicle.

## Fuel

Designation	Premium Unleaded Gasoline
AKI: minimum	91

## Engine oil

Quality	
---------	--

The oil volume between the two marks on the oil dipstick corresponds to approx. 1.1 US quarts (1 liter).

## Tire inflation pressures

	Summer		Winter	
	Front	Rear	Front	Rear
2 persons	35 (240)	35 (240)	35 (240)	35 (240)

**We wish you an enjoyable  
driving experience.**



**The Ultimate Driving Machine**

